



Proceedings of the Eleventh Congress of the European Society for Research in Mathematics Education

Editors: Uffe Thomas Jankvist, Marja van den Heuvel-Panhuizen, Michiel Veldhuis
Organised by: Freudenthal Group & Freudenthal Institute, Utrecht University
Year: 2019

e r m e
european society for research in mathematics education



Editors

Uffe Thomas Jankvist, Danish School of Education, Aarhus University, Denmark.

Marja van den Heuvel-Panhuizen, Freudenthal Group & Freudenthal Institute, Utrecht University, Netherlands; Nord University, Norway.

Michiel Veldhuis, Freudenthal Group, Utrecht University, Netherlands; iPabo University of Applied Sciences, Amsterdam, Netherlands.

Editorial Board

Mario Sánchez Aguilar; Paul Andrews; Pedro Arteaga; Fatma Aslan-Tutak; Michal Ayalon; Jonas Bergman Årlebäck; Anna Baccaglioni-Frank; Anette Bagger; Arthur Bakker; Berta Barquero; Johannes Beck; Aline Bernardes; Angelika Bikner-Ahsbahs; Irene Biza; Laura Black; Laurinda Brown; Orly Buchbinder; Àngela Buforn; Susana Carreira; Renata Carvalho; Patrick Capraro; Esther Chan; Maria Chimoni; Renaud Chorlay; Anna Chronaki; Alison Clark-Wilson; Jason Cooper; Jenny Cramer; Seán Delaney; Javier Diez-Palomar; Ana Donevska-Todorova; Beatriz Vargas Dorneles; Ove Gunnar Drageset; Viviane Durand-Guerrier; Andreas Eckert; Kirstin Erath; Ingvald Erfjord; Nataly Essonnier; Eleonora Faggiano; Marie Therese Farrugia; Fiona Faulkner; Janne Fauskanger; Carla Finesilver; Marita Friesen; Daniel Frischemeier; Eirini Geraniou; Imène Ghedamsi; Inés M. Gómez-Chacón; Orlando Rafael González; Alejandro S. González-Martín; Koeno Gravemeijer; Ghislaine Gueudet; Tanja Hamann; Çiğdem Haser; Dave Hewitt; Jeremy Hodgen; Kees Hoogland; Jenni Ingram; Paola Iannone; Eva Jablonka; Britta Jessen; Heather Johnson; Keith Jones; Sibel Kazak; Beth Kelly; Jeta Kingji; Iveta Kohanová; David Kolloosche; Evelyn H. Kroesbergen; Sebastian Kuntze; Ana Kuzle; Aisling Leavy; Esther Levenson; Peter Liljedahl; Božena Maj-Tatsis; Francesca Martignone; Michela Maschietto; Maria Mellone; Christian Mercat; Vilma Mesa; Siún Nic Mhuirí; Morten Misfeldt; Joris Mithalal; Miguel Montes; Hana Moraová; Francesca Morselli; Reidar Mosvold; Andreas Moutsios-Rentzos; Reinhard Oldenburg; Samet Okumus; Antonio M. Oller-Marcén; Chrysi Papadaki; Birgit Pepin; Alon Pinto; Núria Planas; Joao Pedro da Ponte; Caterina Primi; Elisabeth Rathgeb-Schnierer; Miguel Ribeiro; Ornella Robutti; Helena Roos; Kirsti Rø; Charalampos Sakonidis; Libuse Samkova; Judy Sayers; Petra Scherer; Stanislaw Schukajlow; Priska Schöner; Marcus Schütte; Nathalie Sinclair; Karen Skilling; Michelle Stephan; Hauke Straehler-Pohl; Heidi Strømskag; Andreas Stylianides; Gabriel J. Stylianides; Osama Swidan; Michal Tabach; Rukiye Didem Taylan; Melih Turgut; Marianna Tzekaki; Behiye Ubuz; Anita Valenta; Olov Viirman; Hanna Viitala; Katrin Vorhölter; Geoff Wake; Hans-Georg Weigand; Kjersti Wæge; Constantinos Xenofontos; Stefan Zehetmeier.

Publisher

Freudenthal Group & Freudenthal Institute, Utrecht University, Netherlands and ERME

ISBN 978-90-73346-75-8

© Copyright 2019 left to the authors

Recommended citation for the proceedings

Jankvist, U. T., Van den Heuvel-Panhuizen, M., & Veldhuis, M. (Eds.). (2019). *Proceedings of the Eleventh Congress of the European Society for Research in Mathematics Education*. Utrecht, the Netherlands: Freudenthal Group & Freudenthal Institute, Utrecht University and ERME.

Recommended citation for single entries in the proceedings

Authors (2019). [Title of paper/poster](#). In U. T. Jankvist, M. van den Heuvel-Panhuizen, & M. Veldhuis (Eds.), *Proceedings of the Eleventh Congress of the European Society for Research in Mathematics Education* (pp. xxxx-yyy). Utrecht, the Netherlands: Freudenthal Group & Freudenthal Institute, Utrecht University and ERME.

TABLE OF CONTENTS

Preface: CERME 11 in lovely Utrecht historic sites <i>Susanne Prediger, Ivy Kidron</i>	1
Introduction	
Introduction to the Proceedings of the Eleventh Congress of the European Society for Research in Mathematics Education (CERME11) <i>Uffe Thomas Jankvist, Marja van den Heuvel-Panhuizen, Michiel Veldhuis</i>	3
Plenary lectures	
Embodied instrumentation: combining different views on using digital technology in mathematics education <i>Paul Drijvers</i>	8
History and pedagogy of mathematics in mathematics education: History of the field, the potential of current examples, and directions for the future <i>Kathleen M. Clark</i>	29
Extensions of number systems: continuities and discontinuities revisited <i>Sebastian Rezat</i>	56
Plenary panel	
ERME anniversary panel on the occasion of the 20th birthday of the European Society for Research in Mathematics Education <i>Konrad Krainer, Hanna Palmér, Barbara Jaworski, Susanne Prediger, Paolo Boero, Simon Modeste, Tommy Dreyfus, and Jana Žalská</i>	82

TWG01: Argumentation and proof	99
Introduction to the papers of TWG01: Argumentation and Proof <i>Gabriel J. Stylianides, Orly Buchbinder, Jenny Cramer, Viviane Durand-Guerrier, Andreas Moutsios-Rentzos, and Anita Valenta</i>	100
Understanding geometric proofs: scaffolding pre-service mathematics teacher students through dynamic geometry system (dgs) and flowchart proof <i>Lathiful Anwar and Martin Goedhart</i>	104
Initial participation in a reasoning-and-proving discourse in elementary school teacher education <i>Kristin Krogh Arnesen, Ole Enge, Kirsti Rø and Anita Valenta</i>	112
Epistemological obstacles in the evolution of the concept of proof in the path of ancient Greek tradition <i>Miglena Asenova</i>	120
Teachers' perspectives on mathematical argumentation, reasoning and justifying in calculus classrooms <i>Sabrina Bersch</i>	128
Integrating Euclidean rationality of proving with a dynamic approach to validation of statements: The role of continuity of transformations <i>Paolo Boero and Fiorenza Turiano</i>	136
The role of the teacher in the development of structure-based argumentations <i>Fiene Bredow</i>	145
Prospective teachers enacting proof tasks in secondary mathematics classrooms <i>Orly Buchbinder and Sharon McCrone</i>	147
Developing Pre-service Mathematics Teachers' Pedagogical Content Knowledge of Proof Schemes: An Intervention Study <i>Fikret Cihan and Hatice Akkoç</i>	155
Games as a means of motivating more students to participate in argumentation <i>Jenny Cramer</i>	163
Towards an interactional perspective on argumentation in school mathematics <i>Markos Dallas</i>	171
A pilot study on elementary pupils conditional reasoning skills and alternatives generation skills in mathematics <i>Anastasia Datsogianni, Stefan Ufer and Beate Sodian</i>	179
What do prospective mathematics teachers mean by definitions can be proved? <i>Merve Dilberoğlu, Çiğdem Haser and Erdinç Çakıroğlu</i>	181
The justification of conjectures in the study of the congruence of triangles by 5th grade students <i>Marisa Gregório and Hélia Oliveira</i>	189
Fundamental task to generate the idea of proving by contradiction <i>Hiroaki Hamanaka and Koji Otaki</i>	191

Student teachers' argumentation in primary school mathematics classrooms <i>Helene Hauge</i>	199
The interplay of logical relations and their linguistic forms in proofs written in natural language <i>Kerstin Hein</i>	201
Mathematical Arguments in the Context of Mathematical Giftedness Analysis of Oral Argumentations with Toulmin <i>Simone Jablonski and Matthias Ludwig</i>	209
"Using geometry, justify (...)". Readiness of 14-year-old students to show formal operational thinking <i>Edyta Juskowiak</i>	217
On the effect of using different phrasings in proving tasks <i>Leander Kempen, Petra Carina Tebaartz and Miriam Krieger</i>	225
Task design for developing students' recognition of the roles of assumptions in mathematical activity <i>Kotaro Komatsu, Gabriel J. Stylianides and Andreas J. Stylianides</i>	233
Primary students reasoning and argumentation based on statistical data <i>Jens Krummenauer and Sebastian Kuntze</i>	241
Questions and answers & but no reasoning! <i>Dorte Moeskær Larsen and Camilla Hellsten Østergaard</i>	249
Factors influencing teachers' decision making on reasoning-and proving in Hong Kong <i>Chun Yeung Lee</i>	257
On teachers' experiences with argumentation and proving activities in lower secondary mathematics classrooms <i>Silke Lekaas</i>	265
An epistemological study of recursion and mathematical induction in mathematics and computer science <i>Nicolás León</i>	274
Explanatoriness as a value in mathematics and mathematics teaching <i>Eva Müller-Hill</i>	276
Proof, reasoning and logic at the interface between Mathematics and Computer Science: toward a framework for analyzing problem solving <i>Simon Modeste, Sylvain Beauvoir, Jonathan Chappelon, Viviane Durand-Guerrier, Nicolás León and Antoine Meyer</i>	284
A systemic investigation of students' views about proof in high school geometry: the official and shadow education systems in a school unit <i>Andreas Moutsios-Rentzos and Eleni Plyta</i>	292
Meta-knowledge about definition: The case of special quadrilaterals <i>Shogo Murata</i>	300
Proof comprehension of undergraduate students and the relation to individual characteristics <i>Silke Neuhaus and Stefanie Rach</i>	302

Abduction in argumentation: Two representations that reveal its different functions <i>Chrysi Papadaki, David Reid and Christine Knipping</i>	310
Some linguistic issues on the teaching of mathematical proof <i>Yusuke Shinno, Takeshi Miyakawa, Tatsuya Mizoguchi, Hiroaki Hamanaka and Susumu Kunimune</i>	318
Planning for mathematical reasoning Surprising challenges in a design process <i>Helén Sterner</i>	326
Metacognitive activities of pre-service teachers in proving processes <i>Nele Stubbemann and Christine Knipping</i>	328
Features of mathematics teacher argumentation in classroom <i>Jorge A. Toro and Walter F. Castro</i>	336
Beyond direct proof in the approach to the culture of theorems: a case study on 10th grade students' difficulties and potential <i>Fiorenza Turiano and Paolo Boero</i>	338
Identifying key ideas in proof: the case of the irrationality of \sqrt{k} <i>Xiaoheng (Kitty) Yan and Gila Hanna</i>	346
TWG02: Arithmetic and number systems	354
Introduction to the work of TWG 2: Arithmetic and number systems <i>Elisabeth Rathgeb-Schnierer, Renata Carvalho, Beatriz Vargas Dorneles and Judy Sayers</i>	355
Use of conceptual metaphors in the development of number sense in the first years of mathematical learning <i>Natividad Adamuz-Povedano, Elvira Fernández-Ahumada, Teresa García-Pérez and Rafael Bracho-López</i>	359
Development of an intervention program in counting principles for first-grade students - Pilot study <i>Évelin Assis and Luciana Vellinho Corso</i>	367
Intervention in counting principles with first-grade students <i>Évelin Assis and Luciana Vellinho Corso</i>	369
Design of a board game around the notion of fractions <i>Alix Boissière</i>	377
Exploring students adaptive use of domain specific knowledge <i>Joana Brocardo, Catarina Delgado, Fátima Mendes, Jean Marie Kraemer</i>	379
Mental computation: An opportunity to develop students' strategies in rational number division <i>Renata Carvalho and João Pedro da Ponte</i>	387
Intervention in counting principles: teachers' perceptions on students learning profile <i>Luciana Vellinho Corso and Évelin Assis</i>	395
Teaching and learning decimal numbers: the role of numeration units <i>Lalina Coulange and Grégory Train</i>	403

The offer of tasks to work on multiplication in grades 2 and 3 <i>Sandra Gleißberg and Klaus-Peter Eichler</i>	411
Considerations on developmental stage models, learning trajectories and maybe better ways to guide early arithmetic instruction <i>Michael Gaidoschik</i>	419
Rational number operations: What understandings do children demonstrate? <i>Sofia Graça, João Pedro da Ponte and António Guerreiro</i>	427
Pairing numbers: An unconventional way of evaluating arithmetic expressions <i>Robert Gunnarsson and Ioannis Papadopoulos</i>	435
Interactions between pupils' actions and manipulative characteristics when solving an arithmetical task <i>Doris Jeannotte and Claudia Corriveau</i>	443
An analysis of understanding the algebraic structure in school mathematics: focusing on the extension of number sets <i>Kazuhiro Kurihara</i>	451
Strategy choices and formal algorithms: A mixed methods study <i>Ems Lord and Andreas J. Stylianides</i>	453
Number line estimation and quantitative reasoning: two important skills for mathematical achievement <i>Camila Peres Noguez and Beatriz Vargas Dorneles</i>	461
Mental calculations with rational numbers across educational levels <i>Ioannis Papadopoulos, Styliani Panagiotopoulou and Michail Karakostas</i>	469
Students ability to compare fractions related to proficiency in the four operations <i>Pernille Ladegaard Pedersen and Peter Sunde</i>	477
Flexible mental calculation skills of freshmen and graduates <i>Charlotte Rechtsteiner</i>	485
A tool to evaluate students' performance in solving fraction word problems <i>Maria T. Sanz Garcia, Olimpia Figueras, and Bernardo Gómez</i>	487
Development and variance components in single-digit addition strategies in year one <i>Pernille B. Sunde, and Peter Sunde</i>	495
Learning fractions using a teaching model designed with applets and the number line: The cases of Alvaro and Fernanda <i>Carlos Valenzuela García, and Olimpia Figueras</i>	503
Reflecting on a series of studies on conceptual and procedural knowledge of fractions: Theoretical, methodological and educational considerations <i>Xenia Vamvakoussi, Maria Bempeni, Stavroula Pouloupoulou and Ioanna Tsiplaki</i>	511
Metacognition in non-routine problem solving process of year 6 children <i>Aikaterini Vissariou and Despina Desli</i>	519
TWG03: Algebraic Thinking	527
Algebraic Thinking <i>Maria Chimoni, Dave Hewitt, Reinhard Oldenburg, and Heidi Strømshag</i>	528

Teachers Conceptions of Algebra and Knowledge of Task Purposes <i>Burcu Alapala and Isil Isler-Baykal</i>	532
Strategies exhibited by good and average solvers of geometric pattern problems as source of traits of mathematical giftedness in grades 4-6 <i>Eva Arbona, María José Beltrán-Meneu and Ángel Gutiérrez</i>	534
Investigating early algebraic thinking abilities: a path model <i>Maria Chimoni, Demetra Pitta-Pantazi and Constantinos Christou</i>	542
Students expected engagement with algebra based on an analysis of exams in Norway from 1995 till 2018 <i>James Gray, Bodil Kleve and Helga Kufaas Tellefsen</i>	550
Never carry out any arithmetic: the importance of structure in developing algebraic thinking <i>Dave Hewitt</i>	558
Algebraic thinking in the shadow of programming <i>Cecilia Kilhamn and Kajsa Bråting</i>	566
Linear figural patterns as a teaching tool for preservice elementary teachers the role of symbolic expressions <i>Iveta Kohanová and Trygve Solstad</i>	574
Graphing formulas to give meaning to algebraic formulas <i>Peter Kop, Fred Janssen, Paul Drijvers and Jan van Driel</i>	582
Relational thinking and operating on unknown quantities. A study with 5 to 10 years old children <i>Denise Lenz</i>	590
Enhancing students' generalizations: a case of abductive reasoning <i>Joana Mata-Pereira¹ and João Pedro da Ponte²</i>	598
Body Motion and Early Algebra <i>Ricardo Nemirovsky, Natividad Adamuz-Povedano, Francesca Ferrara, and Giulia Ferrari</i>	606
Color-coding as a means to support flexibility in pattern generalization tasks <i>Per Nilsson and Andreas Eckert</i>	614
A classification scheme for variables <i>Reinhard Oldenburg</i>	622
Transforming equations equivalently? theoretical considerations of equivalent transformations of equations <i>Norbert Oleksik</i>	630
How students in 5th and 8th grade in Norway understand the equal sign <i>Hilde Opsal</i>	638
Fifth-grade students solving linear equations supported by physical experiences <i>Mara Otten, Marja van den Heuvel-Panhuizen, Michiel Veldhuis and Aiso Heinze</i>	646

Representational variation among elementary school students. A study within a functional approach to early algebra <i>Eder Pinto, Bárbara M. Brizuela, and María C. Cañadas</i>	654
Unpacking 9th grade students algebraic thinking <i>Marios Pittalis and Ioannis Zacharias</i>	662
Portuguese and Spanish prospective teachers functional thinking on geometric patterns <i>Irene Polo-Blanco, Hélia Oliveira and Ana Henriques</i>	670
When a number moves across, it changes its sign Investigating Teachers' Conceptual Understanding of Algebra <i>Mark Prendergast, Aoibhinn Ní Shúilleabháin, Paul Grimes and Niamh O'Meara</i>	672
Dealing with quantitative difference: A study with second graders <i>Margarida Rodrigues and Lurdes Serrazina</i>	674
Short note on algebraic notations: First encounter with letter variables in primary school <i>Anna Susanne Steinweg</i>	682
Structures identified by second graders in a teaching experiment in a functional approach to early algebra <i>María D. Torres, María C. Cañadas and Antonio Moreno</i>	690
Comparing the structure of algorithms: The case of long division and log division <i>Christof Weber</i>	698
Relationships between procedural fluency and conceptual understanding in algebra for postsecondary students <i>Claire Wladis, Jay Verkuilen, Sydne McCluskey, Kathleen Offenholley, Dale Dawes, Susan Licwinko and Jae Ki Lee</i>	706
Forming basic conceptions in dealing with quadratic equations <i>Alexander Wolff</i>	714
Provoking students to solve equations in a content-oriented fashion and not using routines by solving slightly modified standard tasks <i>Simon Zell</i>	716
TWG04: Geometry Teaching and Learning	724
Introduction to the papers of TWG04: Geometry Teaching and Learning <i>Keith Jones, Michela Maschietto, Joris Mithalal-Le Doze and Chrysi Papadaki</i>	725
A computer-based environment for argumenting and proving in geometry <i>Giovannina Albano, Umberto Dello Iacono and Maria Alessandra Mariotti</i>	729
The evolution of 9-year-old students' understanding of the relationships among geometrical shapes <i>Melania Bernabeu, Salvador Llinares and Mar Moreno</i>	737
Measuring area on the geoboard focusing on using flexible strategies <i>Øyvind Jacobsen Bjørkås and Marja van den Heuvel-Panhuizen</i>	745
Justifying geometrical generalizations in elementary school preservice teacher education <i>Lina Brunheira and João Pedro da Ponte</i>	753

Professional actions of novice teachers in the context of teaching and learning geometry <i>Caroline Bulf</i>	761
A model of the instrumentation process in dynamic geometry <i>Madona Chartouny, Iman Osta and Nawal Abou Raad</i>	769
Spatial structuring in early years <i>Joana Conceição and Margarida Rodrigues</i>	777
The development of geometrical knowledge starting from arts education <i>Catarina Delgado, Fátima Mendes and Filipe Fialho</i>	779
“Going straight”: discussions and experience at primary school <i>Maria Elena Favilla, Maria Luppi and Michela Maschietto</i>	781
Mathematical creativity and geometry: The influence of geometrical figure apprehension on the production of multiple solutions <i>Panagiotis Gridos, Athanasios Gagatsis, Iliada Elia and Eleni Deliyianni</i>	789
In-service teachers' conceptions of parallelogram definitions <i>Aehsan Haj Yahya, Wajeeh Daher and Osama Swidan</i>	797
Children s use of spatial skills in solving two map-reading tasks in real space <i>Cathleen Heil</i>	805
A step in the development of an evidence based learning progression for geometric reasoning: focus on shape and angle <i>Marj Horne and Rebecca Seah</i>	813
Task design with DGEs: The case of students’ counterexamples <i>Keith Jones and Kotaro Komatsu</i>	821
The connection between angle measure and the understanding of sine <i>Valentin Katter</i>	823
To figure out more than a solution to a geometric problem: What do prospective teachers? <i>Fátima Mendes, Ana Maria Boavida, Joana Brocardo and Catarina Delgado</i>	831
Personal geometrical work of pre-service teachers: a case study based on the theory of Mathematical Working Spaces <i>Alain Kuzniak and Assia Nechache</i>	833
Students’ reasons for introducing auxiliary lines in proving situations <i>Alik Palatnik and Tommy Dreyfus</i>	841
Construction of triangles: some misconceptions and difficulties <i>Paula Vieira da Silva and Leonor Santos</i>	849
Grade 3/4 students’ understanding of geometrical objects: Australian case studies on (mis)conceptions of cubes <i>Ann Downton, Sharyn Livy and Simone Reinhold</i>	857

TWG05: Probability and Statistics Education	865
Introduction to the work of TWG5: Probability and Statistics Education	866
Formalizing students informal statistical reasoning on real data: Using Gapminder to follow the cycle of inquiry and visual analyses <i>Martin Andre, Zsolt Lavicza and Theodosia Prodromou</i>	870
Design of statistics learning environments <i>Dani Ben-Zvi, Koeno Gravemeijer and Janet Ainley</i>	878
Informal statistical inference and permutation tests <i>Øyvind Jacobsen Bjørkås, Kjetil B. Halvorsen and Dag Oskar Madsen</i>	886
Unravelling teachers' strategies when interpreting histograms: an eyetracking study <i>Lonneke Boels, Arthur Bakker and Paul Drijvers</i>	888
The importance of high-level tasks in the access of statistical errors: A study with future teachers of the first years <i>Ana Caseiro, Ricardo Machado and Tiago Tempera</i>	896
Design principles for short informal statistical inferences activities for primary education <i>Arjen de Vetten, Aisling Leavy and Ronald Keijzer</i>	904
Chilean primary school difficulties in building bar graphs <i>Danilo Díaz-Levicoy and Pedro Arteaga</i>	912
How Realistic Mathematics Education approach influences 6th grade students' statistical thinking <i>Bedriye Doluzengin and Sibel Kazak</i>	914
Repurpose and extend: making a model statistical <i>Michal Dvir and Dani Ben-Zvi</i>	922
The role of decision-making in the legitimation of probability and statistics in Chilean upper secondary school curriculum <i>Raimundo Elicer</i>	930
The challenge of constructing statistically worthwhile questions <i>Daniel Frischemeier and Aisling M. Leavy</i>	938
Investigating teachers' pedagogical content knowledge for statistical reasoning via the real life problem scenario <i>Rukiye Gökce and Sibel Kazak</i>	946
<i>It's a good score! Just looks low:</i> Using data-driven argumentation to engage students in reasoning about and modelling variability <i>Orlando González and Somchai Chitmun</i>	954
Prospective teachers' interdisciplinary learning scenario to promote students' statistical reasoning <i>Ana Henriques, Hélia Oliveira and Mónica Baptista</i>	962
The development of a domain map in probability for teacher education <i>Judith Huget</i>	964

Testing the negative recency effect among teacher students trying to generate random sequences <i>Olav Gravir Imenes</i>	972
Statistical Graphs Semiotic Complexity, Purpose and Contexts in Costa Rica Primary Education Textbooks <i>Maynor Jiménez-Castro, Pedro Arteaga and Carmen Batanero</i>	980
Building up students' data analytics skills to solve real world problems <i>Sibel Kazak, Taro Fujita and Manoli Pifarre Turmo</i>	988
Interweaving probability games and other mathematical areas in Tamás Varga's spirit in Hungary <i>Anna Kiss</i>	990
Pitfalls and surprises in probability: The battle against counterintuition <i>Signe Holm Knudtson</i>	992
Why does statistical inference remain difficult? A textbook analysis for the phases of inference <i>Rüya Gökhan Koçer and Fulya Kula</i>	1000
Young children s informal statistical inference experiences through constructing a pictograph <i>Gamze Kurt Birel</i>	1002
What is taught and learnt on confidence interval? A case study <i>Kyeong-Hwa, Lee, Chang-Geun, Song and Yeong Ok, Chong</i>	1010
Prospective high school teachers' interpretation of hypothesis tests and confidence intervals <i>M^a del Mar López-Martín, Carmen Batanero and María M. Gea</i>	1018
Covariational reasoning patterns exhibited by high school students during the implementation of a hypothetical learning trajectory <i>Miguel Medina, Ernesto Sánchez and Eleazar Silvestre</i>	1026
A Case Study of Teacher Professional Development on Game- Enhanced Statistics Learning in the Early Years of Schooling <i>Maria Meletiou-Mavrotheris, Efi Papparistodemou, Loucas Tsouccas</i>	1034
The influence of the context of conditional probability problems on probabilistic thinking: A case study with teacher candidates <i>Beyza Olgun and Mine Isiksal-Bostan</i>	1042
In-service teachers' design, teaching and reflection on probability <i>Efi Papparistodemou and Maria Meletiou-Mavrotheris</i>	1050
Connecting context, statistics and software for understanding a randomization test: a case study <i>Susanne Podworny</i>	1057
Measuring probabilistic reasoning: the development of a brief version of the Probabilistic Reasoning Scale (PRS-B) <i>Caterina Primi, Maria Anna Donati, Sara Massino</i>	1065

An alternative method to compute confidence intervals for proportion <i>Antonio Francisco Roldán López de Hierro, María del Mar López-Martín and Carmen Batanero</i>	1073
Primary school students reasoning about and with the median when comparing distributions <i>Susanne Schnell and Daniel Frischemeier</i>	1075
A case study on design and application of creative tasks for teaching percentage bars and pie charts <i>Balgeum Song, Kyeong-Hwa Lee and Yeong Ok,Chong</i>	1083
Algorithms as a discovery process in frequentist approach to prediction interval <i>Jannick Trunkenwald and Dominique Laval</i>	1085
The investigative cycle: Developing a model to interpret written statistical reports of pre-service primary school teachers <i>Francisca Ubilla, Núria Gorgorió and Montserrat Prat</i>	1093
Introduction of inferential statistics in high school in Hungary <i>Ödön Vancsó, Peter Fejes-Tóth, and Zsuzsanna Jánvári</i>	1101
TWG06: Applications and modelling	1103
Introduction to the papers of TWG6: Applications and modelling <i>Berta Barquero, Susana Carreira, Jonas Bergman Ärlebäck, Britta Jessen, Katrin Vorhölter, Geoff Wake</i>	1104
The configuration of mathematical modelling activities: a reflection on perspective alignment <i>Lourdes Almeida and Susana Carreira</i>	1112
Enhancing future teachers' situation-specific modelling competencies by using staged videos <i>Alina Alwast and Katrin Vorhölter</i>	1120
An extension of the MAD framework and its possible implication for research <i>Jonas Bergman Ärlebäck and Lluís Albarracín</i>	1128
Simulations and prototypes in mathematical modelling tasks <i>Ana Margarida Baioa and Susana Carreira</i>	1136
Modelling praxeologies in teacher education: the cake box <i>Berta Barquero, Marianna Bosch, Floriane Wozniak</i>	1144
Analysis of textbook modelling tasks, in light of a modelling cycle <i>Ingeborg Katrin Lid Berget</i>	1152
Assessing Teaching Competencies for Mathematical Modelling <i>Rita Borromeo Ferri</i>	1154
On the positive influence of product-orientation in mathematical modeling: A research proposal <i>Wolfgang Bock, Martin Bracke, Patrick Capraro and Jean-Marie Lantau</i>	1162

Comprehending mathematical problem texts Fostering subjectspecific reading strategies for creating mental text representations <i>Jennifer Dröse</i>	1164
Mathematical modeling and the role of language proficiency <i>Sevinç Göksen-Zayim, Derk Pik, Rijkje Dekker and Carla van Boxtel</i>	1172
Pre-service mathematics teachers' learning through designing modelling tasks <i>Carolina Guerrero-Ortiz</i>	1174
Teachers learning to design and implement mathematical modelling activities through collaboration <i>Britta Eyrich Jessen</i>	1182
Development of group creativity in mathematical modeling <i>Hye-Yun Jung and Kyeong-Hwa Lee</i>	1190
Creating contact points between empirical modelling and theoretical modelling in teacher education: The case of pendulum problem <i>Masafumi Kaneko, Akihiko Saeki and Takashi Kawakami</i>	1192
Measuring an aspect of adaptive intervention competence in mathematical modelling processes <i>Heiner Klock and Hans-Stefan Siller</i>	1200
Research into students' evaluations of given modelling solutions and their suggestions for improved modelling - Results from two empirical studies <i>Sebastian Kuntze and Julian Eppler</i>	1208
Effective factors of a teacher training concerning the implementation of interdisciplinary STEM-modelling projects <i>Jean-Marie Lantau and Martin Bracke</i>	1216
Instrumental genesis and heuristic strategies as frameworks to geometric modeling in connecting physical and digital environments <i>Diego Lieban and Zsolt Lavicza</i>	1224
On the notion of mathematical model in educational research: Insights from a new proposal <i>Jesús Montejo-Gámez and Elvira Fernández-Ahumada</i>	1232
The extended theoretical framework of Mathematical Working Space (extended MWS): Potentialities in physics <i>Laurent Moutet</i>	1240
Downscaling and upscaling Fermi problems <i>Marta Pla-Castells and Irene Ferrando</i>	1248
Students of Development Studies learning about modelling and simulations as a research approach in their discipline <i>Amrit B. Poudel, Pauline Vos and F. LeRon Shults</i>	1256
On the role of multicriteria decision support in mathematical modelling <i>Stefan Ruzika and Lisa Schneider</i>	1264
Exploring pre-service teachers' flexibility in solving Fermi problems <i>Carlos Segura and Irene Ferrando</i>	1272

Features of modelling processes of group with visual and analytic mathematical thinking styles <i>Juhaina Awawdeh Shahbari and Rania Salameh</i>	1274
Professional competencies for teaching mathematical modelling supporting the modelling-specific task competency of prospective teachers in the teaching laboratory <i>Raphael Wess and Gilbert Greefrath</i>	1276
Horizontal mathematization: a potential lever to overcome obstacles to the teaching of modelling <i>Sonia Yvain-Prébiski and Aurélie Chesnais</i>	1284
TWG07: Adult Mathematics Education	1292
Introduction to TWG07 Adult Mathematics Education <i>Kees Hoogland, Beth Kelly and Javier Díez-Palomar</i>	1293
Doing the time in the mathematics class <i>Catherine Byrne, Brian Bowe and Michael Carr</i>	1301
Numeracy in adult education: discussing related concepts to enrich the Numeracy Assessment Framework <i>Javier Díez-Palomar, Kees Hoogland and Vincent Geiger</i>	1309
Mathematics and Physics Dialogic Gatherings: Fostering Critical Thinking Among Adult Learners <i>Javier Díez-Palomar and Evgenia Anagnostopoulou</i>	1317
Using dialogue scenes with adult mathematics learners: Research questions and methods <i>Graham Griffiths</i>	1325
Reproducing social difference in the concept of numeracy skills <i>Lisanne Heilmann</i>	1333
Numeracy and mathematics education in vocational education: a literature review, preliminary results <i>Kees Hoogland, Karen Heinsman and Paul Drijvers</i>	1341
Initiating a Common European Numeracy Framework <i>Kees Hoogland, Marlies Auer, Javier Díez-Palomar, Niamh O'Meara and Mieke van Groenestijn</i>	1349
What motivates adults to learn mathematics through trade unions in the workplace: social factors and personal feelings <i>Beth Kelly</i>	1356
Adult learners know more about maths than they think: helping learners to embrace their knowing <i>John J. Keogh, Theresa Maguire and John O'Donoghue</i>	1364
Numeracy practices in older age <i>Alina Redmer and Anke Grotlüschen</i>	1372

How theories of language-responsive mathematics can inform teaching designs for vocational mathematics <i>Lena Wessel</i>	1380
TWG08: Affect and the teaching and learning of mathematics	1388
Introduction to the work of TWG 8: Affect and the teaching and learning of mathematics <i>Stanislaw Schukajlow, Inés Ma Gómez-Chacón, Çiğdem Haser, Peter Liljedahl, Karen Skilling and Hanna Viitala</i>	1389
Verbal expression of emotions as entry points to examine failure experiences in secondary mathematics: A preliminary study <i>Lucy Alcântara, Nélia Amado and Susana Carreira</i>	1393
Learning geometry in self-made tutorials: the impact of producing mathematical videos on emotions, motivation and achievement in mathematical learning <i>Daniel Barton</i>	1401
Adolescents' Endorsement of Narratives Regarding the Importance of Mathematics: A Dialogic Perspective <i>Naama Ben-Dor and Einat Heyd-Metzuyanin</i>	1403
Learning styles in mathematics - the strength of the motivational factors at 10th grade Portuguese students <i>Miguel Figueiredo and Henrique Manuel Guimarães</i>	1411
Undergraduate students' mindsets in a computer programming mathematical learning environment <i>Wendy Ann Forbes, Joyce Mgombelo, Sarah Gannon and Chantal Buteau</i>	1419
Situation Specific-Skills Working Backward Reasoning: The Student's Perceptions and Affect Dimension <i>Inés M. Gómez-Chacón, Marta Barbero</i>	1427
Teacher-student eye contacts during whole-class instructions and small-group scaffolding: A case study with multiple mobile gaze trackers <i>Eeva Haataja, Visajaani Salonen, Anu Laine, Miika Toivanen and Markku S. Hannula</i>	1435
Collaborative processes when reasoning creatively about functions <i>Ellen Kristine Solbrekke Hansen</i>	1443
What can metaphor tasks offer for exploring preservice mathematics teachers beliefs? <i>Çiğdem Haser</i>	1445
"I don't like Maths as a subject but I like doing it": A methodology for understanding mathematical identity <i>Fionnán Howard, Siún Nic Mhuirí and Maurice O'Reilly</i>	1453
Students' Engagement in Inquiry-based Learning: Cognition, Behavior and Affect <i>Styliani K. Kourti</i>	1461
Investigating emotional intensity in mathematics classrooms: an enhanced methodology or affective gimmickry? <i>Elizabeth Lake</i>	1469

Pupils' perception of their understanding in mathematics and its connection to private supplementary tutoring <i>Gabriela Novotná</i>	1477
Reflections on the development and application of an instrument to access mathematical identity <i>Patricia Eaton, Christine Horn, Elizabeth Oldham and Maurice O'Reilly</i>	1485
Upper Secondary Mathematics Teachers' epistemological beliefs concerning the nature of mathematics <i>Marilena Pantziara, Alexandra Petridou and Marianna Karamanou</i>	1493
Engagement in mathematics through digital interactive storytelling <i>Giovannina Albano, Anna Pierri and Maria Polo</i>	1501
Self-concept in university mathematics courses <i>Stefanie Rach, Stefan Ufer and Timo Kosiol</i>	1509
First-person vicarious experiences as a mechanism for belief change <i>Annette Rouleau, Natalia Ruiz, Cristián Reyes and Peter Liljedahl</i>	1517
I am scared to make a drawing. Students' anxiety and its relation to the use of drawings, modelling, and gender <i>Stanislaw Schukajlow, Judith Blomberg, Johanna Rellensmann</i>	1525
Distinguishing engagement from achievement: understanding influential factors for engaged and disengaged low achieving mathematics students <i>Karen Skilling</i>	1533
Do students perceive mathematics and the mathematical subdomain of functions differently with regard to their self-concept and interest? <i>Ute Sproesser, Markus Vogel, Tobias Doerfler and Andreas Eichler</i>	1541
How can teachers influence their students' (mathematical) mindset? <i>Marloes van Hoeve, Michiel Doorman and Michiel Veldhuis</i>	1549
Low achiever's mathematical thinking: The case study of Maya <i>Hanna Viitala</i>	1557
The impact of a mathematics game programming project on student motivation in grade 8 <i>Eline Westerhout, Paul Drijvers and Arthur Bakker</i>	1565
"I want a high-educated job that pays well and is fun": Secondary students' relevance beliefs for taking advanced mathematics <i>Anders Wiik and Pauline Vos</i>	1573
TWG09: Mathematics and Language	1581
Introduction to TWG09: Transforming language-sensitive mathematics education research into papers and posters <i>Núria Planas, Marie Therese Farrugia, Jenni Ingram and Marcus Schütte</i>	1582
Taking advantage of the different types of mathematical languages to promote students' meaningful learning <i>Helen Alfaro Viquez</i>	1590

Learning mathematics in French at the undergraduate level in Algeria <i>Nadia Azrou</i>	1598
Textual configurations as an approach to evaluate textual difficulties of mathematical tasks <i>David Bednorz and Michael Kleine</i>	1606
Relations between school achievement and language abilities in mathematics classrooms <i>Aurélie Chesnais</i>	1614
Construction of mathematical discourses on generalization during group interaction <i>Judit Chico</i>	1622
Metacognitive and discursive activities - an intellectual kernel of classroom discussions in learning mathematics <i>Elmar Cohors-Fresenborg</i>	1630
Explorative study on language means for talking about enlarging figures in group work <i>Kirstin Erath</i>	1632
Young children's mathematising during free play with 'loose parts' <i>Marie Therese Farrugia</i>	1640
High school teachers' evaluation of argumentative texts in mathematics <i>Giovannina Albano, Cristina Coppola and Pier Luigi Ferrari</i>	1648
The role of writing in the process of learning to speak mathematically <i>Marei Fetzer</i>	1656
Solving problems collaboratively in multi-age classes - a possibility for learning? <i>Rachel-Ann Friesen, Marcus Schütte, Judith Jung</i>	1664
Exploration of patterns in different contexts <i>Anne Birgitte Fyhn and Lisbet Hansen</i>	1672
Centripetal and centrifugal forces in teacher-class dialogues in inquiry-based mathematics <i>Ingólfur Gíslason</i>	1680
The importance of a meaning-related language for understanding multiplication <i>Daniela Götze</i>	1688
Claims and demonstrations of understanding in whole class interactions <i>Jenni Ingram and Nick Andrews</i>	1696
Talking about standardized units in preschool supporting language and mathematical learning <i>Sarah Keuch and Birgit Brandt</i>	1704
Mathematical reasoning as a classroom discourse <i>Farran Mackay, Marieke Thurlings, Alexander Schueler-Meyer, and Birgit Pepin</i>	1712
Researching translanguaging: Functions of first and second languages in Maltese mathematics classrooms <i>Angel Mizzi</i>	1714

Adopting a discursive lens to examine functions learning and language use by bilingual undergraduate students <i>Máire Ní Riordáin and Éilis Flanagan</i>	1722
Specialized language support in mathematics education through the use of radio resources <i>Franziska Peters</i>	1730
Classroom communication: Defining and characterizing perpendicular lines in high school algebra <i>Valentina Postelnicu</i>	1738
Disentangling students' personal repertoires for meaning-making: The case of newly arrived emergent multilingual students <i>Susanne Prediger, Ángela Uribe, and Taha Kuzu</i>	1746
Preservice teachers' reflections on language diversity <i>Toril Eskeland Rangnes and Andrea Synnøve Blomsø Eikset</i>	1754
Sense and reference of signifiers for elements of polygons <i>Frode Rønning and Heidi Strømskag</i>	1762
Abstract thinking and bilingualism: Impact on learning mathematics <i>Leila Salekhova and Nail Tuktamishov</i>	1770
Teaching mathematics in an international class: Designing a path towards productive disposition <i>Marc Sauerwein</i>	1778
Which factors coincide with mathematical learning gains in bilingual classrooms? German language proficiency and mixed language use <i>Alexander Schüler-Meyer, Susanne Prediger, and Henrike Weinert</i>	1786
Publishing as an English non dominant language author. First results from a survey of support offered by mathematics education journals <i>Rudolf Sträßer</i>	1794
Variations in students' reading process when working on mathematics tasks with high demand of reading ability <i>Frithjof Theens</i>	1802
Generalizing distributive structures in primary school <i>Annika Umierski and Kerstin Tiedemann</i>	1810
TWG10: Diversity and Mathematics Education: Social, Cultural and Political Challenges	1818
Introduction to the work of TWG10: Diversity and Mathematics Education: Social, Cultural and Political Challenges <i>Hauke Straehler-Pohl, Anette Bagger, Laura Black, Anna Chronaki and David Kollosche</i>	1819
Construction of Critical Thinking Skills by the infusion approach in Probability and Statistics in Daily Life <i>Einav Aizikovitsh-Udi</i>	

The politics of early assessment in mathematics education <i>Anette, Helena Vennberg and Lisa Björklund Boistrup</i>	1831
Critical uses of knowledge and identity: Embedded mathematics as a site for/of class struggle in educational praxis <i>Laura Black, Julian Williams, David Swanson, Sophina Choudry and Emilia Howker</i>	1839
Mathematics education's solidarity assimilation methodology <i>Tânia Cabral, Alexandre Pais and Roberto Baldino</i>	1846
Assessing students' perceptions of democratic practices in the mathematics classroom <i>Wajeeh Daher</i>	1854
Diversity, inclusion and the question of mathematics teacher education - How do student teachers reflect a potential-related view? <i>Timo Dexel, Ralf Benölken and Marcel Veber</i>	1862
A farewell to mathematics: A personal choice or social exclusion? <i>Oğuzhan Doğan</i>	1870
A call for nuancing the debate on gender, education and mathematics in Norway <i>Trine Foyen</i>	1878
The relevance of mathematics and students' identities <i>Andualem Tamiru Gebremichael</i>	1886
Social inequalities in mathematics from a socialization theoretical point of view - Analysis of problem-solving processes of students <i>Belgüzar Kara, Bärbel Barzel</i>	1894
Towards guidelines for the analysis of teaching materials in linguistically and culturally diverse mathematics classrooms <i>David Kollosche</i>	1896
How do we teach mathematics to refugee students? A qualitative study of the teaching and learning of mathematics in International Preparatory Classes <i>Maike Lüssenhop and Gabriele Kaiser</i>	1904
Using photo-elicitation in early years mathematics research <i>Dorota Lembrér</i>	1912
Referring and proffering: An unusual take on what school mathematics is about <i>Jean-François Maheux, Jérôme Proulx, Rox-Anne L'Italien-Bruneau and Marie-Line Lavallée-Lamarche</i>	1920
The contextual power dynamics in defining and utilising problem solving tasks: A case study at an Egyptian private school <i>Mariam Makramalla and Andreas J. Stylianides</i>	1928
Discourse of otherness in a Universally Designed undergraduate mathematics course <i>Juuso Henrik Nieminen</i>	1936
Lávvu and mathematics <i>Siv Ingrid Nordkild and Ole Einar Hætta</i>	1944

Interdisciplinarity, culturally sustaining pedagogies, and the problem of pandisability as culture: Co-creating diverse mathematics learning contexts <i>Alexis Padilla and Paulo Tan</i>	1946
The teaching of higher education mathematics by pre-service mathematics teacher educators: How might this contribute to social justice? A consideration of a possible approach <i>Hilary Povey</i>	1954
The student's perspective on school mathematics - a case study <i>Ann-Sofi Røj-Lindberg and Kirsti Hemmi</i>	1962
Agency and identity of female Arab students entering a technological university <i>Soryna Sabbah and Einat Heyd-Metzuyanin</i>	1970
Students' experiences of learner autonomy in mathematics classes <i>Shipra Sachdeva</i>	1978
Locally disrupting institutional racism by enacting mathematics in a U. S. laboratory classroom <i>Sabrina Bobsin Salazar</i>	1986
Visible pedagogy and challenging inequity in school mathematics <i>Pete Wright</i>	1994
Real-life mathematics: Politicization of natural life and rethinking the sovereign <i>Ayşe Yolcu</i>	2002
TWG11: Comparative studies in mathematics education	2010
Thematic working group 11: Comparative studies in mathematics education <i>Paul Andrews, Eva Jablonka, and Constantinos Xenofontos</i>	2011
Order of factors in multiplying decimal numbers and gender differences: a comparison of tasks <i>Cascella Clelia and Giberti Chiara</i>	2014
The centrality of the unit of analysis in comparative research in mathematics education: comparing analytical accounts of student collaborative activity in different social groups <i>David Clarke and Man Ching Esther Chan</i>	2022
Impact of access requirements on the mathematical knowledge of students admitted to Primary Teaching programs: a microcomparative study <i>Núria Gorgorió, Lluís Albarracín, and Anu</i>	2031
Introduction to early algebra in Estonia, Finland and Sweden some distinctive features identified in textbooks for Grades 1-3 <i>Kirsti Hemmi, Madis Lepik, Lars Madej, Kajsa Bråting and Joakim Smedlund</i>	2039
A preliminary comparison of Chinese and German state mandated curricula for mathematics education (years 1 to 6) <i>Eva Jablonka</i>	2047
Reform on a shaky ground? A comparison of algebra tasks from TIMSS and Swedish textbooks <i>Kristina Palm Kaplan</i>	2055

Time series analysis: Moving averages as an approach to analysing textbooks <i>Jöran Petersson, Judy Sayers and Paul Andrews</i>	2057
A cross-cultural study of curriculum systems: mathematics curriculum reform in the U.S., Finland, Sweden, and Flanders <i>Hendrik Van Steenbrugge, Heidi Krzywacki, Janine Remillard, Tuula Koljonen, Rowan Machalow and Kirsti Hemmi</i>	2062
The use of problem in upper-primary and lower-secondary textbooks of the Republic of Cyprus <i>Constantinos Xenofontos</i>	2073
A cross-cultural comparative study into teachers questioning patterns in lower secondary mathematics lessons in the UK and China <i>Wenping Zhang and David Wray</i>	2081
TWG12: History in Mathematics Education	2089
Introduction to the papers of TWG12: History in Mathematics Education <i>Renaud Chorlay, Aline Bernardes, Tanja Hamann and Antonio Oler-Marcén</i>	2090
Generalizing a 16th century arithmetic problem with prospective Secondary education teachers <i>Álvaro Barreras and Antonio M. Oller-Marcén</i>	2093
On the didactical function of some items from the history of calculus <i>Stephan Berendonk</i>	2101
Justifying a calculation technique in years 3 and 6 <i>Renaud Chorlay</i>	2109
New Math at primary schools in West Germany a theoretical framework for the description of educational reforms <i>Tanja Hamann</i>	2117
Relevance of mathematics journals for Dutch teachers in the 18th and 19th century <i>Jenneke Krüger</i>	2125
Semiotic potential of a tractional machine: a first analysis <i>Michela Maschietto, Pietro Milici and Dominique Tournès</i>	2133
On the historical development of algorithms - hidden in technical devices? <i>Regina Möller and Peter Collignon</i>	2141
Historical tasks to foster problematization <i>Bruna Moustapha-Corrêa Aline Bernardes and Victor Giraldo</i>	2149
The development of Thales theorem throughout history <i>Slim MRABET</i>	2158
Original sources, ICT and mathemacy <i>Marianne Thomsen and Inge Marie Olsen</i>	2160
Rizanesander's Recknekonsten or "The art of arithmetic" - the oldest known textbook of mathematics in Swedish <i>Reza Russell Hatami and Johanna Pejlare</i>	2162

I Spy with my Little Eye – Teachers’ linkages about historical snippets in textbooks <i>Sebastian Schorcht</i>	2170
Exams in calculations/mathematics in Norway 1946 2017 content and form <i>Bjørn Smestad and Aina Fossum</i>	2170
History of mathematics in Dutch teacher training <i>Desiree van den Bogaart-Agterberg</i>	2180
History of mathematics and current developments in education <i>Ysette Weiss and Rainer Kaenders</i>	2188
Lucas Bunt and the rise of statistics education in the Netherlands <i>Bert Zwaneveld and Dirk De Bock</i>	2196
TWG13: Early Years Mathematics	2204
Early Years Mathematics: Introduction to TWG 13 <i>Ingvald Erfjord, Bozena Maj-Tatsis, Esther Levenson, Priska Sprenger and Marianna Tzekaki</i>	2205
Pips (times) Pods: Dancing towards multiplicative thinking <i>Sandy Bakos and Nathalie Sinclair</i>	2209
Framework for analysing children s ways of experiencing numbers <i>Camilla Björklund and Ulla Runesson Kempe</i>	2217
Pre-schoolers ability to synchronise multiple representations of numerosity in embodiment of a counting-on-strategy <i>Morten Bjørnebye</i>	2225
Development of strategies for a combinatorial task by a 5 year old child <i>Kerstin Bräuning</i>	2233
Kindergarten teachers’ orchestration of mathematical learning activities: the balance between freedom and structure <i>Svanhild Breive</i>	2241
Creative processes of one primary school child working on an open-ended task <i>Svenja Bruhn</i>	2249
Characterising the mathematical discourse in a kindergarten <i>Ingvald Erfjord, Martin Carlsen, and Per Sigurd Hundeland</i>	2257
Paper plate patterns: teachers developing patterning in pre-school <i>Sue Gifford and Helen Thouless</i>	2265
Investigating mediation strategies used by early years mathematics teachers in Malawi <i>Fraser Gobede</i>	2267
Developing mathematical literacy in an inquiry-based setting working with play-coins in a second-grade classroom <i>Benedikte Grimeland and Svein Arne Sikko</i>	2269
Student teachers' definitions of the concept teaching mathematics in preschool <i>Maria Johansson, Timo Tossavainen, Ewa-Charlotte Faarinen, and Anne Tossavainen</i>	2277

Using finger patterns - the case of communicating age <i>Miriam M. Lüken</i>	2285
Evidence of relational thinking at kindergarten level <i>Andrea Maffia and Simona Mancarella</i>	2293
Task characteristics that promote mathematical reasoning among young students: An exploratory case study <i>Bozena Maj-Tatsis and Konstantinos Tatsis</i>	2301
Exploring how primary teacher education prepares pre-service teachers to teach early years Mathematics <i>Justina Longwe Mandala</i>	2309
Preschool children's understanding of length and area measurement in Japan <i>Nanae Matsuo and Nagisa Nakawa</i>	2311
The use of structure as a matter of language <i>Lara Müller and Kerstin Tiedemann</i>	2319
Children's use of mathematical language <i>Beate Nergård</i>	2321
Fostering children's repeating pattern competencies by physical activity <i>Kathrin Nordemann and Thomas Rottmann</i>	2329
Toddlers exploring structural elements in play <i>Hanna Palmér and Camilla Björklund</i>	2331
What can five-, six- and seven-year-olds tell us about the transition from mathematics in kindergarten to that in school in Norway? <i>Geir Olaf Pettersen and Monica Volden</i>	2339
Inquiry-based implementation of a mathematical activity in a kindergarten classroom <i>Chrysanthi Skoumpourdi</i>	2347
Perceiving and using structures in sets the contribution of eye-tracking in a three- level evaluation process <i>Priska Sprenger and Christiane Benz</i>	2355
Construction of scientific basis for pre-school teacher education <i>Christina Svensson</i>	2363
Shedding light on preschool teachers' self-efficacy for teaching patterning <i>Pessia Tsamir, Dina Tirosh, Esther Levenson, Ruthi Barkai</i>	2365
Generalization in early arithmetic <i>Marianna Tzekaki and Evaggelia Papadopoulou</i>	2373
Characterisation of the learning trajectory of children aged six to eight years old when acquiring the notion of length measurement <i>Yuly Vanegas, Montserrat Prat and Alba Rubio</i>	2381
Chances and obstacles of 'indirect' learning processes in situations with preschool teachers <i>Anna-Marietha Vogler</i>	2389

Developing a social training of spatial perception and spatial cognition <i>Martina Wernicke, Jasmin Kizilirmak, Barbara Schmidt-Thieme and Kristian Folta-Schoofs</i>	2397
TWG14: University Mathematics Education	2399
Introduction to the papers of TWG14: University Mathematics Education <i>Alejandro S. González-Martín, Irene Biza, Jason Cooper, Imène Ghedamsi, Ghislaine Gueudet, Vilma Mesa, Alon Pinto and Olov Viirman</i>	2400
How Lisa’s mathematical reasoning evolved at undergraduate level on the role of metacognition and mathematical foundation <i>Aaltje Berendina Aaten, Gerrit Roorda, Johan Deprez and Martin Goedhart</i>	2408
Students’ conceptions of the definite integral in the first year of studying science at university <i>Inen Akrouti</i>	2416
The transition from high school to university mathematics: the effect of institutional issues on students’ initiation into a new practice of studying mathematics <i>Amalia-Christina Bampili, Theodossios Zachariades and Charalampos Sakonidis</i>	2418
Students’ understanding of the interplay between geometry and algebra in multidimensional analysis: representations of curves and surfaces <i>Matija Bašić and Željka Milin Šipuš</i>	2426
Understanding the secondary-tertiary transition in mathematics education: contribution of theories to interpreting empirical data <i>Christer Bergsten and Eva Jablonka</i>	2434
External Didactic Transposition in Undergraduate Mathematics <i>Marianna Bosch, Thomas Hausberger, Reinhard Hochmuth and Carl Winsløw</i>	2442
Students’ difficulties to learn derivatives in the Tunisian context <i>Rahma Bouguerra</i>	2450
The integration of digital resources into teaching and learning practices of the derivative concept <i>Danilo Christo and Sonia Iglioni</i>	2452
Restored narratives on the agency and disputes of mathematicians and mathematics educators in the education of mathematics teachers <i>Cleber Dias da Costa Neto, Victor Giraldo and Elena Nardi</i>	2454
Evaluation of a connecting teaching format in teacher education <i>Andreas Datzmann and Matthias Brandl</i>	2462
Students difficulties at the secondary-tertiary transition: the case of random variables <i>Camille Doukhan and Ghislaine Gueudet</i>	2464
Participation of female students in undergraduate Mathematics at the University of Malawi <i>Levis Eneya, Lisnet Mwadzaangati and Mercy Kazima</i>	2472
Supporting the use of study skills in large mathematics service courses to enhance students’ success - one example <i>Frank Feudel and Hans M. Dietz</i>	2474

Digital learning materials in traditional lectures and their evaluation at the example of a voluntary pre-university bridging course <i>Yael Fleischmann, Tobias Mai, Rolf Biehler and Alexander Gold</i>	2482
Study and research paths at university level: managing, analysing and institutionalizing knowledge <i>Ignasi Florensa, Berta Barquero, Marianna Bosch and Josep Gascón</i>	2484
Two situations for working key properties of \mathbb{R} <i>Macarena Flores González, Alain Kuzniak, Elizabeth Montoya Delgadillo and Laurent Vivier</i>	2492
To whom do we speak when we teach proofs? <i>Mika Gabel and Tommy Dreyfus</i>	2494
Towards an interplay between TDS and ATD in a Design-Based Research project at the entrance to the university <i>Imène Ghedamsi and Thomas Lecorre</i>	2502
The graph of a function and its antiderivative: a praxeological analysis in the context of Mechanics of Solids for engineering <i>Alejandro S. González-Martín and Gisela Hernandez-Gomes</i>	2510
Calculus students' difficulties with logical reasoning <i>Gabriel Herrera Alva, Antonio Rivera Figueroa and Kinrha Aguirre-De la Luz</i>	2518
The VEMINT-Test: Underlying Design Principles and Empirical Validation <i>Reinhard Hochmuth, Marcel Schaub, Andreas Seifert, Regina Bruder and Rolf Biehler</i>	2526
An exploration of the relationship between continuous assessment and resource use in a service mathematics module <i>Emma Howard, Maria Meehan and Andrew Parnell</i>	2534
How to assess students learning in mathematics literacy education: An attempt to use students' comments for assessment <i>Mitsuru Kawazoe</i>	2542
On tasks that lead to praxeologies formation: a case in vector calculus <i>Margo Kondratieva</i>	2544
What can be 'annoying' about mathematical conventions? Analysing post-exchanges of mathematically competent discursants <i>Igor' Kontorovich</i>	2552
Beliefs about learning attributed to recognized college mathematics instructors <i>Valentin A. B. Küchle and Shiv S. Karunakaran</i>	2560
Features of innovative lectures that distinguish them from traditional lectures and their evaluation by attending students <i>Christiane Kuklinski, Michael Liebendörfer, Reinhard Hochmuth, Rolf Biehler, Niclas Schaper, Elisa Lankeit, Elena Leis and Mirko Schürmann</i>	2562
Students' work with a task about logical relations between various concepts of multidimensional differentiability <i>Elisa Lankeit and Rolf Biehler</i>	2570

Teaching of discontinuous functions of one or two variables: A didactic experience using problem posing and levels of cognitive demand <i>Uldarico Malaspina and Carlos Torres</i>	2578
Identifying sense-making in algebra instruction at U.S. post-secondary colleges <i>Angeliki Mali, Anne Cawley, Irene Duranczyk, Vilma Mesa, April Ström and Laura Watkins</i>	2586
From university mathematics students to postsecondary teachers <i>Sarah Mathieu-Soucy, Claudia Corriveau and Nadia Hardy</i>	2594
The structure of EQIPM, a video coding protocol to assess the quality of community college algebra instruction <i>Vilma Mesa, Irene Duranczyk, Laura Watkins and the AI@CC Research group</i>	2596
University Student Use of Dynamic Textbooks: An Exploratory Analysis <i>Vilma Mesa, Angeliki Mali and Elena Castro-Rodríguez</i>	2604
An exploratory study of calculus students' understanding of multivariable optimization problems <i>Thembinkosi P. Mkhathshwa</i>	2606
Towards a better understanding of engineering students use and orchestration of resources: Actual Student Study Paths <i>Birgit Pepin and Zeger-Jan Kock</i>	2614
Conceptualising knowledge of mathematical concepts or procedures for diagnostic and supporting measures at university entry level <i>Guido Pinkernell</i>	2622
Formative assessment of proof comprehension in undergraduate mathematics: Affordances of iterative lecturer feedback <i>Alon Pinto and Jason Cooper</i>	2630
Relations between academic knowledge and knowledge taught in secondary education: Klein's second discontinuity in the case of the integral <i>Gaëtan Planchon</i>	2638
Theorizing coordination and the role of course coordinators <i>Chris Rasmussen, Jessica E. Hagman and Naneh Apkarian</i>	2640
OPTES+ A Mathematical Bridging Course for Engineers <i>Anna-Katharina Roos, Gerhard Götz, Hans-Georg Weigand and Jan Franz Wörler</i>	2642
The connectivity in resources for student-engineers: the case of resources for teaching sequences <i>Hussein Sabra</i>	2644
TWG15: Teaching Mathematics with Technology and Other Resources	2652
Introduction to the papers of TWG15: Teaching Mathematics with Technology and Other Resources <i>Alison Clark-Wilson, Ornella Robutti, Melih Turgut and Iveta Kohanová</i>	2653
Teachers' strategic choices when implementing technology <i>Henrik P. Bang, Niels Grønbaek and Claus R. Larsen</i>	2661

Turning dilate from point tool into part of an instrument: an example of a preservice mathematics teacher working on a dynamic geometry system <i>Gulay Bozkurt, Candas Uygan and Melih Turgut</i>	2663
Towards linking teaching, technology and textbooks <i>Maike Braukmüller, Angelika Bikner-Ahsbabs and Dirk F. Wenderoth</i>	2671
Project in preparation - Connected classroom technology (CCT) to enhance formative assessment in mathematics education <i>Mats Brunström and Maria Fahlgren</i>	2679
Key Factors for Successfully Embedding a Programming Approach to the Primary Maths Curriculum at Scale <i>Alison Clark-Wilson, Richard Noss, Celia Hoyles, Piers Saunders and Laura Benton</i>	2681
The co-design of a c-book by students and teachers as a process of meaning generation: The case of co-variation <i>Dimitris Diamantidis, Chronis Kynigos, Ioannis Papadopoulos</i>	2689
Addressing the problem of digital tools with digital methods <i>Jonas Dreyøe</i>	2697
The forgotten technology. Teachers use of mini white-boards to engage students <i>Thomas F. Eidissen, Karen Bjerkeli, and Ove Gunnar Drageset</i>	2699
Investigating similar triangles using student-produced videos <i>Anders Støle Fidje and Ingvald Erfjord</i>	2701
Silent video tasks: Towards a definition <i>Bjarnheiður (Bea) Kristinsdóttir, Freyja Hreinsdóttir and Zsolt Lavicza</i>	2709
A new era of manipulatives: making your own resources with 3D printing and other technologies <i>Diego Lieban, Eva Ulbrich, Marina Menna Barreto and Zsolt Lavicza</i>	2711
Surveying teachers' conception of programming as a mathematics topic following the implementation of a new mathematics curriculum <i>Morten Misfeldt, Attila Szabo and Ola Helenius</i>	2713
Designing an problem for learning mathematics with programming <i>Morten Munthe</i>	2721
Developing MAP for integrating mathematical applets in teaching sequence <i>Gal Nakash-Stern and Anat Cohen</i>	2723
The impact of technology on the teachers' use of different representations <i>Helena Rocha</i>	2731
An overview of gamification and gamified educational platforms for mathematics teaching <i>Cecilia Russo and Zsolt Lavicza</i>	2739
Professional development through a web-based portal: The progress of mathematics teachers teaching algebra based on hypothetical learning trajectories <i>Dilek Tanışlı, Nilüfer Köse and Melih Turgut</i>	2741

Self-efficacy the final obstacle on our way to teaching mathematics with technology? <i>Daniel Thurm and Bärbel Barzel</i>	2749
How to distinguish simulations? Development of a classification scheme for digital simulations for teaching and learning mathematics <i>Jan Franz Wörler</i>	2757
Mathematical practices of teachers in technology-enhanced classrooms: A case of teaching slope concept <i>Seçil Yemen Karpuzcu and Mine Işıksal Bostan</i>	2765
TWG16: Learning Mathematics with Technology and Other Resources	2773
Introduction to the papers of TWG16: Learning Mathematics <i>Hans-Georg Weigand, Nathalie Sinclair, Ana Donevska-Todorova, Eleonora Faggiano, Eirini Geraniou, Osama Swidan</i>	2774
Desirable difficulties while learning mathematics: Interleaved practice based on e-learning <i>Maria Afrooz and Rita Borromeo Ferri</i>	2778
Types of graphic interface design and their role in learning via mathematical applets at the elementary school <i>Eitan Ben-Haim, Anat Cohen and Michal Tabach</i>	2780
Meanings in Mathematics: using Internet Memes and Augmented Reality to promote mathematical discourse <i>Giulia Bini, Ornella Robutti</i>	2788
Students Process and Strategies as They Program for Mathematical Investigations and Applications <i>Chantal Buteau, Eric Muller, Kirstin Dreise, Joyce Mgombelo, and Ana Isabel Sacristán</i>	2796
Big events in Mathematics using math trails <i>Amélia Caldeira, Ana Moura and Christian Mercat</i>	2804
Multiplicative reasoning through two-handed gestures <i>Sean Chorney, Canan Gunes and Nathalie Sinclair</i>	2806
Physical and virtual classroom in the learning of mathematics: analysis of two episodes <i>Agnese Del Zozzo and George Santi</i>	2814
Design of a multi-dimensional instrument for reviewing the quality of apps for elementary geometry <i>Ana Donevska-Todorova and Katja Eilerts</i>	2816
Student engagement in mobile learning activities: breakdowns and breakthroughs <i>Khristin Fabian</i>	2818
A picture is worth a thousand words: visualizing collaboration through gaze synchrony graphs <i>Enrique Garcia Moreno-Esteva, Jessica F. A. Salminen-Saari, Miika Toivanen & Markku S. Hannula</i>	2826

University students' engagement with an asynchronous online course on digital technologies for mathematical learning <i>Eirini Geraniou and Cosette Crisan</i>	2828
Dynamic vs. static! Different visualisations to conceptualize parameters of quadratic functions <i>Lisa Göbel and Bärbel Barzel</i>	2836
The effect of digital tools on visual attention during problem solving: Variance of gaze fixations when working with GeoGebra or on paper <i>Markku S. Hannula and Miika Toivanen</i>	2838
An Exploration of the effect of Bray's Activity Design Heuristics on Students' Learning of Transformation Geometry <i>Aoife Harrison, Aibhín Bray and Brendan Tangney</i>	2846
Didactical resource purposes as an aspect of students' decision making regarding resources used to learn mathematics <i>Eivind Hillesund</i>	2848
Guidelines for design of didactic sequences utilizing dynamic geometry affordances related to mathematical reasoning competency <i>Ingi Heinesen Højsted</i>	2850
Issues in modelling terms involving subtraction in a manipulative environment for linear equations and a possible solution <i>Thomas Janßen, David Reid & Angelika Bikner-Ahsbals</i>	2852
Exploring with digital media to understand trigonometric functions through periodicity <i>Myrto Karavakou, Chronis Kynigos</i>	2860
Moving fingers and the density of rational numbers: An inclusive materialist approach to digital technology in the classroom <i>Doyen Kim and Oh Nam Kwon</i>	2868
Investigating students use of dynamic materials addressing conceptions related to functional thinking <i>Edith Lindenbauer</i>	2876
A virtual environment dedicated to spatial geometry to help students to see better in space <i>Xavier Nicolas and Jana Trgalova</i>	2884
Students perceptions in a situation regarding eigenvalues and eigenvectors <i>José Orozco-Santiago, Carlos-Armando Cuevas and Luc Trouche</i>	2892
Why digital tools may (not) help by learning about graphs in dynamics events? <i>Sonia Palha</i>	2900
Learning environments applying digital learning tools to support argumentation skills in primary school: first insights into the project <i>Melanie Platz</i>	2908
Digital media support functional thinking: How a digital selfassessment tool can help learners to grasp the concept of function <i>Hana Ruchniewicz and Bärbel Barzel</i>	2916

Exploring pre-calculus with augmented reality. A design-based-research approach <i>Florian Schacht and Osama Swidan</i>	2925
Exploring critical aspects of students' mathematics learning in technology-enhanced and student-led flipped learning environments <i>Stefanie Schallert and Robert Weinhandl</i>	2933
Practicing place value: How children interpret and use virtual representations and features <i>Axel Schulz and Daniel Walter</i>	2941
Exploring non-prototypical configurations of equivalent areas through inquiring-game activities within DGE <i>Carlotta Soldano and Cristina Sabena</i>	2949
The graphing calculator as an instrument of semiotic mediation in the construction of the function concept <i>Manuela Subtil and António Domingos</i>	2957
Drawing topology using Ariadne <i>Moritz L. Sümmermann</i>	2959
Semiotic analysis of modelling activities in a rich-digital environment <i>Osama Swidan and Eleonora Faggiano</i>	2961
Automated feedback on the structure of hypothesis tests <i>Sietske Tacoma, Bastiaan Heeren, Johan Jeuring and Paul Drijvers</i>	2969
Problem-solving techniques in the context of an educational video game: the Mudwall puzzle in Zoombinis <i>Georgios Thoma and Irene Biza</i>	2977
Repeated sampling in a digital environment: A remix of data and chance <i>Marianne van Dijke-Droogers, Paul Drijvers and Arthur Bakker</i>	2985
Reflections on item characteristics of non-routine items in diagnostic digital assessment <i>Irene van Stiphout and Madelon Groenheiden</i>	2993
Role of tablets in teaching and learning mathematics <i>Fabrice Vandebrouck and Barbara Jaworski</i>	3001
The long-term effects of MathCityMap on the performance of German 15 year old students concerning cylindrical tasks <i>Joerg Zender and Matthias Ludwig</i>	3003
Exploring the role of context in students meaning making for algebraic generalization <i>Angela Zoupa and Giorgos Psycharis</i>	3011

TWG17: Theoretical Perspectives and Approaches in Mathematics

Education Research 3019

Introduction to the Thematic Working Group 17 on Theoretical Perspectives and Approaches in Mathematics Education Research of CERME11 <i>Angelika Bikner-Ahsbabs, Arthur Bakker, Heather Lynn Johnson, Man Ching Esther Chan</i>	3020
--	------

Table of Contents: Thematic Working Group 17	3028
Comparing a priori analyses <i>Ivy Kidron</i>	3029
Rethinking the connection between theory and methodology: a question of mutual affordances <i>Man Ching Esther Chan, David Clarke</i>	3038
Boundary crossing by design(ing): a design principle for linking mathematics and mathematics education in preservice teacher training <i>Erik Hanke, Angelika Bikner-Ahsbabs</i>	3046
How concepts turn into objects: an investigation of the process of objectification in early numerical discourse <i>Felix Lensing</i>	3054
On the epistemology of the Theory of Objectification <i>Luis Radford</i>	3062
An epistemological and philosophical perspective on the question of mathematical work in the Mathematical Working Space theory <i>Alain Kuzniak, Laurent Vivier</i>	3070
A phenomenological methodology based on Husserl's work in the service of mathematics education research <i>Andonis Zagorianakos</i>	3078
Creating art laboratory settings and experiencing mathematical thinking: towards a philosophical dimension in mathematics education research <i>Cláudia Regina Flores</i>	3086
Networking theories in design research: an embodied instrumentation case study in trigonometry <i>Rosa Alberto, Arthur Bakker, Oia Walker-van Aalst, Peter Boon, Paul Drijvers</i>	3088
Generativity in design research: the case of developing a genre of action-based mathematics learning activities <i>Arthur Bakker, Anna Shvarts, Dor Abrahamson</i>	3096
Theory, methodology and design as an insightful bundle: a case of dual eye-tracking student-tutor collaboration on an embodied mathematical task <i>Anna Shvarts</i>	3104
Assembling mathematical concepts through trans-individual coordinated movements: the role of affect and sympathy <i>Elizabeth de Freitas, Francesca Ferrara, Giulia Ferrari</i>	3106
Locally integrating theories to investigate students' transfer of mathematical reasoning <i>Heather Lynn Johnson, Evan McClintock, Amber Gardner</i>	3114
Epistemological and methodological foundations of creating a learning trajectory of children's mathematics <i>Nicole L. Fonger, Amy Ellis, Muhammed F. Dogan</i>	3122

Conceiving teaching trajectories in the form of series of problems: a step for the theoretical reconstruction of the Hungarian Guided Discovery approach <i>Katalin Gosztonyi</i>	3130
Students' learning paths about ratio and proportion in geometry: an analysis using Peirce's theory of signs <i>Georgia Bampatsikou, Triandafillos A. Triandafillidis, Stefanos Asimopoulos, Kostas Hatzikiriakou</i>	3138
Connected Working Spaces: the case of computer programming in mathematics education <i>Jean-baptiste Lagrange, Dominique Laval</i>	3146
Multi-theoretical approach when researching mathematics teachers' professional development in selforganized online groups <i>Yvonne Liljekvist, Jorryt van Bommel, Ann-Christin Randahl, Christina Olin-Scheller</i>	3154
Extending Yackel and Cobb's socio-mathematical norms to ill-structured problems in an inquiry-based classroom <i>Katie Makar, Jill Fielding-Wells</i>	3162
Understanding powers – individual concepts and common misconceptions <i>Christos Itsios, Bärbel Barzel</i>	3170
Questioning the paradidactic ecology: internationally shared constraints on lesson study? <i>Koji Otaki, Yukiko Asami-Johansson, Jacob Bahn</i>	3178
TWG18: Mathematics teacher education and professional development	3186
International perspectives on mathematics teacher professional development <i>Stefan Zehetmeier, João Pedro da Ponte, Laurinda Brown, Àngela Buforn, Janne Fauskanger, Marita Friesen, Maria Mellone, Libuse Samkova</i>	3187
Working with example sets: A productive focus in Lesson Study <i>Jill Adler and Jehad Alshwaikh</i>	3191
Reflections upon a research project seen as a means for teachers' professional development <i>Mette Andresen</i>	3199
Portfolios as a way of documenting and reflecting learning processes in a mathematics teachers professional development program <i>Jennifer Bertram</i>	3201
The story of Maia: I will try to survive! <i>Annette Hessen Bjerke</i>	3203
Connecting mathematical knowledge with engagement in mathematics teaching practices <i>Timothy Boerst and Meghan Shaughnessy</i>	3211
High school teacher training challenges in the Italian interdisciplinary project Liceo Matematico <i>Laura Branchetti, Roberto Capone, Francesco Saverio Tortoriello</i>	3219

Researching as a mathematics teacher educator: analysing mathematics teachers' detailed descriptions of first lessons <i>Laurinda Brown</i>	3221
Using mixed-assessments to evaluate opportunities to learn in mathematics teacher education <i>Nils Buchholtz, Katrin Vorhölter, Anna Orschulik and Nadine Krosanke</i>	3229
Mathematical knowledge for teaching of a prospective teacher having a progressive incorporation perspective (PIP) <i>Esra Bukova Güzel, Gülseren Karagöz Akar, Aytuğ Özaltun Çelik, Semiha Kula Ünver, Nurdan Turan</i>	3231
Teachers' Collaboration in a Mathematics Lesson Study <i>João Pedro da Ponte and Marisa Quaresma</i>	3239
How to visualize classroom norms through social interaction - A pilot study of two frameworks <i>Jonas Dahl, Christina Svensson and Richard Wester</i>	3247
Understanding student teachers' professional development by looking beyond mathematics teacher education <i>Andreas Ebbelind</i>	3249
Retrospective reflections on 'Missions' as pedagogies of practice <i>Elisabeta Eriksen, Annette Hessen Bjerke, Camilla Rodal and Ida Heiberg Solem</i>	3257
Learning to represent students' mathematical ideas through teacher time-outs in rehearsals <i>Janne Fauskanger and Kjersti Wæge</i>	3265
How does the professional vocabulary change when pre-service teachers learn to analyse classroom situations? <i>Marita Friesen, Carmel Mesiti and Sebastian Kuntze</i>	3273
Prospective mathematics teachers' interpretative knowledge: focus on the provided feedback <i>Jeannette Galleguillos and Miguel Ribeiro</i>	3281
Using participant generated influence maps to gain insights into the influences on early career primary teachers' teaching of mathematics <i>Alison Godfrey</i>	3289
A zone theory analysis of identity formation in mathematics teacher educators <i>Merrilyn Goos and Anne Bennison</i>	3297
Analyzing attitude towards learning and teaching mathematics in members of professional learning communities: A case study <i>Birgit Griese</i>	3305
Math MOOC UniTo & MathCityMap - Exploring the potentials of a review system in a MOOC environment <i>Iwan Gurjanow, Eugenia Taranto, Matthias Ludwig, Virginia Alberti, Roberta Ferro</i>	3313
Cross-linking maths: Using keynotes to structure a curriculum for future teachers <i>Tanja Hamann and Barbara Schmidt-Thieme</i>	3321

Teacher education: Developing the individual within the collaborative <i>Fiona Haniak-Cockerham</i>	3323
Teacher Professional Development and Collegial Learning: A literature review through the lens of Activity System <i>Frida Harvey and Anna Teledahl</i>	3331
Between natural language and mathematical symbols (<, >, =): the comprehension of pre-service and preschool teachers' perspective of Numbers and Quantity <i>Dina Hassidov and Bat-Sheva Ilany</i>	3339
Similarities and differences in problem solving: case of "exhibition grounds" <i>Radka Havlíčková, David Janda, Derek Pilous and Veronika Tůmová</i>	3347
Formulating our formulations: the emergence of conviction as becoming mathematics teacher educators <i>Tracy Helliwell and Julian Brown</i>	3349
Tasks Designed for Training Secondary Mathematics Teachers Using Technology <i>Alexánder Hernández, Josefa Perdomo-Díaz and Matías Camacho-Machín</i>	3357
Opportunities for Adopting a Discourse of Explorations in a Professional Development Setting <i>Einat Heyd-Metzuyanin and Talli Nachlieli</i>	3362
On the efficiency of a professional development program for mathematics teachers in upper-secondary schools in Iceland <i>Freyja Hreinsdóttir</i>	3373
Algebraic solutions of German out-of-field elementary school teachers <i>Lara Huethorst</i>	3375
Mathematics teacher educators' critical collegiality <i>Suela Kacerja and Rune Herheim</i>	3384
Prospective Secondary Mathematics Teachers Development of Core-Practices During Methods Courses: Affordances of Quantitative Reasoning <i>Gulseren Karagöz Akar, Esra Bukova Güzel, Serkan Özel</i>	3392
From judgmental evaluations to productive conversations: Mathematics teachers' shifts in communication within a video club <i>Ronnie Karsenty, Yochai Peretz and Einat Heyd-Metzuyanin</i>	3400
Construction of teachers' roles in collegial discussions <i>Odd Tore Kaufmann and Andreas Ryve</i>	3408
From instrumental to relational Malawi mathematics teacher educators' research lessons <i>Mercy Kazima, Janne Fauskanger and Arne Jakobsen</i>	3416
How can we help teachers using guided discovery method, who have not used it before <i>Eszter Kovács-Kószó, Katalin Gosztonyi and József Kosztolányi</i>	3424
Diagnostic competence of future primary school teachers hypothesizing about causes of students' errors <i>Macarena Larrain</i>	3426

Thinking about Mathematics classroom culture through spontaneous videos <i>Cristina Loureiro, Cristina Morais and Helena Gil Guerreiro</i>	3435
Preservice teachers learning about critical mathematics education <i>Camilla Meidell, Diana Paola Piedra Moreno and Georgia Kasari</i>	3443
Retrospective competence assessment in a PD course on teaching statistics with digital tools in upper secondary schools <i>Ralf Nieszporek and Rolf Biehler</i>	3445
Learning through/about Culturally Relevant Pedagogy in Mathematics Teacher Education <i>Kathleen Nolan and Lindsay Keazer</i>	3453
Using teachers' research to elicit professional development among pre- and in-service mathematics teachers: a qualitative meta-analysis of mathematics education in graduate programs <i>Tikva Ovadiya</i>	3455
A quasi-experimental impact study of a professional development course for secondary mathematics teachers in South Africa <i>Craig Pournara and Patrick Barmby</i>	3463
Orchestrating collective mathematical discussions: practices and challenges <i>Ana Maria Roque Boavida, Ana Paula Silvestre and Cátia Prata</i>	3471
Pre-service mathematics teachers interpret observed teachers' responses to students' statements <i>Sigal Rotem, Michal Ayalon and Shula Weissman</i>	3473
Using Concept Cartoons in future primary school teacher training: the case of problem posing and open approach <i>Libuše Samková</i>	3481
Generation and generation tasks in mathematics didactics <i>Marianne Schäfer and Rita Borromeo Ferri</i>	3489
Interweaving Mathematical-News-Snapshots as a facilitator for the development of Mathematical Knowledge for Teaching <i>Ruti Segal, Atara Shriki, Nitsa Movshovitz-Hadar and Boaz Silverman</i>	3497
Examining pedagogical and classroom discourse through the lens of figured worlds: The case of an elementary school teacher <i>Galit Shabtay and Esther Levenson</i>	3505
Impacts of a mathematical mistake on preservice teachers' eliciting of student thinking <i>Meghan Shaughnessy, Rosalie DeFino, Erin Pfaff, Merrie Blunk and Timothy Boerst</i>	3513
Beliefs and expectations at the beginning of the bachelor teacher training program in mathematics <i>Evelyn Süss-Stepancik and Stefan Götz</i>	3521
Pre-service teachers' geometrical discourses when leading classroom discussions about defining and classifying quadrilaterals <i>Gry Anette Tuset</i>	3523

Developing professional development programmes with gamification for mathematics teachers in Uruguay <i>Fabián Vitabar, Zsolt Lavicza and Markus Hohenwarter</i>	3531
Action research as a potent methodology for improving teaching and learning in mathematics <i>Eda Vula</i>	3539
TWG19: Mathematics Teaching and Teacher Practice(s)	3547
Introduction to the papers of TWG19: Mathematics Teaching and Teacher Practice(s) <i>Charalampos Sakonidis, Reidar Mosvold, Ove Gunnar Drageset, Siún Nic Mhuirí, Rukiye Didem Taylan</i>	3548
Comparison of students and researchers' choice of significant events of math lessons <i>Christoph Ableitinger, Astrid Anger and Christian Dorner</i>	3556
Between-desk-teaching as a deliberate act of making content available: The case of Bernie teaching ratio <i>Nick Andrews</i>	3564
Teachers' learning goals for a mathematics lesson <i>Kristin Krogh Arnesen and Yvonne Grimeland</i>	3572
A math teacher's participation in a classroom design research: teaching of ratio and proportion <i>Rukiye Ayan, Mine Isiksal-Bostan and Michelle Stephan</i>	3580
A comparison of the treatment of mathematical errors arising from teacher-initiated and student-initiated interactions <i>Fay Baldry</i>	3588
Teacher responses to public apparent student error: A critical confluence of mathematics and equitable teaching practice <i>Hyman Bass and Reidar Mosvold</i>	3596
Conceptual learning opportunities in teachers' differentiated task designs for inclusive mathematics education <i>Christian Büscher</i>	3604
Effects of a Scaffolding Model for small groups in mathematics <i>Sharon Calor, Rijkje Dekker, Jannet van Drie, Bonne Zijlstra and Monique Volman</i>	3612
How to improve teacher students' awareness of critical aspects in a lesson plan <i>Jonas Dahl, Anna Wernberg and Cecilia Winström</i>	3620
How teachers use interactions to craft different types of student participation during whole-class mathematical work <i>Ove Gunnar Drageset</i>	3622
Beyond the immediate - illuminating the complexity of planning in mathematics teaching <i>Helena Grundén</i>	3630
The work of equitable mathematics teaching: Leading a discussion of student solutions <i>Mark Hoover and Imani Goffney</i>	3638

Learning from Lessons: A study on structure and construction of mathematics teacher knowledge - First results of case study <i>Judith Huget and Andrea Peter-Koop</i>	3646
Balancing the live use of resources towards the introduction of the Iterative Numerical method <i>Lina Kayali and Irene Biza</i>	3648
The King's birthday, potentials for developing mathematics teaching <i>Bodil Kleve, Ida Heiberg Solem and Gerd Ånestad</i>	3656
Learning trajectories and fractions: primary teachers meaning attributions <i>Anna Klothou, Charalampos Sakonidis and Vagia Arsenidou</i>	3664
Good mathematics teaching at lower primary school level <i>Marianne Maugesten</i>	3672
Analysis of differences between teachers' activity during their regular and constructivist lessons <i>Janka Medová, Kristína Bulková and Soňa Čeretková</i>	3680
Noticing mathematical potential - A proposal for guiding teachers <i>Elisabet Mellroth and Jesper Boesen</i>	3688
The work of positioning students and content in mathematics teaching <i>Reidar Mosvold and Raymond Bjuland</i>	3696
Evolving discourse of practices for quality teaching in secondary school mathematics <i>Talli Nachlieli, Yishay Mor, Einat Gil and Yael Kashtan</i>	3704
A lens on two classrooms: Implications for research on teaching <i>Siún Nic Mhuirí</i>	3712
Assessing how teachers promote students' metacognition when teaching mathematical concepts and methods <i>Edyta Nowińska</i>	3720
Teachers probing questions in mathematical classrooms connected to their practice of encouraging students to explain their thinking <i>Anna Östman</i>	3728
Linking the micro and macro context: A sociocultural perspective <i>Maria Pericleous</i>	3730
Teachers attempts to address both mathematical challenge and differentiation in whole class discussion <i>Giorgos Psycharis, Despina Potari, Chrissavgi Triantafillou and Theodossios Zachariades</i>	3738
Investigating the relation between teachers' actions and students' meaning making of mathematics <i>Karin Rudsberg, Marcus Sundhäll and Per Nilsson</i>	3746
Mathematics teaching and teachers' practice: tracing shifts in meaning and identifying potential theoretical lenses <i>Charalampos Sakonidis</i>	3754

Pre-service teachers' experiences in selecting and proposing challenging tasks in secondary classrooms <i>Leonor Santos, Hélia Oliveira, João Pedro da Ponte, Ana Henriques</i>	3762
Teachers actions in classroom and the development of quantitative reasoning <i>Lurdes Serrazina, Margarida Rodrigues and Ana Caseiro</i>	3770
Contradictions in prospective mathematics teachers' initial classroom teaching as sources for professional learning <i>Konstantinos Stouraitis and Despina Potari</i>	3778
Analyzing a novice teacher's instructional actions in response to unexpected moments in teaching <i>Rukiye Didem Taylan and Merve Esmer</i>	3786
Feedback for creative reasoning <i>Anna Teledahl and Jan Olsson</i>	3794
Revisiting teacher decision making in the mathematics classroom: a multidisciplinary approach <i>Steven Watson</i>	3802
TWG20: Mathematics teacher knowledge, beliefs, and identity	3810
Introduction to the papers of TWG20: mathematics teacher knowledge, beliefs, and identity <i>Miguel Ribeiro, Francesca Martignone, Fatma Aslan-Tutak, Kirsti Rø, Miguel Montes, Sebastian Kuntze</i>	3811
Mathematical and didactical knowledge about patterns and regularities mobilized by teachers in a professional learning task <i>Marcia Aguiar, Alessandro Jacques Ribeiro and João Pedro da Ponte</i>	3815
Mathematics Teachers Specialized Knowledge Model as a Metacognitive Tool for Initial Teacher Education <i>Álvaro Aguilar-González and Luis J. Rodríguez-Muñiz</i>	3823
Knowledge of a mathematician to teach divisibility to prospective secondary school teachers <i>Marieli Vanessa Rediske de Almeida, Miguel Ribeiro, Dario Fiorentini</i>	3831
Emergent model for teachers' conceptions of argumentation for mathematics teaching <i>Michal Ayalon & Samaher Naama</i>	3839
A student teacher's responses to contingent moment and task development process <i>Emine Aytakin and Mine Işıksal Bostan</i>	3847
Using the Knowledge Quartet to analyse interviews with teachers manipulating dynamic geometry software <i>Nicola Bretscher</i>	3855
An analysis of the nature of the knowledge disseminated by a mathematics teacher training policy: The PROFMAT case <i>Marlova Estela Caldatto and Miguel Ribeiro</i>	3863

Prospective primary teachers' knowledge about the mathematical practice of defining <i>Myriam Codes, Nuria Climent and Isabel Oliveros</i>	3871
Empowering teachers conceptually and pedagogically through supporting them in seeing connections between school mathematics and relevant advanced mathematics knowledge <i>Cosette Crisan</i>	3879
Teacher educators understanding of mathematical knowledge for teaching <i>Matthew Dahlgren, Reidar Mosvold and Mark Hoover</i>	3887
Exemplifying mathematics teacher's specialised knowledge in university teaching practices <i>Rosa Delgado-Rebolledo and Diana Zakaryan</i>	3895
The probability subjective view: developing teachers' knowledge to give sense to students' productions <i>Rosa Di Bernardo, Maria Mellone, Ciro Minichini and Miguel Ribeiro</i>	3903
"Sometimes it goes wrong!" Teachers' beliefs concerning experiments in mathematics <i>Sebastian Geisler and Sarah Beumann</i>	3905
Chinese and Dutch mathematics teachers' beliefs about inquiry-based learning <i>Luhuan Huang, Michiel Doorman and Wouter van Joolingen</i>	3913
Preservice teachers' mathematical knowledge for teaching combinatorial thinking <i>Veronika Hubeňáková and Ingrid Semanišinová</i>	3921
Malawian preservice teachers' perceptions of knowledge at the mathematical horizon <i>Everton Lacerda Jacinto and Arne Jakobsen</i>	3929
Applying the Knowledge Quartet to student teachers lesson plans: An intervention <i>Lena Karlsson</i>	3937
Preservice teachers noticing of mathematical opportunities <i>Hulya Kilic, Oguzhan Dogan, Nil Arabaci and Sena Simay Tun</i>	3939
Design of repertory grids for research on mathematics teacher conceptions of process-related mathematical thinking <i>Peter M. Klöpping and Ana Kuzle</i>	3947
Constructing tasks for primary teacher education from the perspective of Mathematics Teachers Specialised Knowledge <i>Montes, Miguel, Climent, Nuria, Carrillo, José, Contreras, Luis Carlos</i>	3955
A Look into Turkish Preservice Teachers Translation Skills: Case for Model Representations <i>Zeynep Pehlivan and Fatma Aslan-Tutak</i>	3963
Prospective primary teachers' knowledge of problem solving process <i>Juan Luis Piñeiro, Elena Castro-Rodríguez and Enrique Castro</i>	3970
Conceptualising tasks for teacher education: from a research methodology to teachers' knowledge development <i>Milena Policastro, Maria Mellone, Miguel Ribeiro and Dario Fiorentini</i>	3978

Kindergarten teachers' knowledge in and for interpreting students' productions on measurement <i>Milena Policastro, Miguel Ribeiro and Alessandra Rodrigues de Almeida</i>	3986
Developing an identity as a secondary school mathematics teacher: Identification and negotiability in communities of practice <i>Kirsti Rø</i>	3988
Students abilities on the relationship between beliefs and practices <i>Safrudiannur, and Benjamin Rott</i>	3996
Secondary school preservice teachers' references to the promotion of creativity in their master's degree final projects <i>Alicia Sánchez, Vicenç Font and Adriana Breda</i>	4004
The problem of 0.999 &: Teachers school-related content knowledge and their reactions to misconceptions <i>Verena Spratte, Laura Euhus and Judith Kalinowski</i>	4012
"In school you notice the performance gap and how different it is between the students" - Student teachers' collective orientations about the learners' heterogeneity in mathematics <i>Ann-Kristin Tewes, Elisa Bitterlich, Judith Jung</i>	4020
Teachers noticing of language in mathematics classrooms <i>Carina Zindel</i>	4028
TWG21: Assessment in mathematics education	4036
Introduction to the papers of TWG21: Assessment in mathematics education <i>Paola Iannone, Michal Ayalon, Johannes Beck, Jeremy Hodgen and Francesca Morselli</i>	4037
Strategies of formative assessment enacted through automatic assessment in blended modality <i>Alice Barana and Marina Marchisio</i>	4041
National standardized tests database implemented as a research methodology in mathematics education. The case of algebraic powers. <i>Giorgio Bolondi, Federica Ferretti, George Santi</i>	4049
Students' attitudes and responses to pair-work testing in mathematics <i>Eszter Bóra and Péter Juhász</i>	4057
Classroom assessment tasks and learning trajectories <i>Eleni Demosthenous, Constantinos Christou and Demetra Pitta-Pantazi</i>	4059
Diagnosis of basic mathematical competencies in years 8 and 9 <i>Christina Drüke-Noe and Hans-Stefan Siller</i>	4067
Assessment and argumentation: an analysis of mathematics standardized items <i>Rossella Garuti and Francesca Martignone</i>	4075
Evaluating students' self-assessment in large classes <i>Jokke Häsä, Johanna Rämö and Viivi Virtanen</i>	4083

Large scale analysis of teachers' assessment practices in mathematics <i>Julie Horoks, Julia Pilet, Sylvie Coppé, Marina De Simone and Brigitte Grugeon-Allys</i>	4091
Preservice Middle School Mathematics Teachers Development in Formative Assessment <i>Gözde Kaplan Can and Çiğdem Haser</i>	4099
An assessment of non-standardized tests of mathematical competence for Norwegian secondary school using Rasch analysis <i>Morten Riise Klegseth, Eivind Kaspersen and Trygve Solstad</i>	4107
Mathematics described proficiency levels: connecting psychometric and teaching analyses <i>Cristina Lasorsa, Rossella Garuti, Marta Desimoni, Donatella Papa, Antonella Costanzo and Rosalba Ceravolo</i>	4115
Teachers' Perceptions of Using Incentives in State Examinations to Increase the uptake of Higher Level Mathematics <i>Mark Prendergast, Páraic Treacy and Niamh O'Meara</i>	4117
Teachers use of Descriptive Assessment methods in primary school mathematics education in Iran <i>Ali Akbar Sangari, Marja van den Heuvel-Panhuizen, Michiel Veldhuis and Zahra Gooya</i>	4119
Developing and evaluating an online linear algebra examination for university mathematics <i>Christopher Sangwin</i>	4121
The role of formative assessment in fostering individualized teaching at university level <i>Annalisa Cusi and Agnese Ilaria Telloni</i>	4129
Teaching, learning and assessing in grade 10: an experimental pathway to the culture of theorems <i>Fiorenza Turiano, Paolo Boero and Francesca Morselli</i>	4137
Using student and instructor characteristics to predict student success in Algebra courses <i>Laura Watkins, Rik Lamm, Nidhi Kohli, Patrick Kimani, and the AI@CC Research group</i>	4145
TWG22: Curriculum resources and task design in mathematics education	4153
Introduction to the papers of TWG22: Curriculum resources and task design in mathematics education <i>Birgit Pepin, Sean Delaney, Andreas Eckert, Nataly Essonnier, and Andreas J. Stylianides</i>	4154
Exploring teachers' assignment of mathematical competencies to planned lessons using Epistemic Network Analysis <i>Benjamin Brink Allsopp, Jonas Dreyøe, Andreas Lindenskov Tamborg, Brendan Eagan, Sara Tabatabai, David Williamson Shaffer and Morten Misfeldt</i>	4162

Supporting the reinvention of the slope of a curve in a point: A smooth slope to slide is a smooth slide to slope	4170
<i>Rogier Bos, Michiel Doorman, Kristijan Cafuta, Selena Praprotnik, Sanja Antoliš, Matija Bašić</i>	
Conjecturing tasks for undergraduate calculus students	4178
<i>Sinéad Breen, Caitríona Ní Shé, and Ann O'Shea</i>	
Developing the task progressions framework	4186
<i>Scott A. Courtney and Dubravka Glasnović Gracin</i>	
Combining Differentiation and Challenge in Mathematics Instruction: A Case from Practice	4194
<i>Seán Delaney and Ann Marie Gurhy</i>	
Designing tasks with self-explanation prompts	4202
<i>Anneli Dyrvold & Ida Bergvall</i>	
Designing for digitally enriched Math Talks The case of pattern generalization	4210
<i>Andreas Eckert and Per Nilsson</i>	
Social creativity in the collaborative design of a digital resource embedding mathematics into a story	4218
<i>Nataly Essonnier, Chronis Kynigos and Jana Trgalova</i>	
Building bridges between school mathematics and workplace mathematics	4226
<i>Rune Herheim and Suela Kacerja</i>	
Task design with a focus on conceptual and creative challenges	4234
<i>Jonas Jäder</i>	
The Influence of Teacher Guides on Teachers Practice: A Longitudinal Case Study	4242
<i>Ljerka Jukić Matić and Dubravka Glasnović Gracin</i>	
Community documentation targeting the integration of inquiry-based learning and workplace into mathematics teaching	4244
<i>Elissavet Kalogeria and Giorgos Psycharis</i>	
The use of variation theory in a problem-based task design study	4252
<i>Berie Getie Kassa and Liping Ding</i>	
Web of problem threads (WPT) a theoretical frame and task design tool for inquiry-based learning mathematics	4260
<i>Dániel Katona</i>	
Secondary school mathematics teachers' selection and use of resources	4262
<i>Zeger-Jan Kock and Birgit Pepin</i>	
Multiplicative reasoning task design with student teachers in Scottish schools: valuing diversity, developing flexibility and making connections	4264
<i>Helen Martin</i>	
Comparison of Japanese and Turkish textbooks: Giving opportunities for creative reasoning in terms of proportion	4266
<i>Yasin Memiş</i>	

Making Mathematics fun: The Fear Room game <i>Christina Misailidou and Ronald Keijzer</i>	4274
Examination of mathematical opportunities afforded to learners in grade 1 Malawian primary mathematics textbooks <i>Lisnet Mwadzaangati</i>	4276
Two primary school teachers pedagogical design capacity of using mathematics textbooks in Delhi, India <i>Meghna Nag Chowdhuri</i>	4284
Ability maps in the context of curriculum research <i>Lisbeth Liv Nøhr, Mia Onsvig Gregersen</i>	4292
Task design fostering construction of limit confirming examples as means of argumentation <i>Annalisa Cusi and Shai Olsher</i>	4294
Towards improving teaching and learning of algorithmics by means of resources design: a case of primary school education in France <i>Rafalska Maryna</i>	4302
Length measurement in the textbooks of German and Taiwanese primary students <i>Silke Ruwisch and Hsin-Mei E. Huang</i>	4310
A Hypothetical Learning Trajectory for the learning of the rules for manipulating integers <i>Jan Schumacher and Sebastian Rezat</i>	4318
"First you have to know it exists." Cultivating teachers' thinking about resource options <i>Helen Siedel</i>	4326
Alignment of mathematics curriculum to standards at high schools in Colombia <i>Silvia Solano, Pedro Gómez and María José González</i>	4334
The concept of function in secondary school textbooks over time: An analysis made with the Theory of Conceptual Fields <i>Patricia Sureda and Laura Rossi</i>	4336
The potential of Problem Graphs as a representational tool with focus on the Hungarian Mathematics Education tradition <i>Eszter Varga</i>	4344
From teacher s naming system of resources to teacher's resource system: Contrasting a Chinese and a Mexican case <i>Chongyang Wang, Ulises Salinas-Hernández and Luc Trouche</i>	4346
TWG 23: Implementation of research findings in mathematics education	4354
Introduction to the papers of TWG23: Implementation of research findings in mathematics education <i>Mario Sánchez Aguilar, Ana Kuzle, Kjersti Wæge and Morten Misfeldt</i>	4355
Identification and diagnosis of students' mathematical misconceptions in a dynamic online environment <i>Morten Elkjær</i>	4363

Implementation research in primary education: Design and evaluation of a problem-solving innovation <i>Inga Gebel and Ana Kuzle</i>	4365
Operationalizing implementation theory in mathematics education research - identifying enablers and barriers in the Swedish “Boost for Mathematics” <i>Rikke Maagaard Gregersen, Sine Duedahl Lauridsen and Uffe Thomas Jankvist</i>	4373
A learning path for rational numbers through different representations <i>Helena Gil Guerreiro, Cristina Morais, Lurdes Serrazina and João Pedro da Ponte</i>	4381
Coherence through inquiry based mathematics education <i>Per Øystein Haavold and Morten Blomhøj</i>	4389
Competencies and curricula: Danish experiences with a two-dimensional approach <i>Tomas Højgaard and Jan Sølberg</i>	4397
Adapting implementation research frameworks for mathematics education <i>Uffe Thomas Jankvist, Mario Sánchez Aguilar, Jonas Dreyøe and Morten Misfeldt</i>	4405
Implementation through participation: Theoretical considerations and an illustrative case <i>Boris Koichu and Alon Pinto</i>	4413
Designing inquiry-based teaching at scale: Central factors for implementation <i>Dorte Moeskær Larsen, Mette Hjelmberg, Bent Lindhart, Jonas Dreyøe, Claus Michelsen and Morten Misfeldt</i>	4421
Towards a common understanding of implementation research in mathematics education research <i>Andreas Lindenskov Tamborg</i>	4429
Capturing Problem Posing landscape in a grade-4 classroom: A pilot study <i>Ioannis Papadopoulos and Nafsika Patsiala</i>	4431
Models of school governance and research implementation. A comparative study of two Swedish cases, 1960-2018 <i>Johan Prytz</i>	4439
Implementing alternative models for introducing multiplication <i>Anna Ida Sjöström, Ola Helenius and Linda Marie Ahl</i>	4447
Implementing theories for preschool teaching with play-based pedagogies <i>Nina Ullsten Granlund</i>	4455
TWG24: Representations in mathematics teaching and learning	4462
Introduction to the work of TWG24: Representations in mathematics teaching and learning <i>Anna Baccaglini-Frank, Carla Finesilver, Samet Okumus and Michal Tabach</i>	4463
From concrete to abstract and back: Metaphor and Representation <i>Pierre Arnoux and Jorge Soto-Andrade</i>	4467
“He’s so fast at drawing” – Children’s use of drawings as a tool to solve word problems in multiplication and division <i>Heidi Dahl</i>	4475

Functional representations produced and used by students during their introduction to the concept of derivative: a window on their understanding processes <i>Sarah Dufour</i>	4483
Moving towards understanding graphical representations of motion <i>Carolien Duijzer, Marja Van den Heuvel-Panhuizen, Michiel Veldhuis, and Michiel Doorman</i>	4491
A training in visualizing statistical data with a unit square <i>Andreas Eichler, Carolin Gehrke, Katharina Böcherer-Linder and Markus Vogel</i>	4499
Learning to 'deal': A microgenetic case study of a struggling student's representational strategies for partitive division <i>Carla Finesilver</i>	4507
Utilizing dynamic representations to foster functional thinking <i>Stephan Michael Günster</i>	4515
Connecting the everyday with the formal: the role of bar models in developing low attainers' mathematical understanding <i>Sue Hough, Steve Gough and Yvette Solomon</i>	4523
Visualization of fractions - a challenge for pre-service teachers? <i>Ellen Konstanse Hovik and Camilla Markhus Rodal</i>	4531
Leveraging difference to promote students' conceptions of graphs as representing relationships between quantities <i>Heather Lynn Johnson, Evan McClintock, and Amber Gardner</i>	4539
Diagrammatic representations for mathematical problem solving <i>Vinay Kathotia and Elizabeth Kimber</i>	4547
Capturing 'time': characteristics of students' written discourse on dynagraphs <i>Giulia Lisarelli, Samuele Antonini and Anna Baccaglini-Frank</i>	4549
Effective choices of representations in problem solving <i>Jasmina Milinkovic, Aleksandra Mihajlovic and Mirko Dejjic</i>	4557
Geometric prediction: proposing a theoretical construct to analyze students' thinking in geometrical problem-solving <i>Elisa Miragliotta</i>	4565
Fibre mathematics: exploring topological forms through material practices <i>Kate O'Brien and Elizabeth de Freitas</i>	4573
Prospective mathematics teachers extrapolative reasoning about misleading bar graphs <i>Samet Okumus and Ercan Dede</i>	4581
The role of students' drawings in understanding the situation when solving an area word problem <i>Manuel Ponce de León Palacios and Jose Antonio Juárez López</i>	4589
Exploring Strategies Used to Solve a Non-Routine Problem by Chilean Students; an Example of "Sharing Chocolates" <i>Farzaneh Saadati and Mayra Cerda</i>	4591

Who is right? Theoretical analysis of representational activities <i>Michal Tabach and Boris Koichu</i>	4593
Teaching practice regarding grade 3 pupils use of representations <i>Isabel Velez, João Pedro da Ponte and Lurdes Serrazina</i>	4601
Explaining geometrical concepts in sign language and in spoken language a comparison <i>Annika M. Wille and Christof Schreiber</i>	4609
Characterizing fraction addition competence of preservice teachers using Rasch analysis <i>Marius Lie Winger, Julie Gausen, Eivind Kaspersen and Trygve Solstad</i>	4617
TWG25: Inclusive Mathematics Education – challenges for students with special needs	4619
Introduction to the work of TWG25: Inclusive Mathematics Education challenges for students with special needs <i>Petra Scherer, Evelyn Kroesbergen, Hana Moraová, Helena Roos</i>	4620
Strategies that promote the mathematical activity of students with language disorders: an analysis of language interactions <i>Raquel Isabel Barrera-Curin, Laurie Bergeron and Audrey Perreault</i>	4628
Low entrance or reaching the goals? Mathematics teachers' categories for differentiating with open-ended tasks in inclusive classrooms <i>Sarah Buró and Susanne Prediger</i>	4636
Teaching mathematics to students with intellectual disability: What support do teachers need? <i>Chun-ip Fung and Dichen Wang</i>	4644
K-12 Namibian teachers' beliefs on learning difficulties in mathematics: Reflections on teachers' practice <i>Shemunyenge Taleiko Hamukwaya</i>	4652
An in-service training to support teachers of different professions in the implementation of inclusive education in the mathematics classroom <i>Laura Korten, Marcus Nührenbörger, Christoph Selter, Franz Wember and Tobias Wollenweber</i>	4660
Designing mathematical computer games for migrant students <i>Janka Medová, Kristína Bulková and Soňa Čeretková</i>	4662
Diagnosis tools of dyscalculia contribution of didactics of mathematics to numerical cognition <i>Florence Peteers and Cécile Ouvrier-Bufferet</i>	4664
I just don't like math, or I think it is interesting, but difficult... Mathematics classroom setting influencing inclusion <i>Helena Roos</i>	4672
The potential of substantial learning environments for inclusive mathematics student teachers' explorations with special needs students <i>Petra Scherer</i>	4680

Mathematical discourses of a teacher and a visually impaired pupil on number sequences: Divergence, convergence or both? <i>Angeliki Stylianidou and Elena Nardi</i>	4688
Do hearing-impaired students learn mathematics in a different way than their hearing peers? A review <i>Kinga Szűcs</i>	4696
Supporting braille readers in reading and comprehending mathematical expressions and equations <i>Annemiek van Leendert, Michiel Doorman, Paul Drijvers, Johan Pel and Johannes van der Steen</i>	4704
TWG26: Mathematics in the context of STEM education	4712
Introduction to TWG26: Mathematics in the context of STEM education <i>Behiye Ubuz, Koeno Gravemeijer, Michelle Stephan and Patrick Capraro</i>	4713
Enhancing mathematics and science learning through the use of a Human Orrery <i>Maha Abboud, Philippe Hoppenot and Emmanuel Rollinde</i>	4721
Integrating the methods of mathematical modelling and engineering design in projects <i>Imad Abou-Hayt, Bettina Dahl, and Camilla Østerberg Rump</i>	4729
Mathematics and art in primary education textbooks <i>Teresa F. Blanco, Valeria González-Roel and Jose Manuel Diego-Mantecón</i>	4737
Mathematical modeling of musical fountains and light organs - Where is the M in interdisciplinary STEM projects? <i>Wolfgang Bock, Martin Bracke and Patrick Capraro</i>	4739
STEM analysis of a module on Artificial Intelligence for high school students designed within the I SEE Erasmus+ Project <i>Laura Branchetti, Olivia Levrini, Eleonora Barelli, Michael Lodi, Giovanni Ravaioli, Laura Rigotti, Sara Satanassi and Giulia Tasquier</i>	4747
Promoting mathematics teaching in the framework of STEM integration Maria Cristina Costa and António Domingos	4749
Reflecting on the value of mathematics in an interdisciplinary STEM course <i>Nelleke den Braber, Jenneke Krüger, Marco Mazereeuw and Wilmad Kuiper</i>	4757
Complex modeling: Does climate change really exist? Perspectives of a project day with high school students <i>Maren Hattebuhr and Martin Frank</i>	4765
Inter TeTra Interdisciplinary teacher training with mathematics and physics <i>Eduard Krause, Nguyen Van Bien, Tran Ngoc Chat, Nguyen Phuong Chi, Frederik Dilling, Jochen Geppert, Kathrin Holten, Tuan Anh Le, Simon Kraus and Chu Cam Tho</i>	4767
Student mathematical preparedness for learning science and engineering at university <i>Ciara Lane and Gráinne Walshe</i>	4775
Pre-service teachers' perspectives on the role of statistics in a learning scenario for promoting STEM integration <i>Hélia Oliveira, Ana Henriques and Mónica Baptista</i>	4783

Student conception of angles and parallel lines in engineering context <i>Premkumar Pugalenti, Michelle Stephan and David Pugalee</i>	4791
Opportunities to engage in STEM practices: Technology and design course <i>Behiye Ubuz</i>	4799
Gamification with Moodle in higher education <i>Ana Júlia Viamonte and Isabel Perdigão Figueiredo</i>	4807
Complex Modeling: Insights into our body through computer tomography perspectives of a project day on inverse problems <i>Kirsten Wohak and Martin Frank</i>	4815

Preface: CERME 11 in lovely Utrecht historic sites

Susanne Prediger & Ivy Kidron
ERME President ERME Vice-President
Dortmund (Germany) Jerusalem (Israel)

Each second year, the European Society for Research in Mathematics Education (ERME) organises a conference. The 11th Congress of ERME (CERME 11) took place in Utrecht (The Netherlands), in February, 6 to 10, 2019. The conference was hosted by the Freudenthal Group, in collaboration with the Freudenthal Institute, of Utrecht University. The participants of the conference were offered an excellent academic environment in a place in which important blocks in the foundation of mathematics education research were laid fifty years ago by Freudenthal and his collaborators.

CERME is getting larger from congress to congress: from 774 participants at CERME 10 to 900 participants at CERME 11 - the highest number of participants in comparison with the previous CERMEs. In order to avoid overflow (more than 300 more people were interested in participating), the ERME board had to decide to stop the growth tendencies with stopping at 900 participants. Most participants at CERME 11 are European researchers, but CERME is getting increasingly international with 152 researchers from outside Europe: Asia (30), North–America (54), South-America (40), Australia/New Zealand (9), Africa (19). The European researchers are essentially from Germany (169), Norway (82), United Kingdom (57), Sweden (54), Italy (40), The Netherlands (39), Israel (36), Spain (36), France (33), Portugal (31), Denmark (27), Turkey (26), Greece (23), Ireland (19), Austria (14), Finland (13), Cyprus (11), Hungary (8), Czech Republic (6), Croatia (5), Switzerland (4), Iceland (3), Slovakia (3), and Poland (2), and many other countries with one participant each.

A conference with such a huge number of participants requires a perfect organization in order to be successful, and indeed it was a real success. All the members of the Local Organizing Committee contributed to the excellent organization, especially the chair of the LOC, Marja van den Heuvel-Panhuizen, and her co-chair, Michiel Veldhuis. They did a wonderful work. They paid attention to all the small details before and during the conference. Both paid attention to all the specific needs of each participant. They dealt successfully with all the issues, challenges (small and big), and always with a smile. We thank both of them so deeply! Inclusion and quality is an integral part of the CERME spirit. The success of the conference is tightly connected with the quality of the scientific program, which was excellent. We address our sincere thanks to the International Program Committee, especially to the chair of the IPC, Uffe Thomas Jankvist, and his co-chair, Miguel Ribeiro, for their excellent work before, during and after the conference, taking into account ERME principles: selecting deep and interesting plenaries, organizing a panel discussion, organizing the distribution of Thematic Working Groups and the publication process of the proceedings.

In his plenary lecture, Paul Drijvers offered a deep reflection on a promising integrative approach to tool use, called embodied instrumentation, which is based on three lenses: a Realistic Mathematics Education view; instrumental approaches, and embodied views on

cognition. In the second plenary lecture, Kathleen M. Clark offered a thoughtful analysis of examples in which research on the use of history of mathematics contributed to the broader landscape of research in mathematics education. The examples address the role of history of mathematics in the learning of different mathematical concepts, ranging from the function concept to determinants of matrices, as well as topics in analysis and abstract algebra. The third plenary talk was given by Sebastian Rezat. Using the transition from natural numbers to integers as an exemplary case, Rezat delineated an insightful analysis on transitions from one number system to the other with a particular interest in continuities and discontinuities in the teaching of these number systems. Rezat integrated the results in an approach to achieve learner-centered coherence in the learning of number. Three papers corresponding to these three plenary addresses are included in the proceedings.

On the occasion of the 20th anniversary of ERME, the IPC organized an anniversary panel chaired by Konrad Krainer and Hanna Palmer. The panel offered a deep reflection on ERME contribution to research in mathematics education. Barbara Jaworski and Susanne Prediger (past and current ERME president), Paolo Boero and Simon Modeste (representatives of YESS and YERME - Young Researchers in ERME), and Tommy Dreyfus and Jana Žalská (editor and reader of the ERME book) made up the panel.

The work done in the plenaries and the panel contributed substantially to the success of the conference.

The core and the heart of each CERME are the Thematic Working Groups and the serious work which is done in all of them. In the TWGs, the collaboration between experienced and young researchers supports the scientific development of the young researchers. At CERME 11, 575 papers and 152 posters were accepted. 26 TWGs were organized with 8 TWGs which were divided in two subgroups due to the large number of participants. Our sincere thanks are addressed to the 34 working group leaders and 99 co-leaders for their huge and wonderful work. Before the conference, the leaders and co-leaders organized the review process and devoted much time in planning the program of the TWG. As a result, they were able to lead excellent discussions during the work of the TWG at the conference. A wonderful atmosphere and a lot of motivation characterized the work in the working groups. Every participant was involved in the work. After the conference, the authors had the possibility to further revise their papers, integrating significant changes which emerged in the discussions in the TWGs. The leaders and co-leaders organized this final review process.

The work done by all the organizers and deep involvement of the TWG leaders, IPC members, LOC members and ERME board members contributed to the success of the conference. We thank everybody who has contributed to this success. Specific thanks go to Uffe Thomas Jankvist, Miguel Ribeiro, Marja van den Heuvel-Panhuizen and Michiel Veldhuis for all their work with a wonderful result.

We encourage interested researchers to meet us at the next CERME that will take place in February 2021 in Bolzano (Italy).

Susanne Prediger
ERME President

& Ivy Kidron
ERME Vice-President

Introduction to the Proceedings of the Eleventh Congress of the European Society for Research in Mathematics Education (CERME11)

Uffe Thomas Jankvist¹; Marja van den Heuvel-Panhuizen²; Michiel Veldhuis³

¹Danish School of Education, Aarhus University, Denmark, utj@edu.au.dk

²Freudenthal Group & Freudenthal Institute, Utrecht University, Netherlands, m.vandenheuvel-panhuizen@uu.nl; Nord University, Norway, m.vandenheuvel-panhuizen@nord.no

²Freudenthal Group, Utrecht University, Netherlands, m.veldhuis@uu.nl; iPabo University of Applied Sciences, Amsterdam, Netherlands, m.veldhuis@ipabo.nl

About CERME11

The Eleventh Congress of European Research in Mathematics Education (CERME 11) took place in Utrecht, the Netherlands from 5th to 10th of February 2019. Uffe Thomas Jankvist (Denmark) was the chair of the International Programme Committee (IPC), which comprised Miguel Ribeiro (Portugal/Brazil, IPC Co-chair), Marianna Bosch (Spain), Therese Dooley (Ireland), Eirini Geraniou (UK/Greece), Ghislaine Guedet (France), Jeremy Hodgen (UK), Bożena Maj-Tatsis (Poland), Angel Mizzi (Germany/Malta), Aoibhinn Ni Shuilleabhain (Ireland), Marja van den Heuvel-Panhuizen (The Netherlands, LOC chair), and Stefan Zehetmeier (Austria). Marja van den Heuvel-Panhuizen and Michiel Veldhuis were chair and co-chair, respectively, of the Local Organizing Committee (LOC).

CERME11 hosted 26 Thematic Working Groups, listed in the table below. The TWGs 07, 25, and 26 were new TWGs, created following a call launched just after CERME10, and a selection process involving the CERME11 IPC and the ERME board. They have all been very successful, and all but one (TWG11) will be part of CERME12 in February 2021. Eight of the TWGs received so many submissions they had to be split in two – more precisely the TWGs 01, 05, 09, 14, 16, 18, 19 and 20 – and more TWG leaders and co-leaders had to be invited. In the end, CERME11 had 34 TWG leaders and 99 TWG co-leaders.

Thematic Working Group	Leader	Co-Leaders
TWG 01a Argumentation and Proof	Gabriel J. Stylianides (UK)	Anita Valenta (Norway) Viviane Durand-Guerrier (France)
TWG 01b Argumentation and Proof	Andreas Moutsios-Rentzos (Greece)	Orly Buchbinder (USA) Jenny Cramer (Germany)
TWG 02 Arithmetic and Number Systems	Elisabeth Rathgeb-Schnierer (Germany)	Beatriz Vargas Dorneles (Brazil) Renata Carvalho (Portugal) Judy Sayers (Sweden)
TWG 03 Algebraic Thinking	Reinhard Oldenburg (Germany)	Dave Hewitt (UK) Heidi Strømskag (Norway) Maria Chimoni (Cyprus)

TWG 04 Geometry Teaching and Learning	Joris Mithalal (France)	Michela Maschietto (Italy) Keith Jones (UK) Chrysi Papadaki (Germany)
TWG 05a Probability and Statistics Education	Caterina Primi (Italy)	Sibel Kazak (Turkey) Orlando Rafael González (Thailand)
TWG 05b Probability and Statistics Education	Aisling Leavy (Ireland)	Pedro Arteaga (Spain) Daniel Frischemeier (Germany)
TWG 06 Applications and Modelling	Berta Barquero (Spain)	Susana Carreira (Portugal) Katrin Vorhölter (Germany) Geoff Wake (UK) Jonas Bergman Ärlebäck (Sweden) Britta Jessen (Denmark)
TWG 07 Adult Mathematics Education	Kees Hoogland (The Netherlands)	Beth Kelly (UK) Fiona Faulkner (Ireland) Javier Diez-Palomar (Spain)
TWG 08 Affect and the Teaching and Learning of Mathematics	Stanislaw Schukajlow (Germany)	Inés M. Gómez-Chacón (Spain) Çiğdem Haser (Turkey) Peter Liljedahl (Canada) Karen Skilling (UK) Hanna Viitala (Norway)
TWG 09a Mathematics and Language	Núria Planas (Catalonia-Spain)	Marie Therese Farrugia (Malta) Kirstin Erath (Germany)
TWG 09b Mathematics and Language	Jenni Ingram (UK)	Marcus Schütte (Germany)
TWG 10 Diversity and Mathematics Education: Social, Cultural and Political Challenges	Hauke Straehler-Pohl (Germany)	Anette Bagger (Sweden) Laura Black (UK) Anna Chronaki (Greece) David Kollosche (Austria)
TWG 11 Comparative Studies in Mathematics Education	Paul Andrews (Sweden)	Eva Jablonka (Germany) Jeta Kingji (Slovenia) Constantinos Xenofontos (Cyprus)
TWG 12 History in Mathematics Education	Renaud Chorlay (France)	Aline Bernardes (Brazil) Tanja Hamann (Germany) Antonio M. Oller-Marcén (Spain)
TWG 13 Early Years Mathematics	Ingvald Erfjord (Norway)	Esther Levenson (Israel) Bożena Maj-Tatsis (Poland) Marianna Tzekaki (Greece) Priska Schöner (Germany)

TWG 14a University Mathematics Education	Alejandro S. González-Martín (Canada/Spain)	Ghislaine Gueudet (France) Imène Ghedamsi (Tunis) Jason Cooper (Israel)
TWG 14b University Mathematics Education	Irene Biza (UK)	Olov Viirman (Sweden) Alon Pinto (Israel) Vilma Mesa (USA)
TWG 15 Teaching Mathematics with Technology and Other Resources	Alison Clark-Wilson (UK)	Ornella Robutti (Italy) Iveta Kohanová (Norway/Slovakia) Melih Turgut (Turkey)
TWG 16a Learning Mathematics with Technology and Other Resources	Hans-Georg Weigand (Germany)	Ana Donevska-Todorova (Germany/Macedonia) Eirini Geraniou (UK)
TWG 16b Learning Mathematics with Technology and Other Resources	Nathalie Sinclair (Canada)	Eleonora Faggiano (Italy) Osama Swidan (Israel)
TWG 17 Theoretical Perspectives and Approaches in Mathematics Education Research	Angelika Bikner-Ahsbals (Germany)	Arthur Bakker (The Netherlands) Esther Chan (Australia) Heather Johnson (USA)
TWG 18a Mathematics Teacher Education and Professional Development	Stefan Zehetmeier (Austria)	Laurinda Brown (UK) Maria Mellone (Italy)
TWG 18b Mathematics Teacher Education and Professional Development	Joao Pedro da Ponte (Portugal)	Libuse Samkova (Czech Republic) Marita Friesen (Germany) Janne Fauskanger (Norway) Àngela Buforn (Spain)
TWG 19a Mathematics Teaching and Teacher Practice(s)	Charalampos Sakonidis (Greece)	Rukiye Didem Taylan (Turkey) Ove Gunnar Drageset (Norway)
TWG 19b Mathematics Teaching and Teacher Practice(s)	Reidar Mosvold (Norway)	Siún Nic Mhuirí (Ireland)
TWG 20a Mathematics Teacher Knowledge, Beliefs and Identity	Miguel Ribeiro (Brazil/Portugal)	Fatma Aslan-Tutak (Turkey) Miguel Montes (Spain)
TWG 20b Mathematics Teacher Knowledge, Beliefs and Identity	Francesca Martignone (Italy)	Sebastian Kuntze (Germany) Kirsti Rø (Norway)

TWG 21 Assessment in Mathematics Education	Paola Iannone (UK)	Michal Ayalon (Israel) Johannes Beck (Germany) Jeremy Hodgen (UK) Francesca Morselli (Italy)
TWG 22 Curricular Resources and Task Design in Mathematics Education	Birgit Pepin (The Netherlands)	Seán Delaney (Ireland) Andreas Eckert (Sweden) Nataly Essonnier (France) Andreas Stylianides (UK)
TWG 23 Implementation of Research Findings in Mathematics Education	Mario Sánchez Aguilar (Mexico)	Kjersti Wæge (Norway) Ana Kuzle (Germany) Morten Misfeldt (Denmark)
TWG 24 Representations in Mathematics Teaching and Learning	Anna Baccaglini-Frank (Italy)	Carla Finesilver (UK) Christian Mercat (France) Samet Okumus (Turkey) Michal Tabach (Israel)
TWG 25 Inclusive Mathematics Education – Challenges for Students with Special Needs	Petra Scherer (Germany)	Evelyn H. Kroesbergen (The Netherlands) Hana Moraová (Czech Republic) Helena Roos (Sweden)
TWG 26 Mathematics in the Context of STEM Education	Behiye Ubuz (Turkey)	Michelle Stephan (USA) Koeno Gravemeijer (The Netherlands) Patrick Capraro (Germany)

Editorial information

These proceedings are available as a complete volume online on the ERME website and each individual text is also available on the HAL open archive, where it can be found through keywords, title or author name. This has been the practice since CERME9, to increase the visibility of the huge work done in CERME conferences.

This volume begins with texts corresponding to the four plenary activities of CERME11: the plenary lecture by Paul Drijvers (The Netherlands) on “Embodied instrumentation: combining different views on using digital technology in mathematics education”; the plenary lecture by Kathleen M. Clark (USA) on “History and pedagogy of mathematics in mathematics education: History of the field, the potential of current examples, and directions for the future”; the plenary lecture by Sebastian Rezat (Germany) on “Extensions of number systems: continuities and discontinuities revisited”; and finally the “ERME anniversary panel on the occasion of the 20th birthday of the European Society for Research in Mathematics Education” by Konrad Krainer (Austria), Hanna Palmér (Sweden), Barbara Jaworski (UK), Susanne Prediger (Germany), Paolo Boero (Italy), Simon Modeste (France), Tommy Dreyfus (Israel), and Jana Žalská (Czech Republic).

After the plenaries, the reader will find 26 chapters corresponding to the work done in the TWGs of CERME11 (all the split TWGs chose to do combined introductions). These chapters follow a similar

structure: they start with an introduction; then the long contributions (8-page papers) and the short contributions (2 pages) are presented – in alphabetical order by first author’s name. However, TWG17 has chosen a different order, corresponding to subthemes in the group.

There are two kinds of introductions to the TWGs, according to the team’s choice: short introductions (4 pages) presenting the contributions; or long introductions (8 pages), which propose, in addition, an analysis of the current research on the theme of the TWG, and perspectives for the future. TWGs 06, 07, 09, 14, 15, 17, 19, 22, 23, 25 and 26 have chosen this form of long introduction.

The publication of these proceedings is the result of a collaborative work, involving CERME11 IPC, the TWG leaders and co-leaders, and the LOC co-chair. We warmly thank all these people for their involvement, and hope that this volume will contribute to the development of mathematics education research in Europe and beyond.

Embodied instrumentation: combining different views on using digital technology in mathematics education

Paul Drijvers

Utrecht University, the Netherlands;

HU University of Applied Sciences Utrecht, the Netherlands; p.drijvers@uu.nl

The potential of digital technology for mathematics education has been widely investigated in recent decades. Still, much remains unknown about how to use tools to foster mathematics learning. To address this issue, I first consider the didactical functionalities of digital technology in mathematics education, and the overall modest effects of using these tools for learning. Next, to find possible explanations of these findings I address three relevant views: (1) a Realistic Mathematics Education (RME) view on tool use, (2) an instrumental approach to tool use, and (3) an embodied view on cognition. As a conclusion, I claim that all three lenses share a focus on mathematical meaning. Whereas the RME view provides important general guidelines, an integrative approach to tool use, which I label embodied instrumentation, and which includes the careful alignment of embodied and instrumental experiences, seems promising to generate powerful learning activities.

Keywords: Digital technology, Embodied instrumentation, Embodiment, Instrumental approach, Mathematics education, Realistic mathematics education.

An introduction to tool use

Since the origin of mankind, humans have been using tools to extend their scope and to carry out tasks more easily and more efficiently. A wide range of tools has been developed over time. The most basic ones, such as a stone axe for chopping wood, enabled their users to go beyond their physical limitations to achieve specific goals. The tools were not always designed as such. In some cases, people – or animals, as tool use is not limited to the human species – appropriated objects for a specific task, and in this way ‘turned objects into tools’. For example, one could use a tree branch to hit somebody harder than one could do with bare hands, but the branch did not grow from the tree to facilitate beating.

Over time, tools have become more sophisticated and have been designed to address cognitive tasks. Think, for example, of clay tablets to capture calculations (Proust, 2012). Writing down calculations assumes ways to represent numbers and operations, which are quite abstract mathematical notions; these representations themselves can be considered tools already (Monaghan, Trouche, & Borwein, 2016). Since clay tablets, many other tools for mathematics have been designed and used over the centuries. Physical artefacts such as the abacus and compasses respectively facilitated calculations and geometrical constructions.

Gradually, new types of tools emerged, such as mechanical tools – think of Pascal’s Pascaline (Maschietto & Soury-Lavergne, 2013) – and digital tools. Nowadays, digital technology such as calculators, tablets (but no longer made from clay), smartphones and smart watches, gives access to a wide range of mathematical features, including sophisticated computer algebra engines and statistical packages. In many cases, the mathematics embedded in the latter types of software has a

non-transparent black-box character. In addition to this, the role of mathematics under the hood of advanced tools, such as search engines, navigation tools and credit cards, to mention just some examples, is becoming more and more invisible.

As education prepares for future private and professional life, the development and widespread availability of sophisticated mathematical tools affects mathematics education. These tools transform mathematical activity (Hoyles, 2018). However, much is still unknown about how to exploit the potential of these powerful technologies for mathematics learning. In spite of the available body of literature (for overviews see Ball et al., 2018; Hoyles & Lagrange, 2010; Trgalová, Clark-Wilson, & Weigand, 2018), the mathematics education community is still struggling with the integration of digital technology in teaching and learning. The question of how the use of digital technology may foster mathematics learning and which theoretical lenses may guide us, is waiting to be answered.

To address this question, I will first globally address the didactical functionalities of digital technology in mathematics education, and the overall modest effects of using these tools for learning. To consider possible explanations of these findings, I will then address three relevant theoretical views in more detail: (1) a Realistic Mathematics Education view on tool use, (2) an instrumental approach to tool use, and (3) an embodied view on cognition. Finally, I will claim that these three lenses share a focus on mathematical meaning. Whereas the RME view provides important general guidelines, an integrative approach to tool use, which I will label embodied instrumentation, and which includes the careful alignment of embodied and instrumental experiences, seems promising to generate powerful learning activities.

Digital tools in mathematics education

A taxonomy of digital tools

In the last decades, a myriad of digital tools for mathematics education has been developed. These tools show a wide variety with respect to mathematical focus, didactical functionality, user-friendliness, and other features. All, however, come with affordances and limitations, with opportunities and constraints. Let me try to sketch an overview of the fragmented landscape of digital technology in mathematics education. A first dimension, of course, is the tool's mathematical functionality. A categorization of the mathematical functionality of a tool can be close to a categorization of the field of mathematics itself. Digital tools can carry out algebraic work, graphing tasks, statistical analyses, calculus procedures, and geometric jobs. The traditional domains of school mathematics (e.g., number, ratio, algebra, geometry, calculus, statistics) may do for globally classifying the mathematical functionality of digital tools for mathematics education. It goes without saying that a specific digital tool may cover a range of these domains and as such serve more than one mathematical functionality, but this mathematical categorization still seems to work.

Slightly more complicated is a taxonomy of the didactical functionality of a digital tool, all the more as this is not just a matter of the tool itself, but also highly depends on the type of tasks and on the way the use is embedded and orchestrated in the teaching and learning processes. In spite of this evident limitation, I do feel that the very global model presented in Figure 1 (Drijvers, Boon, & Van Reeuwijk, 2011; Drijvers, 2018b) may help teachers and educators to prepare their teaching with technology, and to be explicit about their main goals and corresponding choices with respect to the

tool to use. The first didactical functionality in Figure 1 is to “do mathematics”. This functionality does not target the heart of the mathematical activity itself, but concerns outsourcing part of the work to relieve the student’s mind. In this way, energy can be saved for the core matter; a division of labour between student and machine, so to say. Next, Figure 1 shows two types of didactical functionality that focus on learning. With respect to learning through practicing mathematical skills, digital tools may offer variation and randomization of tasks, and automated and intelligent feedback. As such, the digital tools form a personal environment in which one can safely make mistakes and learn from them. Finally, tool use for concept development involves using a digital tool to explore phenomena that invite conceptual development. This is probably the most challenging and subtle didactical functionality to exploit, as concept development can be considered a higher-order learning goal.

Of course, the categories in this didactical functionality taxonomy are not mutually exclusive; in many cases, the “developing concepts” didactical functionality rests on the outsourcing function for doing mathematics. Also, the didactical function of a digital tool is just a tool feature to a lesser extent than the mathematical functionality is; it also depends on the type of tasks and student activity, and the educational setting. This being said, the model may help to identify some main roles of digital technology in the learning of mathematics.

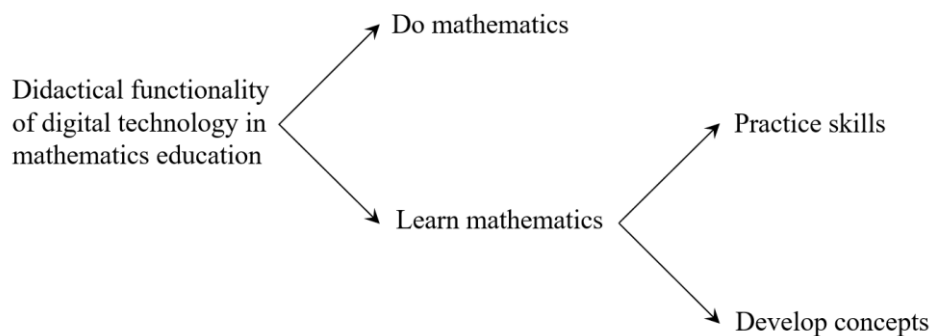


Figure 1: Didactical functionality of digital technology in mathematics education (Drijvers, Boon, & Van Reeuwijk, 2011; Drijvers, 2018b)

The benefits of tool use

After this global sketch of the mathematical and didactical landscape, one might wonder about the benefits of using digital technology in mathematics education. How much evidence is there for the learning gains? Recently, OECD was not very optimistic about this evidence:

Despite considerable investments in computers, internet connections and software for educational use, there is little solid evidence that greater computer use among students leads to better scores in mathematics and reading. (OECD, 2015, p. 145)

To further investigate this, I revisited some review studies in this domain (Drijvers, 2018a). While doing so, a main source was a second-order meta-analysis carried out by Young (2017), who, interestingly enough, took the didactical functionality typology shown in Figure 1 as a starting point. Including 19 meta studies, Young finds a significant positive effect of the use of technology in mathematics education with a small to moderate average effect size of 0.38 (Cohen, 1988). In his calculation, Cohen’s d and Hedges g are considered comparable. This average varies slightly over the

three different didactical functions: 0.47 for the “do mathematics” role, 0.42 for the “practice skills” role, and 0.36 for the “develop concepts” role. This not surprising to me, as the latter functionality usually requires more student reflection than the other two do. For studies in which the different didactical functionalities are combined, however, the average effect size is lower, namely 0.21.

An interesting finding by Young (ibid.) is that the reported average effect size seems to decrease with the increasing quality of the meta-analyses included. Quality here refers to both the meta-analysis itself and to the quality of the studies included in it. For example, the three review studies mentioned in Table 1 are the only ones rated high quality and they show relatively low effect sizes. A more detailed look at these studies also reveals that the effect sizes reported in the different research reports do not significantly increase over time, whereas one might hope that technological tools are improving, along with teachers’ ability to exploit them in teaching. A possible explanation might be that a possible positive development over time is compensated by other factors, such as more rigorous study designs and methods, and bigger sample sizes.

Study	Number of effect sizes	Average effect size	Global conclusion according to the authors
Li & Ma, 2010	85	$d = 0.28$ (weighted)	Moderate significant positive effects
Cheung & Slavin, 2013	74	$d = 0.16$	A positive, though modest effect
Steenbergen-Hu & Cooper, 2013	61	g range 0.01 – 0.09	No negative and perhaps a small positive effect

Table 1: Effect sizes reported in in three high-quality meta review studies (based on Drijvers, 2018a)

Of course, this zooming out approach suffers from important limitations. The review studies are based on older research, so the picture might have changed since then. Also, the review studies only include experimental, quantitative studies and neglect qualitative or design-based research. And, finally, overviews such as these do not distinguish educational levels, types of technology used, and other educational factors that may be decisive.

Still, it would be too easy to ignore the above findings because of these limitations. The effect sizes are not overwhelming and the OECD quote at the start of this section seems appropriate. Why is the integration of digital technology in mathematics education not the success that one might have hoped for? In my opinion, the question “does ICT work in mathematics education?” is too broad. If we would replace “ICT” by “textbook”, for example, no one would be surprised to get an answer like “it just depends on the quality of the textbook”. In a similar way, exploiting the full potential of digital tools in mathematics education is a complex issue that requires more detailed insights into the learning processes that play a role, into the targeted mathematical content, and in the ways in which the mathematical activity is affected by the use of the tool. Therefore, I will now zoom in on three theoretical and more nuanced views on the use of digital tools in mathematics education, that may offer principles and frameworks to better tackle the subtlety of the topic.

A Realistic Mathematics Education view

Even though the theory of Realistic Mathematics Education (RME) applies to mathematics education in general, it might also shed some light on the possible benefits of using digital technology in mathematics education. Let me first explain some general RME features. RME is an instruction theory for the teaching and learning of mathematics that was developed in the Netherlands. A starting point was Freudenthal's (1973) view on mathematics as a human activity, i.e., mathematics should be experienced as meaningful, authentic, sensemaking and real by the students. The following quote stresses that the word "realistic" should not be understood as "real world":

Although 'realistic' situations in the meaning of 'real-world' situations are important in RME, 'realistic' has a broader connotation here. It means students are offered problem situations which they can imagine. This interpretation of 'realistic' traces back to the Dutch expression 'zich REALISERen', meaning 'to imagine'. It is this emphasis on making something real in your mind that gave RME its name. Therefore, in RME, problems presented to students can come from the real world, but also from the fantasy world of fairy tales, or the formal world of mathematics, as long as the problems are experientially real in the student's mind. (Van den Heuvel-Panhuizen & Drijvers, 2014, p. 521).

This starting point is elaborated in some key concepts, including the activity principle, mathematization, and didactical phenomenology. Let me briefly elaborate on each of these three.

- The *activity principle* links to the view of mathematics as a human activity and highlights that students should have the opportunity to explore and to re-invent mathematics, and in this way build up their mathematical knowledge.
- In line with this, *mathematization* refers to the activity of doing mathematics. Treffers (1987) distinguishes horizontal and vertical mathematization. Horizontal mathematization concerns mathematizing reality and the process of formulating a mathematical description, involving the transfer between different domains. Vertical mathematization concerns mathematizing mathematics and the process of reorganization within the mathematical system, involving the genesis of mathematical objects and relations between them.
- A *didactical phenomenology* is an analysis of "how mathematical thought objects can help organizing and structure phenomena" (Van den Heuvel-Panhuizen, 2014, p. 175). It identifies phenomena that beg to be organized with the specific mathematical means that are the topic of the learning, and as such may "show the teacher the places where the learner might step into the learning process of mankind" (Freudenthal, 1983, p. ix). It invites the development of the mathematics at stake and gives meaning to it. As said before, these phenomena can come from different "worlds" as long as they are experientially real to the students (Gravemeijer & Doorman, 1999). Such an analysis on the one hand asks for a thorough analysis of the mathematical topic, and on the other hand for a clear view on the targeted audience of the teaching.

How do these RME principles inform the use of digital technology in mathematics education? First, the interpretation of the word "realistic" in the sense of experientially real suggests that students should experience the activity with the digital technology as meaningful. In line with Ainley, Pratt and Hansen (2006), students may perceive an activity as meaningful if they are aware of its purpose

and its utility, where purpose refers to the activity leading to a “meaningful outcome for the pupil, in terms of an actual or virtual product, or the solution of an engaging problem” (p. 29), and utility to “the ways in which those mathematical ideas are useful” (p. 30). I expect that a certain level of transparency of the tool would foster meaning in terms of experienced purpose and utility.

Second, the activity principle and the human activity view suggest that the digital tool should offer the students opportunities to explore, and to be an actor rather than a passive user. I expect that a degree of ownership and the feeling of being in control may invite this. From a mathematization perspective, being in control also includes the opportunity to easily express yourself mathematically with the amount of freedom that one also has while doing paper-and-pen mathematics. This requires a sound mathematical basis for the tool in use.

Third and final, taking a didactical phenomenology perspective leads me to expect that the phenomena may change in a technology-rich classroom: the digital environment itself may be a meaningful phenomenon to study. For example, if students regularly use digital tools like graphing calculators or software for dynamic geometry, these environments really become part of the classroom environment and as such may elicit inspiring phenomena that invite further investigation. Also, as many students nowadays are familiar with games and tools, digital environments may be quite natural and authentic to them, which offers opportunities to better realize this RME principle.

Let me illustrate these principles through the example of an online lesson series on arrow chains and functions for grade 8 (14-year-old students), implemented in the Freudenthal Institute’s Digital Mathematics Environment¹ (Doorman, Drijvers, Gravemeijer, Boon, & Reed, 2012; Drijvers, Doorman, Boon, Reed, & Gravemeijer, 2010). In this lesson series, students first explore chains of operations in meaningful contexts. As an example, they figure out how the breaking distances of different types of vehicles, the distance needed to stop in case of emergency, depend on their velocity. Next, they act out the chaining by standing next to each other, creating an input-output-chain in which each student is responsible for performing one of the operations, to prepare for the work in the digital environment.

Figure 2 shows some snapshots of the work in the digital environment that follows. The first row shows how students can chain operations to calculate the breaking distance in meters of a scooter with an initial velocity of 40 km/hour. Of course, after their previous experience with series of numerical calculations, the construction of these chains should be experienced by the student as a meaningful way to organize these calculations. In the second row, the breaking distance is investigated as function of the initial velocity, and a graph is added. In the third row, these breaking distance functions are compared for scooters, cars and lorries. As the window got too full, the user has collapsed the function chains into single boxes, allowing for a good comparison of the three graphs.

Even if these activities are described only briefly, some RME principles can be recognized. As for the reality principle, the students have been introduced to arrow chains to organize calculations in

¹ See <https://app.dwo.nl/en/student/> -> Old -> Secondary education -> Algebra -> Lesson function and arrow chains.

whole-class and paper-and-pen activities, so these have become meaningful ways to capture calculations. The open character of the environment, with a big empty window as exploration room for students, is meant to provide the students with means to freely build, change and organize arrow chains and to be in control of what is happening. Horizontal mathematization is addressed through the task of modelling the arrow chains for the case of the breaking distances, and vertical mathematization comes into play as soon as the three quadratic functions and their relationships are compared, independently from the initial breaking distance problem situation. The option to collapse function chains into boxes is intended to support an object view on function. A didactical phenomenology lens led the designers to consider the breaking distance context as a phenomenon that can very well be organized through mathematical functions and arrow chains.

To summarize, the example illustrates how the general RME principles can be applied to the specific situation of using digital tools in a meaningful way, and as such provide guidelines and criteria for sensible tool use. In this way, the RME lens may offer a nuanced view on using digital technology in mathematics education, even if it is not dedicated to this particular case.

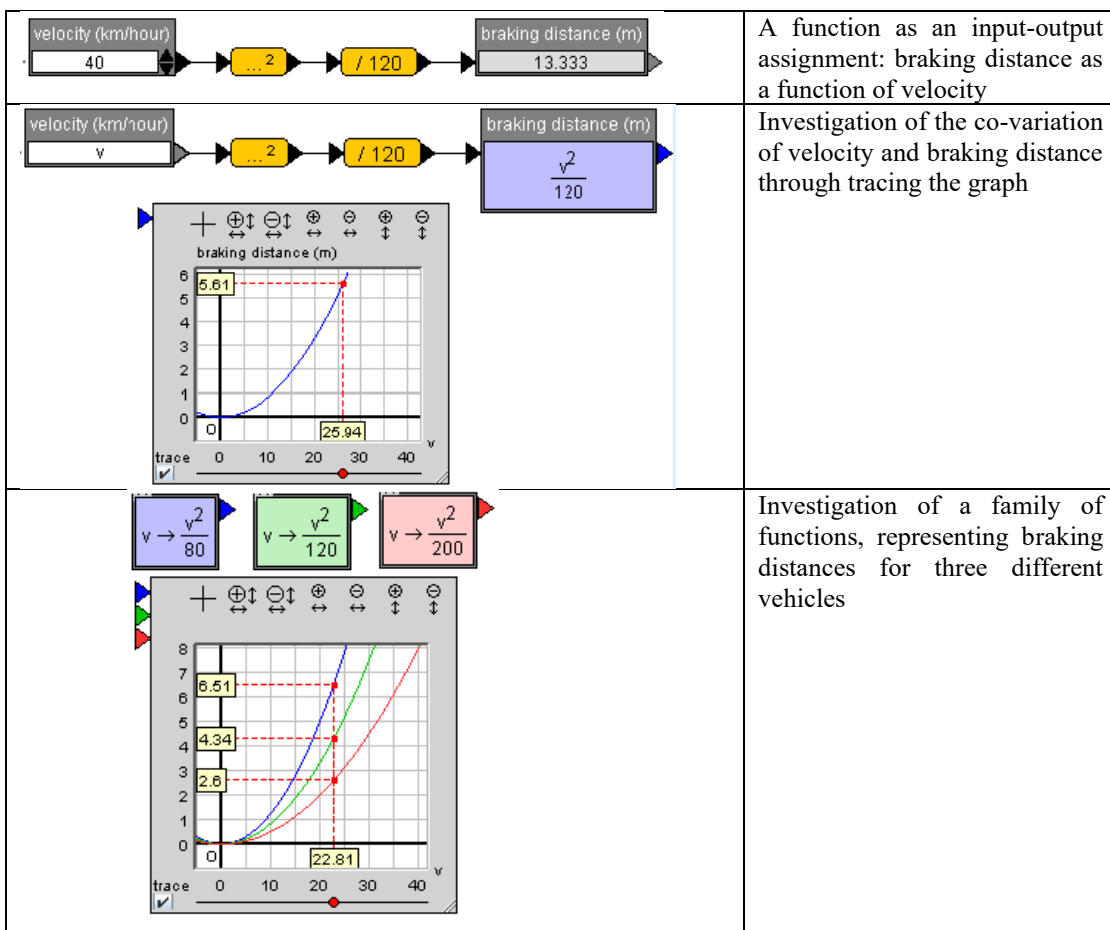


Figure 2: Snapshots from the Function and Arrow Chains material (from Drijvers, Boon, Doorman, Bokhove, & Tacoma, 2013). See <https://youtu.be/OMDjC5yVlr0> for an animation.

An instrumental approach

In addition to the general guidelines offered by RME, a more detailed view on the interplay between mathematics and tool use is needed. A first, somewhat naive view on digital tools and their use in mathematics education might be that tools are just “objective” mathematical assistants that help us to carry out tasks, to “do the jobs”: using them reduces solving mathematical tasks to pressing buttons, and as such simplifies our lives. However, things turn out to be not that straightforward. Tools are not as neutral as one might hope, but come with affordances and constraints, with opportunities and obstacles, and as such guide the user’s mathematical practices:

Tools matter: they stand between the user and the phenomenon to be modelled, and shape activity structures. (Hoyles & Noss, 2003, p. 341)

For example, drawing a circle with physical compasses is quite different from drawing it in a dynamic geometry environment such as GeoGebra. In the first case, one really experiences a circular movement, after deciding on the centre and the radius. In the latter case, the focus is on setting the centre and the radius, but while enlarging the radius, the circle is growing, and the circular movement is no longer needed. Different tools lead to different techniques, and as such to different views on the same underlying mathematical concept.

Indeed, in line with Vygotsky (1978), tools mediate between human activity and the environment. As a consequence, using digital tools for learning and doing mathematics is not just a matter of directly transforming mathematical thinking into tool commands. On the one hand, the user shapes the techniques for using the tool, but on the other hand the tool shapes and transforms the user’s mathematical practice. These considerations gave rise to the development of a new theoretical view, called the instrumental approach to tool use. Key in this approach are the notions of artefact, instrument, instrumental genesis, scheme, and technique. Let me briefly explain these notions.

A starting point in instrumental approaches is the distinction between artefact and instrument (Rabardel, 2002; Vérillon & Rabardel, 1995). The artefact is the object that is used as a tool. In our case, graphing calculators or dynamics geometry software are artefacts, even if we also might want to look in more detail, and consider the graphing window in GeoGebra an artefact, or the Solver option in a graphing calculator. An instrument consists of an artefact and “one or more associated utilization schemes” (Verillon & Rabardel, 1995, p. 87). So, besides the artefact, the instrument also involves the schemes that the user develops and applies while using the artefact for a specific class of instrumented activity situations, in our case often involving a type of mathematical tasks. To summarize this in a somewhat simplified ‘formula’: Instrument = Artefact + Scheme. The process of an artefact becoming part of an instrument is called instrumental genesis (Artigue, 2002; Trouche & Drijvers, 2010).

What are these schemes, key in instrumental genesis? Based on the work by Piaget (1985) and others, a scheme is considered a more or less stable way to deal with specific situations or tasks. Vergnaud claims that “the sequential organization of activity for a certain situation is the primitive and prototypical reference for the concept of scheme” (Vergnaud, 2009, p.84). Referring to the scheme of counting in particular, Vergnaud (1987, p.47) speaks of “a functional and organized sequence of rule-governed actions, a dynamic totality whose efficiency requires both sensorimotor skills and

cognitive competencies.” Later, Vergnaud (2009) prefers to speak about percepto-gestual schemes rather than of sensorimotor schemes, as to go beyond the purely biological level and to highlight the close relationship between perception and gesture on the one hand, and conceptualization on the other. In agreement with these ideas, the term sensorimotor scheme in this rest of this text should be interpreted in this wider sense.

Scheme development involves the intertwined development of sensorimotor skills and cognition. As we see a scheme here as part of an instrument, we speak of an instrumentation scheme. Artigue (2002) highlights the pragmatic and epistemic value of schemes: the pragmatic value in the sense of their productive potential to “get things done”, and the epistemic value in the sense of contributing to the meaning and understanding of the mathematics involved.

The observable parts of an instrumentation scheme, the concrete interactions between user and artefact, are called instrumented techniques. Instrumented techniques are more or less stable sequences of technical interactions between the user and the artefact with a particular goal. As such, an instrumentation scheme consists of one or more observable instrumented techniques, that are guided by the opportunities and constraints the artefact offers, and by the students’ knowledge. In the meantime, the techniques may also contribute to the development of this knowledge. As such, techniques can be seen as actions that reflect students’ knowledge. And, even more important, techniques and knowledge may co-emerge. It is this co-emergence that forms the heart of instrumental genesis and that reflects the main educational potential of using the artefact in a given situation.

In the instrumental approach, a scheme depends on the subject, the artefact and the task. Three comments should be made here. First, this implies that carrying out a similar task with different artefacts is likely to lead to different schemes. The compasses case described above shows that different instrumental geneses will take place. It is interesting to use different artefacts for similar tasks and to confront and compare the different schemes that emerge (Maschietto & Soury-Lavergne, 2013). As a consequence, mathematical practices transform through the use of digital artefacts (Hoyles, 2018). Second, instrumental genesis is not just an individual process, but is part of social learning processes and institutionalization within the specific educational context. Through teachers’ instrumental orchestration (Trouche, 2004), a collective instrumental genesis is taken care of, to assure the convergence towards shared instruments and shared mathematical knowledge. In fact, teachers are involved in a double instrumental genesis, including their personal development of schemes on the one, and schemes for use in teaching their students on the other. Third, some artefacts are more suitable for specific types of instrumental genesis than others. Haspekian (2014) introduced the notion of instrumental distance to stress the change in mathematical practice that may emerge as a result of some type of tool use. If the distance between regular or targeted mathematical practices on the one hand, and techniques invited by the artefact on the other is too big, instrumental genesis might be not productive for the learning process.

The importance of this instrumental view for the use of mathematical tools in mathematics education lies not only in the acknowledgement of the subtlety and complexity of the issue, but also in the concrete guidelines it offers for a fruitful use: as teachers and educational designers, we should set up activities for students and choose appropriate artefacts that together lead to instrumental genesis

processes in which the targeted mathematical knowledge is developed in a meaningful and natural way. A mismatch between the task, the affordances of the artefact, and the mathematical knowledge at stake will not be effective. Outlining these three elements is the game to play; it includes being explicit about the instrumental genesis and scheme development that is aimed for.

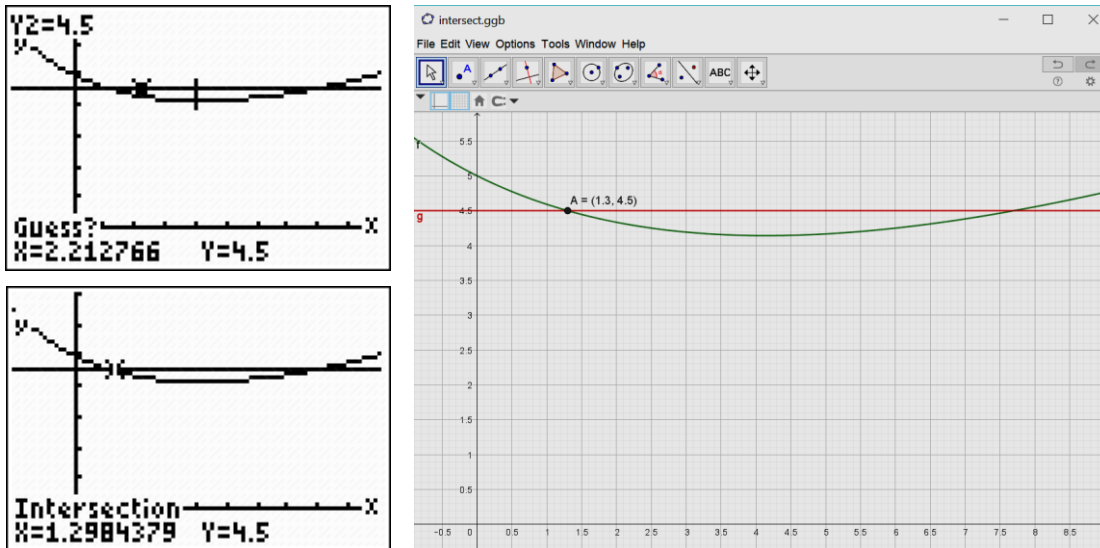


Figure 3: Intersecting graphs to solving equations with two different tools

As an example of such scheme development, Figure 3 shows two ways in which an equation can be solved graphically through an Intersect procedure, one using a graphing calculator (screens on the left) and one using GeoGebra (screen on the right). This equation, $\frac{x^2+100}{2x+20} = 4.5$, appeared in a realistic problem situation in a national examination task in the Netherlands, in which students used a graphing calculator. Technically speaking, the procedure comes down to entering the left-hand side and the right-hand side of the equation separately as functions in the graphing tool. Next, a viewing window should be set so that the two graphs show an intersection point. Then the intersect procedure is called, through selecting the two graphs. This will lead to the coordinates of such an intersection point. Finally, its first coordinate is a solution of the equation. Phrased this way, the technique sounds very straightforward and procedural.

However, several conceptual elements are involved. First, the student needs to be aware of the relationship between solutions of an equation and graphical intersection points. Second, while setting the viewing window dimensions, the student needs to have an idea of where intersection points can be found, which requires some reasoning (or some trial-and-error behaviour). Third, the result consists of not one but two numerical values, and a solution is a numerical, approximated value. Fourth and final, the procedure leads to one, single solution; the procedure needs to be repeated for equations with multiple solutions, that can be visible in the current viewing window, but may also exist outside its boundaries. Again, some reasoning is needed to consider the option of other intersection points outside the current view. Eventually, this technique can be complemented by

zooming in at intersection points, by zooming out to get an overview, or by generating tables of function values.

It is this intertwinement of technical and conceptual elements that makes me speak of an Intersect instrumentation scheme. The development of this scheme impacts on students' view on equation solving in a subtle and somewhat implicit way. Solving an equation is no longer a matter of exact algebraic manipulation while maintaining equivalence, but is replaced by a functional, graphical view that leads to approximated values. As such, the tool use affects the mathematical content. The Intersect scheme, therefore, integrates techniques and mathematical ideas, and this is exactly what instrumental genesis is about.

The instrumentation schemes that students develop depend on the digital tool in use. In Figure 3, the left part shows two screens of a graphing calculator, here a Texas Instruments model (Drijvers & Barzel, 2012). The right-hand side shows a similar screen in GeoGebra, which offers a larger screen and higher resolution. The techniques are also slightly different: GeoGebra does not ask for a starting value, but immediately comes up with a point. This makes the procedure more efficient, but it also makes it harder to find the coordinates of the second intersection point. Also, whether the coordinates are displayed depends on the settings in GeoGebra. The two tools – again, in the default setting – provide the results with different accuracy.

To summarize, this example illustrates the interplay between techniques for using a digital tool, and the related mathematical knowledge involved; an interplay that fundamentally affects the mathematics, but in the meantime is subtle to study. The example shows, to rephrase the quotation by Hoyles and Noss (2003) earlier in this section, that tools and techniques are not neutral, but may highlight or even require specific mathematical views on the task at stake. As a consequence, tool use is less simple than it might seem. Instrumental views are helpful to become aware of this complexity and to identify the interplay between artefacts and tasks, between techniques and schemes. Recognizing instrumental genesis as a path to learning mathematics, and probably also different mathematics, is an important step forward to fostering learning while using digital tools.

An embodied view on cognition

The instrumental approach to tool use has proved valuable in understanding the interplay between the technical and the conceptual when learners use artefacts. So far, however, it focused mostly on higher-level mathematics such as pre-university streams, and on sophisticated digital tools such as computer algebra and dynamic geometry systems. It is maybe due to these foci that mathematics is approached as a cerebral activity, and that the bodily foundations of cognition tend to be neglected. To do justice to the latter aspect, I now consider an embodied view on cognition as a third lens to look at the use of digital technology in mathematics education.

A general starting point here is that body and mind cannot be separated and that a dualistic view on them is inappropriate. Cognition is not considered an exclusively mental affair, but based on bodily experiences, that take place in interaction with the physical and social world (e.g., see Radford, 2009; Lakoff & Núñez, 2000; de Freitas & Sinclair, 2014; Ferrara & Sinclair, 2016). Embodiment “is the surprisingly radical hypothesis that the brain is not the sole cognitive resource we have available to

us to solve problems” (Wilson & Golonka, 2013, p.1). Phrased differently, Alibali and Nathan (2012) claim:

According to this perspective, cognitive and linguistic structures and processes – including basic ways of thinking, representations of knowledge, and methods of organizing and expressing information – are influenced and constrained by the particularities of human perceptual systems and human bodies. Put simply, cognition is shaped by the possibilities and limitations of the human body. (p. 250)

Also for the case of mathematics, often considered a highly abstract and mental subject, cognition is more and more acknowledged to be rooted in sensorimotor activities, and mathematical objects to be grounded in sensorimotor schemes. Two special issues—57(3) and 70(2)—of *Educational Studies in Mathematics*, dedicated to embodiment in mathematics education, testify to the growing interest of mathematics education research in this perspective. Many embodied approaches take “the four E’s” of embodied, extended, embedded and enactive cognition² as a starting point. In these terms, the initial views on tool use in this paper highlight the role of tools to extend the body; now the focus shifts towards the other E’s, and to digital technology providing opportunities to create embodied experiences in particular.

At first glance, a tension might seem to exist between this embodied view on cognition and the use of digital technology in mathematics education. Digital tools such as spreadsheets, computer algebra software and dynamic geometry systems embed an impressive amount of mathematical knowledge. As these tools are not transparent, they seem to “hide this knowledge under the hood”, which may create a distance between user and mathematics used. And, even more importantly, ways to interact with these tools have not so far been ‘body-based’, as the interaction mainly took place through keyboard strokes in the more remote past, and through mouse movements in the more recent past. Recent technological developments, however, open up new horizons to do justice to the multimodality of mathematical knowledge. Maybe partly due to the need for embodied experiences, improved user interfaces – think of multitouch screen technology, handwriting recognition, motion sensors, and virtual and augmented reality – have been developed, offering new opportunities to investigate an embodied approach to tool use. For example, some researchers studied students who “walk graphs” using a motion sensor, and in this way create embodied experiences of distance, speed and acceleration changing over time (Duijzer, Van den Heuvel-Panhuizen, Veldhuis, Doorman, & Leseman, 2019; Robutti, 2006).

In line with the didactical engineering tradition within my institute (Margolinas & Drijvers, 2015), the work done in this field by my colleagues and myself within my institute follows an embodied design approach (Abrahamson, 2009; Abrahamson, Shayan, Bakker, & Van der Schaaf, 2016). We use “design genres” (Abrahamson, 2014; Bakker, Shvarts, & Abrahamson, 2019) in which activities in digital environments. In these activities, students can engage in bodily experience and develop mathematical cognition. Let me illustrate this embodied design approach with two examples.

² <https://4ecognitiongroup.wordpress.com/>

As a first example, Figure 4 shows a task designed by Shvarts (2018) in the Digital Mathematics Environment. The left screen shows a fixed base line and a small, fixed black point. The larger grey dot is projected onto the base line. The three points together define a triangle, which in the left screen is red. The student can move the big grey point with her finger, and the triangle changes accordingly. Suddenly, the triangle becomes green (right screen). The triangle turns green when it is isosceles, otherwise it is red. As a consequence, the triangle is green if the grey, moveable point lies on the parabola which has the base line as directrix and the fixed point as focus. This dashed parabola, however, is not shown to the student, but it is included here for the reader.

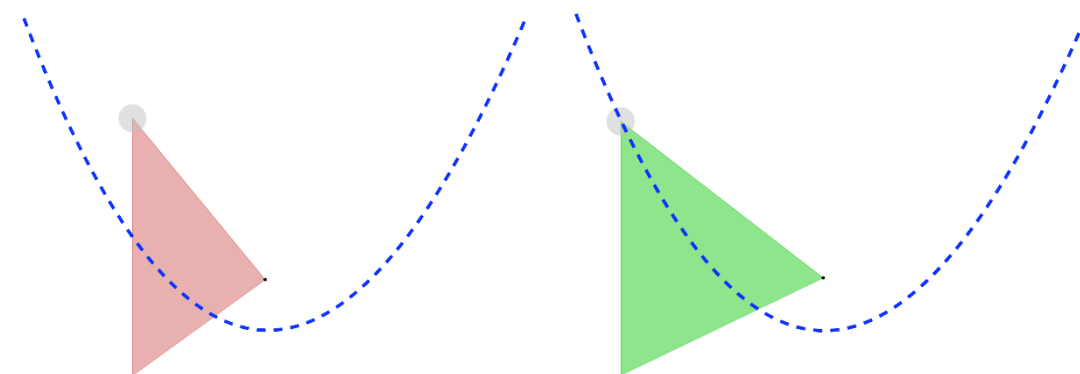


Figure 4: The parabola task (Shvarts, 2018; Shvarts & Abrahamson, 2019). See <https://youtu.be/JHiHfUGtw> for an animation.

The task, now, is to constantly move the grey point so that the triangle remains green. When the students become fluent in their movements, they are asked about the rule that determines the colour of the triangle. The task is challenging from different perspectives. From an embodiment perspective, the sensorimotor coordination is quite complex, as the direction to move should be constantly checked with the orientation of the triangle's base. Eye-tracking data indeed show many eye movements jumping between the movable grey point and the midpoint of the base, along the triangle's median (Shvarts & Abrahamson, 2019). These iterative jumps reveal the most important "attentional anchors" (Duijzer, Shayan, Bakker, van der Schaaf, & Abrahamson, 2017). From a mathematical perspective, the property that makes the triangle green is it being isosceles. As one vertex of the triangle is fixed to a point and another runs through a line, this task provides students with sensorimotor experiences that in the future learning might feed the notion of parabola. At a higher mathematical level, and this goes beyond how the example is presented here, one might elaborate this activity towards reflection on the locus of the grey point for the case that the triangle remains green (Shvarts, 2018). As the triangle is isosceles, and one of the sides is perpendicular to the base line (directrix), we can recognize the property of a conic: the distances to the focus and the directrix remain equal, so the locus is a parabola! This example shows how sensorimotor experiences may draw students' attention to the notion of a triangle being isosceles as preparation to the notion of parabola. Of course, many design decisions need to be taken, such as on how to phrase the task, which support to offer (do we display coordinates, or a grid), how to sequence different variations on this task, how to foster the notion of parabola, et cetera. The learning effect of such tasks may to an important extent depend on these

subtle design decisions, but goes beyond the scope of the present example. Digital design is a relatively new phenomenon, which puts high demands on the designers (Leung & Baccaglini-Frank, 2017).

The second example concerns handwriting recognition. Writing mathematics by hand, whether it is on an old, dusty chalk board or on a tablet, involves hand movements and gestures that may provide a sensorimotor experience to students. Therefore, the Digital Mathematics Environment now has a handwriting recognition module, that allows for the integration of the human experience of hand movements while writing, and the software's intelligence to interpret the handwriting and to evaluate mathematical correctness for the sake of feedback.

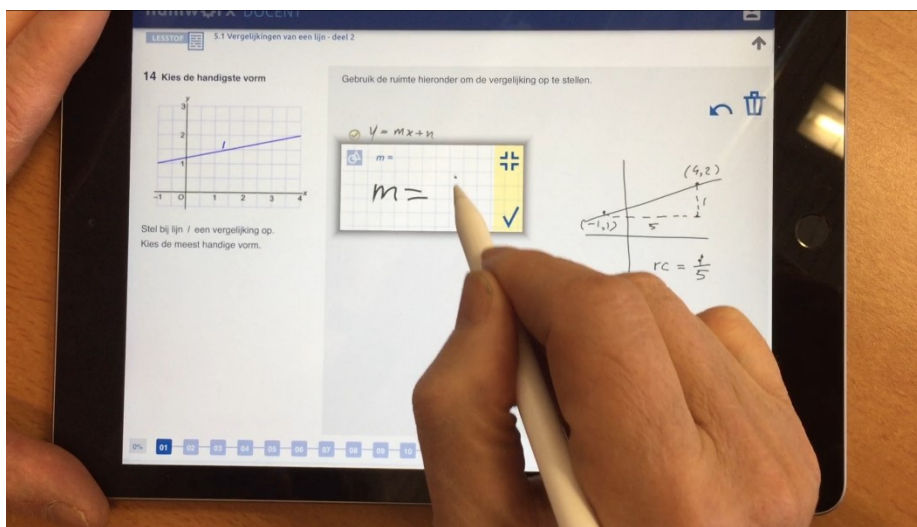


Figure 5: Handwriting recognition in the Digital Mathematics Environment. See <https://youtu.be/YKtrr1IxWaA> for an animation.

To summarize, the two examples illustrate how an embodied design approach may lead to tasks in which sensorimotor experiences form the basis of mathematical cognition, a view that is not explicitly present in the two views presented earlier.

Embodied instrumentation

Instrumental and embodied views on the use of digital tools in mathematics education may seem quite different. On the one hand, instrumental approaches in many cases focus on the development of individual, mental schemes – even if collective instrumental genesis is acknowledged –, on high-level conventional mathematics, and on sophisticated digital tools. Embodied views, on the other hand, focus on sensorimotor schemes, on bodily experiences, on basic mathematical ideas, and make use of dedicated software tools; the convergence to conventional mathematical cognition and techniques sometimes receives less attention. From a networking theory perspective (Bikner-Ahsbahs & Prediger, 2014), however, it seems interesting to compare, contrast, combine and coordinate these different views.

The claim I want to make here is that, in spite of these apparent differences, embodied and instrumental approaches both highlight the complexity of user-tool interaction, share some similar theoretical bases, and can be coordinated and aligned in a meaningful way. In line with researchers

who in the past have been exploring the interface between embodied and instrumental approaches (e.g., Artigue, Cazes, Haspekian, Khanfour-Armale, & Lagrange, 2013; Arzarello, Paola, Robutti, & Sabena, 2009; Maschietto & Bartolini-Bussi, 2009), I argue for an embodied instrumentation approach, to reconcile the embodied nature of instrumentation schemes and the instrumental nature of sensorimotor schemes. As such, an embodied instrumentation approach explores the co-emergence of sensorimotor schemes, tool techniques and mathematical cognition, and offers a design heuristic for ICT activities which align the bodily foundations of cognition and the need for instrumental genesis.

As for the shared theoretical basis, embodied and instrumental approaches share a theoretical foundation in ideas from Vygotsky (1978) on tool use and from Piaget (1985) on schemes, and both approaches acknowledge the subtlety of tool mediation in meaningful mathematical activity. In the meantime, the two approaches can be complementary, in the sense that embodied approaches so far have not overstressed the convergence of tool techniques and conventional mathematical notions, whereas instrumental approaches have tended to neglect the sensorimotor view on schemes and the embodied nature of cognition.

Concerning the coordination and alignment of the two approaches, I can image productive learning trajectories on fundamental mathematical concepts, in which the development of sensorimotor schemes may gradually go hand in hand with, or even be part of instrumental genesis. Such a trajectory might lead to schemes in which embodied experiences still form the basis, and through a process of reflective abstraction (Abrahamson, Shayan, Bakker, & van der Schaaf, 2016) lead to instrumental genesis. In this way, embodied and instrumental approaches might be aligned: the process of instrumental genesis is fostered by embodied activities. As students advance in a learning trajectory, the tool techniques and mathematical knowledge emerge from an instrumental genesis process, and the embodied basis may move more to the background. Ensuring coordination between the development of sensorimotor schemes and instrumental genesis might be a strong design heuristic for technology-rich tasks in mathematics teaching.

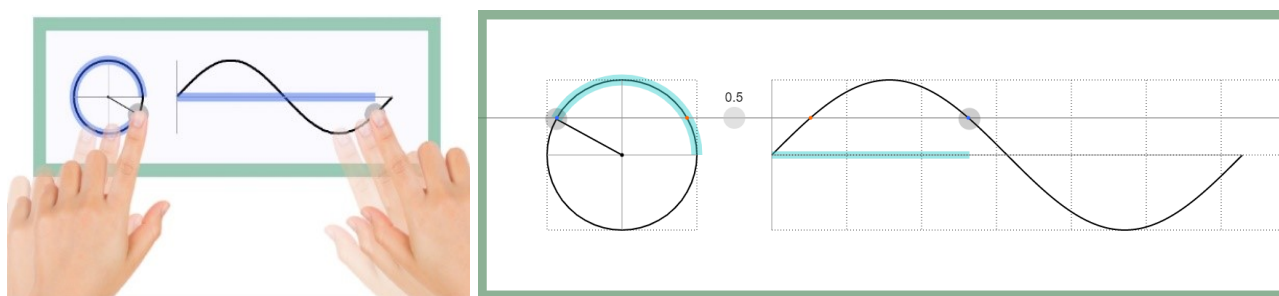


Figure 6: MIT-T tasks (Alberto, Bakker, Walker-van Aalst, Boon, & Drijvers, 2019). See <https://youtu.be/1eOU4XvyHmg> for an animation.

Let me illustrate this embodied instrumentation approach in a final example. Figure 6's left screen shows the so-called MIT-T app, where the abbreviation stands for Mathematics Imagery Trainer – Trigonometry (Alberto, Bakker, Walker-van Aalst, Boon, & Drijvers, 2019). It shows a unit circle and a sine graph, with a movable point on each of them. As a first task, students use the multitouch screen to simultaneously move the two points and, similar to the case in the parabola example

presented above, to explore when the frame around the graphs becomes green. This is the case if a correct match is made between the sine of an angle in the unit circle and the function value of the sine in a point on the horizontal axis, so if the two points are at equal height. The activity of “keeping the frame green” clearly invites appropriate sensorimotor coordination of keeping two points at the same height and is expected to induce a “feeling” for the coordination of the two movements. As was the case for the parabola task (Fig. 4), this may lead to many follow-up activities, each requiring design decisions and subtle arrangements of tasks and tools. As a possible end point of such a sequence, Figure 6’s right-hand screen shows the additional tool of a horizontal line, which can be moved up and down through the central big grey point with label its height, 0.5, thus implementing the coordination that just was enacted. Now both the unit circle and the sine graph can be used to solve the equation $\sin a = 0.5$: in the unit circle, one can move the point to meet the intersection of circle and line, and similarly in the graph. Of course, these two techniques need to be coordinated as well: if the two intersection points do not match, the feedback frame will not become green. In a later phase, one might want to drop the unit circle and focus on the sine graph. At that stage, the task in fact comes down to graphically solving equations of the form $f(x) = c$, which is exactly the example shown at the end of the instrumental view section (see Figure 3).

To summarize, this example illustrates how embodied and instrumental approaches may be coordinated and aligned in a learning trajectory. In this design, the embodied experiences mediated by digital tools prepare for instrumental genesis. Of course, more research is needed to decide whether such alignments would lead to higher effect sizes than the ones reported earlier. Speaking in general, both the common theoretical bases of embodied and instrumental views, and their complementarity make exploring their potential alignment, as expressed in the notion of embodied instrumentation, a highly interesting enterprise.

Conclusion

In this paper, I first outlined a taxonomy for the didactical functionality of digital technology in mathematics education. This taxonomy guided a second-order meta-analysis, the results of which suggest that the effect sizes of technology-rich interventions are significantly positive, but small to moderate. This led to the idea of looking in more detail at three views on tool use in mathematics education. As a first lens, Realistic Mathematics Education theory highlights that students should experience mathematics as meaningful. Applied to tool use, this implies that tools should be transparent and should provide the students with authentic ways to express themselves mathematically. More specifically focusing on tool use, the second lens of instrumentation stresses the intertwinement of techniques for using the tool and the mathematical knowledge involved. Techniques and mathematical meaning co-emerge in processes of instrumental genesis. The third lens of embodied cognition claims that sensorimotor activities form the basis of cognition, and, more than the other two approaches, highlights the need to root mathematical knowledge in bodily experiences.

A key guiding principle shared by all three approaches is mathematical meaning, even if each approach stresses different aspects of it: RME highlights the idea of mathematics being “experientially real”, instrumentation theory points to the mathematical meaning embedded in techniques for using tools, and embodied views see sensorimotor schemes as the foundation of

mathematical meaning. This stress on meaning makes sense: if we do not manage to incorporate digital technology in students' mathematical practices in a way that they experience as meaningful, it is a useless enterprise.

As a conclusion, in my opinion the three views have much to offer for technology-rich mathematics education. The RME view provides some important general guidelines, which may inform instrumental and embodied approaches. As for the interplay between embodied and instrumental views, I strongly believe that the two can be coordinated and aligned in a so-called embodied instrumentation approach. Embodied and enacted experiences, so present in the embodied cognition approach, can form the basis for learning. As such, these experiences are the foundations on which instrumental genesis can build; a bodily-based instrumental genesis during which tool techniques and mathematical cognition co-emerge.

Of course, this argument for an embodied instrumentation approach needs further elaboration on several aspects. First, the RME lens may reveal possible tensions between its reality principle and the instrumental approach's focus on tool techniques. Similarly, the alignment of sensorimotor schemes and tool techniques is a subtle one, even if the examples in Figures 4, 5 and 6 provide some possible approaches. Also, a body of empirical evidence for positive effects of such an embodied instrumentation approach is lacking so far. In spite of these limitations, I do believe that the three lenses do justice to three main elements in the "landscape" of mathematics education: the world around us, our bodily interaction with it, and the tools we use to facilitate this interaction. As such, I suggest that embodied instrumentation, seen as an integrated embodied and instrumental approach in which sensorimotor schemes, tool techniques and mathematical cognition co-emerge, deserves priority in the research agenda of those interested in the use of digital technology in mathematics education.

Acknowledgment

I thank Rosa Alberto, Arthur Bakker, Peter Boon, Alison Clark-Wilson, Michiel Doorman, Anna Shvarts, and Luc Trouche, as well as the CERME IPC reviewers, for their input on previous versions of this contribution.

References

- Abrahamson, D. (2009). Embodied design: Constructing means for constructing meaning. *Educational Studies in Mathematics*, 70(1), 27–47.
- Abrahamson, D. (2014). Building educational activities for understanding: An elaboration on the embodied-design framework and its epistemic grounds. *International Journal of Child-Computer Interaction*, 2(1), 1–16.
- Abrahamson, D., Shayan, S., Bakker, A., & van der Schaaf, M. (2016). Eye-tracking Piaget: capturing the emergence of attentional anchors in the coordination of proportional motor action. *Human Development*, 58(4–5), 218–244.
- Ainley, J, Pratt, D., & Hansen, A., (2006). Connecting engagement and focus in pedagogic task design. *British Educational Research Journal*, 32(1), 23–38.

- Alberto, R. A., Bakker, A., Walker-van Aalst, O., Boon, P., & Drijvers, P. (2019). *Networking theories with design research: An embodied instrumentation case study in trigonometry*. Paper presented at the Eleventh Congress of the European Society for Research in Mathematics Education, Utrecht, the Netherlands, 6-10 February, 2019.
- Alibali, M. W., & Nathan, M. J. (2012). Embodiment in mathematics teaching and learning: Evidence from learners' and teachers' gestures. *Journal of the Learning Sciences, 21*, 247–286.
- Artigue, M. (2002). Learning mathematics in a CAS environment: The genesis of a reflection about instrumentation and the dialectics between technical and conceptual work. *International Journal of Computers for Mathematical Learning, 7*, 245–274.
- Artigue, M., Cazes, C., Haspekian, M., Khanfour-Armale, R., & Lagrange, J.-B. (2013). *Gestes, cognition incarnée et artefacts : une analyse bibliographique pour une nouvelle dimension dans les travaux didactiques au LDAR*. [Gesture, embodied cognition and artefacts: a literature analysis for a new dimension in the didactical work at LDAR.] Paris, France: LDAR.
- Arzarello, F., Paola, D., Robutti, O., & Sabena, C. (2009). Gestures as semiotic resources in the mathematics classroom. *Educational Studies in Mathematics, 70*(2), 97–109.
- Bakker, A., Shvarts, A., & Abrahamson, D. (submitted). *Generativity in design research: the case of developing a genre of action-based mathematics learning activities*.
- Ball, L., Drijvers, P., Ladel, S., Siller, H.-S., Tabach, M., & Vale, C. (Eds.) (2018). *Uses of technology in primary and secondary mathematics education; Tools, topics and trends*. Cham, Switzerland: Springer International Publishing.
- Bikner-Ahsbabs, A., & Prediger, S. (2014). *Networking of theories as a research practice in mathematics education*. Dordrecht, the Netherlands: Springer.
- Cheung, A. C. K., & Slavin, R. E. (2013). The effectiveness of educational technology applications for enhancing mathematics achievement in K-12 classrooms: a meta-analysis. *Educational Research Review, 9*, 88–113.
- Cohen, J. (1988). *Statistical Power Analysis for the Behavioral Sciences*. New York, NY: Routledge.
- de Freitas, E., & Sinclair, N. (2014). *Mathematics and the body*. New York, NY: Cambridge University Press.
- Doorman, M., Drijvers, P., Gravemeijer, K., Boon, P., & Reed, H. (2012). Tool use and the development of the function concept: from repeated calculations to functional thinking. *International Journal of Science and Mathematics Education, 10*(6), 1243–1267.
- Drijvers, P. (2018a). Empirical evidence for benefit? Reviewing quantitative research on the use of digital tools in mathematics education. In L. Ball, P. Drijvers, S. Ladel, H.-S. Siller, M. Tabach, & C. Vale (Eds.), *Uses of technology in primary and secondary mathematics education; Tools, topics and trends* (pp. 161–178). Cham, Switzerland: Springer International Publishing.
- Drijvers, P. (2018b). Tools and taxonomies: a response to Hoyles. *Research in Mathematics Education, 20*(3), 229–235.

- Drijvers, P., & Barzel, B. (2012). Equations with technology: different tools, different views. *Mathematics Teaching*, 228, 14–19.
- Drijvers, P., Boon, P., Doorman, M., Bokhove, C., & Tacoma, S. (2013). Digital design: RME principles for designing online tasks. In C. Margolinas (Ed.), *Proceedings of ICMI Study 22 Task Design in Mathematics Education* (pp. 55–62). Clermont-Ferrand, France: ICMI.
- Drijvers, P., Boon, P., & Van Reeuwijk, M. (2011). Algebra and technology. In P. Drijvers (Ed.), *Secondary algebra education. Revisiting topics and themes and exploring the unknown* (pp. 179–202). Rotterdam: Sense.
- Drijvers, P., Doorman, M., Boon, P., Reed, H., & Gravemeijer, K. (2010). The teacher and the tool: instrumental orchestrations in the technology-rich mathematics classroom. *Educational Studies in Mathematics*, 75(2), 213–234.
- Duijzer, A.C.G., Shayan, S., Bakker, A., van der Schaaf, M. F. & Abrahamson, D. (2017). Touchscreen tablets: coordinating action and perception for mathematical cognition. *Frontiers in Psychology*, 8, 1–19.
- Duijzer, C., Van den Heuvel-Panhuizen, M., Veldhuis, M., Doorman, M., & Leseman, P. (2019). Embodied learning environments for graphing motion: a systematic literature review. *Educational Psychology Review*, 31(3), 597–629.
- Ferrara, F., & Sinclair, N. (2016). An early algebra approach to pattern generalisation: actualising the virtual through words, gestures and toilet paper. *Educational Studies in Mathematics*, 92, 1–19.
- Freudenthal, H. (1973). *Mathematics as an educational task*. Dordrecht, the Netherlands: Reidel Publishing Company.
- Freudenthal, H. (1983). *Didactical phenomenology of mathematical structures*. Dordrecht, the Netherlands: Reidel Publishing Company.
- Gravemeijer, K. P. E., & Doorman, L. M. (1999). Context problems in realistic mathematics education: a calculus course as an example. *Educational Studies in Mathematics*, 39(1–3), 111–129.
- Haspekian, M. (2014). Teachers' instrumental genesis when integrating spreadsheet software. In A., Clark-Wilson, O. Robutti, & N. Sinclair, N. (Eds.), *The mathematics teacher in the digital era* (pp. 241–276). New York, NY: Springer.
- Hoyles, C. (2018). Transforming the mathematical practices of learners and teachers through digital technology. *Research in Mathematics Education*, 20(3), 209–228.
- Hoyles, C., & Lagrange, J.-B. (Eds.) (2010). *Mathematics education and technology: rethinking the terrain*. New York, NY: Springer.
- Hoyles, C., & Noss, R. (2003). What can digital technologies take from and bring to research in mathematics education? In A. J. Bishop, M. A. Clements, C. Keitel, J. Kilpatrick, & F. K. S. Leung (Eds.), *Second International Handbook of Research in Mathematics Education* (pp. 323–349). Dordrecht: Kluwer.

- Lakoff, G., & Núñez, R. (2000). *Where mathematics comes from*. Basic Books.
- Leung, A., & Baccaglioni-Frank, A. (Eds.) (2017). *Digital technologies in designing mathematics education tasks*. Potential and pitfalls. New York, NY: Springer.
- Li, Q., & Ma, X. (2010). A meta-analysis of the effects of computer technology on school students' mathematics learning. *Educational Psychology Review*, 22, 215–243.
- Margolinas, C., & Drijvers, P. (2015). Didactical engineering in France; an insider's and an outsider's view on its foundations, its practice and its impact. *ZDM–Mathematics Education*, 47(6), 893–903.
- Maschietto, M., & Bartolini-Bussi, M. (2009). Working with artefacts: Gestures, drawings and speech in the construction of the mathematical meaning of the visual pyramid. *Educational Studies in Mathematics*, 70(2), 143–157.
- Maschietto, M., & Soury-Lavergne, S. (2013). Designing a duo of material and digital artifacts: the pascaline and Cabri Elem e-books in primary school mathematics. *ZDM–Mathematics Education*, 45(7), 959–971.
- Monaghan, J., Trouche, L., & Borwein, J. (2016). *Tools and mathematics*. Cham, Switzerland: Springer International Publishing.
- OECD (2015). *Students, computers and learning. Making the connection*. Paris, France: OECD Publishing. <http://www.oecd.org/edu/students-computers-and-learning-9789264239555-en.htm>.
- Piaget, J. (1985). *The equilibration of cognitive structures*. Cambridge, MA: Harvard University Press.
- Proust, C. (2012). Masters' writings and students' writings: school material in Mesopotamia. In G. Gueudet, B. Pepin, & L. Trouche (Eds.), *From text to 'lived' resources. Mathematical curriculum materials and teacher development* (pp. 161–179). New York, NY: Springer.
- Rabardel, P. (2002). *People and technology – A cognitive approach to contemporary instruments*. <http://ergoserv.psy.univ-paris8.fr>.
- Radford, L. (2009). Why do gestures matter? Sensuous cognition and the palpability of mathematical meanings. *Educational Studies in Mathematics*, 70, 111–126.
- Robutti, O. (2006). Motion, technology, gesture in interpreting graphs. *International Journal for Technology in Mathematics Education*, 13(3), 117–126.
- Shvarts, A. (2018). A dual eye-tracking study of objectification as student–tutor joint activity appropriation, In E. Bergqvist, M. Österholm, C. Granberg, & L. Sumpter (Eds.). *Proceedings of the 42nd Conference of the International Group for the Psychology of Mathematics Education, Vol. 4* (pp. 171–178). Umeå, Sweden: PME.
- Shvarts, A., & Abrahamson, D. (2019). Dual-eye-tracking Vygotsky: A microgenetic account of a teaching/learning collaboration in an embodied-interaction technological tutorial for mathematics. *Learning, Culture and Social Interaction*, 22, 100316.

- Steenbergen-Hu, S., & Cooper, H. (2013). A meta-analysis of the effectiveness of intelligent tutoring systems on K–12 students' mathematical learning. *Journal of Educational Psychology, 105*(4), 970–987.
- Treffers, A. (1987). *Three dimensions. A model of goal and theory description in mathematics instruction – The Wiskobas project*. Dordrecht, the Netherlands: D. Reidel Publishing Company.
- Trgalová, J., Clark-Wilson, A., & Weigand, H.-G. (2018). Technology and resources in mathematics education. In T. Dreyfus, M. Artigue, D. Potari, S. Prediger, & K. Ruthven, *Developing Research in Mathematics Education. Twenty Years of Communication and Collaboration in Europe* (pp. 142–161). New York, NY: Routledge.
- Trouche, L. (2004). Managing complexity of human/machine interactions in computerized learning environments: Guiding students' command process through instrumental orchestrations. *International Journal of Computers for Mathematical Learning, 9*, 281–307.
- Trouche, L., & Drijvers, P. (2010). Handheld technology: Flashback into the future. *ZDM – Mathematics Education, 42*(7), 667–681.
- Van den Heuvel-Panhuizen, M. (2014). Didactical phenomenology. In S. Lerman (Ed.), *Encyclopedia of Mathematics Education* (pp. 174–176). Dordrecht, Heidelberg, New York, London: Springer.
- Van den Heuvel-Panhuizen, M., & Drijvers, P. (2014). Realistic mathematics education. In S. Lerman (Ed.), *Encyclopedia of Mathematics Education* (pp. 521–525). Dordrecht, Heidelberg, New York, London: Springer.
- Vergnaud, G. (1987). About constructivism, a reaction to Hermine Sinclair's and Jeremy Kilpatrick's papers. In J. Bergerson, N. Herscovics & C. Kieran (Eds.), *Proceedings of the 11th conference of the international group for the psychology of mathematics education, Vol 1* (pp. 73–80). Montréal, Canada: University of Montréal.
- Vergnaud, G. (2009). The theory of conceptual fields. *Human Development, 52*, 83–94.
- Vérillon, P., & Rabardel, P. (1995). Cognition and artifacts: a contribution to the study of thought in relation to instrumented activity. *European Journal of Psychology of Education, 10*(1), 77–101.
- Vygotsky, L.S. (1978). *Mind in society: the development of higher psychological processes*. Cambridge, MA: Harvard University Press.
- Wilson, A. D., & Golonka, S. (2013). Embodied Cognition is not what you think it is. *Frontiers in psychology, 4*(58).
- Young, J. (2017). Technology-enhanced mathematics instruction: A second-order meta-analysis of 30 years of research. *Educational Research Review, 22*, 19–33.

History and pedagogy of mathematics in mathematics education: History of the field, the potential of current examples, and directions for the future

Kathleen M. Clark

Florida State University, School of Teacher Education, Tallahassee, Florida USA; kclark@fsu.edu

The field of history of mathematics in mathematics education—often referred to as the history and pedagogy of mathematics domain (or, HPM domain)—can be characterized by an interesting and rich past and a vibrant and promising future. In this plenary, I describe highlights from the development of the field, and in doing so, I focus on several ways in which research in the field of history of mathematics in mathematics education offers important connections to frameworks and areas of long-standing interest within mathematics education research, with a particular emphasis on student learning. I share a variety of examples to serve as cases of what has been possible in the HPM domain. Finally, I propose fruitful future directions that call for the contributions of both established and emerging scholars in the field.

Keywords: History of mathematics, mathematics education research, primary historical sources, qualitative research.

Introduction

George Sarton (1884–1956), a Belgian-born American historian of science, said:

The main duty of the historian of mathematics, as well as his fondest privilege, is to explain the humanity of mathematics, to illustrate its greatness, beauty and dignity, and to describe how the incessant efforts and accumulated genius of many generations have built up that magnificent monument, the object of our most legitimate pride as men, and of our wonder, humility and thankfulness, as individuals. The study of the history of mathematics will not make better mathematicians but gentler ones, it will enrich their minds, mellow their hearts, and bring out their finer qualities. (Sarton, 1936, p. 28)

Putting aside that to Sarton—in this example—only men experienced this “legitimate pride” (perhaps due to the academic fabric of the 1930s), he beautifully captures one of the often-cited effects of studying the history of mathematics: that such a use of history¹ of mathematics has the ability to humanize the subject, by way of appealing on some aesthetic or non-academic level to the added value of the discipline.

I first experienced this humanistic element of studying the history of mathematics from the desire to provide a different perspective regarding mathematics for my students. At the time some 20 years ago, I was teaching mathematics to students in grades 11 and 12 at a publicly-funded residential school for academically talent students in Mississippi in the United States. I was most concerned about the content that would comprise a history of mathematics course that I was tasked to teach as part of the school’s mathematics course electives. In preparation for teaching the course I became

¹ As part of the plenary talk (and paper), I plan to highlight the different notions of “use of history” —as the variants of “use” (e.g., “incorporate,” “include,” etc.) may be a point of contention for some.

involved with the Institute of the History of Mathematics in its Use in Teaching (IHMT), and my world of mathematics changed forever. As a result of that experience, I not only gained access to materials that would inform the first history of mathematics course I taught, I also acquired a new lens on teaching mathematics in general. Although I was teaching students who chose to attend a school focused on mathematics and science (e.g., *the* Mississippi School for Mathematics and Science in Columbus, MS), not all of the students had a positive relationship with mathematics. For many, they had become trained to view mathematics as a set of procedures to acquire a numerical answer for a “problem.” As a high school mathematics teacher, I felt that I was living the embodiment of what Glaisher (1848–1928) described: “I am sure that no subject loses more than mathematics by any attempt to dissociate it from its history” (1890, p. 466). However, continued participation in IHMT and my eventual doctoral work would provide me with new perspectives, tools, and a community with which to view, study, and teach mathematics. Therefore, in this talk, I hope to share with you a small part of the development of the community—its history, if you will—as well as its exciting present and promising future.

Plan for the plenary paper

In this paper, I will first situate the field of history of mathematics in mathematics education—often referred to as the history and pedagogy of mathematics domain (or, HPM domain) within mathematics education, with careful attention to the development leading up to establishing the International Study Group on the Relations between the History and Pedagogy of Mathematics (HPM Group) in 1976. Precipitated by the creation of the HPM Group, research in the HPM domain has continued to grow in last 40-plus years, and includes all levels of learners and teachers. Part of this growth has been marked by the creation of a thematic working group on history in mathematics education, beginning with CERME6 in 2009. Next, I will provide examples of approaches and frameworks that are useful in empirical research in the HPM domain and I will highlight a collection of specific examples in which research on the use of history of mathematics contributes to the broader landscape of research in mathematics education and will do so with respect to two frameworks useful to mathematics education research. As a first example, I will discuss contributions of working with primary historical sources on pre- and in-service teachers’ mathematical knowledge for teaching. As a second example, I discuss the application of Sfard’s (2008) thinking as communicating framework in research, including work by colleagues in Denmark and Brazil, as well as that currently undertaken within the *Transforming Instruction in Undergraduate Mathematics via Primary Historical Sources* (or, TRIUMPHS) project in the United States. Finally, after a brief analysis of ongoing discussions for calls to strengthen empirical work in the HPM domain in light of certain pitfalls and dilemmas facing the field, I will propose directions for future research and the ways in which various CERME thematic working groups can contribute to bridging research in this important field with the broader mathematics education research community

Development of HPM: A study domain and a group

What is now known as HPM was established as part of the second International Congress on Mathematical Education (ICME) in 1972 in Exeter, UK, first as an official working group there (EWG 11) and then as an official study group (with the onerous original name of International Study Group on Relations between History and Pedagogy of Mathematics, cooperating with the

International Commission on Mathematical Instruction; simplified to the HPM Study Group and later as just the HPM Group) subsequent to ICME3 in Karlsruhe, Germany in 1976. The principle aims of the group were perhaps a description of the culmination of efforts focused on integrating or using history of mathematics in teaching in different contexts around the world since the end of the 19th century. In particular, the principle aims given by the HPM Study Group were:

1. To promote international contacts and exchange information concerning:
 - a. Courses in History of Mathematics in Universities, Colleges and Schools.
 - b. The use and relevance of History of Mathematics in mathematics teaching.
 - c. Views on the relation between History of Mathematics and Mathematical Education at all levels.
2. To promote and stimulate interdisciplinary investigation by bringing together all those interested, particularly mathematicians, historians of mathematics, teachers, social scientists and other users of mathematics.
3. To further a deeper understanding of the way mathematics evolves, and the forces which contribute to this evolution.
4. To relate the teaching of mathematics and the history of mathematics teaching to the development of mathematics in ways which assist the improvement of instruction and the development of curricula.
5. To produce materials which can be used by teachers of mathematics to provide perspectives and to further the critical discussion of the teaching of mathematics.
6. To facilitate access to materials in the history of mathematics and related areas.
7. To promote awareness of the relevance of the history of mathematics for mathematics teaching in mathematicians and teachers.
8. To promote awareness of the history of mathematics as a significant part of the development of cultures. (Fasanelli & Fauvel, 2006, p. 2; originally in May, 1978, p. 76)

It is important to note that the essence of these eight aims have remained relevant and present in subsequent HPM-related meetings and remain a source of motivation for research and practice for many in the field today. It is also important to note that when appropriate, the aims apply to all levels of learners and teachers (e.g., primary (elementary), secondary, tertiary, and teacher education).

After the establishment of the HPM Study Group in 1976, the community continued to grow in important ways, including a focus on practitioners (e.g., school teachers) who wished to humanize mathematics in school teaching but to also engage students with historical materials, methods, and problems in their learning of mathematics. A classic example of the recommendations that were offered to teachers are given by Fauvel (1991) and which resulted from a brief historical look through curriculum documents for school mathematics teachers in the UK. In his introduction, Fauvel noted that for “decades if not centuries now, a few voices in each generation have urged the value and importance of using history in teaching mathematics—but so far without this insight taking firm and widespread root in the practice of teaching” (p. 3). National curriculum documents echoed a similar call for history of mathematics in both the UK and US in 1989:

Pupils should develop their knowledge and understanding of the ways in which scientific ideas change through time and how the nature of these ideas and the uses to which they are put are

affected by the social, moral, spiritual and cultural contexts in which they are developed. (*Science in the National Curriculum*, 1989; as cited in Fauvel, 1991, p. 4).

Students should have numerous and varied experiences related to the cultural, historical, and scientific evolution of mathematics so that they can appreciate the role of mathematics and the disciplines it serves.... It is the intent of this goal—learning to value mathematics—to focus attention on the need for student awareness of the interaction between mathematics and the historical situations from which it has developed and the impact that interaction has on our culture and lives. (NCTM, 1989, pp. 5–6)

However, policy statements and reform efforts tell only one side of the story and to actually enable teachers with materials, techniques, skills, etc., is quite another. Still, in the decades since the HPM Group’s establishment, the community grew in ways that brought together different stakeholders—mathematicians, mathematics historians, mathematics teachers, mathematics education researchers, and others—for the purpose of sharing research, historical materials, and examples of pedagogical practice in which history of mathematics informed the teaching of mathematics. The first HPM Group satellite meeting (associated with an ICME) took place in 1984 at the Stuart campus of the University of Adelaide, and the satellite meetings have taken place every four years (as with ICME) since then. Additional supports to the international community were also established. For example, also in 1984, a meeting took place at University High School in San Francisco, CA, in which the creation of an Americas Section of the HPM Group was planned. The aim for an “HPM Americas” section was to “have a more active presence in the mathematics education community than was forthcoming from the international organization” (Fasanelli & Fauvel, 2006, p. 6). In 1993, the first of regularly-occurring meetings called European Summer University (ESU), were organized by the Institutes of Research in Mathematics (IREM) and took place in Montpellier, France. The ESU was held every three years until 2010², when it was decided that they would occur every four years and would be staggered by two years from the quadrennial ICME/HPM satellite meeting pair.

HPM within CERME

Of course, the inclusion of a working group on history of mathematics in mathematics education at CERME may be the international venue of most interest to the present audience. The working group made its first appearance at CERME6 (Working Group 15: Theory and Research on the Role of History in Mathematics Education), and since then, it was established as Thematic Working Group (TWG) 12, History in Mathematics Education. The TWG has focused on a wide array of concerns to the field, which are represented by nine overarching themes taken from the “call for papers” since 2009:

1. Theoretical, conceptual and/or methodological frameworks for including history in mathematics education;

² There was a five-year gap between the 1999 ESU-3 held in Leuven and Louvain-la-Neuve, Belgium and the 2004 joint ESU-4 and ICME-10 satellite meeting of HPM held in Uppsala, Sweden.

2. Relationships between (frameworks for and empirical studies on) history in mathematics education and theories and frameworks in other parts of mathematics education [this point featured only from CERME 7 onwards];
3. The role of history of mathematics at primary, secondary, and tertiary level, both from the cognitive and affective points of view;
4. The role of history of mathematics in pre- and in-service teacher education, from cognitive, pedagogical, and/or affective points of view;
5. Possible parallelism between the historical development and the cognitive development of mathematical ideas;
6. Ways of integrating original sources in classrooms, and their educational effects, preferably with conclusions based on classroom experiments;
7. Surveys on the existing uses of history in curricula, textbooks, and/or classrooms in primary, secondary, and tertiary levels;
8. Design and/or assessment of teaching/learning materials on the history of mathematics;
9. The possible role of history of mathematics/mathematical practices in relation to more general problems and issues in mathematics education and mathematics education research. (Jankvist & van Maanen, 2018, p. 242)

Table 1 provides the titles and authors of sample papers (and the CERME meeting in which they were presented) corresponding to the nine themes given, as a way to exhibit the variety and context in which work in HPM is conducted within the CERME community.

TWG 12 ³ theme	Sample paper
1	“The Teaching of Vectors in Mathematics and Physics in France During the 20th Century” (Ba & Dorier; CERME6)
2	“Uses of History in Mathematics Education: Development of Learning Strategies and Historical Awareness” (Kjeldsen; CERME7)
3	“The Role of History of Mathematics in Fostering Argumentation: Two Towers, Two Birds and a Fountain” (Gil & Martinho; CERME9)
4	“Mathematical Analysis of Informal Arguments: A Case-Study in Teacher-Training Context” (Chorlay; CERME10)
5	“Teaching the Concept of Velocity in Mathematics Classes” (Möller; CERME9)
6	“Designing Teaching Modules on the History, Application, and Philosophy of Mathematics” (Jankvist; CERME7)

³ Again, for CERME6 only, this was Working Group 15.

7	“The Implementation of the History of Mathematics in the New Curriculum and Textbooks in Greek Secondary education” (Thomaidis & Tzanakis; CERME6)
8	“The Development of Place Value Concepts to Sixth Grade Students via the Study of the Chinese Abacus” (Tsiapou & Nikolantonakis; CERME8)
9	“Lessons from Early 17th Century for Current Mathematics Curriculum Practice” (Krüger, CERME7)

Table 1: Sample collection of CERME papers presented in TWG 12

Jankvist and van Maanen (2018) noted that TWG 12 seeks to “create a forum and a platform for fostering empirical studies in the field of history in/of mathematics education *and to also better link research in this field with research in mathematics education in general*” (p. 241, emphasis added). In the examples that follow, I especially focus on themes 2, 3, and 4 in the list summarized by Jankvist and van Maanen.

History in mathematics education: A very brief history of early research

Early scholarship⁴ (e.g., conducted before 2000) in the field of history in mathematics education was primarily focused on (a) anecdotal reports of interventions used with students; (b) historical research on topics that could serve as the focus of classroom instruction; and (c) survey research, including research on students’ or teachers’ attitudes and beliefs related to history of mathematics. A classic example of empirical research is that of McBride and Rollins (1977), in which, as part of McBride’s doctoral dissertation, they examined the effects of studying mathematics history on attitudes of college algebra students toward mathematics. The research was motivated by the lack of research reports (available at the time) that studied “the problem of determining the effectiveness” (p. 57) of “incorporating items from the history of mathematics into classroom discussions of mathematical topics” (p. 57). For McBride and Rollins, the “incorporation” of items was restricted to the use of vignette material to introduce or comment on mathematical topics in the college algebra curriculum. The authors found a significant increase in attitude (particularly since the attitudes of the treatment group increased and the those of the control group decreased); however, several limitations were identified, including the notion that the teacher effect may have been significant. Limitations aside, the McBride and Rollins contribution represented two impacts for subsequent research in the field of history in mathematics education. First, it placed the potential of history in mathematics education on the radar of future researchers (myself included). And, their use of existing research—that on attitudes towards mathematics by Aiken (such as his early work in the *Journal for Research in Mathematics Education* in 1974)—exemplified the fruitful connections for research on history in mathematics education within the broader landscape of mathematics education research. In more recent years, scholarship has begun to shift to capitalize on empirical methods that are more mainstream, and for which researchers seek a broader application of the interventions that have been the focus of their research. In the following, I discuss more recent examples of different approaches

⁴ Apologies to my colleagues around the globe: for the purposes of this plenary talk (and paper), I focus on English-language scholarship.

and frameworks that are useful in empirical research in the HPM domain, including mathematical knowledge for teaching and thinking as communicating.

Mathematical knowledge for teaching and HPM

Mathematical knowledge for teaching (MKT) is a practice-based theory of the domains of knowledge that are considered necessary for the work of teaching mathematics. The framework itself (often relegated to the “egg model” diagram; see for example, Ball, Thames, and Phelps (2008)) has been applied in a variety of research contexts around the world since the early 2000s and has its foundation in the work of the Learning Mathematics for Teaching (LMT) Project. However, it is important to keep in mind that rather than taking the egg model too literally (as in, trying to situate all relevant and possible knowledge for teaching mathematics into the original six domains of knowledge), the practiced-based theory of MKT comprises two key aspects: knowledge of content in the discipline of mathematics and the recognition that teaching is at the core, and this brings with it the notion that mathematics teaching can be decomposed into tasks of teaching, of which there are many.

In my own early work with prospective mathematics teachers (PMTs), I was struck by the idea that the MKT framework could provide ways to problematize (or clarify) the ways in which studying history of mathematics informs PMTs’ knowledge of topics they would soon teach. In one study (Clark, 2012), I analyzed reflection journal entries of 80 students enrolled in a “Using History in the Teaching of Mathematics” course, across four semesters. In the particular investigation, I examined 15 weeks of journal entries for each of the 80 students for their reference to solving quadratic equations using completing the square. In the course, students worked with English translations of primary source material as part of investigations designed to engage them with the historical development of a mathematical concept, and which would provide them with opportunities to expand their mathematical and pedagogical knowledge, and to consider ways in which student learning may benefit from incorporating content similar to what they worked with in the “Using History” course. The source excerpt was taken from Fauvel and Gray (1987, p. 229):

Roots and squares are equal to numbers: for instance, ‘one square, and ten roots of the same, amount to thirty-nine dirhems’; that is to say, what must be the square which, when increased by ten of its own roots, amounts to thirty-nine? The solution is this: you halve the number of the roots, which in the present instance yields five. This you multiply by itself; the product is twenty-five. Add this to thirty-nine; the sum is sixty-four. Now take the root of this, which is eight, and subtract from it half the number of the roots which is five; the remainder is three. This is the root of the square you sought for; the square itself is nine. [...]

When students elected⁵ to discuss course tasks from al-Khwarizmi’s text on solving quadratic equations in their reflection journals, they revealed what it contributed to their mathematical learning and how they would consider incorporating such content in their future teaching. Brad’s reflection of

⁵ For the reflective journal assignments, students made the choice of what to include in their journals. However, regardless of content selection (typically driven by course readings, tasks, and assignments), PMTs needed to respond to at least one of six fixed reflection prompts, e.g., *In what ways has your understanding of {mathematical topic} changed as a result of considering the history of the topic?*, or, *In what ways do you envision being able to incorporate the history of {mathematical topic} in your teaching?*

his prior and current experience (with respect to his mathematical learning) was representative of the tenor of the PMTs' reflection of the al-Khwarizmi tasks:

I remember learning the quadratic formula in 8th grade. I was in Algebra I and Mrs. Horst had *politely drilled* the “opposite of b plus or minus the square root of b squared, minus four ac , all over two a ” routine into our heads. All I recall knowing is that I could apply *this formula* to solve polynomials of a 2nd degree. [T]he lesson and activity we completed...were particularly influential to my understanding. This was essentially the *first proof of any sort* that I've experienced relevant to the formula itself. It was *this part where I really had the “a-ha” feeling*. As I began to compose the area relationships using algebraic notation, I could see the beginnings of the quadratic formula; I realized that this was actually going to work! More importantly I began to view the quadratic equation as less of an algebraic equation and more of a *geometric relationship*. (Clark, 2012, p. 78)

From another view, Hillary described her idea for the ways in which she might consider history of mathematics informing her future teaching:

If I were going to use this in my classroom I would be sure to explain to them how al Khwarizmi used his vast knowledge of many subjects to work with these numbers and develop a similar quadratic formula, one that is like that of ours today, except for the use of the negative numbers. I would show them that with a few simple manipulations and algebraic transformations, we would have the same equation and we could even have groups each try a different method but with the same equation, then compare answers; that way students can find which method suits them the best.... I feel that math has so many possibilities, so many ways in which something can be taught and or understood, so why not provide those so the students can make sense of what to them might be complicated mathematics. (Clark, 2012, p. 80)

As a result of studying PMTs' reflections of course content and engagement with materials using history of mathematics in teaching, I claimed that the work on the part of teachers to incorporate history of mathematics in teaching is a component of the “something else” that Ball and her colleagues (2008) described as knowledge for teaching beyond the obvious knowledge of “topics and procedures that [teachers] teach” (p. 395). As part of their definition of *horizon content knowledge*, Ball et al. concentrated on “how teachers need to know that content” (p. 395) and they sought to “determine what else teachers need to know about mathematics and how and where teachers might use such mathematical knowledge in practice” (p. 395). My study of PMTs' work to develop knowledge of history of mathematics—and, therefore of mathematics that they were tasked to teach—pointed to the strong potential of the history of mathematics to contribute to the “what else” described by Ball et al. and how this specialized knowledge contributes to PMTs' future practice. I also made the claim, by using Boero and Guala's (2008) component of the “cultural analysis of the content to be taught” (p. 223), that engaging in the mathematical, historical, and cultural aspects of a mathematical concept is an important way in which teachers need to know the content that they teach. Thus, although the call to “focus attention on the need for student awareness of the interaction between mathematics and the historical situations from which it has developed and the impact that

interaction has on our culture and lives” (NCTM, 1989, p. 6) seems to be a distant memory⁶, situating an analysis of what PMTs’ claim as a contribution to their mathematical knowledge within the MKT framework enables researchers to make decisions regarding the development of prospective mathematics teachers, as well as the role that history of mathematics plays in that important work. There are still too few studies that capitalize on investigating the role that the study of history of mathematics, organized in meaningful and powerful ways to inform not only PMTs’ disciplinary content knowledge but the multiple forms of tasks of teaching that they will perform in their future teaching. However, the contribution of history of mathematics on the MKT of practicing teachers is also productive for research in mathematics education.

Additional contexts for the application of MKT

There is further potential for the application of MKT in the HPM domain. Recent scholarship reveals multiple contexts and applications in which the linkages between MKT and the use of history of mathematics in the development of prospective and practicing teachers further contribute to research on teacher knowledge and the work of mathematics teachers. Two examples are worth noting here. Smestad, Janviskt, and Clark (2014) investigated components of horizon content knowledge (HCK) within MKT in relation to curricular demands that teachers experience in general, and with regard to curricular transition periods in particular; that is, when the transition taking place involves “the inclusion of elements of history of mathematics in new curricula and accompanying textbooks” (p. 180). We approached the three cases of interest with a focus on a dual aspect of HCK. For example, “concrete inclusions of history of mathematics...calls for an already developed [HCK] of a teacher” (p. 174), which can be considered “a priori HCK.” Yet this inclusion of history of mathematics in a teacher’s practice may itself contribute to [a] teacher’s HCK—which might then be referred to as “a posteriori HCK.”

The three cases (Denmark, Norway, and the US) discussed in Smestad et al. (2014) each stemmed from concrete directives (yet still considered rhetoric) calling for the inclusion of history of mathematics in school curriculum, and which represented a continuum of curricular demands for teachers in delivering their instruction while heeding the various directives. These particular transitions—for example, shifting the extent to which inclusion of elements of history of mathematics in new curricula or textbooks—impact a teacher’s HCK. For example:

In the transition phase from one curriculum not including elements of history of mathematics to another which does, in-service teachers often lack the associated CCK, KCC⁷, etc. And, at this particular time, in this particular transition period while implementing the new curriculum and training in-service teachers, a priori HCK comes to play a more crucial role. (p. 180)

This example highlights the dynamic nature of a model (MKT) for understanding the nature of the practice (and perhaps, the purpose) of mathematics teaching. Furthermore, there is a synergetic

⁶ By 2000, when NCTM issued its new *Principles and Standards for School Mathematics*, what was originally recognized as a goal for learning mathematics was now reduced to identification of a feature of mathematics, *Mathematics as a part of cultural heritage*: “Mathematics is one of the greatest cultural and intellectual achievements of humankind, and citizens should develop an appreciation and understanding of that achievement...” (p. 4).

⁷ Common content knowledge (CCK), knowledge of content and curriculum (KCC), etc.

relationship between research on history of mathematics in teacher education and the evolution of models for understanding teacher knowledge. As Jankvist, Mosvold, Fauskanger, and Jakobsen (2015) observed, “the MKT framework provides a powerful language to communicate results from research on the uses of history of mathematics to researchers in other areas of mathematics education research” (p. 495).

Thinking as communicating and HPM research

In an attempt to resolve certain quandaries related to mathematical thinking and learning, Sfard (2008) operationally defined thinking as a personalized version of communication. Given the collective nature of communication, she introduced the term *commognition* to highlight the communicative nature of activities in our minds, emphasizing that individual cognitive processes (thinking) and interpersonal communication are “but different manifestations of basically the same phenomenon” (Sfard, 2008, p. 83). Using this communicative, or discursive lens, Sfard (2008) determined that “mathematics begins where the tangible real-life objects end and where reflection on our own discourse about these objects begin” (p. 129). That is, what identifies the objects of communication in mathematics is their discursive nature: they come to exist as we talk about them. Thus, taken from this viewpoint, mathematics is seen as a highly situated human activity which generates itself. As a result, the learner of mathematics faces an interesting and paradoxical situation: How can a person join a discourse for which familiarity with the discourse is a precondition for participation in that discourse?

Yet further complications exist. Sfard (2008) noted that participation in any discourse requires adopting the rules that govern that discourse, in addition to becoming familiar with the objects of the discourse. She referred to the former rules as *meta-level*, or *metadiscursive*, and the latter as *object-level*. For instance, asserting that a particular function is differentiable constitutes an object-level narrative about functions. However, a student’s method of justifying this assertion (e.g., sketching a graph versus an $\epsilon - \delta$ proof) would be indicative of the metadiscursive rules that govern her discourse about functions. Despite the usual implications of the word *rule* as being invariable and strictly deterministic, metadiscursive rules are subject to change in time and space, and they possess certain characteristics; they are tacit, contingent, constraining, flexible, value-laden, and are difficult to change. Sfard posits that these characteristics render meta-level learning possible only through direct encounters with a new discourse that is governed by meta-level rules different from those governing the learner’s current discourse (p. 256). Furthermore, such encounters generally entail a *commognitive conflict* when the discursants unknowingly operate under completely different meta-level rules.

Given their role in governing the actions of the participants in a mathematical discourse, researchers have paid particular attention to factors that affect the learning of metadiscursive rules in mathematics. In a number of these studies, the history of mathematics, and primary source readings in particular, emerged as an instructional approach with strong potential to promote such learning.

Example from Denmark

In their study of university mathematics students, Kjeldsen and Blomhøj (2012) showed that a careful selection of historical sources can help students learn about the metadiscursive rules that govern mathematicians’ discourse about functions and can allow them to recognize that these rules changed

during the development of that concept. This meta-level learning, they argued, fostered students' learning of mathematics at the object-level as well. The authors shared an in-depth analysis of project reports produced by two groups of students, which were based on project work designed and carried out as part of the mathematics bachelor's and master's programs at Roskilde University. The reports result from semester-long work in which students operate within particular project constraints; in the case of the two projects described by Kjeldsen and Blomhøj, these belong to the "mathematics as a discipline" constraint. The projects exemplified were "Physics' influence on the development of differential equations and the following development of theory" and "Fourier and the concept of a function – the transition from Euler's to Dirichlet's concept of function." In their analyses of student projects, Kjeldsen and Blomhøj brought attention to the incongruent discourses of their students when compared to the primary source texts. For example, for the group whose project was "Physics' influence..." students read and studied three original sources from the 1690s:

In order to answer their questions, the students had to read and understand the sources within the mathematical discourse of the time. On one hand, this is a difficult task because the students' points of departure in dealing with the sources are their own mathematical discourses, which are different from the discourse of the authors of the sources. On the other hand, this is exactly the reason why history, and working with original sources, can serve as an effective method for meta-level learning. (p. 336)

In their discussion of students' project work—for both project examples—Kjeldsen and Blomhøj (2012) beautifully situate the power of primary historical sources to promote students' ability to reflect upon metadiscursive rules of mathematics:

Didactically, it is important to find and identify historical sources that are suitable for provoking discussion in classrooms among students and with their teachers about different meta-discursive rules. Likewise, it is important to perform research about how this can be done, how teaching activities that support such discussions and reflections can be designed and how the effectiveness of such teaching and learning situations can be evaluated in practice. (p. 347)

Example from Brazil

In a similar way and drawing upon the work of Kjeldsen and Blomhøj (2012) and Kjeldsen and Petersen (2014), as well as Sfard's theory of thinking as communicating, Bernardes and Roque (2018) conducted two experiments with a small group of undergraduate students in a mini-course focused on the topic of "Different roles of the notion of matrix in two episodes of the history of matrices" (p. 219). The course included two teaching modules which introduced students to original source materials from J. J. Sylvester (1814–1897) and Arthur Cayley (1821–1895). In a similar way to Kjeldsen's empirical work with colleagues, Bernardes and Roque's research consisted of three goals, in which they sought to investigate:

- (1) how historical sources encourage reflections about metarules related to matrices and determinants;
- (2) how reflections about metarules impact students' conceptions about matrices and determinants; and
- (3) the development of a historical consciousness in the students. (p. 211)

In their analysis, Bernardes and Roque (2018) found that students were able to discuss and reflect on the historical metarules present in the primary source texts; as well, they identified three metarules in the student participants' discourse. Furthermore, Bernardes and Roque highlighted the occurrence of commognitive conflicts – that is, “conflicting narratives in which the...participants and the historical sources were guided by different metarules” (p. 224). The combination of these outcomes prompted the researchers to question the order in which they teach topics in a Linear Algebra course. For example, they questioned whether it is appropriate to begin such a course with the “concept of a matrix as an object in itself” (p. 226). In their proposal for a future instructional sequence, Bernardes and Roque observed that historical episodes showed that the introduction and development of the concept of matrix was driven by a need for such a representation (e.g., introduction of multiplication of matrices in conjunction with composition of linear transformations). Thus, in addition to the use of primary sources promoting students' reflection of metalevel rules governing their mathematical discourse, such an innovation has the potential for guiding instructional changes which can serve to impact students' mathematical learning.

Example from the United States: The TRIUMPHS Project

As part of a large grant project, several colleagues and I have begun a study to further investigate the potential that “history can have a profound, perhaps even indispensable, role to play in teaching and learning mathematics from the point of view of learning proper meta-discursive rules” (Kjeldsen and Blomhøj, 2012, p. 328). Before describing features of that work, it is perhaps helpful to describe the greater context in which the research is taking place.

In 2015, the National Science Foundation (NSF) in the United States funded a seven-institution collaborative project to design, test, and evaluate curricular materials for teaching standard topics in the university mathematics curriculum via the use of primary historical sources. The goal of the project is to assist students in learning and developing a deeper interest in and appreciation of mathematical concepts by creating educational materials in the form of Primary Source Projects (PSPs) based on original historical sources written by mathematicians involved in the discovery and development of the topics being studied. The project, *Transforming Instruction in Undergraduate Mathematics via Primary Historical Sources*, or TRIUMPHS, is developing PSPs which contain (1) excerpts from one or several historical sources, (2) a discussion of the mathematical significance of each selection, and (3) student tasks designed to illuminate the mathematical concepts that form the focus of the sources. PSPs are designed to guide students in their explorations of these original texts in order to promote their own understanding of those ideas.

The numerous PSPs are indeed the life force of the TRIUMPHS project. During the grant-funded effort, the principal investigators (PIs) promised that some 50 PSPs (which span the undergraduate mathematics curriculum, from basic statistics and trigonometry, to real analysis, abstract algebra, and topology) will be developed, tested, and evaluated. Of the 50 PSPs, 20 are planned to be “full-length” and 30 are what we refer to as “mini-PSPs.” Full-length PSPs are designed to typically encompass at least two to four class sessions, which represents the same amount of time that it normally takes to teach the mathematical topic of focus within the PSP. However, among the full-length PSPs there

are also longer ones that could be used by instructors to comprise an entire course's content⁸. Alternatively, "mini-PSPs" can be completed in one to two class sessions and each of the mini-PSPs have been developed to teach a particular topic or concept in mathematics that would normally be addressed in a single class session, but which will be done via a primary historical source. To date, 33 full-length PSPs and 28 mini-PSPs have been developed. Though we have exceeded our commitment to develop 20 full-length PSPs, there are additional full-length PSPs in development, as well as the remaining, promised mini-PSPs.

In Fall 2015 the first PSPs were tested⁹ in two undergraduate mathematics classrooms in the United States; in Year 3 (academic year 2017–18), 46 distinct site testers tested one or more PSPs in undergraduate mathematics classrooms. However, in total, by the end of Year 3, 53 instructors have site tested PSPs as part of the TRIUMPHS project, with some one-third of those serving as repeat testers. In the first semester of Year 4, we have 20 student data collection site testers; again, of these, we have several repeat site testers, where 13 are new to site testing TRIUMPHS PSPs.

Whereas this progress across almost four years of a large NSF grant project may seem to some as modest, it is important to note that as only one of three such grants ever funded on this level in the United States, this represents significant progress with regard to efforts designed to promote the teaching of undergraduate mathematics via primary historical sources. The two previous grants – to which three of the seven TRIUMPHS PIs and one of the advisory board members contributed – also produced a number of primary source projects. Table 2 summarizes the origin and availability of these projects.

Years	Name of funded project (URL)	Number of projects developed (and tested in classrooms)
2003–2006	Teaching Discrete Mathematics via Primary Historical Sources; Pilot Grant (https://www.math.nmsu.edu/hist_projects/)	14
2008–2012	Learning Discrete Mathematics (LDM) and Computer Science via Primary Historical Sources; Expansion Grant (https://www.cs.nmsu.edu/historical-projects/)	20
2015–present	Transforming Instruction in Undergraduate Mathematics via Primary Historical Sources; Collaborative Grant (http://webpages.ursinus.edu/nscoville/TRIUMPHS.html)	61, to date

⁸ In fact, this was done recently (Spring 2018) by Janet H. Barnett, in an Abstract Algebra course.

⁹ By "tested" we mean that we collected student data from the implementation of PSPs in these classrooms.

Table 2: PSP development, 2003–2018

There are two features unique to TRIUMPHS when compared to the two previous grants. First, it was difficult to recruit site testers for the projects that were developed. The Pilot Grant (2003–2006) involved only five total site testers and in the Expansion Grant (2008–2012), a total of 10 site testers participated. However, in the TRIUMPHS project we have developed mechanisms to recruit site testers through a variety of outreach efforts, including presentations at conferences, three-day TRIUMPHS-focused workshops (particularly focused on instructors who might not have previously included primary sources in their teaching), mini-courses and short workshops at conferences, and listserv announcements via professional organizations with members who may share interests in history of mathematics and its use in teaching¹⁰. In advance of each autumn and spring semester we advertise the site testing opportunity and accept applications for two different site tester streams: those who will serve as student data collection site testers and those who will serve as instructor-only data collection sites.

The second feature unique to TRIUMPHS (when compared to the previous grant efforts) is the evaluation-with-research (EwR) component of the grant project. The two previous grants included only an evaluation component, which resulted from the analysis of surveys completed by students at the beginning and end of courses at the particular participating institutions “in any course in which a historical project could be used, regardless of whether a project [was] actually used or not” (“Instructions for testers,” LDM, n.d.). The surveys asked students to respond to approximately 30 questions: 18 “Need for Cognition Scale” items, 10 “Understanding Computer Science Scale” (and/or Mathematics, depending upon the course) items, and two open-ended items:

In your opinion, what are the benefits of learning Mathematics (and/or Computer Science) from historical sources?

In your opinion, what are the drawbacks of learning Mathematics (and/or Computer Science) from historical sources?

Thus, in the evaluation of the funded grant projects just prior to TRIUMPHS, assertions were made only with regard to students’ self-reported understanding of mathematics or computer science concepts broadly and beliefs about their problem solving and cognitive efforts. That said, student responses to the two open-ended items did provide the PI team with confirmation that the use of primary historical projects was a worthwhile inclusion in the teaching of mathematics and computer science courses. Typical student responses (LDM, n.d.) include:

I really enjoyed it. I found it to be very intriguing.

As a student you get to see where the math we do today came from and engage in the kind of thinking that was necessary to create it.

It’s a perfect way to given math some context in the world. Historical sources teach you the math while simultaneously fitting math into history and give you meaning for why the math was and is

¹⁰ We have also advertised training opportunities and site testing via inquiry-based learning (IBL) audiences, since mathematics faculty interested in active learning strategies in undergraduate mathematics courses may find PSPs provide useful materials for promoting active learning, particularly in upper-division mathematics courses.

important. Historical sources also break up the monotony of textbooks, making math more accessible for a wider variety of students.

I think that it gives the student a [deeper] understanding of the subject.

The TRIUMPHS Project: Metadiscursive rules investigation (MDRI)

It is important to point out that the EwR component of the TRIUMPHS project was built after the formulation of the main focus; that is, the development and dissemination of the PSPs was the primary focus of the grant effort. Therefore, evaluation questions were constructed that would enable the PI team to report several metrics to the funding agency (in this case, the NSF in the US) regarding the successful completion of the goals and sub-goals of the project. However, developing research questions about what can be learned from TRIUMPHS—given that the design of the development of the PSPs was fixed first—proved difficult in both the development of the grant proposal and the “pilot year” of the project. In particular, the PIs working on the EwR component¹¹ strongly believe that TRIUMPHS provides a unique opportunity to contribute to mathematics education research more broadly, especially given the potential that a large collaborative grant project affords, including working with a variety of university teaching contexts (e.g., two-year colleges and four-year colleges and universities) and student populations. And, in response to the NSF prior to receiving funding, we highlighted the importance of the development of communication skills—and all modes of this: written, verbal, reading—as part of students’ mathematical learning was an area of potential impact. After several iterations, the EwR working group decided that the thinking as communicating framework (Sfard, 2008) would provide the most fruitful lens for our research.

Our investigation builds on prior research concerning the potential of primary source readings for mathematics education (e.g., Bernardes & Roque, 2018; Kjeldsen & Blomhøj, 2012) that has been conducted within the framework of Sfard’s participationist theory of “learning as discourse” (Sfard, 2008). In particular, we focus on the role played within that framework by the metadiscursive rules which govern the actions of the participants in a mathematical discourse. When considering the research literature available which contains similar emphases with regard to using primary historical sources in the teaching and learning of mathematics, we have been empowered with a strong conviction—as have others—that, under the right conditions, the use of history does promote the learning of metadiscursive rules in mathematics. Our goal, within the EwR component of the TRIUMPHS project, is to contribute to the important work of identifying what occurs for student learning under what conditions, work which is important to both the researcher who is interested in, for instance, how the learner is thinking along the way, and to the practitioner, for whom the educational setting that motivates meta-level learning opportunities for students is of paramount importance.

Thus, we launched a metadiscursive rules investigation (MDRI), in which we posed the following research questions:

¹¹ There are actually three foci of the EwR component of TRIUMPHS: “student change,” “faculty expertise,” and “development cycle.”

What is the evidence of students' progress in "figuring out" (Sfard, 2014, p. 201) the meta-level rules that govern a new mathematical discourse as a result of studying specific mathematical concepts when using primary source projects?

To what extent do students' actions (e.g., verbal, written), both during and after engagement with the primary source projects, provide evidence of their acceptance of a new discourse?

The construction of our research questions was heavily influenced by Sfard's (2014) observation that university mathematical discourse is "far removed from what the student knows from school as a discourse can be" (p. 200). Thus, in our work, we investigate an alternative to lecturing that makes use of the history of mathematics (e.g., via PSPs) in order to provide a learner with the opportunities for "watching a mathematician in action and imitating his moves while also trying to *figure out* the reasons for the strange things he is doing" that Sfard suggests "may be the only way to come to grips with [the] objects [that she is supposed to operate upon]" (Sfard, 2014, p. 202; emphasis added).

We are also strongly influenced by the agenda articulated by Kjeldsen and Blomhøj (2012):

Didactically, it is important to find and identify historical sources that are suitable for provoking discussion in classrooms among students and with their teachers about different meta-discursive rules. Likewise, it is important to perform research about how this can be done, how teaching activities that support such discussions and reflections can be designed and how the effectiveness of such teaching and learning situations can be evaluated in practice. (p. 347)¹²

In particular, our MDRI research draws upon three semesters of undergraduate mathematics instruction that took place at one institution during the Autumn 2016 (Introduction to Analysis; 11 consenting students), Spring 2017 (Number Theory; 8 consenting students), and Spring 2018 (Abstract Algebra; 15 consenting students). The contexts, student populations, and PSPs used are somewhat different across the three semesters¹³. However, the data sources were similar in each instance, and included:

- Video recordings of all class sessions;
- Audio recordings of each group during small group work;
- Students' written work on all PSPs implemented during the courses and related "Reading and Study Guides" (RSGs);
- Instructor class notes;
- Pre- and post-PSP student interviews¹⁴; and
- Responses to four surveys per student (pre- and post-course surveys, and two post-PSP surveys).

¹² This passage was previously quoted in this paper, but it bears repeating here because it is particularly critical for the MDRI work as part of TRIUMPHS.

¹³ However, there was a small subset of students (8) who participated in two of the three courses.

¹⁴ Not all consenting students were interviewed pre- and post-PSP, due to students' class and work schedules.

An example from the Autumn 2016 course (*Introduction to Analysis*), which contained source material “suitable for provoking discussion in classrooms among students and with their teachers about different meta-discursive rules” (Kjeldsen & Blomhøj, 2012, p. 347), was the first PSP of the semester (and which students met during the second week of the course): *Why Be So Critical: Nineteenth Century Mathematics and the Origins of Analysis* (Barnett, 2017a). This project explored the question of: *Why, after nearly 200 years of success in the development and application of calculus techniques, did 19th-century mathematicians feel the need to bring a more critical perspective to the study of calculus?* – and did so through selected excerpts from the writings of the nineteenth century mathematicians who led the initiative to raise the level of rigor in the field of analysis (Barnett, 2017a, p. 1).

The project includes excerpts from four mathematicians: Bolzano, Cauchy, Dedekind, and Abel. In the PSP, Barnett (2017a) provided oriented students to the various primary sources with: “...these mathematicians expressed their concerns about the relation of calculus (analysis) to geometry, and also about the state of calculus (analysis) in general. As you read what they each had to say, consider how their concerns seem to be the same or different” (p. 1). For example, Figure 1 displays an excerpt from Dedekind.

Richard Dedekind, 1872, *Stetigkeit und irrationale Zahlen* (Continuity of irrational numbers)

My attention was first directed toward the considerations which form the subject of this pamphlet in the autumn of 1858. As professor in the Polytechnic School in Zürich I found myself for the first time obliged to lecture upon the elements of the differential calculus and felt more keenly than ever before the lack of a really scientific foundation for arithmetic⁷. In discussing the notion of the approach of a variable magnitude to a fixed limiting value, and especially in proving the theorem that every magnitude which grows continually but not beyond all limits, must certainly approach a limiting value, I had recourse to geometric evidences. Even now such resort to geometric intuition in a first presentation of the differential calculus, I regard as exceedingly useful, from the didactic standpoint, and indeed indispensable, if one does not wish to lose too much time. But that this form of introduction into the differential calculus can make no claim to being scientific, no one will deny. For myself this feeling of dissatisfaction was so overpowering that I made the fixed resolve to keep meditating on the question until I should find a purely arithmetic and perfectly rigorous foundation for the principles of infinitesimal analysis.

Figure 1: Excerpt from Barnett, 2017a (source: Dedekind, 1901)

In keeping this excerpt in mind, we found evidence that such sources can prompt classroom discussion around the metadiscursive rules that we see at the time of Dedekind—which constituted a shift from what had been in place—and that are different still from what students were trying to reconcile.

Some weeks later—approximately seven weeks into the course—students spent approximately two weeks working on the second PSP in this analysis course: *Rigorous Debates over Debatable Rigor: Monster Functions in Introductory Analysis* (Barnett, 2017b). In the project, students are introduced to the correspondence between Gaston Darboux (1843–1917) and Jules Houël (1823–1886), in which

Houël has requested feedback on early drafts of his intended textbook on differential calculus. Throughout the correspondence, however, Darboux “offered various counterexamples in a (vain) attempt to convince Houël of the need for greater care in certain of his (Houël’s) proofs” (Barnett, 2017b, pp. 2–3). Examples of this correspondence are provided in Figures 2 and 3.

Here is what I reproach in your reasoning which no one would now find rigorous. When we have

$$\frac{f(x+h) - f(x)}{h} - f'(x) = \epsilon,$$

ϵ is a function of two variables x and h that approaches zero when, x remaining fixed, h approaches zero. But if x and h [both] vary as they do in your proof, or worse yet, if to each new subdivision of the intervals $x_1 - x_0$ there arise new quantities ϵ , then I find it altogether unclear and your proof has nothing but the appearance of rigor. [Darboux, as quoted in (Gispert, 1983, p. 99)]

Figure 2: Excerpt (A): Darboux correspondence with Houël (Barnett, 2017b, p. 6)

Yes, I admit as a fact of experience (without looking to prove it in general, which might be difficult) that in the functions that I treat, one can always find h satisfying the inequality $\frac{f(x+h)-f(x)}{h} - f'(x) < \epsilon$, no matter what the value of x , and I avow to you that I am ignorant of what the word derivative would mean if it is not this. . . . I believe this hypothesis is identical with that of the existence of a derivative. [Houël, as quoted in Gispert 1987, pp. 56 – 57].

Figure 3: Excerpt (B): Houël correspondence with Darboux (Barnett, 2017b, p. 6)

Two project tasks related to these excerpts were:

Do you agree with Houël about this being what the word ‘derivative’ means? Why or why not?

How does what Darboux said in the excerpt (A) seem to be different from what Houël is saying here [excerpt (B)]?

The intensive work on how to analyze the data in order to address our original research questions is just beginning. We produced a preliminary report on an initial discussion of methodological issues that we experienced in our first review of the Autumn 2016 data. In our report (Can, Barnett, & Clark, 2018), we addressed two questions:

1. How can we characterize the nature of students’ participation in mathematical discourse in their written work related to primary source projects?
2. What constitutes evidence of students’ noticing of meta-level rules in this written work?

Since our research report was quite preliminary (and page-limited), we focused on analyzing students’ written work from just one PSP¹⁵ (and associated RSGs) that was implemented in the *Introduction to Analysis* course we studied in Autumn 2016. We sought to document evidence of

¹⁵ For the purposes of the preliminary report, we focused on the PSP, *Rigorous Debates over Debatable Rigor: Monster Functions in Introductory Analysis* (Barnett, 2017b).

students' noticing of metadiscursive rules in the form of meta-level reflections of two kinds: on either the mathematical objects under discussion (what we called *object-reflection*) or the discourse itself (what we called *discourse-reflection*). In the sample student's reflection (given in Figures 4a, 4b, 5a, and 5b), we identified the student's 'talk' as object-reflection, in which she provided meta-level narrative about mathematical objects (i.e., derivative).

2. Complete Task 3 part (a):

Do you agree with Houël about this being what the word 'derivative' means? Why or why not?

I disagree with Houël about $\frac{f(x+h)-f(x)}{h} - f'(x) < \epsilon$ is the derivative because we use $f'(x)$ to define derivative & you would have to find this first before even using the equation above.

How does what Darboux said in the excerpt at the bottom of page 4 seem to be different from what Houël is saying here?

It's a way to describe what Houël trying to do but is not a derivative; they use the derivative in it.

Figure 4a: Student object-reflection (meta-level)

Do you agree with Houël about this being what the word 'derivative' means? Why or why not?

I disagree with Houël about $\frac{f(x+h)-f(x)}{h} - f'(x) < \epsilon$ is the derivative because we use $f'(x)$ to define the derivative & you would have to find this first before even using the equation above.

How does what Darboux said in the excerpt at the bottom of page 4 seem to be different from what Houël is saying here?

It's a way to [describe] what Houël [is] trying to do but is not a derivative; they use the derivative in it.

Figure 4b: Transcription of task and student response given in Figure 4a

1. Read the three excerpts (two from Darboux, one from Houël) on pages 4 – 5.

Write at least one question or comment about these three excerpts.

Darboux really seems to hate Houël's proof.
The third excerpt, however, was a bit confusing to me, especially when it says "hypothesis is identical with that of the existence of a derivative."

Figure 5a. Student discourse-reflection (meta-level)

Write at least one question or comment about these three excerpts.

Darboux really seems to hate Houël's proof.
The third excerpt, however, was a bit confusing to me,
Especially when it says "hypothesis is identified with that
of the existence of a derivative."

Figure 5b: Transcription of task and student response given in Figure 5a

We intended the further application of our definitions for object-reflection and discourse-reflection to serve as tools to characterize the nature of students' participation in mathematical discourse in other course artifacts (e.g., small group work, whole-class discussion, interviews), but we have since found that we need an analytical framework that includes at least two components. One component of the analytical framework is the set of metadiscursive rules that we have identified for each of the PSPs that students used in a given course; it is imperative that our analysis attends to and is informed by the relevant metadiscursive rules present in the PSPs used. The second component is the criteria for evidence of students' "figuring out" the meta-level rules governing a new mathematical discourse. We believe these two components in tandem will enable us to capture a critical perspective in the work surrounding the role of primary sources (and in this case, specifically, the PSPs); that is, the implemented PSPs were intended to promote the mathematical learning goals of a given course. And, given the nature of the *Introduction to Analysis* course curriculum, these included both object- and meta-level learning goals. That said, the data analysis for the research described here is ongoing, and our particular struggle at the moment is figuring out what we mean by "figuring out," as suggested by Sfard (2014, p. 202), in order to move forward through our data to determine not only the progress made by students but what such progress could signal for changing instructional practice at the undergraduate level. This work is complex and draws upon multiple perspectives from mathematics, history, and mathematics education, and consequently, possesses ample opportunity for future collaborations and contexts in mathematics education research.

Calls for the future: Future contributions

Need for collaboration

There has been exciting progress in research conducted in the HPM domain in the last 40 years, and in the last 20 years, this is particularly true. As I shared earlier in this paper, at some point not so many years ago, empirical work (available in the English language) in the field of history in mathematics education was predominantly anecdotal in nature. With the growth of professional conferences—HPM, ICME, ESU, and now CERME—collaboration with colleagues around the world has not only afforded but has increased the demand for ways in which research on history in mathematics education can inform and be informed by research in mathematics education more broadly.

To this end, I would like to end with proposing two areas of research that I believe are particularly important and interesting (and necessary?), which draw upon the themes of different CERME thematic working groups and which present opportunities for fruitful collaboration in the future.

History of mathematics in mathematics teacher education

An overarching question that requires careful and thorough study is:

How does a historical perspective contribute to the mathematical and pedagogical development of mathematics teachers (at all levels, and both pre-service and in-service)?

And, there are numerous questions it motivates, including:

What are the different ways in which history of mathematics is used in the education of teachers?

What are the different challenges (e.g., historical, mathematical, attitudinal, philosophical, methodological, institutional) for each?

Are the outcomes of teachers' study of history of mathematics seen in their classroom practice in explicit ways, and if so how? If not, why? Are the implicit ways equally meaningful?

Although these questions represent only a small sample of what is yet unknown to any extent in the HPM domain, the collaboration with other domains represented by CERME TWGs could provide the means to increase efforts to conduct research in concerted ways. Some of the TWGs, in addition to contributions from TWG 12, well poised to do so include:

TWG 18: Mathematics Teacher Education and Professional Development

TWG 19: Mathematics Teaching and Teacher Practice(s)

TWG 20: Mathematics Teacher Knowledge, Beliefs and Identify

TWG 22: Curricular Resources and Task Design in Mathematics Education

TWG 23: Implementation of Research Findings in Mathematics Education

History of mathematics in the teaching and learning of mathematics

Research on the many ways in which history of mathematics can be used in the teaching and learning of mathematics seems boundless. There are many open questions in the field, yet when considering educational standards set by different countries around the globe and the persistent (primary and secondary) teacher lament that “there is not enough time to teach history of mathematics”¹⁶ in mathematics lessons, addressing the questions through different research efforts can be problematic. Part of the issue with conducting research on the use of history in teaching and learning mathematics is the need to make clear the potential for student learning that research in the HPM domain has shown. Thus, a question of particular interest is: *How do we encourage, enable, and enlighten large-scale research on the ways in which using history of mathematics in teaching impacts learning?*

Similar to proposing research on history of mathematics in mathematics teacher education, inquiry on teaching and learning of mathematics informed by history of mathematics can be addressed by the expertise represented within several CERME TWGs. For example, for research focused on how

¹⁶ Many classroom teachers perceive of “using history” as being equivalent to teaching the history of mathematics. However, this is often a misguided idea. That is, many who propose to use history of mathematics call for robust ways to do so, such as using historical methods to solve problems and to help make sense of the procedures many students find difficult, or reading, interpreting, and applying historical sources in learning mathematics, and not to simply teach who was the first to discover a particular mathematical concept.

history of mathematics can contribute to student learning and engagement with mathematics, collaboration amongst the following TWGs (again, in addition to TWG 12) is valuable:

TWG 1: Argumentation and Proof

TWG 2: Arithmetic and Number Systems

TWG 3: Algebraic Thinking

TWG 4: Geometry Teaching and Learning

TWG 8: Affect and the Teaching and Learning of Mathematics

TWG 14: Undergraduate Mathematics Education

Furthermore, investigating ways in which history of mathematics can connect tools and technologies in the teaching and learning of mathematics may benefit from the expertise of:

TWG 6: Applications and Modelling

TWG 9: Mathematics and Language

TWG 15: Teaching Mathematics with Technology and Other Resources

TWG 16: Learning Mathematics with Technology and Other Resources

And, finally, under the purview of TWG 21 (Assessment in Mathematics Education), there are considerable opportunities to address concerns held by many regarding whether teaching mathematics informed by history of mathematics *actually* contributes to student learning.

An additional consideration: Flipping the research perspective

A large proportion of research conducted on questions regarding the use and impact of history of mathematics has been focused either pre-service or in-service teachers (at the elementary and secondary level) and their students. However, investigating another population of teachers is a promising direction to pursue: teachers of teachers (e.g., university educators). Povey (2014) conducted research conversations with four university instructors designed to address the following research question: What can studying the history of mathematics with initial teacher education students offer us? (p. 148). In her analysis, Povey determined four broad themes, two which seem aligned with affective dimensions and two which are situated more with content and mathematical understanding. The thematic categorizations of the instructors' responses were:

- to deepen mathematical understanding;
- to broaden and humanize mathematics;
- to develop critical thinking; and
- to provide motivation and fun for learners. (Povey, 2014, p. 148)

Povey (2014) provided the foundation for what I believe could promote research that focuses on educators of teachers, who can provide opportunities “for studying history of mathematics [that] sets up a productive relationship with the subject and deepens mathematical understanding” (p. 154). From application and further extensions of existing frameworks such as MKT and Mathematical Knowledge for Teaching Teachers (MKTT; see for example Jankvist, Clark, & Mosvold, 2019),

mathematics education research and history in mathematics education can both capitalize on what many in the field *know* (as in, instinctually know): that historical content, problems, and perspectives in mathematics teaching “requires the development of such critical skills and can develop disposition towards enquiry based on questions posing and evidence” (Povey, p. 155). However, it is imperative that researchers seek to legitimize what has been known for decades, and to do so in concrete and robust ways so that mathematics educators, teachers, and learners can benefit from ways of knowing mathematics to which history of mathematics uniquely contributes. An interesting “flipping” of the research perspective begins with extending research that Povey began with teacher educators, and from what is learned, it is possible to build on these new perspectives coupled with guidance from existing frameworks to develop new knowledge. We may find, as Jo (one of the teacher educators) did:

[finding out about the history of mathematics] has made me realise that there are many more questions to ask than I ever thought about before and there’s probably no end to that, and I think that’s a good thing for maths teachers to know. (Povey, 2014, p. 155)

More importantly, once teacher educators experience this shift, it can permeate their practice with pre-service teachers, which can in turn be impactful in *their* future practice. The greatest imperative, however, is that we must make research in history in mathematics education part of the research landscape, as much as say, how the field has investigated the educational benefit of use of technology in teaching and learning mathematics, or ways to improve concept building in learning algebra.

Wanted: A few good researchers

As previously described, there are numerous perspectives from which researchers can approach important questions regarding teaching and learning of mathematics, of which an historical perspective is just one. Though empirical literature in the field of history of mathematics in mathematics education is much more prevalent today than some 40 years ago, there are several approaches, frameworks, and methodological lenses that are can and should be employed in order to strengthen and expand current examples.

In addition to the examples I have provided, there are other calls for research that have recently been issued and investigated to some degree. However, the potential for future research is significant and importantly, within the field of history in mathematics education, there are applications across age of learners, level of teachers, and mathematical concepts. For example, there are examples for which design-based research seems well-suited, as in the study described by Wang, Wang, Li, and Rugh (2018), in which they proposed a framework to make sense of “how to help teachers...who lack experience in [integrating the history of mathematics in teaching] IHT, use historical materials in their teaching” (p. 135). Wang et al. concluded that

Although the framework provides a new pathway for teachers’ professional development in IHT and a new opportunity for the theoretical development of IHT, *it still requires further empirical studies to confirm its educational value in the future. It is also essential that researchers closely collaborate with teachers and historians* as suggested by the dynamic pyramid model. (p. 153, emphasis added)

In closing, I have attempted to provide a broad landscape of questions, approaches, and collaborative contexts in which educational research of interest to the CERME community is possible and motivated by the field of history of mathematics in mathematics education. I challenge mathematics education researchers to embrace and pursue these questions, approaches, and contexts and to contribute to the expanding perspectives that move teaching and learning of mathematics forward.

Acknowledgments

The author wishes to thank the International Programme Committee and the Local Organizing Committee for their invitation for me to serve as a plenary speaker for CERME11. The research conducted as part of the TRIUMPHS project was funded by the National Science Foundation's (United States) IUSE Program under grant number 1523561. Any opinions, findings, or recommendations expressed in this paper are those of the author and do not necessarily reflect the views of the National Science Foundation.

References

- Aiken, L. R. (1974). Two scales of attitude towards mathematics. *Journal for Research in Mathematics Education*, 5(2), 67–71.
- Ba, C., & Dorier, J.-L. (2010). The teaching of vectors in mathematics and physics in France during the 20th century. In V. Durand-Guerrier, S. Soury-Lavergne, & F. Azarello, F (Eds.), *Proceedings of the Sixth Congress of the European Society for Research in Mathematics Education* (pp. 2682–2691). Lyon, France: Institut National de Recherche Pédagogique.
- Ball, D. L., Thames, M. H., & Phelps, G. (2008). Content knowledge for teaching: What makes it special? *Journal of Teacher Education*, 59(5), 389–407.
- Barnett, J. H. (2017a). Why be so critical? Nineteenth century mathematics and the origins of analysis: A mini-primary source project for Introductory Analysis students. *Convergence*. Retrieved from <https://www.maa.org/press/periodicals/convergence>
- Barnett, J. H. (2017b). *Rigorous debates over debatable rigor: Monster functions in Introductory Analysis*. Retrieved from http://digitalcommons.ursinus.edu/triumphs_analysis/10/
- Bernardes, A., & Roque, T. (2018). History of matrices: Commognitive conflicts and reflections on metadiscursive rules. In K. M. Clark, T. H. Kjeldsen, S. Schorcht, & C. Tzanakis (Eds.). *Mathematics, education and history. ICME-13 Monographs* (pp. 209–227). Cham, Switzerland: Springer.
- Boero, P., & Guala, E. (2008). Development of mathematical knowledge and beliefs of teachers: The role of cultural analysis of the content to be taught. In P. Sullivan & T. Wood (Eds.), *The international handbook of mathematics teacher education, Volume I: Knowledge and beliefs in mathematics teaching and teaching development* (pp. 223–244). Rotterdam, the Netherlands: Sense.
- Can, C., Barnett, J. H., & Clark, K. M. (2018). Investigating students' meta-level object-reflections and discourse-reflections: The provocative power of primary historical sources. In A. Weinberg, C. Rasmussen, J. Rabin, M. Wawro, & S. Brown (Eds.), *21st Annual Conference on Research in*

- Undergraduate Mathematics Education* (pp. 1432–1437). San Diego, CA. Retrieved from <http://sigmaa.maa.org/rume/RUME21.pdf>
- Chorlay, R. (2017). Mathematical analysis of informal arguments: A case-study in teacher-training context. In T. Dooley, & G. Gueudet (Eds.) *Proceedings of the Tenth Congress of the European Society for Research in Mathematics Education* (pp. 1701–1708). Dublin, Ireland: DCU Institute of Education & ERME.
- Clark, K. M. (2012). History of mathematics: illuminating understanding of school mathematics concepts for prospective mathematics teachers. *Educational Studies in Mathematics*, *81*(1), 67–84.
- Clark, K. M., Kjeldsen, T. H., Schorcht, S., Tzanakis, C., & Wang, X. (2016). History of mathematics in mathematics education: Recent developments. In L. Radford, F. Furinghetti, & T. Hausberger (Eds.), *Proceedings of the 2016 Satellite Meeting – HPM 2016* (pp. 135–179). Montpellier, France: IREM de Montpellier.
- Dedekind, R. (1901). *Essays on the theory of numbers* (translator W. W. Beman). Chicago, IL: The Open Court Publishing Company.
- Fasanelli, F., & Fauvel, J. (2006). History of the International Study Group on the relations between the history and pedagogy of mathematics: the first 25 years 1976–2000. In F. Furinghetti, S. Kaisjer, & C. Tzanakis (Eds.), *Proceedings of HPM 2004 & ESU 4* (pp. x–xxviii). Iraklion, Greece: University of Crete, Greece.
- Fauvel, J. (1991). Using history in mathematics education. *For the Learning of Mathematics*, *11*(2), 3–6.
- Fauvel, J., & Gray, J. (1987). *The history of mathematics: A reader*. Basingstoke, England: Palgrave Macmillan.
- Gil, P., & Martinho, M. H. (2015). The role of history of mathematics in fostering argumentation: Two towers, two birds and a fountain. In K. Krainer & N. Vondrová (Eds.), *Proceedings of the Ninth Congress of the European Society for Research in Mathematics Education* (pp. 1817–1824). Prague, Czech Republic: Charles University in Prague, Faculty of Education and ERME.
- Glaisher, J. W. L. (1890). Presidential address at the British Association for the Advancement of Science, *Nature*, *42*(1089), 464–468.
- Jankvist, U. T. (2011). Designing teaching modules on the history, application, and philosophy of mathematics. In M. Pytlak, E. Swoboda, & T. Rowland (Eds.), *Proceedings of the Seventh Congress of the European Society for Research in Mathematics Education* (pp. 1690–1699). Rzeszów, Poland: University of Rzeszów.
- Jankvist, U. T., Clark, K. M., & Mosvold, R. (2019). Developing mathematical knowledge for teaching teachers: Potentials of history of mathematics in teacher educator training. *Journal of Mathematics Teacher Education*, 1–22. Retrieved from <https://doi.org/10.1007/s10857-018-09424-x>

- Jankvist, U. T., Mosvold, R., Fauskanger, J., & Jakobsen, A. (2015). Analysing the use of history of mathematics through MKT. *International Journal of Mathematical Education in Science and Technology*, 46(4), 495–507.
- Jankvist, U. T., & van Maanen, J. (2018). History in mathematics education. In T. Dreyfus, M. Artigue, D. Potari, S. Prediger, & K. Ruthven (Eds.), *Developing research in mathematics education: Twenty years of communication, cooperation and collaboration in Europe* (pp. 239–253). Milton, England: Routledge.
- Kjeldsen, T. H. (2011). Uses of history in mathematics education: Development of learning strategies and historical awareness. In M. Pytlak, E. Swoboda, & T. Rowland (Eds.), *Proceedings of the Seventh Congress of the European Society for Research in Mathematics Education* (pp. 1700–1709). Rzeszów, Poland: University of Rzeszów.
- Kjeldsen, T. H., & Blomhøj, M. (2012). Beyond motivation: history as a method for learning meta-discursive rules in mathematics. *Educational Studies in Mathematics*, 80(3), 327–349.
- Kjeldsen, T. H., & Petersen, P. (2014). Bridging history of the concept of function with learning of mathematics: Students' metadiscursive rules, concept formation and historical awareness. *Science & Education*, 23(1), 29–45.
- Krüger, J. (2010). Lessons from early 17th century for current mathematics curriculum practice. In M. Pytlak, E. Swoboda, & T. Rowland (Eds.), *Proceedings of the Seventh Congress of the European Society for Research in Mathematics Education* (pp. 1720–1729). Rzeszów, Poland: University of Rzeszów.
- Learning Discrete Mathematics and Computer Science vis Primary Historical Sources. (LDM). (n.d.). *Learning discrete mathematics and computer science via primary historical sources*. Retrieved from <https://www.cs.nmsu.edu/historical-projects/>
- May, K. O. (Ed.). Education. *Historia Mathematica*, 5, 76.
- McBride, C. C., & Rollins, J. H. (1977). The effects of history of mathematics on attitudes towards mathematics of college algebra students. *Journal for Research in Mathematics Education*, 8(1), 57–61.
- Möller, R. D. (2015). Teaching the concept of velocity in mathematics classes. In K. Krainer & N. Vondrová (Eds.), *Proceedings of the Ninth Congress of the European Society for Research in Mathematics Education* (pp. 1853–1858). Prague, Czech Republic: Charles University in Prague, Faculty of Education and ERME.
- National Council of Teachers of Mathematics. (NCTM). (1989). *Curriculum and evaluation standards for school mathematics*. Reston, VA: Author.
- National Council of Teachers of Mathematics. (NCTM). (2000). *Principles and standards for school mathematics*. Reston, VA: Author.
- Povey, H. (2014). 'Walking in a foreign and unknown landscape': Studying the history of mathematics in initial teacher education. *Science & Education*, 23(1), 143–157.

- Sarton, G. (1936). *The study of the history of mathematics and The study of the history of science (Two volumes bound as one)*. New York, NY: Dover.
- Sfard, A. (2008). *Thinking as communicating: Human development, the growth of discourse, and mathematizing*. New York, NY: Cambridge University Press.
- Sfard, A. (2014). University mathematics as a discourse—why, how, and what for? *Research in Mathematics Education*, 16(2), 199–203.
- Smestad, B., Jankvist, U. T., & Clark, K. M. (2014). Teachers' mathematical knowledge for teaching in relation to the inclusion of history of mathematics in teaching. *Nordic Studies in Mathematics Education*, 19(3–4), 169–183.
- Thomaidis, Y., & Tzanakis, C. (2010). The implementation of the history of mathematics in the new curriculum and textbooks in Greek secondary education. In V. Durand-Guerrier, S. Soury-Lavergne, & F. Azarello, F (Eds.), *Proceedings of the Sixth Congress of the European Society for Research in Mathematics Education* (pp. 2801–2810). Lyon, France: Institut National de Recherche Pédagogique.
- Tsiapou, V., & Nikolantonakis, K. (2013). The development of place value concepts to sixth grade students via the study of the Chinese abacus. In B. Ubuz, Ç. Haser, & M. A. Mariotti (Eds.), *Proceedings of the Eighth Congress of the European Society for Research in Mathematics Education* (pp. 2058–2067). Ankara, Turkey: Middle East Technical University and ERME.
- Wang, K., Wang, X.-q., Li, Y., & Rugh, M. S. (2018). A framework for integrating the history of mathematics into teaching in Shanghai. *Educational Studies in Mathematics*, 98(2), 135–155.

Extensions of number systems: continuities and discontinuities revisited

Sebastian Rezat

Paderborn University, Institute for Mathematics, Paderborn, Germany; srezat@math.upb.de

The extension of number systems from natural to rational and real numbers and related arithmetic is a prominent theme in mathematics from primary to upper secondary education. In parallel to the development of the number concept and the extension of number systems, students need to proceed from arithmetic to algebra. Students' difficulties in mastering both, the extension from one number system to another and the progression from arithmetic to algebra are well documented. The paper focuses on the extension from natural numbers to integers with a particular interest in the relationship to the progression from arithmetic to algebra. Continuities and discontinuities in the alignment of these two parallel curricular developments are analyzed from three different perspectives, namely an epistemological, a psychological, and a pedagogical perspective. This analysis will include work from TWG02 "Arithmetic and Number Systems", which gives a flourishing account of the multifaceted issues related to the teaching and learning of different number systems since its foundation at CERME7 in 2011 and also draws on the work of TWG03 "Algebraic Thinking". Finally, conclusions will be drawn from the analysis of the relationship between the extension from natural numbers to integers and algebraic thinking in terms of the construction of a more coherent curriculum regarding these two developments.

Keywords: number systems, integers, negative numbers, algebraic thinking, coherence

Introduction

From the beginning of their lives and throughout schooling, students have to develop their number concept and related number sense. The extension of number systems from natural numbers to rational and real numbers¹ and related arithmetic is an endeavor that students are involved in from primary to upper secondary education in mathematics. In parallel to the development of the number concept and the extension of number systems, students need to proceed from arithmetic to algebra, i.e. from operating with known quantities to operating with unknowns, from the particular to the general, from numbers to symbols.

A large body of research shows that learners experience gaps and discontinuities related to both, the learning of number systems (Van Dooren, Lehtinen, & Verschaffel, 2015) and the learning of algebra (Hodgen, Oldenburg, & Strømskag, 2018; Kaput, 2008). In terms of the development of the number concept the transition from natural numbers to non-negative rational numbers (i.e. fractions and decimals) has received much attention. Research has unraveled the problems students encounter at

¹ There are ambiguities in the use of the terms *natural number*, *rational number*, and *integers* in the literature. I use the term *natural number* to refer to set $\mathbb{N} = \{1, 2, 3, \dots\}$. The term *integer* is used to refer to the set \mathbb{Z} comprising positive natural numbers including zero and their additive inverses, while with the term *rational number*, I refer to the set \mathbb{Q} comprising all positive and negative fractions and decimals respectively (and therefore also \mathbb{N} and \mathbb{Z}).

this transition. In particular, it shows that the extension from natural numbers to non-negative rational numbers requires changes in the basic understanding of what numbers can do and what effect operations have on numbers. The problems at this transition exemplify that natural number knowledge on the one hand is a prerequisite for the learning of other number systems, but on the other hand has manifold adverse effects (Vamvakoussi, 2015). This phenomenon is so pervasive that it has been termed the *whole or natural number bias* (Ni & Zhou, 2005). Consequently, students' prior knowledge that was developed with respect to the set of natural numbers has to be reorganized in such a substantial way that Vosniadou and Verschaffel (2004) speak of a “conceptual change” that is necessary at the transition from natural numbers to non-negative rational numbers.

In terms of the transition from arithmetic to algebra, the difficulties that students experience with operating on the unknown led Linchevski and Herscovics (1996) to speak of a “cognitive gap” between arithmetic and algebra. Kaput (2008) calls the separation of arithmetic and algebra in terms of “a computational approach to school arithmetic and an accompanying isolated and superficial approach to algebra” the “algebra problem”. The answer to this problem has been to foster what has been termed *algebraic thinking, relational thinking, functional thinking, or early algebra* in the context of arithmetic, in order to provide students with ways of thinking that are crucial for school algebraic contexts.

Both of these long-term developments require a careful construction of the curriculum in order to facilitate students' understanding of these central mathematical ideas. However, researchers criticize the lack of a coherent vision for the teaching and learning of number systems and related transitions (Bruno & Martinon, 1999). This also seems to be the case for the link of the extension of number systems and the progression from arithmetic to algebra. Both, the discourse on the extension of number systems and the discourse on algebraic thinking only seem to be loosely related. This is also noticeable in CERME in that negative numbers are rarely considered in TWG03 on algebraic thinking.

Therefore, the goal of this paper is to unfold the relationship between the extension of number systems and the progression from arithmetic to algebra in order to analyze continuities and discontinuities in the alignment of these two curricular progressions. For reasons that will become obvious later, I will focus on the extension from natural numbers to integers in my analysis. In particular, I seek to answer the following questions:

- 1) What is relationship between the development of the negative number concept and algebra?
- 2) How could the teaching and learning of the extension from natural numbers to integers be aligned with the teaching and learning of algebraic thinking?

In order to answer these questions, I will analyze the transition from natural numbers to integers from different perspectives: a) epistemological; b) pedagogical; and c) psychological. The epistemological perspective will mainly serve to answer the first question. I will show that the development of the negative number concept and the development of algebra were mutually related. In fact, negative numbers play a crucial role in these two developments. The pedagogical and psychological perspective will yield answers to the second question.

Based on my analysis of the relation between the extension from natural numbers to integers and the progression from arithmetic to algebra from the three different perspectives, I will draw conclusions regarding the construction of curricula, in which both, the extension of number systems and the progression from arithmetic to algebra are more coherently aligned.

Epistemological perspective

In this section, I will show that the same cognitive achievements which underlie the development of algebra were also crucial for the development and acceptance of the negative number concept. I start with a summary of the main cognitive achievements that have been pointed out as characteristic and crucial for the development of algebraic thinking. I will then show, how these cognitive achievements also have been crucial for the development of the negative number concept. However, I will not be able to give a comprehensive overview of this mutual related historical development of the negative number concept and algebra. An analysis of the obstacles in the historical development of the negative number concept was provided by Glaser (1981). Schubring (2005) gives an overview of the historical development of the negative number concept and its relation to the development of algebra.

Hodgen et al. (2018) regard algebraic thinking as the human activity from which algebra emerges. It focuses on generalization and the expression of generalization in increasingly systematic and conventional symbol systems as one core aspect of algebra rather than on syntactically guided actions on symbols (Kaput, 2008). The main cognitive achievements that have been pointed out as being characteristic and crucial for the development of algebraic thinking and algebra are:

1. Algebra deals with objects of *indeterminate* nature (unknowns, variables, parameters) (Radford, 2010)
2. Indeterminate objects are dealt with in *analytic* manner (Radford, 2010).
3. The development of algebraic thinking is characterized by a transition from an operational to a structural or relational perspective, i.e. by “reification“ (Sfard 1995) or “objectification“ (Radford, 2010) of processes into mathematical objects.
4. The new mathematical objects are detached from their original content meanings and achieve a formal character.

In the development of algebra and algebraic thinking, these four aspects are mutually related and difficult to consider in isolation. However, for the sake of clarity I elaborate on them separately.

Algebra deals with objects of indeterminate nature

The epistemological development of algebra is closely related to dealing with objects of indeterminate nature. These indeterminate objects yielded the concepts of variable and parameter. It was also in the realm of dealing with indeterminate objects in the context of solving (systems of) equations that negative numbers became relevant (Gallardo, 2002; Glaser, 1981; Hefendehl-Hebeker, 1991). According to Damerow (2007, p. 49) the use of variables “opens a potential means of representation for a higher level of meta-cognitive insights such as the recognition that the natural numbers can be complemented with negative numbers to the system of whole numbers”. Diophantus was one of the first who solved equations based on transformation methods. Applying these methods also yielded

negative solutions. For example, in his *Arithmetica*, Diophantus referred to the equation $4 = 4x + 20$ as absurd, since it would give the solution $x = -4$.

It was not until the second half of the 19th century that negative numbers were accepted as autonomous mathematical objects. However, in solving equations they were already accepted as auxiliary means, which had to be interpreted correctly after the equation was solved. A famous example is the problem discussed by D'Alembert in the article *Négatif* from Diderot's *Encyclopaedia*:

suppose that we are looking for the value of a number x which when added to 100 yields 50. According to the rules of algebra; we have $x + 100 = 50$, so that $x = -50$. This shows that the magnitude x is 50 and that instead of being added to 100 it must be subtracted. This means that the problem should have been formulated as follows: find a magnitude x which when subtracted from 100 leaves the remainder 50; if the problem had been formulated in this manner, then we would have $100 - x = 50$ and $x = 50$, and the negative form of x would cease to exist. Thus, in computations, negative magnitudes actually stand for positive magnitudes that were guessed to be in the wrong position. The sign “-“ before a magnitude is a reminder to eliminate and to correct an error made in the assumption, as the example just given demonstrates very clearly. (D'Alembert as cited in Hefendehl-Hebeker, 1991).

D'Alembert does not except the existence of a magnitude with value “-50” in his argumentation. To him, this solution only indicated an error made that had to be corrected.

Another way of making sense of negative solutions was to interpret them metaphorically by the opposite magnitude. This metaphorical interpretation of negative solutions by the opposite magnitude developed into the concept of opposite quantities, which cancel each other out:

“Quantities of the same kind which are considered under conditions that one diminishes the other shall be called opposite quantities. E.g., assets and debts, walking forward and walking backward. One of these quantities, as one likes, shall be called positive or affirmative, and its opposite negative or denying” (Kästner as cited in Schubring 2005, 134).

A similar understanding as “something being opposed to something familiar” was also crucial for the development of the concept of variable. There, it was the dualistic opposition to a known or constant quantity. This concept of variable was first overcome by Euler, who replaced this dichotomy by the universal concept of variable (Schubring, 2005). Similarly, the concept of negative quantity was for a long time conceptualized as an opposite quantity and had to be overcome by the formal concept of number.

Indeterminate quantities are dealt with in analytic manner

As a second important characteristic of algebraic thinking, Radford (2010) points out that indeterminate quantities are dealt with in an analytic manner, i.e. it is calculated with these indeterminate quantities as if they were known by referring to their mutual relationships and the relationships to known quantities. (Hefendehl-Hebeker & Rezat, 2015; Radford, 2010).

As negative numbers occurred in the context of solving equations they result from calculations in which indeterminate quantities were treated as if they were known by referring to their mutual relationships and the relationships to known quantities. This aspect is especially apparent in the

formulation of the rules for calculating with negative numbers. For example, although not accepting negative solutions, Diophantus formulated the rules *minus times minus gives plus* and *plus times minus gives minus* (Tropfke, 1980). However, these rules were derived from calculating with complex expressions, such as $(a - b)(c - d)$, by analyzing the internal relationships. The explanation of the rule for subtracting negative numbers by Bernard Lamy (1640–1715) is a revealing example. He explains that when subtracting complex quantities like $c + f$ and $b - d$. One did not want to subtract from $c + f$ the entire b , thus $c + f - b$, but somewhat less. One thus had to change the algebraic sign of d from $-$ into $+$, so as to perform the operation $c + f - b + d$ (Schubring, 2005, p. 76). Consequently, the expression $-(-b) = +b$ in solving the brackets is given sense in its relations to b and of $(b - d)$ to $(c + f)$.

Reification and Objectification

It has been pointed out that “reification” (Sfard, 1994, 1995) or “objectification” (Radford, 2010) of operations or—more generally—processes into mathematical objects had been crucial in the development of algebra. Just as the expression $4x + 20$ can be seen either as a sequence of operations or as a mathematical object such as a representation of a number or as a function, the expression $a - b$ can be seen as the operation of subtracting b from a or as the number resulting from this subtraction. From this perspective, the construction of negative numbers as autonomous mathematical objects required a transformation of mathematical processes into mathematical objects, which is visible in the step from carrying out the “hypothetical” subtraction $a - b$ omitting the restriction $b \leq a$ and accepting the negative number as an own entity. In fact, it may be regarded as one of the cognitive roots of negative numbers (Hefendehl-Hebeker & Rezat, 2015; Sfard, 1994, 1995) that carrying out fictive operations such $50 - 100$ was actually considered as a possibility. Peacock refers to this generalization of operations as the move from arithmetical to symbolical algebra (Chiappini, 2011). While in arithmetical algebra the operations on symbols underlie the same restrictions as in arithmetic (of natural numbers), the operations with symbols in symbolic algebra are defined according to the properties of the operations.

According to Schubring (2005), it was Euler who first constructed the series of negative numbers by “perpetually subtracting unity”. Later, Hankel used the term $a - b$ to construct negative numbers (Tropfke, 1980). It was also Hankel who noticed that it is sufficient to use $a = 0$ and name the resulting number by $-b$.

The new mathematical objects are detached from content meanings and achieve a formal character.

Descartes’ achievement to develop a symbolic language, which primarily relied on the relationships among the symbols and not on justifications through arithmetic or geometry is regarded to be a crucial step in the development of the symbolic language of algebra (Scholz, 1990). This can be understood as a detachment of the mathematical objects from content meanings.

Although at a very different time, the detachment of the number concept from content meanings was crucial for the acceptance of negative numbers. Schubring (2005) points out that the separation between numbers on the one hand and quantities or magnitudes on the other is decisive for understanding the historical development of negative numbers. He shows that in the history of

mathematics the epistemological limitation of the concepts of quantity and magnitude impeded the generalization of operations and thus the development of the negative number concept. As long as the concept of negative numbers was subordinated to that of magnitude, negative magnitudes were not accepted as autonomous mathematical objects. As already shown in the example by D'Alembert, the problems and their solutions were reinterpreted in the domain of positive numbers in order to avoid negative solutions. This view restricted the applicability of negative numbers to operations with “subtractive” or “opposite” quantities, which have a “natural element of opposition as giving and taking” (Schubring, 2005, p. 106). According to Schubring (2005), Euler was the first to consistently present algebra as a science of numbers and to conceptually separate numbers clearly from quantities and magnitudes. However, it was not until the 19th century that these obstacles imposed by the subordination of number to the concept of quantity and magnitude were overcome by a shift of view: The change consisted in the transition from the concrete to the formal viewpoint, which was advanced by Ohm, Peacock and Hankel. Subsequently, the concept of number could be introduced in a purely formal manner without consideration of the concept of magnitude. Hankel, who advanced this viewpoint argues:

Thus, the condition for the construction of a general arithmetic is that it be a purely intellectual mathematics detached from all intuition, a pure science of forms in which what are combined are not quanta or their number images but intellectual objects to which actual objects, or relations of actual objects, may, but need not, correspond (Hankel as cited in Hefendehl-Hebeker, 1991)

Accordingly, the underlying epistemology of justification changed from realism to that of internal consistency (Pierson Bishop et al., 2014). While operating with negative quantities and the related rules were known and used confidently already for a long time, the consistent system of rules for manipulating negative numbers is not deduced from reality, but from the basic rules of natural number arithmetic based on the permanence principle.

Hefendehl-Hebeker (1991) argues that the “separation of the construction of number systems from content considerations did not mean that the extended number systems were detached from content meanings” (p. 31) and provides some examples where negative numbers were successfully applied to real phenomena. The difference is that in these cases the concept of magnitude is subordinated to that of number and numbers are used as modelling tools for real-life situations.

In summary, I argued that the development of the negative number concept and the development of algebra are mutually related. The cognitive achievements, which have been emphasized as being crucial for the development of algebra, also underlie the development of the negative number concept. In particular, these are the possibility of carrying out fictive operations with indeterminate quantities in analytic ways, the “reification” (Sfard, 1994, 1995) and “objectification” (Radford, 2010) of mathematical processes, and the detachment of mathematical objects from content meanings and related formalization. According to Schubring (2005, p. 149), negative numbers “challenged the traditional first understanding of mathematics, its first ‘paradigm’ in Kuhn’s terms, its understanding of being a science of quantities: of quantities that, while being abstracted to attain some autonomy from objects of the real world, continued at the same time to be epistemologically legitimized by the latter” until a formal algebraic introduction and justification of these numbers and their operations

was achieved. Therefore, from the epistemological perspective, negative numbers seem to play a crucial role in the development of number systems aligned with the development of algebraic thinking. This is the reason, why I focus on the case of negative numbers in my analysis of the relation between the extension of number systems and the transition from arithmetic to algebra.

Psychological perspective

Although negative magnitudes are nowadays a natural part of our daily life as relative magnitudes on thermometers and other scales, research has shown that students struggle with the same obstacles that characterize the epistemology of negative numbers. Gallardo (2002) observes the same levels of acceptance of negative numbers that she found in the historical development in students understanding of the concept. However, she points out that the levels of acceptance do not follow a strict chronological order in the students and that the same student might show different levels of understanding dependent on the context of the task. In line with the historical development of negative numbers, Pierson Bishop et al. (2014) identify the magnitude-based perspective on numbers together with their understanding as cardinal numbers as an obstacle, because then negative numbers are perceived in a non-tangible way as less than nothing. This is also an obstacle for the understanding of operations with negative numbers.

Different studies show that students have difficulties with the order of integers. Students exhibit more difficulties in tasks that involve only negative numbers than in tasks with positive and negative numbers (Bofferding & Farmer, 2018). The main problem is that the size of a negative number is determined based on the absolute value or the opposite magnitude respectively. For example, students regard -10 as ‘bigger’ than -5 , because -10 is colder than -5 . This mirrors the understanding of negative numbers as opposite magnitudes, which was persistent throughout the historical development of the negative number concept. The extent to which these difficulties are shown also depends on the language used in comparison tasks (hottest/most hot/least cold vs. coldest/most cold/least hot) (Bofferding & Farmer, 2018). Schindler, Hußmann, Nilsson, and Bakker (2017) and Yilmaz and Isiksal-Bostan (2017) argue that it is important to consider students reasoning related to their answers. Their studies show that even correct answers might be based on faulty reasoning, which builds on prior experiences from the natural numbers.

Students also have difficulties with the different meanings of the minus sign. While in the set of natural numbers the minus sign only denotes subtraction, it additionally obtains a unary function as a structural signifier to denote a relative number and a symmetrical function as an operational signifier to denote the inverse in the set of integers. Vlassis (2004) shows that students do not assign any other meaning to the minus sign than that of subtraction in polynomial expressions. Their procedures of simplifying polynomials can be understood as strategies of making sense of the expressions and being able to carry out simplifications by adhering to this one meaning of the minus sign that originates from the natural numbers. When solving equations students have difficulties to find negative solutions in particular in situations with two successive signs, such as $-6 \cdot x = 24$ (Vlassis, 2008).

In summary, as in the case of the transition from natural numbers to fractions, a natural number bias is also apparent at the transition from natural numbers to integers. The empirical findings of students’ difficulties in understanding the negative number concept mirror the obstacles that characterize the

epistemological development of the negative number concept. However, the studies aiming at identifying students' obstacles vary in the degree, in which they consider students' prior experiences when learning negative numbers. The participants of many studies already learned integer arithmetic. Consequently, how they were introduced to negative numbers might have an effect on their understanding of them. In order to unveil continuities and discontinuities in the learning of the number concept, it would be important to understand how the obstacles that students experience in the learning of the negative number concept relate to the way they have been introduced to the concept and to their prior experiences in the set of natural numbers. Referring to the results from the epistemological analysis, the effects of early algebra on the learning of the negative number concept would be a matter of particular interest. However, studies analyzing students' understanding of negative numbers usually do not control for prior experiences.

Pedagogical perspective

In the epistemological analysis I have shown that there are parallels in the development of algebraic thinking and the negative number concept. Therefore, it seems natural to align the teaching and learning of the extension from natural numbers to integers with ideas of algebraic thinking. From the psychological perspective, it is not yet clear, if the teaching and learning of the negative number concept aligned with ideas of algebraic thinking has positive effects on students' understanding of the concept.

Algebraic thinking is promoted in mathematics curricula for the elementary grades across the world and thus has become an important goal in the teaching and learning of natural number arithmetic (Cai, Ng, & Moyer, 2011; Venkat et al., 2018). The vast majority of tasks, learning trajectories and studies related to algebraic thinking is carried out in the domain of natural numbers. Only rarely are integers and other number systems considered related to algebraic thinking. As already mentioned in the introduction, the scientific discourses on the extension of number systems and on algebraic thinking only rarely seem to be related to each other.

Approaching the transition from natural numbers to integers from a pedagogical perspective, I seek to answer the question how the teaching of the transition from natural numbers to integers could be aligned with the teaching of algebraic thinking. In my presentation, I focus on two aspects: 1) didactic models, which align the extension of number systems and algebraic thinking; and 2) number sense as an important goal related to natural number arithmetic and algebraic thinking.

Didactic models for integers and algebraic thinking

Within the scope of this article, I can only briefly sketch my understanding of didactic models. Space does not allow to elaborate on the rich theory behind it. I refer to an understanding of didactic models as representations of abstract mathematical concepts or structures. Thus, they reflect essential aspects of the mathematical concepts or structures. By allowing students to act upon the tangible or symbolically represented mathematical objects, they are used as tools in the meaning of cultural artifacts (Wartofsky, 1979; Wertsch, 1998) to foster students' conceptual development. I adopt the broad notion of models in Realistic Mathematics Education, in which models have different manifestations. From this perspective hands-on-materials, sketches, paradigmatic situations, schemes, or diagrams can serve as models (Van den Heuvel-Panhuizen, 2003). An important aspect

with regard to transitions is that didactic models need to be flexible in order to be applied to more advanced, sophisticated or abstract levels and thus support vertical mathematization (Van den Heuvel-Panhuizen, 2003).

Different categorizations of didactic models for integers have been suggested. Janvier (1983) distinguishes number-line-models and equilibrium models. While number-line models depict negative numbers and related operations on one continuous number line, equilibrium models introduce two separate (magnitude) representations for positive and negative numbers, e.g. black and red stones. These equilibrium models refer to the meaning of negative numbers as opposite quantities. Operations in equilibrium models are based on the principle of compensation between positive and negative numbers, i.e. the neutralization of equal amounts of opposites, e.g. of black and red stones. Another categorization of didactic models for integers has been suggested by Steinbring (1994). He distinguishes three categories: 1) real-life context as modelling structures; 2) models based on geometric or arithmetic permanence; 3) models providing autonomous representations of negative numbers. Temperatures, assets and depths, elevation, and the elevator model are typical examples of the first category. Freudenthal (1983) was a proponent of models of the second category, which aim to provide plausible reasons for the expansion of rules from the natural numbers to integers. The two categories distinguished by Janvier (1983) both belong to Steinbring's (1994) third category.

As Fischbein (2002) points out, there is no didactic model of negative numbers, which at the same time is intuitive and consistently represents all the algebraic properties of negative numbers. A model, which consistently represents the algebraic properties of negative numbers always needs to build on artificial conventions. Therefore, research has tried to identify the affordances and constraints of particular models in learning integer arithmetic (Hativa & Cohen, 1995; Linchevski & Williams, 1999; Stephan & Akyuz, 2012). Many researchers prefer the number line model for representing operations with integers (Altıparmak & Özdoğan, 2010; Bruno & Martinon, 1999; Hativa & Cohen, 1995). Other research highlights the power and importance of contextual knowledge from real-life situations for the understanding of negative numbers (e.g. Linchevski & Williams, 1999; Stephan & Akyuz, 2012). However, in real-life situations the understanding of negative numbers as opposite magnitudes is also identified as an obstacle (Schindler & Hußmann, 2013). Students need well developed mental networks that relate the opposite magnitudes and their order (Schindler & Hußmann, 2013; Yilmaz & Isiksal-Bostan, 2017).

Due to the artificial conventions that are necessary to develop didactic models for negative numbers (Fischbein, 2002), there is a tendency to develop games (e.g. Hattermann & vom Hofe, 2015; Linchevski & Williams, 1999) and artificial contexts (Altıparmak & Özdoğan, 2010; Streefland, 1996) as didactic models. As opposed to real-life contexts, artificial contexts and games facilitate the implementation of formal rules. On the contrary, most recent textbooks introduce negative numbers in real-life contexts such as temperature, assets and debts, or elevation in order to support the understanding of the negative number concept (Whitacre et al., 2015). Whitacre et al. (2015) show that students solve problems in the context of assets and debts without using negative numbers, but most of them were capable to relate negative numbers to the context if asked to do so.

Only rarely are didactical models for integers discussed in terms of their affordances to foster algebraic thinking. A few examples are Chiappini (2011); Gallardo (2002); Peled and Carraher (2008); Rezat (2014); and Schumacher and Rezat (in press). These authors exploit the potential of particular didactic models for the learning of integers aligned with algebraic thinking. Linchevski and Williams (1999) do not explicitly relate to algebraic thinking, but address reification as a main problem of learning integers, which was shown as being equally important for both, algebraic thinking and understanding the negative number concept. Therefore, their approach is also relevant in the present context. I will exemplify the different approaches by providing an example of each.

Gallardo (2002) builds on the historical-critical method as described by Filloy, Puig, and Rojano (2008). This approach is characterized by recurrent movements between the analysis of historical texts and empirical work in the classroom. Learning sequences are developed based on the historical analysis of the development of concepts. In her study, Gallardo (2002) uses word problems from historical sources, e.g. D'Alembert's problem.

Peled and Carraher (2008) criticize that most word problems, which involve negative numbers do not require the formal rules for manipulating negative numbers and consequently can be solved correctly while circumventing operations with negative numbers. Their main approach may be characterized by generalizing arithmetic problems in the realm of real-life contexts as modeling structures. They adjust problems using real-life contexts in order to foster algebraic thinking when learning integers and illustrate how these algebraic problems are more suited than arithmetic problems to promote meaningful learning of negative numbers.

An example from Peled and Carraher (2008, p. 309f) may illustrate their approach. The example juxtaposes two formulations of the same problem: an arithmetical formulation and an algebraic formulation.

An arithmetical trip: Anne drove 40 kilometers north from her home to an out of town meeting. She then drove back going 60 kilometers out to another meeting. After both meetings were over, she called home asking her husband, Ben to join her.

- a) How far will Ben have to go and in what direction?
- b) Write an expression for writing the length of Bens' trip.

An algebraic trip: Anne drove *a certain number of* kilometers north from her home to an out of town meeting. She then drove back going 60 kilometers out to another meeting. After both meetings were over, she called home asking her husband, Ben to join her.

- a) Write an expression for writing the length of Bens' trip.
- b) *Could Anne have driven less than 60 kilometers north on her first trip? If not, explain why. If she could have, give an example and explain its meaning.*

The example shows that the main idea is to formulate real-life problems in a generalized way in order to foster algebraic solutions which comprise negative numbers. Referring back to my epistemological analysis, their algebraic didactical model seems to be closer to the epistemological roots of negative numbers than the arithmetical counterpart. There, I pointed out that negative numbers became meaningful in the context involving subtractions with variables such as $x - 60$.

Chiappini (2011) exemplifies how the number line model can be used in a digital environment to foster algebraic thinking. He presents the algebraic line in the digital tool AlNuSet as a didactic model, which is supposed to mediate reification (Sfard, 1994) or objectification (Radford, 2010) of negative numbers in the context of the operation $a - b$. Different values of a and b can be chosen by dragging the corresponding points on the number line. The corresponding value of the expression $a - b$ is shown by the system as a point on the number line (Fig. 2).

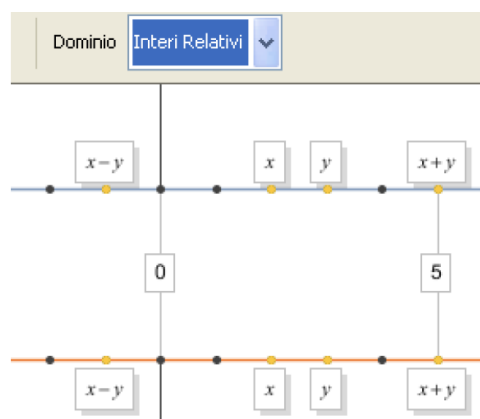


Fig 2: Algebraic line from AlNuSet (Chiappini, 2011, p. 433)

This didactical model focuses on the core operation, which led to the introduction of negative numbers in the history of mathematics and offers a representation for the result. However, it is not clear how this model is to be extended to other operations with integers.

Linchevski and Williams (1999) use the double abacus related to a real-life problem and a dice game. They conclude that by recording scores of a dice game on the double abacus and by operating on them „integers are encountered as objects in social activity, before they are symbolized mathematically, thus intuitively filling the gap formerly considered a major obstacle to reification“ (Linchevski & Williams, 1999, p. 144).

Rezat (2014) exploits the potential of a model building on the permanence principle. In an ongoing design research project, Rezat (2014) and Schumacher & Rezat (in press) developed a learning trajectory for the learning of integers and the operations with them. In the learning trajectory, they aim to implement a didactical model based on the permanence principle building on pattern generalization tasks. In this learning trajectory, negative numbers are introduced through the idea of counting backwards beyond zero. Based on this idea and the representation of negative numbers on the number line, the order of integers and the operations with integers are consecutively introduced in the following order:

1. Introduction of negative numbers
2. Order of negative numbers
3. Subtraction of positive numbers from negative numbers
4. Addition
5. Subtraction of negative numbers from negative numbers
6. Multiplication

Each section has an analogous structure. It begins with pattern generalization tasks followed by analyzing and exploring task relations within and among operations. Finally, the rules of calculating with integers are abstracted from these explorations. I will provide a more detailed account of this structure using the example of subtracting negative numbers.

Each chapter starts with pattern generalization tasks such as represented in Fig. 3.

$$\begin{array}{rcl}
 \text{a)} & 3 - 2 & = \underline{\quad} \\
 & 3 - 1 & = \underline{\quad} \\
 & 3 - 0 & = \underline{\quad} \\
 & 3 - \underline{\quad} & = \underline{\quad} \\
 & 3 - \underline{\quad} & = \underline{\quad} \\
 & 3 - \underline{\quad} & = \underline{\quad} \\
 & & \dots
 \end{array}
 \qquad
 \begin{array}{rcl}
 \text{e)} & 3 - (-1) & = \underline{\quad} \\
 & 2 - (-1) & = \underline{\quad} \\
 & 1 - (-1) & = \underline{\quad} \\
 & \underline{\quad} - (-1) & = \underline{\quad} \\
 & \underline{\quad} - (-1) & = \underline{\quad} \\
 & \underline{\quad} - (-1) & = \underline{\quad}
 \end{array}$$

Fig. 3: Pattern generalization tasks for the subtraction of integers

Pattern generalization tasks are widely incorporated in German textbooks for primary level. The aim of these tasks is to foster students' recognition of patterns and their understanding of number relations. By generalizing the patterns, students can discover basic rules of arithmetic, e.g. that a difference remains constant when both, minuend and subtrahend are lowered or increased by the same number. Pattern generalization tasks are widely acknowledged to foster algebraic thinking (Radford, 2008; Rivera, 2013). Freudenthal (1983) also proposed to use them for learning the operations with integers. Although they are already used in this context, their full potential has only rarely been exploited. In their learning trajectory, Rezat (2014) and Schumacher & Rezat (in press) make intensive use of these tasks in order to support the learning of integer arithmetic aligned with algebraic thinking.

Students are supposed to analyze the relation of the tasks, complete the empty fields in the tasks, solve the tasks, and describe the structure of the pattern. The first three tasks in Fig. 3 a) should be easily solvable for students since they ask students to perform a simple natural number subtraction. Whereas in the fourth task, students encounter the subtraction of a negative number from another number for the first time. It is expected that students draw on their prior knowledge of this task type and derive the solution of this unfamiliar task from the pattern that the minuend remains constant, the subtrahend is lowered by one, and consequently, the result increases by one. In these patterns, students encounter the difficult situations, which incorporate two successive signs (Vlassis, 2008). Drawing on the structure of the pattern, they should be able to conjecture that $3 - (-1)$ equals 4. In that, the prior knowledge of the task type provides a tool for solving tasks involving the subtraction of negative numbers. After more exploration and related reflection, a conjecture about the rule for the subtraction of negative numbers that is consistent with their prior knowledge should be possible. Deeper reflection reveals also new insights, such as that subtraction does not always lower the result. In other structures of task sequences students can encounter the different cases of the subtraction of negative numbers, such as the subtraction of a negative number from a negative number as shown in Fig. 3 e).

In our empirical investigation of students' behavior when working on these tasks we find both, students who solve the tasks correctly based on the pattern (Fig. 4, left) and students, who solve each

task separately and show a natural number bias, which relates to the lowering effect of subtraction (Fig. 4, middle and right):

$3 - 2 = 1$	$3 - 2 = 1$	$3 - 2 = 1$
$3 - 1 = 2$	$3 - 1 = 2$	$3 - 1 = 2$
$3 - 0 = 3$	$3 - 0 = 3$	$3 - 0 = 3$
$3 - (-1) = 4$	$3 - (-1) = 4$	$3 - (-1) = -4$
$3 - (-2) = 5$	$3 - (-2) = 5$	$3 - (-2) = -5$
$3 - (-3) = 6$	$3 - (-3) = 6$	$3 - (-3) = -6$

Fig. 4. Three exemplary student solutions of the task in Fig. 3.

After completing these pattern generalization tasks students are supposed to transfer these tasks into a table such as depicted in Fig. 5.

-																	
						5-0 =5	5-1 =4	5-2 =3	5-3 =2	5-4 =1	5-5 =0	...					
	4-(-5) =	4-(-4) =	4-(-3) =	4-(-2) =	4-(-1) =	4-0 =4	4-1 =3	4-2 =2	4-3 =1	4-4 =0	4-5 =-1	...					
						3-0 =3	3-1 =2	3-2 =1	3-3 =0	3-4 =-1	3-5 =-2	...					
						2-0 =2	2-1 =1	2-2 =0	2-3 =-1	2-4 =-2	2-5 =-3	...					
						1-0 =1	1-1 =0	1-2 =-1	1-3 =-2	1-4 =-3	1-5 =-4	...					
						0-0 =0	0-1 =-1	0-2 =-2	0-3 =-3	0-4 =-4	0-5 =-5	...					
							-1-0 =-1	-1-1 =-2	-1-2 =-3	-1-3 =-4	-1-4 =-5	-1-5 =-6	...				
								-2-0 =-2	-2-1 =-3	-2-2 =-4	-2-3 =-5	-2-4 =-6	-2-5 =-7	...			
									-3-0 =-3	-3-1 =-4	-3-2 =-5	-3-3 =-6	-3-4 =-7	-3-5 =-8	...		
										-4-0 =-4	-4-1 =-5	-4-2 =-6	-4-3 =-7	-4-4 =-8	-4-5 =-9	...	
											-5-0 =-5	-5-1 =-6	-5-2 =-7	-5-3 =-8	-5-4 =-9	-5-5 =-10	...
	⋮	⋮	⋮	⋮	⋮	⋮	⋮	⋮	⋮	⋮	⋮	⋮	⋮				

Fig. 5: Subtraction table for negative numbers

The table shown in Fig. 5 is an extension of the rotated diagram shown in Fig. 6 to the negative case. Tables such as the one shown in Fig. 6 are recommended by German mathematics educators in order to display the relations between all the tasks with summands up to 10 and to support effective memorization of the basic tasks in the early primary grades (Schipper, Ebeling, & Dröge, 2015; Wittmann & Müller, 1997). The structure of the table is supposed to foster students' understanding

of task relations. Based on their understanding of this structure, students should be able to derive the result of a task from a task, which is memorized as a basic fact. For example, the solution of the task $5 + 4$ might be derived from the (memorized) doubling task $5 + 5$ by diminishing the result by one, since one of the summands is also diminished by one.

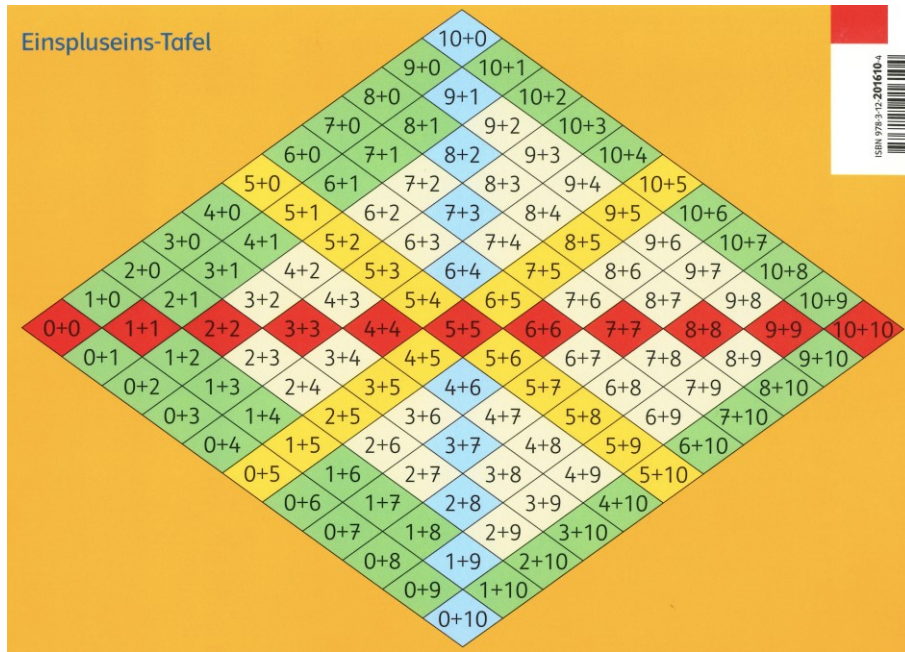


Fig. 6: Basic addition-table (Wittmann & Müller, 2012)

Similarly, students are supposed to complete the table in Fig. 5 by drawing on number relations and thus deriving the contents of the empty fields from adjacent fields. Again, the tasks relate to familiar tasks from the set of natural numbers and students can relate the “new” numbers to their prior knowledge by relying on number relations.

In order to explicate the rules for subtracting negative numbers, students explore number relations in excerpts from different tables as shown in Fig. 7.

$5 - (-5)$ = 10	$5 - (-4)$ = 9	$5 - (-3)$ = 8
$4 - (-5)$ = 9	$4 - (-4)$ = 8	$4 - (-3)$ = 7
$3 - (-5)$ = 8	$3 - (-4)$ = 7	$3 - (-3)$ = 6

$5 + 3$ = 8	$5 + 4$ = 9	$5 + 5$ = 10
$4 + 3$ = 7	$4 + 4$ = 8	$4 + 5$ = 9
$3 + 3$ = 6	$3 + 4$ = 7	$3 + 5$ = 8

Fig. 7: Comparison of subtraction and addition table excerpts

By comparing tasks and results, they can find, for example, that the two tasks $5 - (-5)$ and $5 + 5$ both equal ten. By exploring and analyzing adjacent tasks they can identify the same phenomenon. Therefore, they can conjecture that $5 - (-5) = 5 + 5$. After confirming this relation with more tasks,

they are asked to generalize their findings and formulate a rule for the subtraction of negative numbers.

The learning trajectory by Rezat (2014) and Schumacher and Rezat (in press) was evaluated in a comparative study with a learning trajectory based on real-life contexts as modelling structures. Results are going to be published elsewhere.

Comparing the presented didactical models that introduce negative numbers aligned with algebraic thinking reveals that all of them relate to important cognitive achievements in the epistemology of negative numbers. Chiappini (2011) directly relates to the generalization of the expression $a - b$ and its representation on the number line, which played a crucial role in the epistemological development of negative numbers. Gallardo (2002) uses historical problems and Peled and Carraher (2008) argue for generalizations of word problems. As was shown in the epistemological analysis, problems of this type and their solution played an important role in the historical development of negative numbers. Rezat (2014) and Schumacher and Rezat (in press) relate to the permanence principle, which was the cognitive achievement that led to the formal understanding of negative numbers and their final acceptance as numbers.

While Chiappini (2011) and Peled and Carraher (2008) only present some isolated examples, which might be incorporated in a learning trajectory for negative numbers, Gallardo (2002) as well as Schumacher and Rezat (in press) present didactic models, which consistently make use of one core idea to foster the learning of negative numbers aligned with algebraic thinking.

The epistemological analysis has shown that it was crucial in the development of the negative number concept to overcome the understanding of negative numbers as magnitudes. The understanding of negative numbers as opposite magnitudes was persistent whenever negative numbers appeared in the solution of real-life-problems. It was not until the formalization of the number concept in the 19th century that negative numbers were accepted as autonomous quantities. Therefore, it is questionable if the teaching of the negative number concept solely based on real-life contexts as modelling structures is an appropriate approach to develop an algebraic understanding of negative numbers. According to genetic epistemology it might be appropriate to introduce negative numbers in such contexts, but it equally seems important to proceed towards an algebraic understanding of negative numbers and their operations based on the permanence principle as Rezat (2014) and Schumacher and Rezat (in press) suggest. However, learning trajectories that coherently align the development of the negative number concept and algebraic thinking are still missing in the research literature.

Number sense

So far, I have analyzed the epistemological relation between the negative number concept and algebra as well as didactic models for negative numbers that explicitly relate to algebraic thinking. I will now turn to *number sense*, a construct that is of interest for the scope of this article for two reasons: 1. Like early algebra, number sense usually relates to children's abilities with natural numbers and is rarely used in the context of other number systems; 2. Number sense and algebraic thinking share some commonalities, which are rarely related. In order to unveil continuities and discontinuities in the learning of the number concept, I will firstly elaborate on the question, whether it makes sense to

consider number sense in other number domains. Secondly, I will briefly analyze the relation between number sense and algebraic thinking.

The development of number sense is a commonly shared goal for the learning of natural numbers. It is mentioned about 50 times in the publication of the 23rd ICMI Study on whole numbers in the primary grades (Bartolini Bussi & Hua Sun, 2018). Many papers in TWG02 “Arithmetic and number systems” at CERME stress that the presented research is devoted to the development of number sense.

The very *number sense* is used to denote different concepts (Rezat & Rye Ejersbo, 2018). Number sense in the meaning that is commonly shared in the psychological community refers to a persons’ foundational innate core systems to process quantities. Verschaffel elaborated on the facets of this psychological notion of number sense in his plenary talk at CERME 10 (Verschaffel, Torbeyns, & De Smedt, 2017). In mathematics education, number sense broadly refers to “the well-organized conceptual network that enables one to relate number and operation properties and to solve number problems in flexible and creative ways” (Sowder, 1992, p. 381).

There is a fundamental difference between the two perspectives. While the psychological perspective considers children’s innate abilities, which are not subject to learning, the perspective on number sense in mathematics education relates to abilities that children can develop through learning. Sayers and Andrews (2015) integrate three different perspectives on number sense and offer a model that comprises different conceptualizations of number sense at different stages in children’s learning history. In this paper, I refer to the didactical perspective on number sense.

An aspect that has been discussed repeatedly in TWG02 at CERME related to number sense is flexible and adaptive use of strategies in mental calculation (Carvalho & da Ponte, 2013; Morais & Serrazina, 2013; Rezat & Rye Ejersbo, 2018). Flexibility and adaptiveness in mental calculation require a deep understanding of number and operation relationships and knowledge of basic facts. These are core aspects of number sense (Threlfall, 2002; Rathgeb-Schnierer & Green, 2013). Therefore, number sense is regarded as both, a prerequisite and a goal for flexible and adaptive strategy use in mental calculation (Rezat & Rye Ejersbo, 2018).

Number sense and flexible and adaptive mental calculation usually relate to children’s abilities related to natural numbers. According to the definition by McIntosh, Reys, and Reys (1992) it seems desirable to develop number sense in other number domains. In their framework of number sense, McIntosh et al. (1992) include the understanding of the effect of operations with fractions and decimals. However, flexible mental calculation and number sense have been rarely investigated in other number domains. A slightly increasing interest in these issues related to fractions is noticeable (Markovits & Pang, 2007), which was also discussed in TWG02 at CERME (e.g. Carvalho & da Ponte, 2013). In terms of mental calculation related to number sense these studies differentiate between rule-based or instrumental / procedural strategies and number-sense or conceptual strategies, which are based on equivalence, numerical relationships and properties of operations (Lemonidis, Tsakiridou, & Meliopolou, 2018; Yang, Hsu, & Huang, 2004). Reys, Reys, Nohda, & Emori (1995) and Carvalho & da Ponte (2013) find that students tend to apply rule based strategies, where students perform the formal rule mentally. On the contrary, Yang et al. (2004) show in an intervention study how students are able to develop number-sense mental calculation strategies, which are based on

equivalence, numerical relationships and properties of operations. Rezat (2011) also explored students' strategies in mental calculation tasks with integers. He also finds that students transform the problem with integers into a problem with natural numbers and determine the sign of the result separately applying a procedural and rule-based strategy for calculation with integers. Consequently, all mental calculation tasks including integers were solved referring to mental calculation strategies from the set of natural numbers.

These findings give rise to the question of the relevance of mental calculation in other number sets than the natural numbers. If mental calculation in other number sets is reduced to the mental application of the rules for calculating in these domains and by transformation to problems with natural numbers the relevance for fostering number sense has to be questioned. However, Yang et al.'s findings indicate that it is possible to foster students' number-sense based mental calculation strategies related to fractions. Further investigation of mental calculation strategies, which are associated with number sense is needed. In general, the meaning and conceptualization of number sense related to fractions and integers requires further clarification and differentiation.

I will now turn to the relation of *algebraic thinking* and *number sense*. These two constructs are rarely related. While number sense is situated in the discourse of the development of the number concept, algebraic thinking is situated in the discourse of the development of algebra. However, in the latter context, constructs such as *structure sense* (Hoch & Dreyfus, 2004, 2006) and *symbol sense* (Arcavi, 1994, 2005), which seem to relate to number sense, have been suggested. Within the scope of this article, I am not able to analyze the relationship between number sense, structure sense, and symbol sense. I can only briefly outline some similarities between number sense and algebraic thinking.

McIntosh et al. (1992) have provided a framework of generally agreed components of basic number sense, which gives an account of the richness of the construct. This framework distinguishes between three major areas of number sense: 1. Knowledge of and facility with numbers; 2. Knowledge of and facility with operations; and 3. Applying knowledge of and facility with numbers and operations to computational settings. Each of these areas is divided into several categories.

Among the categories that characterize basic number sense we find several aspects that are repeatedly used to characterize algebraic thinking. In particular, these are related to knowledge of and facility with operations. A number of studies on early algebra focuses on students understanding of operations in terms of relational thinking (Bastable & Schifter, 2008; Carpenter, Colm, & Franke, 2003; Empson, Levi, & Carpenter, 2011; Russell, Schifter, & Bastable, 2011), i.e. "using fundamental properties of number and operations to transform mathematical expressions rather than simply calculating an answer following a prescribed sequence of procedures" (Carpenter, Levi, Franke, & Zeringue, 2005). An example, Carpenter et al. (2003, p. 4) provide to illustrate relational thinking is Robin's solution of the open number sentence $18 + 27 = [] + 29$: "29 is two more than twenty 27, so the number in the box has to be two less than 18 to make the two sides equal. So it's 16". This way of applying associativity in this context is exactly what would be expected from a child, who exhibits number sense.

Due to the similarities of number sense and algebraic thinking in terms of relational thinking, Pittalis, Pitta-Pantazi, and Christou (2016, 2018) argue that number sense has an innate algebraic dimension.

They have empirically validated a model of the structure and development of basic number sense by incorporating an algebraic dimension, which refers to algebraic arithmetic and quantitative relations. In their study, they validate their model, in which number sense is conceptualized as a second order theoretical construct made up of three first order latent factors, namely (a) elementary number sense, (b) conventional arithmetic, and (c) algebraic arithmetic.

This is a first and important step in understanding the relationship between number sense and algebraic thinking. Further research needs to deepen this understanding by also taking constructs like structure sense and symbol sense and their relation to number sense into consideration.

Conclusions

I have focused on the relationship between the extension from natural numbers to integers and the transition from arithmetic to algebra. From an epistemological perspective on this transition, I have shown that the development of the negative number concept is closely linked to core algebraic ideas, such as indeterminate objects and their analytic treatment, reification and objectification, and a detachment from content meanings in order to proceed to a formalized view.

The psychological analysis showed that the same obstacles characterize students' learning of the negative number concept regardless of their prior knowledge and their prior experiences in the set of natural numbers. So far, the effects of early algebra on students' understanding of negative numbers has not been investigated.

The analysis from the pedagogical perspective has shown that two important goals related to the learning of natural numbers, namely the development of algebraic thinking and the development of number sense, are rarely considered in the domain of integers. I presented a few didactical models that have been suggested in the research literature in order to align the learning of integers and the development of algebraic thinking. However, the alignment seems to be quite loose so far and is rarely developed into coherent learning trajectories for the learning of integers. An analysis of didactic models of negative numbers and their potential to foster algebraic thinking in textbooks might complement the analysis and draw a more comprehensive picture.

In the introduction, I mentioned that the extension of number systems and the transition from arithmetic to algebra are two long-term developments that require a careful construction of the curriculum and related learning-trajectories. Many scholars stress the importance of curricular coherence in the construction and implementation of curricula in general (Confrey, Gianopulos, McGowan, Shah, & Belcher, 2017) and in particular related to goals of the number curriculum (Bruno & Martinon, 1999; Van den Heuvel-Panhuizen, 2008). Curricular coherence is defined differently according to the principles that are used in order to provide it (Confrey et al., 2017). While, for example, Bruner (1960) and Schmidt, Wang, and McKnight (2005) refer to the structure of the discipline as the means to provide curricular coherence, Confrey et al. (2017) argue for learner-centered curricular coherence, which they define as

an organizational means to promote a high likelihood that each learner traverses one of many possible paths to understanding target disciplinary ideas. The goal is that students achieve demonstrable and justifiable proficiency in the meanings, relationships, and utility of those target

ideas by building on and continuously broadening and modifying their ideas and experiences. (p. 719)

Looking at the curriculum in terms of the extension of number systems and the transition from arithmetic to algebra yields that there is a close relation of arithmetic and algebraic thinking in the set of natural numbers. However, this close alignment does not seem to be coherently continued in the extension of number systems. Further development of algebraic thinking in the domain of integers (and also in the domain of fractions) seems to be almost suspended. In terms of curricular coherence, it could be important for the learning of the negative number concept and for the learning of algebra to continuously foster algebraic thinking throughout the extension of number systems. Continuously unfolding number sense aligned with algebraic thinking throughout the extension of number systems might also be a means to provide continuity in a content domain where students' experience of discontinuity has been substantiated by a large body of research.

References

- Altıparmak, K., & Özdoğan, E. (2010). A study on the teaching of the concept of negative numbers. *International Journal of Mathematical Education in Science and Technology*, 41(1), 31–47.
- Arcavi, A. (1994). Symbol sense: Informal sense-making in formal mathematics. *For the Learning of Mathematics*, 14(3), 24–35.
- Arcavi, A. (2005). Developing and using symbol sense in mathematics. *For the Learning of Mathematics*, 25(2), 42–47.
- Bartolini Bussi, M. G., & Hua Sun, X. (Eds.). (2018). *Building the foundation: Whole numbers in the primary grades. The 23rd ICMI Study*. Cham: Springer.
- Bastable, V., & Schifter, D. (2008). Classroom stories: Examples of elementary students engaged in early algebra. In J. J. Kaput, D. W. Carraher, & M. L. Blanton (Eds.), *Algebra in the early grades* (pp. 165–184). New York: Routledge.
- Bofferding, L., & Farmer, S. (2018). Most and least: Differences in integer comparisons based on temperature comparison language. *International Journal of Science and Mathematics Education*, 17(3), 545–563.
- Bruner, J. S. (1960). *The process of education*. Cambridge: Harvard University Press.
- Bruno, A., & Martinon, A. (1999). The teaching of numerical extensions: the case of negative numbers. *International Journal of Mathematical Education in Science and Technology*, 30(6), 789–809.
- Cai, J., Ng, S. F., & Moyer, J. C. (2011). Developing students' algebraic thinking in earlier grades: Lessons from china and singapore. In J. Cai & E. Knuth (Eds.), *Early algebraization: A global dialogue from multiple perspectives* (pp. 25–41). Berlin: Springer.
- Carpenter, T. P., Colm, T., & Franke, M. L. (2003). *Thinking mathematically: Integrating arithmetic & algebra in elementary school*. Portsmouth: Heinemann.

- Carpenter, T. P., Levi, L., Franke, M. L., & Zeringue, J. K. (2005). Algebra in elementary school: Developing relational thinking. *Zentralblatt für Didaktik der Mathematik*, 37(1), 53–59.
- Carvalho, R., & da Ponte, J. P. (2013): Students' mental computation strategies with fractions. In B. Ubuz, C. Haser, & M. A. Mariotti (Eds.), *Proceedings of the Eighth Congress of the European Society for Research in Mathematics Education (CERME8, 6–10 February 2013)* (pp. 283–292). Ankara: Middle East Technical University.
- Chiappini, G. (2011). The role of technology in developing principles of symbolical algebra. In M. Pytlak, T. Rowland, & E. Swoboda (Eds.), *Proceedings of the Seventh Congress of the European Society for Research in Mathematics Education (CERME7, 7–13 February 2011)* (pp. 429–439). Rzeszów, Poland: University of Rzeszów.
- Confrey, J., Gianopulos, G., McGowan, W., Shah, M., & Belcher, M. (2017). Scaffolding learner-centered curricular coherence using learning maps and diagnostic assessments designed around mathematics learning trajectories. *ZDM – Mathematics Education*, 49(5), 717–734.
- Damerow, P. (2007). The material culture of calculation. In U. Gellert & E. Jablonka (Eds.), *Mathematisation and demathematisation: Social, philosophical and educational ramifications* (pp. 19–56). Rotterdam: Sense.
- Empson, S. B., Levi, L., & Carpenter, T. P. (2011). The algebraic nature of fractions: Developing relational thinking in elementary school. In J. Cai & E. Knuth (Eds.), *Early algebraization* (pp. 409–428). Berlin: Springer.
- Filloy, E., Puig, L., & Rojano, T. (2008). *Educational algebra: A theoretical and empirical approach*. New York: Springer.
- Fischbein, E. (2002). *Intuition in science and mathematics: An educational approach*. New York: Kluwer.
- Freudenthal, H. (1983). *Didactical phenomenology of mathematical structures*. Dordrecht: Reidel.
- Gallardo, A. (2002). The extension of the natural-number domain to the integers in the transition from arithmetic to algebra. *Educational Studies in Mathematics*, 49(2), 171–192.
- Glaser, G. (1981). Epistémologie des nombres relatifs. *Recherches en Didactique des Mathématiques*, 2(3), 303–346.
- Hativa, N., & Cohen, D. (1995). Self learning of negative number concepts by lower division elementary students through solving computer-provided numerical problems. *Educational Studies in Mathematics*, 28(4), 401–431.
- Hattermann, M., & vom Hofe, R. (2015). Students' argumentation schemes in terms of solving tasks with negative numbers. In K. Krainer & N. Vondrová (Eds.), *Proceedings of the Ninth Congress of the European Society for Research in Mathematics Education (CERME9, 4–8 February 2015)* (pp. 281–287). Prague: Charles University, Faculty of Education and ERME.
- Hefendehl-Hebeker, L. (1991). Negative numbers: Obstacles in their evolution from intuitive to intellectual constructs. *For the Learning of Mathematics*, 11(1), 26–32.

- Hefendehl-Hebeker, L., & Rezat, S. (2015). Algebra: Leitidee Symbol und Formalisierung. In R. Bruder, L. Hefendehl-Hebecker, B. Schmidt-Thieme, & H.-G. Weigand (Eds.), *Handbuch der Mathematikdidaktik* (pp. 117–148). Berlin: Springer.
- Hoch, M., & Dreyfus, T. (2004). Structure sense in high school algebra: The effect of brackets. In M. J. Hoines & A. B. Fuglestad (Eds.), *Proceedings of the Annual Meeting of the International Group for the Psychology of Mathematics Education (PME) (28th, Bergen, Norway, July 14–18, 2004)* (Vol. 3, pp. 49–56). Bergen, Norway: Bergen University College.
- Hoch, M., & Dreyfus, T. (2006). Structure sense versus manipulation skills: An unexpected result. In J. Novotná, H. Moraová, M. Krátká, & N. a. Stehliková (Eds.), *Proceedings of the 30th Conference of the International Group for the Psychology of Mathematics Education* (Vol. 3, pp. 305–312). Prague: Charles University, Faculty of Education and ERME.
- Hodgen, J., Oldenburg, R., & Strømskag, H. (2018). Algebraic thinking. In T. Dreyfus, M. Artigue, D. Potari, S. Prediger, & K. Ruthven (Eds.), *Developing research in mathematics education* (pp. 32–45). London: Routledge.
- Janvier, C. (1985). Comparison of models aimed at teaching signed integers. In L. Streefland (Ed.), *Proceedings of the Ninth International Conference for the Psychology of Mathematics Education (Nordwijkerhout, The Netherlands, 22–29 July 1985)* (Vol. 1, pp. 135–140). Utrecht, The Netherlands: State University of Utrecht, Research Group on Mathematics Education and Educational Computer Centre (OW&OC), Subfaculty of Mathematics.
- Kaput, J. J. (2008). What is algebra? What is algebraic reasoning? In J. J. Kaput, D. W. Carraher, & M. L. Blanton (Eds.), *Algebra in the early grades* (pp. 5–17). New York: Lawrence Erlbaum Associates.
- Lemonidis, C., Tsakiridou, H., & Meliopolou, I. (2018). In-service teachers' content and pedagogical content knowledge in mental calculations with rational numbers. *International Journal of Science and Mathematics Education*, 16, 1127–1145.
- Linchevski, L., & Herscovics, N. (1996). Crossing the cognitive gap between arithmetic and algebra: Operating on the unknown in the context of equations. *Educational Studies in Mathematics*, 30(1), 39–65.
- Linchevski, L., & Williams, J. (1999). Using intuition from everyday life in 'filling' the gap in children's extension of their number concept to include the negative numbers. *Educational Studies in Mathematics*, 39(1), 131–147.
- Markovits, Z., & Pang, J. (2007). The ability of sixth grade students in Korea and Israel to cope with number sense tasks. In J. H. Woo, H. C. Lew, K. S. Park, & D. Y. Seo (Eds.), *Proceedings of the 31st Conference of the International Group for the Psychology of Mathematics Education* (Vol. 3, pp. 241–248). Seoul: PME.
- McIntosh, A., Reys, B. J., & Reys, R. E. (1992). A proposed framework for examining basic number sense. *For the Learning of Mathematics*, 12(3), 2–8.

- Morais, C. & Serrazina, L. (2013): Mental computation strategies in subtraction problem solving. In B. Ubuz, C. Haser, & M. A. Mariotti (Eds.), *Proceedings of the Eighth Congress of the European Society for Research in Mathematics Education (CERME8, 6–10 February 2013)* (pp. 333–342) Ankara: Middle East Technical University.
- Ni, Y., & Zhou, Y.-D. (2005). Teaching and learning fraction and rational numbers: The origins and implications of whole number bias. *Educational Psychologist*, 40(1), 27–52.
- Peled, I., & Carraher, D. (2008). Signed numbers and algebraic thinking. In J. J. Kaput, D. W. Carraher, & M. L. Blanton (Eds.), *Algebra in the early grades* (pp. 303–328). New York: Lawrence Erlbaum Associates.
- Pierson Bishop, J., Lamb, L. L., Philipp, R. A., Whitacre, I., Schappelle, B. P., & Lewis, M. L. (2014). Obstacles and affordances for integer reasoning: An analysis of children's thinking and the history of mathematics. *Journal for Research in Mathematics Education*, 45(1), 19–61.
- Pittalis, M., Pitta-Pantazi, D., & Christou, C. (2016). The development of student's early number sense. In K. Krainer & N. Vondrová (Eds.), *Proceedings of the Ninth Congress of the European Society for Research in Mathematics Education (CERME9, 4–8 February 2015)* (pp. 446–452). Prague, Czech Republic: Charles University, Faculty of Education and ERME.
- Pittalis, M., Pitta-Pantazi, D., & Christou, C. (2018). A longitudinal study revisiting the notion of early number sense: Algebraic arithmetic as a catalyst for number sense development. *Mathematical Thinking and Learning*, 20(3), 222–247.
- Radford, L. (2008). Iconicity and contraction: A semiotic investigation of forms of algebraic generalizations of patterns in different contexts. *ZDM – Mathematics Education*, 40(1), 83–96.
- Radford, L. (2010). Signs, gestures, meanings: Algebraic thinking from a cultural semiotic perspective. In V. Durand-Guerrier, S. Soury-Lavergne, & F. Arzarello (Eds.), *Proceedings of the Sixth Congress of the European Society for Research in Mathematics Education (CERME6, 28 January – 1 February 2009)* (pp. XXXIII–LIII). Lyon, France: INRP.
- Rathgeb-Schnierer, E., & Green, M. (2013): Flexibility in mental calculation in elementary students from different math classes. In B. Ubuz, C. Haser, & M. A. Mariotti (Eds.), *Proceedings of the Eighth Congress of the European Society for Research in Mathematics Education (CERME8, 6–10 February 2013)* (pp. 353–362) Ankara: Middle East Technical University.
- Reys, R. E., Reys, B. J., Nohda, N., & Emori, H. (1995). Mental computation performance and strategy use of Japanese students in grades 2, 4, 6, and 8. *Journal for Research in Mathematics Education*, 26(4), 304–326.
- Rezat, S. (2011). Mental calculation strategies for addition and subtraction in the set of rational numbers. In M. Pytlak, E. Swoboda, & T. Rowland (Eds.), *Proceedings of the Seventh Congress of the European Society for Research in Mathematics Education (CERME7, 7–13 February 2011)* (pp. 396–405). Rzeszów, Poland: University of Rzeszów.
- Rezat, S. (2014). Das Permanenzprinzip erfahren: An der 1+1-Tafel und der 1×1-Tafel das Rechnen mit negativen Zahlen operativ erkunden. *mathematik lehren* (183), 11–14.

- Rezat, S., & Rye Ejersbo, L. (2018). Number sense in teaching and learning arithmetic. In T. Dreyfus, M. Artige, D. Potari, S. Prediger, & K. Ruthven (Eds.), *Developing research in mathematics education: Twenty years of communication, cooperation and collaboration in Europe* (pp. 23–31). London: Routledge.
- Rivera, F. (2013). *Teaching and learning of patterns in school mathematics: Psychological and pedagogical considerations*. Dordrecht: Springer.
- Russell, S. J., Schifter, D., & Bastable, V. (2011). Developing algebraic thinking in the context of arithmetic. In J. Cai & E. Knuth (Eds.), *Early algebraization* (pp. 43–69). Berlin: Springer.
- Sayers, J., & Andrews, P. (2015). Foundational number sense: Summarising the development of an analytical framework. In K. Krainer & N. Vondrová (Eds.), *Proceedings of the Ninth Congress of the European Society for Research in Mathematics Education (CERME9, 4–8 February 2015)* (pp. 361–367). Prague, Czech Republic: Charles University, Faculty of Education and ERME.
- Schindler, M., & Hußmann, S. (2013). About students' individual concepts of negative integers – in terms of the order relation. In B. Ubuz, C. Haser, & M. A. Mariotti (Eds.), *Proceedings of the Eighth Congress of the European Society for Research in Mathematics Education (CERME8, 6–10 February 2013)* (pp. 373–382) Ankara: Middle East Technical University.
- Schindler, M., Hußmann, S., Nilsson, P., & Bakker, A. (2017). Sixth-grade students' reasoning on the order relation of integers as influenced by prior experience: An inferentialist analysis. *Mathematics Education Research Journal*, 29(4), 471–492.
- Schipper, W., Ebeling, A., & Dröge, R. (2015). *Handbuch für den Mathematikunterricht an Grundschulen. 1. Schuljahr*. Braunschweig: Bildungshaus Schulbuchverlage.
- Schmidt, W. H., Wang, H. C., & McKnight, C. C. (2005). Curriculum coherence: An examination of US mathematics and science content standards from an international perspective. *Journal of Curriculum Studies*, 37(5), 525–559.
- Scholz, E. (Ed.) (1990). *Geschichte der Algebra. Eine Einführung*. Mannheim: BI-Wissenschaftsverlag.
- Schubring, G. (2005). *Conflicts between generalization, rigor, and intuition: Number concepts underlying the development of analysis in 17–19th century France and Germany*. New York: Springer.
- Schumacher, J. & Rezat, S. (in press). A hypothetical learning trajectory for the learning of the rules for manipulating integers. In U. T. Jankvist, M. van den Heuvel-Panhuizen, & M. Veldhuis (Eds.), *Proceedings of the Eleventh Congress of the European Society for Research in Mathematics Education (CERME11, 6–10 February 2019)*. Utrecht, the Netherlands: Freudenthal Group & Freudenthal Institute, Utrecht University and ERME.
- Sfard, A. (1994). The gains and the pitfalls of reification—the case of algebra. *Educational Studies in Mathematics*, 26(2–3), 191–228.

- Sfard, A. (1995). The development of algebra: Confronting historical and psychological perspectives. *The Journal of Mathematical Behavior*, 14(1), 15–39.
- Sowder, J. (1992). Estimation and number sense. In D. A. Grouws (Ed.), *Handbook of research on mathematics teaching and learning* (pp. 371–389). Reston: National Council of Teachers of Mathematics.
- Steinbring, H. (1994). Symbole, Referenzkontexte und die Konstruktion mathematischer Bedeutung—am Beispiel der negativen Zahlen im Unterricht. *Journal für Mathematik-Didaktik*, 15(3–4), 277–309.
- Stephan, M., & Akyuz, D. (2012). A proposed instructional theory for integer addition and subtraction. *Journal for Research in Mathematics Education*, 43(4), 428–464.
- Streefland, L. (1996). Negative numbers: Reflections of a learning researcher. *The Journal of Mathematical Behavior*, 15(1), 57–77.
- Threlfall, J. (2002). Flexible mental calculation. *Educational Studies in Mathematics*, 50(1), 29–47.
- Tropfke, J. (1980). *Geschichte der Elementarmathematik. Band 1. Arithmetik und Algebra. Vollständig neu bearbeitet von K. Vogel, K. Reich und H. Gericke*. Berlin: Walter de Gruyter.
- Vamvakoussi, X. (2015). The development of rational number knowledge: Old topic, new insights. *Learning and Instruction*, 37, 50–55.
- Van den Heuvel-Panhuizen, M. (2003). The didactical use of models in realistic mathematics education: An example from a longitudinal trajectory on percentage. *Educational Studies in Mathematics*, 54(1), 9–35.
- Van den Heuvel-Panhuizen, M. (Ed.) (2008). *Children learn mathematics: A learning-teaching trajectory with intermediate attainment targets for calculation with whole numbers in primary school*. Rotterdam: Sense.
- Van Dooren, W., Lehtinen, E., & Verschaffel, L. (2015). Unraveling the gap between natural and rational numbers. *Learning and Instruction*, 37, 1–4.
- Venkat, H., Beckmann, S., Larsson, K., Xin, Y. P., Ramploud, A., & Chen, L. (2018). Connecting whole number arithmetic foundations to other parts of mathematics: Structure and structuring activity. In M. G. Bartolini Bussi & X. H. Sun (Eds.), *Building the foundation: Whole numbers in the primary grades: The 23rd ICMI study* (pp. 299–324). Cham: Springer.
- Verschaffel, L., Torbeyns, J., & De Smedt, B. (2017). Young children’s early mathematical competencies: Analysis and stimulation. In T. Dooley, & G. Gueudet (Eds.), *Proceedings of the Tenth Congress of the European Society for Research in Mathematics Education (CERME10, February 1–5, 2017)* (pp. 31–52). Dublin, Ireland: DCU Institute of Education and ERME.
- Vlassis, J. (2004). Making sense of the minus sign or becoming flexible in ‘negativity’. *Learning and Instruction*, 14(5), 469–484.
- Vlassis, J. (2008). The role of mathematical symbols in the development of number conceptualization: The case of the minus sign. *Philosophical Psychology*, 21(4), 555–570.

- Vosniadou, S., & Verschaffel, L. (2004). Extending the conceptual change approach to mathematics learning and teaching. *Learning and Instruction*, 14(5), 445–451.
- Wartofsky, M. W. (1979). *Models—Representation and the scientific understanding*. Dordrecht: Reidel.
- Wertsch, J. V. (1998). *Mind as action*. New York: Oxford University Press.
- Whitacre, I., Pierson Bishop, J., Lamb, L. L., Philipp, R. A., Bagley, S., & Schappelle, B. P. (2015). ‘Negative of my money, positive of her money’: Secondary students’ ways of relating equations to a debt context. *International Journal of Mathematical Education in Science and Technology*, 46(2), 234–249.
- Wittmann, E. C., & Müller, G. N. (1997). *Handbuch produktiver Rechenübungen. Band 1. Vom Einspluseins zum Einmaleins*. Stuttgart: Ernst Klett.
- Wittmann, E.-Ch.; & Müller, G. N. (2012). *Das Zahlenbuch 1*. Stuttgart: Ernst Klett.
- Yang, D.-C., Hsu, C.-J., & Huang, M.-C. (2004). A study of teaching and learning number sense for sixth grade students in Taiwan. *International Journal of Science and Mathematics Education*, 2(3), 407–430.
- Yilmaz, A., & Isiksal-Bostan, M. (2017): How middle-grade students explain ordering statements within real life situation? An example of temperature context. In T. Dooley, & G. Gueudet (Eds.), *Proceedings of the Tenth Congress of the European Society for Research in Mathematics Education (CERME10, 1–5 February 2017)* (pp. 411–418). Dublin, Ireland: DCU Institute of Education and ERME.

ERME anniversary panel on the occasion of the 20th birthday of the European Society for Research in Mathematics Education

Konrad Krainer¹, Hanna Palmér², Barbara Jaworski³, Susanne Prediger⁴, Paolo Boero⁵, Simon Modeste⁶, Tommy Dreyfus⁷, and Jana Žalská⁸

¹University of Klagenfurt, Austria, konrad.krainer@aau.at; ²Linnaeus University & Dalarna University, Sweden, hanna.palmer@lnu.se; ³Loughborough University, UK, b.jaworski@lboro.ac.uk; ⁴Technische Universität Dortmund, Germany, prediger@math.uni-dortmund.de; ⁵Università di Genova, Italy, boero@dima.unige.it; ⁶Université de Montpellier, France, simon.modeste@umontpellier.fr; ⁷Tel Aviv University, Israel, tommyd@tauex.tau.ac.il; ⁸Charles University in Prague, Czech Republic, zalska@hotmail.com

The general aim of the panel was to offer a reflection on the genesis and the contribution of the European Society for Research in Mathematics Education (ERME) to research in mathematics education, regarding its past, present and future. After a short introduction, the panel focused on three topics: The ERME society, presenting a historical and present view; YERME and YESS, highlighting history and current developments related to supporting young researchers; the ERME book, focusing on its evolution, spirit and results. Each topic started with an input by two panel members who also answered questions by participants of CERME 11 sent in advance or raised during the panel. The panel was concluded by the president and the two co-chairs of the panel.

Keywords: Europe, mathematics education, collaboration, cooperation, communication, quality, inclusion, promoting young researchers

1 Introduction (Hanna Palmer and Konrad Krainer)

An important step for establishing a European Society for Research in Mathematics Education (ERME) was done in a meeting in Osnabrück (Germany) from 2 to 4 May 1997. Representatives from 16 European countries met in Haus Ohrbeck (Figures 1 and 2). The aim was to establish a new society, ERME, that promotes communication, cooperation and collaboration in mathematics education research in Europe. It was also decided that ERME will launch periodical conferences (CERME). At CERME 1, again held in Osnabrück, from 27-30 August 1998 (coordinated by Elmar Cohors-Fresenborg and Inge Schwank), the foundation of ERME took place. In 1999, the three volumes of the first CERME proceedings were published (Schwank 1999a,b; Krainer, Goffree & Berger, 1999). In 2018, the ERME book (Dreyfus, Artigue, Potari, Prediger & Ruthven, 2018) appeared on the occasion of the 20th birthday of ERME. The ERME anniversary panel was held during CERME 11 in Utrecht (The Netherlands) in the Dom Church (Figure 3) on February 2019.



Figure 1 (E. Thoma):
Haus Ohrbeck, Osnabrück



Figure 2 (private photo):
Elmar Cohors-Fresenborg, Host



Figure 3 (free photo):
Dom Church, Utrecht

In preparation for the panel, the community was asked to send questions about ERME research, questions about ERME itself (its role, its possible activities ...) and to share memories on ERME (anecdotes, narratives, pictures ...) by using twitter or mail (Figure 4). The aim with this was to make the panel as dynamic as possible with discussions between speakers, high-level scientific content mixed with narratives and anecdotes about CERME experiences.

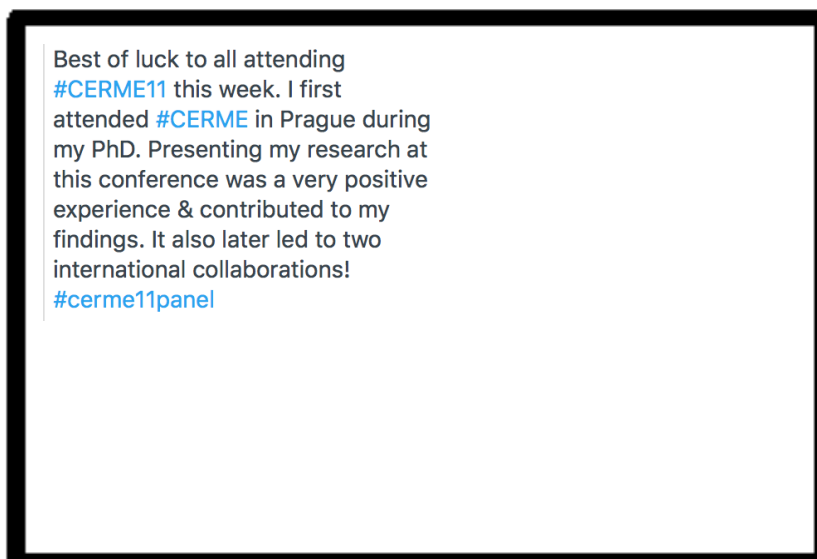


Figure 4 (H. Palmér): Examples of pre-sent tweets

Some of the anecdotes included memories from those who had participated at almost every CERME. During the introduction of the panel, those who had participated at the first CERME in Osnabrück, 1998, were asked to stand up and there were actually about 12 people. In many anecdotes, CERME was described as a conference where people met others and became friends and research colleagues. Through the years there has been a substantial number of research collaborations initiated at CERME. Many people first visited CERME during their PhD and valued the welcoming atmosphere with its dynamic mix of experienced researchers and newcomers.

After a short introduction, the panel focused on three topics: The ERME society, presenting a historical and present view; YERME and YESS, highlighting history and current developments related to supporting young researchers; the ERME book, focusing on its evolution, spirit and results. Answers to present questions were addressed in the pre-prepared presentations of the panel speakers and further questions were provided by the audience at the conference.

In the following, we elaborate on these three topics (for a summary of relevant data about ERME see also Section 10).



Figure 5 (personal photos): The first board members of ERME - Paolo Boero, Marianna Bosch, Elmar Cohors-Fresenborg, Jean-Philippe Drouhard, Konrad Krainer, Jarmila Novotná, João Pedro da Ponte, Leo Rogers and Julianna Szendrei (see details in Section 10)

2 The ERME society: A historical view (Barbara Jaworski)

Probably the first thing to say in the history of ERME is that ERME is an AMAZING success story! From early times to the present it has proved attractive to researchers throughout Europe and beyond and it has blossomed and grown.

The very first meeting in Osnabrück, in 1997, set the scene for what has followed, and the conceptualizations emerging from that meeting have been established and faithfully preserved while simultaneously developing in scale and extent.

In response to an open invitation by German colleagues, representatives from 16 European countries discussed what a European society might involve. We saw here democracy in action as the delegates from across Europe presented their ideas and debated possibilities. Clearly, we were focusing on research in Mathematics Education – our name would be ERME – European Society for Research in Mathematics Education. We wanted there to be a conference, every two years, and we wanted very strongly to support new researchers who should be the future of our society.

There was much debate about the nature of the conference. We already had a range of conferences in our community – particularly PME and ICME – the ERME conference should be different with a more European identity. We wanted a research conference, to be called CERME – Conference of ERME – to enable the sharing, understanding and working together of/on research in mathematics education: three principles emerged

- Communication with our colleagues throughout Europe
- Cooperation in and around research topics
- Collaboration in designing and doing research together

These principles quickly became known as “The Three Cs” and “The CERME Spirit”: they were the foundation on which our community was based and on which our conference developed. The conference should enable participants really to *work* on areas of research, forming research groups, with a significant amount of time to communicate their research and develop cooperative and collaborative relationships. Also, ERME should provide a means of educating and supporting young researchers and research students – bringing young researchers centrally into the community.

In the early years of ERME, an ERME board was initiated to guide developments in ERME, and the conference, CERME, was introduced to take place every two years. For young researchers in ERME, the YERME group was initiated.

The first CERME took place appropriately in the same location as our founding meeting, in Haus Ohrbeck in Osnabrück (Germany). There were around 50 participants and just seven working groups – the groups would have 12 hours for their work over the days of the conference. It was a time of getting used to this new kind of conference environment.

At the beginning of this first conference, a well-known researcher asked “what are we going to do with 12 hours? How are we going to use all this time?” At the end of the conference, she said “I am amazed. The time just disappeared as we discussed our work and debated issues in research.” It was clear that we were learning in practice about possibilities and ways of working; trying out ideas and developing (or rejecting) them in practice.

Thus, CERME was planned as a different kind of conference (from PME, ICME and others). It became a working conference with small working groups in research areas led by ‘experts’ in the field (at least 12 hours). It should be open and inclusive to all researchers in the field. It should have published proceedings of high scientific quality. There should be quality support for, and education of research students, with a dedicated day before each conference.

The importance placed on educating research students led to the provision of summer schools in years alternating with CERME. These were led by ‘experts’ in key research areas (The YESS – YERME Summer Schools) and should be open, inclusive and encouraging full participation.

Key words in planning and development were *Quality* and *Inclusion*. Principles of openness and inclusion permeated principles and practice. ALL researchers in mathematics education (from anywhere in the world) should be welcome participants – no barriers to inclusion. The working language would be English – but sincere attempts should be made to include other languages where necessary. There should be principles of high quality in scientific exchange and publication. Group leaders should ensure the highest quality of academic engagement and publication.

These principles led to issues and questions relating to practices in the working groups regarding quality and inclusion,

- Should ALL papers submitted to a group be accepted? Do principles of inclusion require this?
- What if papers are not of a sufficiently high standard? How can group leaders ensure that what is published is of the high quality we seek?

By the time of CERME 6 in Lyon, France, these issues had become central and potent. Thus, a small group from within the initiating team were tasked by the ERME board to do some research to establish the views of CERME participants. A survey was designed and conducted, and interviews were held with CERME participants. The results of this analysis exposed a wide range of views and highlighted the main issues (see Jaworski, da Ponte & Mariotti, 2011). Clearly the majority wanted to maintain both quality and inclusion, but practical suggestions were made as to how this could be possible. It became practice that most papers submitted for presentation would be accepted to include as many researchers as possible, but there would be additional reviews after the conference through which only papers of high quality would be selected for published proceedings. As CERME has grown in size beyond these early conferences, it has become necessary to review how quality and inclusion can continue to be maintained in practice.



Figure 6 (personal photos): The presidents of ERME - Jean-Philippe Drouhard, Paolo Boero, Barbara Jaworski, Ferdinando Arzarello, Viviane Durand Guerrier and Susanne Prediger (see details in Section 10)

3 The ERME society: A present view (Susanne Prediger)

20 years after the founding of ERME, we can be very happy that ERME has succeeded in establishing the three C's:

- *Communication* is consequently established in the Thematic Working Groups due to the great work of the TWG leaders and co-leaders. Even in a conference with 26 TWGs (and 8 subgroups), communication was guaranteed by the rule of “30 minutes per contribution”. Additionally, we extended the opportunities for communication by ERME Topic Conferences (ETC, see Section 10), six of them have already taken place.
- *Collaboration* was initiated and is evidenced by many joint publications among ERME members (see overview in Dreyfus et al., 2018). However, we feel that collaboration can still be fostered more.
- also *Cooperation* takes place in more stable contexts, for example in joint research and PD projects (funded by EU Horizon 2020 or Erasmus or bilateral foundations such as the German-Israeli foundation). For further deepening also the institutionalized cooperation across European countries, initiating collaboration and following it up is crucial, for the future.

Within the last twenty years, the ERME policy of inclusion and quality has successfully been installed, especially the TWG leaders and co-leaders do an enormous job in enhancing quality. During these years, inclusion has been interpreted as allowing all interested people to participate. However, ERME has not yet achieved to include all European countries, as we still have regional unbalances and emerging communities which are not yet present at the conference.

At the same time, CERME has experienced a massive growth, from 550 participants in 2013 to more than 900 in 2019 (see Figure 7). This success shows that the founders' choice to design CERME as a „thematic working space" (with the possibility of improving submitted texts before and after the conference) is very appreciated, not only in Europe, but also within the world community of mathematics educators. Among the 900 participants at CERME 11, 150 came from other continents. Thus, the founders' idea of offering CCC opportunities to researchers has been successfully spread to other continents, with the possibility of enriching exchanges. On the one hand, we can celebrate this as a huge success that more and more researchers from all over the world are interested in participating in the conference. However, *CERME's success is ERME's challenge*, as the growth of the conferences endangers both, quality and inclusion. That is why the ERME board has taken the decision that eternal growth is not desirable, and 900 participants is the maximum we can take. For the next conference, the ERME board and the IPC will develop new review procedures for selecting papers.

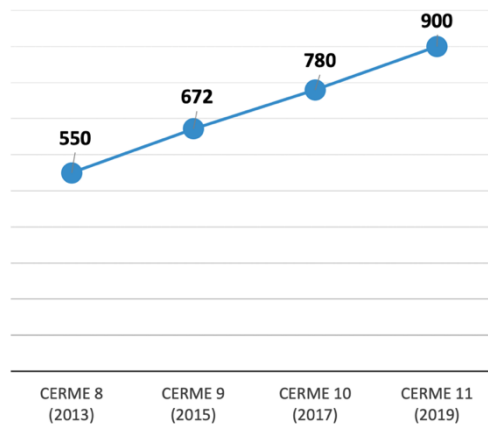


Figure 7: Increasing number of participants for the last conferences

This new situation requires a new interpretation of inclusion in the ERME policy: We must overcome a mainly *quantitative* interpretation of inclusion (as allowing every interested person to participate). Instead, the future inclusion strategies will focus on the heterogeneity of participants and develop approaches for supporting underrepresented groups for finding new balances

- between novices and experts
- between countries
- between well-established communities and newly emerging communities.

At the same time, we will enhance the interpretation of quality: In the future we will not only work on quality of individual contributions, but also on enhancing the three C's. Especially, we will search for new ways of supporting collaboration and cooperation across countries and research groups.

4 YERME and YESS: A historical view (Paolo Boero)

YESS 1 at Klagenfurt in 2002 was my first international experience in math education, I have visited it as postdoc and immediately found my international family.

Figure 8 (H. Palmér): Example of pre-sent tweet

This spontaneous contribution to our panel from an ERME member well represents the “YESS spirit” and its aims, and more generally the orientation of all the ERME initiatives (YESS, YERME, the YERME day) addressed to people who enter the domain of research in mathematics education.

From the very beginning, one of the main ERME goals was to create a community of young researchers, who might grow up as EUROPEAN researchers in the WORLD context, each of them bringing the richness of her cultural, educational and research traditions, to be acknowledged as relevant contributions by the colleagues, each of them being willing (and able!) to Communicate, Collaborate and Cooperate with the other EUROPEAN and WORLD researchers. This goal was coherent with the general perspective, according to which ERME was founded (the “CCC spirit”). At CERME 2 in Mariánské Lázně, a meeting of young researchers was initiated where 22 of them

(mostly PhD students) and six senior researchers met in order to discuss young researchers' recent situation and to allocate suggestions to improve the situation. Finally, the young researchers were invited to meet as a group during the conference and to formulate their ideas and needs. A subgroup (Michele Cerulli, Petra Frantova and Jukka Törnroos, supported by Konrad Krainer) met, negotiated essential basic points and finally presented them at a plenary discussion at the end of the conference. For example, it was fixed that the group of young researchers was named YERME, that it will have three contact persons and will produce a contact list. It was recommended that, in the future, CERMEs could have a young researchers' day; in addition, a summer school (with workshops and feedback sessions) was proposed. In both cases, young researchers offered to be active in programme committees. Based on these suggestions, the ERME board started to design a summer school for young researchers (later named YESS) to be held every two years (starting 2002) and to start each CERME with a YERME day (starting 2005, formally decided 2003 at CERME 3).

YESS 1 and its design

The first summer school was planned in a meeting held in Klagenfurt in June, 2001 (see reports by Borromeo Ferri, Roth & Reinhold, 2002; Krainer, 2003). Two representatives of YERME were there, together with three members of the ERME board and three members of the University of Klagenfurt (which offered to host the first summer school). The design of the summer school was based on the following guidelines:

- The Working Group (WG) structure as the main feature of the summer school, and the request to all WG participants to prepare a written contribution related to the advancement of their research projects. These choices were coherent with the original planning of CERME, based on thematic WGs. A common theme would have allowed WG participants to better share experiences, readings, method and content choices. The request of a 4-6 pages summary on the personal stage of PhD studies (be it initial, or near to the conclusion, or even post-doc) was conceived with three aims: To favor a personal balance of the acquisitions and the needs, in the perspective of sharing them with the other participants; to let participants know in advance the interests and research orientations of the other WG members; to let the expert in charge of the WG prepare suggestions, references, etc. for each member, and plan the WG sessions, in order to tackle common or near problems/topics in each session.
- The role of the "expert" in each WG: Strong expertise in research and in the supervising of newcomers in the field was necessary. But it was not sufficient. An expert had not to be conceived as PhD super-supervisor! She had to play another, complex role: To provide the newcomers in the field with the opportunity of communicating their projects, preliminary results, needs in a CCC climate; to favor productive exchanges between participants; to provide them with "method" and "content" helps and suggestions (according to her research experience); to ensure a pluralistic vision on theoretical and method choices.

YESS, YERME and the YERME day

The interactions between experts, organizers and students in YESS 1 (2002) allowed the ERME board to better focus (and take precise decisions) on two kinds of needs, that had already been considered in more generic terms in the previous years:

- There was a challenge to create and prepare discussion spaces, within YESS and in the occasion of ERME conferences, where participants with interests in different areas of mathematics education could meet together and with experts to deal with topics related to the level of advancement of their PhD studies (e.g. how to choose and read a research paper? How to choose and formulate a research problem and the related research questions? What about the theoretical framework? How to choose a research methodology to deal with the research questions? How to write a research paper? Etc). This need brought to plan in advance Discussion Group sessions within YESS (in order to share the task of better coordinating and supporting them among the experts and the more experienced members of the programme committee); and to implement the idea of the YERME day (it was finally decided that it should consist of two half days of work for young participants in CERME, before the starting of CERME). The first official initiative involving young researchers took place in CERME 3 (2003) as a YERME meeting within the conference; the name YERME day was adopted for the two half days that preceded CERME 4 (2005) and all the subsequent CERMEs. In the two cases (YESS Discussion Groups and YERME day before CERME), the aim is to provide participants with occasions for dealing in depth, with the support of experts, on subjects (like those listed above, gradually made more precise and specific in the programme of subsequent summer schools) of common interest in each stage of the development of PhD studies and research projects. New formats will be found for the future, for example, the ERME Topic Conferences (ETC) can be opened with a YERME day, for discussing individual projects or a survey of the topic at stake, available before an ETC, as an introduction to the conference.
- There was a constant work on further developing YERME, with its autonomy, its tasks related to YESS and the YERME day, and also to CCC specificity for young researchers and to career needs (e.g. information on research jobs opportunities). During YESS, two time slots are dedicated to special Discussion Groups organized and led by the YERME representatives within the programme committee. The discussions concern the participants' challenges as PhD students, as participants in YESS, and their perspectives as regards the post-doc employments. During the YERME day, a special event is the plenary speech of a young researcher who recently entered a research career. She presents an account of the problems met by her during her PhD studies, of how she tackled them, and of how she succeeded in finding an employment opportunity after her PhD.
- At CERME 7 (2011), the ERME general assembly decided to strengthen the YERME voice in the ERME policy making. The ERME byelaws were modified to include two YERME representatives for four years, each from CERME 8 (2013) on.

Conclusion

The increased number of applicants to YESS (from 47, almost all from Europe, in the case of YESS 1, to more than 110, including those from America, Africa and Asia in the case of YESS 5, to 136 in the case of YESS 9 – always with candidates from other continents) encouraged the organizers to maintain and strengthen the original features of YESS. The number of WGs was increased from five in YESS 1 to six; the accepted participants have been 72 in the last editions, and will be 84 in YESS 10. In particular, participation of students from other continents is considered as an added value for

YESS (the same as for ERME!). Indeed the participation of young researchers from other research traditions, and with different cultural needs, was, is and will be an occasion for putting into practice the original reason for the existence of ERME (and YESS as well): A community of researchers, based on the positive evaluation of the rich European diversity, and coherently open to the constructive dialogue with other diversities in the CCC spirit.



Figure 9 (personal photos): Some mentors of YERME - Paolo Boero, Konrad Krainer, Dina Tirosh, João Pedro da Ponte and Viviane Durand-Guerrier

5 YERME and YESS: A young researcher's view (Simon Modeste)

As a young researcher and a participant in CERME, YERME and YESS events, I would like to describe my trajectory, as a testimony for this panel and illustrating the previous section.

My first contact with ERME and the YERME group was in CERME 7 in 2011. I was in the topic group on “Proof and argumentation”. Looking at the “famous” names in the participants of the group (Paolo Boero was one of them), I was quite intimidated. I think this is the case for many young researchers before their first CERME. Fortunately, I had the opportunity to participate in the YERME day. This day, before the conference, is very important for newcomers. It allows young researchers to meet together, as a small group, to discuss, start knowing each other, share experiences and benefit from experts' workshops. Paolo Boero was one of the experts (for many generations of young researchers, Paolo is associated to YERME activities) and I attended his “famous” workshop on writing articles, where he makes you analyse and criticize one of his first articles. This is YERME spirit, and contributes to make you more comfortable as a young researcher in the community. Another important thing is that YERME day is oriented towards stimulating communication (in particular regarding the language issue for non-native English speakers). After the YERME day, you can join the conference and the working groups with much less stress. You meet known faces from the YERME day during the conference and can share experiences from the various groups. You have the feeling that you are part of the group of the European young researchers in mathematics education.

In 2012, I participated in YESS 6 in Faro (Portugal). It was six months before my PhD defence, and my dissertation was not written yet. I was very stressed, and meeting with other young researchers, benefiting from the pieces of advice from the expert of my workgroup, sharing experiences during the Discussion Groups have been very comforting and motivating. And I went back to work on my PhD with more energy.

Participating in YESS is sharing a week with young researchers and experts from ERME, where you feel like cut off from the rest of the world, focused on scientific activities. This is very pleasant and it is a luxury in a young researcher's life. The truth is that I don't know any event for young researchers which would be equivalent to YESS.

I also want to write briefly about the network of YERME. It is through this network that I was aware of post-doc positions and got the opportunity to be a post-doc researcher in another country. This permitted me to discover another school system, and another research culture. It brought me an international experience. I think that this is exactly the kind of opportunities that YERME wants to foster, by promoting international collaborations.

In 2018, I had the possibility to contribute to YERME activities, by organizing YESS 9. I was very proud to organize it after my rich experience from YESS 6. In collaboration with the ERME board and the scientific committee, I tried to base on this experience as a young researcher in the ERME community, to implement an organization that stimulates the interactions between young researchers. During the summer school, I have seen the group bonded, and the YERME community has strengthened during the week.

At YESS 9 in Montpellier, we had 136 applications for 72 places (6 working groups of 12), experts from different parts of Europe. The participants came from many countries in the world, representing all continents (of course, the majority from Europe). Figure 10 shows the whole group of participants at YESS 9.



Figure 10 (S. Modeste): Participants of YESS 9, Montpellier

Finally, I would like to summarize some important aspects of YESS, YERME and YERME day, and to add some new information (<http://www.mathematik.uni-dortmund.de/~erme/>). Essentially, YERME activities comprise two main events, each recurring every two years: The YERME day, and the YERME summer school (YESS). Each YESS has a programme committee, which consists of a scientific coordinator, two ERME Board representatives, three YERME representatives, two representatives from local organizers. Up to now, ERME has organized 9 YESS, the tenth is already fixed (see Section 10). Other YERME activities comprise participation in the ERME board and communication about YERME and relevant activities for young researchers. Two young researchers have seats in the board of ERME to represent the interest of YERME. Recently, these members are Dorota Lembrér, Norway (term ends in 2023) and Andrea Maffia, Italy (term ends in 2021). YERME is active on social media, in particular Facebook and Twitter. The official Facebook page for YERME is: <https://www.facebook.com/YoungResearchersERME>, a Twitter account with the same information can be found at <https://twitter.com/YERMEEurope>.

6 ERME book: Evolution, spirit and results (Tommy Dreyfus)

Upon the initiative of João Pedro da Ponte, the ERME board and its president Viviane Durand-Guerrier (Figure 11) decided that ERME should, on the occasion of its 20th anniversary, publish a book presenting ERME to mathematics educators world-wide.



Figure 11 (personal photos): The initiators - João Pedro da Ponte, Viviane Durand-Guerrier and the 2015 Board

The board named Tommy Dreyfus, Michèle Artigue, Despina Potari, Susanne Prediger and Kenneth Ruthven as editors (Figure 12), with Tommy as coordinating editor and Susanne as liaison person to the ERME board.



Figure 12 (personal photos): The editors - Tommy Dreyfus, Michèle Artigue, Despina Potari, Susanne Prediger and Kenneth Ruthven

The editors met in September 2015, and decided that the aim of the book shall be to present the most important directions, developments and trends of European Research in Mathematics Education in a highly readable text. Hence the book shall report on the main lines of development in ERME in the course of the past 20 years, showing the spirit of communication, cooperation, collaboration in the process;

- showcase past and current European research for audiences inside and outside Europe;
- and establish shared understandings in which to ground future European research in mathematics education.

Since the scientific interaction in ERME happens in the TWGs, a book structure was designed with an introduction by the presidents of ERME, 18 core chapters reflecting the work of the TWGs, and commentaries by two eminent scholars from outside Europe, Marcelo Borba and Norma Presmeg (Figure 13).



Figure 13 (personal photos): The commentary chapter authors - Marcelo Borba and Norma Presmeg

The editors chose a writing team for each chapter from among the leaders of the relevant TWGs – overall more than 60 authors contributed. It is notable that every single person who was asked accepted to contribute, and that the writing teams were very responsive to our editorial suggestions. They were also exemplary in keeping the schedule; this was especially crucial toward CERME 10, where the chapters were discussed in the relevant TWGs, so that the process of writing the book was a paradigmatic case of CCC.

The work on the book, and the commentary chapters in particular, raised some general comments and questions about ERME and research within ERME. A few of them will be raised here.

Borba, in his commentary, describes the dynamics of the creation, life and, in some cases disappearance of TWGs in ERME as a response to crises, for example crises in algebra learning and teaching, the integration of technology in classroom, or the low presence of modeling in school mathematics. He observed that some themes like the philosophy of mathematics education, distance education, and assessment were not or under-represented at CERMEs. While in the case of distance education, this may be due to the geographical nature of Europe, and in the case of assessment a TWG has recently been created, there does not seem to be an obvious reason for the absence of the philosophy of mathematics education.

A striking and possibly typically European phenomenon is that all 18 core chapters relate to theories or models. This begs the question whether the theoretical work of each TWG feeds back to the crisis Borba sees at the origin of the TWG? And it has led Presmeg to ask, in her commentary, whether ERME makes an effort to link the work of different TWGs, and whether theories can possibly serve to link the work of different TWGs, for example if one TWG attempts to understand what other TWGs mean by theory.

Presmeg also noted that the CCC spirit may support such links: Theories are designed in a specific context; they express particular world-views. A common research agenda, on the other hand, implies spelling out research paradigms, theories and methodologies, and therefore requires one to suspend or step outside of one's "natural" attitude (or habits). Work in ERME thus led researchers to use different theories as complementary lenses that provide alternative views of the same phenomenon. But it led far beyond this: A paradigmatic case of CCC with respect to theories was realized within ERME: The theory TWG was initiated at CERME 5; at a serendipitous meeting on the last day of the conference, a group of members of this TWG decided to further explore the issue of connections between theories – a case of *communication*. That group has then *cooperated* over 8 years, at CERME conferences and elsewhere; they developed *collaboration* on four case studies of links between theories, links of different kinds and strengths; and a book resulted from their efforts (Bikner-Ahsbahs & Prediger, 2015). This book would have fit very well into a book series under ERME's auspices.

Finally, is ERME international? And in what ways does ERME offer a distinctly “European” perspective on research in mathematics education? While there is no definitive answer to this, international participation at CERME grows from conference to conference; on the other hand, some specifically European aspects of work within ERME have been pointed out in the previous paragraphs; in particular, research traditions that have grown nationally have undergone a process of networking. ERME presents a healthy tension between national, European and international contributions.

The ERME book titled *Developing Research in Mathematics Education: Twenty Years of Communication, Cooperation and Collaboration in Europe* (Figure 14) appeared with Routledge (a division of Taylor and Francis) in 2018, on ERME’s 20th anniversary. In parallel to the creation of the book, the ERME board has decided to launch an ERME book series (e.g. including volumes initiated by researchers at ERME topic conferences). Hence, the “ERME book” has become the inaugural volume of the ERME book series.

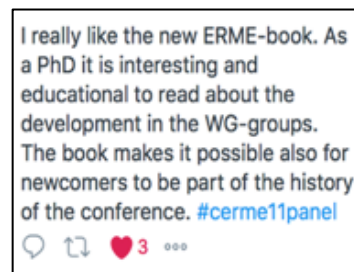


Figure 14: The ERME book **Figure 15 (H. Palmér): Example of pre-sent tweet**

The editors hope that the book shows readers from Europe and beyond how research in ERME has developed, that book chapters are useful to introduce young researchers to areas active in ERME, that the ways in which ERME promotes research through CCC emerge, and that the book will serve as a close companion to each ERME member in their research. The tweet in Figure 15 is a small indication that these hopes are at least to some extent realistic.

7 ERME book: A young researcher’s view (Jana Žalská)

The ERME book “Developing research in mathematics education“ will serve as an enriching volume to any researcher in the field of mathematics education. As a young researcher and a participant in CERME, YERME and YESS events, I appreciated especially its value in providing the valuable sense of context (historical, geographical and cultural), and of the organic and dynamic aspects of the field’s epistemic development.

Making sense of the context

The introductory chapter of the book helps to situate ERME’s endeavors in research, introducing the roots and development of ERME, and explaining not only its guiding values and principles but also the rationale behind them.

Secondly, the core chapters provide overviews on specific areas of research, so they might establish a context for a research question we may pursue. The texts often refer to the geographical (national) context of particular research developments in specific areas of mathematics education, use and developments of concepts and theoretical frameworks etc.

Thirdly, reading about comparable contexts gives us a notion of our own local (e.g., national) context, even when not specifically mentioned through the chapters. It may be an essential contribution to understanding, identifying and describing our own local educational and research context in a similar way.

All of the above contextual notions are vital in determining the direction we envision in participating in the research endeavors within ERME. At the same time, the two commentary chapters bring the activities and principles of ERME under a broader lens, that is to say, zooming out on the bigger picture and reminding us of its current limits and shape.

Organic growth and inclusiveness

The sense of organic growth of the body of knowledge in the community permeates each of the book's content chapters. Finally, Chapter 20 reassures us that striving for "unity in diversity" (Dreyfus et al., 2018, p. 285) is attainable through such an endeavor. For me as a young researcher, this means encouragement in the belief that my own research matters, and the confidence that I, too, am part of this process.

Finally, this book has succeeded in making a significant step toward molding further an identity of a unique community. The book's strong emphasis on reflection and the process of convergent thinking is a tremendous effort of this community to understand itself as much as to understand its subject of research.

8 Conclusion and further directions (Susanne Prediger)

The discussion was insightful and provided hints to promising future activities of ERME in all areas of work, initiating communication, collaboration and cooperation, promoting young researchers, strengthening the visibility of European mathematics education research and increasing inclusion by supporting underrepresented countries. We will think about

- how to keep all the good traditions that were praised by so many members
- how to enhance the CERME programme structure for initiating collaboration
- how to strengthen the three C's between conferences
- how to engage young researchers in the work of the TWGs and to
- elaborate our contacts to mathematicians
- especially, we will explore how to support mathematicians to enter the field of mathematics education research.

Future directions might be as listed in Figure 16.

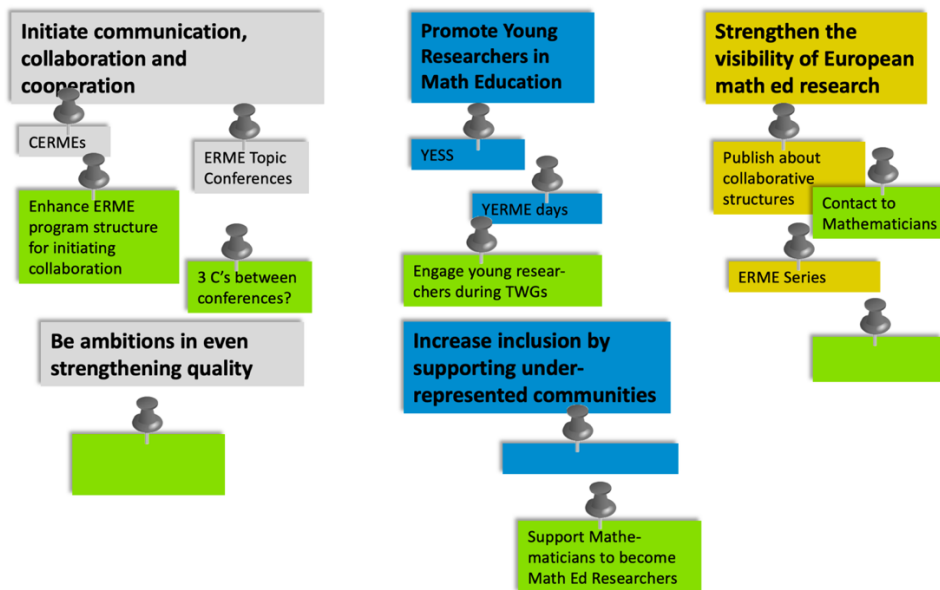


Figure 16: Future directions for ERME work (S. Prediger's final slide from the panel)

9 Resume (Hanna Palmér and Konrad Krainer)

The panel was ended as it started, by concluding that ERME, CERME and YERME are AMAZING success stories. Through these events the community share, work on and develop research in mathematics education. Thus, the initial three C's have been kept,

- Communication *with our colleagues throughout Europe, but also beyond*
- Cooperation *in and around research topics*
- Collaboration *in designing and doing research together*

This fantastic history is presented in all CERME proceedings and also in the ERME book. During the panel a new C was introduced – Challenge. The challenges raised were connected to inclusion, quality, regional unbalances, emerging communities and, maybe also the initiative to use twitter to increase the dynamics of the panel. However, it was concluded that challenges only become obstacles if we bow to them.

The success of ERME, YERME, CERME and its publications has many fathers, mothers, sisters, brothers, friends, etc. A whole network of engaged people and organizations is needed.

The most important people are the participants, YOU! In addition, we need people who take responsibility for working groups, thematic conferences or a CERME itself. Without group leaders, subgroup leaders, IPCs and LOCs, a society cannot live. The young people will shape the future, all others need to take actions that they can do that! Without a strong YERME, we don't will have a good future. A society needs relevant others, like our home institutions like universities, and sponsors etc.; but we need institutional friends like ICMI, PME and other organizations. This means to enact the CCC spirit not only on the individual level, but also on an organizational level.

And of course, we need people who take responsibility for the whole, for ERME as a scientific society. The board has both, the task to live our goals, but also to further develop it, in continuous negotiation with its members.

Having observed the development of ERME from the very beginning, we feel that we can hopefully look into the future! All of you have contributed to the success!

10 Some relevant data about the ERME society (Konrad Krainer and Susanne Prediger)

A variety of background information about ERME can be found at <http://www.mathematik.uni-dortmund.de/~erme/> (ERME, 2019). In the following, some relevant data are presented:

ERME conferences (for proceedings see ERME website)

- CERME 1 in Osnabrück, Germany (1998)
- CERME 2 in Mariánské Lázně, Czech Republic (2001)
- CERME 3 in Bellaria, Italy (2003)
- CERME 4 in Sant Feliu de Guíxols, Spain (2005)
- CERME 5 in Larnaca, Cyprus (2007)
- CERME 6 in Lyon, France (2009)
- CERME 7 in Rzeszow, Poland (2011)
- CERME 8 in Antalya, Turkey (2013)
- CERME 9 in Prague, Czech Republic (2015)
- CERME 10 in Dublin, Ireland (2017)
- CERME 11 in Utrecht, The Netherlands (2019)
- CERME 12 will take place in Bolzano, Italy (2021)

YERME summer schools

- YESS 1 in Klagenfurt, Austria (2002)
- YESS 2 in Poděbrady, Czech Republic (2004)
- YESS 3 in Jyväskylä, Finland (2006)
- YESS 4 in Trabzon, Turkey (2008)
- YESS 5 in Palermo, Italy (2010)
- YESS 6 in Faro, Portugal (2012)
- YESS 7 in Kassel, Germany (2014)
- YESS 8 in Poděbrady, Czech Republic (2016)
- YESS 9 in Montpellier, France (2018)
- YESS 10 on Rhodos, Greece (2020)

ERME topic conferences

- ETC 1 on Anthropological Theory of the Didactic in Castro-Urdiales, Spain (2016)
- ETC 2 on University Mathematics Education in Montpellier, France (2016)
- ETC 3 on Mathematics Teacher Education in Berlin, Germany (2016)
- ETC 4 on Mathematics and Language in Dresden, Germany (2018)
- ETC 5 on Mathematics Education in the Digital Age in Copenhagen, Denmark (2018)
- ETC 6 on University Mathematics Education in Kristiansand, Norway (2018)
- ETC 7 on Language in the Mathematics Classroom in Montpellier, France (2020)
- ETC 8 on University Mathematics in Bizerte, Tunisia (2020)
- ETC 9 on Arithmetic and Number systems in Leeds, United Kingdom (2020)
- ETC 10 on Mathematics Education in the Digital Age in Linz, Austria (2020)

ERME book series

- Volume 1: Dreyfus, Tommy, Artigue, Michèle, Potari, Despina, Prediger, Susanne & Ruthven, Kenneth (Eds.). (2018). *Developing Research in Mathematics Education: Twenty Years of Communication, Cooperation and Collaboration in Europe*. London: Routledge.
- Volume 2: Bosch, Marianna, Chevallard, Yves, García, Francisco Javier & Monaghan, John (Eds.). (2020). *Working with the Anthropological Theory of the Didactic in Mathematics Education: A Comprehensive Casebook*. London: Routledge.
- Volume 3: Zehetmeier, Stefan, Ribeiro, Miguel & Potari, Despina (Eds., in prep.). *Mathematics Teaching, Resources and Teacher Professional Development*. London: Routledge.
- Volume 4: Durand-Guerrier, Viviane, Hochmuth, Reinhard, Nardi, Elena & Winsløw, Carl (Eds., in prep.): *Research and Development on University Mathematics Education* (preliminary title). London: Routledge.
- Volume 5: Planas, Nuria, Schütte, Marcus & Morgan, Candia (Eds., in prep.): *Classroom Research on Mathematics and Language*. London: Routledge.
- Volume 6: Clark-Wilson, Alison, Donevska-Todorova, Ana, Fagiano, Eleonora, Trgalova, Jana & Weigand, Hans-Georg (Eds., in prep.): *Mathematics Education in the Digital Age: Learning, Practice and Theory*. London: Routledge.

The ERME book series editors are Viviane Durand Guerrier, Konrad Krainer, Susanne Prediger and Nad'a Vondrova.

The first ERME board members

- 1998-2005 Paolo Boero (Italy)
- 1998-2005 Marianna Bosch (Spain)
- 1998-2005 Elmar Cohors-Fresenborg (Germany)
- 1998-2001 Jean-Philippe Drouhard (France)
- 1998-2003 Konrad Krainer (Austria)
- 1998-2003 Jarmila Novotná (Czech Republic)
- 1998-2001 João Pedro da Ponte (Portugal)
- 1998-2001 Leo Rogers (United Kingdom)
- 1998-2003 Julianna Szendrei (Hungary)

ERME presidents

- 1997-2001 Jean-Philippe Drouhard (France)
- 2001-2005 Paolo Boero (Italy)
- 2005-2009 Barbara Jaworski (United Kingdom)
- 2009-2013 Ferdinando Arzarello (Italy)
- 2013-2017 Viviane Durand Guerrier (France)
- since 2017 Susanne Prediger (Germany)

References

- Bikner-Ahsbals, A., & Prediger, S. (Eds.) (2015). *Networking of theories as a research practice*. Advances in Mathematics Education series. Cham: Springer.
- Borromeo Ferri, R., Roth, J., & Reinhold, S. (2002). *Wissenschaftlicher Nachwuchs im Bereich der Mathematikdidaktik: YERME-Summer School 2002 – Vernetzung auf internationaler Ebene*. (Young researchers in mathematics education: YERME-Summer School 2002 – “Networking”)

- on an international level; see included in Krainer, 2003). *Mitteilungen der Gesellschaft für Didaktik der Mathematik* (Society of mathematics education in German speaking countries), 75, 114-116.
- Dreyfus, T., Artigue, M., Potari, D., Prediger, S., & Ruthven, K. (Eds.). (2018). *Developing Research in Mathematics Education: Twenty Years of Communication, Cooperation and Collaboration in Europe*. ERME series, Volume 1. London: Routledge.
- ERME (2019). *ERME – European Society for Research in Mathematics Education*. <http://www.mathematik.uni-dortmund.de/~erme> – retrieved 2019-04-13.
- Jaworski, B., da Ponte, J. P., & Mariotti, M. A. (2011). The CERME Spirit: Issues of quality and inclusion in an innovative conference style. In B. Atweh, M. Graven, W. Secada, & P. Valero (Eds.), *Mapping equity and quality in mathematics education*. London: Springer.
- Krainer, K. (2003). *YERME-Summer School 2002. Report to the ERME Board* (Email from February 4, 2003). (The report includes an English translation of a report by participants; see Borromeo Ferri, Roth, & Reinhold, 2002)
- Krainer, K., Goffree, F., & Berger, P. (Eds.). (1999). *European Research in Mathematics Education I.III, From a Study of Teaching Practices to Issues in Teacher Education*. Proceedings of the First Conference of the European Society for Research in Mathematics Education (CERME 1, August 1998). Osnabrück: Forschungsinstitut für Mathematikdidaktik and ERME.
- Schwank, I. (Ed.). (1999a and b). *European Research in Mathematics Education I.I and I.II: Proceedings of the First Conference of the European Society for Research in Mathematics Education* (CERME 1, August 1998). Osnabrück: Forschungsinstitut für Mathematikdidaktik and ERME.

TWG01: Argumentation and proof

Introduction to the papers of TWG01: Argumentation and Proof

Gabriel J. Stylianides¹, Orly Buchbinder², Jenny Cramer³, Viviane Durand-Guerrier⁴, Andreas Moutsios-Rentzos⁵, and Anita Valenta⁶

¹University of Oxford, UK; gabriel.stylianides@education.ox.ac.uk

²University of New Hampshire, USA; orlybuchbinder@gmail.com

³University of Bremen, Germany; cramerj@math.uni-bremen.de

⁴University of Montpellier, France; viviane.durand-guerrier@umontpellier.fr

⁵University of the Aegean, Greece; amoutsiosrentzos@aegean.gr

⁶Norwegian University of Science and Technology, Norway; anita.valenta@ntnu.no

Introduction

The role and importance assigned to argumentation and proof in the last decades internationally has led to a variety of approaches to research in this area, which is reflected in the growing number of submissions to Thematic Working Group 1 (TWG1) on “argumentation and proof”. The 30 papers and 11 posters presented in TWG1 come from 16 countries and offer a wide spectrum of perspectives. These contributions intertwine educational issues with explicit references to mathematical, logical, historical, philosophical, epistemological, psychological, curricular, anthropological, and sociological viewpoints.

Taking into account this diversity, the paper contributions were presented and discussed in working sessions (some of which were parallel) organized under the following themes: (1) argumentation and proof at the school level, (2) argumentation and proof in teacher education, (3) tools for analysing argumentation and proof, (4) task design in argumentation and proof, (5) theoretical and philosophical issues of argumentation and proof, (6) assessment issues of argumentation and proof, and (7) intervention studies on argumentation and proof. Since the themes are intertwined, a paper could be assigned to multiple themes. Therefore, the assignment of papers to themes was guided by a “best fit” approach, as well as practical considerations.

In this introductory chapter, we organize our subsequent discussion across three broad topics that emerged from the discussions we had in our TWG and cut across the aforementioned themes. These topics are the following: (1) argumentation and proof in the society, (2) argumentation and proof in school, and (3) argumentation and proof in research. We will briefly discuss each topic separately. In our discussion, we will refer to a few papers that help illustrate broader points, but it was not our intention here to refer to or discuss all the papers. Rather, we hope that this discussion will spark the readers’ interest to explore all the papers in the Proceedings under TWG1.

Discussion of Papers

Argumentation and proof in the society

Argumentation and proof can be considered within a purely mathematical realm, but such a view might be limited when one considers a larger purpose for *the role of argumentation, reasoning, and proof in the society*. These considerations would ultimately affect the teaching and learning of proof as a way to achieve certain societal goals. However, a first step in this direction is clarifying what

we mean by argumentation and proof. This critical question has been historically addressed by TWG1 members since the group was established back in 1998, however the focus of the discussion has shifted from trying to reach a consensus towards identifying key features and factors that affect our understanding of the concepts of argumentation and proof. Specifically, the group discussed the cultural origins of our perception of proof, including cultural differences in what types of arguments are considered as proof. In this regard, the role of proof by contradiction has been a focus of several group discussions fostered by the papers of Turiano and Boero, and of Hamanaka and Otaki.

Another key feature of argumentation and proof addressed by the group participants was the *relationship between logic and proof with connection to socio-cultural linguistic structures*. The different grammar and/or syntax of different (natural) languages may affect the transition between oral and written communication, influence how students understand statements, their proofs, as well as the relationships between definitions and proofs. These issues were reflected in the works of Hein, of Kempen, Tebaartz and Krieger, and of Dilberoglu, Haser, and Cakiroglu. Furthermore, the influence of culture and language on the perception of proof was considered broadly in the TWG1 discussions, as initiated by various papers, including those of Stubbemann and Knipping, of Asenova, and of Shinno, Miyakawa, Mizoguchi, Hamanaka, and Kunimune. Reference was made not only to the differences between countries and languages, but also to the differences between formal and informal uses of argumentation and proof, as well as to the use of natural logic in everyday life contrasted with academic settings that require greater formalism. Further distinctions were made with regard to its use in pure mathematical courses and in teacher preparation courses.

It is important to consider the relationships of argumentation and proof with society, in particular, when considering the goals of teaching proof to pre-university students who are the citizens of the future societies. Why foster proof? Is our goal mainly technical or do we, as a society, seek to influence students' thinking about how (mathematical) truths are established and, hence, do we mean to foster critical reasoning (for example, when making inferences about statistical data as illustrated in the study of Krummenauer and Kuntze)? Though the group seemed to agree that logical reasoning, argumentation, and proof might provide students with valuable tools for active citizenship, the question of appropriately developing those reasoning competencies to foster a harmonious transfer within and outside of mathematics remains open.

Argumentation and proof in school

The second broad topic, argumentation and proof in school, was a common theme in many of the papers and posters presented in the group, but from different perspectives. In particular, the following four perspectives were raised in the discussions across the presentations.

Why foster proof? Besides the above-mentioned societal considerations and the fact that proof is central to modern mathematics, the explanatory role of proof, as discussed in the paper of Müller-Hill, is also prominent in school mathematics. The reasoning behind teaching mathematical proof to all students, however, needs to be more clearly conceptualized and justified.

What is proof? There are different understandings of what proof is or can be, depending on personal experience, but also on factors such as specific area of mathematics considered and/or the educational level – primary school students' reasoning (see for example Jablonski and Ludwig's contribution) is very different from secondary school students' work on geometry. Proof requires

mathematical meta-knowledge (see, for example, Stubbemann and Knipping's paper), and our group discussed that it would be valuable to develop instructional approaches that promote learners' meta-mathematical knowledge in proving.

Role of the teacher. It is the teacher who, implicitly or explicitly, implements different socio-mathematical norms in a classroom, highlights key ideas in work with proof and can assign value to certain perspectives in mathematics. The studies of Lee, of Bersch and of Lekaas take up different aspects of teachers' views on the role of argumentation and proof in, respectively, Hong Kong, Germany and Norway, while Larsen and Østergaard discuss how teachers' questioning influences students' opportunities to reason. Moreover, the role of the teacher with respect to both the official and shadow education systems was considered in the study by Moutsios-Rentzos and Plyta. Despite the teachers' efforts, proving is difficult for students to learn and master, and, as a result, students often struggle with it and may not value work on proof in mathematics classrooms. Studies in TWG1, such as the one by Yan and Hanna, provide an insight into students' views about proofs.

Task design – how can it foster proof? There are several critical questions to be considered in designing of proof tasks: For whom? For what purpose? In what culture? Tasks need to be designed in order to foster the need for arguments, as discussed for example in the study presented by Cramer. Kempen, Tebaartz, and Krieger examine in their study how the phrasing of a proving task influences students' proof productions, while Komatsu, G. Stylianides, and A. Stylianides propose principles for the design of tasks that promote assumptions in mathematical activity. However, promoting reasoning and proving in school demands more than good tasks, as for example shown in the study of Buchbinder and McCrone. To support teachers' practices, there is a need for appropriately designed material that help teachers to enact the tasks in classroom.

Argumentation and proof in research

During the conference, there were many discussions on argumentation and proof in mathematics education research. A main issue concerns *methodological challenges* and the choice of *theoretical models* in approaching the proof and proving phenomena, including theorising and analysing. Toulmin's model has been used widely in mathematics education research projects on proof and proving (see paper by Jablonski and Ludwig). Due to its frequent application, the reasons for using this model in a given research are not often discussed. We collectively agreed on the importance of justifying methodological decisions for several reasons. First, the epistemic dimension of the mathematical subject area involved in the research and the role of data in the model are depending on the subject area (e.g. statistical versus geometrical reasoning). Finally, Toulmin's model has not been developed to be applied specifically for mathematics. While an advantage of this model lies in its opportunities to connect everyday argumentation to mathematical argumentation, in some cases (e.g. for looking at logical relations) other models more mathematically-oriented might be more suitable. These questions have been discussed in this TWG in previous CERMEs, as presented in Chapter 6 of the ERME anniversary book, *Developing research in mathematics education*, where the authors recall the proposal by Boero and his colleagues to articulate Toulmin's model with Habermas's rationality model (for the latter see Boero and Turiano's paper). Considering proof at the interface between mathematics and computer sciences raised also the need for appropriate methodological tools such as that developed in the paper by Modeste, Beauvoir, Chappelon, Durand-Guerrier¹, León, and Meyer.

When we move to *proof at elementary school level*, new questions arise, necessitating to reconsider the definition of proof and the possibility to identify students' practices that can be qualified as proof and proving. Epistemological considerations motivate the consideration of proof at the elementary school level: looking for what is invariant is at the core of doing mathematics and, thus, proof is important at all grades. Nevertheless, we need to conceptualize proof in a broader meaning to discuss its role and possibilities in elementary school mathematics. In this respect, the work by Balacheff on the Theory of Didactical Situations and Lakatos' work on Proofs and Refutations may offer an appropriate proof development from the empirical to the intellectual through the generic. There seem to be few studies recognizing and investigating opportunities for proof and proving in the elementary school (see, for example, the works of Arnesen, Enge, Rø, and Valenta, and of Datsogianni, Ufer, and Sodian).

Conclusions and Future Directions for TWG1

We believe that the TWG on argumentation and proof has offered the participants the richness of diversity in this research domain and the opportunity for fruitful discussions. In the last session of the TWG, the participants engaged in a discussion to identify areas in which they would like, and hope, to see more research in future CERMEs. The following areas were identified:

The teaching of proof and argumentation in both school and university settings, including in teacher education with particular emphasis on argumentation and proof at the elementary school level. This area covered also developmental perspectives and learning trajectories, the study of the classroom implementation of tasks rich in argumentation and proof, and how teachers can be prepared to scaffold students' learning and to respond to unexpected student responses to help develop all students' learning of argumentation and proof.

Issues of language in argumentation and proof, including: the role of representations, structure, oral and written language, the relationship between mathematical language and natural language, as well as the relationship between the grammatical aspects of language and logic. Due to the complexity of this question, this could be studied in an international group emerging from CERME, in collaboration with colleagues involved on this topic in the TWG9 -Mathematics and Language, and with linguists.

Argumentation and proof in policy documents and curriculum frameworks, including the place and role of argumentation and proof in them, expectations and recommendations, and whether these are research-informed, etc.

The identification of these broad areas is aimed at describing the state of the art of the field, without suggesting prioritizing certain areas of research. The TWG1 is committed to representing the diversity of perspectives and research areas on argumentation and proof in future CERMEs.

Understanding geometric proofs: scaffolding pre-service mathematics teacher students through dynamic geometry system (dgs) and flow-chart proof

Lathiful Anwar^{1,2} and Martin Goedhart¹

¹University of Groningen, Faculty of Science and Engineering, Groningen, Netherlands

²Universitas Negeri Malang, Malang, Indonesia; l.anwar@rug.nl

The objective of this paper is to discuss the pedagogic potential that is offered by the use of a flow-chart proof with open problems and a Dynamic Geometry System in understanding geometric proofs by pre-service mathematics student teachers at an Indonesian university. Based on a literature review, we discuss aspects and levels of understanding of geometric proof and how to assess students' understanding of the structure of deductive proofs, and how the use of a Digital Geometry System may support students' understanding of geometric terms and statements, including definitions, postulates, and theorems. The pedagogic focus consists of exploiting the semiotic potential of a DGS, especially the use of GeoGebra tools that may function as tools of semiotic mediation to understand the geometry statements and the scaffolding potential of flow-chart proof with open problems in identifying the structure of deductive geometry proofs.

Keywords: Understanding, geometry, proof.

Introduction

Proof plays essential roles in mathematics and mathematics education. Proofs help mathematicians understand the meaning of statements or theorems and their validity within a framework. Through the process of proving, mathematicians discover or create new results or meanings (Samkoff & Weber, 2015; Zaslavsky, Nickerson, Stylianides, Kidron, & Winicki-Landman, 2012). In the context of mathematics learning, understanding proof is an essential component of mathematics competence as it offers powerful ways of developing and expressing mathematical understanding (NCTM, 2000). However, research has demonstrated that students at all levels have difficulties to deal with understanding and constructing proofs (Doruk & Kaplan, 2015; Güler, 2016; Knapp, 2005; Weber, 2002).

This paper presents some findings of the literature review we conducted aiming at developing a theoretical framework, which will underpin the design of a learning intervention. This intervention will foster understanding of Euclidean geometry proof by mathematics preservice teacher students. The students are first year students at an Indonesian university and will become teachers for secondary school. In this stage, students start to learn formal mathematical proof for the first time. This paper describes the aspects and levels of understanding of geometric proof and elaborate the use of a digital geometry system (DGS) and flow-chart proof representation as scaffolds in order to understand the structure of proof based on our literature review findings. We focus on these issues because they are relevant for our research project regarding the topic (geometric proof in undergraduate level), context and characteristics of participants, Indonesian university students, who have a little mathematical proof background.

Method

This paper presents some parts of the outcomes of our literature study which focuses on the understanding of proof and the use of DGS and flow-chart proof to support students' understanding of proof. The methodological process of the literature study is *anasynthesis* (coined from the words analysis and synthesis) adapted from Legendre's method (as cited in Jeannotte & Kieran, 2017). First, we create a corpus from a search in three databases of research, namely ERIC, MathEduc, and Web of Science, and select articles/papers having mathematical proof as keywords or associated keywords by entering 'mathematic* proof' or 'mathematical prov*' and 'geometric* proof' or 'geometrical prov*' as keywords. It is followed by selection and un-doubling. To assure the quality of the sources, we characterized the papers regarding their relevance of method and findings for education, quality of author (the number of citations) and quality of journal (impact factor). By the end of the process, 32 English texts (books, chapters, articles, and research reports in proceedings) constituted the corpus (modified corpus).

Secondly, the resulting corpus is *analyzed* for relevant information, namely definitions of mathematical proof, structure of proof, learning difficulties, interventions, role of teacher, successful approaches. In order to analyze, we created a matrix of the resulting corpus consisting of four main aspects: source, research context, method, outcomes/conclusions. Thirdly, the information is then *synthesized* to check convergences, divergences, and to identify the theoretical gaps. Underpinned by this research, we developed a framework and prototype for a teaching intervention to foster prospective teacher's geometrical proof competence. We present this process of analysis and synthesis as linear, but the reader should consider that it is a cyclical process, see Figure 1.



Figure 1: Cyclic process of an Anasynthesis (adapted from Jeannotte & Kieran, 2017)

Framework underpinning understanding of geometrical proof

While the ability to understand, construct and validate proofs is central to mathematics, student difficulties with understanding of proof are well-recognized internationally. In order to help students to understand, teachers need to know levels of understanding to be achieved by their students, and also potential tools and tasks scaffolding their thinking. This information is helpful for the teachers/researchers in designing their learning goals and a sequence of learning activities fostering students' understanding of proofs. As a result of our literature review, we present, in this part, our framework regarding aspects and levels of understanding as frameworks to develop an assessment model to capture students' understanding of geometrical proof, and, next to that, potential tools and methods which can be implemented in the classroom intervention to scaffold students' thinking in constructing geometric figure, emerging the meaning of geometric concepts, axioms and theorems.

Understanding of geometrical proof

Based on literature on reading comprehension of geometry proofs (Yang & Lin, 2008), the assessment model of proof comprehension for undergraduate students (Mejia-Ramos, Fuller, Weber, Rhoads, & Samkoff, 2012), and students' understanding of the structure of deductive proof (Miyazaki, Fujita, &

Jones, 2017), we distinguish three essential aspects in understanding proofs, namely a *functional aspect*, a *structural aspect*, and a *communicative aspect*. These three aspects are inspired by three main aspects of proof and proving proposed by Miyazaki et al. (2017): “*understanding a proof as a structural object, seeing proof as intellectual activity and the role, functions, and meaning of proof and proving*” (Miyazaki, Fujita, & Jones, 2017, page 225).

First of all, the *functional aspect* regards roles or functions of proofs. The ‘*function*’ of proof means the meaning, purpose and usefulness of a proof. In the context of learning, students should regard proof as a meaningful activity, experiencing the functionality (usefulness) of the activities, they are involved in. Second, the *structural aspect* refers to the deductive structure of proofs. Miyazaki et al. (2017) see the structure of a proof as a network of *singular* and *universal propositions* between *premises* and *conclusions*, connected by *universal instantiation* and *hypothetical syllogism*, see Figure 2. That means that the singular propositions are *universally instantiated* from universal proposition and then these singular propositions are connected by a *hypothetical syllogism*. Students need to know the meaning of these terms and statements (e.g. axioms, theorems) involved in a proof, recognize the status of the statements (e.g. premises, conclusions), to be able to justify the claim.

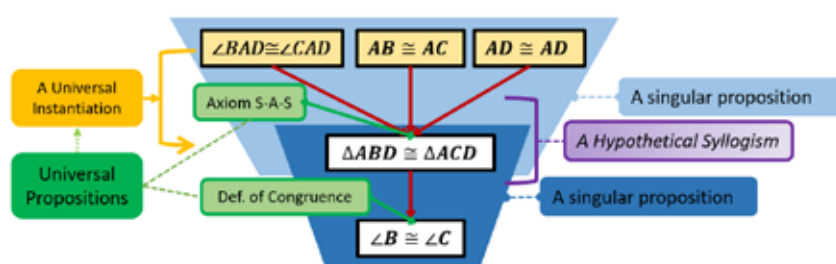


Figure 2: An example of flow-chart of proof visualizing the structure of proof
(adapted from Miyazaki, Fujita, & Jones, 2015)

The last aspect, the *communicative aspect* regards to students’ intellectual activity to read and comprehend proofs, and to justify and persuade others about the validity of a proof. Through a *validating process*, students determine the truth of a proof by line-by-line checking or step-by-step checking of multi-step proofs using their understanding of the structure of deductive proofs. We interpret that this level of understanding relates to a holistic comprehension of proof where the proof is understood in terms of main ideas, methods and applications in other contexts.

Related to the level of understanding, we elaborate two models of understanding of proofs by Mejia-Ramos and colleagues (2012) and by Miyazaki and colleagues (2017). In their model of levels of structural proof understanding, Miyazaki and colleagues distinguish three levels of understanding of proof structure, namely ‘*Pre-structural*’ level, ‘*Partial-structural*’ level, and ‘*Holistic-structural*’ level. Then, they break down the second level into two sub-levels, ‘*Elemental*’ and ‘*Relational sub-level*’. At the first level (*Pre-structural*), students see a proof as a collection of meaningless symbolic objects. When students start to consider the components, they are at the second level, particularly the *Partial-structural Elemental* sub-level. At the *Partial-Structural Relational* sub-level, students understand hypothetical syllogisms and universal instantiations and are able to use theorems, axioms and definitions as supporting their reasoning. At the third level of understanding (*holistic-structural*),

students understand the components, inter-relationships between those components and how to connect them. Then, they are able to reconstruct the proof and become aware of the hierarchical relationship between theorems and will be able to construct their own proofs.

Mejia-Ramos et al.(2012) have developed a model of assessment for proof comprehension in undergraduate mathematics. They distinguish two levels of understanding of proof, namely a *local* and a *holistic understanding*. The local understanding refers to knowing of basic terms and statements in the proof, knowing the logical status of statements in proof and the logical interrelationship between them and the statement which will be proved, and able to justify oh how the claims in the proof follows from the previous statements. Meanwhile, the holistic understanding regards being able to summarize the main idea of the proof, to identify the sub-proofs and the logical relationship between them, to adapt the idea and procedures of proof to solve other proving tasks, and to illustrate the proof regarding its relationship to specific examples.

A semiotic potential of the use of dynamic geometry system (dgs)

In terms of the structural aspects of understanding proof, several studies confirmed that the use of a Dynamic Geometry System (DGS) may help students not only solve construction problems but also helped them to understand geometrical postulates, definitions and theorems of Euclidean geometry, which are elements of the structure of proof (Jiang, 2002; Mariotti, 2012, 2013). Mariotti (2013) summarized that the semiotic potential of the features of DGS relates to specific mathematical meanings, namely “(1) the dragging test can be related to the theoretical validation of a geometric construction, (2) specific tools can be related to specific elements of the corresponding geometry theory: postulates, theorems; (3) actions concerning the management of the DGS’s menu can be related to fundamental meta-theoretical actions concerning the construction of a theory, such as the introduction of a new theorem or a definition.” (Mariotti, 2013, pp. 444-445). In the following paragraph, we elaborate two studies about the use of DGS in supporting students’ ability in proving.

A study by Jiang (2002) investigates learning processes of two pre-service teachers, Lisa and Fred, in exploring geometry problems using the dynamic geometry software Geometer’s Sketchpad (GSP) to develop mathematical reasoning and proof abilities. They use a constant comparison approach in order to analyze participants’ pre-tests, post-tests, and teaching interviews indicating that the geometer’s Sketchpad can not only encourage students to make conjectures but also enhances students’ mathematical reasoning and proof abilities. Particularly, the use of a Dynamic Geometry System (DGS) improves students’ level of geometric thinking in terms of van Hiele levels (e.g. Lisa’s level increased from level 3 to level 4) and positively changes students’ conceptions of mathematics and mathematics teaching. Jiang argues that pre-service teachers’ experience in using DGS to foster their mathematical reasoning and proof abilities helps them to recognize the need to improve students’ knowledge of geometry, to develop their own mathematical power and their ability to develop teaching innovations.

A theoretical study by Mariotti (2012) discusses the potential offered by the use of DGS in supporting and fostering 9th and 10th grade student’s proof competence in geometry. The theoretical framework used to support the use of DGS, Cabri Geometer, is her own Theory of Semiotic Mediation (TSM). In this context, students’ personal meanings emerge and then evolve from personal meanings towards

mathematical meanings, when students use an artefact for accomplishing a task through social interaction. Particularly, the specific DGS tools can also be related to geometrical axioms and theorems. Meanings emerging from the use of virtual drawing tools for solving geometry tasks can be related not only to the theoretical meaning of geometry construction but also the meaning of theorems.

Mariotti (2012) argues that the DGS could support not only the conjecturing process, but also mediate the mathematical meaning of conjectures, particularly premises/singular propositions in the context of geometry proofs. Particularly, the dragging feature provided by DGS (Cabri software) supports the emergence of different meanings related to the notion of conjecture as a conditional statement relating a premise and a conclusion. Mariotti also discusses findings by Baccaglioni-Frank (2010) focused on the analysis of the process of exploration that can be expected by using Maintaining Dragging (MD). Baccaglioni-Frank's teaching experiment involves students from three high schools (aged 15-18), which used Cabri in the classroom. Mariotti concludes that this teaching experiment indicates that the DGS tools and dragging activities help students to solve construction tasks and to understand the notion of theorems; particularly the mathematical meaning of conditional statements such as expressing the logical dependency between premises and conclusions.

GeoGebra as another DGS is an open-source well-developed tool with a stable interface familiar to many users and works in any operating system. The software has a number of features such as dynamic geometry which can help students in steps of problem solving towards a proof (Botana et al., 2015). Botana et al. (2015) conclude that GeoGebra tools provide some useful features. Firstly, GeoGebra could not only give yes/no answers but could also show step-by-step explanations. Secondly, GeoGebra could identify properties on the construction of geometric figures. Thirdly, GeoGebra could give a counterexample to check the truth of a statement. However, research findings by Doruk, Aktumen, and Aytakin (2013) show that some preservice teachers highlighted some limitations, such as difficulties in translating mathematical expressions into GeoGebra. Preservice teachers thought that GeoGebra is a complicated program and that it would take a long time and needs a big effort to become competent in GeoGebra.

A scaffolding potential of the use of flow-chart proof form with open problems

A flow-chart proof form is a means to visualize the deductive connections from premises to conclusion by identifying singular and universal propositions in the chart, see Figure 2. Flow-chart proofs show a storyline of the proof starting with premises from which the conclusion is deduced and includes the theorems or/and axioms being used, how the premises/hypotheses and conclusion are connected, and so on (Miyazaki et al., 2015). Gardiner (2004, cited in Miyazaki, Fujita, & Jones, 2017) claims that this format is a good starting point to learn other formats of proofs such as narrative proofs and two-column proofs.

Miyazaki, Fujita, and Jones (2012) developed a learning progression based on flow-chart proving aimed at providing a basis for introducing the structure of proof in Grade 8 school geometry. Based on the theoretical underpinning of the design, researchers proposed three phases of learning progression: (1) constructing flow-chart proofs in an open problem, (2) constructing a formal proof by reference to a flow-chart proof in a closed situation, (3) refining formal proofs by placing them

into a flow-chart proof format in a closed situation. The term ‘*open*’ refers to a situation where students can construct more than one suitable proof. In the open problem task, students are given a conclusion of the proof in the form of flow-chart proof format, and they are asked to determine the suitable statements to fill in the blank boxes of the flow-chart so the proof is complete. Based on three phases of learning progression, the authors designed nine lessons considering open/closed situations, varying steps of deductive reasoning, and different problems and contexts. The results from a Math test of Japanese Survey Item shows that students who followed the nine lessons are more likely to plan and construct a proof in accordance with their plan. This is due to (a) their experience with open problems that encourage them to think backward and forward to identify assumptions and conclusions in proof, (b) they could grasp the structure of proofs better through using flow-chart proofs.

Another research by Miyazaki et al. (2015), as follow-up of their previous study (Miyazaki, Fujita, & Jones, 2012), showed the role of *flow-chart with open problem* as scaffolding to support Grade 8 students’ learning about geometrical proofs. The results of data analysis of students’ activities during a classroom intervention indicates that flow-chart proof with open problems as scaffolding enhances students to understand the structure of proof by providing a visualization of both the connection between singular propositions (via hypothetical syllogism) and the connections between a singular proposition and the necessary universal proposition in the form of universal instantiation.

Concluding Remarks

We distinguish two levels of proof understanding which are proposed by Mejia-Ramos et al.: *a local understanding* related to knowing the definition of basic concepts/terms, knowing the logical status of statements in proof, knowing how and why each statement connects to previous statements. and *a holistic understanding* when students are able to summarize the main idea of the proof, to identify the sub-proofs and how these relate to the proof structure, to transfer the idea of proof to others, and instantiate the proof with examples (Mejia-Ramos et al., 2012; Miyazaki et al., 2017). Classroom interventions, supporting students’ activities in understanding the structure of proofs including the elements of proofs such as singular propositions (premises/geometric statements), universal proposition (geometric definition, axioms, theorems) and hypothetical syllogism (the inter-relationship of these elements), are needed to help students reach both levels of proof understanding.

Several studies confirmed that the use of a Dynamic Geometry System (DGS), such as Geometer’s Sketchpad, Cabri and Geogebra, may help students not only solve construction problems but also may help them identify properties on the construction of geometric figures, understand geometrical axioms, definitions and theorems of Euclidean geometry, which are elements of the structure of proof, and universal propositions (Botana et al., 2015; Jiang, 2002; Mariotti, 2012, 2013).

The use of the flow-chart proof form may provide opportunities for students to understand the structure of proof and may help students identify the components of proofs and the inter-relationship among the components (Miyazaki et al., 2015; Miyazaki et al., 2017). The use of open problems provides an opportunity for students to construct multiple solutions by deciding about the given statements and intermediate propositions necessary to deduce a given conclusion. This ability promotes student thinking forward and backward interactively when constructing a proof under the flow-chart proof format (Cheng & Lin, 2007; Heinze et al., 2008).

A study by Miyazaki et al. (2017) suggests that the level of understanding of the structure of proof as a part of local understanding should be taken into consideration in designing an effective learning intervention. Mariotti (2012) also recommends future research to better describe how the complex web of meanings emerging from activities with the DGS may be transformed into mathematical meanings such as geometric definitions, axioms and theorems. Hence, the findings presented in this paper indicate our future promising research direction for the study on designing a learning intervention which implements the use of DGS, GeoGebra, as semiotic tools and flow-chart proof format as a scaffolding tool to support a local and holistic understanding of prospective mathematics teachers who have little mathematical proof background.

References

- Baccaglioni-Frank, A. (2010). *Conjecturing in dynamic geometry : A model for conjecture-generation through maintaining dragging*. Doctoral dissertation, University of New Hampshire.
- Botana, F., Hohenwarter, M., Janičić, P., Kovács, Z., Petrović, I., Recio, T., & Weitzhofer, S. (2015). Automated Theorem Proving in GeoGebra: Current Achievements. *Journal of Automated Reasoning*, 55(1), 39–59.
- Cheng, Y.-H., & Lin, F.-L. (2007). The Effectiveness and Limitation of Reading and Coloring Strategy in Learning Geometry Proof. *Proceedings of the 31 Conference of the International Group for the Psychology of Mathematics Education*, 2, 113–120.
- Doruk, B. K., Aktumen, M., & Aytakin, C. (2013). Pre-service elementary mathematics teachers' opinions about using GeoGebra in mathematics education with reference to "teaching practices." *Teaching Mathematics and Its Applications*, 32(3), 140–157.
- Doruk, M., & Kaplan, A. (2015). Prospective mathematics teachers' difficulties in doing proofs and causes of their struggle with proofs. *Bayburt University Journal of Education Faculty*, 10(2), 315–328.
- Güler, G. (2016). The Difficulties Experienced in Teaching Proof to Prospective Mathematics Teachers: Academician Views. *Higher Education Studies*, 6(1), 145–158.
- Heinze, A., Cheng, Y. H., Ufer, S., Lin, F. L., & Reiss, K. (2008). Strategies to foster students' competencies in constructing multi-steps geometric proofs: Teaching experiments in Taiwan and Germany. *ZDM - International Journal on Mathematics Education*, 40(3), 443–453.
- Jeannotte, D., & Kieran, C. (2017). A conceptual model of mathematical reasoning for school mathematics. *Educational Studies in Mathematics*, 96(1), 1–16.
- Jiang, Z. (2002). Developing Preservice Teachers' Mathematical Reasoning and Proof Abilities in the Geometer's Sketchpad Environment. In D. Mewborn, P. Sztajn, D. Y. White, H. G. Wiegel, R. L. Bryant & K. Nooney (Eds.), *Proceedings of the 24th Annual Meeting of the North American Chapter of the International Group for the Psychology of Mathematics Education* (Vol. 2, pp. 717–729). Columbus, OH: ERIC Clearinghouse for Science, Mathematics, and Environmental Education.
- Knapp, J. (2005). *Learning To Prove in Order To Prove To Learn*. Retrieved from https://mathpost.asu.edu/~sjgm/issues/2005_spring/SJGM_knapp.pdf
- Mariotti, M. A. (2012). Proof and proving in the classroom: Dynamic Geometry Systems as tools of semiotic mediation. *Research in Mathematics Education*, 14(2), 163–185.

- Mariotti, M. A. (2013). Introducing students to geometric theorems: How the teacher can exploit the semiotic potential of a DGS. *ZDM - International Journal on Mathematics Education*, 45(3), 441–452.
- Mejia-Ramos, J. P., Fuller, E., Weber, K., Rhoads, K., & Samkoff, A. (2012). An assessment model for proof comprehension in undergraduate mathematics. *Educational Studies in Mathematics*, 79(1), 3–18.
- Miyazaki, M., Fujita, T., & Jones, K. (2012). *Introducing the structure of proof in lower secondary school geometry: a learning progression based on flow-chart proving*. Paper presented in ICME 2012 (pp. 2858–2867). Seoul, Korea: ICMI.
- Miyazaki, M., Fujita, T., & Jones, K. (2015). Flow-chart proofs with open problems as scaffolds for learning about geometrical proofs. *ZDM - Mathematics Education*, 47(7), 1211–1224.
- Miyazaki, M., Fujita, T., & Jones, K. (2017). Students' understanding of the structure of deductive proof. *Educational Studies in Mathematics*, 94(2), 223–239.
- Miyazaki, M., Fujita, T., Jones, K., & Iwanaga, Y. (2017). Designing a web-based learning support system for flow-chart proving in school geometry. *Digital Experiences in Mathematics Education*, 3(3), 233–256.
- NCTM. (2000). Principles and Standards for School Mathematics. *School Science and Mathematics*, 47(8), 868–279. Retrieved from www.nctm.org
- Samkoff, A., & Weber, K. (2015). Lessons learned from an instructional intervention on proof comprehension. *Journal of Mathematical Behavior*, 39, 28–50.
- Weber, K. (2002). Student Difficulty in Constructing Proofs : The Need for Strategic Knowledge. *Educational Studies*, 48, 101–119.
- Yang, K. L., & Lin, F. L. (2008). A model of reading comprehension of geometry proof. *Educational Studies in Mathematics*, 67(1), 59–76.
- Baccaglini-Frank, A. (2010). *Conjecturing in dynamic geometry: A model for conjecture-generation through maintaining dragging*. Doctoral dissertation, University of New Hampshire.
- Zaslavsky, O., Nickerson, S. D., Stylianides, A.J., Kidron, I., & Winicki-Landman, G. (2012). The Need for Proof and Proving: Mathematical and Pedagogical Perspectives. In G. Hanna & M. de Villiers (Eds.), *Proof and Proving in Mathematics Education* (Vol.15, pp. 215-229). Netherlands: Springer.

Initial participation in a reasoning-and-proving discourse in elementary school teacher education

Kristin Krogh Arnesen, Ole Enge, Kirsti Rø and Anita Valenta

Norwegian University of Science and Technology; anita.valenta@ntnu.no

Based on a commognitive framework, we analyse the reasoning-and-proving processes of two teachers, and we identify the actions and routines that are visible when working on a given task. The data consist of video recordings of the teachers' attempts to validate a stated hypothesis involving multiplicative reasoning. Six categories of what characterises the teachers' initiation into a reasoning-and-proving discourse are identified. The findings reveal that some actions related to substantiation routines seem to be applicable for novice teachers. Examples of this include questioning validity and the use of words related to deductive reasoning. However, the teachers' participation in the discourse is characterised by ritualised actions, as in their use of visual mediators. Furthermore, the analysis discloses the teachers' tendency to use construction-related actions in what was designed to be a validating activity.

Keywords: *mathematical discourse, reasoning and proving, elementary school teacher education*

Introduction

Reasoning and proving are central aspects of mathematics as a discipline, and many researchers have argued that they should be a central part of school mathematics at all grades and in all topics. In this paper, we use a broad definition of the word proof (Reid, 2010), to denote mathematical reasoning involved in the process of making sense of and establishing mathematical knowledge. Hence, we follow Stylianides (2008), who used the term 'reasoning-and-proving' to denote the activities involved in this process: identifying patterns, making conjectures and providing arguments.

The reasoning-and-proving process is difficult to learn and difficult to teach. In exploring ways to teach proof, a number of studies have shown the crucial role that a teacher plays in helping students identifying the structure of a proof, presenting arguments and distinguishing between correct and incorrect arguments (see e.g. Stylianides, 2007). Researchers have found that elementary school teachers tend to rely on external authorities, such as textbooks, college instructors or more capable peers, as the basis of their conviction. They also believe it is possible to affirm the validity of a mathematical generalisation using a few examples (see Martin & Harel, 1989). Similarly, Stylianides, Stylianides, and Philippou (2007) revealed that pre-service teachers had two main types of difficulties with proof: the lack of understanding of the logic mathematical underpinnings of different modes of argumentation and the inability to use different modes of representations appropriately.

As exemplified above, research in mathematics education has shed light on different aspects of pre-service teachers' work on reasoning-and-proving, such as their beliefs related to proofs and proving, the challenges they face when deducing proofs and their use of modes of reasoning. However, more knowledge is needed about how pre-service teachers learn to teach reasoning-and-proving, as well as how teacher education can support their learning. A vital part of teachers' learning how to teach reasoning-and-proving is learning how to reason and prove in school-relevant mathematical areas (e.g. multiplicative reasoning). That learning is the topic of our study.

We examine two elementary school teachers' work on a reasoning-and-proving task during a professional development course. Like Remillard (2014), we consider mathematics to be a specific type of discourse where reasoning-and-proving is essential. Thus, mathematics learning is seen as participation in the discourse (Sfard, 2008). The two teachers whose work we analyse have limited experience of reasoning-and-proving in mathematics, and we are interested in their initiation into that discourse. Our research question is: What characterises two in-service teachers' initial participation in a mathematical discourse on reasoning-and-proving in elementary school teacher education?

Theoretical framework

Within a commognitive framework¹, Sfard (2008) take the position that learning mathematics is learning to participate in a specific discourse. Here, discourse is a special type of communication within a specific community that is made mathematical by that community's use of words, visual mediators, narratives and routines. The use of *words* in mathematics includes the use of ordinary words that have a special meaning in mathematics, like function and proof, and mathematical words, like fraction and axiom. Furthermore, people participating in mathematical communication use *visual mediators* to identify the object about which they are talking. These visual mediators are often symbolic, but they also include graphs, illustrations and physical artefacts. Within a discourse, any sequence of utterances, spoken or written, that describes the properties of objects or the relationships between objects is called a *narrative*. Mathematical narratives can be numerical, e.g. " $\frac{1}{2}$ is equivalent to $\frac{2}{4}$ ", or more general, e.g. "addition is commutative". Narratives are subject to endorsement or rejection, that is, being labelled as true or false, based on specific rules defined by the community. Endorsement of narratives is the main goal of the mathematics discourse; this includes the processes of constructing new endorsable narratives, substantiating them and recalling them in new situations.

Routines are well-defined practices that a given community regularly employs in a discourse. Sfard (2008) describe routines as patterns that are guided by two sets of rules: those telling the participants *how* to act, and those indicating *when* to do the given action. In contrast to rules on the object-level, which describe regularities on actions on and relations of objects, routines describe the participants' patterns of actions in a given discourse, and they can be considered to be rules on a meta-level. Lavie, Steiner, and Sfard (2019) emphasise the role of routines when participating in a specific discourse, and they suggest that learning routines can be seen as the routinisation of actions in a given discourse. Thus, on their way to new routines, learners must pass, if only briefly, through the stage of ritualised performance or imitation (Sfard, 2008). Here, *rituals* are understood to be socially oriented; they are acts of solidarity with co-performers. At this transitory stage, learners may become very familiar with the *how* of the new routine, but they will be much less aware of *when* it is used.

Our research question focuses on participation in a mathematical discourse on reasoning-and-proving, involving the processes of identifying patterns, making conjectures and providing arguments for whether or not conjectures are true. Hence, from a discursive stance, we are primarily interested in the routines associated with the construction and substantiation of narratives. New narratives are constructed mainly through operations on previously endorsed narratives. To substantiate a constructed mathematical narrative, one produces a proof—a sequence of endorsed narratives, each

¹ The term "commognition" is a combination of the words "communication" and "cognitive", and it stresses that thinking is a way of communicating with oneself and others.

of which is deductively inferred from previous ones, the last of which is the narrative that is being endorsed. Thus, learning to reason and prove in mathematics is about individualising both the *when* and the *how* of the construction and substantiation routines. In this paper, we focus on substantiation routines as framed by a task in which a hypothesis is already given.

To obtain insight into how individuals learn about reasoning-and-proving, it is useful to delineate the possible patterns of the processes and actions involved in constructing and substantiating narratives. Applying a commognitive perspective, Jeannotte and Kieran (2017) have developed a conceptual model of mathematical reasoning based on exhaustive analyses of mathematics education research. They propose the following definition of mathematical reasoning through commognition lenses: “Mathematical reasoning processes are commognitive processes that are meta-discursive, that is, that derive narratives about objects or relations by exploring the relations between objects” (Jeannotte & Kieran 2017, p. 9). Because their notion of mathematical reasoning involves proving, it coincides with our use of reasoning-and-proving. However, we use the latter to indicate that we look at a special kind of reasoning that is used when validating mathematical hypotheses, as mathematical reasoning *per se* does not necessarily include proving. Furthermore, Jeannotte and Kieran (2017) distinguish between processes related to the search for similarities and differences and processes related to validating. Searching for similarities and differences includes generalising, conjecturing, identifying a pattern, comparing and classifying. All these processes infer narratives about mathematical objects or relations (although on a partly different basis); thus, they are related to the routine of constructing narratives (Sfard, 2008). The processes related to validating include validating, justifying, proving and formal proving (defined inclusively, with an increasing degree of deductive structure and stringency). These processes aim to change the epistemic value (e.g. true, false) of a given narrative; therefore, they are related to substantiation routines (Sfard, 2008).

This study investigated two teachers’ initial participation based on their utterances and actions in a mathematical discourse on reasoning-and-proving in elementary school teacher education. We aim to illustrate how key concepts from the commognitive framework proposed by Sfard (2008) can provide insight into how mathematics teachers learn about the process of reasoning-and-proving.

Method

The two elementary school teachers, Sandra and Nora (pseudonyms), who participated in the research study, were part of a professional developmental course in mathematics for teachers in grades 1–7 in Norway that was held by two of the authors of this paper. Both teachers are 45-50-year-old females, and both completed general teacher education with less than 15 ECST credits in mathematics education. Sandra and Nora represent typical teachers attending the course, due to their age, educational background, gender and having more than 10 years of experience as general teachers.

The course contained materials on mathematics and mathematics education, and it was organised as six, three-day seminars distributed over one year, in addition to the teachers’ individual work on literature and assignments. The topics were sense-making in mathematics, pattern seeking and exploration, use of different representations (e.g. the array model for multiplication) and reasoning-and-proving (in particular, representation-based proofs). The participants noted that the coursework invited them to use new ways of thinking about and working with mathematics. This paper presents an analysis of the data collected through video recordings (in total 24 minutes) of Sandra and Nora

working on a task (Teddy's hypothesis, see Figure 1) on the second day of the fourth seminar of the course. The day before data collection, the topic was multiplication: different properties, strategies, models and reasoning-and-proving.

The task was chosen for the purpose of reasoning-and-proving, starting with a hypothesis proposed by Teddy, an imaginary student (Figure 1). The first step of the task (part a) involves validation of the hypothesis; the second step of the task (part b) entails both stating and validating the new hypotheses. In our analysis, we study validation processes, as exemplified by Sandra and Nora's work on the first step of the task (part a).

Teddy is a grade 5 student. He and his classmates are working on square and cubic numbers. After completing some tasks, Teddy says to the teacher: "Look here, if you multiply ... take two numbers and multiply... and both numbers end with 5... then the result also will end with 5".

- a) Give a proof that shows that Teddy's observation is correct for all such numbers.
- b) The situation can be used to propose and solve other problems, for instance:
 1. Is it only when both numbers end with 5 that the result ends with 5?
 2. Does the result hold only for 5, or when two numbers ending with the same digit are multiplied, does the product also end with that same digit?
 3. Which digits can square numbers end with?

Figure 1. Teddy's hypothesis task (adapted from Skott, Jess, & Hansen, 2008, pp. 223–224)

Teddy's hypothesis can be proved by using a generic example and array model of multiplication. Given any two numbers, both ending with 5, say 125 and 35, one can use the array model for multiplication to represent the multiplication 125×35 , as shown in Figure 2.

	100	20	5
30	100×30	20×30	5×30
5	100×5	20×5	5×5

Figure 2. The array model for multiplication used in a representation-based proof of the hypothesis

Every cell in this array, except the cell with 5×5 , is a multiple of 10. Thus, these cells do not contribute to the ones in the product. Only the cell with 5×5 does, and since 5×5 equals 25, we find that the product ends with 5. There is nothing special about the two numbers (35 and 125) in the example. The product of any two numbers both ending with 5 will have the same structure; thus, the number resulting from such a multiplication will end with 5.

Data analysis

The video recordings of Sandra and Nora's work on the task were transcribed, and then coded. The coding was guided by the research question. The aim was to describe the actions and utterances in the teachers' work, rather than to evaluate the mathematical and logical correctness of their arguments. Four researchers made a descriptive coding of the collected data, individually (Miles & Huberman, 1994). Next, the researchers compared and contrasted their coding and grouped the codes into six categories describing the two teachers' reasoning-and-proving efforts. The following categories were agreed upon: *confirming*; *proposing hypotheses*; *questioning validity*; *warranting*; *searching for patterns*; and *making drawings*.

To illustrate the categories and our findings, we present the teachers' work from part a of the hypothesis task. However, the above-mentioned categories apply to the teachers' discussions on all

the given tasks. The teachers' utterances are sometimes imprecise and difficult to interpret, and we tried to preserve this in the translation. In the analysis presented below, we use italics to emphasise the categories.

Sandra and Nora start their work by reading the hypothesis proposed by Teddy.

- 1 N: It is true, what he says.
 2 S: Yeah.
 3 N: So, the argument is correct.
 4 S: Yes, it is, eh; but it's more. It works for all odd numbers; so, the answer is 5.
 5 N: Yes, exactly.
 6 S: As long as one is a 5, one of ...
 7 N: Yes, in the 5 times table, no matter what you multiply with something with a 5 in, then you'll get a 5 at the end of the answer.
 8 S: Yes, ehm ...
 9 N: But, that's also because 5 is an odd number.
 10 S: Yeah, but do you have an argument that shows that Teddy is correct? Yes, it is, but is it ... is it enough? Now, we have actually, sort of gone further.

The category *confirming* in our analysis is a social act of support. Examples of this are seen in turns [2] and [5]. Furthermore, two new *hypotheses are proposed* in this excerpt of the discussion, one in turn [4] and another in [7]. Both hypotheses are related to Teddy's, but they are partly different, as [4] is more general than Teddy's hypothesis and [7] concerns properties of the 5 times table. In turn [9], the teachers *warrant* the hypothesis stated in turn [7]; in turn [10], they *question the validity* of Teddy's hypothesis. A few turns later, the discussion continues, as follows:

- 17 N: Because, eh, when you, right, in the 5 times table [S: Yeah], when you multiply with an odd number, you'll always end with 5, [S: Yeah] the answer will, the sum will always end, the answer will always be 5, thus ...
 18 N: And, anything that ends with 5 is an odd number, so if you multiply... 35 is an odd number, right.
 19 S: Yes, yes, because of the 5.
 20 N: Yes, so because of the 5 there it will be an odd number.
 21 S: Yeah.
 22 N: And, therefore, it will end with 5.
 23 S: Yeah.
 24 S: Yeah, but, but, if one should have made such a, representation-based proof for it, is that what they want? Or is it enough that we ... it is probably not enough that we say this. [N: [laughs]] Believe me [in English].

In the utterance in turn [17] a new *hypothesis is proposed* (stating that when multiplying any odd number by 5, the product always ends with 5), which can be seen as a generalisation of the hypothesis proposed in turn [7]. At the same time, the purpose of the utterance in turn [17], and also several other utterances in this excerpt ([18, 19, 20, 22]), is *warranting*, as recognised by their use of the words "because" and "therefore". The utterance in turn [24] *questions the validity* of the argument given ("is it enough"). Following her own request for a representation-based proof, Sandra is *making drawings* of arrays on a sheet of graph paper (Figure 3).

- 26 S: Yeah, but if you have a, 1-2-3-4-5, [N: Yes] (draws a 1x5 array on the sheet), that's there. How do I draw this here, then? Eh ... So, you have ... (draws a 2x5 array)
- 27 N: So, each 5 you'll get... Now, there it is an even number. [S: Yeah (draws a 3x5 array)] Then, there is an odd number.
- 28 S: Yeah, do we get a ... pattern? (draws a 4x5 array)
- 29 N: Yes... even number.
- 30 S: Yeah (draws a 5x5 array).

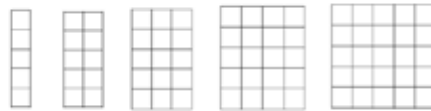


Figure 3. Sandra's drawings for part a of the hypothesis task

- 31 N: Odd number.
- 32 S: Yeah. But it's a ... eh, even number (writes e below the 1x5 array). No, (corrects to the letter o below the 1x5 array) odd number. Odd number plus odd number is always ... even number [N: even number, yeah] (writes $o+o=e$ below the 2x5 array. And here it's [N: odd number] odd number plus odd number plus odd number, equals odd number (writes $o+o+o=o$ below the 3x5 array, then $o+o+o+o=e$ below the 4x5 array)
- 33 N: And five is an odd number.
- 34 S: Yeah, ... Shall we drop this now, and try the next question?

While drawing the arrays, the teachers are *searching for patterns*. The patterns they discuss concern even and odd numbers in the 5 times table [32]. After turn [34], the teachers leave the task in step a, and proceed to step b. It is not clear if they are dissatisfied with the pattern discovered or if they are finding it difficult to identify a way to use the pattern to prove the hypothesis in turn [17] or Teddy's hypothesis, when they choose to leave the task.

Results and discussion

Our analysis shows that Sandra and Nora use several actions related to construction and substantiation routines. According to Sfard (2008), one of the distinct characteristics of discourses is the keywords that are used. In a mathematical reasoning-and-proving discourse, these keywords relate to deductive reasoning, which is “the only form of reasoning that can change the epistemic value of mathematical knowledge from likely to true” (Jeannotte & Kieran, 2017, p. 8). Sandra and Nora use words that are distinctive of a reasoning-and-proving discourse, namely their warranting of statements by their use of the word “because” followed by “then” or “therefore”, as seen in excerpts [18–23]. Moreover, the teachers question the validity of the arguments they provide, and they make drawings and search for patterns. In general, the use of drawings as visual mediators is one of the main aspects of mathematical discourse, and its role in reasoning-and-proving was emphasised in the professional development course. Sandra and Nora's drawings and their search for patterns is initiated by their act of questioning the validity of the arguments, which is part of the process of convincing (oneself or another) and is fundamental to mathematical reasoning (Jeannotte & Kieran, 2017).

At the same time, Sandra and Nora's explicit reference to representation-based proving (as seen in statement [24]), within the framework of Sfard (2008) and Lavie, Steiner, and Sfard (2019), indicate

that the teachers' participation is ritualised. As previously explained, rituals are understood to be socially oriented; they are acts of solidarity with co-performers or authorities. With their questioning of validity, Sandra and Nora express what they assume to be expected by the community, i.e. the teacher educators, regarding substantiation routines ("is that what they want?" [24]). The making of drawings and the search for patterns emerge in the teachers' work as a result of stating this question. This stands in contrast to questioning validity on the basis of the given hypothesis and a discussion of what narratives can be considered to already be endorsed by the community. Apart from the question referring to the teacher educators, Sandra and Nora also frequently confirm each other's contributions. Because their questioning of the validity and confirming each other's statements appears to be an attempt to gain social acceptance rather than their need to support and strengthen their substantiation of Teddy's hypothesis, their initial participation in the reasoning-and-proving discourse appears to be ritualised.

Our analysis also reveals ritualised participation in terms of *how* to act, in particular, how to use drawings. As shown in Figure 3, Sandra has made a drawing based on her own request for a representation-based proof of Teddy's hypothesis. The drawing and the following search for a pattern are related to the teachers' hypothesis (as seen in [17]), and not Teddy's hypothesis. Nevertheless, the chosen drawing does not advance the teachers' reasoning-and-proving process.

Sandra and Nora's actions related to construction and substantiation of narratives also indicate ritualised participation in terms of *when* to do a given action. As previously discussed, meta-discursive processes of reasoning-and-proving can be divided into processes of searching for similarities and differences (constructing narratives) and validating processes (substantiation of narratives). Throughout Sandra and Nora's conversation, these processes seem to intersect: several actions that they use, e.g. proposing hypotheses and searching for patterns, are mainly related to the processes of construction of narratives, and they are not appropriate for modifying the epistemic value of a narrative from likely to true. In a substantiation routine, a sequence of endorsed narratives is used, each of which is deductively inferred from previous narratives. Sandra and Nora propose several *new* hypotheses during their work (e.g. in [17]), and they are not explicit about whether the new narratives are (or can be seen to be) endorsed by the community and how they connect to Teddy's hypothesis. Moreover, Sandra and Nora search for patterns related to even and odd numbers, and it seems that the aim of this action is proving a hypothesis given in [17]. However, their search for patterns does not help them validate the hypothesis, and they leave the task. It is worth noting that the teachers' use of actions related to the construction of narratives happens, even though the Teddy's hypothesis task was designed to direct the teachers to participate in the validating process.

Conclusions and implications

Ritualised participation and challenges in knowing how and when a given action can be used are not surprising results when studying novices' initial participation in a given discourse (Sfard, 2008). Yet, within the frames of commognition, we have highlighted that some reasoning-and-proving actions seem to be more visible and applicable for novice participants than other actions; thus, they are easier to imitate. The teachers in this study employed several actions that are not directly related to substantiation but are regularly applied in a mathematical discourse. They search for patterns, propose a hypothesis and make drawings. They also perform actions related to substantiation routines, such as warranting and questioning validity. Yet, other actions related to substantiation of narratives seem

to be more hidden. For example, being critical is central to substantiation routines; however, Sandra and Nora continuously confirmed each other's contributions.

Moreover, the analysis discloses the two teachers' tendency to use construction-related actions (searching for patterns, proposing hypotheses) in what was designed to be a validating activity. Thus, the findings imply a need in teacher education to be more explicit about what actions are specific for reasoning-and-proving, and also, to be explicit about changes in actions when moving from construction to substantiation of narratives.

In this paper, we have reported on the characteristics of two in-service teachers' learning of reasoning-and-proving in a professional development context in the field of elementary education. Nevertheless, our study is limited by the number of participants, and further research from a commognitive standpoint is needed to shed more light on elementary education teachers' learning of reasoning-and-proving. For example, longitudinal studies are needed to learn more about teachers' evolving routines. Another topic for further research is the role of visual mediators in a reasoning-and-proving context, and how participants can routinise the use of visual mediators in the discourse.

References

- Jeannotte, D., & Kieran, C. (2017). A conceptual model of mathematical reasoning for school mathematics. *Educational Studies in Mathematics*, *91*(6), 1–16.
- Lavie, I., Steiner, A., & Sfard, A. (2019). Routines we live by: From ritual to exploration. *Educational Studies in Mathematics*, *101*(2), 153–176.
- Martin, W. G., & Harel, G. (1989). Proof frames of preservice elementary teachers. *Journal for Research in Mathematics Education*, *20*, 41–51.
- Miles, M. B., & Huberman, A. M. (1994). *Qualitative data analysis: An expanded sourcebook*. Thousand Oaks, CA: Sage.
- Reid, D. A. (2010). *Proof in Mathematics Education. Research, Learning and Teaching*. Rotterdam: Sense Publishers.
- Remillard, K. S. (2014) Identifying discursive entry points in paired-novice discourse as a first step in penetrating the paradox of learning mathematical proof. *The Journal of Mathematical Behavior*, *34*, 99–113.
- Sfard, A. (2008). *Thinking as communicating: Human development, the growth of discourses, and mathematizing*. New York: Cambridge University Press.
- Sfard, A. (2015). Learning, commognition and mathematics. In D. Scott, & E. Hargreaves (Eds.), *The Sage handbook of learning* (pp. 129–138). London: SAGE Publications Ltd.
- Skott, J., Jess, K., & Hansen, H. C. (2008). *Matematik for lærerstuderende. Delta. Fagddaktik*. Fredriksberg, Denmark: Forlaget Samfundslitteratur.
- Stylianides, A. J. (2007). Proof and proving in school mathematics. *Journal for Research in Mathematics Education*, *38*(3), 289–321.
- Stylianides, G. J., Stylianides, A. J., & Philippou, G. N. (2007). Preservice teachers' knowledge of proof by mathematical induction. *Journal of Mathematics Teacher Education*, *10*, 145–166.
- Stylianides, G. J. (2008) An analytic framework of reasoning and proving. *For the Learning of Mathematics*, *28*(1), 9–16.

Epistemological obstacles in the evolution of the concept of proof in the path of ancient Greek tradition

Miglena Asenova

University of Palermo, Department of Mathematics and Informatics, Palermo, Italy;

avcdiem@gmail.com

The paper examines the epistemological evolution of the concept of proof in the Western tradition, highlighting three important epistemological obstacles whose consideration can have significant consequences on the teaching and learning of proof.

Keywords: Proof, epistemological obstacles, to convince, contradiction, semiotic.

Introduction

Bachelard (1938) identifies in the act of knowing the causes of stagnation of the evolution of scientific thought; he calls the psychological causes of inertia in this evolution *epistemological obstacles*. According to the author (Bachelard, 1938), the epistemologist must endeavor to grasp the scientific concepts in an actual, i.e. in a progressive, psychological syntheses, establishing, concerning every notion, a scale of concepts, which shows how one concept has produced another; moreover, the epistemologist must necessarily take a normative point of view, while the historian usually has to avoid it, and what must attract his attention and guide his research is the search for rationality and construction in the evolution of scientific thought. “The epistemologist must take the facts as ideas, inserting them into a system of thoughts. A fact misinterpreted in an era remains a fact for the historian. It is, at the discretion of the epistemologist, an obstacle, it is a counter-thought” (Bachelard, 1938, p. 17). It is clear that in the construction of the epistemological trajectory it will not be possible to provide (nor would it make sense to ask for) a proof of uniqueness; what such a reconstruction can produce is an argument, effective because of its coherence and its explanatory capacity, which testifies in favour of its one existence.

Brousseau (1989) gives to the concept of epistemological obstacle the meaning of knowledge (not a lack of knowledge) that has been effective previously, in a given context, which at a certain point begins to generate answers judged to be false or inadequate and produces contradictions. Moreover, an epistemological obstacle has the characteristic of being resistant and of presenting itself sporadically even after having been overcome; its overcoming requires the passage to a deeper knowledge, which generalizes the known context and requires that the student becomes explicitly aware of it (Brousseau, 1989). According to Brousseau (1989), this reasoning can be applied to analyse either the historical genesis of knowledge or its teaching or the spontaneous cognitive evolution of student’s conception. The search for epistemological obstacles can occur using two approaches: the first is, according to Bachelard, based on historical research by adopting an epistemological lens; the second one is based on the search for recurring errors in the learning process of a mathematical concept; the two research lines are intertwined: the historical-epistemological evolution can help in the identification of possible hidden models and can provide suggestions on the construction of appropriate learning situations to overcome a given obstacle; on the other hand, students’ errors and recurring difficulties can suggest the presence of epistemological obstacles. Given students’ enormous difficulty in understanding proof, it seems to us that the identification of

possible epistemological obstacles can be useful in teaching and learning practice and, even before, in teachers' training, providing awareness of teachers' own epistemology and of the possible gap between their own and students' conceptions.

The historical-epistemological investigations on the concept of proof are not new in Mathematics Education. Barbin (1994) traces briefly a history of proof, highlighting its different meanings in different eras. The author identifies two fractures, one relative to the convincing-explaining contrast and one relative to the role of contradiction, but does not clearly highlight the origins of proof as a conviction from an epistemological point of view; moreover, in the identification of the second fracture, she assumes that modern axiomatization is the result of a need for greater proof rigor, while we intend to show that it arises from the very nature of mathematics. Barbin concludes that deduction constitutes an obstacle and that its overcoming can be achieved through the revaluation of proof as a method. Another historical analysis that takes at times interesting epistemological aspects is that of Grabiner (2012), in which the author mainly aims to highlight the non-absoluteness of the concept of rigor and proof, without however proposing an evolutionary trajectory in which, as Bachelard states, it should become clear how one conception follows from the other (Bachelard, 1938). A last contribution that we take briefly into consideration is that of Longo (2012), in which the author emphasizes the pre-eminence of two fundamental principles for mathematical proof, which have cultural and historical roots: symmetry and order, and highlights the need for an approach in opposition to Hilbert's formalism, which should avoid recourse to actual infinity. Longo's approach is interesting but it is posed in a perspective of synthetic philosophy, which is not however the one on which the current foundation of mathematics is based.

None of the contributions examined searches explicitly for epistemological obstacles, taking at the same time a position in line with the current foundational aspects of mathematics, which are those on which teachers' training is based on and which are transposed in textbooks. Our aim is to understand if there is a path in the epistemological evolution of the object proof in the ancient Greek (and then the Western) tradition that could show changes in the modes proof was considered able to provide knowledge and about the characteristics of that knowledge.

The epistemological evolution of the concept of proof

Ancient Greek tradition

One of the most interesting aspects of proof in the path of ancient Greek tradition is related to its origin in an axiomatic system. Even when analyzing various other aspects, Grabiner (2012) identifies at least the reason of what she calls "a logical proof", in Greek mathematicians' need to be able to prove things that are not evident: "[...] visual demonstration did not suffice for the Greeks. [...]. Such proofs are necessary when what is being proved is not apparent." (Grabiner, 2012, p. 148). We believe that from an epistemological point of view the answer of the question is a bit more complex and should be searched upstream, in Eleatics' rejection of the epistemological validity of the experience of the senses, which led them to assume logical indicators of clarity and necessity as criteria of truth. We will explain our point of view in the next paragraph, following the original sources.

According to Parmenides, the Being is the only reality and the convincement, in the sense of persuasion through thought, is the only way that allows us to acquire reliable knowledge. Parmenides' conception of thought is that of reasoning, of logos, of what can be called "logical reasoning", which

produces *necessary* true conclusions, because when investigating truth (i.e. the Being), we start always from the Being which is not only an unchanging, indestructible whole, but is also connected: “observe how what is far away is reliably approached by your mind because it [the mind] will not separate the Being from the context of Being, nor in such a way that it [the Being] loosen anywhere in its structure nor in such a way that it masses together. Then Being is indeed connected, regardless of where I start [the research] that's where I'll be back again.” (Diels, 1906, p. 116). The last sentence shows exactly the conception of knowledge acquirement in Parmenides: logical reasoning, starting from necessary true premises is convincing and this kind of convincement is the only way that leads to knowledge of truth. Instead the way of investigating the Not-Being, which is not necessary, is the way of opinion linked to the senses: “the only thinkable ways of research are the following: the way of Being, which is and which is impossible but be, is the way of conviction (since it follows the truth); but the other one, that it [the Being] isn't and that this Not-Being is necessary, is a completely inscrutable path since the Not-Being cannot be neither recognized (it is in fact unfeasible) nor pronounced” (Diels, 1906, p. 116). The fundamental Eleatic dialectic is then the dialectic between certain knowledge (and the way of convincement which allows to acquire it) on the one part, and opinion (and the way of the senses which allows to acquire it) on the other part.

Eleatics used different modes of conviction to carry out Parmenides' “way of truth”: Zeno of Elea used the proof by *reductio ad absurdum* (or proof by contradiction) as method to destroy the arguments of the opponents showing that their premises led to contradictions, while other Eleatics, like Melissus, tended to prove arguments also starting from undoubtedly certain premises. (Cambiano, 2004). Zeno's way of *reductio ad absurdum* is coherent with the Eleatic philosophy because there is not only a distinction of Being (real, true) and Not-Being (not real, false), that excludes the possibility of a third value, but also the fact that for the Being not be is impossible, that represents the double negation. Like outlined by Antonini and Mariotti (2008), in the past, starting from 16th and 17th centuries and up to the 20th century, there was a debate about the fact that proof by contradiction collides with the Aristotelian position that causality should be the base of scientific knowledge and that such a proof cannot reveal the causes since it is not based on true premises. We state that in the perspective of Eleatic philosophy, proof by contradiction fits perfectly with the role it has in this philosophy: the role to get knowledge of the truth of a statement by following a convincing logical thought that shows that it is necessarily so and it cannot be in another way. This is just what Zeno probably wanted to do, using such proofs, because they are not suitable to explain, but they are suitable to convince.

The Eleatic dialectic was of great importance for the subsequent development of philosophy and science. Plato's thinking was strongly influenced by Parmenides (Cambiano, 2004) and so all the Western philosophy.

Other important aspects in the epistemological evolution of proof are the roles played by the Megarian school and by the Sophists. The Megarian philosophical school flourished in the 4th century BCE and some of the successors of Euclid of Megara, its founder, developed logic to such an extent, maintaining the Eleatic epistemological assumptions about the importance of conviction in knowledge acquirement, that they became a school in its own (Cambiano, 2004).

In the 5th century BCE the Greek society experienced a period of rapid socio-cultural transformation that led to a new politic system based on democratic principles; in this new society the need to provide

education for the children of the emerging classes arose and Sophists satisfied it (Cambiano, 2004). The ability to convince was considered one of the most important abilities for the citizen who wanted to participate in the political life of the *polis*. Sophists wanted to show that with the art of rhetoric and dialectic, even “weak” speeches could be made “strong”, since it would have been possible to reject even the most evident statements. This was a turning point to relativism with respect to Eleatic doctrine because Sophists negates the existence of absolute truth: truth is a form of knowledge always related to the subject and its experience; they are as multitude of truths as subjects. The dialectic methods used by the Sophists for their argumentations were the same used by the Eleatics: confirmation by proof conducted in rigorous logic steps and refusal by proof of the falsity of the antithesis, but Sophists perfected them; dialectic influenced deeply rhetoric, shifting attention to the persuasive force of speeches.

The Sophists’ relativism pushed many philosophers, e.g. Plato, to look for a transcendent objective basis on which to base behavior and moral conduct but also influenced the way of exposing scientific knowledge, particularly the mathematical one. It becomes clear that the Euclidean axiomatic system was developed at a time when it was necessary to place mathematical knowledge on unquestionable bases. This point of view is clearly expressed for instance by Clairaut: “this geometrician [Euclid] had to convince obstinate Sophists who were proud to reject the most obvious truths” (Clairaut, 1741, pp. 10–11). Hoüel remarks furthermore that Euclid’s frequent recourse to indirect proofs is also motivated by the need to prevent critics due to Sophists’ relativism: “[...] hence his [Euclid's] habit of always proving that a thing cannot be, instead of showing that it is” (Hoüel, 1867, p. 7).

The need to avoid any critic as the tread in organizing the mathematical knowledge can also be detected in the attention placed by Euclid on avoiding arguments which involve concepts that might leave some room for criticism, instead of using direct proofs which involve only subjects conceptually close to the statement to be proved. An example in this sense is the proof of proposition CXVII of book X of the *Elements* which states that in a square the diagonal and the side are incommensurable. In order to prove the statement Euclid uses an indirect proof that involves not only geometrical but also arithmetical arguments (e.g. concepts of odd and even number, of divisibility etc.) instead of using the proposition II of book X, introduced just before, which applies to segments the arithmetical method used in book VII to establish if two numbers are coprime (Barbin, 1994). A proof conducted using the latter method would be direct and would refer only to geometric concepts, but the problem is that it would involve an infinite procedure and might be exposed to the criticism of who asked what is, for example, the limit of the succession of squares that is built.

According to Barbin (1994) we can state that Euclid’s main concern is to be able to persuade and to avoid considerations that might leave room for critiques; an axiomatic system is a good solution to do this. Of course, the methods that could be applied to isolate the axioms might have already been highlighted by Hippocrates of Chios, “who wrote the best logically structured *Elements of Geometry* until Euclid wrote his own *Elements* 150 years afterwards” (Grabiner, 2012, p. 150), but the real motivation to do this should be detected in the philosophical and cultural environment of the time.

In our analysis we cannot avoid to mention Aristotle because of his influence in shaping medieval scholarship, not only in the Western but also in the Islamic world. Aristotle, starting initially from a Platonist position, reversed later in a certain sense the ontological question advocated by the Eleatics and then by his master Plato. Aristotelian ontology, like the Platonic one, distinguishes between

Universal and Particular, but while for Plato universal forms are separate from particular manifestations, for Aristotle the Universal is in the Particular and the only way to access the Universal is through the Particular, using the perception of the senses, in particular the eye, because in perceiving the world we prefer the sight to all the other senses (Aristotle, 1973). One might wonder why the Aristotelian doctrines have not changed the idea of proof and why there is no trace of them in the *Elements* and why the concept of proof contained in the *Elements* remained the prototype of (not only) mathematical proof for a lot of time. We can say that while the ontological aspect is reversed, Aristotle's epistemology remains similar to the Platonic one. Indeed, both, Plato and Aristotle, are interested in the knowledge of Universals though the way to reach them is different: Aristotle's empirical approach is linked to exploration, which can also refer to induction or abduction, but its aim is to arrive at "true" knowledge; this last way is nonetheless deductive and proof is the final step of the process of knowledge acquirement (Cambiano, 2004).

Enlightenment and the "small steps": the first crisis

Until the 17th century the concept of proof in mathematics remained linked to the idea of proof in an axiomatic system such as that of geometry presented in Euclid's *Elements*, even if, due to the lack of adequate mathematical tools, attempts to axiomatize other fields of mathematics remained sporadic and ineffective for a long time (Lolli, 2004). The 17th century was a particular historical and cultural period during which there were a lot of important discoveries and innovative and courageous stances in science. Alongside of Galileo's scientific method, new general mathematical methods were developed in order to satisfy the need to describe the physical phenomena, like Cavalieri's principle of indivisibles, the Cartesian method, Newton's method, Monge's projective method etc. In these rapid innovations the ancient Greek writings, first of all Euclid's *Elements*, were exposed to a hard criticism by the mathematicians. They accused ancient Greek geometer to be more interested in persuasion and in validation than in explanation and discovery. What is criticized is not the content but the form, the setting and the role attributed to proof. In Arnauld's and Nicole's *La logique ou l'art de penser* the authors expose the widespread feeling among their contemporaries summarizing as follow the errors attributed to Greek geometers: (1) to pay more attention to certainty than to evidence and to the conviction of the mind than to its enlightenment; (2) to prove things that have no need of proof; (3) to demonstrate by impossibility; (4) to conduce far-tetched demonstrations; (5) to pay no attention to the true order of nature; (6) to employ no divisions and partitions (Arnauld & Nicole, 1850). The critiques are basically two. The first, which contains the first four errors, concerns the single results and can be summarized in the question: "Is it more important to convince or to enlighten?". The second, which involves the whole structure of the text, is the accusation of a lack of method (the sixth error can be regarded as the consequence of the fifth one).

With regard to the new methods elaborated by mathematicians during the 17th century there was an important epistemological aspect that mathematicians of the time were already asking themselves: the problem of the validity of the new methods. Barbin summarizes as follows the doubt in this regard: "these methods illuminate, clarify the spirit, as they show the way to which we have passed and lead to evidence [...] but what is made evident can be considered as demonstrated?" (Barbin, 1994, p. 223). Thus, for example, Cavalieri's method of indivisibles, which already carried the idea of the integral, aroused some suspicion because of its resort to actual infinity, despite its operational superiority compared to Archimedes' method of exhaustion.

One method that initially does not raise suspicion was instead the Cartesian method which essentially led to a general algebraic conception of proof. The method described by Descartes in his *Discours de la Méthode* (1666), his *small steps*, his *long chains of reasons*, *all simple and easy*, were the attempt to provide a method of discovery to mathematics which quickly imposed itself on a large scale even though it posed some practical difficulties and mathematicians found it difficult to resort to it in practice (Lolli, 1988). We should however keep in mind that there are two different layers of evidence in Descartes' conception: the one is related to the physical evidence of the axioms in Euclidean geometry, which is the basis of mathematics and that remains undisputed; the other is related to the evidence of the starting point and of the "small steps" of reasoning that should be so simple and evident to be intuitively accepted by anybody without any doubt about their correctness. Both these evidences will be questioned by the subsequent development of mathematics.

Mathematical proofs, physical reasons and the second crisis

At the end of 17th and beginning of 18th centuries, with the growing of Analysis, it becomes more and more clear that the algebraic conception of proof was insufficient for the type of investigation mathematics was going to face [see for instance the need to deal with functions and infinitesimals and in general with infinite entities (Lolli, 1988)] and that requires a purely mathematical definition of the involved objects. Furthermore, the development of abstract algebra allowed a new, structural organization of mathematical knowledge. All these reasons allow the take-off of pure mathematics which does not (should not and could not) refer to physical evidence. On the other hand, the birth of non-Euclidean geometries led to a subsequent loss of authority of geometry as foundation of mathematics, based before on the physical evidence of its axioms. The birth of general theories with multiple interpretations and the need to give a unitary organization of mathematics led to increasing awareness of the importance of the definition of mathematical objects through interrelations of formal axioms, which allows multiple interpretations; all this finally led to the modern axiomatic model.

Axiomatization implies an important change of perspective: a change in concept and role of contradiction: in ancient Greek mathematics the contradiction intervened in a social act and was used to convince: to prove means to convince; the modern conception of contradiction is very different: contradiction intervenes in a system of mathematical propositions and it is used for producing mathematical results: to prove means to make evident the non-contradictoriness of a statement within an axiomatic system. The concept of evidence makes no sense in this formalistic conception of mathematics: the objects are *real* inasmuch they are defined by the relations between them; there is no need for physical or metaphysical reality to refer to. The only way to deal with such abstract formal objects is formal reasoning: implicit definition and formal logical principles are needed for the new conception of proof, based on non-contradictoriness; the new axiomatic model is not due to a perverse and arbitrary will of formalization but to the formal character of mathematics (Lolli, 2015).

Modern axiomatization and the need for interpretation

Modern axiomatization underpins and highlights the special ontological condition of mathematical objects to which an ostensive cross-reference is impossible and shows clearly the essentially semiotic nature of mathematical activity; but it poses an important problem: in a formal axiomatic conception of mathematics asking for meaning of mathematical objects makes no sense. The only way to give meaning to them is dealing with them in an interpretation of the formal theory. An interpretation

needs a language that allows to express the relations of the objects occurring in it. Bourbakism rendered clear that set theory is a formal language which is most similar to natural language and that allows to construct mathematical discourses, giving a meaning to mathematical activity. Experts in mathematics are able to give a meaning to a discourse in set-theoretical language (they are able to use it, enriching its expressivity by natural language without losing its mathematical meaning) and so they are usually convinced of the unity between mathematical and natural languages; but this competence is only the confirmation of the fact that the metalanguage (natural language) has successfully fulfilled its role as constructing tool for the object language (mathematical language).

Conclusions

Our analysis shows three epistemological obstacles which forcefully impose themselves in the examined path: (1) the belief that the proof concept in Euclidean Geometry may be used to *explain* mathematical reasoning; (2) the belief that contradiction in mathematics has the role of convincing and that to prove means to convince somebody of the truth of an utterance and not the role to establish the consistency in an axiomatic system, i.e. to establish its validity; (3) the supposition that mathematics is not a discourse in itself but one that is telling something about something that really exists and that to prove means to prove the truth of a statement and not its validity in a metalanguage as well the subsequent supposition of the unity between natural language and mathematical language and the consequent lack of awareness of the complex relation between them.

All three obstacles represent important topics related to the teacher's epistemological beliefs and the way in which teachers implement the didactic transposition of the mathematical object "proof". Moreover, we stress that against the third obstacle, the whole teaching of modern mathematics collides. Without the awareness of the latter, at school we will continue to teach only Euclidean mathematics and the concept of proof present in it, believing that the modern axiomatic method is only a generalization of the Euclidean one.

Furthermore, while the first two obstacles can be considered as obstacles already crystallized in Western culture, the third is an obstacle of very recent formation and it is still little perceived and not recognized. This obstacle also places the cultural aspect in the foreground as it can have very different cultural declensions. Indeed, while the general semiotic aspects might have a general characterization, semiotic aspects related to the natural language can be specific (Lolli, 2015). While the overcoming of the first two obstacles requires the entry into a certain culture of mathematical thought (which has its roots in ancient Greek tradition), the overcoming of the third obstacle requires a specific transposition, dependent on the peculiarities of the natural language of reference.

Concerned to the usefulness of the epistemological obstacles in Mathematics Education, we can say that within Brousseau's (constructivist) theory of didactic situations, acquiring knowledge means adapting to a specially designed situation that has that given knowledge as optimal solution (Brousseau, 1989); it is therefore worth to identify the epistemological obstacles in order to help teachers to construct situations in which the student is forced to use a type of knowledge that leads her/him to overcome the obstacles, supported by teacher's mediation choices. In a socio-cultural perspective, instead, the interpretation of the notion of epistemological obstacle could present some difficulty because of the specificity of mathematical cultural production (D'Amore, Radford, & Bagni, 2006). Nevertheless, also in a socio-cultural perspective, the institutional meaning of

mathematical objects refers to a certain cultural tradition which could hide eventual epistemological obstacles.

References

- Antonini, S., & Mariotti, M. A. (2008). Indirect proof: what is specific to this way of proving? *Zentralblatt für Didaktik der Mathematik*, 40(3), 401–412.
- Aristotele. (1973). *Metafisica*. In G. Giannantoni (Ed.), *Aristotele: Opere*. Roma, Bari: Laterza.
- Arnauld, A., & Nicole, P. (1850). *Logic, or the art of thinking: being the Port-Royal Logic*. (T. S. Baynes, Trans.) Edinburgh: Sutherland and Knox. (Original work published 1662)
- Bachelard, G. (1938). *La formation de l'esprit scientifique*. Paris: Vrin.
- Barbin, E. (1994). La dimostrazione in matematica: significati epistemologici e questioni didattiche. *L'insegnamento della matematica e delle scienze integrate*, 17B(3), 209–249. [Original work: Barbin, E. (1988). La démonstration mathématique: significations épistémologiques et questions didactiques. *Bulletin APMEP*, 366, 591–620].
- Brousseau, G. (1989). Les obstacles épistémologiques et la didactique des mathématiques. In N. Bednarz, & C. Garnier (Eds.), *Construction des savoirs, Obstacles et Conflits* (pp. 41–63). Montreal: Les Editions Agence d'Arc Inc.
- Cambiano, G. (2004). *Storia della filosofia antica*. Milano: Laterza.
- Clairaut, A. C. (1741). *Éléments de géométrie*. Paris: David Fils.
- D'Amore, B., Radford, L., & Bagni, G. T. (2006). Ostacoli epistemologici e prospettive socioculturali. *L'insegnamento della matematica e delle scienze integrate*, 29B(1), 11–40.
- Descartes, R. (1966). *Discours de la Méthode*. Paris: Flammarion. (Original work published 1637)
- Diels, H. (1906). *Die Fragmente der Vosokratiker: Griechisch und Deutsch* (II ed., Vol. 1). Berlin: Weidmannsche Buchhandlung. (Original work published 1903)
- Grabiner, J. V. (2012). Why proof? A historian's perspective. In G. Hanna, & M. de Villers (Eds.), *Proof and Proving in Mathematics Education, The 19th ICMI Study* (pp. 147–168). Dordrecht, Heidelberg, London, New York: Springer.
- Hoüel, G.-J. (1867). *Essai critique sur les principes fondamentaux de la Géométrie élémentaire ou Cômmentaire sur les 32 premières propositions des éléments d'Euclide*. Paris: Gauthier-Villars.
- Lolli, G. (1988). *Capire una dimostrazione*. Bologna: il Mulino.
- Lolli, G. (2004). *Da Euclide a Gödel*. Bologna: il Mulino.
- Lolli, G. (2015). Le parole nella matematica. *Quale didattica dell'italiano? Problemi e prospettive dell'insegnamento dell'italiano: Problemi e prospettive*. Locarno: SUPSI. Retrieved from <http://didattica-italiano.www2.dfa.supsi.ch/iii-lapporto-delle-altre-discipline-scolastiche/>
- Longo, G. (2012). Theorems as Constructive Visions. In G. Hanna & M. de Villers (Eds.), *Proof and Proving in Mathematics Education, The 19th ICMI Study* (pp. 51–68). Dordrecht, Heidelberg, London, New York: Springer.

Teachers' perspectives on mathematical argumentation, reasoning and justifying in calculus classrooms

Sabrina Bersch

University of Augsburg, Germany; sabrina.bersch@math.uni-augsburg.de

An interview study on mathematical argumentation (in a broad sense) was conducted with teachers of upper-secondary calculus classrooms. This paper describes the study's methods and its results. By using qualitative text analysis, four major categories were created to depict the current state of mathematical argumentation in calculus classrooms. Two dominant problem areas were revealed: Students' language difficulties and the heterogeneity of students. To address these problems, a learning environment was designed and evaluated in a follow-up study.

Keywords: Argumentation/Reasoning/Justifying, calculus, secondary school teachers, semi-structured interviews, learning environment.

Introduction and theoretical background

Mathematical argumentation, reasoning, justifying and proof indisputably constitute an important field of mathematical competencies. Nevertheless, the 1995 and 1999 TIMMS Video Studies found that reasoning did not occur frequently in mathematics classes of the examined countries (Hiebert et al 2003, p. 73-75). Since 2003, the *Bildungsstandards* set by the KMK¹ have functioned as an important framework for teaching mathematics in Germany. One of the process-related competences they specify is *Mathematisch Argumentieren* (approximately corresponding to *mathematical argumentation*). This term is used as an umbrella term for working with mathematical conjectures and statements by employing a range of argumentations, from arguments of plausibility through justifications to formal proofs (KMK 2012, p. 14). In the United States, the Principles and Standards for School Mathematics were published by the National Council of Teachers of Mathematics (NCTM) in 2000 as one of the first sets of standards for mathematics teaching. One of the Process Standards set by the NCTM is *Reasoning and Proof*, which also comprises reasoning, proving, using conjectures, argumentation and justification (NCTM, 2000). In this paper, *mathematical argumentation* is used in a broad sense, including all aspects used by the KMK and the NCTM. In addition, pre-formal or semi-formal mathematical activities of argumentation, reasoning and justifying are considered suitable for mathematics in school and useful, necessary steps to formal, deductive proving as an essential mathematical activity. The term *formal* is “referring to the standard language used to talk about mathematics, which encodes the meanings of mathematics” (Barwell 2016, p. 333). Mastering this standard language is considered its own learning item for students. Pericleous similarly states that “explanation, justification and argumentation [...] provide a foundation for [...] developing deductive reasoning” (2015, p. 226). However, the level of formality and deductive reasoning that should be acquired in school is open to debate.

¹ The *Bildungsstandards* are Educational Standards set by the Conference of Ministers of Education and Cultural Affairs in Germany (KMK)

Teachers' perspectives on argumentation in class are of great importance, because teachers are responsible for providing learning environments and tasks for students (Buchbinder, 2017, p. 107). They have gained significant experience with students' processes of acquiring competencies. Yet, there is little research on argumentation from a teachers' perspective to date. The discussed study investigates the role and importance of mathematical argumentation in calculus classrooms, explores teachers' attitudes and ideas about mathematical argumentation and reveals problems and difficulties teachers face when training students' mathematical argumentation competencies. Interviews with 14 teachers of different schools teaching upper-secondary students in calculus were conducted and analysed using qualitative text analysis². In a follow-up study, a learning environment was developed and evaluated based on the results of the interview study. In this paper, the interview study is described in detail including its methods and findings. The paper concludes with a short outlook on the follow-up study.

Methods

There were two main research questions: (1) *Which role does mathematical argumentation play in current calculus classrooms?* (2) *Which problems and difficulties do teachers face with regard to mathematical argumentation in calculus classrooms?* To answer these questions, semi-structured interviews were conducted with 14 upper-secondary school teachers. The interview manual had four parts with different thematic foci. The participants had been informed that the topic would be calculus teaching. However, the emphasis on mathematical argumentation was not mentioned before the second part of the interview, because the first part was about calculus teaching in general and argumentation was only focused on in the other three parts.

14 upper-secondary school teachers, 5 female and 9 male, were chosen from 7 different schools (6 in Bavaria, Germany; 1 in Hesse, Germany), teaching different subjects in addition to mathematics. Their age ranged from 30 to 64 years with teaching experience from 4 to 36 years.

The analysis of the interviews used a combination of methods of qualitative content analysis (Mayring, 2015) and thematic qualitative text analysis (Kuckartz, 2014). First, a selection criterion was applied to detect all passages of the interviews concerning the topic of mathematical argumentation. Then, major categories were created deductively according to the interview guidelines and the research questions. After applying them to the data, they were further differentiated into subcategories inductively using the codes of each major category. Processes of subsumption and clustering were used to establish the final category system with various levels for the analysis.

Results

Figure 1 presents an overview of the category system. The major categories are *Understanding Concepts*, *Current Implementation in Class*, *Positive Aspects* and *Problems and Difficulties*. The numbers in brackets state the numbers of respondents (out of 14) whose statements contained segments for the respective subcategories. Each category is described separately in the following.

² A rough overview of the interview study is being published in (Scheffler, 2018) and parts of the results have been published in (Scheffler, 2017).

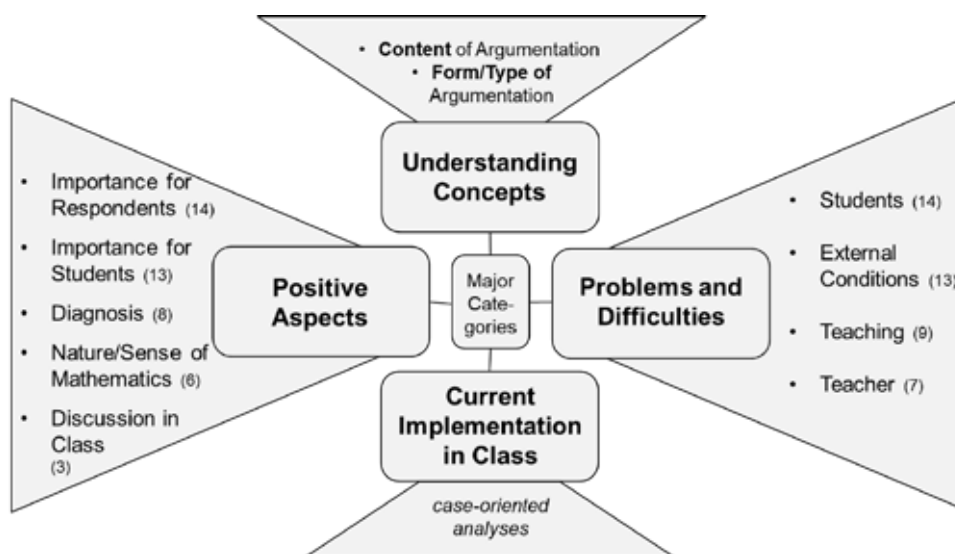


Figure 1: Major categories of the qualitative text analysis of the interviews

Understanding Concepts

The major category *Understanding Concepts* comprises segments from which it can be concluded what teachers mean when speaking of *argumentation*, *reasoning*, *justifying* or *proving*³. Segments within this category were categorized throughout all parts of the interviews, because the participants were not directly asked about their understanding of the terms. Various ideas could be found and subdivided into two subcategories: Ideas about the *Content of Argumentation* and ideas about the *Form/Type of Argumentation*. The teachers' statements do not only contain ideas about their actual teaching but also about their general understandings of argumentation. Both subcategories demonstrated a wide range of understandings. The most frequent opportunities for mathematical argumentation mentioned were situations in which students needed to justify their approaches when dealing with any mathematical exercise or task or justify certain mathematical theorems, rules or formulas. In addition, it was described that students reason when working with properties of various functions or when modelling mathematically. More generally, the teachers stated that mathematical relations or issues can be used for mathematical argumentation in class.

In the subcategory *Form/Type of Argumentation*, it is striking that most teachers talked about formal proving but mostly commented on the lacking feasibility of using proofs in class. Other ways of mathematical argumentation mentioned by several teachers were justifying using calculation, explaining or elucidating, verbal justification and justification supplemented by sketches. This results in a varied field of teachers' understandings of how argumentative competencies can play a role in calculus classrooms and what mathematical content can be used for these purposes. These findings

³ In the interviews, I used the German terms *Argumentieren* and *Begründen* (approximately corresponding to *argumentation* and *justification* in English) as synonyms and avoided the term *Beweis* (*proof*) as it has negative connotations for some teachers. For the category *Understanding Concepts*, all segments of the interviews were used which showed understandings of any of the terms *Argumentieren*, *Begründen* or *Beweisen*.

correspond to the broad understanding of the term used in the German KMK *Bildungsstandards* and in the NCTM standards.

Current Implementation in Class

Descriptions of what the teachers actually do in class concerning mathematical argumentation are collected in the subcategory *Current Implementation in Class*. Each case was analysed separately by summarising and abstracting the main ideas. The following overall tendencies about the current state of mathematical argumentation and proof in calculus classrooms could be found:

- Tasks in which students are asked to give reasons play a significant role.
- Formal proving, theoretical justifying and systematic derivations only occur occasionally, with most argumentations and justifications being informal, oral and not written.
- Teachers reason and justify more than their students.
- Argumentation and reasoning seem to be opposed to standard techniques which are trained mainly for the final examinations.

These practical tendencies are based on teachers' attitudes towards argumentation and reasoning in calculus classrooms. These attitudes are connected to the reasons teachers have to train their students' argumentative competencies. These reasons can be deduced from positive remarks about argumentation collected in the major category *Positive Aspects*. On the other hand, *Problems and Difficulties* with argumentation in calculus classrooms concern reasons why teachers use fewer opportunities for mathematical argumentation in their classes than they ideally should.

Positive Aspects

The positive statements about mathematical argumentation in calculus classrooms can be divided into 5 subcategories: Segments showing that mathematical argumentation is important for the teachers themselves (1) or for the students (2), segments explaining that mathematical argumentation is a good way for diagnosing students' skills (3), segments in which teachers state mathematical argumentation to be an essential part of mathematics (4) and segments in which teachers express that employing mathematical argumentation results in good discussions in class (5). The most interesting results can be found in the subcategory *Importance for Students* (2) which includes segments in which teachers explain how mathematical argumentation in class has positive effects for the students. In their opinion, mathematical argumentation is crucial for the students' content-related competence. It is also considered important for the students' future in mathematics and beyond. Teachers point to students who really like reasoning and to more proficient students who can demonstrate their skills with justification tasks.

Problems and Difficulties

Nevertheless, there are many problems and difficulties with mathematical argumentation in calculus classrooms. As it has been explained above, there is a reluctance to use formal proofs for different reasons which are not focused on in the study. For this reason, remarks stating difficulties and problems specifically with formal proofs were not coded in the major category *Problems and Difficulties*. Emphasis was put on argumentation in general. As Figure 1 and Figure 2 show, 4 subcategories could be created inductively in the major category *Problems and Difficulties*. All

teachers mentioned problems and difficulties concerning the *Students* and nearly all teachers have problems with the *External Conditions* they face. In addition, there are problems and difficulties in the area of *Teaching* and difficulties for the *Teachers* themselves. Notably, difficulties for the *Teachers* themselves all deal with grading mathematical argumentation tasks. Problems with *Teaching* arise because teachers do not consider reasoning and justifying tasks suitable for examinations, and training standard calculation techniques has priority in their teaching. *External Conditions* that cause most problems for teachers are the restricted time available for teaching and the requirements of the centrally organised final examinations.

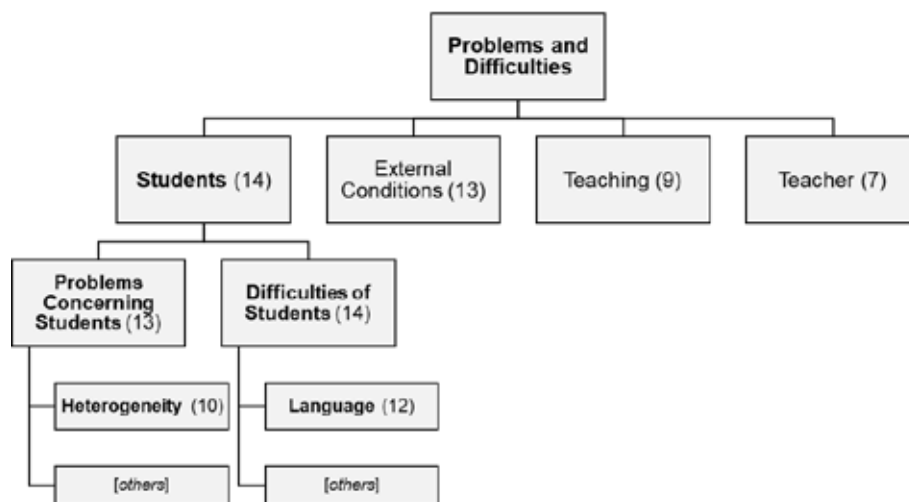


Figure 2: Part of the category system with a focus on *Problems and Difficulties*

The subcategory *Students* contains by far the most difficulties and problems that were mentioned by the teachers. It is further subdivided into *Problems Concerning Students* and *Difficulties of Students*. Due to their size, these subcategories were further subdivided:

Firstly, by far the largest subcategory of the subcategory *Problems Concerning Students* is *Heterogeneity*. Segments in this subcategory are about problems that arise because of students' different performance levels. While teachers are of the opinion that low achieving students have serious problems with mathematical argumentation tasks, such tasks are seen as a particular challenge for high achieving students. Consequently, teachers do not know how to cope with the great span and often decide not to use justification tasks in class. An example segment within the subcategory *Heterogeneity* is the following:

First of all, I often think that these justification tasks are only accessible for a part of the students so that another part of the students is left behind by these justification tasks. And for them, it is important to do tasks in which they can use their learnt strategies. So, I would not use 45 minutes just for training argumentation, because after some time I would sit there just talking to five students and the other 20 are looking into the air (Interview 8, paragraph 58, own translation).

Other *Problems Concerning Students* result from students' aversion to argumentation amongst others.

Secondly, within the other subcategory, *Difficulties of Students*, a dominant subcategory evolved as well: *Language*. This subcategory contains segments dealing with problems students have with, for

example, terminology, formulations, and especially writing down argumentations and justifications. An example segment within the subcategory *Language* is the following:

And of course language, that's an important point, whether mathematical language or German language, stringing two sentences together. What is given? So, what can be concluded? That is what causes most problems (Interview 9, paragraph 56, own translation).

Apart from language problems, there are other issues students have problems with when working on argumentation tasks: the general validity of mathematical statements, mathematical precision and accuracy, recognizing the expectations and technical contents amongst others.

The interview study showed that teachers have a wide range of ideas about which aspects of mathematical argumentation exist and their attitude towards argumentation in calculus classrooms is positive to a large extent. However, teachers state that there is little formal argumentation and proof in their classrooms. Training standard techniques is far more important than training argumentation competencies. In addition, many varied problems and difficulties concerning the training of argumentation competencies could be gathered. As *Heterogeneity* and *Language* could be found as being dominant problem areas, developing a proposal for facing these problems was the aim of a follow-up study.

Follow-up study: Development and evaluation of a learning environment

To address the dominant problem areas found in the interview study, students' *Language* difficulties and the *Heterogeneity* of students, a calculus learning environment⁴ with justification tasks was designed and given to 15 teachers for application and subsequent evaluation.⁵ Language support is provided by a toolbox in two versions, based on ideas of Meyer and Prediger (2012), among others. To cope with the students' heterogeneity, potential for differentiation is given by a task structure orientated towards Bruder and Reibold's concept of *Blütenaufgaben*⁶ (2011). To support students who have problems with argumentation in general on the one hand and students with problems concerning language on the other hand, there is a prepended worked-out example. A study of Reiss et al indicates that "self-explaining heuristic worked-out examples are a qualified instrument for improving students' achievement on reasoning and proof in the mathematics classroom" (2008, p. 463).

The learning environment was evaluated using written interviews. The analysis of these interviews showed that the learning environment is suitable for differentiation and the language support works

⁴ The term *learning environment* is used for a large task with several subtasks embedded in a lesson plan together with instructions and additional material bound together by one central idea. This is based mainly on (Hirt & Wälti, 2008).

⁵ The design principles of the learning environment and first results of study 2 have been published in (Scheffler, 2018).

⁶ *Blütenaufgaben* (literal translation: *blossom tasks*) open like flower heads, which means their subtasks have different requirement levels and vary from closed to open-ended tasks. The subtasks are independent, though (Bruder & Reibold, 2011).

if a suitable version of the learning environment is chosen. As a result, it is important that teachers have distinct diagnostic competencies to be able to support their students.

Discussion and Conclusions

This paper presented an interview study with teachers about mathematical argumentation in upper-secondary calculus classrooms. The qualitative and explorative character of the study provided an insight into current practices of argumentation in calculus teaching. The results might be used to generate possible hypotheses which could be examined quantitatively to learn more from the teachers' perspective. Whether the results can be transferred to other sections of mathematics teaching in upper-secondary school, is debatable. The complexity of calculus in comparison to stochastics and analytic geometry indicate that automatic transfer is not possible. What could be shown is that the interviewed teachers have a wide understanding of mathematical argumentation. They include different aspects of argumentation and reasoning in their calculus classrooms, but they hesitate to incorporate justifications in a written way or let students do so. They are also reluctant to use formal argumentations such as proofs, which is a bit surprising because teachers spoke of the upper-secondary level. This, however, can be justified as long as pre- or semi-formal mathematical argumentation is seen as pre-stage to proving, interested students are able to encounter formal arguments as well, and a realistic and representative view of mathematics is conveyed. Although the KMK *Bildungsstandards* have set a framework for teaching mathematics on an upper-secondary level in Germany, argumentation does not seem to play a role in mathematics teaching as much as it ideally should. Teachers basically have a positive attitude towards training argumentative competencies in their calculus teaching, but they also face a wide range of problems and difficulties. Two dominant problem areas could be found: Students have difficulties with language, especially when writing down their justifications, and teachers have problems dealing with the heterogeneity of their students. To work on these problems, a learning environment with differentiating character and language support has been developed and evaluated in a follow-up study. It could be shown that taking action is possible and that it is important for teachers to choose suitable teaching material for their students. More material should be developed to assist teachers and hence to help students develop argumentative competencies. It is a good basis that the interview study suggests that teachers consider argumentation in calculus classrooms important.

References

- Barwell, R. (2016). Formal and informal mathematical discourses. Bakhtin and Vygotsky, dialogue and dialectic. *Educational Studies in Mathematics*, 92(3), 331-345.
- Bruder, R., & Reibold, J. (2011). Differenzierung im Mathematikunterricht [Differentiation in Mathematics Classes]. In M. Eisenmann & T. Grimm (Eds.), *Heterogene Klassen: Differenzierung in Schule und Unterricht* (pp. 118–136). Baltmannsweiler, Germany: Schneider-Verlag Hohengehren.
- Buchbinder, O. (2017). Supporting classroom implementation of proof-oriented tasks: Lessons from teacher researcher collaboration. In T. Dooley & G. Gueudet (Eds.), *Proceedings of the Tenth Congress of the European Society for Research in Mathematics Education (CERME 10, February 1-5, 2017)* (pp. 107–114). Dublin, Ireland: DCU Institute of Education and ERME.

- Hirt, U., & Wälti, B. (2008). *Lernumgebungen im Mathematikunterricht: Natürliche Differenzierung für Rechenschwache bis Hochbegabte* [Learning Environments in Mathematics Classes: Natural Differentiation for Mathematically Impaired to Highly Gifted Students]. Seelze, Germany: Kallmeyer.
- Hiebert, J., Gallimore, R., Garnier, H., Givvin, K. B., Hollingsworth, H., Jacobs, J., et al. (2003). *Teaching Mathematics in Seven Countries: Results From the TIMSS 1999 Video Study*. Washington, DC: National Centre for Education Statistics.
- Kuckartz, U. (2014). *Qualitative Text Analysis: A Guide to Methods, Practice and Using Software*. London, UK: SAGE Publications.
- Kultusministerkonferenz (KMK). (2012). Bildungsstandards im Fach Mathematik für die allgemeine Hochschulreife [Educational Standards in Mathematics for General Matriculation Standard]. Retrieved from http://www.kmk.org/fileadmin/Dateien/veroeffentlichungen_beschluesse/2012/2012_10_18-Bildungsstandards-Mathe-Abi.pdf
- Mayring, P. (2015). Qualitative Content Analysis: Theoretical Background and Procedures. In A. Bikner-Ahsbals, C. Knipping, & N. Presmeg (Eds.), *Advances in Mathematics Education. Approaches to Qualitative Research in Mathematics Education: Examples of Methodology and Methods* (pp. 365–380). Dordrecht, Heidelberg, New York, London: Springer.
- Meyer, M., & Prediger, S. (2012). Sprachenvielfalt im Mathematikunterricht: Herausforderungen, Chancen und Förderansätze [Language Diversity in Mathematics Classrooms: Challenges, Chances and Promotional Approaches]. *Praxis der Mathematik in der Schule*, 54(45), 2–9.
- National Council of Teachers of Mathematics (NCTM). (2000). Executive Summary: Principles and Standards for School Mathematics. Retrieved from https://www.nctm.org/uploadedFiles/Standards_and_Positions/PSSM_ExecutiveSummary.pdf
- Pericleous, M. (2015). How is proving constituted in Cypriot classroom? In K. Krainer & N. Vondrová (Eds.), *Proceedings of the Ninth Congress of the European Society for Research in Mathematics Education (CERME9, 4-8 February 2015)* (pp. 226–227). Prague, Czech Republic: Charles University in Prague, Faculty of Education and ERME.
- Reiss, K. M., Heinze, A., Renkl, A., & Groß, C. (2008). Reasoning and proof in geometry. Effects of a learning environment based on heuristic worked-out examples. *ZDM Mathematics Education*, 40 (3), 455–467.
- Scheffler, S. (2017). Argumentieren im Analysisunterricht: Erkenntnisse aus Lehrerinterviews [Argumentation in Calculus Classrooms: Results of an Interview Study with Teachers]. In U. Kortenkamp & A. Kuzle (Eds.), *Beiträge zum Mathematikunterricht 2017* (pp. 833–836). Münster: WTM-Verlag. Retrieved from <https://eldorado.tu-dortmund.de/bitstream/2003/36627/1/BzMU-2017-SCHEFFLER.pdf>
- Scheffler, S. (2018). Mathematisch Argumentieren im Analysisunterricht [Mathematical Argumentation in Calculus Classrooms]. In Fachgruppe Didaktik der Mathematik der Universität Paderborn (Eds.), *Beiträge zum Mathematikunterricht 2018* (pp. 1571–1574). Münster: WTM-Verlag.

Integrating Euclidean rationality of proving with a dynamic approach to validation of statements: The role of continuity of transformations

Paolo Boero¹ and Fiorenza Turiano²

¹University of Genoa, Italy; boero@dima.unige.it

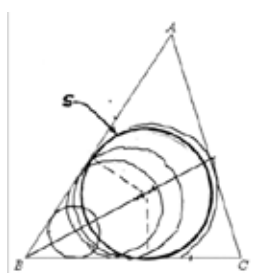
²I. I. S. Arimondi – Eula, Savigliano, Italy; fiorenza.turiano@gmail.com

During a long-term teaching experiment aimed at developing 10th grade students' culture of theorems through a pathway in Euclidean plane geometry, some students' autonomous reasoning moved towards non-Euclidean proofs based on continuity of transformation of geometric figures. Based on the use of existing analytical tools to analyze such episodes, the aim of this paper is to outline a wider scope for synthetic geometry in order to make it more suitable for students' approach to the culture of theorems. Through the introduction of a continuity principle to legitimate such extension, the paper suggests how to exploit students' potential in transformational reasoning, and to bridge the gap between synthetic geometry and analytic geometry rationalities in classroom work.

Keywords: Euclidean geometry, transformational reasoning, continuity principle, rationality.

Introduction

Since 2016 we are engaged in designing and implementing in 10th-grade classes a teaching and learning pathway in Euclidean geometry aimed at promoting students' approach to the culture of theorems (Bartolini Bussi, Boero, Ferri, Garuti, & Mariotti, 2007) – i.e. at developing not only the knowledge of statements, proofs and their applications, but also autonomous proving and the awareness of crucial meta-knowledge about theorems (the role of hypotheses and thesis, the requirements of proof, etc.). Such aim is not easy to attain; the question that originated the study reported in this paper was: is it possible to lessen the students' difficulties with proving by legitimating some spontaneous ways of solving geometry problems and validating statements? Let us consider an episode, a single case of a wider phenomenon observed in the three classes where the experiments on our pathway have been performed. Its role is to put into evidence the potential inherent in students' dynamic approach to solving theoretical problems in geometry. Students have already learnt to construct a circle tangent to both sides of an angle, and to justify the construction. In interaction among them and with the teacher, students have learned to build up the circle with center chosen on the bisector and ray derived from the following construction: to draw the perpendicular line from the chosen center to one side of the angle; to consider its intersection with that side, and the segment joining it with the center as the ray of the circle. They have proved (with the help of the teacher) that the drawn circle is tangent to both sides of the angle through the steps of Euclid' validation of the same construction. Some weeks later they are asked to construct a circle tangent to the three sides of a given triangle. They have at their disposal a worksheet with a drawn triangle, the ruler and the compass.



One student (Ale) draws the bisector of the angle ABC, then he tries to choose a point on the bisector as the center of a circle by taking different points on the bisector and adapting the width of the compass to the sides of the triangle. Finally, he draws the circle S (the arrow and S are added to the original figure). Ale is not satisfied with his drawing. After a while he makes a free-hand drawing of a circle near to B, then other circles more and more near to AC. Finally, he stops and observes the worksheet for several seconds.

Figure 1

Then he starts writing: “The solution of the problem is when the circle, which is tangent to the sides of the angle B, meets the third side”. The participant observer (PO: the first author of this paper) starts an interaction with Ale:

PO: May you explain your reasoning to me?

Ale: The tangent circle becomes bigger and bigger, and a certain moment a circle will meet the third side. It will be the solution!

PO: Why? Are you sure that it is tangent to the three sides of the triangle?

Ale: Yes, when I move the center on the bisector the circle is (pause) the circle becomes bigger and bigger, and remains tangent to the two sides of the bisector (pause)

PO: Are you sure that it becomes tangent to the third side?

Ale: Because the circle (pause) if I continue moving the point on the bisector, one part of the circle will go outside the triangle (pause) Therefore there will be ONE (emphasis) point to get the contact, (pause) the tangency with the third side.

PO: And if the circle becomes bigger and bigger?

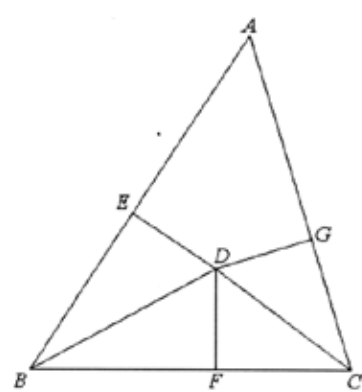
Ale: It will be no more tangent to the sides of the triangle, but... No, if I come back, the two intersections finally join in the tangency point.

Given that the circle exists (by such continuity considerations) it is easy to prove that its center belongs to the three bisectors - provided that students already know that if a point is equidistant from the sides of an angle, it belongs to the bisector of the angle, and that the tangent straight line is perpendicular to the ray in the point of tangency. Hence the ruler and compass construction may be easily made by using the intersection point of two bisectors and the perpendicular straight line from it to one side of the circle. In this case *the method of construction derives from the reasoning used to prove the existence of the tangent circle* and the knowledge of its properties. Note that performed exploration might result in the construction of a theoretical justification (*cognitive unity of theorems*: see later), once Ale’s reasoning by continuity would be legitimated.

In Book IV of the Elements (prop.4) Euclid describes how to construct a circle tangent to the three sides of a given triangle and provides a theoretical justification for it.

PROPOSITION 4 (book 4, Heath’s translation)

In a given triangle to inscribe a circle.



Let ABC be the given triangle; thus it is required to inscribe a circle in the triangle ABC.

Let the angles ABC, ACB be bisected by the straight lines BD, CD [I. 9], and let these meet one another at the point D; from D let DE, DF, DG be drawn perpendicular to the straight lines AB, BC, CA.

Now, since the angle ABD is equal to the angle CBD, and the right angle BED is also equal to the right angle BFD, EBD, FBD are two triangles having two angles equal to two angles and one side equal to one side, namely that

Figure 2 subtending one of the equal angles, which is BD common to the triangles; therefore they will also have the remaining sides equal to the remaining sides;

[I. 26], therefore DE is equal to DF. For the same reason DG is also equal to DF. Therefore the three straight lines DE, DF, DG are equal to one another; therefore the circle described with centre D and distance one of the straight lines DE, DF, DG will pass also through the remaining points, and will touch the straight lines AB, BC, CA, because the angles at the points E, F, G are right.

For, if it cuts them, the straight line drawn at right angles to the diameter of the circle from its extremity will be found to fall within the circle : which was proved absurd; [III. 16] therefore the circle described with centre D and distance one of the straight lines DE, DF, DG will not cut the straight lines AB, BC, CA; therefore it will touch them, and will be the circle inscribed in the triangle ABC. [IV. Def. 5]. Let it be inscribed, as FGE.

Euclid's line of thinking is different from Ale's. Euclid describes how to solve the problem of the circle inscribed in a triangle by *finding candidates to be the center of the circle and three of its rays*, then a *theoretical justification for the chosen solution follows*, which relies on definitions and previously proved theorems, and results in a proof of the existence of the inscribed circle. No continuity or transformational considerations are made.

Based on the above episode and other episodes that will be shortly presented later, and with reference to some constructs in mathematics education literature, integrated with a *principle of continuity to legitimate the widening of the scope of synthetic geometry*, we will present and discuss the potential inherent in students' transformational reasoning (Simon, 2006) in the approach to the culture of theorems, once that principle is assumed.

Theoretical background

Transformational reasoning, and the continuity principle

Transformational reasoning was defined by Simon (1996) as:

The mental or physical enactment of an operation or set of operations on an object or set of objects that allows one to envision the transformations that these objects undergo and the set of results of these operations. Central to transformational reasoning is the ability to consider, not a static state, but a dynamic process by which a new state or a continuum of states are generated (p. 201).

In past research of our group this construct was already used, in particular, to characterize one of the types of generation of conditionality of statements (Boero, Garuti, & Lemut, 1999). In this paper it will be used to describe processes of discovery of the reason why a statement is true, or strategies to solve a construction problem in Euclidean geometry.

In our toolkit we will integrate the construct of transformational reasoning with a *principle of continuity*. Continuity provides students not only with hints for the solution of a construction problem or a proving problem, but also, in some cases, substantial elements for the validity of the construction and the proof. For instance, in the episode presented in the Introduction, Ale "by continuity" proves the existence of the tangent circle. Thus a principle of continuity as a criterion for the epistemic validity of a conclusion derived through transformational reasoning might widen the scope of acceptable proofs, with positive consequences for the approach to the culture of theorems (see Discussion). How to formulate the continuity principle within the perspective of synthetic geometry

(i.e. geometry theory based on constructions performed with ruler and compass)? Continuity axioms (including Archimedes' axiom) were among the axioms added by Hilbert to Euclid's axioms (Trudeau, 1987), but it is not easy to formulate a consequence of them which in simple operational terms accounts for the truth of the "existence theorem" proved by Ale. However, it is possible to provide a formulation of the continuity principle in operational terms by making reference to analytic geometry:

The continuity principle guarantees the solution of a synthetic geometry problem through transformational reasoning provided that the translation of the problem and the related transformational strategy into analytic terms (by using algebraic expressions) allows a treatment which brings to the solution thanks to the continuity of the set of real numbers.

As an example, consider the episode presented in the Introduction. As a generic example (Mason & Pimm, 1984) of the situation, we may assume $B=(0,0)$, a represented by $x=0$, b represented by $y=0$, and the side AC represented by $y=-2x+3$. Then the system $y=-2x+3$ & $(x-K)^2+(y-K)^2=K^2$, will represent the circle centered in the point (K, K) of the bisector, which is tangent to a and b . By varying K we represent the situations of no intersection with the straight line $y=-2x+3$, of tangency (two possibilities, including tangency from the exterior), and of intersection in two points.

We will use the above criterion as a provisional solution for the characterization of the continuity principle; further research (and the analysis of more episodes!) is needed to formulate it in more precise and effective terms.

Theorems

Mariotti (2001) defined a Theorem as a statement and its proof with reference to a theory (and related inference rules). With reference to Guala & Boero (2017), Mariotti's definition

encompasses theorems related to various kinds of theories throughout history (e.g., Euclid's, as well as Hilbert's, geometry; graph theory, with its crucial reference to visual objects; 19th-century classical probability theory as well as Kolmogorov's axiomatic theory, etc.), together with the different ways of considering proof since the Greeks (Grabiner, 2012) along with the cultures these ways came from (Siu, 2012) (p. 210).

In this paper we use the construct of Theorem to consider different, possible ways of proving the same theorem with reference to different theories and different inference rules.

Cognitive unity of theorems

After having found some cases of theorems (in geometry, and in elementary arithmetic) for which students behaved in a similar way, Garuti, Boero and Lemut (1998) defined "cognitive unity of theorem" what happens for some theorems when:

during the production of the conjecture, the student progressively works out his/her statement through an intensive argumentative activity functionally intermingled with the justification of the plausibility of his/her choices. During the subsequent statement-proving stage, the student links up with this process in a coherent way, organizing some of the previously produced arguments according to a logical chain (p. 345).

The cognitive unity construct was also extended to the case of the relationships between the exploratory phase of proving a theorem, and the subsequent construction of a proof for that theorem (Garuti et al., 1998): indeed, the exploratory phase of proving shares some common aspects with

conjecturing (as re-construction of the meaning, and appropriation, of a statement; and identification of elements for its validity).

The cognitive unity construct may be used to account for what happens when students produce, thanks to transformational reasoning, arguments that may be re-arranged in a proof (be it Euclidean, or based on a continuity principle: see the episode in the Introduction).

Rationality

Many cultural activities (including mathematical ones) may be described as discursive activities sharing some common features: First, criteria to establish truth and falsity of propositions, and validity of reasoning. Second, strategies to attain the goal of the activity, which can be evaluated. Third, a specific language for social interaction and self- dialogue.

The *rationality* construct elaborated by Habermas (1998) may be exploited to move from such a superficial description to a deeper treatment of discursive activities. According to Habermas' construct, rational behavior is characterized by: conscious taking in charge of truth and validity criteria (*epistemic rationality*), of strategies to attain the goal (*teleological rationality*), and of communication means (*communicative rationality*); and by dynamic links between knowing, doing and communicating in the rationality perspective (for a discussion of potential and limitations of Habermas' construct as it was adapted to mathematics education, see Boero & Planas, 2014).

Where the episodes come from

We think that it is important to put into evidence some salient features of the long term teaching experiment that provided us with the elements for the theoretical elaboration of this paper (in particular, Ale's and other episodes like those presented here); in particular we agree with Simon (1996) when he says that transformational reasoning is a natural way of thinking, which needs to be "nurtured" - thus suitable cultural and educational choices must be performed in order to allow students to develop it.

A teaching-learning pathway to the culture of theorems

We have chosen to base the approach to the culture of theorems in grade X of high school on the Euclid's plane geometry for the following reasons: First, in Italy, since the end of the XIX century and for several decades Euclidean geometry was the main subject intended to allow secondary students to meet theorems, proofs, proving. Second, Euclidean geometry offers the possibility to approach different kinds of proof (including proof by contradiction – the preferred indirect proof in Euclid's Elements). Third, through the alternation of "theorems" and "constructions to be validated" in Euclidean geometry the teacher is offered the opportunity of stressing the relevance of theoretical thinking in mathematics – in particular the distinction between a drawing and a geometric figure, and the need of moving from visual truth to theoretical truth (even if in Euclid's elements the goal of going beyond visual evidence to validate statements is not completely accomplished: see Trudeau, 1987. However, in our design we have not followed any path taken as such from Euclid's Elements; we have chosen only some constructions and some theorems. In the case of theorems with a thesis consisting of more than one claim we have chosen only one claim (this is in the case of the theorem considered in the second and third episodes below).

The educational context of the episodes

The episodes presented in this paper happened within a pathway to the culture of theorems in the domain of Euclidean geometry that had been experimented for the first time in the year 2016-17 in a 10th-grade class of a scientific oriented high school, and in the year 2017-18 in two 10th-grade classes of the same school, with two 50' lessons per week from October to May (out of 5 hours devoted also to other mathematics subjects: algebra, probability and statistics). Classroom activities were based on an alternation of individual activities, in some cases preceded by a constructive interaction with the teacher, and collective activities. Individual activities concerned six kinds of tasks: solution of construction problems, conjecturing, proving, analyzing, evaluating and improving some schoolfellow's productions, close activities regarding proof texts. Collective discussions were orchestrated by the teacher and in most cases concerned the comparison and the critical analysis of a few students' individual productions selected by the teacher. According to the aim of developing competencies related to the culture of theorems, the assessment method consisted of: the individual revision of individual work at the end of each of the three parts in which the pathway was divided, with careful identification and remediation of "what does not work" in each individual production, and an overall synthesis on the individual itinerary concerning difficulties met, still obscure points, reasons for mistakes, emotional problems, etc. This evaluation method was derived and adapted from a similar method currently adopted in several Genoa University courses for pre-service teacher education aimed at developing professional competencies of cultural analysis of the content to be taught (see Guala & Boero, 2017, for more information on the assessment method and its motivations).

Further episodes

We have chosen three further episodes. Like that presented in the Introduction, they concern relations among circles and straight lines. They show different roles that may be plaid by transformational reasoning and continuity in the field of plane geometry, and how to legitimate them within the proposed theoretical framework, in particular through the continuity principle.

The rolling circle

Students are requested to find if it exists a position of a given circle, such that the circle is tangent to two sides of an angle, and to justify the answer. Some students imagine to roll the circle on one line towards the second line and they discover that "Yes, it exists, because there is a moment in which the rolling circle starts to touch the second line; in that moment it is tangent to both lines". This intuition of the rolling circle facilitates also the discovery that, in the found position of the circle, the center of the circle is the point of intersection of the two straight lines that are parallel to the sides of the angle at the distance of the ray of the circle. Students "see" the movement of the center of the circle in parallel with the first line, and (after the tangency position) with the second line.

By considering the generic case of the straight lines $y=0$ and $y=x$ and of the rolling circle $(x-K)^2+y^2=1$, the continuity principle may be applied to legitimate the solution find by the students.

All this suggests a way both to find the center of the circle when it is tangent to both lines (a heuristic function for the solution of a construction problem), and to explain why in that position it is tangent to both lines (a proving function, once the continuity principle is adopted) – in a perspective of cognitive unity of theorems.

Comparing the length of the chords of a circle

The diameter of a circle is its longest chord, and the length of the chord increases when its middle point approaches the center of the circle.

This is part of proposition 15 of Book 3 of the Elements:

Of straight lines in a circle the diameter is greatest, and of the rest the nearer to the centre is always greater than the more remote.

Euclid proof is rather complex- it needs the proof of 6 intermediate statements.



Figure 3

A student produces a reasoning that may be reported this way: he fixes a point on the circle and considers a chord on that side of the circle “which is opposite to it”, with corresponding angles at the center of the circle. He imagines to move the chord towards the center and he observes that the nearer the chord is to the center, the bigger is the corresponding angle –till when the chord becomes the diameter by collapsing on the two aligned rays. This is not yet a proof of the theorem, but the student’s line of reasoning might be integrated with elements that allow to prove that the length of the chord increases when the chord approaches the diameter. Indeed, the triangles obtained by joining the extremities of the chord with the center of the circle have two sides of equal length (the ray of the circle) and the width of the angle between them increases, thus also the length of the side opposite to the center increases. This may suggest to exploit the triangular inequality –the chord is shorter than the sum of the rays– to prove that the diameter (two rays long) is the longest chord; and it may suggest also to use Pythagoras’ theorem in order to prove that the length of the chords increases when the distance between the chord and the center of the circle decreases, or to find the length $2\sqrt{1-K^2}$ of the chord intersected by $y=K$ on the generic circle $x^2+y^2=1$: the length of the chord attains its maximum value 2 when $K=0$, i.e. when the chord becomes a diameter.

Tangency between a straight line and a circle.

By composing two statements of Euclid’s Elements, we get the following statement:

Given a circle centered in C and a straight line a intersecting the circle in the point T, the straight line a is tangent to the circle (i.e. T is their only common point) if and only if the straight line is perpendicular to CT.

While trying to prove the “if” part of the statement, students were suggested by the teacher to reason by contradiction; they were also invited to consider a second point of intersection T’. Some students reacted to the discovery of a contradiction (an isosceles triangle with two rectangular angles) by imagining to make CT’ collapse on CT by rotating it around C. This movement might be exploited to expand their reasoning through the consideration of the isosceles triangle TCT’ and its height CH. The identity $CH = \sqrt{CT^2 - TH^2}$ (Pythagoras theorem) allows to prove (by continuity) that TT’ is 0 (i.e. there is only one point of intersection – which means tangency) if and only if the height CH of the triangle collapse on CT, i.e. if and only if CT is perpendicular to the straight line a.

In this case transformational reasoning produced by some students might play a double heuristic role: first, to suggest the *necessity* of the condition of perpendicularity for the tangency while proving its *sufficiency*; second, to suggest the way to get a proof (by the continuity principle) of the “if and only if” statement – still, cognitive unity might allow to arrange a valid, simple proof.

Discussion

Transformational reasoning combined with the continuity principle may play three roles for the approach to the culture of theorems and, more generally, for the development of students' mathematical rationalities: first, it may help solving a construction problem and simplifying its proof, in comparison with the Euclid's proof (like in the episode presented in the introduction). Second, it may play a heuristic function by suggesting a method of proving in Euclidean geometry, or eventually a method of proving by relying on the continuity principle (like in the last two episodes). Third, it may allow to compare different ways of proving the same theorem in synthetic geometry, thus contributing to the development of the culture of theorems and at the same time to an initial understanding of the fact that a theorem may be tackled with different strategies and according to different criteria of truth and of validity of proving methods. Concerning the second and the third role, we may observe how the adoption of a principle of continuity would imply changes in the rationality of the discursive activity of proving, in comparison with Euclidean rationality. On the epistemic side: a new criterion of truth is introduced. On the teleological side: for a construction problem, the existence of the solution may be got through transformational reasoning; for the proof of a theorem, transformational reasoning in several cases (see our episodes) guarantees the possibility of the cognitive unity between the exploration phase and the proving phase. On the communicative side, new verbs and expressions are necessary to account for the specificities of transformational reasoning, in comparison with the language of Euclidean geometry. In the perspective of rationality, the principle of continuity might allow to compare (for some theorems) methods of proof corresponding to Euclid's ones with methods of proof which depend not only on Euclid's axioms and theorems, but also on the additional principle, thus contributing to the culture of theorems and prepare students to move to other theories – in particular, Analytic geometry – and help to “cross the borders” between the two domains (and the inherent rationalities: see Boero, Guala, & Morselli, 2013). We observe how, in the problem situations of our episodes, the principle of continuity may be easily related to the algebraic modelization of the situations at stake. For instance, in the case of the last episode we may consider the circle of center (0,0) and ray 1, whose equation is $x^2+y^2=1$, and its intersections with the straight line of equation $y=kx+1$, which meets the circle in the point (0,1). The algebraic treatment of the system of the two equations offers an immediate answer to the problem of tangency by discussing the solutions of the second degree equation: $(1+k^2)x^2+2kx=0$ derived from the system. The equation has the solutions (x-coordinates of the intersection points) $x=0$, $x=k/(1+k^2)$. They are coincident (i.e. tangency, in terms of analytic geometry) for $k=0$, i.e., when the straight line of equation $y=kx+1$ becomes perpendicular to the ray of the circle with extremities (0,0) and (0,1). Conversely, including the principle of continuity in synthetic geometry might allow to give sense to the algebraic expressions that are used in the algebraic modeling process of geometry problems, particularly as regards the role of the variable(s) – which not only are signs to be dealt with according to the syntactic rules of the algebraic language, but also represent dynamic phenomena (in our case, geometric transformations).

In this section we have used the expressions “may”, “might allow” several times to outline possible directions for studies, intended to develop the culture of theorems in the classroom on the reflective and on the operational sides, once the continuity principle (possibly, after further elaboration) is assumed to legitimate an extension of the scope of synthetic geometry and the inherent rationality.

References

- Bartolini Bussi, M. G., Boero, P., Ferri, F., Garuti, R., & Mariotti, M. A. (2007). Approaching and developing the culture of theorems in school. In P. Boero (Ed.), *Theorems in school* (pp. 211-218). Rotterdam: Sense Publishers.
- Boero, P., Garuti, R., & Lemut, E. (1999). About the generation of conditionality of statements. In O. Zaslavsky (Ed.), *Proceedings of the 23rd IGPME conference* (Vol. 2, pp. 137-144). Haifa: PME
- Boero, P., Guala, E., & Morselli, F. (2013). Crossing the borders between mathematical domains. In A. M. Lindmeier & A. Heinze (Eds.), *Proceedings of the 37th IGPME conference* (Vol. 2, pp. 97-104). Kiel: IPN & PME.
- Boero, P., & Planas, N. (2014). Habermas' construct of rational behavior in mathematics education: New advances and research questions. In P. Liljedahl, C. Nicol, O. Oesterle, & D. Allan (Eds.) *Proceedings of the 38th IGPME conference and the 36th Conference of North Chapter of PME* (Vol. 1, pp. 228-235). Vancouver: PME & UBC.
- Garuti, R., Boero, P., & Lemut, E. (1998). Cognitive unity of theorems and difficulty of proof. In A. Olivier & K. Newstead (eds.), *Proceedings of the 22nd IGPME conference* (Vol. 2, pp. 345-352). Stellenbosch: PME.
- Guala, E., & Boero, P. (2017). Cultural analysis of mathematical content in teacher education: The case of elementary arithmetic theorems. *Educational Studies in Mathematics*, 96(2), 207-227.
- Habermas, J. (1998). *On the pragmatics of communication*. Cambridge, MA: MIT Press.
- Mariotti, M. A. (2001). Introduction to proof: The mediation of a dynamic software environment. *Educational Studies in Mathematics*, 44 (1/2), 25–53.
- Mason, J., & Pimm, D. (1984). Generic examples: Seeing the general in the particular. *Educational Studies in Mathematics*, 15(3), 277-289.
- Simon, M. A. (1996). Beyond inductive and deductive reasoning: The search for a sense of knowing. *Educational Studies in Mathematics*, 30, 197-210.
- Trudeau, R. J. (1986). *The Non-Euclidean Revolution*. Basel (CH): Birkhäuser.

The role of the teacher in the development of structure-based argumentations

Fiene Bredow

University Bremen, Germany; bredow@uni-bremen.de

Keywords: Argumentation, teacher influence, symbolic language, algebra.

Motivation

It is a desideratum that mathematical argumentation should be integrated into today's mathematics teaching. In reality, opportunities for learning mathematical argumentation are infrequent. Algebraic language is often understood only as a series of signs that can be transformed according to certain rules and the same applies to algebraic argumentation (Pedemonte, 2008). Such argumentations present an epistemological challenge for students because they are detached from concrete examples. The integration of mathematical argumentation into teaching and the appreciation of different types of arguments is therefore of crucial relevance. The role of the teacher in this needs to be clarified.

The aim of my PhD project is to investigate the role of the teacher in the development of structure-based argumentations in classroom practice. What kind of support can teachers in mathematics education give their students in order to guide their argumentation from concrete examples to general structures? How does this support influence the students' argumentation and their conception of algebraic language? For this purpose, a learning environment at the transition from arithmetic to algebra was designed and implemented in three eighth-grade classes in Germany. The main ideas of my teaching design and learning environment will be presented in this poster.

Theoretical framework

Sfard (1991) distinguishes between an operational and a structural conception of mathematical objects. In an operational conception, mathematical objects are perceived as a process. In a structural conception mathematical objects are conceived as static constructs, objects. Reification is necessary to conceive mathematical objects structurally. There are different types of mathematical arguments. Structure-based arguments use properties of the involved objects instead of only calculation-oriented transformations of algebraic expressions without relation to the content. Mason (1996) describes that, as a first step, learners should investigate examples and their structure in order to be able to develop general arguments using symbolic language. This idea guided the construction of the learning environment in my project. Connections between the conception of algebraic language and the development of structure-based argumentations are examined as well.

All in all, the teacher has an important role in mathematical argumentation. Conner, Singletary, Smith, Wagner and Francisco (2014) describe three different types of support for collective argumentation by teachers: "Direct contributions to arguments", "Asking questions" and "Other supportive actions" (e.g., evaluating, repeating). In addition to that, it is interesting how teachers enact written tasks in classrooms. This can lead students to an interpretation of tasks that can provide rich opportunities for argumentation or create obstacles. Whether and how this support can affect the arguments of pupils has been researched little so far and is a focus of this study.

Research project and methodology

First, tasks for eighth-grade classes and teacher prompts are theoretically constructed, which are supposed to stimulate a structure orientation and provide opportunities for mathematical argumentation. Then, a learning environment is designed and empirically enacted. Two interviews with teachers are conducted to get insights into the teachers' understanding of mathematical argumentation and into their experiences with the designed learning environment. Then, from transcripts of the lessons, argumentation processes and students' conceptions are reconstructed and analysed with a focus on the prompts of the teacher that promote a structure orientation. All this will inform a revision of the learning environment. The following research questions guide my study: How can teachers constructively support their students in developing structure-based argumentations? How do a teaching design and a learning environment for the development of structure-based argumentations in mathematics lessons look?

Structure of the learning environment

An intervention of four lessons (90 min each) was designed and performed. All tasks provide opportunities for mathematical argumentation. The teaching environment and tasks are designed in a way that allows students to build on concrete examples, examine the structure of these examples, and finally develop structure-based arguments. All tasks support this strategic approach to argumentation: 1. Observe; 2. Assume; 3. Analyse and check; 4. Justify. Learners are not simply asked to do calculations in the tasks, but to observe and reflect the mathematical structures of the numbers to support structure orientation (see Wittmann, 1985; Mason, 1996). In the first two lessons, the students get to know four different types of arguments (explanatory arguments in form of a dot pattern; generic examples; algebraic and narrative arguments) and have to solve conjecture-and-proving tasks. In the third and fourth lesson, the students learn to argue in a new format and more sophisticated arguments are demanded in context of “arithmogons”: the sum of two corners is a side (Wittmann, 1985).

All in all, this learning environment should provide students opportunities to learn mathematical argumentation and to establish a structure orientation. How teachers enact this learning environment, support their students and which impact this support has will be analysed in my study.

References

- Conner, A., Singletary, L. M., Smith, R. C., Wagner, P. A., & Francisco, R. T. (2014). Teacher support for collective argumentation: A framework for examining how teachers support students' engagement in mathematical activities. *Educational Studies in Mathematics*, 86(3), 401–429.
- Mason, J. (1996). Expressing Generality and Roots of Algebra. In N. Bednarz, C. Kieran, & L. Lee (Hrsg.), *Approaches to Algebra* (pp. 65–86). Dordrecht, Netherlands: Springer.
- Pedemonte, B. (2008). Argumentation and algebraic proof. *ZDM*, 40(3), 385–400.
- Sfard, A. (1991). On the Dual Nature of Mathematical Conceptions: Reflections on Processes and Objects as Different Sides of the Same Coin. *Educational Studies in Mathematics*, 22(1), 1–36.
- Wittmann, E. C. (1985). Objekte-Operationen-Wirkungen: Das operative Prinzip in der Mathematikdidaktik. *Mathematik lehren*, 11, 7–11.

Prospective teachers enacting proof tasks in secondary mathematics classrooms

Orly Buchbinder¹ and Sharon McCrone¹

¹University of New Hampshire, Unites States; orly.buchbinder@unh.edu, sharon.mccrone@unh.edu

*We use a curriculum design framework to analyze how prospective secondary teachers (PSTs) designed and implemented in local schools, lessons that integrate ongoing mathematical topics with one of the four proof themes addressed in the capstone course *Mathematical Reasoning and Proving for Secondary Teachers*. In this paper we focus on lessons developed around the conditional statements proof theme. We examine the ways in which PSTs integrated conditional statements in their lesson plans, how these lessons were implemented in classrooms, and the challenges PSTs encountered in these processes. Our results suggest that even when PSTs designed rich lesson plans, they often struggled to adjust their language to the students' level and to maintain the cognitive demand of the tasks. We conclude by discussing possible supports for PSTs' learning in these areas.*

Keywords: Reasoning and Proving, Preservice Secondary Teachers, Lesson Plans, Task Design

Integrating reasoning and proving in secondary schools has been an elusive goal of the mathematics education community. Despite agreement of the importance of reasoning and proving in school mathematics among scholars and policy makers, proof has been shown to be a “hard-to-teach and hard-to-learn” concept (Stylianides & Stylianides, 2017, p. 119). Areas that have been identified as being persistently difficult for students, but also critically important for proof production and comprehension, are the following: (1) understanding the role of examples in proving including recognition of the limitation of supportive examples as proofs and the role of a single counterexample as refuting evidence, (2) conditional statements, (3) argument evaluation, and (4) indirect reasoning (e.g., Antonini & Mariotti, 2008; Durand-Guerrier, 2003). We term these areas “proof themes”. Our choice of these four proof themes stems from the literature and our own experience as instructors observing prospective secondary teachers’ (PSTs’) challenges in university coursework. Our study rests on the assumption that these proof themes can be integrated into secondary school mathematics in “intellectually honest” ways that are true to the discipline of mathematics and honor students as learners (Bruner, 1960; Stylianides, 2007). Towards this end we developed and systematically studied a capstone course *Mathematical Reasoning and Proving for Secondary Teachers*, which intended to support PSTs in developing robust knowledge and pedagogical skills for integrating proof in their classroom practices.

The course aimed to increase PSTs’ awareness of the logical aspects of proof and the place of proof in secondary curricula, expose PSTs to common student difficulties with proof, and provide PSTs with pedagogical tools to create or modify tasks that integrate reasoning and proving. In the practical component of the course, PSTs developed lessons on each of the four proof themes and taught them in local schools. In this paper, we focus on two PSTs’ lessons plans that successfully integrated the conditional statements proof theme and analyze how these lessons were enacted in classrooms. Our analysis reveals the aspects of lesson enactment that were successful and those that posed challenges to PSTs. In the discussion, we contemplate potential reasons for these challenges and how we, as

teacher educators, can further support PSTs in the process of integrating proof in their teaching practices.

Theoretical Perspectives

We adopt Stylianides and Stylianides' (2017) definition of proof as “a mathematical argument for or against a mathematical claim that is both mathematically sound and conceptually accessible to the members of the local community where the argument is offered” (p. 212). By “proving” we mean processes such as conjecturing, generalizing and making valid arguments grounded in mathematical deductions rather than authority or empirical evidence (Ellis, Bieda, & Knuth, 2012). Implicit in this definition is that students must develop understanding of what a deductive argument is, and that teachers must provide opportunities for students to develop such understanding through instructional activities. Teachers, on their part, rely on curriculum materials to facilitate student learning of proof.

Stein, Remillard and Smith (2007) distinguish between the *written curriculum*, which includes written artifacts that teachers and students use, the *intended curriculum*, which is the teacher's lesson plan, and the *enacted curriculum* that is the lesson as it unfolds in the classroom (Fig. 1).

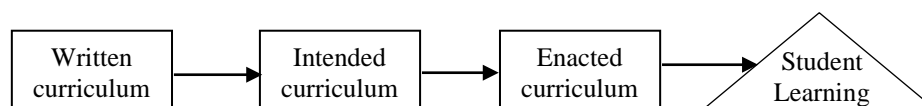


Figure 1: Phases of curriculum. Adapted from Stein, Remillard, & Smith, 2007, p.322

From the perspective of a secondary teacher aiming to integrate reasoning and proof into the mathematics curriculum, we find that each element of this model (Fig. 1) presents unique challenges. First, written curricula in the United States, such as textbooks, offer limited proof-related tasks outside high-school geometry (e.g., Thompson, Senk, & Johnson, 2012). Thus, it becomes the work of the teacher to design tasks and develop an intended curriculum. Next, as the teacher enacts the lesson in the classroom, he/she must use appropriate language and conceptual tools that are within the reach of secondary students to highlight mathematical ideas. Here, again, curriculum materials offer little guidance to teachers on how to enact proof tasks in classrooms (Stylianides, 2008) in ways that support development of students' conceptions which are in line with conventional mathematics. Thus, much of the curriculum design and implementation around proof rests on teachers' own knowledge and beliefs about the importance of proof for their students' mathematical learning.

Supporting PSTs in developing such knowledge and productive dispositions towards proof were the goals of the capstone course. In Buchbinder and McCrone (2018) we describe the course structure and its theoretical underpinnings. Here, we illustrate the design features of the course that were intended to support PSTs in development and enactment of a lesson on conditional statements. We use conditional statements as an example, but our analyses apply to all four proof themes mentioned.

Setting

The course *Mathematical Reasoning and Proving for Secondary Teachers* contains four modules, each addressing one of the proof themes. In the Conditional Statements module, PSTs first engaged in activities designed to strengthen their knowledge of conditional statements. This knowledge includes understanding that a conditional statement has the form: *If P then Q* ($P \Rightarrow Q$), where P is

a hypothesis and Q is a conclusion; how to determine truth-value of such a statement; its equivalent forms such as a contrapositive ($\sim Q \Rightarrow \sim P$) and non-equivalent forms, such as a converse ($Q \Rightarrow P$).

PSTs then examined excerpts of hypothetical student work related to conditional statements, analyzed students' conceptions, and contemplated ways to address students' difficulties. Next, the PSTs reviewed a sample of mathematics textbooks to examine where conditional statements appear in the school curriculum. These activities aimed to equip PSTs with the background for creating their own lessons integrating conditional statements with mathematical topics taught in local schools.

During the lesson development stage, PSTs shared ideas and received feedback on their lesson plans from their peers and the course instructor. The lessons were 50-minutes in length, and were intended for small groups of 5-8 students rather than the whole class. All lessons were videotaped with 360° cameras to capture both the PSTs' actions and the students' participation. PSTs then watched their videos and wrote a reflective report. Sharing lesson plans with peers was intended to support PSTs' enactment of their lesson, while reflection reports and instructor's feedback on it aimed to serve as a mechanism for future improvement. Despite multiple means of support embedded in the course design, PSTs experienced challenges in developing and enacting lessons on conditional statements, as we will show in the results section.

Methods: Participants, Data Sources and Analysis

Fifteen PSTs in their last year of university studies took part in the research. Prior to the capstone course the PSTs completed most of the required courses in mathematics and pedagogy.

The data sources for the analysis reported in this paper comprise the PST-developed lesson plans on conditional statements, the video recordings of the enacted lessons, and PSTs' reflective reports. The lesson plans were analyzed in terms of their focus on the conditional statements proof theme, and assigned a rating of high, medium or low. The *low* focused lesson plans included no more than 3 conditional statements and the activity only required students to determine their truth value. For example, Chuck's (all names in the paper are pseudonyms) 8th grade lesson on exponents had three true or false questions, such as: "*If a negative number is raised to an even power, the result will be a positive number.*" This question offers opportunities to discuss what is needed to prove or disprove such a statement and use the rules of exponents to produce a generic proof accessible to 8th graders. Yet, Chuck's plan merely expected students to produce a "proof" by example, such as $(-2)^2 = (-2)(-2) = 4$, missing the opportunity to attend to a misconception about the limitations of empirical evidence as proof and even enforcing it. Lesson plans with *high* focus on the proof theme contained more than three conditional statements along with a clear plan on how they would be used to advance students' knowledge of conditional statements (as examples in the results section will show). A lesson plan with *medium* focus would be located between these two extremes, for example, Rebecca's lesson on logic riddles dealt with reasoning and justifying, but the place of conditional statements was unclear.

The classroom videos were analyzed using Schoenfeld's (2013) *Teaching for Robust Understanding* (TRU) rubric which was slightly modified to reflect aspects of teacher work and student interaction that are specific to proving. The revised rubric had five dimensions, four related to teacher actions: (a) Accuracy, language, and connections, (b) Explicating reasoning and proof theme, (c) Actions to promote student engagement, (d) Maintaining cognitive demand; and one dimension related to (e)

Student engagement. Each video was divided into thematic episodes, no more than 5 minutes long, and each episode was assigned a score of 3 (high), 2 (medium), 1 (low) on each dimension. In the results section we illustrate the different dimensions of the rubric and the scoring system.

Results

The intended curriculum: Lesson plans

The analysis of the lesson plans in terms of prevalence of the conditional statements revealed 3 plans with low focus on the proof theme, 1 medium and 11 high. Below are examples of two lesson plans with a high focus on the conditional statements theme, developed by Bill and Dylan for students in grade 10. We chose these lessons to illustrate creative integration of conditional statements with regular content in algebra and geometry; as well as the challenges that PSTs encountered while enacting the lessons in classrooms.

Bill's lesson plan integrated conditional statements with triangle geometry. Each pair of students had two sets of notecards: yellow cards had hypotheses written on them (e.g., a triangle is equilateral), and green cards had conclusions (e.g., a triangle is isosceles). Students had to create conditional statements by matching hypotheses to conclusions. Bill intended to use student-produced statements in a whole class discussion to introduce such concepts as *domain* of a statement and a *counterexample*. Bill also planned to have students physically switch between hypothesis and conclusion cards as a way to introduce a *converse*. The lesson plan did not contain any exposition about what a conditional statement is, how it is structured, and what is needed to prove or disprove it. Bill hoped that these ideas would come out naturally as the students engaged in and discussed the card-matching activity.

Dylan's lesson integrated conditional statements with evaluating expressions and solving simple algebraic equations. First, the concept of conditional statements and key vocabulary such as truth value, domain and proposition (in lieu of hypothesis and conclusion) was introduced through non-mathematical examples such as "If a motor vehicle has four wheels then it's a car." Next, students practiced identifying domain, proposition and determining the truth-value of four statements: (1) If a number is divisible by 10, then it is divisible by 5; (2) If a number is not divisible by 10, then the number is not divisible by 5; (3) If a number is not divisible by 5, then it is not divisible by 10; and (4) If a number is divisible by 5, then it is divisible by 10. Notating the first one as $P \Rightarrow Q$, the other statements have the forms: $\sim P \Rightarrow \sim Q$, $\sim Q \Rightarrow \sim P$, and $Q \Rightarrow P$, respectively, which allows making interesting connections. The third task had students identify domain and proposition in statements related to evaluating expressions, such as: "If we have the equation $11x - 12 = 1$, then the solution of x is a whole number", or "If the side length of a cube is a whole number, then the volume is also a whole number." The students worked on these tasks in pairs and then discussed as a group.

Both lesson plans meaningfully integrated conditional statements with the mathematical topics Bill and Dylan planned to teach. The tasks in the lessons were of high cognitive demand (Silver et al., 2009) as they required formulating statements, exploring and justifying claims. In the next section we examine the transition from the intended to enacted curriculum in Bill's and Dylan's lessons.

The enacted curriculum: Classroom implementation

Both Bill's and Dylan's lessons were enacted in 10th grade classrooms with a group of 4 students. The description of the enactment below follows the five dimensions of the modified TRU rubric.

Bill's enacted lesson. Within the dimension of *Accuracy, language and communication* we distinguish between accuracy related to geometry, in which Bill's performance was impeccable, versus accuracy related to the proof theme. Bill's lesson plan suggested that he intended to build on students' contributions to elicit ideas about conditional statements. Thus, throughout the lesson Bill tried to avoid unfamiliar vocabulary and only used informal language. For example, when introducing the card matching activity Bill instructed students to match "if-cards" with "then-cards" to create "if-then" statements. He never introduced the concept of conditional statement and referred to hypothesis and conclusion as the "if-part" and "then-part" of the statement throughout the entire lesson. The lack of proper mathematical language complicated the classroom communication. Towards the end of the lesson Bill wrote a statement and its converse next to each other on the board and asked the students: "what changed?" One student responded by saying "the 'then' became the 'if'." This is a correct observation on behalf of the student, which signals the lack of language to describe it. While intending to build on student knowledge, Bill missed the opportunity to introduce vocabulary that could help to streamline the communication around conditional statements.

In terms of *explicating the conditional statements* proof theme, Bill seemed to follow a similar strategy of minimizing his input. The mathematical task lent itself naturally to discussing such important ideas as generality of a conditional statement and how to determine if it is true or false. Yet, the only concept Bill introduced in the lesson was a counterexample, which he informally defined as an example that "does not fit the statement and disproves it." Bill initiated a discussion on how to distinguish between examples that support, disprove or are irrelevant to the statement. For the latter point he used the statement: "If an angle in a triangle is 45° , then the measure of the third angle is 45° ," and drew a triangle with no 45° angles. Students were initially confused whether this triangle constitutes a counterexample to the statement, so Bill explained that a counterexample must satisfy the "if-part" but not the "then-part". Overall, Bill explicated multiple aspects related to conditional statements, but his insistence on using only informal language kept the discussion at a basic level.

In terms of actions to *promote student engagement*, Bill's lesson was rated very high. He encouraged participation by asking multiple questions, pushing students to provide explanations and justify their thinking. He was attentive to student body language and when he sensed that some students did not follow the discussion, he asked a student to repeat what was said in their own words. Bill made sure that each student contributed something to the conversation, however the level of *student engagement* was rather moderate. Although all students were listening attentively, they appeared uncomfortable when pushed to speak in full sentences, only responding in a few words. As a result, Bill often had to break down his questions to a set of simpler ones, lowering the *cognitive demand* of the tasks. The aggregate scores for Bill along the five dimensions are shown in Figure 2a.

Dylan's enacted lesson. Similar to Bill, Dylan's *Accuracy, language and communication* was different when talking about solving equations versus aspects related to conditional statements. The latter was often imprecise or not properly adjusted to the students' level. For example, Dylan said that

“when we prove the statement is false, we are providing a counterexample - something that does not fulfill the statement.” But since he did not provide a clear explanation of what it means to “not fulfill the statement” students occasionally confused an irrelevant example for a counterexample.

Dylan *explicated the conditional statement* proof theme much stronger than Bill. Dylan introduced some key concepts related to conditional statements, and even some logical notation, e.g., $P \Rightarrow Q$, which contributed to more seamless communication. However, Dylan missed multiple opportunities to draw connections among the concepts. For example, each of the four conditional statements on divisibility by 10 and by 5 was treated as a separate entity during the lesson. We are not claiming that Dylan should have delved deeper into logical notation or introduced a contrapositive, which could have been overwhelming for the students. However, Dylan missed the opportunity to draw students’ attention to the fact that that statements (2) and (4) are disproved by the same counterexample or that statements (1) and (3) require a general proof that uses the same key idea of 5 being a factor of 10. In his lesson reflection Dylan wrote how impressed he was with the students being able to identify the domain and proposition, and correctly justify the truth-value of statements that included negations, the converse, and the contrapositive. However, his lesson plan did not mention any of these connections, suggesting that the missed opportunity occurred at the planning stage.

Dylan did a good job in *promoting students’ engagement* by ensuring that students were on task, following up on students’ input, asking questions and pressing for explanations. For their part, *students participated* in the lesson in meaningful ways such as sharing ideas, responding to prompts, and justifying their work. As the lesson progressed, and its focus shifted to conditional statements involving equations, Dylan payed less attention to the logical aspects, focusing almost entirely on solving equations, possibly because students appeared to have difficulties in this area. While trying to support student thinking, Dylan often took over the explanation, thus lowering *the cognitive demand* of the tasks. The aggregate scores for Dylan along the five dimensions are shown in Figure 2b (four on teacher actions and the fifth on student engagement).

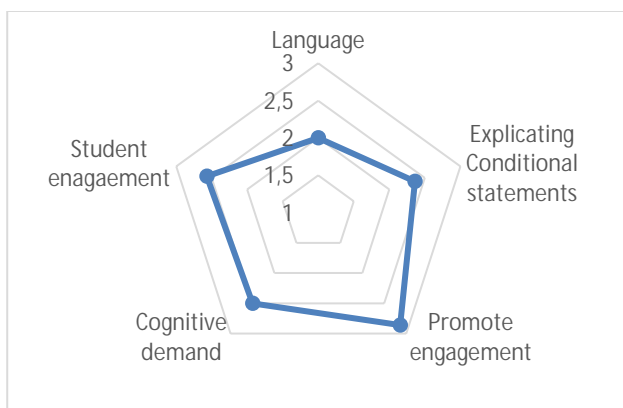
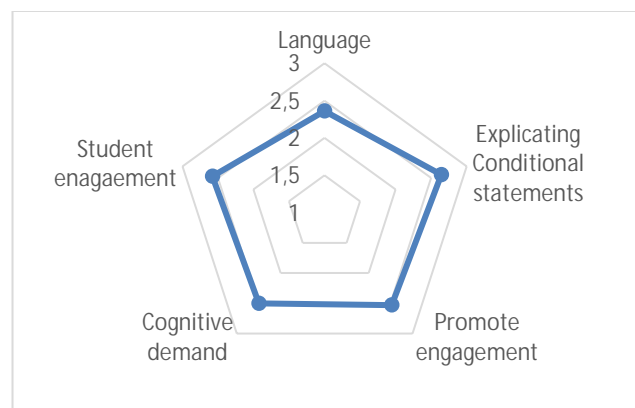


Figure 2a: Bill's enacted lesson.



2b: Dylan's enacted lesson

Figure 2 allows us to compare the various dimensions of Bill's and Dylan's enacted lessons. Both written lesson plans were rated high on explicating the conditional statements theme, however, Bill's insistence on using informal language resulted in lower scores in the areas of *Language* and *Explicating Conditional Statements*. Also, as described above, Bill put more effort into promoting student engagement, which is reflected in the high score for *Promote Engagement* (Fig. 2a). For the

Cognitive Demand dimension, both Bill and Dylan scored about 2.5 on the three-point scale, reflecting the fact that they both tried but did not completely succeed in maintaining the cognitive demand of their intended tasks when enacting their lessons. The *Student Engagement* dimension was also about 2.5 for both Bill and Dylan. We emphasize that in our setting it is not possible to draw direct connections between teacher actions and student engagement. Students' active participation, or the lack of thereof, could be in response to the change in their learning routine, by having a standard mathematics lesson replaced by one taught by a PST. Nevertheless, we include the student engagement dimension in the analysis to show the feasibility of having secondary students participate meaningfully in lessons that integrate conditional statements with the ongoing mathematical topics.

Discussion

Our goal in this paper was to trace how PSTs who participate in the capstone course *Mathematical Reasoning and Proving for Secondary Teachers* developed and implemented, in real classrooms, lessons that integrate aspects of conditional statements with the regular mathematics curriculum. Our analysis was grounded in Stein et al. (2007) curriculum framework. Overall, we were impressed with the fact that 11 out of 15 PST-developed lesson plans rated high on the prevalence of the conditional statements proof theme in them. This is a non-trivial outcome, especially given the limited access to pre-existing proof-oriented tasks in traditional US mathematics textbooks (i.e., the written curriculum). The majority of our PSTs were able to overcome this limitation, with the appropriate instructional support, and use knowledge and skills acquired in the capstone course creatively to develop lesson plans (i.e., the intended curriculum) that integrate logical aspects of proof with a variety of standard mathematical topics.

Despite many of the lesson plans having high focus on the conditional statements proof theme, the actual enactment of the lesson was often challenging for PSTs, as Bill's and Dylan's lessons illustrate. The main difficulties observed were adjusting the language to the student audience and clearly explicating the proof theme. These difficulties can be due to the fact that the PSTs did not know the students prior to the lesson, which impeded their ability to anticipate how students would respond to the conditional statements content. We addressed this issue in the subsequent iteration of the course, by including a requirement that PSTs provide in their lesson plans a list of mathematical-logical concepts they plan to use during the lesson and write a verbatim description of how they intend to introduce these concepts to students. The intention is to have the PSTs play out these aspects of the lesson plans more explicitly, prior to their enactment, so that their lessons are more likely to match the intended curriculum.

Based on the structure of the course, most PSTs taught a different group of students each time; this lack of continuity impedes our ability to make claims about student learning across time. However, our analysis showed relatively high levels of student engagement with proving during the PSTs' enacted lessons. Although we cannot attribute this completely to the PSTs' pedagogical actions, we assume that, if the content of the lessons was completely outside students' interest or conceptual reach, we would be seeing much lower levels of student participation.

The challenges encountered by the PSTs in our study can be partially explained by PSTs' lack of teaching experience. However, we assert that teaching conditional statements, or proof themes, in

general, is inherently challenging. Identifying specific areas of challenge for PSTs can help us, as mathematics teacher educators, to develop support structures that promote PSTs' competence in enacting reasoning and proof in their future classrooms. Some of these support structures were tested in our course design. Through repeated cycles of planning lessons that integrate proof themes within regular school curriculum, enacting these lessons in classrooms, and reflecting on them, the PSTs gained valuable experiences and developed a sense of feasibility of engaging students in proving.

Acknowledgement

This research was supported by the National Science Foundation (NSF), Award No. 1711163. The opinions expressed herein are those of the authors and do not necessarily reflect the views of the NSF.

References

- Antonini, S., Mariotti, M.A. (2008). Indirect proof: What is specific of this mode of proving? *ZDM Mathematics Education*, 40(3), 401-412.
- Bruner, J. (1960). *The process of education*. Cambridge, MA: Harvard University Press.
- Buchbinder, O. & McCrone, S. (2018) Mathematical reasoning and proving for prospective secondary teachers. *Proceedings of the 21st Annual Conference on Research in Undergraduate Mathematics Education* (pp. 115-128). <http://sigmaa.maa.org/rume/RUME21.pdf>
- Durand-Guerrier, V. (2003). Which notion of implication is the right one? From logical considerations to a didactic perspective. *Educational Studies in Mathematics*, 53(1), 5-34.
- Ellis, A. B., Bieda, K., & Knuth, E. (2012). *Developing essential understanding of proof and proving for teaching mathematics in grades 9-12*. Reston, VA: NCTM.
- Schoenfeld, A. H. (2013). Classroom observations in theory and practice. *ZDM Mathematics Education*, 45(4), 607-621.
- Silver, E. A., Mesa, V. M., Morris, K. A., Star, J. R. Benken, B. M. (2009). Teaching mathematics for understanding: An analysis of lessons submitted by teachers seeking NBPTS certification. *American Educational Research Journal*, 46 (2), 501 – 531.
- Stein, M. K., Remillard, J., & Smith, M. S. (2007). How curriculum influences student learning. In F. K. Lester, Jr. (Ed.), *Second handbook of research on mathematics teaching and learning* (pp. 319-370). Charlotte, NC: Information Age Publishing.
- Stylianides, A. (2007). Proof and proving in school mathematics. *Journal for Research in Mathematics Education*, 38(3), 289-321. Retrieved from <http://www.jstor.org/stable/30034869>
- Stylianides, G. J. (2008). Investigating the guidance offered to teachers in curriculum materials: The case of proof in mathematics. *International Journal of Science and Mathematics Education*, 6(1), 191-215.
- Stylianides, G. J., & Stylianides, A. J. (2017). Research-based interventions in the area of proof: The past, the present, and the future. *Educational Studies in Mathematics*, 96(2), 119-127.
- Thompson, D. R., Senk, S. L., & Johnson, G. J. (2012). Opportunities to learn reasoning and proof in high school mathematics textbooks. *Journal for Research in Mathematics Education*, 43(3), 253-295.

Developing Pre-service Mathematics Teachers' Pedagogical Content Knowledge of Proof Schemes: An Intervention Study

Fikret Cihan¹ and Hatice Akkoç²

¹ Kirklareli University, Kirklareli, Turkey; fikret_cihan@hotmail.com

² Marmara University, Istanbul, Turkey; hakkoc@marmara.edu.tr

The purpose of this paper is to examine the effects of an intervention study which aimed at improving pre-service mathematics teachers' pedagogical content knowledge (PCK) of proof schemes. Sowder and Harel's (1998) framework of proof schemes constitutes the conceptual framework of this paper. To explore twenty-two pre-service teachers' PCK, we designed a survey using a scenario. The quantitative findings of the study revealed that the intervention had a meaningful and large effect on participants' PCK of proof schemes. The qualitative findings of the study indicated that participants had difficulties identifying especially symbolic, example-based, transformational and axiomatic proof schemes prior to intervention, but they had overcome these difficulties after the intervention.

Keywords: Proof, proof schemes, pedagogical content knowledge, pre-service mathematics teachers

Introduction

Teaching proof is a extremely difficult matter for teachers to overcome (Heinze & Reiss, 2004). For teaching proof effectively, teachers should be able to determine types of justification used by their students and help them enhance their justification types to be able to reach the axiomatic level. In other words, they should have pedagogical content knowledge (PCK) of proof. In this paper, we are particularly interested in proof schemes which could be described as cognitive characteristics of proving processes (Harel & Sowder, 1998). However, there is a gap in the literature which explores or aims to develop PCK of proof schemes which is crucial for pre-service mathematics teachers. In order to address this problem, mathematics teacher educators should look for different ideas to teach proof in teacher preparation courses (Stylianides & Stylianides, 2017). Lack of such courses and instructional materials in pre-service mathematics teacher education programs call for intervention studies that foster PCK of proof.

Conceptual Framework of the Study: PCK of Proof Schemes

The conceptual framework of this study adopts two different frameworks: pedagogical content knowledge (Shulman, 1987) and proof schemes (Harel & Sowder, 1998; Sowder & Harel, 1998). Shulman (1987, p. 8) describes PCK as an “amalgam of content and pedagogy that is uniquely the province of teachers”. Various researchers describe different components of PCK. Among them, knowledge of students' thinking has been extensively studied in teacher education literature (Depaepe, Verschaffel, & Kelchtermans, 2013). Knowledge of students' thinking in a specific domain such as proof has a topic-specific dimension in it. With this regard, Lesseig (2016) created the "MKT for Proof" framework by adapting the Mathematical Knowledge for Teaching (MKT) framework developed by Ball, Thames, and Phelps (2008). She defines a subdomain of PCK as the knowledge of content and students (KCS) for proof which involves “knowledge of students' typical conceptions or misconceptions of proof as well as an understanding of developmental sequences” (p. 256). More

specifically, it is the knowledge of “characteristics of external, empirical and deductive proof schemes, students’ tendency to rely on authority or empirical examples, typical progression from inductive to deductive proof” (p. 257). In this study, we focus on PCK of proof schemes, knowledge of students’ proving processes and identifying students’ proof schemes in particular.

Proof schemes are cognitive characteristics of the proving process and describe one’s methods of justification. Harel and Sowder (1998, p. 244) discovered undergraduate students’ categories of proof schemes each of which “represents a cognitive stage and intellectual ability in students’ mathematical development”. They offered three main categories and their sub-categories:

The first category, *external proof schemes*, points out to an external source that convinces the student. Also, students persuade others by referring to these external sources. When this source is an authority (e.g. a teacher or a textbook), it is called *authoritarian proof scheme*. The external source might also be the form or appearance of arguments e.g. proofs in geometry must be in two columns. In this case, it is called *ritual proof scheme*. The last sub-category of an external proof scheme is *symbolic proof schemes* which refer to meaningless manipulations of symbols (Harel, 2007).

The second category is *empirical proof schemes*. For this scheme, “conjectures are validated, impugned, or subverted by appeals to physical facts or sensory experiences” (Harel & Sowder, 1998, p. 252). This could be in two ways: (a) relying on evidence from one or more examples (*example-based proof schemes*) or (b) relying on intuition or perception to convince or to be convinced (*perceptual proof schemes*) (Harel, 2007).

The third category is *analytical proof schemes* which is at the highest level of justification. In this case, conjectures are validated by means of logical deductions. It has two sub-categories: transformational and axiomatic proof schemes. *Transformational proof schemes* have three characteristics: generality, operational thought, and logical inference. (Harel, 2007). Generality is concerned with justifying “for all”. Operational thought takes place when a student “forms goals and subgoals and attempts to anticipate his/her outcomes during the proving process” (Harel, 2007, p. 67). Finally, logical inference requires mathematical justification based on the rules of logical inference. In addition to these three characteristics, in the *axiomatic proof scheme*, proving processes are built upon an axiomatic system, therefore must start from accepted principles (Harel, 2007).

The aim of the study and the research question

This study is part of a PhD thesis which aims to design an undergraduate course for developing pre-service mathematics teachers’ (PSMTs) view, content and pedagogical content knowledge of proof. The aim of this study is to report the findings of an intervention study which aims to develop pre-service teachers’ knowledge of proof schemes. As part of the course, a module on proof schemes, was implemented and our research question is as follows: “How does the module affect pre-service mathematics teachers’ pedagogical content knowledge of proof schemes?”

Methodology

This study used designed-based research (DBR) and specifically ADDIE (Analysis, Design, Development, Implementation, and Evaluation) model (Branch, 2009). In the analysis phase, the needs analysis was made based on the literature. Calls for the design and analysis of interventions

that foster PCK of proof and proving, proof schemes in particular, in the context of pre-service teacher education were considered. The objectives and learning outcomes of the course were determined. One of them was related to proof schemes: “PMTs will be able to describe and identify students’ proof schemes”. In the design phase, a 15-week course consisting of various modules (i.e. modern components of proof, proof methods, identifying proof schemes, student difficulties with proving, reasons behind student difficulties, teaching strategies that can overcome student difficulties) was prepared and expert opinion was taken. In the development phase, learning and teaching situations were organized. For the module on proof schemes, the classification of proof schemes by Sowder and Harel (1998) were explained to participants using two scenarios. Participants worked both individually and in groups to identify students’ proof schemes using the scenarios. After the intervention, the learning outcome related to proof schemes was evaluated using a different scenario. In the evaluation phase, the effect of the module on the learning outcome related to proof schemes was evaluated.

Participants are twenty-two PMTs who are in the second year of a teacher education program in a state university in Istanbul, Turkey. To explore PCK of proof schemes, we designed a survey called Pedagogical Content Knowledge of Proof Survey (PCK-P survey) using a scenario (See Appendix). The scenario includes an excerpt of a hypothetical discussion among a mathematics teacher and ten 9th grade students (age of fifteen). Prior to the intervention the PMTs were asked to describe student thinking; after the intervention, the PMTs were specifically asked to describe students’ proof schemes. The topic is set theory which is a typical topic in 9th grade curriculum in Turkey and the class discusses the truth of a proposition. Sowder and Harel’s (1998) proof schemes are illustrated by excerpts of students (See Table 2 for which student has each scheme). For validity concerns, the number of students was chosen to be ten which is bigger than seven (which is the number of proof schemes) to prevent participants from matching students’ work to the proof schemes. The teacher presents a proposition and asks students whether this proposition is true or false and justify their answers: “Let X , Y , and Z be sets. If $X \subset Y$ and $Y \subset Z$ then $X \subset Z$ ”. The survey includes the following questions concerning the scenario: “Describe how students S1,...,S10 justify their answers to the truth of the proposition. Is the proof correct”. To increase the validity of the findings, the scenario used as data collection tool was chosen to be different from the scenario used during the module. The topic was also different. PMTs filled the PCK-P survey before and after the intervention (fifteen weeks later). In the second implementation, PMTs were directly asked to identify proof schemes of students.

We analyzed qualitative data to explore the effectiveness of the module and obtained quantitative findings which will also be supported with written explanations of participants. Each participant identified ten students’ proof schemes, therefore there is a total of 220 answers. 220 answers from 22 participants were coded as “correct”, “incorrect” or “no response”. We used the Wilcoxon Signed Rank Test (Wilcoxon, 1945) to investigate whether the module significantly affected participants’ PCK. The effect size was calculated using the formula $r = Z/\sqrt{n}$.

Findings

Table 1 below presents the frequencies and percentages for correct, incorrect and no response categories. Percentages were calculated out of a total of 220 answers. As can be seen in Table 1,

findings indicate a development of PCK of proof schemes. The percentage of correct answers is 61.4% before the intervention and it increases to 96.4% after the module implementation. The number of correct answers increased by 77 which represents 35%.

	Correct	Incorrect	No Response	Total
Pre-intervention f (%)	135 (61.4%)	82 (37.3%)	3 (1.4%)	220 (100%)
Post-intervention f (%)	212 (96.4%)	8 (3.6%)	0 (0.0%)	220 (100%)

Table 1: Frequencies and percentages for answers before and after the intervention

Mean, standard deviation, minimum and maximum points were also calculated (over 10 which is the number of questions) considering answers to the survey before and after the intervention. The mean value increased from 6.14 to 9.64, minimum value increased from 3.00 to 8.00 and maximum value increased from 9.00 to 10.00. Standard deviation decreased to 0.58 from 1.49.

Student no	Type of Proof Scheme	Correct (Pre-/Post-)	Incorrect (Pre-/Post-)
1	Authoritarian	19/18	2/4
2	Authoritarian	19/22	3/0
3	Perceptual	17/22	5/0
4	Ritual	18/22	4/0
5	Symbolic	0/20	22/2
6	Example-based (a single example of finite sets)	21/22	1/0
7	Example-based (a single example of infinite sets)	13/21	9/1
8	Example-based (multiple)	14/21	8/1
9	Transformational	2/22	19/0
10	Axiomatic	12/22	9/0

Table 2. Frequencies of answers for proof schemes before and after intervention

We used the Wilcoxon Signed Rank Test to decide whether differences in PCK scores is significant. A Wilcoxon signed rank test showed that there was a significant difference ($Z = -4.144, p < 0.001$) between scores obtained before and after the intervention. Outputs for mean ranks of difference scores and sum of ranks imply that this significant effect is in favor of positive ranks, in other words, post-intervention. In addition, all participants' scores of PCK after intervention are higher than their scores prior to intervention. Effect size (r) was found as -0.88 . Since the absolute value of effect size is 0.88 which is greater than 0.50, it can be said that the module has a large effect size on the scores of PCK with regard to proof schemes in favor of post-intervention (Cohen, 1988).

As Table 2 shows, participants had difficulties to identify symbolic, example-based, transformational and axiomatic proof schemes before the intervention. They had overcome most of these difficulties after the intervention. Below, we present examples of these cases.

Student 5 has a *symbolic proof scheme*. He justified his answer considering the number of elements (See the lines 21-22 in Appendix): “ $S(X) < S(Z)$ then $X \subset Z$ ”. Using this statement which is wrong, Student 5 uses a shallow symbolic manipulation. None of the participants correctly identified that this student has a symbolic proof scheme because participants also thought that it is a valid proof. After the intervention, 20 out of 22 participants identified Student 5’s proof scheme correctly. They used the terminology of proof scheme framework.

In the scenario, we prepared three different cases of an *example-based proof scheme* using (a) a single example of finite sets (Student 6), (b) a single example of infinite sets (Student 7) and (c) multiple examples (student 8). Before the intervention, 21 out of 22 participants noticed that Student 6 relied on only one example. After the intervention, all participants identified the proof scheme of Student 6 correctly. For the cases of (b) and (c), frequencies of correct answers increased considerably after the intervention (See Table 2). For (b), after the teacher called out for a more general example, Student 7 justified his answer using the sets N , Z , and R which are infinite (See the lines 32-34 in Appendix). We consider this as an “example-based proof scheme using a single example” as in the case of (a) except the fact that N , Z , and R are infinite sets. However, before the intervention, nine participants could not identify the proof scheme in the case of (b) because they thought that this is a generalization. Since they considered the student’s scheme as a generalization rather than example-based scheme, we coded their responses as incorrect. However, after the intervention, they improved in identifying this scheme (21 out of 22 participants correctly answered).

Student 8 suggested each student find one example so that there would be many examples to justify the truth of the proposition (See the lines 36-37 in Appendix). 8 out of 22 participants could not identify Student 8’s scheme correctly as “example-based” before the intervention. The main reason is that they thought multiple examples are convincing for a generalization:

PMT13: He reaches a generalization by a different example for each one in the class.

PMT17: He justifies by making a generalization and uses many examples that show the truth of the proposition so many times.

After the intervention, 21 out of 22 participants correctly identified Student 8’s justification as “example-based”.

Student 9 has *transformational proof scheme* since he reached a generalization through operational thought based on logical inference (See the lines 42-43 in Appendix). Before the intervention, only two participants could identify the proof scheme correctly, because others did not refer to any components of this scheme (generalization, operational thought or logical inference) in their explanations about Student 9’s justification. After the intervention, all participants identified the proof scheme correctly.

Student 10 has *axiomatic scheme* since he started the proof by using the definition of a subset and successfully completed the proof as can be seen in the scenario in Appendix (See the lines 47-48).

Before the intervention, 12 out of 22 students could identify this scheme. Others just mentioned that it was a mathematical proof. After the intervention, all participants identified the proof scheme correctly because Student 10 used the modern components of an axiomatic system.

Discussion and Conclusion

Data indicated that the course module had significantly affected participants' scores of PCK of proof schemes. The intervention was effective especially in overcoming difficulties with identifying symbolic, example-based, transformational and axiomatic proof schemes. Before the intervention, participants could not identify students' shallow symbolic manipulation. Instead, they were probably convinced that the proof was valid just because it included symbols. For symbolic proof scheme, the course module included discussions of many examples of meaningless symbolic manipulation. After the intervention, participants improved in identifying this scheme. In the scenario, we expanded the notion of example-based proof schemes and included three cases (a single example of finite sets or infinite sets and multiple examples) and participants performed differently in each case. Before the intervention, participants found it more convincing compared to a proof with a single example which includes finite sets. In sum, although they identified an example-based proof scheme, they had difficulties in identifying proof schemes of students who used infinite sets and multiple examples. These findings indicate the importance of teachers' awareness of how students may view examples and noticing aspects of example use (Tsamir, Tirosch, Barkai, & Levenson, 2017). The module which included different cases of example-based proofs helped them overcome their difficulties.

The module was also effective for overcoming participants' difficulties in identifying transformational proof scheme by focusing on practices of generalizations using rules of logical inference and operational thought. Participants were more successful with identifying axiomatic proof schemes when compared to transformational scheme probably because they were more familiar with the modern components of proof such as definitions and axioms. However, before the intervention, they did not refer to these components to explain students' proving processes.

Considering the potential of scenarios to investigate PCK of proof schemes as implied by the findings of this study, we suggest that future studies could design scenarios focusing on proofs in different content areas. We also suggest that scenarios could be used in transition courses in undergraduate mathematics programs as well as teacher preparation programs. However, one should consider potential limitations of assessing the knowledge of identifying proof schemes using scenarios which could not reflect the complexity of a classroom. The second cycle of intervention could focus on teaching and learning situations in real classroom settings. Using Sowder ve Harel's (1998) notion of proof schemes which is a psychological construct, we focused on the psychological aspects of proof. Future studies could consider epistemological and sociological aspects of a mathematical proof.

Acknowledgment

This study is part of a research project sponsored by Marmara University Scientific Research Projects Committee with project number EGT-C-DRP-120418-0202.

References

- Ball, D. L., Thames, M. H., & Phelps, G. (2008). Content knowledge for teaching: What makes it special? *Journal of Teacher Education*, 59(5), 389–407.
- Branch, R. M. (2009). *Instructional design: The ADDIE approach*. New York: Springer.
- Cohen, J. (1988). *Statistical power analysis for the behavioral sciences (2nd ed.)*. Hillsdale, NJ: Lawrence Erlbaum Associates.
- Depaepe, F., Verschaffel, L., & Kelchtermans, G. (2013). Pedagogical content knowledge: A systematic review of the way in which the concept has pervaded mathematics educational research. *Teaching and Teacher Education*, 34, 12–25.
- Harel, G., & Sowder, L. (1998). Students' proof schemes: Results from exploratory studies. In A. Schoenfeld, J. Kaput & E. Dubinsky (Eds.), *Research in collegiate mathematics education III* (pp. 234–283). Providence, RI: American Mathematical Society.
- Harel, G. (2007). Students' proof schemes revisited. In P. Boero (Ed.), *Theorems in school: From history, epistemology and cognition to classroom practice* (pp. 65–78). Rotterdam: Sense Publishers.
- Heinze, A., & Reiss, K. (2004). The teaching of proof at lower secondary level—a video study. *ZDM*, 36(3), 98–104.
- Lesseig, K. (2016). Investigating mathematical knowledge for teaching proof in professional development. *International Journal of Research in Education and Science (IJRES)*, 2(2), 253–270.
- Shulman, L. (1987). Knowledge and teaching: Foundations of the new reform. *Harvard Educational Review*, 57(1), 1–23.
- Sowder, L., & Harel, G. (1998). Types of students' justifications. *The Mathematics Teacher*, 91(8), 670–675.
- Stylianides, G. J., & Stylianides, A. J. (2017). Research-based interventions in the area of proof: The past, the present, and the future. *Educational Studies in Mathematics*, 96(2), 119–127.
- Tsamir, P., Tirosh, D., Barkai, R., & Levenson, E. (2017). Noticing aspects of example use in the classroom: analysis of a case. In T. Dooley & G. Gueudet (Eds.), *Proceedings of the Tenth Congress of the European Society for Research in Mathematics Education* (pp. 3011–3018). Dublin, Ireland: DCU Institute of Education & ERME.
- Wilcoxon, F. (1945). Individual comparisons by ranking methods. *Biometrics Bulletin*, 1(6), 80–83.

Appendix. The scenario used in the PCK-P survey

Teacher: Is the proposition below true or false? If true, why? If false, why? Justify your answer.

Proposition: “Let X , Y and Z be sets. If $X \subset Y$ and $Y \subset Z$ then $X \subset Z$ ”

Student 1: I think, it is false. We've seen a lot of rules about sets. But I don't remember this one.

Teacher: OK. We haven't seen it in a lesson. Couldn't it be still true?

Student 1: I've never heard of a rule like this. Therefore, I think it's false.

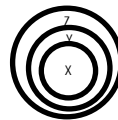
Student 2: Teacher, it is true. Because this theorem is in our maths textbook. So, it is definitely true.

Teacher: Do you think this is enough for a justification? You didn't write or do anything about it.

Student 2: I think it's enough. Why do we need another kind of justification if it's in the textbook?

Teacher: It's very important for us to reason about truth or falsity of a proposition.

Student 3: Teacher. May I draw a picture?



Teacher: Of course, you can.

Student 3: I think it's obvious from the picture.

Teacher: (heading towards the class) Is it enough for a proof? Just to draw a picture?

Student 4: Well, in fact. Every element in X is also an element of set Y . Every element in set Y is also an element of Z . I can express truth of the theorem. But we should do something mathematical. But I can't do it. Theorems should be proven using mathematical statements. But it shouldn't be. Verbal expressions, like I use, convince me much more.

Teacher: How did you come to this conclusion that proofs consist of mathematical statements only?

Student 4: Because proofs I've seen so far are just like that.

Teacher: Is there anyone who could use mathematical statements?

Student 5: If $X \subset Y$ then $S(X) < S(Y)$ and if $Y \subset Z$ then $S(Y) < S(Z)$. Therefore $S(X) < S(Z)$ that is $X \subset Z$.

Teacher: If the number of elements of a set is smaller than the number of elements of another set, then does it mean that the first set is a subset of the second set?

Student 6: I think not. I think that there is an easier way.

Teacher: What is that?

Student 6: Let $X \subset Y$ and $Y \subset Z$. Let $X = \{1,2\}$, $Y = \{1,2,3\}$ and $Z = \{1,2,3,4\}$.

Since $\{1,2\} \subset \{1,2,3\} \subset \{1,2,3,4\}$ then $X \subset Z$.

Teacher: Well. Do you think that this example is sufficient?

Student 6: Now it is true. I think it is sufficient.

Teacher: (heading towards the class) Do you think that this is sufficient?

Student 7: Not that example. But it would be sufficient if we justify with a more general example.

Teacher: For example?

Student 7: $N \subset Z$ and $Z \subset R$. Therefore $N \subset R$.

Teacher: That is a more general example. But still, it is not sufficient for generality issue of a proof.

Student 8: Teacher! If each one of us in the class finds an example to show the truth (of the proposition), then we can reach a generalization.

Teacher: When I talk about a generalization, it means it is true for all X, Y and Z . We can reach a generalisation through the rules of logical inference and operational thought. That is, using other rules we should reach a judgement from a hypothesis through operational thought. Is there anyone who could reach a generalization using what we've done in our previous lessons?

Student 9: Let $X \subset Y$ and $Y \subset Z$. Considering the rules we mentioned in our lessons, if $Y \subset Z$ then $Y \cup Z = Z$. $X \subset Y$ then $X \cup Z = Z$. If $X \cup Z = Z$ then $X \subset Z$.

Teacher: That is correct. However, it is better if we think of the modern components of proof. It is appropriate to start a proof with definitions and axioms. Is there anyone who could prove it using the definition of a subset?

Student 10: Let $X \subset Y$ and $Y \subset Z$. In this case, from the definition of a subset, if $X \subset Y$ then for $\forall a \in X$ $a \in Y$. If $Y \subset Z$ then for $\forall a \in Y$ $a \in Z$. Therefore, since for $\forall a \in X$ $a \in Z$ then $X \subset Z$. It's proven.

Games as a means of motivating more students to participate in argumentation

Jenny Cramer

University of Bremen, Germany; cramerj@math.uni-bremen.de

Mathematical argumentation and proof require students to engage in complex thought processes in which they explore logical connections, solve problems, and learn to trust their own assertions. While in most mathematics classrooms there are some students who show an aptitude for trusting their own reasoning and making logical inferences, this does not generally hold true for the majority of students. In the context of playing games, however, many students overcome such obstacles and become motivated to use logical reasoning and argumentation. In this paper I examine the potential of exploiting logical structures in games as a means of fostering the motivation of students to engage in inner-mathematical argumentation. A three-step-approach leading from a board game into argumentation in calculus is introduced and indications towards the usefulness of the approach for fostering students' motivation are presented.

Argumentation, logical games, calculus, motivation.

Argumentation – a mathematical activity for the few?

Mathematics is a discipline based on logical thinking and inferences, with argumentation and proof at its heart. Proving activities in mathematics provide opportunities to autonomously discover mathematical knowledge and reach a deeper understanding (de Villiers, 1990) and can therefore promote an experience of empowerment to students. They may also teach us how to reason logically outside of mathematics (Grabiner, 2012). The mathematics classroom should thus aim at engaging all students in “suitable mathematical activities of argumentation and proof” (Boero, 2011, p. 1). This demand is even more pressing in the light of existing gaps in the accessibility of high level mathematical activities for students from different backgrounds (Boaler, 2016, p. 173). Argumentation and proof threaten to act as social filters that may increase performance gaps between students of different backgrounds if they are only accessible to few students (Knipping, 2012).

Being important mathematical activities, argumentation and proof have been receiving increasing attention in mathematics education and in school curricula for decades. However, in spite of efforts made to promote argumentation in class, only one in three students reported in the PISA study of 2012 that they like to engage in complex problem solving activities (OECD, 2013, p. 67f), and about 30% of students reported a feeling of helplessness when doing mathematics problems (OECD, 2013, p. 88f). While problem solving is not synonymous to arguing and proving, such tasks almost always rely heavily on logical reasoning, and the results may be taken as an indication for students' attitudes towards argumentation activities: few students appear to enjoy such activities, and a significant number of students is reluctant to engage in them at all. This is surprising, as more than half of the same students questioned for PISA 2012 stated that they sought explanations for things and could easily link facts together (OECD, 2013, p. 67f), and both of these skills are crucial for argumentation.

Mathematical argumentation is a discursive practice, into which students need to be introduced in order to be able to participate (Boaler, 2000). Logical games and puzzles may provide a suitable way of overcoming obstacles to participation, as they require forms of logical, deductive reasoning similar to the reasoning used in mathematical argumentation and proof. Clear rules, balanced starting positions for all players, and the limited scope of knowledge required for argumentation in a game context may help to facilitate students' participation in discourse as they provide circumstances which may support fulfilling discourse ethical requirements (Habermas, 1990). These potential positive aspects of games have been discussed before (Cramer, 2014).

Another positive aspect of games lies in their potential to appeal to the intrinsic motivation of students. High motivation in games can be explained by the needs for competency, autonomy and relatedness postulated by Deci & Ryan's (1993) self-determination theory. The motivational potential of games has been well documented for video games (Rigby & Ryan, 2011), and similar effects may be expected for board games. The *need for competency* describes an inner desire to master challenges and new situations. Games provide such challenges to their players. A fulfillment of the *need for autonomy* is given when we perceive our actions as self-guided. While this is generally difficult to achieve in a school setting, a playful approach may help to fulfill this need. Lastly, the *need for relatedness* describes a need for meaningful social interaction. Board games are characterized by interaction and could prove even more helpful in this area than video games.

From game to graph: A three step approach

In this paper, a three-step approach to fostering the motivation of students to engage in argumentation is presented. It includes several rounds of the logical game *Uluru*, puzzles in the logical game environment, and puzzles in the area of calculus that aim at finding the graph of a function based on certain requirements. The research was conducted in a regular mathematics class with 15-16 year-old students in their tenth year of education (E-Phase) at a German high school (Gymnasium) over the course of five double lessons on four school days. Results are based on students' responses to three questionnaires at different points of the study. Figure 1 shows a timeline of the intervention.

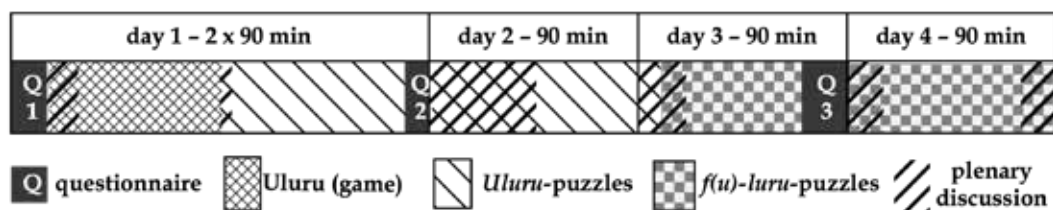


Fig 1: Temporal overview of the study

Step 1: Playing Uluru

In the first step of the intervention, the game *Uluru* (by Lauge Luchau, published by Kosmos) was presented to the students. In *Uluru*'s scenario, animals in Australia transform into dream birds of different colors (white, yellow, orange, pink, red, green, blue and black) at night and fly towards Uluru (Ayers Rock). There are exactly eight spots around the Uluru on which birds may be placed. Each player receives bird tokens in the eight different colors and a game board. At the beginning of each round, wishes are randomly generated from a set of cards to guide the placement of the dream

birds. The wishes correspond either to positions around the Uluru (e.g. “on the short edge”) or to positions relative to birds of other colors (e.g. “next to the green bird”). Situations can arise in which not all wishes can be fulfilled. All players simultaneously try to place their birds according to the wishes within a set time limit. When the time has run out, points are given to the players according to the number of birds correctly placed. The game is played in several rounds.

The types of arguments generated in Uluru are very similar to typical argumentation patterns in mathematics. When evaluating the positions of the birds that each player has found, it is easy to tell whether the requirements given by the wish for a certain bird have been fulfilled or not, and the only possible results of this evaluation are true or false. Furthermore, the game naturally leads to questions characteristically mathematical, such as: “(Why) is this the only possible constellation?”, “Is it possible to fulfill all wishes?”, or “Why can’t all conditions be met at the same time?”. Thus, the game naturally provokes argumentation between players at the end of each round, especially in situations in which no player found a solution yielding eight points or when different solutions occur.

Step 2: Solving Uluru puzzles

For the second step of the intervention, I created eight different puzzles in which different wish constellations were depicted. Students were given the task to figure out the maximum of achievable points for each situation. Two of the puzzles could be solved in exactly one way, two could be solved in different ways, three puzzles had a maximum of seven possible points, and in one puzzle six points were the maximum. The students were asked to record and justify their solutions on a protocol sheet. They were allowed to use the game board and the bird tokens to find a solution.

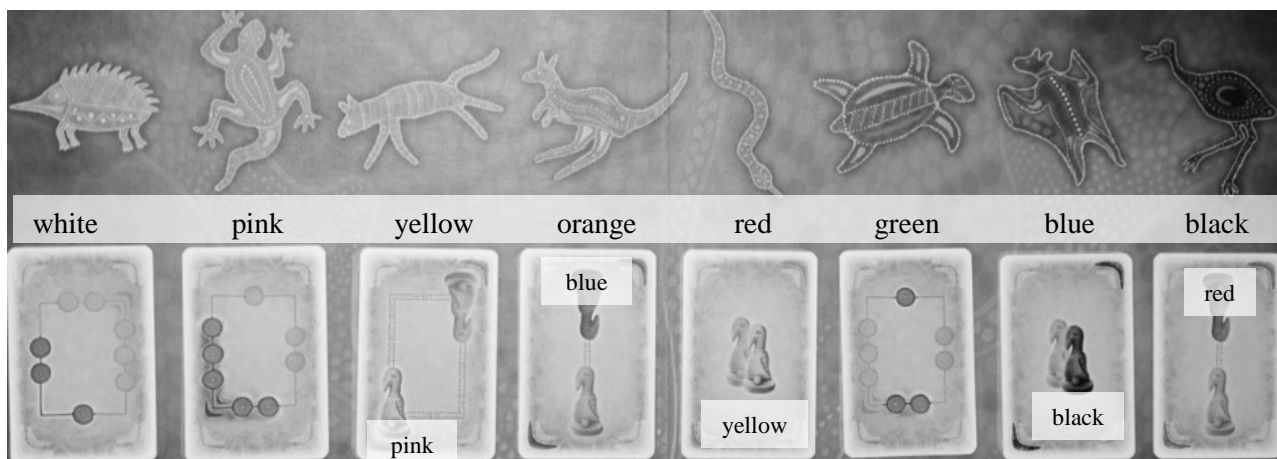


Fig 2: An example for an Uluru-puzzle (colors annotated)

In the example puzzle shown in Figure 2, three wishes (white, pink and green) refer to positions around the Uluru and five wishes (yellow, orange, red, blue and black) refer to birds of other colors. This puzzle has a unique solution. Due to the wishes of the red snake and the black emu, red and yellow need to be placed on adjacent spots and the black bird must be placed opposite the red bird. The blue bat’s wish means that black and blue need to be on adjacent spots. The orange kangaroo’s wish means that the orange bird must be placed opposite the blue bird and thus on the same side as yellow and red. There is only one side of the Uluru that has three spots (cf. Figure 3). The wishes of the yellow dingo (shared corner with pink) and the pink lizard determine the corner in which these two dream birds must be placed.

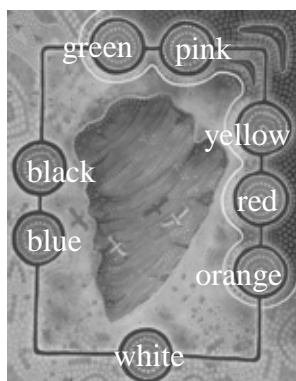


Fig 3: Unique solution

Combined with the already discussed wishes of the other animals, there remains only one spot of the places defined by the wish of the white echidna. The green bird token takes the remaining spot.

The students were allowed to work on these puzzles with a partner. They handed in their protocols at the end of the lesson. The examination of students' answers showed that while they were almost always capable of finding the best possible solution, many students had problems with justifying their answers. Before resuming work on Uluru puzzles in the next lesson, a plenary phase was initiated in which proof by exhaustion of cases and proof by contradiction were discussed in the context of Uluru puzzles.

Step 3: $f(u)$ -luru puzzles

In a third step, the concept of $f(u)$ -luru puzzles was introduced. In these puzzles, the animals of Australia wished for properties of the graph of a function. The puzzles followed the game design. To develop the graph, the students received a laminated coordinate system in a design inspired by the game board, as well as removable foil pens. Table 1 gives an example for conditions of a puzzle.

white	pink	yellow	orange	red	green	blue	black
$f(-1) = -0.5$	exactly 1 maximum	$f''(0) > 0$	$f(-2) = 0$	$f'(0) = 0$	symmetrical to y-axis	$f(0) = 1$	minimum for $x = -1.5$

Table 1 Conditions in the $f(u)$ -luru-"lightning puzzle" (simplified design)

For this puzzle, a maximum of 7 points can be achieved. The wish of green combined with the wishes of orange, white and black provide additional points $f(2) = 0$, $f(1) = -0.5$ and another minimum for $x = 1.5$. The blue and red wishes define the y-intercept as a local maximum or minimum. As the black and green wishes define two minima, pink's wish determines that the y-intercept must be a maximum. This contradicts yellow's wish $f''(0) > 0$. Thus, not all conditions can be fulfilled simultaneously. As seven is the second largest number of achievable points, this is an ideal solution to this puzzle. Figure 4 shows the solution.

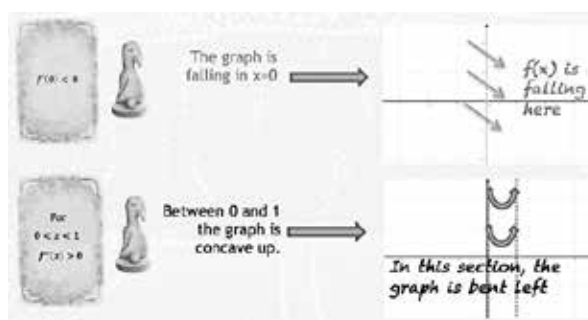
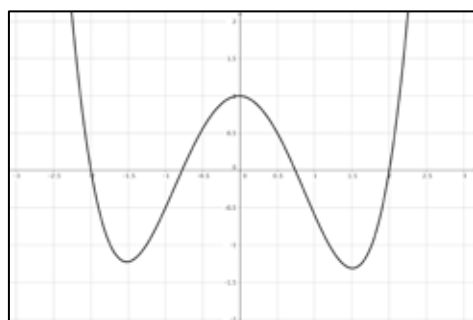


Fig 4: Solution to the puzzle (7 points)

Fig 5: Excerpt from the "wishes"-overview for $f(u)$ -luru

To help students determine possible solutions and formulate arguments, they received an overview which served to clarify and simplify the possible wishes in the $f(u)$ -luru puzzles and to make the mathematical task more playful. Figure 5 shows an excerpt of the overview. The students also

received protocol sheets in a design analogous to the protocol sheets for the Uluru puzzles to document their solutions. Like in the Uluru puzzles, the students were again allowed to work in pairs. The puzzles did not ask the students to find an algebraic solution (no functional equations were expected from the students).

From game to graph: A three step approach

To assess motivation, the Intrinsic Motivation Inventory (IMI, McAuley et al., 1989) was used. It is a suitable tool to measure motivation based on the needs postulated by self-determination theory. The questionnaire consists of 18 items and covers the dimensions *interest-enjoyment* (int-enj), *perceived competence* (perc-comp), *effort-importance* (eff-imp) and *tension-pressure* (tens-pres). For each item, agreement or disagreement was measured on a 7-point Likert-scale. Assessments took place at three points during the intervention. All examined tasks target solving a problem involving a variety of conditions that require reasoning and justifying. The students answered to the questionnaires using a pseudonym, allowing them to freely utter criticism (the researcher being their teacher).

Questionnaire 1 (Q1) was given to the students before the intervention to act as a point of comparison for later responses (cf. Field & Hole, 2003, p. 68). It was coupled to a task from the math textbook in which the graph of a function was to be created from certain requirements. This task had briefly been discussed in class in a lesson before the intervention. Q1's purpose was to facilitate capturing students' attitudes towards tasks in the regular mathematics classroom involving reasoning.

The second questionnaire (Q2) was given after the students had played the game Uluru and after they had been working on Uluru-puzzles for approximately one hour. I decided to forego an assessment of motivation after playing so as not to overstrain students with too many questionnaires.

The students responded to the third questionnaire (Q3) after approximately one hour of f(u)-luru-puzzles. This last questionnaire also covered some free text questions and items focusing on an evaluation of the intervention by the students, which were not statistically validated and can thus only give an indication concerning students' attitudes towards the intervention.

The setting of the evaluation is as a repeated measures design (Field & Hole, 2003, p. 183ff) with interdependent data, which necessitates an analysis of variance (Rasch et al., 2010). Nineteen students participated in all three questionnaires ($n=19$). Shapiro-Wilk tests allow the assumption of normally distributed results for all dimensions except tension-pressure ($p<0.05$) in Q2. Levene's test allows to assume homogeneity of variances except in the dimension of perceived competence.

Results

The needs dimension of interest-enjoyment is a measure of perceived intrinsic motivation. Results for this dimension are thus very interesting, as they refer directly to how students perceived the tasks. A non-significant Mauchly-test ($p = 0.53$) and the clearly significant analysis of variance ($F_{(2,36)} = 7.80$; $p < 0.01$) justify the use of t-tests. Bonferroni-corrected values show significant ($p < 0.01$) differences between Q1 and Q2 and between Q2 and Q3. The boxplot in Figure 6 shows a positive shift of means from the first ($M_1 = 3.63$; $SD = 1.22$) to the second assessment ($M_2 = 5.51$; $SD = 0.83$). The third mean ($M_3 = 4.39$; $SD = 1.06$) lies between the others. Interest and enjoyment decreased in f(u)-luru puzzles compared to the Uluru puzzles. However, the histograms of

questionnaires 1 and 3 (Figures 7 and 8) also show a considerable decrease of very negative evaluations (scale range 1–2).

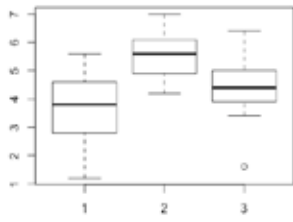


Fig 6: Boxplot int-enj for Q1-Q3

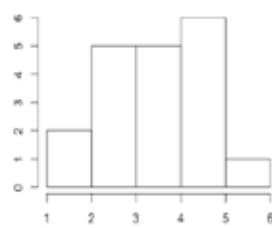


Fig 7: Histogram int-enj Q1

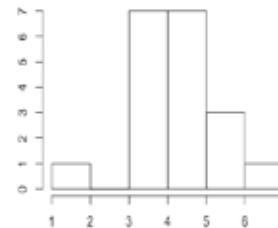


Fig 8: Histogram int-enj Q3

These results can be interpreted as a positive tendency that students preferred the f(u)-luru puzzles over classic mathematical tasks. However, this tendency needs to be treated with care as working arrangements were different for the mathematical task and for the f(u)-luru puzzles.

For the dimension of perceived competence, homogeneity of variances cannot be assumed. A closer look at the data shows that this can be explained by the high mean and small standard deviation in Q2. A comparison of means of questionnaires Q1 ($M_1 = 3.93$; $SD = 1.85$), Q2 ($M_2 = 5.94$; $SD = 0.77$), and Q3 ($M_3 = 4.4$; $SD = 1.75$) shows an increase in perceived competence for the Uluru-puzzles, followed by a decreased for f(u)-luru; the pairwise differences between Q1 and Q2 and Q2 and Q3 are significant ($p < 0.05$). The means for perceived competence did not increase significantly between Q1 and Q3. However, as in the dimension of interest-enjoyment, the distributions of students for the lower scores are instructive. In the classic mathematical task covered in Q1, eight students perceived themselves as scarcely competent (scale range 1–2), whereas only two students gave this response in Q3 for the f(u)-luru puzzles. Taking into consideration that the latter were comparatively harder, this can be taken as an indication that students who otherwise trust little in their abilities might have benefited from the intervention.

Results for effort-importance show significant differences ($p < 0.01$) between Q1 ($M_1 = 3.8$; $SD = 0.77$) and the means of Q2 and Q3 ($M_2 = 4.95$; $SD = 1.15$ and $M_3 = 4.7$; $SD = 1.02$; Mauchly-test $p = 0.38$, ANOVA $F_{(2,36)} = 7.80$ $p < 0.01$). The students appear to have put greater effort into both, solving Uluru-puzzles and f(u)-luru puzzles. These results could point to an increase in students' readiness to get deeply involved in a given task.

Results do not allow to assume normally distributed results for the dimension of tension-pressure in Q2. However, this dimension was rated low in all assessments ($M_1 = 2.88$; $M_2 = 2.01$; $M_3 = 3.06$). The students apparently did not perceive themselves under pressure during the intervention.

The students were asked in Q3 to comment on whether they had liked f(u)-luru puzzles better than classic problems in mathematics. Some notable answers:

I liked the f(u)-luru puzzles more, because it was possible to visualize and understand better.

Yes, because it was something different. Not so "dry", but another method to do math problems.

I liked it better because for some reason I was more motivated.

The majority of students responded positively. Only one student replied: "I personally liked the Uluru puzzles better, because you didn't need to show mathematical understanding like in the f(u)-luru

puzzles. The f(u)-luru puzzles were just as tiresome as normal mathematical problems.” While this answer shows that the intervention did not manage to motivate all students equally to engage in mathematics, it underlines the positive effects of the second step of the intervention.

In addition to the IMI-questions, Q3 also covered items aimed at a more direct evaluation of the intervention, which were rated on the same 7-point Likert scale. The students’ answers to these questions show a positive evaluation. Table 3 shows the items and the means.

Item	mean
I had fun playing Uluru (the game)	6.65
I had fun solving Uluru puzzles	6.15
I had fun solving f(u)-luru puzzles	4.9
I was motivated by the game Uluru to make an effort in Uluru puzzles	5.55
I was motivated by Uluru puzzles to make an effort in f(u)-luru puzzles	4.53

Table 3 Evaluation items in questionnaire 3 and their means

Discussion

The three-step intervention described in this paper covered only a brief timespan of five double lessons, so only small effects may be expected. Furthermore, different working arrangements at different stages of the intervention must be considered when examining the results. However, the results presented here may be taken as an indication that game-based approaches may have motivational benefits for students. The quantitative evaluation of students’ answers yields a significant and noticeable increase of motivation for the Uluru-puzzles. While results for the f(u)-luru puzzles are not as unequivocally positive, the distribution of student responses compared to their assessment of the mathematical task in the dimensions of interest-enjoyment and perceived competence allows for the tentative assumption that the f(u)-luru puzzles are more likely to get a larger number of students involved in mathematical thinking than classic problems. Further research is needed, both to determine the effect of the different conditions in this study (e.g. working arrangements, difficulty of the tasks in Q1 and Q3) and to look at potential long-term effects.

While this paper shows potential motivational benefits of game-based approaches, this study did not include an evaluation of students’ argumentation quality in the Uluru puzzles or in the f(u)-luru puzzles. Therefore, it is unclear whether the intervention managed to actually improve mathematical argumentation skills. This question needs to be tackled in future research. For an evaluation in this regard, a consideration of Hintikka logic can prove helpful (Soldano & Arzarello, 2017).

Interventions like the one presented in this paper can be first steps towards a better integration of more students into argumentation discourse in the classroom. Observations in class and student responses to Q3 show that students worked on all given tasks in a highly concentrated way, which naturally included arguments and justifications. Clearly positive reactions of students to the game and the game-based puzzles show that most students like to engage in logical thinking. Exploiting logical games and puzzles as a stepping stone for more students to get involved in mathematical argument

seems a promising path towards more equally distributed student participation and might provide a means of tackling existing gaps in students' access to argumentation discourse.

References

- Boaler, J., & Greeno, J. G. (2000). Identity, agency, and knowing in mathematics worlds. In J. Boaler, (Ed.) *Multiple perspectives on mathematics teaching and learning* (pp. 171–200). London: Ablex.
- Boaler, J. (2016). Designing mathematics classes to promote equity and engagement. *Journal of Mathematical Behavior*, 41, 172–178.
- Boero, P. (2011). Argumentation and proof: Discussing a “successful” classroom discussion. In M. Pytlak, T. Rowland, & E. Swoboda, (Eds.), *Proceedings of CERME 7* (pp. 120-130). Rzeszów, Poland: University of Rzeszów and ERME.
- Cramer, J. C. (2014). Using Habermas to explain why logical games foster argumentation. In P. Liljedahl, C. Nicol, O. Oesterle, & D. Allan (Eds.) *Proceedings of the 38th IGPME conference and the 36th Conference of North Chapter of PME* (Vol. 2, pp. 345-352). Vancouver: PME & UBC.
- De Villiers, M. (1990). The role and function of proof in mathematics. *Pythagoras*, 24(1), 17–24.
- Knipping, C. (2012). The social dimension of argumentation and proof in mathematics classrooms. Retrieved from http://www.icme12.org/upload/submission/1935_f.pdf
- Deci, E., & Ryan, R. (1993). Die Selbstbestimmungstheorie der Motivation und ihre Bedeutung für die Pädagogik. *Zeitschrift für Pädagogik*, 39(2), 223–238.
- Field, A., & Hole, G. (2003). *How to design and report experiments*. London: Sage.
- Grabiner, J. V. (2012). Why proof? A historian's perspective. In G. Hanna & M. de Villiers (Eds.), *Proof and proving in mathematics education* (pp. 147-167). Dordrecht: Springer.
- Habermas, J. (1990). *Moral consciousness and communicative action*. Translated by C. Lenhardt and S. Weber Nicholsen. Sixth printing 1999. Boston: MIT Press.
- McAuley, E., Duncan, T., & Tammien, V. V. (1989). Psychometric properties of the Intrinsic Motivation Inventory in a competitive sport setting: A confirmatory factor analysis. *Research quarterly for exercise and sport*, 60(1), 48–58.
- OECD. (2013). Students' Engagement, Drive and Self-Beliefs (III). Paris: OECD Publishing. Online: <http://dx.doi.org/10.1787/9789264201170-en>. Last access 16/09/2018.
- Rasch, B., Frieze, M., Hofmann, W., & Naumann, E. (2010). Kapitel 7: Varianzanalyse mit Messwiederholung. In *Quantitative Methoden*. Band 2 (3. Auflage). Heidelberg: Springer.
- Rigby, S., & Ryan, R. M. (2011). *Glued to games: How video games draw us in and hold us spellbound*. Santa Barbara: Greenwood: ABC-CLIO.
- Soldano, C. & Arzarello, F. (2017). Learning with the logic of inquiry: game-activities inside Dynamic Geometry Environments. In T. Dooley & G. Gueudet (Eds.), *Proceedings of the 10th Congress of European Research in Mathematics Education* (pp. 267-274). Dublin, Ireland: DCU Institute of Education and ERME.

Towards an interactional perspective on argumentation in school mathematics

Markos Dallas

University of Agder, Faculty of Engineering and Science, Department of Mathematical Sciences,
Kristiansand, Norway; markos.dallas@uia.no

This paper discusses theoretical and methodological considerations which have emerged from reviewing the literature related to my PhD research project which adopts an interactional perspective on the development of the argumentation process in primary school mathematics. This led me to distinguish the factors involved in mathematics classroom interaction during the development of the argumentation process, as well as to examine the possible relations and interrelation of these factors. The outcome of this process was, first, to clarify theoretical aspects and second, to create a preliminary model, called the “Mathematics Classroom Interactional Model” (MCIM), positing two levels of classroom interaction and the possible relations within each of them and between them.

Keywords: Socio-mathematical norms, participation, mathematical argumentation, mathematical communication, mathematics classroom interaction

Introduction

In the field of Mathematics Education, according to the related literature review, the notions of argument and of mathematical argument can be found in two different strands. The first strand relates to socio-mathematical norms and participation in the learning environment (e.g. Wood, 2002; Yackel & Cobb, 1996), mostly based on situated learning theory in the research (e.g. Boaler, 2000; Greeno, 1997; Lave & Wenger, 1991) and the second strand relates to mathematical argumentation and classroom interaction (e.g. Steinbring, 2005; Stylianides, 2007). However, so far, the literature does not seem to have made any clear attempt to develop a coherent theoretical framework and methodological tools emerging from the two strands. Thus, in my study, I focus on the development of the argumentation process in primary mathematics classrooms, considering the norms, the interactions and the role of the participants in learning and teaching practice. In this paper, I discuss aspects related to mathematical argument, argumentation and participation from the two strands of the literature to formulate the preliminary central research questions of the study, as well as to discuss the coherence –both compatibility and complementarity– of the two strands. On this basis, I develop a preliminary model, called the “Mathematics Classroom Interactional Model” (MCIM), of the concepts and their possible relations that will guide the scope of the study.

Socio-mathematical norms and participation in the learning environment

Lave and Wenger (1991) describe learning as a social phenomenon that is constituted in the real world through a process of legitimate peripheral participation in communities of practice which are in development. This means that pupils are members of wider worlds that are socially and culturally formed, so developing links that cross the identities of ethnicity, gender, religion, etc., acts in classrooms, schools and communities and the practices that govern all these environments. The

word “knowledge” has been replaced by the word “knowing” that declares an action. This fundamental shift indicates that activities cannot be considered independent of the context. The “practice” is mainly characterized by the terms “discourse” and “communication” which implies that a pupil should be regarded as a person interested in participation in certain types of activities not only in the accumulation of knowledge (Sfard, 1998).

While the learning process in the current study is regarded in terms of the participation metaphor (Sfard, 1998), what is important is the person’s participation in activities influenced by the context. The underlying theory is that of Vygotsky’s (1978) socio-cultural approach, considering learning as an outcome of interaction with others, while theoretical approaches in situated learning are preeminent in contextualizing and describing classroom communities. These approaches, according to Lave and Wenger (1991) and Bransford, Zech, Schwarz, Barron and Vye (2000), have led to situated learning theories, in which knowledge is situated in particular forms of experience that arise in specific situations, and are understood in a relational way as something shared between people, activities and environments rather than as a fixed, individual characteristic (Boaler, 2000). Hence, mathematical knowledge, as a dynamic process of mathematization, is “still being open and not fixed in advance of the learning and acquisition processes” (Steinbring, 2005, p. 48).

According to Greeno (1997) many researchers based on situated perspectives, study the development of classroom activities which involve pupils participating “in the discourse of the subject matter, including formulating and evaluating hypotheses, conjectures, arguments, evidence, examples, and conclusions” (Cobb et al., 1993; Cohen et al., 1993; Hatano & Lambert, 1990; Inagaki, 1991; Schoenfeld, 1994 as cited in Greeno, 1997, p. 99). A situated view suggests that activities of different practices are important, for instance involving pupils in classroom discussions is a way of pupils learning not only the content knowledge but also to participate in discourse practices (Greeno & MMAP, 1998 as cited in Boaler, 2000). Pupils learn not only methods and processes in the mathematics classrooms, but they are trained in mathematics, and the learning of the content knowledge cannot be separated from the classroom interaction, as they are two reciprocal components (Boaler, 2000). One question posed in the situated learning theory is whether the pupil’s pattern of participation can be a potential obstacle to his/her membership of the classroom community.

Wood (2002) states that classroom culture consists of a set of social norms, a specific structure of participation, as well as characteristic forms of discourse that support both social norms and the structure of participation. A participatory structure refers to the specific characteristics of the classroom that affect pupils’ participation in the classroom: who is involved, when and how. Wood recognizes three types of culture that characterize a classroom of inquiry and can lead to different patterns of participation. The first relates to the development of alternative resolution strategies, the second relates to a culture of exploration of the strategies developed by their classmates, and the third to a culture of argumentation where social norms require pupils to justify or defend the methods of solution they choose. Wood, Williams and McNeal (2006) investigated primary mathematics classroom interactions and the development of mathematical thinking. One of the most important results was the finding that only in an inquiry/argument classroom culture were there opportunities for all children to be involved in meaning making and shared understanding.

Nevertheless, as Klein (2001) points out, participation in cultures such as the above may be problematic for pupils who either have not conquered the tools of defending or challenging ideas through discussion (e.g. language or norms such as what constitutes a different answer) or lack the self-confidence or self-image expected by an apprentice working in a collaborative learning environment.

Many researchers attach importance to the role of classroom culture, providing cooperative learning opportunities and, in particular, developing intellectual autonomy by pupils. They focus on socio-mathematical norms and argumentative skills in the constitution of mathematical meaning in the classroom. Yackel and Cobb (1996), investigating the role of communication as a cultural tool, concluded that social norms (e.g. explanation and justification of a solution) directly affect the patterns of participation, a conclusion also supported by Sfard (1998), while socio-mathematical norms (e.g. which answer is considered mathematically different) provide equal opportunities to all pupils in that particular structure and regulate mathematical arguments. Finally, Kazemi and Stipek (2001) recognized, defined and described four categories of social norms and socio-mathematical norms respectively. The authors, in their discussion, emphasize the need for future research with longitudinal data that may reveal other norms, how socio-mathematical norms are created and sustained, and how they influence pupils' mathematical understanding.

The discussion so far led me to consider the connection between social and socio-mathematical norms relating to argumentation in the mathematics classroom. It seems that the mediator in this connection is the specific structure of the patterns of participation that allows (or not) the social norms to be transformed, created and sustained as socio-mathematical norms. Thus, the first central research question which emerged is: "what social and socio-mathematical norms relating to argumentation are established in the mathematics classroom, and how are these expressed in terms of patterns of participation?".

Mathematical argumentation and classroom interaction

In the field of Mathematics Education, Krummheuer (2007, 2015) started off using Toulmin's (2003) argumentation scheme to analyse classroom-based mathematical arguments. However, Krummheuer (2007, 2015) used a reduced version (conclusion, data, warrants and backings) of Toulmin's full scheme of argumentation (conclusion, data, warrants, backings, modal qualifier and rebuttal). Many researchers (Cabassut, 2005; Evens & Houssart, 2004; Pedemonte, 2005; Hoyles & Küchemann, 2002; Weber & Alcock, 2005; Yackel, 2001) as cited in Inglis, Mejia-Ramos and Simpson (2007) appear to have followed Krummheuer in using the reduced scheme. While, Inglis et al. (2007) concluded that without using Toulmin's full scheme of argumentation it may be difficult to accurately formulate the full range of mathematical arguments, on the other hand Mariotti, Durand-Guerrier and Stylianides (2018) mention that difficulties of pupils to organize arguments in a deductive chain in the form of proof cannot be fully explained by Toulmin's model.

Despite the widespread use and proven usefulness of Toulmin's scheme of argumentation over the last two decades, researchers in Mathematics Education do not use this scheme in a consistent way; as well as different interpretations emerging, so are some limitations. Thus, I studied further the

related literature to find a model created in the field of Mathematics Education that could serve both aspects of mathematical argumentation and classroom interaction.

Stylianides (2007) developed a theoretical framework about proof and proving in the context of K-12 mathematics. “Proof is a mathematical argument, a connected sequence of assertions against a mathematical claim” (Stylianides, 2007, p. 191). Any given argument can be broken down into three major components: the set of accepted statements, the modes of argumentation and the modes of argument representation. The distinction between base arguments and ensuing arguments could provide the context in which instructional analysis and instructional interventions by teachers influence classroom interactions and vice versa. In terms of this distinction, it is worth to be mentioned that in everyday mathematics classrooms situations, where the learning process is considered in terms of a participation metaphor (Sfard, 1998), the participants could produce a range of arguments, for example, “relatively sophisticated arguments” or “explications of elements of an argument” (Krummheuer, 2015, p. 53). Thus, the basic assumption is that mathematical argumentation can only emerge through interaction and mathematical communication within the classroom culture. Steinbring (2005) developed an analytic framework/tool to examine the relation between mathematical knowledge and mathematical communication. While, “language is the central medium for the creation of possible connections between communication and consciousness” (Steinbring, 2005 p. 53), proof is the communication medium of invisible mathematical objects and the mediator between communication and consciousness (Heintz, 2000 as cited in Steinbring, 2005; Steinbring, 2005).

Instructional school-mathematical interaction is expected to contribute to introducing individuals into mathematical communication practice, and thus to increase these individuals’ ability to participate in (mathematical) communication in the society. (Steinbring, 2005, p. 74)

This interaction could be understood by the term “situational”.

My perspective is situational, meaning here a concern for what one individual can be alive to at a particular moment, this often involving a few other particular individuals and not necessarily restricted to the mutually monitored arena of a face-to-face gathering. (Goffman, 1974, p. 8)

According to Krummheuer (2007), the term “situational” refers not only to a particular situation that could be characterized as “situated”, but to anything that can happen in the interaction between people. Thus, for example, if during a lesson the pupils solve an activity on their own it may be a “situated learning” process (Lave & Wenger, 1991) which is shaped by the pre-knowledge that allows them to face similar activities. The action changes into a “situational” process if the pupils take initiatives to act with their classmates. Levinson (1988) extended the ideas of Goffman (1981) and Krummheuer (2007, 2015) by adapting the concepts of participants’ (speakers’) roles in Mathematics Education: “author”, “relayer”, “ghostee” and “spokesman”. Although Krummheuer’s (2007, 2015) approach to participation in argumentation offers insights on the way that participation is performed in mathematical argumentation, the mechanism of being in one role or another is not obvious and cannot explain the obstacles in pupils’ participation in the developing of mathematical arguments, something also claimed by Cramer and Knipping (2018). Cramer and Knipping (2018) highlight the importance of participation in mathematics classroom argumentation, considering the

discursive and social processes that affect argumentation. Thus, participation is not only a discourse but the practice of constructing arguments through the social order of participants' interactions in the classroom which can be constructed, maintained and transformed. Cramer and Knipping (2018) mention an interesting case of pupils' implicit participation (pupil's initially spoken idea developed further in the classroom discourse but the pupil's voice disappeared), to describe possible obstacles for participation in argumentation and possible interventions by a teacher.

The discussion so far led me to consider the connection between mathematical argumentation and classroom interaction. It seems that the mediator in this connection is the specific role of the participants that regulates the participation in mathematical argumentation. Thus, the other two central research questions which emerged are: "how do pupils' interactions contribute to the development of the base arguments?" and "how do teachers' instructional interventions influence pupils' activity in the developing of ensuing arguments?".

Discussion

The ideas about socio-mathematical norms and participation in the learning environment and those about mathematical argumentation and classroom interaction seem to be related. Socio-mathematical norms seem to be a major factor that regulates classroom interaction in developing arguments. Especially, pupils' and teachers' roles in developing base and ensuing arguments are related to socio-mathematical norms that could foster (or not) mathematical argumentation and participation in the classroom. Thus, I decided to create the preliminary MCIM model, of the basic concepts and their relations as considered in the previous two sections and expressed in terms of the three central research questions.

In this model, Figure 1, I posit two levels of classroom interaction. The first (basic) level of classroom interaction is defined by the relations among the social norms, the socio-mathematical norms and the classroom culture. These are the predominant factors that characterize classroom interaction and are defined fully through the review of the first strand of the literature. The socio-mathematical norms established in the classroom are affected by social norms. Thus, social and socio-mathematical norms define the classroom culture. The second (advanced) level of classroom interaction is defined by the relations among the participation, the mathematical argumentation and the participants' roles. This level includes, A: the three factors as a Structural Unit (Participation-Mathematical argumentation-Participants' roles) and B: three sub-structures: 1) Socio-mathematical Structure: Participation-Mathematical argumentation, 2) Argumentation Structure: Mathematical argumentation-Participants' roles, 3) Social Structure: Participants' roles-Participation. Each of these structures presupposes the connection of factors at the basic level. Thus, the common ground of the structures at the advanced level is the connection among the three factors at the basic level. When a researcher or a teacher in the classroom would like to understand, investigate and further develop the advanced level, they should firstly understand, consider, and develop the connection of the social norms, socio-mathematical norms and the classroom culture, the factors at the basic level.

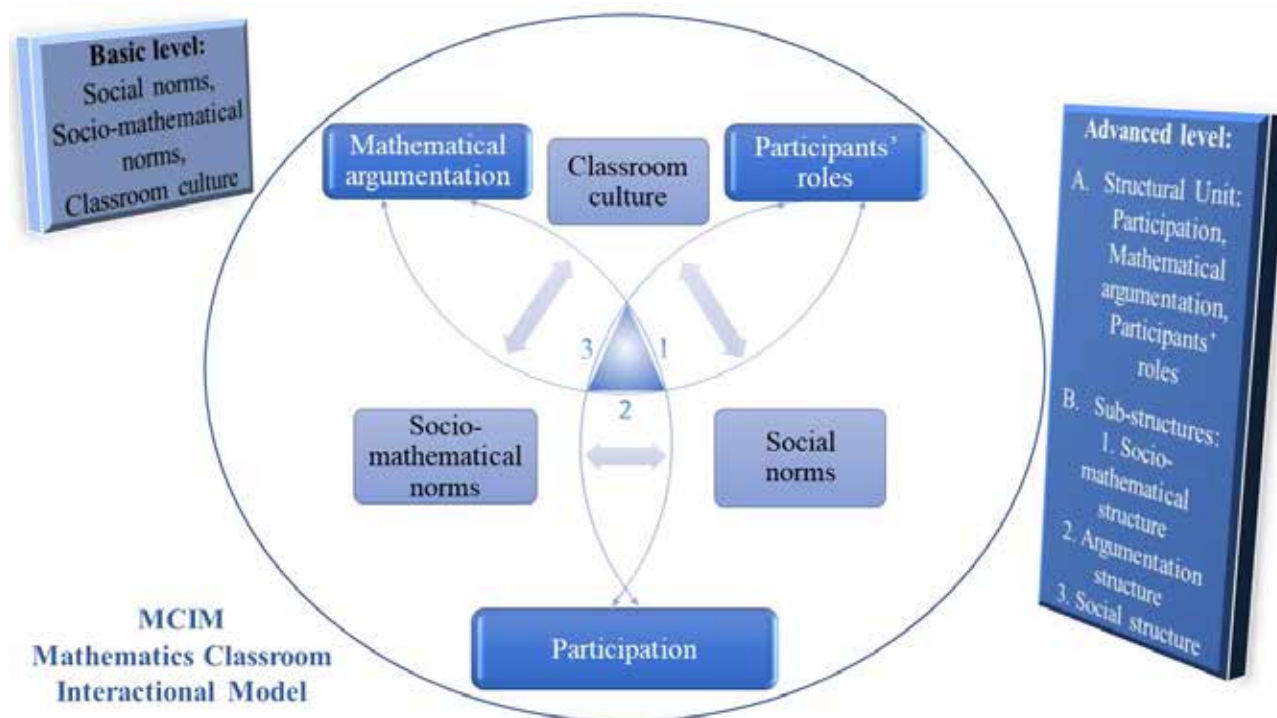


Figure 1: Mathematics Classroom Interactional Model (MCIM)

According to the related literature, the main connection between the two levels rests on social norms and socio-mathematical norms that regulate mathematical arguments, defining participation in the classroom culture (e.g. Yackel & Cobb, 1996; Wood, 2002; Wood et al., 2006). Therefore, in order to define this model with consistency, I consider theoretical and methodological frameworks to get access to mathematical argumentation and classroom interaction. Stylianides (2007) framework could serve as an analytic tool in order to examine the development of mathematical argumentation and teachers' actions, through the processes of instructional analysis and instructional intervention. Especially, the distinction between base and ensuing arguments and the possible differentiation between them and in each of them could be related with the patterns of participation which emerge through the socio-mathematical norms. Nevertheless, it seems that the focus of the framework is from the teachers' perspectives rather than on pupils' and teachers' interactions and their roles in the classroom culture. Stylianides uses the notion of classroom community in the definition of proof with a perspective different from that usually found in the literature, and from the one I have taken in my study. He regards the pupils as the main members of the classroom community, giving the teacher a special membership status and distinct role, while in my study I focus on the dynamic of the classroom interactions and the power of the relationships that shape the participation in the classroom community. Thus, I elaborate Steinbring's (2005) framework of mathematical knowledge and communication where the interactions and communication among participants are presented as predominant in the classroom. In this context, the reference to the role of the language in mathematical communication and argumentation in the classroom is very interesting and this leads me to consider frameworks through which I could get insights on the utterance of the mathematical argumentation through the participants' roles. Levinson's (1988) categorization of speakers' roles seeks to offer insights on the patterns of

participation. However, Krummheuer (2007, 2015) does not seem to undertake or investigate the limitations described by Levinson (1988), where multiplicity and alteration of the participants' roles in some utterance events, as well as new roles, could be recognized, defined and re-defined. Moreover, Cramer's and Knipping's (2018) evidence of implicit participation is an interesting aspect related to participants' roles in mathematical argumentation and could be investigated further, either as forms of participation or non-participation. Considering the roles of the participants and interactions among pupils and teachers in the classroom culture, it could be possible to examine pupils' interactions in developing base arguments and explain teachers' actions in influencing pupils' activity to develop ensuing arguments.

Finally, the way that the socio-mathematical norms and the social order, related to the development of mathematical arguments and argumentation, are created, sustained and transformed could provide the context of an interactional perspective on argumentation in school mathematics through the MCIM model. However, this model has still to be considered and defined fully through empirical research to be conducted, developing the methodological context and the research protocols that fulfil the goal of the study.

References

- Boaler, J. (2000). Mathematics from another world: Traditional communities and the alienation of learners. *Journal of Mathematical Behavior*, 18(4), 379–397.
- Bransford, J., Zech, L., Schwarz, D., Barron, B., & Vye, N. (2000). Designs for environments that invite and sustain mathematical thinking. In P. Cobb, E. Yackel, & K. McClain (Eds.), *Symbolizing and communicating in mathematics classrooms* (pp. 275–324). Mahwah, NJ: Lawrence Erlbaum Associates.
- Cramer, J. C., & Knipping, C. (2018). Participation in argumentation. In U. Gellert, C. Knipping and H. Straehler-Pohl (Eds.), *Inside the mathematics class: Sociological perspectives on participation, inclusion, and enhancement* (pp. 229–244). Cham, Switzerland: Springer Nature.
- Goffman, E. (1974). *Frame analysis. An essay on the organisation of experience*. Cambridge, MA: Harvard University Press.
- Goffman, E. (1981). Footing. In *Forms of talk* (pp. 124–159). Philadelphia, PA: Penn Press.
- Greeno, J. G. (1997). Theories and practices of thinking and learning to think. *American Journal of Education*, 106(1), 85–126.
- Inglis, M., Mejia-Ramos, J. P., & Simpson, A. (2007). Modelling mathematical argumentation: The importance of qualification. *Educational Studies in Mathematics*, 66(1), 3–21.
- Kazemi, E., & Stipek, D. (2001). Promoting conceptual thinking in four upper-elementary mathematics classrooms. *The Elementary School Journal*, 102(1), 59–80.
- Klein, M. (2001). A poststructuralist analysis of mathematics inquiry in a year 6 classroom: The rhetoric, realisation and practical implications. In J. Bobis, B. Perry, & M. Mitchelmore (Eds.), *Proceedings of the 24th annual conference of the Mathematics Education Research Group of Australasia: Numeracy and Beyond* (pp. 347–354). Sydney, Australia: MERGA.

- Krummheuer, G. (2007). Argumentation and participation in the primary mathematics classroom. Two episodes and related theoretical abductions. *Journal of Mathematical Behavior*, 26(1), 60–82.
- Krummheuer, G. (2015). Methods for reconstructing processes of argumentation and participation in primary mathematics classroom interaction. In A. Bikner-Ahsbals, C. Knipping, & N. Presmeg (Eds.), *Approaches to qualitative research in mathematics education* (pp. 51–74). Dordrecht, The Netherlands: Springer.
- Lave, J., & Wenger, E. (1991). *Situated learning: Legitimate peripheral participation*. Cambridge, United Kingdom: Cambridge University Press.
- Levinson, S. C. (1988). Putting linguistic on a proper footing: Explorations in Goffman's concepts of participation. In P. Drew, A. Wootton, & G. Ervin (Eds.), *Exploring the interaction* (pp. 161–227). Cambridge, United Kingdom: Polity Press.
- Mariotti, M. A., Durand-Guerrier, V., & Stylianides, G. J. (2018). Argumentation and proof. In T. Dreyfus, M. Artigue, D. Potari, S. Prediger, & K. Ruthven (Eds.), *Developing research in mathematics education: Twenty years of communication, cooperation and collaboration in Europe* (pp. 75–89). London, United Kingdom: Routledge.
- Sfard, A. (1998). On two metaphors for learning and the dangers of choosing just one. *Educational Researcher*, 27(2), 4–13.
- Steinbring, H. (2005). *The construction of new mathematical knowledge in classroom interaction: An epistemological perspective*. New York, NY: Springer Science & Business Media.
- Stylianides, A. (2007). Proof and proving in school mathematics. *Journal for Research in Mathematics Education*, 38(3), 289–321.
- Toulmin, S. (2003). *The uses of argument*. Cambridge, United Kingdom: Cambridge University Press.
- Vygotsky, L. S. (1978). *Mind in society: The development of higher psychological processes*. (M. Cole, V. John-Steiner, S. Scribner, & E. Souberman, Eds.). Cambridge, MA: Harvard University Press.
- Wood, T. (2002). What does it mean to teach mathematics differently? In B. Barton, K. C. Irwin, M. Pfannkuch, & M. O. J. Thomas (Eds.), Proceedings of the 25th annual conference of the Mathematics Education Research Group of Australasia: *Mathematics education in the South Pacific* (pp. 61–67). Sydney, Australia: MERGA.
- Wood, T., Williams, G., & McNeal, B. (2006). Children's mathematical thinking in different classroom cultures. *Journal for Research in Mathematics Education*, 37(3), 222–255.
- Yackel, E., & Cobb, P. (1996). Sociomathematical norms, argumentation, and autonomy in mathematics. *Journal for Research in Mathematics Education*, 27(4), 458–477.

A pilot study on elementary pupils' conditional reasoning skills and alternatives generation skills in mathematics

Anastasia Datsogianni¹, Stefan Ufer¹ and Beate Sodian¹

¹University of Munich (LMU); Anastasia.Datsogianni@psy.lmu.de,
ufer@math.lmu.de, Sodian@psy.lmu.de

Keywords: Conditional reasoning, alternative generation, mathematics, primary students.

Background and rationale

One of the main aspects of logical reasoning is conditional reasoning, i.e. reasoning with if-then statements. Conditional reasoning tasks usually present a rule of the form “*if p then q*” as a major premise, and a minor premise. Four minor premises differentiate four possible logical forms of inference: *p is true* (Modus Ponens, MP), *p is false* (Denial of the Antecedent, DA), *q is true* (Affirmation of the Consequent, AC), and *q is false* (Modus Tollens, MT). Definite conclusions can be drawn for MP (“*q is true*”) and MT (“*p is false*”), while AC resp. DA do not allow definite conclusions. Even very young children can show conditional reasoning skills in familiar everyday contexts (Markovits & Thomson, 2008). However, a link between conditional reasoning and mathematics has been found only in adolescents and adults in the context of proof (Stylianides & Stylianides, 2007).

According to Mental Model Theories, inferences are drawn by constructing mental models that encode information about specific situations in which the conditional is valid (Johnson-Laird & Byrne, 2002). The reasoners' ability to generate alternative models (beyond a model representing “*p and q*”) for the given conditional is considered a crucial prerequisite to draw valid inferences. Studies on conditional reasoning in the everyday context (De Chantal & Markovits, 2017) have shown that the alternative generation skills do predict early development of conditional reasoning. This raises the question, if the ability to generate multiple alternative models for a given mathematical premise, has an influence on students' conditional reasoning with these concepts.

Methods

Our study aimed at examining the relation between primary students' skills in conditional reasoning with mathematical concepts, and their performance on the corresponding, alternative generation tasks. Participants were 55 elementary students (4th graders $n=13$: $M=9.5$ years, 6th graders $n=42$: $M=11.5$ years) from a public school in Cyprus. Their conditional reasoning skills were assessed in two conditional reasoning tasks including mathematical concepts (Datsogianni, Ufer, & Sodian, 2018). Each task contained one item for each logical form (MP, MT, DA, AC). For example, one conditional reasoning task focused on the circumference of rectangles in a context of dwarf houses. It was explained that dwarf houses always consist of several aligned rows, all with the same number of same-sized quadratic rooms. The major rule in this task was “*If a dwarf house has exactly 2 rows of 4*

rooms each, then it has 12 windows". The alternative generation tasks asked students to generate many examples satisfying the conclusion of the major premise (i.e. "Draw as many dwarf houses as possible, that have 20 windows!").

Results and discussion

Students' solved 62.7% of the mathematics conditional reasoning items correctly, illustrating early conditional reasoning skills under specific conditions. Regarding the first alternative generation task 62% of students gave 4 to 6 correct alternative solutions ($M= 3.42$, $Mdn= 4.00$). The second alternative generation task seemed to be more difficult since only 20% of students gave 4 to 5 correct solutions ($M= 1.81$, $Mdn= 1.00$). This indicates that the alternative generation tasks are feasible, but not too easy for our target sample. The number of generated alternatives correlated with students' reasoning performance (task 1: $\rho=0.358$, $Sig.=0.001$, task 2: $\rho=0.343$, $Sig.=0.003$), supporting our assumption that mathematical conditional reasoning is based on alternatives generation. Some first insights of our main study, which followed the above one, confirm that alternative generation in mathematics predicts correct logical reasoning and especially with AC form.

The results showed that the applied instrument is accessible to students while they replicate early conditional reasoning skills reported in studies from developmental psychology (e.g. Markovits & Thompson, 2008). This study replicates also previous results (De Chantal & Markovits, 2017) regarding the significant relation between alternative generation skills and students' conditional reasoning skills, extending these results to tasks that involve mathematical concepts. The small sample size forbids taking far-reaching conclusions. However, our future research will be based on these developed tasks to describe the role of mathematical knowledge in conditional reasoning with mathematical concepts in more details investigating also whether alternative generation training could be one approach to support students' conditional reasoning in mathematics.

References

- Datsogianni, A., Ufer, S. & Sodian, B. (2018). Elementary students' conditional reasoning skills in mathematical and everyday contexts. In E. Bergqvist, M. Österholm, C. Granberg, & L. Sumpter (Eds.), *Proceedings of the 42nd Conference of the International Group for the Psychology of Mathematics Education* (Vol. 2, pp. 331-338). Umeå, Sweden: PME.
- De Chantal, P. L., & Markovits, H. (2017). The capacity to generate alternative ideas is more important than inhibition for logical reasoning in preschool-age children. *Memory & cognition*, 45(2), 208-220.
- Johnson-Laird, P. N., & Byrne, R. M. (2002). Conditionals: a theory of meaning, pragmatics, and inference. *Psychological review*, 109(4), 646.
- Markovits, H., & Thompson, V. (2008). Different developmental patterns of simple deductive and probabilistic inferential reasoning. *Memory & Cognition*, 36(6), 1066–1078.
- Stylianides, A. J., & Stylianides, G. J. (2007). The mental models theory of deductive reasoning: Implications for proof instruction. In D. Pitta-Pantazi & G. Philippou (Eds.), *Proceedings of the 5th CERME Conference* (pp. 665-674), Larnaca, Cyprus: CERME.

What do prospective mathematics teachers mean by “definitions can be proved”?

Merve Dilberoğlu¹, Çiğdem Haser² and Erdinç Çakıroğlu¹

¹Middle East Technical University, Turkey; armerve@metu.edu.tr, erdinc@metu.edu.tr

²University of Turku, Finland; cigdem.haser@utu.fi

The research reported here is part of an ongoing study³ in which prospective middle school mathematics teachers’ conceptions of definition are investigated through their responses to semi-structured interview questions about defining quadrilaterals. Here we present findings from their responses to a subset of the interview questions, with the purpose of understanding what they mean by the expression “definitions can be proved”- an expression commonly referenced, and considered as erroneous in the research literature. Analysis of the responses, through using thematic coding and Toulmin’s (1958) scheme, revealed that participants attributed two different meanings to the phrase: (1) proving the claim that a written definition accurately designates an intended concept and (2) proving the concept being defined (erroneous). Based on our findings, we point to a reconsideration of the phenomenon by the research community.

Keywords: Meta-mathematical knowledge, conception of proof, conception of definition, prospective middle school mathematics teachers

Introduction

Most teacher education programs offer college level mathematics courses to strengthen prospective teachers’ mathematical preparation. Although these courses provide rich mathematics content and experience of working with definitions and proofs, they do not include explicit information about mathematics at the meta-level (Azrou, 2017). Especially, learning to prove becomes a difficult task for university students (Stylianides & Stylianides, 2009). Previous studies highlight that students at all grade levels experience difficulties related to proofs (e.g., Azrou, 2017; Fiallo & Gutiérrez, 2017), which is most of the time considered as a consequence of an inaccurate understanding of what constitutes a proof (Weber, 2001). Various studies have also informed that prospective teachers lacked an accurate understanding of mathematical definitions (Leikin & Zazkis, 2010; Levenson, 2012). Indeed, that many teachers and students cannot differentiate between definitions and proofs or consider definitions as provable is a robust research finding (Edwards & Ward, 2004; Leikin & Zazkis, 2010; Levenson, 2012).

In this study, we delve deep into prospective teachers’ reasoning about if definitions need to be proved or not. In case of occurrence, we investigate prospective teachers’ expressions and examples, in order to find out what they mean by the expression “definitions can be/need to be proved.” By using Toulmin’s (1958) model of arguments, we look for the existence of concrete claims in participants’ proof-related attempts, because their responses to interview questions provide the key information on “what is being proved” in their perspectives. By detecting the actual

³ The research is funded by Middle East Technical University Research Fund GAP-501-2018-2714.

“proven”, we aim to find out underlying reasons of using this erroneous expression; which might be a first step in developing proper ways of remediation in teacher education programs.

We also refer to arbitrariness aspect of mathematical definitions (not of definitions, but of concepts) in answering our research question: What meaning do prospective mathematics teachers attribute to “proving/proof of a definition”? Since defining in mathematics is arbitrarily naming concepts (Vinner, 1991), concepts do not possess inherent truth-values. They are neither true nor false (Edwards & Ward, 2008). However, by “arbitrariness” we do not mean that definitions are adopted on a complete random base. Rather, we acknowledge that they are open to intelligent refinements through successive work of mathematicians (Lakatos, 1976). In this study, we position that both the concepts and definitions are “arbitrary”, in the sense we use the word. Concepts are “agreed upon conventions” (Levenson, 2012, p. 209); that is why they are arbitrarily named. On the other hand, definitions can arbitrarily be chosen among multiple equivalent definitions of a concept. We use the former in the case we report here.

Background

Two theoretical foundations were employed in this study. The concept definition-concept image distinction and Toulmin’s (1958) model of arguments are introduced in the next sections.

Concept Definition/Concept Image

Concept image is the collection of all mental representations associated with a particular concept in one’s cognitive structure; while the *concept definition* is the mathematical statement that designate that concept (Tall & Vinner, 1981). Although a concept definition is expected to connote the same meaning to everyone, concept image is specific to the individual and may not be fully compatible with the formal definition. In our study, the distinction between *concept image* and *concept definition* is a theoretical keystone for understanding prospective teachers’ hidden claims underlying their use of the erroneous expression “proving a definition”.

Toulmin’s (1958) Model of Arguments

Toulmin (1958) proposed a schema for describing an argument by identifying three main components. The model describes the connection between the claim (C) - that is desired to be established- and the data (D) - the fact, which can serve as a basis for establishing that claim. For the argument to take the arguer from the data to the claim, another element is defined: The warrant. Warrants can be rules, principles or inference-licenses entitled to “show that, taking these data as a starting point, the step to the original claim or conclusion is an appropriate and legitimate one” (Toulmin, 2003, p.91). The three elements constitute the simplest form of the model. The complete model includes additional elements of backing (B), modal qualifier (Q), and the rebuttal (R). Backing is a further evidence for the connection between data and claim, modal qualifier associates a degree of confidence to the conclusion made; and rebuttal states the conditions under which the conclusion is not valid. However, not all arguments have to contain these latter three elements.

Given that proof is a mathematical argument produced with the purpose of convincing oneself and others of the truth of a mathematical statement (Fiallo & Gutiérrez, 2017), we apply Toulmin’s model on prospective teachers’ productions of exemplary proofs, in order to identify the actual

claims they aim to prove, while expressing it as “proving a definition”. Since our focus is on identifying any existing claims in participants’ examples, we use the simplest form of the model, consisting only of the three elements data (D), claim (C) and warrant (W).

Method

Basic qualitative research methods were used in this study.

Context and Participants of the Study

Participants of the study were six senior (4th-year) prospective middle school mathematics teachers in a four-year teacher education program. The program, prepared around 40 mathematics teachers each year to teach at the grade levels from 5 to 8, by offering college-level mathematics courses mostly in the first two years and concentrating more on the teaching-related courses in the last two years. Participants were selected based on their active participation in the educational courses, their inclination to express and discuss mathematical ideas and the variation in their knowledge of mathematics, as observed in the teaching related courses by the authors. All six participants volunteered to participate in the study as an out-of-class activity. Since the data were collected through the end of the academic year, they had nearly completed all the courses in the program. Although the program included the study of undergraduate level mathematics courses (offered by the Mathematics Department) in which definitions and proofs played important roles, students had not been offered any specific information about meta-mathematical constructs of definitions and proofs in these courses. Also, it may worth to highlight that a detailed chapter on the geometry terms, especially the hierarchical way of defining quadrilaterals were covered in the mathematics teaching methods course that participants took in their third year.

Data Collection and Analysis

In semi-structured interviews conducted by the first author in one-to-one settings, prospective teachers responded to a broad range of verbal and task-based questions aimed at revealing their understanding of mathematical definitions. After completing an initial open-ended task about defining quadrilaterals (participants were asked to propose a sequence for introducing quadrilaterals, by supplying their own definitions), they were asked questions such as “What is a mathematical definition for you?” and “Why do we state definitions in mathematics?” One of the questions asked participants to explain their thinking about the relationship between definitions and proofs. They were explicitly asked to indicate if definitions need/have proofs or not, and explain their reasoning. In case of accepting definitions as provable, they were requested to give an example. Participants’ responses were analyzed through thematic coding procedure (Braun & Clarke, 2006) and Toulmin’s (1958) model of arguments was used to describe their examples.

Findings

Analyses of prospective teachers’ explanations and examples resulted in two different interpretations of the expression “proving a definition”. In particular, prospective teachers considered “proving a definition” as (1) justifying the claim that a written definition accurately designates an intended concept (which would be an appropriate action in the discipline of mathematics) and (2) justifying the concept being defined (which remains ambiguous in meaning).

Table 1 presents a summary of each participant's thinking about the phrase, as inferred from their verbal explanations and concrete examples, which were mostly different from what they explicitly said. A representative quotation from each participant is given in order to reveal their use of words in their conversations. Two separate rows are used for the participant (P5) who displayed both type of interpretations.

PST	Sample Wording PST Used	Meaning Inferred from Further Explanations (through thematic coding)	Meaning Inferred from Example Case (through Toulmin's scheme)
P1	"I am proving the triangle (definition)."	Proving the claim	Proving the claim
P2	"I proved the truth of this definition."	Proving the claim	Proving the claim
P3	"Definitions should be proved."	Proving the claim	(Did not provide)
P4	"I could not understand what you mean?"	Proving the claim (if such a thing exists)	Proving the claim
P5	"By ..., we can prove definitions."	Proving the claim	Proving the claim
P5	"After the shape square has been proved."	Proving the concept	(Did not provide)
P6	"If I am defining a concept, it has nothing to do with proving."	Proving the concept (non-existent)	(Not applicable)

Table 1: Meaning attributed to the phrase of "proving a definition" in prospective teachers' (PST) explanations and examples

The two types of interpretation resulting from participants' responses are described in the following sections. In the reporting of quotations and examples, brackets are used for indicating the authors' insertions, and square brackets are used either for indicating excluded parts of the interview (with ellipsis: [...]) or for specifying the components of the participant's arguments (i.e., [data], [claim], and [warrant]).

Interpretation I: "Proving a definition" as "proving the claim that a written definition designates the intended concept"

Four of the six prospective teachers (P1, P2, P3, and P5) indicated that definitions "can be proved" (P1) or "need to be proved" (P3). Although their wording did not reflect the existence of an explicit claim to be proved (e.g., "proving the triangle (definition)" (P1); "I will give a definition and prove it." (P2)), their explanations and examples revealed that what they considered provable was an actual claim. In particular, they were talking about proving that a written definition truly reflects the image of the intended concept in their minds. Following scripts from P1 and P2 illustrate the case.

Researcher: The proof you thought of there... What exactly is that proof of?

P1: Of the triangle (definition), in fact.

Researcher: How is that? Could you open this up a little?

P1: Of the triangle (definition). It is about the shape of the triangle. I mean, in our minds there is a shape about... the shape of the triangle and we are trying to make this definition fit to it. With the proof, we check if it fits the shape or not.

Researcher: Is there a relationship between definition and proof?

P2: Yes. In order to prove that the definition we create is true, we do proofs. I mean I create a definition; but to what extent is that true, when it holds? Maybe under some conditions it does not hold. For proving this, proofs are written.

Their examples were based on proving concrete claims as well. They were basically comparing a written definition with the corresponding concept image in their minds to evaluate their congruence.

Researcher: Now, what exactly is that you try to prove here? [...] Can you give me an example?

P2: I will give a definition and prove it. Hmm... Let me take the parallelogram. Opposite sides need to be equal in length and parallel (reads the definition she wrote in a previous task), I say. I will prove this. (Draws the figure that satisfies the given conditions.) [data] Actually, by drawing this (points to the figure she drew) [warrant: the figure fits into her concept image] I proved it [claim].

Researcher: What is that you proved here?

P2: Properties of the parallelogram. I try if it does hold for the given definition. I do some trials and then I see that it holds for this definition. And I proved the truth of this definition, I mean.

Figure 1 presents P2's example case of "proving" by using Toulmin's (1958) model arguments.

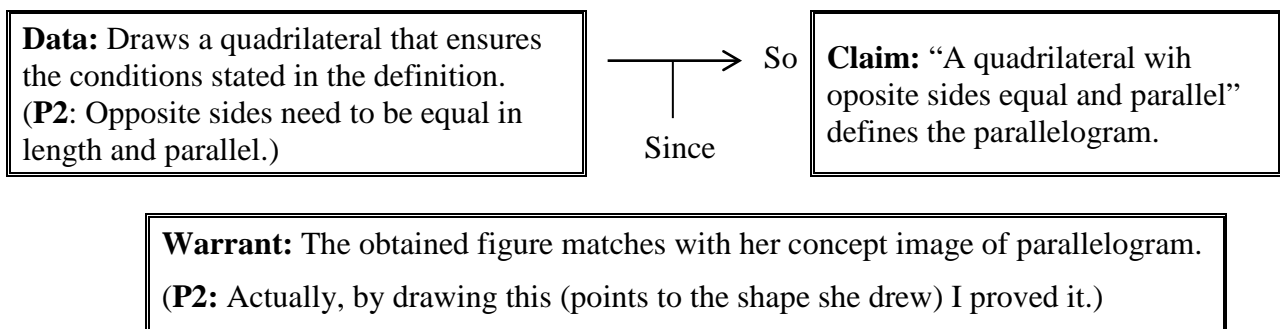


Figure 1: An argument schema for P2's example

On the other hand, the idea of "proof of a definition" did not make any sense to P4 first. However, when she thought over it by the help of an example case, she ended up with the same interpretation as the previous participants:

P4: Let me think about this. Here, I had written something for rectangle (in a previous task). There I have defined rectangle as the parallelogram with a right angle. Now, am I required to prove that this definitely defines the rectangle?

Her exemplary proof attempt provided an accurate representation of the participants' thinking.

- P4: I know what a parallelogram is (Draws a parallelogram-angles very close to 90°). [data] Now, I should have drawn a real rectangle. It is OK, if I do not. One of the angles is 90 degrees [data], I started here (marks one of the angles with the perpendicularity symbol). I know that in a parallelogram opposite sides are parallel. Then, these (two adjacent angles) add up to 180 degrees. This is also 90 (degrees). [...] Then, its all interior angles are 90 degrees. Opposite sides are parallel, equal and so forth... It satisfies all the properties of rectangle. [warrant][...] I mean, I can prove that this definition is rectangle. [claim]

Interpretation II: “Proving a definition” as “proving the concept being defined”

Two of the prospective teachers perceived “proving a definition” differently. They maintained the odd wording of “proving a concept” in their explanations (e.g., “proving the shape square” (P5)). However, their approaches to this idea were different from each other's. P5 thought that it was a possible action to “prove a concept”. Although she could not elaborate much on this idea of her, since she demonstrated two different meanings at the same time (both proving the claim and proving the concept) it was evident that she was talking about an issue different than proving the claim in the following dialog:

- Researcher: Is there a relationship between definition and proof?
- P5: I cannot say absolutely there is, but I think should be. [...] After the shape square has been proved, it must have fit to its definition. Otherwise, if we do not know what is the thing that we call square, without proving this, we cannot make the definition.
- Researcher: What is it that we prove here?
- P5: Which shapes we call “square”? How does the square come into existence?
- Researcher: Can you give me an example of this?
- P5: I do not know. Now... I can't find.

Immediately after, when she was asked if definitions were provable or not, she demonstrated the same understanding of “proving a claim”, similar to what the previous participants did:

- P5: We draw the multiple shapes of what we do (define), I mean by looking for counterexamples, we can prove definitions.

Her example also supported that she was proving a claim (whether a given definition of square would actually define square or not), although she relied on empirical reasoning in her argument.

- P5: Let me think with square again. More than one person draws its definition [data], because it may not represent the same thing to everyone. We check if it does represent the same thing to everyone. If one person draw a thing that is different from what we try to explain [warrant], then that means the definition we have is not correct or not clear, erroneous [claim]. In this way, I think we can prove it.

Unlike P5, P6 seemed to be aware of the fact that “defining was arbitrarily naming concepts” and hence definitions (concepts) needed no justification.

P6: Of course there may be (a relationship in between), but if I am trying to name something, if it is something like a term... You see, here when I am trying to define the trapezoid, I am not proving the properties of the trapezoid [...] Because I am just giving it a name.

As we consider that they are the concepts which are arbitrary, rather than the defining statements (in our case), we name this second type of interpretation with the phrase “proving the concept being defined”. Both P5 and P6 seem to be thinking about proving “why concepts exist in mathematics as they are”. While P6 correctly rejects this kind of thinking about definitions, P5 seem to consider it as a necessity. Also, P5’s erroneous understanding may still be residing in other participants’ minds, as prospective teachers may not be aware of arbitrariness aspect of definitions.

Discussion and Implications

Findings of the study provide insights into participating prospective teachers’ conceptions of proof. Although at the first glance they seem to be trying to prove a non-claim, existence of a real claim in their arguments reveals that they have an implicit (because they do not say so) insight about what needs a proof in mathematics. This is an unexpected finding and a positive outcome for teacher education programs compared to previous research findings, because no such claims were proposed by the participants of other studies who communicated that definitions could be proved (Levenson, 2012) or who could not distinguish between a theorem and a definition (Edwards & Ward, 2004; Leikin & Zazkis, 2010). However, this finding does not necessarily mean that participants are also sure of what cannot be proved in mathematics. P5’s explanations displayed that one of the things she tried to prove was a claim (Interpretation I), while the other was not (Interpretation II). The same might be the case for all of the participants of the study, except P6; but might have remained uncovered in our interviews, because no participants other than P6 mentioned the arbitrariness aspect of defining concepts in their responses. They did not reveal any thinking about if concepts were provable or not, as P5 and P6 did. This addresses that while interviewing prospective teachers, handling the nature of proofs and definitions concurrently and from multiple aspects might provide a more complete picture of their meta-mathematical knowledge. Otherwise we might end up with unrealistic judgments of prospective teachers’ knowledge and understandings.

On the other hand, our observation that most of the prospective teachers attributed the same acceptable meaning (Interpretation I) to the principally imperfect phrase of “proving a definition,” have important implications about the common practice of using the words “proof” and “proving” imprecisely. Besides not questioning the misuse of the word “proving” in the question we directed to them (P4 did only); most of the participants consistently used unclear wordings such as “proving the triangle” (P1) in their explanations. Also, the inconsistency between what they do (or think) and how they talk about it was striking; which would probably have a negative influence on their future students’ learning of mathematics at the meta-level. Previous studies acknowledge the need for discussing notions of definition and proof in teacher education programs, along with the other meta-mathematical constructs such as assumptions and axioms, and the interrelationships among them

(Levenson, 2012). Based on the findings of our study, we want to point out to the importance of using the meta-mathematical terms “proof” and “definition” rigorously within such discussions.

References

- Azrou, N. (2017). Meta-mathematical knowledge about proof. In Dooley, T., & Gueudet, G. (Eds.). *Proceedings of the Tenth Congress of the European Society for Research in Mathematics Education (CERME10, February 1-5, 2017)*. Dublin, Ireland: DCU Institute of Education and ERME.
- Braun, V., & Clarke, V. (2006). Using thematic analysis in psychology. *Qualitative Research in Psychology, 3*(2), 77–101.
- Edwards, B., & Ward, M. (2004). Surprises from mathematics education research: Student (mis)use of mathematical definitions. *American Mathematical Monthly, 111*(5), 411–424.
- Edwards, B., & Ward, M. (2008). The role of mathematical definitions in mathematics and in undergraduate mathematics courses. In M. Carlson, & C. Rasmussen (Eds.) *Making the connection: Research and teaching in undergraduate mathematics education* (pp. 223-232). Washington, DC: Mathematics Association of America.
- Fiallo, J., & Gutiérrez, A. (2017). Analysis of the cognitive unity or rupture between conjecture and proof when learning to prove on a grade 10 trigonometry course. *Educational Studies in Mathematics, 96*(2), 145–167. <http://doi.org/10.1007/s10649-017-9755-6>
- Lakatos, I. (1976). *Proofs and refutations*. Cambridge, UK: Cambridge University Press.
- Leikin, R., & Zaskis, R. (2010). On the content-dependence of prospective teachers’ knowledge: a case of exemplifying definitions. *International Journal of Mathematical Education in Science and Technology, 41*(4), 451–466.
- Levenson, E. (2012). Teachers’ knowledge of the nature of definitions: The case of the zero exponent. *Journal of Mathematical Behavior, 31*(2), 209–219.
- Stylianides, G. J., & Stylianides, A. J. (2009). Facilitating the transition from empirical arguments to proof. *Journal for Research in Mathematics Education, 40*(3), 314–352. <http://doi.org/10.2307/40539339>
- Tall, D., & Vinner, S. (1981). Concept image and concept definition in mathematics with particular reference to limits and continuity. *Educational Studies of Mathematics, 12*, 151–169.
- Toulmin, S. E. (1958). *The uses of argument*. Cambridge: Cambridge University Press.
- Toulmin, S. (2003). *The uses of argument: Updated edition*. Cambridge, UK: Cambridge University Press.
- Weber, K. (2001). Student difficulty in constructing proofs. The need for strategic knowledge. *Educational Studies in Mathematics, 48*(1), 101-119.
- Vinner, S. (1991). The role of definitions in teaching and learning of mathematics. In D. Tall (Ed.), *Advanced mathematical thinking* (pp. 65–81). Dordrecht: Kluwer.

The justification of conjectures in the study of the congruence of triangles by 5th grade students

Marisa Gregório¹ and Hélia Oliveira²

¹Agrupamento de Escolas Rainha Dona Leonor, Portugal; marisaspg@gmail.com

²Instituto de Educação, Universidade de Lisboa, Portugal; hmoliveira@ie.ulisboa.pt

Keywords: Geometry, mathematical reasoning, justification.

Introduction

Mathematical reasoning (MR) is recognized as one of the fundamental aspects of mathematics learning (NCTM, 2000), however, in the literature, sometimes this concept is not clearly defined. From a review of literature, Jeannotte and Kieran (2017) synthesized converging features of MR and developed a conceptual model for MR in school mathematics. According to these researchers, MR is a process of communication that allows to infer mathematical statements from other mathematical statements and that encompasses five processes regarding students' search for similarities and differences (generalising, conjecturing, identifying a pattern, comparing, and classifying) and three processes regarding students' aim for validation (justifying, proving, and formal proving). In this study, we aim to analyse 5th grade students' justifications of a conjecture on the properties of triangles, during a teaching intervention to promote students' MR.

Theoretical framework

For the purpose of this study, we will use the term *justification* as an argument that guarantees (or disproves) the truth of an statement and uses mathematical forms of reasoning accepted as universal in the classroom community. This way of defining justification is similar to the one by Staples, Bartlo and Thanheiser (2012) but to which we add the focus on the community. Therefore justification consists in the process of searching for data and guarantees that allows the change of the epistemic value of a narrative (Jeannotte & Kieran, 2017) and it is supported by the discourse of the community. However, according to these authors, that change does not occur “necessarily from likely to true” but “from likely to more likely” (p. 12) and, as such, this process does not require a deductive structure. In order to analyze students' justifications, we use in this study a framework based on Balacheff (1988) and Harel and Sowder (1998), with five levels hierarchically organized. At level 1 – *external authority* – the justification is based on an element considered as an authority, which can be the teacher, a colleague or the textbook. At level 2 – *empiricism naïf* – we consider two categories: *perceptual naïf empiricism*, when a justification is based on perceptual observations, showing a drawing or gesturing; and *inductive naïf empiricism*, when a justification is based on the verification of some examples. At the intermediate level – *crucial experience* – a justification is grounded on a carefully selected example, revealing intentionality in the choice. At level 4 – *generic empiricism* – operations are used, based on the properties of objects, for justification, however, the student does

not identify or justify the applicability of the property used in the operation. At the most sophisticated level – *mental empiricism* – the justification is based on the properties and relations between objects.

Methods

The study was carried out in a 5th grade class with 30 students, during a teaching intervention on geometry conducted by the first author. The focus of this poster are the students' justifications of a conjecture presented by one student (Mariana) who stated that “If two triangles have the same perimeter, they are equal”, when they were working on the topic of congruence of triangles. Students were asked by the teacher to validate or refute the conjecture individually and then to discuss their ideas with whole class. The methodology of the study is qualitative with data coming from students' written productions and the collective discussion of their work. In this poster we use the 5-level justification framework referred above to analyse the justifications of four students, whose solutions were selected by the teacher to be collectively discussed in order to clarify the refutation of the conjecture and the importance of the counterexample used in this refutation.

Results

The analysis shows that students' justifications of the conjecture are at the second and third levels according with the adopted framework. At the second level, justifications are based on perceptual or intuitive observations. These students perceive other possibilities of different lengths for the sides of the triangle from which an equal perimeter can result, without the triangles being equal, however, the counterexample they present does not take into consideration the triangular inequality. At the third level, students use carefully selected examples, such as two triangles of different lengths and with the same perimeter, that they draw rigorously using the compass and the ruler, and which they present as a counterexample to refute the conjecture. Still, there is evidence that students are producing arguments that may lead to a more general conclusion by making important connections with triangular inequality to choose the counterexample. The analysis of this classroom episode also emphasizes the importance of the teacher's role in promoting the development of MR processes. The fact that the conjecture was based on a wrong assumption was seen by the teacher as an opportunity to trigger MR validation processes and, more generally, for promoting students' MR.

References

- Balacheff, N. (1988). Aspects of proof in pupils' practice of school mathematics. In D. Pimm (Ed.), *Mathematics, teachers and children* (pp. 216-235). London: Hodder and Stoughton.
- Harel, G., & Sowder, L. (1998). Students' proof schemes: Results from exploratory studies. *Research in collegiate mathematics education III*, 234-283.
- Jeannotte, D., & Kieran, C. (2017). A conceptual model of mathematical reasoning for school mathematics. *Educational Studies in Mathematics*, 96(1), 1–16.
- NCTM (2000). *Principles and standards for school mathematics*. Reston, VA: Author.
- Staples, M. E., Bartlo, J., & Thanheiser, E. (2012). Justification as a teaching and learning practice: Its (potential) multifaceted role in middle grades mathematics classrooms. *Journal of Mathematical Behavior*, 31, 447-462.

Fundamental task to generate the idea of proving by contradiction

Hiroaki Hamanaka¹ and Koji Otaki²

¹Hyogo University of Teacher Education, Hyogo, Japan; hammer@hyogo-u.ac.jp

²Hokkaido University of Education, Hokkaido, Japan; otaki.koji@k.hokkyodai.ac.jp

The teaching of proof by contradiction involves a didactical paradox: students' efficient use of this proving method is hard to achieve in mathematics classes, although students' argumentation using this method can occasionally be observed in extra-mathematical contexts. To address this issue, Antonini (2003) proposed a task of the non-example-related type that could lead students to produce indirect proofs. The aim of this paper is to propose a new type of tasks and situations related to counterexamples that can lead students to argument by contradiction, not by contraposition.

Keywords: Mathematical logic, proof by contradiction, indirect proof, counterexample.

Introduction

This paper reports some results of developmental research on the teaching and learning of proof by contradiction. Despite the various studies on the subject, in general, mathematical proving seems to remain difficult to learn for most students over the world, especially regarding proving by contradiction. In Japan, mathematical proof is learned in lower secondary school, while more delicate proof methods are learned in senior secondary school. Proof by contradiction, one such delicate method, can be rather difficult to learn, as reported by several authors (Antonini & Mariotti, 2008; Reid, 1998). In particular, from the didactical and cognitive perspective, it involves curious conflicting aspects. On one hand, it would be far from a desirable understanding of the subject just to learn the fact that proof by contradiction is a correct method and the manner to build such proofs, since students could not be convinced of the conclusions in such proofs unless they understood why this method works. On the other hand, it has been observed that students sometimes spontaneously use the method of proof by contradiction as argumentation in extra-mathematical contexts, even before they develop any notions regarding this method (e.g. Freudenthal, 1973, p. 629).

To manage this paradoxical issue, Antonini (2003) proposed tasks and situations that can help students to generate the idea of indirect argumentations and proof (i.e. tasks involving *non-examples*, which shall be addressed in the second section). This proposal is based on the notion of *cognitive unity*, which emphasizes the similarity between processes of argumentation and proof construction (Garuti, Boero, & Lemut, 1998). The developmental principle of cognitive unity claims the importance of preceding argumentations to produce the conjecture, before the stage of proof construction. In summary, Antonini (2003) conducted a task design for the teaching of indirect proof using of the principle of cognitive unity. Our study follows this same line.

First, we clarify the notion of proof by contradiction especially confirming how it differs from proof by contraposition. Then, we review the preceding result of Antonini (2003) and identify its focus on proving by contraposition rather than by contradiction. Therefore, the main objective of this paper is to propose new tasks and situations that can lead students to argumentation using the idea of proof by

contradiction, beyond proofs by contraposition. We present the task designed for this study and investigate some results of a teaching experiment with this task.

Preliminary analysis for the design of a new task with proving by contradiction

The authors' position on proof by contradiction

This section confirms the definition of proof by contradiction and summarizes its relation to indirect proof. As Chamberlain & Vidakovic (2017) point out, some studies do not distinguish proof by contradiction from that by contraposition. While Lin, Lee, & Wu Yu (2003) attribute proof by contradiction to the law of contraposition, Antonini & Maritotti (2008) refer to such proof methods as 'indirect proving', which may also include the method of proof by contraposition. Logically speaking, the method by contradiction to indirectly prove the statement ' $P \rightarrow Q$ ' is to directly prove the statement ' $P \wedge \neg Q \rightarrow \perp$ '¹. This method is based on the law of excluded middle, which claims that ' $Q \vee \neg Q$ ' is true. In addition, the method by contraposition to indirectly prove ' $P \rightarrow Q$ ' is to directly prove ' $\neg Q \rightarrow \neg P$ '. This method is based on the principle that ' $P \rightarrow Q$ ' and ' $\neg Q \rightarrow \neg P$ ' are equivalent. Here, we observe that $(P \rightarrow Q) \rightarrow (\neg Q \rightarrow \neg P)$ is true, even in the intuitionistic logic, although $(\neg Q \rightarrow \neg P) \rightarrow (P \rightarrow Q)$ requires the law of excluded middle. Moreover, it is known that the law of excluded middle can be verified conversely using this contraposition rule with the intuitionistic logic. Thus, from the *logical* perspective, we can consider these proving methods interchangeable, in the sense that adding either the law of excluded middle or the contraposition principle to the intuitionistic logic results in the same classical logic.

In fact, we can show proof diagrams in which the two proving methods, support each other (Figure 1).

$$\begin{array}{c}
 \frac{\neg Q \rightarrow \neg P}{(P \wedge \neg Q) \rightarrow (P \wedge \neg P)} \\
 \frac{(P \wedge \neg Q) \rightarrow \perp}{P \rightarrow Q}
 \end{array}
 \qquad
 \begin{array}{c}
 \frac{\frac{\frac{\neg Q \wedge (\neg Q \rightarrow \perp) \rightarrow \perp}{\neg Q \rightarrow ((\neg Q \rightarrow \perp) \rightarrow \perp)}}{\neg Q \rightarrow \neg \neg Q}}{\neg Q \rightarrow \neg P} \\
 \frac{P \wedge \neg Q \rightarrow \perp}{P \rightarrow (\neg Q \rightarrow \perp)} \\
 \frac{P \rightarrow \neg \neg Q}{\neg \neg Q \rightarrow \neg P}
 \end{array}$$

Figure 1: Two proving methods mutually supported

However, from the *cognitive* or *epistemological* perspective, we can point out certain differences. How should the argumentation by contraposition against the statement ' $P \rightarrow Q$ ' begin? It would be natural to begin the generation of argumentation by contraposition with the question 'what if Q is not true?', while it is desirable to begin argumentation by contradiction with the question 'is there any situation where " P " and "not Q " is possible?'. In addition, the middle processes of both types of argumentations have differences. In the case of contraposition, the argumentation starting from the assumption 'not Q ' would not result in any contradiction but in the conclusion 'not P '. Thus, the instances in this argumentation are possible and real under this assumption 'not Q '. On the other hand, the argumentation starting from the assumption 'if " P " and also "not Q " are possible' would lead to a contradiction. Therefore, the argumentation in the middle process deals with impossible cases. Moreover, we can see differences in the goal of the argumentations. In the case of contraposition, the conclusion to be reached can be specified as 'not P ' from the beginning, while, in the case of contradiction, the conclusion can be any type of contradiction. Therefore, the goal of this type of

¹ The symbol \perp means the contradiction, which is unconditionally false.

argumentation is not specified in the beginning and proof by contradiction seems to be more difficult than that by contraposition.

Despite these differences, both proving methods tend to be integrated as indirect proofs. We believe this to stem from a didactical reason, instead of a reason based on compatibility in logic. The principle of contraposition in the school mathematical context is not an axiom, but a meta-theorem that can be verified somehow. In fact, faced the question of why ' $P \rightarrow Q$ ' can be implied from ' $\text{not } Q \rightarrow \text{not } P$ ', they can possibly use the method by contradiction: 'if Q is not true under $P \dots$ '. Thus, it is didactically natural to verify the method of proof by contraposition based on contradiction, although the inverse is verifiable by logic. Therefore, from the didactic and cognitive perspectives, we consider that proof by contradiction is more fundamental and supports the method of proof by contraposition, which can be acknowledged as an application of proof by contradiction.

From investigation of non-example to non-existence of counterexample

As mentioned in the first section, Antonini (2003) proposed tasks involving non-examples against almost the same research question. Given a property A , non-example is an instance that negates A , while an ordinary example is one that verifies A . Antonini (2003) argues that, faced with a question such as 'given a hypothesis A , what can you deduce?', students tend to generate examples and (or) non-examples and, through the observation of non-examples that verifies B but does not satisfy A , students can assume that 'if B is true, A is not true'. From this argumentation, students may be led to obtain 'if A is true, B cannot be true', which is an indirect argumentation. Although such tasks and processes are reasonable enough, we would like to indicate room for further improvements: the argumentations that would be observed in these processes are proofs by contraposition, not by contradiction. Such argumentations certainly include ways of thinking such as ' \dots if it were not so, it would happen that...'. However, because this argumentation starts from the observation of a non-example (not satisfying A), such thinking necessarily has the form 'if B is true, A cannot be true', which certainly corresponds to an argumentation by contraposition.

In contrast, our hypothesis is that the *principle of non-existence of counterexample* yields argumentation by contradiction. Generally speaking, the intension to *disprove* some statement may lead to the pursuit of its counterexample. However, it is difficult to prompt disproving activities in mathematics classes, which are usually filled by the requirement for *proof*. In the following subsection, we discuss a favourable condition involving counterexample towards argumentation by contradiction.

Judgement of truth and proof by contradiction

In the former part of this section, we defined the method of proof by contradiction. However, it is written in propositional logic, while there are many propositions of predicative logic that will be addressed in mathematics in upper secondary school or higher. In fact, in Japan, many common propositions to be proved in mathematics are universal propositions. Let S be a proposition such as 'for any x , if $P(x)$ is true, $Q(x)$ is true', and consider a task such as 'is this proposition S true?', that is, the judgement of the proposition S . Facing this type of task, what types of argumentations occur naturally? As a form of naïve argumentation, one may try to verify S in an empirical way: each instance x verifying $P(x)$ is examined to verify whether it satisfies $Q(x)$ or not. Then, the more

instances one checks, the more plausible S would be. In addition, this operative work might prompt students to understand what the negation of the statement S is. If the above examination of each instance x fails even once, in other words, if one finds an instance x satisfying $P(x)$ but not $Q(x)$, S turns out to be false. In class, the task of proving S makes it unquestionable, because such a task *implicitly* means that S is true. However, against the task of judgement, one may suspect its negation quite naturally. Moreover, in this type of task, which will be proposed in the following section, this suspicion is important and can lead students to the idea of proof by contradiction, as this suspicion is the initial point of the proving method by contradiction: if one doubts the truth of S , he or she can start argumentation from the assumption of the counterexample's existence, that is, an instance x satisfying $P(x)$ but not $Q(x)$. If this argumentation comes to a contradiction, the non-existence of a counterexample can be deduced; furthermore, it claims the truth of S , which is an argumentation by contradiction.

Regarding the proving by contradiction, Antonini & Mariotti (2010) point out two difficulties: the treatment of impossible mathematical objects and the link between the contradiction and the statement to be proved. In fact, when proving by contradiction, one should think of impossible and absurd cases and deduce a contradiction. One may not make sense of a contradiction from an absurd assumption that looks trivial and from which nothing is likely to be deduced. This is similar to the low assessment by students of proof of a *trivial* theorem, such as 'the base angles of an isosceles triangle are equal'. Likewise, in proof by contradiction, if the provisional assumption is apparently absurd, the deduced contradiction would make no persuasive argument. Thus, to promote students' argumentation by contradiction, it is important that the provisional situation, where the hypothesis is true but the conclusion is false, is unknown to be possible or impossible, and its possibility should be the focus of the discussion. This is exactly the case in the proposed tasks of judgement.

Proposal of the task and situations

First, it is necessary to recall the characterisations of a parallelogram (i.e. sufficient conditions for a quadrilateral to be a parallelogram). Although Japanese lower secondary schools do not use the word 'sufficient', they adopt the following five conditions in classes as 'conditions for a parallelogram':

- Two pairs of opposite sides are parallel. (Definition)
- Two pairs of opposite sides are equal in length.
- Two pairs of opposite angles are equal in measure.
- One pair of opposite sides are parallel and equal in length.
- The diagonals bisect each other.

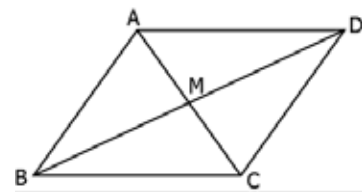


Figure 2: Parallelogram with Labels

Each of these five conditions consists of two conditions out of the following:

- | | |
|--|---|
| – a pair of opposite sides is parallel | – a pair of opposite sides is equal in length |
| – a diagonal bisects the other | – a pair of opposite angles is equal in measure |

Apart from the previous five sufficient conditions, various combinations of two out of the conditions specified above are possible. In particular, we adopt the following combination and the task in

connection with it: for a quadrilateral $ABCD$ with its diagonals crossing at M , does the condition of $\angle A = \angle C$ and $BM = MD$ make this quadrilateral a parallelogram? (See Figure 2.)

Since this condition is actually a necessary condition to make the quadrilateral a parallelogram, the figure of a parallelogram may give an impression that this condition is also sufficient. Thus, one may try to prove its sufficiency directly. In such an attempt to prove it, it would be natural to focus on a congruence of triangles, namely $\triangle AMB$ and $\triangle CMD$. Verifiable facts concerning these triangles from the given condition are $BM = DM$ and $\angle AMB = \angle CMD$. If one could claim that $AM = MC$, it is easy to conclude that this quadrilateral is a parallelogram using the congruence of triangles, although no more properties concerning $\triangle AMB$ and $\triangle CMD$ can be obtained directly from the assumption.

If this was against the task of proving a statement suggested by a teacher, which would be considered correct previously, then this proving attempt would end here and no further argumentation would hardly continue. However, in the task of judgement, one can proceed this argumentation as such a stagnation of verifying argumentation implies the possibility of a counterexample. A student can suspect the congruence of $\triangle AMB$ and $\triangle CMD$. In particular, if $AM = MC$ is true, they are congruent and the quadrilateral $ABCD$ turns out to be a parallelogram. Thus, one can imagine an instance satisfying $\angle A = \angle C$ and $BM = MD$, but $AM \neq MC$, or $AM < MC$. If one tries to draw a figure of an instance satisfying $BM = MD$, $AM < MC$ and also $\angle A = \angle C$, the impossibility of such an instance comes apparent. This might be seen by intuition (See Figure 3) and can also be verified as follows: if one take C' on MC with $AM = MC'$, we can see $\angle A = \angle BC'D > \angle C$ and obtain contradiction. This is proof by contradiction.

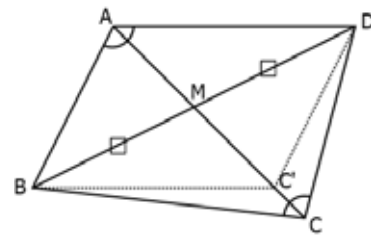


Figure 1: Impossibility of a counterexample

Teaching experiment

In this section, we report a teaching experiment in a typical upper secondary school in Japan. This experiment was mainly designed to investigate the learning about wide logical concepts through inquiries, not limited to the idea of proof by contradiction. The 40 students in our study are first years at a typical upper secondary school in Japan (15-16 years old) and, in general, students in this school are not highly competent in mathematics. The students were about to study logical notions in the small unit of 'sets' and had never studied proof by contradiction, not even the concepts of counterexample, sufficient condition, or necessary condition. They were divided into 12 groups of three or four students each. A main element of this experiment is the inquiry against the following task (Figure 4) given to the groups (cf. Hamanaka & Otaki, to appear).

There is a quadrilateral $ABCD$ with its diagonals crossing at M . Find combinations of two out of the following eight conditions as many as you can, each of which makes this quadrilateral $ABCD$ a parallelogram: (a) $AB = CD$, (b) $AD = BC$, (c) $\angle A = \angle C$, (d) $\angle B = \angle D$, (e) $AM = MC$, (f) $BM = MD$, (g) $AB \parallel DC$, (h) $AD \parallel BC$.

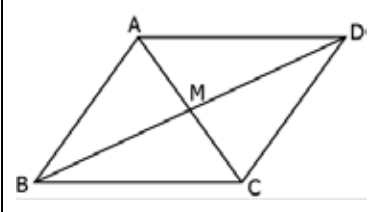


Figure 2: Task given in the teaching experiment

Among the 28 possible combinations of conditions, 16 are sufficient to make a quadrilateral a parallelogram, while 12 are not. Among the sufficient combinations, $\{(c), (f)\}$ and $\{(d), (e)\}$ are relatively difficult to be justified, and their proofs could involve proof by contradiction. The teaching experiment was carried through two teaching terms. While the first term was dedicated to students to do their own inquiries around the task, the second term was devoted to their reflection.

In fact, because of its difficulty, we did not expect the generation of the idea of proof by contradiction at the beginning. However, we could observe the generation of argumentation using that method in their inquiries as we report below. The following is a part of the conversation during the inquiries by a group of three students (A, B, and C) in the first term, which was mainly recorded by a voice recorder and partly by a video recorder. We were not able to identify their voices clearly and the speaker of the speech below was partly unspecified (Indicated as Student X). They were considering the case where $\angle A = \angle C$ and $BM = MD$.

Student X: As these lengths [BM and MD] are specified from the beginning and if we set that these angles [$\angle A$ and $\angle C$] are the same, I think it must be a parallelogram, right?

Student A: If we change these lengths [AM and MC], these angles [$\angle A$ and $\angle C$] must also change...

Student A: So, if we change these lengths [AM and MC] and also fix these angles [$\angle A$ and $\angle C$], these edges cannot meet.

Student A: Wait, yes. If the angles [$\angle A$ and $\angle C$] are specified and the lengths [AM and MC] are different, it cannot be. Under these conditions [$\angle A = \angle C$ and $BM = MD$], it is impossible.

Student B: Well, why is it impossible? (A short silence follows.)

Student A: Well, listen. If we change the lengths [AM and MC], they [the edges CD and AD] cannot meet, can they? Let's see, if we keep these angles [$\angle A$ and $\angle C$] having the same measure, and also if we make this part [MC] longer...

Student C: Oh, they [CD and AD] will not meet... it [CD] cannot reach [D].

The final worksheet did not retain the figures used at the time of the above argumentation. It is assumed that Figure 4 illustrates the situation described by Student A. At that time, she was looking for a counterexample, that is, an instance that satisfies the given condition but is not a parallelogram. This idea led her to the argumentation 'if MC is longer than AM'. Their argumentation continued as follows:

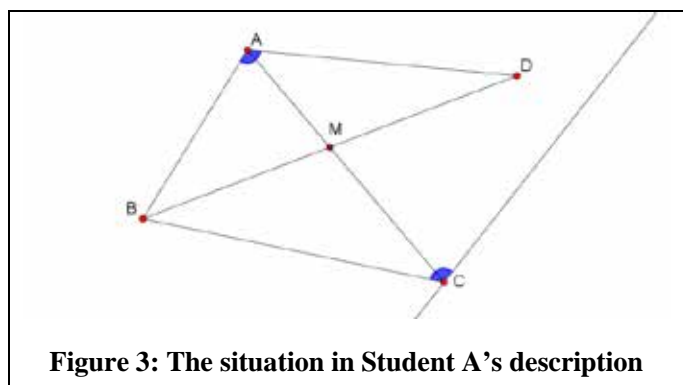


Figure 3: The situation in Student A's description

Student B: Then, let's draw the figure (of the considered situation).

Student A: No way. We cannot draw it because it is impossible.

Student B: Oh, right. I see.

Student C: Oh, we cannot draw it...

These protocols clearly show that their argumentation involves contradiction: a situation that can be considered but cannot be possible. Then, she organized her idea, draw a new figure (see Figure 6), and spoke as follows:

Student A: The answer is yes [sufficient] for this case. Because ... Let us use this line [set AC on this line], [under the assumption $BM=MD$] then look at these lengths [AM and MC]. If these lengths are different and if one is even one block longer, then these angles [$\angle A$ and $\angle C$] cannot be the same in measure. Thus, if we assume that these angles [$\angle A$ and $\angle C$] are same, these lengths [AM and MC] are *definitely* the same, too!

This shows how confident Student A finally was at the correctness of her argumentation and illustrates the possibility of generating the idea of proof by contradiction through this type of argumentation that judges the truth of a universal proposition.

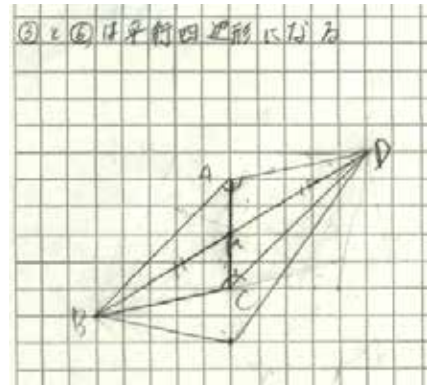


Figure 4: The final diagram in their work sheet

Discussion and conclusion

Although we admit the weakness of our empirical evidence as our teaching experiment was not limited to proof by contradiction, we could observe small but specific data of successful argumentation in the teaching experiment. We would like to discuss how this proposed task relates to the generation of such argumentation. Moreover, this research is highly inspired by the research by Antonini (2003), which also describes that the non-example argumentation is not the only process for the generation of indirect proving. There is also a request for further research that develop other processes and related tasks. Since this paper is one of possible responses to such request, we also compare and discuss the differences between the argumentations by contradiction observed above and the indirect argumentations involving non-examples proposed by Antonini (2003).

As mentioned by Antonini (2003), in the students' argumentations, non-examples may work as generic examples; their observation, which indicates 'if B is true, it cannot be an example', can be generalized or expanded to the universal proposition of 'for any case, if A is true, B cannot be true'. This generalization is possible because the instances in consideration are real. On the other hand, although the proposed argumentation in this paper is also related to a universal proposition, nothing in the argumentation works as a generic example. The principle of this argumentation is the assertion of the non-existence of counterexamples, and it does not involve the effects of generalization or expansion. In fact, they deal with an impossible instance which can hardly be generalized or expanded. Thus, these two types of argumentations are entirely different. This difference comes from the fact that the proposed argumentation is directly based on proof by contradiction, not by contraposition.

In addition, the proposed argumentation essentially requires predicate logic: it is necessary to consider the negation of the predicate statement 'for any x , $P(x)$ implies $Q(x)$ ', that is, 'for some x , $P(x)$ and

not $Q(x)$ are true', while, in the non-example argumentation, the phrase 'for any x ' is hidden or always prepositional. Although it seems rather complex at first glance, such an argumentation is supported by the features of the related task: first, this is not a proving task but a judgement task; second, this task may prompt the empirical verification activity that can stimulate the understanding of the negation of a universal proposition. This fact seems to be a reason of the didactic paradox of proof by contradiction mentioned in the introduction: between spontaneous proving by contradiction in extra-mathematical situations and the difficulty of understanding it in school mathematical situations. In the classroom, both the judgement task (or disproving task) and the empirical verification usually live in a narrower space than the proving task with theoretical ways.

Acknowledgment

This work is supported by JSPS KAKENHI (JP15H03501 and JP17H02694).

References

- Antonini, S. (2003). Non-examples and proof by contradiction. In N. A. Pateman, B. J. Dougherty & J. Zilliox (Eds.), *Proceedings of the 2003 Joint Meeting of PME and PMENA* (Vol. 2, pp. 49–55). Honolulu, USA.
- Antonini, S., & Mariotti, M. A. (2008). Indirect proof: What is specific to this way of proving? In *ZDM Mathematics Education* 40, pp. 401–412.
- Antonini, S., & Mariotti, M. A. (2010). Abduction and the explanation of anomalies: The case of proof by contradiction. In V. Durand-Guerrier, S. Soury-Lavergne & F. Arzarello (Eds.), *Proceedings of the 6th ERME Congress* (pp. 322–331), Lyon, France.
- Chamberlain Jr, D., & Vidakovic, D. (2017). Developing student understanding: The case of proof by contradiction. In A. Weinberg, C. Rasmussen, J. Rabbin, M. Wawro & S. Brown (Eds.), *Proceedings of the 20th Annual Conference on RUME* (pp. 454–468), San Diego, California.
- Freudenthal, H. (1973). *Mathematics as an educational task*. Reidel Publishing Company: Dordrecht, the Netherlands.
- Garuti, R., Boero, P., & Lemut, E. (1998). Cognitive unity of theorems and difficulties of proof. In A. Olivier & K. Newstead (Eds.), *Proceedings of the 22th IGPME Conference* (Vol. 2, pp. 345–352). Stellenbosch, South Africa.
- Hamanaka, H. & Otaki, K. (to appear). Generating the *raison d'être* of logical concepts in mathematical activity at secondary school: Focusing on necessary/sufficient conditions. In *Proceedings of the 6th International Congress of the Anthropological Theory of the Didactic* (pp. 22–26). Autrans, France, 2018.
- Lin, F.L., Lee, Y.S. & Wu, J.Y. (2003). Students' understanding of proof by contradiction. In N. A. Pateman, B. J. Dougherty & J. Zilliox (Eds.), *Proceedings of the 2003 Joint Meeting of PME and PMENA* (Vol. 4, pp. 443–449), Honolulu, US.
- Reid, D. & Dobbin, J. (1998). Why is proof by contradiction difficult? In A. Olivier & K. Newstead (Eds.), *Proceedings of the 22nd PME Conference* (Vol. 4, pp. 41–48). Stellenbosch, South Africa.

Student teachers' argumentation in primary school mathematics classrooms

Helene Hauge

Western Norway University of Applied Sciences, Norway; helene.hauge@hvl.no

Keywords: Argumentation, student teacher, primary school.

Argumentation in mathematics education

In recent years, there has been increased interest in the nature and role of argumentation in mathematics education. Engaging in argumentation can lead to a deeper understanding of mathematics. In the context of mathematics education, argumentation can be defined as:

a term which is generally used to describe the discourse or rhetorical means (not necessarily mathematical) used by an individual or a group to convince others that a statement is true or false. (Stylianides, Bieda, & Morselli, 2016, p. 316)

The teacher plays a key role in establishing mathematical quality of the classroom environment (Yackel & Cobb, 1996). The teachers are representing the mathematical community in the classroom, and their personal mathematical beliefs, values, mathematical knowledge and understanding are important. Research on teachers' knowledge about mathematical argumentation has focused on identifying problems and challenges (for example teachers' lack of mathematical knowledge) rather than finding solutions to these problems (Stylianides et al., 2016).

The Norwegian curriculum is currently under review and in the latest draft reasoning and argumentation is one of six core areas in mathematics (Utdanningsdirektoratet, 2018).

The aim of my PhD research is to investigate preservice primary school teachers' views on, and use of, argumentation in mathematics education. I have three research questions:

1. How do preservice primary teachers argue when evaluating mathematical arguments?
2. How do preservice primary school teachers argue when teaching mathematics in primary school?
3. How do preservice primary school teachers engage primary school students in argumentation when teaching mathematics?

Method

My study focuses on students enrolled in the Norwegian teacher education for Grades 1 – 7, age 6-12. It is a five-year program with an integrated master's degree. After graduation, these students will be qualified to teach mathematics, Norwegian and one subject of their own choice. The education comprises 30 mandatory credits in mathematics, which equals half a year of full-time study. The mandatory mathematics courses are taught in the second and third semester of the education. Later, the students can choose to do 30 more credits of mathematics, and to do their master's thesis in mathematics education. I will collect data when the students are in their third and fourth semester of their education, i.e. I will follow them in their last semester of mandatory mathematics course and following semester.

The research has a qualitative approach. I will do video observation of student teachers when teaching mathematics during practice training and audio-recorded interviews with both student teachers and their practice training supervisor. The students will be interviewed in their practice training groups. The interview will focus on their mathematical argumentation, and on their argumentation when teaching mathematics. I will give the students a statement and several ways of defending this statement. Through a discussion about what is the best way of convincing others that the statement is true, I will get the data to answer research question 1. I will also interview the students about situations from their practice teaching using video clips. Together with the observations, these data will be valuable when answering research question 2 and 3.

The interviews with the practice training supervisors will aim at finding out what development the supervisor observes, encourages and disapproves with the student teachers. This will give me information about the background for the students' choices, to what extent they are students' own independent choices or a result of the supervisors' guidance.

The recordings will be transcribed and analysed. I will identify the discourse by which the student teachers construct mathematical arguments for themselves and for school students; and what discursive space, including gestures and use of artifacts, they provide for their school students engagement with mathematical argumentation. Processes of argumentation will be analysed with methods that are based on Toulmin's theory of argumentation (Toulmin, 1958), as described by Krummheuer (2015).

Research result and implications

The research will contribute to a deeper understanding of student teachers' ability to teach argumentation in primary school classrooms. This can form the basis of future research on how to support student teachers to teach argumentation in primary school classrooms.

The poster will present the design of the study and some preliminary results. I find this poster particularly relevant for the Theme Working Group 1 (Argumentation and Proof).

References

- Krummheuer, G. (2015). Methods for Reconstructing Processes of Argumentation and Participation in Primary Mathematics Classroom Interaction. In A. Bikner-Ahsbabs, C. Knipping & N. Presmeg (Eds.), *Approaches to Qualitative Research in Mathematics Education* (pp. 51–74). Dordrecht: Springer.
- Stylianides, A. J., Bieda, K. N., & Morselli, F. (2016). Proof and Argumentation in Mathematics Education Research. In Á. Gutiérrez, G. C. Leder, & P. Boero (Eds.), *The Second Handbook of Research on the Psychology of Mathematics Education* (pp. 315–352). Rotterdam/Boston/Taipei: Sense Publishers.
- Toulmin, S. (1958). *The uses of argument*. Cambridge: Cambridge University Press.
- Utdanningsdirektoratet. (2018). Siste utkast til kjernelementer i matematikk fellesfag og programfag. Retrieved from <https://hoering.udir.no/Hoering/v2/197?notatId=358>
- Yackel, E., & Cobb, P. (1996). Sociomathematical Norms, Argumentation, and Autonomy in Mathematics. *Journal for Research in Mathematics Education*, 27(4), 458–477.

The interplay of logical relations and their linguistic forms in proofs written in natural language

Kerstin Hein

TU Dortmund University, Germany; kerstin.hein@math.tu-dortmund.de

The Toulmin model and the systemic functional grammar are combined to analyse logical relations and their linguistic forms in students' written proofs for identifying obstacles and possibilities to foster the understanding of proofs. The qualitative analysis of 63 students' products reveals a parallelism between syntactical and content-related explications and condensations. In particular, the use of conjunctions seems to support more options 1.) to make explicit logical relations between premise and warrant or conclusion, 2.) to combine several steps of a proof, and 3.) to recycle conclusions as new premises. The logical relation from the warrant to the conclusion is often only made explicit using causal prepositions as linguistic condensed forms of relations.

Keywords: Formal proof, logical relations, Toulmin model, linguistic analysis

Introduction

There is still a lack of knowledge about the concrete language demands for specific topics, although the importance of identifying academic language and the epistemic role of language has been explored (e.g. Schleppegrell, 2004). For these reasons, a linguistic analysis of the classroom discourse to support teaching-learning processes should be pursued for several subjects and topics, in particular mathematics (Schleppegrell, 2007). Especially, for the challenging topic of proof and proofing an analysis of students reasoning is important (e.g. Mariotti, Durand-Guerrier, & Stylianides, 2018, p. 80), in particular, the analysis of logical rules and their linguistic forms, which cannot be translated from formal language directly (Durand-Guerrier, 2004, p. 2). Within the logical structures, the "implicit logical relationships" (Schleppegrell, 2007, p. 141) in their linguistic forms are one of the major challenges in proof. Because of the high density of academic language, it is demanding for the students to be aware of and to understand the academic language. Therefore, it is important to unpack the meanings in more explicit language (O'Halloran, 1998). The suggestion for teachers is to be explicit and to hold syntactic control within their own language during teaching logic (Durand-Guerrier, Boero, Douek, Epp, & Tanguay, 2011).

As a first step, a linguistic analysis is needed for analysing the language demands of logical relations. The structural and linguistic analysis of students' products in this study follows the above mentioned, general suggestions to identify language demands in logical structures, here for logical relations. It pursues three research questions: 1) *How can logical relations and their linguistic forms be analysed?* 2) *Which pattern can be seen in the interplay between the logical relations and their linguistic forms?* 3) *Which linguistic forms of logical relations can be used to make logical relations explicit?* The first two sections present the theoretical background and methodology of the analysis. The outcome of the qualitative analysis of the written proofs is presented afterwards illustrated by case studies of two texts.

Theoretical background: Logical relations and their linguistic forms

In line with Mesnil (2013), the interaction between logic and language and the importance of explicitness of the language in teaching and learning proof is assumed. This study focuses on the logical relations as one challenging part of the language of proof (Schlepppegrell, 2007). For this reason, the study aims at identifying the linguistic forms of logical relations.

Logical elements

For the analysis of proofs, the Toulmin model (1958) is often applied, although it was developed to describe everyday argumentations. Within mathematics education the structural analysis with the Toulmin model was also applied to analyse mathematical classrooms (Krummheuer, 1995), the structure gap between argumentation and proofs (Pedemonte, 2007), and for proofs with several steps (e.g. Knipping & Reid, 2015), even if there are limits for the analysis of proofs and proofing (also discussed in Mariotti et al., 2018, p. 78). In the structure model of Toulmin, the function of the logical elements as premise etc., not their relations, is crucial. This becomes more important when it is applied for the logical structure analysis of proof. This article refers to the short versions of Toulmin's model and considers premise, warrant and conclusion as the relevant logical elements within deductive steps. These logical elements are connected more or less implicitly by logical relations, which need to be unpacked, here.

Logical relations

In this article, logical relations are understood as relations between logical elements. In deductive proofs, the relations between premise, warrant and conclusion are crucial (as described by Duval 1991, p. 235), but also within a warrant with the logical form of implication or equivalence (Selden & Selden, 1995). In particular, the logical relation from premise to warrant is crucial for the verification of the premises (Duval, 1991). These logical relations are often implicit in the language, creating an obstacle for students (Schlepppegrell, 2007) as they have to be unpacked in order to understand them (Selden & Selden, 1995).

Different linguistic forms

Logical relations are often expressed in natural language by logical connectives such as “because”, “due to” or “if..., then...” (Clarkson, 2004). These logical connectives can be classified as causal-conditional principal markers by the systemic functional grammar of Halliday (1985), describing language from a functional perspective. They have different linguistic forms such as causal conjunctions (“because”), conditional conjunctions (“if... then...”) or causal prepositions (“due to”). However, there is still a research lack of the analysis of the combination of logical relations and their linguistic forms (e.g. Durand-Guerrier et al., 2011; Schlepppegrell, 2007).

Methodology for the analysis of written proofs

Data collection

The students' texts of written proofs have been generated within a teaching-learning arrangement on deductive reasoning in grade 8-12 all with angle sets (Hein & Prediger, 2017; Prediger & Hein, 2017). In the teaching-learning arrangement conjunctions were used to express logical relations. The students were also asked to reason why a theorem can be applied (premises are met). In this paper,

the learning process and the effects of the teaching-learning arrangement are not analysed. Instead, it focuses only on the written products of the teaching-learning arrangement in order to investigate the interplay between logical relations and their linguistic forms. The data corpus consists of 63 written texts from 48 students (20 in grade 8, 6 in grade 9, 4 in grade 10, 18 in grade 12). The result section presents the results of two cases with texts of the twelfth graders Linus and Petra.

Methods for qualitative data analysis

The qualitative analysis of logical relations and their linguistic forms in the written products combines two analysis models: (1) *Toulmin model*: The Toulmin model in its short version (1958) is applied for the logical structure analysis to identify the addressed logical elements (premise, warrant, conclusion) (Pedemonte, 2007) and to disentangle the several steps of the proof (Knipping & Reid, 2015). (2) *Systemic functional grammar*: The linguistic analysis of the logical connectors as language means for logical relations draws upon systemic functional grammar (Halliday, 1985), which can also be used to identify linguistic challenges in mathematics education (Schleppegrell, 2007). The analysis approach systematically identifies lexis used for logically connecting sentences or elements within sentences and classifies their syntactical forms as conjunction (con) respectively prepositions (pre). For these, the English functional grammar (in which the products are presented here) and the German functional grammar (the original language of the products) resonate with each other. For example, causal conjunctions can be described in English and German with conjunctions and prepositions and function in a similar way. Here, first the existence of a logical relation as links between logical elements and then their grammatical form (conjunctions such as “therefore” or preposition such as “according to”) are identified.

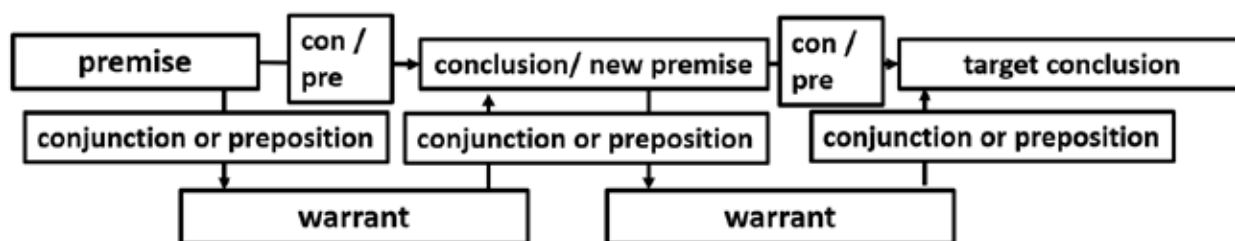


Figure 1: Analysis tool with Toulmin for several steps and both linguistic forms for logical relations

Empirical insights into the cases of Petra’s and Linus’ written proofs

Petra’s and Linus’ texts were chosen for illustrating the results because their texts contain typical linguistic forms for the logical relations – condensed and non-condensed – which were also found in many other written proofs about angle sets. The students work on the proof for the sum of angles in a triangle (Figure 2). Before starting to write individually, they discuss the proof, identify which theorems have to be applied and draw the sketch printed in Figure 3 to which both texts refer.

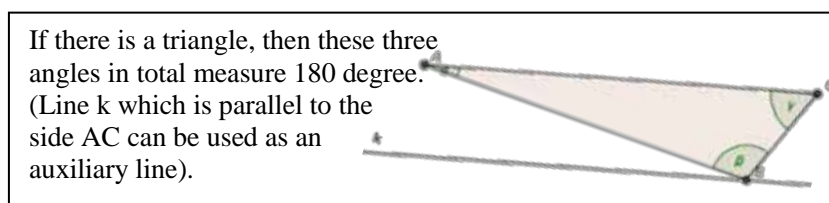


Figure 2: Mathematical statement to be proven by Petra and Linus

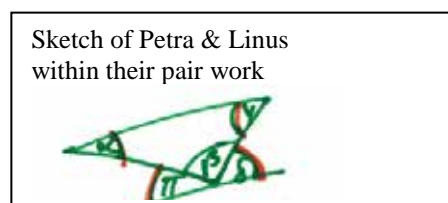


Figure 3: Students’ joint sketch

Analysis of activated mathematical statements: Both students refer to the same mathematical statements, the alternate interior theorem (Step 1 and 2), supplementary angle theorem (Step 3), calculating with angles theorem (Step 4), but both texts show substantial differences with respect to making the logical relations and their linguistic forms explicit. Presentation of the structural and linguistic analysis: The logical elements are illustrated with colours (green: premises (P); blue: warrant (W), orange: conclusion (C)), both in the text and the graphical representations. Only partly explicated logical elements are illustrated with * in the text and with dashed boxes in the graphics. The logical relations (R) (conjunctions (con), prepositions (pre)) are illustrated in black and by arrows in the graphical presentations (continuous arrow for conjunctions, dashed arrow for prepositions).

Linus’ text with causal prepositions for the logical relations




Step	Translated (and original) text	Structural and linguistic analysis
1+2	<p>The triangle ABC has the angles $\alpha := \sphericalangle CAB$; $\beta := \sphericalangle ABC$, $\gamma := \sphericalangle BCA$. Additionally, a line passes through point B. Additionally, the angle π is located at line k and at \overline{AB} and δ is located at line k and the side \overline{BC}. (p*: Parallelism of k to BC is missing.) According to (R/pre) the alternate interior angle theorem (W), the angles α and π have the same measure and δ and γ have the same measure. (C)</p> <p>(German Original: Das Dreieck ABC hat die Winkel $\alpha := \sphericalangle CAB$, $\beta := \sphericalangle ABC$, $\gamma := \sphericalangle BCA$. Zusätzlich geht durch den Punkt B eine Gerade. Zusätzlich liegt der Winkel π an der Geraden k und an \overline{AB} und δ liegt an der Geraden k und an der Seite \overline{BC}. Gemäß des Wechselwinkelarguments sind die Winkel α und π gleich groß und δ und γ gleich groß.)</p>	 <p>The detailed explicated premises (without parallelism) are not verbally connected with the warrant.</p> <p>With “According to” the warrant (alternate interior angle theorem) is connected with the conclusion.</p> <p>“According to” is a preposition within one sentence.</p>
3	<p>According to (R/pre) the supplementary angle theorem (W), the angles β, π and δ sum to 180 degree (C).</p> <p>(German Original: Gemäß des Nebenwinkelarguments sind die Winkel β, π und δ zusammen gleich 180 Grad groß.)</p>	 <p>“According to”: analysis analogue to Step 1+2</p>
4	<p>π can be substituted by α and δ can be substituted by γ (P*: Conclusion of step 3 as new premises is missing.). According to (R/pre) the calculating argument (W), the interior angles α, β and γ have a measure of 180 degree (C).</p> <p>(German Original: Für π kann α eingesetzt werden und für δ γ eingesetzt werden. Gemäß des Rechenarguments sind die Innenwinkel α, β und γ gleich 180 Grad groß.)</p>	 <p>Linguistically, it is not marked as previous conclusion of Step 1+2 (implicit recycling). Conclusion from Step 3 is not explicitly used.</p> <p>“According to” connects the theorem with the conclusion with a preposition.</p>

Table 1: Analysis of Linus’ text

In Linus’ first sentences, the premises for the Steps 1, 2 and 3 are almost explicated. In further sentences, the warrants and the conclusions for Step 1, 2, 3 and 4 are explicated. The

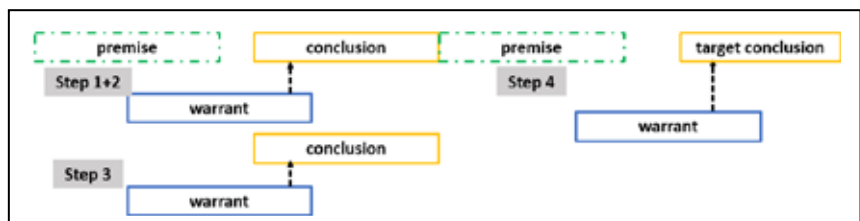


Figure 4: Summary of the analysis of Linus’ text

recycling of the conclusions from Step 1, 2 and 3 to new premises in Step 4 is not made explicit. However, logical relations between these elements are only explicated from the warrant to the conclusions, whereas the logical relations from the premises to the warrants or to the conclusions are not explicated. In each occurrence of logical connectives, Linus activates prepositions such as “according to”.

Petra’s text with more causal conjunctions for the logical relations





Step	Translated (and original) text	Structural and linguistic analysis
1	<p>A triangle with α, β and γ is given. The line k is parallel to line k and crosses point B. To identify the measures of the angles α and γ (crossed out), at the point B to the angle β the angles π and δ are defined (P). Because (R/con) the line k and the side AC are parallel and are crossed by the side AB (P), the angle theorem (W) can be applied. Therefore, (R/con) $\alpha = \pi$ (C).</p> <p>(German Original: Es ist ein Dreieck mit α, β und γ gegeben. Die Gerade k ist parallel zu der Geraden k und schneidet den Punkt B. Um die Größe der Winkel α und γ (durchgestrichen) zu erfahren, definiert man an dem Punkt B zu dem Winkel β die Winkel π und δ. Da die Gerade k und die Seite AC parallel sind und durch die Seite AB geschnitten wird, kann man das Winkelargument anwenden. Daraus folgt, dass $\alpha = \pi$.)</p>	 <p>„Because... can be applied“ connects the premise with the theorem. “Because” is a causal conjunction (within one sentence).</p> <p>“Therefore” connect the warrant (here angle theorem) with the conclusion.</p> <p>“Therefore” is a causal conjunction and connects two sentences.</p>
2	<p>Additionally, the side BC crosses the parallel line k to the side AC (P), therefore (R/con) $\gamma = \delta$ (C) reasoned by (R/prep) the alternate interior angles theorem (W).</p> <p>(German Original: Außerdem schneidet die Seite BC die parallele Gerade k zu der Seite AC, deshalb ist $\gamma = \delta$ begründet durch das Wechselwinkelargument.)</p>	 <p>With „therefore“ (causal conjunction), the conclusion is drawn. “Reasoned by” is used at the end of the sentence to add the logical relation from the warrant to the conclusion.</p>
3	<p>By the fact that (R/prep) Ω and δ are supplementary angles ($\Omega = \beta + \pi$) (P), β, π and $\delta = 180^\circ$ (C), according to (R/prep) the supplementary angle argument (W).</p> <p>(German Original: Dadurch dass Ω und δ Nebenwinkel sind $\Omega = \beta + \pi$, sind β, π und $\delta = 180^\circ$, laut dem Nebenwinkelargument.)</p>	 <p>With „By the fact that...“, the conclusion from the premise is drawn. “By” is a preposition. The premises are condensed to an object with “as a fact” which is explained in a sub-clause. “According to” (preposition) is used at the end of the sentences to add the logical relation from the warrant to the conclusion.</p>
4	<p>So, if (R/ con) $\beta + \pi + \delta = 180$ degree and $\alpha = \pi$ and $\gamma = \delta$ (P), then (R/ con), according to (R/ prep) the calculating argument (W), $\beta + \gamma + \alpha = 180$ degree (C).</p> <p>(German Original: Wenn also $\beta + \pi + \delta = 180$ Grad und $\alpha = \pi$ und $\gamma = \delta$, dann sind nach dem Rechenargument $\beta + \gamma + \alpha = 180$ Grad.)</p>	 <p>With „If..., then“ (conditional conjunction) the warrant is applied to the case. With “so” there is a reference to the previous conclusion, which is used as new premise (recycling). For “According to...“, see Step 3.</p>

Table 2: Analysis of Petra’s text

In her text, Petra addresses the premises, the warrant with the name of the theorems and the conclusions as Linus. For making the logical relations explicit, she connects the premises with the warrants or the conclusions with causal conjunctions such as “because” and “therefore”. In one case, Petra

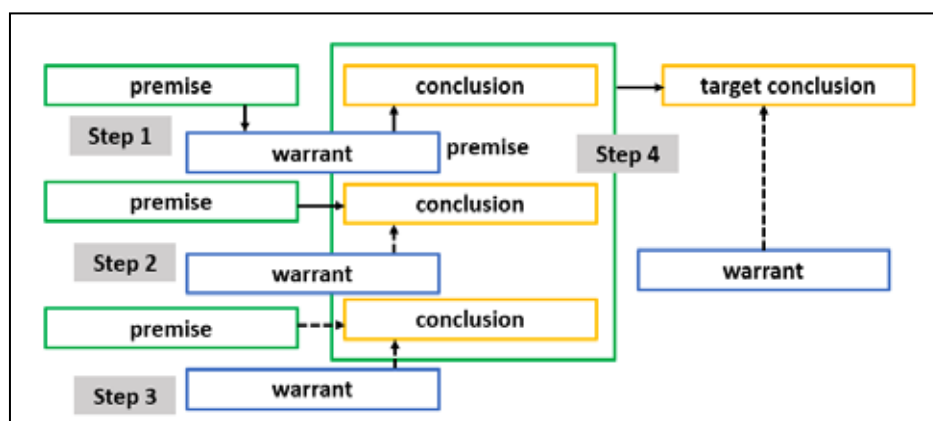


Figure 5: Summary of the analysis of Petra's text

connects the premise with the conclusion by a preposition (Step 3). Petra also uses prepositions such as “due to” by adding the expression “due to the ...-argument” as last part of the sentences after connecting the premise to the conclusion (Step 3 and 4).

Comparison of the case studies of Linus and Petra

In both texts, almost all contents of the elements of the short Toulmin Model are explicated, even Linus only mentions the premises partly at the beginning, respectively not completely in Step 4. The conclusions as new premises in Linus' example are not explicated in their function, in particular, the logical relations from the premises to the warrant or conclusion. The linguistic analysis shows that *causal conjunctions* such as “because” and “therefore” of logical relations are only used in Petra's text, where also the logical relations from the premises to the warrant respectively conclusions and the recycling of previous conclusions are expressed. These findings are in line with those of other written products (see Prediger & Hein, 2017). According to Halliday (1985) conjunctions are non-condensed forms for relations as in everyday language (called by him as *coherent*). In this case, these conjunctions were also used to make explicit the logical relations from the premises to the warrant or from the premises to the conclusion. With *causal prepositions* such as “according to”, “due to” or “by”, virtually nothing but the logical relations between the warrant and the conclusion are made explicit. This was also found in other texts (Prediger & Hein, 2017). Only in Step 3 of Petra's text, the relation from the premises to the conclusion is made explicit with a preposition (“by the fact that...”). Here, the content of the premises is expressed by a sub-clause. One reason for virtually explicating nothing but the logical relation from the warrant to the conclusion (exception: Step 3 in Petra's text) may be that prepositions need nominalizations and here only the warrant is condensed to a nominalization by its name and can be easily integrated by a preposition (“due to the ...-theorem”). By adding the phrase with the preposition (“... according to the ...-argument.”) at the end of the sentences (such as in Step 3 and Step 4 of Petra's text), the logical relations from the premises are also made explicit in the same sentence. In all other cases, in sentences with prepositions only the logical relation from the warrant to the conclusion is expressed. Prepositions are linguistically condensed forms of logical relations (called *metaphorical* by Halliday, 1985). This kind of linguistic phenomena is one of the most important characteristics of academic language to increase lexical density. However, these condensed forms (e.g. prepositions for logical relations) are challenging for students (Martin, 1999) and have to be unpacked first into non-condensed forms

before students can understand their meaning (O'Halloran, 1998, p. 382). In the context of this case study, mainly the logical relations between warrant and conclusion are articulated by condensed forms of prepositions instead of conjunctions. The qualitative analysis shows that the prepositions provide not only challenges to understand the logical relations, they also seem to hinder the explication of logical relations, from the premises to the warrant or to the conclusion or within a theorem. Prepositions also seem to be obstacles for combining several logical elements and steps.

Conclusion

The analysis of students' products reveals three main findings: 1) The Toulmin model has not only limits for analysing proofs in general (Mariotti et al., 2018, p. 78), but in particular, for capturing the logical relations. 2) The linguistic analysis here suggests that in non-condensed forms some aspects are more often expressed than in condensed forms. This finding can be used to be more explicit on language while teaching proof as Mesnil (2013) has recommended. 3.) For these reasons, it might be useful to first offer non-condensed linguistic forms (conjunctions), before condensed forms (prepositions) are used in the classroom. This approach resonates with Martin's (1999) observations regarding the challenging condensed forms in academic language.

Of course, this case study has significant methodological limits as only 63 texts were analysed, that were produced within the specific setting and content. It has not yet been taken into account how the setting and the content influence the students' articulations. Future research is required to overcome these limits. Furthermore, the texts are written in German and not in English, so every interpretation can only be made in the original.

Acknowledgment

I would like to thank my supervisor Susanne Prediger for the great support and intense cooperation. The doctoral thesis on which the article is based was carried out with the financial support of the Foundation of German Business.

References

- Clarkson, P. C. (2004). Researching the language for explanations in mathematics teaching and learning. In P. Jeffrey (Ed.), *Proceedings of the Australian Association of Research in Education*. Melbourne: AARE.
- Durand-Guerrier, V. (2004). Logic and mathematical reasoning from a didactical point of view. A model-theoretic approach. In M. A. Mariotti (Ed.), *Proceedings of the Third Conference of the European Society for Research in Mathematics Education (CERME 3)*. Bellaria, Italy: University of Pisa/ERME.
- Durand-Guerrier, V., Boero, P., Douek, N., Epp, S. S., & Tanguay, D. (2011). Examining the Role of Logic in Teaching Proof. In G. Hanna & M. de Villiers (Eds.), *Proof and Proving in Mathematics Education: The 19th ICMI Study* (pp. 369–389). Dordrecht: Springer.
- Duval, R. (1991). Structure du Raisonnement Deductif et Apprentissage de la Demonstration. *Educational Studies in Mathematics*, 22(3), 233–261.
- Halliday, M. A. K. (1985). *Introduction to functional grammar*. London: Arnold.

- Hein, K., & Prediger, S. (2017). Fostering and investigating students' pathways to formal reasoning: A design research project on structural scaffolding for 9th graders. In T. Dooley & G. Gueudet (Eds.), *Proceedings of the Tenth Congress of the European Society for Research in Mathematics Education* (pp. 163–170). Dublin, Ireland: DCU/ERME.
- Knipping, C., & Reid, D. (2015). Reconstructing Argumentation Structures. In A. Bikner-Ahsbahs, C. Knipping, & N. Presmeg (Eds.), *Approaches to Qualitative Research in Mathematics Education: Examples of Methodology and Methods* (pp. 75–101). Dordrecht: Springer.
- Krummheuer, G. (1995). The Ethnography of Argumentation. In P. Cobb & H. Bauersfeld (Eds.), *The Emergence of Mathematical Meaning: Interaction in Classroom Cultures*. Hillsdale, New Jersey: Lawrence Erlbaum.
- Mariotti, M. A., Durand-Guerrier, V., & Stylianides, G. J. (2018). Argumentation and proof. In T. Dreyfus, M. Artigue, D. Potari, S. Prediger, & K. Ruthven (Eds.), *Developing Research in Mathematics Education - Twenty Years of Communication, Cooperation and Collaboration in Europe* (pp. 75–89). Oxon: Routledge.
- Martin, J. R. (1999). Mentoring semogenesis: 'genre-based' literacy pedagogy. In F. Christie (Ed.), *Pedagogy and the shaping of consciousness* (pp. 123–155). London: New York: Continuum.
- Mesnil, Z. (2013). A reference for studying the teaching of logic teaching in high school in France: A complex request for teachers. In B. Ubuz, Ç. Haser, & M. A. Mariotti (Eds.), *Proceedings of the Eighth Congress of the European Society for Research in Mathematics Education* (pp. 166–175). Ankara, Turkey: Middle East Technical University/ERME.
- O'Halloran, K. L. (1998). *Classroom Discourse in Mathematics: A Multisemiotic Analysis*. *Linguistics and Education*, 10(3), 359–388.
- Pedemonte, B. (2007). How can the relationship between argumentation and proof be analysed? *Educational Studies in Mathematics*, 66(1), 23–41.
- Prediger, S., & Hein, K. (2017). Learning to meet language demands in multi-step mathematical argumentations: Design research on a subject-specific genre. *European Journal of Applied Linguistics*, 5(2), 309–335.
- Schleppegrell, M. J. (2004). *The language of schooling: a functional linguistics perspective*. Mahwah, N.J: Lawrence Erlbaum Associates.
- Schleppegrell, M. J. (2007). The Linguistic Challenges of Mathematics Teaching and Learning: A Research Review. *Reading & Writing Quarterly*, 23(2), 139–159.
- Selden, J., & Selden, A. (1995). Unpacking the logic of mathematical statements. *Educational Studies in Mathematics*, 29(2), 123–151.
- Toulmin, S. E. (1958). *The Uses of Arguments*. Cambridge: Cambridge University Press.

Mathematical Arguments in the Context of Mathematical Giftedness – Analysis of Oral Argumentations with Toulmin

Simone Jablonski¹ and Matthias Ludwig¹

¹Goethe University Frankfurt am Main, Institute of Mathematics and Computer Science, Germany,
jablonski@math.uni-frankfurt.de; ludwig@math.uni-frankfurt.de

Being defined as a main learning goal of mathematical education, arguments and argumentative skills are of high relevance. The development of these skills in the context of a deeper understanding is an important aspect for mathematical teaching and the support of mathematically gifted students, whose interest in mathematics should be increased. To focus more in detail on arguments in the context of mathematical giftedness, the paper poses the question whether it exists a relation between mathematical giftedness on the one hand, and mathematical argumentations on the other hand. For this purpose, the arguments of primary students from an enrichment program for mathematically gifted and interested students are gathered in an interview setting and analyzed by means of the Toulmin scheme. The results show that giftedness might influence the content and quality of arguments, but not the need for argumentations.

Keywords: argumentation, giftedness, Toulmin

Introduction

For curricular, societal and mathematical reasons, argumentative skills are claimed as central learning goals in mathematical education. Especially the view on mathematics as a deductive organized system with theorems and proofs forces fundamental skills in argumentation (e.g. Hanna, 2000). Nevertheless, former research shows that (German) students have deficits in formulating arguments in written and oral form (Cramer, 2011). It is therefore an important aim to support the development of argumentative competences, not solely, but also with regards to mathematical giftedness. The idea that gifted students perform better in the formulation of mathematical arguments seems legitimate, even though the relation is not clear (Fritzlär, 2011). In this context, the study focuses on this relation through analyzing gifted students' oral arguments.

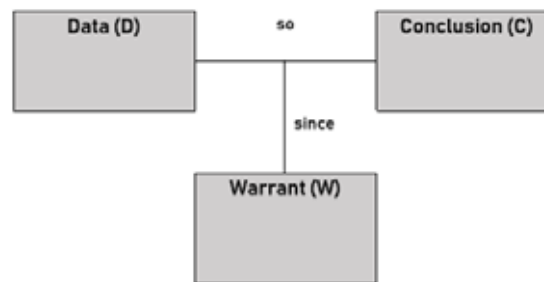
Theoretical Framework

Arguments in Mathematical Education

Not only in every day's communication, but also in mathematical education, arguments are of high relevance. The aim of an argumentation is to convince the communication partner with the help of shared respected statements (Cramer, 2011). Nevertheless, real disputes in mathematical education are rare, so that argumentations are best described in the context of a problem solving process as "a type of dialogical or dialectical game [...] that is associated with collaborative meaning-making." (Baker, 2003, p. 48). In mathematical education, the process of an argumentation involves activities such as to formulate assumptions on mathematical characteristics, to reason on relations, as well as to question assumptions (Bezold, 2009). The paper defines the term 'argument' as a product which results from the processes of former described activities. With this product-oriented focus, it is possible to analyze arguments among different categories, e.g. structure and content.

According to Toulmin (1958/2003), every argument can be structured through different functional elements. Toulmin describes *Data* (D) as “facts we appeal to as a foundation for the claim” and *Conclusion* (C) as claim “whose merits we are seeking to establish” (Toulmin, 2003, p. 90). The step from D to C often requires further considerations, asking for “general, hypothetical statements, which can act as bridges, and authorize the sort of step to which our particular argument commits us” (Toulmin, 2003, p. 91). These kind of statements are called *Warrant* (W). Figure 1 presents the core of the Toulmin scheme.

Figure 1: Core of the Toulmin Scheme (Toulmin, 1958/2003)



Apart from a structural analysis, it is furthermore necessary to analyze arguments according to their content as the analysis by means of the Toulmin scheme does not state anything on the argument’s quality, e.g. whether a warrant is based on authority or a mathematical rule (Koleza, Metaxas & Poli, 2017). Following Toulmin’s definition, an argument is called *analytic* if W includes all relevant information for the step from D to C (Toulmin, 2003), e.g. mathematical rules or laws that are adequate in the specific context. Arguments that do not fulfil this condition are claimed as *substantial* (Toulmin, 2003). These arguments leave open or fail to answer (further critical) questions (Koleza, Metaxas, & Poli, 2017), e.g. “*My calculation is correct, because Anna has the same result*” could be rebutted by the question “*But what if both of you did a wrong calculation?*” (Fetzer, 2012).

Mathematical Giftedness

Mathematical giftedness is a complex construct that lacks a standardized definition and diagnosis as it is not directly observable (Bardy, 2013). It is more a potential that might develop into an outstanding mathematical performance by means of an advantageous interplay of genetic and environmental factors (Käpnick, 1998). Therefore, the construct is approximated by means of lists of characteristics, including special skills such as the memorizing and transferring of mathematical structures, creativity and problem solving competences (Käpnick, 1998).

State of the Art

A main interest of studies on argumentations in the educational context is on the analysis of arguments with help of frameworks and models in order to make characteristics observable (e.g. Nussbaum, 2011). Mostly, studies observe arguments in classroom interactions and collaborative argumentations (e.g. Forman, McCormick, & Donato, 1997). For this purpose, the Toulmin scheme, and especially its core, is often used (e.g. Koleza, Metaxas, & Poli, 2017). Further studies focus on the evaluation of argumentative skills by means of models and methods to improve them (e.g. Bezold, 2009). The studies show quite consistently that arguments in primary school have a low significance and real disputes are rare, so that the teacher has to initiate arguments and show the need for arguments

(Schwarzkopf, 2000). With regards to Toulmin, arguments by primary school children are typically characterized by the missing of a warrant and by substantial arguments (Fetzer, 2012). Koleza, Metaxas & Poli (2017) assume that primary students are able to formulate arguments which can be analyzed using the Toulmin scheme, even though basic elements are not mentioned through a lack of need for argumentation. Focusing on argumentative skills of mathematically gifted students, the relation is not explicitly clarified (Fritzlar, 2011). On the one hand, Fritzlar (2011) assumes that mainly other factors apart from giftedness influence argumentative skills and the need for argumentations. Other models see the potential of gifted students (inter alia through supportive characteristics, such as creativity) to develop outstanding argumentative skills, which can be forced through training (Bardy, 2013).

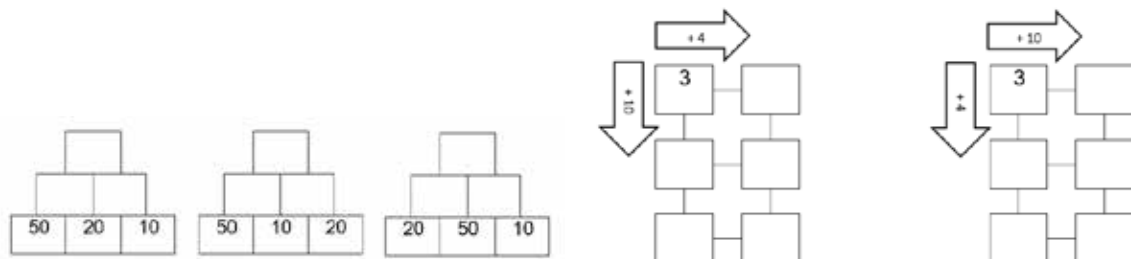
Research Questions and Methodology

Based on this theoretical outline and former research findings, the research questions of this paper is formulated as follows: *What are the characteristics of mathematically gifted and interested primary students' arguments? In how far do they differ from general research findings on the arguments of primary students with special regards to the Toulmin scheme and the need for arguments?*

The research question is answered in a qualitative study. The sample is taken from the participants of the extra-curricular enrichment program “Young Math Eagles Frankfurt”. The aim of the program is to support mathematical interested and gifted students and to increase their mathematical interest and joy on a regular and long-term level. In the school term 2017/2018, about 50 students between 8 and 10 years from 14 schools participate in the program after nomination of their teachers.

To focus on the characteristics of the oral arguments of the participants, task-based and problem-orientated interviews are created (Goldin, 2000). This interview form is characterized by the openness of answers while focusing on a special problem. The interview material includes tasks that emphasize arguments and ask primary students to formulate warrants through irritation or the task itself (Bezold, 2009). The task formats focus on number pyramids and numerical lattices with regard to special number relations. The formats can be expected to be known by the primary students and do not ask for difficult calculations. Therefore, the task formats' focus is basically on argumentation and it can be expected that the students are able to use their findings on number relations as basis for warrants that can be analyzed by means of the Toulmin scheme. In each interview, different components of the formulation of arguments are included. In particular, the students are asked to comment on a wrong assumption e.g. through giving a counter example, to argue on different mathematical relations and to generalize their detections.

Figure 2: Task formats number pyramid (left) and numerical lattices (right)



One task is to answer the question how the basic stones of the number pyramid/the arrow numbers of the numerical lattices have to be arranged in order to maximize the top of the pyramid/the result of the numerical lattices (see Figure 2). Every interview is done individually and includes four tasks which are done within 15 minutes. To make the interviews comparable, they are directed with help of a guideline. The interviews are transcribed on the basis of an audio recording and an observational protocol.

The task formats, as well as the guideline were tested during the pilot phase regarding their appropriateness in terms of the students' age, needed time and mathematical content. Further, they were analyzed according to the need for argumentations. The results show that the formats are adequate in the named categories. Most students were able to identify relevant mathematical characteristics and some were even able to generalize them to some extent. In all interviews, the students formulated arguments which could be reconstructed with the Toulmin scheme. Therefore, the piloting could confirm that the tasks emphasize arguments, which shows the suitability of the tasks for the research question. Nevertheless, many arguments were initiated by the interviewer. Through these initiation processes in the interview, it is therefore possible to analyze the independence of and need for arguments.

On the basis of the results in the piloting and the theoretical framework, a scheme for the analysis of the arguments within the interviews is created. The analyzed categories within this paper are

- (1) Structure of Arguments: Within this part, it is analyzed which of the elements *Data*, *Conclusion* and *Warrant* could be observed during the focus on the specific task.
- (2) Independency of Arguments: Here the focus is led to whether a warrant is initiated by the interviewer through questions/given after mediation, or given on an independent level.
- (3) Content of Arguments: This part involves a categorization of the warrant in terms of its mathematical content (inacceptable/wrong, substantial, analytic).

The use of the Toulmin scheme as a basis for the analysis can be legitimated as the results are to be compared to former research findings on arguments in the primary age and the Toulmin layout is frequently used in these studies. Through adapting the independency and the content, its limitations apart from a structural analysis for this setting are recognized.

During May and June 2018, 32 participants (all students with parental consent form and presence during the interview dates) were interviewed. Within the interviews, 128 argumentation tasks are analyzed. Beforehand, no special training in the formulation and awareness of arguments or an education on the formulation of analytic warrants took place. Argumentation and reasoning tasks were part of some lessons, but not to a greater extent than the focus on other competences, such as problem solving. First observations within the enrichment program did not seem to show obvious differences in the need for argumentations. Nevertheless, the detection of mathematical findings, might be an important influence on the arguments of gifted children. The following results from the analysis should specify the relation of argument and giftedness on a systematic level.

Results

Table 1 shows an example of an interview extract with a functional analysis according to the elements of the core of the Toulmin scheme. At the date of the interview, the student (S) was in ten years old. His interview bases on the task format *numerical lattices*. The sample analysis focuses on the task within the interview, in which the participant has to argue in which case the result is the highest. In advance, he does calculations with changed orders of the arrow numbers and concludes that the results change. Through initiation of the interviewer, he gives a substantial warrant for the relation of the basic elements and result. His argumentation bases on the order of the boxes of the numerical lattices and the switch of numbers comparing both tasks.

On the basis of this observation (which is coded as *Data* for the following task), he is able to identify the case in which the result is the highest, namely when the arrow with the higher number shows downwards (see Figure 2). Without initiation, he uses a substantial warrant and through initiation he supports a conclusion through an analytic warrant by transforming it to a general case.

Table 1: Extract from the transcript (translated from German by the author)

I: [...] In which case do you receive the highest result? You can use your former calculation.	Introduction of Task
S: When the higher number is taken plus here (<i>shows on arrow downwards of numerical lattices</i>).	Conclusion
Because here, there are three and here there are solely two (<i>shows on boxes of numerical lattices</i>). [...]	Warrant (substantial)
I: Do you think this is always the case or solely in our example?	Initiation
S: Well, I think this is in every example like this.	Conclusion
I: Can you tell me why this is the case or/?	Initiation
S: (<i>shows on arrows of numerical lattices</i>) Because when you calculate here the higher number plus at the arrow downwards, then there is one box more, where you can calculate plus and here on top, there is no more	Warrant (analytic)
and therefore I think, this is always like that.	Conclusion

With the former task as data, a conclusion is drawn and supported through a warrant. The task is therefore coded as *Data – Conclusion – Warrant*. For the warrant, the highest observable category before initiation is *substantial*, and after initiation *analytic*. The development of the warrant after initiation can be observed frequently, so correspondingly, two phases within each interview task are distinguished for the following analysis: Phase 1 describing the argument respectively the warrant on an independent level, and Phase 2 after an initiation of a warrant.

Table 2 shows the results from the structural analysis of all interview tasks through categorization according to the included elements on an independent level, namely without a question as initiation

of reasoning (Phase 1). Without initiation processes, only 24.2% of all analyzed tasks include a warrant on an independent level. In the majority of the tasks, a conclusion is drawn, but ungrounded. Taking those tasks that are coded within the category *Conclusion or Data – Conclusion* on an independent level and in which a warrant was initiated afterwards, in 87%, a warrant could be formulated after being initiated. By combining the independently formulated and initiated arguments, within 98 of all 128 tasks the complete core according to the Toulmin scheme (*Data – Conclusion – Warrant*) could be reconstructed. Nevertheless, within 67 of these 98 tasks, the warrant was only formulated after being initiated.

Table 2: Structural categorization according to the Toulmin scheme on independent level

N=128	No Conclusion	Conclusion or Data – Conclusion	Data – Conclusion – Warrant
Argument on an independent level	6 (4.7%)	91 (71.1%)	31 (24.2%)

To focus more in detail on the mathematical content of the arguments, the tasks including a warrant are categorized as *not acceptable/wrong*, *substantial* and *analytic*. Again, the highest observable category is coded, e.g. a task including a substantial and an analytic warrant before initiation is coded as analytic. In Table 3, the independently given warrants from Table 2 are categorized (N=31). In addition to the former finding that in about 75% of all tasks no warrant is coded on an independent level, one can observe that two thirds of the independently given warrants are substantial.

Table 3: Content-related analysis of the tasks with an independently formulated warrant

N=31	Not acceptable	Substantial	Analytic
Independent Warrants	3 (9.7%)	21 (67.7%)	7 (22.6%)

In Table 4, a further categorization is made before and after initiation (Phase 1 and 2) for those tasks in which an initiation of a warrant is coded (N=95). Even though in 10.5% of initiated tasks still no warrant is coded, this number decreases significantly after initiation. In addition, it becomes obvious that the proportion of analytic warrants increases after a question on (further) reasoning is posed.

Table 4: Content-related analysis of the tasks with initiation

N=95	No warrant	Not acceptable	Substantial	Analytic
Before initiation	77 (81.0%)	2 (2.1%)	15 (15.8%)	1 (1.1%)
After initiation	10 (10.5%)	7 (7.4%)	42 (44.2%)	36 (37.9%)

Discussion and Conclusion

A comparison of the results with former research findings gives different insights into the arguments of mathematically gifted and interested primary students. On the one hand, the results can confirm

the general conclusion by Schwarzkopf (2000) that arguments have to be initiated at least partly. In two thirds of all tasks including a warrant, the warrant was only mentioned after initiation of the interviewer. Therefore, one can assume that gifted primary students do not seem to have an exceptionally sensible need for reasoning and arguing. Without initiation processes, the research findings by Fetzer (2012) on the lack of a warrant in primary students' arguments seem to be accurate for this sample. Also the independently formulated warrants are mostly substantial what fits the findings by Fetzer (2012). On the other hand, it is nevertheless noticeable that nearly 40% of the analyzed tasks with initiation involve an analytic warrant after an initiation process took place. Further, only in 10.5%, still no warrant is mentioned after initiation. The focus on initiation emphasizes the hypothesis that a large group of the students is able to formulate (analytic) warrants after being forced to. Nevertheless, only the minority of the students formulates (analytic) warrants on an independent level.

With special regard to the research questions, one can formulate the hypothesis that mathematical giftedness might not influence the need for argumentations. Nevertheless, most of the gifted students are able to formulate warrants after initiation, some of them even analytic. Mathematical giftedness therefore might have an impact on the mathematical basis for the formulation of analytic warrants in order to support (creative) detections and findings. So, incomplete arguments without initiation do not seem to be caused by a lack of ability, but by the low significance of arguments' needs or the missing of structural knowledge of arguments. This finding is further supported by the fact that the students were not taught on arguments in advance. Hereby, former studies of mathematically gifted students' intuition (e.g. Käpnick, 2010) might be relevant in order to explain the low need of giving warrants. In the interpretation of these findings, one has to take some limitations of the study into consideration. The interviews were analyzed on a qualitative level without a control group as it was not possible to exclude many different influencing factors (e.g. differences in school, teacher, language skills and mother tongue). Therefore, the comparison was built on former research findings and studies by different researchers, which mostly show consent in the analyzed categories and therefore allow a certain generalization of the findings for different settings. The comparison nevertheless has to be seen under varying task formats and different settings.

We take up the findings as a basis for a longitudinal study on the changes of the arguments of the students in terms of the structure and content, as well as the need for arguments. During this, the focus will be laid on the individual changes in arguments of the children with special regards to their environmental background in terms of language and family. Moreover, the study focuses on the question whether mathematical giftedness as a potential for outstanding mathematical performance can further be a potential for arguments.

Literature

Baker, M. (2003). Computer-mediated argumentative interactions for the co-elaboration of scientific notions. In J. Andriessen, M. Baker & D. Suthers (Eds.), *Arguing to Learn: Confronting Cognitions in Computer-Supported Collaborative Learning environments* (pp. 47-78). Dordrecht: Springer Science+Business Media.

- Bardy, P. (2013). *Mathematisch begabte Grundschul Kinder* [Mathematically gifted primary students]. Berlin, Heidelberg: Springer Spektrum.
- Bezold, A. (2009). *Förderung von Argumentationskompetenzen durch selbstdifferenzierende Lernangebote* [Support of argumentative competences through self-differentiating learning opportunities]. Hamburg: Verlag Dr. Kovac.
- Cramer, J. (2011). Everyday argumentation and knowledge construction in mathematical tasks. Paper presented at CERME 7, Rzeszów. Abstract retrieved from <http://www.mathematik.uni-dortmund.de/~prediger/ERME/CERME7-Proceedings-2011.pdf>
- Fetzer, M. (2012). Wie argumentieren Grundschul Kinder im Mathematikunterricht? [How do primary children argue in mathematics education?]. In M. Kleine & M. Ludwig (Eds.): *Beiträge zum Mathematikunterricht 2012* (pp. 249-252). Münster: WTM.
- Forman, E.A., McCormick, D.E.; Donato, R. (1997). Learning what counts as a mathematical explanation. *Linguistics and Education*, 9(4), 313-339.
- Fritzlar, T. (2011). Zum Beweisbedürfnis im jungen Schulalter [On the need for proof in young school ages]. In: R. Haug & L. Holzäpfel (Eds.) *Beiträge zum Mathematikunterricht 2011* (pp. 279-282) Münster: WTM.
- Goldin, G. A. (2000). A scientific perspective on structured, task-based interviews in mathematical education research. In A. E. Kelly & R. A. Lesh (Eds.), *Handbook of research design in mathematics and science education* (pp. 517-545). Mahwah, New Jersey and London: Lawrence Erlbaum Associates
- Hanna, G. (2000). Proof, explanation and exploration: an overview. *Educational Studies in Mathematics*, 44, 5 - 23.
- Käpnick, F. (1998). *Mathematisch begabte Kinder* [Mathematically gifted children]. Frankfurt: Peter Lang GmbH.
- Käpnick, F. (2010). Intuitionen. Ein häufiges Phänomen beim Problemlösen mathematisch begabter Grundschul Kinder [Intuitions. A common phenomenon in problem solving of mathematically gifted primary children]. In: T. Fritzlar & F. Heinrich (Eds.), *Kompetenzen mathematisch begabter Grundschul Kinder erkunden und fördern* (pp. 77-93). Offenburg: Mildenberg.
- Koleza, E.; Metaxas, N. & Poli, K. (2017, February). Primary and secondary students' argumentation competence: a case study. Paper presented at CERME 10, Dublin. Abstract retrieved from https://keynote.conference-services.net/resources/444/5118/pdf/CERME10_0192.pdf
- Nussbaum, E. M. (2011). Argumentation, Dialogue Theory, and Probability Modeling. Alternative Frameworks for Argumentative Research in Education. *Educational Psychologist*, 46(2), 84-106.
- Schwarzkopf, R. (2000). *Argumentation Processes in Mathematics Classrooms – Social Regularities in Argumentation Processes*. In: GDM (Eds.), *Developments in Mathematics Education in Germany – Selected Papers from the Annual Conference on Didactics of Mathematics*, 139-151.
- Toulmin, S. E. (2003). *The Uses of Argument*. Cambridge, U.K.: Cambridge University Press.

“Using geometry, justify (...)”. Readiness of 14-year-old students to show formal operational thinking

Edyta Juskowiak

Adam Mickiewicz University in Poznań, Poland; edyta@amu.edu.pl

The article contains information about the preliminary results of pilot studies carried out by the author on 127 students aged 14 years in the period 2017-2018. The aim of the research was to check students' readiness to use formal operations while solving mathematical problems, as well as to check the correctness of the tool construction by means of which the author attempted to search for answers to the questions posed.

Keywords: Piaget's theory, Formal operations, Argumentation, Geometry, Geometric reasoning.

Introduction and theoretical framework

The development of mathematical concepts in school students is inseparable from their intellectual development. The order and methodology of their learning by a young person is organized in advance because learners at school work in accordance with curriculum programs planned by the authors of the textbooks which set the basis for development and cognition in each of the school subjects.

Development is a constant struggle with what we know and with new information on the path of adaptation, by balancing two processes of assimilation and accommodation. The first one is adapting new information of external origin to what the person already knows and is acquainted with, the second is adapting his knowledge to new information. Man builds new patterns, his intelligence develops. There is a kind of competition between accommodation and assimilation based on comparison, a process which is an important basis for the development of mental operations. According to Piaget, the child's development depends primarily on itself, on the actions it undertakes, which underlie thinking, or the continuous cognitive process. It consists of intellectual operations, mental operations as an action which is interiorized and, therefore, runs in the mind (Piaget, 1952; Piaget, 1973, 2005a, 2005b).

As claimed by Piaget, this internalization takes place in four separate stages of the development of intelligence, linearly following one after another: sensorimotor stage, preoperative stage, concrete operations and formal operations. Everyone, regardless of their place of residence and the environment in which they grow up, goes through all the above-mentioned stages of development, in which reasoning changes from simple forms, strongly related to perception and performed activities, to forms implemented in the mind, abstract and hypothetical. These are qualitative changes, not quantitative changes, new behaviors are built on previous ones without eliminating the old forms but complementing and correcting them.

Piaget's research shows that not all people, regardless of where they live and what they do, reach the level of formal operations; it is also true that many of us do not use formal operations for many aspects of their lives (Przetacznik-Gierowska&Tyszkowa, 2000).

A person who thinks at the level of formal operations is characterized by:

- abstract thinking, i.e. the ability to logically use symbols in relation to abstract concepts (without the need to link them with reality), hypothetical-deductive reasoning, and the development of thinking about abstract objects,
- metacognition, or the skill of parallel reasoning and its monitoring; it is the ability to constantly reflect on one's own cognitive process,
- the ability to logically and methodically solve problems, in particular those of mathematics.

In summary, the process of changing the way of solving problems, starting from specific-operational thinking and ending with formal-operational thinking, is long and tedious, begins at the age of 12 and lasts until 16-17. The manifestations of these changes are connected with the students using a different method of tackling tasks and problems (not only mathematical ones), adopting a different, new attitude open to hypothetical-deductive thinking. A student who solves a mathematical task becomes open to correct inference based on mathematical facts and theories with detachment from the specifics, is able to put forward hypotheses and tries to verify them, attempts to generalize his judgments. In his statements, he uses phrases such as "maybe" and "if", he is characterized by the ability to think logically and critically, displays the tendency to conduct discussions and disputes and to make inquiries.

The pace of changes in the process of cognitive maturation as well as the final effect of these changes are closely related to the natural and school environment in which the student was matured. The moment, the type and the strength of the stimulus which becomes provocation and motivation for development is important. Geometry is a perfect area for the observation of changes in the cognitive development process of a student. Being one of the oldest disciplines of mathematics, due to which the concept of proof and formal thinking developed, it is the foundation of many activities characteristic for mathematical formal thinking. Freudenthal wrote: "Greek geometry was the first proper embodiment of the idea of mathematics. Although mathematical activity, both in algebra and geometry, began two or three thousand years before Euclid, words such as *theorem*, *assumption*, *proof*, *analysis*, *theory*, *axiom postulate*, *definition*, and concepts that they signify are an invention of Greek mathematics" (Freudenthal, 1966, p. 83).

Today geometry still plays a secondary role in Poland, especially in the process of mathematics education. Its presence is more frequent than in 1964 but is still insufficient in the programs of mathematical studies and studies for teachers and corresponds with merely 120 hours during the whole 5 years of study (<https://cutt.ly/MITprog>). In elementary schools the geometry issues account for 30% of the content of textbooks. It is mentioned in the comments to the current curriculum that: "The second branch of mathematics which supports learner's mathematical development is geometry. Although it was indispensable to limit the teaching content in geometry (due to time constraints) the main its part, namely mathematical proofs, was kept in the elementary school curriculum" (Brodzik & Pruszyńska, n.d.).

Geometry requires many competences: imagination, ability to draw logical and rational inference, to reason, to form hypotheses, and to read the content of mathematical tasks with comprehension, as well as being acquainted with all representations of mathematical language - words, symbols and graphics. There is always a fear that illustrations will overshadow the awareness of rational, logical

and deductive reasoning, based on the consciously used definition of the concept under examination, and not on the perception of its features based on a picture – ready-made or drawn on one's own.

In every mathematical discipline, but here in particular, each of three types of mathematical reasoning can be used when solving a mathematical problem. Full formal-operational reasoning is characteristic only for the formal reasoning, but the formal operations also occur in the intuitive reasoning, and their manifestations - in the empirical reasoning. Krygowska defines these types of reasoning as follows: empirical inference at the level of school education is the formulation of a mathematical hypothesis based on observation and experience in a specific physical space or on inductive tests already in the field of mathematics itself; student's reasoning is treated as intuitive in the field of mathematics if in the course of solving a certain problem he uses, above all, imagination, i.e. images of concepts which he considers, regardless of their formal definitions and carries out brief reasoning based on obvious premises, regardless of their correspondence within the given system; finally, we consider a student's reasoning as formal if in the course of solving the problem he realizes the accepted basis of deduction and tries to consciously derive any subsequent conclusions as precisely as possible from previously made claims and given definitions within a given system; uses definitions and theorems properly (Krygowska, 1977, pp. 441-45).

In his theory of intellectual development, Piaget determined that most students over the age of 12 apply formal operational thinking in a form specific for its early stage. However, research carried out in the 1970s in a sample of 10,000 British 14-year-old children revealed that the overwhelming majority of them, namely 80%, do not reach this stage (Shayer, Küchemann, & Wylam, 1976).

It is necessary to check the present situation and determine the level at which Polish 14-year-old students currently reason, particularly now when we are in the course of implementing curriculum and organizational reforms which aim at strengthening the development of application of reasoning and critical thinking. Professor Edyta Gruszczyk-Kolczyńska, who has been observing children demonstrating exceptional mathematical abilities and those who struggle with difficulties when learning mathematics for many years, writes in her books that one of the possible impediments in creative development of mathematics in case of Polish children can be a delay in developing formal thinking. The author has not come across any research containing discussion on these matters in Poland in recent years (Gruszczyk-Kolczyńska, 1992; Gruszczyk-Kolczyńska, 2012). She undertook to study the manifestations of formal thinking characteristic of Polish students.

Some research and articles in world literature attach crucial importance to the choice of concepts of teaching geometrical terms at every educational level which aim at the activation of reasoning and, later, providing correct and formal justification. Proofs and formal reasoning applied on the grounds of geometry are treated as a tool supporting the assessment of students' knowledge (Swoboda & Vighi, 2016; Koleza, Metaxas, & Poli, 2017; Pericleous & Pratt, 2017; Soldano & Arzarello, 2017; Mączka, 2016). Training in teaching geometry is also emphasized as teachers, applying particular teaching techniques and organizational skills used to create active educational

environment, are responsible for provoking appropriate attitudes of students (Mata-Pereira & Ponte, 2017).

Goals, organization, methodology and tools

The article will present the results of some pilot studies. They were conducted in two rounds: in 2017 on a group of 100 students from one junior high school in Poznań (these studies were part of the research carried out for the diploma thesis of Mrs. Monika Drgas, prepared under the supervision of the author of the article). The second part of the research was carried out in 2018 on a group of 27 pupils at the 7th grade from one primary school in Poznań.

Both pupils from elementary schools and students from junior high schools were surveyed at the same age, being 14 years old, and in the same period of the school year, i.e. in the second part of summer semester. In Poland an educational reform is currently implemented and it influences both the organization of the teaching process and the content of the curriculum. The foregoing 6-grade elementary school was transformed into 8-grade elementary school and existing junior high schools are being phased out. In 2017 14-year-old children were in the first year of junior high schools and, one year later, in the seventh year of elementary schools. The main criterion for the sample groups selection was age, then it was the textbook ensuring knowledge required to tackle the tasks and, obviously, the agreement of school directors, teachers and parents or legal guardians for children's participation in the survey. The research tool in the first round of tests consisted of three tasks, all of them come from a textbook for class 1, Gdańsk Educational Publishing. The goal of each of these tasks was to provoke students' reasoning to check or justify a certain mathematical regularity or fact.

The aim of the study, apart from checking the correctness of the tool's construction in order to develop a proper research tool, was to check the readiness of Polish students at the age of 14 to use formal operations during their mathematical reasoning provoked by geometry tasks requiring students to justify some statements. The tool used in the second stage of the study consisted of 6 tasks, all geometrical ones, two of the tasks from the first stage were used in the second study and one of them will be analyzed in this article. In each of the stages participants had exactly 45 minutes to solve the problems.

Task

Check what is the ratio of the area of shaded figures to the area of the rectangle.



This task checked the ability to carry out a full and correct analysis of the conditions of the task where all data was provided in the figure attached thereto, and then the way of following the instruction through the adopted reasoning and with the use of acquired knowledge. None of the variables needed to carry out the reasoning was given or named. Viewing the figure suggests the same length of certain segments but this fact is not stated in an obvious way (i.e. by using the same color, describing the length with the same variable). Therefore, the task enforces applying the formal operational thinking with reference to known facts, definitions and theorems, dependencies regarding the areas of flat figures, and test it.

As one can see in the task, the use of symbolic language of mathematics as well as of prior knowledge, and applying hypothetical-deductive reasoning, were indispensable to achieve a full, correct and formal solution. But was the formal-operational reasoning applied by the students?

Here there is a proposition (there are obviously more possibilities; they will not be all presented due to article length constraints) of a correct task solution reflecting capabilities of students at the 7th grade (at the age of 14) and containing some manifestations of formal operations, such as logical usage of symbols, deductive reasoning, reflection and usage of abstract objects. This solution has been proposed by a student - future teacher of mathematics.

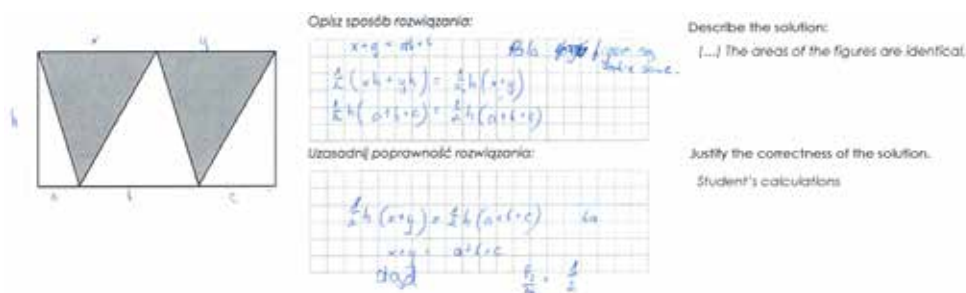


Figure 1: The example of the correct solution

The article presents brief description of the results and more detailed analysis of the selected students' solutions which represent different types of reasoning used by students. Due to the aim of the research, attention will be focused on the description of manifestations of formal operations.

Stage 1

Junior high school students mostly provided correct answers. More than half of the students wrote that the area of the shaded figure is half of the area of the rectangle, but they could not justify it.

Among 100 students participating in the survey, only 12 described the course of their reasoning in the answer sheet; hence only 12 cases were included in the table.

	Feature		
	logically use symbols	reason hypothetically and deductively	think about abstract objects / perceive / perform activities
Number of students	5 - yes 7 - no	4 - no 6 - manifestations 2 - yes	3 - abstraction 9 - perceive
Number of pupils	9 - yes 2 - no	7 - no 4 - manifestations	1 - abstraction 1 - perceive 10 - perform activities

Table 1: Features of formal reasoning - junior high school students and pupils of grade 7

Stage 2

Out of 27 participating in the study, only 11 pupils attempted to solve the task, not every one of them answered the question posed in the task, and those who did it, answered correctly. Most of the pupils did not carry out correct and full reasoning, certainly it was not the formal reasoning, students were not able to use symbolic language, the conclusions were based on intuition - often

infallible but not supported by knowledge - and on specific activities, i.e. measuring the length of segments and indicating certain facts or approximate values.

Analysis of selected student works

Example 1



Figure 2: Student's solution – example 1

The student introduces his own indications corresponding to the areas; however, it is unclear why it is done. The student makes certain assumptions and does not explain this step. In addition, his observations are completely false, do not justify the equality of areas which do not look similar. The student combines a symbolic record with the text, equating them. He puts forward a hypothesis or a thesis on the basis of false premises. He does not attempt to prove the observed regularities and uses phrases - "when combined". In the process of reasoning one can notice some manifestations of formal operations and unsuccessful attempts to use them.

Example 2



Figure 3: Student's solution – example 2

Reasoning fully based on the perception of the figure treated as a specific object to be measured and explored. The student calculated the areas of shaded triangles, calculated the area of the rectangle and subtracted from it the sum of the areas of previously calculated triangles. The calculations do not confirm the fact which was to be proved. There is no reflection or comment, no other attempt to solve the task that could confirm or refute the results.

Exemplar solutions, the correct ones proposed by students and those provided by pupils, are available at https://drive.google.com/drive/folders/1HFo22kdJeG0SnhkwM7eM_IMCIqt9wDrZ. Due to article length constraints they could not have all been included in the paper.

Conclusions

The conclusions presented below are related to manifestations of formal operations in the process of solving the problem selected by two groups of children participating in two stages of pilot studies.

The author refers to the type of reasoning applied by students and to manifestations of formal operations, i.e. logical usage of mathematical symbols, deductions, reflection and the types of actions performed in order to find a solution of the problem.

After the analysis of given responses, it appears that students:

- mostly gave the correct answer,
- sometimes worked out solutions based on formal operations, but nevertheless
- answers in the vast majority were not a result of formal / abstract reasoning,
- answers were due to the perception of certain regularities which students perceived in the figure,
- answers were often a consequence of specific actions performed with the use of a ruler, the segments were measured and although the results were often different, the correct answer was given,
- pupils apparently saw no need to justify their statements,
- students applied faulty reasoning,
- students did not apply the rules of deductive reasoning,
- pupils could not separate their reasoning from the specifics given in the figure,
- pupils' intuition was often infallible but they were not able to give it up and apply formal reasoning.

Summary

The article presents the results of the pilot studies and conclusions drawn on their basis. It describes the readiness of students at the age of 14 to go through the process of solving a selected geometrical problem applying reasoning with the use of formal operations. To make it possible, students must know the properties of the figures as well as be sufficiently mature to conduct theoretical research and reflect upon it. Students should be able to use logical arguments, definitions and statements. Initial conclusions are unambiguous, the vast majority of students are not ready to reason deductively detaching from specifics, imaginary operations and specific activities, although according to Jean Piaget's theory of intellectual development after the age of 12 it should take place in mathematical thinking of students.

The analysis of the material collected during the proper research and an answer to the question whether the hypothesis formulated here will be strengthened or refuted is still ahead of the author. The proper tests were carried out on a sample of 1200 students.

References

- Brodzik, M., & Pruszyńska R. (n.d.). *Podstawa programowa kształcenia ogólnego z komentarzem. Szkoła podstawowa, matematyka* [The core curriculum of general education with a commentary. Primary school, mathematics]. ORE. Retrieved from <https://cutt.ly/PodstProgMat>
- Drgas, M. (2018). *Zadania na dowodzenie – analiza trudności uczniów III etapu edukacyjnego* [Proofs in the Middle School – an Analysis of Difficulties]. Master's thesis.

- Freudenthal, H. (1966). *Rola intuicji geometrycznej we współczesnej matematyce* [The role of geometric intuition in modern mathematics]. *Roczniki Polskiego Towarzystwa Matematycznego. Wiadomości Matematyczne IX*. pp. 83-87.
- Gruszczyk-Kolczyńska, E. (1992). *Dzieci ze specyficznymi trudnościami w uczeniu się matematyki* [Children Specific Difficulties In Learning Mathematics]. Warszawa: WSiP.
- Gruszczyk-Kolczyńska, E. (2012). *O dzieciach matematycznie uzdolnionych* [About Mathematically Gifted Children]. Warszawa: Nowa Era.
- Koleza, E., Metaxas, N., & Poli. K. (2017). *Primary and secondary students' argumentation competence: A case study*. In T. Dooley & G. Gueudet (Eds.), *Proceedings of CERME10* (pp. 179-186). Dublin, Ireland: ERME
- Krygowska, Z. (1977). *Zarys dydaktyki matematyki* [Outline of didactics of mathematics]. (3) Warszawa: Wydawnictwo Szkolne i Pedagogiczne.
- Krygowska, Z. (1986). *Elementy aktywności matematycznej, które powinny odgrywać znaczącą rolę w matematyce dla wszystkich* [Elements of mathematical activity that should play a significant role in mathematics for all]. *Didactics of Mathematics*, (6). Kraków: PWN. pp.25-41.
- Mata-Pereira, J., & Ponte, J. P. (2017). *Principles towards justification: A focus on teacher actions*. In T. Dooley & G. Gueudet (Eds.), *Proceedings of CERME10* (pp. 203-210). Dublin, Ireland: ERME.
- Pericleous, M., & Pratt, D. (2017). *Play and pre-proving in the primary classroom*. In T. Dooley & G. Gueudet (Eds.), *Proceedings of CERME10* (pp. 227-234). Dublin, Ireland: ERME.
- Piaget, J. (1952). *The origins of intelligence in children*. New York: International Universities Press.
- Piaget, J. (1973). *To understand is to invent: the future of education*. New York: Grossman.
- Piaget, J. (2005a). *The psychology of intelligence*. London: Routledge.
- Piaget, J. (2005b). *Language and Thought of the Child: Selected Works* vol 5. London: Routledge.
- Przetacznik-Gierowska, M., & Tyszkowa, M. (2000). *Psychologia rozwoju człowieka* [The Psychology of Human Development], (1). Warszawa: PWN.
- Shayer, M., Küchemann, D.E., & Wylam, H. (1976). *The distribution of Piagetian stages of thinking in British middle and secondary school children*. *British Journal of Educational Psychology*, 46(2), 164-173.
- Soldano, C., & Arzarello, F. (2017). *Learning with the logic of inquiry: game-activities inside Dynamic*. In T. Dooley & G. Gueudet (Eds.), *Proceedings of CERME10* (pp. 267-274). Dublin, Ireland: ERME.
- Swoboda, E., & Vighi p., (2016). *Early Geometrical Thinking in the Environment of Patterns, Mosaics and Isometries*. Hamburg: Springer Open.

On the effect of using different phrasings in proving tasks

Leander Kempen¹, Petra Carina Tebaartz² and Miriam Krieger³

¹University of Paderborn, Germany; kempen@khdm.de

²University of Gießen, Germany; petra.c.tebaartz@math.uni-giessen.de

³Joseph-König-Gymnasium, Haltern am See, Germany; miriamkrieger@ish.de

The research presented in this paper is about the question, if and how the phrasing of a proving task influences students' proof productions. In our study, 381 first-year preservice teachers were asked to work on a proof questionnaire involving two proving tasks, where the phrasings "prove that", "show that", "reason", and "explain" were used alternatively. Students' proof productions were analyzed concerning the kind of reasoning, the use of algebraic variables and the number of words used. While we found statistically significant differences in the proof productions for the easier first task, there were no remarkable differences in the case of the harder second task.

Keywords: Proof, argumentation, socio-mathematical norms, semiotic norms.

Introduction

The learning about proof and proving is considered to be a main hurdle for beginning university students. Several studies have been conducted to describe and to analyze the low proving competences of freshmen (see Gueudet (2008) for a good overview). Despite these results, only little effort has been made to investigate the relationship between research results, the teaching of proving and the proving tasks used in research. Dreyfus (1999) gives a description of several aspects that have to be considered in the teaching of proving. Dreyfus concludes (p. 103):

The examples in Section 2 provide ample room for questioning what is expected by the different formulations used, including 'explain' [...], 'justify' [...], 'prove' [...], and 'show that' [...]. Does 'show that' mean 'formally prove' or 'use an example to demonstrate that' (or something intermediate between these two)? Does 'explain' mean explain to a fellow student or explain in such a way as to convince the teacher that you understand the reasoning behind the claim?

It was this idea of Dreyfus that made us conduct a study on how students' proof constructions vary due to the phrasing of the proving tasks. We chose the four phrasings "prove that", "show that", "reason" and "explain" to investigate possible systematic differences concerning students proof productions. While "prove that" and "show that" are genuine phrasings in proving tasks, "reason" and "explain" are also phrasings that are used in studies to investigate students' proof competencies. In this paper, we will describe our research project and outline the main results of this study.

Theoretical background

There are various phrasings that can be used to formulate a mathematical proving task. In the German school system for example, the concrete phrasings are meant as follows (KMK, 2012; our translation; the added words in quotation marks are the German translation of the former phrasing):

- *to prove* [“beweisen”]: to verify statements mathematically by using known facts and deduction, starting from the assumptions given
- *to show* [“zeigen”]: to verify statements by using valid forms of reasoning, calculations, derivations or logical connections
- *to reason* [“begründen“]: to trace data back to principles or to causal connections by using rules and mathematical relationships
- *to explain* [“erklären”]: to clarify and to make comprehensible data by using personal knowledge and to arrange it reasonably into mathematical relationships

So, there are some definitions or specific requirements combined with these phrasings. Following this differentiation, the mathematical solutions could vary in some detail due to the phrasing used to formulate a mathematical task.

In the mathematical classroom, the meaning of the different phrasing of a mathematical proving task can be considered to be an aspect of sociomathematical norms in the sense of Yackel and Cobb (1996). In the concrete learning contexts, the teacher and the students negotiate what is accepted, when a reasoning, an explanation, or a proof is asked for. Accordingly, the students learn in their daily mathematical class, what they have to do, when dealing with a task starting with “prove”, “show”, “reason”, and “explain”. In this sense, the way students are responding to a specific mathematical (proving) task is a result of a socialization process. This perspective offers the very possibility of existing effects concerning students’ proof productions when using different phrasings in proving tasks and also makes it possible to give an explanation for them.

In line with the theory of sociomathematical norms, semiotic norms have to be considered. The concept of semiotic norms covers the idea that people may develop preferences concerning communicating ideas (e.g. with mathematical symbols, using representations or giving concrete examples) when being confronted with a given and known formulation of a task. Kempen and Biehler (2015) transferred the idea of Dimmel and Herbst (2014) to explain students’ preference of using algebraic variables when being asked “to prove” a mathematical statement. There are some suggestions in the literature that the phrasing of a mathematical task influences students’ solutions. Schupp (1986) discusses the ‘problem of points’ and gives several examples how students’ solutions may vary in reference to a specific phrasing of the task. Knipping et al. (2015) adopt this idea and compare several phrasings of the same task to discuss different solutions obtained in different studies. The authors also consider the influence of sociological factors: students’ solutions in different school contexts (grammar school class and comprehensive or mixed school [“Oberschule”]) differed clearly from each other. Finally, it seems reasonable to link the phrasing of a mathematical task with emotions on students’ side. Hemmi (2006, p. 145) showed that while most of the students felt positive when being asked to solve a task starting with “Show that...”, about 40% of them stated a negative feeling. One might conclude that a negative feeling concerning a given task may lead to the result that a student might not seriously try to answer the task.

Research questions

The theoretical considerations above led us to consider several hypotheses. Students may link different phrasings of proving tasks with different mathematical activities. According to the meaning of the phrasing “show that” in common speech (in German it is “Zeigen Sie”), this phrasing may lead to an answer of a proving task, where a student is justifying a given claim by only testing one or more examples. Whereas this phrasing might lead to an empirical-inductive answer, a phrasing like “reason” is considered to evoke the formulation of arguments (compare research question 1). In line with the idea of semiotic norms, the different phrasings of proving tasks may lead to the use of different notational systems. One might assume that “prove that” may lead to the use of algebraic variables, whereas “explain” might be combined with the use of (verbal) language (compare research questions 2 and 3). For a deeper analysis of the data we also considered social factors (like gender, age, former math courses at school, ...) and also investigated the data concerning the use of word variables, the use of representations, the use of concrete examples, quality of deductive approach and the structure of the proof. But due to the length of this paper, we will only report on the aspects “kind of reasoning”, “use of algebraic variables” and “number of words used”.

We finally came up with the following research questions:

1. In how far do students’ proof attempts vary significantly concerning the kind of reasoning used (empirical-inductive or deductive) with respect to the phrasing of the task?
2. In how far does the occurrence of (algebraic) variables vary significantly with respect to the phrasing of the task?
3. In how far does the number of words students used vary significantly with respect to the phrasing of the task?

Methodology

Following the winter term in October 2015 in Germany, 381 mathematical freshmen, who took part in a degree program leading to different teacher accreditations at the Universities of Gießen, Münster and Paderborn, participated in this study. These students were asked to work voluntarily on an anonymous entrance test. All students were told, that their results would not affect their marks in any ways.

The mathematical statements used in this survey arise from the field of elementary number theory. Both tasks were chosen due to their manageable amount of mathematic operations as well as their contiguousness to topics dealt with in German grammar schools and are as follows: (1) The sum of an odd natural number and its double is always odd and (2) The product of three consecutive natural numbers is always divisible by 6. Each proving task allows for different approaches, e.g. generic or formal solutions. The first statement can easily be proven by making use of generic examples, by using figurate numbers, or by using algebraic variables (see for example Kempen and Biehler (2015)). We felt the need to include a task that is as easy to understand as the first one, but harder to prove, because in the case of the second task, the mere use of algebraic variables and respective computations does not automatically lead to a proof of the statement $(n \cdot (n + 1) \cdot (n + 2) = n^3 + 3n^2 + 2n)$. Here, some additional arguments are necessary to prove the given claim. In this case, a narrative justification seems to be the simplest way of proof. One possible narrative proof for this task might be: If you have three consecutive numbers, one will be a multiple of 3 as every third number is in the

three times table. Furthermore, at least one number will be even and all even numbers are multiples of 2. If you multiply the three consecutive numbers together, the answer must have at least one factor of 3 and one factor of 2. Accordingly, the result will always be divisible by 6 (compare with Healy & Hoyles, 2000). Each statement was introduced with one of the phrasings “Proof”, “Show”, “Justify”, and “Explain”. This allowed for twelve different questionnaire versions in total, as identical operators were excluded. Furthermore, in order to prevent cheating, different colored sheets of paper were assigned to the twelve versions of the questionnaire. Having developed an initial questionnaire, this prototype was piloted in mathematical courses for teacher education at the Justus Liebig University Giessen and the Westphalian Wilhelms-University Münster in May 2015 (N=48). We used the following set of categories to identify the kind of reasoning (see research question 1). Here, the category “empirical-inductive” comprises two aspects. Any mere testing of one or more concrete examples without further arguments or ideas is located in this category. Furthermore, inductive approaches, where the truth of the given statement is asserted on the basis of purely empirical considerations, belong to this category. We combined these two aspects to one category to stress the overall difference to deductive approaches. It has to be mentioned that this distinction of empirical-inductive and deductive reasoning is independent from the correctness respectively the completeness of the argument given; an incorrect deductive argument still counts as deductive.

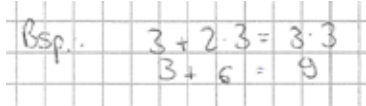
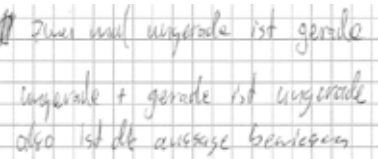
name	explanation	example (taken from students' answers)
empirical-inductive	The answer is just a verification by one or more examples. No more arguments or ideas are mentioned.	 (Example: $3 + 2 \cdot 3 = 3 \cdot 3$ $3 + 6 = 9$)
deductive	The student mentions ideas or further arguments that could be used to prove the statement. Moreover, the mere use of algebraic symbols is considered to be a kind of deductive reasoning.	 (two times odd equals even odd + even equals odd accordingly, the claim is proved)

Table 1: Set of categories to investigate the "kind of reasoning"

Concerning the use of algebraic variables, we applied this code if any algebraic variable had been presented in the answer to a proving task or not. While the use of algebraic variables is measured as a category to code its appearance, we also counted the number of words used in students' proving attempts. In this case, we were not only interested in the appearance of words, because more or less any proof attempt will make use of some words somehow. Accordingly, we had to count the words to investigate a special kind of shift in students' proof attempts leading to more narrative approaches. When counting the number of words used in an answer of the proving tasks, we did not count the words for structuring the proof production (like “example:”, “proof:” or “q.e.d”) or symbols (like “+”

or “...”). Following this categorization, the first example given above in table 1 is considered to be an empirical-deductive answer, with no use of variables and zero words. The second example is a deductive answer without variables containing 14 words.

Results

The following results are based on the answers of 381 first-year preservice teachers at the University of Gießen, Münster and Paderborn. The results concerning the kind of reasoning in accordance to the given phrasings are shown in Figure 1.

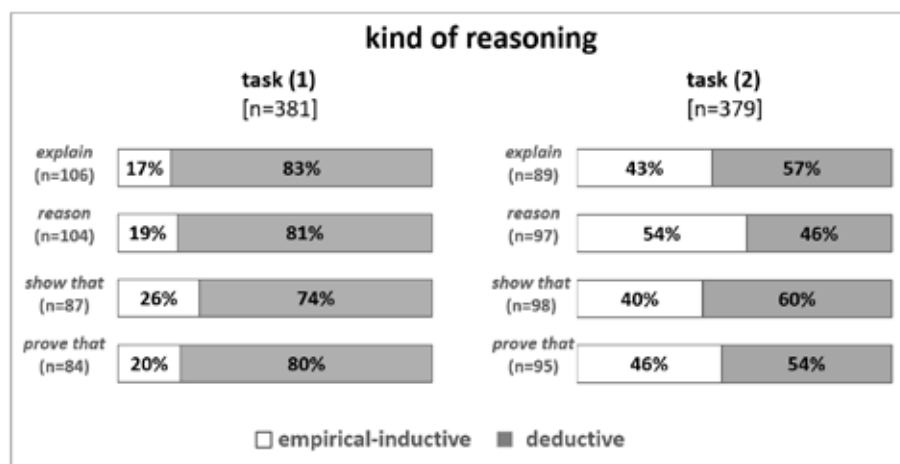


Figure 1: Results concerning the “kind of reasoning”

Concerning proving task (1), the percentage of empirical-inductive answers is the highest for the phrasing “show that” (26%) and the lowest for “explain” (17%). This difference is statistically significant with small effect size [Chi²-test, $p=.021$ with Cramer’s $V=.167$]. In the second task, the results are quite different. Around half of the students give empirical-inductive answers. In this case, there is no statistically significant difference between the kind of reasoning in accordance to the different phrasings of the task. This might be due to the fact that the second task is harder to prove (see above). Accordingly, students might have only given examples because they did not know how to proceed otherwise.

When analyzing the data concerning the use of variables and the number of words used, we only referred to the answers making use of a deductive approach, as the ‘empirical-inductive’ proof attempts will obviously include no variables and contain fewer words. The results concerning the use of algebraic variables with regard to the deductive attempts in accordance to the given phrasings are shown in figure 2. Having a look at the answers to the first proving task, the phrasing “prove that” leads to the highest percentage of the use of algebraic variables (76%), followed by “show that” with 62%. Concerning students’ proof productions for task (1), there are several statistically significant differences considering the use of algebraic variables with small and medium effect size (see table 2). One might assume that something like an implicit semiotic norm would lead to these differences. In task (2), the minor differences concerning the use of algebraic variables in accordance to the given phrasings are not statistically significant (Chi²-test). Here again, the students’ problem in dealing with the second proving task can be considered as an explanation why no differences concerning the use of algebraic variables in accordance to the given phrasings could be observed. However, the results

concerning task (1) hint that a construct like semiotic norms should be considered, because there, the use of algebraic variables differs in accordance to the given phrasings.

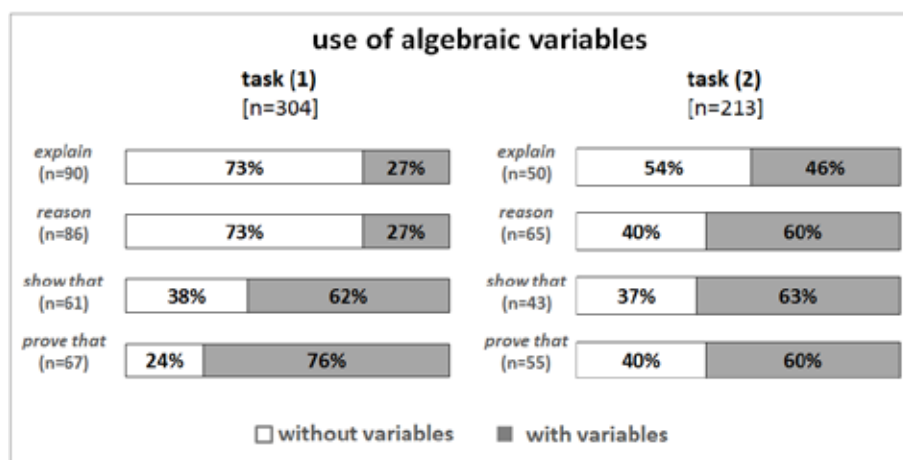


Figure 2: Results concerning the "use of algebraic variables"

	P value (Chi ² -test)	effect size (Cramer's V)
"prove that" vs. "show that"	.021	.158
"prove that" vs. "reason"	<.001	.391
"prove that" vs. "explain"	<.001	.376
"show that" vs. "reason"	<.001	.241
"show that" vs. "explain"	.003	.225

Table 2: Statistical data concerning the differences about the "use of algebraic variables" in accordance to the given phrasings. P value (Chi²-test) and effect size (Cramer's V)

Students used 25.68 words on average to answer task (1) and 18.83 to answer task (2) (see table 3). Having a look at the arithmetic means of number of words used in accordance to the given phrasings in task (1), there are remarkable and statistically significant differences (see table 4). Whereas the phrasings "reason" and "explain" lead to an increased use of words (27.35 respectively 27.52 on average), "prove that" and "show that" lead to a minor use of words (14.83 respectively 13.11 on average). In this case, we consider the phenomenon of an increased use of words due to the phrasing of a proving task as a matter of semiotic norms.

	task (1) [arithmetic mean]	task (2) [arithmetic mean]
"prove that"	17.91	16.46
"show that"	17.11	21.93
"reason"	32.63	17.16
"explain"	31.60	20.91
overall arithmetic mean	25.68	18.83

Table 3: Arithmetic means concerning the number of words used in students proof productions in accordance to the given phrasings

	P value (t-test)	effect size (Cohen's d)
“prove that” vs. “reason”	<.001	1.02
“prove that” vs. “explain”	<.001	.83
“show that” vs. “reason”	<.001	1.05
“show that” vs. “explain”	<.001	.85

Table 4: Statistical data concerning the differences about the “number of words used” in proving task (1) in accordance to the given phrasings. P value (t-test) and effect size (Cohen's d)

Summary and final remarks

The focus of this paper is on if and how the phrasing of a proving task might influence students' proof productions. In the case of the easier proving task (1) about the claim that the sum of an odd number and its double is always odd, remarkable differences could be observed. Here, the phrasing “show that” led to statistically significant more answers consisting only of empirical evidence compared to the phrasing “explain”. While “show that” and “prove that” evoked the use of algebraic variables, “reason” and “explain” led to an increased use of words. While these differences could be observed in the case of the first task, there were no such results in the case of the second task. One explanation might be that the second task (about the divisibility by six of the product of three consecutive natural numbers) was too hard for the students. If the students do not know how to solve a problem in any way, they cannot vary concerning the way they prove the claim. This possible explanation is supported by the fact that much more students only gave empirical-inductive arguments to answer the second proving task (44% vs. 18% in the case of the first task).

Following our theoretical considerations, the differences in students' proof attempts in the context of task (1) can be explained by the framework of sociomathematical norms (in the sense of Yackel and Cobb, 1996). Students had acquired throughout their daily (school) life and their mathematics classes what they are expected to do when being asked “to prove” a statement, “to show” that something is true, “to reason” or “to explain” a given fact. The emergence of respective sociomathematical norms evolves from the (implicit and explicit) discourse taking part in the classroom, where students and teachers negotiate their expectations and requirements. In the case of task (1), the phrasing “show that” led to statistically significant more empirical-inductive approaches than the phrasing “explain”. As a result of sociomathematical norms, semiotic norms can be developed. Students might link a task or the phrasing of a task with the use of certain semiotic resources. In this study, the phrasings “prove that” and “show that” led to an increased use of algebraic variables, whereas “explain that” led to an increased use of words. While we claim, that certain sociomathematical norms have been developed concerning the area of proof and reasoning, we can only guess, which experiences have led to respective phenomena. Here, classmates and (mathematics) teachers will have played a decisive role when negotiating norms. However, other influences from real life might also have affected students' attitude and behavior.

To sum up, the phrasing of a proving task can influence students' proof productions. In this study we could identify differences concerning the kind of reasoning, the use of algebraic variables and the number of words used. This result should be considered in the teaching of proof and in the research in this domain. The teachers at school and at university should be aware of the fact that students seem

to combine different (implicit) norms for phrasings of a proving task when designing tasks for their students. Researcher should consider the fact that the phrasing of a proving task might affect their research results when analyzing the data. But more research has to be done to get deeper into the effects different phrasings may evoke. Beside the formulation of task, also other aspects have to be considered, like social and sociological factors, individual preferences or mathematical thinking styles. These considerations have to be investigated by future research. Finally, as was shown above, the findings of this study seem to be closely related to the two tasks used in this study. More research is needed to confirm or to specify the results obtained in the context of different proving tasks in different domains.

References

- Dimmel, J. K., & Herbst, P. G. (2014). What details do geometry teachers expect in students' proofs? A method for experimentally testing possible classroom norms. In P. Liljedahl, C. Nicol, S. Oesterle & D. Allan (Eds.), *Proceedings of the Joint Meeting of PME 38 and PME-NA 36* (Vol. 2, pp. 393–400). Vancouver, Canada: PME.
- Dreyfus, T. (1999). Why Johnny can't prove. *Educational Studies in Mathematics*, 38(1), 85-109.
- Gueudet, G. (2008). Investigating the secondary–tertiary transition. *Educational Studies in Mathematics*, 67(3), 237–254.
- Healy, L., & Hoyles, C. (2000). A study of proof conceptions in algebra. *Journal for Research in Mathematics Education*, 31(4), 396–428.
- Hemmi, K. (2006). *Approaching proof in a community of mathematical practice*. Unpublished Doctoral Thesis, Stockholm University, Stockholm. Online: <http://www.diva-portal.org/smash/get/diva2:189608/FULLTEXT01.pdf> (07.09.2018).
- Kempen, L., & Biehler, R. (2015). Pre-service teachers' perceptions of generic proofs in elementary number theory. In K. Krainer & N. Vondrová (Eds.), *Proceedings of the 9th Congress of the European Society for Research in Mathematics Education* (pp. 135–141). Prague, Czech Republic.
- KMK (2012). *Operatoren und Beispiele für das Fach Mathematik: Bildungsgang GYMNASIUM*. Online: https://www.kmk.org/fileadmin/Dateien/doc/Bildung/.../270612_Gymnasium.pdf (29.08.2018).
- Knipping, C., Rott, D., & Reid, D. (2016). Disparate arguments in mathematics classrooms. In K. Krainer & N. Vondrová (Eds.), *Proceedings of the 9th Congress of the European Society for Research in Mathematics Education* (pp. 142–148). Prague: CERME.
- Schupp, H. (1986). Zur didaktischen Analyse des Teilungsproblems. *Journal für Mathematik-Didaktik*, 7(2–3), 217-222.
- Yackel, E., & Cobb, P. (1996). Sociomathematical norms, argumentation, and autonomy in mathematics. *Journal for Research in Mathematics Education*, 27(4), 458–477.

Task design for developing students' recognition of the roles of assumptions in mathematical activity

Kotaro Komatsu¹, [Gabriel J. Stylianides](#)² and Andreas J. Stylianides³

¹Shinshu University, Institute of Education, Japan; kkomatsu@shinshu-u.ac.jp

²University of Oxford, Department of Education, UK; gabriel.stylianides@education.ox.ac.uk

³University of Cambridge, Faculty of Education, UK; as899@cam.ac.uk

Mathematics education researchers have highlighted the importance of assumptions in school mathematics given their vital roles in mathematical practice. However, there is scarcity of research aiming at enhancing students' recognition of different roles that assumptions play in mathematical activity. In this paper, we begin to address this issue by formulating two task design principles and reporting on the implementation of a classroom intervention where lower secondary school students in two classes worked, with the same teacher, on a task designed following the proposed principles. Our analysis shows how the task, together with the purposeful teacher's actions in implementing it, led to students' developing appreciation of two roles that assumptions play in mathematical activity.

Keywords: Assumptions, Task design principles, Classroom intervention, Teacher's role.

Introduction

Assumptions refer to statements that doers of mathematics use or accept (often implicitly) and on which their claims are based (Stylianides & Stylianides, 2017). Several researchers in mathematics education have highlighted the importance of helping students be more aware of the roles that assumptions play in mathematics, especially in relation to the notion of *proof*. For example, Fawcett (1938), who treated proof as a key notion in school mathematics, listed four criteria for checking students' understanding of the nature of proof, among which two are closely related to assumptions: students understand “[t]he necessity for assumptions or unproved propositions” and “[t]hat no demonstration proves anything that is not implied by assumptions” (p. 10).

Despite the importance of assumptions in school mathematics, assumptions have received little research and pedagogic attention in school mathematics. Furthermore, existing studies (e.g., Fawcett, 1938; Jahnke & Wambach, 2013; Komatsu, 2017) have mainly focused on geometry at the secondary school level. Research in other mathematical domains is needed that will build on and widen the scope of application of prior research in geometry, given also the recent calls for curriculum reform (see, e.g., NGA & CCSSO, 2010, in the United States) to introduce proof-related mathematical activity across content areas as well as in primary school (e.g., Stylianides, 2016).

To develop students' recognition of the roles of assumptions in mathematical activity, we focus on the design of mathematical tasks, which have potential to affect significantly students' experiences with and understanding of the subject. Specifically, in this paper we propose two principles that can be used to support task design in the area of assumptions, we report on an intervention implemented in two classes where lower secondary school students worked on a task designed following the proposed principles, and we discuss the influence on students' understanding of the roles of assumptions in mathematical activity.

Task design principles for the roles of assumptions

Types of assumptions

Assumptions often refer to statements that are accepted as true without proofs, and their typical examples are axioms like the fifth postulate in Euclidean geometry whose modification led to the formation of non-Euclidean geometries. To expand the opportunity for students to experience the relativity of truth in mathematics, we extend the mainstream notion of assumptions to include two additional types of assumptions, both related to mathematical tasks and their formulation: (1) *conditions* of tasks (including premises of statements mentioned in tasks), and (2) *definitions* of terms mentioned in tasks. This paper reports on an intervention concerning the former type in the context of a function task. We are in the process of designing another intervention addressing the latter type.

Roles of assumptions

Assumptions play multiple roles in the discipline of mathematics. Their primary role has been to introduce the relativity of truth, i.e., whether a proposition is true or false cannot be absolutely determined, but hinges on assumptions (Fawcett, 1938). For example, Euclidean geometry was originally accepted as the standard form of geometry that was deemed to be true in an absolute sense. However, following mathematicians' unsuccessful attempts to deduce the fifth postulate from other postulates, mathematicians created new geometries, the non-Euclidean geometries, by adopting axioms different from the fifth postulate. It was thus recognised that some propositions in Euclidean geometry are true only under the set of Euclidean axioms, and that the conclusions are different under different sets of axioms.

A second role is to mediate disputes that occur concerning the truth of conjectures; mathematicians have managed to resolve such disputes and reach consensus by delving into the assumptions underlying the conjectures. Consider, for example, the conjecture that the limit of any convergent series of continuous functions is itself continuous. According to Lakatos (1976), while Cauchy provided a proof for this conjecture in the 19th century, a counterexample to the conjecture was found in Fourier's work. Mathematicians attempted various explanations for this puzzling situation where the proof for and counterexamples against the conjecture coexisted. Eventually, Seidel analysed Cauchy's proof and discovered a hidden lemma, which once incorporated into the conjecture as a condition (related to the concept of uniform convergence), validated the conjecture.

Learning goals

Considering the importance of promoting authentic mathematical practice in school mathematics (Lampert, 1992), our study aims to help cultivate students' sense of the two roles of assumptions we discussed earlier. Specifically, we set up the following two learning goals for the intervention in our study (similar to the goals discussed in Stylianides & Stylianides, 2017, for prospective teachers):

Learning Goal 1: To recognise that a conclusion is dependent on the assumptions on which the argument that led to it was based.

Learning Goal 2: To recognise that making the underlying assumptions explicit is crucial for reaching a consensus on the conclusion.

Task design principles

Based on our previous studies (Komatsu, 2017; Komatsu & Jones, 2019; Stylianides, 2016, chapter 4; Stylianides & Stylianides, 2017), we formulated the task design principles below in order to address the above learning goals:

Principle 1: Designing tasks that are subject to different legitimate assumptions by leaving purposefully some of the assumptions of tasks implicit or unspecified.

Principle 2: Allowing tasks to have different legitimate answers based on different legitimate assumptions about the tasks.

At the centre of these principles is the deliberate act of keeping some of the assumptions of the tasks implicit or unspecified. The typical way of showing a task to students and promptly clarifying its assumptions eliminates the possibility of multiple interpretations of these assumptions and reinforces the intuitive connection between the clarified assumptions and the expected answer. In our on going research (part of which we report here), we intend to break this norm by creating a situation where an assumption of a task is purposefully unstated by the teacher so that the students can work on the task under their own (implicit and potentially varied) assumptions. We anticipate that the disagreement in the proposed answers likely to emerge in the whole-class discussion will prompt the students to explore the reasons for the inconsistency. This discussion, purposefully orchestrated by the classroom teacher, is expected to help students realise that their answers depend on their respective assumptions and that an explicit assumption is needed to justify each answer.

Method

Task design

Based on the principles stated above, we designed a task shown in Figure 1, which we adapted from a task implemented in the 2016 National Assessment of Academic Ability in Japan (NIEPR, 2016). With respect to Principle 1, the functional relationship between x and y is not specified in the task so that students can work on the task under different assumptions about functional relationships. With respect to Principle 2, the answer to the task is, for example, $y = 6$ if y is inversely proportional to x , and $y = -6$ if y is a linear function of x . Despite the divergence between these answers (as well as an infinite number of other legitimate answers not discussed here), both of them are, or can be, correct as long as the respective functional relationship is assumed.

The table below represents y -values corresponding to the given x -values. Find the y -value when $x = 6$.

x	...	2	3	...	6	...
y	...	18	12

Figure 1: The designed task, which we adapted from a task derived from NIEPR (2016)

Participants

We conducted an intervention study using the task in Figure 1 in two ninth-grade classes (approximately 40 students in each class, aged 14–15 years) in a Japanese lower secondary school

affiliated with a national university. The intervention consisted of one lesson (50 minutes) and was implemented in the two classes by the same teacher who had five years of teaching experience.

We worked together with the teacher in planning the intervention. Specifically, the first author showed to the teacher the task in its original form from the national assessment, and also discussed the intended learning goals and task design principles we presented in the previous section. The teacher then created a lesson plan and discussed it with the first author. Based on the discussion, we decided to use the task as in Figure 1 that was modified from the original form. The teacher then implemented the task following closely the lesson plan as outlined below. The participating students were not introduced to the notion of assumptions before, but they were familiar with the definition of functions and several kinds of functions: proportion ($y = ax$), inverse proportion ($y = a/x$), linear function ($y = ax + b$), a special case of quadratic function ($y = ax^2$), and step function.

Data collection and analysis

The data include the transcripts of the videotaped lessons, the students' worksheets, and the field notes taken by the first author during the lessons. The data analysis aimed to determine whether the learning goals described earlier were achieved in each class. We focused our analysis on the whole-class discussions to examine the learning trajectory of each class as a whole, rather than attempting to trace individual students' thinking. Due to space limitations, results from analysis of students' worksheets are referred to only for triangulation, complementing the results pertaining to the whole-class activity. Because the two classes followed nearly identical paths, we report only the results from one class (38 students) in this paper. All student names are pseudonyms.

Classroom intervention

The relative correctness of answers

The teacher began the lesson by presenting the task in Figure 1; the students individually worked on it for about five minutes. During this work, some students provided the answer $y = 6$, while others the answer $y = -6$. This disagreement surfaced during the subsequent whole-class discussion. Misaki first said, "I think y is 6", but a student objected to her answer, "That's wrong". Aoi then said, "[$y = -6$]", but Shun questioned her answer saying "What?" After that, the teacher posed to the students the pre-planned question of which answer, $y = 6$ or $y = -6$, was actually correct:

- 31 Teacher: Well, now there are two answers. Which is a correct answer?
 32 Students: Both are correct answers.
 33 Teacher: Really? Are both correct answers? Please think everyone. [...] [The students start to discuss with their neighbours.]
 34 Nanami: What? What is the conclusion?
 35 Takumi: I don't know.

As seen in this interaction, an anticipated sense of confusion emerged among students. While some of them considered both answers to be correct (line 32), others had no idea about which the correct answer was (lines 34, 35). To address this confusion, the teacher then asked students to think more about whether both answers were correct and to write their thoughts on their worksheets. The students then shared their thoughts in the whole-class discussion:

- 39 Ren: Um, I think both [answers] are correct. These two. Since we don't know what the function of this graph is, since we can interpret it as both an inverse proportion and a linear function, I think both are correct.
- 40 Teacher: You've described your opinion that both are correct. Well, let's listen to another student. Riko, can you share [your opinion]? What do you think?
- 41 Riko: Um, I also think both are correct. If we change how we read the table, it becomes an inverse proportion and also a linear function.

Ren and Riko's responses (lines 39, 41) are representative of students' responses and are relevant to Learning Goal 1: recognising that a conclusion is dependent on the assumptions on which the respective argument that led to it was based. That is, these students understood that the correctness of their answers was relative to their assumptions, implying that y is 6 if y is inversely proportional to x , and y is -6 if y is a linear function of x . All students in the class agreed that both answers could be correct and most students shared or wrote similar thoughts. For example, Mizuki wrote on her worksheet, "the answer is 6 if we interpret it as an inverse proportion, but -6 if it is a linear function". Similarly, Nanami wrote, "The graph becomes a curve where the y -value becomes 6, and also becomes a line where the y -value becomes -6 , so I think both values are correct depending on how we think about it". These students' responses show that the task has afforded them the opportunity to recognise the connection between different answers and respective assumptions.

Two ways for pinning down the answer

While the students recognised the relativity of their answers, they started to feel dissatisfied with the task they worked on: Nanami said, "That's not good. I don't know what I am solving". The teacher responded to the students' feeling of dissatisfaction by posing two pre-planned questions (written on the blackboard): "(1) What are the reasons for the answer to be ambiguous? (2) What can we do to address the ambiguity?" The students were given approximately ten minutes to tackle these questions, before sharing their thoughts in the whole-class discussion. The students' responses can be divided into two groups, of which Kenta's and Shun's contributions are representative:

- 75 Kenta: Um, um, [regarding question] number 1, [this] is because there is no explanation about whether y is proportional to x or inversely proportional. Um, if there are only points (2, 18) and (3, 12), equations are possible both for $y = 6$ and -6 . Um, if we interpret it as the graph of the inverse proportion of $y = 36/x$, um, we have 6. If we interpret it as the graph of the proportion of $-6x + 30$, we have -6 , I think. Well, [regarding question] number 2, I think, we should add an explanation, like when y is proportional to x or when y is inversely proportional to x . [Kenta misspoke here. He meant linear functions when he talked about proportions.]
- 88 Shun: Um, because there are only two given points, the answer changes depending on whether we connect two points with a line or connect [them] with a curve. [Regarding question] Number 2, I think, if we determine the values of more than two points, the answer will be [uniquely] determined.

According to first group of students (illustrated by Kenta's comment), the reason for the answer to the task to be ambiguous was the absence from the task description a specification of the functional relationship between x and y ; the way this group suggested to address the ambiguity was to clarify the

relationship in the task. According to the second group of students (illustrated by Shun's comment), the ambiguity was because only two pairs of values were given in the task; the way this group suggested to address the ambiguity was to provide in the task more points with given values.

Recognition of the necessity of assumptions

The teacher had anticipated these two kinds of student responses and made a planned move to address them, beginning with the second group's suggestion to increase the number of points with given x - and y -values. He plotted the points (2, 18) and (3, 12) on the coordinate plane on the blackboard and said: "Suppose that in the case of [...] 4, we have 6 [meaning $y = 6$ for $x = 4$]. Is this a linear function? We know three points." Here the teacher selected (4, 6), because the y -value is 6 when $x = 4$, if the function is assumed to be linear.

The alternative possibility of step functions was then proposed by Shota. Shota's suggestion greatly surprised other students, who later began to agree with him and acknowledged that, even if three pairs of x - and y -values were given, the function in the task could not be uniquely determined. Below is the whole-class discussion after Shota drew the graph shown in Figure 2.

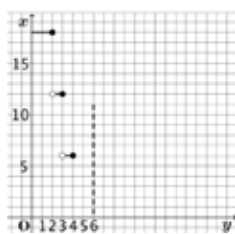


Figure 2: Step function drew by Shota (the dotted vertical line was added later by the teacher)

- 138 Teacher: Well, in this case, what happens? This, this, well, what did you draw?
- 139 Shota: A step function.
- 140 Teacher: Oh, yes, thank you. Is this a linear function?
- 141 Students: No.
- 142 Teacher: Yeah. [...] In the case of 6, this 5, 6, the point in this case... [The teacher added the dotted vertical line in Figure 2, and suggested a question asking the y -value when $x = 6$.]
- 143 Nanami: Anything [would be] okay [meaning that the y -value can be any values].
- 144 Teacher: Can you predict [the value of y]?
- 145 Nanami: Anything [would be] okay.
- 146 Moe: Like quite suddenly [it is] changing.
- 147 Nanami: It could change suddenly, it is changing.

In the above interaction, the students stated that even if another point (4, 6) was added to the table (Figure 1), the function could be a step function rather than linear, and that in this case, the y -value when $x = 6$ could not be uniquely determined (lines 143, 145–147). The class thus realised that increasing the number of points was not a viable option to address the ambiguity in the task. The consideration of step functions motivated the class to seek another way to pin down the answer, returning to the way that was represented earlier by Kenta (line 75), i.e., specifying the functional relationship between x and y in the task. At the end, the teacher summarised the lesson as follows:

- 194 Teacher: Making this clear [meaning to specify the functional relationship] is good. I introduce this [pointing “in the case of a linear function” and “in the case of an inverse proportion” written on the blackboard], this, the one shown at the beginning is, [...] this is called an *assumption, assumption*. So, I believe you see that the answer becomes definite by this assumption.

In this comment, the teacher introduced the term *assumption* and clarified that the conditions, such as “ y is a linear function of x ”, were assumptions one could make based on the task’s phrasing. He also mentioned that making the assumptions explicit was crucial for reaching a consensus answer. This is relevant to Learning Goal 2, which was reached by the class as illustrated by students’ comments at the end of the lesson when they summarised their learning. For example, Takumi said, “If there is no assumption [made explicit], even if we know many points, the graph cannot be fixed into one function’s graph”. Similarly, Yuka said, “If there is no assumption, different functions can be considered. So, when we want to make the answer definite, we write the assumption”.

Discussion

In this paper, we described a classroom intervention involving ninth-grade students with a particular mathematical task (Figure 1), designed based on two principles (Principles 1 and 2). Our analysis showed that the task and its purposeful implementation were useful for stimulating the students to recognise that the correctness of their answers was relative to their respective assumptions (Learning Goal 1), and that it was necessary to make the assumption of the task explicit to reach a consensus answer (Learning Goal 2). Hence, the principles can be regarded as helpful for designing tasks that aim to help students appreciate the roles of assumptions in mathematical activity.

Although in this paper we focused on the role of task design in promoting particular learning goals, the results of our intervention highlight also the important role that the teacher played for achieving these goals. Prior to the intervention, we held meetings with the teacher to discuss the task, the two design principles, and to explain the task’s intended purpose. The teacher well appreciated the learning goals of the task and was able to devise a detailed lesson plan where he anticipated students’ responses to the task and planned some questions strategically, preparing himself to capitalise on these responses during the lesson so as to effectively manage students’ contributions and steer class progression towards the learning goals. The intervention played out in both classrooms as expected, thereby limiting the need for teacher to improvise and make in-the-moment decisions; the lesson naturally progressed towards the learning goals, while the students’ contributions were respected and were integrated into the discussions (Sherin, 2002).

A significant aspect of the teacher’s role was asking probing questions. For example, in response to students’ different answers ($y = 6$ and -6), the teacher asked, “What are the reasons for the answer to be ambiguous? What can we do to address the ambiguity?” These questions triggered students’ interest in exploring ways to obtain a consensus answer, and created an “intellectual need” (Harel, 1998) for the class to be introduced to the notion of assumptions. Another important aspect of the teacher’s role was orchestrating whole-class discussions (Stein, Engle, Smith, & Hughes, 2008). When planning the intervention, the teacher had predicted that some students would come up with responses similar to Kenta’s (line 75) and Shun’s (line 88). When implementing the intervention, the teacher ‘filtered’ and ‘sequenced’ the students’ responses (Sherin, 2002; Stein et al., 2008) so that

Shun's and Kenta's ideas were examined, one at a time, in the whole-class discussion. When the students understood that Shun's idea was not viable, he helped students recognize the advantage of Kenta's idea (line 75) to make explicit the functional relationship in the task.

References

- Fawcett, H. P. (1938). *The nature of proof (1938 Yearbook of the National Council of Teachers of Mathematics)*. New York, NY: Bureau of Publications, Teachers College, Columbia University.
- Harel, G. (1998). Two dual assertions: The first on learning and the second on teaching (or vice versa). *The American Mathematical Monthly*, 105, 497-507.
- Jahnke, H. N., & Wambach, R. (2013). Understanding what a proof is: A classroom-based approach. *ZDM – The International Journal on Mathematics Education*, 45(3), 469–482.
- Komatsu, K. (2017). Fostering empirical examination after proof construction in secondary school geometry. *Educational Studies in Mathematics*, 96(2), 129–144.
- Komatsu, K., & Jones, K. (2019). Task design principles for heuristic refutation in dynamic geometry environments. *Int. Journal of Science and Mathematics Education*, 17(4), 801–824.
- Lakatos, I. (1976). *Proofs and refutations: The logic of mathematical discovery*. Cambridge, England: Cambridge University Press.
- Lampert, M. (1992). Practices and problems in teaching authentic mathematics. In F. K. Oser, A. Dick, & J. L. Patry (Eds.), *Effective and responsible teaching: The new synthesis* (pp. 295–314). San Francisco, CA: Jossey-Bass Publishers.
- National Governors Association Center for Best Practices & Council of Chief State School Officers (NGA & CCSSO). (2010). *Common core state standards for mathematics*. Washington, DC.
- National Institute for Educational Policy Research (NIEPR) (2016). *Reports of National Assessment of Academic Ability in 2016: Lower secondary school mathematics*. Retrieved August 24, 2018, from http://www.nier.go.jp/16chousa/pdf/16kaisetsu_chuu_suugaku.pdf [in Japanese]
- Sherin, M. G. (2002). A balancing act: Developing a discourse community in a mathematics classroom. *Journal of Mathematics Teacher Education*, 5(3), 205–233.
- Stein, M. K., Engle, R. A., Smith, M. S., & Hughes, E. K. (2008). Orchestrating productive mathematical discussions: Five practices for helping teachers move beyond show and tell. *Mathematical Thinking and Learning*, 10(4), 313–340.
- Stylianides, A. J. (2016). *Proving in the elementary mathematics classroom*. Oxford, England: Oxford University Press.
- Stylianides, A. J., & Stylianides, G. J. (2017). Promoting prospective elementary teachers' knowledge about the role of assumptions in mathematical activity. In T. Dooley, & G. Gueudet (Eds.), *Proceedings of CERME10* (pp. 3748–3755). Dublin, Ireland: DCU Institute of Education & ERME.

Primary students' reasoning and argumentation based on statistical data

Jens Krummenauer¹ and Sebastian Kuntze¹

¹Ludwigsburg University of Education, Germany; krummenauer@ph-ludwigsburg.de

Fostering students' competencies of reasoning and argumentation is an overarching goal of the mathematics classroom with relevance also for statistical contents. However, students' argumentation based on statistical data appears to have received less attention so far. In particular primary students' abilities concerning evaluating and generating their own data-based arguments have hardly been investigated. Our analysis of N=167 answers of primary students addresses this need for research and gives insights into students' abilities in generating data-based arguments and students' possible difficulties. The results, therefore, provide an evidence base that can inform subsequent intervention studies.

Keywords: Argumentation, statistics, primary school, scientific reasoning.

Introduction

Statistical data are often used as evidence for decision making in various domains of modern societies so that data plays a key role in decision-related argumentation. It thus can be seen as an important goal for the mathematics classroom to encourage primary students to enter into data-based argumentation. With the term *data-based argumentation* we refer to the process by which students critically evaluate data-related statements, and develop arguments, based on statistical data. In a prior study with N=385 fourth-graders (Krummenauer & Kuntze, 2018) we found that about one-third of the sample was able to develop at least one data-based argument. Consequently, as there is evidence that primary students can be able to develop data-based arguments, our earlier findings opened up the way to investigating now more closely students' abilities and the obstacles students encounter when they develop data-based arguments in different task-related contexts. For this reason, we newly designed a set of tasks adapted to the target group in order to further explore primary students' data-based argumentation. In this paper, we report on our analysis of an exemplary task of our newly developed test. In the following section, we first describe the theoretical background on key aspects of data-based argumentation and requirements students have to deal with when they develop data-based arguments. After having specified the research interest, we will report on sample and methods for a coding that afforded the analysis of students' answers. Finally, we present the results which will be discussed in a concluding section.

Theoretical Background

One of the core aims of argumentation in general is 'to convince others that a statement is true or false' (Stylianides, Bieda, & Morselli, 2016, p. 316). Data-based argumentation can be seen as a specific case of argumentation in which statistical data is used to convince someone that a statement is true or false. In comparison to other argumentation situations such as mathematical proving (e.g. Boero, 1999; Hanna, 2000), data-based argumentation differs in nature, mainly due to the empirical methods used in the data gathering process. Moreover, dealing with phenomena related to statistical

variation (e.g. Watson & Callingham, 2003) leads to specific forms of data-based reasoning and argumentation; even seemingly contradictory statistical interpretations of data can be justified on the base of the same data set. A well-known example for this is the Simpson's paradox (e.g. Blyth, 1972).

However, there are also commonalities of data-based argumentation with generating mathematical proofs. In Toulmin's (2003) approach of analysing arguments, two basic elements of an argument are distinguished: the *datum* and the *conclusion*. The conclusion is a statement that should be substantiated by the argument. The datum is a set of facts which are taken to be true (p. 89–92). So, a core-structure characteristic of arguments is the distinction between available evidence on the one side and the statement that is being supported by the argument on the other side. Inspired by Toulmin's approach, we can structure data-based arguments in a similar way. In data-based arguments, the statement being supported by the argument is often an interpretation of data, or an evaluation of a given statement. The statement then is supported by statistical data, which takes the function of Toulmin's datum. Thus, a consistent connection of a statement with supporting statistical data is the core element of a data-based argument. Additional elements in Toulmin's framework, such as the *warrant* and the *backing*, which can be used to clarify why the conclusion results from the datum, can be assigned to analogous structures of data-based arguments.

These thoughts about the structure of arguments already point to a set of requirements for generating data-based arguments, which can be developed further. As laid out in Krummenauer & Kuntze (2018), requirements of data-based argumentation can be described under a scientific reasoning perspective (e.g. Bullock & Ziegler, 1999; Klahr & Dunbar, 1989; Kuhn, Amsel & O'Loughlin, 1988; Zimmermann, 2007). When students have to generate a data-based argument for evaluating a given statement (as is required in the task in Figure 1, for example), they have to consider the statement as separate from the statistical evidence contained in the available data. According to scientific reasoning, the statement has to be treated as a hypothesis which has to be rejected in case of contradiction with the data. For evaluating the statement on the basis of the statistical evidence the students also have to find out whether the evidence is confirming, contradicting, or irrelevant to the statement (cf. Sodian, Zaitchik & Carey, 1991). In case of relevance, if the data provide evidence contradicting the statement, the statement has to be rejected.

At first sight, these requirements appear as very complex. In particular, it might be expected that younger children lack the necessary skills for mastering such requirements. However, prior empirical research has shown that even primary students already have prerequisites for scientific reasoning and that fostering such skills is possible in primary school (cf. Bullock & Ziegler, 1999; Kuhn, 1989; Sodian et al., 2006; Zimmerman, 2007). On the other hand, these and other studies also show that children often use deficient strategies, such as a positive test strategy, which means that they may seek only for evidence which confirms their prior assumptions. It also has been observed that children tend to accept hypotheses too hastily (e.g. Kuhn et al., 1988; Bullock & Ziegler, 1999; Klahr & Dunbar, 1989) and that they are influenced by their prior views, knowledge and preferences when they evaluate a statement. In contrast, an important strategy for dealing with data-based statements is to challenge them actively by searching for aspects in the data which contradict the statement (Kuntze et al., 2013).

Against the background of such findings it appears as a feasible endeavour to foster primary students in their data-based argumentation, so that the above-mentioned goals can be considered as realistic. Still, the successful development of learning environments requires a fundamentally sound empirical knowledge base about students' abilities and their answering patterns when having to develop data-based arguments.

Research aim

Our analysis consequently addresses this research need. The core aim is to investigate primary students' abilities with respect to data-based argumentation and the obstacles that might prevent them from developing consistent data-based arguments. This leads to the following research questions:

- (1) To what extent do primary students generate consistent data-based arguments?
- (2) Is it possible to assign those answers, which do not fulfil the requirements, to categories which represent different types of answers?

Design and Sample

The analysed task, shown in Figure 1, is part of a newly designed test instrument used in a test with $N=167$ students from southern Germany at the end of the fourth grade (91 female, 76 male; average age $M=10.4$, $SD=0.57$). The task requires to evaluate whether the headline matches the diagram. As a justification is asked ('Justify your answer'), the students have to develop at least one consistent argument based on the data, as these are the only appropriate source of evidence for the required

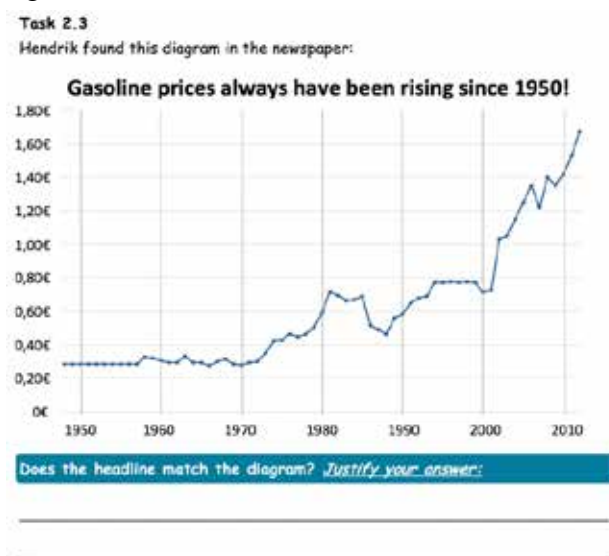


Figure 1: Analysed task (translated)

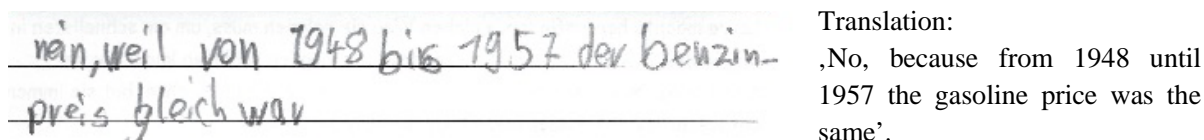
evaluation. The meaning of the word 'justify' was explained in a standardised instruction before the test.

The analysis of the students' answers to the task combines a top-down coding (double coded, inter-rater reliability: $\kappa=.91$), which is derived from a coding we had already successfully applied in a prior study (cf. Krummenauer & Kuntze, 2018), with a bottom-up analysis for exploring possible difficulties of the participants. To answer the first research question, we analysed in a first step whether the students' answers comply with the requirements of the task. Therefore, we analysed the structure of the arguments in the answers with a scheme inspired by Toulmin's (2003) approach. A successful answer was expected to contain, at a minimum, one data-based argument consisting of a conclusion expressing a negative evaluation (e.g. 'no', or 'the headline does not match the diagram') as well as a datum in the form of a consistent reference to aspects of the data which are appropriate to substantiate the conclusion. Additional elements like a warrant or a backing are not required if a consistent connection between the datum and the conclusion can be clearly reconstructed in the context of the task. In a second step, all answers which did not fulfill these requirements were subjected to an interpretive bottom-up analysis to provide answers to the second research question. For developing a set of distinct categories we followed

Mayring's (2015) approach of inductive category formation; again, taking into account the key elements of Toulmin's (2003) approach.

Results

The top-down coding shows that 40% of the participants gave an answer which completely met the requirements of a successful answer described in the prior section. Figure 2 shows an answer from this category:



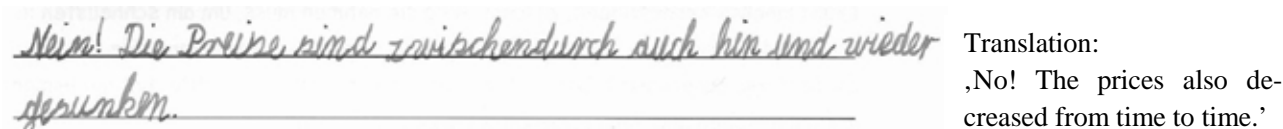
Translation:

„No, because from 1948 until 1957 the gasoline price was the same”.

Figure 2: Example of a successful answer (1)

The answer starts with the statement ‘no’ which is to be taken as a direct response to the question in the task. Following the key elements of Toulmin's terminology, the statement ‘no’ functions as a conclusion and signals that the headline in the task has to be rejected. The second part of the answer (‘from 1948 until 1957 the gasoline price was the same’) contains a statement which refers to aspects of the given diagram. With the conjunction ‘because’ the student connects the conclusion with the reference to the datum and indicates that the reference substantiates the student's conclusion. Therefore, the reference to the data functions as a datum to substantiate the conclusion.

Figure 3 shows another example of an answer rated as successful. It also starts with a conclusion ‘no’ and also gives a reference to the given data set (‘the prices also decreased from time to time’). In spite of the fact that there are no concrete points of data mentioned, in consideration of the given diagram the analysis yields that the student refers to several points of the data set where the trend line decreases. In contrast to the answer in Figure 2, there is no conjunction which links the conclusion with the reference to the data, but the function of the reference as a datum appears as it was asked for a justification in the task.



Translation:

„No! The prices also decreased from time to time.”

Figure 3: Example of a successful answer (2)

In both cases shown above, the reason why the datum substantiates the conclusion remains partly implicit. For example, to understand the argument in Figure 3, the contradiction between the statement (‘gasoline prices *always* have been rising’) and the temporary decline of the prices found in the data has to be considered.

In this context, we would like to note that it is not always necessary to give a warrant or a backing for all connections with data, and that in cases of an evident contradiction between given statement and data the justification required for an argument can be rated as successful. Following Jahnke & Ufer (2015) it is neither helpful nor even possible to refer to all single necessary steps of inference within an argument (cf. p. 332–333). Therefore, the appropriateness of an argument is not only a question of consistency of the argument, but also a question of social convention on what level of justification an argument can be accepted as evident (ibid.). As stated in the previous section, an

argument was rated as successful if it contains at least: 1) a conclusion; 2) a consistent reference to the data; and, 3) if the logical connection of conclusion and datum in the context of the task can be reconstructed.

Besides such answers rated as successful we were able to identify several sub-categories within the answers which did not fulfil the requirements of the task. 5.4% of the sample gave no answer at all; 9.0% were assigned to the category of non-codable answers, which means that the answer was unreadable or the content of the student's answer could not be reconstructed in the context of the task. Further, 9.6% gave an evaluation whether the statement in the headline matches the diagram, but without any justification of their answer; 5.4% gave a context-based answer which means that their answers are based on considerations concerning the context without a reference to the given data. Further, 0.6% developed a mixed data-based and context-based argumentation; 22.8% of the analysed answers were assigned to the category *confirmatory argumentation with selective use of data*. This category includes all answers in which selective aspects of the data are used to generate a confirmatory argument supporting the statement in the headline. In a further 3.6% of the answers, aspects of the data were mentioned in a consistent way, but an inconsistent conclusion is drawn. Another 1.2% of the answers also contained a consistent mentioning of the data, but no clear implication for the evaluation of the statement in the headline is provided. 2.4% of the students' based their argumentation on an inconsistent interpretation of the data set. For example, one of the students who committed this error interpreted the scale on the ordinate axis as the development of the prices. Figure 4 gives an overview of the composition of all analysed answers. In the following we give more detailed insights into examples of students' answers for the most frequent categories developed in the bottom-up analysis.

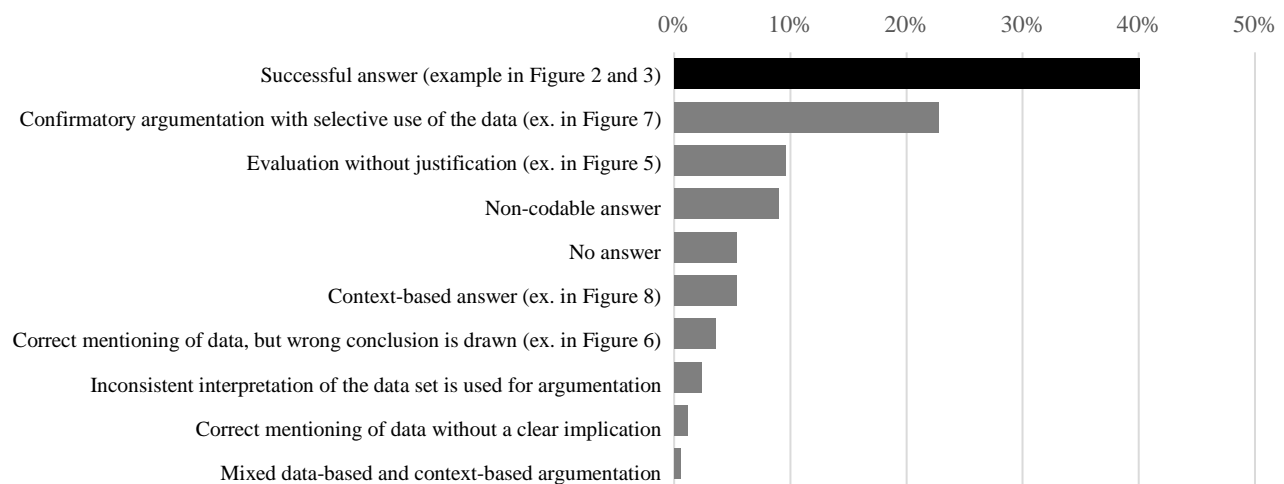


Figure 4: Combined results of the top-down coding and bottom-up coding (N=167)

Figure 5 shows an example of the category 'Evaluation without justification'. In Toulmin's terminology, the answer only contains a conclusion ('Yes the headline is ok') but no other element of an argument. The student does not justify his evaluation of the given headline in any way.

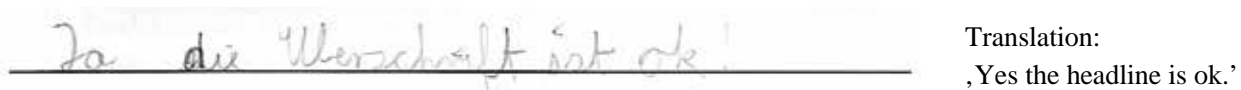


Figure 5: Evaluation of the statement without substantiating by argumentation

Figure 6 shows an example of a category of answers in which correct data is mentioned but a false conclusion regarding the evaluation of the statement is drawn. In the first part of the answer ('sometimes, they went down but they also went up often') a reference to the data is given. The conjunction 'so' indicates that the student draws a conclusion ('the headline is correct') based on the mentioned data. However, this conclusion is not consistent with the given reference to the data as the observation that the prices sometimes 'went down' contradicts the statement that the gasoline prices *always* have been raising. Thus, the criterion of a consistent connection of the data and the evaluation of the statement in the headline is not met.

Manchmal sind sie tiefer gegangen aber auch oft hoch gegangen also ja die über schrift ist richtig

Translation:

,Sometimes, they went down but they also went up often, so yes, the headline is correct.'

Figure 6: Correct mentioning of data, but wrong

Figure 7 shows an answer, in which a student connects her conclusion with particular aspects of the data-set, providing confirming evidence for the conclusion given by the student. How-

ever, the student's analysis of the data remains incomplete, as the word "always" in the given statement shown in the headline implies that all the data in the diagram needs to be considered. This student mentions two values of the data set which support the statement of the headline. The fact that the mentioned data is correct (30ct and 1.70€) suggests that the student was able to read data from the diagram and to understand this data in the context. At the same time, the student appears to neglect other data which would have been necessary to consider in order to generate a consistent argumentation. In this case, the argumentation attempt does not fit to the meaning of the statement presented in the headline ("always"), which makes it inconsistent with what had to be justified. The student might not fully have understood the statement given in the headline. Other possible interpretations are that the student has not searched for counter-evidence in the data but for confirming evidence only or that she might have ignored the counter-evidence as it contradicted her own view.

Ja sie passt weil die Preise sind ja gestiegen von 30ct bis 1,70€

Translation:

,Yes it [the headline] fits because the prices increased from 30ct to 1.70€

Figure 7: Selective use of aspects of data to confirm the statement

An important aspect in (data-based) argumentation is the choice of a source of evidence. Figure 8 shows an example of a category of answers in which the students do not use the given data as evidence but their own considerations about the context. The answer in Figure 8 starts with a conclusion ('yes') which is connected by the word 'because' with a context related statement 'today cars consume more fuel than in the past'. The conjunction 'because' indicates that the statement may be intended to function as a datum. However, the task is designed in such a way that the given data needs to be used as the source of evidence: The task does not require the student to evaluate the statement in the headline in general, but to evaluate whether the statement matches the diagram. Therefore, the given context-related explanation is not an appropriate datum to substantiate the required evaluation. However, the student apparently had the opinion that his context-based explanation is relevant to justify his evaluation. It is to assume that the given conclusion might not refer to the asked question, but to an evaluation of the statement in the headline in general. The given context-based explanation, from a scientific reasoning perspective, also can be seen as a hypothesis which was too hastily accepted.

Translation:

,Yes, because today cars consume more fuel than in the past'

Figure 8: Context-based argumentation

Discussion and Conclusions

The results show that 40% of the sample were able to evaluate a statement by generating a data-based argument. This shows that these students were not only able to apply basic activities such as reading data from a diagram but that they were able to use statistical evidence for evaluating a statement by developing a data-based argument. Against the background that the data of this study were gathered without a preceding intervention, it appears as a feasible endeavour to further foster primary students in their data-based argumentation. For this, the results from the bottom-up analysis provide a starting point to inform prospective interventions for fostering primary students with this concern.

The analysis revealed that about a quarter of the sample used selective aspects of the data to confirm the statement given in the headline despite the fact that there is pertinent counter-evidence against the statement. The answers of these students show that they are principally able to understand the given statement, to read data from the diagram, and to draw the logical conclusion that the aspects of data they quote confirm the statement. The difficulty of these students might be located on a meta-knowledge level: We assume that they did not challenge the given statement actively and did not search for counter-evidence in the given data. Answers containing context-based argumentation and those with an inadequate conclusion drawn on the basis of adequately mentioned data also indicate difficulties which can be explained from the scientific reasoning perspective as described in the theoretical background section. As we found indications for similar answering patterns already in our prior study (Krummenauer & Kuntze, 2018), fostering students' meta-knowledge related to scientific reasoning appears to be a promising approach which will be investigated in an intervention study.

As the participants of our study were tested at the end of year four of primary school, the question arises how their abilities might differ from those of students from lower grades. To this, we already started a follow-up study with a sample of 42 third-graders which solved the same task as the fourth-graders. A first top-down coding of the answers shows that a similar percentage of the sample were able to develop data-based arguments as required in the task. Further in-depth analysis of the students' answers is in progress. Beyond this, an interview study with first graders at the time of their entry in school is in preparation to investigate to what extent students at the beginning of their first year in primary school are already able to develop arguments based on statistical data.

Acknowledgment

This study is supported by research funding from Ludwigsburg University of Education.

References

- Blyth, C. (1972). On Simpson's paradox and the sure-thing principle. *JASA*, 67, 364–366.
- Boero, P. (1999). Argumentation and mathematical proof: A complex, productive, unavoidable relationship in mathematics and mathematics education. *International Newsletter on the Teaching and Learning of Mathematical Proof*, 7/8. Retrieved from <http://www.lettredelapreuve.org>.

- Bullock, M., & Ziegler, A. (1999). Scientific reasoning: Developmental and individual differences. In F. Weinert & W. Schneider (Eds.), *Individual Development from 3 to 12. Findings from the Munich Longitudinal Study* (pp. 38–60). Cambridge: University Press.
- Hanna, G. (2000). Proof, explanation and exploration: An overview. *Educational Studies in Mathematics*, 44, 5–23.
- Jahnke, H. N., & Ufer, S. (2015). Argumentieren und Beweisen. In R. Bruder, L. Hefendehl-Hebeker, B. Schmidt-Thieme & H.-G. Weigand (Eds.), *Handbuch der Mathematikdidaktik* (pp. 331–355). Berlin: Springer.
- Klahr, D., & Dunbar, K. (1989). Developmental differences in scientific discovery process. In D. Klahr & K. Kotovsky (Eds.), *Complex information processing* (pp. 109–143). Hillsdale: Erlbaum.
- Krummenauer, J., & Kuntze, S. (2018). Primary student's data-based argumentation – an empirical reanalysis. In Bergqvist, E., Österholm, M., Granberg, C., & Sumpter, L. (Eds.), *Proceedings of the 42nd Conference of the International Group for the Psychology of Mathematics Education* (Vol. 3) (pp. 251–258). Umeå, Sweden: PME.
- Kuhn, D. (1989): Children and Adults as Intuitive Scientists. *Psychological Review*, 96, 674–689.
- Kuhn, D., Amsel, E., & O'Loughlin, M. (1988). *The development of scientific thinking skills*. San Diego, California: Academic Press.
- Kuntze, S., Aizikovitsh-Udi, E., & Clarke, D. (2013). Strategies for evaluating claims – an aspect that links critical thinking and statistical thinking. In Lindmeier, A. & Heinze, A. (Eds.), *Proceedings of the 37th Conf. of the IGPME* (Vol. 5) (p. 235). Kiel: PME.
- Mayring, P. (2015). *Qualitative Inhaltsanalyse: Grundlagen und Techniken* (12th ed.). Basel: Beltz.
- Sodian, B., Jonen, A., Thoermer, C., & Kircher, E. (2006). Die Natur der Naturwissenschaften verstehen. Implementierung wissenschaftstheoretischen Unterrichts in der Grundschule. In M. Prenzel & L. Allolio-Näcke (Hrsg.), *Untersuchungen zur Bildungsqualität von Schule. Ergebnisse des DFG-Schwerpunktprogramms* (pp. 147–160). Münster: Waxmann.
- Sodian, B., Zaitchik, D., & Carey, S. (1991). Young Children's Differentiation of Hypothetical Beliefs from Evidence. *Child Development*, 62(4), 753–766.
- Stylianides, A. J., Bieada, K. N., & Morselli, F. (2016). Proof and Argumentation in Mathematics Education. In Gutiérrez, A., Leder, G. C., & Boero, P. (Hrsg.), *The Second Handbook of Research on the Psychology of Mathematics Education. The Journey Continues* (p. 315–351). Rotterdam: Sense Publishers.
- Toulmin, S. (2003). *The Use of Argument* (2nd ed.). Cambridge: University Press.
- Watson, J., & Callingham, R. (2003). Statistical literacy: A complex hierarchical construct. *Statistics Education Research Journal*, 2(2), 3–46.
- Zimmerman, C. (2007). The development of scientific thinking skills in elementary and middle school. *Developmental Review*, 27(2), 172–223.

Questions and answers ... but no reasoning!

Dorte Moeskær Larsen¹ and Camilla Hellsten Østergaard²

¹LSUL, University of Southern Denmark; dmla@imada.sdu.dk

²University College Copenhagen, Denmark; choe@kp.dk

Statistical reasoning has often been used synonymously with statistical thinking. In this paper, we focus on the reasoning part and we analyse mathematic lessons about statistics in a primary school class, using a construct from the Anthropological Theory of Didactics approach, called Study and Research Paths. By comparing the a priori tree-diagram of the course with the a posteriori tree-diagram of the observed teaching, it becomes clear that the teacher's questions never make the students engage in statistical reasoning and the students' questions are more concerned with practical and organizational issues than with obtaining a greater understanding of statistical reasoning.

Keywords: Mathematical reasoning, statistical reasoning, study and research path.

Introduction

Teaching reasoning and justification requires more than just asking students to explain their answers or to pose open problems (Ball & Bass, 2003). Teachers' and students' questions and answers are crucial. This paper contributes further insight into teaching reasoning in elementary mathematics classrooms by analysing a teacher and students' questions and answers during a statistics course. We aim to contribute to a more systematic methodology to study what actually takes place in the classroom and to determine if it is possible to do this by looking at the questions and answers of students and teachers during their lessons.

To analyse the students' reasoning processes in the classroom, we will use a tool from the Anthropological Theory of Didactics (ATD), namely, Study and Research Paths (SRP). SRP provides to model mathematical knowledge from a didactical perspective (Chevallard, 2006). The analysis needs detailed information about context, contents, order of questions and answers. In the last decade several studies has focused on the potentials of SRP; Winsløw, Matheron, and Mercier (2013) examine how SRP and a new diagrammatic representations can be used to analyse didactic processes; Barquero, Bosch, and Romo (2015) illustrate how SRP can be used in professional programs for teachers; and (Jessen, 2017) studies how SRP can support the development of knowledge in bidisciplinary settings.

We investigate whether the teacher and the students ask questions and answer questions in a way that allows the students to engage in mathematical reasoning related to statistics; we also reflect on the potentials and limitations we found when using SRP as an analytical tool. More precisely, we ask the following research question: What is the content of the students' and teachers' questions and answers in the "Youngsters and ICTs" intervention, and does it support the students' opportunities to produce statistical reasoning?

Theoretical considerations: mathematical and statistical reasoning

Researchers and educators around the world have advocated that a primary goal of mathematics education for all grades should be the development of mathematical reasoning (Ball & Bass, 2003). Nevertheless, there is no consensus about the definition of mathematical reasoning in the research literature (Jeannotte & Kieran, 2017; Mariotti, Durand-Guerrier, & Stylianides, 2018). Reasoning in statistics can be seen as a particular form of reasoning in mathematics. del Mas (2004) argues that mathematical and statistical reasoning should place similar demands on a student and should display similar characteristics when the students are asked to reason with highly abstract concepts. At first, mathematical and statistical reasoning appear to be similar, but the nature of the tasks in statistics and mathematics are somewhat different. In mathematical reasoning, context may not play a large role, but in the practice of statistics, the inquiry will always be dependent on data and typically grounded within a context (del Mas, 2004). Statistical reasoning is often used to define the same capabilities as statistical thinking, but Ben-Zvi and Garfield (2004) try to separate the two concepts. They define statistical reasoning as “understanding and being able to explain statistical processes and being able to fully interpret statistical results” (p. 7). Statistical thinking, on the other hand, involves an understanding of why and how statistical investigations are conducted, and also when to use appropriate methods of data and analysis. Both statistical thinking and reasoning can be involved when working on the same task, so the two types of activities cannot necessarily be separated. del Mas (2004), however, writes that it is possible to distinguish them through the nature of the task: “For example, a person who knows when and how to apply statistical knowledge and procedures demonstrates statistical thinking. By contrast, a person who can explain, why a conclusion is justified demonstrates statistical reasoning.” (p. 85). Brousseau and Gibel (2005) argue that the teaching of reasoning used to be conceived as a presentation of model proofs, which then had to be faithfully reproduced by the students. Teachers today see reasoning as an activity, which cannot be learned as a simple recitation of a memorized proof; instead, it is necessary to confront students with problems, where they naturally engage in reasoning. If students are presented with model-proofs today, they are meant to serve as a model of others’ reasoning, which students then can use to produce their own original or creative forms of reasoning. However, as Brousseau and Gibel (2005, p. 14) noted, “There is always the risk of reducing problem solving to an application of recipes and algorithms, which eliminates the possibility of actual reasoning”. When it comes to statistical reasoning, most teachers tend to teach concepts and procedures and hope that reasoning will develop as a result (Cobb & McClain, 2004). Cobb and McClain (2004) argue that, in statistical reasoning, students must reason about data rather than attempt to recall procedures for manipulating numerical values.

Study and Research Paths

Study and Research Paths (SRP) is a recent construct in the Anthropological Theory of Didactics (ATD) (Chevallard, 2006). Within ATD SRP were introduced as a design tool for teaching within the paradigm of “Questioning the world” (Chevallard, 2006). The aim is to focus on important and meaningful “big” questions and not just “visit monuments”, meaning a set of rules prescribing, what is to be studied with no place to raise “What for?” or “So What?” questions (Chevallard, 2006).

The fundamental dialectics between questions and answers are at the root of the idea of SRP (Winsløw, 2011). A group or an individual develops knowledge as a result of working with an overall question, Q. Students identify the “official” knowledge that can help them answer Q; the students use this “studying” to justify their answers to Q by engaging in reasoning, which is the “research” about Q. Elaborating on Q generates the “path” (Winsløw et al., 2013). SRP is normally used to design lesson plans but Winsløw et al. (2013) introduce SRP as a modelling tool to analyse didactic processes. Jessen (2014) argues that a tree-diagram of the SRP is a strong tool for analysing didactical processes. We will use a tree-diagram (an example can be seen in figure 1) to make a SRP analysis in an elementary mathematics classroom. Conducting a SRP a priori analysis entails exploring what questions and answers could occur from one particular overall question (the generating question, called Q0). The tree-diagram refers to the possible path the students could follow after generating Q0. The Q0 must be so strong that students can derive new questions, Q_i , from it. The answers to the derived questions add up to an answer to the original question, Q0. The Q0 must be of real interest to the students. This continues with more questions and more answers and

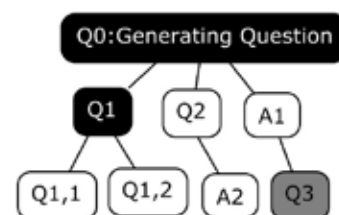


Figure 1: An example of a SRP tree-diagram

could leads to a tree-diagram of pairs of questions and answers (Jessen, 2014). The questions in black are ask by the teachers, and the questions in white are made by the students. The grey-coloured questions are those that are created in collaboration between the teacher and the students. The numbers next to the questions and answers indicate the order of the questions. In the SRP-process the media-milieu dialectics must be taken seriously: the information the teacher brings into the class; the answers available through different books, articles, videos or online resources; and the classroom milieu where the teacher and students manage to establish meaningful actions.

“Youngsters and ICTs”

“Youngsters and ITCs” is a 15-lesson statistics course, which is taught over 3 weeks and intended for grade 6 students; it was designed by C. K. Skott and the second author of this paper, (Skott & Østergaard, 2016)¹. Before teaching the course, the teacher participated in a professional development workshop (6 lessons) that focused on statistical reasoning and digital technologies. The purpose of the course is to improve students’ reasoning in statistics. The course frames and proposes ways that teachers can engage students in statistical investigations; formulate statistical problems; generate, analyse, and reason about data; interpret results; and disseminate them both inside and outside of a school context. The emphasis of the course is to create new habits of classrooms interactions, in which the students raise questions and explore the context with their teacher, who challenges them to come up with new questions and reflect further on possible answers. This approach breaks away from teaching a succession of more or less independent “chapters” where only “small” questions are raised.

¹ The lesson plan (in Danish) is available at:

<http://auuc.demonstrationsskoler.dk/materialer/innovation/forloeb3/faser/hvordan-bruges-statistik-i-hverdagen>.

Methodological approach

We employ a micro ethnographic design; this kind of approach is well-suited for describing, analysing, and interpreting a specific aspect of a group's shared behaviour (Garcez, 1997). We use a case study research design to obtain a thick description of the observed teaching and to understand, how all the questions and answers in the classroom operate together in this context, which is part of a complex system (Stake, 1995).

Within a two-year period, we observed a teacher in 31 classroom lessons; 16 observations from the course and 15 from before or after the course. All the observed lessons were video-recorded. Four audio-recorded semi-structured interviews with the teacher were conducted. The choice of semi-structured interviews was chosen to get a deep understanding of the background of the classroom context. All the interviews were transcribed, and 15 lessons selected from the observations were transcribed.

"Children and young people spend too much time on media ... or?"

"Youngsters and ITCs" was not originally designed as an SRP project. The course was designed by the five design principles by Cobb and McClain (2004) including using technology to support students development of statistical reasoning, establishing norms for students statistical argumentation and the importance of making students explore realistic data - in this case questioning the students media habits, which can be compared with "Questioning the World". The overall question that "Youngsters and ITCs" asks is: "Children and young people spend too much time on media ... or?" (Q0). To answer the overall question, the students must explore the TV patterns and the media habits of each student in their class through a circular working process, which entails collecting data, analysing data, and making conjectures about habits to discuss whether or not the students spend too much time on media. A really important part of the work is to justify how and why the students' conjectures are accurate or true.

The institutional framework for the lessons analysed and presented in this paper is a small elementary school in Denmark. The teacher, Ea, is an experienced mathematics teacher. Her normal teaching is dominated by working with skills framed by a textbook or by iPad exercises. Ea characterizes herself as "a bit old-fashioned. I think it is most important they have skills". When describing dialogs in the classroom, Ea explains, "I fail to tell them anything in twenty minutes ... I do not think they listen when I stand at the blackboard".

In the present article we analyse two lessons (2x45 minutes) of the course (Q3). In this section, the students investigate a set of data that includes 49 students' TV-consumption. They analyse and interpret the data, and make a conclusion, based on that background, about whether the students watch too much TV. The idea is, that the students can use their experiences from the smaller dataset in (Q3), when they work with the authentic and more motivational question Q0. The students are explicitly asked to explain and justify their conclusions.

Presentation of the a priori and a posteriori diagrams

A comparison between the a priori and a posteriori diagrams illustrates (respectively, Figure 2 and Figure 3) how the intended teaching goals and the actual enacted lessons are different:

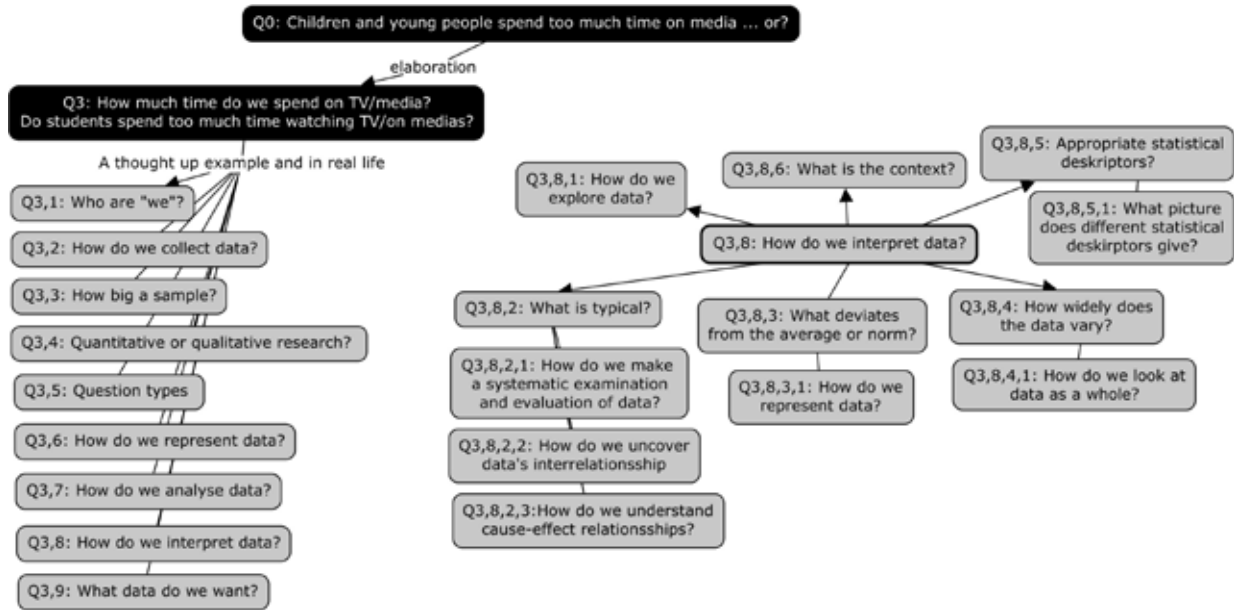


Figure 2: The a priori tree-diagram of the course, Youngsters and ICTs, for Q3

In Figure 2, it is evident that we expect the students to consider and ask many questions in collaboration with the teacher. All the questions from Q3,1 to Q3,9 have extensions like the one shown for Q3,8 to the right. The expectation is that the students' answers will include an explanation of their results and of their choices of models/representations, and that students will use statistical arguments to justify their claims when they generalise about conjectures.

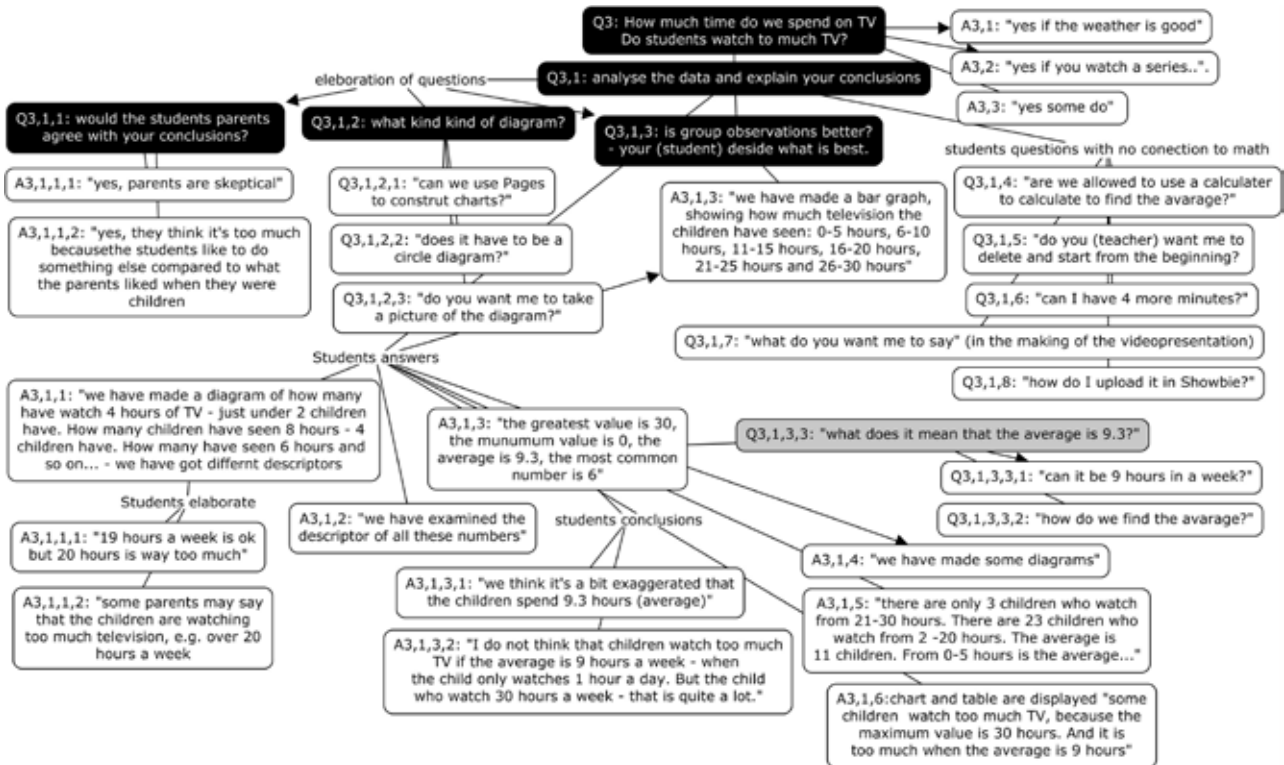


Figure 3: The a posteriori tree-diagram for Q3 in the observed classroom

The posteriori tree-diagram of the observed classroom is constructed by analysing the collected observations from the classroom. Q3 is a question from the teacher Ea, which give rise to three quick answers from the students (A3,1, A3,2, & A3,3) and one new question from Ea (Q3,1). Q3,1 produces six answers (A3,1,1- A3,1,6), and six new questions (Q3,1,1 – Q3,1,8), all with no connection to mathematics. We only see a few questions from the students that focus on specific solutions and procedures (e.g. Q3,1,3,3,1 – Q3,1,3,3,2).

Comparing the a priori tree-diagram with the posteriori tree-diagram

In comparing the two tree-diagrams we do not see any of the expected questions (Q3,1-3,9) from the a priori tree-diagram. Ea does not ask many questions in this lesson, although she does ask a interpretative questions such as Q3,1.1: “Would the students’ parents agree with your conclusions?” The questions Ea asks, do not enable the students to elaborate, explain, or justify their choices. Instead the students answer Ea’s questions with examples from their everyday life and their beliefs about what parents think. In the posteriori tree-diagrams, it also becomes clear that the students ask many questions that are organizational and procedural, including Q3,1,8 (“How do we upload in Showbie?”) and Q3,1,7 (“What do you want me to say [in the presentation]?”). Studying the students’ answers in the posteriori tree-diagram, it is possible to see that there are not any answers that include statistical argumentation like the questions in the a priori tree-diagram Q3,8. Mostly, the students use their own rationale as argumentation: “19 hours a week is ok, but 20 hours is way too much” (A3,1,1,1). However, some answers include calculations of different descriptors, like A3,1,3: “The greatest value is 30, the minimum value is 0, the average is 9,3 and the most common number is 6.”

Discussion

The tree-diagrams reveal a lot of answers that indicate that the students may be unaware of the purpose of the generating question, how to ask questions, and how to answer those questions. The students answer the question, Q3, immediately without any inquiry and without any mathematical argumentations. For example, they say, “yes, [children watch too much TV] if the weather is good” (A3,1), or “yes, [children watch too much TV] if they watch a series” (A3,2). These quick answers could indicate that the students have not understood the premise about “inquiry” that is crucial to this type of investigative work, and the SRP does not contribute to establish a milieu with new norms for working with statistical argumentation. The tree-diagram indicates that the students do not discuss appropriate statistical descriptors. The students simply repeat an approach to analyse data that they have made in earlier lessons by calculating descriptors. Most of the students found the average number of hours spent on media without using any argumentation whatsoever for why it makes sense to calculate the average number of hours or what the average actually says about the dataset. The interpretation of what actually happens in this class may be characterized as ‘model reasoning’ (Brousseau & Gibel, 2005). Overall, the a posteriori tree-diagram does not indicate any joint dialogue in which the students raise questions and explore the context in collaboration with their teacher, who challenges them to create and reflect further on their statistical reasoning. However, we do see that the students apply statistical knowledge and procedures and demonstrate statistical thinking, e.g. when the students draw up charts (A3,1,6), fill tables (A3,1,4), and calculate descriptors (A3,1,3,2). Therefore, this approach can be seen more as “visiting monument” than “questioning the world”

(Chevallard, 2006). To understand the students' development of statistical reasoning, it was rewarding to use SRP as an analytical tool. It helped us to distinguish different strategies for raising and answering questions and to interpret the content in the questions and answers. However, the SRP model has not helped us to clarify the amount of time spent on the different questions and answers and to know if certain areas received a greater focus. The teacher's treatment of students' answers and the possible feedback of students' answers are not visible. Finally, in the model we do not explicit focus on medias and the lack of integrating new medias, and we do not include the teacher's explanations and introductions; e.g. Ea explicitly explained how to make a frequency-table: "So you start counting how many one hours there are in the survey, and then you type the number here...[points at the Excel sheet]." Ea also explicitly explains how to calculate the average: "... to figure out how much the average is in this week per day - you just sum it together and divide it by seven." To make the diagrams, the teacher explains: "Just get Excel to make the diagrams for you by plotting the numbers in the sheet." These instructions can possibly be seen as a basis for 'model reasoning' and are therefore very important for the interpretation of the students' reasoning processes.

The gap between the a priori and the a posteriori tree-diagrams is in many ways not surprising. Ea participated in the 6-lesson professional development workshop and she worked collaboratively with her colleague during this program, but the intended statistical course is very different compared to Ea's normal teaching method and the milieu established in the classroom, which mostly focuses on mathematical skills. It is also important to notice, that the students also experience a very different way of learning mathematics; an approach, which no matter what, stresses some adaptation. The statistical course challenged Ea's view of classroom dialogs and it was difficult for her to establish new practices: "We'll take the arguments afterwards, because we'll first see all the presentations." However, in the end of the lesson Ea did not prioritize to hear the argumentation from the students.

Conclusion

The comparison of the two SRP tree-diagrams displaying the teacher and the students' questions and answers show that the content was focused more on 'model reasoning' and statistical thinking and that the course in many ways did not support the students' opportunities for production of statistical reasoning. The SRP tree-diagram has been found to be a convincing tool for analysing classroom practice. A comparison of the two diagrams provides a rich view of the questions and answers in the classroom, which is closely connected to the students' development of statistical reasoning; however, the use of the model had limitations, in the sense that we did not directly include media aspects as feedback, explanations, and introductions. It could nevertheless be interesting to design a "tree diagram" including not only question and answers, but which also include feedback, explanations and introductions and study if this model in any way gives a deeper understanding. Furthermore, it could be interesting also to focus on the processes and relations between the questions and the answers – to explore why the students respond as they do?

References

- Ball, D. L., & Bass, H. (2003). Making mathematics reasonable in school. In W. G. M. J. Kilpatrick, & D. Schifter (Ed.), *A research companion to principles and standards for school mathematics* (pp. 27-44): Reston, VA: National Council of Teachers of Mathematics.

- Barquero, B., Bosch, M., & Romo, A. (2015). A study and research path on mathematical modelling for teacher education. In K. Krainer & N. Vondrová (Eds.), *Proceedings of the 9th Conference of the European Society for Research in Mathematics Education, CERME 9* (pp. 809-815). Prague.
- Ben-Zvi, D., & Garfield, J. B. (2004). *The challenge of developing statistical literacy, reasoning and thinking*. Dordrecht, The Netherlands: Kluwer Academic Publishers.
- Brousseau, G., & Gibel, P. (2005). Didactical Handling of Students' Reasoning Processes in Problem Solving Situations. In C. Laborde, M.-J. Perrin-Glorian, & A. Sierpiska (Eds.), *Beyond the apparent banality of the mathematics classroom* (pp. 13-58). Boston, MA: Springer US.
- Chevallard, Y. (2006). Steps towards a new epistemology in mathematics education. *Proceedings of the 4th Conference of the European Society for Research in Mathematics Education, CERME 4*, 21-30.
- Cobb, P., & McClain, K. (2004). Principles of instructional design for supporting the development of students' statistical reasoning. In D. Ben-Zvi & J. Garfield (Eds.), *The challenge of developing statistical literacy, reasoning and thinking* (pp. 375-395). Dordrecht, The Netherlands: Kluwer Academic Publishers.
- del Mas, R. C. (2004). A comparison of mathematical and statistical reasoning. In D. Ben-Zvi & J. Garfield (Eds.), *The challenge of developing statistical literacy, reasoning and thinking* (pp. 79-95). Dordrecht, The Netherlands: Kluwer Academic Publishers.
- Garcez, P. M. (1997). Microethnography. In N. H. Hornberger & D. Corson (Eds.), *Encyclopedia of Language and Education: Research Methods in Language and Education* (pp. 187-196). Dordrecht: Springer Netherlands.
- Jeannotte, D., & Kieran, C. (2017). A conceptual model of mathematical reasoning for school mathematics. *Educational Studies in Mathematics*, 96(1), 1-16. doi:10.1007/s10649-017-9761-8
- Jessen, B. E. (2014). How can study and research paths contribute to the teaching of mathematics in an interdisciplinary settings? *Annales De Didactiques Et De Sciences Cognitives*, 19, 199-224.
- Jessen, B. E. (2017). *Study and Research Paths at Upper Secondary Mathematics Education: a Praxeological and Explorative study*. Department of Science Education, Faculty of Science, University of Copenhagen,
- Mariotti, M. A., Durand-Guerrier, V., & Stylianides, G. J. (2018). Argumentation and proof. In T. Dreyfus, M. Artigue, D. Potari, S. Prediger, & K. Ruthven (Eds.), *Developing Research in Mathematics Education: Twenty Years of Communication, Cooperation and Collaboration in Europe* (pp. 97-111). London: Routledge.
- Skott, C. K., & Østergaard, C. H. (2016). How does an ICT-competent mathematics teacher benefit from an ICT-integrative project? *Proceedings of the 40th Conference of the International Group for the Psychology of Mathematics Education*, 211-218.
- Stake, R. E. (1995). *The art of case study research*: Sage.
- Winsløw, C. (2011). Anthropological theory of didactic phenomena: some examples and principles of its use in the study of mathematics education. In M. Bosch, J. Gascón, A. Ruiz, Olarría, M. Artaud, A. Bronner, Y. Chevallard, G. Cirade, C. Ladage, & M. Larguier (Eds.), *Un Panorama de la TAD* (pp. 117-138). Barcelona: Centre de Recerca Matemàtica.
- Winsløw, C., Matheron, Y., & Mercier, A. (2013). Study and research courses as an epistemological model for didactics. *Educational Studies in Mathematics*, 83(2), 267-284.

Factors influencing teachers' decision making on reasoning-and-proving in Hong Kong

Chun Yeung Lee

University of Oxford; chun.lee@education.ox.ac.uk

A project is ongoing to develop an intervention that promotes the teaching and learning of reasoning-and-proving in teacher education in Hong Kong. Since the area of reasoning-and-proving in Hong Kong has not been widely studied, this paper reports the first research cycle of the project: to investigate the potential factors that limited reasoning-and-proving activities in Hong Kong classrooms. In this cycle, seven secondary mathematics teachers were interviewed. The participating teachers' perceptions of reasoning-and-proving, students and learning cultures in Hong Kong were examined, and the results indicate factors that may contribute to the marginal situation of reasoning-and-proving in Hong Kong school mathematics.

Keywords: decision making, Hong Kong, reasoning-and-proving, teachers' perceptions

Introduction

Proof can verify the truth of a mathematical statement and may also promote students' sense making and conceptual understanding in mathematics by providing epistemological justifications (Harel, 2018; Knuth, 2002). Consequently, many mathematics educators suggest that teaching and learning proof and proof-related reasoning activities should spread through school mathematics at different levels and in different content areas. Noting that teachers are the key decision makers of what the students will experience in the classrooms, many studies have been conducted to examine teachers' knowledge and perceptions of proofs (e.g. Knuth, 2002). Yet, reasoning-and-proving (RP, see Stylianides, 2008) tends to have a marginal place in school mathematics. Whilst Western mathematics educators attribute this situation to teachers' counterproductive mathematical knowledge and beliefs about RP, and established mathematical cultures of the schools (e.g. Stylianides, Stylianides, & Shilling-Traina, 2013), studies on factors that influence teachers' decisions around RP activities are scarce in East-Asian countries (e.g. Hong Kong, Singapore, South Korea). The author has begun a project aimed at developing an intervention that promotes teaching and learning RP in teacher education in Hong Kong. Since the area of RP in Hong Kong has not been widely studied, the first research cycle focused on the context, Hong Kong. This paper intends to report the findings of this cycle. This cycle aimed at investigating the factors that limited the teachers' decisions on teaching and learning RP in the situation of Hong Kong classrooms.

The context: Hong Kong

According to the official documents of the Education Bureau, the mathematics education curriculum in Hong Kong aims to develop students' "(a) ability to think critically and creatively, to conceptualise, inquire and reason mathematically, [...]; (b) ability to communicate with others and express their views clearly and logically in mathematical language; [...]" (CDC & HKEAA, 2015, p. 2). Despite the lack of an explicit statement, readers may find some implicit indications of teaching RP among these curricular aims.

Like other East-Asian countries, teachers in Hong Kong are often the primary decision makers of what students would experience in mathematics class through lesson preparation and in-the-moment teaching approaches. Teachers' decisions can be influenced by their perceptions and interpretation of the situation, for example, mathematics and RP, students, and the learning culture (Stylianides et al., 2013). Whilst learning culture in Hong Kong is said to be examination-oriented, which may have influenced decisions on school curriculum and assessments (Brown, Kennedy, Fok, Chan, & Yu, 2009; Choi, Lam, & Wong, 2012), studies have not been widely conducted in Hong Kong to investigate how a teacher's lesson preparation and in-the-moment teaching approaches are influenced by this culture. This study aims at examining the factors limiting or promoting teachers' decisions around teaching and learning RP, with respect to their perceptions of teaching RP, students and the learning culture. As a research cycle of a design-research project, the findings in this study will inform the development of an intervention.

Theoretical backgrounds

To investigate teachers' decision making around teaching, researchers often examined the relationship between teacher's beliefs, knowledge and practice. Conner (2017) examined the differences in argumentation between two U.S. classes, and suggested these differences might be attributed to the teachers' intentions regarding the components of rationality. Kempen and Biehler (2015) investigated 12 pre-service teachers' perceptions of the generic proof, and reported that participants' preference for formal proof over generic proof in a task might be attributed to the situations that they adopted the construction of a formal proof as a norm for solving the task during their time in school, or they (mis)interpreted that construction of a formal proof was asked in the task. These results indicated that teachers' belief constructs could be complex and influenced teachers' teaching practices. However, the process of decision making and transition from teachers' belief constructs to practices were not thoroughly discussed.

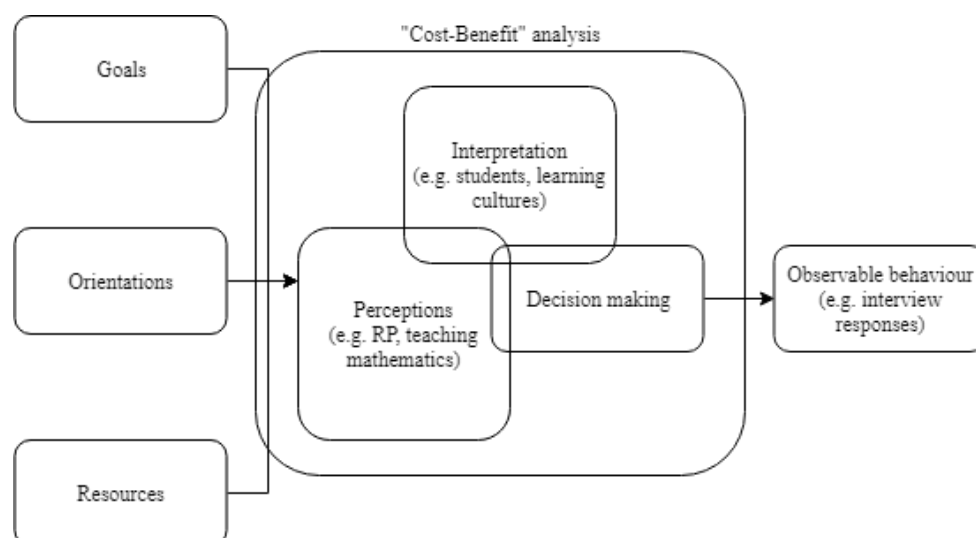


Figure 1: Model of teacher's decision adopted from Blömeke et al (2012) and Schoenfeld (2011)

Blömeke, Gustafsson, and Shavelson (2012) and Schoenfeld (2011) attempted to model teachers' decision making. In the model of Blömeke et al. (2012), when teachers' perceptions are affected by their belief and knowledge constructs, their interpretation of the context may mediate between their

perceptions and decision making (and practices). Schoenfeld (2011) further elaborated the process of transition and decision making using the conceptualisation of goals, orientations and resources; he defines resources (with a focus on knowledge) as “the set of intellectual, material, and contextual [information] available to the teacher” (p. 10) and orientations as “an inclusive term encompassing a group of related terms such as *dispositions, beliefs, values, tastes, and preferences*” (p. 29, italics added). I adopted the models of Blömeke et al. (2012) and Schoenfeld (2011): if teaching RP is a routine practice of a teacher, the teacher will continue this routine practice; otherwise, if teaching RP is an unfamiliar practice of the teacher, the teacher will perform a *cost–benefit* analysis on different options using the variables (perceptions and interpretation), and the decision will be based upon the outcomes of the *calculation of expected values* on the options. Figure 1 depicts a model of a teacher’s decision adopted from Blömeke et al. (2012) and Schoenfeld (2011).

Methods

Seven secondary mathematics teachers participated in this study. These teachers were selected because: (a) they obtained related undergraduate degrees and gained their teacher qualification through postgraduate teacher training programmes; (b) they have been serving local schools differed on locations, school cultures and students’ academic achievements: in Hong Kong, secondary public/government-aided schools and students are divided into three school bands regarding their academic achievement. One participant was serving high-achieving schools, two in mid-achieving schools, two in low-achieving schools, and two were serving private schools that do not belong to any school band; (c) they had worked at schools for at least three years; and (d) they had served at least two schools. Their diverse backgrounds resulted in responses that covered a range of concerns of teachers when considering teaching and learning RP in the situation of Hong Kong classrooms.

The teachers participated in task-based interviews. The tasks and questionnaire items were adopted from the studies of Almeida (2000), Keceli-Bozdog, Ugurel and Bukova-Guzel (2014), Kotelawala (2007), and Yoo (2008) to capture teacher’s knowledge, attitudes and beliefs about RP and their instructional practices. Table 1 lists some sample items. Each interview lasted about an hour, and was conducted and audio-recorded in Cantonese, the teachers’ mother tongue to enable them to express their opinions easily and effectively. The teachers were asked to complete the questionnaire and tasks using think-aloud strategy and then respond to follow-up queries.


Origins of the items	Sample items
Almeida, 2000	<p>Decide which ‘proofs’ you find (a) convincing, (b) not convincing, or (c) incorrect.</p> <p>Proposition: $(1 + 1/2 + 1/2^2 + 1/2^3 + \dots + 1/2^n) \rightarrow 2$ as $n \rightarrow \infty$.</p> <p>Assumptions/assertions that may be used in the proofs: A1. If $a < 1$, then $an \rightarrow 0$ as $n \rightarrow \infty$.</p> <p>‘Proof’ 1 Let $S_n = 1 + 1/2 + 1/2^2 + 1/2^3 + \dots + 1/2^n$. S_5 can be represented in the figure as a portion of 2 squares. S_5 is 2 less a remainder R_5 as shown: Clearly, the figure shows that R_5 becomes smaller as n increases. That is, $R_n \rightarrow 0$ as $n \rightarrow \infty$. It now follows that $S_n \rightarrow 2$ as $n \rightarrow \infty$. This proves the proposition.</p> 

Table 1: Sample items of the tasks

	<p>'Proof' 2 Let $S = 1 + 1/2 + 1/2^2 + 1/2^3 + \dots + 1/2^n + \dots$ (1) Multiplying both sides of the equation above by $1/2$ gives $S/2 = 1/2 + 1/2^2 + 1/2^3 + \dots + 1/2^n + \dots$ (2) Subtracting equation (2) from (1) gives: $S/2 = 1 \rightarrow S = 2$. This proves the proposition.</p>					
Keceli-Bozdag et al., 2014	I think that theorems and proofs are the foundations of mathematics.					
	Strongly agree	Agree	Neutral	Disagree	Strongly disagree	
Kotelawala, 2007	Please divide 100 units of time among the following activities, consider a typical junior secondary mathematics class (12–15 years old) that you teach.					
	Items				Units of time	
	1. Receiving instructions from teacher on how to solve a problem					
	2. Practising calculations for recall, accuracy, and/or speed					
	3. Student solving problems using steps from the day's lesson or the weeks lessons					
	4. Students formulating conjectures					
	5. Student explaining to group why their answers or steps make sense					
	6. Students working on their own methods for solving unfamiliar problems					
Yoo, 2008	Ideally in a proof-based mathematics lesson, students should (a) make conjectures, investigate them, and construct their own proofs, or (b) practise proving statements or conjectures that they know have been proven to be true before by an expert.					
	(a)	towards (a)	both	towards (b)	(b)	neither
	1	2	3	4	5	6

Table 1(con't): Sample items of the tasks

The audio-recorded data were transcribed into written Chinese. The transcripts were then analysed using the model of the teacher's decision (Figure 1) regarding two themes: (a) teachers' perceptions of RP and teaching and (b) their interpretation of the contexts. Based on the teachers' responses, their interpretations of the contexts were further divided into (i) interpretation of students as learners and (ii) interpretation of learning cultures. To report the findings, selected excerpts were further translated into English using word-to-word strategy (that is, English grammatical rules are not strictly followed) assisted with appropriate interpretation.

Results

Perceptions of RP and teaching

All participants related proofs to logical reasoning and its promotion. For example, when asked which items of learning activities are related to proof, Participant 2 stated, "if the activities enable to develop [students'] logical reasoning, I think the options are [formulating conjecture], [explaining why answers or steps make sense] and [working on one's own methods for solving unfamiliar problem]." He also added that making a conjecture may be a precursor of a proof.

Participant 2: Like Pythagoras' theorem, he (the prover) makes a conjecture. If he did not have a conjecture, he would not have tried to prove [it]. Therefore, [we] must first have conjectures.

Participant 4 perceived that, through teaching and learning proofs, students may be provided with epistemological justification of a mathematical statement for promoting conceptual understanding in

mathematical facts and ideas. When discussing ‘proofs’ of “square root of 6 is an irrational number”, Participant 4 expressed his intention and motivation of teaching the proof: to foster students’ conceptual understanding of irrationality of a number:

Participant 4: ... because learning a proof like this means to understand what “irrational” [an irrational number] is... because something is true... like this then [we] can dig out the meaning of “irrational”. Therefore, I will teach [the proof].

The realisation of educational values of proofs may *initiate* teachers’ motivation, like Participant 4, of teaching RP: the teachers initiated the process of *benefit–cost* analysis on teaching RP, but their interpretation of students and learning cultures may mediate between their perceptions, and decisions.

Interpretation of students as learners

Most participants perceived that their students were not capable of nor interested in learning any proof of a mathematical proposition in general.

Participant 1: ... because [in] my school, not many people “accept” (prefer) proofs. They often [prefer], for example Pythagoras’ theorem... it is enough for them to use [the theorem]. Yes, they barely care or think about how this formula was derived. Since they do not want to know, I am not urged to explain. Also, their capability is weak; it will be a trouble if I finish explaining [it] but they still do not understand. Therefore, proofs are relatively limited.

Participant 7: ... Let me say it this way, in my views, [the] ideal [RP lessons] should train (develop) their (students’) that (RP-related) reasoning. Training their logical [reasoning] But in actual lessons, this [training], however, was not emphasised... I think students’ attitudes [towards learning mathematics] are important. In fact, many students are not... enthusiastic [over learning mathematics]. So, I think [if I] keep on asking them (students) to make a conjecture, in fact they are not really making any conjecture. Yes... but if ideally they really can... that is, [if] I ask them to do... use [their] brains to think (make a conjecture)..., then they think. Then, I think [this] is fine. But, in real life, then... in fact, perhaps, not the whole class [would] do (make a conjecture). [I] sometimes, perhaps, find some smarties, and then ask them to do this conjecturing. Therefore, the proportion [of making conjectures] would be far less... in the real life (my actual teaching practices).

To facilitate some RP activities in classroom, the teachers tended to select proofs that they found easy to understand, but there were no systematic selection criteria; instead, the teachers selected a proof by their feelings of its length and complexity.

Participant 5: [I prefer proofs that are] easy to “see”. [The students] all can “see”; that is, easy to explain and understand.

Participant 1: [I choose to teach proofs which are] simple and easy to follow. [Interviewer: What do you mean by simple and easy to follow?] This depends on [my] feelings... This is sometimes my feelings... If, if I am a teacher and have a judgement, if I see this [proof] and I think this can be understood by the majority, from my gut feeling...

Of course, I have to know the characters of my class, then I will evaluate if they can understand what I say... evaluate if they will “accept” (be convinced by and/or understand) this proof. If, after I complete the evaluation, I think [it is] worth saying (teaching) [it], then I will try to say (teach) [it]. If, after evaluation, I think [it is] not worth saying (teaching) [it], then I won't.

Whilst teachers' realisation of the educational values of teaching RP (perceptions) may promote their use of RP when teaching (decisions), the participants demonstrated how teachers' counterproductive interpretation of students' learning capabilities and attitudes may mediate between their perceptions and practices of teaching RP. Participant 1 demonstrated that his counterproductive interpretation interacted with his perception of what students needed to learn/master and teacher-centred disposition. The choice of a “simple and easy” proof (decision) may refer to his interpretation that (a) the length and complexity of the selected proof were aligned with students' capabilities, and/or (b) the main purpose of the selected proof was to convince students of the truth of a proposition with less effort. Participant 7 demonstrated that he developed a positive perception of teaching RP and an ideal practice, but his counterproductive interpretation contributed to investing less in involving students in RP activities (e.g. making a conjecture). As a result, teaching RP was limited in their classes.

Interpretation of learning cultures

Apart from their interpretation of students, teachers' interpretation of the learning cultures where they are situated may also mediate between their perceptions of RP and teaching, and decision making. Like other East-Asian countries, examination-oriented culture is well established in Hong Kong (Brown et al., 2009; Choi et al., 2012). The participating teachers' responses revealed that this examination-oriented culture greatly influenced their decisions on teaching RP and mathematics.

Participant 4: [My lessons tend to be] exam-oriented! Even if I do not want to be like this, students' expectation and parents' expectation are like this... because [we] have examination; [so, we] have drilling exercises... The tasks in examination are not proof-related, so [we] cannot spend much time [on proofs]. If [students] can understand, then understand; if not, then keep on drilling, or solve problems...

Participant 4's responses suggested a connection between his interpretation of students' expectation (attitudes) and that of the examination-oriented learning culture. Participant 7 added that the examination-oriented culture has also contributed to the discrepancy between his ideal RP lesson (perceptions of RP and teaching) and his actual implementation.

Participant 7: ... But [the actual lessons focused] more on whether they could “do the maths” (solve the problem tasks), which is more about examination. Of course, I am not completely saying [that my lessons are] examination-oriented; my lessons are really not so examination-oriented. However, [my lessons] in fact tend more to be the side of calculation. Yes, therefore, when having the term “ideally” here, my... my [ideal] practice will be a bit different [from the actual practice].

The participating teachers perceived that preparing students for public examinations is a main role of being a teacher in Hong Kong (a goal); they also held an interpretation that the public examination in

Hong Kong was calculation-oriented. Any decision that may strengthen students' accurate calculation and problem-solving skills was prioritised over the teachers' ideal practices if the decision and the ideal practices were different. For example, Participant 4 perceived that the examination-oriented culture was deeply rooted in his teaching environments, and, as a result, students expected mathematics class to be oriented towards examination preparation. He prioritised the goal of preparing his students for examination highly over the goal of fostering students' conceptual understanding of mathematics. Since teaching RP was not his routine practice, according to Schoenfeld's (2011) model, a "cost-benefit" calculation was performed by Participant 4. His cost of practising RP in his mathematics class outweighed the benefits that he perceived when teaching RP. Therefore, he found it difficult to practise any RP activity in his mathematics class. Therefore, they invested more in involving students in calculation and problem-solving activities, rather than RP.

Discussion

This study examined the three *interrelated* factors that may influence Hong Kong secondary mathematics teachers' decisions around RP: teacher's perceptions of teaching RP, interpretation of their students as learners, and interpretation of the learning cultures. Whilst the teachers' productive perceptions of teaching RP, for example, recognising that teaching proofs may foster students' conceptual understanding of mathematical ideas and logical reasoning, may promote and develop their ideal practices, their counterproductive interpretation of students' learning needs: in particular, they did not think proofs are needed or suitable for all students (cf. Frasier & Panasuk, 2013; Varghese, 2009), and the learning cultures (examination-oriented culture) may interact with each other and mediate between their perceptions (of students' learning needs) and actual practices.

The teachers perceived examination-oriented culture to be a main factor that limited their decisions on teaching RP; this culture influenced the teachers' interpretation of students' attitudes and their learning needs. Examination-oriented culture is deeply embedded in Hong Kong school mathematics and teachers' interpretation, and the public examination in Hong Kong is interpreted as calculation-oriented. As a result, the teachers deviated from researchers' expectation of making RP spread through school mathematics, and prioritised calculation-oriented teaching materials over RP. If teachers avoid RP in their teaching because they perceive that proofs are less important and/or not suitable for all students in understanding mathematics and preparing for examination, professional development should address teachers' interpretation of students' learning needs and the social contexts (school and learning cultures) and be focused on fostering teachers' reflection on their teaching philosophy and broadening their horizons for learning other trends and visions. Educational reforms including frameworks of public examination and teacher education may also be considered when RP activities should be central of mathematics education in Hong Kong, and worldwide.

References

- Almeida, D. (2000). A survey of mathematics undergraduates' interaction with proof: Some implications for mathematics education. *International Journal of Mathematical Education in Science and Technology*, 31(6), 869–890.
- Blömeke, S., Gustafsson, J.-E., & Shavelson, R. J. (2015a). Beyond dichotomies: Competence viewed as a continuum. *Zeitschrift für Psychologie*, 223(1), 3–13.

- Brown, G. T. L., Kennedy, K. J., Fok, P. K., Chan, J. K. S., & Yu, W. M. (2009). Assessment for student improvement: understanding Hong Kong teachers' conceptions and practices of assessment. *Assessment in Education: Principles, Policy & Practice*, 16(3), 347–363.
- CDC, & HKEAA. (2015). *Mathematics: Curriculum and assessment guide (Secondary 4 – 6)*. Hong Kong: Curriculum Development Council and The Hong Kong Examination and Assessment Authority.
- Choi, K.-H., Lam, C.-C., & Wong, N.-Y. (2012). The process and factors shaping the New Senior Secondary Mathematics Curriculum decision making in Hong Kong. *Educational Research Journal*, 27(1&2), 97–128.
- Conner, A. (2017). An application of Habermas' rationality to the teacher's actions: Analysis of argumentation in two classrooms. In T. Dooley, & G. Gueudet (Eds.), *Proceedings of CERME10* (pp. 123–130). Dublin, Ireland: DCU Institute of Education & ERME.
- Frasier, B. J., & Panasuk, R. (2013). Proofs in Mathematics Education: Expectations and Reality. *Journal of Curriculum and Teaching*, 2(2), 76–85.
- Harel, G. (2018). Types of epistemological justifications, with particular reference to complex numbers. In A. J. Stylianides & G. Harel (Eds.), *Advances in mathematics education research on proof and proving: An international perspective* (pp.35–48). Cram: Springer.
- Keceli-Bozdog, S., Ugurel, I., & Bukova-Guzel, E. (2014). Development of attitude scale towards proof and proving: The case of mathematics student teachers. *K. U. Kastamonu Egitim Dergisi*, 23(4), 1581–1596.
- Kempen, L., & Biehler, R. (2015). Pre-service teachers' perceptions of generic proofs in elementary number theory. In K. Krainer & N. Vondrová (Eds.), *Proceedings of CERME 9* (pp. 142–148). Prague, Czech Republic: Charles University in Prague, Faculty of Education and ERME.
- Knuth, E. J. (2002). Secondary school mathematics teachers' conceptions of proof. *Journal for Research in Mathematics Education*, 33(5), 379–405.
- Kotelawala, U. M. (2007). *Exploring teachers' attitudes and beliefs about proving in the mathematics classroom*. (Unpublished dissertation). Columbia University.
- Schoenfeld, A. H. (2011). *How we think: A theory of goal-oriented decision making and its educational applications*. New York: Routledge.
- Stylianides, G. J. (2008). An analytic framework of reasoning and proving. *For the Learning of Mathematics*, 28, 9–16.
- Stylianides, G. J., Stylianides, A. J., & Shilling-Traina, L. (2013). Prospective teachers' challenges in teaching reasoning-and-proving. *International Journal of Science and Mathematics Education*, 11(6), 1463–1490.
- Varghese, T. (2009). Secondary-level student teachers' conceptions of mathematical proof. Issues in *The Undergraduate Mathematics Preparation of School Teachers*, 1, 1–14.
- Yoo, S. (2008). *Effects of traditional and problem-based instruction on conceptions of proof and pedagogy in undergraduates and prospective mathematics teachers*. (Unpublished dissertation). The University of Texas at Austin.

On teachers' experiences with argumentation and proving activities in lower secondary mathematics classrooms

Silke Lekaas

Western Norway University of Applied Sciences, Bergen, Norway; slek@hvl.no

This article presents an analysis of reports about developmental work written by 23 lower-secondary school teachers from Norway who planned, implemented and reflected upon a lesson involving elements of exploration, argumentation, and proving. An analysis of the tasks that the teachers designed for their students and the scaffolding that they provided during the classroom implementation, revealed that there was little variation in the choice of task and that opportunities for investigation were reduced by providing subtasks and hints. Some teachers also experienced that the unpredictability of the students' contributions and the mathematical content, time constraints and large classes were challenging when leaving traditional teaching practice.

Keywords: Proof, proving, argumentation.

Introduction

The functions that proofs have for mathematicians and within mathematics as a discipline are important to bear in mind when teaching proof (de Villiers, 1990). In addition to the verification of the validity of a statement, de Villiers suggested to consider other functions of proof like explanation, systematization, discovery and communication. In the same spirit, Hanna (2000, p. 6) stated that “in the classroom the key role of proof is the promotion of mathematical understanding, and thus our most important challenge is to find more effective ways of using proof for this purpose”. Following Stylianides (2016), in this article proving is understood in a wide sense, including auxiliary activities such as exploration, pattern identification, making and testing conjectures, and reasoning by analogy.

Teachers' own knowledge about proof seems not to guarantee meaningful proving activities in the classroom. Schwarz et al. (2008) investigated the pedagogical knowledge about proof of three groups of preservice teachers' from Germany, Hong Kong and Australia. The preservice teachers from Hong Kong and Australia tended to consider preformal proving an atypical part of mathematics teaching and did not fully appreciate its potential in the classroom. Schwarz et al. (2008, p. 808) concluded that “even future teachers with strong mathematical backgrounds are not necessarily experiencing proof in such a manner that they can convey a complete image of proving at the lower secondary level”. Similarly, Knuth (2002a, p. 404) stated: “Future research needs to explore more fully the conceptions of proof that teachers must have as they help students learn to reason mathematically”. More knowledge is thus needed about how to prepare future teachers to create meaningful opportunities for students to engage in exploration, generalization, argumentation and proving.

Despite long reform efforts and studies confirming successful changing efforts, traditional models of mathematics education seem to be persistent in many classrooms (Jacobs et al., 2006). As for the topic of reasoning and proving, it was found that none of the US lessons from the 1999 TIMSS video study showed evidence of developing a rationale, making generalizations, or using counter examples. Similar findings about discrepancies between an intended reform curriculum and persistent traditional

classroom practice were made in earlier studies (Spillane & Zeuli, 1999). A number of studies focused on the already established patterns of teacher practice in collaborative inquiry classroom communities (Walshaw & Anthony, 2008). Less research seems to be done that tries to reveal the challenges that teachers face when trying to transform existing traditional practices characterized by brief demonstrations of procedures and computational tasks.

This article looks at reform efforts in a Norwegian context. Following criticism about focus on routine exercises and rote learning (Mellin-Olsen, 1996), communicative skills, conceptual understanding, reasoning and argumentation have become important goals in the Norwegian curriculum that has been valid without major changes since 2006: All students are supposed to take part in explorative activities, pattern exploration in both geometry and arithmetic, and to acquire so called basic skills, among them oral skills and mathematical writing, which include the ability to “forming opinions, asking questions and using argumentation with help from informal language, precise terminology and the use of concepts” and the ability to build up “comprehensive argumentation concerning complex relationships” (Ministry of education and research, 2013). These are proving activities in the sense of Stylianides (2016).

While other studies were based on interviews with teachers or preservice teachers (Furinghetti & Morselli, 2011; Knuth, 2002a, 2002b; Schwarz et al., 2008), this article is based on reports about developmental work written by 23 teachers who participated in a reform oriented teacher development program during which they planned and implemented a lesson involving elements of exploration, argumentation, and proving. The main research questions addressed in this article are: What were the mathematical properties of the tasks designed by the teachers? How were the tasks structured and implemented in the classroom and which impact did this have on the opportunities for exploration, argumentation and proving? What were the teachers’ reflections about challenges that arose during the implementation of the proving tasks in the classroom?

Theoretical perspectives

In this section, three different models for the classification of tasks are introduced that allow to analyze both mathematical properties of tasks and aspects of their implementation with respect to the creation of opportunities to engage in exploration, argumentation and proving.

Classification of tasks

Stylianides (2016) classified proving tasks based on mathematical criteria namely the number of cases to be considered in the task (single, finite, infinite) and the purpose of the task that can either require to verify or to refute a statement. This gives a classification into six cases that can be helpful in order to make teachers aware of different types of proving problems that will require different proving techniques and can potentially result in different types of proving activities in the classroom. The number of cases and the purpose of the task need not necessarily be made explicit to the student.

The same mathematical problem or topic can be implemented in different ways in the classroom, and the model by Stylianides (2016) does not capture this aspect. For example, statements can be given by the teacher or textbook or students can develop their own conjectures, for instance through pattern identification (Stylianides, 2008). Skovsmose (2001) classified tasks according to their openness,

ranging from the traditional exercise paradigm to landscapes of investigation, and whether they are purely mathematical, giving a pseudo-application or are real-world problems. The property of being a landscape of investigation exceeds the initial formulation of the task. It depends on the students to accept the invitation to explore and on the communication between teachers and students during the working process: the teacher should provide questions, hints and suggestions rather than solutions and explanations. Yeo (2007) distinguished the following five dimensions of openness of a task:

- *Goal*: A standard computational task has a closed goal: finding the one correct answer. An exploratory task has a more open goal since different properties of a notion can be discovered.
- *Answer*: A standard computational task is closed with respect to the answer since it has one correct answer. A modelling task, for example, can result in several different, but meaningful models.
- *Solution method*: Most tasks can be solved in different ways, but it is not unusual that textbooks or teachers close tasks by prescribing the method to be used.
- *Scaffolding*: Many textbook tasks provide subtasks guiding to a solution. A task can be more or less open based on the density of subtasks that lead the students to the final solution.
- *Extensions*: All tasks can be extended, but students are not necessarily aware of this, for example because the extension of tasks is not a usual thing to do within the classroom norms.

Method

The data collected for this article consisted of 26 reports about developmental work written by teachers enrolled in a teacher development program who planned and carried out a lesson including elements of exploration, argumentation, and proving in lower secondary school, i.e. years 5 – 10. These teachers were not mathematics specialists, but taught several different subjects in lower secondary school. Three reports had to be removed from the data material because the teachers did not give the permission to use them. The teachers were encouraged to run the lesson in a group work setting in order to facilitate active student communication. The reports contained a description of the designed task, observations made during the implementation in class, and reflections about the support provided to the students and any challenges that the teachers experienced.

When starting the analysis of the reports, the mathematical properties of the proving tasks were examined: three categories were generated from Stylianides' (2016) framework about the mathematical properties of the tasks (proving finitely/infinitely many cases, disproving); in addition, it was analyzed whether the students got an opportunity to make their own conjectures or whether the statements to be proved were provided by the teacher. After a first reading of the data material, it became clear that mathematically similar tasks had been formulated and implemented in different ways, such that the original coding was refined using the model of Yeo (2007) in order to analyze different dimensions of openness.

During the final coding, four additional aspects of the material were investigated: the goal of the tasks, the scaffolding provided to the students, the role assigned to argumentation and proving in the classroom, and potential benefits, challenges and obstacles that teachers experienced during the classroom practice. Only the first two aspects are addressed in this article. Examples of codes characterizing the goal of the tasks were *generalize pattern*, *find a proof*, *make conjectures*,

investigate, and *justify special case*. Examples of codes characterizing the scaffolding were *division into subtasks*, *teaching proving technique* (with subcategories *creating additional examples*, *systematize results*), *visually aided proving*.

Results and discussion

Half of the teachers wrote that their usual teaching was characterized by the exercise paradigm (Skovsmose, 2001), i.e. that they usually demonstrated a method and that their students worked with exercises afterwards. The following comment by a teacher is representative: “I do know that I often use tasks that have a clear solution method and one correct answer (T12).” Although the Norwegian curriculum, in action since 2006, requires that “argumentation”, “sharing ideas with others”, “problem solving” are to be both methods in classroom and competence aims (Ministry of education and research, 2013), the exercise paradigm seems to be persistent in many classrooms. This is consistent with research done after reform efforts in other countries (Spillane & Zeuli, 1999).

Properties of the proving tasks and their implementation in the classroom

Goals: Two goals were predominant, pattern generalization and proof or proving as a topic. Almost half of the proving tasks asked the students to find generalizations based on examples revealing a pattern. Task 1 and Task 3 in Figure 1 are typical examples. Four teachers designed tasks about the interior angles sum of polygons guiding the students to note a pattern starting from triangles, quadrilaterals and pentagons. The generalized formula was not provided a priori such that the students got the opportunity to make conjectures about it. Five teachers designed tasks about number sequences and figurative numbers for students in 8th, 9th and 10th grade that required to continue sequences when the first few elements were given, as in Task 3 in Figure 1. None of the teachers discussed the fact that the number sequences could possibly be continued in different ways since only (pictures of) few elements were given and no rule was stated. Thus, the most obvious rule was applied without any discussion, called the plausible pattern by Stylianides (2008). Several of the number sequences were quite simple and already known to students of these grades, for instance the sequence of natural numbers, even and odd numbers, quadratic numbers and figures composed of these. The general formulas were easy to see from the defining properties such that no need to prove naturally arose from these tasks. Stylianides (2016) gave examples of elementary arithmetic problems that can make students aware of the distinction between empirical and mathematically valid arguments such as generic arguments. Several of the given tasks about number sequences lacked the potential of revealing such distinctions to the students. Only in one case, the relationship between quadratic numbers and the sequence of odd numbers was elaborated during the classroom activity and explained by a visually aided proof.

Several teachers made the learning of proving an explicit goal of the task. Four teachers introduced the proving task as an imaginary dialogue between two fictive characters wondering about a problem (Wille, 2017), in order to stimulate oral argumentation and to exemplify the type of activity that was expected from the students. Task 2 in Figure 1 is an example of this. Only the problem is introduced in the imaginary dialogue while no hints to the solution method are given. The teacher’s report about the implementation in the classroom confirmed that the goal of the task was to learn about exploration and proving techniques: she encouraged the students to systematize results and to formulate and test

preliminary conjectures. A genuine need to investigate seemed to be a requirement for the students' engagement in proving: A teacher in 9th grade, who had similar intentions to give the students the "possibility to train to think mathematically and explore proving" (T09), chose the already well-known statement that the sum of two odd numbers is even for designing a proving task. She consciously lowered the mathematical demands since the students were "not used to working with mathematics in this way". But, lacking the need for investigation, the students found it difficult to understand why they should "prove something that was already known and true".


<p><u>Task 1:</u> (9th grade)</p> <p>1) Knowing that the sum of angles in a triangle is 180°, can you find the sum of angles in a hexagon?</p> <p>Hint: Divide the hexagon into triangles. Make drawings and explain your thinking.</p> <p>2) Using the same method as in 1), find the sum of angles in a pentagon and a heptagon.</p> <p>3) Knowing the sum of angles in a triangle, quadrilateral, pentagon, hexagon and heptagon, can you find a pattern?</p> <p>Can you then make a formula for the sum of angles in an n-sided polygon?</p>	<p><u>Task 3:</u> (8th grade)</p> <p>You have to lay quadratic tables with enough space for one person on each side. Tables for more persons are put together as shown in the drawing.</p>  <p>a) How many persons can sit around the tables? Fill inn:</p> <table border="1" data-bbox="909 958 1252 1400"> <thead> <tr> <th>Number of tables</th> <th>Number of persons</th> </tr> </thead> <tbody> <tr><td>1</td><td></td></tr> <tr><td>2</td><td></td></tr> <tr><td>3</td><td></td></tr> <tr><td>4</td><td></td></tr> <tr><td>5</td><td></td></tr> <tr><td>20</td><td></td></tr> <tr><td>100</td><td></td></tr> <tr><td>n</td><td></td></tr> </tbody> </table> <p>b) Do you see a pattern how the number of persons is changing? Explain.</p> <p>c) Explain how you calculated the number of persons when using 20 tables.</p> <p>d) Explain how you can find the number of persons when you use n tables.</p> <p>e) Can you make a formula for table nr. n?</p>	Number of tables	Number of persons	1		2		3		4		5		20		100		n	
Number of tables	Number of persons																		
1																			
2																			
3																			
4																			
5																			
20																			
100																			
n																			
<p><u>Task 2:</u> (7th grade)</p> <p>Lisa and Per have learned about some properties of numbers (...).</p> <p>Lisa: We've learned that all numbers that finish with an even number, are divisible by 2. Like 12, 14 and 16 that are divisible by 2, because they finish with 2, 4 and 6.</p> <p>Per: Yes, that's easy when we can just look at the last digit.</p> <p>Lisa: How can we know if a number is divisible by four?</p> <p>Per: Well, that's worse. But there must be a rule. Let's find out.</p> <p>Help Lisa and Per. Continue to write the dialogue.</p>																			

Figure 1: Examples of proving tasks

Some teachers experienced that the amount of time needed to do investigative activities was in conflict with requirements to cover curricular content: "This implies also that one uses time to investigate, one can't make plans as with other teaching methods that one will use one hour and then be finished with the topic (T01)." Time constraints and "large classes" (T07) were challenges when teachers had to evaluate students' understanding in order to adapt mathematical content to the

individual student: “It is challenging with respect to the available resources to manage to talk to all student pairs and to adapt the tasks to the level they are on and moving towards (T03).”

Scaffolding: Many teachers provided a lot of scaffolding in the written text, dividing the task into subtasks that led the students to the discovery of patterns or an appropriate argumentation, see Task 1 and 3 in Figure 1. For example, all tasks designed about the interior angles sum of polygons started by guiding the students to note a pattern starting from triangles, quadrilaterals and pentagons. After hints to use visual representations, they resulted in visually aided proofs that showed a division of polygons into triangles. Similarly, a teacher who designed a task about the area formulas of quadrilaterals consciously chose the order of the quadrilaterals to be considered such that the proofs could build on each other. In 14 of 23 reports, at least part of the scaffolding described by the teachers was coded as “guiding the students through an argumentation”, i.e. students’ occasions to do their own explorations were limited. Teaching practices related to proof differ widely and can be divided roughly into two groups, either focusing on the proving process or on the final product, the proof (Furinghetti & Morselli, 2011). One teacher who had designed a task leading the students step by step through an argumentation became aware of the fact that this deprived the task of its explorative character and hindered the students from working like a mathematician: “(...) by designing the task like this, I guided the students in the ‘right’ direction. I took away the possibility of making mistakes, which is an important part of working like a mathematician (T15).” Other teachers reflected about their support during group work having been too leading, depriving the given task of its investigative character, by funneling or by imposing their own argumentation on the students.

About a third of the teachers started the implementation of their activities with a repetition of definitions and properties of the relevant notions in a whole-class setting. These teachers seemed to consider a lack of knowledge about related notions an obstacle for proving that had to be avoided, rather than to look at proving as an opportunity to explore these notions: “It is important to ensure a common understanding of the notions we are using and some of their properties before we start (T01).” Similarly, the following teacher provided precise definitions in order to prevent misunderstandings in the students’ communication: “Whenever I have to explain a notion to students, I make sure that the definitions are such that everyone understands them in the same way. Only then they are useful for communication.” Though precise definitions are important in mathematics, it can be of great value for students’ understanding of concepts to use tasks with ambiguous conditions and let students explore the consequences of different assumptions or definitions. The learning opportunities that can arise from such proving tasks in the elementary classroom are discussed by Stylianides (2016), while Zaslavsky (2005) investigated the learning opportunities evoked by uncertainty in mathematical tasks on secondary level.

Extension: Several of the teachers claimed to have designed landscapes of investigation (Skovsmose, 2001), but none of the activities strictly speaking fulfilled the criteria, since many hints about proof ideas were provided and there was little opportunity for students to extend tasks or to explore their own questions or conjectures.

Underlying mathematical properties of the tasks: There was little variety in the proving tasks when compared to the model by Stylianides (2016). The major part of the proving tasks required

justification in infinitely many cases. Only two proving tasks treated a finite number of cases, for example a task about the probability to get certain sums of points when throwing two or three dice. None of the tasks required to disprove a statement. As the nature of the proving task influences the nature of the proving activity (Stylianides, 2016), this might have restricted the diversity of activities that were developed in the classrooms. Of course, each teacher designed only one task such that we have no information about the variety of tasks in a single teacher's classroom. It might however reveal a general tendency that proving tasks might mostly be associated with infinitely many cases.

Despite the fact that proving tasks with infinitely many cases were predominant and a number of proving tasks used geometric representations, none of the teachers made ICT tools available to the students during their investigation. Hanna (2000) wrote that “dynamic geometry software can be used to enhance the role of heuristics, exploration and visualization in the classroom”. Given that the ability to use digital tools, also for purposes of exploration, is among the competence aims of the Norwegian curriculum and considering their potential with respect to exploration and conjecturing, it was surprising that none of the teachers based their classroom activity on digital tools.

Final remarks

Most teachers provided a lot of scaffolding, both in the task formulation and during group work. This might be related to the teachers' conceptions of the role of proof in school mathematics (Knuth, 2002b), apparently emphasizing systematization and explanation as the functions of proof. Many teachers provided definitions and properties of notions beforehand in order to avoid misunderstandings. Proving tasks with ambiguous conditions were not designed by any teacher. ICT tools were not used either which can strengthen the impression that there was some more focus on systematization, explanation of concepts, and support to build arguments than on exploration and conjecturing. There was little variation in the proving tasks when compared to the model of Stylianides (2016), and this might have restricted the diversity of proving activities that arose in the classrooms. In our teacher education courses, we might therefore have to pay special attention to the variation of tasks, and to discussing the value of exploration and the learning opportunities provided by ambiguous proving tasks for students' understanding of mathematical concepts and notions.

All teachers reported that their experience with the implementation of the proving activity was mainly positive. Benefits that were mentioned, included the acquisition of relational understanding, communicative skills, student autonomy, and higher student motivation than usual. Despite of that, several teachers expressed that it would be challenging to work with argumentation and proving in the everyday school reality. They had concerns about the unpredictability of students' contributions and the mathematical content, making it difficult to follow up students' contributions and being in conflict with obligations to cover a specific curricular content, time constraints and large classes that restrict the possibilities to support students individually. In addition to the fact that half of the teachers were still mainly used to the traditional exercise paradigm, the teachers' choices about scaffolding might be related to such concerns. These are important factors that deserve further investigation.

Acknowledgment

This research project was supported by the Research Council of Norway – program FINNUT.

References

- de Villiers, M. (1990). The role and function of proof in mathematics. *Pythagoras*, 24, 17–24.
- Furinghetti, F., & Morselli, F. (2011). Beliefs and beyond: hows and whys in the teaching of proof. *ZDM Mathematics Education*, 43, 587–599. doi 10.1007/s11858-011-0316-7
- Hanna, G. (2000). Proof, explanation and exploration: An overview. *Educational studies in mathematics*, 44, 5–23.
- Hanna, G. (2018). Reflections on proof as explanation. In A. J. Stylianides & G. Harel. (Eds.), *Advances in Mathematics Education Research on Proof and Proving* (pp. 3–18). Cham: Springer.
- Jacobs, J. K., Hiebert, J., Givvin, K. B., Hollingsworth, H., Garnier, H., & Wearne, D. (2006). Does eighth-grade mathematics teaching in the United States align with the NCTM Standards? Results from the TIMSS 1995 and 1999 video studies. *Journal for Research in Mathematics Education*, 37, 5–32. doi: 10.2307/30035050
- Knuth, E. J. (2002a). Secondary school mathematics teachers' conceptions of proof. *Journal for research in mathematics education*, 33, 379–405. doi: 10.2307/4149959
- Knuth, E. J. (2002b). Teachers' conceptions of proof in the context of secondary school mathematics. *Journal of Mathematics Teacher Education*, 5, 61–88.
- Mellin-Olsen, S. (1996). Oppgavediskursen i matematikk. *Tangenten*, 7(2), 9–15.
- Ministry of education and research (2013). Curriculum for the common core subject of mathematics (MAT1-04). Oslo: Norwegian Directorate for Education and Training.
- Schwarz, B., Leung, I. K., Buchholtz, N., Kaiser, G., Stillman, G., Brown, J., & Vale, C. (2008). Future teachers' professional knowledge on argumentation and proof: a case study from universities in three countries. *ZDM*, 40(5), 791-811.
- Skovsmose, O. (2001). Landscapes of investigation. *ZDM*, 33(4), 123–132.
- Spillane, J. P., & Zeuli, J. S. (1999). Reform and teaching: Exploring patterns of practice in the context of national and state mathematics reforms. *Educational Evaluation and Policy Analysis*, 21, 1–27.
- Stylianides, A. J. (2016). *Proving in the elementary mathematics classroom*. Oxford University Press.
- Stylianides, G. (2008). An analytic framework of reasoning-and-proving. *For the Learning of Mathematics*, 28(1), 9–16.
- Walshaw, M., & Anthony, G. (2008). The teacher's role in classroom discourse: A review of recent research into mathematics classrooms. *Review of educational research*, 78, 516–551.
- Wille, A. M. (2017). Imaginary Dialogues in Mathematics Education. *Journal für Mathematik-Didaktik*, 38, 29–55. doi: 10.1007/s13138-016-0111-7
- Yeo, J. B. (2007). Mathematical tasks: Clarification, classification and choice of suitable tasks for different types of learning and assessment. Mathematics and Mathematics Education technical report series.

Zaslavsky, O. (2005). Seizing the opportunity to create uncertainty in learning mathematics. *Educational Studies in Mathematics*, 60, 297–321.

An epistemological study of recursion and mathematical induction in mathematics and computer science^{1*}

Nicolás León¹

¹IMAG, Univ Montpellier, CNRS, Montpellier, France;

nicolas.leon@umontpellier.fr

Keywords: Recursion, mathematical induction, epistemology, computer science.

The recent introduction of computer science contents in the mathematics programs for French high schools raises several questions about the means and objectives of such a curricular shift: which concepts are relevant for mathematics and computer science? Are these concepts viewed in the same way by both disciplines? What are the didactical consequences of the potential similarities and differences? These questions are studied within the scope of the ANR DEMaIn research project (Didactics and Epistemology of interactions between Mathematics and Computer Science).

In our thesis, taking place as a part of this project, we concentrate on the notions of mathematical induction (MI) and recursion. We choose them as they are (i) pervasive both in mathematics and computer science, (ii) usually present in high school or first-year undergraduate curricula, and (iii) problematic from a didactical point of view, as abundant literature shows (Michaelson, 2008; Rinderknecht, 2014).

We conjecture that recursion and MI are closely related to each other and that their joint study might help solve some of these didactical problems, an idea that is supported by the existing literature (see, for example, Drysdale, 2011). Methodologically, we adopt the approach of didactic engineering (Artigue, 2014), which prompts us to initially perform an epistemological analysis of both notions. In particular, we would like to pinpoint the different conceptions of recursion and MI that mathematicians and computer scientists have. Therefore, we pose the following research questions:

1. What meanings can be found for recursion and MI in the fields of mathematics and computer science?
2. What relations exist between these two notions?

Methodology

To address these questions, we proceed in three steps:

1. We consult various academic books, either exemplifying or discussing the points of view of mathematics, computer science or logic on recursion and MI. We intend to identify the contexts in which the words “recursion” and “mathematical induction” are used and the links between them that are implicitly or explicitly assumed.
2. We complement these findings with the information obtained from interviews with mathematicians and computer scientists, in order to gain insight on practices related to recursion and MI that are less visible in the books.

¹ Communication supported by the French National Research Agency <ANR-16-CE38-0006-01>.

3. We develop a characterization of recursion and MI that is in accordance with the academic literature and expert usage, and appropriate for subsequent didactical analysis.

The books for step 1 have been selected considering that they should be exemplary of a specific look at recursion and MI, that the study of these concepts should take place on an important portion of the book, and that it is desirable for them to have been cited repeatedly in the academic literature. It was not a pre-requisite for them to address undergraduate students, as the epistemological study aimed at characterizing advanced usage.

The choice of experts for step 2 has been made according to availability criteria, and also trying to cover a broad spectrum of research areas. The format of the interview is semi-directed, based on a flexible questionnaire, so as to be able to deepen in specific aspects of the use of the concepts that could appear spontaneously during the conversations.

Results

We discuss preliminary results from the analysis of the first five books and four interviews. New books and interviews will be incorporated into the study before tackling step 3, whose results we also expect to present at CERME.

While the concept of MI seems relatively stable, recursion appears as a weave of fuzzy meanings. Interviewed researchers find it difficult to specify a definition of recursion. Books addressing computability theory will usually put forward the precise mathematical definition of recursive functions, relations, and sets, but even here one can find some ambiguity: “recursive” might also mean, more generally, that something is being defined in terms of (a simpler version of) itself. Computer science books present yet another aspect of the concept, by highlighting its connection with the notions of nested loops or structures: recursion is here viewed as a convenient way to organize procedures or data when certain regularities are observed.

Additionally, the close link between recursion and MI is also noticeable both in the discourse of researchers and book authors, as words like “inductive”, “recurrent” and “recursive” are sometimes used interchangeably, depending on the context.

References

- Artigue, M. (2014). Didactic engineering in mathematics education. In S. Lerman (Ed.), *Encyclopedia of Mathematics Education* (pp. 159–162). Dordrecht, Netherlands: Springer.
- Drysdale, R. L. S. (2011). Mathematical induction is a recursive technique. In T. J. Cortina, E. L. Walker, L. S. King, D. R. Musicant, & L. I. McCann (Eds.), *Proceedings of the 42nd ACM technical symposium on Computer science education* (pp. 269–274). Dallas, USA: ACM.
- Michaelson, M. T. (2008). A literature review of pedagogical research on mathematical induction. *Australian Senior Mathematics Journal*, 22(2), 57–63.
- Rinderknecht, C. (2014). A Survey on Teaching and Learning Recursive Programming. *Informatics in Education*, 13(1), 87–119.

Explanatoriness as a value in mathematics and mathematics teaching

Eva Müller-Hill

University of Rostock, Germany; eva.mueller-hill@uni-rostock.de

In this foremost philosophical paper, I propose a rather holistic idea of (re)establishing mathematical proof in school mathematics by explicating and enacting the particular merits of mathematical proof with respect to a variety of mathematical activities, e.g.: observation, systematic variation of example cases, informal argumentation, defining, hypothesising, inductive and abductive reasoning. Such activities are connected naturally to proving in practices of mathematics, with “practice” referring both to mathematics as a human endeavor in general, and to mathematics a (scientific) discipline. To this end, a concept of “mathematical value” from the philosophy of mathematical practice is employed. I focus exemplarily on the value of explanatoriness, which is both a core merit of good proof in scientific mathematical practice, and an important didactical goal of teaching proof.

Keywords: explanation, mathematical value, proof, philosophy, mathematical practice.

Introduction

From the perspectives of mathematics education research and curriculum development, it is widely agreed to date that mathematical proving shall be encouraged and fostered in school mathematics throughout all content areas and grade levels. At the same time, at least in Germany, standards of rigor and formalization in classroom proving changed rapidly in comparison to, e.g., the traditional Euclidean paradigm of proof in elementary geometry, or to algebraic proving in the $\varepsilon - \delta$ - calculus, and developed into content-oriented, depictive, or intuitive ways of argumentation. In spite of the efforts to make mathematical proving an integrated core element throughout the curriculum, the demand for more proving in German mathematics classrooms frequently produces teachers' complaints: the curriculum is too dense, time is too short, and after all, proof is not that relevant for the final exams; pupils don't like proof, they are afraid they cannot handle it and fall into blockade, and after all, proof is not that relevant for students' future lives. This phenomenon can, probably and partly, be explained as an enduring symptom of a perceived “false dichotomy” (Sierpinska, 2005) of mathematical proving on the one hand, and other kinds of mathematical activities on the other. Such a dichotomy may have been over-emphasized by both the traditional university part of mathematics teacher education (at least in Germany), and by the former, strong curricular focus on proofs in the context of elementary geometry, with a sustainable effect on teaching attitudes and beliefs that cannot be simply suppressed by declarations of curricular intent (compare also Knuth, 2002) for similar aspects of teachers' proof conceptions and attitudes towards teaching proof in the U.S.). Hence, there appears to be an ongoing need for clarification of a reasonable interpretation of the call for more proving in mathematics classrooms. This need was already expressed by Stylianides (2007), together with the proposal of defining a framing core concept of mathematical proof to be explicated and enacted in classroom (pp. 291f.), which can be coherently specified both with regard to different loops of the curricular spiral, and to different fields of mathematical content, and which allows for a clear distinction from inductive, “empirical“ (p. 298) arguments. In recent years, the awareness of this need has also led to a deep discussion in mathematics education about diverging and common aspects of

mathematical proof and argumentation (Mariotti et al. 2018). A substantial part of this debate is devoted to logical or cognitive aspects, including the role of deductive vs. other forms of inferential reasoning, of argumentation base, of language, symbolism, or other semiotic elements (ibid.), e.g., the analysis of structural and referential aspects of argumentations and proofs that provide cognitive unity in conjecturing-and-proving learning settings (Fiallo & Gutierrez 2017), or the examination of the coordination of different registers in the transition from argumentation to proving (Duval, 2007; with a different reading of “epistemic value” than I will use in the following).

Focus and rationale of this paper

The approach I want to propose here is, in a way, a complementary one. One main difference is that it does not aim at a closed definition of what mathematical proof is, nor at an emphasis of a clear-cut distinction of proving vs. non-deductive forms of mathematical activities, e.g., inductive or abductive argumentation based on variation of example cases. A second main difference is the idea that an investigation of mathematical proving and related activities that sticks to the logical and cognitive aspects, might not suffice to grasp all epistemologically relevant facets, which may partially conform to approaches employing Habermas’ model of rational behavior (reported in Mariotti et al. 2018). The term “false dichotomy” cited above refers to Michael Otte’s view of *complementary* facets of proving in mathematics (Otte, 1990, p. 59ff.), and emphasizes intuitive, social, and metaphorical facets of proof which cannot be properly modeled with regard to the logic and cognitive functioning of proof or argumentation. Several much more recent studies from different fields suggest that, in a similar vein, issues of epistemic values essentially connected to mathematical proving, like explanatoriness, transcend the scope of logical and cognitive matters, due to a discursive character, to non-reducible pragmatic and affective aspects, and also to the metaphysics of mathematical proving; compare, e.g., (Müller-Hill, 2011) on the epistemic role(s) of formalizability as a feature of discursive proving actions, (Novaes, 2018) on explanatoriness within a dialogical conceptualization of mathematical proof, (Andersen, 2018) on a socio-empirically informed view on acceptable gaps in proofs, (Johansen & Misfeldt, 2016) on argumentation and problem choice as mathematical values, or (Dawkins & Weber, 2017) on the integral role of values like “increasing mathematical understanding” for the “apprenticeship of students into proving practice” (p. 123). Thus, a focus on explanatoriness as an *epistemic* value does not mean to exclude other perspectives than the epistemological one, but is inclusive to, e.g., sociological, communicative, and pragmatic perspectives. The following sections aim at *indicating first steps into the direction* of a program which consists of (1) explicating the particular epistemic merits of the idea of proof that become manifest in the activity of proving in mathematical practice, (2) understanding these coherently in view of the whole process of hypothesizing, generating and communicating proof, (3) emphasizing aspects and features of what counts as proof in mathematical practice that play a particular role in achieving these merits, and (4) indicating elements of a variety of mathematical activities, particularly the generation, operation with, and variation of examples, that already correspond to these aspects and features of proof. In the next two sections, a number of useful concepts, conceptions and results have to be introduced in quite curtate descriptions. First, I provide conceptual considerations as well as exemplary socio-empirical evidence for an understanding of explanatoriness as a core epistemic value of *scientific* mathematical practice in the sense described above. This goes hand in hand with the

stance that the epistemic nature of the scientific discipline of mathematics, understood as a human practice and endeavor which generates, communicates and imparts mathematical knowledge and skills, is relevant to the teaching and learning of mathematics for principal reasons. I then sketch a philosophically informed didactical model of mathematical explanation, developed in (Müller-Hill, 2017), and a model of the interplay of deduction, induction, and abduction in explanation processes. I shortly review the socio-empirical insights on the background of these models, and finish with a glimpse on future work in enacting explanatoriness as a value in school mathematics.

Explanatoriness as an epistemic value in scientific mathematical practice

I employ a concept of *value* here that emerged in recent discussions within philosophy of mathematics (see Larvor, 2016). I follow Ernest's understanding of value as something that is "expressed through the action of valuing", and "manifested in both the prizing of certain characteristics and in the making of fundamental choices" (Ernest, 2016, p. 190), including besides ontic, aesthetic, and ethical values also *epistemic* values (p. 191). Ernest discusses the epistemic values of truth, provability, universalism, objectivism, and rationalism (pp. 193ff.). *Explanation* is a well-known and frequently discussed *function* of mathematical proof, both from the point of view of philosophy and of mathematics education. Frequently proposed features of explanatory proofs are, e.g., surveyability (Müller-Hill, 2013), reference to characteristic features of the involved mathematical entities and structures (Steiner, 1978), or width (Hanna, 2014). These are more or less intrinsic features of mathematical proofs as objects. Understanding explanatoriness as a fundamental *value*, which manifests itself particularly in activities related to mathematical proving, somehow changes the perspective: Explanatoriness is conceptualized rather dialectically by looking for *traces of valuing actions* (like prizing and choice-making) directed at proving in mathematical practice that may *indicate* this value. The issue of (epistemic) *values* in mathematics has, with exceptions like (Lorenzen, 1974, pp. 152ff.), rather been neglected by philosophy of mathematics until recently (Ernest 2016, p. 191) due to the methodological paradigm of classical analytical philosophy, which also dominated philosophy of mathematics for quite a long time. Accordingly, philosophy can contribute to an epistemology of mathematics by conceptually grasping epistemic features of proof through semantic analysis of, e.g., knowledge attributions, resulting in truth-conditions. Concerning the question of epistemic *values* in actual mathematical practice, a different approach is needed that can take concrete valuing actions like prizing and choice-making of practicing mathematicians into account. Valuing actions directed to mathematical proving may include the way in which examples are chosen and exploited during a proving process, the prizing of alternative hypotheses, the choice of definitions and methods, the degree of formalization and abstraction, the representations used, or the fine-grainedness of the argumentation. Philosophy of mathematical practice, a transdisciplinary endeavor at the intersection of philosophy and sociology of mathematics, has developed conceptual and methodological frameworks that allow appropriate investigation of such issues.

Results from a socio-empirically informed epistemological study

In this paragraph, I will review exemplary empirical results from an interview study (Müller-Hill, 2011) conducted with mathematicians of high standing, from various fields of professional specialization areas, under the lenses of explanatoriness as an epistemic value in mathematical

practice (for further methodological details and results of this study, see also (Müller-Hill, 2013)). In general, the interviewees thoroughly point to a strong relation between explanatory proofs and understanding why the proven theorem holds (*ibid.*; particularly aspects (2)-(4)). This is in line with the close relationship of explanation and understanding which is widely agreed upon in philosophical as well as in didactical discussions (see, e.g., the still prominent, well-differentiated discussion in (Sierpinska, 1994), or the very recent (Dawkins & Weber 2017)). Furthermore, selected quotes from (Müller-Hill, 2011) display that prizing and choice-making within processes of generating, communicating and assessing proofs in mathematical practice happens with respect to the *robustness* of hypotheses and arguments *under local and global attacks*, e.g., when “try[ing] to shoot holes in it” and “ask questions why it is true, why it works this way, not that way” (Interview 4, p. 246). This appears to be particularly relevant in review processes, as “the right way of understanding the contribution that [a] new proof brings” is to ask “what is really the new idea” that “makes something work that previously did not work”, and to find “the key argument that made the proof work”, or instead, “where it breaks”. If the proof is “non breaking” under attacks, one “would see the spark of [a] new idea that finally makes it work” (Int. 5, p. 246). It also includes *variation of perspective or context*, to look at a hypothesis or an argument “from different directions, through different angles” (Int. 4, p. 246). Also, “in the process of understanding it happens that you have a definition, and that you think you understand it, and that you come back to it for one reason, or somebody tells you something about it, and that you realize that you never understood it at all” (Int. 6, p. 246). In prizing and choice-making actions, the *balance between establishing a “big picture” and “the details”* is also valued. The “big picture” conveys “the real understanding of why it is true” (Int. 5, S. 199), a “global idea” of “why it works like that”, an “overview of the proof” (Int. 4, S. 179), which also affects the consistency with already established results. On the other hand, there are “the details, to follow the proof from step to step, the logical consequences” (Int. 4, S. 179), and “the process of writing down these details”, which are sometimes not valued as equally important to the global picture because “not all people are good in this” though they “really know mathematical truths” (Int. 5, pp. 171, 199). A well-balanced proof, in this sense, also makes it easier to “be able to look at it at a later time, and still be able to reproduce the arguments” (Int. 4, p. 179), which is taken as an indicator for understanding (see also (Hanna, 2014)). The different aspects have a *context-dependent impact* on concrete valuing actions: “So one thing: maths is in a sense something personal. [...] When do I think I understand something?” (Int. 4, p. 246), which can be influenced by “deep personal involvement with [a] proof” (Int. 2, p. 313).

Explanatoriness within a didactical model of nomic mathematical explanation

Insights gained from the interview study appear to be in line with the concept of so-called *nomic mathematical explanation* (Müller-Hill, 2017). In this view, an explanation provides a general pattern, expressed by a general conditional sentence, from which a phenomenon can be inferred as a regular consequence under certain conditions. Moreover, an explanatory, nomic pattern has to fulfill certain conditions on form (*ibid.*, p. 181) and content.

Conditions on form: Basic structure of an explanatory pattern

Whenever manifestation condition(s) $\mathcal{M} = \{M_1, M_2, \dots, M_n\}$ would be fulfilled, the event E would take place (as a manifestation of certain properties of the involved objects) **and** whenever manifestation condition(s) $\mathcal{M} = \{M_1, M_2, \dots, M_n\}$ would not be fulfilled (but condition(s) \mathcal{M}' instead), the event E would not take place (but the event E').

The second part of the pattern is usually not formulated explicitly. An example pattern discussed in (ibid., p. 202) was reconstructed from a student's explanation of why the sum of three consecutive natural numbers is divisible by three: *Whenever we would take three consecutive numbers a, b, c , and move 1 from the biggest number c to a , we would get three times b .*

Conditions on content: Basic invariance criteria for an explanatory pattern

Some philosophical contributions on the *concept* of *mathematical* explanation (see Hanna, 2018) provide ontic conditions, like reference to “a characterizing property” or “salient feature“ of the involved mathematical entities, for an argument to qualify as explanatory. Such conditions serve to explicate the conceptual meaning of „explanation“. The account of nomic mathematical explanation developed in (Müller-Hill, 2017) complements the ontic conditions by spelling out *epistemic* invariance conditions as *search keys, test and quality conditions* for explanatory patterns. It is to a good extent compatible with ideas of explanatory unification and causal explanation that are at the heart of well-established views of scientific explanation (Kitcher 1989). Table 1 reports and illustrates conditions that are relevant to grasp the aspects of explanatoriness resulting from the interview study.

Functional invariance		Invariance under intervention at the manifestation conditions: pattern gives correct information, if \mathcal{M} is fulfilled or not (e.g., regarding the example pattern above: <i>What if I intervene at M_i by taking non-consecutive numbers a, b, c).</i>
Scope invariance	<i>Object invariance</i>	Pattern also gives correct information when the involved objects are varied (e.g., by varying the chosen triplet (a, b, c)).
	<i>Contextual & representational invariance</i>	Pattern also gives correct information when the used contexts and/or employed representations are varied (e.g., by changing from symbolic to figurative representations of a, b, c).
	<i>Embedding invariance</i>	Pattern is consistent with corresponding patterns for an embedded or expanded pool of related phenomena (e.g., with the transition from natural numbers a, b, c to integers).

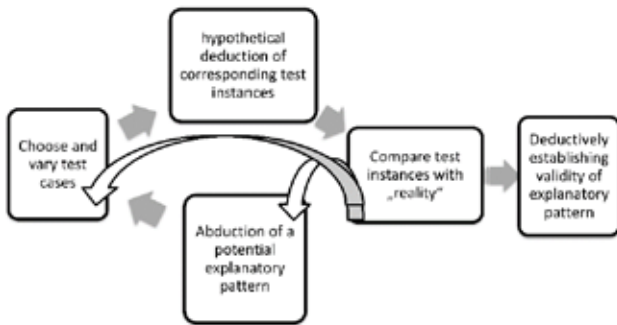
Table 1: Invariance criteria for explanatory patterns (Müller-Hill 2017)

Functional invariance is *necessary* for an explanatory pattern. However, there can be explanatory patterns with different degrees of functional invariance, which affects the pattern's *informativity*: the more differentiated the intervention relation, the more informative the pattern. Scope invariance has different specificities (object, contextual/representational, embedding), each of which can also occur with different degrees. The degrees of scope invariance affect a pattern's *systematization power*.

The process of explanation generation

The *process* of generating a nomic explanation can be described as an iterative cycle of phases of abduction, deduction and induction (Figure 1), starting with *abducting* a potential explanatory pattern.

The abduction may be creative, that is, on the basis of experience gained by working with and varying test cases, the subject identifies a (by her) formerly unknown pattern to explain the phenomenon (e.g.,



by exploring $1 + 2 + 3, 2 + 3 + 4, \dots$). But it may also be rather selective, that is, the subject already knows one or several alternative patterns that are explanatory for a class of somehow related, familiar phenomena, and identifies (by partial analogy, e.g., to familiar opposite-change task formats on addition) one of these that could potentially also explain the phenomenon in question (Magnani, 2001).

Figure 1: Interplay of abduction, induction and deduction

The cycle continues with choosing and varying test cases for the pattern (e.g., for “Whenever we would take three consecutive natural numbers a, b, c , and take 1 from the biggest number c and pass it to a , we would get three times b ”.) Via hypothetical deduction, instances of the proposed pattern are produced for each test case (e.g., $(1 + 1) + 2 + (3 - 1)$ should be equal to $3 \cdot 2, \dots$). These test instances are then compared with “reality”, thereby inductively backing or weakening the pattern (e.g., $(1 + 1) + 2 + (3 - 1) = 2 + 2 + 2 = 3 \cdot 2, \dots$). If the pattern appears to be sufficiently backed up by inductive evidence, one can exploit the experiences already made to collect ideas for a deductive justification of the pattern’s general validity (e.g., by replacing concrete test values for a, b , and c by generic figurative or general symbolic representations), or enter the cycle again with a variation of the former test cases to find a more general or more informative pattern (e.g., by trying out equidistant instead of consecutive number tripels). If not, one may iterate the whole cycle.

Reviewing the results from the interview study

We can now distinguish between explanatoriness in a situated sense, and explanatoriness in a systematic sense (see Table 2), which are complementary.

	Abduction	Quality of invariance	Informativity/systematization
<i>Explanatoriness in a situated sense</i>	creative	Emphasis on functional invariance, detailed and detailed differentiated manifestation conditions	More informative, less systematizing power
<i>Explanatoriness in a systematic sense</i>	selective	Emphasis on scope invariance, generalized manifestation conditions	Less informative, more systematizing power

Table 2: Situated and systematic sense of explanatoriness

Employing this distinction, the interview study results reported above suggest that prizing and decision making within mathematical activities related to proving in scientific mathematical practice happens with regard to explanatoriness both in the situated and in the systematic sense, with context dependent weighting. This includes, particularly, the balancing of informativity and systematization power, as two complementing aspects of explanatoriness.

Outlook and future work: Enacting explanatoriness in class

Regarding educational issues, the framework presented in this paper is meant both as a model and tool for researchers to reconstruct, analyze and understand explanation and valuing processes in mathematics and mathematics teaching, and as a basis for task design, and for initiating such processes in classroom. In this sense, the program formulated at the beginning of this paper entails at least two core messages: under an epistemic reading, „mathematical proof” in any strong sense is an ideal construct that is paradigmatic regarding the virtues and validity claims of the discipline of mathematics (that is one reason why we should still teach about it). However, various kinds of actual mathematical activities directed to providing proofs can and should already be driven and regulated with respect to these virtues and validity claims (that is why they work effectively in mathematical practice, and that is how we should teach them). The paper provides a rough impression of how these programmatic aims can be pursued, regarding exploratoriness as an epistemic value connected to proving. Though tersely presented, the reported results already indicate some opportunities and types of activities related to mathematical proving that can be appropriate to enact explanatoriness as a value in class. As a simple example, think of tasks like the following that could be tackled when introducing the concept of mean value (in German Gymnasium, e.g., in grade six): *Starting with a given data set of natural numbers, think of ways to vary the set in order to increase, lower, or leave invariant its mean value. Justify your answers.* Pilot runs with corresponding learning environments in the form of written tasks produced data that we actually evaluate to revise the learning environment design. However, it needs well-trained teachers to exploit such opportunities properly (compare, e.g., Lesseig, 2016a; 2016b). The next step in our work is to gain and analyse video-data from implementations of the revised learning environments. The results will also be used for developing a video-vignette based teacher training for secondary in-service teachers.

References

- Andersen, L.E. (2018). Acceptable gaps in mathematical proofs. *Synthese*, 1–15.
- Dawkins, P. C., & Weber, K. (2017). Values and norms of proof for mathematicians and students. *Educational Studies in Mathematics*, 95, 123–142.
- Duval, R. (2007). Cognitive functioning and the understanding of mathematical processes of proof. In P. Boero (Ed.), *Theorem in schools: From history, epistemology, and cognition on classroom practice* (pp. 137-161). Rotterdam: Sense Publishers.
- Ernest P. (2016). Mathematics and Values. In B. Larvor (Ed.), *Mathematical Cultures* (pp. 189–214). Cham: Birkhäuser.
- Hanna, G. (2014). The width of a proof. *PNA*, 9(1), 29–39.
- Hanna, G. (2018). Reflections on Proof as Explanation. In A. J. Stylianides & G. Harel (Eds.), *Advances in Mathematics Education Research on Proof and Proving: An International Perspective* (pp. 3–18). Cham: Springer International Publishing.
- Kitcher, P. (1989). Explanatory unification and the causal structure of the world. In P. Kitcher & W. Salmon (Eds.), *Scientific Explanation* (pp. 410–505). Minneapolis: University of Minnesota Press.

- Knuth, E. J. (2002). Teachers' conceptions of proof in the context of secondary school mathematics. *Journal of Mathematics Teacher Education*, 5, 61–88.
- Larvor, B. (2016). *Mathematical Cultures. The London Meetings 2012-2014*. Cham: Birkhäuser.
- Lesseig, K. (2016a). Investigating Mathematical Knowledge for Teaching Proof in Professional Development. *International Journal of Research in Education and Science*, 2(2), 253–270.
- Lesseig, K. (2016b). Conjecturing, generalizing and justifying: Building theory around teacher knowledge of proving. *International Journal for Mathematics Teaching and Learning*, 17(3).
- Lorenzen, P. (1974). *Methodisches Denken* [Methodic Thinking]. Frankfurt: Suhrkamp.
- Johansen, M. W., & Misfeldt, M. (2016). An Empirical Approach to the Mathematical Values of Problem Choice and Argumentation. In B. Larvor (Ed.), *Mathematical Cultures* (pp. 259–269). Cham: Birkhäuser.
- Magnani, L. (2001). *Abduction, Reason, and Science. Processes of Discovery and Explanation*. New York: Kluwer Academic/Plenum Publishers.
- Mariotti, M. A., Durand-Guerrier, V., & Stylianides, G. J. (2018). Argumentation and proof. In T. Dreyfus et al. (Eds.), *Developing research in mathematics education: twenty years of communication, cooperation, and collaboration in Europe* (pp. 75–89). New York, NY: Routledge.
- Müller-Hill, E. (2011). *Die epistemische Rolle formalisierbarer mathematischer Beweise* [The epistemic role of formalizable mathematical proof]. Inaugural-Dissertation. University of Bonn. Accessed 17th September 2018 from <http://hss.ulb.uni-bonn.de/2011/2526/2526.htm>
- Müller Hill, E. (2013). The epistemic status of formalizable proof and formalizability as a meta-discursive rule in actual mathematical practice. In B. Ubuz et al. (Eds.), *CERME8 Proceedings* (pp. 186–195).
- Müller-Hill, E. (2017). Eine handlungsorientierte didaktische Konzeption nomischer mathematischer Erklärung [An action-based didactical conception of nomic mathematical explanation]. *Journal für Mathematik-Didaktik*, 38(2), 167–208.
- Novaes, C. D. (2018). A dialogical conception of explanation in mathematical proofs. In P. Ernest (Ed.), *The philosophy of mathematics education today, ICME-13 Monographs* (pp. 81-98). Springer International Publishing.
- Otte, M. (1990). Intuition and formalism in mathematical proof. *Interchange*, 21(1), 59–64.
- Sierpinska, A. (1994). *Understanding in mathematics*. London: Falmer Press.
- Sierpinska, A. (2005). On practical and theoretical thinking and other false dichotomies in mathematics education. In M. G. Hoffmann, J. Lenhard, & F. Seeger (Eds.), *Activity and Sign* (pp. 117–135). US: Springer.
- Steiner, M. (1978). Mathematical explanation. *Philosophical Studies*, 34, 135–151.
- Stylianides, A. (2007). Proof and Proving in School Mathematics. *Journal for Research in Mathematics Education*, 38(3), 289–321.

Proof, reasoning and logic at the interface between Mathematics and Computer Science : toward a framework for analyzing problem solving¹

Simon Modeste¹, Sylvain Beauvoir¹, Jonathan Chappelon¹, Viviane Durand-Guerrier¹, Nicolás León¹ and Antoine Meyer²

¹IMAG, University of Montpellier, CNRS, Montpellier, France; simon.modeste@umontpellier.fr, sylvain.beauvoir@ac-lyon.fr, jonathan.chappelon@umontpellier.fr, viviane.durand-guerrier@umontpellier.fr, nicolas.leon@umontpellier.fr

²LIGM (UMR 8049), UPEM, CNRS, ESIEE, ENPC, Université Paris-Est, Marne-la-Vallée, France; antoine.meyer@u-pem.fr

After analyzing the relation between mathematics and computer science and the place given to proof, logic and reasoning, we propose and discuss a framework for the study of their interactions based on the ckç model. Then, we exemplify this model in the analysis of a problem, making explicit a mathematical solution and an algorithmic solution.

Keywords: Mathematics, computer science, proof, reasoning, problem solving.

The research presented in this paper is part of a research project funded by the French National Research Agency, called DEMaIn (Didactics and Epistemology of the interactions between Mathematics and Informatics). This project, started in 2017, aims at better understanding the relations between mathematics and computer science, from an epistemological view, in order to tackle didactical issues (Modeste, 2016). It follows from two observations. On the institutional side, computer science enters many curricula at different levels and in many countries (for France, see Gueudet, Bueno-Ravel, Modeste, & Trouche, 2017). On the epistemological side, computer science and mathematics share many concepts and methods (Modeste, 2016) and their frontier is rather blurry. One of the main topics of the project deals with logic, language, proof and reasoning in mathematics, computer science and their interactions. In this paper, we provide epistemological insights regarding this topic and a framework for analyzing proof and reasoning in problem-solving situations in mathematics and computer science, suited to analyze students activities in these fields, including computer-assisted situations.

Proof, reasoning and logic in mathematics and computer science

Mathematics and computer science share common foundations, based on logic. Logic makes explicit the language and the validation rules in both disciplines. This directly relates to the nature of proof and reasoning in mathematics and computer science. In previous works we have shown that the role of proof and reasoning is rather similar in mathematics and computer science, but with an emphasis on different kinds of properties (Meyer & Modeste, 2018; Ouvrier-Bufferet, Meyer, & Modeste, 2018). Some specific types of proofs are particularly important at the interface of the two disciplines, like mathematical induction, and its variations.

¹ Communication supported by the French National Research Agency <ANR-16-CE38-0006-01>.

We consider that the activities in mathematics and computer science share common aspects, in particular the central role of problem solving. Various models in logic can be used to describe and structure the activities in mathematics or computer science. Following Durand-Guerrier (2008), we consider that First-order logic (namely Predicate Calculus) is a relevant epistemological reference for analyzing mathematical activity in a didactic perspective, allowing to take in consideration the articulations between syntax and semantics. We have provided evidence in (Durand-Guerrier, Meyer, & Modeste, to appear) that it is also the case for computer science.

In this paper, we will focus on four concepts and their relations: proof, formal proof, algorithm and program.

Proof. We call *proof* (in mathematics or computer science) a finite sequence of statements organized according to some determined rules (explicitly or implicitly) in order to convince someone of the truth of a statement (Balacheff, 1987). The level of details of the proof generally depends on the source and the recipient of the proof.

Formal proof. A *formal proof* is a text consisting of a finite sequence of statements, expressed in a well defined formal language, where the statements are deduced from the previous ones or from axioms following predefined deduction rules. Most of the proofs could be expressed as formal proofs (if the axioms and deduction rules were made explicit). Nowadays, formal proofs are often produced by or for software called *proof checkers* which can automatically validate a proof.

Algorithm. An *algorithm* is a finite sequence of organized instructions, that describes how to solve a problem, that is, how to obtain a defined goal starting from given data. The steps must be considered as elementary by the recipient of the algorithm, and the algorithm must not be ambiguous. In other words, the producer of the algorithm and its recipient must agree on the granularity of the details of the algorithm.

Program. A *program* is a text consisting of a finite sequence of instructions, written in a well defined (programming) language, that is, having a precise syntax (structure of the language) and semantics (effect of each instruction). An algorithm can be described with a program.

These definitions make clear the fact that the relations between proof and formal proof and between algorithm and program are pretty similar, with, on one side, an informal description, more suitable to human interactions (but also driven by some rationality) and on the other side, a formal language with a precise syntax and semantic, that can be interpreted and checked by computer.

In previous work about algorithmics (Modeste, 2012; Modeste & Ouvrier-Bufferet, 2011), we have made explicit the links between algorithm and proof. In particular, any (constructive) proof can be interpreted as an algorithm. In a more formal context, the *Curry–Howard isomorphism* states there is a strict correspondence between programs and formal proofs.

We hypothesize that it is valuable taking into consideration these four concepts for questioning the place of proof and reasoning in mathematics, computer science and their interactions.

Finally, let us precise what we will consider as *reasoning*. We enclose in reasoning, in mathematics and computer science, all the human activities that permit to solve problems and increase the epistemic value of properties or problem solutions. Reasoning is clearly at the origin of the building of proofs, formal proofs, algorithms and programs, and is strongly related to logic. Indeed, logic is

built in order to model the way of reasoning and reasoning is based on a (not completely explicit) set of logical rules (e.g. Mesnil, 2017).

This leads us to formulate the following research questions: What place and role do proof, formal proof, algorithm and program have in the teaching and learning of mathematics, computer science and their interactions? What is the nature of reasoning in computer science in comparison to mathematics and how can we analyze this reasoning in problem-solving and proving activities?

To answer these questions, we are currently developing a framework that permits to analyze problems, problem-solving and proving activities in mathematics and computer science. We will first introduce our framework and then illustrate its possible use by an example. Finally, we will briefly discuss the future development of this framework, in relation with our project's goals.

A framework for analyzing reasoning and proving in problem-solving activity

Our framework is based on a specific definition of *problem*, on a framework called *concept-problem* and on the *ckç* model.

The central notion of problem

The notion of problem and problem solving is central in mathematics and computer science. In the literature, problems attest of the questions of the two fields and, in practice, they structure the research activity. The notion of problem also carries the issue of generality, important in mathematics and computer science. For our purpose, we will use a definition of problem, based on theoretical computer science and computability and complexity theory (see, for instance, Garey & Johnson, 1979). We consider a problem as a pair (I, Q) where I is a set of instances and Q a question that can be instantiated on any of the element of I (Modeste, 2013). Solving a problem $P=(I,Q)$ is finding the answer to the question Q for any element i of I . This answer can be given by a formula depending on i , any characterizations of the subsets of I for which the answer is a given value, an algorithm that permits to construct the answer for any i , etc. In all cases, a proof can be given that the proposed solution to P is correct, that is, for all i in I , the answer given to $Q(i)$ is correct. This definition is general enough to describe any problem.

In Modeste (2012, 2013) we have shown that this definition allows to conveniently analyze curricula, textbooks and activities in algorithmics, in particular concerning the place given to proof. Giroud (2011), has used a similar definition to develop what he called the “concept-problem”, in order to study the problem-solving activities of students, mainly based on the Theory of Conceptual Fields (Vergnaud, 2009). We will rely on Giroud's idea that different problems can be related to the main problem p studied (called by Giroud the situations “giving meaning to p ”) and follow his idea of representing problem solving with flowcharts between related problems.

The *ckç* model to analyze proof and reasoning

The *ckç* model (Balacheff, 2013) is an enrichment of Vergnaud's Theory of Conceptual Fields. It considers a concept as composed of four elements: a set P of the problems that give meaning to the concept and a representation system L (the *signifier*), similarly to the model of Vergnaud; but it separates the invariants in two types: a set R of operators that permit to transform a problem in another one; and a set Σ of controls that permit to decide whether an operator r applies to a given problem p , and to determine whether or not a problem is solved.

The $ck\phi$ model has been designed to study proof and reasoning (this motivated the separation between operators and controls) and to be appropriate for analyzing computer-assisted learning situations. This leads us to use it in our research project for describing concepts and conceptions.

Description of the framework for analyzing problems

We use the $ck\phi$ model, to describe concept-problems. For us, a concept-problem on a given problem p will be described with:

- a set P of the problems that give meaning to the problem p , that is having a link with p ,
- a set R of operators that transform a problem in another problem, we will denote $p_2=r(p_1)$ if the operator r transforms p_1 in p_2 or $p_1 \rightarrow_r p_2$,
- a set Σ of controls that describe if an operator r is relevant to apply on a problem or if a problem is solved;
- a representation system L , that permits to describe elements of P , R and Σ .

In (Durand-Guerrier et al., to appear; Modeste, 2012) we have used such a framework to analyze the concept “algorithm” and its relation to proof. We proposed to distinguish two levels of problems, to bring to light a tool-object dialectic, and to differentiate the situations where proof concerns the controls level (elements of Σ) and the situations where the studied problem p consists in proving something. In this second case, the operators concern proving strategies and the controls of Σ concern logic rules (Σ can remain mostly implicit while controlling the use of the operators).

In this paper, we extend this framework to any situation in mathematics and computer science, including problem-solving and proving situations, assisted or not with a computer. The framework will allow us to focus on proof and reasoning in these activities.

Finally, we consider that the operators and controls occur at two (intertwined) levels: syntactic and semantic. It is clear that the presence of a computer (programming tool, proof assistant or many other tools²), brings some new controls (including feedback) that have a strong syntactic dimension. For example, a very basic control can come from what is called *syntactical analysis* which checks if an expression (formula, program, logic statement...) is well-formed with respect to the grammar of the language. This kind of feedback from the computer can be considered as a purely syntactic control. On the other hand, any interpretation (by the user) of the expression in terms of the objects represented or for specific values of the variables would be considered as a semantic control.

Example of problem analysis

In this section, we illustrate the use of our framework for problem analysis, focusing on analyzing the problem itself, the *a priori* analysis (analysis of students’ solving of the problem is one of our next perspectives). We have selected a problem from a well-known website called Project Euler: “Project Euler is a series of challenging mathematical/computer programming problems that will require more than just mathematical insights to solve. Although mathematics will help you arrive at elegant and efficient methods, the use of a computer and programming skills will be required to solve most problems.” (<https://projecteuler.net/>). These problems, at the interface between

² For example CAS or softwares like Aplusix: www.aplusix.com/

mathematics and computer science, seem interesting to us to confront our framework. We will consider the following problem:

Problem 1. If we list all the natural numbers below 10 that are multiples of 3 or 5, we get 3, 5, 6 and 9. The sum of these multiples is 23. Find the sum of all the multiples of 3 or 5 below 1000.

In our framework, the problem can be described as an instance of the general problem $P_{3-5}(I,Q)$ with I the set of all natural numbers and $Q(i)$ the question “What is the sum of all the multiples of 3 or 5 below i ?”. Although the problem consists in solving $P_{3-5}(1000)$, the value 1000 is large enough to require to think about the general problem while solving it.

Here, we will describe with flowcharts two ways of solving the problem³, one considered as more “mathematical” and the other considered as more “algorithmic”. In the flowcharts, problems are represented in blue and arrows between them represent the transformations under the action of an operator (in green) selected according to a control in red (controls on operators and on the status of problems). Sometimes, an operator can generate several problems. We will not give details about the representation system L in this paper.

A “mathematical” solution

This solution is based on the observation that if we want to sum all the multiples of 3 and 5 under 1000, we can count the multiples of 3 and the multiples of 5, and only multiples of 15 will be counted twice. Since we can derive from the formula of the sum of the first integers a formula for the sum of the first multiples of any n , we can solve $P_{3-5}(1000)$. In the end, we can write:

$$\sum_{\substack{k=1 \\ 3|k \text{ or } 5|k}}^{999} k = \sum_{k=1}^{999} k + \sum_{k=1}^{999} k - \sum_{k=1}^{999} k = 3 \sum_{k=1}^{333} k + 5 \sum_{k=1}^{199} k - 15 \sum_{k=1}^{66} k = 233168$$

An “algorithmic” solution

This solution is based on an enumeration of the numbers below n , a test of the property “being a multiple of 3 or 5” and an accumulation of the values satisfying the property. This can lead to this algorithm (in a pseudo-code, close to the programming language Python):

<pre>Function Sum_3-5 (n) S = 0 for k from 1 to n-1: if k mod 3==0 or k mod 5 = 0 then S = S+k return(S)</pre>	<pre>% We define a function returning the sum % of the multiples of 3 or 5 below n % S will contain the sum of the multiples % We enumerate the integers below n % if they are multiples of 3 or 5 % we add them to S</pre>
--	---

³

Due to space constraints, we cannot show all the solutions that we have identified in our *a priori* analysis.

The solving process is described more precisely by the flowchart in figure 2.

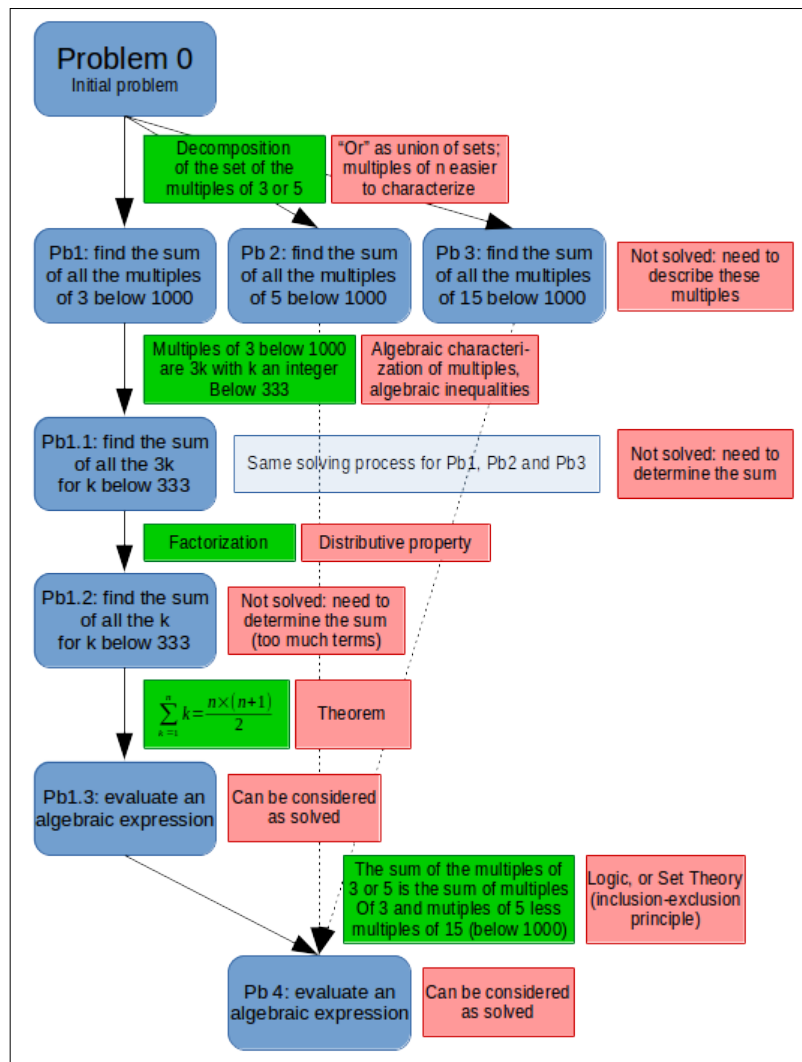


Figure 1: A mathematical solving

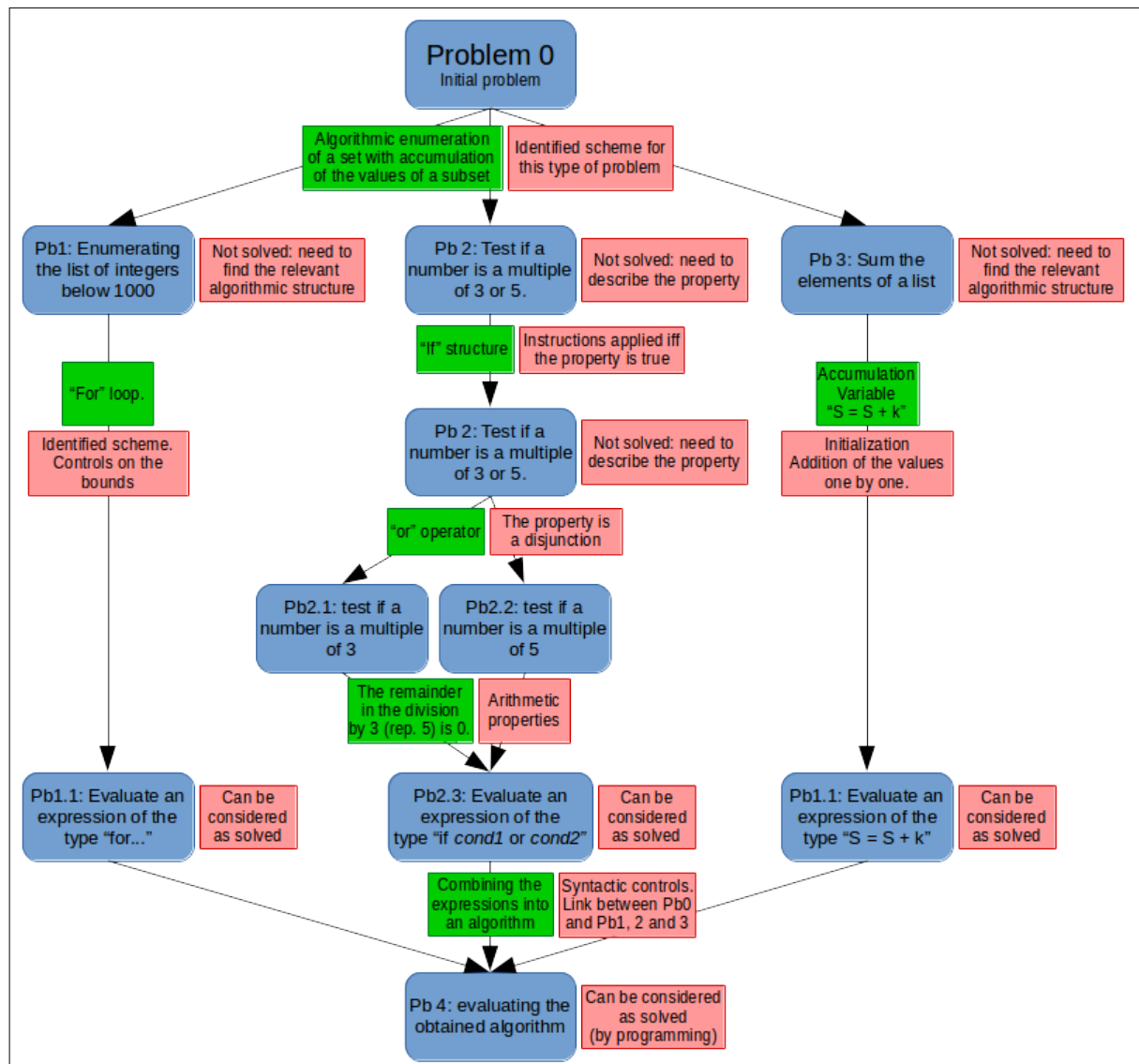
Discussion and comparison of the 2 solutions

The two solving processes analyzed show two very different (correct) strategies. We can clearly distinguish the types of operators and controls that take part in the solutions. In the mathematical solving process, we can notice how the use of algebraic operators (factorization, formula...) are controlled and chosen regarding the sub-problem studied. In the algorithmic solving process, we can notice operators and controls that make clearer the way decisions can be taken about choosing algorithmic tools ("for" loop, "if" structure). Although operators and controls are different between the two solving processes, we can notice that the framework allows to describe finely both of them. This supports our claim that there are many common aspects of the problem-solving process in mathematics and computer science.

Conclusion and perspectives

Our framework permits to analyze problem-solving strategies in mathematics and computer science, with an emphasis on proof and reasoning. On the epistemological side, it puts light on the controls in mathematics and computer science and will permit to discuss their differences and common

points, which can be taken into account in a didactical perspective. The framework should also permit to describe and analyze problem-solving strategies developed by students, in particular faced with problems that can be solved with mathematics and computer science. Another goal is to be able to use this framework for situations that integrate formal tools (computer-assisted situations) – by detailing syntactic controls and their use, which needs to detail the role of the system of representations L – and for situations of proof and proving (by taking into account different levels of control, as aforementioned). In the next step of the DEMaIn project, we will use this framework in the design, analysis and experimentation of didactical situations at the interface of mathematics



and computer science.

Figure 2: A algorithmic solving

References

Balacheff, N. (1987). Processus de preuve et situations de validation. *Educational Studies in Mathematics*, 18, 147–176.

- Balacheff, N. (2013). $cK\phi$, a model to reason on learners' conceptions. In M. Martinez & A. Castro Superfine (Eds.), *Proceedings of the 35th annual meeting of the North American Chapter of the International Group for the Psychology of Mathematics Education* (pp. 2–15). Chicago, IL: University of Illinois at Chicago. Retrieved from <https://hal.archives-ouvertes.fr/hal-00853856/>
- Durand-Guerrier, V. (2008). Truth versus validity in mathematical proof. *ZDM The International Journal on Mathematics Education*, 40/3, 373–384.
- Durand-Guerrier, V., Meyer, A., & Modeste, S. (to appear). Didactical issues at the interface of mathematics and computer science. In G. Hanna, D. Reid, & de V. Michael (Eds.), *Proof Technology in Mathematics Research and Teaching*. Springer. Postprint at <https://hal.archives-ouvertes.fr/hal-01912885v1>
- Garey, M. R., & Johnson, D. S. (1979). *Computers and Intractability: A Guide to the Theory of NP-Completeness*. W. H. Freeman.
- Giroud, N. (2011). *Étude de la démarche expérimentale dans les situations de recherche pour la classe*. Université de Grenoble. Retrieved from <http://tel.archives-ouvertes.fr>
- Gueudet, G., Bueno-Ravel, L., Modeste, S., & Trouche, L. (2017). Curriculum in France. A national frame in transition. In D. R. Thompson, M. A. Huntley, & C. Suurtmamm, *International Perspectives on mathematics Curriculum*. IAP.
- Mesnil, Z. (2017). A reference for studying the teaching of logic. In *CERME 10*. Dublin, Ireland. Retrieved from <https://hal.archives-ouvertes.fr/hal-01865656>
- Meyer, A., & Modeste, S. (2018). Recherche binaire et méthode de dichotomie, comparaison et enjeux didactiques à l'interface mathématiques - informatique. EMF Conference 2018, Paris.
- Modeste, S. (2012). *Enseigner l'algorithme pour quoi ? Quelles nouvelles questions pour les mathématiques ? Quels apports pour l'apprentissage de la preuve ?* (Manuscrit de thèse). Université de Grenoble. Retrieved from <https://tel.archives-ouvertes.fr/tel-00783294/>
- Modeste, S. (2013). Modelling algorithmic thinking: the fundamental notion of problem. In *proceedings of CERME 8*. Antalya (Turkey).
- Modeste, S. (2016). Impact of Informatics on Mathematics and Its Teaching. In F. Gadducci & M. Tavosanis (Eds.), *History and Philosophy of Computing* (pp. 243–255). Springer.
- Modeste, S., & Ouvrier-Buffer, C. (2011). The appearance of algorithms in curricula, a new opportunity to deal with proof? In *Proceedings of CERME 7*. Poland: University of Rzeszów. Retrieved from <http://www.cerme7.univ.rzeszow.pl/index.php?id=wgl>
- Ouvrier-Buffer, C., Meyer, A., & Modeste, S. (2018). Discrete mathematics at university level. Interfacing mathematics, computer science and arithmetic. Presented at the Second INDRUM Conference. Retrieved from <https://hal.archives-ouvertes.fr/hal-01849537>
- Vergnaud, G. (2009). The Theory of Conceptual Fields. *Human Development*, 52(2), 83–94. <https://doi.org/10.1159/000202727>

A systemic investigation of students' views about proof in high school geometry: the official and shadow education systems in a school unit

Andreas Moutsios-Rentzos¹ and Eleni Plyta²

¹ University of the Aegean, Greece; amoutsiosrentzos@aegean.gr

² University of Athens, Greece; lnemath4@hotmail.com

In this paper, we discuss the views that the high school students of a school unit hold about proof in geometry. We consider the school unit as an open system that in Greece functions at the interaction of the official and the shadow education system. We mapped aspects of the institutional discourse that are visible to the students: the school teachers, the geometry textbook and the shadow education teachers. We focused on five different types of reasoning that may appear as a proving argument (acceptable or not): empirical, narrative, abductive, reductio ad absurdum, formal. The results of the mixed methods data collection and analysis revealed complex interactions of the two systems on the students' views and on their mathematical identity construction.

Keywords: Proof, geometry, complexity, high school, shadow education.

Proof in high school geometry: official and shadow education systems

Though proof and proving lies at the heart of modern mathematics, research findings suggest that the high school students experience limited opportunities to be engaged in rich proving practices (Otten, Gilbertson, Males, & Clark, 2014). The geometry course may potentially give the high school students opportunities to deal with different types of proof (Hanna & de Bruyn, 1999), but this feature seems not to be exploited in the geometry classroom, where the vast majority of the experienced proofs seem to be of the form: a deductive argument written in formal mathematical language (Battista & Clements, 1995). Furthermore, though abductive reasoning is at the crux of the proving process (Arzarello, Andriano, Olivero, & Robutti, 1998), the students seem to struggle using an abductive argument in the formulation of a deductive proof (Pedemonte & Reid, 2010). Considering the language of proof, Weber (2010) differentiated the deductive arguments expressed in a *narrative form* (using everyday language) from the *formal* ones (using necessary mathematical relationships for the proof theorem and linking words without explanation steps or texts). Moreover, the students seem to mainly choose an argument that is expressed in a mathematically acceptable way (valid or not), in order to satisfy a teacher, rather than themselves (Hoyles & Healy, 2007).

Drawing upon the fact that a significant number of high school students in Greece attend private tutoring lessons (Bray, 2011; which increases as the students approach the national exams to enter university), our study attempted to map the perceived effect to the students' views about proof in geometry, with respect to *both* the *official education system* and the *shadow education system*. 'Shadow education' refers to the private tutoring, which complements the official school teaching and is focussed on improving the students' performance in the official education system (Bray, 2011; Mazawi, Sultana, & Bray, 2013; Mori & Baker, 2010). In this study, we employ the term *institutional discourse* to refer to all the sources of mathematical authority that are visible to the students, which may communicate to the students what a high school acceptable proof in geometry

should be. The school teachers and the textbook communicate what the students perceive as an officially acceptable proof (Bieda, 2010), but the effect that an un-official source authority (such as the teachers of the shadow education system) would have on their views about an acceptable proof in geometry remains an open question.

In line with our previous studies (Moutsios-Rentzos & Pitsili-Chatzi, 2014; Moutsios-Rentzos & Korda, 2018), we focus on the school unit as an open system interacting with the broader educational system: official and shadow. Considering that the elements and the subsystems of a system are in a reciprocal relationship, constantly changing themselves and the system, we posit that the students in a school classroom who attend private tutoring lessons constitute a sub-system of the school unit, affecting and being affected by the official and the shadow institutional discourse, thus affecting the whole school unit. A similar role is played by the school textbook, which constitutes a seemingly common reference point for both official and shadow teaching. Nevertheless, the teachers' personal views and practices are mediators of the textbook knowledge to the students (Hanna & de Bruyn, 1999). This is a complex situation, since teachers (official or shadow) may choose to differentiate their teaching content from official textbooks (Tarr, Chavez, Reys, & Reys, 2006), whilst at the same time they are influenced by their own views or beliefs about geometry when it comes to teaching practices (Stipek, Givvin, Salmon, & MacGyvers, 2001).

Following these, we adopted a systemic approach to investigate the high school students' views about what constitutes an acceptable proof in high school geometry. We focussed on what is *visibly* communicated to the students as the *institutional discourse* about proof in geometry, in a three-faceted model: the *school teacher practices* and the *textbook* (representing the official education system discourse), as well as the *private tutoring school teacher practices* (representing the shadow education system discourse). In this study, our conceptualisation of the institutional discourse about proof includes the different proving methods and argument types employed in the proving argument, as well as the language employed in expressing the argument. In order to gain deeper understanding about the wholistic impact that the official and shadow education institutional discourses may have on the students' relationship with mathematics, we investigated the students' *mathematical identity*, contrasting their *self-identification* with their *being identified by the others* (Abreu & Cline, 2003; Kafoussi, Moutsios-Rentzos, & Chaviaris, 2017). In this case, the significant 'others' were the school and private tutoring school teachers. The construct of mathematical identity allows us to obtain a measure of the qualitative relationship that the student has with mathematics, as well as of its links with the authority figures of the official and the shadow education system. Consequently, we address the following questions: a) What aspects of proof and proving practices are identified in the three-faceted institutional discourse (the school geometry textbook, the school teachers' practices and the shadow education teachers' practices)? b) How do the students relate these aspects of proof with the three-faceted institutional discourse? c) How do the students identify themselves with respect to mathematics and the three-faceted institutional discourses?

Methods and procedures

The study was conducted with the students attending the first grade (16 years old) of a public Greek "Lykeio" (high school). We included in the study only the students who took private tutoring

lessons (N=47; out of 76), their geometry teachers (with the pseudonyms Petros, Katia and Michalis) and the private tutoring school teachers (with the pseudonyms Thaleia, Nikolas, Dionysis) of a private tutoring school that is chosen by the vast majority of the students. Finally, we considered the official geometry textbook (Argyropoulos, Vlamos, Katsoulis, Markatis, & Sideris, 2010). The data collection was conducted close to the end of the first high school year, including:

- 1) *School textbook analysis* with the task (of both theory and applications) being the unit of the content analysis. We drew upon Otten et al. (2014) and Weber (2010) to investigate the following: a) *proving methods* including: *direct* proof, the Euclidean-type of proving in geometry *analysis and synthesis* (drawing from Pappus; see, for example, Heath, 1956, p. 442), and *reductio ad absurdum*; b) *argument type* including: *deductive*, *empirical*, an *outline* of the proof, explicit indication that is already proven elsewhere or that it will be proved later (*past or future*), no argument but explicitly *left to be proven by the students*, and *no argument*; c) *deductive proof language* (see Weber 2010): *formal* (containing mainly symbolic language) or *narrative* (containing mainly natural language).
- 2) *Structured observations* of the school teachers' teachings (the private tutoring school did not give us permission to conduct any observations), in order to obtain a mapping of the proving practices communicated in the school class by the teachers. We focused on the teachers' practices about proof reasoning and proof language in the school class.
- 3) *Semi-structured interviews* with the school and the shadow education teachers to investigate their proof teaching practices; based on Almeida (2000), Bieda (2010), Moutsios-Rentzos and Korda (2018).
- 4) *Students' views about proof in geometry questionnaire*, to identify their views about which proving argument is more likely to appear in the school textbook, the school class or the shadow education. We chose a theorem from the school textbook (with no proof included) and five arguments (Balacheff, 1988; Weber, 2010): deductive-narrative, deductive-formal, abductive, reductio ad absurdum, empirical (see Figure 1).
- 5) *Being good at maths questionnaire*, investigating the way that the students' identity is constructed, contrasting self-identification ("I am ... at maths") and being identified by the teachers of the two systems ("My school teacher considers me to be ... at maths", "My shadow education teacher considers me to be ... at maths") on a five-point Likert scale (with "3"= "average").

Mapping the official and shadow education systems in a school unit

The geometry textbook

The geometry school textbook includes mainly deductive arguments (see Table 1), which appear in the form of direct proof, with reductio ad absurdum and analysis-synthesis proofs having fewer appearances. Concerning language, students encounter deductive arguments in narrative form in the theory part of the book, while the applications are both in narrative and formal form. Thus, proof in the Greek Geometry textbook is communicated mainly as a direct proof, containing deductive-narrative arguments, which accords with the findings of the analysis of the Greek Algebra textbook of the same Lykeio grade (Moutsios-Rentzos & Pitsili-Chantzi, 2014).

Appearances of proof and proving	Theory	Applications	Total
<i>Argument type</i>			
Deductive	73	32	105
Empirical	6	0	6
Outline	3	0	3
None - Past or future	1	0	1
None - Left for students	4	0	4
None	35	0	35
<i>Proving method</i>			
Direct	63	27	90
Analysis-Synthesis	2	3	5
Reductio ad absurdum	10	0	10
<i>Deductive proof language</i>			
Narrative	45	18	63
Formal	28	14	42

Table 1: Appearances of proof and proving in the school geometry textbook.

The school teachers' proof teaching practices

Considering their teaching practices, as well as the type of arguments and expected students' activity, deductive reasoning came up with the highest appearance in the school classroom. The teachers were mainly asking students about deductive, yet isolated, arguments rather than a complete proof, which later were collected and written by the teacher to constitute the proof. In case of the students' having difficulties in finding arguments or synthesising the proof, the teachers asked additional questions, feeding the students' abductive argumentation. In general, abductive arguments were quite common, but they were not present in the written proof, as they did not include reasoned conjectures (Herbst & Arbor, 2004). No reductio ad absurdum or empirical arguments were included in the teachings we observed: neither by the teachers, nor in the students' responses. Considering the language of the arguments, we noticed a divergence between verbal and written arguments: the teachers constructed the proof in a more narrative form, while the arguments written were closer to formal. The teachers justified this choice, as a result of the limited instruction time within the classroom. Moreover, considering types of reasoning, all three teachers stressed the importance of abductive reasoning in their teaching, as abductive arguments help students to focus, think and find the "right solution". Nevertheless, their reluctance to include them in the written proof is evident, as, for example, Katia stated that she prefers to use the "formal way", indicating the type of arguments used in the official textbook. Commenting about the rest of deductive forms

used in the school textbook, the school teachers noted that *reductio ad absurdum* alienates students, as it is not commonly found in the textbook and the teachers themselves don't use it in the classroom. Finally, all teachers agreed that empirical arguments are employed in the school classroom, but they all said that they emphasise to the students the fact that the idea "it's right because it looks like so" is not acceptable in geometry.

<p>Prove that parallel segments who have their extremes in two parallels lines are congruent.</p>	
<p>Abductive argument We notice that in order to prove that segments AD, BE and CF are congruent, we only have to prove that quadrilaterals ABED and BCFE are parallelograms, because afterwards using parallelogram properties we will be able to assume that the opposite sides are equals. But the latter statement is applicable since $AB \parallel DE$ and $AD \parallel BE$ (using the assumptions given) which means ABED is a parallelogram, and also $BC \parallel EF$ and $BE \parallel CF$ which means that BCFE is a parallelogram.</p> <p>Empirical argument We can notice using the diagram that quadrilaterals ABED and BCFE are parallelograms. Thus they have their opposite sides equals, so $AD = BE = CF$.</p>	<p>Deductive-formal argument $l1 \parallel l2$ thus $AB \parallel DE$. Also $AD \parallel BE$. Using the definition, ABED is a parallelogram, thus $AD = BE$. Working similarly for BCFE. So: $AD = BE = CF$</p> <p>Deductive narrative argument We know that quadrilateral ABED has two pairs of parallel sides: $AB \parallel ED$ since $l1 \parallel l2$ and $AD \parallel BE$ (given as an assumption). So, we can conclude using parallelogram definition that ABED is a parallelogram, thus it has its opposite sides equals, meaning $AD = BE$ (1). Working similarly, the quadrilateral BCFE is a parallelogram, since $BC \parallel EF (l1 \parallel l2)$ and $CF \parallel BE$, so we can conclude that $BE = CF$ (2). From (1), (2) we conclude: $AD = BE = CF$.</p> <p>Reductio ad absurdum Let segments AD, BE, CF be parallel but not congruent. The quadrilaterals ABED and BCFE are parallelograms (since they have two pairs of parallel sides) but they don't have their sides equals (from our assumption). The latter statement is invalid, considering parallelograms properties, thus the segments AD, BE, CF are congruent.</p>

Figure 1: One statement, five arguments

The shadow education teachers' proof teaching practices

Considering the shadow education system, the private tutoring school teachers also chose to talk especially about abductive reasoning and the abductive arguments they use in the classroom. Referring to deductive proofs, they made a special reference to *reductio ad absurdum* and the difficulties the students face, because of their lack of knowledge of mathematical logic. All three agreed that they use this proof type only when it's absolutely necessary in a school textbook case and nowhere else. Finally, they also agreed with the school teachers that they make absolutely clear in their students that they must reject empirical arguments in geometry, because "it says prove that they are parallels, not see that they are parallels" (Nikolas). Considering the argumentation form, the teachers stated that while they accept all argumentation forms that their students would produce, they prefer to use more narrative and less formal arguments. They also expressed their preference for narrative arguments, commenting about textbook's proofs: "I write it the way I think of it at that time or the way my student uses...I want to keep close to the textbook's proof, but I think the language used is very formal and students don't understand it written this way" (Dionysis).

The students' views: the school teacher, the shadow education teacher, the textbook

Considering the students' evaluations about the five argument types, it seems that when focussed on the official discourse (school textbook and teaching), the students evaluate the presented arguments as not to statistically significantly differ from the theoretical neutral, with only the empirical argument getting a statistically significant lower evaluation ($Mdn=2.0$, $P=0.005$; One-sample Wilcoxon Signed Rank Test). Considering the unofficial institutional discourse, three arguments (Narrative, Abductive, *Reductio ad absurdum*) were evaluated as looking statistically significantly

closer to what the students encounter in the private tutoring school teachings (respectively, $Mdn=4.0$, $P=0.001$, $Mdn=4.0$, $P=0.006$, $Mdn=4.0$, $P=0.001$; One-sample Wilcoxon Signed Rank Test). When considering both official and shadow education, the Friedman's ANOVAs (followed by Wilcoxon Signed Ranks Tests with Bonferroni correction applied) revealed that the students considered three argument types (Abductive, Reductio ad absurdum, Empirical) to be statistically significant more like the ones they encounter in the shadow education teaching in comparison with the official system: Abductive (teaching and textbook; respectively, $P=0.024$, $P=0.001$), Reductio ad absurdum (only textbook; $P=0.001$), Empirical (teaching and textbook; respectively, $P=0.497$, $P=0.003$). No statistical differences were identified in the Deductive and Narrative arguments.

Concerning the students' mathematical identity about their 'being good at maths', the students thought that their school teacher's identifying them as being good at maths, would not statistically differ from "Average" (see Table 2). In contrast, their self-identification and their being identified by the shadow education teacher is statistically significantly higher than the "Average". When considering both systems, it is revealed that the students' self-identification does not statistically significantly differ from their school teacher's identification, but it is statistically significantly lower than their shadow school teacher's identification.

<i>Being identified by the ...</i>	<i>M</i>	<i>Mdn</i>	<i>P^a</i>	<i>P^b</i>	school class ^c	shadow education
school class teacher	3.15	3.00	0.340	<0.001		
shadow education teacher	4.17	4.00	<0.001		<0.001	
<i>Self-identification</i>	3.38	4.00	0.028		0.312	<0.001

Notes. ^a One-sample Wilcoxon Signed Rank Test (Median = '3': "Average"). ^b Friedman's ANOVA. ^c Wilcoxon Signed Ranks Test (with Bonferroni correction applied).

Table 2: Student's identification about their "being good at math"

Re-visiting the complexity in the school unit: concluding remarks

Considering the institutional discourse, the school teachers and the textbook seem to converge. The textbook analysis revealed the dominance of deductive, narrative arguments, in the type of direct proof, with few appearances of proof by analysis-synthesis or reductio ad absurdum. The same argument types are evident in the observed proving practices of the school teachers, though they state the importance of abductive arguments in the conjecturing phase of proving. Considering the shadow education teachers' *reported* practices (since no observations were conducted), we identified a bigger variety of the type of arguments and the language used. While they uphold the view of geometry proof as a deductive argument, they explicitly stated that most of the times the teacher has to add more ideas and to differentiate the argument or the language used, in order for the solution to be more transparent and accessible to the students. Furthermore, they agreed with the school teachers about the importance of abductive reasoning and argumentation in teaching, as well as about their stressing to the students that empirical arguments are not acceptable in geometry.

The students' views seem to converge with the institutional discourse, as the empirical and the reductio ad absurdum argument are the least likely to be chosen by the students. Furthermore, the

fact that the institutional discourse favours the narrative form is evident in the students' views. The students' views also support the private tutoring schools claims for a richer proof repertoire, as three arguments types (Narrative, Abductive, Reductio ad absurdum) were evaluated as being statistically significantly looking closer to what they encounter in the private tutoring school teachings than the school class teaching. Though the empirical argument was not evident in our observations and the teachers strongly argued against its being a valid argument, the students' views revealed that for them it is an argument that was missing only in the school textbook.

The students' self-identification about their being good at math converges with their school teacher, even though they think that their private tutoring school teacher would think higher of them. Thus, though both teachers are sources of mathematical authority, the students' self-identification seems to be aligned with the teacher of the official system. The importance of this alignment lies on the general nature of the phrase "being good at math", which embodies the students' positioning about mathematics. Hence, the students identify themselves as being good at mathematics or not, in line with the school teachers' sociomathematical norms.

Consequently, the complex relationship of the two systems is evident on their links with the students' views about proof. The shadow education system seems to offer a richer proof experience, which remains essentially unofficial, in meaning it does not significantly affect the students' mathematics identity construction. Further research should be conducted to map these relationships, as they develop through the three Lykeio grades; especially in the last grade of Lykeio, where the national exams (required to enter university) are a third pole of authority that transcends all school units, thus affecting the authority of both the shadow education teacher and the school teacher.

References

- Abreu, G. D., & Cline, T. (2003). Schooled mathematics and cultural knowledge. *Pedagogy, culture and society*, 11(1), 11–30.
- Almeida, D. (2000). A survey of mathematics undergraduates' interaction with proof: some implications for mathematics education. *International journal of mathematical education in science and technology*, 31(6), 869–890.
- Arzarello, F., Andriano, V., Olivero, F., & Robutti, O. (1998). Abduction and conjecturing in mathematics. *Philosophica*, 61(1), 77–94.
- Balacheff, N. (1998). Aspects of proof in pupils' practice of school mathematics. In D. Pimm (Ed.), *Mathematics, teachers and children* (pp. 216–235). London, UK: Hodder.
- Battista, M., & Clements, D. (1995). Geometry and proof. *The Mathematics teacher*, 88(1), 48–54.
- Bieda, K. N. (2010). Enacting proof-related tasks in middle school mathematics: Challenges and opportunities. *Journal for research in mathematics education*, 41(4), 351–382.
- Bray, T. M. (2011). *The Challenge of Shadow Education: Private Tutoring and its Implications for Policy Makers in the European Union*. Luxembourg: European Commission.
- Hanna, G., & de Bruyn, Y. (1999). Opportunity to learn proof in Ontario grade twelve mathematics texts. *Ontario mathematics gazette*, 37(4), 23–29.

- Heath, T. L. (1956). *Euclid The thirteen books of the elements Vol. 3*. New York: Dover.
- Herbst, P., & Arbor, A. (2004). Interaction with diagrams and the making of reasoned conjectures in geometry. *ZDM*, 36(5), 129–139.
- Hoyles, C., & Healy, L. (2007). Curriculum change and geometrical reasoning. In P. Valero (Ed.), *Theorems in school* (pp. 81–115). Rotterdam, The Netherlands: Sense Publishers.
- Kafoussi, S., Moutsios-Rentzos, A., & Chaviaris, P. (2017). Investigating parental influences on sixth graders' mathematical identity: the case of attainment. In A. Chronaki (Ed.), *Proceedings of the ninth international Mathematics Education and Society Conference: Mathematics Education and Life at Times of Crisis (Vol. 2)* (pp. 592–602). Volos: MES9.
- Mazawi, A. E., Sultana, R. G., Bray, M. (2013) Beyond Shadows: Equity, Diversity, and Private Tutoring. In M. Bray, A. E. Mazawi & R. G. Sultana (Eds). *Private Tutoring Across the Mediterranean* (pp. 205–216). Sense Publishers: Rotterdam, The Netherlands.
- Mori, I., & Baker, D. (2010). The origin of universal shadow education: What the supplemental education phenomenon tells us about the postmodern institution of education. *Asia pacific education review*, 11(1), 36–48.
- Moutsios-Rentzos, A., & Korda, A. (2018). “Is this an acceptable mathematical proof?” A systemic investigation of high school students’ proof beliefs and evaluations. In B. Maj-Tatsis, K. Tatsis & E. Swoboda (Eds.), *Mathematics in the real world* (pp. 112–124). Rzeszow, Poland: Wydawnictwo Uniwersytetu Rzeszowskiego.
- Moutsios-Rentzos, A., & Pitsili-Chatzi, D. (2014). Opseis ths apodeixhs sto scholiko biblio ths Algebras ths A' Lykeiou [Aspects of proof in the school Algebra text book of first grade of the Greek Highschool]. In C. Skoumpourdi, & M. Skoumios (Eds.), *Proceedings of the 1st Panhellenic Conference with International Participation Development of Educational Material in Mathematics and the Sciences* (pp. 561–568). Rhodes: University of the Aegean.
- Otten, S., Gilbertson, N. J., Males, L. M., & Clark, D. L. (2014). The mathematical nature of reasoning-and-proving opportunities in geometry textbooks. *Mathematical thinking and learning*, 16(1), 51–79.
- Pedemonte, B., & Reid, D. (2011). The role of abduction in proving processes. *Educational studies in mathematics*, 76(3), 281–303.
- Stipek, D. J., Givvin, K. B., Salmon, J. M., & MacGyvers, V. L. (2001). Teachers’ beliefs and practices related to mathematics instruction. *Teaching and teacher education*, 17, 213–226.
- Tarr, J. E., Chávez, Ó., Reys, R. E., & Reys, B. J. (2006). From the written to the enacted curricula: The intermediary role of middle school mathematics teachers in shaping students' opportunity to learn. *School science and mathematics*, 106(4), 191–201.
- Weber, K. (2010). Mathematics majors' perceptions of conviction, validity, and proof. *Mathematical thinking and learning*, 12(4), 306–336.

Meta-knowledge about definition: The case of special quadrilaterals

Shogo Murata

University of Tsukuba, Graduate School of Comprehensive Human Sciences, Japan;

smurata@human.tsukuba.ac.jp

Keywords: Defining, meta-knowledge, special quadrilaterals

Introduction

In proving processes, it would be important for us to focus not only on proofs but also on definitions. For example, if the same mathematical object can be defined differently, the chosen definition plays a crucial role in proving different results on properties of the object. The previous studies related to definition and defining focus on interactions between concept images and concept definitions (Vinner, 1991; Zandieh & Rasmussen, 2010), or interactions between examples and definitions (Zaslavsky & Shir, 2005; Zazkis & Leikin, 2008). While it is important for us to focus on the role of the example, it is also important to notice the Meta-Knowledge about Definition (MKD). MKD would be characterized as a controller of constructing definitions. Therefore, it is necessary to answer the question: How can Meta-Knowledge about Definition foster students' defining activities?

Method

The method is theoretical exemplification for prospective empirical investigation, which is the construction a framework and the use it through some examples. When we define mathematical objects, the definitions would be controlled by some criteria. Here, the definitions themselves are described by object-language and the criteria of definitions are described by meta-language. Van Dormolen & Zaslavsky (2003) proposed the seven criteria of definition: hierarchy, existence, equivalence, axiomatization, minimality, elegance, and degenerations. Table1 is proposed by reorganizing these criteria as MKD. It is expected to characterize students' defining activities from the perspectives of definitions, examples, and MKD.

Purpose:	Define it relatively according to the purpose or the context.
Existence:	Confirm the object to define exists in a system.
Equivalence:	Construct equivalent statements about the object to define.
Arbitrariness:	Define it by selecting a statement from the equivalent statements.
Coherence:	Define it by using undefined terms and defined terms.
Non-circularity:	Define it not to make definitions circular reasoning.
Non-contradiction:	Define it not to be a contradiction to other definitions.
Minimality:	Define it by minimal conditions for the existence.
Elegance:	Define it more nicely, more simply, or more applicably.
Exactness:	Define it exactly to exclude examples not to expect.

Table1: The components of Meta-Knowledge about Definition

Result and Conclusion

By using the components of meta-definition, we defined ten special quadrilaterals: (1) Square, (2) Rectangle, (3) Rhombus, (4) Parallelogram, (5) Isosceles trapezoid, (6) Kite, (7) Cyclic quadrilateral, (8) Trapezoid, (9) Ellipse quadrilateral, (10) Tangential quadrilateral (See Figure 1). The *purpose* of defining was to construct a hierarchical classification focusing on sides and angles. According to the *elegance*, we defined these quadrilaterals focusing on duality between sides and angles. The quadrilaterals of (3), (6), (9), and (10) were defined by focusing on equality of sides, while the quadrilaterals of (2), (5), (7), and (8) were defined by focusing on equality of angles. Furthermore, according to the *exactness*, the definition that “A kite is a quadrilateral in which two pairs of adjacent sides are equal” was not accurate. It was necessary to correct “two pairs” to “*distinct* two pairs” for exact definition. As a result, we constructed the hierarchical classification focusing on sides and angles, and discovered the ellipse quadrilateral which is an unfamiliar figure but should exist certainly.

It is concluded that students’ mathematical defining activities could be fostered through some processes in which mathematical definitions are controlled by MKD. We could use the components of MKD as a framework for analyzing students’ mathematical defining activities. The implication for mathematical practice is to pay attention not only to the interactions between example and definition but also to the role of MKD. It is important for teachers to prepare teaching materials that will facilitate students’ activities of examining definitions at a meta-level.

References

Van Dormolen, J., & Zaslavsky, O. (2003). The many facets of a definition. *Journal of Mathematical Behavior*, 22(1), 91–106.

Vinner, S. (1991). The role of definitions in the teaching and learning of mathematics. In D. Tall (Ed.) *Advanced mathematical thinking* (pp. 65–81). Dordrecht: Kluwer Academic Publishers.

Zandieh, M., & Rasmussen, C. (2010). Defining as a mathematical activity: A framework for characterizing progress from informal to more formal ways of reasoning. *The Journal of Mathematical Behavior*, 29, 57–75.

Zaslavsky, O., & Shir, K. (2005). Student’s conceptions of a mathematical definition. *Journal for Research in Mathematics Education*, 36(4), 317–346.

Zazkis, R., & Leikin, R. (2008). Exemplifying definitions: A case of a square. *Educational Studies in Mathematics*, 69(2), 131–148.

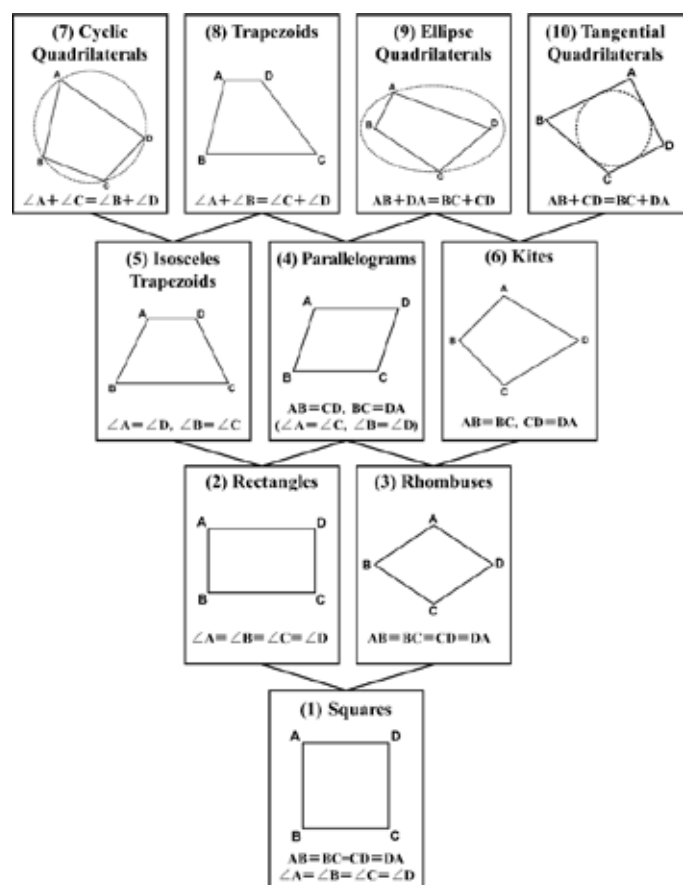


Figure 1: Classification of quadrilaterals

Proof comprehension of undergraduate students and the relation to individual characteristics

Silke Neuhaus¹ and Stefanie Rach¹

¹Otto von Guericke University Magdeburg, Germany; silke.neuhaus@ovgu.de

²Otto von Guericke University Magdeburg, Germany; stefanie.rach@ovgu.de

In tertiary education, proof comprehension, that means reading and understanding written proofs, is an important activity in learning processes. However, to our knowledge there are no (empirical) studies analyzing the influence of reading strategies and the students' individual characteristics on proof comprehension, yet. We developed a proof comprehension test in analysis based on an assessment model of Mejia-Ramos et al. (2012) to test the relation of students' individual characteristics to proof comprehension. To get a first in-depth look which factors influence proof comprehension we analyzed the data of 64 students in their second semester in university. Additionally, we asked the students about their use of reading strategies. The results show that proof comprehension correlates with prior knowledge and with the use of single reading strategies. Possible consequences for mathematical higher education are discussed.

Keywords: Proof comprehension, reading strategies, individual characteristics.

Introduction

Learning how to prove is one of the main components students have to encounter in tertiary mathematics programs. In order to understand, what a proof is and how to construct proofs, students read many proofs for example in their lectures or in their text books. Those proofs are given to the students by their lecturers, not only to show them, that an assumption is true, but also to teach proof methods and general ideas of mathematics that are used in the proof (Mejia-Ramos, Fuller, Weber, Rhoads, & Samkoff, 2012; Weber 2012). In many papers, understanding proof covers and is measured by different aspects like comprehending the written text, validating if a given argument can be categorized as a proof, evaluating of given arguments or even constructing a new proof. Stylianides (2015) questioned the validity and comparability of those different research findings:

“Take, for example, a study that draws conclusions about students' understanding of proof based on students' argument constructions in response to a number of proving tasks. This study is likely to report a poorer picture of students' understanding of proof than another study that considered also students' evaluations of their own constructions (...)” (Stylianides, 2015, p. 213)

Selden and Selden (2015) mention four concepts related to proof or proving in mathematics education research literature: proof construction, proof validation, proof evaluation, and proof comprehension. Proof construction is about doing proofs of given statements. Distinguishing if a written argument is a (correct) proof is defined as proof validation, and assessing if a given proof is nicely written is meant by proof evaluation. Lastly proof comprehension means to understand a written and correct proof. In this contribution, we focus on proof comprehension in the field of “analysis”, concrete which individual characteristics and reading strategies may influence proof comprehension.

Theoretical Framework and related literature

The definition of proof comprehension has to cover many different aspects and is connected to the question of how to measure proof comprehension. A first approach in this direction was done by Mejia-Ramos et al. (2012) by developing an assessment model for proof comprehension. Their model consists of seven dimensions, divided into two categories without a hierarchical order. Understanding a proof on a local basis includes to understand the *meaning of the proof's terms and statements*, the *logical status of statements and proof framework* and the *justifications of claims*. To understand the proof on a holistic basis, one has to *summarize the proof via the high-level ideas*, identify the *proof's modular structure*, *transfer the general ideas or methods to another context* and *illustrate the proof with examples*. Based on this assessment model, Mejia-Ramos and colleagues constructed proof comprehension tests and also gave an instruction manual on how to develop and validate such proof comprehension tests (Mejia-Ramos, Lew, La Torre, & Weber, 2017; Mejia-Ramos et al., 2012). Likewise, Hodds, Alcock, & Inglis (2014) developed proof comprehension tests and measured a positive influence of their self-explanation training on the proof comprehension of undergraduate students. To solve items of a proof comprehension test correctly, learners have to read the proof and sometimes to combine the content of the proof with prior knowledge. Items should be avoided that can be solved by referring to the prior knowledge only and not to the proof. These items would only assess prior knowledge and not proof comprehension.

In order to analyze students' behavior while trying to comprehend written proofs, Weber (2015) videotaped and analyzed four excellent students in their senior year while reading proofs. He identified five strategies which the students used to foster proof comprehension: “(i) trying to prove a theorem before reading its proof, (ii) identifying the proof framework being used in the proof, (iii) breaking the proof into parts or sub-proofs, (iv) illustrating difficult assertions in the proof with an example, and (v) comparing the method used in the proof with one's own approach” (Weber, 2015, p. 289). In a follow-up study reported in the same paper, Weber asked 83 mathematicians, whether they desired their students to implement those strategies, and most mathematicians did. In a separated study, Weber & Mejia-Ramos (2013) found similar strategies while watching major students read proofs and also present results indicating that a majority of students claimed not to use these strategies. In contrast to this Weber & Mejia-Ramos (2011, 2014) interviewed mathematicians why and in which way they read proofs. One reason to read proofs was to discover the proofs' methods which may be useful for the mathematicians own research. To get the main ideas, the mathematicians zoom in on a proof's problematic parts and zoom out and look at the high-level structure.

As far as we are aware, there is no (empirical) study analyzing whether the use of those strategies has indeed an influence on proof comprehension and whereas students benefit from the strategies mathematicians use. Psycho-linguistic studies showed that general reading comprehension correlates with prior knowledge and the use of reading strategies (e.g. Carell, 1983; Crowley & Azevedo, 2007; Pearson, Hansen, & Gordon, 1979;). We find similar results in mathematics education research referring to other concepts of proving. For example, Sommerhoff et al. (2016) analyzed the influence of domain specific and domain general cognitive student prerequisites on proof validation and showed, that conceptual mathematical knowledge influences the students' proof validation skills. Those results suggest a possible relation between prior knowledge and the use of reading strategies

on proof comprehension. Additionally, psycho linguistic researchers looked at the relation between individual characteristics and reading or text comprehension. For example, individual interest has a positive influence on text comprehension (see e.g. the overview of Schiefele, 1992). Despite this, we have not yet found an analysis concerning the relation between individual characteristics like interest or self-concept and proof comprehension.

All in all, we assume that the analysis of the relationship between reading strategies, individual characteristics and proof comprehension provide a deeper insight into the role of proof comprehension in undergraduate learning processes. Besides, such an analysis probably contributes to develop interventions supporting undergraduate students improving their proof comprehension.

Research questions

In this study we analyze the relation between proof comprehension, the use of reading strategies, and individual characteristics like interest in proof. Therefore, we focus on the following research questions:

1. Are proof reading strategies correlated with proof comprehension?
According to the results of Weber (2015) and Weber & Mejia-Ramos (2013) we expected the above mentioned five reading strategies to influence proof comprehension. In addition, we expected some influence of the reading strategies based on the self-explanation training of Hodds et al. (2014).
2. Do individual characteristics (like self-concept, interest or prior knowledge) correlate with proof comprehension?
General reading comprehension research showed relations between reading comprehension, prior knowledge and some individual characteristics, especially interest. We expected prior knowledge to influence significantly proof comprehension and we assumed at least a little relation between proof comprehension and interest in proof or interest in university mathematics.

Method

Sample

Our sample consist of 64 students (21 students in a bachelors' program, 34 students in a teacher education program, to 9 students we have no information concerning their study program) in their second semester at a German university. Both types of students heard the same lectures till now. The mean value theorem, which was used in the proof comprehension test, was part of their Analysis I lecture, but with a slightly different proof.

Measuring proof comprehension

Based on the assessment model of Mejia-Ramos et al. (2012), we developed a proof comprehension test to the mean value theorem, which states that if f is a continuous function on a closed interval $[a, b] \subset \mathbb{R}$ and differentiable on the open interval (a, b) , then there exists a point $c \in (a, b)$, such that the tangent in the point c equals the secant through the endpoints a and b of the interval. The proof of the theorem uses a helper function h , and distinguishes two cases, h constant and h not constant, to show the assertion.

As the proof is not written in detail, for example not all justifications are explained, we could develop items based on the assessment model of Mejia-Ramos et al. (2012). First, we constructed open-ended items for every dimension of the assessment model. Then we wanted to change most of the items to multiple-choice items because the objectivity of the test is raised in this way. Still, most of the items remained as open items, because it was not possible to create good distractors. The first version of the test was given to experts of the *khdm* (Kompetenzzentrum für Hochschuldidaktik in Mathematik, in english: Centre for Higher Mathematics Education) for a review. We improved the test based on their answers and comments. Afterwards the new version was given to 52 students at the end of their first semester in an analysis lecture. Their answers were analyzed, and the test again revised. The final test had 10 items, 5 items referring to a more local comprehension and 5 to holistic comprehension. Four of them were multiple-choice Items. This is an example of a multiple-choice item referring to holistic comprehension:

We prove $h(a) = h(b)$. Why is this useful in the proof?	
<input type="checkbox"/>	$h(a) = h(b)$ shows that h is differentiable in (a, b) . (13.0%)
<input type="checkbox"/>	If $h(a) \neq h(b)$, then the maximum or minimum of h could be on the endpoints of $[a, b]$. (right answer, 53.7%)
<input type="checkbox"/>	If $h(a) \neq h(b)$, then we could exclude the case „ h constant“. (24.1%)
<input type="checkbox"/>	$h(a) = h(b)$ shows $f(a) = f(b)$ and therefore f could be constant. (9.3%)

Figure 1: Item in the proof comprehension test (percentage of chosen answers, $N = 62$)

We took care, that the items could not be answered by prior knowledge only. Each item was scored dichotomously, i.e. one point for a solution which was accepted as correct and zero points for other solutions. Concerning the multiple-choice items only one answer was correct (1 point). The open items were coded separately by two people given 1 point for a correct answer with only small mistakes (for example a missing declaration of variables used in the answer) and zero points for wrong answers. A missing answer was coded zero points if the student still answered items afterwards so that we assumed that the student had have enough time for answering the question.

Measuring the use of proof-reading strategies

In addition to the proof comprehension test, we developed different scales to assess students' use of proof-reading strategies on a four-point Likert scale from 1 (disagree) to 4 (agree). In total we developed 22 items covering different kinds of reading strategies, using ideas from a German reading comprehension test (Schlagmüller & Schneider, 2007), the self-explanation training from Hodds et al. (2014), and the expected effective reading strategies (i) – (iii) from the study of Weber (2015) mentioned above. We assigned the proof-reading strategies to 5 different scales, which are listed in table 1.

Scale	Example
Before reading (4 items)	“I think about the assertion before I read the proof.”

While reading (4 items)	“While reading the text, I highlight important propositions.”
Elaborated reading (5 items)	“I build connections between the different ideas of the proof.”
Reproductive reading (4 items)	“I sum up each line of the proof in my own words.”
After reading (5 items)	“I discuss the proof with my learning group.”

Table 1: Learning strategies sorted in scales

Measuring individual characteristics

Afterwards the students got a test to examine their prior knowledge in analysis (Rach & Heinze, 2017). The eight test items were coded dichotomously and students could gain up to 8 points in this test. The sum of their answers was computed to a test score for further analysis. Moreover, we asked the students to state their German and mathematics school grades and their grade of their analysis I course. At last we asked the students to estimate statements about other individual characteristics. They rated statements covering their *interest* in school and university mathematics (Ufer, Rach, & Kosiol, 2017), their interest in proof (Ufer, Rach, & Kosiol, 2017), their *self-concept* referring to proof (Ufer, Rach, & Kosiol, 2017) and to school respectively university mathematics in general (Ufer, Rach, & Kosiol, 2017) and their *satisfaction* referring to their university career (Schiefele & Jacob-Ebbinghaus, 2006). Because of practical constraints, some characteristics were only covered by one item. The scales of the individual characteristics (interest and self-concept) had good till very good reliabilities, so the individual mean value of a single student on a scale was computed if the student answered half of the items of the scale at least. In contrast, the reliabilities of the predicted scales for the proof-reading strategies were not good, so we only inserted single items in the analysis.

Results

The reliability of the proof comprehension test ($M = 3.59$, $SD = 1.83$, $Max = 10$ points, $\alpha = .57$) was medium. The single items' mean value was $M = .15 - .76$ ($SD = 0.36 - 0.50$, $Max = 1$). An explorative factor analysis did not show any empirical evidence for different factors of proof comprehension, a local or a holistic understanding, so we measured proof comprehension by the sum of the whole test items as a test score. The following correlations were analyzed with Pearson correlation coefficient.

RQ 1: Are proof reading strategies correlated with proof comprehension?

Analyses show that there were only two correlations between proof comprehension and the use of single proof-reading strategies (negative correlation: “I skim read the proof and concentrate on important aspects” ($r = -.28$, $p < .05$), positive: “I divide the proof into coherent parts” ($r = .27$, $p < .05$)). The positive correlation refers to Weber's (2015) third suggested useful proof-reading strategy. The correlation between Weber's (ii) proof reading strategy and proof comprehension is nearly significant ($r = .21$, $p < .1$). As there are not many correlations, we looked at the mean values of the proof-reading strategies for further analysis. The absolute interpretation of mean values is dangerous but carefully interpreting, it can give us a first insight into students reading strategies. Some of the proof-reading strategy items have high mean values, meaning that nearly all students said they do this while reading the proof, for example “I think about the assertion, before I read the proof” or “I read the proof several times”. Whereas the use of other strategies was only mentioned by

a few people, for example “I prove the assertion on my own before reading the proof” which is the first of Weber’s (2015) assumed, useful reading strategies.

RQ 2: Do individual characteristics (like interest, self-concept or prior knowledge) correlate with proof comprehension?

As expected, proof comprehension correlates positively with the grade in the last analysis lecture ($r = .39, p < .01$) and with the prior knowledge in analysis ($r = .46, p < .01$). There is no correlation of the students’ final school grade or their last mathematics school grade. The proof comprehension only correlates negatively with the students’ interest in school mathematics ($r = -.27, p < .05$), there were no other significant correlations.

Discussion

Proof comprehension is an important activity in university mathematics, however students struggle a lot by performing this activity. To get a better insight into proof comprehension, we developed a proof comprehension test in the field of analysis to analyze the relation between proof comprehension and students’ individual characteristics, based on the assessment model of Mejia-Ramos et al. (2012). Our results show no empirical evidence for a separated local or global comprehension of proof. This supports the results of our first study (Neuhaus & Rach, 2018) we made with students at the beginning of their university career. We cannot see any differences between local or holistic items concerning the students’ answers. Mejia-Ramos et al. (2012) also don’t view the different types of their assessment model as part of a hierarchy. So while an empirical distinction between local and holistic proof comprehension might be difficult, we think that a theoretical separation is still helpful to get the whole picture of proof comprehension and to develop items for proof comprehension tests.

The correlation of the proof comprehension with prior knowledge was expected and shows that undoubtedly, for understanding proofs, a solid basis of concept understanding in the field is needed. However, there were no positive correlations between proof comprehension and the students’ interest in university mathematics or their mathematical self-confidence, which is somewhat surprising. We assumed that at least interest in proofs would predict proof comprehension with a small influence. Instead of this, a negative correlation between interest in school mathematics and proof comprehension suggests that interest in school mathematics and interest in university mathematics have to be analyzed separately.

Only one of Weber’s (2015) expected useful proof-reading strategies and none of the reading strategies based on Hodds et al.’s self-explanation training (2014) correlate with proof comprehension, but as only single items were included in the analysis, further studies need to be done. Another difference is, that Weber (2015) looked at good students reading proofs and predicted the used reading strategies to be useful to generate proof comprehension, but maybe only better students can benefit from those strategies. Thus, for the practical context, one should be aware that not for every student every strategy is helpful. In addition, only few students declared to use one of Weber’s suggested helpful strategies and some other strategies, fitting the results of Weber & Mejia-Ramos (2013). Maybe the strategies need to be given to and practiced by the students in advance so they could benefit more from proofs given to them in their lectures.

Our proof comprehension test only refers to one proof in one mathematical topic (in this case analysis). For a broader view, proof comprehension has to be measured by different proofs in different topics. Additionally, we only assessed a partial part of the students' proof comprehension as they were allowed to look at the proof while answering the proof comprehension test and maybe the questions indicated them to look to the proof in more detail. Furthermore, the sample is rather small and the students only report a self-estimation for their individual characteristics and their use of the proof reading strategies. There is no real evidence in which way and how often they really use the strategies. That's why we want to reproduce the presented results with a bigger sample. Additionally, research is needed on the effectiveness of proof-reading strategies, the correlations between proof comprehension and other concepts of proving, like proof validation, and proof comprehension in different topics. With our study, we did a first step to get a deeper look into the concept of proof comprehension that may help us in the future to support students in this activity.

References

- Carrell, P.L. (1983). Three components of background knowledge in reading comprehension. *Language Learning*, 33(2), 183–203.
- Cromley, J.G., & Azevedo, R. (2007). Testing and Refining the Direct and Inferential Mediation Model of Reading Comprehension. *Journal of Educational Psychology*, 99(2), 311–325.
- Hodds, M., Alcock, L., & Inglis, M. (2014). Self-explanation training improves proof comprehension. *Journal for Research in Mathematics Education*, 45(1), 62–101.
- Mashkovskaya, A. (2013). *Der C-Test als Lesetest bei Muttersprachlern [The C-test as a reading test with native speakers]* (Doctoral dissertation, University Duisburg-Essen, Germany). Retrieved from https://duepublico.uni-duisburg-essen.de/servlets/DerivateServlet/Derivate-34531/Dissertation_2014_01_06.pdf [01.03.2019].
- Mejia-Ramos, J. P., & Weber, K. (2014). Why and how mathematicians read proofs: Further evidence from a survey study. *Educational Studies in Mathematics*, 85(2), 161–173.
- Mejia-Ramos, J.P., Fuller, E., Weber, K., Rhoads, K., & Samkoff, A. (2012). An assessment model for proof comprehension in undergraduate mathematics. *Educational Studies in Mathematics*, 79(1), 3–18.
- Mejia-Ramos, J. P., Lew, K., La Torre, J. de, & Weber, K. (2017). Developing and validating proof comprehension tests in undergraduate mathematics. *Research in Mathematics Education*, 19(2), 130–146.
- Neuhaus, S., & Rach, S. (2018). Proof comprehension of undergraduate students. In E. Bergqvist, M. Österholm, C. Granberg, & L. Sumpter (Eds.), *Proceedings of the 42nd Conference of the International Group for the Psychology of Mathematics Education* (Vol. 5, p. 117). Umeå, Sweden.
- Pearson, P. D., Hansen, J., & Gordon, C. (1979). The Effect of Background Knowledge on Young Children's Comprehension of Explicit and Implicit Information. *Journal of Literacy Research* 11(3), 201–209.

- Rach, S., & Heinze, A. (2017). The Transition from School to University in Mathematics: Which Influence Do School-Related Variables Have? *International Journal of Science and Mathematics Education, 15*(7), 1343–1363.
- Schiefele, U., & Jacob-Ebbinghaus, L. (2006). Lernmerkmale und Lehrqualität als Bedingungsfaktoren der Studienzufriedenheit [Features of Learning and Teaching as Conditional Factors of Satisfaction with the Study Program]. *Zeitschrift für Pädagogische Psychologie, 20*(3), 199–212.
- Schiefele, U. (1992). Topic interest and levels of text comprehension. In K. A. Renninger, S. Hidi, A. Krapp & A. Renninger (Eds), *The role of interest in learning and development* (151–183). New York.
- Schlagmüller, M., & Schneider, W. (2007). Würzburger Lesestrategie-Wissenstest für die Klassen 7-12. Ein Verfahren zur Erfassung metakognitiver Kompetenzen bei der Verarbeitung von Texten. [Würzburg's reading strategies test for classes 7–12. A Procedure to assess metacognitive competences while processing texts]. Göttingen: Hogrefe.
- Selden, A., & Selden, J. (2015, February). *A comparison of proof comprehension, proof construction, proof validation and proof evaluation*. Paper presented at the Conference Didactics of Mathematics in Higher Education as a Scientific Discipline, Hannover, Germany.
- Sommerhoff, D., Ufer, S., & Kollar, I. (2016). Proof validation aspects and cognitive student prerequisites in undergraduate mathematics. In C. Csíkos, A. Rausch, & J. Sztányi, (Eds.), *Proceedings of the 40th Conference of the International Group for the Psychology of Mathematics Education* (Vol. 4, pp. 219–226). Szeged, Hungary.
- Stylianides, A. J. (2015). The role of mode of representation in students' argument constructions. In K. Krainer & N. Vondrová (Eds.), *Proceedings of the Ninth Congress of the European Society for Research in Mathematics Education* (pp. 79–85). Prague, Czech Republic.
- Ufer, S., Rach, S., & Kosiol, T. (2017). Interest in mathematics = Interest in mathematics? What general measures of interest reflect when the object of interest changes. *ZDM Mathematics Education, 49*(3), 397–409.
- Weber, K., & Mejía-Ramos, J. P. (2011). Why and how mathematicians read proofs: An exploratory study. *Educational Studies in Mathematics, 76*(3), 329–344.
- Weber, K. (2012). Mathematicians' perspectives on their pedagogical practice with respect to proof. *International Journal of Mathematical Education in Science and Technology, 43*(4), 463–482.
- Weber, K., & Mejía-Ramos, J. P. (2013). Effective but underused strategies for proof comprehension. In M. Martinez & A. Castro Superfine (Eds.), *Proceedings of the 35th Annual Meeting for the North American Chapter of the Psychology of Mathematics Education* (pp. 260–267). Chicago, IL: University of Illinois.
- Weber, K. (2015). Effective proof reading strategies for comprehending mathematical proofs. *International Journal of Research in Undergraduate Mathematics Education, 1*(3), 289–314.

Abduction in argumentation: Two representations that reveal its different functions

Chrysi Papadaki, [David Reid](mailto:dreid@uni-bremen.de) and Christine Knipping

University of Bremen, Germany

chrysi@uni-bremen.de, dreid@uni-bremen.de, knipping@math.uni-bremen.de

Abduction can function in argumentation and proving processes in different ways. In this paper we focus on the ways in which abductive arguments, taking place in argumentation and proving processes, can be reconstructed in the frame of a Global Argumentation Structure (GAS). We propose two different ways to model abductive arguments within a GAS, with a forward or a backward flow, depending on the function of these arguments in the whole argumentation.

Keywords: Abduction, argumentation, proof, Toulmin-model, Global Argumentation Structure.

Introduction

Researchers in mathematics education have seen abduction either as process of reasoning backwards (a kind of reversed deduction) (Pedemonte, 2002; Knipping, 2003) or as a process for creating hypotheses (Peirce, 1878; Pease & Aberdein, 2011). The purpose of this paper is to examine the ways in which abductive arguments have been modelled up to now and to propose two different ways of modelling them, depending on their function in the argumentation. We are interested in modelling abductive arguments in the frame of the whole Global Argumentation Structure (Knipping, 2003) of the argumentation or proving process taking place, rather than in isolation from the other arguments taking place (as done for example by Pedemonte, 2002).

Abduction in argumentation and proof

Abduction is an area of research that has received increasing emphasis in mathematics education, in reference to a number of different processes. Here we discuss abduction in mathematical argumentation. As we consider mathematical proof to be a kind of argumentation, our discussion includes also abduction in mathematical proof.

A simple way to distinguish between abduction and deduction is to consider how they connect a case to a result via a rule. An example often cited in the mathematics education literature comes from an article Charles Saunders Peirce published in *Popular Science Monthly* in 1878. At this time he referred to abduction as “hypothesis”, and characterised the two processes as shown in Table 1 below. From this example it is evident that abduction can be thought of as a reversed deduction, reasoning from a Result via a Rule to a Case, rather than from a Case via a Rule to a Result.

Deduction.	Hypothesis. [Abduction.]
<i>Rule.</i> —All the beans from this bag are white. <i>Case.</i> —These beans are from this bag. \therefore <i>Result.</i> —These beans are white.	<i>Rule.</i> —All the beans from this bag are white. <i>Result.</i> —These beans are white. \therefore <i>Case.</i> —These beans are from this bag.

Table 1: Peirce’s syllogisms for deduction and abduction (1878, p. 472; CP 2.623)

Toulmin (1958) provides a model that can be used to analyse arguments in general, not only deductive arguments. In his model (see Figure 1), an argument includes the following elements:

C (claim or conclusion) the statement of the speaker, D (data) are data justifying C, W (warrant) the inference rule that allows data to be connected to the claim, B (backing) is reason to believe W, Q (qualifier) expresses *how much* to believe C, R (rebuttal) tells you *when* belief in C is *not* supported

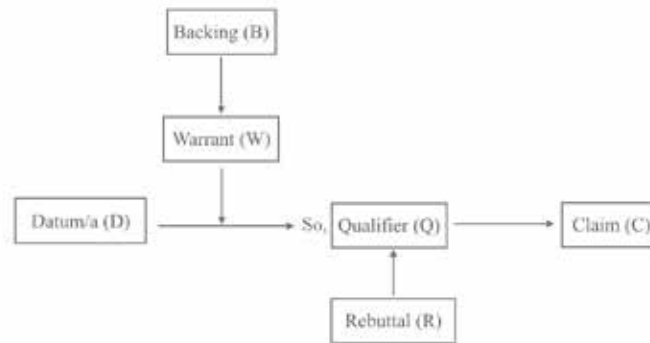


Figure 1: The Toulmin model of an argument (1958)

Toulmin considered only two types of reasoning when he created his model, namely deduction and induction. There are however, several cases in the literature of researchers modelling abduction using Toulmin’s model in different ways. In Table 2 we use Peirce’s example and terminology as a common reference in order to describe and depict the different ways in which abduction has been modelled using Toulmin’s terminology.


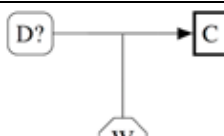
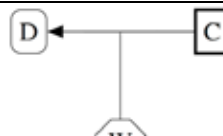
Peirce	Pease & Aberdein (2011)	Pedemonte (2002)	Knipping (2003)
Rule	W 	W 	W 
Result	D	C	C
Case	C	D?	D
Function of abduction	Generating hypothesis	Reasoning backwards	Reasoning backwards
Structure of abduction (Flow)	Forward	Forward	Backwards

Table 2: Peirce’s abduction modelled with Toulmin’s terminology

Pease and Aberdein (2011) keep the forward flow (arrows pointing from left to right) of Toulmin’s model but they characterise as a datum the Result that is known and needs no justification, and the claim as the Case that is inferred. They express the uncertainty of the claim by employing a qualifier (the word “probably”) before the claim (see Figure 2). Pedemonte (2002) was the first researcher in mathematics education to use Toulmin’s model to describe abduction. She too models an abductive argument with a forward flow but reverses Pease and Aberdein’s (2011) placement of data and claim. She considers a claim to be the known target of the inference (Result) and the datum to be the unknown fact (Case), which must hold in order for the claim to stand. She denotes the

status of the unknown datum with a question mark next to the letter D representing the datum. The difference between Pease and Aberdein's, and Pedemonte's modelling of abduction may arise because of the different functions they attribute to it. Pease and Aberdein see abduction as a process of generating a hypothesis, whereas Pedemonte sees it as a reversed deductive process, as "reasoning backwards". It is also important to note that these researchers model individual arguments, in isolation from other arguments.

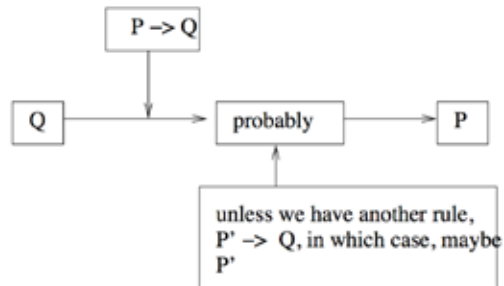


Figure 2: Structure of an abductive argument, Pease and Aberdein (2011, p.12)

In contrast Knipping (2003, 2008) describes a way of linking together arguments analysed using the Toulmin model to describe larger structures of argumentation. She reconstructs the whole argumentation of students, building a Global Argumentation Structure (GAS), which reveals a complete overview of the argumentation that took place. For example, Figure 3 shows her analysis of the argumentation in a lesson in which the Pythagorean theorem was proven. Knipping (2003), like Pedemonte, sees the function of abduction as "reasoning backwards". She reconstructs complex deductive argumentation processes, which may contain some abductive arguments. The flow of the overall GAS is a forward one, but the flow of the abductive arguments is a backward one (see Figures 3 and 4). Like Pedemonte (2002) she considers the claim to be the Result of the inference and the datum to be the Case, which must hold in order for the claim to stand. But she marks the abduction differently, by reversing the arrow to indicate the backward flow, and she does not use a question mark next to the letter D to indicate the unknown fact.

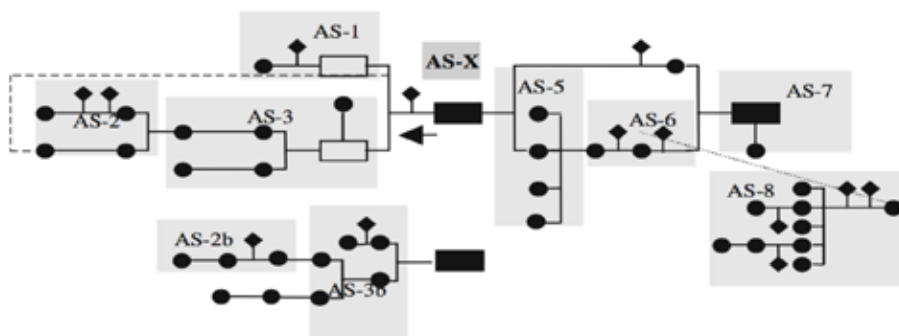


Figure 3: GAS of discussion on the Pythagorean theorem, Knipping (2008, p. 437)

The arrow in AS-X in Figure 3 marks the abduction. The students know they want to conclude that ABCD is a square, and they use abduction to go from this desired conclusion to the datum ($BCD=90^\circ$) needed. The dotted line marks the shift in focus to finding an argument for the conclusion ($BCD=90^\circ$). Through AS-2 and AS-3 they establish $BCD=90^\circ$ and combining this

datum with the previous established statement ABCD is a rhombus, they deduce the desired conclusion, ABCD is a square.

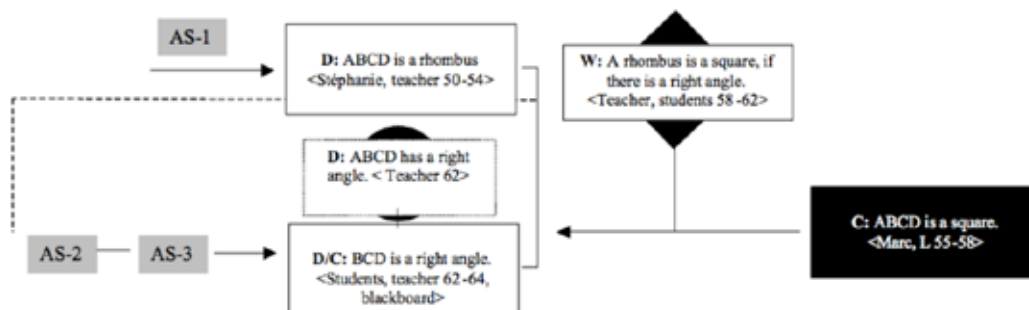


Figure 4: Abductive argument reconstructed with a backward flow, Knipping (2003, p.8)

Methodology of the data analysis

In the following we compare two Global Argumentation Structures developed following the procedures outlined in Knipping and Reid (2013). They describe a three-stage process: reconstructing the sequencing and meaning of classroom talk; analyzing arguments and argumentation structures; and comparing argumentations to reveal their rationale.

Here we are chiefly interested in comparing two Global Argumentation Structures that emerged in two mathematics classrooms and which have some interesting differences regarding the abductive arguments taking place in them. We will describe each context and the abductions that occurred before comparing the two.

Ms James' classroom

The abduction described here occurred in Ms James' grade 9 (age 14-15 years) classroom in Canada. The class was trying to explain why two diagonals that are perpendicular and bisect each other define a rhombus. The students had discovered and verified this property while working in a Dynamic Geometry Environment (DGE).

Figure 5 shows the reconstructed argumentation stream that occurred after the class had identified the given information in the situation and had recorded it in the diagram Ms James was drawing on the board. She then asked the class what information was needed to show that a shape is a rhombus, given the definition. This stream is interesting because the statements that were made first chronologically, appear last, on the right hand side, and vice versa. This is similar to the abductive stream described by Knipping (2003) in that the argument goes backwards from the intended conclusions to the data needed to deduce that conclusion. It differs, however, as it involves several abductive steps connected in a stream.

There are linguistic markers of what is going on in the transcript. For example, Ms James says:

Ms James: If I can prove that that is the same length as that, is the same length as that, is the same length as that [draws in the segments AB, BC, CD, and DA]. If I can prove that, I'm done. Rhombus. [Statement T-28 in Figure 5]

The phrase “If I can” marks this as an abduction. In a classroom proving process, where the main flow of the argument is deductive, it makes sense to diagram such abductions in this way, as if they were deductions, but marking them with arrows showing the flow of the argument in the opposite direction. This is shown in the GAS in Figure 6.

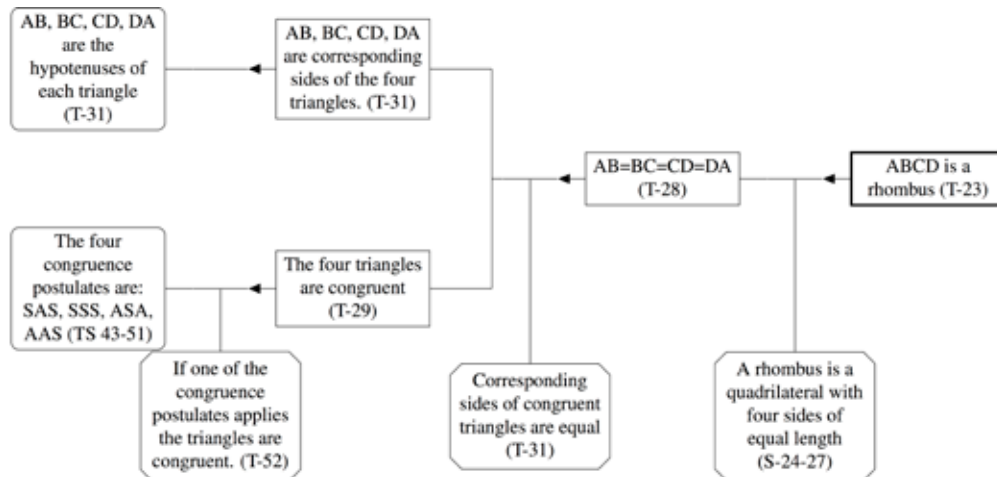


Figure 5: The abductive argumentation stream from Ms James' class (the parenthetical comments after each statement indicate speaker and transcript line)

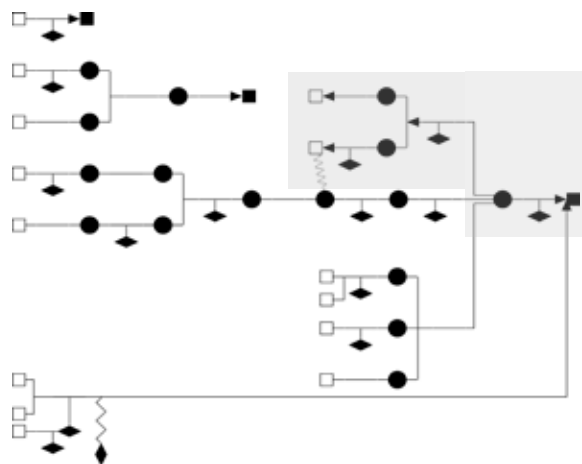


Figure 6: The GAS from Ms James' class. The shaded area is the abductive stream shown in Figure 5

Axel and Dave

In the case presented here two 10th grade students (Axel and Dave) in a German classroom worked together on a geometry task designed in a DGE. All the students in the classroom worked on the geometrical tasks in pairs and at the end all the tasks were discussed in a whole-class discussion with the focus being the argumentation the students provided to justify their answers. In the task the DGE window was divided into two sub-windows (see Figure 7). On the right sub-window (3D Graphics) there was a 3D coordinate system in which a solid had been constructed and hidden, and the plane xOy . On the left sub-window there were three sliders (h for height, n for tilt and d for spin) that the students could manipulate in order to move the invisible solid, and a two-dimensional

depiction of the intersection of the solid with the xOy plane. The main question set to the students was: “What solid do you think this could be, judging from its cross-sections?”. The students were provided with a worksheet, which included an Exploration Matrix with specific (h, n, d) slider positions they could use if they wanted. They were asked to justify their answers in writing. The students were not told how to justify their conclusions, only that they should attempt to explain the validity of their conclusions and to be as complete (leaving no doubts) as possible. There was no requirement that they follow a deductive structure, or that they produce a formal proof.

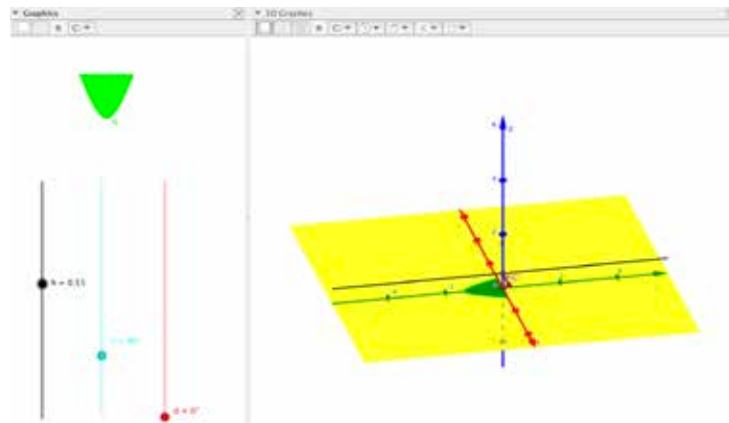


Figure 7: Task in DGE – Position $(h=0,55, n=90^\circ, d=0^\circ)$ of hidden solid

The GAS presented here (Figure 8) represents Axel and Dave’s argumentation that took place in their discussion during their pair work alone, before the classroom discussion. Axel and Dave used the positions in the Exploration Matrix for their explorations. They started by generating four hypotheses and during their exploration they refuted step-by-step three out of the four hypotheses. The remaining hypothesis (H_{16}) became then a claim (Cl_{23-25}), which they would later provide an argument for, in order to verify it. After the verification the epistemic value (Duval, 2007) of the statement “The solid is a cone” changes and from a claim it becomes a conclusion ($C_{118.2-120}$). This GAS has two phases (Argumentation Streams). In the first phase (AS-1) belongs the process of generating hypotheses, during which the students suggest possible solutions to the problem, basing their decisions on the data they gather. This is then followed by the second phase (AS-2), during which more data are provided to support the claim (Cl_{23-25}). With the support of these new data, the claim is then treated by the students as a conclusion ($C_{118.2-120}$).

The abduction here (AS-1) is not represented as reasoning backwards, rather a process of suggesting multiple possible solutions to a problem all of which, at least initially, seem plausible. Here the chronological flow of the statements made corresponds to their logical function in the argumentation. For example, the conclusion $C_{118.2-120}$ (which is usually the last inference drawn in an argumentation) comes last both chronologically (in the argumentation) as well as structurally (in the GAS). In such cases, in which speculation is required and the students engage in hypothetical reasoning, it makes sense to diagram abduction with a forward flow.

In the case of Axel and Dave, unlike in that of Ms James’ classroom, there are no warrants in the GAS. This should not be interpreted as that the students had no warrants in mind when creating hypotheses or drawing conclusions. The absence of warrants is merely the result of our

methodology according to which, what is depicted in the reconstructed argumentation is only what the students state explicitly, and not what they may have been thinking but have not said.

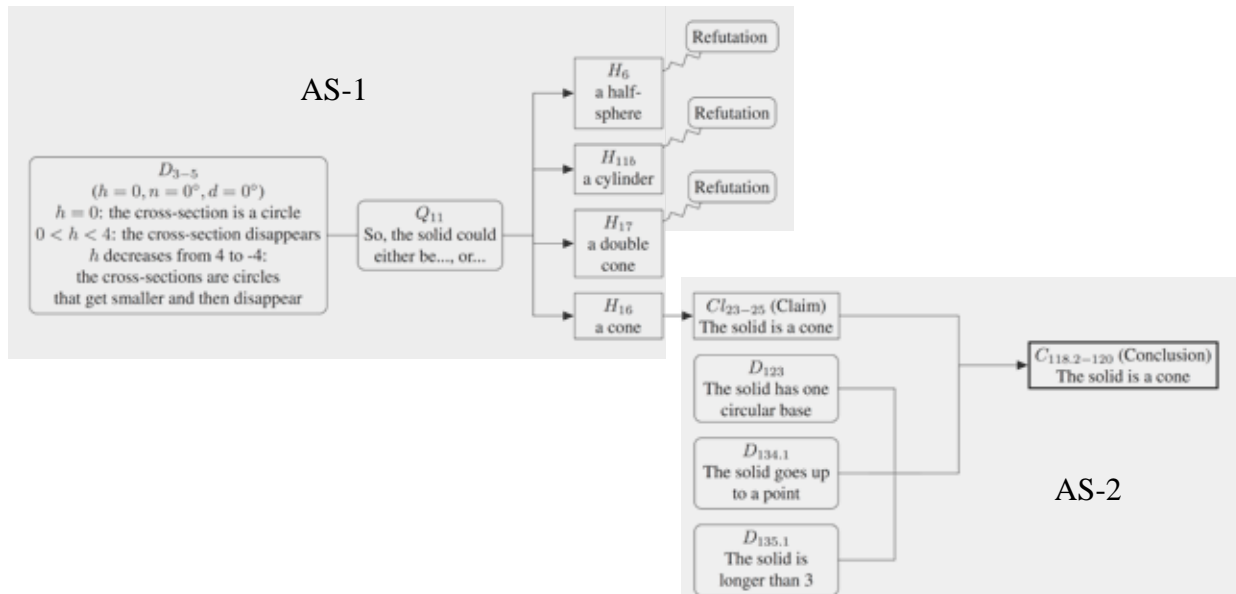


Figure 8: The GAS in Axel and Dave's discussion

Conclusions

Abduction has two different functions, *explaining* and *exploring*, and depending on the function that it has in argumentation, the reconstructed Global Argumentation Structure is also different.

In Ms James' classroom abduction was used to reason backwards from a desired conclusion to the data needed to deduce it. The students know that the shape is a rhombus and they are seeking data that can connect that conclusion to what they know about the diagonals. They are using abduction in order to *explain* the known conclusion. Most of the arguments in the GAS are deductive, and it is important to note that the final 'official' proof omits the abductive steps. Having abduced the necessary data, they then establish it deductively from other data they already know, and then use it to deduce their desired conclusion. In the case of Axel and Dave, abduction is used to generate hypotheses. They are *exploring* to discover something new. Their hypotheses are then tested in the second phase of their argumentation, through comparison with data generated in the DGE.

The differences in the GASs in these two situations reveal an important difference in the way abduction functions in them. This shows how such an analysis can reveal not only the presence of an abduction but also the role it plays in the overall argumentation. The ways in which the abductions in Ms James' classroom and Axel and Dave's pair work were represented, as flowing backwards or forwards, reflect the functions of the abductions. When abductions are used to explain, the flow is backwards to the facts that explain the conclusion. When abductions are used to explore, the flow is forwards, from data that has been collected to possible results, and includes qualifiers to mark the epistemic value of the inference. The role of qualifiers is vital in order to keep a forward flow for the abduction in an overall abductive GAS.

These differences in function, in turn, depend on the nature of the mathematical tasks. In the case of Axel and Dave the geometrical object the students are asked to work with is unknown and they are not told that they need to prove anything. The focus of their argumentation is the generation and justification of hypotheses, rather than proof production. It is not even possible for them to deductively prove a hypothesis is correct; they can only disprove false hypotheses. In Ms James' case the task was explicitly to find a proof of a given statement. The status of the statement as a conclusion is already established, by the students empirical explorations earlier and by the teacher's authority. In such a proof production task it is clear that the overall structure must be deductive, and abductive argument is incidental, not essential to the argumentation. The final proof could have been produced without using abduction.

We have shown in this paper how Pease and Aberdein's (2011) way of modelling abduction (forward flow of the abductive argument) can be embedded into GASs reconstructed using Knipping's (2003, 2008) methodology, when the function of the abduction is exploring. We are not claiming that the two ways that abduction has been modelled in the GASs we described are all the possibilities. Research in other contexts will no doubt reveal other ways in which abduction is embedded in argumentation structures. However, our describing and distinguishing these two ways, along with the associated functions of the abductions in the argumentation, is a contribution to research in this area.

References

- Duval, R. (2007). Cognitive functioning and the understanding of mathematical processes of proof. In P. Boero (Ed.), *Theorems in schools: From history, epistemology, and cognition to classroom practice* (pp. 137–161). Rotterdam: Sense Publishers.
- Knipping, C. (2003). Argumentation structures in classroom proving situations. In M.A. Mariotti (Ed.), *Proceedings of the Third Conference of the European Society in Mathematics Education* (unpaginated). Bellaria, Italy. Retrieved from http://ermeweb.free.fr/CERME3/Groups/TG4/TG4_Knipping_cerme3.pdf
- Knipping, C. (2008). A method for revealing structures of argumentations in classroom proving processes. *ZDM Mathematics Education*, 40, 427–441.
- Knipping, C., & Reid, D. (2013). Revealing structures of argumentations in classroom proving processes. In A. Aberdein & I. J. Dove (Eds.), *The argument of mathematics* (pp. 119–146). New York: Springer.
- Pedemonte, B. (2002). *Etude didactique et cognitive des rapports de l'argumentation et de la démonstration dans l'apprentissage des mathématiques*. Thèse de doctorat. Grenoble I: Université Joseph Fourier.
- Pease, A., & Aberdein, A. (2011). Five theories of reasoning: Interconnections and applications to mathematics. *Logic and Logical Philosophy*, 20(1-2), 7–57.
- Peirce, C. S. (1878). Deduction, induction, and hypothesis. *Popular Science Monthly*, 13 (August), 470-82. (Compiled in Peirce, C. S., 1960, 2.619-644)
- Peirce, C. S. (1960). *Collected papers*. Cambridge, MA: Harvard University Press.
- Toulmin, S. E. (1958). *The uses of argument*. Cambridge: Cambridge University Press

Some linguistic issues on the teaching of mathematical proof

Yusuke Shinno¹, Takeshi Miyakawa², Tatsuya Mizoguchi³, Hiroaki Hamanaka⁴ and Susumu Kunimune⁵

¹Osaka Kyoiku University, Osaka, Japan; shinno@cc.osaka-kyoiku.ac.jp

²Joetsu University of Education, Niigata, Japan; miyakawa@juen.ac.jp

³Tottori University, Tottori, Japan; mizoguci@tottori-u.ac.jp

⁴Hyogo University of Teacher Education, Hyogo, Japan; hammer@hyogo-u.ac.jp

⁵Shizuoka University, Shizuoka, Japan; ecskuni@siren.ocn.ne.jp

There are different meanings of proof-related words and their connotations in different languages. This study aims to reveal issues of the relationship between natural and mathematical language in the teaching of mathematical proof. For this purpose, we examine the grammatical characteristics of language from Japanese and international perspectives, as well as linguistics issues associated with statements with quantifications. A pilot study shows that natural language may influence how statements are formulated by students in mathematical discourse.

Keywords: Mathematical proof, statement, quantification, ordinary language, theory.

Introduction

Proof-related words such as “proof” and “argumentation” are used by different people in different ways. According to recent publications within mathematics education research, the meaning of “proof” is still a subject of debate among researchers (e.g. Balacheff, 2008; Cabassut et al., 2012; Mariotti, Durand-Guerrier, & Stylianides, 2018; Reid, 2015; Reid & Knipping, 2010; Stylianides, Bieda, & Morselli, 2016). In an international context, it is especially important for researchers to consider cultural dimensions that may affect the use of such words in different countries (e.g. Reid, 2015; Sekiguchi & Miyazaki, 2000). As discussed by Shinno et al. (2018), there are two words for “proof” used in Japan: *shōmei* and *ronshō*, as follows.

Some Japanese works distinguish the word *ronshō* from *shōmei* by referring to their relationship with the system of mathematics. [...], such that *shōmei* is related to deriving consequences from premises for establishing the truth of a proposition, while *ronshō* is related to the (axiomatic) system in which logical relations between propositions take place. (Shinno et al., 2018, p. 26)

Sometimes, *ronshō* is used as a special type of *shōmei* (Shinno et al., 2018). This distinction is similar but not identical to the distinction between the French words: *preuve* and *démonstration*, as Balacheff (1987) discussed. According to this distinction by Balacheff, *preuve* and *démonstration* are translated as the English words “proof” and “mathematical proof”, respectively. As a commentary on Shinno et al. (2018), Koichu (2018) also discusses two proof-related words in Hebrew: *hohaha* and *hanmaka*.

Two Hebrew words are frequently used in the official Israeli mathematics curricula: *hohaha* (translates as proof) and *hanmaka* (translates as both argumentation and reasoning). Similarly to Japan, Israeli curricula treat *hohaha* as a particular case of *hanmaka* where the former notion

presumes mathematical rigor and the latter one is somewhat vague and alludes to providing an argument without strictly prescribing what type of argument may be used. (Koichu, 2018, p. 26)

Identifying such proof-related terminologies and their differences and similarities across languages might reveal underlying cultural issues in the educational system or curricula of different countries. For Japan, the word *ronshō* indicates an emphasis on a systematic approach to mathematics, and the word *shōmei* is reserved for validating a general statement (Shinno et al., 2018). This is likely due to the quasi-axiomatic nature of the content and sequencing of the Japanese geometry curriculum and to the fact that all statements required to be proven in the textbook relate to general objects (Miyakawa, 2017). In the case of Hebrew, “the *hohaha* and *hanmaka* notions are complementary in Israeli middle school textbooks, as well as in the intermediate-level high school curriculum” (Koichu, 2018, p. 26). Koichu also mentions that in Miyakawa’s (2017) finding, it “sounds as if the idea of *shōmei* was put forward in Israeli textbooks, but *ronshō* was in the minds of the textbook writers as part of their horizon knowledge” (p. 26). Thus, a linguistic or terminological comparison of the teaching of proof in different countries might be possible. In doing so, it behooves researchers to investigate how such linguistic differences may affect curricula and textbooks (or classroom teaching) in each country.

The meaning of proof-related words differs from culture to culture, depending on the language used in a specific country. Nevertheless, it is possible for researchers to identify similar connotations across different languages. In order to further discuss cultural and linguistic dimensions of proof, the present study attempts to reveal issues concerning the relationship between natural and mathematical language on the teaching of mathematical proof.

Theoretical background and methodology

Mariotti (2006) states, “it is not possible to grasp the sense of a mathematical proof without linking it to the other two elements: statement and theory” (p. 184). Within this triad (statement, proof, and theory), the first two elements, statement and proof, can be subjected to investigation in terms of their different linguistic formulations; the third element, theory, is of a more epistemological nature. A model (a reference epistemological model) proposed by Shinno et al. (2018) consists of three layers—“real-world logic”, “local theory”, and “axiomatic theory”—which are characterized in terms of the epistemological nature of theory, wherein the statement is formulated, and the proof is carried out. For the purposes of international discourse, it is important for researchers to make a distinction and/or connection between the linguistic formulation (representation) of the statement/proof and its epistemological nature (Balacheff, 2008). For example, the linguistic distinction between *shōmei* and *ronshō* can be understood through the epistemological distinction between local and axiomatic theory (Shinno et al., 2018).

This paper pays special attention to linguistic formulations of the statement to be proven in Japanese textbooks. Concerning the linguistic aspects of proof, it is important to take into account the relationship between natural and mathematical language, because word usage in natural language may influence how statements and proofs are formulated and understood by students in mathematical discourse. This topic has been discussed in various ways (e.g. Barton & Neville-Barton, 2004; Cousin & Miyakawa, 2017; Duval, 2017; Mejia-Ramos & Inglis, 2011; Pimm, 1987; Planas, Morgan,

& Schütte, 2018). In this paper, we analyse some typical statements from Japanese textbooks to clarify how ordinary Japanese language is used in mathematical discourse. We also present a pilot study which allowed us to investigate Japanese undergraduate students' difficulties with linguistics issues related to statement with quantifications.

The relation between natural and mathematical language in Japanese textbooks

The grammatical characteristics of the Japanese language

Mathematics sentences such as $5 + 3 = 8$ are introduced at the beginning of the first grade (6- to 7-year-old students) in Japan. As seen in Figure 1, the textbook (both Japanese and English versions) shows how to read the sentence (“5 plus 3 equals 8”), alongside other representations such as blocks.



Figure 1: Math sentence in a Japanese textbook (Shimizu & Funakoshi, 2011, p. 39)

The sentence “5 plus 3 equals 8” is seen as mathematical discourse in English, which translates as “5 *tasu* (たす) 3 *wa* (は) 8” in Japanese. Here “*tasu*” refers to “plus”, and “*wa*” refers to “equals”. From a grammatical point of view, however, this Japanese sentence is not proper. In ordinary Japanese, it should be “5 *ni* 3 *wo tasu to* 8 *ni naru*” (please focus on only the bold words in this sentence, since others are particles which have no counterparts in the English sentence). Here, “*tasu*” means “plus (or add)”, but “*naru*” means “makes (or becomes)” which can be the same as “equals”. This is because, in Japanese grammar, the verb generally appears at the end of the sentence. If the sentence “5 *ni* 3 *wo tasu to* 8 *ni naru*” above is translated literally into mathematical symbols, it would be like “5 3 + 8 =” which contradicts the syntax of mathematics (Hirabayashi, 1994). This fact can be seen as a linguistic peculiarity of Japanese grammatical characteristics. This may cause an obstacle in the understanding of mathematical sentences on the basis of Japanese language, because grammatical order of some statements, which appears at a more advanced level such as AE and EA statements, is crucial for interpreting what a given statement mean in mathematical discourse.

Difficulties related to the linguistic and logical aspects from an international perspective

One characteristic of statements in Japanese textbooks for lower secondary schools is that the statement to be proven is considered a universal proposition (Miyakawa, 2017). However, universal quantification using ordinary language and words such as “any” and “all” is rarely encountered in lower secondary textbooks across domains; that is to say, universality is rarely formulated in written form. Therefore, Japanese students and teachers are required to interpret a universal proposition without any quantification. This is probably because the Japanese language does not use articles (Shinno et al., 2018). As Pimm (1987) comments, the situation is similar in Russian, in which

there is no article marker distinguishing *a* from *the*, the definite from the indefinite. Yet this language contains a sophisticated mathematics register fully capable of distinguishing the meaning ‘there exists’ from ‘there exists a unique’. (Pimm, 1987, p. 81)

Japanese does not have such “a sophisticated mathematics register”, at least in secondary school textbooks. Additionally, according to Durand-Guerrier et al. (2016), it is difficult even for people who speak English (and many European languages) to distinguish an implicit universal quantifier from other meanings of an indefinite article:

A well-known difficulty is related to the meaning of ‘a’ that can either refer to an individual, a generic element, or an implicit universal quantifier. (Durand-Guerrier et al., 2016, p. 89)

Beyond the grammatical aspects of a given language, this issue is related to students’ interpretations of universal quantifications. We will develop this issue when introducing the pilot study.

Most Japanese students have few opportunities to consider quantification in their own language. Most do not encounter quantifiers formulated in mathematical terms or symbols such as “ ” or “ ”, based on predicate logic, until they reach university. To this point, and as a reply to Shinno et al. (2018), Czoher, Dawkins, and Weber (2018) argue that “universal statements in American classrooms are often not explicitly quantified, either” (p. 25). Further, Czoher et al. (2018) introduce an excerpt from a textbook used in the United States:

In a popular undergraduate textbook, Hammack (2013) directly addressed this point:

Now we come to the very important point. In mathematics, whenever $P(x)$ and $Q(x)$ are open sentences concerning elements x in some set S (depending on context), an expression of form $P(x) \rightarrow Q(x)$ is understood to be the statement $\forall x \in S (P(x) \rightarrow Q(x))$. In other words, if a conditional statement is not explicitly quantified then there is an implied universal quantifier in front of it. This is done because statements of the form $\forall x \in S, P(x) \rightarrow Q(x)$ are so common in mathematics that we would get tired of putting the $\forall x \in S$ in front of them. (Hammack, 2013, p. 46).

We interpret this excerpt to mean that a focus on universal statements is an invariant part of mathematical practice. (Czoher et al., 2018, p. 25)

While we agree with both Hammack’s assertion, “if a conditional statement is not explicitly quantified then there is an implied universal quantifier in front of it”, and Czoher et al. (2018)’s commentary, it seems to us that this book is intended to introduce undergraduate students to predicate logic. At the undergraduate level, Japanese students also need to pay attention to the similar point made in the excerpt. We wonder if this phrase still holds true for general statements taught at lower grades in the United States. It might be difficult to examine, however, because “proving opportunities are limited or non-existent in the curriculum as enacted in many American classrooms” (Czoher et al., 2018, p. 24), even though, as they also mention, it is important to make empirical comparisons of the usage of universal quantifications across different countries.

As described above, most students do not encounter quantifiers formulated in mathematical terms or symbols until they reach the undergraduate level. It is worth investigating whether language influences students’ understanding in the transition from secondary school to university. Here, we focus on the linguistic aspects of universal and existential quantifications to be formulated in a given statement, so-called AE and EA statements, as below (e.g. Dubinsky & Yiparaki, 2000)).

- AE statement: *For every x , there exists a y such that $f(x, y)$.*
- EA statement: *There exists an x such that for every y , $f(x, y)$*

Previous studies, conducted in English-speaking countries, reported that students faced difficulties in distinguishing the two kinds of statements (e.g. Dubinsky & Yiparaki, 2000). Difficulties related to AE/EA statements are also prevalent in the Japanese mathematics (education) community, and there is an assumption that these difficulties are affected by ordinary language (e.g. Hosoi, 1981). These difficulties are related to what Selden and Selden (1995) call “unpacking (logical structure of) informal statements”. Let us briefly explain the linguistic issues of the universal and existential quantifiers of AE/EA statements. In terms of English, they can be explained as follows.

In everyday language, statements where the words ‘there is’ precede the words ‘for every’ are almost always interpreted as if the words ‘for every’ precede the words ‘there is’. (Durand-Guerrier et al., 2012, p. 376)

Unlike in ordinary English sentences, it is difficult to interpret this exchange between the words “there is” and “for every” in Japanese. In English, both phrases precede the *variables* such as “for every X ” and “there is Y ”. In Japanese, the words “for every” precede the variable, but the phrase “there is” does not precede. Thus, the grammatical order of the English phrase, “there is Y ”, is not preserved in Japanese (cf. Hosoi, 1981), because “is” or “exist” cannot precede the object “ Y ”. Rather, the phrase “ x exists” is more natural than “there exists x ”. Due to this linguistic issue, it is unusual for Japanese speakers to read and write the words according to the order of EA statements, as in English. In Japanese, when we intend to write two kinds of statements in a distinct way, different formulations or representations by ordinary Japanese are possible, but all of them contain vague words or additional notations (like brackets) to preserve the order.

A pilot study: Japanese students’ interpretations of AE and EA statements

To investigate Japanese undergraduate students’ difficulties or gaps associated with their interpretations of statements involving multiple quantifiers, we conducted a pilot study targeting 47 undergraduate students (as native Japanese speakers) who had already learnt mathematical statements with multiple quantifiers. The questionnaire included both AE and EA statements formulated in two ways: mathematical and English. The participants were asked to translate each statement into Japanese and to judge whether a given statement was true or false. Figure 2 indicates the two types of questions. Different formulations of the same statement are found in 1A and 2A and 1B and 2B; 1A and 2A are AE statements (true), while 1B and 2B are EA statements (false).

The participants were divided into two groups. Twenty-four participants were asked to translate 1A and 1B into the Japanese form, while 23 participants were asked to translate 2A and 2B into the Japanese form. Both groups were then asked to judge whether a given statement was true or false and to write down their justifications. The results are shown in Table 1.

-	Type 1: Mathematical form \rightarrow Japanese form (N=24)
	1A: $\forall n \in \mathbb{N}, \exists K \in \mathbb{N}, 2n < K$
	1B: $\exists x \in \mathbb{R}, \forall y \in \mathbb{R}, x + y = 0$
-	Type 2: English form \rightarrow Japanese form (N=23)
	2A: For every natural number n , there exists a natural number K such that $2n < K$
	2B: Let x and y be real numbers. There exists an x such that for every y , $x + y = 0$

Figure 2: Two types of questions

	1A (true)	1B (false)	2A (true)	2B (false)
True	23	2	21	20
False	1	22	2	3

Table 1: Result of participants' true/false judgments

These results show that most participants could adequately interpret AE statements (both 1A and 2A). However, there are considerable variations in their interpretations of EA statements. Although many participants could judge that statement 1B (in mathematical form) was false, most of them (20/23) failed to interpret statement 2B (in English form) in their own language. It is worth noting how ordinary language influenced their discrepant interpretations. Figure 3 shows a typical example of this confusion, wherein the participant interpreted the false EA statement (2B) as a true AE statement in Japanese. The box on the right in Figure 3 provides our back-translation. It is important to note that this translation is not “correct” in terms of the English language, because the order of Japanese phrases is preserved, and the term “*tonaru* (となる)” which corresponds to “such that” is not translated. The point here is that the condition which comes after “such that” in English precedes “*tonaru*” in ordinary Japanese language, and Japanese people may not clearly know from this sentence whether the first phrase “For every y ” is included in the condition of the existential proposition (EA statement) or not (AE statement). The meaning of the sentence would be clearer if we put the two first phrases into brackets or quotations, but this is not common.

<p>和訳:</p> <p>x, y を実数とする。</p> <p>すべての y に対して、$x + y = 0$ となる x が存在する。</p> <p>真偽: <u>真</u></p> <p>理由:</p> <p>$x = -y$ とおけば、命題は成り立つ。</p>	<p>(Japanese translation):</p> <p><i>Let x and y be real numbers.</i></p> <p><i>For every y, $x + y = 0$, x exists.</i></p> <p>(True/False): <i>True</i></p> <p>(Justification): <i>Set $x = -y$, the statement holds.</i></p>
--	--

Figure 3: A typical example of incorrect interpretation

Conclusion

The logical difference between AE and EA statements may not always be preserved when the two statements are written in everyday Japanese sentences. The pilot study shows that many students are not very conscious of this linguistic characteristic; therefore, most of them failed to interpret EA statements (English) in the Japanese language. To create an opportunity for further international comparative study, it is important to elaborate a meta theoretical language (e.g., a reference epistemological model) for research from international perspectives, since a researcher may need to use different languages for different purposes (Chellougui, Thu, & Winsløw, 2016). Without such a common ground, it would be more challenging for international readers to share “invariant aspects of mathematical reasoning” (Czocher et al., 2018) which we initially associated with a Japanese context.

Acknowledgment

This research is supported by JSPS KAKENHI (JP18H01015 & JP17K04775).

References

- Barton, B., & Nevillle-Barton, P. (2004). *Undergraduate mathematics learning in English by speakers of other languages*. Paper presented at the 10th International Congress on Mathematical Education. Copenhagen, Denmark.
- Balacheff, N. (1987). Processus de preuves et situations de validation. *Educational Studies in Mathematics*, 18(2), 147–176.
- Balacheff, N. (2008). The role of the researcher's epistemology in mathematics education: An essay on the case of proof. *ZDM Mathematics Education*, 40(3), 501- 512.
- Cabassut, R., Conner, A., İşçimen, F. A. Furinghetti, F., Jahnke, H. N., & Morselli, F. (2012). Conceptions of proof in research and teaching. In G. Hanna & M. de Villiers (Eds.), *Proof and proving in mathematics education: The 19th ICMI study* (pp. 169- 190). New York, NY: Springer.
- Chellougui, F., Thu, H. N. T., & Winsløw, C. (2016). Language diversity in research on language diversity in mathematics education. In R. Barwell et al. (Eds.), *Mathematics education and language diversity: The 21st ICMI study* (pp. 263–277). Switzerland: Springer.
- Cousin, M., & Miyakawa, T. (2017). Evolution of proof form in Japanese geometry textbooks. In T. Dooley & G. Gueudet (Eds.) *Proceedings of the Tenth Congress of the European Society for Research in Mathematics Education* (pp. 131–138). Dublin, Ireland: ERME.
- Czocher, J. A., Dawkins, P. C., & Weber, K. (2018). Alternative perspectives on cultural dimensions of proof in the mathematical curriculum: a reply to Shinno et al. *For the Learning of Mathematics*, 38(2), 23–25.
- Dubinsky, E., & Yiparaki, O. (2000). On student understanding of AE and EA quantification. In E. Dubinsky, A. H. Schoenfeld & J. Kaput (Eds.), *CMBS issues in mathematics education* (pp. 239–289). Providence, RI: American Mathematical Society.
- Durand-Guerrier, V., Boero, P., Douek, N., Epp, S. S., & Tanguay, D. (2012). Examining the role of logic in teaching proof. In G. Hanna & M. de Villiers (Eds.), *Proof and proving in mathematics education: The 19th ICMI study* (pp. 369- 389). New York, NY: Springer.
- Durand-Guerrier, V., Kazima, M., Libbrecht, P., Ngansop, J. N., Salekhova, L., Tuktamyshov, N., & Winsløw, K. (2016). Challenges and opportunities for second language learners in undergraduate mathematics. In R. Barwell et al. (Eds.), *Mathematics education and language diversity: The 21st ICMI study* (pp. 85–101). Switzerland: Springer.
- Duval, R. (2017). *Understanding the mathematical way of thinking: the registers of semiotic representations*. Switzerland: Springer.
- Hammack, R. H. (2013) *Book of Proof*. Richmond, VA: Richard Hammack.
- Hirabayashi, I. (1994). *Mathematics experiences for elementary school teachers*. Nagoya: Reimei-Shobo. (In Japanese)
- Hosoi, T. (1981). Logical representation and Japanese language. In I. Tajima & S. Shimada (Eds). *Mathematics and Japanese language* (pp. 106–118). Tokyo: Kyoritsu Shuppan. (In Japanese)

- Koichu, B. (2018). On making epistemological inferences based on linguistic observations: a commentary on Shinno et al. *For the Learning of Mathematics*, 38(2), 25–27.
- Mariotti, M. A. (2006). Proof and proving in mathematics education. In A. Gutiérrez & P. Boero (Eds.), *Handbook of research on the psychology of mathematics education: Past, present and future* (pp. 173–204). Rotterdam, The Netherlands: Sense Publishers.
- Mariotti, M. A., Durand-Guerrier, V., & Stylianides, G. J. (2018). Argumentation and proof. In T. Dreyfus et al. (Eds.), *Developing research in mathematics education: twenty years of communication, cooperation, and collaboration in Europe* (pp. 75–89). New York, NY: Routledge.
- Mejia-Ramos, J. P., & Inglis, M. (2011). Semantic contamination and mathematical proof: can a non-proof prove? *Journal of Mathematical Behavior*, 30, 19–29.
- Miyakawa, T. (2017). Comparative analysis on the nature of proof to be taught in geometry: the cases of French and Japanese lower secondary schools. *Educational Studies in Mathematics*, 94, 37–54.
- Pimm, D. (1987). *Speaking mathematically: communication in the mathematics classroom*. London: Routledge and Kegan Paul.
- Planas, N., Morgan, C., & Schütte, M. (2018). Mathematics education and language: lessons and directions from two decades of research. In T. Dreyfus et al. (Eds.), *Developing research in mathematics education: Twenty years of communication, cooperation, and collaboration in Europe* (pp. 196–210). New York, NY: Routledge.
- Reid, D. A. (2015). Student understanding of proof and proving: Is international comparison possible? In K. Beswick et al. (Eds.), *Proceedings of the 39th Conference of the Psychology of Mathematics Education, Vol. 4* (pp. 65–72). Hobart, Australia: PME.
- Reid, D. A., & Knipping, C. (2010). *Proof in mathematics education*. Rotterdam, The Netherlands: Sense Publishers.
- Sekiguchi, Y., & Miyazaki, M. (2000). Argumentation and mathematical proof in Japan. *The Proof Newsletter*. Retrieved from <http://www.lettredelapreuve.org>
- Selden, J., & Selden, A. (1995). Unpacking of logic of mathematical statements. *Educational Studies in Mathematics*, 29, 123–151.
- Shimizu, S., & Funakoshi, S. (Eds.) (2011). *Fun with Math 1 for elementary school*. Osaka: Keirinkan.
- Shinno, Y., Miyakawa, T., Iwasaki, H., Kunimune, S., Mizoguchi, T., Ishii, T., & Abe, Y. (2018). Challenges in curriculum development for mathematical proof in secondary school: cultural dimensions to be considered. *For the Learning of Mathematics*, 38(1), 26–30.
- Stylianides, A., Bieda, K. N., & Morselli, F. (2016). Proof and argumentation in mathematics education research. In Gutiérrez, Á. et al. (Eds.). *The second handbook of research on the psychology of mathematics education* (pp. 315–351). The Netherlands: Sense Publishers.

Planning for mathematical reasoning – Surprising challenges in a design process

Helén Sterner

Dalarna University and the University of Linnaeus, Sweden; hse@du.se

Keywords: Design Principles, Mathematical reasoning, Patterns

Introduction

Generalizing is a key element in mathematical reasoning as well in early algebra and algebraic thinking (Kaput, 2008). However, students find it difficult to understand the meaning of generalized arguments, which means that teachers need to support students to develop their generalized argument (Stylianides & Stylianides, 2017). A way to increase teachers' possibilities to support students' reasoning may be through intervention studies. Stylianides and Stylianides (2013) write about the importance of research-based interventions of proof and proving in teaching. Since generalized arguments can be seen as a part of proof and proving (Stylianides & Silver, 2009), intervention studies also about generalized arguments should be important. Similar reflections have emerged in the Argumentation and proof group at CERME where a lack of design-based studies promoting investigation in the classroom and a need to shift research focus from the learners to the teacher is emphasized (Mariotti, Durand-Guerrier, & Stylianides, 2018). This poster will exemplify a part of a cyclically recurring intervention process by answering the question: What challenges do teachers meet when trying to understand a given Design Principle (DP) (McKenney & Reeves, 2012) and design and implement teaching based on it?

Mathematical reasoning and algebraic thinking

One part of mathematical reasoning and early algebra as well as of algebraic thinking is the structure and the understanding of relationships in quantities (Kaput, 2008); these relationships could be embedded in figural repeating patterns. Patterns and pattern identification could be seen as essential components in elementary school when working with the activity of reasoning-and-proving (Stylianides & Silver, 2009). Teaching patterns can provide students' understanding and support their arguments why things work the way it do. Mulligan, Mitchelmore, English and Crevensten (2013) make similar assumptions, pointing out that teaching and learning mathematics through patterns and structure as well as generalized approaches may provide students with a deep understanding of mathematics.

Methodology

The frame of this study is based on educational design research, as well as an intervention inspired by classroom design research (Stephan, 2015). In the implementation of the intervention, DPs will be used to address the specific foci in this case, strategies for mathematical reasoning and proving in algebra. Three mathematics teachers (grade 1 and 6) and the author are part of this intervention. DPs are used to guide the content of the interventions and the DPs are used as a framework in the initial analyses. The DPs will guide and give the intervention a theoretical foundation in the ongoing process (three recurring cyclical phases):

first designing the intervention and the teaching, second the three teachers implementing the intervention and the third, the reflection after the implemented intervention. To stimulate mathematical reasoning, and proving in teaching and learning of pattern, six DPs have been created from previous research, and one of them is presented in this poster.

DP1 The students will have possibilities to *identify* a pattern, to *structure* the pattern and to *generalize* the pattern (Mulligan et al., 2013; Stylianides & Silver 2009).

Preliminary results from a part of the design research process

Preliminary results show the complexity involved in teachers' understanding of teaching and learning patterns relating to DP1. The complexity becomes visible when teachers discuss and try to understand the concepts; identify, structure, and generalize patterns in relation to their own practice. Teachers try to exemplify what it means to identify, structure and generalize, and thereby become aware that the concepts overlap. Results also show that teachers' understanding of generalization develops during the discussion; from equalizing generalization with general formulas to generalizations as something possible to show with different representations such as describing with words or showing with concrete material and pictures. In the classroom, teachers meet challenges when trying to challenge students' understanding of a generalized pattern, for example by asking them to explain what is behind a general formula.

References

- Kaput, J. J. (2008). What is algebra? What is algebraic reasoning? In J. J. Kaput, D. W. Carraher & M. Blanton (Eds.), *Algebra in the early grades (5-17)*: Mahwah, NJ: Lawrence Erlbaum/Taylor & Francis Group; Reston, VA: NCTM.
- Mariotti, M. A., Durand-Guerrier, V., & Stylianides, G. J. (2018). Argumentation and proof. In T. Dreyfus, M. Artigue, D. Potari, S. Prediger & K. Ruthven (Eds.), *Developing research in mathematics education. Twenty years of communication, cooperation and collaboration in Europe (75–89)*. Oxon, UK: Routledge.
- McKenny, S., & Reeves, T. (2012). *Conducting Educational Design Research*. London: Routledge.
- Mulligan, J. T., Mitchelmore, M. C., English, L. D., & Crevensten, N. (2013). Reconceptualizing Early Mathematics Learning: The Fundamental Role of Pattern and Structure. In L. D. English & J. T. Mulligan (Eds.) *Reconceptualizing Early Mathematics Learning, Advances in Mathematics Education*, New York: Springer.
- Stephan, M. L. (2015). Conducting classroom design with teachers. *ZDM - Mathematics Education*. 47, 905–917.
- Stylianides, G. J., & Silver, E. A. (2009). Reasoning-and-Proving in School Mathematics, the Case of Pattern Identification. In D. A. Stylianou, M. L. Blanton & E. J. Knuth (Eds.), *Teaching and learning proof across the grades: A K–16 perspective*. New York, NY: Routledge.
- Stylianides, A. J., & Stylianides, G. J. (2013). Seeking research-grounded solutions to problems of practice: Classroom-based interventions in mathematics education. *ZDM—The International Journal on Mathematics Education*, 45(3), 333-341.
- Stylianides, G. J., & Stylianides, A. J. (2017). Research-based interventions in the area of proof: the past, the present and the future. *Educational Studies in Mathematics*, 96, 119–127.

Metacognitive activities of pre-service teachers in proving processes

Nele Stubbemann¹ and Christine Knipping²

¹University of Bremen, Germany; nele.stubbemann@uni-bremen.de

²University of Bremen, Germany; knipping@math.uni-bremen.de

Proving processes are often complex and difficult. Problems during the phase of proof finding are not unheard of. The ability to find out which knowledge and strategies we need to prove a given statement and how to use knowledge and strategies in proving is called metacognition. A study with pairs of pre-service teachers shows that content knowledge is an important factor whether or not metacognitive activities like monitoring can help handling problems in the proving process.

Keywords: Metacognition, monitoring, proving processes, pre-service teachers.

Introduction

To be able to successfully prove a geometrical statement, one needs more than just subject-specific knowledge and methodological knowledge of proving procedures (Heinze & Reiss, 2003). It is important to know if what one is doing makes sense, is promising and productive. This ability to reflect on one's own knowledge is called metacognition, which is important in general life as well as in mathematics and allows one to find out what knowledge and strategies are needed to solve a problem and how to use knowledge and strategies in proving.

In mathematics education a lot of research exists about metacognition in problem-solving (e.g. Kuzle, 2013; Schoenfeld, 1987, 1992). But there is little research about the significance of metacognitive activities for proving processes, in particular there is nearly no research on pre-service primary school teachers' metacognitive activities, even though they will later in their classrooms be responsible to establish the basis for argumentation. Our research project addresses the need of future teachers to be able to understand and perform proving processes, as well as to perceive their argumentation basis. Metacognitive competences can in our view be useful and fruitful, if taken care of in a sensible way.

The metacognitive activity of monitoring is the focus of this paper. How monitoring is in play during the proving process of students, particularly in what we call loops, elongations, circular reasoning and wanderings is of interest to us. We look specifically at what role content knowledge plays in this and what impact content knowledge has on monitoring.

Theoretical background

The colloquial meaning of metacognition is approximately "reflections on cognition or thinking about your own thinking" (Schoenfeld, 1987, p. 189). Schraw (1998) divides metacognition into two big fields. *Knowledge of cognition* is the knowledge about one's own cognition or about cognition in general. The *regulation of cognition* is an accumulation of activities that help to control one's own learning. It includes *monitoring*, which is the activity of controlling and evaluating one's understanding and one's own performance during a process, in our case the proving process. According to Heinze and Reiss (2003) the ability to prove a statement includes metacognition. Wittmann (2014) focusses on two things that are important for proving statements, factual knowledge and metaknowledge about proofs. According to Wittmann students often do not have sufficient

metaknowledge about proof, which includes knowledge of the functions of proof, characteristics of proving as well as knowledge of how to prove.

The difference between proving as a process and proof as a product is important as well. Wittmann (2014) sees the process of proving as the activity of finding a proof. The process is complex, needs creativity and problem solving competencies. It can go in leaps and bounds and includes sudden success as well as phases where one does not know what to do. The proof product on the other hand is the final product of the proving process. It is succinctly verbalised and neatly written down. Looking at the written proof one cannot see the efforts of the proving process.

Empirical methods

The base of this research project are case studies of four pairs of pre-service primary school teachers. These students participated in a lecture course on elementary geometry in the third semester of their Master Studies. Participation in the study was voluntary and took place in the spring of 2018. Video recorded interviews are the basis of the case studies. The students worked in pairs on proof tasks so that discussions between them provided insight into their metacognitive activities. In the first part of the semi-structured interview, questions about their own proving experiences and proving in general were asked. Then the students were given two statements from plane geometry, one after the other, which could be proven with knowledge from the lecture. Afterwards the process of finding the proof was discussed with the students.

The transcripts of the interviews were looked through for obstacles that can occur in the proving process. In a second step these obstacles were scanned for monitoring activities, which were then coded with a system for categorizing metacognitive abilities developed by Cohors-Fresenborg and Kaune (2007a), that divides monitoring into eight subcategories, e.g. the controlling of calculations and the controlling of argumentation. This allowed us a differentiated view on monitoring activities. After coding the data, the effect of monitoring in the identified phases with obstacles were analysed. Particularly the influence of content knowledge was focused on in order to clarify the impact of the assumed relationship between monitoring and content knowledge for the proving processes and specifically their successful performance.

Prototypes for obstacles in proving processes

Proving processes are rarely linear. Having difficulties, getting stuck or trying something that is not constructive is normal. After looking through the data we can distinguish four specific obstacles that the students encountered in their proving processes: *loops*, *elongations*, *circular reasoning* and *wanderings*. In the following we are going to characterise these obstacles with data from all four groups. With these examples we explain to what extent monitoring influences these obstacles and show the important role of content knowledge.

Loops

Loops are one type of obstacle in proving processes. In a discussion one might have a kind of side discussion that is still part of one's proof idea and attempt, but that is not really constructive for the proof. To resolve a *loop* situation one must rein in this discussion and pursue the original proof idea instead.

A typical example for a *loop* is the following discussion of Pia and Charlotte (Group 3). The two students attempt to prove the second statement: “A parallelogram is a rectangle if and only if its diagonals have the same length.” During their discussion they draw a rectangle and a parallelogram and argue whether or not they should use the drawing of the parallelogram to prove the statement or if they should use the drawing of the rectangle instead. While Pia is arguing that in a parallelogram the diagonals cannot have the same length, Charlotte suddenly has a new idea; here a *loop* starts. Charlotte wants to change the statement they have to prove to the following: “A parallelogram is a square if and only if its diagonals have the same length”. She describes her thinking.

At that moment Pia uses the definitions of a square and a parallelogram and the connections and differences between the two (every square is a parallelogram, but not every parallelogram is a square). She intends to make clear to Charlotte why her idea, to substitute the rectangle in the statement with a square, is not helpful for the proof of the original statement. Pia’s behaviour is a reaction to a monitoring activity, which is the examination of her partner Charlotte’s understanding of mathematical objects and their role for their argumentation. According to the system of Cohors-Fresenborg and Kaune (2007b) this can be categorized as the monitoring activity M4c: “Controlling of Argumentation – uncovering mistakes in the argumentation” or M2b: “Controlling of an assessment of (assumed) mistakes – uncovering one’s own false ideas or those of others”. Charlotte then applies this knowledge to squares and rectangles and understands why her idea will not work out as a proof. Both students are back at the “starting point” (arguing about which drawing to use for their argumentation), the *loop* is closed. Their side discussion ends, they do not lose themselves in it. They are back on to their original path.

In this example of a *loop*, Pia’s monitoring activities match the “problem” Charlotte has (Why can we not use a square in our argumentation?) and helps them to end their side discussion. They go back to their original proof idea. Their monitoring was quite precise regarding the comprehension of the geometrical objects square, rectangle and parallelogram. Pia showed that she possessed the content knowledge necessary to make use of the monitoring activity and improve their work.

Elongations

An *elongation* in a proving process occurs when one does not pursue the shortest possible way, but instead substitutes several steps for one step.

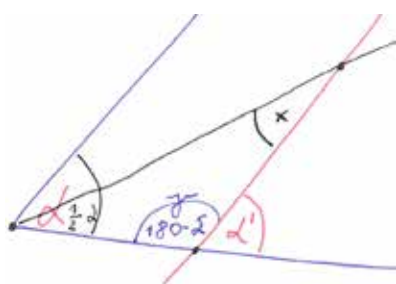


Figure 1: Drawing for the first statement (Group 4)

Elongation simply means to lengthen an action or a process. Often these are hard to determine in data, as a shortest possible way needs to be defined first, in order to be able to find variations of it. To define this, one has to consider (theoretically) available knowledge which may differ between people and in time. The shortest way of a grade 5 student may differ from that of a university professor; the shortest way in a first proof of a new theorem may be an elongation later on, when shorter ways have evolved.

The first statement our students had to prove was: “Given is an angle with arms g and h . If you draw a line k parallel to arm g that crosses arm h , then h and k together with the angle bisector form an isosceles triangle”. The shortest way to prove the statement that one might

follow is using the Alternate Interior Angles Theorem with the angle $\frac{\alpha}{2}$ to show that the base angles have the same size, then the Isosceles Triangle Theorem can be used. Nina and Maja (Group 1), as well as Daria and Leonie (Group 4), proved the statement using the Corresponding Angles Postulate with the angle α (see Figure 1). Then supplementary angles and the Triangle Postulate are used to be able to show that the base angles are equal. This is an example of an *elongation*, as the students had the same basic idea, but for the elongated proof more steps are used than needed.

Neither in the proving process of Group 1 nor in the process of Group 4 a monitoring activity could be found that triggered an *elongation*. The cause of the observed *elongation* seems instead to be the angle the students focussed on (α instead of the angle $\frac{\alpha}{2}$) and therefore more steps were needed to show that the base angles of the triangle are equal. No indication was found why a group decided to focus on α instead of $\frac{\alpha}{2}$. Sufficient content knowledge seems to be the reason that the groups were still able to prove the statement. The students applied all necessary theorems and did not get to a point where they did not know how to proceed.

Circular reasoning

While involved in the proving process *circular reasoning* is hard to see for the students engaged in proving. *Circular reasoning* makes it impossible to produce a correct proof, because one falsely assumes what is meant to be proven by the proof.

Dennis and Julius (Group 2) showed *circular reasoning* in their ‘proof’ for the first statement. After the exploration and discussion of the statement, Dennis and Julius began to write down their ‘proof’. In the first part of their text the students attempted to show that two of the angles in the triangle had the same size. Julius had noted that the angle bisector divided the angle α into two angles of the same size, labelled as base angles of the triangle in his drawing (see the two “ $\frac{1}{2}\alpha$ ” written in red, Figure 2), instead of labelling them as two halves of α (two equal parts of an angle bisector). His argumentation was questioned by Dennis: “Then the question is, whether we can assume that they [Dennis is pointing more at the base angles than at the sides h and k] have the same length”.

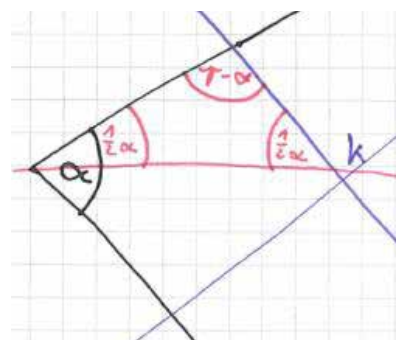


Figure 2: Drawing for the first statement with “red angles” (Group 2)

His question shows a monitoring activity, as Dennis is checking what they are doing while they are still in the proving process. Both students have just started writing down the proof. With his question Dennis controls the effectiveness of their approach and if they are still on target. According to the system of Cohors-Fresenborg and Kaune (2007b) this is the monitoring activity M4a: “Controlling of Argumentation – local examination”. As a reaction to the monitoring question Julius writes a second explanation about why the base angles have the same size. As a reason he mentions the equality of the two sides of the triangle. This explanation is unfortunately circular as he assumes that the length of the two sides of the triangle are equal, which still needs to be proven.

In *circular reasoning* monitoring affects the proving process differently than in the loop. Dennis and Julius end up with a circular argument in their proof of the first statement because of a monitoring

activity. While in the loop the monitoring brings the students back to a reasonable way. Dennis' monitoring activity is also rather imprecise, more like a bad feeling instead of a well-founded suspicion, and the reason for the *circular reasoning*. Both students lack the necessary content knowledge and cannot not use monitoring activities to their advantage. Their monitoring activity did not improve the quality of their proof, but instead guided the students into *circular reasoning*, which also demonstrates their lack of knowledge about logic and the structure of a proof.

Wanderings

The abandoning of a good proof idea in favour of ideas that are not constructive is what we call *wandering*. An example of *wandering* is shown by Pia and Charlotte (Group 3). During their discussions Pia and Charlotte have a productive idea to prove the first statement. They use the Alternate Interior Angles Theorem to show that the base angles of the triangle are equal. For the next step in their proof they need to show that a triangle with two equal base angles has two sides of the same length. For this they have the idea to use the Isosceles Triangle Theorem. But Pia is not sure, if the theorem can be used in both directions and asks: "Can you say that?", which is actually a monitoring question. According to the system of Cohors-Fresenborg and Kaune (2007b) this would be the monitoring activity M5a: "Determination of position: naming of Deficiency of Understanding – defined step". This labelling of a deficiency in her understanding is an important monitoring activity as Pia can only follow and support their argumentation if she understands the concepts and the connections between them.

In this case the monitoring question is the starting point for the *wandering*. Because of Pia's monitoring question her partner Charlotte is now insecure in her belief and understanding of the Isosceles Triangle Theorem. Even though Pia affirms that she believes that they are allowed to use it, Charlotte abandons this proof idea in favour of another idea. Their new idea does not work out; their written proof is more a construction protocol with a proof idea but not a proof. For this statement, both first have a good idea how to prove it, but then they discard their idea and start with new ideas which in the end do not work out. They end in a *wandering*.

Like in the loop, and in contrast to the circular reasoning, Pia's monitoring here is quite precise. She questions the use of one specific theorem, the Isosceles Triangle Theorem, which is important for their proof. Unfortunately, both students lack the necessary content knowledge, in this case the content of the theorem, to make use of their monitoring.

Preliminary results

One can raise the question whether or not metacognitive activities, especially monitoring activities, can help students to prevent problems in their proving processes. In theory, monitoring one's work and progress should help students to prevent or find problems and mistakes.

Our prototypes can be systematized in a fourfold table along the dimension "monitoring" and "content knowledge" (see Table 1). Loops are in the field of monitoring and content knowledge, elongations in the field of content knowledge without monitoring. Circular reasoning and wanderings are in the area of monitoring, but with no content knowledge. In the area without monitoring or content knowledge we suspect another prototype, *dry spells*. A dry spell is a part of one's proving process

where one hits a barrier and does not know how to go on for quite some time. Not actively working at the proof anymore can be a sign for a dry spell, as well as remaking drawings, calculating something or recapping what one already knows in the hope of getting a new idea. Looking at the success that is (or not) shown in the proving process, it is possible to group the observed obstacles (loops, elongations, circular reasoning and wanderings). Both loops and elongations are parts of a proving process where one still reaches the proof in the end, but not in the shortest or easiest way as one's ideas would have allowed. These two are *detours* in the proving process. Circular reasoning and wanderings are parts of one's proving process where one follows an idea that does not end in a proof. These are *drifts* in the proving process. *Dry spells* can be seen as a third group where the proving process pauses, but this still remains to be looked at in our data.





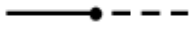
		Content knowledge	
		yes	no
Monitoring	yes	<p><i>loops:</i> side discussion that gets back to the original discussion and proof idea</p> 	<p>drifts</p> <p><i>circular reasoning:</i> using things that are yet to be proven</p> 
	no	<p><i>elongations:</i> using several steps when one step would have been possible.</p>  <p>detours</p>	<p><i>wanderings:</i> abandoning good ideas in favour of proof ideas that do not work out</p>  <p><i>dry spells:</i> parts of a proving process where one does not know how to go on or what to do for a longer period</p>  <p>dry spells</p>

Table 1: Overview of the obstacles and the relation to monitoring and content knowledge

Whether or not one follows detours or drifts in a proving process seems to depend on one's *monitoring activities*. Looking at the monitoring activities described above, one can see that monitoring has many different facets, for example controlling an argument, naming problems in the comprehension of arguments and their connection or uncovering deficiencies in understanding. But our examples show that the mere existence of monitoring activities is not enough to indicate the success of a proving process. There seem to be differences in the way that monitoring activities are expressed. Monitoring formulated in a general way like "Is that possible? Is that right?" like the example of a circular

reasoning by Dennis and Julius (Group 2) seem to be about a gut feeling that something is not quite right, without knowing exactly what. This type of monitoring activities we shall call *lower-level monitoring*. It is not specific enough to help pinpoint a concrete mistake and correct it. Dennis' question "Then the question is, whether we can assume that they have the same length" is one example for this. What we call *higher-level monitoring* is a metacognitive activity that is more precise and aims at specific parts of an explanation or argumentation. For example, if one can use a specific theorem the way it is used in the argumentation or if the comprehension of a specific geometric object is correct. Pia and Charlotte (Group 3) showed higher-level monitoring in both cases, in the loop and in the wandering. In one case Pia questioned the use of a specific theorem, the Isosceles Triangle Theorem, at a specific point of their argumentation. In the other case Pia monitored and corrected Charlottes' understanding of the definition of and the connection between squares, rectangles and parallelograms. These interventions were precise and specific and therefore higher-level monitoring.

The level of monitoring does not seem to be the only factor influencing the quality of a proof as one reason for ending up in drifts can be monitoring activities. In cases where the monitoring could not be used profitably, monitoring activities seem to have a negative effect on the proving process. Looking at the two examples of drifts, in one case, Dennis and Julius (Group 2) show lower-level monitoring, the other students, Pia and Charlotte (Group 3) demonstrate higher-level monitoring. Nevertheless, both groups ended up in a drift. *Content knowledge* is the other factor that influences the success of the proving process. The circular reasoning in Dennis and Julius' proof of the first statement happens because they do not know how to prove the equality of the base angle in the triangle (and lack the logical and methodological awareness that you cannot use what you want to prove). Pia and Charlotte end up in a drift after Pia's monitoring activity, because both cannot remember all of the content of the Isosceles Triangle Theorem, which led them to abandoning their proof idea. Looking at detours, monitoring activities can also show a positive effect, for example ending detours by closing loops. Here the monitoring and the content knowledge used afterwards ended the side discussion and brought the students back to their original proof idea, thereby helping them not to end in a drift. Thinking about these examples, content knowledge seems to be what enables one to find a solution to the obstacles that monitoring activities reveal. One can only benefit from monitoring activities if one has the content knowledge necessary to "fix the problems", for example to discern the problematic parts, to recognise what is wrong or missing or to see possible corrections. Without content knowledge one is less likely to find and correct mistakes, misunderstandings or errors through monitoring.

Monitoring is important in mathematics and especially in proving. It allows to control and evaluate one's own performance and understanding during the process. In the proving process three different categories of obstacles can appear: detours, drifts and dry spells. The interviews with the pre-service primary school teachers show that monitoring activities have a relevant influence. But not every monitoring activity has the same influence on proving processes. One can differentiate between monitoring of a lower and a higher level. Whether monitoring activities support or inhibit the success of the proving process is also highly dependent on one's content knowledge.

References

- Cohors-Fresenborg, E., & Kaune, C. (2007a). *Kategoriensystem für metakognitive Aktivitäten beim schrittweise kontrollierten Argumentieren im Mathematikunterricht (2. überarbeitete Auflage) [System for categorising metacognitive activities during stepwise controlled argumentation in mathematics lessons (2nd ed.)]*. Osnabrück, Germany: Forschungsinstitut für Mathematikdidaktik.
- Cohors-Fresenborg, E., & Kaune, C. (2007b). Modelling classroom discussions and categorising discursive and metacognitive activities. In D. Pitta-Pantazi & G. Philippou (Eds.), *Proceedings of the Fifth Congress of the European Society for Research in Mathematics Education (CERME 5, February 22 - 26, 2007)* (pp. 1180–1189). Larnaca, Cyprus: University of Cyprus and ERME.
- Heinze, A., & Reiss, K. (2003). Reasoning and proof: Methodological knowledge as a component of proof competence. In M. A. Mariotti (Ed.), *Proceedings of the Third Conference of the European Society for Research in Mathematics Education (CERME 3, February 28 – March 3, 2003)* (pp. 1–10). Bellaria, Italy: University of Pisa and ERME. Retrieved from http://www.mathematik.uni-dortmund.de/~erme/CERME3/Groups/TG4/TG4_Heinze_cerme3.pdf
- Kuzle, A. (2013). Patterns of metacognitive behavior during mathematics problem-solving in a dynamic geometry environment. *International Electronic Journal of Mathematics Education*, 8(1), 20–40.
- Schoenfeld, A. H. (1987). What's all the fuss about metacognition. In A. H. Schoenfeld (Ed.), *Cognitive science and mathematics education* (pp. 189–216). Hillsdale, New Jersey, USA: Lawrence Erlbaum Associates, Inc.
- Schoenfeld, A. H. (1992). Learning to Think Mathematically: Problem Solving, Metacognition, and Sense Making in Mathematics. In D. A. Grouws (Ed.), *Handbook of Research on Mathematics Teaching and Learning: A project of the National Council of Teachers of Mathematics* (pp. 334–370). New York, USA: Macmillan Publishing Co, Inc.
- Schraw, G. (1998). Promoting general metacognitive awareness. *Instructional Science*, 26(1), 113–125.
- Wittmann, G. (2014). Beweisen und Argumentieren [Proving and Argumentation]. In H.-G. Weigand, A. Filler, R. Hölzl, S. Kuntze, M. Ludwig, J. Roth, B. Schmidt-Thieme, & G. Wittmann (Eds.), *Didaktik der Geometrie für die Sekundarstufe I [Didactics of geometry at middle level]* (pp. 35–54). Berlin, Germany: Springer Spektrum.

Features of mathematics' teacher argumentation in classroom

Jorge A. Toro¹ and Walter F. Castro²

¹Universidad de Antioquia, Colombia; jandres.toro@udea.edu.co

²Universidad de Antioquia, Colombia; walter.castro@udea.edu.co

We present a case study whose aim is to describe argumentation's features of a high school mathematics' teacher. The data was collected in a geometry class, while the teacher and her students discussed the straight line. In this paper we describe features of class discourse, associated with a conception of argumentation linked to both argumentation and speech acts. Among the findings we point out both the educational purpose of the teacher in promoting argumentation in her class and the uses of argumentation by the teacher.

Keywords: Argumentation, teacher's knowledge, class speech

Introduction

Current research in Mathematics Education recognizes the importance of favoring argumentation in class (Ayalon & Hershkowitz, 2018; Staples & Newton, 2016). It also recognizes the teacher's role, the task's design, opportunities for participation, or the analysis of arguments. However, few studies consider argumentative features of the mathematics teacher while teaching. In this paper, we present some results of a research that we are developing where we are interested in both identifying features of mathematics' argumentation in class and analyzing the influence of the teacher's knowledge on the characteristics argumentation.

Theoretical background

Like different authors in educational research (e.g. Asterhan & Schwarz, 2016), we assume the definition of the argumentation theory presented by Eemeren and his colleagues (1996):

Argumentation is a verbal and social activity of reason aimed at increasing (or decreasing) the acceptability of a controversial standpoint for the listener or reader, by putting forward a constellation of propositions intended to justify (or refute) the standpoint before a rational judge (p. 5).

Even though this definition was not developed in the context of mathematics education, we find it very useful for us to study argumentation in mathematics class. This definition, concerning argumentation, recognizes 'complex interactions' in mathematics class, where teacher and students discuss tasks' solutions. It also implies that we try to move away from the traditional stance, where argumentation is assumed as a set of premises and conclusions formulated with the help of formal symbols whose meaning is established beforehand.

The definition of Eemeren and colleagues suggests that in a math class one can construct claims, provide evidence to support claims, and evaluate this evidence to judge the validity of the claims. This definition puts the argumentation in a social environment. Argumentation not only is part of the class discourse, but also offers opportunities for the articulation of alternative ideas, reflection and reasoning, favoring learning (Ayalon & Hershkowitz, 2018).

Methodology

In order to observe the argumentation in a class context we carry out a case study with a high-school mathematics teacher. The data were obtained in a 9th grade course (15-year-old students), in a public school in Medellin (Colombia), where the teacher and her students discuss the properties of straight lines. The teacher has 8 years of experience in high school mathematics teaching, is a mathematics graduate and holds a master's degree in Mathematics Education. She voluntarily agreed to participate in the study. We observed two classes in September 2017, which were recorded in audio and video. The researchers were just listeners and without intervening during or after the class. The teacher was informed of the purpose of the research; she selected the group and the classes to be observed.

Result and implications

We have discussed two class segments to support the case study. We emphasize the features of the argumentation of mathematics' teacher, on one hand, related to the conception or definition of the argumentation and on the other hand, to the uses of the argumentation on the part of the teacher.

We can identify argumentative features that respond to the verbal, social, rational and educational intentions that the mathematics' teacher spontaneously expresses in the natural environment of the classroom when teaching mathematics. Although we describe a particular case, it is important to describe and analyze other cases of mathematics teachers at different school levels, which could enrich our definition of argumentation, show us other features and possible uses, and generate concepts that could contribute to the study of argumentation in mathematics class.

The description of argumentation' features have allowed us to identify possible links of the teacher's argumentation to mathematics knowledge. We also express the limitations of our study, which seems only descriptive, but which attempts to expand and adapt it to his use in the complex environments of the mathematics class. It seems that more tests and a longitudinal study are needed to validate the findings.

References

- Asterhan, C., & Schwarz, B. (2016). Argumentation for Learning: Well-Trodden Paths and Unexplored Territories. *Educational Psychologist*, 51, 164-187. doi:10.1080/00461520.2016.1155458
- Ayalon, M., & Hershkowitz, R. (2018). Mathematics teachers' attention to potential classroom situations of argumentation. *The Journal of Mathematical Behavior*, 49, 163-173. doi: <https://doi.org/10.1016/j.jmathb.2017.11.010>
- Eemeren, F., Grootendorst, R., Snoeck, F., Blair, J., Johnson, R., Krabbe, E., Plantin, C., Walton, D., Willard, C., Woods, J., & Zarefsky, D. (1996). *Fundamentals of argumentation theory. A handbook of historical and contemporary developments*. Hillsdale, NJ: Lawrence Erlbaum.
- Staples, M., & Newton, J. (2016). Teachers' Contextualization of Argumentation in the Mathematics Classroom. *Theory into Practice*, 55(4), 294-301. doi: 10.1080/00405841.2016.1208070

Beyond direct proof in the approach to the culture of theorems: a case study on 10th grade students' difficulties and potential

Fiorenza Turiano¹ and Paolo Boero²

¹I. I. S. Arimondi – Eula, Savigliano, Italy; fiorenza.turiano@gmail.com

²University of Genoa, Italy; boero@dima.unige.it

In this paper, we aim to contribute to the discussion on the students' cognitive processes inherent in proof by contradiction in geometry, particularly as concerns the role played by images. We will present an episode from a one-year experimental pathway in Euclidean geometry designed to develop the culture of theorems in 10th grade: in crucial moments of proof by contradiction, we observed some students' gestures and reasoning aimed to restore the harmony between visual and conceptual aspects, which had been broken by conflicts due to specific features of that proof in geometry. The students' need of keeping such harmony poses didactical questions, which, if conveniently taken in charge by the teacher, might contribute to design smoother pathways to the indirect proofs.

Keywords: Culture of theorems, euclidean geometry, indirect proofs, figural concepts, meta-knowledge of proof

Introduction

The development of students' competencies concerning theorems is one of the most important goals in the high school. Its relevance is stressed by the Italian national guidelines for curricula in the high school (MIUR, 2010), according to the current definitions of competency (European Community, 2018), in particular, its requirements of autonomy and awareness. In this perspective, developing Culture of Theorems (CoT; Bartolini Bussi et al., 2007) means to acquire, not only knowledge, but also meta-knowledge about theorems: the kind of statements (declarative or hypothetical); the role of hypothesis and thesis; the different methods of proving; the role of previously validated statements and axioms; the distinction between the construction of a conjecture (based on different processes: induction, abduction, analogy, etc.) and the construction of a proof (within a theory). Therefore, autonomy and awareness are two co-present basic requirements in the activities inherent in CoT: exploring to get conjectures; tackling construction problems and their theoretical validation; constructing proofs. We chose the Euclidean geometry as a domain to set up a learning environment suitable for the development of the CoT in two 10th grade scientific oriented classes. In Italian school, the passage from intuitive to deductive geometry takes place in the 9th grade: the students must be educated to justify geometrical facts and to prove theorems. These goals require an evolution in the students' ways of looking at geometrical figures and their awareness of links between a proof of the statement and the theory within which the proof makes sense. Thus, we chose the construct of figural concepts (Fischbein, 1993) and the definition of mathematical theorem (Mariotti, 2001) to frame our experimental pathway. In agreement with the literature, in our pathway the indirect proofs (by contraposition and by contradiction) posed specific cognitive and didactical problems that had been absent in situation of direct proof. We tried to deal with them by using the model for indirect proof elaborated by Antonini and Mariotti (2008). In particular, in this paper we consider a classroom episode concerning proof by contradiction, in which the analysis of students' behaviors, performed

according to that model, allowed us to identify specific instances of the obstacles deriving from the drawings that should support the reasoning in its different phases, and some spontaneous students' ways to escape them. The discussion will concern the choice of suitable tasks for smoother approaches to proof by contradiction, and some aspects of the potential and limitations of Euclidean Geometry, as the privileged field to approach the culture of theorems in high school and, in particular, the issues related to indirect proofs.

Theoretical background

The Theory of Figural Concepts (TFC; Fischbein, 1993) highlights that geometrical figures possess simultaneously conceptual qualities (controlled by constraints within the realm of an axiomatic system) and image features (based on the perceptive-sensorial experience). The interplay between image component of a drawing and theoretical knowledge may (and should) implement a harmonious fusion between concept and image: the theoretical knowledge transforms the image into a geometrical figure. Fischbein calls Figural Concept this complete harmonious fusion. TFC is a suitable construct for our study for at least three reasons: to investigate how and if the students manage to deal with the relationships between different components in the geometrical figures; to interpret the difficulties deriving from a missing or incomplete fusion; to explain different students' behaviors concerning proof by contradiction, when they deal with it in two different domains: elementary number theory (e.g. when proving the irrationality of $\sqrt{2}$), Euclidean geometry.

Mariotti (2001) defines a theorem as the triad (S-P-T) statement-proof-theory: a statement, its proof, and a theory (as a system of shared principles and deduction rules) within which this proof makes sense. Antonini and Mariotti (2008) refine this triad in order to better describe and explain the process involved in an indirect proof, due to its logical structure. According to them, proving by indirect method requires two phases: 1) a shift from a statement S (called principal) toward a statement S^* (called secondary, which is proved by a direct method) obtained assuming as hypothesis the negation of the thesis of the principal one (in proof by contradiction) or of its thesis (in proof by contraposition), and as thesis, respectively, a contradiction or the negation of the hypothesis of the principal one; 2) the validity of the implication $S^* \Rightarrow S$ depends on the logical theory, that is external to the theory in which the principal and secondary statements are formulated. The two authors call meta-statement $S^* \Rightarrow S$, meta-proof the proof of $S^* \Rightarrow S$, meta-theory the logical theory into which the meta-proof makes sense. Then, any theorem with indirect proof consists of a couple of subtheorems belonging to two different levels: the level of the mathematical theory and the level of the logical theory. Unfortunately, usually teaching practice takes for granted the meta-theorem.

Method

Euclidean geometry as a suitable domain for a teaching-learning pathway to the CoT

We chose Euclid's plane geometry to make 10th grade students approach the CoT for at least three reasons: 1) in Italy, since the end of the XIX century, Euclidean geometry has been considered to be the most suitable domain to allow high school students to tackle theorems, proofs, proving; 2) Euclidean geometry offers the possibility to deal with different kinds of proof; 3) the validation task of a geometric construction provides the teacher with the opportunity of making the students aware of the nature and relevance of theoretical thinking in mathematics.

The structure and tasks of the pathway

In the schoolyear 2016-17 our project was designed and implemented for the first time in a 10th class scientific-oriented. It took about 46 hours. In the same school, in the next year, the experiment involved two 10th classes (named 2A and 2D, respectively of 31 and 20 students). It was 7 months long, 2 school-hours (100 minutes) per week, summing up to about 56 hours. All the lessons were held by the same teacher (the first author), in the same day: first in 2A, then in 2D; a researcher (the second author) played the role of participant observer. The pathway was divided into 3 modules: 1) from the construction of a tangent circle to the two sides of a given angle, to the construction of the tangent circle inside a given triangle; 2) from conjecturing about sufficient conditions that create different kinds of triangles inscribed in a circle, to the proof of the relation between inscribed angle and central angle that subtends the same arc; 3) given a circle, from exploring and proving the relationships between its tangent and intersecting straight lines, to solving some problems concerning inscribed and circumscribed quadrilaterals. The classroom activities alternated individual tasks (presented on worksheets to be filled by the students – enough time was allocated to them, in order to develop specific linguistic skills) and collective discussions orchestrated by the teacher. They were addressed to identify gaps, mistakes, linguistic issues and elements of meta-knowledge of proof; and to reflect on different strategies of proof and on the organization of the proof text according to its specific structural constraints. In some cases, the discussion concerned also the comparison and the analysis of a few students' individual productions, selected and made anonymous by the teacher. The individual activities concerned different kinds of tasks: construction problems and related theoretical justifications; proving of produced conjectures (after having been shared and refined under the guide of the teacher in collective discussions); analysing and refining some mates' productions; cloze activities on proof texts; identifying salient meta-mathematical aspects of produced texts. At the end of each module, the summative assessment was made up of two parts: 1) a homework including: a) the written revision of all the personal worksheets, with careful identification of gaps or mistakes, comments on their specific causes of difficulties, with correction or reconstruction; b) a written report on her own experience: if she met difficulties during the work of the module, and when and how (and if) she overcame them; 2) a classroom work: the students were asked to correct and refine 3 worksheets, chosen by the teacher: one produced by a schoolmate, two produced by herself.

The collected data consist of all the individual productions (including home-works and self-reflective reports) and audio-recordings and field notes taken by the teacher and the participant observer.

The student's specific background on proof

The pathway followed a curricular 9th grade geometric course (triangles and quadrilaterals), approaching the basic notions of CoT, included construction problems and theorems with direct proofs. The teacher estimated that more than 65% of the students were at ease with this kind of proof.

The episode: a construction problem for the approach to proof by contradiction

From the first module of 2017/18 pathway we focus on an episode, which concerns the validation of the construction of a circle tangent to the sides of a given angle; it consists of 5 steps carried out in parallel in the two classes. The related Euclid's proof by contradiction consists of a few steps, and most students already knew all the theorems and definitions used in this proof, including Euclid's

definition of tangent to a circle (only one point of intersection). They were also familiar with the construction of the bisector of a given angle. Therefore, in our a priori analysis, we judged that proof suitable for beginners' first approach to proof by contradiction in geometry, and we predicted that at least some students would have been able to perform such mathematical reasoning. Here, we report only that part of Euclid's proof which proves by contradiction that if we assume EA perpendicular to diameter BA (see Figure 1) then it meets the circle in only one point. We didn't show it to the students.

Euclid' Statement (proposition 16 in Book 3): The straight line drawn at right angles to the diameter of a circle from its extremity will fall outside the circle. (Heath's translation)

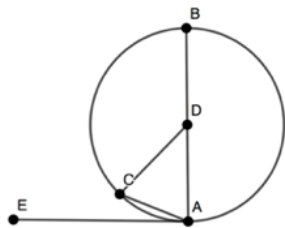


Figure 1

(Proof) For suppose it does not, but, if possible, let it fall within as CA, and let DC be joined. Since DA is equal to DC, the angle DAC is also equal to the angle ACD (prop. I.5). But the angle DAC is a right angle; therefore, the angle ACD is also right: thus, in the triangle ACD, the two angles DAC, ACD are equal to two right angles; which is impossible (prop. I-17). Therefore, the straight line drawn from the point A at right angles to BA will not fall within the circle.

First step: construction of the tangent circle to both sides of a given angle

Lesson 1 (50'). We didn't propose any method of construction and let the students propose it. We collected their worksheets.

Lesson 2 (100'). By collective discussion, we analyzed all their methods (be they right or wrong) and, among them, we chose the following one, because it was aligned with the classroom background:

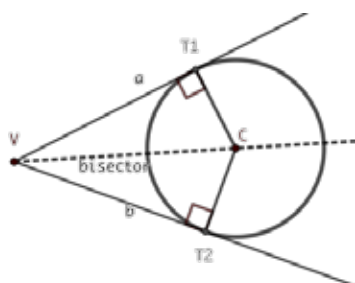


Figure 2

- 1) Take a point C on the bisector of the angle aVb.
- 2) From C draw the perpendicular line to side a and name T₁ the intersection point.
- 3) From C draw the perpendicular line to side b and name T₂ the intersection point.
- 4) Draw the circle of center C and radius CT₁: it is tangent to both the sides of the angle given.

Second step: theoretical justification of the construction

Lesson 3 (100'). Here is the text of the proof task; two hints are added:

By using definitions and theorems that you know, explain why (i.e. prove that) the obtained circle is tangent to both sides of the angle.

Hints: 1) In the 3rd step of the construction we took for granted that also T₂ belongs to the constructed circle. Now you must prove that CT₁ = CT₂. 2) Given the definition of tangent line, in order to prove that each side of the angle is tangent to the circle, you must prove that each side of the angle has only one point in common with the circle: the side a has, in common with the circle, only T₁, the side b has, in common with the circle, only T₂. Try to find a reasoning by contradiction about only one side; for the second one you can re-use it.

Lesson 3) in the 2A class: we observed that almost all students proved that $CT_1 = CT_2$, but no one was able to continue. The difficulty was to find the starting point of proving by contradiction, so, we decided to offer it: “Let us suppose that the circle has two points, T_1 and T_1^* , in common with side a . What consequence can you derive from this new figure?”. While we were waiting for some contributions, we observed gestures simulating reciprocal position of triangle and line, and listened fragments of speech left open. But, the situation reached a stalemate. Thus, the teacher drew the Figure 2 on the blackboard, added the segment CT_1^* (like in figure 3 – see later), and said: “Let’s look at the angles: in T_1 and in T_1^* . Which kind of angles do you think they are?”. Her goal was to hint an isosceles triangle, due to two equal angles (opposite to equal sides). She suggested the students to think about the kind of the resulting triangle, based on the reasoning, in spite of how it looked. But most students saw a scalene one. They looked very uncomfortable, because of the conflict (cf. TFC) between the drawing and the reasoning guided by the teacher. She observed that Fed was slowly moving his index and medium fingers, a scissors-like movement; she interpreted it as a representation of CT_1^* that was collapsing on CT_1 . She asked him the meaning of his gesture. He said: “I see an isosceles triangle, then it has two right angles, (...), I must refuse it; (...)?”. Thus, the teacher mirrored that gesture and asked: “In which case, could the angle in C be the zero angle? Look at your fingers moving”. Fed: “If the two sides collapse in one... and T_1^* in T_1 ”. Fed smiled. This interpretation spread quickly in the classroom and revitalized the atmosphere: almost all the students restarted to work. But, the lesson-time ended: we had to stop and collect their worksheets.

Lesson 3) in 2D: we decided not to distribute the hints sheet, because it had interfered in an ineffective way with the students’ reasoning, and to guide in interaction with students the construction of the proof by contradiction in a smooth way, drawing the side CT_1^* . We proposed to consider the triangle $CT_1T_1^*$ as isosceles. Suddenly, Bea said: “ CT_1^* can’t be a radius of the circle. It’s the hypotenuse!”. By collective interaction, the teacher replied the same gesture made in 2A: several students saw in it the zero angle and carried on their work. Meanwhile, Fra showed his worksheet to the teacher, where he had written: “if there were two points of intersection, then CT_1 would have not been perpendicular to side a (the negation of the hypothesis)”. The teacher told him that his reasoning was the incipit of another kind of proof and encouraged him to complete it. However, the teacher did not share it with the class, in order to not interfere with another way of reasoning, especially because, in that moment, her goal was the proof by contradiction. The discussion was oriented in that direction.

Analysis of the texts: only 6 students out of 51 produced a rather complete proof by contradiction. Students’ difficulties to deal with the impossible figure at the beginning of the proving process were well represented by three students who, when they had to draw the $CT_1T_1^*$ triangle, wrote that they choose T_1^* “very near” to T_1 . Concerning the subsequent phase of proving, in some cases, students’ words resonated with the gesture of closing the two sides of the angle: “The triangle must become the radius CT_1 ”; “The angle goes to 0 and the triangle does not exist anymore”. Some students wrote that the triangle was impossible, because the width of one angle was 0; other students transformed the “impossible” triangle by making it collapse on the segment CT_1 , because “the measure of the angle $T_1CT_1^*$ must be 0”.

Third step: reviewing some proofs produced by mates.

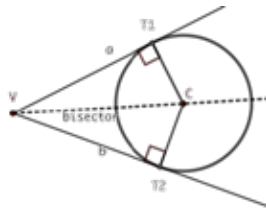
Lesson 4) (100'). In both classes, students were provided with the photocopies of proofs produced by some of them: 2 for the first part of the task, and 5 proofs for the part that concerned proof by contradiction. They were asked to review, correct and improve their mates' proof texts. Most students worked in a rather exhaustive way on the first group of productions (direct proofs), while they had difficulties with the other five productions. A collective discussion followed, still oriented in the direction of putting proving by contradiction into evidence.

Fourth step: individual written refining the proof

Lesson 5) (50'). Task: "Taking into account the discussion, write down in an accurate and complete way the theoretical justification that the circle is tangent to both sides of the angle."

First part:

The circle of center C and radius CT_1 meets side b in a point T_2



Second part:

The circle of center C and radius CT_1 is tangent to the side a of the angle.

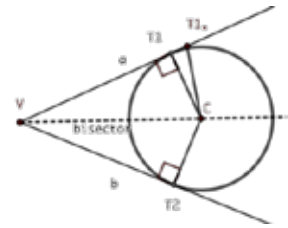


Figure 3: the two parts of the statement

This time, more than one third of students produced more or less exhaustive proofs by contradiction, but in some cases the texts looked like mere transcripts of what the teacher had put into evidence.

Lesson 6) (50'). We provided students with a written theoretical justification of the construction; all the steps were reported, but their justifications were lacking. The conclusion after the emergence of the contradiction was already complete. The drawings of Figure 3 were reported on the worksheet. The students were requested to complete the text by writing the justifications of the statements, which they considered lacking. In this case, most productions were exhaustive and satisfactory.

Interpreting students' difficulties

According to Antonini and Mariotti's (2008) model of indirect proofs, the students were expected to meet difficulties due to the transition from a direct proof initiated by falsifying the thesis of the theorem, to the management at the meta-level of the resulting contradiction. But another, strong difficulty intervened at the beginning of the reasoning: the existence of an impossible figure T_1^* , which contrasted with perceptual evidence (hence the choice of two "very near" points T_1 and T_1^*). It is like if the choice of very near points might make the existence of a second meeting point between line a and the circle more reasonable! In this case, a complementary interpretation of students' difficulties might be provided by TFC, particularly when Fischbein (1993, p. 148) says: "There is certainly a conflict here generated by the fact that the two systems, the figural and the conceptual, did not yet blend in genuine figural concepts [...]. The figural effect is too strong and it seems to cancel the conceptual constraints". Accordingly, in our case, we might interpret students' difficulties in accepting the impossible figure by considering the conceptual assumption of the existence of two points of intersection as the starting point of the direct reasoning that brings to the contradiction, and the conflict with its figural representation. Indeed, in the case of the proof of irrationality of $\sqrt{2}$, most of the same students had easily accepted to start their reasoning from the assumption that $\sqrt{2}=m/n$, with m and n coprime integers. The direct proof could be developed up to the conclusion that m and

n should have had 2 as a common factor. Then, the transition to the logic meta-level inherent in the management of the contradiction made some students hesitant just for a while, without preventing them from reaching a conclusion. On the contrary, in our geometric case the transition to the logic meta-level was problematic: another “impossible figure” worked again as an obstacle, and some students felt the need of collapsing that figure to eliminate the source of the contradiction, instead of accepting the contradiction and coming to the conclusion of refuting the negation of the thesis.

Discussion

The 2017/18 teaching experiment allowed us to better understand some reasons for the difficulties met by students approaching proof by contradiction through a typical theorem of Euclidean geometry. The difficulties in two different phases of proving depended on the figures of the (necessary) visual support to develop the proof (impossible figures!), intertwined (in the second phase) with the difficulties inherent in the management of the contradiction at the meta-level. In order to deal in the future with the approach to proof by contradiction in Euclidean geometry we are now considering three possibilities:

First, to lessen the difficulty inherent in the impossible figure by changing the geometry theorem at stake. Tall et al. (2012) suggest a proving situation related to the proof that the angular bisector of any angle in any triangle intersects the axis of the opposite side in a point that cannot be internal to the triangle. The proof is based on the assumption of an internal point of intersection, and on the consequent reasoning that brings to the conclusion that all the triangles are isosceles.

Second, to approach indirect proofs in geometry through a different treatment of the same situation considered in this paper: the starting point would be to prove that a secant line meeting the circle in T_1 and T_1^* cannot be perpendicular to the radius CT_1 (like the student Fra. did). By this way students would learn to move to the meta-level of logic considerations inherent in indirect proofs without the obstacle of impossible figures; then they might move to a proof by contradiction for another theorem.

Third, to take into account some students' tendency to reason dynamically¹, in order to escape the contradiction related to the impossible figures, and to show how it may result in a valid proof; and then to move either to a proof by contraposition, or to a proof by contradiction as another way of proving the same theorem by reasoning on the impossible figure.

These possibilities are not mutually exclusive. More generally, we may ask ourselves if the domain of Euclidean geometry is suitable for students' approach to indirect proofs. Indeed, in the literature many examples of such approach concern other domains, and even the first encounter of our students happened in the arithmetic field, without any relevant difficulty. For us, two reasons still suggest to privilege Euclidean geometry for a full-fledged approach to indirect proof (in particular, to proof by

¹ Students' dynamical reasoning might result (through a suitable mediation by the teacher) in a direct proof: let us consider the distance between C and the secant line, as the segment of perpendicular CH drawn from the center of the circle to the secant line; the identity: $CH = \sqrt{CT_1^2 - T_1H^2}$ results in the fact that the distance CH approaches the length of the radius of the circle (and thus the radius becomes perpendicular to the straight line) if and only if T_1H^2 goes to 0, i.e. the triangle CT_1T_2 collapse on CT_1 .

contradiction). First, the nature of proof by contradiction: the obstacle of the “impossible figure”, if conveniently dealt with thanks to a suitable preparation, might put into better evidence the nature of the proof by contradiction and the necessity to move to the meta-level (Antonini and Mariotti, 2008). Second, during the process of proving by contradiction, impossible figures do not intervene only in Euclidean geometry, but also in other fields of mathematics (e.g. in Calculus) when students represent the negation of the thesis. Thus, it would be good that students meet impossible figures and deal with them in high school. Moreover, we may add that proof by contradiction entered Western mathematics through Euclid’s elements, while it was absent in other important historical developments of the discipline (like in the case of Chinese mathematics; see Siu, 2012). Thus, it is a cultural product that needs a suitable teacher’s mediation. The field of Euclidean geometry seems to be suitable for it, provided that a smooth approach to indirect proofs is planned.

References

- Antonini, S., & Mariotti, M. A. (2008). Indirect proof: what is specific to this way of proving? *ZDM Mathematics Education*, 40, 401–412.
- Antonini, S., & Mariotti, M. A. (2009). Breakdown and reconstruction of figural concepts in proofs by contradiction in geometry. In F.L. Lin, F.J. Hsieh, G. Hanna, M. de Villiers. (Eds.) *Proceedings of ICMI Study 19, vol. 2* (pp. 82–87). Taipei: ICMI.
- Bartolini Bussi, M., Boero, P., Ferri, F., Garuti, R., & Mariotti, M. A. (2007). Approaching and developing the culture of geometry theorems in school: A theoretical framework. In Boero, P. (Ed.), *Theorems in school: From history, epistemology and cognition to classroom practice* (pp. 211–217). Rotterdam (NL): Sense Publishers.
- European Community (2018). *Commission Staff Working Document - Accompanying the document Proposal for a Council Recommendation on Key Competences for LifeLong Learning*. Retrieved from <https://ec.europa.eu/education/sites/education/files/swd-recommendation-key-competences-lifelong-learning.pdf>
- Fischbein, E. (1993). The theory of figural concepts. *Educational Studies in Mathematics*, 24(2), 139–162.
- MIUR (2010). *Indicazioni nazionali per i percorsi liceali*. Retrieved from http://www.indire.it/lucabas/lkmw_file/licei2010///indicazioni_nuovo_impaginato/_decreto_indicazioni_nazionali.pdf
- Siu, M. K. (2012). Proof in the Western and Eastern Traditions: Implications for Mathematics Education. In G. Hanna & M. de Villiers (Eds.), *Proof and proving in Mathematics Education* (pp. 13–50). New York (NY): Springer.
- Tall, D., Yevdomikov, O., Koichu, B., Whiteley, W., Kondratieva, M., & Cheng, Ying-Hao (2012). Cognitive development of proof. In G. Hanna & M. de Villiers (Eds.), *Proof and proving in Mathematics Education* (pp. 431–442). New York (NY): Springer.

Identifying key ideas in proof: the case of the irrationality of \sqrt{k}

Xiaoheng (Kitty) Yan¹ and Gila Hanna²

¹Simon Fraser University, Faculty of Education, Burnaby, Canada; xkyan@sfu.ca

²OISE, University of Toronto, Canada; gila.hanna@utoronto.ca

The mathematics education literature reveals an ongoing interest in fostering students' ability to construct and reconstruct proofs. One promising tool is the concept of "key idea". This study examined the relationships between how well students identified and formulated key ideas of the proof the irrationality of \sqrt{k} for non-square k and their subsequent ability to reconstruct the proof. The findings show that students' proof reconstructions were closely aligned with key ideas that they identified. Very few students were able to use precise language and point to an idea that helped them both understand the proof and reconstruct it. The findings suggest that mathematics educators, in their desire to see students enhance their understanding of proof and proving by the use of key ideas, need to create opportunities for key idea identification and proof reconstruction with attention to students' differing approaches to reconstructing a proof.

Keywords: Key idea, proof reconstruction, undergraduate mathematics.

Introduction

Since Hanna (1990) highlighted the distinction between proofs that prove and proofs that explain, it has been widely accepted that the purpose of using proof in the classroom is not merely to convince students that a mathematical statement is true, but also, and more importantly, to provide them with mathematical insights (e.g., Hanna, 1995; Mariotti, Durand-Guerrier, & Stylianides, 2018; Mejia-Ramos, Fuller, Weber, Rhoads, & Samkoff, 2012; Stylianides, Stylianides, & Weber, 2017; Thurston, 1995). Closely associated with the notion of "proofs that explain" is that of a *key idea* in a proof. For some scholars this term refers to a central mathematical idea, method, or strategy used in a proof, whereas for others it connotes the outline, overview or architecture of a proof. Despite these different interpretations of *key idea*, this notion has had pedagogical implications that are consistently aligned with the promotion of students' ability to undertake proof construction and reconstruction on the basis of richer understanding (Detlefsen, 2008; Duval, 2007; Gowers, 2007; Hanna & Mason, 2014; Koichu & Zazkis, 2013; Raman, 2003; Robinson, 2000).

Despite the increasing interest among mathematics educators in fostering the ability of students to construct and reconstruct proofs, and in proof reconstructability in particular, there are limited studies that investigated how university mathematics students go about identifying the key idea(s) of a proof, consciously or unconsciously, or how key idea(s) are actually used to help students grasp the overall structure of a proof or the mathematical insights embedded in it. Of those empirical studies that have investigated students' comprehension of proof (e.g., Weber & Mejia-Ramos, 2011), very few have probed the identification of key ideas as a factor that promotes the ability of undergraduate university mathematics students to construct and reconstruct proofs. This paper examines the relationships between the students' ability to identify and formulate key ideas of a proof and their subsequent ability to reconstruct the proof, with specific reference to the use of *key ideas*.

Theoretical underpinnings

Practicing mathematicians have paid considerable attention to the concepts of understanding, remembering, and reconstructing proofs (Byers, 2010; Manin, 1998; Thurston, 1995). Gowers (2007), a Fields medalist, suggests that focusing on the main idea(s) of a proof would enhance its memorability and reconstructability.

Key ideas

The notion of *key idea* in proof construction and reconstruction stems from both mathematical and pedagogical considerations. Lai and Weber (2014) reveal that mathematicians value and emphasize the presentation of the main ideas of a proof over that of a completely rigorous proof. Similarly, mathematics educators have discovered that to help students understand and remember proofs it is more beneficial to put an emphasis on the main ideas contained in the proofs than to teach the students how to build valid sequences of logical steps (Durand-Guerrier, Boero, Douek, Epp, & Tanguay, 2012; Hanna & Mason, 2014; Hemmi, 2008; Knipping, 2008; Malek & Movshovitz-Hadar, 2011). Furthermore, Duval (2007) suggests using main ideas to overcome students' mental blocks in proof construction. Such ideas described above are "key ideas" which carry the flow of information in mathematical proof (Detlefsen, 2008) and capture the gist of a proof (Robinson, 2000).

The term *key ideas* may mean different things to different people. Some scholars refer by that term to the most important mathematical ideas, methods, or strategies used in a proof, whereas others have in mind an outline, overview or architecture of a proof. The former maintain that a proof can foster understanding more successfully if it is constructed on the basis of well understood and internalized key mathematical ideas (Gowers, 2007; Hanna & Mason, 2014; Mason, Burton, & Stacey, 1985). The latter, while also focusing on the central constructive idea, propose a general approach in which a proof task is broken into chunks to highlight its overall structure (Leron, 1985; Mejia-Ramos et al., 2012; Robinson, 2000; Selden & Selden, 2015). Robinson (2000) suggests that it is essential to ignore low-level details while highlighting the overall structure of the proof. Selden and Selden (2015) suggest the construction of a proof framework or outline specifically to reduce the burden on the working memory of the mathematician or student. Raman (2003) understands the term *key idea* differently. For her, it refers to a heuristic idea that one can map to a formal proof with an appropriate degree of rigor.

In this study, the term key idea in a proof was presented to the students as an idea, such as mathematical fact or concept, a specific proving approach or technique that one actually needs to remember in order to know how to go about re-constructing a proof. One might ask "why reconstruction?" At the undergrad level, students often apply a previously learned proof to reconstruct a proof of that type on a new problem. In this sense, proof reconstruction is an outcome measure of the power of key idea.

Here are examples of key ideas. 1) To prove that $\sqrt{2}$ is irrational, a key idea might be: to start with a minimal fraction p/q and look for a smaller such fraction. 2) To prove that the sum of the first n positive integers, $S(n)$, is equal to $n(n+1)/2$, a key idea might be: to notice that each pair $(1 + n)$, $(2 + (n-1))$, $(3 + (n-2))$... has the same sum; another key idea might be: to represent $S(n)$ in a triangular

form of dots. 3. To prove Viviani's theorem, a key idea might be: to use the fact that the area of a triangle is half its base times its height.

Method

Both qualitative and quantitative methods were used in the larger exploratory study on the key ideas of proofs. This paper reports the results based mainly on the qualitative data collected from 17 first year undergraduate mathematics students, who attended a transition-to-proof class in the honours program of mathematics or mathematics education at an urban university in central Canada. The age range of the participants was from 19 to 38.

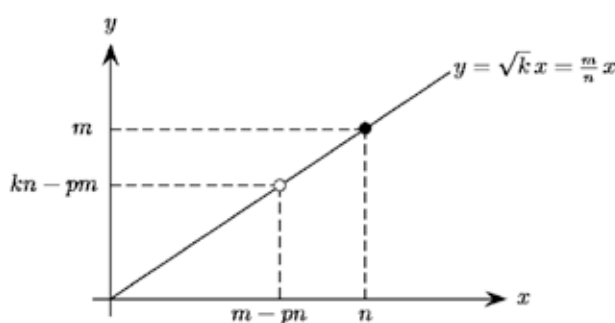
Data Collection and Analysis

The purpose of the quantitative survey' was to gather data on the use of key idea(s) in proof construction and reconstruction. For example, students' agreement to some statements about key ideas were as follows: 1) When I read a proof, I try to identify its key ideas (76%); 2) After constructing a proof, I tend to identify the key ideas used in it (59%); 3) When I reconstruct a proof, I am less likely to get lost if I already know the key idea used in the proof (53%). Student work was the major source for investigating how students identify key ideas in a proof and how they use the key ideas to reconstruct it. It included worksheets, individual assignments, group work, mid-term tests, final exams, as well as snapshots of students' proving products on a board or on paper. Five complete proofs were used for students to identify and formulate key ideas. The paper focuses on the proof of irrationality of \sqrt{k} for non-square k for investigation and discussion.

The proof of the irrationality of \sqrt{k} for non-square k (see Figure 1) was selected from the book *Charming Proofs: A Journey into Elegant Mathematics* (Alsina & Nelsen, 2010).

The irrationality of \sqrt{k} for non-square k

In this proof, we interpret \sqrt{k} as the slope of a line through the origin, as illustrated below.



Theorem: *If k is not the square of an integer, then \sqrt{k} is irrational.*

Proof. Assume $\sqrt{k} = \frac{m}{n}$ in lowest terms. Then the point on the line $y = \sqrt{k}x = \frac{m}{n}x$ closest to the origin with integer coordinates is (n, m) . However, if we let p be the greatest integer less than \sqrt{k} so that $p < \sqrt{k} < p + 1$, then the point with integer coordinates $(m - pn, kn - pm)$ lies on the line and is closer to the origin since $\frac{m}{n}(m - pn) = \frac{m^2}{n} - pm = kn - pm$, and $p < \frac{m}{n} < p + 1$ implies $0 < m - pn < n$ and $0 < kn - pm < m$. Thus we have a contradiction and \sqrt{k} is irrational. ■

Figure 1: The proof shown to the students

This proof was given to the students who attended “Problem, Conjectures and Proofs” course as an in-class exercise which consisted of three components: 1) reading the proof, 2) responding to seven prompt questions such as, “What is the method of the proof?”; “Explain how to use $p < \frac{m}{n} < p + 1$ to prove that $0 < m - np < n$ and $0 < kn - pm < m$. What is the relevance of these inequalities?”; and “What is the idea of the proof? Limit yourself to three or four sentences”, and 3) reconstructing the proof. The instructor gave the students approximately 40 minutes to read the proof and to respond to the prompt questions designed by the instructor. After the students handed in the worksheets, they had approximately 30 minutes to reconstruct the proof. For all the three components of the exercise, the students were asked to work individually.

Fifteen responses were collected. At the end of the course, follow-up question sheets designed to gather more information about students’ perceptions of the notion of key idea were also collected. Email discussions were also conducted with three participants.

Findings

The findings are based on the work of 15 students for whom there is complete data. The students’ work on this proof is organized by the relationship between how well the students identified and formulated the key ideas of the proof and how well they subsequently used them to reconstruct the proof (see Table 1). Each of four qualified judges (two mathematics educators and two mathematicians) assessed the students’ responses independently and then the four settled on a grouping of the responses into three categories: 1) clear key ideas (well-formulated mathematical ideas useful in the proof), 2) unclear key ideas (imprecisely formulated mathematical ideas with no clear way to use them in the proof), and 3) unhelpful key ideas (well-formulated mathematical ideas irrelevant to the proof). The main criteria used to categorize how well the students identified and formulated the key ideas of the proof were relevance and clarity in stating where the contradiction comes from in the proof.

Proof Reconstruction	Identification of Key Idea			Total
	Clear	Unclear	Unhelpful	
Successful	2		1	3
Unclear		3		3
Problematic			9	9
Total	2	3	10	15

Table 1: Relationships between key idea identification and proof reconstruction

Nine out of 15 students identified the key ideas of the proof inappropriately and were unsuccessful in reconstructing the proof. These key ideas, irrelevant to the proof presented, fall into three categories (see Table 2). The first two types reflect students’ misunderstandings of the proof: 5 out

Type	What key ideas focused on	Number of Students
1	Properties of straight lines or linear function	5
2	Well ordering property	3
3	Mechanical procedures	1
Total		9

Table 2: Types of unhelpful key ideas

of 9 students improperly considered that the key idea of the proof involved the properties of straight lines or linear functions, while 3 students claimed incorrectly that the Well Ordering Property was used in the proof. The third type “mechanical procedures” shows that the student simply listed the procedures to be followed to complete the proof without addressing the mathematical ideas used.

Student Kathy displayed a clearly identified key idea of the proof followed by a successful reconstruction. As shown in Figure 2, she offered a well-articulated key idea of the proof by breaking down the key idea into three related elements: 1) an assumption being made – “assume \sqrt{k} can be presented as a rational number $\frac{m}{n}$ in lowest terms”, 2) the consequence of the assumption – “then point (n, m) should be the closet point to the origin on the line $y = \frac{m}{n}x$ for x and y integers”, and 3) what contradicts the assumption – “point $(m-pn, kn-pm)$ is also on the line and that $(m-pn)$ and $(kn-pm)$ are both integers less than n and m respectively, so there is a contradiction”. The logical progression of the three elements was clearly stated and well presented.

In Kathy’s proof reconstruction (see Figure 3), the same structure and wording of the key ideas appeared. In fact, the reconstruction was an expanded version of the key ideas with adequate details of reasoning and verifying. Notice that, from the instructor’s perspective, the proof could have stopped when Kathy reached the point where “the point $(m-pn, kn-pm)$ has integer coordinates and is closer to the origin than (n, m) ”. However, Kathy continued on to explain that “ $y = \frac{m}{n}x$ is linear

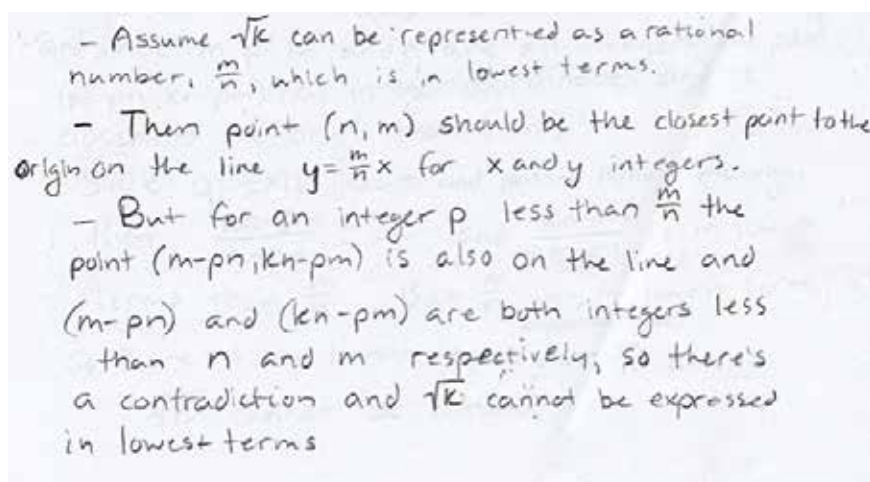


Figure 2: Kathy’s key idea of the proof of the irrationality of \sqrt{k}

and passes through the origin then $\frac{kn-pm}{m-np} = \frac{m}{n}$ and $\frac{kn-pm}{m-np}$ is in lower terms $\frac{m}{n}$ ”, which did not appear in the original proof presented to the students. It seemed that in order to come to the conclusion, Kathy needed to see the integer coordinates of the two points in the form $\frac{kn-pm}{m-np} = \frac{m}{n}$ to argue that now a new point was found such that $\sqrt{k} = \frac{kn-pm}{m-np}$ in lower terms than $\frac{m}{n}$. This intention and action to be more explicit and transparent than the original proof shows that the student reconstructed a proof that she understood, and needed to communicate with herself and the instructor about what she considered critical to reach the contradiction.

Assume \sqrt{k} rational. then $\sqrt{k} = \frac{m}{n}$ for some integers m and n , $n \neq 0$, and $\frac{m}{n}$ in lowest terms.

Then for the line through the origin with the slope $\frac{m}{n}$, (n, m) should be the closest integral point on the line to the origin.

But ~~for~~ ^{there exists} an integer p , where $p < \frac{m}{n} < p+1$, and the point $(m-pn, kn-pm)$ is also on the line $y = \frac{m}{n}x$ and from $p < \frac{m}{n} < p+1$, $0 < m-pn < n$ and $0 < kn-pm < m$

and since m, p, k , and n are all integers, the point $(m-pn, kn-pm)$ has integer coordinates and is closer to the origin than (n, m) ✓

Since $y = \frac{m}{n}x$ is linear and passes through the origin then $\frac{kn-pm}{m-pn} = \frac{m}{n}$ and $\frac{kn-pm}{m-pn}$ is in lower terms than $\frac{m}{n}$. But $\frac{m}{n}$ was ^{enough that point is closer to} in lowest terms, _(supposed to be)

So there is no lowest terms for $\frac{m}{n}$ and \sqrt{k} cannot be rational!

Figure 3: Kathy's reconstruction of the proof of the irrationality of \sqrt{k}

When asked to reflect on what led to the success in understanding and communicating the key ideas of the proof, Kathy stated that:

I have to break the proof into related steps so that I can understand it when I am reading it, and communicating that is just the process of putting the ideas of those steps back into words. When doing this, I choose phrasing that would help me to understand the proof better. So I think that I did well on those questions because they are similar to my own process of understanding the proofs presented.

There was one case of an incorrect key idea followed by a successful reconstruction. A student stated that, "The main idea of this proof is we won't have a line when the slope of it is irrational. The graph will be a curve." However, his reconstruction of the proof was complete and clear, despite the mis-identified main idea. To probe what was going on in the student's mind, attempts were made to discuss the work with him. Unfortunately, the student was not interested in such discussions.

Discussion

The findings indicate that compared to the original proof, students' proof reconstructions varied in some ways. These variations deserve some pedagogical attention given the fact that a deep understanding of a proof often leads to a personal interpretation of the proof. In Kathy's case, she deliberately added some details that did not appear in the original proof. The "unnecessary verification" served her as a necessary self-explanation to make a strong argument. Similarly, another student interpreted "a closer point to the origin" presented in the original proof as the

integral coordinates “below m and n ” so that he could link the point $(m-pn, kn-pm)$ back to the straight line.

Three out of 15 participants identified the key ideas and reconstructed of the proof with limited success, while nine students did not manage to state a key idea clearly. Consequently, these nine students’ reconstructions of the proof tended to lack clarity as well. What seems to have thwarted their ability to reconstruct the proof was their lack of success in identifying clearly a key idea of the proof with the intention of re-using it in future reconstruction. The inadequate level of clarity in these students’ work might be due to a lack of full or partial understanding of the proof, or simply due to a struggle with being precise in expressing their ideas.

The findings are somewhat in line with Raman, Sandefur, Birky, Campbell, & Somer (2009) in that a proof should not be thought as having only one particular key idea: “We refer to “a” key idea rather than “the” key idea, because it appears that some proofs have more than one key idea” (p. 2–156). The findings do support Gowers’ (2007) view that a key idea provides not only a clue how to remember a proof but also to write it up. In fact, the findings bring evidence that the students’ proof reconstructions were closely aligned with the key ideas they themselves identified – varied in type as those key ideas may have been. It is therefore important for mathematical educators to be aware of these variations so as to understand students’ work better. In addition, instructors could be attentive to students’ differing approaches to reconstructing a proof and aim at creating more opportunities for students to identify key ideas and engage in proof reconstruction.

References

- Alsina, C., & Nelsen, R. B. (2010). *Charming proofs: A journey into elegant mathematics*. Washington, DC: The Mathematical Association of America.
- Byers, W. (2010). *How mathematicians think: Using ambiguity, contradiction, and paradox to create mathematics*. Princeton: Princeton University Press.
- Detlefsen, M. (2008). Proof: Its nature and significance. In B. Gold & R. A. Simons (Eds.), *Proof and other dilemmas: Mathematics and philosophy* (pp. 3–32). Washington, DC: The Mathematical Association of America.
- Durand-Guerrier, V., Boero, P., Douek, N., Epp, S. S., & Tanguay, D. (2012). Argumentation and proof in the mathematics classroom. In G. Hanna, & M. De Villiers (Eds.), *Proof and Proving in Mathematics Education: The 19th ICMI Study* (pp. 349–367). New York, NY: Springer.
- Duval, R. (2007). Cognitive functioning and the understanding of mathematical processes of proof. In P. Boero (Ed.), *Theorem in school: From history, epistemology and cognition to classroom practice* (pp. 137–161). Rotterdam, The Netherlands: Sense.
- Gowers, W. T. (2007). Mathematics, memory, and mental arithmetic, In M. Leng, A. Paseau, & M. Potter (Eds.), *Mathematical knowledge* (pp. 33–58). Oxford, UK: Oxford University Press.
- Hanna, G. (1990). Some pedagogical aspects of proof. *Interchange*, 21(1), 6–13.
- Hanna, G. (1995). Challenges to the Importance of Proof. *For the Learning of Mathematics*, 15(3), 42–49.
- Hanna, G., & Mason, J. (2014). Key ideas and memorability in proof. *For the Learning of Mathematics*, 34(2), 12–16.

- Hemmi, K. (2008). Students' encounter with proof: The condition of transparency. *ZDM*, 40(3), 413–426.
- Knipping, C. (2008). A method for revealing structures of argumentation in classroom proving processes. *ZDM*, 40(3), 427–441.
- Koichu, B., & Zazkis, R. (2013). Decoding a proof of Fermat's Little Theorem via script writing. *The Journal of Mathematical Behavior*, 32(3), 364–376.
- Lai, Y., & Weber, K. (2014). Factors mathematicians profess to consider when presenting pedagogical proofs. *Educational Studies in Mathematics*, 85(1), 93–108.
- Leron, U. (1985). Heuristic presentations: The role of structuring. *For the Learning of Mathematics*, 5(3), 7–13.
- Malek, A., & Movshovitz-Hadar, N. (2011). The effect of using transparent pseudo-proofs in linear algebra. *Research in Mathematics Education*, 13(1), 33–58.
- Manin, Y. I. (1998). Truth, rigour, and common sense. In H. G. Dales & G. Oliveri (Eds.), *Truth in mathematics* (pp. 147–159). Oxford, UK: Clarendon.
- Mariotti, M. A., Durand-Guerrier, V., & Stylianides, G. J. (2018). Argumentation and proof. In T. Dreyfus, M. Artigue, D. Potari, S. Prediger, & K. Ruthven (Eds.), *Developing research in mathematics education: Twenty Years of Communication, Cooperation and Collaboration in Europe* (pp. 75–89). Abingdon & New York, Oxon & NY: Routledge.
- Mason, J., Burton, L., & Stacey, K. (1985). *Thinking mathematically* (Rev. ed.). New York, NY: Addison Wesley.
- Mejia-Ramos, J. P., Fuller, E., Weber, K., Rhoads, K., & Samkoff, A. (2012). An assessment model for proof comprehension in undergraduate mathematics. *Educational Studies in Mathematics*, 79(1), 3–18.
- Raman, M., Sandefur, J., Birky, G., Campbell, C., & Somer, K. (2009). “Is that a proof?”: Using video to teach and learn how to prove at the university level. In F.L. Lin, F.J. Hsieh, G. Hanna, & M. de Villiers (Eds.), *Proceedings of ICMI Study 19 on Proof and Proving in Mathematics Education* (vol. 2, 154–159). Taipei: National Taiwan Normal University.
- Raman, M. (2003). Key ideas: What are they and how can they help us understand how people view proof? *Educational Studies in Mathematics*, 52, 319–325.
- Robinson, J. A. (2000). Proof = guarantee + explanation. In S. Holldobler (Ed.), *Intellectics and computational logic: Papers in honor of Wolfgang Bibel* (pp. 277–294). Dordrecht, The Netherlands: Kluwer.
- Selden, J., & Selden, A. (2015). A theoretical perspective for proof construction. *Presented at the 9th Congress of European Research in Mathematics Education, WG-1*. Prague, Czech Republic.
- Stylianides, G. J., Stylianides, A. J., & Weber, K. (2017). Research on the teaching and learning of proof: Taking stock and moving forward, In J. Cai (Ed.), *Compendium for Research in Mathematics Education* (pp. 237–266). Reston, VA: NCTM.
- Thurston, W. P. (1995). On proof and progress in mathematics. *For the Learning of Mathematics*, 15(1), 29–37.
- Weber, K., & Mejia-Ramos, J. P. (2011). Why and how mathematicians read proofs: An exploratory study. *Educational Studies in Mathematics*, 76(3), 329–344.

TWG02: Arithmetic and number systems

Introduction to the work of TWG 2: Arithmetic and number systems

Elisabeth Rathgeb-Schnierer¹, Renata Carvalho², Beatriz Vargas Dorneles³ and Judy Sayers⁴

¹University of Kassel, Germany; rathgeb-schnierer@mathematik.uni-kassel.de

²Instituto de Educação, Universidade de Lisboa, Portugal; renatacarvalho@campus.ul.pt

³Universidade Federal do Rio Grande do Sul, Brazil, beatriz.dorneles@ufrgs.br

⁴University of Leeds, U.K., and Stockholm University, Sweden; j.m.sayers@leeds.ac.uk

Introduction

Working Group 2 was formed in 2011 and has developed as a forum for discussing theoretical and empirical research on the teaching and learning of arithmetic and number systems. Our common work targets to gain and enhance knowledge about students' understanding and meaningful learning in this content area regarding different age and achievement levels. The scope of the TWG comprises kindergarten to 12th grade, and emphasizes research-based specifications of domain specific frameworks, concepts and goals, analysis of learning processes and learning outcomes in different classroom cultures, as well as innovative teaching and diagnostic approaches that balance procedural and conceptual knowledge.

Learning arithmetic and number systems from Kindergarten to High School is a very broad field with a great variety of themes and research approaches. This year, the group intensively discussed twenty papers and four posters that reflected the richness of the field. According to the path we pursued at CERME 10, we had the chance to broaden our discussion by regarding the same topics from different perspectives; cognitive psychologists and mathematics education researchers. In comparison to the TWG work of the last years, there was also a change regarding the research approaches. Whereas the last two CERME conferences were dominated by design based research, this year was characterized by a good balance of qualitative and quantitative approaches.

Overview on discussed papers and posters

The various presented and discussed papers can be pooled in four groups of themes: The role of manipulatives in learning processes in early arithmetic, learning and teaching numbers and operations in kindergarten to first grade, learning and teaching arithmetic in second to sixth grade, as well as different foci on learning rational numbers. Additionally, there was one paper on metacognition.

Role of manipulatives

Natividad Adamuz-Povedano, Elvira Fernández-Ahumada, Teresa García-Pérez and Rafael Bracho-López reported on an exploratory study of 25 students using manipulative materials to develop number sense understanding in 6 year olds by presenting two activities, jumping frogs and skip kangaroo. The findings illustrated how effective active behaviors from the students had enhanced.

Doris Jeannotte and Claudia Corriveau explored the use of manipulatives by children, in particular based-ten blocks and abacus, for solving arithmetical tasks. Considering the concept of affordance, as related to interactions between an individual and the environment, they analyzed both, the use of manipulatives and the affordance in two grade 3 classes, as inseparable units of teaching and learning.

Numbers and operations in early arithmetic

Camila P. Noguez and *Beatriz V. Dorneles* explored deeper into the skills of number estimation and quantitative reasoning through the discussion of the relationship between these two important concepts of understanding. They found indeed a correlation between grades 3 and 4 students' performance in the quantitative reasoning task and number line estimation tasks.

Évelin Assis and *Luciana Vellino Corso* presented an intervention study in Brazil which involved 136 first-grade students in the teaching and understanding of counting principles. A key product of this experiment was to analyze the efficiency of the intervention in order that it could be used in any first grade classroom.

Pernille Sunde and *Peter Sunde* investigated the development of mental strategies in single-digit addition in 83 first grade students. The used strategies were assessed by two interviews that were conducted in a period of five month. Surprisingly, quantitative analysis revealed no influence of instruction for strategy change.

Michael Gaidoschik discussed the “structure-genetic didactical analysis” paradigm, which emphasizes the need of children explore and internalize part-whole relations between numbers. He questioned the role of counting in early math classrooms, and offered a didactic alternative in line with the needs of the children as well as the subject matter.

Luciana V. Corso and *Évelin Assis* analyzed teacher's perceptions of their first grade students' profiles including students' behavior, attention, interaction and knowledge by area of mathematics writing and reading. The findings presented teachers perceptions related very closely to student achievement in a counting principle test, but only for students with a good performance.

Learning arithmetic in second to sixth grade

Joana Brocardo, *Catarina Delgado*, *Fátima Mendes* and *Jean M. Kraemer* presented a teaching experiment with grade 3 students in the domain of partitive division. It aimed to explore how students adapt personal knowledge to varying task conditions. Data analysis confirmed that variation influences students' strategies, and allowed to designate three critical aspect of the learning process.

Ems Lord and *Andreas J. Stylianides* presented results of a mixed methods study that focused on calculation flexibility and written algorithm on Year 6 students. Results revealed that formal algorithms were the most frequently selected strategy, and gender, prior attainment and confidence were all significant predictors of the use of formal algorithms.

Robert Gunnarson and *Ioannis Papadopoulos* analyzed written solutions for arithmetic expressions of Swedish and Greece students (grades 5 and 6) focusing on the order of operation (addition, subtraction and multiplication) and the precedence rules. Data showed that pairing is as frequently used as sequential calculations. Thereby, three qualitatively different types of pairing were identified.

An analysis of four popular German textbooks (grades 2 and 3) with a focus on developing and consolidation of understanding of multiplication was presented by *Sandra Gleißberg* and *Klaus-Peter Eichler*. Using their own conceptual framework based on the work of Bruner, the analysis showed that the vast majority of tasks require working on the non-verbal-symbolic level alone.

Different foci on learning rational numbers

Lalina Coulange and *Grégory Trains'* study aimed to understand the role of register of numeration units (tenths, hundredths) for teaching and learning decimal numbers at primary level in France. Their findings revealed students' difficulties in unit-conversions and in associating the numeration units with the decimal notation. A new perspective on teaching is suggested to prevent those difficulties.

Ioannis Papadopoulos, *Styliani Panagiotopoulou* and *Michail Karakostas* investigated strategies used by primary, secondary and tertiary education students to calculate mentally operations involving rational numbers. The findings revealed the mental form of the written algorithm as dominant strategy across all educational levels.

Pernille L. Pedersen and *Peter Sunde* investigated the relationship between 99 fourth-grade students' ability to compare fractions and to solve tasks all four operations. Data analyzes showed that comparative rational number tasks are correlated with division and multiplicative items, and therefore suggested that understanding of fractions is closely connected to multiplicative reasoning.

A summary of four studies on secondary students' conceptual and procedural knowledge of fractions was presented by *Xenia Vamvakoussi*, *Maria Bempeni*, *Stavroula Pouloupoulou* and *Ioanna Tsiplaki*. The researchers developed and evaluated an instrument to measure both knowledge types, and identified students' individual differences in combining procedural and conceptual knowledge.

Carlos Valenzuela Garcia and *Olimpia Figueras* designed a teaching model for fractions based on applets aiming to support the development of fraction mental objects in elementary students. The performance of two students, described in the paper, showed that working with the applet lead to an enhanced notion of fractions, e.g., from fractions as fracturer to fractions as number and as measurer.

Sofia I. Graça, *João P. Ponte* and *António Guerreiro* developed a study that aimed to identify grade 5 students' knowledge of rational number operations and number sense before and after a teaching experiment. Results indicated that students' performance changed; at the beginning it based on their whole number knowledge, later they exhibited conceptual knowledge, number and operations sense.

Carvalho, Renata and *João P. Ponte* surveyed grade 6 students' strategies in mental computation in rational numbers within a qualitative design research approach including three phases. Data analysis allowed to describe typical strategies regarding tasks with different cognitive demands, and revealed that, e.g., memorized rules are mostly applied without meaning.

Maria T. Sanz Garcia, *Olimpia Figueras* and *Bernardo Gómez* focused on students' performance (15 and 16 years old) in solving particular fraction word problems, and measured their difficulties by accuracy. Results suggested that the increase of steps in a problem leads to the increase of students' difficulties caused by insufficient basic fraction knowledge.

Metacognition in problem solving

Aikaterini Vissariou and *Despina Desli* investigated metacognitive strategies used by sixth graders solving a non-routine mathematics problem. Despite the fact that students reported the use of

metacognition, their demonstration of the used strategies was quite low. Additionally, their successful solution to a problem was not necessarily connected to the employment of metacognitive strategies.

Discussed posters

Évelin Assis and *Luciana V. Corsos*' poster depicted well their analysis of the intervention pilot study discussing the adaptations that needed to occur on route. *Alix Boissière* presented a board game around the notion of fractions for grades 4 to 6. It was developed based on the theory of didactical situations and pretested in several classrooms. *Kazuhiro Kuriharas*' poster introduced a theoretical framework for analyzing the development of students' understanding the algebraic structure. Hereby, the focus is on the extension of number sets. *Charlotte Rechtsteiner* analyzed flexible mental calculation skills of freshmen and graduates. Results indicated that the flexibility scores are not adequate for prospective primary teachers.

Summary and outcomes

The great variety of papers was challenging, but also the strength of this TWG since it ensured interesting and often animated discussions in a supportive quizzical environment. Thereby, we went far beyond the specific topics of the single papers, worked out differences and commonalities of used terms, concepts, theoretical frameworks and methodological approaches. We realized once more different conventions in different countries of naming numbers and operations, as well as partly conflicting views of quantitative and qualitative approaches. Altogether, we broadened our own culturally influenced perspectives and drew new inspiration for further research. The aspects we discussed reflected the whole spectrum of arithmetic in primary and secondary level and comprised

- the importance of counting in different cultures and curricula, as well as a critical reflection on counting for developing strategies in mental calculation.
- the influence of instruction and the need to design learning environments based on our knowledge of students' strategies, conceptions and misconceptions.
- the importance of supporting students' conceptual knowledge regarding numbers and operations in different number systems.
- the clarification of methodology in terms of what is measured, why is a measure used, what does a result mean, and how does it contribute to better understanding of teaching and learning.
- the meaning of 'number estimation' as positioning natural numbers in a segment, and its connection to relational thinking.
- the challenges of transition between number systems, between representations, and from intervention research to students understanding (long term)

Reflecting our work in a conclusive discussion, we agreed that our various research is driven by a common goal: Supporting all student's understanding and meaningful learning to develop conceptual knowledge, number sense and structure sense in different number systems, as well as flexible and adaptive expertise in calculation strategies in all operations. Our further work is directed towards specifying terms and work on common understanding of number sense, structure sense, flexibility, manipulatives and mental calculation. Furthermore, we want to advance our methodological approaches and bridge the gap between quantitative and qualitative by triangulation.

Use of conceptual metaphors in the development of number sense in the first years of mathematical learning

Natividad Adamuz-Povedano¹, Elvira Fernández-Ahumada¹, Teresa García-Pérez² and Rafael Bracho-López¹

¹ University of Córdoba, Faculty of Education Sciences, Cordoba, Spain; nadamuz@uco.es

² Al-Andalus Public Primary School, Cordoba, Spain; teresagarcia20@gmail.com

Promoting experiences to develop the so-called number sense since early school years has become a focus of interest in mathematics education research. By number sense we mean a broad concept that refers to a deep understanding of the decimal number system, the relationships between numbers and operations, and the development of capabilities such as flexible mental calculation, numerical estimation and quantitative reasoning. This paper is an exploratory study (25 pupils), part of an ongoing research, where a methodological approach, based on the use of manipulative materials for developing in six-year-old students' number sense is explored. Particularly, in this study, we present and analyse two activities, in which a jumping frog and a kangaroo are used as conceptual metaphors for the acquisition of calculation strategies that encourage number sense development.

Keywords: Number sense, Conceptual metaphor, Primary Education, Manipulative resource.

Introduction.

Expressions such as "number sense", "numerical consciousness" or "numerical thinking" are being imposed with force in the current studies on mathematical knowledge. In general terms it refers to several important abilities that involve mastering a wide range of skills with numbers. For McIntosh, Reys and Reys (1992) numerical thinking is a person's overall understanding of numbers and operations along with the ability and inclination to use this understanding in flexible ways to make mathematical judgments and to develop useful strategies for managing numbers and operations.

In the Curriculum and Evaluation Standards for Mathematics Education of the National Council of Teachers of Mathematics (NCTM, 1989), five components that characterize numerical sense were identified: (1) correctly understand the meaning of numbers; (2) be aware of the multiple relationships that exist between numbers; (3) recognize the relative magnitude of the numbers; (4) know the relative effect of numerical operations; (5) have reference points for measurements of common objects and situations in the environment. In the same line, Sowder (1992) expresses that number sense is developed when students understand the size of numbers, they think about them and represent them in different ways, they use numbers as references and develop accurate insights into the effects of operations with numbers.

Although there is still no general consensus on the concept and operation of numerical thinking, many authors (Berch, 2005; Godino, Font, Konic, & Wilhelmi, 2009) are trying to define it, identify the keys to its development, establish criteria to evaluate it and analyse its repercussions on children's learning.

The school context is a privileged place to work with the possibilities offered by this powerful tool. Teachers must consider the number sense as an essential objective and articulate the resources and activities necessary to develop it.

Manipulative resources provide us with very advantageous visualizations to present, know and materialize both numbers and operations. To the visual properties of the resources must be added their sensory and motor properties, as they invite manipulation and movement. In this sense, another way of teaching and learning mathematics appears, because it is recognized that mathematical cognition is embodied and is intimately linked to our sensorimotor functioning (Gallese & Lakoff, 2005).

The matching of symbolic mathematics, initially quite abstract and apparently less close for students, with insights from the real world, helps to forge links between conceptual and procedural knowledge, which is critical to success in mathematics (Siegler, 2003). Conceptual metaphors are, among others, methodological strategies that facilitate neurological mechanisms that allow us to adapt the activated neuronal systems through the sensory-motor experience, making possible the seemingly complicated journey from the concrete to the abstract (Lakoff & Johnson, 2003). Thus, there arises a new way of conceiving the teaching and learning of mathematics associated with embodied mathematical cognition linked to sensory-motor functioning, departing from Piaget's theory of cognitive development, which separated motor-sensory development from conceptual development, basing the second on the first, but without the parallel development that we defend.

Conceptual metaphors provide a transition from one mode of representation to another or from a concept that is part of our knowledge to a more abstract one. Consequently, they value the three levels of representation of Bruner (1972): enactive, iconic and symbolic, putting into play and relating the four dimensions of mathematical thought (mathematical contents, non-rational processes, strategies and procedures and perception). Of course, this journey between the three types of representation does not have to be unidirectional and without return, from the enactive to the symbolic representation, passing through the iconic, but it can go back or advance through the levels on its way to conceptual consolidation. Conceptual metaphors do not only respond to a final objective of a cognitive nature, but also contribute to a didactic enrichment by providing resources and useful tools to address complex problem situations (Soto-Andrade, 2007), which makes them even more valuable for the construction of mathematical knowledge and the development of the competences associated with it.

This paper is part of an on-going research, where a methodological approach for developing six-year-old students' number sense is explored. The proposal is based on the use of manipulative materials, rigorously structured (García-Pérez & Adamuz-Povedano, 2016), that keep the relationship number-space very present, giving students a numerical support for the learning of the decimal numbering system, as well as an arithmetic support for operations. Here we present two activities, as specific examples of the use of a variety of conceptual metaphors (maps, routes, characters...) that play an important role for number sense development, as motivating and facilitating elements, both in the teaching and learning processes. In the design of these activities we take into account the limits that Cole and Sinclair (2017) show relative to the use of conceptual metaphors.

Teaching materials

As we mentioned before, this proposal is based on the use of manipulative materials, rigorously structured, which we describe:

- *Number line*: it is a tape in which part of the set of natural numbers is presented. It starts with zero, a number that we will need to represent different situations: starting point, absence of counting elements, total loss, etc., and it ends in 100 example see figure 1.



Figure 1: Detail of the number line

With it we can practice progressive and regressive recitation, form the first series and perform simple addition and subtraction operations. We can also compare positions on both sides of the 10 to begin the observation of regularities and changes.

The tape shows, with great consistency, the numerical order, the pattern that generates numbers and distances. The numbers colored in red, in addition to meaning exact tens, are privileged positions, strategic enclaves when planning routes that take us from one number to another.

- *Numerical panel*: it presents the numbers from zero to ninety-nine by families (figures 2 and 3). This format enhances the display of numbers on the tape expanding the possibilities of analysis and relation.

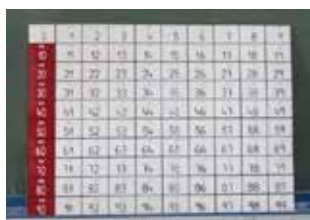


Figure 2: Collective numerical panel **Figure 3: Individual numerical panel**

As in the case of the tape, the complete tens are highlighted with a red background, facilitating their location and indicating they are essential elements within our numbering system. The number-space association in the panel shows very clearly the patterns and regularities of our decimal number system. On this "precise map of the numbers" it is also possible to perform many addition and subtraction operations by tracing horizontal paths (we move forward or backward through the rows) and vertical (we raise or lower the columns by multiples of ten).

- *Numbering box*: this material facilitates full exploration and manipulation of numbers, favoring a correct understanding of decimal numeration system. It consists of abundant plastic sticks and red and green rubber bands, see figure 4 below. The work with the numbering box produces a qualitative leap in the understanding of the decimal structure of the number and its size, since it provides a concrete and faithful model to the visible reality, which gives meaning to the use of written symbols and concepts. Regarding place value, in addition, we should move from that understanding to much more flexible forms. We can achieve this by removing the tens and units from the box and exploring

other groups with total freedom, leaving or removing the rubber bands of the tens. Regarding the calculation, the numbering box directly connects with breakdown strategies and facilitates the graphic transcription that is derived from the manipulation of quantities.



Figure 4: Numbering box

Selected activities

In this paper we only show two activities focused on the number line resource. However, the methodology implies the implementation of other activities based on the use of the other resources. This provides students with greater flexibility in reasoning about numbers, an aspect directly related to the quality of their numerical sense.

Activity 1: Saltarina, the frog

The convenient breakdown of numbers is a fundamental skill to give agility and efficiency to thought calculation, so let children show some characteristics of development of their number sense. Young children find it difficult to acquire because they require complex skills such as observation and analysis of the complete operation, reflection and planning of the tactics to be used, and also a good handling of numbers at the mental and written level. To work on this awareness of what may be suitable for the proposed calculation we use the conceptual metaphor of the jumping frog, it is a frog that jumps forward and backwards through the number line. In addition, Saltarina has a fixation with the colour red: whenever she can, she boots in the numbers coloured in red (see figure 5 below).

Teacher: This is Saltarina, a very funny frog that comes and goes on the number tape jumping without stopping. Do you know what her favourite colour is? ... It's red! ... and the numbers that have this colour look like springboards to take energy to jump higher. You can be sure that whenever she has the opportunity she bounces on them. Today, Saltarina jumps eight, do you know how she will do that if she is on thirty-six?

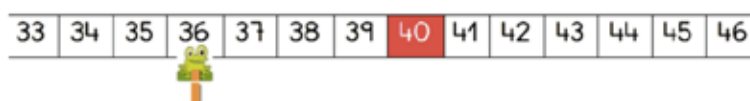


Figure 5: Saltarina is on 36

Student 10: She will jump four to land on forty and later she will jump another four.

Teacher: Very good! Let's check it!

The real movement is made, taking the clamp with the frog that bounces onto forty and ends the jump on forty-four.

Teacher: She has reached forty-four! Now let's say in writing what has happened.

Teacher: Say with me, please.

Teacher and students: Saltarina was on thirty-six [she writes 36 on the blackboard figure 6], first she has made a leap forward of four to reach forty [she writes +4] and then she has made another leap of four [she writes +4]. It has reached forty-four.



Figure 6: Saltarina's jump

Teacher: She has reached forty- four! ... What if she now adds eight again?

Student 10: Now she has to jump six to fifty and then two.

Teacher: And how do we express it with numbers and signs?

On the board, teacher writes the jump in two movements and the arrival number: $44 + 8 =$, and below $44 + 6 + 2 = 52$

In Figure 7, we have examples of two students' activities, one in which Saltarina adds eight and another which goes back six. In both, the empty number line has been used as a scheme for the representation of forward and backward:

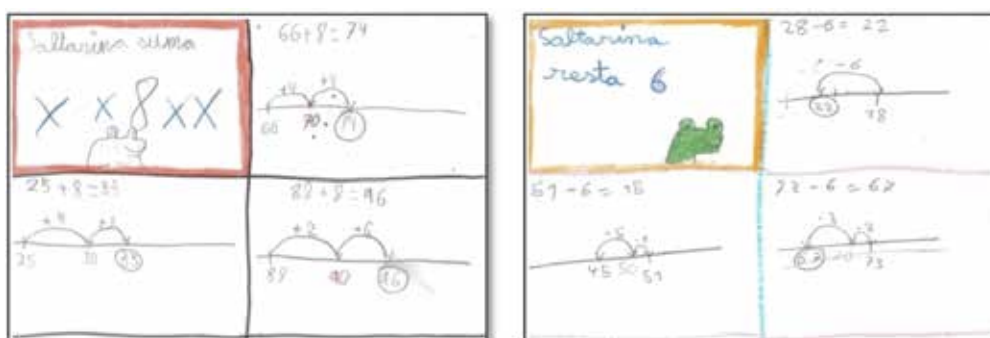


Figure 7: Saltarina's worksheet

Next, we analyse some examples showing different strategies that take part of what we have denominated *tactical calculation* (Adamuz-Povedano & Bracho-López, 2017), shows the operation $63-24$ see figure 8, the student rewrites the operation explaining the plan he will follow, removing three units, then two tens and finally one unit. Since he is not still self-confident in mental calculation he makes partial annotations.

Figure 8: Work out 63-24

Figure 9: Work out 45+29

In Figure 9 the student rewrites the followed mental route to get the result, again Saltarina's strategy appears adding 5 to get 50 and then adds 24 in a convenience way.

Activity 2. Skip Kangaroo!

In this activity we will use the number tape as if it were a numbered track in which a kangaroo makes jumps of different magnitude passing from one family to another. The objective is to reinforce operations in which there is change of tens, i.e. operations of adding and subtracting with taken. The kangaroo should overcome a fence that is placed in an exact ten and can jump progressing in the numerical sequence (we will relate it to the expression "+") or going backwards (expression "-"). The connection between movement in space and numerical operation is being established. This activity places students in front of the control of phenomena and develops their relational thinking. With the tape and the Kangaroo, we configure a "mathematical scenario" in which we can experiment with different possibilities to relate the numbers of two families. Children should determine the starting point, the direction and magnitude of the jump, and the arrival number. They should then insert these data into an arithmetic structure. Very important processes such as estimation, decision making and the translation of each specific situation into the language of numbers and signs, which favour the development of the numerical sense, are involved in all this work.

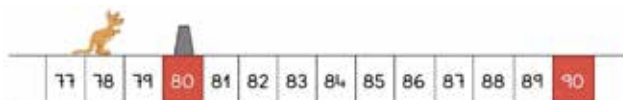


Figure 7: Kangaroo on the number tape

In this episode, see figure 10 above, the kangaroo is at number seventy-eight and it will jump until it reaches some number in the family of the eighties. First, we analyse the situation from a broader perspective, asking the group questions such as: What jumps shall not exceed the fence? It means, how far can he go without going over 80? What will be the minimum jump length? And the maximum?

Student 1: At least he has to jump three, up to eighty-one.

Student 1: And the most you can give is a jump from eleven to eighty-nine.

Then, with the contributions of all, we will be expressing verbally each of the possible solutions and their corresponding written expression.

Student 3: If it takes a jump of five, it reaches eighty-three.

We check on the number tape whether this is a correct solution

Teacher: How will we express this by writing what you have just said? (We write on the board at the same time we relate)

Teacher and Students: it begins at seventy-eight (78), jumps forward five (+5) and reaches eighty-three (= 83).

On the board will be written: $78 + 5 = 83$. We will continue exploring other possibilities from the same starting position. So, we will collect all the arithmetic structures on the board: $78+3=81$, $78+6=84$, $78+9=87$, $78+4=82$, $78+7=85$, $78+10=88$, $78+5=83$, $78+8=86$ and $78+11=89$. Then, we will observe them as a whole, becoming aware that with them we have translated each event into the language of numbers and signs. Moving forward with this observation, the teacher can bring the attention to the amounts that remain and to which they change, thus intuitively introducing the concept of a variable:

Teacher: From what number has the kangaroo always jumped? What jumps has it made? With what jumps did it stay close to the start? With which did it get very far? ...

Two sessions were developed with the dynamics showed; the kangaroo was introduced, working only with components in a sensorimotor and verbal level until we were sure that the whole group understood the proposal. In each participation, the student had to decide first the direction of the jump and the magnitude of the jump; then choose the exit number. These decisions inform the teacher about the students' number sense much more than the calculation itself. Then, the movement was actually made on the number tape verifying that it was feasible and, finally, the operation explaining the jump was verbalized. In the third session this activity is made on written level. To ensure the accessibility of all the students, an image of the tape with the corresponding numerical section was included in the worksheet. Below, we show two cases with interesting results. In figure 11 it is appreciated that the student discovers how to control the situation, the control of phenomena that is so present in the relational thinking, so that the number of arrival is always 41. In figure 12, the student ends, according to his own words, with "a jump from end to end"(that it is to say from 49 to 31)

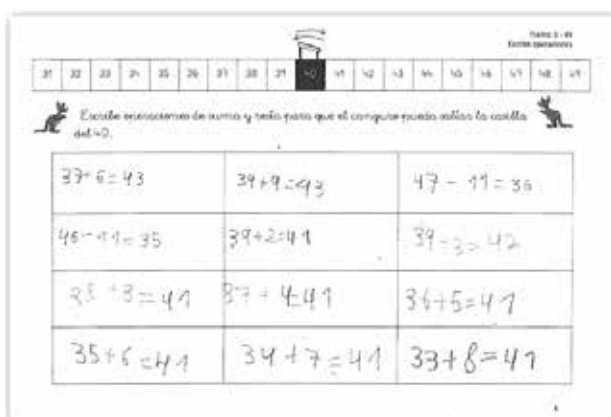


Figure 8: Example of Kangaroo's worksheet

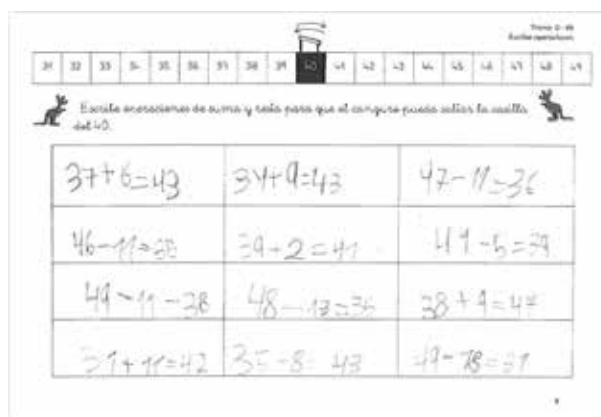


Figure 9: Example of Kangaroo's worksheet

The number tape section showed in this activity is a great help for students with difficulties because it reduces anxiety about the calculations (they can do the count directly) and focuses attention on the reflection and written expression of events. On the other side, there are students that are soon aware of ways to control numerical relationships (i.e. the student who experiments with the arrival at 41 from different positions in Figure 8). The implementation of these activities shows that the sensorimotor experience is very positive since practically the whole group correctly identifies the operation (addition or subtraction) that corresponds to each jump. Although there are students who work more slowly and do not manage to complete the twelve required possibilities, those that do, do it correct.

Final comments

This work is a first approach to the development of number sense by using conceptual metaphors. Authors are aware that evidences should be tested empirically through wider research, but some interesting aspects already arise from this work. Among others, it may be said that (1) the activities proposed develop the relational thinking. They imply an active behaviour of children, provoking reflection on what they should do, and how they are going to solve it. This way of acting involves the

knowledge that children have of numbers and how numbers relate to each other through operations, fostering relational thinking in flexible contexts that admit more than one solution to the challenge posed. (2) It also promotes transparent algorithms for calculation. Our approach, the tactical calculation, shows the reflection and planning designed by the student. (3) A communicative approach is given to mathematical language. The classroom becomes a place where students can talk, expose their plan and discuss the decisions they are making. This oral language gives shape and meaning to expressions with numbers and signs. Children are building an interactive dictionary full of meanings that all share. (4) Working memory is reinforced. Having the number line and the position of the characters in view gives confidence to the students and helps them to concentrate on the choice of tactics and graphic representation. Then, in the absence of resources, these visualizations (already in the mental plane) will be fundamental to solve problems and calculations.

References

- Adamuz-Povedano, N., & Bracho-López, R. (2017). *La aritmética del siglo XXI*. Madrid: Catarata.
- Berch, D. B. (2005). Making Sense of Number Sense: Implications for Children With Mathematical Disabilities. *Journal of Learning Disabilities*, 38(4), 333–339.
- Coles, A. L. F., & Sinclair, N. (2017). Re-thinking place value: From metaphor to metonym. *For the Learning of Mathematics*, 37(1), 3–8.
- Gallese, V., & Lakoff, G. (2005). The Brain's concepts: the role of the Sensory-motor system in conceptual knowledge. *Cognitive Neuropsychology*, 22(3–4), 455–479.
<https://doi.org/10.1080/02643290442000310>
- García-Pérez, T., & Adamuz-Povedano, N. (2016). Conocemos los números. Una experiencia basada en la manipulación. *Epsilon-Revista de Educación Matemática*, 33(1), 73–88.
- Godino, J. D., Font, V., Konic, P., & Wilhelmi, M. R. (2009). El sentido numérico como articulación flexible de los significados parciales de los números. In J. Cardeñoso & M. Peñas (Eds.), *Investigación en el aula de Matemáticas. Sentido Numérico* (pp. 117–184). Granada: SAEM THALES y Departamento de Didáctica de la Matemática de la Universidad de Granada.
- Lakoff, G., & Johnson, M. (2003). *Metaphors we live by*. Chicago: The University of Chicago Press.
- McIntosh, A., Reys, B. J., & Reys, R. E. (1992). A Proposed Framework for Examining Basic Number Sense. *For the Learning of Mathematics*, 12(3), 3–8, 44.
- NCTM. (1989). *Curriculum and Evaluation Standards for School Mathematics*. Reston: NCTM.
- Siegler, R. (2003). Implications of Cognitive Science Research for Mathematics Education. In J. Kilpatrick, W. Martin, & D. Schifter (Eds.), *A Research Companion to Principles and Standards for School Mathematics* (pp. 219–233). Reston, VA: National Council of Teachers of Mathematics.
- Soto-Andrade, J. (2007). La cognición hecha cuerpo florece en metáforas. In D. Cosmelli (Ed.), *Nuevos enfoques de la Cognición: Redescubriendo la dinámica de la acción, la intención y la inter subjetividad* (pp. 71–90). Chile: Universidad Diego Portales.
- Sowder, J. (1992). Estimation and number sense. In D. A. Grouws (Ed.), *Handbook of Research in Mathematics Teaching and Learning* (pp. 371–389). New York: Macmillan Publishing Co.

Development of an intervention program in counting principles for first- grade students – Pilot study

Évelin Assis¹ e Luciana Vellinho Corso²

¹ Universidade Federal do Rio Grande do Sul, Brasil; evelin_assis@hotmail.com

² Universidade Federal do Rio Grande do Sul, Brasil; l.corso@terra.com.br

Development of the intervention program:

This study was designed considering the need of developing effective interventions that could help basic education teachers to favor their students' learning process. The objective of this study was to develop and intervention program focused on teaching counting principles for first-grade-children and to evaluate its applicability through a pilot study. The planning of the program was based on the guiding principles established by researchers of the field (Clarke, Doabler, Nelson & Shanley, 2015; Fuchs & Fuchs, 2001) and in intervention studies (Dyson, Jordan & Glutting, 2011; Praet & Desoete, 2013; Toll & Van Luit, 2013).

Method of the Pilot Study

The objective was to evaluate the applicability condition of the intervention program in terms of: the quality of the proposals, duration of the sessions and the functionality of the idealized dynamics through the pilot study. Participated in this study 10 first-grade students from a public school located in Porto Alegre, Brazil. The application of the intervention occurred in 4 sessions of approximately 1h30 (2 sessions of 45 minutes in each meeting). In total, there were 8 sessions, each one with focus on a specific counting principle. All sessions were structured with the same dynamics (previous motivation, contextualization, activity and systematization) and were applied by the researcher. The researcher registered the progress of the intervention using a field dairy.

Results: with regard to the quality of the proposals, the researcher's notes indicated that most of them worked properly, but needed some kind of adaptations. This could have occurred for two reasons: first, the sample of 10 children ended up being too large, which was an obstacle to maintain the group attention and to give more individualized attention to the students; second, the participating children had good previous knowledge, completing the tasks faster than expected once they understood the instructions of the researcher. Regarding the duration of the sessions, the 45 minutes idealized weren't fully used because the intervention took place in the children's regular classroom and also because they were fast to complete the activities. Finally, the idealized dynamics for the sessions worked well, with the initial moments (previous motivation and contextualization) acting positively to engage the previous knowledge of the students. The final moment of systematization was repeatedly pointed out as needing to be reorganized. All the researcher's notes helped to reformulate the intervention program, culminating in its second version (presented below) to be tested as an experimental study. A paper presenting the experimental study, with the final intervention program in counting principles, was submitted to the TWG2.

Guiding questions:	Tasks:
Session 1: stable order, one-to-one correspondence and cardinality. - where do we find numbers? - what are their purpose? - how can we count them? - is there a right way to count? Which one? - what can we do to know how many things there are in a set?	- observation of the room to search for numbers and their purposes; - analyses of journals and magazines to search for numbers and then ordering them; - game: “which one is missing?”
Session 2: stable order, one-to-one correspondence, cardinality and order irrelevance. - how can we count without getting lost? - how can we know if we already counted one item? - how can we count a set that is not organized?	- demonstration of counting marbles in figures by the researcher; - demonstration of counting marbles in figures using little papers; - individual practice.
Session 3: stable order, one-to-one correspondence, cardinality, abstraction and order irrelevance. - what can we count? - where do we begin to count?	-game board: “color game”; - game board: “two hands”.
Session 4: stable order, one-to-one correspondence, cardinality, abstraction and order irrelevance. - how can we count in our heads? - how can we organize numbers when we’ll count? - how can we find out what number is without knowing its name?	- bingo of numbers; - closing questions: (can you say one thing you learnt during the intervention? Which task was easy? Which task was difficult?).

Table 1: Intervention post adjustments

Conclusions

The pilot study was important and helpful for testing the initial version of the intervention program. It was possible to analyze the activities, structure and time planned to the intervention program and to make improvements culminating in its second version that was applied as an experimental study.

References

- Clarke, B., Doabler, C., Nelson, N. J. & Shanley, C. (2015). Effective instructional strategies for kindergarten and first-grade students at risk in mathematics. *Intervention in school and clinic*, 50(5), 257–265.
- Dyson, N. I., Jordan, N. C. & Glutting, J. (2011). A number sense intervention for low-income kindergartners at risk for mathematics difficulties. *Journal of Learning Disabilities*, 46(2), 166–181.
- Fuchs, L. S., & Fuchs, D. (2001). Principles for the prevention and intervention of mathematics difficulties. *Learning Disabilities Research & Practice*, 16(2), 85–95.
- Praet, M., & Desoete, A. (2013). Enhancing young children’s arithmetic skills through non-intensive, computerised kindergarten interventions: A randomized controlled study. *Teaching and Teacher Education*, 39, 56–65.
- Toll, S. W., & Van Luit, J. E. (2013). Early numeracy intervention for low-performing kindergartners. *Journal of Early Intervention*, 34(4), 243–264.

Intervention in counting principles with first-grade students

Évelin Assis¹ e Luciana Vellinho Corso²

¹ Universidade Federal do Rio Grande do Sul, Brasil; evelin_assis@hotmail.com

² Universidade Federal do Rio Grande do Sul, Brasil; l.corso@terra.com.br

Abstract: The objective of this article is to present an experimental study of intervention in counting principles, aiming to investigate its efficacy. The experimental study involved 136 first-grade students, from 3 public schools located in Porto Alegre, Brazil. The students were divided into control group (n=76) and experimental group (n=60). The intervention occurred 2 times per week, during 2 weeks, with the experimental group, while the control group remained with regular instruction. The results point to the efficacy of the intervention program in counting principles, with students in the experimental group showing higher statistically significant advances in the post-test (counting principles evaluation task) than the students in the control group. Some educational implications are addressed.

Keywords: Counting principles. Intervention. Experimental study.

Number sense and counting principles have been evidenced as important predictive factors of posterior mathematical achievement (Jordan, Glutting & Ramineni, 2010; Martin, Cirino, Sharp & Barnes, 2014; Passolunghi, Vercelloni & Schadee, 2007; Stock, Desoete & Roeyers, 2009). Besides, both, when less developed, appear as characteristics of the group of children that presents mathematical learning difficulties - MD (Bull & Johnston, 1997; Cirino, Fuchs, Elias, Powell & Schumacher, 2013; Dorneles, 2006; Vukovic, 2012). In regard to counting, studies show that children with MD use immature counting strategies (fingers or verbal counting) for a longer period (Bull & Johnston, 1997; Dorneles, 2006) and have difficulties to retrieve basic facts from memory (Cirino et al., 2013). Research results such as these emphasize the importance of helping students to consolidate the counting principles in the beginning of the school years, which in turn, will help them develop efficient strategies and procedures to count efficiently and, thereby, prevent the development of arithmetical difficulties.

Counting is an important knowledge that begins to be developed informally by children, through everyday experiences. Nunes & Bryant (1997) point that many teachers recognize their students get to the classroom knowing a lot of things, including counting. Its relevance is highlighted by several authors and Dorneles (2004) synthesizes well this idea by stating that counting is a cognitive tool important not only to comprehend posterior contents, but also to develop more elaborated mathematics skills. Knowing the relevant role of counting, it is necessary to pay attention to the development of this ability. While children learn to count, they need to put in practice some principles that guide this action, as well as comprehend what is the purpose of counting and the way of doing it correctly (Nunes & Bryant, 1997). Gelman & Gallistel (1978) studied this learning process and established five guiding principles of counting, which must be consolidated by children in order to develop other mathematical knowledge. The principles are: stable order, one-to-one correspondence, cardinality, abstraction and order irrelevance. The first three principles are classified as “how to count”, the fourth is denominated as a definer of what is countable and the fifth one consists of a

synthesis of the application of the other ones. Those five principles are the bases of the children's posterior numerical construction (Dorneles, 2004).

The current study

Considering the extreme relevance the counting principles have in relation to mathematical learning and that most children who have difficulties in this area present problems, specifically, with counting strategies and the retrieval of basic facts, justifies the need of the development and implementation of intervention programs focusing on counting principles. Such an approach, put into practice in the beginning of formal schooling, can facilitate the students' learning process. Besides, most intervention studies developed in the mathematical field focused on number sense (Aragón-Mendizabal, Aguilar-Villagrán, Navarro-Guzmán & Howell, 2017; Bryant et al., 2011; Dyson, Jordan & Glutting, 2011; Fuchs et al., 2010; Praet & Desoete, 2013), which points to the lack of intervention instructions in counting principles.

Method

This is an experimental intervention study focusing on teaching the counting principles to first-grade students. It has the objective of evaluating the effectiveness of a short intervention, comparing the achievement of the experimental and the control groups.

Participants

The study included 136 first-grade students (63 girls and 73 boys), aged between 6 and 7 years old, from 10 classes, belonging to 3 public schools located in Porto Alegre, Brazil. They were divided in control group ($n=76$) and experimental group ($n=60$), both groups were statistically equivalent and, through the analysis of students' performance case by case, were formed by children with different levels of performance in a counting principles task. The parents of all participating students gave their authorization through the signing of the Free and Informed Consent Form and the Dissent Form. Approval for this study was obtained from the Research Ethics Committee of Universidade Federal do Rio Grande do Sul. The intervention was offered to the experimental group, by the researcher, while the control group remained with regular instruction. Unfortunately, it wasn't possible to follow teachers' regular instruction during the execution of this study, so we do not have data about the control group's learning, although, we hypothesize that there was less focus on mathematics and more on literacy, because this is the main concern of first year teachers in Brazil.

Procedures

In august 2017, a pilot study was conducted to evaluate the applicability of the intervention program, that culminated in its second version, the one used in this study. From September to December 2017, the pre-test, intervention and post-test procedures were done. The interval between the pre-test and the intervention was one month and between the intervention and the post-test was 20-30 days.

Instruments

Counting principles task (as pre and post-test): this task was administered individually, by the researcher, in an interview format (see Table 1). The instrument was used to evaluate the construction of the counting principles by the students. It is the same task used by Dorneles (2004, 2006). For each

principle, the students were classified into three groups: principle consolidated (Y – yes); in construction (IC); not consolidated (N). Some criteria were established to classify the children in each group because some of the questions (like 2, 3 and 5) are formed by more than one query. In this case, the child’s answer was classified as “Y” if he/she answered all the solicitations in each question correctly; “IC” if only one part of the question was correctly answered; “N” if the student did not answer any part of the question correctly.

Principle:	Solicitation:
Stable order	The experimenter asks the child: “until how much can you count?” and tell him or her to count out loud until the number said.
One-to-one correspondence	The experimenter shows 10 chips in a row and asks “how many chips are there?”. Then, shows 10 chips misaligned and asks “how many chips are there?”. This procedure is repeated with 15 chips.
Cardinality	By the end of counting 15 items, the experimenter asks “how many are there in total? Can you give me 10?”
Abstraction	The experimenter asks “if you were counting 15 candies, would you count the same way you counted the chips?”.
Order irrelevance	The experimenter asks the child to count the 15 chips, arranged in a row, in a different order, that is, initiating by another chip. Then, the child is asked to say how many chips would remain if the row was undone. After, the experimenter asks the child to count 8 chips of the set, separating them aside, and then, to count the remaining 7 chips of the row. By the end, the child has to say how many chips there are in the total.

Table 1: Counting principles task

Intervention in counting principles

In regard to the intervention, whose development is described in detail in the poster submitted to the TWG2, some guiding principles are on its bases, as the ones presented by Clarke, Doabler, Nelson & Shanley (2015): engaging children’s previous knowledge , through “warming up” exercises in the beginning of the sessions to help them establish connections between previously learned contents and the new ones; promoting interactions, through the gradual responsibility of the students with their learning processes by considering their previous knowledge and the knowledge needed to complete the tasks by themselves successfully; and providing mathematical verbalizations, in a way that it was possible for the students to use specific mathematical language and have the opportunity to speak and think mathematically.

Besides those ideas, the principles established by Fuchs & Fuchs (2001) also contributed to the development of the intervention program in counting principles: fast pace, varied activities and engaging, challenge the patterns of achievement, self verbalization and visual and physical

representations (primary level, to be done with whole classes); adaptations easy to adopt so the teacher can incorporate it in the class routine, adaptations that are adequate for the targeted students as well as for other students (secondary level to help children with more difficulties); focus on the student as unity for instruction and decision making, intensive instruction and explicit instruction of basic skills (tertiary level, as an individual and intensive intervention).

The intervention sessions consisted mainly in providing children with opportunities to work with and practice the counting principles, helping them to be aware of how counting works and how to do it correctly. They occurred twice a week, during two weeks, for 20-35 minutes, including the dislocation time of the children. The sessions were made with small groups (5 students maximum), in a room provided by the schools and were conducted by the researcher see table 2 below.

Guiding questions:	Tasks:
Session 1: stable order, one-to-one correspondence and cardinality. - where do we find numbers? - what are their purpose? - how can we count? - is there a right way to count? Which one? - what can we do to know how many things there are in a set?	- observation of the room to search for numbers and their purposes; - analyses of journals and magazines to search for numbers and then ordering them; - game: "which one is missing?"
Session 2: stable order, one-to-one correspondence, cardinality and order irrelevance. - how can we count without getting lost? - how can we know if we already counted one item? - how can we count a set that is not organized?	- demonstration of counting marbles in figures by the researcher; - demonstration of counting marbles in figures using little papers; - individual practice.
Session 3: stable order, one-to-one correspondence, cardinality, abstraction and order irrelevance. - what can we count? - where do we begin to count?	-game board: "color game"; - game board: "two hands".
Session 4: stable order, one-to-one correspondence, cardinality, abstraction and order irrelevance. - how can we count in our heads? - how can we organize numbers when we'll count? - how can we find out what number is without knowing its name?	- bingo of numbers; - closing questions: (can you say one thing you learnt during the intervention? Which task was easy? Which task was difficult?).

Table 2: Intervention in counting principles

Results

The data analyses were made through the Z test of proportion comparison. This test was chosen because the objective was to compare two proportions: the proportion of progress of the intervention

group and of the control group. The data related to the intervention result will be presented next Table 3. The stable order were not considered in the analysis because all children had consolidated this principle.

Principle	Group	Progress	(%)	p-value
One to one correspondence	Control	29	35,37	0,0016
	Experimental	39	59,09	
Cardinality	Control	9	11,69	0,0138
	Experimental	17	26,15	
Abstraction	Control	14	17,07	0,1093
	Experimental	17	25,37	
Order irrelevance	Control	38	43,18	0,0001
	Experimental	53	71,62	

Table 3: Results of the intervention

It's possible to observe that in activity A (one-to-one correspondence), the improving rate in the principles construction by the experimental group was of 59,09%, being statistically superior (p-value=0,0016) in relation to the control group (35,37%). In activity B (cardinality), again the experimental group demonstrated a bigger improving rate (26,15%) than the control group (11,69%), being statistically significant (p-value=0,0138). In activity C (abstraction), the students in experimental group also got superior improving rate (25,37%) when compared to the control group (17,07%), but this improvement did not show statistical superiority (p-value=0,1093). In activity D (order irrelevance), the experimental group once again evidenced a bigger improving rate (71,62%) than the control group (43,18%), being statistically significant (p-value=0,0001).

Discussion

Both groups showed advances, which was expected, since even the children that did not participate in the intervention process were having regular instruction, and so, they were learning. The results demonstrated that the improving rates of the experimental group were superior to the rates of the control group in all principles analyzed. Besides that, in three counting principles (one-to-one correspondence, cardinality and order irrelevance) this improvement was statistically superior. This result points to the effectiveness of the intervention program focusing on counting principles with short duration (2 sessions per week during 2 weeks). Besides that, it is important to highlight that the program effectiveness can be attributed not only to the tasks, but also to the type of teaching that was offered and the principles underlying the development of the intervention.

This finding is in agreement with other intervention studies that also compared control and experimental groups. Fuchs et al. (2010) developed an intervention in counting practice and evidenced that the three groups of participants (experimental with practice, experimental without

practice and control) improved their achievement, with the children that received some kind of intervention showing more advances than the ones in the control group.

In the same way, Dyson, Jordan & Glutting (2011) indicated that students with low income participating in a intervention condition in number sense showed more improvements than the subjects of the control group in the post-test. Praet & Desoete (2013) also pointed to similar findings: both experimental groups in their study demonstrated better achievement than the control group after getting intervention. Mononen & Aunio (2016) conducted an intervention research on counting abilities to children with low achievement. Their results indicated that the students in the experimental group improved their counting abilities significantly in comparison to the students in the control group, after the intervention. Other authors evidenced that specific interventions, designed to small children, involving one or more aspects of number sense, are effective and promote improvements in mathematical achievement (Aragon-Mendizábal et al., 2017; Bryant et al., 2010; Dowker & Sigley, 2010; Dyson, Jordan & Glutting, 2011; Fuchs et al., 2010; Mononen & Aunio, 2016; Praet & Desoete, 2013).

Implications for education

Our findings have important implications for teaching and learning. It highlighted a fundamental aspect of mathematical learning (counting principles), how to teach them (intervention) and how to help students to participate actively in their learning processes. It is urgent to help teachers to promote pedagogical actions that support students' learning process in relation to mathematics, area in which a lot of students show difficulties. It is important to act positively in this scenario: helping both students, through the teaching of specific strategies to facilitate learning, and teachers, through encouraging their monitoring of teaching and learning mathematics.

Considering these aspects, we believe the study presented here could reached some teachers' needs. The intervention was developed based on guiding principles that need to be incorporated into regular instruction. Besides that, the intervention program used is brief, being developed in a short period of time, and could be included in the teachers' planning of instruction. The materials used by the researcher to conduct the intervention sessions were given to all teachers participating in the study, making it possible their further use by them. The results demonstrated that even a short investment in counting principles caused improvements in the children's performance, showing that it is possible to promote significant learning through concise and quality interventions dedicated to certain content area in the pedagogical planning.

Limitations of the study

The research results described in this paper should be considered in the context of some limitations. First, the time available to conduct this research was limited due to the fact that this study is part of the masters dissertation work of one of the authors and there was a deadline for its development and conclusion. Second, the counting principles task used was selected because it is a short and practical instrument, however, we believe that a broader task could elucidate more aspects to be analyzed and discussed. Another limitation concerns the choice of statistical analysis that was conducted. It is possible that different findings would have emerged if, besides the Z-test, the study included the

association of different statistical tests, which could have made it possible to reinforce or question some of the results found or even to elucidate other possible outcomes.

Conclusions

The study demonstrated improvement in the children's performance in the counting principles task, from pre to post-test, with the participants showing good advances rates. This improvement was attributed to the intervention program because the students in the experimental group showed a bigger proportion of progress than the ones in the control group, showing statistical superiority in three of the four principles analyzed. Also, it is important to highlight the duration of the intervention: it was a short investment of time specifically devoted to the work with the counting principles, with carefully planned opportunities for the students to deal with and practice counting using the principles established by Gelman and Gallistel (1978). The results of this study point to the need of continuing to investigate interventions that target counting principles which consist of a fundamental knowledge to be learnt in the beginning of formal schooling.

References

- Aragón-Mendizábal, E., Aguilar-Villagrán, M., Navarro-Guzmán, J. I. & Howell, R. (2017) Improving number sense in kindergarten children with low achievement in mathematics. *Anales de Psicología/Annals of Psychology*, 33(2), 311–318.
- Bryant, D. P., Bryant, B. R., Vaughn, G. R. S., Pfannenstiel, K. H., Porterfield, J., & Gersten, R. (2011) Early numeracy intervention program for first-grade students with mathematics difficulties. *Exceptional Children*, 78(1), 7–23.
- Bull, R., & Johnston, R. S. (1997) Children's arithmetical difficulties: contributions from processing speed, item identification and short-term memory. *Journal of Experimental Child Psychology*, 65, 1–24.
- Cirino, P. T., Fuchs, L. S., Elias, J. T., Powell, S. R., & Schumacher, R. F. (2013) Cognitive and Mathematical Profiles for Different Forms of Learning Difficulties. *Journal of Learning Disabilities*, 48(2), 156–175.
- Clarke, B., Doabler, C., Nelson, N. J., & Shanley, C. (2015) Effective instructional strategies for kindergarten and first-grade students at risk in mathematics. *Intervention in school and clinic*, 50, (5), 257–265.
- Dorneles, B. V. (2004). Princípios de Contagem: uma construção progressiva. Paper presented at the Seminário Pesquisa em Educação. Curitiba, PA.
- Dorneles, B. V. (2006). Obstáculos cognitivos na aprendizagem matemática inicial: a contagem, as operações iniciais e os diferentes sentidos de número. In M. I. Maluf (Ed.). *Aprendizagem: tramas do conhecimento, do saber e da subjetividade*. São Paulo: Associação Brasileira de Psicopedagogia.

- Dowker, A. & Sigley, G. (2010). Target interventions for children with arithmetical difficulties. *Understanding number development and difficulties*, 11(7), 65-81.
- Dyson, N. I., Jordan, N. C. & Glutting, J. (2011) A number sense intervention for low-income kindergartners at risk for mathematics difficulties. *Journal of Learning Disabilities*, 46(2), 166–181.
- Fuchs, L. S. & Fuchs, D. (2001) Principles for the prevention and intervention of mathematics difficulties. *Learning Disabilities Research & Practice*, 16(2), 85–95.
- Fuchs, L. S., Powell, S. R., Seethaler, P. M., Cirino, P. T., Fletcher, J. M., Fuchs, D. & Hamlett, C. L. (2010) The effects of strategic counting instruction, with and without deliberate practice, on number combination skill among students with mathematics difficulties. *Learning Individual Differences*, 20, (2), 89–100.
- Gelman, Rochel & Gallistel, C. R. (1978). *The Child's Understanding of Number*. Cambridge: Harvard University Press, 1978.
- Jordan, N. C., Glutting, J. & Ramineni, C. (2010) The importance of number sense to mathematics achievement in first and third grades. *Learning and Individual Differences*, 20, 82–88.
- Martin, R. B., Cirino, P. T., Sharp, C. & Barnes, M. (2014) Number and counting skills in kindergarten as predictors of grade 1 mathematical skills. *Learning and Individual Differences*, 34, 12–23.
- Mononen, R. & Aunio, P. (2016) Counting skills intervention for low-performing first graders. *South African Journal of Childhood Education*, 6(1), 1–9.
- Nunes, T. & Bryant, P. (1997) *Crianças fazendo matemática*. Porto Alegre: Artes Médicas.
- Passolunghi, M. C., Vercelloni, B. & Schadee, H. (2007) The precursors of mathematics learning: Working memory, phonological ability and numerical competence. *Cognitive Development*, 22, 165–184.
- Praet, M. & Desoete, A. (2013) Enhancing young children's arithmetic skills through non-intensive, computerised kindergarten interventions: A randomized controlled study. *Teaching and Teacher Education*, 39, 56–65.
- Stock, P., Desoete, A. & Roeyers, H. (2009) Mastery of the counting principles in toddlers: A crucial step in the development of budding arithmetic abilities? *Learning and Individual Differences*, v. 19, p. 419–422.
- Vucovik, R. K. (2012) Mathematics difficulty with and without reading difficulty: findings and implications from a four-year longitudinal study. *Council for Exceptional Children*, 78(3), 280–300.

Design of a board game around the notion of fractions

Alix Boissière

IMAG, Univ Montpellier, CNRS, France; alix.boissiere@umontpellier.fr

Keywords: Rational numbers, educational game, didactic engineering.

Introduction

In 2014, the French ministry of education launched a strategy for teaching mathematics. It favored the use of games to “enhance student motivation and encourage them to be autonomous”¹. But games can also be used to facilitate learning itself. Pelay (2011) showed that Brousseau’s theory of didactical situations (TDS) has an intrinsic play-based dimension articulated to the didactic one and introduced the crucial concept of the didactic and play-based contract. Our PhD project continues Pelay’s work both on the theoretical aspects and implementation ones.

The didactic and play-based contract

One of the key concepts of the TDS is the *didactic contract*, the set of behaviors coming from the teacher and expected by the student and vice-versa (Brousseau, 1997). During his PhD, Pelay observed that in some cases the play-based stakes were more important than the didactic ones. He showed that it was impossible to analyze summer camps’ activities using only the concept of the didactic contract. This led him to develop the concept of *didactic and play-based contract*:

The didactic and play-based contract is defined as the set of rules and behaviors, both explicit and implicit, between an activity leader and one or several participants in a project that links explicitly or implicitly playing and learning (Pelay, 2011, p.278).¹

Pelay studied how the contract is set up and how it evolves when the rules are changed. Furthermore, he introduced the concept of didactic and play-based engineering, grounded on the methodology of didactic engineering (Artigue & Perrin-Glorian, 1991).

Back to the school context

Our research project originates on the hypothesis that the concepts developed by Pelay in the summer camp context are also relevant in the school context: the play-based dimension of the TDS might offer new perspectives to the study of teacher and student interactions when games are used in the teaching and learning of mathematics. We aim to develop a didactic and play-based engineering that will be implemented both in a laboratory setting and in classrooms, taking into account the articulation between the didactic and play-based dimensions from the start.

Methodology

In order to develop a didactic and play-based engineering to use in class, we need to take into account the transmission and reproducibility stakes. Perrin-Glorian (2011, p.68) introduced the didactic engineering of the second kind as “an engineering aiming to produce resources for teachers and study

¹ My translation

the impact of research on ordinary teaching”¹. It consists of planning for two levels of study: a first one, in a laboratory setting, to test the theoretical validity of the situations, and a second one to test the adaptability of the situations to teaching. The preliminary studies, conception and a priori analysis are common to the two levels of study, and they will differ by their experimentations, a posteriori analysis and validation. The first step to our research was the design of a board game to be the core of the didactic engineering.

Designing a game on fractions

Relying on previous research (Pelay, 2011), we hypothesized that board games are likely to favor the active engagement of students in didactic situations build around them. We chose to develop a game that could be used from grades 4 to 6, as it is at the transition between elementary and middle school in France. The notion of fraction was one of the possible topics. The epistemological study has showed different aspects to this notion. We chose to address it from the point of view of size ratio and the composition and decomposition of surfaces. We collaborated with teachers to make sure that the game would be adapted from grades 4 to 6. We ended up creating “L’atelier des potions”, a game in which the students follow recipes for “magical potions”. The game and the choices made in the design will be presented in the poster.

Perspectives

Pretests of the game have been made in a dozen of classes throughout the year and we have developed teaching activities around the game. We are now developing a didactic and play-based engineering around the game and activities.

References

- Artigue, M., & Perrin-Glorrian, M.J. (1991). Didactic Engineering, Research and Development Tool: some Theoretical Problems linked to this Duality. *For the learning of Mathematics*, 11(1), 3–17.
- Brousseau, G. (1997). *Theory of Didactical situations in Mathematics*. Dordrecht: Kluwer Academic.
- Pelay, N. (2011). *Jeu et apprentissages mathématiques, Elaboration du concept de contrat didactique et ludique en contexte d'animation scientifique* (Doctoral dissertation, Université Claude Bernard Lyon 1, France). Retrieved from <https://tel.archives-ouvertes.fr/tel-00665076/document>
- Perrin-Glorian, M.J. (2011). L’ingénierie didactique à l’interface de la recherche avec l’enseignement. Développement de ressources et formation des enseignants. In C. Margolinas, M. Abboud-Blanchard, L. Bueno-Ravel, N. Douek, A. Fluckiger, P. Gibel, F. Vandebrouck & F. Wozniak (Eds.), *En amont et en aval des ingénieries didactiques* (pp. 57–78). Grenoble, France: La pensée sauvage.

Exploring students adaptive use of domain specific knowledge

Joana Brocardo¹, Catarina Delgado², Fátima Mendes³, Jean Marie Kraemer⁴

¹Escola Superior de Educação, IPS de Setúbal and UIDEF, Instituto de Educação, Universidade de Lisboa, Portugal; joana.brocardo@ese.ips.pt

²Escola Superior de Educação, IPS de Setúbal, Portugal; catarina.delgado@ese.ips.pt

³Escola Superior de Educação, IPS de Setúbal, Portugal; fatima.mendes@ese.ips.pt

⁴CITO, The Netherlands; jeanmariekraemer@gmail.com

Adaptive use of meaningful knowledge is widely adopted as key learning objective in the changing society. This paper presents the results of a teaching experiment in the domain of partitive division. It is designed to explore how grade-3 students do adapt personal knowledge to the variation in task conditions. They can use 52 unifix cubes to model the process directly. The second condition requires that they mentally anticipate the results of sharing the same quantity of carts between respectively two and three children. The study shows that the variation in conditions combined with classroom climate challenge a great part of the students to use adaptively “pieces of knowledge” acquired in different areas of reasoning in equal group situations.

Keywords: multiplicative thinking, adaptive expertise.

Introduction

By the turn of the century, “Mathematical proficiency” is proposed as basis for a large consensual agreement about the goal of mathematics instructions in the changing society (Kilpatrick, Swafford, & Findell, 2001). Globally said, primary school students should develop and organize domains of meaningful knowledge in such a way that it should be used adaptively to tackle and solve new or less familiar problems.

According to Hatano & Inagaki (1986), it is “domains-specific knowledge” that develops along the accumulation of learning experiences, and what adapts to constraints of new situation are, according to Vergnaud (2009), the “schemes for reasoning”. Considering the crucial role of developing these schemes for reasoning, we explore in our research (i) what grade-3 students know about the quantitative and numerical relationships involved by combining, sharing, and segmenting in equal groups setting, and (ii) how they do adapt meaningful personal knowledge to well-chosen variations of task-conditions.

Theoretical framework

Our framework connects four aspects of students’ expertise involved in the exploration of the process of partitioning in grade 3 required to analyze the relationship between the conditions of the tasks and the personal way of tackling and solving these tasks (Threlfall, 2002).

Schemes of reasoning

Combining n equal groups to obtain an intended quantity of “things” (e.g. 5 bags with 6 cookies each) constitutes children’s earlier encounter with an application for multiplication (Greer, 1992). Children

extract from their activities the notion of number as composite unit and the invariant relationship between the number of groups and the number of units per group that constitute the conceptual base of the arising scheme “multiplicative double counting” (Tzur et al., 2013).

According to Freudenthal’s (2002) phenomenological analysis of division as mental act, division arises in three ways, as (i) continually taking away (by repeated subtractions), (ii) distributing in equal parts (distributing cyclically the same share to several persons), and (iii) inverting a multiplication. The first and second one correspond to the difference made between quotative division (measurement; ratio) and partitive division, and between the two associated schemes of reasoning: segmenting and partitioning (e.g. Tzur et al., 2013; Thompson & Saldanha, 2003). The third variant consists in figuring out the effect of both segmenting (e.g. 52 cookies into bags of 6 cookies each) and partitioning (e.g. distributing 52 cookies between 6 children) by constructing an appropriate arithmetical sequence of repeated addition (or multiples). In this case, the remainder represents the four simple steps left to reach 52 after 8 steps of 6 on the (mental) number line.

Research results show that sharing one-by-one is rarely used, and that students prefer to build-up the quantity (inverting multiplication by repeated additions) instead of subtracting repetitively (e.g. Heirdsfield, Cooper, Mulligan & Calvin, 1999). Taking advantage of this tendency and adopting the idea that students must observe variation in key variables to constitute deep understanding (Lo, 2012), we focus students’ activity on exploring the critical differences among partitioning problems (variation in total number of objects, number of persons/parts, number of objects in each part; remainder) in relation to the invariant multiplicative structure ($a = q \times d (+ r)$) of any partition. We conjecture that this relationship should function as tie between partitioning and combining on the one hand (Greer, 2012), and between partitioning and segmenting on the other hand (Thompson & Saldanha, 2003).

Mathematical principles and numerical relations

Towards the learning process, we conjecture that to reach the highest level of comprehension, students should (1) formulate the numerical equivalence of $a \times b = c$ and $c \div a = b$ and (2) use it explicitly to derive unknown quotients from memorized correspondent products (e.g. $100 \div 25$ via $4 \times 25 = 100$), as well as tackling and solving partitioning problem using appropriate patterns of multiples (e.g. $13 \times 4 = 52$; $52 \div 4 = 13$; $4 \times 13 = 52$; $52 = 13 \times 4$) knowing that each number and consequently each operation can be composed and decomposed in different ways (Gray & Tall, 1994; Tall, 2013). Last but not least, understanding the product (mn) as being in multiple reciprocal relationships to n and to m , they should derive a lot of quotients from familiar numerical relations (e.g. $60 \div 15$ via $15 = \frac{1}{4}$ of 60) (Thompson & Saldanha, 2003). We expected differences in reasoning, computing and symbolization in function of the progression through the well-documented sequence of multiplication procedures: from counting all strategies, through sequences of repeated addition and doubling procedures, to using patterns in numbers and operations, and finally, to deriving unknown products from surrounding memorize facts (e.g. Verschaffel, Greer & de Corte, 2007).

Strategic skills

Adopting Threlfall’s (2002) conception of flexible mental calculation as interaction between noticing and knowledge, we conjecture that an appropriate variation of task conditions should motivate and

foster students to adapt the above domain-specific knowledge to the constraints of situations (Vergnaud, 2009; Hatano & Inagaki, 1986). In this perspective, specific tasks should give students the opportunity to develop particular strategic skills: (i) relating the numbers of problems to other familiar situations, (ii) composing and decomposing numbers multiplicatively, (iii) using patterns of multiples and (iii) transforming multiplication and division.

Classroom culture

It is well known that classroom climate motivates students to reflect about how they should tackle the situation taking advantage of what is met before. This factor is included in the following three conditions proposed by Hatano and Inagaki (1986) for promoting adaptive expertise: (i) variability inherent to the task environment, (ii) variability permitted in the individual's procedural application and (iii) variability of explanation permitted by the culture.

Methodology

This article reports part of a research project that follows a design research methodology, specifically a teaching experience (Gravemeijer & Cobb, 2006) that has the objective to understand how students can develop the ability to tackle and solve problems, adapting personal knowledge to new situations' constrains.

The project team developed two teaching experiences: one focused in addition/subtraction and the other one focused on multiplication/division. Each teaching experience included a set of tasks that was designed and reformulated using a three-step cyclic process: (1) design tasks, (2) analyse what children noticed in the numbers and how they use their knowledge about numbers and operations to solve the task presented in the class or along clinical interviews and (3) reformulate the previous task.

We present part of the teaching experiment on multiplication/division that involved a third grade class (students age 8-9) with 20 students. The underlying "conjectural hypothetical theory" (Gravemeijer & Cobb, 2006) for this experiment concerns a possible learning process between the construction of the products of the multiplication tables and related quotients (start point) and elementary forms of reasoning proportionally (end point).

The first three tasks of this teaching experiment that involved a total of nine tasks, intend to help students to see the multiplicative structure of equal group situations as "some numbers of composed units". This paper focuses the second task: What is sharing? The objective is to observe how these students adapt personal knowledge to the variation in task conditions. The invariant condition is the number of objects distributed (52 stickers). The variant conditions are: (1) possibility to use (part one), or not (part three) concrete material, (2) the number of persons/parts and (3) with or without remainder.

The teacher of the class analysed and discussed with the researchers all the underlying justifications for the tasks, classroom organization and proposed focus for discussion with students. This teacher's practice promotes reflective discussions based on students' proposals to solve the tasks.

Data was collected through video recordings of the classroom work, researchers' field notes and students' written answers. According to the task design, the teacher organized the class into two

groups of 4 and two of 6 students. In the first part of the task students could model the process of distributing 52 stickers¹ using 52 unifix cubes and register their shares in a given table.

The objective of the second part of the task is to register and connect the numbers of the distribution on a given diagram (Figure 1, two left images) and to symbolize the structure of the distribution using the expression $a = qd + r$ (distributions with rest) or with $a = qd$ (distributions without rest).

The figure shows four task cards for distributing 52 objects. Each card has a title, an illustration of people, and a table with five rows: 'Number of objects to distribute', 'Number of parts (persons)', 'Number of objects for person', 'Number of distributed objects', and 'Remainder'. Each row has an arrow pointing to a box. A 'Control' section at the bottom of each card contains a box with '52 ='.

Figure 1: Distribution numbers

In the third part (Figure 1, two images on the right), students must envision the result of partitioning connecting the numbers of the new partition with those of the first one (Figure 1, two images on the left).

We formulated the following conjectures: (1) as students know that they can approach and solve the task in their own way and that the work will be discussed in a final phase, we expect them to use what they already know, adapting it to the task conditions (Hatano, 2003); (2) as they have 52 objects, we expect students to distribute them in two different ways: one by one or two by two (an intuitive way of distributing); (3) the second part of the task allows students to discern the meaning of the different numbers of the distribution and to connect them in an appropriate way that represents the underlying structure (multiplicative structure of partitioning); (4) as the number of people is half of the number of people in the part 1 of the task, we expect that most students will deduce the part they each receive using the double / half ratio (idea of proportional relations).

The following categories for analysing data were constructed from the theoretical framework: (1) way of modelling connected to (2) the representation of the distribution, and (3) the numbers relations and operations used to calculate the unknown.

We elaborated a detailed written description of how each group of students solved the task, integrating their written productions with video recordings and transcription of episodes that illustrated students' discussion and approach to solve the task. Those descriptions were used to characterize the variation in reasoning and calculations as defined in the categories of data analysis. The results that we synthesize in the following section reflect the interpretation of the observed variation.

¹ In Portugal children often have collections of Panini stickers

Results

Distributing in equal parts

Confirming our conjecture, some groups cyclically distribute the same amount of objects (one or two) to each element of the group. However, some groups did not model the situation as expected and followed a personal way of acting, reasoning and representing.

One of the groups with 4 students organized the cubes in 13 bars with 4 cubes each (see figure 2). They explained:

Student 1: We only need the first round.

Teacher: Why?

Student 2: We formed groups of 4 and we counted.

(...)

Student 1: We formed groups of 4 and we counted them. We have 13.

Teacher: And what does this mean?

Student 2: Each one with 13.

Teacher: Each one has ...

Student 3: 13 stickers.

Teacher: Why did you form groups of 4?

Student 1: Because we had to divide 52 by 4.

The other group with 4 students used the relation “to divide by 4 is the same as half of the half”. One student explained “First of all the number of rounds is 13. It was a quarter of 52. The number of objects distributed in the 13 (points to the thirteenth round) is 52”.

As expected, understanding what happens when some cubes remain, originated some hesitations and discussion within the two groups with six students. For instance, one of the groups understood that there were 4 cards left but still continued to pose other possibilities for the number of cards that each could receive:

Students: We have 4 left.

Teacher: Ok. We have 4 left. And can we have another round?

Student 1: No. We had to rip the card.

Teacher: We do not usually rip cards, do we?

Student 2: And if we give 7 cards to each of us?

Teacher: And if we give 7 cards to each of us? What happens?

Student 3: And if we give 6 cards?

Teacher: And if we give 7 cards to each of us? What happens?

Student 2: There are more left.

The register of the distribution of the 52 objects in the table originated some mistakes. For instance, some of them register the sequence of multiples of 4 instead of the numbers of objects distributed in each round.

Analysed data shows that the table presented in the task was not adequate to register the reasoning used by the groups that modelled the distribution via “one fourth is half of the half” or that related distributing one by one to the final distribution of 8 to each one:

Figure 2: Adapted registration

Relating the numbers of the distribution to control the outcome

It was expected that students, in the extension of the modelling, would recognize and register correctly the meaning of the numbers of both distribution on the dispensed diagram. Relating the number of groups to the numbers of objects per group and what remains, they would understand that the outcomes of both “division” can be controlled by symbolizing the multiplicative structure of the distribution with the adequate sequence of repetitive additive and the corresponding decomposition of 52 into $a = qd (+r)$.

Figure 3: Meaning of the numbers



Figure 4: Multiplicative structure

The video recording, registration of the meaning (Figure 3) and representations of the distribution (Figure 3 and Figure 4) on the individual worksheets show that, in open reflection and discussion under direction of the teacher, all the students succeed to control the outcomes as expected.

Deriving distributing by 2 and 3 from distributing by 4 and 6

The results confirm our conjecture: students do not use cubes and deduce the part that receives each one using the rule that if we have half of the persons each one receives twice as many objects. All students apply the rule by comparing the two distributions without rest: $52 \div 2$ with $52 \div 4$, halving the number of person goes with doubling the number of objects per person.

However, some groups apply this relationship to $52 \div 6$ without considering the 4 remaining objects and give the incorrect answer of 16 objects per person.

Discussion

Data analysis confirms the conjecture that varying conditions of the task (whether concrete material is used or not; different number of persons/parts; division with or without remainder) stimulates the adaptive use of the knowledge and procedures that the students already have, which favours the possibility of adapting the acquired knowledge and procedures to the numbers involved in the task. This complex situation of sharing gives students the opportunity to explore ways of thinking that allow them to take advantage of what they already know. Also, it allows the teacher to promote students' reflection on different ways of understanding the multiplicative relationship involved in this task.

Data analysis suggests three critical aspects of the learning process in this domain that we propose for further investigation and discussion:

- *Envisioning the process and the result of dividing instead of directly modelling.* The fact that some groups do not distribute objects cyclically suggests that modelling with objects does not make sense because students already have an idea of the inverse relationship between combining and dividing that allows a more abstract approach. Our new conjecture is to give only 4 (or 6) cubes to envision, and represent numerically the process of sharing 52 by 4 (or 6) persons.

- *Exploring remainder patterns using the inverse relation.* Several divisions without rest and with rest raise the question "what explains this difference?". Using the knowledge of the inverse relationship between combining and sharing/segmenting students could investigate 'from where the remains come' (divisibility).

- *Understanding the ambiguity of symbolization with numerical expressions.* Segmenting/distributing can be represented with different numerical expressions. Giving students the opportunity to think multiplicatively in the context of division to explore numerical patterns can promote the ability to compose and decompose numbers using operations to represent them (12 is 3×4 , 12 is a quarter of 48, 4 is 48 to divide by 12).

References

Freudenthal, H. (2002). *Didactical phenomenology of mathematical structures*. New York: Academic Publishers.

- Gravemeijer, K., & Cobb, P. (2006). Design research from a learning design perspective. In J. van den Akker, K. Gravemeijer, S. McKenney, & M. Nieveen (Eds.), *Educational design research*. (pp. 45-85). Abingdon, UK: Routledge.
- Gray, E. M., & Tall, D. O. (1994). Duality, Ambiguity and Flexibility: A Proceptual View of Simple Arithmetic. *Journal for Research in Mathematics Education*, 26(2), 115–141.
- Greer, B. (1992). Multiplication and Division as Models of Situations. In Douglas A. (Ed.) *Handbook of Research on Mathematics Teaching and Learning*, (pp. 276–295). New York: Macmillan Publishing Co.
- Greer, B. (2012). Inversion in mathematical thinking and learning. *Educational Studies in Mathematics*, 79, 429–438.
- Hatano, G. (2003). Foreword. In A. J. Baroody & A. Dowker (Eds.), *The development of arithmetic concepts and skills: Constructing adaptive expertise* (pp. xi–xiii). Mahwah, NJ: Lawrence Erlbaum.
- Hatano, G., & Inagaki, K. (1986). Two courses of expertise. In H. Stevenson, H. Azuma, & K. Hakuta (Eds.), *Children development and education in Japan* (pp. 262–272). New York: Freeman.
- Heirdsfield, A.M., Cooper, T. J., Mulligan, J., & Irons, C. J. (1999). Children’s mental multiplication and division strategies. In O. Zaslavsky (Ed.). *Proceedings of the 23rd Psychology of Mathematics Education Conference*, (Vol. 3, pp. 89-96). Haifa, Israel: Israel Institute of Technology.
- Kilpatrick, J., Swafford, J., & Findell, B. (Eds.). (2001). *Adding it up: Helping children learn mathematics*. Washington, DC: National Academy Press.
- Lo, M.L. (2012). *Variation Theory and the Improvement of Teaching and Learning*. Gothenburg, Sweden: Acta Universitatis Gothoburgensis.
- Tall, D. (2013). *How humans learn to think mathematically: exploring the three worlds of mathematics*. Cambridge, UK: Cambridge University Press.
- Thompson, P. W., & Saldanha, L. (2003). Fractions and multiplicative reasoning. In J. Kilpatrick, G. Martin, & D. Schifter (Eds.). *Research companion to the Principles and Standards for School Mathematics* (pp. 95–114). Reston, VA: National Council of Teachers of Mathematics.
- Threlfall, J. (2002). Flexible mental calculation. *Educational Studies in Mathematics*, 50(1), 29–47.
- Tzur, R., Johnson, H. L., McClintock, E., Kenney, R. H., Xin, Y. P., Si, L., Woodward, J., Hord, C., & Jin, X. (2013). Distinguishing schemes and tasks in children’s development of multiplicative reasoning. *PNA*, 7(3), 85–101.
- Vergnaud, G. (2009). The theory of conceptual fields. *Human Development*, 52, 83–94.
- Verschaffel, L., Greer, B., & De Corte, E. (2007). Whole number concepts and operations. In F. Lester (Ed.), *Second Handbook of Research on Mathematics Teaching and Learning* (pp. 557–628). Charlotte, NC: Information Age Publishing Inc.

Mental computation: An opportunity to develop students' strategies in rational number division

Renata Carvalho¹ and João Pedro da Ponte²

¹Instituto de Educação, Universidade de Lisboa, Portugal; renatacarvalho@campus.ul.pt

²Instituto de Educação, Universidade de Lisboa, Portugal; jpponte@ie.ulisboa.pt

Mental computation provides a good environment to develop students' strategies in division of rational numbers. In this paper, we seek to analyze mental computations strategies in rational number division used by grade 6 students, during a teaching experiment. The teaching experiment emphasizes collective discussions and was based on tasks involving number sentences and word problems with the four basic operations. The methodology was design-based research with two experimental cycles involving two teachers and 39 students. All lessons were audio and video recorded. The results show that students mostly use numerical relationships strategies supported by propositional representations in rational number division. Initially, students' strategies are based on applying a procedure and evolve to strategies that relate division and multiplication.

Keywords: Mental computation, students' strategies, rational numbers, division.

Introduction

Learning mathematics is not just about memorizing and replicating a set of procedures. A deep understanding of concepts is needed to learn mathematics with meaning and to develop mathematical proficiency. The development of mathematical proficiency stands on the interrelation between five strands: conceptual understanding, procedural fluency, strategic competence, adaptive reasoning and productive dispositions (Kilpatrick, Swafford, & Findell, 2001). Procedural fluency needs to be built based on conceptual understanding. The development of students' mental computation skills with rational numbers, using word problems and number sentences, can provide a good environment to achieve such conceptual understanding. The discussion of mental computation strategies allows teachers to understand students' thinking about rational numbers, their conceptual understanding. Furthermore, it helps students to construct and reconstruct new knowledge based on what they previously learned. In this paper, we seek to analyze what mental computation strategies grade 6 students use in rational numbers division during a teaching experiment. The teaching experiment emphasizes collective discussions and was based on mental computation tasks involving number sentences and word problems with the four operations

Division of rational numbers

For students, division is a difficult operation. It begins with whole numbers and becomes more complicated with fractions and decimals. According to Sinicrope, Mick and Kolb (2002), division has different meanings that students need to learn and understand. In fact, division can be used to: (a) determine the number of groups (measurement division – when dividing $2 \div 1/2$, we find the number of times $1/2$ falls within 2); (b) determine the size of each group (partitive division – when dividing $3/4$ of a pie equally by 3 people, we find the amount of pie for each person); (c) determine the dimension of a rectangle array (inverse of a Cartesian product – we find one dimension, in a problem of area in which the total area and other dimension are known). When working only with fractions, the authors add two more meanings: (d)

to determine a unit rate (a printer can print 100 pages in two and one-half minutes. How many pages does it print in one minute?), and (e) as the inverse of multiplication. A deep understanding of rational number division involves understanding all these meanings, but, Siebert (2002) emphasizes the key importance of measurement and partitive division. Usually, students use the “invert and multiply” rule to divide fractions focusing only in procedures. For this author, this algorithm does not seem to be associated with division, since it has no signs of division and it is not in line with students’ understanding of what division means (finding the number of groups or finding the size of each group). Sinicrope et al. (2002) consider these meanings important, but highlight the importance of connecting the context of a problem with the algorithm to be used, since each context triggers a set of procedures to solve a problem. In line with this perspective, Siebert (2002) stresses that division with fractions must be explored using real-life contexts to help students to create images and make connections between the solutions of these problems and the knowledge they have about division with whole numbers, as this allows students to extend their knowledge. After constructing these images with meaning, they are prepared to understand the “invert and multiply” rule.

Mental computation with rational numbers

In this study, mental computation is seen as an exact computation made mentally in a quick and effective way, using mental representations and involving number facts, memorized rules, and relationships between numbers and operations (Carvalho & Ponte, 2017). In addition, students need to understand the size and value of numbers and the effect of an operation on a number, as well as to be able to make estimates to check the reasonableness of solutions (Heirdsfield, 2011). When computing with rational numbers, notably with fractions, a reconceptualization is needed because, multiplying and dividing fractions not always produces a product bigger than the factors or a quotient smaller than the dividend. As computing with rational numbers involves more complex reasoning than computing with whole numbers, we assume that the use of memorized rules (e.g., application of procedures such as multiplying/dividing by powers of 10) may sometimes support students’ computation and the establishment of numerical relationships. Number facts used by students in mental computation can involve knowledge about results of some operations (sums, differences, products, and quotients) or relationships among numbers and operations that they have stored in their memory throughout school experiences. Using numerical relationships, involves a deep understanding of numbers and operations, the capacity to use fundamental properties of operations and the notion of equality to analyse and solve problems (Empson, Levi, & Carpenter, 2010). Some numerical relationships strategies used by students are related to the change of rational number representations (Carvalho & Ponte, 2017) (e.g., fraction \rightarrow decimal; decimal \rightarrow fraction or a rational number to a whole number concerning 10/100), to equivalences between mathematical expressions and to inverse relationship between operations. Number facts and memorized rules can emerge as mental computation strategies, *per se*, but they also arise as a support in establishing relationships between numbers and operations and vice-versa.

In the perspective of Dehaene (1997), memory plays a central role in mental computation, not only for its ability to store number facts, but also for the mental models that it creates, based on previous knowledge, supporting students’ reasoning. In mental computation we use mental representations from the world that surrounds us, in sense making and in making inferences. According to the theory of mental models (Johnson-Laird, 1990), such mental representations may be: (i) mental models, if they are general perceptions of the world (e.g., using a general context of fair sharing to share a given

quantity); (ii) mental images, if they involve a more specific perception of the real world where some characteristics are considered (e.g., relating the symbolic representation $1/2$ to a pizza divided in two parts taking only one part); and, (iii) propositional representations, if they represent true or false statements that play an important role in the inference process (e.g., to compute $1/4 \div ? = 1/2$, we realize that if $1/2 \times 1/2 = 1/4$ then the missing value is $1/2$).

Research methodology

This study is qualitative and interpretative with a design research approach (Cobb et al., 2003). As a developmental study, it seeks to solve problems identified from practice, mainly the difficulties in learning rational numbers and near absence of mental computation with this number set. It bases on a teaching experiment with mental computation tasks that provide opportunities for discussing students' strategies. It includes three phases: preparation; experimentation and analysis. In the preparation phase (2010) we undertook a preliminary study in grade 5 (conducted by the first author in her classes) to understand students' strategies when computing mentally with rational numbers, and to figure out practical aspects of students' mental computation strategies, important for planning the teaching experiment. Such planning also considered the research on rational numbers and mental computation with rational numbers. In the second phase (2012-13), cycle 1 (CI) and 2 (CII) were carried out involving two teachers and two grade 6 classes (39 students) from two different schools selected according to teacher's availability to participate in the study, with the first author as a participant observer. During this phase some refinements were made in the teaching experiment (e.g., changing the sequence of tasks). Data were collected through video and audio recordings of the classroom work with mental computation. Finally, in the analysis phase, the dialogues recording students' strategies were transcribed. In this paper we will focus on students' strategies to compute with division of rational numbers with fractions and decimals. To analyze data, we defined three main categories of strategies and several subcategories (Table 1) that we relate with students' mental representations (images, models and propositional representations). These categories emerged from the data informed by the literature review.

Categories			
Numerical relationships		Number facts	Memorized rules
Subcategories	Change representation	Two halves make a unit	Rule to add/subtract fractions
	Part-whole comparison	A half of a half is a quarter	Invert and multiply rule
	Relation between operations		

Table 1. Categorization of mental computation strategies with rational numbers

The categorization was made according to the strongest notion involved in students' strategy. For example, if there is a strong use of numerical relationships, as the change of representation, we coded this strategy in the category "numerical relationships" and subcategory "change representation".

The teaching experiment

The teaching experiment relies on the conjecture that a systematic work with mental computation tasks with rational numbers represented as fractions, decimals and percent, and whole class

discussions may contribute to the development of students' mental computation strategies and understanding of their errors. Before the teaching experiment, the students already had worked with rational numbers in different representations and operations, with emphasis on algorithms. The teaching experiment included ten mental computation tasks with rational numbers (with several number sentences or word problems each) to carry out weekly. All tasks were provided by the first author and discussed in detail with the participating teachers. These tasks were presented at the beginning of a class by using a timed PowerPoint to challenge students to compute mentally in a faster way. The students had 15 seconds to solve each number sentence and 20 seconds to solve each word problem individually. The results were recorded on paper. Each task has two parts, both with 5 number sentences or 4 word problems. Upon finishing each part, there was a collective discussion of students' strategies. These mental computation lessons lasted 30 to 90 minutes. The discussion moments were regarded as very important. They allowed students to show how they think and which strategies they use to compute mentally in tasks with different cognitive demands. These moments were important for students to think, reflect, analyze, make connections, share, and extend mental computation strategies, as well as to identify skills that they should develop about numbers and operations.

The students began to compute mentally with fractions (addition/subtraction in task 1 and multiplication/division in task 2), then with decimals and fractions with the four basic operations (task 3), and then only with decimals (addition/subtraction in task 4 and multiplication/division in task 5). Subsequently, they solved word problems in measurement and comparison contexts involving fractions and decimals (task 6). Percent was used in task 7, as the teacher began working with statistics. Then, students used decimals, fractions and percent in tasks 8, 9 and 10. In task 10 they solved word problems. The tasks were designed following three principles and considering previous research on mental computation and rational numbers: *Principle 1*. Use contexts to help students to give meaning to numbers. A structured knowledge is associated with the context in which it was learned and, most of the time, it is difficult for a student to bridge this knowledge to new situations. *Principle 2*. Use multiple representations of rational numbers. We used fractions, decimals, and percent representations in the same task and in several tasks along the teaching experiment (e.g., $2,4 \div \frac{1}{2}$). We used even numbers and multiples of 5 and 10, benchmarks such as 25% or $\frac{1}{2}$ to facilitate equivalence between decimals, fractions and percent, and to stress numerical and part-whole relationships. *Principle 3*. Use tasks with different levels of cognitive demand. For example, taking into account mental computation levels (Callingham & Watson, 2004) we designed tasks in which the students have to use the concept of half (e.g. 50% of 20 or $\frac{1}{2} + \frac{1}{2}$) or need to use a more complex numerical relationships (e.g., 20% of ? = 8), to do the computation. When planning the lessons, we sought to anticipate students' possible strategies to better prepare the collective discussions. All classroom activities were led by the teachers, with the first author making occasional interventions to ask students to clarify their strategies.

Students' mental computation strategies for division of rational numbers

In this section we analyse students' mental computation strategies in dividing rational numbers with fractions and decimals. The examples selected (Table 2) are representative for the strategies used by students in CI and CII. We begin with questions using division by $\frac{1}{2}$ because we think this is an essential step to understand the division of rational numbers, especially the relation between dividend, divisor and quotient. We used other benchmarks as $\frac{1}{4}$ or the division between a fraction and a whole number to support students' extension of knowledge from the division of whole numbers.

	Mental computation question	Mental computation strategies	Mental representation	Students' meaning of division
Task 2	$\frac{4}{8} \div \frac{1}{2} = ?$	Rita (C I): <i>Memorized rules</i> (invert and multiply rule)	<i>Mental image</i>	<i>Application of a procedure</i>
	$\frac{1}{4} \div ? = \frac{1}{2}$	Ana (C I): <i>Numerical relationship</i> (relation between expressions- multiplication and division) <i>and number facts</i> (half of a half is a quarter)	<i>Propositional representation</i>	<i>Inverse relationship between multiplication and division</i>
	$\frac{3}{4} \div ? = \frac{1}{4}$	António (C II): <i>Numerical relationship</i> (relation between expressions- division/multiplication/ repeat addition) <i>and number facts</i> (quotient known)	<i>Mental model</i> <i>Propositional representation</i>	<i>Partitive division</i>
Task 5	$2.1 \div ? = 8.4$	Maria (C I): <i>Numerical relationship</i> (relation between numbers and expressions- division/multiplication) <i>and number facts</i> (time table)	<i>Propositional representation</i>	<i>Inverse relationship between multiplication and division</i>
Task 6	A tank has the capacity of 22.5 l. How many 1/2 l buckets do you need to completely fill the tank?	Eva (C I): <i>Numerical relationship</i> (relation between operations - 1/2 and the multiplication by 2; part-whole relationship)	<i>Propositional representation</i>	<i>Measurement division</i>
Task 10	$0.75 \div ? = 3$	Rui (C II): <i>Numerical relationship</i> (change representation decimal \rightarrow fraction; relation between numbers)	<i>Propositional representation</i>	<i>Inverse relationship between multiplication and division</i>

Table 2: Synthesis of Students strategies in rational numbers division

In task 2, students compute mentally with fractions in number sentences and open number sentences. To solve “ $4/8 \div 1/2 = ?$ ” students could simply identify that dividend and divisor represent equivalent fractions, so the quotient is 1. However, most of the students apply the “invert and multiply” rule as Rita did: “I inverted the 2 with the 1. I did 4 times 2 and get 8 and 8 times 1 and get 8. I get the unit. I wrote 1”. Rita used a *memorized rule* probably supported by *mental images* of procedures that she knows. In the 2nd part of task 2, Ana’s strategy to compute “ $1/4 \div ? = 1/2$ ” and António’s strategy to calculate “ $3/4 \div ? = 1/4$ ” led to discuss another way of thinking about dividing rational numbers. Ana explained: “I just know that 1/2 times 1/2 is 1/4. So, I put immediately 1/2”. She used a *numerical relationship* strategy (relation between expressions) based on a *propositional representation* (if $1/2 \times 1/2 = 1/4$ so $1/4 \div 1/2 = 1/2$) supported by a *number fact* (half of a half is a quarter). Her strategy emphasizes the relationship between multiplication and division as inverse

operations. To compute “ $3/4 \div ? = 1/4$ ” António explained: “I thought of 3€ I forgot the 4 [in the denominator]. 3€ dividing by 3 persons is equal 1€ to each person... $3/4$ dividing by 3 persons is $1/4$. . . I thought $1/4 + 1/4 + 1/4$ [is] $3/4$ ”. António used a *numerical relationship* strategy (relations between expressions). He relates division ($3/4 \div 3$) with multiplication through repeated addition ($3 \times 1/4 = 1/4 + 1/4 + 1/4$). António uses the context of money (*mental model*) to share money between 3 persons, and so, he “forgot the 4” from the denominator to make an extension of what he knows about whole numbers division. He probably searched in his quotients repertoire, one that gives 1 (*number facts*), and validated his strategy using a *propositional representation* (if $3/4 \div ? = 1/4$ and $3 \div 3 = 1$, so, $? = 1/4$ because $1/4 + 1/4 + 1/4 = 3/4$). António’s strategy shows how a partitive division context that he knows can be a model to think and compute the given mathematical expression.

In task 5, Maria explained her strategy to compute “ $2.1 \div ? = 8.4$ ”, showing flexibility in working with equivalent representations of rational numbers: “I did 2 times 2.1 and then 4 times and I get it [8.4]. But we must divide. The inverse of 4 is $1/4$ that is 0.25”. She used a *numerical relationship* strategy (relation between numbers and operations) supported by *number facts* and *propositional representations*. To find the missing number, Maria used *number facts* (time table of 2 and 4) to find the multiplicative relationship between the 2.1 and 8.4. The given operation was division and she used multiplication (inverse operation) to think. So, she needs to answer using the “inverse of 4 is $1/4$ that is 0.25”. Her strategy could be supported by the *propositional representations*: if $2.1 \div ? = 8.4$ and $2.1 \times 4 = 8.4$ so $2.1 \times 4 = 2.1 \div 1/4 = 8.4$. A sequence of true statements leads to the correct answer.

The word problem presented in Table 2 (task 6) can be solved by using the expression $22.5 \div 1/2$. Eva’s strategy was: “It is 45 baskets. I only multiply 22.5 by 2”. Questioned why she multiplied by 2, she answered: “Because of $1/2$. To get the unit we must add five tenths twice, so we multiply by 2”. This was used to discuss division sense when using a divisor less than 1, since the quotient gets bigger than the dividend, and not smaller as it happens with whole numbers. Eva used a *numerical relationship* strategy (relations between operations and part-whole relationship). She understood that two halves make a unit and explained it using two equivalent representations ($1/2$ and 0.5). This gives meaning to the multiplication by 2 instead of the division by $1/2$. Understanding this, she supported her strategy in a *propositional representation* (if $1/2 = 0.5$ and $0.5 \times 2 = 1$, so, $22.5 \div 1/2 = 22.5 \times 2 = 45$). The meaning of the “invert and multiply” rule was discussed using Eva’s explanation.

In task 10, the last task of the teaching experiment, Rui computed “ $0.75 \div ? = 3$ ” explaining: “I changed 75 hundredths to $3/4$ because it’s equivalent. So, $3/4$ divided by a number that I don’t know to get 3... $3/4$ dividing by $1/4$ is equivalent to 3.3 divided by 1 is equivalent to 3 and 4 divided by 4 is equivalent to 1”. He changed representation from decimals to fractions (*numerical relationships*) and this was essential to see that there is a multiplicative relationship between dividend and quotient ($3/4 \div ? = 3$). He was not explicit about this relation, but when he stated “ $3/4$ dividing by $1/4$ ” he assumed that the result is $1/4$, and this could come from $3 \times 1/4 = 3/4$. To validate his strategy, Rui solved the operation ($3/4 \div 1/4$) after knowing the result 3. Since the denominators are equal he divided numerators and denominator to get the answer $1/4$. His strategy could be supported by a *propositional representation* that gives meaning to his way of thinking (if $0.75 = 3/4$ so $0.75 \div ? = 3$ is equivalent to $3/4 \div ? = 3$. If $3 \times 1/4 = 3/4$, then, $3/4 \div 1/4 = 3$ because $3 \div 1/4 \div 4 = 3/1$). Interestingly, Rui always used the word “equivalent” to talk about the equal sign. This shows that he understood it as a sign of equivalence and not as a sign that requires a solution.

Discussion and conclusion

In this paper we share and analyze the most representative mental computation strategies in division of rational numbers, used by students in CI and CII of our study. To develop students mental computation strategies, we designed tasks that include benchmarks, different rational number representations (Kilpatrick et al., 2001), different levels of cognitive demand and contexts to support students to connect number sentences with world problems and vice-versa (e.g., Sinicrope et al., 2002). This allows students to give meaning to number representations and extend previous knowledge about whole numbers.

In the beginning of the study (task 2) most students use memorized rules such as “invert and multiply” two divide two fractions. This is a procedure that most students use, certainly without meaning, because it does not seem to be associated with division (Siebert, 2002). To divide fractions, students multiply most of the time without relating these two operations. When challenged to compute mentally in open number sentences they use numerical relationships strategies, with an emphasis on the change of representation. Decimal division was more difficult for students than fraction division, probably because they learned a rule to divide fractions and not to divide decimals. Therefore, students prefer to change decimals to fractions to use the rule or to relate division and multiplication (as did Maria and Rui). In open number sentences it is not possible to use directly the “invert and multiply” rule. The use of this kind of task in the teaching experiment was an important step in the development of students’ mental computation strategies in division, since they need to relate numbers and operations instead of applying rules, where mental representations play an important role. Mental representations as propositional representations support students’ reasoning while several relationships are made, and mental models can provide real-life contexts with meaning for students, so they can solve mathematical expressions (as did António). During the teaching experiment, several word problems were used and related with number sentences to help students to create mental representations and make connections between real-life contexts and mathematical expressions (Siebert, 2002). For example, in task 5 we used the expression $12.2 \div 0.5$ to relate later with the problem shown in task 6 (see Table 2). The use of word problems was another important step in the development of students’ strategies as it gives a real-life context where students need to search for an operation to solve it. This search allows students to find mathematical expressions where the contexts facilitate an understanding of relationships previously discussed in the classroom. Eva’s strategy to solve a word problem in a measurement context represented an opportunity to give meaning to the relationship between dividing by $1/2$ and multiplying by 2 as well to the “invert and multiply” rule, used several times by students.

This study shows whenever students apply a memorized rule they mostly apply a procedure without meaning. They explained a set of procedures (as Rita did) where no meaning of division is shared. When students use numerical relationships strategies they use multiplication to solve a division, stressing the relation between these two operations. The inverse relation between these operations emerged in a strong way in students’ strategies, especially in open number sentences tasks. The missing value was the divisor that can be calculated dividing dividend and quotient, but students solved it by searching for a known relationship (as Ana did) or the relation between dividend and quotient (as Maria and Rui did). On one side, the use of multiplication can be a sign of students’ difficulty in dividing rational numbers, so they search a more familiar operation to solve the problem.

On the other side, the use of multiplication emphasizes multiplicative relationships between numbers and the inverse relation between division and multiplication (e.g., Sinicrope et al., 2002). Partitive division meaning was introduced by António when he used a money context to share equally 3€ by 3 people. He drew his knowledge from division of whole numbers and extended it to rational numbers. He used a known context to model the resolution of a number sentence. António's self-validation of his answer shows a strategy made with understanding. The measurement meaning of division was provided in the basket problem, where Eva's strategy was very useful to give meaning to some relations previously made by students as we already stressed above.

To conclude, this is a singular study in Portugal that provides suggestions to teachers who want to develop students' mental computation strategies in rational numbers division. Sharing and discussing students' strategies with the whole class presents an opportunity for teachers to understand students' reasoning, but also to construct collectively an understanding about the division of rational numbers where several relationships can be explored. Further research focusing mental computation with rational numbers involving different representations is needed, as well as their contributions for the transition between arithmetic and algebra in students learning process.

Acknowledgement

This study was supported by national funds through a grant provided by to the first author by FCT – Fundação para a Ciência e a Tecnologia (reference FRH/BD/ 9413/2010).

References

- Callingham, R., & Watson, J. (2004). A developmental scale of mental computation with part-whole numbers. *Mathematics Education Research Journal*, 16(2), 69-86.
- Carvalho, R., & Ponte, J. P. (2017). Mental computation with rational numbers: students' mental representations. *Journal of Mathematics Education*, 10(2), 17-29. DOI:10.26711/007577152790010.
- Cobb, P., Confrey, J., diSessa, A., Lehere, R., & Schauble, L. (2003). Design experiments in education research. *Educational Researcher*, 32(1), 9-13.
- Dehaene, S. (1997). *The number sense: How the mind creates mathematics*. New York, NY: Oxford University Press.
- Empson, S., Levi, L., & Carpenter, T. (2010). The algebraic nature of fraction: Developing relational thinking in elementary school. In J. Cai & E. Knuth (Eds.), *Early algebraization: A global dialogue from multiple perspectives* (pp. 409-428). Heidelberg, Germany: Springer.
- Heirdsfield, A. (2011). Teaching mental computation strategies in early mathematics. *Young Children*, 66(2), 96-102.
- Johnson-Laird, P. N. (1990). *Mental models*. Cambridge, UK: Cambridge University Press.
- Kilpatrick, J., Swafford, J., & Findell, B. (2001). *Adding it up: Helping children learn mathematics*. Washington, DC: National Research Council.
- Siebert, D. (2002). Connecting informal thinking and algorithms: the case of division of fractions. In B. Litwiller & G. Bright (Eds.), *Making sense of fractions, ratios, and proportions* (pp. 247-256). Reston, VA: NCTM.
- Sinicrope, R., Mick, H., & Kolb, J. (2002). Fraction division interpretations. In B. Litwiller & G. Bright (Eds.), *Making sense of fractions, ratios, and proportions* (pp. 153-161). Reston, VA: NCTM.

Intervention in counting principles: teachers' perceptions on students' learning profile

Luciana Vellinho Corso¹ and Évelin Assis¹

¹ School of Education -Universidade Federal do Rio Grande do Sul, Porto Alegre, Brasil.

l.corso@terra.com.br; evelin_assis@hotmail.com

Abstract: The research field about teachers' perceptions on students' performance highlights the importance of understanding this approach in order to help students to improve their learning outcomes. This study aims to contribute to this discussion. It involved 136 first-grade students, from 10 classes of 3 Brazilian public schools. The teachers participated by filling out a questionnaire about the students' learning profile, including aspects such as: behavior, attention, social interaction and knowledge by area (mathematics, reading and writing). The teachers' answers were related to the students' achievement in a counting principles task. The results show that teachers have correct perceptions about the students who master the counting principles, but the same is not true for the ones who did not consolidate or were still developing the principles. The educational implication of the study is pointed out.

Keywords: Teachers' perceptions. Counting principles. Learning profile.

Teachers' role in the learning process of the students is often recognized by researchers in the mathematics field, especially when they present the research outcomes and reflect on its educational implications (Hoge & Coladarci, 1989; Südkamp, Kaiser, & Möller, 2012). Studies focusing on this perspective provide important data concerning teachers' perceptions on students' learning which brings implications for the way teachers plan their pedagogical actions (Hoge & Coladarci, 1989; Südkamp, Kaiser, & Möller, 2012). In this sense, the knowledge provided by this field of research allows to better comprehend and favor the teaching and learning processes.

This research involves the investigation of teachers' perceptions about the learning profile of first year students and seeks to verify if there is a relation between the teachers' perceptions and the students' actual performance in a counting principles task. The counting principles, established by Gelman and Gallistel (1978), are the basis for children's learning how to count with success. The principles are: stable order, one to one correspondence, cardinality, abstraction and order irrelevance. As evidenced by Stock, Desoete & Roeyers (2009), children with good achievement in counting by the end of kindergarten presented good performance in arithmetical abilities in the first year, pointing to the predictive value of the counting principles.

In 1989, Hoge and Coladarci conducted a systematic review on teacher judgments about their students' achievement. Initially, the authors contextualized teacher judgments through two perspectives: the cognition of teachers and their assessment. The first one addresses the decision-making of educators (in relation to planning, for example), noting that this process is influenced by their judgment on their students. The second involves thinking about the importance of the accuracy of teacher judgments in the context of assessment: educational decisions are made on the basis of the

educators' assessment and their judgment is an important source of information about the students (Hoge & Coladarci, 1989).

In 2012, 23 years after the review mentioned, Südkamp, Kaiser & Möller also studied the precision of teachers' judgment about the performance of their students, conducting a meta-analysis on this subject. The authors pointed out that teacher judgment is one of the primary sources of information about students' academic performance, as Hoge and Coladarci (1989) highlighted. An accurate assessment of students' performance is a prerequisite for educators to be able to adapt their pedagogical practices, make decisions and support the students' development of an appropriate academic self-concept (Südkamp, Kaiser, & Möller, 2012).

The literature showed studies involving teachers' judgment/perception with different objectives: to verify predictors of performance (Teisl, Mazzocco & Myers, 2001), to identify students with difficulties in mathematics (Nelson, Norman, & Lackner, 2016), and to observe the relationship between teacher perceptions and students' performance in mathematics, specific math skills, student feeling, motivational factors, and activities choices (Eds & Potter, 2013; Martinez, Stecher, & Borko, 2009, Schappe, 2012).

Although these works show divergences in some aspects, they generally point to a positive relation between the teachers' perceptions on students' performance and the students' actual learning outcomes. The authors note the need for research on this relationship, highlighting the importance of teacher judgment for students' evaluation, pedagogical planning and decision making. The present study seeks to contribute to this discussion. The purpose of this study is to investigate the relationship between teachers' perceptions about the learning profile of their 1st year students and the students' actual performance in a counting principles task.

Method

Participants

The study included 136 Brazilian students (63 girls and 73 boys), aged between 6 and 7 years old, from 10 groups of 1st year of Elementary Schools. It involved 3 public schools. This group of children was participating in an intervention research, entitled "Intervention in counting principles for elementary school students", submitted as a paper to TWG2, this year. Students were assessed in a counting principles task and their teacher filled out a questionnaire focusing on their perceptions about the students' academic achievement. Therefore, besides the students, their teachers (n=10) also took part in this study. All of them were graduated in Pedagogy and 9 had post-graduation in the Education area. Regarding the teaching experience with first year of Elementary School: 1 teacher had 6 months, 1 teacher had 2 years, 2 teachers had 3 years, 1 teacher had 5 years, 1 teacher had 9 years, 1 teacher had 18 years, 1 teacher had 28 years, 1 teacher had 31 years and 1 teacher had 36 years. The parents of all participating students gave their authorization through the signing of the Free and Informed Consent Form and the Dissent Form. Approval for this study was obtained from the Research Ethics Committee of Universidade Federal do Rio Grande do Sul.

Procedures

The researcher administered the counting principles task, between September and December 2017, individually to each child in a room provided by the schools. The teachers received the questionnaire at the beginning of the data collection and returned it according to their availability.

Instruments

1) Counting principles task: The task is conducted in an interview format. There are specific questions to assess each principle. The questions were asked in the following order: stable order (“Until how much can you count?” “Count out loud up to the number you said, please”); one to one correspondence (The experimenter shows 10 chips in a row and asks “how many chips are there?” After, the researcher shows 10 chips misaligned and asks “how many chips are there?”. The same procedure is repeated with 15 chips. This activity will be called “A”); cardinality (by the end of counting 15 items, the experimenter asks “how many are there in total? Can you give me 10?” This activity will be called “B”); abstraction (the experimenter asks “if you were counting 15 candies, would you count the same way (in the same order) you counted the chips?” This activity will be called “C”); order irrelevance (the experimenter asks the child to count the 15 chips, arranged in a row, in a different order, that is, starting from another chip. Then, the child is asked to say how many chips would remain if the row was undone. After, the experimenter asks the child to count 8 chips of the set, separating them aside, and then, to count the remaining 7 chips of the row. By the end, the child has to say how many chips there are in total. This activity will be called “D”). For each principle, the subjects were classified into three groups: principle consolidated (Y – yes); in construction (IC); not consolidated (N). Some criteria were established to classify the children in each group. Some of the questions (2, 3 and 5) are formed by more than one query. In this case, the child’s answer was classified as “Y” if he/she answered all the solicitations in each question correctly; “IC” if only one part of the question was correctly answered; “N” if the student did not answer any part of the question correctly.

2) Teachers’ questionnaire: The teachers received a questionnaire, adapted by the author, based on the scale of "Strengths and Weaknesses of Attention-Deficit / Hyperactivity-symptoms and Normal-behaviors - SWAN" (Swanson et al., 2005), containing questions about attention, behavior, knowledge by area (mathematics, writing and reading) and social interaction. The objective of the questionnaire, presented in the table below, was to investigate the teachers' perceptions about the general learning profile of their students. For each statement, teachers could select one of four frequency options: often, sometimes, rarely, or never.

1 - Shows interest for the proposals	14 – Shows difficulties in writing
2 - Pays attention to the explanations	15 - Shows difficulties in reading
3 - Keeps the materials organized	16 - Shows difficulties in mathematics
4 - Complies with the teacher's requests	17 - Avoid tasks involving numbers
5 - Interacts well to colleagues	18 –Shows counting knowledge
6 - Manages well the time attributed to accomplish a task	19 – Shows difficulties in socializing

7 - Engages in activities	20 – Shows difficulty in understanding instructions
8 - Knows to take turns: when to speak and when to listen	21 - Plays together with colleagues at playtime
9 - Questions when in doubt	22 - Complaints about the class proposals.
10 -Requires a lot of attention from the teacher	23 - Demonstrates slowness to finish the tasks
11 - Moves a lot during class	24 – Is easily distracted
12 - Forgets about making the homework	25 - Expresses him/herself well
13 – Does not comply with the rules	

Table 1: Teachers' questionnaire

Results

The relationship between the questionnaires of the teachers and the performance of the children in the counting principles task was investigated. In order to do the analyses, it was necessary to make an adjustment in the questions of the questionnaire. Although all of them counted with the same frequency for answers, there were distinct kinds of affirmation, which meant that the same frequency attributed to two different questions resulted in opposite answers. For example: the “often” frequency is a positive answer to question number 1 (“shows interest for the proposals”), but negative for the question number 20 (“shows difficulty in understanding instructions”). Considering this fact, before running the analyses, it was necessary to transform the answers so they kept the same direction of association. They were classified as positives (1 to 9, 18, 21, 21 and 25), which had maintained the frequency (often, sometimes, rarely, never), and negatives (10, 12 to 17, 19, 20, 22 and 24), which suffered the transformation (never, rarely, sometimes, often). In this way, the frequency “often” for the positive question number 7 (“engages in activities”) had the same effect of the frequency “never” for the negative question number 23 (“demonstrate slowness to finish the task”). The box-plots, shown below, were constructed to highlight the frequency of distribution of the teachers' answers in relation to the students' constructs. It can be seen that most of the graphs below shows increasing frequency throughout the answers, with few occurrence in "never" and a gradual increase in the following answers. The only graph that does not follow this pattern is related to the construct "IC" (in construction principle) in activity C: this may be due to the fact that only 6 children presented this construct, making the analysis difficult due to the scarcity of data for this variable.

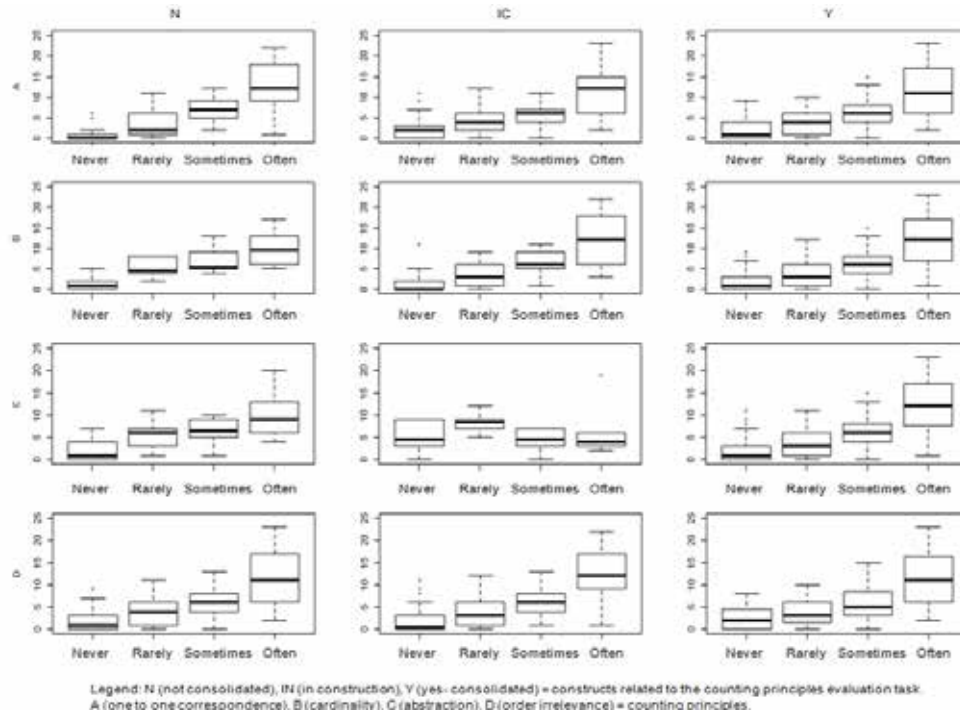


Figure 1: Box-plot graphs

Considering the information presented in the graphs, the Kruskal-Wallis test was applied to verify if the median of performance of the children in the counting principles task, between the four groups of frequencies (never, rarely, sometimes and often), was different, that is, if the oscillations in the graphs were statistically significant ($p < 0.05$). The samples were independent, so if one group has a high median, it does not interfere in the median of another group (high or low).

One to one correspondence						Cardinality						
Construct of the principle	Number of students	Answers of the teachers	Median	p-value	sig	Construct of the principle	Number of students	Answers of the teachers	Median	p-value	sig	
N	29	Never	0	0,0843		N	6	Never	1	0,6615		
		Rarely	2					Rarely	4,5			
		Sometimes	7					Sometimes	5,5			
		Often	12					Often	9,5			
IC	50	Never	2	0,0188	a	IC	17	Never	0	0,089		
		Rarely	4					Rarely	3			
		Sometimes	6					Sometimes	6			
		Often	12					Often	12			
Y	57	Never	1	0,0446	a	Y	113	Never	1	0,0003	a	
		Rarely	4					Rarely	3			b
		Sometimes	6					Sometimes	6			c
		Often	11					Often	12			d
Abstraction						Order Irrelevance						
Construct of the principle	Number of students	Answers of the teachers	Median	p-value	sig	Construct of the principle	Number of students	Answers of the teachers	Median	p-value	sig	
N	14	Never	1	0,3114		N	63	Never	1	0,0061	a	
		Rarely	6					Rarely	4			b
		Sometimes	6,5					Sometimes	6			c
		Often	9					Often	11			d
IC	6	Never	4,5	0,2873		IC	46	Never	0,5	0,2982		
		Rarely	8,5					Rarely	3			
		Sometimes	4,5					Sometimes	6			
		Often	4					Often	12			
Y	116	Never	1	0,0001	a	Y	27	Never	2	0,0096	a	
		Rarely	3					Rarely	3			a
		Sometimes	6					Sometimes	5			b
		Often	12					Often	11			c

Figure 2: Kruskal-Wallis test results

As observed above in figure 2, in the one to one correspondence principle the medians of the "N" (not consolidated) construct were the same, since their p-value was greater than 0.05. In the "IC" (in construction) and "Y" (consolidated) constructs there was a difference between the medians, indicated by p-value less than 0.05, the medians of each response being different from each other. Although a numerical difference was observed between the medians of "N" construct responses, a statistical significance was not found (at 5% level) due to the low sample size. The number of students with the "IC" and "Y" constructs, which presented a significant difference, was 50 and 57 respectively, while the "N" construct had 29 students.

In the cardinality principle, it was possible to observe difference between the four medians only for the "Y" construct ($p < 0.05$), with the "N" and "IC" constructs not showing statistically significant differences. Again, this can be attributed to the size of the sample of each construct, since 113 children showed mastery of the cardinality principle, while only 17 were constructing it and 6 did not demonstrate its consolidation. In the abstraction principle, the "N" and "IC" constructs, with 14 and 6 subjects, respectively, did not present differences between the medians of the responses. The "Y" construct, with 116 students, showed to be statistically significant ($p < 0.05$) with the four medians differing from each other. In the irrelevance of the order principle, the construct "N", with 63 subjects, was shown to be statistically significant ($p < 0.05$), with the four medians being different. The "Y" construct, although with a small number of students, 27, was also evidenced as statistically significant ($p < 0.05$). The answers "Never" and "Rarely" presented median equality, as indicated by the letters in the table. The construct "IC", in turn, even with a larger sample than the previous one, with 63 subjects, was not statistically significant, showing equal medians.

Discussion

It was expected that the results of the data analysis, relating the teachers' perceptions about their students' general learning profiles and the constructs presented by the students in the assessment of the counting principles, would show that children who did not consolidate a certain principle would present a very frequent occurrence of "Never" or "Rarely" answers in the questionnaires; students who were constructing the principles would have "Sometimes" answers more frequently; children who demonstrated a "yes" construct for the counting principles, supposedly, would present a large occurrence of "Often" answers in the teaching questionnaires. In general, it is possible to consider that there was little differentiation in the occurrence of responses for almost all constructs: both those who did not consolidate the principles and those who were constructing them, or who already mastered them, obtained the same types of answers in the questionnaires, varying in the number of times they received them.

The results raise some possibilities of analysis. First, the relationship between teachers' perceptions about the students' learning profiles was in agreement with the performance of the students only in the cases of those who showed consolidation of the counting principles. Such a result converges with other studies demonstrating that teachers' judgements, through rating scales, are good predictors of students' academic performance, more specifically, in relation to students who did not develop learning difficulties in mathematics (Teisl, Mazzocco & Myers, 2001). Another possibility concerns how teachers answered the questionnaires: once they received the documents and were able to fill

them out without the presence of the researcher, it is not known exactly how they did it, what criteria they used to choose a response in to the detriment of another, whether they filled out quickly or dedicated time to think about the issues raised there. A third point refers to the number of students per class. The classes involved in this study had a maximum of 25 students. Although it seems a small number, it is complex for a teacher, alone, to have complete knowledge of all his/her students. Even though the questionnaire was delivered in the second half of the year, a period of time when teachers would have had time to get to know their students, it is difficult to know, precisely, how much and what each teacher knew about their pupils.

Limitations

The research results described in this paper should be considered in the context of some limitations. First, the counting principles task used was selected because it is a short and practical instrument, however, we believe that a broader task could elucidate more aspects to be analyzed and discussed. The same must be said in relation to the Swan questionnaire. Another limitation concerns the choice of statistical analysis that was conducted. It is possible that different findings would have emerged if the study included the association of different statistical tests, which could have made it possible to reinforce or question some of the results found or even to elucidate other possible outcomes.

Conclusion

This study showed that the teachers have correct perceptions of their students when it comes to students with good performance, that is, those with "Y" construct in the counting principles. Students who do not present consolidation or who are constructing the principles were perceived by the teachers in a way that did not correspond to the students' performance in the counting task used in this study.

This work points to the need and importance of deepening and expanding the development of teacher studies and their perceptions. More importantly, it is extremely relevant to investigate how teachers form their perceptions, what criteria they consider when evaluating students and how they see their students.

This study shows that there are still many aspects that need to be discussed between researchers and teachers, seeking to establish a significant link between theory and practice. It is imperative that teachers, especially those responsible for the early years of Elementary School, acquire knowledge about the factors involved in learning the initial mathematics: knowing how the learner learns will help them to identify aspects related to not learning and, therefore, perhaps their perceptions are clearer and they can recognize children who are facing problems. It is imperative that the link between researchers and teachers be built and used in favor of student learning, allowing the two sides to dialogue and understand how academic conceptions can contribute to pedagogical practices and vice versa.

References

Edens, K. M. & Potter, E. F. (2013). An exploratory look at the relationships among math skills, motivational factors and activity choice. *Early Childhood Education*, 41, 235–243.

- Glascoc, F. P. (2001). Can teacher' global ratings identify children with academic problems? *Developmental and Behavioral Pediatrics*, 22(3), 163–168.
- Hoge, R., & Coladarci, T. (1989). Teacher-based judgments of academic achievement: a review of literature. *Review of Educational Research*, 59(3), 279-313.
- Kilday, C. R., Kinzie, M. B., Mashburn, A. J., & Whittaker, J. V. (2012). Accuracy of teacher judgments of preschoolers' math skills. *Journal of Psychoeducational Assessments*, 30(2), 148–159.
- Martínez, J. F., Stecher, B., & Borko, H. (2009). Classroom assessment practices, teacher judgments and student achievement in mathematics: evidence from the ECLS. *Educational Assessment*, 14, 8–102.
- Nelson, P., Norman, E., & Lackner, S. (2016). A comparison of methods to screen middle school students for reading and math difficulties. *School Psychology Review*, 45(3), 327–342.
- Schapee, J. F. (2005). Early childhood assessment: a correlational study of the relationships among student performance, student feeling, and teacher perceptions. *Early Childhood Education Journal*, 33(3), 187–193.
- Südkamp, A., Kaiser, J., & Möller, J. (2012). Accuracy of teachers' judgments of students' academic achievement: A meta-analysis. *Journal of Educational Psychology*, 104(3), 743–762.
- Swanson, J., Schuck, S., Mann, M., Carlson, C., Hartman, K., Sergeant, J., et al. (2005). Categorical and dimensional definitions and evaluations of symptoms of ADHD: The SNAP and the SWAN Ratings Scales. Irvine: University of California.
- Teisl, J. T., Mazzocco, M. M. M. & Myers, G. F. (2001). The utility of kindergarten teacher ratings for predicting low academic achievement in first grade. *Journal of Learning Disabilities*, 34(3), 286–293.

Teaching and learning decimal numbers: the role of numeration units

Lalina Coulange¹ and Grégory Train²

¹Université de Bordeaux, Lab-E3D, Bordeaux, France; lalina.coulange@u-bordeaux.fr

²Université de Bordeaux, Lab-E3D, Bordeaux, France; gregory.train@u-bordeaux.fr

We focus on the teaching and learning of decimal numbers at primary level (grades 4 and 5) in France. We are especially interested in the role played by registers of semiotic representation. Three classroom episodes are analyzed by considering the role played by the discursive register of numeration units in conceptualizing decimal numbers.

Keywords: Decimal numbers, registers of semiotic representation, numeration units.

This paper focuses on the teaching and learning of decimal numbers at primary school (grades 4 and 5) in France. Many authors underline errors specific to decimal numbers (Baturu, 2000; Durkin & Rittle-Johnson, 2015; Steinle & Stacey, 2003). We rely on the theory of registers of semiotic representation by considering a crucial role played by registers (discursive, symbolic, iconic or material) in teaching and learning processes (Duval, 1995, 2017). We grant particular importance to the register of numeration units (tens, units...) or numeration-units-numbers. Most studies (Chambris, 2015; Houdement & Tempier, 2015; Van de Walle, 2010) have highlighted the potential of this register for teaching and learning whole numbers. In our study, we question the extension of these results to decimal numbers. We aim to tackle the role of this register of numeration units (tenths, hundredths...) for teaching and learning decimal numbers. The focus is on case studies based on classroom episodes that illustrate both difficulties and levers in teaching and learning decimal numbers with respect to the role played by this register.

Theoretical frame: registers of semiotic representation of decimal numbers

In Duval's framework, a given mathematical object has multiple representations depending on registers of semiotic representation (discursive, symbolic, iconic or material) that express specific properties of the object while never embodying the object. These registers open the possibility of two fundamental cognitive activities: the activity of treatment (a transformation inside a given register), the activity of conversion (mobilization from one register into another). Duval (1995, 2017) discusses the double designation of mathematical object inside registers, that is, representations of a mathematical object that may be associated and have different functionalities. Duval considers this process a fundamental part of mathematics. Using this approach, we have identified different registers of semiotic representation of decimal numbers. These registers may be used in various teaching situations, sometimes simultaneously: symbolic (fractional notation, in particular those of the type $\frac{1}{10}$, $\frac{1}{100}$, $\frac{1}{1000}$, decimal notation and the sums associated to these symbolic writings); discursive (where numeration units - tenths, hundredths, thousandths - and numeration-units-numbers are involved which can be verbalized or written); mixed (in notations of the form 1 unit + 3 tenths + 2 hundredths or in place value chart); iconic, figurative, or material (such as a square made of 100 tiles 25 of which are grey). These registers may be used both verbally and on paper. For instance, we can "verbalize"

symbolic decimal fractional notation as numeration units ($\frac{1}{10}$ as one tenth or $\frac{15}{10}$ as fifteen tenths). We grant particular importance to the representation register of numeration units. This discursive register of numeration units allows conversions between different types of numeration units (Chambris, 2015; Houdement & Tempier, 2015) or reunitizing strategies (Baturu, 2000) possible by grouping units such as “10 tenths gives 1 unit” or “10 hundredths gives 1 tenth” or partitioning units “partitioning 1 unit into ten equal parts gives 1 tenth” or “partitioning 1 tenth into ten equal parts gives 1 hundredth”. We will name these conversions unit-conversions to distinguish them with conversions in Duval’s meaning. These unit-conversions provide various justifications of comparison and computation with decimal and whole numbers while shining light on decimal and positional principles (Ross, 1989). We hypothesize that the register of representation related to numeration units has specificities with respect to decimal numbers that may provide potential levers or difficulties in teaching and learning.

Methodology

The research study takes place in a French primary school, with a voluntary group of 4 experienced and reflexive teachers involved in a collaborative research effort about the teaching of decimal numbers at primary school. A total of 50 decimal numbers lessons taught in 9 classes of grade 4 or 5 were recorded during 4 years. In this collaborative study, most of the time, teachers have been responsible for the design of tasks for students and researchers have been in charge of the analysis of the mathematical activities of both students and teachers. Even if this methodology differs from engineering design, we have used classical methodological tools such as confrontation between *a priori* analyses of tasks and *a posteriori* analysis of data collected (Artigue, 1992; Hodgson, Kuzniak, & Lagrange, 2016). According to our theoretical point of view we have focused on classroom episodes in which register of numeration units or numeration-units-numbers was specifically used. We focus on both the activity of treatment inside the register of numeration units and the activity of conversion from this register to others (Duval, 2017). Particular classroom episodes allow us to illustrate three types of phenomena related to the use of semiotic register of representation (summarized in the Table below). These episodes are also about different steps in the teaching decimal numbers and symbolic notations, related to the French curriculum.

episodes	tasks	phenomena	indicators
1 (grade 4)	place decimal fractions on number line	difficulties in invoking relations between a unit and its subdivisions	registers: fractional notations, numeration units unit-conversions
2 (grade 5)	compare decimal numbers	difficulties in coming back to the register of numeration units in order to justify comparison techniques	registers: decimal notations, numeration unit unit-conversions
3 (grade 4)	convert sums of decimal fractions (length measurements) to decimal notations.	potential for bringing together numeration units and measurement units	registers: decimal and fractional notations, numeration units, measurement units

Table 1: Tasks, phenomena and indicators used in the analysis process**First classroom episode: unit-conversions and decimal numbers**

According to the French curriculum, students of grade 4 begin to learn decimal numbers as decimal fractions. In this first episode, students have made a decimal number line marked in hundredths. Hundredths have already been introduced as follow: if we divide a unit into one hundred equal parts, one hundredth is one part of these parts. Similarly, tenths arise from partitioning one unit into ten equal parts. Students are able to place five hundredths, both used verbally (five hundredths) and on paper ($\frac{5}{100}$) on this number line. They should place “ $\frac{15}{10}$ – fifteen tenths” on the number line marked in hundredths. Such a mathematical task seems to be difficult for most students. In the transcript below, a student solves the problem on the board. An incorrect response is first proposed as students have mistaken hundredths for tenths (count 15 hundredths instead of 15 tenths).

Teacher: What can we try to plot?

Student: Fifteen tenths [*teacher writes $\frac{15}{10}$ on the whiteboard*].

Teacher: How did you do?

Student: We count on fifteen.

Teacher: You count on fifteen? [...] Ok, if I count on fifteen, you said, the number you stop at fifteen hundredths [*teacher writes $\frac{15}{100}$ on the blackboard*] But we want fifteen tenths. How do we do?

Then, students use unit-conversions, in grouping point of view (such as ten tenths is equivalent to one unit and a hundred of hundredths is equivalent to one unit): fifteen tenths are equivalent to one unit and five tenths. A student notices “it only needs five”, allowing students to focus on five tenths. A brief exchange between the teacher and students points out that five tenths is equivalent to fifty hundredths. Other students seem to be confused about this unit-conversion, both in symbolic register of fractional notation and verbal register of numeration units.

Student: Five tenths are equivalent to fifty hundredths. We add fifty hundredths and get fifteen tenths.

Teacher: OK [*she is writing $\frac{5}{10} = \frac{50}{100}$ on the whiteboard*] What do you think about it? Is that true?

Student: It is the same thing. Ten hundredths are equivalent to one tenth.

Teacher: Show me five tenths [...]

Teacher: Good to you. How many hundredths in one tenth? [...]

Teacher: OK. To make five tenths, we need fifty hundredths.

Students have difficulties with unit-conversions involved in this task. This task relies on understanding relationship between tenths and hundredths (ten hundredths is one tenth). Such a relationship relies on relationship between tenths and units (hundredths and units) built in *grouping way*, that is, not in the way (*partitioning way*) they have been introduced. In that way, decimal numbers differ from whole numbers in regard to numeration units. For whole numbers, numeration units are necessarily introduced in grouping way and partitioning way and grouping units for

reunitizing (Baturu, 2000) can be seen as more evident for students. For decimal numbers, as numeration units (tenths, hundredths...) are introduced in a *partitioning way*, it is necessary to teach explicitly the grouping of such numeration units in order to allow treatments as reunitizing or units-conversions inside this register. Students seem not to be able to (re)build it by themselves.

Second classroom episode: unit-conversion and comparison of decimal numbers

This second episode takes place in a class of grade 5: students have already been introduced to decimal notation and are used to work with it. In this episode (see the transcript and the Figure 1 below), students have to place decimal numbers in ascending order. Decimal numbers are represented in the semiotic register of symbolic writing, using decimal notation. The teacher tries to lead students to justify how they compare decimal numbers. More precisely, she asks a student why he added zeroes ending “1,9” to compare this number to “1,589”. Such a strategy of “similar writing” can be seen as treatment inside the symbolic register of decimal notations. It is possible to justify this treatment by a discourse about unit-conversion in the verbal register of numeration unit: “nine tenths” is converted to “nine thousandth” because “one tenth is the same as a hundred of thousandths”.

Student: So for example here [*E points the decimal notation 1,589 at the interactive whiteboard*] it is not because there are more digits that it is greater than one comma nine.



Figure 1: Compare decimal numbers

[...] because the tenths, it is what we are looking at first in order to know if it is less than. For example / Here we see [*Student points the digit “5” of the decimal notation “1,589”*] five tenths and here nine.

Teacher: How could you justify to someone who believes that five hundred eighty nine is greater than nine? Because five hundred eighty nine thousands is greater than...

Student: Nine is nine tenths.

Teacher: How could we see it? What could prove us it is the greater?

Student: We add two zeroes [*by drawing with his finger at interactive whiteboard*] if for nine we can put two zeroes / and then he will understand that nine is greater than one comma five hundred eighty nine [*Another student: Yes I agree*].

Teacher: And what is it useful for? Putting these zeroes as he did? For example?

Another student: To do the same... the same numbers at each side/ to make easier the//

During this episode, discursive register of numeration units seems to be used by a student to justify the comparison of “1,9” and “1,589” (nine tenths and five tenths). Nevertheless his mathematical explanation remains incomplete and related to place values. Then, the student is not able to justify why it is possible to put two ending “0” at the decimal notation “1,9” by using the unit-conversion from tenths to thousandths. After this classroom episode, most of the students have taken the action

of “adding zeroes” to decimal notations in order to achieve symbolic writings with similar numbers of digits. However, such a transformation of symbolic writings seems to be deprived of mathematical possible reasons. In order to specially focus on the use of unit-conversions, with the help of the researchers, the teacher designed a set of tasks, as follow. Such tasks make various symbolic and discursive semiotic registers appear:

Exercise 1: Compare 45 tenths and 440 thousandths

Exercise 2: Compare $2 + \frac{34}{100}$ and 2,034

Exercise 3: Compare 0,17 and 0,2

Exercise 4: Compare $3 + \frac{4}{10}$ and $4 - \frac{7}{10}$

Exercise 5: Compare $5 + \frac{37}{100}$ and $\frac{54}{10}$

First, most of the students convert given representations of numbers to decimal notations (converting 45 tenth to 4,5). The former session that was devoted to decimal notations and the fact that such tasks (with diverse representations of decimal numbers) may be unusual for French students highlight this point. Furthermore, some of treatments in symbolic register of decimal notations are invalid. For example, a group of students concludes that “ $2 + \frac{34}{100}$ ” is equal to “2,034” after adding a “0” in front of the “3” of “2,34”. This confirms students’ difficulties in treatments related to comparison of numbers, in symbolic register of decimal notation. It also seems difficult for students to formulate justifications in the register of numeration units even if the teacher or the researchers try to seek explanations about their strategy of comparison. The transcript and Figure 2 below (related to interactions between a researcher and a small group of students) illustrate it is not so easy for students to explain why they can add an ending “0” at the decimal notation “5,4” to compare this number to “5,37”. At the end, students manage to formulate the unit-conversion in register of numeration units, saying that four tenth is the same as forty hundredths but it is tough to lead them to this point.

Student 1: The greater would be that one [*by pointing 5,4 at the whiteboard*].

Student 2: Because here, you add a zero [*by adding a zero / writing 5,40 at the white board*].

Researcher: But what does it mean that zero that you are adding?

Student 1: Actually, it is the hundredths. It is zero thousandth here and seven hundredths here.

Student 2: It is to get the same number of digits in the decimal part.

Researcher: Wait, I look at the end [...] when I hide that [*the researcher hides the integer part and the comma*] what do you do when you are adding a zero?

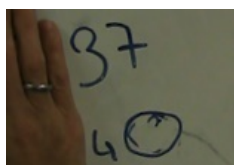


Figure 2: Hide the integer part and the comma

Student 1: Then it makes forty and thirty seven. Actually we can't add the thing [*by pointing the zero*].

Student 2: Yes you can as it doesn't add anything. No...

- Researcher: But why does it add nothing?
- Student 2: So it is zero. It is... ha [...] because it is as if it was zero hundredth more [...]
- Student 1: But it doesn't mean anything at all, zero hundredth more! [...]
- Researcher: You see. If I want to explain to a friend why I am allowed to add a zero.
- Student 1: The zero it does not add anything.
- Researcher: Yes but what can I say? The zero that adds nothing, you agree that it is not so, as you earlier explained it.
- Student 1: Yes! Because the four is the same as forty hundredths [Researcher: The four what?].
- Student 1: Four tenths is the same as forty hundredths [Researcher: And why?].
- Student 1: Because... ten hundredths, it makes one, one tenth.

Third classroom episode: numeration units and measurement units

This third episode takes place in grade 4: students have to build relations between decimal fractional notation and decimal notation. The teacher has introduced a mixed numeration place value and length measurements chart. The columns of this chart are fixed and related to numeration units (hundreds, tens, units, tenths and hundredths) and the units of length measurement (decimeters, centimeters and millimeters) move inside these columns. For example, the centimeters can be fixed in the unit column if a length measurement is given in centimeters or in the tenths columns if the measurement is given in decimeters. This mixed chart has already been used by students to convert given decimal notations of length measurements (as for example “18,2 cm”) to length measurements units values (as for example “1 dm – 8 cm – 2 mm”) and *vice versa*. During this classroom episode, students use the chart to convert sums of decimal fractions (corresponding to length measurements) to decimal notations. This trajectory is not so easy: under this innovative scenario, the conversion of fractional notations to decimal notations has not been taught before. First students convert “ $3 + \frac{5}{10}$ cm” to “3,5 cm”. The transcript and Figure 3 illustrate how the mixed chart numeration place value and length measurements is then used by students to convert the sum “ $1 + \frac{2}{10} + \frac{8}{100}$ dm” to “1,28 dm”.

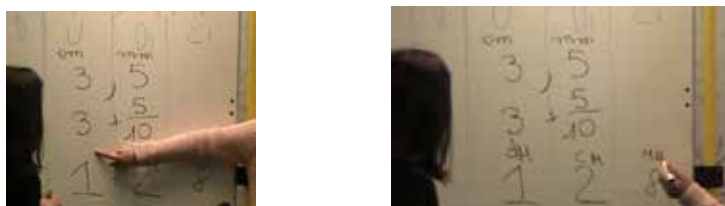


Figure 3: mixed numeration place value and length measurements chart

- Teacher: You can indicate here, measurement units, one is.
- Student: It is decimeters.
- Teacher: One is decimeters [Student is adding “DM” over the “1” in the column of units of the place value chart]. Two you told me. Two tenths of decimeters. It is [Student: Centimeters] Centimeters [Student is adding “CM” over the “2” in the column of tenths of the place value chart]. And hundredths remain.
- Student: Millimeters [Student is adding “MM” over the “8” in the column of hundredths of the place value chart].

Teacher: I agree. So we would have on centimeter, one decimeter, plus two tenths of decimeters, it is the same as two centimeters, plus eight hundredth of decimeters. OK and where is comma, yes, just after units [...] thus it would make one?

Student: One comma twenty eight [...] Centimeters.

Such an innovative scenario of decimal notations teaching reveals that the role of the comma “,” in symbolic registers of decimal notations as numbers or as length measurements may be different. In the case of measurement units, the comma of a decimal notation indicates the measurement unit that is the point of reference. This reference can change (being centimeters or decimeters, etc.). The mobile place of measurement units in the columns of the place value chart highlights this property. At the opposite, in the case of numbers and numeration the comma always refers to the “same” numeration unit, *the unit*. It is the positional mark of the place of *the unit* and then, of the other numeration units (as hundreds, tens, tenths, hundredths, etc.) in decimal notations. So if numeration and measurements units have similarities, they also have differences that it is important to consider.

Conclusion and discussion

Our work unravels the conditions under which results obtained regarding the register of numeration units on whole numbers (Chambris, 2015; Houdement & Tempier, 2015; Van de Walle, 2010) can be extended to decimal numbers. First, the semiotic register of numeration units is linked to the earlier introduction of decimal fractions defined as parts of a whole unit. However, unit-conversions in this register remain difficult. Such treatments inside this register rely on a deep conceptual understanding of relationship between unit, tenths, hundredths... To allow unit-conversions and reunitizing (Baturu, 2000), a more explicit teaching of grouping meaning is needed, especially in the case of reunitizing – these numeration units being built in a sharing meaning in French curriculum. Second, it seems difficult for students to associate the numeration units with the decimal notation. Once this symbolic representation has been introduced, it is commonly verbalized as a couple of integers. For example, the decimal notation “2,58” is mostly verbalized as “two comma fifty eight” and not “two units and fifty eight tenths” by students. Then, the support of the discursive register of numeration units is difficult to make appear in order to justify strategies of decimal numbers comparison. The verbalization of “writing gestures” related to transformations of decimal notations takes precedence in students’ discourse. Those “writing gestures” are also deprived of justifications and coming back to unit-conversions is not so easy. It seems to be important that discursive register remains in use and that they are not replaced by a verbalization of decimal notation with couples of integers. From this point of view, conversions between symbolic register of decimal notation and register of numeration units must be reinforced in technique justification (comparison, calculus...). Third, even if it is possible to think about closer ties between symbolic registers of decimal notations as numbers and as length measurements, we have to be careful with the asymmetric role played by comma for either, or both these two registers. New perspectives to bring measurements units and numeration units closer in the teaching of decimal numbers can be outlined: with the design of specific tasks particularly related to the use of an unusual numeration place value chart mixing the use of numeration units and the units of length measurement.

References

- Artigue, M. (1992). Didactical engineering. In R. Douady & A. Mercier (Eds.), *Recherches en Didactique des Mathématiques Selected papers* (pp. 41–70). Grenoble, France: La Pensée Sauvage.
- Baturo, A.R. (2000). Construction of a numeration model: A theoretical analysis. In J. Bana & A. Chapman (Eds.), *Mathematics education beyond 2000*. Proceedings of the 23rd Annual Conference of the Mathematics Education Research Group of Australia (pp. 95–103). Fremantle, WA: MERGA.
- Chambris, C. (2015). Mathematical foundations for place value throughout one century of teaching in France. In X. H. Sun, B. Kaur & J. Novotna (Eds.), *Conference proceedings of the ICMI study 23: Primary mathematics study on whole numbers* (pp. 52–59). Macau: University of Macau
- Durkin, K., & Rittle-Johnson, B. (2015). Diagnosing misconceptions: Revealing changing decimal fraction knowledge. *Learning and Instruction*, 37, 21–29.
- Duval, R. (1995). *Sémiosis et pensée humaine, registres sémiotiques et apprentissages intellectuels*. Berne, Switzerland: Peter Lang.
- Duval, R. (2017). *Understanding the Mathematical Way of Thinking – The Registers of Semiotic Representations*. New York, NY: Springer.
- Hodgson, B.R., Kuzniak, A., & Lagrange, J.B. (2016). Introduction: Perspectives on Didactics of Mathematics through Michèle Artigue’s Contributions. In B. R. Hodgson, A. Kuzniak & J. B. Lagrange (Eds.), *The Didactics of Mathematics: Approaches and Issues*. New York, NY: Springer.
- Houdement, C., & Tempier, F. (2015). Teaching numeration units: Why, how and limits. In X. H. Sun, B. Kaur & J. Novotna (Eds.), *Conference proceedings of ICMI study 23: Primary mathematics study on whole numbers* (pp. 99–106). Macau: University of Macau.
- Ross, S.H. (1989). Parts, wholes, and place value: A developmental view. *The Arithmetic Teacher*, 36(6), 47–51.
- Van de Walle, J.A. (2010). Elementary and middle school mathematics: *Teaching developmentally*. (7th Ed.). Boston, MA: Pearson Education.
- Steinle, V., & Stacey, K. (2003). Grade-related trends in the prevalence and persistence of decimal misconceptions. In N.A Pateman, B. J. Dougherty & J. Zilliox (Eds.), *Proceedings of the 27th Conference of the International Group of the Psychology of Mathematics*. (Vol. 4 , pp. 259–266). Honolulu: PME.

The offer of tasks to work on multiplication in grades 2 and 3

Sandra Gleißberg¹ and Klaus-Peter Eichler²

¹PH Schwäbisch Gmünd, Germany; sandra.gleissberg@ph-gmuend.de

²NORD University Bodø, Norway; klaus-peter.eichler@nord.no

In this paper, we present an analysis of four teaching materials of grades 2 and 3, which are widely used in Germany. We analyzed the tasks in these textbooks and workbooks with a focus on developing and consolidating the operational understanding of multiplication. For this purpose, we present a framework developed by us. Its foundations are the levels of representation according to Bruner and the fact that mathematical terms are concepts. The analysis shows a homogeneous picture across all four textbooks and workbooks: Already in class 2, the vast majority of tasks require working on the non-verbal–symbolic level alone. Only a small part of the tasks promotes connections to the iconic, to the enactive or to the verbal-symbolic level and challenges students to intermodal translations from one level of representation to another. In grade 3, compared to grade 2, an even larger proportion of tasks are limited to the non-verbal–symbolic level.

Keywords: Elementary school mathematics, multiplication, textbook analysis.

Context of the study.

Multiplication is a core content of teaching mathematics in primary school. The learning objectives in regard to multiplication are that students firstly should acquire a conceptual understanding of the operation multiplication, secondly, should be able to solve any task using different strategies and finally they should be able to retrieve more and more basic multiplication facts directly from memory (e.g., Kling & Bay-Williams, 2015; CCSSI, 2010 p. 23; KMK, 2004, p. 9).

There seems to be an international consensus nowadays that students should both acquire a sound conceptual understanding of multiplication and eventually solve all basic tasks accurately and effortlessly (Gaidoschik, 2017, p. 2).

However, three problems can very often be observed up to the secondary school level. *First*, there are deficits in the mastery of the basic facts¹, i.e. in their retrieval as fact knowledge. Often students have forgotten basic multiplication facts they have once memorized and are unable to reconstruct this knowledge. This can be seen, for example, if they are unable to reduce fractions in secondary school because they cannot identify common factors.

Second, while students are often able to reproduce the basic task equations from memory, they are unable to solve multiplication tasks with a factor greater than 10.

Third, we repeatedly observe difficulties with the conceptual understanding of multiplication: students know that $5 \times 4 = 20$, but they are unable to justify this because they do not know the meaning of this term. Often, they just argue that 5×4 is a shortened notation for the addition task $4 + 4 + 4 + 4 + 4$.

¹ Basic fact means in this paper an equation of multiplication in which both factors are less than 10 or equal 10.

All three problems have the same reason: A lack of the conceptual understanding of multiplication. In light of these observations, it is necessary to investigate the causes and to provide information to improve the teaching and its results. We are sure that no teacher works with the intention of bad results. There are obviously factors with a negative influence on teaching and its results. Such a factor is, for example, practicing with spontaneously chosen tasks, in which subjectively important, especially familiar or widespread tasks dominate, and the exercise then does not meet the need. In our opinion, teachers are obviously not aware of the negative influence of such factors.

Undoubtedly, the success of teaching depends on the selection of tasks and the way teachers work with them (cf. Fanghänel, 2000). One essential source of such tasks is the teaching material². Therefore, the impact of teaching materials such as textbooks and workbooks is given. That is why we investigated four teaching materials of grades 2 and 3 which are widely used in Germany. The objective of our analysis is the suitability of the tasks contained in the materials in regard to promote understanding of the operation multiplication.

About the matter: Understanding multiplication.

Terms like 3×4 or 6×8 are non-verbal-symbolic representations of *concepts*. They are mental reflections of objective reality and describe classes of situations. In this sense, the product $m \times n$ can be represented both by the union of m equal and pairwise disjunctive sets with the cardinality n or by a combinatorial representation:

Def.: If $a, b \in \mathbb{N}$ and $a = |A|$, $b = |B|$, then is $a \times b = |A \times B|$ the product of a and b ³.

Def.: If $a, b \in \mathbb{N}$ and $|B_1| = |B_2| = |B_3| = \dots = |B_a| = b$ and $\forall i, k$ mit $i \neq k: B_i \cap B_k = \emptyset$, then is $a \times b = |B_1 \cup B_2 \cup B_3 \cup \dots \cup B_a|$ the product of a and b .

Both possibilities of representation can be spatial-simultaneous as well as temporal-successive.

This is consistent with the findings of Anghileri and Johnson (1992). They identify six key aspects of multiplication (and division): equal grouping, allocation/rate, number line, array, scale factor, Cartesian product. Regarding the so-called "axiomatic" definition of multiplication as a repeated addition, Park and Nunes (2001, p. 771) emphasize "that the origin of children's understanding of multiplicative relations is in their schema of one-to-many correspondence." and that the „repeated addition is only a procedure for solving multiplication problems, not its conceptual basis" (ibid.).

Content-related understanding of a concept means to be able to identify, realize and systematize it. When identifying a term like 3×4 , an appropriate example is found in an enactive, an iconic, or a verbal-symbolic representation. Realizing a term such as 3×4 means to create an enactive representation (e.g., an action), an iconic representation (e.g., a picture) or a verbal-symbolic representation (e.g., a suitable story, a word problem), which is consistent with this term. This is illustrated in Figure 1. When students systemize terms, they find relationships between two terms.

² The terms "teaching material" and "program" mean in this paper the unity of textbook and workbook.

³ $|M|$ means the cardinality of the set M .

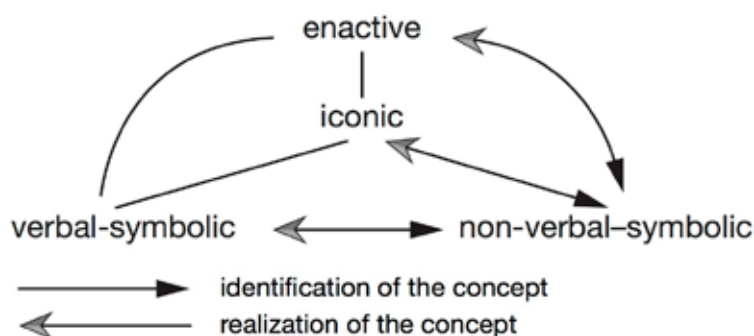


Figure 1: Levels of representation according Bruner (1964)

This can be referenced with an enactive or an iconic representation. Often this relationship is created without any references only on the non-verbal-symbolic level.

The importance of the conceptual understanding of the operation multiplication consists on the one hand in the fact that students can apply this knowledge to describe reality,

e.g., to solve word problems. On the other hand, it enables students to solve every multiplication task, especially those with factors greater than 10, by drawing e.g., dots and skip counting, laying e.g., cubes and skip counting and deriving answers using reasoning strategies based on known facts. (Baroody, 2006, Kling & Bay-Williams, 2015).

Mastery of the basic facts of multiplication must be distinguished from fluently multiplying: Fluently multiplying means to solve tasks using strategies, properties of the operation, means determine the value of a term by calculating at skill level (Kling & Bay-Williams, 2015, p. 550). Mastery of all the basic tasks of multiplication means to be able to retrieve from memory all products of two one-digit numbers. In our opinion, mastery is indispensable at the latest in middle of grade 3 because then this knowledge is needed as a tool for solving tasks with factors greater than 10.

Even if the final goal here is to retrieve the facts from memory, the ability to solve the basic tasks of multiplication is the basis for this and must consequently be secured before memorizing the basic tasks of multiplication. Only if students have a conceptual understanding of the operation multiplication and are able to determine the value of the terms, they can reconstruct forgotten basic facts. The reconstruction of forgotten facts can be done by using connections to other facts, e.g., by using properties of multiplication, by activities with manipulatives or by using mental representations.

Framework for the classification of tasks for the consolidation of arithmetic operations.

Because a suitable work with tasks in the sense of Fanghänel (cf. 2000) is essential for the quality of teaching and its results, we examined this work with tasks and the selection of tasks in more detail. The choice of tasks undoubtedly depends on the range of tasks offered by published programs (textbooks, workbooks etc.). To assess this offer of tasks, we analyzed four widely used programs⁴. We decided to analyse textbooks and workbooks for both grade 2 and grade 3 because teachers

⁴ There were the programs „Fredo Mathematik“ and Super M (both Cornelsen Schulbuchverlag) as well as „Denken und Rechnen“ and „Welt der Zahl“ (both Bildungshaus Schulbuchverlage).

usually use these materials anyway. Supplementary materials such as software or online resources were therefore not analyzed.

Many frameworks exist for analyzing textbooks regarding different aspects. A short overview gives for example O’Keeffe (2013). A specific framework which focusses the appropriation of arithmetic operations and takes in consideration that terms like 3×4 are concepts was not available until now. We developed the following framework to classify tasks for the appropriation of multiplication. It is generally usable for all arithmetic operations. This framework is not limited to analyzing printed materials. It can also be used to analyze educational software etc. The understanding of the operation multiplication must be promoted. Therefore, we were looking for tasks which emphasize the identification, realization, and systematization of concepts, e.g., of terms. In grades 2 and 3, mastering the basic number sentences by memory should be supported. Finally, we determined the number of tasks which aim to determine the value of the term. So, we classified the tasks in the programs as follows:

ICE: Tasks for the **I**dentification of the **C**oncept starting from the **E**nactive level of representation. These are tasks such as ‘Place five times three cubes and write a matching task.’ (The word ‘task’ here means a term in the mathematical sense of the word.)

ICI: Tasks for the **I**dentification of the **C**oncept starting from the **I**conic level of representation. In these tasks, a picture is given and the students should give a task that matches the picture. (The word ‘task’ here means a term in the mathematical sense of the word.)

ICV: Tasks for the **I**dentification of the **C**oncept starting from the **V**erbal–symbolic level of representation. These are tasks such as ‘Three rows of five knights each come out of the castle. Write a suitable task’ or ‘Clown August has five trousers and three jackets. How many different possibilities does he have to be dressed?’

RCE: Tasks for the **R**ealization of **C**oncepts to the **E**nactive level of representation. These are tasks such as ‘Lay with cubes matching 4×3 ’.

RCI: Tasks for the **R**ealization of **C**oncepts to the **I**conic representation level. These are tasks such as ‘Draw a picture matching 4×3 ’.

RCV: Tasks for the **R**ealization of **C**oncepts to the **V**erbal–symbolic level of representation. These are tasks like ‘Write a story matching 4×3 .’

SCE: Tasks for **S**ystematizing **C**oncepts with reference to the **E**nactive representation level. These are tasks such as ‘How do you go from 5×4 to 6×4 ? Lay with cubes and explain’.

SCI: Tasks for **S**ystematizing **C**oncepts with reference to the **I**conic representation level. These are tasks such as ‘How do you go from 5×4 to 6×4 ? Draw and explain’.

SCW: Tasks for **S**ystematizing **C**oncepts **W**ithout reference to the enactive or to the iconic level of representation. Such tasks are, for example, ‘You know 10×8 . How can you then calculate 9×8 ?’ Tasks like those shown below are also tasks for systematization without a reference to the enactive or to the iconic level of representation:

1	0	×	7	=			5	×	8	=			2	×	3	=			5	×	7	=		
	1	×	7	=			2	×	8	=			4	×	3	=			7	×	5	=		
	9	×	7	=			7	×	8	=			8	×	3	=								

VT: All tasks where the **Value** of a **Term** must be determined without any reference.

Our framework offers the possibility to validly classify all tasks in teaching materials, as we implemented all possible forms of representation as well as all steps of the process of learning concepts, as described above.

We are well aware that the determination of term values is indispensable in math lessons. Similarly, it is essential to establish relations between equations without always referring them in enactive or iconic mode. Mastering both requirements - determining the value of a term and establishing the connection between two terms - at skill level is crucial for successful work in the next grades. We use the term skill level as described in the IDMT assessment framework (cf. Brendefur et al., 2016, pp. 177). Nevertheless, these skills can only be used meaningfully if students can represent non-verbal-symbolic expressions at the enactive or the iconic level. The present study, therefore, focuses on those tasks that challenge students to an intermodal translation between the levels of representation.

Findings.

The findings of our analysis are presented in more detail in table 1 below:

		program 1		program 2		program 3		program 4	
		grade 2	grade 3	grade 2	grade 3	grade 2	grade 3	grade 2	grade 3
tasks		1368	368	1421	585	1147	430	1499	731
1	ICE	57	0	0	0	21	3	9	4
2	ICI	175	21	164	0	104	3	175	8
3	ICV	31	3	35	30	94	10	51	12
4	RCE	5	0	0	0	16	10	6	0
5	RCI	62	3	181	0	20	0	54	0
6	RCV	0	0	0	0	7	1	3	10
7	SCE	0	0	0	0	0	0	0	0
8	SCI	0	0	0	0	3	0	0	0
sum (1-8)		330	27	380	30	265	27	298	34
ratio		24.1%	7.3%	26.7%	5.1%	23.1%	6.3%	19.9%	4.7%
9	SCW	279	66	82	58	212	57	318	128
10	VT	759	275	959	497	670	346	883	569
(9) + (10)		1038	341	1041	555	882	403	1201	697
ratio		75.9%	92.7%	73.3%	94.9%	76.9%	93.7%	80.1%	95.3%

Table 1: Tasks of multiplication offered in four different programs (textbooks and workbooks)

Table 1 shows the results of our analysis. It shows that the offer of tasks across all four analyzed programs is approximately equal, one-sided and qualitatively unsatisfactory.

Findings of our analysis of second grade programs.

The result of our analysis shows that tasks requiring translations between the levels of representation are significantly under-represented in all four programs. The only tasks to be found are those in which the students are challenged to draw a matching picture for a given term (RCI). Not every program

contains tasks that require the students to lay or build something with material suitable to a given term (RCE). In three of the programs, there are 5, 16, and 6 tasks. The total number of these tasks is far too small.

Tasks that challenge students to represent a term verbal-symbolically (RCV) are extremely rare. Only two of the programs offer such tasks at all and this only seven respectively three times. This finding explains the well-known shortcomings of the students in solving word problems.

The four programs contained 0, 0, 3, 0 tasks for systematization with reference at the iconic level. Not one of the four programs meets our expectations. The systematization of the basic number sentences on a purely non-verbal-symbolic level plays a major role in all four programs: 279, 82, 212 and 318 tasks are represented here. The tasks of systematization on a purely non-verbal-symbolic level are wrapped in different manners. According to the mathematical core, they are tasks like the ones shown below.

$$3 \times 8 = 24 \triangleright 6 \times 8 = 48 \text{ (doubling),}$$

$$5 \times 8 + 1 \times 8 = 6 \times 8 \text{ or } 10 \times 7 - 1 \times 7 = 9 \times 7 \text{ (so-called neighbourhood tasks),}$$

$$5 \times 8 = 8 \times 5 \text{ (so-called commutativity tasks).}$$

Such tasks are undoubtedly essential and indispensable. In solving these tasks, however, the students do not have to think about the meaning of the operation. They can undoubtedly use these tasks to acquire networked knowledge, the meaning of which they do not necessarily have to grasp: New equations are developed from equations. For quite a few students, this is exactly the picture of mathematics lessons: lessons in which new strings are created from existing strings. Hence it is not surprising that some students consider multiplication as a trick of mathematicians to shorten long equations of addition.

Findings of our analysis of third grade programs.

First of all, it is apparent that the range of tasks offered for multiplication in third grade is considerably less than in second grade: In total there are 368, 585, 430, and 731 tasks for multiplication. This is not even half of the amount that is offered in second grade. The rate of tasks that promote the understanding of the content of the operation by establishing references to the enactive, iconic or verbal-symbolic level drops markedly: the four programs contain only 27 (7.3%), 30 (5.1%), 27 (6.3%) and 34 (4.7%) of such tasks. Tasks that support an active construction of meaning are thus almost completely missing.

The emphasis is on the determination of term values. With regard to networked memorization, it should be noted that, as in second grade, the systematization of equations is always carried out only at the non-verbal-symbolic level. Tasks that promote the development of memorizing techniques, thematize such techniques, etc. are in fact not included: In all four programs there are altogether only 4 (!) such tasks.

Discussion.

The operation multiplication is acquired in grade 2. Here, the focus is first of all on the conceptual understanding of multiplication. This is usually developed on the basis of contexts. Therefore, it is to be expected that the programs of this grade will offer a qualitatively and quantitatively wide range of

tasks with reference to the enactive or iconic level, to ensure the understanding of the meaning of the operation. We expected, that also the grade 3 programs would contain a variety of tasks to systematize and to consolidate the meaning of the operation. We hoped to find a lot of tasks for identification, realization or systematization with reference to the enactive or iconic level.

Accordingly, there are – as expected – in grade 2 many tasks in all the programs in which students have to *identify* a suitable term, particularly to pictures and – more rarely – to actions.

Because the cognitive process that takes place in mathematics lessons only finds a preliminary, relative completion when applying the acquired knowledge, we expected to see many tasks in which the students have to *realize* the term. We expected that students would be challenged to draw a picture that represents a term, to represent the term using manipulatives or to tell a story fitting the term. The evaluation of the four programs in grade 2 shows that in the programs are only 67 (5%), 181 (12%), 43 (4%), and 63(4%) such tasks and that the tasks are mostly from the type ICI.

The range of tasks that support a conceptual understanding is insufficient in both grades, while the dominance of tasks which aim determining the value of a term is remarkable. It starts in second grade and dominates in third grade. In each of the investigated programs, the teacher must use additional tasks that she/he chooses from other sources or that she/he independently develops.

Right from the development of the first basic facts onwards, it makes sense to network these and build up connected, systematic knowledge. Therefore, we expected already in second grade many tasks that promote the systematization of the basic number sentences with reference to images (iconic level - SCE) or actions (enactive level - SCI). The analysis of the programs shows that such systematization, in fact, did not take place. Not one of the four programs contained a task with a suggestion for systematization with an enactive reference.

If the teacher does not supplement the range of tasks offered by the programs, the students have too little opportunity to grasp the meaning of multiplication and to consolidate this knowledge.

The analysis of the grade 3 programs shows that if a child in grade 2 has not understood the meaning of the operation multiplication, the materials in grade 3 hardly offer any chance for building up this understanding.

Based on our findings we cannot draw conclusions regarding classroom practice. But, we can assume that the examined materials are a basis for learning multiplication in math classrooms. The teacher always can compensate deficits of the materials. Therefore, further research is needed, especially the teachers' choice of tasks has to be analyzed.

References

- Anghileri, J., & Johnson, D. C. (1992). Arithmetic operations on whole numbers: multiplication and division. In T. R. Post (Ed.), *Teaching mathematics in grades K-8: Research based methods* (2nd edition) (pp. 157-200). Boston, MA: Allyn and Bacon.
- Baroody, A. (2006). Why children have difficulties mastering the basic number combinations and how to help them. *Teaching Children Mathematics*, 13(1), 22-31. Retrieved from <http://www.jstor.org/stable/41198838>

- Bönig, D. (1995). Multiplikation und Division. Empirische Untersuchungen zum Operationsverständnis bei Grundschulern. Münster, Germany: Waxmann.
- Brendefur, J. L., Strother, S., Rich, K., & Appleton, S. (2016). Assessing Student Understanding: A Framework for Testing and Teaching. *Teaching Children Mathematics*, 23(3), 174-181. doi:10.5951/teacchilmath.23.3.0174
- Bruner, J. S. (1964). The course of cognitive growth. *American Psychologist*, 19(1), 1-15.
- CCSSI Common Core State Standards Initiative (2010). *Common Core State Standards for mathematics*. Retrieved from www.nctm.org/uploadedFiles/Standards_and_Positions/Common_Core_State_Standards/Math_Standards.pdf
- Fanghänel, G. (2000). Arbeiten mit Aufgaben – ein wesentliches Mittel zur Gestaltung eines modernen Mathematikunterrichts. *Mathematikunterricht gestalten* (pp. 23–40). Berlin: Paetec.
- Gaidoschik, M., Deweis, K.M., & Guggenbichler, S. (2017). Do lower-achieving children profit from derived facts-based teaching of basic multiplication? Findings from a design research study. In *Congress of the European Society for Research in Mathematics Education (CERME 10) Conference Proceedings*, Feb 2017, Dublin, Ireland. hal-01873475
- Gleißberg, S. (2018). Man muss es ja doch auswendig wissen – die Behandlung der Multiplikation zwischen Anspruch und Wirklichkeit. *Beiträge zum Mathematikunterricht 2018* (pp. xx–xx) Münster, Germany: WTM.
- Kling, G., & Bay-Williams, J. (2015). Three Steps to Mastering Multiplication Facts. *Teaching children mathematics*, 21(9), 548-558.
- Kultusministerkonferenz (2005). Bildungsstandards im Fach Mathematik für den Primarbereich (Jahrgangsstufe 4). Retrieved from http://www.kmk.org/fileadmin/veroeffentlichungen_beschluesse/2004/2004_10_15-Bildungsstandards-Mathe-Primar.pdf
- Mulligan, J. (1992). Children's solutions to multiplication and division word problems: a longitudinal study. *Mathematics Education Research Journal*, 4(1), 24–41.
- O’Keeffe, L. (2013). A framework for textbook analysis. *International Review of Contemporary Learning Research*, 2(1), 1–13. doi:10.12785/irclr/020101
- Park, J.-H., & Nunes, T. (2001). The development of the concept of multiplication. *Cognitive Development*, 16(3), 763-773. doi:10.1016/S0885-2014(01)00058-2
- Siegler, R. S. (1988). Strategy choice procedures and the development of multiplication skill. *Journal of Experimental Psychology*, 117(3), 258–275.

Considerations on developmental stage models, learning trajectories and maybe better ways to guide early arithmetic instruction

Michael Gaidoschik

Free University of Bozen – Bolzano, Italy, michael.gaidoschik@unibz.it

Current learning trajectories and stage models of arithmetic development advocate the elaboration of counting on as an intermediate computation strategy. At the same time, there is empirical evidence that a considerable share of children fail to overcome this procedural approach to addition and subtraction, with damaging effects to their further mathematical thinking. This theoretical essay argues that it is fundamentally faulty to justify instructional measures by stage models that claim to capture a development without considering that its stages themselves reflect the conditions of children's learning, inter alia: the very instructional measures. As an alternative, the paper uses structure-genetic didactical analysis to delineate a teaching design that derives addition and subtraction out of part-whole thinking from the very beginning, rendering counting on superfluous.

Keywords: Early arithmetic instruction, counting on, computation without counting, part-whole thinking, derived facts strategies.

Preliminary remarks

In this paper, “early arithmetic instruction” refers to contents and aims that are constitutive for first grade primary school in *German* speaking countries. Thus, I write about 6–7-year-old children who, as a rule, have attended kindergarten before; but to what extent and in which ways they have already received targeted *mathematic* education, will differ considerably – within and between German speaking countries – due to different educational plans and levels of specific competences of kindergarten staff. To enable colleagues from other nations to compare with their respective educational systems, I shortly outline just three important areas of goals for first grade arithmetic instruction that (besides others) seem to be widely accepted in the pertinent German literature (cf. Gaidoschik, 2010, pp. 207–232, for details):

First, building upon the rather heterogeneous competences they have thereto already acquired, children should (further) develop and consolidate their knowledge about natural numbers. This starts from being able to count forward and backward fluently and to establish quantities by counting, and should reach the comprehension of numbers as being composed of other numbers at least up to 10, if not 20 (*part-whole concept of numbers*, cf., e.g., Schipper, Ebeling, & Dröge, 2015).

Second, and connected with the former, children should understand addition and subtraction as two arithmetic operations inverse to each other, and learn how to add and subtract *fluently* within the number range up to 20. More precisely: up to 20, they should learn how to *compute without counting* already within year one (cf., e.g., Schipper et al., 2015; Häsel-Weide & Nührenbörger, 2013).

Third, together with all this, they should (further) develop a positive attitude towards mathematics as a worthwhile activity for which it is constitutive to deal with problems which include detecting, exploring, carrying forward, communicating and arguing about patterns and structures, not only but also in the field of natural numbers (cf., e.g., Krauthausen, 2018).

As far as my knowledge of *international* mathematics education reaches, these goals are widely accepted in other nations as well, even if institutional frameworks and time expectations may be quite different. Therefore, for some nations, the following considerations might count for children slightly younger or older than those who attend first grade in German speaking countries; but they should count for them at *some time* of their educational career, if they are of any relevance at all.

Some critical notes on current stage models and learning trajectories

Shortcomings of “developmental stage models” that disregard instructional influences

Within the German speaking literature, in the last decade two competing, quite similar stage models of arithmetic development have been widely noted, both developed by psychologists (Krajewski & Schneider, 2009; Fritz & Ricken, 2008). Fritz, Ehlert and Leutner (2018) recently claimed to have validated the latter by longitudinally testing children between 9 months before and 8 months after school-entry. Now this is not the place to discuss these models in detail (see Gaidoschik, 2010, for a critique on a former version of Fritz & Ricken, 2008). This paper is about the question whether and in what way stage models *of that kind* can be helpful for mathematics educators and pedagogues in supporting children to learn arithmetic. In this vein, I outline in the following the construction of Fritz and Ricken (2008) as a paradigmatic example of a certain approach to mathematical learning.

The model in question encompasses six “levels” that its authors do not want to be interpreted as following strictly distinctly one after the other, but rather in the sense of “overlapping waves”, a metaphor also used by Siegler for his models of strategy development (cf. Siegler & Alibali, 2005). According to Fritz et al. (2018), children, on Level 1, would learn how to establish quantities precisely by counting within a certain number range. On that same level, they would be able to subitize small quantities. Only on Level 2 would children relate numbers to each other by ordering them on a “mental number line”. Building upon this, they now would be able to solve additions and subtractions by “counting all”. “Counting on”, however, would be characteristic for Level 3. Fritz et al. (2018, p. 15) state that only on that stage children would grasp cardinality and the irrelevance of order principle. Cardinal understanding would include knowing that numbers can be composed of and decomposed into other numbers. On Level 3, however, this understanding would be restricted to situations where children use manipulatives, whereas on Level 4 they would “transfer” this concept on a “symbolic-algebraic level” (Fritz et al., 2018, p. 16). However, this would not encompass the understanding of “relationality”. Only on Level 5, children would use numbers to state precisely the difference between two numbers. This, together with Level 6 (bundling and unbundling), would form an indispensable precondition for understanding multiplication, division, and place value (Fritz et al., 2018, p. 17).

Fritz et al. finish their publication with “didactic implications” that remain on a rather general level, yet demand that school instruction should follow the “hierarchy of arithmetic concepts” as described by the model. As children would go through that hierarchy at different pace, this would include the need of differentiating within a class (Fritz et al., 2018, pp. 35–37).

The mathematics education community will certainly acknowledge the latter. However, before taking a closer look at how to *apply* such a model, let us reflect upon its *epistemological status*. What does it really tell us about children’s *thinking*? Fritz et al. (2018) claim to capture a *development* within a certain time span. They describe single stages referring to children’s *performance* in certain tasks,

and interpret what children might be able or not to *conceptualize* on that level. From the mathematics education point of view, at least some of their interpretations lack clearness and coherence. For instance, the model is rather vague about what might distinguish the number *concept* of a child on Level 3 from that on Level 4, as well as on Level 4 and 5. It seems to be that the authors are more interested in differentiating levels of *test performance* than really of arithmetical *concepts*.

What is more fundamental is the model's lack of consideration of the fact that children develop their ideas while constantly dealing with inputs coming from adults as well as from other children. As for counting on, which constitutes Level 3 of the model in question: There is ample evidence that in many countries pedagogues in kindergarten and primary school, and presumably parents as well, encourage children and in fact *show them how* to solve addition problems by counting on instead of counting all (cf. Gaidoschik, 2019). They certainly do so because they think this to be conducive. I will gather some evidence that casts doubt on this assumption in the following paragraph. What has to be stated at this point, is a fundamental *theoretical shortcoming* of any model of learning development that disregards the possibility that what the model claims to be “normal” or even “necessary” within the presumed “nature of children” might rather be the consequence of circumstances that are man-made.

Counting on: A “natural” stage that still needs to be pushed by learning trajectories?

There is a *logical inconsistency* in this shortcoming that becomes even more apparent in the case of “The Learning Trajectories Approach” (Clements & Sarama, 2009) or stage models that are directly formulated to *guide* teacher's actions, such as the “Mathematics programme of study” (UK Department of Education, 2013) or the “Number framework” (New Zealand Ministry of Education, NZME, 2008, 2012). All three guidelines stress that *eventually* children should learn to add and subtract fluently without counting. The “Number framework” is especially clear in that point:

It is important for you to recognise that part-whole thinking is seen as fundamentally more complex and useful than counting strategies. One reason is that counting methods are strictly limited, whereas part-whole methods are more powerful. Counting strategies are an inadequate foundation for these ideas, and this means that for counters, many advanced number ideas are inaccessible. Therefore, your major objective is to assist students to understand and use part-whole thinking as soon as possible. (NZME, 2008, p. 7)

Nevertheless, all three guidelines recommend that teachers *actively work out* counting on as a short-cut strategy for addition, and analogue counting strategies for subtraction with their classes. Thus, if a teacher who follows the “Number framework” notices a child to add by counting all using materials (Stage 2), s/he should work with that child so that it first reaches Stage 3 (“Counting from One by Imaging”) and then Stage 4 (“Advanced Counting”). For that purpose, the teacher should orchestrate activities so that children learn to put “the bigger number first” and count on when confronted with an addition problem (NZME, 2012, p. 36). Only after having reached that stage, the teacher should guide children further to Stage 5 where they should “develop the idea” that “addition and subtraction problems can be solved by part-whole strategies instead of counting” (NZME, 2012, p. 37).

I did not find an explicit justification for this recommendation in the pertinent publications I reviewed, but it seems to be that the authors deem it *indispensable* to intentionally *guide children from one stage to the next* and *not skip a single of these stages* as defined by the underlying stage model.

Thus, these models extract stages of “development” from the evidence that many children progress from *counting all over counting on* to finally computing without counting. Nota bene: *Many* children progress in that way; yet, a considerable number stick to counting strategies in higher grades (Cowan et al., 2011; Hopkins & Bayliss, 2017), and doing so forms an essential part of learning difficulties (Gaidoschik, 2019). Then, there is evidence that the share of children who finally quit counting on strongly relates to instruction. In nations with a tradition of *not* encouraging children to count on, but rather use derived facts strategies already at an early stage, this share seems to be much higher (Geary, Bow-Thomas, Fan, & Siegler, 1996). Intervention and field studies indicate that putting the focus of early instruction on derived facts strategies *instead of* counting on, will reduce the number of children who cling to counting for computing (e.g., Steinberg, 1985; Gaidoschik, Fellmann, Guggenbichler, & Thomas, 2017). Notwithstanding all this, the cited models postulate a *quasi-natural* progression:

“Children follow natural development progressions in learning and development. As a simple example, they learn to crawl, then walk, then run [...] They follow natural developmental progressions in learning math, too [...]” (Clements & Sarama, 2009, p. 2)

Thus, on the one hand, the authors regard counting on as part of a “natural development”. On the other hand, they take their model as a justification to *instruct* children how to count on. However, doing so is a didactic decision, and by no way “natural” nor necessary, as I will argue in the following. Presumably, the authors would deny intervening in this way in a supposedly inevitable process to be logically inconsistent and put forward their endeavor to “promote children’s growth” (Clements & Sarama, 2009, p. 5), so that what is “natural” may move forward without avoidable impediments. Yet, as stated above, research indicates that in fact it may *impede* children when teachers quite *artificially* guide them to count on for addition and subtraction problems (Gaidoschik, 2019).

An alternative approach: Structure-genetic didactical analysis

Whereas learning trajectories and stage models suggest teachers stick to what is supposedly inherent in the “nature” of *children*, Wittmann’s (2015) “structure-genetic didactical analysis” advises instruction to follow the “nature of *mathematics*”. Of course, Wittmann not at all advocates disregarding what empirical research indicates about the ways children learn mathematics, the difficulties they meet, and the misunderstandings that may arise based on their “prerequisite knowledge” as well as on what happens in the classroom. He explicitly rejects the “broadcast” method of transmitting knowledge from the teacher to the student” that he ascribes to “the traditional ‘subject matter mathematics’” dominant in German mathematics education for a long time (Wittmann, 2015, p. 17). Therefore, his idea is *not* that we would only need to unfold the logic of any subject matter to children in order to secure they grasp it step by step. Still he insists that what a subject matter “is about and how it should be introduced in the classroom, cannot be decided by means of empirical methods imported from psychology, but should be based on a sound mathematical and epistemological analysis” (Wittmann, 2015, p. 7).

In the following, I will try to delineate in brief what, in my understanding, such an analysis would imply for the subject matter in focus of this paper, i.e. the introduction of addition and subtraction. In doing so, I take into account the pertinent empirical research, but without considering immutable what might rather be consequence of a certain type of instruction that we could at least try to change.

Deriving addition and subtraction out of part-whole thinking: A sketch

“Emerging from the [mathematical] subject” (Wittmann, 2015, p. 6), addition and subtraction are inverse operations, with the laws of commutativity and associativity being central for addition. Applying these laws allows for powerful computation strategies. Subject matter analysis as well as empirical evidence indicate that in order to grasp these concepts, it is crucial to think numbers as composed of numbers. Young children encounter numbers in many ways, but counting is dominant in the first years. For a child who uses numbers primarily to *count* quantities, *numerical* part-whole relations are not at all obvious; rather, the child might take any number as a single entity, so that e.g. six is conceptualized as being *before* seven, rather than being a *part* of it (cf. Gaidoschik, 2010).

Therefore, if early arithmetic instruction strives to help children acquire a solid fundament of addition and subtraction, it seems sensible *first* to focus on activities that foster *part-whole understanding* of numbers. *Only on that basis*, we can and should convey *addition and subtraction* as two ways of operating with parts and wholes that supplement each other. Following that order, which is of course not dictated by stage models, but advocated by subject matter analysis, we have a good chance to render computation by counting *superfluous from the very beginning* (Gaidoschik, 2019).

In more detail: In order to be able to explore and internalize part-whole relations, when quantities exceed subitizing (see below), a child needs to know how to determine the number of the quantity by counting. Therefore, one main-topic (A) of early arithmetic activities certainly should be *counting* as a means to establish precisely *how many of whatever* you have. This includes the targeted working out of the “counting principles” described by Gelman and Gallistel (1978). Any first-year classroom or group of kindergarteners will be quite heterogeneous in that respect. As a basis for the steps to follow, all children should at least consolidate counting skills and knowledge up to 10, the basis of our number system; most children will exceed that number by far, so there is a need for differentiation.

At the same time (B), it is important to build upon what children, partly independently from their counting competences (cf. Fritz et al., 2018), have already acquired in the field of *subitizing* of quantities up to four and *perceptual subitizing* of bigger quantities structured in a way that allows for establishing their number without counting (cf. Clements & Sarama, 2009). This could start with numbers up to five (number of fingers on a hand) or six (maximum of dots on one side of a die). Yet, we would gain little for the following if a child identifies these quantities with a glance but *without* noticing them as *composed* (four as two and two or three and one, five as four and one or three and two, etc.). Thus, activities should focus on the *structured* perception of these quantities. Schultz and Gerster (2017) delineate how this could form the starting point of targeted elaboration of part-whole thinking: We may request children to construe operations of joining, separating, missing addend etc. as just different interpretations of dot structures, for example, “I see five dots altogether. If I take away the outer four, the central one will remain.” We may then encourage the children to transfer these *nuclei of number knowledge* to real-world situations: “I’ve got one Euro. If mummy gives me four more, I will have five.” Note that the intention of such early activities is *not* that children solve these problems by counting, but by referring to the part-whole interpretation of structured dots, first supported by *seeing* the dots, then by *knowingly imagining* their structures (Schultz & Gerster, 2017).

A third “construction site” (C) of early activities, once again building upon the rather diverse competences that children will already have acquired in that field, is *comparing* quantities and numbers. As a precondition for further arithmetic, children should learn and/or consolidate that two quantities are the same number if it is possible to establish a continuous one-to-one correspondence between their items; no counting is needed for that. On that basis, they should learn that “one more” means that a mapping of the items results in one item left for the bigger quantity (Gaidoschik, 2007).

I use the metaphor “construction sites” to indicate that we should *work* with children in all three Fields A to C more or less *concurrently*, which is, bearing on German speaking countries, within the first weeks of grade one. Certainly, we may concentrate activities on only one site for some days, but switch to another the next day or even combine working on all sites on the same day. This is sensible, as many children in single areas will need quite a lot of practice over a longer period to reach the level required as a basis for next steps. Yet, to achieve desirable *automatisms*, e.g. in counting forward and backward, it would not help to stick to one single theme for too long in a row, but rather provoke tedium. More importantly, the sites relate to each other. We should link *counting* to *comparing*, to help children realize that each number in the sequence is “one more” than its predecessor (and not only “the next number”, see above). Working on *perceptual subitizing* should include *comparing*, etc.

Such as the three sites merge into one another, the next important step is only an extension of the above-mentioned exercises: advanced activities that fit for exploring and internalizing part-whole relations, but now for *all numbers* at least *up to 10*. Gaidoschik (2007) describes in detail how the use of fingers which are not being counted nor unfolded one by one, but moved and perceived in groups simultaneously, could form a starting point for first acquiring *mental pictures* and finally *automatized knowledge* of at least some important compositions of all numbers up to 10. Thus, children could first learn how to “stretch out eight fingers without counting”, then describe how they would do so without really doing it (“I need one full hand and three more fingers”). Then, if already available to the child (see below), s/he could use symbols to record the action ($5+3=8$), think about what could be done subsequently (“So this is eight fingers. What if you take away the one full hand?”), and record that action as well ($8-5=3$). Already at that stage, children can and should try to apply this knowledge to real-world situations, for instance by inventing word problems. In that way, the acquisition of part-whole knowledge is (almost) from the beginning closely linked to addition *and* subtraction.

Note that I am not talking about *writing* equations from the very start, but *operating* with *real*, then *imagined* material. Fingers are very useful “material” at the beginning, as they allow to experience clearly and convincingly the difference between using structure-knowledge (take away five means take away one full hand at once) and counting (take away quite tediously one single finger after the other). In the following, for some purposes, ten-frames are useful, then twenty-frames and 100 dot arrays. Also with these materials, yet, it is paramount to work out *how to see and use structures*, how to *relate* other numbers to 5 and 10; only this enables to operate without having to count one by one.

Fingers might be most convincing to work out the five-plus-x structures of the numbers 6 to 10. Another indispensable structure that should be in the focus of early activities are doubles and halves (6 as $3+3$, 8 as $4+4$ etc.). Therefore, a next step could be to concentrate on these very structures, and again connect them with tasks that elicit their *application* in solving addition and subtraction tasks.

Once more, it will turn out that counting is superfluous to solve these tasks. Presumably, some children might still apply counting strategies; yet, in this context there is high probability that the teacher or other children will convince these children that there is a better, much easier way, by thinking about and applying knowledge of the part-whole structure of the numbers involved.

Closing remarks

This is not the place to unfold a detailed guideline for teaching early arithmetic. The aim of the above sketch is to illustrate the paper's main message: Structure-genetic didactical analysis allows developing a teaching design that avoids engaging children in using counting on for computation *from the very beginning*. It does so in full consideration of pertinent research on how children develop their thinking under certain conditions. However, it strives to change these conditions where analysis shows that they may lead to unnecessary delay, if not continuing problems. Research indicates that the widespread tradition to foster counting on is such an unfavorable condition. Structure-genetic didactical analysis opens an alternative in line with the needs of the children as well as of the subject matter. Of course, an indispensable next step would be to implement these ideas in classrooms, and evaluate and further develop them based on reflected experience – a clear case for educational design research. I have started such research on a small scale, yet this paper is deliberately *not* about the ongoing pilot study. I had rather put the basic concept up for international discussion. After all, it would not make sense to trial on larger scale a design that does not withstand careful scrutiny.

References

- Clements, D. H., & Sarama, J. (2009). *Learning and teaching early math. The learning trajectories approach*. New York, USA/London, UK: Routledge.
- Cowan, R., Donlan, C., Shepherd, D., Cole-Fletcher, R., Saxton, M., & Hurry, J. (2011). Basic calculation proficiency and mathematics achievement in elementary school children. *Journal of Educational Psychology*, 103(4), 786–803.
- Fritz, A., Ehlert, A., & Leutner, D. (2018). Arithmetische Konzepte aus kognitiv-entwicklungspsychologischer Sicht. *Journal für Mathematikdidaktik*, 39(1), 7–41.
- Fritz, A., & Ricken, G. (2008). *Rechenschwäche*. Stuttgart, Germany: UTB.
- Gaidoschik, M. (2007). *Rechenschwächen vorbeugen – Erstes Schuljahr: Vom Zählen zum Rechnen. Das Handbuch für LehrerInnen und Eltern*. Wien, Austria: Verlag öbv-hpt.
- Gaidoschik, M. (2010). *Wie Kinder rechnen lernen – oder auch nicht*. Frankfurt am Main, Germany: Peter Lang.
- Gaidoschik, M. (2019). Didactics as source and remedy of mathematics learning difficulties. In A. Fritz, V. Haase, & P. Räsänen, P. (Eds.), *The international handbook of math learning difficulties: from the lab to the classroom* (pp. 73-89). Cham, Switzerland: Springer.
- Gaidoschik, M., Fellmann, A., & Guggenbichler, S. (2016). Computing by counting in first grade: It ain't necessarily so. In K. Krainer & N. Vondrová, *Proceedings of the Ninth Congress of the European Society for Research in Mathematics Education CERME 9* (pp. 259–265). Prague: Charles University, Faculty of Education.

- Gaidoschik, M., Fellmann, A., Guggenbichler, S., & Thomas, A. (2017). Empirische Befunde zum Lehren und Lernen auf Basis einer Fortbildungsmaßnahme zur Förderung nicht-zählenden Rechnens. *Journal für Mathematik-Didaktik*, 38(1), 93–124.
- Geary, D. C., Bow-Thomas, C. C., Fan, L., & Siegler, R. (1996). Development of arithmetical competences in chinese and american children: influence of age, language, and schooling. *Child Development*, 67, 2022–2044.
- Gelman, R., & Gallistel, C.R. (1978). *The child's understanding of number*. Cambridge, USA: Harvard University Press.
- Häsel-Weide, U., & Nührenbörger, M. (2013). Replacing Counting Strategies: Children's Constructs on Number Sequences. In B. Ubuz, Ç. Haser, & M. A. Mariotti (Eds.), *Proceedings of the Eight Congress of the European Society for Research in Mathematics Education CERME 8* (pp. 303–312). Ankara: Middle East Technical University.
- Hopkins, S., & Bayliss, D. (2017). The prevalence and disadvantage of min-counting in seventh grade: problems with confidence as well as accuracy? *Mathematical Thinking and Learning*, 19(1), 19–32.
- Krajewski, K., & Schneider, W. (2009). Early development of quantity to number-word linkage as a precursor of mathematical school achievement and mathematical difficulties: findings from a four-year longitudinal study. *Learning and Instruction*, 19(6), 513–526.
- Krauthausen, G. (2018). *Einführung in die Mathematikdidaktik – Grundschule* (4. Auflage). Berlin, Germany: Springer.
- New Zealand Ministry of Education (2008). *Getting started*. Wellington, New Zealand: Crown.
- New Zealand Ministry of Education (2012). *Teaching addition, subtraction, and place value*. Wellington, New Zealand: Crown.
- Schipper, W., Ebeling, A., & Dröge, R. (2015). *Handbuch für den Mathematikunterricht an Grundschulen. 1. Schuljahr*. Braunschweig, Germany: Schroedel.
- Schultz, Jakob, & Gerster, H.D. (2017). Teile-Ganzes-Denken über Zahlen und Operationen: Herausforderung und Leitidee des Anfangsunterrichts. In A. Fritz, S. Schmidt, & G. Ricken (Eds.), *Handbuch Rechenschwäche* (pp. 206-224). Weinheim, Germany: Beltz.
- Siegler, R.S., & Alibali, M.W. (2005). *Children's thinking*. Englewood Cliffs, USA: Prentice Hall.
- Steinberg, R. (1985). Instruction on derived facts strategies in addition and subtraction. *Journal for Research in Mathematics Education*, 16(5), 337–355.
- UK Department of Education (2013). *Mathematics programme of study: key stages 1 and 2*. Retrieved from <https://www.gov.uk/government/publications/national-curriculum-in-england-mathematics-programmes-of-study>
- Wittmann, E. Ch. (2015). Structure-genetic didactical analyses - empirical research of the first kind. In P. Błaszczyk, B. Pieronkiewicz, & M. Samborska (Eds.), *Mathematical Transgressions 2015* (pp. 5–19). Kraków, Poland: PWN.

Rational number operations: What understandings do children demonstrate?

Sofia Graça¹, João Pedro da Ponte¹ and António Guerreiro²

¹Instituto de Educação, Universidade de Lisboa, Portugal; soffiagraca@hotmail.com;
jpponte@ie.ulisboa.pt

²Escola Superior de Educação e Comunicação, Universidade do Algarve, Portugal;
aguerrei@ualg.pt

This qualitative and interpretative study aims to identify grade 5 students' knowledge of rational number operations in order to ascertain their rational number sense and operation sense before and after a teaching experiment. Data was gathered using two tests and four individual semi-structured interviews. The results show that, in the pre-test, children performed rational number operations based on their whole number knowledge. In the post-test, after the teaching experiment, they showed conceptual understanding of the operations, demonstrating rational number sense and operation sense.

Keywords: Rational numbers, fractions, fractions operations.

Introduction

Rational numbers are important mathematical entities, with an important place in the mathematics curriculum, particularly in early years. They involve complex ideas, which represent conceptual obstacles for children (Behr & Post, 1992). Mathematics education researchers have identified difficulties in children's work with these numbers, for example, regarding operations (Hansen, Drews, Dudgeon, Lawton, & Surtees, 2014). Teaching methods used in schools, typically oriented towards the application of rules, lead students to perform sequences of procedures without understanding their meaning (Braithwaite, Pyke, & Siegler, 2017), for example, obtain equal denominators and then add or subtract numerators; multiply numerators and denominators on fraction multiplication; and “invert and multiply” on fraction division. Consequently, children do not develop rational number sense (Lewis & Perry, 2014) nor operation sense (Huinker, 2002). Thus, this study aims to identify grade 5 students' knowledge of rational number operations in a pre-test, before a teaching experiment, and in a post-test, after that teaching experiment, in order to ascertain their rational number sense and operation sense.

Rational number operations

General aspects

Students often demonstrate not understanding what happens when they add, subtract, multiply or divide fractions because the teaching of this topic is typically based on the presentation of rules that they do not understand. Usually, they apply their knowledge of integers on rational number operation tasks, and they operate with rational numbers as if they were integers. Thus, children make mistakes that demonstrate misunderstandings in their conceptual understanding: “strategy errors”, for example, applying the operation to numerators and denominators, independently; and “execution errors”, for example, incorrect performing a calculation procedure or failing to change numerators or denominators when attempting to obtain equivalent fractions (Braithwaite et al., 2017).

Rational number understanding involves rational number sense, that is, understanding: (i) that a fraction is a number; (ii) partitioning fractions; (iii) the meaning of denominators; (iv) knowing what is the whole; (v) fraction size; and (vi) fractions can represent quantities greater than one (Lewis & Perry, 2014). Operation sense is another component of rational number sense. According to Huinker (2002), it includes the following understandings: (i) meanings and models for operations, e. g., rectangular, circular or area models, used to represent the operations; (ii) ability to recognize and describe real-world situations for specific operations; (iii) meaning of symbols and formal mathematical language; and (iv) knowledge the effects of operation on numbers. In the perspective of Brown and Quinn (2006), gaps in the conceptual understanding of rational number operations are the cause of poor student performance in these operations. Both number and operation sense represent a way of thinking about numbers and their operations. Problem solving allows children to explore and understand rich mathematical situations, in which operations arise. Thus, problems can more easily assign operations meaning and promote meaningful learning. The use of models can help children to understand the conceptual basis of each operation. As they establish a relationship between models and algorithms, children can understand what each step of an algorithm represent in practice (Behr & Post, 1992).

Addition and subtraction

Fraction addition and subtraction are often taught based on the use of procedures, such as, “denominators have to be equal, and then you can add or subtract the numerators”. However, students often do not understand the need of common denominators or the role of equivalent fractions, which constitute fundamental understandings in these operations (Behr & Post, 1992). This procedure-based approach does not promote the conceptual understanding of fraction addition and subtraction. Together with the prior knowledge of whole numbers, it leads children to make common mistakes, because they confuse the procedures. In addition, children have more difficulty understanding questions involving subtraction than involving addition. Sometimes, they do not identify the correct operation (Behr & Post, 1992). Braithwaite et al. (2017) refer that most children’s difficulties are associated with the nature of denominators. When they are equal, children usually just add or subtract numerators; when they are different, they usually make independent whole number errors, that is, apply the operations to numerators and denominators (strategy errors). Behr and Post (1992) point out that the use of models can help children to understand the involved concepts when they add or subtract fractions.

Multiplication

Multiplication is usually viewed as successive addition of “equal groups”. However, in the rational number field, this is an inappropriate idea because the product can be smaller than both factors and this is not compatible with an additive procedure (Greer, 1992). Tasks with a “multiplicative relation” meaning can be useful on learning rational number multiplication so that children overcome this misunderstanding. The use of models allows children to understand how the unit change during the problem and that the product is not always greater than each of the factors (Behr & Post, 1992). Children multiply both fractions but they do not understand how and why the algorithm works.

Division

The division operation is often linked to sharing situations. In these situations, the goal is to get the unit value. However, learning division only based on this meaning leads students to the incorrect idea that division always decreases or that the dividend should be greater than the divisor (Greer, 1992). The meaning “measure” of division is another way to think about this operation, requesting the number of groups instead of the unit value. This meaning allows a more robust understanding of division. The use of models makes it easier for children to understand this meaning of division and allows them to verify how many times the divisor goes into the dividend. The common denominator algorithm is an interesting strategy to help children understand this situation and how the algorithm works because it represents the way children reason about this meaning of division.

Research methodology

This is a pre-test-intervention-post-test study (carried out in 2017/18). Participants are four grade 5 students from a public school in Portugal, from a disadvantaged socioeconomic environment. They were selected because of their ease in oral communication and the fact that their performances on tasks were representative of the remaining class, as they had different performance levels. A pre-test, applied before a teaching experiment, involved different rational number concepts. Data analysis in this paper focuses on fraction addition and subtraction because these are contents already learned in previous years, so, children already had this knowledge. A post-test was applied after that teaching experiment (in the following lesson) and also involved different rational number concepts. However, the focus was on all four operations because multiplication and division operations were addressed during the teaching experiment since multiplication and division were new contents in this grade. The children solved the tests, individually, for 50 minutes, and then they were individually interviewed in order to explain their reasoning in each question. The interviews took place on the same day they solved the tests and the following day.

The teaching experiment lasted six weeks, consisting of eighteen tasks (45 questions in total). The tasks involving all four operations were the last eleven ones. Addition, subtraction, multiplication and division, in problem solving situations, were addressed separately, in this specific order. These tasks involved 27 questions (13 questions involved the use of models). The teaching experiment followed an exploratory approach (Ponte & Quaresma, 2016), that is, tasks were presented to children and they worked individually, followed by a group discussion and synthesis. To solve the tasks, in an initial phase, the children were guided to use (circular or rectangular) models, provided in the task statements. The actions performed in the models were accompanied by the corresponding numerical sentence (numerical sentences changed as the models changed), so that the children understood the relationship between them. At a later stage, they could choose the solution strategy they preferred. The goal was to progress from the use of models to symbolic manipulation with understanding. On fraction addition, the children had two circular models to represent the quantities to be added. The denominators of fractions and the number of divisions in the models were equal, so, they just had to add the number of pieces. Later, the denominators of fractions and the number of divisions were different, so, they had to make divisions in the models because they could not add pieces with different sizes. Lastly, models had no division and the denominators of fractions were different so, the children had to make their own (equal) divisions to get the result. Subtraction of fractions followed the same procedure. Circular and rectangular models were used to promote understanding about these

operations, allowing to understand the need of equal denominators and the role of equivalent fractions.

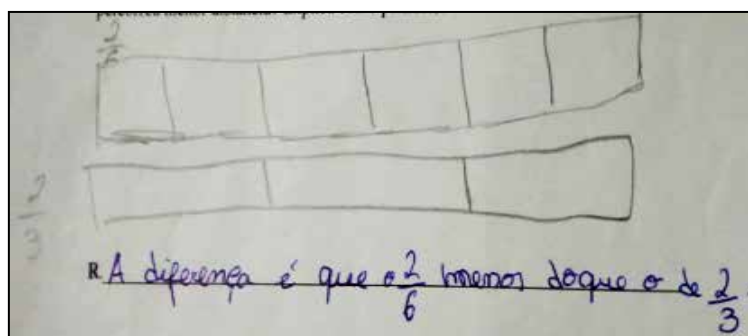
On fraction multiplication (meaning “multiplicative relation”), a rectangular model was used. This model allowed the children to understand the role of different fractions when they are multiplied, for example, the role of operator and the change of the reference unit throughout the problem. When children are asked to solve $\frac{1}{4} \times \frac{1}{2}$, they find a half because is the initial quantity and then they find $\frac{1}{4}$ of that part. Fraction division focused on the “measure” meaning and the common denominator algorithm was addressed. The rectangular model was effective in understanding this meaning of division and allowed to conceptually understand the algorithm. For example, “Luísa had $2\frac{1}{2}$ meters of tape to put in hats and each hat takes $\frac{1}{4}$ meters. In how many hats can she put tape?” The children represented the dividend in models by shading and then they could verify how many $\frac{1}{4}$ are in $2\frac{1}{2}$.

For data analysis, the interviews were all audiotaped, transcribed and analysed in depth, as well as the children solution strategies in both tests. These two methods of data collection allowed us to analyse students’ rational number sense and operation sense according to the Lewis and Perry (2014) and Huinker (2002) categorizations, respectively, before and after the teaching experiment. These methods also allowed to ascertain how they evolved from pre- to post-test, and the role of the models in the development of children conceptual understanding.

Results

Pre-test

A fraction addition operation was involved in the question “Pedro, João and Gonçalo started running a path with 6 km in a park near their school but none of them got to the end. Pedro stopped after $\frac{2}{6}$, João run only $\frac{2}{3}$ and Gonçalo $\frac{1}{2}$. What fraction represents the travelled distance by the three friends together?” Although most children had identified the implicit operation in the story problem, their performance was quite weak. They often added numerators and denominators independently, to get the result (strategy error), and presented the result $\frac{5}{11}$. When they were asked if it would be possible to add fractions with different denominators, they demonstrated not understand the question. Just one child, Ana, tried to use a rectangular model to support her reasoning, but it was not correctly built and she left the question unanswered. In a fraction subtraction question, “What is the difference between the boy who ran the longest distance and the boy who ran the shortest distance?”, again, the children subtracted numerators and denominators independently, to get the result (strategy error). Ana (Figure 1), again, tried to use rectangular models to reason about the question, however, these were not correctly built. She could not identify which operation should use.



"The difference is that the $\frac{2}{6}$ smaller than the $\frac{2}{3}$."

Figure 1: Ana's solution

Post-test

In the post-test, an addition question was posed to children "Clara, Maria and Gabriela started a path. Clara stopped to rest after $\frac{2}{5}$ of the path, Maria stopped after $\frac{4}{10}$ and Gabriela after $\frac{3}{5}$. What fraction represents the distance travelled by the three friends together until the moment they stopped to rest?" Most of children were successful both in identifying the operation and applied the correct algorithm. They demonstrated to understand the situation through the following statements "Here below not everything was the same size. I made it to be and I started here, with 10. [...] Then, I added all parts and left the bottom number which represents the size of the parts that are here!" (Ana), or "The whole course had five parts and all together made seven of these parts, seven bits of $\frac{1}{5}$!" (David). Just one child, Pedro, did not correctly add the numerators after obtaining equivalent fractions. He obtained the fraction $\frac{10}{10}$ and said it was equal to one unit (Figure 2), making an execution error.

Figure 2: Pedro's solution (i)

During the interview, Pedro identified and corrected his error and, after the new result $\frac{14}{10}$, he wrote that "together they did more than a whole path!" or "I think this is so because this boy made six. These only made four!" Fraction subtraction question was posed to children "In the end of the course, they decided to eat sweets from a bag with $\frac{3}{4}$ kg. Together they ate $\frac{1}{3}$ kg. How much did they leave in the bag?" Most children identified the correct operation and used it as solution strategy. They demonstrated understanding its meaning saying that "It's a subtraction operation! If they eat $\frac{1}{3}$ [Kg] from the whole bag, we have to get that part [...] but we can't do three minus one because the parts are not equal and they have to be! We need equal fractions!" (David). Just one child, Pedro, tried to solve this question using a model (Figure 3).

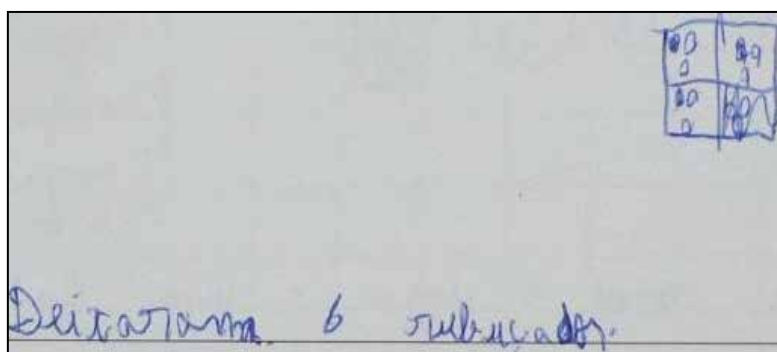


Figure 3: Pedro's solution (ii)

He justified that “each friend ate $\frac{1}{3}$, so, since it is one of three, I counted one because it represents what they ate, and it is one of three because they were all the sweets they had!” Thus, he referred that six sweets were left, because it is the number of unshaded circles. Pedro considered the initial quantity as a continuous entity, as shown by the model that he tried to use, but considered the withdrawn part as a discrete entity. We do not know how much candy is in the bag but its weight. The child considered continuous and discrete quantities as measured with the same unit.

The division as measure was underlying in the following question: “Maria is making chocolate cakes for her sister’s birthday. She has $2\frac{1}{4}$ kg of sugar and each recipe of chocolate cake takes $\frac{1}{8}$ kg of this ingredient. How many chocolate cake recipes can she make?” Most of children had a good performance in this question. They identified the correct operation to be used in the problem, using the common denominator algorithm as solution strategy and demonstrated to understand its meaning “Here, I divided to see how many $\frac{1}{8}$ fit in $2\frac{1}{4}$ [...] she can make eighteen cakes!” (David). Only Ana did not identify the correct operation in this situation. She added both amounts and justified her choice saying that, “she wanted to make a cake with the whole amount, so, I made an addition!” This child also demonstrated difficulties regarding fraction simplification.

The following fraction multiplication question (multiplicative relation) was posed to children: “To decorate a cake, Maria put chocolate in $\frac{5}{10}$ of the whole cake and coconut in $\frac{2}{3}$ of the part that had chocolate. What fraction of the whole cake has both decorations?” Only David identified and used multiplication operation as solution strategy. He justified that “Maria put coconut over the chocolate part, so, I multiplied because it’s one part of another! $\frac{2}{6}$ is the shaded parts twice!” When asked about the relationship between the operation and the model, he said “2 is the number of pieces and 6 is the size of the pieces. It’s just a little bit. [...] So, we have to multiply numerators and denominators!” The remaining children had a poor performance in this question. Nara subtracted both quantities, however, during the interview, she said that “ $\frac{5}{10}$ means there was half of the cake, but $\frac{2}{3}$... well... it was in that part [$\frac{5}{10}$]! I think it was not to subtract, it was to multiply!” So, she demonstrated some understanding about this meaning of multiplication. Pedro and Ana attempted to solve the problem using circular models but they demonstrated some difficulties in understanding this question. They also demonstrated misunderstandings related to divisions in the models. Horizontal and vertical divisions were made in the circular model. Pedro, after representing $\frac{5}{10}$ on his model, said:

Pedro: Then it was $\frac{2}{3}$ with coconut...

Researcher: Where could we shadow this amount ($\frac{2}{3}$)?

Pedro: Here [unshaded part]!

Researcher: Don't forget the coconut was in the chocolate part!

Pedro: Ah! I think I had to split this part [$\frac{5}{10}$]... To put the coconut on top because it is "of"! Its $\frac{2}{3}$ of $\frac{5}{10}$!

Although Pedro was unable to solve the problem correctly, during the interview he showed better understanding about the question as well as its relation with the fraction multiplication.

Discussion and conclusion

The children who participated in this study had already learned fraction addition and subtraction in previous years. However, in the pre-test, their performance in questions involving these operations were very weak. They added and subtracted numerators and denominators to get the result, which constitutes a common mistake especially when denominators are different (Braithwaite et al., 2017). This solution strategy demonstrates lack of understanding that a fraction represents a single number. It also shows misunderstanding related to meaning of the denominator, since they added and subtracted fractions with different denominators, for example, on fraction addition ($\frac{2}{6} + \frac{2}{3} + \frac{1}{2} = \frac{5}{11}$). These mistakes show that these children were unaware of the relationship between numerator and denominator, as in the study of Hansen et al. (2014), reflecting weaknesses in their rational number sense. Children's solutions also show that they did not conceptually understand these operations. Similar results were found in the study of Brown and Quinn (2006), which suggests that the poor performance is a consequence of gaps in the conceptual understanding of operations. These children did not understand the meaning of the operations and they have very limited knowledge of models to represent them, as shown in Figure 1. They also did not reason about the results obtained, which they did not understand to be inadequate in relation to the situation. Thus, their operation sense also had serious shortcomings. Their responses showed that they learned to solve operations applying rules (that they generalized in a wrong way from whole number operations) without understanding their meaning.

In the post-test, the children showed a better understanding of rational number addition and subtraction, compared to the pre-test. On these operations, they demonstrated to understand the use of equal denominators and what they represent, which was possible due to the use of models during the teaching experiment. The children know that it is not possible to add or subtract fractions with different denominators, as reported by Ana. That is, they understood that a fraction represents a number and not two independent numbers. This is an important understanding of student's rational number sense. Knowledge concerning to the meaning of the denominator, another component of rational number sense, was also observed, for example, "I kept the value down, which tells the size of the parts that are here!" (Ana). Justifications such as "The whole course had five parts and together they travelled seven of these parts. Seven bits of $\frac{1}{5}$!" (David), showed that these children know the fraction size and that a fraction can represent quantities larger than one. Regarding operation sense, they began to understand the different meanings of operations and to assign meaning to the symbols. The reasoning "Here I divided to see how many times this [$\frac{1}{8}$] fits in $2\frac{1}{4}$ " (David), was possible due to

the use of models. He showed that he conceptually understood this meaning of division. He reflected in the quantities and how they are related and also identified the appropriate operation. The children also demonstrated understanding the effect of operations on numbers when they analysed the reasonableness of results: “I think it is this way because this boy made six. These only made four!” (Pedro) or “ $\frac{2}{6}$ are the pieces shaded twice. [...] It’s just a little bit!” In general, these children demonstrated conceptual understanding of formal mathematical language. The division operation as measure and the multiplication operation as multiplicative relation, used in this teaching experiment, allowed a deep understanding of these operations. The children overcome the misconception that multiplication always increases and division always decreases. This was possible due to the use of models during the lessons, especially in an initial phase, as recommended by Behr and Post (1992). Therefore, we conclude that this teaching experiment based on the use of models, allowed the students to construct the algorithm from the models, and led them to develop some components of their rational number sense and operation sense. This study represents an alternative way of approaching rational number operations, promoting students’ conceptual understanding, which often does not occur.

Acknowledgment

This study is supported by FCT – Fundação para a Ciência e a Tecnologia, through a doctoral grant to Sofia Graça (SFRH/BD/130343/2017).

References

- Behr, M., & Post, T. (1992). Teaching rational number and decimal concepts. In T. Post (Ed.), *Teaching mathematics in grades K-8: Research-based methods* (2nd ed., pp. 201–248). Boston, MA: Allyn & Bacon.
- Braithwaite, D., Pyke, A., & Siegler, R. (2017). A computational model of fraction arithmetic. *Psychological Review*, *124*(5), 603–625. doi: 10.1037/rev0000072
- Brown, G., & Quinn, R. (2006). Algebra students’ difficulty with fractions: An error analysis. *Australian Mathematics Teacher*, *62*(4), 28–40.
- Greer, B. (1992). Multiplication and division as models of situations. In D. A. Grouws (Ed.), *Handbook of research in mathematics teaching and learning* (pp. 276–295). New York, NY: MacMillan.
- Hansen, A., Drews, D., Dudgeon, J., Lawton, F., & Surtees, L. (2014). *Children’s errors in mathematics*. London: SAGE.
- Huinker, D. (2002). Examining dimensions of fractions operations sense. In B. Litwiller & G. Bright (Ed.), *Making sense of fractions, ratios, and proportions: 2002 Yearbook* (pp. 72–78). Reston, VA: NCTM.
- Lewis, C., & Perry, R. (2014). Lesson study with mathematical resources: A sustainable model for locally-led teacher professional learning. *Mathematics Teacher Education and Development*, *16*(1), 22–42. Retrieved from <https://eric.ed.gov/?id=EJ1046670>
- Ponte, J.P., & Quaresma, M. (2016). Teachers’ professional practice conducting mathematical discussions. *Educational Studies in Mathematics*, *93*(1), 51–66.

Pairing numbers: An unconventional way of evaluating arithmetic expressions

Robert Gunnarsson¹ and Ioannis Papadopoulos²

¹School of Education and Communication, Jönköping University, Sweden;
robert.gunnarsson@ju.se

²Department of Primary Education, Aristotle University of Thessaloniki, Greece;
ypapadop@eled.auth.gr

We have analyzed the written solutions to four arithmetic expressions comprising addition/subtraction and multiplication of 4 to 7 numbers from 235 students (112 in Greece and 123 in Sweden, 11-12 years old). Beside the order-of-operations and sequential (left-to-right) calculations, several students seem to calculate in an unconventional way by pairing numbers. That is, there are students who combine the numbers two-and-two, seemingly regardless of the operations, and then operate on these pairs when evaluating an expression. In our data, pairing seems to be as frequent as sequential calculations. We identify the characteristics of three qualitatively different ways of pairing. The different ways seem to be applied independent of the length of the numerical expression.

Keywords: Arithmetic, Order of operations, Precedence rules.

Introduction and theoretical background

In mathematics, we use conventions for arithmetic expressions to be unambiguously perceived. However, to design successful teaching on how to perceive and calculate arithmetic expressions, we need to first learn what ideas are present among the students. In this report, we present a study of those ideas and can show that evaluating numerical expressions by *number pairing* seems to be more significant in students' ideas than previously reported, and that it can emerge in different types.

Without the mathematical conventions like, e.g., the rules for the order of operations, there would be different ways in which numerical expressions can be evaluated. Accordingly, it has been shown that students who have not yet internalized these conventions use different ways in their calculations (Blando, Kelly, Schneider, & Sleeman, 1989; Glidden, 2008; Gunnarsson, 2016; Headlam, 2013; Libenberg, Linchevski, Sasman, & Olivier, 1999). This might result in errors such as exchanging a number with another number, exchanging an operation with another operation, or, simply, making computational errors. Blando et al. (1989) call these errors “careless” and “substitution errors”. But, there are also errors that are more related to the structure of the expression. Linchevski and Livneh (1999) showed that students, while being inconsistent in the computational aspects, can be very consistent in these structural errors.

There has been substantial research devoted to students' handling of arithmetic expressions from perception and cognitive points of view. It has been shown in several studies that the mere proximity of two numbers can result in that these are calculated first, regardless of the operator in between (Gómez et al., 2014; Jiang, Cooper, & Alibali, 2014; Landy & Goldstone, 2010; Rivera & Garrigan, 2016). More generally, it has been shown that the visual appearance of the mathematical notation can

cause students to disregard mathematical rules (Kirshner & Awtry, 2004). A particular effect of the visual appearance was pointed out by Linchevski and Livneh (1999). They showed that some students can dissociate two parts of an expression, often induced by an operation sign (typically minus), like, e.g., when $50 - 10 + 10 + 10$ is evaluated as $50 - (10 + 10 + 10)$.

In addition, there are several educational research studies showing that students can perceive the structure of numerical expressions in different ways. Kieran (1979) has shown that the rule ‘to be calculated first’ can be perceived as ‘to be put to the left’. Conversely, it appears as if students perceive what is read first (i.e., to the left, if that is the reading order) should be calculated first. At least, several studies describe that students calculate expressions sequentially from left to right (Blando et al., 1989; Headlam, 2013; Liebenberg et al., 1999).

There have also been brief reports that some students pair up numbers when processing arithmetic expressions (Gunnarsson, 2016; Liebenberg et al., 1999; de Villiers, 2015). While de Villiers (2015) mentions it as one type of erroneous calculation (without further discussion) where order of operations should have been used, Liebenberg et al. (1999) describe students who break up expressions in parts. As example, they find students calculating $4 + 5 + 5 \times 2 \times 6 + 4$ by grouping numbers in pairs and then processing these pairs as $4 + 5 + 5 \times 2 \times 6 + 4 \rightarrow (4 + 5) + (5 \times 2) \times (6 + 4) = 9 + 10 \times 10$. However, we have noted that, apart from the example above, the expressions used in most previous studies are quite short and contain two (or maximum three) different operators. Typically, the numerical expressions are of the form $a + b \times c$, occasionally $a + b \times c + d$. The exception found in the study of Liebenberg et al. (1999) with longer expressions (up to seven numbers, thus six operations), may have enabled them to observe a breaking-up-into-parts effect. Hence, in this study we would like to explore this effect further by using long expressions.

Therefore, with the idea that teaching arithmetic conventions must take its point of departure in students’ *actual* ideas on how calculations should be completed, the aim of this study is to further explore students’ idea of pairing when calculating arithmetic expressions. In short, we would like to find what forms of pairing mechanism occur when students evaluate arithmetic expression. This study is part of a larger project to design teaching to improve students’ arithmetic computational competence.

Method

This study engaged 112 Greek students and 123 Swedish students, 11-12 years old (grade 5 in Sweden, grade 6 in Greece). In total students from nine different schools (five Greek schools and four Swedish schools) were included. The schools were chosen from mixed background to represent all achievement levels. According to the curriculum and the teaching traditions in the two countries, the students should have been taught the rules for the order of operations prior to the study. The students were given a written test and sufficient time (no time limit) to answer it. The test comprised several tasks, all typeset with the equation editor of a conventional word-processor, to avoid unintended influence from the visual appearances of the expressions. The test was aimed to test students’ understanding of arithmetic conventions. Four of the tasks were specifically designed to explore students understanding of the order of operations by expressions of different lengths. These tasks are shown in Figure 1.

- a) $9 - 2 \cdot 3 - 2$
- b) $5 \cdot 4 \cdot 3 + 6 \cdot 2 + 1$
- c) $2 \cdot 3 \cdot 5 - 4 \cdot 2 + 6$
- d) $5 \cdot 3 + 2 \cdot 4 \cdot 5 + 3 \cdot 2$

Figure 1: The four different numerical expressions used in this study (in the Greek version of the test, the expressions were numbered a, b, g d, respectively)

The data, comprising the students' written answers to the test – their written evaluations of the expressions in Figure 1 – was subject to a qualitative content analysis as described, e.g., by Leedy and Ormrod (2015). In the analysis, the correctness of the answers was not considered, instead the underlying mathematical idea were in focus for each solution of a numerical expression. In the first step we were looking for well-known ideas, like following the order of operations, sequential calculations (left-to-right), detachment (from Linchevski & Livneh, 1999), and signs of pairing. Hence, data, for each task separately, was first divided into different groups depending on what ideas seemed to have governed the students while solving the task. In some cases, the students used different ways throughout the process of evaluating a single expression. Then, the different groups were combined based on the main underlying mathematical idea the solutions seemed to be based on. This resulted in a few different categories of foundational mathematical ideas.

In the second round of analysis, we focused only on the solutions that have a character of number pairing. Here, no fixed categories were defined prior to the categorization. The categories of ways of pairing numbers emerged from the data in the analysis process. Data were examined separately by the two researchers and discussed to resolve discrepancies. We did not see any significant difference in the data of Swedish and Greek students. Hence, in this study we have not separated the data of the groups. The numbers below are the combined total numbers for the entire data set.

Results and discussion

First, we note that only a minor part of the errors in the students' solutions is due to arithmetic errors. We do find the same type of errors as reported in previous studies (like, e.g., by Headlam, 2013), such as changing operators (e.g., multiplication is replaced by addition), changing numbers and simple arithmetic errors. But, the major part of the operations explicitly described in the data is correctly calculated. Even in the cases of changing numbers or simple arithmetic errors we find that it is easy to trace back the intention of the operation – the actual underlying mathematical idea. This is in agreement with the findings of Linchevski and Livneh (1999). Hence, we can conclude that to a large extent the data (the result of the evaluated numerical expressions) originate from students' ideas on how numerical expressions should be evaluated.

Second, we find three main 'ideas' that seem to influence students' solutions: *order of operations*, *sequential calculation* and *pairing*. In our data, we find students who follow the convention and use the (correct) order of operations, and we find students who use a sequential calculation (left-to-right), see Figure 2. As an example, a student that would have calculated the second expression (b in Figure

1) according to $(((((5 \times 4) \times 3) + 6) \times 2) + 1)$ is considered to have followed a left-to-right, sequential, strategy. This does not mean that the specific student is always following that strategy, but at least did so in this specific expression.

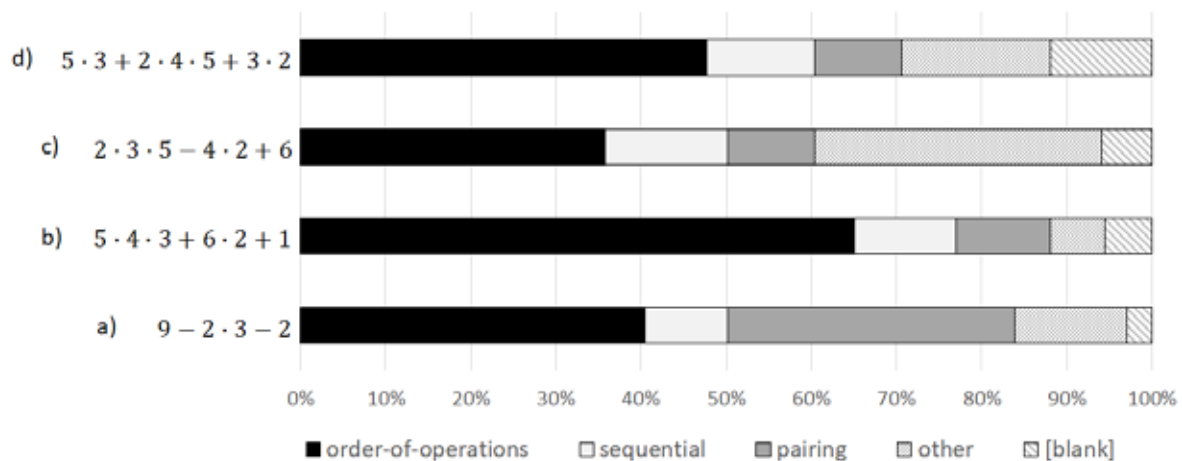


Figure 2: Strategies used to evaluate the different numerical expressions

Some students indeed are consistent in their calculations, in the sense that they calculate all four expressions in the same way, or with the same apparent idea behind the calculation. Most of the students who are consistent have used the order of operations. But there are also students who consistently have used a sequential calculation on all four expressions. For instance, two students consistently used one specific type of pairing (which we denote ‘entangled pairing’ further down in the report). In total, we find that the order of operations was used in 47% of all expressions, sequential calculations in 12% of the expressions, and that pairing seemed to be the main idea in 16% of the expressions in the students’ solutions.

Typically, students’ difficulties with numerical expressions from other aspects of precedence, like e.g. detachment (as from Linchevski & Livneh, 1999) or visual salience (Kirshner & Awtry, 2004), are included in the category named “other”. In task c, $2 \times 3 \times 5 - 4 \times 2 + 6$, we note that many students evaluate the expression as $(2 \times 3 \times 5) - (4 \times 2 + 6)$. We believe this is directly related to the detachment-effect reported by Linchevski and Livneh (1999). However, the number of solutions that seem to be based on detachment is also the reason why the “other” category is relatively much more frequent for the (c) expression, as shown in Figure 2.

Additionally, as will be shown further down (Fig 4 c), there are examples in the data where students have used a pairing strategy in the first term ($2 \times 3 \times 5$), but then, seem influenced by detachment and used that in the continuation of the calculation. Hence, it could be a combined pairing and detachment effect. In Figure 2, these examples have been counted as “pairing”.

Particularly, in the data from the first task we found several students’ responses that could be described as due to pairing. Although, we cannot exclude the possibility that there are other ideas that have influenced the students’ behavior and made them evaluate the expression as $(9 - 2) \times (3 - 2)$.

When we explored the mathematical ideas, we found that the pairing mechanism can come in qualitatively different forms.

Pairing overall

The first type, and perhaps the easiest to separate from the others, is a mechanism of pairing throughout the entire expression. It is a pairing that goes overall. This occurs when the pairs span across different operations. It seems as when one pair of numbers has been “used”, the attention is directed to the next pair. No consideration is taken to the precedence of operations. Instead, it seems that numbers are the focus of the attention. Figure 3 shows three different examples where students have used pairing overall to evaluate the expressions. The brackets were made spontaneously by the students.

(a) $8) 5 \cdot 4 \cdot (3 + 6) \cdot 2 + 1 = 20 \cdot 9 \cdot 3 = 180 \cdot 3 = 540$ Student 127

(b) $c) 2 \cdot 3 \cdot 5 - 4 \cdot 2 + 6$ $5 - 4 = 1$ $2 + 6 = 8$ Student 96
 $2 \cdot 3 = 6$ $1 \cdot 8 = 8$
 $6 \cdot 8 = 48$

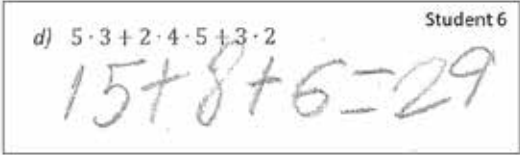
(c) $d) (5 \cdot 3) + (2 \cdot 4) \cdot (5 + 3) \cdot 2 = 15 + 8 \cdot 8 \cdot 2 = 23 \cdot 8 \cdot 2 = 184 \cdot 2 = 368$ Student 126

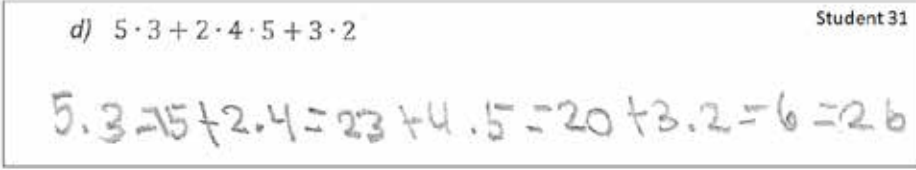
Figure 3: Three examples of students’ answers where pairs have been formed across the entire expression without consideration of what operation should precede the other (“pairing overall”)

This type was particularly evident when there was an even number of numbers in the expression, as in the expressions a – c (cf. Figure 1). We also find examples where students seem to have started with the pairing approach in the expression d with odd number of numbers. One such example is shown in Figure 3(c). Here, the student has paired all the numbers, except the last, which could not form a pair in the same way. However, we also find examples in the data of students’ solutions that indicate that single numbers are explicitly included in the later step of the calculation, as, e.g., the student who explicitly writes $(5 \times 3) + (2 \times 4) \times (5 + 3) \times 2 = (15 + 8) \times (8 \times 2) = 23 \times 16 = 368$, with brackets inserted by the student. Hence, the student has indicated pairing as a mechanism that is applied overall the entire solution.

Pairing within terms

Another type of pairing-mechanism observed in the data is pairs formed within the terms, that is, not across different operations. To some extent, this preserves the order of operations, not breaking the rule that multiplication should precede addition/subtraction. In that respect, this category appears to be some intertwining of the order of operations and the pairing mechanism. Figure 4 shows three examples of pairing within terms that we attribute to this category.

(a)  Student 6

(b)  Student 31

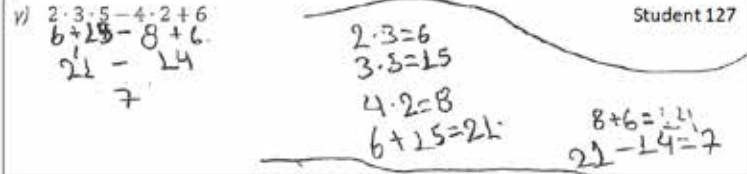
(c)  Student 127

Figure 4: Examples of student answers indicating pairing considered within terms

Pairing within terms is particularly evident when three factors are to be multiplied. Then many students seem to invent some pair where one number is disregarded, as in Figure 4(a), or added/multiplied in the end, similar to the pairing mechanism reported by Liebenberg et al. (1999). However, some students used the numbers twice, as in Figure 4(b, c). Hence, in the latter two examples, there is a double counting of one of the numbers (the centre factor of the term). In Figure 4(b), the number “4” is used both in 2×4 and in 4×5 , separately. In Figure 4(c), the number “3” is double counted. To us, it appears as if this type of pairing can be such a strong idea in the students’ minds that they form pairs regardless if the numbers are used more than once, as in Figure 4(b, c).

Unfortunately, our test did not include any term with four factors. We did not foresee this alternative. If such example would be used, we hypothesize that one could find students who paired the factors within that term without the invention of double-counting.

Entangled pairing

In our data, we find students who are operating with *each* adjacent pairs of numbers. So far, we have only seen two students do like this, but, on the other hand, they are very consistent in this strategy. In this type of pairing mechanism, the operations are subordinate. No consideration is taken to what operations there are in the expression. In the end, the pairs are added. Examples of this type of idea of how numbers should be paired is shown in Figure 5.

Hence, compared to the “pairing overall”-strategy, this type of pairing disregards the operations even more, as pairing is conducted across all operations. In addition, similarly to the “pairing within terms”-type of strategy, double counting of numbers does not seem to be a problem for these students. In this “entangled”-strategy all numbers (except the first and last) are operated with twice.

(a) c) $2 \cdot 3 \cdot 5 - 4 \cdot 2 + 6$ Student 92

$$\begin{array}{l} 2 \cdot 3 = 6 \\ 3 \cdot 5 = 15 \\ 5 - 4 = 1 \\ 4 \cdot 2 = 8 \\ 2 + 6 = 8 \end{array}$$

$$6 + 15 + 1 + 8 + 8 = 38$$

(b) b) $5 \cdot 4 \cdot 3 + 6 \cdot 2 + 1$ Student 113

$$\begin{array}{l} 5 \cdot 4 = 20 \\ 4 \cdot 3 = 12 \\ 3 + 6 = 9 \\ 6 \cdot 2 = 12 \\ 2 + 1 = 3 = 56 \end{array}$$

$$\begin{array}{r} 1 \\ 20 \\ 12 \\ 09 \\ + 12 \\ \hline 56 \end{array}$$

(c) a) $9 - 2 \cdot 3 - 2$ Student 113

$$9 - 2 = 7 \quad 2 \cdot 3 = 6 \quad 3 - 2 = 1 = 14$$

Figure 5: Three examples of where each adjacent pair of numbers are evaluated in an entangled way. In the end, the results of each operation are added

Concluding remarks

Apart from Liebenberg et al. (1999) and a short example by de Villiers (2015), previous research on students' solutions to numerical expressions have focused on arithmetic errors and on sequential (left-to-right) strategies. However, our data suggest that pairing is a much more abundant idea in students' evaluation of numerical expressions than previously shown, at least for longer expressions. We find that 16%, as an average over all students' solutions, are solved with pairing being the underlying mathematical idea. Hence, it seems that the idea of pairing could be as frequent as the idea of sequential calculations.

Moreover, we find three qualitatively different types of pairing ideas. We find ways of pairing bound within terms, and ways of pairing applied in the expressions overall. In addition, we have shown that expressions with an odd number of numbers in the terms can trigger an apparent adaption of the pairing to the order of operations – the double counting of numbers within terms. The origin of pairing seems a deeply rooted idea. We find that despite being taught the order of operations, a considerable amount of the students apply the idea of pairing nevertheless. In addition, as previous research has shown, the mere proximity of numbers can trigger these to be calculated first (Gómez, et al., 2014; Jiang, Cooper & Alibali, 2014; Landy & Goldstone, 2010). Hence, pairing could be closely related to deep cognitive processes. Nonetheless, pairing is a persistent and strong idea and needs to be considered and handled when designing teaching on how to perceive and calculate arithmetic expressions.

References

Blando, J. A., Kelly, A. E., Schneider, B. R., & Sleeman, D. (1989) Analyzing and modeling arithmetic errors. *Journal for Research in Mathematics Education*, 20(3), 301–308.

- Glidden, P. L. (2008). Prospective elementary teachers' understanding of order of operations. *School Science and Mathematics*, 108(4), 130–136.
- Gómez, D. M., Benavides-Varela, S., Picciano, C., Semenza, C., & Dartnell, P. (2014). Symbol spacing and its influence in school children's calculation of mixed-operation arithmetic expressions. In S. Osterle, C. Nicol, P. Liljedahl, & D. Allan (Eds.), *Proceeding of the 35th Conference of the Joint meeting of PME 38 and PME-NA 36* (Vol. 6, p. 310). Vancouver, Canada: PME.
- Gunnarsson, R. (2016). Arithmetic expressions with multiple operations – How to solve it? In C. Csíkos, A. Rausch, & J. Sztányi (Eds.) *Proceedings of the 40th Conference of the International Group for the Psychology of Mathematics Education* (Vol. 2, p. 298). Szeged, Hungary: PME.
- Headlam, C. (2013) *An investigation into children's understanding of the order of operations*. Doctoral thesis, Plymouth University, UK.
- Jiang, M. J., Cooper, J. L., & Alibali, M. W. (2014). Spatial factors influence arithmetic performance: The case of the minus sign. *The Quarterly Journal of Experimental Psychology*, 67(8), 1626–1642.
- Kieran, C. (1979). Children's operational thinking within the context of bracketing and the order of operations. In D. Tall (Ed.) *Proceedings of the 3rd Conference of the International Group for the Psychology of Mathematics Education* (pp. 128–133). Warwick, UK: PME.
- Kirshner, D., & Awtry, T. (2004). Visual salience of algebraic transformation. *Journal of Research in Mathematics Education*, 35(4), 224–257.
- Landy, D., & Goldstone, R. L. (2010). Proximity and precedence in arithmetic. *The Quarterly Journal of Experimental Psychology*, 63(10), 1953–1968.
- Leedy, P. D., & Ormrod, J. E. (2015) *Practical Research – Planning and designing*. (11th ed.) Boston, MA: Pearson.
- Liebenberg, R. E., Linchevski, L., Sasman, M. C., & Olivier, A. (1999). Focusing on structural aspects of numerical expressions. In J. Kuiper (Ed.), *Proceeding of the Seventh Annual Conference of the South African Association for Research in Mathematics and Science Education* (pp. 249–256). Harare, Zimbabwe: SAARMSE.
- Linchevski, L. & Livneh, D. (1999). Structure sense: The relationship between algebraic and numerical contexts. *Educational Studies in Mathematics*, 40(2), 173–196.
- Rivera, J., & Garrigan, P. (2016). Persistent perceptual grouping effects in the evaluation of simple arithmetic expressions. *Memory & Cognition*, 44(5), 750–761.
- de Villiers, M. (2015). Order of operations: The math and the myth. *AMESA news*, 57, 9–11.

Interactions between pupils' actions and manipulative characteristics when solving an arithmetical task

Doris Jeannotte¹ and Claudia Corriveau²

¹Université du Québec à Montréal, Canada; doris.jeannotte@uqam.ca

²Université Laval, Canada; claudia.corriveau@fse.ulaval.ca

In this paper, we explore the use of manipulatives in the classroom to solve an arithmetical task via the concept of affordance. Manipulatives are part of the elementary class culture in different countries, and even if some studies question the efficacy of manipulatives, there seems to have a consensus around the necessity of using it. However, little is known about how mathematics is done with manipulatives. The analysis of pupils' actions helps put to light different affordances of two manipulatives: base-ten blocks and abacus, in a classroom setting where the operations of addition and subtraction are explored with pupils.

Keywords: Elementary School Mathematics, Arithmetic, Manipulatives, Affordance.

Introduction

Research and mathematics education communities at elementary level agree that using manipulatives promote pupil learning (Moyer, 2001). Some researchers see the use of manipulatives as a less abstract way of reasoning than with formal mathematical symbols (Lett, 2007, Özgün-Koca, & Edwards, 2011). According to Domino (2010), Piaget (1964), Bruner (1977) and Diènes' (1973) theories support most of the work on the uses of manipulatives. These theories of learning are based on the idea that manipulatives are necessary for the development of mental images that pupils may eventually summon in situations without manipulatives. In a way, the need, more over the benefit, of manipulatives seems to be taken for granted by many researchers. It leads to many other assumptions such as “doing math with manipulative is a concrete version of doing math” or “manipulatives should support the construct of mathematical objects”. In our research about manipulatives uses, we challenge these assertions. Doing math with or without manipulatives aren't the same activity. Based on this premise, we developed a project called *MathéRéaliser*, in which, we want to understand what it is to do mathematics with manipulatives in a school setting.

Indeed, research shows that the context used to do mathematics structures mathematical activities (e.g. Lave, 1988; Nunès, Schliemann, & Carraher, 1993). These studies, mainly conducted in nonacademic contexts, highlight the situated aspect of mathematical knowledge (Noss, 2002). For example, Pozzi, Noss, and Hoyles (1998) mention that in the professional context (nursing, banking, engineering, etc.), the tools and objects available to actors shape their mathematical activity. In other words, mathematical reasoning is developed in coordination with the “noise” of the situations in which it takes place (Noss, 2002). In this perspective, doing mathematics with manipulatives could be something very different from a concrete version of doing mathematics without them (Corriveau & Jeannotte, 2015). Kosko and Wilkins (2010) were able to show that the use of manipulatives colors the mathematical discourse developed with it. This aligns with a sociocultural point of view where mathematical learning is shaped by the historical culture of the community where the learning takes place and by the learners' culture and experiences themselves (Sfard, 2008). Manipulatives when available during a mathematical activity bear a certain culture and shape the learner experiences.

In this paper, we aim to better understand what it is doing mathematics with manipulative in a calculation task at the elementary level. To do so, the concept of *affordance* is convoked to identify the potentialities of manipulatives in developing number sense through arithmetical operations.

Conceptual Clarification

Manipulatives and arithmetic

In the context of arithmetic, a plethora of manipulatives are available for elementary school. Poirier (2001) classified manipulatives used for developing number sense in three categories. The first category refers to manipulatives where units are visible and accessible. For example, if we use 3 free tokens and four transparent bags of 10 tokens to represent the number 43, the tens, represented by bags that contain 10 tokens, can be “broken” into 10 units (by ungrouping a bag). The second category refers to manipulatives where units are still visible but not accessible (not breakable). Base-ten blocks are a good example of this kind of manipulatives: we have to physically exchange one long for 10 units because the longs are usually unbreakable. The third category refers to symbolic manipulatives, where units are not visible in tens, nor in hundreds, etc. (e.g. abacus, money).

Furthermore, manipulatives can become a support or a constraint for the pupils’ mathematical activity. On the one hand, it can support pupils reasoning. For example, base-ten blocks may help to explain why an algorithm works. On the other hand, it can be considered as a constraint if we impose a certain manipulative to solve a task (Jeannotte & Corriveau, 2015). By imposing manipulatives, the task may gain in complexity.

Affordance

Affordances is linked to interactions between an individual and the environment. Environmental characteristics (classroom setting, properties of the manipulatives, etc.) cannot be detached from pupils (their perceptions, their experiences, etc.). They form an inseparable pair. According to Clot and Béguin (2004), affordances are characterized, on the one hand, by the fact that objects are significant, the user’s experience relates on this signification. On the other hand, by its praxis value: “an object is immediately associated with a signification for action” (p. 53). Also, “[w]hether or not the affordance is perceived or attended to will change as the need of the observer changes, but being invariant, it is always there to be perceived” (Gibson 1977, in Brown et al., 2004, p. 120). So, depending on the needs, the uses and the properties exploited of manipulatives may vary. e.g., the base-ten blocks have been designed to help pupils perceived the structure of our numeration system. As an adult, we can see these properties and exploit them to expose some mathematical patterns. “We are seeing concepts that we already understand” (Ball, 1992, p. 5). What pupils see is also related to what they know. Since manipulatives aren’t solely used by pupils, but also by teachers, what teachers do with manipulatives is also inherently part of pupils’ experiences. Thereby, the concept of affordance can not only offer an insight on learning processes but also on teaching processes.

Methodology

For the aims of this paper, we focus only on a part of the data collected from the *MathéRéaliser* Project. We conducted a collaborative research that solicits the participation of teachers. As Corriveau and Bednarz (2016) uphold:

[t]his perspective leads us to re-think [...] the relations between the researcher, as being the expert, and the teacher, as being the novice or the user, as frequently conceived in research in mathematics education [...] [T]he teacher is assumed to be reflective and knowledgeable (pp. 1–2).

In collaborative research, the concept of “double relevance” (Desgagné, 1998) is fundamental and refers to the construct of argumentation relevant to both communities, research and practice. A “double relevance” underlines every choice made in the collaborative work. For example, if a task is chosen to be experimented with pupils, it means that it makes sense for teachers and researches according to their respective sensible arguments.

Description of the Task

The task we experimented is inspired by Cobb (1994). Three similar questions to the following were answered by the pupils. The task was presented orally.

“Represent 1009 with your manipulative and then, I’ll ask you a question. [Wait for the pupil to represent 1009 with base-ten blocks or homemade abacus.] I had a number, I subtracted 453. [Write it on the blackboard.] I now have 1009. How much did I have at the beginning?”

Description of the co-constructed Lesson

The task was experimented with two grade 3 classes (9–10 years old) of 19 and 18 pupils. They already had learned an algorithm using drawing of base-ten blocks. They were not familiar with the abacus. Pupils worked by two using either base-ten blocks or homemade abacus. After teamwork, a whole class discussion took place about 1) the different answers obtained and 2) the strategies used to resolve the task. Table 1 presents the double-relevance of this task and its experimentation.

Plausible use of the task for teachers	Relevance of the task for researchers
Task congruent with curriculum expectations (choice of operation, adding and subtracting 3–4 digit numbers). Curriculum fosters the use of manipulatives. Opportunity to reflect on the use of manipulative by their pupils. Manipulatives seen as a support to solve the task.	Task that could lead to mathematical argumentation (see Cobb, 1994). Manipulatives seen as a constraint in this particular task. Since pupils used to operate by drawing base-ten blocks, asking them to operate with real base-ten block or abacus is unfamiliar to them. This introduction of foreign elements may serve as a breaching experiment (Garfinkel, 1967) to put to light usual ways of doing.

Table 1. Double-relevance of the task

Characteristics of the manipulatives

To perform the task, two manipulatives were available. Either pupils worked with base-ten blocks or with a homemade abacus (see Figure 1).



Figure 1: Base-ten blocks and homemade abacus

As each manipulative has his own properties, we can conjecture that each manipulative, in relation with pupils and the whole class generates different affordances in the classroom (see Table 2).

Base-ten blocks	Homemade abacus
<ul style="list-style-type: none"> • Proportional model; • Units visible but not accessible (not breakable); • The value does not depend on the arrangement of the manipulatives; • The same manipulative “object” can only take one value. 	<ul style="list-style-type: none"> • Non-proportional model; • Symbolic manipulatives (units not visible nor breakable); • The value depends on the arrangement of the manipulatives; • The same manipulative “object” can change value.

Table 2: Characteristics of each manipulatives

Analysis and Results

Data analysis has involved three stages. First, to explore the affordance in the use of manipulatives by the pupils, we watched the videos multiple times (Powell, Francisco, & Maher, 2003). Secondly, we extracted every pupil’s actions we observed. Every action was then described in association with the characteristics of the manipulatives. Finally, we grouped actions related to three different mathematical activities involved with the task and the classroom setting (the use of manipulatives).

One may think that the main difficulties of this task is to choose the good operation and we are aware that using manipulatives do not help the pupils with this choice. However, in this experimentation, it did not appear as an issue. Moreover, the use of base-ten blocks and the abacus helped the teacher to see at a glance who chose the right operation. Actually, most errors arose from counting strategies. Table 3 presents the analysis of pupils’ actions in relation to the characteristics of each manipulatives. We grouped the different actions according to the mathematical activity involved: representing, operating and interpreting.

When representing numbers, most pupils were able to exploit the manipulatives. For base-ten blocks, they associated the right blocks (units, longs, flats, etc.) to each position. Nevertheless, few of them disposed the blocks in a way they can “recognize” rapidly the number in front of them. For the abacus, some pupils struggle with choosing the right column when representing the second term of the operation. Furthermore, more pupils relied on visual patterning, thus helping them later interpreting the number.

When operating, other than counting mistakes, difficulties arose from converting strategies. Even if pupils referred to changing 10 ones for 1 ten (for example) in their discourse, we observed more than once pupils changing eleven units for 1 long. When using the abacus, to convert a ten into ones, they move one chip from the tens column to the ones column AND add ten new chips in the ones column.

One pupil worked with the abacus inconsistently: he represented one thousand nine from right to left, he managed the calculations, but when interpreting the result, he read the number from left to right. This gave the opportunity to the teacher to talk about communication in mathematics.

Maths Activities		Base-ten blocks characteristics and actions observed	Homemade abacus characteristics and actions observed
Representing		<ul style="list-style-type: none"> Counting the blocks needed for each “place value”: cubes, flats, longs, units. Disposing the blocks so the highest value is far left and the other ones on its right (no empty spaces for zero values). Piling the blocks (e.g. 9 units on a cube represent 1009). Using the space to differentiate positions: e.g. ten flats (instead of a cube), then the other flats, etc. 	<ul style="list-style-type: none"> Counting correctly or not the chips and disposing them in the right or wrong column. Disposing the chips in the same order we read numbers. Only one pupil disposed it in the opposite order. In each column, using or not visual pattern disposition when placing chips in each column (e.g. 3 rows of 3 to represent 9).
Operating			
	Algorithm	<ul style="list-style-type: none"> Place value dealing <ul style="list-style-type: none"> Dealing with positions where no exchange is required first Operating from left to right Calculating the taught algorithm (from units to cubes) Mixed strategies Intermediary calculations <ul style="list-style-type: none"> Counting (e.g.: when adding 4 longs to 8 longs, regroup all longs and count them) 	<ul style="list-style-type: none"> Place value dealing <ul style="list-style-type: none"> First, dealing with columns where no exchange is required Using the taught algorithm (from ones to thousands) Intermediary calculations <ul style="list-style-type: none"> Counting (e.g.: when adding 4 chips to 8 chips, regrouping all the chips in one column and count the result) Mental math, articulating manipulatives and number facts correctly or not.
	Converting	<ul style="list-style-type: none"> Changing one long into ten units (or ten units into one long) <ul style="list-style-type: none"> by counting correctly or not ten units; (from ten units to one long) by removing all the units counted or not; changing eleven units for a long. 	<ul style="list-style-type: none"> Changing one chip into ten chips in another column (vice versa) <ul style="list-style-type: none"> by counting correctly or not ten chips (from one ten to ten ones) by moving one chip from the tens to the ones column and adding 10 new chips. (From ten ones to one ten) by removing all the chips counted or not. By placing in the right or wrong column the chips exchanged.
Interpreting		<ul style="list-style-type: none"> Associating the right value to each sort of block. 	<ul style="list-style-type: none"> Associate the right column to each position Changing the reading direction from the one used when representing

Table 3: Actions made by pupils in relation to the characteristics of each manipulatives

Discussion

With the table presented above, we have tried to better understand what it means to do mathematics with manipulatives when developing calculation abilities at the elementary level. By examining the characteristics associated with action, we put to light different affordances. Even if some affordances are shared, some others are specific to only one of the manipulatives. In this section, we discuss further one idea that emerged from our analysis. This idea allows to put to light some differences in pupils’ actions that are related to manipulatives characteristics. Also, speaking of affordance is speaking of seeing what could be observed but is not. Both, what is observed and what is not can inform of the manipulative practices in the classroom.

Counting Over and Over

In the first grades of the elementary, children are used to count to solve problems. The teachers then try to enrich their number sense and to complexify their counting strategies (with number facts, adding to ten, visual pattern disposition, etc.). However, for most pupils, the counting aspect brought by the use of manipulatives clearly took over other calculation abilities and some control was lost in their mathematical activities. When using base-ten blocks, most pupils counted the blocks even for small quantities. For example, when adding three to nine units, we observed pupils counting three units, then counting nine units, putting them together, counting the total, obtaining twelve units, counting ten units to trade them for one long. This may seem trivial insofar as the counting strategy is achieved with success; it does not mean there is a lack of control. Nevertheless, we have observed several errors that arise from this way of doing even if pupils know their numerical facts. For example, a pupil took eight units, but counted nine. Thus, when he added three units and counted the total, he obtained eleven units (and not twelve). He continued his calculations with eleven units and obtained a very close answer, but the wrong one. However, we observed him mentioned to another pupil, further in the video, that nine and three give twelve.

Also, even if pupils are able to group by tens and ungroup, they do not rely on this property yet visible in the base-ten blocks. They rather count. For example, again, to add three to nine units, pupils could have taken one long and kept only two units directly, but they count as we described it above. However, while we observed the same way of doing with an abacus, we also saw more complex strategies. For example, when adding nine and three, a pupil added to ten. However, he was not able to coordinate his action with the abacus and the mental operation.

In short, the main action observed during the task was counting. Counting over and over seemed to divide the global task into counting sub-tasks. After each sub-task, most pupils had to think again about what they were doing sinking into a vicious cycle: thinking about the global task made them forget about the counting they did and counting again made them forget about the global task. With manipulatives, it is difficult, for pupils, to keep track of what is done and what has to be done.

Does this mean that using manipulatives only suggest this way of doing things for those pupils? There is more than one answer to that question. On the one hand, it does because even if it is not necessary all the time, there is always some counting to do. Using manipulatives to add or subtract involve counting physical objects. The physical aspect of manipulatives asks for this way of doing. However, counting is not always the most efficient strategy to use here. Of course, the environment, i.e. the usual class activities, certainly contributes to reinforcing this strategy. On the other hand, as mentioned years ago by researchers (e.g. Bednarz & Janvier, 1982), the tasks performed with the help of manipulatives relate essentially to number representation and “translation”, a work on the number representation in our numeration system. As pupils presumably used base-ten blocks to count in the first place and less to operate coordinating other strategies as well, we can think that the praxis of this manipulative associate it immediately to counting. While we tend to believe that the use of manipulatives supports mathematical reasoning, in this case, we rather observed that pupils refer to more basic reasoning than they could have used.

In fact, we observed more advanced strategies with the less familiar abacus than with base-ten blocks used since first grade. For McNeil & Jarvin (2007), working with familiar manipulatives might drive

the attention of pupils in the wrong. In our case, it is not a wrong direction, but it seems to lead to more basic strategies and to some lack of control. We could conjecture that using a less familiar manipulative does not drive pupils to usual uses. Indeed, in terms of affordance, the meaning constructed in the interactions between the abacus and pupil is less constraint by the experiences. It gives leeway to integrate skills in a new situation (e.g. visual patterning, use of number facts, etc.).

Conclusion

Carbonneau, Marley & Selig (2013) said that “specific instructional variables either suppress or increase the efficacy of manipulatives suggests that simply incorporating manipulatives into mathematics instruction may not be enough to increase student achievement in mathematics” (p. 397). Looking at affordance help understand that not only the instructional setting, but the culture of the class and pupils’ experiences also play a role when talking about learning with manipulatives. As manipulatives used to solve this task are by definition physical object, counting can’t be detached from it. Doing math with manipulatives was not the same activity in this particular case. We observed that pupils rely mostly on what they used to do with a specific kind of manipulatives rather than what they used to do without them. The question is then how to help the pupils rely on other characteristics of these manipulatives? Drijvers (2003) stressed that the affordance that could be realized in the classroom rely not only on the tool itself, but rather on the exploitation of these affordances the educational context and the teacher drive that. As base-ten blocks are often used in grades 1 and 2 when pupils don’t master the table facts, the teachers’ role is here quite important. They have to help pupils go beyond counting and perceived the power of organizing manipulatives by exploiting the space to “see” table fact and not solely rely on it to count and to represent numbers. To do so, teachers could organize the educational context around manipulatives to provide wider learning opportunities for the pupils.

Acknowledgment

The Canadian Social Sciences and Humanities Research Council fund MathéRealiser.

References

- Ball, D. (1992). Magical Hopes: Manipulatives and the reform of math education. *American Education*, 16(2).
- Bednarz, N., & Janvier, J. (1982). The understanding of numeration in primary School, *Educational Studies in Mathematics*, 13, 33–57.
- Brown, J., Stillman, G., & Herbert, S. (2004). Can the notion of affordances be of use in the design of a technology enriched mathematics curriculum. In I. Putt, R. Faragher, & M. McLean (Eds.), *Proceedings of the 27th Annual Conference of the Mathematics Education Research Group of Australasia* (pp. 119–126). Sydney, Australia: MERGA.
- Bruner, J. S. (1977). Process orientation. In D. B. Aichele, & R. E. Reys (Eds.). *Readings in Secondary School Mathematics* (2nd ed.). Boston, MA: Prindle, Weber, & Schmidt.
- Carbonneau, K. J., Marley, S. C., & Selig, J. P. (2013). A meta-analysis of the efficacy of teaching mathematics with concrete manipulatives. *Journal of Educational Psychology*, 105, 380–400.
- Clot, Y., & Béguin, P. (2004). Situated action in the development of activity. *Activités*, 1(1–2).

- Cobb, P., Perlwitz, M. & Underwood, D. (1994). Construction individuelle, acculturation mathématique et communauté scolaire. *Revue des sciences de l'éducation*, XX(1), 41–61.
- Corriveau, C. & Bednarz, N. (2016). Collaborative research in mathematics education: approaching questions related to teaching practices. Paper presented at International Congress on Mathematical Education (ICME). Hamburg (Germany): University of Hamburg.
- Corriveau, C., & Jeannotte D. (2015) Quelques apports du matériel de manipulation sur l'activité mathématique au primaire. *Bulletin AMQ*. LV(3), 32–49.
- Desgagné, S. (1998). La position du chercheur en recherche collaborative: illustration d'une démarche de médiation entre culture universitaire et culture scolaire. *Recherches qualitatives*, 18, 77–105.
- Dienes, Z. P. (1973). Mathematics through the senses, games, dance, and art. Windsor, UK: The National Foundation for Educational Research Publishing Company Ltd.
- Domino, J. (2010). The effects of physical manipulatives on achievement in mathematics in grades K-6: a meta-analysis. (thèse non publiée). State University of New York at Buffalo.
- Drijvers, P. (2003). *Learning algebra in a computer algebra environment: design research on the understanding of the concept of parameter*. Utrecht, the Netherlands: CD-β Press
- Garfinkel, H. (1967). *Studies in ethnomethodology*. Englewood Cliffs, NJ: Prentice Hall. Paradigm Publishers.
- Jeannotte, D. & Corriveau, C. (2015). Analyse de l'utilisation d'un matériel symbolique en troisième année du primaire : raisonnement mathématique et accompagnement. In A. Adihou *et al.* (Eds.) *Proceedings of the 2015 GDM Seminar*, Québec: Université de Sherbrooke.
- Kosko, K. W., & Wilkins, J. L. (2010). Mathematical communication and its relation to the frequency of manipulative use. *International Electronic Journal of Mathematic Education*, 5(2), 79–90.
- Lave, J. (1988). *Cognition in practice: mind, mathematics and culture in everyday life*. Cambridge: Cambridge University Press.
- Lett, S. (2007). Using manipulative materials to increase pupil achievement in mathematics. *Rapport de recherche*, Marie Grove College.
- McNeil, N., & Jarvin, L. (2007). When theories don't add up: disentangling the manipulatives debate. *Theory into Practice*, 46(4), 309–316.
- Moyer, P. S. (2001). Are we having fun yet? How teachers use manipulatives to teach mathematics. *Educational Studies in Mathematics*, 47(2), 175–197.
- Noss, R. (2002). Mathematical epistemologies at work. *For the Learning of Mathematics*, 22(2), 2–13.
- Nunes, T., Schliemann, A. D., & Carraher, D. (1993). *Street mathematics and school mathematics*. Cambridge: Cambridge University Press.
- Özgün-Koca, S., & Edwards, T. (2011) Hands-on, minds-on or both? A discussion of the development of a mathematics activity by using virtual and physical Manipulatives. *Journal of Computers in Mathematics and Sciences Teaching*. 30(4), 389–402.

An analysis of understanding the algebraic structure in school mathematics: focusing on the extension of number sets

Kazuhiro Kurihara

Graduate School of Comprehensive Human Sciences Doctoral Program in School Education
University of Tsukuba, Japan; kazu08710@yahoo.co.jp

Keywords: algebraic structure, the extension of number sets, the process of understanding

Introduction

Skemp (1976) made a distinction between “instrumental understanding” and “relational understanding”. This paper focuses on understanding in mathematics education and aims to construct models for grasping the condition and process of mathematical understanding of students. Understanding models can be roughly divided into two types: the condition model and the process model. First, the condition model describes the condition that students already understand. Second, the process model describes the process of students’ understanding. This process model has included transcendent recursion that Pirie and Kieren (1989) showed. Pirie and Kieren (1989) asserted that “what is needed is an incisive way of viewing the whole process of gaining understanding” (p.7), and argued the necessity of the process model. As stated above, it is important to analyze the process of understanding, and it is necessary to clarify the object. In our project we focus on the algebraic structure because we think that understanding the algebraic structure is a crucial prerequisite for students’ systematic understanding of mathematics, and helps them learning mathematics more deeply. The aim of this study is to clarify the process of understanding the algebraic structure of learners. This study targets student from seventh grade to twelfth grade and focuses on the extension of number sets in school mathematics.

Method

This paper reflects a theoretical study. One of the main claim is to construct the theoretical framework for the empirical research (see Figure 1). Therefore, we reviewed and interpreted literature about the algebraic structure that Bourbaki (1943/1974) showed, and the dual nature of mathematical conceptions that Sfard (1991) showed. The mathematical structure is compounded of a set, an operation between elements and an axiom of structure. Bourbaki (1943/1974) defined the algebraic structure by the laws of composition and laws of action. Assuming that a set is S , an operation is $*$, an axiom of structure is P , and these three elements are paired, $(S, *, P)$ indicates the structure. Sfard (1991) argued that mathematical conceptions can be grasped in two different methods. One of the two different methods is to think structurally as object and the other is to grasp operationally as process. She grasped the duality of mathematical conceptions and claimed that mathematical conceptions are developed by repeating the

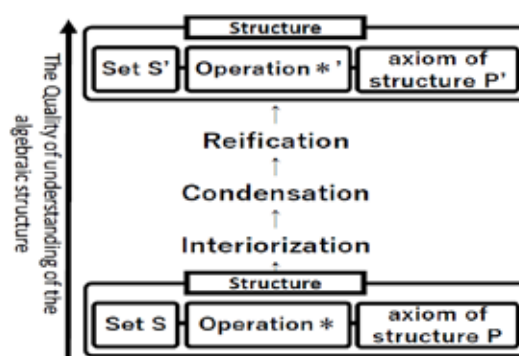


Figure 1: The theoretical framework

transition from operational conceptions to structural conceptions. Then, we focus on closure under an operation in the algebraic structure and clarify the process of understanding the algebraic structure.

Results and Discussion

The generalized model of conception formation by Sfard (1991) shows that transition from operational conceptions to structural conceptions is repeated. We clarify the process of understanding the algebraic structure in the relation between sets focusing on the extension of number sets. So, we take an extension from the set of natural numbers to the set of integers and we focus on the general

model of conception formation that Sfard (1991) showed. In the process of understanding the algebraic structure with the extension of the set of natural numbers to the set of integers four stages are included (see Figure 2). At each stage the students transfer from the operational conception to the structural conception. In the first stage students add and subtract with natural numbers, and then they understand the result of subtraction of natural numbers is not necessarily a natural number. In the second stage they calculate with a concrete number to confirm whether the set of natural numbers is closure, thereby understanding that the set of natural numbers is not closure under subtraction if a subtrahend is bigger than a minuend. In the third stage they introduce new numbers to ensure that the set of natural numbers is closure under subtraction, and then they can calculate even if a subtrahend is bigger than or equals a minuend. In the fourth stage they do addition and subtraction with positive numbers, zero and negative numbers, and then, they can calculate in new number set. We show there are four stages in the process of understanding the algebraic structure with the extension the set of natural numbers to the set of integers. In this process of understanding the algebraic structure, the recognition that the set is closure under an operation is crucial. The second stage is the stage of understanding whether the set of natural numbers is closure under an operation, and the third stage is the stage of introducing a new number from viewpoint that the set is closure under an operation.

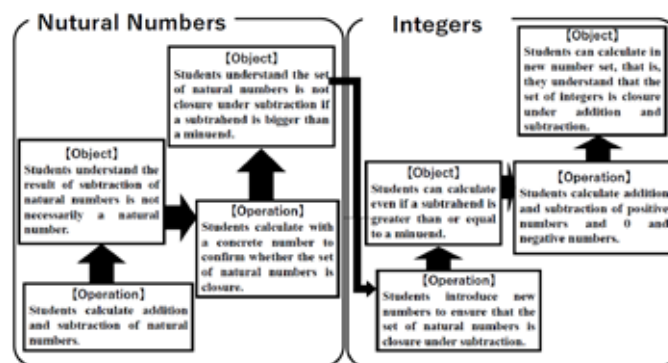


Figure 2: The extension from the sets of natural numbers to the set of integers

We show there are four stages in the process of understanding the algebraic structure with the extension the set of natural numbers to the set of integers. In this process of understanding the algebraic structure, the recognition that the set is closure under an operation is crucial. The second stage is the stage of understanding whether the set of natural numbers is closure under an operation, and the third stage is the stage of introducing a new number from viewpoint that the set is closure under an operation.

References

- Bourbaki, N. (1974). *Elements of mathematics algebra chapter 1-3*. Boston, MA: Addison-Wesley Publishing Company. (The original edition was published in 1943.)
- Pirie, S. & Kieren, T. (1989). A recursive theory of mathematical understanding. *For the Learning of Mathematics*, 9(3), 7-11.
- Sfard, A. (1991). On the dual nature of mathematical conceptions: Reflections on processes and objects as different sides of the same coin. *Educational Studies in Mathematics*, 22(1), 1-36.
- Skemp, R. R. (1976). Relational understanding and instrumental understanding. *Mathematics Teaching*, 77, 20-26 .

Strategy choices and formal algorithms: A mixed methods study

Ems Lord¹ and Andreas J. Stylianides²

¹University of Cambridge, Faculty of Education, UK; el135@cam.ac.uk

²University of Cambridge, Faculty of Education, UK; as899@cam.ac.uk

Although making appropriate strategy choices is arguably a key indicator of calculation fluency, recent curriculum reforms in England prioritise the teaching of formal algorithms. The impact of this policy on students' calculation choices is currently unknown. This paper, which derives from a wider sequential mixed methods explanatory study, consisting of a large-scale survey (N=590) followed by individual interviews (n=23), casts some light on this issue by investigating the strategy choices of the first cohort of Year 6 students (10–11-year-olds) studying under the curriculum reforms. The survey findings showed that gender, prior attainment and confidence were all significant predictors of the use of formal algorithms. The interview findings revealed knowledge of multiple strategies and a willingness to choose alternative strategies as other key variables.

Keywords: Calculation, strategy, fluency, gender, confidence.

Background

This study was motivated by recent curriculum reforms in England (DfE, 2013a) which compelled schools to prioritise the teaching formal algorithms (Figure 1) over and above other calculation strategies. Those reforms signposted a dramatic shift away from previous policy that had encouraged the teaching of a wider range of calculation strategies (DfES, 2007).

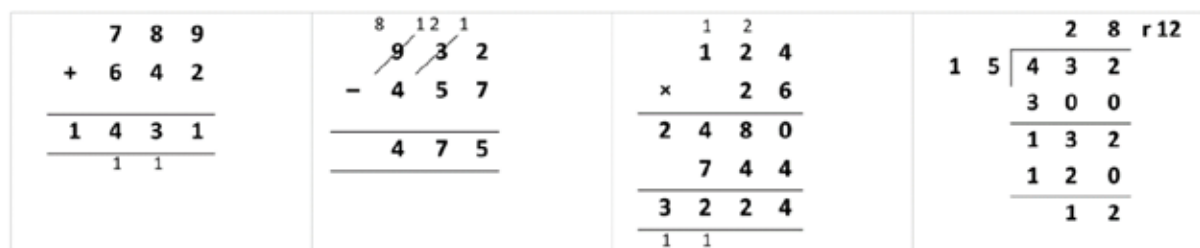


Figure 1: Formal algorithms for the four operations (DfE, 2013a, pp. 46-47)

Alongside the curriculum reforms (DfE, 2013a), corresponding adjustments were made to the assessment procedures; incorrect calculations would receive half marks if and only if students attempted a formal algorithm. The reforms swiftly appeared to have an impact on classroom pedagogy: McClure (2014, para. 3) noted that “Many schools are already interpreting this as practice, practice, practice of formal algorithms.” Although procedural fluency is recognised as a key factor of calculation fluency, the relevant literature highlights other factors too.

Theoretical framework

The notion of *calculation fluency* (also known as *computational fluency*) has been defined in the literature as requiring students to satisfy several different criteria. For example, the US-based National Council of Teachers of Mathematics (NCTM, 2000) stated:

Students exhibit computational fluency when they demonstrate flexibility in the computational methods they choose, understand and can explain these methods, and produce accurate answers efficiently. (NCTM, 2000, p. 152)

The NCTM's definition was consistent with the way we conceptualised calculation fluency in this study as requiring accuracy, efficiency, flexibility and understanding of the chosen strategy. In light of the DfE's (2013a) reforms prioritising formal algorithms, *flexibility* received special attention in our work; due to the particular curricular context and policies, students in this study were deemed to be working flexibly when they deviated from choosing the formal algorithm. Examining the impact of teaching formal algorithms on 9–10-year-old boys in Belgium ($N=21$), Torbeyns and Verschaffel (2013) reported that most of the students prioritised formal algorithms within a year of their introduction to those strategies, even for calculations suited to other strategies such as $482 - 299$.

The DfE's (2013a) reforms prioritising formal algorithms in primary schools were accompanied by an increased focus on problem-solving in secondary schools. The DfE's reforms across both levels of schooling appeared to assume that they satisfied the needs of all students. However, Villalobos (2009) argued that the gender differences in mathematical attainment observed in US schools could be explained by the different curricula that students experienced in their primary and secondary schooling. Her model predicted that young girls might respond positively to the increased focus on formal algorithms but their early success might hamper their later mathematical attainment studying under a problem-solving curriculum. Indeed, significant gender differences already existed in UK schools before the reforms; the DfE (2013b) released data indicating that similar numbers of girls and boys consistently achieved age-related expectations in primary mathematics, yet boys were outperforming girls at higher levels. Examination of the assessment descriptors (DCSF, 2009) revealed that pupils working at age-related expectations were expected to satisfy objectives addressing number recall and performing written calculations whereas pupils working above age-related expectations were expected to demonstrate more problem-solving skills.

The literature also revealed gender differences in calculation strategies. For example, Carr and Davis (2001) conducted a choice/no-choice study with 6–7-year-old students in the US ($N=84$) comparing their addition and subtraction strategies; the boys tended to prefer counting in their heads whereas the girls were more likely to choose counting on their fingers. Also, Hickendorff, Van Putten, Verhelst, and Heiser (2010), investigating the division calculations of 12-year-old students in the Netherlands ($N=362$), reported that boys tended to prefer informal written calculation strategies whereas girls were more likely to adopt formal strategies. Furthermore, when the researchers asked the students to record their division strategies, the boys tended to record fewer steps and work more intuitively than the majority of the girls in the sample. However, the reforms (DfE, 2013a) adopted a 'one size fits all' model which ultimately expected all pupils to use the formal algorithm and did not appear to take into account the differences described above. Moreover, the Programme for International Student Assessments (OECD, 2009) confirmed that 15-year-old English students had one of the largest gender differences favouring boys in mathematical performance.

The role of confidence in the calculation choices of boys and girls remained unexplored in the literature despite evidence revealing that confidence could interact with gender in shaping students'

dispositions, decisions, or achievement. For example, Brown, Brown and Bibby (2008) reported that almost twice as many UK 16-year-old girls than boys indicated that they would not consider studying mathematics post-16 because it was perceived as ‘too difficult.’ Moreover, US-based Heilbrunner (2013) found that confident students were more likely to continue studying mathematics post-16 than their less confident counterparts. Exploring the factors surrounding gender participation in the various STEM-related career paths, Heilbrunner also reported a gender imbalance across the STEM-related subjects where females were less likely to choose engineering or mathematics than males. Hence confidence was regarded as a key issue in this study. For the purposes of this study, we adopted the definition of mathematical confidence as being an individual’s belief in their ability to ‘do’ mathematics (Fishbein & Azjen, 1975).

Research design was another concern. Prior calculation studies tended to adopt choice/no-choice designs which limited their opportunities to explore calculation choices. Few studies explored the reasons behind the strategy choices of the students. Moreover, the DfE’s (2013a) reforms prioritised formal algorithms for the four operations but prior studies tended to focus on a single operation, such as addition. The limited number of studies which did address all of the four operations did not consider gender or confidence. Hence this study adopted a sequential explanatory mixed methods research design which addressed the following research question: *To what extent do gender, prior attainment and confidence predict use of formal algorithms across all of the four operations?*

Method

Participants

For the quantitative phase, 19 schools were randomly selected from a larger cohort taking part in a regional Mathematics Specialist Teacher (MaST) programme, an initiative which aimed to place a Master-level trained teacher in every primary school. This approach resulted in a potential sample of 670 10–11-year-olds. The actual sample consisted of 590 students (324 boys, 266 girls) with 79 students removed (35 - newly arrived in the UK with English as a second language, 33 - working below the required level, 6 - absent, 1 - poor behaviour and 4 - no evidence of parental permission).

Data collection

The quantitative survey consisted of a workbook containing 16 calculations, a mathematics Confidence Questionnaire (CQ) and the prior attainment scores from students’ most recent national assessment at age 7 (Level 1 = below average, Level 2 = average, Level 3 = above average). The class teachers delivered the materials under national assessment test conditions.

The workbooks reflected the overall focus of the study by including some calculations which were deemed suitable for using formal algorithms ($456+372$, $5412+2584$, $632-154$, 27×63 , 568×34 and $517\div 19$) and others which were regarded as suitable for other approaches, such as rounding to the nearest multiple of ten or counting the difference between two numbers ($299+532$, $245+256$, $500-76$, $702-695$, $382-199$, 20×46 , 35×99 , $693\div 3$, $480\div 20$ and $401\div 25$). The draft workbooks were piloted, revised and validated by five education professionals who were asked to confirm their suitability for the use of formal algorithms or alternative strategies; they were also asked to confirm their age-

appropriateness, and their scores exceeded the minimum score of 0.8 recommended for new measures (Rubio, Berg-Weger, Tebb, Lee, & Rauch, 2003).

The CQ was adapted from an existing measure which addressed mathematical competence as well as views on the importance of mathematics (Eccles, Wigfield, Harold, & Blumenfeld, 1993). The original version consisted of ten questions with a five-point Likert-style response scale which had been extensively trialed with similar age groups. For example, students were asked ‘How well do you expect to do in math this year?’ and ‘How good in math are you?’ The questionnaire could be efficiently administered by teachers to their whole class, but the terms *math* and *student* were replaced for my UK-based study. The internal consistency of the revised questionnaire was confirmed using Cronbach Alpha testing, achieving a high rating (10 items; $\alpha=0.88$).

Twenty-four potential interviewees (12 boys, 12 girls) were drawn from three of the schools from the initial phase. This purposeful sample consisted of 12 high attaining students (6 boys, 6 girls) and 12 low confidence students (6 boys, 6 girls). One student, a high attaining girl, was absent which resulted in an actual sample of 23 interviewees. Each pupil was individually interviewed by the first author and the interview was audio recorded (video recording was not possible due to school policies). Since the purpose was to elicit the reasons underlying the students’ strategy choices, semi-structured interviews were deemed the most suitable approach; after a few introductory questions to confirm their name and willingness to participate in the project, the students were asked a series of questions addressing different aspects of their calculation fluency such as the reasons behind their strategy choices, their knowledge of alternative strategies and their checking procedures.

Data analysis

The initial quantitative data analysis informed the subsequent qualitative analysis. Each workbook was checked for accuracy and the individual calculations were coded according to the chosen strategy. An individual’s flexibility was determined by the total number of times they chose formal algorithms across the 16 calculations. Quantitative analysis was conducted using ANOVA to compare the accuracy rates of different strategies and Multiple Linear Regression (MLR) to predict flexibility; the three predictor variables were gender, prior attainment and confidence, and the dependent variable was their use of formal algorithms.

The interviews were transcribed and coded using framework analysis (Richie & Spencer, 1994). This accommodated *a priori* issues from the quantitative phase as well as other themes emerging during the analysis. It began with a familiarisation stage, reading and re-reading the transcribed notes in order to become totally immersed in the data. The *a priori* themes were calculation accuracy, use of the formal algorithm (which reflected the flexibility aspect of calculation fluency), conceptual understanding, efficiency and the most accurate calculation strategies. The notes taken during this stage were organised into a draft thematic framework which was trialed and refined with a limited number of the transcripts, and the revised framework retained its original themes. Charting the data moved the analysis from working with individual transcripts towards analysing the whole data set. Each chart represented a single theme and the data was organised into the sub-themes identified in the previous stages of the process – these completed charts allowed the data to be analysed both

vertically (by sub-theme) and horizontally (by individual pupil). The charts enabled counting of the total number of coded items as well as consideration of the actual text.

Findings

Although formal algorithms were the most frequently selected strategy for each of the sixteen calculations, ANOVA tests confirmed that other strategies were significantly more accurate for three of those calculations ($702 - 695$, $401 \div 25$ and $517 \div 19$) and formal algorithms for two others ($456 + 372$ and $693 \div 3$). The MLR analysis revealed a statistically significant regression equation ($F(4, 585) = 11.98$, $p < 0.001$), $R^2 = 7.57\%$ (Table 1) for predicting use of the formal algorithm.

Use of formal algorithm = $5.5212 + 0.8893(\text{girl}) - 1.3026(\text{Level } 2) - 1.6688(\text{Level } 3) + 0.1439(\text{Confidence})$.

The MLR analysis confirmed that gender, prior attainment and confidence were all significant predictors of flexibility, but the most significant factor was confidence. If a student rated their mathematics confidence with the maximum score of 50, then their predicted use of formal algorithms increased by seven calculations. However those findings did not explain why the confident students tended to choose formal algorithms. Nor did they either explain why the girls tended to choose formal algorithms for one more calculation than the boys, or explain why the high attaining pupils tended to choose formal algorithms for two fewer calculations than the others. Due to the sequential nature of this study, each issue was addressed in the subsequent qualitative analysis. Moreover, the regression model indicated that just under 8% of the variance in choosing formal algorithms was explained by the three predictor variables so the qualitative phase also offered an opportunity to explore other possible variables to account for the remaining variance.

Coefficient	Estimate	Standard Error	t-value	p-value
Intercept	5.5212	0.9884	5.5862	3.56E-08
Girl	0.8893	0.3091	2.877	0.0040
Level 2	-1.3026	0.5379	-2.4217	0.0158
Level 3	-1.6688	0.6225	-2.6806	0.0076
Confidence	0.1439	0.0229	6.2793	6.63E-10

Table 1: Summary of revised coefficients for predicting use of the formal algorithm

Consider the quantitative finding that the more confident students tended to choose formal algorithms: this finding might imply that those students were either confident in their abilities to apply those strategies or they felt confident because they were following their teacher's approach. Alternatively, this finding might appear to imply that the low confidence students drew upon a wider range of calculation strategies than their counterparts by not relying on formal algorithms. However, the interviews revealed that the situation was more complex than it initially appeared; two-thirds of the low confidence interviewees admitted that they only knew a single strategy for some of their operations, some of them had yet to encounter formal algorithms and others were unwilling to attempt

such strategies due to their lack of practice with the strategies. In particular, when asked to suggest another strategy for working out their answers, most of the low confidence students struggled to name an alternative strategy for multiplication or division calculations.

For gender, the quantitative findings showed that the girls were more likely to choose formal algorithms than the boys, and the interviews revealed that the girls preferred to use the same strategy for calculating and checking too. When the girls did know another strategy, such as rounding for 35×99 , several of them either did not identify suitable opportunities to apply it or were reluctant to apply it. Several students stated that their choice of strategy was influenced by their knowledge of the assessment procedures for national tests. However, most of the boys were willing to adopt different strategies such as applying their knowledge of divisibility rules or checking their answers using inverses.

The quantitative findings also showed that the high attaining students were less likely to choose formal algorithms than other students, and their interviews revealed that they knew a greater range of strategies than the other students which enabled them to select alternative approaches. This was most noticeable when the high attaining students were discussing how they checked their answers; half of them employed more than one checking procedure or estimated their answers. Their flexibility ensured that they had a higher mean accuracy score than the other students too.

The interviews also shed further light on the unaccounted for variance in the regression model. Knowledge of multiple strategies and checking procedures emerged as important factors to consider regarding use of formal algorithms. More specifically, the transcripts revealed that students checked their calculations in different ways and at different times, and that those differing strategies might account for different accuracy rates too. The most accurate students were the minority who checked at least some of their answers using multiple strategies such as divisibility rules and using inverses; the majority simply checked each of their calculations by repeating their initial strategy. The students also checked their answers at different times but most of them checked as they went along. Around a fifth of the students, mostly boys, delayed checking their answers until they had finished all of their questions. However, the findings relating to the optimum time for checking their calculations were inconclusive, due to the small numbers of students involved. The interviews also highlighted the potentially negative influence of national testing on calculation flexibility; several students said that their choice of formal algorithms was influenced by national tests.

Discussion

Exploring different calculation strategies offers an opportunity for young students to experience working flexibly in the mathematics classroom, rather than relying exclusively on formal algorithms. However, the findings revealed that formal algorithms were the most frequently selected strategy for each of the 16 calculations in this study, including those deliberately included due to their suitability for other strategies. The subsequent interviews revealed that less confident students tended to be unaware of multiple strategies for multiplication or division calculations, possibly indicating that the renewed emphasis on formal algorithms might have steered some schools towards teaching a narrower range of strategies. The interviews also revealed that failing to recognise an opportunity to work flexibly often resulted in students choosing a less efficient, potentially error-prone, strategy.

The finding that the girls were more likely to choose formal algorithms than the boys was consistent with the early stages of Villalobos' (2009) theoretical model whereby young girls experience *strategy socialization* when they choose to follow algorithms. If the model is correct, those girls may struggle to adapt to the demands for more flexible approaches of later mathematics courses, such as those related to problem-solving. The results also showed that the high attaining students were less likely to choose formal algorithms than others. Their willingness to work flexibly would present a clear advantage for those high attaining students when problem-solving; knowing more than one strategy would enable them to adopt a different strategy if they got stuck (Russell, 2000).

Moreover, the most accurate students were the minority who checked at least some of their answers using multiple strategies, including estimation which was highlighted as important in the literature (e.g., Doreneles, Duro, Rios, Nogues, & Pereira, 2017). Readiness to consider other strategies was also recognised as a key aspect of fluency (McClure, 2014); comparing two answers from different strategies would allow students to identify any possible errors which might not have been noticed by simply repeating their initial strategy.

All study designs have their limitations. Although this project focused on gender, prior attainment and confidence, we accept that future studies might address social class or the enacted curriculum. Due to financial and time restraints, the student interviews were limited to three schools; widening the range of schools might uncover further factors too.

The above findings have clear implications for schools, researchers and policy makers. The decision to focus on all four operations, contrary to most prior research, exposed differences in the extent of students' knowledge of multiple strategies between operations. Also the sequential explanatory mixed methods research design, another notable difference from most prior research, enabled further exploration of the initial quantitative results by revealing potential issues arising from focusing too heavily on formal algorithms. Such issues include: low confidence students lacking knowledge of multiple strategies, restricting their options when they encounter difficulties; girls prioritising algorithmic fluency above all other aspects of mathematics, possibly to the detriment of their future mathematical development; and, students limiting themselves to a single calculation and checking procedure, reducing their opportunities to spot errors. Next steps in this study involve disseminating these findings to a variety of audiences, especially policy makers through contributions towards parliamentary access groups, national conferences and teaching publications.

References

- Brown, M., Brown, P., & Bibby, T. (2008). "I would rather die": Attitudes of 16-year-olds towards their future participation in mathematics. *Research in Mathematics Education*, 10(1), 2–18.
- Carr, M., & Davis, H. (2001). Gender differences in arithmetic strategy use: a function of skill and preference. *Contemporary Educational Psychology*, 26(3), 330–347.
- Department for Children, Schools and Families (DCSF). (2009). *Assessing pupils' progress (APP) in mathematics: Criteria levels 1 to 8*. Nottingham, England: DCSF.
- Department for Education (DfE). (2013a). *National curriculum in England: framework document*. London: Department for Education.

- Department for Education (DfE). (2013b). *National curriculum assessments at Key Stage 2 in England*. Retrieved from https://docs.google.com/spreadsheets/d/1vImVznYbdn0vB47OHOFIm0BhZaDbQW_vINfe1xqZr5g/edit#gid=0
- Department for Education and Skills. (DfES). (2007). *Guidance paper: calculation*. London: DfES.
- Dorneles, B.V., Duro, M.L., Rios, N.M.B, & Nogues, C.P. (2017). Number estimation in children: An assessment study with number line estimation and numerosity tasks. In T. Dooley & G. Gueudent (Eds.), *Proceedings of the 10th Congress of the European Society for Research in Mathematics Education* (pp. 338–345). Dublin, Ireland: DCU & ERME.
- Eccles, J., Wigfield, A., Harold, R. D., & Blumenfeld, P. (1993). Age and gender differences in children's self-and task perceptions during elementary school. *Child Development*, 64(3), 830–847.
- Heilbronner, N. N. (2013). The STEM pathway for women: What has changed? *Gifted Child Quarterly*, 57(1), 39–55.
- Hickendorff, M., van Putten, C., Verhelst, & Heiser, W. (2010). Individual differences in strategy use on division problems: Mental versus written computation. *Journal of Educational Psychology*, 102(2), 438–452.
- McClure, L. (2014, April). *Developing number fluency – what, why and how*. Retrieved from <https://nrich.maths.org/10624>
- National Council of Teachers of Mathematics (NCTM) (2000). *Principles and standards for school mathematics*. Reston, VA: NCTM.
- Organisation for Economic Co-operation (OECD). (2009). *Programme for International Student Assessment (PISA)*. <http://www.oecd.org/pisa/keyfindings/>
- Ritchie, J., & Spencer, L. (1994). Qualitative data analysis for applied policy research. In A. Bryman & R. G. Burgess (Eds.), *Analyzing Qualitative Data* (pp. 173–194). Taylor & Francis.
- Rubio, D., Berg-Weger, M., Tebb, S., Lee, E., & Rauch, S. (2003). Objectifying content validity: conducting a content validity study in social work research. *Social Work Research*, 27(2), 94–104.
- Russell, S. J. (2000). Developing computational fluency with whole numbers in the elementary grades. *The New England Math Journal*, 32(2), 40–54.
- Torbeys, J., & Verschaffel, L. (2013). Efficient and flexible strategy use on multi-digit sums: A choice/no-choice study. *Research in Mathematics Education*, 15(2), 129–140.
- Villalobos, A. (2009). The importance of breaking set: socialized cognitive strategies and the gender discrepancy in mathematics. *Theory and Research in Education*, 7(1), 27–45.

Number line estimation and quantitative reasoning: two important skills for mathematical achievement¹

Camila Peres Nogues and Beatriz Vargas Dorneles

Universidade Federal do Rio Grande do Sul, Brasil;

camilapnogues@gmail.com, beatriz.dorneles@ufrgs.br

Number estimation and quantitative reasoning have been indicated as significant skills for mathematical achievement. In this sense, this paper aims to analyse the students' performance in these two skills and verify possible relations between both. For that, 143 students from 3rd and 4th grades of elementary school were evaluated using two number line estimation tasks. Results showed that there is a direct relation between children's performance in both abilities. From this, it is suggested that both number estimation and quantitative reasoning tasks can be used in daily classroom activities to promote the learning of initial mathematics concepts considering the importance of estimation in daily activities.

Keywords: Number estimation, quantitative reasoning, mathematical learning.

Introduction

Mathematics is an important area of knowledge for children's cognitive development, as it involves several domain-specific skills related to numerical knowledge. Learning mathematics requires the understanding of initial concepts about numbers, quantities and relations, and the ability to make connections between these concepts (Nunes, Bryant, Sylva, & Barros, 2009). Therefore, it is important to provide different teaching and learning situations with the intention of promoting children's mathematical development. In this sense, our study highlights two skills indicated in the literature as significant for mathematical learning: number estimation and quantitative reasoning. Number estimation is a cognitive ability that has been studied and pointed out as important for mathematical performance (Geary, 2011; Moore & Ashcraft, 2015; Schneider et al., 2018; Siegler & Booth, 2004; Siegler, Thompson, & Opfer, 2009). The evidence is that the ability to estimate is related to arithmetic, number categorization and numerical magnitudes (Laski & Siegler, 2007; Link, Nuerk, & Moeller, 2014; Schneider et al., 2018; Siegler et al., 2009). In number estimation tasks, students identify numerical magnitudes and perform number decompositions. More than that, studies have shown that children's ability to accurately locate numbers on a number line is predictive of later mathematical achievement (Geary, 2011; Siegler & Booth, 2004). The number line estimation task, in the version number-to-position (NP), is the task most commonly used to evaluate the ability to estimate numerical magnitudes. In this task, participants are given a number, in the form of Arabic numerals, and are asked to locate that number on a line usually bounded in a numerical range. This task has been used to trace the development of the pupil's comprehension of numerical magnitude throughout the school grades (Booth & Siegler, 2006; Schneider et al., 2018; Siegler & Opfer, 2003).

¹ This study was financed in part by the Coordenação de Aperfeiçoamento de Pessoal de Nível Superior - Brasil (CAPES)

- Finance Code 001

An alternative version of the number line estimation task has also been proposed. The intention of this version is to investigate estimation accuracy differences between tasks and to gain a broader understanding of the development of the ability to estimate. In this version, called position-to-number (PN), participants are asked to estimate a number corresponding to a location on a number line also bounded by a numerical range. Figure 1 shows examples of NP and PN tasks.

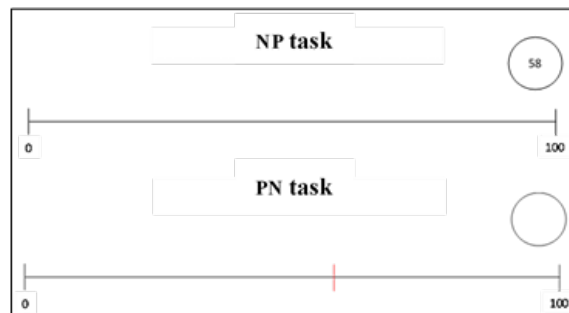


Figure 1: Examples of the number estimation tasks NP and PN

These two versions of the number line estimation task are complementary since they embody the central property of the ability to estimate, which is the translation between numerical and spatial representations (Siegler & Opfer, 2003).

Regarding quantitative reasoning, we can say that it is essential for the construction of initial mathematical concepts, since it is based on the understanding of the relations between quantities, for example, if they are increasing or decreasing (Nunes, Dorneles, Lin, & Rathgeb-Schnierer, 2016). Evidence indicates that quantitative reasoning developed from the beginning of elementary school contributes significantly to mathematical achievement and that understanding the relation between quantities is essential for learning numerical and arithmetic representations (Nunes et al., 2007; Nunes, Bryant, Barros, & Sylva, 2011). Quantitative reasoning is divided into two categories, additive and multiplicative reasoning, which are classified by situations according to the relation established between quantities (Nunes et al., 2016). Additive reasoning is characterized by the ability to join or separate quantities from a total quantity (quantity composition problems), to recognize the inverse relation between addition and subtraction (transformation problems), and to understand comparative situations (comparison problems). Multiplicative reasoning involves the ability to perform one-to-many correspondence and to perform distributions equally. It is classified in situations of direct or inverse relations between quantities and product of measures, in which a third quantity is formed by two other quantities (Nunes et al., 2016). Examples of these quantitative reasoning tasks that were used in this study are presented in Figure 2.

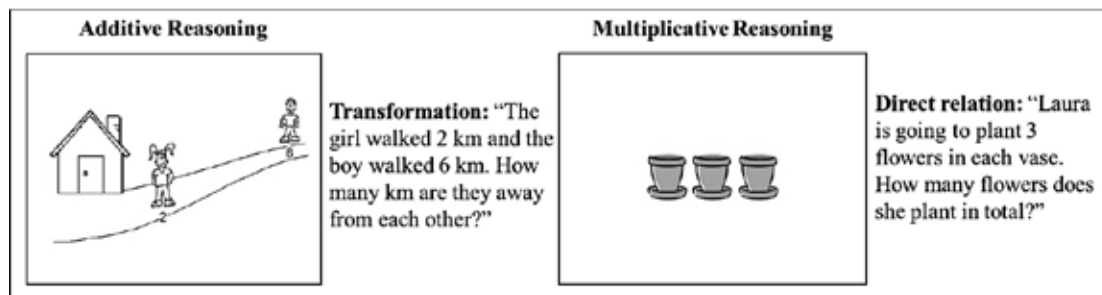


Figure 2: Examples of quantitative reasoning problems

Thus, we perceive that different quantitative relations are necessary in order to understand mathematical concepts and operations. When students understand the relation between quantities and operations, it becomes easier to correctly decide the strategies and schemes to be used to solve the problems. Consequently, this understanding will have a direct influence on mathematical achievement.

Concluding this review, some studies on this topic have been presented in a previous edition of CERME. About number estimation, we found a comparison study between two estimation tasks in 2nd and 3rd graders' performance (Dorneles, Duro, Rios, Nogue, & Pereira, 2017), and another comparing preschool children's performance in a number line estimation task with initial math skills (Elofsson, 2017). On quantitative reasoning, we highlight a study carried out with 2nd graders checking their solution strategies when solving transformation situations to support the development of their mathematical thinking (Serrazina & Rodrigues, 2017).

In this sense, what was intended in this study was to analyse the performance of 3rd and 4th grade students on number estimation and quantitative reasoning and to investigate the relation between their performance in these abilities. This relation, as far as we know, has not yet been the focus of studies. Therefore, this research fills a gap in the literature and provides more evidence of cognitive abilities important to mathematical performance.

Method

The sample comprised a total of 143 children (62 girls and 81 boys) from two public elementary schools in Porto Alegre/Brazil. Schools were chosen by criteria of convenience, number of students and attending to communities of similar socioeconomic classes. The students were 3rd and 4th graders (76 from 3rd and 67 from 4th grade), and ages between 8 to 11 years old ($M=9.8$, $SD=.74$). They were evaluated using two number line estimation tasks (*NP* and *PN*) and one quantitative reasoning task. The 3rd and 4th school grades were chosen because in these grades the students are in similar moments of learning considering the curricular contents, especially in relation to numerical knowledge. And the tasks used require some numeric knowledge established to be solved, like the understanding of the numerical system and of the four mathematical operations. It is important to say that estimation and problem solving are part of the curriculum in Brazil, but these tasks specifically of number estimation and quantitative reasoning are not usual in classrooms. Even though, the children were able to solve the tasks after the researcher's explanation.

To evaluate number estimation ability, two number line tasks were used adapted from Siegler and Opfer (2003). The first one was number-to-position (*NP*) task, which consists in locating the position of a number on a number line bounded by 0 on the left and 100 on the right. The second one was position-to-number (*PN*) task, which consists of estimating a value that corresponds to a mark indicated on a number line also bounded by 0 and 100. There were 22 numbers to be estimated (2, 3, 5, 8, 12, 17, 21, 26, 34, 39, 42, 46, 54, 58, 61, 67, 73, 78, 82, 89, 92, 97), taken from the study by Laski and Siegler (2007). These numbers were presented in a random order and children wrote down their estimates in a notebook containing a number line and a number to be estimated on each page. The task was applied in groups of 10 students and lasted about 30 minutes per group.

The quantitative reasoning task was adapted from Nunes (2009) and aimed to evaluate children's arithmetic reasoning in problem solving. The quantitative relations involved were additive reasoning (including composition of quantities, situations of transformation and comparison) and multiplicative reasoning (containing situations of direct and inverse relations between quantities and product of measures). The task was composed of 18 situations, nine of each kind of reasoning. Task application occurred collectively in groups of 10 students. Each participant received a notebook containing one situation per page, in which only illustrations were presented without written information. The instructions were given orally by the assessor, so the children did not depend on their reading ability.

The analysis of performance in number estimation was determined by calculating the accuracy with which the students estimated each number requested, that is, by calculating the percentage of absolute error of each child's estimate. This computation is adapted from Siegler and Booth (2004) and can be explained by dividing the difference between the child's estimate and the number to be estimated by the number line scale (which in this task is 100). For example, consider that the number to be estimated was 40 and the child made a mark on the number line corresponding to number 30, then the computation will be done as follows: $|30-40|/100$, obtaining an accuracy of 0.1. Therefore, the lower is the value found, the more accurate is the estimation made by the participant.

For the quantitative reasoning task, the total score of correct answers in the task and the hits per reasoning category (additive and multiplicative reasoning) were considered.

Initially, the quantitative analyses were conducted to identify any differences in performance on number estimation and quantitative reasoning tasks according to gender, age and school grade. Then, an association analysis between the performance in the two types of number line estimation tasks was conducted. After which, the children's performance in quantitative reasoning and number line estimation tasks was compared.

Results

Firstly, the results are presented by task type, describing the students' performance in number line estimation tasks and in the quantitative reasoning task. Finally, the results for the correlation between both math abilities evaluated are shown.

The ability to estimate was evaluated using two number line estimation tasks (*NP* and *PN* tasks). The performance in both tasks was organized according to the mean accuracy of each child by task.

In a first analysis, the performance in each of the two number line estimation tasks was related with gender, age and school grade, and a statistically significant difference was only found (*NP*: $U=1827$, $p<.05$; *PN*: $U=1767.5$, $p<.05$) with school grade. This indicates that 4th graders accuracy (mean *NP*=.086, $SD=.038$; mean *PN*=.074, $SD=.037$) was better than 3rd graders (mean *NP*=.11, $SD=.055$, mean *PN*=.099, $SD=.056$) in both tasks. After this, from a correlation analysis, accuracy of *NP* ($M=.10$; $SD=.05$) and *PN* ($M=.09$, $SD=.06$) showed a moderate but significant correlation ($r_s=.66$, $p<.01$), indicating that, the better is the accuracy in *NP* task, the better it is in *PN* task. A descriptive analysis was also conducted to identify which proposed numbers the participants estimated more accurately. From this, we can observe (Figure 3) that children were more accurate in numbers at the ends of the number line (numbers 2, 3, 5 and 97).

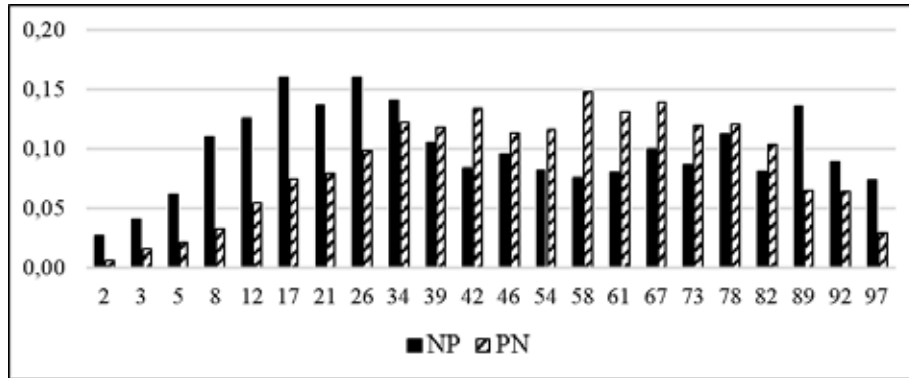


Figure 3: Accuracy mean on NP and PN tasks

Quantitative reasoning

The quantitative reasoning task assessed the children's ability to solve situations involving arithmetic reasoning using the four fundamental mathematical operations. The results were computed by the total of correct answers in the task and by the number of correct answers in each reasoning category (additive reasoning and multiplicative reasoning). In general, students presented a mean of 10.55 hits ($SD=3.22$). When scores were verified according to the reasoning category, the students obtained better scores in additive reasoning ($M=6.03$, $SD=1.92$) than in multiplicative reasoning ($M=4.51$, $SD=1.81$). When correlating performance in the quantitative reasoning task with the variables gender, age and school grade, there was a statistically significant difference with school grade ($U=3256$, $p<.05$) and a direct but weak correlation with age ($rs=.18$, $p<.05$). These results indicate that there was an increase in total score from 3rd to 4th grades (3rd grade: $M=9.74$, $SD=3.32$; 4th grade: $M=11.46$, $SD=2.87$). However, this increase was significant ($U=3486.5$, $p<.05$) only for additive reasoning (3rd grade: $M=5.42$, $SD=2.06$; 4th grade: $M=6.73$, $SD=1.47$).

When analysing the situations involved in both additive and multiplicative reasoning (Figure 4), there is a higher percentage of correct answers in situations of additive reasoning involving quantities composition and transformation. Concerning situations of multiplicative reasoning, students obtained higher scores in situations involving direct and inverse relations between quantities.

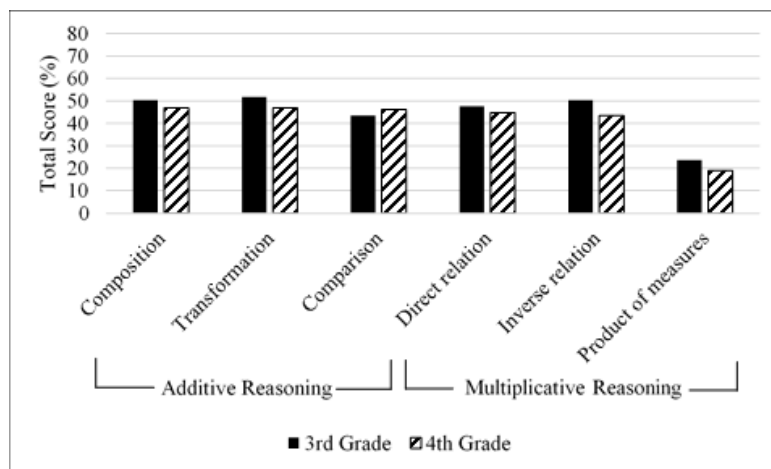


Figure 4: Scores Organized by Category of Problem Types

Number line estimation and quantitative reasoning

A correlation analysis was conducted to verify associations between the measures of number line estimation and quantitative reasoning. Thereby, moderate and significant correlations were found between quantitative reasoning total score and both the NP task ($r_s = -.39$, $p < .01$) and PN task ($r_s = -.42$, $p < .01$). In the same way, there were also moderate and significant associations between score by reasoning category and accuracy in both number line estimation tasks. Correlations index can be seen in Table 1.

Measures	Number Estimation		Quantitative Reasoning		
	1	2	3	4	5
1. NP	1				
2. PN	0,660**	1			
3. AR	-0,378**	-0,394**	1		
4. MR	-0,292**	-0,328**	0,502**	1	
5. QR – Total	-0,389**	-0,420**	0,857**	0,864**	1

* $p < 0,05$; ** $p < 0,01$

Table 1: Correlation between number estimation and quantitative reasoning

Discussion and conclusions

The aim of this research was to verify the relation between number estimation and quantitative reasoning performance of a third and fourth graders group, as well as to analyse their performance in each of these abilities. For this, two number line estimation tasks (NP and PN tasks) and a quantitative reasoning task were used.

Among the research results, we can highlight the significant difference found between the school grades, with 4th graders performing significantly better than 3rd graders in both abilities. These findings indicate that experience and increased schooling improve accuracy in number line tasks, as found in previous studies (Booth & Siegler, 2006; Laski & Siegler, 2007; Siegler & Opfer, 2003). This is a consequence of children becoming more aware of numbers and their relations, learning that larger numbers are located to the right on a number line, and that the distance between 10 and 20 is the same as that between 80 and 90, for example (Friso-van den Bos et al., 2015; Laski & Siegler, 2007).

An association was also found between children's performance in both number line estimation tasks, that is, participants who performed well in the NP task also performed well in the PN task. When analysing the numbers in which children obtained better performance, it was found that in the NP and PN tasks the numbers with the best precision (2, 3, 5 and 97) are close to the extremities of the number line. The worst performances were found in different numbers for each task. Nevertheless, in both cases, the majority of the numbers are located between 25 and 50 and between 50 and 75. This result is similar to previous studies that indicate that children up to the 4th grade are not very accurate in numbers far from the extremities of the number line, (Laski & Siegler, 2007; Siegler & Opfer, 2003).

In quantitative reasoning task, 4th graders scored better than 3rd graders as expected. When analysing the reasoning categories separately, 4th graders presented better scores in both additive and multiplicative reasoning, but this difference was only significant for additive reasoning. This indicates that due to the similarity of contents proposed in the Brazilian school curriculum in these grades, students are learning multiplicative reasoning, that is, the relations between multiplication and division operations, which may explain the fact that the difference between 3rd and 4th graders was not significant for these types of reasoning.

A direct association between number line estimation and quantitative reasoning was found. Students' performance in the quantitative reasoning task showed a correlation with both number line estimation tasks, specifically additive reasoning, which had the highest correlation index in both NP and PN tasks.

However, one limitation of the research must be considered: the collective application of the tasks proposed. Nevertheless, the findings of this study contribute to the planning of tasks that may improve abilities that are not currently approached in classrooms, such as number estimation. As previously mentioned, the development of the ability to estimate can improve students' skills in arithmetic computations. There are several daily situations when an estimation is enough, without the need to get an exact answer, for example, to choose the smallest cashier row in a supermarket, or if it is necessary to run to get to school on time. Therefore, in mathematics teaching it is important to highlight the use of alternative strategies to solve problems, allowing students to increase their set of solution methods. In this way, the use of number estimation in mathematics classes is an option to develop ability in arithmetic computations and may help to explain and to check the results of computations, while allowing students to establish their own solution strategies and appropriate different ways to solve mathematical tasks.

These results add new elements to the discussion of the role of number estimation in math achievement and provide evidence regarding estimation ability. However, future research on the subject is needed, such as longitudinal studies that describe the development of the ability to estimate and studies that verify the strategies used by students in each school grade.

References

- Booth, J. L., & Siegler, R. S. (2006). Developmental and individual differences in pure numerical estimation. *Developmental Psychology*, 42(1), 189–201.
- Dorneles, B. V., Duro, M. L., Rios, N. M. B., Nogues, C. P., & Pereira, C. dos S. (2017). Number estimation in children: In *Congress of the European Society for Research in Mathematics Education (CERME10, 1–5 February 2017)*. Dublin, Ireland: Dublin City University, Institute of Education.
- Elofsson, J. (2017). 5- and 6-Year-Old Children's Number Line Estimation Patterns. In *Congress of the European Society for Research in Mathematics Education (CERME10, 1–5 February 2017)*. Dublin, Ireland: Dublin City University, Institute of Education.
- Friso-van den Bos, I., Kroesbergen, E. H., Van Luit, J. E. H., Xenidou-Dervou, I., Jonkman, L. M., Van der Schoot, M., & Van Lieshout, E. C. D. M. (2015). Longitudinal development of number

- line estimation and mathematics performance in primary school children. *Journal of Experimental Child Psychology*, 134, 12–29.
- Geary, D. C. (2011). Cognitive predictors of achievement growth in mathematics: A 5-year longitudinal study. *Developmental Psychology*, 47(6), 1539–1552.
- Laski, E. V., & Siegler, R. S. (2007). Is 27 a big number? correlational and causal connections among numerical categorization, number line estimation, and numerical magnitude comparison. *Child Development*, 78(6), 1723–1743.
- Link, T., Nuerk, H. C., & Moeller, K. (2014). On the relation between the mental number line and arithmetic competencies. *Quarterly Journal of Experimental Psychology*, 67(8), 1597–1613.
- Moore, A. M., & Ashcraft, M. H. (2015). Children's mathematical performance: Five cognitive tasks across five grades. *Journal of Experimental Child Psychology*, 135, 1–24.
- Nunes, T. (2009). *Teacher notes*. Retrieved from http://www.education.ox.ac.uk/ndcs/Resources/teachersbook_exercises.pdf
- Nunes, T., Bryant, P., Barros, R., & Sylva, K. (2011). The relative importance of two different mathematical abilities to mathematical achievement. *British Journal of Educational Psychology*, 82(1), 136–156.
- Nunes, T., Bryant, P., Evans, D., Bell, D., Gardner, S., Gardner, A., & Carraher, J. (2007). The contribution of logical reasoning to the learning of mathematics in primary school. *British Journal of Developmental Psychology*, 25(1), 147–166.
- Nunes, T., Bryant, P., Sylva, K., & Barros, R. (2009). *Development of maths capabilities and confidence in primary school* (No. Research Report DCSF-RR118). London: Department of Children, Schools and Families.
- Nunes, T., Dorneles, B. V., Lin, P.-J., & Rathgeb-Schnierer, E. (2016). Teaching and Learning About Whole Numbers in Primary School. In *ICME-13 Topical Surveys* (Springer O). Hamburg.
- Schneider, M., Merz, S., Stricker, J., De Smedt, B., Torbeyns, J., Verschaffel, L., & Luwel, K. (2018). Associations of Number Line Estimation With Mathematical Competence: A Meta-analysis. *Child Development*, 89(5), 1467–1484.
- Serrazina, L., & Rodrigues, M. (2017). The role of representations in promoting the quantitative reasoning. In *Congress of the European Society for Research in Mathematics Education (CERME10, 1–5 February 2017)*. Dublin, Ireland: Dublin City University, Institute of Education.
- Siegler, R., & Booth, J. (2004). Development of numerical estimation in young children. *Child Development*, 75(2), 428–444.
- Siegler, R. S., & Opfer, J. (2003). The development of numerical estimation: Evidence for multiple representations of numerical quantity. *Psychological Science*, 14(3), 237–243.
- Siegler, R. S., Thompson, C. A., & Opfer, J. E. (2009). The logarithmic-to-linear shift: One learning sequence, many tasks, many time scales. *Mind, Brain, and Education*, 3(3), 143–150.

Mental calculations with rational numbers across educational levels

Ioannis Papadopoulos¹, Styliani Panagiotopoulou² and Michail Karakostas³

^{1,2,3}Aristotle University of Thessaloniki, Dep. of Primary Education, Greece;

¹ypapadop@eled.auth.gr; ²stella.panagiotopoulou@gmail.com; ³milakis123@gmail.com

In this study primary, secondary and tertiary education students try to calculate mentally the very same tasks involving operations with rational numbers (mainly fractions and mixed numbers). The aim was to record the range of strategies used by the students and at the same time to examine how these strategies are distributed across these three educational levels. The findings give evidence that no matter the educational level, the dominant strategy is the use of mental form of the written algorithm. All the other strategies are underrepresented. Moreover, it seems that the use of rational numbers in mental calculation is in itself an obstacle for the students since a great percentage of them either did not give any answer or the answers they gave were incorrect or non-codable.

Keywords: Mental calculations, rational numbers, written algorithm.

Introduction

Mental calculations in arithmetic refers to the process of calculating the exact result of an arithmetical expression given that the solvers use neither a calculating device nor any kind of writing and which usually demands an application of mental strategies. In 1924, the well-known mathematician Carathéodory, during a lecture he delivered for the Hellenic Mathematical Society highlighted the vital importance of the students' ability "to calculate mentally instead of merely writing down, for example, simple subtractions or multiplications" (p. 87). The main interest of the majority of the relevant research studies lies particularly in identifying and organizing the strategies the solvers use. A considerable body of these studies examines mental calculation in the realm of whole numbers and their four basic operations (Rezat, 2011). Lately, researchers express a growth interest on the mental calculations in the set of rational numbers concerning either comparison of rational numbers (Yang, Reys & Reys, 2009) or operations with rational numbers (Caney & Watson, 2003).

In this study our focus lies on the strategies used by students across all the educational levels when they mentally make calculations that involve rational numbers. More precisely, our research questions are:

- What is the range of the strategies used by the solvers while they mentally make operations that involve rational numbers?
- How are these strategies distributed across the three different educational levels and what similarities or/and differences are identified?

Research literature

Cathy Seeley (2005), NCTM president for 2004-2006, in her "Do the Math in Your Head!" article is making a call to the educational community to realize the significance of the ability to perform mental calculations. She associates mental math with both the students' ability to perform calculations quickly, and their conceptual understanding and problem solving. Furthermore, mental calculations

constitute a useful means for calculations, given that they are used by almost everyone on a daily basis, as a direct and quick way of calculating. According to relevant studies (McIntosh, 2006) over three quarters of the mathematical operations performed by individuals in their daily lives are based on mental calculations. Moreover, they promote creative and independent thinking, develop sound number sense, constitute the basis for developing estimation skills, and finally they facilitate a natural progression through informal written methods to standard algorithms (Thompson, 2010).

As it has already been mentioned, the majority of the research studies focus on mental calculations involving whole numbers, and a wide variety of strategies associated to the four operations has been recorded. However, the corresponding body of research concerning mental calculations with rational numbers is rather limited. A systematic documentation of the strategies used by students in primary and secondary education in operations with fractions, decimals and percentages have been realized by Caney and Watson (2003). One main finding of their study was that many of the strategies used in operations with whole numbers are also used for operations with rational numbers. Furthermore, they identified two kinds of strategies for mental calculations with rational numbers: instrumental and conceptual strategies. The instrumental work refers to the use of procedural strategies learned by rote. Moreover, this work is not accompanied by an explanation displaying conceptual understanding of the involved processes. On the contrary, conceptual work takes place when students make use of their knowledge on the specific set of numbers and operations to calculate mentally. Finally, Caney and Watson (2003) added the ‘mixed’ strategy in case the students combine a rote procedure with a conceptual explanation. In their study they identified a series of strategies the students used to solve 12 problems. More specifically, the students ‘*changed operation*’ (division to multiplication, subtraction to addition), ‘*changed representation*’ (fractions to decimals and vice versa, percent to fractions), ‘*used equivalents*’ (use of equivalent fractions), ‘*used known facts*’ (times table), ‘*repeated addition/multiplication/division*’ (by doubling, halving), ‘*used bridging*’ (bridged to one/whole), ‘*worked with parts of a second number*’ (split by place value or by parts), ‘*worked from the left/right*’, ‘*used mental picture*’, ‘*used mental form of written algorithm*’ and ‘*used memorized rules*’. Carvalho and da Ponte (2015) examined grade-6 students’ mental calculations involving fractions, decimals and percentages. They found that students mainly changed representations (fractions to decimals) or used the relationship between numerical representations when possible. Moreover, data analysis showed that pupils utilized depictive representations such as models or images and descriptive representations like the propositional representations in the sense that these mental models arise as a representation of the real world (i.e., the students used the context of money, clocks, pizzas, etc.). Callingham and Watson (2004) working with students in grades 3 to 10 found that fractions items were easier than decimals and percents and that multiplication and division operations with fractions were more difficult for students than addition and subtraction, thus mirroring similar findings for whole numbers. In the same spirit Lemonidis, Tsakiridou and Meliopoulou (2018) found that teachers exhibit a lack of flexibility in the use of strategies in mental calculations with rational numbers. McIntosh (2006) examined the errors students make during mental calculations with rational numbers and identified two different kinds: procedural and conceptual errors. Procedural errors are connected with simple operations between the terms of fractions. They are mostly careless errors or errors that appear while carrying a step of a strategy even though the steps are known to the student. For example, the student knows that multiplication of fractions means to multiply separately the numerators and

denominators of the participating fractions but calculates mistakenly the product of these terms. So, if the numerators of the fractions are 6 and 7 the student might find that $6 \times 7 = 48$. Conceptual errors are connected with a limited understanding of the rational numbers or the operations they have to execute.

In this context our study focuses mainly on the strategies (rather than on the errors, although they have been recorded) used by primary, secondary and tertiary education students given that all of them had to calculate mentally the very same operations involving rational numbers.

Study design and methodology

The participants were 295 students on a voluntary basis from all the three educational levels (primary, secondary and tertiary education). More specifically, there were 78 grade-6 students [SP], 97 grade 10-12 students [SS] and 120 University students (63 from the Department of Primary Education [SU1] and 57 from the Mathematics Department and the Faculty of Engineering [SU2]). These last ones were chosen due to their strong mathematical background that would provide flexibility in their strategies. The tasks and the process were identical for all the three different groups.

Eleven tasks (Figure 1) were posed and the participants were asked to calculate mentally their results. The tasks included all the four operations and their design incorporated two main principles. First, the answers can be calculated in more than one way thus giving freedom to the participants to work in the way they feel more familiar. Second, the tasks are amenable to a fast and easy calculation if the correct mental strategy is chosen. For example, in task-a the answer is obvious if the solver can see that it is about the sum of two halves. Similarly, in task-f the wanted operation is 2×3.5 . Aiming to cover a variety of different combinations within the spectrum of the operations with rational numbers we included operations between fractions, whole numbers and fractions, mixed numbers and fractions, mixed and whole numbers. The criterion for each task was always to meet the standards for primary school students.

a) $\frac{1}{2} + \frac{4}{8}$	b) $4 \times \frac{3}{4}$	c) $4 \times \frac{2}{8}$	d) $\frac{5}{6} + \frac{4}{3}$
e) $1\frac{1}{2} - \frac{1}{4}$	f) $3\frac{4}{8} \times 2$	g) $3\frac{1}{4} - \frac{1}{2}$	h) $\frac{3}{4}$ of 20
i) $6 \div \frac{2}{6}$	j) $\frac{1}{2} + \square = \frac{7}{8}$	k) $1\frac{3}{4} \times \frac{1}{4}$	

Figure 1: Tasks posed to the students

Individual interviews were used and each participant was asked to solve one-by-one the whole collection of tasks in the order presented in Figure 1. The students were asked to vocalize their thoughts while solving the tasks and were prohibited from taking notes or making written calculations. There was not time limitations and the duration of the interviews varied from 4 to 9 minutes since the solvers could skip tasks they couldn't solve. Neither help nor any feedback were provided to them. The only clarification that was given concerned mixed numbers since they are used mainly in primary education and the older students confuse mixed numbers with the case of

multiplication in algebra. Given that $2x$ means the multiplication 2 times x , in a similar way the $3\frac{1}{4}$ was mistakenly translated as $3 \times \frac{1}{4}$. All interviews were recorded and transcribed. These transcribed protocols constituted our data. The students' efforts were coded according to the following two levels: (i) whether the answer was correct, incorrect, left unanswered, or non-codable, and (ii) whether the strategy used by the student fits to a certain category of the Caney and Watson (2003) model.

The data were coded independently by the authors and validity and reliability were established by comparing sets of independent results, clarifying codes and re-coding data until agreement.

Results and Discussion

Table 1 summarizes the distribution of the total number of answers (3274 answers in total) across the various categories of strategies according to the categories of Caney and Watson (2003). It is worth mentioning that not all their strategies were identified in our sample and also a new one has been added. We've been able to identify the '*changed representation*', '*used equivalents*', '*used known facts*', '*repeated addition/multiplication*', '*worked with parts of a number*', '*used a mental picture*', and '*used mental form of written algorithm*' strategies. The new one is named '*used reduction*'. Finally, the incorrect, non-answered and non-codable strategies have also been recorded.

Strategy	Changed representation	Equivalents	Known facts	Repeated add/ multip	Parts of a number	Mental picture
Frequency	56 (1.71%)	59 (1.80%)	43 (1.31%)	3 (0.09%)	31 (0.95%)	30 (0.92%)
Strategy	Written algorithm	Reduction	Incorrect	Non-answered	Non-codable	
Frequency	1406 (42.95%)	177 (5.41%)	907 (27.7%)	519 (15.85%)	43 (1.31%)	

Table 1: Distribution of answers across strategies

The '*changed representation*' strategy refers to the conversion of a fraction or a mixed number to decimal. Some students considered $1\frac{1}{2} - \frac{1}{4}$ (task-e) as $1.5 - 0.25$. In task-b some preferred to use also decimal numbers to calculate $4 \times \frac{3}{4} = 4 \times 0.75 = 3$. In a similar way some students made use of this strategy to reach faster the answer in task-f converting the product $3\frac{4}{8} \times 2$ to $3.5 \times 2 = 7$. We identified the '*used equivalents*' strategy when a fraction is replaced by an equivalent with an explicit reference to this. Some students' mental solution for task-a was $\frac{1}{2} + \frac{4}{8} = \frac{1}{2} + \frac{1}{2}$, but this was not because they made an immediate reference to the fact that there are two halves but to the fact that $\frac{1}{2}$ is equivalent of $\frac{4}{8}$. The '*used known fact*' strategy was mostly used in task-h ($\frac{3}{4}$ of 20) since the solvers made use of their knowledge of the times table. They started reciting the multiples of 5 and they noticed that $4 \times 5 = 20$ and $3 \times 5 = 15$ which made them to say that the answer is 15. All the three strategies presented until now had a very low frequency (less than 2%). This frequency becomes even lower for the next three strategies. '*repeated addition/multiplication*' was only used by two participants in three different tasks. The first example is from task-b. The solver's reaction to the task was to calculate the

product $4 \times \frac{3}{4}$ as follows: $\frac{3}{4} + \frac{3}{4} + \frac{3}{4} + \frac{3}{4}$. The next example is drawn from another student's effort to cope with task-g ($3\frac{1}{4} - \frac{1}{2}$). The solver considered more convenient to substitute 3 with $\frac{4}{4} + \frac{4}{4} + \frac{4}{4}$. This substitution facilitated the addition that follows since all the fractions have now the same denominator.

SS14.7.1: I will substitute 3 with $\frac{4}{4} + \frac{4}{4} + \frac{4}{4}$.

SS14.7.2: Then, $\frac{4}{4} + \frac{4}{4} + \frac{4}{4} + \frac{1}{4} = \frac{13}{4}$.

SS14.7.3: And then, $\frac{13}{4} - \frac{2}{4} = \frac{11}{4}$

The '*used parts of the numbers*' strategy was recorded only in task-e and task-f. In the first case the solvers decomposed the mixed number to its parts, (i.e., the whole number and the fraction) and then made use of the equality $a + b - c = a + (b - c)$: $1\frac{1}{2} - \frac{1}{4} = 1 + (\frac{1}{2} - \frac{1}{4})$. In the second case the students decomposed again the mixed number and applied the distributive property of multiplication over addition: $3\frac{4}{8} \times 2 = (3 \times 2) + (\frac{4}{8} \times 2) = 6 + 1 = 7$. The '*mental picture*' strategy is connected to the solvers' effort to visualize the activity as a means to mentally calculate the result (Carvalho & da Ponte, 2015). So, some students while trying to solve task-h preferred to consider 20 as a whole unit, 'like a circular pie' which was divided mentally in 4 equal pieces and 3 of them were taken.

SS17.8.1: I am thinking of a circular pie and draw its $\frac{3}{4}$.

However, the strategy that dominated with extremely high percentage (42,95%) was the '*used mental form of written algorithm*' strategy. Solvers worked mentally in a way that appeared to reflect the written algorithm. For task-d a relevant reaction was "I will make sure that denominators are the same... $\frac{5}{6} + \frac{4}{3} = \frac{15}{18} + \frac{24}{18} = \frac{39}{18}$," (SP7.4.1). For task-f the students converted the mixed number to fraction and then they followed the rule for multiplying a whole number with a fraction: "3x8=24, plus 4...28, times...56, 56/8...therefore, 7" (SU1.55.6.1). The '*used reduction*' strategy was the one added by the research team. Instances of this strategy were identified in three tasks. The students simplified the whole number (in tasks b, c and h) with the denominator of the fraction. So, in task-b, they simplified the 4s: $4 \times \frac{3}{4} = 3$. In task-c, the simplification (4 and 8 were divided by 4) resulted in a fraction equal to one: $4 \times \frac{2}{8} = \frac{2}{2} = 1$. In task-h, the word 'of' was translated as 'times' and then the whole number was again simplified with the denominator: $\frac{3}{4}$ of 20, which means $\frac{3}{4} \times 20 = 3 \times 5 = 15$ (20 and 4 were divided by 4).

Sometimes it seems to exist an overlapping between the '*used reduction*' strategy and strategies such as the '*used equivalence*' or the '*written algorithm*'. But it was the solver's aim as this was expressed verbally that made us to decide if the solution is associated with one strategy or another. For example, in task-a, the solution $\frac{1}{2} + \frac{4}{8} = \frac{1}{2} + \frac{1}{2} = \frac{2}{2} = 1$ might be considered as the '*use of equivalence*'. However, the student's wording reveals pure use of fraction reduction: "I will simplify the fraction 4/8 which...I divide by 2... is 2/4 which in turn is 1/2. Therefore, 1/2 + 1/2" (SU1.45.1.1). In the same spirit, for the same task, the answer $\frac{1}{2} + \frac{4}{8} = \frac{4}{8} + \frac{4}{8} = \frac{8}{8} = 1$ sometimes was considered as '*use of equivalence*' and others as '*written algorithm*' (see below extracts SU1.9.1.1-2 and SU1.58.1.1-3 respectively)

SU1.9.1.1: I will make two equivalent fractions. I will multiply both the numerator and denominator by 4.

SU1.9.1.2: It makes $\frac{4}{8} + \frac{4}{8} = \frac{8}{8} = 1$

.....

SU1.58.1.1: I will make fractions with the same denominator and I will add them.

SU1.58.1.2: I need the Least Common Multiple which is 8.

SU1.58.1.3: It becomes $\frac{4}{8} + \frac{4}{8} \dots \frac{8}{8}$, therefore 1.

Errors were surprisingly the second most popular result (McIntosh, 2006). Both procedural and conceptual errors were detected. Procedural errors were mainly due to miscalculations, for example: $\frac{5}{6} + \frac{4}{3} = \frac{5}{6} + \frac{8}{6} = \frac{12}{6}$. Conceptual errors were mirroring students' limited understanding and misconceptions relevant to fractions. We could mention the flawed idea that when we add fractions we just add separately numerator and denominators, $\frac{5}{6} + \frac{4}{3} = \frac{9}{9}$ (task-d) or $\frac{1}{2} + \frac{4}{8} = \frac{5}{10}$ (task-a). We could also add the misconception that when we multiply a whole number with a fraction then the whole number must be multiplied by both the nominator and the denominator: $4 \times \frac{3}{4} = \frac{12}{16}$. Moreover, some the students hesitated or were not able to give an answer. Almost 16 out of 100 instances were actually non-answered. Finally, we sorted as non-codable answers that did not reveal any kind of thought. In this category we also included efforts that were based in a strategy that was not suitable for the specific task. In task-k some solvers tried to calculate the results as $1\frac{3}{4} \times \frac{1}{4} = 1.75 \times 0.25$. This last multiplication was quite demanding, and the students decided to abandon the task.

	SP (Primary)	SS (Secondary)	SU1 (stud. teachers)	SU2 (Math, Engin)
Changed representation	–	3 (0.28%)	17 (2.41%)	36 (5.63%)
Equivalentents	2 (0.23%)	3 (0.28%)	25 (3.55%)	29 (4.54%)
Known facts	12 (1.40%)	11 (1.03%)	13 (1.85%)	7 (1.10%)
Repeated add/multip	–	1 (0.09%)	2 (0.28%)	–
Parts of number	–	5 (0.47%)	22 (3.13%)	4 (0.63%)
Mental picture	8 (0.93%)	7 (0.65%)	13 (1.85%)	2 (0.31%)
Written algorithm	373 (43.42%)	330 (30.78%)	326 (46.31%)	377 (58.99%)
Reduction	12 (1.40%)	24 (2.24%)	40 (5.68%)	101 (15.81%)
Incorrect	296 (34.46%)	406 (37.87%)	147 (20.88%)	58 (9.08%)
Non-answered	151 (17.58%)	264 (24.63%)	88 (12.50%)	16 (2.50%)
Non-codable	5 (0.58%)	18 (1.68%)	11 (1.56%)	9 (1.41%)

Table 2: Number of total responses per strategy per group

It is more than evident the dominance of the written algorithm approach over the remaining strategies. This might raise questions about the effectiveness of the way we teach. This becomes more interesting if we take account of the incorrect, non-answered and non-codable answers. The total percentage of these three categories is 44.86% which actually is more than the percentage of the algorithm. If we consider together these two broad groups of participants (those who used the written algorithm and

those who had difficulties in answering) then it can be said that almost 9 out of 10 participants either used the written algorithm or were unable to solve the tasks ($42.95\% + 44.86\% = 87.81\%$).

Table 2 presents in detail how students' answers are distributed across the groups in the different educational levels. The percentages in each column correspond to the specific group of students and not to the total sample and confirm the strong influence of the written algorithm in each group. A closer look reveals also some interesting issues. On the one hand it appears that both groups of university students rely more than primary and secondary students to the written algorithm (which by far dominates the landscape). Forty five out of 100 preservice teachers and 6 out of 10 Mathematics and Engineering students resorted back to the written algorithm to respond to the tasks. Moreover, it is seeming paradox that the highest percentage for algorithmic use (Table 2) is got by students from the Mathematics Department and the Faculty of Engineering [SU2] who are the ones with the strongest mathematical background.

On the other hand, it appears that as we move from primary to tertiary education there is an increased variety of the correct strategies used (though very small number of instances compared to the total number of answers). We refer to all but the '*written algorithm*' correct strategies. In total 3.96% of the primary school students' answers used these strategies. This percentage is more or less the same for secondary education students (5.04%). However, for the tertiary education students this becomes almost three times bigger (13.07%). This is not because the use of the '*written algorithm*' strategy has been reduced. On the contrary, the relevant percentages of the algorithmic use for SU1 and SU2 students are extremely high and greater than the corresponding ones for younger students. It is the number of the incorrect answers that became smaller.

Having said that, it remains impressive that the main finding of this study is the dominance of the algorithmic use across all the educational levels (Rezat, 2011). This students' preference becomes more interesting because the tasks were designed to be amenable to a variety of strategies for their solution. For example, task-f ($3\frac{4}{8} \times 2$) can be solved directly if one notices that the wanted is the double of 3 and half. But there are other possibilities also. According to the '*changed representation*' this can be seen as 3.5×2 . According to '*written algorithm*' it is $3\frac{4}{8} \times 2 = \frac{28}{8} \times 2 = \frac{56}{8} = 7$. There is also the case of the '*worked with parts*' strategy: $(3 \times 2) + (\frac{4}{8} \times 2) = 6 + 1 = 7$ or its modified version $(3 \times 2) + (\frac{1}{2} \times 2)$. In this last version the fraction $\frac{1}{2}$ might be the result of the '*equivalence*' or the '*reduction*' strategies. However, for this specific task, according to our data, 3 out of 4 who answered correctly preferred the '*written algorithm*' which obviously is not a straightforward calculation. On the contrary it is rather demanding and time consuming. The situation is more or less similar for the total set of the tasks. This highlights the students' obsession with the use of the written algorithm which disqualifies the core idea of mental calculations.

Conclusions

Given the importance of the ability to execute mental calculations involving rational numbers it became evident that although the students exhibit a broad range of different strategies the majority of these strategies is underrepresented. The students mainly follow the steps of the written algorithm. Moreover, it seems that this is not an age-dependent reaction. Very interestingly, the '*written*

algorithm' strategy was the most frequent choice for primary, secondary, and tertiary education students. We do not doubt that possibly the solvers were aware of alternative strategies and able to use them for mentally calculating the results. What can be said on the basis of the data is that their first choice was the application of the written algorithm. Moreover, there was a great number of participants (44.86%) who either did not give any answer or the answer they gave was incorrect or non-codable. This makes evident the difficulty the students have with rational numbers especially when they are invited to handle them mentally. Additionally, it seems that university students exhibit flexibility in their choice of strategies but in an extremely small percentage. All these deepen our understanding of the topic but at the same time challenge us for a future study that will try to give answers to questions such as: Why do they choose these strategies? What alternative strategies do they know? Why do they not use those alternative strategies? Would the results be the same if the students were asked to solve written the same tasks?

References

- Caney, A., & Watson, J. M., (2003). Mental computation strategies for part-whole Numbers. *AARE 2003 International Education Research Conference*, Auckland, University of Tasmania. Retrieved from <https://www.aare.edu.au/data/publications/2003/can03399.pdf>
- Callingham, R., & Watson, A. (2004). A developmental scale of mental computation with part-whole numbers. *Mathematics Education Research Journal*, 6(2), 69–86.
- Carathéodory, C. (1924). About Mathematics in Secondary Education. *Delition of Hellenic Mathematical Society*, vol. E, 83–88 (in Greek).
- Carvalho, R., & da Ponte, J. (2015). Students strategies and errors in mental computation with rational numbers in open number sentences. In K. Krainer & N. Vondrova (Eds.), *Proceedings of CERME9* (pp. 245-251). Prague, Czech Republic: CERME.
- Lemonidis, C., Tsakiridou, E., & Meliopoulou, I. (2018). In-service teachers' Content and Pedagogical Content Knowledge in mental calculations with rational numbers. *International Journal of Science and Mathematics education*, 16(6), 1127–1145.
- McIntosh, A. (2006). Mental computation of school-aged students: Assessment, performance levels and common errors. Paper presented at *The Fifth Swedish Mathematics Education Research Seminar (MADIF-5)*, Malmö, Sweden. Retrieved from <http://www.mai.liu.se/SMDF/madif5/papers/McIntosh.pdf>
- Rezat, S. (2011). Mental calculation strategies for addition and subtraction in the set of rational numbers. In M. Pytlack, T. Rowland, & E. Swodoba (Eds.), *Proceedings of CERME7* (pp. 396–405). Rzeszow, Poland: CERME
- Seeley, C. (2005). “Do the Math in Your Head!” President’s Message, *NCTM News Bulletin* (December). Reston, VA: National Council of Teachers of Mathematics. Retrieved from
- Thompson, I. (2010). *Issues in Teaching Numeracy in Primary Schools*. Berkshire: Open University
- Yang, D. C., Reys, R. E., & Reys, B. J. (2009). Number sense strategies used by pre-service teachers in Taiwan. *International Journal of Science and Mathematics Education*, 7(2), 383–403.

Students' ability to compare fractions related to proficiency in the four operations

Pernille Ladegaard Pedersen¹ and Peter Sunde²

¹Aalborg University, Faculty of Learning, Denmark; pelp@via.dk

²Aarhus University, Department of Bioscience, Denmark; psu@bios.au.dk

In this paper, we investigate the relationship between 99 fourth-grade students' ability to compare fractions ($\frac{1}{4} = \frac{2}{8}$ and $\frac{5}{11} < \frac{3}{5}$) and solve tasks in each of the four operations ($68 + 753$, $547 - 64$, 12×72 $78 \div 3$) in a Danish primary school. The students faced more challenges answering the question where the fractions were equal compared to the non-equal fraction items (32% vs 49% correct answers) although the probability of solving the two types of questions were significantly positively associated (odds ratio = 11.0). Relative to the four operations items, solving the non-equal fraction item associated significantly positively with solving the multiplication (odds ratio = 4.5) and division item (odds ratio = 3.9) while the correct solving of the equal fraction associated significantly positively with the solving of the division item (odds ratio = 2.6). These results support the notion that the understanding of fractions is closely connected to multiplicative reasoning.

Keywords: Arithmetic, whole number division, fractions.

Introduction

Research has shown that students' knowledge of fractions in middle school greatly affects their overall progression in general mathematics (e.g., Bailey, Siegler, & Geary, 2014). There is also evidence that students need to have mathematical proficiency in the four operations of whole numbers to enable them to effectively comprehend rational numbers (Behr & Post, 1988). Additionally, multiplicative reasoning seems especially connected to the development of students' understanding of fractions (Thompson & Saldanha, 2003). Therefore, it is relevant to further investigate the variety of associations between the students' proficiency in the four operations and in fractions. This paper aims to uncover the fourth grade students' abilities to answer equations that require an understanding of fractions as well as the relationship between their abilities to answer tasks and their understanding of the four operations. The primary research question for this paper is: How do students' abilities to solve arithmetic tasks in the four operations (e.g., division) relate to their abilities to answer items that require them to compare fractions?

We expect that the students' proficiency in division and multiplication, but not their capability related to addition and subtraction, will show a strong association to their ability to answer fraction equations because we assume that an understanding of fractions is closely connected to multiplicative reasoning. This paper primarily focuses on students' difficulties with comparing fractions and how this is associated with the four operations. Therefore, the theoretical framework is based on theories of fractions and how these are connected to, for example, multiplicative reasoning.

Theoretical framework

Over the last three decades, several researchers, such as Bailey, Siegler and Geary (2014), Behr and Post (1988), and Ni (2001), have studied aspects of students' understanding of fractions and the complexities related to teaching and learning these concepts. For example, Kieren (1976) described how fractions can be seen as a multifaceted construct. He characterized the understanding and knowledge of rational numbers as sets of sub-constructs, which have since been further developed by Behr, Lesh, Post, and Silver (1983). They defined these sub-constructs as: Part-whole, decimal, ratio, quotient, operator, and measure. They recommended that the sub-construct part-whole should be considered to be distinct from the others as a fundamental scheme. Although we are aware of the limitation, in this paper we choose to focus on the sub-construct of quotient even though rational numbers are a more complex system of sub-constructs, and we are aware of for example the importance of ratio in the proportional understanding of fraction (Behr, Lesh, Post, & Silver, 1983; Behr & Post, 1988).

Quotient

For the sub-construct quotient, the denominator designates the amount of recipients, and the numerator represents the amount of quantities that have to be shared (Behr & Post, 1988; Toluk & Middleton, 2001). Thus, the sub-construct of quotient has a connection to partitive division, also known as sharing division, where an object or a group of objects are divided into a number of equal parts (Fischbein, Deri, Nello, & Marino, 1985). Moreover, division is the only one of the four operations where a rational number can be the outcome. Therefore, division can be regarded as an integral part of an understanding of rational numbers; hence students must develop an understanding of the connections between division and fractions (Behr & Post, 1988; Toluk & Middleton, 2001). Toluk and Middleton (2001) conducted a case study of students' development of fraction schemes and the importance of division in the progression from the part-whole sub-construct to the conceptualisation of the quotient sub-construct. They illustrated the developmental process from Fraction-as-Part-Whole and Whole Number Quotient Division-as-Operation to the final stage, which was Division-as-Number ($a \div b = a/b$, " a/b) (Toluk & Middleton, 2001). When comparing fractions, it is necessary to understand that the magnitude depends on the relation between the two quantities; the denominator and the nominator (Ni & Zhou, 2005), rather than simply viewing the fraction notation as two independent cardinal numbers above and below a bar (Stafylidou & Vosniadou, 2004).

Equivalent fraction

Overall, there is substantial support that students' whole number multiplicative understanding is an important resource for developing fraction knowledge (Hackenberg & Tillema, 2009). In addition, multiplicative reasoning appears to be essential for the effective understanding and accurate representation of equivalent fractions. One basic fraction perception is to understand fraction equivalence (Ni, 2001). Fraction equivalence can be explained as the constancy of a quotient and as the constancy of the multiplicative relationship between the numerator and the denominator (Behr, Harel, Post, & Lesh, 1992). Here, the quotient is involved in an understanding of equivalence; for example, $\frac{1}{2}$ can be viewed as a division, which represents the equivalence between $\frac{1}{2}$ and 0,5 (Behr,

Lesh, Post, & Silver, 1983). Each fraction belongs to a unique equivalence class represented by a multiplicative equation. Each class denotes a distinct rational number; for example $\frac{1}{2} = \frac{2}{4}$. Difficulties related to the understanding of equivalent fractions have been connected to the students' lack of multiplicative reasoning (Ni, 2001). If the students do not develop this understanding of equivalence, they will view for example tasks that involve adding two fractions with different denominators as a purely technical algorithm (Arnon, Neshet, & Nirenburg, 2001). Therefore, both multiplication and division of whole numbers might be more closely connected to understanding fractions than additional reasoning. Hence, we expect to find an association between the fraction equations and the multiplication and division items, meaning that if the students can solve items involving the two operations correctly, they will more likely be able to solve the fraction equations. However, if the students have not developed a proficiency with multiplication and division, we expect that those students will experience difficulties answering the fraction equations correctly, especially the equivalent fraction equations. We will analyse how the two fraction items differ in proportion of correct answers as well as whether and how they differ in association with the four operations.

Methods and analysis

Data consisted of answers provided by fourth-grade students (ages 10–11) on a computerised test. The test consisted of 110 items, including problems on the four operations, fractions, and algebra as well as word problems. The test was time restricted (45 minutes), so not all students finished all of the items. The questions on fractions included in the analysis were items 50 and 52, and only the students who answered these items within the timeframe were included in the analysis. However, we are aware of the constraints of interpreting the students' answers on a computerised test in which the student just enters the answer to the item. This only allows us to review a student's correct or incorrect answers and not the working process itself. In addition, we are aware that neither a whole number multiplication nor a division item can be seen as a strong indicator of student's multiplicative reasoning. A quick review of these answers showed that the students who answered this section were generally quick at calculating and, on average, had the highest scores in the first section of the test (whole number arithmetic operation tasks). In other words, the students who reached the fraction items (items 50 and 52) scored above average on the test ($N = 99$). The items we chose to analyse were items where the students were asked to compare $\frac{1}{4}$ to $\frac{1}{5}$, $\frac{5}{11}$ to $\frac{3}{5}$, and $\frac{1}{4}$ to $\frac{2}{8}$. The students could choose between the following three symbols: $<$, $>$, and $=$ (Figure 1).

<p>A. Indsæt det manglende tegn: >, < eller =.</p> <p>Tryk på pilen.</p> <p>$\frac{1}{4}$ <input type="text" value=">"/> $\frac{1}{5}$</p> <p>$\frac{5}{11}$ <input type="text" value="<"/> $\frac{3}{5}$</p> <p>$\frac{1}{4}$ <input type="text" value="="/> $\frac{2}{8}$</p>	<p>B. Regn opgaverne.</p> <p>$68 + 753 =$ <input type="text"/></p> <p>$547 - 64 =$ <input type="text"/></p> <p>$12 \cdot 72 =$ <input type="text"/></p> <p>$78 : 3 =$ <input type="text"/></p>
--	---

Figure 1: The items used in the analysis. Translated to: A. Choose the right symbol: $>$, $<$ or $=$. (No symbol was preselected). B. Calculate the task

Earlier in the test, the students were asked to solve a whole number equation using the same symbols. There were not any significant differences found in the items containing the equal sign. The first item was created to see the students' answers on a unit fraction equation. Often, students have whole number biases in their learning processes of fractions such that they look at the biggest digit and conclude that this is the largest number; for example 5 is larger than 4 (Ni & Zhou, 2005). The second item, $\frac{5}{11}$ compared to $\frac{3}{5}$, was likewise designed to examine the students' answers on an item where there is a whole number bias since both 5 and 11 are bigger than 3 and 5. In the solving process of this item, the student might use a different strategy, such as the benchmark strategy where $\frac{5}{11}$ is smaller than a half and $\frac{3}{5}$ is bigger than a half (Clarke & Roche, 2009). We considered this item to be the most difficult item for the students to solve because of the different numerator and denominator as well as the fact that the item did not contain any unit fraction. The last item was the equal fraction item where $\frac{1}{4}$ is equal to $\frac{2}{8}$. This item included the unit fraction $\frac{1}{4}$, which we considered to be a commonly used fraction in the fourth-grade curriculum. Therefore, we assumed that the students might have a good mental representation of this fraction. As for the analysis of the relationship between the four operations, we have selected one whole-number problem from each of the operations ($68 + 753$, $547 - 64$, 12×72 , $78 \div 3$) based on the following criteria: The item where the students had the fewest correct answers, the most wrong answers, and the most times it was not answered, in that order. Each of the arithmetic items was designed to evoke solution strategies based on number sense approaches. For example, in the case of item 12×72 , it involves breaking up one of the factors 12 into a 10 and a 2 and then multiply it in parts $(10 \times 72) + (2 \times 72)$.

Analysis

The analysis focused on how the students' answers to one fraction equation associated to the other fraction equation and to answers on the four operations items. The association between the probability of returning a correct answer as opposed to an incorrect one or omitting an answer for one item in relation to whether the student answered another item correctly was analysed as a binary logistic regression (Logistic procedure in SAS 9.5) function. Logistic regression models yield similar p -values for statistical significance of associations as conventional 2×2 contingency χ^2 -tests as well as additionally producing predictions of the conditional probabilities of returning a correct answer for one item in relation to whether the student had answered the other item correctly. The difference between these two predicted probabilities on a logit scale (coefficient of the difference between the two levels in the regression equation) furthermore serves as a coefficient of association in the response patterns between the two items.

The anti-log of this coefficient (the odds ratio 'OR') equals how many more times a student is likely to answer item Y (e.g., $\frac{1}{4} = \frac{2}{8}$) correctly if he/she has answered item X (e.g., $78 \div 3 =$) correctly as compared to if he/she has not answered X correctly. Hence, an association coefficient of 1.0 indicates that the students answering item X correctly are $\exp(1.0) = 2.71$ times more likely to answer item Y correctly as compared to the students who did not answer item X correctly. Note that the ORs derived from the logistic regression equation exceeds the ORs calculated from the arithmetic values of the probabilities because of the infinite state space on the logit scale, whereas values are on the arithmetic

scale \hat{I} $[0;1]$. The conditional probabilities of getting correct answers as a function of correct vs. incorrect or missing answers in other item types were modelled and illustrated graphically for the item $\frac{1}{4} = \frac{2}{8}$ as a function of the item $\frac{5}{11} < \frac{3}{5}$ and $\frac{1}{4} > \frac{1}{5}$. The same was modelled and illustrated for the item $\frac{5}{11} < \frac{3}{5}$ as a function of item $\frac{1}{4} > \frac{1}{5}$. A matrix table of association coefficients between items that represent the different concepts of fractions, addition, subtraction, multiplication, and division was calculated for each of the items.

Results

When analysing data from the test, it was found that the students showed difficulties solving items involving equivalent fractions. Only 32% of the students answered $\frac{1}{4} = \frac{2}{8}$ correctly while 49% answered $\frac{5}{11} < \frac{3}{5}$ correctly (Figure 2). Overall, the two non-equal fraction equations were similar in their answer patterns since both had about 50% correct, about 30% incorrect, and 20% with no answer.

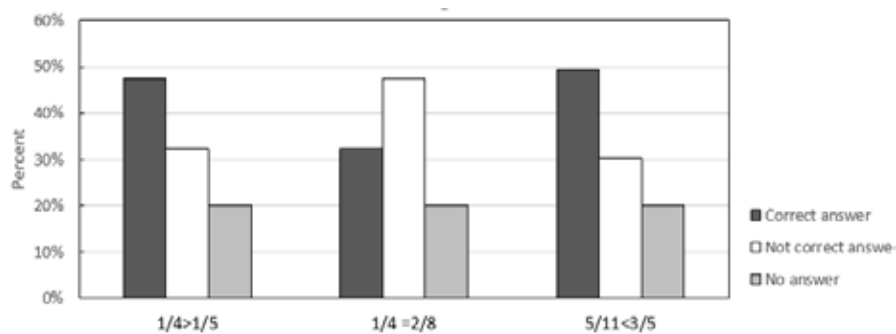


Figure 2: Percent of correct, incorrect or no answer to the three fraction items ($N = 99$)

When comparing, the probability of answering the three items representing equation problems correctly were all strongly and highly statistically significantly associated (Figure 3, association coefficient values: 2.4–4.0, i.e. ORs: 11–54).

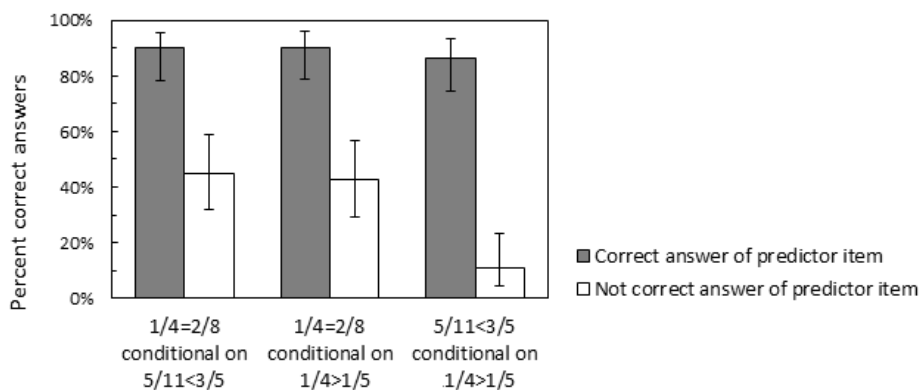


Figure 3: Percent of correct answers on one item type conditional to whether the student answered another item type. Error bars indicate 95% confidence intervals. All differences were highly significant ($p < 0.0001$)

The two non-equal fraction items showed the same pattern when compared to the equal fraction. Hence, in all comparisons, the probability of answering correctly on the item $\frac{1}{4} = \frac{2}{8}$ was about 90% if the student had answered the predictor item $\frac{5}{11} < \frac{3}{5}$ correctly compared to about 50% if they had

answered it incorrectly (Figure3). When comparing the two non-equal fraction items, we found that if the students had answered the predictor item $\frac{1}{4} > \frac{1}{5}$ correctly, only about 10% could then not solve $\frac{5}{11} < \frac{3}{5}$. Therefore, we chose to focus on the equal fraction item $\frac{1}{4} = \frac{2}{8}$ and the non-equal fraction item $\frac{5}{11} < \frac{3}{5}$. When comparing all problem types (Table 1), correct solutions were most strongly associated with the two equation problems (OR = 11.0, $p < 0.0001$), followed by the association between the addition and subtraction (OR = 6.8, $p < 0.0001$), multiplication and division (OR = 5.4, $p < 0.0001$), and subtraction and multiplication (OR = 5.0, $p = 0.001$) items, respectively. The results of the equation item $\frac{5}{11} < \frac{3}{5}$ were highly significantly positively associated with the results of the multiplication (OR = 4.5, $p = 0.0009$) and division items (OR = 3.9, $p = 0.003$). The results of the equation item $\frac{1}{4} = \frac{2}{8}$ only associated positively with the division item (OR = 2.6 $p = 0.02$) (Table 1). The lowest associations (all non-significant) were found between the results of two equation items and the results of addition and subtraction items (all four ORs 1.7–2.4), between equation item $\frac{1}{4} = \frac{2}{8}$, and the multiplication item (OR = 2.1) (Table 1).

	1/4 = 2/8	5/11<3/5	68+753	547-64	12×72	78÷3
5/11<3/5	2.40 ****					
68+753	0.85	0.53				
547-64	0.75	0.88	1.91 ****			
12×72	0.72	1.51 ***	0.83	1.60 ***		
78÷3	0.96 *	1.36 **	1.02 *	0.68	1.68 ****	
N items:	99	99	142	142	142	142
N correct items:	50 51%	67 68%	32 23%	49 35%	98 69%	87 61%

Table 1: Coefficients of association (log odds ratios) of correct vs. incorrect/missing answers of different problem items: The higher the coefficient value, the more likely a correct answer of one item type associated with a correct answer of the other item type. Significance levels: * $p < 0.05$, ** $p < 0.01$, * $p < 0.001$, **** $p < 0.0001$. (A log odds ratio of 1 equals a difference of $\exp(1) = 2.7$)**

Discussion

This statistical investigation of the two fraction items' differences and their associations to the four operations revealed the following three results: Firstly, when comparing the three items with each other, the students' answers showed that the equal fraction item (30% correct answers) was more difficult than the two non-equal fraction items (50% correct). This was unexpected since one of the fractions in the equal item was a commonly referenced unit fraction of $\frac{1}{4}$. It is a fraction which is common in the introduction of fractions in the fourth grade, whereas $\frac{5}{11}$ is a rare fraction notation in school curriculums. As referred to earlier, we therefore expected the item to be easier than the other one. The students' difficulties with the equal item could indicate that the students have difficulties

understanding fractions as an *equivalence class* made by a multiplicative equation (Ni, 2001). This is emphasized by the results in Figure 3, which show that the probability of answering correctly on the item $\frac{1}{4} = \frac{2}{8}$ was still only 50% if the student had answered $\frac{5}{11} < \frac{3}{5}$ incorrectly. However, a probability of only 10% was found for answering $\frac{5}{11} < \frac{3}{5}$ correctly if they had answered $\frac{1}{4} > \frac{1}{5}$ incorrectly, which indicates that the comparison of equal fraction items differed. This could be due to the fact that when solving the equivalent fraction items, the students have a whole number bias (Ni & Zhou, 2005), the equivalence can be difficult for the students to comprehend because it is the first time they have experienced numbers that can be labelled differently and still refer to the same numerical quantity. Secondly, we found that the result of the non-equal $\frac{5}{11} < \frac{3}{5}$ fraction was highly associated with the result for both the multiplication (OR = 4.3) and the division (OR = 3.9) items, whereas there was no significant association with the results of the addition and subtraction items. This result coheres well with the theory that fractions have a stronger connection to multiplicative reasoning than to additive reasoning (Thompson & Saldanha, 2003). According to this theory, one should have expected a closer association with division than with multiplication (Toluk & Middleton, 2001). A possible explanation might be that the result patterns of the two operations were also closely related (OR = 5.4), suggesting that the basis of the understanding necessary for solving division and multiplication problems is so closely related that they could not be discriminated in the analysis.

Thirdly, we found that the results of the non-equal item correlated more strongly and significantly with the results of the division and multiplication items than was the case for the result of the equal fraction item (that only associated modestly with the result of the division item). Thus, there is a component of the equal fraction item making this more difficult for the students to answer. An explanation could be that students have not yet developed the conceptualisation of the *quotient* as *Division-as-Number* (Toluk & Middleton, 2001). Hence, when students look at equal fractions, they can see a *quotient* as a division, which represents the equivalence between both $\frac{1}{4}$, $\frac{2}{8}$ and 0.25 (Behr, Lesh, Post, & Silver, 1983). Overall, these results support the notion that the understanding of fractions is closely connected to multiplicative reasoning; however, it is essential to pursue further investigation since there seems to be a different pattern in the students' proficiency in the equivalence concept. Otherwise, they will experience difficulties in understanding other concepts, like common denominators (Arnon, Nesher, & Nirenburg, 2001). Further research should collect qualitative data to examine the students' working process to overcome the strong limitations of a computer test, which can only offer limited insights. We need to investigate further ways in which the students experience difficulties in the equal fraction task. It may be that this is strongly connected to their understanding of the equal sign or that there is a connection to a whole number bias. On the one hand, the students' whole number multiplicative understanding might support their understanding in some fraction contexts, and on the other hand, the students' understanding of whole numbers can distract them in other fraction contexts.

References

Arnon, I., Nesher, P., & Nirenburg, R. (2001). Where do fractions encounter their equivalents? Can this encounter take place in elementary-school? *International Journal of Computers for Mathematical Learning*, 6(2), 167–214.

- Bailey, D. H., Siegler, R. S., & Geary, D. C. (2014). Early predictors of middle school fraction knowledge. *Developmental Science*, *17*(5), 775–785.
- Behr, M., Harel, G., Post, T. R., & Lesh, R. (1992). Rational number, ratio, and proportion. In D. A. Grouws (Ed.), *Handbook of research on mathematics teaching and learning* (pp. 296–333). New York: Macmillan.
- Behr, M., Lesh, R., Post, T., & Silver, E. (1983). Rational Number Concepts. In R. Lesh, & M. Landau (Eds.), *Acquisition of Mathematics Concepts and Processes* (pp. 91–125). New York: Academic Press.
- Behr, M., & Post, T. (1988). Teaching rational number and decimal concepts. In T. Post (Ed.), *Teaching mathematics in grades K-8: Research-based methods (2nd ed.)* (pp. 201–248). Boston: Allyn and Bacon.
- Clarke, D. M., & Roche, A. (2009). Students' fraction comparison strategies as a window into robust understanding and possible pointers for instruction. *Educational Studies in Mathematics*, *72*(1), 127–138.
- Fischbein, E., Deri, M., Nello, M., & Marino, M. (1985). The role of implicit models in solving verbal problems in multiplication and division. *Journal for Research in Mathematics Education*, *16*(1), 3–17.
- Hackenberg, A. J., & Tillema, E. S. (2009). Students' whole number multiplicative concepts: A critical constructive resource for fraction composition schemes. *The Journal of Mathematical Behavior*, *28*(1), 1–18.
- Kieren, T. E. (1976). On the mathematical, cognitive, and instructional foundations of rational numbers. In R. A. Lesh & D. A. Bradbard (Eds.), *Number and measurement: Papers from a research workshop* (pp. 101–144). Columbus, OH: ERIC Information Analysis Center for Science, Mathematics and Environmental Education.
- Ni, Y. (2001). Semantic domains of rational numbers and the acquisition of fraction equivalence. *Contemporary Educational Psychology*, *26*(3), 400–417.
- Ni, Y., & Zhou, Y-D. (2005). Teaching and learning fraction and rational numbers: The origins and implications of whole number bias. *Educational Psychologist*, *40*(1), 27–52.
- Stafylidou, S., & Vosniadou, S. (2004). The development of students' understanding of the numerical value of fractions. *Learning and Instruction*, *14*(5), 503–518.
- Thompson, P. W., & Saldanha, L. A. (2003). Fractions and multiplicative reasoning. In J. Kilpatrick, W. G. Martin, & D. Schifter (Eds.), *A research companion to principles and standards for school mathematics* (pp. 95–113). Reston, VA: The National Council of Teachers of Mathematics.
- Toluk, Z., & Middleton, J. (2001). The development of children's understanding of the quotient: A teaching experiment. In M. Van den Heuvel-Panhuizen (Ed.), *Proceedings of the 25th Conference of the International Group for the Psychology of Mathematics Education* (4), (pp. 265–272). Utrecht, The Netherlands: Hogrefe.

Flexible mental calculation skills of freshmen and graduates

Charlotte Rechtsteiner

PH Ludwigsburg, University of Education, Institute of Mathematics and Computer Science,
Ludwigsburg, Germany; rechtsteiner@ph-ludwigsburg.de

Keywords: Flexible mental calculation, teacher education, students' content knowledge.

Theoretical Framework

Researchers and mathematics educators agree on the importance of flexibility in mental calculation, and in the last two decades a lot of research on students' development in flexible mental calculation was conducted (brief overview see Rathgeb-Schnierer & Green, 2017). Torbeyns et al. (2011) investigated flexibility and adaptivity in adults and revealed that they frequently and efficiently apply indirect addition on subtraction problems up to 100.

Baumert & Kunter (2011) describe four professional competences: beliefs, motivational orientations, self-regulation and professional knowledge. Professional knowledge is again subdivided in five category groups. The performance of flexible mental calculation can be considered as content knowledge. During their teacher training program students should acquire the competences which are important for their future teaching activity. Therefore, it is necessary to know about students' knowledge at the beginning and the end of university.

Regarding the described aspects, we summarize that teachers are supposed to be flexible in mental calculation. Furthermore, we expect all students who currently entered university to perform flexibly since this has been a central aim in German primary schools for the last 15 years.

Overview on the Project

Due to the fact that there is hardly any research on teachers' professional knowledge regarding flexibility in mental calculation, this study focuses on this aspect. Thereby, there is a special focus on the comparison of freshmen and graduate students as well as students with mathematics as major and minor subject. Three questions are posed in this study: Do freshmen and graduates use adaptive expertise? Do students with mathematics as major subject perform better than students with mathematics as minor subject? Can we find differences both between freshmen and graduates and between students with mathematics as subject and those with mathematics as basic education?

Design

A CRF 2x2 experimental design is used to test the research hypothesis. There are two independent variables: the area of studies (Factor A: a1 = mathematics as major; a2 = mathematics as minor) and the length of study (Factor B: b1 = freshman, b2 = graduate). The dependent variable is a survey with ten different tasks to solve up to 1000.

Procedure and data analyses

The sample size is determined with a type II power analysis – N as a function of power (1- β), Δ , and α . The desired power (1- β) is 0.99, and medium effects ($\Delta = 0.50$) in relation to the dependent variable

are classified as significant; the significance level is $\alpha=0.05$. Our sample were drawn from the university courses for freshmen and graduates, and comprised 77 freshmen and 75 graduates.

We used seven tasks with special problem characteristics (851–426, 960–320, 923–398, 906–891, 999–699, 672–335, 853–497). Firstly, every task was coded with a range zero to three. Therefore, the maximum benchmark for flexibly solving all seven tasks was 21, the minimum benchmark for correctly solving all seven tasks was seven. Secondly, we developed a score for flexible mental calculation from one to six. Score one represents high flexibility, and score six rigidity. This score for flexibility was subsequently mapped with the points of the coding.

For analyzing our empirical data four steps were carried out: (1) First, we screened the data and replaced missing data by the multiple imputation approach. (2) Second, we analyzed the data descriptively. (3) Third, we conducted a two-way ANOVA in accordance with the CRF 2×2 design. (4) We did *a posteriori* *t*-tests to analyze several factor levels.

Results and Discussion

The main effects A (area of studies) and B (length of study) were significant at the α level of .05 ($F_{1,148} = 4.38, p < .04$; $F_{1,148} = 14.40, p < .01$). The corresponding H_0^A and H_0^B were rejected in favor of H_1^A and H_1^B . According to the mapping score, the results show as well that students with mathematics as a major subject start with the mean score of 3,95 and improve to 3,00. Likewise do students with mathematics as minor subject: They improve from 4,16 to 3,61 in mean. Regarding these score-levels, there is an improvement in both groups. However, the reached scores are not adequate at all for prospective primary teachers. Our results suggest a modification of the teacher training program in math courses as well as math education courses in terms of targeting teaching towards flexibility. This could be accomplished by focusing on inherent structures and discussing them on a meta-level in arithmetic and algebra classes, as well as by collaboration of teacher trainees and school students in classes which explicitly emphasize flexible mental calculation.

Acknowledgment

I would like to thank Prof. Dr. Andreas Zandler for his support with the quantitative data analysis. This study is financed by the Pädagogische Hochschule Ludwigsburg, University of Education.

References

- Baumert, J., & Kunter, M. (2011). Das Kompetenzmodell von COACTIV. In Kunter, M., Baumert, J., Blum, W., Klusmann, U., Krauss, S., & Neubrand, M. (Eds.), *Professionelle Kompetenz von Lehrkräften. Ergebnisse des Forschungsprogramms COACTIV* (pp. 29–53). Münster, Germany: Waxmann.
- Rathgeb-Schnierer, E., & Green, M. (2017). Profiles of Cognitive Flexibility in Arithmetic Reasoning: A Cross Country Comparison of German and American Elementary Students. *Journal of Mathematics Education, 10*(2), 1–16. DOI: 10.26711/007577152790009
- Torbeyns, J., De Smedt, B., Peters, G., Ghesquière, P., & Verschaffel, L. (2011). Use of indirect addition in adults' mental subtraction in the number domain up to 1000. *British Journal of Psychology, 102*, 585–597. DOI: 10.1111/j.2044-8295.2011.02019

A tool to evaluate students' performance in solving fraction word problems¹

Maria T. Sanz Garcia¹, Olimpia Figueras², and Bernardo Gómez¹

¹ Departamento de Didáctica de la Matemática Universidad de Valencia, Valencia Spain;
m.teresa.sanz@uv.es, bernardo.gomez@uv.es

² Centro de Investigación y de Estudios Avanzados del IPN, Ciudad de México, México;
figueroa@cinvestav.mx

In this paper a tool to evaluate students' performance in solving particular fraction word problems is described. It is a pencil and paper test with seven tasks, which have been designed ad-hoc from a previous historical-epistemological study of this kind of problems. The tasks have in common that all of them involve iterative processes to calculate part of the part complement. The test was validated through reliability and content validity. The difficulty of each task was obtained through the resolution success probability based on the analysis of the responses of 202 Mexican students between 15 and 16 years old. Difficulty of the task is increased when its structure is more complex. Surprisingly, only a small number of students used algebra to solve the problems.

Keywords: Fraction word problems, part of part of a whole, problem solving methods, validation test.

Introduction

Currently, problem solving emerges with renewed interest in curricular proposals because it is considered a basic competence, particularly in the development of arithmetic and algebraic thinking. An example of this assertion is that it appears explicitly in the curriculum of basic education of various countries (i.e., in Mexico (SEP, 2011)). Word problems have played a central role in the school context (Puig & Cerdán, 1988). Textbooks include a wide range of these problems, whose wording includes a setting, which is not expected to give answer to some practical situation. In Polya's typology (cited by Puig & Cerdán, 1988) such problems are refer as "finding problems" –it is requested that, under certain conditions, a quantity be determined from others that are therefore known–.

The fact that they appear in school curriculum does not imply that their teaching or learning is simple. A big number of authors have studied how this type of problems is a source of serious difficulties for many students (Korpershoek, Kuyper, & Van der Werf, 2015; Nesher & Teubal, 1975; Riley, Greeno, & Heller, 1983; Verschaffel, De Corte, & Pauwels, 1992). Daroczy, Wolska, Meurers, and Nuerk (2015) show that difficulties can be caused by: a) the linguistic complexity of the statement, b) the numerical complexity, or c) the relationship between the linguistic and numerical complexity. Other

¹ This research has been supported by Conselleria d'Educació, Investigació, Cultura i Esport through the GVPROMETEO2016-143 project, the Ministerio de Educación through EDU2017-84377-R (AEI/ERDF, EU) project, and the University of Valencia and Cinvestav within the framework of the Iberoamerica-Santander Research Scholarship Program.

authors consider the problem difficulty as the probability to solve them correctly (Ivars Santacreu & Fernández-Verdú, 2015; Riley, Greeno, & Heller, 1983).

More often than not, these studies about word problems are based on statements that involve whole numbers. However, in the case of fraction word problems the literature is scarce, both regarding its classification, and the identification of students' difficulties encountered when solving them. This lack in the literature leads us to the first aim of the study described in this paper: To characterize students' performance when solving particular fraction word problems and to measure their difficulty through the probability of solving them correctly.

The word problems chosen for this research have a common feature: an unknown quantity, which is partitioned into parts expressed by fractions. These problems repeatedly appear in the history of Mathematics, in books from different times and cultures, often solved in different ways (Gomez, Sanz, & Huerta, 2016). In this report, we chose to focus on problems with the common syntagma "of what remains", that is referred to a part of another part, which is the complement to the unit. The following is an example of this type of problems:

I found a stone, but I did not weight it; after taking away a $\frac{1}{7}$ and then a $\frac{1}{13}$ [of what remains], I found that its weight was 1 manna. What was the original weight of the stone? (Mesopotamian origin, Katz 2003, p. 27)

The common syntagma is often repeated, as in the next example:

A pilgrim carried a certain amount of money. He gave away half the amount (to Brahmins) at Prayaga. He spent two-ninths of the remaining amount in Kashi. One-fourth of the remainder was paid as duty. He spent the $\frac{6}{10}$ th part of the remainder in Gaya. Finally, he returned home with 63 *niskas*. If you know the fractional residues, find the amount he carried. (Lilavati, 1150/2006, p. 59)

This situation allows us to raise the second aim of the research: To determine if the increase of steps in the statement entails an increase in the problem difficulty.

Methodology

Students between 15 and 16 years old were considered for the research. In the inquiry carried out in a public school at Mexico City a sample of 202 individuals was formed.

For data collection, a paper and pencil test was designed with seven fraction word problems of the type aforementioned. A previous study was taken into account in which those problems were classified and mathematical elements necessary for their resolution identified (see Gómez, Sanz, & Huerta, 2016).

In a 90-minute session, students completed individually the test. They were allowed to use a pen, but not calculators, or correctors that could interfere with qualitative analysis that was going to be carried out.

The answers to the tasks were categorized following the guidelines of Taylor and Bogdan (1987), and a validation of the test was carried out according to Lacave, Molina, Fernández and Redondo (2016), as well as an analysis of the answers with a descriptive approach using IBM SPSS Statistics 22.

Design of the test

Paper and pencil test design was structured taking into account two aspects: a Historical and Epistemological Analysis (hereinafter HEA) and a Didactic Analysis (hereinafter DA). According to Gómez (2003), the first aspect allows to investigate how the teaching of mathematics has been configured at different moments in history. In particular, regarding the solving of fraction word problems, it provides information about structure, context, quantities involved and solving methods that most relevant authors have included on documentary sources. The second aspect has the purpose to identify analytical readings, that is, the quantities involved in a problem and relationships between them (Puig & Cerdán, 1988).

Test problems

To design the test's tasks, previous work is considered. Gómez, Sanz, and Huerta (2016) and Sanz and Gómez (2018) made a classification of fraction word problems through an HEA study. In Figure 1, part of this classification is shown; in it, the problems under study in this inquiry are included.

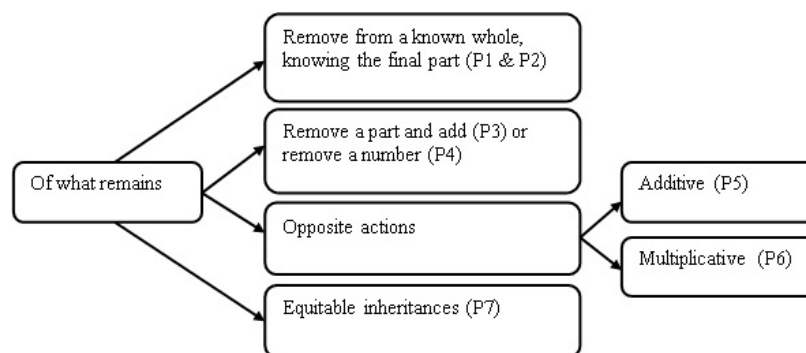


Figure 1: Classification of word problems of the type: “of what remains”

Table 1 shows the problems used in the test, they are an adaptation of the classical problems identified through HEA. Despite the fact that P1 and P2 have the same structure (see Table 1), P1 needs two steps to be solved, and P2 needs three. Given that the easier type was initially considered due to its analysis-synthesis scheme, it was decided to explore a possible change of students' performances when introducing an additional step (aim 2 of this research).

P1. A pole is painted in red, blue and black. The black part is a $\frac{1}{3}$ of the length of the pole, the part in red is $\frac{2}{3}$ of what remains, and the blue part measures 2.70 meters. How long is the pole?

P2. Miguel plays a video game. He has to end it in the time indicated on the screen. He plays one-third of the time scheduled, pauses the game and goes to have dinner. When he comes back, he moves up one-fifth of what remains. After supper, he moves up one-seventh of what remains. A message appears on the screen: ‘32 minutes left’. What time was indicated on the display at the beginning of the game?

P3. A thief went into a palace and found a bag full of coins. When he tried to escape, a palace doorman caught him; the thief offered him half of the coins to let him escape. The doorman gave back 80 coins to the thief and let him go. Another doorman took the thief by surprise, and again the thief offered half of the coins of what remained in the bag to let him escape. The second doorman received the number of coins but he gave 50 coins back. Finally, when the thief goes out, he has 200 coins in the bag. How many coins were there in the bag at the beginning?

P4. A man who has been picking up some oranges returns to his hometown. He visited two friends and he gave to one of them half of the oranges and half an orange. He gave half of the rest of oranges plus the other half orange to his second friend. After his visit, he left 10 oranges. How many oranges had he picked up?

P5. Carlos has a glass of wine and drinks $\frac{1}{4}$ of it. He fills it with water and drinks $\frac{1}{3}$ of the mixture. He refilled it with water and drank $\frac{1}{2}$ of the liquid obtained. What part of pure wine does he have left to drink?

P6. Juan went on an excursion and took a bottle of water. When he found a faucet, he duplicated the content of the bottle and drank $1 \frac{9}{10}$ dl. Later, he doubled the content that he had left and drank $1 \frac{9}{10}$ dl. Surprise! The bottle was empty. How much water was in the bottle at the beginning of the excursion?

P7. A man made his will and divided the heritage among his sons. One received a thousand pesos and $\frac{1}{7}$ of the rest; other received 2000 thousand pesos and a $\frac{1}{7}$ of the rest; another received 3000 thousand pesos and a $\frac{1}{7}$ of the rest, and so successively for all his sons. One of his sons said the distribution was not fair, but the father said all had the same amount of money. How much did each son receive? How many sons did the man have?

Table 1. Fractions word problems included in the paper and pencil test

Theoretical resolution of problems (analysis-synthesis)

The analysis of students’ performances took into account ways to solve problems. In order to obtain all possible strategies that a student can follow in a problem solving procedure, an AD was carried out through an Analysis-Synthesis (A-S) scheme (Puig & Cerdán, 1988) using the graphic symbols employed by Cerdán (2007), see Figure 2.

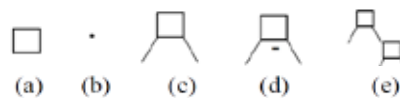


Figure 2: Symbols for A-S: (a) Unknown quantities, (b) Known quantities, (c) Relationships among them, (d) Operation/relationship between them, and (e) Nesting between quantities

In order to show the process followed, an analysis of problem P1 is recorded. Two A-S schemes of the first task (P1 in Table 1) are included in Figure 3 to show that solving procedures are not unique and that each one represents a form of reasoning, a way to relate the quantities involved. For the case of P2, the process starting from Q (see Figure 3) is repeated (due to shortage of space in this paper, the A-S scheme of P2 is not included).

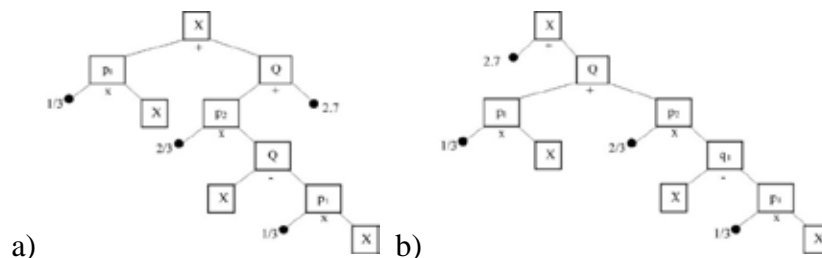


Figure 3: A-S Scheme for P1. a) x =total pole, p_1 =part painted in black, Q =the rest after painting in black, p_2 =part painted in red. b) x =total pole, p_1 =part painted in black, Q =the rest painted in red and black, p_2 =part painted in red, q_1 =the rest after painting in black

Categorization for the analysis of resolutions

The A-S scheme allows us to categorize the task resolutions. These categories will enable to identify profiles of students' performances and to carry out a subsequent qualitative analysis of the answers. In addition, the quantitative analysis, both descriptive and inferential (to be done with a large amount of data), requires this type of categorization in order to obtain more precise analysis.

Table 2 shows an example of the categories and encoded resolutions for a task, in this case P1 (Table 1). There are two different types of categories. On the one hand, the C3, C4, C5 and C6 codes are related with the analysis of students' solving procedures through A-S schemes. For example, C3 is related with p_1 (see Figure 3) or C4 is related with Q (in Figure 3). On the other hand, C1, C2 and C7 codes have the intention to collect other types of information. For example, the method used in C1 could be: graphic, direct arithmetic, algebraic, inverse arithmetic, or trial and error (methods identified by Gómez, Sanz and Huerta (2016) using HEA). Moreover, if a graphic support is used for solving the problem, C2 has been included, since the literature shows how graphic support during solving procedure leads to greater success in finding the solution (Greeno & Hall, 1997). Finally, a category is introduced to value the numerical results obtained, C7, that is, if the solution is correct or not.

It should be pointed out that 'Nothing' is included in all categories; there are students who do not write anything or who wrote calculations, but without any answer highlighted, and this situation must be considered in the analysis.

	C1	C2	C3	C4	C5	C6	C7
Code	Method	Graphic support	Part of a whole	What remains	Part of a part	What remains	Correct Solution
0	Graphic	No	No	No	No	No	No
1	Direct Arithmetic	Yes	Yes	Yes	Yes	Yes	Yes
2	Algebraic	Nothing	Nothing	Nothing	Nothing	Nothing	Nothing
3	Inverse Arithmetic						
4	Trial and Error						
5	Nothing						

Table 2. Categories and encoded resolutions for Problem P1

Test Validation

As mentioned before test validation is done according to Lacave, Molina, Fernández and Redondo (2016). Reliability was tested with the Alpha Cronbach coefficient as a measure of the internal consistency, obtaining 0.9248. The selected coefficient is higher than 0.90 (George & Mallery, 2003, p.231), so reliability is excellent. In addition, the homogeneity index was calculated to decide if any task had to be eliminated, but it was not necessary. Content validity was made through a peer discussion with nine colleagues from different educational levels in México. They modified the wording to adapt it according to students' use of Spanish in Mexico City, but the content and structure of the problems was not modified.

Results

The measure of the difficulty (d) of the fraction word problems (those in Table 1) is shown in Table 3. It is calculated as the probability of solving them correctly according to $d = \frac{\text{Correct}}{\text{Total}-\text{Nothing}}$, where Correct is the number of students who obtained the correct answer; Total is the sample size; and Nothing is the number of students who have left the problem without an answer.

	P1	P2	P3	P4	P5	P6	P7
Correct	25	8	54	6	35	11	1
Nothing	7	58	24	17	14	51	51
Total	202	202	202	202	202	202	202
d	0.128	0.056	0.303	0.032	0.186	0.073	0.007

Table 3: Summary of correct solutions by problem

From results of Table 3 it can be asserted that for Mexican students between 15 and 16 years old, P1 is easier than P2 ($d_1=0.128>0.056=d_2$), this confirms the second aim of this study: to add a step in the statement of the fraction word problems makes its resolution more difficult.

To expand the study about students' performances, a detailed analysis, related to the categorization, for problem P1 is shown. Table 4 exhibits details of the analysis' categories for such problem. C3, C4, C5, and C6 are subsequent categories, that is, if a student reaches C5 it means that C3 and C4 have been achieved. Beside absolute frequencies, percentages are in brackets. Even though the A-S scheme indicated that P1 was the most straightforward problem, only twenty-five students gave a correct solution.

Code	0	1	2	3	4	5	Total
C1 Method	24 (11.88)	162 (80.20)	8 (3.96)	0	0	8(3.96)	202
C2 Graphic support	77 (38.12)	117 (57.92)	8 (3.96)				202
C3 Part-whole	140 (69.31)	54 (26.73)	8 (3.96)				202
C4 What is left	147 (72.77)	47 (23.27)	8 (3.96)				202
C5 Part-part	150 (74.26)	44 (21.78)	8 (3.96)				202
C6 What is left	163 (80.69)	31 (15.35)	8 (3.96)				202
C7 Pole height	164 (81.19)	25 (12.38)	13 (6.44)				202

Table 4: Students' frequencies in each category of analysis, percentage is shown in parenthesis

Seventy-seven students used graphical representations, but always as support for the resolution; the part of a part can be seen only in twenty-four cases. The rest is as indicated: a rectangle is divided into three parts, and each is painted in one colour without pointing out a relationship between them.

Regarding category C7, incorrect answers were very varied, among them the following are highlighted: a) No answer (8/202); b) Pole height 8.10 m (34/202); in this case students considered all parts as equal, 2.7 m long, and since the pole was divided into three parts, they multiplied 3 times 2.7; c) Pole height 3.7 m (46/202), students added $1/2$ plus $2/3$ plus 2.7 m. They could not identify that such fractions did not represent a number but an operator; d) Pole height 10.8 m (16/202), in this

case students computed the part of the whole and the part of the part but could not accomplish correctly the last step of what is left to reach the solution.

Conclusion and Future Research

This research is a part of a project with a general aim: to include this type of problems in an Intelligent Tutorial System (ITS) to help students accomplish learning, by predicting their performance in a following task. A mathematical model to predict student's performance and to provide a sequence of problems adapted to his capabilities will be used. This model will be build up from data obtained from the ITS, but it is necessary to dispose previous information, for instance, the difficulty of each problem, diverse solving methods, previous fraction knowledge, learning comprehension or student's age. Such information is collected by means of paper and pencil tests, and in this paper, we present some of them.

With the tool described in this paper, information about solving a particular word fraction problem was collected, which have a common characteristic, in its statement the syntagma "what remain" appears. The mathematical meaning of this syntagma refers the part of the part of the complement. The information provided is diverse. On the one hand, the difficulty of each problem increases when the steps of the problem as mentioned before increases. This result will be used in the mathematical model as initial information to start the specific sequence for each student. On the other hand, the different solving methods for the same problem have been obtained through the different A-S scheme. This information will be written in the ITS to help the student when they choose one way to solve the task.

Other kind of results obtained in this study remark the arithmetic solving methods in contrast to a remarkable lack of an algebraic approach, even though students had previous contact with algebra in secondary education (SEP, 2011). Moreover, difficulties with fraction knowledge learned in primary and secondary, such as graphic representation or operations, were observed. This result leads us to believe that basic fraction knowledge should be examined previously and therefore, the relationship between them and the solving of fraction word problems should be investigated further.

Finally, note that this research is done with a sample of Mexican students between 15 to 16 years old. But, the ITS can be used by students with different ages and different nationalities, then other random and statistically significant student samples of different ages should be studied.

References

- Cerdán, F. (2007). *Estudios sobre la Familia de Problemas Aritmético-Algebraicos*. València, Spain: Servei de Publicacions de la Universitat de València.
- Daroczy, G., Wolska, M., Meurers, W.D., & Nuerk, H.C. (2015). Word problems: A review of linguistic and numerical factors contributing to their difficulty. *Frontiers in Psychology*, 6(348). doi: 10.3389/fpsyg.2015.00348.
- George, D., & Mallery, P. (2003). *SPSS for Windows step by step: A Simple Guide and Reference*. 11.0 Update (4th ed.). Boston, MA: Allyn & Bacon.

- Gómez, B. (2003). La investigación histórica en didáctica de las matemáticas. In E. Castro, P. Flores, T. Ortega, T. L. Rico, & A. Vallecillos (Eds.), *VII Simposio de la Sociedad Española de Investigación en Educación Matemática* (pp. 79–86). Granada, Spain: Universidad de Granada.
- Gómez, B., Sanz, M.T., & Huerta, I. (2016). Problemas Descriptivos de Fracciones. *Bolema-Mathematics Education Bulletin*, 30(55), 586–604.
- Greeno, J.G., & Hall, R.P. (1997). Practicing Representation: Learning with and about Representational Forms. *Phi Delta Kappan*, 78(5), 361–367.
- Ivars Santacreu, P., & Fernández-Verdú, C. (2015). Evolución de los niveles de éxito en la resolución de problemas de estructura multiplicativa en educación primaria. In C. Fernández, M. Molina, & N. Planas (Eds.), *XIX Simposio de la Sociedad Española de Investigación en Educación Matemática* (pp. 327–334). Alicante, Spain: Universidad de Alicante.
- Katz, V. (2003). *A history of mathematics*. New York, NY: Addison-Wesley.
- Korpershoek, H., Kuyper, H., & Van der Werf, G. (2015). The relation between students' math and reading ability and their mathematics, physics, and chemistry examination grades in secondary education. *International Journal of Science and Mathematics Education*, 13, 1013–1037.
- Lacave, C., Molina, A.I., Fernández, M., & Redondo, M.A. (2016). Análisis de la fiabilidad y validez de un cuestionario docente. *ReVision*, 9(1), 23–36.
- Lilavati (2006). *Lilavati Of Bhaskaracarya Treatise of Mathematics of Vedic Tradition*. Dehli: Motilal Banarsldass Publisher Private Limited. (Original 1150).
- Nesher, P., & Teubal, E. (1975). Verbal cues as an interfering factor in verbal problem solving. *Educational Study Mathematics*, 6, 41–51.
- Puig, L., & Cerdán, F. (1988). *Problemas aritméticos escolares*. Madrid: Síntesis.
- Riley, M.S., Greeno, J.G., & Heller, J.I. (1983). Development of Children's Problem-Solving Ability. In H. P. Ginsberg (Ed.), *The Development of Mathematical Thinking* (pp. 153–196). San Diego, CA: Academic Press.
- Sanz, M.T., & Gómez, B. (2018). Missing curious fraction problems: the unknown inheritance and the unknown numbers of heirs. In K.M. Clark, T.H. Kjelden, S. Schorcht, & C. Tzanakis (Eds.), *Mathematics, Education and History: Towards a harmonious partnership* (pp. 193–208). Berlin: Springer.
- Secretaría de Educación Pública (2011). *Programas de estudios. Guía para el maestro. Educación Básica. Secundaria. Matemáticas*. Retrieved from http://www.curriculobasica.sep.gob.mx/images/PDF/prog-secundaria/sec_matematicas2011.pdf.
- Taylor, S., & Bogdan, R. (1987). *Introducción a los métodos cualitativos de investigación. La búsqueda de significados*. Barcelona: Paidós Ibérica, S. A.
- Verschaffel, L., De Corte, E., & Pauwels, A. (1992). Solving compare problems: an eye movement test of Lewis and Mayer's consistency hypothesis. *Journal Education Psychology*, 84, 85–94.

Development and variance components in single-digit addition strategies in year one

Pernille B. Sunde^{1,2} and Peter Sunde³

¹Danish School of Education, Aarhus University, ²VIA University College, Denmark; pbos@via.dk

³Department of Bioscience, Aarhus University, Denmark; psu@bios.au.dk

In this paper, we aim to quantify students' development of mental strategies in single-digit addition over a five months period in six Danish year one classes dependent on their initial stage based on assessment interviews of 83 year one students' strategy use when answering 36 single-digit addition tasks. Students were interviewed twice (autumn and spring). Students using direct retrieval the least at interview 1 had the highest increase in proportional use at interview 2, whereas students using it the most showed no mean increase. For counting and derived fact, the change from interview 1 to 2 was constant irrespective of initial use. Analysis of how much of the variation in change in proportional use of different strategies was explained by different factors showed that 60-83% of the total variation was explained by the students' initial strategy use. Factors attributable to the specific learning environment and instructional practice did not explain any significant variation.

Keywords: Mental computation, addition, primary education, individual differences.

Background

Whole number arithmetic is a foundational subject in early years' mathematics. The first arithmetic operation students encounter in school is addition and simple arithmetic, which is related to number sense according to Gersten, Jordan, and Flojo (2005). Thus, knowledge on students' early use and development of strategies in addition contributes to the understanding of students' development of arithmetic proficiency in general (e.g., Laski, Ermakova, & Vasilyeva, 2014). Furthermore, students' early qualitative use of strategies in mental arithmetic has been shown to influence development of mathematics competence and to be a valid predictor of later mathematical achievement and difficulties (Carr & Alexeev, 2011; Dowker, 2014; Gersten et al., 2005; Ostad, 1997).

Strategies for single-digit mental addition can be divided into three categories as described by Carpenter and Moser (1984): (1) Direct modelling strategies with fingers or physical objects, where counting sequences are used to count all concrete objects. (2) Counting strategies, where mental counting is used in counting-all or counting-on from either the first or, later, the largest addend. (3) Number fact strategies, which involve either a) direct retrieval, which is the direct recalling of the sum, or b) derived fact strategies, where known facts are used to derive the answer. Interesting to note that derived fact strategies has been the focus for many recent studies (e.g. Dowker, 2014; Gaidoschik, 2012; Laski et al., 2014).

Students strategy use in arithmetic is influenced by many factors related to the individual student, for example working memory (e.g., Imbo & Vandierendonck, 2007) and gender (e.g., Carr, & Alexeev, 2011), as well as the learning environment, such as instructional practice (e.g., Timmermans, Van Lieshout, & Verhoeven, 2007), and parents and teachers' strategy preferences (Carr, Jessup, & Fuller, 1999). Thus, Carr et al. (1999) found that boys would use the strategies their parents use, which

include the use of retrieval strategies. These strategies were also those their teachers were more likely to teach them.

Furthermore, students tend to use the strategies they are confident with in a feedback loop as described by Bailey, Littlefield, and Geary (2012), where early preference for a strategy predicts later use, which in turn predicts later preference. Students, who primarily use counting in early arithmetic at the expense of derived fact strategies, will get less practise in working flexibly with numbers. As a consequence, they will have fewer options to develop the more complex comprehension required in advanced arithmetic (Gersten et al., 2005). Thus, students change in strategy use are found to be dependent on individual factors, such as gender and initial strategy use, as well as factors related to the learning environment and learning opportunities, such as instructional practice.

The study of Gaidoschik (2012) is an example of a study where students' development of strategies for single-digit addition in year one are investigated in relation to both, students' prior knowledge and teachers' instructional practice. Gaidoschik (2012) found that strategy development was significantly related to students' prior number knowledge. Furthermore, he found in a qualitative analysis that although teachers' instructional practice focussed on counting strategies in year one, many students developed derived facts and automatized sums. This finding indicates instructional practice had minor influence on these students development of strategies. Although several studies have documented effects of students' prior knowledge and instructional practice, there is less evidence on the relative contribution of individual differences and instructional practice for students' development of strategies.

The current study

The data presented here are part of a larger project on the relationship between students' development of mental strategies in single-digit addition, teachers' perceptions of the learning of number and arithmetic in year one, and classroom instruction. In this paper, we aim to quantify students' development of mental strategies in single-digit addition over a five month period in six Danish year one classes dependent on their initial strategy use. Furthermore, we investigate how much different variance components contribute to the overall variation in year one students' development of strategies. We are specifically interested in quantifying how much of the total variation in the students' strategy use at time 2 that could be explained by their strategy use at time 1, instruction time and possible differences between classes in general as well as in interaction with time as the latter would include all variation due to possible effects of instruction.

Methods and analyses

The study and participants

The study consisted of 155 assessment interviews on strategy use for single-digit addition conducted on 83 year one students (46 girls; age 7) from six Danish year one classes. In each class, between 11 and 18 students were selected randomly though balanced with respect to gender. 72 students were interviewed in November 2015 and April 2016. 11 students were interviewed only once due to absence. To evaluate differences and similarities in the learning environment of the six classes, the six teachers (three female and three male) were interviewed on the teaching and learning of arithmetic

and number. Furthermore, their instructional practice was documented through classroom video observations. These data will be analysed and discussed in detail elsewhere, but initial analysis indicated the teachers differed with respect to emphasis on teaching mental strategies for arithmetic and focus on procedural as opposed to conceptual knowledge. For example, two teachers emphasised rote learning of facts and procedural learning of counting strategies, two teachers focussed on students' skilled use of derived fact strategies and taught these explicitly, and two teachers were conscious of both rote learning of facts and derived fact strategies but did not emphasise one over the other. Furthermore, a previous study showed that the teachers' expectations for their year one students' development in number and arithmetic differed substantially (with one to two years of learning) (Sunde & Sayers, 2017). Thus, with respect to differences in teachers approach to teaching and learning arithmetic the six classes represents a continuum from high level of focus on explicit instruction of strategies with conceptual understanding to an instructional practice focussing on automatization of facts and procedural understanding.

Assessment of students' strategy use

Students' use of mental strategies for single-digit addition was assessed in one-to-one assessment interviews where students were presented with flashcards of the 36 addition tasks with numerals 2-9, including doubles. Manipulatives, paper and pencil were not accessible for the student. The flashcards were presented with tasks of increasing difficulty to avoid less confident students to give up or only use counting if presented with difficult questions at the beginning of the interview. Interviews took place in a quiet room at the school and each session lasted 10-30 minutes. We asked the student to explain how he or she found the answer. Based on students' explanations and the interviewer's observation, answers were categorised in four categories. 'Error' was used if the student gave up or miscalculated. For correct answers 'Counting' included all variations of counting procedures on fingers, verbal or self-report as mental counting, 'Direct retrieval' was used for automatized sum, and 'Derived fact' included all variations of decomposing addends and using automatized sums to calculate the answer (e.g. $4+5 = 4+4+1$ or $5+5-1$) (for more detail see Sunde, Sunde, & Sayers, 2019).

For each assessment interview, we calculated a strategy use profile on the basis of the proportion of answers (denoted 'proportional strategy use' hereafter) to the 36 addition tasks scored as 'error', 'counting', 'direct retrieval', and 'derived fact'. Hence, if a student used 'counting' to solve 6 of the 36 tasks, the proportion for counting, p_{counting} , was $6/36 = 0.1667$. Original values were logit transformed prior to the analysis ($\text{logit } p_i = \ln[p_i/(1-p_i)]$). Before transformation, we substituted zero values (not defined on the logit scale) by 0.01, which is 2.8 times lower than the minimum achievable value larger than 0 (1 of 36 items = 0.028).

Analysis of change in proportional strategy use

Development in mean use of each of the four strategies over half a school year was analysed by modelling proportional strategy use in the second assessment interview (p_{i2}) as a linear regression function of the students' proportional strategy use in the first assessment interview (p_{i1}) five months earlier. From this regression function ($\hat{p}_{i2} = \beta_0 + \beta_1 p_{i1}$) the mean change in (logit-transformed) p_i from a given level in autumn to the next spring could be derived as the vertical distance between the regression line and the reference line $y=x$ that indicated no change in mean strategy use between the

two test sessions. Hence, the more students increases the proportional use of a given strategy from autumn to spring, the higher above the $y=x$ line will the data points and the regression line be located and vice versa. From the slope of the regression line, it is furthermore possible to test whether the change in use of a given strategy is conditional on how much it was used in the first interview. If the mean change in proportional use (on logit scale) of a given strategy from interview one to interview two is equal for all students irrespective of how much they used the strategy on the first assessment interview, the slope of the regression line would not be significantly different from 1. On the contrary, a slope < 1 indicate a greater change in proportional use of a strategy by those students that used the strategy least in the first interview whereas a slope > 1 would indicate the opposite, i.e. that those students that used a strategy least in interview one are also those that have developed relatively less from interview one to interview two.

Before the linear regression functions were established, we tested for possible quadratic and cubic relationships between p_{i2} and p_{i1} , as well as for possible effects of class (for the case development in strategy use varied between classes between interview one and two) and sex (for the case boys and girls differed in change of strategy use between interview one and two) without finding any significant effects of those predictors.

Analysis of variance components

We quantified how much of the variance in proportional use of each strategy was explained by different factors. The factors were time (difference between interview one and two), student identity nested within class (the systematic difference between students over the two interviews within a given class), class (the systematic difference between students in different classes) and the interaction between class and time (systematic differences in how much students from different classes changed from interview one to two). We calculated variance components as each of the aforementioned factors' sum-of-square compared to the total sum-of-squares in General linear models with all 155 interview results as observation units and the aforementioned variables and interaction terms as fixed effects. In this respect, the interaction term class*time encompasses all variation that could be explained by differential instructional practice because it represents the time a student has received instruction in a specific classroom. We derived statistical significances of each factor from F-tests.

Results

Change in proportional strategy use: Conditional on initial strategy use

As expected, mean use of all four strategies significantly changed from autumn to spring (all p-values ≤ 0.001) as the proportions of errors and counting decreased and direct retrieval and decomposition increased. The coefficients of determination (R^2) when modelling results from assessment interview two as functions of the results from interview one showed that the changes in the students' proportional use of a strategy was highly conditional on initial strategy use (Figure 1: R^2 -values: 0.26-0.69). The slopes of the regression lines were significantly < 1 for 'error' ($t_{71} = 6.52$, $P < 0.0001$) and 'direct retrieval' ($t_{71} = 2.18$, $P = 0.03$), but did not differ from 1 for 'derived facts' ($t_{71} = 1.75$, $P = 0.08$) and 'counting' ($t_{71} = 0.6$, $P = 0.4$).

For ‘error’, the slope lower than 1 indicates that students with the highest error rates in interview one displayed the highest reduction in error rates between assessment interview one and two, probably as the mere result of the vast majority of the students solving all items correctly in general and especially in interview two. For ‘counting’ and ‘derived fact’ slopes not significantly different from 1 indicated that the mean change in use of these two strategies from interview one to two (decrease in counting, increase in derived fact) were constant no matter how much the strategies were used in the first assessment interview situation. For ‘direct retrieval’ a slope lower than 1 and inspection of the confidence zones of the regression line suggested that students using direct retrieval least in the first interview expressed the highest increase in use of this strategy in interview two. Whereas, students with the highest use of this strategy in interview one did not show any mean increase in use of this strategy in interview two.

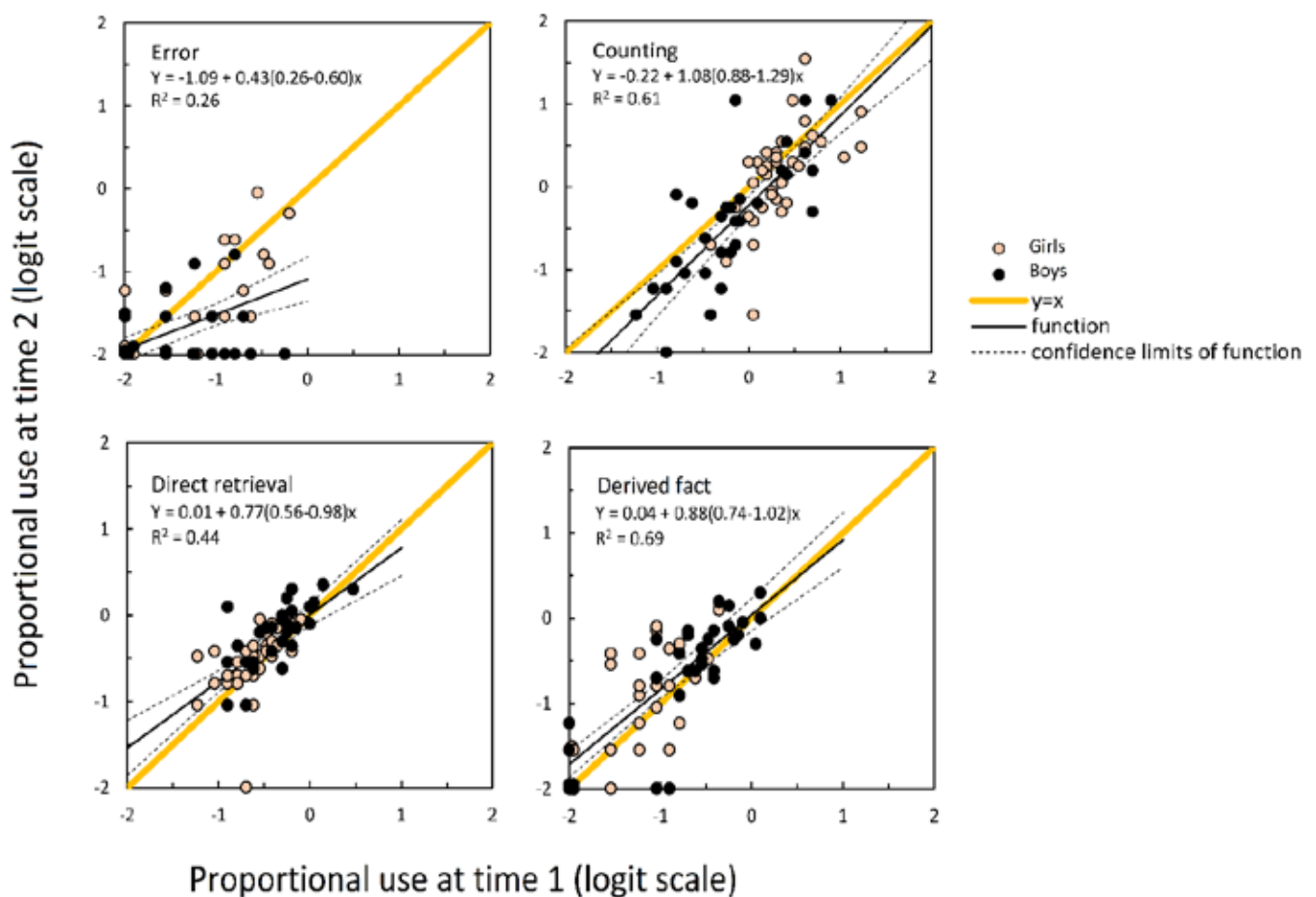


Figure 1: Proportional use (logit-scale: zero-values replaced by 0.01 before transformation) of strategies of 72 year one students in spring (April) plotted against their results achieved in the same assessment interview the preceding autumn (November)

From inspection of Figure 1, one can see that girls generally used counting substantially more than boys, and boys significantly used derived fact more than girls. These sex differences that were already present at interview one are dealt with elsewhere (Sunde et al., 2019). As regards changes from

interview one to interview two, boys and girls did not differ for any of the strategies (additive effect of sex if included in regression models: all p-values > 0.2).

Variance components: Effect of individual differences, time and class

The half school year represented by the mean difference in strategy use between assessment interview one and two explained 3-6 % of the total variation in use of the four strategies, as compared to 60-83% explained by student identity nested within class (all p-values ≤ 0.001) and 3-12 % by class (statistically significant for ‘error’, ‘counting’ and ‘derived facts’: Figure 2). The time-by-class interactions (representing specific instructional practice) explained 0-1 % indicating no measurable class differences in mean progression from interview one to two (Figure 2).

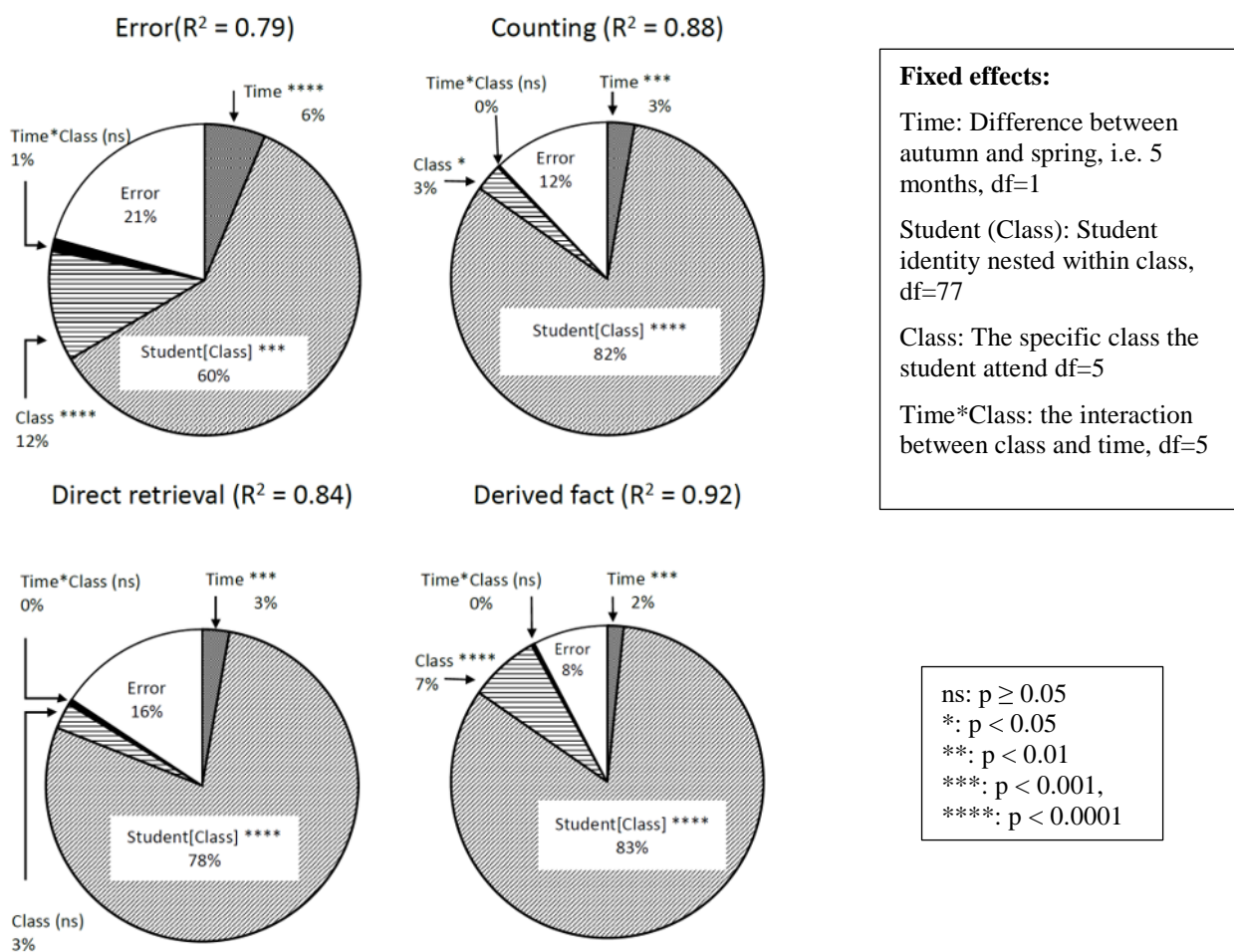


Figure 2: Variance components in terms of Type 3 sum-of-squares of strategy use assessed twice in year one (autumn and spring), derived from general linear models

Discussion

This statistical investigation of strategy use in single-digit addition amongst year one students revealed the following three results worth noting. First, the slopes of the regression lines of strategy use at interview two as function of strategy use at interview one demonstrates that in at least two of four strategies the mean change in strategy use from interview one to two differed significantly between those students who used the strategy most and least. In the present case those students with

highest proportion of errors in interview one expressed the largest reduction in error frequency in interview two five months' later. Those who used direct retrieval least in the first interview expressed the highest increase in use of this strategy to interview two. For counting, the mean change in strategy use did not differ significantly between students with high and low initial use. This corresponds with Bailey et al.'s (2012) feedback loop of relationship between skills and preference for specific strategies.

Considering that use of derived fact strategies are related to high arithmetic ability (Dowker, 2014) and the relationship between excessive use of counting and mathematical difficulties (Ostad, 1997), it is concerning that the students with high initial proportional use of counting do not decrease the use of this strategy more than students with a low initial use. These findings underline the importance of analysing and reporting changes in strategy use (or any other achievement measure) as function of a given time period or intervention type differentially for student groups with different start level. In that respect, the here used graphical and statistical method based on testing the nil-expectation of a slope = 1, may provide an easily used and comprehensible method. One implication for practice of these results is that instruction should support students in developing a diverse strategy use.

Second, albeit mean use of all four strategies significantly changed over the five months between interview one and two (as expected), these changes, reflecting the fundamental 'effect' of learning and maturation, were modest compared to the variation in strategy use between students (evident as the high correlation coefficients of the scatter plots in Figure 1, as well as the amount of variance components explained by student ID in Figure 2). This illustrates the importance of acknowledging the long known but sometimes implicitly forgotten notion that students within a class may vary in strategy use patterns equalling several years' education time.

Third and finally, our analysis revealed that for Danish primary school children little variation (1-7%) appeared to exist between classes in general (main effect of class), and even less (0-1%) between classes and time (class-by-time interaction). Given that the five months' time span represents a big part of the students' first formal mathematics education, we find it interesting that the different classes in effect appeared to develop similarly between interview one and two despite considerable differences in teaching practice.

We want to stress that from this, one cannot conclude that differential teaching practices do not influence learning outcome, just that such differences were barely measurable over a time scale of five month's education time. A delayed effect of different instructional practices in year one on later arithmetic ability is thus possible. It is also important to notice that effects of differential teaching practices may have occurred before November, when interview one took place. Significant main effects of class for counting and especially derived fact indicate that this might have been the case.

In conclusion, Danish year one students' developmental change of strategy use for single-digit addition is primarily determined by their strategy use when entering year one. Development patterns were similar between classes, suggesting no influence of instructional practice, but mean change in error rate and use of direct retrieval differed for students with high or low initial use. The relatively small influence of five months teaching on strategy use patterns and the lack of difference between

classes with different instructional practice is stunning. The findings call for qualitative research on what role different instructional practice play in year one students' development of strategy use.

References

- Bailey, D. H., Littlefield, A., & Geary, D. C. (2012). The codevelopment of skill at and preference for use of retrieval-based processes for solving addition problems: Individual and sex differences from first to sixth grades. *Journal of Experimental Child Psychology*, *113*(1), 78–92.
- Carpenter, T. & Moser, J. (1984). The acquisition of addition and subtraction: Concepts in grades one through three. *Journal for Research in Mathematics Education*, *15*(3), 179–202.
- Carr, M., & Alexeev, N. (2011). Fluency, accuracy, and gender predict developmental trajectories of arithmetic strategies. *Journal of Educational Psychology*, *103*(3), 617–631.
- Carr, M., Jessup, D. L., & Fuller, D. (1999). Gender differences in first-grade mathematics strategy use: Parent and teacher contributions. *Journal for Research in Mathematics Education*, *30*(1), 20–46. doi:10.2307/749628
- Dowker, A. (2014). Young children's use of derived fact strategies for addition and subtraction. *Frontiers in Human Neuroscience*, *8*, 1–9. doi:10.3389/fnhum.2013.00924
- Gaidoschik, M. (2012). First-graders' development of calculation strategies: How deriving facts helps automatize facts. *Journal für Mathematik-Didaktik*, *33*(2), 287–315.
- Gersten, R., Jordan, N. C., & Flojo, J. R. (2005). Early identification and interventions for students with mathematics difficulties. *Journal of Learning Disabilities*, *38*(4), 293–304.
- Imbo, I., & Vandierendonck, A. (2007). The development of strategy use in elementary school children: Working memory and individual differences. *Journal of Experimental Child Psychology*, *96*(4), 284–309. doi:10.1016/j.jecp.2006.09.001
- Laski, E. V., Ermakova, A., & Vasilyeva, M. (2014). Early use of decomposition for addition and its relation to base-10 knowledge. *Journal of Applied Developmental Psychology*, *35*(5), 444–454.
- Ostad, S. A. (1997). Developmental differences in addition strategies: A comparison of mathematically disabled and mathematically normal children. *British Journal of Educational Psychology*, *67*(3), 345–357.
- Sunde, P. B., & Sayers, J. (2017). Danish teachers' expectations of year one pupils' additive competence. Paper presented at The Eighth Nordic Conference on Mathematics Education, Norma 17, Stockholm, Sweden.
- Sunde, P. B., Sunde, P., & Sayers, J. (2019). Sex differences in mental strategies for single-digit addition in the first years of school. *Educational Psychology*. Advance online publication. doi:10.1080/01443410.2019.1622652.
- Timmermans, R. E., Van Lieshout, E. C., & Verhoeven, L. (2007). Gender-related effects of contemporary math instruction for low performers on problem-solving behavior. *Learning and Instruction*, *17*(1), 42–54.

Learning fractions using a teaching model designed with applets and the number line: The cases of Alvaro and Fernanda

Carlos Valenzuela García^{1,2} and Olimpia Figueras²

¹Universidad Anáhuac (campus norte), Ciudad de México; carvaga86@hotmail.com

²Centro de Investigación y de Estudios Avanzados del IPN, Departamento de Matemática Educativa, Ciudad de México; figueroa@cinvestav.mx

As part of a general study, a teaching model for fractions based on applets created with GeoGebra and the number line as a conceptual and didactical resource was designed. The model has eight stages; each one is composed of an interaction-exploration part, and questions to favour students' thinking about their interaction with the applets. The purpose of the model is to contribute to the building up of better fraction mental object of students who finished elementary school. The performances of two students are characterized in this paper; both improved their fraction mental object. Before the teaching experiment, they only had ideas related to the use of fractions as fracturer. After working with the applets, those ideas changed. Both students could do tasks related to fractions as number and as measurer, particularly, they could represent fractions on the number line, identify which of two fractions was bigger, and distinguish proper and improper fractions.

Keywords: Aspects of fractions, applets for teaching, fractions on number line, teaching models.

Introduction

Investigating the processes of teaching and learning fractions has been a significant theme in the field of mathematics education. The previous statement can be linked to the fact that fractions are part of the basic education curriculum in the world (NCTM, 2000; SEP, 2011). Nevertheless, fractions have been considered as one of the complex concepts studied in basic education (Siegler, Fazio, Bailey, & Zhou, 2013), and as a consequence, students have low performance in mathematics. Therefore, it is necessary to design tools that promote the improvement of students' fraction mental object, in Freudenthal's (1983) sense; since a good mental object of this concept will allow pupils to have adequate performance in mathematics from elementary to high school (Siegler, Duncan, Davis-Kean, et al., 2012). Due to the inclusion of digital technologies as a cognitive resource for teaching mathematics (Drijvers, 2013), the design of a teaching model based on the aforementioned resources is one of the main purposes of the research described in this paper.

Research objectives

The main objective is to construct a teaching model in order to enrich the current one for Mexican elementary school. In this context, two particular purposes for students who finished elementary school are 1) to characterize their fraction mental object, and 2) to promote the building up of better fraction mental objects. The aim of this paper is to show evidence of the purposes defined above.

Theoretical framework and related literature

The Local Theoretical Model (LTM) (Fillooy, Rojano, & Puig, 2008) is used as a theoretical and methodological framework. The LTM serves to focus on an object of study through four interrelated

components: (1) formal competence, (2) teaching models, (3) models for cognitive processes, and (4) models of communication. These components serve to design a teaching model.

The formal competence component. From the example of the didactic phenomenology of fractions elaborated by Freudenthal (1983), and taking into account ideas of other authors, for example, those of Kieren (1992) and Behr et al. (1983), the formal component of the LTM is constructed. This component is summarized in a scheme by means of which uses and aspects of fractions and their relationships are identified from everyday language to formalization through mathematical constructions. The aspects of fractions that are considered according to Freudenthal (1983) are descriptor, fracturer, comparer, measurer, operator, and number. For more about those uses and aspects of fractions see Valenzuela, Figueras, Arnau and Gutiérrez-Soto (2017a).

The teaching models component. A characterization of the teaching model of the last cycle of the Mexican primary school - 5th and 6th grades, children between 11 and 12 years old- was made. Results allowed the identification of situations in which all aspects of fractions underlie, and different representations and models are used. However, greater emphasis is placed on fractions as fracturer and as number. This led to design a new teaching model based on technology and focusing on fractions as measurer and as number; in particular, the emphasis is placed on notions of equivalence, order, density and the characterization of proper and improper fractions. To obtain the link for using the teaching model write to the authors (an English version will be available soon).

The cognitive processes component. As part of this component, reference is made to errors, difficulties, and students' actions when they use fractions. An important purpose of this study is to have a catalogue that serves as a reference for analysis of students' performances. Among the difficulties students have, informed by other researchers, are the following: 1) difficulties to identify a fraction represented in a figure with more than one fractional unit (Saxe, Taylor, McIntosh, & Gearhart, 2005); 2) difficulties to identify improper fractions (Tzur, 1999); 3) consideration of the whole as the entire segment and not the defined unit segment in segments of a number line with more than one unit (Ni & Zhou, 2005); and 4) lack of association of a fraction with a point or the right end of the segment on the number line (Petitto, 1990).

The communication component. This component is related to the processes of communication between different actors in a teaching and learning situation. In this case, the fundamental process considered is established between the teacher/researcher and the students via their interaction with the applets. Figure 1 shows how technological tools in this research are designed to promote the communication process. Through a series of codes, the teacher/researcher provides information to students; this favours interaction between student and applet. Students' information provided through applet interaction is saved in a database, which is used for the analysis of their behaviour.

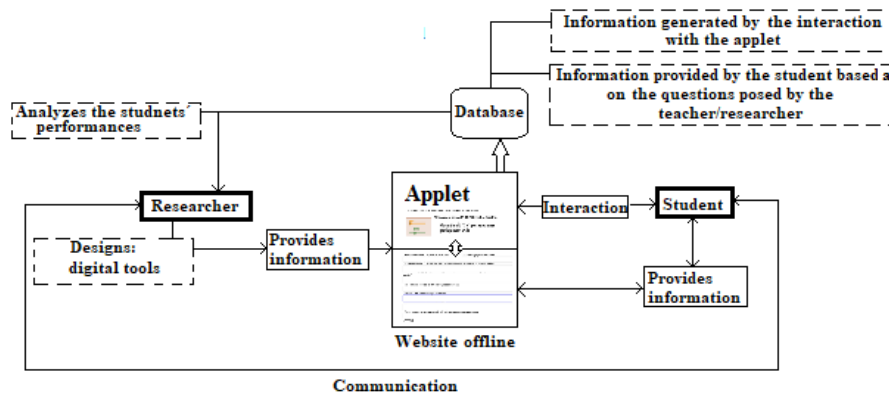


Figure 1: The communication process between Teacher/Researcher-Applet-Student

The teaching model

The final teaching model is formed by eight phases (see Figure 2); in each one, students' interaction is similar as the description in Figure 1, but every phase has a different purpose, related to the study of order, equivalence, density, and characteristics of proper and improper fractions. The design of the first two applets is described in Valenzuela, Figueras, Arnau and Gutiérrez-Soto (2017b).

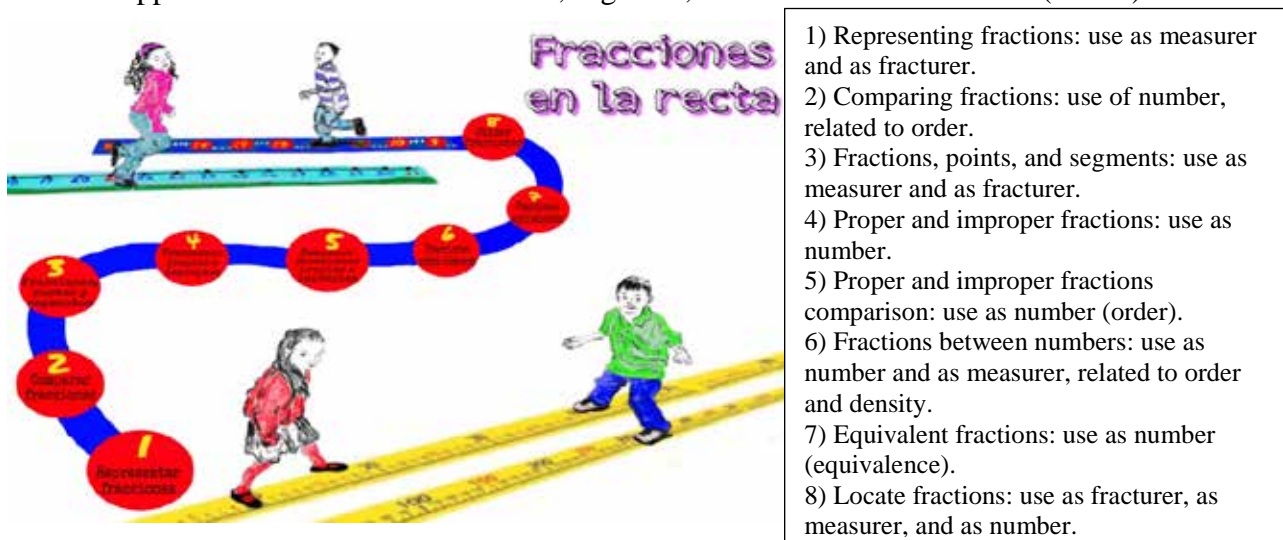


Figure 2. Screenshot of teaching model sequence offline

Population and method

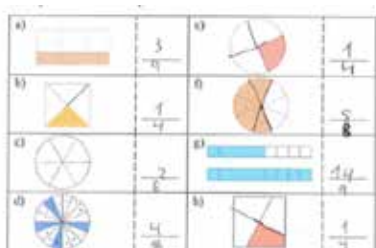
The experimentation component of the study had two phases. A pilot study; 45 students (4 groups) of a public secondary school located in a troubled zone of Valencia, Spain, took place. It helped to validate the teaching sequence, modify questions and verify applets' operation, and was considered necessary to realize an introductory activity to explore GeoGebra. In the main trial, 10 pupils of a public primary school in a marginalized zone of Zacatecas, México participated. In both, students worked individually and no help was given. Teachers only participated when applying the initial and final paper and pencil tests (evaluation and validation instruments). For analysis, the evidence stored in the computer as a product of the student-applet interaction was used. This report concerns Alvaro and Fernanda's performances. Alvaro is a 13-year-old student with low grades who participated in

the pilot study, he had already used a computer before the experimentation. Fernanda is 12 years old, and has medium-high grades, she participated in the main trial and had never used a computer.

The pilot study was carried out in 5 sessions of 45 minutes each, the main trial in 6 sessions from 60 to 90 minutes, including the activity to explore GeoGebra. In both approaches, an initial test was applied, the teaching sequence was carried out, and a final test was used. The tests are employed as evaluation instruments that help to validate the teaching sequence, in which aspects of fraction as measurer, as number and as fracturer are taught. Tests have 6 tasks. The first three assesses aspects related to the use of fraction as fracturer in continuous and discrete models. In task 4, the uses of fraction as measurer and as fracturer in the number line model are evaluated. Task 5 deals with the use of fraction as number, and in task 6, different uses of fractions appear in a context of problem-solving. Following this order, Alvaro's and Fernanda's performances are described below.

Alvaro's performance

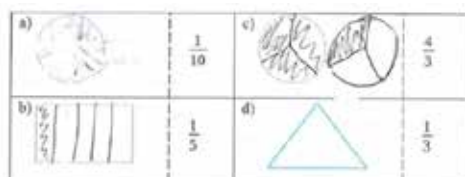
Alvaro's answers in the initial test, confirms that his fraction mental object allows him to establish a fracturing relation in a graphic representation of a fraction, particularly when using discrete and area models. In Figure 3, the processes to establish the fracturing relation is shown, the student extends the linear partitions to identify the minor fractional unit (items b, e, f, and h). The trace of the pen allows seeing that there is a tendency to count the number of parts, especially when the partition has a "large" number of parts (items d and f).



Instructions: In the following figures, what fraction represents the part that is painted? Write your answer on the line in the box.

Figure 3: Alvaro's answers to represent fractions symbolically in an area model, initial test

Alvaro is also successful representing graphically fractions from a symbolic expression (proper and improper), except in the case of a triangle to represent $1/3$, see Figure 4. In the processes of partitioning, Alvaro estimates the equality of the parts by congruence. He has technical difficulties to make a partition, but not conceptual ones as sustained by Streefland (1991).



Instructions: In the following figures, represent the indicated fractions.

Figure 4: Alvaro's answers to represent fractions in an area model, initial test

Alvaro was not able to represent fractions on the number line. Apparently, he fails to transfer his knowledge about partitioning in an area model to a linear model -number line-. He attempts to answer task 5, however, there is a tendency to use decimal numbers to provide fractions between two integers,

but has difficulties to supply fractions. He does not recognize the terminology of proper and improper fractions and faces difficulties in solving problems; he did not answer task 6.

Answers given by students during the interaction with the applets in the teaching sequence are analysed to identify: 1) processes they follow to represent fractions on the number line, 2) recognition and justification of fraction comparison, 3) recognition of equivalent fractions, and 4) characterization of proper and improper fractions.

During the teaching sequence, Alvaro did not achieve the purpose of stage 1. A tendency to dissociate numerator and denominator in his interpretation of symbolic and graphic representations of fractions on the number line was identified. But, this idea changed. In stage 3 he recognized a fracturing relationship between part and whole. In stage 2 the student wrote three proper fractions ($1/2$, $2/3$ and $2/4$) but no improper ones. To justify the order of fractions he focuses on the length of the segment that represents a fraction; he justifies his answer writing: “ $2/4$ is smaller because it occupies less than the others”. In stage 4, Alvaro faces difficulties to express characteristics of proper and improper fractions, but in stage 5 characterizes an improper fraction, comparing the numerator and denominator, he wrote: “the numerator is larger than the denominator”. In the teaching sequence, the student only managed to identify two equivalent fractions: $4/1$ and $40/10$.

As mentioned in the initial test, Alvaro failed to represent fractions on the number line, but after exploring the applets of the teaching sequence, in the final test (solved in a paper), he succeeded locating fractions on the number line, as shown in Figure 5.

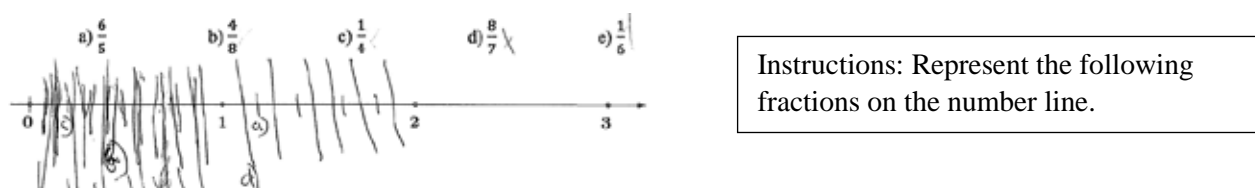


Figure 5: Alvaro's answers in the final test to represent fractions on the number line

As observed, the student makes the complete partition for representing each fraction. One strategy he uses is to make stripes of different sizes to distinguish the different fractional units. In addition, a trace of counting the parts is observed.

Also in Figure 6, there is evidence that Alvaro improved his partitioning processes to represent fractions in tasks related to an area model, although this was not the focus of the teaching sequence.

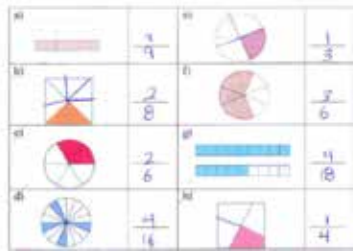


Figure 6: Alvaro's answers to represent fractions in an area model, final test

Fernanda's performance

In the initial test, Fernanda showed solid ideas about fraction as a fracturer, both to establish a fracturing relation in continuous (Figure 7) and discrete models, as well as its use in a fracturing

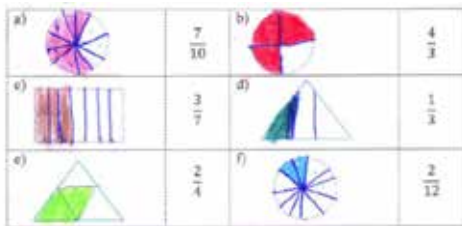
operator aspect (Figure 8). She only faced difficulties in establishing a fracturing relation in graphic models where the difference in the size of the parts is not so evident (items e and f of Figure 7). But after studying the teaching sequence, the student managed to respond even to this type of situations.



Instructions: In the following figures, what fraction represents the painted part? Write your answer on the line in the box.

Figure 7: Fernanda's answers to represent fractions symbolically from area model, initial test

The processes used by Fernanda to establish the fracturing relation are based on counting the number of parts (items d, f, and g). In fact, in item f she did not distinguish the differences between the sizes of parts. The student also extends the partitions to identify the minor fractional unit (items b, e, and h). In item e, probably she had a counting error. Moreover, Fernandas' fraction mental object allowed her to use partitioning processes to establish a fracturing relation in a graphic representation from a symbolic expression of a fraction (see Figure 8).



Instructions: In the following figures, represent the indicated fractions.

Figure 8: Fernanda's answers to represent fractions in an area model, initial test

Fernanda could express the fracturing relationship in continuous models, but did not manage to extend the model to represent improper fractions (item b), she changed numerator by the denominator. She also showed difficulties in fracturing a whole in a large number of parts -12-. With respect to the number line, Fernanda was not able to transfer her knowledge about partitioning in an area model to a linear model -number line-. In the initial test, she did not answer tasks related to representing fractions on the number line, nor those regarding the use of fractions as a number.

Fernanda's performance in the teaching sequence was among the best in her group. She only showed less ability in stage 2, the criteria used to establish order between fractions was a comparison of numerical values of a fraction, which led to errors. However, with respect to the other subjects taught, she was more successful in stages 1 and 3, related to fractions as fracturer and as measurer. She also managed to characterize proper and improper fractions comparing numerator with denominator. Fernanda was able to establish several equivalent fractions during her interaction with the applets in the teaching sequence, but also later, since in the final test she showed skills to write equivalent fractions of some given fraction. After studying the teaching sequence, in the final test, Fernanda was able to answer correctly tasks related to fraction's uses as measurer and as number. Particularly, she managed to represent fractions on the number line (see Figure 9).



Instructions: Represent the following fractions on the number line.

Figure 9: Fernanda's answers in the final test to represent fractions on the number line

In the process to represent fractions, Fernanda made lines of different sizes to distinguish partitions. Apparently, she did not split all the unit segments. For example, to represent fraction $7/3$, only a third part was indicated in the interval $[2, 3]$. Also, she expressed $2/12$ and $1/6$ in the same place, which shows that she recognizes their equivalence, and she puts $2/10$ to the right of $1/6$, an idea about order between fractions. Additionally, the student improved her partitioning processes to establish a fracturing relation in both static and dynamic processes.

Conclusions

Although in the experimentation a small period of time was devoted to interacting with the applets, there is evidence that students learned other aspects of fractions, mainly those related to their location on the number line. In the initial test, it was observed that Alvaro and Fernanda's fraction mental object allowed them to solve mainly tasks related to the use of fracturer in continuous and discrete models. However, this knowledge could not be transferred to represent fractions in a linear model. So the teaching in a single approach is not a guarantee for students to be able to transfer that knowledge to solve tasks where other uses of fractions are required. The proposal to use new technological resources that allow visualization and manipulation of actions that are done on the objects (fracturing, comparing and ordering) helped students to improve their ideas related to fractions as measurer and as number. Moreover, there is evidence that despite the fact that in the teaching model emphasis is not placed on the area model, students were able to improve their partition processes in order to establish a fracturing relation in this type of models. That is, a teaching model based on the number line and the use of applets helps students to improve their ideas about the use of fraction as fracturer in an area model. The use of a computer in a marginalized community did not involve difficulties in the teaching model, in fact, students were able to transfer ideas from the manipulative computer task to the "non-manipulative" paper task.

Acknowledgments

The research described was part of a larger project involving David Arnau and Juan Gutiérrez-Soto from the Department of Didactics of Mathematics of the University of Valencia, Spain (EDU2017-84377-R (AEI/ERDF, EU) Ministerio de Economía y Competitividad/FEDER). Also, thanks to CONACYT for the scholarship (reference number 230188) to obtain first author's Ph. D.

References

Behr, M., Lesh, R., Post, T., & Silver, E. (1983). Rational Number Concepts. In R. Lesh & M. Landau (Eds.), *Acquisition of Mathematics Concepts and Processes* (pp. 91–125). New York, NY: Academic Press. Retrieved from: http://www.cehd.umn.edu/ci/rationalnumberproject/83_1.html

- Drijvers, P. (2013). Digital technology in mathematics education: why it works (or doesn't). *PNA*, 8(1), 1–20.
- Filloy, E., Rojano, T., & Puig, L. (2008). *Educational Algebra. A Theoretical and Empirical Approach*. New York, NY: Springer Science+Business Media.
- Freudenthal, H. (1983). *Didactical Phenomenology of Mathematical Structures*. Dordrecht, the Netherlands: D. Reidel Publishing Company.
- Kieren, T.E. (1992). Rational and fractional numbers as mathematical and personal knowledge: Implications for curriculum and instruction. In R. Leinhardt, R. Putnam, & R. A. Hattrup (Eds.), *Analysis of arithmetic for mathematics teaching* (pp. 323–371). Hillsdale, NJ: Lawrence Erlbaum Associates.
- National Council of Teachers of Mathematics. (2000). *Principles and standards for school mathematics*. Reston VA: The Council.
- Ni, Y., & Zhou, Y.D. (2005). Teaching and learning fraction and rational numbers: the origins and implications of whole number bias. *Educ. Psychol*, 40, 27–52.
- Petitto, A. (1990). Development of number line and measurement concepts. *Cognition and Instruction*, 7(1), 55–78.
- Saxe, G.B., Taylor, E.V., McIntosh, C., & Gearhart, M. (2005). Representing Fractions with Standard Notation: A Developmental Analysis. *Journal for Research in Mathematics Education*, 36, 57–137.
- Secretaría de Educación Pública (2011). *Programa de estudios. Guía para el maestro. Educación Básica. Primaria. Quinto Grado*. México: SEP
- Siegler, R., Fazio, L., Bailey, D., & Zhou, X. (2013). Fractions: the new frontier for theories of numerical development. *Trends in Cognitive Sciences*, 17(1), 151–152.
- Siegler, S., Duncan, J., Davis-Kean, E., Duckworth, K., Claessens, A., & Engel, M. (2012) Early predictors of high school mathematics achievement. *Journal of the Association for Psychological Science*, 23(7), 691–697.
- Streefland, L. (1991). *Fractions in realistic mathematics education. A paradigm of development research*. Dordrecht, the Netherlands: Kluwer Academic Publishers.
- Tzur, R. (1999). An integrated study of children's construction of improper fractions and the teacher's role in promoting that learning. *Journal for Research in Mathematics Education*, 30, 390–416.
- Valenzuela, C., Figueras, O., Arnau, D., & Gutiérrez-Soto, J. (2017a). Mental object for fractions of middle school students with truancy problems. In E. Galindo & J. Newton (Eds.), *Proceedings of the 39th annual meeting of the North American Chapter of the International Group for the Psychology of Mathematics Education* (pp. 227–242). Indianapolis, IN: Hoosier Association of Mathematics Teacher Educators.
- Valenzuela, C., Figueras, O., Arnau, D., & Gutiérrez-Soto, J. (2017b). Number line as a conceptual and didactical resource for teaching fractions using applets. In T. Dooley & G. Gueudet (Eds.), *Proceedings of the Tenth Congress of the European Society for Research in Mathematics Education* (pp. 403–410). Dublin, Ireland: DCU Institute of Education and ERME.

Reflecting on a series of studies on conceptual and procedural knowledge of fractions: Theoretical, methodological and educational considerations

Xenia Vamvakoussi¹, Maria Bempeni², Stavroula Pouloupoulou³ and Ioanna Tsiplaki⁴

¹University of Ioannina, Greece; xvamvak@cc.uoi.gr

²University of Ioannina, Greece; mbempeni@cc.uoi.gr

³Athens University of Economics and Business, Greece; spoulopo@gmail.com

⁴University of Ioannina, Greece; jtsiplaki@yahoo.com

We present an overview of four studies investigating secondary students' conceptual and procedural knowledge of fractions qualitatively as well as quantitatively. We draw on these studies and their results to discuss the problem of measuring conceptual and procedural knowledge; the issue of individual differences in conceptual and procedural fraction knowledge; and related educational implications.

Keywords: Fractions, conceptual/procedural knowledge, individual differences, instruction.

Conceptual and procedural knowledge in mathematics learning

The distinction between procedural and conceptual knowledge has elicited considerable research and discussion among researchers in the fields of cognitive-developmental psychology and mathematics education. Procedural knowledge is typically defined as the ability to execute action sequences to solve problems and is usually tied to specific problem types, whereas conceptual knowledge is defined as knowledge of concepts pertaining to a domain and related principles (Rittle-Johnson & Schneider, 2015). This definition has been contested on the grounds that it depicts a very narrow picture for procedural knowledge as something that one either has, or does not have, ignoring different qualities that such knowledge may have (Star, 2005). Still, this definition captures the distinction between carrying out a procedure that pertains to a domain, and understanding of the entities (e.g., mathematical objects and mathematical relations) that are involved in the procedure. This distinction is valuable, particularly from the point of view of mathematics education that has been tantalized by the phenomenon of procedural skill without understanding before acknowledging that conceptual and procedural knowledge are equally important for students' mathematical development (e.g., De Corte, 2004).

The relation between the two types of knowledge has been difficult to establish empirically, in particular with respect to the order of acquisition (i.e., which type of knowledge develops first). The current prevailing model is the *iterative model* that assumes that there is a bi-directional relation between conceptual and procedural knowledge and accounts for many empirical findings, notably the well-documented finding that the two types of knowledge are typically highly correlated (Rittle-Johnson & Schneider, 2015). However, such correlations found at group level do not accurately reflect what happens at the individual level. Indeed, research shows that there are individual differences in the way students combine the two kinds of knowledge putting a challenge to the

iterative model (e.g., Canobi, 2004; Hallett, Nunes, & Bryant, 2010; Hallett, Nunes, Bryant, & Thrope, 2012). In particular, Hallett and colleagues (2010, 2012) were the first to systematically study such individual differences in the area of fraction learning. They assessed conceptual and procedural knowledge of students at Grade 4 and 5 (2010) as well as at Grade 6 and 8 (2012) and they identified groups of students who were either strong or weak in both types of knowledge. However, they also consistently traced two substantial groups of students for whom there was discrepancy between the two types of knowledge (i.e., students in one group exhibited stronger procedural fraction knowledge, compared to their conceptual knowledge, and vice versa for students in the other group). Hallett and colleagues found that such discrepancies became less salient with age.

Before more progress can be made in understanding the relations between conceptual and procedural knowledge, more attention should be paid to the validity of measures of conceptual and procedural knowledge (Rittle-Johnson & Schneider, 2015). This is a challenging endeavor, particularly with respect to conceptual knowledge, which is considered a multi-dimensional construct; and it becomes even more challenging when it comes to the concept of fraction, itself a multifaceted construct pertaining to a vast variety of situations (Moss, 2005).

In this paper we present an overview of four studies investigating secondary students' conceptual and procedural knowledge of fractions qualitatively as well as quantitatively. We reflect on the challenges we met and we draw on the findings to discuss the problem of measuring conceptual and procedural knowledge; the issue of individual differences in conceptual and procedural fraction knowledge; and related educational implications.

Conceptual and procedural fraction knowledge of Greek secondary students

Study 1: General trends

In this study (Bempeni & Vamvakoussi, 2014) we looked at the development of conceptual knowledge of fractions in the first three years of secondary level (7th to 9th grade in Greece). We administered an open-ended questionnaire to 80 seventh and ninth graders. The questionnaire consisted of 24 items targeting many aspects of fraction knowledge. The tasks included interpreting and constructing fraction representations using the area model and the number line; fraction magnitude estimation and estimation of outcomes of arithmetical operations; fraction comparison tasks that could be tackled with conceptual strategies (e.g., comparing $\frac{3}{2}$ and $\frac{13}{27}$, for which 1 can be used as benchmark); tasks targeting the inappropriate transfer of natural number knowledge to fractions (e.g., “how many numbers are there between $\frac{2}{5}$ and $\frac{3}{5}$?”); and contextualized problems where physical quantities were involved, requiring understanding of the unit of reference (see Task 1 in Figure 1 for an example of the latter, albeit in multiple-choice format). The difficulty of items varied, from very simple ones (e.g., representing a proper fraction using the area model) to quite challenging ones (i.e., items targeting the dense ordering of fractions). In addition, the questionnaire included 4 procedural items on standard school-taught procedures, namely on fraction operations (e.g., “compute the sum $\frac{10}{63} + \frac{8}{9}$ ”). The students were asked to solve the conceptual tasks and explain their solutions; and to carry out the fraction operations.

The results showed no significant difference between the two age groups' overall performance, and no significant difference in the overall performance for conceptual tasks, nor for procedural tasks.

However, we found that older students relied significantly more on procedural strategies (i.e., school-taught procedures). Looking at each task separately, we found that ninth graders performed significantly better in 3 conceptual tasks, albeit relying on transformation strategies. For example, they converted fractions into decimals in order to place them on the number line; and they converted $\frac{3}{2}$ and $\frac{13}{27}$ into similar ones in order to compare them. Performance in procedural tasks was fairly good (at least 70% succeeded in each task), whereas performance in conceptual tasks varied widely (as expected). An interesting pattern emerged: Although the great majority of students were apt to carry out the four fraction operations, about 60% failed in tasks targeting conceptual understanding of the operations (e.g., in estimating the sum $\frac{12}{13} + \frac{7}{8}$). In addition, although practically all students were able to construct an area model for a proper fraction, about 25% asserted that a shaded part of a shape that was partitioned in 3 unequal parts was “one-third”; and more than half of the students failed to represent an improper fraction, or explicitly stated that “it is not possible to take five parts out of three”. Further, about half asserted that “eating $\frac{3}{5}$ of a pie” necessarily means “eating 3 pieces of a pie” (see Task1, Figure 1). Finally, we also traced some students who were flawless in the procedural tasks, but failed in even the simplest conceptual tasks, indicating an asymmetry between the two types of knowledge. We focused on this issue in Study 2.

Study 2: Individual differences in conceptual and procedural knowledge of fractions

In Study 2 (Bempeni & Vamvakoussi, 2015) we recruited 7 ninth graders to participate in in-depth interviews. The selection of the participants was not random. First, based on their school grades, all participants could be characterized as medium to high level students in mathematics. Second, they shared the same mathematics tutor. Based on information provided by their tutor, we had reasons to expect some variation in their conceptual and procedural knowledge of fractions. We used an instrument with 30 fraction open-ended tasks, adjusting and extending the collection of conceptual tasks used in Study 1, and adding few procedural tasks (e.g., operations with mixed numbers). We added one more task focusing on the role of the unit of reference, in contexts where physical quantities were involved (see Task 2 in Table 1, albeit in multiple choice format). We also explicitly asked students not to apply typical school taught procedures in certain fraction comparison tasks that could be tackled with conceptual strategies (e.g., one proper and one improper fraction). The participants were asked to solve the tasks thinking aloud and explaining their answers.

Based on the analysis of their responses in terms of accuracy and strategy used (procedural/conceptual), the participants were distributed in three profiles. The *Conceptual-Procedural* profile consisted of three students who showed advanced conceptual knowledge of fractions, combined with procedural fluency. The *Procedural* profile consisted of three students who succeeded in practically all tasks that could be solved via the use of procedures taught at school (e.g., fraction and mixed numbers operations), but failed systematically in conceptual tasks (e.g., in representing an improper fraction; or in comparing dissimilar fractions when they were not allowed to apply the typical procedure). All three failed in both tasks targeting the role of the unit of reference. Finally, the *Conceptual* profile was represented by one student that failed in all tasks requiring procedural knowledge but managed to deal successfully with most of the conceptual tasks, including the ones targeting the role of the unit of reference.

Thus the findings of Study 2 are consistent with the findings of Hallett et al. (2010, 2012), indicating that there are individual differences in the way students combine the two types of knowledge. Moreover, they illustrated the possibility that these differences can be extreme, even at grade 9. In following studies, we attempted to further investigate this issue, shifting from qualitative to quantitative methods.

Study 3: Developing and evaluating an instrument to measure for conceptual and procedural knowledge

Bearing in mind Rittle-Johnson and Schneider's (2015) plea for valid measures of procedural and conceptual knowledge, we developed a new instrument measuring conceptual and procedural knowledge of fractions (Bempeni, Pouloupoulou, Tsiplaki, & Vamvakoussi, 2018). In its initial form, the instrument consisted of 39 items, 12 procedural items and 27 conceptual items, a total of 39 items. The procedural ones were paper-and-pencil tasks requiring knowledge of procedures taught at school (e.g., to carry out fractions operations and operations with mixed numbers, to find an equivalent fraction, to cross-multiply, to simplify complex fractions, and to compare dissimilar fractions using the standard procedure). The conceptual tasks were based on extensive literature review (e.g., Baroody & Hume, 1991; Van Hoof, Verschaffel, & Van Dooren, 2015) and on our materials from Study 1 and Study 2 which were adjusted and enriched when necessary, based on our experience with testing these tasks with students. First, we opted for multiple-choice items, instead of open ones (see also Van Hoof et al., 2015), with a view to discourage the use of procedural strategies in conceptual tasks (e.g., in comparison tasks), an issue that is highlighted in the literature (e.g., Rittle-Johnson & Schneider, 2015) and was noticeable in Study 1. Second, we added more tasks on fraction representations that proved good indicators of conceptual knowledge (or the lack thereof) in our previous studies (see, for example, Task 4 in Figure 1).

We conducted a clinical pilot study with 61 students and asked 6 mathematics education experts to assist in the evaluation of the instrument. The instrument was assessed with respect to a) face validity and content validity, through the experts' feedback on clarity, accuracy, and relevance of the instrument; b) convergent and divergent validity, via multitrait analysis; c) internal consistency, calculating Cronbach's alpha; and d) external consistency with the test-retest method, calculating the intra-class correlation coefficient.

The instrument showed strong face validity given that all items were assessed as clear and accurate by the experts, who were also highly consistent with each other in rating the relevance of each item to the aim of the instrument (Content Validity Index = 1 > .83). All items of the procedural scale showed convergent validity and divergent validity by demonstrating high correlation with the procedural scale and low correlation with the conceptual scale, respectively. However, eight items of the conceptual scale showed low correlation with the conceptual scale or higher than expected correlation with the procedural scale. Further, the value of intra-class correlation coefficient was high (above 0.8) for all procedural items, but below 0.5 for five conceptual items.

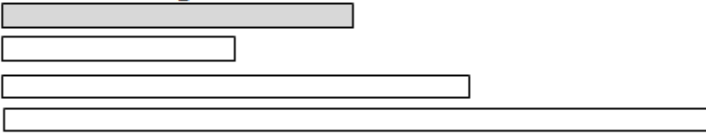
The problematic items were removed, resulting in an instrument consisting of 14 conceptual and 12 procedural tasks, with good indicators of validity, reliability, and objectivity, which we used in

Study 4. However, removing conceptual items from the questionnaire is not an insignificant matter, and we will come back to this issue in the discussion.

1. Somebody ate $\frac{3}{5}$ of a pie. This person ate:
 - a. 3 pie slices
 - b. 3:5 pie slices
 - c. None of the previous responses
2. Maria bought one pizza from Lucullus and ate one quarter of it. John bought one pizza from Vesuvius and ate half of it. Who ate more pizza?
 - a. Mary
 - b. John
 - c. None of the previous responses
3. Helen has two sock drawers. One half of the socks in the first drawer are white. One third of the socks in the second drawer are also white. How many white socks does Helen have?

➤ Which operation do you believe is the correct one to solve this problem?

 - a. $\frac{1}{2} + \frac{1}{3}$
 - b. $\frac{1}{2} \cdot \frac{1}{3}$
 - c. None of the previous responses
4. The gray bar is $\frac{3}{2}X$, where X is one of the white bars. Which one is X?



 - a. The first white bar
 - b. The second white bar
 - c. The third white bar

Figure 1: Examples of conceptual tasks

Study 4: Individual differences in conceptual and procedural knowledge of fractions: a quantitative study

In Study 4 (Bempeni et al., 2018) we administered the aforementioned instrument to 126 ninth graders and we analyzed the data using cluster analysis, testing for individual differences. Following Hallett and colleagues (2010, 2012), we used in the analysis the residualized scores of the procedural and the conceptual scales, the raw scores being the percentages of correct answers out of the total of answered questions. This is because the two scales are expected to be correlated (Rittle-Johnson & Schneider, 2015), and this method provides a way to exclude the common part of variation from both scales (Hallett et al., 2010, 2012). It should be noted that these scores do not represent absolute magnitudes of each type of knowledge; rather, they indicate discrepancies between the two types of knowledge. For example, a positive residual with respect to procedural knowledge means that a person's procedural knowledge is stronger than expected given their conceptual knowledge, and vice versa for negative residuals.

The cluster analysis used the k-means method and Euclidean distance as a distance measure and the optimal number of clusters was determined via statistical methods to be four. Two of these clusters comprised students who did not show great discrepancies between the two types of knowledge and their performance was either rather high in both type of tasks (N=22, 17.5%) or rather low in both types of tasks (N=31, 24.6%). On the contrary, the two remaining clusters comprised students who either performed better than expected in conceptual tasks given their performance in procedural tasks (*Conceptual Profile*, N=21, 16.7%); or performed better in procedural tasks given their performance in conceptual tasks (*Procedural Profile*, N=52, 41.3%).

These results supported the hypothesis that there are individual differences in the way that students combine the two type of knowledge and were consistent with the findings of our previous studies, and also with the results of Hallett et al. (2010, 2012). Moreover, our findings provided evidence that these differences may persist and remain salient for older students.

We note that within the *Procedural Profile*, we traced few extreme cases of students who excelled in the procedural items, but showed a severe lack of conceptual understanding, similar to students in Study 2. For example, one student achieved 100% score in the procedural tasks but only 14.29% in conceptual tasks, failing even in some of the simplest ones. However, we did not trace extreme cases within the *Conceptual Profile*.

Conclusions - Discussion

In a series of studies we examined secondary students' conceptual and procedural knowledge of fractions, qualitatively as well as quantitatively. The findings of these studies converge on the conclusion that there are individual differences in the way that students combine these types of knowledge (i.e., there are students who exhibit stronger procedural than conceptual knowledge, and vice versa); that these differences remain salient up to ninth grade; and that they may even be extreme (Study 2, Study 4). These findings put a challenge to the assumption that conceptual and procedural knowledge develop in a hand-over-hand manner (Rittle-Johnson & Schneider, 2015).

The findings are strengthened by the fact that we measured conceptual and procedural fraction knowledge reliably and validly via a new instrument (Study 4). However, there were several theoretical and methodological issues that we had to tackle in the process of developing the instrument, and some difficult decisions to make. First, measures of procedural knowledge were easy to construct and validate. However, this is due to the fact that we adopted a simple, perhaps over-simplified, definition of procedural knowledge (Star, 2005), as discussed in the introduction.

Second, measures of conceptual knowledge were particularly challenging. On the one hand, it is important to address various aspects of conceptual knowledge (Rittle-Johnson & Schneider, 2015), which requires the use of a great variety of tasks. On the other hand, this variety makes it difficult to construct a measure with good indicators of convergent validity, resulting to the exclusion of tasks (Study 3). Further, the use of multiple-choice items does not exclude the possibility that students in fact use procedural strategies when dealing with conceptual tasks, which was observable in Studies 1 and 2, but not in Studies 3 and 4. This might be an explanation for the fact that some conceptual tasks showed higher correlation with the procedural scale than expected (Study 3), and they also needed to be excluded. For example, locating fractions on the number line were among the problematic conceptual tasks in Study 4, presumably because the students, similarly to the students in Study 1, used transformation strategies to deal with the task. Excluding items may result in a more robust instrument; however, a lot of useful insights in students' understandings are lost. Consider, for example, the three first tasks in Figure 1. These tasks address students' understanding of the role of the unit of reference, in a context where it is necessary to take it into account (Baroody & Hume, 1991). All three had to be removed from the instrument, because the great majority of students, even the ones with overall good performance, failed. Thus, these tasks were not useful in discriminating

between “conceptual” and “procedural” students but removing them meant ignoring an important aspect of conceptual knowledge that students appear to lack.

This brings us to a consistent finding across all four studies: Students fail in elementary, yet fundamental conceptual tasks. Consider Task 1 (Figure 1) which was used in all studies. This task was challenging for half the students in Study 1; for three out of seven middle-to-high level students (based on their school grades) in Study 2; and for the great majority of students who participated in Study 3. This raises certain issues for instruction. First, Study 1 indicates that conceptual knowledge does not improve from seventh to ninth grade, despite the fact that during these years Greek students recapitulate content regarding fractions and are introduced to rational numbers. However, what seems to change is that students tend to rely more on procedural strategies. This may conceal their lack of conceptual fraction understanding in some cases (e.g., when placing fractions of the number line), but not in tasks that cannot be tackled with school-taught procedures (e.g., Tasks 1-3 in Figure 1). Second, it appears that students with very poor understanding of fractions still manage to get good grades at school (Study2). Third, the majority of the students in Study 4 was placed in the *Procedural* profile (i.e., they did better in the procedural tasks, than one would expect based on their performance in the conceptual tasks). These are quite strong indications that students’ school experiences are more favorable to the development of procedural knowledge. In other words, instruction appears to still over-emphasize procedural knowledge, neglecting students’ conceptual difficulties with fractions (Moss & Case, 1999).

This assumption cannot, however, explain the existence of (fewer) students who have stronger conceptual than procedural knowledge. In a more general fashion, the source of individual differences in conceptual and procedural knowledge is still an open question, despite the fact that several hypotheses have been formulated. Factors such as prior knowledge in the domain (Schneider, Rittle-Johnson, & Star, 2011), cognitive profile (Gilmore & Bryant, 2008; Hallett et al., 2012), general conceptual of procedural ability as well as school attendance at different schools have been tested (Hallett et al., 2012), with unsatisfactory results. Further theorizing and research is needed in this respect.

Acknowledgement



References

- Baroody, A.J., & Hume, J. (1991). Meaningful mathematics instruction: The case of fractions. *Remedial & Special Education, 12*(3), 54–68.
- Bempeni, M., & Vamvakoussi, X. (2014). Seventh and ninth graders’ conceptual and procedural knowledge of fractions: what changes with school experience? *Paper presented at the 9th International Conference on Conceptual Change*, Bologna, Italy.

- Bempeni, M., & Vamvakoussi, X. (2015). Individual differences in students' knowing and learning about fractions: Evidence from an in-depth qualitative study. *Frontline Learning Research*, 3, 17–34.
- Bempeni, M., Pouloupoulou, S., Tsiplaki, I., & Vamvakoussi, X. (2018). Individual differences in fractions' conceptual and procedural knowledge: what about older students? In E. Bergqvist, M. Österholm, C. Granberg & L. Sumpter (Eds.), *Proceedings of the 42nd Conference of the International Group for the Psychology of Mathematics Education* (Vol. 2, pp. 147–154). Umeå, Sweden: PME.
- Canobi, K.H. (2004). Individual differences in children's addition and subtraction knowledge. *Cognitive Development*, 19, 81–93.
- De Corte, E. (2004). Mainstreams and perspectives in research on learning (mathematics) from instruction. *Applied Psychology: An International Review*, 53(2), 279–310.
- Gilmore, C.K., & Bryant, P. (2008). Can children construct inverse relations in arithmetic? Evidence for individual differences in the development of conceptual understanding and computational skill. *British Journal of Developmental Psychology*, 26, 301–316.
- Hallett, D., Nunes, T., & Bryant, P. (2010). Individual differences in conceptual and procedural knowledge when learning fractions. *Journal of Educational Psychology*, 102, 395–406.
- Hallett, D., Nunes, T., Bryant, P., & Thorpe, C.M. (2012). Individual differences in conceptual and procedural fraction understanding: The role of abilities and school experience. *Journal of Experimental Child Psychology*, 113, 469–486.
- Moss, J. (2005). Pipes, tubs, and beakers: New approaches to teaching the rational-number system. In M.S. Donovan & J. D. Bransford (Eds.), *How students learn: History, math, and science in the classroom* (pp. 309–349). Washington DC: National Academies Press.
- Moss, J., & Case, R. (1999). Developing children's understanding of the rational numbers: A new model and an experimental curriculum. *Journal for Research in Mathematics Education*, 30, 122–147.
- Rittle-Johnson, B., & Schneider, M. (2015). Developing conceptual and procedural knowledge of mathematics. In R. Kadosh & A. Dowker (Eds.), *The Oxford handbook of numerical cognition* (pp. 1102–1118). New York, NY, US: Oxford University Press.
- Schneider, M., Rittle-Johnson, B., & Star, J. (2011). Relations among conceptual knowledge, procedural knowledge, and procedural flexibility in two samples differing in prior knowledge. *Journal of Developmental Psychology*, 47, 1525–1538.
- Star, J.R. (2005). Reconceptualizing procedural knowledge. *Journal for Research in Mathematics Education*, 36, 404–411.
- Van Hoof, J., Verschaffel, L., & Van Dooren, W. (2015). Inappropriately applying natural number properties in rational number tasks: Characterizing the development of the natural number bias through primary and secondary education. *Educational Studies in Mathematics*, 89, 39–56.

Metacognition in non-routine problem solving process of year 6 children

Aikaterini Vissariou¹ and Despina Desli²

¹Aristotle University of Thessaloniki, Faculty of Education, Thessaloniki, Greece;
vissario@eled.auth.gr

²Aristotle University of Thessaloniki, Faculty of Education, Thessaloniki, Greece;
ddesli@eled.auth.gr

This paper describes a study that investigated the metacognitive strategies used by fifteen Year 6 children while working individually on a non-routine mathematics problem. After attempting the problem, the students completed a questionnaire that elicited their retrospective reports on the metacognitive strategies they had employed while working on the problem. The analysis of the participating students' written work and questionnaire responses revealed that independently of how many metacognitive strategies were observed; children's problem solving success was not guaranteed. Interestingly, children's use of metacognitive strategies was found particularly low. Educational implications for metacognition in both mathematical problem solving and in the learning of mathematics are discussed.

Keywords: Metacognition, Non-routine problem, Problem solving, HISP inventory.

Introduction

In the last decades, metacognition and its development have been identified as having an important role in education and thus underlay in the center of primary and secondary school curricula. Metacognition is popularly defined as 'knowledge, awareness and deeper understanding of one's own cognitive processes and products' (Desoete, 2008, p. 190) and as 'thinking about thinking' (Anderson, 2002). It is often presented as comprising three phenomena: metacognitive knowledge, metacognitive experiences and metacognitive skills (Efklides, & Vlachopoulos, 2012). Moreover, it is commonly divided into two components: knowledge of cognition and regulation of cognition. Knowledge of cognition refers to the individuals' awareness of their own knowledge and includes their declarative, procedural and conditional knowledge. Regulation of cognition, on the other hand, pertains to the procedural aspect of knowledge that enables the effective linking of actions needed to perform a given task. It includes planning, monitoring and regulation, and evaluation.

Of central concern for researchers and educators is the crucial role that metacognition plays in children's academic performance in general as well as in mathematical achievement in particular (Desoete, 2009). Fostering metacognition, students avoid "blind calculations" or a superficial "number crunching" approach in mathematics (Verschaffel, 1999) and learn how to use the acquired knowledge in a flexible way. Through metacognition, students become able to effectively discern information they know from those they do not know and retain new information (Dunning, Johnson, Ehrlinger, & Kruger, 2003). Metacognitive learners have an increased understanding of the control

over their thinking, they employ this control and, thus, they are able to thrive across the curriculum (Zimmerman, 2008).

Different procedures and measures have been used to assess mathematical metacognition. A systematic review of the metacognition assessment in children aged 4–16 years over a 20-year period made by Gascoine, Higgins, and Wall (2017) revealed that the off-line methods, namely the self-reports measures, are the more commonly used, mainly because these measures are perceived as valid, reliable, easy to use and their application doesn't require much time. However, Desoete (2008) asserts the importance of distinguishing the use of different tools or methods when examining different facets of metacognition in relation to other factors such as children's age range among others. Her statement 'how you test is what you get' (p. 204) highlights this importance.

Mathematical metacognition is often examined in terms of monitoring skills with respect to solving problems (Desoete, 2009, 2008; Panaoura, Philippou, & Christou, 2004). Children demonstrating metacognitive functions are usually aware of their own learning and are able to control their learning process. Associated learning skills like these are essential to the development of effective problem-solving ability as well as to academic success in mathematics (Magno, 2009). When working metacognitively students are able to correctly represent and solve mathematics problems, evaluate the effectiveness of strategies and recognize mistakes. In addition, they learn to clarify goals, understand concepts, monitor their understanding, predict outcomes and choose appropriate actions (Pappas Schattman, 2005).

Wilson and Clarke (2004) view children's problem solving as the purposeful alternation between cognitive and metacognitive activities. In particular, the completion of a mathematical problem is a cognitive process that requires the use of cognitive strategies (e.g., adding up). The selection and use of these cognitive strategies, however, shows the solver's reflection on her existing knowledge (e.g., what do I know about the problem to help me work it out?). This is when metacognitive behavior is coming to the fore.

It is possible that school practice could inhibit the development of metacognition during problem solving, since the mathematics problems used within school context are often solved by means of a known method or formula. It is of great interest to study children's engagement in metacognitive activity when solving problems that are unfamiliar to them, like 'non-routine' problems. These problems 'make cognitive demands over and above those needed for solution of routine problems, even when the knowledge and the skills required for their solution have been learned' (Mullis et al., 2003, p. 32). Because non-routine problems require a flexible and strategic way of thinking, children often have difficulties and appear low success (Elia, Van den Heuvel-Panhuizen, & Kolovou, 2009). Interestingly, even good calculus students are not able to solve non-routine problems successfully. Such a failure does not necessarily result from restricted mathematical knowledge, but may be linked to ineffective use of that knowledge (Van Streun, 2000).

Based on the hypothesis that metacognitive functions are more likely to employ during challenging tasks and knowing that metacognition and problem solving is usually studied with older students and adults (Schneider, & Artelt, 2010), the present study aimed to investigate the relationship between metacognition and non-routine problem solving in primary school children. Investigating young

children - apart from providing us with information concerning their ability to reflect upon their problem solving - will make us more sensitive about how metacognition might be further fostered. Research questions are as follows: a) to what extend do children use metacognitive strategies when solving a non-routine mathematics problem?, b) is there an association between children's success in problem solving and their deployment of metacognition?

Method

Participants

Fifteen Year 6 children (8 male, 7 female), coming from the same class of a state primary school in a Greek island, participated in the study. They were randomly selected as they covered from low to high socioeconomic and academic statuses. The average age of the students was 11 years and 8 months (range: 11 years and 4 months - 12 years). The participating students had not received any training on metacognition.

Design of the study - Instrument

All participants were presented with a non-routine mathematics problem that was designed for the purpose of the study in order to examine children's mathematical achievement as well as to establish a situation for revealing their problem solving strategies. The problem was also used as a basis for participating students' reflections on their metacognitive strategies. After attempting the problem, the students completed a questionnaire that asked them to report retrospectively on the metacognitive strategies they had used while working on the particular problem.

More specifically, the non-routine problem used in the present study (see Figure 1) did not require a particular algorithm to be applied neither was connected to a specialized mathematical concept. Because it is recognized that routine mathematics problems often require little student reflection, it was tried to follow the criteria that define the non-routine problems and reveal solvers' critical thinking (e.g, Kolovou, Van den Heuvel-Panhuizen, & Bakker, 2009).

The questionnaire was based on the 'How I Solve Problems' measurement tool of metacognition developed by Fortunato, Hecht, Tittle, and Alvarez (1991), after taking into consideration relevant instruments for measuring metacognition compiled from the literature (e.g., Jr MAI developed by Sperling et al., 2002). The particular instrument was chosen as it is considered valid for research and useful for assessment and intervention in classrooms (Gascoine et al., 2017; Sperling et al., 2002). A few modifications were done to the original version of the tool, mainly concerning rewording a few items in order to make the questionnaire more appropriate for younger children. In the present study, the questionnaire consisted of twenty-one action statements, as many as in the original version. The statements covered a range of likely metacognitive activities during problem solving process. Students were asked to respond to these statements using a five-point Likert scale (ranging from '1=never to 5=always') based on their way of working when solving the mathematics problem.

'The cost of the theater 'Avlea' with 250 seats for a two-hour play is 750€ Last Sunday 30% of the seats were empty. Which will be the profit of the theater if the cost of the ticket for the audience is 9 €each?'

Figure 1: The problem used in the present study

The questionnaire was subdivided into four sections. The first, named '*Before you started to solve the problem*' section referred to reading and understanding the problem as well as planning of a solution method (6 statements). The second, the '*As you worked on the problem*' section involved employment of the solution method when working on the problem (5 statements). The third, the '*After you finished working on the problem*' section presented with ways of confirming and checking for the solution (4 statements) and the '*Ways of working on the problem*' section listed particular heuristics as strategies that a student might have used when working on the problem (6 statements).

Procedure

All participants were asked to solve the problem and answer the questionnaire individually in their classroom during school hours. Their anonymity was ensured.

They were initially required to read carefully the non-routine mathematics problem. The first section of the questionnaire was then given and a 30 minutes period was allocated for solving the mathematics problem. The students were provided with a specific area on a paper in which they were asked to write their working and solution. Immediately after solving the problem, the rest of the questionnaire was administered: the students were required to respond to the statements that were included in the last three sections of the questionnaire regarding specific metacognitive strategies they might have or might have not used.

Results

Problem solving success

Of the fifteen students who attempted the problem, only eight solved it correctly and, for the purposes of the data analysis, they are called 'successful students', whereas those who failed in solving the problem (seven students) were called 'unsuccessful students'. Although children's problem solving strategies were recorded, their analysis will not be described as it goes beyond the purpose of the present paper.

In order to examine whether the successful and unsuccessful students provided similar or different responses to the questionnaire regarding their metacognitive strategies, an independent samples t-test was conducted. The analysis revealed that, although the overall metacognitive level mean score of the successful students (3,46) was higher than that of the unsuccessful students (3,09), this difference was not found statistically significant ($t=-1,159$, $df=13$, $p=.267$). When the same analysis was repeated for each questionnaire section separately, the original results were confirmed ($t=-1,182$, $df=13$, $p=.258$, $t=-1,100$, $df=13$, $p=.291$, $t=-,383$, $df=13$, $p=.708$ and $t=-,926$, $df=13$, $p=.371$ for Sections A, B, C and D, respectively). Thus, no statistical significant differences were observed in

children's responses to the total of the statements in each section of the questionnaire among successful and unsuccessful students. Table 1 shows these findings.

The mean level of students' metacognitive strategy for the 'Ways of working' section (Section D) was the lowest mean level of all the sections for both successful and unsuccessful students (3,02 and 2,76, respectively). This finding shows that the heuristics listed for children to indicate whether they had used when working on the problem were rather under-recognized. In particular, more than 80% of the students reported that they never/ rarely draw a picture or a diagram for the better understanding of the problem (55, 3% and 26, 7%, respectively for never/rarely).

Questionnaire Sections	Problem Solving Success		Total
	Successful	Unsuccessful	
A. Before you started	3,62 (0,93)	3,07 (0,87)	3,34 (0,91)
B. As you worked	3,5 (0,93)	3,03 (0,69)	3,26 (0,81)
C. After you finished	3,85 (0,58)	3,71 (0,73)	3,78 (0,65)
D. Ways of working	3,02 (0,69)	2,76 (0,29)	2,89 (0,49)
Overall	3,46 (0,66)	3,09 (0,54)	3,27 (0,61)

Table 1: Mean scores¹ (and standard deviations) for children's metacognitive level in the questionnaire by their success in problem solving

On the contrary, children's response rates for the 'After you finished' section (Section C) that might imply their use of strategies for verifying their solutions were quite high (3,85 and 3,71 for successful and unsuccessful students, respectively). For example, 53% of the students said that they always go back and check if their calculations are correct. However, no participant was found to say that she always thinks about a different way to solve the problem.

Correlation between metacognitive strategies and problem solving success

Aiming to investigate the existence of correlations between children's responses to the statements in the four sections of the questionnaire (metacognitive strategies) as well as between children's questionnaire responses and their written working of the problem (problem solving success), correlation analysis was conducted, as presented in Table 2. Interestingly, no correlations were found either between problem solving success and overall metacognition (Pearson's $r=.306$, $p=.267$) or between problem solving success and metacognitive strategies at each questionnaire section separately (Pearson's $r=.312$, $p=.258$, Pearson's $r=.292$, $p=.291$, Pearson's $r=.106$, $p=.708$ and Pearson's $r=.249$, $p=.371$, for sections A, B, C and D, respectively). However, participants' overall metacognition was positively correlated to their responses to each questionnaire section (Pearson's $r=.953$, $p<.01$, Pearson's $r=.817$, $p<.01$, Pearson's $r=.869$, $p<.01$ and Pearson's $r=.691$, $p<.01$, for

¹ Responses were measured on a scale from 1 (Never) to 5 (Always)

sections A, B, C and D, respectively) This result shows that participants who responded highly to statements at one section tended to respond highly to statements at any other section.

General Discussion

The present study has attempted to investigate the metacognitive strategies used by sixth graders while working on a non-routine mathematics problem. The analysis of students' written work and questionnaire responses revealed two main findings. First, students reported that they are using metacognition. However, their demonstration of metacognitive strategies is quite low both in general and at different stages of the solution process. In particular, a few reported that they greatly made connections to their previous experiences, reviewed their progress towards the problem solution, checked their calculations while they worked, attempted to verify the accuracy and sense of their answer to the problem. Additionally, an unequal use of metacognitive strategies at different stages of the solution process was also observed.

	Overall Metacognition	Section A	Section B	Section C	Section D
Problem Solving Success	.306	.312	.292	.106	.249
Section A	.953**		.684**	.854**	.603*
Section B	.817**			.657**	.338
Section C	.869**				.430
Section D	.691**				

*Significant correlation at the $p < .05$ level **Significant correlation at the $p < .01$ level

Table 2: Correlations between overall metacognition and problem solving success

Second, a successful solution to the problem was found not necessarily connected to the employment of metacognitive strategies. Although a challenging problem was chosen for use in this study –mainly because it would raise the opportunity for metacognitive strategies to be called into play- so few students succeeded in obtaining a complete solution. This finding is consistent with previous studies in which the success in a mathematical problem is considered a cognitive process that requires the use of cognitive strategies (e.g., Wilson & Clarke, 2004); thus, low metacognitive strategies during problem solving do not undoubtedly lead to failure. This issue further reveals that even if students behave metacognitively (e.g., they are able to recognize when they are stuck), their difficulty with solving the problem remains (e.g., they fail to solve the problem). It is possible that their worthy efforts for metacognitive strategies will be restricted if they are unable to identify alternative successful strategies in the problem solving process. More needs to be known about the impact of the school practice on the development of problem solving and metacognitive strategies in children and implications for teaching should be considered.

From a methodological perspective, it is important to note that a self-report questionnaire as the one used in the present study might provide only a little about children's metacognitive strategy use.

Further research with larger samples is required in order to get detailed information on both children's actual problem solving behavior and children's actual use of metacognitive strategies. Multi-method approaches (Desoete, 2008), such as on-line procedures, might work towards this aim. Interestingly, metacognitive instruction leads not only to the empowerment of students' metacognition but also to the development of the practices from the part of the teachers concerning metacognition in both mathematical problem solving and in the learning of mathematics (Magno, 2009). As many factors as possible need to be further considered in order that any teacher intervention on metacognitive engagement can be informed and effective.

About the authors

Aikaterini Vissariou is a Ph.D student at the Aristotle University of Thessaloniki in the Faculty of Education, in the field of Didactics of Mathematics. She is also doing her second Bachelor degree at the School of Philosophy and Pedagogy at the Aristotle University. She works as a primary school teacher at the Ministry of Education.

Despina Desli is associate professor of mathematics teaching and learning at the Aristotle University of Thessaloniki in the Faculty of Education. Her main research interests concentrate on children's mathematical reasoning, teacher education and mathematics curricula. She has worked on research projects in both primary and secondary schools concerned with mathematics education and in-service teacher training.

Acknowledgment

This research has been financially supported by General Secretariat for Research and Technology (GSRT) and the Hellenic Foundation for Research and Innovation (HFRI) (Scholarship Code: 384).

References

- Anderson, N.J. (2002). *The role of metacognition in second language teaching and learning*. ERIC Digest: ED 463659.
- Desoete, A. (2009). Metacognitive prediction and evaluation skills and mathematical learning in third-grade students. *Educational Research and Evaluation*, 15(5), 435-446.
- Desoete, A. (2008). Multi-method assessment of metacognitive skills in elementary school children: how you test is what you get. *Metacognition and Learning*, 3(3), 189-206.
- Dunning, D., Johnson, K., Ehrlinger, J., & Kruger, J. (2003). Why people fail to recognize their own incompetence. *Current Directions in Psychological Science*, 12(3), 83-87.
- Efklides, A., & Vlachopoulos, S. P. (2012). Measurement of metacognitive knowledge of self, task, and strategies in mathematics. *European Journal of Psychological Assessment*, 28(3), 227-239.
- Elia, I., Van den Heuvel-Panhuizen, M., & Kolovou, A. (2009). Exploring strategy use and strategy flexibility in non-routine problem solving by primary school high achievers in mathematics. *ZDM*, 41(5), 605-618.

- Fortunato, I., Hecht, D., Tittle, C. K., & Alvarez, L. (1991). Metacognition and problem solving. *The Arithmetic Teacher*, 39(4), 38–40.
- Gascoine, L., Higgins, S., & Wall, K. (2017). The assessment of metacognition in children aged 4–16 years: a systematic review. *Review of Education*, 5(1), 3–57.
- Kolovou, A., Van den Heuvel-Panhuizen, M., & Bakker, A. (2009). Non-routine problem solving tasks in primary school mathematics textbooks - A needle in a haystack. *Mediterranean Journal for Research in Mathematics Education* 8(2), 29–66.
- Magno, C. (2009). Assessing grade school students' metacognition in solving mathematical problem. *The Assessment Handbook*, 2, 1–22, PEMEA.
- Mullis, I. V. S., Martin, M. O., Smith, T. A., Garden, R. A., Gregory, K. D., Gonzalez, E. J., Chrostowski, S. J., & O'Connor, K. M. (2003). *TIMSS assessment frameworks and specifications 2003* (2nd edition). Chestnut Hill, MA: Boston College.
- Panaoura, A., Philippou, G., & Christou, C. (2004). Young pupils' metacognitive ability in mathematics. In M. Hejny, G. H. Littler, P. Neshet & M. Rodd (Eds.), *Proceedings of the 3rd CERME (TGW3)*, pp. 1–9. Bellaria, Italy: ERME.
- Pappas Schattman, S. S. (2005). *Fostering kindergartener's metacognition*. Unpublished doctoral dissertation. Ann Arbor, NY: Columbia University.
- Schneider, W., & Artelt, C. (2010). Metacognition and mathematics education. *ZDM*, 42(2), 149–161.
- Sperling, R.A., Howard, B. C., Miller, L. A., & Murphy, C. (2002). Measures of children's knowledge and regulation of cognition. *Contemporary Educational Psychology*, 27(1), 51–79.
- Van Streun, A. (2000). Representations in applying functions. *International Journal of Mathematical Education in Science and Technology*, 31(5), 703–725.
- Verschaffel, L. (1999). Realistic mathematical modelling and problem solving in the upper elementary school: Analysis and improvement. In J. H. M. Hamers, J. E. H. Van Luit, & B. Csapo (Eds.), *Teaching and learning thinking skills. Contexts of learning* (pp. 215–240). Lisse, the Netherlands: Swets & Zeitlinger.
- Wilson, J., & Clarke, D. (2004). Towards the modeling of mathematical metacognition. *Mathematics Education Research Journal*, 16(2), 25–48.
- Zimmerman, B. J. (2008). Investigating self-regulation and motivation: Historical background, methodological developments, and future prospects. *American Educational Research Journal*, 45(1), 166–183.

TWG03: Algebraic Thinking

Algebraic Thinking

Maria Chimoni¹, Dave Hewitt², Reinhard Oldenburg³, and Heidi Strømskag⁴

¹University of Cyprus,

²Loughborough University, UK,

³University of Augsburg, Germany,

⁴Norwegian University of Science and Technology, Trondheim

Keywords: Algebra, early algebra, functions, research frameworks, teaching and learning algebra.

The working group

In CERME11, the Thematic Working Group 3 “Algebraic thinking” continued the work carried out in previous CERME conferences. There was a total of 23 papers and 4 posters with a total of 33 group participants representing countries from Europe and other continents: Germany, Cyprus, Finland, Ireland, Italy, Netherlands, Norway, Portugal, Spain, Sweden, Switzerland, Turkey, UK, and USA.

Structured overview of papers

Papers presented at TWG3 show a broad range of methods, subjects and theoretical underpinnings. It is thus not an easy task to cluster them in a fashion that reflects the structure of the field, however, we have identified the following clusters: Technology innovations and curriculum development; Early algebra; Empirical research in secondary algebra; Conceptual development; and Theoretical issues.

Technological innovations and curriculum development have been discussed in several papers. Ricardo Nemirovsky et al. investigated in “Body motion and early algebra” young students who graph their distance to a wall together with the sum or difference graphs of two sensors. In the conception phase different kinds of abstraction were used to guide the design. James Gray, Bodil Kleve and Helga Tellefsen evaluated in “Students’ expected engagement with algebra based on an analysis of algebra questions on 10th grade exams in Norway from 1995 till 2018” national exams and found a decrease of context, but an increase of the amount of text and moreover a decrease of decisions to be made by students. What kind of tasks work well in teacher education? Iveta Kohanova and Trygve Solstad gave some answers to this question in “Linear figural patterns as a teaching tool for preservice elementary teachers – the role of symbolic expressions” by identifying problems preservice teachers had in finding symbolic rules.

Early Algebra is of central interest and several papers from this research tradition investigated this further. This was done by Margarida Rodrigues and Lurdes Serrazina who showed young students’ ability to establish quantitative relationships involving unknowns in “Dealing with the quantitative difference: A study with 2nd graders” showed young students’ ability to establish quantitative relationships involving unknowns. Similarly, Denise Lenz in “Relational thinking and unknown quantities” monitored the increase in ability to express relations between known and unknown quantities of marbles in boxes from kindergarten to grades 2 and 4. María D. Torres González et al. looked at 2nd graders functional thinking in “Structures identified by second graders in a teaching experiment in a functional approach to early algebra”. While the 2nd graders could think

symbolically, they also had the tendency to stick to the structural form (e.g. $x+x$) that reflected the original problem structure. Eder Pinto et al. in “Representational variation among elementary grade students: A study within a functional approach to early algebra” found that the variety of types of representations used by students was wider when they worked with specific values than with the general case. Thus, the importance of teaching representations explicitly was highlighted. Anna-Susanne Steinweg reported on an unusual experiment in “Short note on algebraic notations: First encounter with letter variables in primary school” where she found that about one out of six primary school pupils without any introduction to formal algebra could spontaneously interpret algebraic expressions for figural patterns in a sensible way.

Empirical research in secondary algebra formed another cluster. Mara Otten et al. showed in “Fifth-grade students solving linear equations supported by physical experiences” that the use of a physical balance can improve performance in solving systems of linear equations. In “Students in 5th and 8th grade in Norway understanding of the equal sign”, Hilde Opsal showed that the operational understanding of the equal sign still dominates in 5th and even the 8th grade. Per Nilsson and Andreas Eckert showed exactly what the title “Time-limitation and colour-coding to support flexibility in pattern generalization tasks” indicates. Marios Pittalis and Ioannis Zacharias in “Unpacking 9th grade students’ algebraic thinking” and Maria Chimoni et al. in “Investigating early algebraic thinking abilities: A path model” both performed confirmatory factor analysis to bring out the structure of algebraic competence. The first paper found that functional thinking and meta-algebra (e.g. proving) are similar, so they concluded that there are three components: generalized arithmetic, transformational ability and meta-algebra. The second paper mainly agreed but used modeling as a third factor. Obviously, this asks for unification. On College level, Claire Wladis et al. in “Relationships between procedural fluency and conceptual understanding in algebra for postsecondary students” showed by latent class analysis that college students showing procedural fluency in standard problem contexts still often lack deeper conceptual understanding.

Next is the group of papers on conceptions and conceptual development. Joana Mata-Pareira and João Pedro da Ponte documented how abductive reasoning can be triggered in “Enhancing students’ generalizations: a case of abductive reasoning”. The context was that of students solving linear equations and discovering the fact that not all of them have solutions. Peter Kop et al. in “Graphing formulas to give meaning to algebraic formulas” used graph drawing by hand and card sorting to improve recognition of function types and graph features and qualitative reasoning about functions. For younger students, Eva Arbona et al. in “Strategies exhibited by good and average solvers of geometric pattern problems as source of traits of mathematical giftedness in grades 4-6” found that a variety of factors influence the way students solve problems. Simon Zell noted student’s inflexibility in performing algebraic tasks and gave in “Provoking students to solve equations in a content-oriented fashion and not using routines” not only empirical evidence, but also suggested how tasks can be used to improve on this.

Several papers considered theoretical issues. Dave Hewitt’s contribution “Never carry out any arithmetic” argued for more complex examples where learners are discouraged from counting and instead are urged to identify structure in figures. Cecilia Kilhamn and Kajsa Bråting, in “Algebraic thinking in the shadow of programming”, reported on ideas to implement computational thinking in

school and especially use programming in algebra and algebraic thinking in the Swedish mathematics curricula. While these activities are computer oriented, for Christof Weber in “Comparing long division and log division algorithms as a way to understand them” the important aspects of algorithms were the insight they provide and the mental models they formulate. Norbert Oleksik considered in “Transforming equations equivalently? – Theoretical considerations of equivalent transformations of equations” different mental models of equivalence relations based on the German tradition of ‘Grundvorstellungen’ and Tall’s notions of concept image and concept definition. Reinhard Oldenburg, in “A classification scheme for variables”, started from the idea to differentiate Grundvorstellungen further according to the linguistic categories of syntax, semantics and pragmatics and claims that there are different kinds of variables (e.g. container vs. reference) that can be identified using these lenses.

Outlook

The discussions in the group identified several questions that cannot be answered in a satisfactory manner based on the current state of research. An eclectic sample of these questions may give an idea about this and may provide motivation for further research.

Figural patterns remain an active domain of investigation. Yet, many discussions showed that not all aspects are understood well enough to guarantee consensus between researchers. One question concerned what kind of tasks might be motivating for what kind of students. Another, and intensively discussed, question concerned the structuring process and how it can be supported. Papers presented at TWG3 already provided important insights in this but still a deeper understanding would be helpful, e.g. concerning the transformation from the visual structure to the algebraic structure.

Work is still going on to build a competence model of algebraic thinking that can be tested by confirmatory factor analysis. Especially Kaput’s model (2008) attracted researchers and proved to be a good basis for empirical research (with slight modification). It would be interesting if this model can also be confirmed with college level students.

How are continuous and discrete relations related? We had papers that investigated how students dealt with relations of the form $a - b = 1$ both in a discrete context (number of marbles in boxes) and in a continuous application (distance measurement). So the question arises, if the same logical structure extends to students’ thinking so that students who master one of these domains will also perform well in the other domain and if training in one can boost understanding in the other.

What benefits do algorithms and programming provide for algebra? After the Logo and Basic period the interest in programming in math education declined partly in reaction to research that showed mostly disappointing (but maybe from too high expectations) effects on algebraic understanding. But now there are several reasons to reinvestigate the issue. First, in several countries programming entered the curriculum for reasons outside of mathematics and this offers opportunities for linking the two subjects without the demand on mathematics to invest time to introduce programming. We had a report on ongoing work in Sweden that explores the possibilities. As many approaches are possible, research needs to investigate them and identify more effective ones. Second, tools are more sophisticated today and hence one might expect students to have less frustrating experiences. And third, the view on algorithms today is more elaborate. On the one hand, they are part of the bigger

concept of computational thinking that still gains momentum. On the other hand, there is a meta-mathematical view on algorithms, i.e. reflecting on algorithms can provide mental models of mathematical concepts. The potential of this has to be explored in much more detail than the important first existing examples on the concepts of long and log division that we discussed in the group.

Another issue that was raised during discussions in TWG 3 is related to task design and the role of tasks in research on algebraic thinking. Accounts of principles for task design, and epistemological analyses of the knowledge aimed at by the tasks, would strengthen the justification of research results. Several other topics could be mentioned but we leave this open – future TWG3 meetings will certainly shed light on some of these and many other issues. We have not yet discussed in the group the longterm effects of early algebra, i.e. how do students that encountered algebra in the first grade perform in the middle grades (Dougherty has done some work on this), in high school, and in the long run, in university?

References

- Hodgen, J., Oldenburg, R., & Strømskag, H. (2018). Algebraic thinking. In T. Dreyfus, M. Artigue, D. Potari, S. Prediger, & K. Ruthven (Eds.), *Developing research in mathematics education: Twenty years of communication, cooperation and collaboration in Europe* (pp. 32-45). London and New York: Routledge – New Perspectives on Research in Mathematics Education – ERME series, Vol. 1.
- Kaput, J. (2008). What is algebra? What is algebraic reasoning? In J. Kaput, D. W. Carraher, & M. L. Blanton (Eds.), *Algebra in the early grades* (pp. 5-17). New York: Routledge.

Teachers' Conceptions of Algebra and Knowledge of Task Purposes

Burcu Alapala¹ and Isil Isler-Baykal²

¹University of Wisconsin-Madison, Madison, USA; alapala@wisc.edu

²Middle East Technical University, Ankara, Turkey; iisler@metu.edu.tr

Keywords: Teacher conceptions of algebra, Teacher knowledge of task purposes, in-service teachers

Background of the study

Teachers are the key stakeholders of the prekindergarten-12th grade algebra reform and their conceptions about algebra is utmost important. Stephens (2008) working with elementary preservice teachers found that they held narrow conceptions of algebra centered around symbols and symbol manipulation. This study aimed to investigate in-service teachers' conceptions of algebra and their knowledge of task purposes across three tasks that focused on equivalence and equations, functional thinking, and variable.

Theoretical framework

Kaput (2008) defined two core aspects of algebra as “a) algebra as systematically symbolizing generalizations of regularities and constraints” “(b) algebra as syntactically guided reasoning and actions on generalizations expressed in conventional symbol systems” (p. 11). This framework was used in the study to help categorize teachers' conceptions of algebra.

The second framework used in the study was Mathematical Knowledge for Teaching (MKT) (Ball, Thames, & Phelps, 2008). This study investigated teachers' knowledge of task purposes (their awareness to engage students in algebraic thinking) which can be categorized under the pedagogical content knowledge (PCK) of the MKT framework across three tasks that focused on algebra.

Methods

The study was conducted with five female mathematics teachers who were working at the same school with the first author. Three teachers were teaching at the primary and middle school levels and two were teaching at the middle school level. Semi-structured individual interviews were conducted. The interview protocol comprised of three parts and developed based on Stephens (2008), and a functional thinking task was taken from Blanton et al. (2015). The first part included demographic information. The second part focused on understanding teachers' conceptions of algebra including the open-ended question “How would you describe what algebra is to someone who has never heard of it before?” This part also included three tasks. Teachers were asked the possible aims of the task. Also, teachers were asked to categorize the tasks as algebraic or not with their justifications. The last part included two student solutions provided to each of the three tasks. Participants were asked to categorize these student solutions as algebraic or not by explaining their reasoning.

The coding was conducted according to a coding scheme that was developed in previous studies (see Alapala, 2018; Stephens, 2008). The second author coded a randomly selected 20% of the data and the agreement between the coders was found as 80%. The disagreements were resolved, and changes were reflected to the analysis.

<p>What number goes in the box?</p> $37 + 54 = \square + 55$
--

Figure 1: Task 1

Results and discussion

When teachers were asked the possible of aims of each task, their awareness regarding the opportunities to engage students in algebraic thinking varied from task to task. For instance, in Task 1 (see Figure 1) while four teachers focused on having students find the unknown using a computational approach, one teacher focused on the relationship between numbers in her response. When they were asked how they would describe what algebra is to someone who has never heard of it before, the majority of the teachers focused on the presence of an unknown or an equation in their responses. Teachers' categorizations of tasks as algebraic or not providing their justifications revealed a similar finding. They mentioned surface features such as the presence of an unknown or an equation in their categorizations. For instance, all teachers categorized Task 1 as "algebraic" because of the presence of an unknown or an equation. T4 said "I think it is an algebra task because there is an unknown. We didn't say x , y but we used an empty box." Lastly, teachers' categorizations of student solutions indicated that the majority of the teachers ranked student solutions that included manipulations and equations as "algebraic" while they ranked solutions that focused on the structure of the equations and patterns as "non-algebraic." For example, in Task 1, while all teachers rated the student response who used a computational approach to find the unknown as "algebraic," only one teacher rated the response that focused on the relationships between numbers (indicating relational thinking) as "algebraic." Therefore, even though teachers demonstrated some awareness regarding the opportunities the tasks can offer in terms of algebraic thinking (PCK regarding algebra), their conceptions were mostly aligned with Kaput's (2008) manipulation of formalisms. This was similar in Stephens (2008). Given what teachers see as "algebra" could be foregrounded in the classroom, researchers should pay further attention to teachers' conceptions of algebra and pose tasks and hypothetical student responses that help uncover these conceptions.

References

- Alapala, B. (2018). *Investigating middle school preservice mathematics teachers' conceptions of algebra and knowledge of task purposes and student thinking* (Unpublished master's thesis). Middle East Technical University, Ankara, Turkey.
- Ball, D. L., Thames, M. H., & Phelps, G. (2008). Content knowledge for teaching: What makes it special? *Journal of Teacher Education*, 59(5), 389–407.
- Blanton, M., Stephens, A., Knuth, E., Gardiner, A. M., Isler, I., & Kim, J. S. (2015). The development of children's algebraic thinking: The impact of a comprehensive early algebra intervention in third grade. *Journal for Research in Mathematics Education*, 46(1), 39–87.
- Kaput, J. J. (2008). What is algebra? What is algebraic reasoning? In J. J. Kaput, D. W. Carraher, & M. L. Blanton (Eds.), *Algebra in the early grades* (pp. 5–17). Mahwah, NJ: Lawrence Erlbaum/Taylor & Francis Group; Reston, VA: National Council of Teachers of Mathematics.
- Stephens, A. C. (2008). What "counts" as algebra in the eyes of preservice elementary teachers?. *The Journal of Mathematical Behavior*, 27(1), 33–47.

Strategies exhibited by good and average solvers of geometric pattern problems as source of traits of mathematical giftedness in grades 4-6

Eva Arbona¹, María José Beltrán-Meneu² and Ángel Gutiérrez¹

¹ Universitat de València, Valencia, Spain; eva.arbona@uv.es, angel.gutierrez@uv.es

² Universitat Jaume I, Castellón, Spain; mmeneu@uji.es

We describe and analyse the strategies used by students in primary grades 4, 5 and 6 to solve linear and affine geometric pattern problems. Based on two problems posed in a teaching experiment, we have identified several profiles of strategies used by students to solve the problems. We consider the profiles of students who were good geometric pattern problem solvers as traits that may help identify mathematical giftedness. Our results show that average students used very often incorrect functional strategies and were consistent in using incorrect proportional strategies along the grades. On the other hand, good geometric pattern problem solvers tended to use correct functional strategies, although, when they had difficulties in identifying the structure of a pattern, they tended to switch to correct recursive strategies, because they are easier to apply and more reliable.

Keywords: Early algebra, geometric pattern problems, mathematical giftedness, primary school.

Introduction

Learning algebra is a very fruitful way to boost mathematical abilities of all primary school students, in particular mathematically gifted students (gifted students hereafter). Algebra is also an essential tool in secondary school, since it is needed to solve problems in the different areas of mathematics. However, most secondary school students have difficulties to understand and learn algebra, which hinder their mathematical progress. Some of those difficulties are understanding the meaning of letters and the equal sign, distinguishing between the notions of variable and unknown, and transforming word statements into algebraic expressions (Banerjee & Subramaniam, 2012; Jupri, Drijvers, & Van den Heuvel-Panhuizen, 2015).

In the early grades, algebra can be introduced through algebraic thinking that allows working and operating with variables and unknowns, avoiding the use of symbolic alphanumeric expressions (Radford, 2011a). The context of geometric pattern problems (gp problems hereafter) has proved to be successful in developing algebraic thinking in primary school (García-Reche, Callejo, & Fernández, 2015; Rivera, 2013).

Gp problems (Figures 1 and 2) present a graphical representation of the first few terms of an increasing sequence of natural numbers and ask for values (V) or positions (n) of specific terms of the sequence. These problems are especially useful to facilitate the access of gifted students to basic algebraic concepts. Furthermore, gp problems are an adequate context to identify possible gifted students, since they have to use their abilities for generalization, abstraction and symbolization. Those abilities are important components of mathematical reasoning, more developed in gifted students than in the majority of students of the same age or the same school grade (we refer to them as *average students*) (Krutetskii, 1976). Amit and Neria (2008) analysed strategies used by gifted students in grades 6 and 7 when solving gp problems, while Fritzlar and Karpinski-Siebold (2012) distinguished

a set of five components of algebraic thinking by observing algebraic abilities of gifted and non-gifted primary school students when identifying and generalising patterns. However, there is little research reporting mathematically gifted students' behaviour when solving gp problems, so it is of interest to inform on traits of mathematical giftedness in the specific context of gp problems.

Teachers should provide all their pupils with opportunities to develop high order thinking. In particular, gifted students require more complex problems compared to average students; thus, it is important to provide teachers with tools to identify their gifted students. Students' solutions to gp problems may be very diverse, depending on the ways of reasoning and performing calculations used, since they reflect different levels of mathematical talent. Gifted students are unusually good problem solvers compared to average students, so a reliable way to identify gifted students, used by most researchers, is to observe their problem solving profiles.

In this context, we present results from a research project aimed to identify and analyse profiles of good gp problem solvers in grades 4, 5 and 6 when solving linear and affine gp problems, to characterise profiles that could differentiate gifted students from average students, and also gifted students in different school grades. The specific objectives of the part of the research presented here are:

- To identify differences between profiles of good gp problem solvers and average students in their solutions of gp problems, as possible traits of mathematical giftedness.
- To identify differences in students' strategies along 4, 5 and 6 primary school grades.

Theoretical framework

Gp problems present realistic contexts to help students give meaning to the pictorial representations of sequences and their numerical values and answer questions (Billings, Tiedt, & Slater, 2007). *Direct questions* ask for values of *immediate*, *near* and *far* terms (Stacey, 1989), i.e., the number of pieces in the graphical representation of those terms, and also ask to write a *general rule* and an *algebraic expression* to calculate the value of any term of the sequence. *Inverse questions* ask for the position of the term with a given value (Rivera, 2013). Here we focus on answers to direct questions.

Gp problems could have several levels of complexity depending on their characteristics. Friel and Markworth (2009) analysed 18 different geometric patterns and ordered them from less to more complex, the most basic patterns being those based on linear relationships $V=an$ (Figure 1). Patterns based on affine relationships $V=an\pm b$ (Figure 2) increase their difficulty. Lastly, patterns based on quadratic relationships $V=an^2\pm bn\pm c$ are more complex than the previous ones.

Several authors (García-Reche, Callejo, & Fernández, 2015; Radford, 2011b; Stacey, 1989) have identified different strategies used by students to solve direct questions in linear or affine gp problems. As some strategies are labelled differently by those authors, we have merged them into a single categorization of students' answers: the *counting* strategy is based on drawing the graphical representation of the term asked and counting its pieces. The *recursive* strategy uses the constant difference between the values of two consecutive terms to calculate the value of another term, by adding this difference to the value of a known term as many times as necessary. The *proportional* strategy assumes that there is a proportional relationship between the positions of a known term (n) and the asked term (m) and their values, $V(n)$ and $V(m)$: if $m=a\times n$, with $a\in\mathbb{N}$, then $V(m)=a\times V(n)$. The *functional* strategy

consists of calculating the value of a term by using an arithmetic or algebraic expression based only on the position of the term in the sequence, and not on the value of a known term. The counting, recursive, and functional strategies give the correct answer if applied properly, while the proportional strategy is correct for linear problems but it is wrong for affine problems.

Gifted students are those who show “a unique aggregate of mathematical abilities that opens up the possibility of successful performance in mathematical activity” (Krutetskii, 1976, p. 77), their problem solving abilities being higher than those of average students. Greenes (1981), Krutetskii (1976), and Miller (1990) detailed several characteristics that gifted students can present, some of them being particularly important to solve gp problems, like identifying patterns and relationships among elements, generalising and transferring mathematical ideas or knowledge between numeric and algebraic contexts, locating the key of problems, abbreviating solution processes, or inverting mental procedures in mathematical reasoning.

The experimental part of our research took place in ordinary classrooms, where, quite often, there are gifted students who have not been identified by their teachers. We did not have any external way to identify gifted students in the sample of our research (e.g., their IQ), so we looked for *good gp problem solvers*. By comparing the solutions provided by the good gp problem solvers and the other students in their classrooms, we aim to identify specific good gp problem solvers’ solution profiles that could be considered as traits of mathematical giftedness and used, together with other procedures, to identify gifted students in ordinary classrooms.

Research methodology

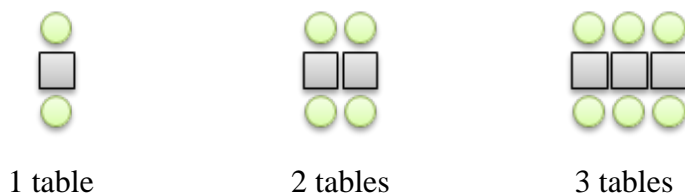
We present results from a study based on grades 4, 5 and 6. These are the last grades in Spanish primary schools, just before students start learning algebra, in grade 7. Two classroom groups in each grade followed an experimental teaching unit for early algebra based on gp problems. There were 43, 34, and 41 students in grades 4, 5, and 6, respectively.

The teaching unit took place during three 45-minutes ordinary mathematics classes. It was aimed to work on: i) the generalisation of functional relationships from the geometric representations, ii) the meaning and use of basic algebraic concepts and symbols, like letter notations and the translation of verbal expressions into algebraic ones, and iii) the reinforcement of the algebraic contents previously learned. The teaching unit was based on linear and affine gp problems similar to those shown in Figures 1 and 2. Students solved individually about 3 problems in each session, depending on their ability and quickness. The teacher (the first author) provided some guidelines to the students; after they had solved each problem, she collected the students’ answers, encouraging them to share on the blackboard their different strategies and debate whether they were correct or wrong. Finally, the teacher explained why the wrong strategies did not work. In this paper, we analyse two problems (Figures 1 and 2) posed in the third session of the experiment.

The two problems are based on the same well-known context of tables and chairs. Both have the same wording (Figure 1), with 2 direct questions (*a*, *b*), an algebraic generalisation question (*c*), another direct question (*d*) aimed to check their generalisation, and an inverse question (*e*). However, they have a difference: the first problem (Figure 1) presents tables (*T*) with chairs (*C*) only at the sides, so the sequence is linear ($C=2T$); the second problem (Figure 2) presents tables with chairs both at the

sides and the ends, so the sequence is affine ($C=2T+2$). The problems were posed to induce students to generalise the relationships, write an algebraic expression, and use it.

María is organising her birthday party with her friends and relatives. She wants to calculate how many tables and chairs she needs to sit people as in the pictures:



- How many people will sit around 6 tables? How do you know it?
- How many people will sit around 50 tables? How do you know it?
- Explain to a friend how she can calculate how many people will sit depending on the number of tables. Write down the formula you have mentioned.
- Use the previous formula to find how many people will sit around 15 tables.
- If there are 22 people sitting, how many tables will be? How do you know it?

Figure 1: The linear gp problem

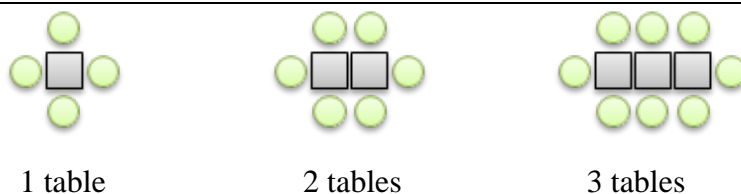


Figure 2: The affine gp problem, with the same wording as in Figure 1

After analysing the answers to the direct questions in the problems (*a*, *b*, and *d*), we have identified different profiles of students' solutions, depending on which strategies were used. For example, the *recursive-functional* profile identifies those students who used a recursive strategy in the linear gp problem and a functional strategy in the affine one.

Analysis of students' answers

We have analysed the types of students' strategies in the direct questions in both gp problems. We have considered as *good gp problem solvers* those students who solved correctly, or with minor errors, all the gp problems in the teaching unit. We identified as good gp problem solvers three students in grade 4, four in grade 5, and three in grade 6. Table 1 shows the number of good gp problem solvers and average students in each grade that used each profile to answer the direct questions. In the average students' profile functional-functional, we use brackets to show the number of their correct answers.

In grade 4, two out of the three good gp problem solvers based their solutions to both problems on functional strategies. On the other hand, 23 average students in grade 4 used functional strategies in both problems, but only 7 students solved them correctly. The other students used a diversity of combinations of functional and proportional strategies, all incorrect.

Linear problem	Affine problem
Student 5B-13: $6 \times 2 = 12$ <i>Because you must multiply the table x2.</i>	Student 5B-13: 14 <i>Because I've been adding.</i>

Figure 3: Functional and recursive strategies in a good gp problem solver's answers to question a

In grade 5, the good gp problem solvers provided solutions based on functional and recursive strategies, half of them changing from using the functional strategy in the linear problem to the less complex recursive strategy in the affine problem (Figure 3), or vice versa. On the other hand, average students mostly used the functional strategy in both problems, but only 8 students produced correct answers in both problems. The change of strategy made by the good gp problem solvers seems illogical, but it allowed them to succeed in solving the problem. On the contrary, the average students used the same strategy in both problems, maybe because they were comfortable using it or considered that both problems were analogous, but many average students produced incorrect answers (Table 1).

Profiles of solutions		Good gp problem solvers			Average students		
Linear	Affine	4th	5th	6th	4th	5th	6th
Recursive	Functional	0	1	0	0	0	0
Functional	Recursive	0	1	0	0	0	0
Functional	Functional	2	2	3	23 (7*)	20 (8*)	27 (22*)
Functional	Proportional	0	0	0	6	2	0
Proportional	Proportional	0	0	0	3	2	6
Other solutions		1	0	0	8	6	5
Total		3	4	3	40	30	38

(*) Number of average students in this profile producing correct solutions to both problems.

Table 1: Profiles of solutions to the direct questions (a, b, and d) in both problems

In grade 6, all good gp problem solvers and most average students used functional strategies in both problems, with a few average students using such strategies incorrectly. As in the other grades, some average students used proportional strategies. The fact that all good gp problem solvers in grade 6 used correct functional strategies, while a part of the average students used wrong proportional and functional strategies, points to traits of mathematical giftedness in the context of gp problems, namely identification of patterns and relationships among different elements, and generalising and transferring mathematical ideas from a numeric context to an algebraic one.

A profile typical of students when they start solving gp problems is that they tend to move from a strategy to another in the consecutive questions of the same problem (Gutiérrez, Benedicto, Jaime, & Arbona, 2018). However, as the problems we are analysing were posed in the third class session of the teaching experiment, the students had already learned that the final aim of the gp problems was to state a generalisation. Then, all students but one in the sample used the same strategy for all direct

questions in each problem, although some students used different strategies for the linear and affine problems, showing diverse profiles in their solutions. Students had also learned that recursive strategies are efficient only for the immediate or near terms.

After comparing the data in Table 1 for the different grades, we get the following conclusions:

- i) The good gp problem solvers used, in each problem, a strategy with which they felt confident and that they were sure it was correct, even using a different strategy in each problem (Figure 3). They were more successful than average students in using simpler recursive strategies, and avoided the proportional strategy even in the linear problems, were it provides a correct answer. The good gp problem solvers also became more efficient along the grades using functional strategies.
- ii) Average students in all grades used mostly functional strategies, with an increase of the percentage of correct answers along the grades, but we do not observe a reduction in the use of (incorrect) proportional strategies in the affine problem.

Due to the relevant number of average students using the same strategy in the linear and affine gp problems, we have analysed the errors caused by this profile. We have identified three types:

Constancy of proportional relationship

Some average students used a (correct) proportional strategy in the linear problem and they used it again in the affine problem, although now it was wrong. Students did not analyse the whole pattern, but only one term: they calculated proportionally the value of the term requested, considering only the number of guests sitting around one table in the first or the second term of the pattern. Figure 4 shows the written answers of an average student who only considered the number of chairs around the table in the first term.

Linear problem	Affine problem
Student 5A-6: $50 \times 2 = 100$ <i>Because there are twice as many guests as tables.</i>	Student 5A-6: $50 \times 4 = 200$ <i>Because, if there are 50 tables, there are 4 guests for each table.</i>

Figure 4: Constancy of proportional relationship in an average student's answers to question b

Constancy of recursive relationship

Some average students identified the difference between the values of two consecutive terms and used it in a repeated addition or a multiplication. In Figure 5, the student did not pay attention to the chairs at the ends of the tables in the affine problem and used the increment of 2 chairs ("two more chairs") as proportional ratio.

Error of analysis of diagrams

Some average students did not analyse correctly the parts of the patterns. They identified a wrong difference between the linear and the affine patterns and used it to create a wrong formula. In Figure 6, the student did not identify correctly the chairs at the ends of the tables and, furthermore, he did not use correctly the number of chairs around the first table (4).

Linear problem	Affine problem
Student 5A-11: $50 \times 2 = 100$ <i>Because each time there are 2 [more] chairs and 50 tables [multiplied] by 2 chairs too.</i>	Student 5A-11: $50 \times 2 = 100$ <i>I multiply the number of tables by 2 more chairs.</i>

Figure 5: Constancy of recursive relationship in an average student's answers to question b

Linear problem	Affine problem
Student 5A-1: $50 \times 2 = 100$ <i>Because, each time, 2 chairs are added with one table.</i>	Student 5A-1: $50 \times 2 = 100$; $100 + 3 = 103$ <i>Because there are 4 guests in 1 table, but 2 guests are added each time.</i>

Figure 6: Error of analysis of diagrams in an average student's answer to question b

Conclusions

We have presented a comparative analysis of strategies of solution used by a sample of good gp problem solvers and average students in grades 4 to 6 when solving direct questions in a linear ($V=an$) and an affine ($V=an+b$) gp problems posed as part of an experimental teaching unit. The analysis of students' answers to those problems shows some significant and original findings: most students used mainly functional strategies, although good gp problem solvers showed a tendency to follow profiles using functional and recursive strategies, which were less complex but more successful than the profiles followed by average students, based on functional and proportional strategies. There is a tendency of average students in all grades to use wrong proportional strategies. According to Van Dooren, De Bock, Hessels, Janssens, and Verschaffel (2005), students are prone to apply proportional strategies when they should not be applied. The frequency of such strategies seems to be higher when students start learning proportional reasoning, which, in Spain, usually happens in grade 4.

The analysis of the data collected suggests a difference between the profiles of good gp problem solvers and average students in the use of recursive strategies of solution in the (more difficult) affine problem. Data also seem to show a clear difference between the profiles of both types of students in the use of proportional strategies, even when they were correct. Hence, a contribution of this research is the suggestion that a trait of giftedness in solving gp problems seems to be the use of correct recursive and functional strategies and the absence of proportional strategies to solve gp problems.

Respect to the differences between grades, we have observed an increment in the amount of solutions based on functional strategies, and an increment in the percentage of correct functional strategies. However, it is not apparent a (expected) reduction in the use of incorrect proportional strategies.

Acknowledgments

The results presented are partially funded by the research projects EDU2017-84377-R (AEI/ERDF, EU) and GVPROMETEO2016-143, and by the predoctoral aid FPU16/04513 (Spanish Ministry of

Science, Innovation and Universities), aimed to train new university teachers.

References

- Amit, M., & Neria, D. (2008). “Rising to the challenge”: using generalization in pattern problems to unearth the algebraic skills of talented pre-algebra students. *ZDM*, *40*, 111–129.
- Banerjee, R., & Subramaniam, K. (2012). Evolution of a teaching approach for beginning algebra. *Educational Studies in Mathematics*, *80*, 351–367.
- Billings, E. M. H., Tiedt, T. L., & Slater, L. H. (2007). Algebraic thinking and pictorial growth patterns. *Teaching Children Mathematics*, *14*(5), 302–308.
- Friel, S. N., & Markworth, K. A. (2009). A framework for analysing geometric pattern tasks. *Mathematics Teaching in the Middle School*, *15*(1), 24–33.
- Fritslar, T., & Karpinski-Siebold, N. (2012). Continuing patterns as a component of algebraic thinking – An interview study with primary school students. Paper presented at the 12th International Congress on Mathematical Education (ICME 12). Seoul, South Korea.
- García-Reche, A., Callejo, M. L., & Fernández, C. (2015). La aprehensión cognitiva en problemas de generalización de patrones lineales. In C. Fernández, M. Molina, & N. Planas (Eds.), *Investigación en Educación Matemática XIX* (pp. 279–288). Alicante, Spain: SEIEM.
- Greenes, C. (1981). Identifying the gifted student in mathematics. *Arithmetic Teacher*, *28*(6), 14–17.
- Gutiérrez, A., Benedicto, C., Jaime, A., & Arbona, E. (2018). The cognitive demand of a gifted student’s answers to geometric pattern problems. In F. M. Singer (Ed.), *Mathematical creativity and mathematical giftedness* (pp. 169–198). Cham, Switzerland: Springer.
- Jupri, A, Drijvers, P., & Van den Heuvel-Panhuizen, M. (2015). Improving grade 7 students’ achievement in initial algebra through a technology-based intervention. *Digital Experiences in Mathematics Education*, *1*(1), 28–58.
- Krutetskii, V. A. (1976). *The psychology of mathematical abilities in school-children*. Chicago, USA: The University of Chicago Press.
- Miller, R. C. (1990). *Discovering mathematical talent*. Washington, DC: Eric.
- Radford, L. (2011a). Grade 2 students’ non-symbolic algebraic thinking. In J. Cai, & E. Knuth (Eds.), *Early algebraization* (pp. 303–322). Heidelberg, Germany: Springer.
- Radford, L. (2011b). Embodiment, perception and symbols in the development of early algebraic thinking. In B. Ubuz (Ed.), *Proceedings of the 35th Conference of the International Group for the Psychology of Mathematics Education* (Vol. 4, pp. 17–24). Ankara, Turkey: PME.
- Rivera, F. D. (2013). *Teaching and learning patterns in school mathematics*. New York: Springer.
- Stacey, K. (1989). Finding and using patterns in linear generalizing problems. *Educational Studies in Mathematics*, *20*(2), 147–164.
- Van Dooren, W., De Bock, D., Hessels, A., Janssens, D., & Verschaffel, L. (2005). Not everything is proportional: effects of problem type and age on propensities for overgeneralization. *Cognition and Instruction*, *23*(1), 57–86.

Investigating early algebraic thinking abilities: a path model

Maria Chimoni, Demetra Pitta-Pantazi and Constantinos Christou

University of Cyprus, Department of Education, Nicosia, Cyprus; chimoni.maria@ucy.ac.cy,
dpitta@ucy.ac.cy, edchrist@ucy.ac.cy

The introduction of algebra in the elementary school mathematics is expected to navigate students from concrete, arithmetical thinking to increasingly complex, abstract algebraic thinking required in secondary school mathematics and beyond. Yet, empirical studies exploring this idea are relatively scarce. Drawing on a sample of 684 students from grades 4, 5, 6, and 7, this study explored a path model which tested associations between students' abilities in solving different types of early algebraic tasks: generalized arithmetic, functional thinking, and modeling languages. Results emerging from latent path analysis showed that students were more successful in generalized arithmetic tasks and only when this was achieved they were able to solve functional thinking tasks; once these were achieved, they could proceed to solve modeling languages tasks. Qualitative analysis of students' solutions provided further insight into these findings.

Keywords: Early algebraic thinking, generalized arithmetic, functional thinking, modeling languages, path model.

Introduction

While the traditional arithmetic-then-algebra curricula have been proved to be unsuccessful in developing deep understanding of abstract algebra in the secondary grades, it has been suggested that algebra should become a cohesive thread in mathematics curriculum from K to 12 grades (Carragher & Schliemann, 2007). Yet, introducing algebra in the early grades does not mean to move the content of secondary algebra courses to elementary mathematics. Instead, it means setting the ground for students to develop ways of thinking that can support the later learning of algebra. To make this idea more clear, different approaches have been pursued, ranging from the identification of core algebra content strands, such as generalized arithmetic, functional thinking, and modeling languages (Kaput, 2008), to the examination of fundamental algebraic concepts, such as the equals sign (Matthews et al., 2012), to the analysis of essential algebraic processes, such as generalization and representation (Blanton & Kaput, 2005). Moreover, several researchers examined developmental paths where intuitive forms of algebraic thinking become more sophisticated through the mediation offered by appropriate instruction in specific areas of early algebra (e.g. Radford, 2014; Stephens et al., 2017).

The findings of these studies imply that the development of early algebraic thinking lies in the extension of arithmetic that is typically taught in elementary school so that students become aware of its underlying structure and properties and gradually develop the ability to identify and describe functional relationships between quantities that co-vary. Yet, more studies are needed to empirically test this idea. Towards this end, this study aimed to investigate the validity of an algebraic thinking path model which describes early algebraic thinking abilities that students seem to develop first and the way these are associated to other abilities that students seem to develop later on.

The rest of this manuscript is structured as follows: The next section provides an overview of studies that explored the nature of early algebraic thinking, its processes and mathematical content. Following

that, the research question is presented and the hypothesis tested. The methodology, including information about the participants, tasks, and analyses, is outlined next. After presenting the main findings, conclusions and implications for practice are discussed.

Theoretical Framework

Algebraic processes that mark the emergence of early algebraic thinking

A critical issue within the field of early algebra has been the way in which early algebraic thinking might occur and be expressed by students. Several researchers tend to agree that students exhibit early algebraic thinking by the time they begin to formulate generalizations about mathematical relationships, properties, and structure (Blanton & Kaput, 2005). Particularly, the process of generalizing is considered as an undisputed characteristic of early algebraic thinking. Generalizing is interrelated with the process of representing, as students make efforts to articulate and represent their generalizations (Blanton et al., 2015). At the same time, a variety of other processes frame generalizing and representing, such as noticing, hypothesizing, and validating (Blanton et al., 2011).

Algebraic processes are not developed or expressed by students in a mere single way (Stephens et al., 2017). For example, students' use of natural language, gestures or diagrams might be an indicator for the emergence of early algebraic thinking, which will in turn mediate the long-term development of alphanumeric symbolism. Particularly, Radford (2003) exemplified that the way students communicate generalizations might differ, varying from concrete numerical actions (*factual* generalization), to situated descriptions of the objects of the actions (*contextual* generalization), to actions with symbols or signs (*symbolic* generalization). Summing up, algebraic processes seem to be central to students' engagement with early algebraic tasks. The following section describes further the content areas in which these processes and forms of thinking are expected to emerge and grow.

Core algebra content strands and concepts

Kaput (2008) suggested that three core content strands involve algebraic thinking from K to 12 grades: generalized arithmetic, functional thinking, and application of modeling languages. These strands, which are interconnected with the processes described in the previous section, provide a unified framework for analyzing the multidimensional and complex nature of early algebraic thinking (Chimoni, Pitta-Pantazi & Christou, 2018).

Generalized arithmetic refers to the study of structure and relationships that are inherent to numbers and arithmetical operations. The emphasis in this strand is about looking at the structure of arithmetical expressions and computations rather than their results (Kaput, 2008). In generalized arithmetic, students are expected to use the properties of operations and relationships on classes of numbers, interpret the equals sign relationally, and solve single-variable equations and inequalities.

Functional thinking involves generalizing relationships between quantities that co-vary and representing them through multiple tools, such as natural language, alphanumeric symbols, pictures, function tables, and graphs (Blanton et al., 2017). Central in this strand are the concepts of variable and functional relationships, such as recursive patterns, co-variational relationships, and correspondence relationships (Stephens et al., 2017).

Modeling languages refers to the application of a cluster of modeling languages both inside and outside mathematics (Kaput, 2008). In this strand students begin with problem situations and make attempts to mathematise the regularities that are implicitly presented through the situation, using appropriate models, such as verbal expressions, equations, and graphs.

Research question and hypothesis

The research question that guided this study was the following: *Is there a consistent trend in the level of difficulty across generalized arithmetic, functional thinking, and modeling languages tasks that describes students' early algebraic thinking abilities?* In addressing this question and based on theoretical implications described in the previous section, this study tested the following hypothetical path model: *Students are able to solve generalized arithmetic tasks first. Once this is achieved, they proceed to solve functional thinking tasks. Solving modeling languages tasks is achieved last.*

Participants

A convenience sample of 684 students was involved in the study. The sample consisted of 170 fourth-graders (10 years old), 164 fifth-graders (11 years old), 184 sixth-graders (12 years old) and 166 seventh-graders (13 years old). The selection of these grades was done purposefully, since some of the concepts embedded in the three algebra content strands are not covered in earlier grades; at the same time, formal algebra is taught in later grades. Moreover, the existence of four age-groups enabled the examination of the stability of the path model or possible changes across age-groups.

Test

The test used to measure students' early algebraic thinking abilities consisted of 18 tasks that were adapted from previous research studies (e.g. Blanton & Kaput, 2005). The test included generalized arithmetic, functional thinking, and modeling languages tasks. Table 1 presents indicative examples.

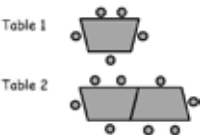
Example	Strand
Is the value of the following expressions the same or not? Justify your answer. <div style="display: flex; justify-content: space-around; align-items: center;"> <div style="border: 1px solid black; padding: 5px; margin: 2px;">$7 + 5$</div> <div style="border: 1px solid black; padding: 5px; margin: 2px;">$7 + 5 + 2 - 2$</div> </div>	Generalized Arithmetic
At a table that has the shape of a trapezium, 5 children can be seated. If two tables are connected, then 8 children can be seated. 	Functional thinking
(a) How many children can be seated at 3 tables? Justify your answer. (b) How many children can be seated at 10 tables? Justify your answer.	
Joanna will take computers lessons twice a week. Which is the best offer? Justify your answer. Offer A: €8 for each lesson Offer B: €50 for the first 5 lessons of the month and then €4 for every additional lesson	Modeling languages

Table 1: Examples of tasks included in the algebraic thinking test

Considering that students had adequate time to complete the test during administration, tasks with no response were graded with 0 marks. For the multiple choice tasks which had four alternative

responses, one mark was given to each correct response and zero marks were given to each incorrect response. For the tasks that had sub-questions, partial credit was given, considering the maximum sum of the marks of the sub-questions to be equal to 1. In the tasks where students had to justify their answers, the scoring was as follows: 0 mark for fully incorrect responses, 0.50 for giving a correct answer without justifying the answer or giving a wrong justification and 1 mark for giving a correct answer and a proper justification. In some tasks, where students were expected to use various strategies to solve them, a second identification mark was given based on the strategy used. Yet, the variation in students' strategies is not under investigation in the current paper.

Analysis

To analyze the quantitative data collected from the test, Latent Path Analysis was used. This kind of analysis is part of a more general class of techniques called Structural Equation Modeling (SEM). Specifically, Latent Path Analysis is used for testing whether a set of factors that are measured from multiple indicators (latent factors) are connected via directional regression paths. In this study, Latent Path Analysis was used for testing whether the three algebra content strands are connected via a specific path model. The analysis was conducted separately for each age-group and for the whole sample as well.

Firstly, the model described in the study's hypothesis was examined (Model 1). Moreover, two alternative models were also examined (Models 2 & 3). Model 2 assumed that students are able to solve both generalized arithmetic and functional thinking tasks first, and then they proceed to solve modeling languages tasks. Model 3 assumed that students are able to solve modeling languages tasks first, then they proceed to solve functional thinking tasks, and finally they are able to solve generalized arithmetic tasks.

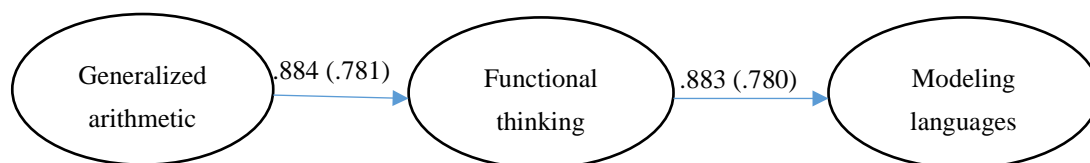
Three fit indices were computed for each model: the chi-square to its degree of freedom ratio (χ^2/df), the comparative fit index (CFI) and the root mean-square error of approximation (RMSEA). For a model to be validated, the observed values for χ^2/df should be less than 2, the values for CFI should be higher than .9, and the RMSEA values should be close to or lower than .08. The analysis was carried out using the MPLUS software (Muthén & Muthén, 1998).

In order to better interpret the quantitative results and illustrate examples of students' thinking in each strand, qualitative information from students' tests was analyzed: ten students were selected and their solutions were examined. The selection of these students was based on the method of purposeful sampling (Patton, 2002) which suggests the selection of cases that provide rich information about the phenomenon under investigation.

Results

The results of the Latent Path Analysis suggested that the best fitting model was Model 1, since it had the best fitting indices and high regression coefficients for each of the three latent factors. This result was the same for each of the four age-groups and for the whole sample. Figure 1 presents the structure of the model and the regression coefficients, as resulted from the Latent Path Analysis conducted to the data of the whole sample. Specifically, the fitting indices were adequate to provide evidence that supports the structure implied in the model (CFI=.959, $\chi^2=201.853$, $\chi^2/df=1.73$, RMSEA=.033). This,

supports the hypothesis of the existence of a consistent trend. Particularly, it appears that students are first able to solve generalized arithmetic tasks, such as using properties of numbers and operations, solving equations and inequalities, and analyzing expressions that involve symbols and numbers. Once they develop these abilities, they are able to solve functional thinking tasks, such as identifying distant terms in patterns, analyzing tables that represent correspondence relationships, and interpreting graphs. Generalized arithmetic and functional thinking appear as stepping stones for students to move on to modeling languages, where they are able to identify relationships between quantities that are presented through a situation and mathematize the situation using an appropriate model.



Note. $*p < .01$, The first number indicates the regression coefficient and the number in parenthesis indicate the proportion of variability that can be explained (r^2)

Figure 1: Associations between students' abilities in different types of early algebraic tasks

The results of descriptive statistics analyses showed that the students' highest performance mean was in generalized arithmetic tasks ($M=.530$). The second highest mean score was in functional thinking tasks ($M=.507$). Students' lowest mean score was in modeling languages tasks ($M=.303$), indicating that these tasks were more difficult for them.

The qualitative analysis of students' responses to specific tasks provided insights into the way students develop and apply the processes of generalizing and representing in each content strand. At the same time, these data allow further interpretation of the trend outlined from the latent path analysis. Figure 2 presents indicative examples of students' responses to three different tasks.

In the generalized arithmetic task (Fig. 2a), the student seems to directly recognize that the value of each expression is the same, without performing computations and comparing their results. The student expresses verbally the observed structure and seems to use the numbers -2 and $+2$ in a general way, as "quasi-variables" (Fujii & Stephens, 2001), to represent a regularity. Student's response shows that a familiar context, as the one of arithmetical expressions, enables noticing structure and regularities, generalizing from these regularities, and using means other than alphanumeric symbols to represent these generalizations, such as verbal descriptions.

The abilities developed within a generalized arithmetic perspective seem to facilitate students to begin making "factual" generalizations from concrete actions (Radford, 2003). Based on the quantitative data, these abilities seem to prompt students to look for structure and relationships in more complex contexts. As shown in Figure 2b, in a figural pattern, the student approaches the first question based on numerical actions, by drawing the next table and seats and probably counting the number of seats. The student seems to focus on one variable (the number of seats) and finds the answer based on the identification of a recursive pattern. Yet, the second question prompts the student to reason about two quantities that co-vary, since drawing and counting would not be a convenient strategy for finding a far term. The student seems to notice the pattern's structure and the relationship between the number

of tables and the number of seats. In this case, the student recognizes that tables at the edges always have 4 seats each and tables in the middle always have 3 seats each, and writes two distinct expressions to reach the final answer. However, the student seems to acknowledge that there is a general rule, despite the fact that there is no use of alphanumeric symbols. The student's generalization at this point seems to be, in terms of Radford (2003), a “contextual” generalization based on a situated description.

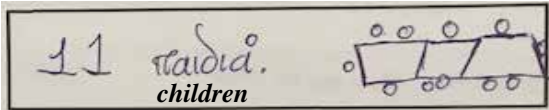
a. Generalized arithmetic task

Is the value of the following expressions the same or not? Justify your answer.

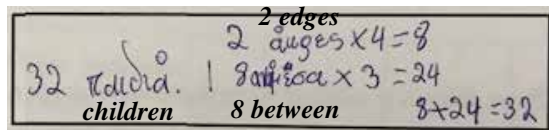
Yes because $7+5$ is the same in both expressions and $-2+2=0$.

b. Functional thinking task

(a) How many children can be seated at 3 tables? Justify your answer.



(b) How many children can be seated at 10 tables? Justify your answer.



c. Modeling languages task

Joanna will take computers lessons twice a week. Which is the best offer? Justify your answer.

Offer A: €8 for each lesson

Offer B: €50 for the first 5 lessons of the month and then €4 for every additional lesson

Figure 2: Indicative examples of students' responses

In the modeling languages task (Fig. 2c), the student identifies first the quantities involved: the dependent variable (the monthly cost of the lessons) and the independent variable (the number of lessons during a month); the student considers the number of monthly lessons to be 8. Furthermore, the student formulates expressions for Offer A and B, taking into consideration all variables described in the problem. In this sense, the student develops the processes of generalizing and representing in order to establish a general mathematical relationship that fits the situation. The student's response implies that arithmetical expressions are used to build a “contextual” generalization (Radford, 2003).

Discussion and Conclusions

In this study, we attempted to validate a path model which describes early algebraic thinking abilities that students seem to develop first and the way these are associated to other abilities that students seem to develop later on. The abilities examined were extracted from Kaput's (2008) theoretical framework about the three core algebra content strands: generalized arithmetic, functional thinking, and modeling languages. The results of the quantitative analyses provide evidence that there is a consistent trend in the level of difficulty across the three strands. It appears that students find it first easiest to solve generalized arithmetic tasks, and then functional thinking tasks. Once this is achieved, they can proceed to solve modeling languages tasks. These results complement but also extend the findings of previous studies that reported the significant role of content strands, such as generalized arithmetic and functional thinking in setting foundations in elementary mathematics for the longterm development of students' algebraic thinking (e.g. Carraher et al., 2006). Particularly, the findings of this study verify the ideas of a number of researchers (e.g. Fujii & Stephens, 2001) that the development of early algebraic thinking lies in the arithmetic that is taught in elementary school so that students pay attention to its underlying structure and properties and gradually develop the ability to identify and describe functional relationships between quantities that co-vary.

The data from the qualitative analysis exemplify the nature of students' thinking while they try to solve these types of tasks. Moreover, these data provide a plausible explanation for the idea that, in generalized arithmetic, students' pre-acquired arithmetical knowledge serves as a turning point for introducing them to early algebraic thinking. Generalized arithmetic encompasses familiar contexts that allow students to develop the processes of generalization and representation, without necessarily using alphanumeric symbols. The strand of functional thinking seems to strengthen the interplay between arithmetic and algebra, by introducing students to the concept of functions (Radford, 2014). Modeling languages appear to involve more advanced forms of algebraic thinking (Blanton & Kaput, 2005) that require the use of algebra as a tool in order for students to generalize, model, and justify relationships that are implicitly presented through problem situations.

Overall, this study provides empirical data that document students' capability to develop essential forms of early algebraic thinking that are foundational for the development of formal and abstract algebraic thinking. Moreover, the results imply that a comprehensive and sustained early algebra approach must build on developing students' abilities not only on one specific content strand but across the strands of generalized arithmetic, functional thinking and modeling languages. It should be noted that the model proposed in this study was formulated based on Kaput's theoretical framework and involved a sample of students with specific mathematical experiences. Future studies may examine the stability of this model in earlier or later grades of schooling. Following recent suggestions (e.g. Blanton et al., 2017), future studies might also confront generalized arithmetic and equation solving as two separated strands and test the associations between them as well as with the strands of functional thinking and modeling languages.

References

Blanton, M., & Kaput, J. (2005). Characterizing a classroom practice that promotes algebraic reasoning. *Journal for Research in Mathematics Education*, 36(5), 412–446.

- Blanton, M., Levi, L., Crites, T., & Dougherty, B. (2011). Developing essential understanding of algebraic thinking for teaching mathematics in grades 3-5. In B.J. Dougherty & R.M. Zbieck (Eds), *Essential understandings series. NCTM*: Reston, VA.
- Blanton, M., Brizuela, B. M., Gardiner, A. M., Sawrey, K., & Newman-Owens, A. (2017). A progression in first-grade children's thinking about variable and variable notation in functional relationships. *Educational Studies in Mathematics*, 95(2), 181-202. doi: <https://doi.org/10.1007/s10649-016-9745-0>
- Carraher, D.W. & Schliemann, A. D. (2007). Early Algebra and Algebraic Reasoning. In F. Lester (Ed.) *Second Handbook of Research on Mathematics Teaching and Learning: A project of the NCTM* (Vol II, p. 669-705). Charlotte, NC: Information Age Publishing.
- Carraher, D. W., Schliemann, A. D., Brizuela, B. M., & Earnest, D. (2006). Arithmetic and algebra in early mathematics education. *Journal for Research in Mathematics Education*, 37(2), 87-115.
- Chimoni, M., Pitta-Pantazi, D. & Christou, C. (2018). Examining early algebraic thinking: insights from empirical data. *Educational Studies in Mathematics*, 98(1), 57–76. doi: <https://doi.org/10.1007/s10649-018-9803-x>
- Fujii, T. & Stephens, M. (2001). Fostering understanding of algebraic generalisation through numerical expressions: The role of the quasi-variables. In H. Chick, K. Stacey, J. Vincent, & J. Vincent (Eds.), *Proceedings of the 12th ICMI study conference: The Future of the Teaching and Learning of Algebra* (Vol. 1, pp. 258–264). Melbourne, Australia: The University of Melbourne.
- Kaput, J. (2008). What is algebra? What is algebraic reasoning? In J. Kaput, D. W. Carraher, & M.L. Blanton (Eds), *Algebra in the early grades* (pp. 5-17). New York: Routledge.
- Matthews, P. G., Rittle-Johnson, B., McEldoon, K. L., & Taylor, R. T. (2012). Measure for measure: What combining diverse measures reveals about children's understanding of the equal sign as an indicator of mathematical equality. *Journal for Research in Mathematics Education*, 43(3), 316–350. doi: 10.5951/jresematheduc.43.3.0316
- Muthén, L. K., & Muthén, B. O. (1998). *Mplus user's guide*. Los Angeles, CA: Muthén & Muthén.
- Patton, M. Q. (2002). Two decades of developments in qualitative inquiry. *Qualitative Social Work: A Personal, Experiential Perspective*, 1(3), 2261-2283.
- Radford, L. (2003). Gestures, speech, and the sprouting of signs: A semiotic-cultural approach to students' types of generalization. *Mathematical thinking and learning*, 5(1), 37-70. doi: https://doi.org/10.1207/S15327833MTL0501_02
- Stephens, A. C., Ellis, A. B., Blanton, M., & Brizuela, B. M. (2017). Algebraic thinking in the elementary and middle grades. In J. Cai. (Ed.), *The compendium for research in mathematics education*. Reston: NCTM.

Students' expected engagement with algebra based on an analysis of exams in Norway from 1995 till 2018

James Gray¹, Bodil Kleve¹ and Helga Kufaas Tellefsen¹

¹OsloMet – Oslo Metropolitan University, Norway; James.Gray@oslomet.no;

Bodil.Kleve@oslomet.no; Helgate@oslomet.no

Using the definition of algebra from the TIMSS framework, algebra questions were identified on a sample of Norwegian mathematics examinations for 10th grade students from 1995 to 2018. These questions were then analysed using a discursive framework to look at the specialisation of the mathematical language. The analysis revealed consistency in the density of the language, a decreasing expectation of the depth of engagement with real world contexts, and a recent tendency to processes that direct the students in solving problems. It is argued that this gives an indication of the expected engagement with and implementation of the algebra curriculum in Norwegian schools.

Keywords: Algebraic thinking, Assessment, Specialised and non-specialised mathematics discourses.

Background and context

An ongoing issue in debates about Norwegian students' performance in mathematics is related to performance on algebraic tasks. On TIMSS tests since 2011, Norwegian 5th grade students were among the top performers in mathematics in Europe (Bergem, 2016). They performed significantly higher than students in the other Nordic countries. However, the performance of 9th grade students on the most recent TIMSS test in 2015 was at an intermediate level in a European perspective. Overall this was an improvement on previous years, but it was “particularly due to low scores in Algebra” (Bergem, 2016 p.22), which have decreased since 2011 and were at a very low level in 2015.

In Norway, the only externally set high-stakes written examination based on the mathematics common curriculum occurs at the end of grade 10. We consider tasks on these mathematics examinations to be important with regard to how students are expected to engage with the mathematical discourse. Like Morgan and Tang (2016), we assume that mathematics examinations mirror how mathematics curricula are implemented in the classroom (Broadfoot, 1996). From a discursive perspective, Morgan and Tang (2016) investigated differences in the language used in mathematics questions on examinations in England and Wales. The identified changes are discussed in the light of debates about ‘standards’, highlighting engagement with algebraic manipulations and independent problem solving. It is interesting to see if similar changes have occurred in other countries, to which our study may contribute.

Within this context, we investigated how algebra questions on the 10th grade examinations have developed since 1995. During this period, there have been several curricula (M87, L97 and LK 06 introduced in 1987, 1997 and 2006 respectively), which differ substantially in their treatment of algebra and contextualisation. In **M87** (*Mønsterplan for grunnskolen: M87*, 1987) “Algebra and Functions” was one topic and “Mathematics in everyday life” was integrated into all topics. **L97** (1999) had the following as separate topics: “Algebra and Number”; “Graphs and Functions”; and “Mathematics in everyday life”. In the current curriculum **LK 06** (Kunnskapsdepartementet, 2006),

there is an emphasis on basic skills. In contrast to M87 and L97, in which the goals were knowledge oriented, each main area in LK 06 is formulated in terms of competence goals. As in L97, “Numbers and Algebra” and “Functions” are still separate topics. Mathematics in everyday life is no longer a separate topic, but integrated into all topics, as it was in the M87.

In light of this, we will investigate the following research question:

How has the nature of students’ expected application of algebra in both mathematical and non-mathematical contexts developed since 1995 in 10th grade school mathematics in Norway?

Theoretical framework

As analytical framework, we have drawn on the work of Morgan, Sfard, and Tang (Morgan & Sfard, 2016; Morgan & Tang, 2016). Related to their project *The Evolution of the Discourse of School Mathematics (EDSM)*, they developed a substantial conceptual framework for analysing examinations. This framework has a theoretical foundation in social semiotics and Sfard’s communicational theory (Sfard, 2010). For the purposes of this paper, it is sufficient to say that mathematics being a human activity is defined in terms of the discourse that one engages in when doing mathematics. Morgan and Tang (2016) argue that the language used on the exams is crucial and that the language use in examinations may change the nature of the mathematics students are expected to engage with. Dowling (2001) emphasised how the language used in school mathematics may both enable and deny access to mathematics. By analysing the language students used when telling stories about their own learning in mathematics Kleve and Penne (2016) found that students who were successful in mathematics, used the subject specific language to a greater extent than those less successful. That is, the successful students were inside the mathematical discourse.

In our project, we aim to apply the whole EDSM framework to our selection of algebra questions. This paper will report on just one section of the framework. It is intended that the framework can be used in this way, and we are following the work of Morgan and Tang (2016) in focusing on the part of the framework that deals with specialisation of the discourse.

To analyse the algebra questions, nouns and verbs were allocated as SM (specialised to the discourse of school mathematics) or NSM (non-specialised). Specialised to the discourse of mathematics means that they were “used in accordance with mathematical definitions or in ways distinctive to school mathematics” (Morgan & Tang, 2016, p. 145). Then the whole questions could be classified as (entirely) SM, (entirely) NSM or *Mixed* (both SM and NSM). Although NSM was not included as a question code in the EDSM framework it was revealed during our analysis. Questions classified as SM were termed *Abstract*. Whole Questions classified as NSM or *Mixed* were further classified according to the depth of engagement with the context in terms of *Ritual* (repetitive exercise or following patterns widely used in text-books), *Mundane* (containing some unfamiliar elements, however requiring minimal engagement) and *Deep* (demanding more extensive engagement to determine how specialised mathematical discourse should be used). Illustrative examples of these categories appear in Morgan and Tang (2016). With regard to vocabulary, we identified objects in terms of nouns, and processes in terms of verbs, coding each word as either SM or NSM.

Method

To explore our research question we needed a representative sample of examinations. We took examinations every five years from 1995 together with the most recent examination from 2018. This yielded a sample that was manageable within the remit of our project, had an even coverage of the study period, and that included an early and a late examination in each curriculum cycle. The sampled examinations and the curricula reforms are illustrated on the timeline below.



Figure 1: Timeline showing sampled examination years (dots), and curricular reforms

To identify the algebra questions from each paper the authors made an initial selection individually. The selections were compared and the selection criteria discussed. It is now common to distinguish between algebra as cultural artefact and algebraic thinking as a human activity (Hodgen, J., Oldenburg, R., & Strømskag, H., 2018). Ideally, we would be able to pick out the questions that the majority of students would be expected to use algebraic thinking. However, we do not have access the thoughts of the candidates and examination setters so we could not identify questions by this criteria. We considered the curricula, but these did not provide us with an adequate definition because algebra has been grouped with different topics in the different curricula (see Background and context). Our project is partially motivated by the poor results in algebra in TIMSS (see Background and context), so we decided to use their definition of algebra to guide our selection ("TIMSS 2019 Mathematics Framework," 2017). For example, the questions asking students to use the Pythagorean theorem to work out the length of one side of a triangle were categorized as geometry and not algebra (as they are in the published TIMSS questions). An example of an algebra question involving geometry is given at the end of the Findings and analysis section. Using the definition from TIMSS, the authors adjusted their initial selection and reached a consensus.

Questions were coded as SM, *mixed* or NSM, and then *mixed* and NSM questions were coded as *ritual*, *mundane* or *deep* (see Theoretical framework). Working individually, one of the authors coded all the questions in the sample of examinations and the other two shared the sample. Revision and recoding of all the data set was then done by two authors in consultation with one another. Similarly at the level of specialised vocabulary. One of the authors coded the process (verbs) as SM or NSM and the other two coded the object (nouns) as SM or NSM. The authors consulted each other during this process so that difficulties could be resolved by a consensus decision. Inter-rater reliability was not calculated because the purpose of the project is to compare examinations and for each coding category each data set was coded completely by one of the authors.

Findings and analysis

Proportion of algebra questions and degree on contextualisation

Figure 2 shows the percentage of algebra questions on each of the examination papers. In the examinations in 2000 and 2005, candidates were given a choice of six questions from 22 (covering a

range of topics) in the last part of the examination. In each of these years, it was possible to avoid, or choose almost exclusively, algebra questions in this part. These two extremes are shown in Table 1, and in Figure 2 by two data points for each of these years. We do not have any data about how many algebra questions a student would typically choose. We note that candidates had the opportunity to make a significant reduction in the proportion of algebra questions in these years, and from the authors' experience, it is very unlikely that many chose the highest proportion possible.

Year	1995	2000	2005	2010	2015	2018
Number of questions on examination	56	32	40	64	55	53
Number of algebra questions (% of questions)	18 (32%)	6 (19%)–12 (38%)	6 (15%)–11 (28%)	16 (25%)	21 (38%)	20 (38%)

Table 1: The number of questions and algebra in each examination in the sample

LK06 was revised in 2013 and more algebra was included (Utdanningsdirektoratet, 2014). The proportion of algebra questions on the examinations in our sample has also increased significantly since 2013. For comparison, the target proportion for algebra in the TIMSS assessment is 30%. The examination in 1995 was approximately at this level. The examinations in 2005 and 2010 were below this level, whereas the examinations in 2015 and 2018 were above this level.

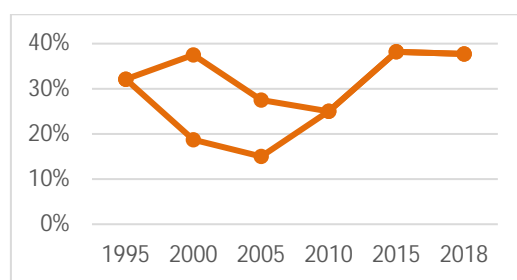


Figure 2: The percentage of algebra questions in each examination in the sample.

Figure 3 shows the number of questions coded as *abstract*, *ritual*, *mundane* and *deep*, and these as a proportion of all of the algebra questions. In the years 2000 and 2005, we have included all the algebra questions that the students could choose in the last part of the examination. (In the year 2000, candidates could not do more than twelve algebra questions, but the figure shows the results for all fourteen algebra questions.) If we exclude the last part of these examinations, there were six abstract and one ritual questions in 2000, and eight abstract and one mundane questions in 2005. (There were fewer questions in total on the examinations under the curriculum L97, but the time given to the candidates has remained constant for all the examinations in the sample.) Thus, there was only one compulsory contextualised algebra question for candidates in each of these years.

There were no questions coded as *deep* in the examinations after 2005 in our sample. Moreover, the questions coded as *deep* in 2005 were all in the last part where the candidates had a choice of questions. Thus, the examination in 1995 was the only one in our sample where candidates were expected to engage in 'deep' algebraic context.

The proportion and number of ritual questions has increased significantly in the examinations in our sample that occurred after the introduction of the present curriculum (2010, 2015 and 2018). In addition, the proportion of abstract questions has decreased. This indicates a trend where there are more contextualised algebra questions, but that the degree of depth with which the students are

expected to engage with the context has fallen. We noted earlier that the proportion of algebra questions had increased significantly in the last two years of our sample. If the motivation for doing this was to raise standards in algebra, then our data indicates that the quality as well as the quantity of algebra questions needs to be addressed. This may be related to the emphasis placed on algebra in the curricula referred to above. However, it is beyond the scope of this paper to go into this further.

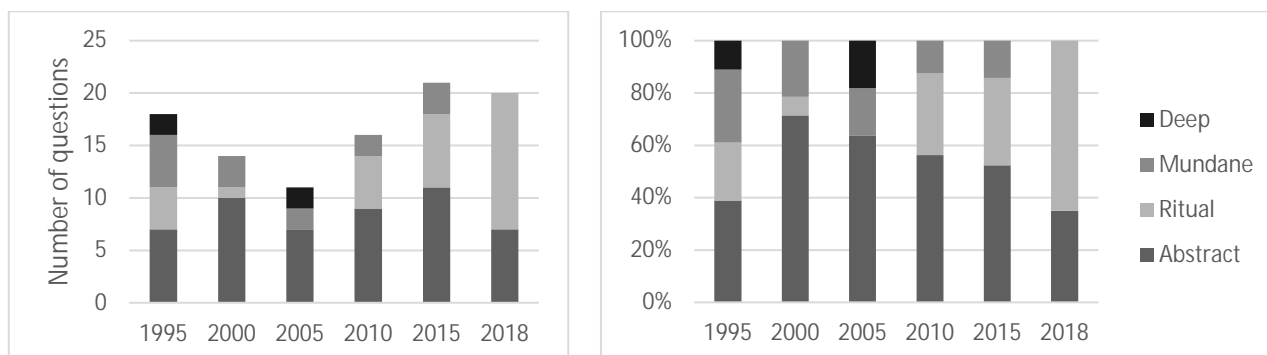


Figure 3. The degree of contextualisation

Specialised and non-specialised processes and objects

The first two rows of Tables 2 and 3 shows the frequency and rate per question of SM processes (verbs) and objects (nouns) respectively. The rate of SM processes and objects per question is lower in 2005 which will be discussed more below. In the other years, the rate of SM processes is similar over the sample. There is more variation in the percentage of SM objects, and the rate of SM objects per question. These appear to increase after each curriculum reform and then decrease, but a larger sample would be required to confirm this.

	1995	2000	2005	2010	2015	2018
SM (% of all processes)	29 (64%)	23 (66%)	13 (42%)	24 (52%)	42 (62%)	34 (60%)
Rate of SM per question	1.6	1.6	1.2	1.5	2	1.8
Distinct SM processes (rate per question)	18 (1.0)	14 (1.0)	11 (1.0)	14 (0.9)	19 (0.9)	17 (0.9)

Table 2: Specialised processes

The number distinct SM processes and SM objects are shown in the third rows of Tables 2 and 3 respectively. This measure gives an indication of richness of the discourse, and the data indicates that this has remained constant over the sample. The number of SM symbolic objects as a percentage of the SM objects is an indicator of the mathematical density of the discourse. This has also remained constant over the sample period apart from the year 2005.

	1995	2000	2005	2010	2015	2018
SM (% of all objects)	68 (64%)	70 (80%)	39 (60%)	118 (90%)	140 (83%)	109 (57%)
Rate of SM objects per question	2.5	3.1	1.8	4.6	4.4	3.5
Distinct SM non-symbolic object words (rate per question)	24 (1.3)	25 (1.8)	14 (1.3)	30 (1.9)	35 (1.7)	30 (1.5)
SM objects in symbols (% of all SM objects)	23 (34%)	26 (37%)	19 (49%)	45 (38%)	48 (34%)	39 (36%)
Total objects (rate per question)	106 (5.9)	88 (6.3)	65 (5.9)	131 (8.2)	169 (8.1)	190 (9.5)

Table 3: Specialised objects

The examinations in the sample under the present curriculum (2010–2018) contained a larger total number of objects, and a larger number of objects per question. However, the number of distinct object words has not increased proportionately to this. This indicates a more lengthy written style and not a richer expected discourse. A recurring feature in these examinations is supplementary information in the text with for example historical notes about mathematicians. This may be a consequence of the greater emphasis on basic skills (in this case reading) in LK 06 (Kunnskapsdepartementet, 2006).

In 2005, the rate of SM processes and objects per question is lower than the other years. A closer inspection of the data revealed that the rate of SM processes was similar with other years on *abstract* questions. However, the only SM processes on a *mixed* question was *find* which occurred just one time. In addition, there were only six SM objects in total on the *mixed* questions. Thus the algebra questions in 2005 were either almost entirely SM or NSM. This may be a consequence of the curriculum having “Mathematics in everyday life” as a separate topic and not integrated into other topics (L97, 1999). The lack of specialisation in the language on *mixed* questions meant that candidates were required to engage with the content, so all of these questions were coded as either *mundane* or *deep* (see Figure 4). However, as noted earlier, students could choose not to do these questions and so these questions may have had less impact on teaching and learning.

Sorting the data by year revealed that, of the 18 distinct SM processes in 1995 and 17 in 2018, there were just seven of these that occurred in both years. This change in language was the result of incremental changes over the sample period. There were, for example, no significant introductions of new processes with the curricular reforms. For objects, there were 17 common objects out of the 24 distinct SM objects in 1995 and 30 in 2018. When the objects were sorted by topic and the largest category was geometry with a total of 25 objects. Nine of these occurred in the exams under the previous curricula, whereas 20 of these occurred in the exams under the current curriculum. This shows the increased use of geometry as a context for algebra questions.

	1995	2000	2005	2010	2015	2018
Solve	2	3	2	6	8	4
Calculate	4	3	1	1	7	1
Use	1	1	0	4	5	6
Show (illustrate)	4	1	0	2	2	7
Draw	2	3	1	2	1	2
Find	6	0	1	0	1	0
Show (prove)	1	1	0	1	2	2
Make	0	1	0	1	2	3
Set	3	1	1	1	0	0
Determine	0	0	0	0	2	4

Table 4: Frequency of the most commonly occurring SM processes

The frequencies of the most commonly occurring SM processes are shown in Table 4. *Find* and *calculate* are the most commonly occurring instructions in 1995. These have not been used so frequently in recent years. The current examination guidelines (Utdanningsdirektoratet, 2014) state that candidates can choose their own solution method when answering questions that are formulated with *find*, *solve* or *determine*. Questions that are formulated with *calculate* require the candidate to use algebraic methods. (Although *calculate* was used as an instruction seven times in 2015, it was only used twice to indicate symbolic manipulation. The other five times were to evaluate expressions,

e.g. “Calculate which Pythagorean triple you get if $n = 6$ ” (2015 paper, p.11).) The data appears to show a tendency away from *find* and *calculate* (regn ut) over to *solve* and *determine* (bestemme) in algebra questions. The word for determine in Norwegian (bestemme) is also used to mean decide, and thus we would argue that *determine* belongs to a less specialised discourse than the other instructions.

The verb *use* has occurred significantly more often since the last curriculum reform. This is often in formulations such as “Use the [given] formula to calculate Monica’s maximum pulse rate” (Question 6, 2018 examination, our translation), and “Use a graph tool to...”. Such formulations give more explicit instructions to candidates, and may also reduce candidates’ role in decision making (Morgan & Tang, 2016, p. 53). Another consequence is that the question becomes an instruction to complete a process, rather than solve a problem. That is, that the discourse becomes one that is about performing actions rather than engaging in mathematics. This reflects the formulation of the current curriculum which is formulated in terms of competency goals and has an emphasis on basic skills (see Background and context). ICT is one of the basic skills (Kunnskapsdepartementet, 2006), so explicit instructions to use ICT tools have been included on the examination (Utdanningsdirektoratet, 2014).

An illustrative example

The following question appeared in the 2018 examination. It contained a picture of Archimedes (not reproduced here), the diagram shown in Figure 4, and each sentence was on a separate line.

A sphere has diameter equal to $2r$. A cone and a cylinder both have height equal to $2r$. Archimedes showed that the volume of the cylinder is equal to the combined volume of the sphere and the cone. Use the formulas below, and show that this holds. (2018 examination, our translation)

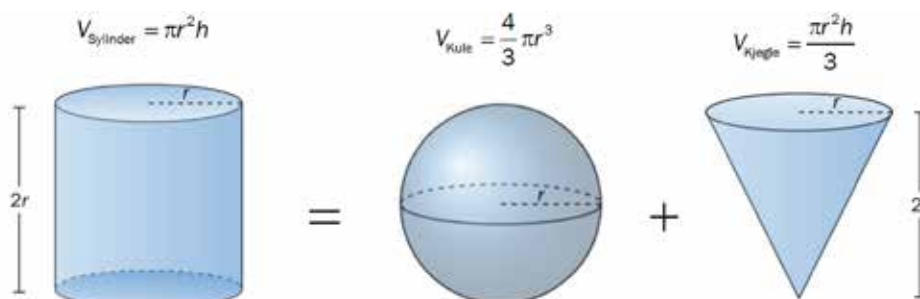


Figure 4: Diagram from question 19 on the 2018 examination

This question was coded as *abstract*: there is a context for algebra, but it is within the SM discourse. Our analysis suggests that geometry contexts have been more prevalent under the current curriculum. The last sentence directs the student as to how to solve the problem. This is further emphasised by the use of the plus sign and equals sign in Figure 4. These prompts reduce the candidates expected engagement with the discourse of the question. The mention of Archimedes is not essential to the question and his picture may be a distraction, especially for weaker candidates (Dowling, 2001).

This example shows that our analysis gives us insight into some of the changes in the expected mathematical discourse of 10th grade students in Norway. However, we see the importance of other factors such as the use of diagrams, and the role of human actors in the discourse. These factors can be analysed by other parts of the EDSM framework, and will be part of our further research.

Concluding remarks

Our sample indicates that the proportion of algebra questions on 10th grade examinations in Norway has increased since the last curriculum reform in 2006. The quantitative analysis at the question level suggests that the expected engagement in real-world contexts has become more ritual. At the level of objects and processes, the analysis suggests that the density of the discourse has remained constant over the sample period. The examination questions have contained more objects under the present curriculum, and the processes have become more directive. This indicates a discourse that reduces the need for decision making on the part of the student. These factors may contribute to the ongoing underperformance of Norwegian students in algebra on international test, but an inspection of the examination questions reveal many more factors that are in play. These need to be researched and synergised with our results to gain a better understanding of Norwegian students' algebra discourse.

Acknowledgment

Thanks to Candia Morgan for email correspondence.

References

- Bergem, O. K. (2016). Hovedresultater i matematikk. In O. K. Bergem, H. Kaarstein, & T. Nilsen (Eds.), *Vi kan lykkes i realfag* (pp. 22-43). Oslo: Universitetsforlaget.
- Broadfoot, P. M. (1996). *Education, assessment and society*. Buckingham: Open University Press.
- Dowling, P. (2001). Reading mathematics texts. In P. Gates (Ed.), *Issues in mathematics teaching* (pp. 180-196). London: RoutledgeFalmer.
- Hodgen, J., Oldenburg, R., & Strømskag, H. (2018). Algebraic thinking. In T. Dreyfus, M. Artigue, D. Potari, S. Prediger & K. Ruthven (Eds.), *Developing Research in Mathematics Education* (pp. 32-45). Oxon: Routledge.
- Kleve, B., & Penne, S. (2016). Learning subjects in School- being outsiders or insiders in the disciplinary discourse of mathematics and Language 1. *International Journal of Educational Research*, 78, 41-49. doi:<http://dx.doi.org/http://dx.doi.org/10.1016/j.ijer.2016.05.014>
- Kunnskapsdepartementet. (2006). *Læreplanverket for Kunnskapsløftet*. Oslo: Utdanningsdirektoratet. Retrieved from <https://www.udir.no/kl06/MAT1-04/Hele/Kompetansemaal/competence-aims-after-year-?lplang=http://data.udir.no/kl06/eng>.
- L97., Hagness, R., & Veiteberg, J. (1999). *The Curriculum for the 10-year compulsory school in Norway*. [Oslo]: Nasjonalt læremiddelsenter, Kirke- utdannings- og forskningsdepartementet, National Centre for Educational Resources.
- Morgan, C., & Sfard, A. (2016). Investigating changes in high-stakes mathematics examinations: a discursive approach. *Research in Mathematics Education*, 18(2), 92-119.
- Morgan, C., & Tang, S. (2016). To what extent are students expected to participate in specialised mathematical discourse? Change over time in school mathematics in England. *Research in Mathematics Education*, 18(2), 142-164. doi:10.1080/14794802.2016.1174145
- Mønsterplan for grunnskolen: M87*. (1987). Oslo: Aschehoug.
- Sfard, A. (2010). *Thinking as Communicating. Human Development, the Growth of Discourses, and Mathematizing*. Cambridge: Cambridge University Press.
- TIMSS 2019 Mathematics Framework. (2017). Retrieved from <http://timss2019.org/wp-content/uploads/frameworks/T19-Assessment-Frameworks-Chapter-1.pdf>
- Utdanningsdirektoratet. (2014). *Eksamensveiledning MAT0010 Matematikk 2014*.

“Never carry out any arithmetic”: the importance of structure in developing algebraic thinking

Dave Hewitt

Loughborough University, Centre for Mathematics Education, UK; d.p.hewitt@lboro.ac.uk

The use of tasks which ask learners to find general rules for growing figural patterns is widely reported in the algebra research literature. Such tasks are sometimes seen as a way to develop early algebra thinking. This paper looks at examples of such activities from the literature and presents a theoretical argument against the common practice of learners creating a table of values and seeking patterns within the numbers. Instead an argument is made for learners to focus on more complex examples where learners are discouraged from counting and turning the original figures into numbers. Instead, it is suggested that learners seek structure within complex examples and express what they see without carrying out any arithmetic but instead just writing down what arithmetic they would do.

Keywords: Early algebra, pattern spotting, algebraic thinking, structure.

Introduction

The difference between arithmetic and algebra has been discussed at some length in the literature. For example, Filloy and Rojano (1989) talked about a didactic cut existing when a letter appears on both sides of an equation. This is, of course, an attribute of the equation rather than a statement about ways of thinking which might differentiate between arithmetic and algebraic thinking. Herscovics and Linchevski (1994) spoke about the need for learners to work with the unknown for something to be considered as algebraic activity. This places a greater emphasis on the learner rather than the object, such as the form of an equation, with which they are working. With the emphasis on a learner, Radford (2010a) talked of a *zone of emergence of algebraic thinking* where expressions of generalisation can be expressed in a variety of forms such as gesturing and actions as well as writing. For Radford, there was not a need for letters to be present for algebraic thinking to be emerging. Kieran (2004) allowed the possibility of thinking algebraically about something even if that something is not explicitly on the list of algebra content within the curriculum. This allows for algebraic thinking to happen in many different areas of the curriculum, one of which is number. In this paper I argue for the case to place structure at the forefront of developing the algebraic thinking of learners. Several researchers have included structure as a key aspect of algebra work, including Kieran (2004). Usiskin (1988) included the study of structures within his four conceptions of algebra; Kaput (1995) did the same within his five aspects of algebra; and NCTM's (1998) discussion document included structure within four organizing themes for school algebra. Yet, I will argue that a number of reported teaching practices do not assist learners in placing their attention on structure; indeed often practices do the opposite and turn attention away from structure and onto what I would consider to be more arithmetic thinking.

Radford (2000) posited that algebraic thinking differed from arithmetic thinking in the form of the mathematical practice in which learners were engaged. For him it was about the focus being on, for example, investigating and expressing the general term of a pattern. At one

level, arithmetic is involved in generality in that $3+4=7$ is an expression of generality: it does not matter what we are talking about, 3 things plus 4 more of the same things result in 7 of those things. This is true no matter what those things are. However, algebra, as generalised arithmetic, requires a second level of generalisation. It stresses the structure of the given situation rather than a 'result'. Thus, $3+4=4+3$ can be judged to be correct through arithmetic thinking, by carrying out calculations and stressing the similarity of the results from both sides of the equation (both sides result in 7). Algebraic thinking will stress the structure inherent within the operation of addition, that of commutativity; the two sides are the same because it does not matter which way round you do addition. Thus algebraic thinking stresses operations as objects of attention and structure whereas arithmetic thinking stresses processes and with the results being the object of attention. Linchevski and Livneh (1999) introduced the notion of structure sense and since then other authors have developed the notion further (e.g., Hoch & Dreyfus, 2004; Mulligan & Mitchelmore, 2009). In particular, they have in common the idea of pattern, connections and relationships. Mulligan and Mitchelmore (2009) offered an example of seeing a 3 by 5 rectangle as three rows of five columns or as five columns of three rows. Each of these views placed a structured way of seeing the object rather than seeing it just as a whole. My own definition of algebraic structure which will be used in this paper is:

A way of viewing an object or expression such that it is seen as a combination of recognizable parts along with recognizable patterns which connect those parts together. Such a way of viewing results in an expression of the object in terms of the parts and connections which places the object as a particular example of a more general type.

The use of figural patterns (either based upon quasi-real life situations, such as the number of chairs around a line of tables, or purely geometrical, such as the length of the perimeter of a line of regular hexagons joined together) is widely reported in the literature (e.g., Montenegro, Costa & Lopes, 2018; Blanton et al., 2015b). I will analyse some examples of such tasks and consider ways in which the students have worked towards trying to find a functional rule for a given initial figural growth pattern. I will argue that taking students' attention away from the original figural situation and onto numbers generated from those patterns reduces the likelihood of students finding functional rules. A key to generalising is to keep attention with the figurative context and to focus on noticing structure. Carrying out arithmetic hides any inherent structure which had been noticed and thus reduces still further the opportunity to express generality. I start off by looking at the common practice of looking at the first few cases of a figural grown pattern and creating a table of values.

Tables of values

Asking learners to create a table of values for the first few cases is a common strategy which is either suggested by teachers or included in the task instructions. Transferring learners' attention from the original problem situation to a table of values means that they can lose contact with three important elements to assist with generality. Firstly the structural properties inherent within the original situation can be lost as learners stare only at numbers. Secondly, the nature of a classic table of values is that it is structured to be in term order from

1 onwards. This brings a natural temporal aspect where recursive rules are more likely to be articulated. Thirdly, if a functional rule is found for the numbers, there can never be certainty by looking at the table of values that the rule will apply to the original situation. I will now consider each of these three elements in turn.

Losing connection with the context

In Blandon et al.'s (2015b) study, one task involved finding the number of people sitting round a certain number of square tables which were joined in a line. Drawings of the first two cases were given and then the learners were asked to record their results in a table of values. They were asked to find patterns in the table. One 1st grade learner noticed a pattern in their table of values (Figure 3) where the numbers were the same along diagonals. Whilst this is, indeed, a pattern in the table, Blanton, Brizuela, Gardiner, Sawrey, and Newman-Owens (2015a) report that this could have been any symbol set where the symbols were the same along a diagonal and was not an observation which necessarily related to a sense of number let alone the contextual situation. Indeed, the creation of a table of values takes away the context within which those numbers were generated.

I observed a group of lower attaining 12-13 year olds spending half an hour building examples of the first few cases of a ring of tiles surrounding a 1 by n rectangle. The task was to find a general rule for how many tiles would be needed to surround such a rectangle. They began by making the first few cases with multi-link cubes and constructed a table of values for these first few cases. They then spent a long time looking at the numbers in the table and not getting further than noticing the recursive rule of the numbers going up in twos. They did not turn their attention back to the multi-link cubes but instead kept staring at the numbers in the table of values. I will say more about how this activity was concluded in a later section. The point here is that they no longer paid attention to the original situation.

These examples are in contrast to when learners' attention remains with the original context and where a structured way of viewing that context can lead to finding a functional rule, as can be seen from the following example. For example, Ferrara and Ferrari (2017) discussed a group of 10-11 year olds working on finding the number of circles in further terms of the sequence shown in Figure 1.

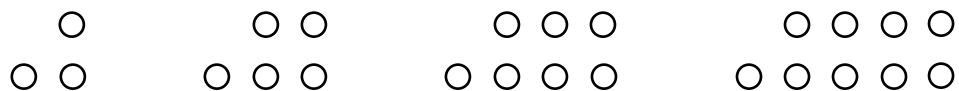


Figure 1: A figural pattern of dots

They were also asked to explain to someone from another class how to find the number of circles in any term in this sequence. An example of work from a group of three students showed how they justified their rule by seeing the figural patterns in a structured way. For example, Figure 2 shows a link between the notational expression and the pictorial situation for the 6th term.

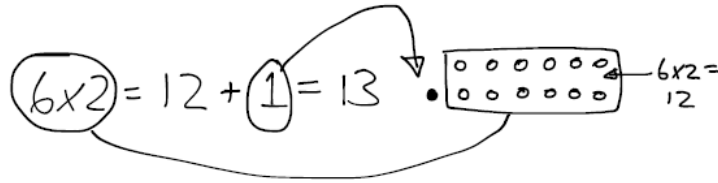


Figure 2: Re-drawn version of a learner's response from Ferrara & Ferrari (2017, p. 28)

They also showed an alternative way of structuring the geometric figure when one of them explained that “The figure is made of two rows: First row, second row, which, the second row is equal to the first row, plus 1” (p. 28). The written explanation for the 6th term (Figure 2) and the more verbal articulation in terms of the two rows, reveal two ways of imposing a structured way of viewing the geometric figure rather than seeing it as a single collection of circles. Both of these ways of viewing reveal a sense of generality where I feel confident they would be able to calculate the number of circles for any term in this sequence.

The seduction towards finding recursive rules

The second concern I have about tables of values is that their usual sequential nature can seduce students into noticing recursive rules rather than functional rules. Recursive rules give a way in which the next term can be generated from the previous term. This can involve the carrying out of a long series of arithmetic operations if a ‘far’ term in a sequence is to be found. Learners can also find it difficult to make use of a recursive rule in order to generate a functional rule; recall, for example, the case of the learners trying to find a rule for a ring of tiles surrounding a 1 by n rectangle. They had a recursive rule but this did not help them towards finding a functional rule.

Montenegro et al. (2018) described a class of 18 Portuguese students aged between 10 and 13 working on a sequence of growing geometric figures in the shape of an ‘L’. Two of the four groups were not able to find a functional rule even though they had found a recursive rule. All groups had turned their attention to working with numbers from the first six cases as this had been encouraged from the questioning of the task. The teacher decided that the students had missed the potential within the visual representation of the ‘L’ shapes and focused their attention on the shapes; asking students to say what was the same and what was different about the figurative representations. This led to students making comments such as “Figure 15 has one common square and 15 on each side” and “figure n will have a common square and n squares on each side”. This led to an exclamation of “Ahhhhh!” (p. 102) and the students were able to quickly find the functional rule. The focus being turned from trying to find patterns in numbers to looking for structure within the original geometric context was significant in the success obtained by those students.

The sequential nature of a table of values encourages learners to see a recursive rule, which is often ‘easier’ than a functional rule as it is usually additive rather than multiplicative, linear rather than quadratic, etc. It also does not always help with finding a functional rule.

Is the rule correct?

The third concern I have about tables of values is that even if a functional rule is found for the data in the table, students can never know from the table alone if that rule is correct for the original contextual situation. For example, without me telling you, you would not know the context which the table in Figure 4 represented. The contextual situation has disappeared and the activity becomes one of pure number pattern spotting. There is a danger that this can lead to little awareness of the mathematical situation from which those numbers originated (Hewitt, 1992). Some patterns spotted may not actually apply to the general situation from which the numbers originated. The table in Figure 4 gives a strong sense of the rule 2^{n-1} , however if the numbers came from the first five cases of looking at the maximum number of regions formed within a circle when n points on the circumference are joined to each other by chords, then this rule would not be correct. The case for six points produces a maximum number of 31 regions and not the 32 which might be expected from looking only at the table of values.

Justification or proof is never possible when attention is solely with a table of values. Palatnik and Koichu (2017) reported a pair of 9th grade students who obtained formulae connected with the problem of finding the maximum number of pieces a pizza can be cut into with n straight ‘cut’ lines. The students had a sense that their formulae were correct as they fitted with the numbers in the table of values. However, when challenged to work on why the formulae worked, the students had to return to the context of the problem to articulate reasons for why they were correct. So, the common practice of encouraging learners to construct a table of values (e.g., Blanton et al., 2015a; Blanton et al., 2015b) restricts any pattern spotting to the level of conjecture at best. Any sense of certainty of generality requires attention to be on the structure of the original problem situation, not a table of numbers.

p	x
3	4
4	5
5	6
6	7

Figure 3: Numbers on a diagonal are the same

1	1
2	2
3	4
4	8
5	16

Figure 4: A table of values. What is the rule?

Never carry out any arithmetic

I will now return to the story of the lower attaining students who were trying to find a functional rule for the number of tiles surrounding a 1 by n rectangle. They spent a long time looking at their table of values without getting anywhere towards finding a functional rule. After a long while observing them, I asked them how many tiles there would be in a situation where the rectangle was 47 long. They replied quickly that it would be two lots of 47 plus 3 for each end. Within one minute

they had expressed the rule of $2n+3+3$. The articulation of $2 \times 47 + 3 + 3$ rather than the single number of 100, which would be the result of carrying out the arithmetic of that expression, meant that the structured way in which they viewed the tiles was contained within that expression. The stressing of the structure allowed them to see the generality that, however long the rectangle was, they needed two lots of that length plus another two sets of three tiles. A significant aspect of this anecdote is that the rectangle was long enough so that they would not attempt to build this and count the number of tiles. As Radford (2010b) noted, it is important to work with a case where the numbers involved are too big for a learner to carry out arithmetic or to count. This forces the need to seek structure. Indeed I go further and say that in order to head towards algebra in such situations, all arithmetic should be avoided.



Figure 5: Chairs round tables

Chimoni, Pitta-Pantazi & Christou (2018) give an indicative answer from a group of 10-13 year olds who were successful in solving all the tasks given to them. In this case they were asked to find how many children could be seated around a group of 10 trapezoidal tables (see Figure 5 for the first two cases). The answer was presented similar to $N_{10} = 5 + (9 \times 3) = 32$. The number 32 may be seen as the answer to the question but it is the expression $5 + (9 \times 3)$ which reveals the structural way of seeing the situation. It is this expression, not the 32, which offers the insight to go on to express a general rule of $5 + ((n-1) \times 3)$, which may be written in the conventional form of $5 + 3(n-1)$. I argue that in order to head towards general algebraic statements *learners should never do any arithmetic, just write down the arithmetic they would do*. This is another reason why a table of values is often not as helpful as it might initially be considered to be; arithmetic is carried out in order to enter each value into the table. This means that any structural insights obtained are lost. Ferrara and Sinclair (2016) describe a teacher who worked with a class of grade 3 learners to see if they could work out the position number of 26 in the sequence 2, 4, 6, ... The teacher stressed that this was not to be done by counting. After a while several children were clear that doubling was involved. The teacher asked what number would be in position 99. One learner answered “Hum, I don’t know the double of 99” (p. 13). For algebra, I argue that you do not need to know the double of 99, you just need to express the arithmetic you would do (i.e. 2×99). This then leads towards an articulation of $2 \times n$, or $2n$. In some ways a learner might struggle to carry out some arithmetic whilst just writing down what arithmetic they would do can feel easier. In that sense expressing an algebraic structure in written form can feel easier than having to carry out any arithmetic involved.

Summary and implications

The research literature has shown a frequent practice of presenting learners with figural diagrams and encouraging them to construct a table of values for the first few terms. This results in learners’ attention being focused on to numbers rather than the context from which those numbers arose. The activity for learners then becomes number pattern spotting and there are examples of students

finding patterns in the numbers which can be detached from the contextual situation. The nature of a table of values is such that recursive rules are likely to be found and students do not always find it easy to translate such rules into a general functional rule. The argument I have made is that it may be preferable to stay with the contextual situation and encourage learners to find ‘structural ways of seeing’. This is supported by Strømskag (2015), who identified staying with the context as important for a successful pattern-based approach to algebra. Indeed, learners who stayed focused on the original figures were more likely to take a functional approach (El Mouhayar & Jurdak, 2016) and find several important *connected* features (El Mouhayar, 2018), whereas those who focused on numbers were more likely to take a recursive approach and noticed features which were *disconnected* with each other.

The principle of *never carrying out any arithmetic but just writing down what arithmetic you would do* can allow the structured way of seeing to be expressed within a written expression. Such expressions, and their associated ways of seeing, are a step towards seeing generality through a particular example (Mason, 1987). To aid this process of not carrying out any arithmetic and stressing structure instead, it is worth teachers considering offering just one example for learners to work on. This example should be one which is sufficiently complex so that learners are not able to count and are unlikely to be able to do any necessary arithmetic (Radford, 2000). This will increase the likelihood of learners expressing the structure they observe and writing it in a form which preserves that structure. Since a large number will be involved, this acts as a quasi-variable (Fujii & Stephens, 2001) in which the number acts as if it were a variable as learners have a sense that this could be any other number and the expression would still be true.

References

- Blanton, M., Brizuela, B. M., Gardiner, A. M., Sawrey, K., & Newman-Owens, A. (2015a). A learning trajectory in 6-year-olds' thinking about generalizing functional relationships. *Journal for Research in Mathematics Education*, 46, 511–558.
- Blanton, M. L., Stephens, A., Knuth, E., Gardiner, A. M., Isler, I., & Jee-Seon, K. (2015b). The development of children's algebraic thinking: The impact of a comprehensive early algebra intervention in third grade. *Journal for Research in Mathematics Education*, 46, 39–87.
- Chimoni, M., Pitta-Pantazi, D., & Christou, C. (2018). Examining early algebraic thinking: insights from empirical data. *Educational Studies in Mathematics*, 98, 57–76.
- El Mouhayar, R. (2018). Trends of progression of student level of reasoning and generalization in numerical and figural reasoning approaches in pattern generalization. *Educational Studies in Mathematics*, 99, 89–107.
- El Mouhayar, R., & Jurdak, M. (2016). Variation of student numerical and figural reasoning approaches by pattern generalization type, strategy use and grade level. *International Journal of Mathematical Education in Science and Technology*, 47(2), 197–215.
- Ferrara, F., & Ferrari, G. (2017). Agency and assemblage in pattern generalisation: a materialist approach to learning. *Educational Studies in Mathematics*, 94, 21–36.
- Ferrara, F., & Sinclair, N. (2016). An early algebra approach to pattern generalisation: Actualising the virtual through words, gestures and toilet paper. *Educational Studies in Mathematics*, 92, 1–19.
- Filloy, E., & Rojano, T. (1989). Solving equations, the transition from arithmetic to algebra. *For the Learning of Mathematics*, 9(2), 19–25.

- Fujii, T., & Stephens, M. (2001). Fostering an understanding of algebraic generalisation through numerical expressions: the role of quasi-variables. In H. Chick, K. Stacey, J. Vincent, & J. Vincent (Eds.), *The Future of the Teaching and Learning of Algebra. Proceedings of the 12th Study conference of the International Commission on Mathematical Instruction* (Vol. 1, pp. 258–264). Melbourne, Australia: The University of Melbourne.
- Herscovics, N., & Linchevski, L. (1994). A cognitive gap between arithmetic and algebra. *Educational Studies in Mathematics*, 27, pp. 59–78.
- Hewitt, D. (1992). Train spotters' paradise. *Mathematics Teaching*, 140, pp. 6–8.
- Hoch, M., & Dreyfus, T. (2004). Structure sense in high school algebra: the effect of brackets. In M. J. Høines & A. B. Fuglestad (Eds.), *Proceedings of the 28th Conference of the International Group for the Psychology of Mathematics Education*. (Vol. 3, pp. 49–56). Bergen, Norway: Bergen University College & PME.
- Kaput, J. J. (1995). A research base supporting long term algebra reform? In D. T. Owens, M. K. Reed, & G. M. Millsaps (Eds.), *Proceedings of the 17th Annual Meeting of PME-NA*. (Vol. 1, pp. 71–94). Columbus, OH: ERIC Clearinghouse for Science, Mathematics, and Environmental Education.
- Kieran, C. (2004). Algebraic thinking in the early grades: what is it? *The Mathematics Educator*, 8(1), 139–151.
- Linchevski, L., & Livneh, D. (1999). Structure sense: The relationship between algebraic and numerical contexts. *Educational Studies in Mathematics*, 40, 173–196.
- Mason, J. (1987). What do symbols represent? In C. Janvier (Ed.), *Problems of representation in the teaching and learning of mathematics* (pp. 73–82). Hillsdale, NJ: Lawrence Erlbaum Associates.
- Montenegro, P., Costa, C., & Lopes, B. (2018). Transformations in the visual representation of a figural pattern. *Mathematical Thinking and Learning*, 20(2), 91–107.
- Mulligan, J., & Mitchelmore, M. (2009). Awareness of pattern and structure in early mathematical development. *Mathematics Education Research Journal*, 21(2), 33–49.
- Palatnik, A., & Koichu, B. (2017). Four-component decomposition of sense making in algebra. In T. Dooley & G. Gueudet (Eds.), *Proceedings of the Tenth Congress of the European Society for Research in Mathematics Education* (pp. 448–455). Dublin, Ireland: DCU Institute of Education and ERME.
- Radford, L. (2000). Signs and meanings in students' emergent algebraic thinking: a semiotic analysis. *Educational Studies in Mathematics*, 42, 237–268.
- Radford, L. (2010a). Algebraic thinking from a cultural semiotic perspective. *Research in Mathematics Education*, 12, pp. 1–19.
- Radford, L. (2010b). Elementary forms of algebraic thinking in young students. In M. F. Pinto & T. Kawasaki (Eds.), *Proceedings of the 34th Conference of the International Group for the Psychology of Mathematics Education* (Vol. 4, pp. 73–80). Belo Horizonte, Brazil: PME.
- Strømskag, H. (2015). A pattern-based approach to elementary algebra. In K. Krainer & N. Vondrová (Eds.), *Proceedings of the Ninth Congress of the European Society for Research in Mathematics Education* (pp. 474–480). Prague, Czech Republic: ERME.
- Usiskin, Z. (1988). Conceptions of school algebra and uses of variables. In A. F. Coxford & A. P. Shulte (Eds.), *The ideas of algebra, K-12* (pp. 8–19). Reston, VA: NCTM.

Algebraic thinking in the shadow of programming

Cecilia Kilhamn and Kajsa Bråting

Uppsala University, Sweden; cecilia.kilhamn@edu.uu.se; kajsa.brating@edu.uu.se

This paper calls attention to how the recent introduction of programming in schools interacts with the teaching and learning of algebra. The intersection between definitions of computational thinking and algebraic thinking is examined, and an example of a program activity suggested for school mathematics is discussed in detail. We argue that students who are taught computer programming with the aim of developing computational thinking will approach algebra with preconceptions about algebraic concepts and symbols that could both afford and constrain the learning of algebra.

Keywords: Algebra, algebraic thinking, programming, computational thinking.

Introduction and background

In the wake of introducing programming into school mathematics curricula (Mannila et al., 2014) we have identified the intersection of algebraic thinking and computational thinking as an important area to explore (Figure 1). Specifically, this intersection has come to the fore in Sweden, where programming has been inserted into the national mathematics curriculum as part of the core content of algebra. Computational thinking (CT) is a fairly new concept in educational research, first introduced by Papert in 1996. The term involves the kind of thinking skills needed to understand and capitalize on computers. Since Wing launched CT as a didactical term in 2006, researchers in computational science as well as mathematics education have attempted to define it. For example, Hoyles and Noss (2015) describe CT as incorporating four central thinking skills: decomposition, pattern recognition, abstraction and algorithmic thinking. Programming, on the other hand, can be seen as a problem-solving activity that can be used to address the different aspects of CT (Mannila et al., 2014). Although CT is generally considered to encompass more than programming, teaching programming requires the use of CT (Hickmott, 2017). Moreover, programming is a feature of CT that does not necessarily involve writing code in any particular computer language (Bocconi, Chioccarello & Earp, 2018). Programming is thus a more inclusive term than coding, and seen as an activity in which students develop computational thinking. In this paper, we limit the discussion to aspects of CT that can be developed through programming. The aim of this paper is to raise the question of how programming in schools, with the goal of developing CT skills, may potentially interact with, afford or constrain students' development of algebraic thinking.

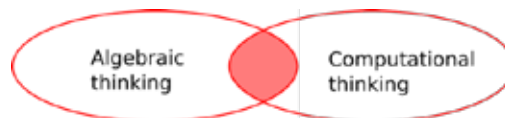


Figure 1: The intersection of CT and AT

A contemporary international movement in school development is to implement programming in the curriculum. This has been done in various ways (Mannila et al., 2014). For instance, in England, “Computing” was introduced as a new subject in the curriculum, while Finland and Sweden adopted a blend of cross-curriculum and single subject integration with the strongest link to mathematics (Bocconi et al., 2018). Unlike other countries, Sweden included programming in the mathematics

curriculum in close connection to algebra through all grade levels. The curriculum change was released in August 2017 and was taken in effect throughout the country by August 2018. There is extensive literature from the last three decades tackling issues of teaching and learning programming at university level (Grover & Pea, 2013), but except for the early work on LOGO programming there are few studies of teaching programming in the early school years (Blikstein, 2018; Hickmott, Prieto-Rodriguez & Holmes, 2018). Furthermore, most educational research about programming concerns the learning of programming per se, rather than learning mathematical ideas through programming. One exception is the ScratchMaths research program, which in light of the recent curriculum changes in England, set out to explore the relationship between computational thinking and mathematical thinking in general, identifying mathematical ideas such as place value, proportional relationships, coordinate systems, symmetry and negative numbers in ScratchMath activities (Benton, Hoyles, Kalas, & Noss, 2017). We wish to broaden the discussion about “learning to program” or “programming to learn” by raising questions about how learning (and knowing) programming influences the learning of algebraic thinking. Until now, research on computational thinking and algebraic thinking has run on separate tracks, but the Swedish case offers a great opportunity to investigate the intersection of these two research domains in the wake of programming activities.

Programming activities in Swedish schools

The description of programming in the Swedish revised curricula and on-line material provided by the government,¹ focuses in grades 1-3 on the use of symbols to construct and follow stepwise instructions either without computers (unplugged) or with simple robots such as Bee Bots or screen equivalents such as Lightbot.² In grades 4-6 algorithms are created in visual programming environments such as Scratch.³ and in grades 7–9 other programming languages are introduced. In the visual environments, an algorithm is often described as a “recipe” or a “function”, and if variables are introduced, they are mostly non-numerical. While a function is described as a correspondence between two sets in abstract algebra, a function in school algebra is commonly interpreted as a co-variation of numerical values possible to represent in a graph (Usiskin, 1988). If students in the early grades meet functions as a correspondence between non-numerical input and output variables in programming activities, they will have experiences that may challenge the school algebra conception of function where one quantity is said to vary depending on another quantity, represented in a cartesian graph. Due to the limited space of this paper, we leave to the side further investigations of early programming activities in relation to algebra and focus our discussion on programming in text-based environments commonly included in later grades.

Algebraic thinking and programming

As algebraic thinking (AT) slowly made its way to the early school years during the last decades, the definition of what algebra is and what comprises algebraic teaching has become wider and more inclusive (Kieran, 2018). A broad definition of AT based on work with young children is suggested by Radford (2018) who describes AT as analytically dealing with indeterminate quantities using

¹ <https://larportalen.skolverket.se/#/moduler/1-matematik/Grundskola/Lärare%20i%20matematik>

² <https://www.bee-bot.us>; <http://lightbot.com>

³ <http://scratched.gse.harvard.edu>

culturally and historically evolved modes of symbolizing. Although this definition excludes operating on specific numbers, it includes generalized arithmetic such as analyzing properties of addition and multiplication or analyzing the structure of an algorithm (for example using the distributive property to work out the partial products in a multiplication algorithm). We set out to investigate if this definition of algebraic thinking excludes or includes aspects of computational thinking that are at the heart of programming. We note that in a contemporary state-of-the-art publication written by members of an ICME topic study group on the teaching and learning of early algebra at ICME 13 (Kieran, 2018) there is no discussion at all about the connections between the learning of algebra and computer programming. The word “programming” is never mentioned and “computer” appears only in one paragraph (out of 17 chapters), where Mason claims that computer languages have emerged from algebra, and that these “expressive and manipulable languages [...] invoke algebraic thinking and algebraic awareness” (Mason, 2018, p. 335). Kaput (2008) describes early algebra in terms of three content strands including: i) the study of structures; ii) the study of functions; and iii) the application of a cluster of modelling languages both inside and outside of mathematics. In addition, symbolizing is described as core aspects of algebra (ibid). We find that all three content strands could also be aspects of computer programming. As an example, constructing code to generate all odd numbers presupposes reflection on what an odd number is and how it could be described and represented. Such an exercise is a study of structure, modelled in a specific programming language. Although the study of structure in algebra (e.g. generalized arithmetic) is emphasized in more recent work (e.g. Kieran, 2018), such structures have not been related to structures that becomes visible when breaking down complex calculations into small steps in a computer program. Although structure seems to be fundamental in both domains, little has been said in previous research literature about the study of structures embedded in computer algorithms in relation to the study of structure described as an aspect of algebraic thinking.

Investigating the intersection between computational and algebraic thinking.

For the purpose of comparison, we have tried to illustrate similarities between two definitions of CT and two definitions of AT by aligning them in Table 1. The definitions are chosen as examples of contemporary definitions in the respective areas, proposed by researchers often cited in the literature. We see that both CT and AT deal with structure, generalization and symbolization in various ways, describing culturally developed organized symbol system where structures can be studied and generalizations made. Questions that arise are if structure, symbolization and generalization represent the same thing in the two domains, and if the syntax and semantics of programming languages are aligned with or divert from corresponding algebraic symbolism. Surprisingly, the definitions of CT do not explicitly mention functions or variables, which are fundamental concepts for AT (see Table 1). In programming activities, these concepts appear up front, where an algorithm in a program is often described as a function, and variables are omnipresent. Perhaps they are simply taken for granted in CT. Algorithmic thinking is not mentioned as part of AT, although it involves features that are fundamental in algebra, such as the ability to analyze a problem, specify it precisely, and find adequate basic actions (Futschek, 2006). Further, Futschek mentions the ability to construct a correct algorithm using the basic actions, to think about possible special and normal cases, and to improve the efficiency of an algorithm. We see such abilities as prominent when algebra is used as a problem-

solving tool where the basic actions are for example rules of equation solving or symbolic manipulation. Finally, according to Futschek, “algorithmic thinking has a strong creative aspect”, which undoubtedly should be true for algebraic thinking as well. Can we assume that students who develop their algorithmic thinking skills through programming also develop their algebraic thinking skills? Could algebra teaching explicitly relate to and build on algorithmic thinking? Note that algorithmic thinking in CT concerns the how and why of algorithms, as opposed to what Hiebert (2003) calls algorithmic reasoning, which is to recall a solution algorithm based on “rote thinking”.

Table 1: Some features of contemporary definitions of CT and AT that are found in the intersection

Features in the intersection	Computational thinking (CT)		Algebraic thinking (AT)	
	Grover & Pea 2013	Hoyles & Noss 2015	Radford 2018	Kaput 2008
Structure	Structured problem decomposition (modularizing)	Decomposition. Pattern recognition.	Deals with indeterminate quantities in an analytical manner	The study of structures
Symbolization	Symbol systems and representations		Using idiosyncratic or specific culturally and historically evolved modes of symbolizing	Acting on symbols within an organized symbol system through an established syntax
Generalization and abstraction	Abstractions and pattern generalizations. Conditional logic.	Entailing abstraction	Deals with indeterminate quantities in an analytical manner	Systematically symbolizing generalizations
Functions and variables	*	*		The study of functions, relations and joint variation
Algorithms	Algorithmic notions of flow of control	Algorithmic thinking	**	**

* there is no mention of functions or variables in these definitions of CT

** there is no mention of algorithms in these definitions of AT

Next, we give an example of a programming activity in order to highlight some points of intersection with AT, in particular the issue of symbolization, taken from government-provided teaching materials available on line in connection to the revised curriculum in Sweden (Rolandsson, 2018).

An example of differences in syntax and semantics in algebra and programming

In this activity, the students are going to write a short computer program inspired by the algorithm of “Sieve of Erasthones”, i.e., an algorithm for finding prime numbers. Examples are given in two programming languages: Python and Javascript. The latter is given in Figure 2 below. By using this algorithm, one can find out if a given integer is a prime number or not. We have highlighted six places in the code that illustrate some crucial passages regarding syntax and semantics. These places are circled and marked from 1-6 in Figure 2 and will be discussed next.

Let us begin to consider the equal sign. At the places 1, 2, 3 and 5 in Figure 2 the equal signs all represent *assignments* of different values to variables. For instance, at place 2 the program declares the variable *a* and assigns it the value 2, i.e., gives the variable the value 2. This usage of the equal sign differs from how it is normally used in algebra, where the equal sign is a symbol for an equivalence *relation*, and different from arithmetic, where pupils tend to interpret the equal sign as an *operator* symbol ($5 + 3$ equals 8) rather than a relation (Kieran, 1981).

In algebra, it would be meaningless to write $a = a + 1$, since it is not true for any value of a . However, in programming the expression $a = a + 1$ makes sense since the equal sign is understood as the assignment “add 1 to the value a ” (see place 3 in Figure 2). This is often used when a program needs to loop through a range of consecutive integers, as in Figure 2 when the program loops from 2 to the input value stored in the variable “number”.

Let us now consider place 4 in Figure 2, where we have two consecutive equal signs ($==$). This is the only place in this code where the equal sign is not used as an assignment. Instead, $==$ is used as a relational operator that tests if two entities are equal. In our example the program tests if the result of the modulo operation “number % a” is equal to 0, i.e. if the remainder is equal to 0 after dividing the input value “number” with the loop variable a . Here, the double equal sign is used in a similar way as the relational equal sign in algebra.

Many instructions in programming, such as `for` and `if`, have built-in checks for truthfulness that closely corresponds to the algebraic equality without including an equal sign in the syntax. An example of this can be seen at place 6 in Figure 2 where the instruction `if(check)` should be understood as ‘if the variable *check* is equal to “true”, then...’. Perhaps one might argue that in programming the relational equality sometimes is applied although it is invisible in the code, similar to the convention in algebra where we write $4 \cdot a$ as $4a$ (Hewitt, 2012).

```

var check = true;
var number = prompt("Your number:");
for (let a = 2; a < number; a = a + 1) {
  if (number % a == 0) {
    console.log(number + ", is NOT a prime number");
    check = false;
    break;
  }
}
if (check) {
  console.log(number + " is a prime number!");
}

```

Figure 2: An algorithm for deciding if a given integer is a prime number

Let us now demonstrate some differences regarding the meaning of the variable concept in programming and algebra. First, in programming variables can be used to *hold non-numbers* such as in places 1 and 5 where the variable *check* holds the Boolean value “true” and then “false”. Second, in programming a variable can *change value* during the execution of the program. This is illustrated at the places 1, 3 and 5 in Figure 2. As already mentioned, at place 3 the variable a increases with 1 for every execution ($a = a + 1$). This means that if, for instance, a is equal to 3, the computer calculates the value $3+1$ and then a is assigned the new value 4, i.e. a *changes value* from 3 to 4. As we are about to see this differs from the algebraic context. In algebra, the concept of a variable is broad and has been further categorized as *unknown*, *variable* (in a more nuanced meaning) and *placeholder* (Ely & Adams, 2012). The term unknown corresponds to a determinate quantity in an equation that remains to be solved. Clearly, an unknown cannot change its value as it is predetermined

from the equation. The term variable is meant to correspond to a varying quantity, typically x and y in the equation $y = x^2 + 1$. It can be perceived that the variables in this equation can change value, but the change is related to different cases of the problem. E.g. “Case 1: we assume x is 1, then y will be 2”, and then “Case 2: we assume x is 2, then y will be 5”. Within each of these cases we allow the variable x to have a determinate value which will make y into an unknown (that can be easily resolved). Observe that we cannot assign x the value 1 and later derive another value for x within the same case, that would constitute a contradiction ($x = 1$ and $x = 2$ imply $1 = 2$) and force us to eliminate this case. The same argument can be applied for the term placeholder. This is different from programming where instructions are executed in order, one after the other. When an instruction assigns a new value to a variable x it does not constitute a new case, instead we are just changing the value recorded in a specific place in the memory of the machine (referred to by the variable).

Discussion

We have shown above how programming activities can interact with students’ development of algebraic thinking in different ways. One of these concerns symbolization. In algebraic thinking, the use of culturally and historically evolved modes of symbolizing (Radford, 2018) is described as a prominent feature. Notice the plural, indicating that algebraic thinking is not exclusively bound to alphanumerical symbols and conventional algebraic syntax, and could thus hypothetically incorporate also programming languages. While many programming languages use similar, but not equivalent, symbol systems, there is no common syntax. For example, in some languages the short hand notation $a++$ (the increment operator) is used instead of $a = a + 1$. Nevertheless, the differences between the established algebraic symbol system and new programming languages could potentially entail difficulties for students learning algebra.

In order to clarify some of these differences we have, from the example in Figure 2, compiled three categories regarding the meaning of some operations (the semantics) and the symbolic representations of these operations (the syntax) that appear in algebra and programming: 1) Different symbols represent the same meaning: e.g., the *modulus operation*, represented by *mod* in algebra and % in programming; 2) The same symbol represents different meanings: e.g., the equal sign (=) representing *relational equality* in algebra and *assignment* in programming; 3) Symbols with no corresponding meaning in the two domains: e.g., *approximately equals* (\approx) in algebra and *increment with one* (++) in programming. These differences could afford the development of algebraic thinking through contrasting examples and awareness of accuracy, or constrain it if the teacher is unaware of the different experiences students have. In particular, the equal sign in algebra is already a cause for much didactical effort in helping students switch from an operational to a relational meaning (Kieran, 1981, 2018). When programming introduces yet another meaning, this could cause more confusion. In contrast, the use of different symbols to represent the same meaning could help students understand that the meaning of a mathematical concept does not depend on the symbol used to represent it.

The meaning of variable is another issue found in the intersection of CT and AT. The use of non-numerical variables (such as true/false) in programming affords a wider understanding of the concept of variable than the traditional use of variables as quantities, and does not correspond to the school algebra idea that letters always represent numbers.

The focus on algorithms and operational execution of instructions in programming may interact with the focus on structure in algebra. As shown in Table 1, both CT and AT value the study of structure, decomposition and pattern recognition. Approaching questions about structure from two perspectives could serve as an affordance for developing AT if differences in structure are noticed, contrasted and discussed. Algorithms are important in programming but absent in descriptions of AT. In school mathematics, the idea and use of algorithms have changed greatly since the introduction of digital tools in the 1980's when traditional algorithms were replaced by an increased emphasis on number sense and conceptual understanding. The fact that the term algorithm was removed from the description of arithmetic in the Swedish national curriculum in 2011 and re-inserted in 2017 as an aspect of the core content of algebra in connection to programming, implies a shift of emphasis from a procedural use of algorithms, to a conceptual understanding in terms of “algorithmic thinking” (Futschek, 2006). An open question for further empirical research is, if this newly awoken interest in algorithms will induce a study of the structures embedded in algorithms, and as such afford the development of algebraic thinking in terms of increased focus on structure and generalizations, or if it will tip over towards a more procedural approach to mathematics as a whole, thus working as a constraint to AT.

We argue that future algebra students who are taught programming in school, will encounter working with variables, structure and patterns, and engage in simplifying, generalizing and symbolizing in computer related contexts. We therefore urge for an awareness of what these experiences might do to how algebra is conceptualized and talked about in school, and what preconceptions teachers need to be aware of. We trust that empirical research into the intersection of AT and CT, as programming evolves in school practices, will highlight possible pitfalls and supply algebra teaching with new input.

References

- Benton, L., Hoyles, C., Kalas, I., & Noss, R. (2017). Bridging primary programming and mathematics: Some findings of design research in England. *Digital Experiences in Mathematics Education* 3(2), 115–138. DOI 10.1007/s40751-017-0028-x
- Blikstein, P. (2018). *Pre-college computer science education: A survey of the field*. Mountain View, CA: Google LLC. Retrieved Feb 2018 from <https://goo.gl/gmS1Vm>
- Bocconi, S., Chiocciariello, A., & Earp, J. (2018). *The Nordic approach to introducing computational thinking and programming in compulsory education*. Report prepared for the Nordic@BETT2018 Steering Group. DOI: 10.17471/54007
- Ely, R., & Adams, A.E. (2012). Unknown, placeholder, or variable: What is x? *Mathematics Education Research Journal*, 24, 19–38.
- Futschek G. (2006). Algorithmic thinking: The key for understanding computer science. In R. T. Mittermeir (Ed.), *Informatics education – The bridge between using and understanding computers. ISSEP 2006*. Vol. 4226. Berlin, Germany: Springer.
- Grover, S., & Pea, R. (2013). Computational thinking in K–12: A review of the state of the field. *Educational Researcher*, 42(1), 38–43 DOI: 10.3102/0013189X12463051

- Hickmott, D., Prieto-Rodriguez, E., & Holmes, K. (2018). A scoping review of studies on computational thinking in K–12 mathematics classrooms. *Digital Experiences in Mathematics Education*, 4(1), 48–69. <https://doi.org/10.1007/s40751-017-0038-8>
- Hiebert, J. (2003). What research says about the NCTM Standards. In J. Kilpatrick, G. Martin, & D. Schifter (Eds.), *A research companion to principles and standards for school mathematics* (pp. 5–26). Reston, VA: National Council of Teachers of Mathematics.
- Hewitt, D. (2012). Young students learning formal algebraic notation and solving linear equations: Are commonly experienced difficulties avoidable? *Educational Studies in Mathematics*, 81, 139–159.
- Hoyles, C., & Noss, R. (2015). Revisiting programming to enhance mathematics learning. Paper presented at the Math + Coding Symposium, Western University, Canada.
- Kaput, J. (2008). What is algebra? What is algebraic reasoning? In J. Kaput, D. Carraher & M. Blanton (Eds.), *Algebra in the early grades* (pp. 5–18). New York: Lawrence Erlbaum.
- Kieran, C. (1981). Concepts associated with the equality symbol. *Educational Studies in Mathematics*, 12, 317–326.
- Kieran, C. (Ed.) (2018). *Teaching and learning algebraic thinking with 5- to 12-year-olds*. Cham, Switzerland: Springer.
- Mannila, L., Dagiene, V., Demo, B., Grgurina, N., Mirolo, C., Rolandsson, L., & Settle, A. (2014). Computational thinking in K-9 education. In A. Clear & R. Lister (Eds.), *Proceedings of the Working Group Reports of the 2014 on Innovation & Technology in Computer Science Education Conference* (pp. 1–29). New York: ACM.
- Mason, J. (2018). How early is too early for thinking algebraically? In C. Kieran (Ed.), *Teaching and learning algebraic thinking with 5-to 12-year-olds* (pp. 3–25). Cham, Switzerland: Springer.
- Papert, S. (1996). An exploration in the space of mathematics educations. *International Journal of Computers for Mathematical Learning*, 1(1), 95–123.
- Radford, L. (2018). The emergence of symbolic algebraic thinking in primary school. In C. Kieran (Ed.), *Teaching and learning algebraic thinking with 5- to 12-year-olds* (pp. 3–25). Cham, Switzerland: Springer.
- Rolandsson, L. (2018). Aktiviteter, del 4. I *Matematikundervisning med digitala verktyg II, åk 7–9*. [Mathematics education with digital tools II, Grades 7–9] Stockholm, Sweden: Skolverket. Retrieved June 2018 from <https://larportalen.skolverket.se>
- Usiskin, Z. (1988). Conceptions of school algebra and uses of variables. In A. Coxford & A. Shulte (Eds.), *The ideas of algebra, K-12. 1988 Yearbook* (pp. 8–19). Reston: National Council of Teachers of Mathematics.
- Wing, J. (2006). Computational thinking. *Communications of the ACM*, 49(3), 33–36.

Linear figural patterns as a teaching tool for preservice elementary teachers – the role of symbolic expressions

Iveta Kohanová¹ and Trygve Solstad²

¹NTNU, Department of Teacher Education, Trondheim, Norway; iveta.kohanova@ntnu.no

²NTNU, Department of Teacher Education, Trondheim, Norway; trygve.solstad@ntnu.no

Figural patterns connect several aspects of mathematical activity central to the work of teaching mathematics. In this pilot study, we investigated the solutions of 16 preservice elementary teachers to linear figural patterns of different levels of complexity after the completion of a series of six teaching sessions of a course in mathematics education. We found that a) most students were able to generalize and find the figural number of an arbitrary figure in the sequence; b) about half of the students produced mathematically imprecise formulas when translating from an arbitrary number into a general algebraic expression; c) the formulas students produced frequently lacked structural correspondence with the figural patterns and d) students had difficulties in interpreting figural patterns that are more complex. These results indicate that although the course successfully trains students to generalize with linear figural patterns, more attention to precisely formulating mathematical ideas and to interpretation of more difficult patterns can further improve the training of preservice elementary teachers.

Keywords: generalization, prospective elementary teachers, algebraic thinking, figural patterns.

Introduction

Research on students' algebraic thinking has drawn considerable interest over the past decades. For Blanton and Kaput (2011), experiences in building, expressing and justifying mathematical generalizations constitute the heart of algebra and algebraic thinking. Mason, Burton & Stacey (2010) highlight the importance of the generalization process in mathematics when stating that “generalizations are the life-blood of mathematics. Whereas specific results may in themselves be useful, the characteristically mathematical result is the general one” (p.8). The placement of algebraic content within the mathematics curriculum has received considerable attention. For example, documents from the National Council of Teachers of Mathematics (2000) in the United States, the Department for Education (2014) in England and The Norwegian Directorate for Education and Training (2013) recommend the development of algebraic ideas at elementary and middle school levels through activities such as generalizing number and figural patterns. Several authors have researched algebraic generalizations, but in most cases the target group were pupils in primary or middle school (e.g. Carpenter, Franke & Franke, 2003; Becker & Rivera, 2005; Rivera & Becker, 2009; Rivera, 2010). There is less research on generalization of pre-service elementary teachers (PSETs). A study by Yeúilderea & Akkoç (2010) indicated that PSETs, when trying to find the general term of number patterns, described number pattern rules in relation to differences between terms and used visual models without a purpose. The study of Rivera & Becker (2003) suggests that PSETs who used figural reasoning acquired a better understanding of the generalizations they constructed than PSETs who reasoned numerically, even if relationships among numerical values had

greater contribution to similarity between the compared entities than the figural patterns. Måsøval (2011) studied the factors that constrain PSETs' establishment and justification of formulae and mathematical statements that represent generality in different quadratic shape patterns. Her findings indicate three such constraints: The first constraint is related to a limited feedback potential in situations where the students are supposed to solve the mathematical tasks without teacher intervention. The second constraint is related to obstacles the students face when they transform informal mathematical statements expressed in natural language into formal algebraic notation. The third constraint is related to challenges with justification of formulae and mathematical statements that the students have proposed. Hallagan, Rule & Carlson (2009) found that after a problem solving-based teaching intervention, PSETs improved in their ability to generalize, however, they encountered more difficulty with determining the algebraic generalization for items arranged in squares with additional single items as exemplified by x^2+1 , than with multiple sets of items, as exemplified by $4x$. Callejo & Zapatera (2016) characterised profiles of the teaching competence "noticing students' mathematical thinking" in the context of pattern generalization. PSETs named various mathematical elements to describe the students' answers but did not always use them to interpret the understanding of pattern generalization of each student. Their findings allow one to generate descriptors of the development of this teaching competence and provide information for the design of interventions in teacher education addressed to support the recognition of evidence of students' mathematical understanding.

To meet the goals of teaching in the elementary school curriculum, we need to understand more about how to better prepare PSETs for this undertaking. As part of a formative evaluation of the mathematics education course design, we set out to identify aspects within the course module about generalization that require increased attention and emphasis. Specifically, we asked: Which are the most common challenges that PSETs still face when solving problems with generalizations of linear figural patterns after completing our six-session course module about algebraic generalization?

Theoretical framework

According to Radford (1996), the goal of generalizing spatial or numerical patterns is to find an expression representing the conclusion derived from the observed facts (concrete numbers). Radford claims that the obtained expression is in fact a formula, which is constructed on the basis, not of the concrete numbers in the sequence, but on the idea of a general number. Radford asserts that "general number" appears as precepts to the concept of variable. Hence, he claims that the notion of letter as variable is consistent with a generalizing approach to algebra, aiming at establishment of relations between numbers. The point is constructing formulae where the symbols represent generalized numbers (Radford, 1996). He highlights that one of the most significant characteristics of generalization is its logical nature, which makes the conclusion possible. This means that the process of generalization is closely connected to that of justification and proof. The underlying logic of generalization can be of various types, depending on the student's mathematical thinking. Radford (2008) distinguish between arithmetic and algebraic generalization of the pattern. While in both domains some generalizations do certainly occur, in algebra, a generalization will lead to results that cannot be reached within the arithmetic domain. Algebraic pattern generalization involves the

students in (1) grasping a commonality, (2) generalizing this commonality to all the terms of the sequence, and (3) providing a rule that allows them to directly determine any term of the sequence (Figure 1; Radford, 2008).

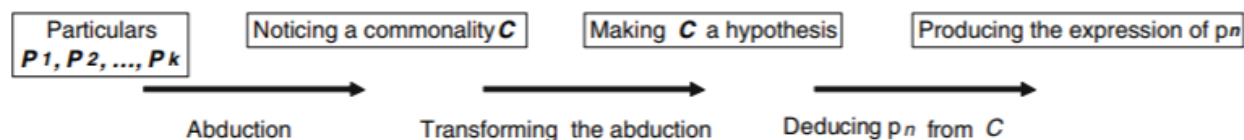


Figure 1: Radford's (2008) architecture of algebraic pattern generalizations

Rivera and Becker (2009) extended Radford's definition by including the necessity of justification at the middle school level. "Students have to provide some kind of explanation that their algebraic generalization is valid by a visual demonstration that provides insights into why they think their generalization is true." (p.213-214) Rivera (2010) claims that meaningful pattern generalization involves the coordination of two interdependent actions, as follows: (1) abductive-inductive action on objects, which involves employing different ways of counting and structuring discrete objects or parts in a pattern in an algebraically useful manner; and (2) symbolic action, which involves translating (1) in the form of an algebraic generalization.

Methodological approach

After a six-session module on algebraic generalization as part of a course in mathematics education, 16 PSETs completed a digital survey with six tasks about generalization of figural patterns. Before data collection, the background of the study and research questions were presented to the PSETs. Participation was voluntary and anonymous. Answers were in the form of multimodal digital texts including text and freehand drawings. Subsequent to data collection, PSETs' responses were downloaded from the server and sorted according to task. A content analysis was performed independently by both authors in order to identify categories of common challenges in the PSETs' algebraic pattern generalization process.

Course content

The Mathematics 2 course is an optional course which integrates mathematics and didactics. The content of the course previous to data collection was: Rich mathematics conversations, Argumentation and proof, Representations, Algebraic thinking, Generalization, Figural numbers, Equality, Relational thinking, Models for negative numbers, Realistic Mathematics Education, Fractions – multiplication and division, Decimal numbers, Percent, Difficulties in Mathematics.

A module with six sessions of 180 minutes was devoted to these topics: algebraic thinking, generalization, figural numbers, equality and relational thinking. These six sessions were taught in English and gave the PSETs the opportunity to discuss several tasks about generalization (not only with figural patterns), their different solutions, and challenges for pupils. PSETs also discussed several research papers on generalization, equality and relational thinking (e.g. Carpenter, Franke & Franke, 2003; Kaput & Blanton, 2005; Becker & Rivera, 2006; Mason, 1996) under the guidance of the course instructor.

Prior to the Mathematics 2 course, in 2016, the PSETs had completed a two-semester compulsory Mathematics 1 course whose main content was: Numbers and the number line; Counting; The position system; Addition and subtraction; Multiplication and division; Fractions – models, comparison, estimation, addition, subtraction; Probability and statistics in primary school.

Survey

The survey consisted of six tasks; for the purpose of this paper we focus only on three of them (Figures 2, 3, 4).

1. Monika began designing the pattern with short sticks. Each day she continues the pattern.
 - a) Describe how she would proceed to make her design on 5th day.
 - b) How many sticks will she need to make her design on 8th day?
 - c) How do you calculate how many sticks she will need to make her design on day number 100? Write down the corresponding formula.
 - d) Write down the general formula for total number of sticks she will need to make her design on day number n . Explain how you got the formula and how do you know that it is correct.



Figure 2: Task 1

2. Having the sequence of figures composed of blue and red squares,
 - a) how many blue squares there would be in Figure 4? Explain how you got the result.
 - b) consider Figure 7. How many more blue squares than red squares will there be in Figure 7? Explain how you got the result.
 - c) consider Figure number n . What is the relationship between number of blue and red squares in Figure n ? Explain how you got the result.

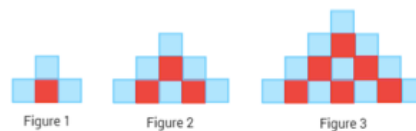


Figure 3: Task 2

4. Jan circled (and coloured) pieces of the figures to illustrate a particular decomposition of the pattern. Describe verbally the pattern in terms of given decomposition. Based on given decomposition, what is the corresponding general formula expressing number of all dots in Figure n ? Explain what all the numbers and variables in your formula stand for. (Hawthorne, 2016)

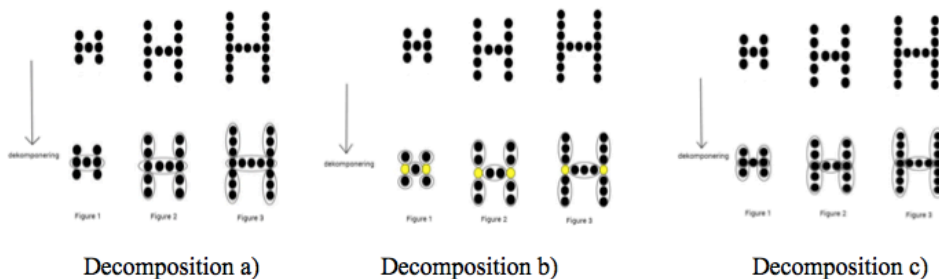


Figure 4: Task 4

Participants

PSETs were in their third year of a 4-year undergraduate teacher education program for Grades 1-7 at Department of Teacher Education, NTNU in Trondheim, Norway. The whole group consisted of 67 students, but only 20 were present in the last session. For technical reasons we only received answers from 16 students. In the third teaching session, PSETs were given a figural pattern task to

solve on their own. Most PSETs did not complete an answer to the first question about near generalization, and all of them gave up answering any of the following questions. All PSETs who answered the survey were present at almost all teaching sessions and the majority of them was participating quite actively during the course. Hence, the subjects in this study were likely among the most highly motivated students in the class.

Findings

Pattern generalization

The majority of students gave satisfactory answers to most of the figural pattern questions, requiring both finding the first few figural numbers (near generalization), as well as generalizing to figure number 50 or 100 (far generalization). This requires successful abductive-inductive action and shows that the PSETs in the study had learned to generalize the figural patterns. This is indeed an encouraging result considering that none of the PSETs could solve figural pattern tasks at the beginning of the course. At the same time, it is likely that the sixteen PSETs who participated in the survey were also among the highest attaining students in the class.

Imprecise symbolic action

For items involving the construction of formulas, typically around half of the subjects formed symbolic expressions containing mathematical imprecisions, indicating a potential for improvement in symbolic action.

Answers from task 1 illustrate this point well. While in task 1 (Figure 2) 75 % of PSETs provided valid generalizations to pattern number 100, only 50 % of PSETs wrote accurate algebraic formulas. Answers from the subjects who did not provide mathematically precise formulas fell into two categories: a) inaccurate use of variables, and b) improper use of the equal sign.

Although the problem text specified that the letter n denotes the figure number, 4 PSETs chose to use the letter x for their formula without defining what x denotes. As for subject 3:

S3: General formula: $N=3*x+1$; Because we always want to start with 3 since this is the "bush" [that makes up the base of the continuing pattern], then we have to multiply this "bush" with x since we do not know which day we want to find. Finally we must add 1 since all these shapes have only one "stem".

The notation $F(n)$ could be used to denote the figural number while the letter x was used instead of n to denote the figure number. Subject 11:

S11: $100* 3 + 1$ Corresponding formula: $fn= x*3 +1$

These inaccuracies indicate an inflexibility in the students' appropriation of variables, which might be rooted in an experience with solving equations where x stands for the unknown.

In some answers, PSETs gave the same variable name to the figural number and the figure number, as for subjects 5 and 10 below:

S5: General formula: $N = (Nx3)+1$; This expression is correct because figure number N will have N number of triangles. These triangles have to be multiplied by 3, since

each triangle consists of three sticks. Then one has to add 1, which corresponds to the stick at the bottom.

S10: General formula: $n = n \times 3 + 1$; Because in each triangle one needs 3 matches, so to make 4 triangles one needs 4×3 (12) matches, and to make 100 triangles one needs 100×3 (300) matches. Therefore $n \times 3$. In the end one needs to add the one match which stands, and then it finally becomes $+1$.

These responses indicate a lack of attention to equality and the meaning of the equal sign. It appeared not only in solutions of task 1, but also in task 4, as shown in the example below for subject 15 (task 4c, Figure 4).

S15 Here he divides into parts where he circles the same dot twice. $n = n + ((n + 1) \times 4) - 2$. Have to subtract 2 since this is counted twice.

Lack of structural correspondence with figural pattern

Finally, both for correct and incorrect answers, the structure of the formulas given by the PSETs often did not correspond to the figural pattern.

For instance, subjects 5 and 13 responded with the same formula for all three different decompositions of the figure in task 4 (Figure 4):

S13: $N = n+2+(n \times 4)$; $n+2$ is the body; $n \times 4$ is the arms

Decomposition c) in task 4 contained overlapping regions that were to be subtracted. Still, subject 7 provided the formula in reduced form, reinterpreting the figure from the second decomposition of the same figure:

S7: $n \times 5 + 2$; n is the figural number, 5 is the number that it increases by for each figure, $+ 2$ are the circles that are overlapping encircled, that are constant

While all students wrote some formula for decompositions in task 4a) and 4b), in task 4c) six students wrote “I don’t know”. We could see a similar phenomenon in task 2 (Figure 3). While all students gave adequate answers to tasks 2a) and 2b), five students answered task 2c with “I don’t know”. Slightly more difficult structures of figural patterns (overlapping regions or the two colors, which add a layer of complexity) seem to be challenging for PSETs.

Discussion and conclusion

In this paper we investigated sixteen preservice elementary teachers’ solutions to linear figural pattern generalization tasks. The analysis of these solutions showed that although PSETs typically recognized the underlying structure of linear figural patterns, their algebraic notation and syntax of algebra was often imprecise. This observation corresponds to the second constraining factor identified in Måsøval (2011), related to formalizing mathematical ideas expressed in natural language. Most of the formulas that PSETs provided were meaningful, i.e. the formulas conveyed the underlying structure in the figural patterns. However, several solutions were characterized by imprecise mathematical language. Variable names commonly were not defined or not used consistently, and indicated a lack of attention to equality and to what a variable represented. The fact that it wasn’t an interview, where PSETs were

not asked for further and detailed explanations of their answers, might support the assumption that this is how their notation and argumentation will look like in the classroom.

A meaningful pattern generalization must be accompanied by a symbolic action (Rivera, 2010). In the study of Hill et al. (2008), mathematical errors, including errors in language (conventional notation, technical language, general language for expressing mathematical ideas), proved the most strongly related to teacher knowledge. In further research we will investigate whether increased attention to equivalence, symbolic notation, dependent and independent variables, variable names and the accuracy of the mathematical language during teaching sessions on generalization might benefit the development of PSETs' teacher knowledge and better prepare PSETs for teaching generalization in real classrooms. The recent decision to incorporate programming into the Norwegian mathematics curriculum is also an invitation to investigate the role of programming in developing the concept of variables and symbolic action in pattern generalization.

References

- Becker, J. R. & Rivera, F. D. (2005). Generalization strategies of beginning high school algebra students. In Chick, H. L. & Vincent, J. L. (Eds.). *Proceedings of the 29th Conference of the International Group for the Psychology of Mathematics Education*, Vol. 4, 121–128. Melbourne: PME.
- Becker, J. R. & Rivera, F. (2006). Establishing and Justifying Algebraic Generalization at the Sixth Grade Level. In Novotná, J., Moraová, H., Krátká, M. & Stehlíková, N. (Eds.). *Proceedings 30th Conference of the International Group for the Psychology of Mathematics Education*, Vol. 4, 465–472. Prague: PME.
- Blanton, M.L. & Kaput, J.J. (2011). Functional Thinking as a Route Into Algebra in the Elementary Grades. In: Cai J., Knuth E. (eds) *Early Algebraization. Advances in Mathematics Education*. Berlin, Heidelberg: Springer.
- Callejo, M. L. & Zapatera, A. (2016). Prospective primary teachers' noticing of students' understanding of pattern generalization. *Journal of Mathematics Teacher Education*, 20 (4), 309–333.
- Carpenter, T. P., Franke, M. L. & Levi, L. (2003). *Thinking mathematically*. Portsmouth, NH: Heinemann.
- Department for Education (2014). *The National Curriculum in England: Key Stages 3 and 4 framework document*. Retrieved May 10, 2018, from <https://www.gov.uk/government/publications/>
- Hallagan, J. E., Rule, A. C. & Carlson, L. F. (2009). Elementary school pre-service teachers' understanding of algebraic generalizations. *The Mathematics Enthusiast*, 6(1). Retrieved May 10, 2018, from <https://scholarworks.umd.edu/tme/vol6/iss1/16>
- Hawthorne, C. W. (2016). *Teachers' Understanding of Algebraic Generalization*. Doctoral dissertations at UC San Diego. Retrieved May 10, 2018, from <https://escholarship.org/uc/item/64m687vf>

- Hill, H., Blunk, M. Charalambous, Ch. Y., Lewis, J. M., Phelps, G. C., Sleep, L. & Ball, D. L. (2008). Mathematical Knowledge for Teaching and the Mathematical Quality of Instruction: An Exploratory Study. *Cognition and Instruction*, 26(4), 430–511.
- Kaput, J., & Blanton, M. (2005). Algebrafying the elementary mathematics experience in a teachercentered, systemic way. In T. A. Romberg, T. P. Carpenter, & F. Dremock (Eds.), *Understanding Mathematics and Science Matters*. Mahwah, NJ: Lawrence Erlbaum Associates.
- Mason, J. (1996). Expressing Generality and Roots of Algebra. In N. Bednarz, C. Kieran, & L. Lee (Eds.), *Approaches to Algebra: Perspectives for Research and Teaching* (pp. 65-86), Dordrecht: Kluwer Academic Publishers.
- Mason, J., Burton, L. & Stacey, K. (2010). *Thinking Mathematically*, second edition, London: Pearson Education Ltd.
- Måsøval, H. S. (2011). *Factors constraining students' establishment of algebraic generality in shape patterns: A case study of didactical situations in mathematics at a university college*. Doctoral dissertations at University of Agder (38).
- National Council of Teachers of Mathematics (2000). *Principles and standards for school mathematics*. Reston, VA: Author.
- Radford, L. (1996). Some reflections on teaching algebra through generalization. In N. Bednarz, C. Kieran, & L. Lee (Eds.), *Approaches to algebra: Perspectives for research and teaching*, 107–111, Dordrecht, The Netherlands: Kluwer.
- Radford, L. (2008). Iconicity and construction: A semiotic investigation of forms of algebraic generalizations of patterns in different contexts. *ZDM*, 40, 83–96.
- Rivera, F. D. (2010). Visual templates in pattern generalization activity. *Educational Studies in Mathematics*, 73(3), 297–328.
- Rivera, F. & Becker, J. R. (2003). The Effects of Numerical and Figural Cues on the Induction Processes of Preservice Elementary Teachers. In Pateman, N., Dougherty, B. and Zilliox, J. (eds), *Proceedings of the 2003 joint meeting of PME and PMENA*, Honolulu, Hawai'i: University of Hawaii, 4, 63–70.
- Rivera, F., & Becker, J. R. (2009). Algebraic reasoning through patterns. *Mathematics Teaching in the Middle School*, 15(4), 212–221.
- The Norwegian Directorate for Education and Training (2013). *Curriculum for the common core subject of mathematics*. Retrieved May 10, 2018, from <http://data.udir.no/kl06/MAT1-04.pdf?lang=http://data.udir.no/kl06/eng>
- Yeüilderea, S. & Akkoç, H. (2010). Algebraic generalization strategies of number patterns used by pre-service elementary mathematics teachers. *Procedia Social and Behavioral Sciences* 2, 1142–1147.

Graphing formulas to give meaning to algebraic formulas

Peter Kop¹, Fred Janssen¹, Paul Drijvers² and Jan van Driel³

¹ICLON Leiden University Graduate School of Teaching, The Netherlands;
koppmgm@iclon.leidenuniv.nl

²Freudenthal Institute, Utrecht University, The Netherlands;

³Melbourne Graduate School of Education, The University of Melbourne, Australia.

Many students have difficulties giving meaning to algebra. In this study, we investigated how graphing formulas by hand can help grade 11 students to give meaning to algebraic formulas, defined as the ability to “read through” an algebraic formula: i.e., to recognize its structure and to link it to graphical features. During five 90-minute lessons, 21 students worked on graphing tasks focusing on recognition and heuristic search. To assess the effects of this intervention, a graphing task, and a card-sorting task were administered to the students. In addition, six students were asked to think aloud during the graphing task. The results of the card-sorting task showed that 14 students used categories similar to the ones experts use, but had trouble in consistently categorizing all formulas. The thinking-aloud protocols showed that the students improved their recognition of basic functions and graph features, and their qualitative reasoning, which allowed them to give meaning to algebraic formulas.

Keywords: Algebra, giving meaning to algebraic formulas, graphing formulas.

Introduction

Many secondary school students have problems with algebraic formulas, which are very abstract for them (Arcavi, Drijvers, & Stacey, 2017; Kieran, 2006; Thompson, 2013). Students, also those in upper secondary school, have difficulties giving meaning to algebraic formulas: they lack symbol sense. Symbol sense has to do with the ability to read through a formula, to recognize its structure and its characteristics (Arcavi, 1994) and would allow students to give meaning to algebraic formulas. It is insufficiently known how to teach these aspects of symbol sense (Arcavi et al., 2017; Hoch & Dreyfus, 2010). In regular education, teaching for giving meaning often starts with realistic contexts and manipulation of formulas. In the current study, we used graphs to give meaning to formulas and used basic functions as building blocks in reasoning with and about algebraic formulas.

Theory

Giving meaning to algebraic formulas

Acquiring meaning is synonymous with assimilating to a cognitive schema, which is a (hierarchical) network of concepts and procedures. Assimilation is the integration of new information into a schema, which results in an adjusted schema (Thompson, 2013). To give meaning to algebraic formulas, different sources are suggested in the literature: for instance, via the problem context, via the algebraic structure of the expression, via multiple representations, and via linguistic activity, gestures, body language, metaphors, etc. (Kieran, 2006). Ernest (1990) used a syntactical analysis to decompose algebraic expressions into meaningful sub-expressions (building blocks). Hoch and

Dreyfus (2010) used structure sense to describe the ability to recognize familiar structures by using compound terms as single entities. Janvier (1987) and many others have shown that functions can be investigated by linking different representations. We chose to link algebraic formulas to graphs, which seem to be more accessible for students than formulas (Leinhardt, Zaslavsky, & Stein, 1990), as they appeal more to the Gestalt aspect of a function and visualize the “story” that an algebraic formula tells. Therefore, graphs can be used to give more meaning to algebraic formulas (Eisenberg & Dreyfus, 1994; Kieran, 2006; Heid, Thomas, & Zbiek, 2013). To link formulas to graphs in order to give meaning to the formulas, graphing tools such as graphic calculators can be used (Heid et al., 2013). Using these tools, it seems easy to make a graph from a formula. However, research has shown that one must know what aspects of graphs to look for (Stylianou & Silver, 2004), and that students establish the connection between formula and graph more effectively when they do graphing by hand than when they only perform computer graphing (Goldenberg, 1988).

The aim of the current study was to improve students’ abilities to give meaning to algebraic formulas by teaching them to graph formulas by hand. We defined giving meaning to algebraic formulas as the ability to “read through” an algebraic formula: that is, to recognize its structure and to link it to graphical features.

Teaching graphing formulas for giving meaning

In expertise research, it has been established that for effective and efficient problem solving one needs recognition, and heuristics when recognition falls short (Chi, Feltovich, & Glaser, 1981). Based on this idea, a two-dimensional framework to describe strategies for graphing formulas was formulated (Kop, Janssen, Drijvers, Van Driel, & Veenman, 2015). In this framework, one dimension is about levels of recognition: from complete or function family recognition, to no recognition of the graph. The other dimension is about heuristic search, from strong heuristics, which provide information about large parts of the graph (e.g., qualitative reasoning about infinity behaviour and/or symmetry), to weak heuristics, which give only local information (e.g., calculating points). See Figure 1.

		<i>Heuristic search (strong \textcircled{R} weak)</i>				
<i>Levels of Recognition (low β high)</i>	A	A1. Graph is instantly recognized as a whole				
	B	B1. Recognition of family (with characteristics)	B2. Search for ‘parameters’ of the graph	B3. Investigate the family characteristics, for instance via zeroes		
	C	C1. Split formula in sub-formulas	C2. Compose the graphs by qualitative reasoning	C3. Compose the graphs by making a table		
	D	D1. Graph unknown; Characteristic aspect of graph is recognized.				
	E	E1. Graph unknown; strategic exploration of algebraic formula	E2. Qualitative reasoning about domain, or vertical asymptote, or symmetry, or infinity behaviour, ...	E3. Algebraic manipulation	E4. Strategic search, for zeroes or extreme values	E5. Calculate strategically chosen point(s)
	F	F1. No recognition at all	F2. Standard repertoire of research	F3. Make random table		

Figure 1: Two-dimensional framework for strategies to graph formulas

For recognition, a repertoire of basic function families and knowledge of attributes to describe graphs are needed (Eisenberg & Dreyfus, 1994; Slavit, 1997). Kop, Janssen, Drijvers, and Van

Driel (2017) found, using a card-sorting task, that experts' repertoires of basic function families resembled the basic function families taught in secondary school, like exponential, logarithmic, and polynomial functions. Experts seem to have linked prototypes of these function families to a set of critical graph attributes. For instance, a prototypical logarithmic graph has a vertical asymptote, only positive x -values as a domain, and is concave down. They use their repertoire of basic function families as building blocks in working with formulas, for instance, when decomposing complex functions into simpler basic functions and when reasoning about characteristic graph features from formulas (Kop et al., 2015, 2017).

Experts often start with a global perspective that enables high levels of recognition (Even, 1998). With the global perspective the whole function and/or graph is in view, whereas with a local perspective only a part is in view. The global perspective is more powerful and gives a better understanding of the relation between formulas and graphs, but the pointwise approach is needed to monitor naïve and/or immature interpretations (Even, 1998; Slavit, 1997).

The question in the current study was whether we could teach these experts' strategies to students. This led to the following research question: How can graphing formulas based on recognition and heuristic search help pre-university students to develop a knowledge base to give meaning to algebraic formulas?

Method

The teaching experiment was performed in a grade 11 mathematics B class, a regular class of 21 students who were 16- and 17-years old. Mathematics B is a course that prepares students in the Netherlands for university studies in mathematics, science, and engineering. The intervention took place during five lessons of 90 minutes. The students were obliged to work in pairs or groups of three which required them to exchange ideas. Each day, the lesson started with a short plenary discussion (max. 10 minutes) with general feedback on the students' work, reflection on the tasks, and modelling of expert thinking processes aloud. During the rest of the lesson, the students worked on tasks, related to the levels of recognition of the two-dimensional framework (Figure 1). These tasks were formulated as exploratory whole tasks with help, concluded with a reflection question. After the lesson, each pair and group handed in their work for feedback.

To assess the effects of the intervention, we collected students' responses to a written graphing task in a pre-test, post-test, and retention-test (four months after the intervention). Each graph in these graphing tasks was reviewed as correct (score=1) or incorrect (score=0), and a total score was calculated for each student.

Written tests give only limited information about the students' thinking processes. Therefore, six students were asked to think aloud during the graphing task in the pre-test and post-test. These protocols were transcribed and analyzed based on the two-dimensional framework (Figure 1): that is, on the use of recognition (function families, formula decomposed into sub-formulas, and/or graph features), qualitative reasoning, and calculation (points and/or derivatives).

In addition, a card-sorting task was assigned in the post-test to gather information about the students' knowledge base of function families. The students were asked to categorize 40 formulas

according to their rough graph, using as many categories as they wished. In addition, the students were asked to give a description and a prototypical formula for each of their categories. Card-sorting tasks are often used in eliciting structured knowledge (Chi et al., 1981). To analyze the card-sorting task, an expert categorization with 12 main categories, similar to the one found by Kop et al. (2017), was constructed and used as the criterion categorization. For each categorization, the student's categories were compared with those of the criterion categorization and it was established which formulas were not consistently categorized. Each corresponding category was graded with a score of two points and an extra point if a distinction between increasing and decreasing had been made. Then the number of correct formulas (consistent with the category) was graded. This method of analysis has been used by others (Ruiz-Primo & Shavelson, 1996); the total score should be an indication of the correctness of a student's categorization.

Results

For the card-sorting task, we found that 14 out of the 21 students used categories almost similar to those in the expert categorization, although different names were used for the categories, like "having a horizontal and vertical asymptote" (linear broken functions), or "only a vertical asymptote" (logarithmic function). Many students made mistakes in categorizing distractors like $y = 8\sqrt{x^3}$, $y = \sqrt{8 - x^2}$, $y = 100 - e^x$, $y = x + 4/x$, and often no distinction was made between increasing and decreasing log-functions.

To illustrate the results, we report about two students: K (a high-achieving student) and M (an above-average-achieving student). Student K's categorization is shown in the Appendix. S/he distinguished increasing and decreasing exponential, root, and polynomial functions. S/he categorized only a few formulas inconsistently, but s/he did not make a distinction between logarithmic and root functions, which resulted in a total score of only 45 points. Student M's categories also resembled those of the criterion categorization. When categorizing the formulas, student M used predominantly zeroes and max/min with polynomial functions, like in $y = (x + 3)^4 - 9$, asymptotes (horizontal and vertical for broken functions, horizontal for exponential functions and vertical for logarithmic functions), and edge points for root-functions. Although, s/he had more inconsistently categorized formulas, her/his categorization had a total score of 44 points.

The thinking-aloud protocols on the graphing tasks showed that, in the pre-test, the students had trouble recognizing (basic) functions, and only high-achieving students were successful now and then because of their reasoning abilities. In the post-test, these students had improved their recognition of basic function families with their characteristics and their qualitative reasoning.

In the pre-test, K scored 9 correct graphs out of 14. As a high-achieving student, s/he was able to compensate for a lack of recognition through qualitative reasoning. However, s/he often had to calculate many points of the graph. We give two citations to illustrate K's strategies in the pre-test. K did not recognize the global shape of a logarithmic function and used calculations and reasoning about the inverse function to sketch the graph of $y = \ln(x - 3)$ correctly:

“I do not know the ln-graph anymore. When $x - 3 = 0$, then When $x - 3 = 1$, then $y = 0$, so $x = 4$. At x -as the x -axis is intersected. When x is increasing then y increases, so the graph increases. When x is negative ... (thinking). Because something to the power of e (e^{\dots}) does not give negative y -values. So, $x - 3$ cannot be negative; the graph only exists from $x = 3$, larger than 3. So, at $x = 3$ a tangent (asymptote?) and outcomes smaller when x is in the neighbourhood of 3”.

At first K showed a correct global shape by gesturing, however her calculating of individual points resulted in an incorrect sketch of $y = \sqrt{6 - 2x}$:

“...root-functions go like this (makes a correct gesture); the fact that it is $6-2x$ means that the function only exists for negative values of x , to the point where x is 3; for x larger than 3 the argument is negative; when $x=3$ than $y=0$; when $x=0$, $y=\sqrt{6}$, which is about 2.5; when x is more negative, the argument becomes larger; ..., $\sqrt{10} \approx 3.3$, $\sqrt{12} \approx 3.5$, differences become larger (and sketches a graph concave up)”

In the post-test, K’s recognition of basic functions had improved and s/he still used her/his abilities of qualitative reasoning, resulting in a score of 13 out of 14. Again, two citations give an illustration.

K sketching $y = \ln(x - 4)$ correctly: “ $\ln(x)$ graph goes like this; $x - 4$, so 4 to the right.”

K used qualitative reasoning to compose two graphs while sketching $y = 2x\sqrt{x + 6}$ correctly:

“ $2x$ goes like this; $\sqrt{x + 6}$ goes like this (sketch); here it is 0; here negative, here 0, and after this it is steeper”.

In the pre-test student, M had many problems with graphing formulas. S/he did not know basic function family characteristics, and did not recognize graph features like zeroes and turning points. This resulted in a score of only 2 out of 14. Two citations illustrate her/his strategies.

M recognized the parabola-shape but did not know how to proceed while sketching $y = (x - 3)^4 - 9$ (not finished):

“...at $x = 3$, $y = -9$. (After some time) The larger x is, the larger y , so it increases. It is a parabola. (S/he stopped talking for a while; after a couple of minutes) I do not know how to proceed.”

M recognized a translation but not the shape of the $\ln(x)$ -graph; s/he tried to construct the graph of $y = \ln(x - 3)$ via the inverse function (not finished):

“...graph of $\ln(x)$ that is translated 3 to the right (s/he did not use this but writes $\log_e(x - 3) = \log(e) / \log(x - 3)$; $e^y = x - 3$). This is an asymptote; x cannot be 3;; when $y = 0$, $x - 3 = 1$ (drew point (4,0) and stopped)”.

In the post-test, M’s repertoire of basic function families and her/his qualitative reasoning had improved, resulting in a score of 10 out of 14. Two citations illustrate this. In the post-test M recognized more graph features like zeroes and turning points; for instance, while sketching $y = -2x(x - 2)(x - 5)$ correctly: “...goes downwards; zeroes at 0, 2, 5. At 1 it is negative”.

M in the post-test, sketching $y = (x^2 + 6)/(x^2 - 4)$ correctly:

“...asymptotes at 2 and -2; zero at $\sqrt{6}$; no, no zeroes, because x^2 cannot be negative; when x is smaller than 2, then it is positive here, and negative here, so it is negative; when x is a bit larger than 2, positive here, positive here, so positive; the same for -2”.

Not only had these two students improved their scores in the post-test, but the results of all students showed a significant improvement in scores, with a large effect-size, from a mean score of 3.1 (SD = 2.6) in the pre-test to a mean score of 8.6 (SD = 2.8) in the post-test ($t(20) = 10.40$, $p < .001$, $d = 2.27$). As expected, the scores in the retention-test dropped: a mean score of 6.3 (SD = 3.4). This result is significant when compared with the pre-test scores: $t(14) = 3.15$, $p = .007$, $d = 0.81$.

Conclusion and discussion

The aim of the current study was to enable students to give meaning to algebraic formulas in terms of a graph. A knowledge base of basic function families with their characteristics is needed for this. In the intervention, students learned to graph formulas through recognition and qualitative reasoning. The results of the thinking-aloud protocols showed that in the pre-test students were either unable to link formulas to graphs or needed to use a lot of time-consuming reasoning and error-prone calculations. Therefore, without explicit teaching, students might not link formulas to graphs. The post-test results of the graphing task showed that the students had improved their recognition of basic function families and, in general, their reasoning about formulas. In terms of the two-dimensional framework: in the pre-test the students mostly used recognition level E, whereas in the post-test they often used higher levels of recognition (recognition of function families, decomposition of the formula, and recognition of graph features).









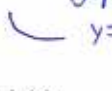

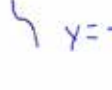
The categorizations gave an impression of the knowledge base and thinking processes of the students. The students' categorizations showed that they used more or less the same categories as experts, but still had problems with categorizing less familiar functions, like $y = \sqrt{8 - x^2}$, $y = 100 - e^x$, $y = 8\sqrt{x^3}$, $y = x + 4/x$. Student M used zeroes, asymptotes (horizontal and/or vertical), and edge points as main strategies when categorizing. In the post-test graphing task, s/he often used these same strategies. Student K's categorization was very detailed, although s/he combined root- and log-functions. However, in the post-test graphing task s/he showed that s/he knew the differences well (see sketching $y = \ln(x - 3)$ and $y = \sqrt{x + 6}$ in the results section). In the post-test graphing task, K used her/his repertoire of function families often. Both students' categorizations seemed to allow them to recognize function families and use these function families as building blocks in reasoning with and about formulas: these function families are objects that they can use to give meaning to algebraic formulas.

These findings suggest that teaching graphing of formulas based on recognition and heuristic search might enable students to develop a repertoire of basic function families, to identify the structure of formulas, to (qualitatively) reason with and about algebraic formulas, and to link formulas to graphical features. This could allow students to “read through” an algebraic formula, that is, to give meaning to algebraic formulas.

References

- Arcavi, A. (1994). Symbol sense: Informal sense-making in formal mathematics. *For the Learning of Mathematics*, 14(3), 24-35.
- Arcavi, A., Drijvers, P., & Stacey, K. (2017). *The Teaching and Learning of Algebra: Ideas, Insights and Activities*. London / New York: Routledge.
- Chi, M. T., Feltovich, P. J., & Glaser, R. (1981). Categorization and representation of physics problems by experts and novices. *Cognitive Science*, 5, 121-152.
- Even, R. (1998). Factors involved in linking representations of functions. *The Journal of Mathematical Behavior*, 17, 105-121.
- Eisenberg, T., & Dreyfus, T. (1994). On understanding how students learn to visualize function transformations. In E. Dubinsky, A. Schoenfeld, & J. Kaput (Eds.), *Research in collegiate mathematics education* (Vol. 1, pp. 45–68). Providence, RI: American Mathematical Society.
- Ernest, P. (1990). The meaning of mathematical expressions: Does philosophy shed any light on psychology? *British Journal for Philosophy of Science* 41, 443-460.
- Goldenberg, E. P. (1988). Mathematics, metaphors, and human factors: Mathematical, technical, and pedagogical challenges in the educational use of graphical representation of functions. *Journal of Mathematical Behavior*, 7, 135-173.
- Heid, M. K., Thomas, M. O. J., & Zbiek, R. M. (2013). How might computer algebra systems change the role of algebra in the school curriculum? In A. J. Bishop, M. A. Clements, C. Keitel, J. Kilpatrick, & F. K. S. Leung (Eds.), *Third International Handbook of Mathematics Education* (pp. 597- 641). New York: Springer.
- Hoch, M., & Dreyfus, T. (2010). Developing Katy's algebraic structure sense. In V. Durand-Guerrier, S. Soury-Lavergne & F. Arzarello (Eds.), *Proceedings of the 6th Congress of the European Society for Research in Mathematics* (pp. 529 - 538). Lyon, France: CERME.
- Janvier, C. (1987). *Problems of representation in the teaching and learning mathematics*. Hillsdale NJ: Lawrence Erlbaum Associates.
- Kieran, C. (2006). Research on the learning and teaching of algebra. In A. Gutiérrez, & P. Boero (Eds.), *Handbook of research on the psychology of mathematics education* (pp. 11-49). Rotterdam: Sense.
- Kop, P., Janssen, F., Drijvers, P., Veenman, M., & Van Driel, J. (2015). Identifying a framework for graphing formulas from expert strategies. *The Journal of Mathematical Behavior*, 39, 121–134.
- Kop, P., Janssen, F., Drijvers, P., & van Driel, J. (2017). Graphing formulas: Unraveling experts' recognition processes. *The Journal of Mathematical Behavior*, 45, 167-182.
- Leinhardt, G., Zaslavsky, O., & Stein, M. K. (1990). Functions, graphs, and graphing: Tasks, learning, and teaching. *Review of Educational Research*, 60, 1-64.
- Ruiz-Primo, M. A., & Shavelson, R. J. (1996). Problems and issues in the use of concept maps in science assessment. *Journal of Research in Science Teaching: The Official Journal of the National Association for Research in Science Teaching*, 33, 569-600.
- Slavit, D. (1997). An alternate route to the reification of function. *Educational Studies in Mathematics*, 33, 259-281.
- Stylianou, D. A., & Silver, E. A. (2004). The role of visual representations in advanced mathematical problem solving: An examination of expert-novice similarities and differences. *Mathematical Thinking and Learning*, 6, 353-387.
- Thompson, P. W. (2013). In the absence of meaning.... In K. Leatham (Ed.), *Vital directions for mathematics education research* (pp. 57-93). New York, NY: Springer.

Appendix: Student K's categorization

<p>Op parabool</p>  <p>bepoelt bereik minimum top $y=x^2$</p> <p>$(x-3)^2+2$</p> <p>$(x+3)^2-9$</p>	<p>Beop parabool</p>  <p>bepoelt bereik 3 toppen maximum lo $y=-x^2$</p> <p>$x(9-x)$</p> <p>$(x+5)(3-x)$</p> <p>$-(x-1)^2+2(x-1)+6$</p> <p>$2x-3(x+2)(x-2)$</p>	<p>W</p> <p>$y=x^4-x^2$</p> <p>$(x^2-7)^2$</p> <p>$3(x^2-4)(x^2-6)$</p>	<p>Postieve derde machtswaard</p>  <p>$y=x^3$</p> <p>$(x^2-7)(x-5)$</p> <p>$x(x-3)(x+3)$</p> <p>$2(x-3)^2(x+3)$</p>
<p>Gebroken functie</p>  <p>$y = \frac{1}{x}$ verticaal en hor. asymptote</p> <p>$8x^{-3}$</p> <p>$\frac{2}{x^2}$</p> <p>$1 + \frac{5}{x+1}$</p> <p>$3x^{-2}$</p> <p>$\frac{4x+2}{x}$</p> <p>$3 \cdot \frac{x}{x-1}$</p>	<p>Wortel functie (afnemend stijgend)</p>  <p>$y = \sqrt{x}$</p> <p>$2x\sqrt{x}$</p> <p>$2\sqrt{x}$</p> <p>$2\sqrt{x}-6$</p> <p>$\ln(x-3)$</p> <p>${}^2\log(x-6)$</p> <p>$8\sqrt{x^2}$</p> <p>$(100x)^{\frac{1}{2}}$</p>	<p>Wortel verticaal gespiegeld</p>  <p>$y = \sqrt{-x}$</p> <p>$(2-x)^{\frac{1}{2}}+2$</p> <p>$\sqrt{8-x^2}$</p> <p>Exponentieel</p>  <p>$y = 2^x$</p> <p>4^{-3x}</p> <p>$2 \cdot (\sqrt{2})^x$</p>	<p>Afnemend dalend</p>  <p>$y = 0,9^x / y = 2^{-x}$</p> <p>$8e^{-x}$</p> <p>2^{2-x}</p> <p>$18 \cdot 0,3^x + 12$</p> <p>$\frac{8}{3^x}$</p> <p>$100 - e^x$</p>
<p>W</p> <p>$y = x + \frac{1}{x}$ verticale asymptote diagonale asymptote</p> <p>$x + \frac{4}{x}$</p>	<p>Wortel horizontaal gespiegeld</p>  <p>$y = -\sqrt{x}$</p> <p>$-\ln(x)$</p>	<p>Lineair dalend</p>  <p>$y = -x$</p> <p>$x+5(4-x)$</p> <p>$3(8-\frac{x}{5})$</p>	<p>Negatieve derde machtswaard</p>  <p>$y = -x^3$</p> <p>$-x^3+2x$</p>

Relational thinking and operating on unknown quantities. A study with 5 to 10 years old children

Denise Lenz

Martin-Luther-University Halle-Wittenberg, Germany; denise.lenz@paedagogik.uni-halle.de

The following research design combines relational thinking as an aspect of algebraic thinking with the understanding of variables. In clinical interviews, 5 to 10 years old children were confronted with tasks that required the description of relations between known and unknown quantities. Their answers were examined regarding the ways in which relations are described and thereby variables are seen.

Keywords: Algebraic thinking, relational thinking, unknowns, primary school.

Introduction

This paper reports parts of a research focused on the abilities of young children to establish relationships between unknown quantities. The aim is to investigate how young children describe relations between known and unknown quantities that are represented with different colored boxes and marbles and how they understand the unknown quantities. First of all, relational thinking as an aspect of algebraic thinking will be described as well as important aspects of variables.

Theoretical Framework

Algebraic thinking and relational thinking

It is hard to give a comprehensive description of what algebraic thinking means. However, many researchers (e.g. Kieran, 2011) highlighted that relational thinking is seen as an important part of algebraic thinking.

Relational thinking refers to students' recognition and use of relationships between elements in number sentences and expressions. When using relational thinking, students consider sentences as wholes (instead of a process to be carried out step by step), analyze them, discern some detail and recognize some relations, and finally exploit these relations to construct a solution strategy. (Molina, Ambrose, Castro, & Castro, 2009, p. 122)

In addition to the understanding of relational thinking regarding equations and formal expressions, this can also be extended to the recognition and use of relations between quantities. It enriches the learning of arithmetic and can be a foundation for smoothing the transition to algebra (Carpenter, Levi, Franke, & Koehler Zeringue, 2005).

Aspects of variables

Radford (2011) described algebraic thinking as dealing with indeterminate quantities conceived of in analytic ways. So dealing with indeterminacy is an important part of algebraic thinking. This indeterminacy leads to different aspects of variables. At least, three different kinds can be distinguished: *unknowns*, *variables*, and *general numbers*. *Unknowns* describe a specific, but undetermined number, whose value can be evaluated, i.e. the x in the equation $10 + x = 30$ (e.g. Freudenthal, 1973; Usiskin, 1988). *Variables* describe a range of unspecified values and a relationship between two sets of values, i.e. variables appear in statements about a functional relationship and indicate how one value depends on another value (e.g. Küchemann, 1981; Usiskin, 1988). *General*

numbers describe indetermined numbers which appear in generalizations, such as descriptions of properties of a set, i.e. the commutative law of addition can be represented by the equation $a + b = b + a$. In contrast to the variable aspect of the unknown, this is not about specifying a value for the letters a and b . The meaning of general numbers lies precisely in the general expression of the relationship found (e.g. Freudenthal, 1973; Usiskin 1988). In addition to these three aspects of indeterminacy, empirical data provide further classifications. Children often use *quasi-variables* to express generality before they develop the capability to use algebraic language (e.g. Fujii & Stephens, 2001): general structures are expressed through the use of examples which stand for the general. For example, children use the number sentence $78 + 49 - 49 = 78$ to express that the number sentence $a + b - b = a$ is true whatever other number is taken away and added again. In this sense, they have an understanding of indeterminacy and can express a general number without the symbolic algebraic expression.

Research interest

Studies focused on relational thinking usually refer to relationships in formal representations (e.g. Carpenter, Levi, Franke, & Koehler Zeringue, 2005). In equations with an unknown, students have the opportunity to calculate. If there are two unknowns, this possibility is not given. It can be assumed that the use of several unknowns increases the use of relational thinking. A study by Stephens and Wang (2008) showed that 6th and 7th-graders use relational thinking in the following task: In each of the sentences below, you can put numbers in Box A and Box B to make each sentence correct. For example:

$$18 + \square = 20 + \square$$

Box A Box B

Based on students responses to tasks like above, they described three stages of relational thinking: *established relational thinking*, *consolidating relational thinking*, and *emerging relational thinking*. *Established relational thinkers* specify the relationship between the numbers in the two boxes with a clear reference to the numbers, including the magnitude and direction of the difference between them. These characteristics decrease in the other two categories. In terms of task design, they found that tasks with two unknowns served the purpose of moving students beyond computations to more in-depth thinking (Stephens & Wang, 2008). Research by Schliemann, Carraher, and Brizuela (2005) showed that even younger children aged 7 to 11 years old are capable of understanding equivalence and solve linear equations with unknown quantities. In that case, the tasks were represented with concrete objects or told as little stories. In contrast to formal representations, concrete materials have the chance to prompt even younger children such as kindergarteners to show their capabilities of relational thinking while handling unknown quantities. Melzig (2013) tested a task design with boxes and beans with 7th graders and found that the boxes can play a meaningful role in developing a viable idea of variables.

The following study addresses the question: *How do young children describe relations between known and unknown quantities that are represented with concrete materials? How do they understand the represented unknown quantities (e.g. as unknowns, as variables...)?*

Methodology

The following interview-study was performed on 82 children aged from 5 to 10 years old. The sample consisted of 5 to 6 years old kindergarteners ($n=27$), 7 to 8 years old 2nd graders ($n=28$) and 9 to 10 years old 4th graders ($n=26$). The children did not receive any special algebra lessons or instructions before.

In order to capture children's competencies describing relations between known and unknown quantities, an exploratory design was created based on the representation of boxes and marbles (e.g. Melzig, 2013; Affolter et al., 2003). The concept of the tasks was to translate different kinds of equations with one or two unknowns into a representation that young children could handle. Known quantities were represented as marbles and unknown quantities were represented as boxes which contained an unknown number of marbles (see table 1). A story was told: "Here you see two children: Tino and Anna. They are playing with marbles. Some marbles are packed up in different colored boxes and some marbles are separate. Boxes with the same color always contain the same amount of marbles." The study includes 12 tasks of four different kinds. Kindergarteners got 10 of the 12 tasks, 2nd and 4th graders got all of them.



Type of task	Examples
A: "The same?": Children have to decide if both children have the same amounts of marbles or not.	A1: boy: $x + 1$ girl: $x + 2$
B: "How many?" (known): The children have to specify how many marbles are in a box so that both children have the same number of marbles. Children can answer with a specific number.	B2: boy: 4 girl: $x + x$ 
C: "How many?" (unknown): In type C a relationship between two unknowns can be stated. Task C1: How many marbles have to be in the boy's box so that both children have the same amounts of marbles?	C1: boy: y girl: $x + 1$ 
D: "Make them equal": Both children have the same amounts of marbles. The interviewer makes a transformation. Children have to decide what amounts of marbles they have to give to one child or take away to the interviewer, to make the quantities equal again.	D1: boy: $x + x$ girl: $y + y + 2$ à The boy gives one of his boxes (x) to the interviewer. How much does the girl have to give to the interviewer?

Table 1: Overview of the types of tasks used in the study. The variables in the last column represent the unknowns, which were represented as colored boxes. Each variable was represented with another color

To get an insight into children's thinking, clinical interviews (Selter & Spiegel, 1997) were conducted. Various semi-standardized questions aimed to let children think more about the tasks. Each child worked on each of the tasks in an individual interview. The request "How did you get your answer?" helped to get an insight into children's way of thinking. The interviews were videotaped and transcribed.

Analysis and results

After the transcription of children's answers, the diversity of children's solutions to the individual tasks was compiled. The tasks of type A were answered correctly by nearly all of the children. The correct answers of type B tasks varied between 40 to 72 % by kindergarteners, 72 to 97 % by 2nd graders and 92 to 97 % by 4th graders. Particularly interesting was the evaluation of the tasks of type C, where relations between two unknowns had to be established. The following presentation of results refers to the answers of the children to the task C1 (see table 1).

Categories of the first answers

In task C1, the children were confronted for the first time with two unknown quantities. In contrast to the last task, no concrete value can be given. Therefore, the first spontaneous answers of children to task C1 are of interest. Table 2 presents the categories of children's answers.

Category:	Kinder- garten	2 nd grade	4 th grade
State a relationship: Children describe a relationship between the amounts of marbles in the boxes.	0%	4%	11,5%
Describe a dependency: Children describe that the amounts of marbles in both boxes depend on each other.	0%	12,5%	30,8%
Numerical values: Children mention values for the amounts of marbles in one or both boxes.	96%	58%	38,5%
... as examples: The values are meant as examples.	12,5%	57%	90%
... as fixed values: The values are meant as fixed numbers.	41,6%	29%	10%
... not to classify exactly: At this point of analysis, it is not clear if the mentioned values are meant as examples or not.	45,8%	14%	0%
Unintended answers: The children interpret the task differently. E.g. children want to change the amounts of given marbles in the task to give an answer.	0%	12,5%	0%
No answer: Children give no answer.	4%	8%	7,7%
Not possible to evaluate: The answers of the children cannot be evaluated more precisely at this point.	0%	4%	11,5%

Table 2: Categories of children's first spontaneous answers to task C1

The overview shows that most children first enter numerical values for the content of the green box. But there are also clear differences between different age groups. While the majority of kindergarten children indicate numerical values, some children in grades 2 and 4 are already able to describe relationships or dependencies. Of particular importance at this point are the interviewer's following requests, which encourage children to overlook different numerical values and consider the relationship of possible numbers of marbles in the boxes. This is especially the case with some children, who initially cannot answer, but often show a deep understanding of relationships in the process of the interview. It can be assumed that the children were unaware that "a marble more" may be an appropriate answer.

Further data analysis

The answers of the children after the requests of the interviewer were very different. Since the task design suggests making relationships between unknowns, the children's responses can be categorized in two directions: establishing relationships and dealing with unknowns, whereas the boxes had to be interpreted as variables. Regarding relational thinking, there are three ways to recognize relationships (children describe a relationship or display the dependency or neither describe a relationship nor a dependency). Regarding the question how children handle the unknown quantities, there were two ways to get the categories: first in a deductive way, because the theoretical framework gave various categories about aspects of variables (as unknowns, as a general number, as a variable, and as a quasi-variable); secondly, the categories are found in an inductive way, because the data also revealed categories that could not previously be found in the theoretical framework. These were interpretations of the boxes as an absolute number and undeterminable.

Children's answers regarding relational thinking

Some children directly describe a relationship between the two unknown quantities as in types of task C (table 1). The 4th grader Luca said: "In the green box is always one marble more than in the orange box". Other children describe that the two unknowns depend on each other, but without describing the relation more precisely. The 4th grader Kathy answered: "It depends on how many marbles are in the orange box". Other children neither describe a relationship nor describe a dependency between the amounts of marbles in the boxes. There are very different answers in this category. Some children mentioned specific quantities or wanted to shake the boxes to find out how many marbles are in them.

Children's answers regarding the understanding of the represented unknown quantities

Children have very different answers by describing the unknowns in tasks of type C. These different types of understanding the unknown quantities are the following:

The unknown amounts of marbles in the boxes as a *general number*: children see the amounts of marbles in the boxes as an unknown, indeterminate number, which cannot be determined and therefore has to be stated as a general relationship. The 4th grader Luca says: "In the green box is always one marble more than in the orange box". The unknown amounts of marbles in the boxes as *quasi-variables*: children describe the general relationship between the amounts of marbles in the boxes with the aid of examples. The difference to the former is less in the recognition of the relationship than in the linguistic expressiveness. The 6 years old kindergartener Adam says: "...if there are eight or nine marbles in the orange box, then I take one marble more, that's nine or ten marbles for the green box". The unknown amounts of marbles in the boxes as *variables*: children

describe the dependency of the amounts of marbles between the different colored boxes. Children say that there is a relation, but they do not specify it. In contrast to the interpretation as a general number, the dependence of both values is indeed recognized, but cannot be described as a fixed relation. Although the children are able to assume different values for the number of marbles in the boxes, they are not able to give a general relationship. The 4th grader Anton says: “There are various possibilities because I don’t know how many marbles are in the orange box”. The unknown amounts of marbles in the boxes as an *absolute number*: the children give a specific number of marbles, sometimes without considering the amount of marbles in the other box. The kindergartener Clara says: “Four. Because the box is so small, there just fit four marbles in”. The unknown amounts of marbles in the boxes as an *undeterminable*: This category results from the empirical data and finds no equivalent in the theoretically elaborated aspects of variables. Children who see the unknown amounts of marbles in the boxes as an undeterminable answer that the amounts of marbles in the boxes can’t be determined without to open it. The 2nd grader Rob answers: “I have to open the box”.

Putting both together: Relational thinking and understanding unknown quantities

The design of the tasks allows putting both dimensions together: relational thinking and the understanding of unknown quantities. The following evaluation schema shows all the combinations found in the data. They indicate that the two dimensions are intertwined. Children who describe relationships between the unknown quantities understand them as either a general number or a quasi-variable. Children who describe dependency take the unknown quantities as a variable. Children who neither establish a relationship nor describe a dependency understand the unknown quantities as either an absolute number or an undeterminable. The interviewer's requests encourage the children to think more profoundly about the tasks¹. After requests of the interviewer, 12% of the children in kindergarten describe a relationship between the unknown quantities and describe them as a general number. This increases to 17% in the second grade up to 73% in the fourth grade. 12% of kindergarten children describe a relationship with the help of quasi-variables. This is also the case for almost 17% of 2nd graders and almost 4% of 4th graders.

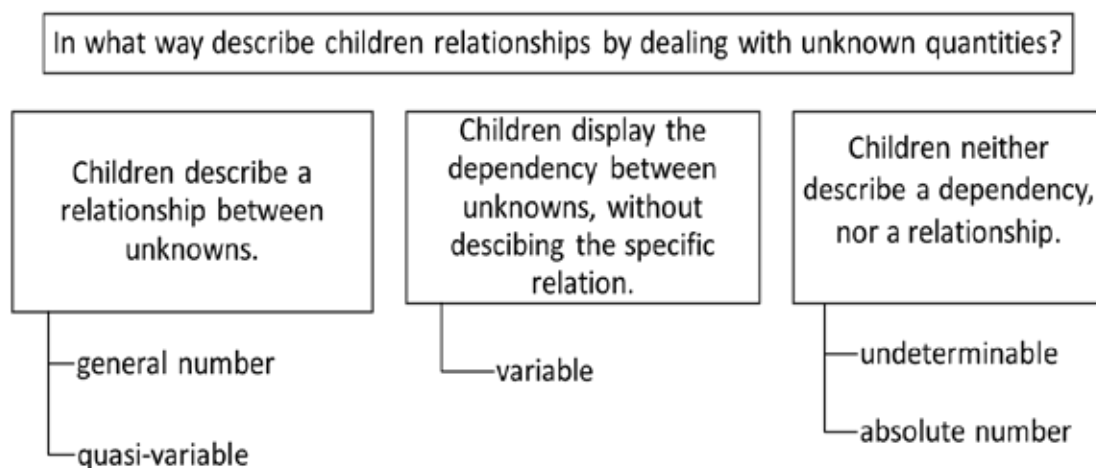


Figure 1: Evaluation scheme

¹ Case studies and their application to the evaluation scheme can be viewed in Lenz (2016) and in Steinweg, Akinwunmi, & Lenz (2018).

It should be mentioned that the fields shown in the evaluation scheme are not to be seen as a fixed classification of individual children. Rather, the analysis scheme describes a single answer in the course of the interview and is not seen as a stable attribution to a child.

Conclusion

The analysis indicates that the task design is actually designed to encourage children to establish relationships between unknown quantities. Particularly interesting is the transition between task types B and C which seems to be a special breaking-point in the use of variables. The role of the unknown amounts of marbles in the boxes changes from an unknown that can be determined to a variable whose value cannot be known but can be described as a relation. It must be distinguished in which way the children interpret the unknown number of marbles in the boxes.

The evaluation scheme allows two dimensions of algebraic thinking to be linked: relational thinking and understanding unknown quantities. The analysis has shown that children from the age of 5 years old as well as primary school children are able to show relational thinking about unknown quantities. However, there are also children who understand the number of marbles in the boxes as an absolute number. A possible reason for this might be due to the concrete representation of the boxes. It is important to investigate whether this would be still the case of representing photos of the tasks. A difficulty is to see in the limitation of the linguistic expressiveness of the children. In particular, the children of the kindergarten found it difficult to express their thoughts in words. They often made gestures and facial expressions to help, which requires further investigation. On an active level, all children have the opportunity to get started with the tasks. Although the task design looks very simple, it allows for variation in primary school and secondary level. For example, tasks with limit value determination or case distinctions can also be created. The design allows continuing these tasks on a formal level. Placeholders, symbols, or letters can replace the boxes. This study can be seen as a starting point to develop classroom lessons that allow relational thinking in elementary school mathematics lessons and a first approach to dealing with different variable aspects. The common exchange in the classroom can be seen as particularly profitable.

References

- Affolter, W., Baerli, G., Hurschler, H., Jaggi, B., Jundt, W. Krummacher, R., ..., Wieland, G. (2003). *Mathbu.ch 7* [mathematics book 7]. Zug, Bern: Klett & Balmer.
- Carpenter, T.P., Levi, L., Franke, M.L., & Koehler Zeringue, J. (2005). Algebra in elementary school: Developing relational thinking. *ZDM*, 37(1), 53–59.
- Freudenthal, H. (1973). *Mathematics as an educational task*. Dordrecht: Reidel.
- Fujii, T., & Stephens, M. (2001). Fostering an understanding of algebraic generalization through numerical expressions: The role of quasi-variables. In H. Chick, K. Stacey, J. Vincent, & J. Vincent (Eds.), *Proceedings of the 12th ICMI Study Conference: The future of the teaching and learning of algebra* (pp. 258–364). Melbourne: University of Melbourne.
- Kieran, C. (2011). Overall commentary on early algebraization: Perspectives for research and teaching. In J. Cai & E. Knuth (Eds.), *Early algebraization. A Global Dialogue from Multiple Perspectives* (pp. 579–593). Berlin Heidelberg: Springer.

- Küchemann, D. (1981). Algebra. In K.M. Hart (Ed.), *Children's understanding of mathematics: 11-16* (pp. 102–119). London: John Murray.
- Lenz, D. (2016). Relational thinking and operating on unknown quantities. In T. Fritzlar, D. Assmus, K. Bräuning, A. Kuzle, & B. Rott (Eds.), *Problem solving in mathematics education. Proceedings of the 2015 joint conference of ProMath and the GDM working group on problem solving* (pp. 173-181). Münster: WTM.
- Melzig, D. (2013). *Die Box als Stellvertreter* [The box as a substitute]. Unpublished Doctoral dissertation). Universität Duisburg-Essen, Essen, Germany.
- Molina, M., Ambrose, R., Castro, E., & Castro, E. (2009). Breaking the addition addiction: creating the conditions for knowing-to act in early algebra. In: S. Lerman & B. Davis (Eds.), *Mathematical Action & Structures Of Noticing: Studies inspired by John Mason* (pp.121–134). Rotterdam, The Netherlands: Sense Publisher.
- Radford, L. (2011). Grade 2 students' non-symbolic algebraic thinking. In J. Cai & E. Knuth (Eds.), *Early algebraization. A Global Dialogue from Multiple Perspectives* (pp. 303-322). Berlin Heidelberg: Springer.
- Schliemann, A.D., Carraher, D.W., & Brizuela, B.M. (2007). *Bringing out the algebraic character of arithmetic: From children's ideas to classroom practice*. Mahwah, N.J.: Lawrence Erlbaum Associates.
- Spiegel, H & Selter, C. (1997). *Wie Kinder rechnen* [How children calculate]. Leipzig: Klett.
- Steinweg, A. S., Akinwunmi, K., & Lenz, D. (2018). Making Implicit Algebraic Thinking Explicit: Exploiting National Characteristics of German Approaches. In C. Kieran (Ed.), *Teaching and Learning Algebraic Thinking with 5-to 12-Year-Olds: The Global Evaluation of an Emerging Field of Research and Practice* (pp. 283-307). Cham, CH: Springer International Publishing.
- Stephens, M. & Wang, X. (2008). Investigating some junctures in relational thinking: A study of year 6 and year 7 students from Australia and China. *Journal of Mathematics Education*, 1(1), 28–39.
- Usiskin, Z. (1988). Conceptions of school algebra and uses of variables. In A.F. Coxford & A.P. Shulte (Eds.), *The ideas of algebra, K-12* (pp. 8–19). Reston, VA: National Council of Teachers of Mathematics.

Enhancing students' generalizations: a case of abductive reasoning

Joana Mata-Pereira¹ and João Pedro da Ponte²

¹Instituto de Educação, Universidade de Lisboa, Portugal; jmatapereira@ie.ulisboa.pt

² Instituto de Educação, Universidade de Lisboa, Portugal; jpponte@ie.ulisboa.pt

The aim of this paper is to understand how a path of teacher's actions leads to students' generalization. Generalization, as a main process of mathematical reasoning, may be inductive, abductive, or deductive. In this paper, we focus on an abductive generalization made by a student. The study is carried out in the third cycle of design of a design-based research involving lessons about linear equations in a grade 7 class. Data is gathered by classroom observations, video and audio recorded, and by notes made in a researcher's logbook. Data analysis focus on students' generalizations and on teacher's actions during whole-class mathematical discussions. The results show a path of teacher's actions, with a central challenging action, that allowed an extending abductive generalization, and also a subsequent deductive generalization.

Keywords: Generalization, Abductive reasoning, Mathematical reasoning, Teacher's actions.

Introduction

Generalizing in algebra is a highly relevant aspect of mathematical teaching and learning as it is an essential part of algebra (Kaput, 2008). In addition, generalizing is a central mathematical reasoning process. As such, what the teacher does in the classroom to enhance students' generalizations is of great importance. To enhance students' mathematical reasoning in the classroom, and hence generalizations, involves setting a challenging learning environment that goes beyond proposing exercises to solve using well-known procedures. In this research, we address mathematical whole-class discussions, unleashed by exploratory tasks (Ponte, 2005), as privileged moments to promote students' mathematical reasoning. Seeking to develop knowledge about how teachers can help students to engage in mathematical reasoning, we conduct a design-based research (Cobb, Jackson, & Dunlap, 2016). In this paper, we focus on a specific situation of the third cycle of design, aiming to understand how a path of teacher's actions, supported by design principles that focus on generalization, lead to students' generalization, particularly in a case of an abductive generalization.

Mathematical reasoning

There are several definitions of mathematical reasoning, but most of them gravitate around the idea of making justified inferences (e.g. Aliseda, 2003; Pólya, 1954; Rivera & Becker, 2009). What differs in those various definitions is the path that takes place from prior knowledge to new knowledge. As such, the perspectives on mathematical reasoning accommodate both logical and intuitive aspects, providing a scope that includes deductive, inductive and abductive inferences. Deductive inference, characterized by a logic perspective, has two main characteristics: (1) certainty, that refers to the necessary relationship between premises and conclusion, where the conclusion follows necessarily from a set of premises, and (2) monotonicity, related to the irrefutability of conclusions, i.e., a valid inference remains valid when additional premises are added (Aliseda, 2003). Deductive inference, despite being often presented as the paradigm of mathematical reasoning (Aliseda, 2003) is not

necessarily the single path to carry out mathematical reasoning. There are other rigorous forms of reasoning, such as inductive and abductive inferences (Jeannotte & Kieran, 2017; Rivera & Becker, 2009), although they do not provide the same certainty and irrefutability as deductive inferences (Aliseda, 2003). Russell (1999) stresses that mathematical reasoning consists in thinking about properties of a mathematical object and developing generalizations that apply to a broad class of objects, thus underlining the inductive aspect of mathematical reasoning. On one hand, inductive inferences occur essentially when predictions are made or conjectures are formulated (Aliseda, 2003), and are also associated with generalization from the identification of a certain characteristic common to several cases (Rivera & Becker, 2009). On the other hand, abductive inferences have mainly an explanatory role, but also have a knowledge-building role. Thus, abductive inferences aim to construct hypotheses for unknown phenomena, being a reasoning used to explain something intriguing (Aliseda, 2003) or to discover something (Magnani, 2001). In this sense, abductive reasoning is identifiable with the formulation of a generalization based on relations between aspects of a given situation and its conclusions are plausible in the context of the situation (Rivera & Becker, 2009).

Generalizations

Given its complex nature, mathematically reasoning involves a variety of processes that are evidenced in the students' individual thinking and sense making, in their classroom work, and in the interactions that take place during whole-class discussions (Brodie, 2010). These processes include formulating questions and solving strategies, formulating and testing generalizations and other conjectures, and justifying them. From these reasoning processes, we hereby highlight generalization as a key process of mathematical reasoning and, hence, of algebraic thinking. Generalizing, by stating that an idea, property or procedure is valid to a given set of objects (Dörfler, 1991; Ellis, 2007), is the basis of many mathematical ideas and concepts. On a day-to-day basis, students are naturally predisposed to generalize (Becker & Rivera, 2005). However, it is important to note that in the classroom, generalizations may be incorrect or only implicit presented (Becker & Rivera, 2005; Reid, 2002). Thus, to promote students' mathematical reasoning, it is necessary to create situations in which generalization plays a central role (Kieran, 2007), in order to lead students to present generalizations based on mathematical ideas, concepts and properties.

Generalizations that students present or use in the classroom may emerge from different approaches and at different levels. To develop the capacity of formulating generalizations, both in empirical and deductive approaches, students may act at three levels: factual, contextual and symbolic (Radford, 2003). Factual generalization comes from empirical observation or particular cases that are applied to new cases in the same set of mathematical objects. Contextual generalization, also based on empirical observation or particular cases, presumes an extension to a new set of mathematical objects. Symbolic generalization emerges from the use and understanding of symbolic language. Within this scope of levels, students' generalizations may emerge from (a) relating, when students create a relation or make a connection between situations, ideas or objects; (b) searching, when students search for an element of similarity, or (c) extending, when students go beyond the situation or case, which originated the generalization (Ellis, 2007). Moreover, as highlighted by Jeannotte and Kieran (2017), generalizing is a process related with the search for similarities and differences. As such, when a student generalizes, it is possible to identify either a continuing phenomenon, an element of

sameness, or a general principle (Ellis, 2007). Generalizations refer to a continuing phenomenon when the students identify properties that go beyond a particular instance. When an element of sameness is at stake, the students identify either a common property, the same objects or representations or the same situations. Regarding generalizing by stating a general principle, the students may identify general rules, patterns, strategies and global rules.

Teacher's actions during whole class discussions

To promote generalization at different levels, and subsequently to contribute to students' competence of a proper use of inductive, abductive and deductive reasoning, teacher's actions are a central aspect. These teacher's actions to promote mathematical reasoning in the classroom should consider the different moments of the lesson. In lessons framed by exploratory teaching (Ponte & Quaresma, 2016), whole-class discussion moments that stand out as very promising to enhance students' mathematical reasoning (Ponte, 2005). Ponte, Mata-Pereira, and Quaresma (2013) identify four main categories of teacher's actions that can be distinguished during whole class discussions and that are directly related to mathematical processes: (i) inviting actions – leading students to engage in the discussion, (ii) guiding/supporting actions – conducting students along the discussion in an implicit or explicit way in order to continue the discussion; (iii) informing/suggesting actions – introducing information, providing an argument or validating students' interventions; and (iv) challenging actions – leading students to add information, provide an argument or evaluate an argument or a solution. Guiding/supporting, informing/suggesting, and challenging actions, are main supports to develop whole class mathematical discussions, and involve key mathematical processes such as (i) representing – provide, revoice, use, change a representation (including procedures), (ii) interpreting – interpret a statement or idea, make connections, (iii) reasoning – raise a question about a claim or justification, generalize a procedure, a concept or a property, justify, provide an argument, and (iv) evaluating – make judgments about a method or solution, compare different methods.

Methodology

This paper reports part of the third cycle of a research study that follows a design-based research (Cobb et al., 2016) aiming to develop a local theory about enhancing students' mathematical reasoning in the classroom. Before this third cycle of design, a first cycle took place in lessons about sequences and a second cycle in lessons about linear equations. In order to achieve the overall aim of this research, we establish a set of design principles (Cobb et al., 2016) based on the literature and on previous cycles of design focusing on tasks and on teacher's actions to enhance students' mathematical reasoning, particularly emphasizing generalizing and justifying. Due to the focus of this paper, here we specifically focus on three principles for teacher's actions that aim to enhance students' generalizations, indicating that the teacher should (a) promote situations that prompt students to share ideas, namely considering and valuing invalid or partially valid contributions, deconstructing, complementing or clarifying them, (b) support or inform students in order to highlight reasoning processes, particularly generalizing, and (c) challenge students to go beyond the task.

The episodes reported in this paper took place in a Portuguese public school in a grade 7 class with 27 students (12-13 years old), and involved nine lessons about linear equations. These were students' first approach to equations, and connections between functions and equations had not yet been

addressed. The particular episodes presented are from lesson 3 and lesson 6 and regard the number of solutions of a linear equation, with a specific focus on equations with no solutions. The main goal of lesson 3 was to introduce the property of invariance of equality by multiplying and the proposed exploratory task included solving an equation in order to generalize this property. In lesson 6, the main goal was to discuss the number of solutions of an equation, particularly in impossible equalities. In order to do this, students are proposed to solve some equations, including $3x + 6 - x - 15 = 2x + 9$. Both lessons were directly observed and video and audio recorded, and notes were made in a researcher's logbook. A detailed plan of each lesson, prepared by the first author and discussed in detail with the teacher, was made attending to the tasks to propose and considering teacher's actions to enhance students' mathematical reasoning. The participating teacher was selected because of her experience, commitment to professional development, and availability to consider changes in her practice. All participants in this study are volunteers, have fictitious names and have given their informed consent to participate. Data analysis is centered on students' generalizations and focus on the design principles and the conceptual framework regarding teacher's actions.

An unexpected generalization

After a whole class discussion about the task that aimed to introduce the property of invariance of equality by multiplication, the teacher begins to register this property on the board. However, while writing down the property, the teacher realizes that during the discussion, the exception of zero was not taken into account. As such, she poses a question to students, regarding possible exclusions:

Teacher: Let us register the multiplication property of equality that says that, if one multiplies or divides each member of the equation by the same number... Any number? Or do I have to ensure something? If we multiply or divide both members of the equation by the same number, my question is, by any number? Or is there any number that I have to exclude?

As the task that students had previously worked on and discussed did not include any question regarding this exclusion, by posing this question to students, the teacher is *challenging* them to go beyond the proposed task (principle c). This question receives an immediate answer from Clara, one of the students. However, the teacher decides on going further on the discussion by *challenging* students to present for a justification (principle c).

Clara: Zero.

Teacher: Why?

Gabriel: Because it is neutral, is neutral! Is the neutral element.

Gabriel provides an invalid justification based on his previous knowledge of the formal properties of operations. At this point, teacher opts on *guiding* students to deconstruct the invalid statement (principle a):

Teacher: Easy there, is the neutral element of which operation?

Several students: Addition.

Teacher: But are we talking about addition?

- Leonardo: Oh, no, is about multiplication.
- Teacher: Is the... Element, how is it called?
- Gabriel: Neutral!
- Leonardo: No, is the one that absorbs everything.
- Clara: Absorbing.

After some students' interventions, one of them presents a justification that is considered by the teacher as being partially correct. However, the teacher keeps *guiding* students in order to go further on their justification (principle a).

- Teacher: Absorbing element. So, can I... Can I divide by zero?
- Several students: No.
- Teacher: No, it doesn't make sense. Can I multiply? What is the problem of multiplying both members by zero?
- Several students: Is going to be zero.
- Teacher: I will get zero equals zero and I will not be able to move forward. So, [continuing to write the property] distinct from zero, the solution-set is preserved.

At this point of the discussion, the teacher *informs* students in order to conclude the introduction to the multiplication property of equality (principle b).

After clarifying why zero has to be excluded in this property, and straight after writing down the property, Clara asks to intervene:

- Clara: Teacher, I don't know why, but after you wrote down that [the property of invariance of equality by multiplication] I believe... I have this feeling that not all equations have a solution.

Supported by the property of invariance of equality by multiplication, Clara *generalizes* that not all equations have a solution. In this generalization, Clara relates aspects of the property that is being discussed with what she knows so far about equations, without relying on a particular example, presenting an abductive generalization. By its relations to the particular property and also by expanding its scope, this generalization is a general principle of a contextual and extending nature. This was not an expected generalization at this moment, however, the teacher *challenges* Clara to elaborate on her statement (principle c).

- Teacher: Why did this [multiplication property of equality] lead you to believe that not all [equations] have a solution?
- Clara: I don't know, but...
- Teacher: But I got curious, why did anything that I have said here...
- Clara: I do not know it myself... I think it is because of zero... I don't know, but I get the feeling that not all of them have. . . .

Teacher: Look [Clara], hold back, if necessary take a register . . . Stating that this made you think that it might have equations that do not have a solution. When we discuss this issue, that won't be right now, we will see.

As Clara cannot go further on her justification, the teacher begins by *challenging* this student again to present a justification (principle c), but then quits to obtain such justification and *informs* the class that Clara's idea will be discussed later.

Validating Clara's generalization

A few lessons after, the teacher proposed a task to students in order to introduce the classification of linear equations according to the number of solutions. While the students were solving an equation proposed in the task using the properties of equality, the equation $0x = 18$ emerged, triggering the discussion that follows:

Leonardo: But that will keep having an infinity of solutions.

Teacher: Will it?

Leonardo: Oh, no, no, it won't work for every number.

Teacher: Won't work for every number? . . .

Leonardo: No, because no number times zero equals 18! . . . So, isn't this a false equality? Is, isn't it? This is a false equality, because any number times zero will equal zero.

Teacher: And?

Gustavo: This one doesn't have a solution, teacher. . . Is impossible! . . .

Leonardo: So, this means that there are equations with no solution!

As a previous equation of the task had infinite solutions, Leonardo wrongly *generalizes* that this equation also has it. By being wrong, this generalization is factual and of a searching nature, as the student considers that it belongs to the same set of mathematical objects, looking for an element of sameness. However, instead of telling the student that he is wrong, the teacher *challenges* him to evaluate his statement (principle a), which he properly does. Once more, the teacher questions the student *challenging* him to justify his statement (principle c), which he does. By *guiding* the student to continue (principle a), students *generalize* that there are equations with no solutions, based on the example of the equation that they are working with. This generalization, by going beyond the previous set of mathematical objects is of a contextual level and has a relating nature. Moreover, it refers to a continuing phenomenon as it identifies a property that does not apply only to this particular instance. After concluding this segment of the discussion, Clara intervenes, recalling that she had already stated this generalization:

Clara: Teacher, do you remember that lesson in which I had... That thing that we had regarding the multiplication property of equality, that I said that... Because I hear about zero and it was...

Teacher: Exactly, it was because of zero. That is why I asked you what made you think [that]. Because it was when we talked about zero that you did that observation. . .

Clara: It was because of zero, but I couldn't [explain].

At this point, teacher *informs* that it was valid and that the argument was also correct, despite incomplete, as Clara was not able to justify her statement (principle b).

Discussion and conclusion

Generalizations on both episodes emerged from a path of teacher's actions with a central challenging action. These paths include this central action followed by other challenging actions or by guiding actions and end up with an informing action from the teacher. These teacher's actions are strictly related to the design principles of the study as challenging. Guiding actions mostly relate to situations where a partially valid or invalid contributions emerge or to situations where the students are challenged to go beyond what was initially proposed. In addition, informing actions have a relationship with situations where the teacher highlights a generalization.

Whereas the paths of actions oriented by the design principles lead, in both episodes, to generalizations, the nature of the generalizations that emerged is not the same. In the first episode, Clara, supported by the discussion around the property of invariance of equality by multiplication, presents an abductive generalization as she relates aspects of the situation being presented, despite not being able to justify her statement. This generalization, is a contextual and extending generalization of a general principle. As Ellis (2007) indicates, this type of generalization is what researchers seek. In the second episode, the valid generalization that emerges is more deductive. This generalization, by its logical form, only needs an example to be valid. As such, the students properly realize that not all equations have a solution. This generalization, despite also being of a contextual level, is considered as a relating generalization of a continuing phenomenon.

This study shades light to what generalizations of different nature can look like in the classroom and particularly on what paths of teacher's actions can lead to such generalizations. In doing so, the framework for teacher's actions proposed by Ponte, Mata-Pereira, and Quaresma (2013) as well as the design principles have a central role. Another aspect highlighted by this study is the idea that developing algebraic thinking does not have to be immediate, as this competence should include the intellectual patience to embrace a partial understanding and the confidence that, with future actions, knowledge will advance (Arcavi, 2007). As such, not only opportunities for deductive generalizations should be considered, but also there should be opportunities for students to generalize abductively and inductively.

Acknowledgment

This study is supported by FCT – Fundação para a Ciência e Tecnologia through a grant to Joana Mata-Pereira (SFRH/BD/94928/2013).

References

- Aliseda, A. (2003). Mathematical reasoning Vs. abductive reasoning: A structural approach. *Synthese*, 134(1/2), 25–44.
- Arcavi, A. (2007). El desarrollo y el uso del sentido de los símbolos. *Revista Uno*, 44, 59–75.
- Becker, J. R., & Rivera, F. (2005). Generalization strategies of beginning high school algebra students. In H.L. Chick & J.L. Vincent (Eds.), *Proceedings of the 29th Conference of the International Group*

- for the Psychology of Mathematics Education* (Vol. 4, pp. 121–128). Melbourne: PME.
- Brodie, K. (2010). *Teaching mathematical reasoning in secondary school classrooms*. Boston, MA: Springer.
- Cobb, P., Jackson, K., & Dunlap, C. (2016). Design research: An analysis and critique. In Lyn D. English & D. Kirshner (Eds.), *Handbook of international research in mathematics education* (3rd ed., pp. 481–503). New York, NY: Routledge.
- Dörfler, W. (1991). Forms and means of generalization in mathematics. In A. Bishop, S. Mellin-Olsen, & J. van Dormolen (Eds.), *Mathematical knowledge: Its growth through teaching* (pp. 61–85). Dordrecht: Springer.
- Ellis, A. B. (2007). A taxonomy for categorizing generalizations: Generalizing actions and reflection generalizations. *Journal of the Learning Sciences*, 16(2), 221–262.
- Jeannotte, D., & Kieran, C. (2017). A conceptual model of mathematical reasoning for school mathematics. *Educational Studies in Mathematics*, 96(1), 1–16.
- Kaput, J. J. (2008). What is algebra? What is algebraic reasoning? In J. J. Kaput, D. Carraher, & M. L. Blanton (Eds.), *Algebra in the early grades* (pp. 5–17). New York, NY: Lawrence Erlbaum.
- Kieran, C. (2007). Learning and teaching algebra at the middle school through college levels: Building meaning for symbols and their manipulation. In F. Lester (Ed.), *Second handbook of research on mathematics teaching and learning* (pp. 707–762). Reston, VA: NCTM.
- Magnani, L. (2001). *Abduction, reason and science*. Boston, MA: Springer US.
- Pólya, G. (1954). *Mathematics and plausible reasoning: Induction and analogy in mathematics. induction and analogy in mathematics* (Vol. 1). Princeton, NJ: Princeton University Press.
- Ponte, J. P. (2005). Gestão curricular em matemática. In GTI (Ed.), *O professor e o desenvolvimento curricular* (pp. 11-34). Lisboa: APM.
- Ponte, J. P., Mata-Pereira, J., & Quaresma, M. (2013). Ações do professor na condução de discussões matemáticas. *Quadrante*, XXII(2), 55-81.
- Ponte, J. P., & Quaresma, M. (2016). Teachers' professional practice conducting mathematical discussions. *Educational Studies in Mathematics*, 93(1), 51-66.
- Radford, L. (2003). Gestures, speech, and the sprouting of signs: A semiotic-cultural approach to students' types of generalization. *Mathematical Thinking and Learning*, 5(1), 37–70.
- Reid, D. A. (2002). Conjectures and refutations in grade 5 mathematics. *Journal for Research in Mathematics Education*, 33(1), 5–29.
- Rivera, F. D., & Becker, J. R. (2009). Algebraic reasoning through patterns. *Mathematics Teaching in the Middle School*, 15(4), 212–221.
- Russell, S. J. (1999). Mathematical reasoning in the elementary grades. In L. V. Stiff & F. R. Curcio (Eds.), *Developing mathematical reasoning in grades K-12* (pp. 1–12). Reston, VA: NCTM.

Body Motion and Early Algebra

Ricardo Nemirovsky¹ Natividad Adamuz-Povedano² Francesca Ferrara³ and Giulia Ferrari^{3 a}

¹Manchester Metropolitan University, ESRI, Manchester, UK; r.nemirovsky@mmu.ac.uk

²Universidad de Córdoba, Spain; nadamuz@uco.es

³Università di Torino, Italy; francesca.ferrara@unito.it, giulia.ferrari@unito.it

This paper focuses on the emergence of abstraction through the use of a new kind of motion detector — WiiGraph — with 11-year old children. In the selected episodes, the children used the sensor to create three simultaneous graphs of position vs. time: two graphs for the motion of each hand and a third one corresponding to their difference. They explored relationships that can be ascribed to an equation of the type $A - B = C$. We propose two distinct paths for the attainment of abstraction, one focused on working with unknowns lacking sensible qualities, and another that involves navigating a surplus of sensible qualities. This study is a case study for the latter, which we portray as a process of opening channels of flow and exchange among sensible qualities, such that these cease to be self-enclosed and start to configure a plane of unity, which, far from denying their differences, brings them into mutual circulation.

Keywords: Body motion, sensors, early algebra, abstraction.

Introduction

Learning mathematics is often seen as a progression from the concrete to the abstract. This progression amounts to a passage across emphases, from the sensible to the intelligible. An archetypal example is that of the straight line. Out of countless acts of drawing, touching straight edges, tracing on the sand, or using tools, a sense grows for physical straightness. There is still a major gap between the latter and a geometric straight line involving a massive drawing out of sensible qualities, such as color, length, material, and thickness, to envision an entity that is intelligible but not sensible. Hence abstraction is depicted as a subtractive process, along which more and more qualities are taken out until a spectral remainder is left that is not amenable to being touched, seen, or heard, and is devoid of causal powers, whose presence is only indirectly evoked by diagrams and formulae. Numerous researchers in mathematics education have questioned this traditional image for the attainment of abstraction (Clements, 2000; de Freitas, 2016; Dreyfus, 2014; Hershkowitz, Schwarz, & Dreyfus, 2001; Noss, Hoyles, & Pozzi, 2002; Roth & Hwang, 2006).

Concluding his commentaries about multiple mythical narratives, such as the one of Thales measuring the height of an Egyptian pyramid by the shadow of a stick, or the use of the gnomon in ancient Babylonia, Serres (2017) insists: “Yes, its abstraction is a sum and not a subtraction” (p. 210), and introduces the image of white light: “Geometry integrates all our practical or ideal

^a All authors contributed equally to the article

habitats the way white light sums up all the colors, in transparency or translucency” (p. 210). This remark has inspired us to distinguish paths for the realization of abstraction corresponding to white and black light. Whereas the path of black light is abstraction by means of subtraction of sensible qualities, the path of white light meanders in the midst of a *surplus* of sensible qualities. In this paper, we aim at investigating a particular case of the pursuit of abstraction along a path of white light.

Generals and Unknowns

To illustrate the difference between abstracting paths of white and black light we invoke Peirce’s distinction between a general and an unknown. Let us start with the notion of a general:

A sign is objectively general, in so far as, leaving its effective interpretation indeterminate, it surrenders to the interpreter the right of completing the determination for himself. “Man is mortal.” “What man?” “Any man you like.” (Peirce, 1994)

A theorem proving a property of triangles, for example, deals with triangles as a general. A general is genuinely indeterminate, which makes the logic principle of the excluded middle invalid: Is the triangle isosceles?: no; is the triangle not-isosceles?: no. In contrast to generals, Peirce characterized unknowns — particulars with certain but unspecified traits — as “vague.” We are uncertain whether the eye color of a friend is green or brown, but we know that it is not, say, red. The vagueness of her eye color includes infinite shades of brown and green and excludes redness. Together with such vague sense of eye color, we may also presume that her eyes are of a particular color, which is the key character of an unknown: its traits are determined but we know them only vaguely.

Grappling with an unknown entails relating to an entity that lacks, perhaps only momentarily, certain sensible qualities both in itself (e.g. her eye color) or in its signs (e.g. a textual description of her eye color). On the other hand, we navigate a general, such as mortals or triangles, by immersing ourselves in a vast and familiar terrain of sensible variations and differences, such as mortals of different age, sex, species, bodies, and behaviors; or triangles differing in shape, size, angles, perimeters, and colors. The question we strive to address in this study is precisely: What kind of navigation arrives at abstraction across a *surplus* of sensible qualities, that is, of the white light type (in terms of generals)? We examine this question through selected episodes in which children explore the kinesthetic production of graphical expressions, for a general that can be named by the equation: $A - B = C$. We situate our study within the growing field of early algebra (Kieran, Pang, Schifter, & Fong Ng, 2016). The emphasis of the early algebra work tends to be on the logic of unknowns and on generalizing processes with respect to patterns, variables, structures and relational thinking (Blanton et al., 2016; Bodanskii, 1969/1991; Carraher, Schliemann, Brizuela, & Earnest, 2016; Kaput, 2008; Kaput, Blanton, & Moreno, 2008; Ng & Lee, 2009; Radford, 2014). While generals are different from the recursive-empirical reasoning often associated with generalizing, they are also significant in the early algebra literature (see Bodanskii, 1969/1991, which discusses Davidoff’s vision of early algebraic thinking — perhaps the closest to engaging children with generals). The work described in this paper belongs to early algebra, we suggest, because algebra can be taken to be the symbolic treatment of unknowns and generals

Sensors, Kinesthesia and Method

In this paper, we attend to the kinesthetic production of graphical expressions by means of a particular mathematical instrument. By “mathematical instrument” we refer to a material implement used interactively by means of individual or collective continuous body movements, to obtain and transform mathematical expressions (Nemirovsky, Kelton, & Rhodehamel, 2013). “WiiGraph” is a mathematical instrument we have used in our study. Among its many possible settings, there is one in which the distances between two hand-held Wiimotes (remotes) and a LED sensor bar are graphed over time, while a third graph, corresponding to the differences between these two distances, is also displayed in real time. The color of each position vs. time graph corresponded to the color of the Wiimote being recorded (i.e. light blue and pink; the presence of two large dots with these colors on the screen indicates the sensor as connected to the Wiimotes), or a different one for the case of the difference graph (i.e. dark blue; see Figure 1). WiiGraph belongs to a family of mathematical instruments based on motion detection, which work at body-scale involving wide body movements like walking or overarm gestures and are responsive to two movements occurring simultaneously, whether performed by one or two people at a time.



Figure 1: A child generating two position vs. time graphs and their difference graph

In the study, we worked with a group of four children aged 11 years, who did not previously know each other, over three sessions. The children had been recruited as volunteers through a network of families practicing home schooling education. They do not attend regular lessons at school, therefore we cannot infer about their mathematical background. The participants were filmed with two fixed cameras during each session and two of them wore a head-based Go-Pro camera. During the first two sessions they explored position vs. time graphs generated by two children, each moving a Wiimote. In addition to free explorations, they engaged in diverse activities anticipating and matching body motions and graphical shapes of position vs. time. In the third session three children worked by holding both the remotes individually, one remote in each hand. As opposed to a pair of children each handling one Wiimote, the one-in-each-hand arrangement differs markedly, among other reasons because of the centrality it confers to relative arm motion (Nemirovsky, Kelton, & Rhodehamel, 2012). The instructor chose to turn on the difference graph, displayed in dark blue, as a significant way of exploring relationships between graphs symbolically, beginning the episodes we examine in the next section. We have selected these episodes because they span the students’ production and exploration of the difference graph. The first two authors were both present in the episodes (respectively, RN and NA below; D, M and Z refer to the children).

Selected Episodes

Episode 1: Introducing the difference graph and trying to keep it on zero

RN: (...) the computer also generates another line [turns on the difference graph] that is, em, dark blue, [points at the dark blue graph; Figure 2] (...) so we'll investigate what this third line is doing there, what it is showing. So the first thing we will try...

M: It's called, it's called minus because that, that purple [dark blue] line, line is, is, is pink minus blue.

RN: OK, how do you know that?

M: It's real, it's quite obvious, where it says pink minus blue [points to the screen, note the area pointed at with a black arrow in Figure 2] at the top of the screen.

RN: Aha (...) So you move [showing the Wiimotes to move with], you do whatever you want, [moves alternately right and left hands] but try to keep the dark blue on zero [points to the dark blue line], on this line [left hand runs along the x axis].

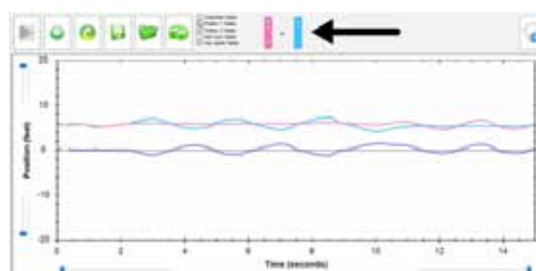


Figure 2: Graphical display in which the dark blue difference graph is displayed for the first time

M begins his first difference graph: he starts with the pink remote in his left hand and the blue one in his right hand. At the beginning of the experiment, the pink remote is kept slightly ahead of the blue one, and then the two are slowly switched in their positions. Holding the two remotes separated, he then walks forward (see Figure 3).

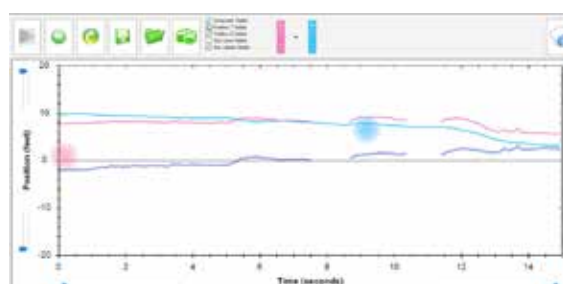


Figure 3: M's first attempt to create a difference graph

During the last seconds of the graph production (see Figure 3), he says:

M: I'm trying as hard as possible not to make the things go opposite.

Commentary

The appearance of a third graph prompted M to examine the screen seeking for additional signs that could name or account for it. There was none with a dark blue color. However, the sign at the top of the screen “pink minus blue,” which had been displayed from the beginning of this session but had remained unused, offered him a compelling interpretation (“it’s obvious”): the dark blue line “it’s called minus.” Besides the two remotes with clear referents, the minus was a third component, which was immediately clasped by the third graph. The dark blue graph seemed to announce its name. M was eager to be the first to use WiiGraph to obtain a dark blue graph that remained on the horizontal axis. M generated the graph shown in Figure 3 slowly moving the pink and blue Wiimotes back and forth in opposite directions. He seemed to move his arms exerting an effort, as if he had to push them back and forth. Perhaps RN’s prior example, in which he had moved his arms in that way, had tacitly suggested to M that this is the kind of motion to perform. However, upon seeing that the dark blue graph refused to stay on zero, except for an interval around the 7th second, his arms tensed as if trying to push the dark blue graph to the center. M reflected on this sense of effort (“trying as hard as possible”) as striving “not to make the things go opposite”. Among other possibilities, this “going opposite” might have been the dark blue graph shifting in a direction opposite to the desired one. This episode suggests how the kinesthetic interpretation of a symbolic expression that we would consider algebraic (i.e. pink minus blue) is not “given” on its own, but demands novel interpretive acts involving matters of a qualitatively different nature, such as the fastness and slowness, or the proximity and remoteness, of his hands. A pattern of motion is not there to be seized, but needs to be created. The use of WiiGraph incorporates body motion — a complex realm of sensibility and performance — to generate graphical shapes, dramatically broadening the sensory qualities at play in obtaining intended and unintended graphical shapes. Furthermore, kinesthesia inherently awakens bodily feelings. How is a minus responsive to kinesthetic actions? In our interpretation, the graph called minus was not just a visual display out there, but also a curve that resisted physical efforts seeming to possess a will of its own.

Episode 2: D works with the difference graph

After M obtained several additional graphs, he gives the Wiimotes to D, who starts a new graph. He stands still in the same position for all the session, keeping steadily the remotes at the same distance from the sensor (See Figure 4).

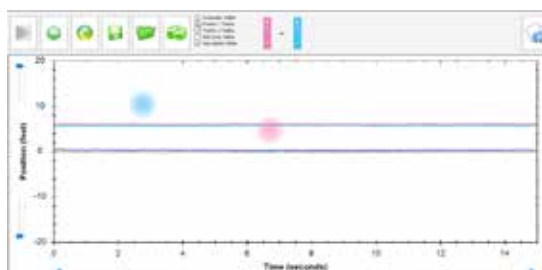


Figure 4: D generates a graph staying still with the Wiimotes next to each other

RN: So that, that’s a perfect zero [around the 8th second, everyone laughs] [ending his graph, D relaxes his position, shrugs his shoulder and smiles].

NA: This is one way to get it.

RN: (...) try to do it while you walk [D generates the graph shown in Figure 5].

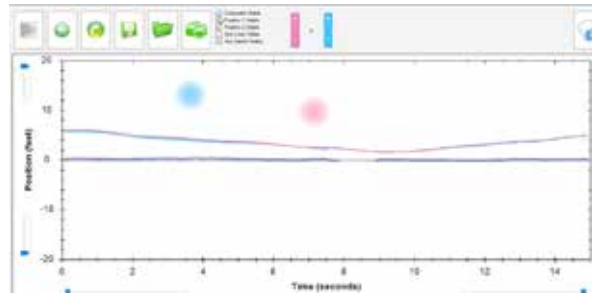


Figure 5: D keeps the difference graph on zero while walking

D: (...) You don't have to keep the remotes in (...) one position.

RN: Like, keeping [them] together?

D: keep them at the same level.

Commentary

D came to create a difference graph with a clear plan: stay still with the two remotes next to each other. He had a well-defined sense that a dark blue graph on the horizontal axis “converted” into the two Wiimotes being equally distant from the sensor. Moreover, D easily showed in Figure 5 that that condition was indifferent to his walking distance from the sensor (“You don't have to keep the remotes in one position”). The point, he said, was to “keep them at the same level.” His choice of words (“same level”) reflects a phenomenon, we think, of great significance: “level” is customarily a term for height, which was relevant to the light blue and pink graphs being at the same height, but not necessarily to the Wiimotes that could be at different heights while keeping equal distances to the sensor. D articulated an instance of a type of semiotic sliding between qualities of the graph and qualities of the remotes, such that they could apply indistinctly to one or the other.

Episode 3: Z works with the difference graph above and below the x-axis

In between Episodes 2 and 3 the children generated graphs to either keep the dark blue graph above or below the horizontal axis. Along that sequence, Z generated the graph shown in Figure 6.

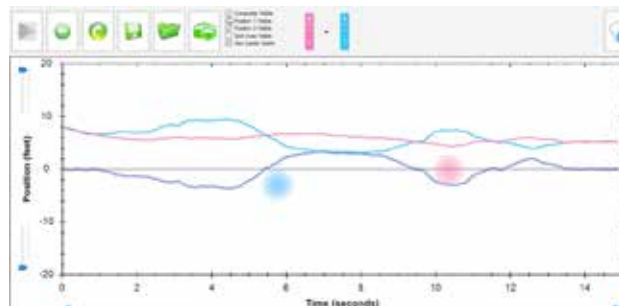


Figure 6: Z generates a graph in which the difference graphs goes above and below zero

RN: So, how did you change [the dark blue line] from below to above?

Z: Em, by changing which controller was in front.

RN: So which one was in front here? [points to the dark blue graph around the 4th second]

Z: Em, [light] blue.

RN: (...) And do you have a sense for why for the blue, for the dark blue line, to be below [the x -axis] then the pink has to be below [the light blue graph]?

Z: Em, yep. Em, it's something to do with like maths and, like, because on there, it says the [likely pointing at the light blue one remote on the screen] has been taken away and then it's hard to tell because it's not actual numbers but if you have more on one side, that will be a negative number... then, then, if you have them on the other side, it'll be a positive number, which is that [points to the screen with the remote].

Commentary

In this exchange Z describes qualitative differences of one kind (i.e. graphical configurations on the computer screen) and qualitative differences of another kind (i.e. bodily motions and postures) percolating onto each other. Sometimes these qualitative differences mutually communicate along critical points, such as the blue and pink Wiimotes being next to each other, as the condition that tips the cases of the minus graph being positive or negative. In other cases, the qualitative differences of each kind adopt corresponding ordinal arrangements along more or less, such as a Wiimote being closer or farther to the sensor bar matching its graph being higher or lower on the screen. Some of these qualitative differences can, in principle, be located on a metric scale, such as the distance between each remote and the sensor or the height of each graph at a given time. However, in this episode Z does not operate with metric scales. He said, for instance, “if you have *more on one side*, that will be a negative number” or “it’s not actual numbers.” Or he distinguished which remote is on front, rather than estimating distances between them. The focus of this commentary is to foreground ordinal arrangements of qualitative differences of unlike kinds, via critical points or corresponding alignments of more and less.

Discussion

In the introduction we distinguished the attainment of abstraction along paths of white or black light. Whereas the mode of white light calls for navigating a *surplus* or overabundance of sensible qualities, the case of dark light is one of deficit of sensible qualities enabling zones of vagueness. In the episodes described above, the radical expansion of relevant sensible qualities encompasses the infinite nuances of kinesthesia. In our commentary for Episode 1, we described such kinesthetic expansion as a vivid broadening of the sensory qualities at play.

The introduction also stated the question of this study: What kind of navigation arrives at abstraction across a *surplus* of sensible qualities, of the white light type (in terms of generals)? Our commentary to Episode 2 suggested a type of semiotic sliding between qualities of the graph and qualities of the remotes, such that they could apply indistinctly to one or the other. Additionally, in the commentary to Episode 3 we considered the notion of qualitative differences of dissimilar kinds percolating onto each other, either via critical points cutting across them or mutual exchanges between corresponding ordinal arrangements of differences of degrees (i.e. more/less). All these processes amount to opening channels of flow and exchange among sensible qualities, such that

these cease to be self-enclosed and start to configure a plane of unity, which, far from denying their differences, brings them into mutual circulation and, therefore, speaks directly to navigating generals.

References

- Blanton, M., Brizuela, B., Stephens, A., Knuth, E., Isler, I., Gardiner, A., . . . Stylianou, D. (2016). *Implementing a Framework for Early Algebra*. ICME-13 Monograph.
- Bodanskii, F. (1969/1991). The formation of an algebraic method of problem solving in primary school children. In V. Davydov (Ed.), *Soviet studies in mathematics education: Psychological abilities of primary school children in learning mathematics* (Vol. 6, pp. 275-338). Reston, VA: The National Council of Teachers of Mathematics.
- Carraher, D. W., Schliemann, A. D., Brizuela, B., & Earnest, D. (2016). Arithmetic and Algebra in early mathematics education. In E. A. Silver & P. A. Kenney (Eds.), *More Lessons Learned from Research* (Vol. 2, pp. 109-122). Reston, VA: NCTM.
- Clements, D. H. (2000). 'Concrete' Manipulatives, Concrete Ideas. *Contemporary Issues in Early Childhood*, 1(1), 45-60. doi: 10.2304/ciec.2000.1.1.7
- de Freitas, E. (2016). Material Encounters and Media Events: What Kind of Mathematics Can a Body Do? *Educational Studies of Mathematics*, 91, 185-202.
- Dreyfus, T. (2014). Abstraction in Mathematics Education. In S. Lerman (Ed.), *Encyclopedia of Mathematics Education* (pp. 5-8). Dordrecht: Springer Netherlands.
- Hershkowitz, R., Schwarz, B. B., & Dreyfus, T. (2001). Abstraction in Context: Epistemic Actions. *Journal for Research in Mathematics Education*, 32(2), 195-222. doi: 10.2307/749673
- Kaput, J. J. (2008). What is algebra? What is algebraic reasoning? . In J. J. Kaput, D. Carraher & M. Blanton (Eds.), *Algebra in the early grades* New York: Lawrence Erlbaum.
- Kaput, J. J., Blanton, M. L., & Moreno, L. (2008). Algebra from a symbolization point of view. In J. J. Kaput, D. W. Carraher & M. L. Blanton (Eds.), *Algebra in the early grades* (pp. 19-55). New York: Lawrence Erlbaum.
- Kieran, C., Pang, J., Schifter, D., & Fong Ng, S. (2016). *Early Algebra. Research into its Nature, its Learning, its Teaching*: Springer.
- Nemirovsky, R., Kelton, M., & Rhodehamel, B. (2012). Gesture and Imagination: On the Constitution and Uses of Phantasms. *Gesture*, 12(2), 130-165. doi: 10.1075/gest.12.2.02nem
- Nemirovsky, R., Kelton, M., & Rhodehamel, B. (2013). Playing Mathematical Instruments: Emerging Perceptuomotor Integration with an Interactive Mathematics Exhibit. *Journal of Research in Mathematics Education*, 44(2), 372-415.
- Ng, S. F., & Lee, K. (2009). The model method: Singapore children's tool for representing and solving algebraic word problems. *Journal for Research in Mathematics Education*, 40, 282-313.
- Noss, R., Hoyles, C., & Pozzi, S. (2002). Abstraction in Expertise: A Study of Nurses' Conceptions of Concentration. *Journal for Research in Mathematics Education*, 33(3), 204-229. doi: 10.2307/749725
- Peirce, C. S. (1994). *The Collected Papers of Charles Sanders Peirce* Vol. I-VI. C. Hartshorne & P. Weiss (Eds.).
- Radford, L. (2014). The Progressive Development of Early Embodied Algebraic Thinking. *Mathematics Education Research Journal*, 26(2), 257-277. doi: 10.1007/s13394-013-0087-2
- Roth, W.-M., & Hwang, S. (2006). On the relation of abstract and concrete in scientists' graph interpretations: A case study. *The Journal of Mathematical Behavior*, 25(4), 318-333. doi: <https://doi.org/10.1016/j.jmathb.2006.11.005>
- Serres, M. (2017). *Geometry. The Third Book of Foundations*. London: Bloomsbury Academic.

Color-coding as a means to support flexibility in pattern generalization tasks

Per Nilsson¹ and Andreas Eckert²

¹Örebro University, School of Science and Technology, Örebro, Sweden; per.nilsson@oru.se

² Örebro University, School of Science and Technology, Örebro, Sweden; andreas.eckert@oru.se

This study investigates how color-coding can support processes of flexibility in figural pattern generalization tasks. A lesson from a Grade 8 class serves the case for our investigation. The lesson is part of a larger research project, which is based on the iterative research methodology of design experiments and involves a total of six lessons, distributed over two classes (three lessons in each class). The study shows how coloring can encourage students to move from recursive strategies, like successive addition, and support processes of flexibility in linking algebraic expressions and the meaning of n to visual structures of an expanding figural pattern.

Keywords: Pattern generalization, visualization, color-coding, time-limitation, flexibility.

Introduction

In the development of algebraic thinking, students need to learn to see connections between the structure of a pattern and how the pattern can be described by a general algebraic expression (Rivera, 2010). It is crucial to discern a pattern unit when making such connections, around which a pattern structure can be modeled in relation to the place order of the elements in a pattern series (Nilsson & Juter, 2011).

Based on a constructivist methodology, educational research in mathematics has significantly contributed to our developing understanding of how students may obtain algebraic generalizations involving figural and numerical patterns. However, our knowledge is less extensive on how teaching can support the learning of pattern generalization (Rivera, 2010). In other words, if students need to learn to connect visual and symbolic elements effectively in relation to a structural unit, there is a need for further investigations on learning activities that can support that coordination to take place (Rivera, 2010). In this study we aim at making a contribution to such investigations by investigating how *color-coding* in task design (Watson & Ohtani, 2015) can support students' pattern flexibility in the visualization of structures in figural pattern generalizations (Figure 1). We address the research question: How can color-coding be implemented in task design to support flexibility in students' visual structure reasoning, in order to reach a general expression of a figural pattern?

Theoretical background

Individuals see patterns differently depending on how they perceive the structure of the pattern and conceptualize pattern-units (Rivera, 2010). Investigating 8-13 year old students' generalization of linear pattern Stacey (1989) found that the constant difference property was largely recognized and used as a unit to find the n^{th} element by a recursive process of successive addition of this property. Stacey also found that some students were using proportional reasoning, according to the constant difference property. However, when adopting proportional reasoning, Stacey saw that students may

tend to ignore additive elements of a pattern; a significant number of students used a direct proportional method, determining the n^{th} element as the n^{th} multiple of the difference. For instance, the constant difference is three in Task 5 (Figure 1). Applying a direct proportional method of the n^{th} multiple of the difference results in the generalization $3n$, which excludes the extra dot that must be added.

Successive addition of the constant difference property is limited to linear patterns. To develop

Task 5. Miriam was thinking according to the picture. Pick the expression you believe best matches her picture.

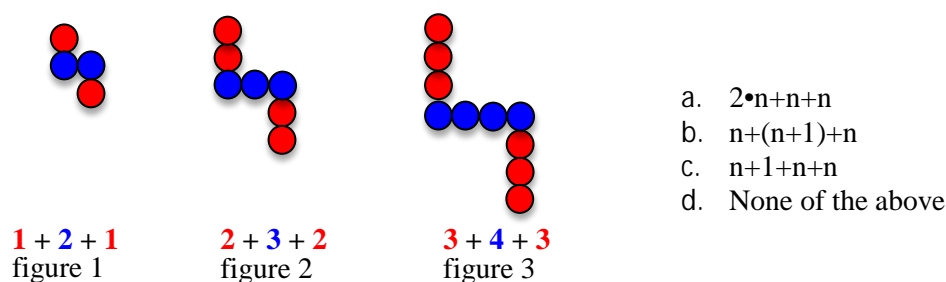


Figure 1: Color-coding in the expansion of a chair

general expressions of patterns where the difference between subsequent elements in the pattern is not constant (e.g. quadratic patterns) one needs to adopt visual structure reasoning (cf. Rivera, 2010; Stacey, 1989). In Task 5, the constant difference is three and, applying the strategy of successive addition, the number of dots for the fourth figure is found from $4 + 3 + 3 + 3$. If we generalize this strategy we reach the expression $3n + 1$. However, in visual structure reasoning we define the unit by partitioning the figures in appropriate parts, in relation to the place order of the figures (El Mouhayar & Jurdak, 2015). In Task 5 we can visually structure the third figure in threes. In other words, the third figure of the pattern is composed by three threes plus one extra dot. Similarly we find out that the fourth figure of the pattern consists of three fours, plus one extra dot. Obviously we come to the same general expression, $3n + 1$, as in the additive situation. However, important to note is that n has a different meaning in the two situations. In successive addition n gains meaning as the number of constant differences, related to the place value of the n^{th} element in the series, whilst in visual structure reasoning n is a structural feature of a figure.

Generalization tasks are often grouped in near generalization tasks and far generalization tasks (El Mouhayar & Jurdak, 2015). Near generalization tasks involve finding the value of a step that is close to previous steps and far generalization tasks consist of determining the value of a step that is relatively far from given steps. Previous research reports that while near generalization tasks are accessible to a majority of the students, solving far generalization tasks is not. In the present study we will use both near and far generalization tasks, to challenge pattern flexibility, towards the formulation of a general expression, which is based on visual structure reasoning.

It has been observed that, once students have fixed on a pattern in a certain way, it can be hard for them to give up their perception (Lee, 1996). The key to success of seeing an algebraically recordable pattern seems to be at the first stage of pattern perception, where a certain flexibility is necessary to hit on a mathematically recordable pattern (Zazkis & Liljedahl, 2002). Visualizations

of a pattern can provide strong support for the symbolic representation of a pattern (Healy & Hoyles, 1999). Perception, or visualization, in pattern generalization is however not a passive process (Nilsson & Juter, 2011). Getting insight to a problem situation includes an operative, analytical activity (Deliyianni, Elia, Gagatsis, Monoyiou, & Panaoura, 2009; Duval, 1998), like structuring a figure into appropriate parts and/or transforming a figure into another figure (Rivera, 2010). In the present study we will investigate how a teacher can use color-coding as a visual means for supporting flexible, visual structure reasoning, to reach a general expression for a figural pattern.

Method

Design research methodology

This study is part of a larger research project that investigates teaching and learning of pattern generalization. The project follows the methodology of design experiments (Cobb, Confrey, Lehrer, & Schauble, 2003), involving a lesson series of three consecutive lessons. The project team consists of two researchers, the authors of the paper, and two teachers (Teacher A and Teacher B). Teacher A taught a class of 13-year old students and Teacher B taught a class of 14-year old students. All lessons were developed and analyzed according to *prospective*, *reflective* and *retrospective* analyzes (Cobb et al., 2003). Each lesson was conducted twice: First in Teacher A's class and then in Teacher B's class. The changes made to Teacher B's teaching were based on reflective analyses of what happened in the corresponding lesson of Teacher A's teaching. In the present study we focus exclusively on Lesson 1.

Lesson 1 involved seven tasks, distributed through Socrative¹, and aimed to support flexibility in visual structure reasoning in pattern generalization. All tasks in Lesson 1 were situated in the task context of the growing chair-pattern (Figure 1) (Rivera, 2010). In Lesson 1, a time-limited far generalization task and color-coding were at the heart of the lesson. We focus, particularly, on Lesson 1B (Teacher B's class). However, the results of the study are based on a retrospective analysis of both Lesson 1A and Lesson 1B, and the relationship between them. All lessons were video-recorded from three different positions; one placed at back of the classroom, one at front of the classroom and one zooming in on a specific group.

The answers of each task were made available to both the teacher and the students, which were intended to reveal students' reasoning and create an opportunity for whole class discussion where students could react on each other's reasoning. No color-coding was added to the first four tasks. The first task was a near generalization task. Here the students were asked to figure out the number of dots in the 4th figure of the chair-pattern. The second task was a semi-far generalization task, where students were asked to figure out the number of dots in the 9th figure. The third task and follow up question were far generalization tasks about the number of dots in figure 1000. In the third task the students had a limited amount of time. They were asked to reflect on whether it was

¹ Socrative is an online student response system where teachers post questions that show up on students' devices and allows them to post answers. Answers become instantly available to the teacher, which s/he can choice to make available to the students.

possible for them to complete the task within a minute with the method they had been using in the second task. Until now the students were expected to reason according to the constant difference property, since that was how they had solved similar tasks in the past. Task four asked students about the meaning of n in pattern tasks. The task was supposed to challenge the students to start to reflect on how n can be connected to place order in a pattern. Figure 1 shows the fifth task, with a color-coded visual structure, designed to stimulate students' visual structure reasoning. The sixth and seventh task flipped task 5 around and asked the students to color-code different versions of algebraic expressions. First the students were asked to apply $n+(n+1)+n$ on the seventh figure; then, in task seven, they color-coded for example $(n+1)+(n-1)+(n+1)$. The tasks, and their relationship, aimed at furthering the students' flexible reasoning; to be flexible in ways of discerning visual structure units by reversing and expanding their reasoning in task 5. To open up for whole class discussions, the students were asked to share their color-coding by publishing them in Padlet².

Method of analysis

The analysis aimed to investigate how color-coding can support flexibility in students' visual structure reasoning, in order to reach a general expression of a figural pattern.

The analysis followed in chronological order, according to the sequence of the seven tasks. In the first step, we coded and grouped the data according to the ways in which students distinguished and built their reasoning on a pattern unit and connected a pattern unit to n , to the place order of the figure in question. Next, we investigated how they changed their way of reasoning about the chair-pattern during the lesson. Particularly, we looked in detail at how color-coding supported students to move from the strategy of successive addition to discern a unit in the visual structure of a pattern, connected to n , i.e. to the place order of the figure in question.

Result and analysis

Successive additive reasoning and n as a symbol for place order of any figure in the pattern

In the first task, 75% of the students claimed that the fourth figure contained 13 dots. Many students discerned three as the constant difference property of the pattern and used this property in successive addition. In order to challenge successive addition and to prompt proportional reasoning the teacher introduced Task 2 and 3. In Task 2 the students were asked to determine the number of dots in the ninth figure. While the students were working on the task, the teacher walked around in the classroom and listened to the groups. He noted that most students conclude that the ninth figure contains 28 dots and that they reached this by successively adding up by three. In order to challenge successive additive reasoning, the students were asked figure out the number of dots in the 1000th figure within one minute, based on the strategy they used in Task 2. This task stimulated monitoring processes (Stylianou, 2002); it challenged the students to reflect on their strategies and how efficient they were. The students submitted their individual answers in Socrative and about 40% of the students believed that they could not determine the number of dots in figure number 1000 within one minute. Strategies that the student found too time-consuming were, for instance, to draw all

² Padlet is an online virtual pinboard that allows students to publish contributions that can be instantly available for the whole class on the white board or on students' own devices.

figures and count the dots or to successively add threes. The formula $3n+1$ had not yet been expressed by the teacher or any student. But from students' group-work the teacher observed that some students expressed aspects of such reasoning. The teacher asked Charlie to explain:

Charlie: Because, as it [the pattern] constantly increases by three, you need to multiply thousand by three and then plus one.

Charlie gives further reasons for his strategy by showing how it works in an example were the number of dots of a figure is known to the class or can be visually confirmed:

Charlie: For instance, if we look at figure 3 [within Figure 1 above], it [the pattern] constantly increases by three, and we take three times three it will be nine and then, as it is ten [dots] there [pointing at the board], you need to add one more. And, then it is the same with the other; thousand multiplied by three plus one.

After the three first tasks we have reason to believe most students in the class came to understand that they can multiply the number of a given figure with three and then add one to reach the number of dots of any figure. However, a general algebraic expression involving n had not yet been formulated. In Task 4 the students were asked to post the meaning of n in Socrative. The most common posts were expressions of $3n+1$ and that n stands for any figure. The teacher asked, "Do we agree, everyone who agrees raise their hands, that n stands for any figure?" Almost all students raised their hands. That the students had a sense of n , as a symbol that stands for any figure, was assumed to be necessary for moving on to Task 5. Task 5 introduced color-coding as a means for supporting students to discern a unit in the visual structure of a figure, in relation to the place order of the figure in question.

Supporting structural flexibility by color-coding

The symbol n was now understood by most students in the class, as a symbol for place order of any figure in the pattern. However, up until now, n was seen as a variable, determining how many constant differences one should multiply to reach the number of dots in any figure. Tasks 5, 6 and 7 were designed to change perspective on n . The tasks were designed to stimulate students' pattern flexibility by pushing them to make sense of n in the visual structure of the expanding chair-pattern.

The students posted individual answers on Task 5 in Socrative. The result were rather even between alternative b) and c) (Figure 1). The students were then asked to discuss in their groups and to explain to each other how they were reasoning. After the group-discussion the students were asked to post an individual answer again and now the majority of students chose alternative b). George was asked to present his reasoning at the whiteboard:

George: I thought I would figure this out first [pointing to $(n+1)$ in the expression]. First I was thinking n plus one. It is this [pointing to the two blue dots in the first figure of the pattern]. This is the blue, one could say. n plus one. And, both of them [pointing to the two red dots in the first figure] are n .

According to flexible processes, George then said that alternative c), displaying $n+1+n+n$, is the same as alternative b). The only difference is the order of the signs. He implicitly manipulated the expression by visualizing a bracket in the expression $(n+1)+n+n$.

A number of students answered a), displaying $2 \cdot n + n + n$. The teacher asked why alternative a) was chosen. Charlie responded:

Charlie: It works for the first figure but not for the other.

We believe this is a relevant interpretation made by Charlie and, supported by his observation, we also suggest that deciding on alternative a) is based on calculations rather than on visual structural reasoning like the one George showed an example of. The color-coding implemented in the design of Task 5 helped George to externalize and show in public his way of reasoning. The design supported George to make sense of n in the visual structure of the pattern and to communicate his meaning making to the class by visually linking parts of the expression to the corresponding parts of the figure.

The class turned to Task 6, to color the seventh figure of the pattern according to $n + (n+1) + n$. In Task 5 the class observed and followed how George linked an algebraic expression to the color-structure of the pattern figures. Task 6 aimed at letting students make sense of and generalize this idea according to a new figure. The students worked in pairs. As they finished, they posted and made their solutions public at the whiteboard. The group-solutions witnessed the fact that several students had changed perspective of the meaning of n , to see n in the structure of the figures. The teacher picked out Rikki's solution to Task 6, where the link between the algebraic expression and the coloring was evident and proper according to the task (Figure 2).

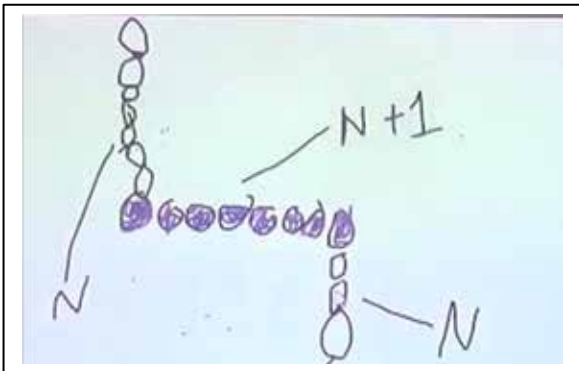


Figure 2: Rikki's color-solution to Task 6

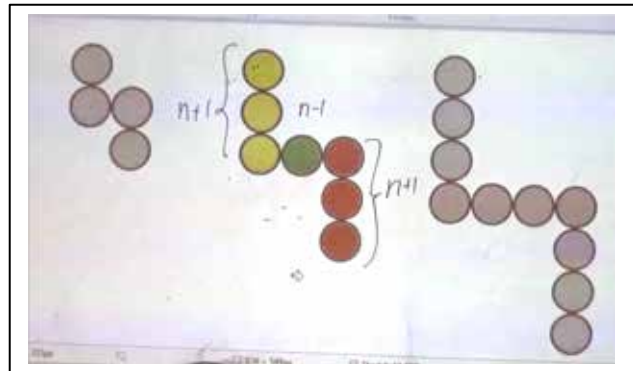


Figure 3: Rikki's color-solution to Task 7

Rikki: First I was taking $n+1$ [saying something audible] and, then I draw that in the middle [The teacher points to the vertical line of eight dots that Rikki has colored in blue]. n is the number of the figure, thus seven [the teacher is nodding in confirmation]. But then it was plus one so, then I did eight. And then it was n on the other sides. Seven down and seven up [the teacher moves his hand over the picture to illustrate down and up of the seven dots Rikki is referring to].

In Task 7 the students were working in pairs and used Paint to color other expressions in the pattern. The teacher noted that Rikki solved the first subtask of Task 7, coloring $(n+1) + (n-1) + (n+1)$. For some reason the teacher did not succeed in presenting Rikki's own solution on the board. Instead, he showed an uncolored picture of the three first figures of the pattern and asked Rikki to guide him through the coloring of $(n+1) + (n-1) + (n+1)$ in the second figure of the pattern (Figure 3). That the teacher failed in up-loading Rikki's solution became something positive from a teaching

perspective. Now Rikki was forced to give details of her reasoning so the teacher was able to understand how he should color the figure. Moreover, in the dialogue between the teacher and Rikki, the rest of the class was provided an opportunity to follow, in detail, how the solution was constructed.

Concluding discussion

In this paper we addressed the research question: How can color-coding be implemented in task design to support flexibility in students' visual structure reasoning, in order to reach a general expression of a figural pattern? In answering the research question, we have shown how coloring in pattern generalization can stimulate processes of flexibility (Stacey, 1989) in linking algebraic expressions and, particularly, the meaning of n to visual structures of expanding figural patterns.

The present study sheds new light on task-design to support reflection on visual structures (Rivera, 2010) and pattern flexibility (Nilsson & Juter, 2011). In pattern generalization, the first stage of pattern perception is crucial, where a certain flexibility is necessary to hit on a mathematically recordable pattern (Zazkis & Liljedahl, 2002). To move beyond linear pattern generalizations one needs to discern a unit from the visual structure of a pattern, connected to the place order of the pattern-figures (El Mouhayar & Jurdak, 2015). The present study shows how color-coding can support such processes of flexibility by turning students' attention to the relationship between an algebraic expression and visual structures of the pattern. The color-coding prompted the students to change perspective of n , from a number variable (how many threes to multiply) to a visual unit in the structure of a figure. In particular, the analysis shows how implementing coloring in pattern generalization task, supported students in discerning and making sense of n in the relationship between n in the structure of a general expression and n in the structure of a figure.

The role of far generalization tasks, and the added condition of time-limitation, has not been the main focus in the present study because of limited empirical evidence. However, the analysis indicates that it might be worth re-considering the role of far generalization tasks in the learning of pattern generalization. Previously, research has focused on students' difficulties to account for far generalization tasks and how students find them more difficult than near generalization tasks (El Mouhayar & Jurdak, 2015). Near generalization tasks can be handled by recursive reasoning, which is not as applicable to far generalization tasks. Recursive reasoning necessitates that the preceding value of the pattern is known. So, to determine the value of the 1000th figure, one needs to know the value of figure number 999. The present study also shows that students find a far generalizing task more difficult than near generalization task due to recursive reasoning, coming in the form of successive addition. Challenging students to a far-generalization task did not support multiplicative, proportional, reasoning in a direct sense. However, the analysis shows how it made students reflect on and examine limitations of a recursive, additive approach and come to be responsive to proportional reasoning. Hence, instead of just accounted for students' difficulties, the far generalization task provided the teacher a context for exposing the limitation of successive additive reasoning and for highlighting and emphasizing multiplicative structures. In the present study the teacher created such a context by making Charlie's reasoning in Task 2 public.

The outcome of the present study calls for further research in the realm of task and lesson design (Watson & Ohtani, 2015). Still many questions are open on a patterning approach to algebra. We need to know more about tasks that challenge students' flexible reasoning and engage students in visual structure reasoning. We encourage research to further explore coloring as principles for

designing tasks in authentic practices of algebra teaching. The current study also indicates the need to carefully sequence tasks in pattern activities, in order to encourage processes of reflection and flexibility that move students' understanding towards multiplicative, structural, reasoning, which can be used to handle patterns that go beyond linear patterns.

References

- Cobb, P., Confrey, J., Lehrer, R., & Schauble, L. (2003). Design experiments in educational research. *Educational Researcher*, 32, 9-13.
- Deliyianni, E., Elia, I., Gagatsis, A., Monoyiou, A., & Panaoura, A. (2009). A theoretical model of students' geometrical figure understanding. In V. Durand-Guerrier, S. Soury-Lavergne, & F. Arzarello (Eds.), *Proceedings of the Sixth Congress of the European Society for Research in Mathematics Education* (pp. 696-706). Lyon, France: CERME.
- Duval, R. (1998). Geometry from a cognitive point of view. In C. Mammana & V. Villani (Eds.), *Perspectives on the Teaching of Geometry for the 21st century* (pp. 37-51). Dordrecht: Kluwer Academic.
- El Mouhayar, R., & Jurdak, M. (2015). Variation in strategy use across grade level by pattern generalization types. *International Journal of Mathematical Education in Science and Technology*, 46, 553-569.
- Healy, L., & Hoyles, C. (1999). Visual and symbolic reasoning in mathematics: Making connections with computers? *Mathematical Thinking and Learning*, 1, 59-84.
- Lee, L. (1996). An initiation into algebraic culture through generalization activities. In N. Bednarz, C. Kieran, & L. Lee (Eds.), *Approaches to algebra: Perspectives for research and teaching* (pp. 87-106). Dordrecht: Kluwer Academic Publishers.
- Nilsson, P., & Juter, K. (2011). Flexibility and coordination among acts of visualization and analysis in a pattern generalization activity. *The Journal of Mathematical Behavior*, 30, 194-205.
- Rivera, F. (2010). Visual templates in pattern generalization activity. *Educational Studies in Mathematics*, 73, 297-328.
- Stacey, K. (1989). Finding and using patterns in linear generalising problems. *Educational Studies in Mathematics*, 20, 147-164.
- Stylianou, D. A. (2002). On the interaction of visualization and analysis: the negotiation of a visual representation in expert problem solving. *The Journal of Mathematical Behavior*, 21, 303-317.
- Watson, A., & Ohtani, M. (Eds.). (2015). *Task design in mathematics education: An ICMI study 22*. Berlin: Springer.
- Zazkis, R., & Liljedahl, P. (2002). Generalization of patterns: The tension between algebraic thinking and algebraic notation. *Educational Studies in Mathematics*, 49, 379-402.

A classification scheme for variables

Reinhard Oldenburg

University of Augsburg, Germany; reinhard.oldenburg@math.uni-augsburg.de

This theoretical paper presents a framework for the classification of variables (as used in school) that goes beyond traditional classifications by clustering variables according to their syntactical, semantical and pragmatological properties. Moreover, the paper associates certain emotional qualities to these aspects of variables and indicated how they help in understanding students' misconceptions.

Keywords: Variable, semantics, classification.

Introduction

Several variable classifications have been proposed. Küchemann (1979) has distinguished empirically several ways to use letters. The question what these letters are from an ontological point of view is not in the focus. Usiskin (1988) describes four conceptions of algebra and the use of variables in each conception. The discussion of what a variable is and how it is used is mixed up. In the German speaking countries, the work of Malle (1993) has been influential who defined three aspects of variables: Variables as placeholders, as calculus elements and as objects. Ely & Adams (2012) describe three usages of variables: unknown, placeholder, variable. Other topics of interest have been the ability to see structure and connections to computer science (Arcavi 1994; Heck 2001). A common defect of these approaches is that there is no clear distinction between the question of what a variable is and how it is used. Moreover, a perspective on the concept development is missing.

Linguistic as a basis

Starting with C. W. Morris (1938) linguistics distinguishes three aspects of language: syntax, semantics and pragmatics. Syntax comprises the formal rules that govern how signs are arranged and treated. Semantics deals with the references to objects and clarifies what is meant by syntactically well-formed expressions. Pragmatics is about the use of language that is adequate in certain situations.

The syntax of languages can be described by grammars. But knowing the syntax of algebra is neither sufficient nor fully necessary to be successful in algebra (Hodgen, Küchemann & Oldenburg, 2011).

Understanding the semantics is the next building block. Semantics is about the interpretation of signs, especially it clarifies how signs refer to objects (cf. Honderich, 1995, p. 820). In algebra inadequate semantic ideas held by students are e.g. that variables stand for real world objects or that different occurrences of the same variable can stand for different objects.

The last aspect is that of pragmatics. In linguistics this is a somewhat fuzzy concept. In (Honderich, 1995) the following definition is given: "The study of language which focuses attention on the user and the context of the language use rather than on reference, truth or grammar." Levinson (2013) discusses several possible definitions, e.g. "Pragmatics is the study of those relations between language and context that are ... encoded in the structure of the language."; that is, the language reaches out in a sense to link with the situation. This high-lights the importance of context!

These three aspects of language will now be used to analyze different notions in turn.

Detailed analysis of the concept of variable

While a lot has been written about variables, it is not that clear what questions are answered. From the perspective of language levels one may ask three questions about variables (here variables is used in a wide sense, including all symbolic uses of letters, not just varying quantities):

- What do variables look like? (syntax)
- What do they mean, i.e. what are they and how are they related to other entities? (semantics)
- How (and to what end) are variables used? (pragmatics)

From this perspective, one sees that the various authors answer different questions. Küchemann (1979) describes how letters are *used*, but nevertheless his classification is not purely pragmatical but also semantical. Malle (1993) uses the word “aspect” and claims that all variables can be seen under each of his three aspects. This suggests that he discusses different pragmatical ways of variable use too, but in fact his aspects (placeholder, object, symbol) are semantical in nature. Heck (2001) states that variables can hardly be defined because there are so many different uses of them. Among the semantical considerations in the literature, many are somewhat unclear. One example is the conception that a variable represents a set of numbers simultaneously (Malle, 1993). As I shall show, this is at odds with sound logical semantics of variables. Summarizing, it seems that most authors give diverse answers to the question what variables are, even on the semantical level. In this paper I start from scratch and give an exposition that covers, I hope, all relevant aspects on all levels.

The syntax of variables

Little is to be said about the syntactical aspect of variable: In most cases, they are letters, on others they are compound symbols such as $x_1, x_i, f(x)$. (Syntax of expressions is richer, of course.)

The semantics of variables

What are variables? I have partially answered this question in (Oldenburg, 2015) and will build upon this in this paper. It turns out that there are two questions that distinguish different kinds of variables:

1. Is the variable a part of language used to talk about mathematical objects, or is it a mathematical object itself?
2. How is the variable linked to its value? Is it a container for or a reference to something?

Here “something” is typically a number or other mathematical object (e.g. vectors, functions, points).

Now, from the two 2-fold distinctions a table can be presented:

Variable is...	Container C	Reference R
An object in its own right: OLA	Placeholder that may contain a number or something: OLA-C	A symbolic object with properties like domain, current value etc.: OLA-R
An element of the language used to speak about objects: LLA	A gap in a sentence to fill in the name of a number or something: LLA-C	A symbol without properties, its only function is to refer: LLA-R

Table 1: Four semantical kinds of variables. (OLA=Object Level Alg., LLA=Language Level Alg.)

Before looking in more detail on this four kinds of variables, I state the hypothesis that there are no more kinds necessary. Especially, concepts like parameters or unknowns are best distinguished on the pragmatic level as will be explained in the next section.

The distinction in this table separates kinds of variables by ontology: They are different not only in their usage but in their being, as I shall show. Yet, all these four kinds are variables in the sense that variables used in mathematics books can be classified into this table and all cells are non-empty.

The upper row (variables as objects) will be called object level algebra (OLA) and the lower row language level algebra (LLA). With this distinction I build on the one of (Oldenburg 2015) but using a somewhat adapted terminology. Moreover, the columns are abbreviated by an appendix C (container) or R (reference) so that the four cells are OLA-C, OLA-R, LLA-C, LLA-R.

OLA-C: Given the equation $5+\square=8$ one inserts 3 into the placeholder to get $5+\boxed{3}=8$. Here the placeholder contains the number, and it is a real object. It still exists after insertion of the number and one may move it around, e.g. to get $\boxed{3}+5=8$. One could operate on these objects, e.g. by drawing different kinds of boxes and moving them as in $\square+\square=\square+\square$.. This kind of variables are sometimes introduced by textbooks using ten metaphor that the variable is a match box (an object) that contains a certain number of matches – the variable’s value.

LLA-C: Given the equation $5+\square=8$ one replaces the placeholder to get $5+3=8$. Here the placeholder was only a language element, a marker of a spot to complete an expression.

LLA-R: Variables are like flexible names, they name some objects, but are not objects themselves. A typical example is given in Fig. 1: Variables there are letters that refer to certain values - they have no further properties, they are just names that link to (i.e. refer to) a value.

2 Übertrage die Tabellen ins Heft. Setze für z sowie a, b und c die angegebenen Zahlen ein. Vergleiche die Ergebnisse in den Spalten.

a)	z	$2 \cdot z$	$7 - z$	$4 \cdot z + 2$	b)	a	b	c	$a \cdot b + c$	$a + b \cdot c$	$a \cdot c + b$
	1	2	6	6		1	2	3	5	7	5
	2	4	5			2	3	4	10	14	
	3	6				3	4	5	17		
	4					4	5	6			

Figure 1: LLA-R use in a German grade 5 school book (Formel 5, Buchner Verlag)

OLA-R: Consider the idea of variation with typical questions such as “how do x and y change together?” If x, y where just (not yet fixed) names for numbers in the sense of LLA-R, then one could substitute them with their referents, but it would be senseless to ask e.g. “how do 5 and 9 change together?”. Hence, these are objects of thought with their own properties. The same holds true in sentences like “ x increases”.

This distinction solves question 1 from above: In case of LLA, the set $\{x, y\}$ (over \mathbb{R}) has one or two elements (numbers), depending on $x = y$, in OLA it has two elements, namely two variables (that may have the same value).

Note that the standard view of mathematical logic – basically coined by Tarski, see (Tourelakis, 2003) – is that of LLA-R¹. In modern logic, variables are syntactical elements of the language of logic. The semantics is defined in terms of interpretations which link each variable to an object it refers to. It should be noted that every horizontal row of Figure 1 gives an interpretation for the variables of the expression so that this seemingly abstract concept from logic is very graspable for students.

LLA variables are used in most programming languages (C, Java², Python, Prolog). Most variables are of reference types, but not all.³ That most programming languages don't use OLA follows from the simple fact, that the symbols (the variable names) are usually not contained in the compiled binaries and that they cannot be stored in data structures (only their values can). In contrast, the languages of computer algebra systems usually allow variables to be stored in lists and sets and so they are (first class, in computer slang) objects and hence OLA variables. This argument is technical, but it shows several important things: First, the distinction can be clearly applied in this area. Second, it lies not in the eye of the observer what kind a variable is, it is not a question of how the variable is used or viewed, but it depends on the way semantics is realized by the language. Third, taking into account the details given in the footnote one sees that all four kinds are realized in languages.

A tricky point comes from the fact one may have LLA-variables that refer to OLA-variables. This is the case e.g. when one considers polynomial rings: In a formula like $p = 2x^2 - 1 \in \mathbb{Z}[x]$ the p is a language reference LLA-R while x is an object in the sense of OLA, because the domain of objects is $\mathbb{Z}[x]$. Note that the variable x of $\mathbb{Z}[x]$ cannot be LLA, because it can be assigned as a value to other variables. Moreover, $x^2 + x \in \mathbb{Z}_2[x]$ cannot be build up from a LLA variable, because for all objects from \mathbb{Z}_2 that x may refer to or stand for or contain, the value is 0: $1^2 + 1 = 0$, $0^2 + 0 = 0$. Thus, if x was just a language element that refers to some element of \mathbb{Z}_2 then this polynomial would be just 0.

While for logic that deals with established math LLA-R (where some special domains like the polynomials may contain OLA-R variables) is sufficient, I suppose that in the process of developing mathematics the upper row is important as well and I suppose that learners initially have least problems with OLA-C (match box metaphor). This is also supported by the following empirical observation: When asking students, teachers and mathematicians what they see in their mind after inserting the solution into $5 + \square = 8$, most students say 'three in the box', teachers are undecided and most mathematicians opt for 'three without box' – supporting that this is a question of expertise level.

1 There has been some discussion about LLA-C as an alternative to LLA-R for variables in first order logic, see (Quine, 1974) for a thoughtful discussion which finally rejected LLA-C. This discussion is interesting from an educational point of view, but I have to skip it due to limited space.

2 In Java, a statement like `int n=1;` clearly defines a LLA-R variable. However, there is a subtle trick to have a kind of OLA-C variable: `Integer m= new Integer(5);` defines a LLA-R variable m which refers to an unnamed object which is in fact a OLA-C variable, namely a container for a value.

3 For example in the C programming language one may define the maximum of two numbers either by a function `int max(int a, int b) {return a>b?a:b}` or by a macro `#define max(a,b) {a>b?a:b}`. In the first version a and b are LLA-R, in the second LLA-C variables.

One should note that these different kinds of variables are present in the literature, but it seems that they are mixed up with the use of variables (which I will deal with in the next section) and on the other hand, often authors claim that one view is the correct one, while the claim of this paper is that these are different kinds of variables. Container types being typical for young learners while the reference types are more common among educated mathematicians. Within the reference types the two kinds of variables (OLA-R, LLA-R) is changing according to the development status of the theory. The object variables are more typical for math in the phase of development, while the language view is typical, when the domain of objects is completely understood and well-constructed.

This subsection closes with some quotes that illustrate how different researchers' positions can be located within the theoretical framework outlined above. Bardini et al. (2005) take the view that variables are objects (in the sense of OLA-R): "In the generalization of patterns, letters such as 'x' or 'n' appear as designating particular objects - namely, variables. A variable is not a number in the arithmetic sense. [...] A variable is an algebraic object.". Moreover, they distinguish different kinds of these objects: "Yet, the algebraic object 'variable' should not be confounded with another algebraic object -the 'unknown'". For Linchevski (2001), on the other hand, variables are transparent language elements in the sense of LLA, not objects in their own right: "Operating on and with the unknown implies understanding that the letter is a number. It does not only symbolize a number, stand for a number, and it does not only tag/label/sign for an unknown number." (p. 143). Epp (2005, p. 54) states: "variables are best understood as placeholders", which follows the standard mathematical logic but may be problematic in educational contexts. Summing up, there is no consensus of what variables are, but I claim that the four types constitute a sound basis for didactical research.

The pragmatics of variables

What most publications on variables discuss, is not what variables are (the semantics), but how variables are used, in what context and for what purposes, i.e. the pragmatics of variables.

A pragmatical distinction from the logic literature that plays only a modest role in educational texts is that between bound and free variables. The point here is simply that the quantification does not alter the variable. The variable itself has the same semantics, regardless of it being free or bound.

There is, however, still a lot to say about the pragmatics of variables. Let's first make a detour into research on computer science education. Sajaniemi (2002) has introduced the notion of a "role of a variable" in (procedural) programming languages. He identified (by analyzing code written by a large number of programmers) several roles, e.g. fixed value (constant), stepper (stepping through a succession of values), follower (a variable that always gets its new value from the value of another variable), most-wanted holder (a variable holding the best value encountered so far). All these roles can be taken by the very same variables of a programming language. The variables' semantics is fixed by the language - the difference here is thus not on semantics but on the pragmatical level. Sajaniemi found that explicitly teaching these roles to novice programmers boosts their learning process. It seems likely that the same may be achieved in mathematics education.

So, what could be variable roles in elementary algebra? The literature gives many hints on this and without tracing back every role to the various studies that have dealt with it, I'll simply present:

- Variable used as a fixed number: $r=5, \pi=3,141\dots$, often such variables are called constants or parameters, depending on the extent to which one expects their reference to be changed.
- Unknown. A number (or more general object) that is (not yet) known
 - It may be a number to be detected (e.g. as the solution of an equation – non-uniqueness causing some troubles eventually).
 - It may be a reference used to argue about it (“tentative number”), e.g. the length of some segment in a construction.
- General number: A reference to or container for many possible values. This can be:
 - an open form (e.g. an odd number $2n + 1, n \in \mathbb{N}_0$).
 - a changing quantity (e.g. the value of an observable (like time, charge, money,...)).

It is a nice exercise to go through all these uses and imagine how they can be realized on the semantical bases of each of the four types of variables.

Some more issues

Working successfully on problems requires competences on all three aspects. To illustrate this, I take the example to choose between two car rental offerings with ingredients like base price and a price per driven kilometer. On a pragmatical level one asks: What is the adequate mathematical tool? Table, graph, equation, inequation? Let’s choose the latter. Then to semantics: Reference to relevant quantities are to be fixed: Let n be the number of kilometers to be driven. Then the prices of the two offerings are linear expressions in n and the condition that the first offering is better is e.g. $50 + 1.5n < 30 + 2n$. Now it comes to syntax (transformation according to rules). At the end one goes back to semantics (the meaning is to be clarified) and pragmatics (is it useful after all?).

The structure of this is displayed in the following table.

Phase	1	2	3	4	5	6
Situation	Problem					
Pragmatics		Choice of math				Application
Semantics			Fix references		Interpretation	
Syntax				Work formally		

Table 2: Phases of mathematical problem solving

In each phase the higher aspects guide work on the lower ones. The situation guides the pragmatical decisions and they in turn the semantical decisions. Finally, syntactical work is guided by semantics.

There is a certain analogy with the modelling circle of (Blum & Leiss 2005). This is not by accident: Modelling is essentially a translation process and hence language aspects come into play. Setting up the real world model requires pragmatic arguments, setting up the mathematical model is a semantical activity. Working inside a formalism is syntactical. When going back to real world, semantical issues come in again and in validation one has to deal with pragmatical issues.

One may object that assigning the labels syntax/semantics/pragmatics to the modelling circle does not give new insights but just groups together phases that are labeled by more specific concepts from the modelling theory such as mathematicising and validation. However, combined with the table above one may get a deeper understanding of the control flow inside modelling processes.

Emotional dimensions

The theory of somatic markers (Damasio, 1996) assigns emotions the task to guide decisions. The word „decision“ has been used in the presentation above several times. This is not by accident. Doing math means taking a lot of decisions, e.g.: Table or Graph? Introduce one or two variables? Factorize or expand? To decide quickly on such cognitive questions emotions are important. Teacher experience is that students hold strong feelings for certain mathematical objects or situations. Research on emotions and math is mostly devoted to negative emotions (fear) and not specific to mathematical objects itself (cf. discussion in Trezise & Reeve (2014)). Trezise and Reeve view this as a shortcoming and they investigate emotional influence on doing algebra, not the direct connection between mathematics and emotions. However it seems plausible that there are emotions (in the generalized sense of (Silvia, 2009)) aligned with specific mathematics. I suggest:

Aspect	Emotion(al source)	Examples of situations with positive (p) and negative (n) emotions
Pragmatics	Utility	p: full decision tree, that handles all cases gives satisfaction n: Table that misses some obvious cases
Semantics	Logical soundness, clarity	p: successful check n: paradoxes
Syntax	Beauty, well-formedness, conformity	n: $3(4+)$ looks ‚broken‘ p: $1+x+x^2+x^3$ looks well ordered

Table 3: Language aspects and emotions

While this table cannot discuss the issue completely (e.g. neglects individual differences) I suppose that the role of emotions in guiding algebraic actions might provide a deeper understanding of algebraic thinking. Research mathematicians use the words beautiful/ugly very often. Related is the notion of algebra sense (e.g. Arcavi, 1994) that may have an emotional basis too.

More algebraic examples

Here I show that linguistic levels are useful in interpreting students' errors. Consider the task to set up and solve an equation for this situation: "There are 84 balls of two colors and there are 10 more red than blue." It was found that even university level teacher students had problems of 3 categories: 1st: Pragmatic difficulties: Use of function (e.g. $f(r, b) = r + b + 10$) or other in-adequate math. 2nd: Semantic difficulties: Many students worked with unclear references, e.g. $r + (r + 10) = 84$. 3rd: Syntactic difficulties: E.g. from the correct system $b + r = 84, r = 10 + b$ one student concluded $r = b - 84$ and thus $b - 84 = 10 + b$ which, surprisingly, turned out to have no solution.

References

- Arcavi, A. (1994). Symbol sense: Informal sense-making in formal mathematics. *For the Learning of Mathematics*, 14(3), 24–35.
- Bardini, C., Radford, L., & Sabena, C. (2005). Struggling with variables, parameters, and indeterminate objects or how to go insane in mathematics. In H. Chick & J. Vincent (Eds.), *Proceedings of the 29th Conference of the International Group for the Psychology of Mathematics Education* (Vol. 2, pp. 129–136). Melbourne, Australia: PME.

- Blum, W., & Leiss, D. (2007). How do students and teachers deal with mathematical modelling problems? The example Sugarloaf and the DISUM project. In C. Haines et al. (Eds.), *Mathematical modelling: Education, engineering and economics*. ICTMA12 (pp. 222–231). Chichester, UK: Horwood.
- Damasio, A. (1994). *Descartes' error: Emotion, reason, and the human brain*. London: Random House.
- Ely, R., & Adams, A. (2012). Unknown, placeholder or variable: What is x ? *Mathematics Education Research Journal*, 24, 19–38.
- Epp, S. (2011). Variables in mathematics education. In P. Blackburn, H. van Ditmarsch, M. Manzano, & F. Soler-Toscano (Eds.), *Tools for teaching logic* (pp. 54–61). New York: Springer.
- Heck, A. (2001). Variables in computer algebra, mathematics and science. *Int. J. Comput. Algebra Math. Educ.* 8, 3, 195–221.
- Hodgen, J., Küchemann, D., & Oldenburg, R. (2013). Syntactic and semantic items in algebra tests – a conceptual and empirical view. In B. Ubuz, Ç. Haser, & M-A. Mariotti (Eds.), *Proceedings of the Eighth Congress of the European Society for Research in Mathematics Education (CERME 8)* (pp. 500–509). Ankara, Turkey: Middle East Technical University and ERME.
- Honderich, T. (Ed.). (1995). *The Oxford companion to philosophy*. Oxford: Oxford University Press.
- Küchemann, D. (1979). Children's understanding of numerical variables. *Mathematics in School*, 7, 23–26.
- Levinson, St. (2013). *Pragmatics*. Cambridge: Cambridge University Press.
- Malle, G. (1993). *Didaktische Probleme der elementaren Algebra*. Wiesbaden, Germany: Vieweg.
- Morris, C. W. (1938). *Foundations of the theory of sign*. Cambridge: Cambridge University Press.
- Oldenburg, R. (2015). Algebra at the meta and the object level. *Turkish Journal of Computer and Mathematics Education*, 6(3), 366–379.
- Quine, W. v. O. (1974). *The roots of reference*. La Salle: Ill: Open Court Publishing Company.
- Sajaniemi, J. (2002). Visualizing roles of variables to novice programmers. *Proceedings of the Fourteenth Annual Workshop of the Psychology of Programming Interest Group (PPIG 2002)* (pp. 111–127). <http://www.ppig.org/workshops/ppig-2002-14th-annual-workshop>.
- Silvia, P. J. (2009). Looking past pleasure: Anger, confusion, disgust, pride, surprise, and other unusual aesthetic emotions. *Psychology of Aesthetics, Creativity, and the Arts*, 3(1), 48–51.
- Treize, K., & Reeve, R. A. (2014). Working memory, worry, and algebraic ability. *Journal of Experimental Child Psychology*, 121, 120–136.
- Tourlakis, G. (2003). *Lectures in logic and set theory. Vol. 1: Mathematical logic*. Cambridge: Cambridge University Press.
- Usiskin, Z. (1988). Conceptions of school algebra and uses of variables. In A. F. Coxford & A. P. Shulte (Eds.), *The ideas of algebra, K-12* (pp. 8–19). Reston, VA: NCTM.

Transforming equations equivalently? – theoretical considerations of equivalent transformations of equations

Norbert Oleksik

University of Würzburg, Germany; oleksik@dmuw.de

Although algebraic transformations of equations are commonly used to identify solutions of equations, it remains unclear, which transformations are explicitly considered to be equivalent transformations, and which are not. Therefore, equivalent transformations of equations are analyzed, by using the notions of concept image, concept definition, aspect, and Grundvorstellungen, as well as their relations to each other. Different formal concept definitions of equivalent transformations of equations are examined to get a first impression of possible characteristics of concept images. As a further approach, Grundvorstellungen are derived from aspects of the equivalence of equations and put in relation to the theory of concept images. Different contradictions can be identified using these notions, which are possible sources of misconceptions.

Keywords: Grundvorstellungen, aspects, mathematical concepts, mathematics education.

Equivalent transformations of equations

Learners of mathematics are being introduced to equations in primary school. Simple arithmetic equations are to be solved by adding, subtracting, multiplying, and dividing numbers. In secondary schools, with the shift from arithmetic to algebra, variables are expressed by the use of letters. This is usually when pupils are introduced to more formal techniques of solving equations. They are transformed to other equivalent equations, so that a formula can be applied, or the solution is apparent (as in the case of the equation $x = 3$). Since equivalent transformations of equations are a central tool for solving equations, the concept of equivalent transformations of equations should be well defined and known to every mathematician and teacher of mathematics. When considering the following two equations, the question whether the initial equation was transformed equivalently provides room for discussion:

$$x^2 = 4 \quad (x \in \mathbb{R})$$

$$x^4 = 16 \quad (x \in \mathbb{R})$$

Squaring the expressions of an equation is usually not considered to be an equivalent transformation of an equation (e.g. Vollrath & Weigand, 2007, p. 214), although it may lead to an equivalent equation, as in the example above. In order to analyze why some transformations are considered to be equivalent transformations, while others are not, even though they share the feature of leading to an equivalent situation, the theory of concept image and concept definition by Tall and Vinner (1981) is used. This theory will then be related to Grundvorstellungen, which has a long tradition in Germany, due to the works of vom Hofe (2016), using a model provided by Greefrath, Oldenburg, Siller, Ulm, and Weigand (2016), which offers a further approach to the concept image. Subsequently the geometric model for teaching transformations of equations as described by Filloy, Puig, and Rojano (2008) is being discussed in regard to the following theoretical considerations.

Concept image and concept definition

An individual's view on a mathematical idea is not only shaped by the subject matter itself but also by further experiences. Therefore, Tall and Vinner (1981) differentiate between mathematical concepts and cognitive processes which resemble an individual's understanding of the concept. For the latter the term *concept image* is used "to describe the total cognitive structure that is associated with the concept" (Tall & Vinner, 1981, p. 152). When looking at the two equations above one may associate functions, variables, or something else with them. Given that within literature squaring is not considered to be an equivalent transformation of equations, it seems rather unlikely that the concept of equivalent transformation of equations is associated with the two equations above. It may even be declined to consider this as an equivalent transformation. Which leads to the assumption that the individual's concept image of equivalent transformations does not contain the operation of squaring. The question that naturally raises, from this little theoretical discourse, is how equivalent transformations of equations are defined. For this matter the term *concept definition* is used, which is "a form of words used to specify that concept" (Tall & Vinner, 1981, p. 152). A concept definition of an individual is referred to as *personal concept definition* and is not necessarily correct or existent (Tall & Vinner, 1981, p. 152). In contrast to the possibly erroneous personal concept definition, the formal concept definition is "accepted by the mathematical community at large" (Tall & Vinner, 1981, p. 152). It should be mentioned, that one can be able to state a "correct formal concept definition whilst having an inappropriate concept image" (Tall & Vinner, 1981, p. 153). It is the concept image that gives meaning to the concept definition (Greefrath et al., 2016, p. 103), while the definition may be just a memorized sequence of words. Prior to planning an empirical investigation of individual concept images and personal concept definitions of the concept of equivalent transformations of equations, it seems wise to examine the concept of these transformations theoretically by comparing different formal concept definitions.

Formal concept definitions of equivalent transformations of equations

Equivalent transformations of equations can be defined as transformations which do not alter the solution set (Vollrath & Weigand, 2007, p. 242). In this definition no further information is given about the characteristics of a transformation. The key is the property of not losing or adding any solutions of (or to) the equation, which is crucial when it comes to solving equations. This would lead to the conclusion that the example above is an equivalent transformation of equations.

Walz (2017, p. 361) defines equivalent transformations of equations in contrast to transformations which *possibly* alter the solution set, which justifies the claim of squaring not being an equivalent transformation. When taking this condition into account, which is rarely made explicit, there are only few types of transformations left to be considered as equivalent transformations of equations. Adding (and subtracting) numbers, as well as multiplying (and dividing by) numbers other than zero always, lead to equivalent equations (Langemann & Sommer, 2018, p. 172). This demand for generality of not altering the solution set can only partially be granted when it comes to adding or multiplying expressions containing variables. One might accidentally divide by zero and lose one or more solutions:

$$x^2 = x$$

$$x = 1$$

Another definition highlights the reversibility of the transformation and states that transformations, which can be reversed, without changing the meaning are equivalent transformations (Langemann & Sommer, 2018, p. 172). Since it is not explicitly stated what meaning refers to in this context, this definition appears rather doubtful. Considering that an equation containing variables determines a set of elements for which it becomes a true statement (Kirsch, 1987, p. 106), it can be assumed, that meaning refers to the solution set as well. Drouhard and Teppo (2004) translate the German term “Bedeutung” (with respect to Frege), as denotation (instead of meaning as done in the translation above) as a subdomain of meaning and refers also to the truthfulness of equations (pp. 232–234). Therefore, it can be assumed that this is the case in this definition. None the less it is interesting in the manner that it highlights reversibility as a property of equivalent transformations.

When comparing these different definitions, it appears crucial, that the solution set does not change when an equivalent transformation is applied. This is the defining property of an equivalent transformation, in the first definition discussed. The second one extends it by demanding a certain generality and claiming it never alters the solution set. Although the third definition is not quite clear, it highlights another characteristic: equivalent transformations have to be reversible. It is noteworthy, that all of these definitions relate, more or less explicitly, to the solution set.

Aspects and Grundvorstellungen an additional approach to the concept image

Given that (formal) concept definitions are the basis of concept definitions (Greefrath et al., 2016, p. 103) predictions about possible individual concept images can be derived from them. In order to draw further conclusions of possible characteristics of concept images the construct is approached by using the idea of *Grundvorstellungen* (GV) as an addition to the concept definition, which may also be part of a concept image (Greefrath et al., 2016, p. 103). Greefrath et al. (2016, p. 101) defined the term in the following manner: “A *Grundvorstellung* of a mathematical concept is a conceptual interpretation that gives it meaning” (for a more detailed discussion, see vom Hofe & Blum, 2016). Unlike the concept image, a GV relates to aspects of mathematical concepts (Greefrath et al., 2016, p. 101), while the concept image describes the whole cognitive structure that is associated with a mathematical context. The term *aspect* of a mathematical concept is defined as “a subdomain of the concept that can be used to characterize it on the basis of mathematical content” (Greefrath et al., 2016, p. 101). Because of these relations, identifying and examining aspects of equivalent transformations of equations offers new insights into possible characteristics of a concept image. Since the equivalence of equations appears to be the defining property of the equivalent transformations of equations and therefore characterizes it, it will be examined in greater detail in the following section.

Aspects of equivalence of equations

Equivalence of two equations means that they share the same solution set (Kirsch, 1987, p. 108). Another possibility to determine the equivalence of two equations is by transforming one equation into the other using valid transformations (Oldenburg, 2016, p. 11). Since this takes into account transformational activities, the focus will be on this aspect of equivalence, which from here on will be referred to as *transformational equivalence*. This aspect of equivalence requires defining valid transformations. For this matter, two similar but different types of rule sets are described in the following.

Balance rules

One type of rulesets for transforming equations are the balancing rules, which are expressed in regard to expressions (Malle, 1993, p. 219):

$$\begin{array}{l}
 A = B \Leftrightarrow A + C = B + C \qquad A = B \Leftrightarrow A - C = B - C \\
 A = B \Leftrightarrow A \cdot C = B \cdot C \quad (C \neq 0) \qquad A = B \Leftrightarrow \frac{A}{C} = \frac{B}{C} \quad (C \neq 0)
 \end{array}$$

The main feature of this ruleset is, that the two expressions on each side of the equal sign is being modified in the same way. The procedure is often visualized, by using scales, which stay in balance when the same amount of weight is added to or withdrawn from both sides. This is the reason why Malle (1993, pp. 220–221) refers to them as balancing rules. It should be noted though, that these rules can be visualized in various other ways as well.

Elementary transformation rules

Another set of rules are the elementary transformation rules, which are again expressed in regard to expressions (Malle, 1993, p. 219):

$$\begin{array}{l}
 A + B = C \Leftrightarrow A = C - B \qquad A - B = C \Leftrightarrow A = C + B \\
 A \cdot B = C \Leftrightarrow A = \frac{C}{B} \quad (B \neq 0) \qquad \frac{A}{B} = C \Leftrightarrow A = C \cdot B \quad (B \neq 0)
 \end{array}$$

These rules may appear very similar to the balancing rules but require three expressions to perform a transformation of an equation. The given expressions of an equation therefore determine what kind of transformations can be performed. This may be seen as an advantage for choosing this ruleset over the balancing rules when teaching (Malle, 1993).

In contrast to the elementary transformation rules, the balancing rules allow working with additional expressions, while the elementary transformation rules only allow using the given expressions. The latter may be considered as special kinds of balancing rules, which require fewer calculations (Malle, 1993) as can be seen in the following example:

$$\begin{array}{l}
 x + 1 = 5 \qquad x + 1 = 5 \\
 (x + 1) - 1 = 5 - 1 \qquad x = 5 - 1 \\
 x = 4 \qquad x = 4
 \end{array}$$

Grundvorstellungen and aspects of equivalent transformations of equations

An aspect is the basis of an individual GV, while at the same time the GV gives the subject meaning to the aspect (Figure 1). When applying this idea to equivalent transformations of equations, two different GVs can be derived, from the aspects described previously (Figure 1). It should be noted, that any GV that is derived from the balance rules can also be derived from the elementary transformation rules, given that they can be considered a shorter version of the balancing rules, which cover only certain cases.

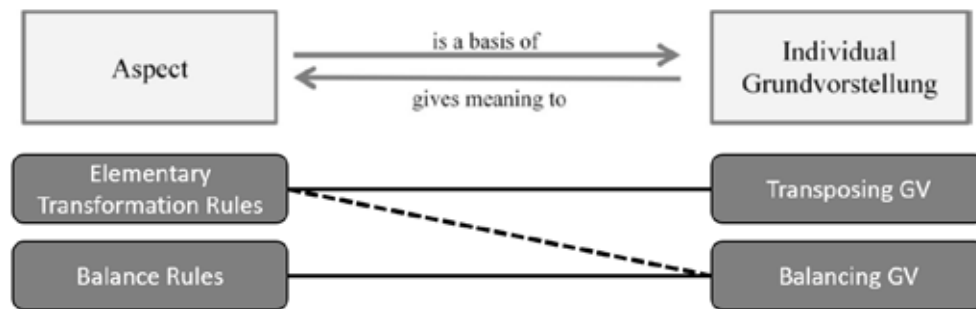


Figure 1: Relations between aspects and GVs (extracted from Greefrath et al., 2016, p. 103) applied to equivalent transformations of equations

Transposing GV

Using elementary transformation rules, the transformation may be perceived as a *transposition* of the expression according to the “change side – change sign rule” (Kieran, 1992, p. 400). This means that you exchange the operator in front of an expression with the inverse operation, while moving the expression to the other side of the equation. This idea of transposition appears to be coherent with the findings of Henz, Oldenburg, and Schöllhorn (2015), in which their hypotheses, that algebraic manipulations take place in an algebraic symbol space (and is linked to movement) is empirically supported. The scheme of this rule can be represented in the following manner (Malle, 1993, p. 218):

$$\frac{\blacksquare}{\blacksquare} = \blacksquare \Leftrightarrow \blacksquare = \blacksquare \cdot \blacksquare$$

Balancing GV

The balance rules may be interpreted as “*doing the same thing on both sides*”. This can be represented visually by a scale that keeps the balance or as a more abstract scheme: $A = B \Leftrightarrow A \circ C = B \circ C$. Overly generalizing a scheme, may lead to errors in performance (Malle, 1993, pp. 172–175). In this case it may lead to the misconception, that squaring two expressions of an equation always leads to an equivalent equation. This demonstrates how problematic generalizations of a scheme may be, if no further knowledge is being acquired about when it is appropriate to apply a certain rule.

Example: geometric model and GVs

So far models for teaching equivalent transformations of equations have only been mentioned, without discussing them in greater detail. One well known model is the balance model using scales which highlights that operations should be carried out on both sides of an equation and therefore may foster the balancing GV. In addition to this model, Filloy, Puig, and Rojano (2008) propose a geometric model for visualizing linear equations and algebraic transformations of these equations (p. 100). Within this model “algebraic expressions are represented as lengths and areas of rectangles (x and its coefficients are lengths, and their products and the independent terms are areas)” (Filloy et al., 2008, pp. 100–101) (see Figure 2). The purpose of this model within the study is to teach early algebra learners how to transform an equation, with the variable occurring on both sides of the equation, such as $A \cdot x + B = C \cdot x$ (with A, B, C being positive integers and $C > A$) into the equation $B = (C - A) \cdot x$ (Filloy et al., 2008). This can be done by coloring and comparing areas (see

Figure 2). Ideally followed by the conclusion, that the two left over areas must be of the same size (Fillooy et al., 2008).

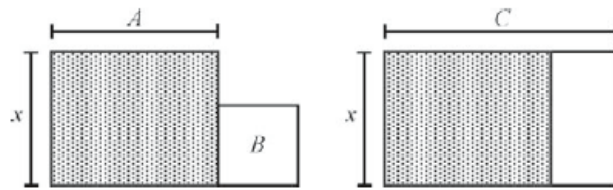


Figure 2: $A \cdot x + B = C \cdot x$ in the geometric model, with $A \cdot x$ being colored (Fillooy et al., 2008, p. 102)

Considering that the colored areas can be faded out, while focusing on the white areas, it seems like this approach embodies a subtraction of $A \cdot x$ from both sides of the equation and therefore leads to the assumption that this model fosters the balancing GV (“*doing the same thing on both sides*”). At the same time the transformation $A \cdot x + B = C \cdot x \Leftrightarrow B = (C - A) \cdot x$ appears to rather fit the elementary transformation rule $A_2 + B = C_2 \Leftrightarrow B = C_2 - A_2$ than the balancing rules. Taking a closer look at the examples provided by Fillooy et al. (2008) from their interviews, it is noticeable that the interviewee appears to move the expression from the left side of the equation, to the right side, while changing the sign (e.g. Figure 3). Therefore the, geometric model seems to rather foster the transposing GV than the balancing GV according to the data samples provided (Fillooy et al., 2008, pp. 108–110; Fillooy & Rojano, 1989, pp. 22–23).

$$15x + 13 = 16x - 15x$$

Figure 3: Example of a learner operating on the unknown, prior to being introduced to formal techniques of transforming equations (Fillooy & Rojano, 1989, p. 110)

All in all, it is not possible to draw a general conclusion on what GV is fostered by the use of the geometric model. Especially when considering that the data examined here was not intended to answer which GV it fosters. None the less it should be noted that GVs are not necessarily a question of model, but of what is made of it by the individual. It is possible that another person understands this model as subtracting the same expression from both sides of an equation.

Summary and discussion

Squaring is usually not considered an equivalent transformation of equations, although it may lead to an equivalent equation. Since this seems to be contradictory it raises the question, what does one consider to be an equivalent transformation of equations? In order to approach this question, the cognitive structure, that leads to certain assumptions, is described as concept image. Different formal definitions of equivalent transformations of equations were examined, all of which contained the idea of not altering the solution sets. Since this demand is fulfilled by squaring in the first example, this might not be what individuals consider as defining property. What seems more suitable in this case is the demand of generality, that an equivalent transformation does always maintain the solution set.

The second approach to identify factors that influence the concept image is, by using the notions of aspects and GVs. Considering that the equivalent transformations of equations should lead to equivalent equations, the transformational equivalence is examined in greater detail. This aspect requires defining valid operations, in this case the elementary transformation and the balance rules.

These two rule sets are the basis of the transposing GV and the balancing GV. Using these rules, it can be argued that squaring is not covered by them and therefore might not be captured within the aspect of transformational equivalence. Then again it can be considered using the balancing GV, that it is an equivalent transformation of equations, even then when it is not, because “you do the same thing on both sides”. Judging in which cases a transformation leads to an equivalent equation, requires the ability to recognize the equivalence of equations.

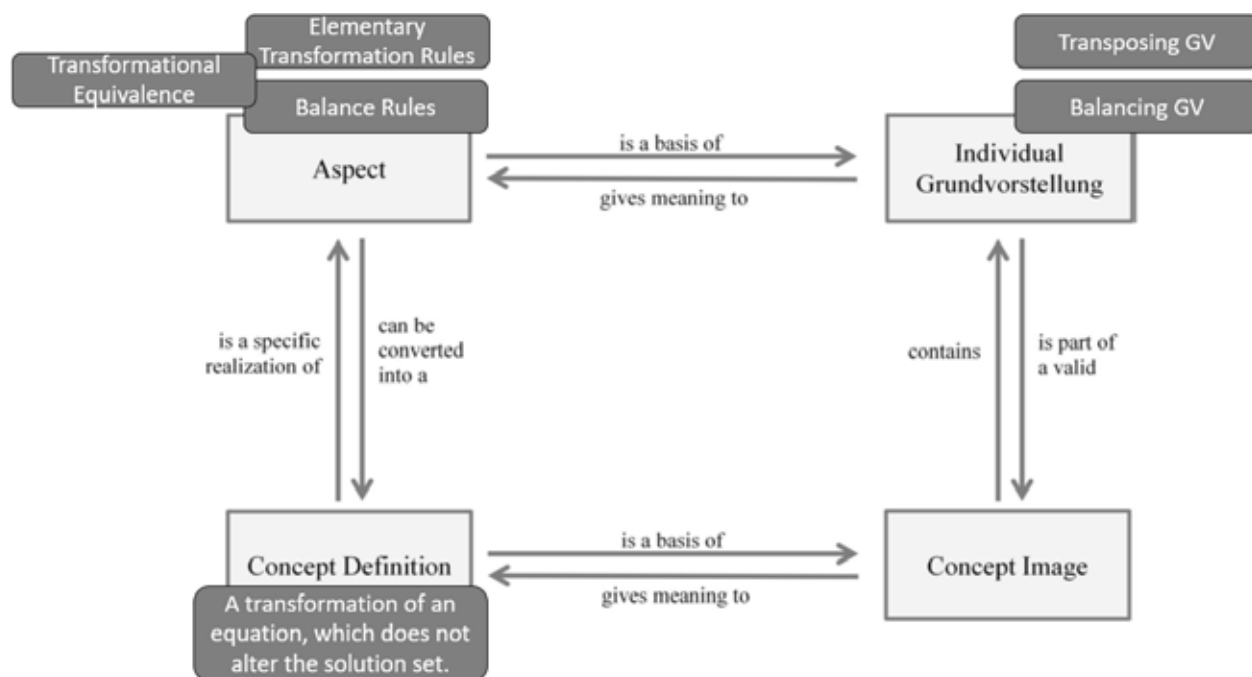


Figure 4: Relations between aspect, Grundvorstellung, concept definition, concept, and concept image (by Greefrath et al., 2016, p. 103) applied to equivalent transformations of equations

Discussing the geometric model of equations and transformations of equations, it was pointed out that it is not necessarily the model that indicates a certain GV, but the individual’s interpretation and use of the model. Rather than formulating a GV for every model, the approach used within this paper suggests deriving them from aspects of a given concept. This seems useful, given that different models may affect our transformation processes in the same manner. However, models cannot be abandoned, if we want to avoid that algebra learners simply perform meaningless transformations. Therefore, the GVs which are described in a rather schematic manner need to be linked to a model. It is rather the reasoning accompanying the model, than the model itself which is important.

Considering that algebraic transformations of equations are located at the transition from arithmetic to algebraic thinking (Filloy et al., 2008, p. 96), it seems like very little attention has been paid to this topic in recent research. Simply addressing it with reference to a certain model or a certain set of rules does not seem to be sufficient. More importantly is the link between models, the underlying concept and the individual, which needs to be addressed with closer regard in the future. It appears useful to examine the concept of equivalent transformations of equations in greater detail. As the discussion above shows, definitions of the concept do not necessarily grasp what is meant by equivalent transformations. But if we do not make explicit what we mean, when we talk about equivalent transformations of equations, it carries the risk that this implicit information is not acquired by the

learner. Does it not make learning and teaching more difficult? The considerations presented within this article can help identifying sources of misconceptions and give an insight to educators about limitations of definitions, rules and models describing equivalent transformations of equations.

References

- Drouhard, J.-P., & Teppo, A. R. (2004). Symbols and language. In K. Stacey, H. Chick, & M. Kendal (Eds.), *The future of the teaching and learning of algebra: The 12th ICMI Study* (pp. 227–264). Boston, Dordrecht, New York, London: Kluwer.
- Fillooy, E., Puig, L., & Rojano, T. (2008). *Educational algebra*. New York: Springer.
- Fillooy, E., & Rojano, T. (1989). Solving equations: the transition from arithmetic to algebra. *For the Learning of Mathematics* 9(2), 19–25.
- Greefrath, G., Oldenburg, R., Siller, H.-S., Ulm, V., & Weigand, H.-G. (2016). Aspects and “Grundvorstellungen” of the concepts of derivative and integral. *Journal für Mathematik-Didaktik* 37(1), 99–129.
- Henz, D., Oldenburg, R., & Schöllhorn, W. (2015). Does bodily movement enhance mathematical problem solving? Behavioral and neurophysiological evidence. In K. Krainer & N. Vondrová (Eds.), *Proceedings of the Ninth Congress of the European Society for Research in Mathematics Education (CERME 9)* (pp. 412–418). Prague, Czech Republic: ERME.
- Kieran, C. (1992). The learning and teaching of school algebra. In D. A. Grouws (Ed.), *Handbook of research on mathematics teaching and learning* (pp. 390–419). New York: Macmillan.
- Kirsch, A. (1987). *Mathematik wirklich verstehen* [Truly understanding mathematics]. Köln, Germany: Aulis.
- Langemann, D., & Sommer, V. (2018). *So einfach ist Mathematik* [This is how simple mathematics is]. Berlin, Germany: Springer-Verlag.
- Malle, G. (1993). *Didaktische Probleme der elementaren Algebra* [Didactical problems of elementary algebra]. Wiesbaden, Germany: Vieweg.
- Oldenburg, R. (2016). Stoffdidaktik konkret: Äquivalenz von Gleichungen [Subject matter related didactics: equivalence of equations]. In: *Mitteilungen der Gesellschaft für Didaktik der Mathematik* [Notes from the community of didactics of mathematics], 101, 10–12.
- Tall, D., & Vinner, S. (1981). Concept image and concept definition in mathematics with particular reference to limits and continuity. *Educational Studies in Mathematics*, 12, 151–169.
- Vollrath, H.-J., & Weigand, H.-G. (2007). *Algebra in der Sekundarstufe* [Algebra in secondary classes]. München, Germany: Elsevier.
- Vom Hofe, R., & Blum, W. (2016). “Grundvorstellungen“ as a category of subject-matter didactics. *Journal für Mathematik-Didaktik*, 37(1), 225–254.
- Walz, G. (Ed.). (2017). *Lexikon der Mathematik Band 4 (2. Auflage)* [Encyclopedia of mathematics Vol. 4 (2nd ed.)]. Berlin, Germany: Springer.

How students in 5th and 8th grade in Norway understand the equal sign

Hilde Opsal

Volda University College, Volda, Norway; hilde.opsal@hivolda.no

Having a relational understanding of the equal sign is seen as important to students in algebra in lower secondary school. The basis for their understanding of the equal sign is laid in elementary school. This paper presents results from two studies in Norway, a quantitative survey and a qualitative task-based interview. In both studies, students in 5th and 8th grade solved an equal sign task. 1230 students participated in the survey and 8 students were interviewed. These latter students also responded to questions about the meaning of the equal sign. Results from both studies show that a majority of the students in 5th grade have an operational understanding of the equal sign, while a majority of those in the 8th grade have a relational understanding of the equal sign.

Keywords: Equal sign, operational understanding, relational understanding.

Introduction

According to Ma (1999, p. 111) the equal sign is “the soul of mathematical operations” and Falkner, Levi, & Carpenter (1999) say that to understand the meaning of the equal sign is a core element to understanding algebra. In Norway, the results from TIMSS show that a major problem in mathematics is the weak results in algebra, with a significant decline in students’ performances from 2011 to 2015 in 8th grade (Grønmo, Hole, & Onstad, 2017). To prepare students in elementary school for algebra in lower secondary school, it is important to work with their understanding of the equal sign. The aim of this paper is to examine how students in 5th and 8th grade in Norway understand the equal sign.

Operational and relational understanding of the equal sign

According to Kieran (2004), one aspect of going from arithmetical thinking to algebraic thinking is for the students to refocus the meaning of the equal sign. Prediger (2010) distinguishes between six different meanings of the equal sign, grouped into three main categories: operational meaning, relational meaning and specification. In this paper, the focus will be on the first two categories. The operational meaning is an asymmetric use of the equal sign. In elementary arithmetic, we often have a calculation to perform on the left-hand side of the equal sign that gives an answer on the right-hand side. By looking at the equal sign as “add the numbers” or “the answer”, students have an operational understanding (Knuth, Alibali, Hattikudur, McNeil, & Stephens, 2008). In the relational meaning of the equal sign, the focus is on a symmetric use of the sign. Students with a relational understanding realize that “the equal sign [is] symbolizing the sameness of the expressions or quantities represented by each side of an equation” (Matthews, Rittle-Johnson, McEldoon, & Taylor, 2012, p. 222). In arithmetic contexts, the symmetric use of the equal sign can both help to express general relations, and also numerical identities (Prediger, 2010).

Knuth, Alibali, McNeil, Weinberg, and Stephens (2005, p. 69) claim that “in algebra, students must view the equal sign as a relational symbol”. This is especially important when they learn to solve equations with operations on both sides of the equal sign. In order to understand that the transformations performed when solving an equation preserve the equivalence relation, it is essential to have a relational understanding of the equal sign. In a study of middle school students’ (6th to 8th grade) understanding of equivalence, they found that “students who have a relational view of the equal sign outperformed their peers who hold alternative views on a problem that requires use of the idea of mathematical equivalence” (Knuth et al., 2005, p. 74).

Rittle-Johnson, Matthews, Taylor, and McEldoon (2011) have made a construct map for knowledge of the equal sign as an indicator of mathematical equality, from *rigid operational* on level 1 to *comparative relational* on level 4. Students at level 1 are only successful at solving task “equations-equals-answer” and giving an operational definition of the equal sign. At level 2, *flexible operational*, students are successful at solving, evaluating and encoding atypical equation structures, for example tasks with the operations to the right of the equal sign. At level 3, *basic relational*, students can handle operations on both sides of the equal sign in equations. They can also recognize and generate a relational definition of the equal sign. At level 4, students can successfully solve and evaluate equations “by comparing the expressions on the two sides of the equal sign, including using compensatory strategies and recognizing that performing the same operations on both sides maintains equivalence” (Rittle-Johnson et al., 2011, p. 87). After using this construct map in the analysis of students’ understanding of equivalence, they comment that “describing children as having an operational or relational view of equivalence is overly simplistic” (Rittle-Johnson et al., 2011, p. 97). There may be students who are in the transition between an operational and a relational understanding of equivalence. They also noted that it was more difficult for students to give a relational definition of the equal sign than to solve equations with operations on both sides of the equal sign. In another study they also mention that the use of letters as variables instead of using blanks, may add difficulty to a task (Matthews et al., 2012).

Rittle-Johnson et al. (2011) claim that 35 years of research on elementary school students’ understanding of the equal sign shows that a majority of them have an operational understanding of the equal sign. It seems that if they get a task such as $8 + 4 = \square + 5$, they either add the numbers to the left of the equal sign or they add all numbers. According to Molina and Ambrose (2006), tasks like this one can only be solved correctly if the students have a “broad” understanding of the equal sign. In this study, I focus on how students answered a similar task. They were also asked about the meaning of the equal sign. Hopefully this study will provide further knowledge of the transition between an operational and a relational understanding of the equal sign. My research question is: *how do students in 5th and 8th grade in Norway understand the equal sign?*

Methods

The data in this paper comes from two projects, one quantitative survey study and a qualitative interview study. In 2013, 1230 students in 5th and 8th grade (age 10 and 13) from two different municipalities in Norway completed a mathematics test as part of a large classroom study (Haug, 2017). The test had 40 tasks for the students in 5th grade and 52 tasks

for those in 8th grade (the same tasks as in 5th grade and in addition 12 others). Results from 584 students in 5th grade and 646 students in 8th grade will be presented in this paper. In 2018, a task-based interview (Goldin, 1993) was conducted of 8 students from other schools in Norway, 4 from 5th grade and 4 from 8th grade. The tasks used in these interviews were all multiple-choice tasks picked from the survey study. All of them had seven response alternatives, including “don’t know”. In addition to the correct answers, the rest were so-called distractors. These interviews also form part of this paper.

In this paper I mainly focus on students’ responses to one of the tasks (Figure 1). In this task they are asked about which number is hidden behind the smiley face to make the arithmetic correct. A student with an operational understanding of the equal sign may answer 9 that matches “operation equal answer” or 16 that corresponds to “add all” (taking the subtract 5 to be negative five). A student who answers correctly (2) probably has a relational understanding of the equal sign. It may also be possible for those who answer 7 or 12 to have a relational understanding. By ignoring subtraction of 5, 7 will be a correct answer and if they do not notice that there are different signs on the left- and the right-hand sides and think there is addition on both sides of the equal sign, 12 will be correct. It is unclear how students get 0 in response to this task.

21. Hvilket tall må skjule seg bak smilefjeset for at regnestykket (ligningen) skal være riktig?

$$14 - 5 = \text{☺} + 7$$

Vet ikke

7 12 0 16 2 9

Figure 1: The English translation of the question is: Which number must hide behind the smiley to make the arithmetic (equation) correct? “Vet ikke” in English “Don’t know”

Results

The results from the survey in the equal sign task (Figure 1) show that 29.6% of the students in 5th grade and 62.2% in 8th grade gave a correct answer (2) to this task (Table 1).

	7		12		0		16		2		9		Don't know	Total	
	N	%	N	%	N	%	N	%	N	%	N	%	N	%	N
5th	14	2.4	13	2.2	0	0.0	100	17.1	173	29.6	250	42.8	34	5.8	584
8th	13	2.0	8	1.2	3	0.5	42	6.5	402	62.2	149	23.1	29	4.5	646

Table 1: Result of the equal sign task in the survey study

These students probably have a relational understanding of the equal sign. The result shows also that the answer that most students in 5th grade have chosen is 9 (42.8%). This corresponds to calculating what is on the left of the equal sign. Of the 8th grade students, 23.1% chose this answer. We also note that the answer with the second highest percentage of incorrect answers among the students is 16, which corresponds to “add all”. In total, 17.1% in

5th grade and 6.5% in 8th grade chose this incorrect answer. This means that approximately 60% of students in 5th grade and 30% of those in 8th grade in this study probably have an operational understanding of the equal sign.

There are 4.6% in 5th grade and 3.2% in 8th grade who answer either 7 or 12. Since only 3 students in 8th grade answer 0, this may indicate that there are few students just guessing an answer. If many students had simply guessed, this answer option would probably also have been chosen by more of them.

As mentioned earlier, a task-based interview was conducted where 8 students were asked to solve the equal sign task. Their names are fictional and the transcripts are translated into English by the author. First, all students were given another task: Calculate $275 - 84 =$. Three of those in 5th grade and all four in 8th grade solved this task without any difficulties. One student, Knut, had problems performing the subtraction algorithm he had chosen to use.

The second task they were given was the equal sign task (Figure 1). First, I will present the results from the students in 5th grade.

The first student, Leif, answered 16.

Leif: Ok ... 14 minus one 5 is equal ... plus ... yes ok ... 14 minus 5 that's 9 and 9 plus 7 is 16 [ticks the box with 16]

Interviewer: That sign there [points to the equal sign in the task] ... what does that mean? ... the sign before the smiley

Leif: Equals? [In Norwegian: Er lik]

Interviewer: Equals. What does that mean?

Leif: It means that it will be ... it's equal ... it should be just the same answer as it is on the other side

Leif then suggested the answer 7, before stating “this was difficult”. When the student solved this task, he showed an operational understanding of the equal sign. But when explaining the meaning of “equals”, he said that it should be similar to what is on the other side, seeing a relation between the left- and the right-hand side of the equal sign. Based on only this one task it is difficult to say whether he has an operational or relational understanding of the equal sign. Perhaps he is a student in the transition between operational and relational understanding.

Olav answered 9 in the equal sign task

Interviewer: How did you think?

Olav: Because 14 minus 5 it becomes 9

Interviewer: What does that sign mean?

Olav: Equals

Interviewer: Equals. What does that mean? Do you know ... can you say anything more than that means equals?

Olav: Like, if you take 1 plus 1 ... then you always have equals because there should be some answer

Interviewer: In order for there to be some answer, yes ... when there is 7 at the end there, what does it mean? Did you>

Olav: < It means that the answer is 9, but then you add 7 afterwards ... then it will be 16

Olav showed an operational understanding of the equal sign both when solving the task and when explaining the meaning of the equal sign. For him the answer was on the right-hand side and the operations on the left of the equal sign. Another student, Knut, showed an operational understanding of the equal sign. He “added all numbers” and answered 16 in this task. On the question of what equals means, he responded “the answer is there”.

Arne answered 12 in the equal sign task.

Interviewer: How did you think?

Arne: Em ... since 4 minus 5 is 9 ... then the answer must be something ... which is under 10 ... so then I thought ... I don't know, I just chose something

Interviewer: You just chose 12?

Arne confirms it with a “yes”. Interviewer then asks about the meaning of the equal sign.

Arne: Equals?

Interviewer: Equals. What does that mean?

Arne: For example, if there is 3 plus 3 then it's 6 ... so then you take equals and then 6

Interviewer: ... That plus 7 there [points to the task] ...

Arne: Mm ... I just thought that ... but I think I thought wrong because that ... I thought I took 2 from there [points to 14 in the task] and gave it to the five and then it became 7 and then I thought what was there then it became 12. But it is ... it's a bit wrong

This student at first tried to explain his thinking when solving the task, then he said he just picked an answer. When asked about the meaning of equals, he gave a concrete example, indicating an operational understanding of the equal sign. Afterwards, he came up with a new explanation of how he solved this task. By subtracting 2 from 14 and adding this 2 to 5 to get 7, he had 7 on both sides of the equal sign. Since he now had 12 on the left-hand side of the equal sign, he thought the answer must be 12. This would be a correct answer if there were addition on both sides of the equal sign. What Arne explained here is an attempt to make the left- and right-hand sides of the equal sign equal. This second explanation indicated that he might have a relational understanding of the equal sign.

Three of the four interviewed students in 8th grade gave a correct answer to this task. These three connected the task to solving an equation, something they know how to do. I will only present a short extract of what they said that shows this.

Lise: [write 2] Well, I thought of the smiley as an x . Then I used the move-swap rule and changed plus 7 to minus 7. Then I took 14 minus 5 minus 7

...

Kari: ... 4 minus 5 is 9. In order for it to be 9 on the other side, there must be 2 ...

Interviewer: Yes, what did you mean by 9 on the other side?

Kari: 14 minus 5, that is 9 ...and an equation ... equal on both sides

...

Nils: ... equation yes ... 14 minus 5 is equal ... yes 14 minus 5 it's now 11 ... 4 mi [interrupt] no ... 14 minus 5 no not 11, 9 is ... and then it must be 2

These three students could solve tasks with calculations on both sides of the equal sign. Two of them said that we must have the same on both sides of the equal sign. Lise solved the task by using rules she had learned about how to solve equations. She was not asked about the meaning of the equal sign. The fourth student in 8th grade, Sven, had problems solving this task. After reading the task he first asked about the “plus 7”. Afterwards, he commented that he had seen such tasks before, and then he answered 9 because “14 minus 5 equals 9”. At the end of the interview, we returned to this task and asked him more about it. First the interviewer reminded him about the answer he gave earlier.

Interviewer: But what does plus 7 means?

Sven: No, I don't know ... oh yes, I'll add 7 or something

Interviewer: If you look at the sign before the smiley [points to the equal sign], what does that sign mean?

Sven: Equals

Interviewer: Yes ... and what does equals mean?

Sven: Aa ... no, I have never thought about that. I don't know

Interviewer: No ... when you see such a sign in your book, what do you think?

Sven: That I will write the answer before

It looks as if this student has an operational understanding of the equal sign. He has not thought about the meaning of the equal sign, even though he has most likely been taught how to solve simple equations.

Discussion, conclusion and implications

In order to answer the question as to how students in 5th and 8th grade in Norway understand the equal sign, I have presented results from a quantitative survey. These show that approximately 60% of the students in 5th grade and 30% in 8th grade give an answer to an equal sign task which corresponds to “operational equal answer” or “add all”. These students most probably have an operational understanding of the equal sign, according to Rittle-Johnson et al. (2011). 29.6% of the students in 5th grade and 62.2% in 8th grade respond correctly to this task. These students have a “broad” understanding of the equal sign, most

likely a relational understanding (Molina & Ambrose, 2006). These results are in line with what 35 years of research have shown (Rittle-Johnson et al., 2011). A higher percentage of students in 8th grade than in 5th grade respond correctly to this task. The reason for this may be that those in 8th grade have worked more with equations and in so doing they might have developed a relational understanding of the equal sign. It may also be the case that they have acquired a mechanical way of solving this kind of tasks (which maybe Lisa has).

The results from the task-based interviews showed that there were students who displayed an operational understanding of the equal sign, both in the way they solved this equal sign task and in the explanation they gave of what the equal sign means. What is more interesting is what was revealed in the interviews with the students Leif and Arne. In solving this task, Leif showed an operational understanding of the equal sign. But when asked what the sign means, he came up with an explanation saying that the left- and right-hand sides of the equal sign must be equal. For Arne, it is the opposite. He explained the equal sign with a concrete example, indicating an operational meaning of the equal sign. But when he solved the equal sign task, he seemed to confuse the subtraction sign with an addition sign on the left-hand side of the equal sign. That gave him a wrong answer, but the explanation he gave would be correct with the correct calculation sign. Leif and Arne were the two interviewed students in 5th grade who seemed to be closest to a relational level. With these two students we saw there was a difference between using a relational strategy when solving equal sign tasks and expressing a relational understanding of the equal sign.

Based on the construction map for knowledge of the equal sign as indicator of mathematical equality, developed by Rittle-Johnson et al. (2011), we saw that all the students who completed the first task in the interviews were at least at the rigid operational level. They were able to solve a task with an operation on the left-hand side and the answer on the right-hand side of the equal sign. Of the four interviewed in the 8th grade, three were able to solve the equal sign task and two of them used argumentation about the two sides being equal. These two students were probably at a relational level (either level 3 or 4). They are able to solve a task with operations on both sides of the equal sign and they reveal a relational understanding of the equal sign. Two of the 5th grade and one of the 8th grade students interviewed may be in the transition between operational and relational understanding of the equal sign.

Despite many years of research on the importance of students at early age developing a relational understanding of the equal sign, this study shows that it does not appear that there has been any progress in Norway with regard to students' understanding of the equal sign. In today's curriculum, the equal sign is not explicitly mentioned. But in Norway, a new curriculum will come into effect in 2020 that applies to 1st to 13th grade. A first draft of the new curriculum was out for consultation in the autumn of 2018. One of the competence aims for 3rd grade states that the students should be able to use equality and inequality in comparing quantities, expressions and numbers, using the equal sign and unequal sign and giving reasons for their choice. If the proposal for a new competence goal is passed, then perhaps we can hope that more students will acquire a relational understanding of the equal sign.

Acknowledgements

The quantitative study was supported by the Research Council of Norway under Grant 218326; Volda University College; and Inland Norway University of Applied Science. The qualitative study was supported by Volda University College and conducted in cooperation with my colleagues Odd Helge M. Tonheim and Arne Kåre Toppol. Neither of these studies would have been possible without all the students who so willingly participated.

References

- Falkner, K. P., Levi, L., & Carpenter, T. P. (1999). Children's understanding of equality: A foundation for algebra. *Teaching Children Mathematics*, 6, 232–236.
- Goldin, G. A. (1993). Observing mathematical problem solving: Perspectives on structured, task-based interviews. In B. Atweh, C. Kanesh, M. Carss, & G. Booker (Eds.), *Contexts in Mathematics Education. Proceedings of the Sixteenth Annual Conference of the Mathematics Education Research Group of Australasia (MERGA)* (pp. 303–309). Brisbane: The Mathematics Education Research Group of Australasia.
- Grønmo, L. S., Hole, A., & Onstad, T. (2017). Hovedresultater i matematikk i TIMSS Advanced, TIMSS og PISA. In L. S. Grønmo & A. Hole (Eds.), *Prioritering og progresjon i skolematematikken* (pp. 31–44). Oslo, Norway: Cappelen Damm Akademisk.
- Haug, P. (Ed.) (2017). *Spesialundervisning*. Oslo, Norway: Samlaget.
- Kieran, C. (2004). Algebraic thinking in the early grades: What is it? *The Mathematics Educator*, 8(1), 139–151.
- Knuth, E. J., Alibali, M. W., Hattikudur, S., McNeil, N. M., & Stephens, A. C. (2008). The importance of equal sign understanding in the middle grades. *Mathematics Teaching in the Middle School*, 13, 514–519.
- Knuth, E. J., Alibali, M. W., McNeil, N. M., Weinberg, A., & Stephens, A. C. (2005). Middle school students' understanding of core algebraic concepts: Equivalence & variable. *ZDM*, 37, 68–76.
- Ma, L. (1999). *Knowing and teaching elementary mathematics. Teachers' understanding of fundamental mathematics in China and the United States*. Mahwah, N.J.: Lawrence Erlbaum Associates.
- Matthews, P., Rittle-Johnson, B., McEldoon, K., & Taylor, R. (2012). Measure for measure: What combining diverse measures reveals about children's understanding of the equal sign as an indicator of mathematical equality. *Journal for Research in Mathematics Education*, 43, 220–254.
- Molina, M., & Ambrose, R. C. (2006). Fostering relational thinking while negotiating the meaning of the equals sign. *Teaching Children Mathematics*, 13, 111–117.
- Prediger, S. (2010). How to develop mathematics for teaching and for understanding. The case of meanings of the equal sign. *Journal of Mathematics Teacher Education*, 13, 73–93.
- Rittle-Johnson, B., Matthews, P. G., Taylor, R. S., & McEldoon, K. L. (2011). Assessing knowledge of mathematical equivalence: a construct-modeling approach. *Journal of Educational Psychology*, 103, 85–104.

Fifth-grade students solving linear equations supported by physical experiences

Mara Otten¹, Marja van den Heuvel-Panhuizen^{1,2,3}, Michiel Veldhuis^{1,4} and Aiso Heinze⁵

¹ Freudenthal Group FSW, Utrecht University, Utrecht, The Netherlands; m.otten@uu.nl,
m.vandenheuvel-panhuizen@uu.nl, m.veldhuis@uu.nl

² Nord University, Bodø, Norway

³ Freudenthal Institute, Faculty of Science, Utrecht University, Utrecht, The Netherlands

⁴ iPabo University of Applied Sciences, Amsterdam, The Netherlands

⁵ IPN - Leibniz Institute for Science and Mathematics Education, Kiel, Germany,
heinze@ipn.uni-kiel.de

The aim of this study was to investigate the effect of a six-lesson teaching intervention on fifth-grade students' linear equation solving abilities. A hanging mobile, a balance model consisting of a horizontal beam with on each side a number of bags hanging on a chain, played a central role in this intervention. In total, 213 fifth-graders participated in one of the two intervention conditions or in the control condition. The intervention conditions differed with respect to the type of hanging mobile; either a physical hanging mobile that students could manipulate or a static version on paper. Preliminary analyses of the scores on the pre- and post-test seemed to show an improvement in students' linear equation solving abilities for students in both intervention conditions. Students, who worked in an embodied learning environment with a physical hanging mobile, seemed to show more improvement than students who worked with a paper-based mobile.

Keywords: Early algebra, linear equation solving, balance model, physical experiences, embodied cognition theory.

Introduction

The importance of laying the foundation for learning algebra at a young age is increasingly being emphasized. (e.g., Kaput, Carragher, & Blanton, 2008; National Council of Teachers of Mathematics [NCTM], 2000). A large number of studies have provided evidence that, by taking students' natural, intuitive ideas and informal reasoning as an entry point, students of primary school age can already engage in algebraic thinking (e.g., Kaput et al., 2008). Research in this area of *early algebra* has revealed that several algebraic concepts such as equivalence, expressions, equations, inequalities, generalized arithmetic, functional thinking, variable, and proportional reasoning can be taught to young students (Blanton, Stephens, Knuth, Gardiner, Isler, & Kim, 2015). In the current study, we investigated how linear equation solving of fifth-graders can be fostered.

Teaching linear equation solving

Studies on early algebraic thinking often investigated students' linear equation solving ability. These studies generally found positive results. It was for example found that third-grade students can successfully deal with equation-related concepts such as equality and the equal sign, crucial for

learning to solve linear equations (e.g., Bush & Karp, 2013), can solve simple equations such as $3 \times n + 2 = 8$, and can use letters to represent unknown quantities (Blanton et al., 2015). Moreover, when starting from a meaningful context, 10-year old students were found to be able to represent, meaningfully discuss, and solve equations with unknowns on both sides of the equal sign (Brizuela & Schliemann, 2004), and, through informal reasoning, sixth- and seventh-grade students have even shown themselves able to solve systems of linear equations (Van Amerom, 2003; Van Reeuwijk, 1995). However, there are only a limited number of studies in which young students had to solve systems of equations and those that were carried out were not set up systematically and contained small samples of students.

A frequently used model to make linear equation solving more accessible to young students is the balance model. This model can support students in different ways when solving linear equations and is particularly deemed suitable for grounding the equality aspect of an equation, as such enhancing the conception of the equal sign as a symbol for representing equality (Otten, Van den Heuvel-Panhuizen, & Veldhuis, 2019). The balance model also can assist students in providing a language base for solving problems, as was shown by Warren and Cooper (2005) in a study involving third-grade students. Furthermore, by means of providing a meaningful context, it can help students to handle problems with unknowns (Gavin & Sheffield, 2015).

Role of physical experiences in learning mathematics

Considering the role of physical experiences for learning has a long tradition. For example, Piaget (Piaget & Inhelder, 1967) already assumed that actions form the basis for learning and are important for understanding abstract ideas. A recent study on the efficacy of teaching mathematics through the use of manipulatives, showed benefits for instruction with manipulatives especially for children aged 7-11 and for the mathematical domain of algebra, compared to children that received abstract symbolic instruction (Carbonneau, Marley, & Selig, 2013). Using manipulatives has also been found to be beneficial for young students to learn to solve simple symbolically presented equations (Sherman & Bisanz, 2009).

Since the emergence of theories of embodied cognition, the attention for physical experiences in learning has been renewed (De Koning & Tabbers, 2011). According to embodied cognition theories, bodily experiences are essential for cognitive learning processes (e.g., Wilson, 2002) and abstract higher-order cognitive processes, such as mathematics, are assumed to be grounded in action and perception (Barsalou, 1999). Hence, embodied learning environments are regarded as important for learning mathematics (Abrahamson & Lindgren, 2014).

Current study

In the current study, we investigated the effects of an intervention, consisting of a six-lesson teaching sequence, on fifth-grade students' linear equation solving abilities. The intervention was based on the idea that embodied learning environments can be beneficial for learning mathematics. A hanging mobile, a balance model consisting of a horizontal beam with on each side a number of bags hanging on a chain, played a central role in this intervention. In this study, we formulated the following research questions: *(1) What is the effect of an intervention based on a balance model on*

students' linear equation solving performance? and (2) What is the difference between the effect of an intervention based on a balance model with a manipulable physical hanging mobile from that with a static hanging mobile on paper on students' linear equation solving performance?

Method

Research design

To investigate these questions, we set up a classroom experiment based on a staged comparison design consisting of two intervention conditions and a control condition. In the first intervention condition, a physical hanging mobile was used that students could manipulate. In the second intervention condition, a paper-based hanging mobile was used. For each condition there were three cohorts, which differed in the timing of the intervention. In each cohort the students' performance on linear equation solving was measured four times (see Table 1). Each measurement contained the same test items. Making use of a staged comparison design made it possible that the same teacher taught all the lessons of the interventions.

Condition	Cohort (<i>n</i>)	Measurement 1 Oct. 2016	Nov.-Dec. 2016	Measurement 2 Dec. 2016	Feb.-March 2017	Measurement 3 March 2017	May-June 2017	Measurement 4 June 2017
Intervention Condition 1	Cohort 1 (<i>n</i> =22)	M1	Intervention	M2		M3		M4
	Cohort 2 (<i>n</i> =18)	M1		M2	Intervention	M3		M4
	Cohort 3 (<i>n</i> =25)	M1		M2		M3	Intervention	M4
Intervention Condition 2	Cohort 1 (<i>n</i> =22)	M1	Intervention	M2		M3		M4
	Cohort 2 (<i>n</i> =21)	M1		M2	Intervention	M3		M4
	Cohort 3 (<i>n</i> =25)	M1		M2		M3	Intervention	M4
Control Condition	Cohort 1 (<i>n</i> =25)	M1	Control intervention	M2		M3		M4
	Cohort 2 (<i>n</i> =30)	M1		M2	Control intervention	M3		M4
	Cohort 3 (<i>n</i> =25)	M1		M2		M3	Control intervention	M4

Table 1: Research design. For the current study we focus on the measures in bold

Participants

Participants included 213 students (47% boys), with ages ranging from 9 to 11 ($M = 10.04$, $SD = 0.49$) from nine fifth-grade classes in seven schools in the Netherlands. The classes were selected by convenience. Three classes participated in Intervention Condition 1 ($n = 65$), three classes in Intervention Condition 2 ($n = 68$), and the final three classes formed the Control Condition ($n = 80$). Students had received no prior instruction on equation solving or other algebra topics.

Intervention program

In both intervention conditions students were taught linear equation solving by means of the same four-episode (six lessons) teaching sequence (see Figure 1). The lessons were taught by the first author of this paper. The overall aim of this sequence was to elicit algebraic reasoning related to

(informal) linear equation solving. In each of the episodes the aim was to provide students with opportunities to develop algebraic strategies related to linear equation solving, such as restructuring strategies (e.g., change the order of terms in an expression, exchange the expressions on both sides of the equation), isolation strategies (i.e., strategies to isolate an unknown, such as taking away similar things on both sides), and substitution strategies (i.e., replacing unknowns by other unknowns or by values). In the first episode, students worked with one hanging mobile to discover relationships between unknowns and were thus reasoning about one equation. Students' main task was to discover all possible ways to maintain the balance of the mobile, for example by exchanging the bags of the left and right side of the mobile, by taking away similar bags from both sides, or by substituting one color of bags by another color. From Episode 2 on, the information from two equations had to be combined to discover relationships between unknowns to solve the problems. Students were thus reasoning about a system of equations, first still in the context of the hanging mobile (Episode 2) and then in new contexts such as a tug-of-war situation (Episode 3). From Episode 3 on, students were additionally challenged to use more symbolic notations. In the final episode, Episode 4, students had to find the values of unknowns in a system of two symbolically notated linear equations.

The two intervention conditions differed as regards whether students gained physical experiences during the teaching sequence (Figure 1). In the first episode of Intervention Condition 1, an embodied learning environment was created in which students worked in small groups (2-3 students) with a physical hanging mobile. While trying to maintain the balance of the mobile, the tilting beam could be in or out of balance, thus providing students real-time feedback on their actions while manipulating the bags. In Episode 2, students in Intervention Condition 1 worked with paper-based hanging mobiles. The physical hanging mobiles were, however, still present in front of the classroom in this episode, but not all students worked on them. Instead, the physical hanging mobiles were used during classroom discussions by the teacher or by some students to make their reasoning processes explicit. Also, in Episodes 3 and 4 the physical hanging mobile was present in front of the classroom.

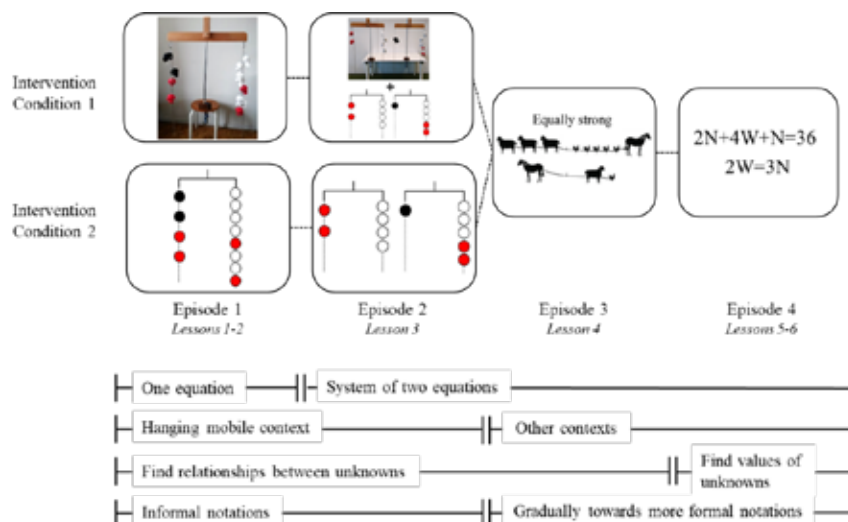


Figure 1: Schematic representation of the intervention (for both intervention conditions)

In Intervention Condition 2, students received the exact same lessons with the exact same assignments; only the physical hanging mobile was replaced by a paper-based hanging mobile so that these students did not gain physical experiences during the lessons. Lastly, students in the Control Condition were not taught any lessons on linear equation solving. Instead they participated in a control intervention consisting of a six-lesson teaching on probability – a topic which is also not taught at primary schools in the Netherlands. Students were taught the probability lessons as a control group, so that possible differences between the intervention and control conditions could not be attributed to the fact that only in the intervention conditions students received additional lessons on a (to them) new mathematical topic.

Test for linear equation solving

Students' performance on linear equation solving was assessed by a paper-and-pencil test, consisting of four items in which students had to solve (a system of) linear equations (see Figure 2). The same test was administered to the students repeatedly before and after the intervention (see Table 1, Measurement 1-4). The items were formulated in such a way that prior instruction on linear equation solving was not essential to solve the problems. The algebraic strategies that students developed during the lessons (i.e., restructuring, isolation, and substitution strategies) could be used to solve the problems. The open-ended questions explicitly invited students to explain their thinking and to reveal their reasoning.

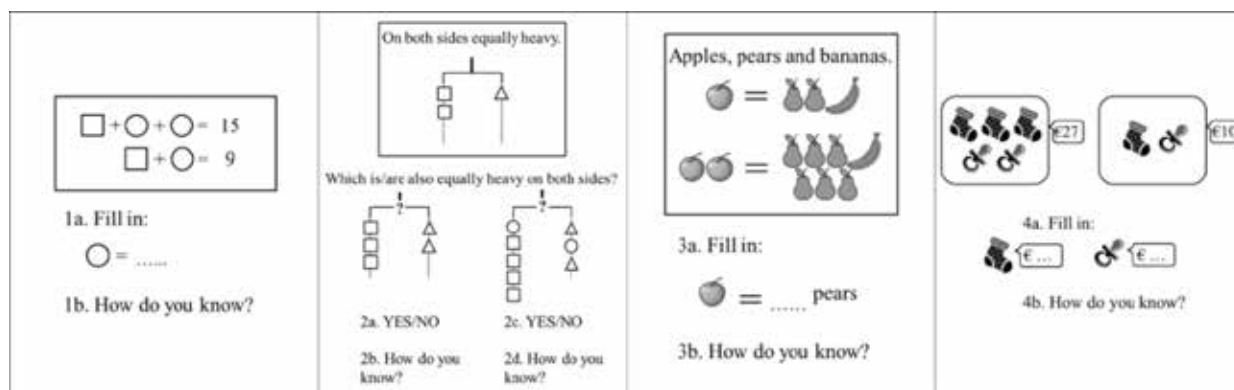


Figure 2: Test items on linear equation solving

Data analysis

Each linear equation solving performance item (Figure 2) was scored as incorrect (0) or correct (1), resulting in a total correctness score with scores ranging from 0 to 4. Items 2 and 4 were only scored as correct when both sub questions were answered correctly. Students' explanations were categorized by means of a coding scheme. In each test item, students had to solve the problem by combining the information of two equations. Taking the information from both equations into account and reasoning on the basis of both equations was crucial for solving these problems. In the coding scheme, we therefore coded students' level of reasoning based on their ability to incorporate information from the different equations in their reasoning process. More specifically, we distinguished between students who did not use any of the equations in the description of their reasoning (Level R0), students who reasoned on the basis of only one of the two given equations

(Level R1), and students who reasoned on the basis of both given equations by combining the information of both of them (Level R2).

For the current paper, we focus on the data of the tests directly before and after the interventions (see Table 1, measures in bold), consisting of students' correctness and reasoning scores. Mean values and standard deviations were calculated for both scores on the pre- and post-test. Effect sizes (Cohen, 1988) were also calculated for each condition.

First results

For both intervention conditions, students' correctness scores increased. For Intervention Condition 1, the correctness scores increased from $M = 2.31$ ($SD = 1.17$) on the pre-test to $M = 3.22$ ($SD = 0.91$) on the post-test ($d = 0.87$). For Intervention Condition 2, the correctness scores increased from $M = 2.43$ ($SD = 1.21$) on the pre-test to $M = 3.15$ ($SD = 0.93$) on the post-test ($d = 0.67$). In contrast, students of the Control Condition almost showed no improvement on correctness scores, going from $M = 2.65$ ($SD = 1.26$) on the pre-test to $M = 2.72$ ($SD = 1.33$) on the post-test ($d = 0.05$). Students' reasoning also improved for both intervention conditions (see Figure 3). When comparing pre- and post-tests, a decrease in percentage of the lowest level of reasoning (Level R0) was observable, while there was an increase in the highest level of reasoning (Level R2). The percentages of the intermediate level of reasoning (Level R1) remained more or less stable.

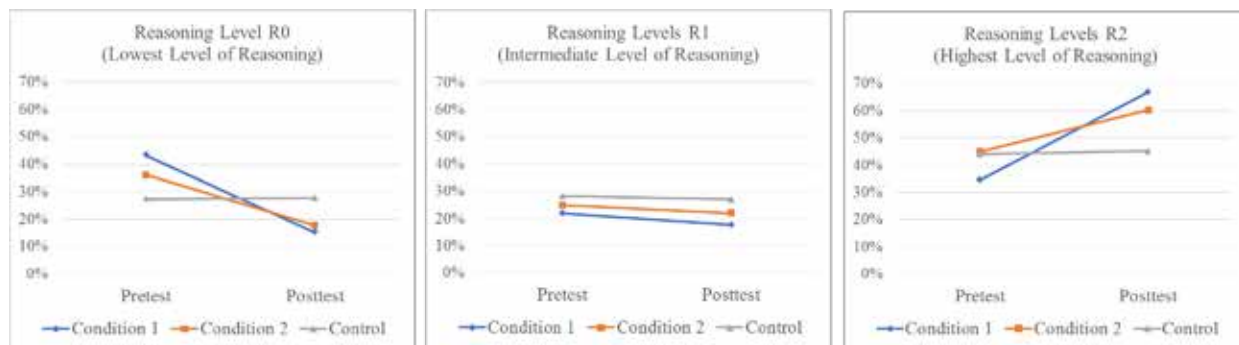


Figure 3: Percentage of students showing each level of reasoning on the pre- and post-test

When comparing both intervention conditions, students in Intervention Condition 1 showed a somewhat larger improvement than students in Intervention Condition 2, both on correctness scores and level of reasoning. For both intervention conditions, there was a decrease in percentage of the lowest level of reasoning (R0) and an increase in the highest level of reasoning (Levels R2), with a somewhat larger decrease of Level R0 and a somewhat larger increase of Level R2 for Intervention Condition 1. The percentages of the intermediate level of reasoning (Levels R1) remained more or less the same for both conditions. For the Control Condition, the percentages of all levels of reasoning (almost) did not change.

To provide an example of an individual learning process of one of the students, we zoom in on the pre- and post-test answers to Item 4 of Omar, who participated in Intervention Condition 1. On the pre-test, Omar gave an incorrect answer to this item, with the explanation “I don’t know”. This response was categorized as Level R0, because he did not use any of the given equations in his

explanation. His answer on the post-test is shown in Figure 4. Here, Omar interestingly represented the equations as hanging mobiles. Then he doubled the second equation ($S + P = 10$) to substitute this in the first equation ($S + S + S + P + P = 27$), so that unknown S was isolated. In this way he found that S equals 7 and then used the second equation to find the value of P . Omar's solution strategy was categorized as Level R2, because he reasoned on the basis of both given equations by combining the information from both equations.

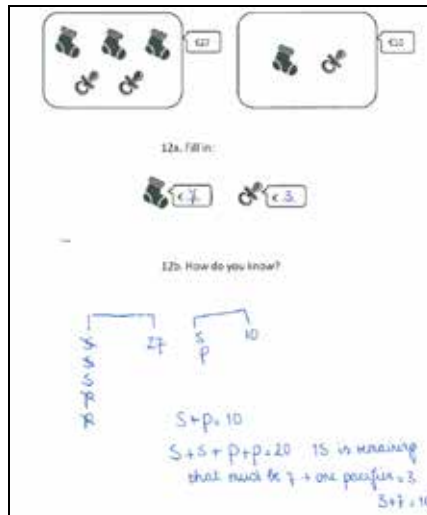


Figure 4: Solution strategy of Omar (translated from Dutch) on the post-test; categorized as Level R2

Discussion

Based on these first results, we can draw the tentative conclusion that our six-lesson intervention in which the balance model in the form of a hanging mobile plays a central role, can improve students' linear equation solving abilities. Moreover, our descriptive data indicate that when this intervention took place in an embodied learning environment in which the students could work with a physical hanging mobile instead of with a version on paper, the performance gain was even larger. This latter finding is in line with the idea that embodied learning environments are beneficial for learning mathematics (e.g., Abrahamson & Lindgren, 2014), and it could add to the use of these environments in whole classroom settings. To be more certain about what we can learn from our study more advanced statistical analyses will be carried out.

References

- Abrahamson, D., & Lindgren, R. (2014). Embodiment and embodied design. In R. K. Sawyer (Ed.), *The Cambridge handbook of the learning sciences* (2nd Edition) (pp. 358-376). Cambridge, UK: Cambridge University Press.
- Barsalou, L. W. (1999). Perceptions of perceptual symbols. *Behavioral and Brain Sciences*, 22, 637-660. doi:10.1017/S0140525X99532147
- Blanton, M., Stephens, A., Knuth, E., Gardiner, A. M., Isler, I., & Kim, J. S. (2015). The development of children's algebraic thinking: The impact of a comprehensive early algebra intervention in third grade. *Journal for Research in Mathematics Education*, 46, 39-87. doi:10.5951/jresmetheduc.46.1.0039

- Brizuela, B., & Schliemann, A. (2004). Ten-year-old students solving linear equations. *For the Learning of Mathematics*, 24(2), 33-40.
- Bush, S. B., & Karp, K. S. (2013). Prerequisite algebra skills and associated misconceptions of middle grade students: A review. *The Journal of Mathematical Behavior*, 32, 613-632. doi:10.1016/j.jmathb.2013.07.002
- Carbonneau, K. J., Marley, S. C., & Selig, J. P. (2013). A meta-analysis of the efficacy of teaching mathematics with concrete manipulatives. *Journal of Educational Psychology*, 105, 380-400. doi:10.1037/a0031084
- Cohen, J., (1988). *Statistical power analysis for the behavioral sciences*. Hillsdale, NJ: Lawrence Erlbaum Associates
- De Koning, B. B., & Tabbers H. K. (2011). Facilitating understanding of movements in dynamic visualizations: An embodied perspective. *Educational Psychology Review*, 23, 501-521. doi:10.1007/s10648-011-9173-8
- Gavin, M. K., & Sheffield, L. J. (2015). A balancing act: Making sense of algebra. *Mathematics Teaching in the Middle School*, 20, 460-466. doi:10.5951/mathteachmidscho.20.8.0460
- Kaput, J. J., Carraher, D. W., & Blanton, M. L. (2008). *Algebra in the early grades*. New York, NY: Lawrence Erlbaum Associates.
- National Council of Teachers of Mathematics [NCTM] (2000). *Principles and standards for school mathematics*. Reston, VA: NCTM.
- Otten, M., Van den Heuvel-Panhuizen, M., & Veldhuis, M. (2019). *The balance model for teaching linear equations: A literature review*. Manuscript submitted for publication.
- Piaget, J., & Inhelder, B. (1967). *The child's conception of space*. New York: W. W. Norton.
- Sherman, J., & Bisanz, J. (2009). Equivalence in symbolic and nonsymbolic contexts: Benefits of solving problems with manipulatives. *Journal of Educational Psychology*, 101, 88-100. doi:10.1037/a0013156
- Van Amerom, B. A. (2003). Focusing on informal strategies when linking arithmetic to early algebra. *Educational Studies in Mathematics*, 54, 63-75. doi:10.1023/B:EDUC.000
- Van Reeuwijk, M. (1995). The role of realistic situations in developing tools for solving systems of equations. *Paper presented at the annual meeting of the American Educational Research Association*, San Francisco, CA.
- Warren, E., & Cooper, T. J. (2005). Young children's ability to use the balance strategy to solve for unknowns. *Mathematics Education Research Journal*, 17, 58-72. doi:10.1007/BF03217409
- Wilson, M. (2002). Six views of embodied cognition. *Psychonomic Bulletin & Review*, 9, 625-636. doi:10.3758/BF03196322

Representational variation among elementary school students. A study within a functional approach to early algebra

Eder Pinto¹, Bárbara M. Brizuela², and María C. Cañadas¹

¹University of Granada, Spain; pinto.eder@gmail.com; mconsu@ugr.es

²Tufts University, Medford, United States; Barbara.brizuela@tufts.edu

This paper describes the differences in the types of representations used by eight third-grade (8 to 9-years-old) and eight fifth-grade (10 to 11-years-old) students when working with problems that involve different linear functions. We present an analysis of students' written and oral answers during a Classroom Teaching Experiment (CTE) and semi-structured interviews from a functional approach to early algebra. The study examines how students' representations varied when working with different types of linear functions ($y = x + a$; $y = ax$; $y = ax + b$), when solving for specific values, and when generalizing. The findings show that students in both grades primarily used the representation present in the problem. The type of linear function involved appears to have had no effect on either group's use of one representation or another.

Keywords: Representation, generalization, linear functions, functional thinking.

Introduction

Functional thinking—which has been found to facilitate the introduction of algebra in the early grades—focuses on the relationships between two or more covarying quantities (Blanton, Brizuela, Gardiner, Sawrey, & Newman-Owens, 2015); these relationships can be expressed through different representations. Representations, which form an integral part of how students think about functions, “can denote and describe material objects, physical properties, actions, and relations, or things that are far more abstract” (Goldin & Shteingold, 2001, p. 4). Therefore, representations help to structure and expand students' thinking (Brizuela & Earnest, 2008). Broadly, our interest is focused on types of representations used by elementary students when working with covarying quantities.

Some researchers have described how elementary school students working with problems that involve single linear functions use, represent, and understand the relationships involved in a given problem (e.g., Brizuela & Earnest, 2008). The originality of this study lies in the exploration of the types of representations used by elementary school students when working with problems involving different types of linear functions. More specifically, this paper analyzes the answers given by eight third- and eight fifth-grade students participating in a CTE, and their answers in semi-structured interviews, after the CTE. The research question is: how do students' representations vary when working with different types of linear functions? Based on this research question, we define two specific aims to describe the type of representations used by these students when: (a) solving problems which involved three types of functions: $y=x+a$; $y=ax$; and $y=ax+b$; and (b) answering questions regarding specific values and when asked to generalize the relationship between variables.

Background

The relationship between generalization and representation is central: both are intrinsic to algebraic thinking and consequently to functional thinking. According to Kaput, Blanton, and Moreno (2008),

representations—a socio-cultural vehicle used to generalize—enable students to build and complete the ideas that help them reason about general statements and compress multiple instances into the unitary form of a single statement that symbolizes the multiplicity. Thus, generalization is the “act of creating that symbolic object” (p. 20).

Several studies highlighted the role of representations in generalizing the relationship between two variables. According to some findings, 8 to 10-years-old students, instructed to use algebraic notation, represented the linear relationship $y=x+a$ by mainly using algebraic notation rather than natural language (Carraher, Schliemann, & Schwartz, 2008), while other studies reported that fifth graders (10 to 11-years-old) spontaneously used algebraic notation to generalize a problem that involve $y=mx+b$ (Pinto & Cañadas, 2018). Another study distinguished between the representations used by students when working with specific values and when generalizing, concluding that students who do not use algebraic notation when they represent a generalization do “not yet have a representational means to compress multiple instances into a unitary form that could symbolize these instances” (Blanton et al., 2015, p. 542). Further research is therefore needed on how the representations used by students vary when working with different linear functions, and how they differ depending on whether they are working with specific values or generalizations.

The types of representations that can be used by elementary school students to solve problems involving linear functions include: (a) natural language – oral; (b) natural language – written; (c) pictorial; (d) numerical; (e) algebraic notation, (f) tabular; and (g) graphic (Carraher et al., 2008). Considering the suggestions of early algebra literature, we stress the role of natural language because it is considered as a useful scaffold to understand symbolic representations (Kaput, 1987; Radford, 2003), and helps to broaden students’ understanding about functions, improving their abilities to solve problems (MacGregor & Stacey, 1995).

Method

This study forms part of a broader project that explores functional thinking among elementary school students in Spain.

Students

Two groups were intentionally selected for the first year of the study: 24 third-grade (8 to 9-years-old) and 24 fifth-grade (10 to 11-years-old) students. The students had not worked previously with such problems. Then, we interviewed eight students in each group to obtain a deeper understanding of how they responded to problems involving relationships between two variables.

Data collection: CTE and interviews

The data were collected during the CTE and individual interviews. The CTE and interviews objectives were to: (a) explore how students relate the variables involved in a problem involving a linear function; (b) introduce different types of representations to express functional relationships; and (c) explore students’ generalization when working with functional thinking tasks.

A four-session CTE was designed for each grade during the last term of 2014/2015 period, with each session lasting approximately 60 minutes. Each CTE session was divided into three parts. First, we introduced the context of the problem, highlighted the representations given and asked the students

questions about specific values to ascertain whether they had understood it. Second, the students were given individual worksheets with questions about specific values and generalization related to the problem. Third, the researchers led a classroom discussion around the responses to some of the questions on the worksheets. During the 2015/2016 period, eight students from each grade were interviewed in two 30-minute interviews. The interviewees were deliberately selected to include children who had performed differently during the CTE and it provided a way to more closely detail individual students' representations from the CTEs. Table 1 shows the general context of problems posed, types of functions, and types of representations introduced during the CTE and interviews.

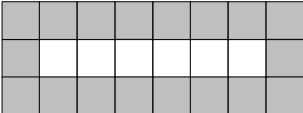
Timing	Problem posed	
CTE	<p style="text-align: center;">Third</p> <p>Session 1. María and Raúl are brother and sister. María is the elder. We know that María is 5 years older than Raúl ($y=x+5$) (<i>natural language – written and table</i>).</p> <p>Sessions 2 and 3. Carlos earns 3 euros for each T-shirt he sells ($y=3x$) (<i>natural language – written, table, and graphic</i>).</p> <p>Session 4. Different corridors are composed of white and grey tiles. All the tiles are square and of the same size and are to be laid in the following pattern: ($y=2x+6$) (<i>natural language – written, and pictorial</i>) (Küchemann, 1981).</p> <div style="text-align: center;">  </div>	<p style="text-align: center;">Fifth</p> <p>Session 1. Carlos earns 3 euros for each T-shirt he sells ($y=3x$) (<i>natural language – written and table</i>).</p> <p>Session 2. Carla earns 3 euros for each T-shirt she sells, while Daniel earns double that amount for each T-shirt and has saved 15 euros ($y=3x$; $y=2x+15$) (<i>natural language – written and table</i>).</p> <p>Session 3. A grandmother tells her grandson that she has some money to give him and proposes two deals ($y=2x$; $y=3x-7$) (<i>natural language - written</i>) (Adapted from Brizuela & Earnest, 2008).</p> <p>Session 4. Different corridors are composed of white and grey tiles. All the tiles are square and of the same size and are to be laid in the following pattern: ($y=2x+6$) (<i>natural language – written and pictorial</i>) (Adapted from Küchemann, 1981).</p>
Interviews	<p style="text-align: center;">Fourth</p> <p>Interview 1. It costs 2 euros to enter a car park and 1 euro per hour to park there ($y=x+2$) (<i>natural language- oral, algebraic notation</i>).</p> <p>Interview 2. Elsa conducts a train. Three passengers get on at each stop ($y=3x+1$) (<i>natural language – oral, algebraic notation</i>).</p>	<p style="text-align: center;">Sixth</p> <p>Interview 1. A geometric pattern with a different number and arrangement of points ($y=4x+1$) (<i>natural language – oral, algebraic notation, and pictorial</i>).</p> <p>Interview 2. Two telephone rates have different costs ($y=10x$; $y=5x+60$) (<i>natural language – oral and algebraic notation</i>).</p>

Table 1: Problems posed in CTE and interviews

The problems proposed involved different linear functions ($y=x+a$, $y=ax$, and $y=ax+b$); some of them were selected from previous studies and others were designed by the research team, considering different types of linear functions. The questions concerning each problem were sequenced according to the inductive reasoning model of Cañadas and Castro (2007), which structures questions from specific values to generalization. For instance, the fourth task for third and fifth grade included questions regarding:

- Specific values. For example, “How many grey tiles do they need for a corridor with 10 white tiles?”, and

- Generalization. For example, “The workers always lay the white tiles first and then the grey tiles. How can they calculate how many grey tiles they need in a corridor where they’ve already laid the white ones?”

The data analyzed in this paper were the students’ CTE and interview worksheets and the transcriptions of the video-recorded interviews.

Data and analysis categories.

The first step was identifying the types of representations used by the students. Figure 1 gives an example of each type of representations¹ used by students when they answered in different tasks.

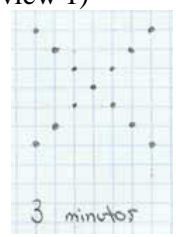
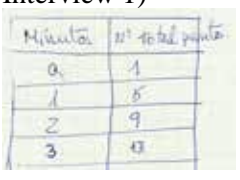
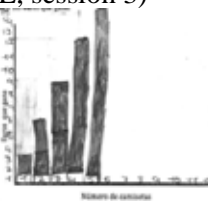
<p>Natural language - oral (Fourth grade, Interview 2) Interviewer: How would you find the number of passengers for any number of stops? Student: (...) <i>multiplying that number times three plus one.</i></p>	<p>Natural language – written (Third grade, CTE, session 1) We found a picture of Raúl’s birthday party and all you can see are the candles on the cake. How could you find María’s age? <i>I add five to Raúl’s age.</i></p>	<p>Pictorial (Sixth grade, Interview 1) </p>	<p>Numerical (Third grade, CTE, session 1) When Raúl is 15, how old will María be? <i>Raúl’s 15 and María’s 20.</i> How did you find your answer? <i>15+5=20</i></p>
<p>Algebraic notation (Fifth grade, CTE, session 4) How many grey tiles do they need for a floor with five white tiles? <i>They need 16 grey tiles.</i> <i>Formula: $(X \times 2) + 6 = 16$.</i> <i>X = number of grey tiles</i></p>	<p>Tabular (Fourth grade, Interview 1) </p>	<p>Graphic (Third grade, CTE, session 3) </p>	

Figure 1: Examples of types of representation in students’ answers

The representations used by the students to solve problems were first identified and then analyzed considering: the type of linear function in each problem ($y=a+x$, $y=ax$, and $y=ax+b$), and the students’ answers when working with specific values and when generalizing.

Results and Discussion

We present the findings for the types of representations used by each group of students, considering our research questions.

Third and fourth grades

Table 2 lists the frequency for each type of representations used by students in CTE and interviews, considering different linear functions and when working with specific values and when generalizing.

¹ Which were not mutually exclusive.

	Representation	CTE			Interview	
		$y=x+a$	$y=ax$	$y=ax+b$	$y=x+a$	$y=ax+b$
Specific values	N-oral				8*	7*
	N-written	2*	4*	5*		
	Pictorial					
	Numerical	4	7	6	1	7
	Algebraic	4*	5*			
	Tabular				1	2
	Graphic					
Generalization	N-oral				7*	6*
	N-written	5*	2*	2*	1	
	Pictorial					
	Numerical					
	Algebraic				6*	5*
	Tabular					
	Graphic					

* = representation introduced in the problem itself

Table 2: Representations used by third- and fourth-graders

As the data in Table 2 shows, the students tended to use the representation introduced in the problem itself, regardless of the type of linear function involved. Specifically, oral and written natural language prevailed in this group of eight students. Mario's response during the first interview to a problem with a function of the type $y=x+b$ is an example.

Interviewer: Let's suppose I don't know how many hours I'm going to park, but I tell you that I'm going to be there for x hours (...). How can I know how much it's going to cost me?

Mario: (...) Well, if you're there for x hours, you add 2. For all the hours [the car is parked] you add 2.

As exemplified in the above extract, the prevalence of oral language is an essential element in learning to recognize and understand a function (MacGregor & Stacey, 1995). The use of a numerical representation was also observed at least once in all the problems involving specific values. This makes sense, since students were being asked about specific, and not general values. Numerical representation was as frequent as natural language in students' answers to problems with functions of the form $y=ax+b$.

During the interviews one year later, some students spontaneously arranged the values of the variables in tabular form. Figure 2 shows how Susana arranged the data to explore the specific values in a problem of the type $y=mx+b$ (interview 2).

3	10
4	13
5	16
6	19
7	22
8	25
9	28
10	31

Figure 2: Susana's answer when working with specific values

As Figure 2 shows, Susana arranged the specific values in two columns separated by a dash (-). She listed the number of stops on the left and the number of people on the train on the right. This table, according to Martí (2009), shows that “data be organized (categorization, establishing correspondences) in a certain spatial layout” (p. 134). Susana’s table is a novel way to represent, relate and understand the values involved in the problem. Spontaneous tabular representations were observed during the interviews in the problems involving functions such as $y=x+a$ and $y=ax+b$.

The eight students used different representations depending on whether they were working with specific values or generalizing. During the CTE, the variety of representations was wider when they were exploring the relationship with specific values (written natural language, numerical, algebraic notation) than when generalizing, when they used written natural language only. One possible explanation for this difference may lie in the complexity inherent in generalizing the relationship between two variables, as suggested by other authors (e.g., Radford, 2003). Nonetheless, natural language would appear to be the way these students explain general rules. During the interviews, the students used the representation present in the problem to generalize the relationship, whereas for specific values they used numerical and tabular representations as well.

Fifth and Sixth Grades

Table 3 lists the types of representations used by the eight students in this group, when solving the problems posed.

	Representation	CTE			Interview		
		$y=x+a$	$y=ax$	$y=ax+b$	$y=x+a$	$y=ax$	$y=ax+b$
Specific values	N-oral				1	1*	1*
	N-written	1*		5*			
	Pictorial			3*	5*		
	Numerical	5	2		2	4	4
	Algebraic			1			
	Tabular				6*	3*	4*
	Graphic						
Generalization	N-oral				4*	3*	3*
	N-written	3*	4*	7*			
	Pictorial						
	Numerical		1	1	1	1	1
	Algebraic	2*	3*	2	5*	3	4*
	Tabular						
	Graphic						

Note. * = representation introduced in the problem itself

Table 3: Representations used by fifth and sixth graders

We can see in Table 3 that these students tended to use the same type of representation as introduced in the problem. Significantly, in the tiles problem (CTE, $y=mx+b$ type function), two of the students used algebraic notation spontaneously. Camila’s answer to the first question associated with that problem is reproduced in Figure 3.

1. How many grey tiles do they need for a floor with five white tiles?
They need 16 grey tiles. Formula: $(X \times 2) + 6 = 16$. $X = \text{number of grey tiles}$

Figure 3: Camila's answer to the tile problem (CTE, session 4)

Camila used a representation not introduced in the problem. Although some of the questions posed in the earlier sessions involved the use of algebraic notation, here the student used it to express the general rule, although she was answering a question about a specific value. This type of representation was also observed in the interviews, specifically in four students' answers to the problem in the second interview, in which the functions were of the type $y=ax$ and $y=ax+b$. That spontaneous use of algebraic notation differed from the findings for the third- and fourth-grade students and suggests that some of the sixth graders were quicker to adopt the use of algebraic notation to express general relationships between two variables.

Most of the students in fifth and sixth grades generalized using (oral or written) natural language or algebraic notation, whereas for specific values they used a wider variety of representations (oral and written natural language, pictorial, numerical, algebraic notation and tabular). Numerical representation prevailed in these students' solutions to the specific value questions. Once again, this make sense given that were being asked about specific values.

Conclusions

This paper seeks to shed light on how the representations used by intermediate and upper elementary school students (8 to 12-years-old) vary when solving problems that involve different types of linear functions. Specifically, in both groups, when the students generalized the functional relationship, they used the same type of representation as introduced in the problem (natural language or algebraic notation). The variety of representations was broader when they worked with specific values. These findings reveal that while they were aware of different types of mathematical representations (used when working with specific values), when generalizing they only used two. As noted by other authors (e.g., Brizuela & Earnest, 2008), this highlights the importance of teaching representations in elementary school to enable students to gradually assimilate them as they are constructing meaning for different types of representations when generalizing and grasping the meaning of functional relationships.

Concerning this study's specific objectives, no major differences were observed in the representations used in one type of function or another by either third- and fourth- or fifth- and sixth-graders. That may be because both groups had participated in a CTE in which they solved problems involving different linear functions. Tabular representations appeared spontaneously in some of the third/fourth-grade students' answers, whereas algebraic notation appeared among the fifth/sixth-graders. Significant use of numerical representation was found in both groups and it was consistent with what the problem asked them. The major difference between the two groups was in the types of representations used when working with specific values and when generalizing. When generalizing, the third- and fourth-graders used a narrower variety of representations than the older group of students. This seems to suggest that in this sample, the students in the higher grades of elementary school had more resources from which to draw when expressing general rules.

Acknowledgment

This study was funded by the Spanish Ministry of Economy and Competitiveness under National R&D Project EDU2016-75771-P; the first author benefited from a PhD. grant awarded by the Chilean Government through the CONICYT, folio 72160307-2015.

References

- Blanton, M. L., Brizuela, B. M., Gardiner, A., Sawrey, K., & Newman-Owens, A. (2015). A learning trajectory in 6-year-olds' thinking about generalizing functional relationships. *Journal for Research in Mathematics Education*, 46(5), 511-558.
- Brizuela, B., & Earnest, D. (2008). Multiple notational systems and algebraic understanding: The case of the “best deal” problem. In J. J. Kaput, D. W. Carraher, & M. L. Blanton (Eds.), *Algebra in the early grades* (pp. 273-302). New York, NY: LEA.
- Cañadas, M. C., & Castro, E. (2007). A proposal of categorisation for analysing inductive reasoning. *PNA*, 1(2), 67-78.
- Carraher, D. W., Schliemann, A. D., & Schwartz, J. L. (2008). Early algebra is not the same as algebra early. In J. J. Kaput, D. W. Carraher, & M. L. Blanton (Eds.), *Algebra in the early grades* (pp. 235-272). New York, NY: LEA.
- Goldin, G. A., & Shteingold, N. (2001). Systems of representations and the development of mathematical concepts. In A. Cuoco, & F. Curcio (Eds.), *The roles of representation in school mathematics. 2001 yearbook* (pp. 1-21). Reston, VA: NCTM.
- Kaput, J. J. (1987). Towards a theory of symbol use in mathematics. In C. Janvier (Ed.), *Problems of representation in the teaching and learning of mathematics* (pp. 159-195). Hillsdale, NJ: LEA.
- Kaput, J. J., Blanton, M. L., & Moreno, L. (2008). Algebra from a symbolization point of view. In J. J. Kaput, D. W. Carraher, & M. Blanton (Eds.), *Algebra in the early grades* (pp. 19-55). New York, NY: LEA.
- Küchemann, D. (1981). Algebra. In K. Hart (Ed.), *Children's understanding of mathematics: 11-16* (pp. 102-119). London, United Kingdom: John Murray.
- MacGregor, M., & Stacey, K. (1995). The effect of different approaches to algebra on students' perceptions of functional relationships. *Mathematics Education Research Journal*, 7(1), 69-85.
- Martí, E. (2009). Tables as cognitive tools in primary education. In C. Andersen et al., (Eds.). *Representational systems and practices as learning tools* (pp. 133-148). Rotterdam, The Netherlands: Sense Publishers.
- Pinto, E., & Cañadas, M. C. (2018). Generalization in fifth graders within a functional approach. *PNA*, 12(3), 173-184.
- Radford, L. (2003). Gestures, speech, and the sprouting of signs: A semiotic-cultural approach to students' types of generalization. *Mathematical Thinking and Learning*, 5(1), 37-70.

Unpacking 9th grade students' algebraic thinking

Marios Pittalis¹ and Ioannis Zacharias²

¹Department of Educational Sciences, University of Cyprus, Cyprus; m.pittalis@ucy.ac.cy

²Pierce- The American College of Greece, Greece; izacharias@acg.edu

The purpose of the present study was to propose and empirically validate a model describing secondary school students' algebraic thinking. Based on a synthesis of the literature, a model for Grade 9 students' algebraic thinking was formulated. The major constructs incorporated in this model were "generalized arithmetic", "transformational ability" and "meta-algebra". The study involved one hundred fourteen students. Data analysis validated the hypothesized model and suggested a sequential effect between the three factors. Transformational ability had a direct effect on generalized arithmetic and the latter had a direct effect on meta-algebra.

Keywords: Algebra, algebraic thinking, secondary school algebra, functional thinking.

Introduction

Recently, there is a growing consensus that algebra is the gateway to school mathematics reform for the next century and school algebra should be reformulated as a K-12 strand of thinking (Kaput, 2008; National Council of Teachers of Mathematics, 2000; Stephens, Ellis, Blanton & Brizuela, 2017). Algebraic thinking can be coherently conceptualized as a synthesis of different content strands, concepts, processes or forms of reasoning that relate to the ideas of equivalence, generalized arithmetic, variable, proportional reasoning, modelling, and functional thinking (Blanton, Stephens, Knuth, Gardiner, Isler, & Kim, 2015; Chimoni, Pitta-Pantazi, & Christou, 2018).

A number of researchers provided diverse conceptualizations of algebraic thinking, focusing on different parameters (Drijvers, Coddijn, & Kindt, 2011). One of the most influential developments of the past decades in respect to conceptualizing the notion of algebraic thinking is Kaput's organizing framework (Stephens et al., 2017). Kaput (2008) suggested that algebraic thinking consists of two core aspects: (a) generalizing and representing generalizations and (b) syntactically guided reasoning and actions on generalizations represented in conventional symbolic systems (Stephens et al. 2017). Kieran (2004), adopting a different methodology, conceptualized algebra as a multifaceted activity that encompasses various types of tasks and ways of thinking. Kieran offered a slightly different view by arguing that algebraic thinking is not only about using symbols in order to express generality; algebraic thinking arises when individuals make use of any kind of representations when they try to manipulate quantitative situations in a relational way. Drijvers, Coddijn and Kindt (2011) provided a different conceptualization of algebraic thinking giving emphasis on the role of functional thinking and solving equations and in-equalities with reference to specific constraints.

Thus, researchers' efforts to describe algebraic thinking through several perspectives are characterized by diversity and there is not a consensus regarding the dimensions of students' algebraic thinking in secondary school (Carraher, Martinez & Schliemann, 2008). In addition, the existing models are based mainly on theoretical conceptualizations of students' algebraic thinking. The aim of this study is the development of a better understanding of the notion of secondary school students' algebraic thinking by proposing a model that takes into consideration existing and well-accepted theoretical frameworks (Kaput, 2008; Kieran, 2004). Thus, the proposed model is founded by

utilizing aspects of algebraic thinking that are well-accepted in the existing literature. In addition, the proposed model will be validated based on empirical data.

Literature Review

Several researchers made efforts to analyse the nature and content of algebraic thinking. There are differing views on what constitutes algebraic thinking, but many agree that a fundamental element is generalization, that is the ability to see the general in the particular (Kaput, 2008; Kieran, 2004; Wilkie, 2016). Generalization is a cornerstone of mathematical structure, while symbolization is a catalyst of algebraic thinking development. In this paper, we examine Kaput and Kieran's models of algebraic thinking, which are considered of the most influential in recent literature (Stephens et al., 2017). Kaput (2008) asserted that generalizing and symbolizing are tightly linked in that symbols allow generalizations to be expressed in a stable and compact form, throughout three strands: (a) generalized arithmetic, (b) functional thinking and (c) modelling. Generalized arithmetic, as a way for applying algebraic thinking in arithmetical settings, involves the use of letters for generalizing rules about relations between numbers, manipulating numbers and operations properties, examining number structure, understanding the equals sign in number relations, notice relationships in operations on classes of numbers and reasoning with forms and representations of equivalence. The generalizations that students make in the realm of generalized arithmetic can serve as a context for developing students' abilities to represent mathematical ideas symbolically. Functional thinking refers to the identification and description of functional relations between independent and dependent variables in different forms of representation and the manipulation of covariance and correspondence relations. Finally, modelling involves the use of symbols for developing models, manipulating variables, and re-translating between models and situations. Emphasis is placed on exploring modelling problems that are derived from complex realistic situations (Blanton et al, 2015).

Kieran's (2004) model for conceptualizing algebraic activity denotes that algebra is not just a topic in mathematics curriculum, but a multifaceted activity that encompasses various types of tasks and ways of thinking. Kieran asserted that algebraic thinking is considered as an approach to quantitative situations that seeks to look for relationships and structure with means that are not strictly letters-symbolic. Kieran, compared to Kaput, emphasized that algebraic thinking is a way for introducing students to the more abstract aspects of formal algebra and pointed out that her model tries to unfold the kinds of meaning that secondary students make when they are engaged with algebraic tasks. This model involved three types of activities: "generational" activities, "transformational" activities, and "global, meta-level" activities. The generational activities refer to the generation of equations and expressions in various situations and involve exploration of problem situations and numerical and geometrical patterns that lead to the formulation of generalization, and exploring numerical relationships. The transformational activities refer to the transformation of expressions by applying specific rules and involve conceptual understanding of algebraic objects. The global, meta-level activities are not strictly algebraic in nature, but algebraic tools are needed to be investigated and involve general mathematical processes, such as proving, studying functional relationships and identifying structure.

In conclusion, Kaput and Kieran's models examine algebraic thinking under a different perspective. Kaput (2008) emphasized the role of generality and symbols by explaining algebraic reasoning under two core lenses: (a) symbolization that serves purposive generalization and (b) reasoning with

symbolized generalizations. Thus, in Kaput's model the use of symbols is a fundamental aspect, while in Kieran's model the use of symbols is not a prerequisite. For instance, Kieran's meta-level activities may be solved without using algebraic symbols at all. In this study, we will synthesize the two frameworks and propose a model that describes students' algebraic thinking in an explicit and parsimonious way. The synthesis of the two frameworks makes possible the combination of the salient parameters of each model to provide a comprehensive description of students' algebraic thinking. In addition, it provides a more accurate conceptualization of students' algebraic thinking by adopting the parameters of each model that are described in a more concrete way. For instance, transformational activities are implicitly integrated in the strands of Kaput's model, while in Kieran's model they are described as a separate type of algebraic activity. In the following section, we explain the rationale of including each parameter in the proposed model.

The Present Study

The purpose of the present study was to propose and empirically validate a model describing Grade 9 students' algebraic thinking. In particular, the aims of the study were: (a) to propose a theoretical model describing the dimensions of 9th grade students' algebraic thinking based on a synthesis of the literature, (b) to examine the validity of the proposed model by using empirical data and (c) to examine the relations between the dimensions of algebraic thinking.

The Proposed Model

The development of the proposed model describing students' algebraic thinking dimensions took into consideration Kaput's (2008) and Kieran's (2004) frameworks. To do so, we thought appropriate to include in the model the common types of thinking of each model and the parameters of each model that are involved to a greater extent in 9th grade algebra. Based on a synthesis of the literature, we hypothesized that 9th grade students' algebraic thinking consists of four distinct, but interrelated factors: (a) Generalized arithmetic, (b) Functional thinking, (c) Transformational ability, and (d) Modelling-meta-algebra. The dimension of generalized arithmetic is a common component of Kieran's (2004) and Kaput's (2008) models. Functional thinking is one of the main components of Kaput's model, while it is a sub-component of meta-algebra in Kieran's model. We included functional thinking as a separate component of the model because functions are a top priority topic in secondary school algebra. Transformational ability is a synthesis of transformational activities in Kieran's model and formalizations of Kaput's model and a fundamental type of activity in secondary school. Finally, the dimension of modelling-meta-algebra is a synthesis of components from both models. It includes Kieran's global, meta-level activities and Kaput's modelling dimension. In particular, it was hypothesized that generalized arithmetic involves applying algebraic thinking in arithmetical settings, by manipulating numbers and operations and exploring their properties, understanding the equal sign in numerical relations and becoming aware of the structure of arithmetic. Functional thinking refers to the identification and description of functional relationships between independent and dependent variables, by manipulating the concept of change and variation and generalizing patterns. Transformational ability refers to the transformation of numeric and algebraic expressions and solving equations by applying specific rules. Modelling-meta-algebra conceptualizes problem solving by using modelling, proving, manipulating variables in problem-solving situations and using symbols to represent situations.

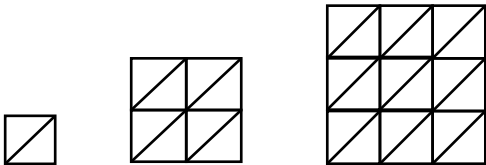
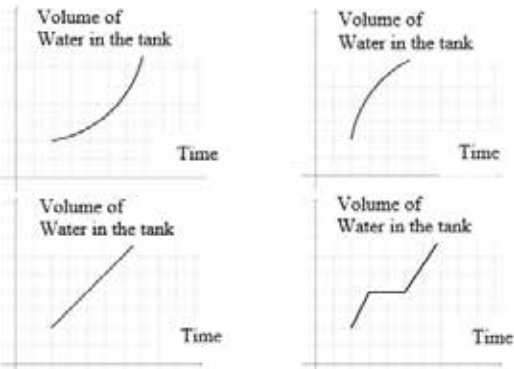
Type of Task	Example												
Patterns	<p>How many triangles are needed to construct the 10th figure?</p> 												
Relation between variables	<p>Which of the following equations corresponds to the relation of the variables in the table?</p> <p> $y=2x$ $y=2x+1$ $y=x^2+1$ $y= x^2+x$ </p> <table border="1" data-bbox="1283 510 1433 741"> <thead> <tr> <th>x</th> <th>v</th> </tr> </thead> <tbody> <tr> <td>0</td> <td>1</td> </tr> <tr> <td>1</td> <td>2</td> </tr> <tr> <td>2</td> <td>5</td> </tr> <tr> <td>3</td> <td>10</td> </tr> <tr> <td>4</td> <td>17</td> </tr> </tbody> </table>	x	v	0	1	1	2	2	5	3	10	4	17
x	v												
0	1												
1	2												
2	5												
3	10												
4	17												
Relation between variables in a graph	<p>Which graph corresponds to the following situation?</p> <p>“Water is being poured into a tank with a constant rate. The faucet is closed for a while and then it is opened again. The rate that the tank is now being filled is slower than the initial one”.</p> 												

Table 1: Functional Thinking Tasks

Measures

The test items were adopted or developed based on previous research studies. The test items were evaluated by three experts in mathematics education who provided feedback on the content validity. The multiple choice tasks were corrected as correct or incorrect, while the open tasks were given partial marks for incomplete correct answers. Three types of tasks were used to measure the factor “generalized-arithmetic” (Kaput, 2008): (a) Properties and relationships of numbers and operations (Tasks 1-3), (b) Structure of numbers and numerical expressions (Tasks 4-6), and (c) Equality and inequality (Tasks 7-9). In Tasks 1-3 students had to use number and operation properties to calculate numerical expressions (e.g., find the result of $-1245 \cdot 15 + 245 \cdot 15$). In Tasks 4-6 students had to treat numbers as placeholders and attending the structure of numbers rather than relying on computations (e.g., find the remainder of the division $(946 + 950 + 952 + 960) \div 950$, and examine whether the number 3^{400} is divisible by 9). In Tasks 7-9 students explored equality and inequality situations (e.g., for what value of a is the inequality $-10 > (-5)a$ valid). Three types of tasks

were used to measure the “transformational ability” factor: (a) Numerical transformations (Tasks 10-11), (b) Algebraic transformations (Tasks 12-13), and (c) Solving equations (Tasks 14-15). In Tasks 10 and 11 students had to make complex calculations with fractions and roots (e.g., $A = 2\sqrt{2} - 3\sqrt{3} + 7\sqrt{2} + 4\sqrt{3} + 5$). In tasks 12 and 13 students had to simplify algebraic expressions (e.g., $A = (a - 2b)(a + b) - (a + b)(a - a) + b(b + a)$). Finally, in Tasks 14 and 15 students had to solve fractional equations. Three types of tasks were used to measure functional thinking factor (see Table 1): (a) Finding the remote or general term of a pattern (Tasks 16-18), (b) Finding the relation between variables (Tasks 19-20), and (c) Finding the relation between variables in a graph (Tasks 21-22). Finally, we used two types of tasks to measure “modelling-meta-algebra” factor. In the modelling tasks (Tasks 23-25) students had to construct a mathematical model to solve a real-life problem, translate a word-situation to an algebraic expression using symbols and to represent a numerical relation using a bar-model (see Table 2). In the meta-algebra tasks (Tasks 26-27) students had to solve a complex problem involving inequalities and to make a proof (see Table 2).

Type of Task	Example																														
Modelling	<p>Which of the following corresponds to the relation: “One less than the double of a number is equal to five more than a second number”.</p> <div style="display: flex; justify-content: space-around; align-items: flex-start;"> <div style="text-align: center;"> <table border="1" style="border-collapse: collapse; margin-bottom: 10px;"> <tr><td style="padding: 2px 10px;">x</td><td style="padding: 2px 10px;">x</td><td style="padding: 2px 10px;">1</td></tr> <tr><td style="padding: 2px 10px;">5</td><td colspan="2" style="padding: 2px 10px;">y</td></tr> </table> <table border="1" style="border-collapse: collapse; margin-bottom: 10px;"> <tr><td colspan="2" style="padding: 2px 10px;">x</td><td style="padding: 2px 10px;">y</td></tr> <tr><td style="padding: 2px 10px;">5</td><td style="padding: 2px 10px;">x</td><td style="padding: 2px 10px;">1</td></tr> </table> <table border="1" style="border-collapse: collapse; margin-bottom: 10px;"> <tr><td colspan="2" style="padding: 2px 10px;">x</td><td style="padding: 2px 10px;">x</td></tr> <tr><td style="padding: 2px 10px;">5</td><td style="padding: 2px 10px;">y</td><td style="padding: 2px 10px;">1</td></tr> </table> </div> <div style="text-align: center;"> <table border="1" style="border-collapse: collapse; margin-bottom: 10px;"> <tr><td colspan="2" style="padding: 2px 10px;">x</td><td style="padding: 2px 10px;">y</td></tr> <tr><td style="padding: 2px 10px;">5</td><td style="padding: 2px 10px;">x</td><td style="padding: 2px 10px;">1</td></tr> </table> <table border="1" style="border-collapse: collapse; margin-bottom: 10px;"> <tr><td style="padding: 2px 10px;">y</td><td style="padding: 2px 10px;">y</td><td style="padding: 2px 10px;">1</td></tr> <tr><td colspan="2" style="padding: 2px 10px;">x</td><td style="padding: 2px 10px;">5</td></tr> </table> </div> </div>	x	x	1	5	y		x		y	5	x	1	x		x	5	y	1	x		y	5	x	1	y	y	1	x		5
x	x	1																													
5	y																														
x		y																													
5	x	1																													
x		x																													
5	y	1																													
x		y																													
5	x	1																													
y	y	1																													
x		5																													
Meta-Algebra	<p>Prove that the product of an even number by an odd number is an even number.</p>																														

Table 2: Modelling-Meta-Algebra Tasks

Participants, Procedure and Data Analysis

One hundred fourteen 9th grade students (55 males and 59 females) were the subjects of the study from one private secondary school in Athens, Greece. The tasks of the study were randomly split into two parts. Each part was administered in the form of a written test during one school period. The two parts were administered in two successive weeks. The instructions were provided in written and verbal form. Confirmatory factor analysis was used to examine the validity of an a priori model, based on past evidence and theory. CFA was conducted by using MPLUS (Muthén & Muthén, 1998-2007). To evaluate model fit, three widely accepted fit indices were computed: χ^2/df should be <2 ; the Comparative Fit Index should be $>.9$; and the root mean-square error of approximation (RMSEA) should be $<.08$. The Cronbach’s alpha index of internal consistency was very good ($\alpha=.83$).

Results

Confirmatory factor analysis (CFA) was used to evaluate the construct validity of the model; by validating that the a-priori model matched the data set of the present study and determined the “goodness of fit” of the hypothesized latent construct. The results of the study showed that the fit-indices were not satisfactory and the hypothesized model could not be supported ($\chi^2/df > 2$, $CFI < .95$, κ and $RMSEA = .08$). Examining the results of the study, we noticed that the correlation between functional thinking and modelling-meta-algebra factors was too high. Thus, we decided to examine the validity of an alternative model hypothesizing students’ variances in functional thinking and modelling-meta-algebra tasks compose a unified factor. Analysis showed that the fit-indices of the alternative model were excellent ($\chi^2/df = 1.07$, $CFI = .97$, and $RMSEA = .03$), validating empirically the fit of the structure of the alternative model to the empirical data. CFA showed that the factor loadings of the tasks employed in the present study were statistically significant and most of them were rather large (see Figure 1). The factor loadings ranged from .38 to .84, giving support to the assumption that all latent factors were adequately measured by the observed variables. Thus, in accordance with our theoretical assumption, all algebraic thinking measures were clustered into three first-order factors in the expected factor-loading pattern.

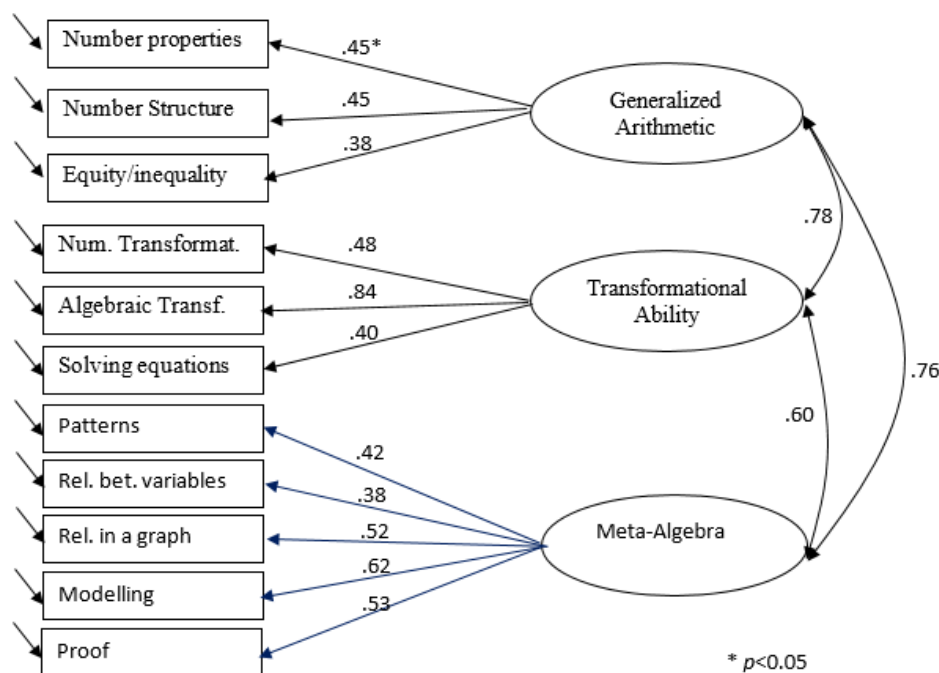


Figure 1: The Algebraic Thinking Model

Thus, analysis showed that algebraic thinking consists of three interrelated factors that is (a) generalized arithmetic, (b) transformational ability and (c) meta-algebra. The factor “meta-algebra” is a synthesis of students’ variances in functional thinking tasks, modelling and proving tasks. The correlations between the three factors were significant. In particular, the correlation between the factors “generalized arithmetic” and “transformational ability” was 0.78 ($p < 0.05$), the correlation between “transformational ability” factor and “meta-algebra” factor was 0.60 ($p < 0.05$) and the correlation between “generalized arithmetic” factor and “meta-algebra” factor was 0.76 ($p < 0.05$).

To investigate the relations between the three algebraic thinking factors, we examined the fit to the data of alternative structural models, hypothesizing a direct sequential path between the three factors. The model that had the best fitting indices ($\chi^2/df=1.04$, CFI=.98, and RMSEA=.02) showed that “transformational ability” factor has a direct effect on “generalized arithmetic” factor and the latter predicts “meta-algebra” factor (see Figure 2). The regression coefficient of transformational ability factor on generalized arithmetic factor was 0.79 ($p<0.05$), while the regression coefficient of generalized arithmetic on meta-algebra was 0.78 ($p<0.05$).

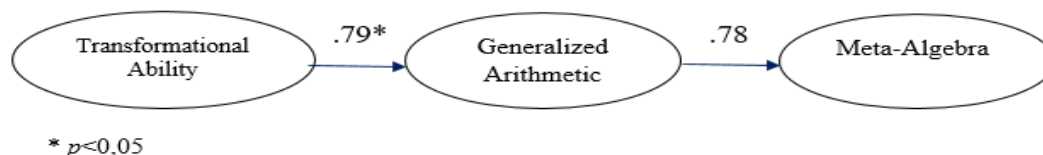


Figure 2: The Relation between Algebraic Arithmetic Factors

Discussion

The contribution of the study lies on the empirical evaluation of a proposed model that unpacks the dimensions of 9th grade students’ algebraic thinking. The results of the study showed that 9th grade students’ variances in algebraic situations might be modelled by three distinct and interrelated latent factors. The first factor involves students’ capacity in generalized arithmetic tasks, the second factor in transformational situations, while the third factor reflects students’ capacity in meta-algebra and functional tasks. The structure of the validated model is in line with the fundamental types of algebraic tasks suggested by Kieran (2004) and integrates ideas from Kaput’s model (2008). In particular, the validated model showed that meta-algebra factor is a synthesis of algebraic thinking parameters suggested by Kieran (2004) and Kaput (2008) and consists of functional thinking, modelling in various situations and proving. The inclusion of functional thinking in meta-algebra factor can be interpreted by the fact that in problem solving situations modelling activities prerequisite understanding the implied functional relations. Analysis showed that functional thinking can be described by adopting Kaput’s (2008) conceptualization that is generalization of patterns and manipulation of relations of variables in different representational forms. In conclusion, the empirically validated model that synthesized existing models in mathematics education could be a valid measurement model of 9th grade students’ algebraic thinking.

Analysis showed that there is a sequential effect between the three factors. Students’ capacity in transformational situations has a direct effect on their capacity in generalized arithmetic tasks and the latter affects directly meta-algebra. This is in line with research findings suggesting that modelling and meta-algebra tasks are the most difficult algebraic activities (Blanton et al, 2015). The finding that students’ capacity in transformational activities predicts generalized arithmetic might be explained by the fact that in 9th grade transformational tasks are mostly procedural and manipulating algebraic structures in a flexible way may help students conceptualize and express arithmetic structures in a generalized way more efficiently. Students’ advancement in transformational tasks might enhance their further development in generalized arithmetic by enhancing awareness of the structure of numeric and algebraic procedures, algebraic language and rules and applying generalizations strategically. Then, students’ advancement in generalized arithmetic might contribute in further enhancing their capacity in meta-algebra tasks, by developing generalization processes and

manipulating numbers and quantities relations strategically in different forms of representation. The aforementioned sequential relation might indicate a possible learning trajectory based on the fact that transformational ability and the ability to use algebraic language are essential so the students are successful in using algebraic structures for generalizing arithmetic tasks. Then students could succeed in meta-algebra that consists of more demanding tasks. Teachers should give students the opportunity to have systematic experience with transformational and generalized-arithmetic activities that lay the foundation to work with symbols and algebraic expressions that build up to an understanding of more abstract tasks. Moreover, teachers should take into consideration the aforementioned learning trajectory, which suggests a specific instructional sequence and the identification of key tasks designed to promote learning for each dimension of algebraic thinking. A future research could examine alternative learning trajectories in different populations and grades to get a further insight of students' difficulties and progression.

References

- Blanton, M., Stephens, A., Knuth, E., Gardiner, A. M., Isler, I., & Kim, J. S. (2015). The development of children's algebraic thinking: The impact of a comprehensive early algebra intervention in third grade. *Journal for Research in Mathematics Education*, 46, 39-87.
- Carraher, D. W., Martinez, M. V., & Schliemann, A. D. (2008). Early algebra and mathematical generalization. *ZDM*, 40, 3-22.
- Chimoni, M., Pitta-Pantazi, D., & Christou, C. (2018). Examining early algebraic thinking: insights from empirical data. *Educational Studies in Mathematics*, 98, 57-76.
- Drijvers, P., Goddijn, A., & Kindt, M. (2011). Algebra education: Exploring topics and themes. In P. Drijvers (Ed.), *Secondary algebra education* (pp. 5–26). Rotterdam: Sense Publishers.
- Kaput, J. (2008). What is algebra? What is algebraic reasoning? In J. Kaput, D. W. Carraher, & M.L. Blanton (Eds), *Algebra in the early grades* (pp. 5-17). New York: Routledge.
- Kieran, C. (2004). Algebraic thinking in the early grades: What is it? *The Mathematics Educator*, 8(1), 139-151.
- Muthén L. K., & Muthén, B. O. (1998-2007). *Mplus user's guide* (5th ed.). Los Angeles: Authors.
- National Council of Teachers of Mathematics (2000). *Principles and standards for school mathematics*. Reston, VA: NCTM.
- Stephens, A. C., Ellis, A. B., Blanton, M., & Brizuela, B. (2017). Algebraic thinking in the elementary and middle grades. In J. Cai (Ed.), *The Compendium for Research in Mathematics Education* (386-420). Reston, VA: NCTM.
- Wilkie, K. J. (2016). Students' use of variables and multiple representations in generalizing functional relationships prior to secondary school. *Educational Studies in Mathematics*, 93, 333-361.

Portuguese and Spanish prospective teachers' functional thinking on geometric patterns

Irene Polo-Blanco¹, Hélia Oliveira² and Ana Henriques²

¹Departamento Matesco, Universidad de Cantabria, Santander, Spain; irene.polo@unican.es

²Instituto de Educação, Universidade de Lisboa, Lisboa, Portugal; hmoliveira@ie.ulisboa.pt,
achenriques@ie.ulisboa.pt

Keywords: Algebraic thinking, functional thinking, geometric patterns, teacher knowledge.

Generalization of patterns and regularities to describe functional relationships is a way for students to develop functional thinking, a core expectation in mathematics curriculum orientations (Blanton, Levi, Crites, & Dougherty, 2011; NCTM, 2000). Thus, it is important to provide students with opportunities to interpret variables and relations between variables, and to use co-variation and correspondence approaches to generalization. The promotion of functional thinking in primary school requires a specific preparation of prospective teachers (PTs), which in turn claims to assess their knowledge on the subject at the beginning of the teacher education programs they are attending. Taking this into account, a study was developed to analyze how Portuguese and Spanish PTs identify and express generalization in a task involving geometric patterns.

The data was collected through a questionnaire which included 6 tasks to evaluate relevant aspects of algebraic thinking. The questionnaire was applied to 94 Spanish and 70 Portuguese PTs attending the 1st year of a degree in primary education teaching, respectively at a public university in north of Spain and at two public schools of education in the center of Portugal. The PTs were not familiar with this kind of tasks and had received no instruction in algebraic thinking before the test. One of the tasks, that is focus on this poster, is a problem of generalization of a geometric growing pattern (linear) intending to assess PTs' functional thinking. Based on the first four terms of a pictorial sequence, made up of squares and indicating the number of vertices of each figure, the PTs are required to provide two possible strategies to find the number of vertices of a distant term of the sequence and to identify a generalization of the functional relation between the number of vertices and the number of squares of the figures of the sequence.

For a descriptive and interpretative analysis of the PTs' responses to this task, the following categories of strategies for obtaining distant terms and general rule were established (adapted from Barbosa, 2010): (1) *difference-recursive*: continues the sequence using the pattern or the numerical difference between consecutive terms (e.g. "with each new square we have to increase the number of vertices by 3"); (2) *difference-covariation*: uses the difference between consecutive terms as a multiplicative factor (e.g. "we add three more vertices in each step, so the general term for the number of vertices is $4+3(n-1)$, with n the number of squares"); (3) *multiplicative reasoning-missing value*: uses the rule of three to find distant terms (e.g. "if a figure with two squares has 7 vertices, then a figure with 25 squares has $7 \times 25 / 2$ "); (4) *multiplicative reasoning-proportional reasoning*: uses multiplicative strategies, starting from one known term of the sequence to find distant terms or a general rule (e.g. "the number of vertices is x times the number of squares"); and (5) *correspondence*: expresses a relation between the two varying quantities, based on the numerical

or pictorial sequence (e.g. “ $v=3n+1$ where v is the number of vertices, and n the number of squares”).

In the poster, we will present a complete analysis of the PTs’ strategies for obtaining distant terms and a general rule, providing a table with the percentage of PTs’ answers displaying each of the described strategies, both for Spanish and Portuguese contexts, as well as examples of those answers. Those results, in summary, indicate that in 62% of the Portuguese PTs’ answers they used a correct strategy to find a distant term of the sequence. In most of these cases they used a recursive strategy but also privileged the difference between consecutive terms as a multiplicative factor to obtain distant terms and the correspondence strategy. As expected, the PTs revealed more difficulties to find a generalization of a functional relation, since 50% of them did not answer and only 31% of their answers were correct. In these answers, they used difference-covariation and correspondence strategies. Almost half (48%) of their generalizations of a functional relation were based on a recursive strategy. However, in this case it resulted on incorrect generalizations.

Spanish results show that only 43% of the PTs’ answers were correct for computing the distant term, most of them based on a correspondence strategy. The recursive strategy was also quite frequent for obtaining distant terms (25%), although unlike in the case of Portugal, it led in most cases to incorrect results. One third of the Spanish PTs did not provide any answer to the question about generalization. Among those who did, correspondence and difference-recursive strategies were predominant, with only 20% of correct responses.

Moreover, it was seen that PTs of both countries adopted both visual and numerical approaches in the generalization of patterns, although they have privileged the former, and that, in general, they took into account the strategies used to find a distant term in the far generalization. However, the results related to the geometric pattern show important gaps in the algebraic reasoning of the PTs evaluated in both countries. These results provide information about the reasoning of PTs in tasks involving functional thinking and reveal the main difficulties they faced. In view of these results, possible considerations could be taken into account, like the benefits of including this type of tasks when designing courses of mathematical contents to help PTs develop their functional thinking.

Acknowledgment

This work was supported by the Ministerio de Economía y Competitividad. Madrid (Spain). Resolución de problemas y competencia matemática en la educación primaria y secundaria y en la formación de profesores. (EDU2017-84276-R).

References

- Barbosa, A. (2010). *A resolução de problemas que envolvem a generalização de padrões em contextos visuais: um estudo longitudinal com alunos do 2.º ciclo do ensino básico* [Problem solving involving pattern generalization within visual contexts: a longitudinal study with elementary students]. PhD thesis, Universidade do Minho, Braga, Portugal.
- Blanton, M. L., Levi, L., Crites, T., & Dougherty, B. J. (2011). *Developing essential understanding of algebraic thinking for teaching mathematics in grades 3-5*. Reston, VA: NCTM.
- NCTM (2000). *Principles and standards for school mathematics*. Boston, MN: NCTM.

“When a number moves across, it changes its sign” – Investigating Teachers' Conceptual Understanding of Algebra

Mark Prendergast¹, Aoibhinn Ní Shúilleabháin², Paul Grimes³ and Niamh O’Meara⁴

¹The University of Dublin, Trinity College, School of Education, Dublin, Ireland;
mark.prendergast@tcd.ie

²University College Dublin, School of Mathematics & Statistics, Dublin, Ireland;
aoibhinn.nishuilleabhain@ucd.ie

³Dublin City University, School of STEM Education, Innovation & Global Studies, Dublin, Ireland;
paul.grimes@dcu.ie

⁴University of Limerick, EPI*STEM, Limerick, Ireland; Niamh.OMeara@ul.ie

Keywords: Algebra, Conceptual understanding, Primary school, Post-primary school.

Background to the Study

Algebra has long been identified as an area of difficulty in the teaching and learning of mathematics. In Ireland such difficulties have traditionally been attributed to an over reliance on transformational-based activities when teaching the domain. These activities place a high emphasis on manipulating expressions and equations in a rote fashion, without a sound conceptual understanding of algebraic concepts. Bale (1999) describes conceptual understanding as an associative or connected body of knowledge, rather than a procedurally based knowledge, which can be applied to a variety of diverse contexts. To address this issue a reformed algebra strand was introduced to all post-primary schools in September 2011. In a shift from the transformational-based approach, the reformed strand followed the lead of several countries and advocated a functions-based approach to teaching the domain. This functions-based approach involves understanding the notion of change and making generalizations about how two or more varying quantities such as patterns of number sequences are related (Tanışlı, 2011). However, a study by Prendergast and Treacy (2018) found that not all teachers had successfully adopted the functions-based approach in their own teaching. As well as a reluctance to deviate from the transformational-based approach, teachers identified a lack of uniformity in the teaching and learning of algebra, particularly between primary and post-primary education. With such findings in mind, this study follows on from that research and focuses on teachers’ insights into their teaching of algebra, particularly during the transition from primary to post-primary school. Data generated in this research specifically investigates upper primary and lower post-primary school teachers’ conceptual understanding of algebra and, more particularly, linear equations.

Methodology

The study was qualitative in nature and involved two phases of semi-structured interviews with a cohort of upper primary (10 – 12 years) and lower post-primary (12 – 15 years) school teachers. Participants were recruited through a purposive sample method from one local education authority in Ireland. The first phase of interviews took place in January 2018 and involved 15 teachers (9 primary [P1-P9] and 6 post-primary [S1-S6]) from 8 different schools (6 primary and 3 post

primary). The second phase of interviews took place in May 2018 and involved 13 of the same teachers from Phase 1 (8 primary and 5 post-primary). For the purpose of this submission, the authors investigate teachers' conceptual understanding of linear equations. This proposal focuses on one question asked of teachers in Phase 1 and the related follow up question posed in Phase 2:

Phase 1 Question: Take a look at the following equation: $2x + 6 = 10$. How would you typically explain to your students how to solve this equation?

Phase 2 Question: In the pre-interview, a number of teachers indicated that they would instruct their students to bring the six across the equals sign and it would change sign to become a minus. Are there any issues that you see with such an explanation? What changes (if any) would you make to the explanation?

Preliminary Findings

Preliminary analysis conducted utilising the domain of expressions and equations as an organising framework (Bush & Karp, 2013), indicates a lack of conceptual understanding of linear equations on behalf of participating teachers and a prevailing over-reliance on 'rules without reason' when teaching algebra. For the Phase 1 Question, four out of the fifteen post-primary teachers effectively demonstrated conceptual knowledge of solving such a linear equation (S4: *So what I would start here is gain the notion of equality. Whatever we do to the left-hand side must be done to the right hand side*). Four of the primary teachers were either unable to generate a response or gave an inappropriate response (P5: *Let's see. Right well I would explain to them we need to find what x is... we haven't done these yet so...*). The other seven teachers' responses (five primary and two post-primary) were procedural in nature and all focused on the notion of numbers moving across the equals sign and then changing signs. (P1: *If it is a plus it becomes a minus and if it's a minus it becomes a plus*). The issue of moving across the equals sign and changing sign was probed further in Phase 2 and there were a variety of responses from the eleven teachers (8 primary and 5 post-primary). Three of the primary teachers did not see any issue with such an explanation (P6: *no I don't see anything wrong with it*). Four of the primary teachers could see where issues might arise but were unable to give an appropriate suggestion on how they would change the explanation (P2: *the biggest thing for me would be how is the +6 changing to a -6?*). While these findings are preliminary, the initial results raise concerns about participating teachers' conceptual understanding of algebra and, more specifically, linear equations. This research is intended to inform mathematics teacher education programmes in Ireland, particularly in the transition from primary to post-primary mathematics.

References

- Bush, S. & Karp, K. (2013). Prerequisite algebra skills and associated misconceptions of middle grade students: A Review. *The Journal of Mathematical Behaviour*, 32, 613-632.
- Bale, V. 1999. "My Practice of Using Manipulatives in Teaching Multiplying and Dividing Fractions Influences the Students' Conceptual Understanding of These Operations." PhD diss., University of Central Florida.
- Prendergast, M., & Treacy, P. (2018). Curriculum reform in Irish post-primary schools—a focus on algebra. *Journal of Curriculum Studies*, 50(1), 126-143.
- Tanişlı, D. (2011). Functional thinking ways in relation to linear function tables of elementary school students. *The Journal of Mathematical Behavior*, 30(3), 206-223.

Dealing with quantitative difference: A study with second graders

Margarida Rodrigues and Lurdes Serrazina

ESELx - Escola Superior de Educação, Instituto Politécnico de Lisboa, UIDEF, Instituto de Educação, Universidade de Lisboa, Portugal; margaridar@eselx.ipl.pt, lurdess@eselx.ipl.pt

The main goal of this paper is to understand students' reasoning when solving a task that involves quantitative difference. A qualitative methodology was used within the modality of teaching experiment. The data collection was done through the participant observation supported by video and audio recording of the work developed by two pairs of second graders, as well as the records of whole class discussions. To analyse data, we organized them into two categories: additive comparisons and complex additive relationships. The results show that these students were able to deal with quantitative difference, establishing relationships between quantities, even in a situation where initial numbers were unknown.

Keywords: Quantitative difference, quantitative additive reasoning, algebraic thinking.

Introduction

This paper reports part of the research developed by a project focused on flexible calculation and quantitative reasoning developed by teachers of the Higher Education Schools of Lisbon, Setúbal and Portalegre in Portugal. The main goal of the project is to build knowledge about the development of quantitative reasoning and calculation flexibility of students from 6 to 12 years old. The paper aims to understand second graders' reasoning when exploring and discussing a task that involves quantitative difference (Thompson, 1993). Specifically, the study aims to contribute to the knowledge of how early years students are capable of modelling situations focusing on their structures, abstracting from computation.

Theoretical framework and empirical studies

Nowadays, algebra is viewed as a generalizing activity (Mason, 2008) with instruments that represent the generality of mathematical relationships, patterns, and rules. According to Kaput (2008), there are two essential aspects of algebraic thinking: (a) generalization and the expression of generalizations in increasingly systematic, conventional symbol systems, and (b) syntactically guided action on symbols within organized systems of symbols. The aspect (b) is developed later than aspect (a). These two aspects are embodied in three strands of algebra:

1. Algebra as the study of structures and systems abstracted from computations and relations, including those arising in arithmetic (algebra as generalized arithmetic) and in quantitative reasoning.
2. Algebra as the study of functions, relations, and joint variation.
3. Algebra as the application of a cluster of modeling languages both inside and outside of mathematics. (Kaput, 2008, p. 11)

The first strand is the primary route into algebra. In the early years, it is important to approach arithmetic focusing on number and operations properties or relationships, thus building generalizations from them. It is also fundamental to focus on mathematical processes (not on the final product), in order to put relationships and transformations as objects of study (Cusi & Malara, 2007).

Such an approach is conducive to the development of students' algebraic thinking. There is another approach within this first strand that is based on quantitative reasoning. This kind of reasoning is not based on the arithmetic of numbers but rather on quantities.

Quantitative reasoning is defined as an analysis of a situation into a network of quantities and quantitative relationships (Thompson, 1993). This kind of reasoning is related with the algebraic reasoning insofar as the focus is on the description and modelling of situations. It involves the relationships between quantities. As argued by Smith and Thompson (2008), situations involving complex additive relationships, that is to say, situations with more than three related quantities, could be fundamental for the development of students' quantitative reasoning. And this development prepares students for algebra in multiple ways. "If we want students to learn and use algebra as a sensible tool for expressing their thinking and solving problems, then work with complex problems must come first" (Smith & Thompson, 2008, p. 113). Quantitative reasoning has two roles: (i) to provide the content for algebraic expressions; and (ii) to support a flexible and general reasoning not necessarily relied on symbolic expressions (Smith & Thompson, 2008). Therefore, quantitative reasoning is foundational for both arithmetic and algebra, providing meaning and content for numerical and algebraic expressions.

There is a conceptual difference between quantity and number. According to Thompson (1993), "a person constitutes a quantity by conceiving of a quality of an object in such a way that he or she understands the possibility of measuring it" (p. 165). For instance, we can reason about the lengths of two objects and the amount by which one is longer than the other without having the numerical values of their measures. Furthermore, numerical difference is not synonymous with quantitative difference. Numerical difference is the result of subtracting, while quantitative difference is the excess found when one compares two quantities additively (Smith & Thompson, 2008; Thompson, 1993). For example, 9 is a numerical difference when we subtract 6 from 15 (doing a computation), and it is a quantitative difference when we compare the quantities 15 and 6, assuming it is the amount by which 15 exceeds of 6 or 6 falls short of 15. Besides this, we can reason about 9 as a quantitative difference without having absolute numbers, conceiving 9 as a relative change related to variables.

Several studies have reported results related with additive quantitative reasoning (e.g. Schliemann, 2015; Thompson, 1993). Schliemann (2015) referred to a study conducted through interviews with second graders and showed that they were able to understand that the equality of two quantities relative to concrete sets of objects, with known or unknown number of elements, remains after performing identical transformations in the two compared quantities. She also reported the results of longitudinal studies from third to fifth graders in USA about algebraic reasoning and function representations. In these studies, the verbal representation of functions emerged from the consideration of relationships between physical quantities and situations of daily life, and involved additive comparison. She concluded that the students, from the age of 8 years old, showed understanding of quantitative relationships which was fostered by the discussion on those functional relations. The students used informal strategies for solving early algebra problems. Examples of such problems are: to represent additive comparison in a situation of having physically two chocolate boxes with equal quantities but unknown absolute number and 3 more chocolates above one of the boxes; to represent additive operations as movements along a line marked with $N-3$, $N-2$, $N-1$, N , $N+1$, $N+2$, $N+3$, $N+4$,... to solve problems where initial value was unknown. The evaluation of the

intervention impact, at the end of 5th grade, demonstrated that the performance of the intervention group in the written test was significantly better in the items related to the intervention and similar to that of the control group in the other items. Another study, driven by a teaching experiment that involved 5th-grade students (Thompson, 1993), showed students' trouble with the distinction between the quantitative operation of comparing two quantities additively and the arithmetical operation of subtraction: they conceived a quantitative difference as an invariant numerical relationship. Thus, they assumed relative change as an absolute amount and needed to know absolute values before they could make comparisons. These studies allow us to compare the respective results with those of the study of our project. On the one hand, comparing results with second and third graders in similar early algebra problems but in more concrete conditions, and on the other hand, comparing results with fifth graders, looking at the difficulties or facilities in the performances of students of different grades in similar algebra problems. Hence, this confrontation allows a deeper understanding of the effective quantitative reasoning abilities of second graders, through the extension to progressively more abstract situations not based on arithmetic computation.

Methodology

The project follows a qualitative approach framed in an interpretative paradigm (Bogdan & Biklen, 1994). It is focused on the educational processes and the meanings of the study's participants. It adopts the modality of teaching experiment conceived with the purpose to develop students' flexibility for calculation and quantitative reasoning. The Project team defined a sequence of nine tasks involving additive structure and discussed it with the classroom teacher.

The task "*More? Or Less?*" was the fifth task in the sequence and was created by the Project team. It has a context of games with marbles and it was presented after another task that had the same context. It is composed by three parts. The first and the second parts are identical but the first one, besides involving different numbers, presents, in the middle, empty and white squares, while the second one presents black squares. The second part aimed to focus on quantitative difference corresponding to the excess found when gains and losses are compared. Figure 1 presents one example of each part.

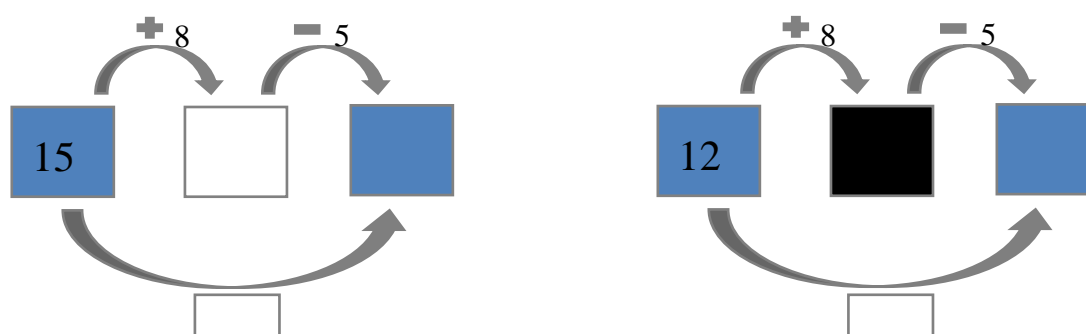


Figure 1: The first and second parts of the task

The 3rd part aimed to focus on the balance between gains and losses and it does not present the absolute initial number of marbles (see Figure 2). At the end, students were asked to circle the face at the end of two days (Monday and Tuesday) and at the end of three days (Monday, Tuesday, and Wednesday). The students were requested to circle a smiley or a sad face depending on their sense of whether there were more gains or more losses at the end of the day(s). Besides this, the students were

expected to find the quantity representing how many marbles have been gained or lost at the end of the day(s), that is, the final quantitative difference. It should be noted, that they had not worked with notation of negative numbers before this task.

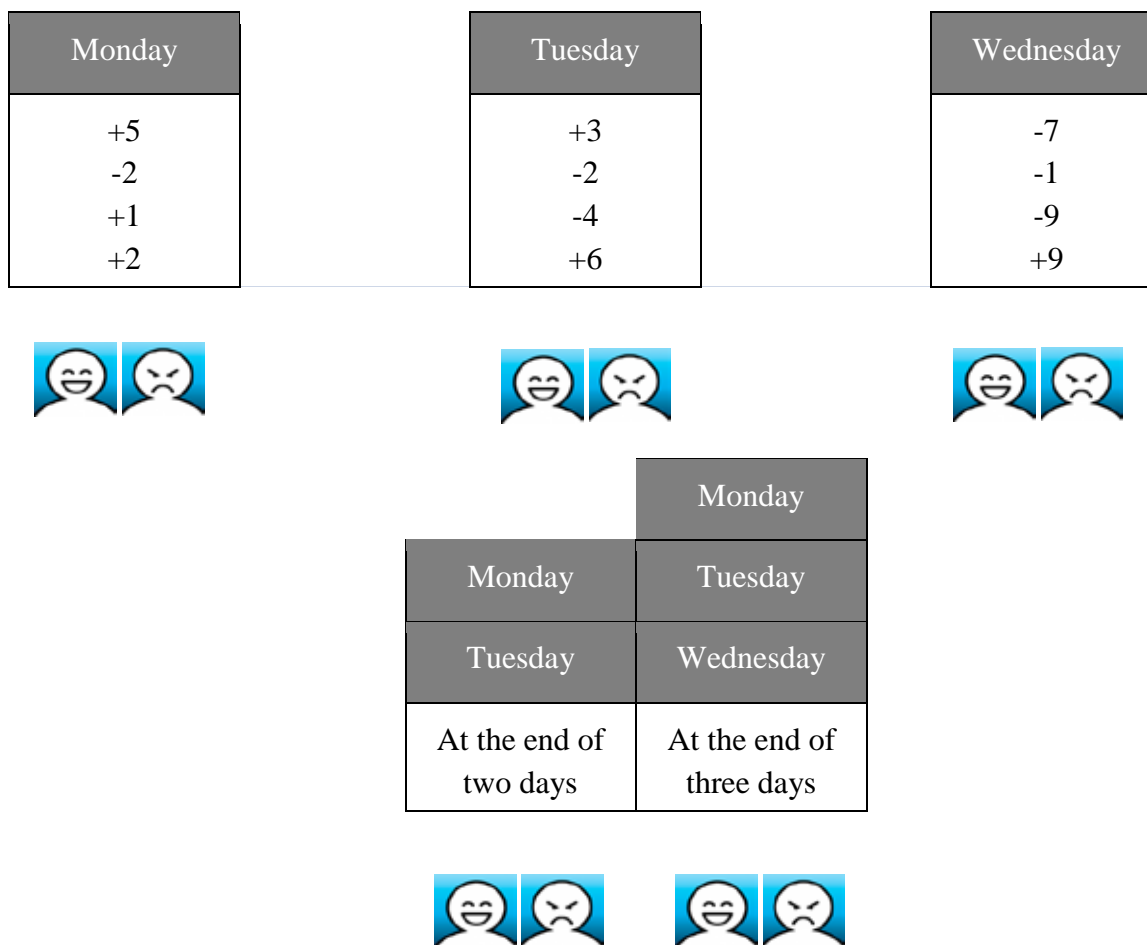


Figure 2: The third part of the task

The data reported in the current article were collected during two lessons of one hour and a half each that took place in the same class and they were conducted in the same way, within an exploratory teaching approach. The names of the students have been changed to ensure confidentiality. The data collection was done through the participant observation of the authors of this article, complemented with field notes and videotaping of the lessons. The students' productions were also collected. In the part of the exploration of the task, the videotaping focused on two pairs of students, Luís and Lúcia, and Paulo and João, selected because they habitually verbalized their reasoning among themselves.

The analysis focused on students' productions, field notes, video recordings and their transcriptions. To analyse data we defined categories built from the theoretical framework of Thompson (1993): (i) additive comparison; and (ii) complex additive relationship. The first one is illustrated for example by comparing 8 gains and 5 losses and determining 3 as the quantitative difference (there are 3 more gains than losses) or by comparing 6 gains and 10 losses and determining 4 as the quantitative difference (there are 4 more losses than gains). The second corresponds, for example, to the balance between several gains (+3, +4) and several losses (-8, -6) conceived as quantities without the necessity

of having the absolute number of marbles in situations with more than three related quantities: at the end, the quantitative difference is -7 .

Results

During the first lesson, the pair Luís and Lucía explored the first and second parts of the task in a consecutive manner, prior to the discussion of the first part. Luís asked: "Why is it here black?". Although informed that they should write nothing there, Luis wrote the various results within the black squares, despite Lucia's reaction ("We cannot!"), thus addressing the second part in the same way as the first one. To do the calculations, they used compensation strategies, adding first 10. For example, for calculating $12+8$, they did: $12+10=22$; $22-2=20$. Also the pair Paulo and João performed all the calculations, as in the first part.

In the whole class discussion, the teacher asked different pairs to go to the blackboard to present their solutions for the first part of the task.

Nádia: Here is 15. Then we added another 8 that gives 23. Minus 5 gives 18.

Teacher: Yes? ... So how did you find the bottom one?

Nádia: Because here (*pointing to 15*) to reach the 18 is 3 more.

Teacher: So the first and the last were enough; the jumps above do not matter?

Maria hesitates.

Teacher: I want to know if the jumps above also help.

Paulo: Yes, they help.

Teacher: Why?

Paulo: (*goes to the blackboard*) Because if from 8 you take out 5, you get only 3 from here (*points to the bottom square*). And knowing that only 3 were missing, here from the first to reach the last we only needed 3 more. For the last.

Teacher: So did they gain or lose?

Guilherme: They gained because they got 3 more.

The students were able to focus on the balance between gains and losses of marbles, rather than on numerical calculations with the help of the teacher's questioning. The classroom discourse was centered on quantitative difference ("3 more") instead of absolute number of marbles (15 and 18).

During the second lesson, the teacher gave the second part of the task. Since Luís and Lúcia had already done it in the previous lesson, the teacher asked them to talk to each other about how they had done it. When the teacher approached the pair, she asked:

Teacher: Do you need this middle square?

Luís and Lúcia: No.

Teacher: Tell me another way to reach this without saying the number in the middle. If it's painted of black, maybe it would not be necessary.

Luís: 8 minus 5 gives 3 (*pointing to the arrows*).

- Teacher: Gains or losses?
 Luís: Gains. 3 more.
 Teacher: And here? (*pointing to the situation below*)
 Luís: $15 + 9...$
 Teacher: But is the middle square necessary?
 Luís: Plus 9, minus 10.
 Teacher: Okay. (*the teacher moves away*)

Luís erased the numbers written in the black squares, indicating that he followed the teacher's guidance that these numbers would not be necessary. Luís seemed to be able to focus on quantitative difference between gains and losses in both games, as encouraged by the teacher. However, in the other situation, he began verbalizing the numerical computations and just after the teacher's intervention, he focused on quantitative difference resulting from *additive comparison* ("Plus 9, minus 10").

With regard to the other pair, Paulo showed the ability to focus on the balance between gains and losses. He decided to invent two other situations, asking João to determine the jumps. When the researcher got closer, Paulo explained the "-6+4" situation: "It's 6 minus 4. It's going to give a negative number". Probably Paulo used a vocabulary from his home context since the teacher had not used this expression in classroom in the previous lessons.

At the moment of whole class discussion, the teacher asked:

- Teacher: Why do you think the square is painted of black?
 Student: It's to guess the number and keep it in our head.
 Teacher: Does it make sense?
 Gil: To not write.
 Maria: To help us think.
 Paulo: The square is painted because the number under that square should not interest.
 Teacher: So how does it solve?
 Luís: It's $+8-5$ that gives $+3$.
 Teacher: Gained or lost, Gil?
 Gil: Gained $+3$.
 Teacher: Without looking to the jumps, how can we see if he gained?
 Students: We see in the numbers, from 12 to 15.

With the help of the teacher's guidance, the students were able to relate the balance between gains and losses with the quantitative difference between 15 and 12 ("It's $+8-5$ that gives $+3$ "; "Gained $+3$ "; "We see in the numbers, from 12 to 15"). Then the teacher introduced the third part of the task:

- Teacher: What if there were no numbers neither at the beginning nor at the end?

Luís: It's just to find out if you gain or lose and how much.

Teacher: This new proposal has only the gains and losses in different games. Let's see what happens at the end of each day.

Paulo seemed to deal easily with quantitative difference whether it is an excess or a deficit. He did this part very quickly, in two minutes. When the researcher got closer, Paulo explained: "these annul each other" (for example, $-2, +2$), having calculated only the remaining ones. His solution presents positive and negative numbers notation (with the signals $+$ and $-$) and it can be seen in Figure 3.

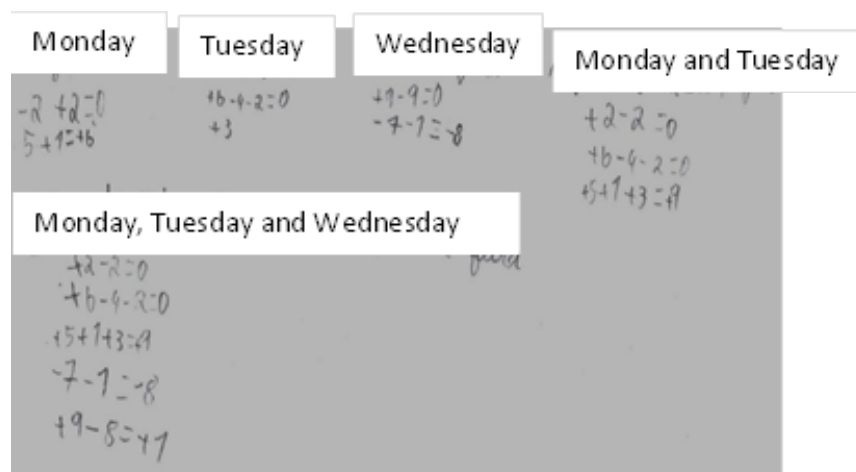


Figure 3: Paulo's resolution of the third part of the task

The pair Luís and Lúcia approached the third part using a different strategy. They added the gains, added the losses, and then did the additive comparison. In the Wednesday's situation, the students surrounded the sad face, understanding that at the end of the day, the player lost 8 marbles. They registered " $-17; +9$ " and " -8 " below the sad face.

In the whole class discussion, the most presented strategy was the one used by Luís and Lúcia: to add the gains and the losses, and then determine the quantitative difference. For example, for Tuesday, the pair Marta and Monica quickly recorded on the blackboard " $+9 - 6 = +3$ " and drew a 'smile'. The students concluded: "The difference between 9 and 6 is 3 to gain".

Teacher: Is there another explanation?

Paulo: Yes, the $+6, -4$ and -2 annul themselves. (*The teacher records on blackboard: $+6 - 4 - 2 = 0$*)

Paulo: And only $+3$ left over.

This idea of 'annulling' was used by other students in situations that followed and many of them used it correctly.

Conclusion

The students were able to focus on difference as a quantitative structure, looking at gains and losses. Thus, on the contrary to what happened with fifth-grade students in the study of Thompson (1993), these second graders were able to conceive a quantitative difference independently of numerical information about quantities (Smith & Thompson, 2008); they did not need to know the initial number of marbles, in the third part of the task, to be able to think about gains and losses. These students were

able to focus on quantities, building relationships from them as stated by Cusi and Malara (2007) and as happened in the studies reported by Schliemann (2015). Hence, they conceived difference as a relative change independently of actual values, considering them as variables within a relational dimension.

This study stresses the fundamental importance of modeling the situations, revealing their structure. Both structural and relational dimensions are key elements of algebraic thinking. The results highlight the easy way in which students manipulated the quantitative differences attributing a contextual meaning, and also suggest the potential of a work focused on quantitative relationships to enhance early algebraic thinking. They open new lines for research in order to understand the multiple factors that may influence students' learning, namely the role of task design, in particular the black square and the final part with unknown initial numbers, as well as the role of teacher's questioning, in particular the funneling questioning, in the development of students' quantitative reasoning.

Acknowledgment

This paper is part of the Project *Flexibilidade de cálculo e raciocínio quantitativo* funded by Instituto Politécnico de Lisboa.

References

- Bogdan, R. & Biklen, S. K. (1994). *Investigação Qualitativa em Educação: Uma introdução à teoria e aos métodos*. Porto: Porto Editora.
- Cusi, A. & Malara, N. (2007). Approaching early algebra: Teachers' educational processes and classroom experiences. *Quadrante*, 16(1), 57-80.
- Kaput, J. (2008). What is algebra? What is algebraic reasoning? In J. Kaput, D. Carraher, & M. Blanton (Eds.), *Algebra in the early grades* (pp. 5-17). New York: Lawrence Erlbaum Associates.
- Mason, J. (2008). Making use of children's powers to produce algebraic thinking. In J. Kaput, D. Carraher, & M. Blanton (Eds.), *Algebra in the early grades* (pp. 57-94). New York: Lawrence Erlbaum Associates.
- Schliemann, A. D. (2015). Aritmética, álgebra, funções e representações múltiplas através do currículo escolar. In L.Santos (Ed), *Investigação em Educação Matemática 2015: Representações Matemáticas*, 9-27. Sociedade Portuguesa de Investigação em Educação Matemática.
- Smith, J. P., & Thompson, P. W. (2008). Quantitative reasoning and the development of algebraic reasoning. In J. J. Kaput, D. W. Carraher & M. L. Blanton (Eds.), *Algebra in the early grades* (pp. 95-131). New York: Lawrence Erlbaum Associates.
- Thompson, P.W. (1993). Quantitative reasoning, complexity, and additive structures. *Educational Studies in Mathematics*, 25(3), 165-208.

Short note on algebraic notations: First encounter with letter variables in primary school

Anna Susanne Steinweg

University of Bamberg, Germany; anna.steinweg@uni-bamberg.de

Algebraic thinking often requires generalisation processes. Generalisations of patterns are one frequently used design in early algebra settings in research and practise. Symbolical letter variables are not common in primary school and actually not needed by the children to articulate their pattern generalisations. Nevertheless, from a research perspective it is interesting to explore children's spontaneous interpretations of letter notations. The reactions of 3rd-and 4th-graders, who participated in an explorative study presented here, might provide a starting point to sensible appreciate the individual thoughts and ideas about letter variables in further studies.

Keywords: Early algebra, generalisation, symbolic notations, variables.

Introduction

Algebraic thinking in all its possible facets are described in detail in several studies (Kieran, 2018). One of the major aspects of algebraic thinking –especially in early algebra– is generalising from given cases to rules and description of the patterns found. Symbolical notations in letter variables can condense these rules in algebra lessons in secondary schools.

In some research approaches, based on the so-called Elkonin-Davydov curriculum, algebraic thinking is assumed as equal to using letter notations (Dougherty & Simon, 2014; Dougherty, 2008; Freudenthal, 1974). Others follow the way to re-invent algebra by the children (Amerom, 2002). Nowadays, almost everyone involved in early algebra research might agree on the fact that the children will not invent letter notations on their own.

Teachers need to introduce unfamiliar terms, representations, and techniques, despite the irony that in the beginning students will not understand such things as they were intended. The initial awkwardness vis-à-vis new representations should gradually dissipate, especially if teachers listen to student's interpretation and provide students with opportunities to expand and adjust their understandings. (Carragher, Schliemann, & Schwartz, 2008, p. 237)

Notation in letter variables does not emerge. It also holds true that letter notation is not needed to adequately describe patterns found (Akinwunmi, 2012). However, a suitable verbal description of complex patterns is sometimes tough to find. Letter notation is therefore a useful condensation and last not least a cultural heritage or an aspect of enculturation: “Enculturation into a mathematical expectation” (Mason, Stephens & Watson, 2009, p. 14). The study described here aims to receive an impression of primary children's initial interpretations of a vis-à-vis confrontation with letter notations, and listen to these ideas. The findings might base teaching advices and further research.

Theoretical framework

Letter notations use variables. Variables have at least three different aspects and features. They can

- represent quantities (Kieran, 2004) as an unknown (Strømskag, 2015; Freudenthal, 1983) in an equation like $5+x=8$,

- express rules of numerical relationships (Kieran, 2004) like in $a+b=b+a$, which Strømshag (2015) identifies as parameters and Freudenthal (1983) as indeterminate,
- express generality arising from patterns (Kieran, 2004) as variables (Strømshag, 2015; Freudenthal, 1983) like $n \times 2n+2$ (cf. Figure 1), which are the main focus in the study presented in this paper.

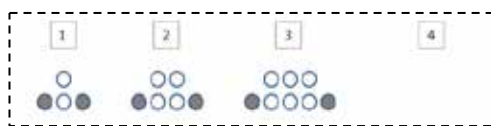


Figure 1: Pattern Sequence $n \times 2n+2$

Working on pattern sequences, like the one given in Figure 1, allows at least four different approaches, which can be summarised in the ReCoDE (Recognise-Continue-Describe-Explain) model (Steinweg, 2014). As mentioned above early algebraic thinking deeply depends on generalisations. A typical task implicitly challenges the children to generalise already whilst recognising the regularities: “Generalizing starts when you sense an underlying pattern, even if you cannot articulate it” (Mason, Burton, & Stacey, 2010, p. 8). Nevertheless, the articulation or even notation is a substantial element in the development of algebraic abilities. Experienced learners may use variables to articulate and to communicate findings with others in describe- or explain- phases.

When students perform a pattern generalization, it basically involves mutually coordinating their perceptual and symbolic inferential abilities so that they are able to construct and justify a plausible and algebraically useful structure that could be conveyed in the form of a direct formula. (Rivera, 2010, p. 298)

Dörfler (2006) regards notation as mathematical object itself, through which mathematical learning can be initiated. In any case letter notation has to be interpreted by the learner. This, of course, is the fact for every mathematical object like digits and operations signs. In line with Steinbring (2015) one has to keep in mind, that “the elements of the mathematical world cannot be perceived directly by our senses but consist of ‘invisible structures’ and relations” (p. 292). Hence, mathematical thinking depends on working on mental objects:

I speak of the constitution of mental objects, which in my view precedes concept attainment and which can be highly effective even if it is not followed by concept attainment (...) The fact that manipulating mental objects precedes making concepts explicit seems to me more important than the division of representations into enactive, iconic, and symbolic. (Freudenthal, 1983, p. 33)

The need for individual interpretation of mathematical objects and operations by images and explanatory models is fundamental for mathematical learning (Hofe & Blum, 2016). The interpretation of letters as notation of variables is nothing else than this usual habit. Rivera (2013) identifies the guessing of a rule of a given figural pattern as abductions and therefore as a fundamental mathematical activity. Of course ‘symbol sense’ is crucial for algebra because it allows

to see algebra as a tool for understanding, expressing and communicating generalizations, for revealing structure, and for establishing connections and formulating mathematical arguments (proofs). (Arcavi, 1994, S. 24).

In the study presented here pattern sequences as “arbitrary patterns” (Strømshag, 2015, p. 475) and no figurate numbers (e.g. square numbers) are used. The given pattern in predefined coloured dots

expects the learners to see a double structure or “a regularity that involves the linkage of two different structures: one spatial and the other numerical” (Radford, 2011, p. 19). In an explicit notation of the underlying rule the commonly used letter (n) corresponds with the position (ordinal) of the figure in the pattern as a whole. The cardinal amount of black and white dots needs to be set in relation to this ordinal number. The explicit formula represents in a direct approach “a functional relationship between position and numerical value of an element” (Strømskag, 2015, p. 475). As mentioned earlier the letter notation is in a way independent from generalising the pattern:

The difference between finding rules and expressing those rules in formal notation highlights a difference I see between these two aspects of mathematics. Spotting patterns and finding rules is algebraic in nature whereas how to express those rules is a matter of language and notation. (Hewitt, 2009, p. 43)

Thus, Hewitt (2012) differentiates between the necessary and the arbitrary in algebraic notations. The notation of spotted regularities also depends on (school) experiences (Radford, 2002). The didactical dilemma is, that “notation is not an afterthought, but rather an inherent part of mathematical activity” (Hewitt, 2016, p. 168).

Some pitfalls of educational approaches to letter notations are well documented. If tasks and learning-teaching-environments encourage pupils to match letters to word beginnings as abbreviation of names for objects in context situations (so-called fruit-salad-algebra (Thomas & Tall, 2001), or positions in the alphabet, these ideas hinder a deeper understanding of algebraic variables: “This ‘letter-as-object’ misconception can haunt students in their efforts to set up equations throughout their algebra careers” (Arcavi, Drijvers, & Stacey, 2017, p. 52).

A recent teaching-experiment study in two first grade classes worked on functional relations in context problems (Blanton et al. 2017). The findings indicate levels of understanding and make clear, that the letters are sometimes viewed as representing the context objects. The context situation therefore might hinder an interpretation of letters as mathematical object. Nevertheless, children in primary school of course need something to refer to while making sense of letter variables. The mediator chosen in this study is dots and dot pattern sequences.

The German situation concerning algebraic thinking is very special because algebra is not a curricular content (Steinweg, Akinwunmi, & Lenz, 2018). Patterns are mentioned in the syllabi and are therefore suitable for German primary school children, even though pattern sequences (like Fig. 1) are not frequently used. The study here tries to figure out the reactions to letter variables of German pupils with –under these conditions assumed– minor or none prior algebraic knowledge and whether the findings on children’s understanding of letters correspond to international findings:

- *What kind of spontaneous interpretations of letter notations of a pattern sequence ($n \in \mathbb{N}$) can be categorised?*
- *Does the age of the pupils or the pattern sequence given effect the interpretations?*
- *Are there any correlations between continuing the sequence, finding the 100th figure, and the ability to interpret the letter notation?*

Methodology and Design

The study is an explorative one-shot written test design with no teaching experiments. Five mixed-age classes 3rd- and 4th-grader (8 to 10-year-olds) and in total 96 children participated in the study.

The designed written test uses three different versions, each focusing on one pattern sequence ($n^{\text{th}} 2n+2$, $n^{\text{th}} 2n+1$, and $n^{\text{th}} 3+n$) in order to allow each child an independent reaction to the task in the classroom setting. Each test version is therefore worked on by 32 children.

Each test version includes only three tasks on one sheet of paper. The first two tasks are placed on the top half of the sheet, the third on the bottom half. The task sheet was folded in the middle, so that the children only see the first two tasks. They are permitted to unfold the sheet only after working on these two tasks.

Each child gets one of the pattern sequences and is asked to draw the next figure (like in Figure 1). The second task asks to describe how to find the 100th figure in this sequence. After unfolding the tasks sheet the third task appears. It is a confrontation with one possible algebraic letter notation for the given relation (example Figure 2). This task invites the child to think about this unfamiliar symbolic letter description and to comment on it. The reactions might reveal mental images the children use.

Adults describe the pattern like this: $2 \cdot n + 2$
Does this fit? What do you think?

Figure 2: Confrontation-task with the algebraic letter notation

The design follows the idea to embed the confrontation with the letter notation in a useful way in a purposeful task. Purposeful is meant here against the background of the definition by Ainley, Bills and Wilson (2003) alongside with utility which is understood as “knowing how, when and why that idea is useful” (p. 2). It is hoped for that the learner sees the connection of the letter symbols after working on the pattern individually. The letter notation, at best, condenses the idea of generalisation of the pattern the child already used in the 2nd task (100th figure in the pattern).

<div style="display: flex; justify-content: space-between; align-items: center;"> Ja!! <div style="border: 1px dashed black; padding: 2px;">Yes!!</div> </div> statement	<div style="display: flex; justify-content: space-between; align-items: center;"> Weiß kh nicht <div style="border: 1px dashed black; padding: 2px;">I don't know</div> </div> none
Ich glaube $2 \cdot n + 2$ heißt 2 normale $2n + 2 = 4$	<div style="border: 1px dashed black; padding: 5px; text-align: center;"> I think $2 \cdot n + 2$ means 2 normal [twos] $2s + 2 = 4$ </div>
individual	
<div style="text-align: center; color: blue;"> $+2$ ausgemalte ●● </div>	<div style="border: 1px dashed black; padding: 5px; text-align: center;"> $+2$ painted .. </div>
partly	
$+2$ sind die 2 schwarzen Punkte. Das h ist nochmal	<div style="border: 1px dashed black; padding: 5px; text-align: center;"> $+2$ are the 2 black dots. The n is again </div>
fully	

Figure 3: Categories and examples of reactions of the algebraic notation $2n+2$

The answers to the first two tasks are analysed in a common way. The continuations are categorised in *none*, *individual*, *correct without coloration*, and *correct*. The description of the 100th figure in the pattern are categorised in *none*, *individual*, *initial approaches*, and *correct*. The reactions to the letter notation are the main focus of the study. Here a wide range of answers are found (Figure 3). The

categories *none*, *individual*, *partly*, and *fully* are suitable. Additionally, the category *statement* is needed, because the task allows yes-or-no-answers, which are frequently used.

Findings and Discussion

Quantitative Results

78 % of the children are able to continue the pattern *correctly* and over one third (35 %) describes the 100th figure *correctly*. Taking into account that pattern tasks –not even on Recognise-Continue-Describe level– are not common in German primary schools, these results are quite pleasing.

The duration of schooling of the participating children differs between just started the 3rd year or rather 4th year. This might have an effect on the reactions. Although, it should be mentioned again, pattern tasks are not frequently used in German mathematics lessons. At first sight it seems like 4th-grades are getting better, because the numbers of *no answers* are dropping (Table 1). But it may only be the case that the older the children the more cheeky or assertive they are, because the number of *statements* increases inversely.

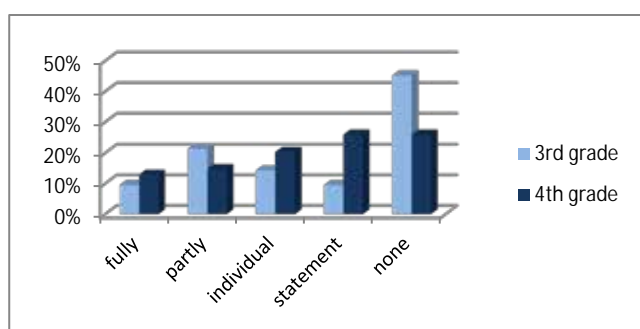


Table 1: Impact of duration of schooling

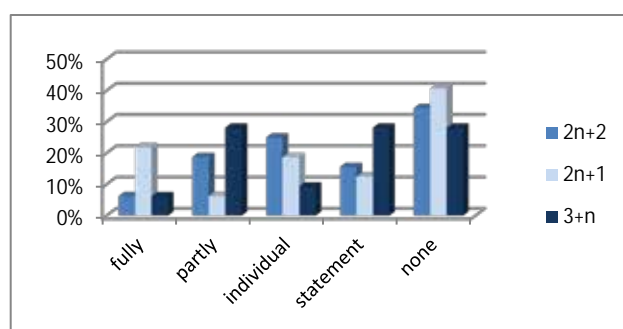


Table 2: Impact of the pattern

Furthermore, an impact of the given pattern, illustrated in Table 2, is visible. The number of *full* interpretations of the pattern $n \textcircled{R} 2n+1$ is considerably higher than the others. Simultaneously the number of *no answers* is the largest as well. The $n \textcircled{R} 3+n$ pattern triggers the most *partly* interpretations and the highest number of *statements*.

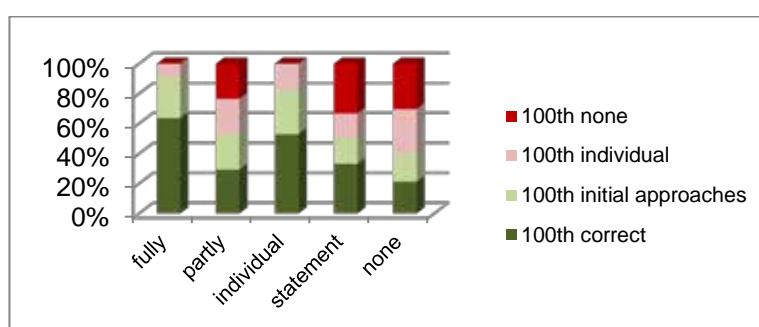


Table 3: Bivariate analysis interpretation of letter notation and finding the 100th figure

Additionally, correlations between the reactions to the first two tasks and the ability to interpret the formula are proved. It can be shown that the ability to continue the pattern *correctly* is necessary but not sufficient for a suitable interpretation. This means, every child who gives a *full* interpretation of the letter notation continued the pattern *correctly*, but not every child who correctly continued the pattern sequence is able to interpret the symbolical letter notation. Moreover, correlations between

the experiences and reactions to the generalising task before (100th figure in the pattern) and the interpretation of the letter notation could be expected –particularly with regard to the focus on generalising in various research studies in early algebra. The bivariate analysis (Table 3) indicates that –although the number of children who are able to read the letter notation *fully* is quite small– it is striking that 9% of them have no clue how to find the 100th figure in the pattern sequence. Regarding the *partly*-readers of the letter notation, the amount of children who have not mastered a suitable 100th figure grows up to 51%. Apart from that, 52% of the children who give *individual* interpretations of the letter notation have found the 100th figure in the pattern sequence beforehand. The expected causal relation –that generalising the pattern by finding the 100th figure in the sequence directly influences the ability to interpret the letter notation– therefore cannot be confirmed in this study.

Qualitative Findings

The reactions of the children categorised as *individual* or *partly* are of great interest to understand children’s first-encounter-interpretations of letter variables of relations in \mathbb{N} ($n \otimes kn+t$). One striking aspect is, that none of the *partly* interpretations refer to the multiplicative part of the term (kn) but in each case the additional part (constant element t) is described (a typical example is given in Figure 3). A recursive idea is read into the explicit letter notation by two other children. One of these children explicitly specifies +2 as the two dots increase from pattern to pattern and does not assign the painted dots (constant element) to +2.

The *individual* reactions try to assign an individual meaning to the given letter. Some regard the variable as an unknown, which has a certain value like 2 (Figure 3). Five children strongly suggest changing the n to an h , because it means 100 in their eyes. This might be a result triggered by the second task, which asks for the 100th figure of the pattern. Two others match n to 14, because n is the 14th letter in the alphabet. One child expects n to equal nine, because nine (‘Neun’) starts with an N . These interpretations are of special interest against the background of fruit-salad-algebra (Thomas & Tall, 2001) and ‘letter-as-object’ misconception (Arcavi, Drijvers, & Stacey, 2017).

Closing Remarks

The study presented here is limited, because research about the importance of “perceptual diversity” (Rivera, 2013, p. 5), the possibility of different colouring, and various individual interpretations of possible structures (Twohill, 2018) are not taken up in the design. The tasks only involve one predefined explicit formula at a time and recursive thinking is somewhat ignored – even though two children stick to their recursive approach anyway. This small study can only be seen as a starting point for verifying or falsifying the results. In summary, the striking findings are:

- The impact of the pattern used in the tasks is noticeable but not coherent.
- Age and duration of schooling might have an effect.
- The ability to continue patterns is necessary but not sufficient for the interpretation of letter notations (symbolic terms).
- The ability to generalise patterns (find the 100th one) seems not necessarily engender (sound) formula interpretations.

Especially the latter result requests further studies. These studies are thinkable in two ways: Larger studies to proof possible correlations or smaller study with a focus on interviews and qualitative

analysis. Some interviews in different age-groups are carried out currently. The deeper inside in children's thoughts while interpreting the letter-symbols will be most interesting.

References

- Ainley, J., Bills, L., & Wilson, K. (2003). Designing tasks for purposeful algebra. In M. A. Mariotti (Ed.), *Proceedings of the Third Congress of the European Society for Research in Mathematics Education (CERME3, February 28 – March 3, 2003)* Bellaria, Italy: ERME. Retrieved from http://www.erne.tu-dortmund.de/~erne/CERME3/Groups/TG6/TG6_ainley_cerme3.pdf
- Akinwunmi, K. (2012). *Zur Entwicklung von Variablenkonzepten beim Verallgemeinern mathematischer Muster* [Development of variable concepts by generalisation of patterns]. Wiesbaden: Springer Spektrum.
- Amerom van, B. A. (2002). *Reinvention of Early Algebra: Developmental Research on the Transition from Arithmetic to Algebra*. Center for Science and Mathematics Education Utrecht: CD-β Press.
- Arcavi, A. (1994). Symbol Sense: Informal Sense-making in Formal Mathematics. *For the Learning of Mathematics*, 3(14), 24–35.
- Arcavi, A., Drijvers, P., & Stacey, K. (2017). *The Learning and Teaching of Algebra: Ideas, Insights, and Activities*. New York: Routledge.
- Blanton, M., Brizuela, B.M., Gardiner, A.M., Sawrey, K., & Newman-Owens, A. (2017). A progression in first-grade children's thinking about variable and variable notation in functional relationships. *Educational Studies in Mathematics*, 95(2), 181–202.
- Carraher, D. W., Schliemann, A. D., & Schwartz, J. L. (2008). Early Algebra Is Not the Same as Algebra Early, In J. J. Kaput, D. W. Carraher & M. L. Blanton (Eds.), *Algebra in the Early Grades* (pp. 235–272). New York, London: Lawrence Erlbaum Associates.
- Dörfler, W. (2006). Inscriptions as objects of mathematical activities. In J. Maasz & W. Schlöglmann (Eds.), *New mathematics education research and practice* (pp. 97–111). Rotterdam, NL: Sense Publishers.
- Dougherty, B. J. (2008). Measure Up: A Quantitative View of Early Algebra, In J. J. Kaput, D. W. Carraher & M. L. Blanton (Eds.), *Algebra in the Early Grades* (pp. 389–412). New York, London: Lawrence Erlbaum Associates.
- Dougherty, B. J., Simon, W. (2014). Elkonin and Davydov Curriculum in Mathematics Education. In S. Lerman (Ed.), *Encyclopedia of Mathematics Education* (pp. 204–207). Dordrecht: Springer.
- Freudenthal, H. (1974). Soviet Research on Teaching Algebra at the Lower Grades of the Elementary School. *Educational Studies in Mathematics*, 5(4), 391–412.
- Freudenthal, H. (1983). *Didactical Phenomenology of Mathematical Structures*. Dordrecht, Boston, Lancaster: Kluwer.
- Hewitt, D. (2009). The role of attention in the learning of formal algebraic notation: The case of a mixed ability year 5 using the software Grid Algebra. *BSRLM (British Society for Research into Learning Mathematics) Proceedings of the Day Conference held at Loughborough University*, 29(3), 43–48.
- Hewitt, D. (2012). Young students learning formal algebraic notation and solving linear equations: are commonly experienced difficulties avoidable? *Educational Studies in Mathematics*, 81(2), 139–159.
- Hewitt, D. (2016). Designing Educational Software: The Case of Grid Algebra. *Digital Experiences in Mathematics Education*, 2(2), 167–198.

- Hofe, R. vom, & Blum, W. (2016). ‚Grundvorstellungen‘ as a Category of Subject-Matter Didactics. *Journal für Mathematik-Didaktik*, 37 (suppl. 1), 225–254.
- Kieran, C. (2004). The core of algebra: Reflections on its main activities. In K. Stacey, H. Chick, & M. Kendal (Eds.), *The future of the teaching and learning of algebra: The 12th ICMI Study* (pp. 21–33). Dordrecht: Kluwer.
- Kieran, C. (2018) (Ed.). *Teaching and Learning Algebraic Thinking with 5- to 12-Year Olds: The Global Evolution of an Emerging Field of Research and Practice*. Cham, CH: Springer International Publishing.
- Mason, J., Burton, L., & Stacey, K. (2010). *Thinking Mathematically*. Harlow: Pearson Education Ltd.
- Mason, J., Stephens, M., & Watson, A. (2009). Appreciating Mathematical Structure for All. *Mathematics Education Research Journal*, 21(2), 10–32.
- Radford, L. (2002). The seen, the spoken and the written: A semiotic approach to the problem of objectification of mathematical knowledge. *For the Learning of Mathematics*, 22(2), 14–23.
- Radford, L. (2011). Embodiment, perception and symbols in the development of early algebraic thinking. In B. Ubuz (Ed.), *Proceedings of the 35th Conference of the International Group for the Psychology of Mathematics Education* (vol. 4., pp. 17–24). Ankara: PME.
- Rivera, F. D. (2010). Visual templates in pattern generalization activity. *Educational Studies in Mathematics*, 73(3), 297–328.
- Rivera, F. D. (2013). *Teaching and learning patterns in school mathematics*. Dordrecht: Springer.
- Steinbring, H. (2015). Mathematical interaction shaped by communication, epistemological constraints and enactivism. *ZDM The International Journal on Mathematics Education*, 47(2), 281–293.
- Steinweg, A. S. (2014). Muster und Strukturen zwischen überall und nirgends - Eine Spurensuche [Pattern and structures every- and nowhere]. In A. S. Steinweg (Ed.), *10 Jahre Bildungsstandards* (pp. 51–66). Bamberg: UBP.
- Steinweg, A. S., Akinwunmi, K., & Lenz, D. (2018). Making Implicit Algebraic Thinking Explicit: Exploiting National Characteristics of German Approaches. In C. Kieran (Ed.), *Teaching and Learning Algebraic Thinking with 5- to 12-Year Olds: The Global Evolution of an Emerging Field of Research and Practice* (pp. 283–307). Cham, CH: Springer International Publishing.
- Strømskag, H. (2015). A pattern-based approach to elementary algebra. In K. Krainer & N. Vondrova. *Proceedings of the Ninth Congress of the European Society for Research in Mathematics Education* (pp. 474–480). Prague: ERME.
- Thomas, M., & Tall, D. (2001). The Long-Term Cognitive Development of Symbolic Algebra. In H. Chick, K. Stacey & J. Vincent (Eds.), *Proceedings of the 12th ICMI (International Group of Mathematical Instruction) Study Conference: The Future of the Teaching and Learning of Algebra* (vol. 2, pp. 590–597). Melbourne: University of Melbourne.
- Twohill, A. (2018). Observation of structure within shape patterns. In C. Kieran (Ed.), *Teaching and Learning Algebraic Thinking with 5- to 12-Year Olds: The Global Evolution of an Emerging Field of Research and Practice* (pp. 213–235). Cham, CH: Springer International Publishing.

Structures identified by second graders in a teaching experiment in a functional approach to early algebra

María D. Torres, María C. Cañadas and Antonio Moreno

University of Granada, Faculty of Education, Spain; mtorresg@ugr.es, mconsu@ugr.es, amorenoverdejo@gmail.com

We describe structures and generalisation in four second graders (7- to 8-year-old) at the beginning and end of a classroom teaching experiment involving an early algebra-related functional context. No significant differences were found in their ability to identify structures and generalise at the beginning and at the end of the teaching experiment. All the identified structures in the questions involving specific cases and all the students generalised when they were explicitly prompted.

Keywords: Functional thinking, structures, generalisation, teaching experiment.

Background and conceptual framework

Traditionally, algebra is not introduced until secondary school in most countries, Spain is one example (Ministerio de Educación Cultura y Deporte, 2014¹). That approach has induced failure in many students who react to the difficulties encountered by rejecting algebra and mathematics in general (Kieran, 2004). In early algebra the discipline is introduced in the first few years of schooling by working, among others, with the generalisation of functional relationships, known as the functional approach to early algebra. Children and adults both generalise by identifying regularity in inter-variable relationships. Notions such as generalisation and the structures in functional relationships are key elements in the study of students' functional thinking (Twohill, 2018). This paper addresses second-year primary school students' ability to identify structures and generalise in a functional approach to early algebra.

Functional thinking, as an approach to introduce algebra in the early grades, involves the relationship between two or more variables, and is based on the construction, description and representation about functions and their constituent elements (Cañadas & Molina, 2016). Patterns and regularities are of significant importance in the study of such thinking, for they interrelate the variables in a situation. Earlier studies reported that primary school students of different ages with no specific prior training were able to perform tasks involving functional thinking (Blanton, Brizuela, Gardiner, Sawrey and Newman-Owens, 2017). The notion of structure acquires different meanings in early algebra (Molina & Cañadas, 2018). In the functional approach, it is associated with how inter-variable regularity is organised, which pupils may represent in different ways when working with specific values as well as when generalising the relationship between variables (Pinto & Cañadas, 2017a). Structures can be semantically equivalent. For example, in algebraic symbolism, $x + 4$, $x + 2 + 2$ and $x + 1 + 1 + 1 + 1$ are equivalent expressions (equivalent semantic structures) because these expressions are the same thing through arithmetic computations, but their external structure is different.

Limited studies have addressed these notions in primary education students. Pinto and Cañadas (2017a, 2017b), in research on structures and generalisation in third and fifth-year students, described differences in the amount and variety of the structures identified, both of which were greater among

¹ Ministry of Culture, Education and Sports of Spain.

the younger children. Third-year students tended to work with specific cases while those in fifth-year were able to establish generalizations; most of them generalised structures and used the same structure for both specific situations and the general case and their answers were more coherent. Three of the fifth-year students generalised in tasks involving specific cases. The authors also distinguished two types of generalisation: spontaneous (when students generalised in tasks describing specific situations) and prompted (when they generalised when asked to do so in connection with the general case). Tasks or worksheets were designed assuming that generalisation would arise in a later stage, so these students evidenced prompted generalisation (Pinto & Cañadas, 2017a). Generalisation and structure are not independent notions. Identifying structure, whether through specific or general situations, is requisite to generalising. We take generalising to mean seeing general patterns in specific situations (Mason, 1996). The inductive model proposed by Cañadas and Castro (2007) was implemented here to foster this kind of abstraction. At the outset, we used specific situations (variables with specific values), aiming to prompt generalisation (of the functional relationship) through the detection of regularities. Structures and generalisation may be represented in different ways by primary school pupils: natural language, algebraic symbolism, tables or graphs (Radford, 2018). The present study explored the identification of structures and generalisation in second year primary school students at the beginning and at the end of a teaching experiment involving functional thinking.

Method

In this paper, we focus on part of a broader teaching experiment (Steffe & Thompson, 2000), about functional thinking in second grades (7-8 years old). We present different problems during the five sessions of the teaching experiment and the two interviews. Three of the purposes of the teaching experiment were to: (a) explore how students relate the variables involved; b) identify structures on students' responses; (c) explore students' generalization process. This paper analyses the information gathered in two interviews: one held after the first session and the second after all the sessions were completed. The data were analysed to ascertain differences between the first and second interviews in terms of the structures identified and generalisation expressed by students.

Participants

The subjects were four 7- to 8-year-old, second graders from a Spanish school. They had not been previously exposed to generalisation tasks involving linear functions. Their prior knowledge included the numbers from 0 to 399, addition with carrying and subtraction with borrowing. After the first session of the teaching experiment, in which a worksheet was administered to the entire class (24 pupils), the students were classified into two groups (intermediate and advanced). Students in advanced group generalized the functional relationship; students in intermediate group did not generalize. Four students, two from each group, were selected for the interviews. The subjects selected in each group were chosen by the classroom teacher considering that they should be participative.

Information gathering instrument

The five classroom sessions conducted were video-recorded. In each session we posed one or two tasks in different contexts involving different functions. Each task was described on a separate

worksheet. Two semi-structured individual interviews were held with the four students selected, one after the first session and the other after the last.

Classroom sessions

A contextualized task involving a linear function was posed in each session. In all sessions, students first worked with specific cases of the function from which, after identifying the structure, they could pose new specific cases or generalise. Some of the tasks were original and others taken from the studies cited in section 1 above. The context and function addressed in each session are listed in Table 1. We first involved an additive structure (it is supposed to be easier following previous studies) and then we combined the additive and multiplicative structures. We observed that the students had more difficulties to reach the generalization in the later, so we involved only multiplicative structure. We selected contexts close to the students' experiences according to the students' teacher. The objective of each session was to explore students' generalization within different contexts.

Context	Functional relationship
Session 1: ball dispenser Session 2: amusement park 1	$y = x+3$
Session 3: amusement park 2	$y = 2x+1$
Session 4: birthday Session 5: train stations	$y = 2x$

Table 1: Characteristics of session tasks

The dynamics were the same throughout the experiment. Three members of the research team were present in the classroom: the teacher-researcher (he was not the usual teacher), a support researcher and a researcher who video-recorded the session. Each session was divided into several parts: first we explained the task to the whole class, then we distributed the session-specific worksheets and lastly the task was discussed by the group as a whole. The students received no feedback on their replies. The worksheet used in the first session is described below as example and because the interviewees were selected on the grounds of their performance in that session.

Session 1 worksheet

The session 1 worksheet contained five questions about a ball dispenser that when fed balls returned a certain number further to the functional relationship $f(x) = x+3$. We introduced the context to the students as follows: "we have a machine in which we introduce and leave balls". Four questions involving specific cases were posed as shown in Figure 1. We organized the balls in such a way that did not facilitate the structures identification through visualization.

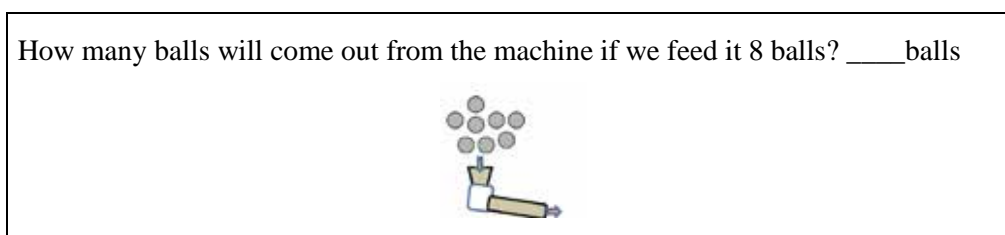


Figure 1. Specific case question

The last question, involving generalisation, is shown in Figure 2.

Now we're going to play a game. The winner has to figure out how the machine works. How can you tell how many balls will come out?

Figure 2. General case question

This worksheet helped to classify the students into two groups based on their answers: intermediate and advanced. The first group included students who had identified regularity in several of the questions and the other students who were able to generalise. The classroom teacher then chose two students from each category (intermediate, S2, S1; advanced, S4, S3). Hereafter, the students are identified by the letter S and a randomised number for anonymity purposes.

Interviews

We designed two semi-structured interviews, each with a different protocol. Two tasks involving additive linear functions were designed for each interview. In the first the context was the same as in session 1 ($y = x + 3$). In the second interview the context was the age of two superheroes, one 4 years older than the other ($y = x + 4$). The structure was the same in the two interviews: We began with specific, non-consecutive (to avoid recursive patterning in students' answers) situations and progressed inductively toward generalisation. The design of the second interview, which built on the first, also involved an addition function to ensure inter-sessional comparability of the students' replies. The guides for the two interviews were analogous. The guide for the second interview is presented in Figure 3. We note that in the last question about generalization, letters were random values that served to express examples, the question did not involve or asked for symbolic letters.

1. Exploration of specific cases

- Identify the functional relationship
- Apply the functional rule in different specific cases
 1. Specific cases
 - When Iron Man was 5 years old, Captain America was 9.
 - When Iron Man was 7 years old, Captain America was 11.
 - When Iron Man was 3 years old, Captain America was 7.
 2. Specific cases proposed by the student
 - Give me an age for Iron Man (___). If he's that old, how old is Captain America?

2. Generalisation

- Express the generalisation
 - How would you explain to a friend what she has to do to figure out Captain America's age?
- Reason with the generalisation
 - One of your classmates said that 'When Iron Man is XX, Captain America is YY'. Do you agree?

Figure 3. Protocol for the second interview

Data analysis

The data gathered during the two interviews were analysed with a system of categories based on the structures identified by the students in both specific and general cases. Students were considered to have identified a structure when they answered two or more questions referred to the same task with the same regularity or generalised a regularity.

Results

Table 2 summarises the results for the specific and general cases posed in the first interview. The analogous information for the second interview is given in Table 3. The structures identified by the students as they worked are listed in tables 2 and 3 in the order in which they were observed and expressed using algebraic symbolism, although the students did not use that system.

Student	Specific cases	General case
S1	$y = x + 3$	$y = x + 3$
S2	$y = x + 3$ $y = x + x$	$y = x + 3$
S3	$y = x + 3$	$y = x + 3$
S4	$y = x + x$ $y = x + 3$ $y = x + x$	$y > x$

Table 2: Structures identified in the first interview

Further to the data in Table 2, each student identified one or two structures for the specific cases during the interview. Overall, three types of structures were observed in the particular and general cases, namely: $x+x$, $x+3$ and $y>x$. In the following extract of the interview, S4 identified different structures for the specific cases, as listed in the table in chronological order.

I (Interviewer): What happened when you put 8 balls in the machine?

S4 (Student 4): If there were 8, we add another 8, 16 balls.

I: I'm going to write down the numbers you give me. When we put 5 balls in, how many came out?

S4: 8

I: And if we put 2 in, how many came out?

S4: 4, I add 2+2

All four students generalised the functional relationship verbally (Table 2, last column). Three identified the structure as $y = x+3$, which they expressed verbally in different ways. S1 and S3 generalised both the specific cases (spontaneous generalisation) and the general case (prompted generalisation). S2 and S4 generalised only when they were prompted. S1 first gave examples of specific cases and then generalised by adding that the answer was found by adding 3: '1 ball we get 3, 2 balls we get 5, 3 balls we get 6, 4 balls we get 7. You always have to add 3. One million, you get

1 million and three.’ That answer was classified as prompted generalisation because the student formulated it when asked the general case question (Figure 2). S4, in turn, noted that ‘more balls come out than went in’, generalising without quantifying: ‘I know the machine spits out identical balls and what I know is that inside it has lots more balls’ (prompted generalisation). The other two students’ answers showed that they were thinking in terms of $x+3$. Three students identified the structure correctly ($x+3$) in both the general and the specific cases. Table 3 lists the structures identified in the second interview.

Student	Specific cases	General case
S1	$y = x + 4$	$y = 4x$ $y = x + 4$
S2	$y = x + x$ $y = x + 4$	$y = x + 4$
S3	$y = x + 4$	$y = x + 4$
S4	$y = x + 4$ $y = x + x$	$y > x$

Table 3: Structures identified in the second interview

As in the first interview, students identified one or two structures for the specific cases. Three types of structures, including the ones given for the general case, were found: $x+4$, $4x$ and $x+x$. S2 and S4 exhibited the same type of structures as in the first interview, identifying the relationship in the specific cases to consist in doubling the value given. Generalisation was expressed verbally by all four students. The structures observed in their generalisations were: $4x$ and $x+4$. The second was identified by all the interviewees. S1’s initial assertion that the age of the older superhero was found by ‘multiplying by four’ was indicative of their difficulty in distinguishing between addition and multiplication. Student S4 generalised the relationship to be $x+4$ saying: ‘you have to add plus 4’. S2 and S3 both instantly answered that what they had to do was ‘add plus 4’. S1 generalised both the specific cases (spontaneous generalisation) and the general case (prompted generalisation). S2, S3 and S4 generalised only when prompted. The following extract exemplifies S1’s spontaneous generalisation when answering questions about specific situations.

I (Interviewer): when Iron Man was 5 years old Captain America was 9, when Iron Man was 7 Captain America was 11 and when Iron Man was 3 Captain America was 7. Can you tell me how those numbers are related?

S1 (Student 1): Captain America always wins: he’s 4 years older.

Comparison of interviews

In the first and second interviews, S1 and S3 identified only one structure, correctly in both cases. S2 and S4 both identified more than one structure, likewise in both interviews. In the second interview S2 continued to identify $x+x$, although in the specific cases only, ultimately identifying the right structure as the interview proceeded. The contrary was observed in S4, who incorrectly identified the structure $x+x$ in the second interview. Fewer differences were observed around the general case. S2

and S3 correctly identified the structure, whereas S1 initially identified a multiplicative structure in the second interview, $4x$, despite having correctly identified the structure in the first. In the second interview S4 correctly identified the relationship between the variables, having failed to do so in the first. All the students correctly identified at least one structure in the specific or general cases and all expressed generalisation in at least one case. In the second interview, however, only one student, S3, identified the sole same structure in the specific and general cases. Two students did so in the first interview. While seeing no clear structure in the specific cases, S4 correctly identified it in the general case. Generalisation was expressed in various ways in both interviews. In the second interview, only S1 generalised spontaneously, whilst in the first both S1 and S3 did so.

Discussion and conclusions

This paper presents evidence of functional thinking in second-year primary school students. Like the fifth-year primary students who participated in the Pinto and Cañadas (2017a) study, most of the second-year pupils in our survey generalised structures, identifying the same structure in the specific and the general cases in the first and second interviews. Their answers were found to be coherent. The number and variety of the structures identified were greater in the first interview. Although the students might have identified $2x$ instead of $x+x$ for the specific cases in both interviews, none did. Students evidenced the $x + x$ structure more easily than the $2x$ because of the kind of structure (additive versus multiplicative structure). All the students expressed generalisation verbally, a finding consistent with the Cañadas and Fuentes (2015) results. All the students generalised in both the first and the second interview. That finding differed from the results reported by Pinto and Cañadas (2017b) for third-year students, only one of whom generalised. In the second interview generalisation was consistently and simply phrased as ‘adding plus 4’. In our study generalisation was normally prompted. In one case, S4 in the first interview, expressed the general relationship as $y > x$. This student was able to see that ‘y is always greater’, without quantifying to what extent is greater.

Whilst differences between the intermediate and advanced groups was not explored in this study, the findings showed that students’ classification in one or the other had no impact on their ability to correctly identify structures. In other words, the advanced students did not correctly identify more structures than the others. In fact, the contrary was found: S1, an intermediate group student, was the only one to correctly identify the structure involved in the specific and general cases in both interviews. Work to enlarge on this study is ongoing to determine how the working sessions might have affected the differences between the two interviews.

Acknowledgement

This study was funded by Spain’s Ministry of the Economy and Competitiveness under National R&D Plan project EDU2016-75771-P.

References

- Blanton, M., Brizuela, B., Gardiner, A., Sawrey, K., & Newman-Owens, A. (2017). A progression in first-grade children’s thinking about variable and variable notation in functional relationships. *Educational Studies in Mathematics*, 95, 181-202.
- Cañadas, M. C., & Castro, E. (2007). A proposal of categorisation for analysing inductive reasoning. *PNA*, 1(2), 67-78.

- Cañadas, M. C., & Molina, M. (2016). Una aproximación al marco conceptual y principales antecedentes del pensamiento funcional en las primeras edades [Approach to the conceptual framework and background of functional thinking in early years]. In E. Castro, E. Castro, J. L. Lupiáñez, J. F. Ruíz, & M. Torralbo (Eds.), *Investigación en Educación Matemática. Homenaje a Luis Rico* (pp. 209-218). Granada, Spain: Comares.
- Kieran, C. (2004). Algebraic thinking in the early grades: What is it? *The Mathematics Educator*, 18(1), 139-151.
- Mason, J. (1996). Expressing generality and roots of algebra. In N. Bednarz, C. Kieran, & L. Lee (Eds.), *Approaches to algebra: Perspectives for research and teaching* (pp. 65-86). Dordrecht, The Netherlands: Kluwer.
- Molina, M., & Cañadas, M. C. (2018). La noción de estructura en early algebra [The notion of structure in early algebra]. In P. Flores, J. L. Lupiáñez, & I. Segovia (Eds.), *Enseñar Matemáticas, homenaje a los profesores Francisco Fernández y Francisco Ruiz* (pp. 129-141). Granada, Spain: Atrio.
- Ministerio de Educación, Cultura y Deporte. (2014). Real Decreto 126/2014 del 28 de febrero por el que se establece el currículo básico de la Educación Primaria [Royal Decree 126/2014, of February 28, which establishes the basic curriculum of Primary Education]. *BOE*, 52, 19388-19393. Spain
- Pinto, E., & Cañadas, M. C. (2017a). Generalization in fifth graders within a functional approach. In B. Kaur, W. K. Ho, T. L. Toh, & B. H. Choy (Eds.), *Proceedings of the 41st Conference of the International Group for the Psychology of Mathematics Education* (Vol. 4, pp. 49-56). Singapore: PME.
- Pinto, E., & Cañadas, M. C. (2017b). Functional thinking and generalization in third year of primary school. In T. Dooley, & G. Gueudet (Eds.), *Proceedings of the Tenth Congress of the European Society for Research in Mathematics Education* (pp. 472-479). Dublin, Ireland: DCU Institute of Education and Erme.
- Radford, L. (2018). The emergence of symbolic algebraic thinking in primary school. In C. Kieran (Ed.), *Teaching and learning algebraic thinking with 5- to 12-year-olds: The global evolution of an emerging field of research and practice* (pp. 3-25). New York, NY: Springer.
- Steffe, L. P., & Thompson, P. W. (2000). Teaching experiment methodology: Underlying principles and essential elements. In R. Lesh & A. E. Kelly (Eds.), *Research design in mathematics and science education* (pp. 267- 307). Hillsdale, NJ: Erlbaum.
- Twohill, A. (2018). Observations of structure within shape patterns. In C. Kieran (Ed.), *Teaching and learning algebraic thinking with 5- to 12-year olds* (pp. 213-235). Cham, CH: Springer.

Comparing the structure of algorithms: The case of long division and log division

Christof Weber

School of Education, University of Applied Sciences Northwestern Switzerland,
Muttenz, Switzerland; christof.weber@fhnw.ch

This paper is a theoretical contribution to the comprehension of logarithms by means of comparing algorithms. First an algorithmic approach to the logarithm (so-called log division) is introduced, which then is compared with the standard division algorithm (long division). By working out mathematical correspondences and differences between the two algorithms, this approach focuses on structural aspects of two mathematical operations and their relations. Comparing algorithms in classrooms is proposed as a way of algorithmic thinking that would go beyond rote memorization.

Keywords: Mathematical algorithms, logarithms, long division, comparison, algorithmic thinking.

Introduction

Algorithms have played a central role in mathematics since antiquity. Examples such as Heron's method (for computing square roots) and the Euclidean algorithm (for computing the greatest common divisor) are impressive evidence of this. Their development is still an integral part of mathematical research (Chabert, 1999; Ziegenbalg, 2016). Accordingly, mathematics education until the late Middle Ages was primarily computational education, that is, the teaching and practice of computational methods (Graumann, 2002; Ziegenbalg, 2016). Still today in school instruction of algorithms occupy an important place. In every case algorithms are “a finite sequence of explicitly defined, step-by-step computational procedures which ends in a clearly defined outcome” (Wu, 2011, p. 57). It is hardly surprising, then, that algorithms and also dealing with algorithms is sometimes regarded as one of the “central ideas” for mathematics education (Heymann, 2003).

As can be seen from the above examples, each algorithm always solves a whole class of structurally related computational problems. Another strength is that we do not have to worry about how it works or validate the result since it turns a problem into a routine task. This is a substantial relief for the user and effectively clears the way to tackle new, unresolved issues. The flip side of this liberating mindlessness is that users can also mechanically execute an algorithm without being able to justify it, to know the limits of its applicability, etc. Thus, learning algorithms takes place within a field of tension between mechanical memorizing and meaningfully acquiring, in short: *memorization by rote vs. conceptual understanding* (Baroody, 2003; Wu, 1999).

The dangers of rote learning have been empirically established in several studies in the case of standard algorithms for the four arithmetic operations (e.g. Kamii & Dominick, 1998). This could also be the reason why some authors contrast knowledge of standard algorithms with conceptual understanding (Baroody, 2003; Fan & Bokhove, 2014), or why the term “algorithmic thinking” is sometimes understood rather in a negative sense. Occasionally, a reduction or even a banishment of certain standard algorithms from the curriculum is advocated (for instance in Canada, see Fan & Bokhove, 2014, p. 482, or in North Rhine-Westphalia / Germany, see Krauthausen, 2018, p. 91).

Understanding algorithms in the classroom and in teacher education

However, not all authors go so far, but rather focus on the role of the teacher: “[Rote learning might take place] when the teacher does not possess a deep enough understanding of the underlying mathematics to explain it well. The problem of rote learning then lies with inadequate professional development and not with the algorithm” (Wu, 1999, p. 6). To defuse this problem, there are different suggestions for classroom instruction and teacher education. They can be divided into two strands:

1. A first strand of proposals recommends that students not be provided with ready-made algorithms and detailed directions for their use. Instead, they should be encouraged to *invent their own methods and individual strategies* for solving computational problems. In mathematics education at primary school level, this includes informal mental arithmetic as well as informal pencil-and-paper arithmetic. The point is, then, that students develop individual strategies in which they operate not with the individual digits of numbers but always with “numbers as wholes”, that are decomposed in meaningful ways. In the case of the division, this could mean subtracting easy multiples of the divisor from the dividend until the dividend has been reduced to zero or the remainder is less than the divisor, then adding together the partial quotients to obtain the quotient (“partial quotient division”, Kilpatrick, Swafford, & Findell, 2001, p. 221).
2. Another strand of suggestions recommends *comparing standard algorithms or individual strategies* in the classroom as a way to understand why they work. For example, Bass (2003) suggests that students in the classroom compare standard with alternative algorithms in terms of their generality or efficiency, while Simonsen and Teppo (1999) suggest this kind of comparison in teacher training programs. Empirical studies of Durkin, Star and Rittle-Johnson (2017) show in which way learners can benefit from comparing different worked-out strategies for solving the same linear equation. There is also a certain tradition in teacher education that elementary teacher trainees must compare standard algorithms such as long division in base-10 with the same algorithm in other number bases in order to understand better the connection between number bases and algorithms (Padberg & Büchter, 2015). The aim is to see the algorithm not only as a recipe and to perform it fluently, but also to see it in its relation to other algorithms by focusing on certain structural aspects.

The present article focuses on the second approach, the comparison of algorithms, in the context of the teaching and learning of logarithms. This calls forth in particular the following questions:

- *How can the logarithm be described algorithmically?*
- *What is the mathematical relation between the algorithmic description of logarithms and that of division? In what respect do the two algorithms correspond, and in what respect do they differ?*

Comparing log division with long division

Primary students learn that division of integers can be seen as partitive (fair-sharing) division as well as quotative (measurement) division (Greer, 1992). It is the measurement interpretation that allows the division to be conceived as an algorithm: in the long division algorithm, the divisor is repeatedly subtracted from the dividend until the remainder is as close to zero as possible (for a justification see Wu, 2011, pp. 110–122). Mathematically, this has to do with the fact that the divi-

sion is the inverse operation of multiplication and multiplication can be conceived as repeated addition (at least for whole numbers). Now, as logarithms are an inverse of powers, and powers are repeated multiplication, the logarithm can be treated algorithmically in a similar way—as a *repeated division* (Vos & Espedal, 2016; Weber, 2016). This allows logarithmic values to be calculated algorithmically. In keeping with the name of the standard division algorithm, “long division”, I call the corresponding algorithm “log division”. It is described now in order to then compare it with long division.

Log division: description of the algorithm

Repeated subtraction and repeated division can be naturally applied to calculate quotients and logarithms that come out even and yield integer answers: $8 : 2$ equals 4 since $8 - \underbrace{2 - 2 - 2 - 2}_{4 \times} = 0$, and

in the same way, $\log_2 8$ equals 3 since $8 : \underbrace{2 : 2 : 2}_{3 \times} = 1$. Relying on repeated division, I now give a

step-by-step description of how the log division algorithm works (Goldberg, 2006; Weber, 2016). Suppose you have to compute $\log_{16} 32$ (see Figure 1):

Step 1: Calculate how many times the argument (32) can be divided by the base (16) before the result is less than the base. In our case, 32 can be divided by 16 only one time (because dividing 32 by 16 two times, the quotient would be less than 1). You record this result of 1 above the bracket (noted as . in Figure 1).

Step 2: Next, you calculate the base raised to this result: $16^1 = 16$. You place this number beneath the argument of the logarithm and divide (instead of subtracting as in long division) the argument by this value ($32 : 16^1$). Note the result (2) as a remainder underneath.

Step 3: You raise the remainder to the 10-th power (recall that in the same step in long division you bring down a further digit from the dividend, in effect multiplying the original remainder by 10). Note the result as the new argument: $2^{10} = 1024$.

Step 4: If (as in our example) the new argument does not equal 1, go back to the Step 1, if it equals 1 (not 0 as in long division), the process has come to an end.

Conclusion: By cycling through the steps 1 to 4 until arriving at the argument 1, you obtain the single digits of the decimal expansion of the result. In our example, you reach the remainder of 1 after two additional cycles (producing 1, 2, 5 as the successive exponents of 16.) Stringing the numbers together, the decimal expansion of $\log_{16} 32$ is found to be to be 1.25.

Figure 1 shows not only the computation of $\log_{16} 32$ digit by digit, but also the corresponding logarithmic expressions that reveal what the algorithm actually “does.” It also shows that the algorithm works not only for natural, but also for non-integer results. In order to emphasize the *mathematical analogy to division*, those who use the colon “:” notation for long division (for instance in countries where Romance languages or German are spoken) could use the non-standard tricolon “:” notation for log division, for instance $\log_{16} 32 = 32 : 16$ (for the historical background, see Weber, 2016).

Those who use the bracket notation “ $\overline{\quad}$ ” (for instance in English-speaking countries, Mexico or Japan) could use the notation “ $\overline{\overline{\quad}}$ ” for log division, $\log_{16} 32 = 16 \overline{\overline{32}}$ (Weber, 2019).

$\log_{16} 32 = 32 : 16 = 1.25$ $\begin{array}{r} : 16 \left(= 16^{\boxed{1}} \right) \\ \hline 2 \\ 2^{10} = 1024 \\ : 256 \left(= 16^{\boxed{2}} \right) \\ \hline 4 \\ 4^{10} = 1048576 \\ : 1048576 \left(= 16^{\boxed{5}} \right) \\ \hline 1 \end{array}$	$\log_{16} 32 =$ $= \log_{16} (16^{\boxed{1}} \cdot 2) = \boxed{1} + \log_{16} (2)$ $= 1 + \frac{1}{10} \cdot \log_{16} (2^{10})$ $= 1 + \frac{1}{10} \cdot \log_{16} (1024)$ $= 1 + \frac{1}{10} \cdot \log_{16} (16^{\boxed{2}} \cdot 4) = 1. \boxed{2} + \frac{1}{10} \cdot \log_{16} (4)$ $= 1.2 + \frac{1}{100} \cdot \log_{16} (4^{10})$ $= 1.2 + \frac{1}{100} \cdot \log_{16} (1048576)$ $= 1.2 + \frac{1}{100} \cdot \log_{16} (16^{\boxed{5}} \cdot 1) = 1.2 \boxed{5}$
--	---

Figure 1: Log division algorithm (applied to $\log_{16} 32$) – to the left. Stepwise explanation – to the right

Comparing the mathematical structure

In order to not only explain the algorithms by means of examples, an approach to a more thorough, mathematical justification is given now, in two steps: To start with, I explain why division is equivalent to repeated subtraction and why finding the logarithm is equivalent to repeated division, which allows us then to compare the respective algorithms with each other.

For this we first consider the following mathematical *equivalence relations*:

- For the division of a whole number b by a whole number a ($a \neq 0$) one has:

$$? = b : a \iff ? \cdot a = b \iff b - ? \cdot a = 0$$

- For the logarithm of a natural number b to a natural-number base a ($a \neq 1$) one has:

$$? = \log_a b \iff a^? = b \iff b : a^? = 1$$

From these relations follow several conclusions:

- The quotient $b : a$ gives (in the context of whole numbers) “how many a ’s are in b ” as a *summand* (Wu, 2011, p. 103). On the other hand, the logarithm $\log_a b$ (or $b : a$, respectively) gives how many a ’s are in b as a *factor*.
- The two equivalence relations structurally resemble each other, since they are each based on a respective inverse operation. In this respect, they are *analogous* to each other. However, they operate at different hierarchy levels: while division and multiplication are second-level operations,

built upon the first-level operation of subtraction, logarithms and powers are third-level operations, built upon the second-level operation of division (see Figure 2).

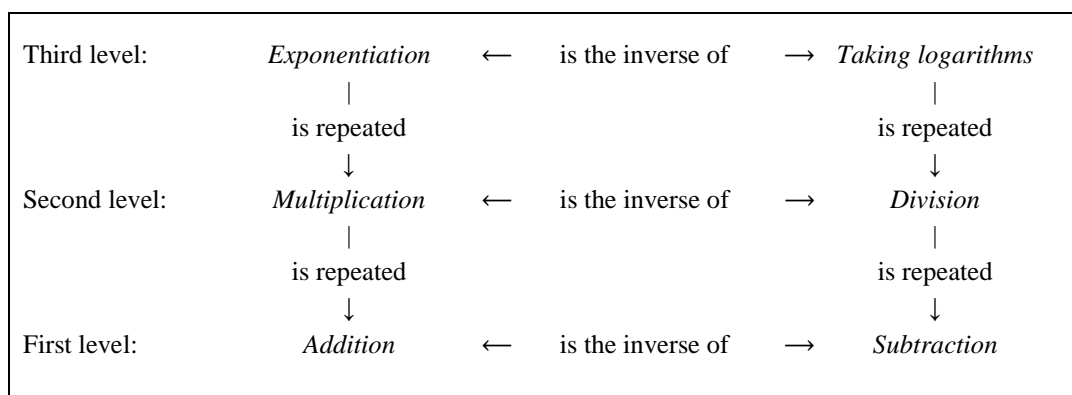


Figure 2: Hierarchy levels of arithmetic operations

3. According to conclusion 1 above, *algorithms* can be derived to calculate the value of the corresponding quotient or the corresponding logarithm. Thus, the algorithm for long division counts how many times the number a is subtracted from the number b . The log division, on the other hand, counts how many times the number a divides the number b . Because of conclusion 2, the two algorithms are also analogous to one another; in particular the individual calculation steps correspond:

- Analogous to the fact that in the long division the remainders are multiplied by 10 (a second level operation), the remainders in the log division must be raised to the power 10 (see the corresponding third level operation) (see Step 3, above).
- The algorithm of long division ends as soon as the repeated subtraction leads to the remainder 0 (the additive identity). Accordingly, log division terminates as soon as the repeated division leads to the “remainder” 1 (the multiplicative identity) (see Step 4). If this occurs, the result is an integer or a finite decimal expansion (see Figure 1), otherwise not.

In addition to this analogy and its consequences, there are also two significant *differences* between the two algorithms that should be kept in mind:

1. Numbers are usually encoded as decimal numbers, meaning they are decomposed as a series of digits, each weighted by a power of ten, and added together. As with all standard algorithms of arithmetic, the strength of the long division is that it does not divide the dividend as a whole, but essentially digit by digit (Wu, 2011, p. 56). That this can be done is due to the fact that division distributes over addition, $(b_1 + b_2) : a = b_1 : a + b_2 : a$. In order to make the division algorithm more accessible in the classroom, it is sometimes suggested to discuss the already-mentioned partial quotient method, which treats the dividend as a whole entity, from which easy multiples of the divisor are subtracted (see above).

Unfortunately, logarithms do not distributive over addition, $\log_a(b_1 + b_2) \neq \log_a b_1 + \log_a b_2$. Hence it is not possible to march along, calculating one digit of the logarithm for each digit of the argument as with division: While $32 = 30 + 2$, $\log 32 \neq \log 30 + \log 2$. As a result, you have to pay attention from the beginning to all the digits of the number, similar to the partial quotients division (see Step 1).

2. The multiplication operation, for example $2 \cdot 4 = 8$, can be inverted in two ways: Either you are interested in the first factor $? \cdot 4 = 8$, or the second factor ($2 \cdot ? = 8$). While the first factor can be found via repeated subtraction (measurement interpretation), $8 - 4 - \dots - 4 = 0$, the second question corresponds to the fair-sharing (partitioning interpretation), $8 \underbrace{- ? - ? - ? - ?}_{4 \times} = 0$, an equation that can only be immediately solved by guessing. Since however multiplication is commutative, the question of the second factor can always be handled as a question regarding the first factor: $2 \cdot ? = ? \cdot 2$. To sum up: *Since multiplication is a binary operation, finding its inverse can be understood in two ways, but due to its commutativity, both lead in the end to one and the same operation, division.* (Wu, 2011, pp. 99–100)

In the same way the operation of exponentiation, for example, $2^3 = 8$, can be inverted in different ways, depending on whether you are interested in finding the exponent $2^? = 8$, or the base $?^3 = 8$. The answer to the first question can be calculated through repeated division step-by-step: $8 \underbrace{: 2 : \dots : 2}_{? \times} = 1$, while the second question leads to the equation $8 \underbrace{: ? : \dots : ?}_{3 \times} = 1$. In contrast to multiplication, the one form of inverse cannot be applied to find the other one, since exponentiation is not commutative. In other words: *On account of its non-commutativity ($a^b \neq b^a$), exponentiation has two distinct inverse operations: taking the logarithm, $\log_2 8 = 3$, as well as extracting the root, $\sqrt[3]{8} = 2$.* Accordingly, the method of repeated division can only be applied to solve inverse questions regarding the *exponent* of a power, but not those concerning its *base*.

Conclusion and questions

There is a certain tradition in mathematics education to place concepts of elementary mathematics into meaningful contexts in order to make them easier to learn, and to promote efficient and flexible application later on (e.g., for long division, see Pratt, Lupton & Richardson, 2015). For secondary schools, the situation is a bit different. So while it may be possible to occasionally identify meaningful contexts, with increasingly abstract content this is not necessarily desired. For concepts such as the logarithm, which can be conceptualized algorithmically, it therefore makes sense to compare them with other mathematical algorithms in order to make them accessible and to understand why they work (Bass, 2003). While I have described the algorithmic approach of “log division” previously, the correspondences and differences between the algorithms seem to have never been worked out before.

This paper also raises various questions. First of all, the question of the mathematical generalization of the log division from natural to rational bases and arguments remains open. The question of the

explanatory power of the log division is also not covered here, that is, in which situations our algorithmic conceptualization of logarithms can serve as a basis for solving tasks and for reasoning (for instance, one could argue that logarithms are not defined for negative arguments because a negative number divided repeatedly by the positive basis will never yield 1, see Weber, 2016). Another group of questions is empirical in nature and asks about the effects and pitfalls that an algorithmic approach combined with comparison would have in teacher education and in subsequent classroom instruction (for a classroom teaching experiment to introduce logarithms by log division, see Weber 2019). In particular, in which ways might comparing the structure of algorithms foster conceptual understanding?

Algorithmic and algebraic thinking

Last but not least, the results of this contribution might be used to clarify the construct “algorithmic thinking” in mathematics education: comparing algorithms might be a way of dealing with algorithms in the classroom beyond just learning to perform them. For instance, in order to bring out further aspects of the construct, the cognitive processes of students and teachers could be studied when they work on the new algorithm of log division by relating it to the familiar long division.

Teaching algorithms by comparing them, as outlined above, focuses on seeing structure and relationships between mathematical operations. While seeing structure in numerical expressions can be seen as algebraic thinking at primary level (Kaput, 2008), comparing algorithms might be seen as a specific form of algebraic reasoning at the secondary level (Kieran, 2018). Kaput’s view that “the heart of algebraic reasoning is comprised of complex symbolization processes that serve purposeful generalization and reasoning with generalizations” (2008, p. 8), raises more questions related to the contents of this paper. For instance, at primary and secondary school, algorithms are never explained or justified in full generality, but by generic examples. To what extent is this characteristic similar to teaching early algebraic reasoning by generic arguments? Furthermore, any given algorithm does not solve just a single task, but a class of multiple problems. To what extent is this characteristic similar to algebraic reasoning, understood as “reasoning with generalizations”? Future research will have to clarify and answer these and several other questions.

References

- Baroody, A. J. (2003). The development of adaptive expertise and flexibility: The integration of conceptual and procedural knowledge. In A. J. Baroody & A. Dowker (Eds.), *The development of arithmetic concepts and skills* (pp. 1–33). Mahwah, NJ: Erlbaum Associates.
- Bass, H. (2003). Computational fluency, algorithms, and mathematical proficiency: One mathematician’s perspective. *Teaching Children Mathematics*, 9, 322–27.
- Chabert, J.-L. (1999). *A history of algorithms*. Berlin, Germany: Springer.
- Durkin, K., Star, J. R., & Rittle-Johnson, B. (2017). Using comparison of multiple strategies in the mathematics classroom: lessons learned and next steps. *ZDM Mathematics Education*, 49, 585–597.

- Fan, L., & Bokhove, C. (2014). Rethinking the role of algorithms in school mathematics: a conceptual model with focus on cognitive development. *ZDM Mathematics Education*, 46, 481–492.
- Goldberg, M. (2006). Computing logarithms digit-by-digit. *International Journal of Mathematical Education in Science and Technology*, 37, 109–114.
- Greer, B. (1992). Multiplication and division as models of situations. In D. A. Grouws (Ed.), *Handbook for research on mathematics teaching and learning* (pp. 276–295). New York: Macmillan.
- Heymann, H. W. (2003). *Why teach mathematics? A focus on general education*. Dordrecht, Netherlands: Springer.
- Kamii C., & Dominick, A. (1998). To teach or not to teach algorithms. *Journal of Mathematical Behavior*, 16, 51–61.
- Kaput, J. (2008). What is algebra? What is algebraic reasoning? In J. Kaput, D. Carragher, & M. Blanton (Eds.), *Algebra in the early grades* (pp. 5–18). New York: Lawrence Erlbaum.
- Kieran, C. (2018). Seeking, using, and expressing structure in numbers and numerical operations: A fundamental path to developing early algebraic thinking. In C. Kieran (Ed.), *Teaching and learning algebraic thinking with 5- to 12-year-olds* (pp. 79–105). Cham, Switzerland: Springer.
- Kilpatrick, J., Swafford, J., & Findell, B. (2001). *Adding it up: Helping children learn mathematics*. Washington, DC: National Academy Press.
- Krauthausen, G. (2018). *Einführung in die Mathematikdidaktik – Grundschule*. Berlin, Germany: Springer.
- Padberg, F., & Büchter, A. (2015). *Einführung Mathematik Primarstufe – Arithmetik*. Berlin, Germany: Springer Spektrum.
- Pratt, S., Lupton, T., & Richardson, K. (2015). Division quilts: A measurement model. *Teaching Children Mathematics*, 22, 103–109.
- Simonsen, L., & Teppo, A. (1999). Using alternative algorithms with preservice teachers. *Teaching Children Mathematics*, 5, 516–519.
- Vos, P., & Espedal, B. (2016). Logarithms – a meaningful approach with repeated division. *Mathematics Teaching*, 251, 30–33.
- Weber, C. (2016). Making logarithms accessible — operational and structural basic models for logarithms. *Journal für Mathematik-Didaktik*, 37(Suppl. 1), 69–98.
- Weber, C. (2019). Making sense of logarithms as counting division. *The Mathematics Teacher*, 112, 374–380.
- Wu, H.-S. (1999). Basic skills versus conceptual understanding. *American Educator*, 23, 1–7.
- Wu, H.-S. (2011). *Understanding numbers in elementary school mathematics*. Providence, RI: American Mathematical Society.
- Ziegenbalg, J., Ziegenbalg, O., & Ziegenbalg, B. (2016). *Algorithmen von Hammurapi bis Gödel*. Wiesbaden, Germany: Springer Spektrum.

Relationships between procedural fluency and conceptual understanding in algebra for postsecondary students

Claire Wladis^{1,2}, Jay Verkuilen², Sydne McCluskey², Kathleen Offenholley¹, Dale Dawes¹, Susan Licwinko¹ and Jae Ki Lee¹

¹Borough of Manhattan Community College at the City University of New York, USA; cwladis@bmcc.cuny.edu, koffenholley@bmcc.cuny.edu, ddawes@bmcc.cuny.edu, slicwinko@bmcc.cuny.edu, jkleee@bmcc.cuny.edu

²The Graduate Center at the City University of New York, USA; jverkuilen@gc.cuny.edu, smccluskey@gc.cuny.edu

In this study we use latent class and distractor analysis as well as qualitative analysis of cognitive interviews to investigate how student responses to concept inventory items may reflect different patterns of algebraic conceptual understanding and procedural fluency. Our analysis reveals three groups of students, which we label “similar to random guessing”, “some procedural fluency with key misconceptions”, and “procedural fluency with emergent conceptual understanding”. Student responses also revealed high rates of misconceptions that stem from misuse or misunderstanding of procedures, and whose prevalence correlates with higher levels of procedural fluency.

Keywords: Elementary algebra in college, conceptual understanding, concept inventory.

In the US, elementary algebra and other developmental courses have consistently been identified as barriers to student degree progress and completion in college, with only as few as one fifth of students ever successfully completing a credit-bearing math course (e.g., Bailey, Jeong, & Cho, 2010). There is evidence that students struggle in these courses because they do not understand fundamental algebraic concepts (e.g., Givvin, Stigler, & Thompson, 2011; Stigler, Givvin, & Thompson, 2010), and many research studies have documented the negative consequences of learning algebraic procedures without any connection to the underlying concepts (e.g., Hiebert & Grouws, 2007). However, developmental mathematics classes currently focus heavily on recall and procedural skills without integrating reasoning and sense-making (Goldrick-Rab, 2007; Hammerman & Goldberg, 2003). This focus on procedural skills in isolation may actually be counter-productive, in that students may often attempt to use procedures inappropriately because they lack understanding of when and why the procedures work (e.g., Givvin et al., 2011; Stigler et al., 2010).

In this paper we explore student responses to conceptual questions at the end of an elementary algebra course in college. We combine quantitative analysis of responses (using latent class analysis and distractor analysis) with qualitative analysis of cognitive interviews to better understand different typologies of student reasoning around some basic concepts in algebra, and to better understand how conceptual understanding and procedural fluency may relate to one another in this context.

Research questions

Is there a latent class structure that adequately represents the heterogeneity of item responses on

an algebra concept inventory among college developmental algebra students? If so, are patterns observed with distractor analysis, procedural assessment scores, and qualitative analysis of cognitive interviews consistent with the class structure, and can they contribute to class interpretation?

Theoretical framework

In this paper we use Fishbein's (1994) typology of mathematics as a human activity as a framework for analyzing student responses and thinking about how conceptual understanding and procedural fluency might inform one another. Fishbein outlines three basic components of mathematics as a human activity: 1) *the formal component* (which we call *conceptual understanding*), which consists of axioms, definitions, theorems and proofs, which need to be "invented or learned, organized, checked and used actively" (p. 232) by students; 2) *the algorithmic component* (which we call *procedural fluency*), which consists of skills used to solve mathematical problems in specific contexts and stems from algorithmic practice; and 3) *the intuition component*, which is an "apparently" self-evident mathematical statement that is accepted directly with the feeling that no justification is necessary.

In this study we use the term conceptual understanding not only to denote a formal understanding of abstract concepts (e.g. axioms), but also of how, when, and why procedures can be used. This is in contrast to procedural fluency in standard problem contexts, in which a student may be able to quickly solve particular types of standard problems correctly but may not understand of how, why, or when these methods work. We say that an item tests conceptual understanding if a student must use *logical reasoning* grounded in mathematical definitions to answer correctly, and it is *not* possible to arrive at a correct response *solely* by carrying out a procedure or restating memorized facts. We define a *procedure* as a sequence of algebraic actions and/or criteria for implementing those actions that could be memorized and applied correctly with or without a deeper understanding of the mathematical justification. Using these definitions, no question is wholly conceptual or procedural, but falls on a spectrum. We recognize that the definition of conceptual understanding and its relationship to procedural fluency has been much debated in the research community with no clear consensus (e.g., Baroody, Feil, & Johnson, 2007; Star, 2005), and that the two forms of knowledge are interrelated (e.g., Hiebert & Lefevre, 1986; National Research Council, 2001).

In fact, each of Fishbein's three components may interact. Intuition may facilitate learning when it is consistent with logically justifiable truths (i.e. the formal component) but may also be an obstacle to learning in cases where it is inconsistent. In this paper we explore how students who develop algorithmic/procedural skills in isolation from formal/conceptual understanding may be prone to developing intuitions that are inconsistent with logically justifiable truths, and as a result, may exhibit simultaneously increased procedural fluency in standard problem contexts and decreased conceptual understanding. We consider how student justifications of answer choices may exhibit intuition components (which may be either correct or incorrect), and we consider how these intuitions may relate to both the processes of developing procedural fluency as well as conceptual understanding.

Methods

This study focuses on student responses to the multiple choice questions on the Elementary Algebra Concept Inventory (EACI). For details on the development and validation of the EACI, see Wladis et al. 2018). Here we focus on 698 students who took the inventory at the end of their elementary algebra class in 2016-2017. In order to supplement quantitative data, 10 cognitive interviews were conducted towards the end of the semester with students who were enrolled in an elementary algebra class and were analyzed using grounded theory (Glaser & Strauss, 1967), although a full qualitative analysis is not presented here due to space constraints. All students currently enrolled in the course were recruited via email to complete the EACI and then to be interviewed about their thinking immediately afterwards. The distribution of interviewees among the three classes was not significantly different from the whole quantitative sample.

In this paper we used latent class analysis (LCA) of the nine binary scored (right/wrong) multiple-choice items on the inventory. LCA is a latent variable model that presumes that items are locally independent conditional on a discrete nominal latent variable (e.g., Collins & Lanza, 2010).

Description of the classes

Latent class analysis on binary (correct/incorrect) scoring of the items was used to look for common response patterns among the students in the quantitative sample, and this analysis revealed three distinct classes of students. While latent class analysis was used to generate the three classes, more fine-grained analyses were needed to generate potential interpretations of each class. After the initial classes were generated by latent class analysis, item response patterns, distractor analysis, and qualitative coding of cognitive interviews were used to generate characterizations of each class, and evidence was found among these different complementary approaches for the following potential characterizations of each class. The remainder of this paper describes in more detail the different approaches that were used to develop the class interpretations presented here:

- C1 (27%): Answers to most items are indistinguishable from random guessing, likely due to low procedural/conceptual knowledge, low self-efficacy, and/or low motivation.
- C2 (28%): Likely have some procedural skills but limited conceptual understanding.
- C3 (45%): Likely have procedural skills and emergent conceptual understanding.

These descriptions emerged from different analyses of the data. Firstly, we consider the response patterns of students from each of the three classes, and we see some clear trends (see Figure 1).

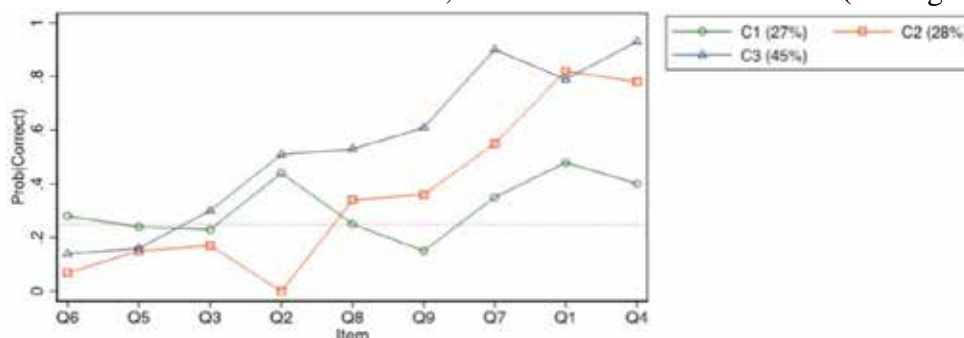


Figure 1: LCA profiles of student responses in each class

Student responses in class 1 do not vary much from what would be expected for random guessing on four-option multiple choice items. While all of the items on the test were designed to test

conceptual understanding, some of them (items 2, 3, 5, and 6) use more abstract or non-standard formulations of algebraic ideas. Class 2 answers significantly worse than chance on questions 2 and 6 because of the presence of attractive distractors that likely tap into misconceptions related to the misuse of procedures. Classes 2 and 3 are distinguished by improved performance on the items overall as well as different proportions of key misconceptions. Students who passed the class were most likely to be in class 3, then class 2, and least likely to be in class 1. An end of course standardized assessment that measures procedural fluency in standard problem contexts showed a similar outcome. To illustrate how different response patterns distinguish these three classes, we performed a distractor analysis and analyzed cognitive interviews for three exemplars: items 2, 4, and 6. We used the Bayes modal assignment to determine the class membership of interviewees.

Three example questions: illustrating different class response patterns

First we consider Item 4:

4. Which of the following is a result of correctly substituting $x - 4$ for y in the equation $3y - 2 = y^2 + 1$
- $3x - 4 - 2 = x - 4^2 + 1$
 - $3x - 4 - 2 = x^2 - 4^2 + 1$
 - $3(x - 4) - 2 = (x - 4)^2 + 1$
 - $3x - 3 \cdot 4 - 2 = x^2(-4)^2 + 1$

The correct answer is c. C1's responses are scattered in a pattern consistent with random guessing (see Figure 2). By contrast, C2 and C3 have a high probability of choosing the correct response, with C3's probability significantly higher than C2. This item is behaving the way we would expect if C1, C2, and C3 were ordered on conceptual ability. Selecting c is also highly correlated with scores on the procedural exam, corresponding to a score that is higher by 10.8 percentage points. ($p=0.000$)

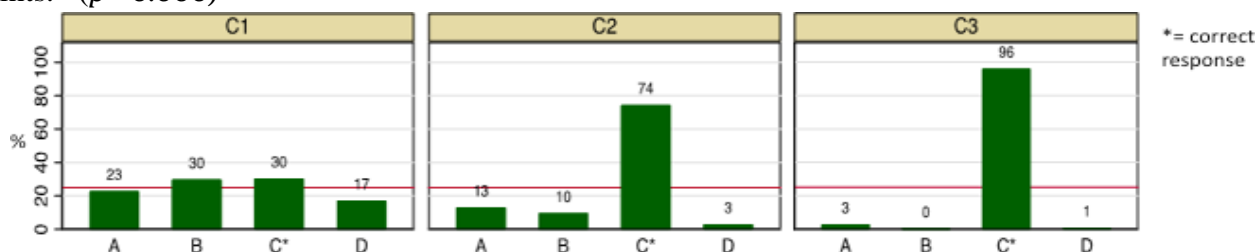


Figure 2: Item 4 Distractor Analysis

Looking at student interview responses reinforces our interpretation of the three classes, and reveals how higher classes appear to have more robust and correct intuitions about substitution.

C1 (chose B): It says $x - 4$ for y , this is what I think like because y^2 . It could be like changed to a 4^2 . I put together like $3x - 4 - 2 = x^2 - 4^2 + 1$. [I didn't pick c or d because] they [pointing to the $x - 4$ in the item stem] didn't have no bracket around them. [I picked B with the x^2 in it instead of A, which doesn't have the x^2] because x equals y^2 so it has to have an x^2 in it because the y is squared there.

C2 (chose C): So usually when a math question says, "substituting" that's basically putting the numbers that they give you into x or y that they say to put it. I automatically substituted it in, and my correct answer was $3(x - 4) - 2 \dots$ I didn't pick any

other answer, because I didn't see the parentheses.

C3 (chose C): I didn't choose A because when trying to multiply the y , which is $x - 4$, you have to put the parenthesis behind 3, unless you already multiplied 3 times $x - 4$... [choice D] does have parenthesis on -4 , but then, it will be missing the complete equation for y because -4 is not the only equation that equals to yy is $x - 4$.

In these examples, the C1 student demonstrates an intuition about substitution that the y should be replaced with $x - 4$ in the equation, but this does not include an awareness of the equation structure (e.g., that the $x - 4$ must be treated as a single unit). The C2 student also demonstrates a partially- correct intuition that parentheses must be used around whatever is being substituted, but doesn't execute this procedure completely correctly on both sides, and doesn't demonstrate any awareness of *why* the parentheses are necessary. In contrast, the C3 student shows both an awareness of the need for the parentheses and an understanding of *why* the parentheses are logically necessary— because without them, the structure of the equation will be altered. Now we consider item 6, which shows a different pattern of responses:

6. A student is trying to simplify two different expressions:

i. $(x^2y^3)^2$ ii. $(x^2 + y^3)^2$

Which one of the following steps could the student perform to correctly simplify each expression?

- For both expressions, the student can distribute the exponent.
- The student can distribute the exponent in the first expression, but not in the second expression.
- The student can distribute the exponent in the second expression, but not in the first expression.
- The student cannot distribute the exponent in either expression.

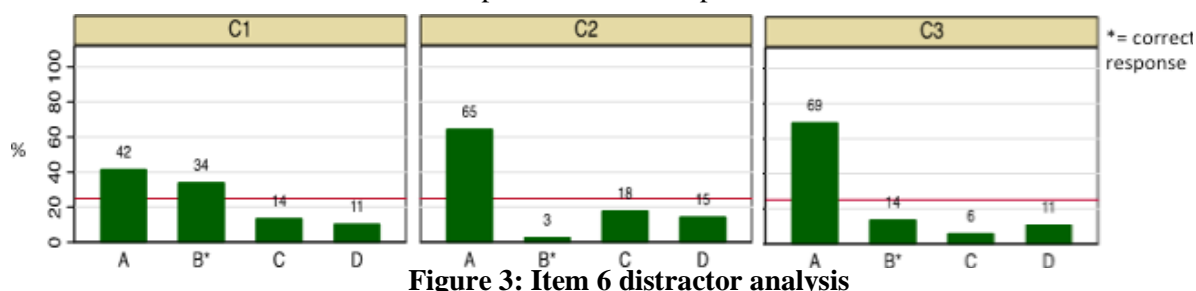


Figure 3: Item 6 distractor analysis

The correct answer is b. C2 and C3 were strongly attracted to option a (see Figure 3), likely because they have intuitions stemming from their experiences with procedures associated with the distributive properties, but they do not recognize the critical differences between distributing multiplication versus exponents—likely because they have no deeper conceptual understanding of how the distributive property works. Unlike item 4, selecting the correct answer is negatively correlated (and selecting the attractive distractor was positively correlated) with scores on the procedural exam—students who selected the incorrect option a scored on average 7.1 percentage points higher on the procedural exam ($p < 0.000$) than others. This suggests that in this context (where procedures are typically taught in isolation from concepts) procedural fluency in standard problem contexts can be inversely related to conceptual understanding of the distributive properties.

Looking at student interview responses reinforces our interpretation of the three classes, and sheds light on how intuitions developed from procedural practice may impede conceptual understanding.

C1 (chose B): [The difference between the first and second equation] is that there's a plus right there [pointing to the second equation]. I think for this one [pointing to the second equation], you have to add and for this one [pointing to the first equation] you don't.... Actually, I think like over here [pointing to the second equation] you add a 3. 3 plus 2. [For the first one] you do x^2 times x^2 and y^3 times y^3 .

C2 (chose A): I feel like that's correct because in order to solve x^2 and y , you have to distribute.... Because I've seen problems like this before and it's like you have to solve it, there is no not solving it because there is no ... there is no solution.

$$\begin{array}{l} \text{i. } (x^2y^3)^2 = x^4y^6 \\ \text{ii. } (x^2+y^3)^2 = x^4+y^6 \end{array}$$

C3 (chose A): That's how you kind of get rid of the parenthesis and get rid of the outer exponents by distributing it in the inside. Whether it's with another exponent or with a number... You want to add or multiply that exponent [outside the parentheses] to the ones inside the parentheses but I can't remember whether you add or multiply...

In these examples, the C1 student notices that there is a difference between the two equations and has an intuition that it is important, but doesn't actually know how to perform the distribution correctly. For the C2 and C3 students, we see a number of ways in which students are citing incorrect intuitions that stem from algorithmic experience—we have included only a few samples here. None of the students interviewed was able to describe when and why it is possible to distribute—they all cited incorrect intuitions related to procedural methods that they had learned in class. Next we consider item 2, which reveals another interesting pattern of responses:

2. Consider the equation $x + y = 10$. Which of the following statements must be true?
- There is only one possible solution to this equation, a single point on the line $x + y = 10$.
 - There are an infinite number of possible solutions, all points on the line $x + y = 10$.
 - This equation has no solution.
 - There are exactly two possible solutions to this equation: one for x and one for y .

For this question, the correct answer is b, (the most popular choice for students in classes 1 and 3) but no examinee in class 2 chose it (see Figure 4).

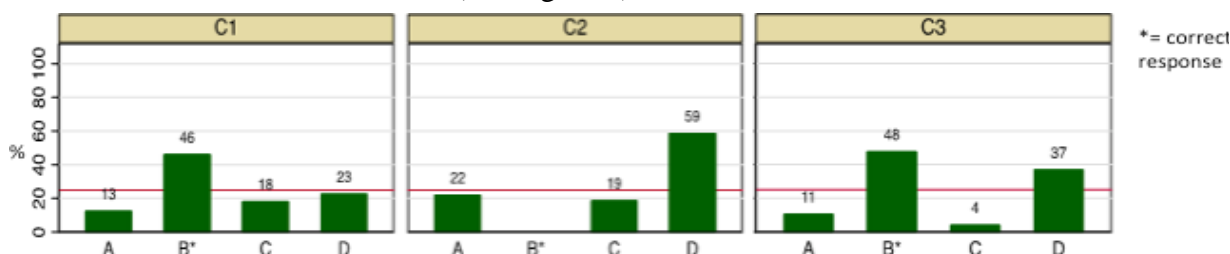


Figure 4: Item 2 distractor analysis

They were strongly attracted to option d, which was also the second most popular choice for students in both of the other classes, although at a much lower rate. Option d is a common response from students asked to solve a system of linear equations for x and y , which may explain its popularity. Both C2 and C3 were attracted to option d, again suggesting they are attempting to apply inappropriate procedural reasoning. This item is responsible for the notable separation

between C2 and C3 because no examinee in C2 chose the option b, the correct response. Looking at student interview responses reinforces our interpretation of the three classes, and sheds light on students' reasons for choosing both correct and incorrect options.

C1 (originally chose C, but drifted towards B in the interview): $x + y$ equals nothing so it can't be 10. Right?... [Maybe infinite means] what could be like possible? I don't know. Like equal number maybe? $x + y = 10$. It could be possible like it equals 10. [D isn't correct] maybe because x and y could be equal to anything?

C2 (chose D): What I assumed was the x term and the y term, you would have to substitute. And I know there are certain numbers that will add up to ten, so there could be two solutions, since there's only a x term and a y term... Like x could equal 5, y could equal 5... since it is two terms, so you could say two different solutions.

C3 (chose B): Ten could equal to many things. Like five plus five could equal ten. Nine plus one could equal ten. Seven plus three. That's why I chose that, because it could be any number that will equal to ten. It's not just one certain number.

The C1 student initially chose “no solution” because they didn't know what x and y could be, but as they discussed their answer, they started to relate this to the idea that x and y could be “anything”. While their reasoning is not strictly correct, they are beginning to explore the idea that x and y may have many possible values, and they show no evidence of faulty intuitions stemming from procedural practice. The C2 student exhibits an intuition about what the equation means (perhaps from standard substitution problems) to find a single solution, but they do not explore whether there might be others. They also confuse the number of solutions with the number of variables in the solution set, suggesting that their intuitions about the definition of a solution set are likely incorrect. The student from C3 describes how this equation could have multiple solutions, demonstrating some conceptual understanding of solution sets, including the fact that they describe the relationship between the two variables.

Discussion and Limitations

This study revealed several trends. Firstly, roughly one quarter of students at the end of the course appeared to guess somewhat randomly on conceptual questions, likely because of low knowledge, self-efficacy, or motivation. However, cognitive interviews suggest that these students may be able to make some progress towards conceptual understanding by relying initially on more naïve reasoning and that they are not typically hindered by incorrect intuitions stemming from misuse of procedures. About one quarter of students demonstrated some mastery of procedures in standard problem contexts, but demonstrated many misconceptions related to misuse of procedures. In contrast, roughly half the class showed evidence of emergent conceptual understanding, with lower frequency of misconceptions related to misuse of procedures. For a number conceptual questions, particularly those that were more abstract or non-standard, conceptual understanding and procedural fluency were significantly strongly inversely related. Cognitive interviews revealed that this may happen when students develop incorrect intuitions stemming from the use of procedures.

Both local observation of courses at the research site, and national research literature on developmental mathematics classes in college (e.g., Goldrick-Rab, 2007; Hammerman &

Goldberg, 2003) provides evidence that almost all instruction in this context teaches procedures isolated from underlying concepts, so this research may be revealing patterns specific to this type of instruction—it may be that repeated procedural practice in isolation may worsen certain kinds of conceptual understanding. We note that this study did not attempt to link student response patterns to specific types of instruction—there is a pressing need for future research to examine this relationship in order to determine which types of instruction impact student growth in conceptual understanding.

References

- Bailey, T., Jeong, D., & Cho, S. (2010). Referral, enrollment, and completion in developmental education sequences in community colleges. *Economics of Education Review*, 29(2), 255-270.
- Baroody, A., Feil, Y., & Johnson, A. (2007). An alternative reconceptualization of procedural and conceptual knowledge. *Journal for Research in Mathematics Education*, 38, 115-131.
- Collins, L.M. & Lanza, S.T. (2010). *Latent Class and Latent Transition Analysis: With Applications in the Social, Behavioral and Health Sciences*. New York: Wiley.
- Fischbein, E. (1994). The interaction between the formal, the algorithmic, and the intuitive components in a mathematical activity. In R. Biehler, R. W. Scholz, R. Strasser & B. Winkelmann (Eds.), *Didactics of mathematics as a scientific discipline*. (pp. 231-245). Dordrecht: Kluwer.
- Givvin, K. B., Stigler, J. W., & Thompson, B. J. (2011). What community college developmental mathematics students understand about mathematics, Part II: The interviews. *The MathAMATYC Educator*, 2(3), 4-18.
- Glaser, B. G., & Strauss, A. L. (1967). *The Discovery of Grounded Theory: Strategies for Qualitative Research*. New York, NY: Aldine Publishing.
- Goldrick-Rab, S. (2007). What Higher Education Has to Say about the Transition to College. *Teachers College Record*, 109, 2444-2481.
- Hammerman, N., & Goldberg, R. (2003). Strategies for Developmental Mathematics at the College Level. *Mathematics & Computer Education*, 37, 79-95.
- Hiebert, J. C., & Grouws, D. A. (2007). The effects of classroom mathematics teaching on students' learning. In F. K. Lester Jr. (Ed.), *Second handbook of research on mathematics teaching and learning* (1st ed., pp. 371-404). New York, NY: Information Age.
- Hiebert, J., & Lefevre, P. (1986). Conceptual and procedural knowledge in mathematics: An introductory analysis. In J. Hiebert (Ed.), *Conceptual and Procedural Knowledge: The Case of Mathematics*. (pp. 1-27). Hillsdale, NJ: Erlbaum.
- National Research Council. (2001). *Adding It Up: Helping Children Learn Mathematics*. Washington, DC: National Academy Press.
- Star, J. R. (2005). Reconceptualizing procedural knowledge. *Journal for Research in Mathematics Education*, 36, 404-411.
- Stigler, J. W., Givvin, K. B., & Thompson, B. J. (2010). What community college developmental mathematics students understand about mathematics. *MathAMATYC Educator*, 1(3), 4-16.
- Wladis, C., Offenholley, K., Licwinko, S., Dawes, D., & Lee, J. K. (2018). Development of the Elementary Algebra Concept Inventory for the College Context. *Mathematical Association of America Research in Undergraduate Mathematics Education Conference* (pp. 605-617). San Diego, CA.

Forming basic conceptions in dealing with quadratic equations

Alexander Wolff¹

¹University of Hildesheim, Faculty of Mathematics and Applied Informatics, Hildesheim, Germany;
wolff@imai.uni-hildesheim.de

Keywords: quadratic equations, solving, transforming, understanding, basic conceptions.

Introduction

Transforming and solving quadratic equations, such as $-2x^2 = -8$, is part of the curriculum taught in school. To support the learning process of equations and their equivalent transformations, models such as the balance scale-, the box or the strip model, can be and are usually used in class (see Holzäpfel/ Barzel, 2010). The work and the support thereby reach its limits when dealing with negative coefficients in quadratic equations or by multiplying/dividing with negative numbers (see Vlassis, 2002). On the one hand its whole variety of formal expressions of quadratic equations and its equivalent transformations cannot be supported and visualized with the above mentioned models. On the other hand the work with the suggested models can lead to inadequate conceptions (misconceptions) of the mathematical concepts: E. g. facing problems to be able to interpret formal expressions such as $2x^2 + 2 = x^2$ or $2 = 3$ as equations as well (with an empty set of solutions). E.g. regarding the division of both sides of the equation by x or the extraction of the square root as an equivalent transformation. But working with models and forming content adequate conceptions for the learning process is indispensable. According to vom Hofe/ Blum (see 2016) the formation of basic conceptions (Grundvorstellungen) belongs to a competent and sensible dealing with mathematical concepts. But which basic conceptions, that students are about to form in the learning process, can be cited up? Two basic conceptions are cited normatively and visualized in a model further down. They allow to interpret a quadratic equation and its equivalent transformations illustratively in a graphical (or tabular) way and consequently grasp the core of understanding

Model

Basic conception 1:

A quadratic equation as an intersection of two functions, whereby at least one has to be quadratic. To determine the set of solutions the x-coordinate of the intersections S_1 and S_2 has to be considered.

Example:

$$-2x^2 = -8$$

$$f(x) = g(x)$$

$$\mathbb{L} = \{-2; 2\}$$

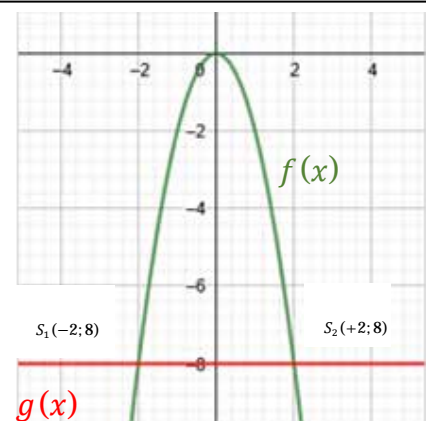


Figure 1: Graphical visualization of basic conception 1 (GV1)

Basic conception 2:

An equivalent transformation keeps the x-coordinate (the set of solutions) constant and simultaneous leads to a change of the functional value of the intersections.

Example:

$$\begin{aligned} -2x^2 &= -8 & f(x) &= g(x) \\ \Leftrightarrow -x^2 &= -4 & \Leftrightarrow h(x) &= i(x) \end{aligned}$$

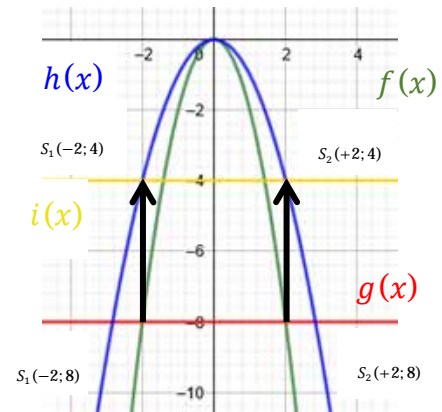


Figure 2: Graphical visualization of basic conception 2 (GV2)

Study design

To evaluate if these normatively cited basic conceptions can be formed by students and hence can be proved empirically, special learning assignments have to be designed. Aim of the presented study is thus to develop a learning environment and subsequently to investigate if those basic conceptions can be formed by students. For this purpose, a teaching sequence of 2x45 minutes was designed. Both sets of 45 minutes dealt with one basic conception. Each set consists of a specially designed common starter with a subsequent individual working phase of 4 learning assignments. The utilized exercises in the working phase were supplementary designed with regard to a high potential of diagnosis implying a written response in addition to the actual task.

Preliminary results and outlook

A first postprocessing of students' solutions of the learning assignments revealed to evaluate the collected data quantitatively through a deductive procedure.

This leads with regard to the formation process of the first basic conceptions to the following preliminary results: The solution quote over the first 4 learning assignments amounts up to 81%.

In summary, it could be said, that the dealing with the exercises for the formation of the first basic conception (GV1) worked out well. Missing percentages are due to a lack of time, inaccurate drawing of graphs and mistakes in reading off exactly the relevant coordinates and distinguishing both from each other.

The evaluation of the learning assignments for the formation of the second basic conception (GV2) showed up to be more difficult. The used tasks were created too open and required for its processing the correct and precise use of mathematical language. These circumstances made the students' solutions difficult to evaluate. The tasks are now going to be revised more closely. The following study is going to be carried out once again, under the revisions of the exercises, this year.

References

- Holzäpfel, L. & Barzel, B. (2011). Gleichungen verstehen. *Mathematik lehren*, 169, 2-7.
- Vlassis, J. (2002). The balance model: hindrance or support for the solving of linear equations with one unknown. *Educational Studies in Mathematics*, 49, 341-359.
- vom Hofe, R./Blum, W. (2016). „Grundvorstellungen“ as a Category of Subject-Matter Didactics. In: *Journal für Mathematikdidaktik* 37(1), p. 225-254.

Provoking students to solve equations in a content-oriented fashion and not using routines by solving slightly modified standard tasks.

Simon Zell¹

¹University of Education Schwaebisch Gmuend, Schwaebisch Gmuend, Germany; simon.zell@ph-gmuend.de

A lot of time in algebra lessons is spent on solving equations using routines. It is assumed that after many hours of training, these routines will be easily recalled and performed fluently. A study of 480 students in grade 10, which was undertaken at the beginning of a school year, showed that many students had forgotten these routines and were not able to reconstruct (alternative) solutions for simple equations. Content-oriented solving, which does not involve algorithms, is one way of helping students to solve equations using insight. Results from the same study indicate that this kind of problem solving can be promoted if standard tasks are modified slightly.

Keywords: Solving equations, content-oriented solving, concept of function.

Introduction

Students solve a great number of equations by using routines. Once a repertoire for these basic procedures has been established, a teacher can consider more challenging tasks in terms of solving equations. However, overemphasizing reproducing procedures monotonously can also be counterproductive (Arcavi, Drijvers, & Stacey, 2017). It may lead to making students inflexible when solving equations. If standard procedures are varied slightly, students cannot adapt the changes to the procedures they know. Solving tasks by routine and insight should be integrated. “In algebra teaching, therefore, procedures should be linked to an understanding of their meaning and to a flexible choice of solution methods; routine and insight go hand in hand and should be reconciled” (Arcavi, Drijvers, & Stacey, 2017, p. 92). Tasks should involve practising skills, but also address students’ thinking, alertness and creativity. Another approach which can support students’ thinking and alertness is solving tasks in a content-oriented fashion. It is a counterpart of solving tasks by routines. One example illustrates this way of solving. In the first week of semester, 30 beginning students of mathematics education were asked by the author to solve the equation $(x - 2)^2 = -9$. Everybody calculated the equation by expanding the brackets, using equivalence transformation and the quadratic formula. Finally, they came up that there is no solution. All of them have noticed the square and triggered the procedure to solve it by the formula. Nobody had taken a closer look at the equation and noticed that on the left side there was a square and on the right there was a negative number, therefore the equation had no solution. The alternative solution can be defined as a content-oriented approach. The algebraic structure was consciously analysed and theoretical knowledge about square numbers was applied. Analogous to the example above, solving $1 - \frac{1}{x} = 0$ the routine way takes quite some time. Solving that equation content-oriented by analysing the structure, instead of just noticing an equation involving fractions can be much quicker and done with more understanding. A content-oriented way of solving could be: The difference has to be zero, therefore $\frac{1}{x}$ must be one, therefore x is equals one. All these steps can be done by mental arithmetic. In both examples the content-oriented approach is the more insightful way of solving. Especially when solving equations students stick to

the routines. Promoting content-oriented solving of equations in class could break students' behaviour of using routines unrelatedly, and making them look at the equations given, using definitions or reflecting on methods already known and help them to solve equations with more understanding. Hence there is a need to find appropriate tasks or task assignments to enhance content-oriented solving.

Solving equations content-oriented

Content-oriented solving is one part of a large framework that characterizes mathematical tasks in school. After analysing hundreds of mathematics lessons, Fanghaenel (1984) concluded that solving mathematical tasks in school should be organized in such a way that all students develop high mental activity by themselves as much as possible (p. 189). His detailed categorization of mathematical tasks has been used to analyse a great number of tasks in schoolbooks. One category describes a method for solving tasks. In addition to following routines, he distinguishes direct and indirect transfer of procedures and content-oriented solving (*ibid.*, p. 98). Content-oriented solving (in German, *inhaltliches Lösen*) is realized if the person solving the task gains a clear understanding of the given situation by realizing characteristics and relationships, interpreting symbols and using theoretical knowledge, and then employs these to solve the given task. It stands in contrast to using routines, which are appropriate for solving a definite set of tasks.

Arcavi, Drijvers, and Stacey (2017) describe a class situation experienced by a teacher. After teaching 14-year-old students about quadratic equations, the equation $(x - 3)^2 + 5 = 30$ was still on the board. The 12-year-old students entering the room for the next class could solve the equation without knowing the formal algorithms. They concluded that the number within the bracket had to be 25, therefore $x = 8$ or $x = -2$. Whereas the 14-year-olds were struggling with the algebraic operations, the 12-year-olds were analysing the structure of the equation and making conclusions. This phenomenon can be explained by the concept of content-oriented solving. The 14-year-olds have had an introduction of formal procedures to solve quadratic equations. According to Fanghaenel (1984) they followed routines or have used a direct transfer, i.e. the equation is identified as a very similar task, which has been solved before and will be solved in the same way. The 12-year-old students couldn't do that, so they needed to apply theoretical knowledge. This way of solving can be identified as content-oriented, since they didn't know the procedure. If they do the same procedure several times, the solving behaviour can change from content-oriented to routine. Hence content-oriented solving depends on the reference field of a student and the tasks given, i.e. the same solution of a task can be seen as a routine or content-oriented, depending on a student's previous knowledge on solving the given task. Therefore tasks have to be chosen carefully to identify content-oriented solving in a written task.

Content-oriented solving is not the same as solving tasks semantically, although there are many commonalities. Kaput (1989) defines semantic actions or elaborations as ones that "are guided by the features of a reference field for the symbol system rather than by its syntax (using the syntax implicitly)" (p. 175). Content-oriented solving encompasses more than semantic approaches. Tasks that are asking for an interpretation of an object are semantic actions, but they do not require content-

oriented solving because only factual knowledge can be used. Tasks which require indirect transfer require semantic approaches and can be assigned to a semantic task.

Content-oriented solving of an equation occurs if students gain a clear concept of given preconditions and their deductions and consciously use these to determine a solution (Flade, Goldberg, and Mounnarath, 1992). A characteristic of solving equations that way is the use of heuristics (Rosin, 1984). Sill et al. (2010) characterize content-oriented solving as the solving of equations or inequalities without the use of routines. The regular use of this approach will continuously develop students' ability to identify term structures. Hence, they will become familiar with variables, terms and equations and tend to operate less with unknown symbols. Considering the variety of ways to solve a task content-oriented, it is likely that this type of solving will lead to a more comprehensive view of terms and equations.

The uses and objectives of content-oriented solving vary from lower grades to higher grades (Flade et al., 1992). Whereas in lower grades it can be applied to elementary equations, involving addition and multiplication, to help students in comprehending the elementary concepts of equations, it can be used at the upper secondary level to offer students creative approaches and allow them to solve mathematical tasks systematically and reflectively.

Seventh-grade students whose teachers promoted content-oriented solving even solved routines slightly better than students whose classes put more emphasis on routines (Fanghaenel, 1976). This result is remarkable because students in the experimental group had less time for practising routines and got slightly better results. However, the major effect of that study was seen in a test at the beginning of the following school year. In the control group (routines), results decreased significantly, whereas, in the experimental group (content-oriented), correct results increased. Emphasizing content-oriented solving led students to work out forgotten routines by themselves.

Such students, who have no formal knowledge of procedures, are forced to solve content-oriented. In elementary school, students are able to solve simple equations like $18 - x = 13$ or $3(x + 2) = 36$. The first one can be solved content-oriented by trying out different values randomly or systematically or by asking oneself 'Which number subtracted from 18 will equal 13?' The second equation can be solved similarly by asking oneself 'Three times how much will be 36? 3 times 12 equals 36, therefore x must be 10'. Such students do not use an algorithm. They solve it by analysing the structure of the equation and using theoretical knowledge. The equation is solved with understanding because the given structure is analysed consciously. According to Fanghaenel's (1976) definition, content-oriented solving can also comprise (un)consciously reflecting on the possible procedures and choosing the most appropriate one. One result could be a student's decision to use a routine to solve a specific task. In that case, the essential difference to using routines is that a student (un)consciously analyses the given structure and reflects on possible approaches to solving a task.

In contrast to using routines, content-oriented solving enhances students' ability to create, combine, and vary mental images of mathematical structures. Therefore, this type of solving should be part of algebra lessons.

How to implement content-oriented solving in class

Whenever a procedure is not yet known, students have to solve problems content-oriented (Fanghaenel, 1984). However, once routines are introduced, using a content-oriented approach can be ignored easily, as Freudenthal (1983) notes: “sources of insight can be clogged by automatism” (p. 469). To maintain student alertness when solving equations, unusual elements can be included in a set of exercises (Arcavi, et al., 2017). Another way to maintain content-oriented approaches is to lead students to constantly check every equation to be solved content-oriented (Sill et al., 2010). This method strongly relies on teachers’ patience and persistence. Hence, it is useful to find other ways to promote content-oriented solving that are more independent of teachers’ methodologies. To highlight the advantage of solving tasks content-oriented, all tasks need to be of the type that can be solved much more quickly in this way than by using a routine.

Provoke students to solve content-oriented by suitable tasks

As part of a study to promote content-oriented solving, research questions included how well students were able to solve equations in that fashion and how the task assignment influenced students’ solving behaviour. For this study, a test was given at the beginning of the school year in September 2017. A total of 480 students in grade 10 at eight different Gymnasiums (schools for higher-skilled students) took part in the 45-minute test. The test included solving linear, quadratic, and exponential equations. All equations were set up with simple numbers and simple structures, i.e., they could be solved content-oriented by analysing the structure, using mental arithmetic and faster than using routines. Some of the items were written in a standard form, such as ‘solve the equation’, and other items were varied slightly.

All items were checked and validated in advance by members of the mathematics department at the University of Education Schwaebisch Gmuend and tested on 149 grade 10 students in nine classes at three different schools in January 2017 (Zell, 2017). As a result, small changes were made to two items and validated by interviews with students attending the University of Education. The coding of students’ solutions was differentiated in routine and content-oriented approaches. Within these categories it was distinguished into correct, incorrect and incomplete. Approaches, in which no routine or meaningful answer could be derived, were classified to other approaches. These categories were created by the author and cross-checked by members of the mathematics department and by the answers of the pre-test. Students are not given any instruction how to write down the solution. They were confronted with these tasks as in a regular testing. The first four tasks follow the familiar assignment “solve the equation”. Task 1c and 1d are slightly modified by not allowing the standard routine to force students solving these equations content-oriented.

Task 1: Determine the solution(s) of the following equations.

- a) $x^2 + 4 = 0$
- b) $2^{x+1} = 16$
- c) Determine the solution of $3^{(x-2)} = 81$ without using logarithms.
- d) Determine the solution of $2^{(x-2)} = -32$ without using logarithms.

The first two tasks can be solved by both routine and content-oriented. A student's solution was considered content-oriented, if he or she didn't follow the routine introduced in class. For tasks 1b-1d using/comparing the exponents to solve the equation was the expected content-oriented solution. This way was not mandatory taught in school and therefore considered content-oriented.

Task 2 had a modified assignment. Students had to give a reason for a statement. Because no concrete solution was demanded, there were more possible ways of solving each task. All tasks could be solved by using both routine and content-oriented approaches.

Task 2: Give a reason for these statements.

- a) $2(x - 4) = 0$ has a positive solution.
- b) $f(x) = x^2 + 2x + 1$ has no positive zeros.
- c) $x^2 - 10x + 25 = 0$ has only one solution.

Hence, if the assignment of a task matters, the percentage of content-oriented approaches on these modified tasks should be considerably different.

Results

The range of correct solutions is from 13.3% solving the equation $2^{x-2} = -32$ to 63.1% solving $2(x - 4) = 0$. Students' answers for four tasks are shown in more detail. Looking at the results for Task 1a shows how using a routine dominated (see Table 1).

Task 1a: Determine the solution(s) of $x^2 + 4 = 0$				
Solved	correctly	incorrectly	incompletely	total
by routine (taking the square root)	32.5%	52.1%	0%	84.6%
Content-oriented (using term structure)	0.2%	0%	0%	0.2%
by writing down the solution without calculation	5.4%	0%	0%	5.4%
by using incorrect other approaches	0%	6.7%	0%	6.7%
nothing by giving no response	0%	0%	3.1%	3.1%

Table 1: Types of solutions for Task 1a

Only one out of 480 students solved it content-oriented by writing down an explanation. Twenty-six who just wrote down the solution might have solved it content-oriented. Because the test was done in a real classroom setting, some students might have copied their neighbour's answer. Consequently, only one student has solved that task content-oriented. Having a more open perspective, 5.6% solved the equation content-oriented. It is possible that they have seen the answer just by looking at the equation, like experts in mathematics do. Those students who solved the equation by using the square root tended to make mistakes. The most common mistakes were taking the square root of the left-hand side, which resulted in $x + 2$, or taking the square root of -4 .

When solving Task 1b, only a small number of students remembered how to use logarithms to solve exponential equations (see Table 2). Because the numbers used in that task were simple, students had

the chance to solve it content-oriented by noticing that 2^4 is 16 and therefore x must be 3, or they could compare the exponents formally. These students who were able to take a content-oriented approach, tended to make less mistakes.

Task 1b: Determine the solution(s) of $2^{x+1} = 16$				
Solved	correctly	incorrectly	incompletely	total
by routine (using logarithm)	17.7%	6.6%	1.5%	25.8%
Content-oriented (looking at the exponents)	19.0%	3.1%	0.2%	22.3%
by writing down the solution without calculation	18.1%	0%	0%	18.1%
by using incorrect other approaches	0%	16.9%	0%	16.9%
nothing by giving no response	0%	0%	16.9%	16.9%

Table 2: Types of solutions for Task 1b

The equation structure in Task 1c is the same as in Task 1b, but using logarithms was not allowed. 54% of all students tried to look at the exponents, and 48.9% of them solved it correctly. Results in Task 1d are similar: 39.8% tried to solve it content-oriented, 13.3% of them correctly. Not allowing the standard procedure made the students to attempt solving the task content-oriented.

Task 2a contains a slight modification to the standard design ‘solve the equation’. Not asking for the solution, but instead, the reason why the solution must be positive, had an effect on students’ answers. Here, 27.9% of all students solved the task content-oriented, and 63.4% of these students did it correctly. 27.9 % is still a low percentage, but it is five times higher than the percentage that solved Task 1a content-oriented. Some examples of content-oriented solutions follow:

- “ x must be positive, because having a negative solution, the result would be a negative value, because 4 is subtracted of x .”
- “Yes, because of product equals zero theorem: When multiplying one number with 0, the product is 0 as well; to attain 0, x must be 4, i.e. positive.”
- “ $2(4-4)=0$ has a positive solution, if x is greater than 4.”

Analysing the solutions to Task 2b (see Table 3), only 19.0% attempted to recall the formula on paper, and only 13.3% of them did so correctly. Only six students used the binomial formula, 23 students tried to solve it by considering parabolas, and 55 students used the term structure. The majority (51.2%) did not write anything down. Many students had forgotten the quadratic formula and were not able to reconstruct given knowledge to come up with a solution.

A small number of students used a content-oriented approach. Some examples will serve to exemplify the approaches used:

- “True, since the whole equation is an addition, the solution is always greater than 0, if one uses positive numbers.”
- “True, since using $x = 0$, $f(x)$ will be the result. All positive x -values are too large.”
- “There are no positive zeros because 1 is always added at the end of the equation.”

- “Because this function has a y-intercept of 1 and because the slope equals 2, it cannot have zeros in the positive section.”

Task 2b: Give a reason for this statement: $f(x) = x^2 + 2x + 1$ has no positive zeros.				
Solved	correctly	incorrectly	incompletely	total
by routine (formula for quadratic equations)	13.3%	5.7%	0%	19.0%
Content-oriented by using binomial	1.3%	0%	0%	1.3%
Content-oriented by using parabola	0.2%	3.5%	1.3%	5.0%
Content-oriented by using term structure	2.7%	5.2%	3.5%	11.4%
by using incorrect other approaches	0%	0%	14.6%	14.6%
nothing by giving no response	0%	0%	48.7%	48.7%

Table 3: Types of solutions for Task 2b

The content-oriented answers of tasks 2a and 2b show how a deep understanding of term structure can be promoted. Incorrect answers can show teachers what types of misconceptions the students have. Hence such tasks are very suitable for exercises recalling routines having been learnt long before. When discussing the students' solutions, not only are routines repeated but also content-oriented solutions. These solutions can show the meaning and properties of all the concepts involved. Students who have forgotten the routine needed also have a chance to find a solution.

Conclusion

The results show that the content-oriented solving of equations is used by only a small minority of students. The more familiar a procedure is, the more routines dominate and alternative ways are less taken into consideration. But changing the tasks slightly has an effect on students' solutions, the percentage of content-oriented solutions increases. Hence, setting up tasks which contain easy numbers does not automatically make students consider alternative approaches. But adding features like asking for reasons, not demanding concrete solutions, forbidding routines on tasks and consciously using functions makes students solve equations content-oriented more frequently. As students' solving behaviour gets socialised during a longer time, regular implementation of such tasks may help students to consider content-oriented approaches more often.

Besides confronting students with unknown tasks (Fanghaenel, 1984) or make them trying to solve every equation content-oriented (Sill et al., 2010), slight modifications of standard tasks can promote this type of solving, too. The additional solutions are a fruitful element in a class discussion. So all students are able to see how equations can be solved in a different way and with more insight. These slight modifications can be created easily; therefore this approach to promoting content-oriented solving is a realizable one. Arcavi, et al.'s (2017) demand for more alertness and flexible use, when solving an equation, can be met by having such slightly modified tasks. When students are to solve similar tasks in the same content-oriented alternative, this approach might become a routine.

However, it is still better having students to choose between two routines than only having one. To prevent such behaviour, suitable tasks for content-oriented solving should be varied appropriately.

The aim of this paper is not to lower the importance of using routines. They are a necessary part of mathematics lessons. The intention is to break the dominance of using algorithms by helping students to be more reflective about a given structure and making them think about it. Then, when looking at an equation, instead of initially starting the routine, a(n) (unconscious) process of consideration of how to solve it appropriately might be initiated. Suitable tasks for content-oriented solving are a possible and a realisable way to reach that goal.

References

- Arcavi, A., Drijvers, P., & Stacey, K. (2017). *The Learning and Teaching of Algebra – Ideas, Insights, and Activities*. London & New York, Routledge.
- Fanghaenel, G. (1976). Zu einigen Problemen der didaktisch-methodischen Gestaltung des Aufgabenlösens. *Mathematik in der Schule*, 8, 443–454.
- Fanghaenel, G. (1984). *Zum Arbeiten mit Aufgaben im Mathematikunterricht an den zehnklassigen allgemeinbildenden polytechnischen Oberschulen der DDR*. Berlin. Akad. d. Paedag. Wiss. d. DDR, Diss. B.
- Flade, L., Goldberg, E., & Mounnarath, V. N. (1992). Inhaltliches Lösen von Gleichungen – eine legitime Methode. *Mathematik Lehren*, 51, 15–18.
- Freudenthal, H. (1983). *Didactical Phenomenology of Mathematical Structures*. Dordrecht: Reidel Publishing Company.
- Kaput, J. (1989). Linking representations in the symbol systems of algebra. In S. Wagner & C. Kieran (Eds.), *Research issues in the learning and teaching of algebra. Research agenda for mathematics education: Volume 4* (pp. 167-194). Reston, VA: NCTM.
- Rosin, H. (1984). Inhaltliches Lösen von Gleichungen. *Mathematik in der Schule*, 22(1), 38–44.
- Sill, H. D., Kowalecko, E., Leye, D., Lindstädt, M., Pietsch, E., Roscher, M., & Sikora, C. (2010). *Sicheres Wissen und Können - Arbeiten mit Variablen, Termen, Gleichungen und Ungleichungen - Sekundarstufe I*. Institut fuer Qualitätsentwicklung Mecklenburg-Vorpommern.
- Zell, S. (2017). Zum inhaltlichen Lösen von Gleichungen in der Klassenstufe 10. *Beitraege zum Mathematikunterricht*. Muenster, WTM-Verlag, 1089–1093.

TWG04: Geometry Teaching and Learning

Introduction to the papers of TWG04: Geometry Teaching and Learning

Keith Jones¹, Michela Maschietto², Joris Mithalal-Le Doze³ and Chrysi Papadaki⁴

¹University of Southampton, School of Education, United Kingdom; d.k.jones@soton.ac.uk

²University of Modena e Reggio Emilia, Dipartimento di Educazione e Scienze Umane, Italy; michela.maschietto@unimore.it

³Université de Lyon, S2HEP, ESPE de Lyon, France; joris.mithalal@ens-lyon.org

⁴Universität Bremen, AG Didaktik der Mathematik, Germany; chrysi@uni-bremen.de

Keywords: Geometry education, instruments, proof and argumentation, spatial skills, visualization.

Introduction

Around 25 participants attended the Thematic Working Group 4 sessions during CERME 11. 75% of them were Europeans, and the other 25% came from the Middle East or from Australia. Five discussion sessions were dedicated to specific topics (manipulation, artifacts, visualization, teacher education), and each contribution (in total 18 papers and 3 posters) was presented and discussed during 20 minutes. The last two sessions were dedicated to small-group debates that supported the writing of the final report that was presented on the final day of the conference.

The call for papers, the contributions, and the discussions, addressed classical issues in geometry education such as the role of manipulation, instruments, investigation and modeling, the ways of describing and training visualization processes or spatial skills, and the role of language in geometry, including problem solving, argumentation or proof. It appeared that the multiple frameworks or methods that helped in addressing these issues were sometimes very close, or sometimes shed different lights upon the phenomena we observed. In order to benefit from these multiple viewpoints, we decided that, rather than summarizing our work following each initial issue, we should identify general questions that reflected the heart of the discussions; these were:

- How is it possible to describe how space intervenes in “doing geometry”?
- What is at stake in learning geometry, from cognitive and didactical points of view?
- Which transversal competencies have to be taken into account in the teaching of geometry, and how are they interrelated?

The way we addressed these questions shows continuity in the group’s work across the CERME conferences. Schematically speaking, we could say that CERME 8 was more about what geometry is, CERME 9 about what is at stake when doing geometry, and CERME 10 about the various theoretical approaches of these questions. We built our discussion on this basis. We managed to address more efficiently these questions, and to understand better the similarity or complementarity of the participants’ points of view.

Space in “doing geometry”

One of the toughest theoretical issues was about space, and the mutual understanding between psychology and mathematics education. We identified during CERME 11 that, on the one hand,

psychology considered that visualization was a part of “spatial skills” and that, on the other hand, to mathematics education spatial skills were a part of the visualization process. It seemed that this was not only a matter of word meaning, and we tried to investigate these opposite points of view.

We used the identification by Perrin & Godin (2018)¹ of three spaces involved in doing geometry: the physical one, the graphical one, and the geometrical² one (see Fig. 1). In a way, geometry consists in establishing relations between these spaces, and solving geometry problems needs to “grasp space” and to make the information usable in another kind of space.

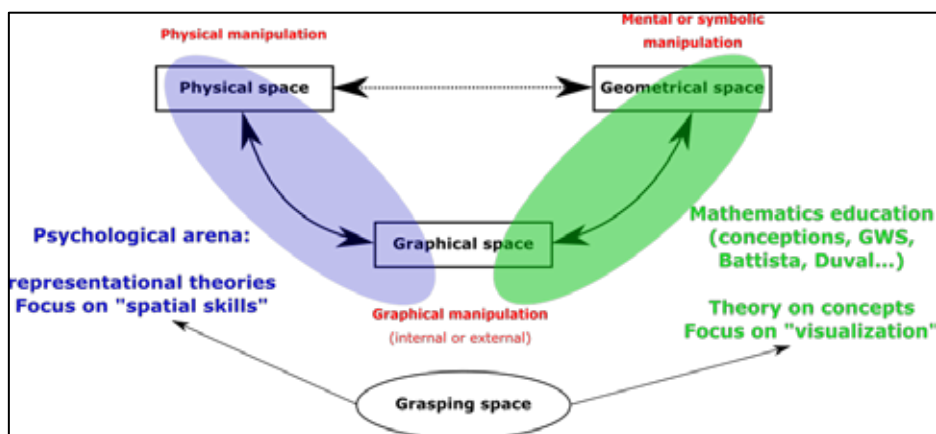


Figure 1: three spaces involved in doing geometry, two points of view on it.

On the one hand, psychological points of view in the group (see Heil; Conceição) were mainly used in order to explore the articulation between physical and graphical space: How do children manage to represent physical space? What are the difficulties? How does it intervene in their solving physical space problems? This point of view put forth representational issue. Visualization is one of the ways to grasp and interpret information; then it is no more than one of the components of the spatial skills.

On the other hand, mathematics education traditionally focuses on the links between graphical and geometrical space. The main issue is the correct use of graphical information to elaborate concepts or to work on ideal objects, or the graphical representation of idealities (see previous TWG4 reports and Downton; Gridos; Jones; Palatnik). In this way, visualization also embraces geometrical knowledge or specific treatments of graphical space. Spatial skills are one of the treatments performed on the graphical space, so in this case they are just a part of visualization.

This clarification aims at improving mutual understanding, and then collaboration, not only by explaining the discrepancies but also by identifying complementary issues and showing that these points of view are in fact two sides of general matters about space.

¹ Perrin-Glorian, M.-J., & Godin, M. (to be published). Géométrie plane : pour une approche cohérente du début de l'école à la fin du collège. In proceedings of the CORFEM, *Ressources pour la formation des professeurs. Savoirs mathématiques à enseigner au collège et au lycée*. A preliminary version is available on <https://hal.archives-ouvertes.fr/hal-01660837v2/document>

² By geometrical space, we refer to ideal objects and their relations, which are mainly elaborated by/in discourse.

We can add that we do not pretend that the relations between physical and geometrical space are not relevant, and some of the works presented in the group examined it (Favilla, Luppi & Maschietto). They highlighted the potential of such direct geometrical interpretation of physical experience, including an instrumental point of view. In this case, though, neither visualization nor spatial skills are at the core of the studies.

Learning geometry

The second main focus of our work was about “learning geometry”. It has to be noted that, even if specific learning topics were examined, the group discussions investigated how general competencies (such as creativity, flexibility, fluency, language, beliefs, etc.) may affect the learning of these specific topics (see Brunheira; Favilla; Gridos; Mendes; Palatnik). In this perspective, the role of everyday life, physical experience, manipulation or spatial skills in creating mental images or developing abstract concepts was more strongly highlighted than in the previous topic (Brunheira; Heil; Palatnik). The role of tools and artefacts was also discussed, highlighting, on the one hand, the limitation of their use (because of difficult instrumental genesis, but also for intrinsic reasons), and on the other hand, their potential, including higher education where it appears that tools, games, and manipulatives are very helpful but generally seen as something that is not needed (Bjørkås; Katter).

Language, and more specifically the emergence of geometrical lexicon, appeared as one great issue in the learning of geometry (Bulf, Favilla, Haj Yahya). Many contributions pointed out that constructing the meanings of the words used in geometry is a long and complex process that cannot be reduced to “vocabulary” issue. These meanings are the result of more general practices (including manipulation), negotiation, social interaction in problem solving contexts, combined to the cultural background – including everyday meaning that influences the understanding of the words. This dynamic and progressive learning of specific lexicon and meanings was coherent with the works on mathematical discourse, but it has to be noted that discourse itself was not studied in this case. This remains an open discussion field in this group.

It was connected to many contributions (Albano; Bernabeu; Brunheira; Gridos; Jones; Palatnik, Vieira da Silva) about argumentation, justification, reasoning or proving. This topic combined various levels of considerations, embracing the multiple facets of proof: required operation for proving in geometry (such as the analysis of figures as components and relations), relations between arguing, reasoning and justifying, or about the specific writing process that is required by formal proof. One contribution proposed a general overview, showing variations of the type of language used during the proving process.

Teaching geometry and teacher education

These two issues have been unified into one only discussion group, as many contributions addressed general topics, relevant for both of them. The participants raised four great topics involved in the teaching of geometry: problem solving, manipulation with tools (including drawings), visualization, and proof (see Fig. 2). Language has been added considering some contributions showing how it is linked to manipulation with tools and to visualization.

Some contributions used these topics to analyze precisely the pre-service and in-service teachers' geometrical knowledge, focusing on specific parts of the diagram we propose (Brunheira; Bulf; Nechache; Haj Yahya; Mendes). It has to be noted that the contributions mixed analysis about specific, local, geometrical knowledge, and more general concerns as described in Fig.2, in a very convincing way.

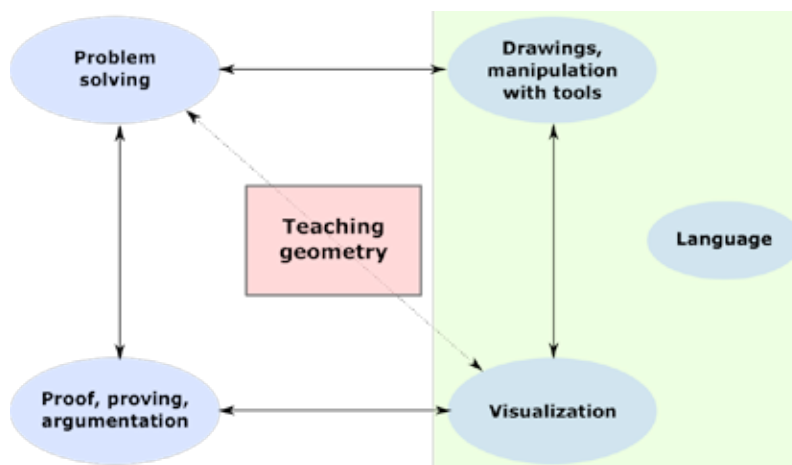


Figure 2. Topics involved in teaching geometry and teacher education

Other contributions proposed results about the relations between these topics (Bjorkas; Boavida; Bulf; Delgado; Mendes; Palatnik). The proving process needs the pupils to identify relations in the drawings, so both manipulation and visualization should be considered in the teaching of proof, and in the teacher training curricula. Moreover, by using specific artifacts (e.g. geoboard), by promoting specific strategies or by giving access to multiple solutions of a single problem, teachers promote efficient manipulation and visualization and, consequently, support solving problems skills development and the understanding of geometrical concepts. Then, teaching sequence design may take into account the relations we indicated in the diagram, and the difficulty to coordinate multiple poles of geometrical activity that was raised by some contributions, and by previous works in the group (e.g. about Geometrical Working Space or language). In a general way, this indicates that neither teaching nor teacher training should be only focused on mathematical contents or on a specific pole, but it should embrace the coordination between many of these poles.

Ultimately, we would like to mention that these general components involved in the teaching of geometry were less intertwined with specific topics, and then were helpful when examining how interactions with other fields (such as arts education) may be productive.

Perspectives and conclusion

As is clear in the papers that follow this introduction, the participants contributed to enrich the understanding of some classical issues in geometry education, and to develop more topical ones. We hope that a careful reading of these papers may also reflect that the work and the discussions promoted mutual understanding about both the frameworks and the issues they address. This seemed to be more productive than seeking a unified and unique framework, and we believe this to be a major contribution of CERME in general, to be continued over the next sessions of the group.

A computer-based environment for argumenting and proving in geometry

Giovannina Albano¹, Umberto Dello Iacono¹ and Maria Alessandra Mariotti²

¹University of Salerno, Italy, galbano.udelloiacono@unisa.it

²University of Siena, Italy, mariotti21@unisi.it

In this paper, we face the issue of argument and proving in geometry. Overcoming difficulties encountered by the students when moving from argumentation to proof may require suitable didactical interventions. Our contribution to research concerns the design of a specific computer-based didactic environment. We report how 14-15 years old students from high school conjecture and prove within the designed environment and we discuss the preliminary findings.

Keywords: Geometry, argumentation, technology integration, design.

Introduction and theoretical framework

For what geometry concerns, Sinclair, Bartolini Bussi, Villiers, Jones, Kortenkamp, Leung, & Owens (2016), among main strands of contributions to the geometry education they found in reviewing the literature since 2008, identified in particular the understanding of the teaching and learning of definitions and of the proving process. Geometry theorems are a logical consequence derived from an available theory, that is from a set of axioms, theorems previously validated, and definitions, necessary to avoid logical circularity (Fujita, Jones, & Miyazaki, 2018). As reported in the survey by Sinclair et al. (2016), one of the major threads in geometry education concerns understanding of the teaching and learning of definitions, in particular for triangle and quadrilateral.

Definitions comes into play when the students try to construct mathematical proofs, meant as “logical sequence of implications that derive the theoretical validity of a statement” (Mariotti, 2006, p. 182). Moore (1994) highlights that students do not necessarily understand the content of the definitions and how to use them (Moore, 1994).

Boero, Garuti and Mariotti (1996), while not denying the distance between argument and proof, do not consider it an obstacle. Researchers, in fact, highlight a continuity between argument and proof, called cognitive unity. During the problem solving process, argumentative activity usually produces a conjecture. The hypothesis underlying the concept of cognitive unity is that there is a continuity between the argument produced and the proof, which means that the argument can be used by the student in the construction of the proof, reorganizing it appropriately according to a logical scheme. In this sense, open problems (Arsac, Germain, & Mante, 1991), which require conjecture for their resolution, appear to be extremely effective in introducing the concept of proof, as the proofing process is favored by the argumentative one (Boero et al., 1996). However, the analysis of cognitive unity does not cover all aspects of the relationship between argument and proof. Pedemonte (2007) points out that cognitive unity does not take into account the structural continuity between argumentation and proof, when the inferences in argumentation and proof are linked together through the same structure (abduction, induction or deduction) (Pedemonte, 2007).

Difficulties can arise when moving from argumentation to proof, as it requires radical changes in the structure, such as moving from abductive to deductive structures. Facing such difficulties and overcoming them constitute an education goal that may require specific didactical interventions.

Our research study intends to contribute to this issue with the design and the experimentation of a specific didactic environment.

The experimental design

In the following, we are describing the experiment. The aim is to explore the educational potential of a certain working environment with respect to the process of producing conjecture and proving it. The setting of the environment have brought to identify three types of working environment that can be combined. In each of them we tried to create elements that would implement certain hypotheses, based on the theoretical framework.

Hypothesis 1. The use of open problems, i.e. problems where conjecturing is required. This is consistent with various studies (Arsac at al., 1991; Boero, Garuti, & Lemut, 1999; Hadas, Hershkowitz, & Schwarz, 2000; Pedemonte, 2008).

Hypothesis 2. The shift from spontaneous arguments - arisen during and/or after the process of producing a certain conjecture - to the proof may present some difficulties both in terms of reference system and in terms of structure. The formalization environment has been designed to provide support with respect to the expected difficulties. This latter hypothesis is consistent with the results of different studies based on the notion of cognitive unity (Pedemonte, 2002, 2007)

Hypothesis 3. The importance of exploratory talk in collaborative situations is crucial for improving the rise of conjectures and their formalization. This fits the dialogic approach in collective geometrical thinking (Fujita, Doney, & Wegerif, 2017). That is why the design foresees to alternate individual and social tasks where students act “as critical friends”.

The aim of our research study is that of exploring the educational potentialities of a computer-based environment with respect to support students in solving a conjecturing open problem, and subsequently providing a proof of the conjecture. According to the Hypotheses, a computer-based environment was designed offering an organized environment where students work alone and with peers for solving conjecturing problems, producing conjectures and their justifications and formal proofs.

In the following, we describe the main components of the computer-based environment, together with the rationale of their design, and an overview of the methodology; then we present some preliminary findings concerning only one of the three experimental settings.

The computer-based environment

According to Hypothesis 1 we selected a conjecturing problem:

Given a parallelogram ABCD, draw a parallel to the diagonal BD passing through one of the other vertices. Extend one of the sides of the parallelogram that does not contain that vertex until it meets the drawn parallel. Which quadrilaterals can be identified in this figure? What kind are they? Please justify your statements.

The student is required to construct the figure, following the given instructions, then to answer to the posed question concerning the identification of specific quadrilaterals and justify her conjectures. Starting from the parallelogram ABCD and drawing the parallel to BD through A, two different figures can arise: the first one obtained by extending the side BC (Figure 1.a) and the second one by extending the CD side (Figure 1.b).

The mathematical theory related to this problem concerns the definition of parallelogram, trapezoid and rectangle. It is expected that the students recognize the characteristics of a certain figure and use the definition in the direction that allows to derive the name of the figure from its characteristics.

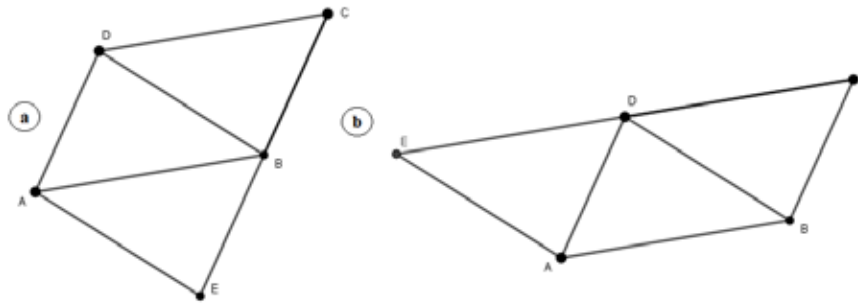


Figure 1: Two possible constructions

The computer-based working environment consists of three working spaces: *Working alone*, *Working with others* and *Assessing the others*, composed of various tasks, some individual and others social. In individual tasks the student does not communicate with her teammates and answers the proposed question herself. In social tasks the student answers individually but discusses with teammates in a forum (Figure 2). The computer-based working environment so designed exploits the potential of the Moodle platform in terms of built-in resources (Questions and Answers Forum, GeoGebra Task, Chat) and of integration of new digital applications (such as ISQ), together with the overcoming of space-time constraints. This allows the design of new activities, inconceivable without the use of the technology - level of Redefinition in the SAMR model (Romrell et al., 2014). Moreover, the automatic reports of the platform allow the teacher to take advantages of an augmented reality for what concerns the students' actions and thinking.

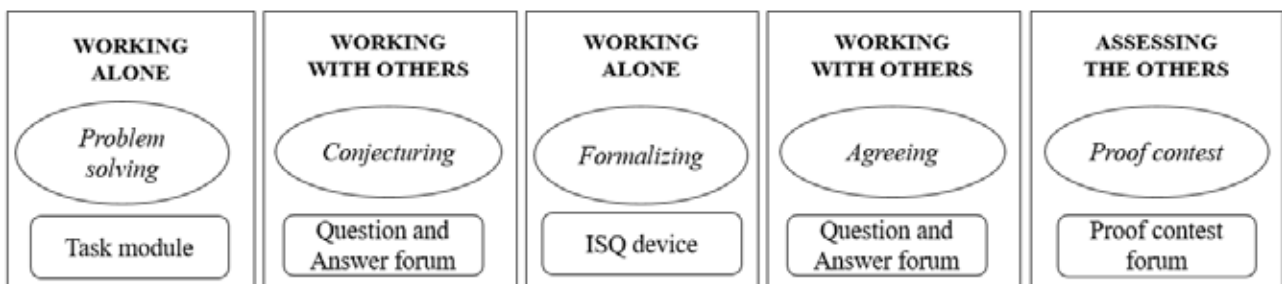


Figure 2: the design of the learning activity

We are detailing only the *Working alone* environment, on which we focus in this paper. It consists only of individual tasks, more precisely, the following two individual tasks:

- *Problem solving*: the student is asked to face the above problem. She is equipped with a “blank” GeoGebra page, predefined by the teacher/designer., suitably customized in order to show only the needed GeoGebra commands. The student submits her answer, consisting in: i) a figure constructed according to the given instructions, in particular the student is required to name the vertices fitting such instructions; ii) the identification of the quadrilaterals; iii) the justification of such identification. Using the Moodle *Task* module, the figure related to her GeoGebra construction is attached as the ggb file and the answer is given as a plain text in a blank box.
- *Formalizing*: the student is required to prove her conjectures reorganizing the justifications previously given according to a logical scheme. At beginning, the student is asked to choose one of the two figures shown in Figure 1, if it is the same of the one she constructed, or if it is not the case, she is required to upload her own ggb file. Therefore, starting from her own construction, for each quadrilateral identified, she is expected to prove her statements rearranging her own arguments into a logical chain. Such formalization is supported by a device consisting in a GeoGebra application, called ISQ (Interactive Semi-open Question), integrated into Moodle. It consists of digital language tiles that can be drag and juxtaposed in order to construct a sentence that represents the answer to a given question (Albano & Dello Iacono, 2018). In this case the ISQ has been enriched by some

fixed digital tiles constituting some kind of “Bank of Theory” which contains definitions, properties, theorems that are useful for proving the mathematical concepts at stake. In our case it contains only the definitions of parallelogram, trapezoid and rectangle. We have chosen to write the definitions, distinguishing explicitly between the two directions of the equivalence. This choice aims to make students aware of the existence of the two directions and of the fact that sometimes it is useful to use one direction and sometimes the other direction (Figure 3). For consistency, we always used the formulation “If ... then” and in particular indicated with Def #a the direction "If DEF then PROPERTY" and with Def #b the direction "If PROPERTY then DEF". The construct “If ... then...” has been implemented as “PROPERTY \Rightarrow DEF” and “DEF \Rightarrow PROPERTY”. Concerning the digital tiles, we have chosen to merge the verb “to be” to the next adjective if it has the meaning of “to have the property of” (e.g. “is isosceles” is equivalent to saying “has the property of being isosceles”). Moreover, causal conjunctions constitute digital tiles in themselves to highlight the causal structure.

DEFINITION OF PARALLELOGRAM				
Def. 1a: A quadrilateral is a parallelogram \Rightarrow it has the opposite sides parallel				
Def. 1b: A quadrilateral has the opposite sides parallel \Rightarrow it is a parallelogram				

DEFINITION OF TRAPEZOID				
Def. 2a: A quadrilateral is a trapezoid \Rightarrow it has two parallel sides				
Def. 2b: A quadrilateral has two parallel sides \Rightarrow it is a trapezoid				

DEFINITION OF RECTANGLE				
Def. 3a: A quadrilateral is a rectangle \Rightarrow it is a parallelogram with congruent angles				
Def. 3b: A quadrilateral is a parallelogram with the congruent angles \Rightarrow it is a rectangle				

A	B	C	D	E			
by hypothesis		by construction		Def. 3b	Def. 3a		
Def. 1a		Def. 1b		Def. 2a	Def. 2b		
is a trapezoid		is a parallelogram		is a rectangle	two		
is parallel to		sides		is on the same line as		the	
opposite		parallel		has	so	it	
in fact		then		because		by	and

Figure 3: ISQ in the Formalizing task

The ISQ contains several overlapped copies of each digital tiles, in order to let using the same tile several times. The available digital tiles allow to build various sentences that can be correct or not correct as well as complete or incomplete answers. The digital tiles, labelled with Def #, allow the production of sentences recalling definitions reported in the Bank of Theory (see on the left of Figure 3).

The methodology

We assume a design based approach with the intention to develop an artifact, i.e. the learning computer-based environment including new developed digital application such as ISQ, which is supposed to be optimized according to the findings of performed empirical studies.

In order to analyze the contribution of the various components of the computer-based environment, we decided to draw three different experimental settings:

- 1) a setting without collaboration but with the support of ISQ, i.e. *Working alone*, to understand the actual contribution of this ISQ device;
- 2) another setting in which students can collaborate with each other, but without the support of ISQ, i.e. *Working with others*, to understand the actual contribution of collaboration;
- 3) the complete setting, with the possibility for students to be supported in the individual phase by the ISQ and, subsequently, to collaborate with each other, so as to be able to observe the contribution of the toolkit and of the collaboration at the same time.

The experimentation involved 72 9th-10th grade students from two different scientific high schools, distributed into the above experimental settings according to the random choice of the teacher. All

the data have been collected by means of the platform's reports and they have been analysed from a qualitative point of view.

In this paper we focus on the setting *Working alone*, for investigating what the ISQ device shows about the students' way of reasoning. To this aim, we have compared the students' transcripts before and after the use of the ISQ device.

Preliminary findings

In this paper we focus on the ISQ device and its functioning within the Working alone setting. We report the analysis of the data and report some findings.

The analysis of the data shows interesting relationships between freely expressed arguments and the corresponding formalized arguments, organized through the use of the predefined digital tiles.

We will discuss in more details the outcomes of three students: Fromix, Antonio and Denisa. For each of them we are considering the figures they freely constructed by GeoGebra (first) and chose among the available (then) and their answer to the question posed by the given problem, in an open-answer mode (first) and by the digital tiles offered by the ISQ (then).

Let us analyze the answer produced by Fromix. He attaches the following GeoGebra figure:

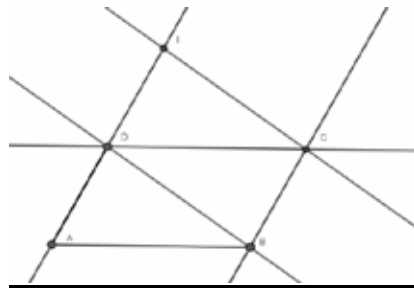


Figure 4: Fromix's GeoGebra construction

and writes the following in the available blank box of the Moodle Task module:

- 1 Fromix: We can highlight as many as 3 figures:
- 2 ABCD : that is the given parallelogram.
- 3 DBCI : another parallelogram, since it has pairs of sides congruent and parallel and we can also notice one of its 2 diagonals (DC).
- 4 AEBC : scalene trapezoid having a longer base parallel to the smaller one and 2 not congruent sides.

Then, Fromix chooses the Figure 1.b and, using the digital tiles (highlighted by grey background) provided by the ISQ, writes the following sentences:

- 5 Fromix: A E B C is a trapezoid by hypothesis because it has two parallel sides
- 6 A B C D is a parallelogram because it has the opposite parallel sides so by Def. 1a
- 7 D B C E is a parallelogram because it has two opposite parallel sides so by Def. 1a

Fromix individuates three quadrilaterals that he classifies as two parallelograms and a trapezoid according to their properties.

We can note that Fromix, moving into the Formalizing task through the use of the digital tiles, does not literally translate the statements freely produced. Some properties that appeared in the first

expressions are neglected, whilst the reference to the definition emerges. According to our hypotheses, the availability of specific digital tiles seems to have determined a shift of attention on the characterizing properties, that is having two parallel sides (row 5), disregarding the presence of two non-congruent sides (row 4). Fromix does not make explicit reference to the digital tiles of the definition of trapezoid. Thus we can interpret this phenomenon as a contribution of the ISQ device that induces the student to analyze the content of the definitions. However, the formalized version is not logically consistent: as matter of fact, it seems that she uses the definition 1a to derive the parallelism of the opposite sides.

Let us analyze the answer produced by Antonio. He attaches the following GeoGebra figure:

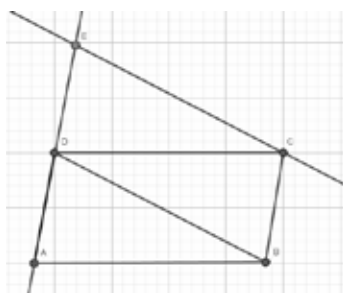


Figure 5: Antonio's GeoGebra construction

and writes the following in the available blank box of the Moodle Task module:

8 Antonio: In this figure it is possible to identify the following quadrilaterals: ABCD, BCED, ABCE.

9 The quadrilaterals ABCD and BCED are two parallelograms because the opposite sides (AB, CD- BC, AD-DB, CE-CB,DE) are parallel,

10 while the quadrilateral ABCE is a trapezoid because it has two parallel sides (AE,CB) and two opposite oblique sides (AB, CE).

Then, Antonio chooses the Figure 1.a and, using the digital tiles provided by the ISQ, writes:

11 Antonio: A B C D is a parallelogram by Def. 1.a

12 E A D B is a parallelogram by Def. 1.a

13 A D C E is a trapezoid because it has parallel opposite sides

We can see that Antonio, using the digital tiles, makes explicit reference to the definition of parallelogram given in the ISQ (rows 11 and 12). Anyway, switching from the free formulation to the one supported by the digital tiles, he loses one step of the argument and it remains unclear how the definition is used, i.e. which are the observed parallel sides needed to apply the definition (row 9), although the digital tiles would have been available to do that. On the contrary, comparing row 10 and 13, we can observe that the characterizing property is expressed but the reference to the definition is missing. Moreover, in any case, moving from the free expression to the formalization, any reference to the specific figure is lost. As in the case of Fromix, we can notice again that the ISQ device seems to divert attention from the non-parallel sides of the trapezium (row 10 and 13).

Let us analyze the answer produced by Denisa. She attaches the following GeoGebra figure:

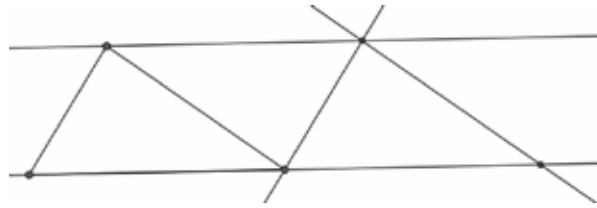


Figure 6: Denisa's GeoGebra construction

and writes the following in the available blank box of the Moodle Task module:

- 14 Denisa: In the figure there are two parallelograms,
 15 because by constructing the parallel to the diagonal BD and extending the side, we have the intersection of the two lines to form another triangle equivalent to half of the initial parallelogram.

Denisa uploads her own figure and, using the ISQ, writes the following sentences:

- 16 Denisa: A B C D is a parallelogram by Def. 1.a it has parallel opposite sides
 17 B E C D is a parallelogram by Def. 1.a it has parallel opposite sides
 18 A B C E is a trapezoid by Def. 2.a it has parallel opposite sides

In the free answer environment Denisa individuates two quadrilaterals, that she identifies as two parallelograms, providing a justification referring to the construction made.

In Denisa's case the change from the free response version and the ISQ-driven version is more evident than in the other cases. First of all, she notices a third figure (a trapezoid) who had not initially identified (rows 18). Furthermore, in the free answer she does not differentiate the two parallelograms and does not provide any real argument to justify the classification, just repeating the construction commands. On the contrary, in the ISQ-driven version, she names the parallelograms and provides arguments referring both to definitions and to the properties (rows 16-17-18). Similarly to Fromix, the use of definition is not logically consistent.

Discussion and conclusions

The previous analysis points out the influence of the ISQ device on the transition from the free expression to the formalized expression, as a matter of fact we can notice a change which highlights interesting elements. On the one hand, the students focus and select the relevant properties, neglecting the others ones, not distinctive. This can be interpreted as due to the availability of the definitions' formulation that shows only the distinctive properties. On the other, formalization is not a simple transcription but it implies a "logical" interpretation of what is expressed in natural language and a transcription of that interpretation into the language using the digital tiles and in particular the connective " \Rightarrow ". Here we can observe how the interpretation of why as explanation is translated by the connective " \Rightarrow ", even if this translation is not consistent with the formal language. What appears is the fact that all students (not only the ones reported above), in the transition to the use of digital tiles, use the wrong direction of the definition. It would seem that they interpret the symbol " \Rightarrow " according to the verbal structure used in the free formulation of the answer. More precisely, comparing the free explanations, it would seem that they reproduce the verbal structure "FIGURE is X because Y" as "FIGURE is X \Rightarrow Y". that is, they replace "because" with " \Rightarrow ", so that in the argument the premise follows the claim.

We want to underline that the logically correct use of the sign “ \Rightarrow ” is not spontaneous, nor the transition from the use of “because” in informal language to the use of “ \Rightarrow ” in formal language. The fact that the ISQ device makes evident such difficulty allows the teachers to identify such kind of obstacle and to intervene opening a discussion on the mathematical meaning of definitions.

Acknowledgment

We thank the teachers Carlo Celoro and Antonella Maffei of the IISS “Umberto Nobile – Roald Amundsen”, Lauro (Italy), and their students, who participated to the experimentation.

References

- Albano, G., & Dello Iacono U. (2018). DIST-M: scripting collaboration for competence-based mathematics learning. In Silverman, J., Hoyos, V. (Eds.): *Distance Learning, E-Learning and Blended Learning of Mathematics* (pp. 115–131). ICME-13 Monographs. Springer, Cham.
- Arsac, G., Germain, G., & Mante, M. (1991). *Problème ouvert et situation-problème*. Lyon: IREM.
- Boero, P., Garuti, R., & Mariotti, M. (1996). Some dynamic mental processes underlying producing and proving conjectures. In Puig, L. & Gutiérrez, A. (Eds.), *Proceedings of the 20th PME International Conference*, vol. 2 (pp. 121-128). Valencia, Spain: Universitat de Valencia.
- Boero, P., Garuti, R., & Lemut, E. (1999). About the generation of conditionality of statements and its links with proving. In *Proceedings of the 22th PME*, Vol. 22(2), Haifa, Israel, pp. 137- 44.
- Fujita, T., Doney, J., & Wegerif, R. (2017). Dialogic processes in collective geometric thinking: a case of defining and classifying quadrilaterals. In Dooley, T., & Gueudet, G. (Eds.), *Proceedings of the CERME 10* (pp. 2507-2514). Dublin, Ireland: DCU Institute of Education and ERME.
- Fujita, T., Jones, K., & Miyazaki, M. (2018). Learners’ use of domain-specific computer-based feedback to overcome logical circularity in deductive proving in geometry. *ZDM Mathematics Education*, 50(4), 1–15.
- Hadas, N., Hershkowitz, R., & Schwarz, B. (2000). The role of contradiction and uncertainty in promoting the need to prove in Dynamic Geometry environments. *Educational Studies in Mathematics*, 44 (1–3), 127–150.
- Mariotti, M.A. (2006). Proof and proving in mathematics education. In A. Gutiérrez & P. Boero (Eds.), *Handbook of Research on the Psychology of Mathematics Education: Past, present and future* (pp. 173-204). Rotterdam/Taipei: Sense Publishers.
- Moore, R.C. (1994). Making the transition to formal proof. *Educational Studies in Mathematics*, 27, 249–266.
- Pedemonte, B. (2002). Etude didactique et cognitive des rapports de l’argumentation de la démonstration en mathématiques. (Unpublished) *Thèse de Doctorat*, Université Joseph Fourier, Grenoble. <http://tel.archives-ouvertes.fr/tel-00004579/>
- Pedemonte, B. (2007). How can the relationship between argumentation and proof be analysed?. *Educational Studies in Mathematics*, 66(1), 23-41.
- Pedemonte, B. (2008). Argumentation and algebraic proof. *ZDM. The International Journal on Mathematics Education* 40, 385-400.
- Romrell, D., Kidder, L., & Wood, E. (2014). The SAMR model as a framework for evaluating mLearning. *Online Learning Journal*, 18(2).
- Sinclair, N., Bartolini Bussi, M.G., Villiers, M., Jones, K., Kortenkamp, U., Leung, A., & Owens, K. (2016). Recent research on geometry education: an ICME-13 survey team report. *ZDM. The International Journal on Mathematics Education*, 48, 691-719.

The evolution of 9-year-old students' understanding of the relationships among geometrical shapes

Melania Bernabeu¹, Salvador Llinares² and Mar Moreno³

¹University of Alicante, Faculty of Education, Alicante, Spain; melania.bernabeu@ua.es

²University of Alicante, Faculty of Education, Alicante, Spain; sllinares@ua.es

³University of Alicante, Faculty of Education, Alicante, Spain; mmoreno@ua.es

We conducted a teaching experiment of ten lessons with third-grade students (9-years-olds) to analyse the evolving understanding of the relationships among geometrical shapes. In the teaching experiment, pupils recognized, described, represented, built and classified two-dimensional figures. Analysis of pre-/post assessments showed some changes in students reasoning about how they began making sense of the relationships among the geometrical shapes. However, the use of formal definitions of geometrical shapes constituted a challenge for students since they imposed linguistics conditions to how the relationships among figures could be established. The results show that understanding the relationships among geometrical shapes is a slow process and depends on the logical terms used in the formal definitions.

Keywords: Geometrical thinking, primary school, geometrical shapes, relationships among geometrical figures.

Introduction

Students develop the comprehension of geometrical figures in a progressive way, initially, they recognise the figures by perceptual similarity, continue with the recognition of attributes and finally they base their thinking on concept based on the definition (Satlow & Newcombe, 1998). Recognizing attributes and relating them to make classifications is considered a relevant aspect in the development of geometrical thinking (Clements, Swaminathan, Hannibal, & Sarama, 1999; Elia & Gagatsis, 2003; Levenson, Tirosh, & Psamir, 2011). Classification of geometrical shapes, links to definition and the analyse of attributes of different geometrical shapes to distinguish between critical and non-critical attributes. Classification process can be hierarchical or partitive (de Villiers, 1994; de Villiers, Govender, & Patterson, 2009).

By the term hierarchical classification is meant here the classification of a set of concepts in such a manner that more particular concepts form subsets of the more general concepts. [...] In contrast to a hierarchical classification there also exists the possibility of a partition classification of concepts. In such a classification however, the various subsets of concepts are considered to be disjoint from one another (de Villier, 1994, p. 11–12).

It has been shown that students have difficulties in the transition from the recognition of the attributes and distinguish critical and non-critical aspects to perform classifications, especially hierarchical classifications of the quadrilaterals (Bernabeu, Moreno, & Llinares, 2018; Erez & Yerushalmy, 2006; Gal & Linchevski, 2010; Jones 2000). To try to better understand this transition in students' primary school, we investigated third-grade students' evolving understanding of the relationships among geometrical shapes, especially to know how pupils understand geometrical figures and establish

relationships among these geometrical figures, that is, consider whether a geometrical figure belongs or no to a figure class.

Theoretical perspectives

The relationship between levels of geometrical thinking and figure comprehension

According to Van Hiele's theory (Clements & Battista, 1992; Battista, 2007), the development of students' geometrical thinking is divided into progressive levels. The first three levels describe the process up to the comprehension of relationships among geometrical shapes:

- Level 1: Visual. Students identify the figures in relation to their appearance. To recognize figures, they do so through familiar prototypes (e.g. saying that a rectangle "looks like a door"). They are not aware of the properties of geometrical figures. The reasoning of students is dominated by perception.
- Level 2: Analytic/Componential (Battista, 2007). Students identify shapes according to their properties and they can characterize the figures by their attributes. Battista (2007) refined this level proposing three sub-levels. He theorized that students begin with "visual-informal componential reasoning" where they begin to focus on parts of shapes and doing visual, informal and imprecise descriptions. Pupils advance to "informal and insufficient-formal componential reasoning" where they use formal terms and informal descriptions, but they make definitions with unnecessary attributes. Occasionally, students advance to "sufficient formal property-based reasoning" where they make descriptions with formal geometrical terms for all the properties of the geometrical figures. The change from insufficient to sufficient definitions is a gradual shift from seeing the figures as a whole to focusing on the parts of these to see the figure as a coherent structure (Pegg & Davey, 1998).
- Level 3: Abstract/Relational. Students identify relationships among shapes and give informal arguments to justify their classifications (e.g., a square is a special type of parallelogram). They can discover properties of kinds of figures by informal deduction. Therefore, it is considered that the hierarchical classification is at this level.

The dual nature of geometrical figures

Tall and Vinner (1981) developed the ideas of concept image and concept definition. Concept image is used to describe, "the total cognitive structure that is associated with the concept, which includes all the mental images, properties, and associated processes" (Tall & Vinner, 1981, p.152). Concept image may include images that are inappropriate and contradict the definition of the concept (Hershkowitz, Bruckheimer, & Vinner, 1987; Vinner, 1991; Levenson et al., 2011). On the other hand, concept definition is "a discursive description to specify that concept" (Tall & Vinner, 1981, page 152) accepted by the mathematical community. One relevant aspect in the relationship between concept image and concept definition is to become to recognize the attributes of the definition as a sufficient condition. This dual nature of geometrical shapes in which concept and image are interrelated is underlined by the notion of "figural concept" (Fischbein, 1993).

In the understanding of this dual nature of geometrical figures, the sufficient conditions to recognize or to represent examples of geometrical shapes can be revealed by the transformations among various

semiotic representations. Duval (1995a, 1999) indicates how his theory of registers of semiotic representation can be used as a tool to analyse the cognitive processes through which pupils develop the geometrical thinking. Duval (2017) indicates that we can analyse the students' productions in terms of registers regarding the coordination between different apprehensions: perceptual, discursive and operative. Perceptual apprehension is the ability to recognize a figure in a global way; the discursive apprehension is the ability to link mathematical properties with the parts of the figure; and operational apprehension is the ability to modify or construct a figure to solve the task (change orientation, decompose it). Duval (1995b, 2006) defined two of such transformations: Treatment and Conversion. Treatments are transformations of representations that happen within the same register: for example, completing a figure using perceptual criteria of connectivity or symmetry. Conversions consist of transformations of representations from one register to another (such as from the visual register to the discursive one), without changing the objects that denote. The association of a figure with mathematical statements, can be done in both directions: from the visual to the discursive (from the figure to the definition) and from the discursive to the visual (from the definition to recognize the geometrical figure) (Duval, 1995b). This translation is the one that allows linking the process of defining a geometrical figure giving a minimum set of relevant attributes. However, there are no descriptors of the cognitive processes through which students develop the geometrical thinking. Therefore, we propose to identify descriptors of the development of geometrical thinking about geometrical figures in 9-year-old pupils, and specifically,

- How students understand geometrical figures and,
- How reasoning about the relationships among them?

Method

Context

Participants were fifty-nine third-grade pupils (9-years-old) from an elementary school located in an area of average socioeconomic status in Spain. This study was conducted as a teaching experiment designed to allow pupils establish relationships among geometrical shapes. A researcher of the research group performed the role of the teacher in both classes during the instruction.

Teaching experiment

In each class, we carried out ten sessions, two per week from May to June during the academic year 2017-2018. Pupils were asked for: recognizing and analysing attributes of different shapes, identifying critical and non-critical attributes, establishing relationships between attributes of shapes. They also had to represent and/or construct the shapes according to the given conditions or classify attending to criteria. Contents used during all sessions are shown in Table 1.

First week	First session. Polygon attributes: closed, straight and non-intersecting sides. Polygons according to the number of sides	Second session. Diagonals. Concave and convex polygons
Second week	Third session. Symmetry axis. Symmetrical figures	Fourth session. Acute, right and obtuse angle

Third week	Fifth session. Types of triangles according to their sides: equilateral, isosceles and scalene triangle. Hierarchical relations: the equilateral is an isosceles	Sixth session. Types of triangles according to their angles: acute, right and obtuse triangle
Fourth week	Seventh session. Types of triangles according to their sides and angles	Eighth session. Types of lines: parallel and non-parallel. Types of quadrilaterals: parallelograms, trapezes and trapezoids
Fifth week	Ninth session. Types of parallelograms: square, rhombus, rectangle and rhomboid. Hierarchical relations: the square is a rhombus, and the square is a rectangle	Tenth session. Properties of parallelograms: equal opposite sides and angles; diagonals cut in half

Table 1. Conceptual characteristics of the sessions of the Teaching Experiment

During the sessions, pupils built different shapes with resources such as *mecano* or geoboard. For working the classification tasks, we used digital board, so students could share their resolution with the whole group. Next, students individually solved other tasks. We used hierarchical definitions. For example, we defined the isosceles triangle as a triangle with two equal sides. In this case, we consider that an equilateral triangle is an isosceles triangle since it has two equal sides. Furthermore, we defined a trapezium as a quadrilateral with one pair of parallel sides. In this case, a parallelogram is a trapezium (British version) (Fujita & Jones, 2007).

For this report, data come from the initial and the final test. The aim was to get evidences about pupils' understanding of geometrical figures. Students' answers were codified and agreed by the research group. For the analysis of the data and the creation of the scheme of emergent codes that we generate from the answers of the students, we rely on van Hiele levels (Clements & Battista, 1992; Battista, 2007); Duval's theory (1995a, 1995b, 1999) that considers the transformations of the registers and the coordination of the apprehensions, the relationships between image concept and definition concept (Tall & Vinner, 1981), and the way that geometrical figures were related (to classify a shape in different ways and label it with different names) (Erez & Yerushalmy, 2006).

Results

The code schemes

The emergent coding scheme changed to accommodate the features that pupils included in their work and regarding the specificity of the tasks (Table 2). We compared the responses to the initial and final test and developed the emergent coded schemes as follow:

- *Students identified geometrical figures by their appearance*: what that it means that the recognition of geometrical figures is purely perceptual. For example, concerning to task 5: "It is a normal and ordinary triangle"; "The same figure as the " figure a"; "All the figures are triangular"; and in the Task 6: "Yes, because it is the same".
- *Students recognized some attributes of geometrical figures without establishing relationships among attributes that define the general set*: that it, students could recognize some attributes

of geometrical figures as number of sides, names of figures or types of figures, but they still made mistakes when they related them to its definition and perform relationships among geometrical figures. The apprehensions are not still coordinated correctly. For example, in task 5: “It has three vertices”; “It is a triangle”; and in task 6: “It has four sides”; “It is a square”.

- *Students were able to establish relationships among figures by recognizing that a figure belonged to a general set.* That is it, pupils related the definition to the parts of plane shapes to realize relationships (hierarchical and partitive relations). They began to coordinate the apprehensions. For example, in the hierarchical relation, concerning to task 5: “Yes, because an equilateral is an isosceles” and in task 6: “Yes, because at least has 2 parallel sides”. Conversely, regarding partitive relation, in task 5 a pupil said: “No, because an equilateral is not an isosceles” and in task 6 another said: “No, because it has all parallel sides” (not including the parallelogram as a trapezium).

Initial and Final test: Progression of thinking about relationships among geometrical shapes

To report the progress of the understanding of plane geometrical figures, we present the answers to two tasks from the initial and final test. In both tasks we had a "Drawing Machine" that could make a set of figures with common conditions (Battista, 2012). In one task, we provided a set of isosceles triangles (a triangle with two sides equals) that the machine could make and a set of scalene triangles (triangles with the three sides different) that the machine could not make. The question was that if the Drawing Machine (Figure 1) could draw an equilateral triangle (visual example).

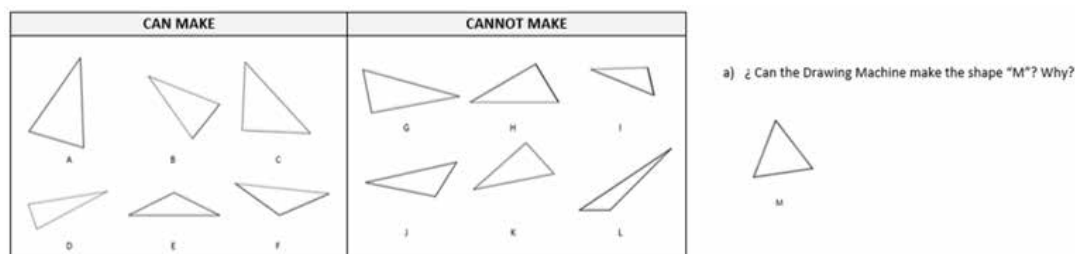


Figure 1. Figures of Triangles in the Task 5

In another task, a verbal description of the shape was given: The Drawing Machine can make “quadrilaterals (polygon with four-sided) with two parallel sides” and it was asked if the parallelogram (square) (visual example) could be made by the machine (Figure 2).

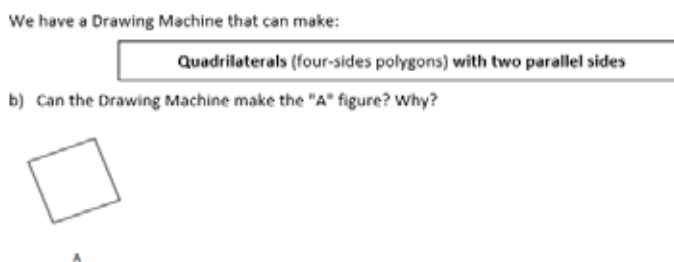


Figure 2. Figure of Quadrilateral in the Task 6

These tasks tried to show how students establish relationships among figures and use the logical relationships among the attributes identified in the figure. In this paper, we present the frequencies of

codes of both tasks (118 answers, that is, 59 of each task) that reflect the progress from perceptual to analytic recognition, and the initial understanding of the relationships among figures (Table 2). The frequency of the students' answers has shown a development in the reasoning of elementary school pupils about geometrical figures and it has also shown how they reason about the relationships among these figures.

Codes (n=118)		Initial-Test	Final-Test
1. Students identify the figures in relation to their appearance		26 (22%)	12 (10%)
2. Recognize some attributes of geometrical figures (but without established relationships with attributes that define the general set)		28 (24%)	48 (41%)
3. The relationship among figures (recognize a figure belong to a general set)	3.1. Recognize the attribute defines the set (recognize hierarchical relationship)	10 (8%)	26 (22%)
	3.2. Recognize the only partitive relationship	2 (2%)	7 (6%)
4. Others (meaningless or blank answers)		52 (44%)	25 (21%)

Table 2. Frequency of codes

The development of the understanding of geometrical figures

Analysis of data has shown that students have modified their way of reasoning from the initial test to the final. First, the purely perceptual recognition decreased from 22% to 10% after the teaching experiment. Also, the recognition of attributes in the figures presented in both tests increased from 24% to 41%. On the other hand, concerning the relationships among geometrical figures, it has been possible to verify how in the final tests, these relationships have been accentuated, since in the hierarchical relations had 8% in the initial test, and this rose to 22% in the final test. Regarding partisan relationships, these results rose by 2% in the initial to 6% in the final test. On the other hand, another positive data is the decrease of the frequencies in the code of "others", in which we coded answers that did not make sense with what was demanded in the statement or this was blank. This code decreased by 44% in the initial test to 22% in the final. In conclusion, the frequencies of the final test, compared with the initial test, provide us with information to intuit that pupils begin to develop their understanding of geometrical figures.

Reasoning about the relationships among geometrical figures

Initially, 12% of the answers were linked to the relationships among geometrical figures to the general set provided in the tasks. However, after the teaching experiment this percentage increased to 33%, where it was intended to develop the recognition of the critical attributes of the figures so that they could make relationships among geometrical figures. Of this total, regarding the hierarchical relations, the answer increased from 8% to 22%. Regarding to partitive relations, it increased from 2% to 6%. These data lead us to think that students begin to develop the relationships among geometrical figures.

Discussion

The aim of this study is to know how students understand geometrical figures and how they reason about the relationships among them. We used a teaching experiment to check how geometrical thinking evolved if we introduced vocabulary and definitions related to hierarchical relationships. As well as, we analysed two tasks, from an initial and a final test, to verify this development of the understanding of geometrical figures. Data has shown us that many pupils answered the tasks perceptually without considering the relationships of the figures or the definition of the concept, in the initial test. In contrast, after the teaching experiment, in the final test, most of pupils began to identify attributes to the plane geometrical figures and to reason about the relationships among them. These data lead us to think that the development of the understanding of geometrical figures is progressive (Pegg & Davey, 1998; Satlow & Newcombe, 1998).

From these data, we have been able to begin to comprise the progress of the understanding of the plane geometrical figures in relation to Duval's theory (1995a, 1995b, 1999). Because students at the beginning did not know how to coordinate the apprehensions and after the teaching experiment, they began to coordinate the apprehensions making the necessary transformations, the relationships among attributes and the use of minimum attributes of the definition for doing the relationships among geometrical figures. In this way, while developing an understanding of geometric figures and how to relate them. They began to develop the personal figural concept (Fujita & Jones, 2007). Thus, we can intuit that the realization of the hierarchical classifications depends on the language that is used in the definitions of the geometrical concepts, which can help identify the minimum attributes to recognize a type of geometrical figure.

Acknowledgment

This research has been financed by Prometeo/2017/135 from Generalitat Valenciana (Spain).

References

- Battista, M. T. (2007). The development of geometric and spatial thinking. In F. K. Lester (Ed.), *Second handbook of research on mathematics teaching and learning* (pp. 843–908). Charlotte, NC: Information Age.
- Battista, M. T. (2012). *Cognition-Based Assessment & teaching of geometric Shapes: Building on Students' Reasoning*. EEUU, Heinemann.
- Bernabeu, M., Moreno, M., & Llinares, S. (2018). Primary School children's (9 year olds') understanding of quadrilaterals. In E. Bergqvist, M. Österholm, C. Granberg, & L. Sumpter (Eds.). *Proceedings of the 42nd Conference of the International Group for the Psychology of Mathematics Education* (Vol. 2, pp. 155-162). Umeå, Sweden: PME.
- Clements, D. H., & Battista, M. T. (1992). Geometry and spatial reasoning. In D. A. Grouws (Ed.), *Handbook of research on mathematics teaching and learning* (pp. 420–464). New York, NY: MacMillan.
- Clements, D. H., Swaminathan, S., Hannibal, M. A. Z., & Sarama, J. (1999). Young children's concepts of shape. *Journal for Research in Mathematics Education*, 30, 192–212.
- de Villiers, M. (1994). The role and function of a hierarchical classification of quadrilaterals. *For the Learning of Mathematics*, 14(1), 11–18.

- de Villiers, M., Govender, R. & Patterson, N. (2009). Defining in geometry. In T. V. Craine & R. Rubenstein (Eds.), *Understanding geometry for a changing world* (pp. 189-203). Reston: NCTM.
- Duval, R. (1995a). Geometrical Pictures: Kinds of representation and specific processes. In R. Sutherland & J. Mason (Eds.), *Exploiting mental imagery with computers in mathematical education* (pp. 142-157). Berlin, Springer.
- Duval, R. (1995b). *Sémiosis et pensée humaine: Registres sémiotiques et apprentissages intellectuels* [Semiosis and human thought: semiotic registers and intellectual learning]. Bern: Peter Lang.
- Duval, R. (1999). Representation, vision and visualization: Cognitive functions in mathematical thinking. *Basic Issues for learning*. Retrieved from ERIC ED, 466-379.
- Duval, R. (2006). A Cognitive Analysis of Problems of Comprehension in a Learning of Mathematics. *Educational Studies in Mathematics*, 61(1&2), 103-131.
- Duval, R. (2017). *Understanding the Mathematical Way of Thinking – The Registers of Semiotic Representations*. London: Springer.
- Elia, I., & Gagatsis, A. (2003). Young children's understanding of geometric shapes: The role of geometric models. *European Early Childhood Education Research Journal*, 11(2), 43-61.
- Erez, M., & Yerushalmy, M. (2006). “If you can turn a rectangle into a square, you can turn a square into a rectangle”: young students' experience the dragging tool. *International Journal of Computers for Mathematical Learning*, 11(3), 271-299.
- Fischbein, E. (1993). The theory of figural concepts. *Educational Studies in Mathematics*, 24(2), 139-162.
- Fujita, T., & Jones, K. (2007). Learners' understanding of the definitions and hierarchical classification of quadrilaterals: Towards a theoretical framing. *Research in Mathematics Education*, 9(1), 3–20.
- Gal, H., & Linchevski, L. (2010). To see or not to see: analyzing difficulties in geometry from the perspective of visual perception. *Educational Studies in Mathematics*, 74(2), 163-183.
- Jones, K. (2000). Providing a foundation for deductive reasoning: Students' interpretations when using dynamic geometry software and their evolving mathematical explanations. *Educational Studies in Mathematics*, 44(1-2), 55-85.
- Levenson, E., Tirosh, D., & Tsamir, P. (2011). *Preschool Geometry. Theory, Research and Practical Perspectives*. Rotterdam: Sense Publishers.
- Pegg, D., & Davey, G. (1998). Interpreting student understanding in geometry: A synthesis of two models. In R. Lehrer & D. Chazan (Eds.), *Designing learning environments for developing understanding of geometry and space* (pp. 109–135). Mahwah, N.J.: Erlbaum.
- Satlow, E., & Newcombe, N. (1998). When is a triangle not a triangle? Young children's developing concepts of geometric shape. *Cognitive Development*, 13(4), 547-559.
- Tall, D., & Vinner, S. (1981). Concept image and concept definition in mathematics with particular reference to limits and continuity. *Educational Studies in Mathematics*, 12(2), 151-169.
- Vinner, S. (1991). The role of definitions in the teaching and learning of mathematics. In D. Tall (Ed.), *Advanced Mathematical Thinking* (pp. 65–81). Boston: Kluwer.

Measuring area on the geoboard focusing on using flexible strategies

Øyvind Jacobsen Bjørkås¹ and Marja van den Heuvel-Panhuizen^{1,2,3}

¹Nord University, Norway; oyvind.j.bjorkas@nord.no

²Freudenthal Institute, FBW, Utrecht University, the Netherlands

³Freudenthal Group, FSW, Utrecht University, the Netherlands; m.vandenheuvel-panhuizen@uu.nl

In this paper we report about a small-scale classroom experiment on teaching area measurement with a digital geoboard. The two-lesson teaching sequence that was developed, was tested in two sixth-grade classes and was aimed at teaching students using measurement strategies in a flexible way. The pre- and posttest data were analysed both on task and student level. The results show that most of the students developed more flexible strategies, but many of them did not use them accurately. Our results indicate that apart from working on the ability of students to find correct answers, also the flexible use of strategies can be realized through education.

Keywords: Measurement, area, digital geoboard, strategies.

Introduction

Students often say that area “is length times width”. This suggest both that the conceptual understanding of area is lacking, and that they only have one strategy available for finding the area of figures, even if they have learned about finding area by counting units earlier: “It [...] is typical of many learning processes, especially in mathematics – that the original sources of insight have been clogged, and the way back to insight is blocked by the processes of algorithmising and automatising.” (Freudenthal, 1983, p. 209). In the new curriculum for Norwegian primary school, in-depth learning is important, and among other things the students are expected do “construct a robust and flexible understanding” (Ministry of Education and Research, 2015). Therefore, it is important to develop teaching that supports the learning of flexible strategies for area measurement.

Theoretical framework and research question

Knowledge about measuring the area of polygons consists of both conceptual and procedural knowledge which are mutually supportive and should both be fostered (Rittle-Johnson, Schneider, & Star, 2015). Having a good understanding of measuring area means that students have several strategies available to determine the area of polygons. For example, they may count square units and/or half square units, make a multiplication to find the area of rectangles, decompose polygons into smaller, simpler polygons and use addition, may embed a polygon into a larger, simpler polygon and use subtraction, and may be able to apply a formula to calculate the area. Essential is that students can apply these strategies in a flexible way fitting to the problems at hand. However, there is evidence (Huang & Witz, 2011) that primary school students fail often in area measurement problems and have difficulties in flexibly handling area measurement problems. According to Huang and Witz (2011) this finding is considered to be linked to the emphasis that in teaching is put on formula memorization rather than on conceptual understanding and explaining your reasoning. Further, students who develop flexibility in problem solving use or adapt existing strategies to unfamiliar problems, and show a greater understanding of concepts (Star, Rittle-Johnson, Lynch, & Perova, 2009). Therefore,

it is important to investigate how students' flexible use of strategies in measuring area and their awareness of using them can be supported.

Most of the research on strategy flexibility or strategy adaptivity has been on mental calculation (e.g., Threlfall, 2009; Verschaffel, Luwel, Torbeys, & Van Dooren, 2009) or on solving non-routine word problems (Elia, van den Heuvel-Panhuizen, & Kolovou, 2009). In the study of Verschaffel et al. (2009) a distinction is made between task, subject, and context adaptivity of strategies. In the present study we built on this research and explored how task flexibility of strategies for finding the area of polygons can be taught. We will not use the term "adaptivity" in this paper because although we will discuss appropriateness of strategies with the students, the main goal is to teach multiple strategies and discuss the relationship between them. Further, we will focus on inter-task flexibility in the tests (Elia et al., 2009), investigating whether students change their strategies from pre- to posttest.

One tool that is sometimes used for teaching measurement of area is the geoboard. However, there are only a limited number of empirical studies on this topic. For example, Bair and Cady (2014) observed that by means of a geoboard students could find Pick's theorem and the study of Britton and Stump (2001) showed that students could develop cut-and-paste strategies. To our knowledge, no research has been carried out to investigate whether the geoboard is suited to foster the development of flexible strategies. Therefore in this study our research question was: *Does working with the geoboard help students to use flexible strategies for measuring area?*

Method

To answer the research question, a small-scale classroom experiment comprising a pre-post-retention-test research design was carried in two sixth-grade classes with 46 students during the period of February-July 2017. For this experiment we designed and tested a teaching sequence of two 75-minute lessons on reasoning about area measurement based on working with a digital geoboard.

The digital geoboard ("Geoboard [Computer software]," 2017) is an app for a tablet or computer that resembles the physical geoboard. Students can manipulate polygons and write computations or explanations on the digital geoboard, and they can share their work with the teacher through a sharing platform ("Showbie [Computer software]," 2018) or show it on a projector in the classroom. This makes it possible to select and present students' strategies to emphasize the connections between different strategies and give value to different strategies for the same task.

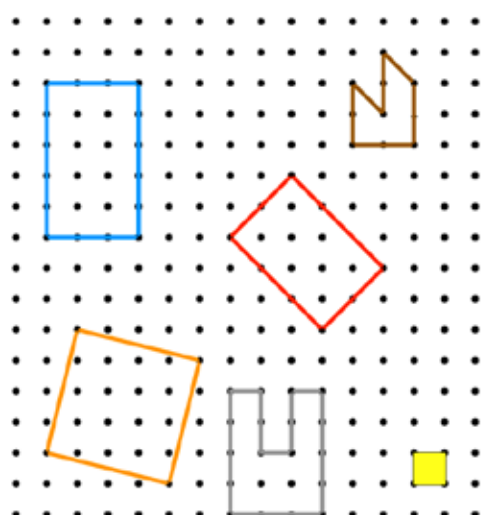
The lessons were taught by the researcher in the presence of the classroom teacher. In the lessons whole-class discussions led by the researcher were interchanged with students' individual work on the geoboard. In the discussions the use of different measurement strategies was stimulated, both strategies proposed by the students and strategies planned by the researcher, and students were made aware of the relationships between the different strategies. To support these relationships, the strategies were represented visually by drawings on the geoboard. To encourage students to think about their strategies it was emphasized that it is very important to be aware of the used strategy and that good understanding means that one can explain how the answer was found. This encouragement was given to the students both during their individual work and the whole-class discussions.

Type of task	Description	Task included in		
		Pretest	Posttest	Retention test
Blue task	Rectangle with sides parallel to the axes of the geoboard	Ü	Ü	Ü
Red task	Rectangle with sides 45° to the axes of the geoboard	Ü	Ü	Ü
Brown task	Polygon in which partitioning into triangles and squares can be used	Ü	Ü	Ü

Table 1: Overview of the tasks in the tests which are used in the paper

The pre-, post-, and retention tests were administered in Week 5, 7 and 22 respectively. They contained several types of measurement tasks presented on paper-and-pencil test sheets. Table 1 shows which type of task is included in which test. In every test, for each type of task the to be measured area was varied a bit in order to avoid retest effect.

Figure 1 shows an example of how the tasks in the retention test were presented to the students. The question asked to the students was: «Can you find the area of the shape? Write how you were thinking. You may use the picture to explain.». The yellow square was given as an area unit. On a next page the students were asked to give a justification for their result. During the pretest it turned out that after giving this prompt it was for most students easy to *say* what their thinking was, but writing this down was harder for them. Therefore, the teacher and the researcher made clear to the student that they just had to write down what they said orally.



Navn: _____

Den blå figuren har areal: _____

Vis hvordan du tenkte: _____

Den røde figuren har areal: _____

Vis hvordan du tenkte: _____

Den brune figuren har areal: _____

Vis hvordan du tenkte: _____

Figure 1: Test sheet with the polygons and the questions the students have to answer

The data from the test sheets were entered into NVivo. Both the students' measurement results and their explanations of the used strategies (see for examples Figure 2 and 3) were coded. When the

students found the correct area, the answer was coded as “1” and an incorrect answer was coded as “0”. Based on these codes we divided the students per task into four classes: the “00” students (incorrect answer in pretest and posttest), the “01” students (incorrect answer in pretest, correct answer in posttest), the “10” students (correct answer in pretest, incorrect answer in posttest), and the “11” students (correct answer in pretest and posttest). For coding the strategies, we used three main categories, namely “counting”, “multiplication”, and “restructuring” (decomposing or embedding strategies). Furthermore, we had two additional categories, namely “other” and “no strategy information available”.

Results

Table 2 shows for each type of task and for each test the percentage of correct answers. For all the tasks which were both in the pre- and posttest, the students improved their performance of which the most gain was obtained for the Blue task. In the retention test this progress continued only for the Red and the Brown task.

Type of task	% correct		
	Pretest (<i>n</i> = 43)	Posttest (<i>n</i> = 41)	Retention test (<i>n</i> = 43)
Blue task	70%	95%	88%
Red task	44%	51%	58%
Brown task	72%	80%	88%

Table 2: Percentage of students who gave correct answers to the different types of tasks

Even if the overall performance on each task was increasing, individual students showed both progress and deteriorating performance on each individual task. Using the red task as an example: Of the 36 students that participated on both the pre- and posttests, 11 students got the answer wrong on the pretest but right on the posttest, but 8 students got the answer right on the pretest but wrong on the posttest. Complete results are in table 3.

Type of task	Number of students belonging to a class of students			
	“00” student	“01” student	“10” student	“11” student
Blue task	0	8	2	26
Red task	8	11	8	9
Brown task	3	5	3	25

Table 3: Number of students (*n* = 36) belonging to a particular class of students split out for the three types of tasks included in the pre- and posttest

The next step in our analysis was figuring out what strategies the students used to find the area of the polygons and how flexible they were in using these strategies. We analyse the Red task as an example, because this is in our view the most interesting task that was on both the pre- and the posttest.

The strategies used in the Red task (see Table 4) were counting (in this case the number of squares and triangles), multiplication (length \times width; leading to mistakes because diagonal distances cannot be measured by counting), and restructuring. In the lessons it was made clear that this latter way of measuring the area for this task is very suitable, and we also showed why the multiplication strategy could not work easily.

Used strategy in the Red task in Pretest à Posttest	Number of students belonging to a class of students				Total
	“00” student	“01” student	“10” student	“11” student	
Counting à Counting	0	3	3	5	11
Counting à Restructuring	0	0	4	3	7
Multiplication à Counting	1	7	0	1	9
Multiplication à Restructuring	2	0	0	0	2
Multiplication à Multiplication	1	0	0	0	1
Other	2	1	1	0	4
No strategy in pre- and/or posttest	2	0	0	0	2

Table 4: Students' ($n = 36$) strategies in the pre- and posttest applied in the Red task

For this Red task, no student used the restructuring strategy before the lessons. Yet, after the lessons, nine students tried to apply this strategy, of which three got the correct answer. The work of one of these students is shown in Figure 2.



Figure 2: Test sheets of students using restructuring as a strategy applied in the Red task in the posttest resulting in a correct answer, and in the Brown task in the pretest making an error

The six students who got a wrong answer made various mistakes. Four of them give a clear explanation of the procedure of embedding the rectangle in a larger square and “subtracting what is in the corners which is not in the red [rectangle]”, but proceeded with computing the wrong area of the square (one student got 7×7 as a result) or computed the wrong area that had to be subtracted (three students). Of the other two students the source of the error is unclear.

The fact that four “10” students go from correctly using a counting strategy to making mistakes with a restructuring strategy, is possibly related to the value we gave to this strategy in the plenary parts of the lessons.

Task type	Strategy	Number of students belonging to a class of students				Total
		“00” student	“01” student	“10” student	“11” student	
Blue	Same	0	6	1	18	25
	Different	0	2	1	5	8
Red	Same	1	3	3	5	12
	Different	3	7	4	4	18
Brown	Same	1	1	0	16	18
	Different	1	2	1	2	6
Total	Same	2	10	4	39	
	Different	4	11	6	11	

Table 5: Number of students using the same or a different strategy in the pre- and posttest split out per task type

Table 5 summarizes the findings of the correctness of the answers per type of task and whether there was a change in strategy between the pre- and posttest. In the Blue and the Brown task more students retained the same strategy than in the other tasks. Moreover, they even did not change the strategy when they got a wrong result in the pretest. In the Red task more changes happened. Here 60% of the students changed their strategy. We see in this table that many students use different strategies in the pre- and posttest, for instance 18 students changed strategies in the red task, but 7 (3+4) did not come up with the correct answer.

Student’s strategy flexibility for the Blue, Red, and Brown task	Number of students (<i>n</i> = 22)
Using only one strategy	3
Not changing strategy between pre- and posttest but changing it over tasks	2
Changing strategy between pre- and posttest in one task	11
Changed strategy between pre- and posttest in two tasks	6

Table 6: Number of students who showed a particular strategy flexibility

Taking again the perspective of the students, we could identify for 22 students their strategy flexibility in the pre- and posttest over the Blue, Red, and Brown task. As it is revealed by Table 6, a few students only used one strategy, but most students changed their strategy from the pretest to the posttest. Note,

that in this analysis the students which applied a strategy that could not be classified or was not available in the pre- and/or the posttest are not taken into account.

Student's inter-task flexibility	Pretest	Posttest
Using the same strategy on all tasks	7	5
Using two different strategies	15	14
Using three different strategies	0	3

Table 7: Student's inter-task flexibility on the blue, red and brown tasks (N=22)

We also analysed whether students used the same strategies or different kinds of strategies on the three tasks on the pretest, and the same question on the posttest, to investigate the inter-task flexibility of the students. We see that the inter-task flexibility of the students have increased on the posttest relatively to the pretest (table 7).

Discussion

In this study, we investigated whether working with the geoboard could help students use flexible strategies for measuring area of polygons.

The problems on the pretest and posttest were routine in the sense that the polygons were shapes that the students could have worked with before. However, the problems were given on a grid and without rulers and calculators that the students might be use to have when measuring areas of rectangles. The students showed some inter-task strategy flexibility already at the pretest, choosing between multiplication and counting strategies. This is in contrast to the situation where students are given unfamiliar, complex problems, where the unfamiliarity and complexity of the problems may hinder the flexible change of strategies (Elia et al., 2009). However, the pretest also showed that some students chose inappropriate strategies, e.g. multiplication on tasks where this could not lead to a correct answer, even though they showed that they knew how to use a counting strategy that would have been appropriate.

Working with the geoboard, the students tried different strategies and shared with each other through whole-class discussion. They also tried the strategies that the researcher emphasized or introduced, e.g. counting or different rearranging strategies. The pre- and posttest results taken together (table 6 and 7) show that many students have developed their inter-task flexibility. Heinze et al. (Heinze, Marschick, & Lipowsky, 2009) raise the question whether the “investigative approach” that was used in the teaching, where students discuss and practice selected strategies, “prevent students from choosing strategies adaptively because they tend to ignore problem characteristics”. Because the posttest items are related to tasks which were discussed in the teaching, we can't address this question with certainty; however, the results show that many students on the posttest used more appropriate strategies e.g. on the Red task, even if they didn't use them accurately.

Conclusion

Considering that this was only a small-scale classroom experiment with an intervention consisting of only two lessons, it was hard to draw conclusions. Nevertheless, although the students did not substantially improve their performance in measuring area, we can say that we have experienced that most of the students were active in thinking and trying out strategies for measuring area which were new to them, so working with the geoboard and discussing strategies in whole class helped many students develop their inter-task flexibility for measuring area. This made us more aware that apart from working on the ability of students to find correct answers, also the development of the flexible use of strategies is an important goal in mathematics education to work on.

In further work, we will do a controlled design experiment where the teaching period is longer, to be able to compare working with the geoboard with the ordinary curriculum, and to give the students the opportunity to develop more accuracy and strategy adaptivity.

References

- Elia, I., van den Heuvel-Panhuizen, M., & Kolovou, A. (2009). Exploring strategy use and strategy flexibility in non-routine problem solving by primary school high achievers in mathematics. *ZDM - International Journal on Mathematics Education*, 41(5), 605–618. <http://doi.org/10.1007/s11858-009-0184-6>
- Freudenthal, H. (1983). *Didactical phenomenology of mathematical structures*. Dordrecht: Riedel Publishing Company.
- Geoboard [Computer software]. (2017). Math Learning Center.
- Heinze, A., Marschick, F., & Lipowsky, F. (2009). Addition and subtraction of three-digit numbers: Adaptive strategy use and the influence of instruction in German third grade. *ZDM - International Journal on Mathematics Education*, 41(5), 591–604. <http://doi.org/10.1007/s11858-009-0205-5>
- Huang, H. M. E., & Witz, K. G. (2011). Developing children's conceptual understanding of area measurement: A curriculum and teaching experiment. *Learning and Instruction*, 21(1), 1–13. <http://doi.org/10.1016/j.learninstruc.2009.09.002>
- Ministry of Education and Research. (2015). *The school of the future*.
- Rittle-Johnson, B., Schneider, M., & Star, J. R. (2015). Not a One-Way Street: Bidirectional Relations Between Procedural and Conceptual Knowledge of Mathematics. *Educational Psychology Review*, 27(4), 587–597. <http://doi.org/10.1007/s10648-015-9302-x>
- Showbie [Computer software]. (2018). Showbie.com.
- Star, J. R., Rittle-Johnson, B., Lynch, K., & Perova, N. (2009). The role of prior knowledge in the development of strategy flexibility: The case of computational estimation. *ZDM - International Journal on Mathematics Education*, 41(5), 569–579. <http://doi.org/10.1007/s11858-009-0181-9>
- Threlfall, J. (2009). Strategies and flexibility in mental calculation. *ZDM - International Journal on Mathematics Education*, 41(5), 541–555. <http://doi.org/10.1007/s11858-009-0195-3>
- Verschaffel, L., Luwel, K., Torbeys, J., & Van Dooren, W. (2009). Conceptualizing, investigating, and enhancing adaptive expertise in elementary mathematics education. *European Journal of Psychology of Education*, 24(3), 335–359. <http://doi.org/10.1007/BF03174765>

Justifying geometrical generalizations in elementary school preservice teacher education

Lina Brunheira¹ and João Pedro da Ponte²

¹Escola Superior de Educação do Instituto Politécnico de Lisboa and Instituto de Educação, Universidade de Lisboa, Portugal; lbrunheira@eslx.ipl.pt

²Instituto de Educação, Universidade de Lisboa, Portugal; jpponte@ie.ulisboa.pt

This paper reports research based on a K-6 prospective teacher education experiment carried out in a geometry course in the 2nd year of studies. The study aims to understand how participants justify generalizations about families of geometric figures in a context of exploratory teaching. Data were collected by audio and video records and from participants' written productions. In the analysis, special attention was given to the kind of arguments, their degree of generality, and the aspects that contribute for the learning of the justification process. The results show that initially the participants had difficulties in understanding how to justify generalizations. They progressed by using valid arguments, but they struggled in fully providing arguments and reasoning beyond specific cases. An improvement of justifications was achieved by the careful design of tasks, the interaction in the classroom and by relating the process of justification to understanding why a statement is true.

Keywords: Geometry, Reasoning, Justification, Generalization, Preservice Teachers Education.

Introduction

Lo and McCrory (2009) argue that prospective elementary teachers need to learn proof: a) as a tool to show or verify that something is true or false; b) as a mathematical object that is regulated by some rules and standards; and c) as a factor of students' development. These levels correspond to knowing how to proof, understand the nature of proof and to adapt proof to different students' developmental levels. However, Stylianides and Stylianides (2009) refer several studies showing that prospective elementary teachers have predominantly misconceptions about proof, particularly regarding the role of empirical arguments. Also Lin et al. (2012) add that, for many of these teachers, their belief in a result rests more on the authority of external entities than on their reasoning.

For Stylianides, Bieda and Morselli (2016), in the last decade, some research studies sought ways to support students in argumentation and proof, particularly in geometry. In teacher education, according to Lin et al. (2012), some studies suggest guidelines to improve the knowledge of prospective teachers in proof: solve tasks individually or in small groups; hold collective discussions; share and criticize one another's proofs; promote cognitive challenges. In geometry, the use of DGS and of suitable tasks may motivate the search for justifications to explain why conjectures are true (Christou, Mousoulides, Pittalis & Pitta-Pantazi, 2004). However, as Stylianides et al. (2016) suggest, in this area, there is still a need for research in designed interventions that focus on the development of prospective teachers' mathematical knowledge about proof. Assuming this, our paper addresses the need to support future teachers in the process of justification in geometry. Its purpose is to understand how they justify generalizations about families of geometric figures. We analyse the following questions: what kind

of arguments do participants use to justify generalizations about families of geometric figures? What are the obstacles and the facilitating aspects of learning to justify suggested by the experience?

Mathematical reasoning and the process of justification

Lannin, Ellis e Elliot (2011) consider mathematical reasoning as an evolving process of conjecturing, generalizing, investigating *why*, justifying and refuting assertions. For these authors, generalizing is about identifying common elements or extending the reasoning beyond the range in which it originated. Investigating *why* involves investigating factors that may explain why a generalization is true or false. A valid justification constitutes a logical sequence of statements, each relying on established knowledge, in order to arrive at a conclusion; it must use general language demonstrating that it applies to more than one particular case, even if it is based on generic examples. In the context of teaching, a successful justification shows that a statement is true and explains *why* it is true.

Considering this characterization, we find the concepts of justification and proof to be very close, which results from the several meanings attributed to proof, both in research in mathematics education (Stylianides et al., 2016) and in mathematics, where there are many conflicting opinions about the role of proof and what makes a proof acceptable (Hanna, 2000; Harel & Sowder, 2007). Stylianides (2007) presents a definition based on the literature on the philosophy of mathematics and mathematics education that addresses mathematics teaching from the first years of schooling:

A proof is a mathematical argument, a connected sequence of assertions for or against a mathematical claim, with the following characteristics: 1. It uses statements accepted by the classroom community (set of accepted statements) that are true and available without further justification; 2. It employs forms of reasoning (modes of argumentation) that are valid and known to, or within the conceptual reach of, the classroom community; and 3. It is communicated with forms of expression (modes of argument representation) that are appropriate and known, or within the conceptual reach, of the classroom community. (p. 291)

Considering that we focus on justifying¹ generalizations concerning geometrical objects, the statements must relate to the geometrical structure of the objects. In this sense, we call on the ideas of Battista (2009), suggesting that reasoning involves spatial structuring—a special type of abstraction corresponding to the mental act of constructing an organization or form for an object or set of objects by identifying its components, combining them into spatial composites, and identifying the way they combine and relate—and geometric structuring (GS), which describes spatial structuring using formal concepts. Also, we should also consider Balacheff's (1988) “generic example” as a form of reasoning particularly suitable for justifying geometrical generalizations, as it “involves making explicit the reasons for the truth of an assertion by means of operations or transformations on an object that is not there by its own right, but as a characteristic representative of its class” (p. 219).

Methodology

This paper addresses an investigation with an intervention, in order to change practices and enhance teachers' preparation in geometry. The research focus is on learning in context, starting from the

¹ From now on, instead of “proof”, we use the term “justification”.

conception of strategies and teaching tools, following a design-based research as methodology, in the form of a prospective teacher experiment (Cobb, Confrey, diSessa, Lehrer & Schauble, 2003) in which the teacher also plays the role of researcher. This approach is referred by Stylianides et al. (2016) as “a promising approach to respond to the need for developing effective ways to address students’ and teachers’ difficulties with argumentation and proof” (p. 344). Two of the design principles of the experience influence directly the tasks that we report in this paper: (i) make use of the intimate relation between sense making and the activity of reasoning and proving to promote learning with understanding; (ii) promote flexible reasoning, providing tools for prospective teachers, including different ways of justifying (Stylianides & Stylianides, 2006).

The data were collected during the second cycle of the study, involving a group of 25 trainees who attended a Geometry course (2nd year of the Basic Education Bachelor’s Degree). The tasks were solved in groups of 4/5 elements. Data gathered includes the participants’ records of two tasks solved in the classroom and audio and video recordings of the groups’ interaction.

We present a framework to analyse the justification of generalizations (Table 1) taking in account, first, the nature of the arguments regarding the geometric structuring of objects which relate mainly to the properties stated and, second, the degree of generalization of the justification.

Level	Argument’s nature	Properties / procedures	Degree of generalization
GS3	Based on the correct geometric structuring of the family of figures	States relevant and established properties	Uses a generic language about the family of figures
			It focuses on a generic example
			It focuses on one or more figures without generalizing
GS2	Based on the incomplete geometric structuring of the family of figures	States relevant and established properties, but omits others	Uses a generic language about the family of figures
			It focuses on a generic example
			It focuses on one or more figures without generalizing
GS1	Based on the incorrect geometric structuring of the family of figures	States irrelevant, non-existent or non-established properties	Uses a generic language about the family of figures
			It focuses on a generic example
			It focuses on one or more figures without generalizing
GS0	Without resorting to the geometric structuring of the family of figures	States numerical relations without connection to the structuring of the figures	It focuses on one or more figures
		Tests the generalization	It focuses on one or more figures
		Uses an external source of validation	Does not apply

Table 1: Levels for justifications of generalizations about families of figures

Results and discussion

In this section, we discuss results from two tasks, one about the congruence of the vertically opposite angles and another about the sum of the amplitudes of the internal angles of a polygon. In a previous lesson, the participants used GeoGebra to conjecture about these relationships, but they were not supposed to use it in these tasks.

Task A – Vertically opposite angles

Previously you discovered that two vertically opposite angles have the same amplitude. Find a justification explaining why this relationship is always true.

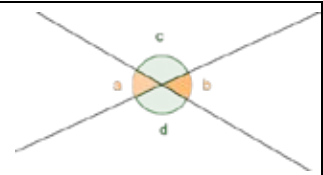


Figure 1: Task for the justification of the congruence of vertically opposite angles

This task was not the first asking for a justification involving angles, but it was the first one using a generalization in which no value was given, so the reaction of the participants was very different from the previous ones. There were only two written answers, one of them from Helena (Figure 2):

As the vertically opposite angles have the same vertices (the straight lines always pass through the same point) any way we put the straight lines (any orientation), the angles were always equal.

Figure 2: Helena's justification for task A

Helena's answer refers to a characteristic of vertically opposing angles, but her justification does not resort to geometric structuring because, by stating "any way we put the straight lines," she is drawing on her prior experience with GeoGebra. In this way, her justification implicitly refers to an external source to validate the claim, so the justification is incorrect (level GS0). Although based on empirical experience, the software represents the authority in which Helena trusts.

The other written answer is similar to most reactions, illustrated by the following dialogue:

Marina: They have to be equal because they have the vertex in common and the sides of one angle are the sides of the other.

Teacher: But what you are saying to me is almost the definition of vertically opposite angles. This statement does not justify the claim.

Marina: So how do we justify it?

In an attempt to help the group, the teacher suggests introducing a value:

Teacher: Imagine that a is equal to 30° . Try to find the values of the other angles without using the property.

Marina: Which property?

Teacher: The one that you want to justify. That vertically opposing angles are congruent. Find the other values from other relationships.

- Marina: Oh! So... c is 150... because adding a it gives 180 degrees. They are... supplementary.
- Teacher: OK...
- Marina: Then b is 30 because it is vertically opposite to a .
- Teacher: Attention! We agreed that we can not use this property. Do you understand why? You cannot justify that a property is true if you are using it in your reasoning.
- Marina: OK... Hum, b is 30 because it's supplementary to c , which is 150.
- Teacher: OK. As you can see you discovered the values 30 and 150 without using the property. Now, try to use a similar reasoning without using a specific value.

Marina shows some difficulties. On the one hand, she does not distinguish the characterization of the vertically opposing angles from the justification of their congruence. This problem may be due to the strong perception that angles have to be congruent by the way they are constructed. On the other hand, the simplified version of the problem using a specific value also shows that Marina does not know she cannot use the property she is seeking to. The group made an effort to continue the task, but they struggled to generalize the justification. Thus, this episode shows an answer based on an incomplete geometric structuring of the family of figures (EG2) which focused on a particular figure without generalizing.

Task B – Sum of the amplitudes of the internal angles of a polygon

You have found a generalization for the sum of the internal angles of a polygon using GeoGebra. Let's try to justify it. To do this, look at the following hexagons. Each one suggests a possible strategy. Use one of the strategies to write the justification.

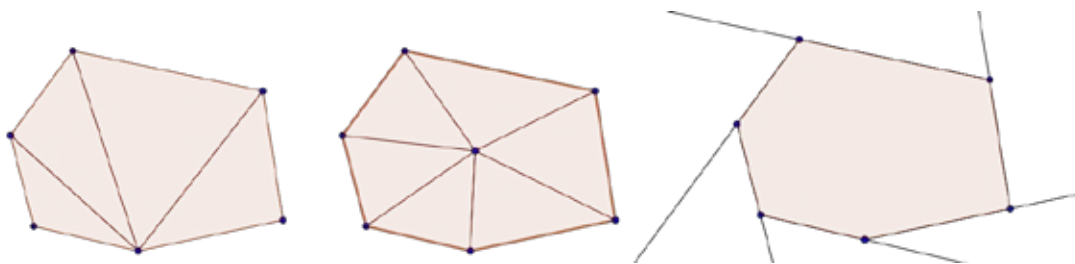


Figure 3: Task for justification of the sum of internal angles of a polygon

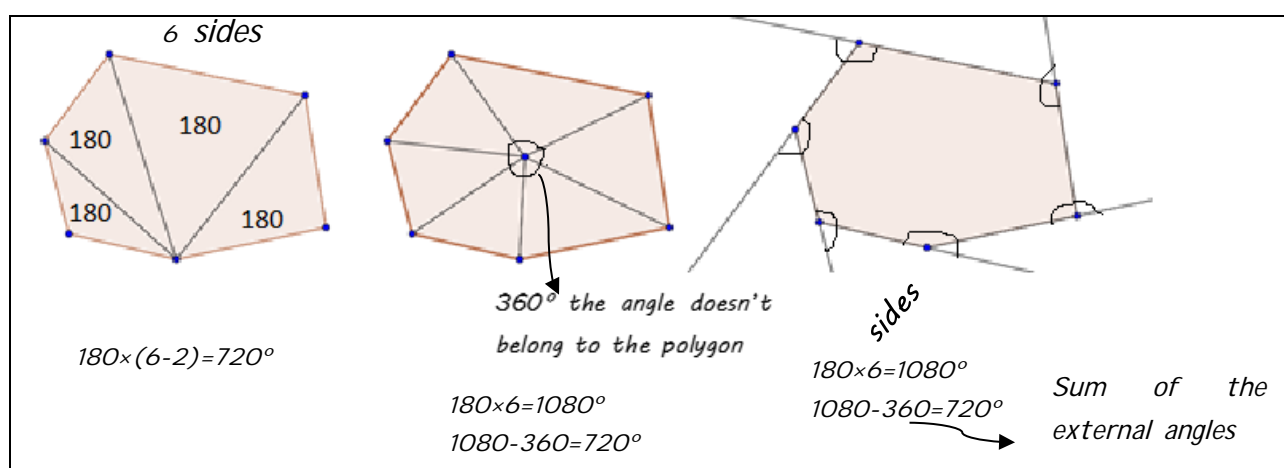
In the beginning, the prospective teachers struggled again with the absence of values because some thought that they would need the value of each angle, but the teacher then stressed that they should continue the strategies presented. This time, all the groups were able to produce some justification.

The first hexagon is divided into 4 triangles. All vertices of each triangle cover all the internal angles of the polygon. If we know that the sum of the internal angles of a triangle is equal to 180° , we can multiply 180 by 4 (4 triangles) and we obtain the amplitude of the whole polygon. The expression that generalizes is $(n-2) \times 180$. If a polygon has 10 sides, it is possible to draw 8 triangles; if you have 6 sides, we draw 4 triangles. If we have n sides, we draw $n-2$ triangles.

Figure 4: Celia's justification using the strategy of the first figure

Celia's answer (Figure 4) is based on the correct geometric structuring because it identifies two relevant properties (the sum of the amplitudes of the internal angles of a triangle and the decomposition the polygon into $n-2$ triangles). Celia uses the hexagon and the decagon with the intention to treat them like generic examples, because it explicitly indicates properties of the class. In this way, her justification is at level GS3².

All groups used the strategy initiated in the first figure, but most of them decided to follow the other strategies as well. The next answer (Figure 5) belongs to Anita:

**Figure 5: Translated reproduction of Anita's justification**

Anita's justification is based on a correct geometric structuring, using relevant and established properties, although she does not explain the relation between the number of sides of the polygon and the number of triangles. In addition, the properties concern only the case of the hexagon, which is not used as a generic example, and are not explained properly, so the justification is incomplete and refers to level GS2. The restriction to the hexagon is a common problem addressed by the teacher:

- Teacher: But that's for the hexagon. What about other polygons? For example, a decagon?
- Isabel: We use... 8 triangles. We took two sides.
- Teacher: So?
- Isabel: Exactly. Then it gives $(n-2) \times 180!$
- Andreia: And for the other we do 6×180 and then we take two triangles. 2×180 .
- Teacher: And why do you take the angles of two triangles?
- Isabel: Yeah... This is you forcing to give the same result...
- Teacher: That's it. If you have to take something, some value, that has to make sense...

² We are only considering the quality of the arguments regardless of language errors.

In this dialogue, we observe that the participants are trying to extend the first strategy to the second case without understanding why. When the teacher confronts them, they recognise their problem.

Conclusion

Task A showed trainees' difficulties related to two factors: the nature of the statement to be justified—a generalization—supported by a generic representation with no values; the principles of a justification, namely the impossibility of using a single example or relying on cyclic reasoning. The fact that the participants are able to solve a similar task by introducing a value shows that difficulties may not arise from the identification of relevant and established properties, but from the construction of an argument that applies this structuring to the entire family of figures. This means that the prospective teachers showed difficulties both in justifying and in understanding the nature of justification (Lo & McCrory, 2009).

The solutions of task B show a correct geometric structuring of the family of figures, using valid arguments, even if incomplete. Most justifications tend to be supported by specific examples, but in some cases, the participants try to present them as generic. The teacher suggests that the justifications shows why the relation is true and participants seem to accept that suggestion.

Thus, the two tasks show some differences with respect to the type of arguments used by the participants to justify generalizations, since they started to rely more on the correct structuring of the geometric figures. These differences may derive from the specificity of tasks, but may also correspond to a more correct conception of what a justification means. However, the solutions from task B show that there are two important aspects to attend. On the one hand, it is necessary to overcome the resistance in constructing an argumentative discourse, which we observe in justifications that are reduced to the schematic interpretation of expressions or visual representations, in order to value the communicative dimension of this process (Yackel & Hanna, 2003). On the other hand, it is important to raise the degree of generality of the discourse which, in some cases, is overly supported by particular examples and does not show that generalization applies to the whole domain of figures (Lannin et al., 2011). In fact, there is an unclear line between presenting a generic example that is representative of the domain (an acceptable strategy to justify) and supporting a justification by empirical examples, which corresponds to a common error and a misconception about the role of empirical results in the validity of a justification (Stylianides & Stylianides, 2009).

The results presented refer only to two tasks used to promote the ability to justify generalizations. However, they confirm the relevance of relating the process of justification to understanding why a statement is true, suggested by several authors (e.g., Harold & Sowder, 2007; Lannin et al., 2011; Stylianides et al., 2016). In particular, the design of tasks that promote the construction and confrontation of different justifications and representations, as well as an environment of peer interaction, seem to be contributing factors in the development of the ability to justify.

Acknowledgment

This paper reports a research developed within the scope of the project Geometric reasoning and visualization in a K-6 prospective teacher education program supported by the Centro Interdisciplinar de Estudos Educacionais – reference ESEXL / IPL-CIED / 2016 / A12.

References

- Balacheff, N. (1988). Aspects of proof in pupils' practice of school mathematics. In D. Pimm (Ed.), *Mathematics, teachers and children* (pp. 216–238). London: Hodder & Stoughton.
- Battista, M. T. (2009). Highlights of research on learning school geometry. In T.V. Craine & R. Rubenstein (Eds.), *Understanding geometry for a changing world* (pp. 91-108). Reston, VA: NCTM.
- Cobb, P., Confrey, J., diSessa, A., Lehrer, R., & Schauble, L. (2003). Design experiments in educational research. *Educational Researcher*, 32(1), 9–13.
- Christou, C., Mousoulides, N., Pittalis, M., & Pitta-Pantazi, D. (2004). Proofs through exploration in dynamic geometry environments. *International Journal of Science and Mathematics Education*, 2(3), 339-352.
- Hanna, G. (2000). Proof, explanation, and exploration: An overview. *Educational Studies in Mathematics*, 44, 5–23.
- Harel, G., & Sowder, L. (2007). Toward comprehensive perspectives on the learning and teaching of proof. In F.K. Lester (Ed.), *Second handbook of research on mathematics teaching and learning* (pp. 805–842). Greenwich, CT: Information Age.
- Lannin, J.K., Elliott, R., & Ellis, A.B. (2011). *Developing essential understanding of mathematical reasoning for teaching mathematics in prekindergarten-grade 8*. Reston, VA: NCTM.
- Lin, F.L., Yang, K.L., Lo, J.J., Tsamir, P., Tirosh, D., & Stylianides, G. (2012). Teachers' professional learning of teaching proof and proving. In G. Hanna & M. de Villiers (Eds.), *Proof and proving in mathematics education, new ICMI study series 15* (pp. 327–346). Dordrecht: Springer.
- Lo, J., & McCrory, R. (2009). Proof and proving in mathematics for prospective elementary teachers. In F.L. Lin, F.J. Hsieh, G. Hanna, & M. de Villiers (Eds.), *ICMI Study 19: Proof and proving in mathematics education* (Vol. 2, pp. 41–46). Taipei, Taiwan: Department of Mathematics, National Taiwan Normal University.
- Stylianides, A.J. (2007). Proof and proving in school mathematics. *Journal for Research in Mathematics Education*, 38, 289–321.
- Stylianides, A.J., Bieda, K. N. & Morselli, F. (2016). Proof and argumentation in mathematics education research. In A. Gutiérrez, G.C. Leder & P. Boero (Eds.), *The second handbook of research on the psychology of mathematics education* (pp. 315-351). Rotherham: Sense.
- Stylianides, G.J., & Stylianides, A.J. (2009). Facilitating the transition from empirical arguments to proof. *Journal for Research in Mathematics Education*, 40, 314–352.
- Yackel, E., & Hanna, G. (2003). Reasoning and proof. In J. Kilpatrick, W.G. Martin, & D. Schifter (Eds.), *A research companion to principles and standards for school mathematics* (pp. 22–44). Reston, VA: NCTM.

Professional actions of novice teachers in the context of teaching and learning geometry

Caroline Bulf

University of Bordeaux, Lab-E3D EA 7441, France ; caroline.bulf@u-bordeaux.fr

This paper aims to describe the professional actions of beginning teachers in the context of teaching and learning geometry. Using different theoretical tools, our research is based on the observation of lessons (with students aged between 6 and 11) delivered by beginning teachers in France. The paper seeks to show how the specific context of geometry impacts on professional actions especially among beginning teachers.

Keywords: Geometry education, teacher professional actions, beginning teachers.

The first part of the article describes the theoretical background and research questions. The second part is dedicated to the methodology and results from several observations of novice teachers in the context of teaching geometry. The final part of the article is an opportunity to discuss with new perspectives in the context of pre and in-service teacher training.

Theoretical framework in terms of *teacher professional actions*

This research takes part of a bigger collaborative research which deals with different fields (mathematics, literature, sciences...); the goal is to study conditions of development of teacher professional actions through the follow-up of a cohort of dozen of beginning teachers. In order to compare analyses we need a common theoretical framework, we describe it in next part.

Jorro (2002) distinguishes *generic teaching actions* from *professional actions*¹. The former are attached to a collective culture shared by a community such as stereotyped actions (*writing on the blackboard, calling a student up to the black-board, putting a finger to the lips meaning quiet, etc.*) while the latter are more a singular and contextual conception. We refer mainly to Bucheton and Soulé (2009) to define more precisely *teacher professional actions*. These authors define professional actions as teacher's acts (physical or verbal) and the permanent "adjustments" in relation to student activity and knowledge at stake. These authors describe their organization and dynamics through the "multi-agenda of entrenched concerns [our traduction]" (*Ibid.*, p.32; schema 1 for an adapted version). The five concerns are:

- *leading the lesson* (organization and coherence of the lesson, through its material, spatial and functional dimensions);
- *atmosphere* (maintaining dialogical spaces);
- *linking* (making connections with what pupils already know or connections between other knowledges);

¹ Our traduction from Jorro's original notions of « geste du métier » and « geste professionnel ».

- *scaffolding* according to Bruner’s meaning i.e. helping pupils do and say things without doing it for them (Bruner, 1983);
- the targeted *knowledge* (central component).

For us, professional actions are specific, situated, on a given context and moment, and led through didactical intention(s) (that means these “intentions” are more or less with direct and conscious links with the teaching project). It is important to notice now this theoretical framework’s goal is not about to give a binary classification generic/specific we refuse. What seems rightly interesting in the use of this general theoretical framework is that it can be mobilized in order to analyze any classroom session. Therefore, this is interesting in the cross of didactical analysis from different fields, which is the goal of the bigger research in which our collection of data fits. This paper deals with professional actions of beginning teachers in the context of teaching geometry.

Focus on beginners

In this framework, the dynamical organization of professional actions determines teachers’ “postures of scaffolding²” some of which can be exaggerated among beginning teachers. The “posture of control”, for example, is frequently observed because they try above all to organize their work in relation to time and space, without taking into account the students’ potential activity. “Linking is rare. Pupils are usually addressed collectively and the atmosphere is relatively tense [our traduction]” (Bucheton & Soulé, 2009, p. 40). Furthermore, Robert and Rogalski (in Vandebrouck, 2013) define teacher’s practices as complex, stable and coherent. According to these considerations, it is therefore relevant to study the practices of teacher since their beginning to better understand the conditions of genesis and development of professional teacher actions. Especially since the generic teaching actions have been identified as being the ones that beginning teachers will try to incorporate into their practices (Jorro, 2002). How do the teacher actions become professional and relevant? What impact do the specificities of teaching geometry have on the implementation and articulation of these actions? What impact on potential students’ learning?

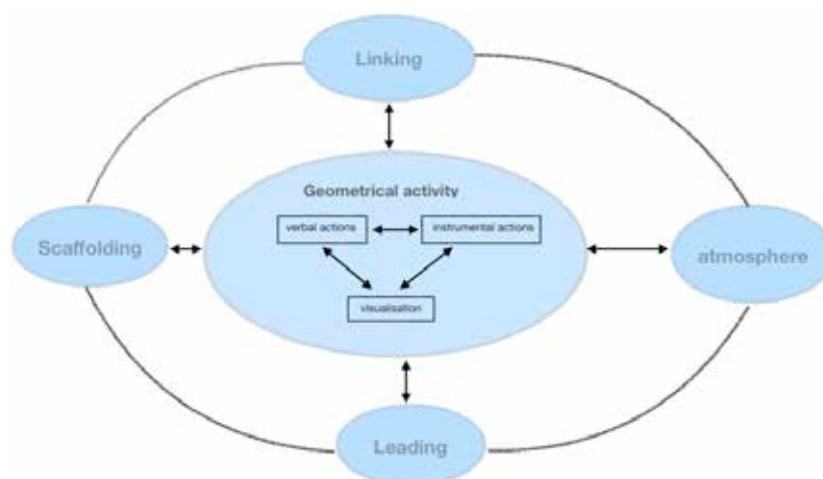
The specific context of teaching and learning geometry

A lot of works relate the difficulties of teaching and learning geometry. Indeed, geometry is unique and complex in terms of the role of material activity (using instrument, manipulation, modeling...), visualization and language for the construction of mathematical concepts, as described in previous CERME (Jones & Al., 2017). We assume in our work there are mutual influences (and not subordinated one to another) between visualization (according to Duval’s meaning, 2005), instrumental action (graphical register) and language (Bulf, Mathé & Miltalal, 2011). In doing so we seek to describe teacher’s actions more precisely in our analysis, taking into account the different manifestations of geometrical concept (graphical register, verbal formulation, coding, physical gesture, etc.). According to Duval’s framework (2005), we refer to the “dimensional deconstruction” to analyze geometrical object at stake in terms of figural units (2D for surface, 1D for line and 0D for point as intersection of lines), and relations between these different units. In

² “Accompaniment, control, letting go, teaching-conceptualization, magician” (Bucheton & soulé, 2009, p. 41)

other words, this is our additional and specific theoretical background to take into account the context of teaching and learning geometry.

The goal of this paper is to highlight the fact that professional actions are formed early (as mentioned at the beginning of this paper) but, depending on the task assigned to students in the context of teaching geometry, that they may hinder understanding of the geometrical concepts under consideration. We try to describe the reasons of these misunderstanding because, precisely, some professional actions could be, on the contrary, relevant in other context of teaching. That's why our theoretical framework seems particularly interesting because it contributes to show clearly the limits of dichotomy genericity / specificity of professional actions in pre and in-service teachers training. We summarize our theoretical framework in the schema 1. The central component (from Bucheton and Soulé' framework) is here the geometrical *knowledge* at stake, and therefore according to our theoretical framework, it is observed in activity through three dimensions: visual, oral and instrumental.



Schema 1. “multi-agenda of entrenched concerns” (Bucheton and Soulé, 2009, p.33) adapted to the context of teaching geometry.

The specific context of geometry teaching with beginning teachers allow us to highlight obstacles or potential levers to better understanding professional development of teacher. This paper tries to answer to the research questions : How do the specificities of teaching geometry (in terms of visualization, instrumental action and language) have an impact on the implementation and articulation of professional actions (schema 1) ? What impact on potential students' learning?

Methodology and results

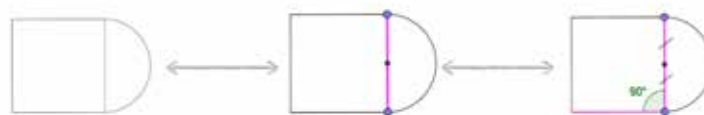
Our corpus is composed of several videos and transcripts of lessons, visit reports, professional writings, interviews, etc. collected during pre-service teachers and during the first years of practice of a dozen of beginning teachers since 2013. In the present contribution we chose to refer to the professional actions of three teachers, Maya, Emilie and Celine observed in 2016 and 2017. We

think these case studies are representative of novice teachers' practices in the context of teaching and learning geometry³.

Our analysis methodology is qualitative and based on classical models in the French field of didactics of mathematics, known as *a priori* or *a posteriori* analysis according to the Theory of didactical situations in mathematics (Brousseau, 1997). A *a priori* analysis is an epistemological reasoning which does not have a predictive sense, but instead a causal one; it involves describing various possible (and therefore potentially reproducible) phenomena in teaching session. Our *a posteriori* analysis places contingent facts in the context created by the *a priori* analysis. Furthermore, our data are analyzed in accordance with our theoretical framework, which means we describe geometrical activity (*a priori* and *a posteriori*) through its different manifestations: visual, instrumental or verbal (as already described in previous paragraph). We infer from these analyzes hypotheses in terms of professional actions as we have described in our general theoretical framework (schema 1). We pay attention on the different type of teacher's scaffolding, leading, linking and atmosphere own to these teachers in relation with the geometrical knowledge at stake.

Over-scaffolding through different dimensions (verbal / visual / instrumental) of geometrical activity

This episode is frequently encountered in classes ; it's about talking collectively about a figure on the blackboard. We refer here to a observation occurred in 2017 in Celine's class (with students aged 8 to 9). Students have to reproduce the figure given on the left extremity of the figures 1.



Figures 1. Different ways of seeing one side of the square

The different ways of seeing one side of the square as also the diameter of the half-circle⁴ is the key to solve this problem. It is necessary to go beyond a first vision as a simple border line between two juxtaposed figures:

- this side is perpendicular to 2 other sides (relationship between 2 objects of dimension 1D);
- this side is a segment, which is also a diameter of the half-circle. The middle of this segment is the center of the circle (different objects 1D and 0D, and their relationships).

These different ways of seeing this “simple” figure are not self-evident because it involves different figural units (lines, points) and different kind of relationships (belonging, middle, perpendicular,

³ Given what we have observed and analyzed so far in our previous researches and in the corpus for this research (corpus made up of a dozen novice teachers).

⁴ « double designation » (Duval, 2014, p.5) of a figural unit.

equal distance...). If we focus on the center of the circle, there is *a priori* a lot of different ways to understand it (without being exhaustive):

- a point belonging to the side of the square (which requires to see a line as a set of – infinite– points, but it is far from being acquired for students of this age);
- the middle of a segment of which the ends are the vertices of the square: here coexist two ways to see points (vertex / end of segment);
- the center of the circle is where we will put one branch of compass ;
- the center is the point located to equidistant from the line (or points) defining the half-circle;
- the center is the junction point of the union of two rays in the same direction (here);
-

At the beginning of the session, Celine tries to explain the task by making the students talk about the instrumented actions. It is kind of over-scaffolding without linking the different possible ways of seeing the side of the square and the center of the circle:

Celine: How do I put my compass on my square?

Student: on the board there is a line in the middle to put the starting mine in the middle of the line

Celine: then in the middle of the line you speak about side [She sweeps the side with a hand gesture and points the middle of the side, figure 2] okay what is it in relation with our circle /// you remember where he is the center of the circle? // How is it called? [Sweeps the side of a hand gesture like the moment before from top to bottom] /// all of this / yes it is the diameter / there [gap between the auriculaire and the thumb, figure 3] it is the radius / you remember the center of circle [pointing finger, figure 2] it is the middle of the diameter/ it shares the diameter in 2 radius.



Figure 2. physical gesture of pointing finger



Figure 3. physical gesture of finger spacing

In less than two minutes, there are 9 different oral designations (*square, side, line, diameter, radius, middle of the line, center of the circle, middle of the diameter, this-there*) and 3 different physical actions that all rely on the same graphical sign on the blackboard. The same sweeping movement of the hand sometimes refers to the diameter of the circle or the side of the square or the radius (if the amplitude is shorter). The pointing finger indicates at the same time where to put the branch of the compass, the center of the circle, the middle of the diameter, the middle of the side of the square, the junction between two rays. This kind of scaffolding, both verbal and physical, characterizes the

teacher's will to help student through multiple designations, reformulations,... and as the beginners think they should provide. But this exemple is, in our opinion, representative of potential misunderstandings on the construction of meaning through these teaching actions. Indeed, different ways of thinking of the same objects are consciously mobilized, but it is as if going from one vision to another is self-evident, without linking: we move from the designation of objects to their relationships and their operationalization through instruments. At this student's age all these connections are not yet built. Here we are one of classical teacher interventions in geometry teaching, not especially with novice... The big question is : how to manage the complex specificity of geometrical activity : *the way of seeing a figure, the way of acting* with geometrical tools or not, *the way of speaking* ? We refer here to researches already exposed in previous CERME (Bulf, Mathé, Mithalal, 2011) (Barrier, Hache, Mathé, 2013) ; they proposed different theoretical tools to analyse geometrical activity in this way.

Different impacts on students' learning from scaffolding on the necessary and sufficient conditions for building a square

Two novice teachers, Maya and Emilie, in 2016 prepared together a lesson (for students aged 8 to 9 years old). The students have to reproduce a square of 10 cm of side. At the end of the collective phase, both teachers chose to proceed by "dictation to the adult" that means students gives oral instructions and the teacher executes them to build the figure. An interesting moment happens when three sides of 10 cm and 2 right angles are correctly drawn at blackboard with expected geometrical tools. Both teachers ask to students « do we need set square to close the square ? » which is, in both cases, a spontaneous move. The question is : is it a relevant professional action ?

In Maya's class, she retains the one who talk about the set square to finish the construction. But Maya asks to students about the validity of another student's proposal who suggests to draw the line directly without the set square. This student, Nicolas, is also a student usually in difficulty.

Maya: Would Nicolas's technique have worked? Nicolas can you explain why it would have worked? [...] So you tell me we did not need the set square to draw the last line we could do directly with the rule to draw the last line.

The students do not validate Nicolas's technic because precisely it does not use the set square. On one hand they may reply this because it corresponds to what is worked precisely in this lesson, this is the didactical contract (Brousseau, 1997) and on the other hand probably because Nicolas is a student usually in difficulty... But here teacher's question is about the necessary and sufficient conditions for building a square, which is out of didactical contract for these students at this age. The teacher is stuck because Nicolas is right, it is mathematically correct. Therefore Maya chose to validate it and she concludes with theoretical argument: « As long as I have 3 sides of the same length and 2 right angles », which is, actually out of contract but in the same time it is also an opportunity to value this student (*atmosphere concern*).

Maya: Nicolas' proposal it would have worked / I connected well / I took my rule and my set square to do it but if I had connected this first line that I had done with it, it would have made me too the 2 right angles in the case ok where I already had the 2 right angles and the 3 sides which made the same length. Alright ... With my set

square I did the same thing as Nicolas proposes, I connected the 2 parts of the line, I did it with the square but we could do it directly with the rule .

Whereas in Emilie's class, Emilie also relies on a student's proposal but the student stands on a graphical argument that Emilie resumes directly : « yes you have already drawn both lines you need to connect» «I just have to connect». We stay in a primary school contract strongly linked to graphical register.

Conclusion, discussion and perspectives about pre and in-service teacher training

From the previous paragraph, we pointed out the necessary and sufficient conditions (here to recognize a square) are usually not anticipated by novice teachers and this may have a direct impact on teacher's scaffolding and therefore on student's learning. In one case, students may be confused at the end of the session on the contract at stake about the use of set square whereas in the other case, we stay in a contract in a paradigm of Geometry I (Kuzniak, 2018) that means validation is done within a graphical register.

This paper is also based on other case studies. We described at the beginning of the paper how Celine was overwhelmed by the managing of different dimensions own to geometrical activity (way of speaking, way of seeing and way of acting -with geometrical tools or not) about graphical figure. This is a typical novice's teacher action : novice teachers want to help students (when they give instructions at the beginning of the lesson) with multiple designations, reformulations,... but in the geometrical context, this may involve over-scaffolding through all registers in the same time (graphical, visual, discursive) and brings more confusion than help.

In previous work (Bulf 2016), we described how novice teachers try to play school teacher through the embodiment of « caricatural » teaching actions with an over-leading about rigor on semiotic representation of geometrical objects (vocabulary, coding, or quality of drawing⁵).

We believe these teacher's actions with novice teachers are actually not reserved for novices... That's why our research gives perspectives for pre-service and in-service teacher training to better understand the conditions of professional development in geometry teaching but not only. Our research in progress crosses results with other fields. We think this kind of research gives the opportunity to discuss the limit about a theoretical framework based on genericity of teaching actions. Indeed, in our different examples we may recognize teachers' actions shared by teacher community (*have students talk about the validity and rigor of their production; to explain in different ways the same thing ; to compare opinions between students etc.*) but it seems important to highlight the fact that these actions may be rich in potential misunderstandings in the context of teaching geometry. Even more, our study, in the context of teaching and learning geometry, suggests that it makes no sense to consider teacher's actions from a generic point of view because

⁵ This is quite typical for beginning teacher in France. We suppose that may come from the fact the competitive exam that these young teachers had to pass requires a theoretical and deductive hypothetico reasoning of the Euclidean geometry.

each teaching actions are always specific and connected to a specific knowledge which requires its own and specific actions. This opens the more theoretical discussion of theoretical frameworks that seek to model teaching activities.

References

- Barrier, T., Hache, C., & Mathé, A.-C. (2013). Seeing – acting – speaking in geometry: a case study. In B. Ubuz, Ç. Haser, & M. A. Mariotti (Eds.), *Proceedings of the Eighth Congress of the European Society for Research in Mathematics Education* (pp. 1458–1467). Antalya, Turkey: ERME.
- Brousseau, G. (1997). *Theory of didactical situations in mathematics (1970-1990)*, Dordrecht : Kluwer Academic Publishers. (N. Balacheff, M. Cooper, R. Sutherland, & V. Warfield, Trans. & Eds.). Dordrecht, The Netherlands: Kluwer.
- Bucheton, D., & Soulé, Y. (2009). Les gestes professionnels et le jeu de postures de l'enseignant dans la classe : un multi-agenda de préoccupations enchâssées, *Education et Didactique*, 3, 28-48
- Bruner, J. S. (1983). *Le développement de l'enfant, savoir-faire, savoir-dire*, Paris : PUF.
- Bulf, C. (2016). Etude didactique des gestes professionnels d'un enseignant débutant en formation, *Recherches en Didactiques*, 22, pp.43-64.
- Bulf, C., Mathé A.-C., Mithalal, J. (2011). Language in geometry classroom. In M. Pytlak, T. Rowland, & E. Swoboda (Eds.), *Proceedings of the Seventh Congress of the European Society for Research in Mathematics Education* (pp. 649– 659). Rzeszów, Poland: ERME.
- Duval, R. (2005). Les conditions cognitives de l'apprentissage de la géométrie : développement de la visualisation, différenciation des raisonnements et coordination de leurs fonctionnements. *Annales de didactique et sciences cognitives*, 10, 5-53.
- Jones K., Maschieto M., & Mithalal J. (2017) *Introduction to the papers of WG4: Geometry Education* in Dooley, T. & Gueudet, G. (Eds.), *Proceedings of the Tenth Congress of the European Society for Research in Mathematics Education (CERME10, February 1 – 5, 2017)*. Dublin, Ireland: DCU Institute of Education & ERME, 605-608.
- Jorro, A. (2002). *Professionaliser le métier d'enseignant*, Paris : ESF.
- Kuzniak, A. (2018). Thinking About the Teaching of Geometry Through the Lens of the Theory of Geometric Working Spaces. In *International Perspectives on the Teaching and Learning of Geometry in Secondary Schools*. Herbst P. et al. (eds), pp 5-21. New York : Springer.
- Vandebrouck, F. (Ed) (2013). *Mathematics Classrooms: students' activities and teachers' practices*, 264 pages, Rotterdam : Sense Publisher.

A model of the instrumentation process in dynamic geometry

Madona Chartouny¹, Iman Osta² and Nawal Abou Raad³

¹Lebanese University, Lebanon; ²Lebanese American University, Lebanon; ³Lebanese University, Lebanon nabouraad@ul.edu.lb

Abstract. The present study investigates students' instrumentation processes while solving open geometry problems in a dynamic geometry environment. It aims at developing an analytical and comprehensive model of students' conceptual schemes and strategies built around the use of the tools available in DGE. The study was conducted in a grade-10 math class in a Lebanese school. Data were collected through whole-class observation with analysis of paper-based data and closer observation of 12 pairs of students. The analysis focused on the instrumentation process that occurred during the construction and manipulation of geometric figures. The results suggest the development of a three-phase model of the instrumentation process.

Keywords: Instrumental genesis, instrumentation process, dynamic geometry, grade 10.

Introduction

For the past few decades, research has investigated students' interactions with digital curriculum materials, analyzing the nature of tasks employed and the ways students act and react in such environments. The Instrumental Approach, elaborated by Verillon and Rabardel (1995) provides an adequate context to analyze such interactions. They made an important distinction between an artifact and an instrument. An instrument does not exist by itself. An artefact, which is the physical object, becomes an instrument when the user appropriates pre-existing schemes, or constructs personal schemes and integrates the artifact within his/her activity. Beguin and Rabardel (2000) and Trouche (2004) defined the concept of instrumental genesis to encompass two dimensions that contribute to the construction and advancement of an instrument: (1) instrumentation: it is subject-oriented and it entails the artifact printing its mark on the subject, i.e. it allows him/her to construct and enhance operative utilization schemes. (2) Instrumentalization, which concerns the development of the artifact component of the instrument.

Many researchers (Alqahtani & Powell, 2016; Artigue & Mariotti, 2014; Baccaglini-Frank & Mariotti, 2010) have used the Instrumental Approach to analyze the use of DGE tools in learning situations. According to Artigue and Mariotti (2014, pp.338) "representations play a fundamental role in the "generation" of mathematical meanings, and this role is assumed to be crucial in the teaching/learning of mathematics. Digital artifacts can provide representations of mathematical objects with a clear potential of generating mathematical meanings." These shared theories concerning artifacts and mathematical representations highlight the essential role that digital tools play in learning mathematics and hence the importance of understanding the way students instrument these tools in a DGE to create geometrical meanings. Alqahtani and Powell (2016) and Baccaglini-Frank and Mariotti (2010) studied the instrumentation process of the dragging tool. The analysis showed that the appropriation and application of the dragging tool started with random dragging and then looking at the characteristics of the objects being dragged in order to understand properties of dynamic constructions. The retroactions of the DGE that occurred while dragging different objects helped in identifying and understanding geometrical relationships such as invariants and

dependencies in the figure. While appropriating the use of the dragging tool, the construction of the dynamic figures came last.

Given that in the literature the primary focus in the process of instrumental genesis has been on the role of DGE tools and their impact on students' learning, this study, focuses on the instrumentation process, and aims at developing an analytical and comprehensive model of students' conceptual schemes and strategies built around the use of the tools available in DGE by answering the following question: "How do grade 10 students develop and structure their conceptual schemes and strategies while constructing a geometric figure using DGE tools?" The study consisted of a series of observations of 12 pairs of 10 graders (15-17 years old) who worked on open geometrical proof problems within Geogebra. Data were collected using video-recording and collection of materials, namely any paper trace (sketches, scribbles, conjecture or proof formulations) generated by students, together with their GeoGebra files. This paper presents students' work on two problems previously used by Olivero (2002) and Arzarello et. al. (2002):

Problem 1 (Olivero, 2002)

Let ABCD be a quadrilateral. Consider the bisectors of its internal angles and the intersection points H, K, L, and M of pairs of consecutive angle bisectors.

- 1) Drag ABCD, considering different configurations, and explore how HKLM changes in relation to ABCD.
- 2) Write down conjectures and prove them.

Problem 2 (Arzarello et. al., 2002)

Given a triangle ABC, consider P the midpoint of [AB] and the two triangles APC and PCB.

- 1) Explore the properties of the triangle ABC which are necessary so that both APC and PCB are isosceles (in this case, the triangle ABC is called "separable").
- 2) Write down conjectures and prove them.

The chosen problems: 1) are in accordance with the definitions of open problems; 2) are problems whose nature is not changed by the DGE, which simply acts as a visual amplifier facilitating the mathematical task; 3) lie in a mathematical conceptual domain familiar to the students, their difficulty does not reside in the understanding of the wording and meaning of the given of the problem; 4) were selected from other studies that analyzed students' work in a DGE.

Analysis of the Instrumentation Process

The observations and analyses showed that, through their interaction with the tool, students gained new geometrical knowledge indigenous to the DGE. These gains were built in a continuous process of exerting intentional actions, processing feedback and adapting techniques. When students employed a certain tool among those offered by the DGE for the first time, or when they employed a tool known to them in a novel context, they processed the feedback it provided and adapted their techniques accordingly. The analysis of the 12 cases helped us identify three phases through which instrumentation and resulting geometric knowledge indigenous to DGE were developed. We illustrate

these three phases using the following examples, chosen among the 12 cases as they are the most representative examples:

Example 1

While working on problem 1, a pair of students started their work by constructing two segments [AB] and [AD] and selected the *Parallel Line* tool to complete the parallelogram ABCD.

Phase 1: The students clicked on D, the point through which the parallel line to (AB) should be constructed, and waited, expecting the parallel line to appear. They were not aware of the fact that the construction needed another input, i.e. the line that determines the direction of the parallel line.

It is observed that the students were not familiar with the type and nature of inputs required by the *Parallel Line* tool. Their choice of input, namely point D, was purely experimental, based on the way they would construct a parallel line through D in the paper-and-pencil environment, i.e. placing the ruler to pass through D in a parallel direction to (AB), without explicitly invoking (AB).

Phase 2: They refined their input by incorporating the line to which the parallel line should be constructed but they started by clicking on (AB), thus the line appeared confounded with [AB]. They still needed to select the point through which the parallel line should pass. They dragged the line and adjusted it visually till it passed by D and constructed a point C, through which the parallel line passes, by placing it as the fourth vertex of the parallelogram ABCD based on perceptual approximation (Figure 1). Although the parallel line appeared to be constructed in the correct position, but the figure did not hold under dragging since it was based on visual approximation. Therefore, they proceeded by constructing a parallel line to [AB] through D, a parallel line to [AD] through B and constructed C as the intersection point of these two lines (Figure 2). In this phase, the students adapted their use of the *Parallel Line* tool to the feedback provided by the tool itself. This adaptation was based on progressively gained knowledge and understanding of the nature of the input requirements for the parallel line to be constructed, rather than on speculations as they did previously.

Phase 3: By the end of the process, the students learned the two defining elements that determine a line parallel to another through a point. They understood the technical functioning of the *Parallel Line* tool. They succeeded in internalizing the utilization scheme of the *Parallel Line* tool since the input was refined based on understanding; their new knowledge was validated for them by the fact that the figure held under dragging.

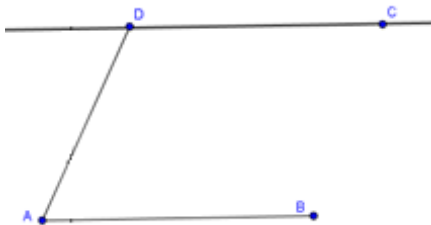


Figure 1: Adapting the use of the *Parallel Line* tool based on the tool's feedback

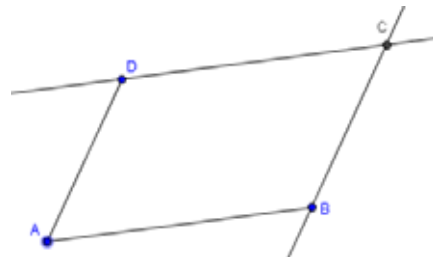


Figure 2: Using the *Parallel Line* tool based on conceptual understanding

Example 2

In problem 2, based on a paper sketch, a student hypothesized that ABC is separable when it is right isosceles. They decided to test her hypothesis in DGE.

Phase 1: They constructed a right isosceles triangle ABC by taking C as the intersection point of the perpendicular bisector of $[AB]$ and the circle centered at P , the midpoint of $[AB]$, with radius $[PB]$ (Figure 3). They selected the dragging tool and attempted to drag C on the circle. We note that the choice of the right isosceles condition and the attempt to drag C on the circle were both experimental processes that needed to be refined.

Phase 2: When C could not be dragged on the circle, the students discussed and analyzed what they observed and deduced that, since C is an intersection point, it could not be dragged on the circle. This novel understanding led them to adapting their construction by considering C as a point on the circle, without belonging to the perpendicular bisector of $[AB]$ as well (Figure 4). They dragged C on the circle and observed that ABC is separable when it is a right triangle.

Phase 3: The students were able to develop novel understanding based on the interaction with the dragging tool:

- They understood that intersection points could not be dragged as they are dependent on other objects. This concept is indigenous to the DGE since in the paper-and-pencil environment students are not trained to distinguish dependent from independent points.
- The students were also able to understand that ABC right triangle at C is a sufficient condition for the triangle to be separable; it does not need to be isosceles as well.

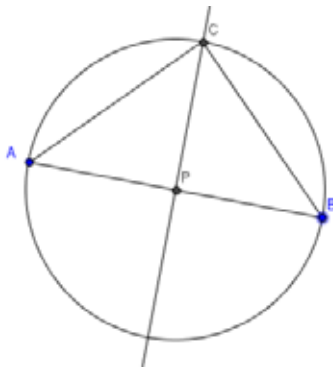


Figure 3: Constructing C based on experimental choices

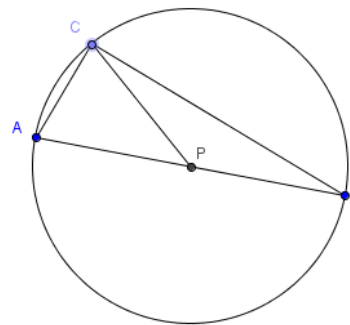


Figure 4: Refining the construction of C based on conceptual understanding

Example 3

A pair of students who worked on problem 2, attempted to measure \widehat{ABC} using the *Angle* tool.

Phase 1: They selected only the vertex of the angle, which does not produce the desired result and keeps the DGE waiting for more input. Then, they selected the three points of the angle but in random order, which, in this case, resulted in displaying the measure of the outer angle.

Phase 2: To solve this problem and find the measure of the inner angle the students read the measure of the outer angle and subtracted it from 360° to find the measure of the inner angle. Here, the students

did not rely totally on the tool, neither did they try to adapt their use of the tool. Instead they solved the problem at hand using a previously acquired geometrical property. They did not attempt to understand the behavior of the *Angle* tool and to adapt their work accordingly.

Phase 3: The students were not able to develop conceptual knowledge indigenous to DGE; although prior geometrical knowledge was used to reach the result that the DGE failed in providing, that knowledge was not novel and was not indigenous to the DGE neither was it invested to build a new knowledge indigenous to the DGE.

The three-phase model of the instrumentation process

From these examples we can identify a common structure for the instrumentation process of DGE tools. Each exploration in each example went through three phases: a phase of *heuristic application* of the tool, followed by a phase of *contextualized adaptation* leading to the third phase of *conceptual understanding*. These phases suggest the development of a three-phase model of the instrumentation process defined as follows:

Phase 1– *Heuristic Application*: The students choose a certain tool, and then select the object(s) they believe to fit the required nature and order of input. The choice of input is experimental based on students' experiences in a paper-and-pencil environment and on assumptions and speculations rather than formal knowledge.

Phase 2 – *Contextualized Adaptation*: After *heuristic application* of the tool, students build on the feedback it provides to adapt their strategies to the situation at hand. This adaptation can be based either on geometrical understanding (i.e. epistemic adaptation) or on practical considerations (i.e. pragmatic adaptation).

- Epistemic adaptation: Heuristic application of the tool evolves into epistemic adaptation as students benefit from the feedback provided by the tool to improve their strategies and construct new meanings. The utilization scheme of the tool is formalized by the mediation of the heuristic experiments carried out in the first phase.
- Pragmatic adaptation: Students manage to accomplish the given task but in a way that is based on practical considerations; the heuristic experiences do not evolve into mathematically grounded application of the tool. In this case, the construction of geometrical knowledge indigenous to the DGE, i.e. phase 3, is limited or even non-existent.

Phase 3 – *Conceptual Understanding*: The epistemic adaptation generates new understanding imprinted on the student by the tool. This understanding is not totally gained in phase 3; instead it is gradually constructed as of the first phase. The conceptual understanding is relevant to:

- The functioning of the tool: Students construct an understanding of the behavior of the tool, i.e. the type of input required, the context in which the input applies and the outcome that the tool provides.
- Dynamic geometry i.e. geometrical knowledge indigenous to the DGE: Students construct first-hand understanding of the geometry underlying the tool, which may be, in some cases, fundamentally different from the geometry learned in the paper-and-pencil environment.

Through these three phases, students gradually conceptualize a new type of geometry, the dynamic geometry.

The following diagram (Figure 5) illustrates the three-phase model of the instrumentation process.

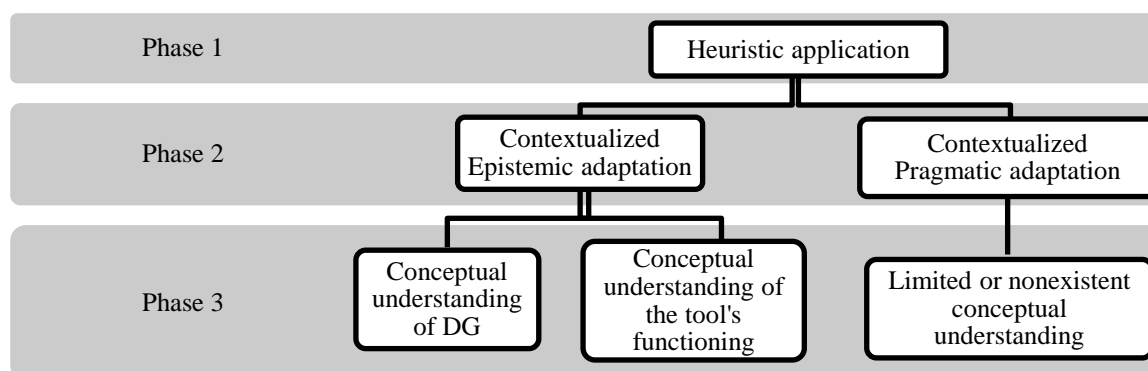


Figure 5: The three-phase model of the instrumentation process

Discussion and Conclusion

According to Beguin and Rabardel (2000), the instrumentation process, which is learner-oriented, entails the artifact printing its mark on the learner; it thus leads to the construction and development of utilization schemes. Therefore the three-phase model of the instrumentation process can be perceived as a more formalized utilization scheme for DGE tools. Beguin and Rabardel define these utilization schemes as contingent upon the meanings attributed by the individual to a situation; this subjective involvement of the students, while using technology, explains why technology does not have the same power and potential for all students. In fact, in phase 2 of the structure, the contextualized adaptation is contingent upon the meaning that students give to the situation; this is why some students are able to develop a *contextualized epistemic adaptation* and exploit the potentialities of the technological environment, whereas others can only develop a *contextualized pragmatic adaptation* limiting the potential of the DGE. Beguin and Rabardel add that utilization schemes are active structures as they are adapted to an expanding range of situations and their construction necessitates the intelligent use of both conceptual and technical knowledge. This idea is illustrated in phase 3 of the structure presented above, where students adapt their use of the tool to different situations and gain conceptual and technical knowledge of dynamic geometry.

We now compare this structure to a model developed by Leung (2011, 2017). The purpose of this techno-pedagogic task design model is to serve as a heuristic to design mathematical teaching and learning tasks in a technological environment. It is useful to compare these two structures in order to verify whether the way a task should be designed in DGE (i.e. according to Leung's model) is in fact consistent with the way students solve a task in DGE (i.e. according to the common structure of instrumentation processes developed in this study). These two structures are compared and contrasted in Table 0.1.

Table

0.1

A comparative summary of the common structure of instrumentation processes identified in the current study and the techno-pedagogic task design model

	The common structure of instrumentation processes (identified in this study)	The techno-pedagogic task design model (Leung, 2011, 2017)
Phase 1	<i>Step 1– Heuristic application:</i> The choice of input for a specific tool is based on students' personal understanding of what is required to define a geometric object and of what is necessary in terms of the nature and order of input.	<i>Establishing Practices Mode (PM)</i> PM1 Construct and manipulate mathematical objects using tools embedded in a technology-rich environment PM2 Interact with the tools in a technology-rich environment to develop (a) skill-based routines; (b) modalities of behavior; (c) modes of situated dialogue.
Phase 2	<i>Step 2 – Contextualized adaptation:</i> Epistemic adaptation or pragmatic adaptation.	<i>Critical Discernment Mode (CDM)</i> Observe, record, re-present (re-construct) patterns of variation and invariant.
Phase 3	<i>Step 3 – Conceptual understanding:</i> The <i>epistemic adaptation</i> generates new understanding of geometrical concepts indigenous to the DGE and/or of the technical functioning of the tool.	<i>Establishing Situated Discourses Mode (SDM)</i> SD1 Develop inductive reasoning leading to making a generalized conjecture. SD2 Develop discourses and modes of reasoning to explain or prove.

In phase 1 of both structures, students practice the use of the tool and develop modes of interaction between them and the tool. Thus the process of instrumentation begins where the student acts on the tool and the tool shapes the student's knowledge thus creating an artefactual and psychological instrument.

In phase 2 of both structures, namely *contextualized epistemic adaptation* and *CDM*, the process of instrumentation continues; the students shift their attention from establishing routine usage of the tool to constructing mathematical meaning. A process of internalization takes place where technical tools are transformed into psychological tools for the purpose of shaping new meanings. However, the common structure of instrumentation processes includes a step, namely *pragmatic adaptation*, which takes into consideration the case where students fail in transforming the tool into a psychological/cognitive one and do not construct new meaning.

Phase 3 of both structures serves as a connection to the theoretical field. In the techno-pedagogic task design model the theoretical field consists of deductive and inductive reasoning, which leads to developing conjectures and proofs. In the common structure of instrumentation processes, the theoretical field consists of dynamic geometry concepts or technical functioning of DGE tools, which also reflects geometrical understanding relative to DGE.

Based on the results of this study, we make the following recommendations for future research:

- Investigate whether the conceptual understanding of geometrical knowledge indigenous to the DGE developed by the students can be detached from the DGE and become formal geometrical knowledge used in other environments.
- Explore whether the three-phase model of the instrumentation process can be seen as a cycle where the newly gained conceptual understandings in phase 3 can be used later in further explorations at the first phase of heuristic application and pass again through the same phases to reach new conceptual understandings, and so forth; thus suggesting a three-phase instrumentation cycle.

REFERENCES

- Alqahtani, M.M. & Powell, A.B. (2016). Instrumental appropriation of a collaborative, dynamic-geometry environment and geometrical understanding. *International Journal of Education in Mathematics, Science and Technology*, 4(2), 72-83.
- Artigue, M., & Mariotti, M. A. (2014). Networking theoretical frames: The ReMath enterprise. *Educational Studies in Mathematics*, 85, 329–355.
- Arzarello, F., Olivero, F., Paola, D., & Robutti, O. (2002). A cognitive analysis of dragging practises in Cabri environments. *ZDM*, 34, 66-72.
- Baccaglioni-Frank, A., & Mariotti, M. A. (2010). Generating conjectures in dynamic geometry: The maintaining dragging model. *International Journal of Computers for Mathematical Learning*, 15, 225-253.
- Beguin, P., & Rabardel, P. (2000). Designing for instrument-mediated activity. *Scandinavian Journal of Information Systems*, 12, 173-190.
- Leung, A. (2011). An epistemic model of task design in dynamic geometry environment. *ZDM: The International Journal on Mathematics Education*, 43, 325–336.
- Leung, A. (2017). Exploring techno-pedagogic task design in the mathematics classroom. In *Digital Technologies in Designing Mathematics Education Tasks* (pp. 3-16). Springer, Cham.
- Olivero, F. (2002). *The proving process within a dynamic geometry environment*. Doctoral dissertation. UK: University of Bristol.
- Trouche, L. (2004). Managing the complexity of human/machine interactions in computerized learning environments: Guiding students' command process through instrumental orchestrations. *International Journal of Computers for Mathematical Learning*, 9, 281-307.
- Verillion, P., & Rabardel, P. (1995). Cognition and artifacts: A contribution to the study of thought in relation to instrumented activity. *European Journal of Psychology of Education*, 10, 77-101.

Spatial structuring in early years

Joana Conceição¹ and Margarida Rodrigues²

¹Instituto de Educação da Universidade de Lisboa, Portugal; conceicaoj@campus.ul.pt

²Escola Superior de Educação, Instituto Politécnico de Lisboa, UIDEF, Instituto de Educação, Universidade de Lisboa, Portugal; margaridar@eselx.ipl.pt

Keywords: Spatial structuring, constructions, composing/ decomposing

Theoretical framework

Spatial structuring, according to Battista (2008), “is the mental act of constructing an organization of form for an object or set of objects” (p.138). It consists in identifying components of shapes, establishing relationships among components into composites and establishing relationships between components, composites and the whole (Battista, 2012). Battista (2008) presents a different perspective on the development of geometric reasoning based on the idea of structuring. Spatial structuring is the first level of geometric reasoning and allows the students to understand the structures of shapes before geometric structuring, when students start to use geometric concepts.

In the early grades, constructions (composing and decomposing) and operations with shapes (geometric transformations) are special kinds of tasks that entail spatial structuring, allowing students to explore relationships among components and between components and the whole (NCTM, 2000).

According to Battista and Clements (1996), students’ spatial structuring is either local or global. Local structuring is related to the identification of components and a possible establishment of relationships among components, but students cannot yet relate components and the whole. In global structuring, students have a mental scheme for the object that enables them to establish relationships among components, composites and the whole. To a better understanding how spatial structuring is characterized, we referred to the work of Sarama and Clements (2009), related to composition and decomposition of 2D and 3D shapes, where they describe the levels of relationships students can establish among components. According to these authors, students progress along several levels: pre-composer (0-3 years old), piece assembler (4 years old), picture maker, simple decomposer and shape composer (5 years old), substitution composer and shape decomposer (6 years old), shape composite repeater and shape decomposer with imagery (7 years old) and shape composer using units of units and shape decomposer with units of units (8 years old). This progression concerning composing and decomposing also highlights a trajectory closely related to spatial structuring. In both cases, the students start by dealing with units, then they begin to establish relationships and form composites, and, in a final stage, they can deal with superunits and relate them with the whole.

Method

This study follows a design-based research approach, where, along two cycles of research, we aim to deepen our understanding of how students develop spatial structuring of 2D and 3D shapes and

how it is related to the learning context proposed for the learning experiment. Through this, we seek to contribute to a further understanding of students spatial structuring.

The results presented in this poster concern a preliminary study, developed during the learning experiment preparation phase. This study had the purpose of testing tasks and manipulatives adequacy and of gathering some information about strategies 1st grade students use to solve the tasks. We selected one task concerning 2D shapes and, for our analysis, we compare constructions and drawings using Battista and Clements' (1996) local and global structuring, with attention to location and orientation of components.

Results

The results of preliminary study, where students had to compose different two-dimensional constructions using four triangles, reveal that students show different levels of structuring, maybe influenced by the type of constructions and the type of components. Namely, triangles seem to present a higher level of difficulty for students, since the possibilities of combining several isosceles triangles are wider, influenced by their orientation and position.

During this preliminary study we also found differences between students' constructions using manipulatives and the drawings of their constructions. Drawing seems more demanding for students to perform, however, the search for relationships between constructions and drawings allow students to deepen their understanding about the relationships among components.

Acknowledgment

This work is supported with national funds provided by FCT - Foundation for Science and Technology by a scholarship granted to the first author (SFRH/BD/130505/2017).

References

- Battista, M. T. (2008). Development of the shape makers' geometry microworld. In G. W. Blume & M. K. Heid (Eds.), *Research on technology and the teaching and learning of mathematics: Cases and perspectives* (vol. 2, pp. 131–56). Charlotte, NC: Information Age.
- Battista, M. T. (2012). *Cognition-based assessment & teaching of geometric shapes: Building on students' reasoning*. Portsmouth, NH: Heinemann.
- Battista, M. T., & Clements, D. H. (1996). Student's understanding of three-dimensional rectangular arrays of cubes. *Journal for Research in Mathematics Education* 27(3), 258–292.
- National Council of Teachers of Mathematics (2000). *Principles and standards for school mathematics*. Reston, VA: NCTM.
- Sarama, J., & Clements, D. H. (2009). *Early childhood mathematics education research: Learning trajectories for young children*. New York and London: Routledge.

The development of geometrical knowledge starting from arts education

Catarina Delgado¹, Fátima Mendes² and Filipe Fialho³

¹ Escola Superior de Educação, IPS de Setúbal, Portugal; catarina.delgado@ese.ips.pt

² Escola Superior de Educação, IPS de Setúbal, Portugal; fatima.mendes@ese.ips.pt

³ Escola Superior de Educação, IPS de Setúbal, Portugal; filipe.fialho@ese.ips.pt

Keywords: Geometrical knowledge, Arts education, interdisciplinary tasks.

This poster is focused on the development of students' geometrical knowledge through connections with arts education. More specifically, we present a set of didactic activities and tasks for elementary school students that involves geometry and arts, in an interdisciplinary perspective, and we also analyze and discuss their potentialities in the development of students' geometrical knowledge.

Theoretical framework

The teaching of geometry should contribute to the development of the geometric knowledge of the students since the kindergarten, namely with regarding to the characteristics and properties of geometric forms and the relationships between them, the spatial relations and corresponding representation systems and the geometric transformations (NCTM, 2000). As Freudenthal (1973) point out "Geometry is grasping space. And since it is about the education of children, it is grasping that space in which the child lives, breathes and moves. The space that the child must learn to know, explore, conquer, in order to live, breathe and move better in it" (p. 403). In this sense, there is a dialogical relationship between the development of geometric ideas and the full exploration and experience of space. These geometrical ideas are useful in representing and solving problems in other areas of mathematics and in real-world situations (NCTM, 2000). In parallel to these ideas, research indicates that when students can recognize and use connections among mathematical ideas and can recognize and apply mathematics in contexts related with other subjects, their understanding is deeper and more lasting (NCTM, 2000). Mathematics are embedded in several tasks that students do at elementary school, so it is crucial that teachers integrate subject areas. When teachers connect mathematics with others content areas the students perceive that they explore more mathematics than they would work in a specified time only for this subject (Bamberger & Oberdorf, 2007).

Research question and method

This poster has underlying the researches developed by two preservice elementary teachers in a context of internship (Nunes, 2017; Sobral, 2015). The goal of these researches is to describe and analyze how students deepen their mathematical knowledge and their knowledge about arts education through the exploration of tasks with interdisciplinary characteristics. From a methodological point of view, the study is of a qualitative nature (Patton, 2012). The participants are second grade students, from two classes, that solved different tasks proposed by their teachers (prospective teachers). In one of that classes were proposed four tasks that have as starting point the observation of famous artist's paintings. In the other class were also proposed four tasks, but in this case these tasks have as context the body expression activities. The data collection was realized in the probationary period, along four

weeks. The data include the solutions of the students, field notes and transcriptions videorecorder excerpts of the task's exploration in the classes.

Results

The results revealed that (i) students increased their spatial sense, in particular they were able to identify geometric figures embedded in work of art; (ii) they had some difficulties in identifying symmetries of reflection; (iii) students produced "works of art" correctly using plastic expression techniques; (iv) students increased some geometrical ideas through the integration of movement with mathematical tasks, in particular, they were able to use geometry specific terms to describe the movements of their own body.

Summing up, it is possible to develop mathematical ideas and deepen knowledge about arts education in an articulated way. Moreover, learning through reflexive tasks about mathematics and arts education is an adequate approach in elementary school that help students to think in an integrated way.

References

- Bamberger, H., & Oberdorf, C. (2007). *Introduction to Connections: Grades PreK-2*. Portsmouth, NH: Heinemann.
- Freudenthal, H. (1973). *Mathematics as an Educational Task*. Dordrecht: Reidel.
- NCTM (2000). *Principles and standards for school mathematics*. Reston: NCTM.
- Nunes, J. (2017). *A expressão e educação artística enquanto indutora da aprendizagem de conceitos geométricos* (Master's thesis). Retrieved from <https://comum.rcaap.pt/handle/10400.26/17308>
- Patton, M. Q. (2012). *Qualitative Research & Evaluation Methods* (3rd ed.). Thousands Oak: SAGE Publications.
- Sobral, S. (2015). *Geometria e Arte: Um estudo com alunos do 2.º ano de escolaridade* (Master's thesis). Retrieved from <https://comum.rcaap.pt/handle/10400.26/11097>

“Going straight”: discussions and experience at primary school

Maria Elena Favilla¹, Maria Luppi² and Michela Maschietto¹,

¹University of Modena e Reggio Emilia, Italy; elena.favilla@unimore.it,
michela.maschietto@unimore.it

²Scuola primaria “Madonna Pellegrina”, Modena, Italy; marialuppi8@gmail.com

Our research concerns the relationship between spatial and geometrical knowledge, assuming that it is essential to have information on the children’s stored linguistic and conceptual experience associated with the terms defining geometrical concepts. This paper presents the first phase of a design experiment in which 8-year-old pupils are involved in two discussions about going straight, before and after the experience of leaving footprints. The analysis provides some elements about pupils’ conceptualization when approaching geometrical concepts.

Keywords: Alignment, line, linguistic, space, trace.

Introduction.

In Working Group 4 at CERME10 (Jones, Maschietto, & Mithalal-Le Doze, 2017) various papers focus on the relations between spatial sense, spatial knowledge and geometrical knowledge. For instance, Houdement (2017) discusses the different perspectives in which research on the relation of a subject with the world is carried out, highlighting the use of non homogeneous terminology. Other authors, as Vandeira and Coutat (2017), point out the institutional request of working on shapes and space from a perceptive approach at kindergarten and a subsequent rupture when the attention is put on geometry, above all between primary and secondary school education. In their work, they propose tasks of shape recognition in different spaces (micro-space and meso-space, following Berthelot and Salin, 1993), taking into account semiotic and manipulative aspects.

In our work, we are interested in the analysis of pupils’ construction of geometrical concepts and in the relationship between spatial and geometrical knowledge (Berthelot & Salin, 1993) at primary school in real-world experiments recalled in the call for paper of this WG4. We propose a point of view on tackling geometry at primary school, which takes into account the ways in which people communicate and think about space and shapes, both verbally and nonverbally, in order to study how to enhance geometrical understanding. For this reason, we refer to the theory of word learning (Tomasello, 2003), in which learning can be facilitated by the “exposition” to a wide range of linguistic contexts and experiences that elicitate those contexts, in order to enrich the children’s linguistic and conceptual experience and favor the construction of increasingly richer and connected semantic representations.

This paper presents a preliminary analysis of a case study, corresponding to the first phase of a design experiment on points and lines, planned in cooperation with a teacher of Italian at grade 3 of an Italian primary school.

Research perspective.

Several studies in mathematics education concern the analysis of cognitive processes involved in mathematical thinking, paying increasingly more attention to the role of movement – considered in a

large sense, not only in gesture by hands – and conceptual constructions – as metaphors, in the learning and teaching of mathematical concepts. For instance, Nemirovsky (2003) assumes an indissoluble link between perception, motion and thinking, highlighting that perceptuo-motor activity is a constitutive element in the conceptualization of mathematics. This is reinforced by works based on a multimodal approach to mathematics knowledge and on embodied mathematics (Arzarello & Robutti, 2004). Radford (2009) highlights that mathematical meanings are constituted of actions accomplished by the subjects on material objects: thinking also occurs through a semiotic coordination of speech, body, gestures, symbols and tools. These perspectives involve an epistemological dimension related to the debate on mathematics foundations.

The next two sections present some basic components of our theoretical background: epistemological elements for mathematics, in particular for point and line, and a theory of word learning.

Mathematics.

In his reflection on mathematics foundation, Longo (2016) proposes to avoid an axiomatic vision of mathematics, arguing that mathematics is primarily the analysis of the invariants and transformations that keep them. Following Poincaré's philosophical position, Longo states that mathematics is not grounded on arbitrary conventions, but that these conventions correspond to the most convenient choices for human beings, who live in a certain world with a specific biological structure. In this sense, mathematical concepts are constructed in the interaction between us and the world around us. In particular, Longo (1997) discusses the origin of geometry, which is considered

as a science of action and of *prediction* of movement in space: line segments, curves, circles are neither the “abstract form” (?) of a material object, nor “ideal shapes” (?), but rather the *prediction* of a path. And a *prediction is in itself an abstraction; the trajectory that is predicted or anticipated by gaze and gesture is abstract* (*Ib.*, p. 29, italic in the original text; our transl.).

In the analysis of the conceptualisation of line and point, Longo (2016) claims that: “The “big-bang” of Western mathematics is perhaps in Euclid's Definition b: *A line is a breadthless length*” (*Ib.*, p. 1, our transl.). He also suggests that it is possible to reconstruct the gesture at the core of this invention:

Such a notion of line can only be told and written, in the language, and it is the result of a philosophy of ideas, but its sense, its continuity is a practice of gesture, of drawing: if we want to understand it, we have to restart the sense, go back to the line drawn by the first teacher on the blackboard, to her/his gesture-trajectory in the space (*Ib.*, p. 2, our transl.).

Concerning the meaning of point, Longo asserts that the point in Euclid's Elements is considered as a position on a line or as the intersection of two lines, a letter of the alphabet at the ends of a segment. In this perspective, the line is not necessarily made of points, as for Cantor, since the points are “put by the geometer or obtained from lines” (*Ib.*, p. 3, our transl.). This type of analysis allows to shift the attention to the structure: the line and the point-sign are the structures at the origin of geometry. They are borderline objects, away from every tangible experience, but they exist in their relation to space referring to the experience. In his writings, Longo suggests a different perspective on mathematics, focusing not only on the objects but also on the processes of their construction.

Giusti (1999) supports the strong assumption that mathematical objects are derived by a process of “objectification of procedure” (*Ib.*, p. 26). In this hypothesis, the line could be derived by the procedure of pulling a rope between two pegs, following the rope on the ground by a stick, and the points as the positions of the two pegs on the ground.

In the educational perspective of integrating the perceptive-motor and symbolic-reconstructive modalities, Arzarello, Danè, Lovera, Mosca, Nolli, and Ronco (2012) suggest to expose students to the cognitive and cultural roots of mathematical concepts. In the analysis of the concept of line they identify three roots: symmetry, going straight and the shortest line between two points/positions.

Linguistics: context and contrast in the “miracle of word learning”.

The geometrical concepts of point and line can be considered in a continuum with other concepts associated to the same terms in different contexts, as well as in actions and experiences of everyday life. In fact, when 8-year-old children meet these lexical labels at school during their first geometry lessons, they do not hear them for the first time, as they have already met them in various everyday expressions and situations, both in literal and figurative sense. Even without having any idea of what geometry is, they should for instance have some kind of conceptualization connected to the word *punto* (point), not only because they have probably learnt that it is used to refer to those small black marks that in English are called dots and spots, but also because they have met it when learning to write letters and to use punctuation (in Italian the dot on the vowel ‘i’ is called *puntino* and the word “point” is used in many punctuation marks, such as full stop or period, colon, semi-colon, exclamation and question mark, etc.), and also because of the wide use of this word in many frequent expressions, such as “meeting point”, “starting point”, “take stock of the situation” (*fare il punto della situazione*).

If we consider how children and human beings in general learn to associate meanings and concepts to lexical labels, we should not undervalue the fundamental role of the exposition to the different contexts in which words are used: as Tomasello (2003) points out, rarely do children learn words in pointing-and-naming games, with words proposed isolated from other words, as during a vocabulary lesson in a foreign language classroom. And this is particularly true if we consider that vocabulary learning does not include only concrete and content words, clearly associable to a picture, but a wider range of words and expressions, such as, for instance, prepositions or articles, and also abstract words and words used in a metaphorical way. In the process that Tomasello defines the “miracle of word learning” (*Ib.*, p. 44), most of the words are learnt by experience in everyday interactions with adults, and the children hear them used in different types of utterances and situations, mixed with other words and expressions and without special explanations by the adults. According to the so-called social-pragmatic theory of word learning adopted by Tomasello, this miracle is allowed by a series of factors. Among these, one important factor is the children’s ability to conceptualize different aspects of their experiential worlds. In later stages of word learning, when the task becomes more complex and concerns more difficult words and expressions, two other factors become crucial: “context” and “contrast”. On the one hand, children learn quite early to exploit their knowledge of the other words present in the utterance in order to understand words that they do not know; on the other hand, they also learn to use their knowledge of other words present in the utterance that might contrast with a word they do not know.

Research questions.

Research in mathematics education investigates the relationships between physical and geometrical space, highlighting a gap in the teaching practice between an approach by physical experiences and the entrance in geometry (Kuzniak, 1995). This seems evident in some Italian textbooks, in which there is a sort of “Euclidean entrance” into the world of geometry, through the definition and representation of the fundamental geometrical entities.

Our hypothesis is that some expressions used in geometry teaching are associated with expressions and experiences in mathematical and non-mathematical contexts. In this perspective, it is essential to have information on the children’s stored linguistic and conceptual experience associated with the terms that define these geometrical concepts, considering that their conceptual representations do not necessarily coincide with the adults’ representations. This investigation is not generally carried out when the geometrical concepts are introduced to the pupils. Our broad research questions are: (a) what are the linguistic and conceptual experiences associated with geometrical concepts in 3-grade pupils before the Euclidean entrance discussed above? (b) how could those elements emerge? In other words, what kind of experiences can foster the pupils’ exposition to the different graphical, verbal and gestural representations associated with geometrical concepts?

Our working hypothesis is that the emergence of these elements can be fostered by offering educational situations in which the pupils can work in different spaces (micro, meso and macro, Berthelot & Salin, 1993), not necessarily with the teacher labelled as the mathematics teacher.

Methods.

We have planned a design experiment composed of five phases, with physical experiences and collective discussions about them. According to the theoretical framework, after every new experience carried out with the class, the pupils should be helped to reflect and discuss on what they have done, seen and learnt, so as to re-order their mental representations and link their new conceptual experiences to their linguistic and conceptual knowledge. For this reason, class discussions are considered the central focus of all the activities that we propose.

The first phase, upon which we focus in this paper, is dedicated to “going straight”. It has been opened by a collective discussion on the pupils’ personal perception on the meaning of going straight, then the pupils have been invited to experience their ability to go straight, by leaving their footprints on a roll of paper using tempera, and finally they have been taken back to the initial question in a collective class discussion. The footprint activity has been carried out in the hall of the school, corresponding to a meso-space for the pupils. The other phases were: activities with the Bee-bot used to program paths (line and polygonal) (Phase 2); finding the shortest path between two positions by using a rope and two pegs in the macro-space of the school garden (Phase 3); activities of alignment (Phase 4); a session with a perspectograph in the lab of mathematical machines (mmlab.unimore.it) on the meaning of point of view and of line as modelling the visual ray (Phase 5).

The activities were carried out in two classes (42 pupils, Grade 3, ages 8-9) in the second half of the school year. They were videotaped and all the pupils’ worksheets have been conserved. All the sessions were managed by the same Italian language teacher of the two classes, both because we were

interested in the pupils' linguistic experiences connected to geometrical concepts and we wanted to avoid that the activities were labelled as mathematical activities.

Results and discussion: “going straight” before and after the experience.

As anticipated, this paper focuses on Phase 1 of the design experiment. In the analysis we investigate the pupils' representations associated with the expression “going straight” emerging in the two discussions before and after the experience of leaving their footprints on paper.

The discussion preceding the experience is opened by the teacher's question “If I say ‘going straight’, what does it raise in our minds?”. In the discussion the pupils describe going straight mainly as going forward without turning, changing direction, making or meeting curves, stopping, “splitting” the pathway, or without interruptions and keeping walking ignoring possible obstacles (see Figure 1 for some examples and their translation).

S.:	andare avanti però mai girare [...] avanti senza interruzioni mh senza girarsi	going forward but never turning [...] forward without interruptions mh without turning around
M.:	per me andare dritti è camminare con un criterio senza fare curve e senza fermarsi mai	to me going straight is walking with a criterion without making curves and never stopping
D.:	per me andare dritti significa che non bisogna mai cambiare la direzione e non fare curve cioè mh andare sempre in avanti	to me going straight means that we must never change direction and make curves that is mh going always forward
L.:	per me andare dritto significa non fare curve	to me going straight means not making curves
J.:	per me dritti vuol dire che andiamo dritti senza fare curve neanche neanche spezziamo la nostra via	to me straight means that we go straight without making curves nor e even splitting our pathway
M.:	per me dritto vuol dire andare sempre dritti senza incontrare curve	to me straight means going always straight without meeting curves
P.:	per me andar dritto è come se tu camminassi e però davanti a te ci sono degli ostacoli però tu continui a camminare [...] e continui ad andare dritto	to me going straight is as if you walked but in front of you there are obstacles but you keep walking [...] and keep going straight

Figure 1. Examples of definitions of “going straight”

The pupil who first enters the discussion is the only one who mentions a starting and arriving point, talking about a person going from one point to another. Besides, only one of the pupils, F., mentions the use of a ruler, by comparing natural entities such as a lake or a river, which “are round or make curves”, to lines drawn with a ruler, which “are not curves”: “to me going straight means ... for instance ... let's look at a lake or a river which are round or make curves ... on the contrary when you use a ruler you draw a straight line ... it is not a curve”.

Most of the descriptions, therefore, seem to suggest the children think about going straight focusing their attention on the movement in itself and on what they have in front of them when they go straight, more than on the (concrete or ideal) line that one draws when he/she goes straight. These kinds of description are consistent with our theoretical background: the conceptualization of going straight is not mediated yet by school geometry and it is connected to everyday experiences and to body movement. In particular, on one side, it reflects a conceptual representation connected to an embodied experience which involves an interaction between us and the world around us, on the other side, from a more linguistic point of view, it recalls everyday expressions such as “going straight home”, as a synonym of “going directly”, and “going straight to the point”, that is without interruptions or

deviations. It is in this sense, in our opinion, that expressions such as “interruption” or “obstacle” should be interpreted in the pupils’ definitions.

It is quite important for the teacher to collect this kind of information, because it provides a starting point upon which the following part of the experience should be based and built. Even if here we have no space to go into the details of the footprint activity, aimed at helping the pupils to experience their ability to go straight, we would like to mention that the activity starts in fact from the teacher’s invitation to see what happens and what one does when he/she tries to go straight, and that during the activity the teacher progressively tries to lead the pupils to shift their attention from the movement in itself to the traces left with the colored footprints.

Another aspect that can be mentioned here only briefly is the children’s use of gestures. Even if we have noticed that they generally tend not to use gestures, in some few cases they do, and their gestures help to understand their conceptions even in the absence of labels and other clear verbal expressions. The most interesting example concerns D., who intervenes in the discussion at two different points, in both cases helping himself with gestures, once adding also some “sound effects”, probably to convey swiftness as well as straightness. So, when D. says that going straight means that you should never change direction nor make curves and keep going forward (see D.’s intervention in Figure 1), while saying “keep going forward” he moves his right arm forward, upon the school desk, with flat hand and lateral palm. Then, quite interestingly, when F., speaking immediately after him, compares round and curvy lakes and rivers to straight lines made by a ruler, D. echoes F.’s definition of round and curvy by drawing an imaginary circle on the desk with his right forefinger and accompanying this movement making a circle also with his shoulders, while he puts both hands in a flat position with the palms oriented one towards the other when F. mentions the ruler. Finally, towards the end, D. enters the discussion again to give a specification about the meaning of going straight as not making curves, putting together the concepts of “curve” and “direction”: “that is eh, .. you don’t have to make round curves, but you can do so [...] doing the tips as well” (D.). The two gestures that he produces as if drawing on the desk to illustrate what one cannot do (round curves) and one can do (tips) make it clear that he has in mind the distinction between a round line and the representation of a polygonal with points, in which the change in direction corresponds to the meaning of angle. Even if the teacher has no time to deepen this aspect, she asks the pupil to describe how the tips are and D. limits himself to repeat the imaginary drawing, this time in the air and not on the desk, maybe in order to be seen better by the teacher, but adding a level of abstraction.

In the class discussion following the experience, the teacher starts with the same question she had asked in the discussion preceding it and tries to induce the pupils to relate their understanding of going straight with the activity just carried out.

After the experience, going straight is defined mainly as “without curves”, with its variants “crookedly” and “without zigzagging”, or as “without interruption”.

In the discussion, the teacher fosters the interpretation of “without interruption” by relating it to the two different kinds of footprints left by the pupils, attached one to each other so as to trace a line, or far from each other as in a normal walking. This way, the experience helps the teacher to shift the attention from the straight movement in itself to the trace of its trajectory and to the footprint line,

which one girl then defines as “a line made by our footprints” (*è una linea fatta dall'impronta dei nostri piedi*).

The change of direction and the representation of a polygonal arc, in a certain way, more specified than in the discussion before the experience, even if only one pupil explicitly refers to the angle. The main element in the pupils' comments concerns keeping going straight after the turning point and being able to “go straight in many different directions” (*puoi andare dritto in tante parti diverse*). In this case, the interruption is interpreted in terms of changing direction.

Moreover, the work on the meso-space provides also a more tangible representation of going straight which can be used to introduce new kinds of reflections. For instance, with reference to the presence of an obstacle in the direction of movement, invited by the teacher to recall the “special solution” proposed by one girl during the activity in order to go straight on a road presenting an interruption, the pupils explicitly speak about “going back” and about “going forward and backward” followed by the specification “on the same line”.

The experience of going straight leaving footprints provides, therefore, a spatial context in which the movement can be seen and performed in the same way at different times (during and after the experience). This graphical object could have been exploited even more by the teacher, for instance to control if the movement was straight or not by checking the alignment of pupils' footprints. It is a task that could be proposed in a next experiment.

In this discussion, the line comes out also to describe one of the strategies used during the experience to go straight. When walking on the paper the kids did not control the trace directly by looking at it, but seemed to rely more on their bodies and sense of equilibrium, on the help of other pupils or on other. One of the pupils, invited by the teacher to recall what he had said during the experience about a line he was following, says that while he was walking he could “see the line in his head” because he was “imagining something like a road next to him” and then he was “staring at a fixed element, a line, which had the same shape as a road”.

This idea of imagining a line in your mind may imply a greater engagement of cognitive control, which two pupils seem to refer to when they mention the difficulty of the task of going straight and the need for concentration when doing it, compared to when making curves.

Finally, to make at least one reference to gestures, we would like to mention the control of alignment by view spontaneously proposed by F., who is the pupil who had already used many gestures in the initial discussion. During the experience he had described (and shown) his strategy to verify the straightness of the footprint line on paper by aligning in front of one eye his outstretched arm and the corresponding shoulder, with the other eye closed. In the discussion after the experience the teacher invites him to recall that gesture and the same gesture is then imitated by another kid.

Concluding remarks.

The analysis of the two discussions preceding and following the experience of leaving footprints on paper in the first phase of the design experiment provides various data on the conceptual representation of “going straight” that 8-year-old children might have before starting to study geometry and on how these representations, together with an experience which involve their bodies

and the meso-space, can provide the basis to reflect on the concept of going straight and begin to introduce the concept of line.

Acknowledgment

This research was funded by the University of Modena e Reggio Emilia: *FAR2016 Prospettive, cornici e punti di vista: per una didattica interdisciplinare nella scuola del primo ciclo*.

References

- Arzarello, F., Danè, C., Lovera, L., Mosca, M., Nolli, N., & Ronco, A. (2012). *Dalla geometria di Euclide alla geometria dell'Universo*. Collana Convergenze. Milano: Springer.
- Arzarello, F., & Robutti, O. (2004). Approaching functions through motion experiments. *Educational Studies in Mathematics*, 57(3), 305–308.
- Berthelot, R., & Salin, M.-H. (1993). L'enseignement de la géométrie à l'école primaire. *Grand N*, 53, 39–56.
- Giusti, E. (1999). *Ipotesi sulla natura degli oggetti matematici*. Torino: Bollati Boringhieri.
- Houdement, C. (2017). Traveling in spatiality, in spatial sense. In T. Dooley and G. Gueudet (Eds.), *Proceedings of CERME 10* (pp. 621–628). Dublin: DCU Institute of Education and ERME.
- Jones, K., Maschietto, M., Mithalal-Le Doze, J. (2017). Introduction to the papers of WG4: Geometry Education. In T. Dooley and G. Gueudet (Eds.), *Proceedings of CERME 10* (pp. 560–563). Dublin: DCU Institute of Education and ERME.
- Kuzniak, A. (1995). L'enseignement de la géométrie en formation initiale. *Documents pour la formation des professeurs d'école en didactique des mathématiques* (pp. 81–89). Angers: COPIRELEM. Retrieved from <http://www.arpeme.fr/documents/546758FA4F122788C679.pdf>
- Longo, G. (1997). De la cognition à la géométrie. Retrieved from <https://www.di.ens.fr/users/longo/files/PhilosophyAndCognition/cogni-geometrie.pdf>.
- Longo, G. (2016). Le conseguenze della filosofia. In R. Lanfredini e A. Peruzzi (a cura di), *A Plea for Balance in Philosophy* (vol. 2, pp. 17–44). Pisa: Edizioni ETS. Retrieved from <https://www.di.ens.fr/users/longo/files/Le-conseguenze-filosofia.pdf>.
- Nemirovsky, R. (2003). Three Conjectures concerning the Relationship between Body Activity and Understanding Mathematics. In: N.A. Pateman, B.J. Dougherty & J.T. Zilliox (Eds.), *Proceedings of the 27th Conference of the IGPME* (vol. 1, 103–135). Honolulu: University of Hawai'i.
- Radford, L. (2009). Why do gestures matter? Sensuous cognition and the palpability of mathematical meanings. *Educational Studies in Mathematics*, 70, 111–126.
- Tomasello, M. (2003). *Constructing a language. A usage-based theory of language acquisition*. MA: Harvard University Press.
- Vandeira, C., & Coutat, S. (2017). Shapes recognition in early school: How to develop the dimensional deconstruction? In T. Dooley and G. Gueudet (Eds.), *Proceedings of CERME 10* (pp. 677–684). Dublin: DCU Institute of Education and ERME.

Mathematical creativity and geometry: The influence of geometrical figure apprehension on the production of multiple solutions

Panagiotis Gridos¹, Athanasios Gagatsis², Iliada Elia² and Eleni Deliyianni³

¹University of the Aegean, Laboratory of Mathematics Education and Multimedia, Rhodes, Greece; p.gridos@hotmail.com

²University of Cyprus, Department of Education, Nicosia, Cyprus; gagatsis@ucy.ac.cy

² University of Cyprus, Department of Education, Nicosia, Cyprus; iliada@ucy.ac.cy

³Cyprus Ministry of Education and Culture, Nicosia, Cyprus; deliyianni6@hotmail.com

The aim of the study is to investigate the creativity demonstrated by students in multiple-solution tasks (MSTs) in geometry taking into account the role of geometrical figure. To this end, the test that was administered among 149 eleventh graders consisted of two types of problems: a. with and b. without the relevant figure. Findings revealed that fluency and flexibility were higher when the verbal description of the problem was accompanied by the relevant figure. The originality of students' solutions, though, did not differ in the two types of problems. The similarity analysis suggested distinct student profiles: (a) poor fluency and flexibility, (b) moderate fluency and flexibility and (c) high fluency and flexibility. Although the majority of students belong to the first two groups, qualitative results provide evidence that students managed to improve and gain high fluency and flexibility. Findings also indicated that geometrical figure apprehension is a prerequisite for high levels of creativity in geometry.

Keywords: Creativity, geometry, multiple-solution tasks (MSTs), geometrical figure apprehension.

Introduction and Theoretical Framework

Creativity has been proposed as one of the major components to be included in Mathematics education, since “the essence of Mathematics is thinking creatively” (Mann, 2006, p. 239). Torrance (1994) defines creativity as multidimensional; fluency, flexibility, originality (or novelty) and elaboration are aspects of creativity. Fluency is related to the flow of ideas, flexibility has to do with the ability to shift between different ideas, novelty is associated with the originality of the individual’s ideas or products, and elaboration is associated with the individual’s ability to describe, illuminate, and generalize those ideas. A number of researchers (e.g. Silver, 1997; Stupel & Ben-Chaim, 2017) suggest that linking mathematical ideas using multiple approaches to solve problems (or prove statements) is essential for the development of mathematical reasoning and fosters better comprehension and increased creativity in Mathematics. Following Torrance, Silver (1997) claimed that in order to develop creativity by means of problem solving it is necessary to advance three components of creativity. Fluency is promoted by raising multiple ideas for the solution of one problem. Flexibility is raised when after one solution is already in hand, the individual searches for more possible solutions. Originality is developed when an individual succeeds in generating a new solution, in addition to those known to him/her at the time.

Geometry provides opportunities for investigation and proving activities that resemble the work of mathematicians (Herbst, 2002). The usefulness of geometrical figures in problem solving in geometry

is beyond doubt as they provide an intuitive presentation of all constituent relations of a geometrical situation (Duval, 1995). Duval (1995) distinguishes four apprehensions for a geometrical figure: perceptual, sequential, discursive and operative. To function as a geometrical figure, a drawing must evoke perceptual apprehension and at least one of the other three. Each has its specific laws of organization and processing of the visual stimulus array. In particular, perceptual apprehension refers to the recognition of a shape in a plane or in depth. Perceptual apprehension indicates the ability to name figures and the ability to recognize several sub-figures in the perceived figure. Sequential apprehension is required whenever one must construct a figure or describe its construction. The organization of the elementary figural units does not depend on perceptual laws and cues, but on technical constraints and mathematical properties. Discursive apprehension is related to the fact that mathematical properties represented in a drawing cannot be determined through perceptual apprehension. In any geometrical representation the perceptual recognition of geometrical properties must remain under the control of statements (e.g. definitions). However, it is through operative apprehension that we can get an insight into a problem solution when looking at a figure. Operative apprehension depends on the various ways of modifying a given figure: the mereologic, the optic and the place way. The mereologic way refers to the division of the whole figure given into parts of various shapes and the combination of them in another figure or sub-figures (reconfiguration), the optic way is when the figure is made larger or narrower, or slant, while the place way refers to its position or orientation variation. Each of these different modifications can be performed mentally or physically through various operations. These operations constitute a specific figural processing which provides figures with a heuristic function. One or more of these operations can highlight a figural modification that gives an insight into the solution of a problem in geometry.

MSTs contain an explicit requirement for solving them in multiple ways. A number of studies (e.g. Levav-Waynberg & Leikin, 2009) used MSTs as an instructional tool for developing knowledge and creativity, as well as a tool for the evaluation of creativity in geometry. Moving a step forward, the present study aims to shed new light as far as MSTs are concerned on evaluating and developing creativity in geometry taking into account the role of geometrical figure. As there is a need for a multidimensional approach as far as teaching and learning in geometry is concerned, we address the following research questions (RQ): (a) what is the influence of geometrical figure apprehension on the production of multiple solutions in geometry problems? (b) what kind of creativity (fluency, flexibility, originality) do students demonstrate when working with MSTs in which the geometrical figure is either given or not in the wording of the problem? (c) what are students' profiles, if any, in terms of the number of solutions in MSTs in geometry?

Methodology

A written test was administered among 149 eleventh graders (77 boys and 72 girls) as follows: 147 of the students completed the test in usual classroom conditions and 2 students took part in an individual interview during the solution process of the test. The test consisted of four geometry problems that were content and face validated by two experienced Mathematics school teachers in secondary education and two professors of Mathematics Education. The students were asked explicitly to solve them in as many ways as possible. In problems 1 and 3 the wording of the problem was accompanied by the relevant figure, while in problems 2 and 4 only the wording of the problems

was given. The duration of the test was 110 minutes. It is worth mentioning that the problems (without the relevant figure) were piloted among a small number of students before the final administration of the test. It was confirmed that all the problems (without the relevant figure) had the same level of difficulty.



<p>Problem 1: Prove in as many ways you can that, that the median drawn to the hypotenuse of the right triangle equals half the hypotenuse.</p> 	<p>Problem 3: Let a rectangular triangle ABC ($B = 90^\circ$), D midpoint of segment AB, E the midpoint of segment AC and Z the midpoint of segment BC. Prove in as many ways you can that $DZ = EB$.</p> 
<p>Problem 2: AB is a diameter on a circle with center O. D and E are points on circle O so that $DO \parallel EB$. C is the intersection point of AD and BE. Prove in as many ways as you can that $CB = AB$.</p>	<p>Problem 4: Find the center of a circle in as many ways as you can, if you only know the circumference of the circle.</p>

Figure 1. The four geometry problems

The solutions provided by the students were classified in view of the strategy they used. Then, the aspects of creativity (fluency - flexibility - originality - total creativity) were calculated based on the scoring scheme that Leikin (2009) proposed for the evaluation of performance on MSTs. The construct of solution spaces that will be explained in the next section was also used to analyze the student problem-solving performance (Leikin, 2007). In order to answer the research questions, descriptive statistics and t-test at 95% significance level were used. Furthermore, a similarity statistical analysis was conducted using the computer software C.H.I.C. It is a method of analysis that determines the similarity connections of the variables (Gras, Suzuki, Guillet, & Spagnolo, 2008). On the similarity diagram we symbolize with P_i , $i=1, 2, 3, 4$ the problem referred to and symbolize with S_j , $j=0, 1, 2, 3, 4$ the number of solutions for each problem. The interviews with the two students and one of the authors were transcribed and examined qualitatively.

Results

In order to examine the influence of geometrical figure apprehension in the development of mathematical creativity, five solutions which were provided by students in problem 2 are presented in Figure 1. These solutions are grouped into three solution spaces based on the strategies and properties that students used. In the first solution space, the main strategy is that the straight line joining the middle of the two sides of a triangle is parallel and equal to half of the opposite side, and includes two solutions (1a, 1b). The first solution was found by 8.1% of the students while the second solution which requires drawing an auxiliary line was only found by the 2.7% of students; the originality of this solution space rated 10 (10.8% < 15%). In the second solution space, the main strategy is that equal corners were formed, and refers to two solutions (2a, 2b). These solutions were provided by the 28.4% of students as it did not require any auxiliary construction. Its originality rated

0.1 (56.8% > 40%). The third solution space includes one solution (3) that refers to the construction and the use of the rhomb properties. This solution which requires constructing an auxiliary line was provided only by 1.4% of the students and the originality rated 10 (1.4% < 15%). As far as the fluency for problem 2 is concerned, 41.5% of the students were unable to solve the problem, while a similar percentage of students (49%) found only one way of solving it. The percentage of students who were able to find 2 or 3 ways was quite low (9.5%).

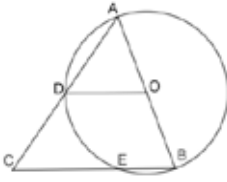
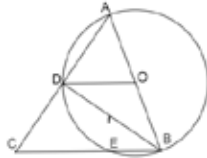
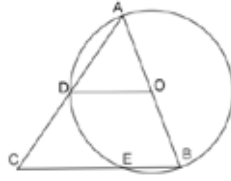
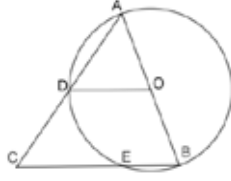
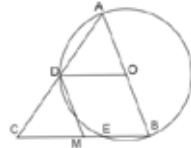
<p>1a Solution 8.1%</p> <p>$DO = 1/2AB$, as equal radii in a circle. $\Rightarrow DO$ is a midline in triangle ABC, as parallel to BC and bisecting AB. $\Rightarrow DO = 1/2AB = 1/2BC \Rightarrow AB = BC$.</p> 	<p>1b Solution 2.7%</p> <p>D is the mean of the AC, since DO joins the medium C with D and $OD \parallel BC$. We construct the median DB of the triangle. The angle D goes to a semicircle so $\angle D = 90^\circ$. Thus, DB is both median and altitude of the triangle ABC. Therefore, ABC is isosceles and $AB = CB$.</p> 	
<p>2a Solution 28.4%</p> <p>$DO = AO$, as equal radii in a circle. $\Rightarrow \angle ADO = \angle A$, as base angles in an isosceles triangle, $\angle ADO = \angle ACB$, as equal corresponding angles within parallel lines, $\angle ACB = \angle A \Rightarrow AB = BC$, a triangle with 2 equal angles in isosceles.</p> 	<p>2b Solution 28.4%</p> <p>$DO = AO$, as equal radii in a circle. $\Rightarrow \angle AOD = \angle ABC$, as equal corresponding angles within parallel lines. $\Rightarrow \angle A = \angle A$, as shared angle $\Rightarrow \triangle AOD \sim \triangle ABC$ (2 equal angles) $\Rightarrow AB = BC$ (a triangle similar to an isosceles triangle is also isosceles).</p> 	<p>3 Solution 1.4%</p> <p>We construct a parallel line from D to AB. Taking into account that it passes through the median D of the AC, it also passes from the median M of BC and $MD = AB/2$. $EB \parallel DO \Rightarrow MB \parallel DO$. Therefore, $MB = DO = BC/2$ and $OD = OB$ as the radius of the circle. Then, $DOBM$ is a rhombus $\Rightarrow OB = MB \Rightarrow 1/2AB = 1/2BC \Rightarrow AB = BC$.</p> 

Figure 2. Collective solution spaces for problem 2

Students who produced solutions 1a, 2a and 2b possess at least three kinds of geometrical figure apprehension. In particular, the students apprehend sequentially the figure as they construct the figure from scratch by organizing its elementary units through constructive constraints and mathematical properties. Furthermore, the students have a perceptual apprehension, since they recognize the various subfigures in the circle and the inscribed triangle. They also have discursive apprehension, since they prove the solution of the problem based on theorems. In order to produce solutions 1b and 3, except the other three types of geometrical figure apprehension, operative apprehension is required as well,

since the students have to construct the auxiliary lines for the construction of the median of the triangle and the construction of the rhomb to find the solution of the problem. It is evident that a geometrical figure can be constructed in many ways (mereologic modification), each of which can lead the student to a different solution of the problem. Nevertheless, from the solutions given by the students we observed that some students construct the same auxiliary line but they solve the problem differently. In fact, students apprehend operatively the figure in the same way but have different discursive figure apprehension as for the same auxiliary structure they use different properties and theorems to find the solution.

On the basis of the results of the t-test, the number of solutions (fluency) that students give to problem 1 and 3 ($M = 2.16$, $SD = 1.42$), in which the problems are accompanied by the relevant figures, are statistically bigger ($t = 6.02$, $df = 146$, $p < 0.001$) than those that students give to problems 2 and 4 ($M = 1.44$, $SD = 1.21$) in which the figures are not given. Concerning flexibility of the solutions to the problems in which the figure is given ($M = 19.88$, $SD = 12.65$), and the problems without the corresponding figure ($M = 13.93$, $SD = 11.37$), significant differences are indicated with an apparently higher score in the problems in which the figure is given ($t = 5.57$, $df = 146$, $p < 0.001$). Even though according to the findings students' fluency and flexibility is higher in problems in which the figure is given, this is not the case with the originality of the solutions ($t = -1.87$, $df = 146$, $p > 0.05$) and total creativity ($t = -0.71$, $df = 146$, $p > 0.05$).

In fact, there are not any significant differences as far as originality and creativity are concerned in the two types of problems.

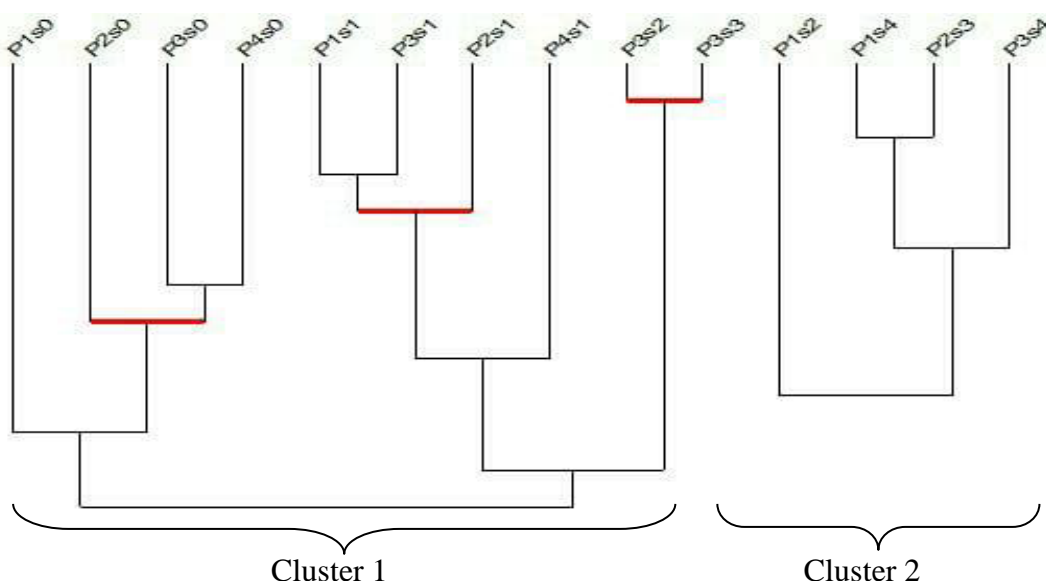


Figure 3. Similarity diagram of students' number of solutions

In the similarity diagram, which concerns students' ability to produce various solutions, there are two significant clusters. Cluster 1 consists of two sub-clusters. The first sub-cluster includes the variables $P1s0$, $P2s0$, $P3s0$, and $P4s0$. It refers to students who do not give any solution to any of the problems, regardless of the presence of figure or not. The second sub-cluster ($P1s1$, $P2s1$, $P3s1$, $P4s1$) is related to students who solve all problems in one way, regardless of whether the figure is given or not. In the second sub-cluster the solutions belong to one solution space. This sub-cluster is associated with the

variables P3s2, P3s3 that involve students who have solved the third problem in which the figure is given, in two or three ways, providing evidence that the figure affected its level of difficulty.

Cluster 2 contains the variables P1s2, P1s4, P2s3, and P3s4 that correspond to the students who are highly fluent and flexible in their solutions. On the one hand, these students give two, three or four solutions which mean they have the fluency to produce multiple solutions. On the other hand they are able to move from one solution to another, using different mathematical properties and representations as their solutions belong to at least two different solution spaces.

In fact, the results suggested that the participants of the study form three distinct student profiles:

- Profile 1: Students with poor fluency and flexibility (0 solutions)
- Profile 2: Students with moderate fluency (1-3 solutions) and flexibility (1 solution space)
- Profile 3: Students with high fluency (≥ 2 solutions) and flexibility (≥ 2 solution spaces)

The majority of the students have poor and moderate fluency and flexibility. In particular, fifty students (34%) have poor fluency and flexibility in at least one problem, sixty six students (45%) provide only one solution in at least one problem and twenty five students (17%) solve one of the problems in two different ways at least. Only six students (4%) have high fluency and flexibility in at least one problem.

The qualitative data provided further insight in to students' potential performance. During the solution process, changes concerning fluency and flexibility of student solutions were observed. The following extract from one of the student's interview (Student A) is indicative::

10. St: I'm not so good at geometry.

17. St: Better find another student who knows them better. I do not remember them at all.

19. St: Okay, I leave the first problem and go to the third problem.

(Having already found two ways in the first problem after solving the other three problems)

165. St: Let me think... I have an idea, half a minute to see something in the third problem.

166. St: Construct a parallel line from C to AB and from B to AC and create a rectangle for $A = 90^\circ$ (the student is drawing the new figure). From this I will say that the diagonals of the rectangle are equal and bisected. Therefore, $AD = 1 / 2BC$.

170. St: I thought of something else.

172. St: Could I construct a circle as we did in the forth problem? Because the right angle ends in a semicircle, let's say that BC will be a diameter and the center will be D. So DC, DB and DA will be radiuses, so they will be equal.

It is evident that, MSTs enhance flexibility in geometric knowledge and student thinking as they encourage connections between different ways of solving them. The student, as soon as he had solved the problems, moved from zero fluency and flexibility during the solution of the first problem to high fluency and flexibility of solutions at the end of the interview. During this process he often made references to the previous problem solutions. It is worth mentioning, that the qualitative data strengthen quantitative results as the construction of auxiliary lines and reconfigurations that reflect

the operative figure apprehension revealed to be the most important aspects for producing new ways of solving and achieving high levels of creativity in geometry.

Discussion

The present study explored students' creativity in MSTs using a multidimensional approach as the following dimensions are considered: (a) mathematical creativity; (b) geometrical figure apprehension; and (c) multiple-solution problem solving in mathematics education. Significant differences in the fluency and flexibility of student solutions were observed depending on whether or not the figure was given (RQb). In fact, students exhibited greater fluency and flexibility in the problems in which the verbal description of the problem was accompanied by the relevant figure. As far as the originality and the total creativity of students' solutions are concerned, they did not differ significantly in the two types of problems. On the one hand these findings are explained taking into account that even though flexibility and fluency are different aspects of creativity, they are strongly related to each other (e.g. Leikin, 2009). On the other hand, researchers (e.g. Levav-Waynberg & Leikin, 2012, Leikin, 2013) pointed out that originality is a more internal characteristic than fluency and flexibility. It is also more related to creativity but less dynamic.

The similarity analysis of the number of student solutions suggested three distinct profiles of students: (a) a poor fluency and flexibility group; (b) a moderate fluency and flexibility group; and (c) a group of high fluency and flexibility (RQc). The majority of students belong to the first two groups. However, qualitative results provide evidence that students managed to move from poor to high fluency and flexibility of solutions through references to previous problems they had solved. This is in line with Leikin's (2013) findings that fluency and flexibility are dynamic, whereas originality is a "gift". As our work deals with relative creativity (Leikin, 2009), we support that mathematical creativity should be developed in all students (Sheffield, 2009). As a matter of fact, creativity is influenced by the teaching, guidance and experiences of the individual (Silver, 1997). Thus, the systematic exploitation in the teaching of MSTs in geometry may enhance student fluency and flexibility.

Furthermore, emphasis should be given to activities that help students overcome the perceptual way of looking at a geometrical figure and moving to operative figure apprehension. The results suggest that the students who apprehend the figure operatively are able to undertake mereologic modifications that enable them to provide different proofs in geometrical problems (RQa). An interesting finding which highlights heuristic functioning of figures is that some students use the same auxiliary construction but their solutions are based on different properties and theorems. In other words, they have the same operative apprehension but different discursive apprehension of a figure. Indeed, operative apprehension of a figure is a source of creativity in geometry as it gives insight into the solution of the problem. Nevertheless, Duval (1995) indicated that the mathematical way of looking at figures only results from the coordination of separate processes of apprehension over a long time. In line with this assertion, our findings revealed that geometrical figure apprehension is a prerequisite for students to provide a variety of solutions to the geometry problems and, thus, have high creativity.

Certainly, there is still need for further investigation into the teaching implications of the subject. In the future, it would be interesting and useful to examine the effects of intervention programs aiming

at developing geometrical figure apprehension in view of MSTs. Furthermore, the validation of a theoretical model that examines the structure and relation of various components of geometrical figure apprehension, mathematical creativity and ability to prove in multiple ways would contribute to this domain of research too.

References

- Duval, R. (1995). Geometrical pictures: Kinds of representation and specific processing. In R. Sutherland & J. Mason (Eds.), *Exploiting Mental Imagery with Computers in Mathematics Education* (p.142-157). Germany: Springer.
- Gras R., Suzuki E., Guillet F., & Spagnolo F. (2008). *Statistical implicative analysis*. Germany: Springer.
- Herbst, P. (2002). Establishing a custom of proving in American school geometry: Evolution of the two-column proof in the early twentieth century. *Educational Studies in Mathematics*, 49(3), 283-312.
- Leikin, R. (2007). Habits of mind associated with advanced mathematical thinking and solution spaces of mathematical tasks. In D. Pitta-Pantazi & G. Philippou (Eds.), *Proceedings of the Fifth Conference of the European Society for Research in Mathematics Education* (pp. 2330–2339). Larnaka, Cyprus: University of Cyprus and ERME.
- Leikin, R. (2009). Exploring mathematical creativity using multiple solution tasks. In R. Leikin, A. Berman & B. Koichu (Eds.), *Creativity in mathematics and the education of gifted students* (pp. 129–145). Netherlands: Sense Publisher.
- Leikin, R. (2013). Evaluating mathematical creativity: The interplay between multiplicity and insight. *Psychological Test and Assessment Modeling*, 55(4), 385-400.
- Levav-Waynberg, A., & Leikin, R. (2009). Multiple solutions to a problem: A tool for assessment of mathematical thinking in geometry. In V. Durand-Guerrier, S. Soury-Lavergne & F. Arzarello (Eds.), *Proceedings of the Sixth Conference of the European Society for Research in Mathematics Education* (pp. 776-785). Lyon, France.
- Mann, E. (2006). Creativity: The essence of mathematics. *Journal for the Education of the Gifted*, 30(2), 236-260.
- Silver, E. A. (1997). Fostering creativity through instruction rich in mathematical problem solving and problem posing. *ZDM*, 3, 75–80.
- Sheffield, L. (2009). Developing mathematical creativity - Questions may be the answer. In R. Leikin, A. Berman & B. Koichu (Eds.), *Creativity in mathematics and the education of gifted students* (pp. 87-100). Rotterdam: Sense Publishers.
- Stupel, M., & Ben-Chaim, D. (2017): Using multiple solutions to mathematical problems to develop pedagogical and mathematical thinking: A case study in a teacher education program. *Investigations in Mathematics Learning*, 9 (2), 86-108.
- Torrance, E.P. (1994). *Creativity: Just wanting to know*. Pretoria, South Africa: Benedic books.

In-service teachers' conceptions of parallelogram definitions

Aehsan Haj Yahya¹, Wajeeh Daher² and Osama Swidan³

¹ Bet-Berl College of Education; aehsanhajyahya@gmail.com

² Al-Qasemi Academic College of Education; wajeehdaher@gmail.com

³ Ben-Gurion University of the Negev; osamasw@gmail.com

The present research examines middle school mathematics teachers' conceptions of geometric definitions, and specifically whether they possess geometric conceptions at the van Hiele fourth level. Sixty two teachers participated in the research. We used an open-ended questionnaire for data collection. The questionnaire included three questions concerned with the equivalence between definitions, sufficient and necessary conditions, and deductive geometric reasoning related to definitions. We used deductive and inductive content analysis to analyse the data. We found that generally, the participating teachers did not possess the geometric conceptions at the van Hiele fourth level and had difficulties in understanding what the imperative and optional features of mathematical definitions are. In addition, the participants' conceptions of definitions have specific features that explain why they have not attained the van Hiele fourth level.

Keywords: Conceptions, parallelogram, definitions, in-service teachers

Introduction

Definitions are used as building blocks for the construction of mathematical theorems (Pimm, 1993), which makes them play a central role in building understanding of the meanings of mathematical concepts (Wilson, 1990). According to van Hiele and van Hiele's (1958) theory about geometric thinking development, at the informal deduction level, the learner understands the importance of precise definitions, how a particular attribute derives from another, and the inclusion relationship between groups of shapes; the learner can construct internal connections between the different properties of the same shape and connections between the properties of different shapes. At the subsequent level; that the formal deduction level, the learner understands the role of definitions and recognizes the features of a formal definition, such as necessary and sufficient attributes and equivalent definitions. At this more advanced level, the learner understands the functions of definitions, axioms and theorems as a deductive chain.

Zaslavsky and Shir (2005) distinguish between two features of the definition: those which are imperative and those which are optional. Some of the imperative features of definitions are their being non-contradicting, unambiguous and hierarchical, while some of the optional features of mathematical definitions is the requirement about their being minimal; in other words include a minimum of sufficient attributes of the concept. In addition to the aspect of imperative and optional features of definitions, van Dormolen and Zaslavsky (2003) mention four criteria for logical necessities of definitions; one of them is the criterion of equivalence. Other criteria are part of general culture but are not necessary from logical perspective, such as the criterion of minimality and the criterion of elegance, which we need when we want to choose between two equivalent definitions. Using these criteria, we take the 'nicer definition'; the one has less words and less symbols and uses

more general basic concepts. Empirical research shows that many mathematic educators prefer mathematical definitions to be minimal and elegant or parsimonious (Vinner, 1991; Van Dormolen & Zaslavsky, 2003; Leikin & Winicky-Landman, 2001). On the other hand, there are those who, in certain cases, also prefer a non-minimal definition (de Villiers, 1998; Pimm, 1993; van Dormolen & Zaslavsky, 2003; Zaslavsky & Shir, 2005). For example, it is possible to define two similar triangles as two triangles in which two angles in one triangle have equal angles in the second triangle. From the pedagogically perspective, adherence only to the minimal definition, may impair the understanding of the concept of similar triangles (Zaslavsky & Shir, 2005).

One feature of mathematical definitions appreciated by mathematicians and mathematics educators is the equivalence of definitions of the same concept (Harel, Selden & Selden, 2006). Leikin & Winicky-Landman (2001) studied mathematical definitions in a non-geometric context, and found that many high school teachers did not notice that a particular concept could be defined in a number of equivalent ways. When the learner attends to the equivalent definition, he/she performs in van Hiele informal deduction level. Haj Yahia, Hershkowitz & Dreyfus (2014) found that many senior school students rejected correct geometric proofs because they failed to notice that there might be more than one definition for a particular concept. When we attend to the equivalent geometrical definitions, however, we perform as expected in van Hiele & van Hiele (1958)'s informal level: we accept the notion that we can derive one attribute from the other/s. For example, if in a quadrilateral every two opposite sides are parallel, then we can deduce that every two opposite sides are equal and vice versa – and these two statements are equivalent.

Another important aspect of definitions is giving a definition that contains non-sufficient attributes (de Villiers, 1998). Many studies reported that when the students asked to define some quadrilaterals a part of the students gave brief definitions but not complete (de Villiers, 1998; Choi, Oh & Kyoung, 2008; Markovic & Romano, 2013). de Villiers (1998) reported that when the students asked to define the rhombus, a part of the students gave brief definitions but not complete. For example, a rhombus is a quadrilateral whose diagonals are perpendicular to each other. Markovic & Romano (2013) reported that some students define the square as "a geometric figure all four sides of which are equal".

Research rational and goals

Since the progress from one level to another on van Hiele and van Hiele's (1958) depends more on teaching than on age or biological maturity, different types of instruction can have a different effect on the progression from level to level. In order to prove and to be able to understand the role of proof, he/she must be at the formal deduction level. Moreover, teachers' conceptions are the basis for their mathematics teaching (Johnson, Blume, Shimizu, Graysay, & Konnova, 2014), especially their teaching of geometry. Thus investigating the teachers' conception about mathematical definition plays central issue in the teaching processes. The teachers are expected to be at the formal deductive level, where they understand the role of definitions and recognize the logical features of a formal definition, such as necessary and sufficient attributes and equivalent definitions. In addition, they are expected to know the imperative features and the optional features of definitions (Zaslavsky & Shir, 2005).

The present research intends to examine mathematics teachers' conceptions of geometric definitions. The results of the research would make us more knowledgeable regarding these conceptions, and in

particular regarding the features of these definitions. This is especially needed because of the little research done on teachers' conceptions of a basic aspect of their ability to teach geometry; i.e. geometric definitions.

Research question

What are the features of middle school teachers' conceptions of geometric definitions?

Methodology

Sixty-two in-service middle school mathematics teachers who constitute theoretical sample (Glaser & Strauss, 1967) participated in this study. These teachers studied for completing their M.Ed. (Master of Education) degree in mathematics education in an academic college for teachers. We used an open-ended questionnaire for data collection. The questionnaire included three questions that are concerned with the following topics related to definitions: the equivalence between definitions of the same concept, sufficient and necessary conditions of a concept, and finally deductive geometric reasoning related to definitions. To provoke teachers' thinking, we used prompts consisting of fictive or real contradicting statements of students that represent common conceptions of definitions of geometrical concepts. The participating pre-service teachers were asked to fill the questionnaire, by commenting on each statement; whether they agree with it or not, and to explain their answers.

For analysing the data, we used a qualitative coding method (Salanda, 2015) that is close to grounded theory (Glaser & Strauss, 1967). We used deductive codes derived from a theoretical perspective (Charmaz et al., 2007) and inductive codes for the themes not present in existing research about geometric education. Using the deductive codes, we characterized the answer of each participant according to its satisfaction of the aspects of definition: being minimal, being hierarchical, awareness of sufficient conditions, awareness of equivalent definitions, etc. Afterwards we looked at shortages of the participants' conceptions, for example being aware of the sufficient conditions but enforcing other conditions. Next we looked at the reasoning behind the answer, for example being not aware of equivalence definitions as a result of considering the lack of the 'edges' term.

The coding was conducted independently by the three authors. The inter-rater reliability of coding by Cohen's Kappa was 0.86, which shows an appropriate value of the interrater reliability.

Results

This section is splitting into four parts. We present the results concerning (a) the equivalence between definitions, (b) sufficient and necessary conditions, and finally (c) the deductive geometrical reasoning.

The equivalence between definitions of the same concept

The first item in the questionnaire related to the following question:

The mathematics teacher asked his students to define the "parallelogram".

Sami** defined the parallelogram as "Parallelogram is a quadrilateral in which every two opposite sides are parallel". **Rami** defined the parallelogram as "Parallelogram is a quadrilateral in which every two opposite angles are equal". **Rafi** defined the parallelogram as "Parallelogram is a quadrilateral in which the diagonals crossing each other" **Salim** defined the parallelogram as "Parallelogram is a quadrilateral in which every two opposite sides are equal". **For each of these claims you need to determine whether it is a definition and explain your response.

Answering the first item, 25.5 % (16) of the participants demonstrated knowledge of equivalent definitions. 14.5% of the participants, though they demonstrated knowledge of equivalent definitions, preferred some of these definitions over others. Specifically, these students preferred the definition of the parallelogram that included properties about the sides of the parallelogram, probably because the name indicates that the sides are parallel. Three of them preferred the definition that mentions the property of "pairs of opposite sides being parallel".

27.5% (17) of the participants claimed that the definition should include conditions about sides of a parallelogram, but did not demonstrate knowledge of equivalent definitions. These students were not satisfied with the definition that includes just the term 'angles' or 'diagonals', but wanted the definition statement to include conditions about the sides. Eight of these students even wanted the statement to include conditions related to two components; sides and parallelism. One student wrote, "This could not be a definition of the parallelogram, for it just talks about angles".

The previous results indicate that the need for a condition about the sides of the quadrilateral or/and the opposite sides being parallel was mentioned by the students who demonstrated knowledge of equivalent definitions and those who did not demonstrate such knowledge.

27.5% (17) of the participants differentiated between definitions and properties. Doing so, they did not accept the statements that describe the parallelogram in terms of its angles or diagonals as definition, saying that it is property and not a definition. Five of these students did not elaborate further. For example, one of them wrote, "This is not a definition because it is a property". The rest of these students (twelve students) argued that the definition should talk about sides and not any other element of the parallelogram. One of them wrote, "This is a property and not a definition of a parallelogram for it includes information about the angles and not the sides".

19.5% (12) of the participants did not accept a statement as a definition because of their little understanding of the sufficient conditions issue of the definition. These students did not accept the property "each pair of opposite sides are parallel" as sufficient for a quadrilateral to be a parallelogram. Instead, they suggested that the correct definition should include also the equality of the edges. One of these students wrote, "the definition should be a parallelogram is a quadrilateral that each pair of its opposite sides are parallel and equal".

For the first item only and because of the various percentages in its results, we will summarize these results in Table 1 to make them more accessible.

Category	Percent
Demonstrating knowledge of equivalent definitions	25.5%
- Preferring definitions that included properties about the sides	
Not demonstrating knowledge of equivalent definitions	
- Preferring definitions that included properties about the sides	27.5%
- differentiating between definitions and properties	27.5%
- little understanding of the sufficient conditions	19.5%

Table 1: Categories of students' responses on the equivalence item and their percentages

Sufficient and Necessary conditions of a concept

The second item in the questionnaire related to the following question:

The mathematics teacher asked his students to define the "parallelogram".

Sami** defined the parallelogram as "Parallelogram is a quadrilateral in which every two opposite sides are parallel". **Rami** defined the parallelogram as "Parallelogram is a quadrilateral in which two opposite sides are parallel". **Rafi** defined the parallelogram as "Parallelogram is a quadrilateral in which every two opposite sides are parallel and equal" **For each of these claims you have to determine whether it is definition And to explain your response!

Answering the second item, 82% (51) of the participants did not consider correctly that the statement "The parallelogram is a quadrilateral in which two opposite sides are parallel" an accurate definition of the parallelogram. Twenty-four of them reasoned that the statement should include 'all opposite sides' and not just two opposite sides. The rest (twenty-seven students), in considering the statement not an accurate one, reasoned that the statement describes a trapezium and not a parallelogram. Eleven students wrote that the statement is an accurate statement because it talks about the opposite sides being parallel.

87% (54) of the participants considered correctly, "The parallelogram is a quadrilateral in which each pair of opposite sides are parallel" an accurate definition of the parallelogram. Eight students considered this definition not to include sufficient conditions because it should also include the equality between the sides as condition".

Almost all the participants considered the statement "The parallelogram is a quadrilateral in which each pair of opposite sides are parallel and equal" an accurate definition of the parallelogram. Eleven of these students wrote that one of the conditions 'equal sides' or 'parallel sides' is enough for a quadrilateral to be a parallelogram. In spite of this knowledge, not any one of them concluded that the definition is not accurate or that it violates the minimalism criterion of definition.

Deductive geometric reasoning

The third item in the questionnaire was related to Deductive geometric reasoning.

*The mathematics teacher defines "The trapezium is a quadrilateral in which two opposite sides are parallel" and "The Parallelogram is a quadrilateral in which two pairs of opposite sides are parallel". Rami claims that the teacher's definitions mean that the parallelogram is a trapezium, while Sami claims that Rami is wrong. **Which of these claims is right? Explain your response!***

Answering the third item, 56.5% (35) of the participants supported the claim of Rami that the parallelogram is a trapezium according to the teacher definition, and also supported the opposite claim of Sami that parallelogram is not a trapezium according to the right definition of the trapezium.

19.5% (12) of the participants argue that Rami's claim that parallelogram is trapezium is wrong while Sami's claim that the parallelogram is a not trapezium is right. They argued that the teacher defined the trapezium as having one pair of parallel opposite sides, but she have to define it as having only one pair of parallel opposite sides and the parallelogram have two pairs of parallel opposite sides. This argument also led them to consider only the second claim is right.

24% (15) of the participants wrote that Rami's claim is right while Sami's is wrong. Doing so, they argued that the claim "The parallelogram is a trapezium" is right because the teacher defined the trapezium as having one pair of opposite angles, while she defined the parallelogram to have two pairs of parallel opposite sides. The shape that has two pairs of parallel opposite sides satisfies the condition of having a pair of parallel opposite sides. This means that according to the teacher, the parallelogram is a trapezium.

Discussion and conclusions

The present research intended to investigate the features of middle school teachers' conceptions of geometric definitions. It could be argued according the research results that the participating teachers have difficulties regarding the understanding the structure of the geometrical definitions and their functions and meaning.

One feature of the participating teachers' conceptions of mathematical definitions is its relatedness to their understanding the sufficient conditions issue of the definition. Some of them did not accept the statement "The parallelogram is a quadrilateral in which each pair of opposite sides are parallel" as an accurate definition of the parallelogram, this statement sufficient in order to deduce the rest of concept attributes These conceptions of the sufficient conditions also led them to demand non-minimal definitions to be the accurate definitions. This feature agrees with other reports about teachers' conceptions of the definition this result is in agreement with the results from Leikin and Winicki-Landman (2000) and from Zazkis and Leikin (2008) where prospective secondary mathematics teachers indicated a preference for the barely-not-minimal definition over a minimal definition.

A second feature of the participating teachers' conceptions of mathematical definitions is that they differentiate between a definition and a property. They did not accept the statements that describe the parallelogram in terms of its angles or diagonals as definition, saying that it is property and not a

definition, although that these statements satisfy all the imperative features of mathematical definition (Zaslavsky & Shir, 2005). This misunderstanding of the relationship between a definition and a property leads to difficulty in understanding the equivalence between definitions. From these participants' perspective of mathematical or geometrical concepts, for every concept there is only one definition (Leikin & Winicky-Landman, 2001). The participating teachers were not aware of the logical necessities of equivalence (van Dormolen & Zaslavsky, 2003).

Third feature of the participating students' conceptions of mathematical definitions is that it takes into consideration the name of the geometric concept. Some of the students only accepted a definition of the parallelogram that included the term 'parallel' or at least sides, and did not accept a definition that is related to relations between its angles or diagonals. Thus, the name affected the participating teachers' acceptance of some statements as definitions and their rejection of other statements as thus. This result confirms the finding of Haj-Yahya, Hershkowitz & Deryfus (2014) who reported that the parallelogram name affects students' proving processes. It seems that this influence of the name on the participating students' conceptions of definitions hindered these students from considering some of the equivalence and alternative definitions of the parallelogram as accurate definitions.

The fourth feature of the participating students' conceptions of mathematical definitions is that it could include contradictions. More than half of the participating students accepted two statements that result in the trapezium being a parallelogram, as well as the opposite, which means that there is no difference between the shapes. The results from the third class of questions was about the deductive reasoning, the results shows that in many cases the students did not rely their reasoning on the concept definition, this confirm previous results of Edward & Ward (2004) about non-geometrical context.

To conclude, the present research examines mathematics teachers' conceptions of geometric definitions. We found that generally, the participating teachers do not possess the geometric conceptions at the van Hiele fourth level didn't understand what are the imperative features of mathematical definition (Zaslavsky & Shir, 2005). The research results directs the preparation of workshops for teachers, so it would be possible to target in these workshops the features of teachers' conceptions of definitions. These workshops would constitute a platform for discussing the impact of mathematics teachers' conceptions of definitions on their teaching. This would make these conceptions sounder and help these teachers take better decisions regarding how to teach definitions in the mathematics classroom. Research is needed here to verify the consequences of educational programs on teachers' conceptions of definitions in particular and on their teaching in general. In addition, future research can utilize theoretical frameworks as those suggested Fujita and colleagues (see for example Fujita (2008)), which will clarify other aspects of in-service teachers' conceptions regarding definitions.

References

- Charmaz, K., & Belgrave, L. L. (2007). *Grounded theory*. John Wiley & Sons, Ltd.
- Choi, K., & Oh, S. Kyoung. (2008). Teachers' conceptual errors related to the definitions in the area of geometry of elementary school mathematics. *Journal of the Korean Society of Mathematical Education. Series A. The Mathematical Education*, 47(2), 197–219.

- de Villiers, M. (1998). To teach definitions in geometry or teach to define? In A. Olivier & K. Newstead (Eds.), *Proceedings of the 22nd Conference of the International Group for the Psychology of Mathematics Education*, Vol. 2 (pp. 248–255). Stellenbosch, RSA: PME.
- Edwards, B. S., & Ward, M. B. (2004). Surprises from mathematics education research: Student (mis)use of mathematical definitions. *The American Mathematical Monthly*, 111, 411-424.
- Fujita, T. (2008). Learners' understanding of the hierarchical classification of quadrilaterals. In M. Joubert, (Ed.), *Proceedings of the British Society for Research into Learning Mathematics*, 28(2), 31-36.
- Glaser, B., & Strauss, A. (1967). Grounded theory: The discovery of grounded theory. *Sociology The Journal Of The British Sociological Association*, 12, 27-49.
- Haj-Yahya, A., Hershkowitz, R., & Dreyfus, T. (2014). Investigating students' geometrical proofs through the lens of students definitions. In Oesterle, S., Liljedahl, P., Nicol, C., & Allan, D. (Eds.). *Proceedings of the Joint Meeting of PME 38 and PME-NA 36*, Vol. 3, pp.217-224. Vancouver, Canada: PME.
- Harel, G., Selden, A., & Selden, J. (2006). Advanced mathematical thinking: Some PME perspectives. In A. Gutiérrez & P. Boero (Eds.), *Handbook of research on the psychology of mathematics education: Past, present and future* (pp. 147-172). Rotterdam: Sense.
- Johnson, H. L., Blume, G.W., Shimizu, J., Graysay, D., & Konnova, S. (2014). A teacher's conception of definition and use of examples when doing and teaching mathematics. *Mathematical Thinking and Learning*, 16(4), 285-311.
- Leikin, R., & Winicky-Landman, G. (2001). Defining as a vehicle for professional development of secondary school mathematics teachers. *Mathematics Teacher Education and Development*, 3, 62–73.
- Markovic, Z., & Romano, D. A. (2013). Gaining insight of how elementary school students conceptualize geometric shape of parallelogram. *Open Mathematical Education Notes*, 3, 31–41.
- van Dormolen, J., & Zaslavsky, O. (2003). The many facets of a definition: The case of periodicity. *Journal of Mathematical Behavior*, 22, 91-196.
- van Hiele, P. M., & van Hiele, D. (1958). A method of initiation into geometry. In H. Freudenthal (Ed.), *Report on methods of initiation into geometry* (pp. 67-80). Groningen: Walters.
- Pimm, D. (1993). Just a matter of definition [Review of the book *Learning mathematics through inquiry*]. *Educational Studies in Mathematics*, 25, 261–277.
- Saldaña, J. (2015). *The coding manual for qualitative researchers*. Sage.
- Vinner, S. (1991). The role of definitions in the teaching and learning of mathematics. In D. Tall (Ed.), *Advanced mathematical thinking* (pp. 65–81). Dordrecht: Kluwer Academic Publishers.
- Wilson P. S. (1990). Inconsistent ideas related to definitions and examples. *Focus on Learning Problems in Mathematics*, 12(3–4), 31–47.
- Zazkis, R., & Leikin, R. (2008). Exemplifying definitions: A case of a square. *Educational Studies in Mathematics*, 69, 131–148.
- Zaslavsky, O., & Shir, K. (2005). Students' conceptions of a mathematical definition. *Journal for Research in Mathematics Education*, 36, 317–346.

Children's use of spatial skills in solving two map-reading tasks in real space

Cathleen Heil

Leuphana University Lüneburg, Germany; cathleen.heil@leuphana.de

Map reading is a cognitively demanding spatio-geometric activity for children that involve understanding and updating person-space-map relations during movement in a large environment. Drawing from the psychological literature, children's skills in reasoning about those relations were tested in two tasks of a map-based treasure hunt on the campus (self-location and place finding), and compared them to their performances in a set of spatial tasks in paper and pencil format. 9- to 12-year old children (N=240) placed colored stickers and arrows on the map to describe their location and orientation at three different places, and laid down three disks to mark locations they identified. Hierarchical linear regression analysis revealed that performances in a set of written spatial tasks predicted up to one quarter of the variance in performances in both map-reading tasks, while sex and strategy choice were not found to be important predictors.

Keywords: Geometry education, map tasks, spatio-geometric reasoning, spatial skills.

Introduction

Geometry education at primary school is often based on Freudenthal's idea of "grasping space" (1973), and thus aims to contribute to children's thoughtful interaction with the three-dimensional space in which they live, play, and move. Ideally, this goal is achieved at school with a range of spatio-geometric tasks that allow children to complete realistic geometric activities that are similar to their own everyday experience (Lowrie & Logan, 2007).

Within TWG4 of CERME, spatial reasoning and spatial skills have been identified as latent underlying cognitive skills that allow children to develop and apply the four core competencies (reasoning, figural, operational and visual) for geometrical thinking (Maschietto et al., 2013). Although their importance has been emphasized in a range of studies, their role in realistic spatio-geometric activities is little understood (Houdement, 2017). A review of the literature revealed that all studies on these activities in the working group are typically located in a space that is very close to the subject, like for example a sheet of paper, a set of small objects, or a computer screen (Houdement, 2017). In contrast, investigating activities that are located in larger, realistic interaction spaces such as map reading in real space would be closer to the original demand for realistic geometric activities that allow children to "grasp space."

Addressing this gap in the literature and extending the literature on spatial-geometric reasoning of primary children, this study presents two map-reading activities (self-location and place finding) as examples of spatio-geometric tasks that can be completed in larger spaces. By doing so, it seeks to empirically investigate the relative importance of spatial skills, sex, and strategy choice in these contexts.

Map reading, person-space-map relations and spatial skills

Maps are symbolic representations of the reference environment that allow to mediate between the immediate perception of space and the cognized inference about it, for instance during navigation with a map (Downs, 1981). Maps have been emphasized to foster spatio-geometric thinking in realistic contexts that require the integration of information from the real space that surrounds the learner rather than being based on material that can be perceived from one single vantage point (e.g. Liben & Downs, 1993). Maps provide therefore an important tool for completing spatio-geometric activities in large interaction spaces, which, in turn, requires cognitive processes (Montello, 1993) and spatial knowledge (Brousseau, 2000) that are different from processes and knowledge used to solve paper- and pencil spatial tasks.

To read a map, in particular to establish a relationship between the real physical environment and its abstract-geometric depiction, is a complex task that requires not only spatio-geometric skills, but also requires the understanding of basic mathematical concepts. Following a rather descriptive argumentation of Muir and Frazee (1986), eight skills relate to map reading: (1) interpreting symbols, (2) understanding scale, (3) calculating distances, (4) understanding perspective, (5) finding locations, (6) determining directions, (7) identifying elevation, and (8) imagining relief. Among those skills, three explicitly relate to spatio-geometrical ones ((4) – (6)). Although map reading can be considered being a complex activity that involves all eight skills in an interrelated way, the focus of this paper is on the skills of understanding perspective, finding locations and determining directions in this study, and approach and conceptualize them further from a psychological perspective.

Two typical tasks of map use that require all three skills outlined above, are direct navigation towards a certain goal (*place finding*) and understanding where you are on a map (*self-location*). Self-location is a prerequisite of further map use and requires linking their current location in the environment to the analogue location on the map. Hereby, locating themselves on a map does not only involve identifying their position on the map, but also considering their current orientation. Following Liben & Downs (1993), to do so, children must understand three different relations between themselves (person), the environment (space) and the representation of the environment (map). These three relations are perception and reflecting on the own location in space (*person-space* relation), understanding and establishing links between the space and its representation (*space-map* relation) and understanding their own location on the map (*person-map* relation).

Children acquire the knowledge to master the person-space relation relatively early in their development due to their sensorimotor exploration of space. That is, children demonstrate relatively early that they are for instance intuitively able to identify their home location or the location of other landmarks. However, adjusting this intuitive person-space understanding by taking information on the environment from a map, thus establishing geometrical correspondences between the environment and its depiction in a map, appears to be achieved much later in the children's development (see Liben & Downs, 1993, for references in the developmental literature).

In particular, understanding geometric correspondences comes to reason about the space-map relation by identifying whether the map aligns correctly with the environment and further involves projective reasoning for establishing the person-map relation. Whenever the map is not aligned with the

environment, children need to engage some form of cognitive compensation. Understanding the person-space-map relation then becomes an intertwined cognitively challenging process of mentally rotating the map to align it with the environment (thus establishing the space-map relation) and imagining the own locating and heading on a map (thus establishing the person-map relation).

Spatial cognition psychologists have modeled the skills to establish and maintain the correct person-space-map relations during navigation by relating them to the concept of spatial skills (e.g. Liben & Downs, 1993, Liben et al., 2013). Spatial skills is an umbrella term that refers to a set of cognitive skills that allow an individual to encode, maintain, and transform a spatio-visual stimulus to induce a certain inference or a spatial behavior. From this perspective, aligning a map with the environment has been modeled as mental rotation skill (e.g. Shepard & Hurwitz, 1984) and imagination of the own position on a map as perspective taking skill (e.g. Liben & Downs, 1993).

While the literature on spatial cognition proposed this relation at the level of latent cognitive processes, it is not clear whether this relation holds true from the perspective of individual differences. The goal of the study was therefore to empirically test whether and to and which extent individual differences in tasks requiring spatial skills are important predictors for individual differences in map-use tasks. It was also tested, whether sex (e.g. Voyer & Voyer, 1995) and spontaneous strategy use (e.g. Liben et al., 2013) were also important predictors.

Methods

Research design

This study used a quantitative design that was based on two psychometric tests: First, a paper-and-pencil test that measured performances in a set of spatial tasks that required the use of spatial skills. Second, a map-based orientation test that measured performances in self-location and place finding tasks that required the skills to constantly update person-space-map relations. Scores in the tests were interpreted as indicators of individual skill and related to each other in multiple regression models.

Participants

The sample consisted of 240 primary school children (111 boys, 129 girls) out of a town in Northern Germany. The children were aged between 9 and 12 years (mean age 9.17, $SD=.50$) and formed a heterogeneous sample in terms of scholar achievement and social background. The sample was not specifically chosen, but consisted of all children in the town that got the permission to participate in the study.

Paper and pencil tasks

The children completed a set of different paper and pencil tasks in 45 minutes. The test consisted of eight different tasks (see Table 1 for examples of tasks), four of them being adoptions of adult tasks (e.g., a 2D mental rotation tasks based on Ekstrom's Card Rotation Test, a 3D mental rotation task similar to the Vandenberg's Mental Rotation Test, a Paper Folding Task analogue to Thurstone's Punched Holes Test, and a perspective taking task analogue to the Guilford-Zimmermann boat test). The four other tasks were developed from the scratch and tested within a pilot study with $N=222$ children. Those tasks required for example perspective taking processes in labyrinths.

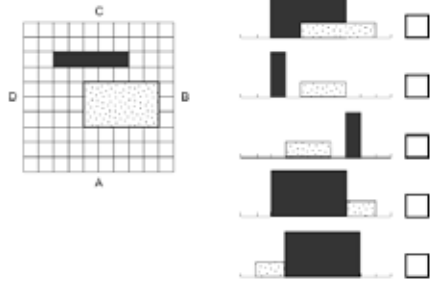

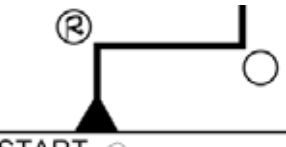
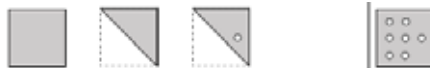
Task	Description and Scoring	Example item
Boxes	Requires sorting the corresponding side views of an array of boxes that is presented in plan view. The children need to sort all four side views out of five possible solutions. 3 items with polytomous scoring (2-1-0).	
MEADOW	Requires determining directions (forward/backward & left/right) of mental movement that explains a shift from picture one to picture two. 6 items with dichotomous scoring.	
LR	Requires imagining going along a path on a map and to decide on each crossing whether to turn left or right. 4 items with dichotomous scoring.	
PFT	Adoption of the Paper Folding Task. 6 items with dichotomous scoring.	

Table 1: Four tasks of the paper and pencil test.

Map-based orientation tasks

The field area was the campus of Leuphana University has a mostly symmetrical of buildings that are connected via perpendicular roads (see Figure 1). On the campus, the experimenter installed a yellow, a blue and a red flag. The children were individually given a map of the campus as well as a set of six stickers, three of them for indicating locations (points of 5mm diameter), and three of them for indicating directions (little arrow stickers). They further obtained a set of three numbered disks. After some preliminary tasks on map understanding, the children completed two map- tasks. During the tasks, they were forbidden to turn the map.

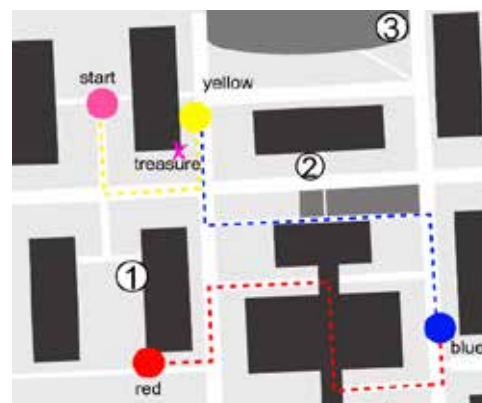


Figure 1: Flags and discs on the campus

1. *Self-location*: The children followed the experimenter to each of the flags and were asked to place the location and direction sticker. Wrong answers were corrected for maintaining equal change for every tasks after putting each sticker.
2. *Place Finding*: At the red flag, the children were told to find numbers on the map and place the corresponding disks at the right location on the campus. The experimenter recorded the locations

where each of the three disks were placed. Whenever a disk was misplaced, the children were corrected afterwards, thus maintaining equal chance for the subsequent disk.

These tasks required the children constantly update the space-map relation since they were not allowed to turn the map. Moreover, solving the tasks required to track where they are on the map, thus updating the person-map relation while integrating visuospatial information from the environment and update their person-space relation.

During the tasks, the experimenter recoded visible strategies such as *tracing* (follow the route with a finger on the map), *matching* (talking aloud about correspondences between map and buildings), *north-orientation* (child orients towards north all the time while walking with the experimenter) and *other* (speaking aloud of left-right changes, gesture, ...).

Data treatment

The X and Y coordinates of each sticker were encoded. Stickers were scored polytomously with a tolerance of 5mm and 7mm radius of the correct position, giving up to 2 points per sticker, and the direction stickers dichotomously. The locations of the discs were scored with up to two points per disk. In a subsequent step, the data was analyzed using listwise deletion for missing values that occurred during data collection in the map-based tasks.

Results

Descriptive statistics

To understand performances of the sample in both tasks, descriptive statistics for the tasks self-location and place location were computed. A descriptive analysis of the two tasks revealed that children performed below the expectation value for the self-location tasks (range=[0,8], M=3.11, SD=2.25, N=231) and about the expectation value in place finding tasks (range=[0,5], M=2.87, SD=1.77, N=207) These results indicate, that self-location tasks remain very difficult to master for children within the sample. In particular marking the correct positions (range=[0,5], M=1.43, SD=1.55) rather than understanding orientation (range=[0,3], M=1.67, SD=0.99) was difficult.

Hierarchical multiple regressions

Self-location performance in relation to individual variables. In a preliminary step, multiple regression analysis was used to test which of the eight spatial tasks that were solved in the test significantly contributed to explain variance in self-location performances. The results indicated that all eight predictors

	Step 1		Step 2		Step 3	
$R^2(p)$.214 (.000)		.215 (.000)		.233 (.000)	
$\Delta R^2(p)$.214 (.000)		.001 (.548)		.017 (.289)	
Predictor	β	p	β	p	β	p
LR	.21	.002	.21	.002	.22	.001
PFT	.22	.002	.22	.002	.20	.005
MEADOW	.18	.007	.17	.009	.18	.008
Sex			.04	.548	.01	.832
Tracing					.03	.648
Matching					-.07	.260
North					.11	.065
Other					-.02	.746

Table 2: Hierarchical linear regression analysis predicting self-location performances (N=230)

explained 23.0% of the variance ($R^2=.23$, $F(8,222)=8.38$, $p<0.001$). Three of these tasks, LR ($\beta =.17$, $p=.016$), PFT ($\beta =.14$, $p=.086$) and MEADOW ($\beta =.14$, $p=.048$), were found to predict self-location performances significantly ($p<0.01$), and kept for subsequent analysis. In the hierarchical multiple regression analysis, the spatial scores of these three tasks were added in Step 1, sex in Step 2 and four different strategy scores in Step3 (see Table 2).

As in the preliminary analysis, the three spatial tasks accounted for significant variance in the self-location performances first level of the model, $F(3,227)=20.61$, $p<0.001$, with PFT emerging as the most important predictor (see Table 2 for standardized betas and the corresponding probability levels for every step in the model). Prediction was not significantly improved by adding sex in Step 2. The addition of strategies in Step 3 led to a marginal increase of .017 in the amount of explained variance, and revealed walking with orientation towards the north as an almost significant predictor. However, in the overall model comparison, the final model did not differ significantly from the first one which explained 21.4% of the variance.

In summary, the results indicated that individual differences in three spatial tasks only can be seen as significant predictors of self-location performance, predicting a fifth of the variance. Sex and strategy use did not contribute significantly to explain variance.

Place finding performance in relation to individual variables. Again, in a preliminary step, multiple regression analysis was used to test which of the eight spatial tasks significantly contributed to explain variance in place finding performances. The results indicated that all eight predictors explained 25.3% of the variance ($R^2=.25$, $F(8,198)=8.37$, $p<0.001$). Three of these tasks, LR ($\beta =.16$, $p=.024$), PFT ($\beta =.14$, $p=.090$) and BOXES ($\beta =.22$, $p=.009$), were found to predict place finding performances significantly ($p<0.10$), and kept for the analysis.

In the hierarchical multiple regression analysis, spatial scores of these three tasks were entered in Step 1, sex in Step 2 and strategy choice in Step 3 (see Table 3). As in the preliminary analysis, the three spatial tasks accounted for significant variance in the first level of the model, $F(3,203)=21.87$, $p<0.001$, with BOXES emerging as the most important predictor (see Table 3 for standardized betas and the corresponding probability levels for every step in the model). Again, prediction was not significantly improved by adding Sex in Step 2. The addition of strategies in Step 3 led to a significant increase of .032 in the amount of explained variance, and revealed that ‘other strategies’ to be a significant inhibitor of place-finding performances. The final model was significant, $F(8,198) =9.579$, $p<0.001$, with an $R^2=.28$.

	Step 1		Step 2		Step 3	
$R^2(p)$.244 (.000)		.247 (.000)		.279(.000)	
$\Delta R^2(p)$.244 (.000)		.003 (.372)		.032 (.072)	
Predictor	β	p	β	p	β	p
LR	.17	.015	.17	.015	.21	.003
PFT	.18	.017	.17	.022	.18	.017
BOXES	.27	.000	.26	.001	.27	.000
Sex			.06	.372	.06	.310
Tracing					-.06	.321
Matching					-.01	.906
North					-.01	.822
Other					-.17	.009

Table 3: Hierarchical linear regression analysis predicting place finding performances (N=205)

In summary, the results indicated that individual differences in three spatial tasks emerged as significant predictors of place finding performance, predicting a quart of the overall variance. Sex did not contribute significantly in the prediction. Strategy use led to an overall predicted variance of 28%, but revealed a less well defined strategy group as inhibitor.

Discussion

This study aimed at investigating children's performances in two map-reading tasks in real space and investigated their prediction by a set of spatial skills and the two other individual variables sex and strategy choice. As anticipated by labelling the proposed activity as a "complex" one, the results indicated that both, self-location and place finding remain challenging tasks for children by the end of primary school. Moreover, a hierarchical regression analysis showed that individual differences in written spatial tasks accounted for up to 25% of the variance in both map-based tasks. I sex nor strategy use were found to be significant predictors in both tasks.

Regression analyses revealed a set of four spatial tasks that predicted the outdoor tasks: LR and PFT were found to be predictors in both outdoor tasks, MEADOW and BOXES for self-location and place finding, respectively. An analysis of these tasks (see e.g. Linn & Petersen, 1985, for the PFT) reveals that they rely on multistep solution processes, in particular require a multistep manipulation of mental images that need to be updated correctly. Tasks that require singular 2D and 3D mental rotations were not found to be predictors. Similarly, perspective taking tasks that are bound to a very particular spatial setting (labyrinth-tasks) were not found to be predictors either. A tentative interpretation of this outcome for educational settings might be that spatial tasks that are interesting for application in real space should fulfill two criteria: first, they should be sufficiently complex, and second, they should not be presented in too particular contexts but rather in general-abstract contexts.

Since we drew on the literature concerning sex-differences in favor of boys in written spatial tasks, we expected to find sex an important predictor in the map-reading tasks in real space as well. In contrast to the literature (Liben et al., 2013), we did not find a male advantage at all. Although we recommend follow-up analyses including interaction terms into the models outlined above, there is an interpretative suggestion that activities with maps in the real space are equally cognitively accessible for boys and girls.

Contrary to other empirical findings (Liben et al., 2013), visible solution strategies did not predict performances in the map-based tasks. One possible explanation is that experimenters just observed the strategies, but the children were not explicitly interviewed. Furthermore, experimenters were not sufficiently sensitized to observe strategies. The documentation of strategies was therefore dependent on the different experimenters that might have documented them in a non-coherent manner. Further studies that focus on strategy use are important.

For a better understanding of the role of spatial skills in realistic spatio-geometric activities from a conceptual point of view, studies should conceptualize and analyze those skills in latent models, thus referring to classes of spatial tasks that share the same cognitive processes and to analyze their relation to the map tasks. This would allow researchers to make more generalized conclusions than it is the case in an analysis based on single spatial tasks.

Conclusion

By empirically testing psychological assumptions, this paper demonstrates that spatial skills are an important underlying cognitive skill in realistic geometric activities that allow children to understand the real space they interact with in their everyday life. Investigating spatial skills and their underlying cognitive processes, but also spatio-geometric activities in larger interaction spaces remain therefore important challenges for conceptual work and discussions in TWG4.

References

- Brousseau, G. (2000). Les propriétés didactiques de la géométrie élémentaire. L'étude de l'espace et de la géométrie. In *Les propriétés didactiques de la géométrie élémentaire; l'étude de l'espace et de la géométrie* (pp. 67–83), Apr. 2000, Rethymnon, Greece.
- Downs, R. M. (1981). Maps and mapping as metaphors for spatial representation. In L.S. Liben, A.H. Patterson, & N. Newcombe (Eds.), *Spatial representation and behavior across the life span* (pp. 143–166). New York: Academic Press.
- Freudenthal, H. (1973). The case of geometry. In *Mathematics as an educational task* (pp. 401–511). Dordrecht: Springer.
- Houdement, C. (2017). Traveling in spatiality, in spatial sense. In Dooley, T. & Gueudet, G. (Eds.), *Proceedings of the Tenth Congress of the European Society for Research in Mathematics Education* (pp. 621–628). Dublin, Ireland: DCU Institute of Education & ERME.
- Liben, L. S., & Downs, R. M. (1993). Understanding person-space-map relations: Cartographic and developmental perspectives. *Developmental Psychology*, 29(4), 739–752.
- Liben, L. S., Myers, L. J., Christensen, A. E., & Bower, C. A. (2013). Environmental-Scale map use in middle childhood: Links to spatial skills, strategies, and gender. *Child development*, 84(6), 2047–2063.
- Lowrie, T., & Logan, T. (2007). Using spatial skills to interpret maps: Problem solving in realistic contexts. *Australian Primary Mathematics Classroom*, 12(4), 14–19.
- Maschietto, M., Mithalal, J., Richard, P., & Swoboda, E. (2013). Introduction to the papers and posters of WG4: Geometrical thinking. In Ubuz, B., Haser, C., & Mariotti, M. A. (Eds.), *Proceedings of the Eighth Congress of the European Society for Research in Mathematics Education* (pp. 578–584). Ankara, Turkey: Middle East Technical University and ERME.
- Montello, D. R. (1993). Scale and multiple psychologies of space. In *European conference on spatial information theory* (pp. 312–321). Berlin, Heidelberg: Springer.
- Muir, S. P., & Cheek, H. N. (1986). Mathematics and the map skill curriculum. *School Science and Mathematics*, 86(4), 284–291.
- Shepard, R. N., & Hurwitz, S. (1984). Upward direction, mental rotation, and discrimination of left and right turns in maps. *Cognition*, 18(1-3), 161–193.
- Voyer, D., Voyer, S., & Bryden, M. P. (1995). Magnitude of sex differences in spatial abilities: a meta-analysis and consideration of critical variables. *Psychological bulletin*, 117(2), 250–270.

A step in the development of an evidence based learning progression for geometric reasoning: focus on shape and angle

Marj Horne and Rebecca Seah

RMIT University; marj.horne@rmit.edu.au

RMIT University; rebecca.seah@rmit.edu.au

The Reframing Mathematical Futures II Project set out to develop an evidence-based learning progression for mathematical reasoning in years 7-10 of schooling. This paper reports part of the process and findings particularly around student reasoning about shape and angle as part of the development of a progression for geometrical reasoning. Concerns are raised about the low level of understanding and reasoning in these areas and the need for further research in the study of the development of the concept of angle.

Keywords: Geometry, measurement, learning progression.

Introduction.

Geometry and spatial visualization is important for STEM (Wai, Lubinski & Benbow, 2009) and the development of number understanding (Verdine, Golinkoff, Hirsh-Pasek, & Newcombe, 2017). Yet in some countries the amount of geometry being taught has been reduced over many decades leading to a decline in teacher knowledge. The improvement of the teaching and learning of geometry requires both attention to the curriculum and enabling teachers to implement the curriculum more effectively.

The Australian Mathematics and Science Partnership Program (AMSPP) funded by the Australian Government Department of Industry, Innovation, Climate Change, Science, Research and Tertiary Education, was established essentially to increase the participation and expertise in STEM related areas. The Reframing Mathematical Futures Project II (RMFP II), as part of the AMSPP aimed to build a sustainable, evidence-based learning and teaching resource to support the development of mathematical reasoning in Years 7 to 10. This paper reports on part of this process with a particular focus on students' reasoning about shape and angle size.

Learning progressions, while not new, relatively recently have become the focus of systematic research efforts (see Siemon et al. 2017). There have been different interpretations of the meaning and use of learning progressions (and the closely related learning trajectories - see the special edition of *Mathematics Teaching and Learning*, 6(2), 2004). The learning progression, as we are using the term, describes stages in the development of geometric reasoning which are evident sequentially in the responses of many students. It assumes that learning takes place over time, and that teaching involves recognising where learners are in their learning journey and providing challenging but achievable learning experiences that support learners' progress to the next step in their particular journey (see Siemon et al., 2017 for recent research and development on this). The learning progression is thus closely linked with teaching and learning. The research presented in this paper is in the context of a larger study which is developing a learning progression for geometric reasoning.

Geometric reasoning is the ability to critically analyse axiomatic properties, formulate logical arguments, identify new relationships and prove propositions. It is demonstrated in early stages

through attention and explanation with students then moving to describing, analysing, inferring, conjecturing and deducing geometric relationships leading to them engaging in formal proof (Brown, Jones, Taylor, & Hirst, 2004). Being able to invent and apply formal conceptual systems to investigate geometric relationships is part and parcel of reasoning geometrically (Battista, 2007).

In common with other developed learning progressions and trajectories a synthesis of relevant research literature was undertaken to establish a hypothetical learning progression for geometric reasoning which included a breadth of geometric concepts from the curriculum since its application was to be with classroom teachers. In constructing the progression, we acknowledge that the dominance of van Hiele levels on geometric thinking research, and their neglect of visualisation, meant that the framework we developed needed to move beyond these factors and recognise that students can reason at multiple levels, at different rates for different concepts. Our synthesis of available research findings led to the development of an initial hypothetical geometric learning progression that included both geometry and measurement concepts and which was based on Battista's (2007) proposed four levels of thinking: visual-holistic reasoning, analytic-componential reasoning, relational-inferential property-based reasoning, and formal deductive proof. He expanded the development of property-based thinking to progress from visual-informal, to informal insufficient-formal reasoning and finally sufficient formal property-based reasoning. The hypothetical learning progression we proposed (Seah & Horne, 2019) made a distinction between descriptive reasoning - using informal language to explain what one sees and analytic reasoning - using formal language to analyze properties of shapes. It also encompassed concepts from a range of aspects of geometry including shape, transformation and location, and measurement. This allowed us to better investigate the growth in the connectedness between visualization and mathematical discourse and contributed to the design of instructions that targeted specific thinking within a framework which was connected to, but not defined by curriculum.

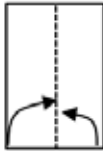
The research question considered in this paper is how do students' reason about angle, angle measure in a two dimensional context of shape. This is set in the overarching project of developing a learning progression for geometric reasoning.

Method


Based on the hypothetical learning progression we designed a series of pen and paper assessment tasks, which were based on practical situations, and would allow students to demonstrate reasoning as well as other knowledge and skills. While there have been some studies (for example, Keiser, 2004; Mitchelmore & White, 1998), angle and angle measure is an area of geometry that has not received a lot of attention yet occupies considerable curriculum space connecting to many aspects of shape and measurement leading through to trigonometry. Typical angle questions in text books in years 7-10 require students to find the magnitude of angles from diagrams. The intention for these assessments was to seat the problems in real situations to which students could relate. An example of such a task is an angles task shown in figure 1 where students physically construct the angles through paperfolding before finding their magnitudes. The intent of this question was to focus on students' ability to use knowledge of properties of shape to make deductions about angle measure hence part a) focused on the properties of the 2D shape while part b) sought angle measures and explanation.

You will need the shape you made in class. The steps and diagrams below show how you made the shape.


Step 1




Step 2




Step 3



Step 4



Step 5



Step 1 Fold an A4 paper in half lengthwise to make a crease line in the middle of the page.
Step 2 Fold two corners to the middle at the bottom
Step 3 Fold two corners to middle at the top
Step 4 Fold the new corners on the sides at the bottom to the middle
Step 5 Do the same with the top

a [GANG1]
 Phoebe made the same shape that you made using A4 paper. She said her shape is a rhombus. Do you agree? Explain your reasoning.

b [GANG2]
 When Phoebe unfolds the paper she found a number of crease lines. Find the marked angles on the crease lines:
 Angle f = _____ Angle h = _____ Angle s = _____
 Explain how you worked out the angles.

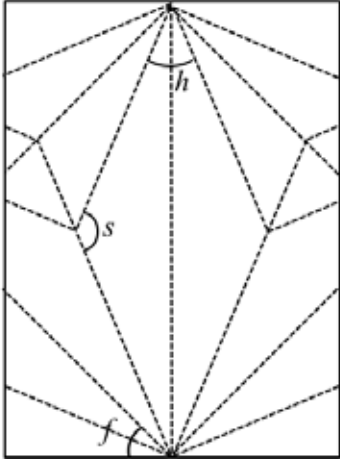


Figure 1: Shape and angles task

Each task was designed with a marking rubric to enable teachers to easily score the students' work. The rubric for the angles task is shown in Table 1. The scoring rubric requires clear reasoning to be given for the responses to attain the higher scores. GANG1.1 refers to a rubric score of 1 on the question GANG1 and is used in later analysis.

SCORE	DESCRIPTION For GANG1
0	No response or irrelevant response
1	Disagree it is a rhombus based on appearance rather than properties
2	Disagree it is a rhombus but claim it is a parallelogram or some other quadrilateral such as kite with some properties specified, or Agree it is a rhombus with reason relying on appearance such as "if you turn it to rest on its edge it is a rhombus".
3	Agree it is rhombus specifying two properties correctly but insufficient / incorrect properties to define it.
4	Agree it is rhombus. Explanation needs to include necessary and sufficient properties, that is, it has 4 equal sides, or is a parallelogram with one of the following properties <ul style="list-style-type: none"> · Adjacent sides equal

	<ul style="list-style-type: none"> · Diagonals bisect each other at right angles or diagonals bisect the angles · Two lines of symmetry
SCORE	DESCRIPTION For GANG2
0	No response or irrelevant response
1	Incorrect angles
2	At least 2 angles correct but no reason given or one angle correct with correct reasoning
3	Two angles found correctly with sensible reasons or all angles correct with insufficient reasoning
4	All angles correct with clear reasons given relating to the folding and properties. <i>F = 45°; h = 45°; s = 135° (e.g., Folding corner to centre creates half right angle; All angles around centre of side equal so any 2 make 45° or Four angles of quadrilateral add to 360°)</i>

Table 1: Rubrics for shape and angle question

A number of assessment forms, each with 6-7 questions, were structured covering a range of geometric content and trialled with students in years 7-10 in order to collect data on the questions and refine them as needed. On the basis of these trials and the student responses assessment forms were finalised and data collected first from a small group of trial schools in three different states and then from the larger group of project schools across Australia. This data was analysed at two levels. The first was at the level of individual questions focusing on the reasoning about specific geometric and measurement constructs while the second was at a meta-level using item response theory (IRT). For a detailed description of this IRT analysis see Siemon and Callingham (2019). The analysis led to the identification of eight zones based on the evidence of what these students could do. From this a learning progression based on the descriptions of these zones was created.

Results and Discussion

The teachers in all the schools had a choice of which assessment forms their students would complete. Many chose not to assess geometry. The data presented here is from 279 students in years 7-10. Table 2 shows the percentage of students attaining each rubric score for the two questions.

Rubric score	Shape (GANG1)	Angle (GANG2)
0	39	50
1	7	25
2	4	8
3	43	9
4	7	8

Table 2: Percentage of students in years 7-10 attaining rubric score

As can be seen many students did not attempt the question or gave irrelevant answers. The following section shows the types of responses to the two questions.

Reasoning about shape

A sample of student responses are shown here in table 3. Orientation was an issue for some students with confusion about diamond and rhombus for many students, like S2, thinking it was only a rhombus when it was positioned with a horizontal edge.

Score		Reasoning
1	S1	I don't agree the shape wasn't wide enough to become a rhombus. It is a diamond.
2	S2	Yes because if you turn it on its side it is a rhombus
2	S3	Yes because its [sic] just a square pushed over which is a rhombus (picture shown of square and 2 pushed over rhombuses)
2	S4	No it's a parallelogram. It has two pairs of parrallel [sic] lines and 2 pairs of angles
2	S5	I agree because to [two] of the opposite sides were equal
3	S6	Yes I agree a rhombus 2 horizontal parallel lines 2 diagonal parallel lines
3	S7	Phoebe is correct when she states that the shape made from the paper is a rhombus as the opposite sides are equal to one another, opposite angles are equal to each other and the sides are parallel
3	S8	This shape is a rhombus because properties of a rhombus all sides are equal, diagonals bisect each other at right angles, all angles are equal
4	S9	I agree. This is because all the sides are the same length. There are also two pairs of parallel lines There are two acute angles and two obtuse angles.
4	S10	Yes all the sides same measurement

Table 3: Student reasoning about shape

The explanations given by students such as S1-3 could be classified as “it looks like ...” with either agreement that it is a rhombus or disagreement because it is a diamond. S3 goes a little further with dynamic imagery showing in the response. S4 and S5 began to use properties in their reasoning though limited and insufficient. S6 and S7 used properties but defined a parallelogram rather than a rhombus with S6 also indicating orientation. While giving a necessary and sufficient property initially, S8 went on to give further properties, the last of which was incorrect. For the highest rubric score S9 also gave extra properties but these were written as an extra while S10 correctly gave just the important property. None of the students specified that the sides had to be straight or that the shape was planar and closed but in the context this was not seen as being necessary.

Reasoning about angle sizes

Table 4 shows some of the students reasoning about the angle size.

Score		Angles	Reasoning

1	A1	acute acute obtuse	f, h smaller s bigger
1	A2	7 7 6	The angles from s are 6 because there are 6 lines finishing at the s angle. All the angles from the h are 7 because they are also reaching the end. All the angles from the f are also touching the end of the page
1	A3	30 45 20	The way I worked it out was I pictured the protractor [sic] in my head and trying to figure the degrees of it
2	A4	45 45 -	I estimated the angles by imagining a 90 degree angle on the f, s, h
2	A5	45 70 160	[a right angle shown divided in two to make 45] h $180/2 = 90$ $90/2 = 45$ because of the 3 angles make 180 so you can divide by 3
4	A6	45, 45, 135	The half creases indicate two right angles. H and f are halves of the right angles so $90/2=45$. Quadrilateral has internal sum of 360 h and the opposite is 90 total $S=(360-90)/2$
4	A7	45 45 135	Angle f is based on a straight line and there are 8 equal angles ($180/8 = 22.5$) but f is two of these $22.5 \times 2 = 45^\circ$ Angle h is the same thing just positioned differently Angle s I found because a triangle equals 180° $22.5 + 22.5 = 45$ $180-45 = 135$ (with diagram)

Table 4: Student reasoning about angle size

A2 demonstrated a lack of comprehension about the concept of angle using the number of lines meeting at the point to provide the angle size. Many of the students associated angle size with protractors and when asked to find the angles, the only way of which they were sure was to measure using a protractor, or for A3 and A4 imagining one, which suggests that they have had little experience of reasoning about angle sizes from given information and their knowledge of geometry. A5 began with a correct calculation using a diagram to illustrate but then became confused. A6 and A7 both calculated correctly giving reasons. The rubrics and students' responses show increasing sophistication in reasoning. However, there was little evidence of students using relational inferential property based reasoning. While the theoretical framework with which we began was useful in the design of questions and aspects of analysis the final learning progression developed is based on descriptions of what the students actually demonstrated in their geometric reasoning.

Based on responses from many students and the responses to 36 different questions on the assessment forms of which this angles question is only one, an item response analysis was done using Rasch modelling (See Siemon & Callingham, 2019). Figure 2 show the logit map returned by the analysis, based on valid responses from 742 students. The responses to the GANG questions have been highlighted on the map. The dotted horizontal lines show where some blank rows were removed.

From the map of the item responses it can be seen that GANG1, the shape question, has responses spanning zones 3 to 7 and GANG2, the angles question, spans zones 4-7. Based on these responses the descriptions of what students could generally do at each of the zones provided the evidence based learning progression for geometric reasoning. From this question at zone 3 the students were

recognizing shape because it looked like it but were not yet correctly finding any angles. At zone 4 they were starting to reason about shape using properties and were responding to angle size with general information such as acute, obtuse and right angles. In zone 6 they were correctly finding some angles and were able to explain their reasoning about some of these. By zone 7 they were able to identify shape giving necessary and sufficient properties and were able to reason about the magnitude of angles providing sound explanations.

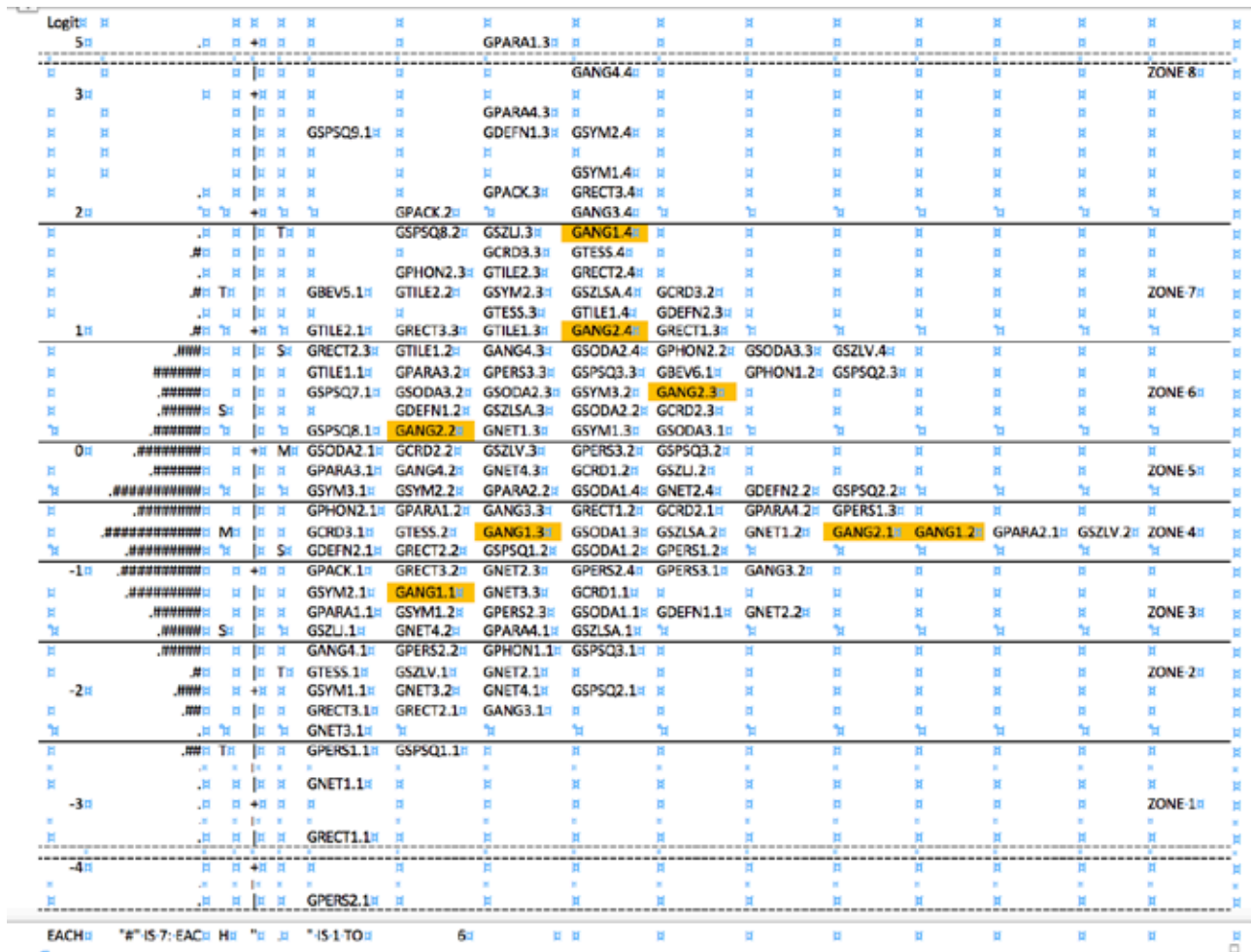


Figure 3 Logit map of responses to assessment forms

According to the curriculum these students are meant to have studied knowledge about angles in geometry and the properties and identification of quadrilaterals before year 8 so it is of some concern that almost 80% of students were operating below zone 6 with 75% unable to find the magnitude of an angle in this situation. Some students showed they were not even clear about the concept of angle.

Concluding comments

The students' reasoning about angle and angle measure was generally at a lower level than indicated by the curriculum. Students often did not have the basic knowledge of the properties of quadrilaterals sufficiently connected to enable them to use these in reasoning about angle size. The student responses indicate many issues in their learning about shape and angle and further investigation is

needed, particularly about the understanding of angle and angle measure. The analysis of the student answers to the questions combined with the item response analysis allowed a learning progression based on students' actual responses rather than just a validation of a proposed hypothetical progression. The full learning progression is based on all the questions used in the analysis and not just the one question and while the focus is reasoning, reasoning cannot be separated from the understanding of the underlying concepts. Since the final learning progression developed is based on what students could actually do it should be of use to teachers enabling them to map students' progress and inform teaching. Further research is needed on the implementation of such a progression.

References

- Battista, M. T. (2007). The development of geometric and spatial thinking. In F. K. Lester (Ed.), *Second Handbook of Research on Mathematics Teaching and Learning*. Charlotte, North Carolina: Information Age Publishing.
- Brown, M., Jones, K., Taylor, R., & Hirst, A. (2004). Developing geometric reasoning. In I. Putt, R. Faragher, & M. McLean (Eds.), *Mathematics education for the third millennium, towards 2010. Proceedings of the 27th annual conference of the Mathematics Education Research group of Australasia*. (pp. 127–134). Townsville, Australia: MERGA.
- Keiser, J. M. (2004). Struggles With Developing the Concept of Angle: Comparing Sixth-Grade Students' Discourse to the History of the Angle Concept. *Mathematical Thinking and Learning*, 6(3), 285–306. doi:10.1207/s15327833mtl0603_2
- Mitchelmore, M., & White, P. (1998). Development of angle concepts: A framework for research. *Mathematics Education Research Journal*, 10(3), 4–27. doi:10.1007/BF03217055
- Seah, R., & Horne, M. (2019 in print). A Learning Progression for Geometric Reasoning. In D. Siemon, T. Barkatsas, & R. Seah, *Researching and Using Progressions (Trajectories) in Mathematics Education*. BRILL/SENSE Publishers
- Siemon D., & Callingham, R. (2019 in print). Researching Mathematical Reasoning: Building Evidence-based Resources to Support Targeted Teaching in the Middle Years In D. Siemon, T. Barkatsas, & R. Seah, *Researching and Using Progressions (Trajectories) in Mathematics Education*. BRILL/SENSE Publishers
- Siemon, D., Horne, M., Clements, D. H., Confrey, J., Maloney, A., Sarama, J., . . . Watson, A. (2017). Researching and using learning progressions (trajectories) in mathematics education. In B. Kaur, W. K. Ho, T. L. Toh, & B. H. Choy (Eds.), *Proceedings of the 41st Conference of the International Group for the Psychology of Mathematics Education (Vol. 1, pp. 109–136)*. Singapore: PME.
- Verdine, B. N., Golinkoff, R. M., Hirsh-Pasek, K., & Newcombe, N. S. (2017). Spatial skills, their development, and their links to mathematics *Monographs of the Society for Research in Child Development*, 82(1), 7–30. doi:10.1111/mono.12280
- Wai, J., Lubinski, D., & Benbow, C. P. (2009). Spatial ability for STEM domains: Aligning over 50 years of cumulative psychological knowledge solidifies its importance. *Journal of Educational Psychology*, 101(4), 817–835. doi:10.1037/a001612

Task design with DGEs: The case of students' counterexamples

Keith Jones¹ and Kotaro Komatsu²

¹University of Southampton, Southampton Education School, UK; d.k.jones@soton.ac.uk

²Shinshu University, Institute of Education, Japan; kkomatsu@shinshu-u.ac.jp

Keywords: Task design, dynamic geometry environment, counterexample, proof.

Introduction

Geometry, being one of the main areas for proof-related activity in school mathematics, is a topic in which learners can work with counterexamples. Sinclair et al. (2016) recently highlighted that more research is needed on task design with dynamic geometry environments (DGEs). We are addressing these issues by elaborating a set of theory-informed task design principles involving DGEs and using these to study students working with geometric diagrams (Jones & Komatsu, 2017; Komatsu & Jones, 2019). Given the importance of networking theoretical approaches, in this short paper we build on our studies by employing a conceptual framework on virtual manipulatives (Osana & Duponsel, 2016). Our research question is how, in using Osana and Duponsel's framework, our task design helps students to produce and address what they think are counterexamples in geometry.

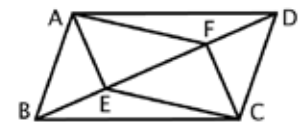
Virtual manipulatives

Following Moyer-Packenham and Bolyard (2016), DGE tasks where on-screen objects are draggable can be regarded as virtual manipulatives. Osana and Duponsel (2016), based on a thorough review, proposed that task design with virtual manipulatives should take into account: the *surface features of representations*, the *pedagogical support*, and *students' perceptions and interpretations*.

Method

We undertook a task-based interview (of 35 minutes) with two prospective teachers from a national university in Japan. Each of the participants had experience of using DGEs. They worked on the tasks in Figure 1, which were based on our design principles (for details, see Komatsu & Jones, in press). For data analysis, we used video records of the task-based interview, transcripts of the undergraduates' talk, their written work, and their DGE file.

Task 1. In parallelogram ABCD, draw perpendicular lines AE and CF to diagonal BD from points A and C, respectively. Prove that quadrilateral AECF is a parallelogram.



Task 2. Construct the diagram shown in Task 1 using a DGE. Move the vertices to change the shape of parallelogram ABCD, and examine whether quadrilateral AECF is always a parallelogram.

Figure 1: Tasks used in the interview

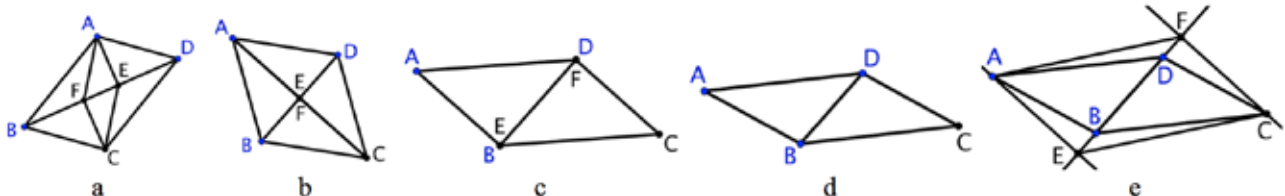


Figure 2: Types of diagrams produced by the undergraduates

The undergraduates completed Task 1 by producing a valid proof where they showed that $AE = CF$ and $AE \parallel CF$. In our analysis, we focus on how the undergraduates worked on Task 2.

Analysis

The undergraduates produced various diagrams with the DGE, as shown in Figure 2. They considered that the cases shown in Figures 2b and 2d were counterexamples to the statement (quadrilateral AECF is a parallelogram). They successfully addressed the case of Figure 2d by extending the original statement (as in Figure 2e) and proving that quadrilateral AECF in this case is a parallelogram. Here, we summarise how the set of tasks in Figure 1 embody the three elements of the virtual manipulatives framework of Osana and Duponsel (2016):

- Task 1 contains a given diagram. This diagram includes a specific representational feature; namely a ‘hidden’ condition implying that perpendicular lines from points A and C *always* intersect with diagonal BD. By this *surface feature*, and the *pedagogical support* in the text in Task 2 explaining the DGE use (i.e. use of the DGE to check the truth of the statement), the undergraduates could discover what they viewed as ‘counterexamples’ to the statement (as in Figures 2b and 2d).
- *Pedagogical support* included in Task 2 was not excessive in the sense that this task gave the undergraduates the opportunity to explore the task on their own by not specifying what they were expected to do when discovering what they might consider to be ‘counterexamples’.
- The sequence of Task 1 and Task 2, designed by taking *students’ interpretations* of counterexamples into account (see Komatsu & Jones, 2019), stimulated the undergraduates’ subsequent activity where they spontaneously dealt with the case of Figure 2d by extending the original statement with proving in Figure 2e.

Conclusion

This analysis illustrates how our theory-informed design principles are further supported with the conceptual framework on virtual manipulatives of Osana and Duponsel (2016) in terms of the *surface features of representations*, the *pedagogical support*, and *students’ perceptions and interpretations*.

References

- Jones, K., & Komatsu, K. (2017). Diagrams in students’ proving activity in secondary school geometry. In T. Dooley, & G. Gueudet (Eds.), *Proceedings of CERME10* (pp. 689–690). Dublin.
- Komatsu, K., & Jones, K. (2019). Task design principles for heuristic refutation in dynamic geometry environments. *International Journal of Science and Mathematics Education*, 17(4), 801-824.
- Moyer-Packenham, P. S., & Bolyard, J. J. (2016). Revisiting the definition of a virtual manipulative. In P. S. Moyer-Packenham (Ed.), *International perspectives on teaching and learning mathematics with virtual manipulatives* (pp. 3–23). Cham, Switzerland: Springer.
- Osana, H. P., & Duponsel, N. (2016). Manipulatives, diagrams, and mathematics. In P. S. Moyer-Packenham (Ed.), *International perspectives on teaching and learning mathematics with virtual manipulatives* (pp. 95–120). Cham, Switzerland: Springer.
- Sinclair, N. et al. (2016). Recent research on geometry education: An ICME-13 survey team report. *ZDM: The International Journal on Mathematics Education*, 48(5), 691–719.

The connection between angle measure and the understanding of sine

Valentin Katter

Bielefeld University, Germany; vkatter@math.uni-bielefeld.de

This paper presents a project in progress that seeks to gain empirical insights into the network of mental representations associated to sine of pre-service mathematics teachers as well as their thinking and typical errors and misunderstandings. First collection of data show that students' concepts of sine vary significantly and that the students have problems associating meaning to the value of sine. It is assumed, that there is a connection between the knowledge of degree and radian measure of angles and the understanding of sine and cosine. Further data will be obtained in a second phase that will include semi standardized interviews. These interviews will also contain aspects of the derivative of sine.

Keywords: Trigonometry, sine, angle measure, Radian, Grundvorstellungen.

Introduction

In the last few years, little attention has been given to the teaching and learning of Trigonometry in Germany. Most of the work focuses on subject-matter analysis (Kornreff, 2018; Filler, 2009; Malle, 2001). Unfortunately, there is not a lot of empirical research on the students learning process and furthermore, Trigonometry is slowly disappearing from the Curricula of many federal districts due to cutbacks of mathematical contents. This is unfortunate for many students who want to engage in a study of Natural Sciences, Engineering or Mathematics, in which the knowledge and the profound understanding of trigonometric functions are basic requirements for successful academic studies. Therefore, it is important to evaluate the current situation of students who start their careers and to draw a picture of their understanding of Trigonometry, including obstacles that they are confronted with. Major issues in the learning process of Trigonometry are the transition from right triangles to the coordinate plane, the understanding and use of radian measure and the modelling of periodic processes with trigonometric functions.

Since Trigonometry is an essential component of the high school curriculum throughout the United States and other countries, there is some international research on the learning and teaching of Trigonometry. There has been some research regarding students learning of Trigonometry with a focus “on the move from right triangle Trigonometry to rotations about the origin, then to the unit circle, and finally to the sinusoid” (Brown, 2005, p.85). In Brown’s study, preliminary interviews suggest the classification of three different ways students think about sine and cosine in the beginning of the learning process, that seem to correlate with their general geometric and algebraic abilities. Students interpreted values of sine and cosine as 1) ratios in right triangles, 2) distances from the axes, and/or 3) coordinates of a point. These different approaches could be traced back to their use of words and to what they wrote down in their solutions of given exercises.

Due to the changes in the school Curriculum and the importance of Trigonometry in many fields of study, it is crucial to know what previous knowledge about Trigonometry students bring to their

academic carrier at the university. Beyond that it is of great interest to know which mental representations were developed by the students and how these Representations interact with each other. When talking about mental Representations I'm referring to the concept of Grundvorstellungen¹ which will be explained further in this paper. These GV prepare the ground for reasonable solving of problems in Trigonometry. The Theoretical Framework of this paper aims to

1. give an Overview over the complex different GV of sine,
2. show the interconnection of different GV of sine, especially the transition from right-angled-triangles to the Unit Circle.
3. present some of the previous mathematical content that these GV are built on, in particular the measurement of angles,

The planned research that is presented in this paper intends to verify whether these Interconnections and Dependencies between GV really exist in the students minds. In this case, the GV of sine can be a useful tool to diagnose learning problems in the field of Trigonometry.

Theoretical Framework

Grundvorstellungen of sine

Apart from the mathematical content that is analyzed in this study, an important didactical question is: What do students (literally) think when dealing with sine and cosine? There are different theories that strive to give a good explanation for the construction of mental representations of mathematical objects using for example the theory of *concept image* and *concept definition* (Tall, D., & Vinner, S. 1981). In German literature, a related theory uses the Terminology of *Grundvorstellungen* (vom Hofe & Blum, 2016). GV present a didactical concept that classify mental mathematical representations.

GVs thus describe relationships between mathematical structures, individual psychological processes, and subject-related contexts, or, in short: the relationships between mathematics, the individual, and reality. (vom Hofe & Blum, 2016, p.231)

The work with GV has a long tradition in the area of didactics of mathematics in Germany and has been developed in various branches of mathematics like basic arithmetics, geometry, algebra, functions etc. Yet, little work has been dedicated to the concept of GV in the area of Trigonometry. A first attempt to categorize these GV of sine on a normative level can be found in the paper of Salle and Frohn (2017). They distinguish four GV of sine and cosine:

1. Proportion – GV
This GV is based on the idea of the sine as the ratio of two sides in a right angled triangle. The value of the sine corresponds to a quotient.
2. Projection – GV
The value of $\sin(\alpha)$ can be interpreted as reduction factor $b = \sin(\alpha) \cdot a$. One can think of a shadow that is casted by orthogonal light rays.
3. Unit-Circle – GV

¹ further abbreviated as GV

The Unit-Circle – GV is associated with the parametrization of the Unit-circle, specifically the circular motion of an object. The value of the sine corresponds to a number which provides information about the position of an object.

4. Oscillation – GV

The mathematical modelling of periodic processes requires the Oscillation – GV. To give a mathematical model of a vibrating string via the sine function, the Oscillation GV is needed.

Apart from this study, there has not been any empirical research regarding the GV students might develop over the course of a learning cycle yet. The first collection of data of the present study indicates that the GV of sine of pre-service mathematics teachers vary significantly. When asked what sine means to them, they mention sinusoids, right-angled triangles, angles, the theorem of Pythagoras and the Unit Circle.

At this point I want to emphasize two important aspects. First of all the GV of sine are quite complex, that is why I will introduce the distinction between primary and secondary GV. Regarding that distinction primary GV need to constitute a relation to real world phenomena whereas secondary GV relate to “imagined actions dealing with mathematical objects and means of representing these objects, such as number lines, terms, and function graphs” (vom Hofe & Blum, 2016, p. 234). Secondary GV therefore can depend on the understanding or the mental representation of other mathematical objects. To give an example: A sustainable GV of sine can rely on the concept of an angle, or on the concept of a function. Secondly it is important to note, that GV form a network. That is they are connected and influence each other, “GVs are not regarded as isolated fixed entities, but as variable parts of a growing and changing system” (vom Hofe & Blum, 2016, p. 229). This influence exists between different mathematical objects as well as between different GV of on mathematical object.

Interconnection of GV - From right-angled triangles to the unit circle

The Interconnection between the different GV of one mathematical object can be seen very clearly in the case of the Proportion-GV and the Triangle-GV. The learning of Trigonometry usually takes place in two learning cycles. In the German curriculum sine and cosine are introduced as the ratios of sides in a right-angled triangle in classes 8 or 9. In this part of the learning process sine takes angles of triangles as an input that are measured in degrees. The most common exercises consist of finding the unknown side of a triangle. At this point sine and cosine can be seen as rather stiff tools that only serve a specific purpose. On this topic, Thompson comments as follows,

In students’ understanding sine, cosine, and tangent do not take angle measures as their arguments. Rather they take triangles as their arguments. [...] Also, angles do not vary in triangle Trigonometry. (Thompson, 2008, p.3)

In class 10 the sine receives new meaning when it is introduced via the unit circle. In this part of the learning process sine takes angles as an input that are measured in radian and is introduced as a periodic function. This transition from the rather stiff representation of sine on right angled triangles to the dynamic representation on the unit circle presents many obstacles to students of Trigonometry. Brown (2005, p.222) found that students have problems understanding the role of the unit in the unit circle and finding rotation angles in standard position in the Cartesian plane. Another finding showed

that more than a quarter of the 119 participants of Brown's study were not able to make the move from the unit circle to the sinusoid and couldn't even explain what was represented on the x - and y -axis of the sinusoid.

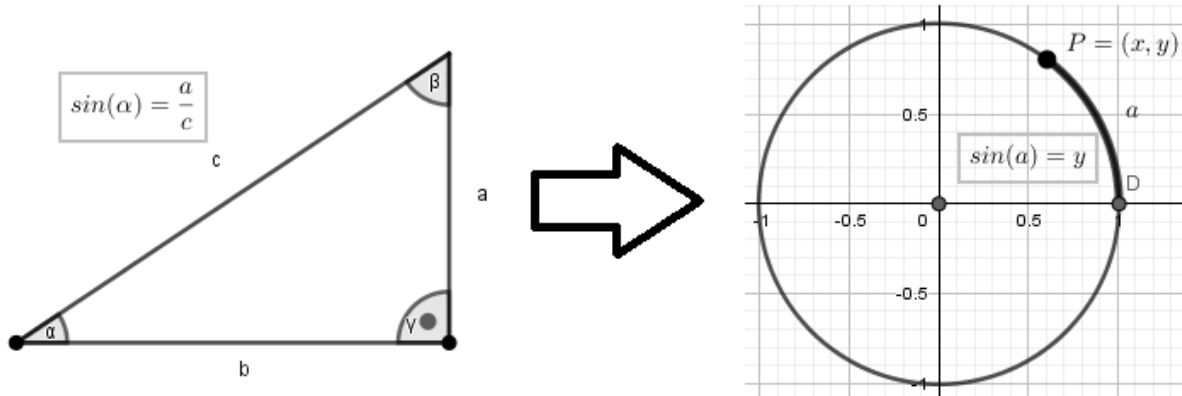


Figure 1. Transition from right-angled triangles to the unit circle

Students struggle with the dual nature of sine as a ratio or a number (Brown 2005). Depending on what resources students have to think about angles, this struggle might be associated with the lack of knowledge and understanding of radian measure.

Building on previous GV - Radian and degree measure

As mentioned earlier in this paper the GV of sine build on previous known mathematical objects, in particular students need to have a concept of angles and angle measure. The understanding of radian and degree measure concerns multiple mathematical aspects. One aspect is certainly about the measuring process itself, besides the way we measure angles is deeply connected with the way we think about angles. What is an angle? What is a measure? How is a unit defined and for what reasons? Concerning the question "what is an angle?" According to Jordan (2006) there are at least three different aspects of understanding related to angles: the notion of rays, the notion of a field and the notion of a rotation. A more thorough investigation of the interpretation of the angle concept can be found in the work of Mitchelmore and White (1998). They argue that the learning process of the angle concept develops in three stages. First, students have a situated angle concept, in the second stage the students develop a contextual angle concept and in the third stage they are able to build an abstract angle concept.

When thinking about angles in 360 degrees, one possible way to interpret 1 degree is to think of it as a piece of a circle, but there are also other ways to think about angles. Instead of thinking about a circle that is cut into pieces it is also possible to imagine parts of a rotation or the arc

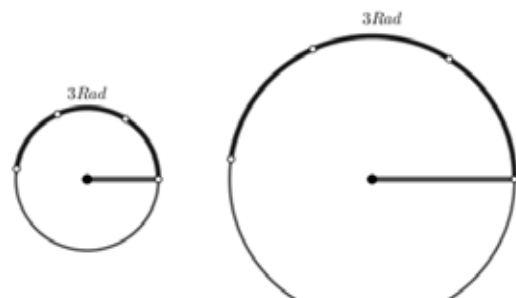


Figure 2. the arc of two circles measured in radian

of a circle. In this sense, a degree is just a tiny part of a movement. For example, the distance a gondola of a ferris wheel has moved within a certain time. If we start thinking about angles in this way, there are also different plausible ways to define the angle measure. It is possible to define the angle measure as the length of an arc of a circular motion. This is when the idea of the radian measure

emerges. To keep the measurement independent of the size of the circle the unit is defined by the radius of the circle and a given arc is measured in relation to this radius.

The way angles are measured is one of the most significant differences between right-angled triangle Trigonometry and Unit Circle Trigonometry. Accordingly, the question arises: Does the way of thinking about angles have an influence on the way of thinking about sine? Because of this important link between angle measure and the different ways the sine can be defined one can assume that a better understanding of radian measure can help with the understanding of Unit Circle Trigonometry.

Research design

The goal of this study in progress is to find out more about the network of GV regarding Trigonometry, in particular find answers to the following questions: What GV do students actually have about sine? How are the different GV of sine connected to each other? Are there GV of other mathematical objects that have an influence in the way students think about sine?

This study will be conducted with pre-service mathematics teachers at the beginning of their academic studies that most likely already had a learning cycle in Trigonometry within their school curriculum. The study will be conducted in two phases. The first phase consists of a written test that gives information over the general abilities and GV that students have developed, concerning the area of Trigonometry. In the second phase the students will be interviewed to get deeper qualitative insight in the way students think about sine and angle measure.

The test is composed of twelve questions that are subdivided into four Categories. Three Categories are attributed to different GV namely the Proportion-GV, the Unit-Circle-GV and the Oscillation-GV. The fourth Category contains three open questions. Every Category has therefore three questions on different difficulty-level. With this test-design it is possible to check if certain GV are present in the students mind and moreover on what level they can work with this GV. The open questions can be solved with reference to various GV and are used to check for dominant GV. The test measures the students' abilities to compute and approximate values of sine, their knowledge about degree and radian measure, as well as their ability to solve exercises on triangles, the unit circle and the function graph. Depending on the scores in the test and the reported GV of sine a preferably wide range of different subjects will be chosen to conduct the interviews.

The test includes open questions as well as questions that can only be solved if the students have access to explicit GV of sine. I want to give a small sample of questions that were used in the test. Some of those were taken from the study of Brown (2005) others developed over time in a course of didactics of analysis. One question that seems to be a good indicator for GV that are accessible to the students is: "Estimate the value of $\sin(80^\circ)$ ". This question can be solved by the students with reference to the unit circle, right-angled triangles or the graphical representation of the sine-function. Another estimation includes radian measure: "The Radian measure of an angle α is exactly 3. Estimate the value of $\sin(3)$. Justify your estimation". In this case not all GV of sine can be used. Moreover, an understanding of the radian measure is needed.

The interviews will be semi-standardized with questions concerning the GV of the students and tasks in which multiple GV of sine need to be activated. In particular, the derivative of the sine-function will be discussed, because it can be approached in various ways. It is possible to justify the connection between the sine function and the cosine function as its derivative with the Proportion-GV, the Unit-Circle-GV and the Oscillation-GV. A very fertile visual Justification is delivered through the Representation of sine in Figure 3. For this argument to be fully understood, students need to be able to switch between the different GV of sine. Moreover they need a good understanding of the derivative as the slope of the tangent and as an instantaneous rate of change.

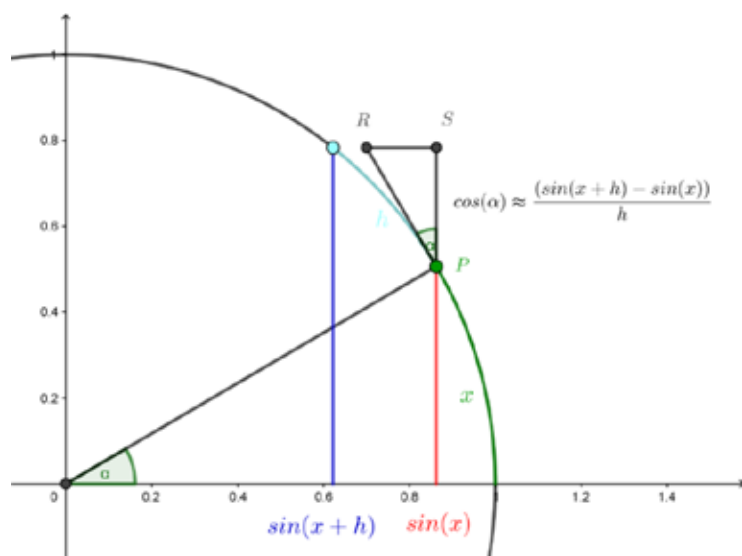


Figure 3. Visual Justification for the derivative of the sine function

First results

First of all, the answers of the students show that the concept definition of sine contains various ideas and GV. When asked what sine means to them, answers often include the mention of Wave-functions and the unit circle. Others describe sine as a tool to determine unknown lengths of sides in a right angled triangle, or gave formulas including complex numbers. These responses could be linked to the four GV of sine mentioned above.

Although the students had good explanations for what sine meant to them in general, when they were asked what precisely $\cos(\pi)$ means to them, most of the answers only included guesses of the values of $\cos(\pi)$. These guesses included -1, 0 and 1 but made almost no connection to their GV of sine. A similar result was found when the students were asked to estimate the value of $\sin(80^\circ)$. Out of 30 students only five could give a correct answer and only two provided an explanation for their correct estimate. Some guesses for $\sin(80^\circ)$ included values higher than 1 and even values given in terms of π . It seems that the students had a vague concept of sine and that it was difficult for them to establish a connection between their definition of sine and the calculation of sines for given angles.

Another difficulty arose when the students were asked what the difference between radian and degree is. Some students openly admitted that they had no idea, while others tried to infer meanings from the words. Overall the answers represented the confusion of the students concerning the terminology, although some could convert radian measure into degree measure. Similar results have been found in the study of Fi (2003) and Akkoc (2008). Some students just regarded degree and radian as buttons on a calculator that need to be pressed. Another answer confirms findings of Akkoc that say, that students only consider numbers in radian measure, when there is π involved. A repeating error of students involves the mentioning of π in the output of the sine-function.



Figure 4. an angle of 53°

access to the correct GV, they couldn't use it in this context. This shows the need of building up flexible and sustainable GV.

One question in particular provided indications to the statement of Thompson (2018) that for some students the sine function only takes triangles and not angles as an argument. When presented an angle of 53° as shown in Figure 4 with the task to identify $\cos(\alpha)$ and $\sin(\alpha)$ graphically, 13 out of 30 students were not able to give a correct answer though some of them used the Proportion-GV in other questions. In some of the answers students replied, that it is not possible to identify the wanted quantities with this figure, because they couldn't find a right-angled triangle. Another common mistake was that students chose to connect the ends of the line segments and ended up with an isosceles triangle instead of a right-angled triangle. Even though the students had

Discussion

The first collection of data showed that students can operate with various GV on different difficulty levels. It will be interesting to know why some students can operate with a certain GV on a basic difficulty level, but could not advance to a higher difficulty level. The last example seen in Figure 4 shows that some GV are linked to special situations and cannot be used when different mathematical objects are involved. It remains to be seen if these difficulties are just singular observations or if there is a pattern. To confirm that students possess and use the GV on different levels it is necessary to conduct further research and to collect data from more students that are willing to participate in interviews. In this respect it is more likely to reveal the true thinking process of the students in a conversation. A second phase of the investigation, with a revised test and follow up interviews is already planned.

References

- Akkoc, H. (2008). Pre-service mathematics teachers' concept images of radian. *International Journal of Mathematical Education in Science and Technology*, 39:7, 857-878.
- Brown, S. (2005). *The Trigonometric Connection: Students' Understanding of Sine and Cosine*. Ph.D. dissertation, Illinois State University.
- Fi, C. (2003). *Preservice school mathematics teachers' knowledge of trigonometry: Subject matter content knowledge, pedagogical content knowledge and envisioned pedagogy*. Ph.D. dissertation, University of Iowa, USA.
- Filler, A. (2009). Trigonometrie. In: H.-G. Weigand, Ausschreiben (2009): *Didaktik der Geometrie für Sekundarstufe I*. Heidelberg: Spektrum Akademischer Verlag, S.239-263.
- Gray, E., & Tall, D. (1994). Duality, Ambiguity, and Flexibility: A "Proceptual" View of Simple Arithmetic. *Journal for Research in Mathematics Education*, Vol.25, No. 2, 116-140.
- Hiebert, J., & Lefevre, P. (1986). Conceptual and procedural knowledge in mathematics: An introductory analysis. In J. Hiebert (Ed.), *Conceptual and procedural knowledge: The case of mathematics* (pp. 1-27). Hillsdale, NJ, US: Lawrence Erlbaum Associates, Inc.
- Jordan, A. (2006). *Mathematische Bildung von Schülern am Ende der Sekundarstufe I - Analysen und empirische Untersuchungen*. Hildesheim: Franzbecker.
- Korntreff, S. (2008). *Didaktische Herausforderung der Trigonometrie*. Wiesbaden: Springer Spektrum.

- Lowsky M. (2013) Die Ableitung des Sinus ist der Kosinus, oder: Wie autoritär ist die Mathematik?. In: Rathgeb M., Helmerich M., Krömer R., Lengnink K., Nickel G. (eds) *Mathematik im Prozess*. Springer Spektrum, Wiesbaden
- Malle, G. (2001). Genetisch in die Trigonometrie. *Mathematik Lehren*, 109, 40-44.
- Mitchelmore, M. & White, P. (1998): Development of Angle Concepts: A Framework for Research. In: *Mathematics Education Research Journal*, 10(3), S. 4-27.
- Rittle-Johnson, B., & Wagner Alibali, M. (1999). Conceptual and Procedural Knowledge of Mathematics: Does One Lead to the Other. *Journal of Educational Psychology*, 91(1), 175-189.
- Salle, A., & Frohn, D. (2017). Grundvorstellungen zu Sinus und Kosinus. *Mathematik Lehren*. 204, 8-12.
- Star, J. (2005). Reconceptualizing Procedural Knowledge. *Journal for Research in Mathematics Education*, 36(5), 404-411.
- Tall, D., & Vinner, S. (1981). Concept image and concept definition in mathematics with particular reference to limits and continuity. *Educational Studies in Mathematics*, 12(2), 151–169.
- Tall, D. et al. (1999). What is the object of the encapsulation of a process. *The Journal of Mathematical Behaviour*. 18(2), 223-241.
- Thompson, P.W. (2008). Conceptual analysis of mathematical ideas: Some spadework at the foundations of mathematics education. In O. Figueras, J.L. Cortina, S. Alatorre, T. Rojano & A. Sépulveda (Eds.), *Plenary Paper presented at the Annual Meeting of the International Group for the Psychology of Mathematics Education* (Vol 1, pp. 31-49)
- vom Hofe, R., & Blum, W. (2016). "Grundvorstellungen" as a Category of Subject Matter Didactics. *Journal für Mathematikdidaktik*. 37(S1), 225-254.
- Weber, K. (2005). Students' Understanding of Trigonometric Functions. *Mathematics Education Research Journal*. 17(3), 91-112

To figure out more than a solution to a geometric problem: What do prospective teachers?

Fátima Mendes¹, Ana Maria Boavida², Joana Brocardo³ and Catarina Delgado⁴

¹ Escola Superior de Educação do Instituto Politécnico de Setúbal, Portugal;
fatima.mendes@ese.ips.pt

² Escola Superior de Educação do Instituto Politécnico de Setúbal, Portugal; ana.boavida@ese.ips.pt

³ Escola Superior de Educação do Instituto Politécnico de Setúbal, Portugal;
joana.brocardo@ese.ips.pt

⁴ Escola Superior de Educação do Instituto Politécnico de Setúbal, Portugal;
catarina.delgado@ese.ips.pt

Keywords: Prospective elementary teachers, geometrical tasks, problem solving.

This poster focuses on the development of prospective elementary teachers' problem-solving capacity and, particularly, on geometric problem solving. More specifically, we present some preliminary results of a research project that is being developed, in a Portuguese School of Education focusing prospective elementary teachers' preparation in geometry and measure, one of the disciplines of their bachelor's degree.

Theoretical framework

Recent recommendations for mathematics teaching highlight that effective teaching of mathematics should involve students in “solving and discussing tasks that promote mathematical reasoning and problem solving and that allow multiple entry points and varied solution strategies” (NCTM, 2014, p.10). In the context of the development of “mathematical proficiency” (Kilpatrick, Swafford & Findell, 2001) of students, it is essential that the teacher develops “the ability to see the mathematics possibilities in a task” (idem, p. 370) as well as the capacity to propose tasks that promote reasoning and problem solving. The teacher must also be able to interpret what students do and say, to analyze their reasoning and to answer to the different approaches they use to solve a mathematical problem (Kilpatrick, Swafford & Findell, 2001). However, this is a challenging task, even by experienced teachers since often it is very difficult to interpret some students' solutions, either because they are not expected or because they do not look at them through the students' eyes. In this sense, we believe that to offer prospective teachers the opportunity to produce more than one solution to the same problem, can help them to develop a ‘lens’ to interpret their future students' problem-solving solutions and to use this understanding to help these students to develop their mathematical proficiency.

Research question and method

This poster reports part of a research that aims to investigate prospective teachers' capacity to produce and analyse different solutions to solve mathematical problems. This research has an exploratory design framed by a qualitative methodology (Patton, 2012). The participants are 39 prospective elementary teachers organized within two classes, that were inscribed in a Geometry and Measurement course (first semester, second year of the bachelor's degree).

The study had three main phases. At the beginning of the GM course, the prospective teachers were asked to solve a diagnosis test, composed by six problems, using, if possible, more than one strategy to solve each one. To solve the problems, they had to mobilize only geometrical contents of the mathematics curriculum of primary, upper primary and middle school. Throughout the GM course, pre-service teachers were challenged to solve problems that could be solved using different strategies and the teacher, the first author of this poster, promoted and supported collective discussions of these strategies. At the end of semester, the preservice teachers were asked to solve a second test with five problems, and, in some of them, to use more than one strategy.

Data includes pre-service teachers' solutions of the problems, field notes focused on the development of the GM course and transcriptions of excerpts of video recorded collective discussions. In this poster we present only the analysis of the data related to the prospective teachers' solutions of the problems.

Results

The results revealed that (i) initially prospective teachers expressed many difficulties in solving geometric problems and even more in to use more than one strategy to solve the same problem; (ii) there has been some progress, although incipient, concerning the production, by the future teachers, of more than one strategy to solve the same problem; (iii) the opportunity to solve problems and to analyze different strategies that can be used to solve each problem, helped the participants to improve their mathematical proficiency in the domain of Geometry and Measurement.

References

- Kilpatrick, J., Swafford, J., & Findell, B. (Eds). (2001). *Adding It Up: Helping Children Learning Mathematics*. Washington: National Academy Press.
- NCTM (2014). *Principles to action: Ensuring mathematical success for all*. Reston, VA.: NCTM.
- Patton, M. Q. (2012). *Qualitative research & evaluation methods* (3rd ed.). Thousands Oak: SAGE Publications.

Personal geometrical work of pre-service teachers: a case study based on the theory of Mathematical Working Spaces

Alain Kuzniak¹ and Assia Nechache²

¹Université Paris-Diderot, LDAR (EA 4434), Paris, France; alain.kuzniak@univ-paris-diderot.fr.

²Université Cergy-Pontoise, LDAR (EA 4434), Paris, France; assia.nechache@hotmail.fr.

Abstract. In this contribution, we intend to revisit the interplay between geometrical paradigms GI and GII in the context of the current French curriculum, which gives an important place to modelling activities in mathematics learning. We asked master students to perform a geometric modelling task on the estimation of the area of a field. The resolution of the task requires an articulation between GI and GII by considering measurement and approximation. From this first study, it results that the vast majority of students have developed a geometric work in the GI paradigm by mobilizing a low use of the classical property-based proof discourse. These results question teacher training and, more broadly, the today's mathematics teaching in France.

Keywords: Geometrical paradigms, Teachers training, Mathematical Working Spaces, Geometry teaching and learning

Presentation and motivations of the study

In this contribution, we revisit the issue of teaching geometry in teacher education, which was the subject of several of our presentations at the CERME conferences in the early 2000s. These presentations enabled the development of the theoretical and methodological framework of geometrical paradigms and Geometric Working Spaces, which is used to describe the forms and conditions of geometric work that is performed by students with the help of their teachers.

Kuzniak and Rauscher (2011) provide a classification of the solutions given by pre-service teachers to a geometry task. The main authors' objective was to raise students' awareness of the interaction between geometrical paradigms GI and GII (see next section). However, their study shows that primary school teachers were not very receptive to this interplay because they were confined to the first paradigm GI. Only secondary school teachers, more experienced in mathematics, understood the relevance of this interaction between paradigms. In the study, it was also questioned the difficulties that future primary school teachers had in teaching geometry because of their often deficient or old knowledge in the field. The goal was both to consolidate their knowledge and make them aware of the existence of several geometric paradigms leading to different forms of validation. It seemed interesting to us to review this work in consideration of the evolution of French curriculum, which has undergone notable fluctuations in recent years. The part given to geometry in education decreases significantly throughout the compulsory curriculum and its teaching is now mainly based on calculation and application, most often mechanical, of Pythagoras and Thales theorems, which are increasingly used to practice algebraic computation techniques. At the same time, more emphasis is put on modelling activities. In addition, from an institutional point of view, primary school teachers are now trained at university and must obtain a specific master's degree in education whereas previously they followed a two-year non-degree vocational training course after passing a competitive examination.

More specifically, this research has two types of objectives that concern students who want to obtain a master's degree in primary education:

- identify the geometric work actually produced by these teacher students in order to understand it and eventually be able to influence it.
- make these students aware of the measurement and area issues in relation with the geometric paradigms GI and GII with the possible interplay between these two paradigms.

In this new study, which extends our recent studies on the teaching of geometry (Kuzniak and Nechache, 2015), teacher students had to perform a geometric modelling task on the estimation of the area of a field. This research is part of a larger project that aims to investigate mathematical work in various institutional contexts. The analysis of students' geometric work is supported on the previously used research framework which, and this is also one of the motivations of this new study, had largely evolved towards what is now referred to as the theory of Mathematical Working Spaces (MWS).

Theoretical and methodological elements

As this research is based on the theoretical framework of Mathematical Working Spaces articulated with the notion of geometrical paradigms, we will briefly outline the main elements of this theory by referring the reader who wishes to know more about it to the literature on the subject, especially that of previous CERMEs.

Geometrical paradigms

According to Houdement and Kuzniak, (2006), in the context of teaching, it is possible to identify three geometrical paradigms named respectively GI, GII and GIII. By taking up the presentation made by Kuzniak (2018) we can introduce them in this way:

“The paradigm called Geometry I is concerned by the world of practice with technology. In this geometry, valid assertions are generated using arguments based upon perception, experiment, and deduction. There is high resemblance between model and reality and any argument is allowed to justify an assertion and to convince the audience. Indeed, mechanical and experimental proofs are acceptable in Geometry I.” (Kuzniak 2018, p. 10)

“The paradigm called Geometry II, whose archetype is classic Euclidean geometry, is built on a model that approaches reality without being fused with it. Once the axioms are set up, proofs have to be developed within the system of axioms to be valid. The system of axioms may be left incomplete as the axiomatic process is dynamic and has modelling at its core.” (Ibidem, p. 10)

Both geometries, I and II, have close links to the real world, albeit in varying ways. In particular, they differ with regard to the type of validation, the nature of figure (unique and specific in Geometry I, general and definition-based in Geometry II) and by their work guidelines. To these two Geometries, it is necessary to add Geometry III, which is usually not present in compulsory schooling, but which is the implicit reference of mathematics teachers who are trained in advanced mathematics. In Geometry III, the system of axioms itself is disconnected from reality, but central. The system is complete and unconcerned with any possible applications to the real world. (Ibidem, p. 11)

The identification of geometrical paradigms contributes to the understanding of the epistemological nature of the work actually produced in a school institution. The study of the circulation of

geometric work within the Mathematical Working Space will provide a more fine-grained characterization of this work.

Mathematical Working Spaces

The theory of Mathematical Working Spaces (Kuzniak, Tanguay and Elia, 2016; Kuzniak and Nechache, 2015), known as MWS, aims to analyse the mathematical work produced by students or teachers in a specific educational institution. Mathematical Working Spaces are designed and thought out in such a way that their users can carry out their work under conditions that promote the emergence of a coherent and complete work. In this theory, mathematical work is structured through the interactions of epistemological and cognitive planes:

- the epistemological plane, composed of three poles: representamen, artifact, theoretical reference frame. It is used to structure the mathematical content of tasks.
- the cognitive level, composed of three cognitive processes: visualization, construction and proving. It reflects user's cognitive activity during task resolution.

The move from one plane to another is ensured by a set of geneses linked to the poles: a semiotic genesis based on the registers of semiotic representation that gives the tangible objects of the MWS their status of operative mathematical objects; an instrumental genesis, which has for function to make the artifacts operative in the constructive process; a discursive genesis of proof, which allows to give meaning to the properties to be implemented in the mathematical reasoning.

These three geneses facilitate the circulation between the two planes by stimulating an articulation between the respective components of the two planes. This set of relationships can be visualized by means of a diagram in the form of a triangular-based prism.

The analysis of geometric work can therefore be done through one of the three dimensions associated with each of the geneses (semiotic, instrumental and discursive), or through the articulation of two of them: semiotic and instrumental ([Sem-Ins]), semiotic and discursive ([Sem-Dis]), or discursive and instrumental ([Dis-Ins]). These different articulations thus define three vertical planes (Figure 1).

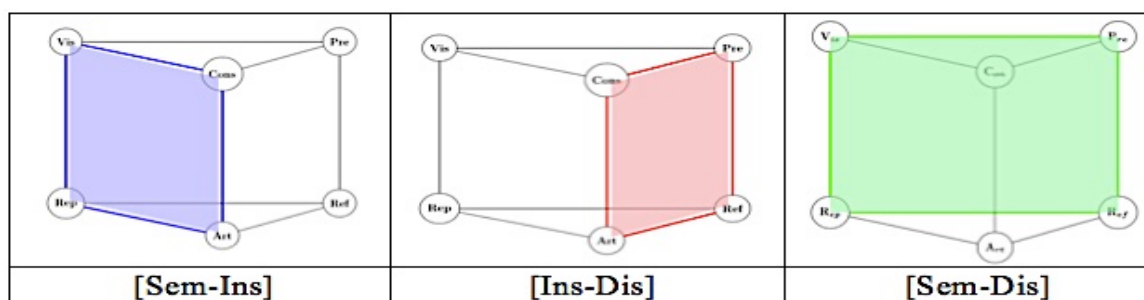


Figure 1. The three vertical planes of the MWS (Kuzniak & Nechache 2014)

The use of these different vertical planes helps to specify the circulation of geometric work in the MWS and the manner in which geometric work is carried out.

The task “Le terrain d’Alphonse”

Experimentation

To carry out the research, the task "Le terrain d'Alphonse" was assigned to two groups of undergraduate and master's students (45 students), who intend to teach in elementary school. The implementation of this task was performed in three phases. In the first phase, the task statement is given to the students in the form of a text to be read.

Alphonse has just returned from a trip in Périgord where he saw a field in the shape of a quadrilateral that had interested his family. He would like to estimate its area. To do this, during his trip, he successively measured the four sides of the field and found, approximately, 300 m, 900 m, 610 m, 440 m. He's had a lot of trouble in finding the area. Can you help him by indicating how to do it?

The purpose of the first phase is to specify that there is a lack of data to establish the exact shape of the quadrilateral that Alphonse wants to know the area. In the second phase, the length of a diagonal (630 m), without specifying which one, is given to the students to discuss the shape of the quadrilateral: convex or non-convex, crossed or not. Finally, once the shape of the quadrilateral has been decided, the third phase is devoted to concluding the resolution of the task. In each of the three phases, after collecting the students' written productions, we proceeded to a pooling. These exchanges allow us to list all the methods used by the students on the blackboard in order to discuss them. In particular, the results obtained are compared in relation to the selected shape of the terrain and the methods used to calculate the area.

Several methods can be used to achieve this task and they involve different geometric paradigms depending on both curriculum expectations and the students' personal work. The resolution of this task requires a modelling approach and involves work on approximation issues related to measurement.

Collection and analysis of data

To conduct our research we collected the students' written productions (45 productions for each phase, for a total of 135 productions). We also recorded and transcribed the exchanges that occurred during the pooling.

The students' written productions were studied by using a grid specifying the type of work done on the figure(s) and the types of discourses related to the area and its measurement. The analysis of the recordings of the pooling complements the analysis of productions and helps to refine student profiles. With the help of a statistical analysis software, we were able to identify five groups of students providing different forms of geometric work. Given the size of the present paper, we have limited ourselves to presenting briefly only four of these forms of work.

The expected geometrical work in master

A teacher trainer was solicited to implement the task in her group. She solved the problem informally before giving it to her students and her reasoning is in line with the work expected from the students who want to pass the competitive examination which presupposes knowledge of the geometry taught at the College (Grade 6 -9). She immediately detects that a data is missing and asks

for a diagonal. Using the value of a diagonal (630 m), she starts by constructing the quadrilateral with ruler and compass (instrumental dimension) to get an idea of its shape (semiotic dimension). She draws the figure using a scale that matches 1 cm on the figure to 1 m on the field. Thus, her work begins in the [Sem-Ins] plane with the intention of using a configuration as a support for the reasoning. She then deduces two possible forms of the quadrilateral, one convex and the other not convex¹. Then, she suggests to start by determining the area of the terrain with a convex shape. Her choice is motivated by the fact that, in this case, the task is easier for the students. To achieve the task, she makes a freehand drawing and decomposes the quadrilateral into two triangles. On the drawing, she specifies known and unknown values used to calculate the height of each triangle thanks to Pythagoras's theorem (discursive dimension). The work of proof is then based on algebraic computation with a strong numerical component. The freehand drawing becomes a support for algebraic calculation (semiotic dimension) by avoiding any direct measurement.

The mathematical work expected from preservice school students at the master's level can be summarized as follows:

1. The work is initiated in the [Sem-Ins] plane in order to distinguish the different cases that may exist. Work is guided by elements of the theoretical referent relating to the quadrilateral: various forms of the quadrilateral and importance of the diagonal to determine the nature of the quadrilateral.
2. The technique of triangulation is completely integrated in work (still in the [Sem-Ins] plane) but it is not explicitly mentioned. Perhaps this is due to the fact that the diagonal line shows the triangles directly and to the non-formal nature of the proof given by the teacher's trainer.
3. Work then moves to the [Sem-Dis] plane associated with algebraic work supported on the freehand figure and on Pythagoras's theorem used as a theoretical tool that switches work to algebraic work without any measurement on the drawing. The whole challenge of proof by calculation that is then made is to avoid any appeal to measurement.

This work is in accordance with the paradigm expected at this school level, which is a paradigm articulating GI and GII insofar as the reasoning is based on a particular figure without any generalization and on approximate values by prohibiting any effective measurement on the drawing.

Different forms of geometric work identified

In the following, we only present the results of the first phase which, contrary to our initial expectations, followed an unexpected and longer course. Indeed, almost all the students did not identify the need for asking additional indications and they engaged in the search for the area by adding certain conditions such “The quadrilateral had to be particular” or “All the quadrilaterals with the same perimeter have the same area”. These assumptions allow them, therefore, to reason on a particular figure. We present below four of the different forms of geometric work that we have identified at the end of this phase.

¹ We leave aside the case of a diagonal outside the quadrilateral or the crossed quadrilaterals that appear, in this modelling exercise, as two triangular fields and not as a quadrilateral.

Form 1. An asserted work of measurement: Francis' work

Francis begins his work with a scale construction with ruler and compass where he gets a trapezoid based on visual adjustment, guided by the idea that the figure should be particular (Sem-Ins).

Francis: I took the large 900 m base then from both ends with the compass, I made 410 on one side and 610 on each side and then with the ruler I tried to find the 300 with the two arcs of circle.

He then justifies why, it is indeed a trapezoid by relying on a geometric property of the theoretical reference frame, discursive dimension, (Sem-Dis).

Francis: I have drawn a perpendicular to the large base and this line was also perpendicular to the small one and since the two lines are perpendicular to the same line, they are parallel to each other so it makes a trapeze.

Finally, he completes his work in the [Ins-Dis] plane with calculations using formulas and by measuring the missing data on the drawing. He explains that he can do this because he has done his figure using a scale. His mathematical work is valid in the GI paradigm and moreover, as we will see again later on, this work is assumed by the student.

Form 2. A geometric work structured around the instrumental dimension: Ivana's work

This work is representative of the work done by students who have used geometric drawing tools by attempting not to use measurement too explicitly. The mathematical work produced by Ivana was initiated in the [Sem-Ins] plane to construct a quadrilateral (ABCD) by means of geometric drawing tools and with the assumption that one of the angles of the quadrilateral was a right angle. This inclusion of an additional property is common among students who have chosen to use drawing tools.

Ivana : In fact I constructed the figure to have a right angle, and so I calculated the area of the first triangle by doing (...).

Then, she decomposes the resulting quadrilateral into two triangles (Sem), one of them ABC is general and the second ADC is right-angled in D so that she can apply the triangulation method (Dis) to determine the area of the quadrilateral as the sum of the areas of these two triangles. Thus, mathematical work is located in the [Sem-Dis] plane. The, she calculates the area of the rectangular triangle ADC in D, then she applies the Pythagoras theorem (Dis) in the same triangle to deduce the length of its hypotenuse [AC]. Finally, Ivana uses the graduated ruler to measure a length (the height of the triangle ABC from B) and she applies the formula of the area of a triangle to determine the area of the triangle ABC. The mathematical work thus ends in the [Ins-Dis] plane with an unspecified use of measurement. Therefore, we can say that the mathematical work is complete and that it is guided by the GI paradigm.

However, this work does not conform to "mathematical rules" since the student has no control over the results obtained. When the professor asked her about the validity of her work, she answered that "all the quadrilaterals have the same surface because they have the same perimeter" and that is why it is possible to reason on a particular figure. This "theorem in action" leads to the fact that her mathematical work is not valid or conform. With this work, we are faced with a fairly common

problem of interpretation about the identification of the exact paradigm in which the student works. Students, because of the very strong didactical contract at this level, generally avoid measurement and thus think they work in the GII paradigm. But, in fact and in part to avoid obstacles linked to the difficulty of giving a proof based solely on properties of the frame of reference, they surreptitiously move into the GI paradigm either, as Ivana, by using measurements not assumed or as we will see below by using data based on perception only.

Form 3. A work without measurement and without theoretical control: Katia's work

The following geometric work is one of the most frequent among students who did not want to use construction instruments. They forbid themselves measurements on the drawing and wish to work in GII but nevertheless they allow themselves a great semiotic freedom to obtain formulas or apply known area calculation formulas.

Let's illustrate this approach with Katia's production. She begins by drawing two freehand figures (Sem), suggesting a transformation from the first to the second that leaves the area of the figure, more or less, invariant.



Figure 2: Katia's work

Katia then explained that one has to take the initial lengths and imagine that the terrain is a rectangle. To determine this area, she applies the technique giving this value by multiplying the lengths of the two sides (Ins). The lengths of each new sides are obtained as an arithmetic average of the opposite sides. Thus, the work is located in the plane [Sem-Ins] because it is oriented towards the use of a well-known area calculation formula by transforming the initial geometric figure. This work is produced without any control by means of material tools (geometric instruments) and theoretical tools (properties). Therefore, if this geometric work may be considered as partially valuable in GI it is not valid in any of the paradigms.

Form 4. A geometric work initiated in GII but unfinished: Severine's work

This form of work was rare in both groups and initiated by students with a good level in mathematics. In her work, Severine starts by producing a free-hand dissection of the quadrilateral into a trapezoid and two rectangle triangles (Sem). She explains her procedure in this way:

Séverine: I started from a general quadrilateral and then I drew two right-angled triangles (inside) in order to complete the quadrilateral.

Then, she explained that it would be necessary to find the heights of the triangles and also to use Pythagoras theorem to do the calculations (Dis). She intended to do this work but she did not perform it. However, at this stage, this can be considered normal because a data is missing, but she did not asked for it. She was thus blocked in the plane [Sem-Dis] and the teacher intervened by trying to motivate the claim of a diagonal.

Teacher: Can you comment on what Séverine suggests, do you have the necessary information to do the calculation

Students then request additional data on measurements but do not ask for the length of the diagonal. Francis intervened once again by indicating that it is possible to measure on the drawing because it was made with a scale. Séverine does not agree with him and she refuses to measure on the figure (GI paradigm) preferring to remain blocked and not complete the task.

Conclusion

In this preliminary study, which is part of a more global research project on teacher training in geometry, we were able to identify some different students' forms of geometrical work when they have to achieve a geometrical task which relates to the estimation of the area of a field. The results we have obtained show blockages and rebounds among students who are trying to meet institutional expectations (a geometric work in GII). The work they produce is profoundly incomplete because it is often confined to a single plane or dimension of the MWS. Moreover, and for us, it is the most worrying from the teacher education viewpoint, these teachers students do not seem to have control tools on their productions other than perceptual and instrumental. When they have tried to use theoretical controls, there were generally based on false "theorems in action" that do not ensure the validity of mathematical work from an epistemological perspective. It should be pointed out, however, that the situation is destabilizing for the students because it does not follow the usual didactic contract, which implies that all the data needed to solve the problem have to be included in the task statement. Moreover, almost all the teacher students think that all the geometric shapes they are asked to study must have some particular shapes and properties. And, on their own initiative, they suppose that the quadrilateral has a specific property (right angle, parallel sides...) which allows them not to be blocked in a dimension or plane of the MWS but it results that their work cannot be considered to be valid. From this observation, we intend to develop didactical situations that ensures a first exploration work on drawing in order to question the construction and validation methods within a geometry I that promotes both modelling and controlled approximation work.

References

- Kuzniak A. & Rauscher J.C, (2011). How do Teachers' Approaches on Geometrical Work relate to Geometry Students Learning Difficulties? *Educational Studies in Mathematics*, 77 (1), 129-147.
- Kuzniak, A, Tanguay, D & Elia, I. (2016). Mathematical working spaces in schooling : An introduction. *ZDM-Mathematics Education*, 48(6). 721-737.
- Kuzniak, A. (2018). (2018). Thinking About the Teaching of Geometry Through the Lens of the Theory of Geometric Working Spaces. In *International Perspectives on the Teaching and Learning of Geometry in Secondary Schools*. Herbst P. et et al. (eds), pp 5-21. New York : Springer.
- Kuzniak, A & Nechache, A. (2015). Using the Geometric Working Spaces in order to plan the teaching of geometry. In K. Krainer & N. Vondrová (Eds) (pp. 543-549). *Proceedings of CERME9*. Prague, Czech Republic.

Students' reasons for introducing auxiliary lines in proving situations

Alik Palatnik¹ and Tommy Dreyfus²

¹ Shaanan Academic Religious Teachers' College, Haifa, Israel; umapalatnik@gmail.com

² Tel Aviv University, Israel; tommyd@tauex.tau.ac.il

We study proving situations in geometry where students introduce auxiliary lines. We examine students' reasons for introducing auxiliary lines. The overarching theme of the tasks proposed to the students is the comparison of areas of triangles and/or parallelograms. The students gave a wide spectrum of reasons when introducing auxiliary lines. Two main groups of reasons have been discerned for modifying a given situation by introducing auxiliary lines: recalling a learned procedure using some known results or definitions, and anticipating more information from the modified situation. We present a case study of a pair of students who combine reasons of recalling and anticipating nature when introducing auxiliary lines.

Keywords: High school geometry, proof, auxiliary lines, reasoning, task-based interviews.

Introduction

The objective of this study is to contribute to research on proving in geometry. Specifically, we investigate the introduction of auxiliary elements by students while proving and characterize reasons students give for their actions. Our interest in this process stems from the following facts: First, proving in geometry is difficult for students in general. Second, the introduction of auxiliary lines contributes substantially to students' difficulty with proofs in geometry (e.g. Hsu, & Silver, 2014; Senk, 1985). Our focus on students' reasons for introducing auxiliary elements led us to build on the seminal work of Pólya (1957), who highlighted the role of auxiliary lines in problem solving.

Theoretical background

It is widely recognized that in secondary school, proof and proving are still mostly taught in the area of geometry (Herbst, 2004; Fujita & Jones, 2014). According to Battista (2007) school geometry presents students with a complex network of concepts, representations and ways of reasoning "...that is used to conceptualize and analyze physical and imagined spatial environments" (p. 843). Combining deductive and spatial reasoning is pertinent to proving activities in geometry. Indeed, in his study of American geometry classes, Herbst (2004) demonstrated, among others, a *generative* type of students' interaction with diagrams in proving activities. Such interactions are characterized by deductive reasoning interrelated with modification of a given diagram. Such interactions are virtually absent from geometry classes, as studies of Japanese secondary schools confirm (Miyazaki, Fujita, & Jones, 2015) but are central for proofs that require the introduction of an auxiliary element.

According to Pólya (1957), "an element that we introduce in the hope that it will further the solution is called an auxiliary element" (p. 46). In our study, a slightly expanded version of this definition is used. Namely, we consider also the modification of an already existing element as an auxiliary element (see Task 1 in the Methodology section). Moreover, an auxiliary element may be only imagined rather than physically drawn.

According to Senk (1985) the introduction of auxiliary lines is a critical part in the solution of geometric proof problems. She concluded that the difficulty with auxiliary lines “exemplifies the need to teach students how, why, and when they can transform a diagram in a proof” (p. 455). Ding and Jones (2006) also identified the introduction of an auxiliary line as a source of great difficulty. Hsu (2007) claims that this difficulty is caused by students’ need to perceive the diagrams dynamically and apply transformational observation to visualize a solution achievable with auxiliary lines.

Students’ difficulty with introducing auxiliary lines when proving can be partially explained by a form of instruction, which does not encourage students to add new lines to the given diagram. For instance, students in the study of Herbst and Brach (2006) self-reported that they expect to play a passive role in interaction with diagrams when proving: They believe that they are usually not expected to introduce auxiliary lines, and if so, they expect to receive a hint to do so from the teacher. This difficulty may be overcome by the incorporation of various types of exploration in proving which makes the introduction of auxiliary lines more transparent (e.g. Fan, Qi, Liu, Wang and Lin, 2017).

Considering these studies and Pólya’s fundamental work, it makes sense to consider the introduction of auxiliary lines through the prism of reasons that led to their introduction. Pólya (1957) lists three main reasons for introducing auxiliary lines (p. 46):

- 1) Trying to use known results;
- 2) Going back to definitions;
- 3) Expecting to make the original problem “fuller, more suggestive, more familiar”.

Pólya makes a distinction between the first two reasons and the third one. He states that in the third case “we scarcely know yet explicitly how we shall be able to use the elements added. We may just feel that it is a ‘bright idea’ to conceive the problem that way with such and such elements added” (ibid.). In our study we sought both, to obtain descriptive reports about students introducing auxiliary elements in proving situations, and to identify the types of reasons they provide for introducing them. We adapt Pólya’s classification to our aims by introducing the terms *recalling* (Pólya 1, 2) and *anticipating* (Pólya 3) reasons.

Given this background, our research aims to answer the following questions:

- A. What reasons do the students give when introducing an auxiliary line in a proving situation?
- B. To which type do these reasons belong, recalling or anticipating?

Methodology

Students and Tasks

The participants in our study were high school students studying geometry in Grade 10—the first grade of Israeli high school. Eighteen students were nominated by their mathematics teachers; ten of them volunteered for the study. The students were grouped into five pairs, following Schoenfeld’s (2000) suggestion that students working in pairs will show reliable and natural behavior.

We sought to create tasks where students would be inclined to draw auxiliary lines in order to make progress. We anticipated that tasks with multiple solutions, each based on different auxiliary lines, will elicit a variety of reasons for introducing auxiliary lines. The topic of areas was suitable as it was

already known to the students, but proofs on areas had not been taught in class at the time of the intervention. We used two tasks with different levels of complexity.

Task 1: Quadrilateral ABCD is a parallelogram. Where on side AB do you have to place point E, so that the area of triangle DEC is a half of the area of the given parallelogram ABCD? Explain your reasoning.

There are multiple ways to show that E can be anywhere on side AB. Figure 1 hints at some of them, highlighting the role of appropriate auxiliary lines in the proofs.

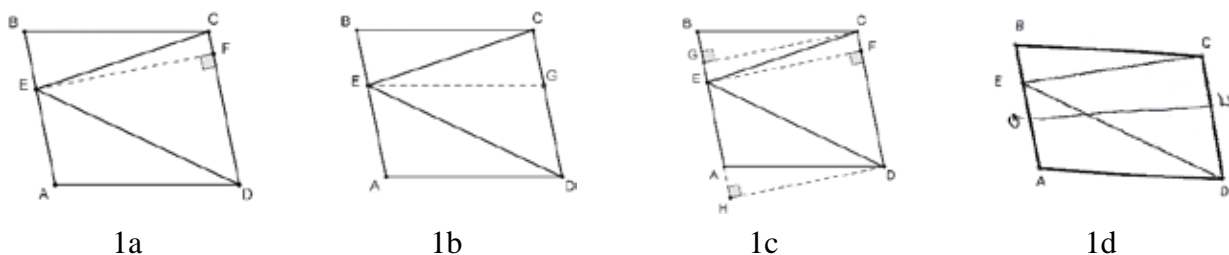


Figure 1. (a-c) Task 1 with auxiliary lines, (d) students' sketch

Task 2: Prove that the quadrilateral formed by the midpoints of the sides of a given quadrilateral is a parallelogram, and that its area is half of the area of the given quadrilateral (Varignon's theorem, Theorem 3.11 in Coxeter & Greitzer, 1967). Task 2 contains two parts, the second of which relates to area. This two-part structure and the large variety of possible auxiliary lines allowing to make use of properties of a triangle's midsegment and of a parallelogram to prove the claim make it especially suitable for our study (see students' sketches in Figure 2 in the Findings section).

Procedure

We used two interview techniques to obtain information on the introduction of auxiliary lines: *stimulated recall* (SR) and *partial revealing* (PR). SR is a reflective method used in qualitative research (e.g., Bikner-Ahsbabs, 2004) in which students carry out a task undisturbed and are later prompted by the use of some visual or auditory stimulus to recall their thoughts while carrying out the task. A crucial advantage of SR is that it does not interfere with carrying out the task. Thus, we decided to use SR in the relatively simple first task. Also, the SR sessions which followed the first task familiarized students with the researchers' request to reflect upon their actions.

In the more complex Task 2, we wanted to make sure that students do not get stuck. For this purpose, we developed and used the idea of partial revealing (PR), a variation on task-based interviews (Goldin, 2000): We prepared a progressively more revealing sequence of 12 visual or verbal hints. The hints were descriptions/ sketches of an auxiliary line or some key idea/ definition, supporting different ways to prove Task 2 (cf. hints to the same problem in de Villiers, 2014). The hints helped students recalling relevant knowledge or focusing on specific information given in the problem. After obtaining a hint, the students were encouraged to reflect upon the new situation created by the hint. This approach helps the students (and the researcher) to understand and describe the possible reasons for introducing an auxiliary line, whether they tried to use a definition, a previously solved problem or just feel that the hint will advance the proof.

In a first meeting (about 20 minutes), each pair of students worked on Task 1 (Figure 1) without researcher intervention. The solution, explanation, or proof, agreed upon by the two students was collected by the researcher without comment. In the second meeting (about 45 min), two days after the first one, the student pairs returned to Task 1, using SR. In the third meeting (about 45 min), the students worked together on Task 2. The PR method was applied.

The qualitative analysis of the data was based on the methodology used by Jones (1998) for the exploration of students' solutions of geometric construction problems on the subject of interplay between students' intuitive and deductive reasoning. First, the video-recordings of all interviews and the students' written productions were searched for auxiliary lines drawn by the students. Then, the videos were transcribed; we read the transcripts of all the meetings line by line, and marked phrases that seemed to relate to reasons for adding auxiliary elements. Next, students' actions and utterances while introducing the auxiliary lines were coded according to our adaptation of Pólya's (1957) list of reasons for introducing of auxiliary lines. For instance, the utterance "The subject of the problem is an area, we need to draw the height" which accompanied introduction of the line segment EF (Figure 1c) was coded as "recalling" (going back to definition/ concretizing a formula). The utterance "It just seems right to draw this line" about the same auxiliary line was coded as "anticipating" (expecting to make the original problem more suggestive). These broad categories of reasons were further divided according to the type of auxiliary line and the type of reason.

When analyzing Task 1, we juxtaposed students' explanations during the SR sessions with their explanations to their partners during the problem-solving meetings and with written productions and sketches. We paid special attention to the general context of the proof and in particular to the change in students' actions and utterances after introducing the auxiliary line; in this, we followed Goldin's (2000) way of analyzing interactions between the subjects and mathematical structures of the tasks. This procedure helped us to confirm and elaborate our initial coding.

When analyzing Task 2 we paid special attention to the moments where specific PR hints (definitions, formulas or visual images) led to the introduction of an auxiliary line; again we followed Goldin (2000), this time with respect to the role of hints in the analysis of students' problem-solving behavior.

Findings

We analyzed five pairs of students. Here¹, we present the case of Bob and Boris whose reasons were of both types: "recalling" and "anticipating".

Task 1

Boris soon drew the auxiliary line GF (Figure 1d) stating: "I want to calculate the area of CED and then the area of the two smaller triangles, to compare." In the SR session, he described GF as a height through the midpoint of AB, and gave the following reasons for the introducing GF: "Because they ask for area, and the height is a part of the area formula" (Bob&Boris SR10). When asked about the reason for drawing the height exactly at the midpoint of AB, Boris can't give a specific reason: "It was the first point to draw the height"; "it was an initial thought" (Bob&Boris SR 28, 36). In the SR

¹ Analyses of two more cases are presented elsewhere (Palatnik & Dreyfus, 2018)

session Bob recalled that immediately after Boris drew the auxiliary line, he thought that there are probably more places where the area is the same.

The students' solution of Task 1 culminated in the following exchange:

- Boris: The height will always be the same!
- Bob: Let's assume that I place it, point E, together with point A [Points at the sketch, draws imaginary AC].
- Boris: [loud] Look, it is at every point!
- Bob: [continues with confidence] So, it happens at every point.
- Boris: The base is the same base, and the height is the same height, so at every point it will be equal.
- Bob: U-hu, if I place it there, at point A (draws imaginary line $AC=EC$), it is diagonal, it halves the parallelogram. If I place it at the point B, diagonal BD also halves the parallelogram.
- Bob: So, it looks to me, that at every point. (Bob&Boris M1 35-41)

Analysis of Task 1. The auxiliary elements introduced by the students in the course of solving the task were: (1) GF—the height through the midpoint of AB; (2) and (3) diagonals AC and BD (imagined). As follows from the students' explanation given above, the reason to use height was that it forms part of the formula for the area and thus of *recalling* nature. A possible explanation for the choosing the height through the midpoint of the side is the intuitive rule same A- same B (Stavy, & Tirosh, 2000), namely, half of the area (A) - half way on the side (B). As for the diagonals AC and BD, Bob imagined them and gestured them in the air. In the SR session, he explained that if E is placed at the vertices A and B it's easy to see that the diagonals AC and BD halve the parallelogram (anticipating).

Task 2

The students started by drawing their own sketch (Figure 2a). Boris soon focused on the second part of the task: the area of the parallelogram is half that of the quadrilateral. Bob drew EG, a height in ABCD, as first auxiliary line, but the students realized that they do not know a formula for the area of a general quadrilateral. They received as hints (a) an accurate sketch of the task; (b) a drawing of a triangle with a midsegment. The midsegment immediately triggered progress. Boris drew the diagonals AC and BD, and Bob formulated a full formal proof to the first part of the task, using the property that a midsegment of a triangle is parallel to the third side of the triangle.

To prove the second part of the task, the students wanted to calculate areas and looked for a place to construct a height. A switch from calculating to comparing areas was initiated when they attended to pairs of congruent triangles and in particular to the triangles AHN and HDI (Figure 2b, 2c). Bob suggested comparing their areas to that of quadrilateral HIMN, and Boris introduced the crucial auxiliary line NI (Figure 2c).

- Boris: I have constructed a diagonal [of HIMN]. And [points to the sketch] this angle equals this, 'cause it is parallel.
- Bob: No, you still have to prove this.

Boris: Wait a minute [rotates the sheet with the sketch]. We have to prove that these areas are equal [points to the triangles AHN, HDI, NMI and IHN]. It will make it a midsegment (of triangle AMD) (Bob&Boris M3 134-140).

Later the students developed this idea into a proof (Figure 2d).

Analysis of Task 2. The main auxiliary elements introduced by the students in the course of task solving were: (1) EG—the segment connecting the midpoints of AB and CD; (2) diagonals AC and BD and (3) NI- the midsegment of the triangle AMD (and the three analogous midsegments in the other parts of the quadrilateral).

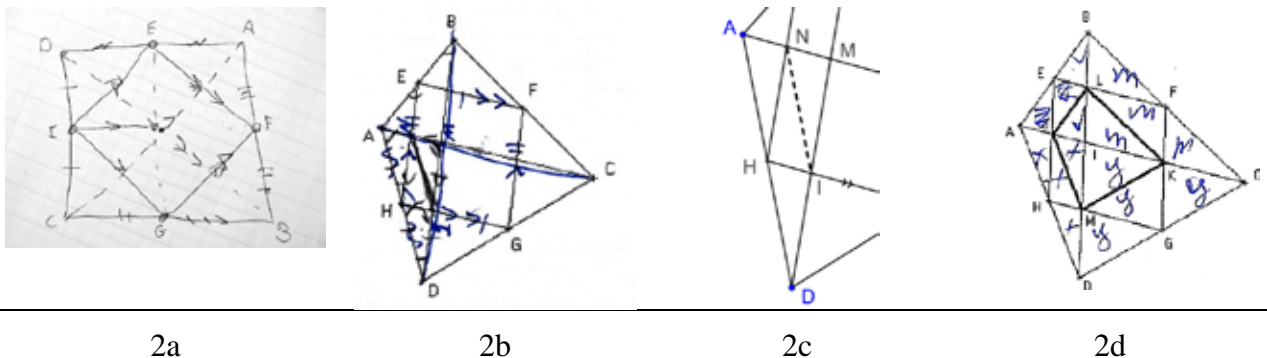


Figure 2. The students' sketches for Task 2 (2c is our copy of a relevant part of students' sketch 2b)

We may assume that the auxiliary line EG, perceived by the students as a height, was introduced as a part of a recalled procedure which connects between height as an auxiliary line and height as a part of the area formula as previously mentioned by Boris.

The diagonals AC and BD were introduced immediately after the visual hint (a drawing of a triangle with a midsegment). We assume that the hint led the students to *recall* the definition and properties of a midsegment, which became a reason for introducing AC and BD which in turn helped them elaborate the sketch into a formal proof.

We interpret that the reason for introducing the crucial auxiliary line NI was an *anticipating* one. Despite the fact that Boris was not sure how this auxiliary line will advance his proof, he introduced it wishing to show that the areas of quadrilateral HIMN and the combined areas of HDI and AHN are equal. It is remarkable that in the collaborative problem-solving efforts of Bob and Boris in Tasks 1 and 2 the reasons to introduce auxiliary lines were both of *recalling* and *anticipating* nature.

Discussion

Our aim was to reveal and characterize students' reasons for introducing auxiliary lines in geometric proof situations. The five pairs of students who participated in the study introduced a total of 26 auxiliary elements of various nature: heights of triangles and parallelograms, diagonals of parallelograms, triangle midsegments, and medians. Some of these elements were actually drawn, others imagined. As we expected, Task 2 was not easy for students to prove (cf. Ding and Jones, 2006; Hsu and Silver, 2014 about the complexity of tasks with auxiliary lines).

The reasons students gave when introducing auxiliary elements are of two types (1) recalling some known formulas, definitions and procedures, and (2) anticipating to receive more information from a modified situation. There were 14 auxiliary elements of the first type and 12 of the second.

In the tasks we used, most of the reasons of a recalling nature were related to the introduction of heights. The students drew heights as part of a learned algorithm for finding areas: height is explicitly present in the area formula; hence students recalled the formula, and almost immediately drew heights as auxiliary lines; this seems to be a pertinent feature of students' proving process in the context of areas. It was very salient in the interview with Bob and Boris.

Our data allow us to elaborate on characteristics of Pólya's third type of reason for introducing auxiliary lines: anticipating to make problem fuller, more suggestive, without knowing exactly how the auxiliary line will be used. Most of the examples of such reasons we found can be organized into two groups. In the first group (4 occurrences), we put reasons related to intuitive rules (Stavy, & Tirosh, 2000). Evidence for this is provided by the intuitive "half side-half area" reasoning when introducing the auxiliary lines through the midpoint of the side (e.g., Bob and Boris, Task 1, line GF). In the second group of *anticipating* reasons for introducing auxiliary lines (6 occurrences), we put reasons related to the students' feeling that they exhausted the available resources and they needed to produce some new source of information (e.g., Bob and Boris, Task 2, NI).

All students used area formulas when proving Task 1; a majority also introduced heights in Task 2, and when this failed, they introduced other auxiliary lines. One possible explanation for this is, that when the students felt that they had exhausted the resources suggested by recall, they tried auxiliary lines based on some anticipation, while keeping in mind that they have to substantiate it (as happened to Bob and Boris when introducing NI in the second part of Task 2).

Based on these findings, we suggest that the introduction of auxiliary lines in proving situations can be expected to provide a rich context for the development of geometrical thinking. Teachers should encourage proactive and reflective approaches to the introduction of auxiliary elements. It is impossible to develop mastery related to the introduction of auxiliary lines without creating experiences of drawing, imagining and dynamically modifying auxiliary lines. This study of students introducing auxiliary elements when proving included only a small number of participants, and only two tasks from a single geometry topic, and it was conducted with paper and pencil only. Further research is required to better understand the complex dynamics of introducing auxiliary lines.

References

- Battista, M. T. (2007). The development of geometric and spatial thinking. In F. Lester (Ed.), *Second handbook of research on mathematics teaching and learning* (pp. 843–908). Charlotte, NC: NCTM/Information Age.
- Bikner-Ahsbals, A. (2004). Towards the emergence of constructing mathematical meanings. In M. J. Høines & A. B. Fuglestad (Eds.), *Proceedings of the 28th Annual Conference of the International Group for Psychology of Mathematics Education*, Vol. 2 (pp. 119–126). Bergen, Norway: Bergen University College.
- Coxeter, H. S. M. & Greitzer, S. L. (1967). *Geometry revisited*. Washington, D.C.: Mathematical Association of America.

- De Villiers, M. (2014). Slaying a geometrical monster: Finding the area of a crossed quadrilateral. *The Scottish Mathematical Council Journal*, 44, 71-74.
- Ding, L., & Jones, K. (2006). Teaching geometry in lower secondary school in Shanghai, China. *Proceedings of the British Society for Research into Learning Mathematics*, 26, 41-46.
- Fan, L., Qi, C., Liu, X., Wang, Y., & Lin, M. (2017). Does a transformation approach improve students' ability in constructing auxiliary lines for solving geometric problems? An intervention-based study with two Chinese classrooms. *Educational Studies in Mathematics*, 96, 229-248.
- Fujita, T., & Jones, K. (2014). Reasoning-and-proving in geometry in school mathematics textbooks in Japan. *International Journal of Educational Research*, 64, 81-91.
- Goldin, G. A. (2000). A scientific perspective on structured, task-based interviews in mathematics education research. In A. Kelly & R. A. Lesh (Eds.), *Handbook of research design in mathematics and science education* (pp. 517–545). Mahwah, NJ: LEA.
- Herbst, P. (2004). Interactions with diagrams and the making of reasoned conjectures in geometry. *ZDM – The International Journal on Mathematics Education*, 36, 129-139.
- Herbst, P., & Brach, C. (2006). Proving and doing proofs in high school geometry classes: What is it that is going on for students? *Cognition and Instruction*, 24, 73–122.
- Hsu, H. (2007). Geometric calculations are more than calculations. In J.-H. Woo, H.-C. Lew, K.-S. Park, D.-Y. Seo (Eds.), *Proceedings of the 31st Conference of the International Group for the Psychology of Mathematics Education*, Vol. 3 (pp. 57–64). Seoul, Korea.
- Hsu, H. Y., & Silver, E. A. (2014). Cognitive complexity of mathematics instructional tasks in a Taiwanese classroom: An examination of task sources. *Journal for Research in Mathematics Education*, 45, 460-496.
- Jones, K. (1998), Deductive and intuitive approaches to solving geometrical problems. In: C. Mammana & V. Villani (Eds.), *Perspectives on the teaching of geometry for the 21st century* (pp. 78-83). Dordrecht, The Netherlands: Kluwer.
- Miyazaki, M., Fujita, T., & Jones, K. (2015). Flow-chart proofs with open problems as scaffolds for learning about geometrical proofs. *ZDM – The International Journal on Mathematics Education*, 47, 1211-1224.
- Palatnik, A., & Dreyfus, T. (2018). Students' reasons for introducing auxiliary lines in proving situations. *The Journal of Mathematical Behavior*.
<https://doi.org/10.1016/j.jmathb.2018.10.004>.
- Pólya, G. (1957). *How to solve it. 2nd edition*. Princeton, NJ: Princeton University Press.
- Schoenfeld, A. H (2000). Purposes and methods of research in mathematics education. *Notices of the American Mathematical Society*, 47, 641-649.
- Stavy, R., & Tirosh, D. (2000). *How students (mis)understand science and mathematics: Intuitive rules*. New York: Teachers College Press.
- Senk, S. L. (1985). How well do students write geometry proofs? *The Mathematics Teacher*, 78, 448-456.

Construction of triangles: some misconceptions and difficulties

Paula Vieira da Silva¹ and Leonor Santos²

¹UNIDEF, Instituto de Educação, Universidade de Lisboa, Portugal; paulasilva@campus.ul.pt

Instituto de Educação, Universidade de Lisboa, Portugal; mlsantos@ie.ul.pt

This study aims to analyze tasks that involve the construction of triangles and which are included in 6th grade national assessment tests in Portugal. More specifically, we analyze the mental processes used by the students, the difficulties experienced and the mistakes made in solving these tasks. The study follows a methodology of an interpretative nature, with data collection from the students' tests, the productions of the students and of interviews recorded in audio. In summary, the results show that, in linear measurement, many students demonstrated a quite acceptable level of sophistication. However, in the construction of angle the causes of their difficulties seem to be the absence of adequate structural components.

Keywords: Geometric thinking, construction of triangles, didactic material.

Introduction

In constructing a school curriculum it is necessary to make choices, and this need to choose is precisely what makes it so difficult to decide on a coherent and balanced curriculum throughout the period of learning in the school (Mammana & Villani, 1998). In Portugal, these choices are also visible in the emphasis given to certain contents in the 6th grade National Assessment Tests (NAT). In these tests, from 2010 to 2015, a task that involves the construction of triangles was always presented. In the Basic Education Mathematics Program (PMEB) of 2007, in the Program and Curricular Goals of Basic Mathematics Education of 2013 - PMCMEB, and in NAT, the construction of triangles has an obvious centrality. The characteristics of the tasks proposed in the NAT, overestimating certain curricular contents and certain mental processes, can induce the teaching methodologies used by the teachers and, consequently, influence the students' learning, and therefore, their analysis is of great importance. So, the main objective of this study is to analyze the 6th grade NAT tasks that involve the construction of triangles. In particular, we consider the following research questions: What mental processes were used by students? What difficulties have been experienced and what mistakes have been made in solving these tasks?

Theoretical framework

A very particular aspect of the study of geometry is the construction of triangles. The triangle is the simplest flat figure. It comprises, with only three sides, three angles and three vertices, a defined part of the plane. Its simplicity makes it a basic tool for decomposing more complex figures and making measurements, and is therefore considered the basic mosaic of geometry (León & Timón, 2017).

In the process of constructing triangles, the abstraction of the concept of angle and of measurement are essential, since some of the errors produced by the students in the resolution of tasks that involve the construction of triangles are related to the construction of angles given a certain amplitude and with the measurement of line segments.

When constructing triangles with ruler, compass and protractor, various concepts and properties should be used. The previously studied concepts and properties must be related and applied at the time of construction. In the various stages involved in the construction of the triangle,

different difficulties can arise if the properties of the triangles are not taken into account in their construction (Zamagni & Crespo, 2016). The students' difficulties in solving tasks involving the construction of two-dimensional representations of triangles are sometimes also due to the lack of experience and skills in the use of the didactic materials needed for this construction (Van de Walle, 2009). These difficulties are also due to the appeal to their properties and the fact that visualization plays an important role in the decoding and transformation of mathematical information.

Understand the concept of measurement

The concept of measurement is built along the construction of the geometric conceptualization, reasoning and application (Battista, 2007). Based on other authors, Battista (2007) considers that despite the importance of geometric measurement, the performance of some students in measurement tasks is low. That is, they do not adequately establish the connection between numerical measurements and the iteration process of unitary measures. For example, students who incorrectly measure an object's length when one of its edges is not zero-aligned in a ruler do not conceptualize clearly how the numerical ruler marks indicate the iteration of the lengths of the unit. According to this same author, many traditional curricula prematurely teach numerical procedures for geometric measurement, students have little opportunity to think about the adequacy of the numerical procedures they apply and do not have sufficient opportunities to develop skills with spatially structuring units of measurement.

Joram, Subrahmanyam, and Gelman (1998) argue that although younger students can learn some simple measurement skills, real physical measurement, such as determining lengths, for example with physical objects serving as a unit of measure, is a challenge for many, which may mean that students' knowledge of linear measures may be more superficial than it seems.

Battista (2007) integrating investigations that describe levels of sophistication in the development of concepts of measurement of length, developed a characterization of the construction of meaning of the students. In this characterization, there are two fundamentally different types of reasoning about length, *reasoning without measurement* that does not use numbers (involves visual-spatial inferences based on direct or indirect comparisons, imagined transformations of geometric properties) and *measurement reasoning* (involves iteration of units of length, that is, the determination of the number of units of fixed length that fit end to end along the object, without gaps or overlaps). Measurement reasoning includes not only the measurement process, but the reasoning about numerical measures (e.g., adding lengths to find the perimeter of a polygon, making inferences about length measurements based on the properties of the figures). Although students usually develop strategies without measurement before measurement strategies, reasoning without measurement continues to develop in sophistication even after the reasoning of the measurement appears. In addition, a more sophisticated reasoning about length involves the integration of reasoning without measurement and measurement.

The research of several authors suggests that students construct a meaningful understanding of the measure of length as they abstract and reflect on the process of iteration of units of length (Battista, 2007).

Understanding the concept of angle

Students have great difficulty in learning the concept of angle (Clements & Battista, 1992). Angle is considered to be a multifaceted concept (Douek, 1998), since there is a great variety of definitions presented in school textbooks and textbooks for teacher training (Mitchelmore & White, 2000). Some authors consider that the angle can be defined based on three different aspects: as a quantity of rotation between two lines meet at a point (turn), as a union of two rays with a common extreme point (ray) and as the intersection of two half-planes (region) (Mitchelmore & White, 2000; Devichi & Munier, 2013). This concept is constructed slowly and progressively (Lehrer, Jenkins, & Osana, 1998; Mitchelmore, 1998). White and Mitchelmore (2003) consider that it is clear from the research literature that students have great difficulty in coordinating the various facets of the angle concept. In addition, several authors have observed that students also have different angle conceptions (Mitchelmore & White, 2000).

The process of constructing the concept of angle crosses several obstacles (Mitchelmore, 1998), and the difficulties that students encounter in learning angles and the mistakes made were observed in several experimental studies (Berthelot & Salin, 1996; Mitchelmore, 1998; Mitchelmore & White, 2000; Devichi & Munier, 2013). Berthelot & Salin (1996) report, based on a Close study (1982), that when students have to compare pairs of angles with the same amplitude but with different lengths of sides, many students respond that the larger angle is the one that has one or both sides longer, without taking into consideration the space between them. These studies reveal other misconceptions of some students because they consider that one side of the angle must always be horizontal and the direction of the angular aperture must always be counterclockwise, or that the angle is a sector of a circle.

Students face some difficulties in using a protractor, which have been emphasized in the literature. Sometimes students align the base of the protractor's body along one side of the angle, rather than the protractor's own reference line; or they do not place the origin of the protractor on the vertex of the angle to be measured. They can also read the angle measure clockwise when they should read counterclockwise or vice versa (Tanguay, 2012). Mitchelmore and White (2000) have suggested that the difficulty students have in learning to use a protractor may result from the fact that in a protractor several lines may be chosen for the initial side of an angle but the terminal side must be imagined. On the other hand, the cause of the students' difficulties seems to be the absence of structural angular components, which leads to failure to establish adequate structural mappings.

Methodology

The present study follows a qualitative interpretive methodology (Bogdan & Biklen, 1997), since it privileges the interpretation of reality according to the perspective of the actors. In total, 171 students who completed the 6th grade participated in the study. The selection of these students was intentional and took into account their performance levels. The fact that students expressed different levels of performance permitted us to access a greater diversity of resolution strategies and, consequently, different mental processes and errors. The tasks were solved after the final internal assessment and in school context, which greatly reduces the probability of interfering factors in the study.

The data collection was carried out in a school context between 2012 and 2015 and used: (i) the collection of documents (tasks of NAT and resolutions of these tasks by the students); and (ii) semi-structured interviews to students recorded on video. The interviews were conducted the day after the task was resolved. Each of the students interviewed had the sheet with the resolution produced by them and, after reading each question, explained how they arrived at the answer.

The selection of the 35 students interviewed was made according to the assumptions of the students' selection for the study.

The analysis of the data for this study initially involved the organization of the information obtained by the written productions of the students and the interviews carried out. Secondly, content analysis was used with pre-defined categories: the mental processes used by the students, the difficulties experienced and the mistakes made.

Results

Of the five tasks of the NAT of the 6th grade between 2010 and 2015, which involve the construction of triangles, two were chosen (one of the test of 2010 and another of 2012). These two tasks have in common the fact that the required final product is the construction of a triangle, but the method of construction of the triangles is different.

Task 20 of the 2010 NAT

*The perimeter of an equilateral triangle is 18 cm.
Construct this triangle in the box below. Shows the calculations you make. Make your construction using pencil, ruler and compass. Do not erase the lines that you do with the compass.*

Figure 1. Task 20

In this task (figure 1), students should know that: in an equilateral triangle the length of the three sides is equal; the perimeter must be divided by the number of sides, obtaining the length of each side. After this procedure, the student can construct the equilateral triangle, proceeding as follows: draw a line segment of 6 cm; draw the circumference arcs at a distance of 6 cm from each end of the line segment until they intersect, marking the point of intersection of the two arcs; draw the two line segments that join the ends of the line segment and the point obtained by intercepting the two lines. The student is not required to mark the vertex designation of the triangle.

Of the 171 students who were asked to solve this task, 106 (62%) correctly constructed the triangle. Of these 106 students, 80 (47%) recorded the calculation of the length of the sides of the triangle. The others 26 (15%) did not register the calculations made, as it was requested in the task. However, some of these students wrote 6 cm on the sides of the triangle. Of the 35 students interviewed, all of them performed the division and correctly constructed the requested triangle. Only the student S1 did not construct the triangle with ruler and compass, instead, he used the protractor, as he explains: "First, I divided 18 by 3 and gave me 6. So, since an equilateral triangle has all angles equal to 60° , I drew a 6 cm line segment and placed the protractor here [the student points to the left end of the line segment he drew] and traced an angle of 60° . So I drew a 6 cm line segment. Here [the student points to the other end of the

initial line segment] I did the same thing and joined the line segments.” When asked if instead of constructing the triangle with ruler and protractor using the amplitude of the inner angles could be constructed with ruler and compass, the student replied "Yes." He was also asked why he did not and the student answered: “Because I just remembered this method”.

Of the 65 students who did not answer correctly, 19 (11%) did not register any work. With the exception of S21, these students did not belong to the group of students interviewed and, therefore, it was not possible to know the reason why they did not solve the task. Student S21 justified himself saying that he had no ruler or compass. However, after the interviewer asked him to reread the question, the student explained step-by-step what he should do to solve the task correctly. The interviewer asked why he did not record the calculations to get the length of each side of the triangle and the student replied that he thought he should draw only the triangle. Although this student knew how to solve the first part of the task, for which the drawing material was not necessary, and to be written in the question "Show the calculations you make", did not make any record.

Of the 46 (27%) students who attempted to solve the task, but were unable to construct the requested triangle, 7 recorded the calculations required to obtain the length of each side of the triangle. It seems that these students understand that in an equilateral triangle the length of its three sides is equal and that the perimeter of the triangle is equal to the sum of the length of its sides. However, when they went to construct the triangle they used other lengths. For example, one student used the lengths 6.5 cm, 5.5 cm and 5.5 cm and records 6 cm on each side of the triangle. In this case there seems to have been some problem with measuring the lengths. The line segment measured with the ruler is 6.5 cm and the other two, which were obtained with the opening of the compass, are 5.5 cm. 10 constructed equilateral triangles whose sum of the lengths of the sides is not 18 cm, for example, equilateral triangles with 4.5 cm on each side. Finally, 6 constructed non-equilateral triangles with perimeter of 18 cm. Other constructions were found in which there is no evidence of the use of the compass. In these constructions, it seems to us that students try to construct the triangle with only the ruler. This strategy is used when students cannot remember the method of construction with the ruler and compass.

Task 12 of the NAT 2012

Constructs the triangle [ABC] that obeys the following conditions:

- $\overline{AB} = 6 \text{ cm}$
- $\hat{BAC} = 30^\circ$
- $\hat{CBA} = 120^\circ$

Use the appropriate drawing material.

Figure 2. Task 12

To solve the task 12 (Figure 2), first, students should draw [AB] and mark points A and B at their ends. Then, with the protractor, they should draw at A an angle of 30° and at B an angle of 120° . When they extend the sides of the angles they find the point of intersection, that is C.

This task was solved by 126 students, having correctly constructed the requested triangle only 40 (32%). Of the other 86 students, 30 (24%) students followed all the steps necessary to construct the triangle, but when they tried to draw the angle of 120° they made incorrectly. For example, student S3 manifested this difficulty, but was able to recognize his own error:

I: Do you think that the measure of this angle is 120° ? [indicating the 60° angle the student had drawn]

S3: No!!

I.: Why?

S3: Because it does not reach 90° . [Marking the sides of an angle with 90° at point B] Because I measured from here to here. [indicating the counterclockwise]

I.: But if angle that is requested is 120° , and is it greater than...?

S3: 90° !

I.: Did not you see that this [the angle of 60° drawn by the student] was less than 90° ? So, how did you draw the 120° angle?

S3: Should start from 0° and count from left to right" [clockwise]

Other type of difficulty in using the protractor was to place the point of reference of the protractor at the point that will be the vertex of the angle and 0° in the extension of the side of the angle. The student S35, after having traced [AB] correctly, cannot explain how to proceed.

I.: The angles of your triangle measure all 45° and the sides measure 6 cm. Here are the arcs made by the compass? Didn't you see the two angles of the triangle in the data?

S35: Yes!

I.: This point marked in the middle of [AB] for what did it serve?

S35: To place the protractor.

I.: And how do you measure the angles from that point?

S35: I didn't know!

Of the 86 students who didn't build the requested triangle, 11 (about 9%) didn't do any work, nor even traced [AB] and 17 (about 13.5%) couldn't geometrically represent the straight segment with the requested measure.

Discussion

The difficulty in understanding the construction of triangles (on a sheet of paper) begins first by understanding the concept of angle and the concept of measurement, then goes through the use of ruler, compass and transferor, and by understanding its properties. With respect to the first task, a large proportion of the students successfully constructed the triangle. However, the resolution method was not always as expected. A significant number of students find it difficult to use the ruler to draw line segment of a given length. As mentioned by Battista (2007), students who measure the length of an object incorrectly, when one of their ends is not aligned with the zero of the ruler, do not conceptualize clearly how the numerical marks of the ruler indicate the iteration of the length of the unit. Others seem to understand what an equilateral triangle is, but they have been unable to correctly calculate the length of the three sides. We can attribute this difficulty to the fact that some 6th graders students still cannot operate the division algorithm or have difficulty calculating mental quotients between integers. Nevertheless, regarding measurement reasoning, and in relation to linear measurement, the majority of the students demonstrated a level of sophistication quite acceptable. However, in relation to the perimeter of a triangle, the level of sophistication of these students is still quite insipient, since a large number of students could not obtain the measure on the side of an equilateral triangle given its perimeter. This would have been the aspect of the task that requires a higher cognitive challenge.

Comparing the results obtained in the first task with the second, we verified that the percentage of students who correctly solved the second one is close to half of the percentage of students who correctly solved the first one. It seems to us that in the case of the second task the construction of an obtuse angle constituted a greater cognitive obstacle to the correct resolution of the task than others detected in the first task. A considerable number of students were not able to draw the angle of 120° correctly. These students have shown difficulties in coordinating the various aspects of the angle concept (White & Micheltmore, 2003), namely they read the angle measurement counterclockwise when it should have been clockwise (Tanguay, 2012). The cause of the students' difficulties seems to be the "absence of adequate structural components" (Micheltmore & White, 2000).

There were students who demonstrated difficulty in the conceptualization of angle and in turn in the use of the protractor (Micheltmore & White, 2000). These difficulties are manifested in the second step, which is to place the point of reference of the protractor at the point that will be the vertex of the angle and 0° in the extension of the side of the angle. Some students demonstrated this difficulty because they did not know how to place the protractor at the apex of the angle to be measured (Tanguay, 2012). This task required a high cognitive challenge regarding the interpretation of the question, in part because of the symbolic mathematical load that is presented to students.

Conclusions

The results evidence that, in linear measurement, many students demonstrated a level of sophistication quite acceptable. They confirm that young students can determine lengths and use correctly material (Joram, Subrahmanyam, & Gelman, 1998), namely developing measurement reasoning (Battista, 2007). However, different difficulties may arise in the construction of triangles (Zamagni & Crespo, 2016), namely due to the absence of adequate structural components. Students' difficulties in the conceptualization of measurement and angle were obstacle to the understanding and resolution of the tasks. Additionally, students have difficulty in decoding and transforming mathematical information. The combination and coordination of motor and visual skills in the use of didactic materials is very relevant in solving tasks of triangles on paper, and for this reason the knowledge of the properties of the triangles and the consolidated knowledge of the concept of measurement and of angle are essential.

References

- Battista, M. (2007). The development of geometric and spatial thinking. In F. Lester, *The Second Handbook of Research on Mathematics Teaching and Learning* (pp. 843-907). Reston VA: NCTM.
- Berthelot, R., & Salin, M.-H. (1996). L'enseignement des angles aux élèves de 10 à 13 ans : identification d'un obstacle didactique. *Revue des sciences de l'éducation*, 22(2), 417–442.
- Bogdan, R., & Biklen, S. K. (1997). *Qualitative research for education: An introduction to theory and methods*. Reino Unido: Pearson Education.
- Clements, D. H., & Battista, M. (1992). Geometry and spacial reasoning. In *Handbook of Research on Mathematics Teaching and Learning* (pp. 420-464). NY: Macmillian Publishing Co.

- Devichi, C., & Munier, V. (2013). About the concept of angle in elementary school: Misconceptions and teaching sequences. *The Journal of Mathematical Behavior*, 32, 1-19.
- Douek, N. (1998). Analysis of a long term construction of the angle concept in the field of experience of sunshadows. In A. Oliver, & K. Newstead(Ed.), *Proceedings of the 22nd Conference of the International Group for the Psychology of Mathematics Education*, v. 3 (pp. 264-271). SA.
- Joram, E., Subrahmanyam, K., & Gelman, R. (1998). Measurement estimation: Learning to map the route from number to quantity and back. *Review of Educational Research*, 68 (4), 413-449.
- Lehrer, R., Jenkins, M., & Osana, H. (1998). Longitudinal study of children's reasoning about space and geometry. In R. Lehrer, & D. Chazan(Eds.), *Designing learning environments for developing understanding of geometry and space* (pp. 137-167). New York: Routledge.
- León, M., & Timón, Á. (2017). *La engañosa sencillez de los triángulos: De la fórmula de Heron a la criptografía*. Madrid: Catarata.
- Mammana, C., & Villani, V. (1998). Geometry and Geometry-teaching through the ages. In C. Mammana, & V. Villani, *Perspectives on the Teaching of Geometry for the 21st Century* (pp. 1-4). Dordrecht: Kluwer Academic Publishers.
- Mitchelmore. (1998). Young students' concepts of turning. *Cognition and Instruction* 16, 265–284.
- Mitchelmore, M., & White, P. (2000). Development of angle concepts by progressive abstraction and generalisation. *Educational Studies in Mathematics*, 41(3), 209-238.
- Tanguay, D. (2012). La notion d'angle au début du secondaire (2ème partie). *ENVOL*, 159, 31-35.
- Van de Walle, J. (2009). *Matemática no Ensino Fundamental: formação de professores e aplicação em sala de aula*. Porto Alegre: Artmed.
- White, P., & Michelmore, M. (2003). Teaching angles by abstraction from physical activities with concrete materials. In N. A. Pateman, B. J. Dougherty, & J. T. Zilliox, *Proceedings of the 27th Conference of the International Group for the Psychology of Mathematics Education held jointly with the 25th Conference of PME-NA* (pp. 403-410). Honolulu, HI: University of Hawaii.
- Zamagni, A. M., & Crespo, C. C. (2016). Dificultades de los estudiantes de geometría en la construcción de triángulos con regla no graduada y compás. *Revista Premisa*, 18 (70), 36-49.

Grade 3/4 students' understanding of geometrical objects: Australian case studies on (mis)conceptions of cubes

Ann Downton¹, Sharyn Livy¹ and Simone Reinhold²

¹Monash University, Melbourne, Australia; ann.downton@monash.edu;
sharyn.livy@monash.edu

²Leipzig University, Leipzig, Germany; simone.reinhold@uni-leipzig.de

Our paper presents early findings from a study that investigated Australian Grade 3 and 4 students' geometrical conceptual knowledge. This study is part of an international collaboration between Australian and German researchers. It draws on earlier research of Year 3 German students' cube constructions, errors and misconceptions and the categorization of these. The student data reported in this paper was analyzed using a framework for guiding and describing sources of errors and/or misconceptions related to cube constructions. These findings highlight the importance for students to construct three-dimensional objects using a variety of materials.

Keywords: Geometrical concept knowledge, cube constructions, primary students, errors.

Introduction

Research relating to children's geometric reasoning has focused on the classification of geometric objects and application of the Van Hiele levels of geometric thinking (Bleeker, Stols & Putten, 2013). Within the early years of primary school, less has been reported on children's knowledge and visualization of three-dimensional objects, in detail. There is also limited Australian research of young children's knowledge of geometry (MacDonald, Goff, Docket & Perry, 2016).

Our research is an international collaboration between German and Australian colleagues, and in this paper we report Australian data collected from Grades 3 and 4 students. Our objective was to investigate whether students' constructions of three-dimensional objects (e.g. prisms) elicits insights into their understanding of the properties of prisms that would not otherwise be revealed. In the German iteration students responded to a one-on-one task based interview using Froebel's Gifts, small wooden blocks (cubes and prisms). These blocks are not commonly used in Australian schools and we were interested in how Australian students might demonstrate their geometrical conceptual knowledge when using Froebel's Gifts to construct larger prisms.

Geometrical conceptual knowledge refers to students' spatial concepts, including visualization, verbal, and construction skills, their understanding of the relationships between two-dimensional shapes (2-D) and three-dimensional (3-D) objects, and their reasoning processes (e.g., Dindyal, 2015). In this study, geometrical conceptual knowledge referred to students' perceptions, visualization skills and identification of distinct properties of 3-D objects, in particular prisms, prior to and when constructing different sized cubes.

Prior to this collaboration, the third author used Froebel's Gifts and construction tasks to investigate Grade 3 German students' knowledge of geometrical solids (Reinhold & Wöller, 2016). Students' construction strategies and products were interpreted according to the Van Hiele framework. The

results indicated a wide variety of students' geometric conceptual knowledge of solids. Further studies of Grade 3 and 4 students' understanding of geometrical objects, including Australian students, would provide further insights of students' conceptual knowledge of 3-D objects, and into common errors or (mis)conceptions that might occur. Ulusoy (2015) suggested a model that identified a wide variety of selection types and errors relating to the identification of 2-D shapes (trapezoids). Our pilot study builds on other studies such as Fujita, Kondo, Kumakura and Kumakura (2017) who described older students' errors in relation to cube representations, and Finesilver (2016), who examined the spatial structuring, enumeration and errors of students working with 3-D arrays. Informed by these previous studies, these research questions guided our study:

- What errors are identified when Australian Grade 3/4 students use small cubes and rectangular prisms to construct cubes?
- What codes and categories can be used to classify students' responses and sources of errors and/or misconceptions when constructing cubes?

Theoretical framework

The initial framework that guided our analysis was developed in a previous study (Reinhold & Wöller, 2016). However, an in-depth analysis of the Australian data necessitated a widening of the initial framework. This also included drawing on the works of scholars who investigated children's errors of cube constructions, providing an opportunity to investigate further insights into children's geometrical conceptual knowledge through the lens of the students' errors.

Cubes and cube constructions: revisiting the Piagetian framework

The Swiss psychologist Piaget is well known for his contributions to children's cognitive development, including a framework of their intellectual development. According to Piaget and his colleagues, young children begin to understand space by exploring simple relationships such as order and enclosure, separation and proximity. This encompasses an understanding of topological relationships – which is ensued by the development of understanding projective and Euclidian concepts of space (Piaget & Inhelder, 1967). Euclidean concept of space, objects (or parts of them) are located not only relative to each other, but also according to co-ordinate axes in 3-D space. These three dimensions and relationships determine an understanding of a cube as one of the five Platonic solids. A cube is classified as a 3-D object comprising 12 edges of equal length, 6 square faces with 3 faces meeting at each of the 8 vertices. In terms of class inclusion, the cube is the only regular hexahedron, and differs from other rectangular prisms because it can be classified as a regular square prism (all rectangular faces are squares).

Children's cube constructions, in particular their errors and strategies when copying (cube) buildings have been investigated from the 1920s onwards (Reinhold, 2007). For example, Piaget and Inhelder (1971) investigated how children copied cube constructions (consisting of seven or more single cubes, displayed on a picture or as a solid model) when using wooden cubes. The analysis of these studies by Piaget and Inhelder included a classification of children's errors. For example, young children may identify units of a construction, but assemble them incorrectly (wrong orientation of segments in the construction). Furthermore, a global similarity of the cube construction may stand in contrast to incorrect details (e.g., wrong number of cubes). These observations are in

line with Piaget's overall notion that young children focus on single aspects of a phenomenon and prevents them from simultaneously taking various viewpoints into account and relates to their struggle when coordinating different perspectives of 3-D objects.

Visualization, coordination and integration of views in cube construction

Recent studies have also explored the notion of children's inability to coordinate and integrate their ideas simultaneously in visualization tasks. For example, Reinhold (2007) found that children tended to focus on isolated features, as they visualize "in bits" rather than sequentially when doing mental rotation tasks that included cube constructions. Instead of visualizing the entire structure of a construction, students were more likely to take into account only small portions of a 3-D array in an additive manner. Gorgorió (1998) found that focusing on single elements of a construction appears to happen more frequently when students construct by themselves, in contrast to drawing their responses.

Battista and Clements (1996) reported students' inability to coordinate two different orthogonal views for the construction of a rectangular prism when counting the number of single cubes. They found a lack of coordination whenever the students were unable "to recognize how they [the orthogonal views of a prism] should be placed in proper position relative to each other" (p. 267). This prevented some students from forming "one integrated mental image of the objects" (p. 272). Students' initial conceptions of rectangular prisms were characterized as uncoordinated sets of faces, and in transition to a more elaborated understanding, students may then reconstruct in layers, yet focus locally, piece by piece. Battista & Clements also argued that in order to enumerate the number of cubes students must have a mental model of the prism, and that spatial structuring provides the input and organization for enumeration. They defined spatial structuring as:

the mental act of structuring an organization or form for an object or set of objects. The process ... includes establishing units, establishing relationships between units ... and recognizing that a subset of the objects, if repeated properly, can generate the whole set (the repeating subset forming a composite unit) (p. 282).

Understanding of class inclusion in the Van Hiele framework

The *development of geometrical conceptual knowledge* from primary to secondary school has been defined as five levels of development (Van Hiele, 1986). According to Van Hiele (1986), younger children identify shapes by recognizing resemblances to everyday objects or by identifying prototypes in the stage of *Visualization*. In the ensuing stage of *Analysis* they are more likely to take a shape's properties into account when they decide upon categorization. Battista (2007) suggested renaming the *Analysis* stage as 'Analytical/Componential' which encompasses three stages. The first is the "visual-informal componential reasoning" stage in which students focus on parts of shapes and then on the spatial relationships between the parts using visually based descriptions, that utilize informal language. In the next stage, "informal and insufficient-formal componential reasoning" their descriptions are a combination of informal and formal language, whereas in the final stage, "sufficient formal property-based reasoning" they use formal geometric language when describing and conceptualizing shapes. Students who have not reached the stage of *Analysis*, as defined by the Van Hiele, are unable to give a concise definition of a geometrical object whilst taking account of

mathematical properties (Reinhold & Wöller, 2016). When students begin debating about the impact of various properties of relationships between shapes, they achieve the stage of *Abstraction*.

Method

We report three case studies that were representative of the Australian cohort in relation to the errors identified from the analysis that investigated Grade 3 and 4 students' (N=24) understanding of geometric objects whilst constructing a "cube". Students responded to a one-to-one interview (designed by German colleagues) using Froebel's cubes and cuboids (rectangular prisms) (see Figures 1-3), identifying insights into their understanding of the properties of prisms. Each interview was conducted by the Australian authors and video-recorded for later analysis. Students were asked to construct different cubes using smaller cubes (Froebel's Gift # 3) and then using rectangular prisms (Froebel's Gift # 4) (Reinhold, Downton & Livy, 2017). Examples of questions asked during interview included:

"Close your eyes and imagine a cube. Describe what you see."

"I want you to build a cube using these blocks (2cm cubes). How do you know this is a cube?"

"Can you build a different cube? How do you know this is a cube?"

"I want you to build a cube using these blocks (small rectangular prisms) ..."

"Compare this cube (one 2 cm cube) with this rectangular prism (small rectangular prism).

"How are they the same and different? (blocks shown to student)"

Following an interpretative paradigm in qualitative data analysis, we used student responses and performance data for the analysis, guided by *Grounded Theory* methods (Corbin & Strauss, 2015). The first two authors independently used open coding, while viewing the videos, identifying key themes related to their responses and to their construction process. We highlighted evidence of students' difficulties with their visualization skills as well as when students mentally structured solids or assembled parts of their constructions. Three case studies are presented to show examples of the following coding and categories:

COORDINATION & INTEGRATION is evident when students notice the properties of the solid they are constructing including an ability to coordinate distinct units of (visual or cognitive) information, and simultaneously integrate all spatial information (spatial relationships and properties). Whenever some of these properties are not yet fully developed, the students focus on isolated units of visual or cognitive information. Elements of this category and visualisation encompass spatial structuring (Battista, 2007).

VISUALIZATION includes cognitive processes related to visual perception, mental images and mental transformation of the entire cube or of smaller units. This may challenge students' ability to see and imagine spatial relationships and the representations of a cube or parts of the object (e.g., mentally rotate or (dis)assemble parts of the cube that is under construction).

CLASS INCLUSION refers to knowledge of the relationships between two solids (e.g., cube as a special rectangular prism) and students' understanding the structure of the hierarchical classification. In single cases, this may include the use of terms indicating class inclusion (e.g., prism, rectangular prism, rectangular square prism). Similarly, when describing a cube, the three students related their

description to everyday objects, such as, *it's like a box, a yellow block*, which is evidence of Level 1, Visualisation (Van Hiele, 1986).

FLEXIBILITY consists of students' ability to visualize and construct more than a single appropriate representation of a cube ($2 \times 2 \times 2$ as most common prototype). This may also address the idea to mentally (dis)assemble their own construction in various ways in order to flexibly find more than one solution (e.g., to enlarge a cube in length, width and height by adding one block). Whereas *STABILITY* refers to having a strong (mental) image of an object.

These categories prompted a critical debate allowing us to consider further interpretations for classifying and discussing students' sources of errors.

Results

The results focus on selected examples of three students' errors and (mis)conceptions showing screenshots to support our findings. We grouped and categorized their errors and (mis)conceptions, providing examples of each category (described above and in Figure 4).

Edward (pseudonyms used throughout) (aged 10 in Grade 4)

When asked to describe a cube Edward said, "A cube has 8 corners and 12 edges and is 3-D." He was able to construct a $2 \times 2 \times 2$ cube (length x width x height) using eight smaller cubes and said, "It is equal on all sides and is 3-D". For his second cube construction, he built a $3 \times 3 \times 3$ cube using 27 cubes stating, "All faces are equal." However, when asked to construct a cube using small rectangular prisms Edward did not draw on this insight. After an attempt to construct a cube using six rectangular prisms (see Figure 1 left), he removed two blocks (top layer) leaving a $2 \times 2 \times 2$ construction (Figure 1 middle). He said, "This is now a cube." Edward was focusing incorrectly on the dimensions of the object ($2 \times 2 \times 2$) rather than the properties of a cube that all faces are equal. Next, he incorrectly constructed another cube (Figure 1 right) he responded that it was a cube because, "All the faces were even," revealing another misconception. Edward's construction of a cube using cubes was the 'prototypical' cube and he recognised that all the faces were equal. This response also aligns with his initial answer to the first interview question, in which he said, "a cube has six faces that are all equal and it looks like a dice". When challenged to construct different cubes using rectangular prisms he struggled. When asked why the third construction was a cube he indicated that all faces are even. It is possible that he was attending to the top face (a square) and did not notice that the other faces were rectangles.



Figure 1: Edwards' response when making cubes with smaller rectangular prisms.

Emma (aged 8 in Grade 3)

When asked to describe a cube Emma said, "It is a yellow block and it has 8 points and 6 sides and [...] is a 3-D square." Emma referred to a cube as a 3-D square and attended to a holistic

appearance (Van Hiele, 1986). With smaller cubes, she constructed a $2 \times 2 \times 2$ cube by using a strategy of trial and error. Again, she said, “It is a cube because it is a 3-D square (counting the edges twice) with 8 points (counting the faces) and 6 sides.” When using the smaller rectangular prisms (Figure 2 left) she struggled and said, “I know it’s not a cube, it’s a rectangle but I don’t know how to make it a cube from here.” After several attempts (Figure 2 right) Emma concluded that she could not construct a cube. Emma had difficulty visualizing and constructing a cube when using rectangular prisms, most likely attributed by her lack of experiences with these blocks.

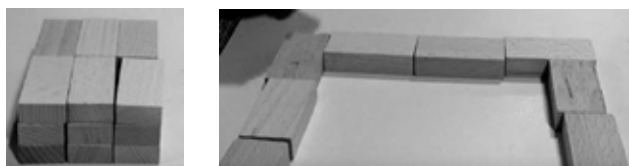


Figure 2: Emma’s response when making cubes with smaller rectangular prisms.

Chloe (aged 8 in Grade 3)

When asked to describe a cube, Chloe said, “A cube is like a box ... it has 12 faces ... is a square shape.” Chloe had difficulty constructing cubes (using cubes) and attempted to build an outline of the base of a cube ($5+5+5+4$) (Figure 3 left). Next, she built “towers” four cubes high on each corner (Figure 3 second) and filled in the ‘walls’ (Figure 3 third). Chloe said, “This is not a real cube because it needs to be filled up,” nor did she recognize the faces were not equivalent. Her final incorrect cube construction (Figure 3 fourth) had an uneven frame ($5+5+6+4$). After several attempts of counting the cubes Chloe still could not identify her error or make each length of the ‘faces’ equal. Her error related to spatial structuring when counting single elements (“Four, four, four and four.”) in a cube construction (Figure 3 right, the arrow visualizes her starting point for counting).



Figure 3: Chloe’s single steps when making a cube with smaller cubes and her counting of each cube.

The results of these case studies highlight the following (mis)conceptions or errors:

- Attention to the dimensions rather than properties of a cube (when using rectangular prisms)
- A focus on the top face being square (rather than all faces being square)
- An inability to visualize and construct a cube (when using cubes and/or rectangular prisms)

Our results confirm those of Reinhold (2007), that students tend to visualize “in bits” rather than visualizing the entire constructions, and their lack of spatial structuring (Battista, 2007), when constructing cubes. Many of these misconceptions or limited conceptual knowledge were evidence of: *co-ordination* and *integration*, *visualization*, *class inclusion* and/or *flexibility* and *stability* (Figure 4).

Discussion

The following discussion includes the results in relation to the four categories shown in Figure 4. Doing so highlights the cognitive demands and developmental aspects that we identified as possibly influencing the variety of students' correct solutions (not reported within this paper) and errors. As indicated in the literature, these categories were not entirely new to this field of research. Each of the four cases revealed difficulties in one or more of these categories.

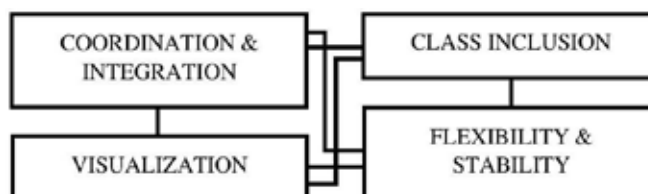


Figure 4: Sources of errors in Grade 3/4 students' concepts of cubes.

COORDINATION & INTEGRATION: Edward focused on the dimensions of the constructions rather than the properties of a cube when constructing a cube using rectangular prisms. He was focusing on isolated bits of information and units when visualising (Figure 1). *VISUALIZATION*: Emma and Chloe had difficulties with their spatial structuring when visualizing and making a cube using smaller rectangular prisms (Figures 2 & 3). They were unable to see and imagine spatial relationships and the representations of a cube or parts of the object (e.g., mentally rotate or (dis)assemble parts of the cube that is under construction). *CLASS INCLUSION*: Students such as Edward had not yet developed class inclusion as they could not conceptualize that a cube could also be classified as a rectangular prism. *FLEXIBILITY*: Most students in our study require further development of their understanding of the properties of cubes and rectangular prisms in order to develop *flexibility and stability*.

Conclusion and Implications

A commonality across the results was students' inability to integrate all spatial information simultaneously (e.g., Battista & Clements, 1996; Reinhold, 2007) and their lack of spatial structuring. Many students within this study could state properties of a cube correctly ("6 faces, 8 vertices and 12 edges") yet further exploration of their ability to construct and classify geometric objects revealed lack of spatial structuring. For instance, some students struggled with the idea that two adjacent cubes formed a rectangular prism (mental transformation referring to visualization). Hence, we argue that a deep understanding of the concept of a "cube" is not entirely developed until a student has the capability to *coordinate* and *integrate*; consider *class inclusion* correctly; *visualize representations* of a cube or parts of an object; and to find an appropriate balance of *flexibility* and *stability*.

These insights into student errors and/or misconceptions has highlighted the need to provide students with many opportunities to construct cubes (and cuboids) beyond the prototypical using a range of materials. An implication of our study is to highlight the importance for (Australian) teachers to use construction tasks to develop students' geometric thinking related to three-dimensional objects. Ongoing in-depth analysis of individual students' geometrical concepts of rectangular prisms aims to strengthen these findings and provide opportunities for further research.

References

- Bleeker, C., Stols, G., & Van Putten, S. (2013). The relationship between teachers' instructional practices and their learners' level of geometrical thinking. *Perspectives in Education*, 31(3), 66–78.
- Battista, M. T. (2007). The development of geometric and spatial thinking. In F. K. Lester (Ed.), *Second Handbook of Research on Mathematics Teaching and Learning* (pp. 843–908). Charlotte, NC: Information Age.
- Battista, M. T., & Clements, D. H. (1996). Students' understanding of three-dimensional rectangular arrays of cubes. *Journal for Research in Mathematics Education*, 27(3), 258–292.
- Corbin, J., & Strauss, A. (2015). *Basics of qualitative research: Techniques and procedures for developing grounded theory*. Thousand Oaks: Sage.
- Dindyal, J. (2015). Geometry in the early years: a commentary. *ZDM*, 47(3), 519–529.
- Gorgorió, N. (1998). Exploring the functionality of visual and non-visual strategies in solving rotation problems. *Educational Studies in Mathematics*, 35, 207–231.
- MacDonald, A., Goff, W., Dockett, S., & Perry, B. (2016). Mathematics education in the early years. In K. Makar, S. Dole, J. Visnovska, M. Goos, A. Bennison, & K. Fry (Eds.), *Research in mathematics education in Australasia 2012-2015* (pp. 169–190). Singapore: Springer.
- Piaget, J., & Inhelder, B. (1967). *The child's conception of space*. New York: Norton.
- Piaget, J., & Inhelder, B. (1971). *Mental imagery in the child: a study of the development of imaginal representation*. New York: Basic Books.
- Reinhold, S. (2007). *Mentale Rotation von Würfelkonfigurationen - Theoretischer Abriss, mathematikdidaktische Perspektiven und Analysen zu Strategien von Grundschulkindern in einer konstruktiven Arbeitsumgebung*. Hannover: Leibniz Universität. (<http://edok01.tib.uni-hannover.de/edoks/e01dh07/527630160.zip>)
- Reinhold, S., Downton, A., & Livy, S. (2017). Revisiting Froebel and his gifts for kindergarten: What are the benefits for primary mathematics education? In A. Downton, S. Livy, & J. Hall (Eds.), *40 years on: We are still learning!* (pp. 434–441). Melbourne: MERGA.
- Reinhold, S., & Wöller, S. (2016). Third graders' block-building: How do they express their knowledge of cubes and cuboids? In C. Csíkos, A. Rausch, & J. Sztányi, J. (Eds.), *Mathematics Education: How to Solve it?* (Vol. 4, pp. 123–130). Szeged, Hungary: PME.
- Ulusoy, F. (2015). A meta-classification for students' selections of quadrilaterals: The case of trapezoid. In K. Krainer & N. Vondrova (Eds.). *Proceedings of the Ninth Congress of the European Society for Research in Mathematics Education* (pp. 598–604). Prague: ERME.
- Van Hiele, P. M. (1986). *Structure and Insight: A theory of mathematics education*. Orlando: Academic Press.

TWG05: Probability and Statistics Education

Introduction to the work of TWG5: Probability and Statistics Education

Leaders:

- *Caterina Primi (Italy)*
- *Aisling Leavy (Ireland)*

Co-leaders:

- *Pedro Arteaga (Spain)*
- *Daniel Frischemeier (Germany)*
- *Orlando Rafael Gonzalez (Thailand)*
- *Sibel Kazak (Turkey)*

Introduction

The working group gathered 42 participants from 20 countries. 27 papers and 9 posters were accepted. In the first session after the organising team presentation we explained the three Cs of CERME, introduced the aims of the conference and of our TWG. In order to create a collaborative atmosphere, that would support the discussions and feedback over the following days, we started with an ice-breaker activity involving all the participants in a “Bingo” game”. Through this activity participants got to know their TG5 colleagues in a low stakes and collaborative context. Following this, the participants were asked to introduce themselves and their expectations for the working group and the conference. Among the expectations communicated were: to receive constructive feedback on their work, to gather new ideas, to get informed and updated on new trends in statistics and probability education, to get better acquainted with emerging research from other countries and develop possible collaborations and networking opportunities.

Participants were introduced to the three subthemes identified as emerging across all submissions. In particular, submissions focused on “Teacher education”, “Reasoning about data” and “Statistical and Probabilistic Thinking and Reasoning”. However, we remarked that there was some overlap and similarities across subthemes: submissions on Teacher education also focus on subtheme 2 (Reasoning about data) or on subtheme 3 (Statistical and Probabilistic Thinking and Reasoning). Additionally subthemes 2 and 3 are not seen in a disjoint way – which means, in both subthemes 2 and 3 we can of course also find submissions with connections between the “data world” and the “probability world”. Following this, participants were split into groups and each group discussed these subthemes. As part of these discussions, the co-leaders introduced and discussed several questions for the discussion in all subthemes during the sessions across the days to follow:

- What experiences can we provide to promote and develop learners understanding when reasoning about data / Statistical and Probabilistic Thinking and Reasoning?
- Which (typical) (mis-)conceptions of learners can be identified when reasoning about data / Statistical and Probabilistic Thinking and Reasoning?

- How should tasks and learning environments be designed to enhance reasoning about data / Statistical and Probabilistic Thinking and Reasoning for learners (primary students, high school students, teachers, etc.)?
- Which research methods are used / should be used to find about students' or learners' reasoning with data / Statistical and Probabilistic Thinking and Reasoning?
- How and in which way can we build bridges between data analysis, probability, and inference? Which role does context play?
- How and in which ways can the use of digital tools enhance statistical reasoning (reasoning about data and statistical and probability reasoning)?
- What about the handling of Big Data in the upcoming Data Science era? How can we (statistics education) profit from the availability of Big and Open Data? Which implications does it have for statistics education?

For all the sessions during the week the participants were split in two groups: TWG5a with Caterina Primi (Leader) and Sibel Kazak and Orlando Rafael Gonzalez (Coleaders) and TWG5b with Aisling Leavy (Leader) and Daniel Frischemeier and Pedro Arteaga (Coleaders). For each subtheme we organized two sessions managed and chaired by one of the co-leaders. We also organized a poster session with all participants (both groups together) where each presenter had 5 minutes to present the poster and the rest of the session had time allocated for the discussion.

The last day we had a culminating session with all participants with the aim being to engage in an in-depth discussion on subthemes and to share the contributions discussed during each session.

Teacher education

From the discussions of various papers addressing pre- and in-service teacher education in our working group, the following ideas and implications emerged, regarding how to prepare teachers to address and foster students' reasoning and thinking about statistics and probability:

- to enhance the pedagogical content knowledge facets of statistical knowledge for teaching, and not just focus on the subject matter knowledge facets;
- to make teachers familiar with performing statistical tasks and investigations from a procedural, interpretative and contextual perspective, while making connections among fundamental ideas of statistics (e.g., data and randomness), chance, relevant and appealing real-life contexts, software and technology;
- to include childhood statistical ideas (both formal and informal) in early years education, and prepare teachers to address and foster them;
- to create Professional Learning Communities (i.e., communities of practice within schools and beyond);
- to consider the affordances of games, university entrance examination tasks, and real-life problem scenarios as triggers for engaging students in high-quality statistical investigations, grounded on production tasks (as opposed to judgement tasks);

- to develop teachers' statistical reasoning and thinking by engaging them in the interpretation, design, teaching and assessment of stochastic tasks and statistical investigations organized around the three stages of teaching (i.e., lesson design, classroom implementation and reflection);
- to develop teachers' assessment skills regarding the most suitable strategies to assess students' statistical reasoning and thinking, in terms of their effectiveness (e.g. peer review among students, projects, written reports);
- to raise pre- and in-service teachers' awareness of the importance of providing interdisciplinary experiences to learn statistics (e.g., STEAM);
- to raise pre-and in-service teachers' awareness of the importance of providing students with opportunities to work with big data and personalized data; and
- to employ qualitative approach (e.g., observations, interviews, analysis of artefacts and final reports), action research, statistical argumentation, and analysis of statistics within social issues as methods to explore teachers statistical and probabilistic knowledge, thinking and reasoning.

Reasoning about data

From the discussions of various papers focusing on the reasoning about data, the following ideas and implications emerged in our working group:

- The Data Science era is emerging: Data are everywhere and the exploration and analysis of Big data and Open data will be a fundamental aspect in reasoning about data. Furthermore, there are other data collection methods which become more relevant (e.g., with Sensors, web scraping, etc.) and which provide new types of data.
- The necessity to cooperate with other disciplines like computer science, social science and citizen science is becoming increasingly evident. Especially for Data Science, collaboration with computer science is inevitable.
- The use of digital tools when exploring data is fundamental. We need to both consider and make the distinction between educational software tools (like TinkerPlots or Fathom) and professional software tools (like R, Python). Also open source and online tools like Gapminder and CODAP can help develop reasoning about data.
- Data competence has to be developed continuously from primary school to adult education. Especially in primary school, data competence and more specifically reasoning about distributions can be enhanced by using pre-formal concepts like modal clumps which offer a pre-stage for the concepts center and spread for example.
- The facets data, chance and context are tied strongly together.

Statistical and Probabilistic Thinking and Reasoning

From the discussions of various papers focusing on the statistical and probabilistic thinking and reasoning, the following ideas and implications emerged in our working group:

- The use of context, real problems and visualization tools can support statistical and probabilistic thinking and reasoning in data and chance explorations.

- The focus on interpretation and justification of results is essential to promote statistical and probabilistic thinking and reasoning.
- Studies suggest that building on learners' intuitions and emerging conceptions, rather than focusing on their misconceptions, becomes more useful for supporting their thinking and reasoning in data and chance.
- The use of real or realistic data can motivate learners to use statistical and probabilistic ideas in their thinking and reasoning.
- To move the field forward considering design based research as an additional methodology can inform how to build statistics learning environments that support learners' statistical and probabilistic thinking and reasoning.

Conclusion

The field of statistics and probability education is a fast evolving area and to draw on the words of H.G Wells (cited in Huff, 1954) 'Statistical thinking will one day be as necessary for efficient citizenship as the ability to read and write'. As such, we identified several critical areas of focus for research and practice in statistics and probability education. Firstly, gaining access to the 'big ideas' in statistics and probability is important for effective citizenship. Exposing young children, in the early primary years, to informal ideas of statistics and probability is a critical step in order to develop and lay the foundation upon which formal understandings will be built upon. Related to this is the second recommendation that we establish a trajectory of learning experiences to support the continuous development of statistical and probabilistic reasoning and thinking from early years to adulthood. A guiding signpost for both educators and researchers alike, is provided in the third suggestion, and that is to maintain the important connection between data, chance and context as we move forward in the field. Two emerging areas to keep abreast of as we make advancements are the need to be prepared for Data Science (the implementation of Big Data) and its' implications and also to continue to develop and makes use of appropriate digital tools (such as Gapminder, CODAP, TinkerPlots, Fathom etc.). Finally, we conclude with a reminder to remain mindful of the need to diversify our research design and approaches to inquiry - incorporating attention to fine-grained studies, eye-tracking research, larger cross-comparative studies, experimental design, to name but a few – all in an effort to advance our understandings of the complex and evolving areas of statistics and probability education.

Formalizing students' informal statistical reasoning on real data: Using Gapminder to follow the cycle of inquiry and visual analyses

Martin Andre¹, Zsolt Lavicza² and Theodosia Prodromou³

¹Pedagogical University of Tyrol & Johannes Kepler University Linz, Austria; m.andre@tsn.at

²Johannes Kepler University Linz, Austria; lavicza@gmail.com

³University of New England, Australia; theodosia.prodromou@une.edu.au

Graphical representations of Open Data facilitate students' personal engagement in discovering and exploring data and enable students to intuitively access certain statistical concepts. The aim of this study is to identify important patterns and fundamental limitations in the learning processes when students acquire deeper understanding of "big ideas of statistics" (Garfield & Ben-Zvi, 2008). The objective of the study is to nurture students' intuitive knowledge (Fischbein, 1987) by using the software Gapminder for data visualization in classrooms. In this exploratory study 19 students aged 14-15 were guided through two lessons of 1 hour and 40 minutes, each, using the Gapminder tool and materials to explore and visualize sets of Open Data while working on several worksheets and test items developed by the research team. Findings of this initial study are being used to further conceptualize and design successive investigations.

Keywords: Statistics education, statistical literacy, visual data analysis, statistical reasoning, intuitions.

Theoretical background

This study is primarily based upon the cycle of inquiry and visual analysis (Prodromou, 2014), complemented by works on students' statistical literacy (Prodromou & Dunne, 2017), their development of the big ideas of statistics (Garfield & Ben-Zvi, 2008) and various research studies on the use of technology in the era of Open Data with a special focus on the visualization of context-based data. Acknowledging that graphical representations play a fundamental role in intuitively understanding of abstract mathematical or scientific concepts (Fischbein, 1987), theories on intuition (Fischbein, 1987), heuristics and biases (Tversky & Kahnemann, 1974) are considered.

Tversky and Kahnemann (1974), Fischbein (1987) stress the influence of connate heuristics, biases and misconceptions on making decisions or judgements under uncertainty (Tversky & Kahnemann, 1974). Studies have examined specific heuristics, biases and misconceptions within the learning processes of statistics and probability theory (Garfield & Ben-Zvi, 2008). Thus, it is a central challenge in statistics education, to address students' intuitions in order to identify their biases and misconceptions and support students to overcome their misconceptions. In fact, misconceptions are strongly bound to context because students think differently about stochastic concepts in various contexts.

Makar et al. (2011), as well as other researchers in Statistics Education, emphasize the importance of context and the use of real data in statistical reasoning. Ben-Zvi and Aridor-Berger (2016) demonstrate students' transition between context and data and also report on students' growing understanding of the ways to combine these contexts and data. Although there is little research on the

question what makes data “real”, we can presume that students perceive data to be real when they get personally affected by the data. Therefore, Open Data on topics of general interest may be considered as real data easily accessible for teachers and students.

Advances of new technology with numerous opportunities for data visualization prompted Prodromou and Dunne (2017) to argue for the profound importance of using Open Data in statistics education. Analyzing Open Data with the software TinkerPlots in classroom, Watson (2017) describes the chances of learning statistics in a transdisciplinary way, integrating statistics education in non-mathematical topics, such as to Health and Physical Education, Social Science or History.

Garfield and Ben-Zvi (2008) outline various research studies on students’ development of different big ideas of statistics, which they identified as crucial for statistical reasoning: a) *data*, including the nature of data and the diverse types and sources of data b) *statistical models*, such as regression and the Normal Distribution as statistical models, c) *distribution*, involving the ideas of shape, centre and spread, d) *centre*, covering the difference between median and mean, e) *variability*, including the measuring of the spread of a distribution, f) *comparing groups* by centre and spread, g) *sampling*, containing, e.g., the effect of sample size, h) *statistical inference* as to testing hypotheses or confidence intervals, and i) *covariation* with scatterplots, correlation and linear regression. The theory-based recommendations given with the presented activities for the development of the big ideas of statistics comprise learning these ideas explicitly, addressed in a constructive way and facilitated by examining real data sets. Furthermore, Garfield and Ben-Zvi (2008) also suggest learning the big ideas of statistics beginning with students’ intuitions and preconceptions, taking their informal notions of the single ideas and turning them into formal notions. Teaching must start with introducing students’ intuitions and preconceptions, identifying intuitions and preconceptions and rectifying them using different techniques including the use of digital technologies and graphical representations of data to display the summaries and visualizations of data.

Visualizing data is one of the most intuitive ways of understanding underlying concepts from data and “graphical excellence is that which gives to the viewer the greatest number of ideas in the shortest time with the least ink in the smallest space.” (Tufte, 1983, p. 51). Moreover, presenting information with diverse graphical representations is a highly important skill for many scientific disciplines aiming to make data meaningful (Tufte, 1983). Therefore, new types and the diversity of data in our age also require new ways of structuring, organizing, and visualizing data. Traditional, static visualization techniques such as bar charts, boxplots or distributions for single variables often fail to meet requirements of current data sources and analyses. Thus, processing and visualizing data with new techniques using specific, sophisticated technology plays an important role in students’ developing understanding of statistics.

Using TinkerPlots for exploratory data analysis in the classroom, Ben-Zvi and Ben-Arush (2014) focus on the instrumentation process of transforming an artifact (i.e., a software with no meaning for the students) into an instrument (i.e., a tool, that is meaningful and useful to the learners). Based upon their observations, the authors suggest three types of instrumentation processes: a) *unsystematic*: students playing and experimenting with the software in a non-intentional way, b) *systematic*:

students being focussed on the tool rather than on the task, but applying the software purposefully, and c) *expanding*: students using the software fluently and focussing on the task.

Prodromou (2014) presents a project concluding that the students were able to flexibly use the software Gapminder to build visual structures that highlight information relevant to their analysis task. In addition, various studies concerned with the implementation of Open Data in school education (e.g., in Prodromou, 2017; Engel et al., 2016) and the technologies used for this purpose (e.g., Forbes et al., 2014) show promising possibilities to beneficially integrate Open Data in statistic courses by operating with visual methods.

To meet the needs of exploring and analysing data particularly by visual methods, Prodromou (2014) presents the cycle of inquiry and visual analysis, especially elaborated for that purpose. The steps of this cycle are: a) identifying the task, b) foraging for data, c) searching for visual structure and implementing visualizations, d) developing insight through interaction with the resulting data visualizations, and e) acting with regards to work further on any step to develop deeper insight or ending the cycle. All these stages are connected to each other and the process of visual analysis includes continuous interactions between the stages. Furthermore, basic statistical literacy is a prior condition for exploring data by visual methods, being deepened with these investigative processes. Therefore, Prodromou and Dunne (2017) have introduced a framework for constructing statistical literacy in schools, incorporating new possibilities arising in the age of Open Data and strongly bound to the diverse graphical representations of data.

In the teaching of basic statistics courses, students' intuitions and preconceptions have to be addressed and we also need to consider their biases and misconceptions. Working with graphical representations assists students to access their *intuitive knowledge* (Fischbein, 1987). According to researchers (e.g., Makar & Ben-Zvi, 2011), it is crucial to work with context-based data that are meaningful and important for students. Thus, meaningful data-processing needs visualizing real data, includes entire cycles of inquiry, and particularly addresses the *big ideas of statistics* (Garfield & Ben-Zvi, 2008). Furthermore, an updated concept of statistical literacy required for our age of data society (Prodromou & Dunne, 2017) should address students' perceptions and assessment of large sets of data. Finally, using technology autonomously and fluently, allowing focus on the task rather than on the software, is a fundamental factor of students' constructing their statistical knowledge and skills (Ben-Zvi & Ben-Arush, 2014). Therefore, the aim of this study is to develop new ways of teaching basic statistics, integrating students' intuitions addressed by the visualizations of Open Data with the software Gapminder. In our exploratory pilot study, we aimed at identifying important patterns and fundamental limitations regarding students' intuitions on statistical concepts, their statistical literacy, and their instrumentation processes to further conceptualize this investigation.

Methodology and implementation

The present pilot study is embedded in a larger study investigating students evolve their intuitions and preconceptions from informal perceptions of statistical concepts to a higher and more formal level by using different visualization tools. The research question concerning the present study is: How do activities related to analyzing real data by visual methods contribute to formalize students' statistical reasoning? The entire study follows the methodology of design-based research (Cobb et

al., 2003), utilizing an iterative design of the implementation of a learning environment and approach based on analysis of variety of data sources at the subsequent stages. We analyze students' conceptualization of the *big ideas of statistics* inherent in the applied worksheets and tests while examining data with the software Gapminder. The worksheets were used to get a broad range of tasks and corresponding answers; the test items included both closed and open-ended questions. Results of the worksheets and tests were anonymized during transcription and translation by using pseudonyms. Transcripts were analyzed qualitatively using MAXQDA qualitative analytics software by categorizing the answers in response to various statistical ideas addressed. Although it was planned to visit classes and conduct interviews with students, researchers were not allowed to collect any additional data from students beyond the worksheets and tests. But, interviews with the teacher before and after the lessons offered further information on the circumstances and settings of lessons and insights into students' work.

In total, 19 students in the 8th grade participated in the study. They had not worked with the software Gapminder previously nor had they received any prior instruction on distributions and variability in their school. However, their pre-knowledge, which could have an influence on solving tasks, includes calculating the mean and graphical representations of functional relationships in non-statistical, linear contents. The participating teacher was introduced by the researcher to the software and the instructional items of the study. Learning activities took place in a computer lab with a PC for each student and had duration of one week with two lessons of 1 hour and 40 minutes. The topic of the lessons was to find out more about poverty in the world.

Using two worksheets, the first lesson aimed at introducing students to the software as well as to ideas of investigating and exploring data sets. In the second lesson, using a third worksheet, students were asked to explore autonomously visualisations of various datasets. Between the different learning sequences, some test items were introduced to find out more about the students' statistical preconceptions and the conceptions they gained. The test questions were partly open-ended and partly closed, a structure familiar to the students from Austrian national standardized tests. The content of the first worksheet is about eight sets of interactive slides on human development trends, provided by the Gapminder foundation as instructional material (<https://www.gapminder.org/downloads/human-development-trends-2005/>). These slides show different visualisations (see figure 3) of the variables

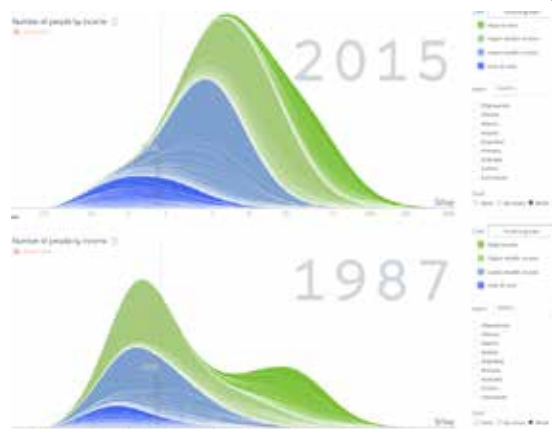


Figure 1: Visualizations of income distributions used in the first test

income and *child mortality rate (health)*. Visualisations explained and described the distribution of income of all countries in the world and the relationship between *income* and *health* over time. This worksheet contains questions on statistical ideas that address central value, variety, distribution's shape, and correlation between variables based on the topic. As the tasks were open-ended and students did not get any instruction before, they were required to describe their ideas on the tasks intuitively. Connected to the first worksheet, the first test items were developed to directly address the students' intuitions of centre, distribution, and variability by giving them two diagrams of different income distributions (see figure 1). The students were asked to reason about the shape of the second distribution and to compare it to the first distribution regarding the centres of these distributions. Additionally, students were asked to explain why the median income in 2015 most probably belongs to a person from a middle-income country and to describe the income of Chinese people in 1987 (light green top of the left peak). The second worksheet was a step-by-step guideline to follow the cycle of visual analysis (Prodromou, 2014) with different variables using the Gapminder software. There was no data collected on this second worksheet. The third worksheet contained some general instructions and suggestions, which variables the students may use for their autonomous investigation of the topic, e.g., income and literacy rate. The students participating were asked to document the findings of their investigations.

A second test, held at the end of the second lesson, included questions on a bubble chart (see figure 2) showing the variables *income* and *sanitation*. The focus of the test was on the ideas of correlation, centre and distribution. Students were asked to describe the bubble chart depending on the income levels and got a set of five statements addressing the various statistical concepts (e.g., variety, centre, or spread) to choose the right ones. With exception of the investigational learning sequences, the students were asked to work independently. The teacher supported the students' learning process by assisting them while working with the software and the topic. When the students solved the tests independently, they did not receive any assistance.



Figure 2: Bubble chart of the variables income and access to improved sanitation used in the second test

Initial results and discussion

In this section we present and discuss some of the main results of the pilot study to pinpoint directions for further investigation. Results presented focus on some of the *big ideas of statistics* (Garfield & Ben-Zvi, 2008) connected to the students' intuitive approaches and their uses of technology. In the study, the main statistical model addressed was the model of regression. In several tasks students

were asked to intuitively reason about the relationship between different variables (e.g., income and health) regarding various countries or a time series of one or more countries. All students recognized a correlation between income and health, building a model of regression. For example, one student, Richard, stated: “The higher the income in a country is, the better is the health rate of children.” (Richard, worksheet 1) Students also interpreted the positive slope of the regression correctly: “That means that the countries constantly develop – in other words the GDP per person is growing – and the percentage of surviving children is heightening.” (Eva, worksheet 1) Still, students did not compare countries’ development by recognizing and building two or more models of regression in one graph (see figure 3) with one exception: “That means that poor people in India are less healthy than the rich ones whereas in Namibia the poor ones have nearly the same rate of health as the rich ones.” (Vincent, worksheet 1). Anyway, most students independently used a model of regression during their autonomous investigations: “The poorer the countries are the worse are the numbers [of other variables] or the more children they have.” (Paul, Peter and Anna, worksheet 3).

Besides using regressions, some models of probabilities were detected in the data as well. The students were asked to decide whether the person with the median income most probably comes from a low, middle or high-income country. For example, Vincent marked the height of the income of middle-income countries in the graphic of the distribution and connected the height to its probability. But some misconceptions were also observed with students building a model for this probability while



Figure 3: Examples of slides from the Gapminder learning materials

maybe having a linear (regression) model in mind, as exemplified by these remarks: “Poor income country, because 6-7 \$ is very little” (Julia, test 1) or “middle income because the number is in the middle” (Ruth, test 1).

These outcomes show that students had an intuitive access to the basic ideas of regression and correlation. The attempts to apply the model of regression to the probability theory may be rooted in the proximity of tasks. Furthermore, we suggest addressing *context, change and causality* as a part of the new framework for statistical literacy (Prodromou & Dunne, 2017) in that connection, as some students intuitively described the relationship between the variables with a focus on causality.

A second statistical idea to be mentioned here is the idea of distribution. With the learning materials on worksheet 1, students were briefly introduced to the idea of statistical distributions. All students recognized a change in the parameters of the income distribution over time and interpreted this change correctly, e.g., “Heavily concerned [with poverty] were South and East Asia (1970). Since then, Africa got poorer” (Anna, worksheet 1). Moreover, some students gave a correct interpretation of the

old-fashioned term “3rd world (in 1987)” regarding the graphic in figure 1. As they did not get any instruction on regular or irregular shapes of distributions, students were not wondering about the different shape of the income distributions of 1987 and 2015.

When asked for the central value of the income distributions in 2015 and 1987, all students gave the right number for the “regularly shaped” distribution of 2015, but around half of the students wrongly identified the higher, more distinctive peak in 1987 (see figure 1) as the centre (in terms of the median) of the distribution, although the poverty line above this peak is marked with “47%”. In our data, we have detected two answers of students autonomously differing between median and mean, but most students did not differentiate between these two. In sum, we can conclude that the ideas of distribution and the centre are intuitively accessible, but certainly should be addressed more explicitly to avoid or eliminate the misconceptions. Especially a more detailed focus on the idea of distribution regarding their shape must be explored.

The collected data show that all students adequately applied the idea of variability in different contexts. They intuitively defined and applied the idea of “variability”, e.g., in terms of “constant appearing dispensation, spread of something; [...] In Namibia there are some people, who earn very little and some who earn very much. Therefore, the spread is as large.” (Anna, worksheet 1), “the diverse levels of economy and rate of child mortality in different countries” (Sarah, worksheet 1), or “continuously occurring distribution/spread” (Clemens, worksheet 1). Moreover, all students used the idea of variability in their autonomous investigation to describe different variables. Therefore, we believe that the basic concept of variability is relatively easy to access for students who have adequate pre-conceptions of spread or range.

Relying on the reports of the teacher, the instrumentation processes (Ben-Zvi & Ben-Arush, 2014) of students can be described as unsystematic in the beginning and partly systematic while they are getting familiar with the tool. This does not seem surprising, especially since the students did not spend a long time working with the software. As students were given hints which variables to use in their autonomous investigation, the development of the instrumentation processes from unsystematic to systematic may have been supported. More detailed observation on students’ use of the Gapminder tool will be necessary to identify helpful and hindering conditions for their instrumentation processes.

Summary

By addressing students’ pre-conceptions and intuitions on various statistical concepts with visual methods, the initial results of the study suggest that some of the basic ideas, such as models of regression, centre or variability, tend to be intuitively accessible for students, whereas especially the idea of distribution seems to demand a more extensive development. In addition, several opportunities to focus on students’ statistical literacy, related to explicating *inferences within data or context, change and causality* (Prodromou & Dunne, 2017), were detected. Offering a selection of adequate variables to explore, students’ instrumentation process using the Gapminder software was apparently supported. Results of this pilot study will lay the basis to redesign this research project and to generalize findings.

References

- Ben-Zvi, D., & Aridor-Berger, K. (2016). Children's wonder how to wander between data and context. In D. Ben-Zvi, & K. Makar (Eds.), *The teaching and learning of statistics* (pp. 25- 36). Cham, Switzerland: Springer International.
- Ben-Zvi, D., & Ben-Arush, T. (2014). EDA instrumented learning with TinkerPlots. In T. Wassong, D. Frischemeier, P. R. Fischer, R. Hochmuth, & P. Bender (Eds.), *Mit Werkzeugen Mathematik und Stochastik lernen: Using tools for learning mathematics and statistics* (pp. 193- 208). Wiesbaden, Germany: Springer Spektrum.
- Cobb, P., Confrey, J., diSessa, A., Lehrer, R., & Schauble, L. (2003). Design Experiments in Educational Research. *Educational Researcher*, 32(1), 9–13.
- Fischbein, E. (1987). *Intuition in science and mathematics: An educational approach*. Dordrecht, Netherlands: D. Reidel.
- Forbes, S., Chapman, J., Harraway, J., Stirling, D., & Wild, C. (2014). Use of data visualisation in the teaching of statistics: A New Zealand perspective. *Statistics Education Research Journal*, 13(2), 187- 201.
- Garfield, J., & Ben-Zvi, D. (2008). *Developing students' statistical reasoning: Connecting research and teaching practice*. Dordrecht, Netherlands: Springer Science & Business Media.
- Engel, J., Gal, I., & Ridgway, J. (Eds.). (2016), *Promoting understanding of statistics about society*. Proceedings of the Round Table Conference of the International Association for Statistics Education. Berlin, Germany. Retrieved from https://iase-web.org/Conference_Proceedings.php?p=Promoting_Understanding_of_Statistics_about_Society_2016
- Makar, K., Bakker, A., & Ben-Zvi, D. (2011). The reasoning behind informal statistical inference. *Mathematical Thinking and Learning*, 13(1-2), 152- 173.
- Prodromou, T. (2014). Drawing Inference from Data Visualisations. *International Journal of Secondary Education*, 2(4), 66- 72.
- Prodromou, T. (Ed.). (2017). *Data Visualization and Statistical Literacy for Open and Big Data*. Hershey, PA: IGI Global.
- Prodromou, T., & Dunne, T. (2017). Data Visualisation and Statistics Education in the Future. In T. Prodromou (Ed.), *Data visualization and statistical literacy for Open and Big Data* (pp. 1- 28). Hershey, PA: IGI Global.
- Tufte, E. R. (1983). *The Visual Display of quantitative information*. Cheshire, CT: Graphics Press.
- Tversky, A., & Kahneman, D. (1974). Judgment under uncertainty: Heuristics and biases. *science*, 185, 1124- 1131.
- Watson (2017). Open Data in Australian schools: Taking statistical literacy and the practice of statistics across the curriculum. In T. Prodromou (Ed.), *Data visualization and statistical literacy for Open and Big Data* (pp. 29- 54). Hershey, PA: IGI Global.

Design of statistics learning environments¹

Dani Ben-Zvi¹, Koeno Gravemeijer² and Janet Ainley³

¹University of Haifa, Israel; dbenzvi@univ.haifa.ac.il

²Eindhoven University of Technology, Eindhoven, Netherlands; Koeno@gravemeijer.nl

³University of Leicester, UK; jma30@le.ac.uk

The goal of this article is to draw attention to the need to think about learning environments and their design as a way of considering how sustainable change in the learning and teaching of statistics can be supported. The goal is not to advocate one particular approach to the design of learning environments, but rather to raise awareness of the need to consider this lens in statistics education. We first present the rationale for the importance of a focus on learning environments for statistics education. We consider six design considerations for statistics learning environments. Finally, we discuss implications and emerging directions and goals for further implementation and research.

Keywords: Learning environment, learning and teaching of statistics, statistics education.

Introduction

Many of the research studies in the learning and teaching of statistics (e.g., Ben-Zvi, Makar, & Garfield, 2018) suggest innovative approaches that differ from the traditional classroom practices through which most current statistics teachers learned this subject themselves. However, innovation which addresses only one aspect of the pedagogical context, for example introducing technological tools in teaching when assessment practices remain unchanged, is likely to have only limited impact. This article offers starting points of design for deep learning of statistics to develop students' statistical reasoning. To do this, we use a *learning environment* perspective to provide a dynamic, holistic, integrated and multi-dimensional framework for sustainable educational change in statistics. The goal of this article is to draw attention to the need to think about learning environments and their design as a way of considering how sustainable change in the learning and teaching of statistics can be supported.

A learning environment is a complex and dynamic educational system, composed of multiple factors: key statistical ideas and competencies (content), engaging tasks, real or realistic data sets, technological tools, classroom culture including modes of discourse and argumentation amongst students and between students and teachers, norms and emotional aspects of engagement and assessment methods. Integrating all these factors in order to reform the way statistics is learnt and taught is a challenging endeavor. The focus in this article is on general characteristics of statistics learning environments that need to be examined and integrated in light of the new developments in mathematics, statistics and science education, and more generally in the learning sciences. Our specific objectives are to first present the rationale for the importance of a focus on learning environments for statistics education; we provide a potential framework for considering aspects of statistics learning environments. We then develop six design considerations for statistics learning

¹ This article is based on a chapter by Ben-Zvi, Gravemeijer and Ainley (2018).

environments. Finally we discuss implications and emerging directions and goals for further implementation and research.

Learning environments

The research literature in statistics education is filled with success stories, which are of importance to the advancement of the field, but have not had a major impact on the way statistics is taught in all levels of education. We propose that one of the reasons for this is the lack of a systematic, comprehensive and integrated approach to design for educational change (e.g., Cuban, 2003). We suggest that what is needed is change in a combination of interrelated dimensions (content, pedagogy, space, time, tasks, tools, assessment, classroom culture etc.) that can bring about significant and sustainable reform in the teaching and learning of statistics by providing a coherent framework in which each dimension operates synergistically with others. Moore (1997) similarly urged a reform of statistics instruction and curriculum based on strong synergies between content, pedagogy and technology. A learning environment perspective can provide such a framework. One of the major goals of statistics education is to educate critical, independent and statistically-literate learners who are able to study topics of their own interest and become involved in data-based decisions. A learning environment perspective can provide fertile affordances to support learners' growth and development in this direction as well as a guiding framework for teachers that can support their professional growth in statistics education.

Design dimensions of statistics learning environments that will be considered and discussed in this article are based on a number of principles arising from recent research. In particular we have drawn on research concerning the importance of prior knowledge and preference for depth over breadth (Bransford et al., 2000), the creation of failure-safe learning communities in which students can learn from their successes and mistakes (Kapur & Bielaczyc, 2012), the nurture and articulation of learners' diverse expertise, encouragement of reflection and feedback (Boud, Keogh, & Walker, 1985), formative assessment (Kingston & Nash, 2011) and enculturation into the statistics discipline (Edelson & Reiser, 2006).

The use of the metaphor of an *environment* emphasizes that classrooms are interacting social, cultural, physical, psychological and pedagogical systems rather than a collection of resources, tasks and activities or a list of separate factors that influence learning. Because of the complex nature of learning environments, successful design requires a working model of how components of the design that help frame forms of student participation and responsibility, are collectively constituted and orchestrated (Lehrer, 2009). To achieve this kind of balance and orchestration we argue that learning environments must be designed on the basis of learning theories, which can guide the design, help choose between the options and lead to better achievement of the pedagogical goals. In Ben-Zvi, Gravemeijer and Ainley (2018), we describe two theoretical frameworks that have been commonly used to guide the construction of learning environments: social constructivist theory as a background theory on teaching and learning and Realistic Mathematics Education (RME) as domain-specific instruction theory that is specific for mathematics education.

Design dimensions for statistics learning environment

In this section, we identify design dimensions that arise from theoretical and empirical sources. These dimensions are not meant to serve as a prescription for what teachers and designers should do, but rather to provide a wide spectrum of factors or starting points, that need to be considered, aligned and balanced in designing statistics learning environments. The goal of designing effective and positive statistics learning environments occurs in a wide continuum of settings. On this continuum, this article focuses on designed learning environments rather than informal and ambient ways of learning. The goal of these learning environments is for students to develop a deep and meaningful understanding of statistics and the ability to think and reason statistically. We discuss and expand on six dimensions of pedagogical design (Figure 1) proposed by Cobb and McClain (2004), highlighting what we see as the important connections between them.

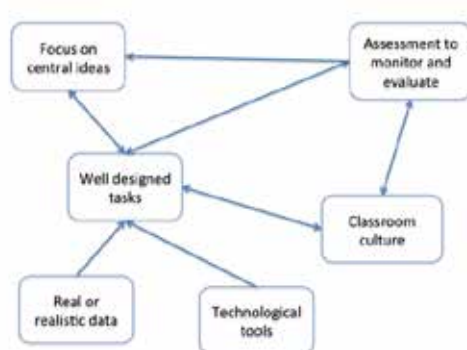


Figure 1: A web of interrelated dimensions of a learning environment

Focus on Developing Central Statistical Ideas Rather Than on Tools and Procedures

There are several key statistical ideas that students are expected to understand at a deep conceptual level (Garfield & Ben-Zvi, 2008). These ideas serve as overarching goals that direct teaching and motivate and guide students' learning. They include data, distribution, center, variability, comparing groups, sampling, modeling, inference and covariation. Garfield and Ben-Zvi (2008), in their Statistical Reasoning Learning Environment (SRLE), advocate a focus on key statistical ideas and the interrelations among them and suggest ways to present these ideas throughout a course, revisiting them in different contexts, illustrating their multiple representations and interrelationships, and helping students recognize how they form the supporting structure of statistical knowledge.

Use Well-Designed Tasks to Support the Development of Statistical Reasoning

An important part of a statistics learning environment is the use of carefully designed tasks, informed by research findings, that promote student learning through collaboration, interaction, discussion and addressing interesting problems (Roseth, Garfield, & Ben-Zvi, 2008). It may be argued that such tasks should be part of a well-considered instructional sequence, informed by the aim of developing central statistical ideas, which is underpinned by a *local instruction theory*. A local instruction theory typically consists of a theory about a potential learning process and theories about the means of supporting that learning process (Gravemeijer & Cobb, 2013). The former offers teachers background information, on the basis of which they may decide, on a daily basis, what learning goals to aim for.

While the latter offer them information on how potential tasks, tools, ways of interacting and the classroom culture may support the intended learning process. This information will help teachers in choosing tasks and tools, anticipating the mental activities of the students, orchestrating classroom interaction and evaluating the implied hypothetical learning trajectories.

Use Real or Realistic and Motivating Data Sets

The design of pedagogic tasks in statistics must take account of the data that will be centrally involved. Data are at the heart of statistical work and data should be the focus for statistical learning as well (Franklin & Garfield, 2006). Throughout their experience of learning statistics, students need to consider methods of data collection and production and how these methods affect the quality of the data and the types of analyses that are appropriate. One approach can be to look for interesting data sets to motivate students to engage in activities, especially ones that ask them to make conjectures about a data set before analyzing it (Ben-Zvi & Aridor, 2016). Another approach would be to start with a question and then discuss what data would be needed to answer it. However the provision of real or ‘realistic’ data is not always sufficient to engage students in tasks that develop statistical reasoning unless the task poses meaningful challenges and provides opportunities to use statistical ideas in realistic ways.

Consider two kinds of activities using real data which are relatively familiar within statistics education research. The first is exploratory data analysis based on a source of real data. Although data about students like themselves may have intrinsic interest, posing meaningful questions about the data can be challenging for school students (Burgess, 2007). Open-ended exploration of relationships in the data without a clear goal may not lead them to use statistical ideas in realistic ways. The second is a sampling task, such as repeatedly drawing small samples to estimate the proportion of sweets of a particular color within a bowl. Here the statistical idea of sampling is being used in a realistic way, to answer a specific question, but the task itself is not a meaningful challenge (Ainley, Gould, & Pratt, 2015). If you really wanted to know the numbers of sweets of different colors it would be quicker and more reliable to empty the bowl and count them. What these tasks have in common is that, although based on real data, they do not emphasize opportunities for students to appreciate the utility of statistical ideas. As a result they may appear contrived and fail to engage and motivate students.

There is a further tension concerning the role and nature of data in statistics tasks. Students, particularly younger students, need to experience collecting, recording and cleaning their own data in order to develop their understandings of different forms of representation (Neumann, Hood, & Neumann, 2013). But data collection is time-consuming, often leaving relatively little time for analysis and discussion and the features of the resulting data sets cannot be predicted. Providing real world data sets, or devising data sets which are not authentic but embody the features that the teacher wants students to experience, will save time but students may find such data sets harder to understand and engage with (Arnold, 2004).

Integrate the Use of Technological Tools That Allow Students to Explore and Analyze Data

The design of tasks and the ways in which students may access and explore data are significantly influenced by the range of technological tools available to support the development of students’ understanding and reasoning, such as computers, graphing calculators, statistical software and web

applets (Biehler, 2003). Students no longer have to spend time performing tedious calculations, or drawing graphs and can focus instead on the more important task of learning how to choose appropriate analytic methods and how to interpret results. Technological tools are used not only to generate statistics, graph or analyze data, but also to help students visualize concepts and develop an understanding of abstract ideas through simulations. For examples of innovative tools and ways to use them to help develop students' reasoning, see Biehler, Ben-Zvi, Bakker and Makar (2013).

Establish a Classroom Culture that Fosters Statistical Arguments

The design of tasks, technological and assessment tools has to take into account the expected forms of classroom *discourse*. In statistics learning environments, the use of activities and technology allows for a form of classroom discourse in which student learn to question each other and respond to such questions, as well as explaining their answers and arguments. Cobb and McClain (2004) describe the effective classroom discourse in which statistical arguments explain why the organization of data gives rise to insights about the phenomenon under investigation and students engage in sustained exchanges that focus on significant statistical ideas.

It can be challenging to create a statistics learning environment with classroom discourse that enables students to engage in discussions in which significant statistical issues emerge and where arguments are presented and their meaning is openly negotiated. Creating a classroom climate where students feel safe expressing their views, even if they are tentative is another challenging task and is related to classroom *culture*, in which the teacher and students have to develop the corresponding classroom social norms and socio-mathematical (or socio-statistical) *norms* (Yackel & Cobb, 1996). These norms encompass the obligation for the students to explain and justify their solutions, to try to understand the explanations and reasoning of the other students, to ask for clarification when needed and eventually to challenge the ways of thinking with which they do not agree. The teacher is not expected to give explanations, but to pose tasks and ask questions that may foster students' thinking. Socio-statistical norms would be tailored to what it means to do statistics, for example what a statistical problem is, what a statistical argument is and so forth.

The shift in the classroom culture is related to a potential shift in the role of the students, from problem solvers to statisticians who analyze and represent data to make them easily accessible for decision makers. When adopting the role of a data analyst, or data detective (Pfannkuch & Rubick, 2002), students can start reflecting on the adequacy and clarity of condensed descriptions and representations of data, which may foster the reinvention of more sophisticated representations and concepts.

Use Assessment to Monitor the Development of Students' Statistical Learning and to Evaluate Instructional Plans

Assessment should be aligned to well-designed tasks that focus on central statistical ideas in a discourse-rich classroom. Much of the value of changes in the other design dimensions will be lost if assessment practices are not aligned in this way, since the attention of students and teachers will be shaped by the requirements of assessment. In recent years, many alternative forms of assessment have been used in statistics classes. In addition to quizzes, homework and exams, many teachers use statistical projects as a form of assessment (MacGillivray & Pereira-Mendoza, 2011). Other forms of alternative assessment are also used to assess students' statistical literacy (e.g., critique a graph in a

newspaper) and reasoning (e.g., write a meaningful short essay), or to provide feedback to the teacher (e.g., minute papers).

Assessments need to be aligned with learning goals, focusing on understanding key ideas and not just on skills, procedures and computed answers. This can be done with formative assessments used during a course (e.g., quizzes, small projects, or observing and listening to students in class) as well as with summative evaluations (course grades). Useful and timely feedback is essential for assessments to lead to learning. Types of assessment may be more or less practical in different types of courses. However, it is possible, even in large classes, to implement good assessment practices (Garfield & Ben-Zvi, 2008, pp. 65-89).

Discussion: Contemporary issues and emerging directions

The goal of this article has been to draw attention to the need to think about learning environments and their design in statistics education as a way of considering how sustainable change in the learning and teaching of statistics can be supported. We have provided six dimensions of statistics learning environments. Designing for educational change to support the development of students' statistical reasoning is a challenging task. Using a lever to make a one-dimensional change (e.g., formulate new tasks, use of a new pedagogical strategy) may make a difference that is not necessarily a sustainable change in students' understanding of statistical ideas. This article has argued for a holistic and integrated approach that advocates a learning environment where students are engaged in making and testing conjectures using data, discussing and explaining statistical reasoning, focusing on the important big ideas of statistics, using innovative tools in creative ways to assist their learning and being assessed in appropriate ways.

A key factor in this discussion is that these six dimensions, which are inter-related (see Figure 1), must be aligned and balanced. Issues of alignment are important for accelerating statistics learning both within and outside of schools. The meaning of these design principles being part of integrative whole is that using one of them separately is not enough to make deep and sustainable change in students' learning. The learning environment approach helps to interlink them. For example, the design of motivating tasks is linked to real data collection; these data can be used to build students' statistical understanding taking advantages of the innovative affordances of technological tools; productive classroom discourse is supported by the design of open-ended tasks that support argumentation and by appropriate responses by the teacher; assessment methods need to align with the design of tasks; a provision of a new tool must consider the potential interactions with content and pedagogy (Moore, 1997).

Thus we argue that pedagogical and research efforts for change must consider the interactions among these dimensions. There are however other important dimensions of learning environments that were not included in this article. One example is the emotional aspects of engagement and identity to motivate all students to participate and reflect on their experiences (Heyd-Metzuyanim, 2013). In addition, the broader community (school level policy makers, local and national authorities, etc.) plays a significant role in the constitution of the learning environment. For example, tensions may arise between required traditional examinations and alternative assessment methods employed in a

learning environment or between national curricula and an emergent and dynamic learning trajectory in the learning environment.

Further research is crucially needed to provide more well-researched holistic examples in different contexts and age levels. Systematic studies are also needed about the effectiveness of statistics learning environments, learning environment design issues, the role of alignment between the various dimensions of statistics learning environments, new possibilities for teaching and learning in innovative designs; and opportunities in cutting edge areas, such as, model-based reasoning, visual representation to teach complex abstract concepts, learning in virtual worlds, net-based collaborative teams and communities and big data.

The difficulty of demonstrating the effectiveness of learning environments, raises profound methodological issues in researching them. The learning environment approach acknowledges a complex system or ecology in which a traditional methodology is not sustainable. Instead, a design research approach (Cobb et al., 2003) is needed, where iterative design of the learning environment sensitizes the research team to the key mechanisms for learning within the design. We recommend that more attention be given to methodological aspects of researching the design of learning environments.

First steps in moving towards the learning environment perspective in the statistics education community are for researchers to consider the implications of this approach in their studies and for professional development to support teachers to consider how current curricula and materials align in the context of social, cultural, physical, psychological and pedagogical components of a learning environment. Careful and steady change over a period of time, rather than a push for radical change, may lead to a successful implementation of a learning environment in the statistics education world, both among researchers and teachers.

References

- Ainley, J., Gould, R., & Pratt D. (2015). Learning to reason from samples: commentary from the perspectives of task design and the emergence of “big data.” *Educational Studies in Mathematics*, 88(3), 405-412.
- Arnold, P. (2014). *Statistical investigative questions: An enquiry into posing and answering investigative questions from existing data*. Unpublished doctoral thesis, University of Auckland, New Zealand.
- Ben-Zvi, D., & Aridor, K. (2016). Children’s wonder how to wander between data and context. In D. Ben-Zvi and K. Makar. (Eds.), *The teaching and learning of statistics: International perspectives* (pp. 25-36). Springer International Publishing Switzerland.
- Ben-Zvi, D., Gravemeijer, K., & Ainley, J. (2018). Design of statistics learning environments. In D. Ben-Zvi, K. Makar, & J. Garfield (Eds.), *International handbook of research in statistics education* (pp. 473-502). Springer Cham.
- Ben-Zvi, D., Makar, K., & Garfield, J. (Eds.) (2018). *International handbook of research in statistics education*. Springer Cham.
- Biehler, R. (2003). Interrelated learning and working environments for supporting the use of computer tools in introductory classes. In International Statistical Institute (Ed.): CD-ROM *Proceedings of the IASE satellite conference on Statistics Education and the Internet*, Max-Planck-Institute for Human Development, Berlin, 11-12 August 2003, Voorburg: Netherlands.
- Biehler, R., Ben-Zvi, D., Bakker, A., & Makar, K. (2013). Technology for enhancing statistical

- reasoning at the school level. In M. A. Clements, A. Bishop, C. Keitel, J. Kilpatrick, and F. Leung (Eds.), *Third International Handbook of Mathematics Education* (pp. 643-690). Springer.
- Boud, D., Keogh, R., & Walker, D. (1985). Promoting reflection in learning: A model. In D. Boud, R. Keogh and D. Walker (Eds.), *Reflection: Turning experience into learning* (pp. 18-39). East Brunswick, NJ: Nichols.
- Bransford, J., Brown, A. L., & Cocking, R. R. (Eds.) (2000). *How people learn: Brain, mind, experience, and school*. Washington, DC: National Academy Press.
- Burgess, T. (2007). *Investigating the nature of teacher knowledge needed and used in teaching statistics*. Unpublished doctoral thesis, Massey University, New Zealand.
- Cobb, P., & McClain, K. (2004). Principles of instructional design for supporting the development of students' statistical reasoning. In D. Ben-Zvi & J. Garfield (Eds.), *The challenge of developing statistical literacy, reasoning, and thinking* (pp. 375-396). Dordrecht, Netherlands: Kluwer Academic Publishers.
- Cobb, P., Confrey, J., diSessa, A., Lehrer, R., & Schauble, L. (2003). Design Experiments in Educational Research. *Educational Researcher*, 32(1), 9-13.
- Cuban, L. (2003). *Why is it so hard to get good schools?* New York: Teachers College, Columbia University.
- Edelson, D., & Reiser, B. (2006). Making authentic practices accessible to learning: Design challenges and strategies. In R. K. Sawyer (Ed.), *The Cambridge Handbook of the Learning Sciences* (pp. 335-354). New York, NY: Cambridge University Press.
- Franklin, C., & Garfield, J. (2006). The Guidelines for Assessment and Instruction in Statistics Education (GAISE) project: Developing statistics education guidelines for pre K-12 and college courses. In G.F. Burrill, (Ed.), *Thinking and reasoning about data and chance: Sixty-eighth NCTM Yearbook* (pp. 345-375). Reston, VA: National Council of Teachers of Mathematics.
- Garfield, J., & Ben-Zvi, D. (2008). *Developing students' statistical reasoning: Connecting research and teaching practice*. Dordrecht, the Netherlands: Springer.
- Heyd-Metzuyanim, E. (2013). The co-construction of learning difficulties in mathematics—teacher–student interactions and their role in the development of a disabled mathematical identity. *Educational Studies in Mathematics*, 83(3), 341-368.
- Kapur, M., & Bielaczyc, K. (2012). Designing for productive failure. *Journal of the Learning Sciences*, 21(1), 45-83.
- Kingston, N., & Nash, B. (2011). Formative assessment: A meta-analysis and a call for research. *Educational Measurement: Issues and Practice*, 30(4), 28–37.
- Lehrer, R. (2009). Designing to develop disciplinary knowledge: Modeling natural systems. *American Psychologist*, 64(8), 759-771.
- MacGillivray, H., & Pereira-Mendoza, L. (2011). Teaching statistical thinking through investigative projects. In C. Batanero, G. Burrill & C. Reading (eds.), *Teaching statistics in school mathematics—challenges for teaching and teacher education* (pp. 109-120). Springer.
- Moore, D. S. (1997). New pedagogy and new content: The case of statistics. *International Statistical Review*, 65(2), 123-137.
- Neumann, D. L., Hood, M., & Neumann M. M. (2013). Using real-life data when teaching statistics: Student perceptions of this strategy in an introductory statistics course. *Statistics Education Research Journal*, 12(2), 59-70.
- Pfannkuch, M., & Rubick, A. (2002). An exploration of students' statistical thinking with given data. *Statistics Education Research Journal*, 1(2), 4-21.
- Roseth, C. J., Garfield, J. B., & Ben-Zvi, D. (2008). Collaboration in learning and teaching statistics. *Journal of Statistics Education*, 16(1), 1-15.
- Yackel, E., & Cobb, P. (1996). Sociomathematical norms, argumentation, and autonomy in mathematics. *Journal for Research in Mathematics Education*, 27(4), 458-477.

Informal statistical inference and permutation tests

Øyvind Jacobsen Bjørkås¹, Kjetil B. Halvorsen² and Dag Oskar Madsen³

¹Nord University, Faculty of Education and Arts, Bodø, Norway; oyvind.j.bjorkas@nord.no

²Nord University, Faculty of Education and Arts, Nesna, Norway; kjetil.b.halvorsen@nord.no

³ Nord University, Faculty of Education and Arts, Bodø, Norway; dag.o.madsen@nord.no

Keywords: Mathematics curriculum, statistical inference, generalization.

Background

In the Norwegian *Curriculum for the Common Core subject of Mathematics*, there are competence aims after the second, fourth, seventh and tenth years in primary and lower secondary education. In the subject area of Statistics, there seems to be little progression through the various grades, in our opinion. The relevant competence aim after Year 4 is “collect, sort, note and illustrate data using tally marks, tables and bar graphs, with and without the use of digital tools, and converse about the process and what the illustrations tell us about the data” (Utdanningsdirektoratet, n. d.).

The competence aims after Year 10 read as follows.

carry out investigations and use databases to search for and analyse statistical data and critically assess sources; order and group data, find and discuss and elaborate on the median, mode, average and spread, and present data with and without digital tools, and discuss and elaborate on different ways of presenting data and what impressions these can give. (Utdanningsdirektoratet, n. d.)

The competence aims in Statistics after Year 10 and are in textbooks often dealt with in grade 8. In the textbook *Faktor* for grade 8 (Hjardar & Pedersen, 2014, p. 110), the following problem is marked as *difficult*. A table that shows the population for each county in Norway is given with the task: “Find the top three counties with the highest population”. In terms of difficulty, there is very little progress to see from tasks given based on the competence aims after grade 4. Even if the competence aims (“analyse statistical data”) and the related document *Mathematics: Characteristics of goal achievement* seem to support a more exploratory approach leading for instance towards informal statistical inference, our impression is that the subject area of Statistics is treated superficially and poorly in textbooks.

Theoretical perspectives

There is already an extensive research literature on teaching experiments introducing statistical inference in middle school (see e. g. Watson, 2008). One common approach is to use graphical representations of datasets, often with the help of digital tools such as TinkerPlots (Konold & Miller, 2005), to make comparisons between samples and informal inferences about differences of populations. We intend to go one step further and introduce to middle school students test procedures that have theoretical justification in permutation methods (Ernst, 2004). The focus will be on the *significance* (perhaps without using this technical word) of difference of means, not just comparing means. Rossmann (2008, p. 17) suggests that “simulation of randomization tests

provides an informal and effective way to introduce students to the logic of statistical inference”. Zieffler, Garfield, Delmas & Reading (2008, p. 44) define informal inferential reasoning as “*the way in which students use their informal statistical knowledge to make arguments to support inferences about unknown populations based on observed samples*”.

Developing a teaching plan

We want to develop a teaching plan aimed at grade 8 or 9 about statistical inference focusing on experiments with realistic problems, perhaps using a design-based research methodology. As mentioned we want to include permutation tests, but they will be presented to the students in an informal way. There should be no instruction about distributions or formal methods, only an appeal to the underlying logic that we hope can be intuitively acceptable for students. This last point should be one focus point of our research. We have tried out one experiment with teacher students about comparing the weight of apples and oranges in samples and then repeatedly and randomly reassign which fruits are “apples” and which are “oranges”. How does the real difference in weight compare with the randomized differences? If there is no significant difference in weight between apples and oranges, then the real difference should not be among the most extreme in the simulation. This is an example of the logic behind permutation tests. But is it *informal* inferential reasoning? This is a question we should have in mind when developing the plan.

The details of the teaching plan are still very much in development. One idea we have is to offer the permutation tests to the students late in a sequence of lectures, where earlier in the sequence more student-driven activities, perhaps involving digital tools and graphical representation of data sets, are planned and where students are encouraged to use their own reasoning. We have done the activity with apples and oranges three times with teacher students and gotten valuable feedback. We want to develop this into a larger project involving real classroom settings.

References

- Ernst, M. (2004). Permutation methods: A basis for exact inference. *Statistical Science*, 19(4), 676-685.
- Hjardar, E. & Pedersen J.-E. (2014). *Faktor 8 Oppgavebok*. Oslo: Cappelen Damm.
- Konold, C., & Miller, C. D. (2005). *TinkerPlots: Dynamic data exploration*. [Computer software] Emeryville, CA: Key Curriculum Press.
- Rossmann, A. J. (2008). Reasoning about Informal Statistical Inference: One Statistician’s View. *Statistics Education Research Journal*, 7(2), 5-19.
- Utdanningsdirektoratet. (n. d.). *Curriculum for the Common Core subject of Mathematics*. Retrieved September 19, 2018 from <https://www.udir.no/kl06/MAT1-04?lplang=http://data.udir.no/kl06/eng>
- Watson, J. M. (2008). Exploring Beginning Inference with Novice Grade 7 Students. *Statistics Education Research Journal*, 7(2), 59-82.
- Zieffler, A., Garfield, J., Delmas, R. & Reading, C. (2008). A Framework to Support Research on Informal Inferential Reasoning. *Statistics Education Research Journal*, 7(2), 40-58.

Unravelling teachers' strategies when interpreting histograms: an eye-tracking study

Lonneke Boels^{1,2}, Arthur Bakker¹ and Paul Drijvers¹

¹Utrecht University, Freudenthal Institute, Utrecht; l.b.m.boels@uu.nl;

a.bakker4@uu.nl; p.drijvers@uu.nl

²Christelijk Lyceum Delft, The Netherlands

The scarce research on teachers indicate that they often misinterpret histograms. We conjecture that the confusion of histograms with case-value plots is the source of many misinterpretations. Therefore, the question for this study is: what are the most common strategies of secondary school teachers when interpreting histograms and case-value plots? To answer this question, we use a method that allows for a more in-depth analysis of twelve teachers' interpretations of graphical representations than was ever possible before: eye-tracking combined with retrospective verbal reports. Preliminary results show that several teachers apply a case-value plot interpretation strategy on a histogram. Furthermore, some participants use an area interpretation strategy or histogram interpretation strategy applied to a case-value plot. In addition, gaze data suggest that teachers use strategies that did not reach awareness and therefore will not be reported during thinking aloud protocols.

Keywords: Secondary school mathematics, statistics, verbal report, graphical representations, bar graphs.

Background

Histograms are very difficult to interpret (e.g., delMas & Liu, 2005; Lem, Onghena, Verschaffel, & Van Dooren, 2013). Misinterpretations of histograms persist despite many interventions aiming to tackle these misinterpretations. For example, Kaplan, Gabrosek, Curtiss and Malone stated in 2014: “the fact remains that the data indicate not only that students entering a statistics course have certain misconceptions about histograms, but also that these misconceptions persist after instruction” (p. 17). In an extensive review of more than 80 publications (Boels, Bakker, Van Dooren & Drijvers, 2019) we identified that most misinterpretations regarding histograms relate to the misunderstanding of two statistical big ideas: *data* and *distribution*. One of the important insights that goes with understanding the big idea of *data* is knowing how many variables are at stake. A misinterpretation existing amongst students, teachers and even researchers is that histograms could display two variables instead of what is correct: only one statistical variable¹ (the one given on the horizontal axis, see Figure 1a; e.g., Boels, Bakker, et al., 2018). The big idea of *distribution* encompasses centre, shape and variability. One misinterpretation is that a histogram has more variability when it is “bumpier,” meaning more variation in the frequency (the heights of the bars) instead of the variation in the data (e.g., Boels, Bakker, et al., 2018; Dabos, 2014; delMas & Liu, 2005; Lem, et al., 2013).

¹ In line with other researchers (e.g., Garfield & Ben-Zvi, 2007), we prefer the term variable over attribute because some people may use attributes for categorical data only.

In line with other researchers (e.g., Cooper & Shore, 2010; Garfield & Ben-Zvi, 2007; Kaplan et al., 2014) we conjecture that the confusion of histograms with case-value plots is the source of many misinterpretations. A histogram and a case-value plot share several salient features (e.g., vertical bars, numbers along the vertical axis). The differences between those two graphical representations—regarding the number of depicted statistical variables as well as the measurement level of the data—are less apparent for most people.

As the number of variables differ in a case-value plot compared to a histogram, so does the interpretation of measures of centre and variability. In Figure 1 the difference for a measure of centre—the mean—is shown for a case-value plot and a histogram. This depicted difference in assessing the mean, also influences the assessment of both the variability and the shape of the distribution. In a histogram, teachers have to look at the horizontal positions of the bars in combination with the bars' heights to assess centre and variability. In contrast, in a case-value plot, teachers have to look at the variation in the heights of the bars only.

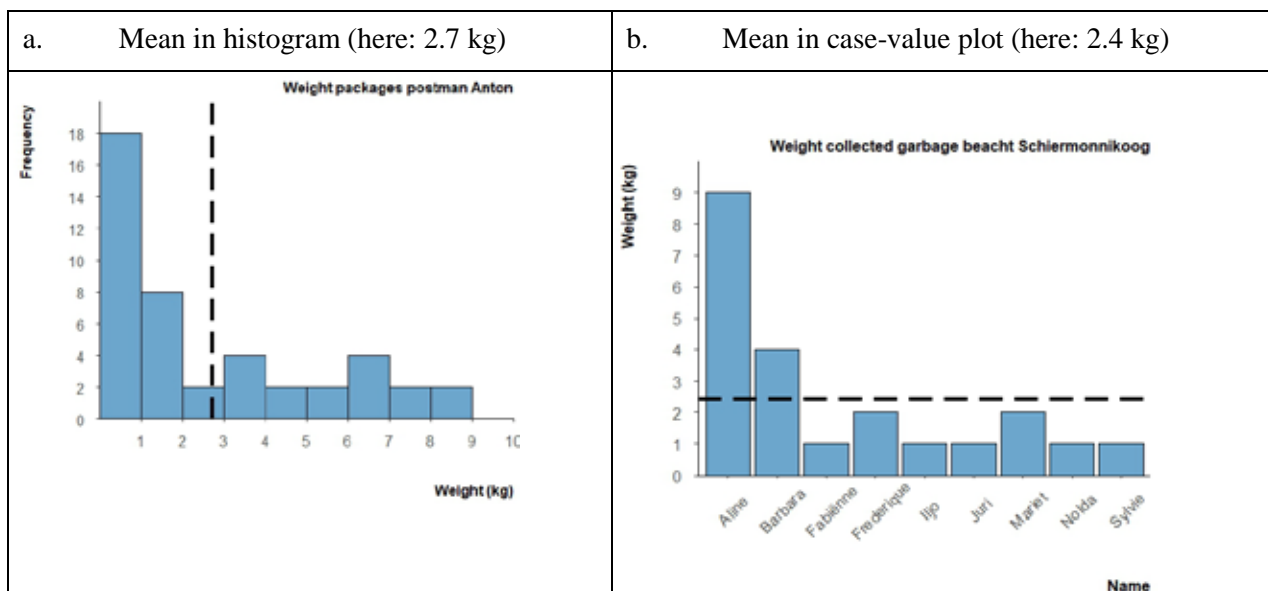


Figure 1: The mean weight (dashed line) is assessed differently in a histogram (left; Item 2) than in a case-value plot (right; Item 8)

The confusion of histograms and case-value plots can explain many of the misinterpretations with histograms reported in the literature but does not answer the question what exactly goes wrong when people interpret histograms. To tackle the persisting problem of misinterpreting histograms, we need to deepen our understanding of the kind of strategies that people use when interpreting histograms. In an exploratory case study we found that students are often unaware that histograms and case-value plots ask for different interpretation strategies (Boels, Ebbes, Bakker, Van Dooren, & Drijvers, 2018). From our personal experience, we conjectured that the same holds true for some of their teachers. The aim of our current study is therefore to identify the most common strategies of teachers when interpreting histograms and case-value plots. Hence, the question for this research is: what are the most common strategies for secondary school STEM teachers when interpreting histograms and case-value plots?

To answer this research question, we used eye-tracking combined with a retrospective interview. The eye-tracking makes it possible to literally see teachers' strategies when solving a task. The advantage of eye-tracking over other techniques, is that it makes an in-depth study possible of the strategies with more detail than was ever possible before. In our exploratory case study, for example, we found that several participants had an initial preferred strategy that they were not aware of and were therefore not reporting during the retrospective interview (Boels, Ebbes, et al., 2018). Eye-tracking has several advantages over other research techniques. For example, using assessments items only, such as CAOS (e.g., delMas, 2005) has already been done extensively and cannot easily answer the question about strategies. Using a thinking aloud protocol (TA) to discover strategies works well if people verbalize their strategy during TA—although TA might slow down the task solving process. But when people need to explain their strategy—why they do what they do, this alters their cognitive processes (Ericsson, 2006) and is therefore unsuitable for our goal. The study of Van Gog and Jarodzka (2013) showed that a retrospective interview improves when a cue is added: the replay of participants' eye movements during the recall. Considering all these arguments we decided to use eye-tracking combined with retrospective reports to unravel teachers' strategies.

From a previous exploratory study with six university students (Boels, Ebbes, et al., 2018) we obtained the following two interpretation strategies that are relevant for the current study: a histogram interpretation strategy and a case-value plot interpretation strategy. A histogram interpretation strategy is associated with a vertical looking pattern and reading of the numbers on the horizontal axis for locating the mean. Furthermore participants using this strategy may use statements as for example “balancing” the graph. A case-value plot interpretation strategy is associated with a horizontal looking pattern and reading of the numbers on the vertical axis. On top of that, these participants may use words like “redistributing” or “make all bars even” (e.g., same height). The exploratory study leads us to the following conjectures for the study reported here:

- 1) The most common strategy for interpreting histograms is a case-value plot interpretation strategy, followed by the histogram interpretation strategy.
- 2) The most common strategy for case-value plots is a case-value plot interpretation strategy. Only a few teachers will apply a histogram interpretation strategy onto a case-value plot.
- 3) Several teachers will have an initial preferred strategy independent of the type of graph at stake.

Method

In total twelve items were either constructed (two) or re-used (ten) from the exploratory study (Boels, Ebbes, et al., 2018). The teachers were asked to either estimate the arithmetic mean of the data in the graph or to compare the arithmetic means of two graphs as estimating the mean can be seen as a necessary prerequisite for assessing the variability. A second reason for choosing the mean was that the target audience of the larger project are secondary school students who are more familiar with measures of centre than measures of variation and the same holds true for their teachers. From the exploratory study we learned that the multiple-choice answers might work as an anchor for the participants (e.g., Tversky & Kahneman, 1974) in items with only one graph. Hence, for the six items with a single graph we used open questions.

We constructed (or re-used from the previous study) a case-value plot for every histogram, with the same salient features such as number of bars, “shape,” range and variable (weight), resulting in a total of twelve questions. Figure 1 gives an example of Item 2 and 8. Items were constructed that differed systematically on the relevant features but that were the same for irrelevant though sometimes salient features as recommended by Orquin and Holmqvist (2017). These features were carefully chosen so that a teacher applying the same interpretation strategy on both the histogram and the case-value plot could be expected to answer the question for the case-value plot correctly and for the histogram incorrectly, and vice versa.

Similar to the previous study we arranged the items in such a way that there were never more than two of the same graph types (histogram or case-value plot) in succession. As we expect that most teachers who confuse case-value plots with histograms will apply a case-value plot strategy onto a histogram, we started with two single left-skewed histograms. This was done to avoid priming (e.g., Lashley, 1951). The first two single histograms were followed by an item in which participants had to compare two case-value plots. Graphs with the same salient features (e.g., Item 2 and Item 8) never directly followed one another. The question for the histogram in Figure 1a was: What is approximately the average weight of the parcels delivered by Anton? The question for the single case-value plot in Figure 1b was: What is approximately the average weight that has been collected per person? In Figure 2, an example of an item with two histograms is given (Item 5). The multiple choice answer options for comparing two histograms were for example: a) Willem delivers on average the heaviest parcels, b) Julia delivers on average the heaviest parcels, c) the average weight of the parcels is approximately the same for both.

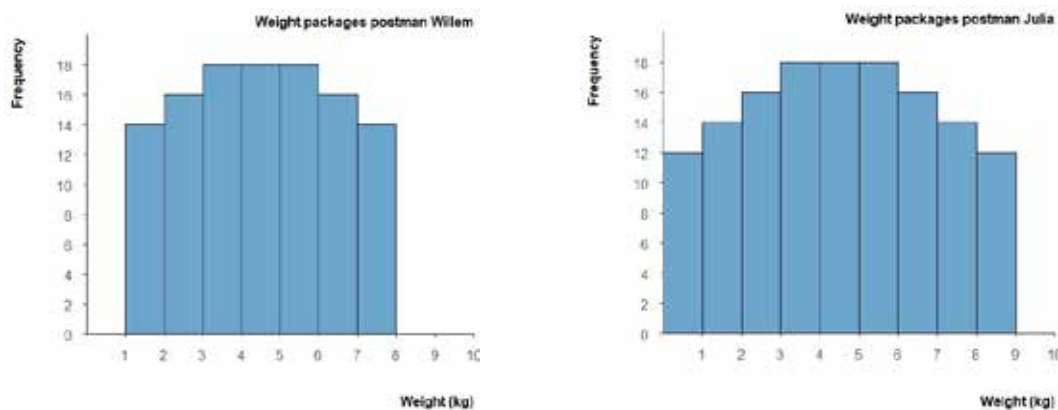


Figure 2: Example of Item 5 in which teachers were asked to compare two histograms and indicate whether the mean weight was higher for one of the two postman or roughly the same

The sample included twelve secondary school teachers of three Dutch secondary schools preparing for college or University grade 7 to 12 (ten teachers were from the same school). Participation was voluntary and science and mathematics teachers were asked to participate. Consent was signed before starting the task. To minimize distractions, the teachers were tested in a one-on-one setting. An explanation was given on the aim of the study as well as how to operate the equipment and software. After completing the task—that included the twelve items mentioned in this research as well as some other items that are not discussed here—participants were asked to report what they thought as well

as their strategy during the specific tasks. To improve the quality of these retrospective verbal reports we used their own gazes as a cue (Van Gog & Jarodzka, 2013).

An eye-tracker measures where a person looks on a computer screen and uses infrared light to detect the position of the eyes. The Tobii Pro X2-60 eye-tracker was used, mounted on a laptop with a 13-inch screen by using magnetic mounting brackets. The sampling rate was 60 Hz. The fixations (where people look) and saccades (going from one fixation on the screen to another) were recorded real time by the software Tobii Pro Studio 3.4.5. The first author qualitatively coded the gaze data and verbal reports using open, axial and selective coding (Corbin & Strauss, 1990). Furthermore, the coding was checked with gaze data. The gaze data were displayed in heat maps that show where participants looked. The colouring is from green (few fixations) via yellow to red (many fixations), see Figure 3. In Table 1 an example is given of the analysis of gaze and verbal data of one participant. In the next part of the study, not reported here, an analytical analysis of the pattern will be done by using so called areas of interest (AOIs) such as the graph area, vertical axis, horizontal axis and so on and also—if technically possible—by using specialised artificial intelligence software.

Item number	Gaze data – open codes	Verbal data – open codes	Selective code for strategy
2 (single histogram)	Reads question Reads title graph Looks at top highest bar Looks in middle of graph area (white space) Looks at low bar (7-th) Looks in middle of graph area (white space) Looks at low bar (9-th) ...	Look at title Looked at highest and/or lowest number on y-axis Look how often lowest bars occur Low bars do not contribute much to mean Higher bars contribute more to mean ...	Case-value plot interpretation

Table 1: Example of qualitative analysis (open coding) of gaze and verbal data of a participant as well as the selective code of the combined data

Results

The most common strategies of these teachers were: a histogram interpretation strategy, a case-value plot interpretation strategy and an area interpretation strategy. Several participants seemed to use the same interpretation strategy for both the histograms and case-value plots. An example of a case-value plot interpretation strategy applied to a histogram is shown in Figure 3a. The heat map shows many fixations around frequency 5. The teacher said during the eye-tracking: “Well, uh, about 4 or 5 or something like that.” In the retrospective report this teacher said: “I looked at the highest number on the y-axis [...]. I looked at the lowest frequency. If this occurs less than you have to count that less and [...] the highest beams you take more of these, so to speak, from their weight. [...] and I have taken the frequency as kilos.” This teacher realised at the end of the tasks that s/he systematically used the frequency axis as the weight axis and refers to that in the explanation. The correct answer for this item would be any number between 2 and 3.4 with the actual mean for this specific dataset being 2.7.

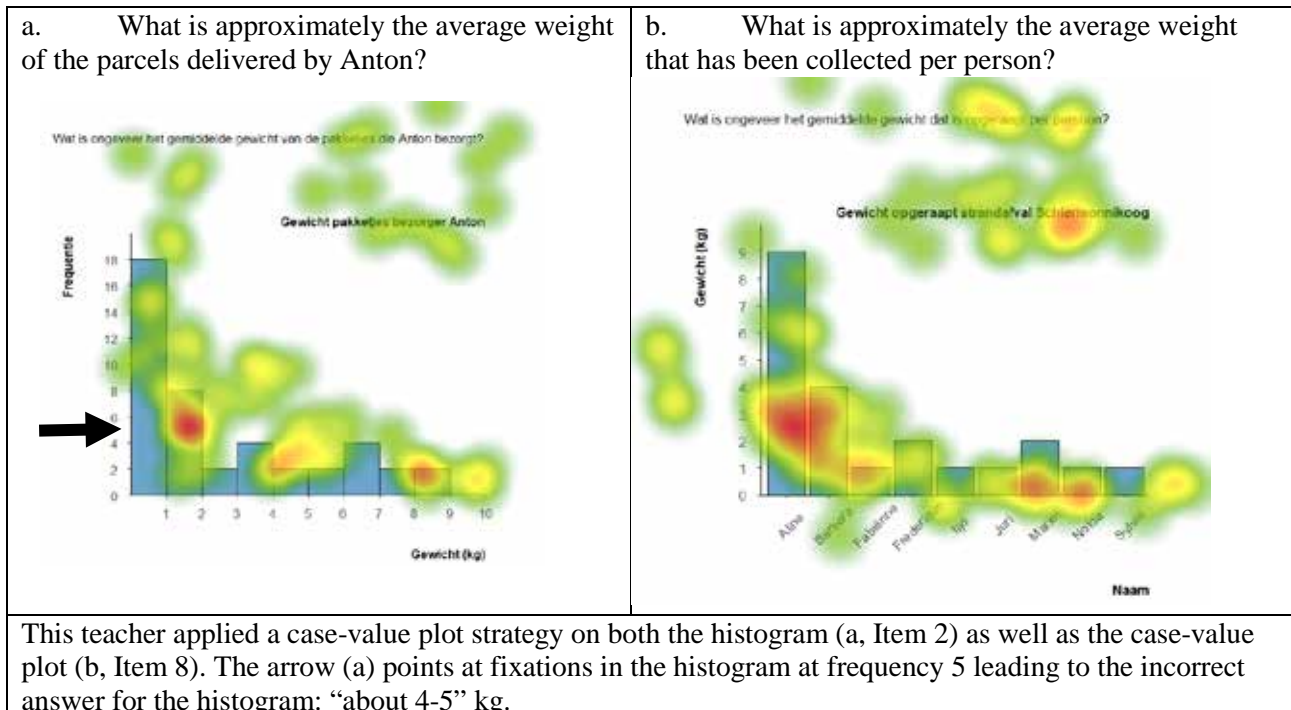


Figure 3: Histogram (a) and case-value plot (b) from Figure 1 with heat map overlay

An example of an area interpretation strategy is where a teacher looked at a histogram using a vertical looking pattern and in the verbal data mentioned that the area of the bars left and right of the mean have to be of the same size. An example of a histogram interpretation strategy applied on a case-value plot is when a teacher looked at Item 10—the case-value plot variant of Item 5 in Figure 2—and said:

Teacher: Only the spread with uh that that right one [the case-value plot on the right with two bars less but the same number of names] is less than that [pause] left one.

Researcher: And why is the spread less?

Teacher: Well, because there are two numbers added thus are, it goes further on.

Researcher: Yes, so you are pointing now [on the screen]: they are wider.

Teacher: Yes, he is wider.

This teacher concluded that the mean was the same and that only the spread differed. In a case-value plot, a higher difference in heights of the bars indicates more spread. The case-value plot with the two students who collected nothing had the lowest mean and most spread. Another finding is that many teachers do not read axis labels and/or graph titles. But even if they do, this does not guarantee that they interpret the histogram or case-value plot correctly. The gaze data indicate that the teacher mentioned above did read the graph title and the labels on the vertical axis—weight (kg)—but still applied the wrong strategy.

Conclusion and discussion

The first conclusion is that the most common strategy for interpreting means in histograms is a case-value plot interpretation strategy. Using a case-value plot interpretation strategy for a histogram implies not understanding that a histogram is for one statistical variable only and that histograms

therefore differ from a case-value plot with two depicted statistical variables. As stated in the background section, understanding the big idea of data implies understanding how many variables are depicted in a histogram. This conclusion is therefore in line with the finding in our review study on histograms (Boels, Bakker et al., 2019). Furthermore it is in line with misinterpretations found by others (e.g., Cooper, 2008; Lem et al. 2013). In addition, we speculate that—although several teachers did not read labels on the axes—teaching teachers to read labels will not suffice to eliminate the confusion of histograms with case-value plots, as—for example—the teacher mentioned earlier who applied a histogram interpretations strategy onto a case-value plot, did read the labels.

The second conclusion is that teachers sometimes used an area interpretation strategy for finding the mean in a histogram. In this interpretation strategy the data in the histogram are correctly interpreted (e.g., the statistical variable is on the horizontal axis) but the misinterpretation is related to the big idea of *centre*. Instead of the mean, the median is found with this strategy of equal areas. This finding is in line with findings from others (e.g., Cooper, 2008). We speculate that this interpretation strategy is due to excessive exposure to symmetric—specifically normal—distributions in histograms in schoolbooks and statistics courses where mean and median are indeed the same.

In addition, the gaze data can be used to identify strategies that participants may not be aware of and therefore will not be reported during thinking aloud protocols or retrospective interviews. Eye-tracking therefore adds a new research tool to researchers' toolkit, making it possible to analyse participants' strategies in more detail than was ever possible before. Furthermore, researchers and teacher educators can use these results to better design curriculum materials. Finally, in line with the wish list from CERME10 in 2017 (Bakker, Hahn, Kazak, & Pratt, 2018), this research concentrate on teachers as well as contributes to teachers' Statistical Knowledge for Teaching (Groth, 2007).

This research is funded with a Doctoral Grant for Teachers from The Netherlands Organisation for Scientific Research, number 023.007.023 awarded to Lonneke Boels.

References

- Bakker, A., Hahn, C., Kazak, S., & Pratt, D. (2018). Research on probability and statistics education: Trends and directions. In T. Dreyfus, M. Artigue, D. Potari, S. Prediger, & K. Ruthven (Eds.), *Developing research in mathematics education - twenty years of communication, cooperation and collaboration in Europe* (pp. 46–59). Abingdon, UK: Routledge
- Boels, L., Bakker, A., Van Dooren, W., Drijvers, P. (2019). *Conceptual difficulties when interpreting histograms: A review*. Manuscript submitted for publication.
- Boels, L., Ebbes, R., Bakker, A., Van Dooren, W., & Drijvers, P. (2018). Revealing conceptual difficulties when interpreting histograms: an eye-tracking study. In M. A. Sorto, A. White, & L. Guyot (Eds.), *Looking back, looking forward. Proceedings of the Tenth International Conference on Teaching Statistics* (pp. 1–4), Kyoto, Japan. Voorburg, The Netherlands: International Statistical Institute.
- Cooper, L. L., & Shore, F. S. (2008). Students' misconceptions in interpreting center and variability of data represented via histograms and stem-and-leaf plots. *Journal of Statistics Education*, 16(2), 1–13

- Cooper, L., & Shore, F. (2010). The effects of data and graph type on concepts and visualizations of variability. *Journal of Statistics Education*, 18(2), 1–16.
- Corbin, J., & Strauss, A. (1990). Grounded theory research: Procedures, canons and evaluative criteria. *Zeitschrift Für Soziologie*, 19(6), 418–427. doi.org/10.1007/BF00988593
- Dabos, M., (2014). A glimpse of two year college instructors' understanding of variation in histograms. In K. Makar, B. de Sousa, & R. Gould (Eds.), *Sustainability in statistics education. Proceedings of the Ninth International Conference on Teaching Statistics* (pp. 1–4), Flagstaff, Arizona, USA. Voorburg, The Netherlands: International Statistical Institute.
- delMas, R., & Liu, Y. (2005). Exploring students' conceptions of the standard deviation. *Statistics Education Research Journal*, 4(1), 55–82.
- Ericsson, K. A. (2006). Protocol analysis and expert thought: Concurrent verbalizations of thinking during experts' performance on representative tasks. *The Cambridge handbook of expertise and expert performance*, 223-241.
- Garfield, J., & Ben-Zvi, D. (2007). How students learn statistics revisited: A current review of research on teaching and learning statistics. *International Statistical Review*, 75, 372–396. doi.org/10.1111/j.1751-5823.2007.00029.x
- Groth, R. E. (2007). Toward a conceptualization of statistical knowledge for teaching. *Journal for research in Mathematics Education*, 427–437. <http://www.jstor.org/stable/30034960>
- Kaplan, J.J., Gabrosek, J.G., Curtiss P. & Malone, C. (2014). Investigating student understanding of histograms. *Journal of Statistics Education*, 22(2), 1-30.
- Lashley, K. S. (1951). The problem of serial order in behavior. In L. A. Jeffress (Ed.), *Cerebral mechanisms in behavior* (pp. 112–131). New York: Wiley.
- Lem, S., Onghena, P., Verschaffel, L., & Van Dooren, W. (2013). On the misinterpretation of histograms and box plots. *Educational Psychology*, 33(2), 155–174.
- Orquin, J. L., & Holmqvist, K. (2017). Threats to the validity of eye-movement research in psychology. *Behavior Research Methods*. doi.10.3758/s13428-017-0998-z
- Tversky, A., & Kahneman, D. (1974). Judgment under uncertainty: Heuristics and biases. *Science*, 185(4157), 1124–1131. doi.org/10.1017/CBO9780511809477.002
- Van Gog, T., & Jarodzka, H. (2013). Eye tracking as a tool to study and enhance cognitive and metacognitive processes in computer-based learning environments. In: R. Azevedo & V. Alevén (Eds.), *International handbook of metacognition and learning technologies* (pp. 143–156). New York, NY: Springer. doi.org/10.1007/978-1-4419-5546-3_10

The importance of high-level tasks in the access of statistical errors: A study with future teachers of the first years

Ana Caseiro, Ricardo Machado and Tiago Tempera

¹²³ Escola Superior de Educação do Instituto Politécnico de Lisboa, Portugal; anac@eselx.ipl.pt, rmachado@eselx.ipl.pt, tiagot@eselx.ipl.pt

Every day we deal with all sort of information presented in different ways. Thus, we need to be able to interpret and analyze that information. This research tends to understand the statistical knowledge of future teachers of the first years and to enlighten the importance of high-level tasks in the access of that knowledge. We assumed an interpretative paradigm and developed an action-research project. The participants were students of the 2nd year of Basic Education course (N=95) who were attending the curricular unit named Data Analysis and the four teacher/researchers who taught the classes. Data was collected through a statistical knowledge assessment instrument (at the beginning of the curricular unit), participant observation, and students' protocols. The results illustrate the importance of high-level tasks in the access of statistical errors in order to (re)construct statistical knowledge with meaning for the future teachers.

Keywords: statistical learning, pre-service teacher education, high-level tasks.

Introduction

Being a citizen became a complex and multifaceted task. Mathematical literacy, particularly statistical literacy, is essential to act as a critical and participative citizen. According to Wallman (1993), statistical literacy is “the ability to understand and critically evaluate statistical results that permeate our daily lives – coupled with the ability to appreciate the contributions that statistical thinking can make in public and private, professional and personal decisions” (p. 1). Thus, this argument highlights that statistical literacy deals with data in context, which is also stated by Watson (2006). Therefore, it is important that students must have a good preparation in learning of statistics being able to put in practice the (statistical) knowledge appropriated (Caseiro, Ponte, & Monteiro, 2015).

This research arises from the need to identify and to know the statistical knowledge that the students that enter the Degree in Basic Education of the Lisbon Higher School of Education reveal. This is of particular importance insofar as statistics enable the development of essential abilities and competencies in an increasingly technological society and, given the specificity of this higher education course, to train future teachers of the first years, which constitutes a unique opportunity for change. In this way, the problem that originated this investigation is related to the little statistical knowledge that the students of the course of the Degree in Basic Education reveal at the beginning of their higher education. The research questions that emerge from this problem and which we addressed in this article are: (1) What statistical knowledge do the students of the Basic Education Degree course reveal at the beginning in the curricular unit Data Analysis?; and (2) In what way do the mathematical tasks proposed, helps us to detect students' difficulties?

Mathematical tasks

According to NCTM (2007), students should be active constructors of mathematical knowledge and teachers should be facilitators of students' learning by providing learning experiences in which students can engage in mathematical tasks given meaning to the (mathematical) knowledge and developed abilities and competencies (e.g. mathematical reasoning, mathematical communication, critical sense, among others). But for that, the nature of mathematical tasks should be different from the usual one (exercises), as well as the working instructions and the way these same tasks are explored in the class (Stein, Grover & Henningsen, 1996). Boston and Wolf (2006) state that the nature of the tasks influence students' learning and the way they engage with mathematical work itself. In other words, "different types of tasks provide different opportunities for students' learning and place different expectations on students' thinking" (Boston & Wolf, 2006, p. 7).

Stein and his colleagues (1996) categorised the nature of the tasks according the level of cognitive demand: between low and high-level. A task with low-level of cognitive demand is associated with the memorization and/or application of procedures without attribution of meaning. Thus, it approaches what Skemp (1978) called instrumental knowledge since that the students are only able to apply rules, formulas or algorithms and they are not able to mobilize this knowledge when they are in other contexts or situations. A task with high-level of cognitive demand is characterised by creating opportunities for students to make connections between (mathematical) concepts and its different representations, to allow different approaches for the same task according to the previous (mathematical) knowledge appropriated by each students, and creating opportunities for mathematical communication (Boston & Wolf, 2006; Stein et al., 1996). Thus, according to Skemp (1978) it corresponds to the relational knowledge. In this way, it is up to the teacher to select, adapt and/or elaborate tasks with different natures regarding students' characteristics, interests and needs (Machado & César, 2013).

The error and the way in which it is faced by the students and teachers assume an important element in the learning process. As stated by Abrantes, Serrazina and Oliveira (1999), when we think in terms of learning, making errors or saying things imperfectly or incompletely is not to be avoid, it is something inherent in the learning process. Therefore, it is important to provide opportunities in which students engage in mathematical tasks that cast doubt on what they took for granted.

Dimensions of statistical work

Franklin and her colleagues (2007) stated that a statistical investigation is characterised by four steps: (1) posing a question; (2) collecting data; (3) analysing data; and (4) interpreting the results. Kader and Perry (1994) suggest an additional step which is related with the dissemination of the results.

According to Shaugnessy (2007) all the steps of investigative cycle are essential in statistical work and recall the four stages of solving mathematical problems presented by Pólya (1945/1973): to understand, to plan, to execute and to review. This author also states that teachers give little time to the problem and to the plan steps. Most students are only taught "pre-statistical" topics, in which the hard decision concerning the problem formulation, conception and production of data are already done for them. This situation makes the investigative cycle poorer (Shaugnessy, 2007).

The knowledge in Statistics of the future teachers

Statistical investigations give students the opportunity to reflect on the information that surrounds them, to develop statistical literacy and to appropriate of statistical knowledge and the knowledge about the stages of the process (Martins & Ponte, 2010).

Some studies point out the difficulty of future teachers in carrying out statistical investigations. Stohl (2005) even mentions that the future teachers of the first years make elementary errors in statistical concepts, similar to those of the students themselves at these levels of education. At the level of statistical work, Heaton and Mickelson (2002) reveal the difficulty of the future teachers in accomplishing the data collection process, not recognizing the need to create a standard unit of measure to standardize the data.

In the representation of data and interpretation of graphs, Espinel, Bruno and Plasencia (2008) conclude that the future teachers involved in their study demonstrate difficulties in the interpretation of graphs and in the selection of graphs suitable for the representation of the information. At a more specific level, they demonstrate difficulty in differentiating quantitative and qualitative variables, which translates into the difficulty of distinguishing between a bar chart and a histogram.

In the dimension of the central tendency measures, Burrill (2008) states that the future teachers demonstrate difficulties in adapting the graphical representations to the different existing measures, opting for an incorrect representation, almost always through bar graphs.

Method

This study is part of the project “Statistical knowledge of students of primary and secondary levels of education and of students of the Basic Education course of the Lisbon Higher School of Education”, whose main goals are: (1) to access the statistical knowledge of students throughout their education and those that integrate, for the first time, the Basic Education graduation; and (2) to analyse the path carried out by the future teachers, in terms of the development of statistical knowledge, during the accomplishment of the mentioned degree.

When entering the Basic Education Degree, at the Lisbon Higher School of Education, the Data Analysis is the first and only curricular unit that students have in the field of Statistics and it appears in the 1st semester of the 2nd year of the cycle of studies. Thus, when students attend this curricular unit they reveal difficulties in working with certain statistical knowledge, especially at the beginning of the course. In this way, the problem that originated this investigation is related to the little statistical knowledge that the students of the course of the Degree in Basic Education reveal in the beginning of their higher education. The research questions that emerge from this problem and which we address in this paper are: (1) What statistical knowledge do the students of the Basic Education Degree course reveal at the beginning in the course unit Data Analysis?; and (2) In what way do the mathematical tasks proposed, helps us to detect students’ difficulties?

We assumed an interpretative approach (Denzin, 2002) and developed an action-research project (Mason, 2002). The participants in this study were all students in the 2nd year of the Basic Education course (N=95, 2017/2018 academic year), who were attending the curricular unit named Data Analysis. The ages range from 18 to 37 years old. We also considered as participants the four teacher/researchers who taught the classes.

Data was collected through a statistical knowledge assessment instrument (at the beginning of the curricular unit), participant observation, and students' protocols. Such data was then treated and analysed through a narrative content analysis (Clandinin & Connelly, 1998), performed in a successive and in-depth way.

Results

The task

The task presented to the students (Figure 1) was intended, along with other instruments applied, to make a diagnosis of the statistical knowledge with which students of the Basic Education course starts their higher education. In order to allow students to reveal the maximum of their knowledge, the variables chosen for the proposal were thought of in order to contemplate the different types of statistical variables. In this way, this task is considered high-level of cognitive demand (Boston & Wolf, 2006; Stein et al., 1996), since the students are required to make connections to underlying mathematical ideas, with the possibility of using several strategies and representations. If this task was limited to engaging students in using a defined procedure (e.g. a direct question: what is the mean of the following data?), the students would not be so confident and could give up on the task. This situation would not facilitate the teachers' access to students' statistical knowledge.

1. Collect the following data from five colleagues who have not been in your work group:			
Gender	Age (in years)	Date of Birth	Height
Eye color	Shoes number	Hand palm (in cm)	Name of a public figure (artist/politician/writer/...)
Number of glasses of water you drink per day	Birth place (village/town and country)	If you recicle (paper/glass/plastic)	Means of transport you use to go to school
Estimate time you spend on coming to school	TV Program/series you usually watch	Average daily time spent watching TV	Name of one of your favorite TV news presenters
If you have driver license	Average daily time spent reading newspapers / magazines	Average time to get ready when you wake up	On a scale of 1 to 5 (1 bad environment) give your opinion about the environment among students
2. Now that you have your data, arrange and organize it so, in order to convey to the class a close idea of the obtained results.			

Figure 1: Mathematical task statement

Students' performances

Throughout our observation of the work of the groups it was possible to verify the inexistence of any kind of planning or organization from them. As soon as they received the task, practically all members of the groups got up and started collecting data with their colleagues, showing that they did not bestow importance to this phase of statistical research, as pointed out by Shaugnassy (2007). However, this situation is usual to happen if the students did not have this experience, during their academic path. As might be expected, this aspect was perceived by some students when organizing the data and later by others, during their discussion in a large group. An example of the lack of planning of the groups concerns how they have collected data on the size of their colleagues' hand palms. It was apparent that different elements of the same group were collecting this data in a different way: while some measured the hands of their colleagues when they sit with the hand as stretched as possible, others did not take that aspect into consideration and others measured the base of the hand instead of the

palm, as requested. Another aspect in which the lack of planning was evident relates to the fact that some members of the same group have collected data with the same colleagues.

On the other hand, the way students decided to represent the data collected also revealed some difficulties in the construction of statistical representations, as well as the non-attribution of meaning to the value of statistical measures determined by them.

Regarding continuous quantitative variables, a common error concerns the use of a bar chart to represent the data instead of the use of a histogram. As can be seen from the example in Figure 2, some students decided to construct a bar chart to represent the heights of the colleagues. In addition to this situation, the representation of the intervals in which the students decided to present the data demonstrates a difficulty on the part of the students, since, as it is visible in the given example, they put the same value of the data in two different intervals, not being able to perceive in which it was actually counted.

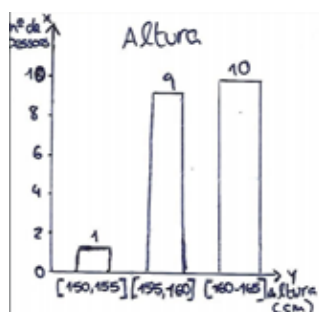


Figure 2: Performance of a Group A1

Nevertheless, the opposite also happens, that is, the students construct histograms with data of nominal qualitative variables (Figure 3), as that is the case of the place of birth.

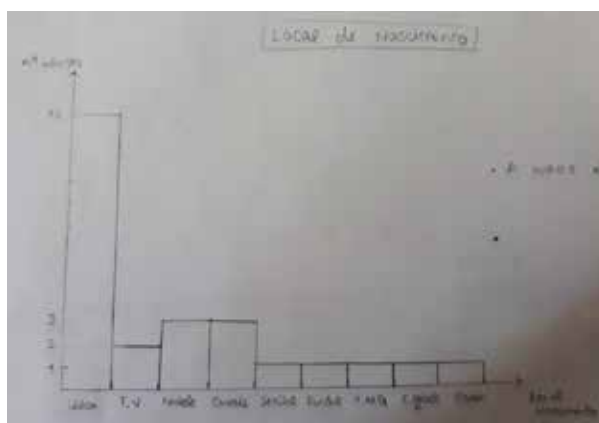


Figure 3: Performance of a Group C1

This error (construction of histograms and bar graphs as if the same representation were and independently of the type of variable) was demonstrated by several students, which seems to be related to the fact that the students assume that any graphical representation with bars is a bar chart.

Another detected situation concerns the construction of pictograms with discrete quantitative variables data. As can be seen in the example on Figure 4, students showed some difficulty in realizing which values should appear on the pictogram axis and which values should be represented with the

symbol chosen for the pictogram. Thus, in the example presented, the group decided to put in the axis the frequencies with which the data appeared and to represent, with the chosen symbol, the number of glasses of water drunk daily, mentioned by the colleagues. In short, students had shown some difficulties in the choice of the adequate graph representation, which is in line with Batanero, Godino, Vallecillos, Green, and Holmes (1994).

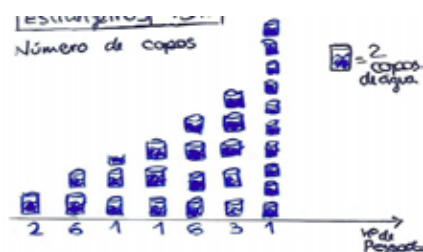


Figure 4: Performance of Group A2

On the other hand, through the example shown in Figure 5 it is possible to verify the non-attribution of meaning to the value of statistical measures by these students. In the presented example, the group decided, after constructing a pie chart, to determine the Mode, Mean, and Standard Deviation of the Eye Color variable data. As a nominal qualitative variable, it would be expected that students, even if they performed the calculations to determine the latter two statistical measures, find that the values obtained would not make any sense for the variable under study. In this way, students revealed knowledge in calculating the Mean and Standard Deviation of statistical variables, but were not able to give meaning to the values obtained, which means that they can only mobilize instrumental and non-relational knowledge (Skemp, 1978), as would be desired.

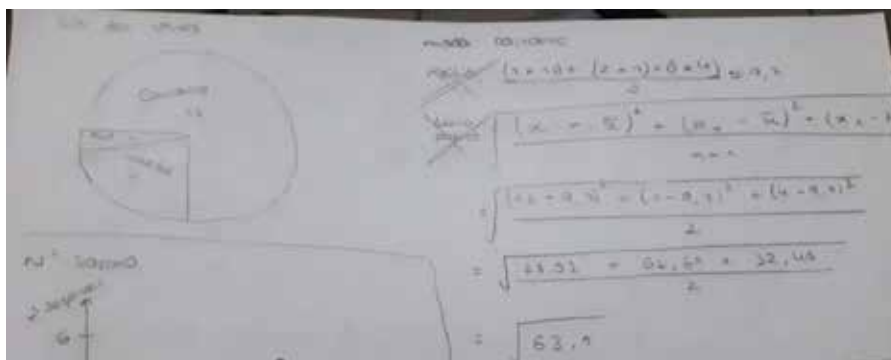


Figure 5: Performance of Group B2

Final Remarks

The analysis shows that students who entered in higher education, in this specific case, in a course for teachers of the first years, reveal lack of knowledge and difficulties in terms of procedures, representations and attribution of meanings to statistical measures.

Regarding statistical procedures, the students' lack of knowledge was evidenced when they did not give importance of carrying out a work plan before collecting data. This aspect seems to be in agreement with what is mentioned by Shaughnessy (2007). On the other hand, the students' difficulty in selecting the most adequate statistical representation to use in relation to a particular type of variable may also be associated with this aspect. But, at the same time, most tasks ask students to

construct a specific representation, which does not allow them to think about which is the most appropriate and advantageous to use in each situation. Also in relation to the difficulties presented in the construction of pictograms with data of discrete quantitative variables, it is possible to notice that, since most of the tasks students are used to do already show parts of the constructed representations, such as the axes in a graph, it limits the experience of the construction of a graph from scratch. Finally, the fact that students calculate statistical measures without analyzing their relevance to the type of variable under study seems to be associated with a mechanized teaching of formulas, which students know without hesitation, but which they can't attribute any meaning.

In this way, this work shows the importance of performing high-level tasks not only for the development of students' statistical knowledge but also for the detection of their errors and difficulties so that we, as teachers, can adjust our classes and, more specifically, the tasks to be proposed, not to what we suppose students need to develop and learn, but to what we concretely know they need.

This paper is part of the Project *O conhecimento estatístico dos/as estudantes do ensino básico, secundário e da Licenciatura em Educação Básica da Escola Superior de Educação de Lisboa* funded by CIED (ESELX/IPL-CIED/2018/A27).

References

- Abrantes, P., Serrazina, L., & Oliveira, I. (1999). *A matemática na educação básica*. Lisboa: ME/DEB.
- Batanero, C., Godino, J. D., Vallecillos, A., Green, D. R., & Holmes, P. (1994). Errors and difficulties in understanding elementary statistical concepts. *International Journal of Mathematics Education in Science and Technology*, 25(4), 527–547.
- Boston, M., & Wolf, M. K. (2006). *Assessing academic rigor in mathematics instruction: The development of the instructional quality assessment toolkit*. CSE Technical Report 672 (No. 672). Los Angeles, CA: National Center for Research on Evaluation, Standards, and Student Testing (CRESST).
- Burrill, G. (2008). Fundamental ideias in teaching statistics and how they affect the training of teachers. In C. Batanero, G. Burrill, C. Reading, & A. Rossman (Eds.), *Proceedings of the ICMI Study 18 and 2008 IASE Round Table Conference*. Monterrey, Mexico.
- Caseiro, A., Ponte, J. P., & Monteiro, C. (2015). Elementary teacher practice in project work involving statistics. In K. Krainer, & N. Vondrová (Eds.), *Proceedings of the Ninth Congress of the European Society for Research in Mathematics Education* (pp. 2995–3001). Prague: Charles University, Faculty of Education & ERME.
- Clandinin, D. J., & Connelly, F. M. (1998). Personal experience methods. In N. K. Denzin, & Y. S. Lincoln (Eds.), *Collecting and interpreting qualitative materials* (pp. 150–178). Thousand Oaks: Sage Publications.
- Denzin, N. K. (2002). The interpretative process. In A. Haberman, & M. Miles (Eds.), *The qualitative researchers companion* (pp. 349–366). Thousand Oaks: Sage Publications.

- Espinel, M. C., Bruno, A., & Plasencia, I. (2008). Statistical graphs in the training of teachers. In C. Batanero, G. Burrill, C. Reading, & A. Rossman (Eds.), *Proceedings of the ICMI Study 18 and 2008 IASE Round Table Conference*. Monterrey, Mexico.
- Franklin, C., Kader, G., Mewborn, D., Moreno, J., Peck, R., Perry, M., & Scheaffer, R. (2007). *Guidelines for assessment and instruction in statistics education (GAISE) report: A preK-12 curriculum Framework*. Alexandria, VA: American Statistical Association.
- Heaton, R. M., & Mickelson, W. T. (2002). The learning and teaching of statistical investigation in teaching and teacher education. *Journal of Mathematics Teacher Education*, 5(1), 35–59.
- Kader, G., & Perry, M. (1994). Learning statistics with technology. *Mathematics Teaching in the Middle School*, 1(2), 130-136.
- Machado, R., & César, M. (2013). Diversity, dialogism and mathematics learning: Social representations in action. In B. Ubuz, Ç. Haser, & M. A. Mariotti (Eds.), *Proceedings of the Eighteenth Congress of the European Society for Research in Mathematics Education* (pp. 1764–1773). Ankara: Middle East Technical University.
- Martins, M. E., & Ponte, J. P. (2010). *Organização e tratamento de dados*. Lisboa: ME/DGIDC.
- Mason, J. (2002). *Researching your own practice: The discipline of noticing*. London: Rand Falmer.
- National Council of Teachers of Mathematics (NCTM) (2007). *Princípios e normas para a matemática escolar* (M. Melo, Trans.). Lisboa: APM.
- Pólya, G. (1945/1973). *How to solve it* (2nd ed.). Princeton: Princeton University Press. [Original published in English, in 1945]
- Shaugnessy, J. M. (2007). *Research on students' understanding of some big concepts. Thinking and reasoning with data and chance* (68th Yearbook). Reston: VA: NCTM.
- Stein, M. K., Grover, B. W., & Henningsen, M. (1996). Building student capacity for mathematical thinking and reasoning: An analysis of mathematical tasks used in reform classrooms. *American Educational Research Journal*, 33(2), 455–488.
- Stohl, H. (2005). Probability in teacher education and development. In G. Jones (Ed.). *Exploring probability in schools: Challenges for teaching and learning* (pp. 345–366). New York: Springer.
- Skemp, R. R. (1978). *Relational understanding and instrumental understanding*. *Arithmetic teacher*, Novembre, 9–15.
- Wallman, K. K. (1993). Enhancing statistical literacy: Enriching our society. *Journal of the American Statistical Association*, 88(421), 1–8.
- Watson, J. (2006). *Statistical literacy at school: Growth and goals*. Mahwah, NJ: Lawrence Erlbaum Associates.

Design principles for short informal statistical inferences activities for primary education

Arjen de Vetten¹, Aisling Leavy² and Ronald Keijzer³

¹Leiden University, Leiden, The Netherlands; a.j.de.vetten@fsw.leidenuniv.nl

²Mary Immaculate College, University of Limerick, Limerick, Ireland; aisling.leavy@mic.ul.ie

³University of Applied Sciences iPabo, Amsterdam, The Netherlands, r.keijzer@ipabo.nl

This paper presents the following set of eight design principles for informal statistics inference (ISI) education for upper primary education in settings where limited time is available for ISI: Create awareness of inferential claims before engaging students in ISI via statistical investigations; use a context for which the students have no clear expectations of the outcome or which challenges current beliefs; use a question that highlights the need for an inferential claim; use a large population that makes sampling inevitable; use activities with tangible populations and samples in which generating representative samples and recording data is easy and quick; use data that require little descriptive analyses; and use the principles of growing samples and repeated sampling in order to create sampling variability. Three exemplar ISI activities illustrate how the design principles can be used to design new ISI activities and evaluate existing ISI activities.

Keywords: Primary education, informal inferential reasoning, informal statistical inference, statistics education.

Introduction

An introduction to informal statistical inference (ISI) in primary education has been advocated by various researchers (Makar, 2016; Makar, Bakker, & Ben-Zvi, 2011). The literature provides examples of activities that introduce ISI in upper primary education (De Vetten, Schoonenboom, Keijzer, & Van Oers, 2018a; Kazak, Pratt, & Gökce, 2018; Leavy, 2009). While design principles for statistics education in general are available (Ben-Zvi, Gravemeijer, & Ainley, 2018), the literature does not report on a comprehensive list of design principles for ISI education for upper primary education. The aim of this paper is to bring together a set of design principles that have been reported in the literature alongside design principles that are distilled from recent research with primary pre-service teachers (De Vetten et al., 2018a; De Vetten, Schoonenboom, Keijzer, & Van Oers, 2019) with a view to generate design principles that apply to upper primary education. The design principles presented in this paper can be used for the design of ISI activities that require relatively little time (e.g. up to an hour), but still allow for an introduction of all key concepts of ISI.

Theoretical background

ISI can be seen as part of the broader field of statistics. For statistics education in general, it is suggested to focus on developing central statistical ideas, to use real, or realistic, and motivating data, and to integrate the use of technological tools that allow students to explore and analyze data (Ben-Zvi et al., 2018). Most of these principles are useful also for ISI education in primary

education. The design principles we describe below therefore build on these principles. However, for eliciting IIR, these principles are not sufficiently specific.

A number of design principles have been targeted specifically towards ISI. First, activities where students are asked to make predictions about another or a larger sample based on the sample at hand, such as the growing samples heuristic (Bakker, 2004), appear to be an effective principle for activities that aim to engage students in IIR (Ben-Zvi et al., 2018; Makar, 2016). Some recent research involving pre-service teachers (De Vetten et al., 2019) and upper primary school students (Kazak et al., 2018) utilizing the growing sample design principle indicates mixed results. The participants used the data as evidence in making predictions of the shape of the distributions of larger samples and thus looked beyond the data. However, pre-service teachers also tended to neglect uncertainty and make deterministic predictions. Moreover, most predictions made of other samples mimic the shape of the original sample, thus suggesting that students did not have a picture in their mind of a sample distribution being the result of an overarching population distribution. Rather, they may have thought that the original sample “produces” the predicted sample. De Vetten et al. (2019) suggest that this could be due to the absence of repeated sampling elements in the activities used. Including such elements confronts students with different sample results, which may make them aware that an inference based on one sample includes some uncertainty.

A second design principle for ISI activities is to have students compare two sample distributions and draw a conclusion about the difference between the means in the population (Zieffler, Garfield, delMas, & Reading, 2008). However, research evidence shows mixed results in terms of the success of eliciting IIR, due to a number of (contextual) factors. First, without proper teacher intervention, such tasks appear not to sufficiently stimulate students to engage in IIR (De Vetten et al., 2019; De Vetten, Schoonenboom, Keijzer, & Van Oers, in press; Pfannkuch, 2006), and, in our research, pre-service teachers tend to restrict their attention to descriptive analyses. Another factor that may contribute to the absence of IIR in activities where students compare two distributions (De Vetten et al., 2019, in press; Pfannkuch, 2006) was that these activities did not involve repeated sampling, thereby missing the opportunity to view sampling variability. Third, while the sample distributions are visible, the populations remain abstract. Finally, tasks that compare sample distributions require substantial time for the necessary descriptive analyses, which goes at the expense of the available time and energy for inferential reasoning (De Vetten et al., 2018a).

A third design principle is to use a modelling approach in which a population is modelled (often using software, such as Tinkerplots). Samples are drawn from this hypothetical population distribution in order to develop an appreciation for the likelihood of various sample outcomes and an understanding of sampling variability (Manor & Ben-Zvi, in press). This approach requires more time and puts demands on the computer skills of the teacher and the student, and may therefore be less suitable for general upper primary students in settings with limited time and support.

In sum, findings from recent studies points towards a number of conclusions regarding effective design principles for ISI education and requirements for effective design principles: First, the use of growing samples and repeated sampling is recommended in order to create sampling variability and to show that usually larger samples reduce sampling variability and thus reduce the uncertainty of

the inference. Second, it appears to be important to make students aware of the distinction between sample and population and when an activity requires a generalization beyond the data. Third, an overemphasis on descriptive analyses, arising from activities involving the comparison of sample distributions, may reduce the opportunity to engage in IIR. Fourth, in many primary school settings with limited available time and support the extensive use of technological tools may not be feasible.

Design principles

Using the above conclusions about (requirements for) effective design principles for statistics education in general and ISI education in particular we formulated eight principles for the design of ISI activities for primary education.

In particular, seven of these design principles are specifications of how statistical investigations activities should look like when the goal is to introduce students to ISI. The first design principle stands apart as it is undertaken prior to students being actively involved in conducting statistical investigations.

1. Create awareness of inferential claims and of the distinction between sample and population, before engaging students in ISI via statistical investigations

De Vetten et al. (2019) and De Vetten et al. (in press) showed that most pre-service teachers appear to only describe the data, rather than engage in IIR. In De Vetten et al. (2018a) we first engaged pre-service teachers in an activity that was designed to make them aware of the existence and use of inferential claims. This activity appeared to promote an awareness of inference. Throughout the intervention the participants retained this awareness.

2. Use a context for which the students have no clear expectations of the outcome, or for which the outcome challenges students' current beliefs.

When the outcome is unpredictable or challenges students' current beliefs, students are stimulated to engage in inferential investigations and to search for explanations (Makar et al., 2011). When the outcome is predictable students may not engage in critical IIR (see for an example De Vetten et al., 2018a).

3. Use a question that clearly highlights that an inferential claim is required and use a population with a sufficiently large number of elements that surveying the entire population is impossible within a limited time frame.

The question posed should lead the student to conclude that merely analyzing the sample data descriptively is insufficient. However, even when considerable care is taken to formulate a good inferential question (e.g. using the guidelines from Pfannkuch, Regan, Wild, & Horton, 2010), other factors may cause students to restrict their attention to descriptive analyses (De Vetten et al., 2019). Therefore, combining a tangible population (see principle 6) with a population that consists of too many elements to survey in its entirety makes drawing a sample natural and generalization inevitable (De Vetten et al., 2018a).

4. Use activities that support the generation of a representative sample and that stimulate critical reflection on the representativeness of the sample.

The effect of this principle is that students may be willing to accept the sample data as reliable evidence for making inferential claims. In case an ISI activity does not permit students to draw representative samples, but only non-representative ones (such as convenience samples from their own class), students may be reluctant to engage in IIR because generalization based on such non-representative samples is not possible anyway. Ideally, the activity is such that it is possible to draw both representative and non-representative samples, with the effect that discussions are elicited about ways to draw a representative sample.

5. Use activities in which generating samples and recording data is easy and quick and in which students preferably collect data themselves.

The effect of this design principle is that an excessive focus on data collection is avoided. At the same time, the data generation and recording process should allow students to make sense of the data and should facilitate mathematization (Treffers, 1987) and engagement in IIR. Therefore, it is preferable that students collect their own data.

6. Use activities with a tangible population and sample.

The effect of this design principle is that students remain aware of the distinction between sample and population and that they are required to make a claim that pertains to the entire population.

7. Use data that require little descriptive analyses.

In the PPDAC-cycle, data analyses comes before interpretation of the results, including making inferences (Wild & Pfannkuch, 1999). Spending too much time on descriptive analyses of the sample data leaves little time and energy for inferential reasoning (De Vetten et al., 2019; Leavy, 2009). The effect of this design principle may be that sufficient time, energy and attention is left for IIR, while at the same time engagement in descriptive analyses helps students to make sense of the results and facilitates further mathematization (De Vetten et al., 2018a).

8. Use the principles of growing samples and repeated sampling in order to create sampling variability.

The effect of using the principle of repeated sampling is that students will consider the uncertainty of their inferences, because sample results will vary (Saldanha & Thompson, 2002). The effect of using the principle of growing samples is that students will see that larger samples usually reduce sampling variability and thus reduce the uncertainty of the inference (Bakker, 2004).

Applying the ISI design principles – Three example activities

This section describes three ISI activities and how the design principles can be used to design new ISI activities and evaluate existing ISI activities. The first activity was designed with the design principles in mind, while the second and third were not. We evaluate the extent to which they are in line with the design principles.

Activity 1: What is the most frequently used word?

The first activity (De Vetten et al., 2018a; De Vetten, Schoonenboom, Keijzer, & Van Oers, 2018b) was implemented in two settings: in a class of second-year pre-service primary school teachers and

in three primary classrooms (grade 3, 5 and 6). The activity centers round a pile of children's novels, that constitutes a population, and the question "Which word is most frequently used in this pile of novels?" First, students make a list of the top 5 words they think are most frequently used in the pile of books. Next, students discuss how to find out which is the most frequently used word. Taking a sample is the expected response. The sampling procedure is discussed. Small groups of students draw small samples and then pool their results in multiple large samples. The inferences for small and large samples are compared. In this way, it could be shown that the proportion that yields the same most frequently used word is greater for large samples than for small samples. If the proportion of samples with the same most frequently used word is high, students could be willing to accept the possibility of making uncertain inferences based on one sample.

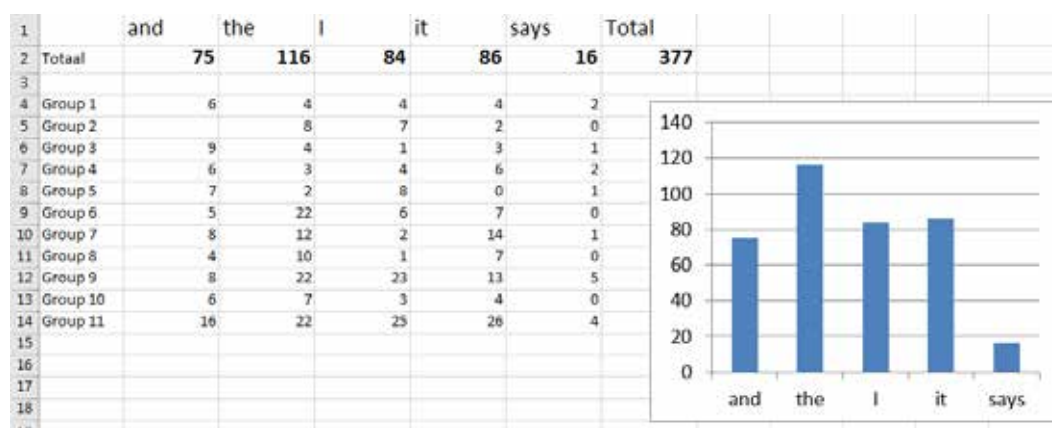


Figure 1: Pooled sample results in the activity "What is the most frequently used word?"

This activity was designed with the design principles in mind and it aligns well with all but one of the design principles. The activity is clearly inferential and uses a tangible and large population and visible sample (design principles [DP] 3 and 6). It requires that students consider how to take a representative sample and it allows for generating a representative sample (DP 4). Students take a book from the pile and count the occurrence of the top 5 words on a number of lines or a page, making sampling, recording and analyzing simple (DP 5 and 7). Without the need to rely on technological tools growing samples and repeated sampling can be achieved by having individual students draw samples and by combining students' samples (DP 8). The number of students may, however, limit the possibilities for repeated sampling for larger samples. Our research shows that pre-service and primary school students were engaged in inferential reasoning (De Vetten et al., 2018a, 2018b). However, the activity included repeated sampling only for smaller samples. It thus missed the opportunity for students to see the sample results converge for larger samples. Repeated sampling for various sample sizes appears crucial to teach students to balance between sampling representativeness and sampling variability. Finally, the activity might not completely align with DP 2, because students may have beliefs about the outcome, based on information they have about word frequency in books in general (De Vetten et al., 2018a).

Activity 2: How many yellow balls are in the Black Box?

The activity "How many yellow balls are in the Black box?" (Van Dijke, Drijvers, & Bakker, 2018) was implemented in a grade 9 pre-university secondary classroom. The activity has students

investigate and estimate the number of yellow balls in a black box, filled with a mix of 1,000 yellow and orange balls, by looking through a small viewing window. It is expected that students will shake the bottle in order to take samples repeatedly and that they will use the average of their sample as an estimate. Findings are recorded and discussed by students as part of a whole class discussion. Following this, a larger viewing window is opened on the black bottle, the experiment repeated, and findings recorded. The contention is that experiences with the physical black box experiment support the development of an informal understanding of samples and sampling variability and promote investigation of the effect of repeated samples and larger sample size.

While this activity was not designed based on the list of design principles presented in this paper and its effects on students' reasoning has not yet been reported, it appears to align well with the principles. As the number of yellow balls is determined by the educational designer, students cannot have any expectations of the outcome (DP2). Generalization is natural, as it is obvious that the sample results are only a means to make a claim about the population (DP 3). It has a visible and large population and a visible sample (DP 3 and 6). It is easy to obtain a representative sample as yellow and orange balls are mixed and shaking the bottle results in a random sample. Since obtaining a non-representative sample appears to be hard in this activity, it might not stimulate critical reflection on sample representativeness. However, sampling variation may lead to discussing representativeness (DP 4). The context, question, sampling, recording and analyzing are simple (DP 5 and 7). Repeated sampling is achieved by repeatedly shaking the bottle and counting the yellow balls and by combining small group results in a whole class graph, while growing samples is possible by enlarging the viewing window from 40 to 80 balls (DP 8).



Figure 2: Black box, used in the activity “How many yellow balls are in the Black Box?”

Activity 3: Comparing math attitude of men and women

This activity is a standard activity in which students are asked to compare two samples and draw a conclusion whether in the population the groups differ (see for example De Vetten et al., 2019; De Vetten et al., in press). One example of such an activity is shown below, where the activity also involves a growing samples activity. It was implemented and evaluated in three groups of first-year pre-service primary school teachers (De Vetten et al., 2019). The driving question was whether in the population there is a difference in math attitude between men and women. During three rounds the students answer this question and make predictions of the shape of the distributions of larger samples.

This activity was not well-aligned with a number of design principles, in particular with the visibility of the population (DP 6), the simplicity of the analyses (DP 7), and the possibilities for repeated sampling (DP 8). Indeed, we showed among the pre-service teachers engaged in this activity, there was a strong tendency to restrict attention to descriptive analyses, rather than to engage in inferential reasoning (De Vetten et al., 2019). The teacher also had strong ideas of the difference between the groups in the population and, therefore, some had problems treating the data as evidence (DP 2). We also contend that, when the population elements are humans, it may be complex to obtain a representative sample, thus leading students to put less trust in the sample and reducing their willingness to make generalizations (DP 4 and 5). On the positive side, the complexity of the sampling process stimulates critical reflection on sample representativeness (DP 5) and the immensity of the population encourages students to take a sample (DP 3). Although the design principles offer suggestions to improve this activity, in particular using repeated sampling, some elements, such as a visible population from which it is easy to generate a representative sample, might not easily be rectified.

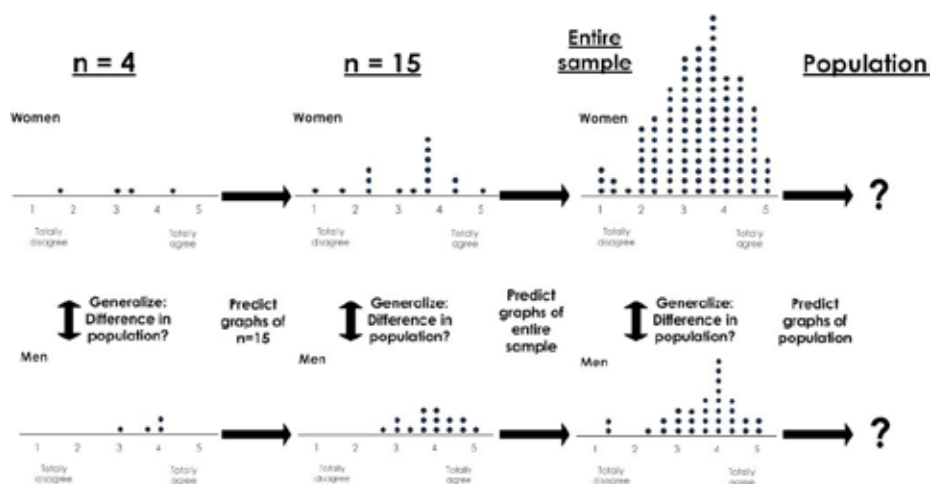


Figure 3: Overview of the activity “Comparing math attitude of men and women”

Conclusion

Designing ISI activities for primary education that align with all the design principles is not straightforward, as it demands very good knowledge of ISI and educational design. We have suggested two activities that to a large extent align with the design principles. Teachers can effectively use these activities in their classrooms. The design principles can also be used by educational designers to align their own activities with the design principles and elicit IIR more effectively. For example, the activity in which two samples are compared could incorporate repeated sampling, and the averages and measure(s) of dispersion could be provided, so that more time can be spent on IIR. Some of the design principles for ISI education presented in this paper are well-known and have been reported before, but some are based on recent ISI education research. In this way, we aim to provide a comprehensive set of design principles, based on recent evidence, that can be useful for educational designers and are ready to be corroborated by future research. Moreover, the principles are potentially applicable beyond the primary education (teacher) setting, to other settings where the design for activities is necessary when first introducing students to ISI.

References

- Bakker, A. (2004). *Design research in statistics education: On symbolizing and computer tools*. Utrecht, the Netherlands: CD-β Press.
- Ben-Zvi, D., Gravemeijer, K., & Ainley, J. (2018). Design of statistics learning environments. In D. Ben-Zvi, K. Makar, & J. Garfield (Eds.), *International handbook of research in statistics education* (pp. 473–502). Cham, Switzerland: Springer.
- De Vetten, A., Schoonenboom, J., Keijzer, R., & Van Oers, B. (2018a). The development of informal statistical inference content knowledge of pre-service primary school teachers during a teacher college intervention. *Educational Studies in Mathematics*, 99(2), 217–234. doi:10.1007/s10649-018-9823-6
- De Vetten, A., Schoonenboom, J., Keijzer, R., & Van Oers, B. (2018b). *Knowledge in action. The informal statistical inference content knowledge of three pre-service teachers while teaching ISI in upper-primary school*. Manuscript in preparation.
- De Vetten, A., Schoonenboom, J., Keijzer, R., & Van Oers, B. (2019). Pre-service teachers and informal statistical inference: Exploring their reasoning during a growing samples activity. In G. Burrill & D. Ben-Zvi (Eds.), *Topics and trends in current statistics education research: International perspectives*. New York, NY: Springer.
- De Vetten, A., Schoonenboom, J., Keijzer, R., & Van Oers, B. (in press). Pre-service primary school teachers' knowledge of informal statistical inference. *Journal of Mathematics Teacher Education*. doi:10.1007/s10857-018-9403-9
- Kazak, S., Pratt, D., & Gökce, R. (2018). Sixth grade students' emerging practices of data modelling. *ZDM*. doi:10.1007/s11858-018-0988-3
- Leavy, A. M. (2009). *Insights into Informal Inferential Reasoning in the Primary Classroom*. Paper presented at the 57th session of the International Statistical Institute, Durban, South Africa.
- Makar, K. (2016). Developing young children's emergent inferential practices in statistics. *Mathematical Thinking and Learning*, 18(1), 1–24.
- Makar, K., Bakker, A., & Ben-Zvi, D. (2011). The reasoning behind informal statistical inference. *Mathematical Thinking and Learning*, 13(1-2), 152–173.
- Manor, H., & Ben-Zvi, D. (in press). Design for reasoning with uncertainty in informal statistical inference. In G. Burrill & D. Ben-Zvi (Eds.), *Topics and trends in current statistis education research: international perspectives*. New York, NY: Springer.
- Pfannkuch, M. (2006). *Informal inferential reasoning*. Paper presented at the Seventh International Conference on Teaching Statistics, Salvador, Brazil.
- Pfannkuch, M., Regan, M., Wild, C., & Horton, N. J. (2010). Telling data stories: Essential dialogues for comparative reasoning. *Journal of statistics Education*, 18(1), 1–38.
- Saldanha, L., & Thompson, P. (2002). Conceptions of sample and their relationship to statistical inference. *Educational Studies in Mathematics*, 51(3), 257–270.
- Treffers, A. (1987). *Three dimensions: A model of goal and theory description in mathematics: The Wiskobas project*. Dordrecht, The Netherlands: Reidel.
- Van Dijke, M., Drijvers, P., & Bakker, A. (2018). *Repeated sampling as a step towards informal statistical inference*. Paper presented at the Tenth International Conference on Teaching Statistics (ICOTS10, July 2018), Kyoto, Japan.
- Wild, C. J., & Pfannkuch, M. (1999). Statistical thinking in empirical enquiry. *International Statistical Review*, 67(3), 223–248.
- Zieffler, A., Garfield, J., delMas, R., & Reading, C. (2008). A framework to support research on informal inferential reasoning. *Statistics Education Research Journal*, 7(2), 40–58.

Chilean primary school difficulties in building bar graphs

Daniilo Díaz-Levicoy and Pedro Arteaga

University of Granada, Spain; parteaga@ugr.es

Keywords: Bar graphs, building, difficulties, primary education.

Introduction and method

A relevant part of the information we face every day is given in statistical graphs, whose interpretation is often needed to make different decisions; therefore there is a need for citizens to achieve enough graphical competence. These reasons led countries like Chile to introduce statistical graphs in the primary education (MINEDUC, 2012).

In a previous study (Díaz-Levicoy, Batanero, Arteaga & Gea, 2016) bar graph were the most common representations in the Chilean curricular guidelines and textbooks. Consequently in this research we intended to assess the students' difficulties in building these graphs.

This research was aimed to identify the 6th and 7th grades Chilean school children's difficulties in the construction of bar graphs, which are recommended in the curricular guidelines and is the most frequently presented graphic in the Chilean textbooks.

To achieve this aim we analyzed the responses of 745 students, from 13 different educational centers and with an average age of 12.3 years to the task reproduced in Figure 1 in which students should form the frequency distribution of data.

Task. The following data result of a survey where children were asked for the number of brothers and sisters: **0, 1, 3, 2, 2, 3, 2, 4, 1, 2, 1, 2, 0, 2, 3, 1, 1, 0, 2, 4, 0, 1, 2, 3, 1, 1, 2, 2, 2**
Buid a bar graph that summarise this information

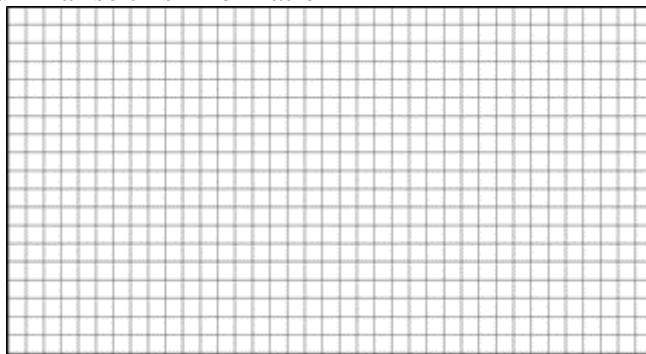


Figure 1: Task given to the students

Main results

We classified the students responses in correct, partly correct or incorrect according to the following criteria, following an inductive and cyclical process characteristic of content analysis and considering the results of previous studies:

- Correct responses correspond to bar graph that represent the data and use the criteria for these representations.
- In partly correct graphs there are minor errors, such as forgetting the general title, or using

bars with different distance between them.

- In incorrect graphs the representation of data make no sense.

Type of graph	6th (n=380)	7th (n=365)
Correct	4,7	7,9
Partly correct	40,3	44,1
Incorrect	31,3	17,8
Do not complete	23,7	30,1

Table 1: Percentage of students according their responses

Results are presented in Table 1, where there are no significant differences between both grades. Results are better than those reported by Bivar (2012) and worse than those by Fernandes, Morais & Lacaz (2011) and Evangelista, Oliveira & Ribeiro (2014) although in these last studies students did not need to form the distribution. The most frequent errors in our research were representing the list of data without forming the distribution (15.4% of students), non-proportional scales (13.7%), lack of titles or labels (34.6%) and bars with different width or separation (18.1%). Some students committed several of these errors. All these results suggest the need of reinforcing the teaching of graphs in Chilean basic education.

Results show the high difficulty, since only 50% of students produce correct or partially correct graphs. The differences between the two groups were not statistically significant. More details about the errors made by the students can be read in Díaz-Levicoy (2018).

Project EDU2016-74848-P and group FQM126 (Junta de Andalucía).

References

- Bivar, D. (2012). *Analisando a transformação entre gráficos e tabelas por alunos do 3º e 5º ano do Ensino Fundamental*. Tesis de Máster. Universidad Federal de Pernambuco, Brasil.
- Díaz-Levicoy, D. (2018). *Comprensión de gráficos estadísticos por alumnos chilenos de educación primaria*. Doctoral dissertation. University of Granada.
- Díaz-Levicoy, D., Batanero, C., Arteaga, P. & Gea, M.M. (2016). Gráficos estadísticos en libros de texto de educación primaria: un estudio comparativo entre España y Chile. *BOLEMA*, 30(55), 713-737.
- Evangelista, B., Oliveira, F.S. & Ribeiro, P.M. (2014). *Analisando a construção de gráficos de alunos do 5º ano do ensino fundamental*. En CONEDU (Ed.), *Anais I Congresso Nacional de Educação* (pp. 1-5). Campina Grande: Realize.
- Fernandes, J.A., Morais, P.C. & Lacaz, T.V.S. (2011). *Representação de dados através de gráficos estadísticos por alunos do 9º ano de escolaridade*. En R. Borba, C. Monteiro & A. Ruiz (Eds.), *Anais da XIII CIAEM* (pp. 1-13). Recife: UFPE.
- MINEDUC (2012). *Matemática educación básica. Bases curriculares*. Santiago: Unidad de Currículum y Evaluación.

How Realistic Mathematics Education approach influences 6th grade students' statistical thinking

Bedriye Doluzengin¹ and Sibel Kazak²

¹Pamukkale University, Denizli, Turkey; bedriyedoluzengin@gmail.com

²Pamukkale University, Denizli, Turkey; skazak@pau.edu.tr

Using Mooney's (2002) framework describing four levels of middle school students' statistical thinking across four different statistical thinking processes, this study aims to investigate the effectiveness of the use of Realistic Mathematics Education (RME) approach on 6th grade students' statistical thinking levels. A quasi-experimental with pretest-posttest comparison group research design was used. In the experimental group the unit on 'data handling and analyses' was taught using RME approach while in the control group it was taught traditionally using the textbook. The data analysis showed that although there was no statistically significant difference between the two groups with regard to their statistical thinking scores, the overall growth at Level 4 across statistical thinking processes was higher for the students who were taught using the RME approach than for those taught traditionally.

Keywords: Realistic mathematics education, statistical thinking, middle school students.

Introduction

We are surrounded by a huge amount of information in our daily lives and it is becoming more important to make sense of the information. To do so, individuals need higher order thinking skills such as questioning, making interpretation and estimation, drawing inference, critical thinking and reasoning. Curricular reforms emphasize these skills in students' learning. For example, the Turkish National Mathematics Curriculum (MEB, 2018) aims to develop students' understanding of mathematical concepts and their use in the daily life, reasoning skills in problems and ability to detect inadequate reasoning, metacognition, making mental calculations and estimations. Similarly, earlier in the Netherlands such reform aimed to change the education system which was based on memorizing (Van den Heuvel-Panhuizen, 1996). In 1971, Freudenthal and his colleagues laid the foundations of Realistic Mathematics Education (RME) with the aim of teaching the connection between real life and mathematics (Van den Heuvel-Panhuizen, 1996). For Freudenthal (1991), two key points in RME are: (1) mathematics should be close to students' everyday lives and (2) mathematics is a human activity.

In daily life, we encounter with various data on newspaper, television and social media. Statistical concepts enable us to make decisions and solve real-world problems using data. However, students' difficulties in learning of statistics and probability can hinder these. Some of the sources of these difficulties in Turkish middle school students appear to be the teaching of statistical concepts and procedures without connections, memorization rather than conceptual understanding, and learning without concrete examples (Çakmak & Durmuş, 2015). This implies that statistics must be relevant to students' experiences and real life situations. The use of RME approach in teaching can support making the statistical problem situation become real for students since the context plays an important role in statistics.

While there are studies on the effective use of RME in learning of other mathematical topics, such as percentages (Van den Heuvel-Panhuizen, 2003) and integers (Ünal Aydın & İpek, 2009), there is a scarce of research in teaching statistics using RME. Therefore, this study, which is part of the first author's master's thesis work, sought to examine the effectiveness of RME approach on 6th grade students' statistical thinking. The research questions addressed in this paper are: 1) Is there a significant difference in students' statistical thinking posttest scores using the RME approach compared to traditional method? 2) What are the students' thinking levels with respect to the statistical thinking processes before and after the intervention in each group?

Statistical thinking

Statistical thinking refers to comprehending the meaning of statistical concepts and understanding where, why and how they are used (Garfield & Ben-Zvi, 2008). That is, statistical thinking is not just calculating something or defining it. It is also about reasoning, making interpretations, predictions and inferences about data. Statistical thinking is important in solving a statistical problem about a real-world phenomenon through an inquiry cycle, called PPDAC (Problem-Plan-Data-Analysis-Conclusion) (Wild & Pfannkuch, 1999). The PPDAC cycle starts with understanding and defining a problem. Then what to measure and how to collect data are planned. Data collection phase is followed by analyzing data through looking for patterns and constructing tables and graphs. Finally, data are interpreted and conclusions are made and communicated.

To interpret middle school students' statistical thinking Mooney (2002) considers four statistical processes used in Jones et al.'s (2000) framework for elementary students: describing data (explicit reading of data presented in visual displays), organizing and reducing data (arranging, categorizing, and summarizing data using measures of center and spread), representing data (constructing visual display of data) and analyzing and interpreting data (identifying patterns in data and making inferences and predictions from the data). According to Mooney's refined framework, students' progress through four levels of thinking in each of these processes: Level 1-idiosyncratic, Level 2-transitional, Level 3-quantitative and Level 4-analytical. In Level 1, student shows no awareness of the given data; gives answers according to his/her own experiences or feelings; cannot use concepts correctly; and cannot read the given situations. In Level 2, student shows little awareness of the problem but it is still not sufficient; the solutions may contain partially correct answers. In Level 3, student shows full awareness of the problem; can correctly use concepts and formulas, and express what they mean and why they are used; can correctly see and explain the relationships between concepts; however his/her solutions or demonstrations may contain some errors. Besides, s/he can use different representations of a given data set and make transitions between them with small errors. In Level 4-analytical, students can do all procedures without any error. That is, s/he can read the given data fully, make connections, use these relationships and necessary computations correctly as well as explain how and why s/he uses them. In addition to these abilities, s/he can display the given dataset with various representations and make transitions between them without any error.

Using Mooney's framework, Koparan and Güven (2013) examined statistical thinking levels

of 90 Turkish middle school students. They found that 6th grade students' statistical thinking generally was at Level 1. For example, the proportions of students at Level 1 varied across four statistical thinking processes: 49,3% in describing data, 65,3% in organizing and reducing data, 74,2% in representing data, and 80,8% in analyzing and interpreting data. These results showed that almost half of the students had difficulties in reading of data contained in tables and graphs. Moreover, majority of them failed to both construct a complete and appropriate display of data and compare datasets and make inferences based on data.

Realistic mathematics education (RME)

Freudenthal's (1991) view of mathematics as a human activity indicates that knowledge becomes the individual's own knowledge only if s/he interacts with and discovers it. To do this, the individual should actively participate in learning situations and deeply understand the meanings of mathematical concepts and their usage. According to Freudenthal, learning mathematics takes place via mathematization, which refers to the process of experiencing the discovery of the mathematics concept. In RME, mathematization is essential; without it, the process of learning mathematics cannot be completed (Freudenthal, 1991). Freudenthal (1991) expresses two forms of mathematizing as follows: Horizontal mathematization is transition from real world to mathematics and the vertical mathematization is doing mathematics in its world. In this study we focus on horizontal mathematization which takes place when the student encounters a mathematical problem and s/he starts to solve it. In this process, student makes drawings, identifies patterns and so on to transfer the real world problem to mathematics.

According to Freudenthal (1991) to learn mathematics, the student actively participate in the process, experience the discovery of mathematical concepts, try to solve the problem, develop ways and then the knowledge becomes his/her own. The teacher guides students when they need. One of the most important parts of RME is the problem situation, which should be concept oriented and make students curious enough to solve the problem.

Method

To explore the effectiveness of RME approach on students' statistical thinking, a quasi-experimental with pretest-posttest comparison group research design was used since random assignment was not possible. The study was conducted in two intact 6th grade classes where the first author taught mathematics at a public school in Aydın, Turkey in the spring of 2018. In the experimental group (n=25), the unit on 'Data Handling and Analysis' was taught using RME approach while in the control group (n=24) it was taught traditionally using the textbook determined by the Ministry of Education. Both classes were taught over a three-week period.

Data Collection and Analysis

The instrument used in this study was the statistical thinking test with seven open-ended questions, some of which were adapted from Koparan and Güven (2013) while others were written by the authors. The questions were addressing the four statistical thinking processes: describing data (question 5), organizing and reducing data (questions 2 and 3), representing

data (questions 1 and 4), and analyzing and interpreting data (question 6 and 7). After experts' evaluation of the test items, it was piloted with 75 sixth graders (in other classrooms in the same school and the same school year as the research) to determine its reliability. The Cronbach's alpha coefficient of the test was found 0.76, which is considered acceptable (Baykul & Güzeller, 2014). Then, the test was administered in both groups to assess students' statistical thinking levels before and after the intervention.

Students' responses on pre- and posttests were coded by both authors and scored using the rubric developed based on Mooney's (2002) framework for statistical thinking levels. There was 88% consistency between two coders. Disagreements were discussed and consensus was reached. The independent samples t-test showed that there was no difference on statistical thinking pretest scores between the groups initially. In the posttest analysis, Mann Whitney U test was used to determine the difference between the groups since the control group data were not normally distributed. Also, descriptive statistics were used for the seven-item test to examine the change in students' thinking levels before and after the intervention.

Procedure and Tasks

In the control group, the 'Data Handling and Analysis' unit was taught with a traditional approach using the 6th grade mathematics textbook (Güven, 2014). The teacher followed the structure and order in the textbook and the problems given in the textbook were solved by the students. In the experimental group using the RME approach, both low and high ability students worked in small groups since both weaker and stronger students can benefit when working in heterogeneous groups (Freudenthal, 1991). Moreover, students first worked in groups and then the whole-class discussion of students' work took place. Ground rules for working together in groups were established with the students and implemented throughout the lessons. These were the rules to promote effective group work, such as "while someone is speaking, others must listen" and "in a group every member must work and help each other".

The Frog Olympics task was adapted from Kazak, Pratt and Gökce (2018) and implemented using the RME approach in the experimental group over eight class periods (each class period=40 minutes). The aim of the task was to create a problem situation that can be viewed real by the students as they engage in all four statistical thinking processes. In the activity students tried to determine which frog would be the best to go to the Olympics. First, students made two different origami frogs that could jump. Each group had one big frog and one small frog. The arithmetic means of these frogs' jumping distances were very close but the range values were not. Then the problem situation was introduced and the students were asked to determine the best jumping frog for the Olympics jumping race. Each group determined a start line and made each frog jumped 13 times on their desk. For each trial they measured the distance jumped and recorded the jumping distance in cm by rounding their measurement into the nearest integer. Next, groups were asked to make a frequency table and each group presented their data to the whole class. Then they were asked to make a graphical representation of the data, i.e. bar graph, using their frequency tables. By doing this, they were expected to make connections between different representations of a dataset. The following teaching episodes focused on analyzing data and making decision. Using their prior knowledge from the science classes, they calculated the range and mean of their datasets and

discussed together in their groups to decide which frog was better in jumping. Students already knew how to compute mean and range, but using them to compare two datasets was a new task for them. During the whole-class discussion, some groups thought that the small frog was better while some thought the big frog was better, and the teacher let them argue about their decisions. While groups were presenting their analysis and decisions, they had to explain why it was like that. Therefore, groups began to compare and contrast their ideas and a decision was made by a whole-class at the end of the discussion. In the next task, over the course of four class periods, the students were asked to collect data about their jump distances and record them during their physical education class. In the schoolyard, each group member jumped 13 times like frogs and another student measured the distance jumped. Then they made frequency tables and bar graphs of their data. As seen in the RME tasks students are expected to experience the whole statistical thinking process in PPDAC (Wild & Pfannkuch, 1999) while the textbook used in the control group puts more emphasis on calculations.

Findings

Before the intervention, independent samples t-test results showed no significant difference in the statistical thinking test scores for both groups ($t(47) = 0.18$ and $p=0.986$). In the posttest analysis, Mann Whitney U test indicated that although the mean rank of the experimental group (26.44) was higher than that of the control group (23.50), there was no statistically significant difference between the groups ($p=0.47$). Since the experimental group had the highest rank, descriptive statistical analysis was used to look closely for the changes in students' thinking levels with respect to the statistical thinking processes for each group.

Figure 1 shows the distribution of the experimental group students' statistical thinking levels for each question organized by the four statistical thinking processes on the pretest. Each column represents the item on the test and the statistical thinking process measured by that item. Colored sections of each column show the statistical levels of students and the number of students in each level for each question. For example, in Figure 1 the first column at the bottom shows the item on describing data (question 5) and there are 18 students at Level 1, 4 students at Level 2, 1 student at Level 3 and 2 students at Level 4.

According to Figure 1, before the intervention students in the experimental group mostly exhibited Level 1 thinking with regard to describing data (question 5), representing data (question 1 only) and analyzing and interpreting data (question 6 and 7). For organizing and reducing data (questions 2 and 3), they generally demonstrated Level 3 thinking. Only a few students exhibited Level 4 thinking overall. Similar to Koparan and Güven's (2013) findings, students' levels of thinking initially were generally at Level 1.

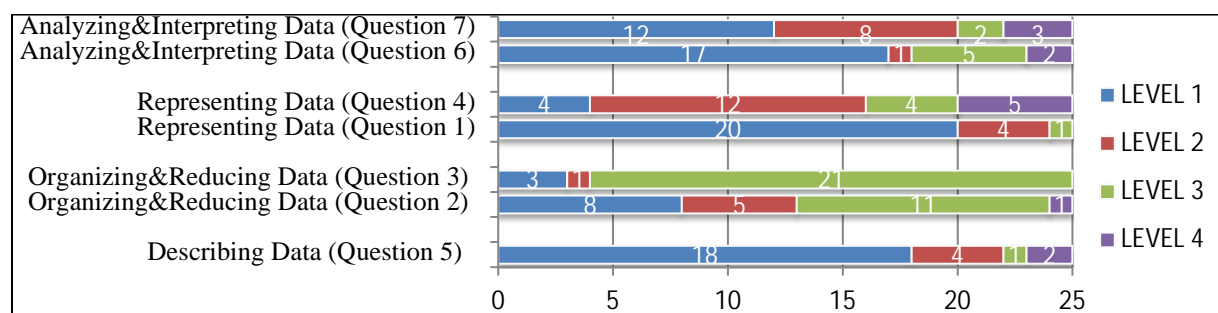


Figure 1: Experimental group students’ statistical thinking levels with respect to statistical thinking processes (by questions) on the pretest

Figure 2 shows the experimental group students’ statistical thinking levels on the posttest. Overall, most development was seen in students’ thinking levels with regard to representing data and organizing and reducing data as almost half of them were at Level 4. In addition, about half of the students demonstrated Level 3 or Level 4 thinking for analyzing and interpreting data. However, slightly more than half of the students still exhibited Level 1 thinking with regard to describing data.

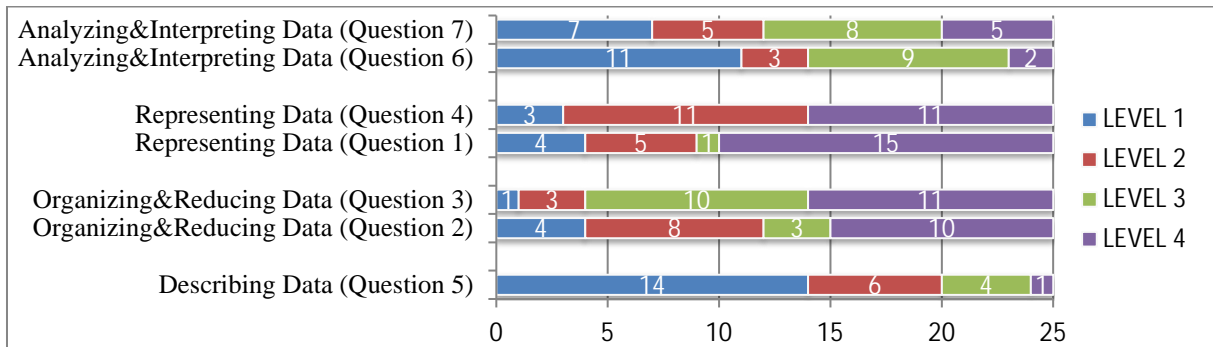


Figure 2: Experimental group students’ statistical thinking levels with respect to statistical thinking processes (by questions) on the posttest

Figure 3 displays the control group students’ statistical thinking levels for the statistical thinking processes on the pretest. While slightly less than half of the students exhibited Level 1 thinking with regard to describing data, majority of them demonstrated Level 1 thinking for representing data and analyzing and interpreting data. There were very few students demonstrating Level 4 thinking for each process.

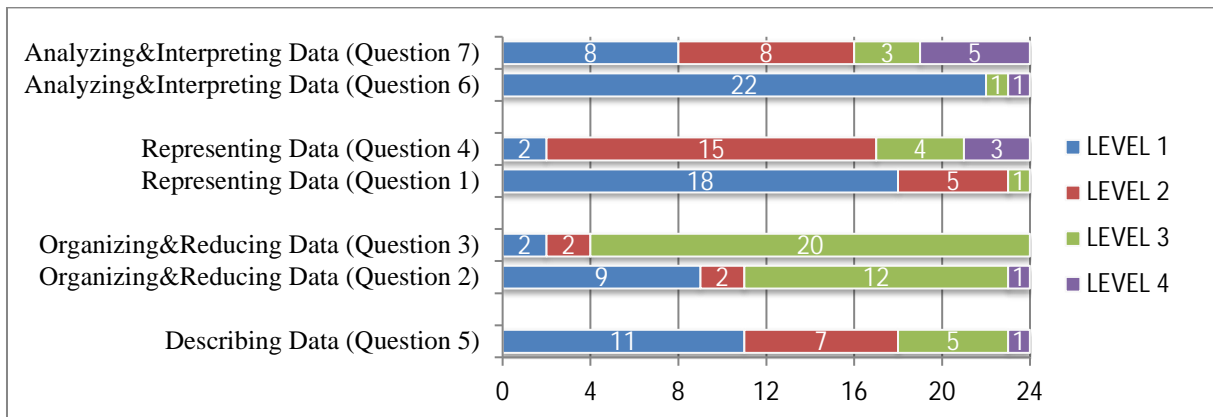


Figure 3: Control group students’ statistical thinking levels with respect to statistical thinking processes (by questions) on the pretest

Figure 4 shows the control group students’ statistical thinking levels for the statistical thinking processes on the posttest. Students mostly exhibited Level 1 thinking for describing data and Level 3 thinking for organizing and reducing data, and analyzing and interpreting data. On the other hand, students’ levels of thinking tended to be at Level 1 and Level 2 with regard to representing data. Overall, there was a growth in the development of students’ thinking after instruction, but less compared to the experimental group.

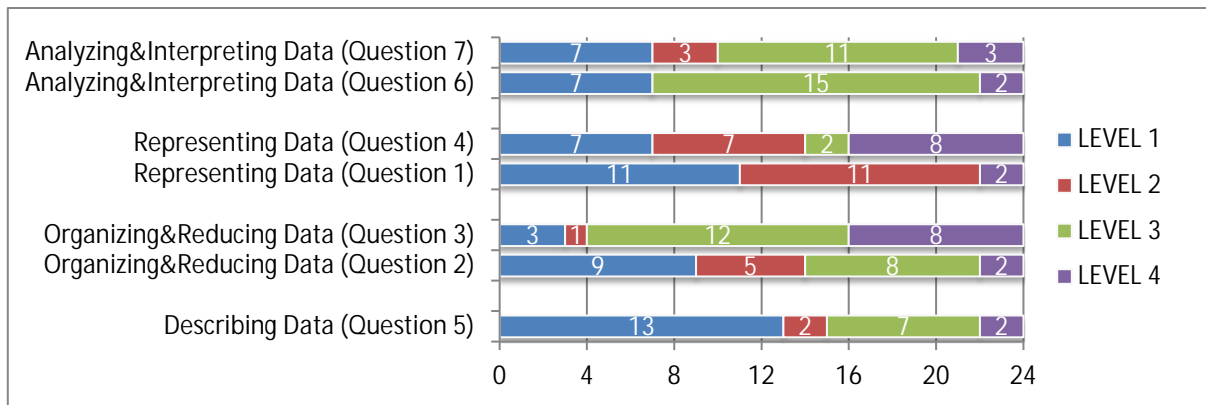


Figure 4: Control group students' statistical thinking levels with respect to statistical processes (by questions) on the posttest

Conclusions

In this study, there was no statistically significant difference in the students' statistical thinking posttest scores between the experimental group and control group. However, our descriptive statistical analysis of the change in students' thinking levels with respect to the statistical thinking processes revealed further insights about the development of students' thinking during the RME activity and the traditional instruction.

After the instruction, the least development in students' thinking levels was seen for describing data process both in the experimental group and the control group. With regard to organizing and reducing data process, there was usually development from Level 1 to Level 3 or Level 4 in the experimental group while many students' thinking levels shifted from Level 1 to Level 3 in the control group. The most development was seen in representing data process with the positive shifts in almost all students' thinking in the experimental group and with many of these was at Level 4. There were also a few shifts in student's thinking for representing data from Level 2 and Level 3 to Level 4 in the control group. While the control group students' thinking levels were mostly at Level 3 and Level 4 for analyzing and interpreting data process after the instruction, the experimental group students' thinking levels tended to shift slightly to Level 3 and Level 4. This could be due to the emphasis given to calculating statistical measures in the textbook used in the control group.

Overall, our findings suggested that the instruction using the RME approach helped students to develop their statistical thinking mainly for representing data and organizing and reducing data processes. For these two processes there was a noticeable increase in the number of students demonstrating Level 4 thinking while there was a corresponding decrease in the number of students exhibiting Level 1 thinking after the instruction. For analyzing and interpreting data process, the increase in the number of students was mainly at Level 3 thinking with a corresponding decrease at Level 1 thinking after the instruction. However, the findings indicated that students would need more experience in describing data when engaging in the RME activity as well as using the textbook. These results are consistent with previous research (e.g. Mooney, 2002) showing low student scores in describing data but high scores in analyzing and interpreting data, organizing and reducing data or representing data processes.

The non-significant statistical test results can be due to the sample size, which is comprised of about 25 students in each group. A study with larger sample size would give more reliable results. The present study is limited to quantitative methodology of data collection. In future a qualitative method can be undertaken for a deeper study of the change in students' statistical thinking after an intervention using the RME approach.

This research was supported by the grant PAUBAP 2018EĞBE008.

References

- Baykul, Y. & Güzeller, C. O. (2014). *Sosyal bilimler için istatistik: SPSS uygulamalı* (2. Baskı) [Statistics for social sciences with SPSS (2nd Ed)]. Ankara: Pegem Akademi.
- Çakmak, Z. T. & Durmuş, S. (2015). Determining the concepts and subjects in the area of learning statistics and probability that 6-8th grade math students have difficulties. *Abant İzzet Baysal Üniversitesi Eğitim Fakültesi Dergisi*, 15(2), 27–58.
- Freudenthal, H. (1991). *Revisiting mathematics education*. Dordrecht: Kluwer Academic Publishers.
- Garfield, J. B. & Ben-Zvi, D. (2008). *Developing students' statistical reasoning*. New York: Springer Science and Business Media B.V.
- Güven, D. (2014). *Ortaokul matematik 6 ders kitabı* [Middle school mathematics 6 textbook]. Ankara: Mega.
- Jones, A. G., Thornton, C. A., Langrall, C. W., & Mooney, E. S. (2000). A framework for characterizing children's statistical thinking. *Mathematical Thinking and Learning*, 2(4), 269-307.
- Kazak, S., Pratt, D., & Gökce, R. (2018). Sixth grade students' emerging practices of data modeling. *ZDM Mathematics Education*, 5(7), 1151–1163.
- Koparan, T. & Güven, B. (2013). A study on the differentiation levels of middle school students' statistical thinking. *Elementary Education Online*, 12(1), 158–178.
- Mooney, E. S. (2002). A framework for characterizing middle school students' statistical thinking. *Mathematical Thinking and Learning*, 4(1), 23–63.
- MEB (2018). *Matematik dersi öğretim programı (İlkokul ve ortaokul 1, 2, 3, 4, 5, 6, 7 ve 8. sınıflar)* [Mathematics curriculum (Primary and middle schools grades 1-8)]. Ankara: MEB.
- Van den Heuvel-Panhuizen, M. (1996). *Assessment and Realistic Mathematics Education* (Unpublished doctoral dissertation). Utrecht University, Utrecht, The Netherlands.
- Van den Heuvel-Panhuizen, M. (2003). The didactical use of models in realistic mathematics education: An example from a longitudinal trajectory on percentage. *Educational Studies in Mathematics*, 54(1), 9–35.
- Ünal Aydın, Z. & İpek, A. S. (2009). The effect of realistic mathematics education on 7th grade students' achievements in multiplication of integers. *Eğitim ve Bilim*, 34(152), 60–70.
- Wild, C. J. & Pfannkuch, M. (1999). Statistical thinking in empirical enquiry. *International Statistical Review*, 67(3), 223-265.

Repurpose and extend: making a model statistical

Michal Dvir and Dani Ben-Zvi

University of Haifa, Faculty of Education, Haifa, Israel; dvirmich@gmail.com

The goal of this article is to examine how learners' repurposing of a model they had previously constructed, possibly by extending its features, can support young learner's reasoning with key statistical features. This process is facilitated by a learning trajectory integrating multiple real world and probabilistic modeling tasks. We introduce our framework describing young learner's reasoning with informal statistical models and modeling (RISM) and focus on a key element in the framework: young learners' expectations regarding the data that can be collected (or generated) from a conjectured population. We offer an illustrative case study of two-sixth graders' reasoning, focusing on a specific model they had constructed and repurposed throughout their investigation, how its features developed and how it ultimately matured to include an underlying probabilistic mechanism. We discuss how this relates to our notion of expected data and close with suggested implications.

Keywords: Statistical model, statistical modeling, integrated modeling approach.

Introduction

There has been a growing interest in the statistics education community in statistical modeling as a pedagogical paradigm to developing learners' statistical reasoning. However, a deeper understanding of what statistical modeling entails is needed to better exhaust its pedagogical potential, especially with regard to young learners. In particular, a better understanding of how novices can be encouraged to construct models that are accompanied with uniquely statistical features, such as accounting for possible variability – that of the data explored, as well as of the sampling procedure that yielded it – is still warranted. The purpose of this article is to explore this, based on an illustrative case study of a pair of sixth grade students' (12 year olds) participation in a uniquely designed learning environment. We track a specific model they had constructed, and gradually repurposed as they participated in various modeling tasks. The new roles assigned to the model were also accompanied by extending and refining some of the models' features, gradually becoming more 'statistical' – that is, it eventually featured uniquely statistical features that distinguish it from a non-statistical model.

Background – The RISM framework and the IMA

A model – a representation serving an explanatory or descriptive purpose (Hesse, 1962) – would serve as a statistical model if it was constructed for a statistical purpose, typically meaning: 1) the phenomenon it is intended to explain has a variability aspect, and 2) utilizing it includes employing probabilistic considerations (Brown & Kass, 2009). The latter is associated with the notion that the description a statistical model offers should be non-deterministic in its nature (Budgett & Pfannkuch, 2015). However, when young learners are the modelers, an informal alternative is necessary, void of the conventional procedures and calculations. Within the context of a statistical inference, a statistical model (formal or informal) needs to serve a dual representative purpose: simultaneously depicting both a conjecture about the explored phenomenon (Konold & Kazak,

2008) and its underlying probabilistic mechanism (Pfannkuch & Ziedins, 2014), as well as the data itself. It is this dual representative purpose that has inspired our framework for depicting young learners' *reasoning with informal statistical models and modeling* (RISM).

The RISM framework suggests describing the statistical modeling process as a continuous development of a set of key elements portrayed in Figure 1. The dual representative purpose of the model is translated into two planes: the data and the conjecture plane. In both, the novice modeler gradually constructs a simplified version of either the explored phenomenon (the phenomenon plane, bottom of Figure 1) or his abstract conjecture (the conjecture plane, top part). The latter may be trivial for an experienced statistician, already familiar with a vast variety of readymade statistical models and formal fit assessment procedures, but challenging for a novice. Alternatively, co-constructing two concurrent models – a data model depicting observed patterns in the data, as well as a conjecture model depicting the data expected to be collected – and assessing their compatibility, can serve as an informal alternative to the practice of model fit evaluation (Dvir & Ben-Zvi, 2018).

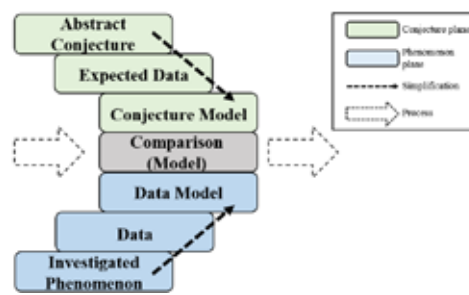


Figure 1: The RISM framework's snapshot

Worth noting is the role the expected data serve in this depiction of the informal statistical modeling process: as the expert statistician's readymade abstract conjecture is a statistical model, it should be already accompanied with previously known considerations regarding the data it can generate, and how the resulting generated data may vary dependent on the type of the model and sample size. In cases where the model is lesser known, the expert would seek to investigate how the data generated from it would behave. However, a young modeler would not typically be aware of the formally expected behavior of such generated data, nor that this behavior may vary and should be explored. Thus by 'expected data' the framework merely refers to the learners' (typically naïve) perception of the data one might collect from the investigated population if his conjecture were true. We believe this expectation is critical when considering whether the investigated conjecture model can be considered a statistical model. For it to be one – the expectation should express some (albeit informal) understanding of the probabilistic considerations associated with generating data from a model.

For this reason, integrating an investigation of the conjecture model's probabilistic mechanism may be beneficial in supporting young learners' reasoning with statistical models and modeling. Therefore, *the integrated modeling approach* (IMA, Manor & Ben-Zvi, 2017) suggests following a 'real world' inquiry with a 'probability world' inquiry, in which the probabilistic considerations of interest becomes the main subject of investigation. The probabilistic inquiry is typically initiated by

students' creating a dynamic model using the TinkerPlots Sampler¹ (Konold & Miller, 2015), based on their real world conjecture models. They then draw multiple simulated (same sized) samples from it, compare between them and eventually construct a sampling distribution of a chosen statistic. The data examined in the probability world is therefore no longer a single sample, rather multiple samples, and the conjecture and inferences made describe the samples' behavior. These inferences, although different in their nature, are closely connected to the real world inquiry that instigated the probabilistic exploration and therefore can be then related back to inform a progression in the real world inquiry.

The real world conjecture model is therefore utilized in the probability world to serve a different purpose (probabilistic rather than real), however what is examined is its underlying probabilistic mechanism, mirrored by the sampling variability students observe. This can lead to refinements of the Sampler model from which the samples were generated, such as adding new attributes to better represent sampling variability (Manor & Ben-Zvi, 2017). Similar extension have also been reported in other integrated modeling endeavors (Lehrer, 2017), however how these occur and how can these be then utilized to inform student's real world instigating inquiries has not been thoroughly examined. This may be in part due to the different visualization students employ when constructing the Sampler model, thus it is unclear how its extensions may manifest in its original real world representation. Therefore, we have chosen to focus on a specific representation first utilized in the preceding real world investigation but also employed during the subsequent probabilistic inquiry, and examine: *How can young learners repurpose a real world conjecture model and extend some of its features in a follow-up probabilistic inquiry?*

Method

This study was conducted as part of the Connections project, a longitudinal design and research project (began at 2005) aiming at promoting young learners' statistical reasoning, in a technologically-enhanced and inquiry-based learning environment. We focus on the data collected in 2016 of a pair of second year participating 12 year-old students from a public school in Israel. Their entire sixth grade class participated in a 19 lesson long learning trajectory, which included three full (data and probability) investigation cycles. The students used TinkerPlots (Konold & Miller, 2015) to both create their data representations, as well as design a generative conjecture model and draw multiple samples from it. The findings we present in this article were taken from the second investigation cycle in which students were asked to make inferences about 1300 students of three schools in the district (including their school) based on a random sample of 60 students. Since our purpose was to learn more about the students' reasoning process employed to elucidate the role of a specific phenomenon, we chose to focus on an illustrative case study. We focus on the reasoning employed by a pair of academically successful students, Noa and Ido, second year participants in Connections. They were selected as they were verbal and communicated their reasoning openly and fluently, and exhibited a behavior observed in several other pairs while disclosing much about the reasoning that encouraged it: they utilized the same visualization in their

¹ The TinkerPlots Sampler allows students to design and run probability simulations, subsequently plotting the results to give a visual representation of the outcome over many samples (a sampling distribution).

inquiry of the real and probabilistic worlds. This facilitated us to more accurately examine how the same model was repurposed and what model features were subsequently extended.

All the activities and participants' actions were videotaped by three cameras during class discussion and Camtasia software to concurrently document the students' computer screen and articulations during their pair work. After transcribing all the pair's videos, the resulting data corpus was reviewed and analyzed according to the interpretative microgenetic method (Siegler, 2006), utilizing the RISM framework to translate the convoluted statistical modeling processes observed to discrete sets of well-organized snapshots (Dvir & Ben-Zvi, 2018). Key scenes and their transcripts, were discussed and triangulated (Schoenfeld, 2007) amongst the co-authors and a third Connections researcher.

Findings

This section illustrates the progression of a specific model the pair had constructed during the second investigation cycle. Figure 2 illustrates the progression we will describe, from its first appearances during the real world investigation, to its development during the following probabilistic inquiry.

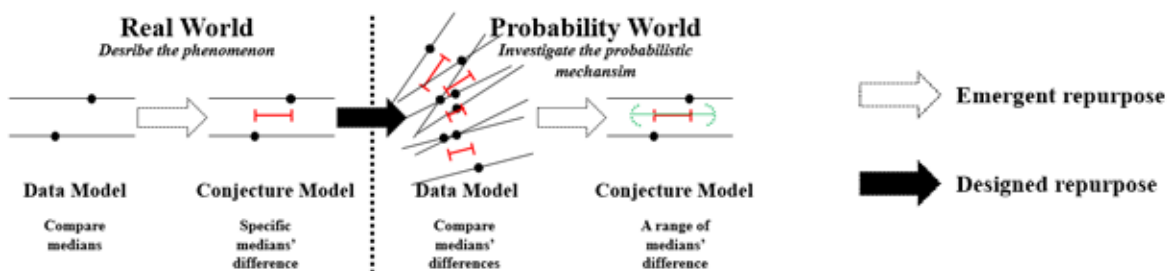


Figure 2: Illustration of repurposes and extensions of the medians model

Initial use of the medians model: repurposing a real world data model to a conjecture model

The second investigation cycle focused on “sportiveness and gender”. Focusing on students’ 600 m running times, Noa formulated their research question: *Is the stigma that girls run slower than boys true?* The pair formulated an initial conjecture: “there is a small difference between boys [and girls, in favour of] the boys”, and began to investigate their real data by examining the 600 m results by gender (Figure 3). Asked by the researcher what can they see in the data, Noa replied:

Noa: That we [girls] do not run so well... 2 minutes and 5 seconds [miscalculation of the boys’ median – 165 sec] is not so good... [and the girls] run even worse. 2 minutes and 13 seconds [miscalculation of the girls’ median – 173 sec].

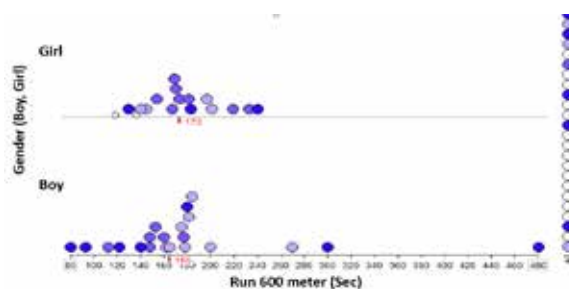


Figure 3: 600 m running times (seconds) by gender, colored according to grade

In response to the researcher's prompt, Noa described the median of each gender, and compared between them stating "[the girls] run even worse." This utilization of the medians, here representing what Noa *saw* in the data (her data model) is what we refer to as '*the medians model*', and its progression is what we will focus on throughout the Findings Section. The researcher, in accordance with the learning trajectory design, encouraged the pair to infer beyond the data, leading Noa to revisit her conjecture:

Noa: I think it [the population of 1300 students] will be less extreme than what I said. There would be a lot more boys than girls that will enlarge the median...

R: And who will be better, boys or girls?

Noa: Boys... I think that the boys' median will be a bit bigger and the girls median will be a little more bigger [means: smaller] ... by 1 [second]

The underlying behaviour of Noa's current conjecture (her abstract conjecture) had not strayed much from her initial conjecture ("there is a small difference between boys [and girls, in favour of] the boys"). The novelty, however, is the model *repurposed* to describe it, as for the first time the medians model is awarded this role. Furthermore, Noa also described here not only which of the medians will be "bigger", but also by how much – a new extension to the medians model. This implies that the data Noa expected her conjectured population to generate is rather specific. The extended feature of acknowledging the actual size (although not necessarily by number) of the difference between the two medians, will gradually take on a bigger role, reflecting a development in the pair's perception of the expected data.

Repurposing in the probability world

During the remainder of the lesson, as well as the one that followed, the pair moved on to the next task of designing a generative model using the Sampler. Their model was based on both the real data sample as well as their perception of the running results of the population of 1300 students, thus reflecting their current conjecture: the girls' and boy results are almost equal, but boys run a little bit faster (Figure 4). After constructing the Sampler model, the pair began to generate simulated random samples from it. In the first sample drawn, the girls' median was significantly smaller than the boys' (Figure 5). Noa addressed this in multiple ways, for example, when the researcher introduced the boxplot in the following lesson. As the researcher asked the pair how the boxplot could be utilized, Noa replied: "We can see where there are more data, and also who is better, because if, for example our [the girls'] median is here [relatively small], and their median [the boys'] is here [larger] it means that we [the girls] are better here [in this sample]". Noa's response indicated that although the addition of the boxplot was an extended feature of the visualization, the underlying data model she was still utilizing is the medians model. Although now analysing a simulated sample, the role this model seemed to serve is similar to that in prior utilizations of the medians model: describe the data (a single sample) at hand. After drawing a second simulated sample, the researcher asked how the pair would like to compare between the samples.

Noa: Here too [in the second simulated sample as well as the first], we [the girls] are better [than the boys]

- R: Because of what?
- Noa: Because again [in another sample we see that] the [girls'] median is at better results and
- Ido: Why? But our [the boys'] median is becoming closer to yours [the girls' median]
- Noa: It is, but still [the girls' median is better than the boys']...
- Ido: It [the difference between the medians] is very similar, all the time...

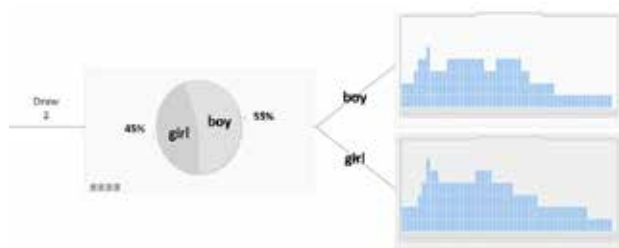


Figure 4: The Sampler model – the attribute on the left is gender and on the right, two “almost equal” distributions were designed for the boys’ (top) and girls’ (bottom) 600 m running times

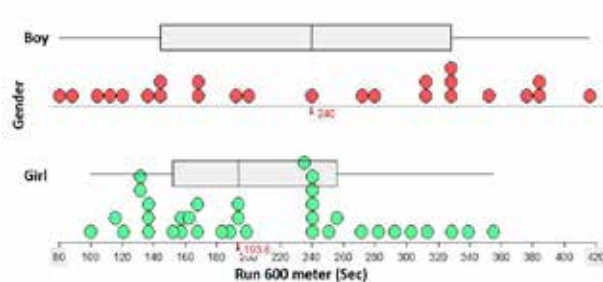


Figure 5: Adding a boxplot to investigate the first simulated sample of the boys’ (top) and girls’ (bottom) running times in which the girls’ median is smaller than the boys’

Noa began by stating the result of the comparison: “here too”. As the researcher prompted her to explain how she had ascertained this result, Noa referred again to the median as an indicator regarding who runs better. However, implied in her response is a possible extended feature: while comparing the medians (which is smaller – the boys’ or the girls’) served as a model for describing what the data in a single sample indicated (regarding who runs better), comparing which of the two medians is “better” across the two samples was a method to compare between the new simulated sample and the previous one. This *repurposing* was implied both by her use of “again” as well as the researchers’ question that instigated this exchange (how would they like to compare between samples).

Ido’s reaction introduced a new aspect, more explicitly addressing the new type of comparison (between samples, rather than between the two distributions within a single sample): comparing differences. Not only was he acknowledging the size of the difference between the two medians, as opposed to Noa’s acknowledging only which of the two prevailed, he was also explicitly focusing on the change that accrued between this current sample and the former: the boys’ median was “becoming closer” to the girls’, meaning the difference is now smaller. Despite Noa’s reply showing she did not consider the smaller gap between the two medians as a relevant indicator, Ido’s final statement takes this new aspect even one step further, as he used a much more general formulation: “all the time”. However, as the pair’s inquiry progressed the extended feature Ido had introduced was indeed picked up by Noa. An example for this can be seen in a later exchange:

- R: What will happen if we draw another sample?
- Noa: It seems to me it [the new sample] is the same. The boys [their median] are slowly slowly getting closer to us [to the girls’ median]

This last statement shows that not only was Noa now considering comparing the differences between the medians as a means of comparing the new sample with the previous samples, it is now even becoming a part of her newly forming conjecture. However, this conjecture does not reflect Noa's view of the real world phenomenon the pair were investigating (who runs better), rather a different kind of phenomenon: how much do samples such as those they were investigating vary? We therefore consider this to be a *repurposing* of the original medians model, here also serving as a conjecture model for the probabilistic phenomenon the pair were investigating.

The pair continued to generate more simulated random samples, and for each compared the difference between the boys' and girls' medians with the differences they saw in other simulated samples: "you [the boys' median] are getting closer to us [the girls' median] but it is taking you a lot of time" (Noa), "now it [the difference between two medians] is almost equal [to the previous difference]!" (Ido). The changes they observed varied, to the extent that in one sample, much to Noa's disappointment, the boys' median even surpassed the girls'. After several samples were drawn, the researcher prompted the pair to consider whether a sample size 60 can be trusted:

Noa: No, because let's say once they [the boys' median] can be here [at one point] and we [the girls' median] can be here [another point], and another time they [the boys' median] can be here [different point] and we [the girls' median] can be here [another different point]. It's confusing.

Ido: It [the difference between the medians] can always change.

Noa: Here [in other samples] it is like that they [the boys' median] slowly slowly closed [the gap] to us [the girls' median], and here [in one sample] they [the boys' median] are before us [is smaller than the girls' median].

Asked to evaluate the trustworthiness of samples size 60, both students responded by referring to the changes they had observed across the simulated samples: While Noa initially referred to variations in which of two medians prevailed, it seems that Ido was still focused on the difference between the two, reflected in his use of the singular form 'it' rather than the more appropriate 'they' had he been referring to the two medians. Nevertheless, Noa's final statement showed that she too was considering changes to the differences ("slowly slowly closed [the gap] to us"). Noa's depiction describes a range of possible differences between the two medians, a long way from her original expectation of one specific result (bigger "by 1"). The range of possible results is a key extended feature of the medians model, making it now much more statistical than its initial version.

Discussion

Focusing on a specific model that emerged during the pairs' real world inquiry – the medians model – we sought to explore how the pair *repurposed* its goal and *extended* its features as they progressed in their inquiry and transitioned into the probabilistic follow up inquiry (Figure 2). As Noa and Ido designed their Sampler generative model to reflect their initial real world *abstract conjecture* (regarding running results), drawing multiple random samples from it allowed them to gradually explore its underlying probabilistic mechanism. Because they chose to repurpose the same visual representation (the medians model) rather than create a new one, they were both learning how the real world expected data would behave (or vary), and how this behavior would be portrayed in their

model (what can happen to the two medians). This indeed required extending some features of the original medians model, possibly as its original use (check each median and compare between them) was too complicated to track over several samples. The end result of this process was a much more elaborate and statistical model – one that serves the dual representative purpose in the real world investigation (both data and conjecture), and also is accompanied by a non-deterministic expectation regarding the data it can generate. Although the pairs' choice to repurpose a model they had used in their real world inquiry might appear coincidental or idiosyncratic, we have observed several other pairs chose to do the same. We attribute this to the IMA design: initiating the learning trajectory with a real world inquiry, and its close connection to the probabilistic follow up investigation. This case study illustrates how integrating a follow-up inquiry regarding probabilistic concerns that emerge from a real world investigation within an informal inferential setting can promote an important aspect of young learners' RISM: experiencing the population as a generative model, one from which various samples can be generated, and cultivating the learners' understanding that this variability needs to be examined and accounted for. In particular, repurposing the same models throughout both types of inquiry, can support reasoning with its underlying probabilistic mechanism.

We thank the *Connections* team, the University of Haifa, the I-CORE Program of the Planning and Budgeting Committee and the Israel Science Foundation Grant 1716/12.

References

- Brown, E. N., & Kass, R. E. (2009). What is statistics? *The American Statistician*, 63(2), 105–123.
- Budgett, S., & Pfannkuch, M. (2015). Building conditional probability concepts through reasoning from an eikosogram model: A pilot study. In *Proceedings of SRTL9* (pp. 10–23). Paderborn, Germany: University of Paderborn.
- Dvir, M., & Ben-Zvi, D. (2018). The role of model comparison in young learners' reasoning with statistical models and modeling. *ZDM - International Journal on Mathematics Education*. doi:10.1007/s11858-018-0987-4.
- Hesse, M. B. (1962). *Forces and fields: The concept of action at a distance in the history of physics*. Mineola, NY: Dover.
- Konold, C., & Kazak, S. (2008). Reconnecting data and chance. *Technology Innovations in Statistics Education*, 2(1), Article 1.
- Konold, C., & Miller, C. (2015). *TinkerPlots* (Version 2.3.1) [Software]. <http://www.tinkerplots.com/>
- Lehrer, R. (2017). Modeling Signal-Noise Processes Supports Student Construction of a Hierarchical Image of Sample. *Statistics Education Research Journal*, 16(2), 64–85.
- Manor, H., & Ben-Zvi, D. (2017). Students' emergent articulations of statistical models and modeling in making informal statistical inferences. *Statistics Education Research Journal*, 16(2), 116–143.
- Pfannkuch, M., & Ziedins, I. (2014). A modelling perspective on probability. In E.J. Chernoff & B. Sriraman (Eds.), *Probabilistic thinking: Presenting plural perspectives* (pp. 101–116). Dordrecht: Springer.
- Schoenfeld, A. H. (2007). Method. In F. Lester (Ed.), *Second handbook of research on mathematics teaching and learning* (pp. 69–107). Charlotte, NC: Information Age Publishing.
- Siegler, R. S. (2006). Microgenetic analyses of learning. In D. Kuhn & R.S. Siegler (Eds.), *Handbook of child psychology: Cognition, perception, and language* (Vol. 2, 6th ed., pp. 464–510). Hoboken, NJ: Wiley.

The role of decision-making in the legitimation of probability and statistics in Chilean upper secondary school curriculum

Raimundo Elicer

Roskilde University, Denmark; raimundo@ruc.dk

Decision-making is argued to be intrinsically embedded in the historical emergence of probability and statistics, as well as in the justification for their inclusion as school mathematics subjects. In this article I investigate the role of decision in probability and statistics in both the current and upcoming Chilean upper secondary school mathematics curricula. Drawing upon Fairclough's model for Critical Discourse Analysis, I analyse selected texts as examples of broader discourse practices, in particular, I focus in assumptions, modalities, and intertextualities. They evidence the role of decision-making as legitimation of the subject matter and as a mediator of agency by teachers and students. I claim there is a shift towards less appeal to authority in legitimising the curriculum, and an increasing responsibility of students in the educational process.

Keywords: Critical discourse analysis, curriculum, decision-making, probability, statistics.

Introduction

As a scientific and mathematical field of knowledge, it can be argued that the history of probability and statistics is the history of making decisions when uncertain outcomes are to be evaluated. According to Hacking's (1975) historical and philosophical address, the notion of probability comes to answer whether a statement is an opinion or demonstrable knowledge during the middle ages. Later on the 17th century, probability, induction and statistical inference come to define the fair share when a gamble game is interrupted, whether an accused person is to be condemned, to decide the price of annuities and policy regarding pensions, and to take a stand about scientific hypotheses to be true or not. So risk and decision-making define the "logic" of probability (Borovcnik, 2015). Risk, as vague as this concept may be, is the way we evaluate decisions under uncertainty beyond the possible impacts of different choices, but also with some weight given to their likelihood. Probability comes to be an attempt to quantify these levels of likelihood.

As for probability and statistics as teaching-learning subjects, Pfannkuch (2018) has identified emerging curricular approaches to be addressed in future research. One proposition is to get "*more insight into fostering statistical argumentation* including learning how to make evidence-based claims in data-rich environments and critically evaluating data-based arguments in diverse media from a statistical literacy perspective" (p. 407, emphasis in original). This trend is grounded in research experiences focused in the complexity and scaffolding of decision-making tasks under uncertainty. Researching the 'critical lens' of decision processes would require different approaches such as action research, phenomenography, and critical discourse analysis (Petocz, Reid, & Gal, 2018, p. 81).

In this article I attempt to join both propositions by investigating the role of decision-making in current and upcoming probability and statistics official curricula, through a version of Critical Discourse Analysis [CDA]. In order to narrow down and have a sense of what is aim for regarding

students' future participation as citizens; I make an exemplary analysis that focuses in the Chilean last two grades of secondary mathematics school curriculum.

The general research questions addressed in this article are: (1) what is the role given to notions of decision-making in the Chilean upper secondary school probability and statistics curriculum? And (2) what has changed from the up-to-date version of the curriculum and the upcoming curricular framework for the same subject and grades?

Interpreting roles and spotting changes are broad intentions, so in the following section I address the conceptual framework and methods concerning a version of CDA, in order to understand these questions in a more precise way.

Methodology

Inspired by Fairclough (2010), I am describing the methodology as an altogether analytical strategy, since “we cannot so sharply separate theory and method” (p. 234) while constructing the object of research. Starting with theoretical generalities, then I provide the necessary conceptual definitions that methods for selection and analysis require.

Fairclough (2010) defines a general methodology for critical research in an interdisciplinary way. In that line, the present discourse analysis dialogues with statistics education research. Key interrelated concepts are social structures, practices and events: “social structures define what is possible, social events constitute what is actual, and the relationship between potential and actual is mediated by social practices” (Fairclough, 2003, p. 223). In this frame language is a social structure. Among its infinite possibilities, choices are made to produce texts as part of social events, mediated by discursive practices, where discourse is understood as semiosis, i.e. the process of meaning-making.

My analytical strategy consists in selecting texts from the upper secondary school Chilean curriculum which refer to decision-making in probability and statistics, and then extracting elements of textual analysis which illustrate broader discursive practices. Textual analysis describes *what* is in the texts, and the discursive aspect addresses how these elements *give meaning*.

Selection of texts

Chilean secondary education is defined from grades 7 to 12. These are called 7th-basic and 8th-basic, and from 1st-middle (9th-grade) to 4th-middle (12th-grade)¹. All of these grades have their own study programs, but more general curricular frameworks are available for 7th-basic to 2nd-middle and the one for 3rd and 4th-middle is under construction. The text selection takes into account 3rd and 4th-middle curricula, and the aforementioned upcoming curricular framework, summarized in table 1.

For current versions of the curriculum, I will only take common plan programs, i.e. those directed to every student in the scholar system. Excluded programs are those differentiated mathematics studies

¹ Not to be confounded with middle school, as in between primary and secondary school. In Chile, *enseñanza media* (middle education) is the bridge between *enseñanza básica* (basic education) and *educación superior* (higher education).

defined for scientific education. Therefore, the texts are extracted from grades 3rd-middle and 4th-middle study programs.

Document	Label	Year	Curriculum	Author
Mathematics Study Programme, Third Middle	3M15	2015	2009	Curriculum and Assessment Unit, Chilean Ministry of Education (MINEDUC)
Mathematics Study Programme, Fourth Middle	4M15	2015	2009	
Curricular proposal for 3rd and 4th-middle: Public consultation document	34M17	2017	2018	

Table 1: Sources of selected texts

Study programs are divided into units (numbers, algebra, geometry, and data and chance). Within the units of data and chance, I look for sentences which make references to ‘decision’ (*decisión* in Spanish), including conjugations of the verb ‘to decide.’ These sentences will compose the texts.

The same selection applies the upcoming curricular proposal for these last two grades, within the mathematics subject. It does not still have the form of study programs, but it can be considered to be of the same genre, for it means to become the next version of such. It is a general proposal based on a process that involved national experts, international experiences and consultation to civil society participants. The document is published in MINEDUC’s website.

Data analysis

The analysis is performed at two levels: textual and discursive.

Among the several possibilities for identifying and categorising elements in the texts, I will focus in three: modality, collocation, and intertextuality. Modality expresses a commitment the author does with truth and necessity, respectively by epistemic and deontic modalities (Fairclough, 2003, p. 165). It can be evidenced –nonexclusively– by the use of modal verbs, such as ‘may’ (epistemic) and ‘must’ (deontic). Collocation is the repeated co-occurrence of certain concepts, such as ‘hard working’ appears as a common binomial in political speeches. Intertextuality is the more or less explicit presence of elements of other texts and their authors’ voices. These elements can be dialogued with, assumed, rejected, and so on (pp. 41–42).

Beyond identification of modality, collocation and intertextuality in texts, I will point out the way they are chosen to be expressed as indicators of discursive practices. In particular, I focus in legitimation strategies. Legitimation is the discursive practice of justifying what is made factual in the texts, through reference to authority, value systems or utility, or conveyed through narrative (Fairclough, 2003, p. 98).

Coming back to the research questions, I define the ‘role’ of decision-making as choices for the use of legitimation strategies as discursive practices. Additionally, I shall identify changes from current to the upcoming version of the curriculum. Characterising this shift is the final stage of the analysis.

Selected texts

As a way of organisation, Chilean study programs are divided into units. Each unit is described having purpose, previous knowledges, key concepts, contents, abilities, attitudes, expected learning outcomes (and their respective assessment indicators), didactical orientations, and suggested activities for each expected learning outcome. The following are the selected texts, and above them are the contexts within the study programs where they are found. All translations from Spanish are made by me as literal as possible.

In the 3rd-middle grade current curriculum (3M15), ‘decision’ appears in the form of ‘decision tree representations’, as a follow up for the goal of understanding the concept of conditional probability. I will not take it as part of the analysis, since it actually refers to ‘probability tree representations.’ Then it forms part of the general didactical orientations for the unit:

3rd-middle. Unit 4: Data and chance.

Purpose

- 1 Experimental problems are worked with **decision** tree representations, which enable a bigger understanding of contents and a tool for probabilistic calculations. (3M15, p. 120, emphasis added)

Didactical orientations

- 2 In this line, it is fundamental that the teacher promotes the development of random thinking, i.e. that students learn to make **decisions** with evidence in situations of uncertainty. (3M15, p. 123, emphasis added)

In the last grade current study program (4M15) there are actually two units about data and chance, with no mentions of ‘decision’ in ‘data and chance 2,’ which includes graphic notions about binomial and normal distributions. In ‘data and chance 1,’ ‘decision’ is part of the didactical orientations as in the 3rd-middle grade. Later on, there is a mention to ‘decision’ as a comment for teachers when engaging in activities for the learning goal to critically evaluates information:

4th-middle. Unit 3: Data and chance 1.

Didactical orientations

- 3 In this unit, it is expected that students critically evaluate information published on the media and internet, from the analysis, interpretation and synthesis of such information, with which they can obtain results about a population considering its size and the variable’s distribution; infer conclusions from the mean, variance and standard deviation; and to make **decisions** grounded in statistically significant information. (4M15, p. 86, emphasis added)

Suggested activities

- 4 Furthermore, it is important that the teacher promotes contextualized learning so students develop progressively the statistical literacy, which gives them tools for making grounded **decisions**. (4M15, p. 88, emphasis added)

As for the public consult document for the upcoming curricular framework (34M17), decision first appears as part of the general purposes of the mathematics subject:

Mathematics: Formative purposes

- 5 In order to achieve the latter, students will work collaboratively in mathematical modelling of situations, to make grounded **decisions** in disciplinary problems, as well as in the interdisciplinary, social, environmental or economic scope. (34M17, p. 49, emphasis added)

And then, utterances about decisions are part of mathematics learning goals in both grades:

Learning goals for 3rd-middle

- 6 [It is expected from students to be capable of] 3. Making **decisions** in situations of uncertainty, with information involving dispersion measures, double entrance tables and conditional probabilities. (34M17, p. 52, emphasis added)

Learning goals for 4th-middle

- 7 [It is expected from students to be capable of] 3. Solving problems in contexts of uncertainty, through the application of the binomial distribution and calculation of probabilities, for **decision**-making and critical analysis of statistical information. (34M17, p. 52, emphasis added)

Both learning goals have a parallel in the previous texts. In the current study programs (3M15 and 4M15), topics such as dispersion measures, conditional probabilities and the critical analysis of statistical information are covered.

Textual analysis

I shall first identify and describe elements of textual analysis found in the excerpts as to provide input to the following discussion. I focus in modality, collocation and intertextuality.

Modality

Modal forms expressed as ‘it is expected from/that students’ (3, 6 and 7) can be identified as epistemic modalities, i.e. as expressions of probability and truth, in this case, the expected and not certain to happen. It can be argued that, given the official character of curricula, these are actual expressions of the necessary, falling into the category of deontic modalities.

Explicit deontic modalities are evidenced as ‘it is fundamental that’ (2) and ‘it is important that’ (4), and they express necessity for particular promotions of the teachers in order to provoke students’ skills for making decisions.

Collocation

References to decisions do not appear alone. A habitual co-occurrence of the substantive ‘decision(s)’ comes with ‘grounded’ as company; both as an adjective as in ‘grounded decision-making’ (4) and ‘grounded decisions’ (5), and as an adverbial form as in ‘decisions grounded in...’ (3). A similar adverbial accompanying form is ‘decisions with evidence’ (2) and ‘decisions with information’ (6).

This collocation suggests a reference to a particular type of decisions or decision-making processes, based on quantitative arguments, distinguishable from a mere act of making a choice.

Intertextuality

Texts 2 and 4 can be read in parallel as having the same structure:

In this line, it is fundamental that the teacher promotes the development of random thinking, i.e. that students learn to make decisions with evidence in situations of uncertainty. (2)	Furthermore, it is important that the teacher promotes contextualized learning so students develop progressively the statistical literacy, which gives them tools for making grounded decisions. (4)
--	---

These texts make references to two different concepts, namely ‘random thinking’ (2) and ‘statistical literacy’ (4) in a similar way: as notions to be promoted by the teacher, implying students to make grounded decisions. So intertextuality is found within selected texts. Moreover, these concepts are not defined in the documents, but they are traces of another text published by the Chilean Statistics Society as experts’ curricular recommendations (Araneda, del Pino, Estrella, Icaza, & San Martín, 2011). The term ‘random thinking’ is not found in the literature, rather I presume the texts intend to refer to ‘statistical’ (Garfield & Ben-Zvi, 2007) or ‘probabilistic thinking’ (Chernoff & Sriraman, 2014). Both ‘statistical thinking’ and ‘statistical literacy’ are described as core answers to the section ‘Why teach statistics?’ (pp. 11–17) referencing a paper published in the *International Statistical Review* (Garfield & Ben-Zvi, 2007). Overall, texts 2 and 4 are referring to authority, introducing notions without further explanation, which are developed within national and international statisticians associations.

Discussion: Discursive practices

Within Fairclough’s model, texts are part of social events, and they are signs of broader discursive practices. In the following I point out legitimization strategies evidenced by preceding elements of the textual analysis.

Legitimation

Making decisions appears as a way of justifying the teaching and learning of statistics in the curricula. The texts fulfil the purpose of not only saying what and how to teach and learn, but also why and for what. Fairclough (2003, p. 219) claims that much of the legitimization of a social order –such as the inclusion of particular knowledge in the official curriculum– is textual. In particular, the texts show three of the legitimization strategies identified by Van Leeuwen (2007), namely through mythopoesis, rationalisation, and authorisation.

Mythopoesis or legitimation conveyed through narrative is evidence by the collocation of ‘decision’ with ‘grounded’ (3, 4 and 5), and similar accompanying adverbial forms such as ‘with evidence’ (2) and ‘with information’ (6). This strategy is stable through the texts and makes the case for justifying probability and statistics, since not just any kind of decision is included, but only those rooted in data and mathematical rationality. It allows a steady association between such school subjects, and rational choice.

Merely associating probability and statistics to rational decisions is not enough, it is still necessary to justify the teaching. Aforementioned deontic modalities are evidence of legitimation through rationalisation, which refers to utility. Within the current curriculum (3M15, 4M15) teachers' promotions are 'fundamental' (2) and 'important' (4) for students to make grounded decisions. The upcoming proposal (34M17) provides a similar rationalisation in the form of 'in order to achieve the latter' and 'to make grounded decisions'(5), but this time it is mediated by the students' action, namely their collaborative work in mathematical modelling situations (5). In a way, this change represents another shift in the agency from teachers to students in the teaching-learning process.

I have already pointed out that traces of an authorisation strategy are found in texts from the current curricula (3M15, 4M15), through the inclusion, without further definition, of 'random thinking' and 'statistical literacy'. What is worth highlighting is the fact that this strategy is not found in the upcoming curricular framework (34M17). This shift resonates with the bottom-up nature of the latter document, where civil society plays a bigger role in the justification of curriculum. This alteration is coherent with another broader mention to 'decision' in the diagnosis chapter of the same document, where students "demand protagonism in decision making and aspire to contribute to solve problems in the world they live in, such as poverty eradication, climate change and sustainable development." (34M17, p. 13)

Concluding remarks

Critical discourse analysis allows us to see texts as part of social structures mediated by discursive practices. In this article I analyse Chilean upper secondary school written curricula as evidence of legitimation strategies, showing that study programs not only describe what is to be taught, but also why. Decision-making appears as a key element of such legitimation, by establishing a narrative of probability and statistics linked to grounded, evidence-based and rational choice.

The analysis illustrates signs of change towards a justification which relies less in professional statisticians and educational researchers as authorities, and more into students' own learning activities as decision makers. This shift is part of the wish for a bigger role in decision processes which go beyond the disciplinary scope.

This article addresses a justification problem in mathematics education research (Niss, 1996). Future works should address whether it is possible connect decision-based motivations and curricular contents, and how this can be approached in teaching practice. Both possibility and implementation problems are part of the broader PhD project this article is embedded in.

This work was funded by the doctoral scholarship CONICYT BCH/DOCTORADO 72170530.

Sources

Ministerio de Educación (2015a). *Matemática, Programa de Estudio, Tercero medio* [Mathematics, Study Programme, Third middle]. Santiago: Unidad de Currículum y Evaluación, Ministerio de Educación de Chile. Retrieved from: http://www.curriculumenlineamineduc.cl/605/articles-34361_programa.pdf

Ministerio de Educación (2015b). *Matemática, Programa de Estudio, Cuarto medio* [Mathematics, Study Programme, Fourth middle]. Santiago: Unidad de Currículum y Evaluación, Ministerio de Educación de Chile. Retrieved from: http://www.curriculumenlineamineduc.cl/605/articles-34362_programa.pdf

Ministerio de Educación (2017). *Propuesta curricular para 3° y 4° medio: Documento de consulta pública* [Curricular proposal for 3rd and 4th-middle: Public consultation document]. Santiago: Unidad de Currículum y Evaluación, Ministerio de Educación de Chile. Retrieved from: http://basesdelfuturo.educarchile.cl/wp-content/uploads/2017/03/Propuesta_Curricular-Consulta-P%C3%BAblica.pdf

References

- Araneda, A. M., del Pino, G., Estrella, S., Icaza, G., & San Martín, E. (2011). *Recomendaciones para el currículum escolar del eje datos y azar* [Recommendations for school curriculum on the axis of data and chance]. Santiago: Sociedad Chilena de Estadística.
- Borovcnik, M. (2015). Risk and Decision Making: The Logic of Probability. *The Mathematics Enthusiast*, 12(1,2&3), 113–139.
- Chernoff, E. J., & Sriraman, B. (Eds.). (2014). *Probabilistic Thinking*. Dordrecht, The Netherlands: Springer.
- Fairclough, N. (2003). *Analysing discourse: Textual analysis for social research*. London: Routledge.
- Fairclough, N. (2010). A dialectical-relational approach to critical discourse analysis in social research. In N. Fairclough (Ed.), *Critical discourse analysis: The critical study of language* (2nd ed., pp. 230–254). Harlow: Routledge.
- Garfield, J., & Ben-Zvi, D. (2007). How students learn statistics revisited: A current review of research on teaching and learning statistics. *International Statistical Review*, 75(3), 372–396.
- Hacking, I. (1975). *The emergence of probability: A philosophical study of early ideas about probability, induction and statistical inference*. Cambridge: Cambridge University Press.
- Niss, M. (1996). Goals of mathematics teaching. In A. Bishop, M. A. (Ken) Clements, C. Keitel-Kreidt, J. Kilpatrick, & C. Laborde (Eds.), *International handbook of mathematics education* (pp. 11–47). Dordrecht: Kluwer Academic.
- Petocz, P., Reid, A., & Gal, I. (2018). Statistics Education Research. In D. Ben-Zvi, K. Makar, & J. Garfield (Eds.), *International handbook of research in statistics education* (pp. 71–99). Cham: Springer.
- Pfannkuch, M. (2018). Reimagining Curriculum Approaches. In D. Ben-Zvi, K. Makar, & J. Garfield (Eds.), *International handbook of research in statistics education* (pp. 387–413). Cham: Springer.
- Van Leeuwen, T. (2007). Legitimation in discourse and communication. *Discourse & Communication*, 1(1), 91–112.

The challenge of constructing statistically worthwhile questions

Daniel Frischemeier¹ and Aisling M. Leavy²

¹University of Paderborn, Germany; dafr@math.uni-paderborn.de

²Mary Immaculate College, University of Limerick, Ireland; aisling.leavy@mic.ul.ie

Recent approaches to statistics education situate the teaching and learning of statistics within cycles of statistical inquiry. This research focuses on the first step – the preparation of prospective teachers to pose statistical questions. We report on an investigation of prospective elementary teachers in Ireland (n=118) and Germany (n=40) as they design statistical questions. Support was provided through tutorials, think-pair activities, peer-feedback and expert-feedback. We describe the features of statistical questions posed, identify obstacles and difficulties experienced when posing questions and evaluate the effectiveness of both peer and expert feedback.

Keywords: Statistical inquiry, teacher education, primary teaching, posing statistical questions.

Introduction

A data analysis cycle such as the PPDAC (Wild & Pfannkuch, 1999) is a structure implemented in statistical inquiries across nearly all age levels. It consists of the phases: problem, plan, data, analysis and conclusion. The first phase, posing a problem (i.e., statistical question), is a critical prerequisite to stimulate a deep and rich analysis of data. It is also critical as the quality of the questions posed informs the types of data collected, determines the representations used and influences the interpretations that can be made. Arnold (2013, p. 19) makes an important distinction between two fundamental types of questions: investigative questions and survey questions. Investigative questions are “the questions to be answered using data” (p. 19), for example ‘What patterns are evident in social media use by teenagers?’ In contrast, survey questions are “questions which are asked to get the data” (p. 19), for example ‘How much time do you spend on social media at the weekend?’ One typical misconception is posing survey questions when being asked to pose investigative questions. We concentrate primarily on the generation and development of investigative questions (which we refer to as statistical questions). Our primary research questions are: What is the quality of initial statistical questions posed by prospective teachers and how does the quality develop across several phases (first version of the question, question revised after peer feedback, question revised after expert feedback)?

Literature review

In the literature review we consider different types and categories of statistical questions. Biehler (2001) distinguishes between the number of variables included in statistical questions. An example of a one-variable question is: “What is the distribution of the variable height?” An example of a two-variable question is: “In which way do boys and girls differ in respect to the variable height?” For two-variable questions, Konold, Pollatsek, Well, and Gagnon (1997) distinguish between three different types. The first type, those investigating the relationship of two categorical variables (Are

boys or girls more likely to play handball?), are termed *categorical × categorical*. Those investigating the relationship of two numerical variables (Is there a relation between hours spent on social media and school grades?) are termed *numerical × numerical*. Questions in the *numerical × categorical* category are referred to as group comparison questions - for example: “Do those with a curfew tend to study more hours than those without a curfew?” (Konold et al, 1997, p. 7).

These categories index descriptive features of statistical questions. A more evaluative approach is taken by Frischemeier and Biehler (2018) who have distinguished different qualities and developed a rating system for statistical questions. In this rating system, questions that take into account two variables are rated higher than those that take into account only one variable. In the subset of one-variable questions they distinguish questions leading to a yes/no answer (“Do 60% of the pupils have a mobile phone?”, p. 759), questions asking for a specific value (“How many pupils have a personal computer?”, p. 759) and more general questions referring to the entire distribution (“How is the variable “mobile phone” distributed?”, p. 759). In the subset of two-variable questions a similar categorization is made. Yes/No questions involving two variables are for example “Is there a difference between boys and girls in their time spent on computer use?” (p. 759) and questions aimed at working out differences in group comparison situations are for example “In which regard does computer use differ between boys and girls?” (p. 759). An example of a more sophisticated and complex statistical questions (called open and complex questions) involving two variables is “which differences exist between boys and girls in regard to their leisure time activities?”

Makar and Fielding-Wells (2011, pp. 349-350) provide specific characteristics of questions for statistical investigations such as “interesting, challenging, and relevant”, “statistical in nature” and “ill-structured and ambiguous” and Arnold (2013, p. 110-111) identified six fundamental criteria for what makes a good investigative question: (1) the variable(s) of interest is/are clear and available, (2) the population of interest is clear, (3) the intent is clear, (4) the question can be answered with the data, (5) the question is one that is worth investigating, that is interesting, that has a purpose, and (6) the question allows for analysis to be made of the whole group. For Criterion 1 this means that the variables are described in a clear way (with regard to the specific situation: summary, comparison, relationship) and have been correctly identified from the actual survey question. Criterion 2 focuses on the population of interest and whether learners focus on individuals, a sample or the population. Another important Criterion 3 is whether the question is clear with regard to whether it is a summary, comparison or relationship question (p. 111). Consideration of whether the question can be answered with the given data is tackled in Criterion 4. Criterion 5 deals with purpose and whether the information arising from answering the question is useful to someone. Finally, Criterion 6 investigates whether the question allows an analysis with regard to a local view (single points, single aspects) or a global view on distributions (characteristics like center, spread, skewness).

Empirical studies examining learners’ reasoning when generating statistical questions reveals that learners across all ages face problems generating adequate statistical questions (Arnold, 2013; Frischemeier & Biehler, 2018; Pfannkuch & Horrying, 2004). In their work with secondary schools students, Pfannkuch and Horrying (2004, p. 208) observed that students frequently forgot to look back to the original questions and use it to guide their discussion of the data. Switching focus to the

teachers, Pfannkuch and Horring (2004) stated that the “teachers tended to pose narrowly framed statistical questions according to a template” (p. 208). Frischemeier and Biehler (2018) investigated the development of the quality of statistical questions posed by primary preservice teachers while engaged in a PPDAC-cycle while enrolled in a course on statistical thinking. One fundamental conclusion of Frischemeier and Biehler (2018) was that the quality of a statistical investigation depends on the statistical question that was posed and subsequently stimulates the investigation. Thus poor statistical questions requiring only a yes/no answer or including only one variable, lead to short and non-sophisticated statistical explorations. Interestingly they concluded that despite the provision of feedback (peer and expert) during two stages of the study, the quality of statistical questions did not improve in a considerable way. Our study reported in this paper investigates how to support prospective primary teachers design statistical questions that motivate a cycle of statistical inquiry suitable for upper grade elementary children.

Methodology

Irish participants ($n=118$) were 3rd years in a 4-year undergraduate degree. They were enrolled in a 12-week compulsory module on the teaching of statistics and probability, the first 8 weeks focused on statistics. They were taught in groups of 30-40 students, once a week for 60 minutes (in Autumn 2017). German participants ($n=40$) were 1st years in a 3.5-year undergraduate degree. They were enrolled in a 14-week compulsory course on the teaching of geometry and statistics (in winter term 2017/2018), the last three weeks focused on statistics. They met twice a week for a 90-minute lecture and a 60 minute seminar. Courses in both settings were designed around the cycle of statistical investigation which focused attention on the problem, plan, data, analysis and conclusion (PPDAC) components (Wild & Pfannkuch, 1999) and its’ implementation in primary classrooms. A core assessment task was the design of a statistical question that would stimulate and drive a cycle of statistical investigation targeted for use with upper elementary grade children (ages 10-12). The content and sequence of the courses was similar across settings and focused broadly on: designing statistical investigations (the PPDAC cycle), types of data, samples and populations, representing and analysing data distributions using graphical visualisations, calculating and interpreting summary statistics (measures of central tendency and variability), and comparing distributions of data.

Study Design

This paper reports on the first part of the investigative cycle: *the design of statistical questions*. Following instruction on the cycle, participants were placed in pairs and informed that they would be required to design a statistical question, and an ensuing statistical investigation, which they would revise and develop over the course of the semester. The three-phase design consisted of:

Phase 1 (Think): Participants worked in pairs to design a statistical question (SQV1) that promoted comparison of two numerical data sets. Course content aligned with this phase, provided examples of strong and weak research questions and explored statistical components relating to question design. Phase 1 culminated with the design of the first version of the statistical questions (SQV1).

Phase 2 (Peer-feedback): Phase 2 provided peer feedback on initial questions. It was envisioned that providing and receiving feedback would develop skills in identifying desirable features of statistical questions. Each pair received the statistical questions (SQV1) of another pair and used a

set of criteria (developed by the authors, Table 1) to guide analysis and feedback. Pairs recorded feedback in the form of questions or statements which were then returned to the original pairs. Phase 2 culminated with participants presenting a revised statistical question (SQV2).

Phase 3 (Expert-feedback): The goal of phase three was the construction of the final research question (SQV3) based on the provision of ‘expert’ feedback to all participants. Expert feedback was provided during a plenum discussion and was generic in nature in that it identified the general shortcomings, strengths and desirable features that emerged in the revised questions (SQV2). Arising from the plenum, participants revised and improve their statistical questions (SQV3).

Look at the question	Is it meaningful? Will the question sustain interest and curiosity of primary children? Is the intent clear and unambiguous?
Think about the variables of interest	Is the variable described clearly? Is the variable available/possible to measure?
Look at the relationship between the question and the data it will generate	Can the question be answered with a simple “yes/no” response [avoid these type of questions]? Will the question generate quantitative data (i.e., numbers)? Will the question motivate a focus on two data sets? Does it promote group comparison of data?
Look at (or imagine) the data	Can you answer your question with the given data? Is there sufficient data collected to answer the question? Is there sufficient variability in data collected (is there the potential for a wide range of possible data values)?

Table 1: Criteria used to provide feedback on statistical questions

Data & Data Analysis

The statistical questions at the phases SQV1-SQV3 constituted the data. Hence our analysis focused on these questions. We identified characteristics of questions posed, rated these characteristics and compared their quality across the three phases. A structuring qualitative content analysis method (Mayring, 2015) was used for rating statistical questions. We constructed our categories mainly using a deductive approach but also took into account inductive elements from our data as a kind of a “mixed approach” (as it is explained in Kuckartz, 2012, p.69). Due to the fundamental theoretical work (see especially Arnold, 2013) carried out on the generation of statistical questions (categories, criteria, etc.) we firstly and mainly used a deductive approach to use and adapt categories and constructs established from existing research studies (Arnold, 2013, Biehler, 2001, Frischemeier & Biehler, 2018, Konold et al. 1997).

The quality of statistical questions was determined using the four question components (Table 1) as an analytical frame. A structured rubric consisting of coding rules and key examples was developed and it carefully guided the assignment of a precise code to each question component. A development process was used to arrive at the components and their sub components (see Column 1, Table 2); however, its description is beyond the scope of this paper. For illustrative purposes, we

will focus only on the development process for the first component “Look at the question” since it considers general characteristics of statistical questions like *Question_meaningful*, *Question_interest*, *Question_clear*, *Question_variables* and *Pop_interest*.

For instance *Question_meaningful* considers whether the question is meaningful (connected to a context, e.g., “Do female students spend more time doing homework than male students?”) and *Question_interest* examines whether the question is interesting for primary school students from an affective point of view (e.g., “Do children with pets spend fewer time with their friends than children without pets?”). Both categories are based on Arnold’s Criterion 5 (Arnold 2013, p. 111).

The category *Question_clear* is based on the third criterion of Arnold (2013, p. 111) that “from the question it needs to be clear if it is a summary, comparison or relationship question”. Thus we determined whether each statistical question was posed in a clear and unambiguous way. A counter-example for a non-clear statistical question found in our data is for example “What is the probability that a boy in your class has glasses?” This sample question does not refer to a statistical investigation and is neither a summary nor a comparison or relationship question.

The category *Question_variables* is based on the categorizations and work of Konold et al. (1997) and Biehler (2001). This category checks which kind of variables (categorical, numerical) are embedded in the statistical question and whether they are implemented in a single form (question with regard to a distribution of a single categorical or numerical variable) or as a combination in the statistical question (categorical vs. categorical, numerical vs. categorical, numerical vs. numerical).

The category *Pop_interest* is based on Arnold’s (2013) second criterion (p. 111). In this category we are interested in the language used in the statistical question and whether the focus is on an individual case, on a sample or on a population. As also mentioned in Arnold (2013), the use of “a” (e.g., a boy) might indicate an individual focus, the use of “the” (e.g., the boys) might refer to cases in the sample and more general the use of “boys” might indicate a focus on a population.

Results

Looking at the question: In Phase 1, the majority of questions posed were meaningful and of interest to children (Rows 2 & 3, Table 2); however, the clarity of these questions posed a greater challenge for Irish participants (see Row 4). Improved clarity was evident across subsequent phases indicating the benefit of peer and expert feedback. By the end of the study, the majority of Irish and Germans (90%, 85%) posed questions involving two variables. A greater number of two-variable questions were posed by Germans in Phase 1 (75%) compared to Irish (44%) (see Row 5, Table 2). Furthermore, the large number of two-variable questions posed in Phase 1 by the Irish (44%) remained stable in Phase 2 (42%) indicating that peer feedback seemed to have little immediate effect. Although there was less room for variation in the German cohort, there was also very little change across the phases. Similarly (see Row 6, Table 2), while the population of interest was clear in 90% of final research questions for both groups, Germans were more successful in identifying the population of interest in Phase 1 (75% versus 58%). The lack of clarity in Irish participants’ initial questions may have contributed to the lack of clarity in identifying the population of interest.

Variables in the question: Initially there was a lack of clarity in describing variables with less than 50% being successful in Phase 1 (see Rows 8 & 9, Table 2). For example, examination of the question (Pair 11, Germans) reveals the lack of clarity in the variable ‘sporting activity’ in terms of what will be measured and the units of measurement. The feedback phases were successful for both groups in improving the clarity of variables (see Pair 11 below). German participants still struggled for clarity in variable description at the end of the study as compared to their Irish counterparts.

Are there differences in the sporting activity of boys and girls? [Pair 11, SQV1]

Are there differences in the *weekly* sporting activities *in hours* of boys and girls? [Pair 11, SQV3]

Relationship between the data and the question: Exploring the relationship between the posed question and the data generated provided insights into how the question opened, or closed, opportunities for exploration of data. Compared with other categories, this category was quite stable over the three phases (see Row 11, Table 2). For both groups, the number of simple survey questions showed a small decrease across the phases. Correspondingly the number of more sophisticated questions showed small increases across phases indicating improvement in the quality of questions posed across the study. Examples of questions categorised as sophisticated in Phase 3 are below.

By how much do the shoes sizes of boys and girls in Class 5 differ? [Pair 3, SQV3, Irish]

Based on your examine of the sugar content of the fruit juices and minerals provided here, explain which drinks are more suitable for consumption. [Pair 1, SQV3, Irish]

Looking at the data: There was no requirement for German participants to submit data sets, hence we report only on Irish data for 3 of the 4 sub-components (see Rows 13-15, Table 2). In Phase 3, 95% were able to answer the question with the given data. Similarly, 95% collected sufficient data to answer the question. When the data sets were examined, the majority (92%) had sufficient structure or variability in the data (that means that a wide range of possible values are given). Both groups demonstrated a steady increase in questions that supported a global view across both phases indicating the benefit of both peer and expert feedback (see Row 16 in Table 2).

Component: Look at the question		Phase 1 (%)	Phase 2 (%)	Phase 3 (%)
Question_meaningful	Ireland	100	100	100
	Germany	100	100	100
Question_interest	Ireland	97	100	100
	Germany	95	95	95
Question_clear	Ireland	59	71	83
	Germany	75	85	90
Question_variables	Ireland: Non statistical	5	5	0
	Ireland: One variable	51	43	10
	Ireland: Two variables	44	52	90
	Germany: Non statistical	20	15	10
	Germany: One variable	5	0	5

	Germany: Two variables	75	85	85
Pop_Interest	Ireland	58	70	90
	Germany	75	85	90
Component: Variables in the question				
Variables_Clear	Ireland	41	59	97
	Germany	45	55	65
Variable_measure	Ireland	85	85	97
	Germany	90	90	90
Component: Relationship between data and question				
Question_type	Ireland: survey	14	7	3
	Ireland: reasonable	72	78	64
	Ireland: Sophisticated	14	15	33
	Germany: survey	20	15	10
	Germany: reasonable	60	50	55
	Germany: Sophisticated	20	35	35
Component: Look at the data				
Answer_question_with_given_data	Ireland	n/a		95
Sufficient_Data_collected	Ireland	n/a		95
Sufficient_Variability_in_data	Ireland	n/a		92
Local_vs_global_view	Ireland	53	64	86
	Germany	75	85	95

Table 2: Categorisation of questions across the three phases

Discussion

When provided with appropriate structured support, prospective teachers can develop the skills and understandings to develop rich statistical questions. However, developing good statistical questions is particularly complex and requires considerable support. Multiple considerations are required. *Question* considerations require attention to the meaningfulness, interest, and clarity of questions in addition to the variables and populations elicited by questions. Consideration of the *variable* requires attention to the clarity of the variables described and the measurement of those variables. Consideration of the *relationship* between the question and the type of data generated is also required in an effort to ensure the data support subsequent analysis. Finally, the *data themselves* require consideration. Attention must be paid to the ability to answer the question from the amount and type of data generated, whether there is sufficient variability in the data and that the question supports a global view of the data. It is not surprising that some of these categories posed lesser or greater difficulty. While participants showed great expertise in addressing the meaningfulness and interest of questions and in identifying the variables available to measure, in contrast, all participants struggled initially to provide clarity when describing the variables. While the purpose of the study was not to compare the Irish and German participants, it is noticeable that German participants performed better across many of the categories in Phase 1. It appears that Irish participants invested their energies in the broader contextual dimensions of questions and in framing questions resulting in the relative neglect of the necessary statistical and content dimensions of the questions posed. The benefits of the peer-feedback process (Phase 2) are not clear from this study. On the one hand by comparing performance across Phases 1 and 2, peer review

brought about improvements in some aspects of question design. It appears to have supported the revision and improvement of some question aspects, most notably in clarifying the question and in identifying the population of interest. For other components, peer-feedback did not seem to support any substantial gains in question quality particularly when selecting and identifying the number of variables embedded in the question and in bringing about improvements in the question type. The effect of feedback when generating and developing statistical questions needs further research into the future.

References

- Arnold, P. M. (2013). *Statistical investigative questions - An enquiry into posing and answering investigative questions from existing data* (Doctoral dissertation, University of Auckland, Auckland, NZ). Retrieved from <https://researchspace.auckland.ac.nz/handle/2292/21305>
- Biehler, R. (2001). Statistische Kompetenz von Schülerinnen und Schülern - Konzepte und Ergebnisse empirischer Studien am Beispiel des Vergleichens empirischer Verteilungen. In M. Borovcnik, J. Engel, & D. Wickmann (Eds.), *Anregungen zum Stochastikunterricht* (pp. 97-114). Hildesheim: Franz Becker.
- Frischemeier, D., & Biehler, R. (2018). *Stepwise development of statistical literacy and thinking in a statistics course for elementary preservice teachers*. Paper presented at the Tenth Congress of the European Society for Research in Mathematics Education, Dublin.
- Konold, C., Pollatsek, A., Well, A., & Gagnon, A. (1997). Students analyzing data: Research of critical barriers. In J. Garfield & G. Burrill (Eds.), *Research on the Role of Technology in Teaching and Learning Statistics: Proceedings of the 1996 IASE Round Table Conference* (pp. 151-167). Voorburg, Netherlands: International Statistical Institute.
- Kuckartz, U. (2012). *Qualitative Inhaltsanalyse. Methoden, Praxis, Computerunterstützung*. Weinheim, Basel: Beltz Juventa.
- Makar, K., & Fielding-Wells, J. (2011). Teaching teachers to teach statistical investigations. In C. Batanero, G. Burrill, & C. Reading (Eds.), *Teaching statistics in school mathematics - Challenges for teaching and teacher education: A joint ICMI/IASE study* (pp. 347-358). New York: Springer.
- Mayring, P. (2015). Qualitative content analysis: theoretical background and procedures. In A. Bikner-Ahsbals, C. Knipping, & N. Presmeg (Eds.), *Approaches to qualitative research in mathematics education* (pp. 365-380). Dordrecht: Springer.
- Pfannkuch, M., & Horing, J. (2004). Developing statistical thinking in a secondary school: A collaborative curriculum development. *Curricular development in statistics education: International Association for Statistics Education*, 204-218.
- Wild, C. J., & Pfannkuch, M. (1999). Statistical thinking in empirical enquiry. *International Statistical Review*, 67(3), 223-248. doi:10.1111/j.1751-5823.1999.tb00442.x

Investigating teachers' pedagogical content knowledge for statistical reasoning via the real life problem scenario

Rukiye Gökce and Sibel Kazak

Pamukkale University, Denizli, Turkey; rukiyegokceimt@gmail.com

The aim of this case study is to identify the levels of pedagogical content knowledge (PCK) of middle school mathematics teachers in relation to statistical reasoning through a real life problem scenario. In this paper we focus on nine teachers' PCK about student thinking and misunderstanding in the context of Leukemia problem scenario. The data from the interviews were analyzed qualitatively. The results indicate some inadequacies in teachers' knowledge of student thinking and misunderstandings with regard to statistical reasoning.

Keywords: Statistical reasoning, pedagogical content knowledge, knowledge of student thinking, knowledge of student misunderstanding, middle school mathematics teachers

Introduction

Statistics is a methodological discipline for dealing with data (Moore & Cobb, 1997). Statistics also has an important role in critical and creative thinking in solving real life problems using data. Individuals who can use statistical knowledge while solving real life problems can be effective citizens. Therefore, using real life problems in teaching statistics is important to prepare individuals to cope with the challenges of daily life more easily. Because a lot of difficult statistical calculations can be made easily by technology, these skills require knowing how statistical information is to be used, analyzed and interpreted, and how to make inferences based on data. Hence it is important that individuals develop their statistical reasoning skills in order to be able to cope with the statistical information surrounding them in daily life. Statistical reasoning is defined as the way in which people reach the correct results from the statistical ideas and make sense of the statistical information (Garfield, delMas & Chance, 2003). Individuals' statistical reasoning skills can be improved during their school education (Garfield & Ben-Zvi, 2007). Teachers play a key role in developing the statistical reasoning skills of students and encouraging them to use these skills. So, teachers need to be well equipped to help students develop such skills. However, the earlier studies (Burgess, 2007; Callingham & Watson, 2011; Madden, 2008; Sorto, 2004; Watson, Callingham & Donne, 2008; Watson, Callingham & Nathan, 2009; Watson & Nathan, 2010) suggest that teachers do not have adequate knowledge of statistics and teaching statistics. Hence, teachers' knowledge about statistical reasoning and how they focus on students' statistical reasoning in teaching statistics become a needed area of inquiry. The purpose of this research is to examine the levels of pedagogical content knowledge (PCK) of nine middle school mathematics teachers with regard to statistical reasoning within the context of a real life problem scenario.

Theoretical Framework

PCK is one of the seven categories of knowledge that a teacher should have in order to make subject matter knowledge accessible to learners (Shulman, 1987). Literature on PCK identifies the knowledge

of student understanding specific to subject matter as one of the sub-dimensions (Ball, Thames, & Phelps, 2008; Shulman, 1986). Burgess' (2007) study on teacher knowledge in teaching statistics showed that teachers were inadequate in using knowledge dimensions that could enrich learning and thus potential learning opportunities were missed. These missed opportunities were related to the following themes in relation to teacher knowledge about teaching statistics: familiarity with the data, interpreting student thinking, student difficulties related to statistical inquiry cycle, understanding of variation, and understanding the development of informal inference.

Callingham and Watson (2011) pointed out the importance of identifying the PCK of teachers in advancing students' statistical understanding. In their study they identified the levels of 42 teachers according to their PCK performances as follows: Aware Level, Emerging Level, Competent Level and Accomplished Level. Teachers at the aware level had less comprehensive statistical understanding and could not make appropriate recommendations to guide student understanding. The classroom interventions proposed by the teachers at the emerging level were, in particular, largely in the form of general strategies. These suggestions were not exactly in the context of statistics, but they pointed to a good teaching. Teachers at the competent level proposed statistically appropriate interventions only in the context of class activities they were familiar with. Teachers at the accomplished level were able to suggest appropriate or inappropriate student responses and student-centered intervention strategies combined with appropriate statistical content.

Watson, Callingham, and Nathan (2009) identified four non-hierarchical components of PCK in a study examining teachers' pedagogical content knowledge in statistics at the middle school level. The first two components that are "recognizing big ideas" and "anticipating student responses" reflect the link between teachers' content knowledge and knowledge of understanding of student thinking. The last two components, "employing content-specific strategies" and "constructing shift to general", include pedagogical practices used by teachers foreseeing the development of student perspectives.

Shulman (1986) and Ball, Thames and Phelps (2008) point to the importance of teacher knowledge of student. Also Burgess (2007), Watson, et al. (2009) and Callingham and Watson (2011) suggest that teacher knowledge needs to be researched more in depth and systematically in statistics education literature. On the other hand, the statistics education literature contains little research on teacher knowledge particularly with regard to statistical reasoning. Thus, this study focuses on investigating the levels of middle school mathematics teachers' PCK related to statistical reasoning.

Method

The case study method was used in the study. The participants of the study consisted of nine middle school mathematics teachers (two female and seven male teachers) from two different schools who volunteered to participate in the research. The participants' years of teaching experience varied between 2 and 35 years. As the interview is the most common data source in case studies (Yin, 2012), data for this study were collected through one-to-one interviews with participants using audio and video recordings. The unit of analysis was teachers' expressions used for each PCK dimension.

Data collection and task

A classroom discussion scenario about the leukemia problem was used during the interviews. The leukemia problem was inspired by the AIDS problem in the study of McClain, Cobb, and Gravemeijer (2000). As shown in Figure 1 the problem requires a comparison of two data groups with different sizes to decide whether the new treatment is more effective than the traditional one in decreasing the number of white blood cells within the given context related to leukemia.

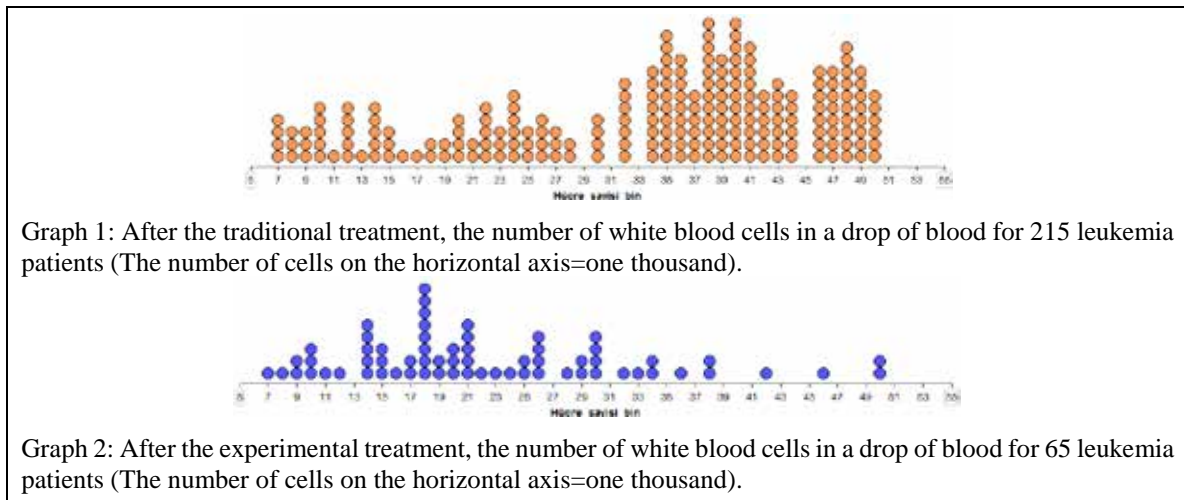


Figure 1: Data given in the Leukemia Problem in the interview protocol

In order to develop the classroom discussion scenario, the leukemia problem was firstly administered to the 6-8th grades students to get a wide range of responses. Then the dialogue in Figure 2 was developed using these students' reasoning. In the interview, teachers were asked to identify which students used appropriate and inappropriate reasoning and the difficulty that might prevent the student from reasoning in an appropriate way.

- 1 **Teacher:** What can you say about whether the experimental treatment used on 65 leukemia patients is more successful than the traditional treatment used in 215 leukemia patients or not?
- 2 **Didem:** I am thinking that traditional treatment is more successful. Because the most people do not want to use the newly developed treatment method.
- 3 **Aylin:** I agree with you, Didem. Number of white blood cell of 43 of the patients treated with the experimental method is between 7000 and 25000. In a drop of blood of 59 of the patients treated with the traditional method there is 7000-25000 white blood cell. Traditional methods have improved more patients. I am thinking that traditional method is more successful, too.
- 4 **Teacher:** Ok then, Tuğçe?
- 5 **Tuğçe:** I think we must consider the traditional method of its own and experimental method of its own, too. 59 of the 215 patients in the conventional treatment and 43 of the 65 patients in the experimental treatment improved. But I don't know how to compare these.
- 6 **Teacher:** What do you think, Kağan?
- 7 **Kağan:** I think that the experimental method is slightly more successful. Because in the experimental method there is no patient in the most high cell values. However, in the traditional method most of the high values of cells are filled. Only in the number of cells 45 thousand, 51 thousand, 52 thousand, 53 thousand and 55 thousand there is no patient.
- 8 **Teacher:** Ok then, is there anybody thinking differently? Sinem?
- 9 **Sinem:** Teacher, I think experimental method is more successful. Because 215 is 3 times 65. If we equalize them, in the experimental method 43, in the traditional method approximately 19 people's white blood cell values return to normal.
- 10 **Hale:** Teacher, it is clear from the shape of the graph. The experimental method is more successful.

- 11 **Teacher:** How did you get that from the shape of the graph, Hale? Can you explain it?
- 12 **Hale:** In the traditional treatment most of the patients stacked on the right side of 25 thousand, in the experimental method most of the patients stacked to the left of the 25 thousand. In the experimental method the number of cells in most patients fell below 25 thousand.

Figure 2: The dialogue between students and teacher about the leukemia problem

Data analysis

In the data analysis, along with the content analysis, the levels of statistical reasoning were defined using the framework and PCK levels used in Callingham and Watson (2011). Codes for PCK dimensions were defined by adapting Watson and Nathan's (2010) codes for statistical reasoning. These codes defined by the levels and PCK dimensions are shown in Table 1.

	Student Thinking		Student Misunderstanding	
	Codes	Explanation	Codes	Explanation
Inadequate Level	No identifying	No explanation	Failure to explain student misunderstanding	No explanation
	Wrong classification	Classifying inappropriate student reasoning as appropriate or classifying appropriate student reasoning as inappropriate	Wrong answers	Identifying misunderstanding incorrectly due to the earlier misclassification of student reasoning
Aware Level	Irrelevant identifying	Expressions different from the answer given by the student	Irrelevant student misunderstanding	Expressions different from the possible misunderstanding of the student
	Identifying based on personal belief	Expressions based on such reasons as carelessness	Student misunderstandings based on personal belief	Expressions based on such reasons as carelessness
	Correct classifying based on wrong reasons	Explanations consisting of classification for wrong reasons	Determining student misunderstandings based on wrong reasons	Identifying student misunderstandings based on wrong reasons
Emerging Level	Uncertain identification	Statements not consisting of clear explanations and repeating the student's response	Uncertain answers	Statements not containing clear descriptions regarding the source of the error/misunderstanding and repeating the student's response
	Incomplete reasons	Insufficient explanations for the reason	Incomplete answers	Insufficient explanations for the source of student error
	Reasons not including clear specific details in relation to the case	Statements based on general statistical interpretations and lack of student knowledge	Responses not including clear specific details in the relation to the case	Statements based on general statistical interpretations and lack of student knowledge

Competent Level	Accurate reasons	Accurate classification of student reasoning based on correct reasons	Accurate reason for student misunderstanding	Explaining the source of student misunderstanding leading to inappropriate statistical reasoning based on correct reason
-----------------	------------------	---	--	--

Table 1: Codes for each level and two PCK dimensions: student thinking and misunderstanding

Findings

Teachers' PCK levels with regard to student thinking

Teachers' success rate for identifying appropriate and inappropriate student reasoning in the given dialogue and the PCK levels based on their explanations regarding student thinking are shown in Table 2. In the leukemia problem scenario teachers have identified six examples of student reasoning as appropriate or inappropriate. The success rate in Table 2 is calculated by the ratio of the number of correct identifications to the number of all student reasoning responses. The purpose of calculating this ratio is to be able to determine the adequacy of teachers in distinguishing appropriate and inappropriate examples of statistical reasoning. Even though several teachers had the same success rate of 67%, as seen in Table 2 the quality of their explanations varied according to the PCK levels described in Table 1.

	Success Rate	Inadequate Level	Aware Level	Emerging Level	Competent Level
Ebru	67%	2	-	-	4
Suat	67%	2	-	1	3
Ismail	50%	3	2	-	1
Güven	83%	1	-	-	5
Eren	17%	5	1	-	-
Semih	67%	2	-	-	4
Seda	67%	2	-	-	4
Orhan	67%	2	-	-	4
Okan	67%	2	-	1	3

Table 2: Teachers' success rates and the number of responses at each PCK level related to student thinking

While the teachers' success rates of correctly identifying students' reasoning change between 17-83%, there are only two participants with a success rate of 50% or less and other success rates are close to each other except for the lowest and highest success rates. In addition, the teachers' statements for the reasons of classifying student reasoning examples are either inadequate level or competent level. This can be related with teachers having more knowledge about some reasoning approaches than the others.

One example of inadequate level was the explanation of Ismail teacher, who considered Aylin's reasoning (Figure 2, statement 3) inappropriate and explained her reasoning as "*there is no need for the new one [treatment], I think she wants to say that it can be carried like that [traditional]*". This

response was considered at the inadequate level because it consisted of details that were not relevant to Aylin's reasoning approach.

Eren teacher classified Aylin's reasoning approach as inappropriate. He explained his reason as "*She has taken into account the number of healthy people. I mean, she did not take into account the entire treatment period.*" The teacher's explanation was evaluated as a response based on incorrect reasons and considered at the level of aware.

Suat teacher who stated that Aylin's reasoning approach was not appropriate, explained his reason as "*She did not consider the patients who were out-of-range.*" Suat teacher's description did not include details on how to handle the number of patients outside the range. For this reason, his answer was dealt with at an emerging level because it did not contain specific details.

The reasoning of Sinem (Figure 2, statement 9) was classified as appropriate. Because Sinem took into account the difference in the sample sizes while comparing two distributions and used proportional reasoning. Güven teacher stated that Sinem used a suitable approach because she equalized the number of data in the groups using proportions. For this reason, the explanation of Güven teacher was evaluated as a correct answer and considered at the competent level.

Teachers' PCK levels with regard to student misunderstanding

Teachers' success rate for identifying the difficulties causing to inappropriate student reasoning in the given dialogue and the PCK levels based on their explanations regarding student misunderstanding are displayed in Table 3.

	Success Rate	Inadequate Level	Aware Level	Emerging Level	Competent Level
Ebru	50%	2	1	-	1
Suat	50%	2	1	-	1
Ismail	50%	2	2	-	-
Güven	75%	1	-	-	3
Eren	25%	3	1	-	-
Semih	50%	2	-	-	2
Seda	50%	2	-	1	1
Orhan	50%	2	-	1	1
Okan	50%	2	-	1	1

Table 3: Teachers' success rates and the number of responses at each PCK level related to student misunderstanding

As seen in Table 3, the teachers' success rates of correctly identifying the difficulties causing to inappropriate student reasoning change between 25% and 75% and it is mostly at 50%. Moreover, the teachers' explanations about the sources of the errors are generally at the inadequate level and some at the competent level. Two of the teachers could not respond at the competent level. These findings point out the inadequacy in teacher knowledge about student misunderstanding.

Ismail teacher considered Kağan's inappropriate statistical reasoning (Figure 2, statement 7) as appropriate: "*Kağan used appropriate reasoning because he took both data groups into account and compared the data*". Therefore, the explanation of Ismail teacher was evaluated as a wrong answer and considered at the inadequate level.

Ebru teacher explained Aylin's misunderstanding as "*Rather than evaluating the information at hand, she made a decision according to her own ideas or her thoughts based on observations around her.*" While Ebru teacher considered Aylin's reasoning as her personal opinions, she did not notice that Aylin failed to take into account the number of data points in each group and did not mention the lack of proportional reasoning. Therefore, the explanation of Ebru teacher was evaluated as an irrelevant answer and considered at the aware level.

Orhan teacher made a statement about the misunderstanding behind Aylin's inappropriate reasoning: "*I think the difficulty is that she cannot understand the text and the question exactly.*" His explanation indicating that "*she does not understand the question*" was evaluated at the aware level because it was mainly an expression that showing an evaluation based on a personal belief.

Seda teacher explained Aylin's error as "*Inability to fully understand the logic. For example, when there are two data [groups] to compare, she cannot specify the method of comparison.*" Since her explanation did not specify the point about how to determine the method of comparison, her statement was evaluated as an uncertain response and considered at the emerging level.

Güven teacher stated that Tuğçe's reasoning (Figure 2, statement 5) was in an inappropriate form and explained her misunderstanding as "*she cannot see the ratio between the values and cannot calculate*". Güven teacher's explanation was considered at the competent level because he based the source of the error on the right reasons.

Discussion and conclusion

The results of this research show that participating middle school mathematics teachers tend to have difficulties in recognizing the appropriateness of student reasoning. We did not see any pattern in teachers' success rate of identifying which students used appropriate and inappropriate reasoning with regard to their years of teaching experience in this study. This could be due to the small number of participants volunteered for this study. Moreover, teachers PCK levels with regard to student thinking and misunderstanding are either insufficient or competent. These findings suggest that while teachers are better in recognizing some students' reasoning approaches, they have no knowledge about some others. Therefore, teachers need to develop a spectrum of student thinking knowledge about statistical reasoning. Inadequacies in teachers' knowledge of student are similar to the findings of earlier research (Callingham & Watson, 2011; Watson & Nathan, 2010; Watson, et al., 2008). As Shulman (1986; 1987) and Ball, Thames, and Phelps (2008) point out, student knowledge is one of the important dimensions of the PCK. According to Burgess (2007), such inadequate knowledge can lead to the missed opportunities for developing student learning. However, we were not able to analyze this since the teachers were not observed in the actual classroom for a long period of time. For future research, both interviews with teachers and lengthy classroom observations can be conducted to gain deeper understanding of teachers' PCK in relation to student thinking and misunderstanding.

References

- Ball, D. L., Thames, M. H., & Phelps, G. (2008). Content knowledge for teaching what makes it special?. *Journal of Teacher Education*, 59(5), 389–407.
- Ben-Zvi, D., & Garfield, J. (2004). Statistical literacy, reasoning, and thinking: Goals, definitions, and challenges. In D. Ben-Zvi & J. Garfield (Eds.), *The challenge of developing statistical literacy, reasoning and thinking* (pp. 3–15). Dordrecht, The Netherlands: Kluwer Academic Publishers.
- Burgess, T. A. (2007). *Investigating the nature of teacher knowledge needed and used in teaching statistics*. (Unpublished doctoral dissertation). Massey University, Auckland, New Zealand.
- Callingham, R., & Watson, J. (2011). Measuring levels of statistical pedagogical content knowledge. In C. Batanero, G. Burrill & C. Reading (Eds), *Teaching Statistics in School Mathematics- Challenges for Teaching and Teacher Education* (pp. 283–293). Netherlands: Springer
- Garfield, J., & Ben-Zvi, D. (2007). How students learn statistics revisited: A current review of research on teaching and learning statistics. *International Statistical Review*, 75(3), 372–396.
- Garfield, J., DelMas, R. C., & Chance, B. L. (2003). *The Web-based ARTIST: Assessment resource tools for improving statistical thinking*. Paper presented at the annual meeting of the American Educational Research Association (AERA), Chicago.
- Madden, S. R. (2008). *High school mathematics teachers' evolving understanding of comparing distributions*. (Unpublished doctorate dissertation). Western Michigan University, Kalamazoo, Michigan, USA
- McClain, K., Cobb, P., & Gravemeijer, K. (2000). Supporting students' ways of reasoning about data. In Burke, Maurice J. & Curcio, R. Frances (Eds.), *Learning Mathematics for a New Century, 2000 Yearbook* (pp. 174-187). Reston, VA: NCTM.
- Cobb, G. W., & Moore, D. S. (1997). Mathematics, statistics, and teaching. *The American Mathematical Monthly*, 104(9), 801-823
- Shulman, L. (1986). Those who understand: Knowledge growth in teaching. *Educational Researcher*, 15(2), 4–14.
- Shulman, L. (1987). Knowledge and teaching: Foundations of the new reform. *Harvard Educational Review*, 57(1), 1–22.
- Sorto, M. A. (2004). *Prospective middle school teachers' knowledge about data analysis and its application to teaching*. (Unpublished doctoral thesis). Michigan State University, Michigan, USA
- Watson, J., Callingham, R., & Donne, J. (2008). Establishing PCK for teaching statistics. In C. Batanero, G. Burrill, C. Reading, & A. Rossman (Eds.), *Joint ICME/IASE study: Teaching statistics in school mathematics. Challenges for teaching and teacher education. Proceedings of the ICMI Study 18 and the 2008 IASE Round Table Conference*. Voorburg, Netherlands: IASE [Online: http://www.stat.auckland.ac.nz/~iase/publications/rt08/T2P10_Watson.pdf]
- Watson, J., Callingham, R., & Nathan, E. (2009). Probing teachers' pedagogical content knowledge in statistics: "How will Tom get to school tomorrow?" In R. Hunter, B. Bicknell, & T. Burgess (Eds.), *Crossing Divides Vol.2* (pp. 563–570). Palmerston North, NZ: MERGA.
- Watson, J., & Nathan, E. L. (2010). Approaching the borderlands of statistics and mathematics in the classroom: qualitative analysis engendering an unexpected journey. *Statistics Education Research Journal*, 9(2), 69-87
- Yin, R. K. (2012). *Applications of case study research* (3rd ed). California, USA: SAGE Publication

It's a good score! Just looks low: Using data-driven argumentation to engage students in reasoning about and modelling variability

Orlando González¹ and Somchai Chitmun²

¹Assumption University, Graduate School of Human Sciences, Bangkok, Thailand; ogonzalez@au.edu

²Teppleela School, Bangkok, Thailand; schitmun@hotmail.com

This paper describes senior high school students' different ways of reasoning about and modelling variability, drawn from the initial phase of an ongoing study. A group of 26 Thai Grade 12 students was engaged in a statistical investigation by addressing a socially open-ended problem based on an unsorted set of varying test scores. Through engagement with this problem, students were able to experience data-driven argumentation and data modelling. From analyzing the answers provided by participants, four different categories of reasoning about variability (i.e., value-relation, magnitude-comparative, proportional, and distributional reasoning) and 11 ways of modelling variability in the context of the given situation were identified. The study also revealed that participants are somehow good proportional reasoners in general, but weak distributional ones.

Keywords: Argumentation, socially open-ended problems, reasoning about variability, variability modelling, statistical investigations.

Introduction

Good citizenship requires being statistically literate. Statistical literacy includes making sense of real-world data, the use of evidence-based arguments and critically evaluating data-based claims (Garfield & Ben-Zvi, 2008). Being critical is essential as claims and arguments are usually presenting selective information to convince another person to adopt or reject a specific point of view (Gal, 2004). On this regard, it has been reported in the literature that data-driven argumentation—which requires using, revising, manipulating, structuring and representing data to explain or persuade others—is very important for data modelling and informal inference (Garfield & Ben-Zvi, 2008; Shaughnessy, Ciancetta, & Canada, 2004).

Such importance has been acknowledged by recent reforms to the mathematics curriculum in many countries, Thailand being an example. In fact, according to the current Thai Basic Education Core Curriculum (MOE, 2008), Grade 12 graduates must be able, among other things, to analyze data and apply the results to express views and persuasive arguments using accurate and appropriate language. However, teacher's guides do not include specific instructional suggestions on this matter.

Under this scenario, socially open-ended problems (Shimada & Baba, 2015) emerge as an appealing and plausible way of providing students with the possibility of using, handling and interpreting data to inform argumentation and decision-making. This kind of problem has been reported as an instructional way to challenge students to structure variability among repeated observations of the same event, to model variability, and to engage in data-driven argumentation (González & Chitmun, 2017). The purpose of the present paper is to answer the following research question: what are the ways, if any, by which Thai senior high school students reason about and model variability, when they are asked to provide persuasive explanations and arguments based on data analysis, in the

context of a socially open-ended problem? A lesson implementation of a socially open-ended problem will be discussed and analyzed, and some conclusions will be given based on its results.

Practicing data-driven argumentation as advocacy

Argumentation refers to discourse for persuasion, logical proof, and evidence-based belief, and more generally, discussion, in which there is reasoning on data, doubt about a standpoint or a disagreement with it, and frequently a question about whether, or at least why, a standpoint is worthy of acceptance (Blair, 2003; Garfield & Ben-Zvi, 2008). Argumentation can take two forms: inquiry and advocacy (Toulmin, Rieke, & Janik, 1984, as cited in Watson, 2018). The practice of argumentation as inquiry presupposes the act or process of deriving conclusions from data, whereas the practice of argumentation as advocacy presupposes the questioning of a standpoint, objections to a person's arguments, and arguments against the standpoint a person is supporting (Blair, 2003). Involvement with statistics in daily life is often about judging claims and arguments of others who practice statistics to some degree or another (Gal, 2004; Watson, 2018). Therefore, arguing against claims made by others (e.g., "your mathematics test score was awful!") is likely to require data-driven argumentation associated with advocacy. This involves the ability to advocate against the claim at hand with some evidence grounded in data, in order to make an alternate claim (Watson, 2018).

Statistical investigations and data-driven argumentation

A statistical investigation is a process comprised of the following five phases: Problem, Plan, Data, Analysis, and Conclusion (PPDAC), regarded as one of the four central dimensions of statistical thinking used in statistical inquiry of real-life problems (Makar & Fielding-Wells, 2011). By engaging in statistical investigations, students are able to fully experience statistical processes such as acknowledging, modelling of and reasoning about variability, data representation, data reduction, data-driven argumentation, decision-making, and informal inference (Watson, 2018).

In order to appropriately conduct statistical investigations in the mathematics classroom, teachers and students need to use problems worthy of investigation, which involve statistical questions, a real-life context, and the following traits: (1) interesting, challenging, and relevant; (2) statistical in nature; and (3) ill-structured and ambiguous (Makar & Fielding-Wells, 2011). Addressing questions with these characteristics demands critical thinking skills and the practice of argumentation as advocacy, because questions developed for statistical investigations usually challenge and question, ambiguously or without proper statistical foundation, the standpoint a person is supporting (Blair, 2003; Gal, 2004; Watson, 2018). Thus, undergoing a statistical investigation requires the ability to challenge statements made in the given context and advocate, with evidence, for an alternate claim (Watson, 2018); in other words, requires the practice of data-driven argumentation as advocacy.

Socially open-ended problems as a trigger for data-driven argumentation

Socially open-ended problems (Shimada & Baba, 2015) are problems embedded in a real-life context, familiar to the students and, by extending the traditional open-ended approach (Becker & Shimada, 1997), have been developed to elicit and address students' mathematical values (e.g., visual appeal, parsimony, abstraction, systematic reasoning), social values (e.g., compliance with the law, fairness, compassion, equity), and personal values (e.g., persistence, integrity, friendliness) through modelling

and argumentation. So, from the past section, it is possible to identify clear similarities between socially open-ended problems and the problems developed for statistical investigations.

In order to ensure triggering data-driven argumentation through the use of socially open-ended problems, the real-life context in which the problem is embedded must be statistical in nature (i.e., must enable students to collect, represent, reduce and/or interpret data to address a statistical question and reach reasonable conclusions under uncertainty; González & Chitmun, 2017). Thus, arguments from addressing the posed problem will have the four building blocks to make a good argument (Blair, 2003; Garfield & Ben-Zvi, 2008, p. 275): (1) A clear claim (and a counterclaim) we are making and/or anticipating; (2) data to support our argument; (3) evidence that the data are accurate and reliable, and (4) a good line of reasoning connecting the data to our argument.

The purpose of this study was not only to engage students in data-driven argumentation, but also to challenge them to reason about and model variability. To that end, the problem should provide students with opportunities to display, structure and model variability among observations of the same event, to make accessible and meaningful to students characteristics of distribution (e.g., center, shape and spread; Lehrer & Schauble, 2004; Mulligan & English, 2014; Petrosino et al., 2003).

Research methodology overview

Participants

On August 31, 2018, data were collected from a Grade 12 mathematics class (17- to 18-year-old youths) in a large public high school in Bangkok. The second author was the classroom teacher. A total of 26 students (boys=3, girls=23) were administered the task shown in Figure 1.

Protocol and data gathering procedure

The task chosen for this study was an adaptation of the “Let’s think of an excuse for the test score” problem (Tamaoki, 2014, p. 120, see Figure 1). This task, a socially open-ended problem, requires from students to put in practice data-driven argumentation as advocacy, because they have to consider the variability in the given empirical distribution of scores and then generate additional arguments to explain Malee’s mother why her test score is not necessary such a bad result in the given context.

LET’S THINK OF AN EXCUSE FOR THE TEST SCORE

The numbers below are the results achieved by a certain class on a mathematics test (100 points maximum), sorted by student number in the class attendance sheet. Malee is the only one who got 33 points. Only by what this score tells, she will be scolded by her mother. What could Malee possibly say to avoid a scolding for her mathematics test score?

25	28	45	44	41	28	58	88	100	21	28
16	50	50	45	33	21	22	24	25	26	28
30	45	28	23	25	22	77	100	26	58	26
14	12	69	28	18	53	100				

Figure 1: Task used in this study (adapted from Tamaoki, 2014)

This task was collected from a Japanese junior high school teacher during a previous study conducted by the authors (González & Chitmun, 2015). In order that Thai students were able to respond to this task without being distracted by names or contexts unusual or non-existent for them, two changes

regarding the general cultural context were made when translating it into Thai: a Thai name for the student and “her mother” (as opposed to “her family” in the original task) were chosen for this version. The adapted task was then printed on single paper sheets and distributed among the students, who individually engaged in solving it after being instructed by the teacher. Fifty minutes were given to complete the task. Students were not assisted in any way that could influence their responses.

Analysis of the collected data

Both authors used open coding and descriptive coding to analyze the information provided by the students, and to group similarly-structured answers into categories for analysis. After consensus between the authors, this process led to four categories on students’ reasoning about variability in the given task. Also, students’ ways of modeling variability were categorized. The authors also agreed on the placement of all the 26 responses into the categories previously created.

Empirical findings and discussion

Participants’ types of reasoning about variability

Students’ reasoning about variability fell into four coding categories: value-relation, magnitude-comparative, proportional, or distributional reasoning. Table 1 shows the percentages of students under each of these categories. Students were allowed to provide more than one argument to present Malee’s low test score as not such a bad result, resulting in a total percentage of more than 100%.

Category of reasoning	Description	%
Value-relation	Arguments using only comparative or ordinal phrases to indicate the difference between Malee’s score and particular data values within the data set.	46.2
Magnitude-comparative	Arguments using both comparative phrases (e.g., “greater than”, “less than”, “more”, “less”) and quantified expressions (e.g., “7 points”) to indicate the difference between Malee’s score and particular data values within the data set.	7.7
Proportional	Arguments using, implicitly or explicitly, the ratio, the actual percentage or the proportion of elements having a particular characteristic within the distribution of outcomes.	100
Distributional	Arguments combining two or more key features of the distribution of outcomes (e.g., centers, shape, skewness, density, outliers, and spread/variability).	15.4

Table 1: Percentage of students using each coding category in this study

Students whose responses included arguments using only comparative (e.g., “greater than”, “less than”, “more”, “less”) or ordinal (e.g., “third”, “fourth from”) phrases to indicate the difference or position between Malee’s score and either some center (i.e., the mean or mode) or a particular data value serving as reference point (e.g., 100 points), fell into the *value-relation reasoning* category. A total of 12 students (46.2%) fell into this category. The next quotes illustrate this category.

Student 20: The mode was 28 points. Malee’s test score is higher than the mode.

Student 26: I got 33 points, which is the 6th best score among all the students who failed the test.

Students whose responses included arguments using both comparative phrases (e.g., “greater than”, “less than”, “more”, “less”) and quantified expressions (e.g., “7 points”) to indicate the difference between Malee’s score and either some measure of center (i.e., the mean or mode) or a particular data value serving as reference point (e.g., 50 points), fell into the *magnitude-comparative reasoning* category. Only 2 (7.7%) out of 26 students fell into this category. Examples of this category follow:

Student 14: Malee got 33 points, which is lower than the passing criterion by 17 points.

Student 15: Tell her mother that Malee’s score is lower than the mean only by 7 points.

Students whose responses included arguments using, implicitly or explicitly, the ratio, the actual percentage or the proportion of elements having a particular characteristic within the distribution of outcomes (e.g., the percentage of students who passed and/or failed the test), fell into the *proportional reasoning* category. All 26 students (100%) gave answers falling into this category. The following two sub-categories were identified under this category: *implicit proportional reasoning* (i.e., responses including arguments suggesting an implicit consideration of sample proportions, population proportions, or percentages); and *explicit proportional reasoning* (i.e., responses including arguments explicitly mentioning the ratio, the actual percentage or the proportion of elements having a particular characteristic within the distribution of outcomes).

In this study, a total of 11 students (42.3%) were categorized as implicit proportional reasoners. The next quote illustrates the category “Implicit proportional reasoning.”

Student 1: Tell mom that Malee’s score is more than the median, and there were only 16 students who got more than 33 points and 23 students who got less than 33 points. Therefore, her score is somehow satisfying under these criteria.

In this study, a total of 15 students (57.7%) were categorized as explicit proportional reasoners. The next quote illustrates the category “Explicit proportional reasoning.”

Student 3: From the box-plot diagram, it was found that Malee’s score (33 points) is higher than ... the scores of 50% of the total students but not reach the score of the 75%.

Students’ responses coded as *distributional reasoning* included arguments integrating two or more key features of the distribution of scores, such as centers (e.g., mean, modes, proportions), shape (e.g., skewness), spread (e.g., range, standard deviation) and outliers. A total of 4 students (15.4%) fell into this category. The next quotes illustrate the category “Distributional reasoning.”

Student 6: From interpreting the standard deviation, Malee’s score lies to the left of the mean, where most of students’ scores are. However, Malee’s score is in the range between Q_2 and Q_3 , which is higher than 50% of students who got similar scores.

Student 12: Most of the students’ scores skew to the left of the median.

Participants’ ways of modelling variability

Eleven ways of modelling variability by the students were identified (see Table 2). Students were allowed to represent the data in more than one way, resulting in a total percentage of more than 100%.

Model code	Type of model	Model description	Frequency (%)
M_1	Visual	Sorted data array	13 (50)
M_2	Visual	Stem-and-leaf plot	7 (26.9)
M_3	Visual	Boxplot*	7 (26.9)
M_4	Visual	Pie chart	1 (3.8)
M_5	Visual	Bar graph	1 (3.8)
M_6	Visual	Visually estimated skewness	2 (7.7)
M_7	Mathematical	Mean	4 (15.4)
M_8	Mathematical	Median	8 (30.8)
M_9	Mathematical	Mode	8 (30.8)
M_{10}	Mathematical	Standard deviation	2 (7.7)
M_{11}	Mathematical	Frequency distribution	13 (50)

Note. * Students who drew boxplots calculated the three quartiles of the distribution of scores. Quartiles are also mathematical models.

Table 2: Summary of the different types of models developed by the participants in this study

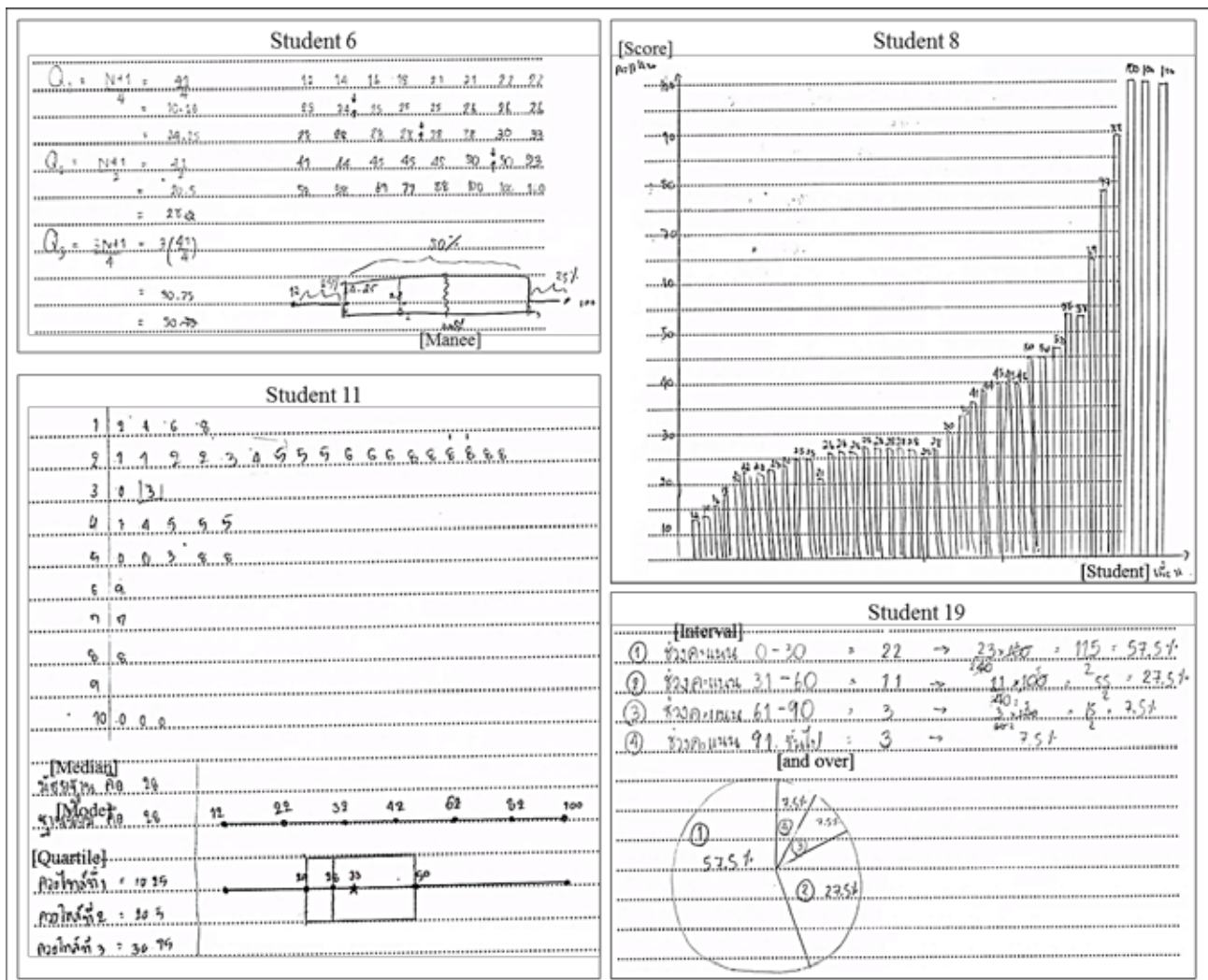


Figure 2: Examples of different types of models developed by the participants in this study

On average, two to three models were provided per student, being the mode 2 models (9 students, 34.6%), and the number of models developed by participants ranged from 1 to 5. As can be seen in Table 2, sorted data arrays (13 students, 50%) and frequency distributions (13 students, 50%) were the models most used by students when answering the given task. In relation to students' reasoning about variability in this task, it is worth noting that only 1 student out of the 14 who provided evidence of either value-relation reasoning or magnitude-comparative reasoning drew and used a boxplot to support her argument. This comes as no surprise, given that value-relation reasoning and magnitude-comparative reasoning focus on attending to individual or groups of cases, rather than aggregate features of data sets as a whole (Watson, 2018). On the contrary, 6 out of 7 of the students who drew a boxplot in this task gave reasons explicitly using proportions (i.e., explicit proportional or distributional reasons). Moreover, all the participants engaged in some total ordering of all sample elements, either via a sorted data array, a frequency distribution, or a stem-and-leaf plot.

Some of the models developed by participants in this study are shown in Figure 2. Some misunderstandings in the construction and use of certain models were identified during the data analysis (e.g., the bar graph in Figure 2). This issue will be addressed in a future publication.

Conclusions

It can be concluded that participants relied more on value-relation or magnitude-comparative reasons in their arguments, in comparison to distributional ones. However, all participants used, implicitly or explicitly, proportional reasoning, which was evident from the use of proportions or relative frequencies in all their responses. This fact suggests that participants are somehow good proportional reasoners in general, but still weak distributional ones. The source of this difficulty could be rooted on the fact that, in Thailand, students learn about stem-and-leaf plots, boxplots and quartiles in Grade 12 (participants' current grade), and they may need more time and/or experience to master those ideas.

It can be also concluded that asking students to provide persuasive arguments based on data, in the context of a socially open-ended problem, will give them opportunities to, among other things, (1) make meaningful use of distribution features such as center, proportions and spread; (2) structure variation and coordinate variability and chance by engaging actively in modeling challenges; (3) develop an aggregate view of data; (4) engage in data-driven argumentation by enacting the practice of argumentation as advocacy; (5) actively engage in the decision-making process, in order to choose and generate models able to concisely describe a body of data and capture the essential characteristics of a real-life phenomenon; and (6) develop students' awareness of variability.

Finally, we can conclude that socially open-ended problems with the characteristics described here seem to be a way to help teachers achieve the aims of the mathematics curriculum about statistics education. Moreover, the results reported here provide teachers and researchers with insight into students' ways of reasoning about and modeling variability, which can be used to improve teaching practice, design better curriculum materials, and uncover misconceptions about statistical ideas.

References

Becker, J., & Shimada, S. (1997). *The open-ended approach: A new proposal for teaching mathematics*. Reston, VA: NCTM.

- Blair, J. A. (2003). Relationships among logic, dialectic and rhetoric. In F. H. van Eemeren, J. A. Blair, C. A. Willard & A. F. Snoeck Henkemans (Eds.), *Anyone has a view: Studies in argumentation* (pp. 91–107). Dordrecht: Kluwer Academic Publishers.
- Gal, I. (2004). Statistical literacy. Meanings, components, responsibilities. In D. Ben-Zvi & J. Garfield, *The challenge of developing statistical literacy, reasoning and thinking* (pp. 47–78). Dordrecht: Kluwer Academic Publishers.
- Garfield, J., & Ben-Zvi, D. (2008). *Developing students' statistical reasoning*. New York: Springer.
- González, O., & Chitmun, S. (2015). Secondary teachers' pedagogical content knowledge to promote students' data-based decision-making ability: The cases of Japan and Thailand. In C. Vistro-Yu (Ed.), *Proceedings of the 7th EARCOME* (pp. 475–484). Quezon City: MATHTED.
- González, O., & Chitmun, S. (2017). Using sport-related socially open-ended problems to coordinate decision-making, variability modeling and value awareness. In T. Dooley & G. Gueudet (Eds.), *Proceedings of the 10th CERME* (pp. 780–787). Dublin: Dublin City University and ERME.
- Lehrer, R., & Schauble, L. (2004). Modeling natural variation through distribution. *American Educational Research Journal*, 4, 635–679.
- Makar, K., & Fielding-Wells, J. (2011). Teaching teachers to teach statistical investigations. In C. Batanero, G. Burrill, & C. Reading (Eds.), *Teaching statistics in school mathematics* (pp. 347–358). New York: Springer.
- Mulligan, J., & English, L. (2014). Developing young students' meta-representational competence through integrated mathematics and science investigations. In J. Anderson, M. Cavanagh, & A. Prescott (Eds.), *Proceedings of the 37th Conference of MERGA* (pp. 493–500). Sydney: MERGA.
- Petrosino, A. J., Lehrer, R., & Schauble, L. (2003). Structuring error and experimental variation as distribution in the fourth grade. *Mathematical Thinking and Learning*, 5(2&3), 131–156.
- Royal Thai Ministry of Education (MOE) (2008). *The basic education core curriculum*. Bangkok: Bureau of Academic Affairs and Educational Standards.
- Shimada, I. (2015). *Nurturing the competence of being engaged with diverse values in mathematics education: An effort through solving socially open-ended problems* (in Japanese) (Unpublished doctoral dissertation). Hiroshima University, Hiroshima, Japan.
- Shimada, I., & Baba, T. (2015). Transformation of students' values in the process of solving socially open-ended problems. In K. Beswick, T. Muir, & J. Wells (Eds.), *Proceedings of the 39th Conference of the IGPME* (Vol. 4, pp.161–168). Hobart, Australia: PME.
- Shaughnessy, J. M., Ciancetta, M., & Canada, D. (2004). Types of student reasoning on sampling tasks. In M. Høines & A. Fuglestad (Eds.), *Proceedings of the 28th Conference of the IGPME* (Vol. 4, pp. 177–184). Bergen, Norway: Bergen University College.
- Watson, J. M., Fitzallen, N., Fielding-Wells, J., & Madden, S. (2018). The practice of statistics. In D. Ben-Zvi, K. Makar, & J. Garfield (Eds.), *International handbook of research in statistics* (pp. 105–138). Cham, Switzerland: Springer.

Prospective teachers' interdisciplinary learning scenario to promote students' statistical reasoning

Ana Henriques¹, Hélia Oliveira¹ and Mónica Baptista¹

¹Instituto de Educação, Universidade de Lisboa, Portugal

achenriques@ie.ulisboa.pt; hmoliveira@ie.ulisboa.pt; mbaptista@ie.ulisboa.pt

Keywords: Learning Scenario, STEM, Representations, Statistical reasoning, pre-service teacher education.

The development of students' ability to reason about data and to use data effectively and critically for prediction and decision-making is a priority in statistics education (Franklin et al., 2007), allowing to prepare 21st century students to succeed in today's society (Watson & Fitzallen, 2010). Statistical reasoning has a clear dependence on adequate data representation to support decision-making and argumentation, a process that has proved to be problematic for the students (Chick, 2004). A successful data analysis depends on students' knowledge on what types of representation are useful and on a set of transnumeration actions that facilitate to transform data in ways that lead to such representations or to alter them, making the representations convincing in terms of the evidence they provide from data claims (Chick, 2004; Wild & Pfannkuch, 1999). Such actions, as proposed by Chick (2004), are: Sorting; Grouping; Calculation of frequency, proportion or statistical measures; and Graphing. A pedagogical possibility to foster students' ability to use the representations fluently and effectively is the use of learning scenarios (Clark, 2009) that promote the integration of science and mathematics with technology. STEM (Science, Technology, Engineering and Mathematics) integration is widely recognized as an important foundation for statistical reasoning, given its potential to deepen students' understanding of the purpose and utility of data in making meaning of the real-world, an aspect suggested in curriculum documents but that has been neglected in statistics education (Fitzallen et al., 2018). Therefore, it is essential to engage prospective teachers (PTs) in activities that provide opportunities to improve their confidence and effectiveness on developing STEM integration activities, in school (Ní Ríordáin, Johnston, & Walshe, 2016). However, research is still needed to document in detail how PTs plan and implement learning scenarios in context of STEM to teach statistics topics and how students benefit from this experience (Huey et al., 2018).

This study is based on a teacher education experience involving 10 PTs of Physics and Chemistry and of Mathematics. The PTs, organized in mixed small groups and in collaboration with the teacher educators (the authors), developed an interdisciplinary learning scenario that includes a sequence of three lessons for the 8th grade, around an inquiry task that integrates Statistics and Physics and requires decision making and argumentation based on data. In this poster, we focus on students' activity regarding Statistics, in this context, aiming to analyse their transnumeration actions when using the software *TinkerPlots*TM (Konold & Miller, 2005), for data handling, in the exploration of the inquiry task.

The study follows a qualitative and interpretative methodology. Data collection methods include the students' written work on the inquiry task, the records of their work in *TinkerPlots* and the video

records of the learning scenario lessons. The results show that students made appropriate choices of graphical representations and intentionally used transnumeration actions, taking advantage of the potential of the *TinkerPlots* to support the interpretation of data and to obtain evidence for their statements. The work carried out around the representations allowed to guide the students to understand how to organize the data and analyze them in order to answer the questions or draw conclusions. These results evidence the benefits of the learning scenario to foster students' ability to reason about data. Nevertheless, it seems that students still need more opportunities to learn how to articulate different representations, either static or dynamically, an issue that demands greater attention from the PTs in the planning and enactment of the learning scenario.

Study supported by national funds through FCT, Project "Technology Enhanced Learning at Future Teacher Education Lab" (PTDC/MHC-CED/0588/2014).

References

- Clark, R. (2009). Accelerating expertise with scenario based learning. *Learning Blueprint*. Merrifield, VA: American Society for Teaching and Development.
- Chick, H. L. (2004). Tools for transnumeration: early stages in the art of data representation. In I. Putt, R. Faragher, & M. McLean (Eds.), *Proceedings of the 27th Annual Conference of the Mathematics Education Research Group of Australasia* (pp. 167-174). Sydney: MERGA.
- Fitzallen, N., Watson, J., Wright, S., & Duncan, B. (2018). Data representations in a STEM context: the performance of catapults. In M. A. Sorto, A. White, & L. Guyot (Eds.), *Proceedings of the 10th International Conference on Teaching Statistics*. Voorburg, The Netherlands: IASE and ISI.
- Franklin, C., Kader, G., Mewborn, D., Moreno, J., Peck, R., Perry, M., & Scheaffer, R. (2007). *Guidelines for assessment and instruction in statistics education (GAISE) report: A pre-K-12 curriculum framework*. Alexandria, VA: American Statistical Association.
- Huey, M., Champion, J., Casey, S., & Wasserman, N. (2018). Secondary mathematics teachers' planned approaches for teaching standard deviation. *Statistics Education Research Journal*, 17(1), 61-84.
- Konold, C., & Miller, C. D. (2005). *TinkerPlots: dynamic data exploration*. Emeryville, CA: Key Curriculum Press.
- Ní Ríordáin, M., Johnston, J., & Walshe, G. (2016). Making mathematics and science integration happen: key aspects of practice. *International Journal of Mathematical Education in Science and Technology*, 47, 233-255.
- Wild, C. J., & Pfannkuch, M. (1999). Statistical thinking in empirical enquiry. *International Statistical Review*, 67(3), 223-248.
- Watson, J., & Fitzallen, N. (2010). *The development of graph understanding in the mathematics curriculum: Report for the NSW Department of Education and Training*. Sydney: State of New South Wales through the Department of Education and Training.

The development of a domain map in probability for teacher education

Judith Huget

Bielefeld University, Faculty of Mathematics, IDM, Germany; jhuget@math.uni-bielefeld.de

The importance of probability increased in German teacher education in the last decades. However, research about the professional knowledge of (prospective) teachers focused on other content such as number theory and functions rather than probability. The project “The development of professional knowledge of prospective teachers in probability” aims at developing a test in order to measure teacher knowledge in probability. In order to measure content knowledge and pedagogical knowledge in this domain, one has to identify categories, concepts and ideas and connections between. This paper shows the development of a domain map, which indicates categories, concepts and ideas. The theoretical framework, the procedure of developing and an outlook is given.

Keywords: Mathematics education, mathematics teachers, teacher competencies, teacher competency test, probability.

Introduction

In the state North Rhine-Westphalia in Germany, stochastics was not obligatory for the general qualification for university entrance until recently. Teachers could decide to exclude topics for the finals. Now stochastics is mandatory. The focus of studies about professional teacher knowledge was not on probability, which is part of stochastics. The main aim of this project is to develop a test to measure the development of content knowledge and pedagogical content knowledge of prospective teachers in probability. While developing items, one has to identify necessary categories in probability to develop items to measure content knowledge in that area. This paper identifies structures and categories by developing a domain map, which shows the content of probability. Those maps, which Hill and Bell developed for their study as well (2007), help distinguish categories in probability and draw important connections between categories in order to develop items. In order to develop this domain map, educational standards and curriculums were analyzed and an expert study was conducted.

The paper is organized as follows. In the first chapter, the theoretical frame will be presented. Afterwards, the two steps of the domain map development will be demonstrated. In the outlook, the domain map is integrated into the test design and the timetable of the test is presented.

Theoretical Framework

Models of Teacher Knowledge and Competencies

In this chapter, models of teacher knowledge and teacher competency tests are introduced. Shulman’s categories of teacher knowledge, the studies COACTIV and TEDS-M are presented to determine the theoretical framework of this paper.

Initially, Lee S. Shulman (1986a, 1986b; 1987) developed categories of teacher knowledge: content knowledge, general pedagogical knowledge, curriculum knowledge, pedagogical content knowledge,

knowledge of learners and their characteristics, knowledge of educational context and knowledge of educational ends. Several other researchers adopted Shulman's model and adapted it (e.g. Bromme, 1992, Hill et al., 2008 and Schumacher, 2017).

In the study COACTIV, conducted in 2003/2004 by Stefan Krauss et al. (2008), which is about professional competence of teachers, cognitively activating instruction and development of students' mathematical literacy, Shulman's category "content knowledge" was specified. Krauss et al. (2008, p. 876) declared content knowledge as "a teacher's understanding of structure" and pointed out possible notions of "content knowledge", while using (3):

1. The everyday mathematical knowledge that all adults should have.
2. The school-level mathematical knowledge that good students have.
3. Mathematical knowledge as a deep understanding of the contents of secondary school mathematics curriculum.
4. The university-level mathematical knowledge that does not overlap with the content of the school curriculum (e.g., Galois theory or functional analysis).

Another study is the first cross-national large-scale study, conducted by Sigrid Blömeke, Gabriele Kaise and Ralf Lehmann. The Teacher Education and Development Study in Mathematics (TEDS-M) had the main aim "to understand how national policies and institutional practices influence the outcomes of mathematics teacher education" (Döhrmann, Kaiser, & Blömeke, 2012, p. 325). The definition of teacher knowledge was also based on Shuman's definition. Pedagogical content knowledge was differentiated into (1) curricular knowledge and knowledge of planning for mathematics teaching and learning and (2) knowledge about enacting mathematics for teaching and learning. Content knowledge was differentiated into three cognitive elements, namely, knowing, applying and reasoning and was tested in four content domains, which were number theory, geometry, algebra and data (Döhrmann, Kaiser, & Blömeke, 2010).

Probability as a content domain was underrepresented in both COACTIV and TEDS-M, but the distinction of content knowledge of COACTIV and the definition of pedagogical content knowledge of TEDS-M is based on this project's definitions. However the definitions of content knowledge of COACTIV and pedagogical content knowledge of TEDS-M will be used as a working definition.

Domain map in probability for teacher education

While content domains like "number" was differentiated in eight categories at TEDS-M, data had only three categories, which included data organization and representation, data reading and interpretation and chance (Döhrmann et al., 2010). Only chance can be allocated to probability. In order to grasp possible developments in professional knowledge in this mathematical field, one has to distinguish it into more categories.

Methodology

The research question is which categories of (future) teacher knowledge the research area of probability can be distinguished. In order to answer this question a domain map was developed.

This distinction can be divided in two steps. First, one can raise the question what students in secondary level should learn, therefore what teachers also have to know. This can be assigned to the second notion of specification of content knowledge, which is the school-level mathematical knowledge that good students have. For carving out details, what students should learn, one will analyze educational standards and curriculums. For this paper, the German educational standards and the curriculum of the state NRW were being taken in to consideration. The statements being made to probability was first collected, analyzed and linked, so a first draft of a domain map can be presented.

The second step is to determine content knowledge in probability on the third notion, which is mathematical knowledge as a deep understanding of the contents of secondary school mathematics curriculum. On this notion, student knowledge is not adequate. In this step, content requirements for teacher education get augmented in the same way as in step 1.

After that, an expert study in a small frame was conducted. Mathematicians and Mathematics educators were being questioned about possible missing or redundant categories. In this study were three Mathematicians and ten Mathematics educators.

Step 1: Analysis of the German educational standards and curriculum of the state NRW in probability

The German educational standard in probability for students in secondary level was resolved by the Permanent Conference of the Ministers of Education and Cultural Affairs of the States in the Federal Republic of Germany. The key content “data and chance” states the following about probability (KMK, 2003, p. 12):

Students

- reflect and evaluate arguments, which are based on a data analysis
- describe appearance of randomness in everyday situations
- calculate probability at random experiments

While the first indent is still clearly located in statistics, it does have some relevance to probability. The second indent establishes the concept of randomness [...] teachers should know about. In the third one, random experiments and probability are not further specified.

In the following, one curriculum, namely the one from North Rhine-Westphalia, will be analyzed to find out about notion 2 of probability. This analysis is one example for analyzing other curriculums to get a good idea of requirements for teachers in probability.

In the curriculum of the state NRW, the Ministry of Education and Training (2014, p. 16) stated more specified information about what students should know at the end of the secondary level:

- They [the students] calculate relative frequencies, mean values (arithmetic mean, median) and measures of variation (range, quartile) and interpret those.
- They [the students] calculate probabilities by using the Laplacian rules, tree diagrams and their rules, use frequencies to estimate probabilities and probabilities to predict frequencies.

Those two indents give a first idea of structuring the domain “probability” by differentiating it into the categories frequencies (relative and absolute), (Laplace) probabilities, graphic representation (tree diagram), as to be seen in Figure 1.

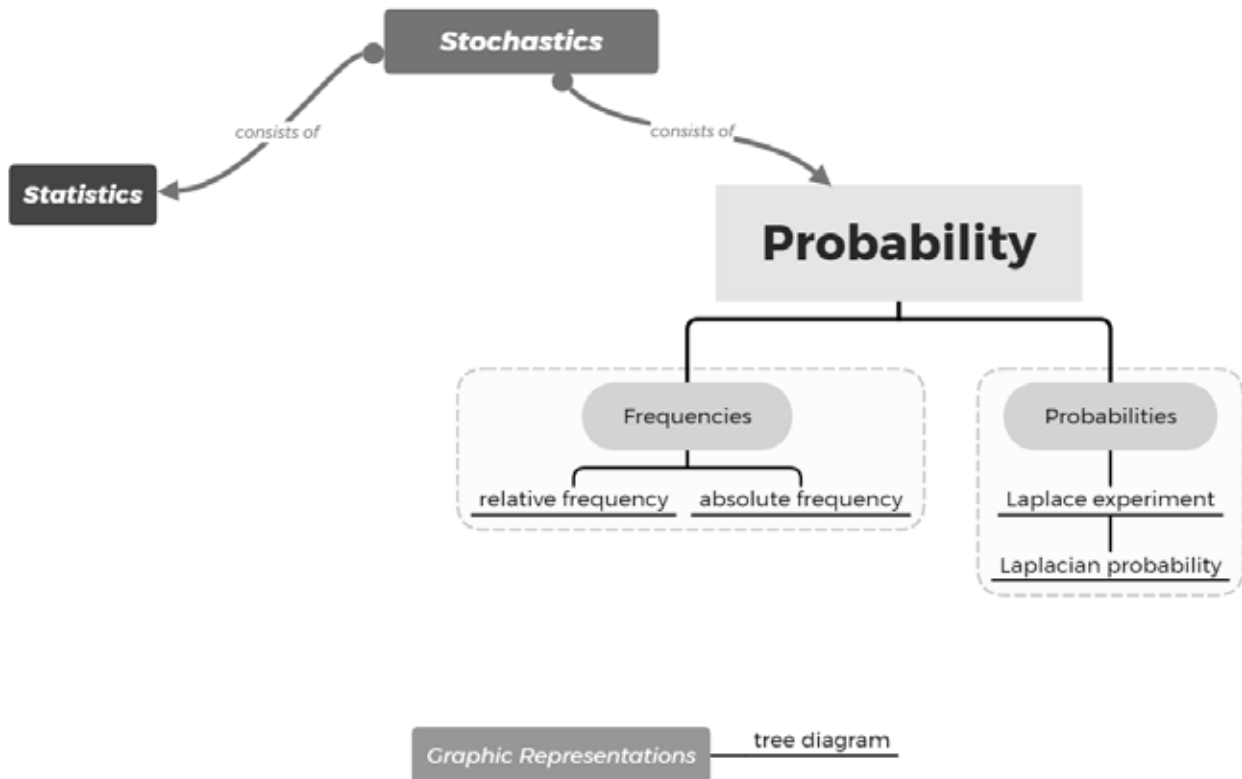


Figure 1: Domain map after step 1

Stochastics can be distinguished into Statistics and Probability. Probability has the category “Frequencies”, which contains relative frequency and absolute frequency, the category “Probabilities”, which contains Laplace experiment and Laplacian probability and the category “Graphic Representations”, which includes tree diagrams.

After completing step 1, one can use Figure 1 and differentiate the categories further and adapt it to achieve a domain map for notion (3).

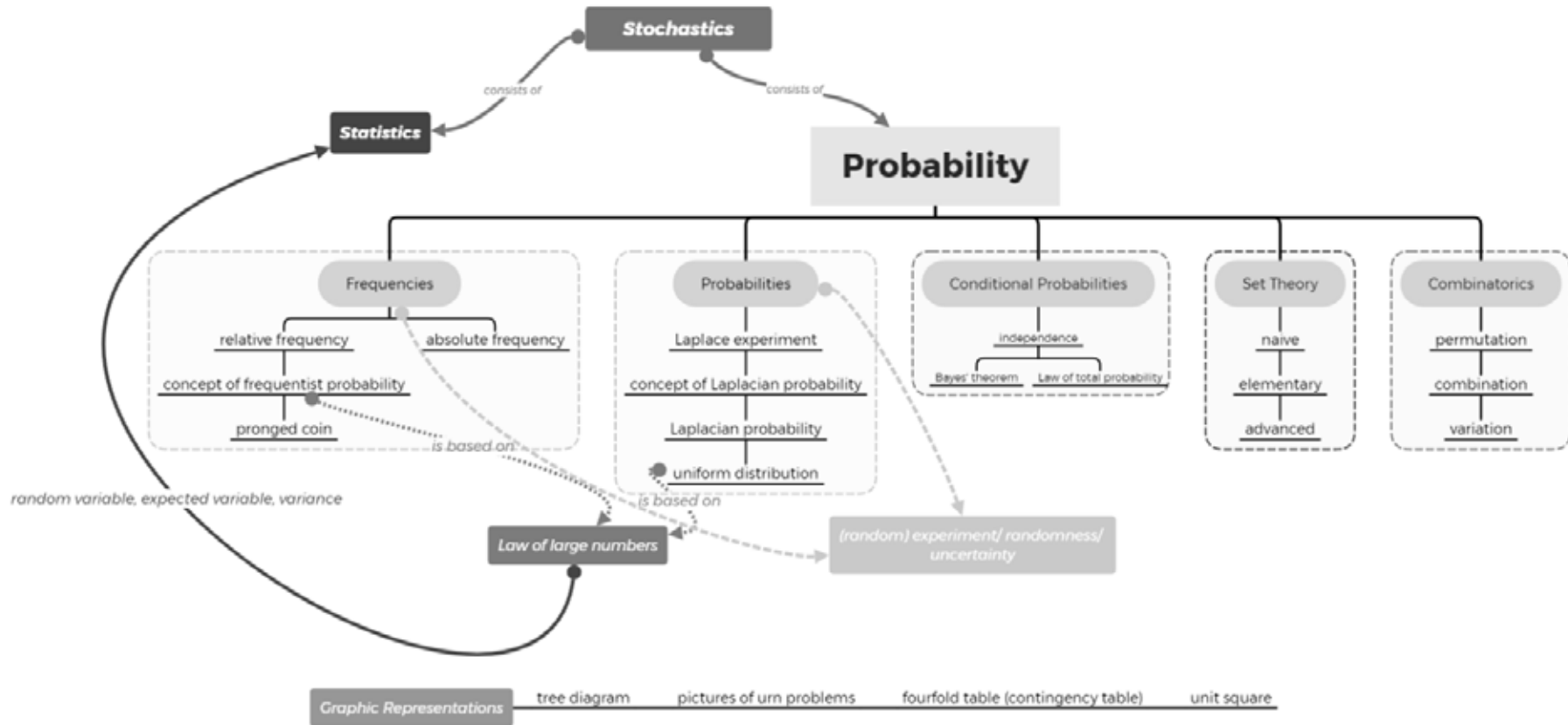


Figure 2: Domain map after step 2

Step 2: Obtaining a domain map for teacher knowledge as the deep understanding of the contents in probability

In order to obtain a domain map for a teacher knowledge as deep understanding of the contents in probability, one augments Figure 1 by analyzing the content requirements for teacher education (KMK, 2008). After that, Mathematicians and Mathematics Educators from the Mathematics department at Bielefeld University were invited to critically analyze the categories. Finally, literature such as Arbeitskreis Stochastik in der Gesellschaft für Didaktik der Mathematik e.V. (2018), Harten and Steinbring (1984), Krüger, Sill, and Sikora (2015), Kütting and Sauer (2011), Tietze, Klika, and Wolpers (2002) and Wolpers and Götz (2002) was taken into account. The results were the following (see Figure 2).

The category “Frequencies” was extended to the concept of frequentist probability and, as an example, a pronged coin, while “Probabilities” has the extension of the concept of Laplacian probability and uniform distribution. Both concepts are based on the law of large numbers, which is indicated by the dotted arrows. In order to obtain a deep understanding of both categories, one needs a profound concept of (random) experiments, randomness and uncertainty. Therefore, those are important connections between frequencies and probabilities.

The law of large number is linked to statistics through the concept of random variables, mathematical expectation and variance, because many concepts of statistics are modeled via random variables. This is indicated by a solid line in Figure 2.

The category “Graphic Representations” was extended by pictures of urn problems, fourfold table and unit squares to cover the main graphic representations used in probability. To achieve a deep understanding of tree diagrams, one should know about “conditional probabilities”, because tree diagrams are based on the law of total probability and Bayes’ theorem. The category “Graphic Representations” stands on its own, because as representations it isn’t any traditional content of probability. However, graphic representations can help understand concepts of probability.

The category “Combinatorics”, which is typically categorized as algebra, was added, because of the importance for random experiments. Teachers should know about permutations, combinations and variations.

The category “Set Theory” was added, because one needs naïve set theory to grasp the idea of probability and complementary probability. Set theory on an elementary level is in use for combinatorics. Advanced set theory is mandatory for conditional probabilities.

This domain map makes no claim to be complete. However, it is the foundation to work on developing items to test content knowledge regarding these topics.

Outlook

The study “The development of professional knowledge of prospective teachers in probability” is focusing on content knowledge and pedagogical content knowledge of prospective teachers. Prospective teachers for secondary school usually take their probability courses in one semester. They will participate in a pre- and post-test, so the development of knowledge in probability is visible. After a certain time, they will also participate at a follow-up-test to measure effectiveness of their

probability education. They will also answer questions about emotions toward probability, demographics and self-efficacy.

The research questions of the study are the following:

- How is the development of professional knowledge of prospective teachers in probability?
- How do emotions influence the development?
- How is the self-efficacy changing during those classes?
- How effective is the university education in probability?

One important preparation for the pre- and post-test was the development of this domain map. Educational standards, curriculums and requirements for teacher education were analyzed and Mathematicians as well as Mathematics educators were being questioned in an expert study. One now has an overview of current research on probability knowledge of (prospective) teachers and is being able to develop items for the study mentioned above. One limitation is that the domain map was only analyzed by German standards. The expansion to an international level is planned. Another limitation is the aspect of the educational standards and teacher requirements. They already are developed and assessed by Mathematics Educators on basis of empirical results, but they are not empirical results themselves. However it is a good estimation for what prospective teachers should learn in probability.

References

- Arbeitskreis Stochastik in der Gesellschaft für Didaktik der Mathematik e.V. (2018). Empfehlungen zu Zielen und zur Gestaltung des Stochastikunterrichts. Retrieved from <https://www.math.uni-frankfurt.de/ak-stochastik/files/bildungspolitische-stellungnahme.pdf>
- Bromme, R. (1992). *Der Lehrer als Experte: Zur Psychologie des professionellen Wissens. Huber-Psychologie-Forschung*. Bern etc.: H. Huber.
- Döhrmann, M., Kaiser, G., & Blömeke, S. (2010). Messung des mathematischen und mathematikdidaktischen Wissens: Theoretischer Rahmen und Teststruktur. In S. Blömeke (Ed.), *TEDS-M 2008: Professionelle Kompetenz und Lerngelegenheiten angehender Mathematiklehrkräfte für Sekundarstufe I im internationalen Vergleich* (pp. 169–194). Münster: Waxmann.
- Döhrmann, M., Kaiser, G., & Blömeke, S. (2012). The conceptualisation of mathematics competencies in the international teacher education study TEDS-M. *ZDM*, 44(3), 325–340.
- Harten, G. v., & Steinbring, H. (1984). *Stochastik in der Sekundarstufe I. IDM-Reihe: Vol. 8*. Köln: Aulis-Verl. Deubner.
- Heather C. Hill, Merrie L. Blunk, Charalambos Y. Charalambous, Jennifer M. Lewis, Geoffrey C. Phelps, Laurie Sleep, & Deborah Loewenberg Ball. (2008). Mathematical Knowledge for Teaching and the Mathematical Quality of Instruction: An Exploratory Study. *Cognition and Instruction*, 26(4), 430–511. <https://doi.org/10.1080/07370000802177235>
- Heather C. Hill. (2007). Mathematical Knowledge of Middle School Teachers: Implications for the No Child Left Behind Policy Initiative. *Educational Evaluation and Policy Analysis*, 29(2), 95–114. <https://doi.org/10.3102/0162373707301711>

- KMK. (2003). Bildungsstandards im Fach Mathematik für den Mittleren Schulabschluss: Beschluss vom 4.12.2003. Retrieved from https://www.kmk.org/fileadmin/Dateien/veroeffentlichungen_beschluesse/2003/2003_12_04-Bildungsstandards-Mathe-Mittleren-SA.pdf
- KMK. (2008). Ländergemeinsame inhaltliche Anforderungen für die Fachwissenschaften und Fachdidaktiken in der Lehrerbildung: Beschluss der Kultusministerkonferenz vom 16.10.2008 i.d.F. vom 12.10.2017). Retrieved from https://www.kmk.org/fileadmin/Dateien/veroeffentlichungen_beschluesse/2008/2008_10_16-Fachprofile-Lehrerbildung.pdf
- Krauss, S., Baumert, J., & Blum, W. (2008). Secondary mathematics teachers' pedagogical content knowledge and content knowledge: validation of the COACTIV constructs. *ZDM*, 40(5), 873–892. <https://doi.org/10.1007/s11858-008-0141-9>
- Krüger, K., Sill, H.-D., & Sikora, C. (2015). *Didaktik der Stochastik in der Sekundarstufe I. Mathematik Primarstufe und Sekundarstufe I + II*. Berlin: Springer Spektrum. Retrieved from <http://dx.doi.org/10.1007/978-3-662-43355-3>
- Kütting, H., & Sauer, M. J. (2011). *Elementare Stochastik: Mathematische Grundlagen und didaktische Konzepte* (3., stark erweiterte Auflage). *Mathematik Primarstufe und Sekundarstufe I + II: Vol. 0*. Heidelberg: Spektrum Akademischer Verlag. Retrieved from <http://site.ebrary.com/lib/alltitles/docDetail.action?docID=10494316>
- Ministry of Education and Training. (2014). Mathematik: Kernlehrplan für Sekundarstufe Gymnasium/Gesamtschule in Nordrhein-Westfalen. Retrieved from https://www.schulentwicklung.nrw.de/lehrplaene/upload/klp_SII/m/KLP_GOSt_Mathematik.pdf
- Schumacher, S. (2017). *Lehrerprofessionswissen im Kontext beschreibender Statistik: Entwicklung und Aufbau des Testinstruments BeSt Teacher mit ausgewählten Analysen. Bielefelder Schriften zur Didaktik der Mathematik: Vol. 4*. Wiesbaden: Springer Fachmedien Wiesbaden.
- Shulman, L. (1987). Knowledge and Teaching: Foundations of the New Reform. *Harvard Educational Review*, 57(1), 1–23. <https://doi.org/10.17763/haer.57.1.j463w79r56455411>
- Shulman, L. S. (1986a). Paradigms and Research Programs in the Study of Teaching: A Contemporary Perspective. In M. C. Wittrock (Ed.), *Handbook of research on teaching* (3rd ed., pp. 3–36). New York: Macmillan.
- Shulman, L. S. (1986b). Those who understand: Knowledge growth in teaching. *Educational Researcher*, 15(2), 4–14.
- Tietze, U.-P., Klika, M., & Wolpers, H. (2002). *Mathematikunterricht in der Sekundarstufe II: Band 3: Didaktik der Stochastik*. Wiesbaden: Vieweg+Teubner Verlag. Retrieved from <http://dx.doi.org/10.1007/978-3-322-83144-6>
- Wolpers, H., & Götz, S. (2002). *Didaktik der Stochastik* (1. Aufl.). *Didaktik der Mathematik: / Uwe-Peter Tietze; Manfred Klika; Hans Wolpers ; Bd. 3*. Braunschweig: Vieweg.

Testing the negative recency effect among teacher students trying to generate random sequences

Olav Gravir Imenes

Oslo Metropolitan University, Norway; ogim@oslomet.no

Students of a teacher training program (N=124) were asked to generate, unaided, a binary sequence of 40 symbols appearing to be as random as possible. It was found that the average probability of alternation, $P(A)$, was 0.61, which agrees with previous experiments described in the literature, and that the students tend to underestimate the occurrence of runs with four or more equal symbols. When comparing to random sequences I argue that only asking for sequences of length 40 will overestimate $P(A)$.

Keywords: Negative recency effect, randomness, probabilistic reasoning.

Introduction

One of the goals of education in the subject of probability is to give students a better understanding of what constitutes random events and how to recognise random events. A democracy needs citizens that can understand and evaluate quantitative information and statistical analyses (Utdanningsdirektoratet, 2012). Media sometimes reports clusters, for example the occurrence of many cancer cases in small communities, without acknowledging that such clusters may arise as a result of randomness. Knowledge of what to expect of random events is necessary in order to know how to process such information. However, it is difficult to get a good grasp of probability, and especially the occurrence of clusters. One type of cluster occurs in binary sequences. A binary sequence is a sequence that consists of two symbols, for example the sequence generated by tossing a coin multiple times and noting whether the outcome was head or tail, or throwing a die and noting whether it displays an even or odd number. The former could look like THHHHTTHTT, while the latter could look like 0111100100. A cluster in a binary sequence is a long run of the same symbol, for example four heads or four odd numbers in a row. Research (Bryant & Nunes, 2012; Chiesi & Primi, 2009; Falk & Konold, 1997; Williams & Griffiths, 2013) shows that people overestimate the number of changes in order for a binary sequence to be random and underestimate the average length of runs, i.e., the number of times a symbol is repeated consecutively.

In Norwegian schools in the last 20 years there has been a stronger emphasis on probability than previously, especially with the introduction of curriculum reform in 1994 for high school, R94 (Kirke, utdannings- og forskningsdepartementet, 1999), and in the curriculum reform in 2006 for both primary and secondary school, LK06 (Kunnskapsdepartementet, 2013). For example, the curriculum for the first year of high school demands that the student should be able to produce examples and simulations of random experiments (Kunnskapsdepartementet, 2013, p. 11).

One might ask what the stronger emphasis on probability means to students' understanding of clusters. If, successively, an even number has been thrown four times with a fair die, and students are asked if there is still a 50% chance to throw an even number in the next throw, most will immediately answer yes. However, when asked to construct sequences, they may tend to

underestimate such probabilities, i.e., seemingly assigning a less than 50% chance of getting the same result as in the previous throw. This paper will focus on Norwegian teacher students' understanding of what constitutes a random binary sequence. In order to measure the randomness of binary sequences, Falk and Konold (1997) presents a framework for analysing binary sequences mathematically, using among other indicators a probability of alternation, $P(A)$. I will be using parts of this framework.

This paper sets out to explore the following question: To what extent are Norwegian teacher students able to understand the probability of forming of clusters in a binary sequence? The guesses will be measured by the calculated $P(A)$, and by testing whether or not the students' guesses for the number of runs of given lengths differ significantly from that of a fair die thrown.

Review of the literature

Children's and adults' understanding of what constitutes a random sequence tends to show some common misconceptions. One such misconception is the negative recency bias (Bryant & Nunes, 2012, p. 10). This is the assumption that after a long sequence of the same result, e.g., six heads in row when tossing a coin, a tail is more likely in the next toss. The counterpart of this misconception is the positive recency bias (Bryant & Nunes, 2012, p. 10), in which people estimate that a certain result is more likely to be the next outcome because it has occurred frequently in the past. Positive recency bias occurs in for example estimating scoring in baseball (Gilovich, Vallone, & Tversky, 1985). Many studies have been carried out investigating the negative recency effect. For surveys of such investigations, see for example Batanero and Sanchez (2005), Bryant and Nunes (2012), Chiesi and Primi (2009) and Falk and Konold (1997).

Some of the studies carried out ask the participant to tell which of two or more sequences or patterns are random and which are not (Batanero & Serrano, 1999; Falk & Konold, 1997; Kahneman & Tversky, 1972) or which result is more likely to come next (Chiesi & Primi, 2009; Fischbein & Schnarch, 1997), and such studies are examples of judgement tasks. Others ask the participants to generate random sequences (Bakan, 1960; Towse & Mclachlan, 1999), and are production tasks. A variation is studied by Rapoport and Budescu (1992), where the participants generated random numbers as part of a game. Bar-Hillel and Wagenaar (1991) argue that judgement tasks are a purer way of studying the perception of randomness. However, the basic biases were discovered by production tasks, since these tasks were the ones in the early research. Another problem with judgement tasks is that when a researcher asks whether or not a given sequence is random, he may not himself know the answer. For example, Green (1982, p. 157) provides an example of two binary sequences of length 150 and 153 respectively and asks the subject to determine which sequence is made up. The one he would classify as not made up has a $P(A)$ as low as 0.44 in addition to having one run of length 9, which is not expected for such a short sequence. At least when assigning production tasks, the researcher does not need to say anything wrong. In addition, when assigned production tasks, the students cannot guess among the alternatives, thus taking a more active role.

Falk and Konold (1997) present a framework for analysing binary sequences with respect to randomness. For every binary sequence a number called probability of alternation, $P(A)$, may be

calculated. It is given by $P(A) = \frac{r-1}{n-1}$, where r is the number of runs, and n is the length of the sequence (Falk & Konold, 1997). In an infinitely long, truly random binary sequence, the expected $P(A)$ is 0.5. The $P(A)$ measure first order dependencies. Another measure is the second-order entropy (EN). This is based on the relative frequency of all ordered pairs, and is a measure of the amount of new information provided by the second symbol of the pair (Falk & Konold, 1997). The second order entropy is maximal ($EN = 1$) when all the four pairs, 00, 01, 10, 11, are equally probable. It is minimal ($EN = 0$) when $P(A) = 1$. Yet another measure is the complexity of the sequence, and can be defined as the “bit length of the shortest computer program that can reproduce the sequence” (Falk & Konold, 1997, p. 306). Another method Falk and Konold describes, due to Garner (1970), is to sort all sequences of a given length n into different disjoint sets based on their $P(A)$. The most random sequences are the ones contained in the set which consist of the maximal number of sequences. In this paper we will focus on the $P(A)$, and also of the number of subsets of length m with $P(A) = 0$, that is, the number of runs with a given length.

The typical value of $P(A)$ for a binary sequence constructed by a person seems to be around 0.6. The nine studies referenced by Falk and Konold (1997) have $P(A)$ ranging from 0.56 to 0.63. For nine experiments, referenced in the same paper, where participants are judging whether or not a certain sequence is random the $P(A)$ range from 0.57 to 0.65 in eight of the experiments while one has a $P(A)$ of between 0.7 and 0.8 (Gilovich et al., 1985). Thus, the literature seems fairly consistent regarding the extent to which people overestimate the number of runs. However, there seems to be a lack in reporting standard deviation. It is also interesting to examine to what extent people tend to underestimate the possibility of long runs, which we may call clusters. The most consistent result on binary sequences is that both in generating and perception people tend to underestimate the number of long runs, i.e., consecutively equal results (Falk & Konold, 1997, p. 302).

Method

I had 127 students enrolled in the first-year teacher education study program providing me with data. For entry into the program the students need more than a passing grade in mathematics from high school. In Norway, the lowest grade in high school is a zero, while 6 is the best obtainable grade. The requirement for entry to the teacher education program is a 4, while 2 is the lowest passing grade. Thus, the enrolled students had a somewhat better understanding of mathematics than that required for other study programs. As they were about to start learning about probability and combinatorics, the students were asked to imagine the following task: Throw a die 40 times and mark for each throw whether you get an even or an odd number. Mark an even number with 0 and an odd with 1. The students were asked to write down as realistic a sequence as possible. Afterwards they were asked to actually throw a die 40 times, and compare the results. Thus, I had about 5000 actual die throws to compare. The students were informed that the data they provided could be used for research. All data were collected anonymously. Among the participants three students did not produce a binary sequence of at least 40 symbols, and thus they were discarded. Therefore 124 student generated guessed sequences were analysed.

In order to determine if the student made a good guess or not, the $P(A)$ was the first indicator, and was compared with the theoretical $P(A)$ of 0.5 and the $P(A)$ of the actual die throws. In the latter comparison, a t -test was used since it was possible to calculate standard deviations. The second criterion was that the number of runs of each length in a guessed sequence should be approximately equal to the number of runs of that length in the thrown results. A list of the number of runs each student guessed for any given length from one to seven was made, and for each run length a t -test was carried out to compare to the corresponding list for the sequences obtained from the actual die thrown. The data was tested for normality using the Shapiro-Wilk test. A t -test ordinarily requires a normal distribution. However, the central limit theorem ensures that when the number of participants is large, it can be used even though the data does not have a normal distribution. Typically, this occurs when the number of participants is more than 30.

The tests described above were carried out using R: A language and environment for statistical computing (R Core Team, 2016).

Results

Each student produced one sequence of 40 binary digits, representing even and odd numbers. The sequence guessed by participant number 85 is provided in Figure 1. An even number is represented by 0 while an odd number is represented by 1. Another example is given in Figure 2, the sequence of participant number 93.



Figure 1: The guessed sequence of participant number 85

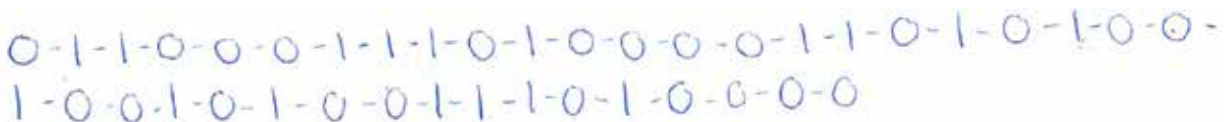


Figure 2: The guessed sequence of participant number 93

In addition to guessing how such a sequence would look like, the students each threw a die 40 times, and recorded the outcome. An example of such a sequence, from participant number 88, is given in Figure 3

1000000110001000011010
10011011110010010

Figure 3: The actually thrown sequence of participant number 88

The probability of alternation was calculated for each participant. The mean $P(A)$ among the participants was 0.61 ($SD = 0.12$). For the random numbers the students threw, the mean $P(A)$ were 0.51 ($SD = 0.08$), quite near the theoretical value of 0.5 for infinitely long sequences. Ten students made guesses with $P(A) < 0.51$. The $P(A)$ for the estimated results were not normally distributed, the Shapiro-Wilk normality test giving $p < .001$, where for the random generated sequences, that is when the die was actually thrown, the $P(A)$ was normally distributed, with the Shapiro-Wilk normality test giving $p = .08$. There was a significant difference between the made-up sequences compared to the actual throws ($t(213.72) = -8.23$, $p < .001$).

The number of runs of a given length in the estimated sequences varied. In Figure 4 the median and the quartiles of the number of runs of a given length for each student's guesses are shown in a boxplot. For each run of a given length, the corresponding result for the actual throws is shown to the right for comparison. The box labeled RLG1 shows the first and third quartile of the number of runs of length one in the guessed data as the lower and upper sides of the box. The solid line in the middle of the box is the median, and the mean is given by an asterisk. Similarly, RLG2 shows the number of runs of length two. RLT1 shows the number of runs of length one for actually thrown dice, and so on.

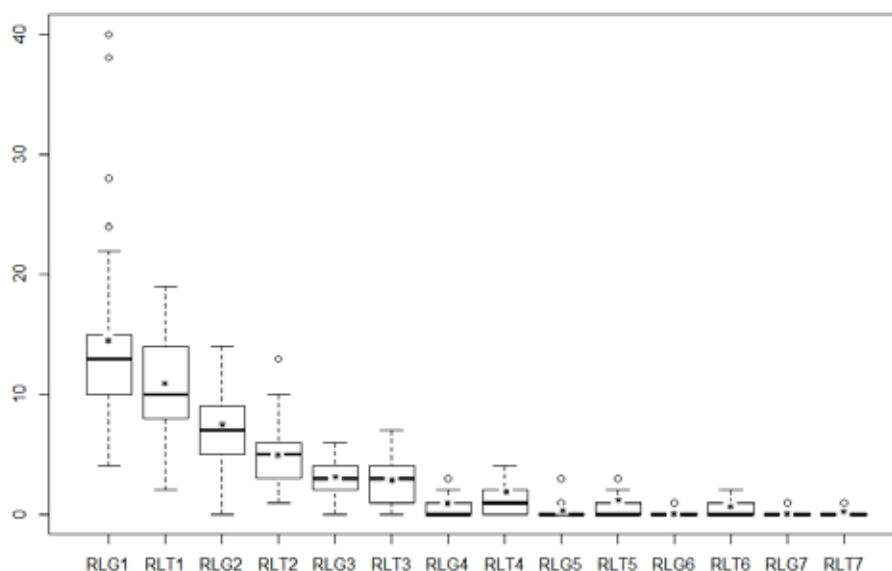


Figure 4: A boxplot of the number of runs of a given length

We note that the students tend to underestimate the number of runs of length four and five, and overestimate the number of runs of length one and two. For each run length, a t -test were carried out, and in particular it showed that for every run length except three, there was a significant difference ($p < .002$) between the guessed results and the actual throws. For runs of length three, the

difference was not significant ($t(243.31) = 1.00, p = .32$). With the sequence length being only 40, we cannot from this data conclude that students underestimate the numbers of run of length six or more. The reason is that with 20 expected runs, and only a $\frac{1}{2^{(6-1)}} = \frac{1}{32}$ chance of getting a run of length six for every run started, a student trying for the most random sequence should not include runs of length six or more. Also, in Figure 4, especially note that the median of the number of runs of length five for the actual thrown dice is zero, even though the average is 0.58. However, remember that the probability to get a run of length five or more is double that of obtaining a run of exactly length five. Therefore, we should expect student guesses to include one run of length five or more, but not be surprised if none were included. We have not included runs of length longer than seven in the boxplot as no students included runs of that length in their guesses.

Among the students there are some that made better guesses than others. Among the 124 students which completed the task, 49 included at least one run of length four or more in their guessing. Of these, 14 students included a run of length five or more.

Discussion

The average results for the probability of alternation, $P(A)$, when the students are guessing, is in line with the literature, being 0.61. This is significantly different from a random binary sequence. I have not found the standard deviations from the previous experiments, so no hypothesis test could be done comparing this $P(A)$ to the $P(A)$'s listed by Falk and Konold (1997). However, I conclude that this number seems fairly constant across countries and time. The list compiled by Falk and Konold (1997) seems to indicate that the $P(A)$ becomes smaller as the length of the guessed sequence increase. The result from the current experiment seems to agree with experiment where sequences of comparable length has been used. One reason for a lower $P(A)$ when longer sequences are used may be that participants then will expect some very long runs. For sequences as short as 40, a student who knew about the correct distribution could argue, that since the median of runs of length five or higher is zero, such sequences should not be included in the guess, even though the mean is closer to one than zero, and that the expectation value for the number of runs of five or more in length is more than one. Excluding runs of length five or higher should lead to a somewhat higher $P(A)$ than 0.5. Thus, it is not surprising that students overestimate the $P(A)$. However, the observed average $P(A)$ of 0.61 is higher than should be expected even when excluding runs of length five or more.

From the results (Figure 4) we observe that the students' guesses are relatively accurate concerning runs of length five, and this is confirmed by the t -test. The problems with underestimating the number of long runs begin with runs of length four or more. Each student should have expected at least one run of length five or more, as this will happen in one of 16 cases when starting on a run, and each student would be expected to start 20 runs. The approximate number of runs is $P(A)$ multiplied by the sequence length, in this case $0.5 \cdot 40$. Out of 124 students, 49 included at least one run of length four or more in their guessing. Of these, 14 students included a run of length five or more. Thus, few students think that clusters are as common as they actually are.

The probability of clusters arising in a binary sequence is comparatively easy to understand compared to the probability of clusters of for example diseases arising in a general population.

Therefore it may be a start to educate students of clusters in such a setting, when known biases can be used to give the students a better understanding of how they tend to underestimate the occurrence of clusters. It is also easier to show them their own bias when using production tasks.

Conclusion

Teacher students do significantly underestimate the number of long runs, i.e., runs of four or more equal symbols when trying to construct binary sequences that shall appear random. They also overestimate the number of runs of length one and two significantly. They do not seem to underestimate the number of runs of length three significantly; the median guess is actually the same as for a random sequence. Also, a t -test could not determine a significant difference when it comes to sequences of length 3.

For further research it would be interesting to ask participants to generate longer sequences, for example of length 150, where 75 runs would be expected, thus at least one run of at least seven, since the probability of getting a run of seven is $\frac{1}{2^{(7-1)}} = \frac{1}{64}$. The current results suggest that students would grossly underestimate the occurrence of the really long runs, but a sequence length of 40 does not allow us to conclude in this case. Another interesting experiment would be to tell some of the students about what constitutes a random binary sequence and tell some of them beforehand that you are to test their sequences on the $P(A)$ and the number of runs of each given length. Then the results of this group of students could be compared to the students not having been given such instructions. Thus one could observe what effects such instructions would have.

It would also be very interesting to ask the students to explain their thinking during the production of these sequences. This would add a qualitative dimension to the results and be useful for improving the education in order to help students understand clusters better.

The author wishes to thank Trude Sundtjonn, Siri Krogh Nordby and Grethe Kjensli for help with data collection and George Hitching for comments.

References

- Bakan, P. (1960). Response-tendencies in attempts to generate random binary series. *The American Journal of Psychology*, 73(1), 127–131. doi:10.2307/1419124
- Bar-Hillel, M., & Wagenaar, W. (1991). The perception of randomness. *Advances in Applied Mathematics*, 12, 428–454. doi:10.1016/0196-8858(91)90029-I
- Batanero, C., & Serrano, L. (1999). The meaning of randomness for secondary school students. *Journal for Research in Mathematics Education*, 30(5), 558–567. doi: 10.2307/749774
- Batanero, C., & Sanchez, E. (2005). What is the nature of high school students' conceptions and misconceptions about probability? In G. Jones (Ed.), *Exploring probability in school: Challenges for teaching and learning* (pp. 241–266). New York, NY: Springer. doi:10.1007/0-387-24530-8_11
- Bryant, P., & Nunes, T. (2012). *Children's understanding of probability: A literature review (full report)*. London, England: Nuffield Foundation.

- Chiesi, F., & Primi, C. (2009). Recency effects in primary-age children and college students. *International Electronic Journal of Mathematics Education*, 4(3), 259–274.
- Falk, R., & Konold, C. (1997). Making sense of randomness: Implicit encoding as a basis for judgement. *Psychological Review*, 104(2), 301–318. doi:10.1037/0033-295X.104.2.301
- Fischbein, E., & Schnarch, D. (1997). The evolution of age of probabilistic, intuitively based misconceptions. *Journal for Research in Mathematics Education*, 28(1), 96–105. doi: 10.2307/749665
- Garner, W. R. (1970). Good patterns have few alternatives. *American Scientist*, 58, 34–42.
- Gilovich, T., Vallone, R., & Tversky, A. (1985). The hot hand in basketball: On the misperception of random sequences. *Cognitive Psychology*, 17(3), 295–314. doi:10.1016/0010-0285(85)90010-6
- Green, D. (1982). *Probability concepts in school pupils aged 11 – 16 years* (Doctoral dissertation, Loughborough University of Technology, Leicestershire, UK). Retrieved from <https://dspace.lboro.ac.uk/2134/7409>
- Kahneman, D., & Tversky, A. (1972). Subjective probability: A judgement of representativeness. *Cognitive Psychology*, 5, 207–232. doi:10.1016/0010-0285(72)90016-3
- Kirke-, utdannings- og forskningsdepartementet. (1999). *Matematikk: Felles allment fag i alle studieretninger*. Oslo, Norway: Kirke-, utdannings- og forskningsdepartementet. Retrieved from https://www.udir.no/globalassets/upload/larerplaner/felles-allmenne-fag/5/lareplan_matematikk.rtf
- Kunnskapsdepartementet. (2013). *Læreplan i matematikk fellesfag: Fastsett som forskrift av Kunnskapsdepartementet 21. juni 2013*. Oslo, Norway: Kunnskapsdepartementet. Retrieved from <http://data.udir.no/kl06/MAT1-04.pdf?lang=nno>
- Rapoport, A., & Budescu, D. (1992). Generation of random series in two-person strictly competitive games. *Journal of experimental Psychology*, 121(3), 352–363. doi: 10.1037/0096-3445.121.3.352
- R Core Team. (2016). *R: A language and environment for statistical computing (version 3.3.2)*. Vienna, Austria: The R Foundation for Statistical Computing.
- Towse, J., & Mclachlan, A. (1999). An exploration of random generation among children. *British Journal of Developmental Psychology*, 17(3), 363–380. doi:10.1348/026151099165348
- Utdanningsdirektoratet. (2012). *Læringsstøttende prøver: Matematikk 5. –10.årstrinn. Ressurshefte. Statistikk. Sannsynlighet. Kombinatorikk*. Oslo, Norway: Utdanningsdirektoratet.
- Williams, J., & Griffiths, T. (2013). Why are people bad at detecting randomness? A statistical argument. *Journal of Experimental Psychology: Learning, Memory, and Cognition*, 39(5), 1473–1490. doi:10.1037/a0032397

Statistical Graphs Semiotic Complexity, Purpose and Contexts in Costa Rica Primary Education Textbooks

Maynor Jiménez-Castro¹, Pedro Arteaga² and Carmen Batanero³,

¹Universidad de Costa Rica, Costa Rica; maynorjc@correo.ugr.es

²Universidad de Granada, Spain; parteaga@ugr.es

³Universidad de Granada, Spain; batanero@ugr.es

The aim of this research was analyzing the way in which statistical graphs which are introduced in the new curricular guidelines for Costa Rica primary education are introduced in the textbooks, and compare the results with previous research in other countries. We analyze the distribution of the graph complexity, purpose and context in 167 activities related to statistical graphs selected from the two most widely used textbooks series. Results suggest a non-uniform distribution in both series and suggest ways to enhance the activities proposed in the textbooks.

Keywords: Statistical graphs, reading level, semiotic complexity, textbooks, primary education.

Introduction

Statistical graphs are a main tool to represent information in the media and professional life and acquiring graphical competence is needed for citizens to manage in the information society. This need led Costa Rica to increase the relevance of statistical graphs in the primary education (M.E.P, 2012), following suggestions such as those of the GAISE project (Franklin, Kader, Mewborn, Moreno, Peck, Perry, & Scheaffer, 2007). More specifically, statistical graphs are included in the Costa Rica curriculum in Primary Education as follows:

- In second grade, bar graphs are introduced, with the main objective that the student makes a simple reading of the information and in third grade, the students are expected to construct such graphs and interpret them, using the mode, maximum and minimum.
- In the fourth grade, the student must interpret information in dot plots and it is proposed to incorporate the spreadsheet as a support tool in graphic representations.
- In the fifth grade, pie charts are included and in the sixth, the line graphs to visualize trends in data series. The graphic comparison of two or more data groups is also suggested.

These goals can only be achieved with a correct teaching of the topic and the use of adequate textbooks. There are however no available empirical studies providing evidence that Costa Rica textbooks follow these guidelines. The aim of this paper is to analyze the graphs included in Costa Rica textbooks and use this information to help teachers to organize the teaching of the topic.

Background

Theoretical framework

Statistical graphs are complex semiotic objects, as suggested by Bertin (1967), who remarked that interpreting a graph requires first the isolated interpretation of each element, such as the title or

scales and finally as a global interpretation of the whole graph. Moreover, Arteaga and Batanero (2011) analyzed the semiotic activity involved in the construction of graphs by prospective teachers, and suggested that different graphs may vary in semiotic complexity, according to the mathematical objects needed in this process. Specifically, the authors described four semiotic levels in statistical graphs that will be used in our analysis:

- S1. Representing isolated data. Graphs classified in this level only represent some isolated data without considering the whole set from which the data were extracted.
- S2. Representing a list of data one by one without any attempt to building a distribution. The list of data or a data set is represented in the same order in which the data are located in the list with no use of the numerical order. There is no grouping of similar values of the variable or computation of frequencies. Consequently, although in this graph the idea of variable is used, the distribution is absent. In Figure 1 we present an example.



Figure 1: Example of graph of semiotic complexity S2 (Source: S4, p. 278)

- S3. Representing a data distribution. These graphs include the representation of a distribution, with values and frequencies for each value; For quantitative variables, the order of the variable values in the graph axes (if used) is the ordinary numerical order (see figure 2)



Figure 2: Example of graph of semiotic complexity S3 (Source: A5, p. 146)

- S4. Representing several distributions on the same graph. At the highest level more than one distribution is represented on the same graph. (an example is given in Figure 3)

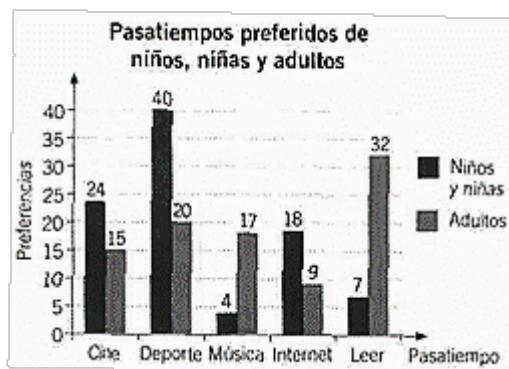


Figure3: Example of graph of semiotic complexity S4 (Source: S6, p. 263)

Following ideas by Kosslyn (1985), we also considered statistical graphs as a resource that can be used with different purposes:

- *Analysis*; when the main goal is using the graph to identify or discover many features that are hidden in the unorganized data set; for example discovering the mode or the asymmetry of the distribution.
- *Communication*; when the graph is used to transmit to another information about the data and its relationships in an efficient way.
- *Construction*; in traditional teaching, an additional purpose is providing procedures to help students learn how to build a correct graph.

Another aspect analyzed is the context of the graph, using the classification established in the PISA studies, which is described in OECD (2016), where it is suggested that the mathematical performance of an individual can be influenced by the context in which he develops his problem situation. In this sense, the context in which the collection, organization and representation of the data are circumscribed may affect the understanding of the graph. This classification contemplates the following contexts:

- *Personal context*: corresponds to situations in the scope of personal activities of the child, his family or peer group. An example of this context is presented in Figure 3, where the graph shows the activities preferred by a group of boys and girls.
- *Social context*: these contexts correspond to the problems where aspects of the social sphere are addressed, beyond the personal life of the child; for example, the neighborhood, or city. They can correspond to voting systems, public transport, government, public policies, demography, publicity, national statistics or economy. Gambling is also included in this context because it is widely used in society.
- *Labor or school context*: consist of those situations where the problem addresses aspects of the world of work: school, work, employment, production, sale, etc.
- *Scientific context*: this context is related to problems in the field of science and technology, and includes aspects such as: climate, ecology, medicine, space science, genetics, etc.

Previous research

Research analyzing different content in textbooks is increasing today, since these books are a main didactical tool for teachers and students, and constitute an intermediate stage between the official

curricular guidelines and the teaching implemented in the classroom (Herbel, 2007). The textbook selected usually provides the main basis why the topic is taught (Shield & Dole, 2013).

Our research is based in other studies that analyzed statistical graphs in the textbooks in other countries, in particular, Díaz-Levicoy, Batanero, Arteaga and Gea (2016), who analyzed the statistical graphs included in three series of Spanish textbooks and three other Chilean series of Primary Education, and compared their results with the curricular orientations. The authors studied the type of graph, level of semiotic complexity, and reading levels implicit in the activity. They conclude the greater presence of the bar chart with little weight of other graphs included in these curricula. Regarding the level of reading, the most frequent were the intermediate ones.

Method

For this study, the curricular orientations referring to the education of statistical graphs in Costa Rica have been analyzed, as well as the two most frequently used series of books in Costa Rica; Asociación Libros para Todos (AL) and Editorial Santillana (S), using content analysis. The sample of publishers was directed or not probabilistic, because we selected the textbooks most spread in the schools of the country (see Appendix). A total of 167 different graphs were analyzed and classified according to the following variables:

- *Semiotic complexity level*: Arteaga and Batanero (2011) observed in their study as a higher semiotic level in the graphs constructed by a sample of prospective teachers implied a higher level of reading of them by the prospective teachers. Therefore, semiotic levels are related to the reading levels of a graph, that is an important ability related to good levels of graphical competence (Wu, 2004).
- *Purpose of the graph*: Cazorla (2002) shows that statistical graphs are an instrument of both data analysis and information transmission, for all this, considering Kosslyn's ideas we classify the graphs according to their purpose.
- *Context of the graph*: Monteiro and Ainley (2007) observed how the interpretation of the graphs mobilizes knowledge and feelings that affect their understanding and how the context of the graph influences the interpretation of it, showing the importance of considering the context of the graphs when interpreting them.

Each graph was analyzed according to these three variables, Maynor, one of the authors of this paper, classified the different graphs as part of his PhD studies, and this process was supervised by the other two authors. The variables analyzed on this paper were previously used in different studies carried out by Díaz-Levicoy and published in relevant national and international journals (Díaz-Levicoy et. al, 2016, Díaz-Levicoy, Giacomone and Arteaga, 2017).

Results

Graph semiotic complexity

Overall the most frequent semiotic complexity level was level 3 (see Table 1) since, 67.7% of the graphs represented a distribution; 24.0% of graphs represented a data list (level 2) and only 8.4% corresponded to the highest level of semiotic complexity, representing two or more distributions in the same graph. In the AL editorial, the percentage of activities at level 2 and level 4 was 10.7%, in

contrast to 78.6% of activities classified at level 3. Similarly, at the S editorial, 62.2% of the activities were classified as level 3 and 30.6% and 7.2% as level 2 and 4, respectively.

This general data coincide with the results obtained from the semiotic analysis of the graphs in Díaz-Levicoy et al. (2016), where 58.6% of graphs analyzed corresponded to level 3. However, the second most frequent semiotic level proposed in the Spanish study was level 4 with 22.3%, while in Costa Rican textbooks it is level 2 with 24.0%. Contrary to the Spanish study's results, in the Costa Rica textbooks since the highest level of semiotic complexity (S4) represents only 8.4% of graphs.

Semiotic Complexity	AL (n=56)	S (n=111)
S2	10,7	30,6
S3	78,6	62,2
S4	10,7	7,2

Table 1: Frequency and percentage of graphs according semiotic complexity and editorial

Regarding the distribution of semiotic complexity by school year, in Table 2 we show the increment of semiotic complexity with school grade. In the first grade only level 2 activities were found, while in the sixth grade graphs in all the semiotic complexity levels are proposed. Moreover, in grades 2 to 5, complexity level 3 is dominant and only in the 6th grade the most common graphs are those of level 4. In Díaz-Levicoy et al. (2016) research, semiotic complexity level 4 graphs are included from grade 2, and are the most common semiotic level at fifth and sixth grades. This includes a clear difference in the way in which activities are addressed in Spanish and Costa Rican textbooks, where representations of several distributions on the same graph are scarce in Costa Rica.

Semiotic Complexity	School grade					
	1 (n=8)	2 (n=44)	3 (n=26)	4 (n=33)	5 (n=28)	6(n=28)
S2	100	29,9		15	13,6	27
S3		70,1	100	76,2	86,4	29,7
S4				8,8		43,2

Table 2: Percentage of graphs by semiotic complexity and school grade

Purpose of the graph

The graph is considered according to Kosslyn (1985), as a resource that is used for analysis, communication and in traditional teaching, for purely constructive purposes. This variable has not been taken into account in previous research, so our results represent an original contribution. The activities analyzed in the textbooks tend to use the graphs for analysis purpose with 60.7% of the total graphs used for this purpose, while only 24.4% are used for communication purposes, as shown in Table 3. The constructive purpose does not seem to be so relevant to both publishers and only represents 15% of the total of activities analyzed.

When analyzing the results by grade (Table 4), we observe that that the most common purpose in the first grade is communicating information and little analysis and graph construction are encouraged. In the remaining grades, the purpose of analysis predominates, although there is always an interest in graphic construction, in particular until grade 3. This variable has not been taken into account in previous investigations.

Purpose	AL (n=56)	S (n=111)
Analysis	58,7	61,8
Communication	21,7	25,9
Construction	19,6	12,4

Table 3. Frequency and percentage of graphs according purpose and editorial

Purpose	School grade					
	1 (n=8)	2 (n=44)	3 (n=26)	4 (n=33)	5 (n=28)	6(n=28)
Analysis	18,8	42	63,6	69,1	69,1	77
Communication	62,5	39,8	12,7	19,8	14,7	17,5
Construction	18,8	18,2	23,6	11,1	16,2	5,4

Table 4. Percentage of graphs by purpose and school grade

4.3 Contexts

The contexts of graphs are summarized in Table 5, where the most common context used in AL is primarily the school /workplace while in S both this context and personal contexts involve 33, 3%, of the activities each. Both publishers point strongly to the school / work context and to a lesser extent to scientific situations.

Context	AL (n=56)	S (n=111)
Personal	3,6	33,3
Social	28,6	18,9
School /work place	48,2	33,3
Scientific	19,6	14,4

Table 5. Frequency and percentage of graphs according context and editorial

The relationship of the context with school grade is shown in Table 6, where the School/work place context dominates along second to the fifth grades, mainly due to situations related to school. In the first year, personal and social contexts are more frequent, in coincidence with Mingorance's research (2014) while social and scientific contexts are more frequent in the sixth grade. Scientific context is scarce in the first school years, but increases after the fourth grade.

Context	School grade					
	1 (n=8)	2 (n=44)	3 (n=26)	4 (n=33)	5 (n=28)	6(n=28)
Personal	37,8	31,8	26,9	21,2	7,1	21,4
Social	37,5	18,2	34,6	21,2	7,1	28,6
School /work place	25,0	38,6	34,6	36,4	64,3	21,4
Scientific		11,4	3,8	21,2	21,4	28,6

Table 6. Percentage of graphs by context and school grade

Conclusions

The two series of books analyzed, concentrate their activities at the semiotic complexity level 3 that is in the representation of a data distribution in coincidence with Díaz-Levicoy et al. (2016) results.

The results of the analysis showed that the main goal of graphs in the textbooks is analysis, followed by communication with only 18% graphs oriented only to learn how to build the graph. In our opinion more activities oriented to build a graph should be included because previous literature show the importance of graph construction as part of a good graphical competence (Wu, 2004) and because this ability is recommended in Costa Rica's curricular guidelines (M.E.P., 2012). There were also variation between the different grades with personal contexts more frequent in first grade and educational context more frequent in grades 2 to 5. In grades 1 to 3 scientific contexts hardly appear, while starting from grade 4 they constitute about a quart of all the graphs.

These results are useful for teachers who should take into account the relevance of variables as semiotic complexity, purpose and context in statistics education and select adequate activities when introducing their students to statistical graphs, because previous research show the importance of taking into account these variables in the teaching of statistical graphs (Arteaga and Batanero, 2011, Cazorla, 2002, Monteiro and Ainley, 2007, Díaz-Levicoy et al., 2016)

Textbooks are a teaching and learning resource with an important tradition within the classroom, because they provide support to teachers and students throughout the instructional process. It is therefore necessary to study how the textbooks present statistical topics as a first step to suggest possible improvement in their content and to check that they follow the curricular guidelines.

Project EDU2016-74848-P and group FQM126 (Junta de Andalucía).

References

- Arteaga, P., & Batanero, C. (2011). Relating graph semiotic complexity to graph comprehension in statistical graphs produced by prospective teachers. In Proceedings of *CERME 7*. (Vol. 7, pp. 725–734). Lyon; ERME.
- Bertin, J. (1967). *Semiologie graphique*. Paris: Gauthier-Villars.
- Cazorla, I. (2002). *A relação entre a habilidades viso-pictóricas e o domínio de conceitos estatísticos na leitura de gráficos*. Doctoral Dissertation. Universidad de Campinas.

- Díaz-Levicoy, D., Giacomone, B. y Arteaga, P. (2017). Caracterización de los gráficos estadísticos en libros de texto argentinos del segundo ciclo de Educación Primaria. *Revista Profesorado*, 21(2), 300–326.
- Díaz-Levicoy, D., Batanero, C., Arteaga, P. y Gea, M.M. (2016). Gráficos estadísticos en libros de texto de Educación Primaria: Un estudio comparativo entre España y Chile. *BOLEMA. Boletim de Educação Matemática*, 30(55), 713–737.
- Franklin, C., Kader, G., Mewborn, D., Moreno, J., Peck, R., Perry, M. y Scheaffer, R. (2007). *Guidelines for assessment and instruction in statistics education (GAISE) report: a pre-k–12 curriculum framework*. American Statistical Association.
- Herbel, B. A. (2007). From intended curriculum to written curriculum: Examining the "voice" of a mathematics textbook. *Journal for Research in Mathematics Education*, 38(4), 344–369.
- Kosslyn, S. M. (1985). Graphics and human information processing. *Journal of the American Statistical Association*, 80(391), 499–512.
- M.E.P. (2012). *Programa de estudio matemáticas, I, II y III Ciclos de la educación general básica y ciclo diversificado*. San José, Costa Rica: Ministerio de Educación Pública.
- Monteiro, C. y Ainley, J. (2007). Investigating the interpretation of media graphs among student teachers. *International Electronic Journal of Mathematics Education* 2(3), 188-207.
- OECD. (2016). PISA 2015 assessment and analytical framework: Science, reading, mathematics and financial literacy. Paris: OECD.
- Shield, M. & Dole, S. (2013). Assessing the potential of mathematics textbooks to promote deep learning. *Educational Studies in Mathematics*, 82(2), 183–19.
- Wu, Y. (2004, Julio). Singapore secondary school students' understanding of statistical graphs. *10th International Congress on Mathematics Education*. Copenhagen, Dinamarca.

Appendix: Books analyzed

- AL1. Calderón, Y. (Ed.) (2017) *Matemática 1*. San José, Costa Rica: Asociación Libros para Todos.
- AL2. Calderón, Y. (Ed.) (2017) *Matemática 2*. San José, Costa Rica: Asociación Libros para Todos.
- AL3. Calderón, Y. (Ed.) (2017) *Matemática 3*. San José, Costa Rica: Asociación Libros para Todos.
- AL4. Calderón, Y. (Ed.) (2017) *Matemática 4*. San José, Costa Rica: Asociación Libros para Todos.
- AL5. Calderón, Y. (Ed.) (2017) *Matemática 5*. San José, Costa Rica: Asociación Libros para Todos.
- AL6. Calderón, Y. (Ed.) (2017) *Matemática 5*. San José, Costa Rica: Asociación Libros para Todos.
- S1. Santillana. (2016). *Matemática 1*. San José, Costa Rica: Author
- S2. Santillana. (2016). *Matemática 2*. San José, Costa Rica: Author
- S3. Santillana. (2016). *Matemática 3*. San José, Costa Rica: Author
- S4. Santillana. (2016). *Matemática 4*. San José, Costa Rica: Author
- S5. Santillana. (2016). *Matemática 5*. San José, Costa Rica: Author
- S6. Santillana. (2016). *Matemática 6*. San José, Costa Rica: Author

Building up students' data analytics skills to solve real world problems

Sibel Kazak¹, Taro Fujita² and Manoli Pifarre Turmo³

¹Pamukkale University, Turkey; skazak@pau.edu.tr

²University of Exeter, UK; T.Fujita@exeter.ac.uk

³University of Lleida, Spain; pifarre@pip.udl.cat

Keywords: Data analytics, technology, informal statistical inference, K-12 education.

Theoretical background

In today's age of information, data is very powerful in making informed decisions. Data analytics, which is a relatively new field, refers to processes used in identifying or discovering the trends and patterns inherent in the data to get useful insights for making data driven decisions (Piccano, 2012). The Strategic Partnership for the Innovative Application of Data Analytics in Schools (SPIDAS) project (funded by Erasmus+ Programme) aims at developing students' data analytics skills at various school levels (from primary to secondary) using innovative and student-centered approach.

In the context of SPIDAS project, we define DA as a process of 'engaging creatively in exploring data, including big data, to understand our world better, to draw conclusions, to make decisions and predictions, and to critically evaluate present/future courses of actions'. Our conceptual framework for the teaching and learning of data analytics in schools consists of two components: data analytics cycle and competence areas. Data analytics cycle is drawn on PPDAC (Problem, Plan, Data, Analysis, Conclusion) statistical inquiry cycle (Wild & Pfannkuch, 1999), statistical thinking process (Wild, Utts & Horton, 2011) and informal statistical inference (Makar & Rubin, 2009, 2018). This cycle involves the following steps in solving real world problems that require data: 1) defining the problem 2) considering data 3) exploring data 4) drawing conclusions 5) making decisions and 6) evaluating courses of actions. Additionally, the data analytics cycle is complemented with various competence areas that are in line with "Framework for 21st Century Learning" (<http://www.p21.org/about-us/p21-framework>) and the Royal Society's (2016) report on the need for data analytics skills. These are statistical literacy, ICT literacy, critical thinking, creativity, communication and collaboration, ethics and social impact.

The study

This study aims to innovate and extend best practice in the teaching of data analytics through student-centered, project-based learning, focusing on the impacts of weather. The project end-product will be the Data Analytics Toolkit, an on-line resource supporting schools across the EU to develop their data analytics projects building on our examination of the state-of-the-art and findings emerging from the pilot projects conducted in partnering schools in the UK, Spain and Turkey (<http://blogs.exeter.ac.uk/spidasatexeter>). To this end, a design study method (Cobb et al., 2003) is used for developing, testing and revising conjectures about how students develop skills and competencies related to data analytics and instructional materials to support it with the use of technology tools. The design of the pilot projects are guided by our data analytics framework. They

are implemented in nine partnering schools with 9–17 year-old students across three countries over two iterations (fall 2018 and spring 2019). One of the project themes to engage 9–12 year-old students in data analytics for solving real world problems is “How does weather affect our health and emotions?” through which we expect them to correlate weather data with other datasets, such as students’ feelings. In the first pilot study, students generated statistical questions and collected their own data from other students as well as obtained them from other sources, such as the meteorology office. Technology tools, e.g. Excel and CODAP (<https://codap.concord.org/>), were used to record, visualize and analyze their data to make decisions. Students’ work on computer and worksheets and classroom observations are analyzed to elaborate on how students interact with ill-structured real world problems to apply data analytics techniques and skills.

Poster presentation

The poster presents an overview of the conceptual framework for the teaching and learning of data analytics in schools, objectives and context of the study, task design and preliminary findings regarding how students deal with multivariate datasets to investigate different possible relationships in solving real world problems using data analytics techniques and skills.

The Strategic Partnership for the Innovative Application of Data Analytics in Schools (SPIDAS) project is funded with support from the European Union’s Erasmus+ Programme. All views expressed are those of the authors and not of the European Commission.

References

- Cobb, P., Confrey, J., diSessa, A., Lehrer, R., & Shauble, L. (2003). Design experiments in educational research. *Educational Researcher*, 32(1), 9–13.
- Makar, K. & Rubin, A. (2009). A framework for thinking about informal statistical inference. *Statistics Education Research Journal*, 8(1), 82–105. [Online: [http://iase-web.org/documents/SERJ/SERJ8\(1\)_Makar_Rubin.pdf](http://iase-web.org/documents/SERJ/SERJ8(1)_Makar_Rubin.pdf)]
- Makar, K., & Rubin, A. (2018). Learning about statistical inference. In D. Ben-Zvi, K. Makar and J. Garfield (Eds.) *International Handbook of Research in Statistics Education* (pp. 261–294). Springer International Handbooks of Education. DOI 10.1007/978-3-319-66195-7
- Picciano, A. G. (2012). The evolution of big data and learning analytics in American higher education. *Journal of Asynchronous Learning Networks*, 16(3), 9–20.
- Royal Society (2016). *Data analytics: the skills need in STEM*. Conference report organised in partnership with the Royal Statistical Society held on 16 November 2016.
- Wild, C. J. & Pfannkuch, M. (1999). Statistical thinking in empirical inquiry. *International Statistical Review*, 67(3), 223–248.
- Wild, C. J., Utts, J. M., & Horton, N. J. (2011). What is statistics? In D. Ben-Zvi, K. Makar and J. Garfield (Eds.) *International Handbook of Research in Statistics Education* (pp. 5–36). Springer International Handbooks of Education. DOI 10.1007/978-3-319-66195-7

Interweaving probability games and other mathematical areas in Tamás Varga's spirit in Hungary

Anna Kiss

Eötvös Loránd University, Hungary; annaboxx@gmail.com

Keywords: Complex mathematics education, probability, games.

Short description of the research topic

The aim of the presentation is to show how it was possible in a pilot project to interweave probability and other mathematical areas in the spirit of Tamás Varga's complex mathematics education model in Hungary.

The project was launched under the Recent Complex Mathematics Education Project¹, the aim of which is to examine how Tamás Varga's relatively old, but no way outdated ideas can be implemented to match present-day challenges effectively. In this sense it is also an interesting question, I intend to address in my later research, at what point digital devices should be introduced to help discovery. As Tamás Varga proposed to use manipulatives for the earliest stages of discovery, in this presentation two games accompanied by using manipulatives are presented.

“Complex” in this sense stands for teaching different areas of mathematics at the same time, often as problems of mathematical nature arise in the real world, and thus giving students a more complex and realistic image of what mathematics and mathematical thinking is.

Theoretical framework

Even though Tamás Varga introduced probability from early primary school (Varga, 1972) in his curriculum as early as in the 1960s (Varga, 1969), in Hungary, similarly to many other countries (Serradó, Azcárate, & Cardenoso, 2006) the majority of teachers tried to avoid or minimize teaching probability in their teaching practice (Pálfalvi, 2000). In today's curricula there are three lessons appointed in fifth grade for dealing with “possible, impossible and sure” situations. In sixth grade, no probability is included, but a chapter for statistics at the very end of the schoolyear, where in practice it is often omitted.

“Guided experience with randomness in earlier years is an important prerequisite to successful teaching of formal probability” (Steen, 1990, p. 120.). In this study guided experience was embedded into the lessons appointed for teaching fractions and arithmetic. This way, instead of linear mathematics teaching, the teacher engaged in complex mathematics teaching where consolidating other mathematical areas and guided experience with randomness became possible at the same time. This way probabilistic concepts could be introduced without need for more lessons.

¹ This paper was supported by the Hungarian Academy of Sciences under the Recent Complex Mathematics Education Project

This research would be worth to be continued to enable teachers to teach more mathematical areas simultaneously.

The method

In the project, probability games were selected to be taught in a complex way in four consecutive schoolyears for fifth and sixth graders, two of which are shown in the poster. One, a modified version of the game called “pig”, where 5 and 6 are out ruled (Tsao, 2016) connects probability and fractions (Sinicrope & Mick, 1992), the other, played with two tetrahedron dice (Nilsson, 2007) connects probability and arithmetic. Student-teacher dialogues were transcribed to be analyzed in a later article to further investigate students’ knowledge construction processes (Ron, Dreyfus, & Herschkowitz, 2010).

Research results

The aim of the pilot project was to introduce probabilistic thinking into lessons where other mathematical areas were in the focus through complex teaching. We have found that through careful planning and selection of games, it was possible to teach more in fewer lessons, and thus “engage children in considerations of chance more often and more systematically” (Lehrer, & English, 2018, p. 248).

References

- Nilsson, P. (2007). Different ways in which students handle chance encounters in the explorative setting of a dice game. *Educational Studies in Mathematics*, 66(3), 293–315.
- Pálfalvi, J. (2000). *Matematika didaktikusan [Mathematics didactically]*. Budapest: Typotex.
- Ron, G., Dreyfus, T., & Herschkowitz, R. (2010). Partially correct constructs illuminate students’ inconsistent answers. *Educational Studies in Mathematics*, 75(1), 65–87.
- Serradó, A., Azcárate, P., & Cardeñoso, J. M. (2006). Analysing teacher resistance to teaching probability in compulsory education. In A. Rossmann & B. Chance (Eds.), *Proceedings of the Seventh International Conference on Teaching Statistics*. Training teachers for statistical education. Retrieved from <https://www.ime.usp.br/~abe/ICOTS7/Proceedings/index.html>
- Sinicrope, R. & Mick, H. W. (1992). Multiplication of Fractions through Paper Folding. *Arithmetic teacher*, 40(2), 116–21. Retrieved from <https://sci-hub.tw/10.2307/41195265>
- Steen, L. A. (1990). *On the shoulders of giants: New approaches to numeracy*. Washington, DC: The National Academies Press.
- Tsao, Y. L. (2008). CETL Capstone Project. Retrieved from www.mnsu.edu/cetl/programs/pdfs/PDF2007/PDF%202008/Yea-Ling%20Tsao.
- Varga, T. (1969). *A matematika tanítása. [Teaching of Mathematics]*, Hungarian, Budapest: Tankönyvkiadó.
- Varga, T. (1972). Logic and Probability in the Lower Grades. *Educational Studies in Mathematics*, 4(3), 346–357. Retrieved from <http://www.jstor.org/stable/3482172>

Pitfalls and surprises in probability: The battle against counterintuition

Signe Holm Knudtzon

University of South-Eastern Norway, Norway; Signe.H.Knudtzon@usn.no

The teaching of probability is a great challenge, not least in the training of maths teachers. This study is built around working with teachers, concentrating on one special problem: “What is the probability of picking one red and one yellow candy from a sack containing two red and two yellow pieces of candy?” From this simple example, we explore three different ways of thinking about the teaching of probability. 1) Experimentally, 2) Combinatorically, 3) Probabilistic. Throughout, we will discuss the question: “What does a student/teacher need to do in order to involve all three approaches in her teaching?”

Keywords: Probability, combinatorics, exploration, representations, working with teachers

Introduction

In general, a teacher does not only need to know that there are several ways to approach a problem in probability, but also that there are more than one method to solve a probabilistic problem. A good teacher also needs to be open to the possibility that some students may think quite differently than the teacher thinks herself. This implies that the teacher must be able to communicate well with the students, listen to their arguments and try to understand their reasoning when they work on mathematical problems. Obviously, this requires that the teacher possesses a solid understanding of the subject she is teaching.

The counterintuitive nature of some probability results makes probability very challenging and difficult to teach and to learn (Koeller, Pittman & Brendefur, 2015; Knudtzon 2010). Many researchers (Afeltra, Mellone, Romano, & Tortora, 2017; Batanero, Godino & Roa, 2004; Chernoff & Zazkis 2011; Falk, Yudilevich-Assouline, & Elstein, 2012; Lecoutre, 1992) have discussed difficulties in teaching probability. Recognising the challenges associated with teaching and learning of probability, the purpose of this article is to explore the question: *How can we as teacher educators help teachers to understand not only probability, but also give them confidence in teaching probability to students?*

Background

Bryant and Nunes (2012) provide four “cognitive demands” for understanding probability. They are:

Understanding randomness; Working out the sample space; Comparing and quantifying probabilities; Understanding correlation (or relationships between events) (Bryant & Nunes, 2012, p.12)

In this study, we discuss two of these points: “Working out the sample space”, Comparing, and quantifying probabilities. One of the problems with “Working out the sample space” is that the student gives all possibilities the same probability. For instance if you flip/toss two coins, there will be three possibilities: HH, HT and TT, and they will all have equal probability. Chernoff and Zazkis

(2011, p.18) call the set HHH, HHT, HTT and TTT a “Sample Set” and see it as a point of departure to develop the complete sample space: HHH, HHT, HTH, THH, HTT, THT, TTH and TTT.

Lecoutre (1992) also describes difficulties in calculating probabilities:

... the most frequent model used is based on the following incorrect argument: the results to compare are equiprobable because it's a matter of chance; thus random events are thought to be equiprobable “by nature”. (Lecoutre, 1992, p.557)

With respect to “Comparing and quantifying probabilities”, one may calculate theoretically or one may do an investigation to study the relative frequencies of the different outcomes. This is a central element in the Norwegian Curriculum:

The aims of the studies are to enable pupils to: - find and discuss probability by experimenting, simulating and calculating in day-to-day contexts and games. (Norwegian Curriculum for the common core subject of mathematics, 2006, p.9)

When teaching probability, teachers must know that obstacles often will occur. “Expect the Unexpected When Teaching Probability” (Koeller et al., 2015).

The Study

The data in this study mainly come from “Probability workshops” with teachers in 2010 and 2016. Both primary teachers (age 6 – 12 years) and secondary teachers (age 13 – 15) attended the workshops. The teachers who joined the workshop in 2010 were part of a four-day summer conference for teachers. The teachers in 2016 joined a one-day mathematics workshop. The sizes of the classes were 22 and 33.

First, teachers were given a task where they were asked to write down their first guess on a piece of paper and then show how they thought about the task individually. These papers were collected afterwards. Thereafter they were asked to work in pairs and “try it out”, by picking pieces of candy twenty times and write down the results. After a discussion in pairs and in small groups, we had a whole class discussion. Different ways of collecting and presenting the data were discussed as well as different ways of finding the probability of getting one piece of candy of each colour. The data collected consist of the teachers’ written responses and my field notes. Field notes from the smartboard gave the numbers in Table 2.

The Candy Problem

The problem, as presented here, is from a textbook for 7th grade in elementary school. (Figure 1.)

“Hege has two red and two yellow pieces of candy in a small bag. Mia picks two pieces of candy (without looking).

What is the probability that Mia gets one red and one yellow piece of candy?”



Figure 1: Two red and two yellow pieces of candy

In the workshops for the teachers, we asked them to answer this question: “What is the probability that Mia gets one red and one yellow piece of candy when she picks two pieces from a bag with two red and two yellow pieces of candy” Guess, write down and try to explain your thoughts.

Results

Guessing

The first group of answers is from a workshop in 2010 and is discussed in Knudtson (2010). Here are some of the written answers:

- 1) RR, YY, RY give $\frac{1}{3}$ probability
- 2) The probability to pick a red piece first is 0.5, but then you have only three pieces left ...
- 3) red-red, red – yellow, 2 of 4 $\frac{2}{4} = \frac{1}{2}$
yellow – yellow, yellow – red
- 4) the probability to first pick a yellow and then a red one is $\frac{1}{2} \times \frac{2}{3} = \frac{2}{6} = \frac{1}{3}$
same with red – yellow

5) $\frac{1}{4} + \frac{1}{4} = \frac{2}{4} = \frac{1}{2} = 50\%$

6)
$$\begin{array}{ccc} y_1y_2 & y_1r_1 & y_1r_2 \\ y_2y_1 & y_2r_1 & y_2r_2 \\ r_1y_1 & r_1y_2 & r_1r_2 \\ r_2y_1 & r_2y_2 & r_2r_1 \end{array} \quad \frac{8}{12} = \frac{2}{3}$$

7) Table

	Y ₁	Y ₂	R ₁	R ₂
Y	YY	YY	RY	RY
Y	YY	YY	RY	RY
R	YR	YR	RR	RR
R	YR	YR	RR	RR

8) Experiment with counting:
16 of 25 was one yellow and one red

2y	IIII
2r	IIII
yr	IIII IIII IIII I

9) (a drawing of the four pieces of candy and)
YY, YR, RR?

The participants at the workshop in 2016 were given small pieces of paper (yellow post-it-stickers), and were asked to write down their guesses and possible explanation individually. The answers and some of the explanations are given in Table 1. (Including the frequency of each answer)

answer	frequency	explanation
1/12	1	$\frac{1}{4} * \frac{1}{3} = \frac{1}{12}$
1/6	4	$\frac{2}{4} * \frac{1}{3} = \frac{1}{6}$ 1 of 6
$\frac{1}{4}$	5	$\frac{1}{2} * \frac{1}{2} = \frac{1}{4}$ one of four
1/3	6	$\frac{2}{4} * \frac{2}{3} = \frac{4}{12} = \frac{1}{3}$ YY, YR, RR one of tree
$\frac{1}{2}$	13	RR, RY, YR, YY $\frac{2}{4}$
$\frac{2}{3}$	2	$\frac{2}{3}$ RY $\frac{2}{4} * \frac{2}{3} = \frac{4}{12}$ YR $\frac{4}{12}$ $\frac{4}{12} + \frac{4}{12} = \frac{8}{12} = \frac{2}{3}$
Other	2	
SUM	33	

Table 1: Quick notes on “post it” notes from the workshop in 2016

Experimentation

After guessing and writing down their first thoughts, the teachers were asked to try out the experiment. They were asked to work in pairs and to write down their results. The participants had received the problem on a paper. We used different bricks, lego or centicubes as candy and different boxes or black socks as bags. This question, which will be discussed later, arose: “Shall we pick one at a time or both at once?”

There were different ways of collecting the data. Some teachers had three choices: RR, RY, YY and some had two: Two of same colour or two with different colours. They made lists: some in a line: RR, RG, RG, RG, RR, GG, RG..., but many in columns. Some kept track of how many times they had tried and some counted after a while to see if they had obtained twenty pieces altogether. Some made tables and used tally marks and fences (grouping in fives).

Some used computers or IPADs. One way of writing on a PC was:

1) yellow and red 2) red and red 3) yellow and yellow

At the whiteboard we collected some of the results (see Table 2.):

YY	4	1	2	4	4	4	4	4	Sum	27
YR	12	16	15	8	11	14	12	14	Sum	102
RR	4	3	3	8	5	2	4	2	Sum	31

Table 2: Results from eight groups

One participant said after a while, “I don’t like that we get so many with one of each.” One teacher said, “It look like there are twice as many with one of each than the other two together”.

The question “Two at a time or one after another?”

In problems mentioned here the question always arises if it matters whether we take two (pieces of candy) at the same time, or take one after another. Many students, teacher students and teachers as well will argue that there is a difference. (One method is to try, to experiment, to use one method twenty times (or more) and the other twenty times and see if there is a difference.)

Sometimes I try the following:

- 1) Put your hand in the bag and grab two candies without looking. Extract your hand and open your fist. Then you have either two red, two yellow or one piece of candy of each colour in your hand.
- 2) Put both your hands in the bag at the same time and take one piece of candy in each hand. Take your hands out and open them simultaneously. Will this be the same as in the first case? Yes, again you will have either two red, two yellow or one of each colour. However, you may also note that you may have one of each colour in two different ways, you may have the red piece of candy in your left hand, or you may have it in your right hand.
- 3) Put both hands in the bag at the same time and take one piece of candy in each hand. Then open one hand first, for instance your left, then open the other hand. You end up with two red, two yellow or one red piece in your left hand and one yellow in your right hand or conversely.

A moment’s contemplation will convince most students (if not all teachers) that the probability of each outcome is not affected by which of these three procedures you use. It does not matter if you use one or two hands (or any other instrument) to pick out two pieces of candy, and it does not matter if you open one hand after another, the piece of candy is in the hand regardless and it does not change colour by waiting to be looked at.

Analysis

Investigation, experimentation

As seen in Table 2, different groups got different answers and the fourth group picked two candies with one colour more often than two of different colours did. Results from a small investigation will always be uncertain. However, in a class with a larger number of trials the results are more reliable.

To do experimentations is a nice variation in the ordinary mathematics classroom. It is an activity that most students can join and participate in on an equal basis. However, it is not clear that they collect and take care of their data in a way that is easy to use in further work. In addition, there is need for experience for both teachers and students.

Combinatorics

Asking the question: In how many ways may we combine the four pieces of candy? Figure 2 shows that we will find two ways of making groups with one colour and four different ways of making two colour groups, if we draw the pieces of candy” and the lines connecting two and two of them.

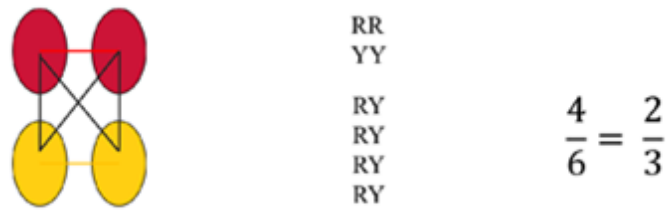


Figure 2: Combinatorics: Finding the sample space. Take two of four

The sample space of taking two from four has six outcomes. Four of these are one red and one yellow. The probability of picking one red and one yellow is $\frac{4}{6} = \frac{2}{3}$. The representation given by drawing the four pieces of candy in this way (two by two, not on a line) was new for many of the participants. They enjoyed it and it is possible to extend this with more pieces of candy.

Probabilistic thinking

I will here use the term “probabilistic thinking” in a more narrow sense than we usually do. *We do not count whole numbers; we work with numbers less than one, fractions, each of them the probability of something.* It can be represented in a tree diagram, see Figure 3.

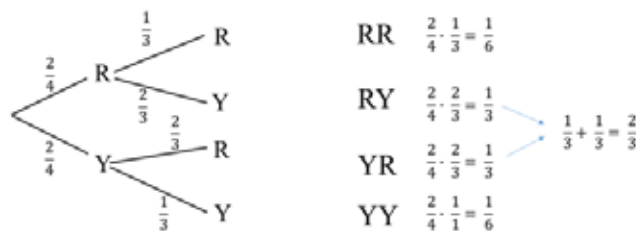


Figure 3: Probabilistic thinking. Tree diagram

You can get one red and one yellow piece in two ways, by getting the red piece of candy first or the yellow piece of candy first. We get a probability of $\frac{2}{3}$ of picking two different colours.

In this case we can “think in probability” in a quick way, because there is an equal amount of each colour. This is represented in Figure 4. If you take one of the four pieces of candy, there will always be two of the other colour and one of the same colour left. This gives a probability of $\frac{2}{3}$ of getting two different colours.



Figure 4: Probability, quick way

Three approaches

We have worked with this problem in many different ways: guessing, thinking, discussing, trying it out (investigating/experimenting), using combinatorics by finding the sample space and finding a fraction of the proportion of the outcomes. We have calculated the probability, for instance by using

a tree diagram, or by using a formula. What are the advantages or disadvantages of the various approaches? Table 3 summarizes some of my experiences.

Experimental	Combinatorial	Probabilistic
Practical	Requires correct counting	Quickest way
Everybody can take part Difficult to use in situations involving conditional probability	A safe method	General, handles complex situations
Works also in situations where there is no mathematical probability		Enhances thinking and understanding
Inaccurate for small numbers, makes it difficult to separate small differences	May get confused, problems with finding all possibilities	May be difficult
Takes much time	Can take much time	

Table 3: Advantages and disadvantages of the three approaches

I want to emphasize the usefulness of investigation and experimentation, especially in the beginning. Everybody may join in, but it is important to write down the results in an orderly manner. Different groups may get different results, which gives good opportunities for discussions. However, the teacher needs to know all three approaches, and how it is possible to make them interact in her teaching.

What may the different answers involve?

If we look at Table 1, we will see that $\frac{1}{4}$, $\frac{1}{3}$ and $\frac{1}{2}$ are quite popular answers. How did they emerge? The fraction $\frac{1}{4}$ may arise from working with a sample space of four: RR, RY, YY and YR thinking that RY is one of four. It can also be a result of thinking in probability: $\frac{1}{2} * \frac{1}{2} = \frac{1}{4}$. Here, one takes first one red piece and then one yellow (without taking into account that there are only three pieces of candy left).

The fraction $\frac{1}{3}$ may result from thinking in sample space; and there are three different outcomes: RR, RY and YY. RY is one of them and then we get $\frac{1}{3}$. Another way is thinking in probability: $\frac{2}{4} * \frac{2}{3} = \frac{4}{12} = \frac{1}{3}$. This is the right thinking if the question was getting the first piece of candy red and the second piece yellow.

The answer $\frac{1}{2}$ may also be the result of different ways of thinking. A sample space of four, RR, RY, YR and YY, gives $\frac{2}{4} = \frac{1}{2}$. Probabilistic thinking may be $\frac{1}{2} * \frac{1}{2} = \frac{1}{4}$ for getting RY and $\frac{1}{2} * \frac{1}{2} = \frac{1}{4}$ for getting YR and together this makes $\frac{1}{4} + \frac{1}{4} = \frac{1}{2}$. Some people will say $\frac{1}{2}$ because there are equal amounts of red and yellow pieces of candy. Others will say that the pieces of candy are either the same colour or two different colours and some will just say $\frac{1}{2}$ and will give no reason. It is interesting to discuss these different ways of thinking and how to move further on from each of them.

Conclusion

Working with teachers, it is my experience that learning probability and discussing ways of teaching probability at the same time is a good way. We have to create situations where it is possible to come up with “wrong answers”. If we do not give room for this, the students may close up and not want to join in. To use wrong answers as a resource, is also recommended by Afeltra et al., (2017). When we study how to collect the data and how to explain them in different ways, most teachers are interested and fascinated. From being afraid of teaching probability, they get curious and excited. By obtaining more experience with different probability situations my hope is that the topic will be less counterintuitive than it was at the outset. When the learners know what to look for and how to handle the most common probability problems, their intuitions will be strengthened.

It is important to make a safe environment, and to look at “wrong answers” as not fully developed answers and as starting points for further work. We can also turn it upside down and ask, “What question may be asked to get this answer?”

References

- Afeltra, L., Mellone, M., Romano, P., & Tortora, R. (2017). Errors or didactic resources: the design of a teacher education task in the context of Probability. *CERME10*, pp 700–707.
- Batanero, C., Godino J. D., & Roa, R. (2004). Training Teachers to Teach Probability. *Journal of Statistics Education*, 12(19). DOI: 10.1080/10691898.2004.11910715
- Bryant, P., & Nunes, T. (2012). *Children's understanding of probability*. A literature review (full report). Nuffield Foundation. Oxford.
- Chernoff, E. J., & Zazkis, R. (2011). From personal to conventional probabilities: from sample set to sample space. *Educational Studies in Mathematics*, 77(1), 15–33.
- Falk, R., Yudilevich-Assouline, P., & Elstein, A. (2012). Children’s concept of probability as inferred from their binary choices—revisited. *Educational Studies in Mathematics*, 81(2), 207–233.
- Knudtzon, S. H. (2010). Sannsynlighet, ikke alltid like enkelt. (Probability – not always easy.) In: *Matematikk - nå snakker vi. Sommerkursrapport 2010*. Trondheim, Norway: NTNU-trykk ISBN 9788291999234, 93–108.
- Koeller, K., Pittman, M., & Brendefur, J. L. (2015). "Expect the Unexpected When Teaching Probability". *Mathematics Teaching*, 61(2), 29–32.
- Lecoutre, M. P., (1992). Cognitive models and problems spaces in “purely random” situations. *Educational Studies in Mathematics*, 23(6), 557–568.
- Norwegian Curriculum (2006). Curriculum for the common core subject of mathematics (MAT1-04). Retrieved from: <http://www.udir.no/k106/MAT1-04/Hele/Kompetansemaal/competence-aims-after-year-10?lplang=eng>

Why does statistical inference remain difficult? A textbook analysis for the phases of inference

Rüya Gökhan Koçer and Fulya Kula

University of Twente, Department of Research Methods, Measurement and Data Analysis,
Netherlands; r.g.kocer@utwente.nl

Keywords: Statistical inference, content analysis, textbook analysis

Introduction

Inference in statistics is one of the crucial issues to be explained as it refers to the process of making probabilistic statements about the entire population under scrutiny by only looking at a small part of it. Inference has been studied among researchers and the students' difficulties in understanding the procedures of inference and reasoning the inferential ideas is widely documented (e.g. Falk and Greenbaum, 1995). The abstract nature of inference with also the underlying complex and abstract concepts such as sample, population, and sampling distribution are documented to result in student difficulties (Bakker and Gravemeijer, 2004; Garfield and Ben-Zvi, 2008). These stubborn difficulties are persistent and also similar among students and adults. In the current study we use the proposed model for the logic of construction for representing the whole idea of statistical inference in the introductory statistics course. This model not only follows the steps in line with the suggestions of the literature (e.g., Bakker and Hoffmann, 2005) but also transcends the suggestions and carries the teaching and learning of inference further.

Methodology

In this study, we analyzed the way in which the logic of construction is explained in one prominent textbook of statistics for the undergraduate level. The book analyzed is the tenth edition of *Introduction to the practice of statistics* (Moore, D. S., McCabe, G. P., & Craig, B. A. (2016), Ninth Edition, Publisher: W. H. Freeman), hence assumed to be used one of the major books of introductory statistics. The textbook covers the inference mainly in one chapter (Chapter 6) which was taken as the content to be analyzed in this study. The steps of construction direction of inference are taken as default and the textbook is analyzed according to these subtended steps with the aim of understanding how the inference framework is being taught in this widely used textbook. The analysis of the content, namely the related chapter, results in a sequence of numbers in the order of appearance.

Results

The results of the content analysis can be seen in Figure 1. The axes of the plot seen in Figure 1 represent the order of the steps of inference as appeared in the logic of construction (See Table 1). Hence if the book covers the steps in the very same way of the construction logic as presented in Table 1, this would yield 13 points on x and y-axes which are exactly on the line: $y=x$. Any deviation from this line is interesting to see how inference is taught in the book different than the proposed steps in the model. The numbers on the scatterplot denote the order of the corresponding step. For instance, the reader first is introduced with step 2a, then step 4a, and 5a, etc. (as expressed by the steps of the logic of construction).

It can be seen in Figure 1 that the book covers the inference in a totally different direction, the order as stated by the steps of the model is: 2a, 4a, 5a, 1, 2b, 8, 4c, 7, 4b, 3a, and 5b. As it can also be observed from the Figure 1 the steps 3b and 6 are not covered at all. So the learner respectively reads

the following concepts or ideas through the chapter: random sampling, sampling distribution, estimating sample statistic, the meaning of population in context, random sampling and sample size, the meaning of amassed probability, normality and characteristics of sampling distribution, the area under the distribution curve, sampling distribution to be a normal distribution emerged as the values estimated accumulate, each sample constituting the sampling distribution to contain the same number of observations, and the estimated sample statistic lands on the real line on which the probabilities are massed by the sampling distribution.

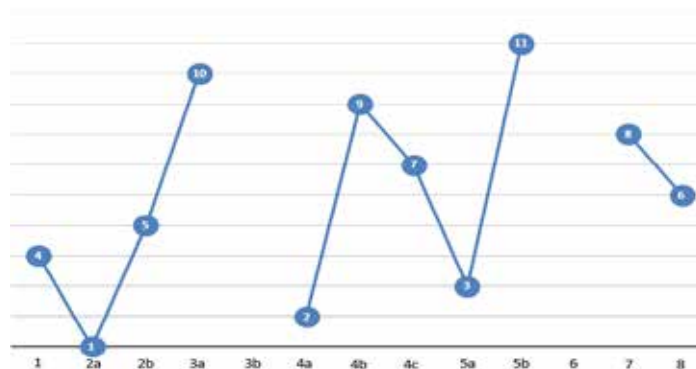


Figure 1: The order of steps of inference followed by the book

Conclusion and Discussion.

It can be seen in the result section that the crucial steps are not presented in the way the model suggests. The model suggests these steps for a better understanding of the statistical inference, which is in fact a difficult topic to understand. The reader of the book, who is also the learner, is being directed to the understanding of inference with some confusions. We believe starting from the random sampling idea, then sampling distributions, focusing on one sample and talking about the population is not the most efficient way of learning or teaching inference. Moreover, some steps (3b and 6 of the model) are missed totally. It is of great importance for students to comprehend the fact that same sized samples all would distribute different than the population, not only to understand the idea of sampling distribution but also that of inference. This step (step 3b of the model) could not be seen to be taught in the book. Besides, the step (step 6 of the model) of grasping that the estimate of the sample at hand would be separated from the center of the sampling distribution by a certain distance “d” was also not covered in the book. The difference between how the order of steps in the model and in the book are covered is worth consideration.. However, the book has a totally different order of teaching this topic. This different approach of the book is important to consider. However, a limitation of the current study is the analysis of only one chapter. We suggest the further research be conducted not only inclusion of all the related chapters but also for the other widely used statistics books.

References.

- Bakker, A., & Gravemeijer, K. (2004). Learning to reason about distributions. In Ben-Zvi, D., & Garfield, J. (Eds.) *The challenge of developing statistical literacy, reasoning, and thinking*. Dordrecht, The Netherlands: Kluwer Academic Publishers.
- Bakker, A., & Hoffmann, M. (2005). Diagrammatic Reasoning as the Basis for Developing Concepts: A Semiotic Analysis of Students' Learning about Statistical Distribution. *Educational Studies in Mathematics*, 60, 333–358.
- Falk, R., & Greenbaum, C. W. (1995). Significance Tests Die Hard. *Theory & Psychology*, 5, 75–98.
- Garfield, J., & Ben-Zvi, D. (2008). *Developing Students' Statistical Reasoning*, Dordrecht: Springer.

Young children's informal statistical inference experiences through constructing a pictograph

Gamze Kurt Birel

Mersin University, Faculty of Education, Mersin, Turkey; gamzekurt@mersin.edu.tr

This study explores the informal statistical inference (ISI) experiences through the graph construction of young children regarding the pictograph as one of the conventional data displays. Within a case study approach, interviews with 7 years-old children were conducted through a module including a task. The task designed here presents a statistical context structure which focuses on the eye colors observed in a class. Through forming a pictograph, children responded the questions in order to investigate their informal inferential reasoning ability. Findings revealed that young children's graph construction experiences could be expressed as a construct of ISI. Besides, it was concluded that the integration of context with data helped their graph construction since they analyzed data within the context.

Keywords: Statistics education, early childhood, informal inferential reasoning, pictograph

Introduction

There is a common understanding that statistical concepts can be developed from the beginning of early childhood education. As well as statistics education is a relatively newer issue for most of the school mathematics program worldwide (introduced during the 1990s in the US) (Friel, Curcio and Bright, 2001), it is even more newer for early mathematics classes. However, accepting the primary and middle school level students' difficulties which they experienced with statistical concepts, statistics education is widely considered important. Suggested *practice of statistics* from the kindergarten to fourth grade level includes both descriptive and inferential statistics such as data collection, data organization, description of data, reading the data, interpretations of data displays (bar graph, pie charts, pictographs, line graphs, etc.) (Watson, 2018). Pictographs are one of data displays which young children are engaged in order to informally investigate data. However, inferential reasoning level is left mostly on the higher levels of education, and that makes the statistics education in lower grades as composed of only computations on some basic graphical representations (Makar & Rubin, 2009). However, according to Makar and Rubin (2009), there are lots of ways to introduce ISI and to develop the ISI abilities to young children as well, such as making predictions, or generalizations or providing a situation where young children can use probabilistic language.

Informal statistical inference (ISI), or informal inferential reasoning (IIR) is a relatively newer concept, that is defined as "the way in which students use their informal statistical knowledge to make arguments to support inferences about unknown populations based on observed samples" (Zieffler, Garfield, Delmas & Reading, 2008, p. 44). They outlined the IIR framework as containing the following three main components: IIR includes (1) making inferences but not using formal statistical procedures, (2) using prior knowledge (formal knowledge of descriptive statistics, but

informal knowledge making inferences about different samples, use of statistical language) and, (3) using arguments, and making claims about populations while using the evidences gathered from samples belonging to those populations (Zieffler et al., 2008, p. 45). In fact, it could be claimed that inferential reasoning embraces an understanding of graph construction. This claim was reflected in the task design suggestions for researchers in order to study informal inferential reasoning as well (Zieffler et al., 2008).

Based on the framework characterized by Zieffler et al. (2008), Makar and Rubin (2009) tried to “broaden accessibility to inferential reasoning with data” and they highlighted three key principles: (1) generalization beyond the data through making predictions, estimations, etc., (2) data usage as evidence in order to make generalizations; and (3) use of probabilistic language in order to explain the generalization drawn while being aware of the level of certainty (p. 85). Authors saw these three elements as observable abilities which comprises the informal inferential reasoning of young children.

Makar and Rubin (2009) points to the findings regarding students’ incapability of making statistical inferences while constructing graphs. The graph construction concept as a construct was addressed as a part of graph comprehension and it was stated that graph construction was less-explained issue as compared to other constructs of graph comprehension (Friel et al., 2001). The graph comprehension highlighted by Friel et al. (2001) treats the data displays as “discovery tools” rather than focusing on the calculations of the data represented in the data display (p. 132). Therefore, the current situation of statistics education cannot be claimed to do so because of it is full of simple arithmetic calculations based on descriptive statistics such as mean, median, etc. This is also valid for early childhood level of education, since most of the activities regarding statistics asks questions like: “what is the most/least observed?”, “what is the difference between the most and the least ... observed?”, etc. Hence, such questions degraded statistics education to basic arithmetic and trivializes the significance of *context* in which answers to such questions could be meaningful only. Focusing on the context maybe the most distinguished property of statistical reasoning rather than mathematical reasoning. Therefore, serving statistical context-structures to young children is important so as to provide them with meaningful statistical inferences while staying in the context.

There are some studies which focuses on the issue from other perspectives. For example, McPhee and Makar (2018) studied with young children in their studies in order to investigate statistical inscriptions they formed. Their approach can be evaluated as a problem solving since it begins with a problem and children were expected to make a data analysis based on inscriptions they formed at the end. They concluded that such kind of teaching approaches can be helpful for children in order to develop desired attitudes towards statistical thinking. Another study had a focus on data representations of primary level students (grade level 4) freely while using a catapult (Fitzallen, Watson, Wright & Duncan, 2018). The researchers present their study in a STEM context and hence they also offer an effective STEM activity which can be used in statistics education. Since the data representations observed during their study were diverse and mostly case-value plots, authors concluded that they couldn’t analyze the data. However, students who selected the frequency bar charts had the opportunity to see the data in an expected manner. This result strengthens the over-emphasis on bar graphs (only in categorical variable) with a focus on calculations.

Here in this study, towards the graph construction, young children were aimed to experience with ISI while focusing on what data tells about beyond the basic calculations. My aim is to present also the ISI abilities of young children so as to claim that statistics education should not be based on the calculations from the very beginning. Since much exposure of basic descriptive statistics calculations in lower grades makes statistics education to be treated in a narrowed and limited understanding, it is currently suggested that foundations of statistical reasoning and ISI can be introduced to the young learners as well (Paparistodemou & Meletiou-Mavrotheris, 2008). Therefore, this study is significant that its findings would reveal the exploration of young children's ISI experiences while constructing a pictograph and what we can learn from their experiences as researchers in order to better introduce them to ISI experiences.

An important issue which was highlighted by Makar (2018) is the statistical context-structures. They are addressed as one of the core notions which young children need to experience in their kindergarten classes. She concluded that statistical context-structures are valuable for teachers while making them precautious about directing questions and emphasizing the informal statistical reasoning while leaving the formal statistical reasoning for the higher-grade levels for students. This suggestion from Makar (2018) in order to develop statistical reasoning abilities of young children is to present statistical context-structures instead of technological tools regarding their capabilities of using a dynamic software such as TinkerPlots. Hence, they can provide a learning environment which Konold and Pollatsek (2002) addressed as a new period of learning while offering an extraordinary data analysis experience for students. As Makar and Rubin (2009) pointed out that such efforts are for understanding the beyond the data, which is aimed in fact for all levels of statistics education, not only beneath the data as it is done in early and primary mathematics classes, nowadays.

With an emphasis on ISI of young children here, conventional graphs (pictographs) were selected in a pre-designed statistical context-structure. On the contrary to what is done regarding statistics education as currently, informal statistical reasoning should be addressed without moving away from the context and without making differentiations based on the grade level. Therefore, the main aim of this study is to explore these experiences of young children with ISI through graph construction in statistical context-structures.

Methodology

This study uses qualitative efforts to respond its research question and analyze the data. The design and the data collection period are based on the case study approach (Yin, 2017). The unit of analysis is each participant and then this study can be named as multiple-case study design. Through the convenient sampling, there were 7 children (3 girls and 4 boys) as participants who are 7 years old in a private school. They were from two first grade classes and were chosen by their teachers, by paying attention to their talkativeness and sociability with a stranger.

Main data collection tool is the interview. Each participant was interviewed nearly 15-20 minutes. Interview was voice-recorded and transcribed verbatim. During interview, a module designed by the researcher used in order to direct questions to the participants. These are the questions presenting a statistical context-structure which will help to explore the experiences of young children's ISI

through graph construction. Through the module each participant was also expected to form a pictograph. During their graph construction, researcher read the questions in the module. At some moments of the interview, researcher took photographs which shows the graph representations of the participants during that moment.

The module specifically presents a context of a class of a child named Ali. There are small colored movable pieces showing the eye color of each child in the class. Participant was expected to organize these onto the paper. In addition to the questions included in this module, which is shown below in Figure 1, researcher asked some further questions for example, “why did you organize in this way?”, “Is there any better way to organize them?”, etc. including the questions regarding descriptive statistics as well. The questions were generated according to the three principles which Makar and Rubin (2009) introduced and they were directed to the children without moving away from the context, which are eye colors observed in Ali’s class.

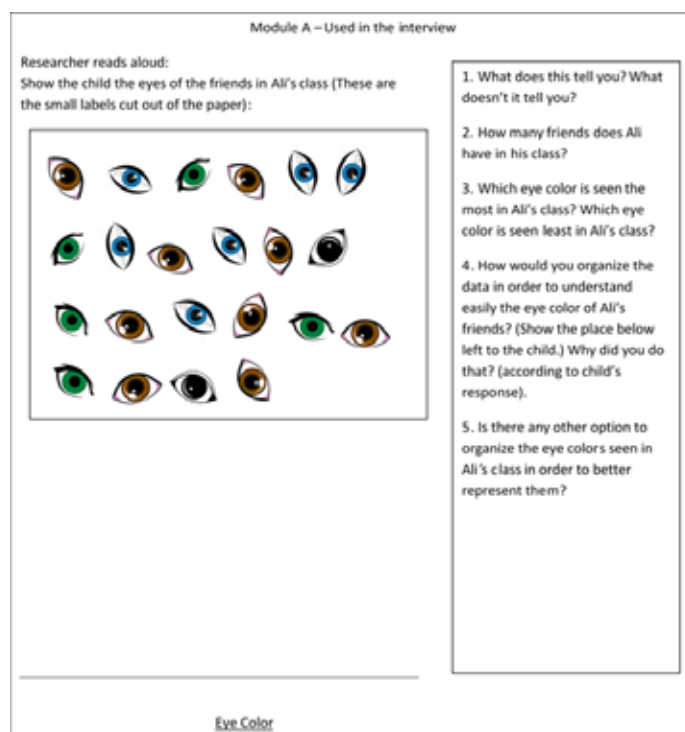


Figure 1: The module used through interview

Findings

The aim of this study is to explore young children’s ISI during graph construction. All of the participants completed the module while keeping the context in mind. As a prior finding, it was observed that use of statistical context-structures in early childhood level of education helps children to think between the lines of context. Then, researcher observed the principles of ISI framed by Makar and Rubin (2009) from children’s module experiences.

All of the seven children correctly gave responses regarding descriptive statistics namely the frequency or the sample size, through the questions related with the most or least seen eye color in Ali’s class, and the number of people in the class. This also strengthens the fact that their familiarity with such kind of frequency-based activities.

Regarding context, there were lots of talk about it. At the beginning of graph construction, participants asked to me how many eyes s/he should use for one person in Ali's class. I directed the question "does a person have different eye colors or not?" and they decided to use one piece of eye label for each person. Real eye colors were also discussed. For example, 2 girls asked to me why I didn't prepare hazel or honey-colored eye labels. They expected to see different blue eye labels. But they were the same since I prepared blue colored eye label in order to represent all real blue eye colors. This means that they were aware that blue eye color can be different from one person to another, in terms of color tone. This shows that they are in context and they could discuss the reality of phenomenon as well.

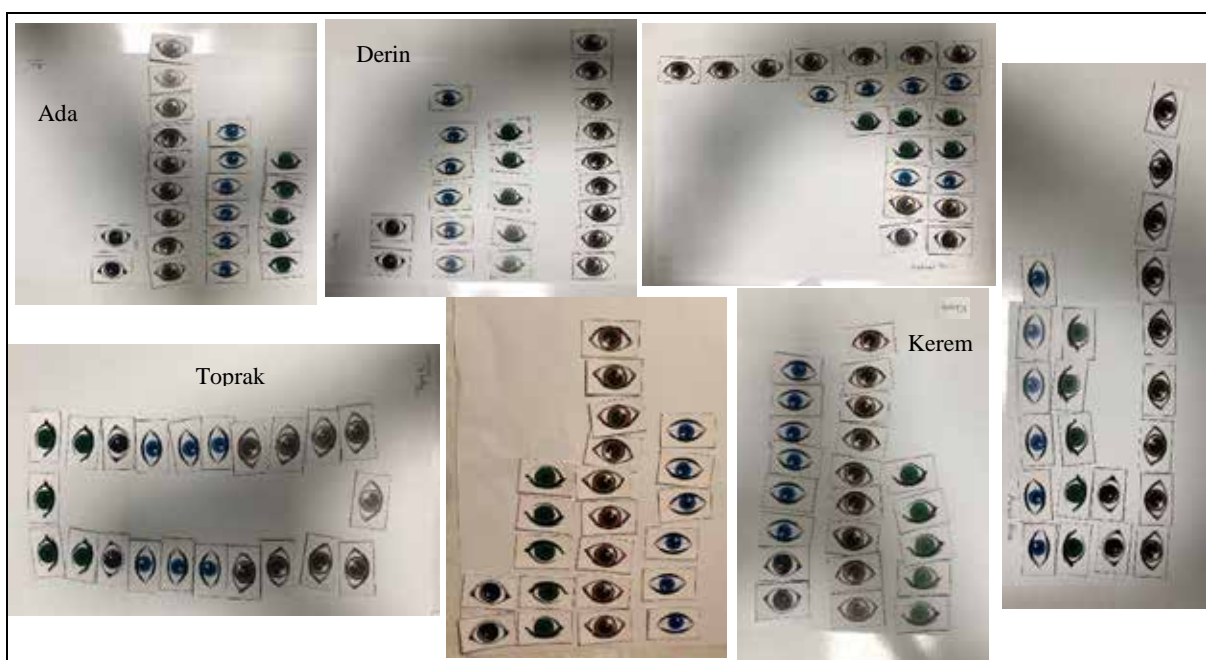
Through the graph construction, I asked them to organize the eye colors seen in Ali's class in order to easily realize the most and least one without counting them, for example. Their initial organizations were in Table 1 below. Four children properly formed the pictograph and they explained that they are grouping the eyes according to the colors in order to understand easily. Some of their explanations are as follows:

Hira: "We can make groups [according to color]."

Derin: "You can see which one is most and which is least in this way."

Although 3 of them (Kerem, Toprak and Emin) were not observed to form a proper pictograph initially, they used different groups of eye colors, they were mostly trying to put them in a pattern. Toprak's representation, for example, shows a nice pattern which can be seen from Table 1.

Table 1: Initial graph constructions of participants



Then, I asked them secondarily to organize the eyes in a different way or in order to realize the least and most one easily. Their explanations are varying differently as in the following:

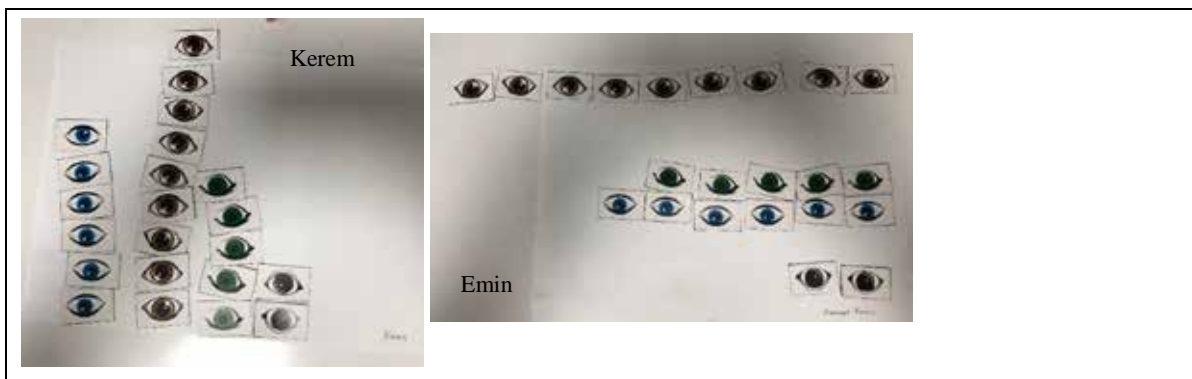
Hira: "We can make a different organization, for example [she changed the direction of the cards.] (she rotated the labels 90 degrees.)"

Emin: “We can do a different graph. For example, we can put the numbers on the bars.”

Poyraz: “We can make a different graph, we can change the places of the bars, in descending order, for example.”

Kerem and Emin grouped the eyes according to the colors and constructed a proper pictograph in their second trials, as can be seen from the following Table 2. When I asked whether we can do a different organization, they both realized making groups of same colors. Although, Toprak also grouped the eyes according to colors, he couldn't represent them in an expected way. He used the bars in the same height and largened the width of the bars instead of extending the bars. Toprak, could not see different eye colors as to be comparable with each other. That is, he did not realize what a representation means or for what purpose it can be used. It can be said that he didn't understand the idea of constructing a graph and its necessity.

Table 2: Secondary graph constructions of Kerem, Emin and Toprak



Regarding the first question in the module, participants tended to think about the eyes in the module in comparison to their real classes. At first, 2 of them thought that Ali, mentioned in the module, was real since they have a same-name classmate as well in their classes (Ali is a common name for boys). Some of them were trying to match the eyes with their friends. For example, Hira said that her class contains only one person whose eye color is blue. This can be explained that they tried to understand Ali's situation while putting themselves in Ali's place. At the end, participants were observed that they understood the context as 'Ali's class' which is an imaginary one. That is, they could *imagine* Ali's class as it should be.

It could also be said that participants could grasp what these data tell them or not. All children could talk about Ali's friends, such as 'Ali has 5 friends who have green eyes.' Before asking the third question in the module, they could talk about these descriptive properties of Ali's class as a context.

The task designed and used in this study could be said a nice example of a suitable one which can be presented to first graders. The context was attractive for them and they were observed as they were enjoying.

Discussion

This study showed that there is a necessity of being exposed to different statistical contexts through class activities. Based on the findings regarding the first question of the module, children were observed to making comparisons with their real-life situations in order to understand the context

presented for them. This shows that they were not accustomed to such questions in which contextual thinking brought to be forefront. As Ben-Zvi and Aridor-Berger (2016) concluded in their study that children need different types of contexts through different class activities. They need to imagine about the context which they were presented.

Regarding Makar and Rubin (2009)'s framework, it could be concluded that children could make sense of use of data as evidence and tried to make generalizations. The comparisons they made with their real classes strengthen this conclusion. For example, comparing the number of blue-eyed students in their class with Ali's class, some of them said that Ali's class has more than usual. They tried to think of the classes they have seen so far. In their school, there are two first grade classes and both class members are familiar with each other. It can also be said that the participants could analyze the data in the context (Ben-Zvi & Aridor-Berger, 2016). Therefore, the task used in this study shows a nice example of providing children to integrate data and context with each other.

The role of graph construction as another construct of informal inferential reasoning can be seen very well here in this study. Almost of the participants could realize the need to see the categories (eye colors) in the given context comparatively. Therefore, they put the first eye labels of each color in a line (horizontally or vertically) as a reference line. They were aware that their representation showed only the comparisons of categories. Suggesting some ideas like putting numbers on each bar, or reversing the graph as upside down or from right to left showed that their understandings are clear for the meaning of representation. That is, they were focused only on what conclusions could be drawn from a data representation, the pictograph in this case. Only one child focused on the pattern which he saw and he couldn't show the comparisons of categories although he responded correctly to the questions related descriptive statistics in the module. It might be because of his interest to the patterns with some objects.

This study overall could be concluded as a contribution to the existing framework for ISI of young children through graph construction. It is explaining the graph construction as a construct with an informal inferential reasoning perspective. The findings outlined here could be concluded as a contribution to the existing suggestions of integrating the statistical context structures into early childhood mathematics education with the use of data. Lastly, the findings of this study give an opportunity to the researchers in order to criticize the current situation of statistics education which was outlined above in the first part of the paper. The overall conclusions might offer a chance to deal with the ISI in the very beginning of school period of students, as well.

References

- Ben-Zvi, D., & Aridor-Berger, K. (2016). Children's wonder how to wander between data and context. In D. Ben-Zvi, K. Makar (eds.), *The Teaching and Learning of Statistics* (pp. 25–36). Springer, Cham.
- Curcio, F. R. (1987). Comprehension of mathematical relationships expressed in graphs. *Journal for research in mathematics education*, 18(5), 382–393.
- Fitzallen, N., Watson, J., Wright, S., & Duncan, B. (2018). Data representations in a stem context: the performance of catapults. In *Looking back, looking forward: Proceedings of the Tenth*

- International Conference on Teaching Statistics (ICOTS10)* (p. 4B2). International Statistical Institute.
- Friel, S. N., Curcio, F. R., & Bright, G. W. (2001). Making sense of graphs: Critical factors influencing comprehension and instructional implications. *Journal for Research in Mathematics Education*, 32(2), 124–158.
- Jones, G. A., Thornton, C. A., Langrall, C. W., Mooney, E. S., Perry, B., & Putt, I. J. (2000). A framework for characterizing children's statistical thinking. *Mathematical thinking and learning*, 2(4), 269–307.
- Konold, C., & Pollatsek, A. (2002). Data analysis as the search for signals in noisy processes. *Journal for Research in Mathematics Education*, 33(4), 259–289
- Makar, K. (2018). Theorising Links Between Context and Structure to Introduce Powerful Statistical Ideas in the Early Years. In A. Leavy, M. Meletiou-Mavrotheris, E. Paparistodemou (eds.) *Statistics in Early Childhood and Primary Education: Early Mathematics Learning and Development* (pp. 3–20). Springer, Singapore.
- Makar, K., & Rubin, A. (2009). A framework for thinking about informal statistical inference. *Statistics Education Research Journal*, 8(1), 82–105.
- Makar, K., & Rubin, A. (2018). Learning about statistical inference. In: D. Ben-Zvi, K. Makar, J. Garfield (eds) *International Handbook of Research in Statistics Education* (pp. 261–294). Springer, Cham.
- McPhee, D., & Makar, K. (2018). Early childhood experiences in informal inferential statistics using an inquiry approach. In *Looking back, looking forward: Proceedings of the Tenth International Conference on Teaching Statistics (ICOTS10)* (p. 4B1). International Statistical Institute.
- Meletiou-Mavrotheris, M., Paparistodemou, E., Mavrotheris, E., Azcárate, P., Serradó, A., & Cardeñoso, J. M. (2008). Teachers professional development in statistics: The Early Statistics European project. In Joint ICMI/IASE study: Teaching statistics in school mathematics. Challenges for Teaching and Teacher Education. Proceedings of the ICMI Study and 2008 IASE Round Table Conference, Monterrey, México.
- Watson, J. (2018). Variation and Expectation for Six-Year-Olds. In: Leavy A., Meletiou-Mavrotheris M., Paparistodemou E. (eds) *Statistics in Early Childhood and Primary Education: Early Mathematics Learning and Development* (pp. 55–74). Springer, Singapore.
- Yin, R. K. (2017). *Case study research and applications: Design and methods*. Sage publications.
- Zieffler, A., Garfield, J. B., & Reading, C. (2008). A framework to support research on informal inferential reasoning. *Statistics Education Research Journal*, 7, 40–58.

What is taught and learnt on confidence interval? A case study

Kyeong-Hwa, Lee¹, Chang-Geun, Song² and Yeong Ok, Chong³

¹Seoul National University, South Korea; khmath@snu.ac.kr

²Seoul National University Graduate School, South Korea; riquelmes@snu.ac.kr

³Gyeongin National University of Education, South Korea; yochong@gin.ac.kr

This study investigated what is taught and learnt with regard to relations of confidence interval and sample size when students were facilitated to reason about the graph of sampling distribution of sample means. For this aim, a teaching experiment was designed and implemented by researchers and teachers in the model of co-learning inquiry. Based on anthropological theory of the didactic, the praxeological analysis was conducted. Observed similarities and differences between the taught and learnt praxeology were discussed.

Keywords: Anthropological theory of the didactic, didactic transposition, confidence interval, sample size

Introduction

The concept of confidence interval is essential in inferential statistics. However, many students are in difficulty with understanding confidence interval (Hagtvedt et al., 2008). In particular, some research reported students' confusing on the relationship between confidence interval and other related concepts such as sample size. For example, Fidler and Cumming (2005) disclosed students' misconceptions that the width of confidence interval increases as sample size increases or is not affected by sample size. However, little research was carried on the teaching and learning of confidence interval (Pfannkuch et al., 2012).

To understand confidence interval, sample size, and their relationships, opportunities should be given for students to engage in mathematical and statistical reasoning (delMas, 2004). This study investigated what is taught and learnt regarding relations between confidence interval and sample size when students were facilitated to reason about the sampling distribution of sample means (Chance et al., 2004). For this aim, a teaching experiment was conducted in an upper secondary classroom. The framework of the Anthropological Theory of the Didactic (ATD) was used in the analysis (Bosch & Gascón, 2014). This paper reports on some preliminary results of the analysis.

Theoretical Background

Anthropological Theory of the Didactic

ATD is a theoretical approach characterized by its institutional perspective on mathematical knowledge. This view builds on the notion of didactic transposition (Chevallard & Bosch, 2014), which assumes that knowledge in classroom setting originates in the scholarly institution and is transformed as it adapts to different institutions. Bosch and Gascón (2014, p. 70) proposed four main institutions related to school didactic system (Figure 1). Our study focuses on the transposition between taught knowledge of teachers to learnt knowledge of students.

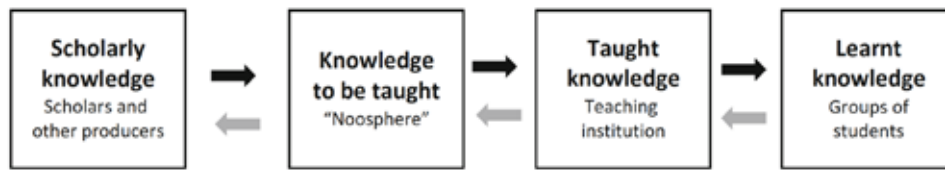


Figure 1: The didactic transposition process (Bosch & Gascón, 2014, p. 70)

In ATD, mathematical activities within each institution are modeled by the notion of *praxeology*. A praxeology consists of four intertwined elements, type of tasks (T), technique (τ), technology (θ), and theory (Θ). *Type of tasks* denotes similar problems which are solved with certain *technique*. The technique is produced, justified, explained, or reasoned by the discourse named *technology*, and the technology, in turn, is justified by *theory*.

According to Bosch and Gascón (2014), researchers should take their own epistemological stance on the knowledge they address to avoid bias in the analysis. The stance is formulated as a Reference Epistemological Model (REM) and is expressed by a praxeology. We briefly introduce our REM on the concept of confidence interval below.

REM on confidence interval

The idea of confidence interval is founded on Frequentism, as opposed to Bayesianism (VanderPlas, 2014). To the frequentist, a probability is defined as the relative frequency of occurrence of a repeatable event in the long run. In this sense, confidence intervals with $C\%$ confidence level mean that we would expect $C\%$ of the confidence intervals under repeated sampling to contain the fixed value of the parameter.

To illustrate the relationship between confidence interval and sample size, we further need another probability theory in our REM. The central limit theorem (Dekking et al., 2005, p. 197) implies that $\bar{X} \sim N(\mu, \frac{\delta^2}{n})$ holds for the sample mean \bar{X} , the population mean μ , the (known) standard deviation of population δ , and sufficiently large sample size n . From this property, we obtain a formula, $P\left(-z_{\alpha/2} \leq \frac{\bar{X}-\mu}{\delta/\sqrt{n}} \leq z_{\alpha/2}\right) = 1 - \alpha$, where $z_{\alpha/2}$ is the $(1 - \alpha/2)$ quantile of the standard normal distribution. Behar and Yáñez (2009) introduced two logically equivalent versions of this formula:

$$P(\bar{X} - d \leq \mu \leq \bar{X} + d) = 1 - \alpha \cdots (1) \quad P(\mu - d \leq \bar{X} \leq \mu + d) = 1 - \alpha \cdots (2)$$

where $d = z_{\alpha/2} \frac{\delta}{\sqrt{n}}$ refers to the margin of error. Formula (1) can be interpreted as the probability of the parameter μ being in the interval $[\bar{X} - d, \bar{X} + d]$, called *confidence interval*, equals to $1 - \alpha$. Contrasting to formula (1), formula (2) represents that the probability of the sample mean \bar{X} being in the interval $[\mu - d, \mu + d]$ equals to $1 - \alpha$. The probability theory shows that the probability of \bar{X} lying in the interval $[\mu - d, \mu + d]$ is equal to the integral of probability density function of \bar{X} over the interval $[\mu - d, \mu + d]$ (Dekking et al., 2005, pp. 57-58). The aforementioned meanings of confidence interval, confidence level, and probability equations (1), (2) constitute the theory Θ in our REM.

Building on the theory Θ , we can consider two techniques and their technology about the type of tasks of finding the relationship between the width of confidence interval and sample size. Based on the

formula (1), the first technique $\tau_{algebra}$ refers to applying the equation $l = (\bar{X} + d) - (\bar{X} - d) = 2z\alpha/2 \frac{\delta}{\sqrt{n}}$, which is often found in curriculum materials (e.g. Lee et al., 2011, p. 181). By proportional reasoning (Post et al., 1988), which includes interpreting of the algebraic representation of proportionality ($\theta_{algebra}$), it is explained that the increasing sample size n decreases width of confidence interval. Another technique τ_{graph} can be found on the formula (2). τ_{graph} refers to comparing the area under graphs of sampling distribution within $[\mu - d, \mu + d]$ for different sample sizes. This technique requires justification by reasoning about statistical or probabilistic idea including “describing what a sampling distribution would look like for different sample sizes based on shape” ($\theta_{graph,1}$) and “interpreting areas under the sampling distribution curve as probability statements about sample means”. ($\theta_{graph,2}$) (Chance et al., 2004, p. 301). Also, the explanation about relations between $[\mu - d, \mu + d]$ and confidence interval is included in the technology (Behar & Yáñez, 2009) ($\theta_{graph,3}$). These kinds of technology should be integrated to justify τ_{graph} as follows. Since the spread of sampling distribution decreases as sample size increases, the margin of error d satisfying the area under the sampling distribution over $[\mu - d, \mu + d]$ equals to $1 - \alpha$ become smaller as sample size increases and, accordingly, confidence interval $[\bar{X} - d, \bar{X} + d]$ become narrower as sample size increases.

Method

This study is qualitative research performed through a case study of a designed teaching experiment (Yin, 2014). We choose our design-based research methodology based on the model of *co-learning inquiry* (Jaworski, 2004). In this model, teachers are treated as *partners* of researchers rather than passive participants of research, and teachers and researchers collaboratively design, implement, and evaluate lessons in the iterative process. The main power of co-learning inquiry model is that the result of the research can contribute to “sustainable new practices” of teachers, since “teachers engage in their own purposeful activity” in this model (ibid., p. 19).

Participants in this study were a high school teacher from a public upper secondary school in Korea and his 35 students. Around the topic of statistical inference, five lessons were designed and implemented. Audio and video recordings of the lessons and students’ worksheets were collected.

In this study, we analyzed the last lesson of which learning objective was to understand the relations among confidence interval, confidence level, and sample size. We emphasize that students were encouraged to use graphs of sampling distribution to explain these relations. The collected data were analyzed by praxeological analysis (Bosch & Gascón, 2014). The focus of the analysis was on the didactic transposition between taught knowledge to learnt knowledge about relations between confidence interval and sample size. Based on our elaborated REM on confidence interval (Table 1), we analyzed the four elements of the taught and learnt praxeology and revealed their similarities and differences. The designed activities were interpreted as *type of tasks* in ATD sense. The teacher’s utterance and the teaching materials were mainly analyzed to figure out the other components of the taught praxeology. On the other hand, worksheets of students and their audio recordings were analyzed to find out the learnt praxeology. In particular, students’ answers on the following task were analyzed to describe technique, technology, and theory parts of the learnt praxeology: *Consider three*

confidence intervals with 90% of confidence level. Size of each sample is 4, 25, and 100. Array these intervals according to their width. Explain your answer using sampling distributions.

Type of tasks	T : To find the relations between the width of confidence interval and sample size
Technique	$\tau_{algebra}$: To apply $l = 2z_{\alpha/2} \frac{\delta}{\sqrt{n}}$ (Lee et al., 2011, p. 181) τ_{graph} : To compare the area under graphs of sampling distribution function within $[\mu - d, \mu + d]$ for different sample sizes
Technology	$\theta_{algebra}$ (for $\tau_{algebra}$): Proportional reasoning (Post et al., 1988) $\theta_{graph,1}$ (for τ_{graph}): Reasoning about the impact of sample size on graphs of sampling distribution (Chance et al., 2004) $\theta_{graph,2}$ (for τ_{graph}): Graphical interpretation of probability statements about sample means (Chance et al., 2004) $\theta_{graph,3}$ (for τ_{graph}): Explanation about relations between $[\mu - d, \mu + d]$ and confidence interval (Behar & Yáñez, 2009)
Theory	Θ : The meaning of confidence interval and confidence level (VanderPlas, 2014); the meaning of $P(\bar{X} - d \leq \mu \leq \bar{X} + d) = 1 - \alpha$ and $P(\mu - d \leq \bar{X} \leq \mu + d) = 1 - \alpha$ (Behar & Yáñez, 2009)

Table 1: REM on confidence interval

Result

What is taught?

Two taught praxeology \wp_1 , \wp_2 were revealed in the lesson. The components of \wp_1 are summarized in Table 2.

Type of tasks	Empty
Technique	Empty
Technology	Graphical interpretation of probability statements about sample means ($\theta_{graph,2}$) Explanation about relations between $[\mu - d, \mu + d]$ and confidence interval ($\theta_{graph,3}$)
Theory	The meaning of confidence interval with confidence level; The meaning of $P(\bar{X} - d \leq \mu \leq \bar{X} + d) = 1 - \alpha$ and $P(\mu - d \leq \bar{X} \leq \mu + d) = 1 - \alpha$ (Θ)

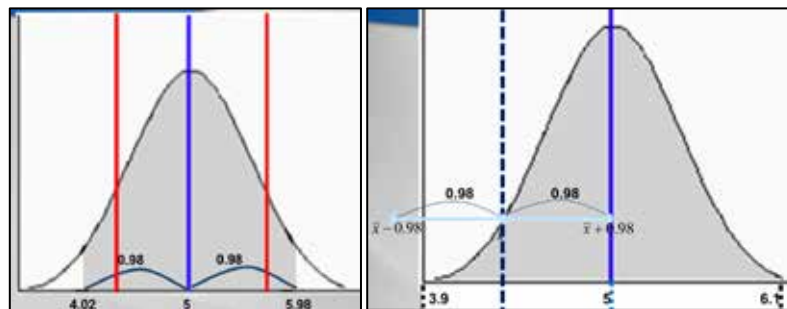
Table 2: Components of the taught praxeology \wp_1

\wp_1 was a local know-how which consisted of only technology and theory parts. The theory part of \wp_1 included the meaning of probability statements of sample means, $P(\bar{X} - d \leq \mu \leq \bar{X} + d) = 0.95$ and $P(\mu - d \leq \bar{X} \leq \mu + d) = 0.95$. The meaning of each statement together with confidence interval and confidence level was explained by the teacher in the sense of Frequentism.

Teacher: As you can see, among 100 confidence intervals, only 5 do not contain and the other 95 contain (the population mean). ... It means that the level of confidence is 95%.

Grounded on the meaning of probability, the relations between $[\mu - d, \mu + d]$ and confidence interval $[\bar{X} - d, \bar{X} + d]$ were explained. Graphic representation of the probability statements $P(\bar{X} - d \leq \mu \leq \bar{X} + d) = 0.95$ and $P(\mu - d \leq \bar{X} \leq \mu + d) = 0.95$ was used with the explanation.

Teacher: Here's the summary. The probability of \bar{X} being contained between $\mu - d$ and $\mu + d$ is equivalent to the probability of population mean contained in this one ($[\bar{X} - d, \bar{X} + d]$). [PowerPoint slides that teacher used with this explanation. Numbers in slides were chosen from an exercise without contextual meanings.]



Although the technology and theory part of \wp_1 ground the robust foundation for its potential practice, this praxeology was 'in a vacuum' in that "what kind of problems it can help to solve" is not known (Barbé et al., 2005, p. 237).

Table 3 describes components of another taught praxeology \wp_2 .

Type of tasks	To compare the probability of sample mean being in a given range when graphs of sampling distribution with different (hidden) sample sizes are given
Technique	To compare the shape of graphs and area under graphs of sampling distribution within a given range (τ'_{graph})
Technology	Reasoning about the impact of sample size on graphs of sampling distribution ($\theta_{graph,1}$) Graphical interpretation of probability statements about sample means ($\theta_{graph,2}$)
Theory	Empty

Table 3: Components of the taught praxeology \wp_2

\wp_2 was organized around a type of tasks, to compare the probability of sample mean being in a given range when graphs of sampling distribution with hidden sample size (4, 25, 100) are given. The technique τ'_{graph} of \wp_2 consisted of two subsequent sub-techniques. The first sub-technique was to compare the shape of sampling distribution function to figure out hidden sample sizes. This sub-technique was justified by the technology $\theta_{graph,1}$, which was the discourse about the impact of sample size on graphs of sampling distribution. The following sub-technique was to compare the area under the graphs of sampling distribution. This sub-technique required interpreting areas under the sampling distribution curve as probability statements about sample means ($\theta_{graph,2}$).

One may note that the technique τ'_{graph} is slightly different from τ_{graph} in that τ'_{graph} did not require the explanation about confidence interval. Hence, the technology and theory related to the concept of confidence interval were missing in \wp_2 . The theory about probability sentences was also void in \wp_2 , which made the theory part of \wp_2 empty.

What is learnt?

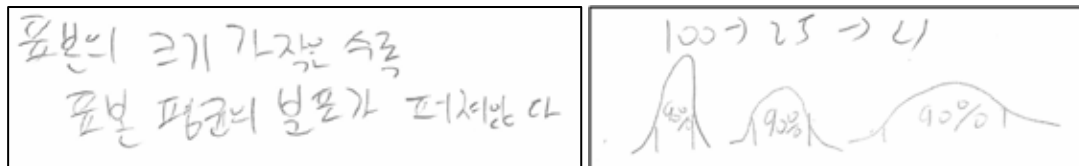
The praxeology of the taught and learnt praxeology are summarized in Table 4.

	Taught praxeology (\wp_1, \wp_2)	Learnt praxeology
Type of tasks	- To compare the probability of sample mean being in a given range (\wp_2)	- To find the relations between the width of confidence interval and sample size
Technique	- To compare the shape of graphs and area under graphs of sampling distribution within a given range (τ'_{graph}, \wp_2)	- To apply $l = 2z_{\alpha/2} \frac{\delta}{\sqrt{n}}$ ($\tau_{algebra}, 8\%$) - To compare the area under graphs of sampling distribution within $[\mu - d, \mu + d]$ for different sample sizes ($\tau_{graph}, 85\%$)
Technology	- Reasoning about the impact of sample size on graphs of sampling distribution ($\theta_{graph,1}, \wp_2$) - Graphical interpretation of probability statements about sample means ($\theta_{graph,2}, \wp_1, \wp_2$) - Explanation about relations between $[\mu - d, \mu + d]$ and confidence interval ($\theta_{graph,3}, \wp_1$)	- Proportional Reasoning ($\theta_{algebra}, 8\%$) - Reasoning about the impact of sample size on graphs of sampling distribution ($\theta_{graph,1}, 85\%$) - Graphical interpretation of probability statements about sample means ($\theta_{graph,2}, 48\%$)
Theory	- The meaning of confidence interval with confidence level; The meaning of $P(\bar{X} - d \leq \mu \leq \bar{X} + d) = 1 - \alpha$ and $P(\mu - d \leq \bar{X} \leq \mu + d) = 1 - \alpha$ (Θ, \wp_1)	Empty

Table 4: Components of the taught and learnt praxeology

Although the taught praxeology \wp_1 and \wp_2 did not contain $\tau_{algebra}$ as a technique, some students (8%) used $\tau_{algebra}$ to explain the relationship between the width of confidence interval and sample size. For example, a student explained that his technique $\tau_{algebra}$ was justified “since the width of confidence interval equals to $2 \times a \times \frac{\delta}{\sqrt{n}}$, the width becomes smaller as n increases”. This kind of justification corresponds to proportional reasoning $\theta_{algebra}$.

Excluding non-replied answers, remaining 30 students (85%) applied τ_{graph} . However, their technology differed in degree (Figure 2). 13 students (37%) only relied on the reasoning about the impact of sample size on the shape of sampling distribution ($\theta_{graph,1}$). The other 17 students (48%) could integrate $\theta_{graph,1}$ with $\theta_{graph,2}$ when they justified their technique. These two technological elements were also found in the taught praxeology \wp_2 . However, $\theta_{graph,3}$, which was another technological element of the taught praxeology \wp_1 , was missing in the learnt praxeology even though $\theta_{graph,3}$ was essential to fully justify technique τ_{graph} of the learnt praxeology.



[Sampling distribution of the sample means is more spread out with the smaller sample size (left)]

Figure 2: Examples of τ_{graph} with $\theta_{graph,1}$ (left) and τ_{graph} with $\theta_{graph,1}$ and $\theta_{graph,2}$ (right)

The meaning of confidence interval and confidence level (in the sense of Frequentism) was implicit in students' worksheets or in their dialogues. Moreover, the expression $P(\bar{X} - d \leq \mu \leq \bar{X} + d) = 1 - \alpha$ or $P(\mu - d \leq \bar{X} \leq \mu + d) = 1 - \alpha$ was hardly dealt with in students works, which leads to the theory part of learnt praxeology lacking the meaning of those expressions.

Discussion

In this study, we analyzed what is taught and learnt in a didactic setting which encouraged reasoning about sampling distribution. Some notable similarities and differences between them were observed.

Firstly, technology $\theta_{graph,1}$ and $\theta_{graph,2}$ were both taught and learnt in the classroom setting. Agreeing with Chance et al. (2004, p. 300) that $\theta_{graph,1}$ and $\theta_{graph,2}$ are kinds of reasoning "students should be able to do with their knowledge of sampling distributions", we argue that essential reasoning about sampling distribution could be integrated in the teaching of relationships between confidence interval and sample size. Furthermore, this kind of reasoning would contribute to the understanding of the relationship between confidence interval and sample size since the notion of sampling distribution and its representation are closely related with each of those concepts.

Secondly, $\theta_{graph,3}$ as well as theory underneath it were found in the taught praxeology but were entirely implicit in the learnt praxeology. These technology and theory were only contained in the local know-how \wp_1 . Similar phenomenon was also appeared at Barbé et al. (2005) in the case of teaching of limits of functions. We infer that the reason of the incongruity between the taught and learnt praxeology was partly because the related practice of the taught praxeology \wp_1 was unknown. Hence, we expect that another taught praxeology with a concrete task whose technique is justified by $\theta_{graph,3}$ and its theory would derive more strict discourse in learnt praxeology.

Finally, $\tau_{algebra}$ with $\theta_{algebra}$ was not taught but learnt in this lesson. This result shows the potential that diverse techniques, including $\tau_{algebra}$ and τ_{graph} , could be employed in the activity of searching relations between confidence interval and sample size. Discussing different techniques and their technology, different local praxeology of students could be connected and integrated into regional praxeology (Bosch & Gascón, 2014).

The research was funded by the Korean Ministry of Education and the National Research Foundation of Korea (NRF-2016S1A5A2A01024273)

References

- Barbé, J., Bosch, M., Espinoza, L., & Gascón, J. (2005). Didactic Restrictions on the Teacher's Practice: The Case of Limits of Functions in Spanish High Schools. *Educational Studies in Mathematics*, 59(1), 235–268.
- Behar, R., & Yáñez, G. (2009). Experts and students' conceptions regarding confidence intervals. *Heurística*, 16, 5–12.
- Bosch, M., & Gascón, J. (2014). Introduction to the Anthropological Theory of the Didactic (ATD). In A. Bikner-Ahshags & S. Predger (Eds.), *Networking of theories as a research practice in mathematics education* (pp. 67–83). Springer.
- Chance, B., del Mas, R., & Garfield, J. (2004). Reasoning about sampling distributions. In D. Ben-Zvi & Garfield (Eds.), *The challenge of developing statistical literacy, reasoning and thinking* (pp. 295–323). Springer.
- Chevallard, Y., & Bosch, M. (2014). Didactic transposition in mathematics education. In S. Lerman (Eds.), *Encyclopedia of mathematics education* (pp. 170–174). Springer.
- Dekking, F. M., Kraaikamp, C., Lopuhaä, H. P., & Meester, L. E. (2005). *A Modern Introduction to Probability and Statistics: Understanding why and how*. Springer Science & Business Media.
- delMas, R. C. (2004). A comparison of mathematical and statistical reasoning. In D. Ben-Zvi & Garfield (Eds.), *The challenge of developing statistical literacy, reasoning and thinking* (pp. 79–95). Springer.
- Fidler, F., & Cumming, G. (2005). Teaching confidence intervals: Problems and potential solutions. *Proceedings of the 55th International Statistics Institute Session*.
- Hagtvedt, R., Jones, G. T., & Jones, K. (2008). Teaching confidence intervals using simulation. *Teaching Statistics*, 30(2), 53–56.
- Jaworski, B. (2004). Insiders and outsiders in mathematics teaching development: The design and study of classroom Activity. *Research in Mathematics Education*, 6(1), 3–22.
- Lee, K. S., et al. (2011). *Hwag-lyul-gwa tong-gye [Probability and statistics]*. Seoul: MiraeN
- Pfannkuch, M., Wild, C. J., & Parsonage, R. (2012). A conceptual pathway to confidence intervals. *ZDM*, 44(7), 899–911.
- Post, T., Behr, M., & Lesh, R. (1988). Proportionality and the development of prealgebra understandings. *The Ideas of Algebra, K-12, 1988*, 78–90.
- VanderPlas, J. (2014). Frequentism and bayesianism: a python-driven primer. *ArXiv Preprint ArXiv:1411.5018*.
- Yin, R. K. (2014). *Case study research: Design and methods* (5th ed.). Thousand Oaks, CA: Sage.

Prospective high school teachers' interpretation of hypothesis tests and confidence intervals

M^a del Mar López-Martín, Carmen Batanero and María M. Gea

University of Granada, Spain; mariadelmarlopez@ugr.es, batanero@ugr.es, mmgea@ugr.es

This research aims to assess the interpretation of results by prospective high-school teachers when performing hypothesis tests and confidence intervals. The responses given by 73 prospective Spanish teachers to an open problem from the university entrance tests were analyzed. Although the majority of participants correctly performed many of the steps in both procedures, only a proportion of them were able to interpret and contextualize the results. The obtained results show that prospective teachers need to be prepared for this topic in order to develop inferential reasoning in their students.

Keywords: Hypothesis tests, confidence intervals, content knowledge, prospective teachers.

Introduction

Statistical inference plays a prominent role in human science research and it is a subject covered in the Spanish high-school curriculum (MECD, 2015) as well as in university entrance exams, which have included an inference problem for each of the last 15 years (López-Martín, Batanero, Díaz-Batanero, & Gea, 2016). This topic is not easy, as shown by research describing the errors that students make (Castro Sotos, Vanhoof, den Nororgate, & Onghena, 2007; Makar & Rubin, 2018). Improving understanding and application of the topic involves adequate preparation for the teachers who are responsible for teaching it; this point has barely been considered in previous research (Harradine, Batanero, & Rossman, 2011, Makar & Rubin, 2018). The aim of this study is to complement previous research by analysing the results interpretation of simple statistical tests and confidence intervals carried out by prospective teachers. The interpretation of statistical data and results is suggested in the high school Spanish curriculum (MECD, 2015).

Previous research

Previous statistical test research has reported on interpreting errors regarding the α significance level and the p-value, where students change the two conditional probability terms in their definition (Falk & Greenbaum, 1985), or interpret these concept levels as the probability of being wrong when rejecting the null hypothesis (Vallecillos, 1999). Other conspicuous errors include: the role played by the null and alternative hypotheses (Batanero, 2000), confusion between unilateral and bilateral tests, defining hypotheses that do not cover the parametric space, and using the sample statistic instead of the population parameter to define the hypotheses (Vallecillos, 1999; Vera, Díaz, & Batanero, 2011). In regards to confidence intervals, students ignore their inferential character (Behar, 2001; Olivo, 2008) or misinterpret the relationship between the different factors influencing the width of the confidence interval (Cumming & Fidler, 2005).

Some research work focusing on teachers' understanding of inference suggests that certain teachers share the same misconceptions as the students. Haller and Krauss (2002) describe errors in understanding the significance level and p-values, as was the case with some prospective teachers

taking part in the Vallecillos research. After interviewing 8 high-school statistics teachers, Liu and Thompson (2009) suggested that they seemed not to understand the purpose of statistical tests as mechanisms for carrying out statistical inference. They also found that the teachers' conception of probability was not grounded in the concept of sampling distribution being the fraction of time that a statistic's value is within a particular range. While recent research studies have attempted to organise teachers' education in terms of informal inferential reasoning, some of them (e.g. Dolor & Kirin, 2018) suggest that prospective teachers use incorrect strategies to compute p-values in re-sampling and simulation approaches; although they also suggest that adequate training may improve these strategies.

Nowadays, statistical interpretation is considered a complex process involving cognitive, affective and technical aspects (Queiroz, Monteiro, Carvalho, & François, 2017). Wild and Pfannkuch (1999) included the integration of statistics and contexts (that is to say, results interpretation) as part of their statistical thinking model. Monteiro (2005) developed the idea of critical sense during the interpretation of statistical graphs, which includes mathematical knowledge, contextual references, affect and personal experiences related to the data. In this work, we analyse prospective teachers' interpretations of the hypothesis test and confidence interval.

Method

The sample group was made up of 73 students on a Master's Degree course that is compulsory for those who intend to become high-school mathematics teachers in Spain. Of these, 56% were graduates in Mathematics or Statistics while the remainder had completed undergraduate studies in Engineering, Architecture or Science. All of them had taken some statistics courses during their undergraduate studies and 57% had some teaching experience. Most of participants recognized that the methodology used focused on teaching procedures rather than the use of technology. The assessment was part of an activity aimed at developing the participants' content knowledge of inference. The participants worked on authentic data obtained from the United Nations. In this paper, we analysed the participants' solutions to the following problem.

Problem: The average life expectancy in a study developed by the United Nations is 69.2 years with a standard deviation 10. In a random sample of 16 European countries, the average life expectancy was 78 years. Assuming that the life expectancy follows the normal distribution:

- a) Propose and interpret a hypothesis test, with a level of significance of 5%, to analyse if the average life expectancy in Europe is higher than that obtained in the whole set of countries;
- b) Determine and interpret a 95% confidence interval for average life expectancy in European countries.

We performed a qualitative analysis on the written solutions to the problem in order to classify the responses into different categories, starting with previous research and refining the categories through a cyclic and inductive process; this is typical of qualitative research. Below, we first summarise the general performance in each part of the problem using a numerical score, and then we analyse the participants' interpretation of the research for each procedure in detail.

Results

General performance in solving the problems

The solution to part a) involved a unilateral hypothesis test on the average of a normal population with a known variance; this is an element included in the compulsory examination to become a high-school mathematics teachers as well as in the curricular guidelines for high-school and university entrance examinations in Spain. By analysing the participants' answers, we examined the prospective teachers' knowledge of the following points: a) the way they established the test hypotheses; b) whether the problem-solving procedure employed was consistent with the hypotheses proposed; c) the computation of the p-value; d) other possible errors in the procedure not listed yet; and e) the interpretation of the results. In order to graduate the prospective teacher's knowledge about the hypothesis contrast, we have marked each participants with a score according to the number of correct answers. This score would be from 0 to 5 points, one point for each correct answer (Figure 1).

Most prospective teachers were able to correctly develop three or more steps, although 6 participants incorrectly developed all the stages in part a) of the problem. Although 67% of the students set correct hypotheses, only 4% selected a test that was consistent with the hypotheses. We would like to point out that only 51 participants computed the p-value, and some of them made errors in either the computation or in other parts of the procedure. Only 38.4% of participants correctly interpreted and contextualised the results.

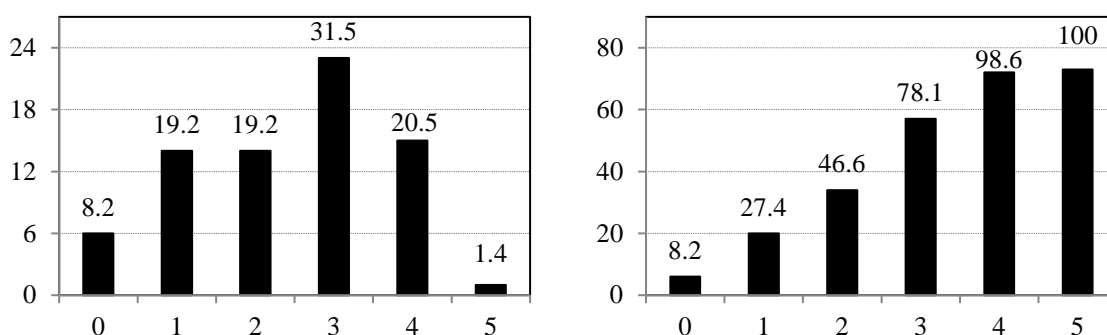


Figure 1. Percentage and cumulative percentage of participants according to the number of correct steps in performing a hypothesis test

The solution to part b) involved a confidence interval for the average of a normal population with a known variance. By analyzing the participants' answers, we examined the prospective teachers' knowledge of the following points: a) the way they established the interval; b) whether the problem-solving procedure they followed was correct and c) the interpretation of the results. By awarding a point to each of these parts of the hypothesis test solution, participants could score from 0 to 3 points (Figure 2). We observed that 46.6% of them correctly solved two of the stages (85% developed points a) and b) whilst the rest developed points a) and c)) and 16 prospective teachers gave correct answers for all the parts.

In summary, these results suggest a moderate knowledge of statistical tests and confidence intervals on the part of teachers in our sample, which is a matter of concern, given that these teachers have to prepare their students in this topic to face the entrance to university tests where an inference problem is included every year.

Below we analyse in depth the final interpretation that prospective teachers perform in each part of the problem, that is, the way they interpret the results of the test and that of confidence interval.

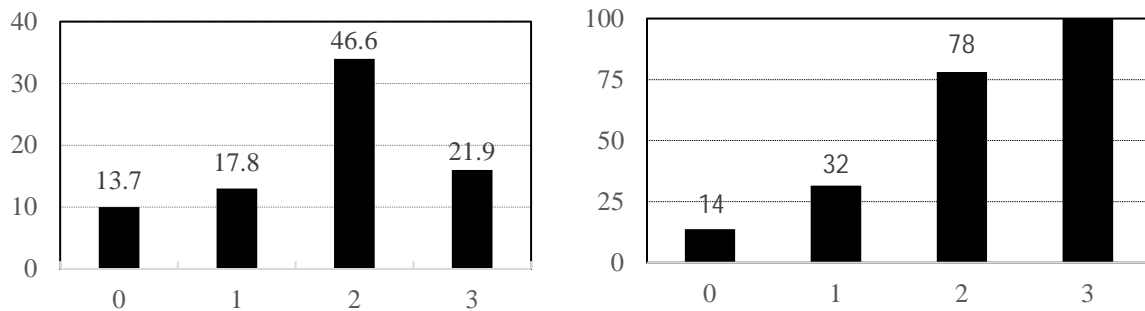


Figure 2. Percentage and cumulative percentage of participants according to the number of correct steps in computing a confidence interval

Interpreting statistical tests

Once the calculations were completed, we expected participants to conclude that the result in part a) was statistically significant and that the null hypothesis should be rejected. When contextualizing this result, the conclusion was that we should reject the hypothesis that the average life expectancy in Europe is the same (or smaller) than that in the group of countries. By taking into account the correctness of the decision and the contextualization made, we defined the following categories:

C1. Correct decision and contextualization. Prospective teachers made an appropriate decision and related the result to the problem's context, as in the following example:

GPF: When comparing the small p-value with the significance level of $\alpha=0.05$, it is reasonable to reject the null hypothesis and conclude that life expectancy in Europe is higher than in the set of countries.

C2. Correct decision and contextualization but the p-value is interpreted as the probability of the hypothesis. Although the decision and contextualization were correct, there was an incorrect interpretation of the p-value, which concluded that the null hypothesis was probably correct, such as in BCM's answer.

BCM: In summary, the average life expectancy in Europe is higher than the average life expectancy in the set of countries, with a probability equal to 0.9998.

C3. Correct decision and contextualization, assuming that the null hypothesis is false. Although the decision and contextualization were correct, there was a deterministic conception of the result that assumed the null hypothesis to be false; an error described by Inzunsa and Jiménez (2013) and Vallecillos (1994):

ALP: [...] we conclude that the null hypothesis is false, so we accept that the average life expectancy in Europe is higher than the average life expectancy in the set of countries with a probability significance level of 0.05.

C4. Correct decision with inconsistent contextualization (see the response by ILG):

ILG: We reject the null hypothesis so the average in Europe cannot be higher than that in the set of countries.

In the following categories, the students made a correct decision with no contextualization (C5; see the response by AGS), explaining how to make the decision (but with no decision being made) and either by contextualising (C6) or not contextualising (C7), made an incorrect decision (C8; see the response by JGM) or did not make a decision (C9):

AGS: [...] for $Z=3.52$, we get 0.99998; by subtracting this from 1, we obtain a probability of 0.0002 and, therefore, reject the hypothesis.

JGM: H_0 = the average life expectancy in Europe is greater than the average life expectancy in the rest of the countries. [76.78; 79.23]. $H_0 \rightarrow$ Not rejected, since the average value for the set of countries is below the values of the confidence interval for a confidence level of 95% for the sample of European countries.

In Table 1, we present the participants' interpretation of the statistical tests, where less than 40% made the right decision and contextualized the problem; nonetheless, 86.2% made the right decision. The remaining participants either did not make a conclusion or decided incorrectly. Some showed that they misunderstood the hypothesis tests; for example, assuming that the p-value indicated that the null hypothesis was probably true or holding a deterministic view of the results.

Code	Interpreting the results	Frequency	Percentage
C1	Correct decision and contextualization	28	38.3
C2	Correct, interpret p-value as the probability of the hypothesis	3	4.1
C3	Correct, assuming that the null hypothesis is false	2	2.7
C4	Correct, no appropriate contextualization	6	8.2
C5	Correct, does not contextualise	24	32.9
C6	Describing how to make the decision and contextualising	1	1.4
C7	Describing how to make the decision and not contextualising	7	9.6
C8	Incorrect decision	1	1.4
C9	Making no decision	1	1.4

Table 1: Frequency and percentage of participants according interpretation of statistical tests

Interpreting the confidence interval.

Once the confidence interval extremes were computed, we expected the prospective teachers to provide an interpretation such as follows: For a 95% confidence interval computed from 16 sample elements, in about 95 of them, the average life expectancy in European countries would be included; that is to say, they should have interpreted the interval extremes as being random variables (Behar, 2001; Olivo, 2008). We found the following response categories:

C1. Correct interpretation. Here, we classified the correct responses given above, and variations of the same, along with those that indicated the percentage of intervals computed from different samples that included the parameter (Behar, 2001); see CBF's answer:

CBF: [...] this is the probability that a number of intervals cover the parameter, not that the parameter is included in the actual interval.

C2. Determinist interpretation. When the participant interprets the interval in a deterministic way, they do not appreciate the randomness of the extremes (Olivo, 2008):

DAM: This means that the average life expectancy in European countries is between 73 and 83.

C3. Interpreting the confidence level as the probability that the parameter is included in the interval. The confidence level is interpreted as the probability that the population parameter is within the range obtained. Authors like Behar (2001) and Olivo (2008) have analysed this misunderstanding:

LUG: You can conclude that the probability that the population average is included in the interval is 95%.

C4. Assuming that the sample average is included in the interval. Another mistake is interpreting that the confidence interval includes the sample average instead of the population average, which also signifies confusion between the statistics and the parameter:

JGM: 95% of intervals computed from samples of European countries will include the sample mean.

The results are presented in Table 2, where the participants' difficulty in interpreting the confidence interval information is evident. Only around 30% gave a correct interpretation whilst the majority were unable to provide an interpretation, and the remaining participants either interpreted the confidence intervals in a deterministic way or reproduced one of the errors described in previous research.

Code	Interpreting the results	Frequency	Percentage
C1	Correct interpretation	21	28,8
C2	Deterministic interpretation	8	11,0
C3	Interpreting $1 - \alpha$ as the probability that the parameter is included in the interval	13	17,8
C4	Assuming that the sample average is included in the interval	1	1,4
C5	Do not interpret	30	41,1

Table 2. Frequency and percentage of participants according interpretation of confidence intervals

Implications for teaching and research

Our results suggest a need to improve the education of prospective Spanish high-school teachers in terms of teaching statistical inference. On the one hand, few in the sample group correctly

performed all the steps for solving the statistical tests or the confidence interval, even when the problem posed was similar to those included in the Spanish university entrance tests.

Similar to previous research, many were unable to properly interpret the results of the procedure, made incorrect decisions in the statistical tests or gave responses that reproduced different errors, h. Although many made correct decisions in the statistical test, few interpreted the result in the context of the problem - this is worrisome because teachers are expected to develop their students' ability to interpret statistical studies; for example, one learning goal in the curriculum (MECD, 2015, pp. 398 and 407) is: "To interpret a statistical study based on situations close to the student."

Therefore, in addition to improving prospective teachers' mathematical knowledge of inference, it is necessary to prepare them to be able to contextualize the information resulting from statistical tests and confidence intervals so that they can help their future students acquire this interpretative capacity. Of course, mathematical knowledge alone is not enough for teaching success. It is necessary to continue this analytical research into pedagogical knowledge regarding statistical inference. In this regard, several studies have shown that an informal approach to statistical inference could help in understanding the logic involved and improve the teaching process. We hope these questions will interest teacher trainers and other researchers in statistical education, and that we can ensure the good mathematical and didactic training of high-school teachers so that they can successfully teach statistical inference to their future students.

Project EDU2016-74848-P (AEI, FEDER) and group FQM126 (Junta de Andalucía).

References

- Batanero, C. (2000). Controversies around significance tests. *Mathematical Thinking and Learning*, 2(1-2), 75-98.
- Behar, R. (2001). *Aportaciones para la mejora del proceso de enseñanza-aprendizaje de la estadística* (Unpublished doctoral dissertation). Universidad Politécnica de Cataluña, Spain.
- Castro Sotos, A.E., Vanhoof, S., Van den Nororgate, W., & Onghena, P. (2007). Student's misconceptions of statistical inference: A review of the empirical evidence form research on statistical education. *Educational Research Review*, 2(2), 98-113.
- Cumming, G. & Fidler, F. (2005, August). Interval estimates for statistical communication: problems and possible solutions. Paper presented at *IASE Satellite Conference on Communication of Statistics*, Sydney: IASE.
- Dolor, J. & Kirin, D. (2018). Post-secondary teachers' understanding of p-value. In M. A. Sorto, A. White, & L. Guyot (Eds.), *Proceedings of the Tenth International Conference on Teaching Statistics* (ICOTS10, July, 2018), Kyoto, Japan. Voorburg, The Netherlands: International Statistical Institute. iase-web.org
- Falk, R. & Greenbaum, C.W. (1995). Significance tests die hard: The amazing persistence of a probabilistic misconception. *Theory and Psychology*, 5(1), 75-98.
- Haller, H. & Krauss, S. (2002). Misinterpretations of significance: A problem students share with their teachers?. *Methods of Psychological Research*, 7(1), 1-20.
- Harradine, A., Batanero, C., & Rossman, A. (2011). Students' and teachers' knowledge of sampling

- and inference. In C. Batanero, G. Burrill & C. Reading (Eds.), *Teaching statistics in school mathematics- Challenges for teaching and teacher education. A Joint ICMI/IASE Study* (pp. 235–246). New York, NY: Springer.
- Inzunza, S., & Jiménez, J. V. (2013). Caracterización del razonamiento estadístico de estudiantes universitarios acerca de las pruebas de hipótesis [Characterization of the statistical reasoning of university students about the hypothesis tests]. *Revista Latinoamericana de Investigación en Matemática Educativa*, 16(2), 179–211.
- Liu, Y., & Thompson, P.W. (2009). Mathematics teachers' understandings of proto-hypothesis testing. *Pedagogies*, 4(2), 126–138.
- López-Martín, M.M., Batanero, C., Díaz-Batanero, C., & Gea, M. (2016). La inferencia estadística en las pruebas de acceso a la universidad en Andalucía [The statistical inference in the entrance exams to the university in Andalusia]. *Revista Paranaense de Educação Matemática*, 5(8), 33–59
- Makar, K., & Rubin, A. (2018). Learning about statistical inference. In D. Ben-Zvi, K. Makar & J. Garfield (Eds.), *International handbook of research in statistics education* (pp. 261–294). Cham: Springer.
- MECD (2015). *Real Decreto 1105/2014, de 26 de diciembre, por el que se establece el currículo básico de la Educación Secundaria Obligatoria y del Bachillerato* [Royal Decree 1105/2014, of December 26, which establishes the basic curriculum of Compulsory Secondary Education and the Bachelor]. Madrid: Author.
- Monteiro, C. (2005). Investigating critical sense in the interpretation of media graphs (Unpublished doctoral dissertation). University of Warwick, Warwick, U.K.
- Olivo, E. (2008). *Significados del intervalo de confianza en la enseñanza de la ingeniería en México* [Meanings of the confidence interval in the teaching of engineering in Mexico]. (Unpublished doctoral dissertation). University of Granada, Spain.
- Queiroz, T., Monteiro, C., Carvalho, L., & François, K. (2017) Interpretation of Statistical Data: The Importance of Affective Expressions. *Statistics Education Research Journal*, 16(1), 163–180
- Vallecillos, A. (1994). *Estudio teórico experimental de errores y concepciones sobre el contraste de hipótesis en estudiantes universitarios* [Experimental theoretical study of errors and conceptions about the hypothesis contrast in university students] (Unpublished doctoral dissertation). University of Granada, Spain.
- Vallecillos, A. (1999). Some empirical evidence on learning difficulties about testing hypotheses. *Proceedings of the 52 session of the International Statistical Institute* (Vol.2, pp. 201–204). Helsinki: International Statistical Institute.
- Vera, O., Díaz, C., & Batanero, C. (2011). Dificultades en la formulación de hipótesis estadísticas por estudiantes de psicología [Difficulties in the formulation of statistical hypotheses by psychology students]. *Unión*, 27, 41–61.
- Wild, C.J., Pfannkuch, M., Regan, M., & Horton, N.J. (2011). Towards more accessible conceptions of statistical inference. *Journal of the Royal Statistical Society (A)*, 174(2), 247–295.

Covariational reasoning patterns exhibited by high school students during the implementation of a hypothetical learning trajectory

Miguel Medina, Ernesto Sánchez and [Eleazar Silvestre](#)

Departamento de Matemática Educativa, CINVESTAV-IPN, Mexico

ingcivi_6@yahoo.com.mx, esanchez@cinvestav.mx, eleazar.silvestre@gmail.com

We report some evidences of an ongoing research on covariational reasoning with high school students concerned with the design and application of a Hypothetical Learning Trajectory (HLT) on problems of correlation and linear regression, as well as the role played by technology (Fathom) employed in the learning process. We observed student's performance was slightly better when using the software in the instructional sequence, such as identifying and using the correlation strength and elaborating more refined arguments when comparing their own estimated model against the least squares line.

Keywords: Covariational reasoning, linear regression and correlation, high school, Fathom

Context and research question

Research by psychologists and statistical educators have produced extensive and robust knowledge about students' covariational reasoning; for example, Zieffler and Garfield (2009, p. 11) summarized the general research findings in six statements: students are often, 1) significantly influenced by their personal beliefs with respect to their covariational judgments; 2) prone to believe that correlation exists where there's actually none; 3) only considering data that support the joint presence of variables but ignore those referring to joint absence of variables; 4) greatly challenged to grasp negative correlation than dealing with a positive one; 5) disposed to make estimates below the actual correlation's strength; and 6), susceptible to imply causal relationships when dealing with covariation tasks. In contrast, it's more difficult to find research reports on how to produce progressive changes in students' covariational reasoning as a result of teaching interventions in classroom, including why such changes would occur. In a recent literature review performed by the authors during the past 10 years, only five reports were found that include teaching interventions, two of which were carried out with tertiary level students (Inzunza, 2016, McLaren, 2012), two at high school level (Gil & Gibbs, 2017; Dierdorff, Bakker, Eijkelhof & van Maanen, 2011) and one at elementary level (Fitzallen, 2012). Such amount of investigations that report on the effects of instruction in students' covariational reasoning reflect Shaughnessy and others' recommendations for future statistical educational research, who highlighted the need to carry out teaching experiments and document the effects of instruction. On the other hand, regarding research on the development of scientific thinking, students' covariational reasoning has been widely investigated at the elementary and middle school levels (Zimmerman, 2007) but rarely at the high school level (even considering replica with adult subjects); in addition, the attended statistical content in most of these studies is mainly restricted to the association between qualitative variables. Thus, the results of our research aim to strengthen the body of knowledge on covariational reasoning within this particular trend.

In Mexico, the topic of numerical bivariate data, correlation and line of better fit is prescribed for most high school curricula, in which is common to find the use of dynamic statistical technology tools (e.g., Excel or Fathom) as a resource that could play a fundamental role in producing progressive changes in students' reasoning; in particular, technology can help promote covariational reasoning because it allows students to optimize the time it takes to make a graph and relieves the burden of making complex calculations. Given this context, the purpose of this study is to identify patterns in students' reasoning emerged from the implementation of a developing hypothetical learning trajectory about linear regression and correlation; we propose a research question consistent with the following analysis strategy: to determine and compare reasoning patterns with some previously detected in an exploratory-diagnostic study where no teaching intervention was performed. Therefore, the new progressive patterns provide cues to the achievements gained during the new teaching strategy, so that our research question becomes: *What reasoning patterns emerge in students' solutions to problems of correlation and line of best fit during and as a result of student participation in a learning trajectory that includes extensive use of Fathom?*

Conceptual framework

We rely on three fundamental ideas: (1) *covariational reasoning*, (2) the notion of *aggregate*, and (3) the mechanism of a *hypothetical learning trajectory*. Covariational reasoning is characterized as thinking process carried out by the subjects related to judgments and interpretations about the relationship that exists between two variables. Carlson, Jacobs, Coe, Larsen & Hsu (2002) indicate that covariational reasoning is defined as the cognitive activities included in the coordination of two quantitative variables while attending to the ways in which they change one with respect to the other; this type of reasoning also entails understanding many features of variation in which variation with respect to the linear fit model is highlighted. Some studies discuss the modeling of variation and the importance of considering both explained and unexplained variation when data is explored; these two characteristics of variation are of particular interest in the study of the linear regression between two quantitative variables because the isolation and modeling of aspects of variation allows to carry out predictions, explanations and control, as well as to question why variation occurs resulting in the search for its causes.

In a linear regression and correlation context, the notion of aggregate is related to the form in which learners perceive a bi-variate data set through its representation in a scatterplot, and it's also related with the objectives of interpreting the possible relation that exists between the variables that generate the data, propose a linear model that best fits the data and estimate new values for the response variable within the available data set. Bakker (2004) and Dierdrop et al. (2011) highlighted the importance of such notion in students' learning process since it allows for drawing conclusions about regression and correlation given that it is through this reasoning that one can identify trends that extend beyond the correlated data; that is, to assume the notion of aggregate as to set a structure opposed to the attributes that could be addressed to aisled data points.

Finally, the notion of an HLT was introduced by Simon (1995) as an essential component of a constructivist teaching and learning posture. The mechanism involves the selection and dynamic interaction between three main components: learning objectives, a set of mathematical tasks, and the associated learning hypotheses as a prediction of students' actions and reasoning in response to

the activities. We intend to employ such mechanism in our research both as a device for planning didactic interventions as well as a research vehicle, which requires a cycling revisiting of the three mentioned elements grounded in students' practices and reasoning patterns.

Method

The previous study, constructing the HLT. Learning activities of the HLT are based on a questionnaire applied in 2016 to two groups of high school students enrolled in their senior year (17-18 years) in a public school; a total of 96 students participated in the study (Medina, Olay & Sánchez, 2016). From the analysis carried out in this exploratory test, students' responses to the problems (described up next) exhibited the following main learning obstacles:

- Students do not assume the data set as a whole, as an aggregate with its own properties, but as isolated cases with independent ones; to draw a line of best fit, they do not consider the variation that exists between the data and the position the model should have, and tend to only consider some points of the data available (such as the first and last ones, or the highest and lowest values of the set).
- The idea of creating a diagram to represent the bivariate data does not arise intuitively; students don't clearly identify properties such as the intensity of the relationship between the variables nor the meaning of the data pairs; and when facing prediction problems, do not use statistical concepts but rely heavily on arithmetic procedures.

Based on the difficulties encountered in this study, learning hypothesis for the design of the HLT were developed: students should be able to convert data collected in tables to a graphic representation (scatter plot diagram); reflect on how to use all data when proposing their line of best fit; understand and discuss the meaning of the line of best fit as the line that minimizes the estimation error; consider the development of a scatterplot as a necessary tool for the analysis of the relationship between two variables; make hypotheses about the relationship between two variables (graduated: none, little, lots of) based on the analysis of a scatter plot diagram; and obtain the least squares linear model to determine the value of the requested response variable. These hypotheses were condensed in two main learning objectives, (1) the *learning about distributions of bivariate data*: which intends for students to identify what elements, like the form and the tendency of a cloud of data points, are determining to establish the type of relation that exists between two quantitative variables, and (2), the *learning about the variation of the data with respect to the linear adjustment model*: which intends for students to identify that the linear adjustment model has an intrinsic random character rooted in the data itself.

Participants, instruments and execution. The current version of the HLT was applied to a group of 40 students (15 males, 25 females; 17-18 years old), arranged in 20 pairs, also enrolled in their senior year on a public high school in Mexico City; they previously received instruction on some essential descriptive statistics topics (statistical graphs, tendency and variability measures) and a mild technical-procedural introduction to linear regression and correlation. The application of the experiment consisted of 4 sessions of approximately 2 hours each: students familiarized with Fathom's basic commands with an instruction activity during the first session; in session 2, students faced the *gas consumption* problem [adapted from Moore, 1998; item (i), figure 1] in which they

proposed their line of best fit using the software, as well as analysis of some characteristics of the possible correlation between the variables (intensity and direction); such evidence which allowed the researchers to produce detailed descriptions of the visual analysis performed by the students and their justifications.

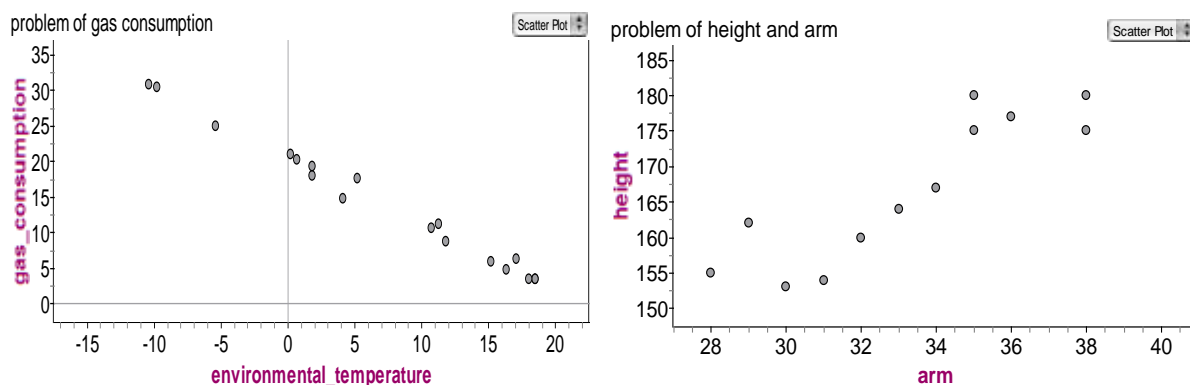


Figure1: Data used in the gas consumption problem [(i), left], and in the arm and height measures problem [(ii), right]

This is, students were asked about the form of the distribution of the data in the scatter plot, with which they could propose their own linear model that best fit the data (all of the instruction required the use of Fathom). In session 3, a further investigation of this problem was performed by adding a prediction item and a comparative analysis of the least squares line provided by the software against the students' own model. Finally, in session 4, students faced the *height and arm measures* problem [item (ii), Figure 1], in which data was produced and taken by and from a sample of the participants. Once again, besides comparing students' own model against the least squares line, the value corresponding to the sum of squares (errors) was provided through the software as a variability measure between the data and the linear models.

Data and analysis tools. Our primary source of data are students' written responses to the activities, fieldnotes and video recordings. We rely on principles and basic coding techniques provided by the *Grounded Theory*, which emphasizes the creation of categories and emergent theory based on the data that is systematically and exhaustively collected during the investigation. Analysis of students' responses consisted of identifying patterns exhibited in at least two pairs of students (open and axial coding); each one was given a code defined below, leading to ten emergent codes assigned into one of three groups: *inconsistent*, *favorable* or *neutral*; these adjectives refer to their relationship with normative covariational reasoning. Inconsistent codes correspond to reasoning features that we consider difficult the understanding of normative ideas embedded in covariational reasoning, while favorable codes prefigure or constitute partially aligned basis for normative reasoning considering that additional teaching support can help to overcome; neutral codes refer to those which we didn't find reasons to be classified as neither of the former.

Results

Inconsistent codes are labelled A1-A5, favorable are labelled B1-B4, and the only neutral corresponds to C1; we now briefly describe and exemplify these codes using the notation "PX" to denote a specific pair of students' response.

A1. *Illusion of linearity (or proportionality)*. When confronted with a prediction problem, it consists of proposing a plausible value of Y given a value x_0 , a specific point of the data set is chosen to formulate and apply a rule of three. An example of this reasoning comes with P8's response (gas consumption problem): "We applied a rule of three with the average temperature of 10.7 cause is the closest to 8, $\frac{10.7m^3}{10.7^\circ}(8^\circ) = 8m^3$ of gas".

A2. *Incidence in the maximum amount of points*. To determine the line of best fit, a line that goes through the maximum number of points is proposed, and the criterion is also used to judge the appropriateness of the model. This reasoning, exhibited in the gas consumption and temperature problem, is directly exemplified by P7: "...we positioned the line so it touched the maximum amount of points".

A3. *Attention to irregularity*. To describe a tendency or when judging the intensity of the correlation, points that deviate from a possible regularity or that are misaligned are noted and used as an argument. For example, when describing the tendency in the data presented in the scatterplot (height and arm measures problem), P4 responded "No [tendency is noted or present], there are only 4 points aligned".

A4. *Software references*. When describing a tendency in the data or justifying a proposal for the line of best fit, actions with the software are mentioned but no response to the actual question is given; as an example of such reasoning, P1 responded (gas consumption and temperature problem) "...we draw the line with the pointer until adjusting it".

A5. *Idiosyncratic*. Answers are given using terms that do not correspond to the common (statistical) usage; most likely, students assign a personal meaning that is not possible to deduce from their written statements. P18 exemplifies this rationale when describe their expectation about how gas consumption varies with the temperature by saying "it all should depend of the weather".

B1. *Describe the tendency*. Students formulate expressions that indicate if the tendency is either positive or negative. Such expressions can be widely general like "goes down/goes up", or much more specific "as long as X increments, Y diminishes". For example, when describing the type of tendency in both problems, P3 and P16 mentioned, respectively, "yes, the points are rising and forming a straight line", and "at a higher temperature the less [gas] consumption, and the lower the temperature the higher [gas] consumption".

B2. *Exclusive reference to the line*. The criterion consists of identifying the staggering of the points around a straight line but without describing its' direction; e.g., when describing the tendency in the data in the gas consumption problem, students like P20 provide answers like "yes, [the points group into] in a straight line".

B3. *Through the middle of the points*. This method consists of proposing a line that goes through the middle of the data set in the scatterplot; in some cases, it refers to getting an equal number of points on each side of the line (one half above and the other one under). As an example of such strategy, P5 justified their proposal of the best fit line in the height and arm measures problem by saying "we placed it in the middle of the points to adjust it the most".

B4. *Closeness*. The best fit line is the one considered as the closest to all points, in which “closeness” implies minimizing the sum of the residuals. This type of responses arises when students observe how the least square method is about using the software. An example of such thinking is provided by P1 in the height and arm measure problem: “...[we placed the line]so that all the points are the closest to it”, or by P9 when comparing and analyzing their own proposal of the best fit line: “...[in our case] the points are farer to the line, so the squares get bigger”.

C1. *Software use*. These responses only provide results or values taken from the software without adding comments or interpretations about them; for example, when P3 is trying to describe the intensity of the correlation in the height and arm measures problem, they just provide the value for r : “0.883844”.

Conclusions and discussion

We consider codes A1 and A2 as central when designing a teaching strategy. The term “illusion of linearity” has been adopted from van Doreen, de Boek, Depaepe, Janssens & Verschaffel (2003) who rely on Freudenthal and define it as “the seduction to deal with each numerical relation as though it were linear”; the authors mention that such reasoning has been found in probability tasks as well as in arithmetic and algebraic domains. Casey (2014) pointed out that “many students required that their line [of best fit] go through the origin [...], they had a preconceived notion that all lines start there”, a similar reasoning we understand as a geometric form of the linearity illusion; however, it should be noted that both reasonings are not fully equivalent but mathematically related to each other. In our previous study (Medina et al., 2016), about 80% of the responses were coded as A1 while in the current one this percentage diminished to 40% (Table 1). We interpret that the often-inadequate exploitation of such resource goes beyond the overvaluation it receives in most elementary educational curricula (e.g., consider Darwin’s famous statement: “I have no faith in anything short of actual measurement and the rule of three”; such reasoning was quite common before Galton and others’ statistical contributions).

<i>Code</i>	<i>A1</i>	<i>B1</i>	<i>Others</i>
Gas consumption problem	8	3	9

Table 1: Incidence of codes in pairs of students given to the prediction item

The rationale behind code A2 (incidence in the maximum amount of points) was also found in Casey’s 2014 revision, in which she explains its presence as a consequence of previous learning gained in other mathematical domains such as analytic geometry. Besides addressing its possible causes, it is also convenient to discuss its possible implications. Students’ reasoning seems to partition the data into two parts, cases that rely directly into the linear model (explicit or imaginary) and those that doesn’t; that is, cases that belong or fulfill the model conditions and the ones that don’t. This lends support to the conjecture that at this point, students are still struggling to assume the data as an aggregate but at the most, as an aggregate partitioned in two.

The logic behind code A3 (attention to irregularity) could be expressed as a particular case of the former but focused exclusively on the points “outside” of the model. In doing so, the points that “deviate” from the model are considered as a different class with respect to the others, which may

be interpreted as a form to deal (or exclude) the notion of error involved in the use of statistical-inferential models, or even as expressions of overprivileged technical-deterministic reasoning (which could be addressed by promoting more reflection into the context of the data; e.g., by elucidating possible causes for the “lack of adjustment” of all the points).

As showed in Table 2, codes B1 (describe the tendency) and B2 (exclusive reference to the line) had an increased frequency when dealing with the second problem (final stage of the HLT), and a significant increase was also evident for code A3. The bigger frequency for code B1 might be attributed to students gained experience in this point of the trajectory despite the fact of dealing with a negative correlation; however, this feature might also have provoked that A3 appeared more often because of attending a more disperse data set.

<i>Codes</i>	<i>B1</i>	<i>B2</i>	<i>A3</i>	<i>Others</i>
Gas consumption problem	2	4	1	13
Height and arm problem	5	5	5	5

Table 2: Incidence of codes in pairs of students when describing the tendency in the data

As previously mentioned, codes B3 and B4 appeared as criteria of students when attempting to elaborate a linear model of their own (Table 3). Such codes were absent in our 2016 study, which led us to believe that their emergence might be motivated by the incorporation of the software to the instruction sequence. Specifically, adding a movable line and then comparing it against the least squares line seemed to have enable students identify how the former “goes through all of the points”; also, displaying and interpreting the sum of the squares through the software helped to capitalize the idea of the line of the best fit as the one that best approximates all points in the data set.

<i>Codes</i>	<i>B3</i>	<i>B4</i>	<i>Others</i>
Gas consumption problem	2	0	18
Height and arm problem	2	6	8

Table 3: Incidence of codes in pairs of students when elaborating a line of best fit on their own

To summarize and conclude this report, codes A1 and A2 are considered patterns that evidence students’ struggle when considering a data set as an aggregate in the context of linear regression and correlation problems. Codes B1 and B2 indicate a progress in students’ conceptions regarding their ability to conceive and identify a general structure subjacent to the data, although with great challenge when it comes to interpret and reconcile the random inferential nature of the model. The emergence of codes B3 and B4 suggest that the use of Fathom might have contributed to improve students’ understanding by helping them to associate the line of best fit to the one that minimizes the sum of errors or deviations between the points and the model. Finally, a major limitation of the HLT is the lack of incidence in promoting reflection upon the reasons of why such correlations might exist (or not); a new version of the HLT and future researches could target such deficiency by addressing students’ reasoning in aspects related to causality and variability.

References

- Bakker, A. (2004). Reasoning about Shape as a Pattern in Variability. *Statistics Education Research Journal*, 3(2), 64–83.
- Carlson, M., Jacobs, S., Coe, E., Larsen, S. & Hsu, E. (2002). Applying covariational reasoning while modeling dynamic events. *Journal for Research in Mathematics Education*, 33 (5), 352–378.
- Casey, S. (2014). Teachers' knowledge of students' conceptions and their development when learning linear regression. In K. Makar, B. de Sousa & R. Gould (Eds.), *Sustainability in statistics education. Proceedings of the Ninth International Conference on Teaching Statistics. ICOTS9 Invited Paper-Refereed*. Voorburg, The Netherlands: International Statistical Institute.
- Dierdorff, A., Bakker, A., Eijkelhof, H.M.C. and van Maanen, J.A. (2011). Authentic practices as contexts for learning to draw inferences beyond correlated data. *Mathematical Thinking and Learning*, 13, (pp. 132–151) (20 p.).
- van Doreen, W., de Boer, D., Depaepe, F., Janssens, D., Verschaffel, L. (2003). The illusion of linearity: Expanding the evidence towards probabilistic reasoning. *Educational Studies in Mathematics*, 53, 113–138.
- Fitzallen, N. (2012). Interpreting graphs: Students developing an understanding of covariation. In J. Dindyal, L. P. Cheng, & S. F. Ng (Eds.), *Mathematics Education: Expanding Horizons* (Proceedings of the 35th annual conference of the Mathematics Education Research Group of Australasia, Singapore, pp. 290-297). Sydney, NSW: MERGA.
- Gil, E. and Gibbs, A. L. (2017). Promoting modelling and covariational reasoning among secondary school students in the context of Big Data. *Statistics Education Research Journal*, 16(2) pp. 163–189.
- Inzunza, S. (2016). Analysis of bivariate data in an environment based on applets and dynamic software. *Mathematics Education*, 28(3), 61–89.
- McLaren, C. (2012). Using the height and shoe size data to introduce correlation and regression. *Journal of Statistics Education* 20(3), 1–9.
- Medina, M. N., Olay, G. E., Sánchez, E. (2016). Razonamiento de estudiantes de bachillerato frente a un problema de regresión [Reasoning of high school students in a regression problem]. *Eutopia. Revista del Colegio de Ciencias y Humanidades para el Bachillerato*, 9(24), 71–78.
- Moore, DS (1998). *Basic Applied Statistics*. Antoni Bosch editor.
- Simon, M. (1995). Reconstructing mathematics pedagogy from a constructivist perspective. *Journal for Research in Mathematics Education*, 26 (2), 114–145.
- Zieffler, A. S., & Garfield, J. (2009). Modeling the Growth of Students' Covariational Reasoning during an introductory statistics course. *Statistics Education Research Journal*, 8(1), 7–3.
- Zimmerman, C. (2007). The development of scientific thinking skills in elementary and middle school. *Developmental Review* 27, 172–223.

A Case Study of Teacher Professional Development on Game-Enhanced Statistics Learning in the Early Years of Schooling

Maria Meletiou-Mavrotheris¹, Efi Papparistodemou², Loucas Tsouccas¹

¹European University Cyprus; m.mavrotheris@euc.ac.cy; louevge@gmail.com

²Cyprus Pedagogical Institute; e.paparistodemou@cytanet.com.cy

The research comes from a multifaceted program designed to provide in-service lower primary school teachers (Grades 1-3; ages 6-9) with the knowledge, skills, confidence, and practical experience required to effectively integrate digital games within the early mathematics curriculum. The article focuses on one of the teachers, employing a single case study approach to document the level of transfer and adoption of the acquired knowledge and skills into actual teaching practice. Findings provide some useful insights into the ways in which the program experiences influenced the teacher's competence in selecting, evaluating, and productively utilizing digital games to enhance learning of key statistical concepts included in the mathematics curriculum.

Keywords: Educational games, professional development, TPACK, early statistics education

Introduction

The expanding use of data for prediction and decision-making in almost all domains of life makes it a priority for mathematics instruction to help students of all ages develop their statistical reasoning. It is now widely recognized that the foundations for statistical reasoning should be laid in the earliest years of schooling rather than being reserved for secondary school or university studies. Consequently, the development of students' statistical literacy has become an important goal of mathematics education at the early school level internationally. This broadening of the mathematics curriculum to encompass statistical literacy, reasoning, and thinking has put considerable demands on teachers (Hannigan, Gill, & Leavy, 2013). In particular, it has been challenging for teachers to design lessons with engaging contexts and a focus on conceptual aspects of statistics, and to pose critical questions. As the research literature indicates, many teachers tend focus instruction on the procedural aspects of statistics rather than on conceptual understanding (Watson, 2001).

Recognizing the need for fundamental changes to the instructional practices employed in the mathematics classroom to teach statistical concepts, researchers have in recent years been experimenting with new models of teaching that are focused on inquiry-based, technology-enhanced instruction and on statistical problem-solving (e.g., Meletiou-Mavrotheris, & Papparistodemou, 2015). One promising approach lately explored is the potential for digital games to transform statistics instruction. Unlike the numerous studies investigating the instructional use of computer simulations, animations, and dynamic software, there only few published studies on the use of games for teaching statistics, the general thrust of the evidence in the existing literature is positive (Boyle, MacArthur, Connolly, Hailey, Manea, Kärki, & van Rosmalen, 2014). Findings concur with the general educational literature on game-enhanced learning which suggests that when suitably designed, digital educational games have many potential benefits for teaching and learning at all levels, including pre-school and early school years (Manassis, 2014). Most of the conducted

studies report that employing games has a positive effect on students' motivation and learning of statistical concepts (e.g. Gresalfi and Barab, 2011; Boyle et al., 2014). Digital games' greatest strength as a medium, involve their affordances for supporting higher order cognitive, intrapersonal, and interpersonal learning objectives (Clark, Tanner-Smith & Killingsworth 2014). Using games, children can individually or collaboratively engage in exploration of virtual worlds, and in authentic problem solving activities. This supports the development of important competencies essential in modern society such as logical and strategic thinking, planning, multi-tasking, self-monitoring, communication, negotiation, group decision-making, pattern recognition, accuracy, speed of calculation, and data-handling. At the same time, games can promote differentiation of instruction by matching challenges to children's skill level, and by providing immediate feedback to students about the correctness of their strategies and thought processes.

While digital educational games provide a range of potential benefits for mathematics and statistics teaching and learning, not all the games are designed to promote optimal development among children. Most of the available educational games tend to be a drill-and practice and to support mainly procedural fluency rather than high-level thinking. Some exceptional exemplars do exist that can help create constructive, and meaningful learning experiences, but their successful deployment in the early statistic classroom is highly dependent upon the knowledge, attitudes, and experiences of teachers. Implementing game-based instruction can be a challenge for teachers, requiring skills not necessarily addressed in current teacher training practices. Teachers need to be proactive, choosing high quality educational games, supporting and scaffolding pupils, and providing appropriate feedback

Acknowledging the educational potential of games for transforming statistics instruction in the early years, but also the crucial role of teachers in any effort to bring about change and innovation, the current study focused on providing in-service teacher education on the effective utilization of digital games in the lower primary classroom (ages 6-9). An exploratory case study took place within a Cypriot teacher professional development program on the integration of games within the early mathematics curriculum developed based on the notion of Technological Pedagogical Content Knowledge (TPACK) as a conceptual framework (Mishra and Koehler, 2006). It focused on one of the program participants and investigated the development of his TPACK of game-enhanced teaching and learning of statistical concepts included in the early primary mathematics curriculum

Methodology

Program Structure, Context and Participants

The professional development program was attended by six lower primary school level educators (Grades 1-3; ages 6-9), and it was designed to provide them with the knowledge, skills, confidence, and practical experience required to effectively exploit digital games as a tool for fostering young children's motivation and learning of mathematics. Following the TPACK model and action research procedures, the program was designed and carried out in three phases:

- *Phase I – Familiarization with Game-Based Learning:* In Phase I (6 hours duration), teachers were offered a critical introduction into the potential and challenges of using serious games in early mathematics and statistics instruction. They experienced some of the ways in which

purposefully selected games, blended with carefully constructed learning experiences, could help improve children's attitudes towards the subjects, while at the same time advancing their mathematical and statistical thinking and problem solving skills. The unit also familiarized participants with the design principles for constructivist gaming environments (Munoz-Rosario & Widmeyer, 2009), and promoted the development of their skills in properly evaluating and selecting games with pedagogically sound design features.

- *Phase II – Lesson Planning:* In Phase II, teachers' TPACK was enhanced through their engagement in lesson planning. They selected a topic from the national mathematics curriculum for Grades 1-3, and developed a lesson plan and accompanying teaching material aligned with the learning objectives specified in the curriculum, which incorporated the use of digital games. They were instructed to integrate into their lessons educational games that adhered to important principles associated well-designed educational games (Gee, 2007) such as facilitation of an authentic learning experience, active participation, collaboration, and promotion of higher order thinking skills. The lesson plans were shared with the researchers for comments and suggestions, and were revised based upon received feedback.
- *Phase III – Lesson Implementation and Reflection:* Next, the participants implemented the lesson plans in their classroom, with the support of the research team. Once the classroom research was completed, teachers prepared and submitted a reflection paper, where they shared their observations on students' reactions during the lesson, noting what went well and what difficulties they faced and making suggestions for improvement.

Detailed information regarding the implementation of the different Phases of the program and their impact on the whole group of participating teachers can be found in Meletiou-Mavrotheris, Paparistodemou, & Tsouccas (2018). In this article, we focus on Phase III of the program. We draw upon the data collected from the case study teacher and his students to investigate the level of transfer and adoption of TPACK competencies acquired through the training to actual teaching practice. This teacher, who was an expert educator (9 years of teaching experience), was the sole program participant whose teaching intervention focused on concepts related to statistical data analysis. The rest prepared and implemented lesson plans focusing on other areas of the mathematics curriculum.

Research Design: Scope and Context of Study

The teaching intervention took place in a Grade 2 classroom with 18 students, and lasted for 80 minutes (two teaching periods). The class teacher selected a topic from the national mathematics curriculum for Grades 1-3, and developed a lesson plan and accompanying teaching material aligned with the learning objectives specified in the curriculum, which incorporated the use of mobile game apps. The lesson plan targeted the following indicators of achievement included in the curriculum for Grade 2: (i) Collect information and data in the environment and present them in an organized way; (ii) Record, organize and present data in tables and graphical representations (pictogram, bar graph, pie chart); (iii) Represent the same data in multiple ways.

The lesson plan was shared with the researchers for comments and suggestions, and was revised based upon received feedback. Next, the teacher implemented the lesson plan in his classroom, with

the support of the research team, and afterwards prepared a reflection paper where he shared his observations on students' reactions during the teaching intervention, noting what went well and what difficulties he faced and making suggestions for improvement.

Central to the teaching intervention was the game app *The Electric Company Prankster Planet*, available on Android and iOS platforms as well as online. *Prankster Planet* is based on the Emmy Award-winning PBS KIDS TV series *The Electric Company*, and it targets children aged 6-10. It features eight unique quests with math curriculum woven throughout that children have to complete to save Earth from the Reverse-a-ball machines of Prankster character Francine, that are scrambling up all the words on Earth and are causing a lot of confusion. Children complete a series of data collection, representation and analysis challenges in order to shut down all eight machines hidden in the jungles, cities, junkyards, and underground world of Prankster Planet. The app features side-scrolling play and exploration in a 2D platformer world, an avatar creator with many customization options, a rewards system to encourage repeat play, and the option of collaborative play through group activities. The online gaming platform Kahoot! was also used during the lesson.

Data collection and analysis procedures

Although multiple forms of data were collected to document changes in teachers' perceptions and attitudes, and in their TPACK of game-enhanced learning as a result of participating in the teacher professional program, only data collected during Phase III in the case study teacher's class was utilized in this study. Researchers were present in the class, observing closely and videotaping the lesson, keeping field notes, and collecting student work samples. Qualitative data were also obtained from the reflection papers written by the teacher at the end of the lesson.

For the purpose of analysis, we did not use an analytical framework with predetermined categories to assess how the teacher's acquired TPACK impacted his teaching practice, due to the lack of well-established frameworks and methodological insights for studying game-enhanced statistics education in the context of in-service teacher training. What we did instead was to identify, through careful reviewing of the transcripts, reflection paper, and other data collected during the study, recurring themes or patterns in the data. To increase the reliability of the findings, the activities were analyzed and categorized by all three researchers. Inter-rater discrepancies were resolved through discussion.

Results

Teaching intervention overview

The lesson started with the teacher informing the class that the headmistress needed information about students' preferences on afternoon activities, to plan for the next school year. Therefore, she would like each class to collect data on their preferences, organize them, and present them in way that would help her come up with a schedule of activities that would satisfy as many children as possible.

To tackle the task, the class first decided to do a census where each student selected their favorite afternoon activity among five options. Then, they recorded their preferences on a tally table, and counted the total number of students selecting each activity. This was followed by class discussion

on how to best present the survey results to the headmistress. During this discussion, children were introduced to bar graphs, the process of their construction, and the ways in which this graphical representation can help to present and interpret the results of a survey, and make decisions.

Next, children played in pairs the digital game Prankster Planet on their iPads. They were asked to go through all eight increasingly difficult missions of the game. Within each mission, they responded to various questions where they had to interpret a bar chart or a pie-chart, or to construct such graphs, in order to collect as many points as possible (see Figure 1). Throughout the activity, the teacher went around the class and offered personalized assistance to each pair of students. Although children were fully engaged with the game and quickly learned its mechanics (possibly due to their high degree of familiarity with digital games as the vast majority owned a tablet at home), they needed some help from their teacher in understanding the posed questions, which were in English.



Figure 1: A pair of students interpreting a bar graph in Prankster Planet

Finally, children completed an exercise adopted from their mathematics textbook. They were presented with a table showing the number of hours of sleep per day of 12 different mammals. First, they worked in pairs to complete a task in Kahoot! where they responded to various questions related to the information included in the table. The task was set up as a contest, where each correct answer gave different points to the pair, depending on their response time. For each question, the right answer appeared on the whiteboard, as well as a bar chart showing the children that answered it correctly, and the score of each pair. After completing the task, the children worked individually to construct a “bar graph” of the data in their notebook (a simple histogram in reality), with each bar corresponding to an interval of hours of sleep (i.e. animals sleeping between 0-5 hours, between 6-10 hours, etc.). Finally, through a second contest, they were again given the opportunity to collect points and to win by interpreting the graph they had just built, and answering various questions (e.g. *How many animals sleep more than 5 hours and less than 16 hours per day?*).

At the end of the lesson, a discussion took place, where the teacher highlighted the main statistical concepts introduced during the lesson. Children were encouraged to express their opinion about the format of the lesson and whether they would like to again use similar digital games in class.

Reflection on the teaching intervention

The case study teacher's past exposure to mathematics education games was limited to drill-and-practice, which he tended to use in class for motivational purposes, and/or for students to practice already acquired skills. However, his participation in the program helped him realize digital games' true potential for supporting learning in educationally powerful ways. Through familiarization with the design principles for constructivist gaming environments and experimentation with a range of game apps, he gained better understanding of how to implement game-based mathematics and statistics instruction in the early years. He also improved his ability to assess the educative power of different games, to properly identify their advantages and disadvantages.

Observation of the teaching intervention, and the quality of the lesson plan and tasks prepared by the teacher, indicated that the specific educator acquired the necessary skills and competencies for teaching this topic and similar statistical topics using tablets and game apps like Prankster Planet and Kahoot! He selected appropriate game apps and then exploited them to organize teaching in a constructive, learner-centered way, so that his young students would have the opportunity to work together in constructing statistical concepts and processes. Specifically, in several activities, children collaborated to build joint understanding of the new concepts they had just encountered. For example, to respond to some of the Prankster Planet questions, students worked together to understand and interpret pie-charts, which had never been mentioned in class before.

As expected, the game-based nature of the lesson was well received by students and increased their morale and motivation. In the end of intervention discussion, children expressed their enthusiasm about the games they engaged with during the lesson, *"because they gave [them] the chance to play and learn at the same time"*. Although expressing a preference for *"the game where [they] had to prevent the Lady from changing the letters"* (i.e. Prankster Planet) which they found to be *"more adventurous"*, they also liked the game on Kahoot! because it was set up as a contest. The children stressed that they would love all their lessons to have a similar format since games enable them *"to learn more things about mathematics and to have a joyful time in class"*.

In the reflection paper he wrote after the teaching intervention's completion, the teacher also noted that he was very impressed by the fact that the lesson ended up being so successful:

Teacher: The children got excited with the games, were constantly active, there was rivalry between the teams, but also collaboration within each team, and this had a positive impact on children's motivation, but also on the attainment of the instructional objectives. Even the supposedly "weakest" students had strong interest and active participation during the lesson and gave several thoughtful answers, with no trace of fear of making a mistake. These are qualities I do not usually experience in lessons where I do not use digital games.

According to the teacher, the use of the games led to an effortless involvement of all children, and contributed substantially to the achievement of the learning objectives, but also to ensuring fruitful cooperation among learners and collaborative construction of knowledge in a creative and enjoyable way. Lastly, use of technology worked exactly as he had anticipated, providing the opportunity to introduce in the classroom activities with added value, that could not otherwise be implemented.

While the classroom experimentation further strengthened the teacher's belief that appropriate use of game apps can help create motivational and more conducive to learning environments, it also helped him to build more realistic expectations about what games' instructional integration might entail in practice. He recognized that games are not a panacea, and that their incorporation into the curriculum does not guarantee improved learning. He mentioned various challenges and drawbacks to digital games' incorporation in the mathematics classroom, including time constraints, difficulties in locating high-level games, the risk of the learning objectives being neglected for the sake of playfulness, and language issues for non-native English speakers:

Teacher: The fact that Prankster Planet is in English, prohibited its optimal use. While students played, I had to constantly move around to translate things to them.

The teacher stressed the key role of educators not only in choosing appropriate digital games with the goals of gameplay being closely aligned with instructional objectives, but also in “*coordinating classroom activities appropriately so as to keep children focused on the achievement of the learning objectives*”, and in facilitating learning by providing continued support and scaffolding. He pointed out that games should not dominate class time, but should be used as part of carefully planned learning experiences, and explained how, in his teaching experimentation, the use of alternative pre-game and post-game instructional activities led to a fuller learning experience. His comments concur with the literature, which indicates that digital games are more effective when acting as adjuncts to more traditional teaching methods rather than as stand-alone applications (Gee, 2007).

Discussion

This case study has several limitations, emerging primarily from its exploratory nature, which constrain the interpretation of the research results. A serious drawback is the limited generalizability of the research findings. The qualitative methodology used to research the case, the small scale of the study, and its limited geographical nature, means that generalizations to cases that are not very similar should be done cautiously as the specific classroom investigated might not be representative of all pre-service teacher classrooms. Despite, however, the tentative and non-generalizable nature of its findings, the conducted research contributes some useful insights into the accumulating body of literature on game-enhanced statistics teaching and learning.

In accord with the research literature (e.g. Niess et al., 2009), our research has illustrated the usefulness of the TPACK framework as a means of both studying and facilitating teachers' professional growth. Although there was no pre-post test assessment to formally track changes teachers' TPACK, there are strong indications in the collected data that the training was quite successful in helping the case study teacher (as well as the other program participants) move beyond his restricted views of digital games as educational tools (for more details see Meletiou-Mavrotheris et al., 2018). Secondly, that it helped to convey to him technological and pedagogical knowledge regarding the teaching of specific mathematical and statistical concepts with games. Thirdly, that it improved the teacher's confidence and ability to transfer and adopt the TPACK competencies acquired through their training to actual teaching practice.

There are important implications for the design or revamping of pre-service or in-service teacher training curricula and programs on digital game integration. Insights from the study suggest that

utilizing a conceptually based theoretical framework about the relationship between technology and teaching like TPACK, can enrich teachers' professional development. Findings also indicate that the development of teachers' TPACK necessitates the provision of opportunities for both theoretical and experiential learning of technology-based pedagogical approaches to mathematics education. Concurring with prior research (e.g. Serradó, Meletiou-Mavrotheris, & Paparistodemou, 2014), this study provides evidence that teachers' involvement in professional development activities such as lesson design and classroom experimentation, can support them in developing their teaching competencies with ICT and understanding of TPACK in ways transferable into their own practice.

References

- Boyle, E.A., MacArthur, E., Connolly, T.M., Hainey, T., Manea, M., Kärki, A. & van Rosmalen. P. (2014). A narrative literature review of games, animations and simulations to teach research methods and statistics. *Computers & Education*, 74, 1-14.
- Clark, D. B., Tanner-Smith, E. E., & Killingsworth S. (2014). *Digital games, design, and learning: A systematic review and meta-analysis*. Menlo Park, CA: SRI International.
- Gee, J. P. (2007). *What video games have to teach us about learning and literacy*. New York, NY: Palgrave Macmillan.
- Gresalfi, M., & Barab, S. (2011). Learning for a reason: supporting forms of engagement by designing tasks and orchestrating environments. *Theory into Practice*, 50(4), 300–310.
- Hannigan, A., Gill, O., & Leavy, A. M. (2013). An investigation of prospective secondary mathematics teachers' conceptual knowledge of and attitudes towards statistics. *Journal of Mathematics Teacher Education*, 16(6), 427-449. doi: 10.1007/s10857-013-9246-3.
- Manassis, D. (2014). The Importance of Future Kindergarten Teachers' Beliefs about the Usefulness of Games-Based Learning. [IJGBL]. *International Journal of Game-Based Learning*, 4(1), 78-90
- Meletiou-Mavrotheris, M., and Paparistodemou, E. (2015). Developing Young Learners' Reasoning about Samples and Sampling in the Context of Informal Inferences. *Educational Studies in Mathematics*, 88(3), 385-404.
- Meletiou-Mavrotheris, Paparistodemou, E., and Tsouccas, L. (2018). Integrating Games into the Early Statistics Classroom: Teacher Professional Development on Game-Enhanced Learning. In: A. Leavy, M. Meletiou-Mavrotheris, and E. Paparistodemou (Eds.), *Statistics in Early Childhood and Primary Education: Supporting Early Statistical and Probabilistic Thinking* (pp. 275-293). Springer, Singapore.
- Mishra, P., & Koehler, M. J. (2006). Technological pedagogical content knowledge: A framework for teacher knowledge. *Teachers College Record*, 108(6), 1017-1054.
- Munoz-Rosario, R. A., & Widmeyer, G. R. (2009). An exploratory review of design principles in constructivist gaming learning environments. *Journal of Information Systems Education*, 20(3), 289-300.
- Niess, M. L., Ronau, R. N., Shafer, K. G., Driskell, S. O., Harper, S. R., & Johnston, C. (2009). Mathematics teacher TPACK standards and development model. *Contemporary Issues in Technology and Teacher Education*, 9, 4–24.
- Serradó, A., Meletiou-Mavrotheris, M., and Paparistodemou, E. (2014). EarlyStatistics: a course for developing teachers' statistics technological and pedagogical content. *Le Revue Statistique et Enseignement*, 5(1), 5-29.
- Watson, J. M. (2001). Profiling teachers' competence and confidence to teach particular mathematics topics: The case of chance and data. *Journal of Mathematics Teacher Education*, 4(4), 305-337.

The influence of the context of conditional probability problems on probabilistic thinking: A case study with teacher candidates

Beyza Olgun¹ and Mine Isiksal-Bostan²

¹Middle East Technical University, Turkey; bolgun@metu.edu.tr

²Middle East Technical University, Turkey; misiksal@metu.edu.tr

This study investigates the influence of the context of conditional probability problems on probabilistic thinking processes of mathematics teacher candidates. Data were collected from four mathematics teacher candidates through semi-structured clinical interviews. Teacher candidates were expected to solve and explain three conditional probability problems, which were selected based on specific contexts. The findings revealed that, when the context is related to a social issue such as health or justice, that can be a hindrance to probabilistic thinking. In addition, while solving questions, teacher candidates focused on their beliefs regarding the social issue rather than using logical and numerical reasoning given in the questions. On the other hand, the findings highlighted the importance of the instruction on conditional probability, as the candidates represented a high-level of probabilistic thinking in the case of consecutive events that were frequently used in curricula.

Keywords: Probabilistic thinking, the context of a conditional probability problem, mathematics teacher candidates

Introduction

As probabilistic thinking involves quantifying uncertainty to arrive at a decision, it has an important role in interpreting uncertain situations in daily life (Amir & Williams, 1999). It helps us better understand whether or not the information gained through our everyday experiences is correct (Metz, 1998). Therefore, probability is recognized as an essential aspect of school mathematics curricula from elementary to undergraduate education (Amir & Williams, 1999). Developing students' skills of probabilistic thinking is one of the main aims of the mathematics curricula in Turkey (MEB, 2018). The development of probabilistic thinking depends on the interactions between "intuition, logical development, and the effects of formal instructions" (Greer, 2001, p. 25). From the educational perspective, the aim is to enhance students' probabilistic thinking from intuitive to more advanced logical and numerical reasoning. However, the instruction of probability concepts in schools may cause discomfort in students' proportional reasoning because probabilistic thinking has a fragile aspect when it intuition is concerned (Fischbein, Nello, & Marino, 1991). This weak aspect may cause students engage in subjective reasoning and to act accordingly or to have some misconceptions. Therefore, while planning their instruction, educators need to consider generating an environment that helps students enhance their conceptual understanding, as well as formalizing their initial intuitive concepts (Greer, 2001).

There are four key constructs regarding probabilistic thinking: sample space, probability of an event, probability comparisons, and conditional probability (Jones, Langrall, Thornton, & Mogill, 1997). Conditional probability is one of the fundamental stochastic ideas that enhance probabilistic thinking throughout the history in Heitele's list (Diaz & Batanero, 2009). It allows individuals to make

appropriate changes in their beliefs concerning random events when new information emerges (Diaz & Batanero, 2009). It also helps individuals understand possible risks and make proper decisions in daily life (Watson, 1995). However, compared to the other three key constructs, it requires more careful thinking (Tarr & Lannin, 2005) because of its interest in the outcomes that are elements of a subset of the sample space (Hogg & Tanis, 1993). Therefore, understanding the conditional probability involves the adjustment of the probability of an event when there is a condition regarding the occurrence of another event (Tarr & Lannin, 2005).

Studies showed that students have various misconceptions regarding conditional probability, such as *the transposed conditional fallacy*, *the fallacy of time axis*, and *the base rate fallacy* (e.g., Diaz & Batanero, 2008; Koehler, 1996). The analysis of these misconceptions reveals the influence of the context of probability problems on students' reasoning. In other words, people can approach the problems of conditional probability in various ways when they fail to use appropriate theories (Tversky & Kahneman, 1982). For example, a Bayesian problem that involves two types of information regarding an event – statistics for a population and its specific part of it – can cause a hindrance to student thinking, which leads to the base rate fallacy (Diaz & Batanero, 2009). Moreover, the probability problems that involve medical issues, such as having cancer and taking a related test can be confusing for students as these problems involve the daily experiences of individuals. Students' ways of thinking can be causal based on the scenario or their motive (Tversky & Kahneman, 1982). On the other hand, in some cases where students are accustomed to school experiences, such as consecutive experiments, they can show high-level probabilistic thinking skills (Jones et al., 1997). For instance, the use of representations, such as 2-way tables in the text of a probability problem, could enhance thinking processes of students as well as their achievement (Olgun & Işıksal, 2018).

In this research study, as a continuation of the research study that investigated the role of representations on prospective teachers' thinking processes in conditional probability (Olgun & Işıksal, 2018), the relationship between the context of the probability problems and probabilistic thinking processes is examined. The initial analysis of the previous study pointed out a probable relationship between the context of probability problems and probabilistic thinking processes. Thus, the research question of the present study was as follows: How does the context of probability problems influences prospective mathematics teachers' probabilistic thinking processes in conditional probability based on the framework developed by Tarr and Jones (1997)?

Theoretical Background

Students' understanding of probability, their misconceptions, and their development of probabilistic thinking were the areas of focus in the research literature. To improve the instruction of probability, a coherent frame that reveals students' ways of thinking about probabilistic phenomena is needed (Jones et al., 1997). Therefore, Jones and his colleagues (1997) developed the "Framework for Probabilistic Thinking" to meet this need. The framework consists of four key constructs of probability; *sample space*, *probability of an event*, *probability comparisons*, and *conditional probability*. Tarr and Jones (1997) enhanced this framework for conditional probability. The new framework, which is called the *Framework for Assessing Students' Thinking in Conditional Probability (FASTCP)*, includes *independence* as a new construct. Four levels, namely subjective,

transitional, informal quantitative, and numerical are described for each construct of the framework. The following example represents the thinking levels for conditional probability.

There is a cup that contains two red and two blue marbles. Two marbles, one after another, are picked up randomly, without replacement. When students were asked what color marble would be picked given that the first marble is red, based on the FASTCP, the response of “red because it is my favorite color” (Tarr & Jones, 1997, p. 51) would belong to a student in level 1 (subjective). To state it differently, level 1 involves the use of subjective reasoning based on personal traits without considering numerical information. At level 2 (transitional), students begin to use quantitative information, but still, their conditional reasoning is not complete, so students can respond by making such utterances as follows “the probability that blue will be drawn is still the same” (Tarr & Jones, 1997, p. 52). In other words, students misuse numerical information and act with representative heuristics at the transitional level of probabilistic thinking. Moreover, they may still revert to subjective judgments. At level 3 (informal quantitative), students recognize the role of quantitative information for conditional probability as well as monitor the composition of the sample space. Level 3 students can respond by stating that there is one red marble instead of four but still they may also show representative acts or assign incorrect numerical probabilities (Tarr & Jones, 1997). At level 4, as students assign numerical probabilities spontaneously and explain the conditions when the events are related, the response could be that the chance of red is one out of three and the chance of blue is two out of three (Tarr & Jones, 1997). In other words, the numerical level involves the awareness of the composition of the sample space and its essential role in determining conditional probability.

Some studies (e.g., Diaz & Batanero, 2008) showed that students whose probabilistic thinking are at the numerical level might revert subjective reasoning and show biases while performing on probability problems. The importance of the role of intuition in probabilistic thinking and the fragility of probabilistic reasoning in some situations make us inquire what factors influence students' probabilistic thinking. The investigation of students' biases represents the influence of the context of the problems in conditional probability on student thinking. Some studies claim that conditional probability problems, which involve cause and effect relations, confuse students' judgments about the probabilistic phenomena (Biaz & Batanero, 2009). Students rely on causal data that include their perceptions formed via daily life experiences rather than diagnostic data (Diaz & Batanero, 2009). In the case of the Bayesian problems, which involve the issue of base rates, students may ignore the information related to the base rate and tend to rely on the specific information given in the problems (Koehler, 1996). When the context of conditional probability problems involves social contexts, such as justice or health issues, students' beliefs based on personal experiences may get ahead of their logical reasoning. Some studies (e.g., Corter & Zahner, 2007; Watson, 1995) suggest that the use of representations can facilitate students' problem-solving processes and lead them to use logical-numerical reasoning. However, students may still resort to erroneous judgments for problems based on certain contexts rather than using representations as a model (Olgun & Işıksal, 2018). Based on the literature it could be deduced that there are limited studies that have focused on the context of probability problems in the case of conditional probability while modelling and representations have been investigated by many researchers (Chaput, Girard & Henry, 2011). These issues necessitate a study investigating how different contexts of probability problems influence probabilistic thinking

processes. Such a study can reveal some information about the instruction of conditional probability as well as students' thinking processes. Therefore, the current study will investigate the influence of different contexts in conditional probability problems on probabilistic thinking processes of teacher candidates based on the FASTCP.

Methodology

Gaining a deep understanding of participants' thinking processes was the main objective of the present study, in which semi-structured clinical interviews were held with the participants, who were selected by means of the convenient sampling method. The participants were students, who were in their 4th semester of teacher education program and who had taken "MATH 112 Discrete Mathematics" and "STAT 201-202 Introduction to Probability and Statistics I-II" courses. These students were informed about the research study. The interviews were conducted with the volunteer students. Four (two male and two female second-year students between the age of 20-22 years) students enrolled in the mathematics teacher education program of one of the largest public universities in Turkey constituted the participants of the study.

In the interviews, the participants were asked to perform on three specific conditional probability problems (see Figure 1), which were selected from the Conditional Probability Reasoning Test (CPR) developed by Diaz and Batanero (2009). Each problem was determined according to its specific context. Problem 1 was related to a consecutive experiment involving computing conditional probability and dependence of the events. Problems 2 and 3 included the social context of justice and health issues, respectively. In problem 2, which is a Bayesian problem, two types of information were given: the frequency of the base rate and specific information about the case. Problem 3 was related to a causal issue including the application of a medical test and whether or not there was an illness.

Problem 1: (Falk 1986). Two black and two white marbles are put in an urn. We pick a marble from the urn. Then, without putting it back into the urn, we pick a second marble at random.

If the second marble is white, what is the probability that the first marble is white? $P(W_1|W_2)$

- i. $1/3$
- ii. Cannot be computed
- iii. $1/6$
- iv. $1/2$

Problem 2: (Tversky & Kahneman 1982a). A witness sees a crime involving a taxi in a city. The witness says that the taxi is blue. It is known from previous research that witnesses are correct 80% of the time when making such statements. The police also know that 15% of the taxis in the city are blue, the other 85% being green. What is the probability that a blue taxi was involved in the crime?

- | | |
|--|---|
| a. $\frac{80}{100}$ | b. $\frac{15}{100}$ |
| c. $\frac{15 \times 80}{100 \times 100}$ | d. $\frac{15 \times 80}{85 \times 20 + 15 \times 80}$ |

Problem 3: (Pollatsek, et al. 1987). A cancer test is administered to all the residents in a large city. A positive result is indicative of cancer and a negative result of no cancer. Which of the following results is more likely or are they all equally likely?

- a. A person has in fact cancer supposed that he got a positive result.
- b. To have a positive test supposed that the person has cancer.
- c. The two events are equally likely.

Figure 1: The problems, adapted from "University Students' Knowledge and Biases in Conditional Probability Reasoning", by Diaz and Batanero (2009, pp. 157–158)

The participants were asked to submit their solutions both in written form and verbally, and the first author asked related questions to understand their in-depth thinking processes. Each interview lasted 90 to 120 minutes and was videotaped and transcribed. The demographic information and the consent of the participants were obtained in advance. In the data analysis process, students' probabilistic thinking processes were explored based on the FASTCP for each problem. Two researchers performed open coding. After the codes were determined individually, the inter-rater agreement was

calculated to be 90%. Different ideas were discussed until a consensus was reached. General codes were identified based on their match with the respective thinking levels from the FASTCP. For instance, the general codes of "assigning numerical probabilities spontaneously and accurately" and "using and explaining logical-numerical reasoning" were matched with level 4; the general code of "reverting to subjective reasoning even though recognizing numerical information" was matched with level 2. Expert opinion was also obtained on the appropriateness of matching the general codes with the thinking levels.

Findings

The analysis of the data showed that the context of the problem had an apparent influence on probability thinking processes of the mathematics teacher candidates. It was observed that when the conditional problem includes a social context, which was, in this case, a health issue or justice for a crime, the participants focused on their beliefs based on their daily life experiences and answered the question accordingly. In other words, most of the time, they resorted to subjective reasoning rather than to logical and numerical reasoning. On the other hand, they presented high-level probabilistic thinking in consecutive experiments.

In problem 1, all participants represented the skills of the numerical level of probabilistic thinking. All participants easily recognized the condition for the consecutive experiment. They were aware of the composition of the sample space, which plays an essential part in determining the conditional probability, and applied numerical probabilities with relative ease when the other situations are considered. They could state the necessary conditions whether or not two events were related. They used numerical reasoning while comparing the probabilities of the events for each trail in non-replacement situations. In the following example, it can be seen that the participant executed the required conditions for conditional probability and assigned precise values for the desired events.

Student C: The probability that the first marble is white if the second marble is white... First I will find the probability that the second marble is white. These are WW (white and white) or BW (black and white). For the situation of WW, the probability is $\frac{1}{2} \times \frac{1}{3} = \frac{1}{6}$. For the case of BW, the probability is $\frac{1}{2} \times \frac{2}{3} = \frac{1}{3}$. Then $\frac{1}{6} + \frac{1}{3} = \frac{1}{2}$ is the probability that the second marble is white. Here, the probability that the first marble is also white is $\frac{1}{6}$. Then, as like before I will calculate the proportion of $\frac{1/6}{1/2}$. It is $\frac{1}{3}$.

In problem 2, only one participant displayed the skills of numerical level thinking. The other participants displayed the transitional level of thinking. They presented acts of representativeness as a confounding effect when they made decisions and ignored Bayesian reasoning in their solutions. They confused the situation of "the probability of the involvement of a blue taxi in the crime" with "the chance of finding the taxi that was involved in the crime if it is blue". Therefore, they were confused because the possibility of the taxi involved in the crime being blue should be higher as there was a witness when their numerical calculations said the opposite. Another participant also had the misconception of the base rate fallacy. He ignored the specific information regarding the witness and only focused on the frequency of blue taxis as can be seen in the following example.

Student A: Is it not an easier thing for us to have 15% blue? Obviously, the thing that blue taxis are 15% of the taxis in the city increase the possibility to find the taxi that was involved in the crime because the less the rate, the more likely it is to find. ... The possibility of telling the truth is 80%. Then the possibility of being blue is 15% but as I said it is a 15% chance of blue from all taxis. For example, here it multiplies $80/100$ with $15/100$ but because I know that 15% of the taxis are blue if I search within this 15%, the possibility of finding will be high. ... I will say that the possibility of finding the taxi that was involved in the crime is one in fifteen...

In problem 3, all participants acted in the transitional level of thinking. They misused numbers in determining probabilities. For example, when the sample space contained two outcomes as positive and negative results, they assumed that these outcomes are equally likely. Students did not use any representation for the information in the problem to facilitate their solutions. Their judgment about the conditional probability reverted to subjective reasoning as can be seen in the following episode:

Student A: In the case of a positive result when the person has cancer, in the case of having cancer when the result of the test was positive... I'm not a person who trusts in tests that related to health, so I think that the probability of having a positive result in the state of being ill will be lower.

Interviewer: It was a subjective judgment; do not you think?

Student A: Yes, but the question is also very subjective

Interviewer: Can we make a numerical comparison?

Student A: If I have this disease, the possibility of my being patient according to the test result %50 likely. I assume I have cancer then there are two possibilities that this device will show me as plus or negative. If not, it is the same for the other also... So, as I said, I still think that the possibility of having a positive test result supposed that the person has cancer will be higher than the probability of the person has in fact cancer supposed that the person has cancer.

Discussion

The findings of the present study revealed the fragile aspect of probabilistic thinking. Teacher candidates' actions varied depending on the context of conditional probability problems. Their intuition, which is one of the main components of probabilistic thinking (Greer, 2001), came into prominence when the context was related to a social issue. On the other hand, they showed high-level probabilistic thinking in consecutive experiments. While they represented all the outcomes via listing or creating a tree diagram for consecutive experiments, they did not use any representation for the other two problems. Therefore, they could not explain their reasoning within logical boundaries based on data representation for the problems associated with social issues. For instance, they could not express the need for the accuracy of the cancer test to solve problem 3. The main reason for this difference might be the standing of the problems related to consecutive experiments in school curricula and the instruction of probability. Consecutive experiments have been frequently used in textbooks as well as in regular instructions. Therefore, teacher candidates may have the appropriate

approach in such scopes. Thus, they may directly focus on logical reasoning and numerical probabilities without resorting to their intuition. On the other hand, in a social context, they resort to subjective reasoning or ignore the importance of the condition.

The frequentist approach that recommends a sequence, which starting with the introduction of data followed by probability through datasets (Chaput et al., 2011), has been implemented in the Turkish school curricula since 2009. Therefore, our participants' initial acquaintance with probability was by means of the old approach, which starts with probability and introduces data environment through chance situations. Thus, the introduction of the conditional probability might have been difficult in adopting probability teaching based on data in high school years. Advanced mathematics courses in undergraduate studies have also been criticized for their instructional methods and the degree to which the required conceptual change regarding the related content is created (CBMS, 2011). These issues highlight the essential role of the instruction of probability. Teachers should enhance students' probabilistic thinking regardless of the context. Therefore, teachers should include both consecutive experiments and probability problems with different contexts in their instruction of conditional probability, rather than continue using similar contexts. Students should adopt logical and numerical reasoning in different contexts, which are used for consecutive events. They should focus on the constructs of probability problems, which help to form conditional probabilistic reasoning, rather than on contextual issues. These suggestions point out adopting a frequentist and problem-solving approach in the context of real data for the instruction of probability (Shaughnessy, 2003).

The current study is limited to the contexts of consecutive experiments and social issues of justice and health. Further studies should be conducted for the comparison of different contexts of probability problems to gain an in-depth understanding of the influence of the context on probabilistic thinking. Moreover, the investigation of how experts use logical and numerical reasoning in different contexts might provide significant insight into the instruction of conditional probability.

References

- Amir, G. S., & Williams, J. S. (1999). Cultural influences on children's probabilistic thinking. *The Journal of Mathematical Behavior*, 18(1), 85–107.
- Chaput, B., Girard, J. C., & Henry, M. (2011). Frequentist approach: Modelling and simulation in statistics and probability teaching. In C. Batanero, G. Burrill, and C. Reading (Eds.), *Teaching statistics in school mathematics-challenges for teaching and teacher education* (pp. 85–95). Dordrecht: Springer.
- Conference Board of the Mathematical Sciences [CBMS] (2001). *The mathematical education of teachers* (Vol. 11). Providence, RI: American Mathematical Society.
- Corter, J. E., & Zahner, D. C. (2007). Use of external visual representations in probability problem solving. *Statistics Education Research Journal*, 6(1), 22–50.
- Diaz, C., & Batanero, C. (2008). *Students' biases in conditional probability reasoning*. Paper presented at ICME 11 (International Congress on Mathematical Education): TSG 13, Monterrey, Mexico.

- Diaz, C., & Batanero, C. (2009). University students' knowledge and biases in conditional probability reasoning. *International Electronic Journal of Mathematics Education*, 4(3), 131–162.
- Fischbein, E., Nello, M. S., & Marino, M. S. (1991). Factors affecting probabilistic judgments in children and adolescents. *Educational Studies in Mathematics*, 22(6), 523–549.
- Greer, B. (2001). Understanding probabilistic thinking: The legacy of Efraim Fischbein. *Educational Studies in Mathematics*, 45(1), 15–33.
- Hogg, R. V., & Tanis, E. A. (1993). *Probability and statistical inference* (4th ed.). New York, NY: Macmillan.
- Jones, G. A., Langrall, C. W., Thornton, C. A., & Mogill, A. T. (1997). A framework for assessing and nurturing young children's thinking in probability. *Educational Studies in Mathematics*, 32(2), 101–125.
- Koehler, J. J. (1996) The base rate fallacy reconsidered: Descriptive, normative, and methodological challenges. *Behavior and Brain Sciences*, 19(1), 1–54.
- Metz, K. E. (1998). Emergent ideas of chance and probability in primary-grade children. In S. P. Lajoie (Ed.), *Reflections on statistics: Learning, teaching, and assessment in grades K-12* (pp. 149–174). New York, NY: Routledge.
- Milli Eğitim Bakanlığı [MEB] (2018). *Orta öğretim matematik dersi (9, 10, 11 ve 12. sınıflar) öğretim programı* [Secondary education (Grades 9-12) mathematics curriculum]. Turkey: MEB. Retrieved from <http://mufredat.meb.gov.tr/ProgramDetay.aspx?PID=343>.
- Olgun, B. & Işıksal, M. (2018, October). *The role of two-way tables in conditional probability problems: The case of prospective teachers*. Paper presented at The European Conference on Educational Research: 24. Mathematics Education Research, Bolzano, Italy.
- Shaughnessy, J. M. (2003). Research on students' understanding of probability. In J. Kilpatrick, W.G. Martin, & D. Schifter (Eds.), *A research companion to principles and standards for school mathematics*, (pp. 216–226). Reston, VA: NCTM.
- Tarr, J. E. & Jones, G. A. (1997). A framework for assessing middle school students' thinking in conditional probability and independence. *Mathematics Education Research Journal*, 9(1), 39–59.
- Tarr, J. E. & Lannin, J. K. (2005). How can teachers build notions of conditional probability and independence? In G. A. Jones (Ed.), *Exploring probability in school: Challenges for teaching and learning*, (pp. 216–238). New York, NY: Springer.
- Tversky, A. & Kahneman, D. (1982). Judgements of and by representativeness. In D. Kahneman, P. Slovic & A. Tversky (Eds.), *Judgment under uncertainty: Heuristics and biases*, (pp. 84–98). New York, NY: Cambridge University Press.
- Watson, J. M. (1995). Conditional probability: Its place in the mathematics curriculum. *The Mathematics Teacher*, 88(1), 12–17.

In-service teachers' design, teaching and reflection on probability tasks

Efi Paparistodemou¹ and Maria Meletiou-Mavrotheris²

¹ Cyprus Pedagogical Institute, Cyprus, e.paparistodemou@cytanet.com.cy

² European University of Cyprus, Cyprus, m.mavrotheris@euc.ac.cy

The development of students' stochastic literacy has become an overarching goal of statistics education internationally. In particular, teachers design lessons with engaging contexts, focus on conceptual understanding (Watson, 2001) and pose critical questions. The present research focuses on the development of early childhood teachers' thinking on designing and teaching probability tasks. Five early childhood in-service teachers participated in this research, which was organized around three stages of teaching: lesson design, classroom implementation and reflection. The study provides some useful insights into the varying levels of attention that teachers paid during their teaching and into the different types of instructional material they used.

Keywords: Statistics education, teacher education, early childhood, tasks, randomness.

Background of the study

Statistics education research suggests that enhancing teachers' subject matter knowledge about uncertainty and statistical inference must be given high priority. Building teachers' knowledge of pedagogical structures and tools by itself is not sufficient. Deep understanding of probability is also needed for identifying student errors and implementing effective teaching practices (e.g., Paparistodemou, Potari, & Pitta, 2006).

Consequently, statistics education researchers have, in recent years, engaged in professional development efforts aimed at facilitating the development of both subject matter knowledge and pedagogical content knowledge of teachers (e.g., Groth, Kent, & Hitch, 2015; Leavy, 2010; Serradó, Meletiou-Mavrotheris, & Paparistodemou, 2014). The importance of introducing probability tasks in the early-mathematics classroom is related to the idea of constructing stochastic knowledge based on children's intuitions. Currently, probability and statistics have an important role to play in everyone's daily life, and particularly in children's lives where most of the games they engage with include the idea of chance. Research on learning stochastics (Paparistodemou & Noss, 2004) has shown that young children use spatial representations for expressing stochastic ideas. Research (Paparistodemou & Noss, 2004; Pratt, 2000) also shows that the design of activities targeting children aged 4-8, is critical for them to be able to express their probabilistic ideas. For analysing the complexity of teaching mathematics, Potari and Jaworski (2002) used the teaching triad (management of learning, mathematical challenge and sensitivity to students) as an analytical device and as a reflective agent for teaching development by teachers. Management of learning describes the teacher's role in the constitution of the classroom-learning environment by the teachers and students, for example planning of tasks and activity. Mathematical challenge describes the challenges offered to students to engender mathematical thinking and activity and sensitivity to students describes the teacher's knowledge of students and attention to their needs. The present research focuses on teachers' planning, teaching and reflection on young children's (4 to 6 years-old) stochastic activities. The work is part of a previous work (Paparistodemou & Meletiou, 2018) and it concentrates on

teachers' attention on the activity in terms of the mathematical challenge it offers and the development of children's stochastic ideas.

Methodology

Participants and context

Five early childhood teachers (all females) participated in this research, which was organized in three stages: Stage 1 – Lesson Planning, Stage 2 – Lesson Implementation, and Stage 3 – Reflection. In Stage 1, the teachers were engaged in lesson planning. They selected a topic from the national mathematics curriculum on probability and statistics and developed a lesson plan and accompanying teaching material aligned with the learning objectives specified in the curriculum. The lesson plans were shared with the researchers for comments and suggestions, and were revised based upon received feedback. In Stage 2, the teachers implemented the lesson plans in their classroom, with the support of the researchers. Once the classroom implementation was completed, in Stage 3, teachers were interviewed and prepared and submitted a reflection paper, in which they shared their observations on students' reactions during the lesson, noting what went well and what difficulties they faced and making suggestions for improvement.

Data collection

Multiple forms of data were collected: (1) Observations and artifacts collected during Stage 1: Early childhood teachers' submitted work (students' entry slips-student's responses on pre-knowledge tasks, lesson plans, etc.), researchers' observations and field notes; (2) Observations and artifacts collected during Stage 2: Each early childhood teacher intervention that took place lasted for 80 minutes (two teaching periods). Researchers were present, observing closely and videotaping the lesson, keeping field notes, and collecting samples of student work; (3) Individual interviews and reflection reports during Stage 3: Upon completion of Stage 2, the researchers conducted semi-structured interviews with each of the teachers. Qualitative data were also obtained from the reflection papers prepared by the teachers.

For the purpose of analysis, we did not use an analytical framework with predetermined categories to assess how teachers' perceptions evolved. Our coding was open and we tried to recognize mathematical challenges (Potari & Jaworsky, 2002). We identified, through careful reviewing of the transcripts, reports, and other data collected during the study, recurring themes or patterns in the data. To increase the reliability of the findings, the activities were analyzed and categorized by the researchers. Inter-rater discrepancies were resolved through discussion.

Designing, teaching and reflecting on probability tasks

Findings, concerning the study research question on what early childhood teachers attend to when designing, implementing and reflecting on probability tasks, will be discussed with regards to one of the three elements of the teaching triad (Potari & Jaworski, 2002): mathematical challenge, which we call here "stochastical challenge". The learning objectives included in all lesson plans refer to stochastic challenges like the probabilistic concepts of certain, impossible and probable events. Moreover, the lesson plans included activities that involved children in authentic statistical inquiry. The activities included in their lesson plans indicated that they tended not to recognize the concept of

randomness, as it appeared difficult for them to see the stochastic idea underlying tasks (the context). In presenting the main insights from our study, we focus to the *existence of randomness*.

The stochastic challenge of making predictions

In Alice’s case, the aim of the lesson plan she designed was for “children to make predictions based on impossible, possible and certain events”. She decided to use the context of children making hats for a party:

Alice: You know, children need an everyday scenario... I decided to ask them to make hats with dots. The dots will be blue and/or red... they [the children] will select a spinner, make a prediction as to whether it would be possible for the hat to have blue dots or not, mark it on their board and then make their hat...

Researcher: So, will they use their spinners?

Alice: If they like to...yes. I know that some students will know beforehand...

The other activities included in Alice’s lesson plan also indicated lack of attention to the concept of randomness. Alice was focusing only on children making decisions on what might have happened and what not. We had a discussion with Alice to find out why she did not ‘allow’ children to spin the spinners. She referred to management issues, but after we pointed out the importance of children experiencing randomness, decided for children to spin their spinners. Figure 1 shows how Alice organized her classroom based on the above task.



Figure 1: Material used in Alice’s task

The stochastic challenge of controlling the uncontrolled

In Sally’s case we recognized an awareness of the concept of randomness. Sally was very specific in her two aims for the lesson, which were the following: “Children should be in a position to select the appropriate sample spaces for certain, impossible and fair events”, and “Children should experience the concept of randomness”. At the beginning of Sally’s lesson, children selected their favorite flavor of ice cream. They had this selection stacked on their chair and were given a “fair” spinner with three flavors. They worked in pairs, with one child spinning the spinner and the other one comparing the flavor that had come up in the spinner with his/her favorite flavor (see Figure 2).



Figure 2: Children playing with spinner in Sally’s task

It was good to see Sally letting the children experience randomness. Another activity she planned and implemented was to show children different spinners, which had different sample spaces (for example, whole brown (as a chocolate flavor), whole red (as a strawberry flavor), whole white (vanilla flavor), $\frac{1}{4}$ brown- $\frac{3}{8}$ red- $\frac{3}{8}$ white etc.). Children were asked questions such as: “Which spinner should you use in order to get your favorite flavor? Why? If I spin this spinner will I get strawberry? Why or why not?”.

Sally’s case is interesting from the point of view that although we recognised from her lesson plan a stochastic challenge awareness, we can see from her teaching that she put a lot of effort in understanding the probability concept and the presence of randomness in her activities. On this point, in her interview she stated:

Researcher: What did you want children to learn?

Sally: Certain, Possible, Different sample spaces... Well, the activity went well. It was not difficult for them... and I think children built a good understanding of the idea of randomness [...] you know, I spent a lot of time to design the lesson... finding the scenario, making the materials... but the “key” was for me to understand... you know... to feel confident that I know... this subject [probability] seems easy but it is not so easy to teach... you need to know.

Researcher: What was it that you needed to know?

Sally: There were many times that in order to continue teaching I had to grasp from their predictions, continue with having the experience and then find a way lets say... giving them [to the children] a chance to “control” this “uncontrolled idea” [randomness]... For example, Dani was sure that he would get brown in a fair spinner... that was not the case... At that point I had to be able to give him an experience of randomness and also help him build his new prediction...

Sally seemed able to recognize some critical incidents in her lessons and to reflect on them. She paid particular attention to the provision of opportunities for children to experience randomness, something that was critical in building on children’s intuitions.

Similarly, Alice reflected on her lesson: “I spent hours trying to find the scenario, making the materials and I felt that everything was ready... In this lesson that was not the case... I had also to be able during my teaching to find ways to help children adjust their predictions, making questions and giving the right spinner...”.

In the above paragraphs we present two cases of the five we observed, as these can be also an example of the other two that are missing. Among the five cases of teachers in our study, there was one teacher who did not recognize at all the importance of randomness in her probabilistic activities. Katie expressed her thoughts as follows: “You know, I feel that the lesson did not go so well mainly because I posed too many closed questions and I didn’t feel confident when I got the ‘wrong’ answer... I didn’t realize the need for children to experience randomness until we talked...”. Katie was aware that a deeper understanding of this important probability concept would have helped her to improve her lesson planning and implementation. Besides that, she also reflected on how she should have given the opportunity for children to experience randomness.

Discussion and conclusions

Teachers in our study recognized that they needed to know not only what randomness is and how to deal with this concept, but also how to make it visible in their lesson. They pointed out that successful introduction of the idea of randomness in the early mathematics classroom requires knowledge of how to build upon children’s prior intuitions regarding random phenomena, as well as how to react during the lesson to students’ predictions regarding stochastic events and to the actual outcomes of such events. Teachers discussed on critical incidents they observed (Goodwell, 2006; Hanuscin, 2013). Critical incidents were crucial for jointing reflection between teachers and researchers on concrete classroom situations (Scherer & Steinbring, 2006).

Most of the teachers’ attention during the planning stages was focused on including knowledge of educational goals, where specific concepts appear. This is what Ball and Bass (2000) spoke about what curriculum knowledge is. This type of knowledge may help teachers appropriately sequence the introduction of statistical ideas in a curriculum (Godino, Ortiz, Roa, & Wilhelmi, 2011). The findings show that it was through actually teaching the lesson and after reflection that the knowledge components/challenges became more evident for these early stage teachers. Similar findings were obtained in a previous study conducted by Papanastasiou et al. (2006), which had investigated prospective teachers’ awareness of young children’s stochastic activities. The fact that similar tendencies were observed in both pre-service and in-service teachers might lead us to conclude that awareness is not only a matter of teaching experience, but also of the extent to which teachers engage with the process of noticing and understanding their teaching. In the case of Sally and Alice, we saw some degree of awareness of important concepts like randomness. At some instances, these two teachers indicated some understanding of randomness and of how it relates to other probabilistic concepts, but this was not always the case. We could say that their awareness remains at the level of action (mathematical) and it does not indicate a greater degree of awareness than that of the awareness in discipline (Mason, 1998).

Summing up, this study adds the term of “stochastic challenge” in Potari’s and Jaworski’s (2002) teaching triad and in addition to previous work of Papanastasiou and Meletiou (2018). Furthermore, it shows the kind of experiences that a small group of early childhood teachers’ incorporated into the design, implementation and evaluation of teaching related to stochastics (for more details see also Papanastasiou & Meletiou, 2018). It can be argued that these teachers did build some relations between theory and teaching practice, but that their transition and reflection to more specific stochastic and pedagogical issues appeared to be a difficult endeavor. This calls upon special attention and reflection on behalf of mathematics teacher educators to tackle this problem.

References

- Ball, D. L., & Bass, H. (2000). Interweaving content and pedagogy in teaching and learning to teach: Knowing and using mathematics. In J. Boaler (Ed.), *Multiple perspectives on the teaching and learning of mathematics* (pp. 83–104). Westport, CT: Ablex.
- Godino, J. D., Ortiz, J. J., Roa, R., & Wilhelmi, M. R. (2011). Models for statistical pedagogical knowledge. In C. Batanero, G. Burrill, & C. Reading (Eds.), *Teaching statistics in school mathematics: Challenges for teaching and teacher education* (pp. 271–282). Dordrecht, The Netherlands: Springer.
- Goodwell, J. (2006). Using critical incident reflections: A self-study as a mathematics teacher educator. *Journal of Mathematics Teachers Education*, 9(3), 221–248.
- Groth, R.E., Kent, K., & Hitch, E. (2015). Journey to centers in the core. *Mathematics Teaching in the Middle School*, 21(5), 295–302.
- Hanuscin, D. L. (2013). Critical incidents in the development of pedagogical content knowledge for teaching the nature of science: A prospective elementary teacher's journey. *Journal of Science Teacher Education*, 24(6), 933–956.
- Leavy, A. M. (2010). The challenge of preparing preservice teachers to teach informal inferential reasoning. *Statistics Education Research Journal*, 9(1), 46–67. Retrieved from [http://iase-web.org/documents/SERJ/SERJ9\(1\)_Leavy.pdf](http://iase-web.org/documents/SERJ/SERJ9(1)_Leavy.pdf)
- Mason, J. (1998). Enabling teachers to be real teachers: necessary levels of awareness and structure of attention. *Journal of Mathematics Teachers Education*, 1(3), 243–267.
- Paparistodemou, E., & Meletiou-Mavrotheris, M. (2018). Teachers' reflection on challenges for teaching probability in the early years. In A. Leavy, M. Meletiou-Mavrotheris, & E. Paparistodemou (Eds.), *Statistics in early childhood and primary education supporting early statistical and probabilistic thinking* (pp. 201–215). Singapore: Springer.
- Paparistodemou, E., & Noss, R. (2004). Designing for local and global meanings of randomness' continuum. In M. Johnsen Høines & A. B. Fuglestad (Eds.), *Proceedings of the Twenty-Eighth Annual Conference of the International Group for the Psychology of Mathematics Education* (Vol. 3, pp. 497–504). Bergen, Norway: PME.
- Paparistodemou, E., Potari, D., & Pitta, D. (2006). Prospective teachers' awareness of young children's stochastic activities. In A. Rossman & B. Chance (Eds.), *Proceedings of the Seventh International Conference on Teaching Statistics*, Salvador, Brazil. International Statistical Institute and International Association for Statistical Education.
- Potari, D., & Jaworski, B. (2002). Tackling complexity in mathematics teaching development: Using the teaching triad as a tool for reflection and analysis. *Journal of Mathematics Teacher Education*, 5(4), 351–380.
- Pratt, D. (2000). Making sense of the total of two dice. *Journal for Research in Mathematics Education*, 31(5), 602–625.

- Scherer, P., & Steinbring, H. (2006). Noticing children's learning processes-Teachers jointly reflect on their own classroom interaction for improving mathematics teaching. *Journal of Mathematics Teachers Education*, 9(2), 157–185.
- Serradó, A., Meletiou-Mavrotheris, M., & Paparistodemou, E. (2014). Early statistics: A course for developing teachers' statistics technological and pedagogical content. *Statistique et Enseignement*, 5(1), 5–29.
- Watson, J. M. (2001). Profiling teachers' competences and confidence to teach particular mathematics topics: The case of chance and data. *Journal of Mathematics Teacher Education*, 4(4), 305–337.

Connecting context, statistics and software for understanding a randomization test: a case study

Susanne Podworny

Paderborn University, Paderborn, Germany; podworny@math.upb.de

Drawing statistical inference with the help of simulations has gained prominence in statistics education as well as introducing statistical inference with randomization tests. This paper describes some selected results of a case study of preservice primary teachers who attended a short learning trajectory on statistical inference with randomization tests. It will be shown how the participants address the context, statistics and software level when conducting a randomization test with software and how the conscious linking of the three levels can support the learning process and help to understand certain elements of a randomization test.

Keywords: Statistical inference, randomization test, simulation.

Introduction

Statistical reasoning is a cornerstone on which statistical practice is based. In almost all areas of daily life, data and thus also conclusions drawn from data play an important role. It is impossible to imagine statistical practice without computer-supported evaluations and methods. In many fields, like in industry, medicine, or politics, decisions are increasingly being made on the basis of data. When looking at a newspaper, a television report or an entry on the World Wide Web, interested citizens increasingly come across the keywords “A study has shown ...” or “The effect of X is Y”. However, it is often suggested that the results and interpretations delivered in this way are by no means certain, as is often suggested in the media.

There are two big areas in inferential statistics: parameter estimation and hypothesis testing and there are two kinds of inferences that may be drawn: generalizations beyond a given sample and causation for a given treatment for a given sample. The latter should be an integral part of stochastic education, as called for in the basic article by Wild and Pfannkuch (1999).

Statistics education should really be telling students something every scientist knows, ‘The quest for causes is the most important game in town.’ It should be saying: ‘Here is how statistics helps you in that quest’. (Wild & Pfannkuch, 1999, p. 238)

One statistical method for drawing causal inferences is the randomization method. About ten years ago, Cobb (2007) strongly advocated introducing the logic of inference via randomization tests. A randomization test is a non-parametric method that allows easy access to inferential reasoning via computer-based simulations. Through simulations, nearly no formulas or calculations are needed, and this is one of the main reasons for the easiness of this method. The “core logic of inference” (Cobb, 2007) can be in the center and conclusions are possible even for data from small or non-random samples.

From this perspective, a learning trajectory on inferential reasoning with randomization tests was developed by the author to be implemented in an existing course on statistics and probability for preservice primary school teachers to complete the general statistics education of these preservice

teachers. Eight weeks after the learning trajectory a case study was conducted with participants who conducted a randomization test for a given problem with computer-based simulations. The objective of this paper is to better understand the reasoning process of these learners. Selected findings of this study will be presented in this paper.

Literature review

Cobb (2007) gave an impetus to rethink the introduction to inference statistics, especially at college level, and to get a new introduction with randomization tests. Some curricula for introductory statistics courses emerged since then (e.g. Rossman, Chance, Cobb, & Holcomb, 2008; Tintle, VanderStoep, & Swanson, 2009; Zieffler & Catalysts for Change, 2013) and some shorter learning trajectories for introducing inferential reasoning were created (e.g. (Budgett, Pfannkuch, Regan, & Wild, 2012; Frischemeier & Biehler, 2014). All these teaching proposals are based on the use of computer-based simulations and focus on the logic of inferential reasoning rather than on calculations. In addition, there are some few empirical studies focusing on special aspects of the process when learners conduct a randomization test.

A common factor of all these learning units is that they use a plan or a scheme to structure the reasoning process. A compilation of elements of these schemes by the author has resulted in nine elements that can be considered central when conducting a randomization test. The first element is the random allocation of experimental units to groups. Explaining this is a core component in understanding the underlying design (Pfannkuch, Budgett, & Arnold, 2015). To find possible explanations for observed differences between two groups of an experiment (Pfannkuch et al., 2015) is the second element. One explanation can be that the treatment is effective, another explanation can be that the observed differences are due to the random allocation of units to the groups. The third element is to pose or reconstruct the research question for the experiment (Wild & Pfannkuch, 1999). Analyzing the observed data and identifying a difference between the two groups is the fourth element (Biehler, Frischemeier, & Podworny, 2015; Rossman et al., 2008). The fifth element is setting up the null model with the null and alternative hypotheses (Biehler et al., 2015). Transferring the null model to a simulation model is the sixth element (Biehler et al., 2015; Lee, Tran, Nickell, & Doerr, 2015). The seventh element is the production of test statistics and the sampling distribution (Lee et al., 2015). The eighth element is to identify the p -value (Biehler et al., 2015; Rossman et al., 2008). And the last element is drawing possible conclusions (Cobb, 2007). Each of these elements has its own difficulties, but one difficulty across all elements is to combine the levels of context, statistics and software.

In our own research (Biehler et al., 2015), we identified three levels when working on a randomization test: the context level, the statistics level, and the software level. Following up on this, Noll and Kirin (2017) conducted a case study with eight learners who created different models in TinkerPlots for the “dolphin therapy problem” (Noll & Kirin, 2017, p. 219) and analyzed what influenced the learners’ reasoning about models. One of their results was, that “Students did not spend much time discussing attribute labels or what type of devices they wanted to use” (Noll & Kirin, 2017, p. 232). This may be an explanation for the reported result that “the concept of no difference between two groups is difficult to operationalize into a TinkerPlots model” (Noll & Kirin, 2017, p. 235). Naming the (simulated) attributes was identified by Noll and Kirin as an important aspect of the modeling process,

because it can act as a bridge between the context and the tool (Noll & Kirin, 2017, p. 236). But they also state, that they “see this work as in its infancy in that we need more research focused on why students create the models” (Noll & Kirin, 2017, p. 240). They also noted that it is not reasonable to separate the three worlds like they interpreted the work of (Biehler et al., 2015). At this connection between context, statistics and software this paper ties in.

The learning trajectory “Inferential reasoning with randomization tests”

A learning trajectory “Inferential reasoning with randomization tests” for preservice primary school teachers was created in the sense of the design based research paradigm (Cobb, Confrey, diSessa, Lehrer, & Schauble, 2003). The aim of the trajectory was to introduce preservice teachers at university to the logic of inference like in the sense of Cobb (2007) in a short period of time. Some design ideas were adapted from Pfannkuch et al. (2015), who successfully introduced inferential reasoning in a short learning sequence to a similar target group. The learning trajectory was designed for the end of an existing course on elementary statistics at Paderborn University. The existing course consisted of three modules data analysis, combinatorics, and probability and used the software TinkerPlots from the beginning. The new learning trajectory was designed for three 90 minutes sessions.

In the first session the students should get in touch with a first example of a randomization test with a significant p -value (Rossman et al., 2008) and with the logic of inferential reasoning as a continuation of group comparisons (Makar & Confrey, 2002), which were already discussed in the data analysis module. The second session focused on the performance of a randomization test by the students. First, a hands on simulation with pen and paper was to be carried out and then transferred to a computer-based simulation, like proposed for example by Gould, Davis, Patel, and Esfandiari (2010). In the third session, the nine elements (see literature review) were to be discussed in detail and possible difficulties addressed.

To get insights into the cognitive processes of students conducting a randomization test with TinkerPlots, an interview study was designed as part of the Ph.D. study of the author.

Methodology

The research question for the case study – that is focused on in this paper – is *How do the participants relate the three levels context, statistics and software to each other?*

The problem given to students was an adaption of the “Fish oil and blood pressure task” of Pfannkuch et al. (2015). This task contains real data from a medical experiment with 14 volunteers on the question of whether fish oil supplements have a blood pressure-lowering effect compared to normal oil supplements. The blood pressure of the participants was measured at the beginning and after four weeks and the blood pressure reductions for the two groups were recorded like in Table 1.

Fish oil group	8	12	10	14	2	0	0
“normal oil” group	-6	0	1	2	-3	-4	2

Table 1: Data on blood pressure reduction after four weeks

The observed data was visualized on the worksheet for the students like in Figure 1 and accompanied by the statement and the question “The observed data are shown in Figure 1 and show that the blood

pressure reduction in the fish oil group tends to be greater than those in the ‘normal oil’ group”. What can be concluded here?”

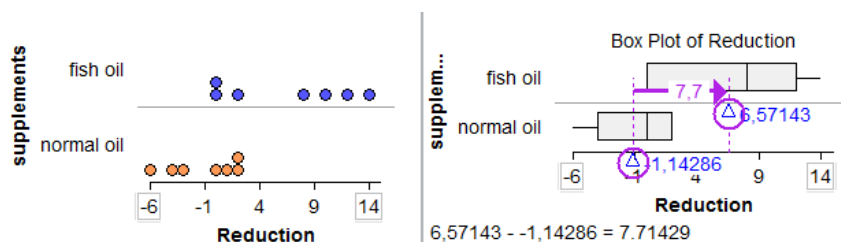


Figure 1: Visualized data on the participants' worksheet

The interview study took place as a semi structured interview (Mayring, 2016) with a large part of the participants working independently on the task. Questions of the participants were allowed in this phase, and some help could be given by the interviewer. This part was followed by interview questions relating to the individual steps and arguments of the working phase.

A total of six participants working in three pairs took part in the interview study. All of them attended the whole course and the learning trajectory, so this was their educational background. Participation in the study was voluntary, so participants cannot be considered representative of the 236 participants in the whole course. The participants' age ranged between 21 and 25 years, being in the third/fourth semester of University. The interviews took place eight weeks after the course and none of the participants used TinkerPlots in between. The conversations were recorded together with the screen activities and then transferred into a transcript. This transcript included the conversations as well as the other activities, with and without software.

The analysis of the transcripts was carried out by means of interaction analysis (Krummheuer & Naujok, 1999). First, the transcripts were divided into 15 interaction units using methods of linguistic conversation analysis (Egbert & Deppermann, 2012). The next step was to reconstruct the solution process interpretatively with interaction analysis. A detailed turn-by-turn analysis took place here and was discussed with other interpreters. For each of the nine elements (see literature review), the level (context, statistics, software) at which the participants communicated was examined. As a third step, the use of the software in the solution process was examined in detail. Summary and comparative analyses between the pairs formed the fourth step.

Results

The levels at which the participants communicate regarding the nine elements are described below. Table 2 shows which level the participants address linguistically when they talk about and work on the various elements.

Element	Context	Statistics	Software
Random allocation	Rebecca & Selina Fabia & Laura Mandy & Alisa	Rebecca & Selina Fabia & Laura Mandy & Alisa	- - -
Possible explanation	Rebecca & Selina Fabia & Laura Mandy & Alisa	Rebecca & Selina Fabia & Laura Mandy & Alisa	- - -
Research question	Rebecca & Selina	-	-

	Fabia & Laura Mandy & Alisa	- -	- -
Observed data	Rebecca & Selina Fabia & Laura Mandy & Alisa	Rebecca & Selina Fabia & Laura Mandy & Alisa	- - -
Null model	Rebecca & Selina Fabia & Laura Mandy & Alisa	Rebecca & Selina Fabia & Laura Mandy & Alisa	- - -
Simulation model	Rebecca & Selina Fabia & Laura Mandy & Alisa	Rebecca & Selina Fabia & Laura Mandy & Alisa	Rebecca & Selina Fabia & Laura Mandy & Alisa
Test statistics and sampling distribution	- - -	Rebecca & Selina Fabia & Laura Mandy & Alisa	Rebecca & Selina Fabia & Laura Mandy & Alisa
P-value	- - -	Rebecca & Selina Fabia & Laura Mandy & Alisa	Rebecca & Selina Fabia & Laura Mandy & Alisa
Conclusions	- - Mandy & Alisa	Rebecca & Selina Fabia & Laura Mandy & Alisa	- - -

Table 2: Overview of the levels at which the pairs communicate during the randomization test process

Table 2 shows a clear pattern. The first two elements are addressed by all three pairs both at the context level and at the statistics level. These are related to the observed data and no reference to the software is necessary. The research question is formulated by the participants at the contextual level. The corresponding interaction units are very short, because this element is obviously clear for all participants. Like the first two elements, the observed data are discussed at the contextual and at the statistical level. As the data had already been evaluated on the worksheet, there was no need to work with the software and therefore no need to talk about it.

The null model element includes the formulation of the null hypothesis and the alternative hypothesis. Communication takes place both at the context level and at the statistics level. However, the null hypothesis formulated by Rebecca and Selina reveals only a small contextual reference. These two formulate “Random group allocation is the cause of observed differences”. Such a formulation is almost arbitrarily applicable to different situations, since a reference to the direct context is not recognizable. The formulation of the other pairs for the null hypothesis are “There is no difference in blood pressure reduction in the effect between both supplements” (Fabia and Laura) and “It does not matter which oil is taken to lower the blood pressure but the results are due to the random allocation” (Mandy and Alisa). Both show a clear connection to the context. Perhaps this explains why Rebecca and Selina do not end up drawing conclusions in context. However, Fabia and Laura do not draw these either, although their null hypothesis is clearly related to the context.

The only element that is addressed by all three pairs on all three levels is the development of the simulation model in TinkerPlots. For this element, all three pairs needed additional help from the interviewer on a technical level, for example how to copy all the observed values into a box of the sampler. The same need of help could be observed for the next two elements for which TinkerPlots had to be used. But, unlike in our earlier research (Biehler et al., 2015), renaming the attributes of the

sampler and of the new groups for the new allocation was a topic for all three pairs. An interesting dialogue for this came about between Rebecca and Selina. This shows that the concept of random allocation developed linguistically by linking the three levels (that was identified as a difficulty by Noll & Kirin (2017)). The sampler built by Rebecca (R) and Selina (S) so far is shown in Figure 2. This sampler is built correctly with all observed blood pressure values in the first box and independently these will be drawn in one of two new groups. TinkerPlots labelled the two stacks in the second device in “a” and “b” automatically.



Figure 2: Sampler created by Rebecca and Selina

Selina first renames the first stack in “fish” like in Figure 2, but then retains the letters a and b and the following dialogue arises.

- R: Do we have to call them that, because we actually divide them up in such a way that we can do it later, for example/. So I'm not quite sure, but it could be that we/.
- S: /That's right, we don't really need it.
- R: /put a fish oil person with a normal oil person/.
- S: /You're right/.
- R: /Together. I think a and b is actually quite neutral.
- S: You can actually take a and b, because then that's more. We want to prove now that it has nothing to do with the oil anymore.
- R: Yes, exactly we will say it/.
- S: /So you have to/
- R: We are representatives of the null hypothesis.
- S: Exactly, because then in the one group possibly always both come, a person with fish oil and one with normal oil. It is now only about lowering blood pressure.
- R: Yes, that's exactly what it can be/.
- S: /Yes.
- R: That you have maybe five of them (*points to the fish oil group in the plot in TinkerPlots*) and then (.) the rest of them (*points to the “normal oil” group in the plot*). Well, it can be that way/.
- S: /You're right. (*laughs*) Well, I would spontaneously agree with you. (*laughs*)

In the end, Rebecca and Selina decide not to rename the new groups.

For the next two elements, sampling distribution and *p*-value, none of the three pairs have a conversation at context level. They operate only on the software level and on the statistics level.

Conclusions are correctly formulated at the statistical level by all three pairs, which is a good result for the whole process. The written formulations are as follows:

- Rebecca & Selina: Research hypothesis can be accepted and null hypothesis can be rejected, but with slight uncertainty

- Fabia & Laura: We reject the null hypothesis and accept the research hypothesis at a P-value of 1%.
- Mandy & Alisa: The null hypothesis can be rejected. Blood pressure reduction depends on the type of oil.

However, only Mandy and Alisa apply their conclusion to the treatment carried out. A deeper look at the transcripts shows that the greatest difficulties are with the last element formulating contextual conclusions, and that a statistical formulation seems to be the easiest for the participants.

Discussion

Like Noll and Kirin (2017), who did not find a separation of the three levels context, statistics, and software to be beneficial, connecting the three levels seems to be extremely useful in the present work. Only when the levels are differentiated a conscious connection between them can take place and thus promote the learning process. An example for a helpful connection can be seen in the selected dialogue between Rebecca and Selina, in which they clarify the meaning of random assignment and its implementation in the software.

For the process of understanding it can be concluded that the dialogue between Rebecca and Selina is one of the most important parts of the conversation, because here the two make it clear that during the simulation (level of software) a random reallocation (level of statistics) of the persons with the blood pressure values (level of context) happens independently (level of statistics) of the oil consumed (level of context). Such discussion would have been desirable for further settings at the software level, as it would enhance understanding by linking the three levels. Unfortunately, very few such dialogues have taken place throughout the case studies. Even though the data are taken from a real scientific experiment, the participants seem to have been given too little opportunity to deal with the context in detail. This would be a better prerequisite for a deeper interpretation of the context.

However, the context caused a confrontation with the data, as reported by González (2015), in order to promote understanding of the need of decision-making in situations with uncertainty. The demands of Cobb (2007) were implemented here in a learning trajectory and the learners were successfully introduced to statistical inference.

References

- Biehler, R., Frischemeier, D., & Podworny, S. (2015). Preservice teachers' reasoning about uncertainty in the context of randomization tests. In A. Zieffler & E. Fry (Eds.), *Reasoning about uncertainty: Learning and teaching informal inferential reasoning*. Minneapolis, Minnesota: Catalyst Press.
- Budgett, S., Pfannkuch, M., Regan, M., & Wild, C. (2012). *Dynamic visualizations for inference*. Paper presented at the The International Association for Statistical Education Roundtable Conference: Technology in statistics education: Virtualities and Realities, Cebu City, The Philippines.
- Cobb, G. (2007). The Introductory Statistics Course: A Ptolemaic Curriculum? *Technology Innovations in Statistics Education*, 1(1), 1–15. doi:<https://escholarship.org/uc/item/6hb3k0nz>
- Cobb, P., Confrey, J., diSessa, A., Lehrer, R., & Schauble, L. (2003). Design Experiments in Educational Research. *Educational Researcher*, 32(1), 9–13.

- Egbert, M., & Deppermann, A. (2012). Introduction to conversation analysis with examples from audiology. In M. Egbert & A. Deppermann (Eds.), *Hearing aids communication. Integrating social interaction, audiology and user centered design to improve communication with hearing loss and hearing technologies* (pp. 40–47). Mannheim: Verlag für Gesprächsforschung.
- Frischemeier, D., & Biehler, R. (2014). Design and exploratory evaluation of a learning trajectory leading to do randomization tests facilitated by TinkerPlots. *Proceedings of the Eighth Congress of the European Society for Research in Mathematics Education*, 799–809.
- González, O. (2015). Mathematics teachers' conceptions of how to promote decision-making while teaching statistics: The case of Japanese secondary school teachers. In K. Krainer & N. Vondrová (Eds.), *Proceedings of the Ninth Congress of the European Society for Research in Mathematics Education (Cerme9, 4-8 February 2015)* (pp. 665–671). Prague, Czech Republic: Charles University in Prague, Faculty of Education and ERME.
- Gould, R., Davis, G., Patel, R., & Esfandiari, M. (2010). *Enhancing conceptual understanding with data driven labs*. Paper presented at the The Eighth International Conference on Teaching Statistics, Ljubljana, Slovenia.
- Krummheuer, G., & Naujok, N. (1999). *Grundlagen und Beispiele Interpretativer Unterrichtsforschung*. Opladen: Leske+Budrich.
- Lee, H., Tran, D., Nickell, J., & Doerr, H. (2015). Simulation approaches for informal inference: Models to develop understanding. In K. Krainer & N. Vondrová (Eds.), *Proceedings of the Ninth Congress of European Society for Research in Mathematics Education (Cerme9, 4-8 February 2015)* (pp. 707–713). Prague, Czech Republic: Charles University in Prague, Faculty of Education and ERME.
- Makar, K., & Confrey, J. (2002). *Comparing Two Distributions: Investigating Secondary Teachers' Statistical Thinking*. Paper presented at the Sixth International Conference on Teaching Statistics, Cape Town, South Africa.
- Mayring, P. (2016). *Einführung in die qualitative Sozialforschung: eine Anleitung zu qualitativem Denken* (6., überarbeitete ed.). Weinheim: Beltz.
- Noll, J., & Kirin, D. (2017). TinkerPlots model construction approaches for comparing two groups: Student perspectives. *Statistics Education Research Journal*, 16(2), 213–243.
- Pfannkuch, M., Budgett, S., & Arnold, P. (2015). Experiment-to-causation inference: Understanding causality in a probabilistic setting. In A. Zieffler & E. Fry (Eds.), *Reasoning about uncertainty: Learning and teaching informal inferential reasoning* (pp. 95–128). Minneapolis, Minnesota: Catalyst Press.
- Rossman, A., Chance, B., Cobb, G., & Holcomb, R. (2008). *Concepts of statistical inference: Approach, scope, sequence and format for an elementary permutation-based first course*. Retrieved from <http://statweb.calpoly.edu/bchance/csi/CSICurriculumMay08.doc>
- Tintle, N., VanderStoep, J., & Swanson, T. (2009). *An active approach to statistical inference, preliminary edition*. Holland, Michigan: Hope College Publishing.
- Wild, C., & Pfannkuch, M. (1999). Statistical Thinking in Empirical Enquiry. *International Statistical Review*, 67(3), 223-265.
- Zieffler, A., & Catalysts for Change. (2013). *Statistical Thinking. A simulation approach to modeling uncertainty* (3. edition ed.). Minneapolis, Minnesota: Catalyst Press.

Measuring probabilistic reasoning: the development of a brief version of the *Probabilistic Reasoning Scale (PRS-B)*

Caterina Primi¹, Maria Anna Donati¹, Sara Massino¹,

Elisa Borace¹ Edoardo Franchi¹ and Kinga Morsanyi²

¹NEUROFARBA – Section of Psychology, University of Florence, Florence, Italy; primi@unifi.it

²School of Psychology, Queen's University Belfast, Belfast, UK

The assessment of probabilistic reasoning skills is important in various contexts. The aim of this study was to develop an abbreviated, open-ended version of the Probabilistic Reasoning Scale (PRS-B), applying Item Response Theory (IRT). The analyses based on the open-ended version of the 16-item scale suggested the exclusion of seven items that did not perform well in measuring the latent trait. The resulting 9-item scale (PRS-B), which included highly discriminative items, covered a wider range of the measured trait than the original scale and it showed high measurement precision. Concerning validity, the results showed the expected correlations with numerical skills, math anxiety, and statistics achievement. In conclusion, the PRS-B can be considered a shorter, open-ended version of the PRS that maintains excellent reliability and validity.

Keywords: Assessment, item response theory, short form, probabilistic reasoning, validity.

Introduction

The ability to think about uncertain outcomes and to make decisions on the basis of probabilistic information is relevant in many fields (e.g., business, medicine, politics, law, and psychology). However, people often struggle with interpreting probability information (see Chernoff & Sriraman, 2014). In particular, when they solve probability problems, people tend to make some typical mistakes instead of applying formal analytic procedures (see e.g., Gilovich, Griffin, & Kahneman, 2002). These mistakes, including heuristics, biases and misconceptions, make it difficult for people to interpret and critically evaluate probabilistic information, understand data-related arguments, and make reasoned judgments and decisions (e.g. Garfield & del Mas, 2010, Morsanyi et al., 2009; Pratt & Kazak, 2017).

Regarding education in probabilistic reasoning, previous studies demonstrated the difficulty of improving probabilistic reasoning ability or, rather, a resistance to eliminate probabilistic reasoning biases once these had consolidated (for a summary of the literature, see e.g., Gilovich et al., 2002; for adolescents, see Klaczynski, 2004). Nevertheless, training activities that target specific difficulties can reduce some misconceptions (e.g. Fong & Nisbett, 1991). Additionally, in statistic courses, which have been incorporated into a wide range of school and university programs in many countries, students often encounter difficulties and, eventually, many of them fail to pass the exams. Some authors (Konold & Kazak, 2008) pointed out that one of the reasons students have difficulties in learning basic data analysis stem from a lack of basic understanding of probability and in grasping the fundamental ideas of probability.

Given the important role of probabilistic reasoning skills in various contexts, it is important to accurately measure probabilistic reasoning skills, in order to improve these skills. This, in turn, can

lead to other beneficial outcomes, such as better academic achievement. For this reason, recently we developed a new scale, the *Probabilistic Reasoning Scale* – PRS (Primi, Morsanyi, Donati, Galli, & Chiesi, 2017) to measure probabilistic reasoning ability, which can be used to identify people with difficulties in this domain. The PRS was developed with a focus on some typical biases and fallacies that are known to lead to incorrect responses. Indeed, the PRS is a useful tool in educational contexts to identify individuals who could be targeted by specific interventions.

However, the scale has the limitation that the items measure probabilistic reasoning skills most precisely in the lower ability ranges and it is not ideal for the measurement of ability levels around the mean. Additionally, the scale is composed of 16 items and it does not seem appropriate for large, multivariate studies in which many tests and scales need to be administered at the same time. Indeed, with research questions becoming increasingly complex, and involving a growing number of constructs, such as when investigating the role of probabilistic reasoning in decision making (e.g., Schiebener & Brand, 2015) or in risk taking (Donati, Primi, & Chiesi, 2014), shorter scales potentially offer added value.

In sum, the aim of this study was to develop an abbreviated, open-ended version of the PRS. To achieve this goal, we used Item Response Theory (IRT) analyses, which make it possible to select items that offer the most information in measuring the targeted underlying trait, that is, probabilistic reasoning. Specifically, IRT has potential benefits in shortening a scale because it makes it possible to evaluate the amount of information provided by each item of the scale for each trait level on the trait dimension through the Item Information Function (IIF). In other words, if the amount of information is large, the trait level can be estimated with high precision, if the amount of information is small, the trait cannot be accurately estimated. Thus, on the basis of item information, it is possible to select items that convey the higher amount of information along the entire range of the measured trait. Through the selection of items that perform better and assure adequate information along the different levels of the trait, a well-performing shortened scale can be obtained.

Additionally, IRT provides the Test Information Function (TIF), which evaluates the precision of the test at different levels of the measured construct instead of providing a single value (e.g., Cronbach's α) for reliability (Embretson & Reise, 2000). More precisely, the TIF provides information on how accurate the test is at estimating a trait along the whole range of trait scores. The more information the test provides at a particular trait level, the smaller the error associated with ability estimation, and the higher the local reliability. Since the TIF is generated by aggregating the IIFs, in general, longer tests will measure an examinee's attribute with greater precision than shorter tests. Nonetheless, in the IRT framework, item selection can be done ensuring that the TIF of the shortened scale maintains an adequate amount of information along the trait continuum, which is similar to the original scale.

Finally, given that a short form of a test should meet the same standards of validity as the full form (Smith, McCarthy, & Anderson, 2000), validity measures were administered to provide evidence that the abbreviated scale still measures probabilistic reasoning adequately. Thus, we expected to replicate the pattern of relationships established for the construct as measured by the long form of the test. In particular, we investigated the relationship between the PRS-B, numerical skills, anxiety and self-confidence related to numbers, and statistics achievement.

Methods

Participants

The participants in this study were 316 psychology students (mean age = 20.53; SD = 2.9; 76% female) enrolled in an undergraduate introductory statistics course at the University of Florence in Italy. All students participated on a voluntary basis.

Materials

The original Probabilistic Reasoning Scale (PRS, Primi et al., 2017) consists of 16 multiple-choice questions. In this study, the scale was administered in an open-ended format, which required some minor changes in the wording of the items. The items include questions about simple, conditional and conjunct probabilities, and the numerical data are presented in frequencies or percentages (e.g., “A ball was drawn from a bag containing 10 red, 30 white, 20 blue, and 15 yellow balls. What is the probability that it is neither red nor blue?”).

The Mathematics Prerequisites for Psychometrics (MPP; Galli, Chiesi, & Primi, 2011) was developed with the aim of measuring the mathematics skills needed by students enrolling in introductory statistics courses. The test consists of 30 problems, and it has a multiple choice format (one correct out of four alternatives). A single composite score, based on the sum of correct responses, was calculated. In the present sample, Cronbach’s α was .74. We used this measure as an estimate of students’ math knowledge.

The *Abbreviated Math Anxiety Scale* (AMAS; Hopko, Mahadevan, Bare, & Hunt, 2003; Italian version: Primi, Busdraghi, Tomasetto, Morsanyi, & Chiesi, 2014) measures math anxiety experienced by students in learning and test situations. Participants have to respond on the basis of how anxious they would feel during the events specified (for example, “Listening to another student explain a math formula”). High scores on the scale indicate high math anxiety. A single composite score was obtained, based on participants’ ratings of each statement. In the present sample, Cronbach’s α was .84.

The *Subjective Numeracy Scale* (Fagerlin et al., 2007) is a subjective measure (i.e., self-assessment) of quantitative ability. An example item is “How good are you at working with fractions?” The items have to be rated on a 6-point Likert scale. A single composite score was computed based on participants’ ratings of each item. Coefficient α in the current sample was .78.

Measure of statistics achievement. As a measure of achievement, we used the final examination grade. The exam consisted of a written task that included three problems to be solved by a paper-and-pencil procedure without the support of a statistics computer package, 5 multiple-choice and 2 open-ended questions (e.g., describe the properties of a normal distribution) and 1 output of data analyses conducted with *R-Commander* to interpret. For the problems, students were given a data matrix (3-4 variables, 10-12 cases) and they had to compute descriptive indices, draw graphs, and choose and apply appropriate statistical tests (identifying the null and the alternative hypotheses, finding the critical value, calculating the value of the test, and making a decision regarding statistical significance). Grades range from 0-30. From 0 to 17 the grade is considered insufficient based on the

Italian University Grading System. Thus, only students who obtain 18 or higher grades pass the examination.

Procedure

Participants completed the measures individually in a self-administered format in the classroom. Each task was briefly introduced, and instructions for completion were given. The answers were collected in a paper-and-pencil format. All participants completed the scale during the first week of an introductory statistics course. *Achievement* in statistics was measured at the end of the course during the exam session.

Data Analysis

Preliminarily, we tested the unidimensionality of the PRS evaluating local dependence (LD). LD is an excess of covariation among item responses that is not accounted for by a unidimensional IRT model and it was assessed using the χ^2 LD statistic (Chen & Tiessen, 1997), computed by comparing the observed and the expected frequencies in each of the two-way cross tabulations between responses to each pair of items. This diagnostic statistic is approximately distributed as standardized χ^2 . Given this approximation, as a rule of thumb, values of 10 or greater indicate the presence of LD.

After having verified this assumption, unidimensional IRT analyses were performed. IRT models use the original response data for estimating probabilities of responses as a function of the latent trait θ (i.e., in the current study, probabilistic reasoning), which is defined as a continuous variable that conventionally has a mean of zero and *SD* of 1.0. This function describes the relation between the probability of endorsing a response given not only the respondent's level of θ but also the item's characteristics. A model with two parameters (2PL) was tested in order to estimate the item difficulty and discrimination parameters. The parameters were estimated by employing the marginal maximum likelihood estimation method with the Expectation-Maximization (EM) algorithm implemented in the IRTPRO software (Cai, Thissen, & du Toit, 2011). In the 2PL model, the two item parameters are item difficulty and item discrimination. The item difficulty parameter (β) or "location" represents the latent trait level corresponding to a .50 probability of correctly endorsing the item. The item discrimination parameter (a) or "slope" represents the item's ability to differentiate between people at contiguous levels of the latent trait. This parameter describes how rapidly the probabilities change with trait levels. In order to test the adequacy of the model, the fit of each item under the 2PL model was tested computing the $S\chi^2$ statistics. Additionally, for each item was calculated the IIF, graphically represented by the Item Information Curve (IIC), that describes the amount of information that a particular item provides across the entire continuum of the latent construct, and it depends on both the discrimination and location parameters. Thus, we used IIFs to select the items that conveyed the higher amount of information along the range of the trait measured by the PRS, looking at the area above the IICs, which equals both the size of the a parameters and the spread of the b parameters. Once the shortened scale was defined, all the above described analyses were repeated for the brief scale in order to confirm the item and test psychometric properties. In particular, we investigated the reliability of the shortened scale. IRT makes it possible to assess the measurement precision of the test through the TIF. TIF is generated by aggregating the IIFs of items in a single measure and it allows to compute the information (I), that is, the expected value of the inverse of the standard error (SE),

provided by the test at each level of the trait. Thus, the more information the test provides at a particular trait level, the smaller the error associated with trait estimation and the higher the test's reliability. Graphically, the TIF shows how well the construct is measured at different levels of the underlying construct continuum, and the peak of the TIF is where measurement precision is greatest. Regarding validity, Pearson product-moment correlations were computed.

Results

Preliminarily, we tested the unidimensionality of the probabilistic reasoning construct, a fundamental criterion underlying IRT models, evaluating the presence of LD. The results confirmed that a single factor model adequately represented the structure of the scale, as none of the LD statistics were greater than 10. Additionally, the factor loadings ranged from .54 to .80. Each item had a non-significant $S-\chi^2$ value, indicating that all items fit under the 2PL model. Concerning the difficulty parameters (b), the results showed that the parameters ranged across the continuum of the latent trait from $-2.68 \pm .53$ to $.49 \pm .12$ logits (i.e., the logarithm of the odd, that is, the ratio of the probability of producing a correct response and the probability of responding incorrectly). Compared to the difficulty of the original scale ($-2.97 \pm .5$ to $-.07 \pm .08$ logits), results showed that the parameters spanned a wider range of the latent trait. With regard to the discrimination parameters (a), following Baker's (2001) criteria, all items showed adequate discrimination levels (a values over .60). Having verified the preliminary assumptions for IRT modelling, we looked at the IICs to select the items that conveyed the higher amount of information along the range of the trait measured by the open-ended PRS (see Figure 1). The figure clearly shows that items 1, 2, 3, 5, 13, 15 and 16 provide lower amount of information.

Consequently, we retained nine items and we repeated the analyses for this shortened version of the PRS scale with an open-ended format. None of the LD statistics were greater than 10, indicating the absence of LD. All factor loadings were significant, ranging from .49 to .83. Each item had a non-significant $S-\chi^2$ value, indicating that all items fit under the 2PL model. Concerning the difficulty parameters (b), the results showed that the parameters ranged from $-1.57 (\pm .29)$ to $.46 (\pm .11)$ logits across the continuum of the latent trait. With regard to the discrimination parameters (a), all items were above .60, indicating adequate discriminative power. Thus, still concerning item difficulty, the shortened version showed that the items had a low-medium level of difficulty. Nonetheless, the discriminative measures showed that the items could discriminate individuals with different trait levels.

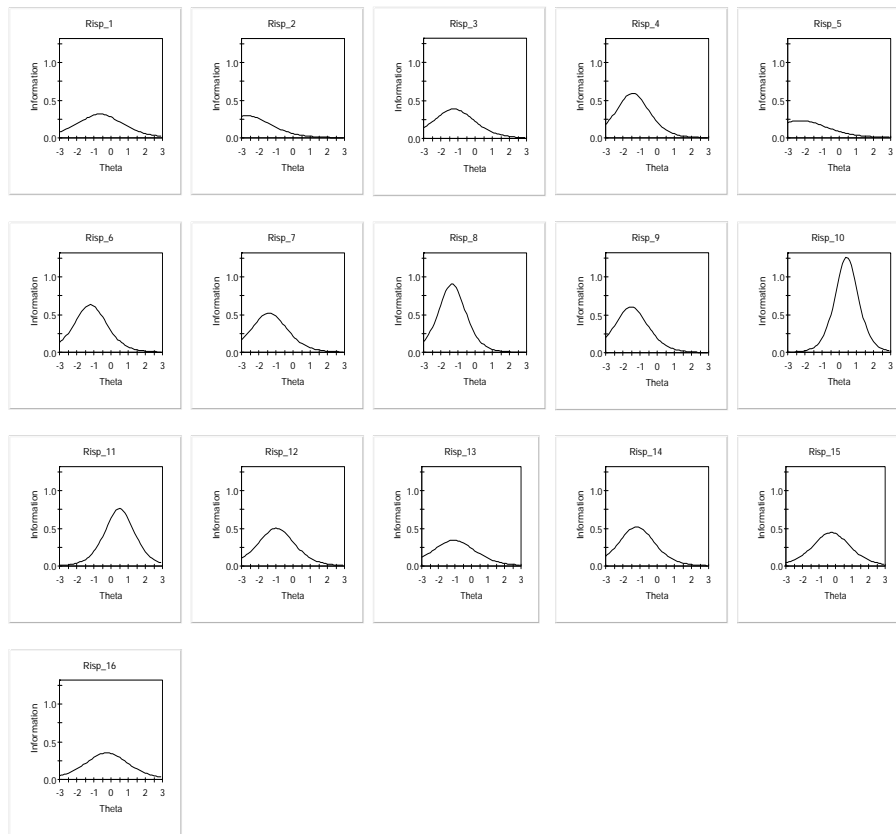


Figure 1: Item information curve (IIC) of the original 16-item PRS open format. Latent trait (theta) is shown on the horizontal axis and the amount of information and the SE yielded by the test at each trait level is shown on the vertical axis

Next, we investigated the TIF that provides test reliability estimations indicating the precision of the whole test for each level of the latent trait. As shown in Figure 2, from 2 standard deviations below the mean to 0.5 above the mean (fixed at 0), the amount of test information was equal to or greater than 4 indicating that the instrument was sufficiently informative for this range of the trait. Thus, compared to the original scale that adequately measured low levels of probabilistic reasoning ability, the PRS-B accurately measures a wider range of the underlying trait.

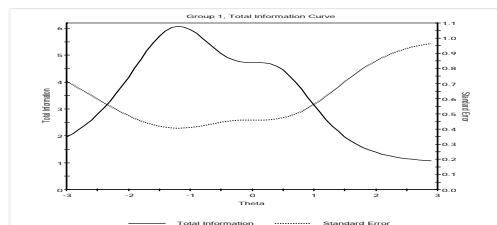


Figure 2: Test information function of the Probabilistic Reasoning Scale-Brief

Finally, we looked at the validity of the scale. Table 1 presents descriptive statistics for all measures in the study, and the relations between the PRS-B, and all other variables. As expected, in line with the original scale, the PRS-B was significantly and positively correlated with mathematics skills and subjective numeracy, and negatively with mathematics anxiety. Concerning the relationship between PRS-B and statistics achievement, we found a significant positive correlation.

	1	2	3	4	5
1. PRS-B	--				
2. PMP	.53***	--			
3. AMAS	-.19*	-.37***	--		
4. SN	.45***	.56***	-.42***	--	
5. STATISTICS ACHIEVEMENT	.28**	.18*	-.15*	.09	--
M (SD)	5.99 (2.25)	22.38 (3.69)	23.39 (5.76)	32.14(6.70)	22.63 (3.49)

* $p < .05$; ** $p < .01$; *** $p < .001$

Table 1: Descriptive statistics for the measures, and correlations between the PRQ-B and MPP, AMAS, SN, and statistics achievement

To ascertain the predictive value of probabilistic reasoning as measured by the PRS-B, we tested a regression model in which the PRS-B was entered as a predictor of statistics achievement along with math competence (MPP), math anxiety (AMAS), and subjective numeracy (SN). The results showed that when all predictors were entered in the regression analysis together ($F(4,133)=3.29$, $p=.013$; $R=.30$; $R^2=.09$), the PRS-B was a significant predictor of statistics exam performance ($\beta =.26$; $p=.009$), whereas the MPP, SN, and AMAS did not significantly predict statistics achievement.

Conclusion

In this study, we presented the PRS-B scale to assess probabilistic reasoning skills. Applying IRT, we obtained a shorter version of the original PRS, where all remaining items had good discriminative power and they measured a large spectrum of the trait which covered a wider range than the original scale. Additionally, the PRS-B accurately measures average levels of probabilistic reasoning ability, and it is helpful in identifying individuals who have difficulties in this domain. Finally, the validity results confirm that the shortened form replicates the pattern of relationships established for the construct as measured by the long form, with positive relations with mathematics and statistics skills and subjective confidence, and a negative relationship with mathematics anxiety. In conclusion, the PRS-B could be a useful tool in educational contexts, as well as in research.

References

- Cai, L., Du Toit, S. H. C., & Thissen, D. (2011). IRTPRO: Flexible, multidimensional, multiple categorical IRT modeling [Computer software]. *Chicago, IL: Scientific Software International.*
- Chen, W. H., & Tiessen, D., (1997). Local dependence indices for items pairs using item response theory. *Journal of Educational and Behavioral Statistics*, 22, 265–289. doi: 10.2307/1165285
- Chernoff, E. J., & Sriraman, B. (2014). Commentary on Probabilistic Thinking: Presenting Plural Perspectives. In *Probabilistic Thinking* (pp. 721–727). Springer, Dordrecht.

- Donati, M. A., Primi, C., & Chiesi, F. (2014). Prevention of problematic gambling behavior among adolescents: Testing the efficacy of an integrative intervention. *Journal of Gambling Studies*, 30(4), 803-818.
- Fagerlin, A., Zikmund-Fisher, B. J., Ubel, P. A., Jankovic, A., Derry, H. A., & Smith, D. M. (2007). Measuring numeracy without a math test: development of the Subjective Numeracy Scale. *Medical Decision Making*, 27(5), 672–680.
- Fong, G. T., & Nisbett, R. E. (1991). Immediate and delayed transfer of training effects in statistical reasoning. *Journal of Experimental Psychology: General*, 120(1), 34.
- Galli, S., Chiesi, F., & Primi, C. (2011). Measuring mathematical ability needed for “non-mathematical” majors: the construction of a scale applying IRT and differential item functioning across educational contexts. *Learning and Individual Differences*, 21(4), 392–402.
- Garfield, J., & DelMas, R. (2010). A web site that provides resources for assessing students' statistical literacy, reasoning and thinking. *Teaching Statistics*, 32(1), 2–7.
- Gilovich, T., Griffin, D., & Kahneman, D. (Eds.). (2002). *Heuristics and biases: The psychology of intuitive judgment*. Cambridge university press.
- Hopko, D. R., Mahadevan, R., Bare, R. L., & Hunt, M. K. (2003). The abbreviated math anxiety scale (AMAS) construction, validity, and reliability. *Assessment*, 10(2), 178–182.
- Klaczynski, P. A. (2004). A dual-process model of adolescent development: Implications for decision making, reasoning, and identity. *Advances in child development and behaviour*, 32, 73–125.
- Konold, C., & Kazak, S. (2008). Reconnecting data and chance. *Technology Innovations in Statistics Education*, 2(1).
- Morsanyi, K., Primi, C., Chiesi, F., & Handley, S. (2009). The effects and side-effects of statistics education: Psychology students' (mis-) conceptions of probability. *Contemporary Educational Psychology*, 34(3), 210–220.
- Primi, C., Busdraghi, C., Tomasetto, C., Morsanyi, K., & Chiesi, F. (2014). Measuring math anxiety in Italian college and high school students: validity, reliability and gender invariance of the Abbreviated Math Anxiety Scale (AMAS). *Learning and Individual Differences*, 34, 51–56.
- Primi, C., Morsanyi, K., Donati, M. A., Galli, S., & Chiesi, F. (2017). Measuring probabilistic reasoning: The construction of a new scale applying item response theory. *Journal of Behavioral Decision Making*, 30(4), 933–950.
- Pratt, D., & Kazak, S. (2018). Research on Uncertainty. In *International Handbook of Research in Statistics Education* (pp. 193–227). Springer, Cham.
- Schiebener, J., & Brand, M. (2015). Decision making under objective risk conditions—a review of cognitive and emotional correlates, strategies, feedback processing, and external influences. *Neuropsychology review*, 25(2), 171–198.
- Smith, G. T., McCarthy, D. M., & Anderson, K. G. (2000). On the sins of short-form development. *Psychological assessment*, 12(1), 102.

An alternative method to compute confidence intervals for proportion

Antonio Francisco Roldán López de Hierro, [María del Mar López-Martín](mailto:maria.del.mar@ugr.es) and Carmen Batanero

University of Granada, Spain; aroldan@ugr.es, mariadelmarlopez@ugr.es, batanero@ugr.es

Keywords: Proportion, confidence level, confidence interval, interpretation.

Introduction

Confidence intervals are a main inferential procedure with many applications to real life, such as studying the percentage of voters will finally vote for a particular political party or the proportion of the population that suffers from asthma. This topic is taught in Spain to high school students in the Social Sciences specialty and in most of university grades. Since the available time for teaching is scarce, students are mainly taught the computing procedure, with no much attention to interpretation of results. Olivo, Batanero and Díaz (2008), and references therein, described some difficulties appearing in students' interpretation of confidence intervals for proportion.

The aim of this paper is to present an alternative methodology to compute confidence intervals for proportion by using the approach due to Wilson (1927). It would be of interest for students to discover that there is not a unique way to compute such interval. With the help of computers, by comparing Wilson's procedure to classical one, students would be able to improve their interpretation of the confidence interval for proportion and its confidence level.

Usual methodology to determine confidence intervals for proportions

Below, we summarize the usual procedure for computing the confidence interval. Suppose we are interested in estimating the proportion p of individuals in a population that satisfy certain condition. We take a random sample of the population, and observe the number X of individuals in the sample that verifies that property, which follows a Binomial distribution of parameters n and p . When n is large enough, we approximate this distribution by the normal distribution $X \approx \tilde{X} \mapsto N(np, npq)$, where $q = 1 - p$, and it can be typified as $(\hat{p} - p) / \sqrt{pq/n} \mapsto N(0,1)$ where \hat{p} is the sample proportion defined as the number of the successes divided by total number of observations in the sample. Let denote by $1 - \alpha$ the confidence level (usually $1 - \alpha \in \{0.9, 0.95, 0.99\}$) and let $z_{1-\alpha/2} > 0$ be the unique positive real number such that $P(-z_{1-\alpha/2} < Z < z_{1-\alpha/2}) = 1 - \alpha$, where Z is any random variable following the standard normal distribution $N(0,1)$. Then the following approximation can be considered:

$$P\left(-z_{1-\alpha/2} < \frac{\hat{p} - p}{\sqrt{p(1-p)/n}} < z_{1-\alpha/2}\right) = 1 - \alpha. \quad (1)$$

Since p is unknown, we replace it by its maximum likelihood estimator, \hat{p} , from which it is easy to deduce that the confidence interval for p , at the confidence level $1 - \alpha$, is

$$IC(p) = \left[\hat{p} \pm z_{1-\alpha/2} \sqrt{\hat{p}(1-\hat{p})/n} \right]. \quad (2)$$

The advantage of this expression is that it is very simple to use in practice and it produces good results. Its main weakness is that it has been obtained through a process in which, without apparent justification, the true value of p has been replaced by its estimator \hat{p} . This replacement transforms a

non-linear problem into a linear problem. One of the most important drawbacks of expression (2) is that this formula does not reach the confidence level.

Wilson's methodology to determine the confidence interval for proportion

This method proposes to solve the equation (of second degree after squaring):

$$\frac{\hat{p} - p}{\sqrt{p(1-p)/n}} = z_{1-\alpha/2}$$

before replacing p by \hat{p} in the denominator. Its two solutions determine the extremes of the confidence interval for proportion, which are:

$$IC_W(p) = \left[\frac{2n\hat{p} + z_{1-\alpha/2}^2 \pm z_{1-\alpha/2} \sqrt{z_{1-\alpha/2}^2 + 4n\hat{p}(1-\hat{p})}}{2(n + z_{1-\alpha/2}^2)} \right]. \quad (3)$$

Since this formulae is more complex than (2), we propose to use a spreadsheet to generate a lot of random samples of distribution $B(n, p)$ (for instance, 1000 or more), when n and p are previously set by students. By using that random samples, we can compute both (2) and (3) intervals, and to determine how many of them indeed contain the true value of p . This comparison will help students to understand that the correct interpretation of confidence interval relies on the methodology, but not on the interval: when lots of intervals are randomly generated, we trust that $100(1 - \alpha)\%$ will contain the (unknown) true value of the proportion p . Furthermore, we are interested on overcoming the wrong student's usual affirmation that establishes that, after computing the confidence interval, the probability that p belongs to such interval is the confidence level. This novel view-point could be of interest for both undergraduate and graduate students.

To compare both methods, we present the results of 10000 and 1000000 simulation with $n = 30$ (see Table 1). We highlight that only around the 88% of the intervals constructed using (2) contains the real value of p and the greater confidence of Wilson's method.

Usual method		Wilson's method	
$N = 10000$	$N = 1000000$	$N = 10000$	$N = 1000000$
87.19%	87.54%	94.88 %	95.23 %

Table 1: Proportion of confidence intervals in simulation containing the true value of p

Project EDU2016-74848-P (AEI, FEDER) and Research groups FQM126 y FQM268 (Junta de Andalucía).

References

- Wilson, E.B. (1927). Probable inference, the law of succession, and statistical inference. *Journal of the American Statistical Association*, 22, 209–212.
- Olivo, E., Batanero, C. and Díaz, C. (2008). Dificultades de comprensión del intervalo de confianza en estudiantes universitarios. *Educación Matemática*, 20(3), 55–82.

Primary school students reasoning about and with the median when comparing distributions

Susanne Schnell¹ and Daniel Frischemeier²

¹ University of Paderborn, Germany, Susanne.Schnell@math.upb.de

² University of Paderborn, Germany, dafr@math.upb.de

Statistical reasoning can be enhanced at an early stage by facilitating informal statistical reasoning and developing conventional measures based on individual conceptions. This paper aims at identifying young students' conceptions of the median and their relations to its definition. For this, we present a design research study with grade 3 students (age 9) focusing on the comparison of two groups. The qualitative analysis of complementary interviews shows that young students already develop an initial understanding of the median but struggle to find the conventional reference for the middle. Consequences will be drawn for further design cycles.

Keywords: statistics education, early statistics, primary school, comparing groups, median

Introduction: Early statistics in German curriculum

Statistical literacy is a fundamental component for active citizenship (Engel, 2017). Some facets of statistical literacy can be approached as early as primary school – an overview is presented in Leavy, Meletiou-Mavrotheris, and Paparistodemou (2018). In Germany, nation-wide standards for primary education in mathematics require students to gain competences in dealing with “data, frequency, and chance” (Hasemann & Mirwald, 2012). The core idea is to develop conceptual fundamentals, e.g. by posing statistical questions, collecting data, and creating and interpreting representations of data (Hasemann & Mirwald, 2012). German textbooks and teaching materials for primary school, however, often emphasize singular aspects such as reading a diagram rather than introducing context-rich and complex data analysis projects as sustainable teaching-learning arrangement (Bakker, 2004). Such an arrangement aims at developing students' competences in drawing and dealing with informal statistical inferences (Makar, Bakker, & Ben-Zvi, 2011) and building on existing informal conceptions in order to develop conventional ideas (Bakker, 2004). Hence, researching initiated learning processes is an important task (Makar, 2014). This paper presents a design-based research project (Prediger et al., 2012) which was conducted over four cycles so far in order to develop a statistics teaching-learning arrangement for classrooms in German primary schools. After summarizing theoretical considerations, the main design principles and framework of the teaching-learning setting are discussed. Lastly, we will present empirical insights of students' statistical reasoning about and with the median from interviews with students grade 3 (age 9) conducted after the whole-classroom activities.

Statistical projects in primary school

Going beyond calculation and algorithms in statistics education means enabling students to deal with statistical inquiries and applying the phases *problem*, *plan*, *data*, *analysis* and *conclusions* of the PPDAC-cycle (Wild & Pfannkuch, 1999). Especially at the starting point of a statistical inquiry – e.g., when posing statistical questions – the desire arises to not only consider the distribution of one variable, but to look for a relationship between two or more variables. So, for example, the question whether third graders tend to have more games on their smartphones than fourth graders

leads to the comparison of two groups. While easily motivated, group comparisons are also sophisticated statistical activities taking into account many of the fundamental statistical ideas like data, variation, representation, etc. (Burrill & Biehler, 2011). Frischemeier (2017) identified several important and sustainable group comparison elements like center, spread, skewness, shift, p-based and q-based comparisons. While these concepts can be quite complex, the fundamental ideas behind them can be addressed already in primary school. Informal comparisons are a fruitful task to provide in-depth insights into students' conceptual development and informal statistical reasoning (e.g. Schnell & Büscher, 2015, Makar, 2014). In this paper, we focus on using (informal) conceptions of the median as well as visual features of distributions for comparing groups in early statistics.

To describe the center of a distribution is a key idea of statistics (e.g. Bakker, 2004; Makar, 2014). The concept of the median can be introduced on an enactive level via “animated statistics” in the sense of embodied cognition by Lakoff & Núñez (2000). In this case the students are statistical units themselves, line up in an ascending order in regard to a certain attribute (e. g. their height) and identify the middle. Even the more formal procedure of determining the median (sorting values and finding the middle value) is easily and non-formally presentable, but the interpretation and a deeper conceptual understanding can be challenging (Mokros & Russel, 1995) as it is interwoven with ideas like representativeness and typicality. However, these ideas can be pre-formally existent from even young students' everyday experiences (Mokros & Russel, 1995). Mokros and Russel (1995) identified approaches to the average, which include among others the average as an algorithm without predominant focus on contextual interpretation or the average as midpoint which is chosen as representative of the data and draws on the ‘middle’ which alternately is the median, the middle of the X-axis or the middle of the range. To be able to interpret the median correctly and in a meaningful way, it has to be understood as a value in reference to the rest of the distribution (e.g. cutting the data set in two halves). Overall, even students who are familiar with formal ways to determine the median sometimes do not apply it when comparing distributions (e.g. Watson & Moritz, 1999; Konold et al., 1997). This might be due to a lack of understanding that measures such as the median are representative of a distribution (Konold et al., 1997). However, Makar (2014) shows how even young students of age 8 can be supported in developing a fundamental understanding of the median and using it for informal inferential reasoning when presented with an adequate teaching-learning arrangement. The key is to give students room to develop informal ideas which serve as important base for building foundational knowledge of statistical concepts (Makar, 2014; Bakker, 2004; Smith, diSessa, & Rochelle, 1993).

Especially in terms of visual aspects, young students draw on a variety of different strategies to describe and compare distributions (e. g. Watson and Moritz, 1999). For instance, they focus on ‘hills’ to describe the shape of the data (Bakker, 2004). To facilitate a proto-concept of center, Konold et al. (2002) introduced so-called modal clumps as “a range of data in the heart of a distribution of values” (p. 1) in order to find ways to identify the center in stacked dot plots and “allow students to express simultaneously what is average and how variable the data are” (p.1). Bakker and Gravemeijer (2004) build on these concepts to lead students from a local perspective (focusing on singular dates such as the minimum) to a global perspective on distributions (with a

certain shape, spread etc.) and see modal clumps as proto-concepts not only for center but also for spread and therefore provide students with the opportunity to compare two distributions.

Overall, our aim is to design and realize a teaching-learning arrangement to enhance the statistical reasoning of primary school students and to enable them to compare groups with proto-concepts like modal clumps and concepts like medians when working on statistical projects. This paper focusses on exploring which concepts of the median were developed by the children during the teaching-learning unit and applied in the interview. Therefore, the research question is: *Which conceptions of the median do students verbalize in the interviews and what is their (visual) point of reference for the median?*

Research Design

Methodological framework: Design Research

This study is situated in the methodological framework of topic-specific didactical design research (Prediger et al., 2012). Thus, it aims at designing a specific teaching-learning arrangement for data competence in primary school on the one hand, and the development of local theories of teaching and learning conceptual basics at an early age on the other hand. These intentions are addressed in iterative research cycles of (re-)designing, implementing, and analyzing the materials (Prediger et al., 2012). So far, four cycles were conducted, exploring different settings with whole classes and special interest groups in grade 3 and 4. After the classroom-activities, additional interviews for in-depth analysis of students' reasoning were conducted.

Design principles and teaching-learning arrangement

For the design of the teaching-learning unit we implemented several recommendations for the design of Statistical Reasoning Learning Environments (Garfield & Ben-Zvi, 2008) such as using real data sets and using digital tools like TinkerPlots (Konold & Miller, 2011), which can help young students to manipulate and modify the data in regard to a specific question. Furthermore, we facilitated collaborative work on statistical projects (first with small datasets, later with larger datasets), introduced the students to data analysis concepts on different representation levels (enactive, iconic, symbolic) and promoted the use of informal concepts such as modal clumps (Konold et al., 2002).

In the following we refer mainly to the version of the teaching-learning arrangement by Breker (2018) from the last design research cycle in which 22 third grade students participated. All of the students have no specific statistical pre-knowledge – they have only been introduced to the reading and interpreting of pie graphs and tallies. The teaching-learning arrangement consisted of seven modules spread over 13 lessons (45 minute each):

Module	Content
0	Getting to know each other
1	First basics in data analysis and getting to know the questionnaire
2	Statistical representations on different representational levels (enactive, iconic, symbolic)
3	Introduction to data analysis with TinkerPlots and creating stacked dot plots in TinkerPlots

- 4 Getting to know modal clumps, medians and hatplots to compare groups
- 5 Group comparison projects: Preparing the posters
- 6 Presentation of the group comparison posters
- 7 Conclusion of the project

The median was introduced in module 4. As mentioned above, one fundamental idea was to present data analysis concepts on different representation levels. Hence the median was introduced on an enactive level with animated statistics: The students were asked to line up in a row ascending by their height and determined the child in the middle. After completing a fill-in-the-blank text with the characteristics of the median, the teacher demonstrated how to use TinkerPlots to identify the median in a distribution. The median was then used by the students to compare different distributions.

Our aim was to investigate the ways in which the students use statistical concepts such as the median to compare groups in data sets in TinkerPlots after completing the teaching-learning arrangement in class. Hence we conducted subsequent interviews with a convenience sample of participants. Here, we provided them with a real data set including variables about leisure time activities and media use of about 680 primary school students (grade 3 and 4). The participants' task was to investigate whether the third or the fourth graders have more games on their smartphones. The interview consisted of two main activities with regard to the task: First the students were asked to conjecture two dot plots (grade 3 vs. grade 4) based on their expectation. Second the students were asked to use TinkerPlots to compare the groups of third and fourth graders in the real data set.

Data collection and analysis

Ten students participated in the interview study of cycle 4 after they completed the teaching-learning arrangement with their class. In the interviews, the students worked in pairs of two. All interviews, including the activities in TinkerPlots, were recorded and fully transcribed. The analysis was conducted under the interpretative paradigm, scrutinizing the transcripts for sequences in which the students use the median and then reconstructing their cognitive activities and conceptions.

Findings

The middle of what? – The case of Paula and Linda

Paula's and Linda's initial hypothesis is that fourth graders have more games on their smartphone. After creating two conjectured dot plots, the researcher asks the students to explain the meaning of the median.

80 R: Could you maybe explain it again: what is the median, Paula?

81 Paula: The center point of the/ well it's the center of the dot plot.

Paula calls it the 'center point' and seems to be aware that she has to specify the point of reference of the center. Her offered reference 'the center of the dot plot' (line 81) is ambiguous as it could refer to the X-axis, the range of data dots or the distribution of data dots (similar to *average as midpoint*, Mokros & Russel, 1995). For determining the median, she counts only the columns of dots (with the same value) rather than every single dot, which equals determining the center of the

range. Both girls interpret this median correctly in terms of the higher median indicating more games for fourth graders.

When introduced to the real data set, the girls first determine and interpret the hills. Asked to summarize the findings in regard to the overall question (line 218), Paula argues with the median which they have not determined for this distribution, yet.

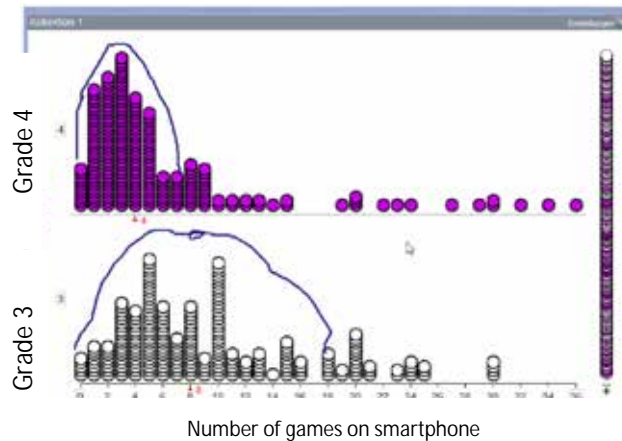


Figure 1: Paula and Linda's TinkerPlots screen with drawn-in hills and later added medians (median of 3rd graders: 8, median of 4th graders: 4)

- 218 R: Okay. Good. Now, what did you find out for your question, when you look at the hills? 3rd or 4th graders – who has more games on the smartphone? (...)
- 223 Paula: 4th graders. (...) Because 4th graders moved farther to the right with their dots and if you take the exact center, now, only of the dots, not of the stripes [i. e. X-axes]. Because otherwise the median would be the same. Just from the dots, the median of the 4th graders is farther in the middle than of the 3rd graders.
- 224 Linda: Yes, definitely. But really, if you just take half somehow, then it really looks like the 3rd graders were furth/ had more (*incomprehensible*)

Describing how the distribution of fourth graders “moved” more to the right in comparison to the third graders, Paula describes *the center* as a point of reference (line 223). It is likely that Paula is not thinking of the correctly determined median (which - in contrast to her expectation - is smaller for the fourth graders than for the third graders), but rather her individually determined center of the range. However, her remark about the X-axis shows again awareness of the reference for this value. While both children are at first confident in their answer of the 4th graders having more games, Linda mentions doubts in line 224. By “taking half”, she could either refer to the left half of dots (e.g. the data between 0 and 16 games) or possibly to the lower “half” (e.g. the range of 0 to 36 games but cutting of each column above a certain frequency). This idea is not followed up upon, though.

When the girls determine the median in TinkerPlots, it seems to differ from their expectation:

- 238 Paula: They just took it of the hills. And in the hills, 3rd graders have more.
- 239 Linda: Right.

- 240 R: In the hills? I didn't get that.
- 241 Paula: So the median of the hills.
- 242 R: The median of the hills? What is that/
- 243 Linda They didn't use all of them. They just drew it within the hills. (...)
- 247 Paula Yes, but otherwise the [median] of the 4th graders would be much further in the middle and the one of 3rd graders, too. (...)
- 250 Linda If you cut off the hill completely, then it should be sitting somewhere here, and of this one here at 14, 12, 16. Somewhere there. (...)
- 271 R: So, if you only look at the medians, who has more games on the smartphone?
- 272 Paula: Yes, in this case, where they used only the hills, it's the 3rd graders. But if you had done it without the hills, it would be the 4th graders.

Paula explains the unexpected median by the way she thinks it was determined in the program, i.e. by determining the center of the hill's width (cf. figure 1). Thus, she still interprets the TinkerPlots median as referential but differing from the learned definition. In line 247, Paula suspects the true median of the 4th graders to be farther in the middle (i.e. right). This indicates that she stays with her initial interpretation of the median as center of the range. In line 250, Linda suggests a manipulation of the data by "cutting of the hill". As she says the median would then be between 12 and 16, she might refer to cutting of the dot plot horizontally, thus evening out the number of dots per number of games and making Paula's procedure of determining the median correct. Thus, Linda twice offers ways to manipulate the data set and thinks about the effects on the median. Overall, the girls use the idea of two different medians in order to support her initial expectation that fourth graders have more games on the phone (line 272).

In regard to the research question, the girls developed conceptions of the *median as the middle of the range* and *median as the middle of the modal hill*. They are very consistent with their way of determining it, which might have its roots in the animated statistics activity. It is remarkable that they consider different options of manipulating the data set and their effects on the median, which hints that they perceive it as a value that is closely connected to the distribution and that has representative value. By assuming that TinkerPlots uses the hills' boundaries rather than the whole distribution for determining the median, the girls establish a pre-formal connection between the visual approach and the calculated measure.

Additional interpretations of the median

The students in the interview study showed a variety of different conceptions of the median:

- Layla and Sandra as well as Burak and Tarik call the median "the middle (of the dots)" (LS_line 483, BT_line 103) but do not specify it further other than using the learned procedure to determine it $\hat{=}$ *median as unspecified middle*
- Johannes and Nils interpret it as the center with "roughly the same amount [of dots]" in each half (JN_line 53) $\hat{=}$ *median as the middle of two halves*

- Lara and Lia seem to make a connection between the modal value and median “A median is the middle of the biggest. Of the biggest amount.” (LL_line 171) à *median as the middle of modal clump*

Conclusion

This paper aimed at identifying young students' conceptions of the median and their relations to the conventional measure (Bakker, 2004). The analysis shows how the students are integrating visual and calculated aspects of the distribution in order to compare groups. Building on Mokros and Russell (1995), we could identify several conceptions of the median which draw on different references in the data set: *median as middle of the range*, *median as middle of the modal hill*, *median as the middle of two halves*, *median as the middle of modal clump or column* and *median as unspecified middle*. While all pairs were able to interpret the shift of the medians correctly, the in-depth analysis shows their struggle with the referential concept. Even though these conceptions were not yet in-line with the conventional conception of the median, they serve as important starting points for the development of more formal conceptions (Smith, diSessa, & Rochelle, 1991). Overall, the teaching-learning arrangement clearly supports young students in informal reasoning about statistical concepts while comparing groups. For instance, Linda's considerations of manipulating the data set in order to change the median are promising starting points for further design cycles.

Another implication from the analysis is to be careful when introducing the median via animated statistics. When choosing this way, a scale should be prepared so that the distances between the children (i.e. data dots) become apparent and stacked distributions should be discussed. For a hypothetical learning pathway, we suggest to introduce first the modal clump as main area in the heart of the data distribution and then the median as a special value in relation to the modal clump, indicating the center of the distribution. Next discuss different distributions in which the position of the clump and the median differ. These ideas will be realized in the next design cycle of the teaching-learning arrangement.

References

- Bakker, A. (2004). Reasoning about shape as a pattern in variability. *Statistics Education Research Journal*, 3, 64–83.
- Bakker, A., & Gravemeijer, K. (2004). Learning to reason about distributions. In D. Ben-Zvi & J. Garfield (Eds.), *The Challenge of Developing Statistical Literacy, Reasoning and Thinking* (pp. 147–168). Dordrecht, The Netherlands: Kluwer Academic Publishers.
- Breker, R. (2018). *Verteilungen vergleichen mit der Software TinkerPlots – Eine Interviewstudie mit Schülerinnen und Schülern der Klasse 3*. Unpublished master thesis, supervised by D. Frischemeier.
- Burrill, G., & Biehler, R. (2011). Fundamental statistical ideas in the school curriculum and in training teachers. In C. Batanero, G. Burrill, & C. Reading (Eds.), *Teaching statistics in school mathematics - Challenges for teaching and teacher education* (pp. 57–69). Netherlands: Springer.
- Engel, J. (2017). Statistical Literacy for active Citizenship: A Call for Data Science Education. *Statistics Education Research Journal*, 16(1), 44–49.

- Frischemeier, D. (2017). *Statistisch denken und forschen lernen mit der Software TinkerPlots*. Wiesbaden: Springer Fachmedien Wiesbaden.
- Garfield, J., & Ben-Zvi, D. (2008). *Developing students' statistical reasoning. Connecting Research and Teaching Practice*. The Netherlands: Springer.
- Hasemann, K., & Mirwald, E. (2012). Daten, Häufigkeit und Wahrscheinlichkeit. In G. Walther, M. van den Heuvel-Panhuizen, D. Granzer, & O. Köller (Eds.), *Bildungsstandards für die Grundschule: Mathematik konkret* (pp. 141–161). Berlin: Cornelsen Scriptor.
- Konold, C., & Miller, C. (2011). *TinkerPlots 2.0*. Emeryville, CA: Key Curriculum Press.
- Konold, C., Pollatsek, A., Well, A., & Gagnon, A. (1997). Students analyzing data: Research of critical barriers. In J. B. Garfield & G. Burril (Eds.), *Research on the role of technology in teaching and learning statistics: Proceedings of the 1996 IASE Roundtable Conference* (pp. 151–167). Voorburg: International Statistical Institute.
- Konold, C., Robinson, A., Khalil, K., Pollatsek, A., Well, A., Wing, R., & Mayr, S. (2002). Students' use of modal clumps to summarize data. Paper presented at the *Sixth International Conference on Teaching Statistics*, Cape Town, South Africa.
- Lakoff, G., & Núñez, R. (2000). *Where mathematics come from: How the embodied mind brings mathematics into being*. New York: Basic books.
- Leavy, A., Meletiou-Mavrotheris, M., & Papanastasiou, E. (2018). *Statistics in Early Childhood and Primary Education: Supporting Early Statistical and Probabilistic Thinking*. Singapore: Springer.
- Makar, K. (2014). Young children's explorations of average through informal inferential reasoning. *Educational Studies in Mathematics*, 86(1), 61–78.
- Makar, K., Bakker, A., & Ben-Zvi, D. (2011). The reasoning behind informal statistical inference. *Mathematical Thinking and Learning*, 13(1–2), 152–173.
- Mokros, J., & Russell, S. J. (1995). Children's concepts of average and representativeness. *Journal for Research in Mathematics Education*, 26(1), 20–39.
- Prediger, S., Link, M., Hinz, R., Hußmann, S., Thiele, J., & Ralle, B. (2012). Lehr-Lernprozesse initiieren und erforschen—fachdidaktische Entwicklungsforschung im Dortmunder Modell. *Mathematischer und Naturwissenschaftlicher Unterricht*, 65(8), 452–457.
- Schnell, S., & Büscher, C. (2015). Individual concepts of students comparing distributions. In K. Krainer & N. Vondrova (Eds.), *Proceedings of the 9th Congress of the European Society for Research in Mathematics Education* (pp. 754–760). Prague: Charles University in Prague and the European Society for Research in Mathematics Education (ERME).
- Smith, J. P., diSessa, A. A., & Rochelle, J. (1993). Misconceptions Reconceived - A Constructivist Analysis of Knowledge in Transition. *Journal of Learning Sciences*, 3(2), 115–163.
- Watson, J. M., & Moritz, J. B. (1999). The beginning of statistical inference: Comparing two data sets. *Educational Studies in Mathematics*, 37(2), 145–168.
- Wild, C. J., & Pfannkuch, M. (1999). Statistical thinking in empirical enquiry. *International Statistical Review*, 67(3), 223–248. doi:10.1111/j.1751-5823.1999.tb00442.

A case study on design and application of creative tasks for teaching percentage bars and pie charts

Balgeum Song¹, Kyeong-Hwa Lee² and Yeong Ok,Chong³

¹Graduate School of Education, Seoul National University, Korea; bgsong@snu.ac.kr

²Seoul National University, Korea; khmath@snu.ac.kr

³Gyeongin National University of Education, Korea; yochong@ginue.ac.kr

Keywords: Mathematical creativity, percentage bar, pie chart, statistical thinking.

Introduction

There is a need to discuss on teaching and learning situations which include graph comprehension and construction to promote students' conceptual understanding of graphs, however, little attention was given to this until the present day (Friel, Curcio, & Bright, 2001). Since several research have indicated that creative tasks and teaching strategies effectively enhance students' conceptual understanding and mathematical thinking (Luria, Sriraman, & Kaufman, 2017), in this study, we investigate how creative tasks and instructional strategies for lessons on percentage bars and pie charts are used to elicit students' growth in conceptual understanding and statistical thinking.

Theoretical framework

Percentage bars, Pie charts and Statistical thinking

Percentage bars and pie charts show how sectors constitute a whole (Reys et al., 2012). Learning these graphs relates to percentage, proportional relationship between the area of each sectors and their percentages, and interpreting graphs connecting data and the context (Reys et al., 2012; Curcio, 1987). In terms of statistical thinking, it is necessary to guide students to develop global view from local view as we can discern the general feature of the data set with global view (Ben-Zvi & Arcavi, 2001).

Mathematical creativity

Four main components of mathematical creativity are fluency, flexibility, originality and elaboration (Luria et al., 2017). Here we define creative task as open-ended and multiple solution task which can be performed in various ways, inclusive of informal method and representations, especially, applying one's experience and prior knowledge using fluency, flexibility, originality and elaboration.

Methodology

In this study, case study methodology was used and a class of 28 sixth-grade students participated. These pupils had not learnt about percentage bars and pie charts before. The first task asked students to discuss the claim which includes certain percentage value and to visualize given percentage value. The second was about construction of percentage model from given data table. In the last task, each group of students was given a percentage bar or a pie chart without label. They were asked to infer the percentage and the item of each sector and then interpret the given graph. Discussions among students were conducted for social interaction. All teaching-experiment sessions were videotaped and recorded. These data were transcribed later for analysis. The students' individual worksheets were

collected. Researchers attended all lessons and recorded field notes. We established four phases of learning percentage bars and pie charts based on Curcio(1987)'s three levels of graph comprehension and Ben-Zvi and Arcavi(2001)'s research about the process of the construction of global view from local view. Students' responses and models were classified according to these four phases in order to verify if students' conceptual understanding and statistical thinking were improved.

Phase	Construction	Interpretation	
		Data	Context
0	Focused on context	Considering personal experience	
1	Focused on pointwise information	Considering appropriate context situation	
2	Focused on the difference between individual data	Comparison of the meaning of each part	
3	Focused on the proportional relationship among data	Suggestion of alternative, prediction, implication	

Table 1: Phases of learning percentage bars and pie charts

Findings and Conclusion

The students constructed and developed percentage models, and interpreted percentage bars and pie charts using their fluency, flexibility, originality and elaboration in this study. Meanwhile, they showed increases in the phases of learning percentage bars and pie charts. If the tasks did not allow diverse approaches and representations using students' own method to perform the tasks, we believe that it would be hard to expect these increases. The findings showed that creative tasks with proper instructional strategies promote conceptual understanding and statistical thinking by stimulating students' creativity. Furthermore, the analysis indicated that the creative tasks provide various learning opportunities for students who differ in their levels. This study provides empirical evidence to support previous claims that the use of creative tasks and instructional strategies in the mathematics classroom enhance students' conceptual understanding and mathematical thinking (Luria et al., 2017).

This study is part of "Siheung City - Seoul National University Partnership for Primary/Secondary School Education Program" funded by Siheung City, Gyeonggi-do, Republic of Korea.

References

- Ben-Zvi, D., & Arcavi, A. (2001). Junior high school students' construction of global views of data and data representations. *Educational Studies in Mathematics*, 45, 35-65.
- Curcio, F. R. (1987). Comprehension of mathematical relationships expressed in graphs. *Journal for Research in Mathematics Education*, 18(5), 382-393.
- Friel, S. N., Curcio, F. R., & Bright, G. W. (2001). Making sense of graphs: Critical factors influencing comprehension and instructional implications. *Journal for Research in mathematics Education*, 124-158.
- Luria, S. R., Sriraman, B., & Kaufman, J. C. (2017). Enhancing equity in the classroom by teaching for mathematical creativity. *ZDM*, 49(7), 1033-1039.
- Reys, R. E., Lindquist, M., Lambdin, D. V., & Smith, N. L. (2014). *Helping children learn mathematics*. Hoboken.

Algorithms as a discovery process in frequentist approach to prediction interval

Jannick Trunkenwald and Dominique Laval

Université Diderot-Paris, France; jannick.trunkenwald@yahoo.fr ; dominique.laval@gmail.com

This article deals with the contribution of algorithmic to introduce the frequentist approach to probability. Our attention is focused on teachers in training who have to perform a sampling simulation program in order to solve a probabilistic task. The mathematical work corresponding to this discovery process of the prediction interval is analysed in its semiotic, discursive, and instrumental dimensions, within each of involved fields (probabilities, descriptive statistics and algorithmic). Synergies and interactions between these various fields are taken into account. Methodological tools MWS (Kuzniak, 2011) and AWS (Laval, 2018) are used to lead this study.

Keywords: Algorithmic, Work Spaces, frequentist, probability, field

Introduction

In France, teaching of probability in upper school commences with a double approach: “combinatorial” and “frequentist”. This makes it possible to connect the abstract notion of probability to “real” world, as it is perceived through our senses. The approach of frequency derives from binomial distribution with a deductive reasoning based upon random variables. The approach of probability is based on sampling fluctuation with empirical observations of frequencies. We choose to analyse the introduction to sampling fluctuation that empirically establishes the prediction interval principle, which is the only formalized rule taught at 10th grade level. We make the choice to observe the work of teachers during a training course, by taking in account *instrumental*, *semiotic* and *discursive* dimensions. More particularly, this paper deals with existing interactions between fields such as probability and descriptive statistics, but also algorithmics during teacher’s work.

Frequentist approach to sampling fluctuation

The 10th grade program in French school system leads to the discovery of sampling fluctuation with the following property: *Let p be the probability of success, and let n be the number of repeated random experiments. Any frequency f of success verifies $f \in \left[p - \frac{1}{\sqrt{n}}; p + \frac{1}{\sqrt{n}} \right]$ with at least a 95% level of confidence.* Nechache (2016) notices the absence in 10th grade of a probabilistic theoretical reference that would make it possible to approach this interval of fluctuation by deductive reasoning. The discovery process of this interval remains indeed at this stage, experimental and based on observation of samples which have the same size. Each frequency value corresponds to a sample obtained itself by repeating the considered random experiment. This is an empirical approach based on inductive reasoning. In addition, the “time cost” corresponding to the need of repeating the same experiment a large number of times entails a need for automation. And this idea is “facilitated” by using of computing which is based on a pseudo-random generator operation. Thus the “frequentist” approach requires consideration of three fields: probabilities, descriptive statistics and algorithmics.

A digital environment (“spreadsheet” or “programming software”) makes possible to reduce the time spent on repeating the random experiment. Specific skills are needed to digital field (algorithmic, syntax of machine language, user interface...), and the lack of computing expertise could cause

additional difficulties for students. It could also cause a meta-cognitive (or even cognitive) concern to teachers. Using digital field makes possible to automate an experimental protocol that requires the use of gestures, syntax, and specific modes of thinking. However, we can also question the specific contribution resulting from the use of a machine-implementable method, for a better comprehension of the frequentist approach (from a mathematical point of view). This question seems being even more important for teachers. Indeed, they are supposed to look closely at their practices. We can thus consider three main ways of exploiting a digital field to modelize the random experiment: - a spreadsheet; - the construction of “paper-and-pencil” algorithms and the actual implementation on the computer in order to test them; - the use of simulation algorithms or spreadsheet provided and already built. Each of these forms of use can be assimilated to an *instrumentalization* of computing or algorithmics *artifacts* to construct a “frequentist” approach in probabilistic or statistical fields.

We choose not to approach the spreadsheet case and to restrict the scope to algorithms. We believe that focusing on algorithms enables us to study the instrumental, semiotic and discursive dimensions which will be involved during mathematical and algorithmic work on sampling fluctuations. We thus seek to study the contribution of an *algorithmic thought* (Laval, 2018; Modeste, 2012) in the context of a mathematical work on probabilities and statistics. In particular, we think that writing the simulation algorithm corresponds to a higher stage of formalization for different involved statistical protocols, and that the role of “language” will take on particular importance in this sense.

Observations carried out in teacher training

Training on the simulation of sampling fluctuation at 10th grade level is conducted during an internship at the French High School in Algiers on May 2018. Five groups of three teachers (A, B, C, D, and E) have to solve the following problem: “What is the probability that the distance between two points randomly chosen along a line segment S , is more than half the length of the segment S ?”.

We build on existing work previously undertaken by Nechache (2016) and Trunkenwald (2018), to consider this task as being representative of institutional expectations for the “frequentist” approach. It is possible to explore sampling fluctuation with a real repetition of the random experiment (case of strings of twines cut with scissors), but considering this long process with randomization by a human being choice, our hypothesis is that teachers will use a numerical simulation operating with a pseudo-random generator ($Alea()$), which returns a random number between 0 and 1 simulating the position of a randomly selected point on the S -segment. The modelling work highlighting sampling fluctuation can find its formalized expression through a simulation algorithm. Indeed, the random experiment providing distance between two selected points can be simulated with $|(Alea() - Alea())|$ as computing instruction which can be considered as a *level 0 algorithm* used for each simulation of the random experiment. Another *level 1 algorithm* can be constructed from the *level 0 algorithm*, by repeating the random experiment to obtain directly a simulated frequency of success (Figure 1).

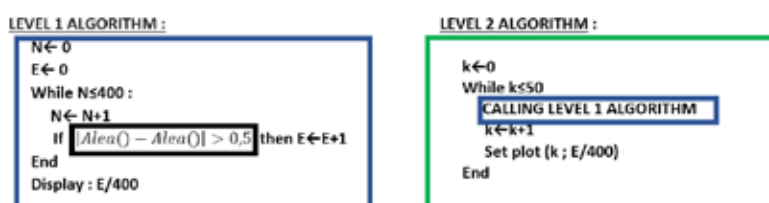


Figure 1: Level 1 and level 2 algorithms written in pseudo-code.

Running several times *level 1 algorithm* generates a list of frequencies, which can be represented as a cloud diagram (scatter plot). For this purpose, a third step can be envisaged in digital field: the *level 2 algorithm* (Figure 1) automating the layout of the cloud. Then *level 2 algorithm* is constructed from *level 0 algorithm*, by repeating the simulated frequency of success to draw directly the cloud.

The working groups do not have access to any pre-existing files to accomplish their task. But the algorithms they will design can be adapted for a later activity based on a roll of three dice. The groups manage more or less easily, with the help of the trainer when it is necessary, realizing a numerical model for the simulation of a frequency calculation. Only one group (the E) uses the spreadsheet, and only one group (the C) manages to finalize *level 2 algorithm*. Indeed, the transition from level 1 to level 2 corresponds to a tricky stage, especially the algorithmic writing of a statistical protocol that would consist in exploiting (on “paper”) the results provided by *level 1 algorithm*. Our hypothesis is that it is an epistemological obstacle linked to the encapsulation of an algorithm in another (principle of a procedural subroutine), in order to automate the execution of the first one. Other difficulties at the interaction of statistical and algorithmic domains are identified during the training session. We present (Figure 2) an excerpt from the transcription of exchanges between the trainer and the group B, concerning the implementation in *level 1 algorithm* of a counter.

Stagiaire 1 :	Le compteur moi je veux qu'il compte. Donc c'est la position...	Student 1	I want the counter to count. So, it is the position...
Tuteur :	D'accord. Donc comment on peut faire un compteur ?	Tutor :	OK. Then how can we make a counter?
Stagiaire 1 :	C'est... Donc il faut l'initialiser...	Student 1 :	It is... So, we have to initialize it...
Tuteur :	D'accord. L'initialiser à combien ?	Tutor :	OK. To initialize it at what value?
Stagiaire 1 :	Au départ de 0, puisqu'il n'y a aucun... mais...	Student 1 :	Starting at 0, because there is no one... but...
Tuteur :	Et quand est-ce que vous l'augmentez ?	Tutor :	And when do you increase it?
Stagiaire 1 :	C'est ça ! C'est la position où le mettre !... Est-ce que...	Student 1 :	That's it! It is the position where to put it!... Is it...
Tuteur :	Il va compter quoi ?	Tutor :	What will it count?
Stagiaire 2 :	Il va compter le nombre de cas favorables...	Student 2 :	It will count the number of favourable cases.
Tuteur :	... Voilà, donc à côté du « oui » vous l'augmentez de 1.	Tutor :	That's the point, then besides the “yes” you increase it of 1.
Stagiaire 1 :	... avant ou après ? ...	Student 1 :	... Before or after?...
Tuteur :	Avant ou après. Au même niveau.	Tutor :	Before or after. At the same level.
Stagiaire 2 :	On l'a mis ici... ça n'a pas marché.	Student 2 :	We put it here... It didn't work.
Tuteur :	Vous mettez compteur devient compteur + 1.	Tutor :	You set counter becomes counter + 1.
Stagiaire 1 :	On l'a mis, mais ça n'a pas...	Student 1 :	We did that, but it didn't...
Tuteur :	Où est votre compteur ?	Tutor :	Where is your counter?
Stagiaire 1 :	n.	Student 1 :	n
Tuteur :	Ah non, n ce n'est pas le compteur, c'est le numéro de l'étape.	Tutor :	No, n is not the counter, it is the step number.
Stagiaire 1 :	Oui c'est ça !	Student 1 :	Yes, it is!
Tuteur :	Vous devez ajouter une autre variable qui, elle, va compter les succès. n c'est autre chose... n c'est le numéro de votre étape parmi les 100 étapes.	Tutor :	You should set another variable which will count the achieved successes. n is another thing... n is the step number among all the 100 steps.
Stagiaire 1 :	Donc il nous faut deux... Donc on aura deux compteurs.	Student 1 :	So, we need two... So, we will have two counters.
Tuteur :	Il y a un compteur de l'étape en cours et un compteur du nombre de succès.	Tutor :	There is a counter for the current step and a counter for the number of achieved successes.
Stagiaire 1 :	Voilà ! Mais le compteur du nombre de succès c'est à la fin de la boucle ? Et après le sinon...	Student 1 :	Here it is! But the counter for the number of successes, it is at the end of the loop? And after the “else”.
Tuteur :	Il prend sa valeur à la fin de la boucle. Quand vous êtes sortis de la boucle.	Tutor :	It will get its value at the end of the loop. When you have got out from the loop.
Stagiaire 1 :	Voilà donc c'est après le « sinon ».	Student 1 :	Here it is, so it is after the “else”.
Tuteur :	La fin de la boucle ce n'est pas dans le « sinon ». La fin de la boucle c'est après le « Fin pour ».	Tutor :	The end of the loop is not in the “else”. The end of the loop is after the “End for”.

Figure 2: Excerpt of a 8'14''record with group B

In this excerpt the counter with its initialization, conditioned incrementation, and final exploitation appears as a complex construction. Its drafting is integrated into three levels of the algorithm script, with consideration of other instructions. Trainees try to locate a specific position which does not really exist for the counter... We observe a confusion between “success counter” and “simulation step counter”. Step counter is a “natural” process in statistics that becomes a difficulty in algorithmics. Finally, a similar difficulty appears in a confusion between the instructions “result value” provided by the counter, and “incrementation” of intermediate values used for its calculation. We can also

observe a difficulty between probability and statistics fields: S2 speaks of “favorable case” instead of “success achieved”.

In addition, transcripts of the session show difficulties related to the numerical modelling of the random experiment. Some difficulties appear in other groups, such as reluctance to use a pseudo-random generator, reference to the geometry field with consideration of lengths ratio $|x_A - x_B|/L$ as a probability, and lack of definition for abscissa. All these observations show us the importance of interactions between various fields, as probability and statistics, but also with algorithmics, when introducing the frequentist approach of the prediction interval. We believe that an analysis of the mathematical and algorithmic work in these various fields with their interactions, can help us to refine our understanding of some difficulties encountered by trainees.

The choice of theoretical framework and research question

Nilsson, Schindler, and Bakker (2017) presented a literature review of theoretical work apparent in Statistics Education Research (SER) over the past 11 years, encouraging educators and researchers to be explicit about their background theories and orienting: “in the reviewed articles there was no deeper theorization of computer assisted instruction in statistics. (...) In the 35 articles we found no theoretical attempts on a more specific level (...) such as guiding principles for designing tasks and sequencing tasks in a digital learning environment or frameworks for explaining and understanding the relationship between digital and analogue learning environments.”

Activities that involve a mathematical task associated with multiple domains can be analysed by considering that entities involved in the task appear under different semiotic, instrumental, and discursive representations. Some researchers have developed frameworks to conduct studies of these activities according to the type of studied representations. Duval (1993) named “registers” the representations organized in semiotic systems. Processes of handling and conversions are located inside and between these registers, and this description is also supplemented by the idea of “instruments” in the mathematical activity of students. Rabardel theoretical framework (1995) focused on this “instrumental approach”, and described the use of digital technologies to teach and learn mathematics in different contexts. Such a framework consisting of “objects” from mathematical fields with relationships between them, and different expressions or associated mental images, had already been addressed earlier by Douady (1986). However, some researchers have emphasized the inseparable development of instrument-related knowledge and mathematical knowledge, all in an *instrumental genesis*. An implementation of these issues for analysing articulation between the algorithmic and mathematical fields is presented in a didactic engineering of Laval (2018) based on the *Work Spaces* framework. And we wish to see taken into account the induced relations by instrumental and mathematical signs. Then we hypothesise that coordinating the activity in several fields could provide answers in this sense.

Indeed, in algorithmics the activity is located into an instrument for solving the mathematical task, with a specific system of signs for computer science. On the other hand, in mathematics the activity consists on solving the task from a mathematical point of view and using signs making it possible to understand and justify. Next, we have to choose an appropriate theoretical framework that can give meaning to the learner’s work during an activity involving several fields with their interactions, considering the *semiotic*, *instrumental*, and *discursive* dimensions specific to each field. We assume

that articulations between *Spaces of Specific Mathematical Work* (MWSs) (Kuzniak & Richard, 2014) and *Spaces of Algorithmic Work* (AWS) (Laval, 2018), will allow to study the different *geneses* of the *representamen* and *processes*, from the point of view of the learners' MWSs and AWS, but also to approach the interactions between the probability/statistics and algorithmics. We briefly present this theoretical framework in the following section. Then the research question of this article is how this framework can analyse a learner's work involving computer programming in a frequentist approach to the prediction interval. French programs also emphasize a potential contribution of algorithmic work to the understanding of mathematical concepts, which raises the question of interactions between domains in learners' activity (Lagrange & Laval, 2019; Laval, 2018).

The working spaces MWSs AWS – First analyses

The methodological tools MWSs (Kuzniak, Tanguay, & Elia, 2016) and AWSs (Laval, 2018) help us to decompose intellectual perceptions at stake, during activity in mathematics and algorithmics fields. Three *instrumental*, *semiotic*, and *discursive dimensions* are considered, each generating a dynamic relationship between an *epistemological plane* and a *cognitive plane* (Figure 3).



Figure 3: Case of Algorithmic Space Work (Laval, 2018)

Technological (artifact), *semiotic* (representamen), and *theoretical* (referential) tools of *epistemological plane* can then be exploited using appropriate *schemes*. In this case, we respectively refer to *instrumental*, *semiotic*, and *discursive geneses*, which respectively produce *constructs*, *visualizations*, and *proofs* in the *cognitive plane*. The activation of two *geneses* can lead to a *circulation* between *dimensions* that carry them, which could sometimes be assimilated to the idea of modelling (Laval, 2018). We call “projection” of MWS_s (or AWS) the restriction to a specific field of what we analyse in the *Workspace*. We write projections of the MWS on probability and statistic fields, as respectively MWS_{Prob} and MWS_{Stat}. In order to avoid visual overload, we present diagrams of these projections with a view from above. Points and bolded lines represent the different *discursive* (D), *instrumental* (I), and *semiotic* (S) *geneses*, as well as *circulations* in planes located between these *geneses*' axes.

The main interaction between MWS and AWS is related to the use of a pseudo-random generator. This *artifact* is first *instrumentalized* within AWS to build a simulation of the random experiment. The link between this construction and the associated formulation causes an I-D *circulation* and leads to a *discursive genesis* enriching the AWS referential. With reference to Laval (2015), algorithmic design work presents a triple *instrumental*, *semiotic*, and *discursive dimension* within AWS. We link this discursive dimension with the idea of “language”. Indeed, level 0, 1, and 2 algorithms are

formalized writes of experimental protocols. Algorithmic expressions in “natural” language, with their three encapsulated structures, then constitute an explicit formulation of the procedure to be followed in the statistical field to carry out a “frequentist approach” to the prediction interval. This explanation may be associated with the idea of proof. This consideration brings us back to *discursive genesis* which, according to Laval (2015), is confirmed when the program is able to run (at the first level of paradigm corresponding to an intuitive view of the algorithm).

It should be noted that this AWS *discursive dimension* tends to fade from “semiotico-instrumental” plan, when working with a spreadsheet tool, whose syntactic aspects are more related to nature of *artifacts* (even if *discursive dimension* is still activated from *cognitive plane* to mobilize tools of AWS *referential*). A complex construction with a spreadsheet can also reduce “intellectual visualization” of a phenomenon and thus *semiotic dimension*, to be limited to *instrumental dimension*. Finally, AWS loses all activity when the algorithm implemented in a digital environment is provided to learners to be executed and used without any modification work expected in its own structure. The algorithm is then reduced to an *artifact* ready to be *instrumentalised* in MWS projection on another field.

Simulation programs and dynamic tables are very active in the *instrumental dimension* of MWSs outside AWS. The “simulation programs” are instrumentalized as tools to build a statistical observation, within MWSstat (and within MWSprob if this construction shows properties resulting from chance).

Case of algorithms written in “pseudo-code” of levels 0, 1, and 2

The *level 2 algorithm* aims to resume the experimental protocol of drawing a cloud diagram. We expect that trainees automate the cloud diagram of frequencies by improving *level 1 algorithm* which gives the simulation of a frequency. Then implementation of *level 2 algorithm* makes it possible to observe different clouds, and to conjecture the property of prediction interval. Figures 4, 5 and 6 present the exploded diagram (top view of MWSs and AWS) corresponding to designs and executions of each algorithm level. More specifically as regards interactions between probability and statistics, a more detailed description is presented in Trunkenwald (2018) for the chosen task.

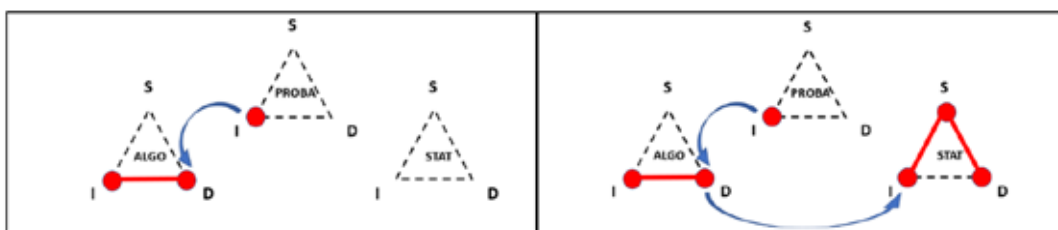


Figure 4: AWS, MWS_{Prob}, and MWS_{Stat} for level 0 algorithm (conception and exploitation).

At level 0, the algorithm is designed in an instrumental genesis of the random generator artefact in AWS, simulating a distance between two randomly selected points along the segment. This numerical modelization generates a *discursive validation* of the random experiment simulation, through a *discursive genesis* in AWS. This *level 0 algorithm* is then used as a *technological tool* in MWS_{Stat} through an *instrumental genesis* in MWS_{Stat} (activating the *discursive dimension* by mobilizing frequency, and the *semiotic dimension* by mobilizing a type of data management). An experimental protocol for calculating a frequency is then constructed by running the *level 0 algorithm* many times (Figure 4).

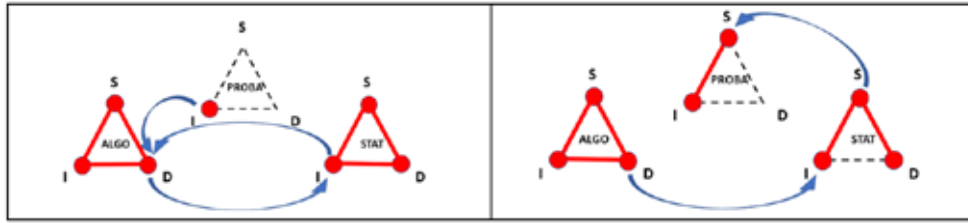


Figure 5: AWS, MWS_{Prob}, and MWS_{Stat} for level 1 algorithm (conception and exploitation).

At level 1 (Figure 5), the frequency simulation protocol is totally automated. This algorithmic work generates a *complete circulation* in AWS. And the *level 1 algorithm* (new frequency simulation algorithm) is then used as a technological tool in MWS_{Stat} through an *instrumental genesis* (activating the *discursive dimension* by mobilizing cartesian coordinate system). This protocol builds a frequency cloud diagram protocol by running the *level 1 algorithm* many times. This work generates a *semiotic genesis* in MWS_{Stat} by *visualizing* the sample fluctuations. Supported by this new *semiotic link* between frequency and probability, this *semiotic genesis* in MWS_{Stat} leads to a *semiotic genesis* in MWS_{prob} (“intellectual visualization” of fluctuations of chance).

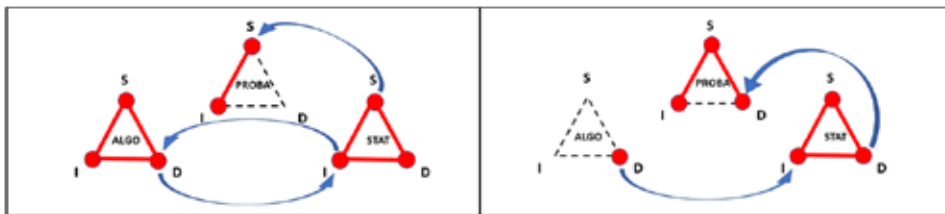


Figure 6: AWS, MWS_{Prob}, and MWS_{Stat} for level 2 algorithm (conception and exploitation)

At level 2 (Figures 6 and 7), the cloud drawing protocol is totally automated. This algorithmic work generates again a *complete circulation* in AWS. And this *level 2 algorithm* (new cloud drawing algorithm) is then used as a technological tool in MWS_{Stat} through an *instrumental genesis*. This *construction* of a new protocol leads a *complete circulation* in MWS_{Stat} to build a conjecture of the prediction interval formula by inductive reasoning. This work generates a *discursive genesis* in MWS_{Stat} with this new understanding of the interval meaning, in light of sample fluctuations. Supported by this new *discursive link* between frequency and probability, *discursive genesis* in MWS_{Stat} leads to a *discursive genesis* in MWS_{prob} (understanding of the prediction interval formula meaning, in light of the frequentist approach of probability).

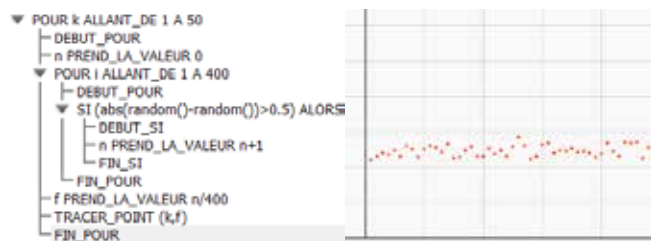


Figure 7: Level 2 algorithm implemented on Albox

Conclusion

The three described phases allow us a construction by successive encapsulations of the simulation algorithm. These algorithmic steps also resonate with the experimental statistical protocol phases. And this semantic congruence finds its expression in a certain aspect of algorithmic work: the organization of in-blocks “subroutines” procedures.

The MWS_S tool highlights interactions between the three considered domains: the *level 0 algorithm* designed in an interaction between the instrumental dimension of MWS and AWS. Then *level 0 algorithm* is executed in order to construct a new experimental protocol. The *level 0 algorithm* is then considered as a technological tool through an instrumental genesis in MWS_{Stat}. Then *level 0 algorithm*, taken as theoretical tool in a discursive genesis of AWS, finalizes a new algorithmic object aiming to automate this new experimental protocol: the *level 1 algorithm*. Two new identical cycles of interactions between MWS_{Stat} and AWS can successively generate the *level 2 algorithm*, which could establish a conjecture to frame the fluctuations. Then, this conjecture makes it possible to visualize in a semiotic genesis of MWS_{Prob} the prediction interval, in order to activate the discursive dimension of MWS_{Prob} to enrich the repository of the prediction interval property.

In addition, to highlight this dialectic of evolving interaction cycles between the three involved domains, our analysis can be used to design a prototype for teacher training session, or an activity for students, that avoid confronting learners with the simultaneous difficulties of different domains. Such a prototype can also be used as a remediation tool.

References

- Douady, R. (1986). Jeux de cadres et dialectique outil-objet. *Recherches en didactique des Mathématiques*, 7(2), 5–31.
- Duval, R. (1993). Registres de représentation sémiotique et fonctionnement cognitif de la pensée. *Annales de didactique et de sciences cognitives*, 5(1), 37–65.
- Kuzniak, A., Tanguay, D., & Elia, I. (2016). Mathematical Working Spaces in schooling: an introduction. *ZDM*, 48(6), 721–737.
- Lagrange, J. B. & Laval D. (2019). *Connected working spaces: The case of computer programming in mathematics education*. Paper presented at the Eleventh Congress of the European Society for Research in Mathematics Education (CERME-11). Utrecht, The Netherlands.
- Laval, D. (2018). *L'algorithmique au lycée entre développement de savoirs spécifiques et usage dans différents domaines mathématiques*. Thèse de doctorat. Université Paris-Diderot.
- Modeste, S. (2012). *Enseigner l'algorithme pour quoi? Quelles nouvelles questions pour les mathématiques? Quels apports pour l'apprentissage de la preuve?* Thèse de doctorat. Université de Grenoble, France.
- Nechache, A. (2016). *La validation dans l'enseignement des probabilités au secondaire*. Thèse de doctorat. Université Paris-Diderot, Paris, France.
- Nilsson, P., Schindler, M., & Bakker, A. (2017). The nature and use of theories in statistics education. In D. Ben-Zvi, K. Makar, & J. Garfield (Eds.), *International handbook of research in statistics education* (pp. 359–386). Cham: Springer.
- Rabardel, P. (1995). *Les hommes et les technologies : Approche cognitive des instruments contemporains*. Paris : Armand Colin.
- Trunkenwald, J. (2018). L'Espace de Travail Mathématique : Une respiration pour analyser la fluctuation d'une simulation d'échantillonnage. *Mathematical Working Space, Proceedings Sixth MWS Symposium*. Valparaiso, Chili. New submission ETM 6.

The investigative cycle: Developing a model to interpret written statistical reports of pre-service primary school teachers

Francisca Ubilla¹, Núria Gorgorió² and Montserrat Prat³

¹Universitat Autònoma de Barcelona, Catalonia, Spain; francisca.manriquez@e-campus.uab.cat

² Universitat Autònoma de Barcelona, Catalonia, Spain; nuria.gorgorio@uab.cat

³ Universitat Autònoma de Barcelona, Catalonia, Spain; montserrat.prat@uab.cat

With the aim of contributing to the study of the statistical knowledge of pre-service primary school teachers, here we present the creation of a system of categories of analysis to characterize the written reports of a group of students who carried out a task that reflected the five stages of the statistical investigative cycle. The analysis answers to a deductive/inductive process, since we look at the theory to understand our data and, at the same time, themes emerge that had not yet been described in the literature. Our contribution is a system of categories for the characterization of the statistical investigative cycle, which consolidates, refines and extends what has been published so far. The proposal presented here may be useful not only for researchers and teacher educators, but also for pre-service teachers themselves to understand the investigative cycle.

Keywords: Pre-service primary school teachers, statistics education, statistical thinking, investigative cycle.

Introduction and theoretical framework

In recent years the Spanish national curriculum has included statistics from the first year of primary school. At the end of compulsory education, students are expected to be able to formulate questions, select and use statistical methods, and draw conclusions based on data. It makes sense to assume that if this is what students are expected to achieve, teacher educators should train future teachers to be able to create educational instances focused on the development of such competences.

Batanero, Díaz, Contreras and Roa (2013) define statistical sense as the whole of statistical culture and statistical reasoning. This definition is based on the constructs of statistical literacy (Gal, 2002) and statistical thinking (Wild & Pfannkuch, 1999), including the idea of statistical reasoning as well as the fundamental ideas to be developed in statistical education. Wild and Pfannkuch (1999) propose four dimensions to characterize statistical thinking: the investigative cycle, types of thinking, the interrogative cycle, and dispositions.

Dimension 1, the investigative cycle represented in Figure 1, involves five stages consisting of problem, plan, data, analysis and conclusions. Dimension 2 includes types of thinking, and here Wild and Pfannkuch (1999) establish a general type and types fundamental to statistical thinking. In the latter, we find: a) recognition of the need for data to solve a problem that involves statistics; b) transnumeration corresponding to the idea of changing the format of the data in order to obtain new information; c) variation, which consists of noticing that variation is present in all the aspects of a problem involving statistics; d) a distinctive set of models; e) integration of context, statistical knowledge, and information on the data. Dimension 3 corresponds to the interrogative cycle, which involves five phases: imagining possible plans of attack or generating explanations, searching for

information and ideas, interpreting, checking against reference points (criticizing), and deciding what to believe or discard (judging). Finally, dimension 4 involves dispositions, which include skepticism, imagination, curiosity and awareness.

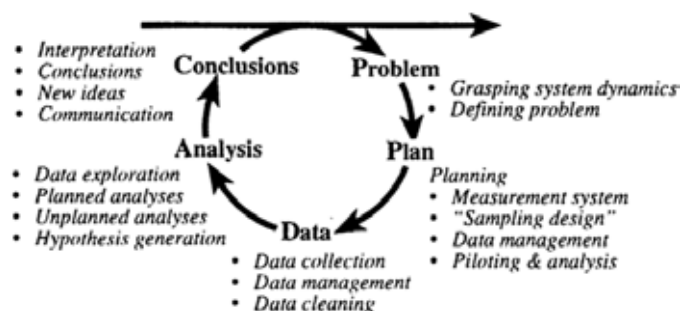


Figure 1: The investigative cycle (Wild & Pfannkuch, 1999, p. 226)

With the long-term aim of contributing to the understanding of the statistical knowledge of students starting on a primary school teacher education program, here we present the development of the system of categories used to characterize how a group of pre-service teachers approached the stages of a statistical investigative cycle (hereafter referred to as IC). Our contribution is a system of categories that consolidates, refines and extends the existing theoretical ideas.

Instrument and data collection

According to Wild and Pfannkuch (1999), the IC is a coherent structure that links the different dimensions of statistical thinking. Since the aim of the present study was to create a tool to characterize the way pre-service primary teachers developed an IC, we set an activity that guided them explicitly through an investigative process. The activity consisted of six steps. The first five steps were related to the proposal of Wild and Pfannkuch (1999), and in the sixth step we asked the students to reflect upon the activity, identifying strengths and weaknesses of the investigative process they had carried out. The activity proceeded as follows:

1. *Define a topic of interest and a research question.*
2. *Justify the relevance of the research topic and of the research question.*
3. *Develop a data collection tool, justifying its construction and the questions that comprise it.*
4. *Analyze the data and present results.*
5. *Give a possible answer to the research question and establish conclusions.*
6. *Evaluate and reflect upon the whole process, identifying strengths and weaknesses.*

In February 2017, 134 students who had just started their four-year program in primary teaching at the Autonomous University of Barcelona were organized into 34 working teams of three or four members and developed the proposed activity in six 90-minute sessions. Our data consists of each team's written output, complemented by the classroom observations collected by the first author. This output is associated with a number: for example, G3 corresponds to Group 3.

Analysis

The analysis took a deductive/inductive approach. First, in line with Wild and Pfannkuch (1999), we grouped data according to the different stages of the IC and the components of each stage (already

shown in Figure 1). The process was deductive in that, for each component, we looked for theoretical references to explain our data and from there we tried to organize it according to the theoretical specification of the component. While coding and grouping units of meaning according to their similarities and differences, themes emerged that had not yet been described in the literature. In this sense, the analysis process was also inductive.

Next, we present the analysis for each stage, and for each component – written in italics in the text – we introduce the categories used or created for our analysis. When the category is related to existing theory, we quote the reference. The references are introduced here rather than in the theoretical framework because we understand that they are part of our analytical framework. When the categories arose from the data, they appear underlined in the text, and together with the name given to the category we present a definition and examples where necessary.

IC analysis: PROBLEM

The initial stage of the IC involves two components, with the first one *capturing the dynamics of the context*. Before defining the research problem, the teams justified their choice of research topic. Thus, an initial category arose – research rationale – with different subcategories:

- Relevance: their selection of the topic was justified by its relevance in the context. “We believe that reading is an essential source of knowledge. As future teachers, it would be important for us to spread the enjoyment of reading to the students. Therefore, we would like to know the literary preferences of our classmates.” (G1)
- Curiosity: their selection responded to their own curiosity about some aspect of their context, with no justification of its relevance. “By quickly observing our classmates, we detected that there are people wearing make-up and people that aren’t. We would like to dig deeper into the main reasons that have led them to wear make-up and find out at what ages they started to do so.” (G8)
- Unspecified interest: they stated that they were interested in the topic, without specifying why. “We have chosen this topic because it interested and motivated all the team members.” (G30)

When analyzing the component *problem definition*, we organized the written reports according to the preciseness of their problem formulation, creating three categories:

- Focus: the formulation established the topic they prioritized in their research.
- Purpose: the formulation established what they wanted to know about their topic of interest; however, they did not necessarily formulate a research question as such.
- Research question: they explicitly stated the research question that guided their investigation.

The definition of the problem could include some or all of these elements, as can be seen in the sentence we use to exemplify the different degrees of preciseness: “The topic we covered was books. More specifically, the interest in reading [focus]. The relevance of the chosen topic lies in the fact that for us, as future teachers, it would be interesting to find out how keen our classmates are on reading [purpose] so that we can influence future generations. Once we have chosen the topic, we will focus on the research question: Are we interested in reading? [research question]” (G10).

On looking at the nature of both the purpose and the research question and taking into account Makar and Fielding-Wells (2011), we distinguished two subcategories that respectively included questions

that either were or were not statistical in nature, depending on whether or not statistical work was involved. Regarding the type of research questions, we organized our data according to the three types put forward by Pfannkuch and Horrying (2005). Each type generated its corresponding category. Thus, both the research questions and purposes collected were organized into three categories: summary, comparison and relationship. Furthermore, as proposed by Arnold (2013), the first two, summary and comparison, could have been further subdivided according to Arnold (2013) proposal.

IC analysis: PLAN

In this stage, our data did not allow categories to be established within the *hypothesis formulation component*. Regarding the *data collection instrument*, we observed that all groups used questionnaires with questions that were either open-ended or closed-ended. Thus, we created a first category, format of questionnaire, which is subdivided into three, closed-ended, open-ended or mixed, depending on whether all the questions in the questionnaire were of the first or second type, or a combination of the two. We created a second category, type of questions, which generated two subcategories, sample and aim. In turn, these were further subdivided.

- Sample: included the questions that referred to the population under study:
 - × Characterization: those questions whose purpose was to collect information on the variables that characterized the population under study, such as age or gender.
 - × Selection: questions intended to distinguish between those participants who could provide information to adequately answer the research question and those who could not. “¿Are you currently reading by choice?” (G1) [It did not make sense to ask those who did not currently read willingly to continue answering the questionnaire].
- Aim: included the questions intended to obtain information related to the research topic:
 - × Target: included those aimed at gathering information to answer the research question.
 - × Satellite: included those questions that did not ask for information crucial to the investigation, but which might complement it: “At school, did they motivate your interest in reading? (G10)
 - × Redundant: included those questions that did not contribute anything to the research topic.

IC analysis: DATA

In this stage of the cycle, we identified two techniques that generated two categories with regard to the *data collection* component: ticking options in a table that anticipated possible answers, and listing answers, copying them as provided by informants. Regarding the component *data cleaning*, we observed that some groups identified and separated the data provided by informants who did not belong to the sample, either visually or non-visually. For instance, in Figure 1, we see how the students separated the answers given by the teacher and the observer by placing them outside the table, since they were not part of the target population.

Pregunta 4

	Has accedit a aquest grau amb 37/38 anys?	No fan el grau de primera
Si		(45)

Figure 1: Visual recording of data provided by informants who did not belong to the sample

IC analysis: ANALYSIS

At the outset, we saw that in this stage we had to consider a component previously unspecified in the literature, namely *initial data processing*. Within this component, we observed that the teams either recorded frequencies (absolute and/or relative) of answers to closed-ended questions or constructed categories from the answers to open-ended questions. When the *transnumeration* component (Wild & Pfannkuch, 1999) appeared in the reports, we observed two types of format change which gave rise to the following categories: numerical representations (percentage, centralization measures) and graphical representations (bar graphs, histograms and pie charts).

IC analysis: CONCLUSIONS

In this stage of the cycle, we constructed two categories related to the *interpretation of results* component: graphical representations and numerical representations, strictly linked to the type of format change of their analysis. To organize our data within the first category, we followed Gea, Arteaga and Cañadas (2017). Thus, we established four subcategories, namely reading the data, reading between data, reading beyond data and reading behind data.

To describe how the written reports that fall into the category of numerical representations reached their conclusions, we looked at two aspects that generated a new category each. The first category, approach, was further subdivided in two, partial and relational, depending on whether the conclusions referred to the numerical results considered one by one, or whether they related the different results obtained, giving more complex answers to the research question.

The second category was related to meaning conveyance and concerned the character of each team's conclusions. It was split into two further categories:

- Descriptive: their conclusions only consisted of showing percentages, absolute frequencies or measures of centralization, without any further interpretation: “Question 3: of the 69 persons surveyed, 73.9% prefer to study on their own, 18.8% choose to study with another person.” (G34).
- Interpretative: their conclusions were interpreted in relationship with different elements:
 - × Context: they interpreted their results by integrating information about the context. “We think that this low percentage could be caused by the rise of new technologies, compulsory reads in primary and secondary school, and the little free time available.” (G1)
 - × New information: when interpreting their results, they incorporated new information encountered during data collection “We have observed that younger people start drinking alcohol at a younger age, while older people took longer to try it.” (G18)
 - × Beliefs: they interpreted their results on the basis of their own beliefs. “We believe this may be due to a change in mentality. A pet is no longer seen as a toy but as a responsibility.” (G3) Since the team's results showed that 85% of the surveyed people had had a pet at some point, and 50% of the surveyed population currently owned a pet, this unit of meaning would also be an example of the relational category.

Finally, for what refers to the *relationship between conclusions and the research question* component, several categories arose depending on whether the conclusions answered, partially

answered or did not answer the initial research question or purpose, thus allowing the teams to complete or not the IC. Regarding the *critical reflection* of their process, we observed that they identified strengths and weaknesses, focusing their criticism essentially on the data collection tool they had constructed. Some teams also made suggestions for improvements to their own IC.

Results

For the purposes of this paper, we are neither interested here in determining how many groups there were in each category, nor in characterizing the work of the different groups, but rather in highlighting the categories as a set. Thus, our main result is a category system that refines, consolidates and broadens the characteristics appearing in the literature. We note the inclusion of two new components: in Stage 4, *initial processing of data*, and in Stage 5, *criticism of their own work process*. Table 1 shows the new study categories on a grey background.

<i>Components</i>	Categories			
Stage 1: PROBLEM				
<i>Capture the dynamics of the context</i>	Rationale	Relevance		
		Curiosity		
		Unspecified interest		
<i>Problem definition</i>	Focus			
	Purpose		Nature	Statistical
				Non-statistical
	Research question		Type	Summary
				Comparison
Relationship				
Stage 2: PLAN				
<i>Hypothesis formulation</i>				
<i>Data collection instrument</i>	Format	Closed-ended		
		Open-ended		
		Mixed		
	Type of question	Sample	Characterization	
			Selection	
		Aim	Target	
Satellite				
		Redundant		
Stage 3: DATA				
<i>Data collection</i>	Techniques	Ticking options		
		Copying answers		
<i>Data cleaning</i>	Visual			
	Non-visual			

Stage 4: ANALYSIS				
<i>Initial processing of data</i>	Frequency records			
	Category construction			
<i>Transnumeration</i>	Numerical representation			
	Graphical representation			
Stage 5: CONCLUSIONS				
<i>Interpretation of results</i>	Graphical representation	Reading data		
		Reading between the data		
		Reading beyond data		
		Reading behind data		
	Numerical representation	Approach	Partial	
			Relational	
		Meaning conveyance	Descriptive	
			Interpretative	Context
				New information
				Beliefs
<i>Conclusions and RQ</i>	Answer			
	Partially			
	Did not answer			
<i>Criticism of their own work process</i>	Strengths			
	Weaknesses			
	Suggestions for improvement			

Table 1: Categories system

Conclusions

An IC requires having and applying statistical knowledge, completing its stages and thinking statistically. It is a complete structure and we found it useful for the description of the statistical knowledge activated by future teachers when they face a task that reflects an IC. In this paper, we present the creation of a system of categories of analysis based on existing theory and the data we collected, consisting of the written reports of a group of pre-service teachers.

In the process of generating categories we observed the same phenomenon as Wild and Pfannkuch (1999) in the sense that “The thinker operates in all four dimensions at once” (Wild & Pfannkuch, 1999, p. 225). Our proposed analysis revolves around the first dimension, but to interpret our data we need the support of the other three. Thus, the idea of transnumeration included in the second dimension is key to our interpretation of the analysis stage. Likewise, the idea of integration of context, statistical knowledge, and information on the data, is essential if we are to interpret the conclusion stage. Similarly, the stage of searching for information and ideas and the stage of criticizing and judging, both part of the third dimension, are linked to the generation of categories, within data collection and interpretation of results respectively. Likewise, the fourth dimension,

which involves dispositions, is key to the criticism of the teams' own work processes, a new component that emerged from our analysis.

As far as our new system of categories is concerned, we would like to point out that it is not a closed object, since it can be modified or expanded to analyze data obtained from other groups of students (at this and other educational levels) when constructing their own investigative cycles. Furthermore, the subcategories should include the knowledge and processes that we would like our students to have at their disposal as teachers. Meanwhile, the categories may already be useful to researchers when approaching the characterization of statistical knowledge and to teacher educators when identifying their student-teachers' starting point and interpreting their responses.

This research was carried out with the support of research grants EDU2013-4683-R and EDU2017-84427-R –Spanish Ministry of Science, Innovation and Universities.

References

- Arnold, P. M. (2013). *Statistical investigative questions - An enquiry into posing and answering investigative questions from existing data*. (Doctoral dissertation). University of Auckland, New Zealand. Retrieved from <https://researchspace.auckland.ac.nz/handle/2292/21305>
- Batanero, C., Díaz, C., Contreras, J. M., & Roa, R. (2013). El sentido estadístico y su desarrollo. *Números. Revista de Didáctica de las Matemáticas*, 83, 7–18.
- Gal, I. (2002). Adults' statistical literacy: Meanings, components, responsibilities. *International Statistical Review*, 70(1), 1–25.
- Gea, M., Arteaga, P., & Cañadas, G. (2017). Interpretación de gráficos estadísticos por futuros profesores de educación secundaria. *Avances de Investigación en Educación Matemática*, 12, 19–37.
- Makar, K., & Fielding-Wells, J. (2011). Teaching teachers to teach statistical investigations. In C. Batanero, G. Burrill, & C. Reading (Eds.), *Teaching statistics in school mathematics-Challenges for teaching and teacher education: A joint ICMI/IASE study* (pp. 347–358). NY: Springer.
- Pfannkuch, M., & Horing, J. (2005). Developing statistical thinking in a secondary school: A collaborative curriculum development. In G. Burrill & M. Camden (Eds.), *Curricular development in statistics education: International Association for Statistics Education*. (pp. 204–218). Voorburg, The Netherlands: ISI.
- Wild, C., & Pfannkuch, M. (1999). Statistical thinking in empirical enquiry. *International Statistical Review*, 67(3), 223–248.

Introduction of inferential statistics in high school in Hungary

Ödön Vancsó¹, Peter Fejes-Tóth², and Zsuzsanna Jánvári³

¹Eötvös Loránd University, Budapest, Hungary; vancso@caesar.elte.hu

²Szent István University, Budapest, Hungary; fejestothpeter@yahoo.com

³Szerb Antal Gimnázium, Budapest, Hungary; zsjanvari@gmail.com

Keywords: Statistical inference, probability distribution, interdisciplinary approach.

Introduction, theoretical background

Inferential statistics is not part of the secondary school curriculum in Hungary. The current plans to reform the national curriculum include the introduction of basic inferential statistics. A working group of the Hungarian Academy of Sciences, of which these authors are members, is exploring possibilities and designing tasks and feasible learning paths. Descriptive statistics – though mainly from a didactical rather than a mathematical point of view – is taught in teachers' education since the early 2000s, while teachers learn basic probability at the university since 1959. Because of this lack in teachers' background, the aim of the project is to design an acceptable way of introducing inferential statistics in high-school curricula both for students *and* their teachers.

This paper is linked to the project „Complex Mathematics Education”. Our work is based on the ideas about teaching probability and statistics of T. Varga and T. Nemetz. We have designed several experiments and tested them by one of the authors (Jánvári) in Szerb Antal Secondary School (grade 11, 17 year-old students). The experiments are determined by their fit into our theoretical views on modelling probability and to the approach of teaching classical and Bayesian statistics together developing the concepts in parallel (Vancsó, 2009; 2018). In these studies, teacher's and students' beliefs and skills were developed by a “parallel course”, which helped to understand classical *and* Bayesian ideas. While the *informal* approaches to teaching *inference* in Garfield and Ben-Zvi (2008) focus on simplifying statistical inference by re-randomisation and Bootstrap, we try to make inference more understandable by integrating the Bayesian view. This is in line with Borovcnik (2017), who describes shortcomings of *informal inference*. It also fits to an analysis of statistical inference from the statistician's perspective by Vic Barnett, which is summarised in a comparative educational study of statistical inference by Borovcnik (2013).

Conclusion and results

Our first experiment is rolling dice judging whether the die used is well-balanced or loaded by a probability statement. Though this method was introduced in earlier papers (e.g., Lawton, 2009; Dambolena, Eriksen, & Kopcso, 2009), our approach places greater emphasis on the hands-on in-class experiment. It is used to introduce hypothesis testing. In this case, the Bayesian way is technically too complicated but becomes manageable through the use of software. The second example is a reaction test using a stopwatch. This interactive game among students unfolds connections between different school subjects such as physics, biology, and mathematics. Furthermore, it is also suitable to discuss about discrete and continuous quantities. It is our goal to

use more games in teaching, which is motivating for students and provides an excellent opportunity to discuss basic notions and misconceptions in probability and statistics. Also, application of modern ICT tools in itself can be interesting and challenging for secondary-school students. Moreover, the gamification element (see Papp, 2017) can increase their involvement and consequently their motivation and understanding of the scientific material.

This paper was supported by the Hungarian Academy of Sciences' "The Complex Mathematics Education Project".

References

- Borovcnik, M. (2013). A comparative educational study of statistical inference. In *Proceedings of the 59th World Statistics Congress* (p. 1114-1119). The Hague: ISI. Retrieved from: 2013.isiproceedings.org/Files/IPS112-P4-S.pdf.
- Borovcnik, M. (2017). Informal inference – Some thoughts to reconsider. *Proceedings of 61st ISI World Statistics Congress*. The Hague, The Netherlands: International Statistical Institute.
- Dambolena, I. G., Eriksen, S. E., & Kopcsó, D. P. (2009). An intuitive introduction to hypothesis testing. *INFORMS Transactions on Education*, 9(2), 53-62.
- Garfield, J. B., & Ben-Zvi, D. (2008). Learning to reason about statistical inference. In J. B. Garfield, & D. Ben-Zvi (Eds.), *Developing students' statistical reasoning* (pp. 261-288). New York: Springer.
- Lawton, L. (2009). An exercise for illustrating the logic of hypothesis testing. *Journal of Statistics Education*, 17(2).
- Papp, T. A. (2017). Gamification effects on motivation and learning: application to primary and college students. *International Journal for Cross-Disciplinary Subjects in Education (IJCDSE)*, 8(3), 3193-2301.
- Vancsó, Ö. (2009). Parallel discussion of classical and Bayesian ways as an introduction to statistical inference. *International Electronic Journal of Mathematics Education (IEJME)*, 4(3), 291-322. Retrieved from: hwww.iejme.com/article/parallel-discussion-of-classical-and-bayesian-ways-as-an-introduction-to-statistical-inference.
- Vancsó, Ö. (2013). Teaching statistical inference from multiple perspectives integrating diverging schools of inference. *Proceedings of 59th ISI World Statistics Congress* (pp. 1108-1113). The Hague, The Netherlands: ISI. Retrieved from: 2013.isiproceedings.org/Files/IPS112-P3-S.pdf.
- Vancsó, Ö. (2018, July). How visualisation using software helps understanding classical and Bayesian statistics. *Invited paper in session 6C. ICOTS 10*, Kyoto, 8-13 July, 2018. Retrieved from: www.researchgate.net/profile/Oedoen_Vancso.

TWG06: Applications and modelling

Introduction to the papers of TWG6: Applications and modelling

Berta Barquero¹, Susana Carreira², Jonas Bergman Ärleback³,

Britta Jessen⁴, Katrin Vorhölder⁵, Geoff Wake⁶

¹ Faculty of Education, University of Barcelona, Spain; bbarquero@ub.edu

² University of Algarve, & UIDEF, Institute of Education, University of Lisbon, Portugal;
scarrei@ualg.pt

³ Department of Mathematics, Linköping University, Sweden; jonas.bergman.arleback@liu.se

⁴ Department of Science Education, University of Copenhagen, Denmark; britta.jessen@ind.ku.dk

⁵ Faculty of Education, University of Hamburg, Germany; katrin.vorhoelder@uni-hamburg.de

⁶ Faculty of Social Sciences, University of Nottingham, United Kingdom;
geoffrey.wake@nottingham.ac.uk

Introduction

The thematic working group 6 (TWG6) in CERME focuses on the research field of teaching and learning mathematical modelling and applications at various educational levels ranging from primary to tertiary education, including vocational courses. The working group also addresses initial and continuing teacher education, where an increasing number of contributions have been offered. TWG6 started at the fourth ERME Congress (CERME 4) in 2005 and it has, since then, continued to be an active thematic working group in the eight meetings through to CERME 11. In total the working group has produced and presented 161 papers and posters.

In its discussions at CERME 11, the thematic working group TWG6 on applications and modelling aimed to seek answers to some open questions in the research field (Schukajlow, Kaiser, & Stillman, 2018), and continue to advance the work from previous ERME conferences. The contributions discussed at the congress are characterized by a strong and fruitful diversity in the research questions considered, the school levels addressed and the theoretical approaches taken. On the whole, TWG6 received 41 papers and posters from 17 countries—most of them from Europe, but also from South and Central America, Iran, South Africa, South Korea and Japan. Finally, a total of 21 papers and 7 posters were presented in the conference, with a total of 40 participants from 14 countries. The next table summarizes the evolution of papers and poster presented in TWG6 in the different CERMEs.

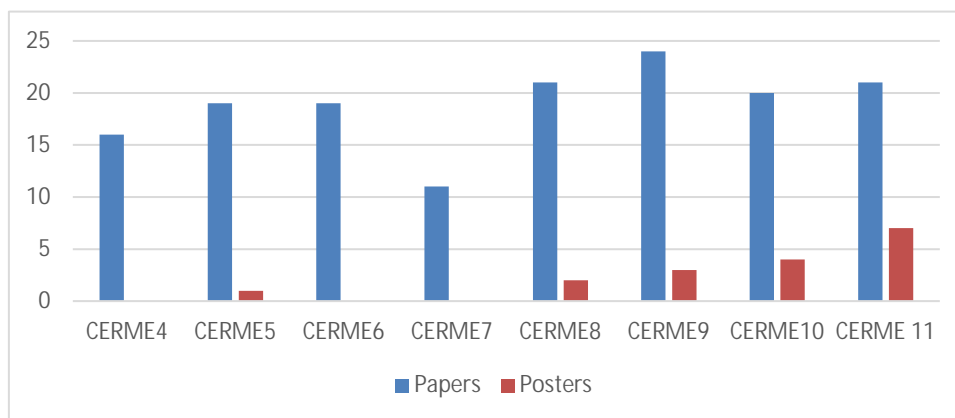


Table 1: Evolution of the papers and posters presented in TWG6

In the seven TWG sessions the different papers were discussed organized around five leading themes, which were established after reading and revision of the submitted proposals. Although some of the papers cover more than one of the identified leading themes, the proximity to other research papers facilitated their distribution among the various themes (Table 1).

<i>Leading themes</i>	<i>Papers</i>
T1. Analysis of modelling processes when solving modelling problems	3
T2. Mathematical modelling and simulations in connection to other disciplines	3
T3. Strategies to support design and implementation of modelling	4
T4. Use of resources to support teaching and learning of modelling	2
T5. Teacher education for modelling and its application	9

Table 2: Leading themes defined and papers assigned in each

As a first important leading theme papers focusing on creating and testing tools for the analysis of the modelling processes that are carried out when students solve modelling problems were identified. These research papers aimed to elaborate specific tools and methodologies for analysing and evaluating modelling practices. The second theme focused on the interplay and connections between mathematical modelling and other subjects, especially in engineering teaching. The third theme addressed different strategies to support the teaching and learning of mathematical modelling; this includes strategies to foster students work on modelling problems, ways in which teachers can guide their implementation and evaluation as well as ideas regarding the design of modelling activities by researchers (and/or teachers). The fourth theme focused on the use of experimental materials and technology in modelling, and covered two topics: the first primarily focused on the role of the auxiliary material and its impact on the modelling activity and a second concerned with how to combine different resources with technology in concept development by means of real word contexts. Finally, the fifth theme covered teacher education for modelling and its applications. As this theme had a lot of contributions, we organized the contributions into two sub-topics. The first topic was about assessing and measuring teaching competencies for mathematical modelling. The second focused on several instructional proposals for prospective and in-service teacher education for modelling and applications.

Leading themes and overarching questions

Analysis of modelling processes when solving modelling problems

This first theme focused on proposing tools and methodologies to analyse the modelling processes individuals or groups of individuals engage in when solving modelling problems. Firstly, *Ärlebäck* and *Albarracín* investigated the potential of extended Model Activity Diagrams as an analytical tool for analysing students' modelling processes by including a sub-division of the modelling tasks at hand in terms of the sub-problems that students work on. Secondly, the paper of *Montejo* and *Fernandez* considered the conceptualisation of the notion of model/s. Based on their analysis of a diversity of definitions about what a model is, according to the educational research literature, the authors introduce a conceptualisation of the notion of model/s as a triplet system-mathematization-representation, and propose for this to be used in future research. Lastly, *Moutet* uses the theoretical framework of the Mathematical Working Space (MWS) to extend the notion of the modelling cycle and to analyse the tasks associated with certain stages of a modelling task in physics, in particular concerning special relativity. This research intends to show how the extended MWS offers a tool for the analysis of the mobilization of the epistemological planes of physics and mathematics and how it relates to the cognitive plane. Although the discussions of the three papers partly focused on different aspects, the following common and overarching questions surfaced in the discussion of the contributions in this first theme:

- § What do these new frameworks (or development of existing ones) add to our understanding of, and our research practices in, the field of teaching and learning of modelling?
- § What are the implications of these frameworks when considering supporting different communities with modelling: students, teachers or modelling task designers, etc.?
- § In what ways can we broaden 'our' perception of what modelling is by comparing different approaches and their interpretation of what modelling is?

Mathematical modelling and simulations in connection to other disciplines

This theme focuses on the role of modelling and simulations when mathematics is integrated with other disciplines. Some of the papers in this theme touch upon parts of the topic of TWG26 - Mathematics in the Context of STEM Education. However, the aim of the papers in this leading theme is to study the role of mathematical modelling in the context of mathematics education rather than the notion of STEM more generally. Within this thematic strand, we find a diversity of studies, proposals and results that easily connect with other leading themes. The paper by *Poudel*, *Vos* and *Shults* describes an empirical study with students of Development Studies, which aims at introducing examples of real research and methods in social sciences to the students. The authors describe their experience from a university seminar on introducing a research approach to the social sciences with the aim of investigating how students use and gain knowledge about modelling and simulations. *Lantau* and *Bracke* present a study about the use of a STEM-modelling project involving the functional principles of a Segway, within a teacher development programme which later guided their implementation of the STEM-project in secondary school settings (grades 10 to 12). Their aims are to analyse the effective factors and obstacles that teachers manifest concerning the implementation of these modelling activities. In the context of STEM-projects, *Ruzika* and

Schneider advocate a multicriteria perspective in relation to mathematical modelling, optimization and decision-making. Their paper presents several examples from real-world problems (including some STEM projects) illustrating the need of multicriteria decision-making and gives some first hints toward incorporating this multicriteria perspective in the teaching paradigm of mathematical modelling. In the general discussion about this theme, we addressed questions such as:

- § How can we facilitate and progress the implementing of interdisciplinary modelling projects given regular school conditions (and not only in the modelling-projects weeks, days, etc.)?
- § What limitations emerge when adapting modelling projects to school and university conditions? What can be done to favour interdisciplinarity modelling projects in schools?
- § What role could or should the other disciplines (natural sciences, social sciences, engineering, etc.) play in mathematical modelling and in mathematical modelling lessons?
- § What new disciplinary and interdisciplinary knowledge needs to be introduced and how do we do this in secondary schools and universities?
- § Can mathematical modelling be considered as a support for the construction and development of inter-disciplinary knowledge? Which constraints do we have to overcome?

Strategies to support students and teachers in the design and implementation of modelling

The papers related to this topic refer to different strategies to support students when solving modelling problems, teachers when guiding their implementation and evaluation as well as researchers (and/or teachers) with the design of modelling activities. The pursued aims are varied, but when organising their complementarities we found some common questions these papers deal with:

- § What strategies do we have (for example: reading strategies and text representations, students' evaluation of given modelling solutions) to help students in modelling? What complementary information can several approaches give us?
- § How can the configuration of modelling activities, or their reconfiguration into different modelling problems, serve different teaching and learning objectives? Which principles for the design of modelling tasks may be established?

Related to the first questions, *Dröse* presents research about the impact of fostering reading and comprehension strategies to support students in successfully solving modelling problems. Through the analysis of some particular case studies with students solving modelling tasks, this research focuses on analysing how certain reading strategies can contribute to different steps in constructing mental text representations, which is an important step in modelling. In their work, *Kuntze* and *Eppler* propose that an effective strategy to support students' modelling practices is to ask students to evaluate some particular given solutions of modelling tasks. In particular, this paper presents some empirical findings relating to secondary students when they review and refine modelling solutions cooperatively in the classroom; the students have to face specific requirements, such as reconstructing modelling thoughts, examining alternative modelling steps and comparing the quality of different modelling solutions.

Concerning the second questions, we discussed two papers dealing with task design issues. *Almeida* and *Carreira* present a theory-based discussion on the configuration of modelling activities to show

how the design of modelling tasks is strongly dependent on the perspective adopted for its implementation. Based on some particular examples, an analysis of the task configuration is carried out in light of the more implicit or explicit aims of mathematical modelling in teaching and their connection with various modelling perspectives. From the examples, it is possible to argue that the configuration of modelling tasks is adaptable, which entails flexibility and reinforces the relevance of an educational standpoint in designing modelling problems. Last but not least, *Pla-Castells* and *Ferrando* describe an empirical study with the objective of designing a sequence of modelling tasks focusing on solving a big number estimation problem. They use the so-called downscaling - upscaling techniques for the design of this particular Fermi problem, which is later used to analyse the implementation with primary school students of second grade (7-8 years old).

Use of resources to support teaching and learning of modelling

This theme focused on the use of different kinds of resources: digital technology, physical resources, etc., at the different stages of the modelling process. In particular, some papers aim to discuss the role of the physical or digital prototypes and of simulations at the different stages of the modelling process. In *Baioa* and *Carreira*, the authors explore and discuss the use of simulations with physical models and prototype constructions in the process of modelling. They choose some examples in the inter-disciplinary context of STEM to analyse the use of prototypes and simulations in students' activity going through the entire mathematical modelling cycle. The paper links to *Lantau* and *Bracke*'s research in their detailed analysis of the potential of combining STEM and mathematical modelling. *Lieban* and *Lavicza* discuss the affordances of using and combining physical and digital resources for exploring geometrical modelling. Within the context of pre-service teacher education, the authors explore the use of physical simulation and digital resources, in particular using Geogebra, to support modelling in the transition between 2D and 3D models construction. These papers also establish connections with the aforementioned paper by *Moutet* on the use of digital technologies to simulate physical phenomena involving special relativity. Some of the matters largely discussed were:

- § How can we conceptualise simulations within mathematical modelling processes? What do simulations change for model building in the different steps of the modelling cycle?
- § How can digital and physical tools change ways of approaching modelling problems? How do they change the meaning of “working mathematically” today?
- § Do we need to rethink the definition and conceptualizations of the steps of the modelling processes when using technology and simulations?

Teacher education for modelling and its application

This last theme is the one that attracted most papers. The topic of teacher education is a valued one within the group, based on the acknowledged need of preparing pre-service and in-service teachers for the teaching of applications and modelling. Papers in this leading theme were organised in two sub-topics to facilitate their discussion. The first topic focussed on assessing and measuring teaching competencies for mathematical modelling. The second topic covered works on the proposal of different teacher education courses for pre-service and in-service teachers of primary and secondary school education.

Concerning the first topic, *Borromeo-Ferri* focuses on the question about how mathematical modelling competencies can be assessed and, more concretely, how to see an increase of teaching competencies after a course on ‘learning and teaching of mathematical modelling’. A test instrument was presented and used to assess modelling competencies for students and teachers participating in several empirical studies at secondary level. In their paper, *Klock* and *Siller* emphasize the importance of providing teachers appropriate ways of supporting students working on modelling processes, in particular, through a precise diagnosis in the intervention process. Based on a process model, another instrument for measuring teaching competencies was presented. Thus, based on the data measured by this instrument, the cause-and-effect relationship between a correct diagnosis and the selection of an adaptive intervention can be analysed. Some of the questions that emerged from the group discussion were:

- § How to ensure that the test instruments for assessing modelling competencies are significant enough, in the sense of sufficiently independent, from the modelling perspective adopted?
- § How can these instruments (assessment, diagnosis, intervention) be useful for teachers’ practice when implementing modelling activities with students?

Closely related to the previous papers, using the conceptualization of the modelling cycle and competencies, and presenting particular instructional proposals we considered several papers. *Wess* and *Greefrath* focus on the modelling-specific task competency of prospective teachers in the teaching laboratory MiRA+. In this laboratory, teachers are encouraged to design their modelling tasks and apply them in practice with emphasis on the acquisition of competency by their students. *Guerrero-Ortiz* present the results developed with prospective mathematics teachers who took part in a seminar with the aim of developing their mathematical and pedagogical content knowledge in the process of designing modelling tasks and discussing about these teaching proposals. Furthermore, *Alwast* and *Vorhölter* discuss the important gap between the theory conveyed at university and the teachers’ practical work at school and how to help future teachers make their knowledge applicable to practice. They use staged video vignettes to simulate real classroom situations and support future teachers episodic memory through repeated practice with these videos.

In their paper, *Yvain-Prébiski* and *Chesnais* identify horizontal mathematization as a crucial component of mathematical modelling. Based on this conceptualization of horizontal modelling, the authors analyse the implementation of a modelling task about the growth of an exotic tree with a large group of secondary school classrooms to analyse how teachers spontaneously manage these initial steps for modelling, especially analysing their difficulties on implementing horizontal mathematization. *Kaneko*, *Saeki* and *Kawakami* aims at creating contact points between empirical modelling and theoretical modelling in teacher education. The authors explore the case of a pendulum modelling problem and the analysis of modelling lessons related to this problem to make teachers reflect on the significance and complementarities between theoretical and empirical modelling.

In her paper, *Jessen* presents a model for upper secondary in-service teacher courses based on the anthropological theory of the didactics and explores how to train teachers to design and implement

mathematical modelling in their classrooms. The course evolves around the proposal of study and research path based teaching and strives to create paradigmatic infrastructures as a framework for collaborative development of teachers' teaching practice. Under the same theoretical approach, *Barquero*, *Bosch* and *Wozniak* address the problem of the teachers' lack of discursive tools to teach modelling processes and how it can be addressed through teacher education. This paper describes a teacher education course with pre-service primary school teachers where the terminology of modelling and the questions-answers maps are proposed to provide future teachers with a discourse—a logos—to explain and analyse the modelling praxis.

Due to the diversity of research questions and of proposals about teacher education, the discussion was particularly rich. Some of the overarching questions addressed when discussing the papers, were the following:

- § How does the process of designing modelling tasks contribute to improved knowledge about modelling and modelling processes for teachers?
- § How do the course 'elements' impact on the practice of the teachers? What tools are better transferred and adopted by teachers?
- § How can we get information (and/or measurements) about the success of teacher appropriation or adoption of the tools introduced in the instruction?
- § What different formats, of training teachers for modelling, may lead to a stronger integration of modelling in school contexts?
- § Why are we not achieving autonomy amongst in-service teachers with respect to implementing mathematical modelling activities in their classrooms?
- § How can we ensure a long-term collaboration between teacher and researchers in the implementation and analysis of modelling activities in regular school conditions?

Concluding remarks and perspectives

The leading themes addressed by the TWG6 show the variety of research approaches and questions the papers dealt with (Kaiser & Sriraman, 2006). Furthermore, the educational levels spanned from primary to tertiary education, also covering teacher education and in-service courses. Comparing the papers and approaches considered to the different perspectives described in Carreira, Barquero, Kaiser and Cooper (2019), that summarises the evolution of the group we can conclude that in CERME 11 the research presented covered most of these perspectives.

In the first theme we discussed the use and applicability of specific tools and methodologies for the analysis of students' modelling processes and its evaluation. The modelling cycle (and its variations) has been prominent in the group. But other approaches to modelling were also discussed, such as Model Activity Diagrams, Mathematical Working Space or the one proposed by the anthropological theory of the didactics. The discussions broadened our focus and opened new questions about possible complementarities between different approaches. Furthermore, a question for future research was about how to transform all the analytic tools for analysing students' cognitive processes into tools facilitating the teacher's task of analysing students' modelling processes.

The second theme focused on the role of modelling in connection to other disciplines. More concretely, on the interdisciplinary approach to the teaching of mathematical modelling, in particular in the context of engineering and STEM education. There is a long tradition in TGW6 of discussing examples under this theme, and we hope to continue to attract work that involves consideration of modelling in different interdisciplinary contexts and practitioners enlightening mathematical modelling from perspectives of other disciplines or contexts.

The third theme, more associated with the instructional perspective, argued for different strategies to support the teaching and learning of modelling, in particular, different approaches to support students in solving modelling problems, and teachers in guiding their implementation and in evaluating modelling activities. Related to this, the fourth theme we addressed focused on the use of technology and physical or digital resources in the teaching and learning of modelling. Questions about “how to conceptualise simulations within the modelling process” or “what do we mean by ‘working mathematically’ when using technology and simulation” have been largely discussed. Moreover, open issues for future research arose from the discussion in TWG6 as, for instance, the need for extending research on teacher education for the use of simulations and modelling.

At CERME 11, teachers and their role in teaching modelling as well as teacher education played a prominent role, as more than half of the papers were dealing with prospective and/or in-service teachers. This shift shows a clear further development of the discussions and the work of TWG6, which needs to be fostered and broadened. Teachers and their professional development are crucial for the integration of mathematical modelling into mathematics education at various levels. Some questions remain open for future research about how to evaluate the impact of teacher training on the use of modelling in the classrooms as well as the teachers’ autonomy in doing so.

Acknowledgment

We want to thank to all the participants of TWG6 at CERME 11 for their presentations and participation on the discussion and working together in the sessions. We had the chance to reflect on the present and future lines of our research on modelling and applications.

References

- Carreira, S., Barquero, B., Kaiser, G., & Cooper, J. (2019). Introducing CERME’s Thematic Working Group 6 – Applications and Modelling. *Newsletter of the European Mathematical Society, Mathematics Education, ERME Column*, 111, 48-49.
- Kaiser, G., & Sriraman, B. (2006). A global survey of international perspectives on modeling in mathematics education. *ZDM Mathematics Education*, 38(3), 302–310.
- Schukajlow, S., Kaiser, G., & Stillman, G. (2018). Empirical research on teaching and learning of mathematical modelling: a survey on the current state-of-the-art. *ZDM Mathematics Education*, 50(1-2), 5–18.

The configuration of mathematical modelling activities: a reflection on perspective alignment

Lourdes Almeida¹ and Susana Carreira²

¹ Universidade Estadual de Londrina, Londrina – PR, Brazil; lourdes@uel.br

² Universidade do Algarve & UIDEF – Instituto de Educação, Universidade de Lisboa, Portugal; scarrei@ualg.pt

The article proposes a theory-based discussion on the configuration of modelling activities in the teaching and learning of mathematics. The design of modelling tasks is strongly dependent on the perspective adopted for its implementation. Based on two examples, an analysis of the task configuration is carried out in light of the more implicit or explicit aims of mathematical modelling in teaching and their connection with various modelling perspectives. From those examples, it is possible to argue that the configuration of modelling tasks is adaptable, which entails flexibility and reinforces the relevance of an educational standpoint in designing modelling problems.

Keywords: Task design, configuration, educational aims, modelling perspectives.

Introduction

Recently, in an article offering a synthesis of the relevant knowledge on the teaching of mathematical modelling, Blum (2015) revisits the main arguments – long-established since the influential ideas of Blum (1991) and of Blum and Niss (1991) – that justify the implementation of mathematical modelling activities in school mathematics. The four main arguments, which can also be seen as aims for the integration of mathematical modelling in mathematics education, are: i) the *pragmatic* argument; ii) the *formative* argument; iii) the *cultural* argument; and iv) the *psychological* argument. The first tells us that we need to use mathematics to understand the real world, so we must learn to model the world mathematically; the second affirms that in solving real problems through modelling we develop fundamental competences; the third argues that without applying mathematics and constructing models we cannot truly get a comprehensive view of mathematics; the fourth claims that mathematical modelling contributes to a better understanding and structuring of mathematical content in mathematics learning. In retrieving those reasonably established arguments, Blum (2015) adds an important note: there is a certain duality embedded in the four arguments; shortly put, one of them points to the value of knowing mathematics for solving real problems; the others consider the value of solving real problems for the learning of mathematics. He also states that examples are needed to advance those different aims in mathematics education and offers several specific contexts and situations that may suit each of them. The examples are in fact essential for several reasons. One is that different examples may fit better with some aims than others; the other reason is that a modelling activity is always based on a task, whether it is a real open problem, a research project, or a more direct question focusing on studying a particular model. In principle, there is no reason why a single basic problem or situation cannot be configured in different alternatives and that it can thus contemplate several aims of mathematical modelling. A mathematical modelling situation has the possibility of being extended, enlarged, or deepened and explored, in many and various ways. This

may be seen in the later work proposed within the models and modelling perspective, in terms of the design of model development sequences (e.g., Ärlebäck, Doerr, & O’Neil, 2013).

A first highlight is that there is a well-recognized plurality of perspectives concerning the educational aims for modelling in mathematics education. In their synthesis of the work developed within the TWG6, at CERME 9, Carreira, Barquero, Kaiser, Lingefjard, and Wake (2015) found clear evidence of a “plurality in the visions and arguments of researchers from different countries about the purposes of including modelling in the mathematics curriculum and in regular classroom activities” (p. 792). A second idea to be underlined is that creating mathematical modelling tasks is about formulating problems, asking questions, generating outbreaks of inquiry and investigation. Moreover, we cannot forget that the formulation of problems based on real or realistic situations is something that can be done by both teachers and students, autonomously or collectively.

Keeping in mind these general ideas, our purpose is to capture how the configuration of modelling activities or their reconfiguration into different modelling problems may serve different teaching and learning aims. This motivates our reflection on the adaptable configuration of tasks from the point of view of the perspective of modelling that drives the teaching and learning practices.

Principles in the design of modelling tasks and their relation to educational aims

Some important progress has been made on developing criteria to guide the design of mathematical modelling tasks for educational contexts. Such work may be found, among others, in the contributions of Bock, Bracke and Kreckler (2015); Borromeo Ferri (2018); Leiss, Schukajlow, Blum, Messner and Pekrun (2010); or Maaß (2010).

Maaß (2010) developed a taxonomic model for modelling tasks. According to her proposal, the aims for the integration of modelling into mathematics classes are numerous and diverse and can be linked to different educational perspectives. In her words, “the objectives are not to be viewed as characteristics of modelling tasks but as criteria for their selection” (p. 289).

The work of Czocher (2017) relates the task design to specific features that incite going through the steps and processes established by the generally accepted modelling cycle. The idea that the choice and design of tasks involve decisions that are not made in a vacuum is here reinforced: “How the tasks are intended to be used should be a determining factor in their design” (p. 138).

In an action-research project involving curricular integration and classroom practice of modelling in pre-calculus classes, Buhrman (2017) formulates a broad research question: “How does a teacher design and enact authentic modeling tasks in a diverse secondary mathematics classroom?” (p. 45). Buhrman presents a rich and systematic account of the many decisions and educational aims that she dealt with in designing and refining the tasks proposed to the students.

Geiger (2017) explores guidelines for modelling tasks that reflect the availability of digital technologies and its integration in the process of mathematical modelling. Within a teachers-researchers collaborative project, the author shows the result of putting the role of digital tools to the fore in the design of modelling tasks. The fundamental role of educational aims in the design of tasks is also acknowledged: “task selection, adaptation, and creation are intertwined with choices of pedagogies for realising opportunities that lie within specific tasks” (p. 289).

The enlightening work of Borromeo Ferri (2018) also speaks about the fact that it is not trivial to design a good modelling problem and suggests that good tasks are generally linked to instructional quality: “task competency is necessary for teaching modeling in all grades. Furthermore task competency leads you to instructional flexibility” (p. 42).

Perspectives on the integration of modelling and applications

A well-known differentiation of modelling perspectives, according to their central aims in connection with modelling, was proposed by Kaiser and Sriraman (2006). Blum (2015) suggests a slightly different classification, although essentially both can be seen in a similar way, as we suggest in Table 1. Blum’s proposal, however, emphasizes some interesting aspects related to the kind of tasks that tend to be dominant or privileged by each perspective. In his view, a modelling perspective could be formally characterised by the pair: aim – suitable examples. His idea of the aim-task association provides a simple way to imprint the core of each perspective as a form of its identification. Having in mind that both classifications seek to bring out the most distinctive aspects of each perspective, it will be likely that many different aims can fit into more than one perspective. Activities and their different configurations are not good or bad *per se*; it depends on their purpose (Blum, 2015). This suggests that flexibility and craftwork are crucial in the configuration of modelling activities in the educational context (Borromeo Ferri, 2018; Buhrman, 2017).

Table 1: Brief outline of modelling perspectives

Perspectives (Kaiser & Sriraman, 2006)	Perspectives (Blum, 2015)	Aim Task
Realistic	Applied	pragmatic authentic
Didactical	Educational	formative cognitively rich
Socio-critical	Socio-critical	cultural and emancipatory authentic
Epistemological	Epistemological	cultural concerning mathematics epistemologically rich
Contextual	Pedagogical	Psychological, marketing intention motivating
Conceptual	Conceptual	psychological mathematically rich

Multiple configurations of modelling activities

We then present two examples of modelling tasks or problems that allow us to realise the adaptable configurations of modelling tasks for teaching. In the first, we chose a particular starting situation regarding the world economic inequality and elaborate on that, in view of different modelling perspectives. In the second, we show how students independently formulate problems, inquire and develop mathematical modelling guided by purposes that are connected to the pragmatic solution of a real problem that is relevant to them.

Diverse configurations aligned with modelling perspectives

The first activity – world wealth distribution – was developed in a class of 20 students, divided into 4 groups, in a course of Mathematical Modelling for pre-service mathematics teachers, in a Brazilian university. In this activity the image shown in Figure 1, along with a report on the explosion of inequality in the world, published by the Brazilian magazine *Exame*, on January 19, 2015, was delivered to the students¹. The report draws attention to the fact that inequality has increased in the

¹ Available at <https://exame.abril.com.br/economia/4-graficos-que-mostram-a-explosao-da-desigualdade-no-mundo/>

period from 2000 to 2014. According to the report, the distribution of global wealth is striking when one compares the wealth share of the world's 1% richest people to the wealth share of the other 99% of the population. The aims underlying the configuration of the activity concerned the development of students' ability to mathematize a situation (the distribution of wealth) and to obtain answers to a question arising from it. Thus, the students would have to define strategies to answer the question and, in this case, those strategies should prioritize mainly the 'how to' use mathematics to achieve a prediction.

Figure 1: Share of global wealth of the top 1% and bottom 99% respectively; Credit Suisse data available 2000–2014.

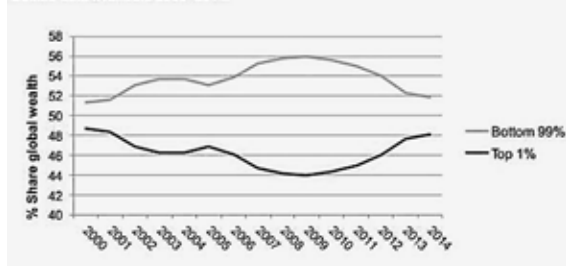


Figure 1: Curves of economic inequality

Based on the impression that the two curves will intercept in some year after 2014, assuming “business as usual”, can we say in which year the wealth of the richest 1% equals the wealth of the other 99% of the population?

Configuration A (Didactical modelling)

Based on the impression that the two curves will intercept in some year after 2014, assuming “business as usual”, can we say in which year the wealth of the richest 1% equals the wealth of the other 99% of the population?

With this configuration, the activity seems to be in line with what Kaiser and Sriraman (2006) characterize as the “didactical perspective” of modelling. In this case, the focus was the process of solving the problem rather than the mathematics content itself. The purpose of the mathematization was to predict a future event.

We refer here to the work of two groups of students (G1 and G2) who decided to tackle the problem situation by means of using the software GeoGebra, which was already familiar to them. The students from both groups started their work by inserting the image in the GeoGebra graphics view and created points on the curves for successive years (Figure 2).

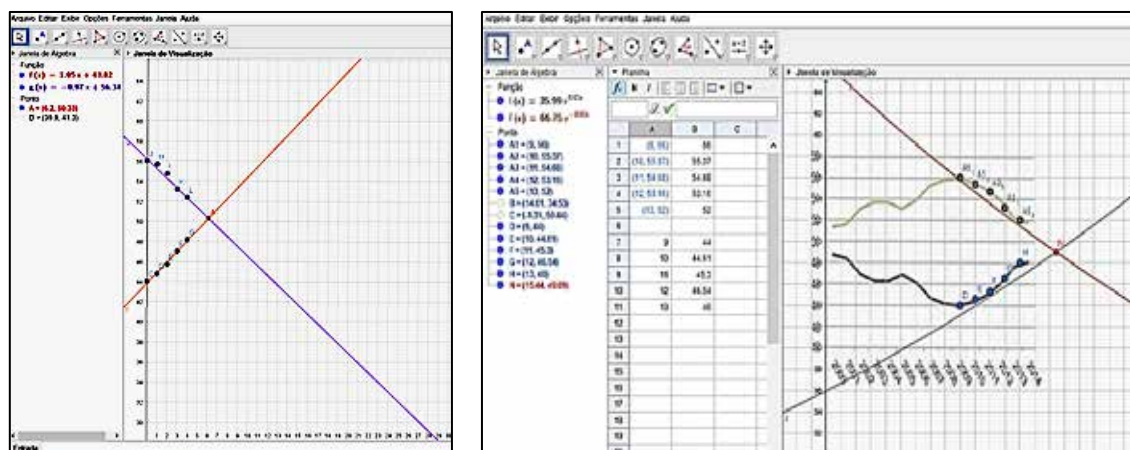


Figure 2: (Left) Linear model from group G1 and (Right) exponential model from group G2

Considering that their goal was to use the data from the picture to make predictions after the year 2014, the students considered the points relative to the years 2009–2014. Using the spreadsheet view and the bivariate regression analysis tool in GeoGebra, students in G1 selected a linear regression model to determine the predicted growth of the richest as well as the poorest shares (Figure 2, left). On the other hand, students in G2 opted by exponential regression models (Figure 2, right). Although

the two groups have adjusted different models, both concluded that after the year 2016 the wealth of the richest 1% already surpasses that of the other 99% of the world population.

Starting from the given situation, other configurations, involving the design of other modelling problems, may be produced, in line with other educational aims and modelling perspectives. Next, we refer to two of such variations. In the second configuration, which is in line with “conceptual modelling”, one aim is the eliciting of models leading to concepts such as Riemann sums and the average value of a function over an interval. The affordances of GeoGebra would also be relevant, namely by interconnecting the graphic window and the spreadsheet window. Many explorations would be feasible in that approach; in fact, another aim could be the integration of technology in the modelling process.

Configuration B (Conceptual modelling)

Based on the data from the graph what could you say about the average gap between the shares captured by the top 1% and the bottom 99%, between 2000 and 2014? According to your approximate model reflecting the trend, how will this gap change over the following 14 years?

In the third configuration, the emphasis is on critically reflect on the world inequality portrayed by the 2016 situation, where the top 1% of the population captures half of the world wealth. Here, in line with a “socio-cultural perspective” the objective concerns the use of mathematics to unveil social and political phenomena and promote informed critical positioning. The need to produce a good representation of a clearly asymmetric distribution will require creative thinking. Either the students look for information about the values of the percentiles for 2016 or they may run a simulation that generates 100 numbers (where one number is 50 and the sum of the all the others is also 50). The usefulness of mathematical representations is intended to be a topic of deliberation. But mostly, reflective and critical examination of the real world by means of mathematics is a fundamental implicit aim in this task configuration.

Configuration C (Socio-critical modelling)

A student responsible for the newsletter of his school/faculty wonders about how to depict the current distribution of wealth among the world population, in an article about economic inequality. What would be a good mathematical representation of the distribution that people would easily understand?

Write a boxout text (half page) to accompany the student’s article where you show your representation of the wealth distribution, indicating the source of your data and explaining the fundamental ideas that may be drawn from it. Remember that boxouts are intended to be visually interesting and have condensed information. They should incite the reader to think and to know more on the subject.

A task configuration serving different perspectives

In the following example, unlike the previous one, the teacher did not present a modelling problem to the class of pre-service student-teachers. Instead, each group of students was asked to choose a real situation to investigate and create a modelling problem that should be solved. One group of students used to fish in a Fish & Pay Lake and became interested in studying the potential profit that the use of tilapia leather could provide to the owner of the pond.

First, the students thought about how to measure the amount of leather obtained from each fish. For that end, they caught fishes with weights varying between 280g and 720g. To determine the surface of the leather of each fish they used an approximation by means of triangles (Figure 3). They recorded the measures of the sides as well as the area of each triangle, by applying Heron's formula and using the Excel software. From there, they sought to relate the weight and surface of the fish. They defined the variables: $x(t)$ as the weight (in grams) of a tilapia aged t weeks and $y(t)$ as the tilapia leather useful area (in cm^2) after t weeks. The growth rates of these two properties of the fish in relation to time are, respectively, $\frac{dx}{dt}$ and $\frac{dy}{dt}$.



Figure 3: Approximation by triangles

To relate the surface to the weight, the students used the Allometry Principle, according to which one has $\frac{1}{y} \frac{dy}{dt} = k \frac{1}{x} \frac{dx}{dt}$, where k is a constant. By solving the differential equation, they arrived at the solution: $y = cx^k$. Finally, the students resorted to their spreadsheet table and used Excel for getting the best fitting curve: $y(x) = 2.165x^{0.751}$.

To consider the issue of the revenue from the sale of the tilapia leather, the students talked to the staff in charge of the fisheries and learnt that the average weight of the caught fish is 500 grams. So they applied their model: $y(500) \approx 230 \text{ cm}^2 = 0.023 \text{ m}^2$. Taking into account that 2.5 tons of fish are sold per month, that the average weight of each fish is 500 grams, that the price of a square meter of leather is R\$ 6.00, and that each fish provides approximately 0.023 m^2 of leather, the students concluded that the owner could earn R\$ 8,280 per year from the tilapia leather.

The configuration of this activity indicates that the aims of the teacher and those of the students can be different and complementary when modelling activities are carried out.

Configuration D (Applied modelling and Contextual modelling)

Teacher's configuration: Formulate a real problem of your choice, connected to the real world and life, and use mathematical modelling to solve it.

Students' configuration: What is the potential profit that the use of tilapia leather could provide to the owner of the pond where I often go fishing?

The teacher is interested in giving students the opportunity to engage in an investigative activity and encourages their autonomy in finding authentic situations where mathematics could be useful and valuable. As such, the students formulated a problem stemming from their interest and curiosity, looked for the available mathematics to model the situation, and found a solution, which is in line with the "applied/realistic perspective". One important aim for the teacher is the students' learning and experience of the mathematical modelling process; for the students, the aim is formulating a real world problem, which they can solve through mathematical modelling. In fact, part of the students' modelling process involved applying relevant models they had available, such as the Heron formula and the Allometric model. In this sense, the task also led students to activate and apply their

mathematical and extra-mathematical knowledge to a real situation, and therefore it may be considered to be aligned with the “contextual perspective”.

Concluding remarks

The discussion on the nature and design of mathematical modelling tasks for diverse educational and curriculum contexts is worth continuing. Not because the tasks decide in any absolute way the results that will be achieved with the students, but because they constitute a recognized central element of the pedagogical practices (Borromeo Ferri, 2018). In particular, the tasks reflect, to a large extent, the centrality of the teaching and learning aims. In embracing this idea, we have looked at two very distinct types of modelling tasks proposed by the teacher to undergraduate students in a university course in mathematical modelling for teaching. In one of them, we explored variations in the outline and the target of the task, keeping in the background the same real situation concerning the evolution over the years of economic inequality in the world today. We have suggested possibilities to make the task coupled with different aims of teaching and learning, which implied, in particular, to formulate relevant questions that direct the activity to different targets: didactic aspects regarding the search for suitable models to predict results (e.g., the use of graphic tools and curve fitting to develop models); conceptual development (e.g. introducing or developing mathematical concepts); or reflexive and critical understanding (e.g., using mathematics to unveil and raise awareness of social phenomena). We have also made its connection with different perspectives of modelling, echoing, in some way, an idea previously proposed by Kaiser, Sriraman, Blomhøj, and Garcia (2007), about a situation concerning the structure of the price of a taxi. This allowed elucidating the degree of adaptability of good modelling tasks to various configurations and that means that the configuration of modelling activities is part of the teacher’s role that implies her/his positioning in some perspective, more or less explicitly. Afterwards, we looked at another modelling task configuration in which the teacher proposes the search for a real situation that may be interesting to study from a mathematical point of view; thus, the teacher invites the student to investigate the world around and to identify a problem that is both relevant and possible to analyse through mathematics; the teacher expects the students to formulate problems and to go through the modelling cycle in their modelling process. Drawing on the case of a group of students we have shown how the students’ inquiring attitude entails other aims that are equally relevant and aligned with a realistic perspective, since the students adopt a position similar to the applied mathematician. The diverse aims involved are complementary and reveal that some configurations can actually serve different modelling perspectives.

The examples reveal that the design and choice of tasks are intertwined with different aims and perspectives of mathematical modelling for mathematics education. Our reflection reinforces the idea of flexibility, emphasized by Borromeo Ferri (2018), but it also highlights the relevance of taking an educational standpoint in designing modelling problems.

References

Ärlebäck, J. B., Doerr, H. M., & O’Neil, A. H. (2013). A modeling perspective on interpreting rates of change in context. *Mathematical Thinking and Learning*, 15(4), 314–336.

- Blum, W. (1991). Applications and modelling in mathematics teaching - A review of arguments and instructional aspects. In M. Niss, W. Blum, & I. Huntley (Eds.), *Teaching of mathematical modelling and applications* (pp. 10–29). Chichester: Ellis Horwood.
- Blum, W. (2015). Quality teaching of mathematical modelling: What do we know, what can we do? In S. J. Cho (Ed.), *Proceedings of the 12th International Congress on Mathematical Education* (pp. 73–96). Cham, Switzerland: SpringerOpen.
- Blum, W., & Niss, M. (1991). Applied mathematical problem solving, modelling, applications, and links to other subjects – State, trends and issues in mathematics instruction. *Educational Studies in Mathematics*, 22, 37–68.
- Bock, W., Bracke, M., & Kreckler, J. (2015). Taxonomy of modelling tasks. In K. Krainer & N. Vondrová (Eds.), *Proceedings of the Ninth Congress of the European Society for Research in Mathematics Education*, (pp. 821–826). Prague, Czech Republic: ERME.
- Borromeo Ferri, R. (2018). *Learning How to Teach Mathematical Modeling in School and Teacher Education*. Cham, Switzerland: Springer.
- Buhrman, D. (2017). *The design and enactment of modeling tasks: A study on the development of modeling abilities in a secondary mathematics course*. (Doctoral Dissertation). University of Nebraska, Lincoln, USA. Retrieved from: <http://digitalcommons.unl.edu/cehsdiss/282>.
- Carreira, C., Barquero, B., Kaiser, G., Lingefjord, T., & Wake, G. (2015). Introduction to the papers of TWG06: Applications and modelling. In K. Krainer & N. Vondrová (Eds.), *Proceedings of the Ninth Congress of the European Society for Research in Mathematics Education* (pp. 790–793). Prague, Czech Republic: ERME.
- Czocher, J. (2017). Mathematical modeling cycles as a task design heuristic. *The Mathematics Enthusiast*, 14(1), 129–140.
- Geiger, V. (2017). Designing for mathematical applications and modelling tasks in technology rich environments. In A. Leung & A. Baccaglioni-Frank (Eds.), *Digital technologies in designing mathematics education tasks* (pp. 285–301). Cham, Switzerland: Springer.
- Kaiser, G., & Sriraman, B. (2006). A global survey of international perspectives on modelling in mathematics education. *ZDM Mathematics Education*, 38(3), 302–310.
- Kaiser, G., Sriraman, B., Blomhøj, M., & Garcia, F. J. (2007). Modelling and applications – Differentiating perspectives and delineating commonalities. In D. Pitta-Pantazi & G. Philippou (Eds.), *Proceedings of the Fifth Congress of the European Society for Research in Mathematics Education* (pp. 2035–2041). Lanarca, Cyprus: ERME.
- Leiss, D., Schukajlow, S., Blum, W., Messner, R., & Pekrun, R. (2010). The role of the situation model in mathematical modelling – Task analyses, student competencies, and teacher interventions. *Journal für Mathematikdidaktik*, 31(1), 119–141.
- Maaß, K. (2010). Classification scheme for modelling tasks. *Journal für Mathematik-Didaktik*, 31(2), 285–311.

Enhancing future teachers' situation-specific modelling competencies by using staged videos

Alina Alwast¹ and Katrin Vorhölter²

¹University of Hamburg, Germany; alina.alwast@uni-hamburg.de

²University of Hamburg, Germany; katrin.vorhoelter@uni-hamburg.de

Although discussed frequently, there is still a gap between theory conveyed at university and the teachers' practical work at school after finishing their degree, which can lead to the problem that new teachers do not act based on theoretical constructs although they know about them. The paper describes an innovative project, which aims at tackling this problem and fostering teachers' situation-specific competencies by helping future teachers making their knowledge applicable. Therefore, staged video vignettes are created to support future teachers episodic memory through repeated practice with videos, which simulate real classroom situations. This theoretically informed paper focuses on identifying criteria for staged video vignettes based on the concept of teacher's expertise in mathematical modelling, using those when creating video vignettes and implementing them in an innovative learning environment.

Keywords: Mathematical modelling, teachers' situation-specific competencies, teachers' expertise, video vignettes, staged videos.

Introduction

In the last decade a great number of small-scale as well as a few large-scale studies in the field of mathematics education have focused on teachers' expertise (e.g., large-scale studies: TEDS-M, see Blömeke, Kaiser, & Lehmann, 2010; COACTIV, see Kunter, Baumert, & Blum, 2011). These studies focus on conceptualizing the teacher's knowledge and observe their performance in comparison. However, there exists a gap between knowledge and performance, which is addressed by Blömeke, Gustafsson, and Shavelson (2015) in their PID-model. Their conception of competence as a continuum consisting of dispositions (knowledge and an affective-motivational component), situation-specific competencies and performance suggest a greater relevance of situation-specific skills for the teaching profession. In an innovative project at the University of Hamburg these situation-specific skills are enhanced by the intensive use of videos during a master seminar for future teachers, which deals with the content of mathematical modelling. This paper will describe the development of criteria for staged video vignettes in a theoretically informed approach and the usage of the thereby developed video vignettes during a modelling seminar.

Teachers' professional competencies

As mentioned above this project especially pays attention to the situation-specific competencies as a mean to bridge the gap between theory and practice. A close connection of theory and practice according to the concept of *practice transfer* is aimed at through the analysis of video vignettes. Prenzel (2010) defines transfer (based on studies by Messner, 1978 & Renkl, 1996) as the implementation of a solution developed or knowledge acquired in situation A to another situation B. Effectively solving the problem in situation B means the transfer was successful. Nölle (2002) suggests that professional competence can only be improved through broad knowledge as a basis but

also through episodic experiences. Apparently, a categorical system of knowledge combined with episodic elements is required for the useful application of knowledge and favours a differentiated perception of teaching (Nölle, 2002).

A model, which covers all aspects of teachers' expertise, namely knowledge as well as the skills needed to transfer knowledge into action (called situation-specific skills¹) and the observable behaviour, was developed by Blömeke et al. (2015). The so-called PID-model (see Figure 1) combines the analytic view on teachers' competencies, which analyses teachers' dispositions in all its aspects (knowledge and affective-motivational components), with the holistic view, which focuses on the teacher's performance. The situation-specific skills serve as a link between dispositions and performance and can be distinguished in the professional perception of a teaching situation, the interpretation of the perceived situation and the decisions made, which are based on the interpretation. For this project, the PID-model is used as a theoretical basis.

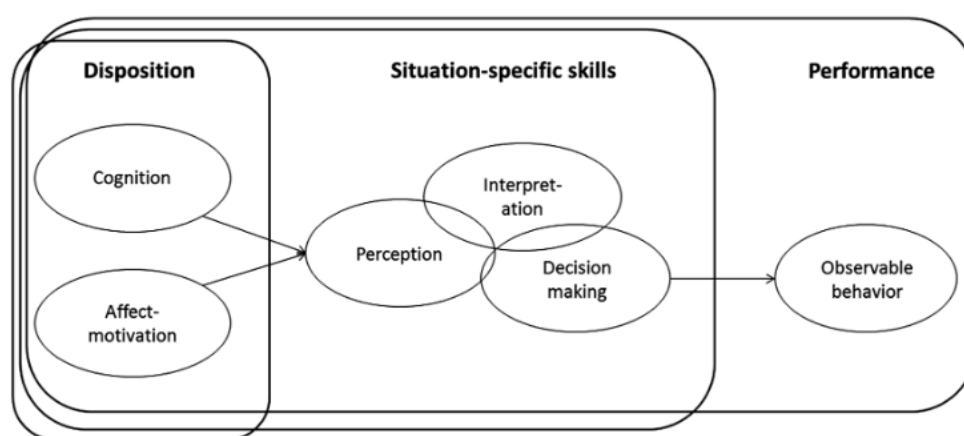


Figure 1: Competence as a continuum (Blömeke, Gustafsson, Shavelson, 2015, p. 7)

The PID-model describes general teaching competencies but can be applied to specific domains as well. However, in every domain certain knowledge and concepts are required. For teaching mathematical modelling specifically, there exists little research on what exactly is needed to foster students' modelling competencies. Mathematical modelling is a complex task for students, because it demands a lot of cognitive work. Thus, supporting students during their modelling process is also a major challenge (Blum, 2011).

Borromeo Ferri and Blum (2010) developed a model, in which they divided teacher's pedagogical content knowledge (PCK) regarding modelling in four dimensions:

- (1) a theoretical dimension (incl. modelling cycles or aims and perspectives of modelling as background knowledge),
- (2) a task dimension (incl. multiple solutions or cognitive analyses of modelling tasks),
- (3) an instructional dimension (incl. interventions, support and feedback), and
- (4) a diagnostic dimension (incl. recognising students' difficulties and mistakes). (Blum, 2015, p. 89)

¹ The ability to notice and interpret remarkable situations in the classroom is also known as *professional vision* (cf. among others Goodwin (1994) or Seidel and Stürmer (2014)) or as *noticing* (cf. Van Es & Sherin (2002)).

Blum (2015) also highlights that a transfer from knowledge into actions cannot be expected automatically. Supporting teachers in applying their knowledge, which is based on Borromeo Ferri and Blum's four dimensions, is therefore an important aim of this project.

Furthermore, Blum (2015) summarizes ten important characteristics for adequately teaching mathematical modelling based on the concepts of quality mathematics teaching. Besides the principles named above, he mentions an "effective and learner-oriented classroom management", providing a variety of examples and exercises for different real-world and mathematical contexts, encouraging multiple solutions, supporting students' positive beliefs and attitudes towards modelling and using digital tools as an aid.

Moreover, in a study evaluating the modelling seminar university students mention the importance of interventions and the wish to deepen their knowledge and practical skills in this area (Vorhölter, 2018b). As shown in various studies, a crucial tool in supporting students are strategic interventions, which are already mentioned in Borromeo Ferri and Blum's third dimension as PCK. In his study with a focus on the procedural aspect Leiß (2007) points out the importance of strategic interventions to support students' independent modelling process. Stender and Kaiser (2015) discover similar findings adding that strategic interventions can only take place if the teacher is trained in this special field. This is based on the Zech (2002) taxonomy of assistance, which categorizes interventions from minimal help such as motivational interventions to content-related interventions.

Besides, enhancing students' metacognitive-strategies is essential as shown by various studies (for an overview see Stillman, 2011). Metacognitive strategies are needed to independently overcome problems during the modelling process and a lack of these will most probably lead to considerable problems (Vorhölter & Kaiser, 2016). Therefore, teachers need to promote cognitive but also metacognitive strategies.

For overcoming the gap between theory and practice, staged videos can be used during teacher education. According to Oser, Heinzer and Salzmann (2010) videos are situation-specific, authentic, complex and context-bound, which makes them the closest tool to imitate real classroom situations. Thus, the substantive aspect of construct validity (Messick, 1995), which is defined as measuring the cognitive processes of competence as close as possible to the theoretical construct, is met. In a meta-analysis of studies regarding the use of videos in teacher education Coles (2014) summarizes that positive effects can be found when "engaging in a process that makes evaluative discourse unlikely" (Coles, 2014, p. 271). Therefore, it is important to explicitly focus on details and their interpretation when watching video clips in contrast to judging the behaviour of students and teachers in the video.

Concept of the modelling seminar

The University of Hamburg offers a modelling seminar during the master's program - usually attended in the first semester-, which every future mathematics teacher gets the chance to attend. The seminar is open for future teachers of primary and secondary school as well as special-needs school and about 30 students attend it every year. Supervising year 9 students during a two-day modelling project is part of the seminar, which aims at enabling future teachers to independently and adequately teach modelling at school in their future job.

The content of the seminar follows the model by Borromeo Ferri and Blum (2010) and can therefore be divided into four aspects:

1. The *theoretic dimension* is implemented by reflecting and discussing articles regarding the following topics: modelling cycles, goals and perspectives of modelling, students' modelling competencies, beliefs and both heuristic and metacognitive strategies. With different methods knowledge about these topics is gained and practiced using worked examples by school students.
2. To acquire knowledge in the *task dimension* the university students have to solve complex modelling tasks themselves and discuss the appropriateness of different solutions including the three tasks they have to supervise during the modelling days. Furthermore, modelling tasks are analysed concerning their demands and difficulties.
3. The *instructional dimension* is discussed by planning the modelling days, e.g. preparing and reflecting the structure, the introductory phase and especially appropriate interventions, which support independent student work.
4. To address the diagnostic dimension, the university students analyse past students' posters presenting their work and identify difficulties and obstacles.

The seminar concludes with the modelling days at school, where the gained knowledge can be implemented and reflected on. Usually the future teachers work in a tandem to discuss each other's performance and reflect on the success of their interventions (for a detailed description of the modelling days and the role of the university students' see Stender and Kaiser (2015)).

Besides providing declarative knowledge, not only relevant for teaching mathematical modelling but also for other domains in mathematics education, a major focus is the transfer from theory to practice. Due to the university's structure, the future teachers usually do not have hands-on experience with teaching when joining the seminar. Therefore, to support the application of knowledge, videos are used as an import tool to simulate real classroom situations, which will be further discussed in the next section. For a more detailed description of the modelling seminar, see Vorhölter (2018b). The transition between theory and praxis is an ongoing process including knowing theoretical constructs, implementing them and reflecting on experience to deepen those theoretical constructs. Group discussions during the seminar regarding university students' video analyses as well as self-reflections on the modelling days in the context of a final assessment also allow them to refer empirical knowledge back to theoretical constructs.

Developing criteria for staged videos

A previous evaluation of the modelling seminar shows that the theoretical knowledge was not perceived as relevant for the university students when teaching at school and could not be translated into practical and usable knowledge in a satisfactory manner (Vorhölter, 2018b). To help them make their knowledge applicable videos will be used as stimulation of the reality. As video recordings usually contain distracting background noises, show long stretches of irrelevant behaviour and sometimes do not catch the students' material or facial expressions, we aim at creating staged videos based on authentic situations found in the original recordings.

To create videos, which show typical situations during a modelling process relevant for future teachers on the one hand, but also limit the amount of irrelevant and time-consuming information on the other hand, a cyclic process characterized by various revisions took place. First, recorded lessons were used to identify relevant situations. These were developed during the project MEMO (Vorhölter, 2018a), which includes 2 fully recorded lessons of over 50 small groups of students each time, in

which mathematical modelling takes place. Only a few of the original recordings could be used due to their length and the great number of distractors.

Therefore, a script was written based on teachers' required modelling competencies and students' typical mistakes regarding modelling. These aspects were identified based on the theoretical construct of teacher expertise in modelling. The script empathizes relevant aspects in order to make them noticeable without being in the context of the lesson in real-time. Important aspects were:

1. Each video shows a different *phase of the modelling cycle*, which can be expected to be recognized. Different phases generate different problems and are therefore crucial for a diagnosis.
2. Because modelling is a cognitive demanding task, it can lead to *various difficulties and obstacles*, which can be mathematical, group work related, concerning the modelling process in general and so forth. The video vignettes try to address a wide range of these problems.
3. To tackle these problems, sometimes the teacher has to intervene. *Interventions* are part of the video vignettes as well as the request for the viewer to describe his or her own intervention as if he or she were there to support the students during a difficult situation at the end of the video.
4. To overcome problems during the modelling process students not only use heuristic but also *metacognitive strategies*, which can especially be helpful. Different metacognitive strategies such as planning and regulation can be found in the videos.
5. Modelling problems are usually solved in a group. Therefore, heuristic and metacognitive strategies influence the group work process and each member of the group plays a *different role* during the process.

The script created, which considers these aspects, was revised by an expert group, which has already worked with staged videos. Another group of experts in mathematics education afterwards played the role of the students following the script, which was videotaped, and improvised in a second take to adapt the situation to a more reality-based setting. Changes in language as well as in behaviour instructions were made and added to the script. Furthermore, a second revision took place based on expert ratings, where the experts were either specialized in the field of mathematical modelling or in the creation and use of staged video vignettes. Finally, three short videos were made by filming year 9 students, who acted according to the script.

Implementing the developed videos

As described above the university students lacked the ability to implement their theoretical knowledge sufficiently during the modelling days. The project aims at providing an innovative learning environment, which offers the opportunity to practice the implementation of knowledge by using staged videos as well as five extracts of recorded lessons.

Important theoretical constructs are conveyed as described above but also exemplified through the staged video vignettes: The videos are used to practice noticing relevant aspects based on theoretical constructs discussed before in a short time. Furthermore, the following discussion and reflection in plenum can lead to a better understanding of the lesson shown and improve the perception and interpretation of the next video. Moreover, decision-making is required when evaluating the possible interventions at the end of the video. The repeated use of these videos with different content and various modelling-specific problems is sought to lead to a better application of knowledge. This will become clear during the last part of the course, where the future teachers supervise students at school

during a two-day modelling project and can implement their knowledge and skills in their performance.

Looking ahead

Making knowledge applicable is an important aspect in teacher education. This innovative project, which uses videos during the described modelling seminar to foster future teachers' perception, interpretation and decision-making, is embedded in a study evaluating the development of teachers' situation-specific competencies and its underlying dispositions as well as the consequences with a mixed methods study design.

Hence, video vignettes serve a dual purpose: Staged videos as well as recorded video clips are used during the modelling seminar to enhance situation-specific competencies. Furthermore, staged videos are used in a pre-post-test design to analyse the development of situated competencies. The Pre- and Post-test also includes a questionnaire, which assesses through closed and open questions knowledge facets based on the model by Borromeo Ferri and Blum (2010). Therefore, the effect of knowledge on the situated competencies and the development of both aspects can be examined. During the modelling days a few selected university students are filmed while supervising the students. Thus, their performance can be observed and all aspects of the PID-model can be analysed and possible connections identified.

In the long term, all three staged videos can sustainably be used in the modelling seminar without further effort or may serve as a means for assessment of the university students' development and performance.

References

- Blömeke, S., Gustafsson, J.-E., & Shavelson, R. J. (2015). Beyond dichotomies. *Zeitschrift Für Psychologie*, 223(1), 3–13. <https://doi.org/10.1027/2151-2604/a000194>
- Blömeke, S., Kaiser, G., & Lehmann, R. (Eds.). (2010). *TEDS-M 2008: Professionelle Kompetenz und Lerngelegenheiten angehender Mathematiklehrkräfte für die Sekundarstufe I im internationalen Vergleich*. Münster, Germany: Waxmann.
- Blum, W. (2011). Can Modelling Be Taught and Learnt? Some Answers from Empirical Research. In G. Kaiser, W. Blum, R. Borromeo Ferri, & G. A. Stillman (Eds.): *Vol. 1. Trends in teaching and learning of mathematical modelling: ICTMA14* (pp. 15–30). Dordrecht, the Netherlands: Springer Science+Business Media B.V. https://doi.org/10.1007/978-94-007-0910-2_3
- Blum, W. (2015). Quality teaching of mathematical modelling: What do we know, what can we do? In S. J. Cho (Ed.), *Proceedings of the 12th International Congress on Mathematical Education* (pp. 73–96). Cham, Switzerland: Springer International Publishing. https://doi.org/10.1007/978-3-319-12688-3_9
- Borromeo Ferri, R., & Blum, W. (2010). Mathematical modelling in teacher education – Experiences from a modelling seminar. In V. Durand-Guerrier, S. Soury-Lavergne, & F. Arzarello (Eds.), *Proceedings of CERME 6* (pp. 2046–2055). Lyon, France: Institut National de Recherche Pédagogique.

- Coles, A. (2014). Mathematics teachers learning with video: The role, for the didactician, of a heightened listening. *ZDM Mathematics Education*, 46(2), 267–278. <https://doi.org/10.1007/s11858-013-0541-3>
- Goodwin, C. (1994). Professional vision. *American Anthropologist*, 96(3), 606–633. <https://doi.org/10.1525/aa.1994.96.3.02a00100>
- Kunter, M., Baumert, J., & Blum, W. (Eds.). (2011). *Professionelle Kompetenz von Lehrkräften: Ergebnisse des Forschungsprogramms COACTIV*. Münster, Germany: Waxmann.
- Leiß, D. (2007). „Hilf mir, es selbst zu tun“: Lehrerinterventionen beim mathematischen Modellieren. *Texte zur mathematischen Forschung und Lehre: Vol. 57*. Hildesheim/Berlin, Germany: Franzbecker.
- Messick, S. (1995). Validity of psychological assessment: Validation of inferences from persons' responses and performances as scientific inquiry into score meaning. *American Psychologist*, 50(9), 741–749. <https://doi.org/10.1037/0003-066X.50.9.741>
- Messner, H. (1978). *Wissen und Anwenden: Zur Problematik des Transfers im Unterricht; eine psychologisch-didaktische Analyse. Pädagogik Grundlagen*. Stuttgart, Germany: Klett-Cotta.
- Nölle, K. (2002). Probleme der Form und des Erwerbs unterrichtsrelevanten pädagogischen Wissens. *Zeitschrift Für Pädagogik*, 48(1), 48–67.
- Oser, F., Heinzer, S., & Salzmann, P. (2010). Die Messung der Qualität von professionellen Kompetenzprofilen von Lehrpersonen mit Hilfe der Einschätzung von Filmvignetten. Chancen und Grenzen des advokatorischen Ansatzes. *Unterrichtswissenschaft*, 38(1), 5–28.
- Prenzel, M. (2010). Geheimnisvoller Transfer? *Zeitschrift Für Erziehungswissenschaft*, 13(1), 21–37. <https://doi.org/10.1007/s11618-010-0114-y>
- Renkl, A. (1996). Träges Wissen: Wenn Erlerntes nicht genutzt wird. *Psychologische Rundschau*, 47, 78–92.
- Schön, D. A. (1983). *The reflective practitioner: How professionals think in action*. New York, NY: Basic Books.
- Seidel, T., & Stürmer, K. (2014). Modeling and measuring the structure of professional vision in preservice teachers. *American Educational Research Journal*, 51(4), 739–771. <https://doi.org/10.3102/0002831214531321>
- Stender, P., & Kaiser, G. (2015). Scaffolding in complex modelling situations. *ZDM Mathematics Education*, 47(7), 1255–1267. <https://doi.org/10.1007/s11858-015-0741-0>
- Stillman, G. A. (2011). Applying metacognitive knowledge and strategies in applications and modelling tasks at secondary school. In G. Kaiser, W. Blum, R. Borromeo Ferri, & G. A. Stillman (Eds.), *Trends in teaching and learning of mathematical modelling: ICTMA14* (pp. 165–180). Dordrecht, the Netherlands: Springer Science+Business Media B.V.
- Van Es, E. A., & Sherin, M. G. (2002). Learning to notice: Scaffolding new teachers' interpretations of classroom interactions. *Journal of Technology and Teacher Education*, 10(4), 571–596.

- Vorhölter, K. (2018a). Conceptualization and measuring of metacognitive modelling competencies: empirical verification of theoretical assumptions. *ZDM Mathematics Education*, 50(1-2), 343–354. <https://doi.org/10.1007/s11858-017-0909-x>
- Vorhölter, K. (2018b). Notwendige Kompetenzen zur Betreuung von Modellierungsaktivitäten aus Sicht von Studierenden – Evaluation und Weiterentwicklung eines Seminars zur Vermittlung modellierungsspezifischer Lehrerkompetenzen. In R. Borromeo Ferri, & W. Blum (Eds.), *Realitätsbezüge im Mathematikunterricht. Lehrerkompetenzen zum Unterrichten mathematischer Modellierung: Konzepte und Transfer* (pp. 201–212). Wiesbaden, Germany: Springer Fachmedien Wiesbaden GmbH. https://doi.org/10.1007/978-3-658-22616-9_9
- Vorhölter, K., & Kaiser, G. (2016). Theoretical and pedagogical considerations in promoting students' metacognitive modeling Competencies. In C. R. Hirsch & A. R. McDuffie (Eds.), *Annual perspectives in mathematics education 2016: Mathematical modeling and modeling mathematics* (pp. 273–280). Reston, VA: National Council of Teachers of Mathematics.
- Zech, F. (2002). *Grundkurs Mathematikdidaktik: Theoretische und praktische Anleitungen für das Lehren und Lernen von Mathematik*. Weinheim, Germany: Beltz.

An extension of the MAD framework and its possible implication for research

Jonas Bergman Ärlebäck¹ and Lluís Albarracín²

¹Linköping Universitet, Mathematics Department, Linköping, Sweden;
jonas.bergman.arleback@liu.se

²Serra Hünter Fellow in Universitat Autònoma de Barcelona, Mathematics Education Department, Cerdanyola del Vallès, Spain; lluis.albarracin@uab.cat

In this paper we investigate the potential in extending Model Activity Diagrams (MADs) as an analytical tool for studying the activities students engage in when working on modelling problems. By including a sub-division of the task students work on in the MAD framework, we are able to make a more nuanced analysis that in a more explicit way reveals the structure of the students' modelling process. The framework is applied to groups of students engaged in solving a Fermi problem using a two-level analysis, and the result is contrasted and discussed by comparing the outcome of the analysis with the corresponding analysis made using the modelling cycle. In addition, possible applications of the extended MAD framework in research and the training of teachers are discussed.

Keywords: Mathematical modelling, Fermi problems, modelling activities diagrams.

Introduction

In this paper we present a qualitative study focusing on developing a tool to aid researchers in the analysis of mathematical modelling processes students engage in. Existing literature features several theoretical developments that attempt to describe students' modelling processes. Most of these theoretical perspectives are based on the division of the students' work into two domains by separating the real world from the mathematical realm. It is mostly accepted that students go through different stages in a cyclical manner when engaged in modelling as exemplified for example by the so-called modelling cycle of Blum and Leiss (2007). Although this cyclic representation of modelling provides a useful tool and heuristics for teaching and thinking about modelling, there are some concerns and limitations when it comes to its applicability as a research tool.

Firstly, the modelling routes that students are seen to follow when engaged in modelling are complex and typically deviate from the depicted idealized view of the modelling cycle (Borromeo Ferri, 2007). Secondly, some studies (e.g., Ärlebäck, 2009; Czocher, 2016; Aymerich & Albarracín, 2016) highlight the difficulties in identifying the different stages of the modelling process of students' work in a reliable way. In an attempt to provide a complementary perspective on these issues and to partly overcome these difficulties, we propose a construct that extends Modelling Activity Diagrams (MADs) to characterize the activities of students engaged in a mathematical modelling process as an alternative analytical tool to the modelling cycle. To do this, we sought to extend the information provided by the original MAD framework by including a representation of the internal structure of the sub-problems the students engaged in when solving a problem and applied this extended MAD framework on video-data of students aged 15 to 16 solving a Fermi problem (see Ärlebäck, 2009).

Thus, the aim of this paper is to explore the possibilities of Modelling Activity Diagrams, extended to also explicitly include and represent the structure of the modelling problem in question as well as the complexity of modelling processes. The goal of this paper is to determine whether this extended tool actually provides additional information on the structures underlying the activities the students engage in compared to analyses based on the modelling cycle or the original MADs.

Representations of mathematical modelling: The Modelling Cycle and Modelling Activity Diagrams

In the general discussion, mathematical modelling is often considered to be cyclical in nature, involving going back and forth between the real world and the world of mathematics. Even though there are several ways of conceiving and viewing the structure of a modelling process, it is generally understood that it can be divided into different stages and that the students go through these sequentially, moving from one stage to the next once they consider the work in the current stage has been concluded satisfactorily (Perrenet & Zwaneveld, 2012). The conceptualization of Blum and Leiss (2007) has been widely used to describe the modelling process but has shown to be difficult to use as a tool for analysis when it comes to describe and explain the students' work (Borromeo Ferri, 2007; Ärlebäck, 2009; Czocher, 2016; Aymerich & Albarracín, 2016).

When faced with the need to describe the modelling processes implemented by students, Borromeo Ferri (2007) proposed so-called individual modelling routes with the aim of broadening the modelling cycle's analytical reach. These routes consist of arrow diagrams that show students' work within the theoretical diagram of the modelling cycle, illustrating the non-conformity of students' work relative to the modelling cycle as well as students' seemingly stochastic modelling behaviour. Acknowledging the work by Borromeo Ferri, Ärlebäck (2009) introduced Modelling Activity Diagrams (MADs) as a bi-dimensional graph that depicts the types of modelling activities the students engage in when solving novel modelling problems. The activities proposed by Ärlebäck (2009) and used to characterize the modelling processes in terms of MADs can be found in Table 1.

R: Reading	Reading the statement of the task and understanding it
M: Modelling	Simplifying and structuring the task mathematically
E: Estimating	Making quantitative estimates
C: Calculating	Performing mathematical calculations, such as arithmetic calculations, working with equations, drawing sketches or diagrams
V: Validating	Interpreting, verifying and validating the results, calculations and the model itself related to the real-life context of the problem
W: Writing	Summarizing the findings and results in a report, drafting the solving process as well as the solution

Table 1: Activities that make up MADs

Mathematical modelling and Fermi problems

The use of so-called Fermi problems in our work allows us to propose simple situations that require students to engage in mathematical analysis that promotes the construction of models. Following Ärlebäck (2009), we consider Fermi problems to be open, non-standard problems that require students to make assumptions about the problem situation and estimates of certain quantities before they engage in, often, a series of simple calculations. Efthimiou and Llewellyn (2007) characterised Fermi problems based on their formulation since these always appear to be open questions offering little or no specific information to the solver directing them in the solving process. The key aspect to Fermi problems from the perspective of mathematical modelling is the need to conduct a detailed analysis of the situation presented in the statement of the problem with the objective of decomposing the original problem into simpler and connected problems – addressed as sub-problems in the present work – to reach a solution to the original problem by means of reasonable estimates and reasoning.

Some research studies conducted to date on the use of Fermi problems in the teaching and learning of mathematics have been shown to facilitate the introduction of mathematical modelling in primary and secondary school classrooms as well as at college level. While engaging in solving Fermi problems primary students develop new mathematical knowledge in arriving at their solutions (Peter-Koop, 2009). Social relations and extra-mathematical knowledge in the problem-solving situation are also relevant to the problem-solving process (Ärlebäck, 2009). Czocher (2016), who used Fermi problems to analyse university engineering students' performance in terms of MADs, confirms that the MADs reveal the students' mathematical thinking about variables and constraints related to the problem contexts. Czocher adds an interesting dimension to the interpretation of the MAD when she writes that when a task has become routine for an individual, the modelling route displayed by that individual for solving that particular task resembles the idealized working process of the modelling cycle (e.g., Blum & Leiss, 2007).

Methodology

The aim of our research presented in this paper is to develop an extension of Modelling Activity Diagrams and to investigate the potential and possibilities of this extended framework. For this purpose, we explicitly included a representation of the sub-problems elaborated by the students to achieve their objective within the activity (e.g., solving a Fermi problem). The data analysed in the paper was collected in a secondary school located in the metropolitan area of Barcelona and consists of video-recordings of the problem-solving processes of groups consisting of three regular Grade 4 secondary school students (ages 15 to 16) engaged in solving a Fermi problem. The groups were constructed by choosing students that suggested well elaborated and different solution strategies to previous Fermi problem. The problem the students worked on deals with the estimation of the number of objects needed to fill a large volume presented in a specific context. The problem statement provided to the students was the following:

Water is a scarce resource and it is necessary to be aware of the use we make of it. We have organised a debate to address the amount of water used for different purposes, and, in order to provide concrete data, we need to answer the following question: How many bathtubs can we fill with the water of a public swimming pool?

The video-recordings were transcribed in terms of the utterances the students made, with each students' single uninterrupted verbal contribution considered as one utterance. We analysed the data in two levels: first both in terms of the modelling cycle and the MAD framework respectively. In the second level of analysis we re-analysed the data and additionally identified the sub-problems the students engaged in to solve the main problem and incorporated this information graphically in the MAD. Notably, the generally most common model used for this type of problem and this particular age-group of students is the iteration of a unit (Albarracín & Gorgorió, 2014), in which the students determine the volume of a (larger) object and compare it to that of its containing (smaller) base units, decomposing the problem into three sub-problems – the calculation of each volume and a final comparison – as illustrated in the diagram shown in Figure 1.

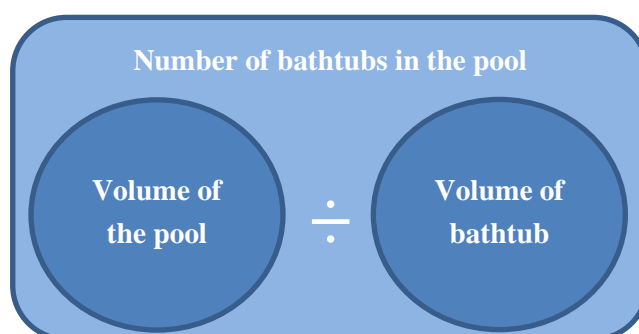


Figure 1: Structure of the Fermi problem used in this study

With this second level of analysis based on identifying the modelling activities manifested through each sub-problem, we intend to describe and investigate the relationship between the MAD and the underlying structure of the modelling processes induced by the sub-problems.

Results

The students in group A worked on the assumption of a swimming pool being 25 metres in length, arriving at an estimated result that 480 bathtubs would fit inside the swimming pool. The participation in the discussion was unevenly distributed, and the problem was mainly modelled and discussed by Ada and Arnau, while Aina drafted the report and participated in the validation process. The total number of utterances for the members of the team were: Ada, 33; Aina, 26; and Arnau, 37. The result of the analysis of group A's performance using the modelling cycle of Blum and Leiss (2007), as was also done in Aymerich and Albarracín (2016) and by focusing on identifying the different stages in the modelling process the students engaged in, can be seen in Figure 2a. This figure shows a complex problem-solving process involving many of the stages in the modelling cycle. One can note however, that none of the students' iterations in terms of modelling routes are closed in the sense of completing (the) stages in the modelling cycle in a clockwise manner, and that the students seem to be struggling in the initial phase of solving the problem. Using the MAD framework Figure 2b illustrates the switching between the different activities the students engaged in, the complexity of how the groups' modelling process unfolded, and hence conveys, analogous to the representation in Figure 2a, a picture of a somewhat disorganised process.

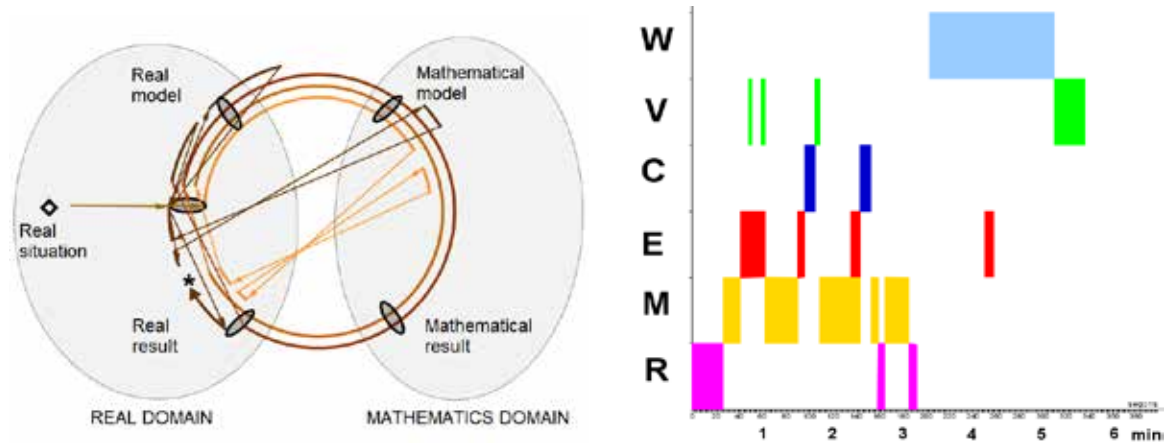


Figure 2: a. Analysis of group A's modelling route in terms of the modelling cycle (left); b. Analysis of group A's modelling route in terms of the MAD framework (right)

If we turn to the analysis including the division into the sub-problems that the students engaged in and how the coded activities are distributed in relation to these, a more nuanced and clear structure is revealed. The MADs show the activities the students engaged in along a timeline, and departing from this, the extension of the MAD is generated by introducing a graduation of intensity of colour to differentiate each of the sub-problems in which the students work. In the lower part of the graph, the specific sub-problems are labelled. In this way, the extended MAD provides a representation merging both the identified modelling activities and the sub-problems the students addressed.

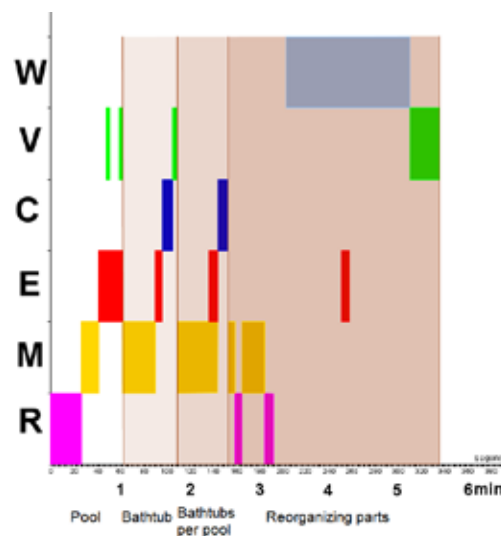


Figure 3: A MAD with the sub-problems group A engaged in during their problem-solving process

Figure 3 shows the activities the students engaged in to solve each of the sub-problem they tackled. The students started working on deciding the size of their swimming pool of choice and estimating its volume (sub-problem one), and then worked on estimating the volume of a bathtub (sub-problem two). The third sub-problem consisted of calculating the number of bathtubs that would fit in the swimming pool, before finally re-organising the information obtained in order to present a solution and write the report.

Coming back to the point made by Czocher (2016), that students' modelling processes of routine problems tend to better line up with the stages in the modelling cycle, we conclude that this is by no means obvious in terms of students' modelling routes as depicted in Figure 2.a or the activities in the MAD in Figure 2.b. Rather, the impression conveyed by these representations is that the problem solving process the students engaged in is ill-structured and complex. However, the resulting diagram from the extended MAD analysis (Figure 3) provides a more accurate and nuanced representation of the students' engagement within the problem. The MAD in Figure 3 clearly reveals the structure of the activities the student engaged in when solving the problem and shows that the model needed to solve the problem was accessible to them and that they controlled all the details needed to reach a solution. To contrast this straight forward problem-solving process, we illustrate the activities engaged in by a different group of students in solving the same problem. Figure 4 shows that the extended MAD for a second group B and reveals some difficulties in their solution process. These students also calculated the volume of a bathtub and a pool, but they initially used different units in the respective calculations. Hence, which can be seen between 5:39 and 7:41 in Figure 4, they had to decide how to go about to combine their calculated values in order to obtain a result.

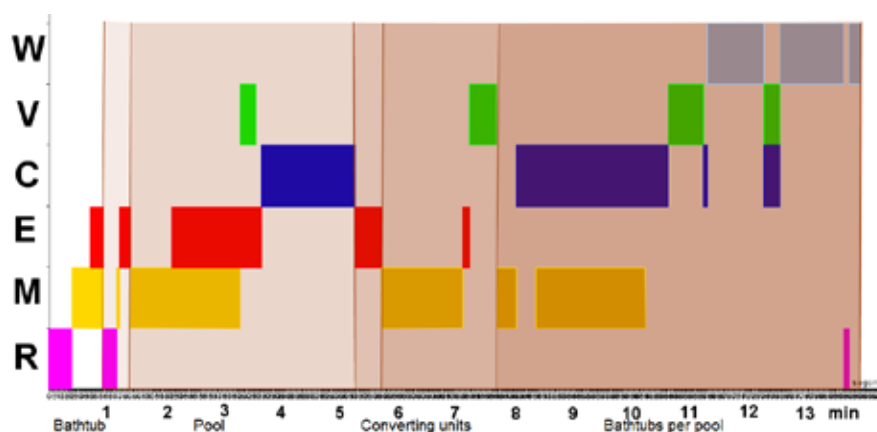


Figure 4: MAD with separation into sub-problems for group B's modelling process

The comparison between the different approaches to analyse the data leads us to conclude that the extended MAD do facilitate an analytical narrative that is closer to the actual activities the students engage in. It does this in the sense that the extended MAD provides more localised information that allows for a clearer and more detailed interpretation of the students' actions and decisions.

Discussion and conclusions

From a methodological point of view, we reaffirm the idea that characterizing the different activities students engage in when solving a modelling problem is straighter forward and clearer in terms of MAD activities compared to that in terms of stages of the modelling cycle. However, we must emphasize that analysing the tasks carried out by a group is a complex task since we can only rely on the observable elements the collected data provide. Sometimes the students in a group split their focuses and interests when working towards the solution, resulting in the students not working together. Due to their inherent structure, the MAD diagrams make it possible to show this fact explicitly by mapping out different bars for the different activities for the time period in question. In this way, we consider MAD diagrams to be both a richer and more robust tool from a methodological

point of view when it comes to make and visualize the connection between the activities the students actually engage in during the problem-solving process and the codes aiming to capture these activities explicitly. From the point of view of the development of an analysis tools, Fermi problems appear suitable as a type of modelling activity for validating the utility of extended MAD. To investigate limitations, the framework needs to be applied to more complex situations where students are engaged in other types of activities (statistical data collection, measurement, prototyping, ...) as well as to the different parts of larger and more complex modelling problems and projects.

Another aspect to note is that the results show that even in the case of students engaged in solving a Fermi problem that is accessible to them, the modelling process involved in arriving to a solution is complex. This complexity is manifested in the large number of the instances that students engage in different activities needed to characterize the problem-solving process, but also in the significant differences between the problem-solving processes of the different groups. This study allows us to affirm that although this complexity exists, the extended MAD framework facilitate us to reveal the internal structure of the proposed Fermi problem, and thus more clearly showing the work pattern of the students. Group A's initial MAD (Figure 2.a) shows a complex problem-solving process that is, however, clearly possible to divide into the solving of several sub-problems as displayed using the extended MAD (Figure 3). For this group the problem given did not pose any great difficulties, neither from a decision-making point of view regarding the modelling process, nor in the workings of the mathematical tools used. This results in an extended MAD of the students' problem-solving process that in a trustworthy way reflects the activities the students engaged in. In part, the modelling behaviour displayed by the students in this group is concurrent with the findings of Czocher (2016), that when students experience the modelling problem at hand as routine, the problem-solving process is more or less straightforward.

This latter fact suggests the possibility of using the extended MAD as a way of representing the activities students engage in during modelling in teacher training programmes. In this context, the extended MAD can be used as the point of departure for discussions on students' performance in different stages of the modelling process and to differentiate between those instances where students have difficulties compared to those in which students make progress and are constructing (sub-) solutions easily. In this sense, and in line with the benefits reported from the use of modelling cycles in teacher preparation courses (Sevinc & Lesh, 2018), we understand that extended MADs can act as an access point or as an element to foster other types of discussions, allowing students' procedures to be connected to the content used. An example of this extra explanatory information the extended MAD makes it easier to identify, is the activities the students in the second group engage in when they detected the inconsistencies in their calculated values due to the units chosen when considering the volumes of the pool and bathtub respectively. The lack of specificity in the formulation of the given problem is part of the nature of Fermi problems and promotes discussion between students, as well as connecting mathematical and extra-mathematical knowledge. The analytical approach developed in this study shows that extended MAD diagrams can be a helpful tool to visualize some of these hidden elements, and that previously seemingly messy and haphazard problem-solving processes can be understood as highly structured. In fact, we are hopeful that extended MAD diagrams can be further developed and readily applied to study also mathematical modelling

processes beyond mere Fermi problems. Given that the MADs were designed to specifically study these types of problems, one of the activities included in the original analysis is estimation, but we suggest that this activity is broadened, or complemented with other types of activities, so that activities such as making measurement, statistical data collection, experimentation or simulation are included in the next version of the extended MAD framework.

Acknowledgements

Research supported by the projects EDU2017-82427-R (Ministerio de Economía, Industria y Competitividad, Spain), 2017 SGR 497 (AGAUR, Generalitat de Catalunya) and José Castillejo program (CAS17/00289 reference).

References

- Albarracín, L., & Gorgorió, N. (2014). Devising a plan to solve Fermi problems involving large numbers. *Educational Studies in Mathematics*, 86(1), 79–96.
- Ärlebäck, J. B. (2009). On the use of realistic Fermi problems for introducing mathematical modelling in school. *The Mathematics Enthusiast*, 6(3), 331–364.
- Aymerich, À., & Albarracín, L. (2016). Complejidad en el proceso de modelización de una tarea estadística. *Modelling in Science Education and Learning*, 9(1), 5–24.
- Blum, W., & Leiss, D. (2007). “Filling Up” – The problem of independence-preserving teacher interventions in lessons with demanding modelling tasks. In M. Bosch (Ed.), *Proceedings of CERME4* (pp. 1623–1633). Sant Feliu de Guíxols, Spain: ERME.
- Borromeo Ferri, R. (2007). Modelling problems from a cognitive perspective. In C. Haines, P. Galbraith, W. Blum, & S. Khan (Eds.), *Mathematical modeling: Education, engineering, and economics* (pp. 260–270). Cambridge, UK: Woodhead Publishing Limited.
- Czocher, J. A. (2016). Introducing Modeling Transition Diagrams as a tool to connect mathematical modeling to mathematical thinking. *Mathematical Thinking and Learning*, 18(2), 77–106.
- Efthimiou, C. J., & Llewellyn, R. A. (2007). Cinema, Fermi problems and general education. *Physics Education*, 42(3), 253.
- Perrenet, J., & Zwaneveld, B. (2012). The many faces of the mathematical modeling cycle. *Journal of Mathematical Modelling and Application*, 1(6), 3–21.
- Peter-Koop, A. (2009). Teaching and understanding mathematical modelling through Fermi-problems. In B. Clarke, B. Grevholm, & R. Millman (Eds.), *Tasks in primary mathematics teacher education* (pp. 131-146). Dordrecht, the Netherlands: Springer.
- Sevinc, S., & Lesh, R. (2018). Training mathematics teachers for realistic math problems: a case of modeling-based teacher education courses. *ZDM Mathematics Education*, 50(1–2), 301–314.

Simulations and prototypes in mathematical modelling tasks

Ana Margarida Baioa^{1,3} and Susana Carreira^{2,3}

¹ Group of Schools D. Manuel I – Tavira, Portugal; ambaioa@gmail.com

² Faculty of Sciences and Technology, University of Algarve, Portugal; scarrei@ualg.pt

³ UIDEF, Institute of Education, University of Lisbon, Portugal

This paper aims to explore and discuss the use of simulations with physical models and prototype construction in a mathematical modelling activity in a context of science, technology, engineering and mathematics (STEM). This study aims to understand the role of simulations and prototypes in student activity and how the use of prototypes and simulations modifies the mathematical modelling cycle. The study is based on a teaching experience in two 9th grade classes. From the analysis we can say that the integration of simulations and prototype construction in an educational STEM context is an important factor for students in assigning meaning to the various phases of the mathematical modelling cycle and in working effectively through those phases.

Keywords: Mathematical modelling cycle, prototype, simulation, STEM.

Introduction

In the last decade, both in conference papers and in articles published in various journals on science and mathematics teaching, the emphasis has increased regarding the educational plea for the integration and connection between knowledge, methods and concepts of different disciplines in school. This movement, in particular, embraces the perspective of an interdisciplinary teaching of Science, Technology, Engineering, and Mathematics, known today as STEM Education (acronym for Science, Technology, Engineering, and Mathematics).

The drive towards interdisciplinary teaching has been a constant trend both in reports from the PISA studies (OECD, 2016) and in official curricular guidelines from different countries, endorsing more relevant, less fragmented, and more stimulating learning opportunities for students (Furner & Kumar, 2007). STEM education represents an effort to combine science, technology, engineering and mathematics in a single classroom or lab or in more open and interconnected multipurpose school facilities, based on the relationships that can be generated between contents and real-life problems, in which the four areas of knowledge may be relevant, although they do not have to be present at the same time (Moore, 2008; Zawojewski, 2010; Michelsen, 2006).

Many examples of studies within a STEM perspective involve experimental work using simulations and physical materials where the engineering design process is put into practice in the learning activities and projects (Stohlmann, Moore, & Roehring, 2012). In some cases, the activities combine engineering and mathematics and the mathematical modelling cycle is used as a reference for the organization and orientation of the work to be developed with the students (Mousoulides & English, 2011; Gallegos, 2018). The aims may include learning and exploring new aspects involved in a real system, or designing new products and processes.

In this article, we consider the combination of engineering, biology, and mathematics, in a modelling task where the simulation of the situation and the mathematical modelling of real-world

systems are involved. The three research questions underpinning a larger research study, which is the basis of this partial report, are the following:

- (1) What is the role of simulation in the students' mathematical modelling activity when solving problems taken from a STEM context?
- (2) What is the role of a prototype in a mathematical modelling activity within a STEM context?
- (3) How does the use of prototypes and simulations impact the mathematical modelling cycle phases?

Theoretical Framework

The theoretical underpinnings of the study are here generically presented, under the intention of making salient a pedagogical perspective on the use of simulations with physical models, aligned with an engineering and mathematical modelling approach for teaching and learning mathematical concepts and ideas that are interconnected with other areas of knowledge, like hand biometry, for example.

Engineering Modelling Eliciting Activities (EngMEAs)

An engineering model eliciting activity (EngMEA) is formulated from a real-world problem, which is usually framed as a response to a customer's request. Its design and implementation is supported by the broader framework of the Models and Modelling perspective (M&M) (Lesh & Doerr, 2003; Diefes-Dux & Imbrie, 2008). The accomplishment of the task usually requires one or more mathematical concepts as well as engineering models and processes, which are not openly specified in the problem (Mousoulides & English, 2011). The fact that there is a client to whom a response or result should be provided seems to be a relevant element in this type of task, since it contributes to make the context of the problem more credible for the student, and the solution to be found is not abstractly required, but rather has a presumed recipient (Carreira & Baioa, 2017).

In this perspective, when solving the task, students should bring about their knowledge to formulate a mathematical model that can be used or applied by the client for the solution of a given problem or other similar problems (Diefes-Dux & Imbrie, 2008). An EngMEA type of task may, under adequate settings, promote the ability to develop conceptual tools and to construct, describe and explain complex systems; it also brings forth communication and collaborative work. An EngMEA should be elaborated according to the six principles stated below (Table 1).

Principle	Description
Construction of the model	Requires the construction of an explanation, description or procedure leading to a meaningful mathematical model development according the user's needs.
Generalization	The model must be useful to the user, sharable, re-usable and modifiable.
Documentation of the model	Students should document their activity and their thinking explicitly in the form of a report in some communicational setup.
Reality	The context and form of the task must be credible in order to promote a meaningful interpretation by the students, according to their levels of

	mathematical knowledge and general knowledge.
Self-assessment	The task should contain criteria that students can consider for testing and reviewing the model found.
Effective Prototype	In addition to the mathematical model, a physical/metaphorical prototype may be produced as a real outcome and as a response to a customer.

Table 1: Principles for the development of an engineering model-eliciting activity (adapted from Diefes-Dux & Imbrie, 2008)

In the present study, a simulation of the situation, by means of physical models, is expected to be carried out as a support for the production of the effective prototype.

Relation between simulation and prototype

Pollak (2003) argues that a major obstacle related to the integration of mathematical modelling in the classroom is the need for students to understand how to connect mathematics with the rest of the world. One difficulty has to do with the lack of a clear formulation of a conceptual model (which implies an understanding of the problem, of the relevant conditions, and forms of mathematization). A way to overcome this obstacle is giving students the opportunity to engage in performing real simulations, since a simulation is an imitation of the real situation, is closely linked to experimenting, predicting, testing, solving problems, imagining alternative solutions, making the situation real, visible and tangible through representations conveyed by physical models.

In production processes, the simulation with physical models allows observing the system, predicting, supporting decisions, modelling, verifying product quality and performance prior to marketing, and refining production processes (Landriscina, 2013); such physical models offer means that produce behaviours, reproduce some aspects of a system, create a variety of reactions that depend on actions and assist on testing hypotheses in a research problem.

One of the fundamental aspects of a simulation lies on its close relationship with a model, in the sense that it establishes a representation of the real world, whether the model is an image or scheme, an object built to scale, a formula that can be used during a simulation, or even the product of the simulation (Gilbert & Boulter, 2000). The use of a physical model supports the exploration and manipulation of the situation until the creation of a final model (physical or conceptual) that can be called a prototype. The concept of prototype is the basis of the engineering design process where simulations and mathematical modelling are abundantly present, being the prototype a solution to the original problem.

Mathematical modelling and engineering design process

According to Birta and Arbez (2007), the modelling and simulation process in an engineering context, where the objective is the creation of a prototype, consists of six essential steps: (1) The description of problem/project; (2) The construction of a conceptual model of the system; (3) The simulation with physical models; (4) The creation of a prototype and associated mathematical model; (5) The prototype validation in terms of credibility and stability; and (6) Obtaining an end product. These steps are repeated until a satisfactory result is obtained.

Something very similar is typically found in the description of the mathematical modelling cycle (Blum & Leiß, 2007), where the main steps are described as: (1) Understanding the problem; (2) Simplification of the original situation; (3) Mathematizing; (4) Working in the mathematical domain; (5) Interpretation of the result obtained; (6) Validation; and (7) Presentation of results.

The common points between these two forms of conceptualizing the processes that involve reality and the search for a solution to a given problem are evident. Thus, it seems reasonable to admit that both descriptions can be conformed to the other as suggested in the following sequence (Figure 1): (a) Understanding the problem; (b) Identification of the relevant variables in the situation to be modelled; (c) Development of a conceptual model; (d) Data collection through simulation and forms of mathematization; (e) Production of a prototype and associated mathematical model; (f) Validation of model and prototype through stability and credibility; and (g) Presentation of final product and final mathematical model. This is a cyclical process that can be fully or partially repeated, depending on the validation of the prototype or the mathematical model.

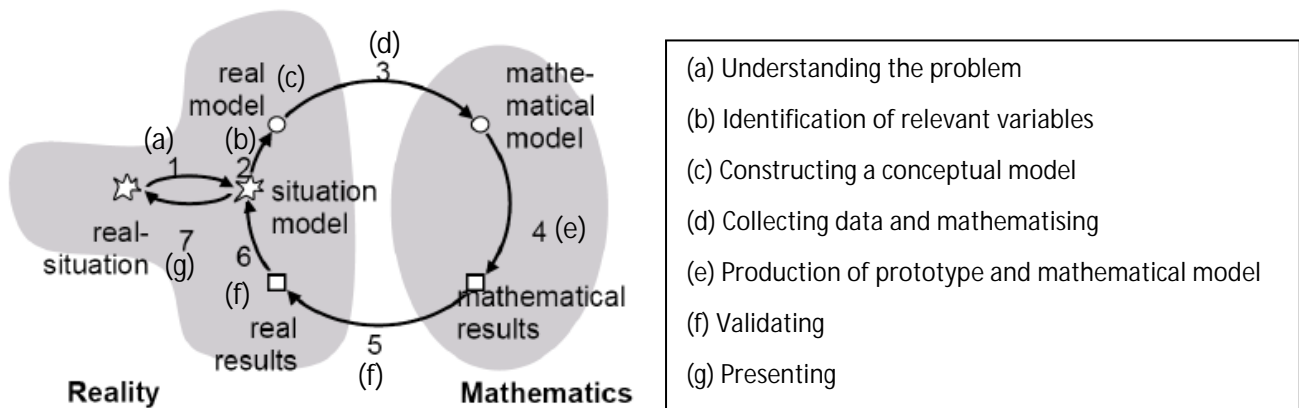


Figure 1: The mathematical modelling cycle coupled with prototype development

Methodological approach

In our study we used physical models in tasks that involved problems driven by the scenario of a request from a client. All the tasks involved simulation and practical work. According to studies that share similar elements, design-based research has been adopted (Cobb, 2000; Kelly et al., 2008). Two classes (46 students aged between 13 and 15) participated in this study. Students were organized in the class into 4 or 5 groups and received identical sets of physical materials and instruments for the development of simulations. The empirical data here addressed were collected from the third out of totally five modelling tasks implemented during the school year, through video and audio recording of group work, as well as detail photographs.

Each modelling task was designed according to a structure that involves four parts: (1) Introduction of the task (when the situation and the various elements are presented and clarified); (2) Practical work with physical models, involving data collection; (3) Representation, analysis of collected data and construction of a prototype; and (4) Preparation of a written report and sharing and discussion of the products obtained.

The task refers to the creation of a biometric database and to the development of a recognition system through biometry/hand geometry. The students had at their disposal a set of paper images of their own hands (obtained through photocopies) and the purpose was to create a recognition system

that validated the biometric data of the elements of each group and rejected those of a person who did not belong. After a prototype of such a recognition system was created by each of the groups, a new image of an unidentified hand was given for testing and validation of the respective prototype.


The categories created for the analysis of the data from the implementation of the biometric recognition task refer to the general purpose of perceiving how the simulation and the construction of a prototype play a role in the mathematical modelling activity of the students and, in particular, how they integrate it in the mathematical modelling cycle. Thus, the categories are defined in terms of the phases of this cycle, as described theoretically (Table 2).

Categories	Prototype development	Modelling cycle phases
understanding	Ⓜ	(a) Understanding the problem and the goal to be achieved
exploration	Ⓜ	(b) Identification of the relevant variables in the situation
representation	Ⓜ	(c) Development of a conceptual model
experimentation	Simulation Ⓜ	(d) Collection of data and mathematization of the situation
construction	Prototype construction Ⓜ	(e) Development of a prototype and associated mathematical model
validation	Prototype testing Ⓜ	(f) Model and prototype validation
communication	Ⓜ	(g) End product and mathematical model

Table 2: Categories of data analysis

Summary of the results

The selected data were organized to represent the path of the students' work during the task and according to the categories above (Table 2). This path depicts the main features of the students' ways of thinking throughout the task (Table 3).

Understanding	<ul style="list-style-type: none"> • Watching a video about security systems that use biometric data to recognize individuals. • Reading of the task and clarifying questions. • Understanding the problem and the goal.
Exploration	<ul style="list-style-type: none"> • Naming the biometric database of the group and defining a code for each group element. • Deciding the measures to collect. (Lengths of the fingers, widths of the phalanges; palm area were different choices suggested). 
Representation and experimentation	<ul style="list-style-type: none"> • Collecting information and data from the image of each hand. • Establishing the main variables to use in the mathematical model. • Recording the numerical data in tables.
Construction	<ul style="list-style-type: none"> • Defining a rule for the process of comparing and checking a given hand with the database elements (conceptual prototype). An example:

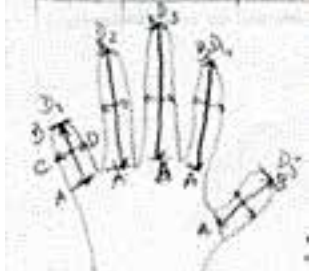
	Finger 1 (Little finger)		Finger 2 (Ring finger)		Finger 3 (Middle finger)		Finger 4 (Index finger)		Finger 5 (Thumb)	
	width	length	width	length	width	length	width	length	width	length
	$\overline{C_1D_1}$	$\overline{A_1B_1}$	$\overline{C_2D_2}$	$\overline{A_2B_2}$	$\overline{C_3D_3}$	$\overline{A_3B_3}$	$\overline{C_4D_4}$	$\overline{A_4B_4}$	$\overline{C_5D_5}$	$\overline{A_5B_5}$
	<ul style="list-style-type: none"> • Assuming an approximate match. • Establishing an acceptable “margin of error” of 0,2 cm to be taken in the comparison between some given data and the stored data. 									
Validation	<ul style="list-style-type: none"> • Delivering one unidentified hand image for each group. • Obtaining the necessary data from the unidentified hand according to the biometric variables of the identification model. • Checking whether the “scanned” or “standardized” hand belonged to the group or not, according to the recognition model. • Validating the model and the biometric recognition system developed. 									
Communication	<ul style="list-style-type: none"> • Preparing and delivering a report describing the steps taken and presenting the data collected, the mathematical model considered for the recognition, and its validation. 									

Table 3: A synthesis of the students’ main processes and actions on the task

Discussion and conclusions

Much of the students’ thinking and struggling was around the idea of reliability of the process for comparing experimental data with unknown data (of an unidentified hand). The fact that students were simulating a process of capturing biometric data, using full size photos of hands, and realizing the many details and variations of that part of the human body, led them to reflect at length on how to integrate this knowledge in a recognition system performed by a machine, which aims to accept or reject biometric data. Many of the students were quite cautious about creating a model that did not generate false positives, revealing the understanding that the control to be performed by the model would have to be “strict enough” not to allow “a false hand to be accepted”. This resembles what in reality the biometric security systems are concerned with. In fact, a general result from the activity of the students in creating a biometric recognition conceptual prototype was the strong interconnection between ideas and concepts from mathematics, human body biology, and engineering. The idea of creating a prototype engages students on a real attempt to find the most credible model for a real problem in STEM context. The students’ mathematical model for the biometric recognition system was based on the idea of tolerable margin of error. For example, one of the groups assumed that acceptance of an individual would be confirmed in the case where the deviation found for every variable was less than 0.2 cm. Otherwise the system would reject the individual as unrecognized. They therefore based their model on a logical rule of the type if-then-else. The value of 0.2 cm was chosen through the scaling of the hand. The students decided to spread their hands against the table to get an indication of a tolerable dilation of the hand.

The work with physical models in a simulation, such as the use of the actual images of the palms of the students, was a facilitating element for the need to collect real data and for the development of a conceptual model of the situation. The identification of a set of variables to be used was, from the beginning of the activity, an important source of exploration of the situation in the various groups. Different groups considered different ways of defining the measures they assumed as hand identifiers. Thus, the simulation based on physical models has one clear effect over the emergence of different conceptualizations and ways of approaching the real problem; the task allowed students to create different identification criteria for the biometric database.

The ideas of variability, and error or deviation were the focal points of the mathematical approach to the construction of a recognition prototype. This prototype, in turn, elicited a recognition model, which was founded on mathematical ideas and concepts.

Being in the position of obtaining a prototype, that is, of imagining a data capture system and a model aimed to accept or reject new data by comparison, helped students to understand that their model would have to be reliable, that is, it would have to be tested with a new simulation. This gave added meaning to the process of acquiring new data from an unidentified hand, consistent with the system of variables previously defined for data capture.

The mathematical modelling cycle phases are not modified by using simulation and prototype. The students go through all the phases realizing micro modelling cycles.

In general, we conclude that the use of physical models and simulations in experimental tasks, involving the construction of a prototype, promotes the activity of mathematical modelling under conditions that reveal an evident parallelism with real settings where solutions for real problems are searched. Students are faced with genuine obstacles that do not always arise in other types of problems and use their own everyday knowledge and concepts to find ways of establishing the relationship between mathematics and reality. Thus, the integration of simulations and prototype construction, in a STEM educational context, is an important factor to make sense of and also to perform the various steps of the mathematical modelling cycle, so that they become part of a coherent entire process and not just conventional steps to accomplish.

References

- Birta, L. G., & Arbez, G. (2007). *Modelling and simulation – Exploring dynamic system behaviour*. London, United Kingdom: Springer.
- Blum, W., & Leiß, D. (2007). How do teachers deal with modeling problems? In C. Haines, P. Galbraith, W. Blum, & S. Khan (Eds.), *Mathematical Modeling – Education, engineering and economics* (pp. 222–231). Burlington, United States: Elsevier Science.
- Carreira, S., & Baioa, A. M. (2017). Mathematical modelling with hands-on experimental tasks: on the student's sense of credibility. *ZDM – Mathematics Education*, 50(1–2), 201–215.
- Cobb, P. (2000). Conducting teaching experiments in collaboration with teachers. In A. E. Kelly & R. A. Lesh (Eds.), *Handbook of research design in mathematics and science education* (pp. 307–330). Mahwah, NJ: Lawrence Erlbaum.
- Diefes-Dux, H. A., & Imbrie, P. K. (2008). Model-eliciting activities for engineering education. In J. S. Zawojewski, H. A. Diefes-Dux, & K. J. Bowman (Eds.), *Models and modeling in*

- engineering education: Designing experiences for all students* (pp. 17–35). Rotterdam, The Netherlands: Sense Publishers.
- Furner, J., & Kumar, D. (2007). The mathematics and science integration argument: a stand for teacher education. *Eurasia Journal of Mathematics, Science & Technology*, 3(3), 185–189.
- Gallegos, R. (2018). Building bridges between the math education and the engineering education communities: a dialogue through modelling and simulation. In G. Kaiser, H. Forgasz, M. Graven, A. Kuzniak, E. Simmt, & B. Xu (Eds.), *Invited lectures from the 13th International Congress on Mathematical Education, ICME 13 Monographs* (pp. 501–519). Cham, Switzerland: Springer International Publishing.
- Gilbert, J., & Boulter, C. (2000). *Developing models in science education*. Dordrecht, The Netherlands: Kluwer Academic Publishers.
- Kelly, A., Baek, J., Lesh, R., & Bannan-Ritland, B. (2008). Enabling innovations in education and systematizing their impact. In A. Kelly, R. Lesh, & J. Baek (Eds.), *Handbook of design research methods in education: Innovations in science, technology, engineering, and mathematics learning and teaching* (pp. 3–18). New York, United States: Routledge.
- Landriscina, F. (2013). *Simulation and learning – A model-centered approach*. New York, United States: Springer.
- Lesh, R., & Doerr, H. (Eds.). (2003). *Beyond constructivism: Models and modelling perspectives on mathematics problem solving, learning, and teaching*. Mahwah, United States: Lawrence Erlbaum.
- Michelsen, C. (2006). Functions: A modelling tool in mathematics and science. *ZDM – Mathematics Education*, 38(3), 269–280.
- Moore, T. (2008). Model-eliciting activities: a case-based approach for getting students interested in material science and engineering. *Journal of Materials Education*, 30(5/6), 295–310.
- Mousoulides, N., & English, L. (2011). Engineering model eliciting activities for elementary school students. In G. Kaiser, W. Blum, R. Borromeo Ferri, & G. Stillman (Eds.), *Trends in Teaching and learning of mathematical modelling, International perspectives on the teaching and learning of mathematical modelling – ICTMA 14* (pp. 221–230). New York, United States: Springer.
- OECD (2016), *Ten questions for mathematics teachers ... and how PISA can help answer them*. Paris: PISA, OECD Publishing. <http://dx.doi.org/10.1787/9789264265387-en>.
- Pollak, H. O. (2003). A history of the teaching of modelling. In G. M. A. Stanic, & J. Kilpatrick (Eds.), *A history of school mathematics* (Vol. 1, pp. 647–672). Reston, United States: NCTM.
- Stohlmann, M., Moore, T., & Roehring, G. H. (2012). Considerations for teaching integrated STEM education. *Journal of Pre-College Engineering Education Research*, 2(1), 28–34.
- Zawojewski, J. (2010). Problem solving vs modelling. In R. Lesh, P. L. Galbraith, C. Haines, & A. Hurford (Eds.), *Modeling students' mathematical modelling competencies* (pp. 237–243). New York, United States: Springer.

Modelling praxeologies in teacher education: the cake box

Berta Barquero¹, Marianna Bosch², Floriane Wozniak³

¹Universitat de Barcelona, Spain; bbarquero@ub.edu

²Universitat Ramon Llull, Barcelona, Spain; marianna.bosch@iqs.edu

³Université de Montpellier, France; floriane.wozniak@umontpellier.fr

This article presents a teacher education activity with pre-service Primary school teachers who are asked to address modelling problems before describing their activity using new discursive and conceptual tools. The terminology of modelling and the questions-answers maps are proposed to enrich the logos of teachers' modelling praxeologies, that is, to provide future teachers with a discourse—a logos—to explain and analyse the modelling praxis.

Keywords: Modelling, teacher education, mathematical discourse, anthropological theory of the didactic, praxeologies.

Introduction: Teacher difficulties with the modelling discourse

When teaching mathematics is considered as the teaching of already-produced knowledge (concepts, procedures, properties, etc.), teachers dispose of discursive resources to talk about the content at stake: “Here we can use proportionality”, “Be careful with the distributive law”, “The problem leads to a quadratic equation”, etc. All these resources have been elaborated during long processes of didactic transposition (Chevallard, 1985) and can be found in textbooks, syllabi, curriculum guidelines, etc. They belong to what is called the *knowledge to be taught* and appear as crucial tools for teachers and students to manage learning processes, to talk about what is already done, what is still to be done, what mathematical tools can be used, what difficulties might appear, what mistakes have been identified, and so on.

In contrast, in the case of teaching modelling, the content at stake is not only a set of mathematical contents that are to be known and used to solve problems. Modelling is also taught as a process to follow, where all the steps—and not only the final result—are equally important. In this case, teachers and students are not always provided with the appropriate words or discursive elements needed to describe the different steps of the process.

The importance of language in teaching and learning modelling has been pointed out by many researchers (Barbosa, 2006; Borromeo Ferri & Blum, 2010; De Oliveira & Barbosa, 2013; Doerr, 2007). For instance, focusing on the students' performances, Redmond, Brown and Sheehy (2013) propose to use “the principles of collective argumentation to enable students to analyse mathematical contexts, to synthesise strategies to mathematize these tasks, and to communicate solutions and conclusions to others.” (p. 13). This paper addresses the problem of the teachers' lack of discursive tools to teach modelling processes and how it can be addressed through teacher education processes.

Research problem: mute modelling praxeologies

In this section, we analyse the lack of words in teaching modelling using the anthropological theory of the didactic (ATD). In spite of a diversity of representations (Perrenet & Zwaneveld, 2012), there

is a widespread consensus about the modelling process, and its decomposition in different steps synthesised in the diverse versions of modelling cycles, where models are built and used to produce knowledge about a given piece of reality considered as a *system*. As Serrano, Bosch, and Gascón (2010, p. 2193) explain: “the productivity of the model, that is, the fact that it produces new knowledge about the system, requires a certain ‘fit’ or ‘adaptation’ to the system. This process is rarely done once and for all. It requires a forth and back movement between the model and the system, in a sort of questions-answers or trial-error dynamics.”

In the ATD, mathematical activities are described in terms of praxeologies. A praxeology is the connection between know-how (*praxis*), made of types of problems and techniques to solve them, and a discourse about the praxis (*logos*), composed of descriptions, justifications and theoretical organisations of the problems and techniques. Any human activity (solving an equation, driving a car, combing one’s hair, etc.) can be assigned to a praxeology or a set of praxeologies, with a more or less developed praxis and logos. We use praxeologies to describe both the activity of modelling and the teaching of modelling. In a teaching situation, the mathematical knowledge at stake is commonly revealed through the teacher’s discourse, which updates, describes, explains, justifies, questions and validates the knowledge aimed for. Wozniak (2012b, pp. 65–66) considers three kinds of mathematical praxeologies in teaching situations: “mute”, “weak” and “strong” praxeologies. A “mute” praxeology is one with its *praxis* component visible only, that is, the types of tasks and techniques used to carry them out without any explicit discourse to describe them. In a “weak” praxeology, the *logos* component is visible through the parts of the technique used, but the discourse is limited to the description of the technique through an incomplete formulation. Finally, a “strong” praxeology links its two components, the *praxis* and the *logos*, dialectically.

In the case of modelling praxeologies, Wozniak (2012a, 2012b) speaks of *mute* praxeologies when the hypotheses about the initial system are not explicitly stated (delimitation of the system), the model used is prebuilt and the work within the model gives results that are not validated against the system. *Weak* modelling praxeologies appear when the hypotheses are formulated but their validity domain is not clearly discussed. In this case, the model is not necessarily prebuilt but will not be validated. To develop them into *strong* praxeologies, all steps of the modelling process should be present throughout a discourse that explains their roles and validates the whole process. Wozniak (2012a) uses the three kinds of praxeologies to analyse five primary school teachers working with a modelling problem. Students are presented the photograph of the boot of a giant’s sculpture with some people around (Figure 1) and are asked to find the approximate giant’s height. The main phenomena observed—and which can be found in other investigations about teaching modelling activities—can be summarised as follows:

- The modelling activity is not identified as knowledge at stake and the modelling process is never questioned or taken as an object of study.
- The delimitation of the system remains implicit and is not discussed; the hypotheses are not explicitly formulated and only the missing data are identified.
- The discussion focuses on the choice of the values of the system variables to apply a pre-established model (proportionality).

- All 5 teachers lead the study towards their own solution, and then reduce the study to the same kind of techniques.
- In all but one case, a single model is used without discussing its legitimacy and validity. Teachers do not use the properties of the system (realism) to evaluate the answers obtained and even directly propose the model to be used.
- The fifth teacher includes discussions about the legitimacy of the measures estimated but does not talk about the domain of validity of the model used.



Figure 1: Picture of the Giant activity

Wozniak (2012a) concludes that the modelling praxeologies used in all these classrooms correspond to *mute* or *weak* praxeologies, which emphasizes the teachers' need of new knowledge and tools to deal with this kind of activities. In the following section, we propose an example of teacher education activity that aimed at transforming the *mute* praxeologies into *voiced* ones, that is, modelling praxeologies with a *logos* that give them voice to “talk about” the modelling praxis.

How to turn mute praxeologies into voiced ones: the cake box

The teacher education activity was designed and implemented by this paper's first author. It took place during eight 2-hour sessions with a group of 40 pre-service teachers in their 3rd year of a double university degree in preschool and primary school education. Although this activity has been tested since the academic year 2012-2013, we here focus on its last implementation in 2017-2018. Its design follows the first three modules of the proposal of *study and research paths for teacher education* (SRP-TE) (Barquero, Bosch, & Romo, 2018, pp. 3–4).

In the first module, pre-service teachers were proposed a general teaching question: “*How can modelling be introduced in Primary school education? Through what kind of modelling activities? With what kind of shared discourse about modelling?*” In this particular implementation, we used the giant height activity as an introduction, to make the students familiar with a modelling activity. The activity was also used to establish some common terms to refer to modelling: system, model, hypotheses, variables of the system, mathematical results, interpretation, model validation, etc. Some of the main results described in Wozniak (2012a) were also explained to the students. Then, in the second module, we started with the implementation of another modelling activity: the *cake box* (an adaptation of the activity described in Chappaz and Michon (2003)). The following three sessions were devoted to implement the cake box activity with the pre-service teachers assuming the role of *students*. The main goal was to make teachers carry out an unfamiliar mathematical activity that could, to a certain extent, exist in an ordinary classroom. The third module covered three sessions, in which students were asked to analyse the modelling process as it was experienced.

The cake box and the different modelling phases

The modelling activity starts by presenting the case of a baker who needs help for packing her cakes in boxes. She wants to use the same type of boxes she has been using (Figure 2). The following question opens the activity: “How can we build boxes to help the baker packing the variety of cakes she offers? Which relation does exist between the sizes of the initial material (paper or cardboard) and the dimensions of the resulting box?” From this initial question, the activity is structured in three phases depending on what is given as known (the sizes of the paper, box or cake) and what remains unknown.

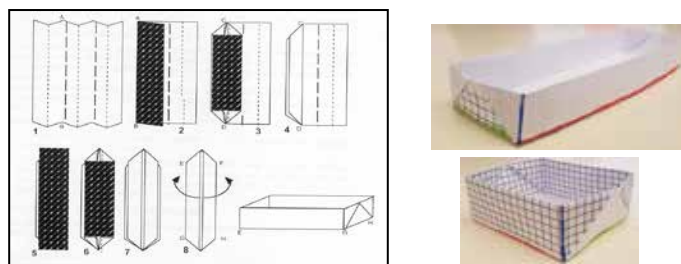


Figure 2: Instructions to build the box and examples of the resulting boxes

First phase: We considered that the paper sizes (width and length) are given and focused on question Q_1 : *Which are the dimensions of a box resulting from a paper whose sizes are fixed?* Students started by considering some particular cases, such as:

$Q_{1.1}$: What dimensions of the box resulting from an A4 paper? Is there only one possible result?

$Q_{1.2}$: If we take an A5 (half A4), do we obtain a box measuring half of the previous one?

$Q_{1.3}$: Which box sizes do we get from a squared sheet? Do we get a squared-based box?

At this phase, all the students worked using *manipulative* and *measuring techniques*, by concretely building the box and measuring the sizes of the box using different instruments (paper grid, ruler, etc.). This experimental work facilitates to *delimitate a rich system*, which had many possibilities to be extended by considering other paper dimensions and raising new questions about the sizes of the resulting boxes. Students also agreed on which variables had to be considered, for the paper (width and length) and for the box (width, length and height), and how to *agree on a common notation*. Some of the more advanced questions came from the arithmetical comparison of the papers and resulting boxes' sizes: students started formulating the first hypotheses about the likely relationships between the different variables. Most of them referred to relationships of proportionality between the sizes of the paper and the box. Although, in most of the occasions, none of the groups working with these initial *arithmetic-geometric models* could validate their first hypotheses, the possibility to experimentally build new boxes helped them to refuse or refine the hypotheses, but not to validate them.

At the end of this first phase, some of the questions students raised were about a possible relationship of proportionality between the paper and the box sizes, and about how to get a particular sized box. When these types of questions appeared, the modelling activity moved to a second phase.

Second phase: It was assumed the baker gave the box sizes she needed and the question Q_2 was stated: *Which are the initial paper sizes needed to build a box with some specific dimensions?*

Students propose to consider new auxiliary questions with particular sizes of boxes, special forms (squared-based boxes) and possible changes in specific dimensions of the box:

$Q_{2.1}$: What initial paper sizes do we need to get a box with base of 6cm x 13cm?

$Q_{2.2}$: How to get a box with a base of 8cm x 10cm and 3cm high?

$Q_{2.3}$: How to get boxes with a square base (such as: 5cm x 5cm, 8cm x 8cm, etc.)?

$Q_{2.4}$: How to modify the sheet of paper to get a box with the same base and different height?

Students started trying to use the same *manipulative-measuring* techniques developed in the first phase, by selecting box sizes close to the ones they looked for. Most of them proposed to apply *models of proportionality* to deduce the sizes of the paper, in many occasions expressed by a rule of three (Figure 3, left-hand side). When they estimated the sizes of the paper, they built the box to check if their deductions were true. When students checked that the “rule of three” did not work (as not all variables have relationships of proportionality), they looked for new models. The most common models that appeared were *pre-algebraic* ones obtained by opening the box, analysing the 2-dimensional geometrical pattern and describing the relationships (Figure 3, right-hand side). Some other groups proposed *algebraic models*, by assigning algebraic values to the different dimensions of the paper-box and looking for the algebraic equations synthesizing these relationships.

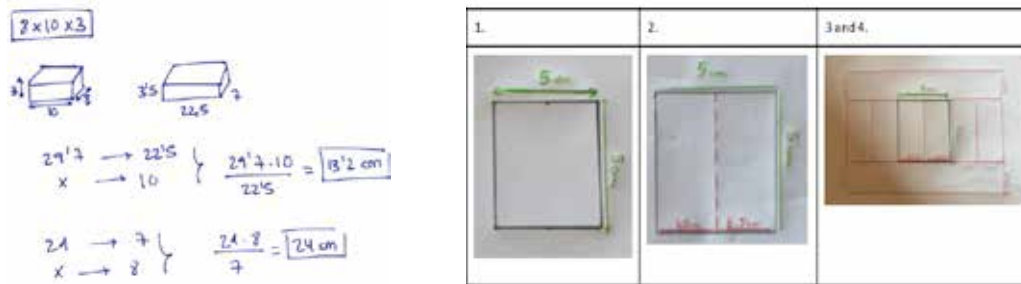


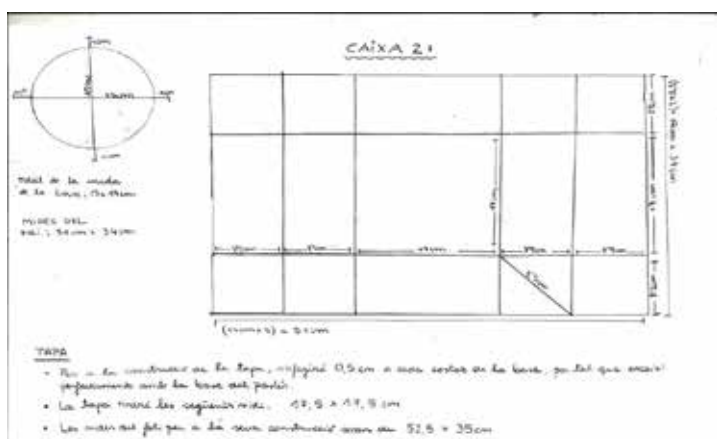
Figure 3: Models of proportionality (left-hand), pre-algebraic-geometric models (right-hand)

Concerning the modelling process, two traits may be stressed. First, the modelling work developed in Phase 1 constitutes a productive system from which Phase 2 starts. That is, thanks to the experimental work developed, students have many paper-box sizes collected, which constitutes a rich experimental *milieu* from where some first hypotheses about the relationships were explicitly formulated and against which students could evaluate their answers. Second, in this phase, more advanced models were built by students given the failure of the proportionality model. Several questions about how to reformulate the hypotheses (*Do any of the box or paper variables maintain a relationship of proportionality?*), about the comparison of models (*Are the pre-algebraic and algebraic models expressing the same?*) and about the scope and limitations of the models (*Can we follow working with the pre-algebraic models for all the box cases?*) could be explicitly stated.

This second phase finished when students were able to predict the sizes of the paper/box, without manipulating the paper/box. The following questions were posed by the teacher:

$Q_{\text{final.1}}$: How can we predict the size(s) of the box (without building it) from the dimensions of the initial paper? $Q_{\text{final.2}}$: How to predict the size of an initial paper sheet given the dimensions of the box (without building it)?

Third phase: The aim of this phase was to prepare a letter-report as an answer to the baker's demand. A list of the cakes the baker wanted to pack, and their sizes, was provided. Students were asked to prepare the final report for the baker by letting her know about the paper sizes she had to order to pack all her cakes. Moreover, students were asked to add a tray for each box, following the same pattern of construction. At this stage, students had no necessity to build new models, but the main issue was to agree about the way to build the tray (*How many cm do we have to leave between the box and the tray (margins)? Where to add these differences?*). At this stage, they could better formulate the paper-box relationships, and took advantage of using the model (see Figure 4). Furthermore, some time could be devoted to work on how to report the results, given the extent of numerical work and results, with many variables, they had to communicate and organize.



Translation of the students' proposal:

BOX 2:

Base of the box: 17 cm x 17 cm

Size of the paper: 51 cm x 34 cm

TRAY:

§ To build the tray, we add 0.5cm to each side of the box base to guarantee that it fits correctly.

§ The tray base will be 17,5 cm x 17,5 cm

Figure 4: Pre-algebraic-geometric models for the box and the tray

A progressive construction of the modelling discourse

When experiencing the cake box activity, participants managed to assume the role of students and carried out the proposed modelling activity although, as they stated, they were not used to this kind of long and open activities. After each session, the working teams (3-4 persons) had to deliver a written report about the modelling activity developed. Participating in the classroom debate and writing the reports was not an easy task for them, as they were conscious they needed new terms to describe the process. At this stage, the previous work with the giant activity was very helpful, since modelling terminology was then introduced. Still, students had many difficulties with, for instance, formulating questions, describing and categorising the kind of models they were suggesting, accepting different possibilities of models and answers, reformulating hypotheses and models, etc.

The instructor decided to follow three main strategies during Module 2. First, she fixed the structure of the reports in terms of: questions studied, data and variables selected, mathematical models considered, answers obtained, new questions opened. This helped participants explicitly describe all these elements. Second, during the debates, she asked participants to explain their proposals and to *create names* to designate the models they were using (arithmetic, geometric, pre-algebraic, algebraic, etc.). This illustrated that there was not only one-way to work on this activity and that several valid models could cohabit. Third, in the debates and reports, the instructor paid special attention to the questions the working teams were posing to help them in their formulations and in relating them to each other.

In Module 3, students were asked to provide an analysis of the modelling work previously carried out, using the session reports and class debates. The instructor proposed to do this work using questions-answers maps (Barquero et al., 2018). She proposed an initial map with the first questions and answers (Q-A) that appeared in the classroom and asked the students to complete it with the description of their own work. This way of describing the modelling process not only provided students with new terminology. It also appeared as an alternative way to talk about doing mathematics, breaking with the usual and “static” way of describing school activities, more focused on concepts, notions and techniques to the detriment of questions, models and provisional answers. Students could also use the Q-A maps to distinguish between their own modelling trajectories—the path followed—and the more complete one they could describe after the work done in class (see Figure 5), thus evidencing the possibility of finding several possible solutions to the same problem.

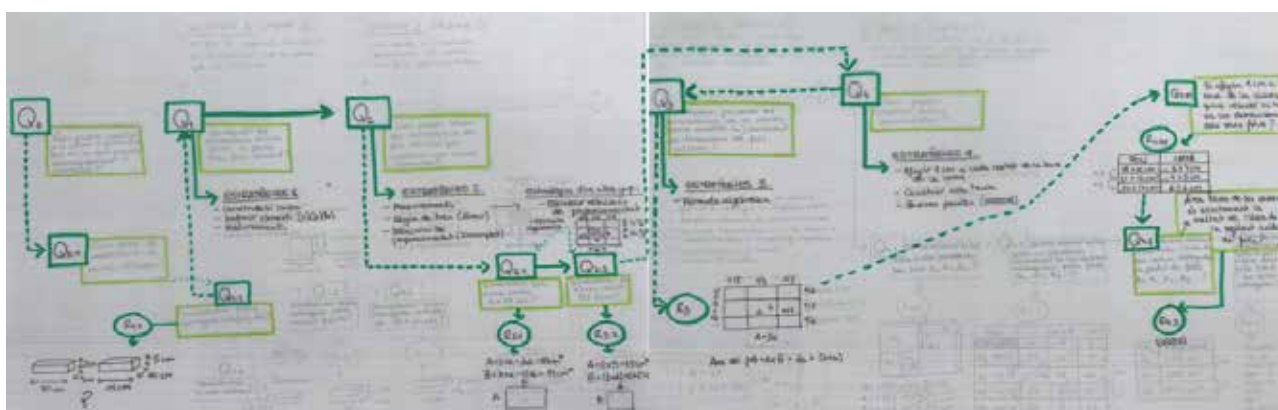


Figure 5: Example of questions-answers map used to analyse a modelling trajectory of a group

Conclusion

We have seen how Wozniak (2012b) describes the problem of the teachers’ lack of discursive tools to talk about modelling processes in terms of *mute* praxeologies, that is, praxeologies where the *logos* component remains implicit. This *logos* is part of the mathematical praxeologies to be taught related to modelling activities. However, it also seems to be a crucial didactic tool to teach modelling—therefore, part of the teacher’s didactic praxeology. It is difficult for teachers to highlight some important modelling procedures when they are not familiar with any specific mathematical terminology to talk about models, systems to be modelled, possible fits (and misfits) between models and systems, etc. To start addressing this problem, we propose to use *study and research paths for teacher education* to elaborate new epistemological tools, such as the questions-answers maps, with the teachers as part of the modelling praxeologies to later on develop them as didactic tools to better describe and analyse the modelling activities carried out in classrooms. This strategy needs to be developed, but at the present, it seems helpful to fill in the gap between the traditional way of describing—and conceiving—school mathematics and the new epistemological and didactic necessities raised by the teaching of modelling processes.

Acknowledgments

Funded by Ministerio de Ciencia, Innovación y Universidades with the research projects Retos Investigación of the Programa Estatal de I+D+I: EDU2015-69865-C3-1-R; RTI2018-101153-A-C22.

References

- Barbosa, J. C. (2006). Mathematical modelling in classroom: A critical and discursive perspective. *ZDM Mathematics Education*, 38(3), 293–301.
- Barquero, B., Bosch, M., & Romo, A. (2018). Mathematical modelling in teacher education: dealing with institutional constraints. *ZDM Mathematics Education*, 50(1-2), 31–43.
- Borromeo-Ferri, R., & Blum, W. (2010). Insights into teachers' unconscious behavior in modeling contexts. In R. Lesh, P. Galbraith, C. Haines, & A. Hurford (Eds.), *Modelling students' mathematical modeling competencies* (pp. 423–432). New York, NY: Springer.
- Chappaz, J., & Michon, F. (2003). Il était une fois ... La boîte du pâtissier. *Grand N*, 72, 19–32.
- Chevallard, Y. (1985). *La transposition didactique – Du savoir savant au savoir enseigné*. Grenoble, France: La Pensée Sauvage.
- De Oliveira, A. M. P., & Barbosa, J. (2013). Mathematical modeling, mathematical content and tensions in discourses. In G. A. Stillman, G. Kaiser, W. Blum, & J. P. Brown (Eds.), *Teaching mathematical modeling: Connecting to research and practice* (pp. 67–76). Dordrecht, the Netherlands: Springer.
- Doerr, H. M. (2007). What knowledge do teachers need for teaching mathematics through applications and modelling? In W. Blum, P. Galbraith, H. Henn, & M. Niss (Eds.), *Modelling and applications in mathematics education: The 14th ICMI study* (pp. 69–78). New York, NY: Springer.
- Perrenet, J., & Zwaneveld, B. (2012). The many faces of the mathematical modeling cycle. *Journal of Mathematical Modelling and Application*, 1(6), 3–21.
- Redmond, T., Brown, R., & Sheehy, J. (2013). Exploring the relationship between mathematical modelling and classroom discourse. In G. A. Stillman, G. Kaiser, W. Blum, & J. P. Brown (Eds.), *Teaching mathematical modeling: Connecting to research and practice* (pp. 349–360). Dordrecht: Springer.
- Serrano, L., Bosch, M., & Gascón, J. (2010). Fitting models to data. The mathematising step in the modelling process. In V. Durand-Guerrier et al. (Eds.), *Proceedings of the Sixth Congress of the European Society for Research in Mathematics Education* (pp. 2185–2196). Lyon, France: INRP 2010.
- Wozniak, F. (2012a). Des professeurs des écoles face à un problème de modélisation : une question d'équipement praxéologique. *Recherches en Didactique des Mathématiques*, 32(1), 7–55.
- Wozniak, F. (2012b). Analyse didactique des praxéologies de modélisation mathématique à l'école : Une étude de cas. *Éducation & Didactique*, 6(2), 63–88.

Analysis of textbook modelling tasks, in light of a modelling cycle

Ingeborg Katrin Lid Berget

Volda University College, Norway; bergeti@hivolda.no

Keywords: Mathematical modelling, modelling competence, task analysis.

Introduction

Even if the focus on mathematical modelling in education has increased the last decades, the presence of modelling activities in day-to-day teaching is still limited (Frejd, 2012). This study concern classroom practices comprising mathematical modelling. It is a part of a project, which involves more studies of classroom modelling activities. In this study, we analyze modelling tasks in Norwegian mathematics textbooks evaluating their potential to develop students modelling competency. The tasks are analyzed using the modelling cycle from Blum and Leiß (2007).

Theory

Modelling competency is defined as “being able to autonomously and insightfully carry through all aspects of a mathematical modelling process” (Blomhøj & Højgaard Jensen, 2003, p. 126). In line with other definitions of modelling competency, the process is essential. The modelling process is often visualized by a cycle. The cycle by Blum and Leiß (2007) sees modelling from a cognitive perspective. This is relevant for this study, which focuses on students’ possibility to evolve modelling competency by solving textbook tasks. The seven steps in the modelling process described in this modelling cycle is 1) Construct, 2) Simplify, 3) Mathematise, 4) Working mathematically, 5) Interpret, 6) Validate and 7) Expose. The steps are operationalized as shown in Figure 1. The study is guided by the research question: Which steps of the modeling cycle are requested for solving textbook modelling tasks?

Method

Because of the link between the modelling competency and the modelling cycle, it is relevant to make each of the steps a category for the analysis. To identify the categories, identifying questions were made to each modelling step. An example is given, and the identifying questions are presented in Figure 1. The questions are answered in the analysis of the task in Figure 1. This shows that this task only requires step 4, 5 and 6 to be solved.

<p>The table shows the world's population in billions in the period 1970-2010. Here, x is the number of years after 1970.</p> <table border="1"> <thead> <tr> <th>Year</th> <th>1970</th> <th>1980</th> <th>1990</th> <th>2000</th> <th>2010</th> </tr> </thead> <tbody> <tr> <td>x (years)</td> <td>0</td> <td>10</td> <td>20</td> <td>30</td> <td>40</td> </tr> <tr> <td>Population (billion)</td> <td>3,7</td> <td>4,4</td> <td>5,3</td> <td>6,1</td> <td>6,8</td> </tr> </tbody> </table> <p>a) Use the population in 1970 and in 2010 to make a linear model for the world's population $f(x)$ in billion, x years after 1970. b) How does the other numbers in the table fit with the model? c) A prognosis from UN shows that the population will be 9.4 billion in 2050. How does this the model in a) fit</p>						Year	1970	1980	1990	2000	2010	x (years)	0	10	20	30	40	Population (billion)	3,7	4,4	5,3	6,1	6,8	<ol style="list-style-type: none"> 1. Is the task formulated as an open question, without sufficient numbers given? NO 2. Do the students need to make assumptions? NO 3. Is the task formulated without mentioning how to solve it, and without mathematical language? NO 4. Do the student have to calculate/graph/do a regression analysis? YES, step 4 5. Is the task formulated in a context? YES, step 5 6. If a model is made, is there a question about how valid the answers from the model is? YES, step 6 7. Do the students need to present assumptions done, to explain the answer? NO 					
Year	1970	1980	1990	2000	2010																								
x (years)	0	10	20	30	40																								
Population (billion)	3,7	4,4	5,3	6,1	6,8																								

Figure 1: A typical textbook modelling task, and questions to identify the seven steps

Most of the textbook tasks have several sub-questions, as the task in Figure 1. For more open tasks ‘validate’ was operationalized by the identifying question “Does the task have a given correct answer?” If a correct answer is given, there is no need for validation. The textbooks are from the subject Mathematics 2P (practical mathematics) in second year of upper secondary school (age 17-18). The curriculum recognizes modelling providing an overarching perspective to mathematics, and modelling is one of four main subject areas. The analyzed sample consists of all tasks in the modelling chapters, a total of 514 tasks from the three most used textbooks in this subject.

Results

#ex		Step in the modelling cycle						
		1) Constructing	2) Simplifying	3) Mathematizing	4) Working mathematically	5) Interpreting	6) Validating	7) Exposing
257	Textbook 1	-	-	-	256	138	29	-
108	Textbook 2	2	2	7	102	70	40	2
149	Textbook 3	1	1	10	131	84	43	1
514	Overall	3	3	17	489	292	112	3

Table 1: Results

The result shows that step 1, 2 and 3 are only requested in 3 of the 514 tasks. If the textbook authors have already constructed and simplified the problem, there are no need for the student to expose the answer by explaining which simplifications are done. The first two and the last step are connected.

Discussion and concluding remarks

The results show that the understanding of mathematical modelling within the textbook tasks are different from the theory used in this analysis. The tasks are from the chapters of the books named modelling. Even if the curriculum states that the starting point in a modelling process is something that actually exists, only 17 of the 514 tasks request mathematizing. Even if 292 of the tasks are formulated in a context, most of them are already mathematized. The tasks are formulated using mathematical language, and numbers are given, as in the task in Figure 1. More studies are needed to say if this understanding of mathematical modelling also is current in the classrooms.

Even if mathematical modelling is one of the four main subject areas in the subject Mathematics 2P, this study shows that working with the textbook tasks of the subject do not provide modelling competency. The starting point for the tasks is often step 4) working mathematically, and not 1) construct the problem from “something that actually exists”, as formulated in the curriculum.

References

- Blomhøj, M., & Højgaard Jensen, T. (2003). Developing mathematical modelling competence: conceptual clarification and educational planning. *Teaching mathematics and its applications*, 22(3), 123–139.
- Blum, W., & Leiß, D. (2007). How do students and teachers deal with modelling problems? In C. Haines, P. Galbraith, W. Blum, & S. Khan, *Mathematical modelling: Education, Engineering and Economics-ICTMA 12* (pp. 222–231). Chichester, UK: Horwood.
- Frejd, P. (2012). Teachers’ conceptions of mathematical modelling at Swedish Upper Secondary school. *Journal of Mathematical Modelling and Application*, 1(5), 17–40.

Assessing Teaching Competencies for Mathematical Modelling

Rita Borromeo Ferri

University of Kassel, Institute of Mathematics, Germany; borromeo@mathematik.uni-kassel.de

The question of how mathematical modelling competencies can be assessed has been well investigated and discussed in the last decades within the modelling research field. The test instrument, originally from Haines and Crouch, was adapted for learners in secondary and high-school and as well for teachers in many empirical studies. The results of these investigations also helped to conceptualize the term of modelling competencies. Far more at the beginning of research efforts is the question of how teaching competencies for mathematical modelling, based on the model of Borromeo Ferri, can be assessed. The complexity of the four dimensions is challenging in order to develop a test instrument with the goal to see an increase of teaching competencies after a course on ‘learning and teaching of mathematical modelling’. The paper describes recently developed test items used in an intervention study with prospective teachers, and presents first results of this pilot study.

Keywords: Mathematical modelling, teaching competencies, assessment.

Teaching competencies for mathematical modelling

Since the beginning of research in the field of mathematical modelling education it is of great interest to get insight into how teachers in school, but also lecturers at university, should teach mathematical modelling to their learners in the best way. Many best-practice university courses or seminars can be found in the literature concerning this aspect (e.g., Lesh & Doerr, 2003; Schwarz & Kaiser, 2004; Borromeo Ferri & Blum, 2010; Maaß & Gurlitt, 2011; Burkhardt, 2018; Vorhölter, 2018). The cited authors describe in their courses or training workshops for mathematical modelling in teacher education several activities and thus competencies, which teachers should learn for teaching modelling successfully. The variety of didactical approaches, contents and aims in these course descriptions are very broad. Thus the conceptualization and operationalization of teaching competencies in mathematical modelling was necessary from the author’s perspective in order to get also a theoretical framework.

Based on a Designed-Based Research (DBL) approach, Borromeo Ferri (2018b) developed, within the last 10 years, a module for a modelling course for university and also for teacher training, which led to a model for competencies needed in teaching mathematical modelling (Borromeo Ferri 2014, 2018, Borromeo Ferri & Blum 2010). The goal is that the lecturer of a university seminar for prospective math teachers or a teacher trainer covers all competencies of the model in a balanced way and sometimes with different emphasis due to the timeline of the course or the workshop. This works very well, because I practiced and investigated these courses since a long time. Figure 1 shows the model with its 4 dimensions and sub-competencies:

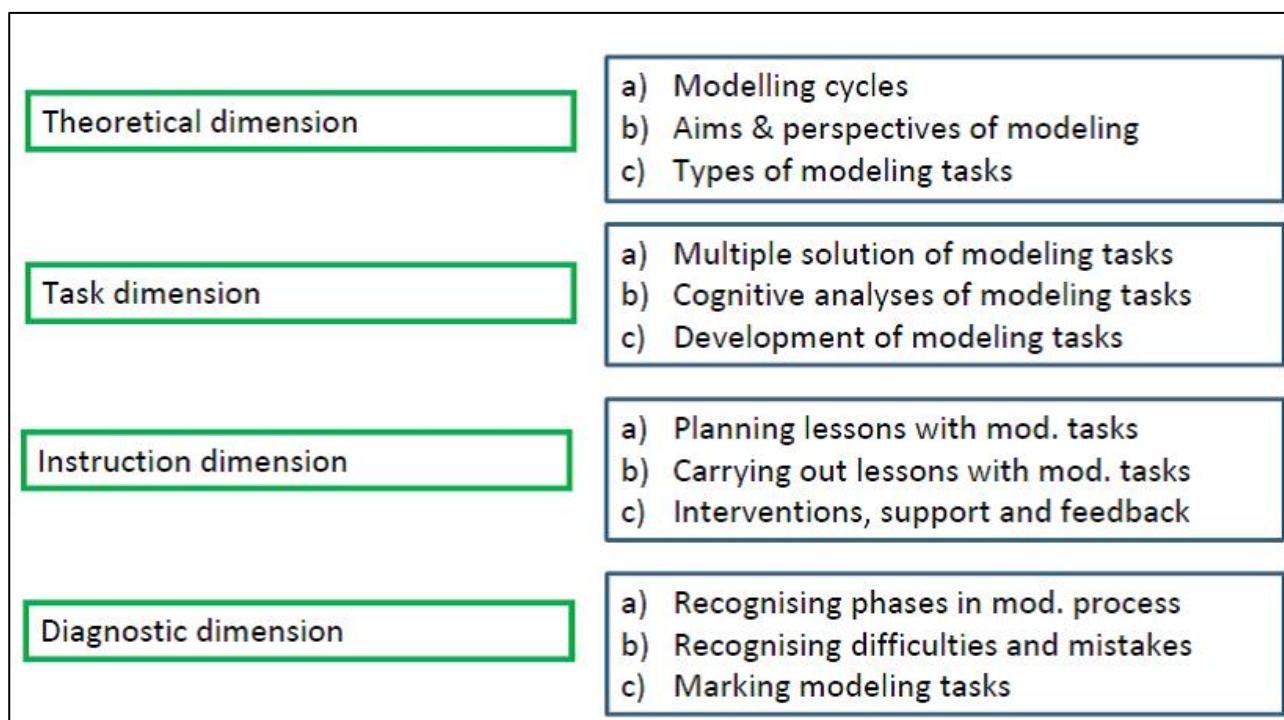


Figure 1: Model for competencies needed in teaching mathematical modelling (Borromeo Ferri, 2018)

The structure of my modelling courses is based on this model, which means going through each dimension starting with the theory and ending with discussing about assessment in modelling. Step after step the participants gain more competencies and understand how everything is linked together. Due to the aspect that participants should develop a modelling problem, teach it at school and finally reflect on it, a Theory-Practice Balance is given. This greatly helps to understand what modelling means in the school context and in particular that teaching modelling is possible. For more details concerning the full module, the used of modelling problems, materials or teaching methods, see Borromeo Ferri (2018a). The continuous modification of the modelling course is one aspect, a further aspect is of course to measure systematically how teaching competencies of the participants increase during and after the modelling course, which means at the end of a semester or after a teacher training of two full days. Based on the observations and evaluation sheets of the university students and teachers, I can definitely argue that an increase of teaching competencies takes place after these courses, but the goal is to assess this from a scientific and empiric point of view. This is a challenge when recognizing the complexity of the model. Klock et al. (in press) and Klock et al. (2018) also developed a test instrument for facets of a modified version of the model of Borromeo Ferri. This test instrument is piloted and used already in intervention studies.

However, I developed items for the four dimensions of mathematical modelling teaching competencies based on my model in order to get a test instrument. These items were recently applied and piloted with a pre- and post-test design for a university modelling course for prospective secondary teachers, in order to get knowledge on how their teaching competencies increase. In the following, the item development is briefly described, which shall show the difficulties of building scales, but also some examples of final items are presented. Furthermore first results of the pilot study are shown and discussed.

Development of test items for the teaching competencies

When looking at the model for teaching competencies it becomes clear that items are needed, which should test both declarative and conceptual knowledge. The four dimensions build on each other and are connected. The diagnosis of mistakes in students' modelling process for example is much easier, if the teachers have knowledge about the modelling phases and about modelling tasks. Learning to diagnose does not only mean to give a definition of several types of diagnosis (product oriented/process oriented), but also to practice it with school students and also with concrete examples presented in video clips. The same applies for the topic teacher interventions while modelling. Although this is a strong part within the modelling course, it is not easy to test these competencies.

Within the first approach of test development and evaluation, most of the items were open. This test version was used for 24 prospective secondary and high-school teachers in their fourth semester at university. A prominent open question for the theoretical dimension is: "What is mathematical modelling?", because on the one hand one would expect some kind of definition and on the other hand it is interesting to see what prospective teachers really have understood, when they describe it before and at the end of the course. According to this, very broad answers were given at the end of the course. Often, modelling was described as a process referring to the modelling cycle, for example: "Mathematical modelling means to follow the steps of a modelling cycle." This is not wrong, but also not completely right, because the nature of mathematical modelling is not emphasized. In a further open item the students should draw a modelling cycle, write down and describe the several steps. This is a nice activity, but difficult for coding the results at the end. How to code only partly answers or not precise descriptions? In sum, this kind of test items by using open questions for the teaching dimensions offered a lot of insight of university students' increase of their teacher competencies only on the basis of their elaborate answers and statements from the pre-test to the post-test, but not in the sense of a classical test. Furthermore, the test time was about 45 to 60 minutes, because answers needed intensive writing and the test construction with its complex items does not allow to cover all sub-competencies within the dimensions. Thus the decision for a multiple choice format with closed items was made for assessing declarative and conceptual knowledge in a balanced and economic way for all teaching dimensions.

Like for the previous version, the construction of new test items was based on the content of the modelling course. All items of the new test instrument were developed in such a way that one has to choose a correct answer according to a statement or after the analysis of a written dialogue from learners while modelling. Options between two or five possibilities, depending on the item, are given to pick out the right answer or one has to write down the correct term for which is asked. Thus, this answering format offers the possibility for dichotomous coding. The table gives an overview about the number of items per scale (teaching dimension):

	Theoretical D.	Task D.	Instruction D.	Diagnostic D.
Number of items	26	11	14	14

Table 1: Number of items per scales (4 teaching dimensions)

Within the theoretical dimensions the testing of declarative knowledge with 26 items was in the foreground. In the following three examples items are shown.

Here, your theoretical knowledge is asked. Choose, if the statement is right (yes) or wrong (no):

	yes	no
The basis of mathematical modelling are problems from real life	<input type="checkbox"/>	<input type="checkbox"/>
The "Complexity" describes one criterion of a modelling problem	<input type="checkbox"/>	<input type="checkbox"/>

Figure 2: Example items of the scale "Theoretical dimension"

For the scale "Task dimension" 11 items were developed, which tested declarative and conceptual knowledge. In order to assess the conceptual knowledge, a modelling problem was given with corresponding solutions of learners. It was asked to choose the right phase of the modelling process, where the solution belongs to. Because of the fact that only one answer from five options is right, one has to analyze the solution more in detail. Not only the knowledge about the terms and the phases is of importance, but to apply it based on own experiences during the course while solving and reflecting modelling problems. The "Instruction dimension" is, compared to the other dimensions, quite hard to assess. First of all it is not possible to test if an individual is really able to teach modelling in the class, nor if the lesson is good or bad. However items were developed, which asked for basics of quality teaching concerning modelling and furthermore about the aspects of teacher interventions as well. Hence 14 items are in the scale "Instruction dimension", which cover declarative and conceptual knowledge. Two items of this scale are shown in Figure 3.

Here, your knowledge about teaching modelling is asked. Choose, if the statement is right (yes) or wrong (no):

	yes	no
The introduction of modelling activities works with over-determined problems	<input type="checkbox"/>	<input type="checkbox"/>
Responsive interventions lead back to the teacher	<input type="checkbox"/>	<input type="checkbox"/>

Figure 3: Example items of the scale "Instruction dimension"

In particular the teacher interventions were tested along different short written conversations of learners while working on a modelling problem in the classroom. The levels or activators of the interventions, for example, had to be determined correctly.

The last dimension and scale is the "Diagnostic dimension" with 14 developed items. Like in the task and instruction dimension, both declarative and conceptual knowledge was tested with several items. To diagnose in which modelling phase learners worked and also problems, mistakes and misconceptions were in the focus for the item development. Again, items were used, which showed a conversation of learners working on a modelling problem. Then one right answer has to be chosen.

Diagnose the modelling phase, in which the learners work primarily. Choose one option!

understanding the problem	<input type="checkbox"/>
simplifying/using extra-mathematical knowledge	<input type="checkbox"/>
mathematizing	<input type="checkbox"/>
working mathematically	<input type="checkbox"/>
interpreting	<input type="checkbox"/>
validating	<input type="checkbox"/>

Figure 4: Example item of the scale “Diagnose dimension”

A crucial part of the modelling course is the development of students’ own modelling problems, which are finally taught in school. This includes besides planning, executing and reflecting on the lesson also to diagnose learners while they work on the problem. This kind of real life observation is connected with the usage of video-clips of learners while modelling within the course. Thus the diagnostic dimension is stressed as very important in the course, because it gives a résumé and the possibility to apply all the competencies learned within the previous dimensions.

What you test is what you get! – First Results of the Pilot Study

The test instrument was piloted in September 2018 in a modelling seminar with 17 prospecting secondary teachers at university in their third semester. This course was a blocked seminar with four sessions each three hours. Between the third and fourth session, the students taught their developed modelling lesson in school and observed learners during modelling activities. The pre-test was done at the beginning of the first session and the post-test at the end of the fourth and last day of the course. In contrary to the first test version with open items, the new test time was now 25 minutes. All participants already had basic knowledge about mathematical modelling from one lecture in the first semester within the lecture-series with the topic “Introduction in Mathematics Education”. In this lecture the university students learn about the modelling cycle and they also solve a modelling problem. However, only basics about modelling are stressed in this lecture and of course one goal of introducing modelling in this lecture-series is that the prospective teachers are interested to choose a modelling course in the upcoming semesters.

Due to the fact that $n=17$ is a very small sample in the current pilot study, however, the very first results are promising concerning the quality of the items and α -values. Thus for the upcoming testing in the winter term with a larger population, the test instrument will be checked and if needed, modified again. In the following descriptive analysis the results of the pre- and post-tests are presented. The results are based on a dichotomy coding procedure, showing the means of the dimensions before and after the treatment. Because of the fact that n is smaller than 21, a test of Gaussian distribution was necessary. Not all scales had Gaussian distribution and in order to test the level of significance, the Wilcoxon-Rank test (Bortz et al., 2010) was necessary. In Figure 5 the significance values become evident:

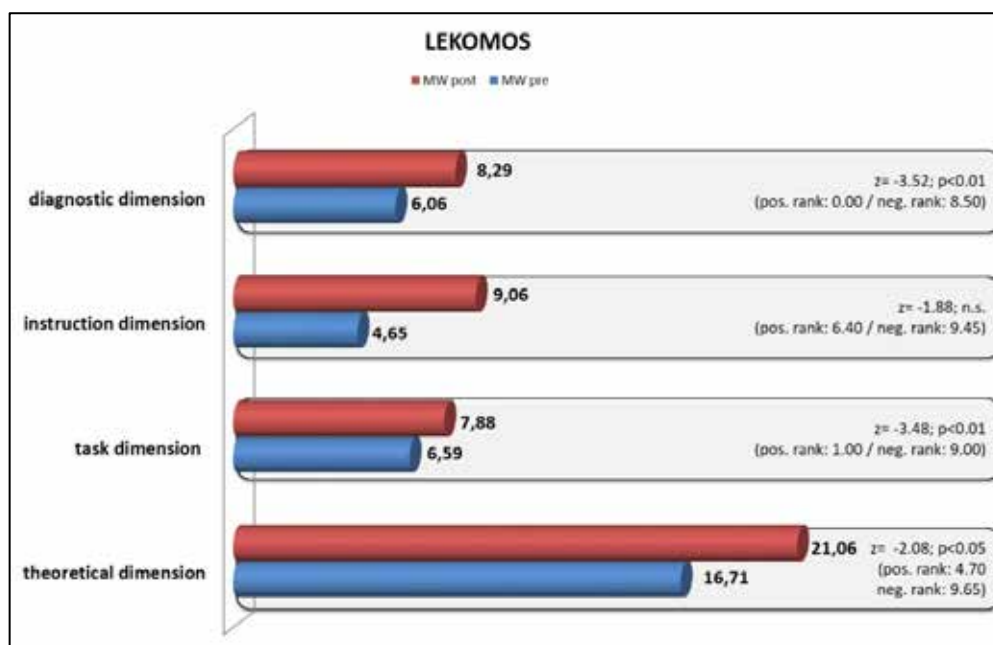


Figure 5: Results of pre- and post-test

The results show statistical significant differences after the treatment for three of the dimensions. Although no significance value could be stated for the instruction dimension, an increase of teaching competencies becomes evident like for the rest of the dimensions as well. The modelling course as the dependent variable can be seen as an effective predictor, so that teaching competencies for mathematical modelling increase. The mean of several items also makes clear that the treatment and thus the structure and content of the modelling course focuses on the central aspects of teaching and learning mathematical modelling. The last item within the Theoretical Dimension for example shows two tasks and one has to decide, which of them is a modelling problem. This item could also be put in the Task Dimension, but in this case, this item focuses more on the question of what mathematical modelling means and what characterizes it. In the pre-test the mean was 0.65 and in the post-test 1.00. Although students had basic pre-knowledge about modelling, it was not a trivial question at the beginning. During the modelling course, the university students again recognized several criteria of (good) modelling problems and that a real context leads not automatically to the conclusion that one can speak of a modelling task.

The Diagnostic Dimension contains many items for testing the declarative knowledge. As described in the previous section, items were developed, which show a short conversation of learners working on a modelling problem. One right answer had to be chosen according to the modelling phase the learners in the presented scene worked primarily. An increase of the means becomes visible from pre to the post-test from 0.65 to 0.88 for such a diagnostic item or from 0.41 to 0.71 for a similar item. Beneath this testing, the university students also evaluated the course separately, which is a normal procedure in my seminars. The aspect of the Theory-Practice-Balance is always strongly emphasized from the prospective teachers (see Borromeo Ferri, 2018). In particular the development of an own modelling problem and teaching this at school is for most of the students crucial for understanding the nature of mathematical modelling.

Summary, Discussion and Outlook

The model of teaching competencies for mathematical modelling is based on a long-termed Design-based research approach. Until now a test instrument for the four teaching dimensions did not exist in order to assess the increase of these competencies in a modelling course by using a pre- and post-test design. In fact it became evident that a test instrument with open items offered a great insight into prospective math teachers thinking concerning their knowledge about mathematical modelling, but it was difficult to evaluate and the test time was too long. The goal was to develop items and scales in order to grasp each of the teaching dimension by reducing the test time.

The presented results are only based on a pilot-study with a small population of students and thus no generalization is possible at this time. However the results allowed an insight into the quality of the items on the one hand and on the other hand statistically significant differences can be stated for three of the four dimension concerning an increase of the teaching competencies on a descriptive level. The pilot study focuses on the test instrument and also on the course as a dependent variable with the hypothesis that prospective teachers, who participate in this seminar, get an increase of their teaching competencies. Hence, a control group is needed. These university students could attend for example a seminar on mathematical problem solving. Then both groups can be compared and a further hypothesis is that mathematical modelling needs more specific teaching competencies than mathematical problem solving, although both topics are very close. Definitely it is clear that the sample size must be enlarged anyway, in order to guarantee the reliability of the test instrument.

Normally the goal of a developed test instrument is that it is universally applicable. The test of modelling competency from Haines and Crouch is such an example. The idea of developing tasks for the sub-competencies of the modelling cycle was great and in the last decades, several researchers adapted these tasks for learners in secondary or high-school. That requires that learners at school or university students were taught in modelling in order to assess them. The same idea is behind the test instrument for the four dimensions of teaching competencies. You can only get what you test, when the contents of the modelling course are in line with the test items, if you want to measure for example an increase of these competencies. This means that the test instrument can, in principle, be used worldwide, but it will certainly work best if the contents of the modelling courses are very close to the one presented here. This is also a big limitation for this test instrument at this stage, but the goal is to use this test instrument together with colleagues from Germany and further countries in order to see if a transfer is possible.

References

- Borromeo Ferri, R. (2018a). *Learning how to teach mathematical modeling – In school and teacher education*. New York, NY: Springer.
- Borromeo Ferri, R. (2018b). Universitäre Lehrerausbildung zum mathematischen Modellieren – Innovationen durch Design-Based Research. In R. Borromeo Ferri & W. Blum (Eds.), *Lehrerkompetenzen zum Mathematischen Modellieren – Konzepte und Transfer* (pp. 153–170). Wiesbaden, Germany: Springer.

- Borromeo Ferri, R., & Blum, W. (2010). Mathematical modelling in teacher education – Experiences from a modelling seminar. In V. Durand-Guerrier, S. Soury-Lavergne, & F. Arzarello (Eds.), *Proceedings of CERME 6*, (pp. 2046–2055). European Society for Research in Mathematics Education.
- Bortz, J., Lienert, G., & Boehnke, K. (2010). *Verteilungsfreie Methoden in der Biostatistik* (3rd edition). Berlin, Germany: Springer.
- Burkhardt, H. (2018). Ways to teach modelling—A 50 year study. *ZDM Mathematics Education* 50(1–2), 61–75.
- Kaiser, G., & Schwarz, B. (2010). Authentic modelling problems in mathematics education – Examples and experiences. *Journal für Mathematikdidaktik*, 31(1–2), 51.
- Lesh, R., & Doerr, H. (Eds.) (2003). *Beyond constructivism: A model and modeling perspective on mathematics problem solving, learning, and teaching*. Mahwah, NJ: Lawrence Erlbaum Associates.
- Maaß, K., & Gurlitt, J. (2011). LEMA – Professional development of teachers in relation to mathematics modelling. In G. Kaiser, W. Blum, R. Borromeo Ferri, & G. Stillman (Eds.), *Trends in the teaching and learning of mathematical modelling* (pp. 629–639). New York, NY: Springer.
- Klock, H., Siller, H.-S., & Wess, R. (2018). Adaptive Interventionskompetenz in mathematischen Modellierungsprozessen – Erste Ergebnisse einer Interventionsstudie. In *Beiträge zum Mathematikunterricht 2018*, (pp. 991–994). Münster, Germany: WTM-Verlag.
- Klock, H., Wess, R., Greefrath, G., & Siller, H.-S. (in press). Aspekte professioneller Kompetenz zum Lehren mathematischer Modellierung bei (angehenden) Lehrkräften - Erfassung und Evaluation. In T. Leuders, E. Christophel, M. Hemmer, F. Korneck, & P. Labudde (Eds.), *Fachdidaktische Forschungen zur Lehrerbildung*. Münster, Germany: Waxmann.
- Vorhölter, K. (2018). Notwendige Kompetenzen zur Betreuung von Modellierungsaktivitäten aus Sicht von Studierenden – Evaluation und Weiterentwicklung eines Seminars zur Vermittlung modellierungsspezifischer Lehrerkompetenzen. In R. Borromeo Ferri & W. Blum (Eds.) (2018), *Lehrerkompetenzen zum Mathematischen Modellieren – Konzepte und Transfer* (pp. 203–215). Wiesbaden, Germany: Springer.

On the positive influence of product-orientation in mathematical modeling: A research proposal

Wolfgang Bock¹, Martin Bracke¹, Patrick Capraro¹ and Jean-Marie Lantau¹

Technische Universität Kaiserslautern, Germany; bracke@mathematik.uni-kl.de

Keywords: Product-orientation, modeling, best-practice examples.

Motivation

The term *mathematical modeling* as we have observed in 25 years of modeling projects (Bock & Bracke, 2015), bears for many students and teachers the notion of something visible and touchable. In our opinion mathematical modeling can and has to be considered in a broader fashion, also allowing what Blum and Leiss (2007) call a mathematical model, namely the mathematical description of a real process. Experts in applied mathematics, i.e. scientists working with mathematical modeling, however describe the necessity of an *end product* to be presented as solving a client's problem in a suitable way (see Neunzert & Prätzel-Wolters, 2015), like a real prototype made from metal or plastic or developing a software or a process simulation, all based on the mathematical model. In the last CERME, Bock, Bracke, and Capraro (2017) defined the term product, closely related to the notion given in economics or marketing:

Definition

In a mathematical modeling situation (with an authentic and real-world problem) a product is a deliverable in the language of the client which satisfies the needs incorporated in the task given by the client to the provider in such a way that the client can use it directly for his purposes.

Based on former modeling week reports since 1993, Bock, Bracke, and Capraro (2017) proposed a second cycle within the modeling cycle based on client interaction. This poster is an outline for our future research, i.e. the analysis of the positive influence of product-orientation in mathematical modeling processes.

Best-practice examples for product-orientation in modeling

During different modeling activities (Bock & Bracke, 2015) a positive influence of product-orientation for the motivation and the quality of the mathematical modeling process was observed in contrast to projects without product orientation. Recently several product-oriented modeling activities have been carried out (Lantau & Bracke, 2019; Lantau, Bracke, Bock, & Capraro, 2017). During a modeling week (3.5 full days + 1 day for presentations), 5 students of Grades 11 and 12 were asked to build a 3d scanner. They were provided with electronical devices and components, such as *Raspberry Pis*, microcontrollers, sensors, etc. The students handled electric circuits and learned to control the stepper motor, the sensors and data processing. As the construction is mainly a problem of electrical engineering and programming, the data processing contains many mathematical questions. In fact it is impossible to build a working device without having a good mathematical model and awareness of the mathematical toolbox! Due to the project-orientation however, mathematical difficulties had no need to be pointed out explicitly, since the product itself is going to raise the right questions.

Research questions

A positive influence of product-orientation in mathematical modeling has been observed. The next step is to analyze this fact both in an empirical as well as in a theoretical way. The aims are: 1. *To model and understand the underlying processes*; 2. *To analyze the influence of product-orientation on students' learning processes*; 3. *To analyze the influence of product-orientation on the quality of results*; 4. *To develop new methods for interventions and guidance in mathematical modeling*. For this we plan to analyze several product-oriented, long-term modeling projects. We are going to use videotaping, questionnaires, interviews. Moreover we plan to analyze of the modeling processes using a new model of dynamical network graphs. Finally, it will be important to create and study adequate forms of teacher training suitable to train teachers in creating and supervising product-oriented modeling projects. First steps have already been undertaken (cf. Lantau & Bracke, 2019; Bock, Bracke, & Capraro, 2019; Lantau, Bracke, Bock, & Capraro, 2017).

Acknowledgement

This work is partially supported by the European Social Fund (ESF) project SchuMaMoMINT.

References

- Blum, W., & Leiss, D. (2007). How do students and teachers deal with mathematical modelling problems? In C. Haines, P. Galbraith, W. Blum, & S. Khan (Eds.), *Mathematical modelling: Education, engineering and economics* (pp. 222–231). Chichester, UK: Horwood Publishing.
- Bock, W., & Bracke, M. (2015). Applied school mathematics – Made in Kaiserslautern. In H. Neunzert, & D. Prätzel-Wolters (Eds.), *Currents in industrial mathematics: From concepts to research to education* (pp. 403–437). Heidelberg, Germany: Springer.
- Bock, W., Bracke, M., & Capraro, P. (2017). Product orientation in modelling tasks. In T. Dooley, & G. Gueudet (Eds.), *Proceedings of the Tenth Congress of the European Society for Research in Mathematics Education (CERME 10)* (pp. 1028–1030). Dublin, Ireland: DCU Institute of Education and ERME.
- Bock, W., Bracke, M., & Capraro, P. (2019). Mathematical modeling of musical fountains and light organs – where is the M in interdisciplinary STEM projects? Paper presented at the *Eleventh Congress of the European Society for Research in Mathematics Education (CERME11, TWG26)*. Utrecht, the Netherlands. In press.
- Lantau, J.-M., & Bracke, M. (2019). *Effective factors of a teacher training concerning the implementation of interdisciplinary STEM-modelling projects*. Paper presented at the *Eleventh Congress of the European Society for Research in Mathematics Education (CERME11, TWG6)*. Utrecht, the Netherlands. In press.
- Lantau, J.-M., Bracke, M., Bock, W., & Capraro, P. (2017). *The design of a successful teacher training to promote interdisciplinary STEM modeling projects*. Paper presented at *ICTMA18*, Cape Town, South Africa. In press.
- Neunzert, H., & Prätzel-Wolters, D. (Eds.) (2015). *Currents in industrial mathematics: From concepts to research to education*. Heidelberg, Germany: Springer.

Comprehending mathematical problem texts – Fostering subject-specific reading strategies for creating mental text representations

Jennifer Dröse

TU Dortmund University, Germany; jennifer.droese@math.tu-dortmund.de

The comprehension of mathematical problem texts has been identified as one of the essential steps towards solving modelling problems successfully. Understanding in this context means constructing an adequate situation model by using reading and understanding strategies. A separate strategy training might foster those strategies as studies indicate. Therefore, the presented study reports on a design research project with the aim of fostering subject-specific reading and comprehension strategies. Presented are further specifications of the processes of constructing mental text representations as well as insights into the use of strategies. The case study indicates that the fostered strategies contribute to different steps in the process of constructing mental text representations. Those strategies seem to be constantly used by the students to deal with word problems within the teaching-learning arrangement and might therefore be relevant for modelling processes in general.

Keywords: Situation model, mental text representations, subject-specific reading strategies, strategy training, comprehending mathematical problem texts.

Introduction

“Understanding the content of a task is fundamental for solving it (...)” (Leiß, Schukajlow, Blum, Messner, & Pekrun, 2010, p. 123). There is a wide range of mathematical tasks used to link or apply mathematical models, concepts and procedures to reality, ranging from simple word problems to complex modelling problems. Greefrath and Vorhölter (2016) categorize different accesses to mathematical modelling referring to Griesel (2005) when describing the term modelling in general as “the process of developing a model based on an application problem and using it to solve the problem” (Greefrath & Vorhölter, 2016, p. 8). Many kinds of those application problems are presented to the students in text format. This requires reading and understanding the problem text as the basic step in the modelling and solution process (Plath & Leiß, 2018). Understanding a text in general and a (modelling or word) problem text specifically goes along with understanding the described situation, i.e. constructing an adequate situation model (Leiß et al., 2010; Tapiero 2007; Weimer, Reusser, Cummins, & Kintsch, 1988). As Leiß et al., (2010) point out precisely the step of constructing a situation model is one of the most challenging ones in mathematical modelling. Reasons for difficulties in modelling and word problem solution processes have been hypothesized to lie in “a lack of strategic understanding both of the language involved and of the situation denoted by its verbal description” (Reusser, 1987, p. 474). Furthermore, Leiß et al. (2010, p. 119) point out: “strategies for constructing an adequate situation model have a significant influence on the modelling competence.” Meanwhile, there are indications that the use of these strategies can be trained separately (Leiß et al., 2010). Therefore, specific teaching-learning arrangements for fostering students’ reading strategies are required as a first step towards fostering modelling competencies in general. The presented study reports on a design research project in which a teaching-learning arrangement was iteratively developed and investigated, that aims at fostering subject-specific reading strategies for fifth graders

by using strategic scaffolding (Prediger & Krägeloh, 2015). So, following the distinction of Blomhøj and Bergman Ärlebäck (2018) on research in the field of modelling and application, this project can be located within the development, implementation and evaluation of a specific aspect of modelling activities (namely fostering understanding strategies for constructing a situation model).

After further specifying the theoretical background of generating a situation model in the following section, the methodological framework and empirical insights are presented.

Theoretical Background

Mental text representations as units of understanding

There exists a wide consensus within reading theories that during reading processes (of mathematical problems) four text representations are to be mentally constructed (Tapiero, 2007, Kintsch, & Greeno, 1985; Reusser 1987): the representation of (1) the text-surface, (2) the propositional structure, (3) the situation described in the text and (4) the problem. The term *mental text representations* resumes those four kinds of representations. Steps towards constructing those representations have also been included in different conceptualizations and models describing modelling processes (cf. modelling cycle by Blum and Leiß, further illustrated in Leiß et al., 2010) or solution processes of mathematical word problems (see Reusser, 1987). As different terms have been allocated to those four representations, their characteristics are briefly outlined with reference to Reusser's model for treating word problems (1987), which is chosen due to its focus on reading and comprehension processes.

- (1) The *representation of the text-surface* (not directly displayed in the model) is mainly the representation of the surface structure, text order, syntax and wording of the text (Tapiero, 2007). Only directly expressed propositions are represented here (Kintsch & van Dijk, 1978).
- (2) The *representation of the propositional structure* (named *text base* in Reusser's model) is a coherent text representation constructed by forming and organizing propositional units into a global structure (Kintsch & Greeno, 1985).
- (3) In the *representation of the situation* (named *situation model*), the information given by the text are integrated with the readers' prior knowledge or goals (Kintsch & Greeno, 1985) to make inferences of different kinds (drawn from text or prior knowledge) (Weimer et al., 1988). Reusser (1989) therefore defines the situation model as "the personal cognitive structure to which the process of understanding is directed. The situation model is the cognitive correlate to the situation structure either supposed from the author's point of view or understood from the reader's point of view" (Reusser 1989, p. 136ff., translated by Plath & Leiß, 2018, p. 161).
- (4) The *representation of the problem* (named *problem model* in Reusser's model) is an extension of the situation model focussing especially on the aspect of the goal (generated or given problem question) guiding the construction process (Kintsch & Greeno, 1985; Reusser, 1987).

As stated above, for mathematical modelling tasks, the process of constructing a situation model is the most challenging one (Leiß et al., 2010). Meanwhile, most of the mathematical problem texts examined by researchers are restricted to one mathematical relation mathematized in one step (c.f. Reusser, 1987). Therefore, they do not further specify the process of building situational or problem representations (Kintsch & van Dijk, 1978). As many applied mathematical problem texts display

more than one relation and multiple steps, the model needs to be differentiated to take the processes of constructing mental text representations into consideration (Prediger & Krägeloh, 2015).

Processes of constructing mental text representations

Considering the situational or problem representation of multi-step problems, different mental elements must be related to each other. In line with Schnotz (1994), these mental elements form the basic units of the writer's and the reader's communication process: (A) the *writer* identifies the relevant units of the mental representation, constructs an adequate language representation for each of them and integrates them into a text, (B) after that, the *reader* needs to identify the relevant textual or language units, interpret their meaning and integrate them into a mental representation (Schnotz, 1994). In order to include these considerations into Reusser's model, the model is extended as shown in Figure 1 in order to capture the reader's processes of achieving local or global coherence. The detailed specification of the reader's activities and processes are integrated. Following from the investigation of Weimer et al. (1988): (1) relevant elements have to be *identified*, (2) elements have to be *structured* and *related* and (3) elements have to be *interpreted* and new elements have to be *inferred* (see Figure 1). Apart from these processes, the kinds of mental elements are further specified. Those relevant mental elements can be of (a) *textual*, (b) *propositional* or (c) *situational* type. At first, the (a) *text elements* and (b) *propositional elements* have to be (1) *identified* from the problem text or the text base, according to the problem question. Afterwards, (a) *text* and (b) *propositional elements* can be (2) *related* to (3) *interpret* or (3) *infer* new (c) *situational elements* that have not been identified before. Then those (c) *situational elements* can be (3) *related* and (3) *integrated* to form the problem model (see Figure 1).

These kinds of processes of text comprehension are initiated and monitored by *reading strategies* (Tapiero, 2007; Leiß et al., 2010). Whereas the steps in the model themselves cannot be taught directly, reading strategies can be fostered in separate strategy trainings (Leiß et al., 2010). Most relevant for the texts in view are the comprehension strategies identified by Prediger and Krägeloh (2015, p. 951):

- (S1) Focus on the question to find relevant information
- (S2) Focus on the information together with their meaning
- (S3) Focus on relations connecting the information

Reusser (1987) indicates that strategies might support special processes in his model. One might consider that the named strategies can be linked to the processes as follows: S1 to the process of

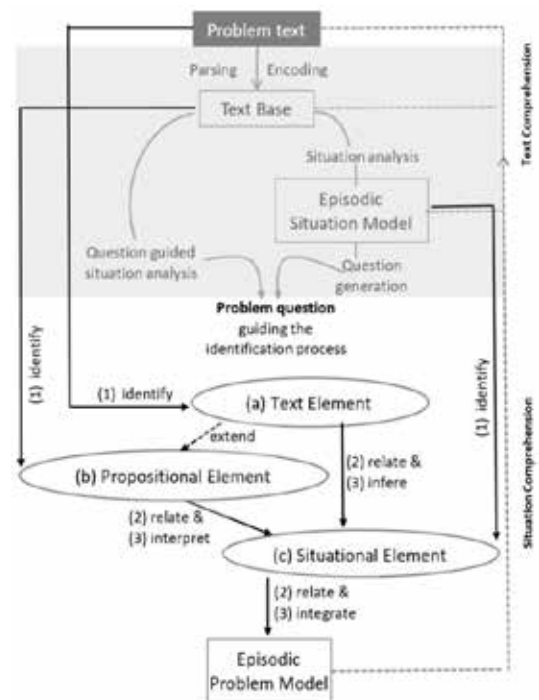


Figure 1: Extended model for treating word problems (adapted from Reusser, 1997; Prediger & Krägeloh, 2015)

question generation and (1) *identifying* elements, S2 to the process of (1) *identifying* elements and S3 to the process of (2) *relating* elements (see Figure 1). However, further investigations are required on how these strategies can support the displayed processes to construct a situation or problem model and how the use of strategies might differ when dealing with different problem texts. For considering those research aspects and getting first insights, the focus is laid on word problems where the construction of the mental text representations is the main aim rather than on rich modelling tasks, which require additional processes after understanding the problem text.

Research demands and questions

The considerations described above called for designing a teaching-learning arrangement to foster students' comprehension strategies. The corresponding qualitative analysis of the initiated comprehension processes pursued two research questions:

- (RQ1) How can the three comprehension Strategies S1, S2, S3 contribute to students' mental construction processes described in the extended model for treating word problems?
- (RQ2) How do students' use of strategies differ for different word problems?

Methodology of the design research study

Design research as methodological framework. Due to the dual aims of designing a teaching-learning arrangement to foster students' use of subject-specific reading strategies as well as describing and analyzing the use of comprehension strategies, which is in line with the considerations by Blomhøj and Bergman Ärleback (2018) concerning theory-practice relations, the framework of topic specific design research has been chosen. It iteratively connects (1) the specification and structuring of the learning content, (2) the creation of the teaching-learning arrangement, (3) the use of the teaching-learning arrangement in design experiments, which are afterwards analyzed to (4) generate contributions to local theories on the learning content and learning processes (Prediger & Zwetschler, 2013).

Design experiments as a method for data collection. In the presented study, six design research cycles have been conducted, five in laboratory setting with 2-3 students each and the last one in a classroom setting. Each cycle consisted of approx. 4-7 sessions of 90 minutes each. This paper focuses on Cycle 5 in which six pairs of students have worked on the teaching-learning arrangement (in total 4320 minutes of video data).

Methods of qualitative data analysis. For the qualitative data analysis, a category-led deductive procedure has been chosen. The use of strategies has been coded (according to a categorical scheme presented in Dröse and Prediger (in press)). Afterwards, the moments in which the use of strategy was identified, have been categorized with respect to the processes of *identifying text, situation* or *propositional elements; inferring situational elements* or *relating* mental elements (see Figure 1). Here, the case study of Metin and Yaren (both boys are 11 years old and attend a secondary school in a German urban area) is presented, based on 120 minutes of video data (partly transcribed).

Empirical insights: Yaren’s and Metin’s construction of mental representations

The case of Yaren and Metin provides an insight into their process of constructing mental text representations and their use of Strategies S1–S3 concerning RQ1. The two boys work on Task 3 “Bear child” (Fig. 2) in Sequence 1 and on Task 5 “Parrot feeding” (Fig. 3) in Sequence 2.

Bear child

The brown bear child in the zoo weighted 700g at his birth. After his birth it lost 200g because it was ill. Over the last weeks, his weight has increased by 4000g and it is healthy again.

How much does the brown bear child weight now?

Figure 2: Task 3

Parrot Feeding

In the zoo, the children are feeding the parrots. Felix fills parrot Tobi’s bowl with 10g sunflower kernels and 15g berries. In the bowl, there have already been 3g feed before the feeding. Parrot Piet eats 5g of parrot Tobi’s feed.

How much feed does parrot Tobi have in the end?

Figure 3: Task 5

Sequence 1: Inferring implicit situational elements in Task 3

At the beginning of Sequence 1, Metin and Yaren have already *identified* the relevant *text elements* and have written them down on three cards. Metin now tries to express the relations between those elements to *infer* the needed *situational elements* as well as the problem model.

- 1 Metin: Yaren look, at first he has weighted 700g [*puts down the card on which he had written the text element weighted 700 g*], then he got down to 200g [*points at the corresponding second card*], later to 4000g [*points at the third card*].

Metin’s explanation reveals an inappropriate *problem model*. This could be either (1) due to a lack of understanding of the propositional structure of the individual *text elements* or (2) due to the fact that he relates the elements to each other by interpreting them as fixed states rather than considering other relationships. Afterwards, Metin tries to organize the information in a concept map.

- 101 Teacher: If I understood correctly, you wanted to start with 700. What happens then? (...)
- 102 Metin: Yes, 200g, because he loses 200g. And then later rises to 4000g. [*connects the two element cards with an arrow, see Figure 4*]
- 104 Teacher: So, he weighted 700g at his birth, then he loses 200g, then this was 4000g altogether. Does that fit?
- 105 Metin: Yes, that fits (...)
- 107 Metin: or if, wait look, if he loses 200g of 700g, then that would be 500g, so then this have to be 4500g?

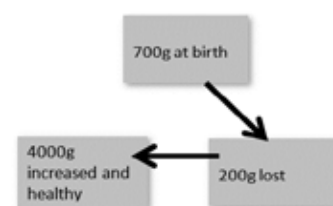


Figure 4: Metin’s concept map of the situation

When the teacher verbalizes the relation that Metin has visualized (l. 104), Metin implicitly *infers* the two *situational elements*, “state after the bear was ill” and “state now that the bear is healthy again” (l. 107) that are not explicitly mentioned in the problem text. After finishing his visualization with cards and arrows, Yaren explicitly describes the relation between the two states implicitly mentioned above (l. 206).

- 206 Yaren: (...) It has weighted 500g and then it got healthy and got 4000g, because it was healthy afterwards (...).

Regarding RQ1 the sequence gives an example for a pattern we have often found in the data: When students activate the Strategies S2 (focus on meaning of information) and S3 (focus on relation of information) as triggered here by the cards and arrows, they can *identify* not only *text elements*, but *infer* also further *situational elements* and create an appropriate *situation and problem representation*.

Sequence 2: Expressing relationships between identified and inferred elements in Task 5

After solving Task 3 and 4, Metin and Yaren work on Task 5 “Parrot feeding” (Figure 3). At first, they write down the relevant *text elements*, and then the teacher asks them to express the given relations.

- 1 Teacher: Tell me, what happens to the 10g and the 15g in the task? What about them? (...)
- 3 Metin: So at first, there were 10g sunflower kernels, then 15g berries and then he has eaten 5g of Parrot Piet’s feed.
- 4 Yaren: (...) Ah yes, then there were 20g left.
- 5 Metin: (...) Ah so (...) now I understand (...) I found the result. He had 25g in total [*points at the cards and arrows*] and then (...)

When being asked to articulate the actions taking place in the task, Metin uses the Strategies S2 (focus on meaning) and S3 (focus on relations). He puts the given information into the described order to symbolize the relation between the *text elements* (l. 3) and the inferred *situational elements* (l. 5). Yaren explains that there are only 20g left (l. 4). The teacher points to one information that has already been written down but not used, so far:

- 101 Teacher: Okay and now, you have one card left written 3g on it. Do you need this?
- 102 Metin: No, not really... but [*is reading the text*]. Yes, we can use it, because (...)
- 108 Metin: Ah, Felix has given him something and he has had 3g before.

Metin’s explanation reveals that he has focused on the meaning of the 3g first (S2) and then tries to relate the *text element* to the information already given (S3). In this sequence, the teacher is not expressing the relation among *elements* herself as she has done in Task 3; instead, first she prompts the students to do so (l. 1). Later on, she prompts the students to take the meaning of the *text element* into consideration (l. 101). Being familiar with the scaffold, the boys use Strategies S2 and S3 to *relate* mental elements and the teacher’s prompt for activating S2 suffices to activate S3 as well (l. 108). Concerning RQ1, this shows how both strategies are intertwined in the process of *relating* elements. This observation reoccurred in further data.

Overview of used strategies to construct and process mental elements

Concerning RQ2, Table 1 gives a short overview on the strategies, which Metin and Yaren used to construct mental elements. For each task, the relevant *text* and *situational elements* as well as the relations between them have been specified. For the Tasks 3 – 5 those *text elements* can be either the starting point or a change of the situation (Change 1, Change 2), as described in the problem text. The *situational elements*, that have to be *inferred*, can be the state of the situation either after the first or after the second described change (State 2, State 3). After specifying the relevant mental elements, the coded strategies (S1 – S3) were assigned to the prevailing mental elements, when the strategies

are used before a successful *identification*, *inference* or *relation* of this mental element. The use of those strategies is displayed in Table 1 without focusing on its frequency or its order.

Identified/ Inferred/ Combined Elements:	Task 3 (solved together)		Task 4 (solved separately)		Task 5 (solved together)	
	Metin	Yaren	Metin	Yaren	Metin	Yaren
Identify problem question	S1, S2		S1	S1	S1	
Identify Text element 1: Starting point	S2	S1, S2, S3	S2	S2	S2, S3	S2
Identify Text element 2: Change 1	S2	S3	S2	S2	S2	S1, S2
Identify Text element 3: Change 2	S2	S2	S2	S1, S2	S2	S2
Construct Situation element 1: State 2	S1, S2, S3 , S1, S2, S3	S2, S3	S3	S2, S3	S2, S3	
Construct Situation element 2: State 3				S2	S2, S3	
Relate Element 1, 2 and State 2	S1, S2, S3	S1, S2, S3	S2, S3 , S3	S2-S2 , S3-S3	S2, S3 , S2, S3	
Relate Element 2, 3 and State 3	S1, S2 , S2, S3	S3, S2, S3 , S3	S2, S2 , S3-S3	S2, S3 , S3	S2, S3	S2

Table 1: Strategies used to assimilate elements of different kinds (S3-represents unsuccessful strategy use)

For answering RQ2 the following differences and similarities in the use of strategies can be observed: The analysis of Table 1 reveals that both boys use Strategy S2 to *identify* relevant *text elements*, having also focused on the question (S1). Furthermore, in Task 3 all strategies are used to *infer* and *relate* mental elements, while in Task 4 or Task 5 mainly Strategies S2 and S3 are used. This underlines the close entanglement of those strategies. With regard to RQ2 the boys' use of the identified strategies seems to become more stable with frequent use of the scaffold.

Discussion and outlook

The case study of Metin and Yaren provides first insights into the use of the fostered strategies to *identify*, *infer* and *relate* mental elements. The analysis reveals the contribution of the identified strategies to the *inference* of implicit situational elements (Sequence 1) and the processing of *relations* between these elements (Sequence 2). Furthermore, the importance of the interplay between Strategies S2 (focus on meaning) and S3 (focus on relations) can be lined out (RQ1). The use of strategies to *identify*, *infer* or *relate* the prevailing mental elements seems to become more stable during the process of task comprehension (RQ2).

These results are of particular interest for research on modelling against the backdrop of difficulties in constructing a situation model (Leiß et al., 2010). Therefore, two indications might follow from the empirical insights: (1) as the strategies named above might contribute to generating a situation model it is possible that those strategies belong to the strategies having an impact on modeling competencies (see Leiß et al., 2010), (2) the use of those strategies might be fostered by strategic scaffolding and their use seems to become more stable independent of the tasks' characteristics. So, the use of those strategies might be extended to rich modelling tasks – presented in written format and with more than one relation described – to facilitate the understanding of the situation.

The presented study is limited at first because of the small number of students that have been analyzed as well as the laboratory setting in which the research was conducted. Further research needs to extend the investigation of the use of strategy to more students and different problem texts. It should especially take the interplay between the named strategies as well as between the teacher and students

into consideration. At least the investigation of reading strategies might be extended from fostering reading strategies for word problems to reading strategies for modelling problems.

Acknowledgment

The study is conducted within the MuM-research group (mathematics learning in language diversity) in cooperation with the project Mastering Math funded by the Deutsche Telekom Foundation (2011-2020, grant holder Susanne Prediger and Christoph Selter).

References

- Blombøj, M., & Ärlebäck, J. B. (2018). Theory-practice relations in research on applications and modelling. In T. Dreyfus, M. Artigue, D. Potari, S. Prediger, & K. Ruthven (Eds.), *Developing research in mathematics education – Twenty years of communication, cooperation and collaboration in Europe* (pp. 90–105). Abingdon, UK: Routledge.
- Dröse, J., & Prediger, S. (in press). Scaffolding für fachbezogene textsortenspezifische Lesestrategien – Entwicklungsforschungsstudie zur Förderung des Umgangs mit Textaufgaben. In B. Ahrenholz, S. Jeuk, B. Lütke, J. Paetsch, & H. Roll (Eds.), *Sprache im Fach*. Berlin, Germany: De Gruyter.
- Greefrath, G., & Vorhölter, K. (Eds.). (2016). *Teaching and learning mathematical modelling*. Cham, Switzerland: Springer International Publishing.
- Kintsch, W., & van Dijk, T. A. (1978). Towards a model of text comprehension and production. *Psychological Review*, 85(5), 363–394.
- Kintsch, W., & Greeno, J. G. (1985). Understanding and solving word arithmetic problems. *Psychological Review*, 92(1), 109–129.
- Leiß, D., Schukajlow, S., Blum, W., Messner, R., & Pekrun, R. (2010). The role of the situation model in mathematical modelling. *Journal für Mathematik-Didaktik*, 31(1), 119–141.
- Plath, J., & Leiß, D. (2018). The impact of linguistic complexity on the solution of mathematical modelling tasks. *ZDM Mathematics Education*, 50(1-2), 159–171.
- Prediger, S., & Krägeloh, N. (2015). Low achieving eighth graders learn to crack word problems. *ZDM Mathematics Education*, 47(6), 947–962.
- Prediger, S., & Zwetzschler, L. (2013). Topic-specific design research with a focus on learning processes. In T. Plomp & N. Nieveen (Eds.), *Educational Design Research: Illustrative Cases* (pp. 407–424). Enschede, the Netherlands: SLO.
- Reusser, K. (1987). From text to situation to equation. In H. Mandl, E. de Corte, N. S. Bennett, & H. F. Friedrich (Eds.), *Learning and instruction* (pp. 477–498). New York, NY: Pergamon.
- Schnotz, W. (1994). *Aufbau von Wissensstrukturen. Untersuchungen zur Kohärenzbildung beim Wissenserwerb mit Texten*. Weinheim: Psychologie Verlags Union.
- Tapiero, I. (2007). *Situation models and levels of coherence: Towards a definition of comprehension*. New York, NY: Erlbaum.
- Weimer, R., Reusser, K., Cummins, D. D., & Kintsch, W. (1988). The role of understanding in solving word problems. *Cognitive Psychology*, 20(4), 405–438.

Mathematical modeling and the role of language proficiency

Sevinç Göksen-Zayim, Derk Pik, Rijkje Dekker and Carla van Boxtel

University of Amsterdam, The Netherlands;

s.goksen@uva.nl; d.r.pik2@uva.nl; r.dekker@uva.nl; c.a.m.vanboxtel@uva.nl

Keywords: Mathematical modeling, conceptualization, mathematization, language proficiency.

Theory

Modeling is defined as "a practical and creative process in which realistic problems are translated into mathematical form" (cTWO, 2007, p. 25). Usually, modeling problems in context-rich assignments are offered to learners through texts. One of the first obstacles students encounter is reading and interpreting text. In secondary school, being able to read a problem is a decisive factor in solving a problem (Korhonen, Linnanmäki, & Aunio, 2012). The language used at school often forms an obstacle to learning mathematics (Van Eerde & Hager, 2009). It is thus to be expected that language is an important factor at the various phases of the modeling process, although the role of language proficiency may be different. To analyse the different difficulties concerning language, we have to split up the modeling process in different phases. According to Spandaw and Zwaneveld (2012), modeling encompasses various activities that are carried out consecutively, as shown in Figure 1.

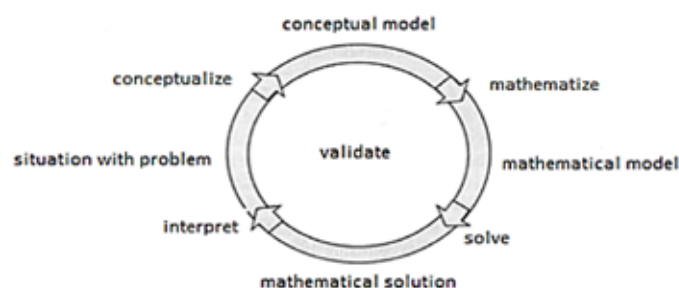


Figure 1: The modeling cycle (Spandaw & Zwaneveld, 2012, p. 240)

Language proficiency may play a different role in every phase of the modeling cycle. The phases are indicated by:

The phase of conceptualizing: the student is able to understand the text in which the problem is posed in order to make the translation into a conceptual model.

The phases of mathematization and solving: the student goes from the conceptual model to the mathematical model. Then the student will try to solve the problem. Mathematical reasoning occurs in both of these phases.

The phase of interpretation: translating the mathematical model into reality appeals to language skills. This skill is similar, but inverse to the language proficiency in the conceptualization phase.

Mathematical modeling is absent in the greater part of lower secondary education in the Netherlands. For that reason, this study will emphasize modeling in lower secondary education. This study will answer the following research question: *Which language problems occur in the three phases of mathematical modeling in context-rich assignments?*

Method

Participants of the study are students from grade six, eight and ten. These students are 11 up to 15 years and participated from four primary schools and four secondary schools located in an urban environment. 260 students performed two mathematical modeling tasks. The first modeling task is directed towards algebra and the other towards geometry. Each individual task consists of two parts. The first part is a modeling assignment in a rich context and the second assignment is a mathematical core assignment, focusing on the mathematical content without context. In consultation with the teacher of each participating class we selected two students ($n=26$), one with strong language proficiency and the other with weak language proficiency, with whom we performed a task based interview. Six teachers were interviewed about the levels of the designed modeling tasks. 12 students (two from each class, from 11 up to 15 years) were asked to do the assignment while thinking aloud.

Results

The analyses of students' answers, the task based interviews and the think-aloud protocols showed that language is an important obstacle, especially in the conceptualization phase. In all grades most of the students repeatedly reread the text of the modeling task. In many cases learners fail to construct a meaningful representation of the described situation. The transition from reality presented by the text towards a conceptual model often halts halfway. The outcome of the students' answers for the geometry modeling task did not show big differences between the rich context part and the mathematical core part, for all three grades. From the outcome of the task-based interviews with the learners, feasible components and levels for the different modeling phases are formulated. The think-aloud sessions gave more insight in the language problems students encounter while solving the modeling task and showed the strategy that students use.

Acknowledgment

This research is funded by The Netherlands Organisation for Scientific Research (NWO), number 023.009.047

References

- cTWO, Rijk aan betekenis, Visie op vernieuwd wiskunde-onderwijs, 2007, retrieved from www.fi.uu.nl/ctwo/publicaties/docs/Rijkaanbetekenisweb.pdf
- Korhonen, J., Linnanmäki, K., & Aunio, P. (2012). Language and mathematical performance: a comparison of lower secondary school students with different level of mathematical skills, *Scandinavian Journal of Educational Research*, 56(3), 333–344.
- Spandaw, J., & Zwaneveld, B. (2012). Modelleren, van werkelijkheid naar wiskunde en weer terug. In P. Drijvers, A. van Streun, & B. Zwaneveld, *Handboek Wiskundededidactiek* (pp. 235–264). Utrecht, the Netherlands: Epsilon.
- Van Eerde, D., & Hajer, M. (2009). The integration of mathematics and language learning in multiethnic schools. In M. César & K. Kumpulainen (Eds.), *Social interactions in multicultural settings* (pp. 269–296). Rotterdam, the Netherlands: Sense Publishers.

Pre-service mathematics teachers' learning through designing modelling tasks

Carolina Guerrero-Ortiz¹

¹Pontificia Universidad Católica de Valparaíso, Chile; c_cguerreiro@yahoo.com.mx

The results of analysing the projects for the teaching of mathematics and modelling developed by future mathematics teachers are discussed in this paper. The participants were part of a seminar in which the objective was to develop their mathematical and pedagogical content knowledge related to the teaching of mathematics through the design of modelling tasks. With a qualitative methodology the written reports of and interviews with the pre-service teachers were analysed. The results bring to light some elements associated with their knowledge and how this knowledge is constructed in their experience with modelling activities and then reflected in the creation of teaching tasks.

Keywords: Modelling task, future teachers, teacher training.

Introduction

The design of novel tasks and teaching activities represents a challenge for teachers and future teachers. They must be able to involve students in meaningful activities and create environments in which students construct and reflect on their own learning. In designing modelling tasks, the future teachers' knowledge about the context and the mathematics related to it, joined with the knowledge about the teaching and learning of the students becomes structured and shapes the tasks. The design and implementation of modelling tasks has been subject of innumerable studies with attention to the characteristics of the final product; but few investigations consider the processes that are favoured in this activity (Czocher, 2017), for example the construction of the teacher's pedagogical content knowledge.

When modelling activities are introduced to the classroom, teachers must adopt an adaptive view of new teaching methods. This involves a challenge that requires the mastery of mathematical knowledge associated with the context of the task and adapting that knowledge to the environment in which students will work with the task according to the learning objectives (Doerr & English, 2006). In the setting of a teachers' training seminar, we analyse: 1) how future teachers, when designing teaching tasks, construct and transform their mathematical knowledge associated with the modelling of population growth and 2) how this knowledge is adapted for teaching in a middle school mathematics course. The research question is: *What elements associated with pedagogical content knowledge emerge in the design of modelling tasks for teaching mathematics?* An important aspect in this study is the design process where participants learn to model to teach modelling. This fact is evidenced in the exploration of several situations and in how future teachers simplify and idealise the initial situations to adapt the task to the knowledge of the students.

Conceptual framework

When studying task design in mathematics education two perspectives can be identified: the design as implementation or the design as intention. The task design analysed here is characterized as

design as intention since it addresses the initial formulation of the design (Czocher, 2017) and the analysis is supported by constructs for studying teacher's pedagogical content knowledge (Ball, Thames, & Phelps, 2008; Doerr & English, 2006; Carrillo-Yañez et al., 2018). By teaching modelling it is intended that teachers become competent at modelling activities, they also should be able to link knowledge about modelling cycles, about goals and about types of tasks. Solving, analysing and creating tasks as well as planning and performing modelling lessons are important aspects here (Borromeo Ferri & Blum, 2010; Huincahue-Arcos, Borromeo Ferri, & Mena-Lorca, 2018). Designing and modifying tasks to be easier or harder for presenting mathematical ideas constitutes a part of the teacher's knowledge (Ball, Thames, & Phelps, 2008). When designing tasks for learning mathematics and modelling, the teacher's pedagogical content knowledge comes into play in teaching organization, in the understanding of how to present the concepts to favour learning and when understanding the mistakes associated with the domain (Doerr & English, 2006). In addition, the teacher must know the specifications of the curriculum and maintain a critical position to organize the learning and management the class (Carrillo-Yañez et al., 2018). The practice of modelling leads to the development of modelling skills (Blomhøj & Kjeldsen, 2006), so that when the teachers design a task, they structure their specialized content knowledge related to models with the intended knowledge for the students. On the other hand, when modelling students build knowledge depending on the characteristics and cognitive demands of the tasks (Henningsen & Stein, 1997). Therefore, it is expected that the tasks created by future teachers support progress in the modelling abilities of the students. According to the model of three dimensions (Blomhøj & Kjeldsen, 2006), the modelling competences can be distinguished as: (1) Technical level, related to the kind of mathematics the students use and to how flexible they are in their use of mathematics. (2) Radius of action, related to the domain of situations in which students can perform modelling activities and (3) Degree of coverage, according to the phase of the modelling process the students are working in, and the level of their reflections.

Context and method

In most Chilean teacher training programs, modelling has not been explicitly part of the education for future teachers. The future teachers take part in several courses of mathematics, didactics and pedagogy. They learn mathematical concepts and theories of education, but they have few experiences with modelling situations; as Blomhøj and Kjeldsen (2006) pointed out modelling is different than the nature of mathematics. In this context, it is described and analysed the process developed by a group of pedagogy in mathematics students, when they designed an activity for teaching. The experimentation was carried out with a group of six students, who participated in a research seminar for future teachers. Here, the case of a group with two participants is presented. They were selected because of their willingness to participate in the research. In the seminar some topics of differential (and integral) calculus and differential equations were discussed and among these functions, derivatives, logistic equations and systems of differential equations. Some perspectives of modelling (Blomhøj & Kjeldsen, 2006; Borromeo Ferri, 2006) were also reviewed. During the seminar several discussions about the use of technology and the content knowledge for teaching (Ball, Thames, & Phelps, 2008) were carried out. The students explored modelling different phenomena and proposed a teaching activity for middle school level (15 years old). The

process of designing a task (for approximately three months) was documented, where participants studied how some growth situations are described in reality. Then, after simplifications and idealizations their initial study took shape of a teaching activity. The design phase considered aspects such as, idealization and exploration of the initial conditions, parameter values and the domain of the solutions. Meetings with students once a week during one semester were developed in where the design process was followed. At the end of the course, they presented the teaching task and a description of the process of designing it in a written report.

Data analysis was carried out following a qualitative perspective (Cohen & Manion, 1989). First the episodes related to the modelling phases along the process of designing the task were identified. Then, units of meaning associated with mathematics, modelling and pedagogical content knowledge were identified. At the end of the seminar participants were interviewed by two researchers to verify the first interpretations of the author. Finally, the units of analysis identified in the written report and those from the interview were contrasted and discussed in the modelling seminar, where the author took part. Thereby, the validity of the results was verified.

Discussion and analysis of results

In this section, the study carried out by the participants related to the phenomenon in question is initially presented. It is not the intention in this paper to inform about a common process of population growth modelling, however, in order to analyse the knowledge that emerges when future teachers design a modelling task, we present a summary of the facts that they recognise as relevant. It should be noted that most researches on teacher's knowledge do not explicitly address the role of modelling (Ball, Thames, & Phelps, 2008; Carrillo-Yañez et al., 2018) but consider it as an element of mathematical practice. Here modelling is posed as a precursor element of the development of future teachers' knowledge. Furthermore, the experiences with modelling activities can be related to the improvement of the mathematical knowledge of the future teachers. Subsequently the teaching task proposed by the participants was analysed where some elements from the pre-service mathematics teachers' pedagogical content knowledge were identified. Three episodes were recognized: first when participants explored the growth of penguin populations reported by the research literature, where the case was analysed by statistical methods. Second, when the relevant information was identified and linked with an idealised mathematical model. Third, when information gathered in the first and second episodes was adapted to create a task for teaching.

Study of real situation

After consulting literature related to different growth phenomena, a growth situation of Magellanic penguins was selected (Pozzi et al., 2015; Valdebenito, 2013). The habitat places of this type of penguin were located on a map. In addition, the total population of penguins in the world was identified (1.5 million pairs of reproductive age). This led the future teachers to focus their attention on the population of penguins in Chile (700 pairs), particularly a population that is located on an ecological reserve that hosts around 400 specimens. Here participants observed the existence of infrastructure designed to allow tourism without affecting the reproduction of the penguins. This fact allowed them to transit from the study of a more general situation to the case of a growing population limited by a border. When doing the first exploration participants observed that studying

a population in freedom, implies considering predators and death of penguins due to the fishing process. By exploring the reproduction of the population, they identified the nesting seasons, the number of eggs per pair (2) and the places where the nests were located. They also noticed the existence of other predators like seagulls that attack eggs. Considering this information, participants associated the successful breeding with the number of chicks that survive per nest on each breeding season. These considerations were initially associated with logistic equations and systems of ordinary differential equations (predator-prey model).

Then, an idealisation of the situation was made, when participants saw the case as population growth in a limited place where the necessities of feeding (anchovies, sardines and some crustaceans) also influence the size of the population. Thereby, pre-service teachers made relationships between the competition for limited resources in the environment and the population size; this led them to model the situation using the logistic equation of population growth. The elements used to determine the parameter values in the equations were: the reproduction age (the females reproduce between 4 to 5 years old, while the males reproduce when they are 6-7 years old), and the penguins are monogamous. The average life expectancy is about 20 years. With this information students calculated an approximation of the growth rate.

This phase was a support for pre-service teachers to: a) recognise the reasons why some simplifications are necessary, b) recognise and explain the frequent difficulties students find in mathematizing a situation and c) identify and explain the behaviour of some situations. In addition to the ideas of Ball, Thames, and Phelps (2008) it is assumed that those elements must be part of the teacher's mathematical knowledge for teaching modelling.

Simplification of the real situation and modelling

When simplifying the real situation, the participants made decisions that were reflected in the design of the task as will be discussed below. In summary, the literature gives information about the penguins' birth and mortality rates per year. Then by calculating an average students approximated this values by a constant (intrinsic rate of increase) to be used in the expressions to describe the population growth. From here, by comparing continuous and discrete exponential growth future teachers were aware of the complexity of modelling realistic situations. They also realised the limitations of modelling population growth with simple models. Hence, when pre-service teachers explored open modelling situations, they built their mathematical knowledge associated with the situation (Carrillo-Yañez et al., 2018), and when they used that knowledge to design the task, they strengthened their pedagogical content knowledge related to modelling practices (Doerr & English, 2006). Thus, the experience they got by exploring the characteristics of the phenomena served as the basis for the design of the teaching situation.

Below some of the arguments from the participants regarding to the relevant information and the simplification they made are shown:

Initial population – the literature mentions that in 1993 a population of 400 penguins was estimated in the reserve.

Birth- [...] paired penguins lay 1 to 2 eggs, but not all penguins are in pairs and not all couples get two eggs, for this reason the birth rate can be considered to be 50%. However not all chicks are born, which leads us to consider a birth rate of 40% of the total population. This rate is consistent with the data in the literature [...].

Mortality- [...] the longevity due to natural death of penguins is almost 20 years, in addition there are other factors that cause the death of this species [...], the spilled oil and the fishing nets, that add up to 16% mortality [literature information]. If [mortality] is adapted only to natural causes of death (Diseases, poisonings, etc.) an estimate of 14% can be made since the reserve has the necessary care to maintain the health of the penguins.

Predators- The presence of predators was not taken into account for the design of this task, since the penguins are in a reserve and are protected from these threats.

With this information the participants analysed two cases described by the equations $\frac{dN}{dt} = kN$ y $\frac{dN}{dt} = r \left(1 - \frac{N}{K} \right) N$, getting the solutions $N(t) = 400e^{kt}$ y $N(t) = \frac{Ze^{rt}K}{Ze^{rt} + 1}$. When studying the graphs of these expressions they identified the behaviour of a population modelled by the logistic equation and described it as below:

[...] if the population is less than the carrying capacity, the graph behaves increasingly, but when it approaches (K) the graph begins to stabilise, instead if the population was greater than the capacity of load the graph behaves decreasingly and begins to stabilise when it is closer to K .

In this episode, stand out identification and simplification processes of relevant information and the participants' mathematical work using analytical and graphical representations. The experience gained studying the real situation helped future teachers to identify and anticipate appropriate mathematical representations to be used in the teaching activity. Those elements are related with the Specialized Content Knowledge (Ball, Thames, & Phelps, 2008).

The teaching task

In this section the task designed by two participants is analysed. The learning objectives were defined as: Analysing the behaviour of a population based on birth and mortality rates in relation to the time. The task is the following:

In 1991 a massive death of penguins of the Magellanic species was evidenced. To revert the situation a group of people in 1993 decided to create a Natural Reserve of Magellanic Penguins called "Seno Otway". The reserve has capacity for hosting 6500 penguins. At the beginning the reserve started with an initial population of 300 Magellanic penguins. From a census they calculated a mortality rate of 70 per 500 penguins and a birth rate as 200 per 500 penguins.

Some of the questions that the future teachers posed are:

- 1) What do you think would happen if the population exceeds the capacity of the reserve?
- 2) Use the data for graphing the situation.

3) Analyse what should happen when reaching the load limit.

Those questions show that teachers focused on the carrying capacity as the relevant aspect that affects the growth of the population. The first question demands an intuitive answer from the students, with the third question they are challenged to prove or reject their initial conjecture by studying the data. To answer the second question, students were encouraged to organizing the data about the time and the population in a table, using this information they could build a graphical representation. Here, the future teachers' knowledge related to the different registers in which a mathematical content can be represented (Carrillo-Yañez et al., 2018) and their strength to interpret situations becomes evident. This is also related to the knowledge of some theories of learning as it is shown in the next fragment related to the characteristics of the task:

The activity is designed for the students to articulate the same information in different semiotic representations, and to look for a generality that represents the behaviour of the population [...]

The teachers' knowledge associated with the characteristics of modelling was also evident when they described the processes through which the student should transit when answering the questions. They anticipated that students would go through a spiral-shaped cycle increasing as they require more knowledge to answer the questions. This is shown in an extract of the written inform:

In order to solve successfully the task, it is necessary to carry out several modelling processes that respond to different situations, we could group the questions into three categories, easy (1, 2), medium (3, 4) and hard (5, 6); each of them corresponds to a separate modelling cycle that adds more difficulty as the students respond.

In the previous transcript the knowledge of pedagogical content was evidenced in the design of the task when teachers anticipated the students' reaction in relation to the difficulty in answering the items (Ball, Thames, & Phelps, 2008).

While designing the task, future teachers recognised the importance of students being aware of the idealization processes involved in the analysis of a phenomenon. In the following fragment, when justifying the pertinence of the question number three, they referred to the idealization that implies modelling the situation through the differential equation $\frac{dN}{dt} = kN$ and compared it with the case

modelled by the equation $\frac{dN}{dt} = r \left(1 - \frac{N}{k} \right) N$:

[...] the students should reflect on the exponential growth of the population, because so far we have only analysed an ideal case, where no carrying capacity or predators in the area have been taken into account.

In relation to the graphical representation of the behaviour of the population, future teachers pointed out that working with graphics could generate some errors of interpretation when students superficially see the generated curves; this is associated with the knowledge of the structure of mathematics (Carrillo-Yañez et al., 2018). They point it out as follows:

They [students] may build a more flattened exponential, arguing then that the growth population should be slower.

In the previous analysis a strong relationship between the (mathematical and extra-mathematical) knowledge constructed by future teachers when experiencing modelling to design a teaching task was observed. And the pedagogical content knowledge was evidenced when they were able to anticipate the students' actions with the modelling task. The task was designed to cross through the modelling cycle in different ways. However, the activity was subordinated to only working with the data in the tasks (Blomhøj & Kjeldsen, 2006).

Comments and conclusions

It was evidenced that in the challenge of designing teaching tasks the future teachers experiment with mathematical and extra-mathematical knowledge and bring to light what they learn for planning the teaching. The future teachers' learning endured a transformation from studying pure mathematics to study the mathematical and extra-mathematical content associated with several phenomena. When exploring the situation, the participants' work highlighted activities as identifying relevant information, simplifying the situation, formulating a task, systematising, mathematising and analysing mathematically. Those activities reinforce their knowledge about the mathematical characteristics of the models. They also had the opportunity to link concepts, understand procedures, rules and meanings. The knowledge constructed in this way was a support for designing the task, so that it strengthens their pedagogical content knowledge. In relation to the progress of mathematical competence (Blomhøj & Kjeldsen, 2006), it was observed that the future teachers' performance with the modelling activity and the task designed by them are situated in the technical level, related to the use of mathematics and its representations. However, it is desirable that future teachers widen their radius of action.

The experience in this research showed that – in addition to the knowledge pointed out by Ball, Thames, and Phelps (2008) – for implementing modelling as a vehicle for teaching mathematics, the teacher should be able to: recognize the reasons why some simplifications are necessary, recognize and explain the frequent difficulties students find in mathematizing a situation, identify and explain the reasons for the behaviour of some situations, identify and anticipate appropriate mathematical representations, identify and enhance the transit through the different phases of a modelling process. On the other hand, some tension between developing modelling competences and teaching the content was identified. That is, although the task could be more open allowing students to build their own strategies, the final characteristics of the task limit the actions of the students to whom it will be directed. This situation has a strong relationship with the educational system because most institutions expect that teachers taught the content as it is described by the curriculum where modelling is considered closer to word problems. In the same way, Chilean teachers training programs are more directed toward the teaching of content rather than developing skills. Therefore, our challenge is to encourage pre-service teachers to explore innovative ways for teaching mathematics.

Finally, the construction of pedagogical and mathematical knowledge was analysed when pre-service teachers design a task; this fact does not allow us to know how future teachers put into play their pedagogical content knowledge in the practice. This aspect is been explored in parallel studies.

Acknowledgment

I thank to VREA-PUCV and to the research project EDU2017-84276-R.

References

- Ball, D., Thames, M., & Phelps, G. (2008). Content knowledge for teaching: What makes it special? *Journal of Teacher Education*, 59(5), 389–407.
- Blomhøj, M., & Kjeldsen, T.H. (2006). Teaching mathematical modelling through project work. Experiences from an in-service course for upper secondary teachers. *ZDM Mathematics Education*, 38(2), 163–177.
- Borromeo Ferri, R. (2006). Theoretical and empirical differentiations of phases in the modelling process. *Zentralblatt für Didaktik der Mathematik*, 38(2), 86–95.
- Borromeo Ferri, R., & Blum, W. (2010). Mathematical modelling in teacher education – Experiences from a modelling seminar. In V. Durand-Guerrier, S. Soury-Lavergne, & F. Arzarello (Eds.), *CERME6 – Proceedings of the Sixth Congress of the European Society for Research in Mathematics Education* (pp. 2046–2055). Lyon, France: INRP.
- Carrillo-Yañez, J., Climent, N., Montes, M., Contreras, L., Flores-Medrano, E., Escudero-Ávila, D., Vasco, D., & Rojas, N., Flores, P., Aguilar-González, A., Ribeiro, M., & Muñoz-Catalán, M. (2018). The mathematics teacher's specialised knowledge (MTSK) model. *Research in Mathematics Education*, 20(3), 236–253. DOI:10.1080/14794802.2018.1479981
- Cohen, L., & Manion, L. (1989). *Research methods in education*. London, UK: Routledge.
- Czocher, J. (2017). Mathematical Modeling Cycles as a Task Design Heuristic. *The Mathematics Enthusiast*, 14(1), 129–140.
- Doerr, H., & English, L. (2006). Middle grade teachers' learning through students' engagement with modelling tasks. *Journal of Mathematics Teacher Education*, 9(1), 5–32.
- Henningsen, M., & Stein, M. K. (1997). Mathematical tasks and student cognition: Classroom-based factors that support and inhibit high-level mathematical thinking and reasoning. *Journal for Research in Mathematics Education*, 28(5), 524–549.
- Huincahue Arcos, J., Borromeo Ferri, R., & Mena-Lorca, J. (2018). El conocimiento de la modelación matemática desde la reflexión en la formación inicial de profesores de matemática. *Enseñanza de las ciencias*, 36(1), 99–115.
- Pozzi, L.M., Borboroglu, P.G., Boersma, P.D., & Pascual, M.A. (2015). Population regulation in magellanic penguins: What determines changes in colony size? *PLoS ONE*, 10(3), 1–16. <https://doi.org/10.1371/journal.pone.0119002>
- Valdebenito, M. (2013). *Censo de la población de Pingüino de Magallanes (Spheniscus magellanicus)*. Colonia Seno Otway [Census of the population of Magellanic Penguin (Spheniscus magellanicus). Colonia Seno Otway], Punta Arenas, Chile. Retrieved from http://www.turisotway.cl/INFORME_OTWAY_TEMPORADA_2012-2013.pdf

Teachers learning to design and implement mathematical modelling activities through collaboration

Britta Eyrich Jessen

University of Copenhagen, Department of Science Education, Denmark; britta.jessen@ind.ku.dk

In this paper, we present a model for upper secondary in-service teacher courses based on the Anthropological Theory of the Didactics and explore how we can teach teachers to design and implement mathematical modelling in their classrooms. The course evolves around Study and Research Path based teaching and strives to create para-didactic infrastructures as a framework for teachers' development of teaching practice. The novelty in this study is the sequence of shared preparation, observation and evaluation of teaching in the course. We describe the structures and their functioning through an example of a group of teachers' work. Based on the activity we discuss the potentials of creating such structures and the needs for further research in this field.

Keywords: Study and research paths, modelling activities, professional development, para-didactic infrastructures, upper secondary education.

Introduction

Throughout the years, several examples of in-service teacher courses on modelling have been presented with the purpose of supporting teachers to design modelling activities, promoting different theoretical approaches to mathematical modelling (Kjeldsen & Blomhøj, 2006; Doerr 2007; Blum & Borromeo Ferri, 2009; Barquero, Bosch, & Romo, 2018). These approaches have ways to engage students in modelling activities, where students sometimes choose strategies different from those foreseen by researchers or teachers. This is challenging for teachers, and might cause them not to implement new knowledge gained from in-service courses, professional development (PD) activities, in their teaching practices. García argues that PD initiatives require existence of structures supporting teachers while implementing more inquiry based teaching methods and he suggests lesson study or other versions of action research (García, 2013). According to Artigue and Blomhøj (2013), mathematical modelling can be regarded as one approach to inquiry-based teaching, which is why those supporting structures, mentioned by García (2013) should be implemented in PDs on mathematical modelling.

In this paper, we present the result of a pilot study, where upper secondary in-service teachers were taught to design mathematical modelling activities based on Study and Research Paths (SRP) from the Anthropological Theory of the Didactic (ATD) including elements of lesson study. García, Higuera, and Bosch (2006), Barquero (2009) and Jessen (2014) have shown how SRP can be used for the design of modelling activities for students at all levels of the educational system. In those studies, modelling functions as a vehicle for learning mathematical content knowledge (see further in Julie & Mudaly, 2007, p. 504). This was also the purpose of the SRPs, developed by the participants of our PD. However, it has been reported that Study and Research Paths for Teacher Education, SRP-TE (Barquero et al., 2018) proved to be difficult for teachers to implement and they turned to transmission of knowledge when back in their own classrooms with designs developed in a PD. In our study, we draw on the suggestion of creating supporting structures for in-service teachers as part

of courses on SRP (Muñoz, García, & Fernández, 2018). We adopt the model suggested by Miyakawa and Winsløw (2013), called para-didactic infrastructures, to describe the use of elements of lesson study structures in our PD. These structures cover shared preparation, observation and reflection upon some teaching. Miyakawa and Winsløw (2013) use the model to describe an open lesson observed during a lesson study festival in Japan and to point out why open lesson represents an attractive element of PD for Japanese teachers. We find it interesting to study, how elements of this PD practice can be explored in other contexts. This is the objective of this paper, which address the research question: How can we employ para-didactic infrastructures in PD for upper secondary teachers in order to support teachers' implementation of SRP based teaching in their own classrooms? To answer this, we provide a short introduction to basic notions of ATD, a description of the course and an implemented SRP.

The theoretical framework of ATD – and its use in the course

Praxeology is a core notion in ATD, where we consider it possible to describe all human activities in terms of praxeologies. A praxeology consists of two elements: praxis and logos. If we consider mathematical praxeologies, *praxis* consist of a *type of task* and the *technique(s)* to solve it. An example could be how to find the surface area of an open cylinder with radius r and length l . The technique to solve it, is the formula $A = 2 \cdot \pi \cdot r \cdot l$. Logos is the justification of praxis and consists of *technology* and *theory*. In the case of the cylinder, the technology is the articulation of how we can cut the cylinder open and unfold it as a rectangle. The length is then the one of the cylinder, l , and the width is the circumference of a circle with radius r . The theory is a higher level of justification, which in this case will be geometric shapes, their measures and properties. Praxeologies are connected through shared techniques, technology or theory, which form mathematical organisations (MO) from local ones sharing techniques to global ones, describing a whole domain, e.g. vector algebra (Barbé, Bosch, Espinoza, & Gascón, 2005). We can consider teachers' actions in the classroom, as the realisation of didactical praxeologies. What is observable in teaching situations, is often the techniques: the way to introduce new content knowledge, the way to pose questions, the way to organise students' work in groups etc. The didactical tasks, which the techniques answer, are addressed by the teacher when preparing the lesson. The logos of the didactical praxeologies are rarely evident, but might be based on teachers' initial education and courses on learning theory, didactics of mathematics or their teaching experiences. The latter might not count as real theory, but is still a level of justification from the perspective of the teachers. Teaching can then, be considered a set of mathematical and didactical organisations (DO) intertwined and to be realised in the classroom. Miyakawa and Winsløw presents "a theoretical approach to study mathematics teacher knowledge and the conditions for developing it in direct relation to teaching practice" based on ATD (Miyaka & Winsløw, 2013, p. 186), which is depicted in Figure 1. The model illustrates how teacher knowledge can be developed and described in terms of mathematical and didactical praxeologies, relevant for teaching a certain piece of knowledge. The didactic infrastructures refer to the interaction between the MO and DO employed. The PO's represent the paradidactic organisations. The PO₁ is the pre-didactic organisation, including knowledge and practices involved in teachers joined exploration and formulation of the MO to be taught and the DO required to do so. PO₂ is the post-didactical organisation involved in the evaluation of the realised MO and DO. In our PD, we strived

to provide teachers with situations in terms of PO_1 and PO_2 and to exploit those, reconsidering the knowledge to be taught, why to teach it and how to teach it – to free the teachers from habits and to construct new knowledge about teaching practices based on SRP.

SRP is a design tool suggested to design modelling activities and inquiry based teaching (García et al., 2006). The design of an SRP starts by formulating a generating

question, Q_0 . Students should be able to understand, but not able to answer Q_0 unless they engage in study and research processes. The study process is when students study different media: textbooks, online webpages, video materials, data from an experiment etc. to gain knowledge on a subdomain, method, formula and more. This process is considered to be the deconstruction of knowledge. In the research process, students combine knowledge acquired in the study process with their existing knowledge forming answers to derived questions (which in the end lead to a coherent answer to Q_0). This reconstruction of knowledge is considered the result of students' interactions with the milieu (Jessen, 2017, p. 224). The dialectic between study and research is assumed to give rise to derived questions. As for the SRP described below, a derived question could be: “in order to answer how long the route is, I need to know how to find the length of a vector?”. This question addresses the content, but derived questions can also be technical in their nature, such as how to define a vector in Geogebra? In ATD we consider those questions and their answers as mathematical and instrumented praxeologies. In the planning of a SRP, it might also be relevant to consider meta-cognitive teacher questions such as “what have you done so far in order to answer Q_0 ”. This would be considered part of the didactical praxeologies employed by the teachers. Providing teachers with paradidactic infrastructures, meta-cognitive questions would be addressed in the PO_1 , when preparing the lesson discussing whether to pose such a question and how it would affect the students learning outcomes. This shared preparation is supposed to develop their didactical praxeologies. During the PO_2 , the teachers' didactical equipment will be further developed, when discussing the learning outcomes of the students in relation to the group of teachers' choices regarding didactical techniques.

A way to share the learning potentials of an SRP, is to map the derived questions and how they are related, which form a mind map like tree-diagram. In ATD these diagrams are created by researchers based on the epistemological analysis of the domain being taught (e.g. see Jessen, 2014). In our PD, the participants were encouraged to develop these maps based on their knowledge on the students' prerequisites, knowledge to be taught, preferred textbooks, possible google hits etc. This is one way to engage the teachers in studying the MO of their teaching, which is the first challenge for teachers engaging with SRP in PD (Barquero et al., 2018). In our PD, the participants were suggested to use the tree-diagrams, named ‘knowledge-maps’, as navigation tools when teaching (see Jessen & Rasmussen, 2018). When evaluating the teaching design in PO_2 , we wanted the teachers to discuss what questions and answers were raised by the students during the teaching, and based on this, discuss

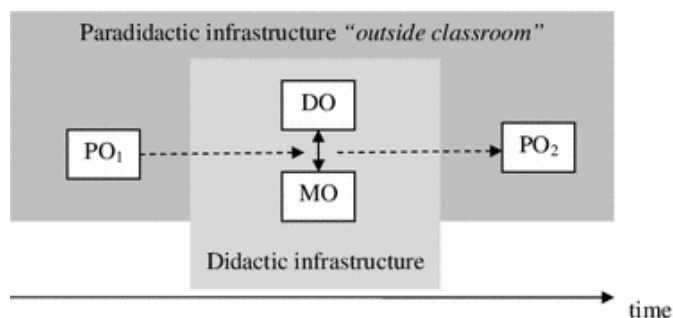


Figure 1: The sketch show the didactic and paradidactic infrastructures surrounding teaching (Miyakawa & Winsløw, 2013, p. 189)

the learning outcomes. In ATD research, we use discourse analyses to identify what answers or part of answers students developed and, through those discuss, what questions they might answer. Students raise those implicitly or explicitly. This methodology is fully described in Jessen (2014, 2017). In the PD, the participants did not complete such an a posteriori analysis, but we discussed questions and answers raised by students, as result of the realised MO and DO, which led to suggestions for improving the SRP designs and a revision of the lesson plans. As inspiration for the DOs required to realise an SRP, the participants in our PD were presented with the DOs employed in Jessen (2014, 2017) (group work, sharing sessions, strict time schedules etc.). They were articulated as methods to realise SRPs. The participants were encouraged to develop their own methods, drawing on their teaching experiences. For each group of teachers, the planned teaching was materialised in a lesson plan similar to those developed for the MERIA project (Jessen & Winsløw, 2018, p. 3) with formulations of concrete learning goals, broader goals, age of students, time of school year, type of institution, teaching materials including Q_0 , media suggested to the students and the knowledge-map showing the teachers a priori analysis. In the end, we had four columns indicating: timeline, teachers' actions, students' actions and observation notes. During the realisations, the observing group members took field notes on how the lesson differed from the plan and what questions and answers were provided by the students. Depending on, what was possible, the participants in the PD collected testimonial from the lessons in terms of: video recording of students presenting their work, pictures of students' presentations, handed in assignments etc. Inspired by Barquero et al. (2018), we describe the realisation of the PD through one group of teachers' work with a SRP on vector algebra, after providing the context of the PD.

The context of the PD and course design

In 2017 upper secondary education was reformed in Denmark, where mathematics was altered with respect to suggested teaching methods and elements of content knowledge (re)introduced, where others were skipped. This created a need for a PD on didactics related to the specific changes of the content (see elaboration in Jessen & Rasmussen, 2018, p. 346). The course was designed as 7 teaching session lasting 4 hours each. The course covers: the why's and how's of inquiry based teaching and modelling based on SRP as a design tool, piecewise linear functions, vector algebra, discrete mathematics and probability theory. Participants were encouraged to join with a colleague so the teachers could collaborate between sessions, and potentially build para-didactic structures as described in Figure 1. A total of 47 teachers participated (with 1-30 years of teaching experience) from all over Denmark and formed groups of approximately 4 teachers, which they kept working with throughout the course. Every teaching session, except the first one, had an element of sharing and peer-feedback on SRP designs (Q_0 , knowledge maps, media, etc.) and on the realised SRPs of each group, based on testimonial from the classroom shared with the rest of the participants. Before ending each session, all groups presented their ideas for the next SRP and got feedback on formulation, feasibility of the lesson plan and further media. The groups then improved their SRPs and lesson plans before realising them in their classrooms. Not all teachers were able to complete or test their SRPs due to extraordinary workloads implementing the reform. But most participants were eager to share and get feedback on their ideas and experiences. The knowledge collected on the PD (from the PO_1 and PO_2) is the teacher's notes (which is also the author of the paper), the finalised

lesson plans and the documentation collected and shared by the participants from their implementation of SRPs. Hence, the course does not as such create para-didactic infrastructures around the teachers' practice, but rather it offers the teachers *para-didactic situations* to initiate reflections and professional development.

An example of para-didactic infrastructures from the course

In this section, we will describe an example of how the para-didactic situations were implemented in the PD. A group of teachers worked with the problem of introducing vector algebra in grade 10, which earlier was taught at grade 12. During the third session of the PD, the participants shared teaching materials on vectors. Participants compared materials with the new curriculum and discussed what elements could be captured in a generating question, Q_0 . They agreed, that a problem concerning routes and navigation, could create a need for the geometric definition of a vector, which they found interesting. The Q_0 should not require any knowledge from physics, since a great number of the mathematics students do not take physics. This is considered the initiation of the PO_1 .

During the fourth session of the PD, the groups shared initial formulations of their Q_0 's, they orally explained possible paths or strategies for the students to take, when trying to solve the problem. Our group presented the idea of letting students imagine they were a captain in the Caribbean Sea, who needed to guide his crew from one city to another. The group had found a map and a compass rose and wanted to include Geogebra, but hesitated on how to do this: should they provide students with coordinates or let them draw gridlines on the paper version of the map in order to transfer the route to Geogebra? The choice of media depended on this decision. It was discussed in general at the PD, if students would need vectors or simply use geometry – would suggested media inspire the students to use the notion of vector? It was discussed if the word *vector* should be mentioned in the Q_0 and how that would affect the students' learning. These questions are considered tasks, which might develop teachers' didactical praxeologies and a further enrich the PO_1 . The group of teachers completed their SRP design and lesson plan after this session. The learning goals, stated in the lesson plan, for the 120 minutes teaching were: "to know the geometric definition of vectors including position vector, be able to construct a sailing route according to the problem in terms of vectors or linear combination of vectors (incl. being able to add vectors based on their coordinates, be able to scale up vectors), determine the length of a vector and be able to do this in Geogebra". The broader goals of the lesson were: "to gain intuition of vector addition being commutative and associative as well as gain knowledge on unit vectors, see the need for them and deduce one from any given vector". Further the group expected the students to develop problem solving competency and aid and tool competency, while working with the problem. The generating question the group formulated was as follows:

" Q_0 : You are a captain in the Golden Days of piracy in the Caribbean and you are to guide your ship from Havana to Santo Domingo (see the attached map). Your crew covers 'landlubbers', 'treasure hunters' and sailors. They only answer to directions formulated as: "go 20 miles south (S), then 30 miles south east (SE) and then 100 miles North West (NW)". A while ago you made the distance from Aruba to Montserrat in 3 days and you expect to travel by the same average speed. What orders would you give your crew and when do you expect to arrive?"



Figure 2: A screen dump showing the Geogebra file and the compass rose handed out

The students were provided with a Geogebra file where the window looks like the picture on the left side of Figure 2, where unit vectors indicating the directions of N, S, E and W were defined together with points indicating the mentioned cities. Furthermore, students were provided with a compass rose on a piece of paper as the one shown in the right side of figure 2. Media suggested to the students, but not required to use, was: 10 pages in a textbook and a short manual introducing vectors in Geogebra created by the teachers. The group expected students to find media online e.g. Wikipedia and Webmatematik, both in Danish. The lesson was planned to start by showing the students Q_0 and the suggested media. Furthermore, the teacher had added a function to the Geogebra file called “vector from starting point”, forcing Geogebra not to draw all vectors from origin. From the perspective of ATD, we consider the Geogebra file the milieu of the SRP. Students were expected to explore how they can construct a route based on points, lines and vectors depending on how they adapt to the milieu, study the notion of vector and develop an answer in the Geogebra file. In this respect, students are learning from the dialectic between media and milieu, between research and study processes.

The introduction of the problem, media, the Geogebra file, the connection of computers, and dividing the class into groups of three is estimated to take 20 minutes. The students are planned to work on the problem for 20 minutes, where the teachers observe the students and assist them with technical problems in Geogebra. The students present their work during the last 20 minutes. After the lunch break the teacher spends 5 minutes reminding the class of strategies presented earlier and introduce the Geogebra function “vector from starting point”. Then the groups had another 20 minutes preparing before using 20 minutes on students’ second presentations. During the last 15 minutes the students are asked to write down their solutions and strategies with arguments, why they chose the described strategies. After the lesson the students hand in the description together with their Geogebra file. During the following lesson, vector exercises similar to those of the written examinations were worked on by the class. The lesson plan represents the group of teachers’ outcome of the PO_1 .

The teachers summarised their experiences and observations and wrote it down straight after the class. Together with the observation notes taken during the lesson, they completed the lesson plan, and from this we get a picture of the initiation of the PO_2 . Furthermore, the teachers video recorded the two sharing sessions, where the students connected their computers with the projector and shared their

work. During the fifth session of the PD, the teachers presented their experiences with their SRP by sharing the lesson plan, and video recordings. Based on this it was discussed, if the learning goals were achieved and how they were achieved. The videos showed that many students started working with line segments creating a need for directions corresponding to NW, SE etc. This led the students to experiment with the notion of vector and Geogebra syntax. Some students created a compass rose, defining the vector NE as starting from (0,0) and ending in (1,1) and NNE as the vector with end point $(\frac{1}{2}, 1)$. But the groups found it unpractical with “unit” vectors of different lengths, when calculating the length of the route. Hence, the students needed real unit vectors, which were discussed in relation to the unit circle. In the PD, participants agreed that most students had achieved the intended learning during the two hours. However, it was questioned, if all students were able to solve the tasks of the following lesson, if not being allowed to use Geogebra. What was questioned was the strength of the logos of the developed praxeologies and if those could be used in other contexts e.g. pen and paper mathematics. The peer-feedback and discussion of the realised SRP led to suggestions for improvement of the design and the lesson plan, which concluded the PO₂.

Concluding remarks

From an electronic survey evaluating the PD, we know that the participants felt obliged to prepare, to implement and share experiences because of the structure of the PD. Participants noted that it was the first time they were allowed and encouraged to dwell on and discuss students learning in this detail – and similar for the planning of teaching. This seemed to be sufficient support, making participants comfortable enough to implement their SRP designs in their classrooms. The sharing further encouraged them to realise their SRPs, because of the contagious enthusiasm from those who already tried it. The numbers of realised SRPs indicates, that creating para-didactic situations might further teachers’ outcomes of PDs in terms of implementing SRP based modelling in their practice. Still, more research is needed in this area. What is the role of the researcher, teaching the PD? How does the PD affect teaching practices in the long run? Are the collaborations between participants sustainable and under what conditions? And what research methodologies can capture the MO and DOs developed by students and participating teachers respectively in large-scale studies?

References

- Artigue, M., & Blomhøj, M. (2013). Conceptualizing inquiry-based education in mathematics. *ZDM Mathematics Education*, 45(6), 797–810.
- Barbé, J., Bosch, M., Espinoza, L., & Gascón, J. (2005). Didactic restrictions on the teacher’s practice: The case of limits of functions in Spanish high schools. *Educational Studies in Mathematics*, 59(1–3), 235–268.
- Barquero, B. (2009). *Ecología de la modelización matemática en la enseñanza universitaria de las matemáticas*. (Unpublished Doctoral Dissertation). Universitat Autònoma de Barcelona, Spain.
- Barquero, B., Bosch, M., & Romo, A. (2018). Mathematical modelling in teacher education: Dealing with institutional constraints. *ZDM Mathematics Education*, 50(1–2), 31–43.
- Blomhøj, M., & Kjeldsen, T. H. (2006). Teaching mathematical modelling through project work. *ZDM Mathematics Education*, 38(2), 163–177.

- Blum, W., & Borromeo Ferri, R. B. (2009). Mathematical modelling: Can it be taught and learnt? *Journal of Mathematical Modelling and Application*, 1(1), 45–58.
- Doerr, H. M. (2007). What knowledge do teachers need for teaching mathematics through applications and modelling? In P. Galbraith, H-W. Henn, & M. Niss (Eds.), *Modelling and applications in mathematics education* (pp. 69–78). Boston, MA: Springer.
- García, F. J. (Ed.) (2013). *Primas – Guide for professional development providers*. Retrieved from: http://primas-project.eu/wp-content/uploads/sites/323/2017/11/FINAL_WP4_Guide_PD_providers_licence_150708.pdf
- García, F. J., Pérez, J. G., Higuera, L. R., & Bosch, M. (2006). Mathematical modelling as a tool for the connection of school mathematics. *ZDM Mathematics Education*, 38(3), 226–246.
- Jessen, B. E. (2014). How can study and research paths contribute to the teaching of mathematics in an interdisciplinary settings? *Annales de Didactiques et de Sciences Cognitives*, 19, 199–224.
- Jessen, B. E. (2017). How to generate autonomous questioning in secondary mathematics teaching? *Recherches en Didactique des Mathématiques*, 37(2-3), 217–246.
- Jessen, B. E., & Rasmussen, K. (in press). What knowledge do in-service teachers need to create SRPs?. Paper presented at the *Sixth International Congress of the Anthropological Theory of Didactics*. Grenoble, France. [Online Pre-Proceedings, pp. 339–351]. <https://citad6.sciencesconf.org/resource/page/id/8>
- Jessen, B. E., & Winsløw, C. (2018). *MERIA Template for Scenarios and Modules*. Retrieved from: <https://meria-project.eu/activities-results>
- Julie, C., & Mudaly, V. (2007). Mathematical modelling of social issues in school mathematics in South Africa. In P. Galbraith, H-W. Henn, & M. Niss (Eds.), *Modelling and applications in mathematics education*, (pp. 503–510). Boston, MA: Springer.
- Miyakawa, T., & Winsløw, C. (2013). Developing mathematics teacher knowledge: the paradigmatic infrastructure of “open lesson” in Japan. *Journal of Mathematics Teacher Education*, 16(3), 185–209.
- Muñoz, E. L., García, F.J., & Fernández, A. M. L. (in press). *Propuesta de un proceso de estudio de clases para la formación inicial del profesorado de Educación Infantil desde el paradigma del cuestionamiento del mundo*. Paper presented at the *Sixth International Congress of the Anthropological Theory of Didactics*. Grenoble, France. [Online Pre-Proceedings, pp. 186–201]. <https://citad6.sciencesconf.org/resource/page/id/8>

Development of group creativity in mathematical modeling

Hye-Yun Jung¹ and Kyeong-Hwa Lee²

¹Graduate School of Seoul National University, Korea; hy0501@snu.ac.kr

²Seoul National University, Korea; khmath@snu.ac.kr

Keywords: Mathematical modeling, group creativity, interaction, creative synergy.

Introduction

In many previous studies, mathematical modeling is considered an instrument to develop mathematical creativity, in rather individual contexts (e.g., Palsdottir & Sriraman, 2017, p. 49). However, there is a growing consensus that group creativity is important for the 21st century (Woodman, Sawyer, & Griffin, 1993). This study aims to explore interaction supporting the development of group creativity during mathematical modeling activities and the impact of group creativity on the mathematical modeling process.

Theoretical Background and Methods

Mathematical modeling is a cyclic and recursive process that requires understanding a real situation and creating a model (Jung et al., 2018, p. 155). Figure 1 illustrates key stages in this iterative modeling process. Vorhölter (2017, p. 345) discuss a perspective of group based modeling activities that potentially can support the development of group creativity. Group creativity has been considered a function of individual behavior, the interaction of the individuals involved, and the creative synergy of the interaction within the group (Woodman et al., 1993, pp. 302-304). Jung and Lee (2018, p. 373) made a distinction between three types of interaction when investigating group creativity, namely: mutually complementary-, conflict based-, and metacognitive-interaction. This study aims to investigate the following two questions: (1) What types of interaction can be observed during modelling activities that support the development of group creativity? (2) What impact on the modelling process can be observed in the interactions?

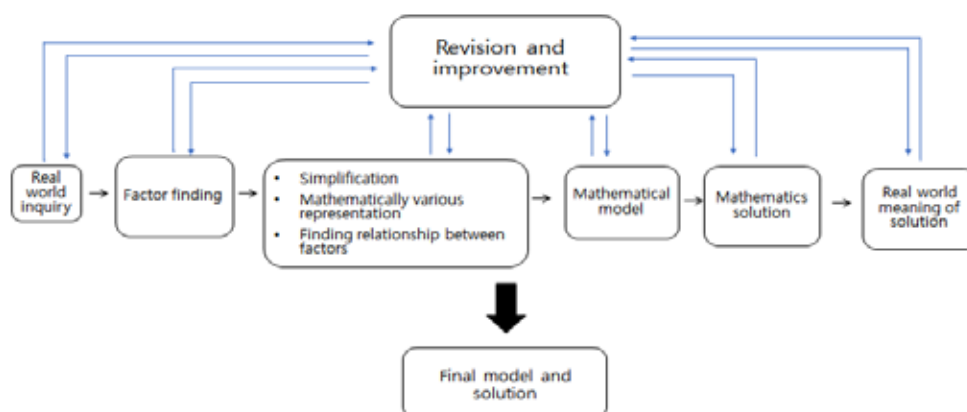


Figure 1: Mathematical modeling process chart (Jung et al., 2018, p. 155)

Six 11th grade students and a teacher participated in this research. Based on our previous study suggesting that 3 to 4 members were appropriate, the students were divided into two groups. The researchers and the teacher worked together to design the task, and how to implement based on the

question: “What are your own strategies to prevent or cope with blackouts?”. All the lessons were videotaped, audio-recorded and transcribed. Field-notes were made during the lesson observations. Students’ worksheets were collected. The unit of analysis was the observed types of interaction at each stages of the mathematical modeling process.

Result and Discussion

The three types of interaction supporting the development of group creativity and its creative synergy were observed in the activity and found to impact the development of their group creativity. Both mutually complementary- and conflict based-interaction were observed in both groups, but metacognitive-interaction was observed only in Group A. First, mutually complementary interaction was observed at the real world inquiry and the factor finding stages. Although each group member shared their various thoughts, meaningful information for deriving mathematical model was made by the accumulation of all those thoughts through mutual complementary interaction. The creative synergy and effect of the interaction was the expansion of factors that could affect real world phenomena related to blackouts. Second, conflict based interaction was observed at the simplification stage. Because of the diversity of thoughts and their inconsistency, conflicts had occurred among group members. This interaction resulted in rich evidence, as the creative synergy, for key factors to consider and clarification and validation of the criteria to evaluate the selected key factors. Third, metacognitive interaction was observed at the mathematical model derivation stage. Each group reflected on the modeling process and their initial mathematical model. As a result, the students could have an elaborated mathematical model with reasonable justification. In this study we extended the scope of the effectiveness of mathematical modeling to develop creativity education from the individual context to the group context. Previous studies stressed the necessity of practical studies on interaction as a process of supporting the development of group creativity (Sawyer, 2012, pp. 243–244). This study provides the first steps in this direction.

References

- Jung, H. Y., Lee, K. H., Baek, D. H., Jung, J. H., & Lim, K. S. (2018). Design for mathematical task inquiry subject’s task based on the mathematical modeling perspective. *School Mathematics*, 20(1), 149–169.
- Jung, H. Y., & Lee, K. H. (2018). Manifestation examples of group creativity in mathematical modeling. *The Mathematical Education*, 57(4), 371–391.
- Pasdottir, G., & Sriraman, B. (2017). Teacher’s views on modeling as a creative mathematical activity. In R. Leikin & B. Sriraman (Eds.), *Creativity and giftedness* (pp. 47–55). Cham, Switzerland: Springer.
- Sawyer, R. K. (2012). Group creativity. In R. K. Sawyer (Ed.), *Explaining creativity: The science of human innovation account* (pp. 231–248). New York, NY: Oxford University Press.
- Vorhölter, K. (2017). Conceptualization and measuring of metacognitive modeling competencies: Empirical verification of theoretical assumption. *ZDM Mathematics Education*, 50, 343–354.
- Woodman, R. W., Sawyer, J. E., & Griffin, R. W. (1993). Toward a theory of organizational creativity. *The Academy of Management Review*, 18, 293–321.

Creating contact points between empirical modelling and theoretical modelling in teacher education: The case of pendulum problem

Masafumi Kaneko¹, Akihiko Saeki² and Takashi Kawakami³

¹Naruto University of Education, Graduate School of Education, Japan; mkaneko@naruto-u.ac.jp

²Naruto University of Education, Graduate School of Education, Japan; asaeki@naruto-u.ac.jp

³Utsunomiya University, Faculty of Education, Japan; t-kawakami@cc.utsunomiya-u.ac.jp

Both empirical modelling (EM) and theoretical modelling (TM) are essential in mathematical modelling. This study explored how graduate students promoted teaching competencies for mathematical modelling by conducting EM and TM with the pendulum task. Through the analysis of modelling lessons, we found that the experiences of both EM and TM with the same material were important for the students to understand a modelling cycle and the aims and perspectives of modelling.

Keywords: Mathematical modelling, teacher education, empirical modelling, theoretical modelling.

Introduction

Educating teachers about teaching mathematical modelling is crucial, because the instruction is demanding for teachers (Blum, 2015). Several courses, programmes and materials for supporting pre-service and in-service teachers in teaching modelling have begun to be developed around the world including CERME community (e.g., Cai et al., 2014; Barquero, Carreira, & Kaiser, 2017). Various competencies are required for teaching modelling. Borromeo Ferri (2018) elaborates four competencies for teaching modelling: *Theoretical competency (incl. modelling cycles or aims and perspectives of modelling as background knowledge)*, *Task competency (incl. multiple solutions or cognitive analyses of modelling tasks)*, *Instruction competency (incl. interventions, support and feedback)*, and *Diagnostic competency (incl. recognising students' difficulties and mistakes)*. She mentions that these four competencies are the basis for the structure of teacher education on teaching modelling. Although these four competencies are related each other strongly, theoretical competency is necessary and important background for teachers' practice on teaching modelling (Borromeo Ferri, 2018).

Some of the common modelling approaches include empirical modelling, theoretical modelling and so on (Ang, 2018). Berry and Houston (1995) mention that both empirical modelling and theoretical modelling are essential in mathematical modelling. Similarly, it might be valuable for teachers to experience both modelling and understand their features in order to foster Borromeo Ferri's (2018) teaching competencies for modelling (e.g., theoretical competency). Limited research exists, however, on teacher education involving both empirical modelling and theoretical modelling. In this study, we explore how teachers promote Borromeo Ferri's (2018) teaching competencies for modelling through teacher education addressing both empirical and theoretical modelling.

Study Background

Empirical modelling (EM) and theoretical modelling (TM)

Berry and Houston (1995) define data-driven modelling cycle as *empirical modelling (EM)*. EM cycle includes collecting data through experimentation and measurement, making sense of data, and making graphs and regression equations that fit to the data. Berry and Houston (1995) mention that “[e]mpirical models are fairly easy to find providing that we are given or can collect the data from appropriate experiment.” (p. 10), and that “[empirical modelling] has severe limitations in the validity of our interpretations from the graph.” (p. 10), and that “[t]he mathematical answer might be perfectly correct but the interpretation in the context of the real world is meaningless.” (p. 12). On the other hand, Berry and his colleague call theory-driven modelling process a *theoretical modelling (TM)*. They recognize TM process as a different one from EM process. They conceive TM process as mathematical modelling including understanding the problem, identifying the important features, making assumptions and simplifications, interpreting and validating the model, and improving the model and explaining the outcome. Both EM and TM are required to understand and describe the real world, and predict results (Berry & Houston, 1995, p. 23). This paper focuses on both EM and TM as components of mathematical modelling.

Teacher education on empirical modelling and theoretical modelling

We reviewed how EM and TM were addressed in pre-service teacher education on modelling from the International Community of Teachers of Mathematical Modelling and Applications (ICTMA) (see table 1). We focused on six chapters mentioning the concrete teaching tasks and materials. One chapter addressed only EM task; four chapters addressed only TM tasks; one chapter addressed both EM tasks and TM tasks. None of chapters used same material throughout EM and TM. If pre-service teachers tackle both EM task and TM task, they can understand modelling in a multifaceted manner. Furthermore, they can grasp the connection between EM and TM by experiencing EM and TM using the same material.

Authors	EM Task	TM Task
Tan & Ang (2013)	Car stopping distance task	Fuel tank calibration task
Winter & Venkat (2013)		Contextual word problems
Widjaja (2013)		Parking space task
Hagena (2015)		Modelling task “Brickhouse”
Villarreal, Esteley, & Smith (2015)	Trash and recyclable collection	
Villa-Ochoa & Berrio (2015)		Planting trees problem

Table 1: EM and TM tasks in pre-service teacher education from ICTMA-book chapters

This study addressed the research question: *How did graduate students promote teaching competencies for modelling (e.g. understanding of modelling cycle and significance of mathematical modelling) by experiencing both EM and TM with the same material?*

Design and Methodology

A pilot study of mathematical modelling lessons for teacher education which comprised four lessons (90 mins each) was designed and implemented for two Japanese in-service teachers and two pre-service teachers. Student A had 16-years teaching experience in lower-secondary schools, whereas student B had 20-years in upper-secondary schools. Student C and B were pre-service teachers and graduate students in mathematics education at the first level. The instructors were the first and second authors. The participants had little knowledge about modelling.

Berry and Houston (1995) illustrate two examples of EM and TM (i.e., audio cassette recorder and pendulum). We consider the pendulum example a better case for novice teachers of modelling and chose that. From the viewpoint of EM, the pendulum example is easy to image its movement, to realize important variables, and to collect data. From the viewpoint of TM, the needed knowledge of mathematics and physics for the pendulum is less than the recorder example. Hence, in the pendulum phenomenon is easy to connect EM with TM. The pendulum phenomenon sometimes induces students' misconceptions and their own ideas about matter (Osborne & Freyberg, 1985) through EM, and students' cognitive conflicts result from the misconceptions (Saeki, Ujiie, & Tsukihashi, 2001). TM, explaining the mechanism of the phenomenon, becomes inevitable activities to resolve the cognitive conflicts. The main theme of the lessons and main pendulum EM tasks and TM tasks are shown in Figure 1.

Main Theme of the Lessons

To consider and clarify the key points for the development of teaching materials and problems that are related to the daily situation like the pendulum.

Main Pendulum EM Tasks

Let's find the relationship between the pendulum length and period empirically.

- There is the scene of a girl rowing a huge swing in the introduction of the Japanese famous animation video. How long is the huge swing length when the swing period is twelve seconds?
- Let's confirm your conjectures of the huge swing length based on the result of the pendulum empirical experiment.

Main Pendulum TM Tasks

Is the empirical result of the huge swing length true? Let's verify it theoretically.

- Let's find theoretical formula with the knowledge of mathematics and physics.
- Compare the regression equation elicited from EM with the formula elicited from TM.

Figure 1: Main theme of the lessons and main pendulum EM and TM tasks

The activities of modelling lessons for teacher education are shown in Table 2. In the first lesson, the students elicited and choose variables concerning the pendulum empirically through graphing calculators and sensor kits. In the second lesson, they drew graph using data from experiments and performed regression. In the third lesson, they conjectured and verified graphs of Displacement-Time, Velocity-Time, and Acceleration-Time about pendulum based on the physical knowledge. In addition, they elicited the formula about the proportional relationship between displacement and acceleration. In the fourth lesson, they elicited the formula $T=2\sqrt{l/g}$ and confirmed the consistency between the

theoretical model and empirical model in the first lesson. At last, they looked back on the learning processes in the lessons from the viewpoint of modelling cycle.

Sequence of Lessons	Activities in Lessons	EM	TM
1 st lesson	<p>Eliciting variables concerning the pendulum (e.g. mass of bob, amplitude, and pendulum length)</p> <p>Finding that the pendulum period depends on the pendulum length through teacher's demonstration</p> <p>Collecting data about the pendulum length (l) and pendulum period (T) through graphing calculators and sensor kits</p>		
2 nd lesson	<p>Plotting data and draw the graph from the data</p> <p>Eliciting the regression equation $T=2\sqrt{l}$</p> <p>Checking the equation using data from experiment</p> <p>Drawing hypothesis graphs of Displacement-Time, Velocity-Time, and Acceleration-Time about pendulum</p>		
3 rd lesson	<p>Verifying students' graphs of Displacement-Time, Velocity-Time, and Acceleration-Time about pendulum based on the physical knowledge</p> <p>Drawing hypothesis graphs of Displacement-Restoring force, and Displacement-Acceleration</p> <p>Verifying students' graphs of Displacement-Restoring force, and Displacement-Acceleration based on the physical knowledge</p> <p>Eliciting the formula $F = -Kx$ about the proportional relationship between restoring force and displacement based on the graphs</p> <p>Eliciting the formula $F = ma$ about the proportional relationship between restoring force and acceleration based on the graphs</p> <p>Eliciting the formula $-Kx = ma$ about the proportional relationship between displacement and acceleration</p>		
4 th lesson	<p>Eliciting the formula $T = 2\pi/\omega$ between pendulum period and angular velocity based on the definition of angular velocity</p> <p>Reformulating the relationship $F = -m\omega^2x$ between restoring force and displacement by using angular velocity and the mass of the bob</p> <p>Reformulating the relationship $T = 2\pi\sqrt{m/K}$ between pendulum period and the mass of the bob by using $T = 2\pi/\omega$ and $F = -Kx$</p> <p>Eliciting the formula $F = -mgx/l$ about the relationships between restoring force and pendulum length by using the mass of bob, gravity and displacement</p> <p>Eliciting the formula $T=2\pi\sqrt{l/g}$ by using $T = 2\pi\sqrt{m/K}$, $F = -mgx/l$ and $F = -Kx$</p> <p>Confirming the consistency between the theoretical model and empirical model, the regression equation, in the first lesson</p> <p>Looking back on the learning processes in the lessons from the viewpoint of modelling cycle</p>		

Note: =EM activity; = TM activity

Table 2: Outline of modelling lessons

Our data collection comprised students' descriptions in the post-lesson questionnaires about material development, teaching design, and teaching implementation with real-world context. Their descriptions were coded and categorised according to Borromeo Ferri's (2018) teaching

competencies for mathematical modelling. In this study, three of the four abilities were confirmed as shown in Table 3.

Competencies and focused contents	Examples of students' descriptions
<i>Theoretical competency</i>	(A) Descriptions about process and phases related to the transitions between real world and mathematical world
(A) Knowledge about modelling cycles	(B) Descriptions about the significance of modelling and modelling tasks
(B) Knowledge about goals/perspectives for modelling and modelling tasks	
<i>Instruction competency</i> (Knowledge about interventions, support and feedback)	Descriptions about the necessity of the interventions for connecting between the real world and the mathematical world
<i>Diagnostic competency</i> (Knowledge about students' difficulties and mistakes)	Descriptions about designing teaching modelling according to students' abilities

Table 3: Students' descriptions according to Borromeo Ferri's (2018) teaching competencies for modelling

Results

This section illustrates the findings about students' understanding of modelling cycle, aims and perspectives of modelling, and beginning of understanding related to teaching modelling.

Students' understanding of modelling cycle including EM and TM

Student B summarized the modelling cycle including EM and TM (Figure 2).

1. The contents of the task are interesting for students.
2. Students can experiment and analyse phenomenon in real society.
3. Students can elicit mathematical expressions like equations from the experimental results.
4. Phenomenon in real society can be translated into mathematical contents.
5. The mathematical contents can be solved with students' mathematical knowledge.
6. The mathematical results can be validated and be applied to the phenomenon in real society.
7. Students can realize the usefulness of mathematics.

Figure 2: Student B's description to post-lesson questionnaires

Student B clarified the modelling cycle through the modelling lessons. Description related to the modelling cycle was only one; however, whole students discussed about the modelling cycle in the reflection of the lessons. They all might understand the modelling cycle including EM and TM.

Students' understanding of aims and perspectives of modelling and modelling tasks

Three students described aims and perspectives of modelling and modelling tasks. Student C understood the difference between EM and TM as perspectives of modelling: "Modelling with experiments was concrete for me and was pleasant to imagine the result of pendulum. But, I wondered if the result is right or not", "Modelling without experiment was difficult for me, but the process and the result of formula was right", and "The modelling with the experiment of pendulum was very interesting. The pendulum experiment deepened the understanding of the period of

pendulum”. Student A and Student B identified the usefulness of mathematics as an aim of modelling. Student A described that the lessons of modelling could convey the usefulness of mathematics to school students: “Through the lessons that connected between mathematics and the real world, students would be surprised that mathematics is hidden in real-world situations and they might be able to notice the usefulness of mathematics”. Student B described the role of mathematics in real world and society: “Mathematics is used at various places in the real world. For example, the cord, GPS, and statistics. I would like to develop the lessons emphasizing to realize that mathematics might be powerful and useful for students to solve real world problems”.

Beginning of understanding related to teaching modelling

In the fourth lessons, four students reflected the learning processes from the viewpoint of modelling cycle. From these experiences, they found the importance of observing students’ situation and of preparing teaching materials for EM and TM. Students A, C, D realized the necessity of the interventions in EM and TM. Student A emphasized that teachers should grasp students’ mathematical knowledge before modelling lessons, especially TM activities: “I would like to design my lessons that the students are able to consider real world problems and to grow their viewpoint for consideration using previous mathematical knowledge. Student D described similarity as follows: “I experienced EM and TM. Through my experience, I thought that TM was difficult for students who did not get some knowledge of mathematics and physics. I think it is important to consider students’ situation and to prepare for teaching materials to diverse students”. Student C described the importance of teachers’ pre-experiment in EM: “For modelling with experiment, I must make plan to have included time for carrying preparations of experiments and means thoroughly”. Student A understood the necessity of the intervention for connecting between the real world and the mathematical world. He described as follows: “The facilitation of connecting the mathematical world and the real world is necessary”. He realized the needs of preparation for mathematical modelling. Student B found the importance of modelling lessons according to students’ abilities: “Through the lessons for modelling, I should plan the lessons flexibly and diagnose students’ situation and understanding in case of the difficult modelling with mathematics for students”.

Discussion and Conclusion

This paper has addressed some aspects of students’ understanding about modelling cycle and significance of modelling through the experiences of both EM and TM with the pendulum task. From the results of the transcripts and the descriptions in the post-lesson questionnaires, three results became clear. First is students’ understanding of modelling cycle including EM and TM. Second is students’ understanding of aims and perspectives of modelling and modelling tasks. Third is beginning of understanding related to teaching modelling that included the necessity of the interventions for connecting between the real world and the mathematical world, the necessity of the facilitation in EM and TM, and designing teaching modelling according to students’ abilities.

These results demonstrated the development of Borromeo Ferri’s (2018) theoretical competency, instruction competency and diagnostic competency. For example, the first and the second results correspond to the theoretical competency. Student A’s description on the necessity of the intervention for connecting between the real world and the mathematical world and students A, D, C’s

descriptions on the necessity of the facilitation in EM and TM correspond to the instruction competency. Student B's description on designing teaching modelling according to students' abilities corresponds to the diagnostic competency. However, Niss and Højgaard (2011) point out that competences are difficult to measure and should be done in a 3D model with technical level, degree of coverage, and radius of action. This study focused on the technical level and degree coverage; hence, the in-depth assessment of competency is our future work. We believe that experiencing EM and TM with the same material (Berry & Houston, 1995) worked for the above results. The students confused the difference between the misconception (Osborne & Freyberg, 1985) and the result of experiment in EM. In fact, Student D answered this situation: "Findings from my experience of pendulum were uneasiness". This uneasiness born in EM became the driving force for TM elucidating mechanism inherent in pendulum phenomenon mathematically and physically. Through the experiences of both EM and TM using the same material, the students were able to consider real-world problems deeply connecting between inductive and deductive viewpoints. They were able to recognize that EM and TM were like opposite sides to the same coin and essential components of modelling cycle through the reflection of learning processes via a diagram of modelling cycle (Kawakami, Saeki, & Kaneko, 2018). In this study, EM produced intellectual curiosity and uneasiness and elicited inevitability of the TM. However, the previous study on teacher education on modelling did not focus on the relationships between EM and TM. We need rethink the role of experiencing both EM and TM with same material in developing teachers' teaching competencies for modelling in other cases.

Acknowledgment

This work was supported by JSPS KAKENHI Grant Numbers JP15K00923, JP17K00975, & JP17K14053.

References

- Ang, K. C. (2018). *Mathematical modelling for teachers: Resources, pedagogy and practice*. New York, NY: Routledge.
- Barquero, B., Carreira, S., & Kaiser, G. (2017). Introduction to the papers of TWG06: Applications and modelling. In T. Dooley & G. Gueudet (Eds.), *Proceedings of the Tenth Congress of the European Society Research in Mathematics Education* (pp. 877–883). Dublin, Ireland: DCU Institute of Education & ERME.
- Berry, J., & Houston, K. (1995). *Mathematical modelling*. London, UK: Edward Arnold.
- Blum, W. (2015). Quality teaching of mathematical modelling: What do we know, what can we do?, In S. J. Cho (Ed.), *Proceedings of the 12th International Congress on Mathematical Education* (pp.73–96). Cham, Switzerland: Springer.
- Borromeo Ferri, R. (2018). *Learning how to teach mathematical modeling in school and teacher education*. Cham, Switzerland: Springer.
- Cai, J., Cirillo, M., Pelesko, J. P., Borromeo Ferri, R., Borba, M., Geiger, V. ..., & Kwon, O. N. (2014). Mathematical modeling in school education: Mathematical, cognitive, curricular, instructional and teacher education perspectives. In P. Liljedahl, C. Nicol, S. Oesterle, & D. Allan (Eds.), *Proceedings of the 38th Conference of the International Group for the Psychology of*

Mathematics Education and the 36th Conference of the North American Chapter of the Psychology of Mathematics Education (Vol. 1, pp.145–172). Vancouver, Canada: PME.

- Hagena, M. (2015). Improving mathematical modelling by fostering measurement sense: An intervention study with pre-service mathematics teachers. In G. A. Stillman, W. Blum, & M. S. Biembengut (Eds.), *Mathematical modelling in education research and practice: Cultural, social, and cognitive influences* (pp.185–194). Cham, Switzerland: Springer.
- Kawakami, T., Saeki, A., & Kaneko, M. (2018). Secondary teachers constructing perspectives on developing mathematical modelling problems: Use of a modelling diagram for ‘Kyozaikenkyu’. In F-J. Hsieh (Ed.), *Proceedings of the 8th ICMI-East Asia Regional Conference on Mathematics Education* (pp.502–512). Taipei, Taiwan: EARCOME.
- Tan, L. S., & Ang, K. C. (2013). Pre-service secondary school teachers’ knowledge in mathematical modelling – A case study. In G. A. Stillman, G. Kaiser, W. Blum, & J. P. Brown (Eds.), *Teaching mathematical modelling: Connecting to research and practice* (pp. 373–383). Dordrecht, the Netherlands: Springer.
- Niss, M. A., & Højgaard, T. (Eds.) (2011). *Competencies and mathematical learning: Ideas and inspiration for the development of mathematics teaching and learning in Denmark*. Roskilde, Denmark: IMFUFA.
- Osborne, R., & Freyberg, P. (1985). *Learning in science: The implications of children’s science*. Auckland, New Zealand: Heinemann Education.
- Saeki, A., Ujiie, A., & Tsukihashi, M. (2001). A cross-curricular integrated learning experience in mathematics and physics. *Community College Journal of Research and Practice*, 25(5–6), 417–424.
- Villa-Ochoa, J. A., & Berrio, M. J. (2015). Mathematical modelling and culture: An empirical study. In G. A. Stillman, W. Blum, & M. S. Biembengut (Eds.), *Mathematical modelling in education research and practice: Cultural, social, and cognitive influences* (pp. 241–250). Cham, Switzerland: Springer.
- Villarreal, M. E., Esteley, C. B., & Smith, S. (2015). Pre-service mathematics teachers’ experiences in modelling projects from a socio-critical modelling perspective. In G. A. Stillman, W. Blum, & M. S. Biembengut (Eds.), *Mathematical modelling in education research and practice: Cultural, social, and cognitive influences* (pp. 567–578). Cham, Switzerland: Springer.
- Widjaja, W. (2013). Building awareness of mathematical modelling in teacher education: A case study in Indonesia. In G. A. Stillman, G. Kaiser, W. Blum, & J. P. Brown (Eds.), *Teaching mathematical modelling: Connecting to research and practice* (pp. 583–596). Dordrecht, the Netherlands: Springer.
- Winter, M., & Venkat, H. (2013). Pre-service teacher learning for mathematical modelling. In G. A. Stillman, G. Kaiser, W. Blum, & J. P. Brown (Eds.), *Teaching mathematical modelling: Connecting to research and practice* (pp. 395–404). Dordrecht, the Netherlands: Springer.

Measuring an aspect of adaptive intervention competence in mathematical modelling processes

Heiner Klock¹ and Hans-Stefan Siller²

¹University of Koblenz-Landau, Department of Mathematics, Koblenz, Germany;
hklock@uni-koblenz.de

²Julius-Maximilians-University of Würzburg, Chair for Mathematics V, Würzburg, Germany;
hans-stefan.siller@mathematik.uni-wuerzburg.de

To provide appropriate support during modelling processes is challenging for teachers. Especially modelling tasks based on a holistic approach offer a multitude of solutions that the teacher has to deal with. Several authors therefore emphasize the importance of a precise diagnosis in the intervention process. Adaptive interventions are a suitable support for students whereas a previous diagnosis should be the basis. A process model is presented that describes an idealized intervention adapted to students' modelling processes. In this model, a diagnostic and an intervention-related part can be distinguished. We investigate the question whether adaptive intervention competence can be described through a one- or two-dimensional model and whether a cause and effect relationship between a correct diagnosis and the selection of an adaptive intervention can be determined. The results indicate that the meaning of a previous diagnosis can be confirmed empirically in this sample.

Keywords: Diagnosis, intervention, adaptive behaviour, linear regression.

Introduction

When using modelling tasks according to a holistic approach, group work is an effective instructional strategy (Clohessy & Johnson, 2017). In less structured and independently carried out working processes, adaptive teacher interventions provide appropriate help for students. When difficulties arise in group work, teacher interventions should ensure progress without giving too many content-related hints on the solution. Frequently, a spontaneous reaction is necessary and there is little time available. Adaptive interventions should create a balance between direct instruction and students' independent work (Leiss, 2010). However, intervening adaptively is therefore a challenging activity for teachers (Blum & Borromeo Ferri, 2009).

For this reason, a modelling seminar was developed and integrated into university teacher training. The overall intention is to facilitate pre-service teachers' adaptive intervention competence and evaluate their development through the seminar. By a teacher intervention, we generally mean a verbal intrusion into the students' solution process (cf. Leiss, 2007). We present the construct of adaptive intervention competence which is measured using a quantitative test instrument. In this article, the data of the seminar are used to examine the dimensionality of the construct and to investigate the cause and effect relationship between diagnostic and intervention-related aspects.

Adaptive interventions

Leiss (2007) has developed a general model for teacher interventions (see Figure 1) in which he differentiates between three aspects: the basic knowledge, the area and the characteristics of an intervention (Tropper, Leiss, & Hänze, 2015). A diagnosis of the situation (trigger of the intervention,

previous interventions, knowledge required to solve the task, students' competence level, time available) and a diagnosis of difficulties (type of difficulty, area and cause of the difficulty, assignment in a theoretical model – here: the modelling cycle) is necessary to create a *basic knowledge* which is crucial for the selection of an adequate intervention.

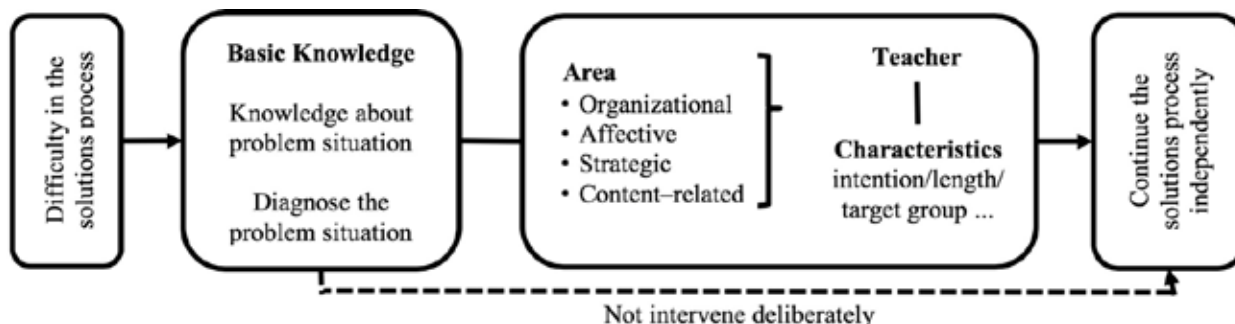


Figure 1: Process model for general teacher interventions (Leiss, 2007; translation by authors)

The *area of intervention* describes to which aspect the intervention refers to. *Organizational interventions* concern the design of the learning environment (“Watch the time!”). *Affective interventions* influence students’ emotional aspects extrinsically (“You can do this!”). *Strategic interventions* are help on a meta-level (“What is still missing?” (Blum & Borromeo Ferri, 2009, p. 52)). *Content-related interventions* are related to concrete contents of the task (“A car consumes 7 litres per kilometre.”). The area is the central feature of an intervention (Leiss, 2007). In particular, strategic interventions are considered to have high potential to support students to overcome difficulties in the modelling process (Link, 2011; Stender & Kaiser, 2017).

Interventions can be classified by different *characteristics* like the intention of the intervention (statement, question, request), its duration and the addressee (single student, group, whole class) (Leiss, 2007). The aspects basic knowledge, area and characteristics of an intervention describe a general and idealized intervention. Based on that, Tropper et al. (2015) defined the notion of adaptive teacher interventions which

are based on a diagnosis of the situation and can be described as an independence-preserving form of support, adapted in form and content to students’ learning process, in order to enable them to overcome a (potential) barrier in the process and to continue the process as independently as possible. (2015, p. 1226)

Four essential characteristics of adaptive interventions can be identified from this and further definitions (see Leiss, 2007; Stender & Kaiser, 2017). In our work adaptive interventions:

- are based on a diagnosis.
- are adapted in form and content to students’ learning process.
- provide minimal help.
- preserve independence.

These four aspects are crucial for supporting students in mathematical modelling processes. They are the basis for assessing interventions in terms of adaptivity.

Adaptive intervention competence in mathematical modelling processes

Due to the high demands on adaptive interventions in mathematical modelling processes, a process model was developed using the work of Leiss (2007). The model describes an idealized intervention supporting groups of students *in mathematical modelling processes* (see Figure 2).

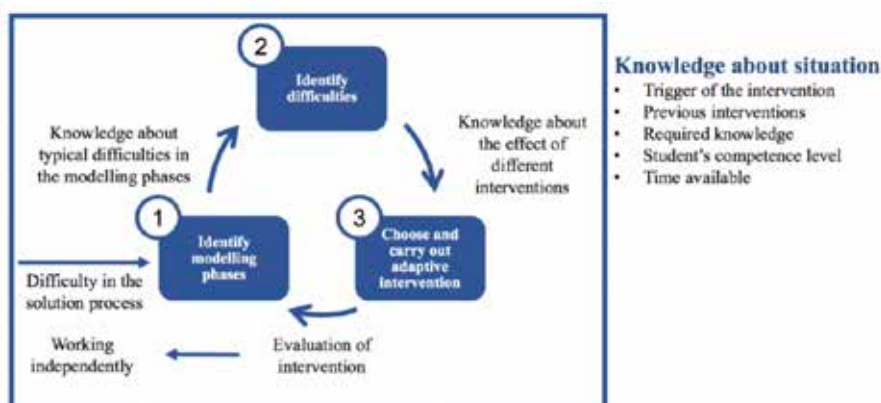


Figure 2: Process model for adaptive interventions in mathematical modelling processes

The Steps 1 and 2 form the diagnostic part of the model and thus the diagnostic competence. An accurate diagnosis is essential for the selection of an adaptive intervention (Blum & Borromeo Ferri, 2009; Leiss, 2007). If difficulties arise in the solution process, they have to be diagnosed. It is useful to identify the modelling phase first (Step 1 in Figure 2) in which the students are currently working (Borromeo Ferri & Blum, 2010). Based on knowledge about typical difficulties in the individual modelling phases, initial indications for the cause of the difficulty can be obtained. Several studies indicate potential difficulties in single modelling phases (e.g., Galbraith & Stillman, 2006). With the help of this knowledge a focused diagnosis is possible (Step 2 in Figure 2). Step 3 describes the choice and realization of the intervention. Few studies examined the effectiveness of various interventions. Studies by Link (2011), Stender (2016) and Vorhölter, Grünwald, Krosanke, Beutel and Meyer (2013) indicate that strategic interventions are particularly suitable. Interventions that follow rules of good communication consist of several interventions at different strategic levels (Link, 2011). However, depending on the situation and its framework conditions, organisational, affective or content-related interventions may be suitable. In Steps 1 to 3 – but especially in Step 3 – the knowledge about the situation (see Figure 2; Leiss, 2007) influences decision making. This knowledge is ideally acquired before the intervention process due to its crucial meaning for the selection of an adaptive intervention. At this point, it may be suitable not to intervene prematurely. This provides students with the opportunity to overcome the difficulty by themselves (Leiss, 2007). The adaptivity is appraised before implementation – *a priori* – on the basis of the four characteristic aspects mentioned above. Finally, an evaluation must be carried out after implementation – *a posteriori*. It has to be determined whether the intended behaviour has occurred, whether the difficulty has been overcome and whether students are working independently. The adaptivity of an intervention can finally be determined afterwards. Even if it matches all aspects of an adaptive intervention, *a priori*, it needs not be successful (Stender, 2016; Vorhölter et al., 2013), *a posteriori*. The intervention is assessed by the teacher before and after implementation. Therefore, we distinguish

between a priori and a posteriori intervention competence. If necessary, the teacher has to go through the intervention process again.

The process model describes cognitive and action-related aspects of an intervention. The ability to perform this process appropriately is what we call *adaptive intervention competence in mathematical modelling processes*.

Hypotheses

In this article, we investigate the dimensionality of the measured construct and whether the diagnostic competence (Steps 1 and 2) and the a priori intervention competence (Step 3) show an empirical interrelation. Since various authors emphasize the importance of an accurate diagnosis for the adaptivity of an intervention (Blum & Borromeo Ferri, 2009; Leiss, 2007), our hypotheses are:

- (H1) The cognitive part of adaptive intervention competence can be described by a two-dimensional model (diagnostic and a priori intervention competence).
- (H2) There is a cause and effect relationship between diagnostic and a priori intervention competence (Klock & Siller, 2019).

Method

Pre-service teachers were surveyed with the help of a quantitative test instrument in a pre-post-design before and after attending a teacher training seminar on mathematical modelling. We use this data to answer the mentioned research questions. Since the evaluation of the seminar is not part of this article, we refer to another publication for a description of its contents (Klock & Siller, 2019).

Sample

The data were collected in the winter term 2017/2018 and in the summer term 2018. The pre-service teachers are all trained for teaching professions at secondary schools. The sample description is given in Table 1. The genders are distributed almost evenly, the students are on average 23 years old and are in their sixth to seventh term of study.

<i>n</i>	Gender	Age		Term	
	male/female	<i>M</i>	<i>SD</i>	<i>M</i>	<i>SD</i>
78	35/43	23.06	2.69	6.71	2.89

Table 1: Sample description

In order to generate a sufficient sample size for the analysis of dimensionality, the method of *virtual persons* according to Hartig and Kühnbach (2006) was applied. In this approach pre- and post-test data of the same persons ($n=156$) are used in a simple logistic Rasch model. The advantage of this approach is that items' difficulty parameters are estimated using the same model in pre- and post-test. However, potential dependencies between the measured values of the same person are not considered.

Instrument

Piloting the test in another sample ($n=66$), four of ten task vignettes were eliminated based on statistical quality criteria. The test instrument (Klock & Wess, 2018; Klock, Wess, Greefrath, & Siller, 2019) consists finally of six text vignettes, each showing a modelling task and a typical students'

conversation while solving the task. The scale “diagnosis” consists of three multiple-choice items per text vignette (18 items) with four possible answers each. The scale “intervention” consists of complex multiple-choice items with four items per text vignette (24 items; see Table 2).

Scale	Number of items	Item examples															
Diagnosis	6	To which phase of the solution process can the group of students mainly be assigned to? A. construct/understand .. B. simplify/structure .. C. mathematise .. D. interpret ..															
		Diagnose students’ difficulty working on the task in this situation. The students ... A. ... have difficulties in making assumptions. .. B. ... draw the wrong conclusion from their mathematical result. .. C. ... have difficulties in understanding the context. .. D. ... use an unsuitable mathematical model. ..															
		Please indicate which support goal you would formulate for the group following this situation. A. Independent acquisition and evaluation of information. .. B. Critical questioning of results in the modelling process. .. C. Independent construction of mental models for given problem situations. .. D. Reliable translation of simplified real situations into mathematical models. ..															
Intervention	24	Please indicate which of the following interventions are suitable for an independence preserving support of modelling skills in this situation. <table style="width: 100%; border-collapse: collapse;"> <thead> <tr> <th></th> <th style="text-align: center;">suitable</th> <th style="text-align: center;">unsuitable</th> </tr> </thead> <tbody> <tr> <td>A. “First of all, estimates how long a car is.“</td> <td style="text-align: center;">..</td> <td style="text-align: center;">..</td> </tr> <tr> <td>B. “First, consider only part of the problem, e.g. how many cars are in traffic jams at all.“</td> <td style="text-align: center;">..</td> <td style="text-align: center;">..</td> </tr> <tr> <td>C. “Exactly, calculate this value.“</td> <td style="text-align: center;">..</td> <td style="text-align: center;">..</td> </tr> <tr> <td>D. “Think about how you could get the missing data.“</td> <td style="text-align: center;">..</td> <td style="text-align: center;">..</td> </tr> </tbody> </table>		suitable	unsuitable	A. “First of all, estimates how long a car is.“	B. “First, consider only part of the problem, e.g. how many cars are in traffic jams at all.“	C. “Exactly, calculate this value.“	D. “Think about how you could get the missing data.“
	suitable	unsuitable															
A. “First of all, estimates how long a car is.“															
B. “First, consider only part of the problem, e.g. how many cars are in traffic jams at all.“															
C. “Exactly, calculate this value.“															
D. “Think about how you could get the missing data.“															

Table 2: Item examples for the two scales “diagnosis” and “intervention” (Klock & Wess, 2018)

The test construction is based on the presented process model (see Figure 2). The diagnostic part is operationalized by the scale “diagnosis”. The scale measures the ability to identify the modelling phase, the difficulty in the modelling process and to select a support goal. A priori intervention competence is operationalized by the scale “intervention”. The statements have to be assessed with regard to the last three of the four aspects of adaptivity mentioned above and aspects of the situation shown by the text vignette. The items were evaluated based on expert ratings assigning scores dichotomously (0 and 1 raw points).

Results

To evaluate the dimensionality of the construct, the simple logistic Rasch model (Rost, 1996, p. 115) was applied to compare two models (H1). The two models and the results of Rasch analysis are shown in Figure 3. The two models are compared with the help of the residual estimates (final deviance, AIC). The residuals are significantly smaller in the 2-dim. Model which indicates a better description of the data. In both models, all item-fit values are within the recommended interval (standardized weighted mean squares > 0.8 and < 1.2) by Bond and Fox (2013, p. 279), which points to a general fit of the Rasch model. The reliabilities are acceptable with regard to the EAP-reliability. All

indications point to a better fit of the two-dimensional model. We choose the 2-dim. model since it describes the data better and the reliabilities are acceptable.

The scales in the 2-dim. model correlate with high significance ($r = .70$). The diagnostic and intervention-related part can thus be empirically separated but also form the construct of adaptive intervention competence in mathematical modelling processes since they are highly correlated. (H1) can be confirmed in this sample.

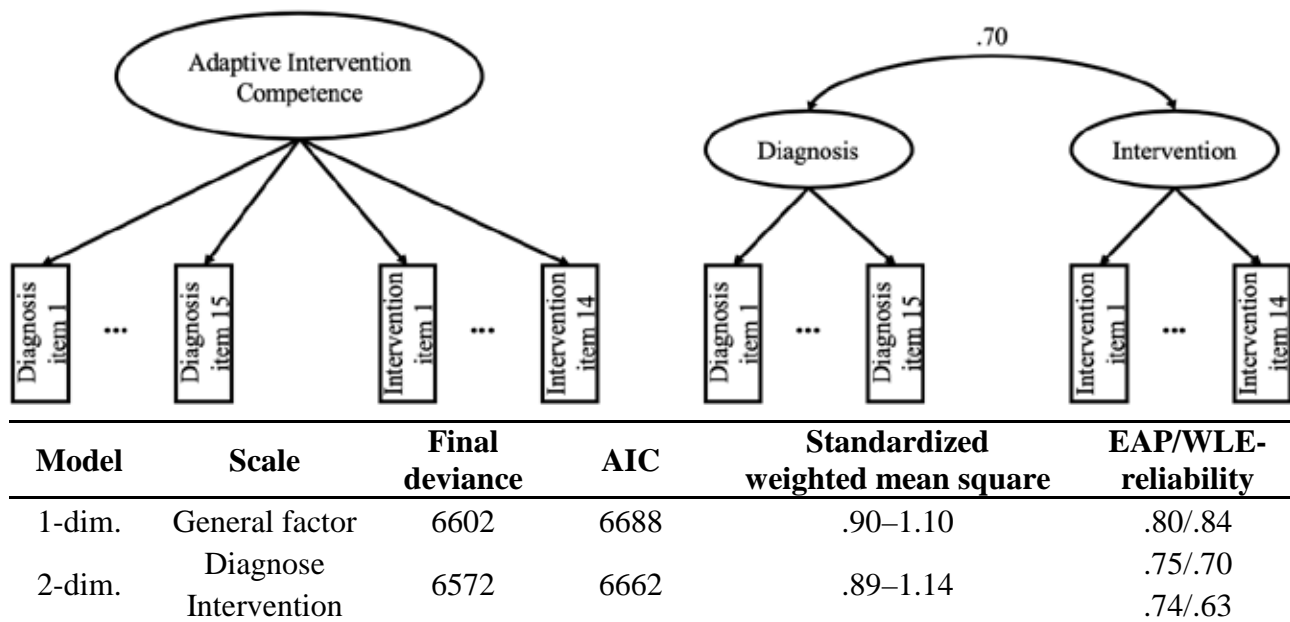


Figure 3: One- (left) and two-dimensional (right) model and results of Rasch analysis

(H2) examines the relationship between these two dimensions. For this reason, a linear regression was performed using the post-test-scores ($n=78$). The weighted likelihood estimates of the Rasch model (WLE-scores) are used to calculate a linear regression between the scales “diagnosis” (independent variable) and “intervention” (dependent variable). Table 3 shows the results. The two scales “diagnosis” and “intervention” show a medium correlation ($R = .45$). There is a medium goodness-of-fit for the data ($R^2 = .20$) and a high test power ($1-b_{\text{error}} = .99$). The variable “diagnosis” predicts statistically significant the variable “intervention” ($F(1, 73) = 18,701, p < .001$). If the score of the scale “diagnosis” increases by one standard deviation, the score of the scale “intervention” increases on average by $b = .45$ standard deviations. According to that (H2) can also be confirmed in this sample.

R	R^2	Regression coefficient B	Standard error of B	95% - confidence interval of B	Standardized correlation coefficient b	Significance
.45	.20	.26	.06	[.14 ; .39]	.45	<.001

Table 3: Results of linear regression

Discussion and conclusion

Within the scope of our survey, cognitive performance dispositions of adaptive intervention competence were measured. With the help of text vignettes in some extent situational abilities are

measured via the selection of a suitable but predetermined answer alternatives. The test does not operationalise the construct of adaptive intervention competence completely. Only the diagnostic and a priori intervention competence is measured. Action-related aspects are not considered in the test instrument. They can be evaluated by means of videos recorded during the seminar. The videos show pre-service teachers supporting groups of students working on a modelling task. However, it can be assumed that the cognitive skills measured are a prerequisite for an adequate diagnosis and intervention.

It was found that a cognitive aspect of adaptive intervention competence can be described by a two-dimensional model consisting of diagnostic and intervention-related parts. There is a cause and effect relationship between these dimensions. The scale “diagnosis” predicts skills measured by the scale “intervention” significantly. This can be confirmed by similar results when pre-test scores are analysed. In these data, the effect of the scale “diagnosis” is smaller than in the post-test data. Since diagnostic and intervention competences are acquired in the seminar, the significance of diagnostic skills seems to increase at higher skill levels (Klock & Siller, 2019). The diagnosis plays an important role in the intervention process. However, these preliminary results have to be confirmed by further data.

Acknowledgment

We thank the German Ministry for Education and Research for funding the project MoSAiK (Kauertz & Siller, 2016) – support code 01JA1605 – in the framework of “Qualitätsoffensive Lehrerbildung”.

References

- Blum, W., & Borromeo Ferri, R. (2009). Mathematical modelling: Can it be taught and learnt? *Journal of Mathematical Modelling and Application*, 1(1), 45–58.
- Bond, T., & Fox, C. M. (2013). *Applying the Rasch model: Fundamental measurement in the human sciences*. New York, NY: Routledge.
- Borromeo Ferri, R., & Blum, W. (2010). Mathematical modelling in teacher education – experiences from a modelling seminar. In V. Durand-Guerrier, S. Soury-Lavergne, & F. Arzarello (Eds.), *Proceedings of the Sixth Congress of the European Society for Research in Mathematics Education* (p. 2046–2055). Lyon, France: Institut National de Recherche Pédagogique and ERME.
- Clohessy, E., & Johnson, P. (2017). Examining the role of group work as an effective instructional strategy when teaching problem solving. In T. Dooley & G. Gueudet (Eds.), *Proceedings of the Tenth Congress of the European Society for Research in Mathematics Education* (pp. 924–931). Dublin, Ireland: DCU Institute of Education & ERME.
- Galbraith, P., & Stillman, G. (2006). A framework for identifying student blockages during transitions in the modelling process. *ZDM Mathematics Education*, 38(2), 143–162.
- Hartig, J., & Kühnbach, O. (2006). Schätzung von Veränderungen mit „plausible values“ in mehrdimensionalen Rasch-Modellen. In A. Ittel & H. Merckens (Eds.), *Veränderungsmessung und Längsschnittstudien in der empirischen Erziehungswissenschaft* (pp. 27–44). Wiesbaden, Germany: VS Verlag für Sozialwissenschaften.

- Kauertz, A., & Siller, H.-S. (2016). *MoSAiK – A project of the University of Koblenz-Landau as a part of “Qualitätsoffensive Lehrerbildung”* Retrieved from <http://mosaik.uni-koblenz-landau.de>
- Klock, H., & Siller, H.-S. (2019). Diagnose als Prädiktor adaptiver Interventionen beim mathematischen Modellieren - Intervenieren lernen im Lehr-Lern-Labor. Submitted for publication.
- Klock, H., & Wess, R. (2018). Lehrerkompetenzen zum mathematischen Modellieren – Test zur Erfassung von Aspekten professioneller Kompetenz zum Lehren mathematischen Modellierens. Universität Münster: MIAMI. Retrieved from <https://nbn-resolving.org/urn:nbn:de:hbz:6-35169679459>
- Klock, H., Wess, R., Greefrath, G., & Siller, H.-S. (2019). Aspekte professioneller Kompetenz zum Lehren mathematischer Modellierung bei (angehenden) Lehrkräften – Erfassung und Evaluation. In T. Leuders, E. Christophel, M. Hemmer, F. Korneck & P. Labudde (Eds.), *Fachdidaktische Forschungen zur Lehrerbildung* (pp. 135–146). Münster, Germany: Waxmann.
- Leiss, D. (2007). „Hilf mir es selbst zu tun“. *Lehrerinterventionen beim mathematischen Modellieren*. Hildesheim, Germany: Franzbecker.
- Leiss, D. (2010). Adaptive Lehrerinterventionen beim mathematischen Modellieren – empirische Befunde einer vergleichenden Labor- und Unterrichtsstudie. *Journal für Mathematik-Didaktik*, 31(2), 197–226.
- Link, F. (2011). *Problemlöseprozesse selbstständigkeitsorientiert begleiten*. Wiesbaden, Germany: Vieweg + Teubner Verlag.
- Rost, J. (1996). *Lehrbuch Testtheorie – Testkonstruktion* (2nd Ed.). Bern, Switzerland: Hans Huber.
- Stender, P. (2016). *Wirkungsvolle Lehrerinterventionsformen bei komplexen Modellierungsaufgaben*. Wiesbaden, Germany: Springer.
- Stender, P., & Kaiser, G. (2017). The use of heuristic strategies in modelling activities. In T. Dooley & G. Gueudet (Eds.), *Proceedings of the Tenth Congress of the European Society for Research in Mathematics Education* (p. 1012–1019). Dublin, Ireland: DCU Institute of Education & ERME.
- Tropper, N., Leiss, D., & Hänze, M. (2015). Teachers’ temporary support and worked-out examples as elements of scaffolding in mathematical modeling. *ZDM Mathematics Education*, 47(7), 1225–1240.
- Vorhölter, K., Grünewald, S., Krosanke, N., Beutel, M., & Meyer, N. (2013). Teacher behaviour in modelling classes. In B. Ubuz, C. Haser, & M. A. Mariotti (Eds.), *Proceedings of the Eighth Congress of the European Society for Research in Mathematics Education* (pp. 1127–1136). Ankara, Turkey: Middle East Technical University and ERME.

Research into students' evaluations of given modelling solutions and their suggestions for improved modelling – Results from two empirical studies

Sebastian Kuntze¹ and Julian Eppler²

^{1,2}Ludwigsburg University of Education, Germany

kuntze@ph-ludwigsburg.de; epplerjulian@stud.ph-ludwigsburg.de

Modelling occurs not only when students solve tasks which require modelling activities – also when students evaluate given solutions of such tasks, activities which can be described by elements of the modelling cycle may be elicited. In particular, when reviewing and refining modelling solutions cooperatively in the classroom, students have to face specific requirements, such as reconstructing modelling thoughts, examining alternative modelling steps and comparing the quality of different modelling solutions. However, there is still relatively little empirical evidence related to how students deal with these specific requirements. This paper therefore focuses on empirical findings from two studies on this topic. The evidence suggests that the participating secondary students identified relevant possibilities of improving the modelling solutions, even if it was difficult for some of them to implement all suggestions in their own improved modelling solutions.

Keywords: Modelling, given modelling solutions, empirical study, students' suggestions for improved modelling.

Introduction

When implementing modelling activities in the mathematics classroom, one of the difficulties concerns the phase *after* the students' individual or group modelling work: In this phase, a dialogue about the potentially very different modelling solutions which have been produced can offer valuable learning opportunities related to broadening the students' repertoire of modelling strategies, and also related to identifying and improving non-optimal aspects of the modelling solutions. However not only for the teacher, but also for the students, this phase can be expected to be very challenging, as they have to evaluate others' solutions and to think of or even implement suggestions for improved modelling related to these solutions. Despite the importance of this phase for the mathematics classroom, empirical research on how the students deal with such challenges is still needed. The two studies reported here consequently focus on this research aim. In a corresponding instrument, secondary students were asked to comment on given modelling solutions and to give suggestions for improving the modelling thoughts shown in the given solutions. The given solutions were pre-designed in a way that offered several aspects in which the modelling could be improved. On the base of their answers, the students were further asked to actually implement the suggestions in an improved modelling attempt. The results show that a majority of the students was able to suggest appropriate improvements, but also that it was not easy for them to combine all suggestions for improvement, especially when implementing the suggestions in the solution. We conclude from the findings that specific learning material focused on given modelling solutions could be a help for the learners. We will in the following first give an outline of the theoretical background of our approach, which will

lead to the research aim of the two studies. After describing the design and methods of the two studies, we will present results, which will be discussed in a concluding section.

Theoretical background

A key characteristic of tasks with substantial modelling requirements is their open-endedness, in the sense that the modelling cycle (Blomhøj & Jensen, 2003; Blum & Leiß, 2005) can be completed several times, in order to revise and improve the modelling, corresponding assumptions, and the modelling results again and again. This task characteristic can be seen at the very heart of mathematical modelling, as mathematical models very often only afford approximating exact descriptions or predictions for situations in the “rest of the world” (Blum & Leiß, 2005). As models can mostly be improved, refined in their complexity, or adjusted as far as modelling assumptions are concerned, such activities can be seen as typical for modelling. This underlines the importance of corresponding activities also for the mathematics classroom (Lesh, 2003): requirements students have to deal with when evaluating given modelling solutions or striving to improve them hence correspond to substantial learning goals when building up modelling competencies (Maaß, 2006; Blum et al., 2007; Kuntze, 2010; Brand, 2014). Evaluating given modelling solutions is hence important to study – for deepening these thoughts further, we will first introduce our understanding of tasks with substantial modelling requirements. On this base, we will then turn to key aspects of activities of evaluating given modelling solutions and identifying suggestions for improved modelling.

Tasks with substantial modelling requirements

Tasks are central for the over-all instructional quality in mathematics classrooms (e.g. Jordan et al., 2006); their characteristics are key for creating cognitively activating learning opportunities. In particular, for building up modelling competencies of the students (e.g., Kuntze, 2010; see Borromeo Ferri, Greefrath, & Kaiser, 2013; Maaß, 2006) characteristics of tasks play a key role. In tasks for instance, in which the mathematical model is already given or pre-determined (e.g., Lenné, 1975), specific learning opportunities which correspond to key stages of the modelling cycle (e.g. Blomhøj & Jensen, 2003; Blum & Leiß, 2005) remain systematically unconsidered. In contrast, tasks with substantial modelling requirements emphasise activities of translating between mathematics and the “rest of the world” (see Blum, 2007; Galbraith 1995). As for such tasks there is not only one single thinkable solution, the students are offered the possibility of own decision-making, students often need to make their own modelling assumptions and to select and use mathematical knowledge which may be helpful for their modelling. (see, e.g., Maaß, 2006; Blum et al., 2007; Kuntze, 2010). The importance of task characteristics thus results from the possibilities the tasks offer to the learners with respect of modelling activities. This implies also that task characteristics can make a significant difference for the process of working on the task in the classroom. If tasks require, for instance, that explicit modelling assumptions need to be made, and if different solution approaches and results are possible, this creates the opportunity of discussing different modelling approaches with the students, of comparing these approaches, of reflecting on the assumptions and on their role for the modelling results, as well as the opportunity of reasoning about students’ evaluations of the different modelling solutions. In these activities, it makes sense to consider less the “better” or “worse” modelling results, but to focus more on reconstructing, describing, and reflecting the different modelling approaches:

such a focus promises deeper and richer learning opportunities as far as knowledge about models and modelling strategies is concerned (e.g. Lesh, 2003). The learning opportunities contained in tasks may hence have an impact on the modelling-related classroom culture (e.g., Borromeo Ferri, Greefrath, & Kaiser, 2013; Blum et al., 2007; Galbraith 1995, Lesh et al., 2010).

As space limits of this paper restrict us in discussing all relevant aspects of tasks in detail (for more detail on this topic see, e.g., Kuntze & Zöttl, 2008), we would like to shortly introduce tasks with substantial modelling requirements as tasks which are open as far as given mathematical information is concerned, which offer multiple individual solution possibilities, which relate to life contexts and corresponding material (e.g., Galbraith, 1995), which require translation processes between mathematics and the rest of the world (see Blum, 2007), which require multi-step solution processes (see results related to modelling processes in Borromeo Ferri, 2006), which encourage and enable learners to connect situation contexts with available mathematical models and to use meta-knowledge about modelling and about elements of the modelling process (see Blum & Leiß, 2005; Blomhøj & Jensen, 2003).

Evaluating given modelling solutions and identifying suggestions for improved modelling

It follows from the considerations above that tasks with substantial modelling requirements will mostly lead to a variety of different solutions in the classroom, e.g. if students work in small groups on these tasks. Reviewing and reflecting on these different solutions constitutes a rich learning opportunity, as students may learn to evaluate solutions in a criteria-based way and enlarge their reservoir of modelling strategies (e.g., Lesh, 2003). When reviewing given modelling solutions that have been produced by other students, full modelling cycles can be carried out, even if the emphasis is less on producing a modelling solution and more on understanding the mathematical model and the underlying assumptions, as well as evaluating the relevance of the modelling results for the situation in the rest of the world. It is almost evident that the focus of these activities differs from a task in which a modelling solution has to be produced – but still, reviewing, reflecting on and improving given modelling solutions is highly relevant for modelling competencies.

As evaluating given modelling solutions requires multi-step thinking, such tasks can be expected to be complex for students. This highlights the importance of empirical research which focuses on students' difficulties and competencies in evaluating and improving given modelling solutions, in particular non-optimal modelling solutions. Related questions for research are the following, for instance: Are students able to make sense of given modelling solutions? What may make it more difficult or what may facilitate students' understanding of such modelling solutions? Are students able to identify non-optimal assumptions or aspects of the model? What suggestions for improved modelling can be expected from secondary students? Are the students able to really implement their suggestions in an improved modelling solution? What role can learning environments play in which the comparison between different modelling solutions is explicitly encouraged?

In this research area, the two exploratory studies presented here aim to provide insight. In the following section, we introduce our specific research aim.

Research aim

In line with the research need outlined above, the two studies presented here aim to cast light on the question “*Can students develop suggestions for improving given examples of modelling solutions and to what extent are they able to implement these suggestions for improvement in revised modelling attempts?*” For finding out about this mainly exploratory question, an instrument was designed in which students were asked to evaluate non-optimal modelling solutions by fictitious students for three tasks with substantial modelling requirements. In Study A, one given modelling solution was given for each task. In Study B, two different solutions for each task were presented to the students. An additional exploratory research aim combining the two studies was consequently: *May a specific stimulus to the students to consider different modelling solutions encourage them in developing suggestions for improvement of the modelling solutions?*

Design and methods

The instruments used in Studies A and B consisted of tasks, given modelling solutions and questions the students had to answer. Figure 1 shows a part of the instrument of Study B with the so-called car park task, with two given modelling solutions and with questions to the students. Study A used the car park task as well, but with only one given modelling solution, which was relatively similar to the first solution in Figure 1 (“Nicole”). From Study A to Study B, the instrument was varied systematically in the sense that study A presented only one given modelling solution per task, whereas the possibility of comparing two given modelling solutions per task in Study B might encourage the participants to reflect on different modelling approaches and corresponding modelling assumptions. The answers to the open format questions (cf. Figure 1) from the students were coded according to a top-down coding scheme, with acceptable inter-rater reliability (Cohen’s kappa amounted to 0.87 in Study B). It was coded which expected suggestions for improvement were given by the students, and whether and how the students implemented these suggestions in their own improved modelling solutions. As examples, the codes “doors” and “access pathway” will be shortly explained below at the beginning of the results section.

Both in Study A and B, the instrument was divided in three sections of 45 minutes, so that the students could work on the questions in three separate lessons. For example, the students worked on the instrument section represented in Figure 1 for 45 minutes during the first lesson. The second author and the usual teacher were present, but their role was rather passive, and clarification questions from the students were rare.

The sample of Study A consisted of 21 year 6 students (12 girls, 9 boys, aged 12 or 13 years) at a South German technical track secondary school, who worked on all three sections of the instrument. 19 of these students worked on the instrument section shown in Figure 1, as two students were absent on this school day. The participants of Study B were 17 year 7 students (7 girls, 10 boys, aged 12 or 13 years) at another technical track secondary school, all 17 worked on the instrument section shown in Figure 1. Due to space limitations, we will in the following concentrate on the students’ answers to the instrument section associated with the car park task (see Figure 1).

In class 7a, the students had to work on the following task:

Task: Car park

A new car park will be built on the grassland shown here.

How can you find out how many cars can be parked on this car park?



Solution by Nicole:

Das Auto ist 4m lang, also ist die Wiese 12m breit und 20m lang.
 Fläche der Wiese: $12m \cdot 20m = 240m^2$
 Fläche Auto: $2m \cdot 4m = 8m^2$
 Anzahl Autos: $240m^2 : 8m^2 = 30$
 Es passen 30 Autos auf den neuen Parkplatz.



The car is 4 m long, so the grassland is 12 m wide and 20 m long.

Area of the grassland: $12m \times 20m = 240 m^2$

Area car: $2m \times 4m = 8 m^2$

Number cars: $240 m^2 / 8 m^2 = 30$

30 cars fit on the new car park.

Explain in your own words how Nicole has thought and what she has calculated.

[Space for answer]

What else should Nicole take into account? What could she improve in her solution?

[Space for answer]

Solution by Sally:

Ich schätze die Wiese ist 50m lang und 20m breit.
 Fläche der Wiese: $50m \cdot 20m = 1000m^2$
 Der Supermarktparkplatz bei mir im Ort ist 15m breit und 20m lang. Er hat eine Fläche von $300m^2$.
 Er hat 18 Stellplätze zum Parken.
 $1000m^2 : 300m^2 = 3,3$
 $3,3 \cdot 18 = 59,4$
 Auf dem Parkplatz finden 60 Autos Platz.

I estimate the grassland is 50 m long and 20 m wide.

Area of the grassland: $50m \times 20m = 1000 m^2$

The supermarket car park in my town is 15 m wide and 20 m long. Its area is $300 m^2$.

It has 18 parking positions.

$1000 m^2 / 300 m^2 = 3,3$

$3,3 \times 18 = 59,4$

On the car park, there is space for 60 cars.

Explain in your own words how Sally has thought and what she has calculated.

[Space for answer]

What else should Sally take into account? What could she improve in her solution?

[Space for answer]

What do YOU think how many cars can be parked on the car park? Write down your thoughts and a calculation.

[Space for answer]

Figure 1: Example of task, given modelling solutions (translated), and questions to students

Results

In *Study A*, 19 students worked on the instrument section around the car park task. In their answers, we identified 24 suggestions for improvement, all students taken together. There were two categories for suggestions of improvement of the modelling solutions, namely the category “area per

car”/“doors” (i.e. there needs to be space for opening the cars’ doors, so the assumed area per car is too low) and the category “access pathway” (i.e. the cars need an access pathway to reach the parking positions). We observed that all suggestions by the students were expressed using terms of the context (e.g. “there needs to be space between the cars”), four answers additionally used expressions related to the mathematical model (e.g. “You have to do 50:2, because between the cars there needs to be space in order to open the car doors”). Among the 19 students, 10 students mentioned one suggestion, 7 students mentioned two suggestions, and 2 students did not mention any suggestion for improving the given modelling solution.

Figure 2 shows results related to the implementation of the suggestions for improvement in the students’ own modelling solutions. The data shows that out of the 10 students who made one suggestion for improvement, 7 successfully implemented this suggestion in their own improved modelling, with 1 of these students lacking of an adequate interpretation of the improved mathematical solution.

Study A: Implementation of the suggestions for improvement	Making modelling assumptions	Generating improved mathematical model	Finding improved solution according to model	Interpreting solution adequately
One suggestion for improvement ($N_1=10$)				
“doors” ($N_{1a}=4$)	3	3	3	3
“access pathway” ($N_{1b}=6$)	4	4	4	3
Two suggestions for improvement ($N_2=7$) (“doors” and “access pathway”)	6	4	4	4

Figure 2: Code frequencies related to the implementation of suggestions for improved modelling

In *Study B*, there were two given modelling solutions, which meant that there were more possibilities for making suggestions for improvement. Figure 3 presents the numbers of students with certain numbers of suggestions. The data shows a range from (two) students who could not make any suggestion for improvement at all to a student who made four suggestions related to Nicole’s solution and four suggestions related to Sally’s solution (in this case corresponding to the same four codes). The codes for the suggestions relate to the area per car, the space needed for the tree, the measures assumed for the car, the inclusion of the access pathway in the model, possibilities of improving the sketch, the estimation of the size of the car park, and further suggestions.

Figure 4 displays the results related to the implementation of the suggestions in improved modelling attempts. The Figure shows clusters of cases of students: There are two students who have not improved the modelling and not made any suggestions, there are eight students who have not been successful in implementing all of their suggestions, there is a further cluster with students who succeeded in implementing all of their suggestions and two students who have implemented even more improvements than they had initially suggested. As the data of Study B was more complex than the data of Study A with only one given modelling solution, Figure 4 summarizes the elements of the modelling cycle which have been displayed individually in Figure 2 in such a way that the answers had to show that the suggestion for improvement were implemented in a complete modelling cycle.

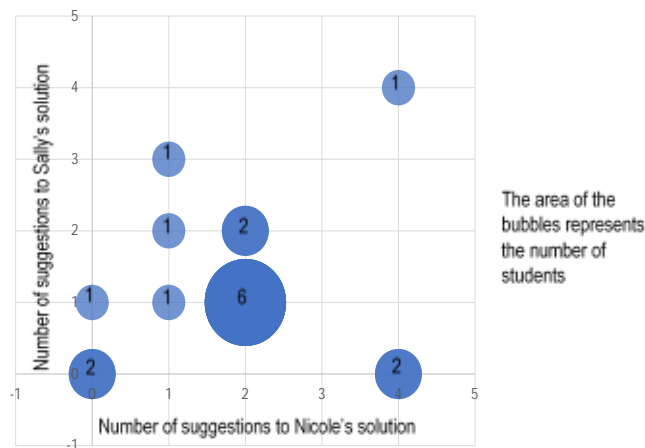


Figure 3: Frequencies of suggestions to Nicole's and Sally's solutions (Study B)

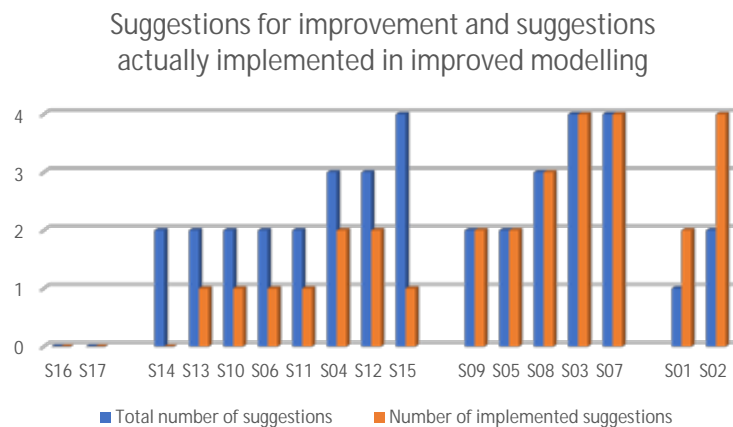


Figure 4: Suggestions and actually implemented suggestions in improved modelling (Study B)

Discussion and conclusions

The key aim of the study was to explore to what extent students can develop suggestions for improving given examples of modelling solutions and to what extent are they able to implement these suggestions for improvement. The findings of both studies suggest that a majority of the students was able to identify suggestions for improving the given modelling solutions. Moreover, many of the suggestions could be implemented by the students in their improved modelling solutions. However, there are also students who fail in developing suggestions for improvement. These students might either have had difficulties in understanding the given modelling solutions and/or it might have been difficult for them to consider possible alternatives to the given modelling solution. For follow-up research, it would not only be interesting to enlarge the data base and to further explore these students' difficulties, but also to compare all students' proficiency related to developing own modelling solutions with their proficiency in evaluating and improving given modelling solutions.

A further focus concerns the support of students' implementation of their suggestions for improved modelling. In the mathematics classroom, specific learning environments and learning material should concentrate on supporting corresponding modelling competencies of the students.

Considering study A and B together, the question whether only one or multiple modelling solutions should be offered to students in order to encourage their evaluation and the development of suggestions for improved modelling, the results rather do not provide a simple picture: For deciding on how many given modelling solutions should be provided in the everyday classroom, also the learners' individual competencies may be an important factor and should be taken into account.

References

- Blomhøj, M., & Jensen, T. H. (2003). Developing mathematical modelling competence: conceptual clarification and educational planning. *Teaching Mathematics and its Applications*, 22(3), 123–139.
- Blum, W., Galbraith, P. L., Henn, H.-W., & Niss, M. (Eds.). (2007). *Modelling and applications in mathematics education. The 14th ICMI study*. New York, NY: Springer.
- Blum, W., & Leiß, D. (2005). Modellieren im Unterricht mit der „Tanken“-Aufgabe. *mathematik lehren*, 128, 18–21.
- Borromeo Ferri, R., Greefrath, G., & Kaiser, G. (Eds.). (2013). *Mathematisches Modellieren für Schule und Hochschule*. Wiesbaden, Germany: Springer Spektrum.
- Borromeo Ferri, R. (2006). Theoretical and empirical differentiations of phases in the modelling process. *ZDM Mathematics Education*, 38(2), 86–93.
- Brand, S. (2014). *Erwerb von Modellierungskompetenzen*. Cham, Switzerland: Springer Spektrum.
- Galbraith, P. (1995). Modelling, Teaching, Reflecting – What I have learned. In C. Sloyer, W. Blum, & I. Huntley (Eds.), *Advances and perspectives in the teaching of mathematical modelling and applications* (pp. 21–45). Yorklyn, DE: Water Street Mathematics.
- Jordan, A., Ross, N., Krauss, S., Baumert, J. Blum, W., Neubrand, M., Löwen, K., Brunner, M., & Kunter, M. (2006). *Klassifikationsschema für Mathematikaufgaben. Materialien aus der Bildungsforschung, Nr. 81*. Berlin, Germany: Max-Planck-Institut für Bildungsforschung.
- Kuntze, S. (2010). Zur Beschreibung von Kompetenzen des mathematischen Modellierens konkretisiert an inhaltlichen Leitideen – Eine Diskussion von Kompetenzmodellen als Grundlage für Förderkonzepte zum Modellieren im Mathematikunterricht. *Der Mathematikunterricht*, 56(4), 4–19.
- Kuntze, S., & Zöttl, L. (2008). Überzeugungen von Lehramtsstudierenden zum Lernpotential von Aufgaben mit Modellierungsgehalt. *Mathematica didactica*, 31, 46–71.
- Lenné, H. (1975). *Analyse der Mathematikdidaktik in Deutschland*. Stuttgart, Germany: Klett.
- Lesh, R. (2003). *Models and modeling in mathematics education. Monograph for the International Journal for Mathematical Thinking and Learning*. Hillsdale, NJ: Lawrence Erlbaum.
- Lesh, R., Galbraith, P., Haines, C., & Hurford, A. (Eds.). (2010). *Modeling students' mathematical modeling competencies: ICTMA 13*. New York, NY: Springer.
- Maaß, K. (2006). What are modelling competencies? *ZDM Mathematics Education*, 38(2), 115–118.

Effective factors of a teacher training concerning the implementation of interdisciplinary STEM-modelling projects

Jean-Marie Lantau¹ and Martin Bracke¹

¹Technische Universität Kaiserslautern, Germany; {lantau} or {bracke}@mathematik.uni-kl.de

The modelling of the functional principle of a Segway requires an understanding of physical, technical and mathematical concepts, which are usually taught at university level. Nevertheless, the focus of two two-day-teacher trainings lied in the preparation of 11 teachers and 3 teacher students, such that they can implement interdisciplinary STEM-modelling projects with their students of Grade 10 to 12. Since 5 school projects were implemented by 7 teachers and 3 teacher students during summer 2018 we focus on the detection of effective factors and obstacles of the teacher training, concerning the implementation of the modelling projects. This paper describes the design of a one-year-study, especially the concept of the two-day teacher training and the resulting school projects. We also present first results of a qualitative study focusing on the effective factors of the teacher training based on guided interviews, which were conducted with all participants.

Keywords: Teacher training, STEM-modelling projects, interview study.

Introduction

The question of a pilot school project (Lantau, 2016) with 12 students of Grade 12 was if a STEM-modelling project concerning the functional principle of a Segway can be implemented at school. The comprehension of the functional principle of a Segway requires knowledge about modelling a Segway as an inverted pendulum to detect physical forces and energies leading to a mathematical model of a linear state space system. This system is controllable and therefore stabilizable by feedback- or PID-control which can be implemented practically to control a Lego Mindstorms[®] Segway (Lantau, 2017). The students in the pilot project learned many mathematical and physical concepts, mostly at university level, which are used in practice to control a Segway. Furthermore, we received the feedback of the supervising teachers that this kind of STEM-modelling-project shows their students the important role of mathematics in real-life-problems, *but* that they are not able to supervise such a STEM-modelling project on their own. This observation lead to the research question of a PhD-project, of how teachers have to be trained such that they are able to supervise this kind of STEM-modelling project on their own or in a teacher team. By this mean, in 2017 two two-day teacher trainings were offered for 9 teachers. The teacher trainings content was designed to follow the modelling cycle of Blum and Leiss (2007) and will be described in the section teacher training. Based on the teacher training, four school projects were implemented with students of Grade 12 (Lantau, 2017). Three of four school projects concentrated on the comprehension of the functional principle of a Segway, so the students learned how to use the PD-control theoretically and practically to counteract tangential forces to stabilize a Segway. The essence of the first year's PhD-project was that the design of the teacher training was successful in a way that teachers are able to supervise STEM-modelling projects with their students. Therefore, we focus on the analysis of effective factors and obstacles of the teacher training concerning the implementation of STEM-modelling projects at school with students of Grade 10 to 12 by teachers and teacher students.

Research focus

In recent years some projects and research studies concentrated on the professional development of teachers concerning the teaching of mathematical modelling in regular lessons. In their work, Blum and Borromeo-Ferri (2011) stresses that teachers need to be aware of an optimal balance between the maximal independence of the students and the minimal help of teachers. In addition, the results of the LEMA project show that a professional development course has a positive effect on self-efficacy and on pedagogical content knowledge of teachers (Maaß & Gurlitt, 2011). Gastón and Lawrence (2015, p. 9) investigated in their work that “the research does not reveal one perfect method or set of techniques that can prepare each individual teacher to effectively teach mathematical modelling as a transferable process”. Nevertheless, most of the professional development courses for mathematical modelling concentrate on teaching teachers to use mathematical modelling processes in regular lessons or small tasks. For despite, the long tradition of mathematical modelling in Kaiserslautern focuses on interdisciplinary and real-life STEM-problems which students usually investigate in project-based learning environments such as modelling days and weeks (Bock & Bracke, 2015) it was not clear how a teacher training has to be designed such that teachers are able to supervise interdisciplinary STEM-modelling projects. Since one first approach of a teacher training concerning the mathematical modelling of a Segway seemed to be successful (Lantau, 2017), the research focus was set on the detection of effective factors and obstacles of the teacher training. In our work we refer to the model of Lipowsky, in which he describes factors and constraints to explain the effectiveness of teacher training courses (Lipowsky, 2010). Quite similar to Lipowsky’s model, Wilson (2013) and Desimone et al. (2002) investigated 5 core features for professional developments, namely the content focus, an active learning process, a collective participation, coherence and a significant duration of the teacher training.

Nevertheless, since it exists only few research results concerning teacher trainings for interdisciplinary STEM-modelling projects our research question is to explore the effective factors of the teacher training such that interdisciplinary STEM-modelling projects can be implemented at school. We want to answer our question by the help of a qualitative study in which we used guided interviews based on Lipowsky’s model. At first, the participants were asked to reflect their meaning and experiences towards STEM- modelling projects and later the interview focuses on effective factors of the teacher training which encourages teachers to implement this STEM-modelling-project. Furthermore, teachers were asked to describe obstacles during the teacher training. The participants (11 teachers and 3 teacher students) of the teacher training were interviewed after the training and those who implemented their modelling project as a result of the teacher training in summer 2018 (7 teachers and 3 teacher students) were interviewed again after their projects to detect successful factors after the transfer process of the teacher training. The interviews will be analyzed by the method of content-structured analysis (Kuckartz, 2018). Figure 1 shows the design of the one-year-project.



Figure 1: The study design

Teacher training

The teacher training followed the intention that teachers learn the modelling process concerning the understanding of the functional principle of a Segway actively. Therefore, the training started by an experimental phase in which the teachers got the opportunity to drive with a Ninebot Mini Street to get aware of a Segway's functional principle. After the teachers made their driving experiences, the control process of a Ninebot Mini Street and a Lego Mindstorms[®] Segway were compared. Based on their own experiences and observations of the control process, the teachers set up a model for the functional principle of the Segway. During this phase, the teacher recognized that they are in their students' role while modelling a Segway, so they reflected what kind of modelling approaches can students have when they model the functional principle of a Segway. In a following phase the teachers considered possible questions which they can implement with their students concerning the context Segway. For example, such a question could be the exploration of a shortest and fastest driving of a Segway in a given course. Further contexts are to investigate the effect of the center of mass' location for the control process or to calculate an optimal route for a Segway tourist tour. The collection of possible project ideas gave the teachers the opportunity to think about possible interdisciplinary modelling projects for their students. After further project ideas were collected, the focus of the teacher training was set on the control principle of a Segway, which is described in Figure 2.

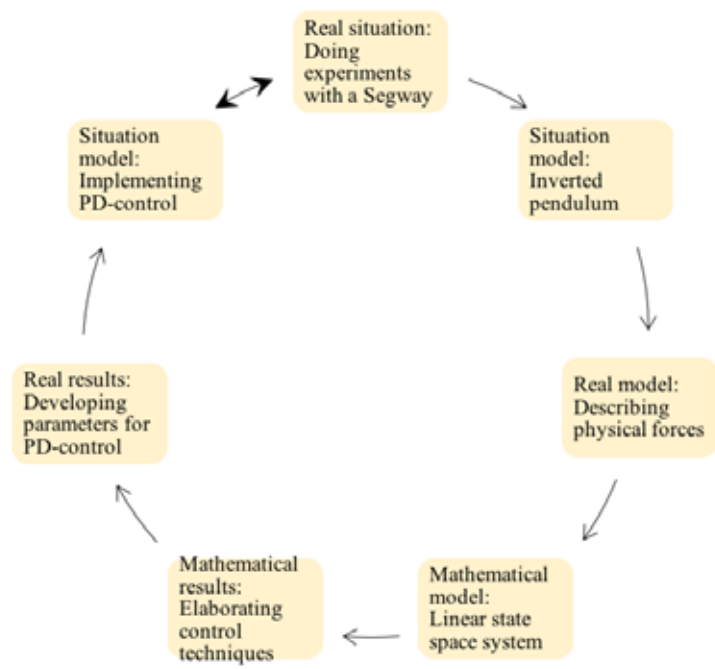


Figure 2: The design of the teacher training

Figure 2 shows that the design of the teacher training followed the modelling cycle of Blum and Leiss (2007), in which each step is connected to a module, which has either a physical, technical, or mathematical focus. By this design, a bilateral learning approach was offered: First, teachers experienced an interdisciplinary STEM-modelling process on their own (active learning) and secondly, they reflected on each module, whether it can be transferred into their school projects,

based on the knowledge of their students (coherence). The different modules are described in the following.

Physics module: Situation and real model

A first model for the control process of a Segway is set up by an inverted pendulum, which contains two mass-centers, one for the wheel axis M and one for the center of mass of the Segway m . The mass centers are connected with a massless pole of length l . The aim of the control principle is to counteract acting tangential forces by a motor force u of the Segway. One can describe the inverted pendulum by two approaches. Once, by analysing acting tangential forces, leading to a nonlinear, inhomogeneous ordinary differential equation of second order: $mg \sin \varphi - ml\ddot{\varphi} = u$

The second approach is done by describing the movement of the inverted pendulum by the *Euler-Lagrange-formalism* (Goldstein, 1980) in which the Lagrange function (difference of kinetic and potential energy) for the generalized coordinates *position* x and *angle* j is set up:

$$\mathcal{L} = \frac{1}{2}(M + m)\dot{x}^2 + \frac{1}{2}m\dot{\varphi}^2\ell^2 + ml \cos(\varphi)\dot{x}\dot{\varphi} - mgl \cos(\varphi) + ux$$

In a second step the *Euler-Lagrange equation* is calculated for both generalized coordinates:

$$\frac{d}{dt} \frac{\delta \mathcal{L}}{\delta \dot{\varphi}} - \frac{\delta \mathcal{L}}{\delta \varphi} = 0 \wedge \frac{d}{dt} \frac{\delta \mathcal{L}}{\delta \dot{x}} - \frac{\delta \mathcal{L}}{\delta x} = 0$$

This process leads to two equations, one describing horizontal forces and the other describing tangential forces of an inverted pendulum:

$$0 = (M + m)\ddot{x} + ml\ddot{\varphi} \cos(\varphi) - ml\dot{\varphi}^2 \sin(\varphi) - u \wedge 0 = ml^2\ddot{\varphi} + ml \cos(\varphi)\ddot{x} - mgl \sin(\varphi)$$

Mathematics module: Mathematical model and results

A mathematical model for the inverted pendulum is generated of the physical model by applying Taylor-series-approximations of first order around $\mathbf{x}^T = (x \ \dot{x} \ \varphi \ \dot{\varphi})^T = (0 \ 0 \ 0 \ 0)^T$

which leads to the linear state space system $\dot{\mathbf{x}} = A \cdot \mathbf{x} + b \cdot u$

$$\dot{\mathbf{x}} = \begin{pmatrix} \dot{x} \\ \ddot{x} \\ \dot{\varphi} \\ \ddot{\varphi} \end{pmatrix} = \begin{pmatrix} 0 & 1 & 0 & 0 \\ 0 & 0 & \frac{-mg}{M} & 0 \\ 0 & 0 & 0 & 1 \\ 0 & 0 & \frac{g \cdot (M+m)}{M \cdot \ell} & 0 \end{pmatrix} \cdot \begin{pmatrix} x \\ \dot{x} \\ \varphi \\ \dot{\varphi} \end{pmatrix} + \begin{pmatrix} 0 \\ \frac{1}{M} \\ 0 \\ \frac{-1}{M \cdot \ell} \end{pmatrix} \cdot u$$

In order to stabilize the linear state space system a first control technique, the PID-control (Sontag, 1998) can be applied, in which the motor force u is chosen as a weighted sum of the generalized coordinates (proportional control), its time-integral (integral control) and its time-derivative (derivative control). The parameters for the P-, I-, D-control part are usually determined experimentally regarding some conditions that have to be fulfilled to generate asymptotic stable solutions for the linearized system. Based on the *PD-control approach*, one can analytically solve a linear differential equation of second order to elaborate constraints for the control parameters k_P and k_D in order to stabilize the Segway. Furthermore, an explicit Euler-method visualizes the control process of a Segway, which was implemented in GeoGebra.

Technics module: Real results and situation model

Even though the implementation of a simulation in GeoGebra is some kind of a technical product, a more ambitious technical approach is to combine the theoretical results with a practical control of a Lego Mindstorms[®] Segway. This can either be done by using preconceived Lego Mindstorms[®] robots and balancing programs (Valk, 2014), or by developing a practical control in Lego Mindstorms[®]

School projects

As a result of the two-day teacher training 5 school projects took place in summer 2018. The structure and content focus of each project was different based on the learning group, the supervision and the time framework of the project days. The following table summarizes the school projects briefly:

<i>School and time framework</i>	<i>Participating students</i>	<i>Supervisors</i>	<i>Content focus</i>
2 days at a grammar school in Bolanden	24 students (4 female, 20 male) of Grade 10 and 11	1 teacher and 1 teacher student, as well as the teacher trainer	a) PD-control b) Functional principle of a gyroscope c) Video analysis of Segway movements
2 days at a vocational school in Wissen	16 students (7 female and 9 male) of Grade 12	2 teachers and the teacher trainer	Video analysis of a fastest Segway tour through a given course
3 days in a grammar school in Mainz	17 female students of Grade 12	1 teacher, 1 colleague and the teacher trainer	a) PD-control b) Taylor-approximations c) “Modern curve sketching” by using video analysis of Segway movements d) Shortest paths for Segway tourist tours in Mainz
3 days in a vocational school in Kusel	18 students (2 female and 16 male) of Grade 12 and 13	1 teacher, 1 colleague and the teacher trainer	a) PD-control b) Explicit-Euler-method in GeoGebra c) Control of a Lego Mindstorms-Segway
3 days in a grammar school in Daun	13 students (5 female and 8 male) of Grade 12	2 teachers, 2 teacher students, 1 colleague and the teacher trainer	a) PD-control b) Explicit-Euler-method in GeoGebra c) Euler-Lagrange-formalism

Table 1: The resulting 5 school projects

Preliminary results

In our point of view, considering the brief exposition of the resulting school projects, one can assess the design of the teacher training successful concerning the implementation of *different* interdisciplinary STEM-modelling projects by teachers and teacher students. The focus of research is set on the investigation of effective factors and obstacles of the teacher training (i), as well as of the school projects (ii), such that this quite ambitious modelling project can be implemented at school. Therefore, the participants were interviewed individually after the teacher training and after their school projects. The process of content-structuring qualitative content analysis has started by analyzing all interviews along the main categories of effective factors, obstacles and assessment of the teacher training and school projects, as well as along school dependent factors, or the meaning and experience towards modelling projects by teachers in their daily life work. In this section we will give an insight into preliminary results, mainly considering effective factors and obstacles.

Effective factors

The analysis of effective factors was done by analyzing once theoretical core features of professional development like the content focus of the training, the active learning during the teacher training, the coherence, and the collective participation (Desimone et al., 2002; Lipowsky, 2010; Wilson, 2013) and secondly indicate effective factors inductively by elaborating sub categories during the analysis of the interviews. The first results hint that most of the teachers who wanted to implement a STEM-modelling project with their students reported that it is very helpful for them that they know that the teacher trainer will support them during the project days. By this fact they know that they can ask the teacher trainer for support if they feel unsure in supervising the project. Furthermore, the teachers indicated that the mathematical and physical background of the STEM-modelling project is very profound, so that their students get an insight where mathematical concepts are used in real-life situations (content focus). On the other hand, based on the teacher training, they feel sure when elaborating the physical and mathematical concepts with their students (active learning). Some of the teachers reported that they had a lot of fun during the teacher training to learn mathematical and physical concepts of university level (content focus). Beside the theoretical background of the functional principle of a Segway, many teachers reported that the simulation of the functional principle in GeoGebra is very useful for their students, so that they get a better understanding of the mathematical background, when they can compare their theoretical results with a simulation (coherence). The most important factor concerning the implementation of a STEM-modelling project however is, that teachers have seen a concrete project concept for an authentic real-life context, which can be described by mathematical concepts, which their students are able to learn with their knowledge (content focus). Finally, teachers indicate that it was very helpful for them to explore a specific modelling project, which can be implemented at school (content focus).

Obstacles

Since the implementation of this STEM-modelling projects requires a profound mathematical, physical and technical knowledge, most of the teacher reported that this project is very ambitious and complex to implement with students of Grade 10 to 12. As the description of the physical and

mathematical modules show, it does not surprise that teachers indicate that the advanced level of the project is an obstacle for them and their students. Furthermore, some teachers indicated that they don't have any experience concerning the work with Lego Mindstorms[®]. Since the teacher training was designed with phases in which the teacher could work on their own ideas, they got an insight in technical and theoretical obstacles during the working phase. In addition to that fact, almost every teacher reflected that it is quite hard to prepare the modelling project, since the possible questions, that students might ask themselves in the project can't be foreseen.

Discussion and Outlook

The short description of the school projects and the section of the preliminary results point out that interdisciplinary STEM-modelling-projects can be implemented by teachers after a respective training. Although the analysis process of the interviews by the method of qualitative content analysis has not been finished yet, there are some hints that some of the theoretical effective factors for professional development, namely content focus, active learning, collective participation and coherence (Desimone et al., 2002; Lipowsky, 2010; Wilson, 2013), were also effective factors for the implementation of interdisciplinary STEM-modelling-projects. The first results of the analysis show that main effective factors for the implementation of interdisciplinary STEM-modelling-projects are the collective participation at the teacher training and the following collaborative supervision (i), the possibility of implementing different projects based on the context Segway (ii), the exposition of a concrete modelling-project (iii), the motivating product of a Segway (iv) and the support of the teacher trainer during the school projects (v). Furthermore, the teachers indicated that the teacher training was a necessary condition for the implementation of their school projects. The participants of the teacher training reported the deep mathematical and physical knowledge, which is necessary to supervise the project (i) as the main obstacle. The main obstacles during their implementations were the supervision of open-structured project lessons (ii) and a non-fitting learning group for the interdisciplinary school project (iii). Besides the first analysis of effective factors and obstacles of the teacher training, one main open question still is how to support teachers such that they are confident enough to implement STEM-modelling projects on their own. In order to answer this question, we asked teachers during the interviews to report us necessary conditions to implement further STEM-modelling projects in future. Fortunately, almost every teacher who successfully implemented their project reported that he or she has the principle intention to implement further STEM-modelling projects in future. First hints for necessary conditions for the implementation of further STEM-modelling projects are the collective support of colleagues during the project days and the external support, for example by offering specific teacher trainings, or the external support during the project days. Finally, it has to be stressed that the focus of this work is not on the implementation of modelling activities in *regular lessons*, since from our experience this complex and interdisciplinary STEM-modelling project is recommended to be implemented in project days.

Acknowledgment

This work is partially supported by the European Social Fund (ESF) project SchuMaMoMINT and by U.EDU (Technische Universität Kaiserslautern) as part of the national and federal project "Qualitätsoffensive Lehrerbildung", funded by the Federal Ministry of Education and Research.

References

- Blum W., & Borromeo-Ferri, R. (2009). Mathematical modelling: Can it be taught and learnt? *Journal of Mathematical Modelling and Application*, 1(1), 45–58.
- Blum W., & Leiss D. (2007). How do students and teachers deal with mathematical modelling problems? In C. Haines, P. Galbraith, W. Blum, & S. Khan (Eds.), *Mathematical modelling: Education, engineering and economics* (pp. 222–231). Chichester, UK: Horwood Publishing.
- Bock, W., & Bracke, M. (2015). Applied school mathematics – Made in Kaiserslautern. In H. Neunzert, & D. Prätzel-Wolters (Eds.), *Currents in industrial mathematics: From concepts to research and education* (pp. 403–437). Heidelberg, Germany: Springer.
- Desimone, L., Porter, A., Garet, M., Yoon, K., & Birman, B. (2002). Effects of professional development on teachers' instruction: Results from a three-year-longitudinal study. *Educational Evaluation and Policy Analysis*, 24(2), 81–112. doi:10.3102/01623737024002081
- Gastón J., & Lawrence, B. (2015). Supporting teacher's learning about mathematical modeling. *Journal of Mathematics Research*, 7(4), 1–11. doi:10.5339/ijsp.v4n4pl
- Goldstein, H. (1980). *Classical mechanics* (2nd ed.). San Francisco, CA: Addison Wesley.
- Kuckartz U. (2018). *Qualitative Inhaltsanalyse. Methoden, Praxis, Computerunterstützung* (4th ed.). Weinheim, Germany: Beltz Juventa.
- Lantau, J. (2016). *Mathematische Modellierung eines Segways mit Umsetzung in der Schule als interdisziplinäre Projektarbeit*. <https://kluedo.uni-kl.de/frontdoor/index/index/docId/4441>
- Lipowsky, F. (2010). Lernen im Beruf. Empirische Befunde zur Wirksamkeit von Lehrerfortbildungen. In F. Müller, A. Eichenberger, M. Lüders, & J. Mayr (Eds.), *Lehrerinnen und Lehrer lernen – Konzepte und Befunde zur Lehrerfortbildung* (pp. 51–70). Münster, Germany: Waxmann.
- Maaß, K., & Gurlitt, J. (2011). LEMA – Professional development of teachers in relation to mathematics modelling. In G. Kaiser, W. Blum, R. Borromeo Ferri, & G. Stillman (Eds.), *Trends in the teaching and learning of mathematical modelling – Proceedings of ICTMA14* (pp. 629–639). New York, NY: Springer.
- Sontag, E. (1998). *Mathematical control theory: Deterministic finite dimensional systems*. New York, NY: Springer.
- Valk L. (2014). *Lego-EV-3-Roboter: Bauen und Programmieren lernen mit LEGO MINDSTORMS EV3*. Munich, Germany: dpunkt.verlag GmbH.
- Wilson, S. (2013). Professional development for science teachers. *Science*, 340(6130), 310–313. doi: 10.1126/science.1230725

Instrumental genesis and heuristic strategies as frameworks to geometric modeling in connecting physical and digital environments

Diego Lieban¹ and Zsolt Lavicza²

¹Federal Institute of Education, Science and Technology, Bento Gonçalves, Brazil;

¹Johannes Kepler University, Linz, Austria; diegolieban@yahoo.es

²Johannes Kepler University, Linz, Austria; lavicza@gmail.com

This study aims to offer frameworks for exploring geometric modeling while combining physical and digital resources in teaching and learning of mathematics. Originally designed as a task to tackle pre-service teachers' learning transition from 2D to 3D under the lens of instrumental genesis approach, our study revealed how heuristic strategies from Polya spontaneously emerged through the process of digital representations. The use of physical simulation was helpful in supporting participants to better comprehend and describe action of joints and to (re)interpret their mathematical behaviour, which was not possible when they were working only in the digital environment. The combined use of both physical and digital resources appears to bring a relevant contribution for refining students' thinking and enhance their mental schemes or strategies through of the modeling processes.

Keywords: Geometric modeling, teacher training, GeoGebra.

Introduction

In this work, pre-service teachers, students in a teacher training program, were assigned to represent the kinetic simulations based on real objects' movements through physical and digital resources. Geometric modeling of seesaws using GeoGebra was analysed with a special focus on the use of perpendicular lines, symmetry features and circular movements. This was mainly related to handling geometric concepts while transitioning between both 2D and 3D representations. The aim of observing the process, including integrated and multiple representations, was to identify the benefits coming from either physical and digital prototypes and how they can support one another. Such experience fed us with some elements to our posed research question:

In a geometric modeling approach, how can the combined use of physical and digital resources to represent joints and their movements support the 3D geometric knowledge of prospective teachers?

Following our research approach, we observed that on the one hand, the modeling task as such played a crucial role together with the software and enhanced participants' geometric understanding; prospective teachers' behaviour could be examined and understood through the Instrumental Genesis theory (Bussi & Mariotti, 2008). On the other hand, procedures adopted by participants were aligned with Heuristic Strategies proposed by Polya for problem solving. Hence, we decided to share excerpts where these evidences were more apparent, above all the strategies related to *backward thinking, generalization, specialization and decomposing* (Polya, 1973).

While working with geometric modeling in technology-enhanced environments, students are faced with different construction procedures, compared to their physical modeling experiences, which are mainly caused by the features and constraints of the software. The different approaches to physical and digital modeling could offer opportunities for teachers and students to further their learning. In addition, modeling real world problems could enable connections and new perspectives between science and mathematics. Before discussing the analysis of these examples¹ we will outline the theoretical frameworks used for this work.

Theoretical framework

The idea for this study was originally to develop geometric modeling from real and physical daily objects to investigate the ways they could foster mathematical exploration. As claimed by Carreira and Baioa (2015), students' behaviours in class usually do not reflect experimental sciences since they are not in the position to examine and interpret their surroundings mathematically.

Through this geometric modeling approach, we intended to enhance students' modeling competencies and mathematical thinking:

[...] to interpret a situation mathematically from iterative cycles of describing, testing, and revising mathematical interpretations as well as identifying, integrating, modifying, or refining sets of mathematical concepts drawn from various sources. (English, Lesh, & Fennewald, 2008, p. 8)

Considering the recent significant changes in mathematical thinking led by new technologies as well as social aspects such as communication and collaboration led by new technologies (English, Lesh, & Fennewald, 2008), we started this investigation under the lens of the instrumental genesis approach. We examined the transition of GeoGebra from an artifact to an instrument and later we witnessed practices emerged that could be explained by Polya's strategies of problem-solving, then how these strategies further assisted students in their instrumental genesis.

Instrumental Genesis

According to Bussi and Mariotti (2008), Rabardel's instrumental genesis framework is based on the distinction between artifact and instrument. While the artifact can exist by itself, the instrument is a mixed entity with two components: the artifact produced for the subject, and the associated schemes of use. They are the results of a construction of the subject itself or of an appropriation of already existing schemes of use. The instrument describes an artifact and it is constituted in the use(s) that the subject develops. In this way, the uses of the artifact also depend on the needs and objectives of the user. According to Stormowski (2015) the importance of transforming a software, in our case GeoGebra, into an instrument is an evolution of the reorganization and modification of users' schemes, structuring of teachers' actions, and relations to mathematical concepts. In our particular case, participants had their strategies influenced by software outcomes even when such results were not exactly as they expected. As pointed out by Sinclair and Robutti (2012), if participants 'internalize' the use of a Dynamic Geometry Software (DGS) the artifact becomes a mean that offers

¹ The mentioned students' constructions are available online and can be utilized for other researches and teaching activities: <https://www.geogebra.org/m/Tng4JXDk>.

opportunities to solve problems. We observed that GeoGebra contributed to participants' reflections on simulation tasks and reorganization of their thinking schemes, as well as forming mathematical concepts. Nevertheless, these transformations were occasionally need to be assisted by teachers' external minimal guidance and supported by physical models.

Heuristic Strategies

Polya's (1973) work on problem-solving listed a range of heuristic strategies that can be used to tackle a diversity of problems, not only restricted to mathematics. In our research, we consider "*the problem to be solved*" as the challenge to develop physical and digital representations as equivalent as possible. In this case, the seesaws' digital simulation was in the main focus of our investigation as we were already considering students' instrumental genesis with GeoGebra. For this purpose we have identified different strategies that were strongly connected to the geometric modeling approach: *guess and check*, *use of symmetry*, *draw a picture* and *be creative* to mention some of them. In the results section, we aim to outline more explicitly how some of these strategies connected the instrumental genesis with Polya's problem-solving. Stender and Kaiser (2017) state that there is little empirical research exploring how these heuristic strategies can be implemented in classroom teaching. They suggest that heuristic strategies can be transferred into strategic interventions by tutors. Through our current research and further results we intend to share geometric modeling tasks designs beyond teacher training programs. Once prospective teachers have the opportunity to experiment with different strategies with DGS they can feel more confident to reapply them in their teaching and encourage their students to carry out similar tasks.

Methodology and Methods

The explorative nature of the study demanded an interpretative approach comprising qualitative methods as observation, data collection, and analysis (Cohen, Manion, & Morrison, 2011). Our experiments were carried out with 19 volunteer prospective mathematics teachers in Brazil and lasted a period of four months with meetings in every second week on average, to follow the evolution of the modeling process. All participants had already been introduced to GeoGebra during an introductory ICT course, where they explored the main software functions and features. For this experiment, students worked mostly in pairs and were assigned the task to build a seesaw using materials (e.g. wood, plastic, metal, etc.) of their choice. Then, they were asked to digitally model the same seesaw using a Dynamical Geometry Software.

The data collected in the initial part of the research came from three different sources: i) the digital modeling process of individual students or pairs was video-recorded; ii) the GeoGebra files were shared by students with the research team; and iii) an explanatory section, where participants presented their solutions based on their previous constructions was also video-recorded. In addition, all participants attended other four meetings with the whole group in order to expose their progress, exchange their ideas and discuss exercises with geometric modeling and joints.

Data Analysis and Results

For the purposes of this paper, we will outline steps of constructing digital examples that we consider valuable to be supported by physical prototyping for learning. Through the connections of

both modeling approaches, participants first *worked backwards* to define the order of dependencies and the sequence of elements that they had to create. After students' trials they had to occasionally redefine the sequence of their constructions in order to obtain better results. This indicated that participants were constrained by the development processes and by their interactions with the software to rethink their strategies or "schemes of thinking". Both unexpected outcomes and inactivity from the software, due to for example inconsistent inputs, led students to rearrange their strategies of constructions. Valuable discussions arose from these experiments and often students had to re-evaluate their ideas and return *back to* basic mathematical *definitions*. Problem-solving strategies such as *generalization* and *specialization* were also recurrent in students' practices while sharpening their solutions². The following examples aim to highlight the nature of the heuristic strategies utilized by students. They also offer some insights into how the use of these strategies makes physical and digital artifacts become instruments. In our first example, we examine the importance of using physical prototyping to trigger conceptual discussions about circles and tangents while students are digitally modeling the joints' movements. Such approach in this experiment encouraged students to make connections between the physical and digital models, using one of them to better understand the other. Figure 1 illustrates parts of this process.

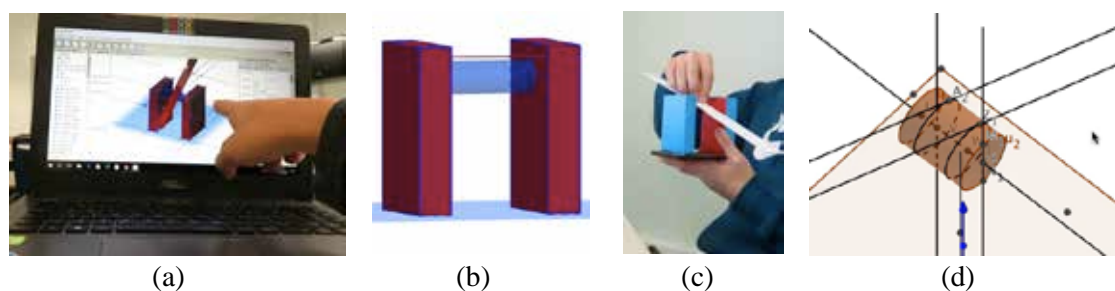


Figure 1: Physical and digital resources supporting participants' rethinking of their solution strategies

After the first digital prototype of the seesaw was modelled, students were asked about the accuracy of their constructions. They were asked to identify and explain in which aspects their two models were, or were not, representatives of each other. Students identified that the ratio of the elements in the physical prototype was preserved in the digital model (Figure 1a). They also reported that the movements of the main seesaw board and the cylinder, on which the board should rotate, did not represent exactly the wanted physical movements. In their digital model, the board was intersecting the cylinder or (depending on how it was moving) the board and the cylinder did not even touch each other (Figure 1b)! While reviewing their digital model students felt the necessity to explore their physical model again (Figure 1c) to more concretely visualize movements and connections of the elements. In their words, they explained that: "ideally the main board is supposed to be connected to the cylinder, which should rotate around its axis of revolution." In continuity they should move from this "optical trick solution" to a most realistic representation. After few days they presented a new version (Figure 1d), in which they fixed the problem described above. They used

²*generalization*: circles and lines before arcs and segments;

specialization: board in a parallel position to the basis plane to rotate afterwards;

tangent lines to particular circles, which were obtained as a section of the cylinder and rotating the cylinder as the last step of the process. Therefore, the main board would stay connected.

The second excerpt brings another example of how the combination of digital and physical resources contributed to rethink geometric definitions in 3D space.

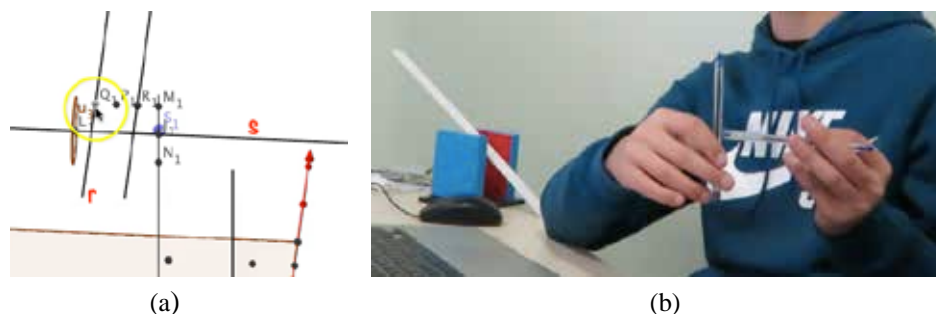


Figure 2: Physical and digital resources enhancing proper meaning in 3D

In a particular step of the construction³ (Figure 2a), students needed to trace a perpendicular line passing through a point in 3D space and belonging to a given line (r). However, while doing this, students were puzzled why GeoGebra did not trace such perpendicular line. When asked to explain why the software was inactive, they assumed that it was an operational problem. They repeated the same procedure twice without any result. Finally, students solved their practical problem using another line (s). However, this was not enough for them to realize that they were skipping a “conceptual action mistake”. In order to give students some insights, the researcher suggested the use of concrete objects (Figure 2b). Part of this approach is registered in the following conversation:

Student: What I can do is a perpendicular line to this one that passes here (the point Q_1 that belongs to r). [*There is no effect in GeoGebra.*]

Researcher: Why do you think nothing happened?

Student: I guess is because I've clicked on the wrong spot. [*He repeats exactly the same procedure and again achieved no usable results.*]

As a third attempt, they considered a different line (s) that was convenient for his purpose and finally the perpendicular line emerged. Then the student continued:

Student: Actually I was taking the wrong line, I guess.

Researcher: What did you intend to do in the beginning?

Student: Exactly like that, a perpendicular line passing through Q_1 .

Researcher: Ok, that is what you wanted as a final goal and you finally got it, but why it didn't work on your first attempt?

After some new trials similar to the preceding ones and some vague conjectures, he finally said:

³ Note that this screenshot is from a 3D representation, that means the lines r and s are not in the same planes. In this construction, Q_1 belongs to r but not to s .

Student: I really don't know.

Researcher: Ok, go ahead. Let's discuss it later [...]

Student: The issue is that GeoGebra is quite intuitive, so you can get results through trial and error. Sometimes there is a hidden fundamental math principle, but you have been making so many constructions that you might eventually miss some math behind these constructions.

Interesting to note that even though the student was not able to identify the real reasons why he was stuck at this time, he recognized a consistent performance of GeoGebra and as a benefit for his learning due to GeoGebra's intuitive interface. At that moment the researcher felt the necessity to intervene with some pens to simulate, using physical objects, how the software was "thinking".

Researcher: Do you want to see something? [*The researcher hands him the pens and asks to represent a perpendicular line passing through a point belonging to another line*]

The student then immediately presented a possible solution.

Researcher: Is this one? [*Referring to the solution presented by him*]

Student: In order to obtain a perpendicular line it might need to pass through this point and make a right angle with the first one... [*He slightly rotates the second pen keeping the right angle*]

Student: [...]or like that maybe. [*He presents another solution*]

Researcher: But is there only one solution?

Student: Actually, not. I have thought about that. Somehow that is the reason it worked with the second line (the line that the point did not belong to), but not with the first one (the line that the point belonged to). If I had done it in 2D the software would understand that there is only one option (whether the point belongs or not to the first line).

The student's observation of linking 2D and 3D representations confirms that he realized that there was a significant difference between both 2D and 3D spaces. This is because the conditions to define a perpendicular line through a given line with a point lying on it were not properly the same. The transition from plane to space was quite recurrent among all participants and it happened as a natural step in the geometric modeling process. In particular cases, it was a bit conflicting when students kept the 2D concept, but ignored the new dimension in 3D. If something worked in 2D it did not necessarily work in 3D as well. In the previous example, the student realized the subtle difference caused by the new dimension in his solution after such interventions. Similarly as in the previous example, another challenging situation happened while the student was working with symmetry in 3D space. For example, students tended to use lines instead planes to reflect solids, which was misleading. This example was presented with further details in a previous paper (Lieban & Lavicza, 2017). The use of 2D geometry was useful in general as an auxiliary intermediate step in the construction of the seesaws. This process is what Polya labelled as *decomposing*, or splitting the problem into simpler steps. For instance, when students were struggling with reflecting solids,

they “reduced” the problem to a planar case and then continued with the extrusion afterwards. This change in strategy exemplifies the connection between the two theoretical frameworks. First students utilize the tool, which respond with an unexpected result by them, but through this process students operationalize the tool and it became an instrument. However, to be able to solve the problem they need to change their solution strategies. This is when heuristic strategies emerge, students start to decompose the problem and develop new solutions by using their instruments, but with subsequent steps from their decompositions. Another situation to exemplify the connection between theories happened when in the digital environment students had to define two points of a line as the ends of a segment in 3D space. They could do this construction directly with 3D features of the software, for example, spheres or circles with the normal (perpendicular to a plane) directions. While encountering such difficulties, they chose to use an auxiliary plane to continue the construction from this planar view as an alternative strategy. We present these steps in Figure 3, in which an auxiliary plane was used to construct a circle on it.

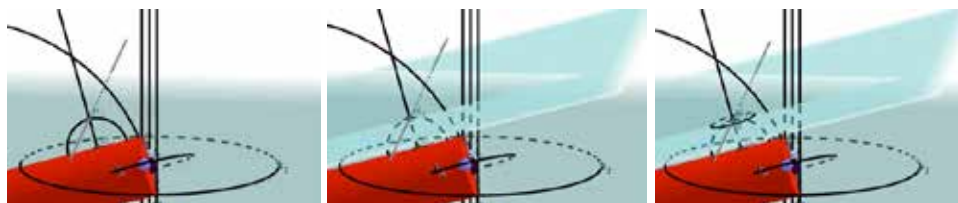


Figure 3: Circles into 3D space as a tool to define distances

Based on these examples, it can be assumed that the instrumental genesis and heuristic strategies can be combined to better understand student thinking. We observe that participants’ progress in their solution strategies and their schemes of using the software were triggered by the challenge to represent objects in 3D space and fixing this process through Polya’s *decomposing* strategy. The problem-solving approach by Polya seems to assist in the transition of GeoGebra from a tool to an instrument.

Conclusions

Geometric modeling was applied in this research to investigate perspectives in teaching and learning of mathematics from real-life objects combining physical and digital resources. Several of Polya’s strategies are intuitively used when solving mathematics problems with DGS. To take further advantage of using the software it is important not only apply these strategies, but also identify, practice, and organize them. Nevertheless, it is important to emphasize that using the digital tools without constant reflections on various responses of the software can be difficult to achieve valuable learning outcomes. Thus, the assistance and supervision of teachers in such activities is crucial. In this study we observed the value of the use of physical simulation in supporting students to better comprehend and describe the action of joints as well to (re)interpret some mathematical behaviours often hidden while interacting with a software tool. The combined use of both physical and digital resources seem to bring a relevant contribution for refining students’ thinking and enhance their mental schemes or strategies during their geometrical modeling. With this approach, while hands-on prototypes were bound to physical barriers, digital representation helped to reinforce either geometric relationships or algebraic descriptions. The

outlined examples are only parts of a wider set of exercises and activities developed in our study. In future papers, we will report additional insights into connecting physical and digital modeling approaches.

Acknowledgments

This work was supported in part by Federal Institute of Education, Science and Technology of Bento Gonçalves, Brasil, and Johannes Kepler University, in Linz, Austria.

References

- Bussi, M. G. B., & Mariotti, M. A. (2008). Semiotic mediation in the mathematics classroom: artifacts and signs after a Vygotskian perspective. In L.D. English, M.B. Bussi, G.A. Jones, R.A. Lesh, B.Sriraman, & D. Tirosh (Eds.), *Handbook of International Research in Mathematics Education* (pp. 746–783). New York, NY: Routledge.
- Carreira, S., & Baioa, A. M. (2015). Assessing the best staircase: Students' modelling based on experimentation with real objects. In K. Krainer & N. Vondrová (Eds.), *Proceedings of the Ninth Congress of the European Society for Research in Mathematics Education* (pp. 834–840). Prague, Czech Republic: Charles University in Prague, Faculty of Education and ERME.
- Cohen, L., Manion, L., & Morrison, K. (2007). *Research methods in education* (6th edition). London, UK: Routledge.
- English, L., Lesh, R. A., & Fennewald, T. (2008). Future directions and perspectives for problem solving research and curriculum development. In 11th International Congress on Mathematical Education. Monterrey, Mexico. Retrieved from <https://eprints.qut.edu.au/28450/1/c28450.pdf>
- Lieban, D., & Lavicza, Z. (2017). Geometric Modeling as Spatial Thinking Approach among Prospective Teachers. *Electronic Proceedings of the 22nd Asian Technology Conference in Mathematics*. Chungli, Taiwan: Mathematics and Technology, LLC. Retrieved from http://atcm.mathandtech.org/EP2017/contributed/4202017_21497.pdf
- Polya, G. (1973). *How to solve it. A new aspect of mathematical methods* (2nd ed.). Princeton University Press.
- Sinclair, N., & Robutti, O. (2012). Technology and the role of proof: The case of dynamic geometry. In M. Clements, A. Bishop, C. Keitel, J. Kilpatrick, & F. Leung (Eds.), *Third international handbook of mathematics education* (pp. 571–596). New York, NY: Springer
- Stender, P., & Kaiser, G. (2017). The use of heuristic strategies in modelling activities. In T. Dooley & G. Gueudet (Eds.), *Proceedings of CERME 10* (pp. 1012–1019). Dublin, Ireland: DCU Institute of Education and ERME.
- Stormowski, V. (2015) *Formação de professores de matemática para o uso de tecnologia: uma experiência com o GeoGebra na modalidade EAD* [Mathematics teachers training for the use of technologies: An experience with GeoGebra through online courses]. PhD Dissertation. Universidade Federal do rio grande do sul, Porto Alegre, Brazil

On the notion of mathematical model in educational research: Insights from a new proposal

Jesús Montejo-Gámez¹ and Elvira Fernández-Ahumada²

¹University of Granada, Faculty of Education Sciences, Granada, Spain; jmontejo@ugr.es

²University of Córdoba, Faculty of Education Sciences, Córdoba, Spain; elvira@uco.es

This paper introduces a definition of mathematical model which is intended to be applied in educational research. A synthesis of the background literature leads us to a notion of mathematical modelling that summarises contributions from a wide range of authors. This notion can be made operational in research by using the concept of mathematical model introduced in this study. This resulting proposal for defining model allows the establishing of suitable dimensions of analysis for research. The main features of this new conceptualization and its application to investigate mathematical models are also discussed.

Keywords: Mathematical models, problem solving, educational purposes, research tools.

Introduction

In recent years, the discussion about which capabilities are linked to the mathematical competence points towards modelling skills. These capabilities include not only knowledge related to mathematical contents, but also transversal competences such as problem solving, representation and connections (Montoya Delgado, Viola, & Vivier, 2017; Niss & Højgaard, 2011). Therefore, modelling is a focus of interest for researchers in mathematics education (Carreira & Baioa, 2017). A great number of authors have addressed this issue from a wide range of perspectives.

Our synthesis of the different approaches reveals five features that describe how educational researchers understand mathematical modelling: (i) Modelling is a student's activity. Indeed, Chevallard, Bosch, and Gascón (1997) stated that mathematical knowledge is a human activity and, as a part of Mathematics, so is modelling. What is more, they emphasised that a great part of all mathematical activities can be understood as modelling activities; (ii) Modelling is connected to a problem originated from a certain system. In this regard, Castro and Castro (1997) identified “modelling” and “problem solving”, whereas other researchers claimed that the purpose of modelling is to produce knowledge about the studied system (Chevallard, 1989). A third group distinguished between modelling “for”, if the purpose is to solve a problem, and modelling “of”, if the purpose is to generalise to produce knowledge (Streefland, 1985); (iii) Modelling entails a process, i.e., modelling follows a sequence of steps that individuals carry out when tackling a problem. These steps can make up an ideal cycle (Blum & Leiß, 2007; Borromeo Ferri, 2006) or just a set of activities (Ärlebäck, 2009); (iv) Modelling drives students to acquire mathematical skills. On this point, Niss and Højgaard (2011) understand modelling as a competence to be developed in school. Likewise, Blomhøj (2004) interprets it as a teaching practice that links real world and mathematics. Further, García, Gascón, Higuera, and Bosch (2006) pointed to a double didactic power of mathematical modelling, namely that it can be used to teach mathematical contents, or it can constitute the objective of learning; (v) Modelling leads to the construction of a model, which is the product of modelling

(Sriraman, 2006). In this sense, modelling means a translation between real world and mathematics (Blum & Borromeo Ferri, 2009) or between different mathematical domains (García et al., 2006). The discussed five features above allow us to understand modelling in mathematics education as *the activity that entails the development of some mathematical skills, originating from a question within a system and is carried out during the process of design, application and evaluation of models. These models allow the use of mathematics to produce knowledge about the system.*

Importance of the concept of model and research question

The synthesised notion of modelling given above relies on several ideas that researchers must specify depending on their goals: What kind of *skills* are entailed by modelling? Which activities are related to *the process of design, application and evaluation*? What is a *model*? As commented on above, there is an extensive literature addressing the process and competencies associated with modelling (see Kaiser, 2014 for a review). Nevertheless, there is a lower number of papers addressing the analysis from the notion of model. The importance of having an operational definition of model is crucial for research purposes. Firstly, it allows focusing the research on the actual model whenever the whole modelling process is inaccessible or too complex to analyse. Secondly, it also provides what elements to focus on when analysing a mathematical model, and which in addition is also useful when discussing other dimensions of modelling.

In this context, the research questions addressed in this paper are: Which elements comprise a mathematical model in the framework of modelling outlined above? Can these elements make up a functional definition of mathematical model? With the aim of answering these questions, we now turn to discuss and elaborate on the main features of the preceding discussion.

Definition of mathematical model for research

Background and relevant items

The importance of lending meaning to the term “mathematical model” has been discussed in the past years. Even though almost all the authors share the intuition of a model as a mapping between a system and a mathematical structure enabling to answer questions or get information about the system, there is no agreement on the nature of mathematical models or what their key components are. An early explicit definition of mathematical model was proposed in the context of engineering (Minsky, 1965). Under this approach, a model is a supporting decision-making tool. This pioneer idea focuses on the usefulness for the system but is far away from being functional for research. However, it contains the first relevant item to define a model up: the analysis of a problem within a system. Connecting back to mathematics education, Lesh and Harel (2003) proposed a notion of model which was based on two components: a mathematical conceptual system together with its accompanying procedures. Both components are expressed through different representations in order to solve a problem. Lesh and Harel complementary perspective is more aligned with the purposes of our paper, which from our point of view stresses two elements that must be considered in educational research: a mathematical description of a problem and the representations that allow working with that description to solve the problem. Niss (2012) defined the term mathematical model without associating it with a problem through the triplet (D, f, M) that connects an extramathematical domain (D) with a mathematical realm (M) via the “mathematisation” mapping (f). Niss’ definition included

the domain as a part of the model and also objectified the intuition of the mapping that links the system with mathematics. However, f is not always easy to use in analysis. Sometimes it is quite difficult to find the D-M-correspondences because the objects/variables of interest might be implicit (e.g. the best value for money in the second example below). In other cases, the key point of the model does not rely on the connection but in the use of mathematical properties (the extensive nature of area in the first example). Velten (2009) avoided the mathematisation mapping by defining a mathematical model using another triplet, (S, Q, M) , but with a different interpretation: S is a system, Q is a question related to S and M is a set of mathematical statements that can be used to answer Q . As with Niss' definition, Velten's approach provides suitable categories of analysis, but it focuses on a problem and does not (explicitly) take representations into account.

The synthesis of the ideas explained above stress the following key features of a mathematical model: (i) that a model is determined by a set of specific components, that lead to define suitable categories of analysis; (ii) that a model is associated with a system (instead of a problem); (iii) that a model includes a mathematical structure that allow working with the model; and (iv) that a model includes representations. Our integration of these features gives rise to the new definition of model we propose below and which we suggest being used for research in mathematics education.

Definition of model

A mathematical model is a triplet (S, M, R) , where

- S is the *system* the model is concerned with. It consists of a set of objects, their properties, and the relationships between objects and properties.
- M is the (conceptual) *mathematization* of the system, i.e., the set of mathematical concepts and properties that abstract the relevant information from S , along with the set of relationships applied to produce mathematical knowledge from the system.
- R is the set of mathematical *representations* of the system. It contains the explicit representations that enable to work mathematically with the elements of M and, thus, produce knowledge about the system.

This definition is constructed from three inseparable components that show different levels of abstraction S is real (as well as the context in which the system is framed), but M is purely conceptual, so it is inaccessible and usually not evident. It is necessary, therefore, to use R (observable) to describe and work with the model. Figure 1 represents these levels and two types of connections between the components of a mathematical model, which are discussed below.

Categories of analysis

The main characteristic of this definition is its functionality, since it allows establishing categories for the analysis of mathematical models produced in educational contexts. In order to provide a complete view of what a model creator (the research participant) contributes, the analysis based on the triplet (S, M, R) may be decomposed into two parts. The first part is composed of the elements received by the model creator, that is, the explicit information he/she receives (the enunciation of a task, for example). The second part is constituted by the elements contributed by the creator, which may include identified objects in, or hypothesis about, S , latent concepts or relationships of M , or

new representations incorporated in R in order to generate knowledge by working mathematically. It is of interest to specify two subcategories of contributed elements within the mathematization (M) component: (i) premises, which are mathematical statements used without justification (they might be explicit or latent and made visible through R); and (ii) deductions, which are those statements justified by an explicit rationale. These categories are not exhaustive, since one can find contributed elements of mathematization that are neither premises nor deductions (see the examples below).

The argument above give rise to six categories of analysis: system received (S_r), mathematization received (M_r), representation received (R_r), system contributed (S_c), mathematization contributed (with premises M^p_c and deductions M^d_c) and representation contributed (R_c). These are the elements of the mathematical model to be studied. The categories induce a first stage of analysis (the description of what model creator has received) and a second stage of analysis of what he/she has contributed. In addition, within the analysis of a model, an S-R-M natural strategy emerges, so that the researcher can obtain complete information about the model by (i) paying attention to the involved elements of the system S, then (ii) focusing on the representations R and finally (iii) analyzing the conceptual mathematization of the system M. This analysis sequence deviates from the order of the components (S, M, R) in our definition. The sequence S-M-R was chosen for the definition since it evokes the ideal mental process of building a model. Components of the model may be described following this procedure (Figure 1).

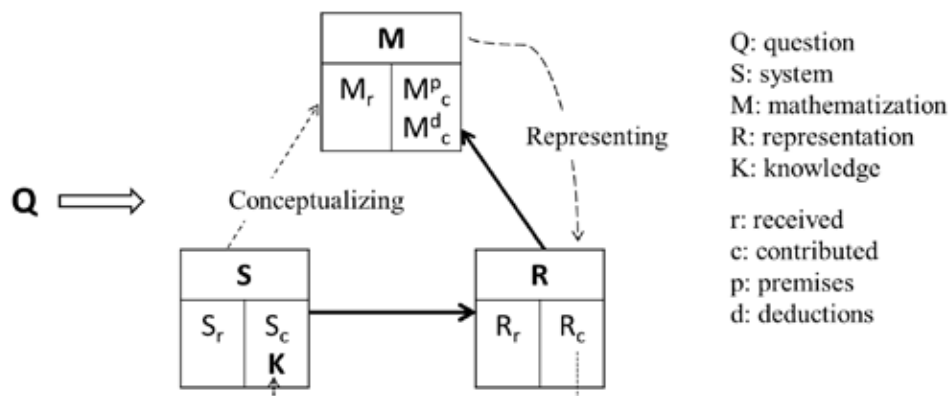


Figure 1: Scheme of the proposed model concept. Note that the analysis strategy (continuous line) and the mental process that generates the model (dashed line) follow different trajectories

Application of the proposed definition: The analysis of school models

Two practical examples

The examples below show the models that two different pre-service teachers at the University of Cordoba (Spain) proposed for solving two released items from the PISA 2003 framework (OECD, 2006). The analyses were carried out following the S-R-M strategy explained above, by first focusing on the elements received by the pre-service teachers and secondly on what the pre-service teachers contributed, with special attention paid to the premises and deductions in the analysis of the used mathematization (M). The results of the analyses are summarized in Figures 2 and 3.

Example 1: Antarctica (Figure 2). The student does not contribute any elements to the system (S). She mostly bases her answer on the picture and provides some verbal reasoning. There are no explicit

mathematical concepts, although she implicitly uses the extensive nature of the area. She estimates the area of Antarctica as a portion of an imaginary squared surrounding the island. This approximation is a premise, which shows no clue about how she would proceed for an island with different shape.

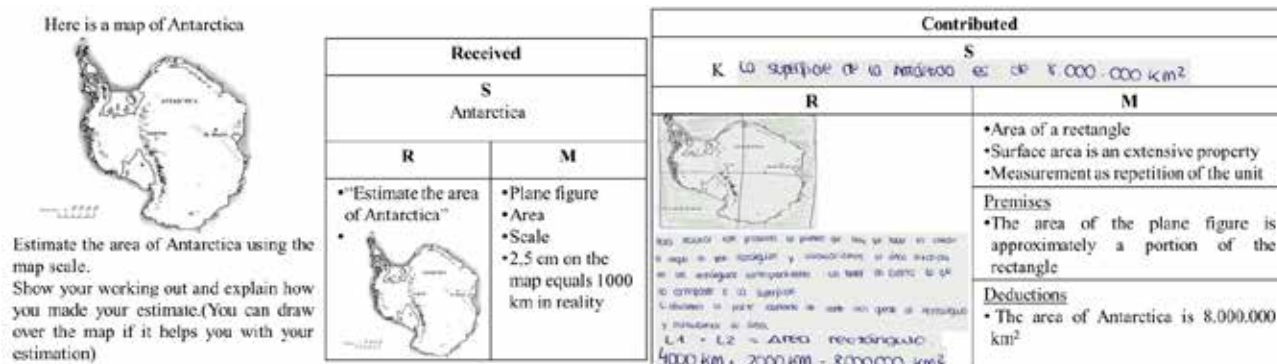


Figure 2: Proposed analysis for a given answer to the task “Antarctica”

Example 2: Pizzas (Figure 3). The student does not contribute any explicit element to the system. However, he tacitly introduces the value for money notion when he states “with one zed, I am buying a portion of 31,416 cm²”. He mostly uses symbolic representation. The premises are relevant because he (i) identifies that the relation diameter-area is not linear and (ii) recognizes the area as the correct variable for estimating the best value for money. This is evidence of a possible general procedure to apply for other kind of sizes of pizzas.

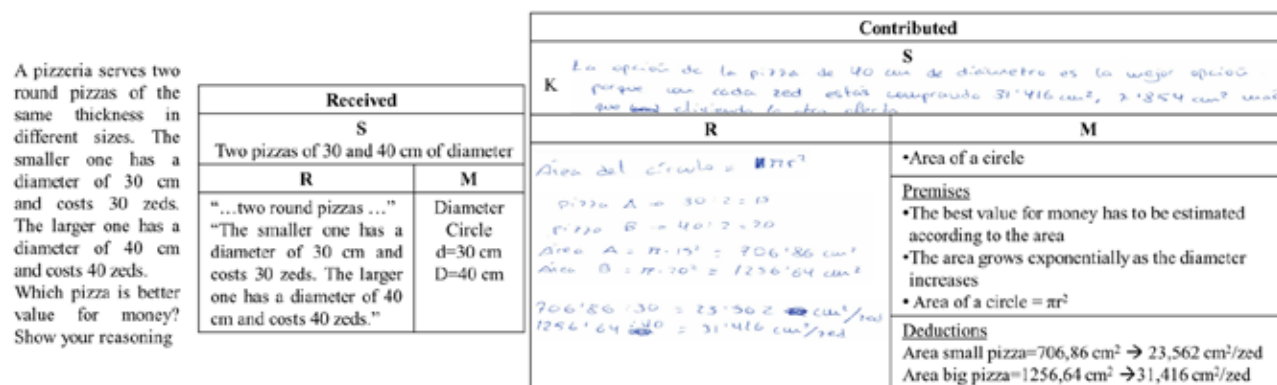


Figure 3: Proposed analysis for a given answer to the task “Pizzas”

Discussion

We now turn to discuss some of the aspects and features of the provided definition of the notion of mathematical model in this paper. Firstly, readers should note that the components of a model are not specified univocally in the formal nature of the definition (Velten, 2009). This is intentionally done in order to let each researcher specify the meanings of each component according to his/her various needs.

Secondly, when dealing with the components S, M, and R of the definition, these should be understood as inseparable elements. In this way, the definition is applicable from different perspectives and at different levels of abstraction. In Mathematics Education, S very often depends on the task context (which may be mathematical or extra-mathematical). Therefore, S is susceptible to empirical or conceptual experimentation. In turn, R contains the evidences of the application of the

model in specific cases. Particularly, *R* captures the representations of the knowledge of the system obtained by the model creator and represents the source of information for the analysis of the models linked to tasks. This is the reason why *R* should be of special interest for research in mathematics education. Finally, *M* contains information about the level of abstraction of the model. *M* is not limited to a conceptual structure or a set of affirmations. As Niss (2012) pointed out, *M* contains a large number of objects, relationships, properties, results, hypotheses and ways of reasoning that enable understanding of the evidence collected in *R*. Subcategories within *M* (premises and deductions) are specified to provide a better understanding of the model. Premises offer information about how the modeller conceives the system and what mathematics can be applied to get knowledge of relevance to *S*. On the other hand, deductions show the way of reasoning and the conclusions obtained. By combining the analysis of both elements, the researcher is able to identify whether there is an underlying general model. It should be pointed out that premises are sometimes not evident to identify and that they have to be conjectured based on the collected information. For instance, in the example of Antarctica, it is difficult to identify the premises used by the student to create her model. Nevertheless, the student in example 2 provides evidence that he would be able to tackle the task given pizzas of different prices, shapes and sizes.

Thirdly, we provide a comment on the role played by the question or problem posed. Velten (2009), in engineering, emphasized the importance of including the problem to be solved (*Q*) within the model. From Velten's perspective, without including a question about the system, the model would not emerge. However, we decided not to include this element (the question) in our model definition for simplicity reasons and also because we consider a model as an instrument used to generate knowledge, and hence to go beyond specific problems (Chevallard, 1989). Furthermore, the same model is able to answer different questions in a system (for instance, Cuisenaire's strips are useful to answer different arithmetic questions). On the other hand, the knowledge generated (*K*), which includes possible answers to *Q*, can be seen as belonging to the model, namely as part of *S* since *K* establishes relationships within the system which were previously unknown (see Figure 1 for different relationships between *Q*, *K*, *S*, *M* and *R* within the framework of the proposed definition).

Fourthly, the potential of the proposed definition to be a flexible analysis tool should also be highlighted. As indicated above, the system *S* and its conceptual mathematization *M* may contain very diverse elements and relationships. Hence, it is natural to establish subcategories for the exploration of the elements of *S*, *R* and *M* in order to obtain a greater depth in the analysis. However, the generality of the definition prevents establishing univocal criteria *a priori* to discriminate between different types of entities in the analysis. These reasons led to the establishment of broad categories. However, as discussed above, subcategories were only included in the study of *M*, but in any case, when required, the scheme (*S*, *M*, *R*) does admit that particular subcategories are developed to specify a finer categorization or a hierarchy of properties associated with the system under study.

Finally, it is important to draw attention to the specific character of the proposed definition for research in mathematical education. Especially two properties may be highlighted: (1) The inclusion of *R* as a component of the mathematical model (Lesh & Harel, 2003). This element, not considered in other areas, is essential in education, since most of modelling performed in school mathematics consists of choosing a suitable representation (a manipulative material, the number line, a tree

diagram in probability); (2) The application of the model with the focus on the student's activity. When considering the part received and the part contributed by the student, the definition seeks to make the contribution explicit, differentiating the information of S and representations provided (the statement of a task, for example). This distinction also has didactic applications enabling to control the task variables and generate situations of different difficulty within the same system.

Conclusions

This paper provides a definition that includes all the elements a mathematical model should possess according to our literature review. The novelties of this approach are the focus on the model, instead of on the process or the competencies (like in most of the background literature) and the functional nature of the definition provided, which has been exemplified and discussed throughout the paper.

Regarding the elements that comprise a mathematical model and how they can make up a functional definition, this proposal combines three inseparable elements which, as a whole, account for a mathematical model from different levels of abstraction. A system, S, that includes elements of the context; its mathematical conceptualization, M; and the set of representations, R, that a student uses to describe S, M and to work mathematically. Each of these components provides flexible focus of attention for research and an internal logic that offers an analytical strategy suitable for the analysis of modelling in schools. The main advantage of this definition lies in its applicability for the analysis of scholar models. Its disadvantages are also related to its operational nature: on one hand, at least 6 categories must be distinguished to define a model; on the other hand, the desirable idea of a model as a mapping between reality and mathematics (Niss, 2012) then becomes diluted.

We expect that our proposed definition not only is functional, but also general (applicable to a wide range of modelling scenarios). Future research will need to focus on this and of analyzing the effectiveness and usefulness of the given proposal, as well as its applicability to different contents and educational levels. In addition, also the potential didactic applications need to be explored in future work.

References

- Ärlebäck, J. B. (2009). Exploring the solving process of group solving realistic Fermi problems from the perspective of the Anthropological Theory of Didactics. In M. Pytlak, T. Rowland, & W. Swoboda (Eds.), *Proceedings of the CERME7* (pp. 1010–1020). Rzeszów, Poland: CERME.
- Blomhøj, M. (2004). Mathematical modelling. A theory for practice. In B. Clarke, D. Clarke, G. Emanuelsson, B. Johnansson, D. Lambdin, F. Lester, A. Walby, & K. Walby (Eds.), *International perspectives on learning and teaching mathematics* (pp. 145–159). Göteborg, Sweden: Göteborg University, National Center for Mathematics Educations.
- Blum, W., & Borromeo Ferri, R. (2009). Mathematical modelling: Can it be taught and learnt? *Journal of Mathematical Modelling and Application*, 1(1), 45–58.
- Blum, W., & Leiß, D. (2007). How do students' and teachers deal with modelling problems? In C. Haines et al. (Eds.), *Mathematical modelling: Education, engineering and economics* (pp. 222–231). Chichester, UK: Horwood.

- Borromeo Ferri, R. (2006). Theoretical and empirical differentiations of phases in the modelling process. *Zentralblatt für Didaktik der Mathematik*, 38(2), 86–95.
- Carreira, S., & Baioa, A.M. (2017). Creating a color palette: The model, the concept, and the mathematics. In T. Dooley & G. Gueudet (Eds.), *Proceedings of the CERME10* (pp. 916–923). Dublin, Ireland: DCU Institute of Education and ERME.
- Castro, E., & Castro, E. (1997). Representaciones y modelización. In L. Rico (Ed.), *La Educación Matemática en la enseñanza secundaria* (pp. 95–124). Barcelona, Spain: Horsori.
- Chevallard, Y. (1989). Le passage de l'arithmétique à l'algébrique dans l'enseignement des mathématiques au collège–Deuxième partie: Perspectives curriculaires: la notion de modelisation. *Petit x*, 19, 45–75.
- Chevallard, Y., Bosch, M., & Gascón, J. (1997). *Estudiar matemáticas. El eslabón perdido entre la enseñanza y el aprendizaje*. Barcelona, Spain: ICE/Horsori.
- García, F. J., Gascón, J., Ruiz-Higueras, L., & Bosch, M. (2006). Mathematical modelling as a tool for the connection of school mathematics. *ZDM Mathematics Education*, 38(3), 226–246.
- Kaiser G. (2014) Mathematical modelling and applications in education. In S. Lerman (Ed.) *Encyclopedia of mathematics education*. Dordrecht, the Netherlands: Springer.
- Lesh, R., & Harel, G. (2003). Problem solving, modeling and local conceptual development. *Mathematical Thinking and Learning*, 5, 157–189.
- Minsky, M.L. (1965) Matter, minds and models, *Proceedings of the International Federation for Information Processing (IFIP) Congress* (pp. 45–49). Washington, DC: Spartan Books.
- Montoya Delgado, E. Viola, F., & Vivier, L. (2017). Choosing a Mathematical Working Space in a modelling task: The influence of teaching. In T. Dooley & G. Gueudet (Eds.), *Proceedings of the CERME10* (pp. 956–963). Dublin, Ireland: DCU Institute of Education and ERME.
- Niss, M. (2012). Models and modelling in mathematics education. *Newsletter of the European Mathematical Society*, 86(4), 49–52.
- Niss, M., & Højgaard, T. (Eds.) (2011). *Competencies and mathematical learning: Ideas and inspiration for the development of mathematics teaching and learning in Denmark*. Roskilde: Roskilde University. IMFUFA-tekst: I, om og med matematik og fysik, No. 485.
- OECD (2016). *PISA released items – Mathematics*. Available at <http://www.pisa.oecd.org/dataoecd/14/10/38709418.pdf>
- Sriraman, B. (2006). Conceptualizing the model-eliciting perspective of mathematical problem solving. In M. Bosch (Ed.), *Proceedings of the CERME4* (pp. 1686–1695). Sant Feliu de Guíxols, Spain: FUNDEMI IQS, Universitat Ramon Llull.
- Streefland, L. (1985). Wiskunde als activiteit en de realiteit als bron, *Nieuwe Wiskrant*, 5(1), 60–67.
- Velten, K. (2009). *Mathematical modelling and simulation. Introduction for scientists and engineers*. Weinheim, Germany: WILEY-Springer.

The extended theoretical framework of Mathematical Working Space (extended MWS): Potentialities in physics

Laurent Moutet¹

¹ Laboratoire de Didactique André Revuz, UFR de mathématiques, Université Paris Diderot, Paris, France; laurent.moutet@ac-amiens.fr

The aim is to show how the extended Mathematical Working Space (extended MWS) theoretical framework makes it possible to analyse the tasks implemented during a few stages of a modelling cycle in physics. The study begins with a special relativity teaching sequence using a diagrammatic approach in “Terminale S” in France (Grade 12). The analysis using the extended MWS theoretical framework allows to highlight the learning advantages of this diagrammatic approach during a complete didactic engineering. This work is proposed for TWG6 to CERME11.

Keywords: Mathematics, physics, extended MWS, modelling.

Presentation of the extended MWS theoretical framework

The Mathematical Working space (MWS) was developed to better understand the didactic issues around mathematical work in a school environment by Kuzniak, Tanguay, and Elia (2016). The MWS has two levels: one of a cognitive nature in relation to the student and another of an epistemological nature in relation to the mathematical content studied. The epistemological plane contains a set of representations (signs used), a set of artefacts (drawing instruments or software) and a theoretical reference set (definitions and properties). The cognitive plane contains a visualization process (representation of space in the case of geometry), a construction process (function of the tools used) and a discursive process (arguments and evidence). Mathematical work results from an articulation between the cognitive and epistemological planes through instrumental genesis (operationalization of artefacts), semiotic genesis (based on the register of semiotic representations) and discursive genesis (presentation of mathematical reasoning). The different phases of mathematical work associated with a task can be highlighted by representing three vertical planes on the ETM diagram. Semiotic-instrumental interactions lead to a process of discovery and exploration of a given academic problem. Those of an instrumental-discursive type favour mathematical reasoning in relation to experimental evidence. Finally, those of the semiotic-discursive type are characteristic of the communication of mathematical results as well as of more elaborate reasoning. The MWS diagram was transformed by Moutet (2018) by adding an epistemological plane corresponding to the rationality framework of physics (Figure 1). It was chosen to keep only one cognitive plane. We hypothesized that students' conceptions in mathematics and physics can be highlighted using a students' personal extended MWS. The functioning of the schemes (Vergnaud, 2013) specific to these conceptions could appear during the activation of the various geneses. The Concepts in mathematics would be highlighted by the activation of geneses, between the cognitive plane and the epistemological plane of mathematics, those in physics would be highlighted by the activation of geneses, between the same cognitive plane and the epistemological plane of physics. A single cognitive plane would therefore be

sufficient to describe conceptions in mathematics, physics and to analyse student tasks from both a mathematics and a physics perspective. The term “proving” is retained, but in the case of the extended MWS, it will take a narrower meaning of justification or reasoning. The extended MWS framework makes it possible to analyse in detail the interactions between the various rationality frameworks, and the student’s cognitive plane and then to qualify the nature of the work accomplished by the student.

The epistemological plane of mathematics studied here concerns Euclidean geometry. The tasks to be carried out are associated with the construction of lines, segments, symmetries parallel to a line, projections passing through a point and parallel to an axis. The epistemological plane of physics is associated with the reference frame of special relativity studied in class. These are the notion of the Galilean reference frame (two reference frames moving in a straight line and at a constant speed with respect to each other), of an event (a point located on a space-time diagram and associated with a position x and a time t), of Einstein’s two postulates, of the notion of proper duration and improper duration as well as the relationship of dilation of durations. Lorentz transformations are not studied in Grade 12.

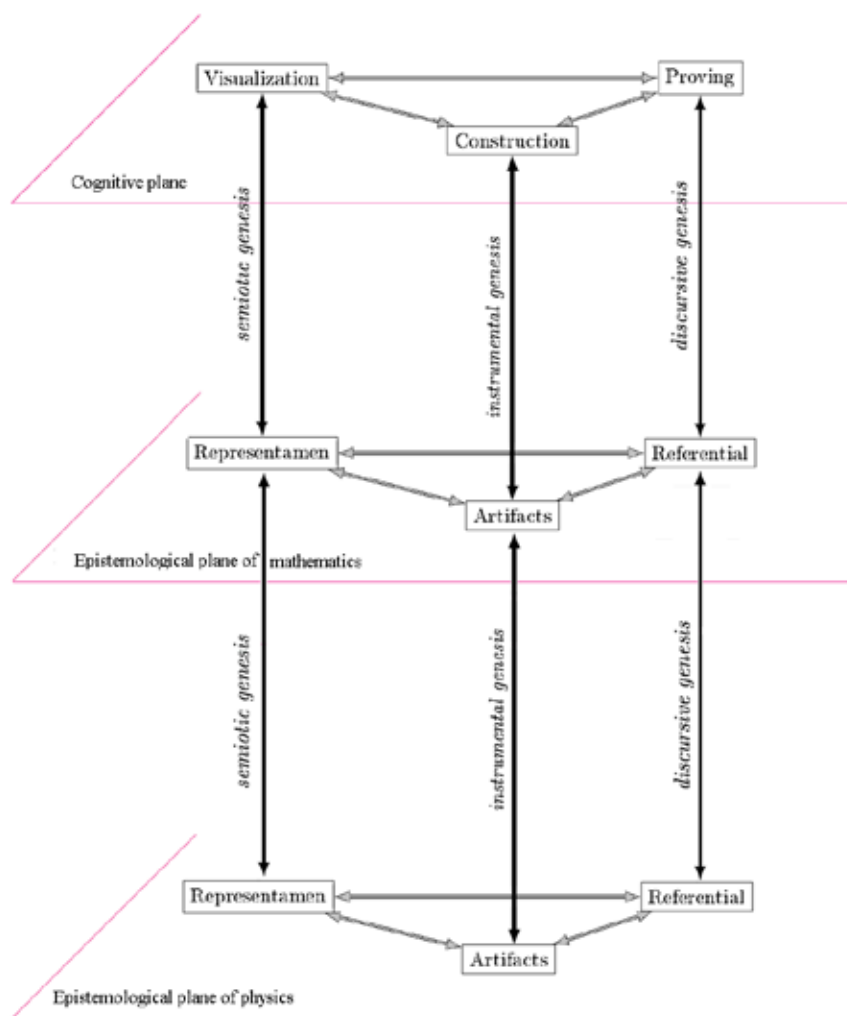


Figure 1: Extended MWS Model

From the “model situation” to the “real results” during a special relativity modelling

A teaching sequence developed by Moutet (2018) is destined for students in “Terminale S” (Grade 12) on the topic of special relativity following the work of de Hosson, Kermen, and Parizot (2010). It follows the learning of the course, and the correction of exercises in the manual, and participates in the conceptualisation of notions of special relativity, by allowing them to be reinvested in a different and unknown context (Vergnaud, 1990).

Two research questions guided this work: 1) How does the extended MWS framework allow the analysis of the sets of rationality frameworks between mathematics and physics during a sequence dealing with special relativity with “Terminale S” students via a geometric approach? 2) To what extent does the analysis of the use of dynamic geometry software by the extended MWS framework show that it promotes conceptualisation in students?

The teaching sequence can be described in the following context: Armineh drives a car moving at a speed v near the speed of light relative to Daniel. The latter is on the roadside next to three flash lights S_1 , S_2 and S_3 associated with three events E_1 , E_2 , E_3 and initially known in Daniel's reference frame (Figure 2). An event E_i corresponds to a coordinate point $(x_i, c.t_i)$ in the Minkowski space-time diagram. S_1 and S_2 have the same position in Daniel's reference frame.

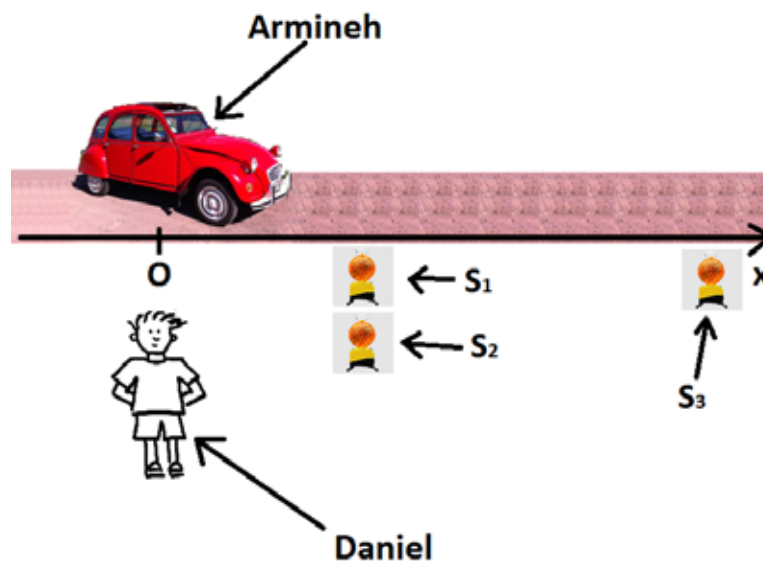


Figure 2: The “real model” of the situation

We can use the modelling cycle proposed by Blum and Leiss (2005) to position the teaching sequence on the chronological order of events as a function of the reference frame in the context of special relativity. We carried out a preliminary study of a sequence by studying the passage real model \rightarrow real results with the objective of developing a longer-term sequence covering a complete modelling cycle real situation \rightarrow real results. In this case, it will not be appropriate to use a “2CV” as a vehicle to favour the passages real situation \rightarrow situation model and situation model \rightarrow mathematical results.

We can also take the point of view of Vince and Tiberghien (2000) who studied the articulation between the world of objects and events and that of theories and models in the physical sciences. The objects resulting from the simulation are observable and can be manipulated. They are not real objects or elements of the world of theories and models. They act as intermediaries, facilitating the transition, through the problem-solving activity, between the world of objects/events and the world of models.

The Minkowski diagram is a space-time diagram allowing to know the space-time coordinates of an event in a reference frame of Armineh or Daniel. In the Minkowski diagram, the line $x = 0$ is described by the axis $(Oc.t)$ in the Daniel reference frame. Similarly, the line $x' = 0$ is described by the axis $(Oc.t')$ in the Armineh reference frame. c is the speed of light in vacuum or air. Projections on this type of diagram are made parallel to the axes. The axis (Ox') is the symmetric of the axis $(Oc.t')$ with respect to the line $x = c.t$. It is the same for the axes (Ox) and $(Oc.t)$.

The dynamic geometry software GeoGebra and the Minkowski space-time diagram were used by the students. It represents the reference frame $(xOc.t)$ relative to Daniel's reference frame and the reference frame $(x'Oc.t')$ relative to Armineh's reference frame. The latter moves at the speed v of 0.6 times the speed of light in vacuum with respect to Daniel along an axis (Ox) . The straight lines (Ox) or (Ox') correspond to the route in Daniel's or Armineh's reference frames (Figure 3).

With respect to Daniel, the chronological order of production of the three events is E_1 , E_2 and E_3 while with respect to Armineh the order is E_1 , E_3 and E_2 . The GeoGebra cursor allows to modify the experimental conditions by changing the speed v and thus observe a change of chronological order of events production in the Armineh frame of reference. The corrected activity file with the Minkowski diagram is available by clicking on the following hyperlink: https://drive.google.com/open?id=0B_f8SgBLz2P0N0xfazFCSmU3MHM

The epistemological plane of mathematics and the cognitive plane are mobilised during the construction of the cursor because it is necessary to know how the Ox' and $Oc.t'$ axes are modified according to the speed v . The two axes are symmetric with respect to the line $x' = c.t'$ which is also confounded with the line $x = c.t$. The epistemological plane of physics is also mobilised when the students conclude on the chronological order of events according to the two reference frames (Figure 4).

A class of 34 students from a secondary school in Picardy participated in the experiment. A first paper-pencil session was performed to construct and use the Minkowski diagram with strong teacher guidance. The work focused on the phenomena of time dilation for a given speed from one reference frame to another. The activity, corresponding to the second session, was then given to groups as a homework. The speed conditions were different from one group to another. The students had to model in autonomy the situation where the speed of one reference frame compared to another is modified and close to the speed of light. It was therefore necessary to use dynamic geometry software in autonomy, build the dynamic Minkowski diagram and deduce results on the chronological order of events according to the reference frames. Most students had not used GeoGebra software in high school. The students completed a first version of their homework assignments, and then worked for two hours in half class in the computer room to finalise their

GeoGebra file. Each student also made an MP3 recording to summarize the entire sequence, which totalled five hours. The work of four students was analysed, and they were selected based on their academic performance (success and difficult students).

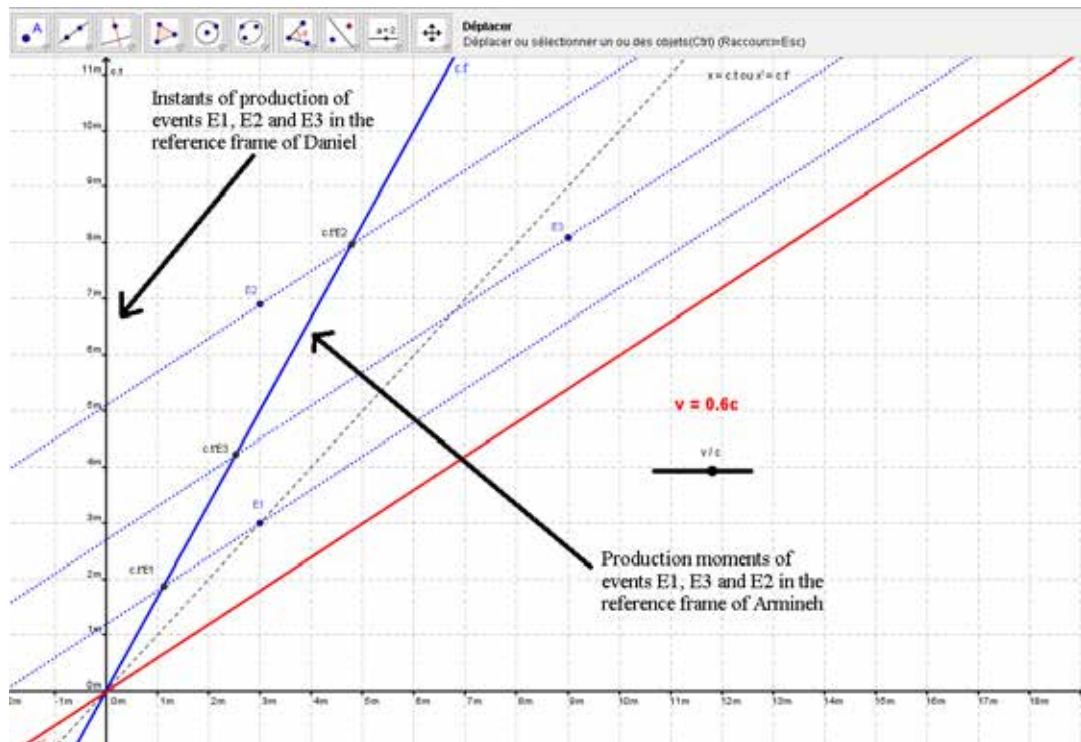


Figure 3: The mathematical model of the situation

With the MWS extended model we can perform a priori analysis of each of the tasks to be executed by the students. The level of difficulty of each task, can be appreciated by looking at the portion of the genesis instrumental-discursive or semiotic-discursive, more difficult, compared to the genesis semiotic-instrumental. A posteriori analyses allow us to study the tasks assigned to the students, and those carried out by them, considering the rationality frameworks of mathematics and physics. This study focused on the links between epistemological and cognitive planes. It led to the identification of the sets of rationality frameworks when solving this problem of special relativity treated by a diagrammatic approach. The dynamic geometry software GeoGebra allows to perform an additional semiotic genesis with its dynamic aspect. The cursor allows the speed conditions to change from one reference frame to another and the student can see the results directly on the screen. An instrumental genesis different from the paper-pencil activity, is also used during the construction of the Minkowski diagram. Finally, we hypothesise that GeoGebra, by making it easier to make conclusions about the relative chronological order of events, leads to the activation of an original discursive genesis. The audio recording, which the students made to summarise all the tasks performed during this sequence, allows them to communicate on the Minkowski diagram without directly implementing it. It is the sign of semiotic and discursive interactions favouring a conceptualisation of notions of special relativity.

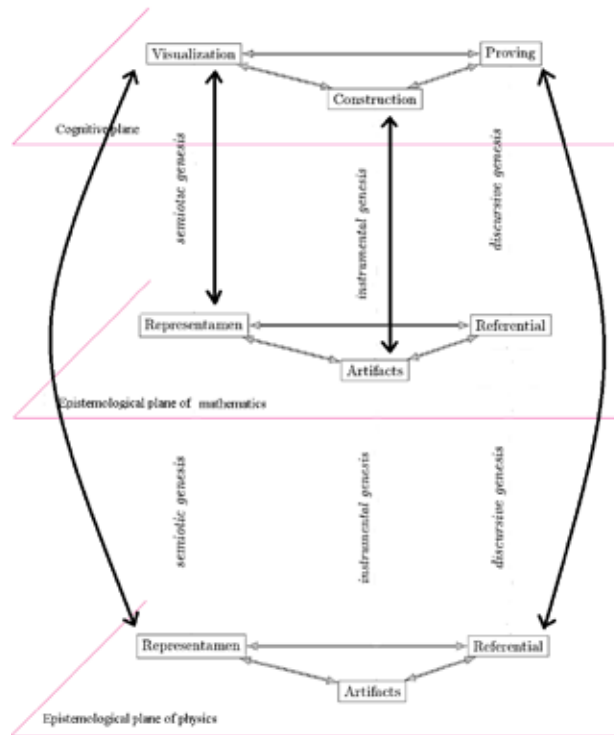


Figure 4: A priori analysis of cursor usage with GeoGebra

Student B's work is presented here. The Minkowski diagram includes the three events, the Ox , $Oc.t$, $Oc.t'$ axes, the $x = c.t$ line, and projections parallel to the $Oc.t'$ axis cutting an Ox' axis that is not correctly positioned. Also, the cursor does not appear. The notion of event seems to be mobilised as well as that of reference frame since the two reference points appear explicitly even if it remains imperfect. The notion of relative chronological order does not seem to be a well-known one (Figure 5).

The second version which has been reworked in class (personalised help from the teacher to give technical information on the cursor and on the meanings of the lines $x = c.t$. or $x' = c.t'$) includes the different elements which were missing in the first version. The Ox' axis is well positioned, the cursor for changing the v/c value appears and the $c.t$ coordinates of the different events also. Parallels to the $Oc.t'$ axis or to the Ox' axis passing through the different events are also represented.

This work highlights tasks described by semiotic-instrumental interactions, properly performed by Student B and more marginally tasks described by instrumental-discursive interactions. Important confusions are shown in the audio recording, on the construction of the line $O.c't'$ with an incorrect coefficient director (coefficient director of 0.6 instead of $1/0.6$ when $v = 0.6.c$). This recording also shows that Student B is saying results without using the Minkowski diagram or in a basic way. There is confusion about the goal of the activity (comparing speeds from Student B), or about the notion of the speed of a system in a given reference frame (Student B speaks rather of the speed of a reference frame). The explanations of the plot of the line $x = c.t$. are ambiguous as the positions of the $c.t'$ coordinates of the various events (Figure 6).

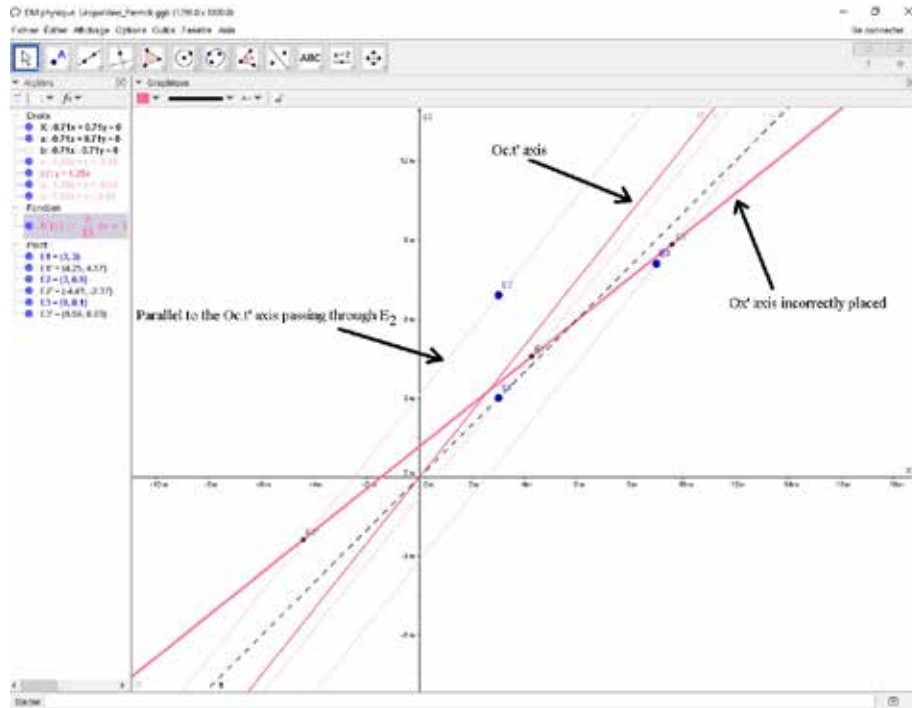


Figure 5: Screenshot of the first GeoGebra version of Student B

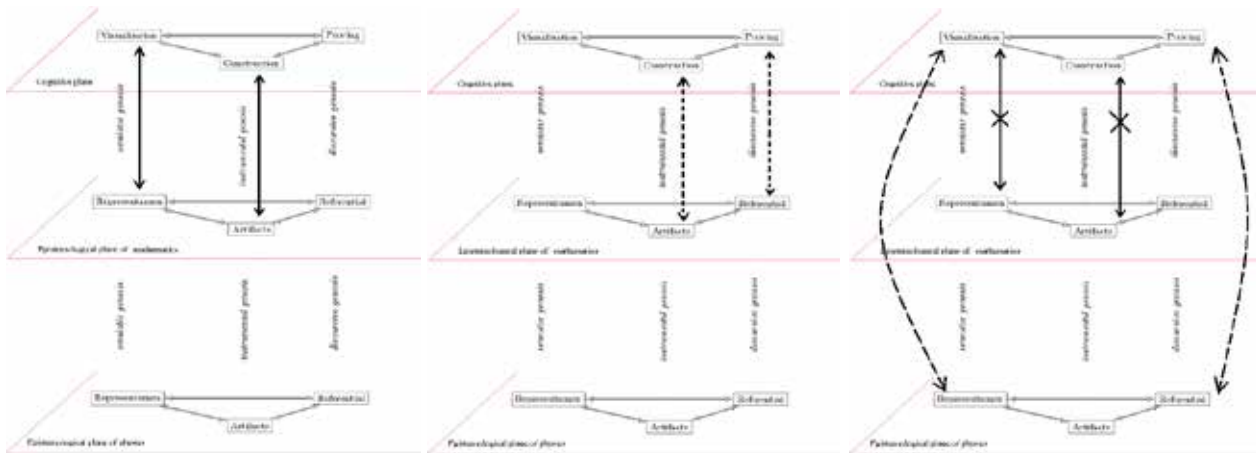


Figure 6: A *posteriori* analysis of the tasks performed by Student B

The black arrows describe a genesis on the extended MWS corresponding to a correctly performed task, the black arrows crossed out an incorrectly performed task and the dotted arrows, a partially successful task.

Conclusion

The extended MWS framework, allowed us to analyse the tasks associated with certain stages of the modelling cycle in a problem involving special relativity. It considers the mobilisation of the epistemological planes of mathematics, and/or physics for each of the tasks requested. The extended MWS framework also led us to show that the GeoGebra software develops specific geneses in relation to a paper-pencil activity. A new semiotic genesis leads to a visualisation of the change in the time coordinates of events as a function of Armineh’s speed v with respect to Daniel. A new

instrumental genesis corresponds to the manipulation of the dynamic geometry software, with the cursor functionality allowing to simply change the experimental conditions. Finally, a new discursive genesis makes it possible to conclude on the chronological order of events, according to the reference frame of study and the speed v . The extended MWS model leads to an *a priori* analysis of each of the tasks to be performed by the students and to a successful *a posteriori* analysis of the work performed by them. We then plan to analyse, using the extended MWS model or one of its evolutions, the tasks implemented at each stage of the global modelling cycle during other sequences using special relativity. Preliminary results tend to show that the genesis as well as the epistemological plans of mathematics and physics are not mobilised in the same way according to the stage of the modelling cycle, and that the teacher often, assumes implicitly an important part of the stages of the modelling cycle (we suppose an important assumption of responsibility for the stages going from the real situation to the real model), which does not help “in our opinion” the students to understand the problems which are given to them. Problem-solving exercises allow this understanding, but it takes time to complete. We plan to carry out the same study from the point of view of the theory of both worlds, that of objects/events and theories/models. It would thus be possible to finely analyse the passage between the two worlds via the simulated world using the extended MWS model.

Acknowledgement

I would like to thank all the members of the LDAR MWS working group.

References

- Blum, W., & Leiss, D. (2005). „Filling Up “– the problem of independence-preserving teacher interventions in lessons with demanding modelling tasks. In M. Bosch (Ed.), *Proceedings of the Fourth Congress of the European Society for Research in Mathematics Education* (pp. 1623–1633). Sant Feliu de Guíxols, Spain: FUNDEMI IQS – Universitat Ramon Llull and ERME.
- de Hosson, C., Kermen, I., & Parizot, E. (2010). Exploring students’ understanding of reference frames and time in Galilean and special relativity. *European Journal of Physics*, *31*(6), 1527–1538.
- Kuzniak, A., Tanguay, D., & Elia, I. (2016). Mathematical working spaces in schooling: An introduction. *ZDM Mathematics Education*, *48*(6), 721–737.
- Vince, J., & Tiberghien, A. (2000). Simuler pour modéliser. Le cas du son. *Sciences et techniques de l’Information et de la Communication pour l’Éducation et la Formation*, *7*(2), 333–366.
- Moutet, L. (2018). Analyse d’une séquence d’enseignement de la relativité restreinte: L’apport du modèle de l’ETM étendu. *Annales de didactique et de sciences cognitives*, *23*, 107–136.
- Vergnaud, G. (2013). Pourquoi la théorie des champs conceptuels ? *Infancia y aprendizaje*, *36*(2), 131–161.
- Vergnaud, G. (1990). La théorie des champs conceptuels. *Recherches en Didactique des Mathématiques*, *10*(2-3), 133–170.

Downscaling and upscaling Fermi problems

Marta Pla-Castells and Irene Ferrando

Universitat de València. Facultat de Magisteri. Valencia, Spain; marta.pla@uv.es
irene.ferrando@uv.es

The introduction of modeling tasks in the first grades of primary school requires a deep reflection from the point of view of both the design and the implementation. In this paper we describe an empirical exploratory study developed with the objective of designing a sequence of modeling tasks focused on solving a big numbers estimation problem that, in origin, is inaccessible for students. The key to the design of our sequence is to use a technique that we have called downscaling - upscaling, inspired by heuristic strategies. So, by resizing the initial problem, 2nd grade students are able to tackle a problem that seemed very big using complex mathematical procedures.

Keywords: Problem solving, measurement techniques, early childhood education, real context problems, heuristic strategies.

Introduction

In the last years, tasks based on real contexts are becoming increasingly important in primary and secondary school curricula. Even so, due to the complexity of carrying out this type of tasks in a classroom, both by teachers and students (Cabassut & Ferrando, 2017), there are few studies that analyze the implementation of this kind of task in the first years of primary school. All this makes of special interest the study of the concepts related to the measurement of magnitudes and the estimation of large quantities in a real context, using the so-called Fermi Problems.

Theoretical framework

Fermi problems

Jonas Ärlebäck (2009) defines Fermi problems as “open, non-standard problems requiring the students to make assumptions about the problem situation and estimate relevant quantities before engaging in, often, simple calculations”. According to the research presented by Ärlebäck and Albarracín in the previous edition of CERME, this definition is the most used in mathematics education research literature. Here we will focus on a particular kind of such problems: *Big numbers estimation problems* (Albarracín & Gorgorió, 2013).

Twenty years ago, Clements (1999) already claimed that children, in their first experiences with length measurement, should be given a variety of experiences in order to develop measurement strategies. According to Hogan and Brezinski (2003), an important part of teaching measurement concerns the development of estimation. Nevertheless, there are still few studies that refer to the way estimation is worked in primary school classroom (Pizarro et al., 2015).

In previous works, other authors have made experiences based on the use of Fermi problems with students of the higher levels of primary education (Peter-Koop, 2009) and very recently with students of the first cycle of primary education (Gómez & Albarracín, 2017). In the present work we have tried to take advantage of environments close to the students to introduce some elementary concepts

related to the calculation of a magnitude that is often complicated and leads to confusion: the perimeter of a polygon (Mason, Stephen, & Watson, 2009).

Modelling sequences

Ärlebäck, Doerr and O’Neil (2013, p. 316) gave importance to the development of sequences of modeling tasks so that through these sequences students “engage in multiple cycles of descriptions, interpretations, conjectures, and explanations that are iteratively refined while interacting with other students”. In this way, by constructing a sequence of modeling tasks, we can deepen the study of complex concepts in the first years of primary school. Based on the previous works of Pólya (1973) and Stender and Kaiser (2017) we have also focused on the use of heuristic strategies directed by teachers when solving complex modeling tasks. We propose a design of a sequence of tasks based on the heuristics recommendations provided by Pólya (1973, p. xvi): “If there is a problem you can’t solve, then there is an easier problem you can solve: find it.” Stender and Kaiser (2017) affirm that, ideally, students should use heuristic strategies during the modeling process that teachers should convert into strategic interventions. Since our experience is addressed to very young students, our aim is to allow them to approach a complex problem using techniques based on downscaling and up-scaling the original problem as a heuristic strategy.

Research objectives

Our work is in an initial phase. We will give some details about the first phase of an empirical exploratory study where we intend to describe a technique, called downscaling-upscaling, to design sequences of Fermi problems in the first years of primary school. Since this is an early-stage investigation, our objective is limited to: (1) Describe in detail the aspects considered in the design of the sequence of tasks; (2) Describe a qualitative exploratory analysis of the results of implementation with a natural group of second grade students.

Methodology. Design of the empirical study

Sample

Our study focuses on a natural group of 21 second grade students of primary education who have not yet worked on the concepts of area and perimeter nor have ever faced a modeling task. They have already worked on arithmetic concepts like addition and subtraction but they have very little notions about multiplication. The activity was implemented in May 2017.

Treatment: downscaling – upscaling design of tasks sequence

The starting point of the activity is a very general question that, a priori, the students are not able to answer. The objective of establishing an initial problem is to observe that a complex problem that seems difficult to tackle – estimate the number of people necessary to surround the town – can be simplified if we try to solve similar smaller problems where the resolution strategies are equivalent. Following Pólya’s heuristics, we propose them to “solve a simpler problem”. In this case, what we try is to reduce (downscale) the scope of the initial question, first to the schoolyard and secondly to their classroom, giving them the opportunity to make measures in a very close context. Once they have attempted a solution of the simpler problem, we foster the generalization of the procedures

developed in the first part of the sequence (there the upscaling process starts). In the following, we give the details of the activities developed during each session of the experience.

1st session: A “Big Problem”. The introductory session aimed exclusively to present to the students the problem to be solved. Thus, this first activity started with an open question that students did not know how to answer: “*If we asked all the inhabitants of Sueca¹ to surround the town by standing next to each other, could they do it or would they have to ask for reinforcements from the people of the next town?*” At this point we just wanted to catch the attention of the students and identify some ideas about perimeter and big numbers conceptions.

2nd session: Progressively reducing the “Big Problem”. The first step was to propose to the students to make a smaller human chain. In this case, they were asked to think about how to estimate the number of students needed to surround the schoolyard. At this point, we just ask them to think about possible strategies to obtain, graphically, a procedure to get an estimation, not to measure or even compute. The second step was to answer to the smallest question: “*How many small wooden cubes do we need to surround a large wooden board?*” Here, we try to show them that the previous problems were the same as this one. In this case, we provide them with manipulative materials in order to foster measure strategies based on the iteration of the unit as explained in Barrett et al. (2011).

3rd and 4th session: We solve the problem of the schoolyard. During the third and fourth sessions, the students worked on the rectangular schoolyard. So, based on the strategies worked on in the previous session, the students would try to solve a bigger problem. They had to estimate the number of students needed to surround the perimeter of the yard. In these sessions, we provide students with one-meter-long ropes.

5th session: We work on scaled ground plans. In order to answer the “Big problem”, it is necessary to introduce the perimeter measurement on scaled plans. Therefore, the fifth session was devoted to work on a scale plan of a relatively small space close to students; a garden close to the school. We asked them to use the ruler and, using the scale and the estimations made in the schoolyard in the previous session, to estimate the number of people needed to surround the yard.

6th session: Solving the big problem. During this session each group of students was given a map in A3 format of the town of Sueca in a grid in order to finally give an answer to the “Big problem”.

Data collection and data evaluation

The experience was organized sequentially through five activities that were carried out over six sessions of 50 minutes. Students worked sometimes individually and sometimes in 4 groups of 4 children and one group of 5 (we will specify this in the following section). The teacher who conducted the sequence had previous experience in modelling activities and was working under the supervision of two researchers. During the group work sessions, we video-taped two groups, and we audio-taped the other groups. In Session 1 and at the end of the Session 6 there were whole group discussions that

¹ A Spanish town with around 28000 inhabitants.

were also video-recorded. In our analysis we have also considered the written productions (individual and grouped ones).

Since this is an exploratory study, we are limited to analyze the actions of students' groups to each of the tasks. In fact, the sample is not big enough to establish a grounded analysis. That is why we will not include any quantitative analysis; we'll just describe some aspects that we have considered important for further research. Our objective, at this point, is to identify whether the design of the sequence allows students to face, without blockages, the resolution of each task. We want also to identify, if possible, different strategies for solving equivalent problems and their evolution throughout the sequence. In the following section we summarize the description of the results for each session.

Description of the results

First session. The objective of this session was to collect general impressions of the students about a problem of estimating a big number. It is not expected that they will base their answers in mathematical arguments. Here are some of the answers collected: *“In the village there are too many people (S1)”*, *“There won't be enough people (S2)”*, *“There are many people who work (S3)”*, *“The planet is very large and we would not be enough (S4)”* and *“If we put one next to the other and put also the dogs and cars, yes we will be enough (S5)”*.

Since students were not asked for more than an unjustified spontaneous response, none of the reflections contain references to neither calculations nor mathematical concepts. This first activity allows us to detect difficulties linked to the understanding of the question (it is not clear in the case of the student S5), problems associated with the concept of perimeter (this we observe, for example, in the answer of the student S4) and the process of obtaining an estimation (response of student S3).

Second session. 1st part: Let's reduce the problem: the schoolyard: *“To surround the yard, are there enough children in this class? Or would we need to ask for help from children in the other classes?”* The students, working individually in the classroom, represented graphically how they would make the estimation. In the productions shown in Figure 1, different schemes are observed. In the third one there is some confusion between the perimeter and the area since the student tries to cover all the space of the schoolyard with children and not just surround its perimeter.

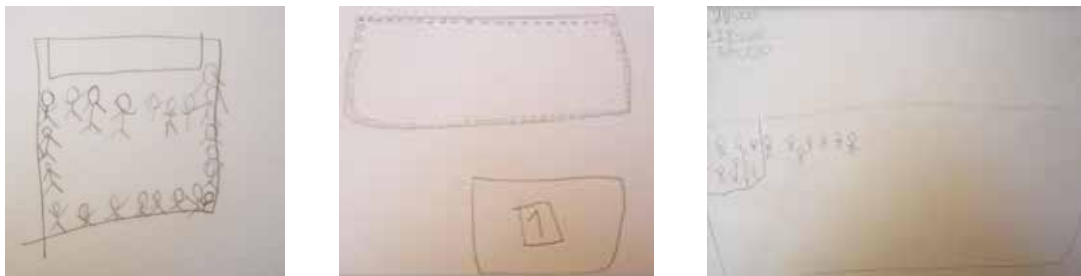


Figure 1: Some of the schemes made by students in the first part of Session 2

Another element detected in this part of the experience is the difficulty of the students to simultaneously handle elements of very different dimensions (the sides of the yard and the linear space occupied by a person). Indeed, when we asked the children to explain their answer from their

drawings, the unanimous answer was that they had to count the drawn “dolls”. Anyway, this part of the experience was rich to detect difficulties (linked to the difference between perimeter and area) and different levels in the resolutions.

As we have already noticed, the problem was still big for the students. Once all the students had graphically described their strategy to estimate the result of the problem of the schoolyard, workgroup began. At each group, students shared their ideas they previously represented. In order to help them better understand what they had done, they were encouraged to estimate the number of students needed to surround their tables. Here we observed that some students infer the most effective way to find the perimeter of a rectangular surface from the measurement of two unequal sides: add them and then make double. Once the notion of perimeter has been introduced intuitively, the second part of the session aimed to further reduce the initial problem.

2nd part: Deduction from manipulation. To answer the question “*How many small wooden cubes do we need to surround a large wooden board?*” only 5 small cubes were provided to the children. The boards provided to each group differed in their dimensions. In some of them the solutions were whole values, while in others there was too much or too little space, in order to observe how the students faced the problem.

Some groups proposed strategies based on the cyclic movements of the group of 5 cubes in order to count the number of cubes needed to cover one side. This strategy is interesting because the idea of an effective five-in-five counting is introduced and this improves the strategy of exhaustive counting. The concept of the measurement and estimation of the perimeter of a polygon was now formally introduced to the students.

3rd and 4th session: Each group was provided with a pair of ropes of the same length (one meter) in order to solve the problem of the number of children needed to surround the schoolyard. To clearly describe the two strategies observed, we will focus on the description of the groups that we will call Group A and Group B. One of the groups was totally lost and was not able to finish this activity.

The students of Group A counted effectively (making repeated sums of four-by-four) the number of children needed to cover the four sides of the rectangle that makes up the schoolyard using their bodies as a unit. They measured two unequal sides of the yard (in which they fit 29 and 38 children), then they doubled the values and then added both values. This group of students obtained as a result that 134 children were needed to surround the schoolyard.

Group B, although they obtained the measure in “children” of one of the sides of the yard, chose to measure the uneven side using the ropes. The students measured first with the ropes, and then they were urged to find out, from that measurement, the measure in “children”. Thus, during the development of the activity, Group B students obtained a measure of “9 ropes and 3 children” for the minor side of the schoolyard. In this way, from their first measurements, the teacher asked the students to try to find out how many children fit in each string. This part is particularly interesting because two complex aspects are worked on in a simple manipulative way: the notion of linear density (*how many children complete a rope?*) and the change of units (*how to transform a measure given in big unit –rope– in a smaller one –child–?*). The students estimated that they could cover each rope with 7 children. Thus, they faced the question: “*If we know that 7 children fit in each string, how many*

children do we have in 9 strings + 3 children?” After discussing this problem, the students came to the conclusion that the operation to be performed was to multiply 9×7 and then add 3. In this way, measuring the two unequal sides of the schoolyard, they infer the total of children that they needed to surround it: they estimate 292.

5th session: Work on scaled ground plans. During this session the students worked individually, each of them was given a scaled ground plan, a 15 cm graduated ruler and a calculator. Since they had already worked with the concept of perimeter, the first part consisted in answering the question: *“How many centimeters does the perimeter of the garden measure in the ground plan?”*

We did not identify any problem in the use of the graduated ruler (each side had a whole number measure), but we observed different strategies to obtain the total perimeter in centimeters. Some students followed the strategy of measuring each of the sides and adding the successive measurements of the sides as they got them (using the calculator). Others preferred to take note of the partial measures and, finally, add them. Once they had obtained the perimeter of the garden on the ground plan, they had to infer the real perimeter from the use of the scale (each centimeter of the plane represents 5 meters of reality). With the help of the calculator and after a whole group discussion, the students deduced that they should multiply the measurement found in the plan by 5. Next, they were asked to estimate, based on the measure of the perimeter in meters (approximately 360 meters), the number of children needed to surround the garden. Since in the previous session they had found, experimentally, that in each one-meter string 7 children can fit in, they simply had to 360 by 7. The children were very surprised by the result: they could not imagine that 2520 children were needed to surround the entire perimeter of the garden!

6th session: Solving the big problem. Before starting to do the calculations, the difference between a map and reality was explained again. Some students had difficulties with this concept, but we observed that those that had understood this idea were able to explain it to their classmates. Anyway, the intention of using a grid was to facilitate the use of scales, so the students were told that each side of each square of the grid corresponded to 250 people in line. Figure 2 shows a picture of the students working on the map. First, the students obtained an approximation to the perimeter of the town using the side of the square as unit. Since we told them that around 250 people fit in one square side of the grid, they just had to make one operation: multiply (using calculator) their previous result by 250. The obtained results varied between 51500 and 64500 people.



Figure 2: Working on the gridded map

At the end of the activity, it was important that the students could validate their solution. For this aim, we used the Google Maps tool that allows to measure distances on a plan. The perimeter of the town of Sueca measures approximately 10.5km, that is, 10500 meters. Since the students knew –from the resolution of the previous task – that 7 children fit in each meter, it was enough to multiply by 7, being the final result 73500 children. Since the number of adults that fit online in a meter is surely lower than the number of children, the result obtained by the students working on the grid was quite approximate. Therefore, the inhabitants of Sueca (around 28000 inhabitants) would not be enough to surround the perimeter of the town.

Conclusions

The procedures associated with the measurement of magnitudes, particularly the measurement of lengths, are strongly linked to estimation processes. The choice of the appropriate unit, the use of a specific unit, the strategy of iterating a unit, more than one unit, changes of scale (moving from one unit to another), etc., are, among others, procedures associated with the act of measuring. But in addition, in real life problems, these procedures also appear when making estimations. That is why, in our current research -which begins with this work- we intend to design a sequence of tasks whose starting point is a problem of estimating large quantities that allows us to introduce, at an early age, procedures linked to the length measurement.

We have presented here the design of a sequence of tasks that starts from a Fermi problem that is unapproachable for students. Thus, from two elementary heuristics of Pólya's work, a sequence of tasks is constructed. The sequence begins with the simplification (named downscaling in our context) of a large problem. In this way, when students are able to develop a procedure in a reduced context, we encourage them to generalize (upscaling process, in our context) that procedure to apply it in a larger context. We have implemented the sequence with a natural group of 21 second grade students. A first qualitative analysis of this intervention allows us to identify some aspects of interest to work on in the future. The following are the most interesting ones. At the start of the sequence, in the second session, we have detected that the children have difficulties in differentiating the reality from the representations of the real world. Thus, they try to find out the number of children that fit on the perimeter of the track by simply counting the children (or their abstract representations) in their own drawings. This reminds us of the importance of introducing, even in a very simplified way, the idea of scale. We have also observed some difficulties in the process of using physical elements as units of measure. This is why we think that our proposal, and the future versions we'll make of it, has to foster students to make use of different units (cubes, children, ropes and, finally, graduated rules). In this sense, we have observed that, in the third and fourth session, a group of students was totally lost. The problem was not, apparently, the mathematical activity itself, but the fact that they were not used to work outside the classroom. This is an aspect that should be considered in our future work.

The proposed sequence has also allowed us to observe the evolution of the students. Given that this is not an isolated activity but a sequence, some of the students had the opportunity, in the next activity, to assimilate or discover the procedures they were working on. In addition, they were able to put them into practice in another context. This seems to us a strong point of our sequence, but we will have to test its efficiency by working with more students.

Furthermore, the sequence design aims to support the teacher's task that, in many cases, feels overwhelmed to bring this type of activity to the classroom. In this way, its own design serves the teacher as a guide to be able to offer what Stender and Kaiser (2017) call strategic interventions. Finally, we want to highlight that the designed activity allows working the validation phase that, from our perspective, is fundamental when solving any problem of real context.

Acknowledgements

Research supported by the project EDU2017-84377-R, Programa Retos de la Sociedad of the Agencia Española de Investigación and FEDER.

References

- Ärlebäck, J. B. (2009). On the use of realistic Fermi problems for introducing mathematical modelling in school. *The Montana Mathematics Enthusiast*, 6(3), 331–364.
- Ärlebäck, J. B., Doerr, H. M., & O'Neil, A. H. (2013). A Modeling Perspective on Interpreting Rates of Change in Context. *Mathematical Thinking and Learning*, 15(4), 314–336.
- Albarracín, L., & Gorgorió, N. (2014). Devising a plan to solve Fermi problems involving large numbers. *Educational Studies in Mathematics*, 86(1), 79–96.
- Barrett, J. E., Cullen, C., Sarama, J., Clements, D. H., Klanderma, D., Miller, A. L., & Rumsey, C. (2011). Children's unit concepts in measurement: a teaching experiment spanning grades 2 through 5. *ZDM Mathematics Education*, 43(5), 637.
- Cabassut R., & Ferrando I. (2017). Difficulties in Teaching Modelling: A French-Spanish Exploration. In G. Stillman, W. Blum, & G. Kaiser (Eds.), *Mathematical Modelling and Applications. International Perspectives on the Teaching and Learning of Mathematical Modelling* (pp. 223–232). Cham, Germany: Springer.
- Clements, D. H. (1999). Teaching length measurement: Research challenges. *School Science and Mathematics*, 99(1), 5–11.
- Gómez Bedmarz, C., & Albarracín, L. (2017). Estimación de grandes cantidades, en primaria. *Uno: Revista de didáctica de las matemáticas*, 76, 57–63.
- Hogan, T. P., & Brezinski, K. L. (2003). Quantitative estimation: One, two, or three abilities? *Mathematical Thinking and Learning*, 5(4), 259–280.
- Mason, J., Stephens, M., & Watson, A. (2009). Appreciating mathematical structure for all. Mathematics. *Education Research Journal*, 21(2), 10–32.
- Peter-Koop, A. (2009). Teaching and Understanding Mathematical Modelling through Fermi-Problems. In B. Clarke, B. Grevholm, & R. Millman (Eds.), *Tasks in Primary Mathematics Teacher Education. Mathematics Teacher Education*, Vol. 4 (pp. 131–146). Boston, MA: Springer.
- Pizarro, N., Gorgorió, N., & Albarracín, L. (2015). Primary teacher' approach to measurement estimation activities. In K. Krainer & N. Vondrova (Eds.), *Proceedings of the Ninth Congress of the European Society for Research in Mathematics Education* (pp. 3227–3233). Prague, Czech Republic: Charles University in Prague, Faculty of Education and ERME.
- Pólya, G. (1973). *How to solve it. A new aspect of mathematical methods* (2nd ed.). Princeton University Press.
- Stender, P., & Kaiser, G. (2017). The use of heuristic strategies in modelling activities. In T. Dooley, & G. Gueudet (Eds.), *Proceedings of the Tenth Congress of the European Society for Research in Mathematics Education* (pp.1012-1019). Dublin, Ireland: DCU Institute of Education & ERME.

Students of Development Studies learning about modelling and simulations as a research approach in their discipline

Amrit B. Poudel¹, Pauline Vos¹ and F. LeRon Shults¹

¹University of Agder, Norway; amrit.poudel@uia.no; pauline.vos@uia.no; leron.shults@uia.no

Researchers in the social sciences are increasingly using modelling and simulation (M&S) as a research approach. They create virtual worlds to discover relations across variables, and to test theories and potential policies. We introduced this research approach to students in the department of Development Studies at our university. The goal was to investigate the way in which such students can gain meta-knowledge about M&S-based research, that is, general knowledge about its nature and rationale. We organized a seminar to introduce the research approach and illustrated it with a simulation of the behaviour of agents with varying levels of tolerance towards their out-group neighbours (based on Schelling's segregation model). We analysed students' interactions through a socio-cultural lens. Students were able to gain meta-knowledge about M&S-based research, which they judged as useful for their future as professionals when working on development projects.

Keywords: Development studies, mathematical modelling, meta-knowledge, Schelling's segregation model, simulation-based research.

Introduction

A growing number of universities are running programs in *Development Studies*, a relatively new, interdisciplinary field building on economic and social sciences. This discipline focuses on issues regarding regional, national, and global development, such as food security, health, energy, and migration. Graduates from Development Studies departments often find placement in organizations whose agendas relate to social responsibility, sustainability and economic development (e.g., UNESCO, FAO). Research published in the *Journal of Development Studies* utilizes both quantitative and qualitative methods to shed light on both macro and micro variables that impact economic and social development, typically focusing on less affluent regions. Increasingly, researchers in Development Studies use mathematical models to simulate complex social and economic systems. For example, Kumar and Venkatachalam (2018) used survey data from bank loan applicants of various castes in rural India to create a model that enabled them to run simulations of different hypothetical scenarios; they found that lower loans were given to farmers from lower castes but, surprisingly, this discrimination did not affect owners of small farms. This research approach, in which modelling and simulation (M&S) is utilized, typically involves the following steps. Researchers begin with a real-world problem revealed by statistical, ethnographic or other analysis. Often, these problems are of particular interest to politicians and others attempting to improve the conditions for those in less affluent contexts. Researchers then identify relevant variables and construct a *causal architecture* that reflects both insights from theoretical literature and findings from empirical data. This work results in a mathematical or computational model. Using software such as NetLogo, they then simulate in the virtual world the phenomena observed in the real world. In this way, the real world data help to validate the model. However, the main goal

of M&S-based research approaches is not to create models, but to answer ‘*what if?*’ questions by varying parameters in the model. Researchers can create a variety of scenarios and run a large number of simulations, often visualized in graphs, in order to discover complex interactions in the relevant socio-economic systems and, in some cases, to ‘predict’ the future behavior of those systems under certain conditions.

The steps in a M&S-based research approach can be illustrated by the modelling cycle in Figure 1, which is an adaptation from Greefrath, Hertleif, and Siller (2018), and based on earlier work by Blum (2015) and Kaiser (2014). Researchers start by investigating real world data and potential causalities to build a mathematical model, after which they run simulations to control whether the model aligns with the real data. They will iteratively improve the computational model until it fits the data, thereby repeatedly ‘going through’ the modelling cycle. In a subsequent phase, they ask ‘what-if’ questions and experiment, based on givens in the real-world (e.g., possible policy measures). By varying parameters in the model, and running new simulations, they obtain mathematical results that they translate into real results. After publishing, their results may be implemented and, possibly, solve real world development issues.

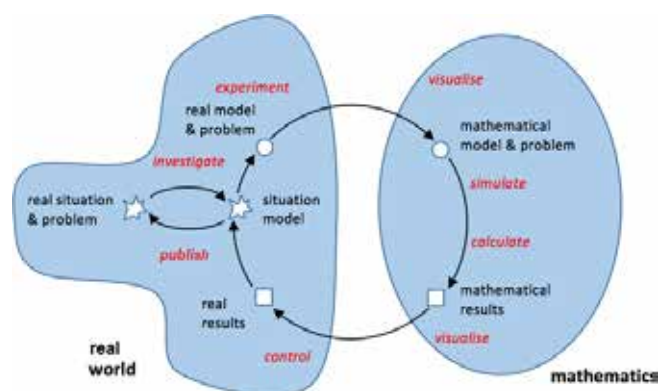


Figure 1: The modelling cycle, with visualizing and simulating digitally

Curricula of Development Studies differ across universities. According to Djohari (2011) and Engel and Simpson Reeves (2018), curricula emphasize the teaching of academic theories (e.g. social justice theories), critical and anti-colonial thinking, or skills useful for future development workers (e.g. project management). Most universities offering Development Studies include a course on research methods, typically focusing on qualitative methods. Only a few require statistics, since quantitative methods are known to be a hurdle for many social sciences students (Onwuegbuzie, 2004; Zeidner, 1991). At this point, curricula in Development Studies rarely incorporate the newer M&S-based research approaches, although these are increasingly used in this discipline. This lacuna in the curricula challenged us. We hypothesized that any Bachelor or Master’s student could understand generally how social simulations can assist academic researchers in their research. In other words, they can gain a *meta-knowledge* of M&S-based research, that is, general knowledge about the nature of such research, its rationale, the way it is conducted, and the extent to which it can provide policy-relevant information. For our definition of meta-knowledge, we borrow from Brown and Stillman (2017), who also used the term meta-knowledge in relation to modelling. To explore our hypothesis, we organized a voluntary seminar aimed at giving students a ‘feel’ for the

explanatory power of simulations, so they could gain meta-knowledge about the research approach without a technical introduction to the simulation software, the computer codes, etc.

Theoretical frame

We based our analysis of students' interactions in the seminar on Cultural-Historical Activity Theory (CHAT) (Engeström, 1987). This theory focuses on the way in which, for example, the learning environment and students' social backgrounds interact with what students think and how they communicate. Within mathematics education, CHAT has proved useful in various studies; e.g., in research on how college students negotiate a workplace's and school mathematics' worlds (Wake, 2014). Following CHAT, the students in our seminar are understood as *actors* participating in different *worlds*. In the first place, they are participants in a learning context (in a Development Studies program, attending lectures, pursuing a degree). Second, they are oriented toward becoming professionals within a development organization (e.g. an urban planner in a less affluent country). Third, they might have the ambition to become member of a research community (within a university, publishing academic articles). Fourth, they are citizens in the real world (as consumers, migrants, etc.). Each of these worlds has its own conventions, norms, jargon, tools, etc.

When connecting the above CHAT-based *worlds* to insights from research on mathematical modelling education, we observe that in the modelling cycles of Blum (2015) and Greefrath et al. (2018), there are two worlds: the real world and the mathematical world. These are two *worlds* that both an M&S-researcher and a student in a mathematical modelling classroom *negotiate*. As Doerr et al. (2017) pointed out, describing modelling activities in terms of real and mathematical world is challenging. For example, the real world is far larger than the context of a modelling problem. Students and researchers participate in this larger world, and they may or may not have experiences with the problems addressed in M&S-research or in the classroom. Employees within development organizations also participate within this larger real world, but professionally they focus on a narrower world of specific problems in less affluent contexts. Researchers using M&S-based approaches operate primarily within the mathematical world of Figure 1; their work consists of identifying variables, creating relations between these, creating computer codes, running thousands of simulations, creating numerous graphs, and writing technical academic articles. So, although they work typically for the sake of the real world (global, national and regional development issues), the world of M&S-based research is mainly a mathematical world. The distinction between real world and mathematical world as depicted in Figure 1 has emerged from research into mathematical modelling in classroom contexts. However, this differs in several ways from the modelling activities of professional researchers. Students in classrooms often only 'go through' the modelling cycle once rather than several times, they use existing models rather than create new ones, they work with descriptive models rather than explanatory ones, they use educational digital tools if any (e.g., Geogebra) rather than professional computational programs, and their errors are less likely to have social and political implications (Doerr et al., 2017; Vos, 2018). In our study, we didn't ask students to engage in modelling activities, but rather to learn about the work of researchers utilizing M&S-based approaches. Therefore, we were not expecting to observe them operating in a mathematical world.

Our overarching research question was: to what extent can students in a Development Studies program gain meta-knowledge about the relevance of M&S for their discipline during a short intervention seminar? We had several sub-questions: to what extent can this interactive process enable these students 1) to understand the way in which these research approaches describe and explain social dynamics, 2) to grasp the basic benefits and limitations of M&S-based research, 3) to gain a sense of how researchers in Development Studies use such research approaches, and 4) to imagine themselves as future researchers using M&S-based approaches?

Methods

We used a design-based research approach for this project. This involved designing a seminar, implementing it, evaluating it, and then planning to repeat iteratively the intervention. Design-based research aims to improve educational practice in cases where new content is taught (Plomp & Nieveen, 2013). The study reported here was the first of its kind; in forthcoming iterations, we intend to have improved seminars on the same topic with another group of students. In this study, the participants were three Nepali students from a master's program in Development Studies: we refer to them as Student B (female), Student K (female), and Student S (male). The first author of this paper was the leader of the seminar, which was conducted in Nepalese. The seminar was designed to last 3 hours and consisted of three sections. The first section introduced some relevant social problems (e.g., the 2015 earthquake and its social consequences, segregation and violence) and the impossibility of using experiments to study this sort of phenomena (i.e., exposing participants to exclusion or violence is unethical), and a first introduction to M&S-based research approaches. The second section involved a semi-guided activity, described in more detail below. The third section consisted of a discussion triggered by probing questions by the seminar leader. To illustrate the research approach, we included a hands-on simulation experience regarding an issue relevant for Development Studies: the migration and segregation of a city's inhabitants. In this part of the seminar we used an educational applet, which offers a simulation of the well-known Schelling Segregation model from Nobel Prize laureate Th. Schelling (Schelling, 1971). This applet, available from <http://nifty.stanford.edu/2014/mccown-schelling-model-segregation>, see Figure 2, begins with a random distribution of a population with two groups of *agents* (indicated by red and blue blocks). Depending on an agent's wish to live with same-colour neighbours (in other words: its tolerance for living with neighbours from the out-group), it will move to a new location. In Figure 2 the slider for similarity tolerance is set to 54%, which means that an agent is 'satisfied' when at least 54% of its neighbours share its colour. If the number of same-coloured neighbours falls below this threshold, an agent moves to an empty spot (a white block). The simulation famously shows that even with a relatively high level of tolerance at agent-level, clustering quickly begins and segregation takes over in the city.

Students' interactions were video recorded and transcribed. We analysed these in light of the theoretical frame by going through the transcripts and identifying utterances, in which the students positioned themselves in a *world* (for example, by their use of the term 'we' or by their description of experiences). We coded when the students engaged (1) as participants in a learning environment, (2) as future development professionals, (3) as potential M&S-researchers in Development Studies, or (4) as citizens in a dynamic society. The analysis resulted in clear, and sometimes multiple codes.

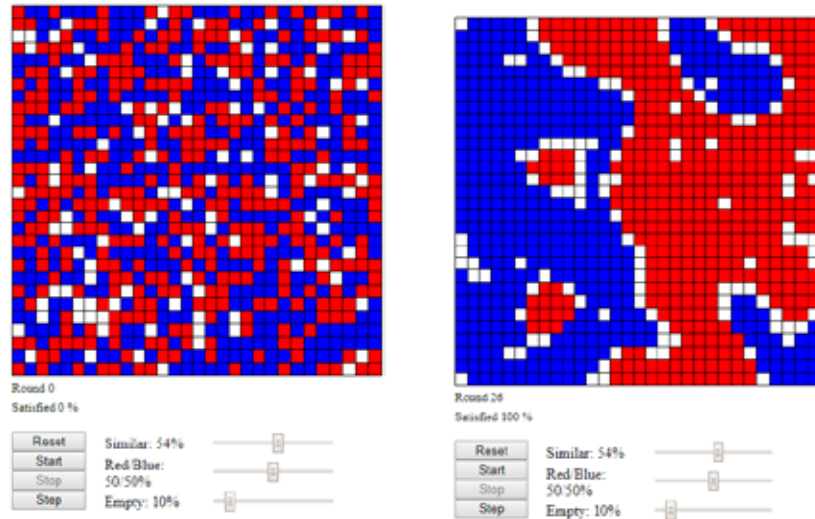


Figure 2: The Schelling Applet, at the start (left), and after 26 simulation rounds (right)

Results

The first part of the seminar was basically a lecture, which we didn't code due to the absence of students' utterances. The second part was a semi-guided activity with the Schelling Applet. The students sat together at one laptop, and interactively ran simulations to see the effects of varying the tolerance parameter. They tried many scenarios, and consistently found that raising agents' bias leads quickly to segregation, and that even relatively low levels achieved the same result, albeit more slowly. They also tried removing the empty spaces and discovered that no segregation could occur since *"no options are available anymore"* (Student S). They had experienced that in times of crises, people need to be tolerant: in the case of the Nepalese earthquake, people moved in with each other or lived peacefully in overcrowded tents. Student S was critical of the applet, commenting that in real life the space of a city is not restricted, and people would move beyond the city borders to build bigger houses. Student B mentioned that she knew of an influential person who moved to another place after the earthquake, after which his whole clan soon followed; in this case, the clustering tendency was already present before the segregation. In terms of the CHAT framework, the students were primarily participants in a learning environment (discovering the effects of changing sliders in the applet), but also expressed their real-world experiences as citizens. During this second part of the seminar, we observed the students speak neither as future professionals nor as researchers. The third part of the seminar was a discussion guided by probing questions, the first of which was: "what questions from Development Studies could be answered by studying virtual worlds?" Student S suggested that the different clusters of people could be studied with respect to their socio-economic status. The seminar leader realized that such a study would likely require a survey, rather than a simulation, but did not comment so the others could respond. Student B then said that simulations provide a dynamic visualization of phenomena and enable researchers to observe long-term changes visually. She suggested that simulations could be a medium for communication *"for those who hate large data sets"* and do not have a strong background in mathematics. At this stage, the students were participating as potential future Development Studies researchers, in a world in which they anticipated executing and publishing quantitative research.

To focus on their future professions, the seminar leader asked the students to think as *urban planners*; how might the latter make use of simulations? This triggered a lively discussion on how urban planners could promote a tolerant community. The students agreed that the Schelling Applet represented a certain underlying structure in society, although agents' movement in the real world is related not only to the colour of their neighbours but also to other factors, such as economic concerns, or a desire to live close to relatives. They then discussed ways in which a simulation of road networks could show how certain groups have better facilities (e.g., close to hospitals, accessible to firefighters), and how M&S-research could contribute to improve urban lives:

Student B: We can find out the road conditions, specifically in Kathmandu. Because they are constructing roads in different places. I want to know whether it [the road network] is effective or not, basically, already at the planning stage.

Leader: How effective is that planning? Any examples?

Student B: For example, roads in Kristiansand [Norway] are well planned. If you walk in this city, nobody gets lost. But in Kathmandu, we always get lost or run into a wall [dead-end]. With these [simulations], we can study the trend of urbanizations. We can compare the situations. Find out the areas where more housing is needed.

Student B was imagining ways in which a simulation could help her understand and predict dynamics of urban life. This triggered the other students to identify additional scenarios, in which simulations could be used. Here, the students were thinking of themselves as potential researchers who might use M&S methods for urban planning. In addition to seeing themselves as citizens (travellers, migrants, etc.), they also perceived themselves as future professionals contributing to developing their communities through simulations to analyse and predict social dynamics.

Student B: Here is a different thought... If I have a virtual Nepal, I think we can find vulnerable places for a natural disaster. We can find out how likely it is.

Student K: If we talk about health facilities, there is one health post in a VDC [Village Development Committee; Nepalese term for a rural organization unit]. Isn't that right? Any VDC has 9 wards and the health post will be in one ward. For [people in] other wards, it is far. So, if we can see distance virtually, then it will help us to decide whether there is a need for an additional health post.

Student B: For example, in the Artificial Intelligence Systems course, we studied the PredPol model [an Artificial Intelligence system used by the police in Los Angeles]. If we borrowed the PredPol model, which will be helpful to identify key places where crime is increasing. It will be helpful to estimate sufficient armed forces for those identified places. Find out the crime spots observing past situations. This PredPol model is helpful to predict future crime using previous data.

Student K: A predictive tool

Leader: (...) Is that model a simulation?

Student B: I think it is a simulation model, because it helps us to predict.

We see here that the students used “we,” speaking as future policy makers who assist their societies prepare for natural disasters, set up health posts, or fight criminality. At the same time, they speak as researchers, using verbs such as “find.” When asked to identify the limitations of M&S-based research, Student S pointed out that simulations do not produce realistic pictures, Student B wondered whether M&S methods were sufficiently scientific, and Student K asked about the expense and training required for creating models. However, Student B noted that a simulation’s visualizations could be helpful for communicating with less-educated people. All three agreed that simulations can serve as a tool for prediction in guiding critical decisions, as well as facilitating understanding of the social dynamics of urban life, enabling governments to develop better policies. The students grasped that development professionals might implement the recommendations of M&S-based researchers even if they did not use the tools themselves. Finally, when asked if they could imagine themselves doing M&S-based research, Students K and S were silent, but Student B said *“your presentation made clearer what a model is. Before coming here, I didn’t know what a model is. I am interested.”*

Conclusion, discussion and recommendations

We observed that the students were largely able to understand the opportunities and challenges of studying social dynamics through M&S-based approaches, connecting it to prior knowledge of artificial intelligence systems that simulate future scenarios. They described possibilities for using simulations for planning roads or identifying places vulnerable to natural disaster or crime spots. Mostly, they expressed themselves as future professionals in development projects who would use results from M&S-based research. In the process, they shifted roles from learners, to citizens, and future development professionals, but not to researchers at a university using M&S-based approaches. Thus, the seminar assisted them in gaining meta-knowledge about the relevance of M&S for development professionals, but to a lesser extent for researchers in their discipline. The students understood that the Schelling Applet was an example of a simulation, which simplified real life processes, but that despite its limitations the simulation had explanatory power for certain social dynamics. Thus, the applet served as an educational tool helping students to transcend the learning environment into other worlds and to imagine what other simulations could look like when used by development professionals. However, students’ erratic interchanging of terms like ‘model’ and ‘simulation’ showed that they had only a cursory sense of M&S-based approaches. Their capacity to gain meta-knowledge was restricted by their lack of experience in creating models and running simulations. Since we didn’t ask students to engage in modelling activities, we kept them away from the mathematical world. So, they learned about M&S, but not the advanced aspects of the real work done by M&S-based researchers (identifying variables, creating relations, coding, etc.). How best to introduce novices to creating simulations remains an open question.

In a future iteration of the seminar we could put more emphasis on how and why researchers in Development Studies increasingly embrace M&S. Inspired by a comment from one student, we might also show how M&S provide a powerful tool for communication. Further, we could stress the way in which M&S-based approaches can capture link the micro- and macro-level (e.g., tolerance between individuals and the segregation of a city), as well as their relevance for their future as professionals studying issues such as urban planning, disaster preparation, or crime prediction.

CHAT provided a productive framework for understanding the way in which students engaged in the seminar as participants in different worlds. This study revealed that a seminar was sufficient for promoting meta-knowledge about the nature and relevance of M&S in Development Studies but highlighted the additional competencies that will be required if they pursue these approaches as professionals. These findings will help us improve future seminar iterations with other students.

References

- Blum, W. (2015). Quality teaching of mathematical modelling: What do we know, what can we do? In S. J. Cho (Ed.), *The proceedings of the 12th International Congress on Mathematical Education* (pp. 73–96). Cham, Switzerland: Springer.
- Brown, J. P., & Stillman, G. A. (2017). Developing the roots of modelling conceptions. *International Journal of Mathematical Education in Science and Technology*, 48(3), 353–373.
- Djohari, N. (2011). 'Breaking other people's toys': Reflections on teaching critical anthropology in development studies. *Teaching Anthropology*, 1(1), 21–29.
- Doerr, H. M., Ärlebäck, J. B., & Misfeldt, M. (2017). Representations of modelling in mathematics education. In G. Stillman, et al. (Eds.), *Mathematical Modelling and Applications: Crossing and Researching Boundaries in Mathematics Education* (pp. 71–81). Cham, Switzerland: Springer.
- Engel, S., & Simpson Reeves, L. (2018). What do they need to know? Core skills for postgraduate development studies students. *Asia Pacific Viewpoint*, 59(2), 212–225.
- Engeström, Y. (1987). *Learning by expanding: An activity-theoretical approach to developmental research*. New York: Cambridge University Press.
- Greefrath, G., Hertleif, C., & Siller, H.-S. (2018). Mathematical modelling with digital tools: A study on mathematising with DGS. *ZDM Mathematics Education*, 50(1–2), 233–244.
- Kumar, S. M., & Venkatachalam, R. (2018). Caste and credit: A woeful tale? *The Journal of Development Studies*, 1–18.
- Onwuegbuzie, A. J. (2004). Academic procrastination and statistics anxiety. *Assessment & Evaluation in Higher Education*, 29(1), 3–19.
- Plomp, T., & Nieveen, N. (2013). *Educational design research*. Enschede, The Netherlands: SLO.
- Schelling, T. C. (1971). Dynamic models of segregation. *Journal of Mathematical Sociology*, 1(2), 143–186.
- Vos, P. (2018). “How real people really need mathematics in the real world”—Authenticity in mathematics education. *Education Sciences*, 8(4).
- Wake, G. (2014). Making sense of and with mathematics; the interface between academic mathematics and mathematics in practice. *Educational Studies in Mathematics*, 86(2), 271–290.
- Zeidner, M. (1991). Statistics and mathematics anxiety in social science students: Some interesting parallels. *British Journal of Educational Psychology*, 61(3), 319–328.

On the role of multicriteria decision support in mathematical modelling

Stefan Ruzika¹ and Lisa Schneider²

^{1,2} University of Kaiserslautern, Department of Mathematics, Germany

ruzika@mathematik.uni-kl.de; lisa.schneider@mathematik.uni-kl.de

Modelling is one of the key skills in applied mathematics. This is reflected by the Standing Conference of the Ministers of Education in Germany, and, consequently, mathematical modelling is one of six competences mentioned in the Educational Standards. There is a vast amount of literature representing, discussing, and teaching modelling. In practice, a mathematical model serves the purpose of making fast, cheap and – probably most importantly – reliable decisions. Having this in mind, one should reconsider the way mathematical models are treated in activities with students. In this paper, we advocate a ‘multicriteria’ perspective on mathematical modelling, optimization and decision making. We present several examples from real-world problems illustrating the need of multicriteria decision making and give some first hints toward incorporating this multicriteria perspective in the well-known mathematical modelling paradigms.

Keywords: Mathematical models, decision making, multicriteria optimization, STEM education.

Introduction

Mathematical modelling is considered to be an important topic in our daily life. The usage of mathematical models is often not apparent, but they are omnipresent. Moreover, modelling and applications have been an important topic in mathematics education with growing importance since the late 1990s (Blum, 1993; Blum & Borromeo Ferri, 2009). Showing the applicability of mathematical ideas to real-world problems increases the motivation of students to study mathematics as well as their knowledge of several mathematical concepts (Borromeo Ferri, 2009). Furthermore, modelling provides opportunities to integrate mathematics in the curriculum that allow multidisciplinary teaching. Therefore, the need and the benefits of teaching mathematical modelling competences at school have already been recognized several years ago (Blum, 1993; Blum & Borromeo Ferri, 2009). Students should be able to set-up, simplify, analyse and compare mathematical models (KMK, 2012). The mathematical modelling competences of students should be stimulated with regard to other mathematical and general competences: the ability of communicating and discussing mathematical problems as well as designing and applying problem solving strategies. Moreover, the methodological, social and personal competences are increased (KMK, 2012). Obviously, mathematical modelling becomes a more and more important skill for students.

A general view of mathematical modelling

Mathematical models and modelling

Having stressed the necessity of mathematical models and modelling, we now review these concepts briefly. Though the notions of ‘modelling’ and ‘mathematical model’ show overlaps, differences are observable: Modelling means to construct a mathematical model, so we first discuss the mathematical modelling process before we consider modelling cycles. There is a broad consensus in the

international discussion, that mathematical modelling is a process which translates between reality and mathematics in both directions (Blum & Niss, 1991). Pollak (1979, p. 233) defines mathematical modelling as a special aspect of applied mathematics. He distinguishes between several definitions: The “classical applied mathematics” and the applied mathematics with focus on a “significant practical application” are part of the mathematics as a whole. Furthermore, applied mathematics implies going around the cycle once: “Beginning with a situation [...] in real life, making a mathematical [...] model, doing mathematical work within that model, and applying the results to the origin situation”. Another definition of applied mathematics refers to the preceding definition, but means going around the cycle more than once. The last two definitions are process-oriented and focus on the real world. This implies that modelling is a process for solving real-life problems. Borromeo Ferri and Blum (2009, p. 45) define a mathematical model as “the process of translating between the real world and mathematics in both directions”. Reit (2016) states, in the tradition of Pollak (1979), that mathematical modelling is not a process in both directions: The translation from reality to mathematics is a mathematical model, the reversal, the process from mathematics to reality, is an application. Thus, modelling emphasizes the process – the implementation of real problems in mathematics – while applications focus on the mathematics. The aim of a mathematical model is, as already stated by Blum (1993), the comprehensible simplification of the real problem for enabling the application of mathematical methods. Just a few details from reality are considered. The fundamental properties will be extracted and translated into mathematics; the simplification of the problem usually results in a solution. These models are not unique and non-linear processes; there often exist several mathematical models for a real-life situation (Greefrath et al., 2013). For Blum (1993, p. 4), the mathematical modelling begins with a situation in the real world. The problem has to be structured and simplified, so the solver gets “a real model of the situation”. Then, the real model will be translated into mathematics. The result is a mathematical model. In the next step, the model is solved and translated back into the real model. Often, the first model-based attempt to solving a problem is not satisfying. Thus, more attempts might be necessary which is why mathematical modelling should be regarded as a cyclic task.

The concept of modelling cycles

As Blum (1993) illustrated, the process of mathematical modelling is often depicted in terms of modelling cycles – a representation which is widely accepted. Modelling cycles are useful to describe a mathematical process. A huge number of such cyclic representations are discussed in the literature: They mainly differ in the concept of the sub-steps, the number of sub-steps or the chronological order of the sub-steps. We are geared to the categorization due to Borromeo Ferri and Kaiser (2008), which characterizes the modelling cycles by their phases: The easiest example of a cycle has a real-life problem at the beginning. This problem leads to a real model, which has to be translated into a mathematical model. This model is treated mathematically, and the result is transferred to the real-life problem. Greefrath et al. (2013) define three categories of modelling cycles with the focus on mathematisation: the direct, the two-step and the three-step mathematisation. For the directed mathematisation, it is typical that there exists only one step from the real-life problem to the mathematical model. The direct transition between real-life problem and mathematical model refers to the definition of applied mathematics. In contrast to the directed modelling, the modelling cycles

in the two-step mathematisation include an additional step between the real-life situation and the mathematical model. The most famous modelling cycle of this category is from Blum (1985). The simplification of reality is called the real model and is a phase of its own. This kind of modelling cycle is typically used for modelling in school. The three-step mathematisation is characterized by the cognitive process. In modelling cycles, this cognitive process is described by an own phase: the situation model, i.e. the mental representation of the situation (Borromeo Ferri, 2006). For Blum and Leiss (2007) the phase of the situation model is the most important one during the modelling process. This phase characterizes the translation between the real situation and the situation model, so it can be seen “as a phase of understanding the task” (Borromeo Ferri, 2006, p. 87).

Research question

Literature on mathematical modelling, especially on modelling cycles, has not focused much on aspects of discussing of a solution provided by using a mathematical model. Multicriteria decision making as an element of mathematical modelling has not been addressed at all to the best of our knowledge. Our proposal is to take multiple criteria and perspectives into account and to research how the multicriteria perspective can be incorporated in mathematical modelling. In this paper we examine how decision making affects mathematical modelling in schools and extracurricular activities with students by elaborate and discuss two example cases (see below).

Multicriteria decision making (MCDM)

Decisions are an important part of our life, they consider multiple, often contradicting criteria. Thus, solving decision problems is difficult: The simultaneous consideration of different alternatives and their consequences often prevents us from making a good decision. We all strive for a “good” decision and frequently “solve” MCDM problems. From a mathematical point of view, trading-off between contradicting criteria needs the integration of multicriteria optimization and decision-making methods into modelling cycle.

Mathematical background

One of the main characteristics of multicriteria decision making is the presence of several, non-commensurable objectives to be pursued by an entity (e.g. a person, a group or a company) called Decision Maker (DM). It is generally assumed that a DM tries to maximize his/her utility while choosing one out of a set of alternatives. Utility is a theoretical concept which describes the value of some alternative for the DM; however, it is assumed that the DM is not able to describe ‘utility’ in a closed-form function. Instead, a DM may only be able to provide partial information about specific preferences or tendencies. Depending on how much information is provided by a DM before or during the establishment of a mathematical model, one can distinguish three basic approaches in multicriteria decision making: ‘a priori’, ‘interactive’ and ‘a posteriori’ approaches (T’Kindt & Billaut, 2002).

In ‘a priori’ approaches, the DM is able to express preferences before a model is built. These preferences are taken into account during a process e.g. as parameters, as weights or as ordering relations. The result is a model which reflects the DM’s utility as well as possible, and the set of ‘reasonable’ alternatives delivered by the model or the decision support is consistent with the DM’s preference information.

In ‘interactive’ methods, the DM takes part in the modelling process by providing some initial, yet vague information about preferences. A first rough model is built and treated mathematically, thus showing consequences and possibilities of different alternatives to the DM. Based on this information, the DM is able to specify preferences more precisely, since he/she is now more educated. The model is refined, the consequences are shown to the DM who then refines the information provided and so on. This process is iteratively repeated until a satisfactory model is set up. It is then treated in detail and, as a result, a set of reasonable alternatives is presented to the DM, among which a final preference has to be chosen when making a decision.

In ‘a posteriori’ approaches, it is assumed that the DM is not able to specify any kind of preference information beforehand. This may be due to the complexity of the real-world problem and the fact that certain meta-information or expert knowledge which may be important in decision making can often not be captured by a mathematical model. Moreover, a DM often makes decisions based on ‘experience’ or ‘depending on the specific case’ and, again, these issues are hard or even impossible to model. Under such circumstances, a mathematical model and the mathematical methods for dealing with such model (i.e., simulating, optimizing, etc.) often rely on the concept of Pareto dominance: an alternative is preferred to another, if it is at least as good in any of the objectives.

Multicriteria decision making and mathematical modelling

Methods for solving decision problems are helpful to support students within the modelling process, especially they motivate to remodel the mathematical model. In this section, we point out the relation of the three basic approaches in multicriteria decision making to perspectives on mathematical modelling. In the ‘a priori’ approach, the simplifications are done in the real model from the DM, before a mathematical model is developed. The preferences made by the DM are implemented in the mathematical model in terms of parameters, weights, etc. The set of alternatives which are found in the mathematical model, correspond to the DM’s preference information. No further loop in the modelling cycle is needed. In the ‘interactive’ approach, the real model has to be formulated and then translated into the mathematical model. The DM can specify preferences based on the results of the mathematical model, since he/she has more information. The real model will be adapted and a suitable mathematical model is (iteratively) solved. More attempts might be necessary to find a final preference for making a decision. In the ‘a posteriori’ approach the DM does not specify any preference before the modelling process. Therefore, the real model is set up and then translated into a mathematical model. After solving the mathematical model, a set of alternatives can be presented after the modelling process. The DM can choose the alternative which fits best to his/her most important criteria. Because of the complexity of the problem and the huge set of alternatives, the DM might need additional support in choosing the finally preferred solution.

Cases and experiences

In the following subchapters, we report about several cases in which we extended mathematical modelling perspectives by aspects of multicriteria decision making.

Case 1: *Stiftung Warentest* – Analysis of product tests

Stiftung Warentest investigates and compares objects with multiple, often contradicting criteria such as functionality, price or usefulness. It supports consumers in making their decision between alternative products. Ratings are issued and supplemented by rankings. Thus, these rankings are used for a first orientation and support the decision-making. Products are usually tested in a certain way: There are multiple categories, i.e. criteria, which are important for the rating of the product. In a further step, several methods for the product rating will be developed. Next, the products will be tested, and the results will be evaluated. The method for establishing a ranking can be implemented in school, since it uses various techniques dealing with topics in the range of analytic geometry and linear algebra (points, planes, distances) and stochastic (mean, variances). The central content of the teaching unit is to develop a method for ranking objects with the means of the multicriteria optimization (Ruzika, Klöckner, & Gecks, 2018). This teaching unit was situated within a classroom context in three units of 90 minutes. The execution of the teaching unit was conducted in a 12th grade class with 17 students at a *Gymnasium*. The teaching unit is opened by demonstrating examples of rankings from several areas, e.g. electronics or restaurants. The students are motivated to discuss about attributes of rankings and point out the difficulties of such rankings. It is obvious that the multiple criteria which influence the rating are contradicting, for instance price versus quality. Then, the students investigate how the multiple, contradicting criteria are treated by a weighted sum aggregation and how this method of establishing a ranking of products can be analysed geometrically. Students work out how the rating is compounded and how the best product can be determined. To simplify the problem, the number of categories of the ranking will be reduced, so that the students can develop how the test of a product can be implemented in mathematics. Using the weighted average of the rating in each objective, the ranking can be established and analysed with the help of a coordinate system. This leads to the observation that several products can make the top of the list depending on the chosen weights. More surprisingly, it can be observed that under some circumstances, ‘reasonable’ products which a customer would intuitively prefer, are not rated best in any scenario. But what if the test includes more than two categories? In a next step, the students have to revise and extend their mathematical model, which considers now more categories. With the help of a spreadsheet, they simulate the influence on the ranking, while different weights for each of the categories are chosen. Just as in the mathematical model with two categories, the application of different weights causes different rankings. After this teaching unit, it can be investigated how a ranking can be done in a fair and consumer-friendly way. The goal will be to find a product which is robust in a certain sense.

Case 2: *Navigation for electrical vehicles*

Decision making in the context of finding routes for electrical vehicles requires the consideration of multiple, often conflicting criteria. Thus, the selection of a route involves the consideration of several aspects: The battery consumption should be as small as possible while simultaneously the travel time should be as short as possible. The determination of efficient and optimal routes can be based on analytic geometry. In an extracurricular activity, we have worked on this problem for three days with a group of girls aged 16 to 18. The course was opened to introduce the students into the basic problem: Finding optimal routes for electrical vehicles. In a first step, the students simplified the problem and

focused for the beginning on one criterion only – the shortest path for a route. For solving such a problem, they obtained a theoretical input in form of a short teaching unit about network optimization containing the basics about (directed) graphs and Dijkstra’s algorithm. In order to achieve a motivating connection to the real world, students applied their knowledge about finding a shortest route on a selected example themselves. The goal was to find optimal routes for electrical vehicles, so students were motivated to discuss about several criteria which should be considered: price, energy consumption, speed, location of charge stations and travel time. After observing that, for an electric vehicle, energy consumption is increased by driving with higher speed and, that energy consumption is directly connected to the cruising range, the students realized that one important problem is the selection of a route that satisfies both criteria – consumption and distance. But how to compare routes with two objective functions? Next, students received a little more input – this time in multicriteria optimization. They learned about methods for the computation of efficient routes. With the knowledge of these methods, they extended their mathematical model from the beginning. The students chose two solving strategies: One group focused on the implementation, e.g. with GeoGebra. They plot the objective values for the different routes for the criteria travel time and energy consumption. The students recognized that efficient routes can be determined by considering the dominance cones of each route and that an efficient route is never contained in the dominance cone of another route. The second group implemented a multicriteria Dijkstra variant, e.g. using Python, in order to find an efficient route. In conclusion, the students compared their methods: The implementation in GeoGebra is descriptive but has the disadvantage that this method can only be used for given routes. This is the advantage of the implementation in Python: This method can be used for arbitrary areas and routes; the graph of the road network can be imported.

Conclusion

The cases *Stiftung Warentest* and *Navigation for Electrical Vehicles* follow the ‘a posteriori’ approach. In the teaching unit *Stiftung Warentest*, students discuss attributes of a ranking. They point out that it is very difficult to express preferences about the most important criteria. Thus, in a first step, they simplify the problem because of its complexity. After solving the mathematical model, which is based on the weighted-sum method, they observe that one alternative is preferred to another. In a further step, they extend the mathematical model and include more than two criteria. Based on a method from multicriteria optimization, they reach a solution which is at least good for one of the criteria. It is obvious that the students remark any preference for the criteria before they build the mathematical model. In the extracurricular activity *Navigation for Electrical Vehicles*, the students are not able to make a ‘good’ decision for finding an optimal route, since several aims are contradicted. Because of the complexity of the problem, they cannot weigh a criterium more than another. Thus, they simplify the problem in a first step and solve it for one criterium. It is very hard to establish a mathematical model based on their experiences and their meta-information. Thus, they apply methods from the multicriteria optimization to solve the mathematical problem, e.g. solving the real-life problem. Students are not able to express preferences before they establish the model. Hence, the usage of the Pareto concept of dominance helps modelling and solving the problem.

The input about multicriteria optimization, especially about methods for solving decision problems, support the students in their modelling process. The usage of multicriteria optimization methods

supports the establishment of the mathematical model and the extended remodelling of the real model. Furthermore, they obtain an overview on how the process of multicriteria decision making is staged. They learn how to handle multiple, contradicting criteria and find a trade-off between them. We support their modelling process with input for several reasons: Using the ‘a priori’ approach, preferences are taken into the model, e.g. criteria are weighted. The result is a model which reflects the student’s, i.e., DM’s utility. In contrast, in the ‘a posteriori’ approach, no criteria are weighted before the modelling, and several alternatives can be presented after the modelling process. Thus, the DM can choose the alternative which mostly reflects their most important criteria. With regard to the competences, it is apparent that, apart from the modelling competence, other competences are promoted and extended as well: They use mathematical tools, such as GeoGebra and Python, to solve problems, they communicate mathematically using terms like ‘efficient’ or ‘dominating’, and they apply solving problem strategies.

We have seen that methods of the multicriteria optimization can be didactically reduced for students. The focus on the most important aspects and their proper visualisation lead to an adequate implementation in a school context. Both examples show a contribution to authenticity – real world problems reinforce the students’ motivation obviously. Students get to engage in critical thinking: They can ask provocative questions and concentrate on finding their answers. Based on the answers well-founded decisions are made. By giving them additional input, we enable the students to work with these methods on their mathematical model. We call this process modelling: We influence the modelling process in a way, but – what is more important in this case – we support the establishing of a mathematical model, so that students are supported to make decisions and solve problems with multiple, contradicting aims. The students go through the modelling cycle more than once: They simplify the real-life situation to a real model, establish a mathematical model, improve the real model, extend the mathematical model and solve this with the help of given methods. These results are applied to the origin problem. The emphasis lies on the “last node” of the modelling cycle: the application of the mathematical results to the real world problem. After the modelling process the used mathematics are discussed, reflected and justified. In conclusion, these two cases show how the multiple perspective can be incorporated in mathematical modelling. We have shown that decision making affects the mathematical modelling in a school context and also an extracurricular activity. Our aim is to evaluate the benefits and the drawbacks of this approach rigorously in future research.

Acknowledgment

This work was supported by the European Social Fund (ESF) project *SchuMaMoMint*.

References

- Blum, W. (1985). Anwendungsorientierter Mathematikunterricht in der didaktischen Diskussion. *Mathematische Semesterberichte*, 32, 195–232.
- Blum, W., & Niss, M. (1991). Applied mathematical problem solving, modelling, applications, and links to other subjects – state, trends and issues in mathematics instruction. *Educational Studies in Mathematics*, 22(1), 37–68.

- Blum, W. (1993). Mathematical modelling in mathematics education and instruction. In T. Breiteig, I. Huntley, & G. Kaiser (Eds.), *Teaching and learning mathematics in context* (pp. 3–14). Chichester, UK: Ellis Horwood.
- Blum, W., & Leiss, D. (2007). How do students and teachers deal with mathematical modelling problems? In C. Haines, P. Galbraith, W. Blum, & S. Khan (Eds.), *Mathematical modelling: Education, engineering and economics* (pp. 22–231). Chichester, UK: Horwood publishing.
- Blum, W., & Borromeo Ferri, R. (2009). Mathematical modelling. Can it be taught and learnt? *Journal of Mathematical Modelling and Application*, 1(1), 45–58.
- Borromeo Ferri, R. (2006). Theoretical and empirical differentiations of phases in the modelling process. *ZDM Mathematics Education*, 38(2), 86–95.
- Borromeo Ferri, R., & Kaiser, G. (2008). Aktuelle Ansätze und Perspektiven zum Modellieren in der nationalen und internationalen Diskussion. In A. Eichler & J. Maaß (Eds.), *Materialien für einen realitätsbezogenen Mathematikunterricht*, 12 (pp. 1–10). Hildesheim, Germany: Franzbecker.
- Ehrgott, M. (2005). *Multicriteria optimization*. Berlin/Heidelberg, Germany: Springer.
- Greefrath, G., Kaiser, G., Blum, W., & Borromeo Ferri, R. (2013). Mathematisches Modellieren – Eine Einführung in theoretische und didaktische Hintergründe. In R. Borromeo Ferri et al. (Eds.), *Mathematisches Modellieren für Schule und Hochschule. Realitätsbezüge für den Mathematikunterricht* (pp. 11–37). Wiesbaden, Germany: Springer.
- Kaiser, G., Blomhøj, M., & Sriraman, B. (Eds.) (2006). Mathematical modelling and applications: Empirical and theoretical perspectives. *Zentralblatt für Didaktik*, 38(2), 82–85.
- KMK (2012). *Bildungsstandards im Fach Mathematik für die Allgemeine Hochschulreife* (Beschluss der Kultusministerkonferenz vom 18.10.2012). Köln, Germany: Wolters Kluwer.
- Pollak, H. O. (1979). The interaction between mathematics and other school subjects. In UNESCO (Ed.), *New Trends in Mathematics Teaching* (pp. 232–248). Paris, France: UNESCO.
- Reit, X.-R. (2016). Denkstrukturen in Lösungsansätzen von Modellierungsaufgaben. Eine kognitionspsychologische Analyse schwierigkeitsgenerierender Ansätze. Wiesbaden, Germany: Springer.
- Ruzika, S., Klöckner, V., & Gecks, S. (2018). Wie man einen Testsieger kürt. Multikriterielle Entscheidungsfindung in der Schule. *Realitätsbezüge im Mathematikunterricht. Themenband Modellieren und Simulieren*. Wiesbaden, Germany: Springer.
- T'Kindt, V., & Billaut, J-C. (2002). Multicriteria scheduling problems. In X. Gandibleux (Ed.), *Multiple criteria optimization. State of the art annotated bibliographic surveys* (pp. 445-491). New York, NY: Springer.

Exploring pre-service teachers' flexibility in solving Fermi problems

Carlos Segura¹ and Irene Ferrando²

^{1,2} Universitat de València, Spain; carlos.segura@uv.es; irene.ferrando@uv.es

Keywords: Flexibility, estimation, modelling, problem solving, pre-service teacher training.

Theoretical framework and purposes

Realistic Fermi problems are open problems, connected to the real world, which require students to make assumptions about the situation of the problem and estimates about the relevant quantities, and whose solution is accessible to all students, admitting different levels of complexity (Ärleback, 2009). Students do not immediately have known procedures to solve this type of problems, so their solutions include a variety of strategies (Albarracín & Gorgorió, 2014). This exploratory work is a part of a research started two years ago focused on studying problem-solving process of Fermi problems based on obtaining an approximation to the number of elements in a bounded enclosure. In Ferrando et al. (2017) the solution processes of this class of problems have been analyzed (following Lesh & Harel, 2003) using a mathematical model characterization that includes a conceptual system for describing the relevant mathematical objects and their relations, and accompanying procedures for generating useful constructions, manipulations or predictions. This work has allowed us to identify three types of solution strategies for this class of Fermi problems: (i) based on the notion of population density; (ii) based on the use of a base unit; (iii) based on the use of a geometrical pattern (Ferrando et al., 2017, p. 229).

Star and Rittle-Johnson (2008) define flexibility in problem solving as knowledge of (a) multiple strategies and (b) the relative efficiency of these strategies. According to CCSSI (2010) flexibility in problem solving is related with mathematical competence. Nevertheless, teachers have still some difficulties to develop flexible reasoning when solving mathematical tasks. This leads us to consider whether pre-service primary school teachers know and use different strategies to solve Fermi problems. In particular, this study will address the following research questions:

Q1) According to the different strategies identified in a previous study (Ferrando et al., 2017), which characteristics of the context of the problem prompt particular solution strategies?

Q2) Does the variation of these characteristics effect students to choose between several solution strategies, or do they always use the same one?

Q3) In what way, when students confront their individual solutions in group and in the physical space posed by a problem, do they arrive at a consensual strategy?

Methodology

This study, which contained two phases, was carried out during the academic year 2017-2018 with $n=112$ students from the last course of primary education degree at the University of Valencia. In both phases they have been given the same sequence of problems.

Phase 1: Individual and purely estimative solution

In this phase of the study, students had to solve the sequence of problems individually. The physical spaces involved in the problems belong to the environment of the Education Faculty and are

familiar to the students, but they do not have any data and they should only explain the procedures about how to get an estimation of the solution. The design of the sequence of problems has been carried out in collaboration with other researchers in the working group and has been based on the results obtained in Ferrando et al. (2017). The analysis of the individual solutions in this phase allowed us to answer the Q1 and Q2.

Phase 2: Empirical solution by groups

In this phase, heterogeneous groups (depending on the solutions obtained in Phase 1) of 3 to 5 students are configured. They had to solve the same sequence of problems as in phase 1 in situ, but this time they must agree on a joint strategy. The analysis of their solutions allowed us to answer Q3 and also complete the answer to Q1. Indeed, we have identified what we call *problem variables*. These variables are related to the size and shape of the elements, the ratio of sizes between element and surface, the shape of the surface and the distribution of the elements on the surface.

Implications

This exploratory study is the starting point of a PhD thesis in which it is intended to analyse the knowledge, use and promotion of flexibility in solving realistic Fermi problem among future teachers. The results of this study can help to led up to formulate a specific definition of flexibility for the domain of the Realistic Fermi problems and to raise new questions such as: What type of instruction is most effective in promoting flexibility in this class of problems? What is the relationship between the validation of the solution and the choice of the most efficient strategy? When the future teachers solve this type of sequence, does it influence their conception of flexibility?

Acknowledgements

Research supported by the project EDU2017-84377-R, Programa Retos de la Sociedad of the Agencia Española de Investigación and FEDER.

References

- Albarracín, L., & Gorgorió, N. (2013). Devising a plan to solve Fermi problems involving large numbers. *Educational Studies in Mathematics*, 86(1), 79–96.
- Ärlebäck, J. B. (2009). On the use of realistic Fermi problems for introducing mathematical modelling in school. *The Montana Mathematics Enthusiast*, 6(3), 331–364.
- CCSSI (2010). *Common core state standards for mathematics*. Retrieved online http://www.corestandards.org/wp-content/uploads/Math_Standards.pdf on November, 2018.
- Ferrando, I., Albarracín, L., Gallart, C., García-Raffi, L. M., & Gorgorió, N. (2017). Análisis de los modelos matemáticos producidos durante la resolución de problemas de Fermi. *Bolema*, 31(57), 220–242.
- Lesh, R., & Harel, G. (2003). Problem solving, modeling, and local conceptual development. *Mathematical Thinking and Learning*, 5(2), 157–189.
- Star, J. R., & Rittle-Johnson, B. (2008). Flexibility in problem solving: The case of equation solving. *Learning and Instruction*, 18, 565–579.

Features of modelling processes of group with visual and analytic mathematical thinking styles

Juhaina Awawdeh Shahbari¹ and Rania Salameh²

¹Al-Qasemi Academy & Sakhnin College, Israel; juhaina@qsm.ac.il

²Al-Qasemi Academy, Israel; salamerania84@gmail.com

Keywords: Modelling, modelling cycle, visual thinking style, analytic thinking style.

Mathematical thinking styles denote how individuals prefer to present mathematical tasks, and to understand and process mathematical facts (Borromeo Ferri, 2010). Thus, teachers' awareness of different mathematical thinking styles is particularly important when students are exposed to mathematical modelling activities that offer them the opportunity to meet everyday challenges and demands, and that provide them with the capabilities to deal with real-world situations. Mathematical modelling is the process of translating between the real world and mathematics (Blum & Borromeo Ferri, 2009). Knowledge about students' modelling processes can ameliorate their teachers' interventions (Blum & Leiß, 2005). Though modelling processes have been studied widely almost no studies have focused on modelling processes with respect to thinking styles characterizing groups, in which all modelers have the same mathematical thinking style. This study aims to shed light on the influence of group mathematical thinking style on members' modelling processes while engaged in modelling activities. This leads to the research questions: Do groups of students with different mathematical thinking styles (visual or analytic) differ in their modelling processes while working on a sequence of modelling activities, and if so, how?

Method

For the first stage of the study, a questionnaire comprised of eight tasks for identifying participants' thinking style was administered to 35 students in an eighth-grade class. We adopted the categories (visual thinking style, analytic thinking style and integrated thinking style) described by Borromeo Ferri and Kaiser (2003) for analyzing students' problem-solving processes. In these tasks, the visual thinking style was characterized by sketches and drawings, while the analytical thinking style was expressed in a formula-oriented task. Based on the thinking styles reflected in solving the tasks in the questionnaire, students were classified as: analytic (14 students), visual (11 students), and integrated analytic and visual (10 students) thinking styles. In the second stage, we selected five students in the analytic group and in the visual group respectively. We made the selection with the assistance of their mathematics teacher, in order to maximize the similarity between the groups. Each group worked on three modelling activities adapted from the literature (e.g., Blum & Borromeo Ferri, 2009). Their work was documented by video recordings and transcribed. We used the constant comparative method to analyze the students' modelling processes, taking into account the cognitive aspect of modelling cycles (Blum & Leiß, 2005).

Findings

The findings indicate that the analytic and visual groups demonstrated similar features in working on the three modelling activities, but differed in their modelling processes. The analysis of the modelling

processes of the two groups when doing the three activities revealed that the major differences between them were in their real model and their ways of simplifying, mathematizing, and creating a mathematical model. The students in the analytic group tried to simplify the three activities by mathematizing them. In contrast, the visual group tried to simplify the activities by drawing and illustrating. In addition, the findings revealed differences in the illustration of the mathematical model. The findings also indicate that the analytic group went through more modelling cycles than did the visual group to obtain the final model in each activity. In addition, the analysis indicates that the analytic group skipped more of the modelling phases than did the visual group. The modelling cycles of the analytic and visual groups for the same activity are presented in Figure 1 and 2 respectively.

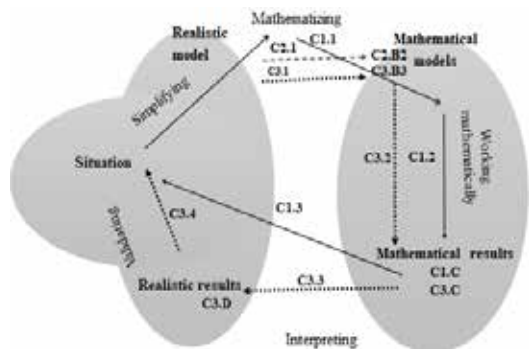


Figure 1: Modelling cycle of analytic group

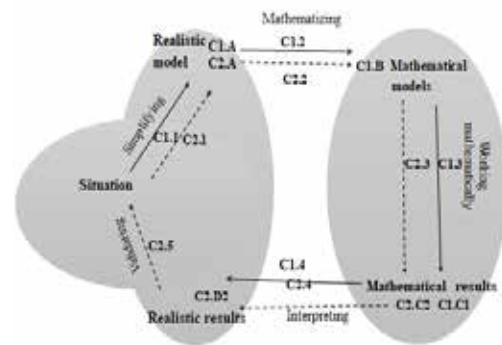


Figure 2: Modelling cycle of visual group

Summary

The findings revealed differences in the two groups' modelling processes and in features of modelling cycles. The major difference between the groups was in their ways of simplifying, mathematizing, and creating a mathematical model of the real-world situation. In the light of these findings, it is important to improve teachers' awareness of students' mathematical thinking styles, because this awareness can play a vital role in designing effective interventions for their students who are engaged in modelling activities.

References

- Blum, W., & Borromeo Ferri, R. (2009). Mathematical modelling: Can it be taught and learnt? *Journal of Mathematical Modelling and Application*, 1(1), 45–58.
- Blum, W., & Leiß, D. (2005). "Filling up"– the problem of independence-preserving teacher interventions in lessons with demanding modelling tasks. In M. Bosch (Ed.), *Proceedings of the Fourth Congress of the European Society for Research in Mathematics Education (CERME 4)* (pp. 1623–1633). Sant Feliu de Guíxols, Spain: URLL and ERME.
- Borromeo Ferri, R., & Kaiser, G. (2003). First Results of a Study of Different Mathematical Thinking Styles of Schoolchildren. In L. Burton (Ed.) *Which Way in Social Justice in Mathematics Education?* (pp. 209–239). London, UK: Greenwood.
- Borromeo Ferri, R. (2010). On the influence of mathematical thinking styles on learners' modelling behaviour. *Journal für Mathematikdidaktik*, 31(1), 99–118.

Professional competencies for teaching mathematical modelling – supporting the modelling-specific task competency of prospective teachers in the teaching laboratory

Raphael Wess¹ and Gilbert Greefrath²

¹University of Muenster, Germany; r.wess@wwu.de

²University of Muenster, Germany; greefrath@wwu.de

Mathematical modelling has been a mandatory component of the German educational standards in mathematics for the last 15 years. Teachers need a range of cognitive abilities and skills to adequately teach modelling to their students. Within the MiRA⁺ teaching laboratory, we focused on supporting the development of the professional competencies associated with mathematical modelling in prospective teachers. Encouraging teachers to design own modelling tasks and apply them in practice successfully aided the development of modelling-specific task competencies with a crucial role in the acquisition of competency by their students. This article presents a promising array of initial results on the development of task competency in teacher education.

Keywords: Mathematical modelling, modelling task, task competency, teacher education.

Introduction

As part of the teacher training project “Qualitätsoffensive Lehrerbildung”, the University of Muenster has created learning opportunities in the form of practical sessions with structured reflection to equip prospective teachers with productive ways of managing heterogeneous learning groups. Teaching-learning laboratories provide invaluable opportunities to incorporate practical elements that specifically facilitate the professionalisation of prospective teachers at an early stage of their studies by hosting interactive reflection on teaching-learning processes. In the spirit of a potential-driven approach to managing heterogeneity in the classroom, this allows teachers to gain experience working with groups of students who display different levels of individual performance, e.g. by testing and discussing differentiated learning materials and varying the instructions given to specific students.

From the perspective of mathematics education, mathematical modelling processes are inherently good at organically differentiating between students. Open modelling tasks represent a constructive heterogeneity management strategy that allows students to work individually and in a differentiated manner according to their own prior knowledge, interests, and performance levels. However, despite its extensive potential, mathematical modelling is found to be challenging by both the students themselves and their (prospective) teachers (Blum, 2015). As a result, a detailed study of the teaching competencies needed to support mathematical modelling is urgently needed by the current quality development initiatives in teacher education.

This paper studies the development of modelling-specific task competency, which is viewed as one of the aspects of professional competency for teaching mathematical modelling, in the teaching laboratory MiRA⁺ (mathematics in real applications) attended by university candidates during the first phase of teacher education.

Mathematical modelling

Mathematical modelling is the basis of the teaching-learning processes facilitated by the MiRA⁺ teaching laboratory. Realistic settings provide an abundant source of authentic problems that can be solved mathematically and then reapplied to the original context. Modelling is defined as “the process leading from a[n] [authentic] problem situation to a mathematical model” (Blum, 2002, p. 153). The following section presents some of the theoretical and pedagogical background of modelling, introducing a few ideas that will be essential for the subsequent discussion.

Modelling as a competency

Mathematical modelling is one of the six general-purpose mathematical competencies encountered at every level of the German educational standards. Students are expected to be capable of translating problems from reality to mathematics and vice versa, as well as being able to work mathematically within the model itself. Blum (2015) defines modelling competency as the ability to construct, exploit, or adapt mathematical models by executing each step of the modelling process adequately and appropriately for the given problem, together with the ability to analyse and critically compare specific models. The student’s ability to carry out specific subprocesses can be viewed as the subcompetencies of mathematical modelling (Niss, 2003). Table 1 characterises selected subcompetencies in accordance with the modelling cycle by Blum and Leiss (2007).

Subcompetency	Indicator
Constructing	Students construct their own mental model from a given problem and thus formulate an understanding of their problem
Simplifying	Students identify relevant and irrelevant information from a real problem
Mathematising	Students translate specific, simplified real situations into mathematical models (e.g., terms, equations, figures, diagrams, and functions)
Interpreting	Students relate results obtained from manipulation within the model to the real situation and thus obtain real results
Validating	Students judge the real results obtained in terms of plausibility

Table 1: Selected subcompetencies of modelling (Greefrath & Vorhölter, 2016, p. 19)

Working mathematically itself is not explicitly listed as a modelling subcompetency, since it is not specific to modelling processes and is therefore not specifically emphasised when teaching mathematical modelling.

Modelling tasks

Tasks represent a strongly dominant component of mathematical teaching. The communication of mathematics to students during the teaching-learning process has always heavily relied on setting and solving tasks (Neubrand et al., 2011). More concretely, modelling processes can be stimulated in the classroom by setting suitable tasks. Various categories of tasks can be defined to analyse and classify modelling tasks. For example, Maaß (2010) proposes a comprehensive classification of modelling tasks that considers the nature of their reference to reality, their openness, and their focus on modelling activities, among other criteria. Greefrath, Siller, and Ludwig (2017) refine the criterion of “reference to reality” by considering the authenticity and the contextual relevance of

each task in further detail. For the criterion of “focus on modelling activities”, they adopt the modelling subcompetencies listed above. Building upon this theoretical background, we compiled the list of criteria (see Table 2) reproduced for the development and evaluation of modelling tasks.

Criteria	Concretisation
Reference to reality	Does the problem refer to an extra-mathematical factual context?
Relevance	Is the factual context relevant to the students (factual problem)?
Authenticity	Is the factual context authentically related to the actual situation? Does the factual context apply mathematics in an authentic manner?
Openness	Is there more than one possible way to solve the problem (solution variety)? Are there different levels of solutions?
Modelling subcompetencies	Which modelling subcompetencies are required to work on the problem?

Table 2: Criteria for the creation and evaluation of modelling tasks

Professional competency for teaching mathematical modelling

To achieve quality development during the first phase of teacher education, a detailed analysis of the professional competencies associated with teaching mathematical modelling needs to be performed. Models that accurately characterize the requirements placed upon teachers must also be formulated to measure these competencies. Research on mathematical teaching is not only concerned with competence models that characterize the general areas of responsibility of educators, for example by establishing a global description of teaching knowledge, but also with professional competence models that focus on specific parts of the educational standards. A collaborative project by the Universities of Koblenz-Landau and Muenster sought to provide some initial structural answers for mathematical modelling by developing an instrument that measures certain key aspects of the professional competency for teaching mathematical modelling (Klock, Wess, Greefrath, & Siller, 2019).

Task-related dimension	a) Ability and knowledge to solve a modelling task in multiple ways b) Ability and knowledge to analyse modelling tasks c) Ability and knowledge to develop modelling tasks
------------------------	---

Table 3: Task-related dimension for teaching modelling competency (Borromeo Ferri & Blum, 2010)

This conceptualisation is primarily oriented towards the COACTIV model, which gives a description of the professional competency of teachers (Baumert et al., 2010). Formulating modelling-specific interpretations of the competency facets of teaching knowledge identified by this model along the competency dimensions proposed by Borromeo Ferri and Blum (2010) gives facets of modelling-specific teaching knowledge that serve as the basis for the proposed conceptualisation of professional competency for teaching mathematical modelling (Klock et al., 2019).

Modelling-specific task competency

At a theoretical level, the modelling-specific task competency is directly derived from the task-related dimension in Table 3 and represented in terms of the knowledge facets of modelling tasks specified by the professional competence model for teaching mathematical modelling. The task

competency characterising mathematical lesson planning (Neubrand et al., 2011; Borromeo Ferri, 2018) was found to be significant, not just in relation to the model cited above, but also for the professional competency review of prospective teachers performed as part of the quality development initiative. Thus it became clear that a positive development of this aspect of professional competency in particular helps to overcome obstacles to the use of modelling tasks in the classroom and to exploit their organically differentiating potential in the sense of a constructive heterogeneity management strategy. The general task competency of a (prospective) teacher may be defined as:

“the ability to design and use tasks to cognitively stimulate students and evaluate their learning performance, as well as the ability to analyse the work performed by students on these tasks” (Sjuts, 2010, p. 807).

These abilities, together with an understanding of the diverse pedagogical potential of tasks, represent a key dimension of teaching knowledge. The task competency aspects of teaching mathematical modelling are just as crucial. Properly understanding the multiplicity of possible solutions, cognitive analysis, and the process of developing modelling tasks results in high lesson flexibility and serves as a modelling-specific interpretation of the task competency (Borromeo Ferri, 2018).

Research question

In light of the theoretical discussion given above, the global research objective is to determine the extent to which the professional competencies of prospective teachers in mathematical modelling can be supported by a teaching laboratory. In particular, we are interested in studying any task-related abilities of (prospective) teachers that are relevant to the acquisition of competency by students. The research objective can therefore be formulated more concretely as follows: *To what extent do self-prepared modelling tasks in a mathematical teaching laboratory environment improve aspects of the modelling-specific task competency of prospective teachers relative to well-established modelling tasks?*

Methodological approach

Sample and design

To answer this research question, a paper-and-pencil questionnaire with a pre-post comparison group design was used to collect data from 107 candidates at the Universities of Koblenz-Landau and Muenster who were studying for a teaching position at secondary schools. In addition to the treatment group (TG) in Muenster ($N=35$) and the comparison group (CG) in Koblenz ($N=43$), data were collected from a baseline group in Muenster ($N=29$) to control for any test repetition effects.

Teaching laboratory concept

For this study, based on the concept of a teaching-learning laboratory (Lengnink & Roth, 2016), a series of teaching seminars on mathematical modelling featuring practical components were developed at the two participating institutions. The contents of the seminars were coordinated but emphasised different facets of modelling-specific competency. The seminars in Muenster focused on developing the task-related skills of prospective teachers by asking them to develop and apply

their own modelling tasks. By contrast, the seminars in Koblenz focused on developing modelling-specific intervention competency by applying well-established modelling tasks without analyzing and adapting them. The teaching laboratory MiRA⁺ discussed in this paper consists of a theory-based preparation phase, a practical phase, and a reflection phase (see Figure 1).

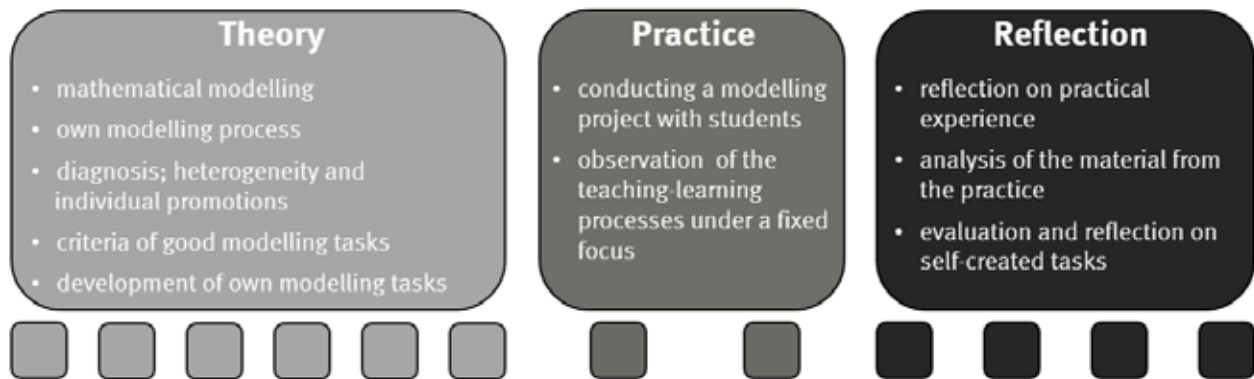


Figure 1: Concept of the MiRA⁺ teaching laboratory

Modelling processes represent the core content of every phase, together with sensitisation to potential-driven methods of managing heterogeneity in the classroom. The term “teaching laboratory” reflects the emphasis on teacher education. However, the teaching-learning processes of the university candidates naturally unfold in parallel to the learning processes of the high school students. The theory phase of the seminar serves to impart the theoretical foundations of mathematical modelling and pedagogical diagnostics. The dimensions of heterogeneity are discussed as well as the basics of individual promotion. Finally, modelling tasks for use in the practical phase are developed on the basis of the criteria mentioned (see Table 2). During the practice phase, a small team of prospective teachers look after a small group of high school students to work on the designed modelling tasks. Each team focuses its observations of the teaching-learning processes on subcompetencies of mathematical modelling (see Table 1). After the sessions, implications will be drawn from the insights for the upcoming teaching laboratory appointments, for example addressing a variation of the instructions. The reflection phase serves to reflect practical experiences from the observed teaching-learning processes. The focus is on the managing of heterogeneity in the classroom, the insights gained from it for the professionalisation of the prospective teachers own teaching activity as well as the consequences for the conception and the execution of the own modelling tasks. The aforementioned conception of a teaching laboratory as a seminar with practice integration should especially promote the acquisition of professional knowledge and competency. In addition, the testing of theory-based practical didactic action with regard to the participating prospective teachers is a central element of teaching laboratories. Thus, the acquired didactic and professional knowledge in the development of tasks as well as in the supervision of the students is interlinked and implemented.

Test for measuring aspects of professional competency

An instrument was developed and piloted in the summer semester of 2017 to measure specific aspects of the professional competency for teaching mathematical modelling (Klock & Wess, 2018). The modelling-specific task competency was measured using dichotomous combined-single-

choice items targeting cognitive analysis, solution multiplicity, and the development of modelling tasks. The scale values are based on the standardised sum scores of the dichotomous coding and are examined in a group comparison using a repeated measures analysis of variance for developmental differences. An example of a test item is given in Table 4.

Scale	Number of items	Item example
Task-related competency	12	A. Modelling tasks can be underdetermined. .. right .. wrong
		B. Modelling tasks can be overdetermined. .. right .. wrong
		C. Modelling tasks should be as closed as possible. .. right .. wrong

Table 4: Example test item measuring the modelling-specific task competency (Klock & Wess, 2018)

Results

This section presents the progression of the competency aspects cited above observed in the study participants. There were no significant differences between groups in the facets of modelling-specific task competency at the time of first measurement.

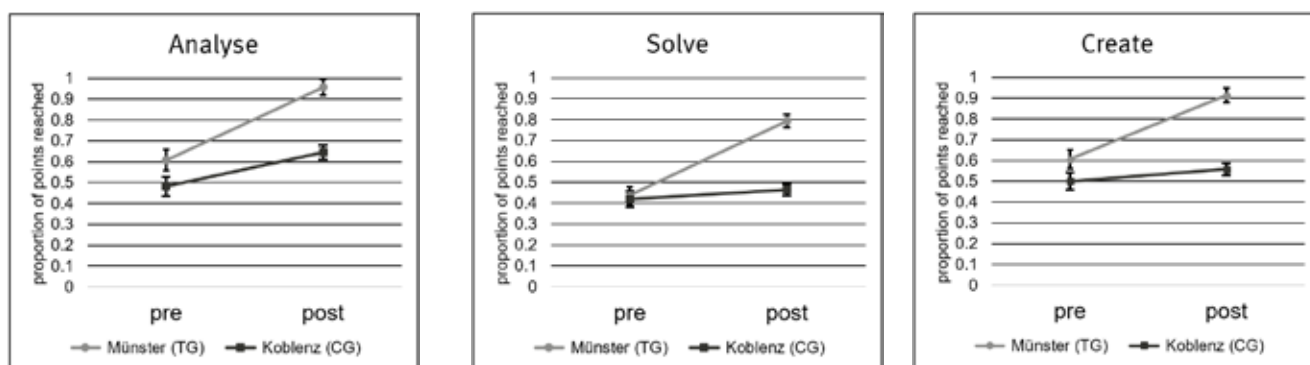


Figure 2: Analyse modelling tasks Figure 3: Solve modelling tasks Figure 4: Create modelling tasks

Repeated measures analysis of variance reveals that the cognitive analysis aspect of modelling tasks ($F(1,76) = 12.109$, $p = .001$, $\eta^2 = .185$; Figure 2) in the treatment group (TG) at Muenster progressed significantly more favourably with a greater effect size than the comparison group (CG) at Koblenz. For the solution multiplicity aspect of modelling tasks, a significantly higher increase with a larger effect size ($F(1,76) = 24.322$, $p = .00$, $\eta^2 = .242$; Figure 3) was observed in the TG relative to the CG. Similarly, for the development aspect of modelling tasks, the TG displayed a significantly stronger progression with a larger effect size ($F(1,76) = 12.558$, $p = .001$, $\eta^2 = .182$; Figure 4) when measured against the progression of the CG.

No significant changes in the aspects of modelling-specific task competencies considered by this study were observed in the baseline group (Analyse: $t(28) = 1.154$, $p = .258$; Solve: $t(28) = 1.410$, $p = .169$; Create: $t(28) = 1.797$, $p = .093$; see Figure 4). Consequently, there were no test repetition effects.

Summary and discussion

On the basis of a widely accepted competency concept and a well-established structural model of professional competency, we were able to constructively apply a survey instrument measuring the

teaching of mathematical modelling to prospective teachers in a teaching laboratory. Our study of the modelling-specific task competency, which has a strong effect on the acquisition of mathematical modelling competency by students, found clear signs that the professional competency for teaching mathematical modelling can be successfully enhanced within the teaching laboratory MiRA⁺ by encouraging teachers to apply criteria-led self-prepared modelling tasks. Significant contrasts with large effect sizes were observed relative to the progression of the comparison group, which used well-established modelling tasks. These contrasts were concretely measured by the aspects of development, cognitive analysis, and multiplicity of solutions.

Limitations and outlook of the study

Despite the large effect sizes and the significant differences, the number of participants in the experimental group ($N = 35$) does not provide a sufficiently robust basis for any definitive statements regarding the professional competency for teaching mathematical modelling. The conclusiveness of these findings can be increased in future by cumulating over multiple seminar cycles – provided of course that the treatment is controlled appropriately.

Acknowledgment

This project is part of the „Qualitätsoffensive Lehrerbildung“, a joint initiative of the Federal Government and the Länder which aims to improve the quality of teacher training. The programme is funded by the Federal Ministry of Education and Research. The authors are responsible for the content of this publication.

References

- Baumert, J., Kunter, M., Blum, W., Brunner, M., Voss, T., Jordan, A., Jordan, Klusmann, U., Krauss, S., Neubrand, M., & Tsai, Y. (2010). Teachers' mathematical knowledge, cognitive activation in the classroom, and student progress. *American Educational Research Journal*, 47(1), 133–180.
- Blum, W. (2015). Quality Teaching of Mathematical Modelling: What Do We Know, What Can We Do? In S. J. Cho (Ed.), *Proceedings of the 12th International Congress on Mathematical Education* (pp. 73–96). Cham, Switzerland: Springer International Publishing.
- Blum, W., & Leiss, D. (2007). How do students and teachers deal with mathematical modelling problems? The example sugarloaf and the DISUM project. In C. Haines, P. L. Galbraith, W. Blum, & S. Khan (Eds.), *Mathematical modelling (ICTMA 12). Education, engineering and economics*, (pp. 222–231). Chichester, UK: Horwood.
- Blum, W. (2002). ICMI Study 14: Applications and modelling in mathematics education – Discussion document. *Educational Studies in Mathematics*, 51(1), 149–171.
- Borromeo Ferri, R. (2018). *Learning how to teach mathematical modeling in school and teacher education*. New York, NY: Springer.
- Borromeo Ferri, R., & Blum, W. (2010). Mathematical modelling in teacher education – experiences from a modelling seminar. In V. Durand-Guerrier, S. Soury-Lavergne, & F.

- Arzarello (Eds.), *Proceedings of CERME 6* (pp. 2046–2055). Lyon, France: Institut National de Recherche Pédagogique and ERME.
- Greefrath, G., Siller, H.-S., & Ludwig, M. (2017). Modelling Problems in German Grammar School Leaving Examinations (Abitur). In T. Dooley & G. Gueudet (Eds.), *Proceedings of CERME 10* (pp. 932–939). Dublin, Ireland: DCU Institute of Education & ERME.
- Greefrath, G., & Vorhölter, K. (2016). *Teaching and Learning Mathematical Modelling: Approaches and Developments from German Speaking Countries* [ICME-13 Topical Survey]. Cham, Switzerland: Springer.
- Klock, H., Wess, R., Greefrath, G., & Siller, H.-S. (2019). Aspekte professioneller Kompetenz zum Lehren mathematischer Modellierung bei (angehenden) Lehrkräften – Erfassung und Evaluation. In T. Leuders, E. Christophel, M. Hemmer, F. Korneck, & P. Labudde (Eds.), *Fachdidaktische Forschungen zur Lehrerbildung* (pp.135–146). Münster, Germany: Waxmann.
- Klock, H., & Wess, R. (2018). *Lehrerkompetenzen zum mathematischen Modellieren – Test zur Erfassung von Aspekten professioneller Kompetenz zum Lehren mathematischen Modellierens*. Münster, Germany: MIAMI.
- Lengnink, K., & Roth, J., (2016). „Lehr-Lern-Labor Mathematik“ als Ort der Forschung. In Institut für Mathematik und Informatik der Pädagogischen Hochschule Heidelberg (Eds.), *Beiträge zum Mathematikunterricht 2016, 3* (pp. 1267–1268). Münster, Germany: WTM-Verlag.
- Maaß, K. (2010). Classification scheme for modelling tasks. *Journal für Mathematik-Didaktik*, 31(2), 285–311.
- Neubrand, M., Jordan, A., Krauss, S., Blum, W., & Löwen, K. (2011). Aufgaben im COACTIV-Projekt: Einblicke in das Potenzial für kognitive Aktivierung im Mathematikunterricht. In M. Kunter, et al. (Eds.), *Professionelle Kompetenzen von Lehrkräften. Ergebnisse des Forschungsprogramms COACTIV* (pp. 115–132). Münster, Germany: Waxmann.
- Niss, M. (2003). Mathematical competencies and the learning of mathematics: The Danish KOM project. In A. Gagatsis & S. Papastavridis (Eds.), *3rd Mediterranean Conference on Mathematical Education* (pp. 116–124). Athens, Greece: The Hellenic Mathematical Society.
- Sjuts, J. (2010). Aufgabenkompetenz erwerben – ein modellhafter Berufsfeldbezug in der Lehrerbildung. In A. Lindmeier & S. Ufer (Eds.), *Beiträge zum Mathematikunterricht 2010* (pp. 807–810). Münster, Germany: WTM-Verlag.

Horizontal mathematization: a potential lever to overcome obstacles to the teaching of modelling

Sonia Yvain-Prébiski¹ and Aurélie Chesnais¹

¹ University of Montpellier, France; sonia.yvain1@umontpellier.fr,
aurelie.chesnais@umontpellier.fr

Research shows the importance of the development of the learning and teaching of mathematical modelling in secondary school but also highlights some barriers, especially concerning the difficulties of teachers to implement modelling activities. An epistemological study of mathematical modelling and a contemporary epistemological study of modelling experts' practices led us to identify horizontal mathematization as a crucial component of mathematical modelling. Based on this conceptualization, we then came up with a task for teachers to implement in their classrooms, within a professional development program, which provides us some data to study the constraints and conditions of teaching practices concerning modelling. Our results suggest that a teaching strategy stressing horizontal mathematization is likely to foster a consistent modelling activity of students and that teachers don't identify horizontal mathematization as a learning issue.

Keywords: Horizontal mathematization, teaching practices, modelling.

Introduction

Research in mathematics education shows how developing the learning and teaching of mathematical modelling in secondary school is important, but also points out some hindrances, especially concerning the difficulties for teachers to implement modelling activities in their classrooms. Numerous studies point out some obstacles concerning teaching practices (Schmidt, 2011; Blum & Leiss, 2007; Kaiser et al., 2011; Maaß & Gurlitt, 2011; Ramirez, 2017; Barquero et al., 2018). For instance, mathematics teachers don't consider modelling as an essential component of mathematics learning; they doubt of their own competencies about mathematical modelling; they find it difficult to implement modelling tasks in class in particular because students might come up with a lot of different solutions and identifying what is at stake in such tasks is not easy; choosing an appropriate task is difficult for them. They also find it hard to identify students' difficulties and to evaluate modelling competencies; finally, they say they are lacking time to organize their teaching of modelling. Research on French teachers (Cabassut & Ferrando, 2017; Yvain-Prébiski, 2018) confirms that these international findings also apply to French teachers.

These hindrances mainly concern the conception and implementation of modelling activities in classrooms, which relate to elements formalised as institutional, cognitive, mediatory and personal constraints of teaching practices in the theoretical framework of the double approach of teaching practices of mathematics teachers (Robert & Rogalski, 2005; Vandebrouck, 2013). It leads us to hypothesize that overcoming some obstacles to the effective teaching of mathematical modelling in classrooms implies a more effective conceptualization of the modelling process. A literature review and a contemporary epistemological study of experts' practices in research about modelling in life sciences lead us to identify the crucial role of horizontal mathematization in this process and to characterize some forms of it that could enrich the conceptualization of mathematical modelling in

classrooms. The hypotheses we want to test in our research are: first, a teaching strategy emphasizing horizontal mathematization is likely to foster a consistent modelling activity of students in classrooms; then, despite its identification by teachers as an important component of mathematical modelling, they don't seem to consider horizontal mathematization as a learning issue. In the next section, firstly we present our conceptualization of mathematical modelling, stressing horizontal mathematization as a crucial component of the process. In the second part, we are exposing the theoretical framework we used to study teaching practices and our experimental design. In a third part, we will expose our findings. Conclusion will allow us to design some perspectives about teacher training.

Horizontal mathematization: a fundamental component of mathematical modelling

Mathematics education researchers working on mathematical modelling in an educational perspective, especially in the RME framework (for example, Rasmussen et al. 2005; Barnes, 2005) consider the distinction introduced by Treffers (1978) and Freudenthal (1991), between horizontal mathematization which “leads from the world of life to the world of symbols” and vertical mathematization, as work within the mathematical system itself. In our research, we focused on the teaching and learning of mathematical modelling based on extra-mathematical situations. We then followed the idea of Israel (1996), who defines a mathematical model as “a piece of mathematics applied to a piece of reality” and defined different forms of horizontal mathematization that seem relevant to explore educational issues: choosing a piece of reality to question in order to answer the problem; identify and choose the relevant aspects of the piece of reality (context elements, attributes); relating the chosen aspects together in order to construct a mathematical model; and last, quantification (Chabot & Roux, 2011), which refers to the association of some aspects of reality to quantities (which essentially consists in measuring).

To deepen our epistemological study of modelling, we analysed the practices of experts (researchers) on mathematical modelling in life sciences, through interviews (Yvain, 2017). The main findings consist in the identification of three invariant features in the practices of researchers that contribute to the transformation of reality to mathematical solvable problems. The first invariant, which we labelled P_{i1} , consists in simplifying the problem and selecting a piece of reality. It supposes to identify relevant variables and choose relevant relations between the selected variables. The second invariant P_{i2} consists in choosing a model among those known by the researcher in order to initiate vertical mathematization, at the risk of further having to refine or reject the initial model. The third invariant consists in quantifying in order to compare the “real data” with the results obtained within the model. We assume that taking into account horizontal mathematization in the teaching and learning of modelling is likely to foster students' competencies.

Theoretical framework for the study of the teaching and learning process

Our conception of learning relies on the idea that students' learning depends on their activity which results from the tasks they have to solve in class. However, we assume that solving a task is not enough to guarantee conceptualising. Indeed, the role of the teacher is also to allow students to identify mathematical knowledge in their activity to ensure the “transformation of activity into

learning”. We will then consider that actively practicing horizontal mathematization when solving the task would constitute a first step on the way to the appropriation by students of horizontal mathematization within the process of modelling: it corresponds to a “local devolution” (Perrin-Glorian, 1997) of this learning issue. Considering that the devolution of it is complete (and hence that substantial opportunity for conceptualising is offered) supposes that the knowledge at stake is explicitly identified – by the teacher – as something to be learned (i.e. remembered in order to use it again later).

Our theoretical framework to study teaching practices is the double approach of mathematics teachers’ practices, developed by Robert and Rogalski and their followers (Robert & Rogalski, 2005; Vandebrouck, 2013). Teaching practices are considered as complex, embedding five components. The first two of these are the cognitive and mediatory ones, which are directly observable in classrooms. The cognitive one corresponds to the teacher’s choices regarding content and tasks, including their organization. Choices corresponding to class events and to the effective implementation in classrooms of the tasks make up the mediatory component. The three other ones are the social, institutional and personal components, which allow taking into account elements that crucially impact some choices made by teachers. This framework leads us to investigate constraints that are more likely to impact teachers’ choices, would it be related to personal, social or institutional constraints. First, institutional constraints are essentially related to official instructions. Then, we have conducted analyses of classroom sessions, considering both the cognitive and the mediatory components of practices, and analyses of questionnaires filled by teachers during the development program, which allowed us to make some hypotheses on personal and social constraints.

Experimental design

Relying on our epistemological study, we tried to characterize tasks likely to support the learning of horizontal mathematization and hence students’ activities inspired by P_{11} - P_{12} and P_{13} practices. Such tasks should then be “realistic fictions” conceived as adaptations of a professional modelling problem. Here is an example of such a task that we designed for our experiments:

The tree: Botanists from Botanical Garden have discovered an exotic tree. To study this new species, the botanists have sketched the tree every year since 2013.



The botanists want to build a greenhouse to protect it. They believe it will have reached its full size by 2023. To help them, predict how the tree will be in 2023.

Figure 1: Text of the task “The tree”

In order to have teachers implementing this task in their classrooms, we worked with a group of teachers in the context of a professional development program about mathematical modelling¹. Not

¹ This program has been existing for ten years and was designed by a group where researchers and some teachers work collaboratively (one of the two authors of this paper is part of the group). Every schoolyear, this program offers a collaborative project to volunteering teachers with their classes from 6th grade till the end of secondary school.

only shall the program include the fact of asking teachers to implement the task in their classroom, but it will also do it with a specific scenario. The scenario included five sessions. Groups of three classes were conformed and all the classes interacted using a platform regulated by the designers of the program. We will not give more details about the professional development program (see Yvain & Modeste, 2018, for more details) except for one point which we will linger on in this paper: the original first phase of “questions-and-answers”. The first step of the scenario requires teachers to devote the first session to students asking questions about the problem, to send them to two other classes and then to devote the second session to trying to answer those questions.

Collected data and methodology

In order to identify constraints related to the institutional component of teaching practices, a preliminary study of French official instructions for secondary school allowed us to identify the importance of mathematical modelling as a learning issue, but it remains a lot of implicitness about the role of horizontal mathematization in this process (Yvain, 2018). To explore the cognitive and mediatory components of teaching practices, we collected videos of the sessions in the classrooms of three teachers who took part to the program. We postulate that if teachers identify the learning issue related to horizontal mathematization, we would find traces of it in the cognitive and mediatory components of their practices, in the way they introduce the questions-and-answers phase to students and in the content they summarize at the end as what should students remember. We then designed four levels that indicate how much this learning issue is identified by teachers, according to what they had said during the introduction phase and the closing phase. These indicators are based on the forms of horizontal mathematization described above.

Identification of horizontal mathematization as a learning issue	In the introduction phase	In the closing phase
Level 1: no identification	No element indicating the function of the questions-and-answers phase in the solving of the problem	The teacher doesn't make a summary of what should be remembered or the summary doesn't mention anything related to horizontal mathematization.
Level 2: vague identification	Some elements indicating the function of the questions-and-answers phase in the solving of the problem	The summary includes the idea that some information was missing in the initial problem to be able to solve it.
Level 3: partial identification	Elements inducing the idea of the necessity of making choices	The summary mentions the necessity of making choices in order to be able to solve the problem.

Level 4: complete identification	Elements inducing the idea of the necessity of making choices on context features and about relevant attributes to model the problem. Idea that modelling the problem will depend on the choices made.	The summary mentions the necessity of making choices in order to be able to solve the problem and explains that different models could be used to solve the problem. The summary mentions the importance of choosing relevant attributes, depending on the problem to be solved, in order to choose a model.
----------------------------------	--	--

Table 1: Indicators of the identification by teachers of horizontal mathematization as a learning issue

Findings: A task and a strategy effectively supporting students' activity of horizontal mathematization

Findings concerning students' activity during the phase of questions-and-answers

The analysis of questions and answers produced by students shows that they made simplifying hypotheses to handle the problem by selecting one or some pieces of reality: they focused on branches, the greenhouse, the leaves etc. They identified relevant variables that impact the real situation (for example, the number of branches) and non-relevant variables or elements of context (possibility to use organic fertilizer, or leaves); they chose relevant relations between the selected variables and used several mathematical tools (functions, proportionality, and geometry). These activities attest that students implemented P_{11} -like activities.

Students also identified the necessity of modelling the situation to be able to predict the tree's growth. Students authentically questioned the variables to choose in order to solve the problem mathematically. The realistic aspect of the situation lead them to reflect on the important elements of context to be taken into account. This also helped them understand that not all information on the real context was useful to solve the problem or that it was suitable to ignore them in order not to come up with a too complex model. Our analysis showed that students mainly tried to use models that they knew (particularly, those using proportionality) and that they sometimes rejected it when they confronted the results they obtained to contingency, which attests their ability to implement P_{12} -like activities.

Finally, the mention of the scale in the text of the task allowed students to use instruments to make measures, which lead them to quantify some attributes and confront measures with real data, which attests of P_{13} -like activities. The analysis of traces of students' activities allows us to conclude that the characteristics of the task and the questions-and-answers phase fostered activities of students that resemble experts' practices and correspond to horizontal mathematization. This attests that the first level of devolution of horizontal mathematization was reached. However, what it still remains open for future research is how students responsibility was really involved in these activities and to what extent this issue was identified by teachers in a way that allows a full devolution of the learning issue.

Analyses of teachers' practices

The analyses of the classroom sessions we observed, with the study of answers teachers provided to a questionnaire during the development program, show that the impact on the motivation of students. The main advantages that teachers identify are the collaborative aspect of the questions-and-answers phase and the fact that this phase develops a better appropriation of the problem by students. About the mediatory component of teaching practices, the analysis of the different implementations show that teachers encourage students to produce questions and then answers in order to solve the problem. This is what guarantees the local “devolution” of horizontal mathematization to students, during the questions-and-answers phase. However, when considering teachers discourse during the introductory phase, it appears that the purpose of the questions-and-answers phase is not completely explicit. Two out of the three teachers discourses correspond to level 2 (see the first excerpt below) and one to level 3 (see the second excerpt below). Note that none of the teachers we observed attained level 4, neither for the introductory phase nor the conclusion phase.

Teacher 1 Your job is to come up with questions, things that you didn't understand, things that are missing, ok, here we miss some information, we need to know this or that to try to answer, or to clarify some things, you decide.

Teacher 2 The challenge of the session is to try to provide some elements of answer. Do you have an opinion, an answer to propose? What is your point of view? Ok and if you had to make choices, which choices would you make? Because in my opinion, some choices are necessary or they will never be able to do anything.

During the concluding phase, two teachers discourses correspond to level 2 (“the aim was to focus all the classes on the same problem in order to have everybody researching the same thing and to give you more information to proceed.”); one teacher's discourse corresponds to level 3: “modelling is what we have been doing all along: making choices, ok?” All in all, even if some teachers mention the necessity of making choices to solve the problem, they don't seem to identify this necessity as a learning issue. In particular, they never offer students any formalization of the knowledge at stake about horizontal mathematization. Based on our theoretical framework, this makes us conclude that the devolution of the learning issue constituted by horizontal mathematization is not complete.

Discussion and conclusion

Our research shows that a conceptualization of mathematical modelling stressing the process of horizontal mathematization allows us to deepen our understanding of the learning and teaching issues related to mathematical modelling. Such conceptualization provides tools to support building efficient teaching strategies in order to guarantee consistent students' activities of horizontal mathematization. These strategies include, in particular, a questions-and-answers phase that seems to play a fundamental role. Let us note that these conclusions meet the preoccupations of other researchers working on the same subject. For example, the MERIA project also stresses the opportunities offered by a questioning phase in order to develop some skills about modelling.

However, our study also suggests that teachers, even if they identify the necessity of making choices in mathematical modelling, don't completely understand it as a learning issue. Yet, this appears as a

condition for the complete devolution of the issue, in order to have students practice horizontal mathematization in ordinary classes, i.e. when teachers are not engaged in specific programs, imposing them teaching strategies. It leads us to postulate that a conceptualization of mathematical modelling in a way that includes horizontal mathematization, as a crucial and explicit component, would also constitute a good tool for teachers in order to overstep some of their difficulties and to improve their teaching skills about mathematical modelling – and hence, to improve learning. Our perspective is then to enrich our professional development program with an explicit work on horizontal mathematization with teachers and to make them able to identify it as a learning issue and as a tool to support the full devolution of it to students. For example, we suppose it would be fruitful to work with teachers on building summaries of such classroom sessions, suggesting them that elements about the necessity of making choices on relevant attributes and context elements in order to be able to model a situation and solve a problem would be valuable to explicit with students. Our research constitutes only a first step but points out a potential fruitful approach of teacher training about mathematical modelling, provided that teaching practices are considered in their complexity.

References

- Barnes, H. (2005). The theory of Realistic Mathematics Education as a theoretical framework for teaching low attainers in mathematics. *Pythagoras*, 2005(61), 42–57.
- Barquero, B., Bosch, M., & Romo, A. (2018). Mathematical modelling in teacher education: Dealing with institutional constraints. *ZDM Mathematics Education*, 50(1-2), 31–43.
- Blum, W., & Leiss, D. (2007). How the students and teacher deal with mathematical modelling problems? In C. Haines, G. Galbraith, W. Blum & S. Khan (Eds.), *Mathematical modelling (ICTMA 12): Education, engineering and economics* (pp. 222–231). Chichester, UK: Horwood Publishing.
- Cabassut, R., & Ferrando, I. (2017). Difficulties in teaching modelling: A French-Spanish exploration. In G. A. Stillman, W. Blum & G. Kaiser (Eds.), *Mathematical modelling and applications* (pp. 223–232). Cham, Switzerland: Springer.
- Chabot, H., & Roux, S. (Eds.). (2011). *La mathématisation comme problème*. Paris, France: Archives contemporaines.
- Freudenthal, H. (1991). *Revisiting mathematics education*. Dordrecht, the Netherlands: Kluwer Academic.
- Israël, G. (1996). *La mathématisation du réel: essai sur la modélisation mathématique*. Paris, France: Seuil Eds.
- Kaiser, G., Blum, W., Borromeo Ferri, R., & Stillman, G. A. (Eds.). (2011). *Trends in teaching and learning of mathematical modelling. ICTMA14*. International Perspectives on the Teaching and Learning of Mathematical Modelling. Dordrecht, the Netherlands: Springer Science & Business Media.
- Maaß, K., & Gurlitt, J. (2011). LEMA–Professional development of teachers in relation to mathematical modelling. In G. Kaiser, W. Blum, R. Borromeo Ferri, & G. A. Stillman

- (Eds.), *Trends in teaching and learning of mathematical modelling* (pp. 629–639). Dordrecht, the Netherlands: Springer.
- Perrin-Glorian, M.-J. (1997). Que nous apprennent les élèves en difficulté en mathématiques. *Repères IREM*, 29, 43–66.
- Ramirez, P. (2017). Teachers' beliefs about mathematical modelling: An exploratory study. In T. Dooley & G. Gueudet (Eds.). (2017), *Proceedings of the Tenth Congress of the European Society for Research in Mathematics Education* (pp. 972–979). Dublin, Ireland: DCU Institute of Education & ERME.
- Rasmussen, C., Zandieh, M., King, K., & Teppo, A. (2005). Advancing mathematical activity: A practice-oriented view of advanced mathematical thinking. *Mathematical thinking and learning*, 7(1), 51–73.
- Robert, A., & Rogalski, J. (2005). A cross-analysis of the mathematics teacher's activity. An example in a French 10th-grade class. *Educational Studies in Mathematics*, 59(1–3), 269–298.
- Schmidt, B. (2011). Modelling in the classroom: Obstacles from the teacher's perspective. In G. Kaiser, W. Blum, R. Borromeo Ferri, & G. A. Stillman (Eds.), *Trends in teaching and learning of mathematical modelling* (pp. 641–651). Dordrecht, the Netherlands: Springer
- Treffers, A. (1978) *Wiskobas doelgericht*. Utrecht, the Netherlands: IOWO.
- Vandebrouck, F. (Ed.). (2013). *Mathematics classrooms: Students' activities and teachers' practices*. Rotterdam, the Netherlands: Sense Publishers.
- Yvain, S. (2017). Etude de la transposition du processus mathématisation aux élèves. In M. Bächtold, V. Durand-Guerrier, & V. Munier, *Epistémologie et didactique* (pp. 235–249). Besançon, France: Franche-Comté: Presses Universitaires de Franche-Comté.
- Yvain, S. (2018). Favoriser la dévolution de la mathématisation horizontale aux élèves engagés dans une activité de modélisation. *Quaderni di Ricerca in Didattica (Mathematics)*, 27(2), 279–284.
- Yvain, S., & Modeste, S. (2018). Faire entrer les élèves dans la mathématisation horizontale. Des fictions réalistes et un dispositif de résolution collaborative. *Quaderni di Ricerca in Didattica (Mathematics)*, 27(2), 285–289.
- Yvain-Prébiski S. (2018). *Etude de la transposition à la classe de pratiques de chercheurs en modélisation mathématique dans les sciences du vivant. Analyse des conditions de la dévolution de la mathématisation horizontale aux élèves*. Doctoral dissertation. Montpellier, France: Université Montpellier.

TWG07: Adult Mathematics Education

Introduction to TWG07 Adult Mathematics Education

Kees Hoogland¹, Beth Kelly² and Javier Díez-Palomar³

¹HU University of Applied Sciences Utrecht, The Netherlands; kees.hoogland@hu.nl

²University College London, United Kingdom; beth.kelly@ucl.ac.uk

³University of Barcelona, Spain; jdiezpalomar@ub.edu

This paper is a summary paper of the Thematic Working Group (TWG) on Adult Mathematics Education (AME). The theme AME made its first appearance on CERME11 and in this paper we provide an overview of the growing and blossoming field of AME and the results of the working group. The main themes associated with AME are: the definition, scope, and assessment of numeracy, the role of language and dialogue, the role of affect, including motivation, and the role of societal power structures, including subthemes like equity, inclusion, vulnerable learners, agency and self-efficacy. We conclude with the opportunities and challenges for this theme from both scientific and societal perspective.

Keywords: Adult Mathematics Education, Numeracy, PIAAC, Language, Agency.

Introduction

Adult mathematics education is a fast growing tree in the mathematics education forest. Many countries have in recent decades adopted policies on lifelong learning and, in most cases, mathematics and numeracy are included in these policies (see for instance the Lifelong Learning Platform, llplatform.eu). This is a consequence of the rising awareness that the current society is rapidly changing due to technological, digital and environmental developments, and that citizens need a broad repertoire of mathematical knowledge, skills, and confidence to deal with those changes, both in work situations as in daily life.

This idea is not completely new. An increasing interest in the relevance of mathematics needed for a well-functioning citizen started in the late 1950s in the UK with the Crowther report (DES Department of Education, and Science, 1959) but really blossomed two decades later with the Cockcroft report (DES Department of Education and Science, 1982), the foundation of Adults Learning Mathematics – an international research forum (ALM) established in 1993 with a strong European input (see e.g., Safford-Ramus, Keogh, O’Donoghue & Maguire, 2018), and the start of the Adults Numeracy Network (ANN) established in 1994 with a main focus on the USA. Numeracy was at that time defined in the Crowther report (1959) as scientific understanding and thinking quantitatively and in the Cockcroft report (1982) as the capacity to understand and use basic principles of mathematics and science presented in mathematical terms.

With the rapid growth of adult education in the 1970s (Milana & Nesbit, 2015) we witnessed a rise in formal mathematics education for adults, as a result of growing opportunities for adults to take another chance in getting mathematics certificates for further study or new careers. During this time, a large part of adult numeracy and mathematics education took place in informal and non-formal education environments, for instance in community centres or in the workplace, or was

hidden in vocational or literacy courses for adults, which made it hard to get a complete overview of the field. Therefore, the mathematics referred to in AME has many appearances. It ranges from formal mathematics for advanced technological careers, to typical school mathematics content supporting the attainment of formal certificates and diplomas, and to the multifaceted concepts of mathematical literacy and numeracy, which deal with the use of numbers, patterns and structures in daily activities. This last appearance can also be described as *Numeracy as a social practice* (Yasukawa, Rogers, Jackson, & Street, 2018). This makes the concept of numeracy relevant to large segments of the populations in many countries; Indeed, the results of the Programme for the International Assessment of Adult Competencies (PIAAC), discussed in the next section, found that many adults have their optimal functioning in daily life hampered by numeracy problems.

In this paper we show the subthemes raised by the participants in the TWG on AME. We consider this TWG as new platform for scientific discussion to push AME towards a more recognized position within the scientific international community. We present a brief summary of each of the contributions presented in the TWG during the conference. Finally, we conclude with some remarks on new avenues and challenges for the research in AME in the forthcoming years.

Emerging themes in Adult Mathematics Education

In TWG07 on AME the breadth and depth of the emerging field of AME is mirrored. Contributions come from various backgrounds, cultures, and experiences. In the first working group discussion the various themes of the contributions were made explicit and put into categories.

These are the categories covered by the contributions of the participants in this TWG:

- The definition, scope, and assessment of numeracy;
- The role of language and dialogue;
- Affect, including motivation;
- Special groups and vulnerable learners;
- Teaching and learning activities, including vocational education;
- The role of power structures, inclusion, agency and self-efficacy.

These themes more than anything else make clear that AME is a multi-layered phenomenon and much more than just mathematics education for a special target group. Mathematics education for adults intertwines the learning of mathematics with language and dialogue, affect, and dealing with learners' reality, but also with societal power structures and sociological concepts like equity, inclusion, and agency.

Regarding the definition, scope and assessment of numeracy

“Adults’ numeracy and literacy practices matter” (p. 75) is the opening line of the chapter by Coben and Alkema (2018) in the ICME13-monograph series title *Contemporary Research in Adult and Lifelong Learning of Mathematics – International perspectives* (Safford-Ramus, Maaß, & Süss-Stepancik, 2018). This brief sentence summarizes in the shortest possible way the importance of the theme numeracy in the field of AME.

The results of the last PIAAC survey show that in all but one participating country, at least 10% of the adults are proficient below level 1 of the 6-point scale in literacy or numeracy (OECD, 2013;

PIAAC Numeracy Expert Group, 2009). In other words, significant numbers of adults do not possess the knowledge, skills and confidence to succeed in today's society regarding quantitative matters. These results on numeracy give rise to serious concern for the economic development of Europe. This is an even more pressing issue since the amount of numerical data that needs to be interpreted and used is rapidly rising and all pervasive due to technological developments and the prevalence of (big) data. To gain a better insight in these trends a second cycle of PIAAC will be starting in 2021, which is now in preparation (Tout et al., 2017).

David Kaye, chair of ALM, made a contribution to the discussion in the group on the development of the definition and historical development of the concept of numeracy, based on his earlier publications in an ICME13 monograph (Kaye, 2018). In the Crowther report (1959), numeracy was closely related to understanding science and developing technologies in society. In the next twenty years, the meaning changed to basic operations, whereby the association with science was no longer present and the level of mathematical understanding to which numeracy refers became much lower and not much more than “able to perform basic arithmetic operations”. The persistence of the latter definition makes it hard to develop, disseminate, and implement a concept of numeracy which better equates to an ability to cope confidently with the mathematical demands of adult life. For that purpose this latter definition is much too restricted because it refers only to more mechanical and lower-order skills like performing arithmetic operations and not ‘mathematizing’, which is the skill of translating an encountered problem into an adequate operation so that the mathematics can be used with confidence to cope with practical everyday situations. What is so significant about these shifting definitions is that the debate about what numeracy might include was already twenty years old in 1982, and that the tension between numeracy being little more than arithmetic versus being a significant part of everyone's social practice is still being repeated in debates on numeracy policy development. The continuing tension can most likely be explained by the fact that it is not just an academic and educational debate, but rather a political one. In many countries we see a reoccurring ‘back-to-the-basics’-movement as a simple answer to the complex issue of how to prepare children and adults to deal with situations in everyday life which involve numbers, patterns, and structures.

Two contributions especially address this issue too. Diez-Palomar, Hoogland, and Geiger are members of the PIAAC Numeracy Expert Group, which is responsible for the development of an assessment framework and the items in the next PIAAC international comparative assessment, which is happening from 2021 onwards. They performed a limited literature review to explore which concepts from mathematics education theories could enrich the numeracy framework to make it more appropriate to adults functioning adequately in our number-drenched society (Tout et al., 2017). The most relevant concepts taken into account are number sense, big ideas in mathematics, and embeddedness and authenticity. Common in these concepts is that they all acknowledge the richness and multifaceted aspects of adults' cognitive processes in dealing with numeracy situations.

Furthermore, Hoogland, Auer, O'Meara, Diez-Palomar and Van Groenestijn report in their contribution on the first steps towards creating a *Common European Numeracy Framework (CENF)* for adults. These steps are made in an Erasmus+ project with the same name, which started in 2018, and is aims to broaden the perspective on numeracy, foremost by considering numeracy as a social

practice, focusing on numerate behaviour and numeracy practices. For a much more sophisticated discussion on seeing numeracy as a social practice, we further refer to the work of Coben and Alkema (2018) and Yasukawa (2018).

Regarding the role of language and dialogue.

The importance of the role of language and dialogue in AME was emphasised by no less than three contributions by Griffiths, Wessel, and Diez-Palomar & Anagnostopoulou respectively.

Griffiths report on his investigations into discussions that took place during and following a particular small group activity in which a scene is read aloud and a mathematical task is undertaken. In his research, the concept of ‘thinking as communication’ is utilised and employs an overarching framework for analysis. To understand what happens when the ‘reading aloud’ activity is undertaken, it is important to investigate what happens when learners undertake related activities. Griffiths describes the key elements to the research with some initial analysis drawing on data from an exploratory phase along with observations from the main study.

Wessel gives an overview of an Erasmus+ project that aims to empirically identify the potentials and challenges of language-responsive teaching designs for low-achieving students in vocational contexts. Using topic-specific designs the research delivers first insights into developing and experimenting with two teaching units (percentages and proportional reasoning) and summarizes the questions that come up when adapting design principles for language-responsive mathematics to the teaching and learning in vocational education. The empirical investigations are carried out with young adult pre-apprentices in lower level vocational education in Germany in the technical sector. These young adults often struggle with mathematics and have only limited proficiency in the language of instruction.

Diez-Palomar and Anagnostopoulou discuss the effectiveness of dialogic learning as an adults’ learning theory. Their paper specifically focuses on how so-called *Mathematics and Physics Dialogic Gatherings* can enhance the critical thinking of adult learners and hence develop their learning in both topics. Two studies were considered where the participants engaged in dialogic reading activity reading classics in mathematics or physics. The former study took place in Barcelona, Spain and involved adult women of above 40-years-old with low literacy skills engaging in mathematics. The latter took place in Kendal, UK and involved two groups of adults. Although the samples were extremely diverse, the results indicate that using classical readings can significantly improve critical thinking and dialogic talk in all groups and provide the potential to create further learning opportunities.

Regarding affect, including motivation

In various contributions, attention is given to the role of affect as an important factor influencing the outcomes of AME in the classroom. It acknowledges that learning mathematics involves not only cognitive processes, but also, to a substantial level, an array of psychological and affective factors.

Kelly undertook extensive doctoral research on the role of motivation in AME. Her research is based on interviews with adults about their motivation to study mathematics in the workplace, through classes organised and funded by trade unions in the UK. The findings point to motivation

as a function of individual's emotions and cognition that are influenced by social experiences. The research identifies a difference between the initial motivation to re-engage with learning and that required to continue, or persist. Continuing learning relies on a socially and emotionally supportive learning environment which adults identify as 'different' from previous learning experiences. The term 'Affective Mathematical Journey' is developed to describe the positive emotional changes experienced by adults, which helps them overcome negative memories. The adults' resultant increase in confidence and motivation encourages them to successfully develop and use their mathematical skills both inside and outside the classroom.

Regarding special groups and vulnerable learners

Engaging in mathematics education as well as trying to improve the management of various numeracy situations, such as finances, is a big step for many adults, especially when their past experiences with education are negative.

Redmer used PIAAC data to get a better insight into the numerate behaviour of older people. Demographic changes render basic numeracy skills increasingly important in older age. Among them, skills in financial matters are increasingly relevant. The skills measured in PIAAC and Competencies in Later Life (CiLL) represent comprehensive cognitive abilities that can be seen as the basis for successful participation in social and economic life. In a secondary analysis, Redmer shows that financial practices continue to be important for older people, although their numeracy skills proficiency may be lower than those of younger people. The analysis clearly indicated a gender difference in dealing with financial matters: men handle bills and bank statements, whereas women manage the household, although there was some discussion about whether this distinction would continue in following generations.

Byrne did research on a very special group. Her exploratory study is part of a larger study on assessment and teaching in mathematics classrooms in Irish prison education centres. Her purpose is to enhance knowledge in this field, to enhance practice and to enable better learning and teaching through research. A so-called Mathematics Teaching Triad is used as a theoretical construct for the study. This triad looks at management of learning, sensitivity to students, and mathematical challenges. When finished, the research project will present data derived from a wider investigation, including data from teachers in the secure sector across Ireland and data from prisoners attending mathematics classes. In this paper Byrne analyses the data gathered from a survey on small sample of teachers, covering the time available for mathematics classes, class composition, teacher satisfaction and teacher's identities through metaphor.

Regarding teaching and learning activities

Keogh reports on developing and validating an instrument to let people recognise their own numerate behaviour. His reasoning is that adults know more about mathematics than they think and use it more often than they realise. Despite their apparent self-perception of being a 'non-maths' person, they behave in mathematics-informed ways, which are dismissed, routinely, as common sense or something other than mathematics. The doctoral research found that given the opportunity to reflect on their own behaviour at work, through a mathematics-sensitive lens, people readily recognise their numerate behaviour even if they talk about it in different ways. This work introduces

a set of tools and a methodology to harvest real tangible benefits for the learner. The tools explore the locus of a person's expertise in increasing granularity, building a platform from on which to capture a learner's mathematics knowledge, skills and competence, to help revise possible mistaken self-perceptions and to inculcate confidence in his/her learning of mathematics.

Hoogland, Heinsman and Drijvers report on conducting a literature review on how numeracy is used in vocational education and whether there are effective practices identified in peer-reviewed literature of the last five years. The rationale for this study is that numeracy and mathematics education in vocational education is under pressure to keep up with the rapid changes in the workplace due to developments in workplace mathematics and the ubiquitous availability of technological tools. Vocational education is a large component of education for 12- to 20-years-olds in the Netherlands and the numeracy and mathematics curriculum is on the brink of a reform. Preliminary results show that in most of the articles the concept of numeracy was not clearly explained, however when specified the PIAAC definition is used. In the search for articles on numeracy education practices which also reported on effects of those practices, only four such articles could be found out of more than 600 publications on numeracy and vocational education. Discussion in the group suggests a wider search of publications which includes practices involving problem solving, motivation, and math-anxiety.

Regarding the role of power structures, inclusion, agency and self-efficacy

Last but certainly not least is the notion of the use of numeracy in society, including the importance of being numerate, equity in access to relevant numeracy education and the perception of gender issues around mathematics and numeracy, all of which are never value-free. In her research Heilmann uses adults' numeracy skills in the PIAAC data to analyse the issue of power. She states that theoretical discussions increasingly view numeracy as embedded in power relations, and if this is the case, these power relations should be visible in the results. She gives an overview of the underlying theories, focusing on three elements of numeracy skill proficiency: the distribution of skills in society, the process of defining a hegemonic view of numeracy skills and finally, the value of numeracy skills in the context of power relations. The value of numeracy skills is analysed using the example of gender relations in the labour market. The analyses explores how gendered hegemony might influence the way numeracy skills matter in terms of monthly wages and the probability of getting into leadership positions.

Forwarding the field

Although there is a broad acknowledgment that an array of psychological and sociological factors are important in (the results of) adult education, there is not yet a well-researched set of examples how in practice this can be taken into account in a more systematic and effective way. The practice of adult numeracy education is still a plethora of different content descriptions and goals that vary from very back-to-the-basics to very sophisticated higher-order skills. Reported teaching practices and lesson materials for adults are quite often not very different from those used in primary schools. Research-validated practices explicitly addressing the psychological and sociological issues are still very rare. The twin goals of trying to establish a firm definition of numeracy which acknowledges

the multifaceted nature of adult's mathematical practices while identifying consistent teaching approaches should be of concern to the global AME community.

Currently in Europe there are some developments which are promising to come to a more common definition of numeracy and identify effective teaching approaches. The ALM organisation is strongly anchored in Europe and functions through its yearly conference in July as a community of practice for researchers in the field of AME in Europe and beyond. The European Basic Skills Network (EBSN) in combination with the EPALe-website of the European Union provides a platform where practitioners, policy makers and researchers can share their ideas, thoughts and results. Furthermore, in 2018 an Erasmus+ project started, which originated in The Netherlands, Austria, Ireland, and Spain, and is aiming to involve all European countries in an attempt learn from each other experiences to find some common ground for terminology, perspectives, development and practice, and policy making .

In the future, it could be helpful if national and regional level policy documents explicitly define and openly discuss the chosen definitions of numeracy in relation to the European or world-wide used definitions, like the one by OECD in the PIAAC programme. Especially when societies become globalised, as Safford-Ramus, Misra and Maguire (2016) advocate, numeracy must remain a dynamic concept that recognises and responds to changes in society.

Conclusion

AME plays a vital role in empowering individuals to fulfil their full potential, enriching their repertoire to cope with situations and problems in daily life and the demands made by a globalised world, increasing reliant on technology. In the second cycle of PIAAC, which will be conducted from 2021 onwards, a large body of data will become available, which will for the first time provide a longitudinal comparison with the results of the first cycle of PIAAC. To some extent, this will also point to trends in the development of give aspects of the field of AME

Despite the relevance of numeracy in our society, the role that AME plays in the field of research into mathematics education is still rather small. There are international research associations in AME, but the main educational mathematics conferences that are referents in the field do not usually include AME as working group. We have over seventy years of “numeracy” as research topic devoted in national and international reports and studies. In the last decade, results of important large-scale surveys such as PIAAC have becoming available. However, there are still numerous gaps in terms of research understanding how adults learn and use mathematics, develop their quantitative understanding of everyday facts or situations, understand particular mathematical objects (proportions, functions, big numbers, shapes, etc.), and their properties, relationships and representations. The themes identified in this CERME working group layout a possible research agenda. The discussion will continue on the scope and definition of numeracy. Furthermore, sociological aspects will remain in the foreground of discussions on AME, such as its relationship with societal power structures and promoting individual inclusion, agency and self-efficacy for special groups and vulnerable learners. Another important aspect in AME is that adults bring their own life experiences to the learning environment, which implies that teaching and learning is influenced by a broad range of factors including the recognition that motivation to learn is

developed through social and emotional experiences, while teaching activities need to be sensitive to the role of language and dialogue as well as relevant to the context of learners' lives.

References

- Coben, D., & Alkema, A. (2018). Scoping the Development of a Measure of Adults' Numeracy (and Literacy) Practices. In K. Safford-Ramus, J. Maaß & E. Süß-Stepancik (Eds.), *Contemporary Research in Adult and Lifelong Learning of Mathematics: International Perspectives* (pp. 75–92). Springer.10.1007/978-3-319-96502-4_5
- DES Department of Education and Science. (1982). *Mathematics Counts - Report of the Committee of Inquiry into the Teaching of Mathematics in Schools (Cockroft report)*. London: HMSO.
- DES Department of Education, and Science. (1959). *15 to 18. A Report of the Central Advisory Council for Education (Crowther Report)*. London: HMSO.
- Kaye, D. (2018). Defining Adult and Numeracy: An Academic and Political Investigation. In K. Safford-Ramus, J. Maaß & E. Süß-Stepancik (Eds.), *Contemporary Research in Adult and Lifelong Learning of Mathematics: International Perspectives* (pp. 11–37). Springer. 10.1007/978-3-319-96502-4_2
- Milana, M., & Nesbit, T. (Eds.). (2015). *Global Perspectives on Adult Education and Learning Policy*. UK: Palgrave MacMillan.10.1057/9781137388254 Retrieved from <http://www.palgraveconnect.com/doi/10.1057/9781137388254>
- OECD. (2013). *OECD Skills Outlook 2013: First Results from the Survey of Adult Skills*,. Paris, France: OECD Publishing.10.1787/9789264204256-en
- PIAAC Numeracy Expert Group. (2009). *PIAAC Numeracy: A Conceptual Framework*. (Working group paper).OECD. 10.1787/220337421165 Retrieved from <http://econpapers.repec.org/paper/oeceduab/35-en.htm>
- Safford-Ramus, K., Keogh, J., O'Donoghue, J., & Maguire, T. (Eds.). (2018). *Adults Learning Mathematics - A Research Forum 1993-2018. Celebrating 25 years: A lot done, a lot more yet to do*. London, UK: ALM.
- Safford-Ramus, K., Maaß, J., & Süß-Stepancik, E. (Eds.). (2018). *Contemporary Research in Adult and Lifelong Learning of mathematics - International Perspectives*.Springer.10.1007/978-3-319-96502-4
- Safford-Ramus, K., Misra, P. K., & Maguire, T. (2016). *The Troika of Adult Learners, Lifelong Learning, and Mathematics : Learning from Research, Current Paradoxes, Tensions and Promotional Strategies*. Springer.
- Tout, D., Coben, D., Geiger, V., Ginsburg, L., Hoogland, K., Maguire, T., . . . Turner, R. (2017). *Review of the PIAAC numeracy assessment framework: Final report*. Melbourne, Australia: Australian Council for Educational Research (ACER).
- Yasukawa, K., Rogers, A., Jackson, K., & Street, B. V. (2018). *Numeracy as social practice : global and local perspectives*. Routledge.10.4324/9781315269474

Doing the time in the mathematics class

¹ [Catherine Byrne](#), ² [Brian Bowe](#) and ³ [Michael Carr](#)

¹ Dublin Institute of Technology, School of Multidisciplinary Technologies, Dublin, Ireland;
Catherine.byrne8@mydit.ie

² Dublin Institute of Technology, School of Multidisciplinary Technologies, Dublin, Ireland;
brian.bowe@dit.ie

³ Dublin Institute of Technology, School of Multidisciplinary Technologies, Dublin, Ireland;
michael.carr@dit.ie

This exploratory study is part of a larger study on assessment and teaching in mathematics classrooms in Irish prison education centers. Our purpose is to enhance knowledge in this field, to enhance practice and to enable better learning and teaching through research. We are using the Mathematics Teaching Triad (TT) theoretical construct for the study. This triad looks at Management of Learning (ML), Sensitivity to Students (SS) and Mathematical Challenges (MC). When finished, this research project will present data derived from a wider investigation, including data from teachers nationwide and data from prisoners attending mathematics classes. This paper analyses the data gathered from a survey on small sample of teachers, covering the time available for mathematics classes, class composition, teacher satisfaction and teacher's identities through metaphor.

Keywords: Assessment, mathematics, prison time, metaphor.

Introduction and context

Irish Prison Education

The Council of Europe document *Education in Prison* (1990) states that education of prisoners must “be brought as close as possible to the best Adult Education in society outside” in philosophy and content and that it must “link prisoners to the outside community” (p.14).

Prison education in Ireland is a partnership between the Irish Prison Service and the Education Training Boards (Irish Prison Service 2016). The Joint Strategy Statement states that its aims are to

assist persons in custody to cope with their sentences, to prepare for life after release, to develop an appetite and capacity for lifelong learning and to achieve their full potential as learners. It also aims to promote the importance of prison education. (IPS, 2016, p.6)

So prisoner learners can access similar education and accreditation to learners in adult education elsewhere, through accredited (leading to state certification) and non-accredited courses (not leading to state certification). An adult education approach is followed in prison education which looks at the whole person rather than deficit models, which see the student's weaknesses or mainly as an offender (Warner, 2007).

Teaching in Prisons

Students entering prison education may have low levels of education (O'Mahoney, 1977; Kett & Morgan, 2003) and a history of negative or disrupted educational experiences (Muth, 2008).

People are motivated to start education in prison for many reasons, including personal development, family and work preparation (Costelloe, 2003). School in prison represents freedom, an escape, a distraction and stops them from sinking (Behan, 2014). They come to have a laugh, make the most of their time, and to learn how to learn (Carrigan & Maunsell, 2014). In prison education they feel trusted (Behan 2014), feel normal and their true selves (Carrigan et al., 2014). The positive feelings of the students seem to have an impact on the teachers. Prison teachers interviewed by Michals (2015) were positive about their work, felt satisfaction and felt that they had learnt from their students. Muth (2008) and Byrne & Carr (2015) state that teachers in prison have noted the transformative nature of prison education, and the growth of their students. This may lead to teachers feeling empowered in the classroom, as Messemer (2013) states that teachers interviewed in US correctional education centers felt they had a strong level of influence to make the necessary instructional decisions in their classrooms. We decided to investigate if there were other reasons for mathematics teacher feeling satisfied in their work. As classes in prison are generally longer than in schools outside, we adapted a study on this topic with mathematics teachers in secondary schools. This found that longer more frequent classes increased teacher satisfaction, which led to increased innovation in methodology and more teaching for understanding (O’Meara & Prendergast, 2018).

Why I am doing research?

Our study is based on the Jaworski Teaching Triad (Jaworski, 1992) which has three components, the Management of Learning (ML), Sensitivity to Students (SS) and Mathematical Challenges (MC). We chose this because it offers a framework for all the proposed data from this study, both qualitative and quantitative. ML refers to the role of the teacher in the classroom learning environment. In this context this refers to groupings, timetable, resources, interactions. Sensitivity to Students (SS) describes the teacher’s knowledge of the learners, attention to their needs, affective, cognitive and social. In this context it describes the engagement with students, from the point of entry. Mathematical Challenges (MC) describe the challenges offered to the learners to help them develop mathematical thinking through tasks, questions and reflections, in accredited and non-accredited tasks.

The domains are interlinked and interdependent. A balance between SS and MC is needed to enable teaching to take place. In prison education there could be a risk of too much SS, due to vulnerability of learners, and too little MC which could mean strong relationships in class but little mathematical progression. Too much MC and too little SS could cause stress to an already traumatized and stressed group. Harmony leads to achievement when there is a balance between challenge, support and stimulation. The results from the teachers (see below) show their SS, ML MC.

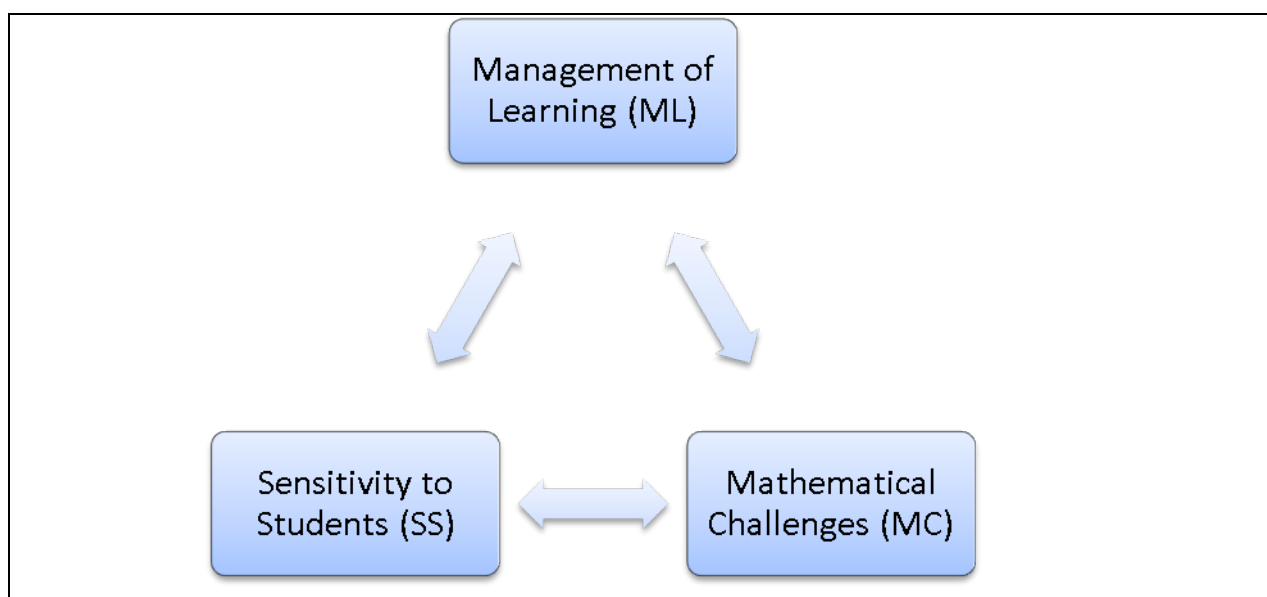


Figure 1: Teaching Triad, Jaworski, B. (1992)

The prison education center is where two cultures collide, the culture of the classroom and the prison (Wright, 2005). There has been very little research on the everyday experience of prison education internationally, so we decided to gather data on the practices and rationale. We built this study on previous studies of mathematics teachers, in Ireland, Finland and Switzerland. O'Meara & Prendergast (2018) investigated the length of mathematics classes and the impact on teacher satisfaction. Oksanen & Hannula (2013) used metaphor to explore mathematics teachers' beliefs about their profession and Beeli-Zimmermann (2014) explored adult numeracy teachers' beliefs.

We distributed the survey by email after a discussion with each teacher. During the call, the rationale for the study was given and the invitation was issued to take part. All who were contacted responded. We will extend the study nationwide in future.

The questions are divided into two types; quantitative information on the class structure and allocation and qualitative questions on the teachers' identity using metaphor (Table 1).

1	How long are mathematics classes in your center?
2	How often can people attend mathematics?
3	How satisfied are you with this?
4	How many students are in your mathematics classes
5	Are students of similar or mixed ability?
6	Do you like teaching mathematics?
7	What metaphor describes you as a mathematics teacher?
8	Please explain

Table 1: The survey for prison mathematics teachers

The O'Meara & Prendergast (2018) study is interesting because it showed that mathematics teachers in secondary schools were more satisfied with longer and more frequent mathematics classes. Classes in prison are longer so we wanted to investigate the impact of the longer class time on the satisfaction of prison mathematics teachers. Teachers' beliefs can shape their actions, and this could have an effect in prison education, where teachers' values may differ from the prison culture (Wright, 2005). So, we decided to evaluate how mathematics teachers in prison felt about their work as this can impact on their teaching Beswick (2011). We are interested in doing this research because there is a lack of research in the field of prison mathematics education. After teaching for many years in this sector, I felt it was timely to investigate it.

What am I doing?

So, we developed a survey for teachers of mathematics in prison center, based on other studies and issued it to a pilot group of mathematics in prison. We intend to involve a wider group in future. The survey has quantitative and qualitative parts: the quantitative part investigates the timetabling, the composition and the access to mathematics classes. The qualitative part used metaphor to assess teachers' identity and feelings about their work through metaphor. We will analyze this data using a framework such as Linguistic Metaphor Identification (Steen 2010). This was originally planned as an online survey, but these can be problematic in the prison context, so we simplified it and used email. Five emails were sent and five responded.

There is a small number of responses for several reasons. There is a small number of mathematics teachers in the Irish prison education system. There are 13 centers in total and all have at least one teacher, either part time or full time. This data will be part of the next stage in this study. It is a subject with relatively low participation rates, which will be investigated in the next stage of the research. This is the first stage of the research and in the next stage, further data will be gathered from the remaining mathematics teachers in Irish prisons. The final stage of the project will consist of surveying the students attending mathematics classes in prison.

There is often conflict over mathematics, mathematics or numeracy (Kaye, 2015) and the discussion is beyond the scope of this paper. This paper uses the term mathematics, as that is the term used widely in prison education by teachers and students.

The research questions in this study are:

- (1) Are long mathematics classes common practice in Irish prison education centers and how often can students attend?
- (2) Is there a link between teachers' level of satisfaction to the availability of mathematics classes?
- (3) How do Irish mathematics teachers in prison see their identity?

Results

The quantitative data was analyzed using Excel. Teachers surveyed stated that their mathematics classes varied between 1.5 and 2 hours long (Figure 2). They also stated that students could enrol in as many classes as they wished each week. All teachers stated that they were satisfied with this.

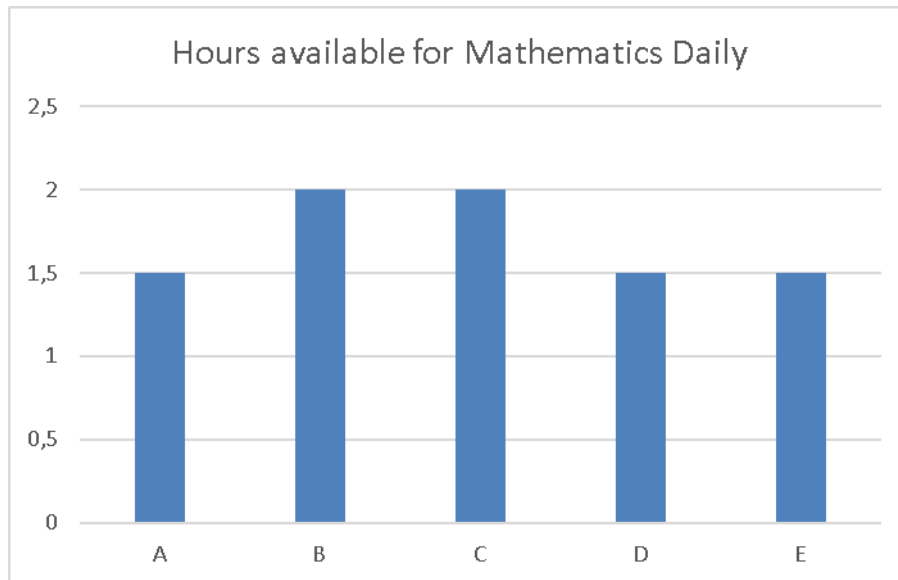


Figure 2: Hours available for Mathematics classes in prison education centers daily

We found that mathematics classes in prison were longer, at least one hour (Figure 2). Students could come more often if they wished; all levels and abilities attend at the same time, so students could join classes with people they choose to learn with.

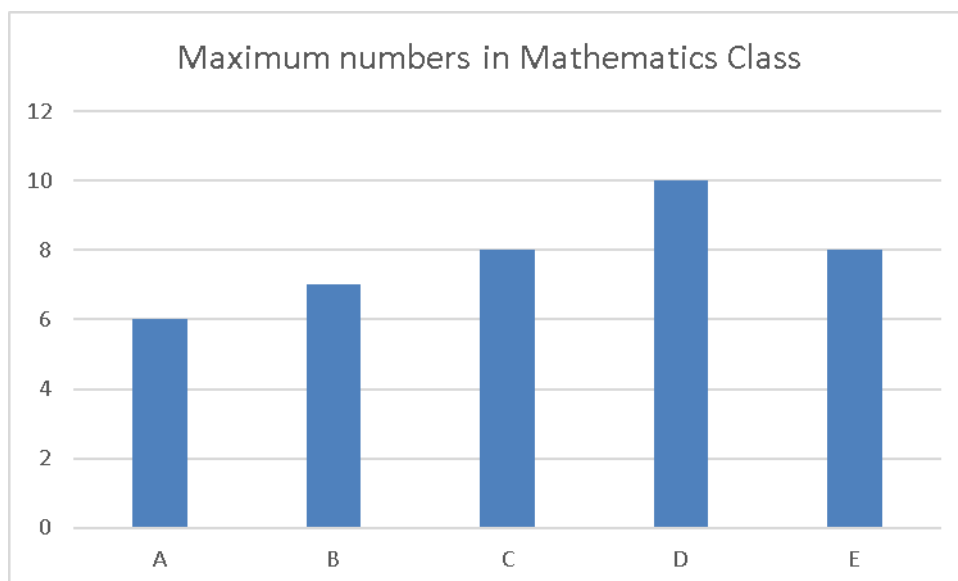


Figure 3: Maximum numbers attending mathematics classes in prisons surveyed

In Figure 3, the numbers attending range from 1 to 10 and one respondent was unhappy with the low numbers. 10 is the maximum number in any class according to the respondents.

Students worked individually within the group as all were at different levels and the teachers respected and protected their privacy. This mixture in the class was a challenge at times and took a toll on teachers, in terms of emotional and physical energy, according to some respondents.

A challenge that teachers felt in this context was getting more students to class, as they knew there were many who were not coming to school or who were in other classes but had not enrolled in mathematics yet. They also felt that the students were anxious at the beginning so had to work individually rather than in groups as at the start, they were afraid to let others see where they were at. Some teachers were the only mathematics teacher in their center, some were part of a team in their center.

In response to the question “Are students of mixed ability?” all teachers stated that all students are mixed level. Teachers were asked: “Do you like teaching mathematics in prison?”

Those surveyed all said they enjoyed teaching mathematics in prison and seeing their students grow in confidence and in skills. Teachers stated:

“I enjoy it”

“I love it”

“I like it”

“Yes, I love teaching mathematics ...to see a student’s absolute pleasure at reaching their target.”

Responses to the question “What metaphor describes you as a mathematics teacher?” ranged from “bit of everything” (2 responses) to “facilitator”, “member of a band” and “jazz musician” and “juggler” and “bridge builder” and “breaking down barriers”. Teachers stated that they wanted to ensure students had a positive experience and would return to mathematics class the next day, so adapted their behavior according to the needs of the students during each class. These teachers see themselves in different ways, as facilitators of the group, as led by the group and as a mixture of both. Oksanen & Hannula (2013) stated that in their findings teachers saw themselves in five categories: subject specialist, pedagogue, didactics expert, self-referential and contextual metaphors. We will develop our coding into categories in the future wider study.

As part of my own reflective practice, I picked a metaphor which I felt represented my work as a teacher of mathematics in prison. I feel that I am a tightrope walker, balancing on a fine line in class between challenging my students with mathematics, being sensitive to them and managing the learning while keeping an eye out for risks.

Discussion

There were many findings from this initial stage of gathering the research. Looking at the data from teachers, they had long mathematics classes of and mixed levels and were generally satisfied with the amount of time students could access classes. They were concerned that so few came to mathematics class. Teachers showed flexibility of approach in their use of words related to their management of learning, such as juggle, rotate, flexibility. Their actions showed a tolerance and

acceptance of where the students were at. The irregular attendance, mixed ability groups, different groups, different class lengths, and frequent breaks during class allowed the students to feel comfortable and enjoy being mathematics class. These factors presented a challenge to teachers at times. Teachers showed an awareness of the role of emotions in mathematics class and noted that they allowed respect and privacy to students, offered individualized teaching within the group. They saw their role as breaking down barriers around learning mathematics and acknowledged that learning is challenging. Teachers expressed their pleasure at seeing student reach their target and acknowledged the difficulties they had in their mathematics learning histories.

References

- Beeli-Zimmermann, S. (2014). Beyond questionnaires: Exploring adult education teachers' mathematical beliefs with pictures and interviews. *Adults Learning Mathematics*, 9(2), 35-53.
- Behan, C. (2014). Learning to escape: Prison education, rehabilitation and the potential for transformation. *Journal of Prison Entry and Reentry*, 1(1), 20-31.
- Beswick, K. (2011). Knowledge/beliefs and their relationship to emotion. In K. Kislenko (Ed.), *Current state of research on mathematical beliefs XVI: Proceedings of the MAVI-16 conference* (pp. 43-59). Tallinn, Estonia: Tallinn University.
- Byrne, C. P. & Carr, M. (2015). Maths in prison. *Journal of Prison Education and Reentry*, 2(2), 33-37.
- Carrigan, J., & Maunsell, C. (2014). 'Never really had a good education you know, until we came in here': educational life histories of young adult male prisoner learners. *Irish Educational Studies*, 33(4), 399-417.
- Council of Europe. (1990). *Education in prison: Recommendation No. R(89)12 of the committee of ministers to member states on education in prison*. Strasbourg, France: Council of Europe.
- Department of Education and Skills. (DES). (2010). *Report of the project mathematics implementation support group*. Retrieved from <https://www.education.ie/en/Publications/Policy-Reports/Report-of-the-Project-Maths-Implementation-Group.pdf>
- Irish Prison Service. (2016). *Joint IPS/ETBI education strategy 2016 – 2018*. Retrieved from http://www.irishprisons.ie/wp-content/uploads/documents_pdf/education_strategy_2016.pdf
- Jaworski, B. (1992). Mathematics teaching: What is it. *For the learning of Mathematics*, 12(1), 8-14.
- Kaye, D. (2015). What do we teach? Mathematics, numeracy, or maths?. In A. Hector-Mason & S. Beeli-Zimmermann (Eds.) *Adults learning mathematics: Inside and outside the classroom. Proceedings of the 21st International Conference of Adults Learning Mathematics: A Research Forum* (pp. 141-149).
- Messemer, E. (2013). The level of influence that six dimensions have on teacher decision-making in the correctional education classroom. *International Journal of Humanities and Social Science*, 3(13), 8-19.

- Michals, I., & Kessler, S. (2015). Prison teachers and their students: A circle of satisfaction and gain. *Journal of Correctional Education*, 66(3), 47-62.
- Morgan, M., Kett, M. (2003). *The Prison Adult Literacy Survey: Results and implications*. Dublin, Ireland: Irish Prison Service.
- Muth, B. (2008). Radical conversations: Part one social-constructivist methods in the ABE classroom. *Journal of Correctional Education*, 59(3), 261–281.
- Oksanen, S., & Hannula, M. S. (2013). Finnish mathematics teachers' beliefs about their profession expressed through metaphors. In M. S. Hannula, P. Portaankorva-Koivisto, A. Laine, & L. Näveri (Eds.). *Current state of research on mathematical beliefs XVIII: Proceedings of the MAVI-18 Conference*. Helsinki, Finland: Suomen ainedidaktinen tutkimusseura ry.
- O'Mahony, P. (1997). *Mountjoy prisoners: A sociological and criminological profile*. Dublin, Ireland: The Stationary Office
- O'Meara, N., & Prendergast, M. (2018). Time allocated to mathematics in post-primary schools in Ireland: are we in double trouble? *International Journal of Mathematical Education in Science and Technology*, 49(4), 501-516.
- Steen, G. J., Dorst, A. G., Herrmann, J. B., Kaal, A., Krennmayr, T., & Pasma, T. (2010). *A method for linguistic metaphor identification: From MIP to MIPVU*. Amsterdam, The Netherlands: John Benjamins.
- Warner, K. (2007). Against the narrowing of perspectives: How do we see learning, prisons and prisoners? *Journal of Correctional Education*, 58(2), 170-183.
- Wright, R. (2005). Going to teach in prisons: Culture shock. *Journal of Correctional Education*, 56(1), 19-38.

Numeracy in adult education: discussing related concepts to enrich the Numeracy Assessment Framework

Javier Díez-Palomar¹, Kees Hoogland² and Vincent Geiger³

¹University of Barcelona, Faculty of Education, Barcelona, Spain; jdiezpalomar@ub.edu

²HU University of Applied Sciences Utrecht, The Netherlands; kees.hoogland@hu.nl

³Australian Catholic University, Institute for Learning Sciences and Teacher Education, Brisbane, Australia; Vincent.Geiger@acu.edu.au

This work draws on the Programme for the International Assessment of Adult Competencies (PIAAC) survey. Last year a first review was conducted on the PIAAC Numeracy Framework (Tout. et al., 2017). In 2018 and 2019 the framework for the second cycle of PIAAC will be developed. This second cycle of the PIAAC survey aims to update the data about the numeracy skills of adults in different countries around the World (Hoogland, Díez-Palomar, Maguire, 2019). The objective of this paper is to highlight some relevant findings from literature on the concept numeracy in order to discuss a potential enrichment of the PIAAC Numeracy Assessment Framework (NAF).

Keywords: Numeracy, assessment, adult learning.

Introduction

We are now well into the 21st century, and lifelong learning is becoming a crucial feature in adults' lives, especially in terms of numeracy, because of the need to live in an increasingly globalized world characterized by rapid technological and economic change. There are major societal and policy pressures on education to prepare citizens for a complex and technologized society (Hoogland, Díez-Palomar, & Vliegenthart, 2018; Voogt & Roblin, 2012). What is expected from numeracy education in the current situation? New means of communication and types of services have changed the way individuals interact with governments, institutions, services and each other, and social and economic transformations have, in turn, changed the nature of the demand for skills as well. Globally, too many adults and young people lack the necessary numeracy competencies to participate autonomously and effectively in our technologized and number-drenched society. As a consequence, many people are disadvantaged in terms of employment and face preventable challenges in relation to social well-being and financial security. The results of the last PIAAC survey (OECD, 2016) show that a quarter of the participating countries in PIAAC have numeracy outcomes below level 2 of the 6-point scale. These outcomes give rise to serious cause for concern for the future economic development for many nations. This is an even more pressing issue since the amount of mathematical data that needs to be interpreted and used is increasing rapidly due to technological developments and the emergence of (big) data. However, numeracy is a complex notion that entails different components (Geiger, Goos & Forgasz, 2015). More than a decade ago (in 2003), several scholars meeting in Strobl discussed, during an ALM (Adults Learning Mathematics) conference, the meaning of numeracy versus mathematical literacy (Maasz & Schloeglmann, 2003). It was not clear whether numeracy was just referring to the ability to use mathematics in different situations, or something wider that we can call "mathematics literacy." In this paper we adopt the definition of numeracy developed for the first cycle of the PIAAC survey as

starting point, to discuss the concept of “numeracy” seeking to identify what numeracy concepts are, so a meaningful assessment framework can be developed to recognize these concepts. We will discuss the notion numeracy in order to enrich the basis to develop the NAF that will be used in the second cycle of the PIAAC survey. We draw in a literature review exploring different concepts of numeracy, putting the emphasis on its components. In the next section we present the methodology used to conduct the review discussed in this paper. Then, we introduce the main findings.

Methodology

In order to answer the research question mentioned above, we conducted a literature review on the concept numeracy. Typically, a literature review is used to frame the problem presented in the introduction of the study (Creswell, 2003). In our case, we are using the literature review as a research instrument to identify relevant literature in order to discuss the different definitions about numeracy. According to Creswell (2003), the first step of doing a literature review is identifying “key works useful in locating materials” (p. 34) that may be relevant for the purposes of the study. In our review we elaborated on past finding by cross-referencing the concept numeracy with a number of reoccurring concepts in the discussions on numeracy. These concepts are: big mathematics ideas, number sense, embeddedness, and authenticity. We decided using those categories since they emerge from the first cycle of PIAAC. We have carried out a documental analysis of articles published in scientific journals included in the main databases and repositories, including the Web of Science, Scopus, for relevant journal articles, and ERIC Database for scholar documents and reports. Additionally, Google Scholar was used to identify potentially relevant literature, that we have subsequently contrasted with the Web of Science and, especially, with the Journal Citations Report database. We used the mentioned categories above as keywords to conduct the searches.

Results

Following Creswell (2003) recommendation, we present the global results of the review for each of the selected concepts. We also use what Creswell calls a literature map to illustrate the different components regarding to numeracy found in the literature review. Drawing mainly on the documents produced by the OECD (PIAAC, etc.), we created a first approach to the concept of numeracy, using a web-based software to count the number to times (frequency) that each word is used. This provided a first view of the concept of numeracy and how is it being used (Figure 1).

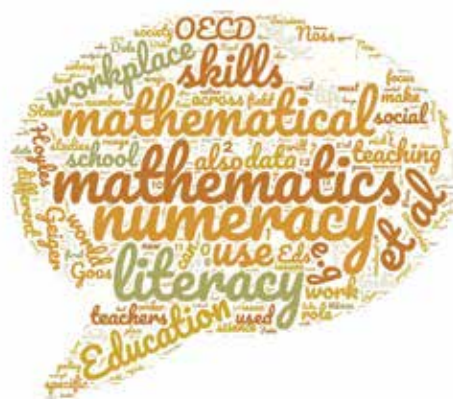


Figure 1: Word cloud of terms related to numeracy (based on OECD documents)

We can see that the word “numeracy” is usually connected to concepts such as mathematics, skills, literacy, education, teaching, workplace, use, work, and data (see Figure 1). However, this first approach is based in a limited exploration. For this reason, we conducted a more fine-grained analysis, using a purposeful procedure (Creswell, 2003) using the three key words, as cited above, in the methodological section. As we can see in Figure 2, those three keywords provided a conceptual network in which aspects such as competence, access, use and interpret mathematics, embeddedness and social practice, invisibility, authenticity, workplace, powerful mathematical ideas, appears interconnected.

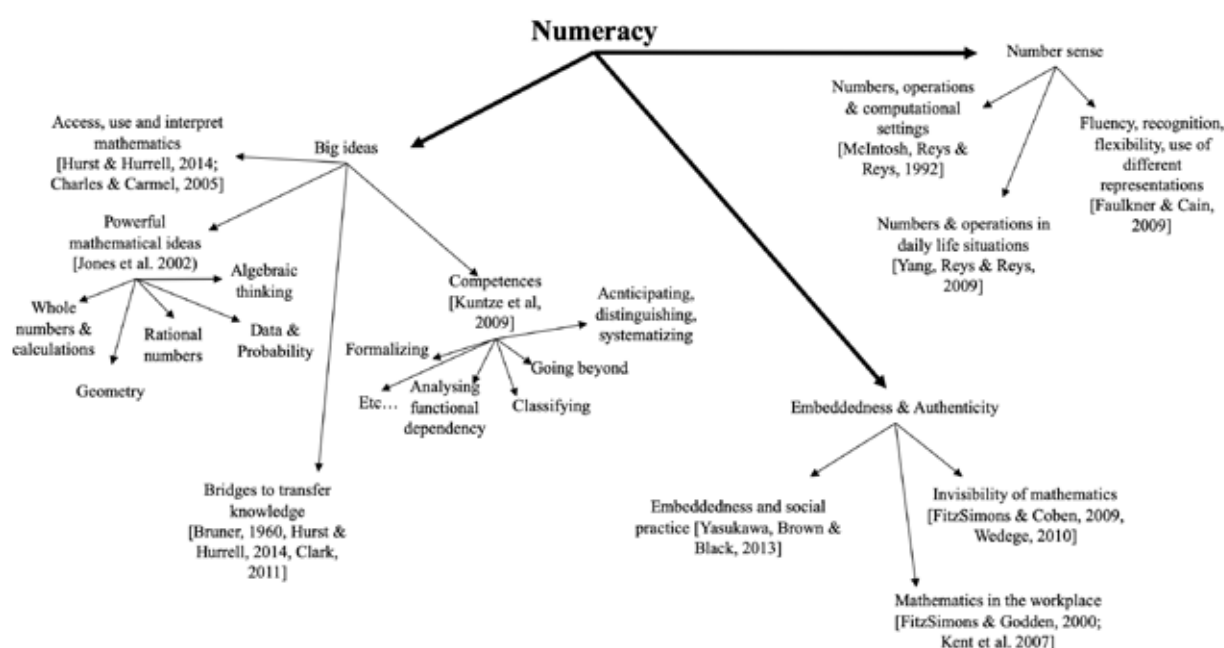


Figure 2: Literature map about the notion of numeracy

Numeracy and big ideas in mathematics

An entry point to identify relevant schemes, models or instruments to establish the basis of the new numeracy components is the so-called “big ideas in mathematics.” This is a well-known research domain in mathematics education (Jones et al. 2002). There is a general agreement that mathematics proficiency means noticing connections among different mathematics’ concepts and competence in using them. After many decades of mathematics education as a sort of utilitarian discipline looking for ways and strategies for children to perform calculations and solve problems, the vast majority of the mathematics education researchers defend a more relational focused approach to teach and learn mathematics. Jones and his colleagues (2002) provide a great summary of the main contributions of the research to what they call “powerful mathematical ideas”, including the following domains: whole number and operations, rational numbers, geometry, probability, data exploration and algebraic thinking and other underrepresented

domains. It could be argued that being numerated means using the contents of all these domains not just as procedures (instrumental understanding in Skemp's terms) but in a critical / meaningful manner.

In a more recent article, Hurst and Hurrell (2014), quoting Charles and Carmel (2005), state that "big ideas" allow us to see mathematics as a coherent set of ideas, encouraging a deep understanding of mathematics. It could be suggested that being numerate as defined within the PIAAC NAF may link to the idea of being able to access, use, interpret and communicate mathematical information around what the international scientific community calls "big ideas in mathematics." Although it seems that everyone might understand what "big ideas in mathematics" encompasses, the reality is that the construct remains contentious. Kuntze and his colleagues (2011) mention a plethora of different terms referring to the area of big ideas, e.g. fundamental ideas (Schweiger, 2006), central ideas or universal ideas (Schreiber, 1983), core ideas (Gallin & Ruf, 1993), leading ideas (Vollrath, 1978), basic ideas and basic conceptions (Hofe, 1995).

Charles and Carmel (2005) define "big idea" as "a statement of an idea that is central to the learning of mathematics, one that links numerous mathematical understandings into a coherent whole." This definition is also shared by other authors such as Hurst and Hurrell (2014). In their article, they track the notion of "big idea" back to the work of Bruner (1960), who inspired Clark's (2011) definition of big idea as a "cognitive file folder" that we can file with "an almost limitless amount of information." (Clark, 2011, p. 32). Big ideas became conceptual structures (schema in Skemp's terms) that we can use to provide a NAF where content might be characterized by multiple connections. As Bruner (1960), Hurst and Hurrell (2014), Clark (2011) and other authors claim, big ideas may become bridges for the transfer of learning. Drawing on their thoughts, we suggest here using big ideas in mathematics as a skeleton for developing PIAAC NAF.

Numeracy and number sense

Number sense appears to be one of the main components of "numeracy." Being numerate means having a certain sense of numbers and how we use them to represent, inform, predict, estimate the reality.

McIntosh, Reys and Reys (1992) develop a framework for number sense including three components: numbers, operations and computational settings, which are interconnected. According to them, number sense involves being able to use numbers, operations and their applications in different computational settings. They talk about the meaningful understanding the Hindu-Arabic number system, the development of a sense of orderliness of the number, the multiple representations for numbers (including the idea of composition / decomposition), the understanding of mathematical properties, and the relationship between operations. For them, having "number sense" means being able to solve problems in the real world, providing suitable answers, using (or creating) effective strategies to compute, count, etc. It is not just reproducing instrumentally a certain algorithm but being able to use the mathematical knowledge and components in a flexible manner.

Yang, Reys and Reys (2009) define number sense as "a person's general understanding of numbers and operations and the ability to handle daily life situations that include numbers. This ability is used to develop flexible and efficient strategies (including mental computation and estimation) to

handle numerical problems.” (Yang, Reys & Reys, 2009, p. 384). Regarding the components of number sense, these authors argue “Number sense is a complex process involving many different components of numbers, operations, and their relationships.” (Yang, Reys & Reys, 2009, p. 384). Among these processes, they highlight two aspects, (1) the use of benchmarks in recognizing the magnitude of numbers, and (2) the knowledge on the relative effects of an operation on various numbers.

Faulkner and Cain (2009) claim that “the characteristics of good number sense include: (a) fluency in estimating and judging magnitude, (b) ability to recognize unreasonable results, (c) flexibility when mentally computing, (d) ability to move among different representations and to use the most appropriate representations” (p. 25). The main components of their approach to number sense are: quantity and magnitude, numeration, equality, base ten, form of a number, proportional reasoning, algebraic and geometric thinking.

Numeracy, embeddedness and authenticity

The concept of embedded mathematics emerges primarily from studies related to mathematics in the workplace but also has significance in the broader notion of numeracy. The embeddedness of mathematics refers to a deep connection to the context in which it is utilized. This can mean that the way mathematics is used to operate on a task is fundamentally shaped by the context in which it is employed. This includes socio-cultural influences that afford or constrain action in school, civic, personal or workplace environments. In this view there is a clear separation between school mathematical knowledge, how it is taught, learnt and practiced, and the use of this knowledge outside of schooling. As Harris (1991) notes:

In work [. . .] mathematical activity arises from within practical tasks, often from the spoken instruction of a supervisor and always for an obvious purpose which has nothing to do with the numbers working out well. Thus, students taught to react to isolated, abstract and written commands in the specialist language and carefully controlled figures of a school mathematics class, find themselves confronted with the urgent spoken, if not shouted, instructions in a completely different context and code (p. 138).

Yasukawa, Brown and Black (2013) make a clear connection between embeddedness and social practice arguing that numeracy practices cannot be understood independently of the social, cultural, historical and political contexts. They illustrate this point, they compare students completing calculations individually, using paper and pen and perhaps a calculator against the use of mathematics in the supermarket, in which the same calculations completed at a checkout counter by the shop assistant using a cash register. In this situation the shopper might perform an estimation to avoid being overcharged. However, the shop assistant is equally concerned with charging the customer the correct price and recording accurate record of the items sold via the cash register. The calculations are the same but the purpose – which is related to context - is different.

Embeddedness has led some researchers to talk about the invisibility of mathematics within work or social contexts. This means that mathematics can be fundamental to activities that are not obviously mathematical (FitzSimons & Coben, 2009). This is most clearly apparent in the use of technology in the workplace where digital tools used to complete tasks often obscure underpinning

mathematical activity. As Kent, Noss, Guile, Hoyles and Bakker (2007) argue, within techno-mathematical situations in workplaces there is a shift from ‘fluency in doing explicit pen and paper mathematical procedures to a fluency with using and interpreting output from IT systems and software, and the mathematical models deployed within them’ (p. 2-3).

Building on this point, Wedege (2010) defines two forms of invisible mathematics as (a) subjectively invisible mathematics where people do not recognize the mathematics that they do as mathematics and (b) objectively invisible mathematics in which mathematics is hidden in technology.

Discussion

Drawing on the contributions coming from the literature review, some considerations emerge.

First, big ideas in mathematics, number sense, embeddedness, and authenticity are important concepts in trying to define the notion of numeracy in the context of the 21st century. The *Numeracy Expert Group* working at the PIAAC survey defined numeracy as “ability to access, use, interpret and communicate mathematical information and ideas” (PIAAC Numeracy Expert Group, 2009, p. 21). However, this definition does not provide clues about what “mathematical information and ideas” means. This is a relevant topic, since in the 21st century the “mathematics” that may be relevant for adults probably include some of the components highlighted by the scholars working around the notion of big ideas of mathematics. This is also interlinked to the notion of authenticity, since relevant mathematics, perhaps, must to be also authentic (or they are relevant because they are also authentic). If we want to create a new framework for numeracy assessment, then probably we need to look for the mathematics embedded in real situations and draw on them in order to be able to measure adults’ numeracy.

Second, more research is required to identify other important elements of numeracy, especially in the current context of the 21st century and the “new” skills that adults must to develop. In fact, numeracy capability is increasingly vital in a world characterized by rapid technological and economic change.

Third, numeracy is vital for social well-being, financial security and informed citizenship. Hence, a framework to assess numeracy must explore how this notion is embedded in authentic practices related with those societal dimensions mentioned above.

Fourth, the critical aspect of numeracy, (not discussed here) related to making evidenced based judgements and decisions, is an aspect of numeracy that has often been underplayed for adults but is an essential element for informed participation in personal, civic and work life. More work is needed in identifying how to promote this critical capability.

Fifth, evidence suggest that adult numeracy has been limited to studies in context (workplace, personal settings or activities, such as shopping, etc.). However, there is a lack of research in terms of cognitive, epistemological considerations of how adults learn/ use mathematics (numeracy skills), which means that additional research is needed to cover those aspects.

Acknowledgment

This work is supported under the OECD *Programme for the International Assessment of Adult Competencies* (PIAAC) survey.

References

- Bruner, J. (1960). *The process of education*. New York: Random House/Vintage.
- Charles, R. I., & Carmel, C. A. (2005). Big ideas and understandings as the foundation for elementary and middle school mathematics. *Journal of Mathematics Education*, 7(3), 9-24.
- Clark, E. (2011). Concepts as organizing frameworks. *Encounter*, 24(3), 32-44. Retrieved from: www.ojs.great-ideas.org/Encounter/Clark243.pdf (Original work published in 1997).
- Creswell, J.W. (2003). *Research design. Qualitative, quantitative and mixed methods approaches*. Thousand Oaks, London, New Delhi: SAGE.
- Faulkner, V. N., & Cain, C. (2009). The components of number sense: An instructional model for teachers. *Teaching Exceptional Children*, 41(5), 24-30.
- FitzSimons G., & Coben D. (2009). Adult numeracy for work and life: Curriculum and teaching implications of recent research. In Maclean R. & Wilson D. (Eds.), *International Handbook of Education for the Changing World of Work* (pp. 2731-2745). Dordrecht, The Netherlands: Springer
- FitzSimons, G. E., & Godden, G. L. (2000). Review of research on adults learning mathematics. In *Perspectives on adults learning mathematics* (pp. 13-45). Dordrecht, The Netherlands: Springer.
- Gallin, P., & Ruf, U. (1993). Sprache und Mathematik in der Schule. Ein Bericht aus der Praxis. *Journal für Mathematik-Didaktik*, 12(1), 3-33.
- Geiger, V., Goos, M., & Forgasz, H. (2015). A rich interpretation of numeracy for the 21st Century: A survey of the state of the field. *ZDM–Mathematics Education*, 47(4), 531-548. Doi: 10.1007/s11858-015-0708-1
- Harris, P. (1991). *Mathematics in a cultural context: Aboriginal perspectives on space, time and money*. Australia: Deakin University.
- Hofe, R. (1995). *Grundvorstellungen mathematischer Inhalte*. Heidelberg Berlin Oxford: Spektrum Akademischer Verlag.
- Hoogland, K., Díez-Palomar, J., & Maguire, T. (2018). Towards a second cycle of PIAAC. Programme for the International Assessment of Adult Competencies. In D. Dalby, D. Kaye, B. Kelly & J. Stacey (Eds). *Proceedings of the 25th International Conference on Adults Learning Mathematics (ALM25): Boundaries and Bridges: adults learning mathematics in a fractured world*. London, UK.
- Hoogland, K., Díez-Palomar, J., & Vliegthart, M. (2018). Towards a Common European Numeracy Framework. In D. Dalby, D. Kaye, B. Kelly & J. Stacey (Eds). *Proceedings of the 25th International Conference on Adults Learning Mathematics (ALM25): Boundaries and Bridges: adults learning mathematics in a fractured world*. London, UK.
- Hurst, C., & Hurrell, D. (2014). Developing the big ideas of number. *International Journal of Educational Studies in Mathematics*, 1(2), 1-18.

- Jones, G.A., Langrall, C.W., & Thornton, C.A. (2002). Elementary students' access to powerful mathematical ideas. In L. English (Ed.), *Handbook of international research in mathematics education* (pp. 113-141). Mahwah, New Jersey: Lawrence Erlbaum Associates.
- Kent, P., Noss, R., Guile, D., Hoyles, C., & Bakker, A. (2007). Characterizing the use of mathematical knowledge in boundary-crossing situations at work. *Mind, Culture, and Activity*, 14(1-2), 64-82.
- Kuntze, S., Lerman, S., Murphy, B., Kurz-Milcke, E., Siller, H. S., & Winbourne, P. (2011). Professional knowledge related to Big Ideas in Mathematics—an empirical study with pre-service teachers. In *Proceedings of the Fourth Congress of the European Society for Research in Mathematics Education* (pp. 290-306). Lyon, France.
- Maasz, J., & Schloeglmann, W. (Eds.). (2003). *Learning mathematics to live and work in our world. Proceedings of the 10th International Conference on Adults Learning Mathematics (ALM10)*. Stroebel, Austria.
- McIntosh, A., Reys, B. J., & Reys, R. E. (1992). A proposed framework for examining basic number sense. *For the learning of mathematics*, 12(3), 2-44.
- OECD. (2016). *Technical report of the survey of adult skills (PIAAC) (2nd edition)*. Paris, France: OECD Publishing.
- PIAAC Numeracy Expert Group. (2009). *PIAAC Numeracy: A conceptual framework*. Paris, France: OECD Publishing.
- Schreiber, A. (1983). Bemerkungen zur Rolle universeller Ideen im mathematischen Denken. *Mathematica Didactica*, 6, 65-76.
- Schweiger, F. (2006). Fundamental ideas: A bridge between mathematics and mathematical education. In J. Maaß & W. Schloeglmann (Eds.), *New Mathematics Education Research and Practice* (pp. 63–73). Rotterdam/Taipei: Sense Publishers.
- Tout, D., Coben, D., Geiger, V., Ginsburg, L., Hoogland, K., Maguire, T., . . . Turner, R. (2017). *Review of the PIAAC numeracy assessment framework: Final report*. Camberwell, Australia: Australian Council for Educational Research (ACER).
- Vollrath, H.-J. (1978). Rettet die Ideen! *MNU*, 31(8), 449–455.
- Voogt, J., & Roblin, N. P. (2012). A comparative analysis of international frameworks for 21st century competences: Implications for national curriculum policies. *Journal of Curriculum Studies*, 44(3), 299-321.
- Wedegé, T. (2010). People's mathematics in working life: Why is it invisible? *Adults Learning Mathematics*, 5(1), 89-97.
- Yang, D. C., Reys, R. E., & Reys, B. J. (2009). Number sense strategies used by pre-service teachers in Taiwan. *International Journal of Science and Mathematics Education*, 7(2), 383-403.
- Yasukawa, K., Brown, T., & Black, S. (2013). Production workers' literacy and numeracy practices: using cultural-historical activity theory (CHAT) as an analytical tool. *Journal of Vocational Education & Training*, 65(3), 369-384.

Mathematics and Physics Dialogic Gatherings: Fostering Critical Thinking Among Adult Learners

Javier Díez-Palomar¹ and Evgenia Anagnostopoulou²

¹University of Barcelona, Faculty of Education, Barcelona, Spain; jdiezpalomar@ub.edu

²University of Sussex, Brighton, UK; ea434@sussex.ac.uk

This paper discusses the effectiveness of dialogic learning as an adults' learning theory. It specifically focuses on how Mathematics and Physics Dialogic Gatherings (M&PDG) can enhance the critical thinking of adult learners and hence develop their learning in both topics. Two studies were set where the participants engaged in dialogic reading activity reading classics in mathematics or physics. The former study took place in Barcelona, Spain and involved adult women of above 40-years-old with low literacy skills engaging in mathematics. The latter took place in Kendal, UK and involved two groups of adult A Level students, one studying Psychology and the other Physics. Although the samples were extremely diverse, the results demonstrated that classical readings can significantly improve critical thinking and dialogic talk in all groups and provide the potential to create further learning opportunities.

Keywords: Dialogic learning, adult scientific literacy, gatherings.

Introduction

Dialogic learning has been one of the main approaches to adults' learning theories in the last decades (Flecha, 2000). This approach suggests that adults are self-responsible of their own learning. They become active agents, creating social spaces for learning, drawing on solidarity and social interactions. In order for adults to be active in their learning and express themselves, they must use processes that promote their way of thinking, understanding and their ability to reason; in other words, they must develop their critical thinking (as defined by the Foundation for Critical Thinking, 2017). The aim of this paper is to discuss Mathematics and Physics Dialogic Gatherings (M&PDG) as learning spaces for adults to develop their learning in both topics. Dialogic gatherings were originally implemented by Flecha in La Verneda Adult School, in Barcelona, in the late 1970s. In 1978, a group of people asked for popular education for adults and occupied a public building to offer literacy courses for adults who never had the opportunity to attend school. Drawing on Freire's work (who also visited the school several times), the adults participating in La Verneda Adult School created a democratic popular movement of education based on the principles of dialogic learning (Flecha, 2000). M&PDG are part of this initiative (Díez-Palomar & Cabré 2015, Díez-Palomar, 2017). In the following sections, we will introduce the theoretical framework, the methods used in the research reported here, and the main findings, for further discussion.

Theoretical framework

According to Flecha (2000), learning is framed by seven principles: egalitarian dialogue, cultural intelligence, solidarity, transformation, the creation of meaning, instrumental dimension of learning, and equality of the differences. Dialogic gatherings are spaces where all these seven principles are evident. Flecha coined the term "dialogic literary gatherings" (DLG) in the late 1970s. He created the first DLG in Barcelona, with a group of non-academic women, most of them barely literate,

drawing on debates between some of the most outstanding scholars in adult education and social sciences at that moment, such as Freire or Habermas. Freire (1970) believed that learning matters because individuals discover that through learning they can make and remake themselves because they realize that they are beings capable of knowing. Learning for individuals is a practice of freedom. We can resist oppression and transform situations of domination, such as the lack of schooling, for example. Habermas (2001) also assumed understanding as a universal ability of human beings. In his *Pragmatics of Social Interaction*, he claims that meaning and understanding are two categories eminently human. Individuals develop their understanding through social interaction, sharing repertoires of meaning embedded in particular actions denoted by linguistic or semiotic signs (Habermas, 2001). Drawing on this idea, Flecha (2000) states that all individuals may be able to develop understanding (learn) using social interaction as a form of scaffolding. The DLG is defined as learning spaces where a) adult learners with low literacy skills participate, b) the readings are universal literature classics, and c) the process is based on dialogic learning (Puigvert, Sordé, & Soler, 2000). The DLG become spaces where individuals participate, interact, and share meanings around particular readings / words/concepts. The DLG became one of the successful educational actions validated in the research project *INCLUD-ED. Strategies for inclusion and social cohesion from education in Europe* (2006-2011).

Drawing on this background, La Verneda Adult School developed the Mathematics Dialogic Gatherings (MDG) using classic readings in mathematics to conduct the gatherings (Díez-Palomar, 2017). The research discussed in this paper starts with this experience and extends the MDG to science (Physics). The second author of this paper used this approach to create PDG in the UK, drawing on the principles of DLG (Soler, 2004, 2016).

Methodology

The research question

In this paper, we discuss some of the main findings from two independent studies focused in the same research question: “Can mathematics and physics classical readings promote the development of critical thinking of adult learners?”.

The setting and participants

The first study reported in this paper was held in Barcelona (Spain). The setting for the study was an adult school placed in a working-class neighbourhood in Barcelona, Spain. Data was collected from May to June 2016 (seven sessions). Participants included six women between 40-years-old and over seventy-years-old, with low literacy skills. The second study discussed in this paper was conducted in Kendal College, Cumbria, in the United Kingdom. Data was collected during the last semester of the academic year 2016-2017. It involved two groups of A Level students, male and female: group PSY, who studied psychology and group PHY, who studied physics.

Research design

In both studies, we created Dialogic Gatherings. These gatherings are spaces in which participants engage in dialogic reading activity involving classic texts in mathematics or science. Participants are the ones choosing the readings. The book selected for the first study was *Historia de las matemáticas*, the Spanish translation Jean-Paul Collette (1979) book *Histoire des Mathématiques*.

For the second study, the reading selected was *Dialogue Concerning the Two Chief World Systems*, by Galileo Galilei (1632). In both cases, we used the methodology of the DLG created by Flecha (see Figure 1).

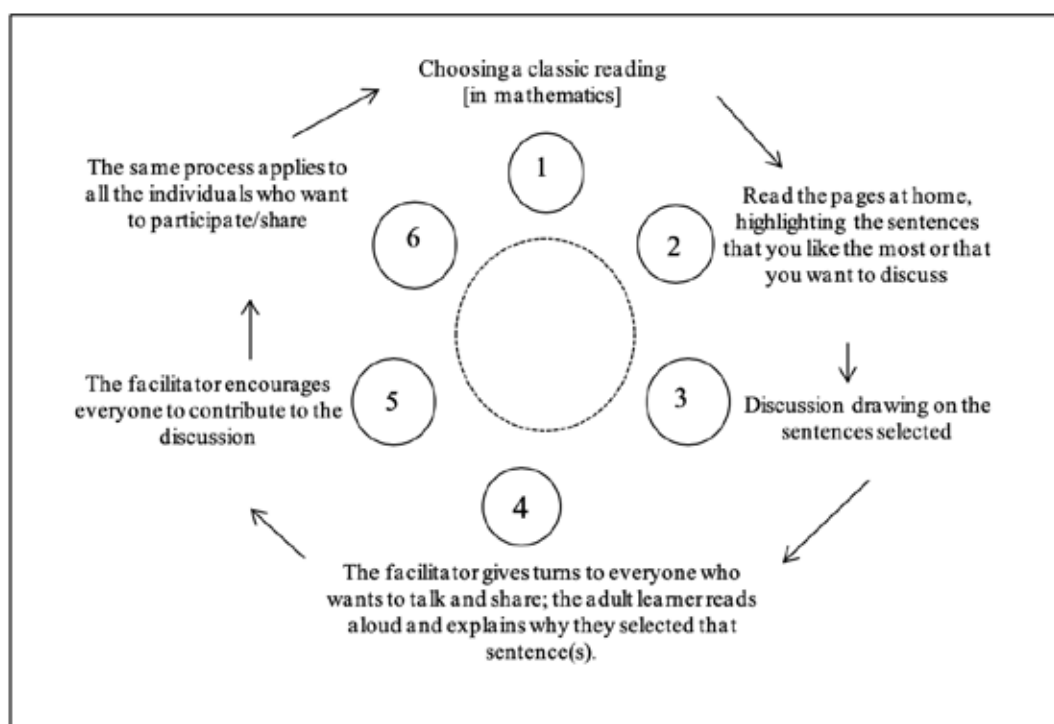


Figure 1. Scheme of how a M&PDG works (Díez-Palomar, 2017)

Results

The participants in the Mathematics Dialogic Gatherings (MDG) engaged from the very beginning in mathematical discussions around the history of mathematics. The six women seemed comfortable talking about the first traces of mathematics in the Palaeolithic Era, the mathematics used by the Babylonians, the contributions made by the people living in ancient Egypt, the mathematics formalized by the Greeks, etc. Drawing on the description of how humankind developed counting, grouping and the idea of number as the strategy to keep track of cattle, crop, the six women discussed such notions as number system, algorithm, unit of measure, value, equivalence, and so forth. They related some of these concepts with their everyday life. For instance, when discussing the concept of the base of a number system, they rooted their arguments in their previous knowledge about using different coins whose value is defined by groupings in base 1, 5 or 10. Their knowledge about *duros* (a coin equivalent to 5 pesetas in the old Spanish currency) facilitated their understanding about ancient number systems which a base different from the Hindu Arabic numbers that we use nowadays. Jean-Paul Collette mentions in the first chapter of his book that a bone was found in the Czech Republic with some tally marks carved in groups of approximately 30. According to the experts, it could be a moon calendar. Interestingly, one of the women in the group highlighted this excerpt of the book because she stated: "I remember that I read somewhere that some people think that those marks correspond to the menstruation cycle." Then, a further discussion about mathematics and human biology started, connecting mathematics to gender issues. During the sessions, many other issues arose: Why the Romans didn't have the zero in their number

system?, How to translate quantity from one unit of measure to another?, and What strategies are best in problem solving?

For every topic, the participants in the MDG used their own personal background to, in Flecha's (2000) terms, "create meaning with the mathematical content. The book presented many symbols and codes (numerals, formulas, graphical and visual representations), that usually are abstract representations of real phenomena. Data suggest that women were able to create a zone of proximal development where everyone was free to contribute with their piece of knowledge drawing on their own experiences. According to Hutchins (2000) this can be defined as episodes of distributed cognition. That was the case when developing an understanding an ancient algorithm for multiplication presented by Jean-Paul Collette (1985) in his book.

In the same vein, the Physics Dialogic Gatherings project further examined participants' progress with respect to their background knowledge, in a different setting.

During the first sessions, the psychology group got involved in discussions in a descriptive and philosophical manner. They felt more confident to discuss philosophical ideas, such as the definition of *perfection* in the text, and they tend to avoid or ignore any scientific or mathematical part of the book. An example from a participant:

"If I were in this conversation I would question the definition of perfect and what is exactly they are trying to achieve by defining these principles? What are they going to achieve if they finally define that the Earth is perfect? What does perfect mean?"

They often exchanged information directly quoting from the text without showing any understanding of the ideas transmitted. For example:

"Pythagoras says it's defined by beginning, middle and end, but others are saying perfect is how you form the body; the length, and thickness."

They did not challenge the obvious. They preferred to agree with that. Direct quotation from the text:

"They say about the lines that the straight line is the shorter one and obviously you can have many other lines. I agree with that."

During the later sessions, they felt confident to discuss science too, starting with simple arguments and poor terminology. Their dialogic skills evolved with time when they felt the need to use definitions and self-created terminology. They created their own terms when the lack of scientific knowledge did not help.

"I think it depends what fast is. In our situation our fast is like steady and we have air-resistance and when it reaches terminal velocity, it will be like balanced. Whereas if you are in a car and it speeds up and in fact you are in control of the fastness, you will just accelerate until you reach where you want to go and then you will put another force acting into it because you want to slow it down. So it depends on which fast it is acting on."

They could formulate arguments where critical thinking was evident. As they were feeling more comfortable, they progressed to using scientific terminology, which emerged either from the text or

from prior knowledge that they had not used for a long time, but they recovered it for the sake of their argument.

“So, say you have a forward motion, velocity and then you have the air resistance and gravity. They would balance out in a way that the one motion is still more than the others because it still moving forward, because if the others weren’t there it wouldn’t have to speed up.”

Their critical thinking was developing, and they were more involved in discussing their ideas in a dialogic manner, even if these ideas could be wrong.

“If the plane is tilted, the ball starts moving and speeds up until it reaches towards the end. And then reaches a flat surface again. So yes, I agree with that. There has to be some kind of limit, because... I don’t know... It can’t just speed up, speed up, speed up. It has to be some kind of limit.”

Towards the final sessions, they were able to combine physics and philosophy into their arguments, which triggered further discussions and carried forward their learning skills.

“It’s got to have some purpose to move. A body which is not moving, will move if it has a purpose.”

The physics group seemed more open to disputes and reasoning than the psychology group, possibly because they considered the text to be more on their area of expertise. They approached the ideas presented with scepticism and doubt, rather than with unquestioning acceptance, which already indicates a level of critical thinking (Scriven, 1987). In the early sessions, the group was dealing with the texts purely scientifically, ignoring any philosophical quotations in contrast to the psychology group. The physics group was seeking for proofs and they even performed their own in-class short experiments to prove a point.

“Salviati is saying that he doesn’t believe that 3 is necessarily more perfect than 4 or 2, and gives the example of legs on a chair or table. And I was wondering if it is harder to knock over a table with 3 legs or 4 legs, because with 2 legs obviously it is not stable.”

They employed their scientific background knowledge to explain the ideas presented in the reading.

“Triangle is the strongest shape in nature so I guess it may be stronger.”

“...because there are more ways where you can pass the center of gravity.”

At later sessions, the group was involved in philosophical critical thinking too. The engagement with the philosophical terms expanded their discussion away from the actual text and they were able to connect science with philosophy. Their critical thinking and dialogic talk development evolved to a point where they were disputing scientific methods that they had never disputed before. They questioned science and mathematics and they concluded that they had more trust in their senses than some scientific proofs.

“Does mathematics support or help science, do you believe things because you see them to be mathematically true or do you believe things because you see them to be physically true? What creates new knowledge?”

Discussion

In 1976 Wood and his colleagues coined the term “scaffolding” as a metaphor to analyse how adults assist children when solving problems. They defined it as an action that “enables a child or novice to solve a problem, carry out a task or achieve a goal which would be beyond his unassisted efforts” (Wood et al, 1976, p. 90). This concept moved forward the old Vygotskian notion of ZPD (Bruner, 1986). Cazden (1979) extended the concept from its original use in the context of dyadic adult-child interactions, to a study of teacher-student interactions in classroom settings. More recently, a special issue published in 2015 in the journal *ZDM Mathematics Education* (47,7) explored the interlink between this metaphor and the idea of dialogic teaching. Evidence suggest that dialogic teaching pushes forward to notion of scaffolding, since *dialogue* creates opportunities for participants to exchange and share knowledge from which create their own understandings. In this paper, we found evidence suggesting that this approach can also be used in the context of adults learning in both mathematics and physics.

Overall, the Mathematics and Physics Dialogic Gatherings project proved to be an enjoyable method for the teaching and learning of physics and mathematics. Data collected suggest that egalitarian dialogue can create opportunities for learning. The participants, drawing on their dialogic talk, created Vygotsky’s (1978) zones of proximal development where all participants contribute with their cognitive potential. Our results also confirm Hutchins’ (2000) notion of distributed cognition, since many times the different participants ended with a complete explanation of a particular notion, such as the uses of the zero in a number system, after sharing different pieces among them. The egalitarian dialogue, as defined by Flecha (2000), means that everyone has the same opportunity to share his/her previous knowledge throughout a dialogic process in which every participant shares arguments based on valid claims. The participants of the psychology and the physics groups as well as the mathematics group were able to make valid claims on the understanding of mathematical, scientific and philosophical concepts. This suggests that the critical thinking of both groups was significantly improved.

In addition, the results also reveal that using an egalitarian dialogue based on personal previous knowledge, adults were, in Freire’s terms, able to *read (and re-read) critically the world*. The different notions discussed during the sessions in both settings gained from this personal way to present them to the audience in the M&PDG. Linking them to personal situations in the everyday life appears to be a successful strategy to create meaning around the concepts discussed in the group. As Flecha (2000) states: “the creation of meaning is one of the more seminal principles of the Dialogic Learning theory since learning is strongly connected to motivation, as previous studies have largely demonstrated (Mehler & Bever, 1967)”. Freire narrates the case of a woman who learned to read and write by sending love letters to her husband. For this woman, the words acquired full meaning because they transmitted her feelings to her husband, who was far away. In a similar vein, for the women participating in the MDG recalling their memories about duros and pesetas was a way to make meaning to the idea of base in a number system. In this situation, grouping, which is an important component of numbers in number systems (as well as in the development of number sense), was fully understood by the six women participating in the MDG. They not only used the notion of grouping (base); they were also able to explain different algorithms to do mental calculation drawing on the use of grouping as a cognitive strategy to solve

particular cases of calculations (mainly addition and subtraction, and sometimes multiplication as well).

The research demonstrated that background knowledge is important to establish an egalitarian dialogue, in the sense that everyone uses their own repertoire of knowledge to participate in the dialogue. Although the two groups were very diverse in terms of background knowledge, they ended up in parallel ideas when combining mathematics, philosophy, and science. They approached the notions from a different perspective but somehow, they concluded in similar ways. Combining mathematics, science and philosophy opened new perspectives into their learning of physics and mathematics. In fact, results suggest that “heterogeneity” may be a successful component of M&PDGs. Without that heterogeneity, participants in the gatherings would not be able to introduce different examples to illustrate particular scientific or mathematical notions, making learning more depth and meaningful for everyone in the group. The Dialogic Gatherings method can, therefore, benefit heterogeneous groups, where people can learn from each other, taking advantage of the knowledge that everyone shares within the discussion. This is consistent with previous research in the educational arena (Flecha, 2000; Vygotsky, 1978; Wertsch, 1990).

Summarising, evidence suggests that classical readings and egalitarian dialogue could be an excellent method to improve critical thinking in mathematics and physics and have the potential to create further learning opportunities in classrooms.

Conclusions and further research

In this paper, we have discussed how adults in two different settings (Barcelona and Cumbria) draw on their participation in the M&PDGs to develop their critical thinking around mathematics, science, and philosophy. Results suggest that adults use their own personal background to make meaning to the academic concepts in the books selected. Egalitarian dialogue mediates learning through a participatory process in which adults share their personal understanding of the topics discussed in the gathering. They use practical examples, drawing on their memories and looking for plausible explanations. In doing so, they acquire proficiency in using expert scientific and mathematical jargon. However, evidence reported here are limited since they belong to two single case studies. The sample is neither representative nor random. The examples introduced in this paper illustrate some intuitions about how adults, using classic readings in mathematics and science, can further learn and create a critical thinking aligned to what some authorities claim as being critical citizens in the rise of the 21st century. However, due to the limitation of the research design, more research is needed in order to generalize the benefits of the MP&DGs in supporting adult learners’ critical thinking, in other settings.

Acknowledgment

The authors want to express their gratitude and acknowledgment to all the adult people participating in the M&PDGs.

References

Bruner, J. (1986). *Actual mind, possible worlds*. Cambridge, MA: Harvard University Press.

- Cazden, C.B. (1979). Peekaboo as an instructional model: Discourse development at home and at school. In *Papers and reports on child language development* (No. 17). Palo Alto, CA: Stanford University, Department of Linguistics.
- Collette, J. P. (1985). *Historia de las matemáticas*. Madrid, Spain: Siglo XXI.
- Díez-Palomar, J. (2017). Mathematics dialogic gatherings: A way to create new possibilities to learn mathematics. *Adults Learning Mathematics: An International Journal*, 12(1), 39-48.
- Díez-Palomar, J., & Cabré, J. (2015). Using dialogic talk to teach mathematics: The case of interactive groups. *ZDM- Mathematics Education*, 47(7), 1299-1312. doi:10.1007/s11858-015-0728-x
- Flecha, R. (2000). *Sharing words: Theory and practice of dialogic learning*. Lanham, MD: Rowman & Littlefield.
- Freire, P. (1970). *Pedagogy of the oppressed*. New York, NY: Continuum.
- Habermas, J. (2001). *On the pragmatics of social interaction: Preliminary studies in the theory of communicative action*. Cambridge, MA.: The MIT Press.
- Hutchins, E. (2000). Distributed cognition. In N. J. Smelser and P. B. Baltes (Eds.), *International encyclopedia of the social and behavioural sciences* (pp. 2068-2072). Oxford, England: Elsevier Science.
- Mehler, J., & Bever, T. G. (1967). Cognitive capacity of very young children. *Science*, 158(3797), 141-142. doi:10.1126/science.158.3797.141
- Puigvert, L., Sordé, T., & Soler, M. (2000). La Tertulia: A dialogic model of adult basic education in the new information age. *Adult Education Research Conference*. Retrieved from <http://newprairiepress.org/aerc/2000/papers/70>
- Scriven, M. (1987). *A statement by Michael Scriven and Richard Paul, presented at the 8th Annual International Conference on Critical Thinking and Education Reform, Summer 1987*. Retrieved from: <http://www.criticalthinking.org/pages/defining-critical-thinking/766>
- Soler, M. (2004). Reading to share: Accounting for others in dialogic literary gatherings. In Bertau, M. (Ed.), *Aspects of the Dialogic Self. International Cultural-Historical Human Sciences* (pp. 157–183). Berlin, Germany: Lehmanns Media.
- Soler, M. (2016). People understand everything, and the better it is written, the better it is understood. *International Review of Qualitative Research*, 9(2), 222-227. doi:10.1525/irqr.2016.9.2.222
- Vygotsky, L. S. (1978). *Mind in society: The development of higher psychological processes*. Harvard, MA: Harvard University Press.
- Wertsch, J. (1990). The voice of rationality in a sociocultural approach to mind. In L. C. Moll, (ed.) *Vygotsky and Education* (pp. 111-126). New York, NY: Cambridge University Press.
- Wood, D., Bruner, J. S., & Ross, G. (1976). The role of tutoring in problem-solving. *Journal of child psychology and psychiatry*, 17(2), 89-100. doi:10.1111/j.1469-7610.1976.tb00381.x

Using dialogue scenes with adult mathematics learners: Research questions and methods

Graham Griffiths

UCL Institute of Education, United Kingdom; g.griffiths@ucl.ac.uk

This paper is an outline of the research questions and methods, informed by an exploratory phase of data collection and some initial observations from the main phase, selected as part of my doctoral studies into adults learning mathematics. The work is an investigation into the discussions which take part during and following a particular small group activity type in which a scene is read aloud and a mathematical task is undertaken. This paper outlines research utilising ‘thinking as communication’ as proposed by Sfard (2008) and employs an overarching framework for analysis developed by Morgan and Sfard (2016). To understand what happens when the ‘reading aloud’ activity is undertaken, it is important to investigate what happens when learners undertake related activities.

Keywords: Collaborative discussion, discourse analysis, dialogue, adult education, mathematics.

Introduction

This work started with an interest in teaching practices and a wish to investigate, in some detail, the collaborative discussions that occur between learners when undertaking a particular type of activity (Griffiths 2014). From this starting point, my work has become more focused on generating data to inform a theoretical perspective on learner-learner discussions. I am interested in the interactions that occur between learners during the implementation of a form of classroom activity, namely the reading aloud of a scene of dialogue concerning mathematics and a linked, collaborative mathematical task.

Theoretical perspectives on learning

Dialogue (and conversation) has been seen as a useful focus of attention in the educational world and utilised in a variety of ways. For example, classroom dialogue has been investigated within the framework of dialogic teaching by Alexander (2017) and has resulted in a special edition of ZDM (see Bakker, Smit, & Wegerif (2015)). Much of this work has been interested in the dialogue that occurs between teacher and learner whereas I am interested in learner-learner interactions with minimal input from teachers when undertaking the specified task. Having said this, there are important ideas that are in common to such work and my research. For example, notions such as the importance of sense making and socio-cultural influences on learning involved in such discussions are also important in my work. Such sense making and socio-cultural perspectives draw upon literature that stretches back to writers such as Bakhtin (published in English in Bakhtin 1986), and Vygotsky (published in English in Vygotsky et al. 1978). These writers have also influenced more recent work that I am utilising (in particular Sfard 2008).

Central to my work is the question of whether reading aloud has an effect on the resulting collaborative discussions compared to reading silently. This was initially motivated by my own experience of observing such activity. Nonetheless, there is a question as to what the literature says

about the effects of reading aloud and silently. Much work has already been undertaken into studying the effects of reading aloud compared to reading silently when related to language and the effect on subsequent educational performance. For example, García-Rodicio, Melero & Izquierdo (2018) provide evidence that suggests there is no significant difference in performance between reading aloud and reading silently when dealing with comprehension exercises (in fact, they note that individuals following others reading aloud can result in significantly worse performance on tests). It is worth noting that this type of study takes an acquisitional perspective (in the sense of Sfarid 1998) and is concerned with performance on some standardised test. My study has an interest in participation in a given activity type and the evidence in the transcriptions of discussion related to that rather than the effect on some standardised test. As such the perspective taken by Garcia-Rodicio, Melero & Izquierdo (2018) and similar work is not of interest to me. Other work, for example Duncan (2015), has a focus on the perceptions of individuals and their practices related to reading aloud. This work does suggest positive aspects to the practice of reading aloud. Although Duncan's work is not interested in mathematical development, I am more interested in the practice focused work of this type of work.

The theoretical perspective that I intend to use, that of thinking as communication, has been developed in recent years and been given a detailed rationale by Sfarid (2008). My research takes the participatory approach of seeing *thinking as communication* that Sfarid argues for. Within this perspective, learning is not seen as concerned with changes to some internal schema, that is responding to experiences, but rather the communication itself is viewed as thinking and learning. Sfarid argues that the job of the researcher is to investigate communication. The discussions that happen during and following an activity would provide an example of communication which could be investigated and Sfarid (2001) proposes a form of discourse analysis and suggest some aspects to look for in such work. In particular, she identifies for analysis the *mediating tools* involved in discourse and a set of *meta-rules* that govern discourse.

For example, the text in the scenes provides an example of a mediating tool. When discussing the scenes and engaging in classroom discourse related to mathematics, it is not surprising to hear direct extracts from a text being used by participants along some paraphrasing of sections. In addition, the mathematical examples used within the text are mirrored back in many cases. Indeed, one of the reasons that Swan (2006) has constructed the scenes (DfES 2005) that initiated my work is for discussion to focus attention on key elements of mathematics. It seemed a reasonable working assumption that by asking learners to read text aloud, it is likely that, at least for some groups and individuals, focus will be put on those words and phrases. Part of my research is investigating this aspect, to see the ways in which specific parts of the text are employed in discussion of the scenes.

The term 'meta-rules' might suggest a strict set of guiding principles while, in reality, this might be less rigid. Indeed, Sfarid suggests that there could be a wide range of possibilities for a hypothesis to govern a discussion and such a meta-rule will need to be interpreted from the discourse. As an example, in a discussion of mathematics between two boys, she proposes that one of the contributors is focused on mathematical meaning while the other appears to avoid discussing mathematical ideas while employing, for example, face saving devices (such as humour) which suggest a concern for social position. This can be seen as another, different form of, socio-cultural

issue raised by Lerman (2001) who argued that the role that individuals play and aspect of power and position in society will have an impact on discourse and need to be considered.

Within the discussions that I am concerned with, such meta-rules may be related to resources that the participants utilise other than those in the text (identified as mediating tools). Such additional resources include the use of mathematical discourse that draws upon prior experiences (either within their present educational setting or from an earlier situation) as well as non-mathematical discourse. In the case of our task, which involves a discussion around the price of rail tickets, it is not a surprise to note that participants have contributed with discourse concerning their own use of the rail system (thus introducing an element of socio-cultural influence).

In my research, I use an overarching framework developed by Sfard, Morgan and others (in particular Morgan & Sfard 2016). The framework structures the characteristics of discussions into two main categories for analysis: (a) the mathematising aspects of discourse and (b) the subjectifying aspects of discourse. Further elaboration on this, with examples, is provided below. The reason for selecting this form of analysis is that it is designed to be of interest to mathematics education rather than utilising more general categories that occur with other forms of discourse analysis. The analysis of the collaborative discussions consists of investigating a range of factors and I have been interested in the following sub questions under the two identified categories.

(a) The mathematising aspects of discourse:

- (i) What resources do the individual participants use in the discussions (please note that resources here might mean physical resources such as a calculator but also the examples that are chosen by the participants and the proposed calculations that are employed)?
- (ii) To what extent do these resources relate to the text in the activity (a mediating tool) or draw upon other experiences (and therefore suggest meta-rules are being employed)?

(b) The subjectifying aspects of discourse:

- (i) How do the individual participants contribute to decision making within the group?
- (ii) How is the discussion regulated by the individual participants involved?
- (iii) How do the participants see themselves in relation to mathematics (in general and specific to the activity)?

The specific activity that my work is concerned with consists of a mathematical task along with a scene in which four characters discuss the task (see Figure 1 and Figure 2 for details of the task and activity). The task asks participants to agree or disagree with a given statement related to a percentage problem. The activity of interest involves the learners taking and reading aloud the parts of four characters who argue different positions related to the task. This is then followed by a discussion in which the participants are intended to come to their own conclusion concerning the task.


Task	Scene 1 (as in DfES 2005)	Scene 2 (amended features)
<p><i>Rail Prices</i></p>  <p>In January, fares went up by 20%.</p> <p>In August, they went down by 20%.</p> <p>Sue claims that:</p> <p>“The fares are now back to what they were before the January increase”</p> <p>Do you agree?</p> <p>If not, what has she done wrong?</p>	<p>Harriet: That’s wrong, because ... they went up by 20%, say you had £100 that’s 5, no 10.</p> <p>Andy: Yes, £10 so its 90 quid, no 20% so that’s £80. 20% of 100 is 80, ... no, 20.</p> <p>Harriet: Five twenties are in a hundred.</p> <p>Dan: Say the fare was 100 and it went up by 20%, that’s 120.</p> <p>Sara: Then it went back down, so that’s the same.</p> <p>Harriet: No, because 20% of £120 is more than 20% of £100. It will go down by more so it will be less. Are you with me?</p> <p>Andy: Would it go down by more?</p> <p>Harriet: Yes because 20% of 120 is more than 20% of 100.</p> <p>Andy: What is 20% of 120?</p> <p>Dan: 96...</p> <p>Harriet: It will go down more so it will be less than 100.</p> <p>Dan: It will go down to 96.</p>	<p>Harriet: That’s wrong, because ... they went up by 20%, say you had £100 that’s 5, no 10.</p> <p>Andy: Yes, £10 so its 90 quid, no 20% so that’s £80. 20% of 100 is 80, ... no, 20.</p> <p>Harriet: Five twenties are in a hundred.</p> <p>Dan: Say the fare was 100 and it went up by 20%, that’s 120.</p> <p>Harriet: And, because 20% of £120 is more than 20% of £100. It will go down by more so it will be less.</p> <p>Andy: What is 20% of 120?</p> <p>Dan: 96...</p> <p>Harriet: It will go down more so it will be less than 100.</p> <p>Dan: It will go down to 96.</p> <p>Sara: No, it has gone up £20 to £120 and then it went back down the same, so that’s £100.</p>

Figure 1: The task and scenes 1 and 2.

Activity RAS1&2	Activity RSS1&2	Activity NS
<p>In groups of 4:</p> <p>Choose to read out the parts of:</p> <p>Harriet, Andy, Dan & Sara</p> <p>Then read out the scene and discuss what you think about Sue’s claim that “the fares are now back to what they were”.</p>	<p>Read the scene below</p> <p>In groups of 4:</p> <p>Discuss what you think about Sue’s claim that “the fares are now back to what they were”.</p>	<p>In groups of 4:</p> <p>Read the statement from Sue below.</p> <p>Discuss what you think about Sue’s claim that “the fares are now back to what they were”.</p>
<p>Activity RAS1 is then followed by the Task and Scene 1 from Figure 2 (and similarly for RAS2), Activity RSS1 is then followed by the Task and Scene 1 from Figure 2 (and similarly for RSS2) and Activity NS is followed by the Task only from Figure 2.</p>		

Figure 2: The three activity types

During an exploratory phase, examples of the activities described in Figure 1 and Figure 2 were undertaken and reported on in Griffiths (2014). Examples of discussions were included which showed some different responses to the different activity types. Data taken from this exploratory phase along with early observations from the main phase will be used to illustrate issues in this text.

Methodology

My study takes a qualitative, inductive approach, using a series of case studies and utilising the theoretical frameworks noted earlier for analysis. The work explores the data that is gathered to see how it fits the proposed framework with an aim of suggesting variables for further study.

The data collected consists of audio recordings and observational notes of learners undertaking the activities along with audio recordings of short focus group discussions (one per cohort) about the process immediately following the activity.

The research design of the main phase

To identify some characteristics in the response of learners to the activity involving reading aloud, it is helpful to identify what happens when the activity involves reading silently. In addition, the use of the mathematical task without a dialogue scene is used as a way of identifying the extent to which elements of analysis relate to the use of mathematical scenes whether read silently or aloud. A final issue concerns the nature of the scene itself. It is possible that responses may be produced as a result of the particular elements of the text. For example, characters within a text may have more dialogue and thus be given priority, or the first and last statements might have more dominance. In order to take this set of issues into account, alternative versions of the text have been developed and used.

The research design chosen considers 5 activities (see Figure 2) which are used as interventions with additional (to the exploratory phase learners) groups of (four) learners across 4 institutions (giving a total of 20 groups and 80 learners):

RAS1 – activity which involves reading aloud the scene as described by Swan (in DfES 2005)

RAS2 – activity which involves reading aloud an alternative version of the scene

RSS1 – activity which involves reading silently the scene as described by Swan (in DfES 2005)

RSS2 – activity which involves reading silently an alternative version of the scene

NS – activity which involves the task without the scene

To distinguish which characteristics are related to reading aloud, the overarching research question is then refined to become the following question:

What are the similarities and differences in the characteristics of learner discussions during and following the identified activities?

The analysis is considered in relation to contextual information, such as participant backgrounds and experiences, that becomes known as the research progresses including information noted when agreeing the groups to be studied with centres, the recording of the discussions that occur while undertaking the full activity and focus group discussions following the activity.

Observation and discussion

The following text describes some initial thoughts utilising data collected from the exploratory phase along with initial observations from the main data collection without detailed analysis. The first category concerns the nature of the mathematical tasks involved in the research, thereby addressing the mathematising aspects of the activities (and resulting discourse). The second two categories are concerned with the responses of participants to the activities, and with others in a group, thereby addressing issues related to subjectifying aspects of the activities (and discourse).

The relationship between mathematics, the context of the activities and the activity types

The three activity types (RAS, RSS, NS) have one thing in common in that the notion of percentages is linked to rail prices and as such is making links to the ‘everyday’. The task, deciding whether an individual is correct or not, is not necessarily what might be understood as a traditional task, that is, one in which a calculation is undertaken and presented with an answer. In addition, the task, while relating to aspects of real world activity - the buying of tickets, the notion of sales and discount – involves the combination of information that can be seen as somewhat artificial (and perhaps encourage responses involving humour for example in the exploratory phase a contributor suggested that a passenger will be “ripped off”).

In the main phase of data collection, while participants most often use the example of the price given within the scene (that of £100), other examples of mathematising are clear such as the strategies used to calculate 20% which were not evident in the text. From early observations of the main data collection phase, it is not yet clear whether reading aloud or not is significant in relation to this.

The relationship between participants and the activity types

A key aspect to consider is how participants in the activities relate to the information and roles presented in the scene. One example is the scene use of the proposed £100 ticket price. This would suggest the use of rail travel between towns and cities rather than more local commuting. Another example concerns the (assumed) genders of the participants in the scene and the selection of roles for reading aloud. I have seen the choice of character being led by gender on a number of occasions (and discussed in the focus groups).

In the exploratory phase, one contributor talks about ‘they’ (“what they’re saying...”) and another specifically mentions the character Harriet by name. In the main phase, some individuals undertaking RSS noted that they only read the first few lines of the scene. One of the groups selected to read aloud had identified, and agreed, mathematical statements which would lead to them saying Sue was wrong but did not want to commit to this judgement. In another discussion following the non-scene task, participants suggested £5 as a rail ticket. These are examples of subjectifying aspects of the discussion while on some occasions being linked to mathematising aspects such as related calculations.

The regulation of discussion

The utterances that are involved in a discussion will follow some, usually unspoken, set of rules (meta-rules in Sfard’s terms). I have already noted that Sfard (2001) argues that some participants

will have a focus on mathematical meaning while others may focus on alternative, and potentially face saving, aspects of discussion. I draw upon two aspects of discussion that have been written about which can be interpreted as involving subjectifying aspects of discourse, one concerning school discussion, uncertainty and hedging, and another that has been noted in relation to adults and the use of humour.

The significance of uncertainty and signs of hedging in discussions has been noted (in particular Lakoff (1973)). In my exploratory investigation, one participant starts by suggesting that she does not understand what is happening and yet then follows with the mathematically expected responses.

Oughton (2010) has noted the importance of humour in the interactions between learners. She suggests that adults use positive, affiliative humour in group working in order to deal with anxieties that they feel undertaking mathematics. Interestingly, within the exploratory data we see the use of humour to end discussion (“So... you still get ripped off whichever way”). The comment seems to be a mechanism to end the discussion and may be an attempt to disguise uncertainty about meaning.

Conclusion

Having noted that the study is anchored in practice, the study itself is likely to be of interest to researchers interested in forms of discourse analysis within mathematics education. The study has generated data that is intended to inform a theoretical understanding of the effect of reading aloud on classroom discussion with such mathematical scenes. This detailed analysis is still to be undertaken although observations so far suggest some interesting indicators of what to focus on.

While of primary interest in the research field, it is expected that the study will help to inform classroom teachers of (adult) mathematics classrooms. It is not intended to identify a toolkit that enables teachers to produce their own scenes but rather to identify a potential use of the existing scenes in two main ways:

- a) To propose and describe (including key features) the classroom activity of reading aloud dialogue scenes involving mathematics (not an expectation of the original Swan scene)
- b) To outline what might be expected to happen in the discussions between learners when undertaking the activity

This will then allow teachers to make their own decisions about whether to employ these activities (or perhaps similar ones) with their own learners.

Acknowledgment

The author thanks the many individuals who have supported this project so far including the staff and learners involved and particularly supervisors Prof. Candia Morgan and Dr. Samantha Duncan.

References

- Alexander, R.J. (2017) *Towards Dialogic Teaching: rethinking classroom talk* (5th edition), York: Dialogos.
- Bakhtin, M. M. (1986). In C. Emerson & M. Holquist (Eds.), *Speech genres and other late essays* (V. W. McGee, Trans.) Austin: University of Texas Press.

- Bakker, A., Smit, J., & Wegerif, R. (2015). Scaffolding and dialogic teaching in mathematics education: Introduction and review. *ZDM*, 47(7), 1047- 1065. <https://doi.org/10.1007/s11858-015-0738-8>
- DfES (2005). *Improving learning in mathematics*. Sheffield, UK: Department for Education and Skills Standards Unit.
- Duncan, S. (2015), Reading aloud in Lewisham: an exploration of adult reading-aloud practices. *Literacy*, 49(2), 84–90. <https://doi-org.libproxy.ucl.ac.uk/10.1111/lit.12046>
- García-Rodicio, H., Melero, M. & Izquierdo, M. (2018) A comparison of reading aloud, silent reading and follower reading. Which is best for comprehension? / Una comparación de lectura en voz alta, lectura en silencio y lectura de seguimiento. ¿Cuál es mejor para la comprensión?, *Infancia y Aprendizaje*, 41(1), 138- 164. <https://doi-org.libproxy.ucl.ac.uk/10.1080/02103702.2017.1364038>
- Griffiths, G. (2014). Using dialogue scenes with adult learners: some exploratory data. In A. Hector-Mason, J. Gibney, & G. Griffiths (Eds.) *Critical moments in adult mathematics. Proceedings of the 20th international conference of Adults Learning Mathematics - A Research Forum (ALM20)* (165- 172). Caerleon, UK: University of South Wales / ALM, Retrieved from <http://www.alm-online.net/images/ALM/conferences/ALM20/alm13-proceedings.pdf>
- Lakoff, G. (1973). Hedges: A study in meaning criteria and the logic of fuzzy concepts. *Journal of Philosophical Logic*, 2(4), 458-508. <http://dx.doi.org/10.1007/BF00262952>
- Lerman, S. (2001). Cultural, discursive psychology: A sociocultural approach to studying the teaching and learning of mathematics. *Educational Studies in Mathematics (2001)* 46(1-3), 87- 113. <https://doi.org/10.1023/A:1014031004832>
- Morgan, C. & Sfard, A. (2016). Investigating changes in high-stakes mathematics examinations: a discursive approach, *Research in Mathematics Education*, 18(2), 92- 119. <https://doi.org/10.1080/14794802.2016.1176596>
- Oughton, H. (2010). “*We all play teacher.*”: A study of student discourse in adult numeracy classrooms. (Unpublished doctoral dissertation). University of Sheffield, UK
- Sfard, A. (1998). On two metaphors for learning and the dangers of choosing just one. *Educational Researcher*, 27(2), 4- 13. <https://doi.org/10.3102/0013189X027002004>
- Sfard, A. (2001). There is more to discourse than meets the ears: Learning from mathematical communication things that we have not known before. *Educational Studies in Mathematics* 46(13), 13- 57. <https://doi.org/10.1023/A:1014097416157>
- Sfard, A. (2008). *Thinking as communicating*. Cambridge, UK: Cambridge University Press.
- Swan, M. (2006). *Collaborative learning in mathematics: A challenge to our beliefs and practices*. Leicester, UK: NIACE
- Vygotsky, L., Cole, Michael, Cole, Mike, & Luria, A. R. (1978). *Mind in society: The development of higher psychological processes*. Cambridge, Mass.; London: Harvard University Press

Reproducing social difference in the concept of ‘numeracy skills’

Lisanne Heilmann

University of Hamburg, Germany; Lisanne.heilmann@uni-hamburg.de

This paper is concerned with adult numeracy skills as these are presented within the Programme for the International Assessment of Adult Competencies (PIAAC). It will focus on what we can learn from PIAAC results about adult skills, about the assessment and about societal structures. Theoretical discussions increasingly view numeracy as embedded in power relations. If so, these power relations should be visible in the results. This paper will provide a brief overview of underlying theory in the field, focusing on three elements of numeracy skill proficiency: the distribution of skills in society, the process of defining a hegemonic view of numeracy skills and finally, the value of numeracy skills in the context of power relations. This value of numeracy skills can be analysed by the example of gender relations in the labour market. The analyses will use PIAAC-data to indicate how gendered hegemony might influence the way numeracy skills matter in terms of monthly wages and the probability of getting into leadership positions.

Keywords: Basic skills, gender bias, labour market, adult education, PIAAC.

Introduction

Educational research often looks at skills as something to acquire. Once acquired, it is anticipated that skills bring benefit to their possessor by transforming skills into success. Following that line of argument, a common aim is to make education available and suitable for more people; assuming, that if education would only find a way to convey knowledge more efficiently, this would bring direct benefit to people in terms of happiness, health, or success in the labour market (Grotlüschen, Mallovs, Reder, & Sabatini, 2016; Kittel, 2016; OECD, 2016a). Craig (2018) argued – in a paper called ‘the promises of numeracy’ - that numeracy education is largely associated with empowerment and seen as relevant for social participation, while innumeracy is connected to “personal, social, and cultural costs” (Craig, 2018, p. 64). This paper is a reflection on PIAAC results with this perspective in mind. The OECD assessed via PIAAC the literacy and numeracy skills of 16-65 year-olds. In 2011/12, 24 countries participated in the first round of assessment. Nine other countries followed in a second round in 2014/15 (OECD, 2016a).

There is a variety of definitions and concepts around numeracy, mathematics, quantitative literacy used in international contexts. (e.g. Karaali, Villafane-Hernandez, & Taylor, 2016; Vacher, 2014). For this paper, the terms *numeracy* and *numeracy skills* refer to PIAAC’s definition:

PIAAC defines numeracy as the ability to access, use, interpret and communicate mathematical information and ideas, in order to engage in and manage the mathematical demands of a range of situations in adult life. (OECD, 2012, p. 34)

An alternative view on skills focusses more on their embeddedness in society and in power relations. Being embedded in social constructs means being greatly influenced by power structures. Thus, it is worth asking, whether Craig’s ‘promises’ are equally true for those who acquire them.

Using the example of gender to look at a concrete representation of societal power relations, PIAAC results offer the potential to analyse the intersection of gender and numeracy empirically and with quantitative methods. In this paper, I choose a regression analysis to test the value of numeracy skills in terms of income and the chance of getting into a leadership position. The scope of difference between these values for men and women will also be explored.

Numeracy in relations of power

Distributing numeracy

How do people acquire numeracy skills and why do some attain higher skill proficiencies than others? Focusing on gender differences, the achievement of young boys and girls has received much attention for the past decades and continues to be of high importance (OECD, 2016b). Surveys such as PISA¹ and TIMMS² test students at the ages of 10 (TIMSS) and 14/15 (TIMSS, PISA). These assessments show that boys tend to perform higher on numerical and science-related tests. The difference is small, but nevertheless significant (Mullis, Martin, Foy, & Hooper, 2016; OECD, 2016b). A comparison between these and further assessments of numeracy and mathematical competencies from the years 1994 to 2007 show that gender differences increase with age and grade. The performance of boy's on numeracy and mathematical proficiency increases from the seventh grade on. The difference between boy's and girl's performance on such assessments can be related to stereotypes and expectancies. Not only do teacher seem to expect and (unconsciously) support different skills and interests of boys and girls, but also, students expectations of themselves have been shown to align with their interests and their self-concept to what they think is expected from them (Budde, 2009).

Regarding the adult population, results from PIAAC show men scoring higher on the numeracy scale than women with the gender gap greater in older age cohorts (OECD, 2016a). The presented findings on young students and adults show differences in how numeracy skills are distributed among genders.

Determining numeracy

In a comprehensive look at the social aspects of numeracy, Street, Baker and Tomlin (2008) transferred insights from the New Literacy Studies to the field of numeracy and argued that numeracy is a social practice. This idea of a multiple of skill interpretations originates in the New Literacy Studies (Street, 1993). Contemplating the great variety of numerate practices – numeracy itself has to be seen as *multiple numeracies*. The relativity of numeracy is not only evident in the social distribution of skills but also in determining what constitutes as mathematics or as numeracy. As such, all numeracies are embedded in power relations and subject to the societal hegemony. A variety of studies have demonstrated how numeracy skills and practices are embedded in economic outcomes (Grotlüschen et al., 2016) or how values, beliefs and power relations determine the idea and the relevance of numeracy and mathematical education (c.f. Ares & Evans, 2014). The

¹ Programme for International Student Assessment (by OECD)

² Trends in International Mathematics and Science Study (by IEA, International Association for the Evaluation of Educational Achievement)

relativity of numeracy is not only evident in the social distribution of skills but also in determining what constitutes as mathematics and as numeracy. Different studies showed how skills and practices are embedded in economic outcomes (Grotlüschen et al., 2016) or how values, beliefs and power relations determine the construct of numeracy and mathematical education (Ares & Evans, 2014). Following postmodern theories, some researchers view mathematics and numeracy to as constructed in discourse in every aspect (Ernest, 2004). Veleró (2004) suggests this perspective allows us “to perform a very fine grained analysis of how mathematics and mathematics education are used by people in particular discourses and of the effects of those discourses on social practices and, consequently, on people's lives” (p. 11).

Rewarding numeracy

Continuing from the perspective of that power relations shape numeracy conceptualizations and acquisition, the following analyses will show empirically that gender relations affect the value of numeracy skills on the example of labour market outcomes. Regression analyses of PIAAC data will be used to show how numeracy proficiency does not have the same value for everybody. Looking at two labour market outcomes (wages and leading positions), the analyses that follow will reveal how the effect of numeracy skills changes with gender.

Method: Data and sample

The presented research was carried out with PIAAC datasets for 13 European countries. The analysis disregarded those European countries whose PIAAC data did not disclose all variables employed. It therefore includes the following thirteen European countries: Belgium, Czech Republic, Denmark, Spain, Finland, France, Germany, Greece, Ireland, Italy, Netherlands, Norway and Poland.

PIAAC scales its numeracy test items based on item response theory (IRT) to account for differences in item difficulties. Based on the IRT scaling of the items and a population model, plausible values are drawn. This approach increased the measurement accuracy (Yamamoto, Khorramdel, & Davier, 2013). PIAAC views numeracy skills on a scale from 0 to 500, which it sections into five levels³ (OECD, 2013).

To exclude a possible bias arising from any gendered occupational segregation, different areas of work were included as control variables in the regression analyses. To exclude any effects of women working part-time, those participants who are unemployed, out of the workforce or work part-time⁴ were not incorporated in the analysed data.

Method: Variables and analyses

Variables on monthly income and leadership positions⁵ serve as indicators of labour market outcomes. The income variable indicates the monthly income exchanged into US-Dollars and

³ The score boundaries for numeracy in PIAAC are: 0-175 points (below level 1); 176-225 points (level 1); 226-275 points (level 2); 276-325 points (level 3); 326-375 points (level 4); 376-500 points (level 5).

⁴ Excluding all participants who work less than 31 hours in an average week (D_Q10).

⁵ Variables names are EARNMTHALLPPP for monthly wages and J_Q07a and J_Q08a for leading positions.

transformed as purchase power parity (PPP). This way, all outcomes are given on the same scale. Both income and leadership variables include employees as well as self-employed workers.

The effect on monthly income was regressed with a multinomial linear model. Logistic regressions were used for the leadership positioning. On both occasions, three models were employed: Model 1 regressed against male gender and numeracy; model 2 added background variables (b.v.)⁶ and model 3 regressed against the interaction term between numeracy and male gender. For the analysis on monthly income, the average work hours per week (h/w) were also controlled for in the first model.

Result: Same numeracy, different wages

Table 1 shows the result of the first two models on the monthly wages; showing significant results⁷.

Country	adjusted for h/w	adjusted for b.v.	Average equivalent of income differences in numeracy points
Belgium	718 ***	977 ***	61
Czech Republic	719 *	756 **	n.s.
Finland	493 ***	664 ***	58
France	304 ***	385 ***	44
Germany	516 ***	686 ***	30
Greece	330 ***	395 ***	60
Ireland	565 *	905 ***	32
Italy	614 ***	703 ***	88
Norway	748 ***	994 ***	59

Table 1: Difference of monthly income of men and women with the same numeracy proficiency

The results indicate how much higher men's monthly wages are when having the same average numeracy proficiency as women. A comparison of the two models suggests that structural differences cannot explain men's higher wages, as in most countries the differences in income rise in the further adjusted model. In Norway, for example, women on average earn almost 1.000 USD (PPP) less than men despite having the same level of skill proficiency.

⁶ Background variables include: Age (AGE_C), educational qualifications (EDLEVEL3), the parent's educational background (PARED), native language (NATIVELANG), different fields of work (ISCO1C) and the average hours of work per week (D_Q10)

⁷ Significant results are marked as follows: *** (p < 0.001); ** (p < 0.01); * (p < 0.05). n.s. (not significant).

The last column in Table 1 shows how many points on the numeracy scale are the equivalent of the gender difference in income. Men in these European countries seem to score from 30 (Germany, Ireland) to 60 (Finland, Norway, Greece, Belgium) to 88 (Italy) points lower on the 500 scale when earning a similar income to women. There are no significant differences in Denmark, Spain, Netherlands, and Poland.

Result: Exchanging numeracy into wages at different rates

Table 2 presents the third model of regression on the monthly income. The analysis tested for the increase of income against numeracy proficiency – again, not for individuals but structurally. The table indicates how much additional skill points relate to higher income for men in comparison to women. For all genders, higher numeracy scores relate to higher income. However, for men higher numeracy points relate to a higher increase in income. The difference is smallest in Ireland (with Germany as a close second). Here, a man's increase equals 117 percent (118 percent) of women's. In Italy, men's income increase equals more than 140 percent of the average woman's increase in income.

Country	Men's increase in income compared to women's increase
Belgium	138 %
Finland	130 %
France	122 %
Germany	118 %
Greece	122 %
Ireland	117 %
Italy	141 %
Norway	129 %

Table 2: Average value of men's numeracy in relation to women's

There are no significant differences in Denmark, Spain, Netherlands, Poland and the Czech Republic. For all thirteen European countries, higher numeracy scores relate to an increase of income by 123 percent of women with equivalent scores.

Result: The probability of leadership

Regarding the probability of men and women of getting into a leading position, we found similar results, which are shown in Table 3. These results show the effect coefficient of the binomial logistic regression analyses. The effect coefficient is the exponent of the regression results. In both models, men show a higher probability of being in a leadership position. In the unadjusted model, men in Italy and Germany are between 14 and 20 percent more likely to be in a leadership position when having equal numeracy skills as women. In Finland and Belgium, men are 81 and 89 percent more likely to be in a leadership position.

In the adjusted model, men in Spain and Finland are almost twice as likely to be in a leadership position as women with similar numeracy proficiency, educational background, in the same field of work, and with further background variables controlled. In the Czech Republic they show a more than two and a half times higher probability.

Women in Finland or Spain are almost half as likely to get into a leading position with the same numeracy proficiency, education and further background variables. There are no significant results in Ireland.

Averaged for all analysed European countries, men's probability to be in a leadership position is 148 percent of that of a woman with equivalent numeracy skills. When controlled for background variables, the overall average for men is 59 percent higher in relation to women.

Country	not adjusted	Adjusted for b.v.
Belgium	1.89 ***	1.62 ***
Czech Republic	1.75 ***	2.60 ***
Denmark	1.77 ***	1.52 ***
Spain	1.75 ***	1.93 ***
Finland	1.81 ***	1.95 ***
France	1.68 ***	1.65 ***
Germany	1.21 *	<i>n.s.</i>
Greece	1.52 **	<i>n.s.</i>
Italy	1.14 ***	1.61 ***
Netherlands	1.57 ***	1.37 **
Norway	1.55 ***	1.26 *
Poland	1.40 **	1.72 ***

Table 3: Odds ratios of logistic regression results: average probability of men getting into a leading position compared to women with equal numeracy skills

Discussion

As a consequence of the use of IRT, plausible values and the nature of our calculations, these results cannot be interpreted at the level individual case. In addition, countries' results can't be compared because of the different economic positions and related purchasing power within countries. However, the strong and significant correlation in at least nine of the 13 analysed countries indicate strong gender differences in the way (numeracy) skills can be transformed into labour market outcomes.

Furthermore, it seems numeracy does not correlate (strongly) with all job-specific skills. In contrast, there is no reason to assume that the gender difference in numeracy is bigger than in other job-specific skills.

In this paper I have argued that numeracy is embedded in hegemonic structures of society in (at least) three specific ways: (1) influencing what is recognised in definitions of numeracy, (2) selecting who acquires numeracy, and (3) determining the societal value of numeracy skills. The analyses of PIAAC data could show women's numeracy skills relate to a lower income and to lower probabilities of being in a leadership position. On a scale of 500, men score between 32 and 88 point lower than women while having a similar income. With the same numeracy proficiency, men on average earn between 300 and 750 USD more than women. Similarly, men's probability of getting into a leadership position is around one and a half times that of women with the same numeracy proficiency.

In some cases, the adjustment of the model for various background variables increased the respective coefficients. This might indicate, that part of the gender differences in the labour market are intensified by (some of) those background variables, like different fields of work or educational attainments. This result, however, cannot be explained by the first model.

In conclusion, this study provides evidence that numeracy skills are entwined in power relations. A multitude of factors, which - in some way or another – appear to be influencing women's opportunities along gender lines, accumulate to different outcomes in the labour market. My analysis indicates that higher levels of numeracy skills relate to an increase in labour market outcomes – but it is not an equal increase for everybody. This might suggest a deeper reflection on our concepts of numeracy and skills and our willingness to use real-life outcomes as promises for numeracy education.

References

- Ares, N., & Evans, D. M. (2014). Mathematics and numeracy as social and spatial practice. *Education Research International*, 2014, 1–14. <https://doi.org/10.1155/2014/742197>
- Baker, D., & Street, B. (2004). Mathematics as social. *For the Learning of Mathematics*, 24(2), 19–21. Retrieved from <http://www.jstor.org/stable/40248453>
- Budde, J. (2009). *Mathematikunterricht und Geschlecht: Empirische Ergebnisse und pädagogische Ansätze*. Bonn; Berlin, Germany: Bundesministerium für Bildung und Forschung.
- Craig, J. (2018). The promises of numeracy. *Educational Studies in Mathematics*, 99(1), 57–71. <https://doi.org/10.1007/s10649-018-9824-5>
- Ernest, P. (2004). Postmodernity and social research in mathematics education. In P. Valero & R. Zevenbergen (Eds.), *Researching the socio-political dimensions of mathematics education: Issues of power in theory and methodology* (pp. 65–84). Boston, MA: Springer Science + Business Media Inc.
- Grotluschen, A., Mallows, D., Reder, S., & Sabatini, J. (2016). *Adults with low proficiency in literacy or numeracy: OECD education working papers no. 131*: Paris, France: OECD Publishing.

- Janssen, A. (2018). *Verletzbare Subjekte: Grundlagentheoretische Überlegungen zur conditio humana*. Opladen; Berlin; Toronto: Budrich UniPress Ltd.
- Karaali, G., Villafane-Hernandez, E., & Taylor, J. (2016). What's in a name? A critical review of definitions of quantitative literacy, numeracy, and quantitative reasoning. *Numeracy*, 9(1). <https://doi.org/10.5038/1936-4660.9.1.2>
- Kittel, A. (2016). Mathematische Grundbildung im Erwachsenenalter. In M. Löffler & J. Korfkamp (Eds.), *Handbuch zur Alphabetisierung und Grundbildung* (pp. 422–445). Stuttgart, Germany: UTB; Waxmann.
- Mullis, I. V.S., Martin, M. O., Foy, P., & Hooper, M. (2016). TIMSS 2015 International results in mathematics. Retrieved from: <http://timssandpirls.bc.edu/timss2015/international-results/>
- OECD (2012). *Literacy, numeracy and problem solving in technology-rich environments: Framework for the OECD survey of adult skills*. Paris, France: OECD Publishing. <https://doi.org/10.1787/9789264128859-en>
- OECD (2013). *Technical Report of the Survey of Adult Skills (PIAAC)*. Paris, France: OECD Publishing.
- OECD (2016a). *Skills matter: Further results from the survey of adult skills: OECD skills studies*. Paris, France: OECD Publishing. <https://doi.org/10.1787/9789264258051-en>
- OECD (2016b). *PISA 2015 Results (Volume I): Excellence and Equity in Education*. Paris, France: OECD Publishing. <https://doi.org/10.1787/9789264266490-en>
- Ricken, N. (2013). Anerkennung als Adressierung: Über die Bedeutung von Anerkennung für Subjektivationsprozesse. In T. Alkemeyer, G. Budde, & D. Freist (Eds.), *Selbst-Bildungen: Soziale und kulturelle Praktiken der Subjektivierung* (pp. 69–99). Bielefeld; Berlin, Germany: Transcript; De Gruyter.
- Street, B. (1993). Introduction: The new literacy studies. In B. Street (Ed.), *Cross-cultural approaches to literacy* (pp. 1–21). Cambridge, UK: Cambridge Univ. Press.
- Street, B. V., Baker, D., & Tomlin, A. (2008). *Navigating numeracies: Home/school numeracy practices*. Dordrecht, Netherlands: Springer. <https://doi.org/10.1007/1-4020-3677-9>
- Vacher, H. L. (2014). Looking at the multiple meanings of numeracy, quantitative literacy, and quantitative reasoning. *Numeracy*, 7(2). <https://doi.org/10.5038/1936-4660.7.2.1>
- Valero, P. (2004). Socio-political perspectives on mathematics education. In P. Valero & R. Zevenbergen (Eds.), *Researching the Socio-Political Dimensions of Mathematics Education: Issues of Power in Theory and Methodology* (pp. 5–23). Boston, MA: Springer Science + Business Media Inc.
- Yamamoto, K., Khorramdel, L., & Davier, M. v. (2013). Scaling PIAAC Cognitive Data. In OECD (Ed.), *Technical Report of the Survey of Adult Skills (PIAAC)* (Chapter 17). Paris, France: OECD publishing.

Numeracy and mathematics education in vocational education: a literature review, preliminary results

Kees Hoogland¹, Karen Heinsman² and Paul Drijvers³

¹HU University of Applied Sciences Utrecht, The Netherlands; kees.hoogland@hu.nl

²HU University of Applied Sciences Utrecht, The Netherlands; karen.heinsman@hu.nl

³HU University of Applied Sciences Utrecht, The Netherlands; paul.drijvers@hu.nl

Numeracy and mathematics education in vocational education is under pressure to keep up with the rapid changes in the workplace due to developments in workplace mathematics and the ubiquitous availability of technological tools. Vocational education is a large stream in education for 12- to 20-years-olds in the Netherlands and the numeracy and mathematics curriculum is on the brink of a reform. To assess what is known from research on numeracy in vocational education, we are in the process of conducting a systematic review of the international scientific literature of the past five years to get an overview of the recent developments and to answer research questions on the developments in vocational educational practices. The work is still in progress. We will present preliminary and global results. We see vocational education from the perspective of (young) adults learning mathematics.

Keywords: Numeracy, mathematics, vocational education, VET.

Introduction

Practical background / Our aim

Vocational education in the main stream of the educational system in the Netherlands (preparatory vocational for 12- to 16-year-olds and specific vocational for 17- to 21-year-olds) is on the brink of bringing the curriculum up-to-date to the needs of the current society and the contemporary workplace. In the 1990s the curriculum was built around four domains: numeracy, algebra, geometry & measurement, and information processing & statistics. In that timeframe the curriculum was considered quite modern and ahead of developments in other countries, mostly caused by the Realistic Mathematics Education movement which was inspired by the “mathematics is a human activity” -approach by Hans Freudenthal (Gravemeijer, 1994).

In the 2010s, however, from an alleged low level of arithmetic skills of the students, a strong top-down ministerial policy was introduced by adding to the existing mathematics curriculum a separate numeracy/arithmetic programme with a digital nation-wide summative examination. After 10 years of piloting and political quarrels, this path was abandoned again.

Now new paths are explored to see whether the vast body of knowledge on mathematics for the workplace and mathematics for the future citizens can provide valuable clues for a modern, relevant and effective numeracy or mathematics curriculum for students who will work with mathematics in very practical situations and who will have to deal with the quantitative world around them. From this perspective the students in vocational education are seen as young adults who can benefit from the body of knowledge collected around adult mathematics education.

From this perspective we started a review of the most recent literature on numeracy in vocational education.

Theoretical background

For a theoretical background, we address the following issues:

- Societal changes
- Shifts in mathematics education
- Previous reviews

To start with, there are major societal and policy pressures on (mathematics) education to prepare young learners and school leavers for a complex and technologised society. In literature, these new educational goals are referred to as *21st century skills* or *21st century competences* (Voogt & Pareja Roblin, 2012), *global competences* (OECD, 2016) or the *4th industrial revolution* (Schwab, 2016). Common among the concepts mentioned above is the acknowledgement that across education, government, and business, the skills and knowledge needed to succeed in work, life and citizenship have significantly changed in the 21st century. As workplaces are being transformed, the skills and knowledge workers now need are intertwined with technology. New means of communication and types of services have changed the way individuals interact with governments, institutions, services and each other, and social and economic transformations have, in turn, changed the demand for skills as well.

These major societal and policy pressures translate also into pressures on mathematics education to prepare young learners and school leavers for a complex and technologised society. For instance, PriceWaterhouseCoopers (2015) reported recently that businesses “competing in a global economy driven by data, digital technologies and innovation will need more employees trained in science, technology, engineering and mathematics (STEM). Research indicates that 75 per cent of the fastest growing occupations now require these skills” (PWC, 2015, p. 4). Similarly, in their recent 2017 review, the National Council of Teachers of Mathematics (NCTM) (2017), stated that “Today mathematics is at the heart of most innovations in the information economy. Mathematics serves as the foundation for STEM careers and, increasingly, careers outside STEM, and mathematical and statistical literacy are needed more than ever to filter, understand and act on the enormous amount of data and information that we encounter every day” (p. 6). Many of the mentioned changes are related to technological developments, particularly information and communications technologies (ICT), and have profoundly altered what are considered to be the key knowledge and skills that individuals need as economies and society continue to evolve.

There is a growing body of knowledge on the desired numeracy and mathematics competences in workplaces (D. Coben et al., 2010; Geiger, Goos, & Forgasz, 2015; Hoyles, Wolf, Molyneux-Hodgson, & Kent, 2002; Hoyles, Noss, Kent, & Bakker, 2010; Straesser, 2015; Wake, 2015). Consistent in the reported results are conclusions which boil down to the observation that the mathematics tasks which people undertake at work in the 21st century involve more than plain calculation skills or straightforward procedural proficiency. Nowadays, workplace practices involve sophisticated mathematical problem-solving skills and the ability to recognise and engage with the mathematics embedded within multifaceted, real-life workplace settings. Many 21st century

workplace mathematics requirements and practices are integrated with technology. Hoyles et al. (2010) argue that this requirement for mathematical capabilities is driven by the need to improve production processes and productivity, and that there will be greater demand for what they call ‘techno-mathematical literacies’. This involves “a language that is not mathematical but ‘techno-mathematical’, where the mathematics is expressed through technological artefacts” (Hoyles et al., 2010, p. 14). Furthermore, the pressures for moving toward the teaching and learning (and assessment) of 21st century skills include a consistent demand for students to be digitally and technologically competent, to be able to engage with technology in all its guises, and to be highly ICT literate (Voogt & Pareja Roblin, 2012).

There have been a few recent reviews on related topics. At the start of this century Coben (2003) did a comprehensive review on adult numeracy focusing on research and related literature. The results of this review are relevant to our research questions as far as vocational education can be considered as (young) adults who are learning mathematics. This is indeed the perspective we chose.

The main conclusions from Coben’s review were:

- Numerate practices are diverse and deeply embedded in the contexts in which they occur.
- The transfer of learning between contexts is problematic.
- The impact of adult numeracy tuition is under-researched and more detailed studies are required.
- Adult numeracy teacher education needs continuing professional development.

At the same time, Falk and Millar (2001) conducted a review of research on literacy and numeracy in vocational education and teaching from an Australian perspective. Their main conclusions were:

Significant and multiple implications for literacy practice have emerged from forces for change such as globalisation and technological advancement. (...) Adult and Community Education (ACE) and VET sectors have been merged to a large extent. These changes have had important consequences for the way practitioners carry out their work. (Falk & Millar, 2001, p.3)

The overall picture of adult education and vocational education and training (VET) is that it is a rapidly developing field with a strong focus on connecting mathematics education to the world around us. Effective practices to incorporate these ideas in courses and educational programmes are still under-researched.

Research questions

In the Netherlands a broad curriculum reform has started which includes redefining the mathematics curriculum in vocational education. This review is also intended to collect scientific results of research on vocational policies and practices to support this process and make it more evidence-informed.

To get a better grip on how the concepts of numeracy and mathematics are used in the international scientific community our first research question is:

1. Which concepts of numeracy (or mathematics) are used in research in a vocational context?

Furthermore, we are interested in well-researched practices in mathematics or numeracy education in vocational tracks or streams. Hence our second and third research questions:

2. Which numeracy teaching practices are described in research in a vocational context?
3. Which effects of numeracy teacher practices are reported in research in a vocational context?

The review of literature is still ongoing. The results we report in the results section are preliminary and still quite general.

Method

Search terms

We conducted a systematic review (Gough, Oliver, & Thomas, 2017; Petticrew & Roberts, 2016) of the research literature through the definition of search terms derived from the research questions.

In various countries the concept numeracy is used when referring to the mathematical activities in the vocational classroom, for instance in Australia. In The Netherlands two words are used to distinguish the more basic numeracy as is taught in primary education (Dutch: rekenen) and the more advanced use of mathematics as is taught in secondary education (Dutch: wiskunde). In most countries, however, mathematics is used to refer to all the kinds of activities which deal with the numbers, patterns and structures in the vocational education or in the workplace.

Regarding the specific part of the educational infrastructure we are focusing on, two labels are used most common to refer to this specific kind of education which prepares students for the workplace. These labels are “vocational education” and VET, which is short for vocational education and training. So our main logical string of search terms is:

Search string = (Numeracy OR mathematics) AND (“vocational education” OR VET).

Search engines and databases

We used our search string in a variety of educational databases which together assemble most international educational research: WorldCat, ERIC, PsycInfo, Web of Science, Scopus, and Education Research Complete.

Scope

We narrowed down our search using the following limitations:

- Scientific literature
- Published in peer-reviewed journals
- English language
- Recent, last five years, date of publishing: 2014-2018 or 2014+.
- Search terms present in title, abstract, or keywords.

Further narrowing down

The search-string led to 611 hits in the selected databases. There were several ways in which we narrowed down the amount of initial hits (see Figure 1).

First, the articles in this ‘technological catch’ were brought together, deduplicated and checked for obvious mishits, such as articles on veterans or veterinarian issues. This resulted in a set of 477 articles to be considered by experts.

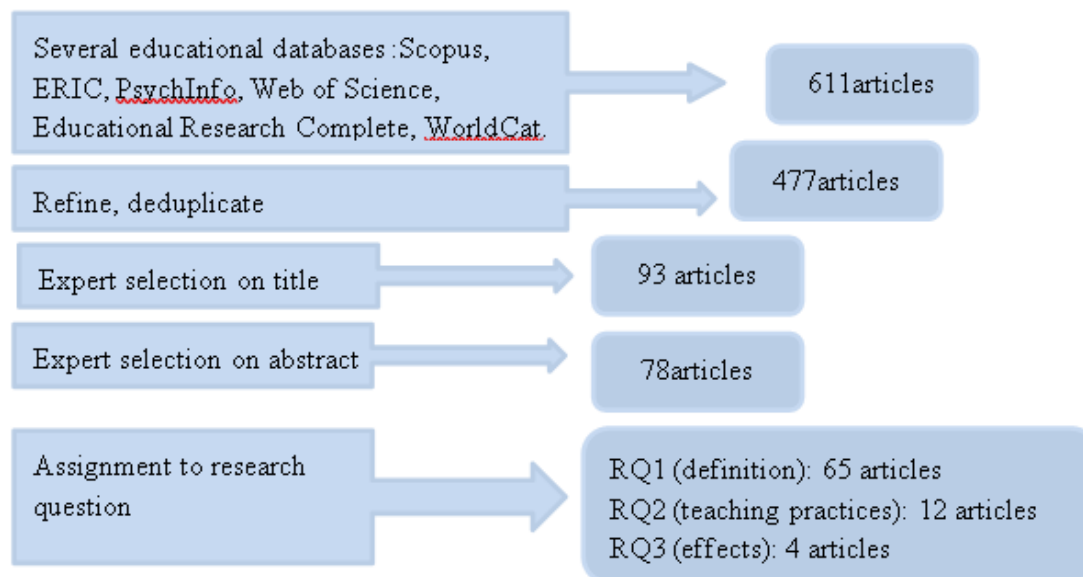


Figure 1: Search strategy and remaining articles after each step

Second, the first expert screening followed, based on the titles of the articles. Three experts scored independently whether the article was supposed to be relevant for the three respective research questions. For each a score 1 (relevant), 2 (possibly relevant), 3 (maybe relevant) or 9 (not relevant) was given. After this, articles with three 9-scores by each experts (i.e., not relevant for any of the research questions) were discarded from the selection. This reduced the set to 93 articles remaining.

Third, the abstracts of the remaining articles were scored by three experts, again independently. The experts decided from the content of the abstract whether they supposed the article to be relevant for either of the three research questions. After this, again articles with three 9-scores by each expert (i.e., not relevant for any of the research questions) were discarded from the selection. This reduced the set to 78 articles remaining.

Fourth, the 78 articles were linked to the respective research questions to be examined further: 65 articles were judged to be relevant for research question 1 about the definition of numeracy, 12 articles seemed relevant to answer research question 2 about teaching practices and 4 articles were scored as relevant for research question 3 on the effects of teaching practices.

Fifth, the full text of the remaining articles are being analysed for relevant sections which can be used to answer the actual research questions. This analysis is ongoing.

Cross-referencing and snowballing

In the next phase of our research, we will cross-reference our set of relevant sources with Google Scholar, which is nowadays considered to be the search engine which uses the most comprehensive database of products from the scientific community. However, the ways to refine searches in Google Scholar are still rather limited.

In a preliminary analysis of the remaining articles we found multiple references to specific books and journal specials (for instance, ZDM 2015, 47-4, and Educational Studies in Mathematics 2014, 86-2) of particular interest for our research questions. In a later stage of our research we will add some of these sources to the set of sources we use as corpus to answer the research questions.

Results

The review is ongoing. The results and conclusions in this paper must be read as preliminary findings.

Regarding research question 1 - on the used definition of numeracy - we found that a large part of the articles address policy matters, like comparative studies (for instance PIAAC), country policies, regional and school policies, most of the cases assuming the definition of numeracy from the PIAAC framework as the working definition. In articles, which were not on policy matters, in roughly half the cases the definition of numeracy is not explicitly defined, making it difficult to value the inferences made from the gathered data. This problem will be elaborated in a later article.

Regarding research questions 2 and 3 – on actual practises - , the major conclusion is that from the found hits and relevant articles only a very few are addressing actual educational practices on numeracy in vocational education (12 of 477) and even fewer (4 of 477) report on effects of educational practices or interventions. Most of the 12 articles addressing educational practices describe observations in classrooms, providing conclusions and implications for education based on these observations. These articles tend not to be on describing current teaching practice and their effects, but in most cases report on how the authors would like to see the teaching practice change. The importance of real context in education for transfer of the numeracy-skills and motivation of the students is emphasized.

Some themes are reoccurring in the selected articles. First, all articles describe the importance of connecting numeracy to work-related situations. This transfer or boundary crossing is important since students can solve mathematical problems in class, but often do not recognize these problems in work-related knowledge; the integration of mathematics and statistics learnt in school with work related knowledge is a problem (Bakker & Akkerman, 2014). Wake (2014) speaks about ‘hidden mathematics’; workers (and students) do not recognize mathematical situations as such and therefore do not use school knowledge in work-situations. Dalby and Noyes (2015) as well as Coben and Weeks (2014) stress the use of ‘real work’ problems in which students can use mathematics as a tool, instead of the mathematics they know as a school subject. Contextual math provides motivation since students experience the need of it for their own work. According to Bakker and Akkerman (2014) students themselves report to appreciate a work-related approach and claim they learned a lot in only five one-hour meetings. Second, a reoccurring theme is problematic transfer from numeracy interventions to practice. Ter Vrugte et al. (2015) show in their research how in a math computer game proportional reasoning increases, but analyses of transfer problems showed that there was no measurable transfer. They conclude students in vocational education have trouble applying school knowledge in another context. Van Schaik, Terwel and Van Oers (2014) describe a science workplace in which students have to build a trike. This article shows how numeracy is predominantly hidden in other subjects, like science. And also in science transfer is

difficult for teachers to achieve. When given a practical assignment, students seem to forget the need to apply the knowledge they learned before, but also teachers do not always teach their students the missing school-math when they need it and connect the classroom knowledge with the practical assignment.

Only four articles provide experimental research in which a specific teaching practice, differing from the regular approach is being implemented. These articles are too small in number and too divers to find trend-setting answers to our third research question.

Conclusion and Discussion

When we used the search string (Numeracy OR mathematics) AND (“vocational education” OR VET) is used in Google Scholar for products since 2014, we found 16,500 hits. There is no lack of output around these themes. Refining the sources to a corpus of relevant literature from which some conclusions could be drawn or trends could be discerned is not a straightforward task. The sources are multifaceted and of very different quality, scope and choice of themes.

The articles are from dozens different journals, which reflect the multifaceted character of both the concepts numeracy and vocational education. It also reflects that the research area is young, not well- established and literally ‘all over the place’.

The definition of numeracy used in the articles is influenced heavily by the work around the PIAAC Numeracy Framework. In that sense the PIAAC programme has a formatting power on the development of the concept of numeracy.

References

- Bakker, A., & Akkerman, S. F. (2014). A boundary-crossing approach to support students' integration of statistical and work-related knowledge. *Educational Studies in Mathematics*, 86(2), 223-237. doi:10.1007/s10649-013-9517-z
- Coben, D., Hall, C., Hutton, M., Rowe, D., Weeks, K., & Wolley, N. (2010). *Benchmark assessment of numeracy for nursing: Medication dosage calculation at point of registration*. Edinburgh, UK: NHS Education for Scotland.
- Coben, D. (2003). *Adult numeracy: Review of research and related literature*. London, UK: NRDC.
- Coben, D., & Weeks, K. (2014). Meeting the mathematical demands of the safety-critical workplace: Medication dosage calculation problem-solving for nursing. *Educational Studies in Mathematics*, 86(2), 253-270. doi:10.1007/s10649-014-9537-3
- Dalby, D., & Noyes, A. (2015). Connecting mathematics teaching with vocational learning. *Adults Learning Mathematics*, 10(1), 40-49.
- Falk, I., & Millar, P. (2001). *Literacy and numeracy in vocational education and training - review of research*. Kensington Park, Australia: NCVER.
- Geiger, V., Goos, M., & Forgasz, H. (2015). A rich interpretation of numeracy for the 21st century: A survey of the state of the field. *ZDM*, 47(4), 531-548. doi:10.1007/s11858-015-0708-1

- Gough, D., Oliver, S., & Thomas, J. (2017). *An introduction to systematic reviews*. London, UK: Sage
- Gravemeijer, K. (1994). *Developing realistic mathematics education*. Utrecht, the Netherlands: CDBeta press.
- Hoyles, C., Noss, R., Kent, P., & Bakker, A. (2010). *Improving mathematics at work the need for techno-mathematical literacies*. London and New York: Routledge.
- Hoyles, C., Wolf, A., Molyneux-Hodgson, S., & Kent, P. (2002). *Mathematical skills in the workplace*. London, UK: Science, Technology and Mathematics Council. Retrieved from <http://eprints.ioe.ac.uk/1565/1/Hoyles2002MathematicalSkills.pdf>
- OECD. (2016). *Global competency for an inclusive world*. Paris, France: OECD Publishing. Retrieved from <https://www.oecd.org/education/Global-competency-for-an-inclusive-world.pdf>
- Petticrew, M., & Roberts, H. (2016). *Systematic reviews in the social sciences: A practical guide*. Oxford, UK: Blackwell Publishing.
- PwC. (2015). *A smart move: Future-proofing Australia's workforce by growing skills in science, technology, engineering and maths*. Sydney Australia: PwC. Retrieved from <https://www.pwc.com.au/pdf/a-smart-move-pwc-stem-report-april-2015.pdf>
- Schwab, K. (2016). *The fourth industrial revolution: What it means, how to respond*. www.weforum.org: *World Economic Forum*. Retrieved from <https://www.weforum.org/agenda/2016/01/the-fourth-industrial-revolution-what-it-means-and-how-to-respond/>
- Straesser, R. (2015). "Numeracy at work": A discussion of terms and results from empirical studies. *ZDM*, 47(4), 665-674. doi:10.1007/s11858-015-0689-0
- ter Vrugte, J., de Jong, A. J. M, Wouters, P., Van der Cruysse, S., Elen, J., & van Oostendorp, H. (2015). When a game supports prevocational math education but integrated reflection does not. *Journal of Computer Assisted Learning*, 31(5), 462-480. doi:10.1111/jcal.12104
- van Schaik, M., Terwel, J., & van Oers, B. (2014). Representations in simulated workplaces. *International Journal of Technology and Design Education*, 24(4), 391-417. doi:10.1007/s10798-014-9261-4
- Voogt, J., & Pareja Roblin, N. N. (2012). A comparative analysis of international frameworks for 21st century competences: Implications for national curriculum policies. *Journal of Curriculum Studies*, 44(3), 299-321. doi:10.1080/00220272.2012.668938
- Wake, G. (2014). Making sense of and with mathematics: The interface between academic mathematics and mathematics in practice. *Educational Studies in Mathematics*, 86(2), 271-290. doi:10.1007/s10649-014-9540-8
- Wake, G. (2015). Preparing for workplace numeracy: A modelling perspective. *ZDM*, 47(4), 675-689. doi:10.1007/s11858-015-0704-5

Initiating a Common European Numeracy Framework

Kees Hoogland¹, Marlies Auer², Javier Díez-Palomar³, Niamh O'Meara⁴ and Mieke van Groenestijn⁵

¹HU University of Applied Sciences Utrecht, The Netherlands; kees.hoogland@hu.nl

²BFI Oberösterreich, Linz, Austria; marlies.auer@bfi-ooe.at

³University of Barcelona, Spain; jdiezpalomar@ub.edu

⁴University of Limerick, Ireland; niamh.omeara@ul.ie

⁵HU University of Applied Sciences Utrecht, The Netherlands; mieke.vangroenestijn@kpnmail.nl

This paper is a discussion paper to support an Erasmus+ project with the name Common European Numeracy Framework (CENF) (for adults) which will start at the end of the year 2018. In the first months of 2019 the team with participants from The Netherlands, Austria, Spain and Ireland will be in the process of collecting European examples of numeracy practices and current numeracy frameworks. At the conference we will show the results of this collection to date and the initial outline of a tentative CENF. We intend to spark comments, suggestions and insights from the participants of TWG07 - Adults Mathematics Education - to enrich the collection and as feedback on the initial outline of the CENF. Another aim is to create a network of national or regional stakeholders which will support the development of a shared framework for numeracy goals and numeracy education for adults in the 21st century.

Keywords: Numeracy framework, professional development, pilot courses, Erasmus+.

Introduction

In 2017 four educational institutes from The Netherlands, Austria, Spain, and Ireland respectively, took the initiative to develop a numeracy framework for adults. A grant was awarded by the European Union in an Erasmus+ project to work towards such a framework in the years 2019-2021.

As result of this project a tentative Common European Numeracy Framework (CENF) will be established and based on this framework a set of professional development modules (PDM) for adult numeracy educators will be developed. The CENF will incorporate the latest insights into numeracy skills and competencies which are relevant for our technologised and numbers-drenched society.

The suite of professional development modules developed for teachers and volunteers who teach on numeracy courses will be based on the CENF. The PDMs will foster the capability of teachers and volunteers to effectively develop basic skills and competences among adult learners in order to strengthen their employment prospects, develop their socio-educational and personal skills, and counteract social exclusion. It will also equip adult learners with the skills highly needed to participate in civic and social life.

In short, the objective of this project is to first develop a Common European Numeracy Framework and secondly to expand and to improve the number and the quality of numeracy courses (or other relevant educational activities) offered to adults to improve their life chances of prospering in

society. To reach this objective, we will use on a multi-level approach for addressing teachers and volunteers that are involved in the delivery of numeracy courses, the teacher educators who deliver courses to those teachers and volunteers, and policy makers and other stakeholders who are responsible for creating opportunities for such courses. This multi-level approach already has started by connecting the associated partners to our goals in this application.

The CENF will comprise of information on the effective teaching and learning of numeracy, especially in relation to adults who have left school early and those from disadvantaged backgrounds. Such a framework can also be used as a mechanism for systemically tracking and monitoring the progress of adult learners in the field of numeracy. The professional development modules will be made available on-line in an attempt to actively contribute to extending and developing educators' competences and maximize the chance of European wide use of the project outputs.

Background

Too many European citizens lack the necessary numeracy competencies to participate autonomously and effectively in our technologized and number-drenched society. Consequently many citizens are overlooked for certain jobs and have problems in their daily life, dealing with the abundance of number-related issues. In literature, these competencies are referred to as '21st century skills' or '21st century competences (Voogt & Pareja Roblin, 2012), global competences (OECD, 2016a) or skills for "the 4th industrial revolution" (Schwab, 2016).

The results of the last PIAAC survey (OECD, 2013, 2016b; PIAAC Numeracy Expert Group, 2009) show that a quarter of the participating countries in PIAAC have results below level 2 of the 6-point scale. Scores below level 2 are associated with having problems in daily activities due to low numeracy skills. These results on numeracy give rise to serious cause for concern for the future economic development of Europe. This is an even more pressing issue since the amount of numerical data that needs to be interpreted and used is rapidly rising due to technological developments and the prevalence of (big) data. To gain a better insight in these trends a second cycle of PIAAC will be starting in 2020 (Hoogland, Diez-Palomar, & Maguire, 2019; Kirsch & Lennon, 2017; Tout et al., 2017).

On average, school leavers between the age of 16 and 24, perform at a lower level than people between the ages of 25 and 44 (OECD, 2016b). The lack of numeracy skills among these people increases the risk of unemployment and may influence family life and social inclusion. In particular, low-skilled workers are at risk in the labour market, particularly when faced with adaptations in the labour market. The Council of the European Union emphasizes that adult learning is a means for upskilling or reskilling those affected by unemployment, restructuring and career transition, while simultaneously it makes an important contribution towards social inclusion, active citizenship and personal development. The European Council recommends the enhancement of basic skills including literacy, numeracy, problem solving and digital skills as part of the Europe 2020 Strategy (European Commission, 2017).

In the frame of lifelong learning, therefore, adult numeracy education has an important role in the development of good programs for basic skills for the future.

Evidence-informed adult numeracy education may be the key for attaining the goals set out in the Europe 2020 strategy. In most European countries, adult numeracy education is a locally based endeavour with a plethora of practices, some efficient, some less so. Furthermore, there is a variety of underlying assumptions on what constitutes good adult numeracy education. The availability of a good collection of (piloted) professional development modules, based on the CENF (which contains relevant content and insights for adults learning numeracy and mathematics), will generate a quality adult numeracy education across Europe, and thereby contribute to policies and activities which address the low-numeracy levels in many European countries. Effective numeracy education in European countries, based on a common framework, may lead to a higher level of societal participation and inclusion of adults, and thereby to the improvement of the European economy.

Project methodology as starting point for workgroup discussion

In this section we present the methodology which will be used in the Erasmus+ project (Hoogland, Diez-Palomar, & Vliegthart, 2019). In the working group of CERME11 we will use these headings as a guide for the discussion. The aim of this discussion paper is to inform the participants of TWG07 and to tap into their knowledge, experiences, and networks to strengthen the impact of the project.

The project methodology can be laid out as follows.

The context

The number of European citizens lacking the necessary numeracy competences to participate autonomously and effectively in our technologised and number-drenched society is a serious concern for the economic development of Europe. (OECD, 2012, 2013, 2016b; PIAAC Numeracy Expert Group, 2009). The European Council recommends enhancement of the basic skills - literacy, numeracy, problem solving and digital skills - as part of the Europe 2020 Strategy (European Commission, 2017).

Evidence informed adult numeracy education is the key for reaching the goals as mentioned in the Europe 2020 strategy. In most European countries adult numeracy education is a locally based endeavour with a plethora of practices, some efficient, some less so and with a great variety of underlying assumptions on what constitutes good adult numeracy education. A good set of (tried-out) professional development modules based on a common European numeracy framework (which contains relevant content and insights in adults learning numeracy and mathematics) will generate a qualitative and quantitative impulse in adult numeracy education across Europe, and thereby contribute to policies and activities which address the low-numeracy levels in many European countries.

The objectives

The ultimate objective of the project is to enlarge the number and to improve the quality of numeracy courses (or other relevant educational settings) offered to adults to improve their chances in society. To reach this objective we develop a Common European Numeracy Framework (CENF) and set of professional development modules (PDMs)

The target group and the participants in the project.

The ultimate target group of the project are the participants in adult numeracy courses. The aim is to provide them with numeracy competences which will benefit them in participating adequately in daily life and work-related situations in our number-drenched society. Numeracy to this regard is considered to be a social practice (Yasukawa, Rogers, Jackson, & Street, 2018). However, the availability and quality of adult numeracy courses around Europe are dependent on many factors, of which many are outside the scope and influence of this project. Therefore, we choose a multi-level approach of addressing teachers and volunteers who are actually involved in the numeracy courses, the teacher educators who provide courses to those teachers and volunteers, and policy makers and other stakeholders who are responsible to create opportunities for such courses (both by teachers and by teacher educators). In doing so, the project will involve the local, regional, national and international communities of practitioners, researchers, and policy makers around adult numeracy education by information, surveys, presentations, and presenting a CENF.

The activities

On the basis of literature studies and broad European surveys on used frameworks, good practices, and theoretical insights we will develop a draft framework and draft modules. This will be followed by try-outs in the partner countries to test the drafts empirically and to collect feedback from various stakeholders from the adult numeracy community. The framework and modules will be revised with the gathered experiences, evaluations and comments. The end result will be made available as a blended on-line course, while the availability as cMooc will be investigated.

The methodology

The ways of gathering the information are literature reviews, surveys and peer reviewed development of products, according to academic standards for research methodology.

The methodology for dissemination, implementation and sustainability is based on the multilevel approach of educational changes as for instance propagated by Hargreaves, Lieberman, Fullan, and Hopkins (2010) and Fullan (2008); Fullan, Hill, and Crévola (2006).

The result

The result will be an increase in the quality and quantity of numeracy courses and professional development courses on adult numeracy education. The concrete results of the project are a CENF and a set of PDMs for teachers and volunteers who work in adult numeracy education. Both outputs we consider as essential in reaching the ultimate objective.

The impact

The existing European networks on adult numeracy education support the project as associate partners and express their willingness to advocate the results through their network communications and in their network meetings. The CENF will have an impact across Europe.

Long term benefits

A common approach and a reinforcement to create high quality national professional development courses based on a common framework can have a long-lasting effect on the development of high quality adult numeracy education around Europe.

Discussion

The discussion points on the starting project followed the project methodology. Below, to each discussion point a short outcome of the discussion in the Thematic Working Group is mentioned

The context and the objectives

Q: What should be added to the context to make the picture more complete or richer in examples?

A: Special attention is needed for participants who are vulnerable learners, often with negative educational experiences.

Q: Can a Common European Numeracy Framework be helpful in the further development of adult numeracy education?

A; Yes, as long as it is developed bottom-up and connects to existing practices and frameworks.

The target group and the participants in the project.

Q: Should the framework aim at participants in adult numeracy courses, at practitioners in adult numeracy education in the European countries, at adult numeracy course designers, or at policy makers?

A: Both practitioners and policy makers must be able to read and understand the framework. For participants materials can be designed which are closely relate to the framework, for instance rubrics or descriptions of typical behaviour.

The activities, the methodology, the results of the project

Q: Which other activities are paramount to reach the envisioned goals?

A: The project would strengthen as the participants' voices were heard in the developmental stages of the framework. The participants are adults who have an opinion on how learning goals could and would look like.

Q: Which activities should be added to make the results stronger and more widely-spread?

A: The design and the implementation of the framework would benefit by international parallel research and validation of parts of the framework

The impact and the long term benefits

Q: Which actions might increase the chance to reach a really *common* European Numeracy Framework on adult numeracy education? Who are the most important stakeholders?

A: Both policy makers and networks of practitioners and researchers are important. Translating the framework in as many European languages as possible can help the acceptance and use.

The results of this discussion will be input for the further development of the Common European Numeracy Framework..

Acknowledgement

This project is carried out in an European project Common European Numeracy Framework with the support of the Erasmus+ programme of the European Union.

References:

- European Commission. (2017). *A renewed EU agenda for higher education SWD(2017)264*. Retrieved from <https://eur-lex.europa.eu/legal-content/EN/TXT/PDF/?uri=CELEX:52017SC0164&from=en>
- Fullan, M. (2008). *The six secrets of change: What the best leaders do to help their organizations survive and thrive* (1st ed.). San Francisco, CA: John Wiley & Sons.
- Fullan, M., Hill, P., & Crévola, C. (2006). *Breakthrough*. Thousand Oaks, CA: Corwin Press.
- Hargreaves, A., Lieberman, A., Fullan, M., & Hopkins, D. (Eds.). (2010). *Second International handbook of educational change*. Dordrecht, The Netherlands: Springer.
- Hoogland, K., Díez-Palomar, J., & Vliegthart, M. (2019). Towards a common European numeracy framework. In: B. Kelly, D. Kaye, D. Griffiths, D. Dalby, & J. Stacey (Eds.), *Boundaries and Bridges: Adults learning mathematics in a fractured world. Proceedings of the 25th International Conference of Adults Learning Mathematics: A Research Forum (ALM)* (pp. 64–66). London, England: UCL Institute of Education.
- Hoogland, K., Díez-Palomar, J., & Maguire, T. (2019). Towards a second cycle of PIAAC. In: B. Kelly, D. Kaye, D. Griffiths, D. Dalby, & J. Stacey (Eds.), *Boundaries and Bridges: Adults learning mathematics in a fractured world. Proceedings of the 25th International Conference of Adults Learning Mathematics: A Research Forum (ALM)* (pp. 67–68). London, England: UCL Institute of Education.
- Kirsch, I., & Lennon, M. L. (2017). PIAAC: a new design for a new era. *Large-scale Assessments in Education*, 5(1), 11. doi:10.1186/s40536-017-0046-6
- OECD. (2012). *Literacy, numeracy and problem solving in technology-rich environments: Framework for the OECD Survey of Adult Skills*. Paris, France: OECD Publishing.
- OECD. (2013). *OECD Skills Outlook 2013: First results from the survey of adult skills*. Paris, France: OECD Publishing.
- OECD. (2016a). *Global competency for an inclusive world*. Paris, France: OECD Publishing.
- OECD. (2016b). *Technical report of the survey of adult skills (PIAAC)* (2nd Edition). Paris, France: OECD Publishing.
- PIAAC Numeracy Expert Group. (2009). *PIAAC Numeracy: A conceptual framework*. Retrieved from

[http://www.oecd.org/officialdocuments/publicdisplaydocumentpdf/?cote=EDU/WKP\(2009\)14&doclanguage=en](http://www.oecd.org/officialdocuments/publicdisplaydocumentpdf/?cote=EDU/WKP(2009)14&doclanguage=en)

Schwab, K. (2016). *The Fourth Industrial Revolution: what it means, how to respond*. Retrieved from <https://www.weforum.org/agenda/2016/01/the-fourth-industrial-revolution-what-it-means-and-how-to-respond/>

Tout, D., Coben, D., Geiger, V., Ginsburg, L., Hoogland, K., Maguire, T., . . . Turner, R. (2017). *Review of the PIAAC numeracy assessment framework: Final report*. Camberwell, Australia: Australian Council for Educational Research (ACER).

Voogt, J., & Pareja Roblin, N. N. (2012). A comparative analysis of international frameworks for 21st century competences: Implications for national curriculum policies. *Journal of Curriculum Studies*, 44(3), 299-321. doi:10.1080/00220272.2012.668938

Yasukawa, K., Rogers, A., Jackson, K., & Street, B. V. (Eds.). (2018). *Numeracy as social practice: global and local perspectives*. London, UK: Routledge. doi:10.4324/9781315269474

What motivates adults to learn mathematics through trade unions in the workplace: social factors and personal feelings

Beth Kelly

University College London/ Institute of Education, United Kingdom; beth.kelly@ucl.ac.uk

This research is based on interviews with adults about their motivation to study mathematics in the workplace, through classes organised and funded by trade unions in the UK. The findings point to motivation as a function of individual's emotions and cognition that are influenced by social experiences. The research identifies a difference between the initial motivation to re-engage with learning and that required to continue, or persist. Continuing learning relies on a socially and emotionally supportive learning environment which adults identify as 'different' from previous experiences. The term an 'Affective Mathematical Journey' is developed to describe the positive emotional changes experienced by adults, which helps them overcome negative memories. The adults' resultant increase in confidence and motivation encourages them to successfully develop and use their mathematical skills both inside and outside the classroom.

Keywords: Mathematics, motivation, teaching methods, affect, emotions.

Introduction

There is much research into learning mathematics that seeks to explain why children and adults have problems with the subject and subsequently struggle to learn mathematics (Boaler, 2000; Coben et al, 2007). Those interviewed for this research reported obstacles to their learning such as; previous unsuccessful learning experiences, demands of shift work and family responsibilities. Yet they had chosen to re-engage with learning mathematics at or below GCSE level in the workplace through opportunities negotiated by trade unions with employers. It was not a requirement of their current job, so this group of adults must have been highly motivated to return to learning mathematics and were chosen to develop a better conceptual understanding of motivation.

The adults in my research have taken up a learning opportunity at work enabled by national trade unions allocating resources to this purpose. Trade Union officers, usually ULRs, are activists whose job it is to encourage workers to develop their skills, give advice and guidance, identify workers needs, and negotiate on-site learning opportunities with employers). Trade unions fund the teachers and equipment needed to support that learning, while employers provide the physical space and sometimes time off work to learn. In 2016, nearly 10,000 ULRs across the UK were involved in training through TUC Education and over 27,000 individuals took up an opportunity to improve their English and maths skills through their union (Unionlearn, 2017, p. 4).

This research identifies the importance of how people feel about the learning in relation to their motivation. Adults need to trust people who are encouraging them to join the classes and feel safe in the learning environment in order for them to develop confidence with mathematics. Union Learning Representatives (ULRs), are trusted colleagues that play a key role in encouraging and supporting adults to join classes in the workplace. Trade unions also promote a 'different' learning approach in their courses, influenced by the 'collective ethos' of trade union culture. The learners identify this different pedagogic approach as key to them persisting learning (Kelly, 2018).

Research into learning in the workplace has usually focused on mathematical concepts used for work or the more contentious notion of the ‘transferability’ of mathematical concepts between school and the workplace (Lave & Wenger, 1991; FitzSimons & Godden, 2000). In an endeavour to understand differences in learning approaches research has also usefully included descriptions of pedagogical characteristics (Evans, Wedege, & Yasukawa, 2013) in terms of formality: this research concentrates on adults’ motivations to learn mathematics in the workplace, to gain a formal qualification in a less-formal learning setting.

Research into affective issues in mathematics education have been explored by McLeod (1994), who conceptualised emotions, attitudes and beliefs in relation to motivation in terms of stability and intensity. Eynde, De Corte and Verschaffel (2006), posited motivational concepts act in different levels of social contexts. Hannula (2012) further theorised affect in mathematics education suggesting it could be explored in three dimensions, as concepts: cognitive, affective or motivational; as varying in relation to time and in relation to ontological traditions of research. This moves us on from simply identifying ‘maths anxiety’ (Buxton, 1981) as an emotional barrier to learning, to exploring the wider, more complex domain of affect in relation to motivation to learn.

During this research, the concept of an *Affective Mathematical Journey* (AMJ) was developed to describe changes in learners’ feelings in relation to mathematics. An AMJ occurs when positive (or negative) learning experiences inspire adults to modify their feelings towards mathematics. In this research, the change in affect becomes more positive and this change not only contributes to adults’ increased confidence and motivation to learn the subject but also influences their potential to use their new skills beyond the classroom. Elliot, Dweck and Yeager’s (2017) research supports these findings recognising the possibility of ‘socialisation practices’ to foster different mind-sets in learners which have a ‘cascade of effects, altering their meaning systems and their academic outcomes’ (p. 135).

Research by Hannula, Pantziara, and Martino (2018) highlighted the tradition of research into affect and mathematics education in CERME conferences, but the focus is still on school education. Boaler’s (2000) research into motivation and mind-sets has also focused on children. This research points to the contribution that adults who experience a ‘stalled education’ can add to research into affect and mathematics education.

Methodology and methods

The analysis is based on twenty in-depth semi-structured interviews with members of trade unions, aged between 25 and 65, twelve males and eight females. They come from a range of trade unions, employed in a variety of contexts, in small and large organisations, publicly and privately owned. They studied in a variety of environments; individually following on-line courses with tutor support or in teacher-led groups. However, this is small sample with no claim to be representative of the characteristics of the broader union learning population, especially since learners who were studying basic mathematics up to level 2, the equivalent to a GCSE.

The identification and recruitment process of interviewees relied upon the agreement and support of trade union officers and ULRs. Hence the method of sampling was a combination of purposeful, ‘criterion sampling’ (Bryman, 2012, p. 419), as I was seeking adults that fulfilled a particular set of criteria and snowball sampling (Atkinson & Flint, p. 275) in that I needed key gatekeepers (ULRs)

to agree to help me access potential participants. The research centres on individuals and their ‘interpretations’ of situations, so naturally relies on qualitative data, which was tested for the trustworthiness and authenticity of the findings (Bryman, 2012, p. 390). The whole interview and storage process followed BERA (2011) guidelines, ensuring interviewees anonymity especially when their words would be used in the research. Nvivo™ was utilised to help track and analyse the learner’s words. Enabling me to interrogate the data and build and group ideas in different ways; as well as identifying commonly used words such as ‘confidence’.

The analysis takes a critical approach because the researcher is a teacher trainer who explores how research into adults learning in the workplace might usefully influence mainstream mathematics education practice. The research is also built on the feminist research tradition of exploring personal viewpoints, as Reinhartz and Davidson (1992) suggests when citing Datan (1989, p. 175) ‘it is an axiom of feminism that the personal is political’ (p. 234). Therefore, when analysing the adults’ words there is a subjective encounter with the individual that seeks to understand different perspectives, relating this motivation at the individual level to emotions and cognition, within particular social contexts.

Hence in this research, motivational factors are considered at three levels: the individual, the social and the societal, which all influence each other. At the individual or personal level McLeod (1994) focuses on needs and goals. Evans, Wedege and Yasukawa, (2013) broaden the notion of personal motivational factors to include ‘the cognitive and affective as part of the whole person’ (p.222). In this research individual learners feelings are key to their descriptions of their motivations to learn mathematics, reflecting Hannula’s (2012) dimension of the ‘domain of affect’ linking cognitive, motivational and emotional factors.

At the social level, local face-to-face groups include people who adults trust and influence their motivation (Barbalet, 1996), such as; fellow learners, families, union members and Union Learning Representatives. Families play an important support role but ULRs and fellow learners also play a key role in motivating trade union members to engage with learning and persist in classes.

The wider socio-economic environment, is a context where individual members are given a ‘second chance’ to learn mathematics through trade unions who have negotiated resources with both central government and employers to enable this to happen. Therefore, the social context of learning is influenced by the values, history and culture of both the trade union movement and the workplace, acting in wider United Kingdom society.

Findings

Motivation to learn mathematics: initial and continuing

Adults in the sample indicated their initial motivation differed from that required to continue or persist in learning. Their initial motivation to re-engage with learning was related to their individual needs and goals, such as: improving job security, filling a perceived personal knowledge or skills gap, gaining public recognition of their knowledge or skills through certification and helping their children. However, their motivation to re-engage with learning was also supported and encouraged by significant social local face-to-face groups such as work colleagues, ULRs, fellow trade union colleagues, other learners and family members. At the wider societal level, the opportunity for

learning is reliant upon trade unions negotiating funding with central government and workplace agreements with employers, as stated above.

Motivation to continue, or persist, with learning relied more on the action of the social face-to-face groups, both teachers and fellow learners providing what the interviewees called a ‘different’ learning experience to that previously encountered. The adults described the characteristics of the learning as: more collaborative than previously experienced, taking place in smaller classes, in a relaxed atmosphere where they felt they could talk openly about mathematics and their problems. They also spoke about the mathematical topics being relevant to their life experience, in the sense that the concepts, where possible, were related to practical applications (such as building a shed) or finances (interest rates) or trade union issues (regarding health and safety).

Emotions and motivation

During the analysis it became clear that emotions played a key role in the adults’ descriptions of their learning experiences. Eight people, out of twenty interviewed, used such words as hate, phobia, fear and horrendous to describe their previous experiences with mathematics. When talking about the learning organised through the trade unions seven interviewees spoke about feeling more “relaxed”, four described the learning experience as “fun” and five as “brilliant”. When discussing their motivations to learn and use mathematics eleven interviewees used the word ‘confidence’ to describe the changes in their *feelings* and *beliefs* about their abilities and motivation.

The notion of developing confidence through the achievement of mathematics contributed to the interviewees being more motivated to learn in the classroom but also to act differently when outside. For example, when they were negotiating on behalf of fellow trade union members, dealing with home finances, training to become trade union mathematics teachers or supporting children to learn mathematics at home. Combining personal feelings (of confidence) developed through social experiences (learning mathematics) creating those intentions to act differently, I describe this as adults experiencing a positive *Affective Mathematical Journey*, relating motivation to emotions, and cognition.

Relevance of the Findings to the Research Field

When considering the notion of increased confidence adults’ motivation to learn mathematics relates to affective domains, reflecting Hannula’s (2012) two dimensions of motivation acting at an individual emotional and cognitive level but something that can change over time. However in this research the support of various members of local social groups was also key to learning, reflecting Eynde et al’s (2006) focus on the dynamic interaction between the individual and the social group.

Developing individual’s Confidence: an Affective Mathematical Journey

Interviewees often used emotional words when discussing their motivation to learn mathematics, indicating that successful learning experiences, especially after previous ‘failures’, lead to changes in how they saw themselves and how they act in social situations. Psychological research into motivation reinforces the idea of a positive correlation between self-confidence and achievement in mathematics (McLeod, 1994; Zan et al. 2006). This research suggests that achievement increases self-confidence while Hannula (2012) argues self-belief and achievement are reciprocal influences.

Although theoretically confidence can be a problematic concept when used to judge others, the way the interviewees use the term to describe their own beliefs and feelings about themselves and their willingness to act in different social situations, suggests it as an ‘emotion of self-projection’ as described by Barbalet (1996, p. 77). McLeod (1994) argues confidence is mainly cognitive but the emotional words used in this research reinforce Barbalet’s (1996) argument. Mahn and John-Steiner (2002) further maintain developing confidence has a strong social dimension developed through group activities, which strengthens the findings of this research suggesting the use of the word confidence links the adult’s motivation to emotions and social experiences.

When adults report feeling more confident about themselves and more positive about learning mathematics it suggests a change in their identity development at a ‘profound’ level after a ‘transformative’ learning experience (Illeris, 2014). The conjecture is that feelings towards mathematics can change and effect an individual’s motivation and this concept contributes to the theoretical construct an *Affective Mathematical Journey* (AMJ), where adults’ beliefs, motivation and feelings about mathematics change. DeBellis & Goldin (2006) argue a range of emotions are experienced during problem solving in the mathematics classrooms, describing them as ‘pathways’, this research builds on that idea but points to changes in adult’s emotions happening over a longer period of time, in some cases years, thus it is more of a journey.

Further research could be undertaken, exploring ways that enable adults to experience *Affective Mathematical Journey* in relation to ‘different’ learning experiences described earlier. Particularly so for teachers in Further Education in the UK who have to teach 16-19 year olds, who have already experienced failure to achieve GCSE mathematics, at least once.

The role of different social face-to-face groups in motivation

Bandura (2004) identifies social persuasion as key to motivation, this goes beyond verbal persuasion alone, because getting someone to attend a mathematics class would not be enough to develop their self-efficacy. Adults also need to feel supported in order to achieve and to develop their own self-belief. In this research trusted ULRs take on this role persuading members to join mathematics classes; ensuring the classes are accessible and providing a supportive and ‘emotionally safe’ environment (discussed below), leading to positive learning experiences.

Helping children with their skills development is also an important motivator for adults, particularly for females, findings supported by research by Swain, Baker, Holder, Newmarch, & Coben (2005) and Coben et al., (2007). This research accentuates the importance of supporting children as both an initial motivational force to re-engage with learning as well as a reason to persevere. For those adults who are newly arrived in the UK, with English as their second language, supporting children to learn can also help them to understand and integrate into the wider ‘home’ society. Hence, learning mathematics can be a positive contributor to a better functioning family in both economic and social terms.

Motivation related to pedagogical approaches used in the learning group

The adults spoke regularly of the importance of having a ‘different’ learning experience, when re-engaging with mathematics. The pedagogical approach promoted by trade unions (Rees, 2007) and described by adults was ‘more relaxed’, ‘more social’ and ‘supportive’; closer to notions of

informal or non-formal (Coben et al., 2007; Evans et al., 2013) ways of learning. The learning experiences were described by some as being ‘easier’ than previous ones linking cognitive to emotional factors in motivation.

Bibby (2002) suggests there is a connection between traditional mathematics class and shame, where mathematical tasks are often seen as right or wrong and in the classroom are open to public scrutiny, judgement and, if not ‘correct’, humiliation and shame. Wojecki calls these remembered encounters as ‘wounding learning experiences’ (2007, p. 170) although he posits that adults can and do get over them, something this research supports. Schorr and Goldin (2008) argue it is possible to facilitate changes in emotions given the right circumstances, which they describe as ‘emotionally safe environments’ (p. 131). This is a place where it is safe to expose misconceptions and where learners’ will not suffer public humiliation for getting a calculation wrong.

The interviewees also spoke about the importance of relating the mathematical practice to previous and current experiences in life and work, an approach trade unions promote (Rees, 2007). Linking mathematics to life or work links to the idea of social belonging and relatedness, (Ryan & Deci, 2017) where motivation is something that is culturally relevant, such as trade union activities, or meaningful to the individual, for example calculating interest rates on loans.

Conclusion

The findings indicate that adults’ initial motivation to re-engage with learning mathematics can be understood differently from their motivation to continue learning, but that both rely on the dynamic interaction between the individual and social groups. Motivation can be seen as a change in behaviour, which is a function of an individual’s motivation, emotions and cognition; developing within social face-to-face groups, all acting within a wider enabling social context.

The research has focused on a special group of learners, that have not succeeded in mainstream education but have achieved in an alternative learning environment that gives us a real insight into ways that adults’ motivation and confidence to learn mathematics can be developed. It foregrounds the important role that social face-to-face groups such as trade unions play in developing ‘different’ learning experiences using less traditional or formal methods but that can be successful in developing adults’ mathematical skills and confidence. It also highlights the important role personal emotions play in a motivation, and how trust in others plays a key role in re-engagement with learning, overcoming long held negative views on mathematics and developing confidence with mathematics. This change in feelings in relation to mathematics can be described as them experiencing a positive *Affective Mathematical Journey* (AMJ), where they feel more confident and motivated to both learn and use the subject.

References

- Atkinson, R., & Flint, J. (2003). Sampling, snowball: accessing hidden and hard-to-reach populations. In R. L. M. A. Miller & J. D. Brewer (Eds.), *The A-Z of social research : a dictionary of key social science research concepts* (pp. 274–279). London; Thousand Oaks, California: SAGE.
- Bandura, A. (2004). Social cognitive theory for personal and social change by enabling media. In A. Singhal, M. J. Cody, E. M. Rogers, & M. Sabido (Eds.), *LEA's communication series*.

- Entertainment–education and social change: History, research, and practice* (pp. 75–96). Mahwah, NJ: Lawrence Erlbaum Associates Publishers.
- Barbalet, J.M. (1996). Social emotion: confidence, trust and loyalty. *International Journal of Sociology and Social Policy*, 16(9/10), 75–96.
- Bibby, J. (2002). Shame: An emotional response as an adult and a teacher. *British Educational Research Journal*, 28(5), 705–721.
- Boaler, J. (2000). *Multiple perspectives on mathematics teaching and learning*. Westport, Connecticut; London: Ablex.
- British Educational Research Association (BERA) (2011). *Ethical guidelines for educational research*. London: BERA.
- Bryman, A. (2012). *Social research methods* (4th ed.). New York, USA: Oxford University Press.
- Buxton, L. (1981). *Do you panic about maths?: coping with maths anxiety*. London: Heinemann Educational.
- Coben, D., Brown, M., Rhodes, V., Swain, J., Ananiadou, K., Brown, P., & Ashton, J. (2007). *Effective teaching and learning numeracy. Summary report*. London, England: NRDC.
- DeBellis, V., & Goldin, G. (2006). Affect and meta–affect in mathematical problem solving: A representational perspective. *Educational Studies in Mathematics*, 63(2), 131–147.
- Elliot, A. J., Dweck, C. S., & Yeager, D. S. (2017). *Handbook of competence and motivation: theory and application*. New York; London: Guilford Press.
- Evans, J., Wedege, T., & Yasukawa, K. (2013). Critical perspectives on adults' education. In M. A. Clements (Ed.), *Third international handbook of mathematics education* (pp. 203–242). New York; London: Springer.
- Eynde, P. O., De Corte, E. & Verschaffel, L. (2006). Accepting emotional complexity: A socio–constructivist perspective on the role of emotions in the mathematics classroom. *Educational Studies in Mathematics*, 63(2), 193–207.
- FitzSimons, G. E., & Godden, G. (2000). Review of research into adults learning mathematics. In D. Coben, J. O'Donoghue, & G. E. Fitzsimons (Eds.), *Perspectives on adults learning mathematics: research and practice* (pp. 13–45) Dordrecht; London: Kluwer Academic Publishers.
- Hannula, M. (2012). Exploring new dimensions of maths–related affect: Embodied and social theories. *Journal for Research in Mathematics Education*, 14(2), 137–161.
- Hannula, M., Pantziara, M., & Di Martino, P. (2018). Affect and mathematical thinking. Exploring developments, trends and future directions. In T. Dreyfus (Ed.), *Developing research in mathematics education: twenty years of communication, cooperation, and collaboration in Europe* (pp. 323–329). Abingdon, Oxon: Routledge.
- Illeris, K. (2014). *Transformative learning and identity*. Abingdon, Oxon: Routledge, Taylor & Francis Group.

- Kelly, B. (2018). Motivating adults to learn mathematics in the workplace: a trade union approach, *International Journal of Lifelong Education*, 38(2), 132-147. DOI: 10.1080/02601370.2018.1555190
- Lave, J., & Wenger, E. (1991). *Situated learning: legitimate peripheral participation*. Cambridge: Cambridge University Press.
- Mahn, H., & John–Steiner, V. (2002). The gift of confidence: A Vygotskian view of emotions. In G. Wells & G. Claxton (Eds.), *Learning for life in the 21st century: sociocultural perspectives on the future of education* (pp. 46–58). Oxford: Blackwell.
- Mcleod, D. (1994). Research on affect and mathematics learning in the JRME: 1970 to the present. *Journal of Research in Mathematics Education*, 25, 637–647.
- Reinharz, S., & Davidson, L. (1992). *Feminist methods in social research*. New York; Oxford: Oxford University Press.
- Rees, L. (2007). New developments in union Learning. In S. Shelley, & M. Calveley, *Learning with trade unions: A contemporary agenda in employment relations* (pp. 225–241). Aldershot : Ashgate.
- Ross, C., Kumarappan, L., Moore, S., & Wood, H. (2011). *Learning journeys: trade union learners in their own words*. London: England: TUC Unionlearn.
- Ryan, R. M., & Deci, E. L. (2017). *Self-determination theory: basic psychological needs in motivation, development, and wellness*. New York: Guilford Press.
- Schorr, R., & Goldin, G. (2008). Student's expression of affect in an inner–city SimCalc classroom. *Educational Studies in Mathematics*, 68(2), 131–148.
- Swain, J., Baker, E., Holder, D., Newmarch, B., & Coben, D. (2005). *'Beyond the daily application': making numeracy teaching meaningful to adult learners*. London, England: NRDC.
- Unionlearn (2017) *Inspiring learners to achieve: Unionlearn annual report 2017*. London, England: TUC Unionlearn.
- Wojecki, A. (2007) What's an identity got to do with it anyway? Constructing adult learning identities in the workplace. *Studies in the Education of Adults*, 39(1), 168–182.
- Zan, R., Brown, L., Evans, J., & Hannula, M. (2006). Affect in mathematics: An introduction. *Educational Studies in Mathematics*, 63(2), 113–121.

Adult learners know more about maths than they think: helping learners to embrace their knowing

John J. Keogh¹, Theresa Maguire² and John O'Donoghue³

¹Technological University Dublin, Science Department, Ireland; john.keogh@tudublin.ie

²National Forum for the Enhancement of Teaching and Learning, Director, Ireland;
tmaguire@teachingandlearning.ie

³University of Limerick, EPISTEM, Limerick, Ireland; john.odonoghue@ul.ie

Adults know more about mathematics than they think and use it more often than they realise. Despite their apparent self-perception of being a 'non-maths' person, they behave in mathematics-informed ways, which are dismissed, routinely, as common sense or anything but mathematics. The doctoral research underpinning this paper reports that given the opportunity to view their behaviour, especially in work, through a mathematics-sensitive lens, people readily recognise their numerate behaviour even if they talk about it in different ways. This work introduces a set of tools and a methodology to harvest real tangible benefits for the learner. The tools explore the locus of a person's expertise in increasing granularity, to build a platform from which to capture a learner's mathematics knowledge, skills and competence (MKSC), to revise the mistaken self-perception and to inculcate confidence in his/her learning of mathematics.

Keywords: Numerate behaviour, invisible mathematics, workplace, non-maths-person.

Introduction

The phenomenon of 'invisible maths' has been explored and explained across a spectrum of political, educational, industrial, technological, economic, psychological, personal, and anthropological and social themes (Benedicty & Donahoe, 1997; Coben, 2008; Hoyles, 2008; Hoyles, Noss, Kent, & Bakker, 2007; Maaß, 2005; Strasser, 2003; Wake & Williams, 2007; Wedege, 2010). It encapsulates the paradox that people deny their use of mathematics or dismiss it as common sense or anything but mathematics (Coben, 2000). It is common for people to declare themselves as 'not a maths person' while behaving in numerate ways. This doctoral research offers a key to resolving the use/denial paradox, not only as an end in itself, but to help people to recognise their mathematics knowledge, to embrace it, and to be able to repurpose it to different contexts and for different outcomes. This paper takes a broad view of people as workers and people as learners or prospective learners. The term 'practitioner' denotes a person trained in the support of learners.

In companion documents, the authors provide a comprehensive explanation of invisible mathematics and how it arises. (Keogh, Maguire, & O'Donoghue, 2016; Keogh, Maguire, & O'Donoghue 2018). The purpose of this paper is to draw attention to how practical benefits can be harvested for the learner or worker as learner, given all that is known about 'invisible maths', and its consequences for individuals, their families, their communities and society as a whole. That formal learning of mathematics takes place in the classroom is self-evident. The expectation of such learning being somehow transferred to another context is rendered problematic (Evans, 1999) for

want of a channel through which the transfer to a contrasting context may be facilitated. This compounds the challenge to recognise mathematics outside of the classroom, partly because it is not conveniently packaged and labelled as discrete pods of MKSC that reflect a syllabus. For the purposes of this work, MKSC is determined by the context in which it is realised and refers to instances of behaviour that are underpinned by the ‘big ideas’ of mathematics, viz, Quantity & Number, Space & Shape, Pattern & Relationship, and Data handling & Chance. The focus in work shifts away from mathematics, to the achievement of aims and objectives, guided by processes and procedures, which, nevertheless, are shaped by mathematics concepts and thinking. In this way, we suggest, people develop high levels of expertise in the performance of the activities without appreciating the extent of their ‘knowing’ which underpins their ‘doing’. Adults are smart in a variety of ways that reflect their lived experience both inside and outside the classroom. The self-perception of not being ‘a maths person’ seems to prevent the recognition of mathematics activity, while assimilating it as common sense or ‘just part of the job’. To this end, the authors have developed a process and a suite of supporting tools.

The overall purpose of this process is to make explicit a person’s capacity for, and use of, mathematics that might otherwise remain hidden from view and unavailable for development. This is important in a dynamic landscape where employability and re-employability of workers, the recognition of their prior learning (RPL), and their continuous development is of paramount concern for themselves, their employers and society in general.

How the tool and the approach works

Process Stage 1: Use of Mathematics Survey (Tool 1)

The Use of Mathematics Survey consists of a set of 37 statements, 8 of which are included as exemplars due to space restrictions in Table 1. The full survey is amenable to translation into other languages and is available in a book entitled *Adults Mathematics and Work: from Research into Practice* (Keogh et al., 2018). For each statement those being surveyed are asked to rate how often they do the things suggested in the statements with the stated caveat that there are no wrong answers because what is of interest is their opinion about their job. For each statement participants select the option which most closely matches their opinion from this list: *Never or Hardly ever; About once a year; About once a month; About once a week; About every day; Don’t understand the question*.

The workplace survey instrument may be self-administered or completed with the support of a practitioner, depending on the learner’s needs and starting point. It is designed to prompt self-reflection on the learner’s activity, whether social or professional, by locating him/her in the midst of his/her own expertise. In this way, the learner begins to appreciate the mathematics underpinning the work and/or play and to realise that the impact of mathematics ranges across space and shape, pattern and relationship, data and chance, as well as quantity and numbers. It presents a mathematics-nuanced perception of what may be seen otherwise as common sense or anything but mathematics.

I interpret information from a variety of sources to form an opinion about a work/hobby situation.
--

I use measurements to describe the solution to a work/hobby problem.
--

I apply ready-made solutions to familiar problems that arise in work/hobby.
I notice a problem in work/hobby when the measurements and dimensions seem to be out of line with the usual.
From among possible solutions, I select the one most likely to solve the immediate problem.
When trying to solve a work/hobby problem, I take into account that a change in one part of the problem could have an affect on another part.
I use my knowledge of the system to trace fault back to the cause.
I think about the shapes involved in a problem to find the solution.

Table 1: Use of Mathematics Survey (extract)

While the frequency of use of MKSC is not important at this stage, it invites the learner to reflect on a behaviour that may have become embedded in a habit-forming routine through repetition. More importantly the learner becomes more tuned to the mathematics-informed activities comprising the job that may have become invisible. This outcome may be sufficient in itself by succeeding in shifting the learner's dismissal of MKSC to one of accepting the prominent presence of mathematics in their activities, however it may be talked about. That realisation sets the learner up for a deeper exploration of his/her mathematics-disposition and is a prelude to a discussion regarding the context in which his/her work occurs.

Process Stage 2: Task Context Tool (Tool 2)

The Task Context Tool (TCT) is designed to be used by a trained practitioner. It comprises a series of questions in the Socratic style (see Table 2).

Question	Purpose
Tell me about your work, hobby, past time.	Locates the learner in their comfort zone, where they are expert.
What happens there?	Invites the learner to explain; helps the practitioner to ask relevant questions and to understand the answers, in addition to recognizing gaps in the explanation.
Why?	Open questions such as why, when, who, and how helps to describe the context in which the work takes place and may reveal issues that would be assumed.
How do you know what to do?	Helps to locate the learner in work among the surrounding streams of work.
What happens next?	Reveals that which might remain concealed.
How does that happen?	Elicits detail that might be assumed to be common knowledge or self-evident.
Have I got this right so far?	Check for accuracy bearing in mind that the learner may not have discussed work in such detail before.
What have I left out?	Check for completeness.

Table 2: Task Context Tool: suggested questions and their purpose

The TCT is not intended to be a prescribed script, but rather an illustration of the type of questions that help the learner to begin to unpeel the layers of familiarity, habit and routine that hide the detail of the work environment. With a little training, a practitioner can produce a model of the broader context in which the 'job' takes place in a way that makes sense of the workflow to the outsider. It is crucial that, no matter what familiarity practitioners think they have with the job being described or their prior knowledge derived in other circumstances, they must put that and its inherent

assumptions to one side and listen carefully to the learner. The TCT is not usefully self-administered as it would allow the assumptions to remain embedded and concealed. The expected outcome is a ‘work-flow diagram’ that depicts the flow of actions and information that underpin the aims and objectives of the work activity, including the attendant motivations, constraints, conditions and problems. The suggested questions neither challenge nor judge, but intend to place the practitioner in the learner’s shoes, Table 2. The conversation between the practitioner and the learner is an iterative process as the learner recalls more relevant information.

The work-flow diagram of the context serves to acquaint the practitioner with the locus of the learner’s area of expertise, rapidly, to ask intelligent questions and to understand the answers, to enable a closer understanding of what the job/leisure pursuit entails in terms of the tasks that are ‘done’, in order to access the extent and kind of the underpinning ‘knowing’. Having established the surrounding circumstances, and having taken account of the relevant discourse, the essence of the job can be explored in more granular detail.

Process Stage 3: Task Exploration Tool (Tool 3)

The next stage of the process sees the practitioner use the Task Exploration Tool (TET) to drill more deeply into what the learner actually does in order to uncover the numerate behavior that s/he exhibits. This is a more detailed enquiry of the processes and procedures that guide the work activity rather than a list of duties and is informed by the outcome of the context tool (see Table 3).

Question	Purpose
What is the first thing you do on arrival in work?	This question places the learner at the beginning of his/her day and is an <i>aide memoir</i> .
Why?	This is intended to expose the rationale of the learner’s approach to his/her work or hobby.
What happens next?	This enables conditions and constraints that influence following activities to be articulated and to explain how they are evaluated, talked about and reconciled.
How do you know what information/resources you need?	Allows the different kinds of input for the job and hints at identifying, evaluating, talking about and acting upon mathematical information in a variety of forms.
What can go wrong?	Invites a discussion about systems, patterns, relationships and chance, as well as shape, space and quantity.
What solutions have you for when things go wrong?	Introduces a range of topics that arise in the case of a breakdown in the ‘system’ for whatever reason, whether equipment, non-conforming product, incomplete documents or instructions.
How can you avoid things going wrong?	This is likely to introduce patterns and relationships, data handling and chance.
What makes things awkward?	This is an exploration of non-routine activities.
How would you change your work?	The learner’s insights offers the possibility of uncovering a deeper understanding of the MKSC that underpins the work.
What causes you trouble?	This shines a light on non-routine activities.
How do you deal with it?	Offers insights into the learner’s thinking style.
What is not covered by the SOPs (Standard Operating Procedures)?	Explores how the learner manages to anticipate problems that may be overcome by his/her ingenuity.
How do you work around problems?	This is another opportunity for the learner to articulate how smart s/he is.

What makes one day different from the next?	This is another opportunity to capture the complexity of the job as distinct from an account of the routine.
What's the last thing you do?	The answer to this question may be revealing regarding anticipation, chance and planning.

Table 3: Task Exploration Tool: Suggested questions and their purpose

Particular attention should be paid to codified references and acronyms that tend to conceal rather than explain. While many of the task components may be superficially repetitive, they can be constrained by sets of conditions that temper the worker's responses.. This is not an exhaustive list of questions, nor should it be considered a prescribed script, but a methodology for stripping back the occluding layers to access detailed numerate behavior. The information provided should be sufficient to enable the development of a diagram of the relevant actions and their conditions described in as much detail as possible, such that they may be numbered for inclusion in the Linking Tool (Tool 4). The role and aims of the practitioner are key in determining the appropriate level of detail. The combination of the Survey, TCT and TET will reveal range of instances of numerate behaviour to the learner and help them to overcome their 'non maths-person' bias. However, the practitioner may wish to map the numerate behaviour on to the local framework of mathematics described in terms of the 'big ideas' of mathematics viz, Space & Shape, Pattern & Relationship, Quantity & Number, and Data-handling & Chance, and to calibrate the evidence-based starting point level at which the learner's development can continue. This step is supported by the Linking Tool.

Process Stage 4: Linking Tool (Tool 4)

The Linking Tool (LT) is a template to help the practitioner to organize the information elicited by the other stages and mapping them to the underpinning mathematics concepts, for a particular job e.g. warehouse picker in this case (see Figure 1).

In the course of the application of these tools, the practitioner is tuned to hear clues as to the numerate behavior embedded in the activities the learner describes. This enables the practitioner to establish the link to the Irish National Framework (QQI, 2012) and to demonstrate the learner's familiarity with the underlying mathematics concepts with which they have demonstrated their familiarity, albeit expressed in non-mathematics terms.

It must be borne in mind by the practitioner that work is designed to achieve an outcome for the benefit of the employer without regard to the curriculum, topic disciplines or levels of complicatedness. It is unlikely that all of the requirements of a credit-bearing course of study would be contained in a particular job.

Why does it matter?

The denial/use of mathematics paradox is well established. So too is the self-declared perception of not being a maths-person as though it was a binary condition. The negative effects of insufficient MKSC is well documented regarding limiting life-choices. That a person may constrain their development due to a mistaken perception of their capacity for mathematics is unjust and unjustifiable, not only for themselves but for those over whom they exert influence, i.e. their children. The survey of people in work corroborated by several case studies conducted in the

doctoral research stated very clearly that people were very aware of their MKSC even though they did not describe it as such. There can be little doubt that a learner's first requirement is the confidence in being able to know, without which, very little learning may be achieved. This is not about whether mathematics is more important than any other topic. Rather it offers a research-informed intervention that enables a limiting and mistaken self-perception to be exposed and dismissed.

There are several converging strands that compete to attest to the achievement of what are thought to be complementary outcomes. Learners have needs that are influenced by their interests, cultural background, career objectives and what they perceive to be their innate talent. Policy makers encourage and support the development of knowledge skills and competence for the benefit of society in the broader sense, while at the same time catering for the needs of industry by prescribing standards of quality and consistency. Practitioners and trainers devise curricula that comply with the terms of the national standards while at the same time appealing to and meeting the ambitions of the learners, insofar as they can be known in advance, and measured with reference to learning outcomes.

Employers operate in a more dynamic and fluid context that prioritises marketability, cost efficiency, competitiveness and profitability, but not fully conversant with the implications of the QQI-NFQ levels. The factors that drive these things are made volatile by the necessity to react to change in demand, technology, innovation and expectation. It is impossible, despite Government funded initiatives, to anticipate fully the sets of knowledge skills and competence that may become scarce within a few years and therein lies the kernel of the problem. Educators must equip learners with the resources to perform in an environment that is undergoing constant change. This must be done in compliance with a programme that has been in gestation for two years prior to being implemented in a four year degree programme. A person in employment for that same six years will have acquired a profound understanding of the workplace and its requirements, albeit specific to and probably contained by that workplace.

The process outlined in this paper and the accompanying tools enable individuals to highlight what they 'know' as distinct from what they 'do' to establish the confidence in learners that they are capable of 'knowing' whatever they choose, especially mathematics. It provides a platform from which people can embrace their knowing for the benefit of their employability and re-employability to meet the challenges of the emerging and exhilarating new World of the 21st Century. The interventions described herein have emerged from the finding of, and reflection on, the preceding research work. They have been introduced in real, adult learner situations with very promising results.

The authors would like to acknowledge the contribution of Ciarán O'Sullivan, Applied Mathematician, TU Dublin, for his invaluable insights into how best to present the process and associated tools in a way that would be more easily accessible to practitioners.

References

- Benedicty, A., & Donahoe, S. (1997). Math course revisited. In R. Richart, D. P. Wolf, J. Craven, & D. Balick (Eds.), *Through mathematical eyes: Exploring functional relationships in math and science* (pp. 71-101). Portsmouth, NH: Heinemann.
- Coben, D. (2002). Mathematics or common sense? Researching 'invisible' mathematics through adults' mathematics life histories. In D. Coben, J. O'Donoghue, & G. E. Fitzsimons (Eds.), *Perspectives on adults learning mathematics: Research and practice* (Vol.21, pp. 53–66). Dordrecht, Netherlands: Kluwer Academic Publishers.
- Coben, D. (2008, 7/3/2008). Numeracy for nursing: The scope for international collaboration. In: *Proceedings of the 15th International Conference on Adults Learning Mathematics (ALM)*. Philadelphia, USA
- Evans, J. (1999). Building bridges: Reflections on the problem of transfer of learning in mathematics. *Educational Studies in Mathematics*, 39(1), 23–44.
- Hoyles, C. (2008). Empowerment through mathematics in the workplace. *Reflect*, 10, 20-21.
- Hoyles, C., Noss, R., Kent, P., Bakker, A & Bhinder C. (2007). Techno-mathematical literacies in the workplace. A critical skills gap. In *Teaching and Learning – Research Briefing*. www.tlrp.org
- Keogh, J. (2013). *Looking at the Workplace through Mathematical Eyes*. (Ph.D. Thesis), Institute of Technology Tallaght Dublin, Ireland.
- Keogh, J., Maguire, T., & O'Donoghue, J. (2016). Re-Contextualising Mathematics for the Workplace. Paper presented at the 13th International Congress on Mathematics, Hamburg.
- Keogh, J., Maguire, T., & O'Donoghue, J. (2018). *Adults, mathematics and work: from research into practice*. Leiden, Boston: Brill, Sense.
- Maasz, J. (2005). A new view of mathematics will help mathematics teachers. *ALM International Journal*, 1(1), 6-18.
- QQI. (2012). National Framework of Qualifications. Retrieved from <http://www.nfq.ie/nfq/en/>
- Straesser, R. (2003). Mathematics at Work: Adults and Artefacts. In J. Maasz & W. Schloeglmann (Eds.) *Proceedings of the 10th International Conference on Adults Learning Mathematics (ALM)*. Ströbl, Austria.
- Wake, G., & Williams, J. (2007). Metaphors and models in translation between college and workplace mathematics. *Educational Studies in Mathematics*, 64(3), 345-371. <https://doi.org/10.1007/s10649-006-9040-6>
- Wedeg, T. (2010). People's Mathematics in Working Life: Why is it Invisible? *ALM International Journal*, 5(1), 89-97.

Linking Tool		Summary				
Site Code: A Job: 1.1 Warehouse Picker		Mathematics Domain				Non-Mathematics
Insert Job Description here		Pattern & Relationship	Quantity & Number	Space & Shape	Data handling & Chance	
instructed by work orders and guided by handheld scanner, retrieve files and documents that have been stored amongst 3 million other documents. Locations are identified by an 8 digit barcode, files by a further 8 digits.						
Boxes may also bear an owner provided identification number / barcode or text. Location codes are hierarchical by Building, Floor, Row, Bay and shelf. There are 3 buildings each with 3 or more floors, each floor has an access stairwell and is served by a centrally located goods lift. Each floor has up to 52 rows, each with 26 bays, each bay has a series of numbered columns of shelves on 3 levels, A,B and C at the top. Example LEV118J10C means that the building is LEV, on floor 1, row 18, bay J, column 10, top shelf. There are also Vaults and Data storage locations on some floors. Work orders are customer specific. There may be more than 1 work order for a customer. Customers are assigned to delivery routes. The scanner is a representation of the work orders that have been assigned to the picker. The information on the scanner is presented in the order of the location code. However, this does not inform the picker as to the most efficient way or picking, because it does not take into account the load at each location, its proximity to access and egress, the lift, openings in the rows (one in the middle and (sometimes) one at each end, nor does it take account of whether it is more efficient to complete all rows on one side before crossing to the other. When a file is not found, the picker will look for it as thoroughly as the time allows, giving rise to the NF category of CBA (couldn't be ar***d).						
Task no.						
1.1.010	Download Work Orders to Scanner in alphabetical sequence of the location code					ICT
1.1.011	Access Scanner Centre Ops software	√				ICT
1.1.012	Select Download option	√				ICT
1.1.013	Enter User Id			√		ICT
1.1.014	Place in download Cradle (or use wireless if available), ensuring that contact points meet to complete circuit			√		ICT
1.1.015	Complete operation and remove from cradle	√		√		ICT

Figure 1: Example of the output from using the linking tool

Numeracy practices in older age

Alina Redmer¹ and Anke Grotlüschen²

¹University of Hamburg, Faculty of Education, Hamburg, Germany; alina.redmer@uni-hamburg.de

²University of Hamburg, Faculty of Education, Hamburg, Germany; anke.grotlueschen@uni-hamburg.de

Demographic changes render basic skills important at an increasingly older age. Among them, skills in financial matters are becoming increasingly relevant. The skills measured in PIAAC and CiLL represent comprehensive cognitive abilities that can be seen as the basis for successful participation in social and economic life. In a secondary analysis, this paper shows that financial practices remain important for older people, although their numeracy skills proficiency appears to be lower than those of younger people. The analysis also indicates a gender difference in dealing with financial matters: men handle bills and bank statements, women manage the household.

Keywords: Numeracy, practices, older adults, PIAAC, large-scale assessment.

Introduction

As a result of demographic changes, it is becoming increasingly important to actively shape one's life in a longer post-employment period (Kruse 2008). Financial security and the ability to act have an ever-increasing importance in times of possible restrictions in income among the elderly. People who are low-skilled or whose employment biographies show gaps are more likely to be disadvantaged in this process (Wienberg & Czepek, 2011).

The question is whether the increased requirements become problematic due to higher financial burdens in older age, if they are accompanied by lower numeracy skills, or whether existing numeracy skills will prove to be sufficient. Instead of merely declaring a decrease of skills in relation to older age, the actual numeracy practices of people of higher age need to be more closely considered.

This article is dedicated to examine the numeracy skills of people of older age (66-80 years at the time of assessment) and their everyday numeracy practices. According to anthropologist Jean Lave (1988), mathematics is used in various situations in everyday life. This includes the comparison of prices, but also the calculation of costs and the household budget. PIAAC (Programme for the International Assessment of Adult Competencies) and CiLL (Competencies in Later Life) define numeracy as the ability to apply and interpret mathematical information and ideas to deal with different everyday situations (Zabal et al., 2013).

In this paper, data from the CiLL survey (Friebe, Schmidt-Hertha, & Tippelt, 2014) is used to compare numeracy practices of individuals aged 66 to 80 years with the practices of individuals aged 16 to 65 years as surveyed by PIAAC. The focus of the following secondary analysis is on practices (also referred to as skills-use variables) that provide information on how often numeracy skills are applied in the lives of older people.

Relevance of numeracy and financial skills in older age

Images of older age have changed in Germany in recent years (Vogel & Motel-Klingebiel, 2013). The boundaries indicating who belongs to the older adults may not simply be determined on the basis of the calendar age. However, since PIAAC looked at people up until the age of 65 and CiLL assessed participants in the ages of 66 to 80, the integral boundary between these two surveys is used as a proxy to distinguish adults and older adults. Older people are thus in this paper the over 65-year-olds.

Medical and technical developments make an ever-increasing lifespan possible, thus creating a longer post-employment phase of life (Mahne, Wolff, Simonson, & Tesch-Römer, 2017). The aspect of financial security plays an important role for a good way of living in this post-employment period. In Germany, income in retirement is mainly determined by the statutory pension as well as by assets and inheritances. Therefore, people whose employment biographies show gaps or who had had low incomes are disadvantaged and in danger of poverty in older age. In addition, this group of people often inherited less frequently and accumulated less assets during their employment period (Mahne, Wolff, Simonson, & Tesch-Römer, 2017). In this respect, the proportion of people who have to work after retirement has increased (Franke & Wetzels, 2017). This raises the questions about how older people can get along with limited financial resources. Increasing financial skills in older age will not entail an increase of funds or pensions, but can help to manage low income successfully.

Referring to older people, Kruse describes competence as skills and abilities of the human being (Kruse, 2018, p. 1193) that contribute to the preservation as well as to the possible restoration of an independent, self-responsible and meaningful life. For older people there maybe a reduced ability with regard to orientation in new problem situations and new learning, but there is the necessary skill to solve familiar problems and to expand existing knowledge systems into old age (Kruse, 2008). As a result, it can be assumed that basic mathematical skills also contribute to solving financial tasks in everyday life.

According to Geiger, Forgasz, & Goos (2015) the financial competence can be seen as an extension of numeracy that is expressed in numeracy practices. From this perspective, a financially literate person must have both the necessary knowledge to carry out financial transactions and plans and the ability and confidence to make financial decisions (Geiger, Goos, & Forgasz, 2015).

The results of the CiLL study show that the average everyday mathematical competence of the population between 66 and 80 years of age is 240 points (Knauber & Weiß, 2014). This corresponds to the lower third of competence level 2 and indicates that on average older people are capable of dealing with mathematical information embedded in everyday contexts, solving everyday mathematical tasks with little competing information and processing steps (Knauber & Weiß, 2014).

Nevertheless, in adult education research in Germany, financial literacy is discussed more frequently than numeracy. Mania and Tröster (2014) describe financial literacy as a sub-area that concerns the existentially basal and practical demands of everyday life and lifestyle in monetary matters (Mania & Tröster, 2014). They developed a competence model describing the requirements

for dealing with money at the level of basic education. The model covers six domains of basic financial education (income, money and payments, spending and buying, households, lending and borrowing, pensions and insurance). Thus they can make an important qualitative contribution to the discourse. Representative results in the field of financial literacy are still lacking. Our study refers to the numeracy aspect of financial literacy in order to explain the financial capacity of older people to act.

Research questions

Starting from a position that skills are complemented by practices, the focus of this contribution is on numeracy practices of older adults (66-80 years). Accordingly, the overarching question is how numeracy practices are used in older age and whether they help people to be financially capable.

In particular, the following questions are addressed:

- a) How do numeracy skills work with increasing age?
- b) How do numeracy practices work with increasing age?
- c) How do numeracy practices change according to gender at the ages of 66 to 80?

Methods

The data from the PIAAC survey and the supplementary survey CiLL can provide a differentiated picture of numeracy skills and practices for the German population. The representative survey PIAAC was initiated by the OECD, and it was conducted for the first time in 2011/2012 and reached a sample of 5,465 persons aged between 16 and 65 years in Germany. In addition to the survey of the domains literacy, numeracy and problem solving in technology-rich environments, questions on the use of skills were asked in an extensive questionnaire. The subsequent supplementary survey CiLL used the same background questionnaire and the skills were measured in the same way as in PIAAC. This enables a comparison of these two surveys (e.g. Schmidt-Hertha 2018). The representative sample of 1,339 persons aged between 66 and 80 years was conducted in Germany in 2012 (Friebe et al., 2014). In both surveys, twelve questions on work- and non-work-related practices were asked. We are looking at post-employment phases, only the questions that are not work-related are relevant for this research.

Numeracy skills for different birth cohorts

First, the numeracy skills for persons between 16 and 65 years and between 66 and 80 years were evaluated. It should be noted, that ages in PIAAC and CiLL are derived from the indicated birth year. Comparisons between age groups are therefore not statements on an individual decline in competence over the lifespan but statements on differences between groups in the birth cohorts. The mean skill values for numeracy indicate a decrease for both men and women for the older birth cohorts.

When comparing the data of the two birth cohorts 16 to 65 and 66 to 80 year olds, men in the older groups score almost 50 skill points lower and women almost 60. For both groups these are differences equivalent to one whole skill level (men level 3 to level 2; women level 2 to level 1) and indicate that women on average tend to do the simplest calculations. The differences may point to

an historical effect, especially for the oldest cohort. Those who are born between 1931 and 1936 often have had interrupted educational careers and different social and cultural expectations to those of the younger cohort.

The average skill value of the entire CiLL cohort (66-80 years) is 240 points, which is below the average skill value of the entire PIAAC cohort (16-65 years) of 272 points.

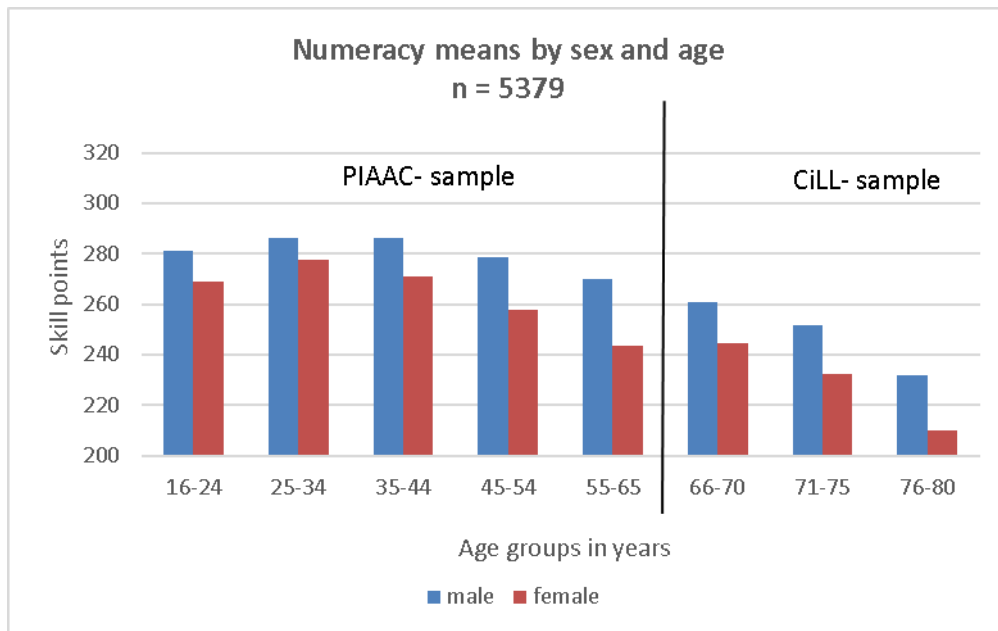


Figure 1: Numeracy skills average for the PIAAC Germany (N=5,379) and CiLL (N=1,338) samples compared

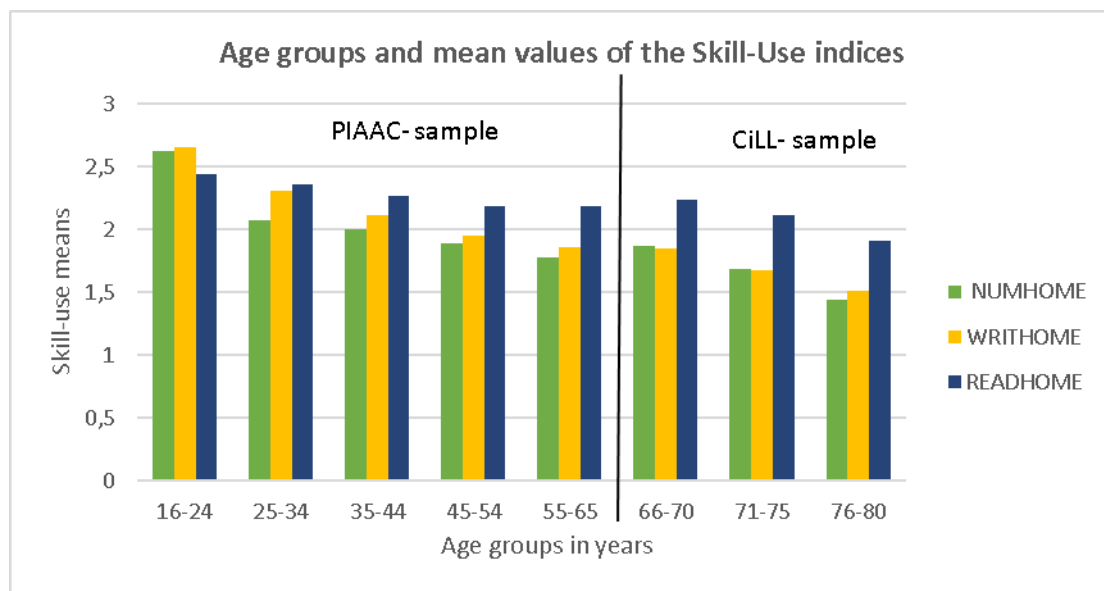


Figure 2: Average of skills-use variables for the German PIAAC (N >5,000) and CiLL (N >1,200) sample comparison

The next step is to check how the skills-use variables (indices) of the two samples differ. In order to assess how the practices are used in general, the analysis took into account the skills-use variables

of literacy skills (frequency of reading and writing in everyday life). For all everyday practices, a decreasing frequency of use across age groups can be observed (see Figure 2). However, this development is not comparable to the skills variable described above. For numeracy, there is a small increase in the average frequency of use from the 55-65 age group to the 66-70 age group.

Numeracy practices in older age

Based on practices to be considered in the context of the social and economic system, the variable H_Q03b (Calculation of prices, costs and budgets)¹ is divided by gender. There is a highly significant difference between men and women in the application of simple numeracy skills: 42.3% of men said they used calculation of prices, costs and budgets at least once a week or daily, while 58.8% of women gave the same answer (see Figure 3). 20.3% of men said they "never" used the practices. Among women, 16% said they "never" calculate prices, costs and budgets.

It shows overall both groups frequently used the practices, but women use them significantly (level of significance below 0.01) more than men do.

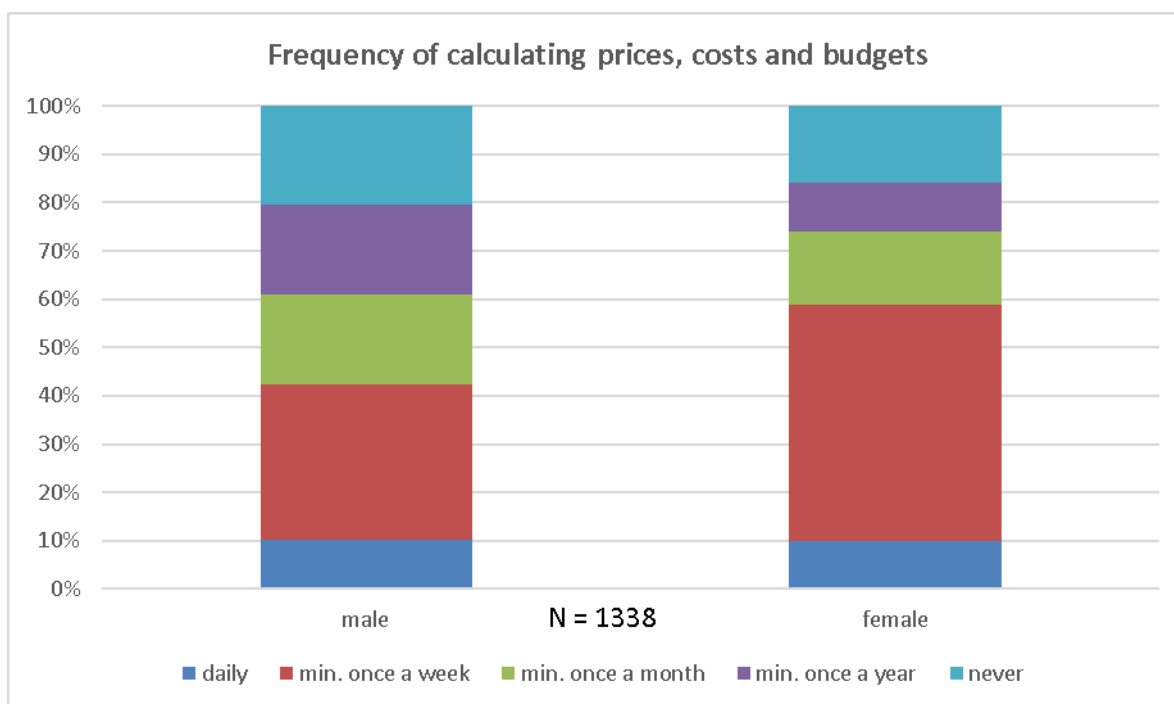


Figure 3: Frequency of calculating prices, costs and budgets by gender in the CiLL sample (N=1,338)

The variable that asks for the reading frequency of bills or bank statements (H_Q01g, see Figure 4)² reveals that men say they use this practice more frequently. 51.2% said they read bills or bank statements at least once a week, while 42.9% of women gave the same answer.

¹ Background questionnaire H_Q01b: "In your everyday life, how often do you normally calculate prices, costs or budgets?"

² Background questionnaire H_Q01g: "In your everyday life, how often do you usually read bills, bank statements or the similar?"

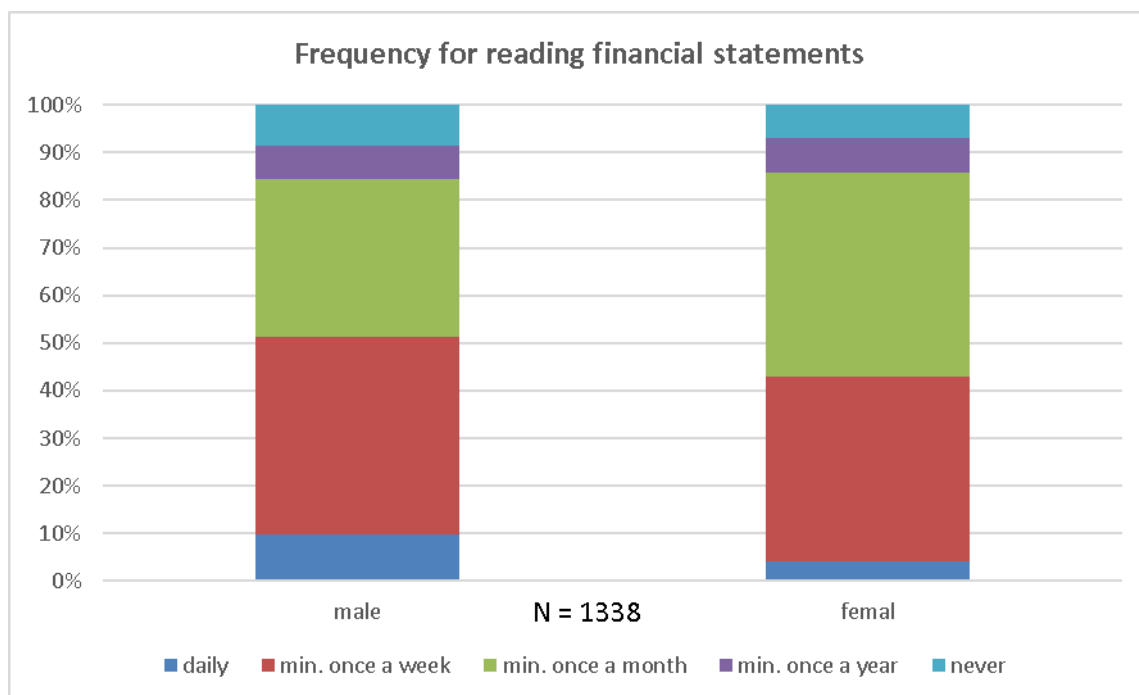


Figure 4: Frequency of reading bills and bank statements by gender in the CiLL sample (N=1,338)

Discussion

We see that the variables on the use of skills recorded in PIAAC and CiLL can provide some information on the frequency in which the skills required for financial decisions are applied.

a) How do numeracy skills work with increasing age?

Despite a lower average skill proficiency in older age groups, numeracy practices are still regularly used. This should enable them to act financially for themselves. After a peak in the age cohorts of 25 to 34 year-old women and 35 to 44 year-old men, the mean skill values are steadily declining. This finding reinforces the results on the course of numeracy skills in PIAAC (Maehler et al., 2013) and in CiLL (Knauber and Weiß 2014; Gebrande & Setzer, 2014), which have only been reported separately so far.

b) How do numeracy practices work with increasing age?

The comparison shows that the mean values of the skill-use indices for numeracy between the age groups 55 to 65 and 66 to 70 increase slightly. This could also indicate that the transition to the post-employment phase is accompanied by an increase in the use of numeracy practices. Such as dealing with pensions, paying of mortgages or applying for new state benefits.

Similar to reading and writing practices, a decrease in numeracy practices can be observed with increasing age, with reading overall remaining at a higher level. However, changes in skill-use remain marginal compared to the differences of skills.

c) How do numeracy practices behave according to gender between the ages of 66 and 80?

The index of numeracy practices, consisting of six questions, was further analysed, these included the handling of budgets and prices as well as the handling of decimal and percentage values, which

increased. Another variable is used from the index of reading practices, which concerns the reading of bills and bank statements. The results show that 58.8% of women perform simple calculations weekly to daily. Only 42.3% of men do this weekly or daily.

It can be assumed that women manage household budgets weekly and are apparently more often confronted with numeracy practices than men are. The handling of bank statements and bills per week less frequent for men in the 65 to 80 age group. It remains to be examined whether this distribution will change for in the now younger cohorts or whether it is essentially due to a still classical distribution of household chores (c.f. Hobler, Klenner, Pfahl, Sopp, & Wagner, 2017).

Overall, it can be seen that numeracy practices in the area of "calculating prices, costs and budgets" are still used at least once a week by about 42% of men and more than half of women (59%) despite their older age. Having lower skills could make these activities more difficult, but at the same time qualitative studies that this older age group also show a considerable range of numeracy practices (card games, mental arithmetic, payroll tax, photography/development, club treasury, cf. Knauber & Weiß, 2014).

Numeracy practices could guarantee self-confidence in everyday life and in socio-political judgements to a certain extent, because "being numerate is being critical" (Tout, 1997).

References

- Franke, J., & Wetzels, M. (2017). Länger zufrieden arbeiten? Qualität und Ausgestaltung von Erwerbstätigkeit in der zweiten Lebenshälfte. In K. Mahne, J. K. Wolff, & C. Tesch-Römer (Eds.), *Altern im Wandel: Zwei Jahrzehnte Deutscher Alterssurvey (DEAS)* (pp. 47–64). Wiesbaden, Germany: Springer VS.
- Friebe, J., Schmidt-Hertha, B., & Tippelt, R. (Eds.). (2014). *Kompetenzen im höheren Lebensalter: Ergebnisse der studie „Competencies in Later Life“ (CiLL)*. Bielefeld, Germany: W. Bertelsmann Verlag.
- Gebrande, J., & Setzer, B. (2014). Lesekompetenz. In J. Friebe, B. Schmidt-Hertha, & R. Tippelt (Eds.), *Kompetenzen im höheren Lebensalter: Ergebnisse der studie „Competencies in Later Life“ (CiLL)* (pp. 61–80). Bielefeld, Germany: W. Bertelsmann Verlag.
- Geiger, V., Forgasz, H., & Goos, M. (2015). A critical orientation to numeracy across the curriculum. *ZDM*, 47(4), 611–624.
- Geiger, V., Goos, M., & Forgasz, H. (2015). A rich interpretation of numeracy for the 21st century: A survey of the state of the field. *ZDM*, 47(4), 531–548.
- Hobler, D., Klenner, C., Pfahl, S., Sopp, P., & Wagner, A. (2017). *Wer leistet unbezahlte Arbeit? Hausarbeit, Kindererziehung und Pflege im Geschlechtervergleich*. Düsseldorf, Germany: Wirtschafts- und Sozialwissenschaftliches Institut (WSI).
- Knauber, C., & Weiß, C. (2014). Alltagsmathematische Kompetenz. In J. Friebe, B. Schmidt-Hertha, & R. Tippelt (Eds.), *Kompetenzen im höheren Lebensalter: Ergebnisse der studie „Competencies in Later Life“ (CiLL)* (pp. 81–98). Bielefeld, Germany: W. Bertelsmann Verlag.

- Kruse, A. (Ed.). (2008). *Weiterbildung in der zweiten Lebenshälfte: Multidisziplinäre Antworten auf Herausforderungen des demografischen Wandels*. Bielefeld, Germany: W. Bertelsmann Verlag.
- Kruse, A. (2018). Bildung und Erwachsenenbildung im Alter. In R. Tippelt & A. v. Hippel (Eds.), *Handbuch Erwachsenenbildung/Weiterbildung* (6th ed., Vol. 2, pp. 1189–1206). Wiesbaden, Germany: Springer VS.
- Maehler, D. B., Massing, N., Helmschrott, S., Rammstedt, B., Staudinger, U. M., & Wolf, C. (2013). Grundlegende Kompetenzen in verschiedenen Bevölkerungsgruppen. In B. Rammstedt (Ed.), *Grundlegende Kompetenzen Erwachsener im internationalen Vergleich: Ergebnisse von PIAAC 2012* (pp. 77–124). Münster, Germany: Waxmann.
- Mahne, K., Wolff, J. K., Simonson, J., & Tesch-Römer, C. (2017). Alter im Wandel: Zwei Jahrzehnte Deutscher Alterssurvey. In K. Mahne, J. K. Wolff, & C. Tesch-Römer (Eds.), *Altern im Wandel: Zwei Jahrzehnte Deutscher Alterssurvey (DEAS)* (pp. 11–28). Wiesbaden, Germany: Springer VS.
- Mania, E., & Tröster, M. (2014). Finanzielle Grundbildung - Ein Kompetenzmodell entsteht. *Hessische Blätter für Volksbildung*, 64(2), 136–145.
- Schmidt-Hertha, B. (2018). Kompetenzerwerb im Lebenslauf – Ergebnisse aus PIAAC und CiLL. In C. Hof & H. Rosenberg (Eds.), *Theorie und Empirie Lebenslangen Lernens. Lernen im Lebenslauf: Theoretische Perspektiven und empirische Zugänge* (pp. 121–139). Wiesbaden, Germany: Springer Fachmedien Wiesbaden.
- Tout, D. (1997). Some reflections on adult numeracy. In D. Coben (Ed.), *Adults Learning Maths-3: Proceedings of the Third International Conference of Adults Learning Maths* (pp. 13–15). London.
- Vogel, C., & Motel-Klingebiel, A. (2013). Die Rückkehr der Altersarmut? In C. Vogel & A. Motel-Klingebiel (Eds.), *Altern im sozialen Wandel: Die Rückkehr der Altersarmut?* (pp. 13–24). Wiesbaden, Germany: Springer VS.
- Wienberg, J., & Czepek, J. (2011). „Aktives Altern“ unter Vorbehalt: Ungleiche Teilhabechancen von der Wiege zur Bahre. *Magazin erwachsenenbildung.at*, 13(5), 2-9.
- Zabal, A., Martin, S., Klaukien, A., Rammstedt, B., Baumert, J., & Klieme, E. (2013). Grundlegende Kompetenzen der erwachsenen Bevölkerung in Deutschland im internationalen Vergleich. In B. Rammstedt (Ed.), *Grundlegende Kompetenzen Erwachsener im internationalen Vergleich: Ergebnisse von PIAAC 2012* (pp. 31–76). Münster, Germany: Waxmann.

How theories of language-responsive mathematics can inform teaching designs for vocational mathematics

Lena Wessel

University of Education Freiburg, Germany; lena.wessel@ph-freiburg.de

This paper gives an overview of an Erasmus+ project that aims at empirically identifying the potentials and challenges of language-responsive teaching designs for low-achieving students in vocational contexts by means of topic-specific design research. It delivers first insights into developing and experimenting with two teaching units (percentages and proportional reasoning) and summarizes the questions that come up when adapting design principles for language-responsive mathematics teaching for the teaching and learning of young adults in vocational education. The empirical investigations are carried out with young adult pre-apprentices in lower vocational education in Germany in the technical sector. These young adults are often low achievers in mathematics and often have only limited language proficiency in the language of instruction.

Keywords: Vocational education, language, percentages, scaffolding, design research.

Theoretical background for designing teaching-learning arrangements in vocational settings

Legitimization and justification for further developing mathematical literacy in vocational education to a certain degree, amongst others, lies in the utility of mathematics in the workplace. However, we can draw on empirical research gained in different vocational sectors showing that the workplace mathematical practices often differ from school mathematical practices (Noss, Hoyles, & Pozzi, 2000). With reference to Noss et al. (2000), LaCroix (2014) summarizes that

it is recognized that mathematics practices in the workplace are shaped by the immediate and practical requirements of workplace production; that is, getting particular tasks accomplished with ease and efficiency using resources at hand rather than the goals and norms of generality, formality, and internal consistency commonly associated with school mathematics. (LaCroix, 2014, p. 159)

These differences can serve as an important starting point for joint reflection in vocational mathematics classrooms so that the mathematics teaching and learning is meaningful for the students. When it comes to designing teaching and learning arrangements for mathematics in vocational education, a further important aspect, which can be perceived as a challenge as well as a resource, is the huge variety of vocational sectors in which students are accomplishing their vocational education and which lead to many differences in the way that students meet the mathematical demands, since the mathematical demands on the job are not only topic specific, but especially also vocation specific (for an overview of vocation-specific research see LaCroix, 2014, p. 159).

Many students are mathematically unprepared to face the demands of vocational education or vocational training (Hoyles, Noss, Kent, & Bakker, 2010). While mathematical literacy is important

for meeting these demands, PISA results for Germany show that 17.2 % of the middle school students cannot rely on sufficient mathematical competencies to continue education in an apprenticeship training position. As a consequence, many German students (mostly aged 16-22) continue schooling at vocational schools as pre-apprentices and enroll in classes to obtain a middle school degree.

Besides experiencing difficulties in test situations, students with low language proficiency experience difficulties in the learning situations themselves. This relates to the role of language as a learning medium in classrooms: Language in mathematics classrooms is at the same time a medium of knowledge transfer and discussion and a tool for thinking (*communicative* role of language vs. *epistemic* role of language, Pimm, 1987). Taking both roles of language into account, research in mathematics education repeatedly emphasizes the intertwinement of language and mathematical thinking for all students, but especially for students still acquiring the language of instruction (e.g., Moschkovich, 2015). As a consequence, current design research studies in primary and secondary mathematics education focus on developing and investigating content and language integrated instructional approaches for fostering students with low language proficiency (e.g. Prediger & Wessel, 2013). Theoretical and empirical approaches are pursued to postulate design principles for intertwining conceptual and language learning trajectories, while language unfolds into the different levels e.g. the lexical and discursive level of language (Pöhler & Prediger, 2015; Wessel & Erath, 2018).

With respect to vocational education, the importance of language proficiency for successfully meeting the demands of the workplace is also well recognized, especially from the perspective of general didactics and more general vocational pedagogy (compared to vocational *mathematics* education research) (Ziegler, 2016). Specific vocational language demands - such as the discursive demand of counseling situations in communication with customers - are identified. On the lexical level, challenges are often traced back to the specific vocabulary relevant and needed in a specific profession or vocational sector.

However, an analysis of language demands only 'on the job' is too restrictive and shortsighted, because students are already confronted with vocation-specific language demands in workplace-related mathematics teaching and learning situations. In mathematical learning processes, language plays an important role in an epistemic role for developing students' understanding of mathematical concepts. Thus, in intended learning trajectories in which linguistic and mathematical learning trajectories are intertwined also the vocation-specific language demands have to be taken into account.

When aiming at unfolding the relation of language, especially vocation-specific language and corresponding language demands, and mathematics embedded in workplace settings, one recognizes and has to admit an enormous complexity along with a lack of theoretical approaches to acknowledge this complexity. Thus, this research wants to contribute to theorizing the complex relation with respect to topic-specific vocabulary and discourse practices as learning opportunities for deeper mathematics learning.

Research and task design gap

Empirical research on language-responsive teaching and learning of mathematics for the primary and secondary school levels is still relatively young; however, important theoretical considerations by now are more than 30 years old (Pimm, 1987) and there is a constantly growing and consolidating theoretical foundation from mathematics education and linguistic theory to be drawn on in design research projects. At the same time, the practical realization of well-defined design principles in content and language integrated approaches is topic-specific (e.g. language for understanding *percentages* differs to a certain extent from language for *understanding functions*) and there is still a huge lack of research which aims at systematically specifying the topic-specific language demands for the different mathematical topics.

When it comes to vocational teaching and learning of mathematics, the aspect of language in vocational mathematics learning processes is at the moment not that much in focus as it is in primary and secondary mathematics education; however, aspects of language are implicitly touched due to the deep connection of language and the theoretical approaches (like webbing and boundary crossing) being pursued. Still, like language-responsive teaching designs are always topic-specific, recent insights into content and language integrated teaching can neither simply, nor entirely be transferred to vocational settings (just to mention age, previous experiences with mathematics in middle school, the often described very huge heterogeneity, the case of remedial learning, (mathematical) practices of and at the workplace, the many different vocational sectors etc. as a small selection of the changing surroundings that must be taken into account).

That is why there is an urgent need for empirical qualitative and quantitative research that carefully investigates the situative effects and potentials of language-responsive vocational mathematics teaching and learning. We hereby rely on the notion of language-responsiveness as mathematics teaching that accounts for and is sensitive to multiple languages (which, amongst others, can be conceptualized as different national languages, different language registers, or non-verbal semiotic means) in order to enhance deeper understanding of mathematics (sometimes different terms like “language-sensitive mathematics” or “content- and language integrated teaching” are used, see Wessel & Prediger, 2013 for further elaboration).

Research questions

For minimizing the above described design and research gap, in this paper vocational-specific resources and differences when extending the approach of language-responsive mathematics to vocational mathematics education are pursued. Thus, the paper aims at answering the following research question: Which differences can be identified when consolidated design principles for language-responsive mathematics teaching for middle school teaching are adapted to lower strands of vocational education?

Research context and methodological framework

The project “*Language for Mathematics in Vocational contexts*” is an Erasmus+ funded research project in which mathematics education researchers collaborate with teachers from vocational schools from Germany, the Netherlands, and Sweden. The team develops empirically consolidated

language-responsive mathematics teaching units for the mathematical fields ‘understanding percentages’, ‘proportional reasoning’, and ‘understanding diagrams and graphs’ for vocational education of pre-apprentices as well as professional development modules for mathematics teachers at vocational schools. For this paper, the focus will be on the classroom level. The developmental work on the classroom level concentrates on those strands of vocational education for young adults who are not yet in an apprenticeship training position, but aim at completion of a middle school degree. The mathematical foci were chosen because of their importance for the target group, and because the researchers already gained experiences with developing language-responsive teaching material for these topics in secondary school classrooms.

The young adults (16-22y) in the German part of the project often did not yet successfully develop the main mathematical concepts and are often not yet fully fluent in applying the main procedures which are in the fore of the middle school mathematics curriculum. Consequently, the teaching units take into account design principles for remedial learning. In addition to that, the young adults enrolled in these strands of vocational education also belong to the group of vulnerable students with respect to language proficiency.

The research is conducted in the methodological framework of topic-specific didactical design research (Prediger & Zwetzscher, 2013) in which the analysis of teaching-learning processes takes place in carefully designed teaching experiments. Design experiments are considered the methodological core of design research studies as they allow in-depth investigations of learning *processes* rather than only learning *outcomes* (Gravemeijer & Cobb 2006). They serve as means of data gathering for qualitative in-depth analyses of the young adults’ learning processes.

The design experiments are video-taped and conducted in small-group or partner design experiments as well as whole-class teaching experiments. The video data is analyzed qualitatively with well-proven language activation categories of our previous research which is combined with inductive development of categories. All whole-class teaching experiments are carefully planned in each national team of researchers and teachers, e.g. in the here reported German team of two mathematics education researchers and seven teachers from three partner vocational schools. Furthermore, the researchers draw on classroom observations and field notes from all whole-class teaching experiments and subsequent discussions on what works well and does not work well.

Throughout the project and for the different mathematical topics being investigated, specifying and structuring the learning trajectories differs due to the different disposability of previous research. In the first year (Sept. 2017 - Sept. 2018) and for the teaching unit ‘percentages’, the developmental work relies on a consolidated intertwining of conceptual and lexical-discursive learning opportunities (Pöhler & Prediger, 2015; Pöhler, 2018) for middle school teaching that is being adapted. The following results and conclusions for the raised research questions rely on the adaptation process of the teaching unit ‘percentages’ and draw on teachers’ and researchers’ observations and field notes from six vocational classes in which the adaptations of the teaching unit have been used in the academic school year 2017/18. The teaching unit was taught over 4-5 lessons of 90 min. each in each of the classes and video-data for at least one lesson per class was gathered.

First conclusions from adapting a language-responsive teaching unit

In order to understand the changes that have been identified as important when adapting a language-responsive teaching unit for vocational classes of a lower strand of vocational education, the next paragraph gives an overview of important design principles for language-responsive mathematics teaching and which have been realized in the teaching unit designed and empirically investigated by Pöhler (2018).

Design principles for language-responsive mathematics teaching and learning

Design principle “Macro-scaffolding by intertwining language and conceptual learning trajectories”. The general structure of intended language learning trajectories is well described in the principles of *macro-scaffolding*, namely from students’ everyday resources to academic and formal technical registers (Gibbons, 2002). For their developmental work, Pöhler and Prediger (2015) connect the level principle from *Realistic Mathematics Education* for conceptual learning trajectories with macro-scaffolding of language. According to the level principle, a hypothetical learning trajectory is to be sequenced over four levels of increasing deepness of understanding (from the situational level to the referential level, to the general level, to the formal level) (Gravemeijer, 1998).

Levels	Conceptual learning trajectory: Mathematical conceptions	Lexical learning trajectory through different vocabularies
Level 1: Informal thinking starting from students’ resources	Constructing meaning for percents by representing and estimating rates	Intuitive use of students’ resources in everyday register, no offer of new lexical means
Level 2: Informal strategies and meaning-related vocabulary	Developing informal strategies for determining rates, amounts and later bases	Establish basic meaning-related vocabulary in the academic school register for constructing meaning for rates, amounts, bases in context
Level 3: Procedures for standard problem types	Calculating amounts, rates and later bases	Introduce formal vocabulary in the technical register
Level 4: Extending the repertoire	Widening to other problem types: change and comparison	Enrich the basic meaning-related vocabulary to more complex problem types
Level 5: Identification of different problem types	Identifying problem types of (non-) standard problems (in diverse contexts)	Explicit use and training of formal and basic meaning-related vocabulary
Level 6: Flexible use of concepts and strategies	Cracking more complex context problems flexibly (in non-familiar contexts)	Introduce extended reading vocabulary for various non-familiar contexts

Figure 1: Combining conceptual and lexical learning trajectories – macro-scaffolding example for percentages (Pöhler & Prediger, 2015)

By intertwining the two dimensions of sequencing (conceptual dimension and lexical dimension), Pöhler and Prediger (2015) develop the dual learning trajectory towards understanding percentages depicted in Figure 1: The conceptual learning trajectory is sequenced in six steps starting from students’ resources in informal thinking to informal strategies, formal procedures and their flexible use. Each step requires other discourse practices and different vocabularies which are sequenced in the lexical learning trajectory (Fig. 1 on the right).

On the lexical learning trajectory, the teaching unit starts from the students’ individual language resources (level 1) and the basic meaning-related vocabulary. These lexical means from our vocabulary are especially important for explaining the meaning of concepts: meaning-related vocabulary grasps mathematical relations and meanings (e.g., *take away* for the meaning of subtraction). It usually belongs to the academic school register and should be introduced before

formal vocabulary (Wessel, 2015) (see level 3 where introduction of formal vocabulary begins). Empirical evidence has been given that this intertwinement can be effective for mathematics learning (Pöhler & Prediger, 2015).

For pursuing the research question “Which differences can be identified when consolidated design principles for language-responsive teaching for middle school teaching are adapted to lower strands of vocational education?”, the focus is put on the design principle *Macro-scaffolding by intertwining lexical and conceptual learning trajectories*. Figure 2 depicts the adapted combined learning trajectory for the teaching unit percentages for vocational education. Reasons for how the adaptations have been made are (amongst others) explained in the following.

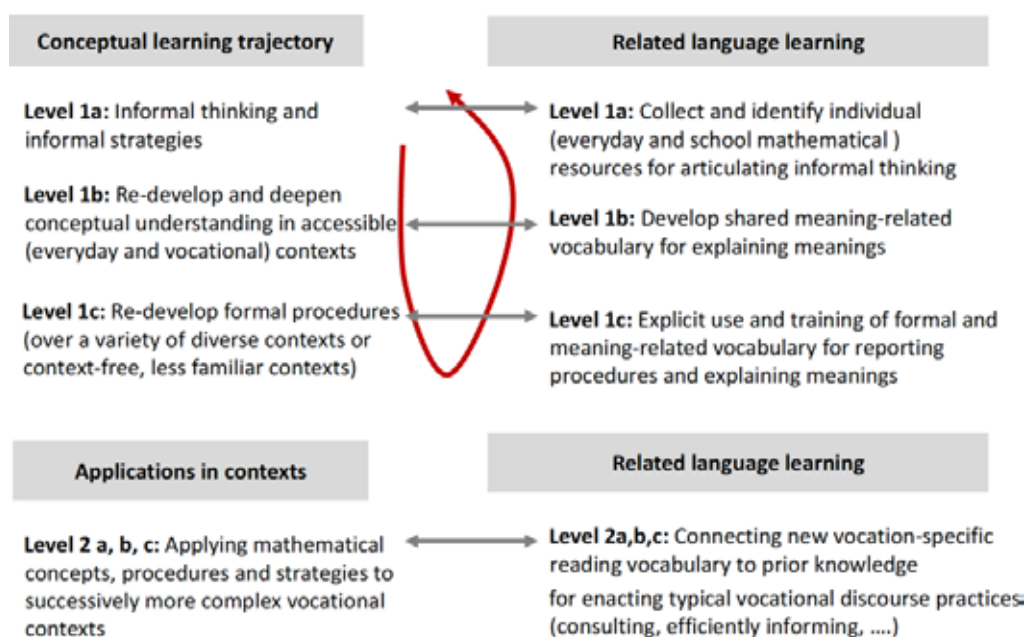


Figure 2: Adapted combined conceptual and lexical learning trajectory for workplace-related teaching and learning of percentages

In the case of lower vocational strands in which the research is conducted, teachers only have little teaching time for remedial learning of percentages and the young adults have prior knowledge from their middle school teaching. That is why the learning trajectory has been condensed to two levels in each dimension. The transition to workplace-related, vocational contexts is implemented in level 2, which means that on purpose the re-activation of understanding percentages happens in familiar, everyday contexts (shopping, downloads). Consistently, the vocation-specific language is accounted for on level 2 in the language learning trajectory.

Insights from teaching experiments with the adapted teaching unit and conclusions

When conducting and reflecting on the teaching experiments with the adapted percentages tasks, two main insights have been gained with respect to the design principle under investigation and task design.

Firstly, the young adults already know percentages, to some extent some calculation procedures, and percent-specific language like the formal (more technical) vocabulary, so that they can recall on

this knowledge. However, we experience many instances in which procedures are carried out without understanding, as well as instances in which the formal vocabulary is not filled with adequate meaning. As a consequence, the formal vocabulary can be used as starting point for raising students' awareness for the need to developing deeper conceptual understanding. Working on conceptual understanding of percentages builds on meaning-related vocabulary and reflecting on the different registers in carefully designed teaching activities. In a concrete task design, the vocational discursive demand of counseling was thus taken as a resource to initiate meta-reflections on language: In a language-responsive activity students are asked to translate a dialogue with customers given in very technical language into a more natural meaning-related form. We thus conclude that a further analysis of the authentic, vocation-specific discursive demands is promising, because they serve as meaningful situations to be drawn on in language-responsive teaching of workplace-related mathematics.

Secondly, it turned out that the levels 1a to 1c of the adapted learning trajectory in practical teaching are not realized as levels but resulted rather in a back- and forth between the three levels, both in the conceptual and in the language dimension. We hypothesize that this is also due to prior knowledge of percentages that the young adults have already acquired in their middle school mathematics. As a consequence, the question must be raised to which extent the design principle of sequenced learning trajectories is fruitful in those strands of vocational remedial education.

Outlook

The above empirical insights led to the question which further design principles are relevant to make language-responsive teaching work fruitfully at vocational level. At the moment, the project team is working on this question and implements for example the principle "Accounting for high heterogeneity without neglecting rich communication". Thus, we account for the so far often referred to different conditions of lower vocational education compared to general middle schooling. In a next step, further research is conducted to analyze the hypotheses and raised questions concerning the implemented design principles as well as to identify the potentials and effects of language-responsive teaching in vocational contexts.

Acknowledgment

The research project LaMaVoc ("Language for Mathematics in Vocational Contexts") is funded as an Erasmus+ grant by the National Agency BIBB from 2017-2020 (research grant KA202-004130). The author conducts this research together with Susanne Prediger, Patricia Epke, Monica Wijers, Vincent Jonker, Eva Noren and thanks them for their collaboration.

References

- Gibbons, P. (2002). *Scaffolding language, scaffolding learning: Teaching second language learners in the mainstream classroom*. Portsmouth, NH: Heinemann.
- Gravemeijer, K. (1998). Developmental research as a research method. In J. Kilpatrick & A. Sierpinska (Eds.), *What is research in mathematics education and what are its results?* (pp. 277–295). Dordrecht, Netherlands: Kluwer.

- Gravemeijer, K. & Cobb, P. (2006). Design research from a learning design perspective. In J. v. d. Akker, K. Gravemeijer, S. McKenney, & N. Nieveen (Eds.), *Educational design research* (pp. 17–51). London, England: Routledge.
- Hoyles, C., Noss, R., Kent, P., & Bakker, A. (2010). *Improving mathematics at work: The need for techno-mathematical literacies*. New York, NY: Routledge.
- LaCroix, L. (2014). Learning to see pipes mathematically: Preapprentices' mathematical activity in pipe trades training. *Educational Studies in Mathematics*, 86(2), 157-176.
- Moschkovich, J. N. (2015). Academic literacy in mathematics for English learners. *Journal of Mathematical Behavior*, 40, 43-62.
- Noss, R., Hoyles, C., & Pozzi, S. (2000). Working knowledge: Mathematics in use. In A. Bessot & D. Ridgway (Eds.), *Education for mathematics in the workplace* (pp. 17–36). Dordrecht, Netherlands: Kluwer.
- Pimm, D. (1987). *Speaking mathematically: Communication in mathematics classrooms*. London, England: Routledge.
- Pöhler, B. (2018). *Konzeptuelle und lexikalische Lernpfade und Lernwege zu Prozenten. Eine Entwicklungsforschungsstudie*. Wiesbaden, Germany: Springer.
- Pöhler, B., & Prediger, S. (2015). Intertwining lexical and conceptual learning trajectories: A design research study on dual macro-scaffolding towards percentages. *Eurasia Journal of Mathematics, Science & Technology Education*, 11(6), 1697-1722.
- Prediger, S., & Wessel, L. (2013). Fostering German-language learners' constructions of meanings for fractions - design and effects of a language- and mathematics-integrated intervention. *Mathematics Education Research Journal*, 25(3), 435-456.
- Prediger, S., & Zwetzschler, L. (2013). Topic-specific design research with a focus on learning processes: The case of understanding algebraic equivalence in grade 8. In T. Plomp & N. Nieveen (Eds.), *Educational design research: Illustrative cases*, (pp. 407–424). Enschede, Netherlands: SLO, Netherlands Institute for Curriculum Development.
- Wessel, L., & Erath, K. (2018). Theoretical frameworks for designing and analyzing language-responsive mathematics teaching-learning arrangements. *ZDM Mathematics Education Special Issue: Making frameworks for the study of language in mathematics education research visible*, 50(6), 1053-1064. <https://doi.org/10.1007/s11858-018-0980-y>
- Wessel, L. (2015): *Fach- und sprachintegrierte Förderung durch Darstellungsvernetzung und Scaffolding: Ein Entwicklungsforschungsprojekt zum Anteilbegriff*. Wiesbaden, Germany: Springer.
- Ziegler, B. (2016). Sprachliche Anforderungen im Beruf: Ein Ansatz zur Systematisierung. *Berufsbildung in Wissenschaft und Praxis*, 45(6), 9-13.

TWG08: Affect and the teaching and learning of mathematics

Introduction to the work of TWG 8: Affect and the teaching and learning of mathematics

Stanislaw Schukajlow¹ (Chair), Inés M^a Gómez-Chacón², Çiğdem Haser³, Peter Liljedahl⁴, Karen Skilling⁵ and Hanna Viitala⁶

¹University of Münster, Germany; schukajlow@uni-muenster.de

²Universidad Complutense de Madrid, Spain; igomezchacon@mat.ucm.es

³University of Turku, Finland; cigdem.haser@utu.fi

⁴Simon Fraser University, Canada; liljedahl@sfu.ca

⁵King's College London, School of Education, UK; karen.skilling@kcl.ac.uk

⁶Luleå University of Technology, Sweden; hanna.viitala.edu@gmail.com

Introduction

In this chapter, we would like to introduce discussions about the affective constructs and their relation to teaching and learning of mathematics. Before the conference, we agreed to change the title of TWG from “Affect and mathematical thinking” to “Affect and teaching and learning of mathematics”. The new title of the group better reflects the broad scope of research that we welcome in our group. All types of affective constructs that emerges in relation to both *learning* and *teaching* of mathematics could be represented and discussed in the working group during the conference.

The number of submissions and participants confirmed the interest of mathematics education researchers in affect. In total 26 papers and 3 posters were submitted to our group, with 24 papers and 2 posters were accepted for presentation, and 23 papers and 2 posters accepted for publication in these conference proceedings. Our group included presentations from Canada, Israel and different European countries. Participation of researchers from 15 countries (including 13 newcomers) reflected the spirit of inclusion that is traditional for this group that has been discussing affect in mathematics education in recent years.

We started our work with an introductory, ice-breaking activity and a reflection of the work done in previous conferences. This year we decided to considerably increase the time for discussions of each paper and structured the paper and poster presentations and discussions in a new way. After a short presentation (7 min) and clarifying questions (3 min) of papers that we scheduled within each session, authors of presentations discussed their research (30 – 40 min) with other group members in small groups. Participants could decide which paper or poster they would like to join for discussion. We assigned contributions to the sessions in groupings related to: affect; emotions; identity; beliefs; and motivation or attitudes/engagement. At the end of each session, we shared our thoughts about these topics with the whole group. In the final session, we discussed new perspectives on affect and related constructs that emerged during our work.

Reflection on prior research in affect

Peter Liljedahl presented a comprehensive overview of the work that has been done during the past CERME conferences. Çiğdem Haser and Stanislaw Schukajlow picked up and elaborated on this

overview during the presentation of the report about the work of the TWG8. The starting point for systematic research on affect in mathematics education is usually a review paper by McLeod (1992). In his seminal work, the author introduced an influential taxonomy of affect. According to this taxonomy, affective constructs can be assigned to different points on the line that ranges between beliefs through attitudes to emotions. Beliefs were proposed to be most stable, less affective and most cognitive, whereas emotions were noted as less stable, most affective and less cognitive.

In the last decades, researchers underlined repeatedly that the complexity of affect requires elaborating the taxonomy proposed by McLeod. For example, Hannula (2012) analyzed research in mathematics education and suggested a need to distinguish between three dimensions as common foundations for a theoretical framework. These included: cognitive, motivational and affective dimensions; unstable states and stable traits; and social, psychological or physiological nature of affect.

Recently, object of the affect (affect about life, learning, problem solving or strategy use), subject (teacher or students) or valence (positive or negative) were suggested to be important for research on affect (Schukajlow, Rakoczy, & Pekrun, 2017). Further, the theoretical approach (acquisitionist or participationist) play an important role. Affective constructs that were explicitly anchored in the taxonomy by McLeod were investigated and new dimensions were proposed. For example, teacher beliefs about the nature of mathematics and their relation to learning can be assigned to beliefs about nature of mathematics, beliefs about mathematics teaching and beliefs about mathematics learning (Beswick, 2012). Teacher beliefs build a so-called belief system that start its development in the school years, changes in university years and is shaped based on the practical experience encountered by in-service teachers.

An important point raised in prior discussions related to the definitions used for characterization of affective constructs. As affective constructs are seen as complex phenomena the definitions of particular constructs often overlap with other affective constructs and are criticized as being circular. For example, emotions are defined as phenomena that included cognitive, affective, motivational, physiological and expressive parts. Affect and motivation are used in this definition thus for characterization and grounding of emotions.

Finally, reciprocal relationships between affective constructs and students' achievement is acknowledged and are crucial for understanding the role of the affect in teaching and learning. Most of the studies in the TWG8 targeted affect and implied problems with affective constructs as a reason for difficulties in teaching and learning. However, another perspective is also valuable, whereby students' or teachers' affective problems while learning or teaching might result from problematic achievements in the past.

Contributions in the TWG8

In this section, we would like to present the papers that we included in these proceeding. Gómez-Chacón and Barbero investigated students' perception of backwards strategy in problem solving. Forbes et al. analyzed students' mindsets and its relation to self-confidence in programming. A low achiever's mathematical thinking was analyzed by Viitala in a case study.

Alcantara et al. explored students' failure experience and identified emotions hopeless, shame, frustration and fear. Relation between anxiety about generating drawings and students' gender, strategical and cognitive factors was analyzed by Schukajlow et al. Lake reported on the study that investigated how data about emotional state can be used during reflection on teachers practice.

An instrument for measurement of students' identity was developed and applied by O'Reilly et al. Narratives on student identity within a social-cultural environment were explored by Ben-Dor and Heyd-Metzuyanim. Howard et al. applied thematic topic analysis for research on students' identity and its relation to mathematics in higher education.

Figueiredo and Guimarães carried out a study on learning styles and their relation to performance. Van Hove et al. investigated students' mindset. An analysis of questionnaires for students' self-concept of mathematics in school and university was presented in the contribution by Rach et al. Westerhout et al. analyzed the effect of the project about game programming. The development and evaluation of the general and domain-specific scales for self-concept and interest were analyzed by Sproesser et al.

First-person vicarious experiences was found to be crucial for the change of beliefs by Rouleau et al. Pantziara et al. presented a study on validity of the scale about teachers' epistemic beliefs. Wiik and Vos reported on the study about reasons of choosing advanced mathematics courses in secondary school. Using metaphors for exploring pre-service teachers' beliefs was analyzed by Haser. Liljedahl presented an analysis of master and doctoral students' beliefs about research (Liljedahl, 2018).

Engagement in students' interactive storytelling and its impact on attitudes were explored in the contribution by Pierry et al. Novotna analyzed private supplementary tutoring and its relation to students' attitudes. Different levels of engagement (high and low) were distinguished in students with the same achievement level in the study by Skilling. Haataja et al. demonstrated that gazes at teachers' and at students' faces differed in small- and whole-group instructions. Kourty analyzed cognitive, behavioral and affective aspects of engagement in inquiry-based learning.

In posters, Hansen discussed collaborative processes while solving problems and Barton introduced a study on self-made tutorials.

Evolution of the TWG

The overall quality of the submitted contributions increased and this resulted in acceptance of nearly all papers and posters for presentation at the conference. Contributions investigated affective measures of different subjects: primary and secondary school students, pre- and in-service teachers and doctoral students. Most of the researchers applied qualitative analysis and performed case studies, in order to answer their research questions. Thus, the distribution of submissions followed the general trend toward the dominating role of qualitative studies in research on affect (Schukajlow et al., 2017). One reason for this trend might be the efforts of researchers to capture the whole complexity of the affective phenomena and analyze it in relation to cognitive and strategical behavior. In our discussions about methodological issues, we pointed out that even researchers who applied qualitative methods should be aware that they can get only one "slice" of phenomena, even though it is usually more rich than in quantitative studies. On the other hand, researchers who applied quantitative analysis often

pretend to produce objective and valid results. In this type of analysis, limitations concerning operationalization and generalizing should be carefully addressed. The choice of research method should be derived not by general preferences of what is the “right” or “wrong” type of analysis, but by research questions that the researcher is interested in.

A new trend in the group was the appearance of several papers on identity. In their studies, researchers reported on how they assess identity and tried to understand this complex phenomenon. Assessment and theoretical background seem to be closely related to each other in research on identity. New theoretical approaches, such as theory of mindsets and theory of identity appeared in the papers this year. Further, we had again contributions that referred to psychological theories such as control-value theory of achievements emotions, theory of self-concept and other theories. Most of the studies investigated students affective state reflecting researchers’ interest in what is going on during learning. The new object of affective construct, emotions and perceptions regarding strategies used during problem solving, appeared for the first time in our group. Another trend is an investigation of the affect in learning environments that included programming as part of the treatment.

During our general discussion, Liljedahl summarized by using the scheme for assessment categories in research on affect (Table 1). Studies can address individuals or social variables (subject) within social or individual context. For example, if researchers investigated beliefs of individuals during group work, the subject is the individual and context is social.

		Subject	
		social	individual
Context	social		
	individual		

Table 1: Assessment categories in research on affect

References

- Beswick, K. (2012). Teachers' beliefs about school mathematics and mathematicians' mathematics and their relationship to practice. *Educational Studies in Mathematics*, 79(1), 127–147.
- Hannula, M. S. (2012). Exploring new dimensions of mathematics-related affect: embodied and social theories. *Research in Mathematics Education*, 14(2), 137-161.
- Liljedahl, P. (2018). Mathematics Education Graduate Students’ Thoughts About Becoming Researchers. *Canadian Journal of Science, Mathematics and Technology Education*, 18, 42–57.
- McLeod, D. B. (1992). Research on affect in mathematics education: A reconceptualization. In D. A. Grouws (Ed.), *Handbook of Research on Mathematics, Teaching and Learning* (pp. 575–596). New York: Macmillan.
- Schukajlow, S., Rakoczy, K., & Pekrun, R. (2017). Emotions and motivation in mathematics education: theoretical considerations and empirical contributions. *ZDM Mathematics Education*, 49(3), 307–322.

Verbal expression of emotions as entry points to examine failure experiences in secondary mathematics: A preliminary study

Lucy Alcântara¹, Nélia Amado² and Susana Carreira²

¹Instituto Federal do Mato Grosso – Campus de Primavera do Leste, Brazil;

lucy.alcantara@pdl.ifmt.edu.br

²University of Algarve & UIDEF – Institute of Education, University of Lisbon, Portugal;

namado@ualg.pt; scarrei@ualg.pt

The article draws on preliminary results from a qualitative exploratory study on the emotions reported by students in relation to their experiences of school failure, particularly in mathematics. The research involves students at risk of failure in mathematics attending vocational secondary education in Brazil. As a theoretical approach, the attribution theory is interrelated with theory development in the study of emotions in mathematics education. When considering the hypothesis of distinguishing factors of failure between facilitators and inhibitors, we have identified in the students' verbal expressions several negative emotions that are tied to objects, agents and events of: the mathematics class, the mathematics as a discipline, and the mathematics assessment.

Keywords: Students' emotions, attributions, school failure, vocational education

Introduction

In Brazil, the Federal Institutes (FIs) offer young people a three-year training course that has the dual function of obtaining a professional qualification and simultaneously completing secondary education. The annual curriculum of vocational courses consists on average of seventeen subjects, twelve of them being part of the common national basis and five of a technical nature, totalling, on average, 36 classes per week. From the first year on, mathematics plays a central role, both because it is a subject of the secondary education common core and because it is strongly applied in the various technical disciplines. Although the FIs are generally viewed as schools that offer a quality education and contribute to better opportunities of access to an undergraduate course, the high failure rate in this subject results in a high dropout rate in this particular schooling system.

As part of a strategy for increasing the indices of permanence and success of the students in the IFs, the identification of students at risk became a priority. This entails knowing more about them, not only at the cognitive level, but also at the affective one, particularly with respect to mathematics.

Many studies have shown that school failure is not only due to cognitive aspects; the affective ones also play a very important role in the students' learning (Evans, Morgan, & Tsatsaroni, 2006). With this study we aim to understand how vocational secondary students experience situations of failure and poor achievement in mathematics that put them at risk of retention and/or evasion. Thus, the research has a focus on the student individual history with the discipline through capturing experiences failure in mathematics from an emotional point of view.

Theoretical background

Research on the causes of school failure has a long history and has evolved through the contributions of various areas of knowledge given its complexity and multidimensionality. Broadly put, one may say that at least the cognitive (e.g. Rösken, Hannula, Pehkonen, Kaasila & Laine, 2007), the affective (e.g. Gomez-Chacón, 2003; Di Martino & Zan, 2013), and the socio-cultural perspectives (e.g. Lerman & Tsatsaroni, 1998; Heyd-Metzuyanim, 2013) have been called for the understanding of school failure.

There are two major ways of conceptualizing school failure, which imply different approaches to its study. Seen as a product, failure is the result of a judgment made by the agents of the educational system on the distance of the students in relation to the prevailing norms of school excellence. Those who meet the standards and advance in grades-based and retention-based courses will be successful. Failure, in turn, is determined by the poor academic performance of the students, who for various reasons are not been able to reach the competencies expected in a given period of time. Seen as a process, critical moments of developing failure involve low achievement, retention, school avoidance and dropout, and non-adaptation to the workplace (Dupéré et al. 2015).

School failure can be analyzed through deterministic variables and, in that case, it is described by disapproval, retention, and dropout in quantitative terms; it can also be approached through individual and social events that are more difficult to capture and in, that case, it is expressed in qualitative terms, such as individual frustrations, inadequate preparation, and alienation from democratic participation. Many symptoms of failure, which are usually veiled and not quantified, but constitutive of school failure (Nardi & Steward, 2003) are revealed in particular ways, such as: the student does not feel she/he belongs in school and does not like the school, refuses the pedagogical relationship, is aggressive and disengaged, and alienates from the school environment.

Attributional dimensions in students' failure

Attribution theory is one of the well-known approaches to the study of the causes of school failure. It is based on getting individuals' perceptions about the factors that best explain the situations they live in and the states they go through. Studies aimed at determining the causal attributions of academic failure are abundant, both in the field of cognitive psychology and in the various domains of education (Almeida, Miranda, & Guisande, 2008).

Most of the studies carried out under this perspective assume that students are able to produce a conceptual framework that explains the causes of their results and, in particular, their failures in school. Moreover, this implicit theory can be seen as composed of unitary causes that are organized according to dimensions, which can be seen as the critical causes of academic performance.

Drawing on the work of Weiner (1985), causal attributions can fit into three commonly accepted global categories: internal and external causes (i.e. inside and outside the person); stable and unstable causes (i.e. remaining relatively constant or changing over time); and, finally, controllable and uncontrollable causes (i.e. under control or out of control of the will of the subject). More recently, Forsyth, Story, Kelley & McMillan (2009) have reexamined and reframed some of the findings of previous research studies by using a phenomenological approach. They asked college students right

after receiving their grades in a course exam about the factors that led them to get the grade they did. The researchers hypothesized that the causes would be structured in a hierarchical fashion but admitted that, as other studies have shown, some might not be mutually exclusive. The results show that the causes of failure emerged from a practical thinking that renders two broad categories: facilitators and inhibitors of success. This suggested placing the causes of failure in predominantly one-dimensional terms, where the bad-good, or high-low polarity seems to fit within the range between facilitating factors and inhibiting factors. The following diagram (Figure 1) illustrates the condensed causal attributions, which may not be exclusively in one side of the scale.

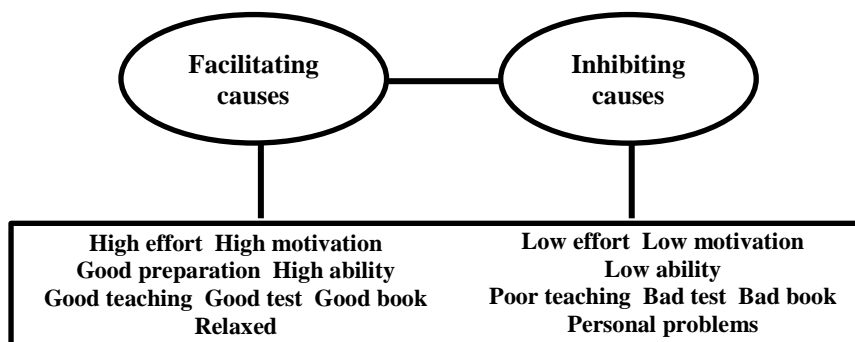


Figure 1: Model of attributions (adapted from Forsyth, Story, Kelley & McMillan, 2009)

According to the authors, several specific factors can be assigned to explaining failure; all those unitary causes are linked by a common attributional dimension: inhibitory factors.

Attributional thought can thus be considered to be a special case of a hierarchically organized schema, with a small number of global factors or dimensions subsuming a relatively greater number of more specific causal factors (Forsyth, Story, Kelley & McMillan (2009, p. 171).

Our research brings this theoretical view as a background and seeks to complement it with a theoretical view of emotion, according to which emotions or emotional states are expressible by individuals as ways of proposing their understanding of failure situations to others.

Emotions in students' interpretation of failure

Several researchers have already embraced the construct of emotion as a dynamic system, where emotion cannot be seen as either the origin or the end point of a causal relationship between affect and performance. In her work, Gomez-Chacón (2003) has discussed the interplay between affect and learning as a cyclical process. On the one hand, the experience of learning mathematics provokes different reactions in the student and acts on his/her beliefs; on the other hand, sustained beliefs have a direct consequence on the student's behavior in learning situations and ability to learn. Similarly, in his review of the research literature linking emotions and mathematics, Xolocotzin (2017) has found some investment on the study of emotions as predictors and outcomes.

Di Martino and Zan (2011) have suggested a way of distinguishing emotions in terms of reactions to: i) Objects: a class of emotions that are linked to objects (attraction emotions) and refer to all variations of the affective reactions of liking and disliking (like love and hate); ii) Events: a class of affective reactions that relate to being pleased and displeased, consistent with the perceived consequences of an event as being desirable or undesirable (like joy, hope, fear) and, iii) Agents: a class of affective

reactions of approving and disapproving (like shame, admiration, reproach). These three kinds of emotions also differ with respect to the factors that influence them: attraction emotions are influenced by the subject's tastes; affective reactions of being pleased and displeased are influenced by the subject's goals; and affective reactions of approving and disapproving are influenced by the subject's beliefs and values.

Based on these theoretical assumptions, our research aim is to understand the emotions revealed by students in a situation of failure and how these emotions connect with the causes that they attribute to their failure.

Methodological considerations

Given the subjectivity of emotions, in this preliminary study, we chose to give the students the opportunity to speak about what they consider decisive in their own experience of failure and poor achievement in mathematics, through a focus group interview. The qualitative study of emotions requires instruments consistent with an interpretative approach, capable of capturing students' emotions (Di Martino & Zan, 2013). Although revealing emotions when in a situation of failure may be difficult to individuals, we believe that a conversation among several students having failure in common may be a facilitator element, as also suggested by Martínez-Sierra (2015).

The conversation sought, in a first phase, to know the reasons that led the students to choose the courses they attended and their perspectives for the future. Next, we sought to hear the students about their relationship with mathematics throughout their schooling and, in particular, on their first year at the IFMT. Another leading question was: What emotions do you experience about mathematics and how are they affecting your relationship with other disciplines? This issue led students to talk about their emotions they experienced, namely during classes and assessment situations. Finally, the students were invited to comment on the remedial opportunities at the IFMT.

The group included 13 students (7 females and 6 males) who attended the first year of a vocational course at the Instituto Federal do Mato Grosso (IFMT) and are at risk of retention and/or evasion. The students accepted to participate in the focus group that took place after the academic activities and lasted approximately 1 hour. Their parents were previously informed of this interview, as part of the ongoing research, and consent forms were obtained, by guaranteeing anonymity and confidentiality of the data. The interview was conducted by the first author and audio-recorded.

Due to space limitations, we selected the voices of four students whose reports allow a sufficient reduction of the data in order to illustrate the emotions shared by the group during the initial conversation. From the data, we extracted some key elements that allow a brief presentation and characterization of those four subjects, as follows.

Ana is 15 years old; she is very talkative and effusive. She looks for all the help that is offered by the IFMT. Ana intends to take a higher degree. Carlos is 17 years old, is very shy and rarely interacts with the other classmates. He is repeating the 1st year and is still failing in most subjects. Amanda is 15 years old and reserved. She reveals some difficulties but not always attends the remedial classes. Bruna is 15, a very shy student but always with a smile. Her father supports her choice of electro-mechanics. She believes that her future will improve from studying at the IFMT.

The data analysis followed an interpretative process of content analysis based on two combined targets: i) Students' verbalised emotions in referring to failure; and ii) Verbalised indicators of causal attributions, linked to such emotions. Such indicators were later condensed and labelled as instances of inhibiting factors (emphasized in italics below).

Results

Emotions related to the mathematics class

The mathematics class was shown to be a source of events generating various emotions. For these students mathematics classes are monotonous and boring. The classroom environment is described as uninspiring and conducive to deprived concentration, inattention, and disinterest for the learning of mathematics. Boredom is one of the emotions portrayed in students' words. It is related to *poor teaching*, *bad atmosphere*, and *high confusion*. Boredom is linked to failing in following the class and in understanding the lesson and to feeling lost. As such, hopelessness is also an emotion that arises from their words.

- Ana: Boring! Always! Somehow monotonous, it's always: going to school, sitting down, listening to the teacher talking, working out some activities.
- Carlos: Everything distracts me. The mess in the classroom... Last year, for example... I did not understand anything.
- Carlos: When the teacher is explaining, my head is flying ... We feel that a lesson is boring when we cannot reason correctly.
- Ana: Then, you go to class... Like what he said, you can understand but at the same time, you cannot. It's like when you're reading a book, and your head for a millisecond flies... and then, you look at the book and think: What's this? Where did I stop? What was I reading?

Classes are also generating emotions related to agents. Schoolmates correspond to sources of shame and frustration for some students, who are in failure. Bruna reports that the classes generate displeasure, a fear of being censured, and shame for feeling inferior. The stare of her classmates is seen as reproachful by the student, who seems to value negatively her inability to understand what others apparently find easy. The student does not ask questions and gives up seeking support. Thus, she holds herself in silence and turns to the remedial classes for greater safety so as to be able to expose her difficulties, which she sees as a weakness of her. So, shame, frustration and fear are tied to *high censure* from classmates and to *low safety*.

- Bruna: I'm ashamed to ask. If I don't understand, I don't ask. Because at my side there are people who know, and if I say: 'Ah, Teacher, I didn't understand', they stare at me. So, I won't ask. The teacher is explaining and sometimes the teacher asks: 'Do you understand?' In my head, I think: 'No, I don't understand'. But, I say: 'Yes, I understood, Teacher'.
- Bruna: In the tutorial classes, I feel more at ease to ask the teacher what I can't understand.

Ana: Then you see your classmates talking, laughing... those little jokes: ah, you're smart, ah you're dumb... but you just couldn't understand... The teacher has explained a few times but people wouldn't be quiet! So, you couldn't pay attention.

Amanda: In my opinion, this is what happens: you have that hope, I mean, the teacher is explaining the content and then you think you'll understand it. Then he gives a task, he will present the resolution and... mine wasn't right. You get... like... discouraged.

The comments of schoolmates provoke reactions of shame and also of hurt because these students apparently feel that their schoolmates do not understand their difficulties. The comments made provoke humiliation that leads to a need of quieting them. Discouragement is another emotional reaction in these young people. After the hope of understanding a new content comes the disappointment for not being able to properly solve the task proposed. In brief, shame, frustration, fear and discouragement go hand in hand with *low sympathy* but also with *poor ability* in new tasks.

Emotions associated with mathematics

Regarding mathematics, the reactions of these students are ruled by dislike. They react to that as a more difficult discipline than the others and recognize the weight it has in the other areas of the technical component of their courses. Thus, another associated reaction that can be identified in relation to mathematics is stress and irritation.

Amanda: I don't like mathematics, but I try to do it.

Carlos: My experience with maths is a negative one. I got here but I don't know anything... I only failed in the fifth year and then here, in the first... I got here but knowing nothing. That's why it's hard! I'm trying hard!

The dislike of mathematics is linked to a perception of its difficulty. This seems to be revealed in the student's sense of a poor ability to learn it. They keep trying to overcome this obstacle but end up giving in to the conviction that they do not know and they must continue to strive. There is also a maladaptive feeling that transpires from the words of the students, who blame their lack of preparation before secondary school for the difficulties they face. Therefore, dislike, stress, and irritation are emotions related to *bad preparation*, *low ability*, and a *hard subject*.

Emotions associated with mathematics assessment

Finally, the evaluation tests in mathematics emerged as the triggers of various emotional reactions, notably nervousness in performing the tests and despair for not being able to think and recall.

Amanda: Every time I'm going to take any test, I get very nervous and I end up shuffling everything (...) it's very bad because it stops us to recall what we studied; we may have even learnt but at the time of the test it seems that there is a mind blank, so... And this year it seems to be getting worse because I get very nervous, it's because of the pressure of thinking that if you cannot recover you'll 'perish'...

Ana: And the day before a recovery test, I went to the teacher's tutoring and the teacher helped me and saw that I had learned the content. She said: 'your problem is that

you get nervous when you take the test'. When I take it, I forget all those easier things like plus and minus. In the test I'm really a child.

Bruna: I had always been a good student, but as soon as I entered the IFMT, I went down like a balloon. (...) now, here, if I take a test, I'm too nervous, I forget everything, even my name...

The tests seem to have to do with objects, with agents, and with events that arouse various emotions in these students. There are events that seem to reinforce the emotion of anxiety and nervousness, as the case of the teacher who confirms this same idea with Ana, the day before a test. On the other hand, the test itself is a disruptive factor because it is seen as a time when learning is compromised and becomes ineffective. The students describe themselves as apparently powerless and bewildered, and about to lose their identity and rationality. Moreover, the students refer to a particular object, the recovery test, as a threat because it means an ultimate opportunity that they feel they must not fail. So the fear of failing gets into action once again. To conclude, the fear, the nervousness and the hopelessness are involved in experiences of *personal disability*, *high pressure*, and *high threat*.

Final remarks

The study of failure often falls on cognitive aspects, with relatively little attention paid to the affective and socio-cultural aspects. As reported in the literature, affective aspects are usually veiled and not quantifiable, which makes it difficult to study. According to the theoretical assumptions adopted in this study, emotions are seen as reactions to different situations that students experience in their school journey. As factors inhibiting the success of these students, we can point out: i) mathematics classroom (poor teaching, bad environment, high censure, low safety, and high confusion); ii) relationship with mathematics (bad preparation, low ability, and a hard subject), and iv) mathematics assessment (personal disability, high pressure, and high threat) and those are linked to a set of negative emotions, namely: boredom, hopelessness, shame, frustration, fear, dislike, stress, irritation, nervousness. Some of those causes are stable and others unstable, and some are controllable and others are uncontrollable. Like previous studies, we acknowledge the interplay between affect and learning as a cyclical process. Moreover, our preliminary results indicate that emotions and failure are mutually reinforcing. In this sense, changes in various aspects of the classroom practices and socio-cultural norms may represent facilitating factors of success and generate more positive emotions; it is also likely that more positive emotions about mathematics itself and assessment practices can arise from breaking the logic of test-based retention. The next steps of our research will examine the link between emotions and critical events of failure and also of accomplishment, throughout a school year, by means of emotionally triggered narratives.

References

- Ahmed, W., van der Werf, G., Kuyper, H., & Minnaert, A. (2013). Emotions, Self-Regulated Learning, and Achievement in Mathematics: A Growth Curve Analysis. *Journal of Educational Psychology*, 105(1), 150–161
- Almeida, L. S., Miranda, L., & Guisande, M. A. (2008). Atribuições causais para o sucesso e fracasso escolares. *Estudos de Psicologia*, 25(2), 169–176.

- Di Martino, P., & Zan, R. (2011). Attitude towards mathematics: a bridge between beliefs and emotions. *ZDM – Mathematics Education*, 43, 471–482.
- Di Martino, P. & Zan, R. (2013). Where does fear of maths come from? Beyond the purely emotional. In B. Ubuz, C. Haser, & M. A. Mariotti (Eds.), *Proceedings of CERME 8*, (pp. 1309–1318). Antalya, Turkey: ERME.
- Dupéré, V., Leventhal, T., Dion, E., Crosnoe, R., Archambault, I., & Janosz, M. (2015). Stressors and Turning Points in High School and Dropout: A Stress Process, Life Course Framework. *Review of Educational Research*, 85(4), 591–629.
- Evans, J., Morgan, C., & Tsatsaroni, A. (2006). Discursive positioning and emotion in school mathematics practices. *Educational Studies in Mathematics*, 63(2), 209–226.
- Forsyth, D., Story, P., Kelley, K., & McMillan, J. (2009). What causes failures and success? Students' perceptions of their academic outcomes. *Social Psychology Education*, 12, 157–174.
- Gomez-Chacón, M. I. (2003). *Matemática emocional. Os afectos na aprendizagem matemática*. Porto Alegre, Brazil: ARTMED.
- Heyd-Metzuyanım, E. (2013). The co-construction of learning difficulties in mathematics – teacher-student interactions and their role in the development of a disabled mathematical identity. *Educational Studies in Mathematics*, 83, 341–368.
- Lerman, S. & Tsatsaroni, A. (1998). Why children fail and what mathematics education studies can do about it: The role of sociology. In P. Gates (Ed.), *Proceedings of the First International Conference on Mathematics, Education and Society (MEAS1)*, (pp. 26-33). Centre for the Study of Mathematics Education, University of Nottingham, UK.
- Martínez-Sierra, G. (2015). Students' emotional experiences in high school mathematics classroom. In K. Krainer & N. Vondrova (Eds.), *Proceedings of CERME 9*, (pp. 1181–1187). Prague, Czech Republic: ERME.
- Nardi, E. & Steward, S. (2003). Is Mathematics T.I.R.E.D? A Profile of Quiet Disaffection in the Secondary Mathematics Classroom. *British Educational Research Journal*, 29(3), 345–366.
- Rösken, B., Hannula, M., Pehkonen, E., Kaasila, R., & Laine, A. (2007). Identifying dimensions of students' view of mathematics. In D. Pitta-Pantazi & G. Philippou (Eds.), *Proceedings of CERME 5*, (pp. 349–358). Larnaca, Cyprus: ERME.
- Weiner, B. (1985). An attributional theory of achievement, motivation and emotion. *Psychological Review*, 92(4), 548–573.
- Xolocotzin, U. (2017). An Overview of the Growth and Trends of Current Research on Emotions and Mathematics. In U. Xolocotzin (Ed.), *Understanding Emotions in Mathematical Thinking and Learning*. Academic Press.

Learning geometry in self-made tutorials: the impact of producing mathematical videos on emotions, motivation and achievement in mathematical learning

Daniel Barton

Bielefeld University, Germany; daniel.barton@uni-bielefeld.de

Keywords: project, media, emotions, motivation, achievement.

Emotions, motivation and achievement in learning environments

Learning is a complex process, which is influenced by many parameters. “Emotions and motivation are important prerequisites, mediators, and outcomes of learning and achievement” (Schukajlow, Rakoczy & Pekrun, 2017, p. 307). Emotions, which are related to achievement activities and to success and failure outcomes, are achievement emotions (Pekrun, 2006). Accordingly emotions in school are achievement emotions, which effect students’ interest in contents or subjects and motivation to learn (Pekrun, 2006). Interest in mathematics, motivation and as a sequel of these factors a positive effect on grades and test scores can be emerged by positive activating emotions, such as enjoyment, during mathematic lessons (Murayama, Pekrun, Lichtenfeld, vom Hofe, 2013; Schukajlow & Rakoczy, 2016). It is assumed that achievement emotions are influenced by certain appraisals. In the control-value theory of achievement emotions, perceived control over and perceived value of achievement activities and outcomes are in particular relevant for the evocation of achievement emotions (Pekrun, 2006). “From an educational perspective, appraisals are important as well, since they can be assumed to mediate the impact of situational factors, and can be targeted by educational interventions intended to foster positive emotional development” (Pekrun, 2006, p. 317). To influence control, values and emotions positively Pekrun (2006) mentions important factors, like creating learning environments, which support autonomy and cooperation, giving cognitive quality instructions and inducting values, finding a performance-enhancing choice of tasks and fostering students’ self-regulation of emotions. The project, which is presented subsequent, is geared to these factors. It is assumed, that this modelling-related and applied learningconcept is based in a social and learning environment, which fosters students’ emotions, increases interest in mathematic and generates a learning effect on geometric basic competences.

The project

In the project students of a ninth grade (N=68) of a German high school produce in groups mathematical tutorials in the field of space geometry. After an introduction of the tasks and technical equipment, each group works self-contained. The project is conducted after the students already studied the topic of space geometry, so the students have experiences in this mathematical content. In the project it is being investigated whether and to which extent a learning effect and a positive impact on emotions and motivation can be achieved by the participation. First, the students analyze a geometric body. They describe the shape, name and explain the formulas of the surface and volume and put it into an example in the real world. The focus of this working phase is on the process-related competences of mathematical arguing, modeling, using mathematical representation and elements and the mathematical communication. Furthermore the groups develop a concept for the medial

implementation of the compiled mathematical content. Afterwards the groups present their findings and concepts. Thereafter each group starts filming and implementing their mathematical results into a medial setting. Finally the groups present their self-made tutorial. It is assumed that a high degree of individual value inheres in the project. The autonomous and cooperative working, like developing a creative concept, incorporating the mathematical content into this concept and presenting their tutorials and the integration of media reinforce this assumption (Ludwig, 2008). The project-setting constitutes a learning environment like Pekrun (2006) demands.

Research design

To determine the projects influence on stable emotions, motivation and interest in mathematics, a survey of the Project for the Analysis of Learning and Mathematics longitudinal study (Pekrun, Goetz, Jullien, Zirnbibl, vom Hofe & Blum, 2002) is used in a pre-, post- and follow-up scheme. The intrinsic motivation inventory (Deci & Ryan, 2000) is used for researching on unstable situational emotions while the project is processing. For investigating a learning effect of the project a self-developed pre-, post and follow-up test is used. The test is applied to the competence-oriented course of instruction of Nordrhein-Westfalen and comprises tasks on geometrics bodies like describing, reproducing, explaining, representation of mathematical content and appliance, working and solving complex mathematical issues. The evaluation of the findings is in progress.

References

- Deci, E. L., & Ryan, R. M. (2000). *Intrinsic motivation inventory*. Retrieved December 11, 2017, from <http://www.psych.rochester.edu/SDT/measures/intrins.html>
- Ludwig, M. (2008). Projekte im Aufwind. In B. Barzel, R. Bruder, A. Büchter, J. Heitzer, W. Herget, L. Holzäpfel, J. Roth, R. vom Hofe, & H.-G. Weigand (Hrsg.), *Mathematik Lehren, 149*, 4–9.
- Murayama, K., Pekrun, R., Lichtenfeld, S., & vom Hofe, R. (2013). Predicting long-term growth in students' mathematics achievement: The unique contributions of motivation and cognitive strategies. *Child Development, 84*(4), 1475–1490.
- Pekrun, R. (2006). The control-value theory of achievement emotions: Assumptions, corolaries, and implications for educational research and practice. *Educational Psychology Review, 18*, 315–341.
- Pekrun, R., Goetz, T., Jullien, S., Zirngibl, A, vom Hofe, R., & Blum, W. (2002). *Skalenhandbuch PALMA: I. Messzeitpunkt (5. Jahrgangsstufe)*. Universität München: Department Psychologie.
- Schukajlow, S., & Rakoczy, K. (2016). The power of emotions: Can enjoyment and boredom explain the impact of individual preconditions and teaching methods on interest and performance in mathematic? *Learning and Instruction, 44*, 117–127.
- Schukajlow, S., Rakoczy, K., & Pekrun, W. (2017). Emotions and motivation in mathematics education: Theoretical considerations and empirical contributions. *ZMD Mathematics Education, 49*(3), 307–322.

Adolescents' Endorsement of Narratives Regarding the Importance of Mathematics: A Dialogic Perspective

Naama Ben-Dor¹ and Einat Heyd-Metzuyanin²

Technion, Israel Institute of Technology, Israel; naamabd@gmail.com¹; einat.metz@gmail.com²

Sociocultural accounts of students' identity emphasize the endorsement of narratives about learning from "significant narrators". In contrast, psychological accounts highlight adolescences as a time of separation from parents and other authority figures. In this study, we attempt to reconcile these two views based on the Bakhtinian concepts of Authoritarian discourse and Internally Persuasive discourse. The study examined the mathematical identity narratives of five adolescents, 2nd generation to former Soviet Union immigrants in Israel, participating in a STEM afterschool activity. The findings focus on three students' endorsement of one narrative, "math is important", in both individual interviews and a focus group. The analysis showed that all participants endorsed the narrative and related it to their designated identities. However, participants differed in the level of endorsement of this narrative, ranging from 'full' endorsement to 'oppositional' endorsement.

Keywords: Sociocultural narratives, mathematics identity, adolescents, immigrants.

Rationale and Goal

In recent years, students' mathematical identities have attracted increasing attention (Darragh, 2016; Radovic, Black, Williams, & Salas, 2018). Many of these studies focus on adolescence as a critical time for the development of such mathematical identities (Black et al, 2010; Heyd-Metzuyanin, 2015). Yet historically, adolescence has been treated very differently by psychological and sociocultural (or sociological) accounts of human development. Sociocultural accounts, especially those leaning on structural sociological theories which theorize individuals as products of social structure, assume that the construction of identity narratives draws on narratives authored by "significant others" (e.g. Sfard & Prusak, 2005). In contrast, psychological theories highlight adolescence as a time where individuals construct their unique identity in separation from the adults around them (e.g. Blos, 1967). This disparity, between studies that point to adolescence as a time of separation vs. studies assuming the adoption of socioculturally based narratives into one's identity, invites a closer examination of the endorsement and separation processes of students' mathematical identity. Hence, this report aims to investigate this duality of endorsement and separation in the case of three adolescents who belong to a minority community of former Soviet Union immigrants in Israel.

Theoretical framework

The concept of identity has been notoriously ambiguous and difficult to define (Radovic et al., 2018; Sfard & Prusak, 2005). To answer this ambiguity, Sfard and Prusak (2005) suggested an operational definition of identity as "narratives about individuals that are reifying, endorsable and significant" (p. 16). They differentiated between actual (or current) identities, namely stories about the current state of affairs, and *designated identities* – stories of what is expected to be the case in the future, stating that learning resides in the gap between current and designated identities. Black and colleagues (2010) pointed to the importance of vocational aspirations and their connection to

mathematics in relation to adolescents' designated identities. Sfard and Prusak also distinguished between 1st person (1st P) identity stories (narrative told by the author about him/herself), 2nd P and 3rd P stories (narratives told by others about the protagonist, to him/her or to others respectively). They, as well as Heyd-Metzuyanim (2015), showed how 3rd P identity stories of significant narrators turn over time into 1st P identity stories.

Despite the operational clarity of Sfard and Prusak's (2005) definition, this definition is unclear regarding the status of narratives about mathematics and learning mathematics, such as "math is hard", "math is about calculations" or "math is important". Such narratives, often related to in the literature as "beliefs about mathematics", play a crucial role in shaping students' relationship with mathematics (Törner, 2014). For this matter, we incorporate into our conceptual framework Holland and her colleagues' (1998) concept of the *space of authorship*. Bakhtin (1981) suggested that a human being is always in a state of addressing different sociocultural voices and *authoring herself* and others. Holland and colleagues (1998) define this space of authorship as a "broad venue, where social languages meet, generically and accentually, semantically and indexically, freighted with the valences of power, position, and privilege" (p. 191). Drawing on these ideas, we conceptualize the *space of authoring mathematics identity* as a dynamic arena containing narratives relating to mathematics, learning mathematics and the person as a mathematics learner.

In order to reconcile the "endorsement vs. separation" conflict between psychological and sociological views of adolescence as a time of identity development, we draw on another Bakhtinian concept: the process of ideological becoming. Bakhtin (1981) conceptualized, from a discursive point of view, the process whereby individuals selectively assimilate others' words. This process begins, according to Bakhtin, with a separation between *authoritarian discourse and internally persuasive discourse*. Authoritarian discourse mostly belongs to parents, teachers, adults and other authoritative social figures. Bakhtin described this discourse as demanding unconditional allegiance and permitting no play with its borders, no arguing or dialogue. However, the words of others, according to Bakhtin, do not have to remain isolated and static; they can be internally persuasive and become "half-ours and half-someone else's" (p. 345). In this process the other's narratives are questioned and challenged. Morson (2004) defined these dialogically tested narratives as *internally persuasive*. Our research question in this study was thus: to what extent are adolescent students' narratives in the Space of Authoring their Mathematical Identity, internally persuasive?

Methodology

The study included five 8th grade students (13-14 years old) that participated in a weekly STEM-oriented afterschool activity at the Technion (hereafter "the Activity"). They all studied in the same school. The study was a pilot study aiming to build conceptual and methodological tools for a future larger study on students' identity in relation to dialogic instruction in mathematics. Hence, we chose this specific population because the students were participating in a STEM activity held in our university and could be easily accessed. The students' age corresponded with the age of our future study's population. Participation in the study was voluntary, and anonymity and confidentiality were guaranteed through an informed consent letter signed by the participants and their parents. Only four cases were analyzed. The four participants were born in Israel, 2nd generation of former Soviet

Union (hereafter: 'Russian') immigrants; the fifth participant was a recent immigrant from Russia. This difference between her and the other participants became known during the data collection stage. Due to her limited ability to communicate in Hebrew, as well as our wish to maintain a cohesive framework of participants who are 2nd generation to Russian immigrants, her data was not analyzed in the study.

The study included semi-structured individual interviews with four participants that preceded one focus group interview with all five participants, all recorded and transcribed. The interviews were conducted by the first author in a separate room. Each individual interview took approximately 45 minutes and included questions intended to elicit current 1st and 3rd current identity and designated identity narratives such as "what subjects are important for you?", "what kind of student are you?", "how would your parents answer that same question?", and "what would you like to be when you grow up?". Since our focus was the dialogic aspect of the endorsement of narratives, the interviewer questioned the participants on the sources of their narratives (e.g. "who says that math is important?") and asked for justifications (e.g. "why is it important?"). The focus group lasted 90 minutes. It began with a discussion of important subjects in school and ended with discussion of participants' wishes for the future. The rationale for holding a focus group in addition to interviews was double. First, there were participants who did not want to participate in the interview but agreed to participate in the focus group. Second, we wanted to observe processes of identity construction and endorsement of narratives from students' space of authorship in a more natural, "conversational" situation, where the voices of different students could meet and be negotiated.

Data analysis consisted of a two-stage analysis. The first stage included searching the whole interview dataset for common endorsed narratives belonging to the participants' Space of Authoring Mathematics Identity as well as current and designated identity narratives and their related narratives. Here, we encountered a difficulty with relation to narratives indicating "separations", since often, narratives authored as "truths" about the world have lost their sociocultural origin. For example, "I am a student" is a narrative that rarely contains evidence of its sociocultural source, although at a certain point in time, the author must have learned from others that this narrative identifies him. For this methodological reason, we chose in our analysis to focus only on those narratives that included indications of sociocultural sources. For example, "when I was young, my father told me that art is just a hobby" is a narrative ("art is a hobby") where the identified sociocultural source is the "father". A narrative was categorized as *endorsed* if the participant voiced the narrative, at least in part, in her own voiced or agreed with the narrative voiced by others (interviewer or peers).

The second stage analysis included a close-up examination of the dialogical aspect of the narrative's endorsement. Narratives which were voiced as solely coming from an authoritative voice (for example "my parents say that...") were categorized as *Authoritative*. Signs of separation of the participant's voice from the voice of the source were derived from positioning statements that included the opinion or thoughts of the "I" in relation to the narrative. For example, "my mother thinks art is a hobby, **but I** would like to pursue it". If signs of separation were identified, we further searched for signs of *internally persuasive endorsement*. These can appear in the form of providing justifications for the narrative, such as "art is a hobby because you cannot earn money

with it". We further examined those justifications as "sub-narratives" along the same line to determine if those sub-narratives were themselves internally persuasive. Endorsed narratives, along with their justifications and sub-narratives were compared and related to students' designated identities. For reliability, we employed a consensual coding process based on both authors' mutual agreement.

Results

For the purpose of this report, out of the four cases, we chose the three cases of Benny, Sonia and Denis, which could best exemplify the different levels of endorsement in relation to the same narrative, "math is important". The fourth participant showed a level of endorsement similar to Benny. The overall results included the examination of other endorsed narratives related to the participants' designated identities such as "art is just a hobby" and "I need these studies". The narrative, "math is important" was stated by all students during the interviews as a response to the interviewer question "which (school) subjects are important?"

Benny's case – full endorsement

Benny participated only in the focus group, since at the time of individual interviews, he did not yet volunteer to participate in the study. In the focus group, after several students talked about the importance of different subjects, the interviewer (1st author) turned to Benny and asked: "Benny, what do you think, because I think you also said math (is important)". To this, Benny answered:

It's very important, like if you want to get accepted for the good jobs that you have regular hours and all that ... you must understand mathematics well, otherwise you get stuck in hard jobs where you break your back to get a few shekels.

Notably, these claims were authored in his own voice, as facts about the world, even though some of them (such as those relating to jobs with "good hours" in contrast to jobs "where you break your back") most probably were authored by adults around him. We base this interpretation on our acquaintance with students of Benny's age and social position who rarely have direct access to different jobs' "hours", their "regularity" and the exact physical activities that are entailed by them. Although we interpret these narratives as sourcing from the sociocultural world, the way they are authored by Benny completely hides their sociocultural origin. By that, Benny shows full separation from the sociocultural origins of this narrative; it is not related by him in any way to what his parents or other authority figures say.

In relation to his designated identity, Benny talked about his wish to become a surgeon and said he would have liked to study the subject of surgery in school and in the Activity. When asked what in the Activity was relevant to his wish to become a surgeon, he asserted: "math is always relevant" and elaborated this claim with the following justifications:

In many ways (math is important) ... measurements... say you are doing a cardiac surgery, then it is important, say, how long you have between transferring the heart, between the body from which you are taking out the heart until he gets another heart and how long it... a lot to calculate...

We see here that Benny links his designated identity as a surgeon to the narrative "math is important" and describes specific future situations as a surgeon in which he could find himself using math. Although some of the relations Benny made between the job of a surgeon and mathematics do not actually fit the place of mathematics in the surgery world, it is clear that Benny uses his conceptions of mathematics (as mostly calculations) to link to what he imagines the world of surgery to be. Since there is no mention of anyone who told Benny about this relation of surgery and mathematics, and since the connections themselves are a bit constrained and indicative of Benny's own yet limited grasp of what mathematics (and surgery) is all about, we categorize the endorsement of this narrative as internally persuasive. In no place does Benny offer conflicting narratives to the narrative "math is important" (neither in his own voice nor in revoicing someone else's voice), thus strengthening our identification of his discourse about the importance of mathematics as full endorsement.

Sonia's case – conflictual endorsement

In her interview, Sonia reported liking best the subject of art and sports. Despite that, and similarly to the other participants, she claimed both in her individual interview and in the focus group, that math and English are the most important subjects studied at school, thus providing evidence of endorsement of the narrative.

When the interviewer asked her why it is so, Sonia replied:

First, (they¹) say it is most important, and also, like, it's needed...it's also a very very important part of the matriculation exams...(they) always say that most important are math and English... I also think English is important.

The interviewer then asked again why math is important, and the following exchange took place:

(implied words), [overlapping speech]

- 45 Sonia: (They) say, I still don't understand why... But (they) say math is important... okay... [fine...]
- 46 Interviewer: [Who says? Who says?]
- 47 Sonia: The parents say. Like, for my mother all subjects matter, no matter which one, but like almost all people say that... English and math, I still don't understand why math. I want someone to explain it to me, why?
- 48 Interviewer Because what? Because you don't find in it anything to do with...?
- 49 Sonia Like, it's important in engineering and all that... I don't know... maybe because I don't really like the subject

Excerpt 1

¹ In literal translation the word "they" would be omitted. The omitting of "they" is often used to avoid the passive voice in Hebrew.

In line 47, Sonia specifies the identity of the source to be her parents and "almost all people". There are clear signs of separation between her own voice ("I still don't understand why math" [47]) and her parents' voice ("The parents say" [47]). We thus see Sonia's endorsement of the narrative "math is important" as conflictual. Although she claimed not to have internally persuasive reasons for the narrative and even challenged the interviewer to provide her with justifications, Sonia did initially author the narrative as her own (in answering the interviewer's question which subject was most important at school), as well as provided a reason: engineering (49). The mentioning of engineering as a reason for the importance of mathematics was related to Sonia's designated identity. She said: "I already have one idea for what I want to go study... software engineer". When asked why she wants to study software engineering, she said:

...I really like computer games and I want to do software for computer games, and also actually in my opinion I think that the fact that I like drawing and with all the thoughts and fantasy, it will help me in computer games to invent something interesting.

Although in her interview Sonia mentioned the plan to be a software engineer as her own idea, two weeks later, in the focus group interview, she said, "My mother wanted me to be a software engineer. For that I need five math units²..." Despite the identification of her mother as the source of her future plans, Sonia displayed in her justifications an internally persuasive endorsement of her reason for studying mathematics (studying engineering). Thus, like Benny, Sonia links her designated identity (as a software engineer) to the endorsement of the narrative. However, she also poses conflicting narratives doubting this narrative and confirming its authoritative nature. To summarize, Sonia's endorsement of the narrative "math is important" is double-voiced and conflictual, showing signs of internally persuasive discourse together with authoritarian discourse.

Denis's case –oppositional endorsement

In his individual interview Denis reported he liked computer games and sports, and that he wants to have "two degrees" and study in the "biggest university". Both in the individual interview and in the focus group interview Denis listed exact sciences (including math) as most important. When the interviewer asked why, Denis cited his mother "because she always has this thing with numbers", thus identifying his mother as the source for the narrative. In the focus group, when the subject of why math is important was raised, Denis said:

a. Because the parents force you; b. Because they came from the Soviet Union and for them math is in the blood; c. Because we are in Israel and (you) don't earn much in Israel

This claim was consistent with Denis's claim in his individual interview that 'Russian' parents try harder to teach their children math at home:

because they want the children to come out smart in the country... and Israel for them is not an easy country, not a lot of money, problems, they want their children to come out lawyers and doctors... geniuses...

² The matriculation exams in Israel have different level of "units". The most advanced level is "5 units".

He then added that, as their (the 'Russians') child, you need to "make as much effort as possible to impress the parents at the end of the year to show them the report card". Examining the endorsement of the narrative "math is important", it is clear that Denis separates his own voice from the identified source by positioning himself as being coerced to study hard and earn high grades because of his immigrant community. Thus, implicit in Denis words, is a narrative that in fact opposes the narrative "math is important", a narrative that could be explicated as *there are no relevant reasons for me to study mathematics aside from pleasing my parents*. The justifications to the narrative provided by Denis are all related to the source (his mother and other 'Russians') and thus cannot be categorized as internally persuasive. The links Denis makes between designated identities and the endorsement of the narrative are all related to 3rd P designated identities, that is, what others expect him to become. We thus label Denis's endorsement as oppositional.

Discussion

This study sheds light on the process by which narratives in the Space of Authoring Mathematics Identities, originating in sociocultural voices, are endorsed and incorporated into adolescent students' 1st P identities. In addition, it highlights the connection of narratives such as "math is important" to students' designated identities. We see this in the fact that Denis, whose endorsement of the narrative was oppositional, connected the "math is important" narrative to his future ability to earn money without specifying how this narrative would be relevant to his designated identity. In contrast, Sonia and Benny (whose wishes were to become a surgeon and a software engineer) related the importance of mathematics specifically to their future desired careers. This link between narratives in the Space of Authoring Mathematics Identity and designated identities reinforces Black and colleagues' (2010) suggestion that motives, derived from students' aspiration, may play a crucial role in shaping their relationship with mathematics. In other words, although narratives about the importance of mathematics circulate around students, the answer to whether these narratives would turn from authoritative discourse to internally persuasive discourse may lie in the connection of these narratives to students' plans and aspirations for the future.

Rather than assuming a relatively straightforward adoption of narratives authored in the sociocultural sphere as some structural sociological accounts do, the present study examined the dialogic process of endorsement, based on the Bakhtinian concepts of authoritative discourse and internally persuasive discourse. Although in all three cases reported herein there were indications of sociocultural sources to the narrative "math is important", these cases showed different degrees of *separation* of the adolescents' voice from the voices of significant narrators around them. This exemplifies the process by which narratives authored by significant others are not simply "facsimiled", in the words of Holland et al. (1998) onto their children's identity. Moreover, the endorsement of the narrative by the three adolescents was different in subtle yet noticeable ways. The analysis revealed three levels of endorsement of the narrative: full endorsement, conflictual endorsement, and oppositional endorsement. Full endorsement was established by signs of an internally persuasive discourse regarding the narrative; conflictual endorsement was established by evidence of both authoritative discourse as well as internally persuasive discourse; and oppositional endorsement was established by signs of an authoritative discourse. These findings suggest that students' endorsement of narratives in the space of authorship is a complex process. The fact that a

student states for example that "math is important", and even cites his parents or author authority figures as the source of this narrative, does not provide the whole picture regarding the endorsement of the narrative and the separation of the adolescent from the authoritative discourse.

Although we present a small-scale study and our report focuses on one narrative only, our findings foreground the need to use dialogical concepts and tools when examining students' mathematical identities. Furthermore, the theoretical approach we adopted in this study goes some way in mediating between psychological approaches emphasizing adolescence as a critical time of separation from authoritative figures, and sociocultural approaches signifying the importance of narratives surrounding the students. By this, the study contributes to bridging the gap between studies taking a psychological approach to identity and studies taking a sociological, discursive take on this concept.

Acknowledgements

This research was partially supported by ISF grant 2699/17.

References

- Bakhtin, M. M. (1981). *The dialogic imagination: four essays*. Austin: University of Texas Press.
- Black, L., Williams, J., Hernandez-Martinez, P., Davis, P., Pampaka, M., & Wake, G. (2010). Developing a 'leading identity': the relationship between students' mathematical identities and their career and higher education aspirations. *Educational Studies in Mathematics*, 73(1), 55–72.
- Blos, P. (1967). The second individuation process of adolescence. *The Psychoanalytic Study of the Child*, 22(1), 162–186.
- Darragh, L. (2016). Identity research in mathematics education. *Educational Studies in Mathematics*, 93(1), 19–33.
- Heyd-Metzuyanin, E. (2015). Vicious cycles of identifying and mathematizing: a case study of the development of mathematical failure. *Journal of the Learning Sciences*, 24(4), 504–549.
- Holland, D., Lachicotte, W., Skinner, D., & Cain, C. (1998). *Identity and agency in cultural worlds*. Cambridge: Harvard University Press.
- Morson, G. S. (2004). The process of ideological becoming. In A. F. Ball & S. W. Freedman (Eds.), *Bakhtinian Perspectives on Language, Literacy, and Learning* (pp. 317–332). Cambridge: Cambridge University Press.
- Radovic, D., Black, L., Williams, J., & Salas, C. E. (2018). Towards conceptual coherence in the research on mathematics learner identity: a systematic review of the literature. *Educational Studies in Mathematics*, 99(1), 21–42.
- Sfard, A., & Prusak, A. (2005). Telling identities: in search of an analytic tool for investigating learning as a culturally shaped activity. *Educational Researcher*, 34(4), 14–22.
- Törner, G. (2014). Beliefs—no longer a hidden variable, but in spite of this: where are we now and where are we going. In L. Sumpter (Ed.), *Current state of research on mathematical beliefs XX: Proceedings of the MAVI-20 conference* (pp. 7–20). Falun, Sweden: Dalarna University.

Learning styles in mathematics – the strength of the motivational factors at 10th grade Portuguese students

Miguel Figueiredo¹ and Henrique Manuel Guimarães²

¹Universidade de Lisboa, Instituto de Educação, Lisboa, Portugal; mafigueiredo@campus.ul.pt

²Universidade de Lisboa, Instituto de Educação, Lisboa, Portugal; hmguiaraes@ie.ulisboa.pt

This paper reports on a research project aimed at describing the learning styles in mathematics of the Portuguese students at the 10th grade and at relating them to the students' performance. For this quantitative, descriptive and correlational research, we used an adaptation of the ILS (Inventory of Learning Styles) of Vermunt (1994) that was answered by a sample of 579 students. An important result was the detection of a learning style that is strongly correlated to the motivational learning orientations, being however still undefined it what concerns the cognitive processing strategies. This style, if hold in a favorable context, may turn into a “meaning oriented” learning style. We also detected the four styles usually reported at Vermunt's ILS' applications: “meaning oriented”, “reproduction oriented”, “application oriented” and “not oriented”, as well as the positive contribution of a “meaning oriented” style to the scholar performance in mathematics, opposite to the effect of the “reproduction oriented” one.

Keywords: Learning style, secondary school mathematics, motivation.

Introduction

The aim of our research was to characterize the learning styles and each of its components in relation to the learning of mathematics by 10th grade Portuguese students and to find out whether either the learning styles or any of their components show any correlation to the learning results. Such components are those considered in the Vermunt's model of the regulation of the learning processes (Vermunt & Van Rijswijk, 1988; Vermunt, 1998, 2005): cognitive processing strategies, regulation strategies, conceptions of learning and learning orientations. We opted for this model, because it follows a socio-constructivist insight of learning (Goldin, 1989) that has got in account both personal and contextual factors that influence the evolution of the individual learning styles. The reason for choosing mathematics as the discipline-object of this research lies on the personal interest of the researchers in the field of the Didactics of Mathematics, having in mind that several empirical studies reveal that the students don't use the same learning style in all the disciplines. For example, Severiens & Dam (1997) report different patterns of learning styles in four disciplines using the same sample of six secondary schools in Holland.

Following the above mentioned aim of the research, we present the questions of the study that are relevant to this paper, concerning the Portuguese 10th grade students:

- Which learning styles are more present at mathematics learning?

Which correlations can be found between the performance in mathematics and the learning styles?

Theoretical Framework

One of the most used definitions of “learning style” was written by a *task-force* of *NASSP* (*National Association of Secondary School Principals*), created in 1979 to set the diagnostics of the learning styles of secondary school students in USA:

The learning style is the composite of characteristic cognitive, affective, and physiological factors that serve as relatively stable indicators of how a learner perceives, interacts with, and responds to the learning environment. (Keefe, 2001, p. 140)

Though this study is not a longitudinal one, therefore limited by a synchronic data collecting, we conceived a conceptual framework (Figure 1) that has included some variables that, regardless the fact that they are not targeted to be measured in this research, we assume as being closely related to the four components of Vermunt’s model of the regulation of the learning processes. Therefore, the conceptual framework includes this model as a subset that interacts with other variables. For instance, the performance, as perceived by the student, feedbacks the components of the regulation model (Cassidy, 2011) and generates emotions that influence the affect for mathematics (McLeod, 1992). As a result, some changes in the motivation to learn may happen (Hannula, 2004). Besides that, the effect of the perceived performance on the self-confidence of the student may change the degree of the self-regulated learning (Malmivuori, 2006). The learning contexts, such as the school culture and the classroom dynamics, or even the social and familiar environments, are also considered at the framework. The goals of the student and the available resources also have an impact on the learning orientations (Hannula, 2006). The different mixes of attitudes and behaviors of a student within each of the learning styles components, shown in Figure 1, define the learning styles proposed by the model: reproduction oriented, meaning oriented, application oriented and not-oriented.

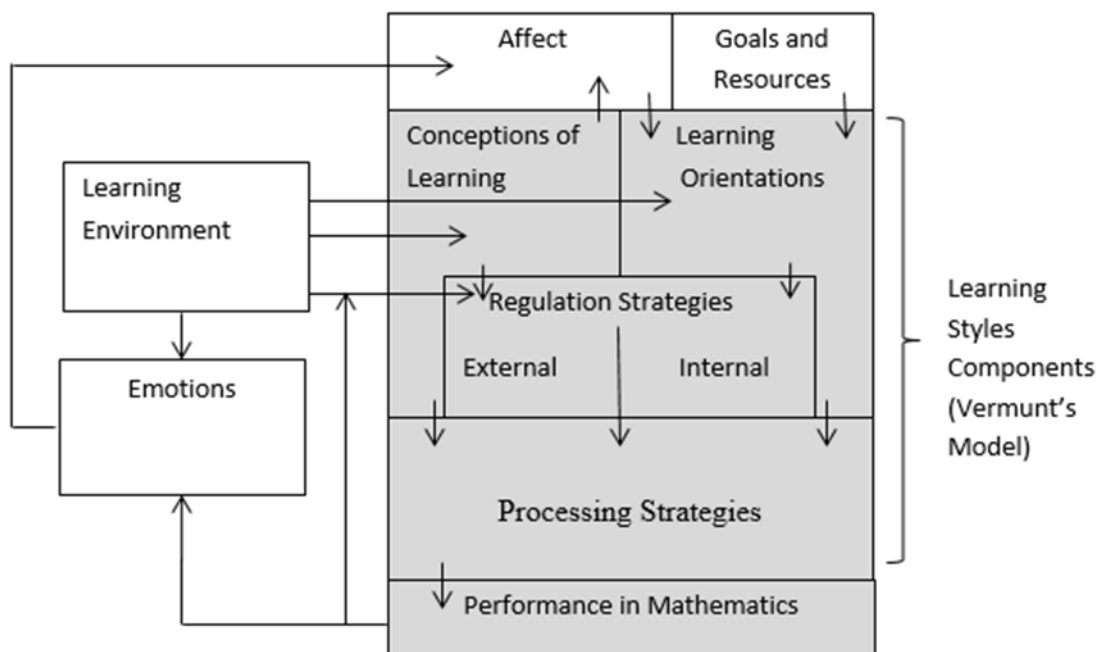


Figure 1: Research conceptual framework (the measured variables are those of the grey area)

Research Method

For this study, we targeted the 10th grade students that were learning the discipline “Mathematics A”. The advantage of choosing the 10th grade classes was the opportunity to observe students that have just done the qualitative step of the transition from basic to secondary school and that are supposed to be able to interpret the questions written on the inventory. This quantitative, descriptive and correlational research was implemented in two steps: there was a small-scale study (n=108) that allowed us to tune up the survey tools, followed by the large-scale study (n=579). At both studies, we used a multi-stage sampling process, as shown in Figure 2.

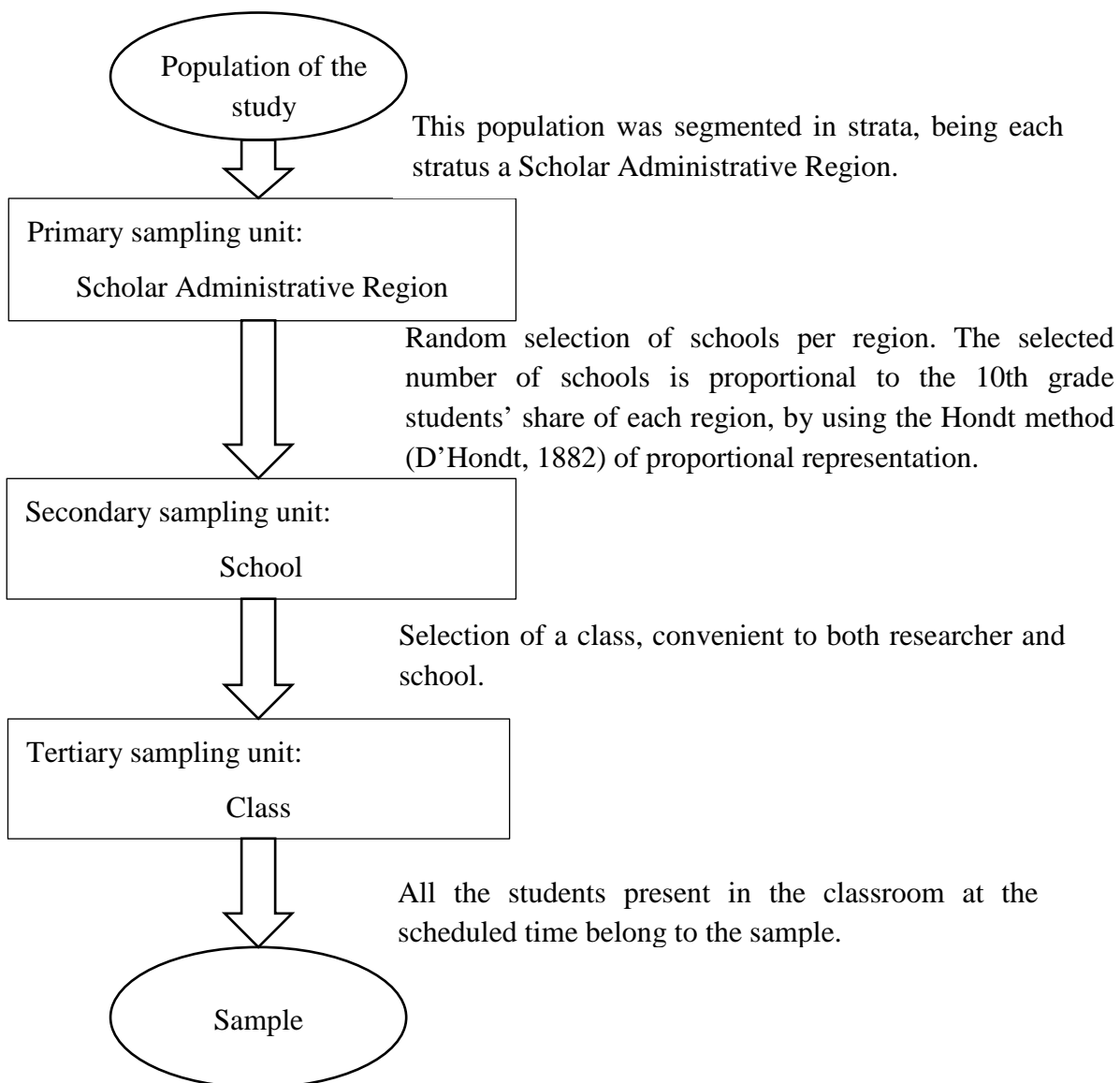


Figure 2: Research multi-stage sampling process scheme

The tool that we used for the primary data collection was an adaptation of Vermunt’s ILS – Inventory of Learning Styles (Vermunt, 1994). We adapted this questionnaire to a secondary school context and to the focus on the learning of mathematics. In this adaptation, we kept the structure of the Likert

scales used at the original inventory for measuring the attitudes and behaviours related to the four components of Vermunt's model (Table 1).

Processing Strategies	Regulations Strategies	Learning Orientations	Beliefs about Learning
<u>Scales:</u> Deep processing Stepwise processing Concrete processing	<u>Scales:</u> Internal regulation External regulation Lack of regulation	<u>Scales:</u> Personal Interest Certificate Self-Test Vocational Ambivalent	<u>Scales:</u> Intake of Knowledge Construction of Knowledge Use of Knowledge Stimulated Education Cooperation

Table 1: Scales of the Inventory of Learning Styles

The questionnaire also included three questions related to the results in Mathematics (self-assessment and school assessments in the former year and in the current year) and two questions about the demographic variables of gender and age. For the two first components, that concern the processing and the regulation strategies, the scales are behavioural. For example:

When a mathematical problem is presented at the classroom, I prefer to wait for an explanation about how to solve it, either from the teacher or from my colleagues.

Never Sometimes Often Always

For the other two components, concerning the learning orientations and the beliefs about learning, the scales are attitudinal. For example:

I like to learn Mathematics.

I totally disagree I tend to disagree I tend to agree I totally agree

The data used at the large-scale study were collected in 2016, from 15th January to 15th March, at 28 schools along the continental territory of Portugal. A researcher was always present at the classroom during the fulfilling of the questionnaire by the students, in order to assure the homogeneity of the procedures and to guarantee the anonymity of the students answers.

Results

The results here reported are those of the large-scale study. However, it is remarkable that the findings were very similar to those of the pilot-study. This feature can be seen as a confirmation of the robustness of the adapted ILS used for the data collection. Concerning the internal validity of the scales, almost all the results of the calculations of *Cronbach's alpha* ranged from 0.6 to 0.9, showing an acceptable or even good internal validity. The single component with some scales with *Cronbach's alpha* lower than 0.6, but higher than 0.5, was the one concerning the beliefs about learning. This may have happened due to the fact that the concepts involved in the questions about those beliefs are probably not yet clear at the students mind.

The sample was quite balanced in what concerns the gender of the students: 52% female and 48% male. Most of them (78%) were 15 years old and there was a significant group (18%) aged 16 years. The minimum age was 14 and the maximum age was 18. Concerning their performances in

Mathematics, only 16% of the surveyed students assess their own performance as non-satisfactory. However, both school assessments of the 9th year and of the first trimester of the 10th year point out to 22% non-satisfactory performances.

Using factorial analysis, an adequate tool to reduce the amount of behavioural and attitudinal variables to identifiable learning styles, some common trends of attitudes and behaviours at mathematics learning could be found out. As expected, the Kaiser-Meyer-Olkin test value reached nearly 0.9 and the significance level obtained at the Bartlett test was less than 0.01, so both tests revealed that the sample was very good for this purpose. Proceeding to the factorial analysis and selecting the principal components with eigenvalues higher than 1, we could obtain five components that explain 70% of the variance within the sample. The factorial structure of these components in terms of the ILS' scales is shown by the matrix of Table 2, where we can find out the correlational saturations after the use of Varimax rotation at the analysis.

Scale	Component				
	1	2	3	4	5
Deep processing			.828		
Stepwise processing		.856			
Concrete processing				.637	
Internal regulation	.408		.775		
External regulation		.604	-.426		
Lack of regulation	-.396	.445	-.429	.355	
Personally interested	.870				
Certification oriented	-.544	.361			
Self-test oriented	.730				
Vocation oriented	.838				
Ambivalent	-.725		-.364		
Learning as intake of knowledge		.838			
Learning as construction of knowledge			.338	.625	
Learning as use of knowledge	.564			.440	
Learning as stimulated education				.738	
Learning through cooperation					.971

Table 2: Factorial structure with 5 components

The first component is strongly associated to the three learning orientations that result from the motivation to learn mathematics: personal interest, self-test and vocational orientations. So, it can represent a learning style that has got features that belong to the “meaning oriented” style, but it neither correlates to the deep processing strategies, nor to the belief that learning is knowledge construction. We named this style “personal fulfilment oriented” and we propose the conjecture that this style may evolve to the “meaning oriented” one, if the context of learning is favourable to this evolution. This conjecture must be submitted to longitudinal research. The second component shows features that correspond to the “reproduction oriented” style of Vermunt’s model, namely the stepwise processing, the external regulation, the certification orientated learning and the belief that

learning is an intake of knowledge. The third component sticks totally to the attitudes and behaviours associated to the “meaning oriented” learning style, such as the deep processing, the internal regulation and the belief of learning as a construction of knowledge. What is noticeable is that the motivational aspects are very strong at the “personal fulfilment oriented” style, but almost absent in the “meaning oriented” one. Our interpretation of this fact is that the first one, observable at the beginning of secondary school is more determined by the discipline-object than the latest, which is not so dependent on motivation, thus more stable. The fourth component that was extracted at the factorial analysis reveals a style similar to the “application oriented” one of Vermunt’s model, though not so clearly defined as the other styles. The main features of this style are the relevance of the concrete processing and the belief that learning is a result of educational stimulation. The fifth component is absolutely undefined in what concerns the processing and regulation strategies as well as the learning orientations, so it may be seen as a “not oriented” style. However, in this study, this style appears strongly and exclusively related to the belief in learning through cooperation. Having in mind that, as mentioned above, the correlation of this belief with the performance in mathematics tends to be negative, it is possible that the individual lack of learning strategies at this school level leads some students to look for support at group work. Observing the results that concern the linear correlation between the learning styles and the performance in mathematics assessed through three different ways (Table 3), we find that all but one are significant for $p < 0.05$, but not strong.

Learning Style		Self-assessment	School assessment (9th grade)	School assessment (10th grade, 1st trimester)
Personal fulfilment oriented	Pearson’s r	.453	.284	.328
	Sig. (bilateral)	.000	.000	.000
Reproduction oriented	Pearson’s r	-.233	-.256	-.346
	Sig. (bilateral)	.000	.000	.000
Meaning oriented	Pearson’s r	.281	.181	.248
	Sig. (bilateral)	.000	.000	.000
Application oriented	Pearson’s r	-.091	-.027	-.115
	Sig. (bilateral)	.029	.517	.006
Not oriented	Pearson’s r	-.152	-.144	-.148
	Sig. (bilateral)	.000	.000	.000

Table 3: Correlation between the learning styles scores and the assessments

It is however important to notice that the polarity of the correlations is coherent along the three different assessments. The correlations with the assessments are positive for the “personal fulfilment oriented style” and for the “meaning oriented style” and negative for all others. So, we conclude that there is a slight but observable trend of these two learning styles to generate a better performance in mathematics, whereas the other styles conduct to worse results. It’s also noticeable that the positive correlations of the styles with the assessments are more positive with the self-assessment than with the other assessments and the negative correlations are more negative with the school assessments than with the self-assessment. Our interpretation is that those students whose learning styles are predominantly “personal fulfilment oriented” or “meaning oriented” are more aware of the results of their learning processes.

Conclusions

Starting to discuss the results by the constitutive components of the learning styles, we conclude that, in what concerns the beliefs about mathematics learning, the students at the 10th grade still didn't develop clear concepts and that the motivational dimensions are those that play the strongest differentiating role between their learning styles in mathematics. We believe that it is very important that all the contextual factors, such as the teaching methods and styles, keep this motivational predisposition in a high level, in order to give way to the evolution towards a meaning oriented style. For example, if too much stress is put on the assessment of mathematics performance, particularly when such assessment is required for any kind of certification, it may cause a drift to certification oriented learning and therefore to a learning style of a more reproductive kind, which tends to lower the performance of the student in mathematics. The four learning styles found out in many researches that used Vermunt's ILS at university or high-school students were also found in this investigation. However, another learning style, that we named "personal fulfilment oriented", is preponderant and contains features that may lead to a "meaning-oriented style", if the contextual variables help to induce the concept of constructive learning as long as the student will develop clearer concepts. These two styles of learning tend to be more suitable for better performances in Mathematics at the secondary school.

Having exposed the conclusions of our research, we must express some limitations that are inherent of our methodology. First of all, one may ask whether these results can be generalized to the population of the study. There are some factors in the sampling process that could cause interference in the randomness of the sample, namely: the convenience of the selection process of the classes, the risk of having selected classes instead of individual students, considering that some of these might be absent at the moment of the data collection, and the stratification of the population by regions in order to obtain a representative territorial distribution of the sample. If we define a random process in terms of the equiprobability of selection for each sampling unit, the assumed no correlation between the conveniences of the researcher and the schools makes this part of the sampling equivalent to a random process. Concerning the absent students, generally there were no more than one or two missing the class. Therefore, we consider that there is a high degree of generalization of the research results and that another sampling process would hardly obtain a so close approach to a random process. There are also limitations that result from the data collection process. The answers given by the students can be influenced by subjective norms, in the sense that they may consider answers in terms of the opinion of contextual agents and not of their own. Besides that, some answers may require cognitive constructs that need the use of the memory of the thoughts and emotions that have occurred at mathematics learning. The possible misinterpretation of some questions and terms might have been a limitation too. However, we believe that these limitations had little impact at the research, since the results of the pilot study and of the large scale study were very similar.

Some follow up of this research would contribute to further knowledge about the learning styles in mathematics of the secondary school students. Longitudinal studies along the secondary school cycle would help to describe the evolution of the learning styles and to test our conjecture that there is a learning-style that can turn into a meaning oriented style, if some contextual conditions are favourable

to this development. Those studies could also check to which extent the assessment methods at the end of the secondary school are influencing the learning styles adopted by the students.

References

- Cassidy, S. (2011). Self-regulated learning in higher education: Identifying key component processes. *Studies in Higher Education*, 36(8), 989–100.
- D'Hondt, V. (1882). *Système pratique et raisonné de représentation proportionnelle*. Bruxelles, Belgique: Muquardt.
- Goldin, G. (1989). Constructivist epistemology and discovery learning in mathematics. *Proceedings of PME13 (Paris)*, Vol.2, 15–22.
- Hannula, M. S. (2004). Affect in mathematical thinking and learning. *Doctoral Dissertation*, University of Turku, Finland.
- Hannula, M. S. (2006). Motivation in mathematics: goals reflected in emotions. *Educational Studies in Mathematics*, 63, 165–178.
- Keefe, J. (2001). Assessment of learning style variables: the NASSP Task Force model. *Theory into Practice*, 24(2), 138–144.
- Malmivuori, M.-L. (2006). Affect and self-regulation, *Educational Studies in Mathematics*, 63, 149–164.
- McLeod, D. (1992). Research on affect in mathematics education: a reconceptualization. In D. A. Grouws (Ed.), *Handbook of research in mathematics teaching and learning*, 575–596. NY: MacMillan.
- Severiens, S. & Dam, G. T. (1997). Gender and gender identity differences in learning styles. *Educational Psychology*, 17(1–2), 79–93.
- Vermunt J. D. (1994). *Scoring key for the Inventory of Learning Styles (ILS) in higher education – 120 item version*. Department of Educational Psychology, Tilburg University, The Netherlands.
- Vermunt, J. D. (1998). The regulation of constructive learning processes. *British Journal of Educational Psychology*, 68, 149–171.
- Vermunt, J. D. (2005). Relations between student learning patterns and personal and contextual factors and academic performance. *Higher Education*, 49, 205–234.
- Vermunt, J. D., & Van Rijswijk, F. (1988). Analysis and development of students' skill in selfregulated learning. *Higher Education*, 17, 647–682.

Undergraduate students' mindsets in a computer programming mathematical learning environment

Wendy Ann Forbes, Joyce Mgombelo, Sarah Gannon and Chantal Buteau

Brock University, Canada; wendyannforbes@gmail.com

This paper focuses on how undergraduate students' mindsets are enacted and constructed in a programming and mathematics learning environment. This research draws from year one of a five-year study entitled "Educating for the 21st Century: Post-graduate Students Learning Progmatics (Computer Programming for Mathematical Investigation, Simulation, and Real-world Modeling), which addresses the need to empower students within the STEM field. A narrative approach is employed to present findings from two students, Sydney and Jim (pseudonyms), followed by a discussion on their enacted mindsets during a first-year 'progmatcs' course.

Keywords: Mindset. University mathematics education. Programming. Identity.

Introduction

Jobs in the STEM field are on the increase. A major percentage of those jobs require computer science-related knowledge (CBC News, 2015). However, students in undergraduate computer science programs often feel defeated, having little confidence in their ability because of obstacles they encounter that are inherent to programming (Cutts, Draper, O'Donnell & Saffrey, 2010; Murphy & Thomas; 2008). Moreover, many mathematics students avoid engaging in mathematical tasks that require reasoning, exhibiting phobias and anxiety in extreme cases, because they perceive these tasks as difficult (Boaler, 2016). The pressing need to educate students in STEM, combined with students' often negative responses to learning programming and mathematics, necessitate inquiry of how students perceive their intelligence and abilities as they learn these disciplines.

This paper draws from year one of a five-year study funded by the Canadian Social Sciences and Humanities Research Council (SSHRC) entitled "Educating for the 21st Century: Post-graduate Students Learning Progmatics (Computer Programming for Mathematical Investigation, Simulation, and Real-world Modeling). This study addresses the need to empower students within the STEM field and to better understand the complexities involved when students learn to appropriate tools such as 'progmatcs'. The study focuses on the question of how mathematics students come to appropriate programming as a computational thinking instrument in the context of three 'progmatcs'-focused undergraduate mathematics courses, called Mathematics Integrated with Computers and Applications (MICA). This course sequence teaches students the fundamentals of programming for conducting mathematical explorations and applications. Analysis of data gathered within this study provides a suitable opportunity to investigate students' mindsets as they grapple with the complexities of a 'progmatcs' learning environment. Specifically, this paper will focus on how students' mindsets are enacted and constructed while learning 'progmatcs' during the first MICA course. To achieve this aim, the narratives of two students, Sydney and Jim (pseudonyms), will be explored.

Mindset refers to the brain's potential to formulate perceptions, affecting attitude and achievement. Mindset was first introduced in educational research in the 1920s but in recent years, Carol Dweck's work on oppositional theories of growth and fixed mindsets has popularized mindset (Popan, 2016).

Dweck's notion of growth mindset has been applied in various contexts. Cutts et al. (2010) assert that the barrage of obstacles faced by students during their undergraduate programs promote fixed mindset beliefs. Furthermore, Murphy and Thomas (2008) contend that while self-theories are applicable in all disciplines, the way students perceive their abilities may be more significant in computer science education, particularly in computer programming, due to inherent challenges such as contending with elusive and puzzling syntax and runtime errors. Based on these arguments regarding the significance of self-theories to mathematics and programming, a growth mindset may be even more important for learning mathematics within a programming environment, given the added difficulties stemming from both disciplines. Our study adds to other mindset research focusing on mathematics or programming as it involves not only one aspect (programming or mathematics), but the combination of both disciplines.

Conceptual Framework

Our view of learning relies on Lave and Wenger's (1991) work on communities of practice. Lave and Wenger (1991) contend that learning takes place relative to the context in which it is learned through legitimate peripheral participation, whereby *newcomers* become *oldtimers* by authentically taking part in a seamless process of gradually increasing responsibilities. The newcomer, starting at the periphery, may initially observe, but contributes within a community of practice almost immediately by doing small tasks which are progressively increased until he/she becomes an oldtimer. For Lave and Wenger (1991), the process of becoming a legitimate member of a community involves not just change in knowledgeable skill, but also a change in identity. Wenger (1998) defines this identity as "a layering of events of participation and reification by which our experience and its social interpretation inform each other" (p. 151). This definition implies that a change in mindset results from a change in identity because individuals' perceptions of their own abilities is shaped as they experience their sociocultural environment. In this sense, individual stories and narrative approach are relevant in inquiry on one's experienced mindsets. Storying or constructing narratives are common means utilized by humans to make sense of the myriad of complex experiences they encounter; contributing to the formation of their identity (McAdams, 2008), and by extension, their mindset. A narrative approach is a growing trend in research relating to identity and, in general, educational research (McAdams, 2008).

Dweck (2010) describes two mindsets, fixed or growth, that influence student performance in two distinct ways. Students with a fixed mindset perceive their abilities as stable traits, believing that they have a set capacity to be successful that cannot be changed. Students with a growth mindset, however, understand that with effort and perseverance, their abilities can be improved. Solomon (2007) asserts that a students' mathematical mindset plays a key role in developing their identity. Mindset is also a critical factor in determining a student's attitude towards learning and their level of achievement (Boaler, 2016; Dweck, 2015; Murphy & Thomas, 2008). Dweck (2010) claims that in general, individuals with a fixed mindset avoid challenges, give up easily, do not value effort, dismiss positive feedback, and are threatened by others' success. In contrast, individuals with growth mindset flourish on challenges, remain persistent despite setbacks, value effort as a path to mastery, use criticisms to improve learning, and use others' success as motivation and a source of valuable lessons. Furthermore, Murphy & Thomas (2008) note that as it relates to challenges, students with fixed

mindsets focus on performance goals by opting for easier tasks as their ultimate objective is to display their ability. In contrast, students with growth mindsets focused on learning goals and are not deterred by difficult tasks or by making mistakes, in fact, they will seek out opportunities for challenge (Dweck, 2010). Importantly, a growth mindset goes beyond effort, referring to the extent to which students use innovative strategies and seek help when they are stuck (Dweck, 2015).

Methodology

Throughout the duration of the larger five-year study, a mixed-methodology approach will be utilized. An iterative design approach (Plomp & Nieveen, 2013) will be employed to refine and develop the research tools for yearly data collection and analysis. The study employs a naturalistic case study approach to examine how students' instrumental genesis of programming for mathematics develops in the MICA course sequence. This research takes place in the mathematics department of a university in Ontario, Canada. The present paper draws from data gathered in year one of the larger study, where six participants in the MICA I course were recruited voluntarily. Data gathered included each participant's four 'prognostics' projects, including both their program (called exploratory objects (EOs)) and assignment report, and semi-structured individual interviews that were conducted as a follow up to each assignment. Interview prompts were informed by a model of a student's developmental process in designing, programming and using a mathematics EO (Buteau & Muller, 2010). Data also included online post-laboratory session reflections, where after each of the ten weekly two-hour MICA lab sessions, participants recorded reflections on their learning during the lab as prompted by guiding questions. Finally, all participants completed an online questionnaire before beginning the MICA I course, followed by individual interviews where participants were asked to elaborate on their questionnaire responses. The purpose of the questionnaire and follow-up interview was to uncover baseline information about participants' background experiences in learning mathematics with technology, as well as their early sentiments towards the MICA I course.

Analysis of the study's qualitative data followed Creswell's (2008) general principles of qualitative data analysis: preparing and organizing data, exploring data, and describing and developing themes from the data. To begin the analysis, codes were developed according to categories informed by the theoretical framework (Buteau, Muller, Mgombelo & Sacristán, 2018) and related literature, with additional codes emerging during the analysis process. Each participant's qualitative data was coded individually by two researchers, who then jointly completed a thematic analysis of the data. Themes were consolidated among the six participants' analyses, leading to the development of sixteen overall themes. These themes were further regrouped into five meta-themes. In this paper, we focus on the meta-theme of identity and its subthemes of affect and students' perceptions of learning mathematics.

Findings and Discussion

In this section, we present and discuss findings from two participants, Jim and Sydney (pseudonyms).. We present two narratives of the participants' individual enactment of mindsets upon entering and during the MICA I course, followed by a comparative discussion.

Sydney's Story

With no prior programming experience, Sydney approached the MICA I course with feelings of nervousness and apprehension. In the first MICA I labs, her anxious sentiments were somewhat alleviated through interactions with her instructor, helping her to grasp basic programming concepts. She faced some challenges in the first assignment (EO1), where students were tasked with creating a program to explore a mathematical conjecture of their choosing. Sydney posed a conjecture that was a minor modification of one previously covered in the MICA I labs. She kept her program relatively simple, ensuring that she did not go “beyond [her] limits” during the coding process. The greatest obstacle she faced in completing this task was debugging her code, but with the help of a more experienced peer she created a functioning program. Sydney felt relieved that she was able to successfully complete the assignment, but was still hesitant about her programming ability and hoped that the next assignment would be easier.

Sydney experienced varying levels of success and confidence throughout the remainder of the MICA I course. The second assignment, involving the design of a program about RSA encryption, presented many challenges for Sydney. She was frustrated that she was unable to create a functioning program, compounded by the fact that she did not have enough time to seek help from a peer or an instructor before the submission deadline. Sydney felt discouraged by this assignment, claiming that she was unsure she could achieve success in the MICA program. By consulting her notes from lab and collaborating with a peer, she was able to complete the final assignments successfully and gained some confidence in her programming ability. However, Sydney ended the course hesitant about MICA II, feeling significant doubts toward her ability to learn the new programming material.

Jim's Story

Jim began the MICA I course with a general disposition of curiosity and excitement. Though Jim had limited formal experience in programming, he had been raised by a mother employed in the computer science field and was often given the opportunity to experiment with technologies throughout his childhood. This informal understanding of programming helped Jim to feel excited at the opportunity to formally learn to code. Jim's openness towards learning programming was also reflected in his greater attitude towards learning mathematics. He believes that individuals must keep an open mind towards their mathematical abilities to avoid feeling prematurely defeated and be able to persevere through challenges.

For EO1, Jim first developed a conjecture by creatively representing prime numbers and exploring patterns amongst them. Unfortunately, Jim was unable to pursue this ambitious idea within the scope of the course and his basic programming knowledge, eventually settling for a doable yet challenging alternative conjecture, that of Pólya conjecture suggested by the course instructor. However, he expressed the desire to follow up on his conjecture, feeling confident that he could develop a program to explore it when he has greater knowledge of programming. Once his program was complete, he was pleased to see it running, but stated that he always had faith it would work. Jim encountered challenges while completing the remaining assignments and coursework but did not seem bothered by these setbacks. When Jim was limited by his beginner level knowledge of programming, he would conduct research or try to find an alternative method of solving his problems. He ended the course

understanding the advantages of working within a ‘pragmatics’ learning environment, only feeling disappointed that he was not able to do more.

Comparison between two enactments of mindsets

Dweck (2015) notes that mindset is a critical factor in determining students’ attitudes towards learning and their level of achievement. Analysis of both Sydney’s and Jim’s accounts of their experiences provide evidence of their mindset upon entering and throughout the course. The following quotes, taken from Sydney’s and Jim’s baseline questionnaires, provide insight into their initial sentiments and mindsets towards learning at the beginning of MICA I:

Question: This MATH 1P40 [MICA I] course has a significant component of (computer) programming. This makes me feel...

Sydney: Nervous

Jim: Very confident

Question: Because:

Sydney: I barely have any knowledge in programming

Jim: If I'm finally going to get a chance to learn this stuff, I'm all for it. I've never had problems in the past, and if anything, I was annoyed that I wasn't being taught enough.

Here, Jim describes his confidence and excitement about entering the course, explaining how he looked forward to learning the programming content. In contrast, however, Sydney highlights her nervousness resulting from her lack of programming knowledge, suggesting her initial confidence level in the MICA program was low. Notably, although Jim also had limited programming knowledge, it did not cause him to feel this same apprehension. This could indicate that he was open to challenges, possessing characteristics of a growth mindset as Dweck (2010) asserts.

There are several notable elements regarding both students’ enacted mindsets as they experienced “pragmatics” over the semester, first in terms of how they approached challenges. Throughout the course, Sydney demonstrates a desire to avoid tasks that present significant challenge. For EO1, Sydney chose a conjecture that was quite similar to a conjecture covered in one of the lab sessions (see Sydney’s Story). In her EO1 follow-up interview, she explains that she did not investigate a more creative conjecture in order to avoid going “beyond [her] limits” with the coding. She also expressed that she was looking forward to EO2 due to its more specific nature, stating, “I hope it’s going to be easy”. Later in the course, Sydney noted that she enjoyed the graphing component of her EO3 because “it wasn’t that tough”.

Unlike Sydney, Jim was not afraid of taking on challenges during his time in MICA I. When asked how he selected his conjecture for his EO1, Jim explained how he tried to develop a complex conjecture by himself through creatively exploring a variety of mathematical concepts. Though his mathematical ideas could not be explored with his startup programming knowledge, and he ultimately explored a more feasible (yet challenging) conjecture as advised by his professor, he expressed interest in pursuing his ideas in the future. In his EO1 follow-up interview, Jim reflected on his initial idea, stating, “I don’t think it is as hard as everyone makes it out to be, it just requires a bit of a

different way of thinking”. Similarly, in Jim’s final assignment, he again expressed the desire to go beyond his level when developing his question and was disappointed that he did not yet have the required knowledge of programming to do more with his project.

Students’ approaches to challenges provide a strong indication of their mindset towards both learning and intelligence. The fixed mindset approach was consistently evident in Sydney’s data, as her actions and perspective routinely demonstrate how she chose to explore simpler problems and favoured assignments that were seemingly easier. In contrast, Jim routinely attempted to challenge himself when developing conjectures and mathematical questions, demonstrating a growth mindset approach.

A second notable point about Sydney’s and Jim’s enacted mindsets is how they overcame the challenges they encountered and the effects of these challenges on their attitudes towards their abilities. While Sydney was able to overcome difficulties in her first assignment with the help of a peer, her EO2 presented much more significant issues. Because of external time constraints, Sydney was unable to seek help from a peer or the course instructor, and was frustrated when trying to get her program to work. Due to her inability to create a functioning program, Sydney doubts her ability to continue in the MICA program, stating, “if [my EO2 program] goes poorly I don’t think I want to continue”. This doubt persisted until the end of the semester, despite greater success in her EO3 and EO4 tasks. When asked how she felt about taking the MICA II course next year, she responds, “I’m still hesitant... about the new things we will learn and if I can manage to understand them”.

Jim’s approach to setbacks was markedly different from Sydney’s. Throughout the course, it seemed that he used challenges to improve his strategies for future assignments instead of allowing them to diminish his confidence. Though he experienced setbacks in his EO2, Jim reflected on this process and how those challenges helped him improve. When he was asked in his EO3 follow-up interview if he would do anything differently, he expressed the following:

Jim: I feel like in assignment two... halfway through I had stopped planning and kind of regretted that afterwards, as you kind of get lost in the code but... for this [EO3] project I planned fairly well, I didn’t get lost... I’m pretty happy with the way I did it.

In EO3, Jim had to do a fair amount of debugging to get his program to work, but he did not seem frustrated and used clear strategies to get his program to work. When asked about the obstacles he faced in EO3, Jim stated, “with computer programming, you accept that you are going to run into some bugs, which is why you test it at different stages”. Jim maintained this attitude when completing his final assignment. When asked about debugging his program in the EO4 follow-up interview, he responded, “It didn’t work for a bit. I went back and looked at it and realized that I had forgotten something, but nothing really significant”. At the end of the course, Jim did not face the same doubts as Sydney towards his ability to be successful in MICA II. When asked about moving forward, he claimed, “I think it would be a reasonable course to take next year”.

This approach to assignments and challenges is linked to two broader themes of mindset noted by research in a variety of contexts (Boaler, 2016; Murphy & Thomas, 2008; Cutts et al., 2010), underscoring much of Dweck’s work. These contrasting mindset themes are labelled as the helpless pattern and the mastery-oriented pattern. Students that view intelligence as fixed are more likely to demonstrate a helpless response to significant challenges; whereas students with a growth mindset

display a mastery-oriented response to setbacks. Students who exhibit the helpless pattern are easily defeated when faced with challenges, measuring their capability against the obstacles and significantly doubting their ability to succeed when faced with a difficult task. Conversely, students who display mastery-oriented responses remain motivated through setbacks, persevering through the problem and overcoming it by applying innovative strategies (Diener & Dweck, 1978). Sydney's and Jim's responses to the challenges they face could give further insight into how these patterns are enacted within a 'progratics' learning environment. Sydney's response to challenges shows aspects of the helpless orientation stemming from her fixed mindset, as she is quickly overcome with doubt and discouraged by setbacks. In contrast, Jim was not deterred by mistakes and setbacks, which he perceived as a natural part of programming. Jim's ability to persevere and flourish when faced with obstacles illustrates a mastery-oriented response in accordance with his growth mindset.

Conclusion

This paper highlighted the enactment of two students' mindsets in the context of an introductory 'progratics'-focused undergraduate course. Because of the inherent challenges in learning programming and necessity of resilience in the field of mathematics, having a growth mindset holds particular importance in a computer programming mathematical learning environment such as MICA I. The assignments and reflections of two MICA I students, Sydney and Jim, were compared to illustrate their differing mindsets towards their intelligence as they engage with 'progratics' through legitimate peripheral participation (Lave & Wenger, 1991). As a result of their differing mindsets, Sydney finished the course feeling doubtful towards her ability to be successful in MICA II, while Jim maintained his confidence and expressed the desire to further develop his programs. Considering the important role played by programming and mathematics in STEM jobs, it is critical that students are encouraged to pursue and achieve success in these fields. Our work provides a beginning of how we can explore students' mindsets as they learn using programming for mathematics investigations and applications.

References

- Boaler, J. (2016). *Mathematical mindsets: Unleashing students' potential through creative math, inspiring messages, and innovative teaching*. San Francisco, CA: Jossey-Bass.
- Buteau, C., & Muller, E. (2010). Student development process of designing and implementing exploratory and learning objects. In V. Durand-Guerrier, S. Soury-Lavergne, & F. Arzarello (Eds.), *Proceedings of the 6th Conference of European Research in Mathematics Education* (pp. 1111-1120). Lyon, France: Institut National de la Recherche Pédagogique.
- Buteau, C., Muller, E., & Ralph, B. (2015, June). Integration of programming in the undergraduate mathematics program at Brock University. In *Online Proceedings of Math+Coding Symposium*, London, ON. Retrieved from <http://researchideas.ca/coding/docs/ButeauMullerRalph-Coding+MathProceedings-FINAL.pdf>
- Buteau, C., Muller, E., Mgombelo, J., & Sacristán, A. (2018). Computational thinking in university mathematics education: A theoretical framework. *Proceedings of RUME*, San Diego, CA.

- Boaler, J. (2016). *Mathematical mindsets: Unleashing students' potential through creative math, inspiring messages, and innovative teaching*. San Francisco, CA: Jossey-Bass.
- CBC News. (2015, September 1). Back to school: Canada lagging in push to teach kids computer coding. Retrieved from <http://www.cbc.ca/m/news/topstories/back-to-school-canada-lagging-in-push-to-teach-kids-computer-coding-1.3185926>
- Creswell, J. (2008). *Educational research: Planning, conducting, and evaluating quantitative and qualitative research* (3rd ed.). Upper Saddle River, NJ: Pearson.
- Cutts, Q., Cutts, E., Draper, S., O'Donnell, P., & Saffrey, P. (2010, March). Manipulating mindset to positively influence introductory programming performance. In *Proceedings of the 41st ACM Technical Symposium on Computer Science Education* (pp. 431-435). New York: Association for Computing Machinery.
- Diener, C. I., & Dweck, C. S. (1978). An analysis of learned helplessness: Continuous changes in performance, strategy, and achievement cognitions following failure. *Journal of Personality and Social Psychology*, 36(5), 451-462.
- Dweck, C. (2015). Carol Dweck revisits the “growth mindset.”. *Education Week*, 35(5), 20-24.
- Dweck, C. S. (2010). Even geniuses work hard. *Educational Leadership*, 68(1), 16-20.
- Lave, J., and Wenger, E. (1991). *Situated Learning: Legitimate Peripheral Participation*. Cambridge: Cambridge University Press.
- McAdams, D. P. (2008). Personal narratives and the life story. In O. P. John, R. W. Robins, & L. A. Pervin (Eds.), *Handbook of personality: Theory and research* (3rd ed.) (pp. 242-262). New York: Guilford Press.
- Murphy, L., & Thomas, L. (2008, June). Dangers of a fixed mindset: Implications of self-theories research for computer science education. In *Proceedings of the 13th Annual SIGCSE Conference on Innovation and Technology in Computer Science Education* (pp. 271-275). New York: Association for Computing Machinery.
- Plomp, T., & Nieveen, N. (Eds.). (2013). *Educational design research: Introduction and illustrative cases*. Enschede, Netherlands: SLO, Netherlands Institute for Curriculum Development. Retrieved from <http://international.slo.nl/publications/edr/>
- Popan, E. M. (2016). Mindset. *Salem Press Encyclopedia*. Retrieved from <https://proxy.library.brocku.ca/login?url=http://search.ebscohost.com/login.aspx?direct=true&db=ers&AN=113931187&site=eds-live&scope=site>
- Boaler, J. (2016). *Mathematical mindsets: Unleashing students' potential through creative math, inspiring messages, and innovative teaching*. San Francisco, CA: Jossey-Bass.
- Solomon, Y. (2007). Not belonging? What makes a functional learner identity in undergraduate mathematics? *Studies in Higher Education*, 32(1), 79-96.
- Wenger, E. (1998). *Communities of Practice*. Cambridge: Cambridge University Press.

Situation Specific-Skills Working Backward Reasoning: The Student's Perceptions and Affect Dimension

Inés M. Gómez-Chacón¹, Marta Barbero^{1,2}

¹Universidad Complutense de Madrid, igomezchacon@mat.ucm.es, ²Università di Torino

This study focuses on the perceptions of mathematical students on the use of backward reasoning. Since an integrative model of interactions between emotions and thinking is showed new understanding of cognitive phenomena of backward reasoning. Based on a questionnaire to assess the mathematical cognitive processes, difficulties of backward reasoning and emotions among mathematical undergraduate students, the rule structure obtained from the use of the CRT (Classification and Regression Tree) methodology analysis is reported.

Keywords: Backward reasoning, Heuristics, Cognition and affect, Mathematics, Perception, Regression trees

Introduction

The purpose of this study was to determine the perceptions of mathematical students on the use of backward reasoning and how this perception may mediate between the disposition and performance of mathematical and cognitive processes involved in this type of reasoning. Backward reasoning has great potential in the study of mathematics - it can be used to improve student achievement and to help develop mathematical argumentation and proof processes. Among the challenges in university teaching we focus on mathematical thinking, where learning the method of analysis is a critical issue (Antonini, 2011, Peckhaus, 2002, Wickelgren, 1974, Xu, Xing & Van Der Schaar, 2016). Wickelgren (1974) analyses and systematizes the methods of problem solving, introducing contradiction and working backwards as two strategies that require operations to be performed on the expected result, as well as on the information given. Addressing mathematics and engineering students, he examines how the explicit teaching of theoretical and practical analyses of problems can overcome the difficulties experienced by the students. This author indicates it is more difficult to work backwards than to work forwards, so it is necessary to offer students a large class of problems to which the method of working backwards is appropriate, such as games of the Nim family of games presented here. In our previous research papers at university level (Gómez-Chacón, 2017; Barbero & Gómez-Chacón, 2018), it was identified that explicit teaching of theoretical aspects is not enough, that there might be factors in the cognitive and affect interplay, which would inevitably cause difficulties for students to construct and work backwards. These studies showed emotions continually exert numerous so-called operator effects, both linear and nonlinear, on attentional activity and on the ability to perceive relative to goal-path obstacles and overcoming them. Understanding is linked with the appraisal of their ability to influence (control dimension), with their ability to predict, and with mental flexibility.

Hence, a conscious integration of backward reasoning when learning mathematics at university, raises the need for an articulation between dispositional and cognitive aspects. In this study we try to contribute to a more comprehensive understanding of the origins of the difficulties and identify conceptual and methodological challenges involved in assessing competencies about backward reasoning in higher education, using strategy games as specific tasks.

When integrating a cognitive and a situated perspective, Blömeke et al. (2015) suggested considering competence as a continuum (cf. Fig. 1), they stated that “processes such as the perception and interpretation of a specific situation, together with decision-making may mediate between disposition and performance” (p. 7). This framework considers competence as a multidimensional construct, and resolves the dichotomy of “disposition versus performance” as

follows: “[...] our notion of competence includes ‘criterion behaviour’ as well as the knowledge, cognitive skills and affective-motivational dispositions that underlie that behaviour” (Blömeke et al. 2015, p. 3). Following this understanding, a key role is assigned to situation-specific skills, as in-between processes that explain how dispositions are translated into classroom performance. The aim of this article is to focus on perception, as the way in which something is regarded, understood, or interpreted, as a situation-specific skill that is linked to students knowledge about backward reasoning and its practice. A set of variables measuring difficulties and appraisal cognition helps us to identify these relationships.

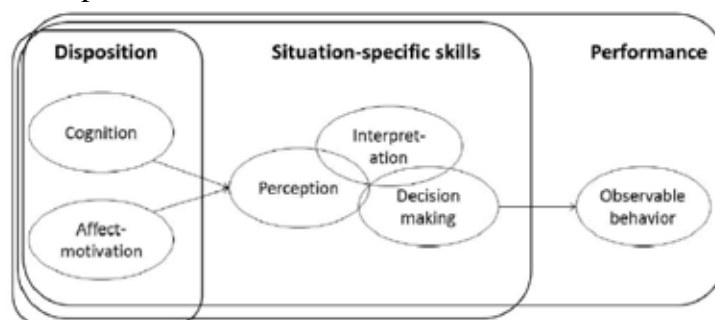


Fig. 1 Competence modelled as a continuum (Blömeke et al. 2015a, p. 5)

A specific methodological challenge in the context of the affect-cognition interplay is to explain the gradualness of the processing of affective mechanisms. This paper explores the use of decision trees to analyse data from questionnaires, which focus on the use of backward reasoning. Thus, here we will report our results in the form of a tree structure, providing rules to assess the state on the use of backward reasoning (perception, difficulties and mathematical and cognitive processes) in mathematical undergraduate students.

Characteristics of backward reasoning

The typical mathematical thinking process that is used in the discovery phases, is the backward reasoning. Pappus was the mathematician who has contributed substantially to the clarification and exemplification of the method. In the seventh book of his *Collectio* (~340 AD) he deals with the topic of Heuristics (methods to solve the problems). He exemplifies the method of analysis and the method of synthesis, therefore making the development of this reasoning clearer. Pappus defines the method of analysis as follows: “In analysis, we start from what is required, we take it for granted; and we draw correspondences (*ακολουθον*) from it, and correspondences from the correspondences, until we reach a point that we can use as a starting point in synthesis. That is to say, in analysis we assume what is sought as already found (what we have to prove as true).” (elaboration by Polya, 1965 by Hintikka and Remes, 1974).

The concept of Backward Reasoning involves some characteristics that allow us to identify its development throughout the resolution of a task. Different philosophers and mathematicians from the ancient Greeks, through the authors of the 17th and 18th centuries to the year 2000 have studied its characteristics. The main features are the following:

- *Direction vs cause-effect*. In Pappus’ definition, the backward direction of reasoning is highlighted. This entails going from the end of the problem to its beginning. By applying the method, the premises of a certain idea are sought. In the 17th and 18th centuries, authors such as Arnauld and Nicole interpreted the method as a search for cause-effect relationships between ideas. By these, the connection between the notions in background and the problem are identified. The knowledge of the development of the resolution of the task and the effects and causes of each notion involved in the process arise (Beaney, 2018; Peckhaus, 2002).

- *Decomposition*. According to Plato and Pappus, this kind of reasoning allows for the reduction of the problem to its simplest components. The properties that define the relationships between the most complex and the simplest objects involved in it are identified by extracting and investigating the principles that are at the base of the task. Aristotle, for example, underlines the fact that "sometimes, to solve a geometrical problem, you can only analyse a figure", breaking it down into its basic components and understanding the different parts of it (Beaney, 2018).

- *Auxiliary elements*. Kant, Polya and Hintikka, focus their attention on a fundamental part of the process: the introduction of new elements. In the progressive and deductive processes all the bases are given and from these, consequences are elaborated. Unlike the backward reasoning, new notions appear and develop throughout the resolution at specific moments, according to the needs of the solver (Beaney, 2018; Hintikka & Remes, 1974).

- *Strategies*. Backward reasoning involves different problem-solving techniques: backtracking heuristic, method of Diaeresis, Reduction ad Absurdum (Beaney, 2018).

We will focus on the *backtracking heuristic*. This is the strategy of working backwards, it consists rather of doing some steps backwards in the process. These steps can be done starting from, the end of the problem, or during the process of resolution in combination with progressive steps.

Research questions and methodology

Research Questions

We particularly pursued the following research questions: RQ 1: What are students' perception of the use of the *backtracking heuristic*? RQ 2: What difficulties are more prevalent in the development of the *backtracking heuristic*? RQ 3: What are the affective, mathematical and cognitive processes that have impact on the development of the *backtracking heuristic*?

Participants and instrument

Data was collected from 32 (19 women and 13 men, aged between 21 and 23) Caucasian undergraduates working toward a BSc. in mathematics. All of the participants were in their last year of academic study. They were following advanced courses in several areas of geometry, algebra, probability and analysis. With regard to solving problems, the students had been introduced to the problem solving heuristics and they received training as students in one subject related to advanced professional knowledge, practice and relationship skills relevant to teaching. They had not received any special training about backtracking heuristics.

The work dynamic started with individuals being given paper and pencil, with which they needed to resolve two games, each lasting one and a half hours. Fig. 2 shows the problem which we will analyse in the results section. Strategy games allow for the natural development of regressive reasoning. These games are disconnected from the mathematical content which forces the student to use their mathematical knowledge acquired in their university degree.

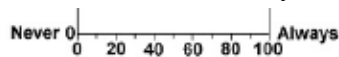
The Triangular Solitaire is a game for a single person that requires a board with 15 boxes, as the figure 2 shows.

	<p><i>These are the rules:</i></p> <ol style="list-style-type: none"> 1. Place the pawns in all boxes, except in the one marked in black. 2. The player can move as many pawns as are the chances of jumping a pawn, adjacent to an empty box (along the line); at the same time, he "eats" and retreats from the table the pawn that was jumped. All pawns will move in this way. Pawns can move around the table. <p><i>Target: The player wins when there is only one pawn on the table.</i></p>
--	---

Fig. 2. The Triangular Solitaire

Students were given the game and asked to describe their approaches to solving the problem on protocols including: thought processes in the resolution, explanations of the difficulties they might face, and strategies they would use in order to solve with paper and pencil. Afterwards, each game was followed by a questionnaire focused on heuristics related to backward thinking and the difficulties that are generated during the process of solving problems, emotions and cognitive processes (Gómez-Chacón, 2017). The cognitive dimension refers to the characterization of the personal meanings of the subjects on the cognitive dimension of backtracking heuristic, or backward reasoning, and the cognitive appraisal processes of the interaction feeling puzzled.

1. Indicates how often you use the working backwards strategy when you are solving the problem



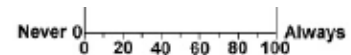
Now focus on the solving process of *Triangular Solitaire*

2- Have you used backward reasoning or backward strategy to solve the problem? Yes/No. Why?

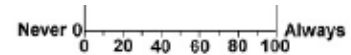
3- If you did not use the strategy, what type of processes did you consider to have failed to take account of in the *backtracking heuristic* in your solutions. You have to choose between the following items (You can justify your statements with "extracts of the problem".):

1. Actions involved basically in the determining of the mathematical model
2. Attainment of sufficient conditions
3. Actions of discovery
4. Recognition and explanation of the meaning of representational equivalence
5. Creation of the object solution
6. Formulation of axioms
7. Characterisation and establishment of relations
8. Attainment of justifications of adequate conditions in propositional equivalences.

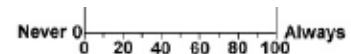
7. When you tried backward strategy, how well could you predict what was going to happen in this situation? (Ability to predict).



8. When you wanted to use backward strategy, how much did you feel there were problems that had to be solved before you could get what you wanted? (Goal-path obstacle).



9. When you were feeling puzzled, how much of an ability did you feel you had to switch between modes of thought and to simultaneously think about multiple concepts? (Mental flexibility).



10. Indicate the degree to which the following emotions were felt whilst solving the problem: confidence, pleasure, confusion, surprise.

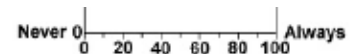


Fig. 3 Examples of some items from the questionnaire

In Fig. 3 shows examples of some items from the questionnaire. Items 1, 2, 3 are focused on the perception of difficulties, (the difficulty in the creation of the solution, the actions of discovery, the characterisation and establishing of relationships, and the basic actions involved in determining the mathematical model can generate) while items 7, 8, 9 are referred to the processes of evaluation (cognitive appraisal) and item 10 about emotions. The cognitive dimensions of assessment were as follows: pleasantness, attention activity, control, certainty, goal-path obstacle, anticipated effort, and mental flexibility. Furthermore, emotions such as confidence, pleasure, confusion, surprise were assessed (Gómez-Chacón, 2017).

Data analysis

Both qualitative and quantitative methods were used to address the subject of this study. This paper presents the quantitative analysis performed on the undergraduate students' written responses to the questionnaire. The CRT (*Classification and Regression Tree*) methodology is a data mining approach widely employed to develop 'IF-THEN' rule models in order to explain the behaviour of a variable of interest (the dependent variable) in terms of logical conditions over a set of explanatory or independent variables (see Breiman et al., 1984). Particularly, the CRT methodology allows for the determination of a subset of the available independent variables as well as a set of conditions over these variable's values that separate the data into groups as homogeneous as possible in terms of the values of the response or dependent variable. Regarding this aim, the CRT method performs successive dichotomous splits of the data by identifying both the independent variable and its cut-point that provide the greatest variability (i.e. variance) reduction at the split data groups verifying either condition (i.e. being greater or lower than such cut-point).

In this work we apply this regression tree methodology to develop a rule model capturing the relationships between a numerical dependent variable, measuring either the intensity of perception of using backward reasoning experienced by students while solving a mathematical problem, or a set of independent variables measuring the difficulties and mathematical and appraisal cognition. Different regression trees analysis were performed with SPSS to uncover the prescriptive nature of the variables. Two regression trees, together with their associated rule models, are reported next.

Results

Students' perception of the use of backtracking heuristics

In the comparison between the analysis of the protocols and the questionnaires, a discrepancy emerged between the real use of the backward strategy and the perception of its use by the students. 14 students (43.75%) were aware of using the strategy, 9 students (28.13%) were aware of not using the strategy, 4 students (12.5%) planned to use it, but it does not appear in the protocols and 5 students (15.63%) were not aware of having used it. This led us to track the students' perceptions in depth.

Difficulties of mathematical cognition in backtracking heuristics

Table 1 shows the percentages of students (in the questionnaire) who, according to the cognitive aspects of reasoning have failed to consider the *backtracking heuristic* use in their solutions.

To analyse the relationships between the difficulties expressed by the students and their perception of the use of backtracking heuristics (BH), we will use the classification tree of Figure 4 (Classification and Regression Tree (CRT) analysis). For the interpretation of the classification tree, we should go looking at the nodes and branching them until the final leaves. First, we look at the root node 0 that describes the dependent variable: Perception of the use BH to solve the problem (Q1). It indicates that 56, 2% has this perception. Then, note that the data is split into nodes 1 and 2 depending on the variable "*I consider that my process lacked the characterisation and*

establishment of relations” (Q3_7), indicating that this is the main predictor variable. The node 1 indicates that 75% of the students do not consider that the process *lacked the characterisation and establishment of relations*”. The 70,8% of these students have perception of the use of backtracking heuristics (BH)

Actions involved basically in the determining of the mathematical model	31%
Formulation of axioms	25%
Actions of discovery	22%
Characterisation and establishment of relations	22%
Attainment of sufficient conditions	19%
Creation of the object solution	16%
Attainment of justifications of adequate conditions in propositional equivalences.	16%
Recognition and explanation of the meaning of representational	13%

Table 1. Mathematical cognition processes in backtracking heuristics

This node 1 is again split up into nodes 3 and 4 depending on variable Q3_3 (*I consider that in my process there lacked the actions of discovery*”). We note in node 4 formed by the students that have difficulties in *the actions of discovery* (15,6% of the group) only have the perception of the use BH to solve the problem the 20%, , while students at node 3 that do not have this difficulty (59,4% of the group) have the perception of the use BH to solve the problem a 84,2%. These two nodes 3 and 4 are leaves that allow us to infer rules 2 and 3 below. Particularly, each path from the root of a decision tree to one of its leaves can be transformed into a rule simply by conjoining the conditions along the path to form the antecedent part, and taking the leaf’s mean as the rule prediction or consequent. Similarly, in order to define the rest of the rules, node 2 and the following ones are studied. The inferred rules are the following:

Rule 1 (node 2): IF *there are difficulties in the characterisation and establishment of relations* (Q3_7) THEN the prediction of the use of BH is supported by 12,5% of students.

Rule 2 (node 3): IF *there are not difficulties in the characterisation and establishment of relations* (Q3_7) AND *there are not difficulties in the actions of discovery* (Q3_3) THEN the prediction of the use of BH is the 84,2% of students.

Rule 3 (node 4): IF *there are not difficulties in the characterisation and establishment of relations* (Q3_7) AND *there are difficulties in the actions of discovery* (Q3_3) THEN the prediction of the use of BH is the 20% of students.

As we described in section 2, *characterizations of backward reasoning*, there are some fundamental elements that characterise the development of this type of reasoning on which relationships are identified with the affective and cognitive aspects. These processes necessarily involve different cognitive processes and specific skills in the subject such as, mental flexibility, control or ability to identify the problems that need to be solved beforehand as well as feelings of confidence and pleasure.

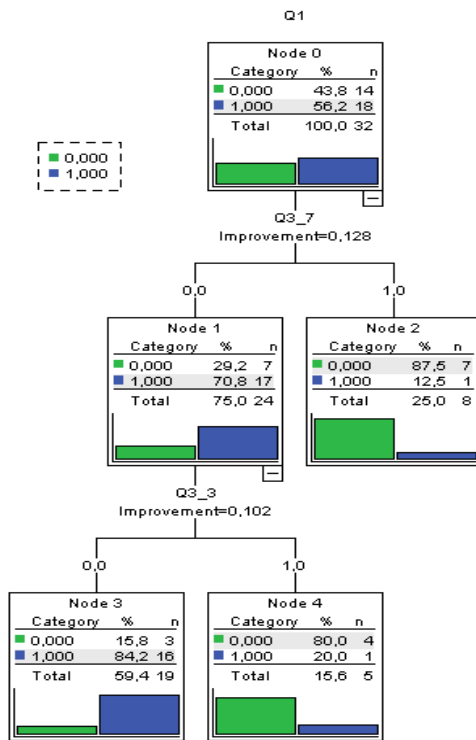


Fig. 4: Difficulties on mathematical cognition in backtracking heuristics according to the student's perception

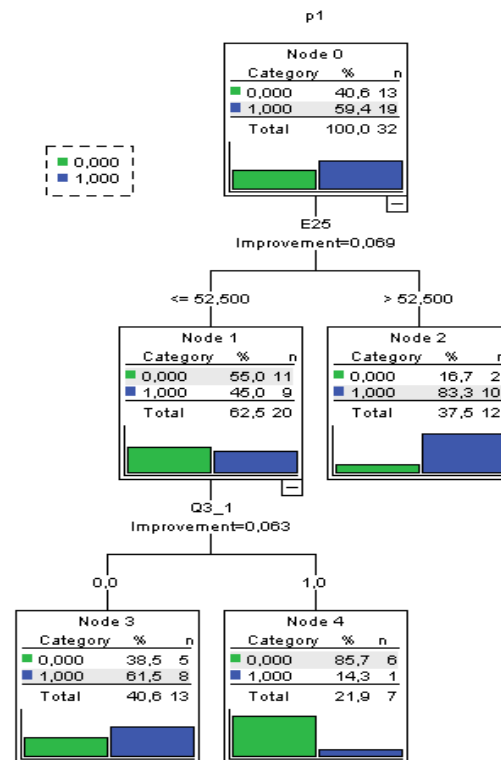


Fig. 5: Cognitive appraisal dimensions affecting the real use of backtracking heuristics

Affective and cognitive appraisal dimensions influencing the real use of backtracking heuristics

In the process of solving the problem, results indicate that only a 47 % of students show confidence working backtracking heuristics, and a degree of pleasure of mean: 36.86, indicating that *actions involved basically in the determining of the mathematical model* is the main predictor variable. The pleasure is greater (mean: 47.81) for those who use models.

From the classification tree ((CRT) analysis), the exploration of the real use of backtracking heuristics and some of the cognitive appraisal dimensions (Fig.5), we can infer the following rules:

Rule 1 (node 2): IF (*Mental flexibility* (E25)(>52.50)) the prediction of the use of BH is the 83,3%.

Rule 2 (node 3): IF ((*Mental flexibility* (E25) ≤ 52.50)) AND (“*There are not difficulties in the actions involved basically in the determining of the mathematical model*” (Q3_1)) THEN the prediction of the use of BH is the 61.5% of students.

Rule 2 (node 4): IF ((*Mental flexibility* (E25) ≤ 52.50)) AND (“*There are difficulties in the actions involved basically in the determining of the mathematical model*” (Q3_1)) THEN the prediction of the use of BH is the 14,3% of students.

Conclusions and discussion

The data shows that knowledge and use of backward reasoning are linked to situation-specific skills, namely, perception and planning of action through cognitive process. From the regression

trees analysis of the data, the following hierarchy of themes emerged as components of students' perceptions of the use of BH: associations between difficulties in the characterisation and establishment of mathematical relations and difficulties in the actions of discovery; and in the real use of BH: the person's ability of mental flexibility and the actions involved basically in the determining of the mathematical model. The perception of the use of BH is related to the difficulties while the real use of it is related to personal cognitive skills and specific concrete actions that entail the BH. The emotions, such as confidence and pleasure, arose out of information-oriented appraisals and the use of models or *actions involved basically in the determining of the mathematical model*.

These variables can significantly predict students' performance in backward reasoning in terms of: (a) identifying that backtracking heuristics are important in a problem solving situation; (b) using some characteristics of backward reasoning (mathematical processes, skills and the person's ability); and (c) making connections between broader features of backward reasoning to overcome specific difficulties.

Acknowledgments: The paper's elaboration has been supported by Dynamisation Networks Excellence Actions (EDU2016-81994-REDT) grant from the Government of Spain, and European Erasmus+ Programme *Partnership for Learning and Teaching in University Mathematics* (PLATINUM) (2018-1-NO01-KA203-038887).

References

- Antonini, S. (2011). Generating examples: focus on processes. *ZDM Mathematics Education*, 43: 205–217
- Barbero, M. & Gómez-Chacón, I. M. (2018). Analyzing Regressive reasoning at university level. In V. Durand-Guerrier, R. Hochmuth, S. Goodchild & N.M Hogstad (Eds.), *Proceedings of the Second Conference of the International Network for Didactic Research in University Mathematics (INDRUM 2018, 5-7 April 2018)*, 204-213. Kristiansand, Norway: University of Agder and INDRUM.
- Beaney, M. (2018). Analysis. In *The Stanford Encyclopedia of Philosophy*. Edward N. Zalta (ed.). Metaphysics Research Lab, Stanford University.
- Blömeke, S., Gustafsson, J.-E., & Shavelson, R. J. (2015). Beyond dichotomies: Competence viewed as a continuum. *Zeitschrift für Psychologie*, 223(1), 3–13.
- Breiman, L., Friedman, J. H., Olshen, R. & Stone, C. J. (1984). *Classification and Regression Trees*. Wadsworth International Group, Belmont, California.
- Gómez-Chacón, I. M. (2017). Emotions and heuristics: the state of perplexity in mathematics. *ZDM-The International Journal on Mathematics Education*, 49, 323-338.
- Hintikka, J., Remes, U. (1974). *The Method of Analysis: Its Geometrical Origin and Its General Significance*. Dordrecht: Reidel.
- Peckhaus, V. (2002). Regressive Analysis. *Log. Anal. Hist. Philos.*, 5: 97–110.
- Wickelgren, W. (1974). *How to solve problems. Elements of a theory of problems and problem solving*. San Francisco: Freeman and Company.
- Xu, J., Xing, T., Van Der Schaar, M. (2016). Personalized Course Sequence Recommendations. *IEEE Transactions on Signal Processing*, 64 (20), 5340-5352.

Teacher-student eye contacts during whole-class instructions and small-group scaffolding:

A case study with multiple mobile gaze trackers

Eeva Haataja, Visajaani Salonen, Anu Laine, Miika Toivanen and Markku S. Hannula

University of Helsinki, Finland, eeva.haataja@helsinki.fi, visajaani.salonen@helsinki.fi, anu.laine@helsinki.fi, miika.toivanen@helsinki.fi, markku.hannula@helsinki.fi

Recent gaze tracking research have illustrated patterns of teachers' visual attention in the classroom. However, the reciprocity of teacher-student interaction needs to be explored using multiple mobile gaze tracking. This descriptive case study is our first step to chart the role of dyadic eye contacts in the teacher-student interaction during collaborative mathematical problem solving. Our results indicate that, during mathematical problem solving, teacher gaze at student faces and student gaze at teacher face vary between whole-class instruction and small-group scaffolding moments. As a conclusion, we suggest that forming dyadic eye contact requires optimal interactional, personal, and environmental states, and this method can offer us fruitful information on the micro-level processes of teacher-student interaction.

Keywords: classroom orchestration, multiple gaze tracking, mathematical problem solving, teacher-student interaction

Introduction

The teachers' complex task of orchestrating the classes and lessons consists of interaction on various social levels (Prieto, Sharma, Kidzinski, & Dillenbourg, 2017). In the classroom, a great deal of teacher's visual attention focuses on her students (McIntyre, Mainhard, & Klassen, 2017). The teacher's visual attention is affected by the social interaction in the classroom (Prieto, Sharma, Kidzinski & Dillenbourg, 2017).

Recent research have illustrated the patterns and characteristics of teachers' visual attention during instructing the students (cf. Haataja et al., 2018a; McIntyre, Jarodzka, & Klasse, 2017; Prieto et al., 2017). This study brings new dimensions to this discussion by using multiple gaze tracking between the teacher and the students in the context of collaborative problem solving. We claim that connecting teacher's gaze at student face and student's gaze at teacher face in authentic classroom contexts reveals us unexplored micro-level information on teacher-student interaction.

Classroom interaction as whole-class instruction and small-group scaffolding

Teacher actions of classroom orchestration vary from whole-class instructing to guiding an individual student (Prieto et al., 2017). In whole-class interaction, the teacher's visual attention distributes unevenly between the students (Dessus, Cosnefroy & Luengo, 2016). Gaze tracking research has shown that instructing the class as a whole and paying attention at students' faces increase the cognitive load of a teacher. Cognitive load decreases when the teacher focuses on single student's solutions or his own notes (Prieto et al., 2017). Cognitive load increases person's perseverance and experiences of positive emotions during the task (Maranges, Schmeichel, & Baumeister, 2017).

In this study, we investigate two forms of teacher-student interaction during collaborative problem solving: whole-class instructing and small-group scaffolding. Scaffolding refers to the teacher's actions in a student group during a problem-solving learning process (Wood, Bruner, & Gail, 1976). The content and the direction of scaffolding influence the learning and the social interaction of the group. The teachers offer scaffolding on both mathematical contents and procedures and on peer interaction (Akkus & Hand, 2011; Ding, Li, Piccolo & Kulm, 2007). Our previous analysis on the data of this study showed that the teacher's intention in scaffolding interaction directs her visual attention mostly between mathematical solutions, student faces and hands (Haataja et al., 2018a; Haataja, Garcia Moreno-Esteva, Toivanen, & Hannula, 2018b). The teacher's role in supporting beneficial collaboration and successful discourse within the class is crucial (Cross, 2009).

Eye contact in teacher-student interaction

In social interaction, eye contact conveys warmth and communion on one hand, and agency and status on the other (Mehrabian, 1972). The occurrence of eye contact is found to be dependent of various variables. Other person's friendly response to eye contact initiative increases the experienced liking of her (Frischen et al., 2007). Teacher's eye contact, together with her open body position, use of personal examples, and humor form warmth that encourages students into participation and interaction (Roberts & Friedman, 2013). Teacher's gaze towards students, while asking questions and listening to them, increases their experience of close interpersonal relationship with the teacher (McIntyre et al., 2017).

The teacher can also address her authority in the classroom with direct gaze at student face (Mehrabian, 1972). With eye contact, the teacher can communicate that the students are in the locus of her attention and instructions (Adams, Nelson, & Purring, 2013; McIntyre et al., 2017). Additionally, an eye contact can convey the teacher's emotional state to students (Zeki, 2009).

The shorter the distance between the teacher and student is, the higher is the quality and amount of visual interaction between them. Beyond five metres, the visual interaction decreases significantly, as the distance to the source of information distracts the attention (Cardellino, Araneda & García Alvarado, 2017).

Research questions

The aim of this case study was to explore the general tendencies of teacher-student eye contacts during mathematical problem solving. Thus, our research question were:

1. How do one-way face-targeted gazes and dyadic eye contacts between teachers and students distribute during collaborative problem-solving phase of a mathematics lesson?
2. Does this distribution differ between whole-class instruction and scaffolding interactions?

Methods

The participants of this study were two Finnish mathematics teachers and their 9th grade classes. Both classes included 19 students. The first teacher, called by pseudonym Joanne, was 39 years old and had 14 years of teaching experience at the time of the data collection. In Joanne's class, the target group students were four girls. The second teacher, Fred, was 30 years old with three years of teaching

experience. In his class, the target group consisted of four boys. Both teachers and their students had volunteered for participating in this research. Written consent for data collection was inquired from the school principals, all the students in the classes, and the teachers.

We collected the data in both schools in May 2017. To record the interaction in the classrooms, we used three video cameras and several microphones. The teachers' and target students' visual attention was recorded using self-made mobile gaze tracking devices consisting of eye cameras, a scene camera and goggles (for further information, see Toivanen, Lukander, & Puolamäki, 2017). The laptops, that recorded the gaze-tracking data, were located in backpacks to enable moving around the classroom for the participants. After the lessons, we conducted stimulated recall interviews with the teachers and target students. Unfortunately, one student gaze data and Joanne's interview were missing due to technical problems.

During the data collection lessons, the students worked on a geometrical problem task. The goal of the problem solving process was to find the shortest way to connect vertices of a square. For this report, we have analyzed the collaborative phases of the lessons. During these phases (16 minutes in Joanne's and 18 minutes in Fred's class), the students worked on the problem task collaboratively. They were encouraged to discuss their ideas and solutions in small groups. In both classes, the four target students worked together as a collaboration group. Both teachers walked around the classrooms scaffolding student groups one-by-one. Additionally, they gave whole class instructions to orchestrate the course of the lesson.

To analyze the gaze data, we used ELAN software. Using gaze targets and dwell times as coding units, we annotated the gaze data during the collaborative phases of lessons. Dwell time means the duration of one gaze at a certain target, (Holmqvist et al., 2011) such as a student face, and offers us information on the distribution of a person's visual attention. Further analysis was conducted on IBM SPSS and Microsoft Excel. The face-targeted gazes from the same lessons were synchronized and categorized into four categories. The categories were 1) *Teacher gaze at student face*, 2) *Teacher-started dyadic eye contact*, 3) *Student-started dyadic eye contact*, and 4) *Student gaze at teacher face*. We chose this analysis to explore the amount of reciprocal nonverbal interaction between teachers and students and these categories to chart the initiative roles of this interaction. We also compared the gaze data with the transcribed stationary video data from the lessons to form qualitative and quantitative descriptions. From the classroom videos, we separated the moments of teacher instructions to the whole class from moments of scaffolding with collaboration groups of two to four students. In this report, we analyze these variables of face-targeted gazes and teacher interaction descriptively.

Results

The teacher-student interaction differed between Joanne's and Fred's lessons despite the similar problem task and lesson structure. Joanne's students seemed more motivated and the atmosphere in class was warm and supportive throughout the lesson. Fred's students expressed more negative emotions, but also enthusiasm and joy of learning. The Figure 1 shows all the individual face-targeted gazes across the collaborative phase in Joanne and Fred's lessons.

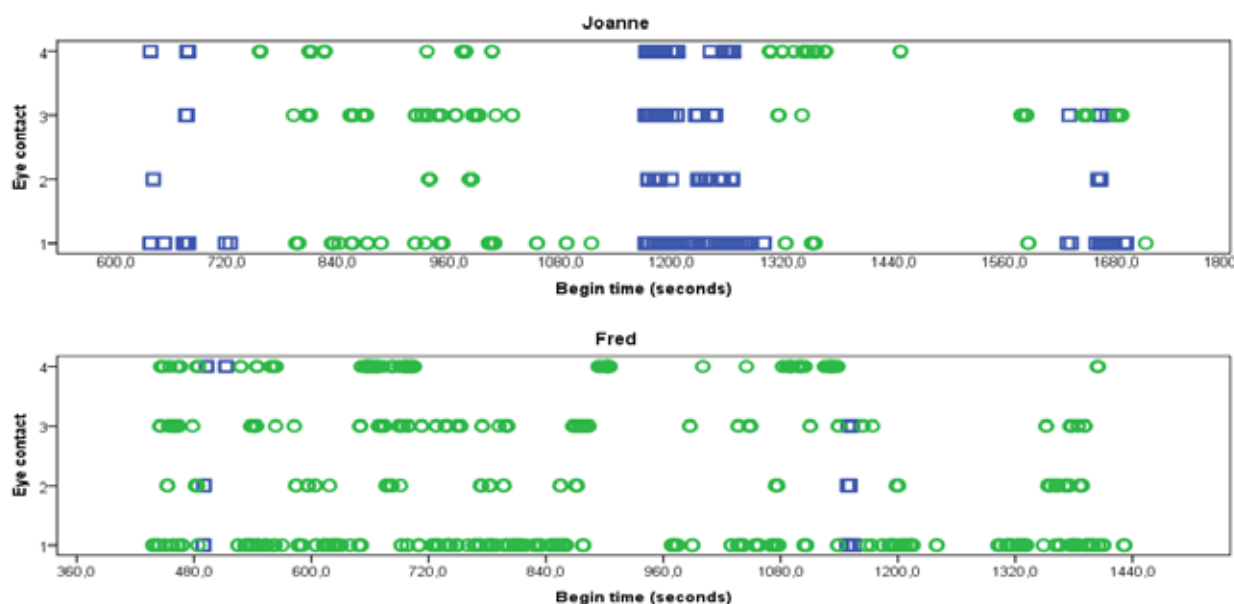


Figure 1 Face-targeted gazes during the collaborative problem solving sessions. The moments of whole-class instructions marked with blue squares and the phases of small-group scaffolding with green circles. The horizontal axis shows the beginning time of the gazes (seconds from the beginning of the lesson) with the frequency of 0.5 seconds and the vertical axis (1-4) the division into four categories: 1) teacher gaze at student face, 2) teacher-started dyadic eye contact, 3) student-started dyadic eye contact, and 4) student gaze at teacher face.

During collaborative problem solving phase, Joanne instructed the whole class more than Fred. In these moments, Joanne gave the students information and instructions on the progress of the lesson. During Joanne's problem solving phase, 63% ($n = 149$) of gazes occurred during whole-class instructions, while in Fred's class the proportion was only 4% ($n = 13$). While instructing, Joanne looked at her student's faces 88 times, even though the instruction moments covered only four minutes of the 16-minute-long collaboration phase.

During whole-class instructions, the target students looked at Joanne's face 20 times, and dyadic eye contacts between students and Joanne occurred 41 times, thrice with the target group. Fred gazed at his students' faces only five times and they looked at him twice without eye contact. Dyadic eye contacts occurred six times between a student and Fred during whole-class instructions but none of these was with a target student.

In Fred's class, the proportion of dyadic eye contacts was higher during the short moments of whole class instructions (46%, $n = 6$) than in Joanne's class (27%, $n = 41$). When giving whole-class instructions, Joanne spoke with loud voice and stood in front of the class. In these moments, the students' tendency to create or respond to dyadic eye contacts with the teacher decreased. In Fred's class, the interaction during collaborative problem solving phase happened almost completely in scaffolding interaction with student groups and he did not seek for capturing the attention of the whole class while the students were working on the task.

Figure 2 presents the distribution of four types of face-targeted gazes between the teacher and target students. Again, the gazes are categorized according to the direction between the teachers and students, and compared between interactional categories of whole-class instructions and scaffolding.

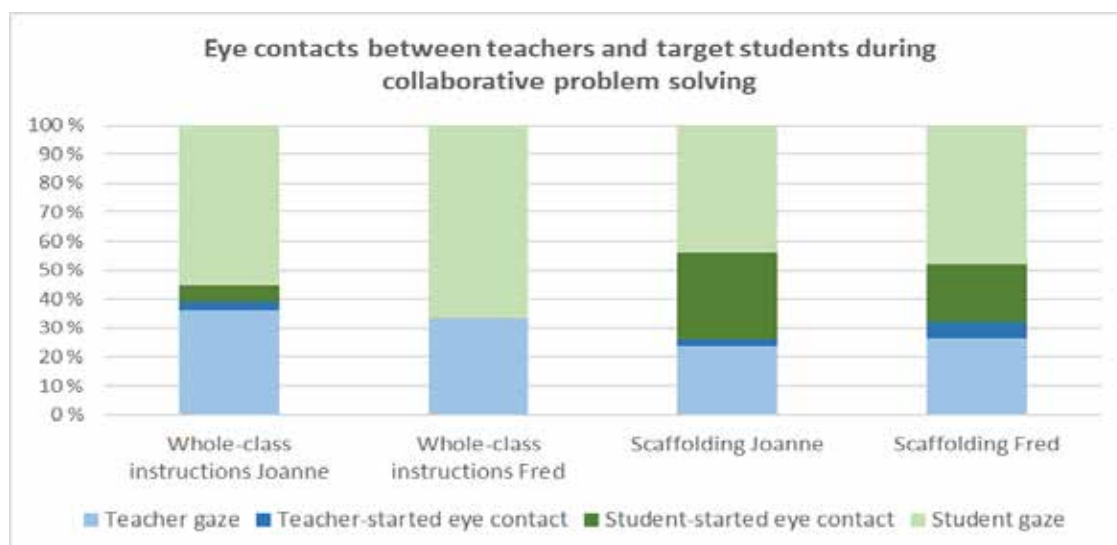


Figure 2 The distribution of teacher and student face-targeted gazes during two collaborative problem solving session with teachers called Joanne and Fred.

During scaffolding the target group, the eye contacts distributed similarly with both teachers. The observed four girls in Joanne's class and three boys in Fred's class gazed at their teachers more than other way around. While the teachers focused on one student's solutions or face at the time, the other three or two students often gazed at the teacher. Student gazes at teacher faces covered 44% ($n = 22$) of face-targeted gazes during scaffolding interaction in Joanne's class and 48% ($n = 60$) in Fred's class. The teachers seemed to have different intentions for the scaffolding interaction than the students. While the teachers' intention in the group varied between the problem-solving process and the motivational and emotional states of the students, students were willing to focus on the teachers as they arrived to the groups. The teachers' arriving to the group seemed to capture students' attention and pause their problem solving process. During verbal communication, the students often looked the teacher in the face even if the teacher was looking at and talking about the solutions.

While scaffolding other small-groups than the target group, Fred (74%, $n = 131$) scanned the students with one-way teacher gaze more often than Joanne (41%, $n = 15$) and Joanne had more dyadic eye contacts with students in other groups (54%, $n = 20$) than Fred did (23%, $n = 41$). In general, Joanne's students were more motivated and less frustrated than Fred's students and he had to be more critical in the interaction with them. In Joanne's classroom, the interaction throughout the problem solving process was warm and immediate, while Fred's lesson included also negatively loaded communication. However, Fred's class also included students who were concentrated in solving the challenging task, and hence not in need of the teacher's scaffolding.

In Fred's class, also the teacher's emotional state seemed to affect his gaze behavior. In the beginning of the collaborative phase, the target students joked at Fred, and they were not enthusiastic to solve the problem throughout the lesson. The uncertainty and pauses in Fred's speech in this moment

indicated that this event annoyed or embarrassed him and he avoided eye contacts with these students. After the confusion, Fred told the students to concentrate and continued scaffolding successfully. During scaffolding, three moments occurred, during which the target students tried to create an eye contact with Fred unsuccessfully. They directed several gazes ($n = 14, 8, \text{ and } 8$) at Fred's face without receiving any response. During these moments, Fred guided them with verbal interaction but directed his gaze at student papers. Interview with him indicates that this aversion was more of pedagogical than purely emotional origin, as Fred wanted to calm the students and behave as an authority.

Discussion

Orchestrating collaborative instruction and classroom interaction is a complex and challenging task that is affected by various different factors (Prieto et al., 2017). The educational research field has rapidly adopted mobile gaze tracking as a method of data collection in real learning contexts. The use of multiple gaze tracking opens unexplored aspects of micro-level teacher-student interaction. In this paper, we have moved towards capturing the social nature of teaching and learning by using multiple gaze trackers simultaneously.

To summarize the results, the teachers' gaze behavior seemed to vary more depending the interactional state than the students' did. The students looked their teacher in the face both during whole-class instruction, and when the teachers were scaffolding the small-groups. This seems to be a result of teachers' social status and high agency in the classroom (Mehrabian, 1972). Even though collaborative problem solving is a student-centered learning method, the teacher's contribution in orchestrating the learning process is essential (Cross, 2009). The students need teacher's guidance, advice, and confirmation, which she can offer through eye contact and verbal instruction.

However, the teachers, especially Joanne, focused on her students' faces during whole-class instruction moments. In these moments, she looked at her students with numeral, short gazes. This finding is in line with the literature on teacher orchestration load (Prieto et al., 2017) and expertise (McIntyre et al., 2018). When speaking in front of the class, regardless of the content of the instructions, Joanne concentrated in addressing her message through direct gazes at student faces.

In Joanne's class, the target group was located closer to the front of the classroom, while in Fred's class the target students were seated in the back. As Cardellino et al. (2017) suggest, this may affect to the count of eye contacts between the students and the teachers. In Fred's class, no dyadic eye contacts were formed between him and the target students when Fred was standing in the front. Additionally, Fred's target students were not as motivated in solving the task as Joanne's were, and he may have unconsciously directed his instructions to those students he knew were waiting for them.

When changing the interactional state from whole class to a collaboration group, we found general characteristics in the gaze behaviors of teachers and students. The teachers were in the locus of students' attention in all interactional moments. While in whole class interaction the teacher's attention distributes unevenly (Dessus et al., 2016), we interpret that in small-group scaffolding moments all kinds of students had an opportunity to be seen and heard. Despite their misbehavior, the target students in Fred's class pursued his attention. Fred seemed to avoid dyadic eye contact with them after the confusions to act as an authority and direct their attention to the learning task.

Naturally, this exploratory study has certain limitations. First, the missing data (one student gaze recording and one teacher interview) and the differences in the counts of gazes between the lessons hinder the comparative interpretations. However, this is a case study, and all the comparisons are qualitative by nature. Their purpose is to chart the phenomena for more statistical analysis in the future. For instance, in this report the student groups happened to be of same gender as their teachers. In this analysis, the attentional patterns were quite similar between the two lessons. In future, the effect of altering the gender structure of the participants might be relevant to investigate. The quality of the gaze and video data was very high, which helped us in making analysis and interpretations. Each recording was annotated by only one researcher. Nevertheless, the research group negotiated on controversial issues during the annotation and interpreted the data collaboratively.

This study shows that adding student gaze data to teacher gaze data reveals aspects that would not be possible to be explored with only one gaze tracker. For instance, students' unsuccessful attempts to create eye contacts with the teacher and vice versa are indicators of the complexity of teacher-student verbal and nonverbal interaction. In future, we wish to examine more how teacher-student eye contacts are affected by aspects emerging in this analysis: the teacher and student personalities, methods of teacher-student interaction, and the physical learning environment.

Acknowledgments

We would like to thank Jessica Salminen-Saari and Tran Phuoc for their contribution in collecting, organizing and annotating the data. This research is a part of MathTrack project that is funded by the Academy of Finland (grant 297856).

References

- Adams, R. B. Jr., Nelson, A. J., & Purring, K. (2013). Eye behavior. In J. A. Hall & M. L. Knapp (Eds.), *Nonverbal communication* (pp. 229–262). New York, NY: de Gruyter Berlin.
- Akkus, R., & Hand, B. (2011). Examining teachers' struggles as they attempt to implement dialogical interaction as part of promoting mathematical reasoning within their classrooms. *International Journal of Science and Mathematics Education*, 9(4), 975–998. doi: 10.1007/s10763-010-9266-8
- Cardellino, P., Araneda, C. & García Alvarado, R. (2017). Classroom environments: an experiential analysis of the pupil–teacher visual interaction in Uruguay. *Learning Environment Research*, 20. doi: 10.1007/s10984-017-9236-y
- Cross, D. (2009). Creating optimal mathematics learning environments: Combining argumentation and writing to enhance achievement. *International Journal of Science and Mathematics Education*, 7(5), 905–930. doi: 10.1007/s10763-008-9144-9
- Ding, M., Li, X., Piccolo, D., & Kulm, G. (2007). Teacher interventions in cooperative-learning mathematics classes. *The Journal of Educational Research*, 100(3), 162–75. doi: 10.3200/JOER.100.3.162-175
- Frischen, A., Bayliss, A. P., & Tipper, S. P. (2007). Gaze Cueing of Attention: Visual Attention, Social Cognition, and Individual Differences. *Psychological Bulletin*, 133(4), 694–724. doi: 10.1037/0033-2909.133.4.694

- Haataja, E., Garcia Moreno-Esteva, E., Salonen, V., Laine, A., Toivanen, M., & Hannula, M. S. (2018a). *Teacher's Visual Attention when Scaffolding Collaborative Mathematical Problem Solving*. Manuscript submitted for publication.
- Haataja, E., Garcia Moreno-Esteva, E., Toivanen, M. & Hannula, M. S. (2018b). Teacher's gaze behavior when scaffolding peer interaction and mathematical thinking during collaborative problem-solving activity. In E. Bergqvist, M. Österholm, C. Granberg, & L. Sumpter (Eds.), *Proceedings of the 42nd Conference of the International Group for the Psychology of Mathematics Education*. Vol. 2, (pp. 475–482). Umeå, Sweden: PME International Group.
- Maranges, H. M., Schmeichel, B. J., & Baumeister, R. F. (2017). Comparing cognitive load and self-regulatory depletion: Effects on emotions and cognitions. *Learning and Instruction, 51*, 74-84, doi:10.1016/j.learninstruc.2016.10.010.
- McIntyre, N.A., Jarodzka, H. & Klassen, R.M. (2017). Capturing teacher priorities: Using real-world eye-tracking to investigate expert teacher priorities across two cultures. *Learning and Instruction*. doi:10.1016/j.learninstruc.2017.12.003.
- McIntyre, N. A., Mainhard, T., & Klassen, R. M. (2017). Are you looking to teach? Cultural, temporal and dynamic insights into expert teacher gaze. *Learning and Instruction, 49*, 41–53. doi: 10.1016/j.learninstruc.2016.12.005
- Mehrabian, A. (1972). *Nonverbal communication*. Chicago, IL: Aldine.
- Prieto, L. P., Sharma, K., Kidzinski, Ł., & Dillenbourg, P. (2017). Orchestration load indicators and patterns: In-the-wild studies using mobile eye-tracking. *IEEE Transactions on Learning Technologies*. doi: 10.1109/TLT.2017.2690687
- Roberts, A., & Friedman, D. (2013). The impact of teacher immediacy on student participation: An objective cross-disciplinary examination. *International Journal of Teaching and Learning in Higher Education, 25*(1), 38–46.
- Toivanen, M., Lukander, K., & Puolamäki, K. (2017). Probabilistic approach to robust wearable gaze tracking. *Journal of Eye Movement Research, 10*(4), 1–26. doi: 10.16910/jemr.10.4.2
- Wood, D., Bruner, J., & Gail, R. (1976). The role of tutoring in problem solving. *Journal of Child Psychology and Psychiatry, 17*(2), 89–100. doi: 10.1111/j.1469-7610.1976.tb00381.x
- Zeki, C. P. (2009). The importance of non-verbal communication in classroom management. *Procedia - Social and Behavioral Sciences, 1*(1), 1443–1449. doi:10.1016/j.sbspro.2009.01.254.

Collaborative processes when reasoning creatively about functions

Ellen Kristine Solbrekke Hansen

Norwegian University of Life Sciences, Faculty of Science and Technology, Norway;
ellen.hansen@nmbu.no

Keywords: Collaborative processes, creative reasoning, function problems.

As observed for the last 50 years, students in upper secondary school struggle with the function concept (Dubinsky & Wilson, 2013). The function concept can be represented in different ways, for example as a graph, a table, or an algebraic expression. Translating from one representation to another, transforming a situation into a function, and discovering the function notation are important for students' ability to "describe relationships of change between variables, explain parameter changes, and interpret and analyze graphs" (Clement, 2001, p. 745). Students' exploration and engagement in making connections, for instance among different function representations, is important for understanding mathematical concepts and for learning to apply it as a tool in problem solving (Francisco & Maher, 2005; NCTM, 2014). In a student-centered environment with focus on collaboration, students have the opportunity to investigate, share and evaluate each other ideas. Research on mathematical communication, supporting students' collaborative activity and reasoning, is crucial for students' mathematical understanding (Maher, Sigley, Sullivan, & Wilkinson, 2018; Mueller, Yankelewitz, & Maher, 2012).

Lithner (2017) defines reasoning as "the line of thought adopted to produce assertions and reach conclusion in task solving" (p. 3), and proposes two main types of reasoning while solving a mathematical problem: imitative and creative. Students' reasoning do not have to be formal, a mathematical proof or a high-quality argument, it simply has to make sense to the student himself (Lithner, 2015). Creative mathematical reasoning (CMR) sequences are created (or re-created) by the student, plausible to him, and anchored in intrinsic mathematical properties (Lithner, 2015). Imitative reasoning, on the other hand, refers to imitating a solution procedure or memorizing facts (Lithner, 2015). Imitative reasoning is closely linked to rote learning, whereas creative reasoning to a larger extent will promote conceptual understanding (Lithner, 2017). Roschelle and Teasley (1994) define collaboration as a "coordinated, synchronous activity that is the result of a continued attempt to construct and maintain a shared conception of a problem" (p. 70). If mutually engaging in problem solving "students share ideas and ways of solving problems; thus individual understanding becomes shared" (Mueller et al., 2012, p. 372). Creating a shared understanding between collaborating students, is what Roschelle and Teasley (1994) call a Joint Problem Space (JPS). Constructing JPS is processes of building (suggesting and agreeing upon ideas), monitoring (questioning and explaining ideas) and repairing (negotiations and corrections of conflicting ideas), through the use of language and the situation (Roschelle & Teasley, 1994).

There are many theoretical frameworks for analyzing students' difficulties with the function concept, but not corresponding literature providing pedagogical strategies helping students overcome these difficulties (Dubinsky & Wilson, 2013). The current ongoing research project focuses on both student-student interaction, as well as the interaction between the student and the teacher. In line with Design-Based Research (DBR) methodology, three teachers and their mathematics students (age 16)

from a Norwegian upper secondary school participated in an iterative cycle for testing and developing an intervening design (Juuti & Lavonen, 2006). In the student-student interaction, the aim is to provide insight in the collaborative processes when reasoning about a function problem. Combining such insight with perspective on teacher-student(s) interaction, could give further insight to pedagogical strategies for promoting students' reasoning in collaboration, for deeper understanding of mathematical concepts.

This paper poster will illustrate a student-student interaction in a pair creating their JPS through processes of building, monitoring and repairing, when engaging in creative mathematical reasoning. Particularly, different aspects in their argumentation connected to the process of repairing their shared understanding. Some periods in their conversation were identified as CMR-sequences, characterized by turn-taking and creative mathematical reasoning solving a part of the function problem. However, not every uttering in the turn-taking was identified as creative. In situations where students had conflicting ideas, they often argued for their thoughts. Students used superficial arguments to support ideas, as well as arguments built on mathematical properties. If a counter-suggestion was made, without any support, and conflicting the other students' idea, the following process was significant. If only accepting the counter-suggestion, they were not likely to explore different representations and deeper meaning of the function concept together. Thus, experiencing ownership in the problem solving process, or over the mathematical content, was not likely to happen. If not agreeing on the counter-suggestion, the peer could ask questions about the idea, or make a counter-suggestion. Anchoring the counter-suggestion, question or suggestion in properties regarding the function concept, were important for the process of creating the JPS. Hence, repairing of the shared conception of the problem, or sub-problem, indicated to a greater extent mutual ownership.

REFERENCES

- Clement, L. L. (2001). What do students really know about functions? *The Mathematics Teacher*, 94(9), 745–748.
- Dubinsky, E., & Wilson, R. T. (2013). High school students' understanding of the function concept. *The Journal of Mathematical Behavior*, 32(1), 83–101.
- Francisco, J. M., & Maher, C. A. (2005). Conditions for promoting reasoning in problem solving: Insights from a longitudinal study. *The Journal of Mathematical Behavior*, 24(3-4), 361–372.
- Juuti, K., & Lavonen, J. (2006). Design-Based Research in Science Education: One Step Towards Methodology. *NorDiNa*, 4, 54–68.
- Lithner, J. (2015). Learning mathematics by creative or imitative reasoning. In S. Cho (Ed.), *Selected Regular Lectures from the 12th International Congress on Mathematical Education* (pp. 487–506). Cham, Switzerland: Springer.
- Lithner, J. (2017). Principles for designing mathematical tasks that enhance imitative and creative reasoning. *ZDM Mathematics Education*, 49(6), 937–949.
- Maher, C. A., Sigley, R., Sullivan, P., & Wilkinson, L. C. (2018). An international perspective on knowledge in teaching mathematics. *The Journal of Mathematical Behavior*, 51, 71–79.
- Mueller, M., Yankelewitz, D., & Maher, C. (2012). A framework for analyzing the collaborative construction of arguments and its interplay with agency. *Educational Studies in Mathematics*, 80(3), 369–387.
- NCTM. (2014). *Principles to actions: Ensuring mathematical success for all*. Reston, VA: NCTM.
- Roschelle, J., & Teasley, S. D. (1994). The construction of shared knowledge in collaborative problem solving. *NATO ASI Series F Computer and Systems Sciences*, 128, 69–69.

What can metaphor tasks offer for exploring preservice mathematics teachers' beliefs?

Çiğdem Haser

University of Turku, Faculty of Education, Finland; cigdem.haser@utu.fi

The purpose of this study was to investigate preservice middle school mathematics teachers' (PMT) beliefs about the nature of mathematics in metaphor tasks when they are designed and analyzed in different ways and their beliefs about mathematics teacher. Nine PMTs attending the practice teaching course completed four metaphor tasks (two open-ended, two structured) about mathematics, mathematics teacher, mathematics teaching and learning through the semester. The metaphors they produced were analyzed both by the revised version (Löfström et al., 2010) of the identity framework by Beijard et al. (2000) and with an inductive analysis. Findings suggested that employing open-ended task structure and inductive analysis might provide more information about PMTs' beliefs about the nature of mathematics even in metaphors that are not constructed for mathematics.

Keywords: Metaphors, beliefs about mathematics, preservice middle school mathematics teachers.

Metaphors and beliefs

Metaphors are the constructs that are used to explore one concept/happening/issue by the help of another (Lakoff & Johnson, 1980) and are used to interpret the complexity of teaching and learning interaction components (Saban, 2006). Metaphors are among the tools that enable teacher educators have access to and explore the preservice teachers' beliefs (Reeder, Utley & Cassel, 2009). Researchers have often asked preservice teachers about their metaphors especially about teaching and learning to make sense of their beliefs and their implicit theories about education (Leavy, McSorley, & Bote, 2007). Metaphors are also used in teacher education programs to make preservice teachers reflect on their beliefs (Noyes, 2006) and to increase their awareness of their beliefs and teacher selves, to build connections between these selves and teaching, and further to change their beliefs (Saban, 2006).

Several studies have explored preservice (Haser, Arslan, & Çelikdemir, 2015) and inservice (Oksanen & Hannula, 2013; Pantziara, Karamanou, & Petridou, 2017) mathematics teachers' beliefs about mathematics teacher through metaphors by using the framework developed by Löfström et al. (2010) based on the identity framework of Beijard, Verloop and Vermunt. (2000). Beijard et al. (2000) suggested three teacher identity categories as *subject matter expert*, *pedagogical expert* and *didactical expert*. They explained that teacher as a subject matter expert knows mathematics well and transmits this knowledge to the students. Teacher with a pedagogical expertise cares about students' well-being and their growth as a person. When teachers are didactical experts, they organize teaching and learning environments to guide students in their learning efforts. Löfström et al. (2010) further suggested that teachers have characteristics that do not fit the three identity categories defined earlier as in *self-referential* metaphors, and the *contextual* references to the teacher identity could also be seen in metaphors. The mentioned studies showed that the identity framework could be used to explore preservice and inservice teachers' beliefs about mathematics teacher and what they prioritize

for the work mathematics teachers do. These studies have found that Cypriot teachers of grades 10-12 (Pantziara et al., 2017) and Finnish teachers of grades 7-9 (Oksanen & Hannula, 2013) prioritized didactical expertise for mathematics teachers. Mathematics teachers in these studies addressed self-referential metaphors after didactical expert metaphors. Although these metaphors are likely to address teachers' other mathematics-related beliefs (Haser et al., 2015), such an analysis has not been reported in these studies.

Similarly, when we asked Turkish preservice middle school mathematics teachers (PMTs) to write a metaphor for the mathematics teacher and explain it, they prioritized didactical expertise (Haser et al., 2015). In our unpublished analysis, we found that PMTs referred to the nature of mathematical knowledge, how it is related to other fields of science and that mathematics teachers needed to know about these characteristics of mathematical knowledge, while explaining their metaphors for mathematics teacher. Such reference to the nature of mathematics suggested adopting an inductive approach to the analysis of metaphors' explanations in order to trace PMTs' beliefs about the nature of mathematics, even when these metaphors were not constructed for mathematics.

Considering the findings of previous studies, which explored preservice and inservice teachers' mathematics related beliefs through metaphors, the purpose of this study was to investigate what metaphors can offer for understanding PMTs' mathematics related beliefs, and specifically beliefs about the nature of mathematics, even when they were not constructed for mathematics. The study also explored the change in PMT's beliefs about mathematics teacher. PMTs' explanations for metaphors, which were used in a practice teaching course as a reflection tool, were analyzed by the above-mentioned revised identity framework and by inductive analysis to explore PMTs' beliefs.

Method

The study was conducted in a middle grades (5 to 8) mathematics teacher education program in Turkey. All nine (female) PMTs attending the practice teaching course section that I taught were the participants of the study. PMTs have completed mathematics teaching methods courses and school experience course, and they were in the last semester of the program except for one student who had two more courses to take. They attended the same practice school for six hours each week, observed several mathematics teachers during the semester, completed emerging tasks in the school, and taught mathematics for at least one class hour. They also attended two hours of University course that I taught every week and discussed the emerging themes and issues of the week from the mathematics lessons they observed, and completed in-class tasks such as constructing metaphors and their explanations for mathematics related themes. The data of the study were PMTs' responses to the four metaphor tasks they completed during the class hours (50+50 minutes) and the detailed course notes that I kept during the course. Table 1 presents the content of the metaphor tasks used in the study through the semester (15 weeks).

Task 1 and Task 2 were considered as *open-ended tasks* because PMTs were only asked to construct a metaphor and explain it, and they were not asked to consider this in a certain way. Task 3 and Task 4, however, were considered as *structured tasks* because PMTs were asked to select one theme, construct a metaphor for it, then think about relationships of this theme to the others, and construct metaphors for these themes.

Tasks and weeks	Content of the metaphor tasks
Task 1 (1 st week)	Math teacher is like Because..... Math teaching is likeBecause
Task 2 (2 nd week)	Math is like Because
Task 3 and Task 4 (3 rd week and 15 th week)	Choose a starting theme (math, math teacher/teaching/learning) and construct a metaphor for this theme. Then, connect it to the remaining themes by constructing related metaphors for them. Please explain the relationships.

Table 1: Metaphor tasks

Initial data analysis focused on the explanations for mathematics teacher metaphors to reveal PMTs' beliefs about mathematics teaching by employing the revised framework. Then, I conducted an inductive analysis (Miles, Huberman, & Saldana, 2014) for all metaphor explanations in order to explore PMTs' beliefs about mathematics. First, I read all the explanations for metaphors in detail and took notes on possible codes such as, mathematics in daily life and connectedness of mathematical knowledge. Next, I went through data once more and coded the data with the code list I developed with room for possible new codes such as, mathematics-related skills. The analysis was completed after no new codes were generated and all data were analyzed with all the codes. The metaphors themselves were not the focus of the analysis because there were several cases that PMTs explained the same metaphor in different ways throughout the tasks. Or, they used different metaphors in each of the tasks for mathematics teacher and still referred to the same teacher expertise in their explanations for these metaphors. Therefore, the focus of the analysis was on PMTs' explanations for their metaphors.

Findings

First, findings related to the mathematics teacher expertise that PMTs prioritized are presented. Then, findings about beliefs about the nature of mathematics extracted from PMTs' explanations for all the metaphors were presented for each metaphor task. Metaphors PMTs used are reported briefly.

Beliefs about mathematics teacher through the semester

PMTs wrote a metaphor for mathematics teacher and the explanations for their metaphors in Task 1, Task 3 and Task 4. The analysis of the explanations for their mathematics teacher metaphors through the revised framework is given in Table 2. The types of expertise identified in the metaphor explanations are indicated by "D" for didactical expert, "SM" for subject matter expert, "P" for pedagogical expert, and "SR" for self-referential as indicated in the revised framework.

PMTs prioritized didactical expertise (cook, driver, pine tree) for mathematics teachers. Almost all participants in all tasks explained how a mathematics teacher is a didactical expert. PMT6 and PMT9 addressed only didactical expert in their explanations in all three tasks and PMT1, PMT5 and PMT8 prioritized other expertise (mostly subject matter) in their explanations in addition to the didactical expertise. PMT2, PMT3 and PMT4 addressed didactical expertise in two of the three tasks and PMT1,

PMT5 and PMT7 addressed subject matter expertise (calculator manual, tour guide) in their explanations for two of the three tasks.

Participants	Task 1	Task 3	Task 4
PMT1	D, SM	D	D, SM
PMT2	D, P	D	SR
PMT3	D, SR	SR	D
PMT4	P	D, SM	D
PMT5	D, SM	D, P	D, SM
PMT6	D	D	D
PMT7	SM, SR	SR	D, SM
PMT8	D, SM	D	D
PMT9	D	D	D

Table 2: Participants' identities as determined in the metaphors about mathematics teacher

These findings showed that in the beginning of the semester PMTs tended to believe that mathematics teachers were mostly didactical experts. This focus on teachers' didactical expertise increased as the semester progressed. They also addressed subject matter expert, self-referential and pedagogical expert identities. Hybrid metaphors mostly included didactical and subject matter expertise, and did not include more than two expertise. Context did not appear in PMTs' metaphors.

Mathematics in mathematics teacher and mathematics teaching metaphors (Task 1)

Five PMTs mentioned about the nature of mathematics in their explanations of the mathematics teacher metaphor. Mathematics is discovered by the help of the teacher (PMT1, PMT6) who also guides for other skills such as "*problem solving, critical thinking*" (PMT9) and building connections between mathematics, daily life and other sciences (PMT5).

Seven PMTs mentioned about the nature of mathematics while explaining the mathematics teaching metaphor (using magnifying glasses, making the light available for everyone). There were references to mathematics in real life (PMT3, PMT5, PMT6) and mathematics related skills such as "*interpreting the world differently*" (PMT3). Teaching mathematics was also framed in terms of characteristics PMTs associated with the nature of mathematics such that it can be discovered (PMT1, PMT3), it includes connections (PMT8), and it is expanding (PMT3, PMT9).

Most of these PMTs stated in their explanations that since mathematics has certain characteristics, mathematics teacher or mathematics teaching must be in a certain way. Some even constructed a metaphor for mathematics for the explanation first, and then framed mathematics teacher or teaching based on this metaphor. Even though mathematics was a beginning point for most PMTs, the teacher and teaching metaphors they constructed seemed disconnected in Task 1, such as P9's metaphor for mathematics teacher (bitter syrup for students) and teaching (filming an advertisement).

Mathematics in mathematics metaphors (Task 2)

PMTs' explanations for their metaphors about mathematics (the code for existence, atmosphere, infinite chain of paper-clips) emphasized the necessity of mathematics in daily life (PMT6, PMT7, PMT9). Besides, mathematics is fundamental to understanding the life, the nature, and the other sciences (PMT2, PMT3, PMT6). Therefore, mathematics is important and needed (PMT2, PMT6, PMT9). PMT5 mentioned about the infinite nature of the mathematical knowledge. Only PMT9 emphasized that we use skills such as “*understanding situations, problem solving, foreseeing causes [and related] consequences, or evaluating*” while doing mathematics. PMT8 used “*being an explorer*” as a metaphor for mathematics and emphasized that mathematical knowledge is discovered or newer ways of reaching mathematical knowledge are discovered.

Mathematics in mathematics related metaphors – 1 (Task 3)

Task 3 and Task 4 asked PMTs to select one theme, construct a metaphor for that theme, and then continue to construct metaphors for the other themes. Eight of the PMTs started with a metaphor for mathematics in Task 3. Then, seven of them continued with either mathematics teacher or mathematics teaching themes. PMT4 started with mathematics teacher, continued with mathematics and then, with mathematics teaching.

The explanations for mathematics metaphors (flower, second mother tongue, fruit tree) emphasized that mathematics is fundamental to life and other sciences and humanity needs mathematics (PMT6, PMT9). Mathematics concepts are related to each other:

Mathematics is like chess. Because mathematics has rules, theorems and formulas [...] related to each other and all of those compose mathematics. Chess also has certain rules, strategies; and since there are relationships between strategies and more explicitly, since [strategies] change based on each move, mathematics is like chess. (PMT1)

There is always something to discover in mathematics (PMT9), it promotes analytical thinking (PMT2), and we always come across mathematics in our daily lives (PMT2, PMT6, PMT7, PMT9).

Metaphors about mathematics teaching and mathematics teacher did not reveal beliefs about mathematics in Task 3. Only PMT1 referred to the new ways to reach mathematical knowledge in her metaphor for mathematics teacher and PMT8 emphasized that mathematics helps us develop real life relationships in her explanation for her metaphor for mathematics teaching.

Mathematics in mathematics related metaphors – 2 (Task 4)

Similar to Task 3, all participants except PMT4 started Task 4 by constructing a metaphor for mathematics, and they continued with a metaphor for the mathematics teacher or mathematics teaching. This time, PMT4 started with a metaphor for the mathematics teaching, and then continued with mathematics and mathematics teacher.

Metaphors for mathematics (second mother tongue, water, endless travel) addressed that mathematics is an expanding field and it is infinite (PMT2, PMT3, PMT7). It is fundamental to life like “*the atmosphere. Atmosphere covers the earth and it is important for life*” (PMT6) and human beings need

it. Similarly, they need mathematics. It improves and changes our ways of thinking (PMT9) and it is in our everyday life (PMT5, PMT6, PMT9).

Only PMT9 wrote about discovering mathematical concepts in her metaphor for mathematics teacher and PMT5 stated that mathematics is in our daily life. PMT9, in her metaphor for mathematics teaching, referred to the skills that (knowing) mathematics provides, the coherence among the mathematical concepts and that human beings need mathematics.

PMTs realized that they could not connect their metaphors about mathematics, mathematics teacher and mathematics teaching all the time and claimed that this was challenging in both Task 3 and Task 4. They did not prefer to state metaphors for mathematics learning in Task 3 and Task 4. The metaphor explanations did not refer to students most of the time.

Conclusions and discussion

The analysis of explanations for the mathematics teacher metaphors showed that most of the PMTs seemed to prioritize teachers' didactical expertise, most probably due to spending considerable time in the practice school and program's emphasis on improving didactical skills (Haser et al., 2017) especially in the last semester. This didactical expertise emphasis and explanations for mathematics teaching metaphors included several references to the nature of mathematical knowledge.

PMTs expressed very similar beliefs about mathematics across the tasks and these beliefs did not change much as the semester progressed. Mathematics was at the center of real life and other sciences. Therefore, humanity needed mathematics. Knowing or being able to do mathematics provided several skills such as problem solving and analyzing complex situations better. Mathematical knowledge was expanding and it could be discovered. These beliefs were not only in their metaphors for mathematics, but also in their metaphors for mathematics teacher and teaching in Task 1, and they did not change from the beginning to the end of the semester, suggesting that these beliefs might be held by the PMTs more strongly.

Inductive analysis of open-ended metaphor tasks about mathematics teachers and teaching provided more clues about PMTs' beliefs about the nature of mathematical knowledge when the metaphors were not constructed for mathematics in Task 1. However, the metaphors for mathematics teacher and teaching in Task 1 were very disconnected even though these metaphors were asked in the same task. This disconnectedness might have led them towards describing the nature of mathematical knowledge in all the metaphor explanations to provide a base for framing their metaphors for teachers and teaching. This, in turn, provided more clues about PMTs' beliefs about the nature of mathematics and suggested that these beliefs could be the base for their beliefs about mathematics teaching and teacher. It might also be the case that PMTs' beliefs about the nature of mathematics are persistent but their beliefs about mathematics teachers, teaching and learning are still under construction. Therefore, they might prefer to build their metaphors for teacher and teaching around mathematics metaphors and explanations.

PMTs preferred to start the structured tasks in Task 3 and Task 4 by first constructing a metaphor for mathematics, and then the others. These findings might address that even when PMTs prioritize didactical expertise for mathematics teachers, their beliefs about the nature of mathematics might be

at the center of their beliefs about a mathematics teacher and teaching. They might be building an understanding of the work of mathematics teacher and the duties of mathematics teaching around how they believed about the nature of mathematical knowledge.

PMTs' explanations for mathematics teacher and mathematics teaching metaphors in structured tasks in Task 3 and Task 4, on the other hand, rarely referred to the nature of mathematical knowledge. Starting the structured tasks by first constructing a metaphor for mathematics, and then connecting this metaphor with the metaphors for other themes without referring to the nature of mathematics might indicate that they already have constructed the metaphor for mathematics and this provided them with the necessary base for their metaphors for mathematics teacher and teaching.

There were very few mathematics learning metaphors even though PMTs were encouraged to construct in Task 3 and Task 4. The explanations for other metaphors rarely referred to the students, most probably due to focusing more on the teachers in the practice school.

In both types of metaphor tasks, the theme-metaphor-explanation flow did not seem coherent in many cases. Mathematics, for example, was addressed with verb metaphors, such as "*playing chess*", and mathematics teaching was addressed by noun metaphors, such as "*gossip*." PMTs seemed to describe one theme while actually explaining another. Such incoherence might show that PMTs were confused about the properties of the metaphors while they were trying to construct them. Indeed, field notes indicated that PMTs struggled and spent considerable effort and time to construct metaphors and explanations, although all tasks included information about metaphors and their functions. We discussed through the semester about how metaphors would help them to think deeply and increase their awareness about the issues of teaching mathematics. Yet, they had difficulties in finding metaphors in at least one task. They wrote detailed explanations that did not always fit the metaphor.

Why not asking directly about PMTs' beliefs but asking metaphors instead? Constructing a metaphor for a concept requires thinking about the characteristics of the concept in order to find a metaphor object, which shares similar characteristics with the construct (Saban, 2006). This process might direct PMTs to think about details, connections, and relationships more deeply than responding to a direct question. In this study, the inconsistencies between metaphors and explanations might indicate that PMTs are still struggling with building these concepts or have realized the complexity of these concepts and have difficulties in finding a metaphor for such complexity. Therefore, metaphors might be a powerful tool to reveal PMTs' such incomplete processes for teacher educators and to increase PMTs' awareness of their thinking process.

Although the actual metaphors were not the major focus of the present report, it appeared that PMTs' metaphors resembled similarities to the ones reported in the literature such as mathematics as a language, journey, structure and toolkit (Noyes, 2006) and mathematics teaching as a journey and growth (Reeder et al., 2009). A further analysis is needed to explore these metaphors.

Findings of the study showed that different uses and analyses of metaphor tasks might provide different ways of exploring PMTs' mathematics related beliefs. However, the findings are limited to the nine PMTs who participated in this study, the metaphors and explanations they constructed, the ways metaphors were asked and written data. They expressed difficulty in constructing a metaphor and the need to know the properties of the metaphor object to construct it better. Therefore, the key

issues in employing metaphors as tools of reflection in teacher education might be helping PMTs focus on connectedness and coherences of their ideas, reflect more on their beliefs, and their willingness to adopt and use metaphors in this process.

References

- Beijaard, D., Verloop, N., & Vermunt, J. D. (2000). Teachers' perceptions of professional identity: An exploratory study from a personal knowledge perspective. *Teaching and Teacher Education*, 16, 749–764.
- Haser, Ç., Arslan, O., & Çelikdemir, K. (2015). Mathematics teachers in preservice teachers' metaphors. In K. Krainer & N. Vondrova (Eds.), *Proceedings of the ninth congress of European research in mathematics education (CERME9)* (pp. 1188–1194). Prague, Czech Republic: Charles University.
- Lakoff, G., & Johnson, M. (1980). *Metaphors we live by*. Chicago: University of Chicago Press.
- Leavy, A. M., McSorley, F. A., & Bote, L. A. (2007). An examination of what metaphor construction reveals about the evolution of preservice teachers' beliefs about teaching and learning. *Teaching and Teacher Education*, 23, 1217–1233.
- Löfström, E., Anspal, T., Hannula, M. S., & Poom-Valickis, K. (2010). Metaphors about 'the teacher': Gendered, discipline-specific and persistent? In J. Mikk, M. Veisson, & P. Luik (Eds.), *Teacher's personality and professionalism. Estonian studies in education* (pp. 105–122). Frankfurt am Main, Germany: Peter Lang Publishers House.
- Miles, M. B., Huberman, A. M., & Saldana, J. (2014). *Qualitative data analysis: a methods sourcebook (3rd ed.)*. Thousand Oaks, CA, United States: Sage Publications, Inc.
- Noyes, A. (2006). Using metaphor in mathematics teacher preparation. *Teaching and Teacher Education*, 22, 898–909.
- Oksanen, S. & Hannula, M. S. (2013). Finnish mathematics teachers' beliefs about their profession expressed through metaphors. In M.S. Hannula, P. Portaankorva-Koivisto, A. Laine, & L. Naveri (Eds.), *Current State of Research on Mathematical Beliefs XVIII: Proceedings of the MAVI 18 Conference* (pp. 315–326). Helsinki: Finnish Research Association for Subject Didactics.
- Reeder, S., Utley, U., & Cassel, D. (2009). Using metaphors as a tool for examining preservice elementary teachers' belief about mathematics teaching and learning. *School Science and Mathematics*, 109(5), 290–297.
- Pantziara, M., Karamanou, M., & Petridou, A. (2017). Upper secondary mathematics teachers' beliefs expressed through metaphors. In T. Dooley, & G. Gueudet (Eds.). *Proceedings of the Tenth Congress of the European Society for Research in Mathematics Education (CERME10)* (pp.1170–1177). Dublin, Ireland: DCU Institute of Education and ERME.
- Saban, A. (2006). Functions of metaphor in teaching and teacher education: A review essay. *Teaching Education*, 17(4), 299–315.

“I don't like Maths as a subject but I like doing it”: A methodology for understanding mathematical identity

Fionnán Howard¹, Siún Nic Mhuiri² and Maurice O'Reilly³

^{1, 2, 3}Dublin City University, Ireland;

¹fionnan.howard@dcu.ie, ²siun.nicmhuiri@dcu.ie, ³maurice.oreilly@dcu.ie

This paper presents a thematic analysis methodology which uses a hybrid coding process to understand how science and engineering students in higher level education relate to mathematics. This process utilises and builds on previous research on mathematical identity amongst student teachers by using deductive coding while continuing to be grounded in the new data through inductive coding. Many authors have written on both or either of these methods. Most treat it as a simple choice between one or the other. Few have addressed best practice in integrating these approaches.

Keywords: Mathematical identity, transition, higher level education, thematic analysis.

Introduction

To create an effective learning environment for science and engineering undergraduates, an awareness of how they relate to mathematics is vital. Investigating mathematical identity can help educators better understand this relationship and help determine potential issues with pedagogy and the learning experience of students. Such issues may contribute to marginalisation and thus impact students' relationship with mathematics and their decision to continue, or not, their mathematical studies (Grootenboer & Zevenbergen, 2008; Solomon, 2007). Reflecting on their mathematical identity can help students engage more effectively as mathematics learners while they transition to higher level education (Kaasila, 2007). In the same vein, Sfard and Prusak (2005, p. 16) suggest that “identity talk makes us able to cope with new situations in terms of our past experience and gives us tools to plan for the future.”

Mathematical identity has been investigated in the context of Initial Teacher Education in Ireland since 2008. A series of previous studies developed an instrument for exploring mathematical identity of pre-service teachers which has been adapted for this new context. The ‘Mathematical Identity of Student Teachers’ (MIST) study used grounded theory among 9 students to develop two open-ended questions: a broad opening question to allow participants make responses that are “indicative of their personal mathematical identity” and a follow-up question which included some prompts “to balance the need for some direction” (Eaton & O'Reilly, 2009, p. 2). ‘Mathematical Identity using Narrative as a Tool’ (MINT) involved 99 students and not only converted the questionnaire to an online tool but also added a third question about self-reflection which had become evident as a key element of mathematical identity in MIST (Eaton, Horn, Liston, Oldham, & O'Reilly, 2013).

Although mathematical identity has enjoyed increased attention in recent years within education (Darragh, 2016), a lack of cohesion and agreement on ontological, epistemological, and methodological issues has produced a fractured body of research (Kaspersen, Pepin, & Sikko, 2017b). Despite this new attention, Hannula and Garcia Moreno-Esteva (2017) found that identity had featured in just four of 100 papers in this working group (TWG8) between CERME4 and CERME9.

At CERME10 Kaspersen, Pepin, and Sikko (2017a) in TWG20 focused on the link between mathematical identity and grades much like Cobb, Gresalfi, and Hodge (2009) did. A study by Craig (2013) took a narrower view of identity, thinking only of procedural versus conceptual learning, ignoring the many other facets of identity that interact with this specific strand. In Ireland, MIST/MINT (Eaton & O'Reilly, 2009; Eaton et al., 2013) focused on developing an instrument to collect narrative data, but the process of analysing this data requires some clarification in order to be reliably used in other contexts or amongst larger groups of students. Although some studies have investigated engineering identity, and incidentally addressed mathematics, studies dealing with the mathematical identity of engineering students are rare.

This paper will outline how we adapted and integrated inductive and deductive techniques to facilitate a thematic analysis. This addresses the need to incorporate the knowledge gained from previous work on mathematical identity in Ireland while also continuing to be grounded in the new data. We refined the MIST/MINT coding process by deconstructing the themes they developed amongst student teachers (which may not accurately represent the mathematical identity of this new cohort) into codes and constructed new themes based on the current data. We will demonstrate how the coding process aided the thematic analysis, already established in MIST/MINT, for cohorts of students not previously considered there. We expect this to advance the drive toward an effective process for accessing students' mathematical identities.

Background and Theoretical perspective

Sfard and Prusak (2005) and Kaspersen et al. (2017a) both noted that researchers in mathematics education had yet to agree upon a working definition of identity while Cobb et al. (2009, p. 41) conceded that it is “vague and ill-defined.” Authors often operate from different viewpoints: the sociological viewpoint where identity is an action, constructed and reconstructed over time, which has long characterised identity at CERME (Hannula & Garcia Moreno-Esteva, 2017), and the psychological viewpoint where identity is a core stable phenomenon (Cobb et al., 2009). Sfard and Prusak (2005) detailed the similarities between identity and other concepts such as attitudes, conceptions and beliefs but pinpointed the constantly changing and evolving nature of identity as the key power behind the concept. The sociological viewpoint of identity acknowledges that it is ever-changing and communicated best through narratives authored by the participants. They can communicate mathematical experiences they consider to be influential and reflect on them as they write often leading to realisations or re-interpretations of the experiences.

This study is conducted under a social constructivist paradigm and mathematical identity is defined as the “multi-faceted relationship that an individual has with mathematics, including knowledge, experiences and perceptions of oneself and others.” (Eaton & O'Reilly, 2009, p. 228; See also Grootenboer & Zevenbergen, 2008) We propose that empirical information about experiences is not enough to reveal mathematical identity and we aim to establish the meaning of these experiences from the views of participants (Creswell, 2009, p. 16). We follow the narrative approach detailed by Creswell (2009, p. 13) whereby the narrative produced by the research represents a repackaging of the experiences and stories communicated by the participants. The resulting narrative represents a

combination of these experiences with those of the researcher, positioning the participants as co-researchers who shape the research process (Cohen, Manion, & Morrison, 2007, p. 37).

Methodology

We identified 16 cohorts of science and engineering students in DCU who study mathematics in their first year. They represent a significant portion of the undergraduate population and of students taking mathematics modules, but they have not previously been included in research on mathematical identity. Participants were recruited in lectures where the lead author explained the study, distributed plain language statements and returned one week later to voluntarily sign up students who were interested in taking part. An online questionnaire (adapted from MIST/MINT) consisting of three open-ended questions was employed with each question appearing on a separate page. A pilot study conducted in Winter 2017 involved 18 respondents (10 science and 8 engineering students). There were 32 respondents to the main study (22 science and 10 engineering students), contributing a total of 8000 words. The first two questions are the focus of this paper and are presented in Figure 1. Note that third level is an Irish term for higher level education.

Q1. Think about your total experience of mathematics. **Tell me about the dominant features that come to mind.**

Q2. Now think carefully about all stages of your mathematical journey from primary school to university mathematics. Consider:

- Your feelings or attitudes to mathematics
- Influential people
- Critical incidents or events
- Specific mathematical content or topics
- How mathematics compares to other subjects
- Why you chose to study a course which includes mathematics at third level

With these and other thoughts in mind, describe some further features of your relationship with mathematics over time.

Figure 1: First two questions of the online questionnaire which were presented on separate pages

To analyse the open-ended responses to the online questionnaire we used a hybrid process of inductive (data-driven) and deductive (theoretical) coding adapted predominantly from Fereday and Muir-Cochrane (2006) with influence from Braun and Clarke (2006), Boyatzis (1998) and Crabtree and Miller (1999). The latter authors noted that codes “can be constructed a priori, based on prior research or theoretical perspectives or created on preliminary scanning of the text” and that “...some initial codes are refined and modified during the analysis process.” (p. 167) Their claim that constructivists tend to lean towards co-created codes fits well with Braun and Clarke's categorisation of thematic analysis as “grounded theory ‘lite’” (Braun & Clarke, 2006, p. 81) since this research builds on the grounded theory research of MIST/MINT.

Our approach consisted of seven stages (of which, the first four will be described further on):

Stage 1 Development of codebook from literature review of MIST/MINT and pilot study.

Stage 2 Code stratified sample of main data.

Stage 3 Broad reading and summarising of entire data set.

Stage 4 Code data using inductive and deductive codes. Elaborated in detail below.

Stage 5 Group codes to develop thematic map.

Stage 6 Review themes and use the data to check for internal and external homogeneity.

Stage 7 Define and name themes.

Stages 3-7 broadly align with the five steps suggested by Braun and Clarke (2006) who treated inductive and deductive coding as separate techniques. Stages 1-5 correspond to steps from Fereday and Muir-Cochrane (2006) but with a significantly expanded fourth stage as well as stronger interplay between the data analysis stages. Crabtree and Miller (1999) have a simple four step model (with stages 2-4 combined) which omits the testing stage although they do go on to discuss such a step (p. 168). All authors participated in stage 2 coding but stage 3 and 4 were conducted by the lead author.

Although most authors recommend an iterative line-by-line coding process where codes are developed, applied and immediately examined for groupings without reference to the data (Braun & Clarke, 2006), we realised that the density of these responses (on average every 9 words resulted in a code) meant that it was considerably more difficult to extract meaningful codes from the data in a single round of coding without including multiple perspectives (Strauss & Corbin, 1998). We thus developed stage 4 significantly beyond what is described by other authors. The remainder of this section will describe stages 1-4, which have been completed, with particular emphasis on stage 4. It is intended that Stages 5-7 will follow the recommendations given by Braun and Clarke (2006).

Stage 1

MINT/MIST participants' responses were used to develop seven main categories: self-reflection, influential people, ways of working in mathematics, comparing other subjects, nature of mathematics, right and wrong and mathematics as a rewarding subject (Eaton, Oldham, & O'Reilly, 2011, p. 32). These categories were expanded into codes using the examples and discussion from five MINT papers, three MIST papers (one unpublished) and two papers from an interim 'bridging' study. Codes that did not clearly fit in any of these categories were simply left uncategorised.

The pilot study helped to further demarcate the codes under each category. We followed Fereday and Muir-Cochrane (2006, p. 85) and Boyatzis (1998) by naming the codes, providing a description, some keywords (if possible) and giving at least one example from the pilot study of an instance of the code. From the start we adopted the use of an extra miscellaneous code for items which do not fit any existing category. This step is used to check the comprehensiveness of the codebook and to ensure nothing relevant is overlooked the coding process because it is difficult to categorise. For example:

ID86 I think its good that I'll be practicing something I'm bad at.It means I'll be eventually not so bad at it.

Stage 2

A codebook consisting of 37 codes was applied to a stratified sample of 8 from the 32 respondents, based on grouping, cohort, gender, word count and age. All three authors coded this data separately. We discussed the results with reference to the codebook and adapted the codebook by splitting, combining or creating codes as appropriate changing the number of codes to 47. The definitions were also updated, keywords added and examples from the sample included in line with the relevant codes. Our initial main coding principles were derived from the sample coding at this stage. They are given here with examples to show their effectiveness:

1. Code in-line by including a number at or near each instance. Codes can run across sentences, overlap and a single statement may require multiple codes.

Pay attention to context between sentences or along entire paragraphs.

ID 118 Physics is about explaining everything essentially, and making sense of everything. That's why maths is interesting to me...

This student talks about making sense of everything but the second sentence makes clear that mathematics also plays a role either intrinsically or in tandem with physics.

2. Codes should be broad enough to allow a range of responses to be grouped. Especially where a continuum exists, e.g., mathematics is exciting/boring or hard/easy.

3. Often participants will express a combination of both positive and negative, e.g., elements they like and elements they don't like or parts they find hard or easy:

ID124 I enjoy certain parts of it.

ID78 Certain aspects came easier to me than others...

ID98 Leaving a hard topic and starting to learn a harder one makes the first hard topic seem very easy.

They may give a 'middle-ground' response:

ID96 Generally ok experience...

ID120 I found mathematics okay.

Students sometimes mitigate their opinions:

ID40 I don't like Maths as a subject but I like doing it.

Stage 3

The entire dataset was read through for "close contact and familiarity" (Boyatzis, 1998, p. 45) and to make the important first step towards understanding the narratives therein. To accomplish this the data was read through repeatedly, "taking notes or marking ideas for coding" (Braun & Clarke, 2006,

p. 87) as well as noting the key points made by participants (Fereday & Muir-Cochrane, 2006, p. 86). These notes were used later for comparison with coding.

Stage 4

To enact the principles stated at the beginning of this section, the coding process consisted of several steps (ways of looking at the data):

- (a) Apply codes using a fine-grained, line-by-line approach.
- (b) Write a summary of each participant's response and compare with the codes allocated.
- (c) Compare with original notes from broad reading of the data.
- (d) Code each 'piece of interest' by removing chunks of text and re-reading them in isolation.
- (e) In tandem:
 - i. Pick each code and read through data for possible extra occurrences of the code.
 - ii. Use keywords to identify possible extra occurrences of each code.
- (f) Interrogate data coded as miscellaneous to determine if re-categorisation is possible.

This resulted in the creation of 20 inductive codes to be reviewed at the next stage. Each step shown above added to the exhaustiveness of the coding by illuminating more opportunities for codes to be applied but was also useful for adding new ideas as notes under each participants' response. Step (a) arose because we found that students' responses contain a lot of information even in short pieces of text:

ID 55 I generally did well in maths exams [*good at maths*] compared with other subjects [*comparing subjects*], which made me enjoy the subject more [*I enjoy maths*], and gave me confidence and a belief that I could do well [*origin of interest in maths*] in the field [*confidence in maths*].

In step (c) almost every initial note had been encapsulated in the coding. Of the remainder, most notes were now either obviously unfounded or involved too high a level of interpretation to be included:

ID 118 ...explaining the reasoning behind what we were learning. We just learned for the sake of learning...

This was initially considered as "I like to understand the content rather than learn it off" which requires a leap of interpretation. It fit much better in the inductive code "Learning/doing maths without knowing why."

In step (e) we discovered that searching for keywords often resulted in hits from the summaries in part (b). This was useful for identifying via a paraphrasing whether the correct codes had been applied. Searching for 'pace' brings up my comment "Pace. Quicker (because I was good?)" Original statement was "I would be finished far ahead of everyone in my class" (ID69).

In (f) the miscellaneous code proved useful for collecting statements that were hard to categorise or would require a new code to be classified. Of the 36 statements coded, 28 were reclassified leaving only 8 statements remaining as miscellaneous.

Discussion

This paper outlined a hybrid inductive and deductive methodology to facilitate a thematic analysis which incorporated the knowledge gained from previous work on mathematical identity in Ireland while also continuing to be grounded in the new data from this study. We built on the previous grounded theory research by MIST/MINT while acknowledging that we do not yet have a fully validated and reliable process for accessing mathematical identity. The categories developed by MIST/MINT were particularly helpful to determine whether a code might be present in a statement. Adopting a finer, detailed coding approach at stage 4 with many steps acknowledges that students' narratives are a link or window to their identities rather than being their putative 'actual' identities. The ever-changing nature of identity necessitated a semantic approach where one does not look "beyond what a participant has written" when coding. The interpretative stages happen during analysis after coding has taken place. This is in line with the advice of Braun and Clarke (2006, p. 98) but contrary to that of Boyatzis (1998). All steps of coding proved useful for combating discounting of evidence in uncoded text (Crabtree & Miller, 1999, p. 171) particularly coding 'pieces of interest' and using keywords. Using a miscellaneous code represented 53 of the 116 (or 46% of) code changes made and thus was the most effective way to ensure that meaningful responses did not go undetected. The small sample size of 32 facilitated this multi-step coding.

We expect this methodology to advance the drive toward an effective process for accessing students' mathematical identities. We see this approach as providing insights for students to improve their learning experiences and for educators to ease the transition to higher education for such students.

References

- Boyatzis, R. E. (1998). *Transforming qualitative information*. Thousand Oaks, CA: SAGE Publications Inc.
- Braun, V., & Clarke, V. (2006). Using thematic analysis in psychology. *Qualitative Research in Psychology*, 3(2), 77–101.
- Cobb, P., Gresalfi, M., & Hodge, L. L. (2009). An interpretive scheme for analyzing the identities that students develop in mathematics classrooms. *Journal for Research in Mathematics Education*, 40(1), 40–68.
- Cohen, L., Manion, L., & Morrison, K. (2007). *Research methods in education*. Abingdon, UK: Routledge.
- Crabtree, B., & Miller, W. (1999). *Doing qualitative research*. Thousand Oaks, CA: SAGE Publications Inc.
- Craig, T. S. (2013). Conceptions of mathematics and student identity: Implications for engineering education. *International Journal of Mathematical Education*, 44(7), 1020–1029.
- Creswell, J. W. (2009). *Research design: Qualitative, quantitative and mixed methods approaches*. Thousand Oaks, CA: SAGE Publications Inc.
- Darragh, L. (2016). Identity research in mathematics education. *Educational Studies in Mathematics*, 93(1), 19–33.

- Eaton, P., Horn, C., Liston, M., Oldham, E., & O'Reilly, M. (2013). Developing an instrument to explore mathematical identity: A study of students from several third level institutions in Ireland. In E. Arntzen (Ed.), *Proceedings of the Association for Teacher Education in Europe 38th Annual Conference* (pp. 280–296). Halden, Norway: ATEE.
- Eaton, P., & O'Reilly, M. (2009). Who am I and how did I get here? Exploring the mathematical identity of student teachers. In D. Corcoran, T. Dooley, S. Close, & R. Ward (Eds.), *Proceedings of Third National Conference on Research in Mathematics Education (MEI 3)* (pp. 228–237). Dublin, Ireland: St. Patrick's College.
- Eaton, P., Oldham, E., & O'Reilly, M. (2011). Nature and nurture: an analysis of mathematical identity of distinct cohorts of prospective teachers. In I. Žogla, & L. Rutka (Eds.), *Proceedings of the Association for Teacher Education in Europe 36th Annual Conference* (pp. 29–43). Riga, Latvia: ATEE.
- Fereday, J., & Muir-Cochrane, E. (2006). Demonstrating rigor using thematic analysis: A hybrid approach of inductive and deductive coding and theme development. *International Journal of Qualitative Methods*, 5(1), 80–92.
- Grootenboer, P. J., & Zevenbergen, R. (2008). Identity as a lens to understand learning mathematics: Developing a model. In M. Goos, R. Brown, & K. Makar (Eds.), *Navigating Currents and Charting Directions (Proceedings of the 31st Annual Conference of the Mathematics Education Research Group of Australasia)* (pp. 243–250). Brisbane, Australia: MERGA.
- Hannula, M. S., & Garcia Moreno-Esteva, E. (2017). Identifying subgroups of CERME affect research papers. In T. Dooley, & G. Gueudet (Eds.), *Proceedings of the Tenth Congress of the European Society for Research in Mathematics Education (CERME10)* (pp. 1098–1105). Dublin, Ireland: DCU Institute of Education and ERME.
- Kaasila, R. (2007). Using narrative inquiry for investigating the becoming of a mathematics teacher. *ZDM: The International Journal on Mathematics Education*, 39(3), 205–213.
- Kaspersen, E., Pepin, B., & Sikko, S. A. (2017a). The association between engineering students' self-reported mathematical identities and average grades in mathematics. In T. Dooley, & G. Gueudet (Eds.), *Proceedings of the Tenth Congress of the European Society for Research in Mathematics Education (CERME10)* (pp. 2137–2144). Dublin, Ireland: DCU Institute of Education and ERME.
- Kaspersen, E., Pepin, B., & Sikko, S. A. (2017b). Measuring STEM students' mathematical identities. *Educational Studies in Mathematics*, 95(2) 163–179.
- Sfard, A., & Prusak, A. (2005). Telling identities: In search of an analytic tool for investigating learning as a culturally shaped activity. *Educational Researcher*, 34(4), 14–22.
- Solomon, Y. (2007). Not belonging? What makes a functional learner identity in undergraduate mathematics? *Studies in Higher Education*, 32(1), 79–96.
- Strauss, A. L., & Corbin, J. M. (1998). *Basics of qualitative research: Techniques and procedures for developing grounded theory*. Thousand Oaks, CA: SAGE Publications Inc.

Students' Engagement in Inquiry-based Learning: Cognition, Behavior and Affect

Styliani K. Kourti

University of Athens, Department of Mathematics, Athens, Greece; stellakour@gmail.com

The present study focuses on the constructs of students' engagement in Inquiry-based learning (IBL). We analyzed two mathematics classrooms, using videos and interviews with the two teachers. After recognizing the IBL phases, a synthesis of Kong, Wong and Lam (2003) and Liem and Martin (2012) models was made in order to determine each student's engagement, in the framework of the IBL. Then the constructs of three students' engagement were also studied in relation to the phases of IBL, trying to identify the type of engagement that prevails at each phase of IBL. According to the results 35 out of 47 students studied were highly engaged. All high achieving students were highly engaged, having all three constructs of engagement increased. Low achieving students with high engagement presented intense behavioral and affective engagement. There were also low achieving students that presented low engagement during IBL.

Keywords: Inquiry-based learning, engagement, affect, workplace.

Introduction

Over the last few decades, serious concerns have been expressed about the quality of teaching and learning in mathematics and science and the need for improvements in order to meet the increasing needs of society (Artigue & Blomhøj, 2013). Inquiry based learning (IBL) approaches are promoted in research and developmental programs in mathematics and science (Pedaste et al., 2015). Several research projects, such as, the European, Mascil project (<https://mascil-project.ph-freiburg.de/>), seek to diffuse IBL in science and mathematics teaching in primary and secondary education. Much of current IBL's research focuses on cognitive issues, communication, mathematical competence, tools and resources for planning or implementing inquiry, professional development and collaboration-based learning (Dreyøe, Larsen, Hjelmberg, Michelsen, & Misfeldt, 2018), and less on affect during IBL.

In the educational context, students' motivation and engagement play an important role in their achievement and their interest in school (Liem & Martin, 2012). Students' disengagement is a contemporary issue of mathematics education, as it may affect long-term development of our communities (Attard, 2012). Although many IBL projects showed some positive benefits for students' learning, engagement's complex and multifaceted construct may be the reason why little research has been done to study engagement in IBL context.

Therefore, we consider it necessary to study IBL in relation to students' cognition and affect, arguing that the use of IBL approaches can contribute to the increase of their engagement. This study focuses on the constructs of students' engagement while IBL approaches are adopted in mathematics teaching. The research questions are: Can the implementation of IBL affect students' engagement? Which constructs of students' engagement (cognitive, behavioral, and affective) appear and intensify in the IBL phases?

Theoretical Framework

Inquiry-based learning, according Pedaste et al.'s (2013), is a process in which learners construct knowledge by discovering new casual relations, formulating hypotheses and testing them through experiments, and making observations. An important characterization of IBL is the development of an inquiry cycle (the phases of IBL with their sub-phases, and their interactions), a concept that has various definitions in the research literature. Pedaste et al.'s (2013), bibliographic review and synthesis of 60 articles identified the exploratory cycle that includes the phases of orientation, conceptualization (questioning and hypothesis generation sub-phases), investigation (exploration, experimentation and data interpretation sub-phases), conclusion and discussion (communication and reflection sub-phases), while almost all phases are related to each other.

Motivation is a central concept of affect research, and it can manifest itself in knowledge, emotion and/or behavior (Hannula, Evans, Philippou & Zan, 2004). The structures of engagement and motivation are often used together and are very closely linked. Motivation is defined as people's energy and boost for learning, effective work and achievement of their full potential, while engagement is defined as behaviors that align with this energy and lead (Liem & Martin, 2012), but engagement is more complex than observed behaviors. Kong, Wong and Lam (2003) developed an instrument for detecting students' engagement in the mathematics classroom, which operates in three levels: cognitive, behavioral and affective engagement. Cognitive engagement involves the idea of recognition of the value of learning and the willingness to go beyond the minimum requirements, while behavioral engagement encompasses the idea of active participation and involvement in academic and social activities (Attard, 2012). Affective engagement implies a sense of belonging and acceptance of the goals of schooling, and is related to the notions of self-efficacy, expectation, interest, perceived control, and autonomy (Kong et al., 2003). Several studies have found that the three constructs of students' engagement do not work individually but support and complement each other in a cooperative way. Also, Liem and Martin (2012) developed the Motivation and Engagement Wheel, which is a multidimensional framework representing salient cognition and behavior pertinent to motivation and engagement, and offers a discrimination tool for cognitive and behavioral elements of engagement (see Liem & Martin, 2012, pp. 4-7).

Methodology

The context of the study and the process of data collection

The present study is a case study of two mathematics classrooms, conducted in Athens, Greece. The data used were videotaped lessons and semi-structured interviews with both teachers. The lessons were designed within the context of a European research project, Mascil (www.mascil-project.eu), that aims to support teachers in using IBL approaches into their teachings, and making connections to workplace (activities that involve authentic problems, and can be more or less similar to activities actually carried out by workers in the workplace with more or less use of authentic tools/artefacts).

A grade 10 class, (27 students, boys and girls, mixed cognitive dynamics, 15-16 years old), and a grade 11 class (21 students, boys and girls of mixed cognitive dynamics, 16-17 years old) were studied. Two videotaped lessons were analyzed in which the teachers used the "Drug concertation" task, from Mascil's platform, where students partly adopt the role of pharmacologist in finding out

how drugs work in the body, using mathematical models instead of experimenting in a laboratory (<http://www.fisme.science.uu.nl/toepassing/22038/>). The grade 10 classroom was divided into seven groups of students, while the grade 11 classroom into five groups. Each group's students were chosen by the teachers, so that groups of mixed dynamics were created.

Both interviews with the teachers lasted about one hour. Teachers responded to questions about each student's performance and participation before and during IBL. Episodes related to students' engagement from the videotaped lessons were selected by the researcher and discussed with the teachers, and questions related to the IBL process were asked in relation to the selected episodes.

Data analysis

The groups formed in the classroom were the groups of our analysis. In order to facilitate this process, based on individualized students' data drawn from the interviews with the teachers, students were grouped into two groups. The group of high achievers includes students with a great interest in mathematics, a high cognitive mathematical level, active participation in the mathematics discourse in the classroom. The group of low achievers includes students with moderate, low or no interest in mathematics, medium or low cognitive level, low or no participation in the mathematics discourse in the classroom. One student out of 48 couldn't be studied because of inadequate data.

In order to distinguish IBL phases in each lesson, each teaching was studied at classroom level, using the videos and teachers' interviews, trying to identify the points of change of the phases, and their localization, based mainly on the cognitive processes of the students. Then, after determining the relationships between the phases and the sub-phases of IBL, the IBL framework for each of the teachings was formed, according to the pedagogical learning framework of Pedaste, et al. (2015).

A synthesis of Kong et al.'s (2003) and Liem and Martin's (2012) models was made, in order to determine students' engagement, in IBL's framework. Kong et al.'s (2003) model was used for the engagement constructs (cognitive, behavioral, and affective) enriching it with the sub-constructs of the Liem and Martin's (2012) model. The videos were observed and transcribed. Based on this scheme, the data of each classroom's video was coded student by student. Through this process, the coding scheme used for the analysis of each student's engagement is presented below in Table 1.

	Engagement	Indicators
Cognitive	Connecting with previous knowledge, Dependence on the teacher, Trying Examples, Comprehend question, Justification of arguments, Explanation to the other members of the group, Independent work , Dependent work, Memorization, Abstraction (limit notion intuitively), Superficial strategies, Passive	Questions, Completing peers' phrases, Exchange of ideas, Give directions explanations and information, Justification of an argument, Answer teacher's questions, Give information, Explain processes and justify, Question the teacher, Gestures
Behavioral	Attention, Persistence, Thoroughness, Participation, All over the task, Partial Participation, Surface participation	Body movements, Face expressions, Verbal expressions, Interaction with peers (verbal, body), Gestures

Affective	Anxiety, Uncertainty, Interest, Enthusiasm, Joy, Disruption, Boredom, Curiosity, Uncertain control, Failure avoidance, Anger, Goal achievement	Face expressions, Verbal expressions, Body Stance, Gestures
------------------	--	---

Table 1: The constructs of student engagement and their indicators

Recognizing the constructs of students' engagement was a complex methodological process, as the engagement is a multidimensional concept also related to the internal affective structures of each individual. An example of our analysis is illustrated below, concerning the engagement of a high achiever, in mathematics, student:

Listening to the explanations of the other members of the group (behavioral- attention), he is crouched over his notebook (behavioral- all over the task), hitting his pencil on the desk and overcrowding his eyebrows (affective- anxiety and uncertainty). Using footnotes in a tooltip over the paper to help organize the presentation of the solution (behavioral- thoroughness). At the same time he says: "no, we do not have to do that because our teacher will not like it ... though it seems to me right (cognitive- dependence on the teacher and dependent work) ... I do not know what to do [puff and blow] (affective-uncertain control and anxiety) ... let's ask him to be sure he (referring to the teacher) knows better (cognitive- dependence on teacher, affective- failure avoidance)".

Then each student's engagement was evaluated as high or low based on the three constructs of engagement he had presented. Each of the three constructs was equally accounted for, for the above evaluation. High is recognized as the engagement of a student who has an intensified engagement in at least two of its constructs (cognitive, behavioral and affective engagement).

The constructs of student engagement were also studied in relation to the IBL phases, in three cases of students, trying to identify the type of engagement that prevails at each IBL phase. The first student (boy, grade 11) was a high achiever and presented high engagement, the second student (girl, grade 10) was a low achiever and presented high engagement while the third (girl, grade 10) was also a low achiever but presented low engagement. The students 1, 2 and 3 were typical representatives of their achievement groups and an overall picture of students' engagement in the IBL phases could be formed.

Results

The results of this research showed that both classrooms during IBL presented all IBL phases and sub-phases, except experimentation (investigation phase- no experiment was required to test the hypotheses), as well as reflection (discussion phase- limited time spent on this phase).

In grade 10, one of the twenty-seven students could not be analyzed because of inadequate data. Seven of twenty-six students presented low engagement, while the remaining nineteen presented high engagement. Seven of the highly engaged students were low achievers, while the other twelve were high achievers. Regarding the highly engaged, low achievers group, all of them had intense affective and behavioral engagement, but six of them had low cognitive engagement, as they were only using

superficial strategies. For the twelve highly engaged, high achievers, all three constructs, particularly cognitive, were intensified.

	Total	Highly Engaged	Cognitive engagement	Behavioral engagement	Affective engagement
Low Achievers	24	12	Limited	Intensified	Intensified
High Achievers	23	23	Highly Intensified	Intensified	Intensified

Table 2: Overall results of students' engagement

In grade 11, fifteen out of the twenty-one students presented high engagement while the remaining six students presented low engagement. Five of the highly engaged students were low achievers, while the other ten were high achievers. The highly engaged, low achievers had intensified affective and behavioral engagement while the cognitive engagement of three of them was low, since they were only using superficial strategies. All high achievers were highly engaged, having all three engagement constructs intensified, especially their cognitive one. Table 2 presents aggregated results of students' engagement.

The constructs of engagement in the phases of IBL: Three cases of students

Then, an attempt was made to identify the intensified constructs of students' engagement in each IBL phase, of three representative cases of students. The findings are summarized in Table 3 (where CE, BE and AE are cognitive, behavioral and affective engagement respectively, and with bold are the intensified engagement constructs of each phase).

Student 1 was a highly engaged, high achiever. He was highly affective engaged in orientation phase, demonstrating interest and enthusiasm for the activity. In conceptualization phase, his behavioral engagement was intense, as he was constantly all over the activity, paying attention and showing persistence. Affectively, in the same phase, he was very enthusiastic about both the context and the solution process of the task. In investigation phase, all three constructs of his engagement were intensified. Of particular interest was the development of his cognitive engagement as he addressed questions of understanding both to the teacher and to the other members of his group, he used trying examples, connected the old knowledge with the new one, and almost at the beginning of the investigation phase he realized, through the diagram, that the function tended to be limited in a number, and later he explained his thought to both the professor and the rest of the group, being very joyful about it. In conclusion phase, his cognitive engagement was intense as he tried to explain his thoughts to the rest of the group using arguments. Finally, in discussion phase, all constructs of his engagement were intensified, as he revived the entire previous inquiry process. While he was communicating his group's results to the rest of the class, he was very enthusiastic about their solution.

Student 2 was a highly engaged, low achiever. She, in the orientation phase, did not seem to have any interest in the activity, and she also presented signs of boredom. In conceptualization phase, her curiosity was triggered, so she began to ask questions of understanding the activity, while at the same time she was paying attention. In investigation phase and in conclusion phase, all three constructs of

her engagement were much intensified, and were kept unabated throughout these phases. Affectively, she was very interested and curious in getting involved with the task. Feeling uncertain control, she tried to explain to the other members of her group her understanding of the solution given. Finally, in the discussion phase, during which the group presented its results to the rest of the class, the student's 2 engagement was limited, while only her behavioral engagement was intensified, leaving some other members of her group to present the cognitive part.

	Student 1 High Engagement	Student 2 High Engagement	Student 3 Low Engagement
Orientation	CE: Comprehend questions BE: All over the task AE: Enthusiasm, Interest	CE: None BE: Attention AE: Boredom	CE: None BE: Partial Participation AE: Boredom
Conceptualization	CE: Comprehend questions, Trying examples BE: All over the task, attention, Persistence AE: enthusiasm, interest	CE: Comprehend questions BE: Attention AE: Curiosity, Interest	CE: Passive BE: Partial participation, Attention AE: Curiosity
Investigation	CE: Connecting with previous knowledge, Trying Examples, Comprehend question, Justification of arguments, Explanation to the other members of the group, Abstraction (limit notion intuitively) BE: All over the task, attention, Persistence, Participation AE: Interest, joy, uncertain control	CE: Comprehend questions, Trying examples, Connecting with previous knowledge BE: Attention, Thoroughness, Participation AE: interest, curiosity, uncertain control	CE: Passive BE: Partial participation, Attention AE: Curiosity
Conclusion	CE: Connecting with previous knowledge, Explanation to the other members of the group, Abstraction BE: Attention, Participation AE: Interest, joy	CE: Trying Examples, Explanation to the other members of the group BE: Attention, Participation, Thoroughness AE: Interest, Curiosity	CE: Passive BE: Partial participation AE: Interest, Boredom

Discussion	CE: Connecting with previous knowledge, Explanation to the classroom, Abstraction BE: Attention, Persistence, Participation AE: Interest, enthusiasm, joy	CE: Connecting with previous knowledge BE: Attention, Thoroughness AE: Interest	CE: Passive BE: Attention AE: Disruption, Boredom
-------------------	--	--	--

Table 3: The constructs of student engagement in the stages of IBL

Student 3 was a low achiever who presented overall low engagement, especially in the phases of orientation, conclusion and discussion. In conceptualization phase she showed interest and thus her affective engagement was intensified, while in investigation phase her behavioral engagement was intensified as she showed some attention and partial participation. In all phases she was cognitively passive, like the other students of this case. Affectively, the students of this case seemed to be bored during the whole activity, except from conceptualization phase, during which some of them showed a bit of interest, or curiosity, mainly for the context of the activity.

Discussion

According to the results 35 out of 47 students were highly engaged. This may be due to the possibilities offered by Inquiry-based learning and teaching, as according to Artigue and Blomhøj (2013), it becomes a potent tool in personal and collective response efforts of an important question, making these experiences not only unpublished but inspired and structural for the whole educational project.

The students of case 1 were cognitively highly engaged in the investigation, conclusion and discussion phases. This is probably due to the fact that IBL, on average, increases conceptual understanding in science, mathematics, engineering and technology courses (Freeman et al., 2014, as cited in Capaldi, 2015), while traditional teaching can lead to low levels of conceptual comprehension (Epstein, 2013, as cited in Capaldi, 2015). The students of case 2 were all highly engaged, especially in the investigation and the discussion phase. This may be due to the fact that these two IBL phases are relying on group-work and collaboration provides support for tackling difficult problems or concepts (Capaldi, 2015), which encourages students to be active participants in the construction of their knowledge. Yet several students in this group showed low cognitive engagement in the entire IBL process. This might be due their previous cognitive deficiencies, or to their dependence on their group's highly achieving students, in a cognitive and affective way.

Highly engaged students, of both cases 1 and 2, showed intense behavioral engagement and positive affective engagement. This may be due to the authenticity of the workplace activity, allowing them to realize the usefulness of their school mathematics education and redefining their motives. Students' positive affective engagement may be due to the dissociation of the IBL activity from their grade retention. Grade retention often leads to maladaptive behavior, impeding cognition (Liem & Martin, 2012), causing negative emotions (for example anxiety) about mathematics education. All three

constructs of engagement are interrelated (Kong et al., 2003), thus negative affective engagement relates to negative behavioral and cognitive outcomes, and vice versa.

But the results from students of case 3 showed that despite the opportunities offered by IBL to increase students' engagement, there are students who are not motivated by them, without this, however, rendering them ineffective, since the number of these students is small compared to our rest sample. These students, according to their teachers, have no interest for the lesson, do not participate and most of them are mathematically weak. This is probably due to affective variables, which can be seen as indicative of learning outcomes or as predictive of future success (Hannula et al., 2004) or failure. At this point, further research into the subject's discipline is necessary.

One of the limitations of this study is that its inferences were mostly drawn from (replicated) observations, and in a subsequent phase, it would be good to combine with personalized interviews with the students to deepen more the analysis. Finally, some critical questions for future research arise: Can the more frequent use of IBL approaches alter the engagement of weak learners? If so, which constructs of engagement could be affected and in what way the IBL cycle may change?

References

- Artigue, M., & Blomhøj, M. (2013). Conceptualizing inquiry-based education in mathematics. *ZDM*, 45(6), 797–810.
- Attard, C. (2012). Engagement with Mathematics: What Does It Mean and What Does It Look Like?. *Australian Primary Mathematics Classroom*, 17(1), 9–13.
- Capaldi, M. (2015). Inquiry-Based Learning in Mathematics. In Emerald Group Publishing Limited (Eds.), *Inquiry-Based Learning for Science, Technology, Engineering, and Math (Stem) Programs: A Conceptual and Practical Resource for Educators*, 283–299.
- Dreyøe, J., Larsen, D. M., Hjelmborg, M. D., Michelsen, C., & Misfeldt, M. (2018). Inquiry-based learning in mathematics education: Important themes in the literature. *Nordic Research in Mathematics Education*, 329–337.
- Hannula, M., Evans, J., Philippou, G. and Zan, R. (2004). Affect in mathematics education- exploring theoretical frameworks. In M. Johnsen Høines and A. Berit Fuglestad (Eds.), *Proceedings of the 28th Conference of the International Group for the Psychology of Mathematics Education*, Bergen, Norway, Vol. 1, 107–136
- Kong, Q. P., Wong, N. Y., & Lam, C. C. (2003). Student engagement in mathematics: Development of instrument and validation of construct. *Mathematics Education Research Journal*, 15(1), 4–21.
- Liem, G. A. D., & Martin, A. J. (2012). The Motivation and Engagement Scale: Theoretical framework, psychometric properties, and applied yields. *Australian Psychologist*, 47(1), 3–13.
- Pedaste, M., Mäeots, M., Siiman, L. A., De Jong, T., Van Riesen, S. A., Kamp, E. T., & Tsourlidaki, E. (2015). Phases of inquiry-based learning: Definitions and the inquiry cycle. *Educational research review*, 14, 47–61.

Investigating emotional intensity in mathematics classrooms: an enhanced methodology or affective gimmickry?

Elizabeth Lake

UCL Institute of Education, UK; elizabeth.lake@ucl.ac.uk

One known issue when working with emotions in context is the challenge of observing what are often transitory, fluid, and unconscious emotions, that vary in intensity and valency, and can change depending on when or who is asking. This paper reports on how one physiological measure, a simple galvanic skin response (GSR) sensor, which has become possible to use in class due to technological advances, can be used in conjunction with other methods such as observation and stimulated recall interview and can give insight into variations of a mathematics teacher's emotional intensity as they interact with students. The addition of physiological data to a common form of methodology provided useful prompts for teacher reflection and hence has potential for supporting development and is potentially a powerful addition to more common methodologies.

Keywords: Emotions, Intensity, Teachers, Physiological data, Mathematics.

Introduction

This paper discusses a method for examining emotional intensity in mathematics lessons, addressing this challenge through the incorporation of physiological data in addition to more common methods. Pekrun (2018) lists five ways to assess emotions; self-report, implicit assessment, neuro-imaging, behavioural observation (e.g. facial or postural expression) of emotionality (De Simone, 2015), and peripheral physiological analysis. In this paper, the focus is on incorporating the use of Galvanic Skin Response (GSR) to the study, a physiological measure applicable to studying intensity of emotions. There are studies of undertaking Mathematical tasks whilst being measured for heart rate and temperature, however measuring GSR is less intrusive than, for example, heart rate.

The wider study originated from a desire to explore how experienced teachers (past the emotional transition of training) use emotions, particularly positive emotions, within the social interactive context of teaching. There is evidence that exposure to positive emotions supports recall (Titsworth, McKenna, Mazer & Quinlan, 2013). Whilst, from a student perspective, Mottet & Beebe (2000) suggest that affect directly determines time spent on a task. Additionally, experiencing a social environment that includes emotions such as enthusiasm (Kunter et al., 2008), is likely to encourage perseverance and engagement. Early in the investigation of affective practices, I realised that little is known about the use, or the degree of intensity of emotional expression, but that emotional intensity and engagement are closely associated.

The data comes from experienced secondary mathematics classroom teachers in the UK. The method is illustrated by two teachers from the same school, Carol and Debbie, both deemed 'good' teachers by the school, in that they both have a strong rapport with students. The full research design incorporated that emotions are transitory, that they depend on context and evocation, and explored what teachers bring to the classroom (through pre-observation interviews), interaction (through videoed and audio-recorded lessons), and how teachers perceived the interaction (through stimulated recall interviews). The method was designed to explore the use of positive emotions when teaching

mathematics and to examine whether teacher affective interpretations match the observer perceptions. Embedding the element of GSR measurement offers an additional means of gauging intensity of emotions. This paper aims to show how a measurement of intensity can be incorporated into contextual emotion research, and to identify advantages of such incorporation.

Definitions and the wider context

Emotion can be conceptualised as energy that boosts cognitive functioning; energy that moves back and forth between individuals and the social. Emphasising the intensity of emotions, Lakoff and Johnson (1999) consider emotion is "...better understood as the tension of excitement level produced by the interaction of brain processes of perception, expectation, memory and so forth" (p. 176). The physical temporality emphasised by this definition is appealing as incorporative of the complexity of emotions. I retain the term emotion for use 'in-the-moment', as identifying the fluid and transitory nature of emotions. The energy definition seems applicable to the study of intensity within the dynamic and complex context of classroom teaching. Especially, as Graham and Taylor (2014) note, "[e]motions, then, can be a filter through which the perceiver may make rapid judgements in situations where there is much ambiguity" (p. 115). It seems reasonable that emotions as a filter would elicit internal intensity and the study was designed to capture such intensity. An experienced teacher often intervenes by instinct, as part of apparently effortless 'expert' teaching, and that the intensity of such an instinctive reaction may be internalised. Yet Kahneman (2011) suggests that changing a task, especially rapidly, is effortful. At such points, a teacher might increase their internal engagement, and hence an internal indicator such as skin conductance would show change, as emotional intensity increases. Barsade (2002) confirms that stronger emotions are more effective in communicating emotion, perhaps even with negative valence, as higher energy draws more attention.

The surge of physiological data in social sciences and education

Technologies that support the use of physiological data are becoming more accessible and portable, yet the use of GSR in active contexts remains sparse, usually taking place as study of individuals under static laboratory conditions. For example, within biological psychology, the use of skin conductance is common, with studies ranging from ADHD in boys to antisocial and violent behaviour, whilst many studies involve children where self-reporting is potentially less reliable. However, the application is now wider than sciences. For example, Oxley et al. (2008) suggest that political views have a biological basis. The physiological measures used include measuring change in skin conductance whilst participants were exposed to threatening or non-threatening images. Intriguingly, they found that, for participants with strong political views, lower physical sensitivities correlated with being more likely to support foreign aid, liberal immigration policies, pacifism, and gun control. Skin conductance is also used within risk analysis research. For example, when given a gambling card game task, it appears that, for successful performers, skin conductance levels (SCL) increase before selection of bad decks i.e. a risky choice (Crone, Somsen, Van Beek & Van Der Molen, 2004) which may suggest an internality associated with expertise. Such internality may also apply to experienced teachers who are likely to be skilled at concealing their emotions in class.

Outside the laboratory, Doberenz, Roth, Wollburg, Maslowski & Kim (2011) recorded the GSR of people over a 24-hour period and suggest the technology has become feasible for use outside the lab

with some concerns, such as time delay and interpreting rapid response changes. The context of a mathematics classroom bears little similarity to experiments conducted in a lab, a point that has led to studies on the real-world applications of physiological data, including in education. For example, Koren (2016) developed a device to use with young children in school “to take measurements in children's most natural environment and where authentic behaviors are exhibited” (p. 14). Teachers are significant in forming emotional climates and deciding pedagogical approaches. In a university study about learning geography, student engagement during various pedagogical approaches, was measured using skin sensors on a subset of student participants (McNeal, Spry, Ritayan & Tipton, 2014). Unsurprisingly, they found movies and class dialogues to be more engaging than lectures.

The GSR version used

GSR measures small changes in skin humidity as one indicator of either stress or excitement in the body; an approximation to emotional intensity. The eSense ESensor® (Mindfield Biosystems Ltd, 2013), a simple affordable portable device which attaches to a mobile phone and according to the website, has been previously been used in studies on excitement, anxiety & stress. The sensor records bodily response, either positive or negative, and quickly produces data which is easily converted into an intensity graph. For practical purposes, despite differences in skin response activity being greatest on the palms or soles of the feet, and fingertip measurement (distal phalanges) not possible (a teacher needs to use their hands to write or gesture), researchers recommended using the intermediate phalanges on the first and second fingers of the non-dominant (usually left) hand (e.g. Crone et al., 2004), so the recording is less prone to interruption by loosening of the sensor fastenings or similar.

Whilst observing, I noted intensity points from the teacher, thus using the device to corroborate what I, as observer, experienced and felt. Researchers suggest there is delay between experiencing intensity and recording by the sensor of up to 10 seconds (Oxley et al., 2008) although other researchers suggest a shorter time. Using video recordings surrounding an episode of interest (the 2/3 minutes around the peak value) is crucial to provide corroborative data and raises the importance of subsequent teacher interpretation of the data, as only the teacher can suggest why or what stimulated any GSR change. I incorporated stimulated recall into my method as the final dimension of a holistic and temporal (before, during and after) design; forming a methodology based around case studies using interviews, observation and stimulated recall discussion. The post-observation discussions were designed to enable each teacher to talk about their thoughts and emotions during the videoed lesson, using the clips of their teaching as a prompt with discussion centred on an extract(s) of video. Only at the end of the interview sharing the resulting GSR graph and discussing interpretation of the graphical results.

The study's use of GSR sensor data: Carol and Debbie

By the time I was observing classes in school, much of the crucial (and intense) norm setting that takes place at the start of a new academic year was in place, so I observed normal daily practice rather than norm establishment. Participants were all teachers qualified (QTS) to teach mathematics at secondary school level with a least 3 years' experience, thus limiting the influence of extremes of emotions associated with novice change processes.

The teachers wore the device in earlier sessions, without recording, until they felt comfortable, as wearing an ESensor device whilst teaching may unintentionally affect classroom interaction. I

informally practiced with the device with lecturers in university seminars, and within a few minutes, wearers behave as normal and all the participants reported forgetting about the recording and, although aware of the device, there is no apparent change in their observable behaviour. Software for video editing (Microsoft moviemaker) was used to extract clips to share with teachers. The two episodes presented here were based on highest intensity readings. Observation notes enabled me to use the device to corroborate what I, as an observer, experienced. Occasionally, the ESensor device failed to work. Although I provided a belt pouch for phone and voice recorder, there were still trailing wires, which were occasionally pulled out. In order to conduct the post-observation discussions as soon after lessons as possible, preparing for discussion required rapid examination of the video, and the ESensor graphs proved particularly useful in the process of episode selection. The excitement and interest engendered by the use of the device was notable in all cases; it has novelty, even if it is occasionally unreliable. Participants were aware of, and were happy with, the risk that GSR measuring may reveal more than a teacher wishes to share, as what triggers emotional reactions can be deeply personal and is often hidden, even from self. Combined, the data of interview, video and ESensor recordings and post observation discussion tell one possible story of each teacher and their affective professional life. The physiological measure, through the use of the ESensor, results in numerical data, that, when graphed, provides a visual insight into a lesson to share with each teacher. I next present illustrations of the use of the ESensor with two participants, Carol and Debbie, showing one of the videoed lessons in each case.

CAROL

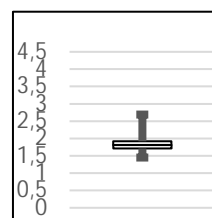
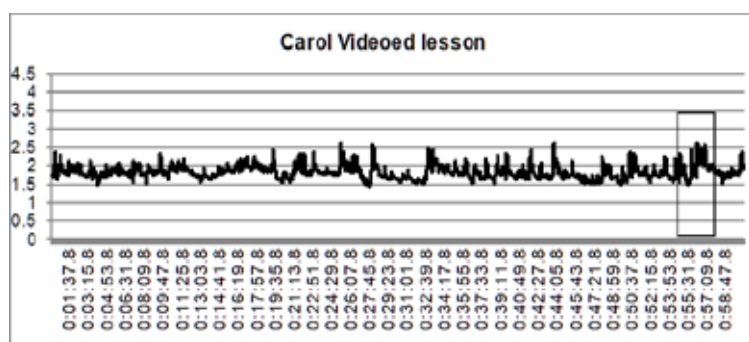


Figure 1: Graph of lesson (Carol)

Figure 2: Teacher C (Carol) ESensor distribution

In the episode selected by the maximum reading in microSiemens (μS) over time (indicated by the box in Figure 1), Carol exhibits characteristics of mild frustration or puzzlement in a predominantly calm yet positive lesson. I do not think I would have noted this episode based on observation alone. In the episode Carol is modelling a careful assessment of the situation before acting, as well as patience and thoughtfulness when doing mathematics. She encouraged explanation from students with her head on one side, with expectant body posture and interested face (Figure 3). Finally, we have emotional uncertainty or doubt. This is visually expressed as biting her lip and putting her head on one side and then the other, and articulated later as apprehension, "... because I knew they should be able to do it [Draw the graph], but they weren't giving me anything back". In post observation discussion, she assigns this doubt to either lack of understanding or to the group dynamic. Her behavioural response, both observed and subsequently explained, is to shift from instructional mode

to conversational level. Accordingly, she sits down with the group. She explains this action as, “...trying to get down on their level and having more of a conversation”.



Figure 3: Episode images (Carol)

One student in the group (shown to her left) is unknown to her, and she later expresses concern that she does not have a strong relationship with him. She thought that this unknown factor could potentially shift her out of her comfort zone and may account for the higher ESensor measurement. There were multiple possible reasons discussed in post-observation interview.

DEBBIE

The box in Figure 4 indicates the video clip used with Debbie. The higher values at the end occurred after the end of the lesson. Given the active nature of Debbie whilst teaching, with rapid movements and many emotional expressions, I would have predicted more variation in the graph (e.g. Figure 4), which are relatively consistent, although with a higher median value than for Carol (Figure 2, Figure 5) The base values for each teacher differ. This perhaps draws attention to the internal and external nature of emotions. For example, a teacher who is overtly emotional whilst teaching may have reduced internal affect or vice versa. Without the use of a physiological measure this potentially important difference is invisible.

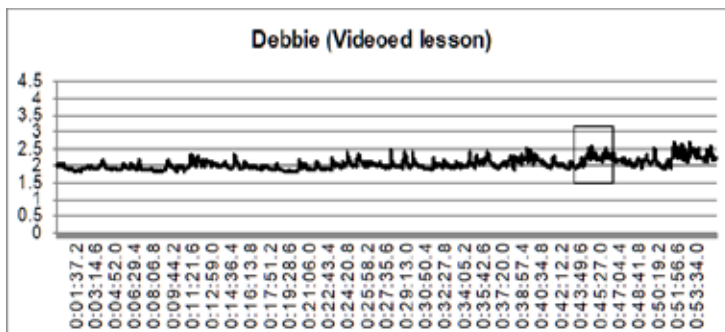


Figure 4: Graph of lesson (Debbie)

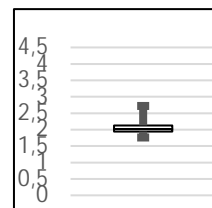


Figure 5: Teacher D (Debbie) ESensor distribution

In the selected episode, identified by uniting observation and ESensor, we see Debbie multitasking, moving rapidly from one group of students to another, answering and asking questions, a repeated pattern within the observed lessons. Even her discourse changes attention rapidly.

Student: Miss, we've done it!

Debbie: Woo! [Excited voice] Can you please put it in your um...Right, you are going to take that and you're going to do that now...Put it in your paperclip and come and see me... so that's Kim and Lee, ok Lee. Right, take one of those, you are going to work on that between you...and stick it in... [To another student] Ooh...swearing? [Louder] No!

My impression from this is that modelling enjoying doing mathematics is important to her. For example, in the selected episode she uses playful language and body movements. She waves her arms

to show an aeroplane flight path to two students who were engaged in an extension task on angles of elevation and depression. One of the considerations for ESensor use was movement, but comparing readings across the lesson, similar value appears without being associated with movement, a point verified by other studies (e.g. Koren, 2016).

Both teachers commented on their graphs in general at the end of the stimulated recall interview. Carol, whose graph is more variable, yet presents as mainly unemotional in the observed lessons, says of the video before seeing her graph, “I was shocked how calm I looked, I don’t feel like I’m that calm... perhaps I am not conveying it [excitement], because a lot of it is the day to day of it, I’ve done it 20 times, 50 times, 100 times...” whereas Debbie, who is constantly active in her teaching, comments afterwards, “that’s intriguing, maybe I look like I’m a bit mental but I’m actually pretty calm.”

Discussion

The teachers were intrigued by emotional intensity research and I suggest the resulting discussions were focused and relevant. The exemplar teachers, despite no intention to compare, offer contrast in terms of visible emotions in the classroom. Debbie is overtly emotional as she teaches and Carol the opposite, yet their ESensor graphs appear to indicate otherwise, suggesting there is more to be learnt from the use of this tool. The use with Carol and Debbie, has challenged a common view that, in order to engage students in learning, there must be some notable teacher expression of positive emotions; that they have to be overtly expressed to be useful. However, this somewhat validates the use of the ESensor, as Carol is still experiencing emotions, albeit hidden, and her comments in interview confirm this. Both Carol and Debbie take pleasure in their classroom teaching, in having strong relationships and effectively communicating the mathematics that students need, as well as care for the student emotional needs (Lake, 2015). In this endeavour, emotions play a subtle, yet central, part within their different classroom practices. I would suggest that the use of the ESensor to hone in on their emotions in-the-moment, has strengthened attending to this aspect of the study.

A valuable contribution of the ESensor use is as director for the selection of episodes. The tool enabled a quick turnaround with creating a video extract to share with teachers (in all cases the next working day). Usually selection of stimulated video recall relies on repeated watching of lengthy video to select a suitable episode, and when selected inherently has bias through observer selection and interpretation. Some (although not all) bias is reduced by using the ESensor graph to select episodes. There are limitations to acknowledge; GSR offers a rough approximation of intensity, whilst the rapidity of change in emotions means interpreting the graphs can be challenging. This is one reason for attending to the teacher interpretation, but even then, there are many reasons for intensity at any point, some of which may not be shared with an interviewer. The most significant limitation is the multiple possible interpretations and hence the unreliability, unless intense emotions are involved. However, overall, a strength is in facilitating a more focussed discussion in many cases, so more perhaps than affective gimmickry. A further limitation to acknowledge is that some lessons do not have notable indications of intense emotions. In these cases, the choice made was to use the maximum value, and to share the episode around this value with teachers. In some cases, the choice was little above the median for the lesson.

Three main implications arise from the use of the ESensor. Firstly, that awareness of use of emotions as a precursor to self-development has potential for developing self-regulation. Secondly, the data produced some potentially intriguing patterns for further investigation, albeit based on a small sample. Thirdly, as in both examples used here, the peaks frequently occurred in conjunction with supporting students to understand a specific point. This has implications for where a teacher should use intensity, something the experienced teachers may do instinctively and merits further investigation.

Consciousness of emotions, or even awareness of the activity of teaching is an issue especially pertinent to studying experienced teachers. New teachers are cognitively conscious, although not so effective at noticing wider than singular activity, such as when working one-to-one (Mason, 2002). Whilst experienced teachers often find it hard to articulate what happens when teaching, as only discrepancies are memorable. The use of the ESensor may support examination of engagement in contexts such as training. The second implication is that early indications imply that teachers who might be identified (by their students) as more engaging teachers are repositioning more frequently, which is associated with being responsive to students, but which is potentially more effortful. The ESensor may have a future role in identifying such patterns. One might speculate that it is this characteristic of engagement that the ESensor is helpful in identifying for early career teachers.

In the two examples, peaks occurred in conjunction with supporting students to understand a specific point. In Carol's case, how to create an appropriate graph, and for Debbie, what it means to visualise an elevation whilst managing other tasks simultaneously. One might suppose that both episodes require intensity to communicate the ideas, and as such is effortful, as highlighted by the ESensor. Teachers direct their communicative effort and intensity towards points of most impact on learning, meaning to change pace, to interrupt as in performance, or to restore emotional balance. Yet teachers cannot continually sustain high intensity, so there is much to be learnt about deliberate and instinctive placing of intensity. The idea of managing emotions of others through meta-awareness of intensity is not new. Mason (1989) talks of meta-awareness in terms of 'Knowing-to', which is, "...the kind of knowledge which enables people to act freshly and creatively" (p245). Amongst the participants, I observed apparently unconscious and almost instinctively managed tailoring of intensity. The use of the ESensor was aimed at partially addressing this methodological challenge, as assessing the degree of emotional regulation is important to interpreting emotions of classroom teachers.

To conclude, there are indications that the incorporation of physiological data is a powerful addition to common methodology for examining emotions in-the-moment. The use and sharing of each resultant graph, by acting as a focus for discussion, has facilitated discussion between myself and the participant teacher, and enabled each teacher to explore their emotions during the selected episode, and to articulate these through the medium of the ESensor. The use of the ESensor seems to have focused attention on what may be critical moments in a lesson. The potential is rich, the study is encouraging of the potential for GSR use in future research, both to validate the use of a sensor as having value within affect research and as a means to address the concern of affect researchers around the unavailability of emotions and hence one known limitation in any study of emotions. The ESensor usefully guided the selection of extracts from a lesson, focussing attention on indications of intensity, in addition to observation notes and my own response to the teacher.

References

- Barsade, S. G. (2002). The ripple effect: Emotional contagion and its influence on group behavior. *Administrative Science Quarterly*, 47(4), 644–675.
- Crone, E. A., Somsen, R. J. M., Van Beek, B., & Van Der Molen, M. W. (2004). Heart rate and skin conductance analysis of antecedents and consequences of decision making. *Psychophysiology*, 41(4), 531–540.
- De Simone, M., (2014). The mathematics teacher: An emotional rational being. In K. Krainer & N. Vondrová (Eds.), *Proceedings of CERME9*, Prague, Czech Republic, 1167–1173.
- Doberenz, S., Roth, W. T., Wollburg, E., Maslowski, N. I., & Kim, S. (2011). Methodological considerations in ambulatory skin conductance monitoring. *International Journal of Psychophysiology*, 80(2), 87–95.
- Graham, S. & Taylor, A.Z. (2014). An attributional approach to emotional life in the classroom, In Pekrun, R., & Linnenbrink-Garcia, L. (Eds.), *International handbook of emotions in education*, p. 96–119. New York, USA: Routledge.
- Kahneman, D. (2011). *Thinking, fast and slow*. London, UK: Allen Lane.
- Koren, G. (2016) Senti: A Wearable Sensor for Physiological Data Acquisition in Early Education, MA Dissertation, Sept 2016, Massachusetts Institute of Technology. Available at <http://hdl.handle.net/1721.1/113157> [Accessed 15/9/18].
- Kunter, M., Tsai, Y. M., Klusmann, U., Brunner, M., Krauss, S., & Baumert, J. (2008). Students' and mathematics teachers' perceptions of teacher enthusiasm and instruction. *Learning and Instruction*, 18(5), 468–482.
- Lake, E. (2015). ‘Two things I like, maths and chocolate’: Exploring ethical hedonism in secondary Mathematics teaching. In K. Krainer & N. Vondrová (Eds.), *Proceedings of CERME9*, Prague, Czech Republic, 1209–1215.
- Lakoff, G. & Johnson, M. (1999). *Philosophy in the flesh: The embodied mind and its challenge to western thought*. New York, USA: Basic books.
- McNeal, K. S., Spry, J. M., Ritayan, M., & Tipton, J. L. (2014) Measuring Student Engagement, Knowledge, and Perceptions of Climate Change in an Introductory Environmental Geology Course. *Journal of Geoscience Education*. 62, 655–667.
- Mason, J. (1989). Mathematical abstraction as the result of a delicate shift of attention. *For the Learning of Mathematics*, 9(2), 2–8.
- Mason, J. (2002). Mason, J. (2002). *Researching your own practice: the discipline of noticing*. London, UK: Routledge Falmer.
- Mindfield Biosystems Ltd. (2013). Using the eSense skin response. <http://www.mindfield.de/en/products/eSense/eSense-Skin-Response.html> [Accessed 15/9/18].
- Mottet, T. P. & Beebe, S. A. (2002). Relationships between teacher nonverbal immediacy, student emotional response, and perceived student learning. *Comm. Research Reports*, 19(1), 77–88.
- Oxley, D. R., Smith, K. B., Alford, J. R., Hibbing, M. V., Miller, J. L., Scalora, M., & Hibbing, J. R. (2008). Political attitudes vary with physiological traits. *Science*, 321(5896), 1667–1670.
- Pekrun (In press) Plenary presentation, MAVI24, Helsinki, Finland, 20–22 Aug 2018.
- Titsworth, S., McKenna, T. P., Mazer, J. P., & Quinlan, M. M. (2013). The bright side of emotion in the classroom: Do teachers' behaviors predict students' enjoyment, hope, and pride? *Communication Education*, 62(2), 191–209.

Pupils' perception of their understanding in mathematics and its connection to private supplementary tutoring

Gabriela Novotná

Faculty of Education, Charles University, Czech Republic; gabriela.novotna@jeida.cz

Very little research has been done in the area of pupils' perception of their understanding and in tutoring in the Czech Republic, so this paper describes one of prime attempts to find any connections between them. In a sample of 142 lower secondary pupils, distinctive attitudes were sought towards their desired understanding in mathematics and towards their attendance on tutoring lessons in mathematics. The results show there might not be much connection between these two areas, therefore, reasons are discussed and questions for further research are stated.

Keywords: Mathematics, understanding, knowledge, private supplementary tutoring.

Introduction

It may seem self-evident that pupils would like to understand mathematics. This claim is supported by various research (e.g. Ali, Reid, 2012), nevertheless, researchers agree on the fact that when understanding is too difficult, pupils tend to memorize concepts by rote (Ali, Reid, 2012; Skemp, 1978).

The quality of pupils' understanding is often investigated, however, not much attention is paid to pupils' notion of their own understanding and its quality. Attitudes towards one's own understanding could also influence whether someone attends private supplementary tutoring (PST) lessons, therefore, a connection between pupil's attitudes towards their understanding and towards tutoring is analyzed in this paper.

The incentive for writing this article was a small-scale study conducted by the author, where 19 pupils of private supplementary tutoring were given a short questionnaire concentrating on their attitudes towards their own understanding and quality of their knowledge in mathematics (Novotná, 2018a). The study showed that pupils have differing comprehensions of what it means to "understand mathematics". Thus, a follow-up study was realized where a similar selection of pupils was asked a question: "Try to put into words what it means for you that you understand something in mathematics" (Novotná, 2018b). Analogously, two kinds of understanding were exposed, the deep and the surface one (see section Theoretical background).

As a consequence, a larger and more detailed study has been done, which is presented in this paper. Do pupils mind when they do not understand something in mathematics properly? Do they seek tutoring lessons to help their understanding? Or is there any connection between understanding in mathematics and attending private supplementary tutoring lessons?

Theoretical background

Understanding in mathematics

Understanding is based on images or imagined feelings, situations, etc., or conceptual representations (Sierpiska, 1994). The level of understanding also influences the way we perceive and process new information.

Skemp distinguishes two kinds of understanding. *Relational understanding* is seen as “knowing both what to do and why”, while the *instrumental understanding* is characterised as “rules without reason”, because a pupil is able to formulate a rule, uses it in a standard situation, but does not understand why it works (Skemp, 1978, p. 9). None of the types of understanding should be refused, according to the author, nevertheless the relational understanding seems to be more suitable for mathematics due to its complexity, because it tends to be easier to remember, more permanent, adapts easily to new tasks, etc. (Skemp, 1978).

Types of understanding are also captured by Hiebert and Lefevre’s notions of *procedural* and *conceptual knowledge*. Conceptual knowledge is defined as “knowledge that is rich in relationships” and can be imagined as a web of knowledge where “the linking relationships are as prominent as the discrete pieces of information” (Hiebert & Lefevre, 2009, p. 3–6). Procedural knowledge consists of two distinct parts – a formal language or a symbolic representation system, and algorithms and rules for completing a mathematical task. Star supplements the theory saying that both types of knowledge can be unequally deep, complex, or shallow or restricted, so we should distinguish different levels of procedural and conceptual knowledge, too (Star, 2005). For purposes of this paper,¹ the types of understanding like relational and conceptual are referred to as a *deep understanding*, types of understanding as instrumental and procedural are labelled as a *surface understanding*².

Private supplementary tutoring

PST is defined in this paper as tutoring in a school subject (e.g. Mathematics, or English), which is taught in addition to mainstream schooling. This definition of private tutoring includes private tutoring lessons and preparatory courses (e.g. for entrance exams). The definition is inspired by Bray and Silova (2006, p. 29). However, they take into account only tutoring for a financial gain. Very little research on PST has been conducted in the Czech Republic. The only quantitative study was done by Šťastný (2016) who, within his doctoral thesis, compared his data with international surveys and analyzed the reasons of similarities and differences. The author collected questionnaire data from 1 265 students in the last year of higher secondary education in two regions of the Czech Republic, interviewed 22 tutors and analyzed tutoring offers on a specific tutoring website. He found out that, after foreign languages, Mathematics is the second most common subject for tutoring (Šťastný, 2016).

¹ There are other attempts to capture types of understanding, for example, in the Czech context, Hejny’s distinction between mechanical and non-mechanical knowledge is elaborated.

² Among the authors, there, of course, are minor differences in their conception of deep and surface understanding. However, for the purpose of this paper, these are not of a high importance.

The most common reasons for attending tutoring lessons were labeled “bad marks” and “preparation for a school-leaving exam”.³

Authors often point out that in mathematics tutoring it is often procedures and methods which are emphasized (e.g. Bray, 2010; Hohoff, 2002). Pupils are taught to solve tasks only mechanically, without deep understanding, which usually means that it is impossible to further develop their knowledge. The procedures and methods are often soon forgotten.

Perception of one's understanding and its implications

Mathematics is often labelled as one of the least popular and most difficult school subjects (e.g. Hrabal & Pavelková, 2010; Chvál, 2013). According to Chvál (2013), it is very difficult to measure all three components of an attitude (cognitive, affective, and behavioural) quantitatively. Qualitatively, we can pose extensive questions to a respondent or observe their reactions when solving mathematics problems; but mostly, only the cognitive and affective components are measured.

Some research on attitudes towards mathematics has been done: there is a reciprocal relationship between attitudes towards mathematics and achievement in it (Ma, 2012), learners' attitudes are also greatly influenced by school teachers (Ponte et al., 1991), and the social context is an influential factor, too (Hannula et al., 2018). However, as far as we know, the notion of one's understanding or knowledge has not been paid attention to. Some links can be found to self-efficacy, since positive beliefs and higher self-efficacy tend to be correlated with high performance in maths (Hannula et al., 2018).

Study

Research questions

RQ1 – Is there any specific kind of understanding that pupils of selected lower secondary schools seek in mathematics?

RQ2 – Is there any connection between a desired kind of understanding and attendance on PST?

RQ3 – Does the attendance on PST change the notion of one's understanding in any way?

The study was realized in two lower secondary schools in Prague, Czech Republic during the first week of the school year. 149 pupils were given a questionnaire, seven of them were later excluded from further analysis, due to their incomplete and/or contradictory answers and/or their different mother tongue, making 142 respondents in total (see Table 1). The questionnaire was given to the whole class, no selection of pupils was made, all the grades were given the same questionnaire.

³ The reasons for seeking tutoring differ between the majority of European and Asian countries. In Europe, such as in the Czech Republic, pupil's bad marks are the common motivation, whereas in many Asian countries, tutoring lessons are attended by successful pupils, since they want to further broaden their knowledge (Lee, 2013).

	girls	boys	total
6 th grade	15	23	38
7 th grade	24	23	47
8 th grade	14	18	32
9 th grade	16	9	25
total	69	73	142

Table 1: Respondents of the study

topic	set	items
PST in general		1, 2
PST of M (Mathematics)		3–10
attitudes towards PST of M	C, D	11–13
attitudes towards M at school	B	14
attitudes towards M in general		15
attitudes towards own understanding in M	A	16
about the respondent		17–19

Table 2: Items in the questionnaire

The questionnaire consists of the following parts (see Table 2): PST in general, PST of mathematics, attitudes towards PST of mathematics, attitudes towards Mathematics at school, attitudes towards mathematics in general, and attitudes towards one's own understanding in mathematics. The questionnaire was constructed on the basis of available literary sources, mostly the following: Silova, Būdienė and Bray (2006) and Šťastný (2016) – PST in general, PST of mathematics; PISA questionnaire (OECD, 2013) – attitudes towards PST of mathematics, attitudes towards Mathematics at school; Hrabal and Pavelková (2010) – attitudes towards mathematics in general; Code et al. (2016) – attitudes towards own understanding in mathematics; and it was further developed and modified by the author.

Four sets of items are mainly important for this paper⁴: A, B, C & D. The following set of items (set A) explores the type of desired understanding in mathematics. Pupils were asked to label their level of agreement on a 5-point Likert scale to each of the 12 statements (only 10 of them were relevant to the research question and thus are presented here). Agreement to the statements marked as + supports deep understanding, whereas agreement to the statements labelled as – supports surface understanding.

- a) – I am satisfied when I manage to solve a task, even if I don't understand the solution.
- b) – Formulas are only for counting, they don't help to understand mathematical concepts.
- c) + It is important for me to understand how formulas and procedures work.
- d) – It's a waste of time trying to understand how formulas were created.
- e) – When solving a task, I only need to know the formula, not why it works.
- f) – Understanding mathematics means that I remember something well.
- g) – When I forget a formula during a test, there is nothing I can do to come up with it.
- h) – The best way to learn mathematics is to learn sample tasks by heart.
- i) + When I learn something new in mathematics, I always look for connections to something I already know.
- j) – All I need to solve a task is to know the necessary formulas.

There are two similar sets of items (sets B and C), measuring how often concrete situations appear. Set Bis aimed at the actual teaching of mathematics, asking: “How often do these situations happen

⁴ The questionnaire was given to the pupils in Czech language and was pilot tested. Only some of the results are discussed in this paper.

in your Mathematics lessons at school?"; whereas set C concentrates on ideal tutoring lessons, hence asking: "How often would you like these situations to happen during a perfect mathematics tutoring". The situations⁵ in set B are taken directly from a PISA questionnaire (OECD, 2013), for tutoring the same situations are used, only "a teacher" is exchanged for "a tutor", singular is used instead of plural (pupils), etc. Deep understanding is supported by an agreement to these situations. Four-point scale is used, going from "every lesson" to "never or almost never".

In the set D, the respondents were given four reasons why they either attend, attended or would choose to attend tutoring lessons in mathematics. They were asked to label their level of agreement to each of them on a 5-point Likert scale, and subsequently choose the most and least important reason.

The data from the questionnaires were transcribed and analyzed, using different types of t-tests (see the section Results) and methods of a descriptive statistics (arithmetic mean [AM], standard deviation [SD], etc.) in Excel. It was observed, whether there are differences in the evaluations of girls and boys, between respondents with PST experience and without it, and within individual school grades.

Results

Almost 46% respondents acknowledged participation in private tutoring lessons in Mathematics (see Table 3), with no bigger difference between girls and boys.

	with PST in M	with PST in M (%)	total
6 th grade	13	34.2%	38
7 th grade	25	53.2%	47
8 th grade	9	28.1%	32
9 th grade	18	72.0%	25
total	65	45.8%	142

Table 3: Pupils attending/attended PST lessons in mathematics

As the most important reason for PST attendance was usually chosen "I want to understand the subject matter in depth" (AM=1.98, SD=1.17, chosen in 38%), whereas as the least important reason it was "I want to do homework" (AM=3.15; SD=1.44, chosen in 71%). However, the reason which was most agreed to was "I want to practice the subject matter from school" (AM=1.07, SD=1.07). No significant difference was found between pupils with and without PST experience ($p > 0.1$).

When we compare the evaluation of items in the sets B (Mathematics at school) and C (ideal tutoring) using a paired sample t-test (i.e. evaluation of sets B and C by the same respondent), two items appear statistically significant: "The teacher (tutor) helps us (me) to learn from mistakes we (I) have made", $p < 0.000$ ⁶; and "The teacher (tutor) presents problems for which there is no immediately obvious method of solution", $p < 0.05$. These two items should therefore create the biggest difference between the Mathematics at school and mathematics tutoring.

However, there are almost no significant differences in the evaluation of the set B and C apart, using an independent sample t-test. Among pupils who acknowledge participation in PST lessons, in the set B there is only one significant item, "The teacher presents problems that require students to apply what they have learned to new contexts", $p < 0.05$, which was agreed to more by pupils without PST

⁵ An example of such a situation is: "The teacher asks questions that make us reflect on the problem", or "The teacher asks us to explain how we have solved the problem".

⁶ This item was statistically significant ($p < 0.01$) even in smaller samples – girls vs. boys, with vs. without tutoring, school 1 vs. school 2, and in individual grades (with exception of grade 6).

experience. There was no significant difference found, neither between the pupils who acknowledged participation in private tutoring lessons and who did not; nor between boys and girls.

Those pupils who took part in mathematics tutoring were asked (measuring their level of agreement on a 5-point Likert scale) how their understanding changed. Deterioration of understanding is strongly disagreed by most of the pupils (AM=4.51, SD=1.01), while improved understanding is agreed by the majority (AM=2.07, SD=1.25). The majority of respondents also strongly disagree that it is shame attending tutoring in mathematics (AM=4.52), SD=0.99).

The data from items *c* and *i* in the set A were inverted, so that they support surface understanding as the rest of the items in the set (see Table 4). The item *a*⁷ supports the surface understanding the most (highlighted in the table), on the other hand, items *d*⁸ and *e*⁹ support it the least, therefore, endorse the deep understanding (highlighted in the table). All the other items are placed around the mean (3.0), which means that there is no outstanding trend in them.

	<i>a</i>	<i>f</i>	<i>j</i>	<i>i</i>	<i>g</i>	<i>c</i>	<i>b</i>	<i>h</i>	<i>d</i>	<i>e</i>	<i>total</i>
AM	2.25	2.63	2.69	2.78	3.05	3.18	3.21	3.48	3.56	3.70	3.05
SD	1.20	1.19	1.12	3.99	1.03	4.14	0.98	1.25	1.14	1.11	

Table 4: Items from the set A with their AM and SD

There was no significant difference between the evaluation by pupils with PST experience and without it. The biggest difference was in the item *a*, which was evaluated slightly better by pupils with acknowledged PST experience (AM_{with PST}=2.09, AM_{without PST}=2.39, p=0.14).

Discussion and conclusions

The attendance on PST lessons in Mathematics was acknowledged by almost 46% respondents, which is a bit more than other research shows – Štastný (2016) claims 36.8% of the respondents took part on PST (and only 53% of these in mathematics), Behr (1990) only 31% of the respondents in Germany. The difference is probably caused by our definition of tutoring, since also tutoring without any financial gain was taken into account in this study. Another reason could be the choice of a sample, since the study was conducted in the capital city. In peripheral areas it may not be so common to attend a tutoring. On the other hand, the study was conducted in the first week of a school year, so it may be expected that more students are about to join tutoring lessons later in the year.

RQ1 – Is there any specific kind of understanding that pupils of selected lower secondary schools seek in mathematics?

According to the data, there is no prevailing tendency towards one type of understanding by the majority of the respondents (AM=3.05¹⁰). This finding is supported by Skemp (1978), who claims that both types of understanding are useful, and one pupil can actively use both. However, there is a slight tendency that the respondents with PST experience incline a bit more towards a surface understanding (in 7 out of 10 items). The reason why would need some further research, we may only

⁷ I am satisfied when I manage to solve a task, even if I don't understand the solution.

⁸ It's a waste of time trying to understand how formulas were created.

⁹ When solving a task, I only need to know the formula, not why it works.

¹⁰ 1 – preference of a surface understanding, 5 – preference of a deep understanding

assume that one of the reasons can be pupils' attendance on preparatory courses, in which there is often (such as at school) no time for going under the surface of algorithms and procedures (Brousseau, 2002). Another explanation may be that pupils do not even know they do not understand something properly (deeply).

RQ2 – Is there any connection between a desired kind of understanding and attendance on PST?

Taking PST lessons may not be bound to one's desired type of understanding, no connection was found statistically significant. This may be caused by the great range of types of PST which a small number of respondents evaluated. To find any connections among various specific types of tutoring (individual, in a group, at school by their teacher, preparatory courses, etc.) and pupils' notion of understanding, a greater sample of respondents would be needed.

RQ3 – Does the attendance on PST change the notion of one's understanding in any way?

Respondents mostly agree their understanding in mathematics was improved with the help of PST. Nevertheless, by this they can mean both, deep and surface understanding. Further and longitudinal research would be needed to show, if individual preferences in the type of understanding can be changed with the help of PST.

This study has its limitations and it probably poses an equal number of questions as it answers. Due to the lack of research on how one sees the quality of his/her understanding, this study is seen as an exploratory one. Further studies are needed.

Acknowledgment

The study was financially supported by the Grant Agency of Charles University, Faculty of Education (project GA UK No 424119).

References

- Ali, A. A. & Rei, N. (2012). Understanding mathematics: Some key factors. *European Journal of Educational Research*, 1(3), 283–299.
- Behr, M. (1990). *Nachhilfe. Erhebungen in einer Grauzone pädagogischer Alltagsrealität*, Darmstadt: Wissenschaftliche Buchgesellschaft.
- Bray, M. (2010). Blurring boundaries: The growing visibility, evolving forms and complex implications of private supplementary tutoring. *Orbis scholae*, 4(2), 61–73.
- Chvál, M. (2013). Změna postojů českých žáků k matematice během školní docházky [Change of attitudes of Czech pupils towards mathematics during school attendance]. *Orbis scholae*, 7(3), 49–71. [doi:10.14712/23363177.2015.13](https://doi.org/10.14712/23363177.2015.13).
- Code, W., Merchant, S., Maciejewski, W., Thomas, M., & Lo, J. (2016). The Mathematics attitudes and perceptions survey: an instrument to assess expert-like views and dispositions among undergraduate mathematics students. *International Journal of Mathematical Education in Science and Technology*. 47(6), 917–937. doi:10.1080/0020739X.2015.1133854.
- Hannula, M. S, Pantziara, M., & Di Martino, P. (2018). Affect and mathematical thinking: exploring developments, trends, and future directions. In Dreyfus, T., Artigue, M., Potari, D., Prediger, S., &

- Ruthven, K. (Eds.). *Developing Research in Mathematics Education –Twenty Years of Communication, Cooperation and Collaboration in Europe* (128–141). Oxon: Routledge.
- Hiebert, J. & Lefevre, P. (2009). Conceptual and procedural knowledge in mathematics: An introductory analysis. In J. Hiebert (Ed.). *Conceptual and procedural knowledge: The case of mathematics*. New York, Oxon: Routledge.
- Hohoff, S. (2002). Mathe auf Rezept. Eine Interaktionsanalyse von Nachhilfeunterricht in Mathematik. *Journal für Mathematik-Didaktik*, 23(1), 3–27.
- Hrabal, V. & Pavelková, I. (2010). *Jaký jsem učitel* [What kind of teacher I am]. Praha: Portál.
- Lee, J. Y. (2013). *Private tutoring and its impact on students' academic achievement, formal schooling, and educational inequality in Korea* (Doctoral thesis). Available from: <https://academiccommons.columbia.edu/catalog/ac:161564>.
- Ma, X. (2012). Reciprocal relationships between attitude toward mathematics and achievement in mathematics. *The Journal of Educational Research*, 90(4). 221–229.
- Novotná, G. (2018a). Pupils of private supplementary tutoring and their perception of their understanding in mathematics. In *QUAERE 2018. Reviewed Proceedings* (762–770). Hradec Králové: MAGNANIMITAS.
- Novotná, G. (2018b). *Vnímání porozumění v matematice* [Notion of understanding in mathematics]. Manuscript submitted for publication.
- Organization for Economic Cooperation and Development (OECD). (2013). *Žákovský dotazník* [Student questionnaire – Czech version]. OECD [online]. Available from: <https://www.csicr.cz/Prave-menu/Mezinarodni-setreni/PISA/Datove-soubory-a-dotazniky/Datove-soubory-PISA-2012>.
- Ponte, J.P., Matos, J.F., Guimares, H.M., Leal, L.C., & Canavarro, A.P. (1991). Students' views and attitudes towards mathematics teaching and learning: A case of a curriculum experience. *Educational Studies in Mathematics*, 26(4), 347–365.
- Sierpiska, A. (1994). *Understanding in Mathematics*. London and Bristol: The Falmer Press.
- Silova, I., Būdienė, V., & Bray, M. (Eds.). (2006). *Education in a hidden marketplace: Monitoring of private tutoring. Overview and country reports*. New York: Open Society Institute.
- Skemp, R. R. (1978). Relational understanding and instrumental understanding. *The Arithmetic Teacher*, 26(3), 9–15.
- Star, J. R. (2005). Reconceptualizing procedural knowledge. *Journal for Research in Mathematics Education*, 36(5), 404–411.
- Šťastný, V. (2016). *Fenomén soukromého doučování jako stínový vzdělávací systém v České republice* [The private tutoring phenomenon as a shadow educational system in the Czech Republic] (Doctoral thesis). Available from: <https://is.cuni.cz/webapps/zzp/detail/133187/>.

Reflections on the development and application of an instrument to access mathematical identity

Patricia Eaton¹, Christine Horn², Elizabeth Oldham³ and Maurice O'Reilly⁴

¹Stranmillis University College Belfast, Northern Ireland; p.eaton@stran.ac.uk

²Dun Laoghaire Institute of Art, Design and Technology, Ireland; christine.horn@iadt.ie

³Trinity College Dublin, The University of Dublin, Ireland; eoldham@tcd.ie

⁴Institute of Education, Dublin City University, Ireland; maurice.oreilly@dcu.ie

Mathematical identity is understood in this paper as the multi-faceted relationship that an individual has with mathematics, including knowledge, experiences and perceptions of oneself and others. The researchers developed a protocol for accessing mathematical identity, initially designed for use with initial teacher education (ITE) students. The protocol has been refined and its use extended to students of mathematics in other contexts in Ireland. This paper reviews the iterations of the protocol, its development into an instrument, and the context and use of such an instrument. It addresses the issue of robustness of the instrument when applying it to contexts within and outside ITE.

Keywords: Mathematical identity, personal narratives, online survey.

Introduction

Mathematical identity has been a topic of interest especially over the last twenty years, and many studies have addressed the mathematical identity of teachers or students in initial teacher education (ITE) programmes. The work described in this paper is intended to contribute further to exploring students' mathematical identity. Originally focused on ITE students, it now includes other cohorts.

In 2009, as part of the project MIST (The Mathematical Identity of Student Teachers), a protocol was developed that scaffolded students in writing about their encounters with mathematics. It was used with two groups of ITE students in the island of Ireland (Eaton & O'Reilly, 2009). The aim was to encourage them to reflect on their mathematical identity with a view to facilitating discussions around how that identity may impact on their own classroom practice. The students' narrative responses allowed certain themes to be identified that spanned the responses of both cohorts. These themes also sufficed to describe the results of using a very similar protocol with undergraduate mathematicians taking modules on mathematics education (Eaton, Oldham, & O'Reilly, 2011). For the next iteration, in the study Mathematical Identity using Narrative as a Tool (MINT), the protocol was developed into an instrument that could be administered online, with the aim of accessing further cohorts with greater ease and efficiency. It was used with six cohorts of students in both jurisdictions in Ireland, within and outside ITE (Eaton, Horn, Liston, Oldham, & O'Reilly, 2014, 2015). Details of these cohorts, and of the development of the instrument, are given below.

The main aim of this paper is to address the usefulness of the instrument in a variety of settings. The paper first situates the work of the projects MIST and MINT within traditions of research on identity as distinguished in recent reviews of that research, and then traces the evolution of the

original protocol into the instrument used in MINT. In particular, the authors focus on how the themes identified initially in MIST apply to other cohorts (even outside ITE), and reflect on how robust the outcome themes appear to be, regardless of the cohort of students addressed.

Literature review and outline of a theoretical framework

Research in mathematical identity has attracted, and received, overviews and critical analyses for at least two decades. Earlier syntheses are discussed and expanded in some more recent surveys (Darragh, 2016; Goldin et al., 2016; Hannula, Pantziara, & Di Martino, 2018; Lutovac & Kaasila, 2018). From these overviews, several aspects of relevance to this paper can be distinguished; they provide a framework within which the studies of mathematical identity can be addressed.

A notable aspect is that there is still no agreement on the *definition of mathematical identity*. Darragh (2016) highlights and critiques the differing and indeed conflicting versions, or, in some papers, the absence of any clear definition. In Lutovac and Kaasila's (2018) overview, the uncertainty created by multiple definitions is regarded as a given; however, following Sfard and Prusak (2005), they demand that studies should provide at least a working definition.

Approaches can also be categorized as *broadly social* or *broadly psychological*. Many of the studies on mathematical identity draw on Wenger's (1998) work on communities of practice. In this respect, they tend to follow what Lerman (2000) calls the social turn in mathematics education research that has been a prominent feature especially from the mid-1980s (Goldin et al., 2016). However, Lutovac and Kaasila (2018) argue that "neglecting the individual, i.e. how one thinks and feels and who one is, is at odds with the core concept of identity itself" (p. 767); they advocate for a more balanced psychosocial approach that allows for a focus on individuals' thinking and feeling.

Methodology constitutes another aspect. Qualitative approaches have dominated, with sample sizes typically being small, and just a few studies using coding and counting techniques (Darragh, 2016; Goldin et al., 2016; Hannula et al., 2018). The use of narrative has been particularly important; in a seminal paper, Sfard and Prusak (2005) actually take the narratives as constituting identities, hence opening the way to approaches requiring "close attention to the words used" (Darragh, 2016, p. 25).

The *mathematical identity of ITE students* has been a topic attracting considerable focus. The value of research in the area is highlighted, for example by adverting to "some evidence that encouraging pre-service teachers to narrate their own or listen to their peers' personal experiences with the subject makes them cope better, which may lead to the development of a more suitable identity for mathematics teaching" (Goldin et al., 2016, p. 17). Lutovac and Kaasila (2018) also note the process of change in ITE students' mathematical identity, for example by emphasizing affective facets.

Methodology and evolution from MIST to MINT

The *definition* of mathematical identity formulated for the studies considered here is the following:

Mathematical identity is considered as the multi-faceted relationship that an individual has with mathematics, including knowledge, experiences and perceptions of oneself and others.

(See Eaton et al., 2014, for references.) This situated the work primarily in the *broadly social* tradition, with some psychological aspects. The *methodology* has chiefly involved students writing narrative accounts; analysis of the resulting qualitative data has been done by coding and counting as described below. Most work has involved *ITE students*; extension to other cohorts is a focus of this paper.

The protocols and instrument, student cohorts, and establishment of themes

The first study (of three), MIST, considered the identity of ITE students (pre-service primary teachers) who were at one of two institutions – one in Northern Ireland and one in the Republic of Ireland – and were specialising in mathematics (see, for example, Eaton and O'Reilly, 2009). Introductory demographic questions and Likert items were used along with a two-part protocol:

- P1. Students were asked to respond in writing to the prompt: “Think about your total experience of mathematics. Tell us about the dominant features that come to mind.”
- P2. They were then offered a more structured prompt: “Now think carefully about all stages of your mathematical journey from primary school (or earlier) to university mathematics. Consider:
- Why you chose to study mathematics at third level
 - Influential people
 - Critical incidents or events
 - Your feelings or attitudes to mathematics
 - How mathematics compares to other subjects
 - Mathematical content/topics

With these and other thoughts in mind, describe some further features of your relationship with mathematics over time.”

The narrative responses were used to provide guidelines for focus group discussions, one in each institution. Discussion transcripts, together with the original narratives, were analysed to identify common threads and themes (Clandinin & Connelly, 2000). Using an approach informed by grounded theory, seven themes were identified; their main features can be summarized as follows:

- T1. **Students’ self-reflection on learning and teaching** relates to how students’ exploration of their mathematical identity leads them to deepen their insight into learning and teaching mathematics.
- T2. **The role played by key figures in the formation of mathematical identity** focuses not only on teachers and family members, but also on peers and society at large.
- T3. **Ways of working in mathematics** explores what students find effective in learning mathematics and why, either through individual endeavour or through collaboration.
- T4. **How learning mathematics compares with learning in other subjects** considers the particular characteristics of learning mathematics, usually at school, that distinguish the process from learning in other subject areas.
- T5. **The nature of mathematics** draws from a broad range of students’ perceptions touching on the philosophy of mathematics and on what doing mathematics is about.

T6. **“Right” and “wrong” in mathematics** concerns students’ perception that what is important in mathematics is to find the correct answer, and also a more general notion around the unambiguous nature of mathematical truth.

T7. **Mathematics as a rewarding subject** examines the extent to which students enjoy the subject, often relating to how they persist with it or to significant moments of insight. (Eaton et al., 2011, pp. 156–157)

These reflect both social and psychological aspects. For instance, T4 involves both aspects, and T7 in particular includes affective issues, as highlighted by Lutovac and Kaasila (2018).

In the second study, the students were undergraduate mathematicians at another institution, had elected to take modules in mathematics education, and thus were considered as “prospective” teachers despite not being in an ITE programme. Students wrote responses to P1 and P2 in their own time as part of the module assessment. Analysis was based on the MIST themes, which were found to be adequate for describing these narratives (Eaton et al., 2011; Eaton et al., 2015).

In its third iteration, MINT, the research team of three people – the two from MIST, one from the second study – was augmented to five, with new members coming from two institutions in the Republic of Ireland. The protocol was extended (Eaton et al., 2015) to include a third part:

P3. What insight, if any, have you gained about your own attitude to mathematics and studying the subject as a result of completing the questionnaire?

The items, including introductory demographic questions and Likert items as used for MIST, were gathered into one instrument and made available online to six cohorts of students using SurveyMonkey, allowing students to respond at their chosen time and location. The students in four of the cohorts were in Initial Teacher Education (ITE) programmes. The other two cohorts were not; one comprised first year students of entrepreneurship (involving a one-year business mathematics module), while the other consisted of fourth year students of applied psychology (taking research methods and statistics-related modules in all of their four years of study). For the purposes of this paper, these two cohorts were denoted as Non Teacher Education (NTE).

Coding the MINT data

Of the 99 respondents in the MINT study, 86 provided data (narrative responses) for at least one of the three open questions, P1, P2 and P3; detail relevant to this discussion is provided in Table 1 below. The five members of the research team were assigned respondents, ensuring that the data from each respondent was studied by three people; each person coded the data using the MIST themes and also sought to identify any other themes. No other themes were found. Several meetings were held to compare the coding and reconcile differences; this entailed clarifying the scope of some of the themes to obviate confusion and/or overlap, as elaborated below. Consensus was reached, so the question of inter-coder reliability did not arise. Overall, the seven themes provided adequate descriptions and coverage of the data, though themes T4 and T6 were less prominent than the others. Once the coding was complete for each element (respondent and question, P1-P3) of data, the instances of each theme (T1-T7) were counted. Analysis of data coded T1 (**students’ self-reflection on learning and teaching**) from the 56 ITE students is reported by Eaton et al. (2015).

As regards clarification, when the MINT research team discussed the responses that were potentially to be coded T1, for example, the theme was refined as follows: T1 (i) applied when students explicitly reflected on their mathematical journey with reference to “then” and “now”; (ii) was extended to include reference to how students see themselves teaching and learning into the future; (iii) did not apply to data that comprised lists without context. There was also some development concerning potential overlap of themes, particularly T3 (**ways of working in mathematics**) and T5 (**the nature of mathematics**). The research team agreed that T3 applied to (i) what students did as they learned mathematics, inside or outside “the classroom”, and (ii) what students find effective in learning mathematics and why, either through individual endeavour or through collaboration. Moreover, it was agreed that T3 would include “rote learning” and “learning for understanding” where the learner is the agent (rather than experiencing teaching for rote learning or understanding, for example). In the summary description of T3, it was agreed that “effective” would be interpreted as anything on the spectrum of effectiveness (including ineffective); T5 would include (i) the “relevance versus abstraction” dimension and (ii) applications in the real world. After clarifying such matters in relation to coding, it was judged that the MINT instrument was appropriate for exploring characteristics of mathematical identity among different cohorts of students or in different settings.

Extending the instrument to NTE students

The application of the instrument to NTE students in MINT is considered in this section, and a comparison is made between the data from this cohort and the ITE data. It was found that the same themes could be applied satisfactorily across the entire MINT study; however, more detailed analysis is of interest.

Cohort (ITE or NTE); questions from protocol (P)	Number of respondents	Percentage of students in each cohort coded in each theme						
		T1	T2	T3	T4	T5	T6	T7
ITE; P1	52	29	44	58	4	17	6	83
ITE; P1, P2 & P3 combined	56	48	84	63	36	38	23	98
NTE; P1	27	22	19	30	4	52	4	89
NTE; P1, P2 & P3 combined	30	63	70	47	33	67	10	97

Table 1: Coding of themes in response to open questions

A feature of the protocol (for both MIST and MINT) is that respondents did not see P2 until after they had responded to P1. The importance of this open-ended and non-directive initial question is discussed in Eaton and O'Reilly (2009). Of the 56 ITE students who answered at least one of the three open questions, 52 responded to P1. Likewise, 27 out of 30 NTE students answered P1. On examination of the responses from all six cohorts (four ITE and two NTE), Table 1 summarizes the coding for the themes (T1-T7) for ITE and NTE students, drawing attention to the frequencies of

the codes in responses to P1 and to all three parts (P1-P3) of the protocol combined, as percentages of the number of respondents.

The table reveals that themes T6 and T4 are weakest for each cohort; their frequency is especially low in response to P1. The theme most related to affect, T7, is by far the strongest for each cohort. With the prompts offered by P2 and P3, the codes for each theme are more frequent, as might be expected. However the profile of the two cohorts differs between themes and according to the prompts given. From a qualitative perspective, we should expect that the narrative around mathematical identity would depend on the cohort to which students belong, reflecting factors such as programme focus, teaching culture or maturity of students. To test if there are any significant differences between the ITE and NTE cohorts, a Fisher's exact test was conducted for each of the themes. When all three questions in the protocol were considered together, the only statistically significant difference was for theme T5. NTE students were found to capture this theme significantly more frequently than did ITE students (with $p = .013$ in the Fisher test). For all other themes there was no statistically significant difference ($p > .15$ in all cases). However, when the responses to P1 alone are considered, the contrast between the two cohorts in relation to T5 is more stark ($p = .003$), while significant differences between the cohorts in relation to T2 and T3 are apparent (with $p = .027$ and $p = .032$, respectively). This indicates that prospective teachers are more likely to draw attention to the influence of others (such as their own teachers) and to the importance of ways of working with mathematics than are NTE students.

Focusing on T1, it was noted that ITE students' narrative relevant to this theme emphasized how the evolution of mathematical identity from second to third level education was intertwined with their commitment to teaching mathematics (Eaton et al., 2015). Naturally, such a perspective was found to be absent from the NTE cohort. However, significant evolution across the same educational transition was intertwined with the new focus that students appreciated regarding the applicability of the subject to the "real world". It is exemplified in the following quotation from one respondent:

Whereas in Maths in secondary once the problem was solved that was the end of the matter, in college we use the solution after its completion ... and apply them to everyday/business/social scenarios ... My experience of maths in 3rd level has given me a new opinion on the subject, I can clearly see its uses, and an understanding of where to apply them. (P1, NTE)

As far as T5 (the nature of mathematics) is concerned, the importance of application of mathematics to real-world problems comes out strongly for 17 of the 20 NTE students whose responses were coded for this theme. Here is an example of what one student wrote:

Mathematics, in particular statistics is vital within the area of Psychology. I really enjoyed it during third level because I could see what the analyses were being used for. ... Also, while I really enjoy maths now, I feel that the style of teaching through primary and secondary school had given me a complete misconception into what maths really is. (P2, NTE)

In summary, the data show that the NTE students in MINT emphasise the practical nature and importance of mathematics and its relevance to business or psychology. It is reasonable to argue that precisely this aspect gives rise to the much higher instance of T5 among the NTE students than among ITE students.

Robustness of the instrument

Two aspects of robustness are considered here. They are *robustness of the themes* (their adequacy in describing data for different cohorts), and *inter-coder reliability* in using the instrument.

The seven themes identified in MIST, using a grounded approach following the steps of thematic analysis, were re-evaluated and basically endorsed in MINT by the members of the larger research team. The argument so far has shown that these themes appear to be robust in facilitating access to the mathematical identities of differing cohort of students: ITE students in different types of ITE programme, and in two different (yet neighbouring) countries; and also NTE students who had some element of mathematical work in their courses. No new themes have emerged. While variations are evident in the frequency with which the themes figured for the two cohorts, these could be related to the backgrounds and interests of the cohorts and are of intrinsic interest. It can be noted that placing the instrument online for MINT, using SurveyMonkey, reduced the influence of the researcher and strengthened anonymity for the respondents (as well as allowing them to respond where and when suited them); it also facilitated data collection for the research team.

With regard to ensuring inter-coder reliability, considerable work was needed. Some of this involved clarification of the borderlines between themes, as described above. Future coders might need training, as well as time to grasp the definition or description of each theme. However, while the “coding and counting” approach was important for research, the narrative data elicited can, in any case, be of value for lecturers in appreciating their students’ preoccupations. As judged by answers to P3, it is also of value to at least some of the respondents themselves, in line with the original aims for the studies (and perhaps aligning with the work of Goldin et al. (2016), cited above). In fact (though details are outside the scope of this paper), two of the authors have used the instrument with several cohorts of students, and have found that their own teaching was enriched by what students wrote and that many of them reported finding the exercise helpful.

Conclusion

The importance of mathematical identity is well established, particularly in teacher education, notwithstanding the challenges in establishing clear definitions and a shared understanding in the academic community. This paper has drawn attention to the development of one protocol and instrument that have proved stable when working with a range of students both within and outside teacher education and in different countries. The online instrument used has elicited both social and psychological aspects of identity. It can be easily administered to students, and allows teachers and even students themselves to gain insight into mathematical identity, which can be beneficial for learning and teaching mathematics. The value of the data collected, for research and also for teaching and learning, promises well for further use in both similar and different contexts.

Acknowledgment

The authors acknowledge the funding received from SCoTENS for this research, and thank all the contributors to the studies, especially Miriam Liston as a member of the original MINT team.

References

- Clandinin, D. J., & Connelly, F. M. (2000). *Narrative inquiry: Experience and story in qualitative research*. San Francisco, CA: Jossey-Bass.
- Darragh, L. (2016). Identity research in mathematics education. *Educational Studies in Mathematics*, 93, 19–33.
- Eaton, P., Horn, C., Liston, M., Oldham, E., & O'Reilly, M. (2014). Developing an instrument to explore mathematical identity: A study of students from several third level institutions in Ireland. In E. Arntzen (Ed.), *Educating for the future: Proceedings of the ATEE 38th Annual Conference, Halden 2013* (pp. 280–297). Brussels, Belgium: ATEE.
- Eaton, P., Horn, C., Liston, M., Oldham, E., & O'Reilly, M. (2015). From learner to teacher: Using reflection to develop mathematical teacher identity. In L. Leite, M. A. Flores, L. Dourado, M. T. Vilaça, & S. Morgado (Eds.), *ATEE Annual Conference 2014: Transitions in teacher education and professional identities* (pp. 367–375). Brussels, Belgium: ATEE.
- Eaton, P., Oldham, E., & O'Reilly, M. (2011). Looking back to look forward: The mathematical identity of prospective mathematics teachers. In T. Dooley, D. Corcoran, & M. Ryan (Eds.), *Proceedings of Fourth Conference on Research in Mathematics Education (MEI 4)* (pp. 155–167). Dublin, Ireland: St. Patrick's College.
- Eaton, P., & O'Reilly, M. (2009). Who am I and how did I get here? Exploring the mathematical identity of student teachers. In D. Corcoran, T. Dooley, S. Close, & R. Ward (Eds.), *Proceedings of Third National Conference on Research in Mathematics Education (MEI 3)* (pp. 228–237). Dublin, Ireland: St. Patrick's College.
- Goldin, G. A., Hannula, M. S., Heyd-Metzuyanim, E., Jansen, A., Kaasila, R., Lutovac, S., ... Zhang, Q. (2016). *Attitudes, beliefs, motivation and identity in mathematics education: An overview of the field and future directions*. New York, NY: Springer.
- Hannula, M., Pantziara, M., & Di Martino, P. (2018). Affect and mathematical thinking: Exploring developments, trends, and future directions. In T. Dreyfus, M. Artigue, D. Potari, S. Prediger, & K. Ruthven (Eds.), *Developing research in mathematics education: Twenty years of communication, cooperation and collaboration in Europe* (pp. 128–141). Oxford, England: Routledge.
- Lerman, S. (2000). The social turn in mathematics education research. In J. Boaler (Ed.), *Multiple perspectives on mathematics teaching and learning* (pp. 19–44). Westport, CT: Ablex.
- Lutovac, S., & Kaasila, R. (2018). Future directions in research on mathematics-related teacher identity. *International Journal of Science and Mathematics Education*, 16, 759–776.
- Sfard, A., & Prusak, A. (2005). Telling identities: In search of an analytic tool for investigating learning as a culturally shaped activity. *Educational Researcher*, 34(4), 14–22.
- Wenger, E. (1998). *Communities of practice: Learning, meaning, and identity*. Cambridge, England: Cambridge University Press.

Upper Secondary Mathematics Teachers' epistemological beliefs concerning the nature of mathematics

Marilena Pantziara¹, Alexandra Petridou² and Marianna Karamanou³

¹Cyprus Pedagogical Institute and University of Nicosia, Cyprus; marilena.p@cytanet.com.cy

²Centre of Educational Research and Evaluation, Cyprus; petridou.a@cyearn.pi.ac.cy

³Ministry of Education and Culture, Cyprus; mkaramanou@hotmail.com

This study aimed to explore the structure and level of Grade 10-12 mathematics teachers' epistemological beliefs regarding the nature of mathematics. Data was drawn from the international comparative study New Open Research: Beliefs about Teaching Mathematics (NorBa) investigating mathematics teachers' beliefs in more than 15 countries. A total of 147 mathematics teachers completed the NorBa's questionnaire in Cyprus. Exploratory factor analysis was employed to explore the underlying structure of mathematics teachers' epistemological beliefs and MANOVA was employed to examine for differences in epistemological beliefs in relation to background characteristics. The results are discussed and compared with those of other countries in an attempt to explore for cultural differences.

Keywords: mathematics, teachers, epistemological, beliefs

Introduction

It is generally acknowledged that beliefs are part of teachers' professional competence. In line with this view, almost all theoretical classifications of teachers' professional competence (e.g. Ernest 1989; Thompson 1992) include, apart from knowledge, teachers' beliefs and attitudes. Beliefs are thought to be crucial to the perception of situations since they influence teachers' choices of actions (Felbrich, Müller & Blömeke, 2008; Felbrich, Kaiser & Schmotz, 2012). Hence, teachers' beliefs play an important role in teaching as they serve as a bridge between teachers' knowledge and their actual teaching (Wilkins, 2008; Felbrich et al., 2012).

Teachers' epistemological beliefs about the nature of mathematics present an issue that has been prominent in empirical research (Felbrich et al., 2008; Felbrich, et al., 2012; Törner & Pehkonen, 1996). In their recent overview of the research literature concerning mathematical epistemological beliefs, Depaepe, De Corte and Verchaffel (2016) state the importance of teachers' epistemological beliefs since these beliefs affect teachers' selection of learning tasks and classroom activities and also influence students' epistemological beliefs. Different categorization schemes for teachers' epistemological beliefs concerning the nature of mathematics have been developed (Ernest, 1989; Blömeke, Felbrich, Müller, Kaiser, & Lehmann, 2008; Felbrich et al., 2012) indicating that teachers differ regarding their epistemological beliefs. It is stated that beliefs have an experiential and context-bound nature and can be understood as socially and culturally shaped mental constructs (Felbrich et al., 2012; Schoenfeld, 1998). Thus, teachers' epistemological beliefs may differ according to background variables or across different countries.

This study focuses on mathematics teachers' epistemological beliefs about the nature of mathematics. Specifically, we investigated the structure and level of 10-12th grade mathematics teachers'

epistemological beliefs. Furthermore, we investigated for differences in these teachers' epistemological beliefs in relation to their background characteristics.

Theoretical framework

Teachers' epistemological beliefs about mathematics

Beliefs in a more broad meaning could be described as “psychologically held understanding, premises, or propositions about the world felt to be true” (Richardson 1996, p.103). In the domain of mathematics, teachers' epistemological beliefs refer to beliefs concerning the nature of mathematics or beliefs concerning the acquisition of mathematical knowledge (Depaepe, et al., 2016; Felbrich, et al., 2012).

Different categorizations for teachers' epistemological beliefs concerning the nature of mathematics have been developed in the respective literature. Ernest (1989) distinguishes between three views on the nature of mathematics: an instrumentalist, a Platonist and a problem-solving view. Another classification is that of Grigutsch, Raatz and Törner (1998) who developed four distinct views on the nature of mathematics: (a) the formalism-related view where mathematics is conceived as an axiomatic system, developed by deduction, (b) the scheme-related view, where mathematics is regarded as a collection of terms, rules and formulae, (c) the process-related view, where mathematics can be understood as a science which mainly consists of problem solving processes and (d) the application-related view, where mathematics can be understood as a science which is relevant for society and everyday life. The formalism-related view corresponds to Ernest's Platonist view, the scheme-related view parallels Ernest's instrumentalist perspective while the process view resembles Ernest's problem solving view (Ernest 1989; Felbrich et al., 2012). Grigutsch et al. (1998) suggested, based on empirical work, that these four views could be subsumed under two perspectives of mathematics: the formalism together with the scheme-related view, describing mathematics as a static science and the process together with the application-related view, characterizing mathematics as a dynamic process. In their study they found that application and process views positively correlated with each other and the same happened with formalism and scheme views. Moreover, they found that the process view correlated negatively with the formalism and scheme orientations whereas there could be no systematic correlation traced between the application view and any other view except for the process view.

Some empirical studies on teachers' epistemological beliefs regarding the nature of mathematics involved teachers at different levels of mathematics education. The study by Felbrich et al. (2008) investigated the structure and level of beliefs concerning the nature of mathematics of future mathematics teachers in Germany at the beginning and at the end of their education and also the epistemological beliefs of their educators in three academic disciplines (mathematics, mathematics pedagogy and general pedagogy). Using an adaptive version of the questionnaire developed by Grigutsch et al. (1998), they confirmed a solution of four factors corresponding to the four categories of teachers' epistemological beliefs. With respect to the overall level of beliefs, both groups of future teachers' highly agreed with process-related statements while they agreed less with scheme-related statements. Another interesting result was that future teachers' views seemed to be dominated by the dynamic aspect of mathematics (process and application) while the static aspect (formalism and

scheme) received less agreement; this pattern was more pronounced at the end of their education. In addition strong positive relations between formalism and scheme as well as between process and application views have been found for future teachers. The belief structure of these future teachers could not be characterized by the two poles as antagonistic (static and dynamic). Mathematics educators agreed with process, application and formalism related aspects and showed a less positive attitude toward scheme-related aspects while educators of mathematics pedagogy hold a more antagonistic view of mathematics as indicated by their preference towards dynamic aspects and relatively lower preference towards the static aspect.

As Depaepe et al. (2016) concluded, research has revealed that it is not easy to describe one's epistemological beliefs as either static or dynamic. Investigating the structure of epistemological beliefs with respect to a different population, this of mathematics instructors at university, Grigutich & Törner (1998) found that the antagonistic structure of beliefs regarding the nature of mathematics could not be found. The epistemological beliefs of these mathematicians could be described by both the dynamic and the static aspect co-occurring at the same time, revealing a complex understanding of mathematics. In the same vein, Roesken and Törner (2010) found that university mathematics teachers can hold simultaneously static and dynamic epistemological beliefs.

Regarding cultural differences, Felbrich et al. (2012) analyzed pre-service primary teachers' epistemological beliefs in mathematics in 15 different countries and investigated whether differences in these beliefs could be explained in terms of cultural differences between countries, using Hofstede's terminology, individualistic versus collectivistic orientation. For this purpose, they used instead of the four views of mathematics the two perspectives, mathematics as a static science and mathematics as a dynamic process, stating that this was more useful in quantitative large-scale research. In individualistic countries (e.g. Germany, Switzerland, Norway), learners are perceived as autonomous subjects acquiring knowledge mainly independently on their own. In collectivistic countries (e.g. Philippines, Thailand, Malaysia) the role of social relationships on the acquisition of knowledge is more prominent. Learners participate in learning due to an obligation towards their teachers, their families and society. The results of the study showed that the epistemological beliefs of these future teachers varied strongly within but also between countries. Future primary teachers from highly collectivistic oriented societies agreed more strongly with the static aspects of mathematics while in highly individualistic oriented societies, the future teachers more strongly stressed the dynamic nature of mathematics. Additionally, in countries that could not clearly be characterized as individualistic or collectivistic, future teachers emphasized both aspects of mathematics to the same extent. The data also showed that future primary teachers with high mathematical content knowledge conceived mathematics as more dynamic in nature compared to the future primary teachers with lower mathematical content knowledge.

Depaepe et al. (2016) stated that there is a strong need for a clear conceptualization of mathematics epistemological beliefs. In addition, the studies concerning mathematicians' epistemological beliefs are rare. Hence, the purpose of this study was to investigate (a) the structure and patterns of the epistemological beliefs for a different population, i.e. 10-12th Grade mathematics teachers in the Cyprus context and (b) the differences in these teachers' epistemological beliefs in relation to their background information.

Methodology

Data collection, instruments and participants

According to the Annual Report of the Cyprus Ministry of Education and Culture (2014), the Public Secondary General Education in Cyprus is offered to pupils between the ages of 12 - 17, through two three-year levels: the Gymnasium (Grades 7-9, ages 12-14) and the Lyceum (Grades 10-12, ages 15-17). Currently, there are 38 Lycea and 7 joined Gymnasias and Lycea in Cyprus, where approximately 280 mathematics teachers are employed. In Cyprus, there are minimum requirements to work as a mathematics teacher for grades 7-12 which refer to a bachelor's degree in mathematics and also to the attendance to a one year course in pedagogy offered by the Ministry of Education and Culture.

Data for this study was gathered from mathematics teachers working in Lyceum during the 2015-2016 academic year. The study was conducted in the context of the international comparative study New Open Research: Beliefs about Teaching Mathematics (NorBa) investigating mathematics teachers' beliefs in more than 15 countries. In the context of the NorBa project, a questionnaire was developed and culturally adapted in all participating countries. The questionnaire comprised of seven parts: one of them qualitative and six quantitative (86 items). The current study used data only from two parts (Part A and Part F) of the afore-mentioned questionnaire. Part A collected data on teachers' background variables (gender, age, their teaching experience and highest level of formal education) while Part F explored mathematics teachers' epistemological views on mathematics.

Part F included the shortened version (20 items) of an instrument developed by Grigutsch et al. (1998) also used in Mathematics Teaching in the 21st century (MT21) study by Schmidt, Blömeke and Tatto (2011). The formalism-related and scheme-related scales consisted of 5 items each whereas the process-related and the application-related scales were approached using 6 and 4 items respectively. Example items for all subscales are presented below: for the formalism scale, "Mathematical thought is characterized by abstraction and logic", for the scheme scale, "Mathematics is a collection of rules and procedures that prescribe how to solve a problem", for the process scale, "Mathematical problems can be solved correctly in many ways" and for the application scale, "Mathematics entails a fundamental benefit for society". Respondents were asked to show their agreement or disagreement to each item on a five-point Likert scale ranging from strongly disagree to strongly agree.

Informative letters along with the questionnaire and prepaid envelopes were sent to mathematics teachers in all Lyceums inviting them to participate in the study on a volunteer basis. A total of 147 mathematics teachers (44,8 % men and 55,2% women) completed and returned the questionnaire. The response rate was 52,5%.

Various statistical techniques were employed to analyze the data of the current study. Confirmatory factor analysis (CFA) and Exploratory factor analysis (EFA) were employed in order to investigate the possible underlying structure of mathematics teachers' epistemological beliefs, correlation analysis aimed to explore the relationship between the resulting factors and finally MANOVA was employed to investigate for differences in epistemological beliefs in terms of background variables. Data was analyzed using the statistical packages AMOS and SPSS.

Results

Regarding the first research question of this study, a CFA using AMOS was carried out in order to validate the suggested structure for the 20 items. By employing a maximum likelihood estimation method, three types of fit indices were used to assess the overall fit of the model: the chi-square index, the comparative fit index (CFI), and the root mean square error of approximation (RMSEA). Hu and Bentler (1999) suggest using a combination of cutoff values for the aforementioned fit indices (CFI ≥ 0.95 and RMSEA ≤ 0.06). The model fits the data sufficiently when the ratio of chi-square statistic over degrees of freedom does not exceed 3. A solution with four factors as suggested by the respective literature did not achieve satisfactory fit indices ($\chi^2 = 272.334$, $df=164$, $p<0.001$, CFI=0.847, RMSEA=0.068). Therefore, we proceeded with exploratory factor analysis in order to explore a new country-specific structure for the 20 items. EFA was employed on the 20 items of the epistemological beliefs using maximum likelihood with orthogonal rotation (varimax). The Kaiser-Meyer-Olkin statistic (0.77) and Bartlett's Test of Sphericity ($\chi^2(120) = 694.872$, $p<.001$), indicated that data was suitable for factor analysis. To determine the number of factors to be retained two criteria were used: a) Kaiser's criterion for eigenvalues greater than one and b) the scree plot (Kaiser 1974).

	1	2	3	4
Factor 1: Formalism				
Essential for mathematics is definitional rigor, i.e. an exact and precise mathematical language.	.784			
Fundamental to mathematics is its logical rigor and preciseness.	.744			
Mathematics is characterized by rigor, namely rigor of definition and rigor of formal mathematical argumentation.	.673			
Mathematical thought is characterized by abstraction and logic.	.462			
Hallmarks of mathematics are clarity, precision and unambiguousness.	.410			
Factor 2: Application				
Mathematics helps solve everyday problems and tasks.		.776		
Mathematics entails a fundamental benefit for society.		.755		
Many aspects of mathematics have practical relevance.		.540		
Mathematics is useful for every profession.		.484		
Factor 3: Scheme				
To do mathematics requires much practice, correct application of routines, and problem solving strategies.			.877	
When solving mathematical tasks one has to know the correct procedure else one is lost.			.570	
Mathematics means learning, remembering and applying.			.565	
Mathematics is a collection of rules and procedures that prescribe how to solve a problem.			.517	
Factor 4: Process				
Mathematical problems can be solved correctly in many ways.				.762
In mathematics many things can be discovered and tried out by oneself.				.601
Usually there is more than one way to solve mathematical tasks and problems.				.567

Table 1: Factor analysis of the epistemological beliefs about mathematics

In line with respective literature, only items with component loadings larger than 0.30 were retained (16 items). Both criteria supported a four-factor solution explaining 48.08% of the total variance. Factors were named according to the items included in each group. Items that loaded on Factor 1 represent the formalism-related view, items that loaded on Factor 2 represent the application-related view, Factor 3 items represented the scheme-related view and Factor 4 items represented the process-related view. All factors had sufficient internal consistency values (Formalism- $\alpha=0.78$, Application- $\alpha=0.76$, Scheme- $\alpha=0.72$ and Process- $\alpha=0.70$).

Table 2 presents the mean scores of mathematics teachers' epistemological beliefs for each dimension. Mathematics teachers' epistemological beliefs are characterized by a high level of agreement to statements representing the application and process view. Additionally, they display a strong agreement with statements representing a formalism view whereas they stand somewhere in the middle towards the schematic view.

Scale	Mean	SD
Formalism	4.08	.57
Application	4.46	.46
Scheme	3.47	.70
Process	4.30	.48

Table 2: Mean estimates for mathematics teachers' epistemological beliefs

Table 3 presents the correlations between the different dimensions of epistemological beliefs. According to Table 3, correlations were very low and statistically insignificant for the four dimensions concerning the nature of mathematics.

	Scheme	Application	Process
Formalism	.060	.051	.021
Process	-.026	.105	
Application	.040		

Table 3: Bivariate correlations between the four beliefs concerning the nature of mathematics

Finally, in order to explore for differences regarding mathematics teachers' epistemological beliefs in relation to various background variables (gender, age, their teaching experience and highest level of formal education), we employed a multivariate analysis of variance (MANOVA). However, we found no statistically significant differences between teachers' epistemological beliefs in terms of these background variables.

Discussion

In this paper, we investigated the beliefs concerning the nature of mathematics of upper secondary Cypriot Mathematics teachers. Regarding the first aim of the study, the results confirmed a solution of four factors corresponding to the four categories of teachers' epistemological beliefs, suggested by relative literature. These teachers highly agreed with application- and process-related statements, whereas schematics statements were less agreed with. Compared to the results of Felbrich et al.

(2008), the ranking of the four views was slightly different. While in Felbrich et al. (2008) study, the process view received the highest agreement level, in this study the highest agreement level was received by the application view. Cypriot mathematics teachers strongly agreed with both application and process-related statements, perhaps due to the new curriculum which has been implemented since 2011 and follows current trends in education, approaching mathematics as a dynamic tool for thought (Cyprus Ministry of Education and Culture, 2014). More specifically, the new mathematics curriculum has been designed according to principles, such as that students should be involved in mathematical investigations, based on real life situations and that interdisciplinary questions and emphasis should be placed on problem-solving (Cyprus Ministry of Education and Culture, 2014).

The results of the current study showed no statistically significant correlation between the four factors contrary to the results of other studies (Felbrich et al., 2008; Grigutsch et al., 1998). No correlation between the dynamic aspects of epistemological beliefs was also reported in the study by Liebendörfer & Schukajlow (2017). Moreover, the two fundamental dimensions of mathematics, namely the dynamic and the static dimension could not apply to this sample of mathematics teachers, supporting Depaepe's et al. (2016) conclusion that it is not easy to describe one's epistemological beliefs as either static or dynamic. Furthermore, the results of this study supported the results of other studies (Felbrich et al., 2008; Grigutsch & Törner, 1998; Roesken & Törner, 2010) which suggest that mathematics teachers can hold simultaneously static and dynamic epistemological beliefs.

These mathematics teachers agreed with both the dynamic and static epistemological beliefs' dimensions, exhibiting, using Hofstede's terminology, characteristics of both collectivism and individualism aspects. Countries in which teachers adopted both dimensions were also mentioned in Felbrich et al. (2012), with a different population (i.e. future primary school teachers). However, further study is needed using related scales (e.g. Individualism scale of Hofstede) in order to substantiate this argument.

Finally, an interesting result worth mentioning is that no statistically significant differences were found regarding these teachers' epistemological beliefs in terms of background variables (gender, age, their teaching experience and highest level of formal education). These results do not agree with the results reported by Felbrich et al. (2012) in which future teachers with high mathematical content knowledge endorsed dynamic beliefs more strongly than static beliefs. We presume that background variables are shadowed both by the centralized nature of the educational system in Cyprus and the centralized in-service training these teachers' received regarding the new mathematics curriculum.

In conclusion, there is more to be done in this field concerning mathematics epistemological beliefs held by mathematics teachers in various grade levels. More research is also needed regarding the relationship between epistemological beliefs and other beliefs such as teacher authority and self-efficacy beliefs. Moreover, mathematics teachers' epistemological beliefs and their instructional approaches worth more attention since empirical evidence in this direction remains scarce (Depaepe et al., 2016).

References

Blömeke, S., Felbrich, A., Müller, C., Kaiser, G., & Lehmann, R. (2008). Effectiveness of teacher education. *ZDM*, 40, 719-734.

- Curriculum Development Unit. Cyprus Ministry of Education and Culture (2014). *Annual Report*. Nicosia, Cyprus.
- Depaepe, F., De Corte, E., & Verchaffel, L. (2016). Mathematical epistemological beliefs: A review of the research literature. In G. Greene, W. Sandoval, I. Bråten (Eds.), *Handbook of Epistemic Cognition* (pp. 147-164). New York: Taylor and Francis.
- Ernest, P. (1989). The impact of beliefs on the teaching of mathematics. In P. Ernest (Ed.), *Mathematics teaching: The state of art* (pp.249-253). New York: Flamer.
- Felbrich, A., Kaiser, G., & Schmotz, C. (2012). The cultural dimension of beliefs: An investigation of future primary teachers' epistemological beliefs concerning the nature of mathematics in 15 countries. *ZDM*, 44, 355-366.
- Felbrich, A., Müller, C., & Blömeke, S. (2008). Epistemological beliefs concerning the nature of mathematics among teacher educators and teacher education students in mathematics. *ZDM*, 40, 763-776.
- Grigutsch, S., Raatz, U., & Törner, G. (1998). Einstellungen gegenüber Mathematik bei Mathematiklehrern. *Journal für Mathematikdidaktik*, 19, 3-45.
- Grigutsch, S., & Törner, G. (1998). World views held by university teachers of mathematics science. *Schriftenreihe des Fachbereichs Mathematik* (pp.420). Universität Duisburg.
- Kaiser, H.F. (1974). An index of factorial simplicity. *Psychometrika*, 35, 401-415.
- Liebendörfer, M., & Schukajlow, S. (2017). Interest development during the first year at university: do mathematical beliefs predict interest in mathematics? *ZDM*, 49, 355-366.
- Richardson, V. (1996). The role of attitudes and beliefs in learning to teach. In J. Sikula, T. Buttery & E. Guyton (Eds.), *Handbook of Research on Teacher Education* (2nd ed., pp. 102-119). New York: Macmillan.
- Roesken, B., & Törner, G. (2010). Beliefs of university teachers of mathematics. In F. Furinghetti & F. Morselli (Eds.), *Proceedings of the conference MAVI-15: Ongoing research on beliefs in mathematics education* (pp. 35-46). Genova: Department of Mathematics, University of Genova.
- Schmidt, W., Blömeke, S., & Tatto, M. T. (2011). *Teacher education matters. A study of the mathematics teacher preparation from six countries*. New York: Teacher College Press.
- Schoenfeld, A.H. (1998). Toward a theory of teaching-in-context. *Issues in Education*, 4, 1-94.
- Thompson, A. (1992). Teacher's beliefs and conceptions: A synthesis of the research. In D. A. Grouws (Ed.), *Handbook of Research on Mathematics Teaching and Learning* (pp. 127-146). New York: MacMillan.
- Törner, G., & Pehkonen, E. (1996). On the structure of mathematical belief systems. *Zentralblatt der Didaktik der Mathematik*, 4, 109-112.
- Wilkins, J. (2008). The relationship among elementary teachers' content knowledge, attitudes, beliefs and practices. *Journal of Mathematics Teacher Education*, 11, 139-164.

Engagement in mathematics through digital interactive storytelling

Giovannina Albano¹, [Anna Pierri](mailto:anna.pierri@unisa.it)² and Maria Polo³

¹University of Salerno, Italy; galbano@unisa.it

²University of Salerno, Italy; apietri@unisa.it

³University of Cagliari, Italy; mpolo@unica.it

This paper presents the preliminary results of an experimental work conducted on the digital storytelling in Mathematics, as part of the project Prin 2015 “Digital Interactive Storytelling in Mathematics: a competence-based social approach”. In particular, it examines how the immersive aspect of a storytelling can influence students’ engagement and attitude to learning Mathematics by comparing their usual attitude in the classroom. Early findings show that the immersive aspect of the storytelling, together with collaborative work and online interaction, may lead to a change in students’ attitudes towards mathematics.

Keywords: Attitude change, storytelling, role taking

Introduction

This paper presents the preliminary results of an experimental work conducted on the digital storytelling – as part of the project Prin 2015 “Digital Interactive Storytelling in Mathematics: a competence-based social approach”¹. The key elements of the project are in a way expressed in its title’ single terms, which are briefly described below:

- *Mathematics*: object of learning. The focus is on the development of competencies in mathematics (Niss, 2003), starting from a specific mathematical content.
- *Storytelling*: the methodological context in which the teaching/learning process develops. The storytelling has been used since the beginning as a fundamental method enabling knowledge transfer. Its captivating power attracts the students at non-cognitive level of emotions and creativity. In addition, as they enter the story by playing one of the characters, the approach to storytelling is immersive, (Robin, 2008).
- *Interactive*: mode of learner’s participation. In the project, the student interacts with the story, he/she is not simply a listener. Actually, all his/her interaction influences the development of the story.
- *Digital*: the instrumental context in which the teaching/learning takes place. Everything happens in an online digital environment, including storytelling and interaction.

More specifically, the paper takes into consideration the immersive approach of the storytelling, and analyzes the way such an aspect can modify the type of students’ participation compared to how they usually behave in their traditional classroom. For the purpose of our analysis, we have focused on the following research questions: RQ1: How does the immersive approach of the storytelling influence

¹ This work is part of the project PRIN 2015 “Digital Interactive Storytelling in Mathematics: A Competence-based Social Approach”, funded by MIUR, effective from 5 February 2017.

learner's engagement in mathematical activities? RQ2: Can the immersive approach of the storytelling change the students' attitude towards Mathematics?

Intending to better explain our research theme, we have referred to a definition of "attitude" towards Mathematics, given by Di Martino & Zan (2007). This definition is based on the following three correlated concepts: learner's emotional disposal, revealed by the expressions "I like/I don't like"; learner's view of Mathematics, reflected by his/her beliefs "Mathematics is..."; learner's view of themselves as learners of mathematics (sense of self-efficacy), revealed by the expressions, "I'm successful/I'm not successful".

Theoretical background

This work integrates findings from different fields of research and, therefore, cannot be referred to a single theory. Below, we recall the theoretical aspects that are referred to.

Our activity design has mainly regarded collaborative learning, in particular the computer-based collaborative learning (Weinberger et al., 2009), where the need for pre-structuring and regulating social and cognitive processes is even more evident. To this aim, researchers in education have based their study on the concept of *script*, which refers to a sequence of actions directed to define a well-known situation (Schank & Abeson, 1977). Here, each actor has a specific role and specific actions to take part in, and the script is activated whenever one is in a similar situation. In didactics, scripts are imposed externally and support students in a collaborative/cooperative learning context through roles and actions they are required to play and carry out in order to succeed in learning (King, 2006).

The collaborative groups envisages a number of predetermined roles, each of them devoted to a given disciplinary function (Pesci, 2004) such as: *task-oriented*, responsible for all actions oriented to achieve the best result, *group-oriented*, responsible for the communication mood within the group, *speaker*, spokesperson, to speak on behalf of the group about all proposals, *memory*, responsible for saving a written recording of the achieved results, *observer*, responsible for observing all group interactions. Subsequently, a new role, born in the context of an *inquiry* approach (Arzarello & Soldano, 2016) has been added to the initial set, listed above, which we called *devil's lawyer*, i.e. a person who questions about what his/her classmates propose or say, and insinuates doubts.

Concerning mathematics instead, we have referred to the theoretical framework of story-problems (Zan, 2012) placing the mathematical structure in a situation with which the student is familiar and taking the form of a narration. In order to modulate the two dimensions in the text of the problem, Zan suggests the adoption of the C&Q model (Context and Question), as characterized by the following points: There is a story: temporal evolution of a situation, at least one animated character; There is a natural connection between history and question: a character with a purpose and context from which the mathematical problem arises in a natural way; The story is well structured: the parts of a text are linked together; the information has a "narrative" meaning.

A case study

The mathematical problem

In order to introduce the students to algebraic modelling, by reasoning and proving, we proposed the following mathematical problem (Iannece & Romano, 2008; Mellone & Tortora, 2015): "*Take four*

consecutive numbers, multiply the second and the third numbers together and then the first and the fourth ones. Calculate the difference between the two products obtained. Repeat the exercise with four more numbers. Can you observe any regularity?”.

The students are expected to conjecture that the result is always 2 and to prove such a result through the algebraic representation of the generic four numbers as in the sequence $n \ n+1 \ n+2 \ n+3$, then the conversion of the given instructions as in $(n+1) (n+2) -n(n+3)$ and finally the treatment of the found expression, which determines the constant 2. The problem opens up questions of algebraic calculation, as well as linguistic and logical questions associated with terms such as “all” and “always”. It can also be used to stimulate students’ thinking on key mathematical concepts such as the meaning of “consecutive” numbers or the density of rational numbers in \mathbb{R} .

The story and its characters

The pedagogical model taken into account for creating the story is the C&Q Model of Zan (2012), as already illustrated in the theoretical background. The entire educational path and specifically the students are immersed in a story. The story, precisely, is set in a Science fiction situation, which sees a group of four friends engaged in the fairly unusual attempt to communicate with aliens from whom they had received mysterious messages made up of numbers and operations (Figure 1).

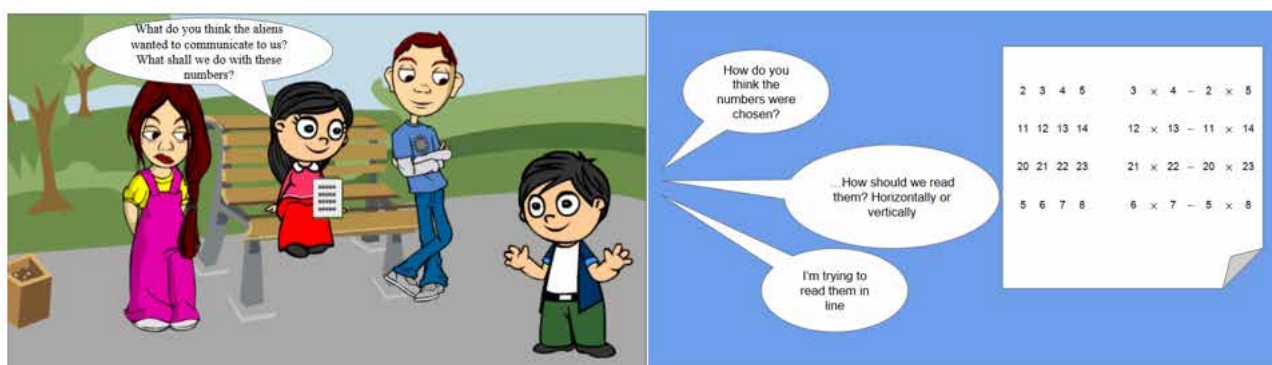


Figure 1: The problem

All roles used in the task, refer to those mentioned in the previous paragraph. It is important to note that the roles of *memory* and *observer*, involved in the activities conducted on digital platforms, are carried out by the platform itself that, at the same time, keeps track of everything happening in the group during the activity. Moreover, since the story makes use of technological tools, basing on previous experiences (Albano, Dello Iacono, & Mariotti, 2016; Albano & Dello Iacono, 2018), we have envisaged a new role, i.e. *technology-oriented*, able to support the teammates and to help them overcome possible problems arising from the use of technological tools. Our four friends correspond to the four roles provided: group-oriented, speaker, devil’s lawyer and technology-oriented, which all have been appropriately contextualised within the story as characters’ profile:

- Marco, called ‘the BOSS’ (i.e. the group-oriented), is the leader within the group of friends, and has won the trust of his teammates for his leadership behaviours;
- Sofia is passionate about reading and writing, she hopes to become a journalist and has got a craze for blogging. In fact, she is called ‘the BLOGGER (i.e. the group-oriented);

- Clara is a wary girl and constantly pesters her classmates with doubts and question; she is ‘the PEST’ (i.e. the devil’s lawyer);
- Federico is a computer enthusiast, convinced of the existence of extraterrestrial lives, he is always fiddling with electronic devices in search of alien signals. That is why he is called ‘the COMPUTER GEEK’, (i.e. the technology-oriented).

The four students of the group, within their Chat discussions, had to agree and chose an avatar that best represented themselves during the progression of the story, depending on the profile they saw as the most matching to their own features. Alongside the four friends, there is an adult, Gianmaria, Federico’s uncle, who is also an expert in computer devices and who loves mathematics. Gianmaria is a teacher/tutor’s avatar and acts as an expert in the learning process.

The story-problem starts with Federico who, fascinated by any possible life beyond the planet Earth, has developed an electronic device in the hope of capturing some signal from the distant sky. Finally, one day, a sequence of characters appears on the screen. (Figure 1). Unfortunately, during data reception the device breaks down and the message remains incomplete. Federico is so much curious as to involve his friends in this adventure, scanning and searching for a meaning to give to those signs and a way to communicate with strangers/aliens. In turn, to get help for the task, the four friends decide to involve their uncle Gianmaria, who accepts and offers them his support in solving the mystery. All interactions among the students and with Gianmaria guide the story flow (and the learning path), and lead them to hold communication with the aliens, after Federico has adjusted the reception device and connected it to their single smartphones. This new feature allows the aliens to send each of them a specific message, such that, in a second phase, they find themselves thinking about different sequences and discovering what they have in common (case of consecutive odd and even numbers, which lead to the number 8).

Methodology

The general aim of our work is to understand how the role playing and the actions carried out by the students in the Digital Interactive Storytelling environment impacts on their learning. In this paper we focus on the affective aspects of the students’ learning, that is on whether and how these elements can generate changes in their attitude towards mathematics.

The experimentation involved a 9th grade school class from a Foreign Language High School, consisting of 30 students, in the period April-June 2018. With the intention of investigating around our aim, the students were split into groups, each of them corresponding to the original group of the friends (characters) in the story. Each student in a subgroup took on one of the possible roles.

All students participated in the activity, interacting online, at distance, during extracurricular time. The meeting aroused engagement and shared intentionality by the classmates, and stimulated the participants’ interest in investigating the proposal presented by the researchers. In fact, after the meeting, the students could write an article in the school newspaper, in which they state among other things: “We think this method is important, not only from a didactic point of view but also to keep us together and to engage those who usually do not take an active role during the classroom activities. The questions, asked in the form of comics, intrigued them very much, and that first meeting made them impressed” (Figure 2).



Figure 2: Students' interaction with the problem story

Preliminary findings and discussion

This section focuses on the chat interactions of one of the groups of students who participated in the story. The initial step consists in an interview made to the teacher for the purpose of exploring her students' engagement and attitude interacting with the problem story, and also receiving her perceptions of the changes possibly intervened in the students' behaviours.

Let us read an excerpt of a Chat discussion. The role played by each student is reported in brackets:

- | | | |
|---|--------------------------|---|
| 1 | Dario (Boss): | What do you do? |
| 2 | Ivana (Blogger): | I' m a blogger. |
| 3 | [..] | |
| 4 | Dario (Boss): | A Blogger cannot go any further than the Introduction |
| 5 | Ivana (Blogger): | How do I select characters? |
| 6 | Alessio (Computer geek): | Scroll down page then click on a blue dot and select |

In the excerpts 4-6, we can observe that Ivana faced with some technical issues, while Dario and Alessio intervened to: first, draw attention; second, help her, according to their own roles. Indeed, Dario takes care of engaging Ivana trying to explain how to solve her technical problems; to this aim he calls upon Alessio. Then, Alessio, playing his role of Computer geek, gives instructions on how to fix the problem.

Despite those initial difficulties, both technical and general, Ivana keeps acting her role: after Dario's affirmation (rows 7-9 below), she synthesizes/reformulates what they expressed in the discussion; in the reformulation she moves from numerical to verbal examples allowing to describe all four cases.

- | | | |
|----|------------------|---|
| 7 | Dario (Boss): | 2 is the result of the first operation, i.e. $3*4-5*2$ |
| 8 | | and the results is $12-10 = 2$ |
| 9 | | all the operations are on the right, by doing them all we obtain 2 as a result. |
| 11 | | Thus one of the numbers is certainly 2 |
| 12 | Ivana (Blogger): | Yes, he has multiplied the product of the means minus the |
| 13 | | product of the extremes. |

A change in Ivana's attitude is also confirmed by the teacher's interview.

At the beginning, she did not expect Ivana to choose that role (row 12).

- 14 Researcher: Do the roles that the students chose reflect what you
 15 would expect them to choose? Did their choices surprise you
 considering the roles they normally have in the classroom?
 17 Teacher: Ivana's role was a bit of a surprise since she has always
 18 been an introverted girl.

Moreover, her changed engagement also impacted on her relationship with the teacher (rows 26-28) and with mathematics:

- 19 Researcher: Did you find the students involved in the digital activities were more
 engaged than they generally are in other classroom activities?
 20 Teacher: After the experience with the digital interactive storytelling, I noticed
 21 a change in the way some students relate to me.
 22 In particular, there were excellent results from a motivational and
 23 emotional point of view: see for example Maria, Ivana, Rosaria whose
 24 interaction and engagement in the platform had positive effects not
 25 only on their advancement but also on the way they relate to
 mathematics.
 26 In a case, for instance, at first Ivana (Blogger) had refused to interact
 with me, after I had asked her to solve an exercise on the blackboard.
 At the end of this experience, she offered spontaneously to do it,
 showing she was no longer afraid of mathematics....
 29 Also Maria, witnessed her engagement by saying: "*Teacher, I have
 surprisingly discovered another mathematics*".

Ivana' case was not isolated (rows 20-25). Other students changed their view about mathematics – see for instance what Maria said (row 29) – and also their attitude towards their teacher – see what the teacher perceived of the students' mood through Maria's words.

Furthermore, we investigated whether the students' engagement had somehow been linked to the assessment, asking the teacher if she had used such an element.

- 30 Researcher: Did you think to include an assessment session to engage students in
 online activities?
 31 Teacher: I have always told the students that the online activity is important but
 32 I would never use it as an evaluation activity. I would instead assess
 each student on the ground of many elements, not only individual
 tasks or questions, but the way they participate in the activities (in
 class or at home),
 35 their attendance and attention.

The above teacher's words suggest that the online activity has been considered as part of a more global evaluation, which takes into account a general active participation in the whole path of didactics of mathematics during the school year. The conclusion that the evaluation had a very low

impact is also justified by the fact that the students continued to participate in the activity even after the end of the school year (rows 44-47).

- 36 Researcher: Did you happen to intervene to prompt student's attention and/or
 37 participation during the story evolution??
- 38 Teacher: Some groups did it spontaneously, others instead, needed to be
 39 prompted– we can say that 3 out of 5 groups, moved
 40 independently and 2 had some technical problems that required
 41 my intervention and made them unable to hold their rhythm.
 42 The highest number of notifications occurred after the end of the school
 year, perhaps because the students had thought that the activity was
 over
- 44 However, let me underline that the students, even though
 45 no longer subjected to evaluation, have nevertheless continued to
 46 interact within the platform being curious about the evolution
 47 of the story.

Most of the groups involved in the activity proceeded autonomously during the activity flow, without being pressed by the teacher (row 38-39), and slow-downs were only due to technical problems.

Conclusion

In this work, we have meant to show significant aspects of a preliminary experimentation conducted on a designed digital storytelling in mathematics. The results show that the immersive aspect of storytelling, together with collaborative work and online interaction, typical of platform activities, may lead to a change in students' attitude towards mathematics (RQ2) and in their relationship with the teacher. Today, chat interactions are a familiar context for the students, and even those who get shy in face-to-face situations, may be active participants when interacting online (RQ1). Given the number of students involved in our case study, the results are clearly not generalizable. However, they allow us to identify both the potential of this type of interaction and scenario variables connected with the digital storytelling in mathematics. The interview made by the teacher confirms to be an interesting research methodology that allows us to reflect on other important variables, like the relationship between teacher and students. The preliminary findings will be considered in an experimentation project foreseen for the next phase (March 2019) of the PRIN Project that will involve many schools from different Italian regions. The preliminary results will be also used for defining an adequate experimentation protocol that may enable us to validate our approach on a large scale.

Acknowledgment

We would like to thank the teacher Rossella Ascione and her students of the I.S. "A. Tilgher" Institute in Ercolano (Italy) who contributed to the realization of this work.

References

- Albano, G., Dello Iacono, U. (2018). DIST-M: scripting collaboration for competence-based mathematics learning. In Silverman, J., Hoyos, V. (Eds.): *Distance Learning, E-Learning and Blended Learning of Mathematics*, pp. 115–131. ICME-13 Monographs. Springer, Cham.
- Albano, G., Dello Iacono, U., Mariotti M.A. (2016). L'argomentazione in matematica: la mediazione attraverso il digital interactive storytelling. *Form@are - Open Journal per la formazione in rete*, Vol. 16(1), pp. 105–115.
- Arzarello, F., Soldano, C. (in press). Da Peirce a Hintikka (senza dimenticare Dewey): la logica dell'indagine in classe. In: F. Morselli, G. Rosolini, C. Toffalori (eds), *Educare alla razionalità. In ricordo di Paolo Gentilini*, Atti del Convegno di Sestri Levante 9-11 Giugno 2016.
- Di Martino, P., Zan, R. (2007). Attitude toward mathematics: overcoming the positive/negative dichotomy. *The Montana Mathematics Enthusiast*, Monograph 3, pp.157–168.
- King, A. (2006). Scripting collaborative learning processes: A cognitive perspective. In: F. Fischer, I. Kollar, H. Mandl, & J. Haake (eds.). *Scripting computer-supported collaborative learning: Cognitive, computational and educational perspectives*. New York: Springer.
- Iannece, D., Romano, P. (2008). *What does it mean to have a “scientific approach” for a teacher? A reflection*. Proc. of 5th international colloquium on the didactics of mathematics, Crete
- Mellone, M., Tortora, R. (2015). Ambiguity as a cognitive and didactic resource. In Krainer K., Vondrová N. (Eds.), *Proc. of CERME 9*, Praga, pp. 1434–1439.
- Niss, M. (2003). Mathematical competencies and the learning of mathematics: The Danish KOM project. *Third Mediterranean conference on mathematics education*, pp. 115–124.
- Pesci, A. (2004). Insegnare e apprendere cooperando: esperienze e prospettive, *L'insegnamento della matematica e delle scienze integrate*, Vol. 27 A-B(6) 6, pp. 637–670.
- Robin, B. (2008). *The effective uses of digital storytelling as a teaching and learning tool*. Handbook of Research on Teaching Literacy through the Communicative and Visual Arts, Vol. 2, pp. 429–440. Lawrence Erlbaum Associates, New York, NY.
- Schank, R., Roger, C., Abelson, R.P. (1977). *Scripts, plans, goals and understandings*. Hillsdale, NJ: Erlbaum.
- Sfard, A. (1991). *On the dual nature of mathematical conceptions: reflections on processes and objects as different sides of the same coin*. Educational Studies in Mathematics, Vol. 22, pp.1–33.
- Weinberger, A., Kollar, I., Dimitriadis, Y., Makitalo-Siegi, K., Fischer, F. (2009). Computer-supported collaboration scripts. *Technology enhanced learning*, Springer Netherlands, pp. 155–173.
- Zan, R. (2012). *La dimensione narrativa di un problema: il modello C&D per l'analisi e la (ri)formulazione del testo*. Parte I. L'insegnamento della matematica e delle scienze integrate. Vol.35A(2).

Self-concept in university mathematics courses

Stefanie Rach¹, Stefan Ufer² and Timo Kosiol²

¹Otto-von-Guericke-University Magdeburg, Faculty of Mathematics, Magdeburg, Germany,
stefanie.rach@ovgu.de

LMU Munich, Department of Mathematics, Munich, Germany,
ufer@math.lmu.de, kosiol@math.lmu.de

Many researchers agree that mathematical self-concept is an important factor in (university) learning processes. Mathematics learning at university differs substantially from learning mathematics at school. Especially the character of the learning domain mathematics changes at the transition to university. In this contribution, we present newly developed instruments for self-concept that take the specific character of mathematics at university into account. We applied the instruments in a first-semester course with 344 students. The results of exploratory factor and correlation analyses indicates that it is possible to differentiate facets of self-concept according to different characters of the learning domain mathematics. Finally, we discuss how precise information concerning learners' self-concept can promote to support students at this challenging transition to university.

Keywords: Mathematical self-concept, Transition school-university, Mathematical practices, Learning prerequisite.

Introduction

There is no doubt that affective variables are important factors in successful, mathematical learning processes (Hannula, 2011). In this contribution, we concentrate on self-concept concerning mathematics. In a recent study, self-concept was identified as an essential learning prerequisite to predict achievement in school mathematics (Feng, Wang, & Rost, 2018). Moreover, self-concept substantially mediates the relation between achievement and emotions (Van der Breek, Van der Ven, Kroesbergen, & Leseman, 2017). Many existing studies deal with the role of self-concept in mathematical teaching and learning processes at school. In contrast, only few studies analyze its role in learning processes at university. As learning processes in these two institutions differ significantly from each other, we claim the need for specific research on the role of self-concept in mathematics courses at university and in particular during the transition to university mathematics.

Questionnaires are the most common instruments to survey mathematical self-concept. The learning domain, for which self-concept should be reported, is mostly broadly described using the word "mathematics". At the transition from school to university, however, it is not clear if students refer to school or to university mathematics when reporting their self-concept. To obtain a more differentiated insight into students' self-concept, we developed questionnaires for mathematical self-concept that take the specific learning domain at university into account. In this contribution, we present the conceptualization of these instruments in detail. In a study with 344 first-semester students, we studied if the assumed facets of self-concept can be measured and differentiated empirically.

The role of self-concept in mathematical learning processes

Self-concept, self-efficacy, and self-esteem are important constructs which describe students' views about themselves. The source of students' views about themselves are often experiences of past

success or failure. As self-esteem has a focus on emotions and is not as prominent as the other two constructs in analyzing subject-specific learning processes, we concentrate on the constructs self-concept and self-efficacy. Self-concept has its focus on the persons' skills and abilities, whereas self-efficacy refers to one's beliefs to successfully perform a certain action in the future (Marsh et al., 2019). Researchers use both concepts to explain and predict learners' action and success (Bong & Skaalvik, 2003). As we are interested in students' views of themselves as learners in mathematics at the period of transition, we also want to analyze the sources of students' beliefs about their own mathematical knowledge and skills. That is why we use the construct self-concept. We refer to "mathematical self-concept (of ability)" as *students' beliefs about their own mathematical knowledge and skills*. Theoretically, self-concept is often placed between motivational and cognitive variables, since it is built on views (affect side) which refer to knowledge and skills (cognition side).

One mechanism leading to the relationship between self-concept and achievement might be that learners with a strong self-concept choose to engage in more demanding tasks, which results in better learning and higher achievement. Moreover, there is much evidence that underpins the relation between self-concept and other motivational variables, like interest (Cai, Viljaranta & Georgiou, 2018; Rach & Heinze, 2017). It is assumed that self-concept mediates the relation between achievement and emotions (van der Breek et al., 2017). In university contexts, explorative studies claim that a low self-concept and the decrease of self-concept in the first study year even of students with excellent learning prerequisites probably lead to dropout (Bampili, Zachariades, & Sakonidis, 2017; di Martino & Gregorio, 2018).

However, the studies mentioned above mainly relate to the school context (e.g. Cai et al., 2018). Analyses of learning processes at university often show only weak or non-significant relations between self-efficacy respectively self-concept and study success (Bengmark, Thunberg, & Winberg, 2017; Rach & Heinze, 2017). One reason for this unexpected result might lie in the differences of the learning domain between school and university. When students rate their mathematical self-concept in the first semester at university, they might refer to their beliefs about their knowledge and skills according to mathematics as a school subject, which could be less relevant for learning in this context than self-concept regarding university mathematics.

Teaching and learning mathematics at university

In Germany, as in many other countries all over the world (e.g. South Africa: Engelbrecht, 2010; France: Gueudet, 2008), there seems to be a substantial gap between school and university concerning teaching and learning of mathematics. Not only the social contexts (e.g. the peer group) and the learning opportunities and their use (e.g. from a more guided form in school to a more self-regulated form at university) change at this institutional transition, but also the learning domain itself. At school, one important goal of teaching and learning mathematics is to apply mathematics for solving real-world problems. Thus, classrooms instruction focuses on describing situations mathematically and performing calculations. We call this special character of mathematics "school mathematics". In contrast to that, "university mathematics" denotes the character of mathematics presented in mathematics university courses, which refer to mathematics as a scientific discipline that is built on formal definitions of concepts and deductive proofs (Engelbrecht, 2010). Central practices in the first year of studying mathematics at university include dealing with formal presentations of concepts and proving statements. As demands of proving tasks are mainly high and unfamiliar to freshmen at

university, students often struggle in their first year of university and a substantial share of them drop out from their study program (Heublein, Richter, Schmelzer, & Sommer, 2014).

Summarizing, the learning subject changes at the transition from school to university from a school subject focusing on applications to a scientific discipline focusing on the structure of a mathematical theory. That is why instruments which measure mathematical self-concept in a generic way and results concerning the role of mathematical self-concept in learning processes at school might not be transferable to processes at university.

The current study

As part of the project SISMa (“Self-concept and Interest when Studying Mathematics”), it is the goal of this study to differentiate self-concept concerning different characters of the learning domain mathematics. The aim of the project is to clarify the role of affect in mathematical learning processes during the transition to university mathematics (see Ufer, Rach, & Kosiol, 2017). In this contribution, we focus on mathematical self-concept and present instruments that measure different facets of self-concept according to different characters of mathematics (Table 1, see also Schukajlow, Leiss, Pekrun, Blum, Müller, & Messner, 2012 for a similar approach concerning self-efficacy; see also Ufer et al., 2017 for the construct interest). To measure the different facets of self-concept we constructed two types of scales: The first type of self-concept scales surveys beliefs about knowledge and skills regarding mathematics as it has been experienced respectively anticipated in a specific context. These statements directly address one of the two institutions, in which mathematics is taught and learnt: school versus university. The second type of scales addresses self-concept regarding mathematical practices, which are characteristic for school mathematics (applying mathematics), for university mathematics (proving and dealing with formal representations), or for both contexts (using mathematical calculation techniques). These five scales were developed based on prominent models of self-concept taking into account different frames of reference (Bong & Skaalvik, 2003). In contrast to other scales, e.g. Kauper, Retelsdorf, Bauer, Rösler, Möller, and Prenzel (2012), different aspects of mathematics as points of reference for individual beliefs are specified.

To study whether these facets of self-concept can be differentiated empirically, we conduct a study with first-year mathematics students. The following questions deal with the structure of the questionnaires and the relation of the self-concept measures to other learning prerequisites:

- 1) *Is the theoretical structure of the subscales reflected in the factorial structure of the newly developed instruments?*

We expected that factor analyses would underpin the theoretical conceptualization of the subscales. Moreover, we expected self-concept in applying mathematics to be primarily correlated to self-concept concerning school mathematics and self-concept concerning proving and dealing with formal representations to be primarily related to self-concept concerning university mathematics.

- 2) *Are the different facets of self-concept related to other learning prerequisites?*

We expected that self-concept concerning school mathematics relate to interest concerning school mathematics, the same pattern with university mathematics. In line with previous research (e.g., Cai et al., 2018), we expected a relationship between self-concept measures and mathematical knowledge respectively the school qualification grade.

3) *Is there a relation between facets of self-concept and study choice?*

As a mathematics teacher education program is not as much focused on mathematics as a mathematics bachelor program, we expected that, on average, students with lower mathematical self-concept concerning university mathematics respectively self-concept concerning proving and dealing with formal representations would be more likely to choose a teacher education program. This should result in lower average self-concept concerning university mathematics respectively proving and dealing with formal representations of the teacher education students than of mathematics bachelor students. We had no specific hypotheses regarding self-concept concerning school mathematics respectively concerning applying mathematics and using calculation techniques.

Method

The sample of this study comprised 344 first-semester-students of the mathematics courses “Analysis I” from one university in the southern part of Germany. In this course, mathematics is presented as a scientific discipline with a focus on formal concept definitions and deductive proofs. We use a complete survey of all students who start their study in a teacher education program or in a mathematics respectively business mathematics bachelor program. As the study took place in the first lecture of the first-semester mathematics courses “Analysis I” and students participated in the survey voluntarily, we can’t say anything about students who did not participate in the study. Most of the participating students were in a teacher education program for two secondary school tracks (Realschule, Gymnasium) in Germany, $N = 130$, and in a mathematics respectively business mathematics bachelor program, $N = 184$.

Self-concept scale		Sample item	M (SD)	Cronbach's α
General		I am very good in mathematics. (4 items)	2.07 (.50)	.76
Institution	School mathematics	The mathematics that I know from school is easy for me. (3 items)	2.35 (.57)	.73
	University mathematics	The mathematics that is done at university is easy for me. (3 items)	1.51 (.65)	.84
Practice	Applying mathematics	Applying mathematics to real-world problems is not so easy for me. (reversed item) (5 items)	2.00 (.51)	.80
	Proof and formal mathematics	Understanding mathematical proofs is easy for me. (8 items)	1.73 (.48)	.82
	Using calculation techniques	I am very good in transforming complex terms. (5 items)	1.91 (.47)	.71

Table 1: Measurement instruments for self-concept with means, standard deviations, and reliability coefficients, $N = 252$ -333. Statements rated on a four-point Likert scale from 0 (disagree) to 3 (agree)

We used a general scale for mathematical self-concept (Kauper et al., 2012, for sample items see Table 1) to compare our newly developed instruments with an approved scale. Moreover, we applied

the new self-concept scales as differentiated measures of self-concept (see Table 1). The participants were asked to assess all mixed statements on a four-point Likert scale from 0 (disagree) to 3 (agree). The individual mean value of a single student on a scale was computed if this student had answered at least half of the items of the scale. We assessed additional affective and cognitive variables in the first lecture: the school qualification grade (grades were recoded so that 4.0 is the best and 1.0 is the worst value), prior knowledge for advanced mathematics, and interest in school mathematics respectively university mathematics (see Ufer et al., 2017).

Results

Differentiated measures of self-concept

Table 1 shows the mean values, standard deviations, and reliability coefficients of the self-concept scales. There are no floor or ceiling effects.

Two explanatory factor analyses (Principal Component Analysis with Varimax rotation) – one for the three self-concept scales concerning practices and one for the two self-concept scales concerning the institutions – showed three respectively two factors, that were in line with the theoretical structure of the instruments. Reliability analyses underpin the internal consistency of the general self-concept scale and the five newly developed scales, as all scales show a moderate to good consistency. Correlation analyses also partly promote the expected structure: For example, self-concept concerning proving and dealing with formal representations correlates with self-concept concerning university mathematics strongly, $r = .65$ (Table 2). The lower correlation, $r = .26$ between self-concept concerning applying mathematics and self-concept concerning school mathematics was unexpected, because applying mathematics to real-world problems should be a prominent activity in mathematics classrooms. All specific facets of self-concept are correlated significantly and positively with the general measure. In sum, the different facets of self-concept can be separated empirically, and their correlational pattern reflects the assumed specific nature of university mathematics.

	General (SCG)	Application (SCA)	Calculation (SCC)	Proof and Formal (SCP)	School (SCS)	University (SCU)
SCG		.35**	.51**	.49**	.61**	.51**
SCA			.31**	.35**	.26**	.27**
SCC				.38**	.48**	.34**
SCP					.29**	.65**
SCS						.25**

Table 2: Correlations for the self-concept scales, ** $p < .01$

Connection to other learning prerequisites

As expected, correlations of variables focusing the same character of mathematics, school respectively university mathematics, are stronger than correlations concerning variables on different characters of mathematics (Table 3). Only self-concept concerning school mathematics correlates with the school qualification grade significantly. Both self-concept scales weakly relate to mathematical knowledge.

	Interest school	Interest university	Mathematical knowledge	School qualification grade
Self-concept school	.34**	.18**	.13*	.20**
Self-concept university	-.01	.50**	.21**	.05

Table 3: Correlations of the self-concept scales with other learning prerequisites, ** $p < .01$, * $p < .05$

Differences between study programs and study choice

Table 4 shows mean values (and standard deviations) for students from the two programs on all facets of self-concepts. Group differences were tested for significance and we calculated effect sizes.

	General	Application	Calculation	Proof and formal	School	University
Mathematics bachelor program	2.13 (0.55)	2.00 (0.53)	1.88 (0.48)	1.80 (0.48)	2.36 (0.58)	1.61 (0.65)
Teacher education program	2.07 (0.39)	2.03 (0.50)	1.99 (0.46)	1.71 (0.45)	2.40 (0.54)	1.42 (0.62)
<i>d</i>	0.10	-0.05	- 0.23 ^t	0.19	-0.06	0.29*

Table 4: Mean values (standard deviation) and results of tests of group differences between study programs, * $p < .05$, ^t $p < .10$

As expected, students in the bachelor program show a moderately, but significantly higher self-concept than teacher education students concerning university mathematics, and, though not significantly, also concerning proof and formal representations.

Discussion

While the prominent role of self-concept for successful learning processes at school is well established (Cai et al., 2018), its role in the university context is yet worthy of discussion. With this project, we shed light on the role of self-concept in the transition to university mathematics using differentiated measures of self-concept. Applying newly developed instruments, we distinguish different facets of self-concept of first-semester students and relate these facets to other learning prerequisites respectively the choice of the study program. The results on correlations and group differences provide first evidence that the scales do differentiate between the theoretically conceptualized facets of mathematical self-concept. However, qualifications are warranted for a broad application of the scale. For example, the results indicate that students seem to judge their knowledge and skills to apply mathematics to real-world problems not primarily based on their beliefs about their knowledge and skills regarding school or university mathematics. This might reflect that authentic applications are not considered specific to university mathematics, but also rare in German

school classrooms (Jordan et al., 2008). The small differences in self-concept between the two programs indicate that primarily self-concept regarding university mathematics is related to study choice. This facet of self-concept turned out to be related to prior mathematical knowledge, but not to the school qualification grade. It remains an open question, if the school qualification grade, which predicts success in the first semester above and beyond prior mathematical knowledge (Rach & Heinze, 2017), has an influence on study choice that is not mediated by self-concept. Of course, the results of our study are based on students' self-reports about their self-concept. To get a clearer picture of the impact of self-concept in concrete learning processes, it seems worthwhile to combine our approach with analyzing students' reported experiences and their concrete learning behavior in the first year of study (e.g. di Martino & Gregorio, 2018).

In sum, we presented the conceptualization of instruments to measure different facets of self-concept concerning school respectively university mathematics and corresponding mathematical practices. Using these measures, it is possible in the future (1) to investigate the development of these variables during students' learning processes and their effect on students' learning activities in undergraduate mathematics programs, and most importantly their tendency to drop out of a study program. (2) The differentiated measures may allow more differentiated insights into students' affect. This, in turn, may allow (3) to develop adequate approaches to support students during the challenging transition to a university mathematics program. One idea to support students is to adaptively select mathematical tasks in the courses that fit individual students' prior knowledge so that they can approach these tasks in a meaningful way. If students perceive competence (Deci & Ryan, 2002) when working on these tasks, this should probably lead to the development of self-concept concerning university mathematics, for example mediated by intrinsic motivation (see Krapp, 2005). A higher self-concept, in turn, might lead to a better learning behavior, specifically to students choosing more demanding tasks and showing more perseverance when dealing with these tasks. All in all, such interventions aiming at a higher, yet realistic self-concept, are a promising approach to decrease the rate of students dropping out of mathematics study programs.

References

- Bampili, A.-C., Zachariades, T., & Sakonidis, C. (2017). The transition from high school to university mathematics: a multidimensional process. In T. Dooley & G. Gueudet (Eds.), *Proceedings of the Tenth Congress of the European Society for Research in Mathematics Education* (pp. 1985–1992). Dublin, Ireland: DCU Institute of Education & ERME.
- Bengmark, S., Thunberg, H., & Winberg, T. M. (2017). Success-factors in transition to university mathematics. *IJSME* 48(7), 988–1001.
- Bong, M., & Skaalvik, E. M. (2003). Academic Self-Concept and Self-Efficacy: How Different Are They Really? *Educational Psychology Review* 15(1), 1–40.
- Cai, D., Viljaranta, J., & Georgiou, G. K. (2018). Direct and indirect effects of self-concept of ability on math skills. *Learning and Individual Differences* 61, 51–58.
- Deci, E. L., & Ryan, R. M. (2002). *Handbook of self-determination research*. Rochester, NY, USA: Univ. of Rochester Press.

- Di Martino, P., & Gregorio, F. (2018). The mathematical crisis in secondary–tertiary transition. *IJSME*. doi.org/10.1007/s10763-018-9894-y.
- Engelbrecht, J. (2010). Adding structure to the transition process to advanced mathematical activity. *International Journal of Mathematical Education in Science and Technology* 41, 143–154.
- Feng, X., Wang, J.-L., & Rost, D. H. (2018). Akademische Selbstkonzepte und akademische Selbstwirksamkeiten: Interdependenzen und Beziehungen zu schulischen Leistungen [Academic self-concepts and self-efficacies: interdependencies and relations to performances in school]. *Zeitschrift für Pädagogische Psychologie* 32(1–2), 23–38.
- Gueudet, G. (2008). Investigating the secondary–tertiary transition. *Educational Studies in Mathematics* 67, 237–254.
- Hannula, M. S. (2011). The structure and dynamics of affect in mathematical thinking and learning. In M. Pytlak, T. Rowland, & E. Swoboda (Eds.), *Proceedings of the seventh congress of the European society for research in mathematics education* (pp. 34–60). Rzeszów, Poland: University of Rzeszów and ERME.
- Heublein, U., Richter, J., Schmelzer, R., & Sommer, D. (2014). *Die Entwicklung der Studienabbruchquoten an den deutschen Hochschulen* [The Development of drop-out rates at German Universities.]. Hannover: DZHW.
- Jordan, A., Krauss, S., Löwen, K., Blum, W., Neubrand, M., Brunner, M., & Baumert, J. (2008). Aufgaben im COACTIV-Projekt [Tasks in the COACTIV-project]. *JMD* 29(2), 83–107.
- Kauper, T., Retelsdorf, J., Bauer, J., Rösler, L., Möller, J., & Prenzel, M. (2012). *PaLea – Panel zum Lehramtsstudium* [PaLea – Panel to teacher education programs]. http://www.palea.uni-kiel.de/wp-content/uploads/2012/04/PaLea%20Skalendokumentation%204_%20Welle.pdf.
- Krapp, A. (2005). Basic needs and the development of interest and intrinsic motivational orientations. *Learning and Instruction* 15, 381–395.
- Marsh, H. W., Pekrun, R., Parker, P. D., Murayama, K., Guo, J., Dicke, T., & Arens, A. K. (2019). The Murky Distinction Between Self-Concept and Self-Efficacy – Beware of Lurking Jingle-Jangle Fallacies. *Journal of Educational Psychology* 111(2), 331–353.
- Rach, S., & Heinze, A. (2017). The transition from school to university in mathematics: Which influence do school-related variables have? *IJSME* 15(7), 1343–1363.
- Schukajlow, S., Leiss, D., Pekrun, R., Blum, W., Müller, M., & Messner, R. (2012). Teaching methods for modelling problems and students’ task-specific enjoyment, value, interest and self-efficacy expectations. *Educational Studies in Mathematics* 79, 215–237.
- Ufer, S., Rach, S., & Kosiol, T. (2017). Interest in mathematics = interest in mathematics? What general measures of interest reflect when the object of interest changes. *ZDM Mathematics Education* 49(3), 397–409.
- Van der Breek, J. P. J., Van der Ven, S. H. G., Kroesbergen, E. H., & Leseman, P. P. M. (2017). Self-concept mediates the relation between achievement and emotions in mathematics. *British Journal of Educational Psychology* 87, 478–495.

First-person vicarious experiences as a mechanism for belief change

¹Annette Rouleau, ²Natalia Ruiz, ²Cristián Reyes and ¹Peter Liljedahl

¹Simon Fraser University, Canada: arouleau@sfu.ca; liljedahl@sfu.ca

²Universidad de Chile, Chile: nruiz@dim.uchile.cl; cristian.reyes@ciae.uchile.cl

Changes of beliefs do not happen arbitrarily; there are underlying mechanisms that enable the shift. This study outlines a problem-solving implementation in which two teachers experienced changes in their beliefs. We describe these belief changes and propose a new mechanism for the shift: first-person vicarious experiences. Our results suggest that, despite their initial uncertainties, teachers who agreed to make a change in their practice underwent a change in belief regarding the efficacy of the practice through first-hand experience of its implementation.

Key words: Beliefs, teacher belief change, first-person vicarious experiences, problem solving.

Introduction

Underlying the heart of this study is the belief in the importance of problem solving in mathematics classrooms. Widely recognized as leading to a deeper understanding of key mathematical principles and content (Pehkonen, Näveri, & Laine, 2013), problem solving has become an integral aspect of curricular reform (Törner, Schoenfeld, & Reiss, 2007). This has led to an emphasis not only on the teaching of problem solving but on the teaching of mathematics through problem solving (Liljedahl, Santos-Trigo, Malaspina, & Bruder, 2016). Yet ours is not a study of problem solving in mathematics. Rather, it is a study of belief changes that occurred *because of* the implementation of problem solving.

When the Chilean government, in response to deepening concerns over the low results of their students in international standardized mathematics assessments, decided to reform the country's mathematics curriculum, it was the belief in the importance of problem solving that provided direction. Problem solving was seen as integral and with that came the mandate that it be implemented in Chilean primary and secondary classrooms where, prior to this, it had been practically non-existent. (Felmer & Perdomo-Diaz, 2017). It was into this context that ARPA (Activando la Resolución de Problemas en las Aulas/Activating Problem Solving in Classrooms) was born. Developed in response to the mathematics curriculum reform, ARPA is a research and development initiative that seeks to implement teacher professional development (PD) strategies that promote problem solving in an integrated classroom setting (Felmer & Perdomo-Diaz, 2017). Organized as a series of workshops held over the course of 10 months and led by trained monitors, ARPA is based on principles of teachers doing and reflecting. As such, its initial focus is the development of the teachers' own mathematical skills through collaborative problem-solving experiences that incorporate non-routine problems and randomized groupings (see Liljedahl, 2016). This leads to opportunities for the teachers to reflect on their own abilities, their mathematical knowledge, the strategies they used, and the emotions they experienced. This gradually moves to the teachers preparing and implementing analogous collaborative problem-solving activities in their classrooms for all their students. In our study we outline how this reform, predicated on the belief of the importance problem solving in mathematics, resulted in a cascading effect that was felt at the micro level of the classroom. In particular, we focus on the phenomena of belief changes experienced by two teachers as a result of the imposed implementation.

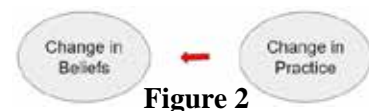
Framing Beliefs

Writing on beliefs requires treading on shifting sands. One of its challenges is the lack of consensus regarding an accepted definition (Skott, Mosvold & Sakonidis, 2018). Noting the difficulty in reaching a definition that is acceptable across all types of studies and disciplines, McLeod and McLeod (2002) suggest, “There is no single definition of the term “belief” that is correct and true, but several types of definitions that are illuminative in different situations” (p. 118). From Leatham (2006) comes a view of beliefs as anything an individual regards to be true. His sensible system framework for understanding beliefs assumes “that what one believes influences what one does” (p. 92). With this framing of beliefs comes the understanding that beliefs cannot be directly observed but must be inferred. Following Leatham (2006), for the purposes of this study, we call beliefs those things we just hold to be true and must be inferred from what we say and do.

The second area where writing on beliefs requires careful attention is the realm of stability of beliefs. As Liljedahl, Oesterle, and Bernèche (2012) argue, “The field of mathematics education has assumed for too long that stability is an inherent and definable characteristic of beliefs” (p. 101). Their meta-study of beliefs in mathematics education found that stability has many meanings, “from difficult to change, to slow to change, to resistant to change” (p. 112). Further impacting our understanding of the stability of beliefs is Green’s (1971) stress on distinguishing what we believe and how we believe it. He suggests that beliefs that are held evidentially are less resistant to change than are beliefs held nonevidentially. By this he is referring to the basis on which the belief is held—with or without regards to evidence. For Green (1971), beliefs held on the basis of evidence or reason “can be rationally criticized and therefore can be modified in the light of further evidence or better reasons” (p. 48). For example, a teacher may hold an evidentiary belief that group work is untenable because she tried it unsuccessfully once. There is potential to change her belief by providing her with a positive experience with group work. Following Liljedahl et al. (2012) and Green (1971), we propose a further understanding of beliefs as changeable truths that must be inferred from what one both says and does.

Models of Change in Belief and Change in Practice

Early models proposed that changes in beliefs would lead to change in practice (see Figure 1). Accordingly, teacher PD models focused on occasioning belief changes as a change in belief was seen as a necessary precursor to change in practice (see Philipou & Christou, 2002). However, this does not capture what happened in our phenomenon. As we shall detail later, what we suggest happened for our participants is that changes in practice led to changes in beliefs (see Figure 2).



To better understand this phenomenon, we turn to Guskey (1986) who, noting the abysmal success of PD programs, proposed an alternative model. Arguing that the previous models failed to take into account the process by which change in teachers typically occurs, he proposed a model in which the elements were reordered around student outcomes (see Figure 3).



His model suggests that significant change in teachers' beliefs occurs primarily after they gain evidence of improvement in student learning, which for Guskey can include not only cognitive achievement but also elements such as behaviour or attendance. These improvements typically result from changes teachers have made in their classroom practices—a new instructional approach, the use of new resources, or simply a modification in teaching procedures. It is important to note that, for Guskey, it is not the PD per se, but the experience of successful implementation that changes teachers' beliefs. They believe it works because they have seen it work in their students, and that experience shapes their beliefs. Equally important is Guskey's view of change as gradual and difficult—new practices require incremental implementation.

Liljedahl (2016) also talks about this phenomenon of a change of practice leading to change of belief. He differs from Guskey (1986) in that the participants are asked to implement a practice for which they have no personal certainty will work. In doing so, this method bypasses the classroom norms that frequently act as an impediment to change in practice (Liljedahl, 2016). Liljedahl came to call this a first-person vicarious experience:

They are first person because they are living the lesson and observing the results created by their own hands. But the methods are not their own. There has been no time to assimilate them into their own repertoire of practice or into the schema of how they construct meaningful practice. They simply experienced the methods as learners and then were asked to immediately implement them as teachers. As such, they experienced a different way in which their classroom could look and how their students could behave. (p. 384)

For example, in order to promote the practice of student collaboration, Liljedahl had to first bypass the classroom norm that the doing of mathematics was an individual pursuit. To that end, he had teachers work on problem-solving tasks in visibly random groups during a 90-minute PD session. At its conclusion, the participants were required to introduce visibly random grouping in their classrooms. The result was a significant uptake in the practice that Liljedahl attributes to two factors: (1) the ease of modelling it in a PD setting and (2) the teachers having personally experienced the impact on their own learning when visibly randomly grouped.

Similarly to Liljedahl (2016), the ARPA problem-solving initiative also incorporates Guskey's (1986) notion of changing practice to change beliefs—the teachers in our study were required to implement changes in practice which resulted in changes of beliefs. We were curious about the mechanism behind that change and this curiosity led to our research question: Can we understand their belief changes through the lenses of Guskey (1986) and Liljedahl (2016)?

Methodological Considerations

While the difficulty in ascertaining beliefs is generally acknowledged (Skott, Mosvold, & Sakonidis, 2018), it is argued that qualitative studies have much to offer in the study of beliefs in that they offer a deep understanding of the ways in which people develop and change their beliefs (Olafson, Grandy, & Owens, 2015). For the purposes of our study, talking with the participants and allowing them to tell their stories provided a rich description of the phenomenon and allowed us to respond to our research question regarding the nature of their changes. Note, ours is a small-scale study meant to document the occurrence of a phenomenon rather than its prevalence.

The source of our data was interviews with two participants: Luisa, a primary education teacher who was teaching in a Chilean public school at the time of the study and Josefa, a special education teacher who was assigned to a student in Luisa's fifth-grade classroom. These interviews were originally conducted as part of a larger project that studied the problem-solving experiences of a child with special needs. During their separate interviews, her teachers were also asked a series of questions intended to elicit their perceptions of changes experienced as a result of the problem-solving implementation. Ranging from 40 to 60 minutes in length, the interviews were audio recorded and transcribed in their entirety in Spanish. As this study is an international collaboration conducted by researchers from Canada and Chile, the transcripts were subsequently translated from Spanish to English by a researcher at the University of Chile and later reviewed by another researcher at the University. When first analyzing the interviews, we realized that not only was there a change in the student, but also in her teachers. So, guided by Guskey (1986) and Liljedahl (2016), we reanalyzed the transcripts for evidence of changes in practice. For example, one teacher detailed the change in how she offered a student support in terms of 'before and after'. In keeping with our understanding of beliefs as inferable truths, we attended to those before and after descriptions to establish the teachers' beliefs prior to the change in practice and the resultant new belief.

Findings

In the following we present two situations, which best exemplify instances in which we noted that an imposed change in practice led to change in beliefs. Each analysis begins with a summation of the original belief and the circumstances surrounding its change.

Change in teachers' beliefs regarding integration in mathematics classrooms

Prior to participating in ARPA, Luisa and Josefa's students with special education needs were usually taught mathematics using individual materials prepared by Josefa, the special education teacher, in a resource room isolated from the classroom. While both supported integration in theory, they were uncertain whether it could be successful in their classroom. This is common among mathematics teachers with 80% ($n = 228$) holding positive beliefs regarding integration yet less than one-third believing they possessed useful philosophies or strategies to implement its practice (DeSimone & Parmer, 2006). For Josefa and Luisa, this changed when, as part of their commitment to the ARPA program, they prepared and delivered a multi-level problem-solving lesson. Their success at meeting the needs of students with varying levels of ability in this lesson changed their beliefs regarding their own ability to successfully integrate their students. Their theoretical belief in the importance of integration was now reflected in their practice where they moved to a full inclusion model.

One of the expectations of teachers participating in ARPA is preparing lessons incorporating the strategies they have been introduced to in ARPA. At the urging of their ARPA monitor, Luisa and Josefa decided to prepare a public problem-solving lesson. Unique to this lesson was that it was designed to be multi-grade and open to observation by the community. Teachers are sometimes hesitant to prepare materials for multi-level students as they believe the wide range of needs and abilities may be an obstacle to success (Kiely, Brownell, Lauterbach, & Benedict, 2015). Luisa and Josefa were no exception to this belief as we see in this excerpt from Josefa: "*We were worried about the reactions of the girls to working with younger girls*". Luisa was worried in particular about the students with special education needs and felt unsure whether they would be able to contribute

effectively in this type of group dynamic. She was especially concerned for one girl saying, “*Maybe she won’t to be able to talk, because all the other girls do not know her, because they are from second and eighth grade*”. It was concerns such as these that had prevented both teachers from implementing the integration practices that they valued. It is not that the teachers opposed integration, rather they struggled to believe it could be effectively implemented, as Josefa states,

There is this integration and diversity discourse, theoretical stuff, but how do we face it? There is a lot of talk about how everybody is different, that we must work with our diversity, but what I used to do was to bring the girls [with special education needs] to the resources classroom. I’d take them out of the classroom and give them their individual material, that I created and used.

However, despite their uncertainty, they prepared a task in which students from grades 2, 5, and 8 all worked in visibly random groups within their grade levels on the same problem. Both teachers expressed satisfaction with the outcome of the public lesson with Josefa noting, “*And, you know what? Surprisingly, it turned out very well*”. They had observed the students successfully working and learning together regardless of age or ability. Their general fears for the success of the students were eased by observing the students respond to each other as Josefa explains, “*For example, when the fifth-grade girls were in front of the class explaining their solutions, the eighth-grade girls would listen and say: “Hey, I didn’t think about that”*”. Their particular fears for their special education students were negated as they watched them be included in the groups and share their contributions. Although initially reluctant to implement this public lesson, its success impacted their beliefs about their own classroom practice with Josefa remarking, “*If we can prepare a lesson for three different [grade] levels, shouldn’t we be able to do that inside the classroom? I mean, it was empirically demonstrated that we can—when you talk about diversity in the classroom—it is obvious that we can do it*”.

Concerning the initial inconsistency between the professed beliefs of the teachers in our study and their actual practice, Leatham (2006) notes that we must look deeper, “for we must have either misunderstood the implications of that belief, or some other belief took precedence in that particular situation” (p. 95). In our study, we found the latter—while both teachers believed that integration of students with special education needs was important, they also held a stronger belief that it only works in theory, which possibly prevented them from enacting their belief in practice. Their involvement with ARPA and its expectation that they integrate all students in lessons offered a first-person vicarious experience that changed their belief regarding the difficulties of integration. This allowed for a match between their professed belief and their actual classroom practice.

Change in teachers’ beliefs about low-performing mathematics students

We view the teachers’ beliefs regarding integration as being contained within a cluster of beliefs that also comprised beliefs regarding low-performing students’ ability to work successfully in collaboration on non-routine problems. Most simply put, they did not believe it was possible. They believed that low-performing and/or students with special needs would be unable to cope with the vagaries of group dynamics and have little to offer in the way of solutions for non-routine problems. Despite these beliefs, and with the encouragement of their ARPA monitor, they changed their mathematics practice to include all students in visibly random groupings that worked collaboratively on non-routine problems. The results surprised them. The students were not only accepted within

their groups, they were viewed as contributing members. Observing the success of their students led both Josefa and Luisa to change their beliefs regarding their students' capabilities.

Luisa recalls that when the ARPA monitor suggested, *“Those children who have more difficulties are the first to solve the problems”*, both her and Josefa's initial response was a disbelieving, *“Yeah, hopefully”*. Similarly, they held low expectations for successful collaboration, particularly for Cristina, a student with special education needs. As Luisa explains, *“Well, I thought her [Cristina's] participation and the acceptance of her classmates would be minimal”*. However, with little expectation of success, they implemented the non-routine problems and visibly random grouping recommended by their ARPA monitor. The teachers were pleased with the results. In particular, Josefa shares that Cristina, the student with special needs, *“has improved a lot. She can solve a problematic situation and face it, read it and look for solutions. She doesn't sit still, she tries to solve it”*. Additionally, Cristina's peers valued her contributions and were willing to work with her in groups too. As Josefa notes, *“Working in groups is like a second-nature to her and she can work in any group”*. Likewise, Luisa recalls the other students saying *“Look, she [Cristina] did it”*. She goes on to add that *“although Cristina wouldn't say “Girls, let's do it this way”, she was making small contributions that were useful for what they were doing as a group”*. Similarly, the teachers observed the success of other low-performing students, like Daniela, who solved a difficult problem. As Josefa explains,

She [Daniela] was present the class when we were teaching the problem of Theresa's floor tiles. Nobody in the class could find the solution. And it is a class where all the girls think they are very good at math. They are very competitive and this girl, Daniela, raises her hand and answers the problem. Luisa and I look at each other surprised.

The teachers came to realize that low-performing students did not need simpler problems, nor special resources, but that they could solve challenging problems. As Josefa notes,

And many times, we had simplifications, we'd plan a simple problem, or with more concrete support, or we'd plan problems with smaller numbers. And we realized it wasn't necessary. Do you get it? That helped us to realize that the students were more capable than we thought. So, you have a different disposition. And according to that, you start giving different support too, things that maybe you didn't even plan, but you go with the flow and you realize that they can do it.

We suggest that it was the change in the teachers' beliefs regarding their students' ability to work on non-routine problems in visibly random groupings that allowed the change in the belief regarding integration to occur. The teachers believed in integration, but until now did not believe they could successfully implement it. To enact their beliefs, the teachers needed the necessary pedagogical knowledge of how to implement practices that support integration (Buehl & Beck, 2015). In speaking of the difference that visibly random grouping and non-routine problems made in the classroom, Josefa explains that *“Those things [visibly random groups and non-routine problems] make the things you want to happen, happen”*. We can infer from this that, within their belief cluster, the successful implementation of integration practices is positioned as an overarching belief—it is the ‘thing’ they want to make happen. And it happened because ARPA's requirement that the teachers implement specific practices allowed them to observe positive results in their students. This changed their beliefs regarding students' abilities, which in turn allowed them to change their belief of their own ability to

integrate. And as Josefa explains, “*That was a process we had to go through. But it was very good for us*”.

Discussion and Conclusion

Although not all imposed changes in practice result in changes in beliefs, our participants implemented imposed practices that did change their beliefs. As our data was collected post-hoc, we did not directly observe the changes nor were we able to conduct pre-interviews. However, we were able to infer that, after being asked to prepare and teach a public problem-solving lesson, the teachers changed their beliefs regarding their ability to effectively integrate children with special education needs and their belief regarding the ability of low-performing students. Fitting with Guskey (1986), a partial answer to our research question then, is that their beliefs changed after noting evidence of improvement in student learning. They believed it works because they saw it work and that experience shaped their beliefs. Not fitting with Guskey (1986), however is how the belief change occurred. Guskey (1986) views change as gradual and difficult with new practices requiring slow implementation. Our participants experienced something quite different. There was no gradual assimilation—they were required to change their practice even if they were uncertain about its effectiveness. They were given personal assurances that it would work from their ARPA monitors, but they were not given time to assimilate the methods into their own schemas. They had simply experienced the changes themselves as learners in the ARPA sessions where they were exposed to collaborative problem-solving and then been required to implement the new practice. They had undergone a first-person vicarious experience (Liljedahl, 2016).

Leatham (2006) reminds us that “The challenge for teacher education is not merely to influence what teachers believe—it is to influence how they believe it” (p. 100). To further answer our research question, the findings suggest that first-person vicarious experiences influence the how—the teachers now believe it experientially, which we argue, motivated the belief change. Additionally, the PD aspect is vital as our participants needed to feel or see the changes themselves before their beliefs changed. They still had no certainty it would work in a different context, but they had experienced first-hand that it could. Our findings also suggest that first-person vicarious experiences are effective at altering evidential beliefs—those beliefs that are based on evidence or reason (Green, 1971). For example, the teachers believed that integration only worked in theory because of their previous unsuccessful attempts, which only served to reinforce the belief. Buehl and Beck (2015) would point out quite rightly that the teachers were lacking the pedagogical tools to enact their belief in integration. However, if this was all that was missing, teacher practice would be easy to change. We suggest that they were also lacking a first-person vicarious experience that provided the necessary evidence to change the belief. For our teachers, the success of their public lesson gave them new evidence that they could effectively integrate students and resulted in a change of beliefs.

References

- Buehl, M., & Beck, J. (2015). The relationship between teachers’ beliefs and teachers’ practices. In H. Fives, & M. Gill (Eds.), *International handbook of research on teachers’ beliefs* (pp. 66–84). Abingdon, UK: Routledge
- DeSimone, J., & Parmar, R. (2006). Middle school mathematics teachers' beliefs about inclusion of students with learning disabilities. *Learning Disabilities Research and Practice, 21*(2), 98–110.

- Felmer, P., & Perdomo-Díaz, J. (2017). Un programa de desarrollo profesional docente para un currículo de matemática centrado en las habilidades: la resolución de problemas como eje articulador. *Educación Matemática*, 29(1), 201–217.
- Green, T. (1971). *The activities of teaching*. New York, NY: McGraw-Hill.
- Guskey, T. (1986). Staff development and the process of teacher change. *Educational Researcher*, 15(5), 5–12.
- Kiely, M., Brownell, M., Lauterbach, A., & Benedict, A. (2015). Teachers' beliefs about students with special needs and inclusion. In H. Fives, & M. Gill (Eds.), *International handbook of research on teachers' beliefs* (pp. 475–491). Abingdon, UK: Routledge.
- Leatham, K. (2006). Viewing mathematics teachers' beliefs as sensible systems. *Journal of Mathematics Teacher Education*, 9(1), 91–102.
- Liljedahl, P. (2016). Building thinking classrooms: Conditions for problem solving. In P. Felmer, W. Van Dooren, & J. Kilpatrick (Eds.), *Posing and solving mathematical problems* (pp. 361–386). New York, NY: Springer.
- Liljedahl, P., Oesterle, S., & Bernèche, C. (2012). Stability of beliefs in mathematics education: A critical analysis. *Nordic Studies in Mathematics Education*, 17(34), 101–118.
- Liljedahl, P., Santos-Trigo, M., Malaspina, U., & Bruder, R. (2016). *Problem solving in mathematics education*. Cham, Switzerland: Springer.
- McLeod, D., & McLeod, S. (2002). Synthesis - Beliefs and mathematics education: Implications for learning, teaching, and research. In G. Leder, E. Pehkonen, & G. Törner (Eds.), *Beliefs: A hidden variable in mathematics education?* (pp. 115–123). Dordrecht, Netherlands: Springer.
- Olafson, L., Grandy, C., & Owens, M. (2015). Qualitative approaches to studying teachers' beliefs. In H. Fives, & M. Gill (Eds.), *International handbook of research on teachers' beliefs* (pp. 128–149). Abingdon, UK: Routledge.
- Pehkonen, E., Näveri, L., & Laine, A. (2013). On teaching problem solving in school mathematics. *CEPS Journal: Center for Educational Policy Studies Journal*, 3(4), 9–23.
- Philippou, G., & Christou, C. (2002). A study of the mathematics teaching efficacy beliefs of primary teachers. In G. Leder, E. Pehkonen, & G. Törner (Eds.), *Beliefs: A hidden variable in mathematics education?* (pp. 211–231). Dordrecht, Netherlands: Springer.
- Skott, J., Mosvold, R., & Sakonidis, C. (2018). Classroom practice and teachers' knowledge, beliefs and identity. In T. Dreyfus, M. Artigue, D. Potari, S. Prediger, & K. Ruthven (Eds.), *Developing research in mathematics education: Twenty years of communication, cooperation and collaboration in Europe*, (pp. 162–180). London, UK: Routledge.
- Törner, G., Schoenfeld, A., & Reiss, K. (2007). Problem solving around the world: Summing up the state of the art. *ZDM*, 39(5), 353–353.

I am scared to make a drawing. Students' anxiety and its relation to the use of drawings, modelling, and gender

Stanislaw Schukajlow¹, Judith Blomberg¹, Johanna Rellensmann¹

¹University of Münster, Department of Mathematics, Germany; schukajlow@uni-muenster.de

Emotions are important for students' learning and achievement. In the present paper, we report on a study of ninth- and tenth-graders (N=194) in which we investigated the relations between anxiety about strategy use, learning outcomes, and gender. We found that anxiety about making a drawing to solve a modelling problem was higher in female than in male students. Further, anxiety about strategy use was negatively related to different indicators of learning outcomes: strategic knowledge about drawing, number of drawings generated spontaneously while solving modelling problems, and modelling performance. Moreover, after we controlled for intra-mathematical performance, strategic knowledge about drawing, and gender, anxiety about self-generated drawing was negatively related to the use of drawings and modelling performance. This finding indicates the importance of anxiety about strategy use for learning and performance.

Keywords: Anxiety, Emotions, Strategy, Drawing, Modelling problems

Introduction

Emotions are important for the learning of mathematics, mathematical achievement, a person's future career, and human well-being (Schukajlow, Rakoczy, & Pekrun, 2017). One of the best-researched emotions is students' anxiety about mathematics. Students have been found to experience test anxiety often, and it can negatively influence students' test performance. However, much less is known about the impact of anxiety on students' strategies. In the present paper, we present a study carried out in the framework of the research project "Visualization while solving modelling problems" (ViMo). The main aim of the ViMo project is to investigate the strategy of learner-generated drawing and its relation to affective and cognitive learning factors. In the present study, we explored anxiety about making a drawing (anxiety about self-generated drawing) and its importance for students' learning outcomes. Our results contribute to clarifying the role of anxiety in strategy use, which was recently identified as an important research gap (Ramirez, Shaw, & Maloney, 2018).

Anxiety, drawing strategy, modelling, and gender

Anxiety as an achievement emotion

Definitions of emotions have emerged from different paradigms, such as the Darwinian, Freudian, or cognitive-psychological traditions (Hannula, 2015). Emotions are typically defined as phenomena that include affective, cognitive, physiological, motivational, and expressive components. The components of anxiety are uneasiness and nervous feelings (affective component), worry (cognitive), avoidance motivation (motivational), anxious facial expressions (expressive), and peripheral physiological activation (physiological) (Pekrun, 2006). In the control-value theory of achievement emotions, anxiety is considered to be a prospective emotion that is related to learning outcomes such as mathematical performance (Pekrun, 2006). Control and value appraisals are assumed to be important for the emerging of

emotions. Students feel test anxiety if they ascribe a high value to an exam and perceive themselves as not able to avoid failure on the exam. Similar to other affective constructs, anxiety has state and trait components that refer to the temporal stability of this emotion (Schukajlow et al., 2017): If students are anxious while solving a specific problem, this is an emotional state; if they are disposed to often being anxious while solving a problem, this is an emotional trait. Another important characteristic of emotions is their object, which varies from more general objects (e.g. the learning of mathematics) to specific objects (e.g. a mathematical problem) (Schukajlow et al., 2017). Mathematical activities (e.g. strategy use) can also serve as objects for emotions.

Self-generated drawing and modelling

Self-generated drawing describes the process and the product of generating an illustration that corresponds to the objects and relations described in a problem (Rellensmann, Schukajlow, & Leopold, 2017), and it has been identified as an important strategy for problem solving (Hembree, 1992). Strategic knowledge makes part of the static knowledge component of metacognition as opposed to the dynamic process component of metacognition, which includes the application of strategies (strategy use). In a prior study, we investigated the importance of strategic knowledge about drawing for solving modelling problems. Modelling problems are problems with a connection to reality, whose solutions require demanding transfer processes between reality and mathematics (Niss, Blum, & Galbraith, 2007). Modelling performance can be clearly distinguished from students' ability to solve problems without a connection to reality, called intra-mathematical performance. Students' strategic knowledge about drawing comprises students' views on the characteristics of a drawing that fits a given problem. This knowledge is positively related to students' performance in modelling problems that can be solved by using the Pythagorean theorem (Rellensmann et al., 2017). Another important predictor of student performance is their strategy use. Students who spontaneously apply a drawing strategy were found to demonstrate higher performance in mathematics than students who did not apply the strategy (Hembree, 1992). However, this finding was not always confirmed when students were asked to construct a drawing. One reason why students do not always spontaneously generate drawings might be their affective perceptions of this strategy such as anxiety about making a drawing to solve a problem.

Anxiety, gender, and performance-related outcomes

Anxiety accompanies solitary problem solving processes (DeBellis & Goldin, 2006), and because working individually is important for gaining new knowledge, different contextual factors have been accessed to explore anxiety in mathematics. One such factor is students' gender. Most studies on anxiety have revealed that female students report a higher level of anxiety in mathematics than male students do (for an overview, see Ramirez et al., 2018). To account for this finding, researchers have primarily discussed two reasons that are both related to stereotypes about gender and mathematics. One explanation refers to the hypothesis that female students report their true level of mathematical anxiety because they do not feel bad about having negative feelings toward mathematics, whereas male students try to repress their anxiety because of the stereotype that males have to be good at mathematics. Another explanation of the higher level of anxiety in women refers to the stereotype that women are

worse at math than men. The crucial role of stereotypes for gender differences in anxiety is supported by the findings that gender differences disappear when students report their real-time (state) anxiety before, during, and after an exam, and they do not have time to reflect on their anxiety (Goetz, Bieg, Lüdtke, Pekrun, & Hall, 2013). Although these findings refer to anxiety about mathematics in general and not anxiety about the use of strategies for solving mathematical problems, we expect similar gender differences for anxiety about self-generated drawing while solving modelling problems.

Anxiety about the use of a specific strategy might be one factor that prevents students from applying this strategy while solving a problem. If a student fears failure when it comes to drawing, he or she might not try to generate a drawing, might solve the problem by using another less effective strategy, or might even give up at the very beginning. The relation between anxiety and students' strategies has rarely been investigated yet. We know that students' negative emotions (including anxiety) seem to impede their use of creative strategies (Pekrun, 2006) such as self-generated drawing. The use of inappropriate strategies is considered to be one factor that can explain why students with high levels of anxiety show poor mathematical performance in primary school (Ramirez, Chang, Maloney, Levine, & Beilock, 2016). However, the negative relation between anxiety and performance depends on students' cognitive abilities and is stronger for students with high working memory capacity. This finding indicates that anxiety about self-generated drawing might be negatively related to students' use of this strategy while solving modelling problems. A similar relation can be expected for strategic knowledge about drawing because students with high levels of anxiety about drawing tend to practice this strategy only rarely and do not have the opportunity to acquire advanced knowledge about this strategy. The relation between anxiety and modelling performance might be negative because anxious students do not make drawings to solve modelling problems. Further, students with high levels of anxiety might perform worse in modelling because their working memory might be overloaded with negative feelings, and they cannot focus on problem solving to the same degree as students who do not feel anxious.

Research questions

On the basis of prior research, we investigated the following research questions:

1. Does anxiety about self-generated drawing differ for female and male students? We hypothesized higher anxiety for female students.
2. Is anxiety about self-generated drawing related to strategic knowledge about drawing, use of drawings, and modelling performance? We expected a negative correlation between anxiety and these learning outcomes.
3. Is anxiety about self-generated drawing related to the use of drawings and modelling performance after strategic knowledge about drawing, intra-mathematical performance, and gender are controlled for? We expected that the relation would remain negative even after the strategic factor, the achievement factor, and gender were controlled for.

Method

Sample and procedure

Two hundred twenty German ninth- and tenth-graders from ten classes in middle- and high-track schools participated in the presents study (mean age 14.9 (SD = 0.64), 109 female students). On the first day of the study, among other questionnaires, students filled out a questionnaire on mathematical anxiety, age, and gender and took a test on strategic knowledge about drawing. On the second day, they worked on a modelling test and an intra-mathematical test. Students were not instructed to make a drawing. Their spontaneous use of drawings was coded by analyzing students' solutions.

Measures

Anxiety about self-generated drawing was assessed with a new Likert scale that we adapted from the anxiety scale from the Achievement Emotions Questionnaire (Pekrun, Goetz, Frenzel, Barchfeld, & Perry, 2011) by focusing on the items from the drawing strategy. It consisted of five items that ranged from 1 (not at all true) to 5 (completely true) and addressed emotional trait. Example: "When I make a drawing for a difficult word problem, I am very nervous." The reliability (Cronbach's α) was .860.

The strategic knowledge about drawing scale was developed and validated in a prior study (Rellensmann, Schukajlow, & Leopold, under review). It comprised eight real-world problems, each of which was followed by an item concerning situational drawings and an item concerning mathematical drawings (see Figure 1). On the 16-item test, students were asked to evaluate the utility of the drawings provided for each problem by comparing the drawings with regard to their helpfulness in solving the problem. Each item consisted of three drawings (a correct and complete drawing, a correct but incomplete drawing, and an incorrect drawing) that students rated on the scale from 1 (not helpful at all) to 5 (very helpful). The scores for each item ranged from 0 to 3, as each item offer 3 comparisons. The number of points depended on the sequence of drawings concerning their usefulness for solving the task. For example, if students identified that the correct and complete drawing was more helpful than the correct but incomplete drawing and that the correct and incomplete drawing was more helpful than the incorrect drawing, they were given 3 points (Cronbach's α .762).

The modelling performance test comprised eight problems that could be solved by applying the Pythagorean theorem (for an example, see Schukajlow, Krug, & Rakoczy, 2015). Students' solutions were scored by two raters on a scale ranging from 2 (correct problem solution) to 0 (incorrect solution resulting from an incorrect mathematical model or a missing solution). The inter-rater reliability (Cohen's κ) was $>.81$ for all modelling problems. Cronbach's α reliability was .772.

Students' use of the drawing strategy was assessed via the number of drawings they constructed while solving the eight problems on the modelling test. If students made a drawing for a problem, they received a score of 1; if they did not make a drawing, they received a score of 0.

The intra-mathematical test comprised ten items on applying the Pythagorean theorem or solving quadratic equations (e.g., $x^2 = 3.8^2 - 2.5^2$). They received 1 point for the correct solution and 0 points for an incorrect or missing solution. Cronbach's α Reliability was .760.

Statistical analysis




To analyze the relations between the constructs, we used Pearson product moment correlations and partial correlations. Because students worked on the tests on two different days, some data were missing (3% and 8%). Thus, we applied listwise deletion for our analysis. This means that we excluded students from the analysis if they missed the first or second test session, and we performed the analysis on 194 students.

Wind

The rotor blade of a 70 m high wind turbine has a length of 35 m and a so-called wind area of about 3,800 m². The wind area is the area that is swept by a rotor blade during a complete rotation. Can the information on the swept area be correct?

You do not have to solve the task!

First compare these three drawings with one another. Evaluate how useful each drawing is for solving the task.

Drawings	Not helpful at all	Not helpful	Rather not helpful	Rather helpful	Helpful	Very helpful
	<input type="checkbox"/>	<input type="checkbox"/>	<input type="checkbox"/>	<input type="checkbox"/>	<input type="checkbox"/>	<input type="checkbox"/>
	<input type="checkbox"/>	<input type="checkbox"/>	<input type="checkbox"/>	<input type="checkbox"/>	<input type="checkbox"/>	<input type="checkbox"/>
	<input type="checkbox"/>	<input type="checkbox"/>	<input type="checkbox"/>	<input type="checkbox"/>	<input type="checkbox"/>	<input type="checkbox"/>

Next compare these three drawings with one another. Evaluate how useful each drawing is for solving the task.

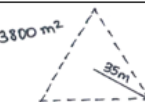
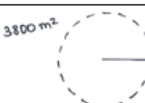
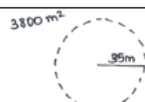
Drawings	Not helpful at all	Not helpful	Rather not helpful	Rather helpful	Helpful	Very helpful
	<input type="checkbox"/>	<input type="checkbox"/>	<input type="checkbox"/>	<input type="checkbox"/>	<input type="checkbox"/>	<input type="checkbox"/>
	<input type="checkbox"/>	<input type="checkbox"/>	<input type="checkbox"/>	<input type="checkbox"/>	<input type="checkbox"/>	<input type="checkbox"/>
	<input type="checkbox"/>	<input type="checkbox"/>	<input type="checkbox"/>	<input type="checkbox"/>	<input type="checkbox"/>	<input type="checkbox"/>

Figure 1: An item from the knowledge about drawing scale (Rellensmann et al., under review)

Results

First, we analyzed the differences in anxiety for female and male students. As expected on the basis of prior research, students' level of anxiety about self-generated drawing was significantly higher for female students ($M = 2.12$, $SD = 0.96$) than for male students ($M = 1.67$, $SD = 0.63$). About 11% of the female students and 18% of the male students denied feeling anxiety about drawing for all 5 statements. The medium effect size (*Cohen's d* = .56) indicates that women feel anxiety more often than men if they make a drawing while solving a demanding modelling problem.

The second research question was about the relation between anxiety about making a drawing and learning outcomes. The analysis of Pearson correlations revealed that students' anxiety about making a drawing was negatively related to all constructs measured in the present study (see Table 1). The effect size for the relation between anxiety about making a drawing and modelling was medium in size, and the effect sizes for the correlations between anxiety, use of drawings, and intra-mathematical performance were weak.

		SKD	UD	IM	MOD
Anxiety	<i>r</i>	-.118	-.154	-.140	-.327
	<i>p</i> ^a	.041	.016	.026	<.001

Note. ^a *p*: one-tailed. SKD: strategic knowledge about drawing, UD: Use of drawings, IM: intra-mathematical performance, MOD: Modelling performance.

Table 1: Correlations between anxiety and the learning- and achievement-related measures

Students who felt anxious about making a drawing had lower levels of strategic knowledge about drawing, applied this strategy less often while solving modelling problems, and demonstrated poorer modelling performance.

The third research question focused on the analysis of the relation between anxiety about drawing, strategy use, and modelling performance after strategic knowledge about drawing, use of drawings, intra-mathematical performance, and gender were controlled for. The partial correlations confirmed a significant relation between anxiety and the use of drawings ($r = -.161$, $p = -.026$) and between anxiety and modelling performance ($r = -.236$, $p < .001$). The relations between anxiety about drawing and the use of drawings and modelling performance go beyond the contribution of the strategic factor (SKD), the cognitive factor (IM), and gender.

Discussion

In the present study, we explored the role of students' anxiety about self-generated drawing. Our analyses confirmed the gender differences for anxiety about self-generated drawings that were found for mathematical anxiety in prior studies. Although mean values for anxiety about self-generated drawing were low, our results indicate that more than nine tenths of female students and more than one sixth of male students might be worried, feel uneasiness, or feel nervous while making a drawing for a difficult modelling problem. Giving prior findings about the importance of spontaneous drawings for problem solving (Hembree, 1992) and the importance of drawings for solving modelling problems that can be solved by applying the Pythagorean theorem (Rellensmann et al., 2017), anxiety about using drawings seems to be an important construct that should be investigated in future studies. Moreover, female students might be disadvantaged while solving modelling problems because of their anxiety about using advanced strategies such as self-generated drawing. The main reason for gender differences in anxiety is considered to be social stereotypes that occur in the trait measures of anxiety. In future studies, it will be interesting to assess anxiety about self-generated drawing as a state, directly before or during problem solving, in order to clarify the stability of gender differences.

The analysis of the relations between anxiety about self-generated drawing and learning outcomes was the second main point of the present study. We hypothesized two ways in which anxiety about self-generated drawing can affect learning outcomes. First, students with high anxiety about making self-generated drawings might avoid using this strategy during problem solving because of their fear of failure, and they might look for other ways to solve the problem. The results of our analysis confirmed this hypothesis because we found a negative relation between anxiety and the number of drawings used while solving modelling problems. Moreover, a negative relation between anxiety and strategic knowledge about drawing indicates that students with high anxiety did not know the important characteristic features of good drawings. One reason for this negative relation might be that anxious students make drawings less frequently, and thus, they do not have many opportunities for improving this strategy. The relation between anxiety and the use of drawings while solving modelling problems remained negative after strategic knowledge about drawing, intra-mathematical performance, and gender were controlled for, indicating that affective constructs such as anxiety might influence the use of the strategies beyond strategic knowledge, general mathematical abilities, or gender. Second, anxiety is considered to have a negative influence on performance because it diminishes cognitive resources (e.g. working memory) while problem solving. If students are anxious during problem solving, they cannot focus on the entire problem and perform worse than students who do not feel this emotion. We found a negative correlation between anxiety about drawing and modelling performance that remained significant after strategic knowledge about drawing and intra-mathematical performance were controlled for. This finding might indicate the specific relevance of anxiety about self-generated drawing for students' modelling performance.

In sum, our findings revealed the importance of overcoming anxiety about the use of strategies. In the case of drawing, we suggest that students should learn how to apply this strategy in the classroom and to reflect on differences between more and less helpful drawings. Engagement with drawings should begin in primary school because anxiety about mathematics emerges in the early school years, and decreases performance in secondary school (Ramirez et al., 2018).

Finally, we would like to point out one limitation of the present study. Although anxiety, students' drawings, and modelling performance were ordered along the timeline, we cannot draw conclusions about causal effects of anxiety on the use of drawings or on modelling performance. Prior research has revealed some evidence of reciprocal causation between emotions and achievement (Putwain, Becker, Symes, & Pekrun, 2018). In mathematics, however, the relation between emotions and performance has yet to be clarified. For example, students' prior performance in modelling did not influence enjoyment during lessons, whereas enjoyment during lessons affected modelling performance after mathematics lessons (Schukajlow & Rakoczy, 2016). We interpret this result as evidence of possible effects of anxiety about drawing on performance in modelling. In future studies, we suggest to pay more attention to the interaction of affective, strategic and cognitive factors while solving mathematical problems.

Acknowledgments

The present study was funded by the German Research Foundation [Deutsche Forschungsgemeinschaft]. Grant SCHU 2629/3-1.

References

- DeBellis, V. A., & Goldin, G. A. (2006). Affect and meta-affect in mathematical problem solving: A representational perspective. *Educational Studies in Mathematics*, 63(2), 131–147.
- Goetz, T., Bieg, M., Lüdtke, O., Pekrun, R., & Hall, N. C. (2013). Do girls really experience more anxiety in mathematics? *Psychological Science*, 24(10), 2079–2087.
- Hannula, M. S. (2015). Emotions in Problem Solving. In S. J. Cho (Ed.), *Selected Regular Lectures from the 12th International Congress on Mathematical Education* (pp. 269–288). Cham: Springer International Publishing.
- Hembree, R. (1992). Experiments and relational studies in problem solving: a meta-analysis. *Journal for Research in Mathematics Education*, 23(3), 242–273.
- Niss, M., Blum, W., & Galbraith, P. L. (2007). Introduction. In W. Blum, P. L. Galbraith, H.-W. Henn, & M. Niss (Eds.), *Modelling and Applications in Mathematics Education: the 14th ICMI Study* (pp. 1–32). New York: Springer.
- Pekrun, R. (2006). The control-value theory of achievement emotions: Assumptions, corollaries, and implications for educational research and practice. *Educational Psychology Review*, 18, 315–341.
- Pekrun, R., Goetz, T., Frenzel, A. C., Barchfeld, P., & Perry, R. P. (2011). Measuring emotions in students' learning and performance: The Achievement Emotions Questionnaire (AEQ). *Contemporary educational psychology*, 36, 36–48.
- Putwain, D. W., Becker, S., Symes, W., & Pekrun, R. (2018). Reciprocal relations between students' academic enjoyment, boredom, and achievement over time. *Learning and Instruction*, 54, 73–81.
- Ramirez, G., Chang, H., Maloney, E. A., Levine, S. C., & Beilock, S. L. (2016). On the relationship between math anxiety and math achievement in early elementary school: the role of problem solving strategies. *Journal of Experimental Child Psychology*, 141, 83–100.
- Ramirez, G., Shaw, S. T., & Maloney, E. A. (2018). Math anxiety: Past research, promising interventions, and a new interpretation framework. *Educational Psychologist*, 53, 145–164.
- Rellensmann, J., Schukajlow, S., & Leopold, C. (2017). Make a drawing. Effects of strategic knowledge, drawing accuracy, and type of drawing on students' mathematical modelling performance. *Educational Studies in Mathematics*, 95(1), 53–78.
- Rellensmann, J., Schukajlow, S., & Leopold, C. (under review). Measuring and investigating strategic knowledge about drawing to solve geometrical modelling problems. *ZDM Mathematics Education*.
- Schukajlow, S., Krug, A., & Rakoczy, K. (2015). Effects of prompting multiple solutions for modelling problems on students' performance. *Educational Studies in Mathematics*, 89(3), 393–417.
- Schukajlow, S., & Rakoczy, K. (2016). The power of emotions: Can enjoyment and boredom explain the impact of individual preconditions and teaching methods on interest and performance in mathematics? *Learning and Instruction*, 44, 117–127.
- Schukajlow, S., Rakoczy, K., & Pekrun, R. (2017). Emotions and motivation in mathematics education: theoretical considerations and empirical contributions. *ZDM Mathematics Education*, 49(3), 307–322.

Distinguishing engagement from achievement: understanding influential factors for engaged and disengaged low achieving mathematics students

Karen Skilling

King's College London, School of Education, Communication and Society, London, UK;
Karen.skilling@kcl.ac.uk

The engagement construct, comprised of three interrelated components including behaviour, emotions and cognition, is crucial when considering students approach to learning mathematics and by implication, for teaching. In this study, 37 Year 7 students (11-12 years) self-reported measures of engagement and motivation which established unique engagement/achievement groupings. In-depth interviews then investigated factors influencing student engagement distinct from levels of achievement. This paper reports findings from the two low achieving groups differentiated by engagement. The low achieving engaged students reported upwards shifts in adaptive factors: self-efficacy, valuing, task management, persistence and enjoyment, coupled with downwards shifts in anxiety, avoidance, and uncertainty. The low achieving disengaged students reported declines in self-efficacy, valuing, planning and enjoyment with rises in anxiety, uncertainty and self-handicapping.

Keywords: Student engagement, mathematics achievement, motivation.

Introduction

The importance of promoting student engagement, participation and interest in learning mathematics continues to concern mathematics teachers and educators with still too few students continuing to study mathematics beyond post compulsory requirements (Barrington, 2011) and pursuing mathematics related courses and pathways. Increasing student participation in and enjoyment for learning mathematics, addressing declines in student engagement and understanding influencing factors is of central concern, particularly for the transition from primary to secondary school (Martin, Way, Bobis & Anderson, 2015).

Framing student engagement beyond narrow and observable behaviors to include emotional and motivational factors affecting individuals is recognized as fundamental to engagement research. Stipek et al., (1998) identified the 'convergence' and relevance of academic motivation research to reform-orientated mathematics education approaches. In particular, teaching practices emphasising the importance of goal orientations, mastering understanding, risk taking, positive emotions, enjoyment and perceptions of academic competency were seen as beneficial for student outcomes. Subsequent research identifies a lack of relevance, value of mathematics and disaffection with mathematics with students who described mathematics as tedious, isolating, elitist, and depersonalized (Nardi & Steward, 2003). When investigating student emotions, Pekrun & Linnenbrink-Garcia, (2012) revealed a nuanced range of emotions that influence the extent to which individual students participate and engage in mathematics learning. In combination, motivational and emotional factors along with cognitive strategies and approaches of individual students act to shape students dis/engagement profiles. Recent research found that students were more alike in terms of their dis/engagement than their level of achievement (Skilling, Bobis, & Martin, 2015). This

highlights the importance of looking beyond achievement as an indicator of engagement and identifies the significance of investigating engagement levels separate to achievement. This paper incorporates quantitative survey with qualitative interview data of two low achieving students differentiated by their level of engagement. Specific factors underpinning student dis/engagement and how these vary for individual students are revealed. This information is valuable for interventions whereby teachers can purposefully meet students' engagement and achievement needs and is particularly relevant for supporting low achieving students with different dis/engagement profiles.

The engagement construct

Together, aspects of *doing*, *feeling* and *thinking*, comprise the engagement construct, and are referred to respectively as behavioural, emotional and cognitive engagement (Fredricks, Blumenfeld, & Paris, 2004). This multidimensional framework is widely accepted, albeit with variations in terminology and definitions for different types of engagement (e.g. academic engagement is sometimes used). However, clarifying conceptions of engagement, and theorizing about modes of operation and understanding the relationship between engagement and motivation is needed.

For this study, definitions from Fredricks et al.(2004) are adhered to. *Behavioural engagement* refers to participation and involvement in academic and social activities and include, “effort, persistence, concentration, attention, asking questions and contributing to class discussion” (Fredricks et al. 2004; p, 62). *Emotional engagement* is concerned with students' positive and negative reactions to teachers, schoolwork, peers and school and includes non-cognitive aspects such as interest, values and attitudes. *Cognitive engagement* is more strongly linked to improving student learning and draws from two perspectives: the psychological investment in learning that emphasises the efforts students make (Fredricks et al., 2004), and the other focuses on practices used to enhance learning and instruction such as self-regulation strategies and metacognitive processes.

Conceptually engagement is seen to operate in an interrelated way, and is dynamic and likely to fluctuate due to individual factors and varying contexts (school and home). It is also expected that intensities of engagement vary for individual students depending on the types of activities and cognitive demands of tasks. Therefore, the engagement of individual students is expected to fluctuate over time and at different levels of intensity depending on activities, the learning context and motivational factors (Fredrick et al., 2004).

Motivation and engagement

Although the terms motivation and engagement are frequently used interchangeably, they are distinct. Motivation is concerned with the psychological processes of an individual that are the sources for taking actions and displayed as visible engagement characteristics (Skinner & Pitzer, 2012). Therefore, motivations explains why individuals behave in particular ways and are seen as encompassing the internal, private and unobservable factors of the outer, public and observable engagement (Skilling, 2014). Goldin, Epstein, Schorr, and Warner, (2011) also note the importance of considering student engagement in the context of social practices within classrooms and suggest combining motivational and affective structures for creating nine *structures* of engagement. Each *structure* identifies particular characteristics that occur ‘in the moment’ for example ‘Get the job

done'; 'Look how smart I am'; 'I'm really into this' (pp. 549-554) with each emphasising different motivations, features of social situations and subsequent behaviour and emotions.

The direction of underlying motivations leading to engagement (behaviors and emotions) depicted by Goldin et al. (2011) is also discussed by Martin (2007; 2017). Broadly, the motivation and engagement relationship is seen as cyclical, with motivation occurring before and during activities leading to engagement as well as prior engagement explaining "significant variance in subsequent motivation" (Martin, Ginns, & Papworth 2017, p.157). To provide a more integrative approach to motivation and engagement research, Martin (2007) combines multiple motivational and engagement constructs on a single framework, known as the 'Motivation and Engagement Wheel' (MEW). The MEW reflects several important motivation theories that capture both adaptive and maladaptive factors. This framework is also used in the Interview Study as it complements Fredricks et al. (2004) engagement framework and because it includes adaptive and maladaptive factors and therefore addresses both engagement and disengagement constructs.

The aims of the Interview Study were to understand individual, classroom, and school level factors that influence engagement and achievement. The research questions included:

What beliefs do engaging and disengaging students hold about their achievements in mathematics?

What individual characteristics, classroom and home factors differentiate high and low engaging students?

Methodology

The Interview Study reported here used data collected from a related larger project to obtain measures of engagement and achievement of students in Grade 6 (primary school in Time 1) and then Grade 7 (secondary school in Time 2) (11-12 years of age). Following the Time 2 quantitative data collection, in-depth interviews with specific students took place.

Identifying specific students participants

In keeping with the aims of the study it was important to consider engagement and achievement separate from each other. The Interview Study aimed to understand individual students beliefs and characteristics underlying shifts in engagement in the first year of secondary school therefore quantitative data from the Year 7 student group in Time 1 and 2 was drawn upon from the larger project to determine potential participants for interview. Parameters for dis/engagement and achievement were applied to establish students evincing the greatest upwards and downwards shift in dis/engagement and those with the highest/lowest achievement. A further refinement took into account each students mathematical achievement score (out of 30) at Time 2. A tripartite split was set: scores of 18 and over determined high achievers; scores of 13 and below determined low achievers. Using the students engagement/disengagement and high/low achievement characteristics, students were placed into one of the following four categories: high achieving + engaging ('HAE'); low achieving + engaging ('LAE'); high achieving + disengaging ('HAD'); and low achieving + disengaging ('LAD'). In total 37 students from the four categories were interviewed and this is represented in Table 1.

Engaging Students		Disengaging Students	
High Achieving (HAE)	n=9	High Achieving (HAD)	n=8
Low Achieving (LAE)	n=10	Low Achieving (LAD)	n=10

Table 1: Engaging and disengaging student groupings

Data instruments, collection and analysis

The quantitative component of the larger project used a purposively designed survey, called the Motivation and Engagement, Survey (Martin, 2007) known as the MES, and a mathematics achievement assessment instrument to establish shifts in students' engagement, motivation and achievement levels over time and academic year. The MES included 44 items representing 11 first-order factors each representing various constructs of motivation and engagement adapted to a mathematics context (Martin, 2007), against which the students rated themselves from a scale of 1 (strongly agree) to 7 (strongly disagree). The 11 factors are made up of six adaptive factors (self-efficacy, mastery orientation, valuing, persistence, planning and task management) and five maladaptive dimensions (anxiety, failure avoidance, uncertain control, self-handicapping and disengagement) and an additional measure of *enjoyment of mathematics* was included. The mathematics assessment instrument adapted from the Wide Range Achievement Test 3 (WRAT) (Wilkinson, 1983) was used to measure student achievement.

Qualitative data was obtained through in-depth, semi-structured interviews. The interviews involved eliciting student beliefs about their mathematical capabilities, reports on their behaviour in mathematics classrooms and their feelings towards mathematics—and how this affected their engagement and achievement in mathematics. The interviews took place in the final year of term, were recorded on an audio device and later transcribed and supplemented by field notes that recorded information about the students' favourite subject at school, homework habits, and intended career choices. The approach to analysing the interview data was inductive and guided by the interview questions. Comments were coded as being descriptive of an aspect about mathematics learning, such as: liking mathematics; views about mathematics ability; and use of strategies for learning mathematics forming the main themes reported in the findings. Inter-rater reliability was established by following one of the recommendations by Krippendorff (2004) by using an additional coder who independently coded a 13.5% sample of the student interviews and coding reliability an average accuracy of 95.8%, satisfying suggested recommendations.

Findings and Discussion

This paper draws on the combined quantitative and qualitative results of two low achieving students representative of the LAE and LAD groups. This is a unique approach for investigating the nuance of specific beliefs and characteristics of students with contrasting engagement profiles: student LAE8

is a *low achieving engaged* student and LAD2 is a *low achieving disengaged* student. The measures of engagement and disengagement are presented graphically using spider graphs to illustrate shifts in individual student engagement and disengagement between Time 1 and 2. The spider graphs show adaptive factors (self-efficacy, mastery orientation, valuing, enjoyment, persistence, planning and task management) on the upper semicircle and maladaptive factors (anxiety, failure avoidance, uncertain control, self-handicapping and disengagement) on the lower semicircle. Figures 1 and 2 respectively display the results of student LAE8 and LAD2: the darker line shows Time 1 results: the lighter line shows Time 2. The quantitative data is supplemented by the interview data.

Low achieving engaged

Student LAE8 attended an all male school and was in a mixed ability mathematics class. When asked about favourite subjects, LAE8 reported that mathematics was probably one of his favourite subjects in secondary school because he was “learning a lot of new things” and he “likes to listen and enjoys maths”. LAE8 stated that he would like to do well in mathematics, as “it is good for actual life” and aspired to be an architect. When asked his beliefs about his maths achievement, LAE8 responded, “I go pretty good” and he judged this by reporting that he “usually gets most right” when marking his work in class. When asked if the marks matter, LAE8 replied, “If it’s just normal work and I get 50% I learn to do it again. If it is a test then I know I have [mucked] up” although later in the interview he reports that “Sometimes I make silly mistakes, sometimes I still can’t get it”. These responses indicated that despite not achieving highly in mathematics LAE8 was emotionally engaged in mathematics demonstrating a strong belief in his mathematics ability, he liked learning mathematics and valued its use for the future. These reports are supported by the upward shifts showing high adaptive scores for self-efficacy, valuing and enjoyment in Figure 1.

LAE8 reported proactive behaviors, describing strategies for seeking help at school and home. In class, this included asking the teacher for further explanations because “sometimes she explains it in a way I can understand”. Other strategies included: going through his notes: spending “some more time on it” to see if he could “get it”; or going around the class to see “if other people might know”. LAE8 reported that if he needed help at home with maths he could ask both his mum and dad stating, “my parents help me a lot”.

Although LAE8 believed that “we [the class] get a lot of homework” he reported planning time after school to attend to this. He reported using the textbook for support by referring to examples asking the teacher in the next mathematics lesson. The actions taken by LAE8 indicated active behavioral and cognitive engagement by planning to do maths work in class and at home, persistence with trying to complete work rather than avoid it. These behaviors are reflected in Figure 1, where shifts in higher measures for planning, task management and persistence and downward shifts in measures for avoidance and self-handicapping are evident. Further, LAE8 did not report feeling anxious but portrayed a positive attitude towards mathematics learning. LAE8 was also able to describe students he believed were not engaged or motivated in class reporting, “sometimes they just don’t want to listen. They usually muck around when the teacher is explaining on the board”. This description contrasts with how LAE8 describes himself indicating high levels of behavioral, emotional and cognitive engagement.

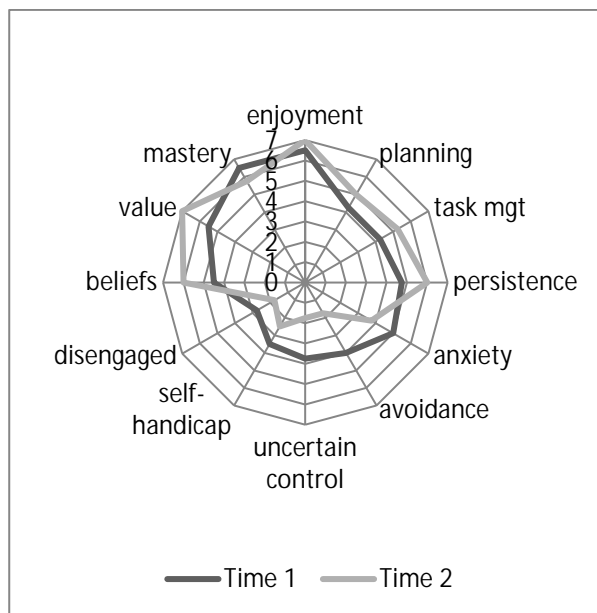


Figure 1: Low achieving engaged (LAE8)

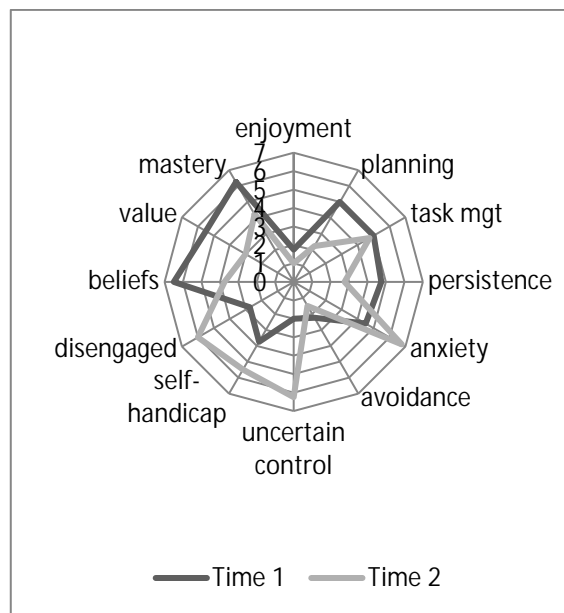


Figure 2: Low achieving disengaged (LAD2)

Low achieving disengaged

LAD2 attended an all female school and was also in a mixed ability class reports a contrasting report from that of student LAE8. Despite scoring several marks higher than LAE8 in the Time 2 maths quiz, when asked how she felt about mathematics LAD2 reported “I don’t really like it” explaining “I think it’s boring and I don’t really get it”. She was aware of her lack of understanding, stating that when the teacher “tries to explain something I don’t understand it and some of the bookwork I don’t understand”. LAD2 reported that she rarely asked the teacher for help, preferring to ask her friend “because she gets good grades” or looks at examples in the textbook. When asked to describe her achievement in mathematics LAD2 responded, “I don’t really think I do good. Like I get bad marks in it. I get 10 out of 30 for a quiz or something” and placed herself as “sort of near the bottom” of the class. Although LAD2 reported that she continued to try she also said that she is not engaged or motivated by mathematics. When asked about her future intentions for studying mathematics she reported, “I don’t want to...because I don’t find it very interesting”. LAD2 also commented that she finds mathematics “confusing” and this make her “feel annoyed and angry” explaining “I’m angry at it because I want to get it”. These descriptions by LAD2 of her mathematics experiences in Year 7 relate negative emotions and are reflected by reduced measures in several adaptive factors in Figure 2, particularly in self-efficacy, valuing and enjoyment. Significantly, there are also large increases in maladaptive measures such as anxiety, uncertain control, self-handicapping and overall shifts towards disengagement.

In class, LAD2 finds that when the teacher starts a new topic although she doesn’t really “get it” she tries to ask the teacher questions but reports: “You will have your hand up for 15 minutes and he won’t pick you. So, I put it down and ask someone else”. LAD2 said that she did homework “most of the time but sometimes” she just does not “get it” and then tends to “give up”. At home, LAD2 reported that she can talk to her dad about mathematics but does not do this “very often” and although

the school offers students an online mathematics programme for use at home she does not use it. Regarding homework, LAD2 says that when given work from the textbook she rarely completes this or follows up for explanations. She also finds that the textbook “doesn’t really explain it properly” resulting in not understanding the topic and “the whole chapter”. LAD2 believed that her achievement was lower than in primary school reporting, “last year I did average...but this year I have gone down”. This shift has led to her feeling that mathematics is now a “bit harder”, and that she “understood it more” in primary school where the teachers explained mathematics better as they “drew it on the board and explained it again”. LAD2 summarized her thoughts as: “last year I felt oh yeah, I am doing alright but this year, oh my god I am doing badly”.

In summary, by investigating the reports of these two students with similar achievement but differing engagement levels, insights for understanding influential motivational, class and home factors are revealed. For example, student LAE8 showed higher measures across most adaptive factors and declines in maladaptive factors between Time 1 and 2. He also portrayed a positive approach and enjoyed mathematics while demonstrating proactive behaviors and using cognitive strategies for monitoring and regulating his learning. In contrast, the disengaged student, LAD2 evinced large shifts in maladaptive measures particularly anxiety, control and self-handicapping. Unfortunately, this student also reports strong negative emotions such as dislike, confusion, and frustration that seem to stem from her lack of understanding and strategies for addressing the mathematics being taught.

Conclusion

In combination, the quantitative survey data effectively measured shifts of adaptive and maladaptive factors for individual students. Analysis of these measures assisted in identifying students with pronounced positive and negative shifts in engagement in mathematics over one year. This provided for a unique and purposeful qualitative investigation of two low achieving students with different engagement characteristics. These characteristics were explored using in depth interviews to better understand their beliefs about mathematics competency, feelings towards mathematics and strategies for approaching mathematics learning (Goldin et al, 2011; Nardi & Steward, 2003; Martin et al, 2015). The findings revealed that although both students were low achieving, the engaged student reported a stronger sense of self-efficacy, valuing, persistence, enjoyment and task management. The low achieving disengaged student however, reported declines in self-efficacy, valuing, enjoyment and planning and increases in anxiety, uncertainty and self-handicapping. This information highlights the individual variation in student engagement characteristics despite displaying similar levels of achievement and reveals vital information for teachers when planning instruction with a view to improving individual student learning outcomes (Stipek et al, 1998) and for maintaining student interest and participation in mathematics (Barrington, 2011).

Acknowledgment

This research was funded by an Australian Research Council Linkage Projects grant LP0776843 in partnership with the Catholic Education Office, Sydney.

References

Barrington, F. (2011). *Australian Mathematical Science Institute interim update on year 12 mathematics student numbers*. Melbourne, Australia: Australian Mathematical Science Institute.

- Fredricks, J. A., Blumenfeld, P. C., & Paris, A. H. (2004). School engagement: Potential of the concept, state of the evidence. *Review of Educational Research*, 74, 59–109.
- Goldin, G. A., Epstein, Y. M., Schorr, R. Y., & Warner, L. B. (2011). Beliefs and engagement structures: Behind the affective dimension of mathematical learning. *ZDM Mathematics Education*, 43, 547–560.
- Krippendorff, K. (2004). Reliability in content analysis: Some common misconceptions and recommendations. *Human Communication Research*, 30(3), 411–433.
- Martin, A. J. (2007). Examining a multidimensional model of student motivation and engagement using a construct validation approach. *British Journal of Education Psychology*, 77, 413–440.
- Martin, A. J., Way, J., Bobis, J., & Anderson, J. (2015). Exploring the ups and downs of mathematics engagement in the middle years of school. *Journal of Early Adolescence*, 35(2), 199–244.
- Martin, A. J., Ginns, P., & Papworth, B. (2017). Motivation and engagement: Same or different? Does it matter? *Learning and Individual Differences*, 55, 150–162.
- Nardi, E., & Steward, S. (2003). Is mathematics T.I.R.E.D? A profile of quiet disaffection in the secondary mathematics classroom. *British educational Research journal*, 29(3), 345–367.
- Pekrun, R. & Linnenbrink-Garcia, L. (2014) Introduction to emotions in education. In R. Pekrun & L. Linnenbrink-Garcia (Eds), *International handbook of emotions in education* (pp. 1-10). New York, NY: Routledge.
- Skilling, K., Bobis, J., & Martin, A. (2015). The Engagement of students with high and low achievement levels in mathematics. In K. Beswick, T. Muir, & J. Wells (Eds.), *Proceedings of the 39th Psychology of Mathematics Education conference* (Vol. 4, pp. 185–92). Hobart, Australia: PME.
- Skinner, E. A., & Pitzer, J. R. (2012). Developmental dynamics of student engagement, coping and everyday resilience. In S. L. Christenson, A. L. Reschly, & C. Wylie (Eds.), *Handbook of research on student engagement* (pp. 21–44). New York, NY: Springer.
- Stipek, D., Salmon, J. M., Givven, K. B., Kazemi, E., Saxe, G., & MacGyvers, V. L. (1998). The value (and convergence) of practices suggested by motivation research and promoted by mathematics education reformers. *Journal of Research in Mathematics Education*, 29(4), 465–488.
- Wilkinson, G. S. (1983). *Wide Range Achievement Test–3*. Wilmington, DE: Wide Range Inc.

Do students perceive mathematics and the mathematical subdomain of functions differently with regard to their self-concept and interest?

Ute Sproesser¹, Markus Vogel¹, Tobias Doerfler¹ and Andreas Eichler²

¹Heidelberg University of Education, Germany; sproesser@ph-heidelberg.de; vogel@ph-heidelberg.de; doerfler@ph-heidelberg.de

²University of Kassel, Germany; eichler@mathematik.uni-kassel.de

Motivational variables such as self-concept and interest accompany learning processes and hence are considered as relevant target variables of schooling. In order to evaluate effects of a teacher training on their students' domain-specific self-concept and interest, established mathematics-related scales for these variables were adapted to the domain of functions and administered in a pre-, post-, follow-up-design to a sample of 1177 secondary school students. Results of confirmative factor analyses in Mplus indicate that the scales mathematics- and functions-related self-concept and interest are empirically separable despite relatively large latent correlations for the functions-related scales in the pre-test. Together with satisfying values of Cronbach's alpha, this finding implies that the instrument can be used to reliably assess students' functions-related self-concept and interest and hence fulfills the requirements for further analysis steps.

Keywords: Confirmative factor analysis, self-concept, interest, mathematics, functions.

Introduction

The project ProfiL9 of Heidelberg University of Education evaluates the effects of a teacher training about learning difficulties related to elementary functions (e.g., Sproesser, Vogel, Doerfler, & Eichler, 2017). The field of functions was chosen because of its relevance within mathematics (education) and its difficulty for many students (e. g. Selden & Selden, 1992). Effects of this teacher training are to be evaluated both at the teacher and the student level. Beyond investigating students' competency development related to elementary functions in the course of the corresponding teaching unit, this study focuses on changes in students' self-concept and interest. In the context of assessing effects of teacher trainings at the student level, Yoon and colleagues (2007) state that the corresponding instruments have to meet high scientific standards. Hence, a reliable and valid instrument is mandatory. In order to get insight in particular cause-effect-relations, such a test instrument should target variables directly related to the subject of the teacher training, in the present case related to the mathematical subdomain of functions. This paper presents results of a confirmatory factor analysis showing that self-concept and interest for mathematics in general and functions in particular are empirically separable within our sample. Therefore, in the next section, we will introduce the theoretical background related to self-concept and interest. Afterwards, we will outline the methods of this study and finally present and discuss our findings.

Theoretical Background

Motivational dispositions such as self-concept and interest nowadays are considered to be relevant for learning (e.g., Schiefele, 1991; Valentine, duBois, & Cooper, 2004) as they accompany learning processes and affect (the development of) students' achievement in and beyond school (e.g., Jacobs,

Lanza, Osgood, Eccles, & Wigfield, 2002). Therefore, they represent important target variables also of mathematics schooling (e.g., Pekrun & Zirngibl, 2004). In the following, the motivational variables self-concept and interest will be described in more detail.

An individual's beliefs about the own abilities in a particular academic or non-academic domain are subsumed as *self-concept* (e.g., Bong & Skaalvik, 2003). Among other self-belief constructs domain-specific self-concept can be considered as ranging between the more general self-esteem, i.e., an "emotional attitude towards the self" (ibid., p. 11) and the more particular self-efficacy expressing a conviction of how to perform in a concrete task. Self-concept is considered to be relatively stable and based on prior (achievement) experience in the corresponding domain (ibid.) on the one hand. On the other hand, there is a reciprocal relationship between self-concept and achievement: achievement in a certain domain is clearly influenced by prior self-concept levels (e.g., Calsyn & Kenny, 1977). An example for domain-specific (academic) self-concept is mathematics-related self-concept, i.e., a person's confidence in his or her abilities in mathematics. Such domain-specific self-concept was found to be positively correlated to achievement in the corresponding domain (e.g., Baumert & Köller, 2000), because – for instance – a positive self-concept can support success-oriented behaviors like practicing (Valentine et al., 2004). Because of the domain-specificity of self-concept, e.g. Marsh and Craven (1997) recommend that researchers should measure this variable as closely connected as possible to the domain focused in the corresponding research.

According to Schiefele (1991, p. 302) individual *interest* is a "relatively enduring preference for certain topics, subject areas, or activities". Hence – similarly to self-concept – individual interest is domain-specific and it makes sense to assess it closely related to the corresponding domain. Moreover, Schiefele (ibid.) states that an interested person attributes a personal relevance to his or her target of interest (i.e., value-related valences) and that interest usually is accompanied by positive feelings such as involvement and enjoyment (i.e., feeling-related valences). Therefore, an interested person engages in an activity or subject for its own sake and makes efforts in order to learn about it. Various studies show that interest and achievement are correlated (e.g., Baumert & Köller, 2000; Helmke & Weinert, 1997). Schiefele (ibid.) gives several reasons for this relationship: For instance, interested students are more likely to employ meaning-oriented learning activities and they use more elaborated learning strategies. In the present study, we focus on the relatively stable (individual) interest for the domain of mathematics and functions as opposed to the more fluctuating situational interest (e.g., Hidi & Renninger, 2006) that won't be considered here.

In order to investigate certain cause-effect-relations, it makes sense to measure self-concept and interest particularly related to the focused domain (cf. Bong & Skaalvik, 2003; Marsh & Craven, 1997; Schiefele, 1991). This consideration does also reflect the finding that empirical correlations, e.g., between self-concept and achievement are found to be larger when these variables are measured as domain-specific as possible (Hansford & Hattie, 1982). As stated above, self-concept and interest differ between certain school subjects such as Mathematics and English. In this sense, it can be assumed that students can also hold different perceptions of, e.g., particular mathematical subdomains such as functions with regard to these motivational variables. However, this assumption still has to be verified empirically. Considering all combinatorial possibilities, the following alternatives appear to be particularly plausible: As mathematics and its subdomain of functions as well as self-concept

and interest are closely connected, it is possible that students do not differentiate between these variables at all. A second possibility is that they discriminate between self-concept and interest but do not perceive mathematics distinct from functions as the latter represents a subdomain of mathematics. A third possibility is that students perceive mathematics distinct from functions but do not discriminate between self-concept and interest within each domain. A fourth possibility is that students discriminate between self-concept and interest within mathematics because they have long-time experiences with this subject. However, and due to less experience with the domain of functions, self-concept and interest related to this domain could be not distinguishable for them. The latter possibility of students being not able to distinguish between self-concept and interest related to functions particularly applies for the data collection before the teaching unit of functions when students were not familiar with this domain.

Research questions

Concerning the domain of mathematics, motivational variables have been examined by various studies including PISA and TIMSS; they document for instance considerable correlations between self-concept, interest and achievement (e.g., Baumert & Köller, 2000; Pekrun & Zirngibl, 2004). However, to our best knowledge these variables have not been investigated specifically related to the mathematical subdomain of (elementary) functions and hence there are no approved instruments to reliably measure them. Taking into account that self-concept and interest are both domain-specific, it is reasonable to assess these variables related to the particular domain of functions (cf. Marsh & Craven, 1997) for investigating the above assumption that students can hold different perceptions of mathematics and functions with regard to their self-concept and interest. In this study, we investigate the following research questions:

- Are mathematics- and functions-related self-concept and interest empirically separable?
- How reliable do the scales measure these variables?

Methods

Sample and context of the study

In this study, data from 1177 German students (45.6 % female) from 53 classes in 32 German secondary schools was analyzed. Due to missing values the concrete number of subjects varies for the different analyses and hence is indicated in the corresponding part of the Results Section. The classes were recruited among teachers that participated in the teacher training mentioned above as well as from schools that were in contact with the project contributors. In both cases, the participation of the classes and the individuals were voluntary. The students were aged between 11 and 17 years ($M = 13.20$, $SD = 0.94$). The large range of age is due to the fact that in Germany the teaching unit of linear functions is taught in different grades (mainly in grade 7 and 8) depending on the level of academic performance of the corresponding class or school, respectively. In all the participating classes, the assessment was done before (pre-test) and after (post- and follow-up-test) the teaching unit of linear functions as it focuses on the development of functions-related competence and motivational variables in the course of this teaching unit. As many students were not familiar with functions at the pre-test, they were told that the tasks focusing on interpreting graphs in the preceding

competency test were examples for functions tasks. Moreover, they were given the option not to answer the functions-related items if they did not feel comfortable responding to them. In each class a regular teacher of the corresponding school as well as a researcher (the first author or a specifically trained assistant) were present during the testing.

Measures

Motivational variables referring to mathematics and functions were assessed using 5-point Likert scales. Mathematics-related self-concept (6 items) and interest (3 items) were measured through scales established by Pekrun and colleagues (e.g., 2007). In order to tap students' self-concept (6 items) and interest (3 items) related to functions, the mathematics-related items were adapted to the mathematical subdomain of functions. More information about the scales, e.g., sample items are displayed in Table 2 in the Results Section.

Analyses

The confirmatory factor analysis (research question 1) was conducted with the software Mplus 7.3 with type = complex which accounts for nested data in school classes. The implemented Full Information Maximum Likelihood (FIML) procedure estimates missing values except for cases with missing on all variables. The robust maximum likelihood (MLR) estimator was used which corrects for non-normality in the measures. For each factor, the regression weight of one item was fixed to 1.0 by default. In order to assess global model fit, we refer to the comparative fit index (CFI), the root mean squared error of approximation (RMSEA) and the standardized root mean squared residual (SRMR). Hu and Bentler (1999) suggest using a combination of cutoff values such as $CFI \geq 0.95$, $RMSEA \leq 0.06$ and $SRMR \leq 0.08$ for a good model fit. As the χ^2 statistic is sample-size dependent the χ^2/df ratio was additionally determined. According to Bollen and Long (1993) the model fits the data sufficiently when this ratio does not exceed 5. The different (nested) models are furthermore compared by the sample-size adjusted Bayesian Information Criteria (adj. BIC). Values for Cronbach's alpha (research question 2) were determined with SPSS 25.

Results

Research question 1 investigates whether the mathematics- and functions-related scales were empirically separable within our sample. For this purpose, we specified several models with the items for mathematics- and functions-related self-concept and interest as stated above: Model A integrates all 18 items to a single factor. Model B assigns the items to the two factors self-concept (for mathematics and functions) versus interest (for mathematics and functions). Model C differentiates between mathematics (self-concept and interest) and functions (self-concept and interest). Model D contains three factors, namely self-concept for mathematics, interest for mathematics and a combining factor for functions (self-concept and interest). The full Model E incorporates the four factors mathematics-related self-concept, mathematics-related interest, functions-related self-concept and functions-related interest. Details about the fit of these models are displayed in Table 1 for the pre-, post- and follow-up-test. Concerning all times of testing, global fit indices (χ^2/df , CFI, SRMR, RMSEA) indicate except for slight deviations that the full Model E fits the data reasonably whereas the other models do not meet most of the recommended thresholds (see Analysis Section). Similarly, model comparisons based on the adjusted BIC are in favor of Model E.

Model	Pre-test (N = 895)	Post-test (N = 915)	Follow-up-test (N = 708)
Model A (1 factor): Self-concept and interest for mathematics and functions	$\chi^2/df = 23.2$ CFI = .658 RMSEA = .157 SRMR = .128 Adj. BIC = 37901.3	$\chi^2/df = 22.2$ CFI = .728 RMSEA = .152 SRMR = .102 Adj. BIC = 40697.5	$\chi^2/df = 18.9$ CFI = .707 RMSEA = .159 SRMR = .101 Adj. BIC = 31181.1
Model B (2 factors): self-concept for mathematics and functions vs. interest for mathematics and functions	$\chi^2/df = 22.5$ CFI = .671 RMSEA = .155 SRMR = .124 Adj. BIC = 37676.6	$\chi^2/df = 18.0$ CFI = .783 RMSEA = .136 SRMR = .093 Adj. BIC = 39950.0	$\chi^2/df = 15.6$ CFI = .763 RMSEA = .144 SRMR = .090 Adj. BIC = 30536.4
Model C (2 factors): self-concept and interest for mathematics vs. self-concept and interest for functions	$\chi^2/df = 7.0$ CFI = .908 RMSEA = .082 SRMR = .053 Adj. BIC = 35182.2	$\chi^2/df = 12.7$ CFI = .851 RMSEA = .113 SRMR = .069 Adj. BIC = 38946.2	$\chi^2/df = 10.7$ CFI = .843 RMSEA = .117 SRMR = .068 Adj. BIC = 29724.9
Model D (3 factors): self-concept for mathematics vs. interest for mathematics vs. self-concept and interest for functions	$\chi^2/df = 4.7$ CFI = .944 RMSEA = .064 SRMR = .042 Adj. BIC = 34779.3	$\chi^2/df = 10.0$ CFI = .887 RMSEA = .099 SRMR = .059 Adj. BIC = 38464.1	$\chi^2/df = 8.3$ CFI = .884 RMSEA = .101 SRMR = .059 Adj. BIC = 29322.7
Model E (4 factors): self-concept for mathematics vs. interest for mathematics vs. self-concept for functions vs. interest for functions	$\chi^2/df = 3.3$ CFI = .967 RMSEA = .050 SRMR = .033 Adj. BIC = 34536.7	$\chi^2/df = 5.3$ CFI = .948 RMSEA = .068 SRMR = .038 Adj. BIC = 37661.5	$\chi^2/df = 3.8$ CFI = .957 RMSEA = .062 SRMR = .033 Adj. BIC = 28588.6

Table 1: Global fit indices for the tested models (pre-, post- and follow-up-test)

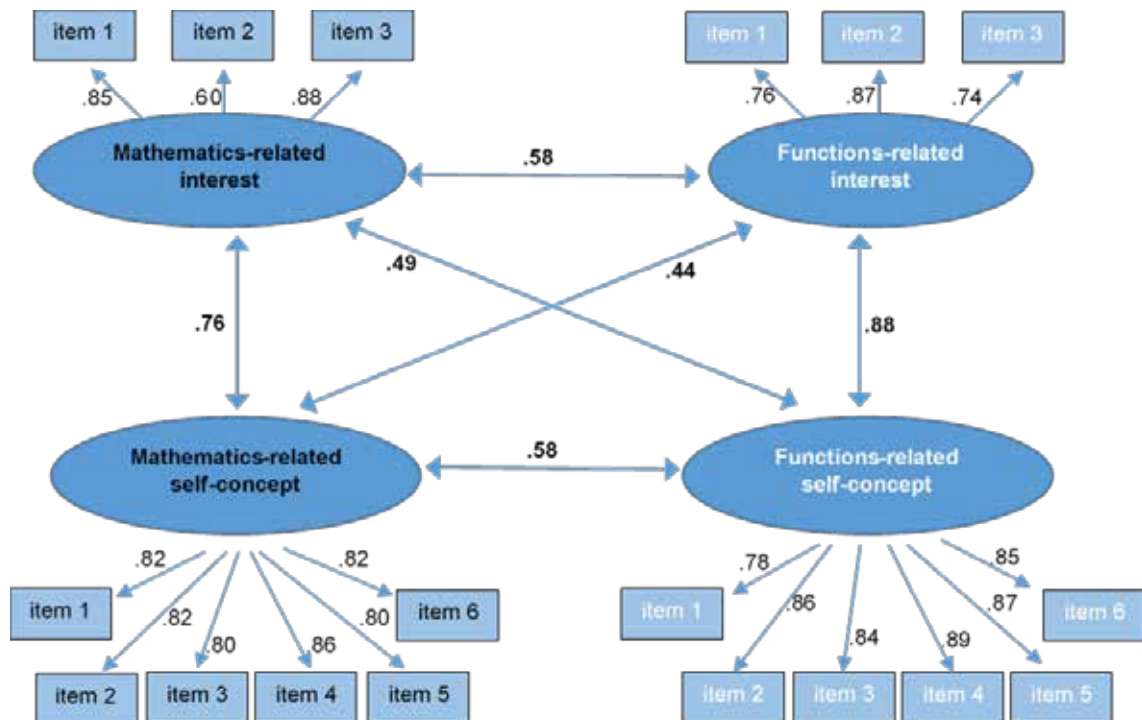


Figure 1: Factorial structure and parameters of Model E (pre-test)

The structure, factor loadings and correlations of the full Model E are displayed in Figure 1 for the pre-test. Similar results were found for the post- and follow-up-test. The rather low factor loading of Item 2 referring to mathematics-related interest is comparable, respectively slightly higher for the post- (.59) and follow-up-test (.63). Analyzing Model E without this item did not lead to better fit indices. Although the four scales mathematics- and functions-related self-concept and interest turned out to be separable, they expose latent correlations of .44 to .88. The correlation between functions-related self-concept and interest is lower for the post- and follow-up-test (both .80).

Table 2 shows Cronbach's alpha in pre-, post- and follow-up-test (fut) for mathematics- and functions-related self-concept and interest ranging from .81 to .94. All in all, the values for the functions-related scales are comparable to the corresponding mathematics-related counterparts.

Construct	Number of items	Sample item	Cronbach's Alpha pre	Cronbach's Alpha post	Cronbach's Alpha fut
Self-concept (mathematics)	6	Understanding mathematics is easy for me.	.92 (N = 811)	.92 (N = 878)	.93 (N = 674)
Interest (mathematics)	3	Doing mathematics is one of my favorite activities.	.82 (N = 831)	.81 (N = 892)	.83 (N = 683)
Self-concept (functions)	6	The domain of functions is easy for me to understand.	.94 (N = 675)	.94 (N = 863)	.94 (N = 677)
Interest (functions)	3	I like best working on functions.	.83 (N = 745)	.88 (N = 895)	.89 (N = 701)

Table 2: Reliabilities and sample-items of mathematics- and functions-related self-concept and interest

Discussion

The purpose of this study is to investigate whether student's self-concept and interest related to mathematics and functions are empirically separable. If students actually perceive mathematics and functions differently with regard to their self-concept and interest, it appears to be reasonable to assess these motivational variables as domain-specific as possible. Doing so is not only recommended by Marsh and Craven (1997) but also enables investigating particular cause-effect-relations of the teacher training under evaluation in the project ProfIL9.

Although single global fit indices show slight deviations from the recommended cutoff values, they all favor the full Model E that differentiates between the four scales mathematics- and functions-related self-concept and interest. This finding is also supported for pre-, post- and follow-up-test by model comparisons based on the adjusted BIC. Moreover, the magnitude of the (significant) factor loadings as well as good values of Cronbach' alpha suggest that the latent variables are reliably measured by the corresponding items. In particular Cronbach's alpha is comparable or even better for the adapted scales than for the established ones. This means that the students of our sample perceive mathematics and functions differently from a motivational point of view and hence that it is reasonable to evaluate self-concept and interest with the adapted functions-related scales. In this sense, we will use these function-related scales in order to investigate particular cause-effect-relations in further analysis steps of our project. Developing and using domain-specific instruments appears to

be applicable also for other studies investigating the effects of domain-specific interventions on motivational variables such as self-concept and interest.

At the pre-test, students were not familiar with functions. Therefore, it could have been assumed that the distinction between mathematics and functions and in particular between functions-related self-concept and interest would not have been perceptible for them (see Model D). However, the factor analysis favors the four-factor Model E already for the pre-test. Hence, students appear to differentiate between these variables even before they participated in the teaching unit of functions.

In any case, latent correlations of about .6 emphasize the relatedness between mathematics and functions. The magnitude of the correlations between self-concept and interest within each domain are in line with the literature and underline the proximity of these variables. The particularly high correlation between functions-related self-concept and interest found in the pre-test decreases in post- and follow-up-test to a level comparable to the mathematics-related counterparts. This is in line with our expectation that at the beginning of the teaching unit of functions students do not differentiate between these variables to the same extent as they do afterwards.

Although the presented results justify the use of the adapted instrument for further analyses such as investigating the development of student's functions-related self-concept and interest, the following limitations should not be disregarded. Some of the global fit indices still show potential for improvement and single factor loadings were lower than they should be. As the scale of mathematics-related interest only contains 3 items and as it proved in other research, we favor to maintain Item 2. However, we will further analyze if a model can be found that provides better fit indices. Concerning future analyses, the instrument will be used to examine how functions-related self-concept and interest develop for students with / without teacher participation in the teacher training mentioned above. In these analyses, covariates such as age or gender will also be introduced in order to monitor the effectiveness of the teacher training in more detail.

Acknowledgment

This study is supported by the Ministry of Science, Research and the Arts in Baden-Wuerttemberg (Germany) and by research funds from Heidelberg University of Education.

References

- Baumert, J., & Köller, O. (2000). Unterrichtsgestaltung, verständnisvolles Lernen und multiple Zielerreichung im Mathematik- und Physikunterricht der gymnasialen Oberstufe. In J. Baumert, W. Bos, & R. Lehmann (Eds.), *TIMSS III. Dritte Internationale Mathematik- und Naturwissenschaftsstudie – Mathematische und naturwissenschaftliche Bildung am Ende der Schullaufbahn* (pp. 271–316). Opladen, Germany: Leske + Budrich.
- Bong, M., & Skaalvik, E. M. (2003). Academic self-concept and self-efficacy: How different are they really? *Educational Psychology Review*, *15*(1), 1–40.
- Bollen, K., & Long, J. (1993). *Testing structural equation models*. Newbury Park, CA: Sage.
- Calsyn, R. J., & Kenny, D. A. (1977). Self-concept of ability and perceived evaluation of others: Cause or effect of academic achievement? *Journal of Educational Psychology*, *69*, 136–145.

- Hansford, B. C., & Hattie, J. A. (1982). The relationship between self and achievement / performance measures. *Review of Educational Research*, 52(1), 123–142.
- Helmke, A., & Weinert, F. E. (1997). Bedingungsfaktoren schulischer Leistungen. In F. E. Weinert (Ed.), *Enzyklopädie der Psychologie, Band 3: Psychologie der Schule und des Unterrichts* (pp. 71–176). Göttingen, Germany: Hogrefe-Verlag.
- Hidi, S., & Renninger, K. A. (2006). The four-phase model of interest development. *Educational Psychologist*, 41(2), 111–127.
- Hu, L.-T., & Bentler, P. M. (1999). Cutoff criteria for fit indexes in covariance structure analysis. Conventional criteria versus new alternatives. *Structural Equation Modeling* 6, 1–55.
- Jacobs, E. J., Lanza, S., Osgood, D. W., Eccles, J. S., & Wigfield, A. (2002). Changes in children's self-competence and values: Gender and domain differences across grades one through twelve. *Child Development* 73(2), 509–527.
- Marsh, H. W., & Craven, R. (1997). Academic self-concept: Beyond the dustbowl. In G. Phye (Ed.), *Handbook of classroom assessment: Learning, achievement, and adjustment* (pp. 131–198). Orlando, FL: Academic Press.
- Pekrun, R., vom Hofe, R., Blum, W., Frenzel, A. C., Goetz, T., & Wartha, S. (2007). Development of mathematical competencies in adolescence: The PALMA longitudinal study. In M. Prenzel (Ed.), *Studies on the educational quality of schools. The final report on the DFG Priority Programme* (pp. 17–37). Münster, Germany: Waxmann.
- Pekrun, R., & Zirngibl, A. C. (2004). Schülermerkmale im Fach Mathematik. In M. Prenzel, J. Baumert, W. Blum, R. Lehmann, D. Leutner, M. Neubrand, R. Pekrun, H. G. Rolff, J. Rost, & U. Schiefele (Eds.), *PISA 2003. Der Bildungsstand der Jugendlichen in Deutschland – Ergebnisse des zweiten internationalen Vergleichs* (pp. 191–210). Münster, Germany: Waxmann.
- Schiefele, U. (1991). Interest, learning, and motivation. *Educational Psychologist*, 26(3&4), 299–323.
- Selden, A., & Selden, J. (1992). Research perspectives on conceptions of function: Summary and overview. *The concept of function: Aspects of epistemology and pedagogy*, 1-16.
- Sproesser, U., Vogel, M., Dörfler, T., & Eichler, A. (2017). How to deal with learning difficulties related to functions – assessing teachers' knowledge and introducing a coaching. In T. Dooley, & G. Gueudet (Eds.), *Proceedings of the Tenth Congress of the European Society for Research in Mathematics Education* (S. 2996–3003). Dublin, Ireland: DCU Institute of Education and ERME.
- Valentine, J. C., DuBois, D. L., & Cooper, H. (2004). The relation between self-beliefs and academic achievement: A meta-analytic review. *Educational Psychologist*, 39(2), 111–133.
- Yoon, K. S., Duncan, T., Lee, S. W.-Y., Scarloss, B., & Shapley, K. (2007). *Reviewing the evidence on how teacher professional development affects student achievement*. http://ies.ed.gov/ncee/edlabs/regions/southwest/pdf/rel_2007033.pdf [27.01.2015].

How can teachers influence their students' (mathematical) mindset?

Marloes van Hoeve^{1,2}, Michiel Doorman² and Michiel Veldhuis^{3,4}

¹ Goois Lyceum Bussum, The Netherlands; m.l.vanhoeve@uu.nl

² Freudenthal Institute, Utrecht University, The Netherlands; m.doorman@uu.nl

³ Freudenthal Group, Utrecht University, The Netherlands; m.veldhuis@uu.nl

⁴ iPabo University of Applied Sciences, Amsterdam, The Netherlands

Interventions aimed at fostering students' growth mindsets have been carried out in 21 classrooms (with a focus on Grade 7 and Grade 10) in the Netherlands. The intervention consisted of three main elements: introduction to neuroplasticity, the importance of learning from errors in learning processes, and growth-mindset feedback. Before and after the intervention, the students finished a questionnaire, and during the intervention, students and their teachers were interviewed. Results indicate that the students' mindsets tended to be more towards a growth mindset after the intervention, in particular for the Grade 10 students. Students were very positive about the intervention, especially the neuroplasticity and the attention for and learning from errors. Teachers and students valued the changes in attitudes and interactions with a new language for teaching and learning mathematics.

Keywords: Learning motivation, teacher influence, psychology.

Introduction

“I don't understand anything” or “What a stupid mistake” are phrases students often say out loud. For teachers, when they pay attention, these words can be an important signal to indicate that students are working with a fixed mindset. Recognition of the mindset by the teacher and explanation of the theory of mindset can help students change their mindset, and by that change their beliefs and attitudes towards mathematics. To influence students' mindset the role of the teacher is indispensable.

Theory of the mindset

The concepts of fixed and growth mindset were introduced by Carol Dweck (Dweck, 2006; Dweck, Chiu, & Hong, 1995). She distinguished, based on 20 years of research, two types of mindset:

- **FIXED:** you have certain talents, and they remain the same throughout your life.
- **GROWTH:** what you can do or learn now forms the starting point from which you can develop.

Their studies show that the effects of these different mindsets on how students learn are significant, especially in how they deal with challenges and obstacles. When students have a fixed mindset they prefer not to get any challenges. One might think: “Suppose I fail, then people will think I am not very clever, and as this cannot change, I will stay dumb for the rest of my life.” If something goes wrong, and the students have a fixed mindset, then they will feel stuck in a situation to which they cannot change anything. On the other hand, when students are working with a growth mindset then they want challenges. The outcome does not really matter to them; they know and feel that it is

important just to try, that they can learn from their mistakes, that their brains are at work, and that they can change (Boaler, 2016; Dweck, 2006).

The mindset students have is influenced by their upbringing. For example, parents who say “I was never able to do mathematics when I was young” unintentionally influence their children into a fixed mindset. The emphasis on performance in our school systems also plays an important role. High grades and quick results are seen as positive, while they can make students insecure and tend to create a fixed mindset (Dweck, 1995; Dweck, 2006; Mueller & Dweck, 1998). A recent large scale study among undergraduate students showed that their teachers’ mindset beliefs influenced classroom experiences and had a substantial effect on their achievements in STEM fields (Canning, Muenks, Green & Murphy, 2019).

‘Mindset’ is not a trait and it cannot be measured exactly. A mindset may vary with context and over time (Dweck, 2006). However, one’s mindset has an impact on how one approaches and becomes involved in an activity. When students behave according to a fixed mindset while encountering a problem, they are likely to give up quickly and tell themselves: “I will never learn this.” In contrast, when students are working with a growth mindset, they ask themselves “what can I learn from this”, and “how can I try not to make the same mistake too many times.” (Dweck, 2006). For teachers, when they pay attention to the words of their students, these words can be an important signal to indicate that students are working with a fixed or growth mindset. Recognition of the mindset by the teacher and explanation of the theory of mindset can help students change their mindset, and by that change their beliefs and attitudes towards mathematics (Boaler, 2016).

Interventions that encourage a growth mindset

For everybody, students and teachers, it is important to become aware of the impact of their mindset and of its possibilities and challenges (Dweck, 2006). With this awareness, in combination with relatively small social psychological interventions, it has been found that teachers can encourage students to adopt a growth mindset (Yeager & Walton, 2011).

If students believe that they can be smarter and that hard work can help them with this, then they are more willing to exercise (Blackwell, Trzesniewski, & Dweck, 2007). This process has a lot in common with ‘self-efficacy’ that Hattie (2018) is using in his work. Hattie emphasizes the strong correlation between self-efficacy (the confidence that students have in themselves and that can make their learning happen) and student achievement.

Mathematics is eminently a subject where mindset plays an important role. On the one hand, the discipline is highly regarded in our society and it is often associated with something you are good at or not. Good grades for mathematics are seen as a clear proof for being intelligent. And parents compare the results of their children quickly with their own school experience and, unconsciously, emphasize the perspective of being either good or bad in it. Unluckily all these aspects foster a fixed mindset. On the other hand, doing mathematics can give students frustration when they do not see the solution right away. Consequently, working with a growth mindset will help them a lot.

Many ideas for mathematical activities that invite students to develop a growth mindset are provided by Boaler (Boaler, 2016). Some of these interventions, especially the ones that are also described in the studies of Yeager & Walton (2011), Blackwell (2007), and Hattie (2008), have been tested in the school year 2016-2017 at the Goois Lyceum, a secondary school in a small town in the Netherlands.

The evaluation of these tests showed that three main elements of the intervention were easy to implement and were experienced as very valuable: (1) an introduction to the theory of mindset and the importance of neuroplasticity, (2) attention for the importance of learning from errors in the teaching process, and (3) classroom as well as individual growth mindset feedback.

In this study, we investigated to what extent this growth mindset-oriented intervention can improve students' attitude towards mathematics.

Method

During the school year 2017-2018 the intervention was further developed and implemented in the first grade of secondary school (grade 7) and in upper secondary school mathematics A classes (mainly grade 10). Grade 7 was chosen because these students recently switched to a new school. In upper secondary education, classes with mathematics A were chosen because mathematics A (preparing for humanities) is seen as 'easier' than mathematics B (preparing for natural sciences). These students often feel that they have chosen a 'lower' form of mathematics and that they cannot perform well in this subject. This lower self-efficacy might indicate a fixed mindset, and it is interesting to see whether this can be changed by the interventions. We advertised the possibility to join the project in a newsletter reaching mathematics teachers all over the Netherlands. In total 512 students in 21 classrooms, from nine schools, joined the experiment, of which 383 filled in both the questionnaires.

Preparation of the teachers

The teachers that were involved in the intervention were given a training of 5 hours at Utrecht University in which the theory of mindset was explained. During the training, teachers got the opportunity to work on some sample activities (low-floor-high-ceiling tasks, Boaler, 2016, or 'My favorite no', Alcalá, 2011) followed by an extensive instruction of the different elements of the intervention. The presentations of the training, the presentations and tasks for the students, and suggestions for further reading were shared online. During the intervention there was a regular exchange of experiences, questions and information through email with the teachers. The intervention contained the following three main elements:

1) Explanation about mindset and the functioning of the brain (neuroplasticity). Although the theory of mindset is a psychological theory it is well supported by brain researchers in relation to the plasticity of the brain (e.g. Woollett & Maguire, 2011; Helden & Bekkering, 2015). Nerve cells, or neurons, can make better and more connections throughout our lives (or loose connections when not in use). This allows a rich distributed dynamic network with many opportunities to learn new things, also referred to as neuroplasticity. Because of this neuroplasticity people have the opportunity to learn and expand their knowledge. It is not just the capacity to learn a new language but also new hobbies and new habits. For example, if you fear failure through training you can learn to become more confident (Hanson, 2009). It is like walking a new path through the jungle; first you need a machete to break through, but after some time when you use the same track more often, a path is created and it gets easier and easier to travel.

At the schools this part of the intervention started with a presentation for all students on the functioning of the brain and on the theory of mindsets. The corresponding task was to make a difficult mathematical assignment without the explanation of new theory. A student with a fixed

mindset would not like this, they avoid starting out of fear of making mistakes. A student with a growth mindset would like to continue, thinking “I’m going to try it” or “If it doesn’t work out I ask it.” The role of the teacher is to give the right growth feedback and to regularly remind students of the neuroplasticity of the brain.

2) The importance of making mistakes and learning from errors. Brains of people who make mistakes with a growth mindset are more active than the brains of someone who makes mistakes with a fixed mindset (Boaler, 2016). When students do not understand the assignment right away and they are thinking with a fixed mindset, they might believe “Now everyone will notice that I am not smart.” They start to get stressed and stress hormones ensure that no new connections between the neurons grow (Dirksen, 2012). Students with a growth mindset will see obstacles more as challenges. They can see that making a mistake is the beginning of learning something new (Chödrön, 2006). They then start to feel more confident which in turn sets the brain in a responsive mode, and this stimulates making new connections in the brain (Hanson, 2009). The teachers are stimulated to use feedback like “I want to understand the way you think and together we can discover what the next step is.”

This intervention started with a presentation about the function of making mistakes and the role of mindset. The teachers started several lessons with “My favorite no” (Alcala, 2011). To change the way in which teachers cope with mistakes is also an aspect of this intervention.

3) The use of feedback. It is important that teachers are aware of the feedback they give, especially while making errors. If they say “what a stupid mistake” they can bring students more towards a fixed mindset. And it is not just the words but also the body language and tones they use. The challenge is to give feedback not on properties or features but on the process (Boaler 2016). It may seem great to hear that you are smart. However, it is a kind of label, leading to overconfidence, or to self-doubt like: yes I am smart now but what if I make a mistake, will they call me dull-brained? (Mueller & Dweck, 1998). When giving feedback on the process it should be true feedback; only when a student has really worked hard one can evaluate this.

It is not just the feedback that students get from others, it is also the feedback they give themselves. In a class, it is helpful to listen carefully to what students say while making the assignments or as they chat. For example, when they say “this is too hard”, this can be associated with a fixed mindset. Whereas when they are saying “this may take some time” this can be associated with a growth mindset.

The attitude of the teacher is important; when a teacher, from a fixed mindset, has the opinion that the performance of the students stays the same throughout the year it might lead to stagnation. On the other hand, when a teacher, from a growth mindset, believes that the performance of the students can grow than students evolve more easily. Good teachers believe in development of intelligence and talent, which is a growth mindset, and they are fascinated by the learning process (Dweck, 2006).

At the start of this intervention on feedback the students were shown a short presentation on feedback, words, and the link to mindset. The assignments they then got were low-floor-high-ceiling tasks, for example “what is the largest surface you can make with 36 piles of 1 meter?”. Students can easily start and while working can make things more and more difficult. The teacher helps them by giving growth and encouraging feedback and challenge them.

To participate in this study teachers were asked – as a minimal requirement – to teach the previously described elements of the intervention (on the plasticity of the brain and the consequences for learning, the importance of errors, and the role of feedback in learning). Furthermore, they were asked to implement at least one growth-mindset task with every intervention. Finally, they were invited to examine their own attitude towards mistakes and to practice with growth-mindset feedback in their classroom.

Procedure of the intervention

At the start and at the end of the intervention, students filled in a questionnaire to determine their mindset. This questionnaire consisted of 25 statements that were compiled from the literature of Blackwell and Dweck (Blackwell, Trzesniewski, & Dweck, 2007; Dweck, 2006). Students were asked to label their level of agreement to the statements on a 6-point Likert scale. The statements were divided in four types: mindset, effort belief, response to failure, and learning goals. With these different types the impact of the intervention could be measured in different domains. Example questions were:

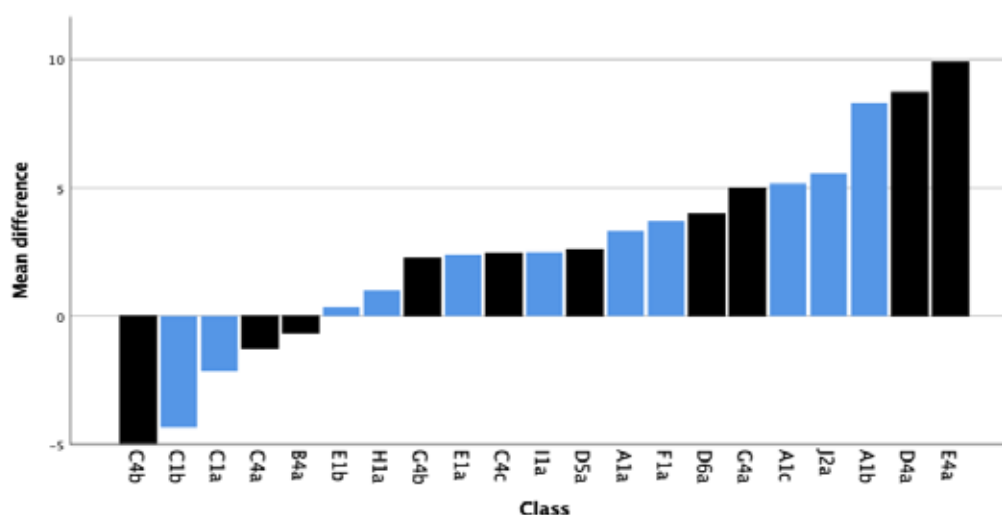
- Q1. You have a certain amount of intelligence and you cannot do much to change it
- Q3. An important reason why I do my schoolwork is because I like to learn new things
- Q5. It does not matter who you are and where you come from, you can always change your level of intelligence
- Q16. If you have to work hard for a subject, you are probably not very good at it.

During the interventions at five schools a lesson with the intervention was observed and students and teachers were interviewed about their experiences.

Results

In Figure 1 the mean differences in the total score of the questionnaire are represented. It can be seen that in only five classes the total scores after the interventions had lowered, indicating a more fixed mindset. In the remaining sixteen classes the scores went up, indicating a more growth mindset. The Grade 7 classes are drawn in black and Grade 10 in blue, with no clear differences emerging.

Figure 1. The mean differences in the total scores per class



In Table 1 the average scores on the different scales are given for the two grades. It can be seen that the effect of the interventions is most clear for the mindset score (e.g. +3.1 for the Mindset scale in Grade 7). Both in Grade 7 and Grade 10 the post intervention mindset scores are higher.

Table 1: Results of the scores of the pre- and posttest (the questionnaire before and after the mindset interventions); the average of the different grades in the different domains

(Grade 7 N = 246 Grade 10 N = 137)

Sub scale	Grade level	Pretest		Posttest		Difference
		<i>M</i>	<i>SD</i>	<i>M</i>	<i>SD</i>	
Mindset	<i>Grade 7</i>	27.8	6.8	30.9	6.6	+3.1
	<i>Grade 10</i>	27.1	6.2	29.0	7.0	+1.9
	<i>Total</i>	27.5	6.5	30.2	6.8	+2.6
Learning goals	<i>Grade 7</i>	16.2	3.4	15.6	3.8	-0.6
	<i>Grade 10</i>	14.3	3.6	14.8	3.7	-0.5
	<i>Total</i>	15.5	3.6	15.3	3.8	-0.2
Effort belief	<i>Grade 7</i>	28.8	3.4	29.0	3.7	+0.2
	<i>Grade 10</i>	27.3	3.3	27.8	3.8	+0.5
	<i>Total</i>	28.2	3.5	28.5	3.8	+0.3
Response to failure	<i>Grade 7</i>	38.8	4.9	38.8	5.0	0.0
	<i>Grade 10</i>	37.5	5.4	36.9	5.8	-0.6
	<i>Total</i>	38.4	5.1	38.1	5.3	-0.3
Total score	<i>Grade 7</i>	111.6	12.9	114.2	12.8	+2.6
	<i>Grade 10</i>	106.3	13.2	108.4	14.8	+2.1
	<i>Total</i>	109.7	13.2	112.1	13.8	+2.5

In Table 2 the results of the changes of the individual students show a similar pattern of more pronounced changes in the mindset score compared to the scores in the other domains. Also, here the change towards a more growth mindset is larger in the Grade 7 classes (67.5%). This trend may indicate that the mindsets of the Grade 7 students are more intensely influenced by the interventions.

Table 2: Results of the changes of the individual students

Change on	Percentage of changes*	Difference between grade 7 and 10
Total score	39.7% negative change 4.7% no change 55.6% positive change	Grade 7: 38.6% negative, 6.1% =, 55.4% positive Grade 10: 41.6% negative, 2.2% =, 56.2% positive
Mindset score	29.0% negative 7.3% no change 63.7% positive	Grade 7: 26.4% negative, 6.1% =, 67.5% positive Grade 10: 33.6% negative, 9.5% =, 56.9% positive
Learning goals	45.2% negative 14.4% no change 40.4% positive	Grade 7: 49.6% negative, 16.3% =, 34.1% positive Grade 10: 37.2% negative, 10.9% =, 51.8% positive
Believe in effort	39.7% negative 14.6% no change 45.7% positive	Grade 7: 42.7% negative, 12.2% =, 45.1% positive Grade 10: 34.3% negative, 19.0% =, 46.7% positive
Response to failure	45.4% negative 14.1% no change 40.5% positive	Grade 7: 41.9% negative, 15.9% =, 42.3% positive Grade 10: 51.8% negative, 10.9% =, 37.2% positive

* a negative change is a change towards a fixed mindset; a positive change is a change towards a growth mindset.

All the teachers were very much involved in the intervention. During the interviews they made comments like: “As a mentor, and as a teacher in mathematics, I can now discuss more easily how important it is to learn from your mistakes. I also designate my own mistakes more consciously, and I explain how I deal with them.”

Another teacher writes that she has become more careful with her words. Even small, seemingly unimportant words like quickly (make your assignments quickly) she tries to avoid as it disempowers her lessons. The classes that show a decrease or stability in mindset scores are one Grade 7 class and two Grade 10 classes. Two of these teachers were starting teachers who were very enthusiastic about the intervention but for whom teaching itself was relatively new. The third teacher was a more experienced teacher and also very committed to the interventions. However, in his class there were a lot of changes in the composition of the class, which may have influenced the outcome.

The questionnaire at the end of the intervention included questions about which part of the intervention the students appreciated most. They valued the entire intervention because of its content and also because of the changes in their teacher’s attitudes. The lesson on the brains and on the mistakes were most highly appreciated. One student explained: “I have to stop thinking ‘this will cost too much time’, or ‘I really cannot do this’; instead I can persevere or try again later.”

The personal interviews with students also revealed that the lesson on making mistakes was experienced as the most positive, though also after the interventions one student made the following remark: “I did learn that making mistakes does not matter, however I still do not like it.”

Students and teachers reported during the interviews that an important element of working with mindset is the use of words. One student noticed “It sometimes seems as if we have learned a new language together.” Another student said “Sir, this feels like a fixed remark, do you mean it like that?” One teacher said: “I find it a real challenge, you have to pay attention to all the words the students are saying, also the words they say to each other and to themselves. To be able to do that of all the students is not (yet) possible, however with a few students separately I do succeed.”

Discussion

The mindset theory addresses issues that are highly relevant for current teaching practices in mathematics education. We are aware that changing teachers’ teaching and students’ learning behavior can hardly be achieved through a one-day training for teachers. Nevertheless, this study shows that teachers did become sensitive for changing their practice towards fostering a growth mindset after a training of only five hours and some initial experiences with the interventions. From this study, the effects of changing practices on student achievements are not clear. What it does show is an obvious attitude change towards students’ own learning and towards the importance of making mistakes in learning mathematics. These are important first steps towards a changing culture in the mathematics classrooms. Finally, teachers reported that the mindset theory provides an inspirational vocabulary and set of tools to implement and improve daily teaching practices.

The training of teachers was first seen as a preparation for the three elements of the intervention mentioned above, but actually it turned out to be a separate intervention. Once teachers were familiar with the theory of the mindset they changed their lessons: teachers were more aware of the mindset from which they taught their students, of the importance of learning from their mistakes and the feedback they gave. And this had a direct impact on the mindset of their students.

Acknowledgments

We would like to acknowledge all the students and teachers that have worked with the interventions. We have learned so much from all of you. Thanks for being so open to all new ideas. Also thanks to everyone from The Goois Lyceum, for being experimental subject in this study.

References

- Alcala, L. (2011). My favorite no. [Video file]. Retrieved from <https://www.youtube.com/watch?v=uuDjke-p4Co>
- Blackwell, L.S., Trzesniewski, K.H. & Dweck, C.S. (2007). Implicit theories of intelligence predict achievement across an adolescent transition: a longitudinal study and an intervention. *Child Development*, (1). 246.
- Boaler, J. (2016), *Mathematical mindset*. New York, USA: John Wiley And Sons Ltd
- Canning, E., Muenks, K., Green, D. & Murphy, M. (2019). STEM faculty who believe ability is fixed have larger racial achievement gaps and inspire less student motivation in their classes. *Science Advances*, (5), eaau4734.
- Chödrön, P. (2006). *The places that scare you – a guide to fearlessness*. Boston, USA: Shambhala.
- Dirksen, G. (2014), *Breindidactiek*. Utrecht, The Netherlands: Uitgeverij Synaps
- Dweck, C.S., Chiu, C. & Hong, Y (1995). Implicit theories and their role in judgement and reactions: a world from two perspectives. *Psychological Inquiry*, 6 (4), 267-285.
- Dweck, C.S. (2006) *Mindset, The new psychology of success*. New-York, USA: Random House USA.
- Hanson, R. (2009). *Buddha's brain; The Practional Neuroscience of Happiness, Love and Wisdom*. Oakland, USA: New Harbinger Publications.
- Hattie, J. (2008). *Visible learning, A Synthesis of Over 800 Meta-Analyses Relating to Achievement*. Abingdon, UK: Taylor & Francis Ltd
- Hattie, J. (2018). Collective Teacher Efficacy (CTE) according to John Hattie. Available from: <https://visible-learning.org/2018/03/collective-teacher-efficacy-hattie/>
- Helden, J. van der, & Bekkering, H. (2015). *De lerende mens; over dat we ons leven lang kunnen leren!* Amsterdam, Nederland: Uitgeverij Boom
- Mueller, C.M., & Dweck, C.S. (1998). Praise for intelligence can undermine children's motivation and performance. *Journal of Personality and Social Psychology*, 75 (1), 33-52.
- Woollet, K, & Maguire, E., (2011). Acquiring 'The Knowledge' of London's layout drives structural brain changes. *Current biology*, 21 (24), 2109-2114.
- Yeager, D.S., & Walton, G.M. (2011). Social-psychological interventions in education: they're not magic. *Review of Educational Research*, 81, 267-301.

Low achiever's mathematical thinking: The case study of Maya

Hanna Viitala

Luleå University of Technology, Sweden; hanna.viitala.edu@gmail.com

In this paper, one low achiever's, Maya's, mathematical thinking is reported. Mathematical thinking is studied through problem solving and view of mathematics. The results indicate that Maya has severe gaps in mathematical knowledge and problem solving. Furthermore, affect hinders her learning and activities in mathematics. Despite the challenges, Maya wants to learn mathematics and succeeds in giving an answer to every mathematical problem in the study. In addition to further support in mathematics and affect, she could benefit from learning to use different representations in mathematics and picturing the tasks in real life.

Keywords: View of mathematics, problem solving, metacognition, affect, meta-affect.

Introduction

Finnish pupils' success in mathematics has been acknowledged in international studies such as PISA and TIMSS (see e.g. Välijärvi, 2014) and national assessments show that Finnish pupils' performance is at a satisfactory level (e.g. Hirvonen, 2012). However, the most recent studies indicate that Finnish pupils' performance is descending (ibid.; Rautopuro, 2013), showing also the diminishing number of high achievers and the growing share of low achievers in Finland (Kupari & Nissinen, 2015). Furthermore, pupils' affect towards mathematics is alarmingly low at the end of lower secondary school (Tuohilampi & Hannula, 2013).

To understand the recent development, we need to know more about Finnish pupils' mathematical thinking. What is it like at the end of comprehensive school? Previously, Viitala (2017a) has reported on four Finnish high achieving pupils' mathematical thinking. These pupils all liked mathematics, were successful problem solvers and enjoyed learning mathematics. However, a deeper look into their problem solving and view of mathematics revealed very different skills and competences in mathematics. Nevertheless, whatever their strengths and weaknesses were, their strengths compensated their weaknesses in mathematics. How is the situation different with low achievers? What is it that separates low achievers from high achievers? In addition to differences in mathematical knowledge, what might be the possible reasons for the low performance in mathematics?

In this paper, one low achiever's, Maya's, mathematical thinking is reported. The data is collected through problem solving and view of mathematics. The purpose is to study Maya's strengths and weaknesses in mathematics that go beyond her mathematical knowledge. The purpose is to answer the question 'What characterizes Maya's mathematical thinking at the end of lower secondary school?'

Theoretical framework

Following the recent theories on affect, mathematical thinking can be viewed through two temporally different aspects; state and trait (cf. Hannula, 2011; 2012). While thinking is always situational and contextual, a state, it is also influenced by more stable constructs such as beliefs and attitudes, traits (cf. ibid.). These two temporally different sources of data together can reveal the dynamic and

complex thinking processes that pupils go through while thinking mathematically (for an example, see e.g. Viitala, 2017b).

In this study, the state aspect is studied through problem solving. The pupils' actions and explanations during problem solving are interpreted as visible signs and expressions of their mathematical thinking. In addition to the mathematical knowledge and heuristics in problem solving, pupils' problem-solving behaviour is influenced by their metacognition, affect and meta-affect that occur in a problem-solving situation (cf. Schoenfeld, 1992).

The successful application of problem-solving activities at the correct moment is a result of metacognitive skilfulness (e.g. Schoenfeld, 1987; Flavell, 1979). These skills include for instance monitoring one's actions and directing resources in a problem-solving situation (Schoenfeld, 1987). Affective state influences problem-solving activities for instance through the feeling of confidence, and meta-affect transforms individuals' feelings (DeBellis & Goldin, 2006) directing pupils' problem-solving behaviour (Carlson & Bloom, 2005).

Problem-solving processes can show patterns of thought that can be interpreted as signs of more stable ways of thinking. These patterns, together with pupils' view of mathematics, represent the traits in this study. Pupils' view of mathematics is studied through five components: mathematics as a science and as a school subject, oneself as a learner and user of mathematics, learning mathematics, teaching mathematics (Pehkonen, 1995), and view of mathematical thinking.

The structure of pupils' view of mathematics is derived from belief-research that has traditionally been studied as traits (see e.g. Op't Eynde, de Corte, & Verschaffel, 2002). However, in separation from many earlier studies, in this study pupils' view of mathematics is considered as psychological phenomenon that is a mixture of cognitive, motivational and emotional processes (Hannula, 2011; 2012). In addition to beliefs, these processes include also for instance attitudes, values, feelings and motivation (ibid.; thus the word 'view', see Rösken, Hannula, & Pehkonen, 2011).

Methods

Data collection

At the time of data collection, Maya was 15 years old. She was in 9th and final year of Finnish comprehensive school. She was a low achiever in mathematics (mathematics grades between 5 and 6 on a whole number scale of 4 to 10).

The data was collected in three cycles over the course of three months. In each cycle, 1-2 mathematical problems (PISA tasks) were solved in an ordinary classroom situation. In class, Maya solved the tasks individually, but she could talk about the tasks with her friends and ask help from the teacher. In the third cycle, Maya was absent from class and solved the problems in the interview. Maya was video recorded while she solved the tasks and her solutions on paper were collected.

Here is an example of a PISA task used in data collection: 'This problem is about planning the best route for a holiday. Figures A and B show a map of the area and the distances between towns [in a table]. [...] Calculate the shortest distance by road between Nuben and Kado.' (OECD, 2006, pp. 77-78; for a part of the task, see also Figure 1).

Maya was interviewed three times, on the same day or on the next day after each of the problem-solving lessons. The interviews were semi-structured and contained two parts. The first part concentrated on Maya's view of mathematics. It followed the categorisation introduced in theoretical framework: background, mathematics as a school subject and as a science, oneself as a learner of mathematics, learning mathematics, teaching mathematics (following Pehkonen, 1995; cf. Op't Eynde et al., 2002), and view of mathematical thinking (for example questions, see Table 1).

Theme	Example question
Background	Tell me about your family.
Mathematics	Does mathematics exist outside of school? Where?
Oneself and mathematics	Is mathematics important to you?
Mathematics learning	How do you learn mathematics?
Teaching mathematics	Does teaching matter to your learning? How?
View of mathematical thinking	How do you recognise mathematical thinking?

Table 1: Interview themes and example questions

The second part concentrated on problem solving. The data from class was used as stimuli when Maya's problem-solving processes were discussed. She was asked to explain her thinking and actions during the problem-solving situation. Also supporting questions were asked (e.g. What are you thinking now? Why are you doing so?).

Finally, in each of the three interviews, Maya was asked to assess her confidence before, during and after solving the problems, as well as to assess her confidence in school mathematics using a 10 cm line segment (scale from 'I couldn't do it at all' to 'I could do it perfectly'). All interviews were video recorded.

Data analysis

The analysis was divided into two sections: problem solving (state) and view of mathematics (trait). First, problem-solving processes were analysed through four problem-solving phases: orienting, planning, executing and checking (Carlson & Bloom, 2005). Then, the results were complemented with the metacognitive activities of orienting, planning, evaluating and elaborating (see examples in van der Stel, Veenman, Deelen, & Haenen, 2010), affect (cognitive, emotional and motivational states and traits; Hannula, 2011; 2012) and meta-affect (DeBellis & Goldin, 2006) emerging in the problem-solving processes. Finally, Maya's confidence to solve the problems were analysed.

Second, Maya's view of mathematics was analysed following the themes of data collection (Pehkonen, 1995). After data condensation, a pupil profile was created. Pupil profile is a short description of the pupil that is used as background information. It is based on Maya's mathematics grade, motivation to learn mathematics, and ability, success, difficulty, and enjoyment of mathematics also known as the core of herself as a learner of mathematics (Rösken et al., 2011).

In the end, the results from problem solving (state) and view of mathematics (trait) were compared and combined to get a holistic view of Maya's mathematical thinking.

Results

Pupil profile: Maya is a low-achieving, very unsure and quite anxious mathematics learner. She does not value mathematics as important, but would still like to learn it. Her low level of mathematical knowledge and skills go hand in hand with her low level of affect and meta-affective skills in mathematics.

The most prominent result of the study is the low level of affect that Maya has in and towards mathematics. When we begin discussing about mathematics, Maya starts by saying that she is very bad at mathematics, has always been. She then continues to express her low level of affect throughout the study: She explains that she has no idea what mathematics is as a science because she is very bad at mathematics; Mathematics is not important because she does not really know mathematics; She does not feel confident in mathematics; She feels anxious in mathematics classes and especially so in tests; She feels that she has never succeeded in a mathematics test; Or simply, mathematics is too difficult for her.

Maya has great difficulties also in solving problems. She felt stressed in problem-solving situations and the tasks felt difficult. Before she could start solving the problems, she needed confirmation from the teacher (or from the researcher in the interviews) that she had understood the problem correctly. Unfortunately, Maya is not initiative in asking help in class. She feels afraid of making mistakes, she

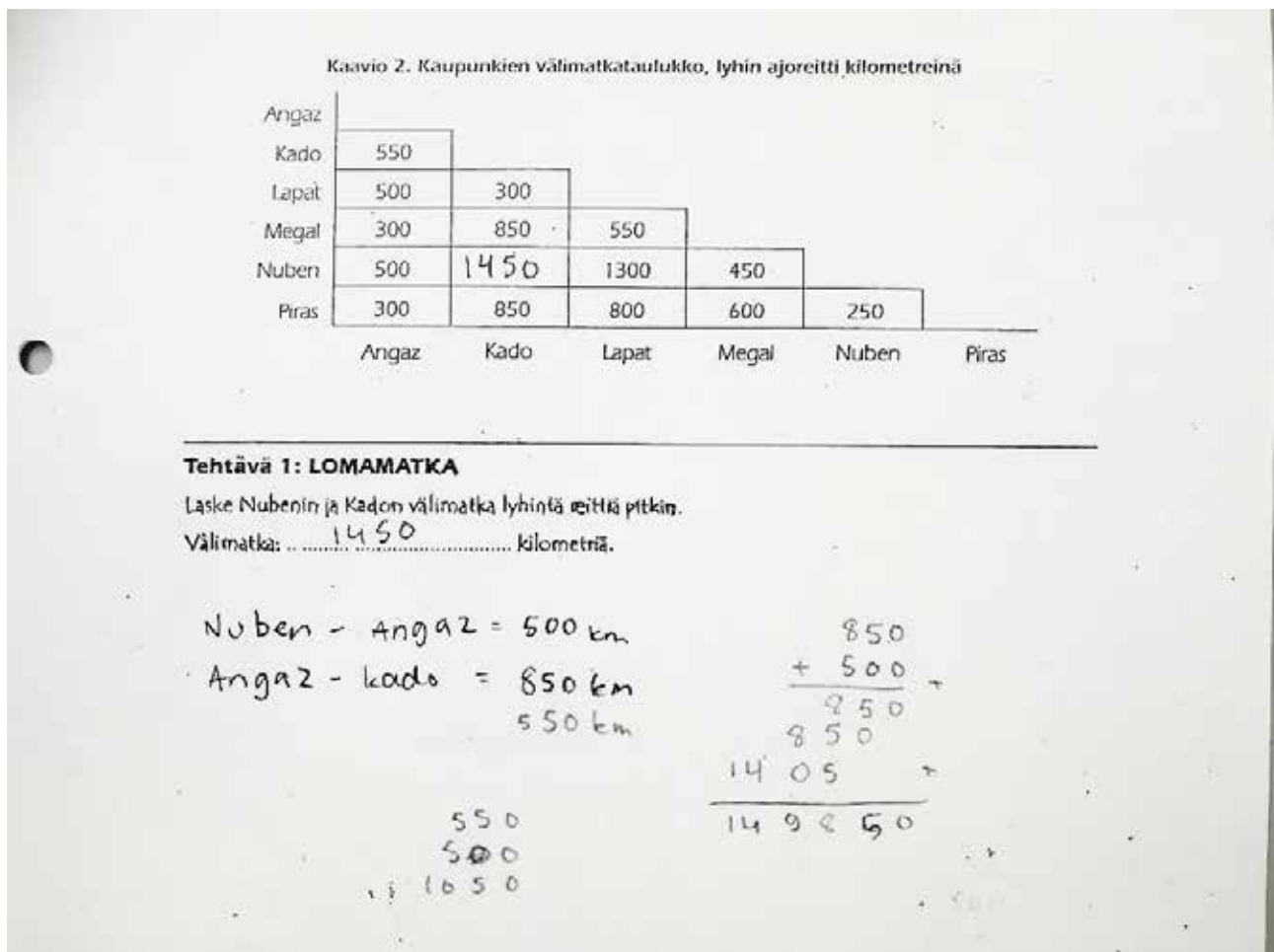


Figure 1: A partial caption of the task 'Holiday' (OECD, 2006, p. 77) and Maya's interview notes

is afraid that the teacher asks questions or gives critique, and she is afraid that her classmates notice her problems. This mismatch between the need for help and not asking for it, and consequently staying stuck, is just one example of the low level of meta-affective skills that Maya has in mathematics. Fortunately, though, when the teacher approaches her, she usually gets the help she needs to continue with the problem.

In addition to the low affect and meta-affective skills in mathematics, Maya's mathematical skills are quite limited. For example, in the problem introduced above, Maya had difficulties in reading the table and in adding. First, she did not understand what the numbers in the table represent before the teacher explained the table to her. Even then, she took the distances she needed from the first cell next to the town names (500 next to Nuben and 850 above Kado; see Figure 1). Maya explained that she did not understand the table until the interview.

After getting the distances she needed from the table, Maya had to add the numbers together. She explained that she could not add the numbers (500 and 850) mentally, so she calculated them on paper (for a reproduction of the calculation, see Figure 1). Maya's calculation was a mixture of adding and multiplying rules and the result was incorrect. In the interview, Maya explained that she took the first and last two numbers as the result and ignored the third and fourth numbers. Even though the method seems absurd, there is something positive: she had a realistic view of the magnitude of the answer.

There are severe problems in Maya's knowledge base and affect. Metacognitive actions are almost non-existent, also meta-affective actions, and she needs very much and very concrete help to solve the problems. However, there too is something positive: She does want to learn mathematics. She recognizes that for her own learning, she needs to follow teaching in mathematics classes and ask questions. She has noticed that when the teacher relates new knowledge to old knowledge, it helps her to learn mathematics. Even though she has emotional obstacles in communicating with her teacher, she seeks and gets more mathematical help from their special needs teacher. She emphasizes the importance of doing homework alone and undisturbed. And, she recognizes that she needs mathematics in future studies and jobs.

In mathematics learning, Maya needs help in developing her conceptual and procedural skills, and support to overcome many emotional issues. However, in connection to problem solving, there is one concrete thing that rose above other issues. When Maya got stuck in problem solving, she understood the problem best with a new representation. Moving the task to real life or drawing a picture was enough to help Maya to understand the problem. Moving between different representations in mathematics could help her to improve her problem-solving skills and her conceptual knowledge.

Discussion

This paper aimed at answering the question 'What characterizes Maya's mathematical thinking at the end of lower secondary school?' Maya is best characterized through the low level of mathematical knowledge and skills, and through the low level of affect towards mathematics. More specifically, the very negative view of herself in mathematics seem to hinder her learning and solving mathematical problems. This negative trait connected with the negative state reactions to the problems and problem-solving situations, as well as nearly non-existent meta-affective skills, almost

prevented her to solve the problems in the study. The low level of mathematical and metacognitive skills support the situation.

In addition to the low level of mathematical knowledge, the low level of meta-affective and metacognitive skills seem to be what separates Maya most from the high-achieving students in the research project (see the high-achieving students' results in Viitala, 2017a). Being unsure and having negative affect towards mathematics are features that students in all achievement levels experience. In fact, the most recent national studies show that Finnish pupils' affect towards mathematics is unnecessary negative at the end of comprehensive school (Tuohilampi & Hannula, 2013; Hirvonen, 2012). However, while Maya seem to paralyse when experiencing difficulties in solving mathematical tasks, the high-achievers use their meta-affective and metacognitive skills to overcome them (see e.g. Viitala, 2017a). What all students in the research project have in common, though, is the positive feeling they get when they succeed in mathematics, and the will to learn mathematics, on their own levels and on their own terms.

The national studies also show that pupils start school with positive attitudes, but their attitudes towards mathematics as well as self-efficacy beliefs decrease consistently throughout comprehensive school, and pupils' anxiety in mathematics increase in lower secondary school (Tuohilampi & Hannula, 2013; Metsämuuronen & Tuohilampi, 2014). Maya's affect fits well with the results of Finnish large-scale studies at the end of comprehensive school. However, the results indicate that the situation has not been positive even at the beginning of her school years. For instance, Maya states that she has always been bad at mathematics and she cannot remember ever succeeding in a mathematics test. Having a different mathematics teacher in every grade might also been a factor in Maya's learning of mathematics: While Maya is shy and very unsure of herself in mathematics, it takes time for the teacher to get to know her thinking so that the teacher could have the best tools to help Maya to develop mathematically.

So, what can be done to help pupils like Maya first to create and then to maintain more positive attitude towards mathematics, and to build mathematical knowledge and skills at their own rate? One solution could be to increase the amount of problem solving in mathematics classes. Even one monthly problem-solving lesson has shown to slow down the decreasing trend in girls' attitudes towards mathematics (Tuohilampi, Näveri, & Laine, 2015). Problem solving is also an effective tool for the teacher to learn about pupils' mathematical knowledge and thinking. Additionally, referring to real-life situation helped Maya to solve problems. Problem solving and applying mathematics to real-life situations are written as learning goals also in the Finnish curriculum (see FNBE, 2014).

One way of supporting Maya's growth in mathematics could also be setting long-term goals for her learning. In Maya's case, the long-term goal could be referring to real life and learning to use different representations in mathematics and problem solving (cf. Heinze, Star, & Verschaffel, 2009). Setting and evaluating the long-term goals in learning discussions, using written self-evaluation and supporting the development through formative assessment in mathematics classes, have shown promising results for students learning in a small pilot study implemented during spring semester 2018 (see more in Viitala, 2018). However, how and if these activities help pupils in a longer period of time, is a matter of a long-term continuation study with a larger number of pupils.

References

- Carlson, M. P., & Bloom, I. (2005). The cyclic nature of problem solving: An emergent multidimensional problem-solving framework. *Educational Studies in Mathematics*, 58(1), 45–75.
- DeBellis, V. A., & Goldin, G. A. (2006). Affect and meta-affect in mathematical problem solving: A representational perspective. *Educational Studies in Mathematics*, 63(2), 131–147.
- Flavell, J. H. (1979). Metacognition and cognitive monitoring: A new area of cognitive-developmental inquiry. *American Psychologist*, 34, 906–911.
- FNBE. (2014). *Perusopetuksen opetussuunnitelman perusteet 2014* [National core curriculum for basic education 2014]. Määräykset ja ohjeet 2014: 96. Helsinki, Finland: Finnish National Board of Education.
- Hannula, M. S. (2011). The structure and dynamics of affect in mathematical thinking and learning. In M. Pytlak, T. Rowland, & E. Swoboda (Eds.), *Proceedings of the Seventh Congress of the European Society for Research in Mathematics Education* (pp. 34–60). Rzeszów, Poland: University of Rzeszów.
- Hannula, M. S. (2012). Exploring new dimensions of mathematics-related affect: Embodied and social theories. *Research in Mathematics Education*, 14(2), 137–161.
- Heinze, A., Star, J. R., & Verschaffel, L. (2009). Flexible and adaptive use of strategies and representations in mathematics education. *ZDM Mathematics Education*, 41(5), 535–540.
- Hirvonen, K. (2012). *Onko laskutaito laskussa? Matematiikan oppimistulokset peruskoulun päättövaiheessa 2011* [Are calculating skills declining? Mathematics learning outcomes at the end of the comprehensive school in 2011]. Koulutuksen seurantaraportit 2012:4. Helsinki, Finland: FNBE.
- Kupari, P., & Nissinen, K. (2015). Matematiikan osaamisen taustatekijät [The background for mathematical performance]. In J. Välijärvi & P. Kupari (Eds.), *Millä eväillä uuteen nousuun?: PISA 2012 tutkimustuloksia* (pp. 10–27). Julkaisuja 2015:6. Helsinki, Finland: Ministry of Education.
- Metsämuuronen, J., & Tuohilampi, L. (2014). Changes in achievement in and attitude toward mathematics of the Finnish children from grade 0 to 9: A longitudinal study. *Journal of Educational and Developmental Psychology*, 4(2), 145–169.
- OECD. (2006). *Assessing scientific, reading and mathematical literacy: A framework for PISA 2006*. Retrieved from http://www.oecd-ilibrary.org/education/assessing-scientific-reading-and-mathematical-literacy_9789264026407-en
- Op't Eynde, P., de Corte, E., & Verschaffel, L. (2002). Framing students' mathematics-related beliefs. In G. C. Leder, E. Pehkonen, & G. Törner (Eds.), *Beliefs: A hidden variable in mathematics education* (pp. 13–37). Dordrecht, The Netherlands: Kluwer Academic Publishers.

- Pehkonen, E. (1995). *Pupils' view of mathematics: Initial report for an international comparison project*. Research report 152. Helsinki, Finland: University of Helsinki, Department of teacher education.
- Rautopuro, J. (Ed.). (2013). *Hyödyllinen pakkolasku. Matematiikan oppimistulokset peruskoulun päättövaiheessa 2012* [Useful forced landing. Mathematics learning outcomes at the end of the comprehensive school in 2012]. Koulutuksen seurantaraportit 2013:3. Helsinki, Finland: FNBE.
- Rösken, B., Hannula, M. S., & Pehkonen, E. (2011). Dimensions of students' views of themselves as learners of mathematics. *ZDM Mathematics Education*, 43(4), 497–506.
- Schoenfeld, A. H. (1987). What's all the fuss about metacognition? In A. H. Schoenfeld (Ed.), *Cognitive science and mathematics education* (pp. 189–215). Hillsdale, NJ: Lawrence Erlbaum.
- Schoenfeld, A. (1992). Learning to think mathematically: Problem solving, metacognition and sense making in mathematics. In D. A. Grouws (Ed.), *Handbook of research on mathematics teaching and learning* (pp. 334–370). New York, NY: Macmillan.
- Tuohilampi, L., & Hannula, M.S. (2013). Matematiikkaan liittyvien asenteiden kehitys sekä asenteiden ja osaamisen välinen vuorovaikutus 3., 6. ja 9. luokalla [The development of mathematics related attitudes and the interplay between attitudes and performance in 3rd, 6th and 9th grades]. In J. Metsämuuronen (Ed.), *Perusopetuksen matematiikan oppimistulosten pitkäjäsenarviointi vuosina 2005-2012*. Helsinki, Finland: FNBE.
- Tuohilampi, L., Näveri, L., & Laine, A. (2015). The restricted yet crucial impact of an intervention on pupil's mathematics-related affect. In K. Krainer & N. Vondrová (Eds.), *Proceedings of the Ninth Congress of the European Society for Research in Mathematics Education* (pp. 1287–1293). Prague, Czech Republic: Charles University and ERME.
- van der Stel, M., Veenman, M. V. J., Deelen, K., & Haenen, J. (2010). The increasing role of metacognitive skills in math: A cross-sectional study from a developmental perspective. *ZDM Mathematics Education*, 42(2), 219–299.
- Viitala, H. (2017a). A case study on Finnish pupils' mathematical thinking: Problem solving and view of mathematics. In T. Dooley & G. Gueudet (Eds.), *Proceedings of the Tenth Congress of the European Society for Research in Mathematics Education* (pp. 1218–1225). Dublin, Ireland: DCU Institute of Education and ERME.
- Viitala, H. (2017b). A tool for understanding pupils' mathematical thinking. *Nordic Studies in Mathematics Education*, 22(2), 5–31.
- Viitala, H. (2018). Using formative assessment to support student development in lower secondary school mathematics. In E. Bergqvist, M. Österholm, C. Granberg, & L. Sumpter (Eds.), *Proceedings of the 42nd Conference of the International Group for the Psychology of Mathematics Education* (Vol. 5, p. 184). Umeå, Sweden: PME.
- Väljjarvi, J. (2014). Osaaminen kestäväällä perustalla: Suomen PISA-tulosten kehitys vuosina 2000-2009. Tilannekatsaus helmikuu 2014. [Know-how on solid ground: The development of Finnish PISA results in 2000-2009. Review in February 2014]. Muistiot 2014:1. Helsinki, Finland: FNBE.

The impact of a mathematics game programming project on student motivation in grade 8

Eline Westerhout, Paul Drijvers and Arthur Bakker

Utrecht University, Freudenthal Institute, Utrecht, The Netherlands; e.n.westerhout@uu.nl,
p.drijvers@uu.nl, a.bakker4@uu.nl

In this paper, we describe the impact of a mathematics game programming project on the intrinsic motivation of eighth grade students ($n = 8$). We investigate which aspects of the project contributed to student motivation based on a taxonomy that distinguishes individual (e.g., challenge) and interpersonal motivation aspects (e.g., recognition). We also employ these aspects to compare the programming project to regular mathematics education. The findings reveal that students appreciated the project because it was challenging and they had freedom of choice. All group members had a positive attitude towards learning. In regular mathematics classes, they experienced a lack of challenge while the freedom of choice was minimal.

Keywords: Intrinsic motivation, autonomy, mathematics education, programming.

Introduction

To foster intrinsic motivation, a learning environment needs to respond to students' needs for autonomy, feeling of competence, and social belonging (Ryan & Deci, 2000). A key question in secondary mathematics education is: what can teachers and educators do to create such an environment? As the motivation¹ for mathematics decreases during secondary school (OECD, 2013), we need to find ways to make educational practice more motivating.

The need for autonomy is especially complicated to promote in a formal learning context. Autonomy can be supported by anticipating students' intrinsic values and interests and by creating a context in which they feel at the root of their own learning behavior. This is diametrically opposed to the situation in mathematics education in many countries including our own, where educational practice is strongly guided by textbooks and national examinations.

The research question addressed in this paper is: how can aspects of a formal learning environment in which students' autonomy is supported contribute to an increase of the intrinsic motivation of students with a positive attitude towards learning? We describe the results of an intervention in which such an environment has been developed in the form of a mathematics game programming project for eighth graders. The learning goal was two-fold: while the main goal was to learn programming, as a secondary goal the project also aimed to extend students' mathematical knowledge. Since joining the project was on a voluntary basis, the eight participants were all motivated at the beginning of the project. Following them for a period of nine months and interviewing them at the end of this period gave us the opportunity to analyze what kept them motivated. The results of this study provide insights into the potential of giving (supervised) autonomy and a challenging task to students that are willing to learn.

¹ In the remainder of this paper, when we speak of 'motivation', we mean 'intrinsic motivation'

Theoretical framework

Research has delivered opposite findings with respect to the possible gain of playing computer games in education. Whereas several researchers measured a positive impact on problem solving capacities, no consensus has been reached with respect to the influence on motivation and attitudes towards mathematics (Kebritchi, Hirumi, & Bai, 2010; Perrotta, Featherstone, Aston, & Houghton, 2013; Wouters, Van Nimwegen, Van Oostendorp, & Van der Spek, 2013; Wouters, & Van Oostendorp, 2017). Wouters et al. (2013) came up with three reasons for the lack of improvement of students' motivation: they had limited autonomy, the connection between game design (focus on entertainment) and instructional design (focus on learning) is not natural, and the instruments used to measure motivation may not be appropriate.

Although research has been conducted on the potential of playing computer games in education (student as consumer), the potential of letting students develop and create such games (student as producer) has been explored insufficiently. Ke (2014) concluded after a six-week experiment using the *Scratch* programming environment that developing games stimulated the process of mathematical thinking and gave students a more positive attitude towards mathematics. He did not investigate why students' attitudes improved.

Intrinsic motivation is a multi-faceted concept that can be investigated from different perspectives. Self-determination theory (SDT) takes the learners' needs as a starting point and states that a motivational environment supports the needs for autonomy, feeling of competence, and social belonging (Ryan & Deci, 2000). The ARCS model of motivational design distinguishes four steps of promoting and sustaining motivation in the learning process: attention, relevance, confidence, and satisfaction (Keller, 2009). According to Malone and Lepper's (1987) model based on what makes gaming fun, motivation can be supported at the individual level (challenge, curiosity, control, and fantasy) and at the interpersonal level (cooperation, competition, and recognition). Elements that threaten to reduce students' intrinsic motivation are tangible rewards, threats of punishment, time pressure, and overly close surveillance (Ryan & Deci, 2009). The exploratory study described in this paper focuses on the impact of creating mathematical games on student motivation on the basis of Malone and Lepper's model and contrasts the programming project with regular mathematics education. The project was based on a constructionist approach to education (Papert & Harel, 1991): students learned through creative making processes and discovered the necessary knowledge themselves instead of receiving it passively.

Methods

The design of the programming project was driven by students' need for autonomy. During the first phase, they learned the basics of the *Processing* programming language, and all had to do the same assignments. This phase ended with the design and creation of a simple computer game. The second phase started with an advanced programming course. As the students' skills developed, their level of autonomy increased, which also meant that they got more freedom. In the final assignment, they designed and created their second computer game, with the only requirement that their game included a mathematical element (in the topic and/or in the code).

This assignment required many skills from students: they had to be creative (mathematical topic, design, rules, goals), to estimate their level of competence, to acquire new skills (mathematical and programming), and to manage their own process. The mathematical knowledge they acquired differed depending on their game.

Eight students (aged 13–14, grade 8) took part in the programming project, which was organized as an extracurricular activity open for all eighth graders in the school pursuing junior university preparatory education (VWO, 171 students) or junior general secondary education (HAVO, 94 students). Twelve students started in the project, but four of them withdrew after completing the introductory course due to health problems (1), a lack of interest (1), or school results (2). This paper focuses on the eight remaining students, who all pursued junior university preparatory education. They had in common that they were all motivated to learn programming, while they differed in intelligence, diligence with respect to schoolwork and math interests. Three of them had been diagnosed as gifted students of various types (Neihart & Betts, 2010): type 1 (opts for safe route), type 5 (demonstrates inconsistent work), and type 6 (autonomous learner). For the statistical analysis, the students who dropped out have been included in the test group.

Since the programming project was a long-term, extracurricular project, random selection of participants was not possible. As a consequence, we were not able to compose a control group that was similar to the test group. To position the participants within their cohort of eighth graders ('comparison group', $n = 171$), they all completed the *Attitude towards Math Inventory* (ATMI) questionnaire before and after the project, which consists of 40 five-point Likert-scale items on attitudes towards mathematics related to self-confidence, value, enjoyment, and motivation (Tapia & Marsh, 2004). For this research, the motivation scale (5 items; $\alpha = .793$ (pre-test), $\alpha = .803$ (post-test)) is especially relevant. The scores on mathematics tests in grade 8 have been collected for all students from the test and comparison groups as well.

Before joining the project, students were asked to write a motivation letter. At the end of the project, they completed a questionnaire covering several themes: (1) their motivation for programming, (2) the learning outcomes, (3) the transfer from programming to mathematics, (4) a comparison between the programming project and regular classes, and (5) the supervision during the project. Their answers to the questions were the starting point for semi-structured individual video-recorded interviews. We analyzed the motivation letters and interviews to identify students' reasons for joining the programming project and the factors of the learning environment within the project that contributed to the students' motivation using the categories distinguished by Malone and Lepper (1987) as a frame of reference: challenge, curiosity, control, cooperation and recognition. Fantasy and competition have been left out, since these were not relevant in this intervention. In addition, the interviews were analyzed to find out what lessons can be learned from the project for traditional mathematics class in grade 8.

Results

Preliminary analysis

As could be expected on the basis of students' voluntary participation and preference for STEM subjects, the score on the ATMI motivation scale was significantly higher in the programming

($M = 3.58$, $SD = 0.48$) than in the non-programming ($M = 2.66$, $SD = 0.71$) group ($t(159) = 4.05$, $p < .001$, effect size Hedges' $g = 1.32$). This was still the case after the project ended ($t(155) = 3.16$, $p = .002$, $g = 0.99$).

Students' intentions

The students' reasons for joining the project as described in the motivation letters can be summarized into four types, all of them related to cognitive curiosity. The first and most common reason concerned preparation for their future. They had a preference for STEM subjects in school and considered a programming job in the future as a likely option. As a second reason, students liked the challenge of learning something completely new. Third, some students who had already been introduced to programming wanted to deepen their skills. They did not manage to learn programming on their own, either because the learning materials were not suitable or because they missed support and guidance. As a last reason, one of the students wanted to learn programming, because the possibilities with respect to programs that can be coded are limitless. In the interviews, the eight students indicated that the project lived up to their expectations: it was more challenging, the assignments were more open, and they learned more than expected. The results are described in more detail below on the basis of Malone and Lepper's (1987) motivation taxonomy.

Individual motivation

Challenge

Providing an optimal level of difficulty for learners is important for motivation (Malone & Lepper, 1987). During the project, it went too fast or was too complicated for some students at the beginning of the introductory course and at the beginning of the advanced course. Despite the level of difficulty being too high during these moments, the eight participants did not withdraw. Their reasons to persevere were diverse: practical ("waste to stop after investing so much time"), social ("nice group"), and personal ("want to be proud of own accomplishment").

At the end of both phases, in which students designed and built their own games, the difficulty level was adapted to the skills of the student in a natural way, which made it challenging for everyone. The outcome was uncertain, as they did not know in advance whether they would manage to implement all their plans. They were creating something completely new that had not been created in the same way by others before. The students challenged themselves to make the best games possible and acquired additional skills when needed, both at the programming and at the mathematical level (e.g., gravity, radians). Both the weaker and stronger programmers appreciated that they were able to work at their own pace and difficulty level.

A challenging learning environment provides learners with structure in the form of short-term and long-term goals. This was the case in the programming project as well. During the learning phases, weekly short-time goals had to be accomplished. The final assignment (creating a math game) was split into some smaller short-term goals as well. For example, the students were not allowed to start programming before tutors approved their idea on paper. Although the students got frustrated when they did not get the green light directly, they were aware that the detailed

plan helped them during the rest of the development process. In this phase, the students also had to set their own goals, because all of the games were different and required their own planning.

Performance feedback helps to keep students motivated (Malone & Lepper, 1987). An advantage of programming is that some basic feedback is provided directly by the computer: does the game do what I want it to do? However, when a program does *not* work properly, it is often difficult to understand what is going wrong, and therefore human feedback is useful as well. The small group size, the weekly sessions, and the availability of the WhatsApp group enabled prompt performance feedback. The feedback was always constructive and if an explanation was not immediately clear, students kept asking until their problem was solved. Tutors and peers promoted the self-esteem of the students during class as well as during group presentations.

Whereas the programming project was challenging for all students, this was not the case with their mathematics classes. When it comes to giving feedback, programming was considered superior to mathematics as well. The direct feedback provided ‘for free’ in programming (e.g., error messages, output on the screen, behavior of the game) is not available when making mathematics homework where it requires effort from students to receive feedback.

Curiosity

Cognitive curiosity was one of the motives for students to participate in the project. Some of them had basic programming knowledge and wanted to learn more while others had no experience at all. When such curiosity and eagerness to learn something new is not present at the start, it will be more complicated to get students involved. Despite the absence of formative tests, students stayed actively involved and were willing to invest time and effort to achieve their learning goals because of their cognitive curiosity. According to one of the students, cognitive curiosity is not always stimulated properly in math class. Their teachers explain everything instead of promoting inquiry-based learning.

Control

According to Malone and Lepper (1987), having influence on your own learning process is a prerequisite for being motivated. All students appreciated the fact that they had the opportunity to follow their own paths in the introductory and the final assignment. Only one of the students indicated that the assignments could have been even more open (not restricted to games). The final assignment, where the students got several months to create their own math game, especially promoted their feelings of autonomy. It gave them a sense of power to be able to create their own game:

I really liked programming. It was problem solving, which took a great deal of time and when I then succeeded, it made me happy: “Yes, I finally did it”.

The final assignment created a highly responsive learning environment, where students and tutors were continuously interacting on how to proceed. Even during holidays and weekends, questions were being asked and answered in the project WhatsApp group.

In the video-interviews and on the questionnaire all students (strongly) agreed that they got enough freedom to work on their own plans. One of them explained why he enjoyed the level of

freedom in the project over the common practice at school: in the programming project he could use his own imagination and creativity instead of “following a cookbook recipe”.

Interpersonal motivation

Cooperation

Although programming is partly a lonely activity, the programming project incorporated cooperation between students at several levels as well. The first way in which cooperation was ensured was the level of instruction. Instead of a teacher being in charge, peers who were only three years older (‘tutors’) gave the lessons and guided the students’ projects. This peer-to-peer structure made the setting more informal and lowered the threshold for students, especially when they needed help outside of the classroom. As a second way of promoting cooperation, there were no classroom rules with respect to seating, walking around or talking. Throughout the project, the students got to know each other and they got more and more involved in each other’s games. They also started to help each other and shared ideas. The third cooperation mechanism was the WhatsApp group, where students shared their questions with their peers. Students who asked more questions during class were also more active in the app group, both in asking and answering questions. The tutors did not always provide ready-to-use solutions, but asked questions and gave suggestions to stimulate students to come up with their own solutions.

Cooperating on school tasks was not common for these students during class. The reasons given for their difference in behavior between the programming project and regular classes are the lack of challenge and social pressure in their regular classes.

Recognition

The students developed real games that could be played by others and their efforts were clearly appreciated by their surroundings. They were given the chance to present both their games once they were (almost) finished. The first presentation marked the transition of the introductory course to the advanced course. Their parents and siblings were invited at school for this presentation, where the students also received a certificate. They presented their games, but there was also time to try and play all games. The second presentation was given at the end of the project. The students sometimes showed their games to their friends and got recognition from them as well for their efforts.

Discussion and conclusions

The question to be answered was how aspects of a formal learning environment in which students’ autonomy is supported contributed to an increase of the intrinsic motivation of students that have a positive attitude towards learning. Malone and Lepper’s (1987) taxonomy provided an appropriate framework for understanding what happened during the intervention. Although the number of participants was small and the outcomes could not be compared with a control group, we have reasons to believe that providing autonomy indeed had positive consequences for many motivational aspects, both at the individual (challenge, curiosity, and control) and the interpersonal (cooperation, recognition) level. Most importantly, compared to traditional mathematics classes, the learning process became more challenging, because students were

allowed to set their own goals and could make their games as complicated as they wanted. Focusing on the need for autonomy directly affected the needs for feeling competent and social belonging as well (Ryan & Deci, 2010). Integrating autonomy with guidance and support increased students' feelings of competence and thus the motivation potential. In addition, the autonomy to choose their own level of difficulty allowed all students to feel competent. The need for social belonging was unintentionally met: the eight students coming from five different classes developed a pleasant working atmosphere together, which increased their motivation to proceed and persevere even when they found it difficult.

As a follow-up of this project, it would be interesting to implement the motivational aspects from the programming project in a regular class, including students with less positive attitudes towards learning. Another question for future research is whether focusing on the need for autonomy in regular mathematics classes could also strengthen students' feelings of competence and social belonging. The current attention for problem solving in mathematics education in the Netherlands (Doorman et al., 2007) is a promising step in this direction, because this provides opportunities for responding to students' need for autonomy. Lessons learned from our intervention are that it is important to make problems as open as possible allowing students to use their own creativity and to make them understand why problem-solving skills are relevant.

The focus of the current study was on the impact of autonomy on motivation. Another aspect that could be analyzed would be the influence of such a programming project on the students' creative thinking skills and their mathematical knowledge. The students indicated in the interviews that the programming project was more challenging and more interesting than their mathematics classes. Although the participants' motivation for mathematics was higher in the current study, they did not outperform their peers with respect to mathematics test scores before the project started. The learning outcomes with respect to mathematics have not been analyzed in detail in this study.

The way in which the programming project was organized shares characteristics with the Maker Movement, a community of hobbyists, engineers, hackers, and artists that builds on each person's ability to create things (Martin, 2015). The movement did not start in education, but educators are becoming interested in adopting the *making* activity into secondary education to enhance opportunities for students to engage in STEM practices. The Maker Movement makes learning more tangible and less abstract. The programming project has shown that this motivates students and that it makes them proud if they manage to create something they designed themselves. As a follow-up of the programming project, the eight project participants decided to participate in a national competition in which they are going to program a robot (the micro:bit).

References

Doorman, M., Drijvers, P., Dekker, T., Van den Heuvel-Panhuizen, M., De Lange, J., & Wijers, M. (2007). Problem solving as a challenge for mathematics education in the Netherlands. *ZDM – Mathematics Education*, 39(5-6), 405–418.

- Ke, F. (2014). An implementation of design-based learning through creating educational computer games: A case study on mathematics learning during design and computing. *Computers & Education*, 73, 26–39.
- Kebritchi, M., Hirumi, A., & Bai, H. (2010). The effects of modern mathematics computer games on mathematics achievement and class motivation. *Computers & Education*, 55(2), 427–443.
- Keller, J. M. (2009). *Motivational design for learning and performance: The ARCS model approach*. New York: Springer.
- Malone, T. W., & Lepper, M. R. (1987). Making learning fun: A taxonomy of intrinsic motivations for learning. In R. E. Snow, & M. J. Farr (Eds.), *Aptitude, learning and instruction* (pp. 223–253). Hillsdale, NJ: Lawrence Erlbaum Associates.
- Martin, L. (2015). The promise of the maker movement for education. *Journal of Pre-College Engineering Education Research (J-PEER)*, 5(1), 30–39.
- Neihart, M., & Betts, G. (2010). Revised profiles of the gifted and talented. Paper presented at the *11th Asia Pacific Conference on Gifted, Sydney, Australia*.
- OECD (2013). *PISA 2012 results: Ready to learn. Students' engagement, drive and self-beliefs. Volume III*. Paris: OECD.
- Papert, S., & Harel, I. (1991). Situating constructionism. *Constructionism*, 36(2), 1–11.
- Perrotta, C., Featherstone, G., Aston, H., & Houghton, E. (2013). Game-based learning: Latest evidence and future directions. *Slough: NFER*.
- Ryan, R. M., & Deci, E. L. (2000). Self-determination theory and the facilitation of intrinsic motivation, social development, and well-being. *American Psychologist*, 55(1), 68–78.
- Ryan, R. M., & Deci, E. L. (2009). Promoting self-determined school engagement: Motivation, learning, and well-being. In K. R. Wentzel, & D. B. Miele (Eds.), *Handbook of motivation at school* (pp. 171–195). New York: Routledge.
- Tapia, M., & Marsh, G. E. (2004). An instrument to measure mathematics attitudes. *Academic Exchange Quarterly*, 8(2), 16–22.
- Wouters, P., Van Nimwegen, C., Van Oostendorp, H., & Van der Spek, E. D. (2013). A meta-analysis of the cognitive and motivational effects of serious games. *Journal of Educational Psychology*, 105(2), 249–265.
- Wouters, P., & Van Oostendorp, H. (2017). Overview of instructional techniques to facilitate learning and motivation of serious games. In P. Wouters, & H. van Oostendorp (Eds.), *Instructional techniques to facilitate learning and motivation of serious games* (pp. 1–16). Cham, Switzerland: Springer.

“I want a high-educated job that pays well and is fun”: Secondary students’ relevance beliefs for taking advanced mathematics

Anders Wiik and Pauline Vos

Faculty of Science and Engineering, University of Agder, Norway

anders.wiik@uia.no, pauline.vos@uia.no

Many students experience the content of the mathematics classroom irrelevant to their lives. At the same time, achievement in mathematics is widely regarded as an important part of general education. In this paper, we report on a study regarding students’ relevance beliefs. For this, we network Engeström’s cultural-historical activity theory with Skovsmose’s theory on foregrounds, and introduce the terms ‘realized’ and ‘emergent’ activity systems. Students provided a wide variety of beliefs, in which the belief of mathematics as door opener to higher education and key to options in life was leading. The belief in the exchange-value of mathematics overshadowed beliefs on the use-value of school mathematics (for other school subjects, for undefined jobs or for mental training). We recommend teachers and textbook authors to include more information on the relevance of mathematics in future studies and jobs.

Keywords: Beliefs, exchange-value (of mathematics), cultural-historical activity theory, emergent activity systems, relevance (of mathematics).

Introduction

Many teachers of mathematics encounter the question “*why do we need to learn this?*”. While sitting in the mathematics classroom, listening to the teacher, doing tasks and tests, many students find little relevance in the mathematical activities they are made to engage in (Bishop, 1988; Onion, 2004). Rather than learning about the usefulness of mathematics or using mathematics to solve authentic problems from out-of-school contexts, the students learn that mathematics is about mathematical objects (numbers, triangles, x , etc.), and that they must find an appropriate procedure to reach a correct answer (and only one) within a short time frame (Dowling, 2002).

The finding that students ask this ‘why?’ question has been consistent for several decades. It opens a range of questions: why is it that many students find school mathematics irrelevant, how can mathematics teachers convey relevance, can mathematical modelling improve students’ experiences of relevance, do experiences of relevance influence performances, and so forth. We cannot cover all these issues. In the present study we focus on students and their reasons for engaging in advanced mathematics; if they chose that path, then they must somehow see it as relevant.

Students’ reasons for engaging in advanced mathematics are part of their belief system. Students have beliefs about themselves, about the school, about their peers, about life, and so forth. According to Skott (2014), beliefs are mental constructs that are subjectively true for the person in question, beliefs are considered relatively stable, and beliefs affect the person’s interpretations of experiences.

Following Hernandez-Martinez and Vos (2018), relevance is a connection between (1) a person’s subjective perception, (2) an activity by the same or another person, (3) an objective (an aim), and

(4) a value. In the present study, we consider *relevance beliefs* as a category of students' beliefs connected to a deliberate activity, in this case, choosing a certain course. Students' relevance beliefs can be mediated by the mathematical content, but also by interactions with others. A different category of relevance beliefs is part of teachers' beliefs and pertains to a teacher's perception of the relevance of mathematics to their students.

In the Norwegian school system, students in upper secondary can choose among several mathematics courses with differing aims, scope and difficulty. Students make a selection while negotiating contradictions, such as those between the apparent irrelevance of school mathematics, and the image of mathematics that is drawn out in the media as a subject of paramount importance for the future economic development of society (Lange & Meaney, 2018; Valero, 2017). This duality puts the students who engage in the hardest mathematics in an interesting position: how do they reason about selecting and pursuing the most advanced mathematics course available to their age group? Once they are in this course, they encounter mathematical topics such as derivatives, integrals, and trigonometry. In the school system, they encounter little information on how these mathematical topics are useful out-of-school. The few situated tasks are quite inauthentic. Also, teachers of such courses, generally, have a background in university mathematics with little emphasis on the mathematics' use-value outside of the school context. Our research on students' relevance beliefs regarding school mathematics was operationalized by the research question 'what reasons do students provide for engaging in a challenging mathematics course?'

Literature review

The discussion on the reasons for teaching mathematics has developed over the past two decades. According to Heymann (2003), mathematics is taught as preparation for later life, for promoting cultural competence, developing an understanding of the world, developing critical thinking, developing a willingness to assume responsibility, as practice in communication and cooperation, and to enhance student's self-esteem. Ernest (2005) provides a similar list, although he differentiates between reasons to teach practical versus advanced mathematics. In either case, it remains questionable whether students get to 'see' these reasons. Also, it has been argued that the above reasons remain at the pupil's level without considering the social role of school mathematics. For example, Pais (2013) suggests that school mathematics is important not only for its intrinsic purposes (use-value, aesthetics, etc.) but also because it has exchange value, for example as a testing and grading device that gives some students access to prestigious positions in society, and other students not. In the public discourse, school mathematics is typically associated with socio-economic development, in particular with the development of advanced technology (Lange & Meaney, 2018) and economic parameters on the individual and national level (Valero, 2017). In this cultural-political tug-of-war, it seems that school mathematics is struggling to communicate the use-value of mathematics.

A crucial challenge is the dialectics of two processes, the mathematization of knowledge and the demathematization of society (Jablonka & Gellert, 2007). The first has to do with mathematics being increasingly important in social, economic and political issues, for example in dealing with complex data through modelling and visualizations. This mathematization process is accompanied

by a demathematization process where mathematics is hidden and trivialized, for example when software encapsulates mathematical practices and datavisualizations can be generated in standardized formats by a few clicks.

Various teaching approaches to mediate relevance have been proposed. For example, in a study with engineering students, Hernandez-Martinez and Vos (2018) used tailored mathematical modelling activities and an invited talk by a professional to demonstrate how mathematics is used and valued amongst engineers. They found that several students experienced these activities as relevant to their future career, but some found the extra activities irrelevant, because their primary aim was to obtain a passing grade for the course.

Theoretical background: Cultural-historical activity theory

To study relevance beliefs, we consider students as having different backgrounds (where they come from) and foregrounds (aspirations, opportunities). The term *foreground* was developed by Skovsmose (2005) as analytic construct for interpreting learning processes, and is framed within the students' current political, cultural and social context. Additionally, we wanted to capture students' engagement in activities (doing mathematical tasks), which take place within a community (a classroom, peers, etc.), in which there are norms and conventions (e.g. the answers must be correct), tools (incl. language and symbol systems). To engage into an activity, a person is driven by a motive. In order to capture how the student (subject) is connected to the community and the object (aim of the activity), we adopted cultural-historical activity theory (CHAT) (Engeström, 2015), in which an activity system is a basic unit of analysis, see Figure 1.

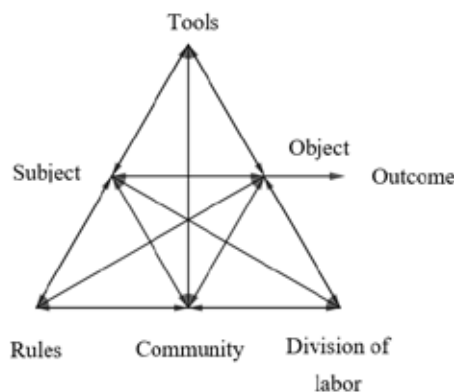


Figure 1: Engeström's (2015) model for an activity system

To analyse students' relevance beliefs, in particular their reasons for engaging with advanced mathematics, we assume that these can be affected by (1) the students' backgrounds (e.g. having a parent who uses mathematics in her workplace), (2) the environment in which the learning of mathematics takes place (the activity system of the classroom), and (3) the students' foreground (Skovsmose, 2005). This foreground can entail complex imagined activities, of which the student may not know much about; a student imagining herself as a future engineer may not know anything about the daily activities of an engineer, but nevertheless can aspire to become one. Thus, the activities envisioned in a student's foreground are not *realized activity systems* but *emergent activity systems*.

Method

To find participants, we contacted a teacher from an urban public upper secondary school. The teacher and the school were well-known to the first author, as he had previously worked there. The teacher agreed and informed the students in his class about the project in advance. Thus, students had time to consider whether or not they wanted to participate. When the interviewer visited the class, eight students (3 f, 5 m) agreed to participate. The interviews were conducted three days later.

The students were in grade 12, which in Norway is the second year in upper secondary school, and the year before the final exams. All had chosen the most challenging mathematics course available, referred to as *R1*, the name used in the local context. The students were interviewed in pairs for mutual support and comfort. All student names were anonymized, and the pairs follow the alphabet: A(ndré) and B(jørn); C(hristian) and D(aniel) and so on. The student pairs were interviewed for approximately 20 minutes on their back- and foregrounds. The interviews were semi-structured (Wellington, 2015) and the interview guide followed Kvale and Brinkmann (2015).

All interviews were audio-taped, transcribed, and analyzed using Skovsmose's (2005) constructs of back- and foreground, and the CHAT frame by identifying activity systems, particularly communities and associated objects and whether the activity systems were emergent or not. The statements were then interpreted in terms of relevance beliefs based on categories from the literature (exchange-value, use-value) and themes emerging from the data (Wellington, 2015).

Results

In the following, we present excerpts from the interviews. Due to space limitations, some answers very similar to others were left out. First, we asked the students why they chose the R1 course:

- Bjørn: I like mathematics and get good grades.
- Daniel: It's pressure from parents of course, and also some from my friends. Many of them are performing very well. I want to be on the same level, you know. Also, I suppose, career aspirations and further studies are... about having a relatively high-educated job which pays well... and is fun. I think that's very important.
- Fredrik: The reason I chose R1, it is kind of a continuation. I always performed well in maths ... and it went well in grade 11, so R1 was the natural choice.
- Gjertrud: I think math is fun. It's great fun when you get the same answer as the answer list. There aren't tons of pages about "it may be this", or "it may be that". It's great!
- Hilde: Because I want to keep the possibilities open because I don't know what to do next.

We see that students reacted very differently to this question. Two students, Gjertrud and Bjørn, answered to have chosen R1 because they liked mathematics, whereby Gjertrud emphasizes the clarity, and Bjørn likes getting good grades. Their answers are within the activity system of the present classroom, unlike the other students, who mention their background (e.g. parents' pressure, having been good in maths in the past), or their foregrounds (e.g. keeping options open, getting a

well-paid job). The second question asked the students explicitly about wishes and ambitions for future studies and career (foregrounds). They answered as follows:

- André: Likely that it'll be something related to science or technology. Or I'd study sports!
- Bjørn: I'm very unsure about further education, but probably I will do some university studies, and that will most likely be within science or technology. But I don't know much more than that, really, I'm a little unsure. It could be sports but it could also be social anthropology or psychology, those are things that I'm also interested in.
- Christian: I always had a dream of going into ... engineering direction for example ... be a marine engineer. That's what I have always wanted. But ... I don't know yet. I like to draw things, be creative, look at buildings, how they are built. And boats, how they break waves, how they manage to stay on water, not go down, like that.
- Emilie: I don't know what I want to become, but I'm taking IB [International Baccalaureate, a prestigious examination program] next year and then perhaps NTNU [Norwegian University of Science and Technology].
- Fredrik: I just try to keep all the doors open.
- Gjertrud: I think it will be something within science, like biology. But I also want to study psychology, I think everything is very exciting and I can't decide!
- Hilde: Nothing (...) I don't know.

The question on students' foreground showed that all students mentioned a future, but the range and focus differed. With the exception of Christian who had a clear goal, all were insecure and wished to keep options open. Many of them indicated future studies, most of which were within science and technology, and no one mentioned economy or business administration. Above, we see only Christian and Emilie mentioning a future profession beyond their studies, although for Emilie it was vaguer than for Christian. Towards the end of the interview, we asked why they thought they had to learn mathematics:

- André: I think [maths] is mostly about ... just having the foundation for further study.
- Bjørn: I think maths is really only about testing understanding and testing how the mind can assemble patterns and stuff. (...) it's about exercising the mind, IQ-testing ...
- Christian: ... ehh I think especially the maths we are learning now, for example, we will need it in physics. It is ideal for the ... calculations there ... to figure things out there.
- Daniel: I think a lot of mathematics we're learning is a little redundant. Of course, I see that many topics can be useful. Like what we're learning about now with differentiation, I think finding rate of change everywhere, can be relevant. But there are also the unnecessary things. Logarithms are actually one of the things that I'm not so sure of whether it is useful or not.

Emilie: I can help my kids, my little brother [with homework].

Gjertrud: I really feel that what we're learning is, like, further, that we're learning something we can use for ... Just like when you learned the multiplication table. Why do we need to learn multiplication? Now I use it all the time.

Most of the students considered their foreground. They mentioned that mathematics can be useful in future activities, for example in future studies. One student, Daniel, expressed concern that some mathematical topics may be useless. Only one student, Bjørn, considered the present activity system of the classroom when mentioning that the subject of mathematics has the purpose to train and test students' mental abilities. Emilie considered her present and emerging family activity system when she mentioned helping her kids and little brother. However, we must acknowledge that by first asking the students about their foregrounds, we primed the students to focus on their foregrounds thus biasing them towards focusing on the exchange value of mathematics.

Conclusion, Discussion, Recommendations

The present study on relevance beliefs was guided by the research question: what reasons do students provide for engaging in a challenging mathematics course, R1?. The interviews revealed that for some students, their backgrounds (parents, earlier success) and their present achievement and enjoyment in mathematics play a role. However, most students mentioned the belief that the R1 course is relevant for their future. Here, we saw different patterns emerging. For example, Daniel (“I want a relatively high-educated job which pays well... and is fun”) did not have a concrete plan for his future and strived to “keep his doors open”, he aspired a high-status job, possibly within engineering. Similarly, Christian (“I always had a dream of going into engineering and be a marine engineer”) looked beyond the course. The object of their engagement in the mathematics classroom had an exchange-value for getting into some form of higher education that led to a desired job. Their image of activities in higher education and workplaces were emerging activity systems, rather than realized activity systems. So, two subsequent emerging activity systems are in their foreground, see Figure 2 (left). For other students, such as Emilie (“I don't know what I want to become, but I'm taking IB and then perhaps NTNU”) and Gjertrud (“It will be something within natural sciences, everything is exciting, I can't really decide”), the R1 course was relevant as having exchange-value to enter some form of higher education and keep options open. They looked at a nearer future in higher education without concrete ambitions regarding professions. Thus, their foreground was one or more emergent activity systems at early stages, see Figure 2 (right).

Two students believed mathematics to be useful, for other subjects (Christian mentions physics) or in an undefined use (Gjertrud: “we're learning something we can use”). Not one mentioned usefulness for their daily life, nor did they say anything about how mathematics can be useful, for example in modelling, data analysis or data visualization. Others believed that some mathematics could be useless (Daniel: “logarithms, I'm not sure of whether it is useful”). They also mentioned the mental strengthening function of mathematics (Bjørn: “exercising the mind”). The most frequently given reason for choosing the R1 course was that they believed it keeps their options open, apparently knowing the hurdle function of mathematics. This exchange-value of mathematics overshadowed its use-value, as already indicated by earlier research on Scandinavian secondary

students (Nosrati & Andrews, 2017; Pedersen, 2013). This suggests that a demathematization of school mathematics has happened, where the usefulness of mathematics has become obscured, and beliefs about other social functions of mathematics, for example its exchange-value, have taken over.

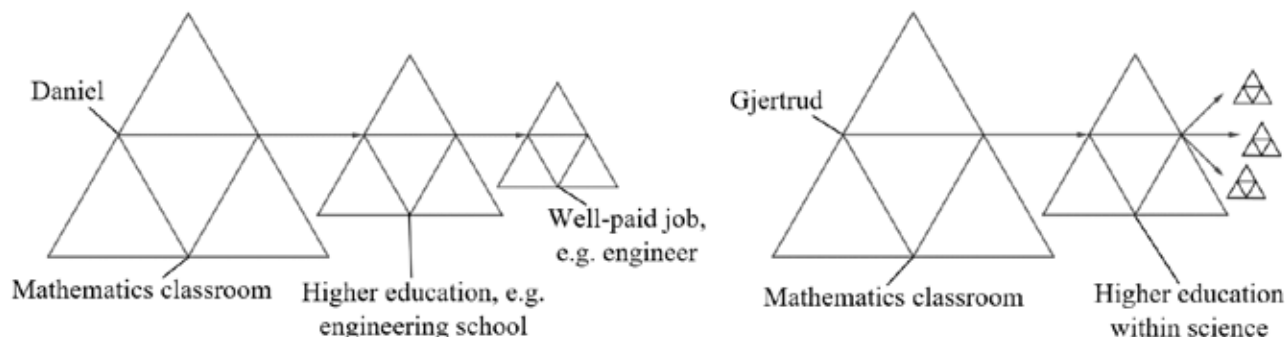


Figure 2: Students realized activity systems in the mathematics classroom, with emergent activity systems as objects; the case of Daniel (left) and the case of Gjertrud (right)

The networking of Engeström's (2015) and Skovsmose's (2005) theories proved fruitful in our analysis for connecting relevance beliefs to an activity (choosing a particular mathematics course). As a result of this, we found that for research on relevance beliefs regarding school mathematics, it is necessary to take into account students' (1) background, (2) current situation and (3) foreground.

Among the items on Heymann's (2003) list of reasons for teaching mathematics, the students on our study are clearly aware of its role in preparing for later life, although exclusively for further education and future workplace activities. The frequent reference to 'keeping all doors open' shows clearly that the students were aware of school mathematics' exchange value: a passing grade in this course is critical to many study programs that are otherwise not accessible. Furthermore, Daniel's assertion that the advanced mathematics course might lead to a "high-educated, well-paid and fun job" indicated an awareness of Pais' (2013) suggestion that school mathematics has a role in distributing prestigious positions in society. Based upon our research, we recommend, first, that beliefs may be divided into different categories, and 'relevance beliefs' regarding the usefulness of school mathematics is a separate category within students' belief system. Second, teachers, teacher educators and text book authors ought to create resources for students to inform them about the use-value of mathematics, not only within professions typically associated with mathematics (e.g. engineering and economy) but also its use-value in medical and social disciplines for purposes of modelling, analyzing, communicating and visualizing data. Clearly, many of the reasons for teaching mathematics mentioned in the literature have not reached the students.

References

- Bishop, A. J. (1988). *Mathematical enculturation: A cultural perspective on mathematics education*. Dordrecht, The Netherlands: Kluwer.
- Dowling, P. (2002). *The sociology of mathematics education: Mathematical myths/pedagogic texts*. London, UK: Routledge.

- Engeström, Y. (2015). *Learning by expanding: An activity-theoretical approach to developmental research* (2nd ed.). New York: Cambridge University Press.
- Ernest, P. (2005). Platform: Why teach mathematics? *Mathematics in School*, 34(1), 28–29.
- Heymann, H. W. (2003). *Why teach mathematics? : A focus on general education*. Dordrecht, The Netherlands: Kluwer Academic.
- Hernandez-Martinez, P., & Vos, P. (2018). “Why do I have to learn this?”: A study on students’ experiences of the relevance of mathematical modelling activities. *ZDM*, 50(1–2), 245–257.
- Jablonka, E., & Gellert, U. (2007). Mathematisation–demathematisation. In U. Gellert & E. Jablonka (Eds.), *Mathematisation and demathematisation: Social, philosophical and educational ramifications* (pp. 1–18). Rotterdam, The Netherlands: Sense Publishers.
- Kvale, S., & Brinkmann, S. (2015). *Det kvalitative forskningsintervju* (3rd ed.). Oslo: Gyldendal.
- Lange, T., & Meaney, T. (2018). Policy production through the media: The case of more mathematics in early childhood education. In M. Jurdak & R. Vithal (Eds.), *Sociopolitical dimensions of mathematics education: From the margin to the mainstream* (pp. 191–207). Cham, Switzerland: Springer.
- Nosrati, M., & Andrews, P. (2017). Ten years of mathematics education: Preparing for the supermarket? In T. Dooley & G. Gueudet (Eds.), *Proceedings of the 10th Congress of the European Society for Research in Mathematics Education (CERME10)* (pp. 1642–1649). Dublin, Ireland: DCU Institute of Education and ERME.
- Onion, A. J. (2004). What use is maths to me? A report on the outcomes from student focus groups. *Teaching Mathematics and its Applications*, 23(4), 189–194.
- Pais, A. (2013). An ideology critique of the use-value of mathematics. *Educational Studies in Mathematics*, 84(1), 15–34.
- Pedersen, I. F. (2013). “I need advanced mathematics to pursue the career of my choice”: Norwegian students’ motivations for enrolling in mathematics and plans for post-secondary studies. *Nordic Studies in Mathematics Education*, 18(1), 61–83.
- Skott, J. (2014). The promises, problems, and prospects of research on teachers’ beliefs. In U. Fives & M. G. Gill (Eds.), *International handbook of research on teachers’ beliefs* (pp. 13–30). New York: Routledge.
- Skovsmose, O. (2005). Foregrounds and politics of learning obstacles. *For the Learning of Mathematics*, 25(1), 4–10.
- Valero, P. (2017). Mathematics for all, economic growth, and the making of the citizen-worker. In T. S. Popkewitz, J. Diaz, & C. Kirchgasler (Eds.), *A political sociology of educational knowledge: Studies of exclusions and difference* (pp. 117–132). New York: Routledge.
- Wellington, J. (2015). *Educational research: Contemporary issues and practical approaches* (2nd ed.). London: Bloomsbury Academic.

TWG09: Mathematics and Language

Introduction to TWG09: Transforming language-sensitive mathematics education research into papers and posters

Núria Planas¹, Marie Therese Farrugia², Jenni Ingram³ and Marcus Schütte⁴

¹Autonomous University of Barcelona, Catalonia-Spain; nuria.planas@uab.cat

²University of Malta, Malta; marie.t.farrugia@um.edu.mt

³University of Oxford, England-UK; jenni.ingram@education.ox.ac.uk

⁴Leibniz Universität Hannover, Germany; marcus.schuette@ifs.uni-hannover.de

In pursuing the writing and presenting of ‘autonomous’ conference texts –i.e., conference texts functioning in terms of meaning making on their own–, all authors deal with issues of reduction, transformation and representation of the concepts and contexts of initiation and development of their research. In this introduction, we point to challenges tied to the writing and presenting of language-sensitive mathematics education research for communication in conference formats. We discuss some ideas for the improvement of current guidelines and standardised decisions relative to processes and texts produced within the CERME culture. Drawing on experiences provided through our roles as co-leaders of the ‘Mathematics and Language’ thematic working group (TWG09), along with the insights gained from the TWG09 set of papers and posters on the occasion of CERME11, each of us brings a focus to the discussion of challenges and changes that might be feasible and worthwhile.

Keywords: Research communication, conference formats, written and oral languages, language-sensitive mathematics education research, representational challenges.

Introduction

In conference papers, but also in journal articles, we often read sentences like “because of space restrictions, we do not show the totality of the interview transcript”, or “the lesson data transcribed has been translated into English”, “the lesson data translated into English have been transcribed”. It is also common to find written research without explanation of, or reference to, the original languages involved in data collection and/or the ways of addressing the transformation and reduction of data into certain written formats. These types of omissions and their implications at many levels deserve discussion in any domain of study. Such discussion is even more relevant in mathematics education research that is largely language-sensitive, regardless of the analytical traditions and theoretical standpoints taken. Indeed, throughout meetings of the ‘Mathematics and Language’ Thematic Working Group of ERME (TWG09), including the most recent meeting at CERME11 in Utrecht, many participants have expressed interest in challenging and improving some of the tacit typical practices when dealing with lesson and interview oral data in papers and posters.

In the following sections, we identify four major challenges around fostering a more language-responsive communication of research work, and propose specific changes and directions that could help in this respect. The two guiding questions that we pose to ourselves are as follows:

- What are some of the challenges of communicating language-sensitive mathematics education research in written and oral conference formats, particularly the CERME format?

- What changes in both the tacit positions of researchers and the written/oral products could improve the communication and understanding of the research reported?

Drawing on the experiences provided by our roles as co-leaders of TWG09, along with the insights gained from the TWG09 set of 28 papers and 2 posters on the occasion of CERME11, each of us brings a different focus to the discussion of challenges and changes that might be feasible and worthwhile. We hope that the sections below will give a sense of how research in the domain of mathematics education and language can inform important reflections for the whole field. Although there is increased understanding of the relevance of language in the various domains of mathematics education research, the point at which language issues are considered in written and oral conference formats is inconsistently reported and sometimes treated as a minor question. In our discussion below, each challenge is based on and arises in a number of papers and posters presented at CERME 11, however, each paper and each poster is only used once to illustrate the points being made.

The challenge of original language information

The papers of Azrou, of Mizzi, of Prediger, Uribe and Kuzu, and of Salekhova and Tuktamishov are examples of work conducted in multilingual classroom settings addressing issues of mathematics education and language diversity. Mizzi provides two-column transcripts with the bilingual lesson data in the source languages, Maltese and English, in one column and the target English language in the other, hence doubling the length of the transcript in terms of space taken in the paper. When confronted with text formats of eight pages, doubling transcripts may require about two-thirds of the totality of the report for data presentation. In the papers of Azrou, of Prediger, Uribe and Kuzu, and of Salekhova and Tuktamishov, transcripts of the Arabic-French, Turkish-German and Tartan-Russian source versions of bilingual talk in the respective lessons are not shown, with all the written pieces of data translated into English, its alphabet and writing direction. Similarly, Ranges and Eikset refer to Norwegian students' home language, while presenting transcripts in English, and Rønning and Strømskag present data of conversations in a planning meeting with teachers of Norwegian schools in English. The use of Norwegian is limited to translating technical vocabulary and occasional incorrect terminology. In their presentations, some of these authors claimed practical reasons for the option chosen and particularly mentioned their willingness to share the original data with those participants who had further interest in their works.

Looking back at the whole set of papers and posters across ERME thematic working groups compiled in the CERME10 Proceedings (Dooley & Gueudet, 2017) and given the space restrictions, it is not surprising that the presence of original languages tends to be avoided with the resulting monolingual bias in the perception, representation and communication of the contexts of research. Any option in this respect is problematic. For those papers that incorporate information of original language with translated language text, accomplishment of space restrictions is not trivial. On the other hand, for all papers that have languages other than English in their contexts of research, translation between languages is not trivial either. At CERME11, in his paper, Sträßer refers to the many challenges of translating data and ideas from a source language to a target language (see also Geiger & Sträßer, 2015). Overall, we find several examples of papers dealing with the decision of how to communicate in English what is said in the source language. In Chesnais' paper, the discussion refers to French

grammatical features of the students' interactions, while the presentation of interaction transcripts and of their interpretation is done in English. This can also be found in Erath's paper, where the focus is on lexical and syntactical means produced in German but are presented and written in English. At the most recent meeting of TWG09, only the papers of Ingram and Andrews and of Postenilcu report work developed in a situation in which the source language of data is English exclusively.

Despite the difference of options being used, over these years the discussions in TWG09 clearly reveal that groups of authors, and in general all participants, consider data in the original languages as relevant evidence, not a technical distraction or tangential to the work we do. Reflections in this respect can be found in Planas, Chronaki, Rønning and Schütte (2015), Planas, Ingram, Rønning and Schütte (2017), Planas, Schütte and Morgan (2018), and Rønning and Planas (2013), among other CERME presentations and publications. The belief that untranslated source data is worthwhile, and that access to it is key, are strongly shared and rooted in our working group. We are very aware that untranslated source material retains a great deal of linguistic information that is of interest and can disappear in translation, with important implications for data analysis, interpretation and results. Importantly, the source languages provide vital information for gaining insight and understanding in multilingual contexts of mathematics education research, as well as for developing critical awareness of the monolingual emphasis under which most research products are shaped in our field.

Furthermore, the body of CERME Proceedings brings up paradoxical situations such as having a paper with the source data in French that is only read in its English translation by researchers who are French speakers or who are proficient in this source language and could therefore have a more comprehensive and direct understanding of the research reported in its original language. For each paper or poster, a number of researchers have the expertise and are able to review material in the original languages. With that in mind, ERME could possibly consider some changes oriented to facilitate access to the source languages without the necessity for a dramatic reduction of the space available for discussion in papers. In the age of technological developments and virtual environments, new arrangements could be made to include a multilingual site for registered access to repositories of source data matched with printable texts in the conference proceedings. Such arrangements would be similar to the practical experiences of what some journals do in the electronic version. This way, after consultation, authors could choose the option of linking their papers to the protected site containing information regarding the materials and texts that can be made available in the data's original languages. By using this option, authors could improve the communication of the research reported in the conference format.

The challenge of choosing what data is relevant for the paper

The current practice of CERME papers is to offer authors who are transcribers the choice of two transcript styles. Either they may use Transcript or Numbered Transcript if the author needs to refer to specific lines in the text. However, the template does not number lines, it numbers turns. In language and interactional research within mathematics education, there is often a need to be more precise. For example, it is frequently interesting to consider interactions where two or more people are speaking at once, or when their turns overlap, particularly when considering classroom interactions where there are multiple speakers and the data is often messy, such as in the work by

Friesen, Schütte and Jung. Gestures, gazes and movements, such as pointing, that occur in social interaction are also often highly relevant to the analysis and these often occur concurrently with the spoken discourse. In these situations, line numbers rather than turn numbers are more appropriate, as well as the potential to use specifically designed transcription systems. Conforming to the transcription styles often results in a reduction of the data that members of TWG9 can present, and in some cases results in the loss of that data in the written presentation, as authors need to rely on their short presentation to share certain features of their data. More flexibility in the transcription formats is necessary if we are to offer closer representations of the language data that we are researching.

Greater flexibility in the transcription formats also implies some reference in the template for authors who choose to emphasize the multimodal nature of the data they work with, and who particularly do not produce verbal representations of gestures, body movements and uses of physical space and material objects, but opt for multimodal transcription systems. With the increasing use of video recording in our research field and the development of newer visual methods and analytical frameworks such as digital ethnography, the question of inserting photos and images in the transcript is very timely. Much of the research in TWG09 combines gestural, visual and verbal data, and hence goes beyond the purely verbal mode. This is the case of the papers by Fyhn and Hansen on how meaning of pattern changes depending upon the objects with which students are familiar and interact with, and by Götze on meaning-related language for understanding multiplication where the language is tightly associated with visual representations. The idea of communication ‘mode-switching’ (Sindoni, 2014), which relates to an important feature of multimodal data, is also present in the paper by Peters regarding learners’ reactions and responses to auditory material from radio podcasts.

Some theoretical traditions (e.g., conversation analysis, corpus linguistics) have a specific transcription system of annotation and coding associated with them where not only line numbers are required. There is a specific font and way of spacing transcripts to illustrate features such as pausing, overlapping speech and concurrent gestures (see the topic of transcription decisions and related representational differences and analytical implications in Ingram & Elliott, 2019). These systems often come with complex notation to indicate not only what was said, but also how it is said and this notation needs to be explained in the paper in order for the reader to make sense of the transcripts, which is another challenge to face in meeting the length requirements. Many of the papers in TWG09 are focusing on how students make sense of the mathematics they are engaging with, and this involves a combination of spoken interactions, written materials, and ways of interacting with objects. The current traditions around the written presentation of papers limit how this data can be shared as well as how much data can be shared. As suggested above, the repository of source data could enable the sharing of video or audio data that is often used during the presentations. This might also be a solution to the issue around the need to share transcription conventions, as well as offering an opportunity to share longer (multimodal) transcripts or additional transcripts for the interested reader.

The challenge of comprehensibility of theory development

The last two challenges differ in nature to the previous ones since they focus on how to make theory and conceptual development more accessible to the readers and the audience. In the domain of mathematics and language, many researchers are guided by a qualitative-reconstructive methodology

and they use methods of qualitative social research in their inquiry design. The aim of many research endeavors is to reconstruct underlying structures and patterns of specialized verbal processes of negotiation through extensive analysis of data and the help of a comparative approach (“constant comparative method” in Strauss & Corbin, 1994, p. 273). Generally, research gaps can be identified and based on these gaps components of local theories or theories with limited scope but high comprehensibility are developed using the processes of conjecture and abduction (Peirce, 1991). In the conference proceedings and oral presentations of TWG09 –presumably similar to what happens in other working groups of CERME– only a small portion of the data can be communicated in form of a transcript. However, a transcript excerpt does not usually display, nor even illustrate with precision, the complex process of theory development. Rather, the process emerges across many structural comparisons within an analysis of constant selection of features, decontextualization to a certain degree, and theoretical abduction. In oral presentations and conference proceedings authors can usually only show the best possible visualization, explanation and synthesis of the developed theories, which are mostly striking examples from instances of data materials.

Some of the papers declare and address the challenge of presenting moving from concrete instances of data to theory development in the short space available. The papers by Sauerwein, by Keuch and Brandt, by Alfaro, by Bednorz, and by Umierski and Tiedemann all include some mention to the complexity of making theoretical development explicit and precise by means of the choice and use of selected empirical material. In some of these papers, the examples mirror the process of gradual theory development with local scope in a limited way and are not as comprehensible as originally intended or expected. The empirical material in the transcripts does not, and cannot, provide a sufficiently clear illustration of the theoretical argument. Cohors-Fresenborg and Mackay, Thurlings, Schüler-Meyer and Pepin, during the time for oral presentation of their respective posters, were reflective about the limits of communicating theory development and conceptual abstraction through the examination of examples. For understanding the concepts in the poster of Cohors-Fresenborg, for example, the relationship between what is observed in the lesson data and the scope of application of the concepts introduced by this author is very important.

For compatibility reasons with future research endeavors, especially from early career researchers, it would be preferable if publications and presentations could give a deeper insight into the cumulative process of theory development. Following the line of suggestions in the previous sections, this could also be made possible through a protected area, where researchers could provide further material for the working group. Thus, the gradual process of theory development for a certain period of time could be demonstrated and shared. This would include transcripts that are not yet published but were crucial for the forming of the developed theory components in the course of the constant comparative method. Additionally, there would be an opportunity to allow any author including early career researchers who have completed their PhD, to present their research process at the conference and give them the opportunity to publish a longer paper in the protected area. Anyone interested could hand in an 8-page paper, from which some could then be selected to be offered the opportunity to write a longer ‘master-paper’. All this would certainly contribute to the generation of more activity and transparency in theory building.

The challenge of meeting informed audiences

The struggle of TWG09 participants to find new ways of expressing an updated understanding of what research on mathematics and language means today, and what the identity features of the domain are, frames the context for this last challenge. On the occasion of CERME11, due to the increase of the group size, a division of TWG09 into participants attending either Group 09A or Group 09B for all sessions was necessary. There were no ‘subtitles’ for the subgroups; rather, papers and posters were grouped into (usually) sets of threes by the TWG co-leaders, based on a perceived commonality among them. The organizational need for a practical division due to the number of participants, however, brought up a more profound conceptual discussion. Half of the papers had multilingual settings in common and hence, the recognition that a number of papers shared some multilingual specificity and fitted with each other was used in the final grouping. In the end, one language group consisted mostly of papers that considered language, interaction or mathematics within contexts that are (at least overtly) monolingual, as was the case for the paper of Theens (Swedish), and of Farrugia, which describes a context wherein English was used as *lingua franca*. In these studies, the languages of the speakers are (generally) not taken into account, unless the speakers themselves make it relevant. The second language group was then mostly constituted by papers wherein the presence of two or more languages in the mathematics classroom is a key element of the discussion, as were the papers of Schüler-Meyer, Prediger and Weinert (German-Turkish), of Ní Ríordáin and Flanagan (Irish-English), and of Chico (Catalan-Spanish).

While the arrangement appeared to make sense and to ‘work’, and participants’ collaboration ensured that things ran smoothly, during the last day it was suggested that multilingual specificity and interactional foci had been central to both Group 09A and Group 09B. In fact, throughout the working sessions the emergent discussion of the multilingual specificity in the papers presented in each subgroup became somehow problematic. The characteristic of ‘multilingual’ as being restricted to group languages was unintentionally suggested at some points in the discussions of the two subgroups and hence, the broader interpretation of switching between vocabularies, grammatical constructions, intonations, gestures, and so on was less attended to in one of the subgroups but considered in parallel to multilingualism in the other. For a long time, our group has discussed studies that focus on linguistic challenges faced by students that are not necessarily related to a diversity of ‘natural’ language systems but generally involve multilingualism in the form of (mode) switching between ways of communicating in mathematics lessons. In his paper at Utrecht, for example, Gíslason presented the linguistic and communication repertoires and challenges faced by students who are low attaining in mathematics. The determination of operational criteria for splitting TWG9 is not trivial at all and what is difficult indeed is to find labels of conceptual distinctiveness that do not diminish the opportunities for all participants to share their research with the interested audience.

In particular, the challenge of the group size with the subsequent splitting of TWG09 leads to the challenge of allocating the papers and posters for their presentation to the most appropriate audience. The conference format of short presentations does not allow much time for clarification of approaches and meanings that participants in the audience must then infer. What can be a rather comprehensible presentation for an audience, may not be equally comprehensible for an audience unfamiliar with specific theoretical stances and research emphases. With respect to this situation, it seems again

important to offer authors the possibility of uploading additional material of their work in a protected site so that other participants can more easily follow the ideas and reasoning both in advance and after the working sessions. It is important, for instance, to know what is involved in the use of common terms like ‘*linguaging*’ that may refer to very different stances and emphases (Shohamy, 2006). As can be attested by the variety of topics addressed by the papers and posters in TWG09, studying language in mathematics education may take many forms of *linguaging*, some of which involve different ‘*natural*’ languages or language systems, while some others are related to the alternation of discursive practices necessary for participation in mathematical activity. The papers by Fetzer and by Albano, Coppola and Ferrari show a kind of *linguaging* focused on written practices of argumentation, with shifts between ‘*natural*’, symbolic and pictorial languages within one language system (German/Italian). Other papers with multilingual lesson data show a kind of *linguaging* placed in the newer tradition of ‘*translinguaging*’ as the act of utilizing one’s full linguistic repertoire (García & Kleyn, 2016). Participants also need to know what is involved in the use of the term ‘*multilingual*’. TWG09 participants are aware that attempting to talk about group languages in the classroom context as separate (or separable) systems is artificial and hence, unhelpful for research purposes, but there may be substantially different ways of consider multilingual specificity in data. Of course, the use of group languages overlaps with the use of classroom- or subject-specific discursive practices, so that ‘*language in the mathematics classroom*’ is a complex area of study with a number of stances and emphases that cannot be introduced in short presentations.

We anticipate that the group size will require organizational measures in the near future. Due to the overlap between general language or discursive elements and the ‘*media of instruction*’ of the classroom, but also to questions regarding the precise meaning for contested terms in the domain, it would be important that the two subgroups find the time to have a joint session. There is a lot of commonality in the theoretical and methodological approaches that all members of the group draw upon or consider in their work, and thus identity distinctiveness should be addressed very cautiously. It will be an internal decision amongst TWG09 participants as to how to utilize the separate and joint sessions, in order to encourage fruitful and deeper discussion; however, it will be equally crucial that the CERME organization allows for the flexibility needed with regard to the organization of sessions as well as the provision of additional information and materials.

More challenges in what comes next

The idea for this introduction paper began as a response to guiding questions posed to ourselves regarding challenges and revisable options of communicating language-sensitive mathematics education research in the written and oral CERME formats. Attention to these questions has been of help to uncover a number of theoretical and reflective issues behind the intricacies of improving the representation and sharing of our work within the CERME community. In our role of co-leaders we have done our best to become openly critical in bringing together some of the challenges that emerge when addressing the writing and presenting of language-sensitive mathematics education research for communication in conference formats. Despite the focus on, and discussion of, conference formats, we can also learn something important about the heterogeneous nature and theoretical complexity of the activity that goes in TWG09. Some of these many different challenges and approaches to mathematics education research on language will be investigated more closely in the diverse papers

and posters that constitute this chapter of the proceedings. Through these papers and posters, we will be able to find out what the authors themselves consider the challenges to be that make a strong case for their studies and professional development as researchers in the domain. The creative dialogue with all their points of view will enrich what we have written in more specific and unique ways.

References

Dooley, T., & Gueudet, G. (Eds.) (2017). *Proceedings of the Tenth Congress of the European Society for Research in Mathematics Education*. Dublin, Ireland: DCU Institute of Education and ERME.

García, O., & Kleyn, T. (2016). *Translanguaging with multilingual students: Learning from classroom moments*. New York: Routledge.

Geiger, V., & Straesser, R. (2015). The challenge of publication for English non-dominant-language authors in mathematics education. *For the Learning of Mathematics*, 35(3), 35-41.

Ingram, J., & Elliott, V. (2019). *Research methods for classroom discourse*. Oxford, England: Bloomsbury Academic.

Peirce, C. S. (1991). *Schriften zum Pragmatismus und Pragmatizismus* (Trans. K. O. Apel). Frankfurt am Main, Germany: Suhrkamp.

Planas, N., Chronaki, A., Rønning, F., & Schütte, M. (2015). Challenges and research priorities in the context of mathematics and language. In K. Krainer & N. Vondrová (Eds.), *Proceedings of the Ninth Congress of the European Society for Research in Mathematics Education* (pp. 1318-1324). Prague, Czech Republic: Charles University and ERME.

Planas, N., Ingram, J., Rønning, F., & Schütte, M. (2017). Introduction to the papers of TWG09: Mathematics and language. In T. Dooley & G. Gueudet (Eds.), *Proceedings of the Tenth Congress of the European Society for Research in Mathematics Education* (pp. 1231-1234). Dublin, Ireland: DCU Institute of Education and ERME.

Planas, N., Schütte, M., & Morgan, C. (2018). Mathematics and language. Lessons and directions from two decades of research. In T. Dreyfus, M. Artigue, D. Potari, S. Prediger, & K. Ruthven (Eds.), *Developing research in mathematics education: Twenty years of communication, cooperation and collaboration in Europe* (pp. 196-210). London, England: Routledge.

Rønning, F., & Planas, N. (2013). WG9-Language and mathematics: Its origin and development. In B. Ubuz, C. Haser, & M. A. Mariotti (Eds.), *Proceedings of the Eighth Congress of the European Society for Research in Mathematics Education* (pp. 1491-1497). Antalya, Turkey: Middle East Technical University and ERME.

Shohamy, E. (2006). *Language policy: Hidden agendas and new approaches*. London, England: Routledge.

Sindoni, M. G. (2014). Through the looking glass: A social semiotic and linguistic perspective on the study of video chats. *Text & Talk*, 34(3), 325-347.

Strauss, A., & Corbin, J. (1994). Grounded theory methodology. In N. K. Denzin, & Y. S. Lincoln (Eds.), *Handbook of qualitative research* (pp. 273-285). London, England: Sage.

Taking advantage of the different types of mathematical languages to promote students' meaningful learning

Helen Alfaro Víquez

University of Tampere, Finland; helen.alfaroviquez@tuni.fi

The low performance in mathematics of non-mathematics majors has forced higher education institutions to implement different measures to address the problem. Many of these measures have focused on curriculum modifications. This study presents a methodological way of approaching the problem, using written exercises, which combine symbolic, natural and pictorial languages to improve the mathematical learning of university students. These exercises promote the development of essential mathematical skills to achieve successful mathematical learning. In this paper, I describe one exercise and analyze the solutions of 28 students of Calculus I course, at the University of Costa Rica. The results suggest that the exercises allow exploring the benefits of different mathematical languages, so that the students can make connections between knowledge and theoretical concepts.

Keywords: Mathematical languages, university mathematics education, languaging exercises.

Introduction

During the last few years, improving the mathematics performance of university students has been an important issue. Special attention has been paid to students of non-mathematics majors in the transition process from school to university (Goodchild & Rønning, 2014), since the students' mathematical background is not strong enough when they enter university. They may reach the levels of reproduction of procedures, but without understanding the mathematical significance of the contents involved (Winsløw et al., 2018). Thus, the students do not have the level of mathematical reasoning, abstract thinking and rigor required at university (Gruenwald, Klymchuk, & Jovanoski, 2004). This situation is reflected in the alarming failure and dropout rates presented in the initial courses, from many students who have mathematics in their academic programs (Biza et al., 2016).

This gap in the mathematical knowledge of students has led universities to implement several measures to improve the problem. For instance, peer work, bridging courses, mathematical support centers, interactive lectures, videos, digital assessment, among others (Mustoe & Lawson, 2002). White-Fredette (2009) highlights that the actions taken for facing this situation should consider the instructional level. Similarly, Gruenwald et al. (2004) suggest that teachers should look for effective ways to help students to “understand the abstract concepts, master the formal language, follow rigorous reasoning, get a good feeling for the mathematical objects and acquire so-called mathematical maturity” (p. 12). In a nutshell, attention should be paid to the students' understanding of the mathematical concepts and the need to develop their mathematical thinking.

Considering this need, I present the written languaging exercises as a teaching resource to improve the understanding of mathematical concepts by students, using different languages. The exercises ask students to provide written explanations or justifications using symbols, drawings or their own words. In this way, they must organize their thoughts and review the reasoning that led to their solution, being aware of the knowledge and concepts used, and the connection between them. In Finland, the

linguaging exercises applied in university engineering mathematics (Joutsenlahti, Ali-Löytty, & Pohjolainen, 2016) and honor mathematics courses (Silius et al., 2011) have showed promising results. In this paper, I present the outcomes of applying linguaging exercises in a Calculus I course for non-mathematics majors in Costa Rica.

Theoretical background

As literature indicates, it is necessary to promote conceptual understanding in students (Engelbrecht & Harding, 2015), teach them how to make connections between concepts (Nardi, 1996) and how to deal with the abstract nature of mathematical concepts and the complexity of mathematical thinking (Biza et al., 2016) required at the university level. Those actions may help students to experience a successful learning of mathematics and facilitate the process of transition from school to university. The mathematical proficiency theory offered by Kilpatrick, Swafford, and Findell (2001), proposes the development of key mathematical skills that help in this purpose. The theory suggests five main competences that are necessary to accomplish effective mathematics learning: conceptual understanding, procedural fluency, strategic competence, adaptive reasoning and productive disposition. These competences promote, among other, the ability to identify connections between concepts; to understand and provide justifications and reasons for procedures; to perform procedures flexibly, accurately and efficiently, knowing how, when and why to do it; to think logically, to represent, formulate and solve mathematical problems in different context; and to consider different strategies of solution. All the strands are therefore interwoven and should be practiced equivalently.

The mathematical proficiency competences can be developed by means of linguaging exercises, which are designed based on the linguaging theory. Linguaging is defined as the students' expression of their mathematical thinking using different languages (Joutsenlahti et al., 2016), including mathematical symbolic language (SL), natural language (NL) and pictorial language (PL). In this way, the linguaging written exercises combine models and tasks, which aim to promote different mathematics competencies. As well, the exercises use different languages to access the characteristics of the mathematical objects and students' mathematical thinking.

Languages play an important role in mathematics communication. Following the semiotic approach, it is a tool for representation, communication, thinking and constructing knowledge (Schleppegrell, 2010). Lemke (2003) argues that the integration and cross-referring of NL, SL and PL languages "form a single unified system for meaning-making" (p. 215) and is the combination of them that make possible the mathematical reasoning (Schleppegrell, 2010). In addition, research evidence that for students, the use of the three languages facilitates the understanding of concepts and mathematical exercises (e.g. Alfaro, 2018; Joutsenlahti et al., 2016). The use of different languages allows the exploration of more properties of a mathematical object than using only one (Dreher, Kuntze & Lerman, 2016), because each one shows specific features and connotations (O' Halloran, 2015).

The choice of written linguaging exercises is based on research which suggests that by writing, students have to organize their thoughts, review and clarify the mental processes they went through in the solution of a task (Morgan, 2002). Furthermore, they must try to express it in a clear and concrete way, so that readers can understand their mathematical thinking (Morgan, 2002). According to Kline and Ishii (2008), this process improves students' understanding.

Context and method

Due to the high rates of failure of non-mathematics majors in Calculus 1 course in the University of Costa Rica, the School of Mathematics decided to introduce the pre-calculus course, in order to provide students with the necessary knowledge for studying mathematics at university level. However, the high failure rates simply transferred to this new course, and the problem remains unsolved. Therefore, in this study, I suggest a different way of approaching the problem, with a resource that can be introduced in classes for students to have meaningful learning, by analyzing their solution processes when they have to write or explain them.

These languaging exercises were applied to 28 voluntary participants of non-mathematics major taking Calculus 1 course at the University of Costa Rica. There were 17 languaging exercises (see Alfaro, 2018, for details) that were used in class or as homework during the study of the derivative. The exercises were designed combining different tasks, including: explain with your own words, complete missing steps, identify mistakes, argumentation of the solution, organizing solution steps, and follow given solutions; combined with the use of the three languages. The purpose of the exercises is to promote the different competences of the mathematical proficiency theory, especially procedural proficiency, conceptual understanding and adapting reasoning; and to allow students to experience the use of different languages to express their thoughts.

The aim of this paper is to answer the research question: how the students' understanding of the cases where the function is not derivable, can be evidenced by SL, NL and PL. For that purpose, I describe one exercise (number 3) which exemplifies the use of the three languages to make different representations of a mathematical knowledge. The intention is to provide evidence of the languaging exercises as an effective teaching resource for improving students understanding of mathematical concepts. For the analysis of students' solutions, I did a qualitative analysis based on the established knowledge of derivatives for the Calculus I course, studies about students' difficulties with derivatives (e.g., Asiala et al., 1997) and my teaching experience.

Description of the exercise

Exercise three (Figure 1) consists of a table that presents three cases in which a function is not derivable. Each case is exemplified with one language: symbolic, natural or pictorial, and the students must complete the empty boxes with examples in the missing languages respectively, as shown in Figure 1. The use of the three languages allows students to explore different characteristics and properties of each case. Case I is described in NL with the phrase "At points where the curve presents peaks, since the lateral derivatives would be different." This statement has several characteristics. First, it does not refer to a particular function; therefore, students are not limited to the examples they can provide. In addition, it emphasizes the pictorial features by mentioning the graphical form (sharp points) of the function where the derivability requirement is violated. Finally, it refers to the theoretical aspect that fails (the lateral derivatives are different as shown in Figure 1).

For the case II, the example is given in SL, and refers to the situation in which the function has a vertical tangent line, at a point. This example refers to a specific function. However, the students must interpret from the symbolic expression what case it refers. It means that the student has to recall the definition of derivability to identify the characteristic that makes the function not derivable. Finally,

case III shows a graph of a function that presents a discontinuity in the point x_0 . As in the previous case, the student must identify which case is presented in order to express it in NL.

The objective of the exercise is to observe if students understand the concepts and rules involved, in such a way that they can interpret them from any of the given representations and can express them in different ways.

What are the possible cases in which a function is not derivable?
Give examples of each of them using the three types of language.

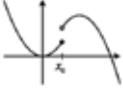
	Mathematical symbolic: numbers, symbols.	Natural Language: written words.	Pictorial Language: drawings, graphs, etc.
I		At points where the curve presents peaks, since the lateral derivatives would be different.	
II	$f(x) = \sqrt[3]{x}$, in $x = 0$		
III			

Figure 1: Language exercise #3

In the next section, I will present some excerpts of the students' solutions, as an evidence of the different uses of the languages they made, the different ways in which the students expressed the cases in their own words and some errors of interpretation and formality.

Results and discussion

Case I: Statement in natural language

For this case, students have to offer examples in symbolical and pictorial language. In the column of SL, they wrote diverse function samples such as absolute value and piecewise functions, with criteria of minor and greater complexity (Figure 2). As well, some included general expressions such as $f'_-(c) \neq f'_+(c)$, and calculated the values of the lateral derivatives.

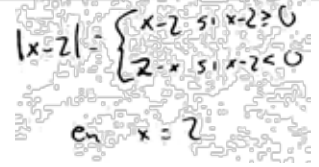
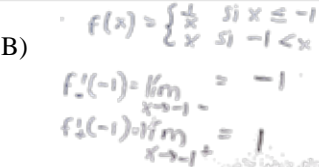
A)		B)	
----	---	----	--

Figure 2: S9 and S15 examples in SL

In most cases, students ($n=10$) did not make explicit in which point of the function the derivative does not exist, neither in the SL, nor in the PL. From this situation the questions of whether the students are aware of what is important in their example is the specific point where the derivative does not exist and what happens in it, can be raised. In the solutions in which it was possible to associate the example in SL with PL, one could verify if the student knew in what point the function described was not derivable by referencing the drawing. However, in the others, it was not clear. There were students' examples in which the function presented two cases where the derivative does not exist, and if they did not mark the point, one cannot know if they understood the case under discussion.

It is important to note that all the examples chosen by the students were correct and represented the given case, which means that they were able to interpret correctly the sentence in NL. In addition, by combining the SL and PL columns, it was possible to evaluate the students' abilities to graph functions correctly, pointing out asymptotes and points of intersection, as shown in Figure 3.

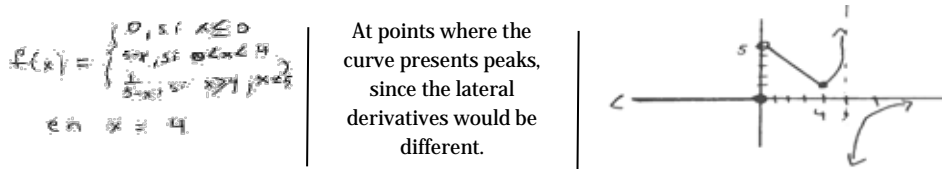


Figure 3: Function with two cases of no derivability (S10)

Finally, some errors of rigor can be observed when writing in SL, as in example B of Figure 2, where the student writes the limit without indicating the function involved.

Case II: Example of the criteria of a function in SL

In this case, the most interesting results were presented in the NL column. In the PL column, most of the students drew the plot of the given function and a few drew the tangent line. The results in NL, however, show that the students were not sure about how to explain this case. Among the expressions, there were students ($n=11$) who could not even identify what was happening, arguing that the function was indefinite at that point, was discontinuous, had vertical asymptote or was constant. Nevertheless, there were cases ($n=8$) in which the students seemed unable to express their ideas in a mathematically correct way. Examples as such are when referring to a vertical line as the function: “where the function is a vertical line” or when associating the derivative with the line instead of the slope: “where the derivative is vertical.”

Within the phrases they used to explain the phenomenon in case two, we can identify different connections between concepts that students used to justify their claims. Some made references to the calculation of the limit of the derivative at that point and others properly to the relationship between the derivative and the slope. Examples can be found in Table 1. Although in these sentences one can identify some conceptual errors, such as the idea of a “vertical function”, they show that the students had an idea of what was happening in the given case.

When the tangent of the point is vertical, as in this case, it is considered that the function is not derivable at that point. (S3)

In the points where there are vertical lines, because this has no slope and therefore has no derivative. (S15)

In the points where the derivative tends to $+\infty$, since this would mean a perpendicular tangent line, which does not exist. (S10)

When solving the limit results in $\frac{x}{0}$, then it is a vertical function. (S5)

Table 1: Students' answers in NL

Case III: The graphic of a discontinuous function

The task of the students in this case was to complete the SL and NL columns. In the SL column, responses with different characteristics were presented. Some students wrote piecewise functions in

which, as in case one, they forgot to point out the point of discontinuity. However, in other cases, the students, in addition to the criterion of the function and the point where the function was not derivable, also added the calculations of the conditions of continuity: lateral limits and the value of image in the point (Figure 4A). This was also evidenced in answers as in figure 4B. Nevertheless, in this case they used a more general form.

<p>A)</p> $f(x) = \begin{cases} 2x-1 & x \geq 3 \\ x^2-2x-2 & x < 3 \end{cases}$ <p>1) $f(3) = 4 = 2$</p> <p>2) $\lim_{x \rightarrow 3^-} f(x) = 1$ $\lim_{x \rightarrow 3^+} f(x) = 2$ $\lim_{x \rightarrow 3} = \text{no existe}$</p> <p>3) $f(x) \neq f(3)$.</p>	<p>B)</p> $f(a) \neq \lim_{x \rightarrow a} f(x)$ $\nexists \lim_{x \rightarrow a} f(x)$
--	--

Figure 4: S12 and S4 examples in SL

Regarding the answers in NL, students were able to express the case of discontinuity recurring to the graphical feature of the “jump” or “breaks” ($n=2$) and others mentioned conceptual aspects as the fact that the lateral limits were different or the that limit does not exist at the point ($n=9$), the discontinuity of the function ($n=15$) and the fact that if a function is not continuous in $x = a$, then it is not derivable in $x = a$ ($n=6$). Considering the different answers, it is possible to observe that students were able to recall different knowledge about continuity and the conditions of derivability to correctly explain what happened in the point.

Final considerations

As stated at the beginning, when students begin their university studies, they lack mathematical skills and knowledge required for university level. I suggest languaging exercises as a methodological tool to address those issues and promote students’ meaningful learning. The written languaging exercises offer an option for boosting students’ understanding of mathematical concepts and noticing the connections between concepts, the rules and properties that justify the procedures and the different representations. The use of the three languages reinforces different strands of mathematical proficiency, such as conceptual understanding, adaptive reasoning and strategic competence. For example, from the results it is possible to conclude that for solving the exercise students must understand, identify and verbalize the connections between concepts, as well as represent mathematical situations in different situations. These actions are associated with conceptual understanding. It is important to highlight that in each case, in order to complete the empty boxes, the students had to interpret the given example, and from that point they were already connecting between representations. The adaptive reasoning is evidenced in the justifications and explanations that the students provide in natural language, and the strategic competence is present since the task presented to the students is not common for them, so they must show a flexible approach to solve this novel situation. All these actions helped them to experience meaningful learning and think about the concepts involved in the exercises instead of solving them mechanically.

The different languages allow studying different characteristics of the mathematical concepts involved. NL evidenced the theoretical knowledge involved and, how the connections between the ideas were made. SL showed aspects related to the correct use of the symbols and specificities in relation to the examples, as in the mention of the point where the derivability was violated. In PL, all

the features were combined and represented. In addition, the use of different languages makes it possible to observe the gaps in knowledge, misconceptions or difficulties the students have. As evidenced in case 2, where most of the students could make the graph from the interpretation of the symbolic expression, but they faced problems when trying to explain the situation in NL, for which deeper knowledge of the subject was required.

This experience shows the potential of the use of different languages to improve the mathematical learning of the non-mathematics major students and to promote their competences to become mathematically proficient. However, more studies are required to explore various ways to integrate different languages in mathematics learning at the university level.

References

- Alfaro, H. (2018). *Appealing multimodal languages to access first year university students' understanding of mathematical concepts in Costa Rica* (Unpublished master's thesis). University of Tampere, Finland.
- Asiala, M., Cottrill, J., Dubinsky, E., & Schwingendorf, K. E. (1997). The development of students' graphical understanding of the derivative. *The Journal of Mathematical Behavior*, 16(4), 399-431. doi: 10.1016/S0732-3123(97)90015-8
- Biza, I., Giraldo, V., Hochmuth, R., Khakbaz, A., & Rasmussen, C. (2016). Research on teaching and learning mathematics at the tertiary level: State-of-the-art and looking ahead. In I. Biza et al. (Eds.), *Research on teaching and learning mathematics at the tertiary level* (pp. 1-32). Cham, Switzerland: Springer.
- Engelbrecht, J., & Harding, A. (2015). Interventions to improve teaching and learning mathematics in first year courses. *International Journal of Mathematical Education in Science and Technology*, 46(7), 1046-1060. doi: 10.1080/0020739X.2015.1070441
- Dreher, A., Kuntze, S., & Lerman, S. (2016). Why use multiple representations in the mathematics classroom? Views of English and German preservice teachers. *International Journal of Science and Mathematics Education*, 14(2), 363-382. doi: 10.1007/s10763-015-9633-6
- Goodchild, S., & Rønning, F. (2014). Teaching mathematics at higher education. In H. Silfverberg, T. Kärki, & M. S. Hannula (Eds.), *Proceedings of NORMA 14* (pp. 396-400). Turku, Finland: Finnish Research Association for Subject Didactics.
- Gruenwald, N., Klymchuk, S., & Jovanoski, Z. (2004). Reducing the gap between the school and university mathematics: university lecturers' perspective. *The New Zealand Mathematics Magazine*, 41(3), 12-24.
- Joutsenlahti, J., Ali-Löytty, S., & Pohjolainen, S. (2016). Developing learning and teaching in engineering mathematics with and without technology. *Proceedings 44th SEFI Conference*. Tampere, Finland. Retrieved from http://sefibenvwh.cluster023.hosting.ovh.net/wp-content/uploads/2017/09/joutsenlahti-developing-learning-and-teaching-in-engineering-mathematics-with-and-without-technology-153_a.pdf

- Kilpatrick, J., Swafford, J., & Findell, B. (2001). *Adding it up: Helping children learn mathematics*. Washington, DC: National Academy Press.
- Kline, S. L., & Ishii, D. K. (2008). Procedural explanations in mathematics writing: A framework for understanding college students' effective communication practices. *Written Communication*, 25(4), 441-461.
- Lemke, J. L. (2003). Mathematics in the middle: Measure, picture, gesture, sign, and word. In M. Anderson, A. Sáenz-Ludlow, S. Zellweger, & V. V. Cifarelli (Eds.), *Educational perspectives on mathematics as semiosis: From thinking to interpreting to knowing* (pp. 215-234). Ottawa, Canada: Legas.
- Morgan, C. (2002). The place of pupil writing in learning, teaching and assessing mathematics. In P. Gates (Ed.), *Issues in mathematics teaching* (pp. 232-244). London, England: Routledge.
- Mustoe, L., & Lawson, D. (2002). Mathematics for the European engineer: A curriculum for the twenty-first century. *Report by the SEFI Mathematics Working Group*. Brussels, Belgium: SEFI HQ.
- Nardi, E. (1996). *The novice mathematician's encounter with mathematical abstraction: tensions in concept-image construction and formalisation* (Unpublished doctoral dissertation). University of Oxford, England.
- O'Halloran, K. L. (2015). The language of learning mathematics: A multimodal perspective. *The Journal of Mathematical Behavior*, 40, 63-74. doi: 10.1016/j.jmathb.2014.09.002
- Schleppegrell, M. J. (2010). Language in mathematics teaching and learning: A research review. In J. N. Moschkovich (Ed.), *Language and mathematics education: Multiple perspectives and directions for research* (pp. 73-112). Charlotte, NC: Information Age Publishing.
- Silius, K., Pohjolainen, S., Kangas, J., Miilumäki, T., & Joutsenlahti, J. (2011). What can be done to bridge the competency gap between upper-secondary school and university mathematics? *Proceedings Global Engineering Education Conference* (pp. 428-436). Amman, Jordan: IEEE.
- White-Fredette, K. (2009). *What is mathematics? An exploration of teachers' philosophies of mathematics during a time of curriculum reform* (Unpublished doctoral dissertation). Georgia State University, Atlanta, GA.
- Winsløw, C., Gueudet, G., Hochmuth, R., & Nardi, E. (2018). Research on university mathematics education. In Dreyfus, T., Artigue, M., Potari, D., Prediger, S., & Ruthven, K. (Eds.), *Developing research in mathematics education: Twenty years of communication, cooperation and collaboration in Europe* (pp. 82-96). London, England: Routledge.

Learning mathematics in French at the undergraduate level in Algeria

Nadia Azrou

University of Yahia Fares, Faculty of Sciences, Medea, Algeria; nadiazrou@gmail.com

In this paper, some students' difficulties, related to learning mathematics in a second language (French) when entering university, in Algeria, are examined. I present these difficulties as part of other difficulties caused by the transition from high school to university. The analysis of students' interviews, using Cummins' theoretical framework, revealed that low mastery of French as natural language and low mastery of Arabic as academic language impeded several students from performing well in mathematics and expressing them in French academic language.

Keywords: French as second language, learning mathematics, students' difficulties.

Introduction

While mathematics is often seen as language free, in many ways learning mathematics fundamentally depends on language (Barwell, 2008; Planas, 2014). The relationship between language and mathematics has been considered within a range of perspectives: political perspective, social and cultural perspectives, epistemological perspective and cognitive perspective. Learning mathematics in a second language at different school levels has also been a subject of many investigations.

On the other hand, Ní Ríordáin and O'Donoghue (2007) expose two opposite positions about learning mathematics in a second language with many references; studies which argue about positive aspects and satisfying achievement (immersion programs) and studies which argue about the underachievement of pupils (submersion programs). Research about teaching and learning mathematics in a second or a third language is very popular at many school levels, but little research has investigated this issue at the undergraduate level so far.

The present study has been motivated by a PhD research about undergraduates' difficulties with proof and proving in Algerian universities. The findings indicated that the weak mastery of French as a second language for learning mathematics was one of the reasons for third year university student' difficulties with writing a proof text. Even though I acknowledge that low students' proficiency in languages is associated with underachievement in mathematics (Cummins, 2000), I tried to understand better how this really works. In this paper, I studied this relationship particularly with students at the beginning of the university, where they learn mathematics completely in French for the first time. I focused on the mathematical difficulties that are originated in the relationships between French language, dialect and Arabic considered as tools to approach, develop and report mathematical thinking; I also investigated students' behaviours when they make mathematics in French and their related opinions.

Linguistic overview of Algeria

Algerian population communicate in different languages, according to different regions, ethnic groups, institutions and circumstances. The most spread languages are Classical Arabic, Dialect, Berber language and French (first foreign language). Classical Arabic is shared by Arabic countries. The Dialect is the common language; it is the most used spoken language in daily life in Algeria; it's

a mixture of classical Arabic, French and other languages (Spanish, Turkish, Italian...). In Algeria, people speak in their families either Berber language (indigenous language) or dialect, which is the same in all the country with slight differences in some words and accents. The language of instruction in schools is classical Arabic, so children learn from primary school on in a different language. Only Arabic language is used for writing, but for the oral, the situation has declined; around thirty years ago, Arabic language was used also for the oral, but dialect has been used more and more. Actually, it's rare for teachers and students to speak only Arabic in the school. French is the first foreign language in Algeria, it is taught from grade 3 to grade 12. With the exception of French language, all courses in all school levels are taught in classical Arabic. Teaching French has been affected during the dark decade of the civil war (1990-2000) by the lack of teachers in many regions; consequently, many students have not had French courses for many years. On the other hand, the technological development and the increasing use of English for computers, cell phones and social media have pushed students to be distant from French. At the end of high school level it is quite rare to find students who master correctly the speaking and the writing of this language, in spite of ten years of learning French.

Languages of teaching mathematics in Algeria

The teaching of mathematics in Algeria has shifted from French to classical Arabic (oral, writing and mathematical symbols) for the three school levels (primary, middle and secondary school) since the 70's. Teaching mathematics in classical Arabic (including Arabic symbolism) has lasted more than thirty years, till the beginning of the 21st century, when it shifted again. In 2005, there was a big change in teaching mathematics: in school formulas and symbols are written from left to right with Latin alphabet (that stands for French), while comments, terminology and verbal expressions are maintained in classical Arabic (from right to left). This is an example to see how to read and write in both senses: the area of the square ABCD is equal to 20 m^2 (arrows show the direction to read).

$$\text{مساحة المربع ABCD تساوي } 20 \text{ m}^2$$

This reform has been undertaken to make the transition to university mathematics (taught in French) less difficult. However, this situation has resulted in a mess and caused some difficulties for students at different school levels. The language of higher education, in Algeria, has always been French for scientific and technical disciplines (medicine, mathematics, architecture, computer science, engineering sciences, etc.) with French textbooks; while the other disciplines (history, Arabic literature, humanities, psychology, etc.) are taught in Arabic.

Literature review

The interest is in investigating undergraduates' difficulties when they learn mathematics in a second language. Durand-Guerrier et al. (2016) pointed out delicate points related to language, which might present difficulties for students. In particular, some words in two languages have different mathematical meanings when we translate from a language to another (decimal in English and decimal in French); and even mathematical notations that “contain a lot of information, so that being able to decode or unpack such information is an important part of mathematical proficiency” (Durand-

Guerrier et al., 2016, p. 87), like gcd (greater common divisor). The difficulty of interpreting formal statements in their native language that undergraduate face might be worsened when learning in a second language. Students might have problems when they learn new mathematical words they already know in the natural language (like group or distance) “learning the new vocabulary that is centrally mathematical may be easier than learning the technical meanings for words that students already know in other contexts” (Schleppegrell, 2007, p. 142). Students should be encouraged to express mathematics using a language, otherwise, their learning would be sterile, “at college level, there are few opportunities to put into practice long term activities aimed at improving linguistic skills. Requiring high degrees of correctness to students with a poor linguistic background just means inducing them to learn by heart or to use stereotyped expressions with no understanding” (Ferrari, 2004, p. 389). When students do not master the second language they fail to understand their teachers communication (spoken and written), mostly the part that is expressed in a highly academic language; “the language of textbooks and instruction frequently calls for a high degree of familiarity with words, grammatical patterns, and styles of presentation and arguments that are wholly alien to ordinary informal talk (Fillmore, 1982, p. 6)” (Cuevas, 1984, p. 135); what Cummins (1980, p. 43) has identified as the difference between basic interpersonal communicative skills (BICS) and cognitive academic language proficiency (CALP) as “the manipulation of language related to literacy skills in academic situations” Another major issue is the assessment of mathematics achievement of students when made in the second language, many researchers argue that one principal reason for inappropriateness of tests is the use of language that students do not understand (Cuevas, 1984).

Method

Theoretical framework

Given that this research concerns difficulties of undergraduates when learning in a second language, it is important to examine how do students shift from Arabic to French and how do they behave with their teachers talking, and with their written courses. I will use, for the analysis, Cummins’ theory. Cummins distinguishes between conversational and academic languages, as being respectively basic interpersonal communicative skills (BICS) and cognitive academic language proficiency (CALP). The latter is defined as “the extent to which an individual has access to and command of the oral and written academic registers of schooling” (Cummins, 2000, p. 67), in other words, it is the ability to think in and use a language as a tool for learning, by using abstractions in a sophisticated manner. What is important to note here is that, while second language learners may pick up oral proficiency (BICS) in their new language in as little as two years, it may take up to seven years to acquire the decontextualized language skills (CALP) necessary to function successfully in a second language classroom (Cummins, 1979). Later, Cummins expanded these concepts to include two different types of communication, depending on the context in which it is involved: context-embedded communication and context reduced communication; both concern conversational fluency and academic language proficiency. Context-embedded communication provides supports to the listener or the reader (as gestures, images or basic math computations) in order to make the information comprehensible. Context-reduced communication provides less support to understanding (as a phone conversation or lecture with few illustrations). Moreover, Cummins makes the difference between cognitively demanding and cognitively undemanding communications. And considers that BICS (in

both contexts) are cognitively undemanding, while both contexts of CALP are cognitively demanding, as shown in his model, illustrated in Figure 1.

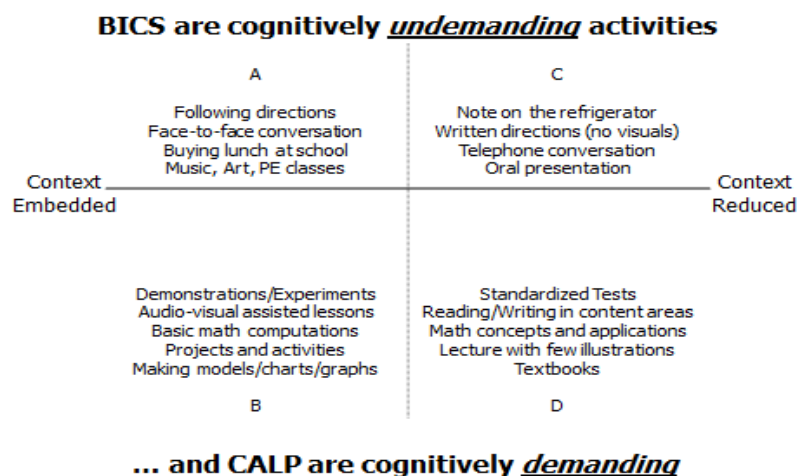


Figure 1: BICS and CALP (Cummins, 2000)

This theory is furthered by his Interdependence Hypothesis, which proposes that the greater the level of academic language proficiency developed in the first language, the stronger the transfer of skills across to the second language (Cummins, 2000). I suppose that, for many students, BICS in French language are poor, which would effect the development of their CALP, and the few students who could have developed BICS in French, need much more time to develop their CALP. Moreover, I hypothesize that students did not develop university mathematics in an academic Arabic language in high school because school mathematics are reduced to algorithms and management of formulas that do not require such a level of academic language proficiency. Consequently, students are faced with the difficulty of going from context-embedded tasks (B quadrant, Figure 1) to context-reduced tasks (D quadrant), which is the most difficult for students.

Formulation of research questions

I would like to answer the principal research question: How undergraduates' difficulties with mathematics are related to learning in French as a second language?

According to literature and my PhD work, I made two research sub-questions, each question related to specific difficulties, about how students deal with the teaching and learning of mathematics in French during the first university year, taking into consideration Cummins' theory. Being inspired by the research cited before and observing students and interacting with them as a teacher made us aware of some facts that stand for first hypotheses.

1. Students confuse some French words as they have close pronunciation in French, for example: 'ou', 'où' and 'd'où' (same pronunciation) which are 'or', 'where' and 'hence or thus'. Example: $x=1$ ou $x=0$, où $x \neq 0$, d'où $x=1$, this might mean ' $x=0$ ' for a student who considers all of them as the same as 'ou (or)', (because 'P or Q' is true if either P or Q is true). Students miss the meaning of the uniqueness when we use 'le' or 'la' (as 'the') with the use of 'un' or 'une' (the article 'a') – a difficulty which might not depend on mastery of French only. When we talk about bases in vector spaces, we

say B is ‘une’ base and ‘la’ dimension because we can have more than one base for a vector space but only one dimension. This meaning packed in these articles is not clear for students.

RQ1. Why do students not perform well in French as an academic language? Is it only about second-language performance?

H1. I suppose that their weak BICS is a major reason for their problems in CALP. But also their CALP in Arabic has not been developed, which prevents them to make the transfer to French CALP.

2. Most of the time, students are not able to read parts of their course notes, written by them, because they might not know what is the meaning of what they wrote or even to spell exactly what they wrote (written sometimes wrong). In general, I perceive students’ big difficulties when I observe their behaviours when dealing with CALP with context reduced tasks (and communication). Taking into consideration that teachers write in French, explain in French and in Arabic (both classical and dialect), while students write in French – but several of French words are unknown to them.

RQ2. Why do students meet difficulties in managing their mathematics activities (reading, memorizing and revising their notes from lectures and exercises’ sessions)?

H2. I suppose that even if teachers would simplify their explanation in Arabic (or dialect), students face the difficulty of shifting between three languages when copying, revising the courses and writing their own responses in French.

Interviews and students’ responses

In order to confirm my hypotheses and find out more about the difficulties of students when they learn mathematics in a second language, I designed semi-structured interviews for first university year (18-19 year old) students in the University of Medea (Algeria). The statistics show that more than half of the students (first year) fail, but only one third repeat the year. Eighteen students were chosen (half of them are male) within the discipline of mathematics and computer science. This discipline has two main courses, at the first year, algebra and analysis, where students manifest many difficulties. I included two students with very few difficulties and good marks, ten students with some difficulties and average marks, and six students who are remaking the first year (had many difficulties and low marks last year: RPT student). Interviews have been audio-recorded in May 2018. I have categorized the questions according to the two stated hypotheses as follows:

Q1. If teachers write and speak only in French, would it be better? H1.

R1. 18 students said ‘no’. *In the first year, some student are bad in French language, that’s why they give up when teachers speak and write only in French’; ‘no, it depends on the level of students in French language but for me, this method did not help me’* (4 RPT students).

Q2. If teachers translate orally into Arabic (classical and dialect), would it be better? H1

R2. 18 students said, yes. *‘We could at least follow what teachers is dealing with, otherwise, we are lost’; ‘if the teacher explains in Arabic, yes it would help us, because we memorize the words better’* (a RPT student).

Q3. When you make mathematics in French, do you translate to Arabic or do you try to understand in French language? H2

R3. 17 students said they always translate in Arabic then try to understand. *'I always translate to be able to understand in Arabic language'* (a RPT student).

Q4. How do students copy their courses in French? What if some words are not clear? H2

R4. 14 students said, they write everything even if they do not understand. *'we should copy, in case a word is not clear we copy it as it is'*. Students say they should copy any unclear words because they are part of the course: *'If the teacher wrote them, they are part of the course and must be important, so we copy them as they are, even if we have to draw them'*. *'Students do not ask questions about the unclear words, because they do not understand them and because they cannot speak French very well.'* One student said that he writes just what he needs (a good student), two students said, they write and try to understand, one student said *'when I write I try to understand what I am writing, and if I can't understand I ask the teacher to help, because if I try to translate maybe it's not the same meaning as the teacher's'* (a good student).

Q5. What happens when a student writes the solution, in French, on the exam-sheet? H1, H2

R5. All the 18 students declared to have difficulties with the use of words when they write their solution on the exam paper. Four students said, they wrote in classical Arabic if they could not write in French language. *'I am not good at French language so, if I can't write a solution in French I write in classical Arabic'* (a good student); *'Naturally, I translate the question in Arabic in order to get the solution but often when I try to shift into French language it is difficult'* (a RPT student); *'If I write something wrong the teacher would not understand it'*; *'I had always difficulties in writing the solution, this is why I'm always scared'* (a RPT student).

Q6. In which language do you think when you solve an exercise? H1, H2

R6. All students said, they think in Arabic language first, then they write their solution in French language. *'I think in Arabic to understand the question then I write in French language'* (a RPT student).

Q7. There is almost no student speaking good French and understanding perfectly French, but how did students who succeeded do, according to you? H1

R7. 10 students responded that students, who cannot speak French and succeeded, rely on memorization (3 RPT students). Among the responses *'I think those students learn with memorizing'*. 8 students said that students rely on mathematics formulas without using words, *'maybe they are good in mathematics and so they don't need language, they would use only symbols'*.

Results of the analysis of the interviews

All students do not accept that teachers speak only in French, they need teachers speaking in Arabic to better understanding, according to responses to Q1 and Q2. Students who failed last year declared that they are lost if they hear explanations only in French; according to them, Arabic would help them also to memorize the words they need often in mathematics (as mathematical terms or as verbs and

words that are used regularly). Responses to Q3 and Q5 show that almost all students translate into Arabic language to understand mathematics (the exception was for one good student). In lack of developed CALP in Arabic language, translating in Arabic is not of much help too. In fact many confusions, and misunderstandings can occur. This validates H1 about weak mastery of natural language that affects logical aspects of mathematics.

Answers to questions Q4, Q5, and Q6 show that students have difficulties with the writing, most of them copy down what teachers wrote on the blackboard as it is, even without deciphering the letters. Because students believe that it is their job and cannot ask questions about unclear words (literally or semantically) as their understanding is very limited and also, because of their weak mastery of French language (to make a clear question). This impedes them to revise their course notes at home. The difficulty of writing is showed more during the exams, when students have to translate from Arabic (used to think), to French (used to write). Most students have doubts about their written texts to be not understood by the teacher when correcting them; consequently, they feel powerless and unconfident. These responses show the big difficulty when they deal with tasks involving context-reduced communication with a high cognitive level, as expected in H2. Responses to Q7 reveal two criteria that were mentioned by students: memorization and focusing on symbols and formulas. Students' conception of mathematics from their long school experience dictates them the fact that language is not so important. They believe that formulas or symbolic expressions are more important and so, language has a secondary role. In doing so, their BICS do not improve and so will be their CALP. This sustains H2.

Conclusion

Students depend completely on translation, they expect teachers to talk in Arabic, explain in Arabic and translate all the words given in French. They also think in Arabic, translate in Arabic and then try to translate again to French for the writing. This fact shows that students' BICS in French is weak and will persist to be so. This fact persists longer as sustained by students' beliefs about language as being not so important in learning mathematics that are reduced to formulas and calculations. I also think that this belief is strengthened by the way they learnt mathematics before (formulas in French and verbal expressions in Arabic). They repeat the same experience: as mathematics in high school focus mainly on calculation, the role of Arabic language is minimal, consequently, students behave similarly with university mathematics whose formulas are clear for them (as they are written as before), and verbal language (in French) might not be important, as before. Thus, students would ignore verbal expressions and focus only on mathematical formulas; consequently, they might memorize a chain of formulas as a procedure for solving some exercises as they are used to do in high school. This is caused, according to me, by two important factors; the first one is due to their mathematical conception from school; that presents to students mostly exercises that are solved by a chain of formulas based on calculation rules. The second factor is the loss of the logical structure in mathematical statements and the lack of knowledge about the process of solving problems. This suggests the validity of H1. If students manage what teachers say orally in Arabic, when it comes to writing, students are in front of a difficult process. When they copy down from the board, they might lose the ideas they got before (in the listening process) because the words (in French) are meaningless for them, that is why they copy them incorrectly or just transcript them as they are presented. Under

the didactic contract, students think that they have to copy down what teachers write in the boards, even if it means nothing for them. Moreover, they hesitate and do not ask questions because their French is so weak. The problem of writing rises again, when students have to write by their own, the solution of the tasks of the exams. Students face serious difficulties with CALP with reduced context tasks. This validates H2.

References

- Barwell, R. (2008, July). ESL in mathematics classroom. In The Literacy and Numeracy Secretariat and the Ontario Association of Deans of Education Research, *Research Monographs #14*. Retrieved from http://www.edu.gov.on.ca/eng/literacynumeracy/inspire/research/ESL_math.pdf
- Cuevas, G. (1984). Mathematics learning in English as a second language. *Journal for Research in Mathematics Education*, 15, 2, 134-144. doi: 10.2307/748889
- Cummins, J. (1979). Cognitive/academic language proficiency, linguistic interdependence, the optimum age question and some other matters. *Working Papers on Bilingualism*, 19, 121-129.
- Cummins, J. (1980). Psychological assessment of immigrant children: Logic or intuition? *Journal of Multilingual and Multicultural Development*, 1, 97-111.
- Cummins, J. (2000). *Language, power and pedagogy: Bilingual children in the crossfire*. Clevedon, England: Multilingual Matters.
- Durand-Guerrier, V., Kazima, M., Libbrecht, P., Ngansop, J.N., Salekhova, L., Tuktamyshev, N., & Winslow, C. (2016). Challenges and opportunities for second language learners in undergraduate mathematics. In R. Barwell, P. Clarkson, A. Halai, M. Kazima, J. Moschkovich, N. Planas, M. Setati-Phakeng, P. Valero, & M. Villavicencio (Eds.), *Mathematics Education and Language Diversity. The 21 ICMI Study* (pp. 85-101). New York, NY: Springer.
- Ferrari, P. L. (2004). Mathematical language and advanced mathematics learning. In M. Johnsen Høines, & A. B. Fuglestad (Eds.), *Proceedings of PME 28* (Vol. 2, pp. 383-390). Norway: Bergen University College.
- Ní Ríordáin, M., & O'Donoghue, J. (2007, February 26). *Mathematics teaching in a second language in Ireland*. Retrieved from <http://www.leeds.ac.uk/educol/documents/161229.htm>
- Planas, N. (2014). One speaker, two languages: Learning opportunities in the mathematics classroom. *Educational Studies in Mathematics*, 87(1), 51-66. doi: 10.1007/s10649-014-9553-3
- Schleppegrell, M.J. (2007). The linguistic challenges of mathematics teaching and learning: A research review. *Reading & Writing Quarterly*, 23, 139-159. doi: 10.1080/10573560601158461

Textual configurations as an approach to evaluate textual difficulties of mathematical tasks

David Bednorz and Michael Kleine

Bielefeld University, Germany; david.bednorz@uni-bielefeld.de

Language is a major factor in learning mathematics. Language learners or those with a low socioeconomic status have special difficulty solving mathematical tasks with high language demands. The project evaluates linguistic task difficulties in mathematics. This paper discusses the first step of the project: empirical evaluation of textual configurations and analysis of the lexical and grammatical structures of a corpus of 348 tasks. An explorative factor analysis is used to analyze the configuration of 17 linguistic variables. The analysis revealed a reduction of the variables to five factors, which are interpreted as different textual configurations of mathematical tasks based on their obligatory allocation of typical situational use. The structure offers potential for an empirical model to evaluate the difficulties.

Keywords: Language, language variation, mathematics education.

Introduction

Language is omnipresent in human life; it helps us to create a cultural base for human interaction. Language enables a direct interaction to make meaning between people. To define what language is and what potential relevance language has to learn math, this paper introduces the systemic functional linguistic (SFL) theory. The important theoretical terms to describe language for the analysis are the instantiation and realization of language. Furthermore, the notions of register and the contextual configuration are presented in the theoretical part of this paper. Registers and contextual configurations are only considered in terms of the objectives of the empirical results in this paper. Afterwards, the research questions of the project “Language Difficulties in Mathematical Tasks” (LIMiT) are presented, followed by the empirical method and the results of the factor analysis. Finally, a prospectus is made of the next goals of the project LIMiT.

Theoretical framework

The framework conditions for successful pedagogical processes are constantly changing, and the importance of language is becoming more relevant for mathematics classrooms. In addition to the content specific requirements of mathematical tasks, language requirements are a factor that determines the complexity of mathematical tasks (Abedi & Lord, 2001). To solve tasks with content related subject, on the one hand students need to have contextual knowledge, which are essential to solve the problem which are presented in the tasks. On the other hand, the grammatical and lexical textual basis of mathematical tasks are important factors of difficulties for understanding (Abedi & Lord, 2001). In particular, language learners and learners with a low socioeconomic status show special difficulty in mastering mathematical tasks (Abedi, Hofstetter, & Baker, 2001; Haag & Heppt, 2015; Martiniello, 2008). The academic language and mathematical language are theoretical constructs to explain the language requirements in mathematics tasks (Maier & Schweiger, 1999; Morek & Heller, 2012; Prediger, Wilhelm, Büchter, Gürsoy, & Benholz, 2015). On the perspective of academic and

mathematical language as register, the difficulties can be explained by the variation of language. Register tend to vary, especially in lexical and grammatical features (Morek & Heller, 2012).

Language in mathematics classrooms

With the focus on language variation, a possible theoretical approach to explain the relevance of language in mathematics classrooms is the SFL theory (Halliday, 2014; Halliday & Hasan, 1989). The SFL theory describes, theorizes and analyzes language through the meaning of the environment (Halliday, 2014). Language is considered in a systemic functional approach as a resource for making meaning. To develop meaning, humans use different kinds of semiotic systems which are useful or functional in a specific context (Eggins, 2004).

Instantiation of language

According to Halliday (2014, p. 28) language is described through a “cline of instantiation”, with two different poles, one potential pole and one instance pole. On the instance pole, a specific textual instance is embedded in the context of a situation. The context of a situation is characterized after Halliday (2014) with three variables called field, mode and tenor. According to Eggins (2004, p. 90), field refers “what the language is being used to talk about”, mode describes the way language functions in interaction and tenor focuses on the relationship of interactants involved in the discourse which are a short description of the three variables. The potential of a particular language is described by the contextual conditions within a culture (Halliday, 2014). Halliday (2014, p. 33) defines this contextual potential of a community as the “context of culture”. The context of culture describes what members of a community may mean by cultural terms. Culture is described as a system of higher importance, as an environment of meanings in which different semiotic systems function. This describes a “multi-dimensional semiotic space” (Halliday, 2014, p. 34) that we also find in mathematics classrooms. The perspective for exploring culture is the reduction to specific cultural domains, such as analyzing different contexts of situations within an institution. The isolation of culture relative to the institution allows the linguistic analysis of language used within the institution.

The concept of register

It is clear that situations vary depending on the location, time and participants. It is not quite so clear that at the same time, language varies corresponding to various situations. The notion of a register describes the variation in language in relation to the context of situation (Eggins, 2004). One viewpoint to define registers, especially for a quantitative purpose is that registers are systemic probabilities of the use of language in specific situations or a set of possibilities for the entry in a situation (Halliday, 2014; Halliday & Hasan, 1989). For example, symbolic notation will occur more frequently in mathematical texts than in stories, and the graphic proof of the Pythagorean theorem will occur more frequently or even exclusively in mathematical texts compared to geography textbooks. According to Morek and Heller (2012) as mentioned above, registers vary according to usage and tend to vary within semantics, especially in grammar and vocabulary. This leads us to Table 1, which shows a possible categorization for the variation of language in typical situations (Eggins, 2004). Furthermore, the three variables field, tenor and mode constitute the language used in a situation. Because of the changing situation, these three variables are also called register variables (Eggins, 2004). The value of

each register variable defines the language used in a text. Eggins (2004) combined the three variables with typical situations of use which enables a lexical and grammatical fixation of the systemic probability of specific lexical features.

Register variables	Field		Mode		Tenor	
Typical situations of language use	Everyday situation	Technical situation	Spoken language	Written language	Informal	Formal
Selection of characteristic features	everyday terms (words we all understand), standard syntax	technical terms (words only 'insiders' understand), acronyms, abbreviated syntax	everyday lexis, content-dependent, low lexical density, open-ended, non-standard grammar	prestige lexis, context independent, high lexical density, closed, standard grammar	attitudinal lexis, colloquial lexis, typical mood choices	neutral lexis, formal lexis, incongruent mood choices

Table 1: Summary of register variables and characteristic features (Eggins, 2004)

Contextual configuration

Within cultural practice, similar linguistic structures or obligatory linguistic features are used among other things for pragmatic reasons. Halliday and Hasan (1989) describes these structures as contextual configurations which are recurring in similar situations. Similar situations, framed by a context of culture or an institutional basis, lead to the realization of specific values for field, tenor and mode, which can be described as a contextual configuration. The contextual configurations do not imply a concrete situation, but a type of related situations. As such, the contextual configuration instantiates through a multiplicity of instances of related types which can be classified by specific values for a particular purpose. Applied to mathematical learning processes, this means that the contextual configuration of specific, similar situations is characterized by the inclusion of recurring elements or structures. Thus, the introduction to a mathematical problem differs from the solving of the task and each sequence has a set of possibilities for the realization of the register variables.

Theoretical model and research question of LIMiT

For mathematical tasks, as a standard mathematical classroom situation, the same conclusions apply to contextual configurations. A mathematical task is contextualized with a textual structure which forms the textual basis of a mathematical task. In addition to the textual structures, there are additional activities that determine the contextual configurations in the process of solving a task, including receptive processes such as extracting information and productive processes such as creating a solution. However, the textual basis of mathematical tasks forms the initial structure of mathematical problems which can be interpreted as

particularly crucial for the further processes of problem solving. The starting point of the study is the analysis of textual configurations of mathematical tasks and the interpretation of the specific values for field, mode and tenor, based on a selection of grammatical and lexical features as seen in Figure 1. The model lies in terms of the cline of instantiation between the system pole and the instance pole. Considering the fact that registers vary in lexical and grammatical structures in particular, and this variation may present difficulties for learners, textual structures should be analyzed in the project. This model is preliminary in the way that it serves to illustrate the empirical analysis. For the project, a further extension of this model based on the metafunctions *ideational*, *interpersonal* and *textual function*. The textual configurations will be analyzed, and the following questions emerge: Which textual configurations can be extracted from mathematical tasks? How can the extracted structures be interpreted?

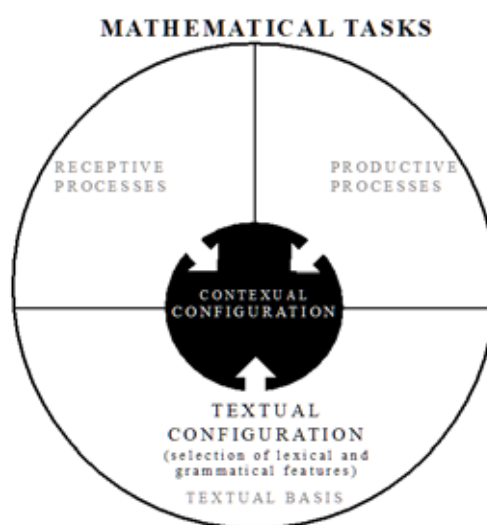


Figure 1: Theoretical model of LIMiT

Method

The empirical analysis was based on 348 tasks from nine different secondary-school textbooks for mathematics classrooms. The textbooks are designed for students aged between 10 and 16 years. For each task, 17 different lexical and grammatical features were determined. A part of the lexical and grammatical features was quantified by expert ratings, such as mathematical terms, other parts of the data was quantified using corpus analysis, such as determining the frequency of words in a comparable corpus to determine the rarely used words (Michalke, Brown, Mirisola, Brulet, & Hauser, 2017). The selection of the lexical and grammatical features was made because of their relevance in the literature. The findings on difficulty-generating traits indicate that there are particular difficulties, especially in vocabulary, the presence of compressed structures but also in relational connections (Caplan & Waters, 1999; Kintsch, 2007; Leisen, 2013; Maier & Schweiger, 1999; Ozuru, Rowe, O'Reilly, & McNamara, 2008). Table 2 shows the chosen association between lexical and grammatical features and the typical situations of language use. Compared to Table 1 some changes were made. Thus, the category *relator* was added in *mode*, which can be regarded as essential for math problems, and

furthermore, the everyday situations were excluded from consideration for the empirical analysis, since there is no clear evidence regarding difficulty-generating traits.

Register variables	Field	Mode			Tenor	
Typical situations of language use	mathematical situations	spoken language	written language	relator	informal	formal
Lexical & grammatical features	mathematical terms, mathematical symbols, discontinuous text, numbers	compound s, lexical density, synonyms, passive voice	filler words, present perfect	prepositions, conjunctions	modal verbs	nominalization, propositional density, rarely used words, impersonal language

Table 2: Selection and arrangement of lexical features

Results

The suitability of the correlation matrix for the use in a factor analysis was checked with the Bartlett test of sphericity, the test criteria have been met ($\chi^2 = 454.31$, $p < 0.001$). The KMO test for checking the adequacy of the data indicates only a moderate fit (overall MSA = 0.67). The moderate result can be explained by the fact that in the case of lexical and grammatical variables, a low share of common variance can be assumed. Accordingly, the present MSA may be considered sufficient for the adequacy of the data. Overall, a potential five-factor solution, can achieve a variance explanation of 45%, with a reduction of totally 70.6 % of the variables. The scree plot in Figure 2 shows the possible number of factors. To select the number of factors, the parallel analysis, shown in Figure 2, was used. According to the parallel analysis, a choice of 5 factors is sufficient.

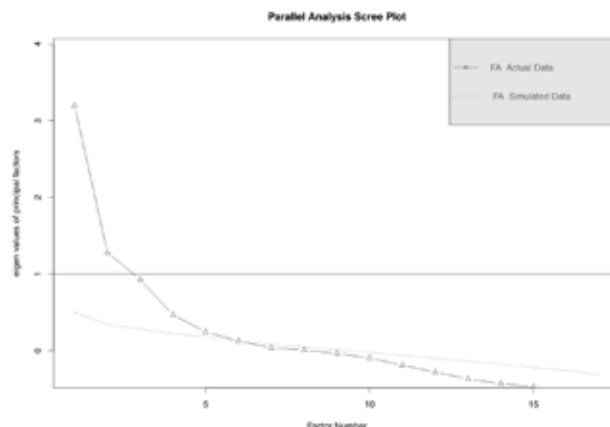


Figure 2: Scree plot to determine the factor solutions

Figure 3 and 4 presents the five-factor solution in different versions. Figure 3 shows the loadings of the variables for each factor. This figure illustrates the specific characteristics variation of the variable for each factor. To illustrate which are the central variables with high

loadings, the simplified factor diagram in Figure 4 is used. The figures illustrate that factor 5 and factor 3 have a simple structure, which means that on these factors only single variables have high loadings. For factor 5, the variable *mathematical symbols* has the highest loading. In addition to *mathematical symbols*, the variable *mathematical terms* have also a characteristic loading on factor 5. Small loadings on factor 5 also show *prepositions*, *numbers*, and *lexical density*. The second factor with a simple structure is factor 4. Particularly relevant variables for this factor are the *lexical density*, *rarely used words* with a high negative loading *numbers*.

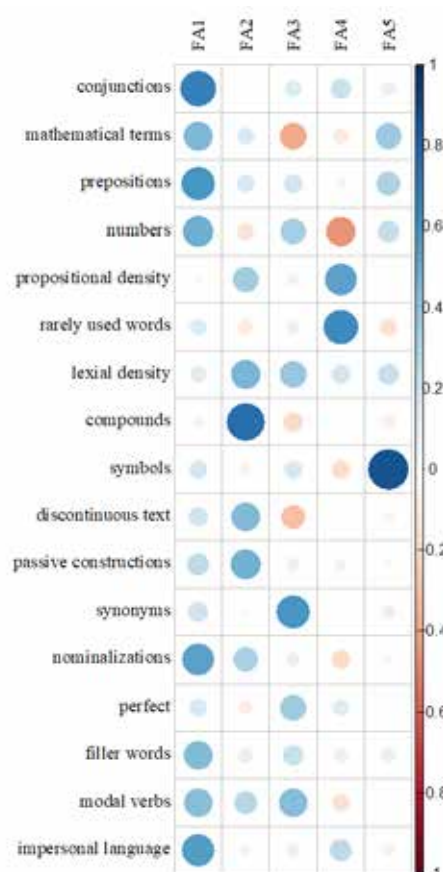


Figure 3: Factor loading diagram

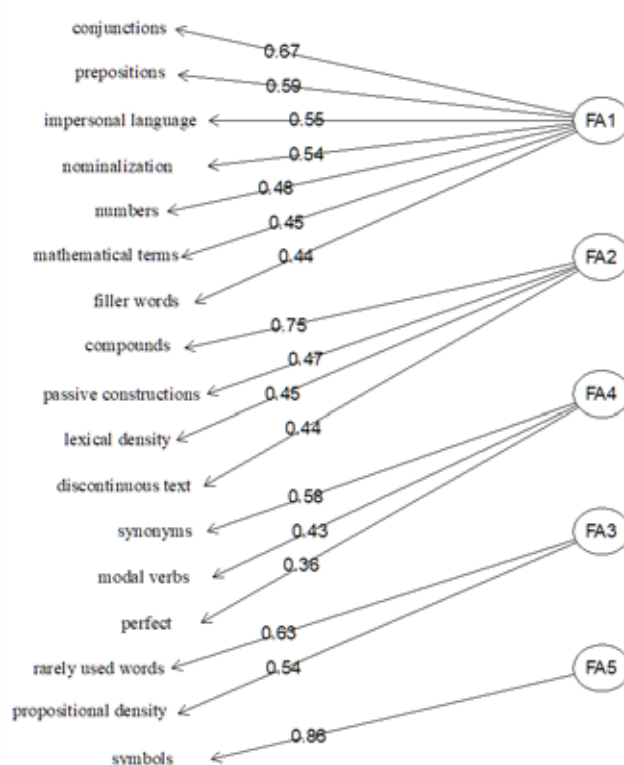


Figure 4: Simplified factor diagram

The remaining three factors have more complex structures. At factor 3, the three variable *synonyms*, *modal verbs* and *perfect* are the variables with the highest loadings. In addition to the three factors, mentioned in the simplified factor diagram, *lexical density*, and *numbers* are variables with characteristic loadings. Furthermore, as can be seen in Figure 3, *mathematical terms*, and *discontinuous text* have relevant high negative loadings. For Factor 2, the variables *compounds*, *passive constructions*, *lexical density* and *discontinuous text* loading high on this factor. Other loadings with characteristic loadings are *propositional density*, *nominalization*, and *modal verbs*. The results of Factor 1 show high loadings of seven variables. On this factor, *conjunctions*, *prepositions*, *impersonal language*, *nominalization*, *numbers*, *mathematical terms* and *filler words* are loading high.

Interpretation

To interpret the results of an exploratory factor analysis, simple structures are the easiest way to choose appropriate names. However, in the present results of the explorative factor analysis,

three out of two factors do not show a simple structure, and the designation of the factors may be problematic. To simplify the problem, Table 3 is used to assign the different variables to the typical situations of language use. To name the factors, the variables with the highest loadings are considered and to which situation of the language use they can be assigned to.

The factor 5 is referred to *mathematical textual configurations* due to the high loadings of variables from typical *mathematical situations* of language usage. The variables from typical *formal* language situations load high on factor 4. This results in the naming *formal textual configuration* for factor 4. The term *informal written textual configuration* for factor 3 derives from the association of high loading variables from *informal* and *written* situations of language use. For factor 2, situations of *written* and *mathematical* use are central. However, it should be noted that the assignment applies only to *discontinuous text*. Accordingly, the term *written discontinuous textual configuration* for factor 2 is chosen. As expected, Factor 1 has the greatest variety of characteristic situation of language use. Here are *relational*, *mathematical* and *formal* situations of language use characteristic elements. Hence the term *formal relational mathematical textual configuration* was chosen.

In summary, there are five textual configurations due to the loadings and the variations of the variables on the different factors: *mathematical TC*, *formal TC*, *informal written TC*, *written discontinuous TC*, and *formal relational mathematical TC*.

Outlook

The naming of the factors shown above are qualitatively further specified in the present project in more details by individual instances. This means that regression scores are calculated for the individual variables and extreme cases are used to allow a further qualitative specification of the factor names. However, this specification is not possible at this point due to the focus of the paper. Rather, this paper should show that lexical and grammatical variables can be reduced to factors on which each variable varies.

In summary, the SFL-theory shows potential to analyze linguistic difficulties of learners in mathematical classroom. With SFL theory, the patterns of variation in the empirical study can be explained theoretically and thus, it is possible to present relevant implications for teachers. Moreover, the analysis of language on an SFL-perspective is content specific and therefore, more concrete for mathematics classes and provides pedagogical accessibility. The factor analysis, as an empirical method, is useful to identify textual configurations, but also contextual configuration in general of mathematical tasks. As shown above five factors can be identified, which provides an approach, on the one hand, to evaluate the difficulties. On the other hand, on this basis, a model for language proficiency in mathematical classrooms can be developed and implications for the practice of teachers can be made. The analysis provides an approach to determine the difficulty for each factor. The next steps of the project LIMiT are the theory-based interpretation and designation of the five textual configurations of the mathematical task. This is to be followed by the use of a further empirical method to evaluate the difficulties. Based on the results, a conception of an empirical model of task difficulties in mathematics and the construction of a pedagogical model for language proficiency in mathematics classrooms will be carried out.

References

- Abedi, J., Hofstetter, C., & Baker, E. (2001). *NAEP math performance and test accommodations: Interactions with student language background*. Retrieved from <http://cresst.org/wp-content/uploads/newTR536.pdf>
- Abedi, J., & Lord, C. (2001). The language factor in mathematics tests. *Applied Measurement in Education*, 14(3), 219–234.
- Caplan, D., & Waters, G. (1999). Verbal working memory and sentence comprehension. *Behavioral and Brain Sciences*, 22(1), 77–126.
- Eggs, S. (2004). *An introduction to systemic functional linguistics* (2nd ed.). London, England: Continuum.
- Haag, N., & Heppt, B. (2015). Effects of mathematics items' language demands for language minority students: Do they differ between grades? *Learning and Individual Differences*, 42, 1–7.
- Halliday, M. A. K. (2014). *Halliday's introduction to functional grammar* (4th ed.). London, England: Routledge.
- Halliday, M. A. K., & Hasan, R. (1989). *Language, context, and text: Aspects of language in a social-semiotic perspective*. Oxford, England: Oxford University Press.
- Kintsch, W. (2007). *Comprehension: A paradigm for cognition*. Cambridge, England: Cambridge University Press.
- Leisen, J. (2013). *Handbuch Sprachförderung im Fach. Sprachsensibler Fachunterricht in der Praxis* [Handbook of language support in the classroom. Language sensitive subject teaching in practice]. Stuttgart, Germany: Klett.
- Maier, H., & Schweiger, F. (1999). *Mathematik und Sprache. Zum Verstehen und Verwenden von Fachsprache im Mathematikunterricht* [Mathematics and language. About the understanding and using of subject terminology in the mathematics classroom]. Wien, Austria: öbv & hpt.
- Martiniello, M. (2008). Language and the performance of English-language learners in math word problems. *Harvard Educational Review*, 78(2), 333–368.
- Michalke, M., Brown, E., Mirisola, A., Brulet, A., & Hauser, L. (2017). Package 'koRpus'. Retrieved from <https://reaktanz.de/?c=hacking&s=koRpus>
- Morek, M., & Heller, V. (2012). Bildungssprache – Kommunikative, epistemische, soziale und interaktive Aspekte ihres Gebrauchs [erudite language- communicative, epistemic, social and interactive aspects of its use]. *Zeitschrift für angewandte Linguistik*, 57(1), 67–101.
- Ozuru, Y., Rowe, M., O'Reilly, T., & McNamara, D. S. (2008). Where is the difficulty in standardized reading tests: The passage or the question? *Behavior Research Methods*, 40(4), 1001–1015.
- Prediger, S., Wilhelm, N., Büchter, A., Gürsoy, E., & Benholz, C. (2015). Sprachkompetenz und Mathematikleistung – Empirische Untersuchung sprachlich bedingter Hürden in den Zentralen Prüfungen 10 [Language competence and mathematical performance- empirical inquiry of linguistic barriers in the central exam 10]. *Journal für Mathematikdidaktik*, 36, 77–104.

Relations between school achievement and language abilities in mathematics classrooms

Aurélie Chesnais

University of Montpellier, France; aurelie.chesnais@umontpellier.fr

My research aims at studying how school achievement is related to social background in mathematics classrooms. I am comparing two sessions held in two contrasted schools, by the same teacher on the same subject. The analyses show that the fact that some elements related to the language of mathematics are “transparent” to the teacher might explain the differentiation in students’ achievement. The discussion will show how this research, conducted in a French context, meets preoccupations of the international community of researchers, in particular about the characterization of mathematical language and the question of multilingualism.

Keywords: Teaching practices, learning inequalities, multilingualism.

Introduction

My research focuses on the social dimension of language in order to investigate how learning inequalities are produced inside mathematics classrooms. This meets some preoccupations of CERME researchers, but with a point of view built in the French didactic research context. Building on the seminal work of Bourdieu and Passeron in the sixties that drew attention to the correlation between school achievement and sociocultural background, sociologists in France assume a “relational hypothesis”, stating that “the production of learning inequalities results from a confrontation between the socio language and the socio cognitive dispositions of the students on the one hand, and the obscurity and the implicit character of school requisites on the other hand” (Bautier & Goigoux, 2004). This implicit character results from the fact that these requisites are “transparent” to teachers which renders them “invisible” to students (Rochex & Crinon, 2011). This implicitness, which is nevertheless a condition of learning (Erath & Prediger, 2015; Planas, Morgan, & Schütte, 2018) sometimes creates ‘misunderstandings’ (Rochex & Crinon, 2011) for students who don’t have the ‘keys’ to decode it.

Moreover, sociolinguists like Bernstein, or Lahire and Bautier in France established that among these requisites, the ones concerning linguistic competencies play a fundamental role in the production of learning inequalities. This concerns not only linguistic competencies, but also competencies related to uses of language (Bautier, 1995; Planas et al., 2018): in everyday life, language is mostly used to support action in a given situation, whereas in learning activities, language is used to reflect on the world, speculate on it and categorize it using concepts. Students are more or less familiar with these latter forms, according to their sociocultural background.

An open question that interests researchers in mathematics education is trying to understand how the learning and teaching process within the classroom produces these learning inequalities, when specific knowledge is at stake (here, mathematics). Investigating this question supposes to identify, among the features of the language of mathematics and mathematics education (Pimm, 2004), linguistic competencies that might be unequally mastered by students, and the way they interfere in

the teaching and learning process in classrooms. The issue here is also to be able to consider alternatives especially to provide resources to support new teaching practices, in order to contribute to reducing learning inequalities by fostering every student's learning.

In this study, I considered the way language issues are handled in mathematics classrooms and the potential effects on learning outcomes in relation to students' sociocultural background. In this paper, I compare lessons held in two contrasted schools, one of which was situated in a 'disadvantaged' area, while the other school was not. The lessons were given by the same teacher on the same mathematics topic. Our analyses of the lessons aim at pointing out how differences in what occurs might induce differentiated learning for the students in the two classes; in particular, I try to understand the role played by linguistic competencies in these differences.

After presenting the theoretical framework and my methodology, I am presenting the preliminary analysis of the knowledge at hand, and of the tasks students are working on, during the observed sessions. I shall particularly stress linguistic issues. In the third part, I will present the results of the analyses.

Theoretical framework and methodological implications

My theoretical framework is based on Activity theory adapted to mathematics teaching and learning in a school context (Robert & Rogalski, 2005; Vandebrouck, 2013). The main hypothesis is that learning results from students' activity which results (mainly) from the tasks the teacher chooses for students and the way s/he implements them in the class. Learning is defined as conceptualising. Conceptualization (as a product) of a specific piece of knowledge is characterized by three aspects, namely: the 'availability' of the knowledge to solve tasks in which it is relevant, its integration in the network of prior knowledge, and the use of associated 'signs' (in particular linguistic ones). Conceptualisation results from opportunities to use this piece of knowledge in various tasks, with various "adaptations" in the activity to solve the tasks¹. From a Vygotskian perspective, managing specific linguistic signs - in particular verbal language - is an integral part of conceptualising, and the use of signs and the availability of a piece of knowledge to solve tasks develop dialectically. Our hypothesis on the role of the teacher in this process, resulting from the combination of Vygotskian and Piagetian ideas (Rogalski, in Vandebrouck, 2013), is that the teacher has to foster the activity of students to solve mathematical tasks, but s/he should also ensure that the solving of tasks actively supports opportunities for conceptualising. Interactions in classroom are then considered as potential opportunities for students' conceptualising but also as traces of how students interpret the mathematical and classroom norms (Planas & al., 2018).

The collected data consists of videos of the sessions about the notion of angles in two different classrooms of the first year of secondary school (6th grade) in two different schools: one which is situated in a disadvantaged area and one which is not. I shall respectively call them class 1 and class 2. In the two classrooms, the teacher, 'Mathew', is the same one and he is the regular teacher of both

¹ Robert, in Vandebrouck 2013, identified seven types of adaptations including the fact of mixing different pieces of knowledge or having to establish a procedure with several steps.

classes. Mathew explained in an interview that he sees no reason to make differences between the tasks he chooses for students of the two schools because his choice is made based on the coherence between the task and the aimed knowledge.

In the following section, I first explain the learning issues related to the mathematical content at stake (including official instructions), particularly stressing linguistic issues. I then describe the tasks set by Mathew to his students, predicting the possible activities that students might develop when completing them. Following this, I analyse the implementation of the tasks in the classroom. Using video-recordings, transcripts and in-situ observations (especially of the tracks of students' activity - what they do or say), I characterize students' activities as precisely as possible. Analysis of the videos also includes identifying what the teacher does or says and how it impacts directly on students' activity, but also the transformation of students' activity into learning.

Analysis of the mathematics at stake in the classroom sessions

Preliminary study of mathematical contents

In France, official instructions recommend to introduce the notion of right angle in grades 1 to 3 when pupils learn to distinguish between different geometric shapes (triangle, square ...), but the general angle concept is introduced in grades 4-5. In grades 4-5, pupils learn how to compare angles (by superimposing one on the other) and how to reproduce a given angle using a template of it on tracing paper. They discover the different types of angles (acute, right or obtuse angles), and they use a set square to validate visual estimations.

In 6th grade, students are still supposed to deepen their understanding of angle as an attribute, but the main teaching objective is learning how to use a protractor to measure angles and to construct an angle with a given measure. Moreover, the objects of geometry are supposed to change progressively, from drawings to theoretical objects, from the end of primary school to the end of lower secondary school. At the end of primary school, conceptualising of elementary geometrical figures is then still in progress: students are expected to know, in particular, about squares and right, isosceles and equilateral triangles and they can use instruments to confirm that a given figure is one of them, checking right angles using a set square and checking the equality of sides' lengths using a ruler. However, this does not guarantee that these figures are already fully conceptualised. In particular, students may know about squares and equilateral triangles, but do not necessarily conceptualise "the" square or "the" equilateral triangle as a figural concept. In particular, considering elementary geometrical figures as concepts eliminates the ideas of position and orientation in space, thickness and particularly size: the concept of square represents any square whichever dimensions it has. Indeed, what discriminates forms is angles, which is the element which is invariant under similitudes.

Thus, a crucial linguistic issue is to be able to discriminate between "a" square, "the" square, "all" squares or "any" square². These terms may be used correctly unconsciously by experts, but carefully considering these variations appears to be fundamental when it comes to mathematics learning and teaching. Following Vygotsky, it may be assumed that a reasoned use of these determiners constitutes

² The same distinctions also exist in French: "un carré", "le carré", "tous les carrés", "n'importe quel carré".

a tool to foster the conceptualising of elementary geometrical figures. It also constitutes an indication of this conceptualisation when it is used by students. However, discriminating between these uses is complicated by the fact that the determiner “the” could either be used to refer to the concept, in its generic sense (“the square is a figure which angles are all right ones”), but also to refer to a specific object, in its deictic use (“look at *the* square we draw on the board”). Note that in French, unlike in English, the determiner used to signify singular or plural is not the same and the adjective also agrees with the noun (“the equilateral triangle” translates as “le triangle équilatéral”, whereas “the equilateral triangles” translates as “les triangles équilatéraux”).

Analysis of the tasks

During the two sessions I observed, Mathew uses two tasks he found in a paper in a specialized journal³. The paper contained the description of a whole scenario about the teaching of angles which had been designed by a group of teachers. The idea of the project was to use a polyhedral box with faces that are squares, equilateral triangles and right isosceles ones. The first task of the scenario consisted of cutting models of the box with different scales to separate the faces and then group them to make ‘families’. Students are then asked to name and describe the families.

The second session was devoted to finding the measures of each angle of the faces, knowing that a right angle measures 90° (this value being announced by the teacher). I will particularly focus on the goal of establishing that the angles of the equilateral triangle(s) measure 60° . The expected activity of students is to put together three equilateral triangles (in adjacent positions) and observe that they obtain a “flat angle” (they are not supposed to know this expression) and that it corresponds to two right angles put together. They are then supposed to compute the double of 90 and divide the result by 3. This constitutes a complex reasoning in 6th grade, because there are a lot of subtasks and adaptations: for example, a lot of different knowledge is supposed to be used (about geometry, measure and numbers). Moreover, it relies (more or less implicitly) on the use of the property of additivity of adjacent angles’ measures. It also supposes to use the fact that angles of any equilateral triangle are equal and/or that all the angles of all equilateral triangles are equal. These properties are trivial for mathematicians (one can even consider that they define the equilateral triangle as a figure), but they are not necessarily known by 6th graders. At this age, a triangle still refers to a specific drawing and not necessarily to a figure as a concept; moreover, the notion of angle is not yet conceptualized either. In particular, students may not master the fact that angles are invariant under similitudes, i.e. that the measure of an angle does not depend on the length of its sides. Finally, equilateral triangles are generally characterized for students by the equality of their sides. Mathematically speaking, these properties concern THE equilateral triangle as a concept. The options offered to students then are either to first observe the fact that all three angles of a given equilateral triangle are equal, then apply the procedure and then generalize to all the equilateral triangles of any size, or to observe the fact that all the angles of all the equilateral triangles that they have are equal, whatever their size might be, and then apply the procedure. Both options seem to be difficult for 6th

³ A journal that includes papers that present propositions for teaching (or for teacher training), coming either from researchers in mathematics education or from teachers.

graders. Completing the task and understanding what knowledge is at stake also implies considering the pieces of paper as representing geometrical figures and that some of them are the same figure, whichever size they are or even if they are not exactly superimposable because of the imprecision of cutting. Given all these considerations, these tasks might contribute to the conceptualizing of elementary geometrical figures as concepts, but it is not an explicit objective in the initial scenario, which is centered on angles.

The two classroom sessions

At the end of the first session, families have been characterized in both classrooms by properties stated by the students: right angles and equal sides for the squares, one right angle and two equal sides for the right isosceles triangles; finally, about the equilateral triangles, students in both classes mentioned the equality of the sides, but only in class 2 did they mention the equality of angles.

Differences in students' activities

Analyses show that in class 2, almost all students suggest solutions after 10 minutes. In class 1, Mathew observes that after 6 minutes students seem lost and he suggests putting some equilateral triangles together and observing if anything special happens. Only 5 students suggest answers (which remain partial) when the teacher stops individual work after 12 minutes. These differences suggest that students in the different classes were not equally able to complete the task: whereas students from class 2 do not seem to experience major difficulties completing it, the task seems very difficult for students from class 1. Analyzing the concluding phase in class 1 provides some clues to understand these differences. After showing that putting together three equilateral triangles gives a straight line (which is suggested by the most advanced students) Mathew tries to have students understand how this helps finding the measures of the angles. The addition of two right angles and the resulting 180° is mentioned, as well as the idea of dividing by 3 and the resulting value of 60° . After this, Mathew suggests writing down the whole solution on the board, but what appears is that some students' activity remains very far from what is expected, making me doubt their ability to seize the task as a real opportunity for learning. The following excerpt illustrates the misunderstanding lies:

- T: If I put the angles together, the angles of, of, which angles?
 S1: of 60° .
 T: each one measures 60° , but they are angles from which piece(s)⁴?
 S2: equilateral triangle.
 T: [writing on the board] if we put together three angles.
 S1: the three angles of each triangle, one angle from each triangle.
 S3: from each triangle.
 T: from which triangle(s)? From any triangle?

⁴ French language doesn't allow discriminating between singular and plural in the oral discourse.

- S1: the three over there [pointing at the board, where pieces are magnetically hung]
 T: yes, but from which- Are they all three the same or not the same?
 S1: they are identical.
 S2: equilateral
 T: [writing on the board] yes. If we put together three angles from equilateral triangles [...]

The question the teacher asks about “which piece(s)” and later “which triangle(s)” refers to the type of triangle and waits for “equilateral triangle(s)” as an answer but S1 refers to the material pieces: the discourse is not about the same objects. One might reasonably doubt that the students previously identified that all equilateral triangles have all their three angles that are equal (whereas, in class 2, students knew it from the first task). Note that, at the end, Mathew resolves the (theoretical) problem by mentioning the fact that all these triangles are “the same”, but it is probably not sufficient to make sure that all the students understand the reasoning.

The question that remains and is of great importance (in order to understand how why school achievement in mathematics is differentiated according to the sociocultural background of students) is to understand if these differences in students’ achievement could result from teacher’s choices, either because he does things differently or because some things he does similarly don’t have the same effect on all the students.

Differences in the teacher’s discourse in the two classes

This excerpt suggests that the teacher has not understood what enables students, in class 1 to understand the reasoning. Moreover, the role of the property that all angles of all equilateral triangles are equal seems “transparent” to him: not only is it not explicitly stated when exposing the proof, but Mathew has students check that all the angles of all the equilateral triangles (all the pieces they have in their hands) are equal *only afterwards*.

I also compared the discourse of the teacher during the whole sessions. What appears as common between the two sessions is that Mathew alternates between saying “the equilateral triangles” and “the equilateral triangle”, attesting that these two expressions are equivalent for him. A difference that appears and seems important is that in class 2, he will earlier and more systematically use geometrical language: when presenting the task, he talks about “finding the measure of the angles of each figure”, whereas in class 1, the question is firstly formulated as “if I take this piece, the question is, this point, can I know how much it measures?” which is rapidly rephrased as “the aim is to say, for each piece, each angle, what is its measure?”. Vocabulary is more mathematical in the last formulation (for example he uses “angle”), and I conjecture that talking about the pieces instead of the figures does not help students to focus on the relevant objects. Moreover, it might explain why, at the end of the session (see excerpt above), some students still have not identified that what is at stake is the measure of the angles of the figure represented by the pieces of paper of the same family, and not the measure of the corner of each piece of paper.

Discussion and conclusion

Differences between what happens in the two classrooms might explain some of the variability of students' activity and hence, learning. These differences seem to be related to elements introduced by either the teacher or the students, but without the teacher being aware of the possible impact of these differences (i.e., transparent elements). For example, mentioning “the” equilateral triangle might have implicitly helped some students to identify what was at stake but was not sufficient for others, especially in class 1. Moreover, the fact that the teacher mentions the pieces of paper in class 1 might have helped the students to start working, but jeopardized their identification of the learning issue.

Our study illustrates how the combination of socio linguistic and sociocultural characteristics of students on one hand and the transparency of some elements for the teacher on the other hand, appears to result in differentiating students' opportunities for learning in the two classes. The question that remains concerns the causes of the transparency for the teacher of elements that seem crucial to explain differentiation in students' achievement. I hypothesize that the issue of conceptualizing elementary geometrical figures is hidden behind language elements: the fact that “the equilateral triangles” becomes “the equilateral triangle” is very subtle. This is probably aggravated by the fact that elementary geometrical figures (and associated verbal language) are elements that are “naturalized” for teachers, like most of elementary mathematical knowledge, especially concerning mathematical logic (see Durand-Guerrier, 2013, or Chesnais, 2018).

Even if this research appears as closely related to the French context (by the fact that observations were conducted in French classrooms and concern French language but also that the research was conducted using French theories), it meets some crucial CERME's preoccupations for three reasons. First, following Pimm (1987), some features of mathematical language are common to diverse languages. Thus, considering the issue of the use of determiners in relation to quantification and conceptualization could constitute a relevant common object of research. Second, the transparency of issues related to mathematical language in classrooms is shared by teachers in all countries, and this hypothesis would be worth investigating. Third, the impact of the sociocultural background of students in school achievement could meet some preoccupations related to multilingualism. When multilingualism is related to poorer school achievement, it is often related to social backgrounds (in France and countries like South Africa as Phakeng, 2018, shows). Mixing the two preoccupations could help, in research about multilingualism, not to focus essentially on the mastery of language in terms of lexical and syntactical elements, but also on uses of language, which might be of greater importance to explain difficulties in school achievement (Bautier, 1995). This could explain why multilingualism seems to be an obstacle for students with lower sociocultural background whereas it appears as an advantage for students with upper sociocultural background. Even if the French educational system deliberately ignores multilingualism (except for new arrival students), French schools situated in disadvantaged areas often have a large number of students for whom French is not the first language. Considering the impact of multilingualism in mathematics achievement may allow enrich the approach of these students' difficulties and resources (Planas et al., 2018).

References

- Bautier, E. (1995). *Pratiques langagières, pratiques sociales, de la sociolinguistique à la sociologie du langage*. [linguistic practices, social practices, from sociolinguistics to sociology of language] Paris, France: L'Harmattan.
- Bautier, E., & Goigoux, R. (2004). Difficultés d'apprentissage, processus de secondarisation et pratiques enseignantes: Une hypothèse relationnelle. [Difficulty of learning, processes of abstraction and practices of teaching: A relational hypothesis] *Revue Française de Pédagogie*, 148, 89–100.
- Chesnais, A. (2018). Diversity of teachers' language in mathematics classrooms about line symmetry and potential impact on students' learning. In Planas, N. & Schütte, M. (Eds.), *Proceedings of the Fourth ERME Topic Conference 'Classroom-based research on mathematics and language'* (pp. 41–48). Dresden, Germany: Technical University of Dresden and ERME.
- Durand-Guerrier, V. (2013). Quelques apports de l'analyse logique du langage pour les recherches en didactique des mathématiques [some uses of the logical analysis of language for the research of mathematics didactics]. In A. Bronner et al. (Eds.), *Questions vives en didactique des mathématiques: Problèmes de la profession d'enseignant, rôle du langage* (pp. 233–265). Grenoble, France: La Pensée Sauvage.
- Erath, K., & Prediger, S. (2015). Diverse epistemic participation profiles in socially established explaining practices. In K. Krainer & N. Vondrová (Eds.), *Proceedings of the ninth congress of the European Society for Research in Mathematics Education* (pp. 1374–1381). Prague, Czech Republic: Charles University and ERME.
- Phakeng, M. (2018). One country, many languages: Exploring a multilingual approach to mathematics teaching and learning in South Africa. In N. Planas & Schütte, M. (Eds.), *Proceedings of the Fourth ERME Topic Conference 'Classroom-based research on mathematics and language'* (pp. 8–16). Dresden, Germany: Technical University of Dresden and ERME.
- Pimm, D. (2004, July). *Discourse analysis and mathematics education: An anniversary of sorts*. Paper presented at the ICME10 Conference, Copenhagen, Denmark.
- Pimm, D. (1987). *Speaking mathematically: Communication in mathematics classrooms*. London, England: Routledge and Kegan Paul.
- Planas, N., Morgan, C., & Schütte, M. (2018). Mathematics education and language: Lessons and directions from two decades of research. In T. Dreyfus, M. Artigue, D. Potari, S. Prediger & K. Ruthven (Eds.), *Developing research in mathematics education. Twenty years of communication, cooperation and collaboration in Europe* (pp. 196–210). New York, NY: Routledge.
- Robert, A., & Rogalski, J. (2005). A cross-analysis of the mathematics teacher's activity. An example in a French 10th-grade class. *Educational Studies in Mathematics*, 59, 269–298.
- Rochex, J.-Y., & Crinon, J. (Ed.) (2011). *La construction des inégalités scolaires*. [The construction of educational inequalities] Rennes, France: PUR.
- Vandebrouck, F. (Ed.) (2013). *Mathematics classrooms: Students' activities and teachers' practices*. Rotterdam, Netherlands: Sense Publishers.

Construction of mathematical discourses on generalization during group interaction

Judit Chico

Universitat Autònoma de Barcelona, Barcelona, Catalonia-Spain; judit.chico@uab.cat

This study aims at analysing the impact of group interaction on the construction of learners' mathematical discourse on generalization in the classroom. Comparative and inductive analysis were applied to examine five group discussions with learners aged 15 and 16 involved in problem solving. I report the analyses of two segments of group discussion to illustrate how certain forms of interaction influence the production of mathematical language and the construction of discourses on generalization of patterns. Results show the positive effect of social interaction by minimizing the ambiguity of the language, connecting different linguistic expressions of a mathematical object and identifying the variables to construct a symbolic generalization.

Keywords: Group discussion, mathematical language, social interaction, generalization discourse.

Introduction

In Planas and Chico (2013), we reported the analysis of learning opportunities around the construction of algebraic thinking in the context of classroom group discussion. In that report, we established the bases for the study of the impact of social interaction on students' mathematical learning in a middle school classroom. On this occasion, I present the analysis of group discussion of another lesson of the same data corpus, with the purpose of arguing the impact of certain forms of interaction on the development of the language of mathematics in class. The mediation role of social interaction on classroom mathematical learning is key to social theories (Planas, 2014, 2018), but it is still necessary to expand and refine arguments about how this mediation occurs and with what effects for tasks focused on specific mathematical topics. Data, results and reflections in this report respond to the goal of identifying the impact of certain forms of interaction on the production of mathematical language and the construction of discourses on generalization processes.

In what follows I briefly present my theoretical views of social interaction, mathematical learning and discourse on generalization. Then I introduce the orientation of the methods applied in the research. From here, I comment on two lesson episodes to illustrate how certain forms of interaction influence students' mathematical discourses on generalization with specific implications for the development of languages of mathematics. I end with reflections on the relationship between social interaction and students' mathematical discourses on generalization.

Social interaction, mathematical learning and discourses on generalization

Within the social theories of learning, I draw on the tradition of symbolic interactionism and socio-constructivism in mathematics education research (Krummheuer, 1995). Here social interaction is seen as a process in which individual actions are influenced by the interpretation of, and reaction to, the system of actions taking place in a setting. Specifically, my study is based on the tradition of micro-analyzing classroom discourses by interpreting empirical data in terms of participants' actions. The focus is on actions aimed at communicating and negotiating mathematical meanings articulated

in, and for the production of, mathematical discourse on generalization. A collective action is generated by linking participants' actions and depends on the individual meanings constructed in the interpretation process of the interaction (Blumer, 1969). If we add the vision of learning as recognition and use of meanings assignable to a discourse, we can say that while collective construction of the language of mathematics is produced, the bases for the individual mathematical learning of the participants in the interaction are established (Morgan, 2005). Accordingly, mathematical learning results from social interaction in contexts of use of the language of mathematics and the meanings associated with the appropriation of the school culture. From this perspective, I understand the notion of discourse as language in use with meanings depending on the context in which it occurs (Planas, 2018). Then, the conception of mathematical learning can be refined, seeing it as the recognition and use of meanings of a discourse by participating in it.


Mathematical learning understood as the development of the language of mathematics in a school culture requires the modification of student's discourse in those aspects that are far from the formality of the school mathematical discourse. Drouhard and Teppo (2004) claim that clear ordinary languages are a basic resource to facilitate the understanding of algebraic symbolism and syntax in problem-solving environments. The interpretive nature of assigning meaning to algebraic symbols and syntax requires substantial experiences with meaning-making activities around letters, words, and syntactic structures in ordinary school languages used to represent and discuss the problem to be solved (Planas & Chico, 2013). Difficulties in the recognition, understanding and symbolic representation of variables and their functional relationship endure over time for lower, upper secondary and university students (Ursini & Trigueros, 2006). Sorales and Kieran (2013) recommend classroom activities that allow connecting and developing syntactic and semantic levels to achieve a rich understanding of algebra. The problem-solving approach of generalization of patterns adopted in this research helps to develop both levels since it facilitates meanings for symbols from a functional perspective (Carraher & Schliemann, 2007).

As Radford (2010) claims, not all patterning activity leads to algebraic thinking in the same way as using symbolic language to express a pattern does not imply generalization reasoning. This is the case of inductive reasoning, frequently used by students, even if the inductive process can be expressed using symbolic language. Accordingly, I distinguish between inductive discourse originated by guessing strategies and generalization discourse that requires seeing something general in the particular. Moreover, algebraic generalization of patterns requires the use of symbols to reason about and to express a generalization (Kieran, 1989). If we see generalization of patterns as a route to algebra, there are different degrees of generalization (arithmetic, factual, contextual and symbolic) depending on the material form used to reason and to express the general (Radford, 2010). While an arithmetic generalization is based on "a local commonality observed in some figures, without being able to use this information to provide an expression of whatever term of the sequence" (Radford, 2010, p. 47), factual, contextual and symbolic generalization depend on the way a general rule is expressed, namely, using gestures and movements (factual), linguistic expressions (contextual) or algebraic language (symbolic).

Research context and methods

A sequence of five lessons with five problems involving generalization of patterns was designed to facilitate algebraic thinking in a mathematics classroom with eight students aged 15 and 16. For each lesson, the teacher presented a problem and then the students discussed it in pairs while the teacher walked around the room. For the last thirty minutes, students were asked to discuss their approaches in a group and to examine and compare resolution strategies. The teacher acted as a facilitator of students' interactions. The students were used to pair work and group discussion. They were also used to problem-solving dynamics, to listening to each other, and to communicating their mathematical ideas. The problems included imaginable contexts outside mathematics and drawings of the first terms of a sequence. The questions were structured considering algebraic thinking: 1) concrete, considering small quantities; 2) semi-concrete, considering big quantities; and 3) abstract, using symbols (Carraher & Schliemann, 2007). Within the 5-problems sequence, the difficulty of a problem was also controlled by omitting the semi-concrete question and introducing a question that requires understanding of symbolic expressions as objects that can be manipulated (see Figure 1).

A farmer plants orange trees following a square shape and wants to plant pine trees all around. Here you can see the idea for 1-, 2-, and 3-row square.



1. How many orange and pine trees does the farmer need to plant for 5-row square?
 2. For an n -row square, how many orange trees does he need? How many pine trees?
 3. The main income for the farmer comes from selling oranges, and thus he wants to plant more orange than pine trees. Keeping the shape, is this possible?
 Explain how you proceed for each case.

Figure 1: Example of one of the problems in the study

Data collection consisted of audio and video recordings of lessons. We began by transforming audio and video files into transcripts. First, I explored data of pair work and constructed a narrative detailing some aspects of students' interaction and generalization processes (Chico & Planas, 2011) to better understand the mathematical activity in group discussion. Regarding group discussion data, I began a process of comparative and inductive analysis (Glaser, 1969) to elaborate interactional codes. These codes mark students' actions informing about the continuation of mathematical content initiated in prior turns. In the interpretative process of codifying social interactions, two criteria were followed: i) attending to the closest context of interaction by differentiating the interaction between peers of a pair, ii) giving priority to the function of the language in relation to the mathematical content rather than to the linguistic form (see more detail in Chico, 2014). The interactional codes discussed in this report are: *Initiating* (new approach to the resolution), *Co-Initiating* (new approach to the resolution in pairs), *Co-Reflection* (on a resolution in pairs). To segment the transcript into episodes, I looked for changes in students' discourse on generalization, distinguishing between inductive discourse and arithmetic, factual, contextual or symbolic generalization discourses (Radford, 2010). The transcript of each episode was examined to complete the interactional codes with mathematical actions. From a linguistic perspective, I focused on mathematical actions that have an effect on the language used

such as word refinement, word (symbol)-meaning clarification, pattern linguistic (symbolic) expression or variable linguistic (symbolic) expression. At this point I had episodes characterized with interactional codes and mathematical actions. It took time to search for relationships between interactional codes and mathematical actions and regularities among the episodes. According to my goals, I looked for regularities of mathematical actions involved in a particular type of interaction. It gives information about the impact of social interaction on the production of mathematical language. Then, I looked for regularities in the combination of certain forms of interaction involved in changes in students' discourses on generalization. Hereunder, I present two episodes that represent what happened at different moments of the group discussions throughout the sessions.

From inductive to symbolic generalization discourse

In the excerpt below, students discuss solutions for the second question of the problem in Figure 1. The interactional codes in this excerpt are *Initiating*, *Co-Initiating* and *Co-Reflection*. *Initiating* [1] and *Co-Initiating* [2-9] refer to the introduction of a resolution in the group discussion but while the first code is an individual action the second code refers to consecutive actions articulated by the peers of a pair to explain a new resolution. This is also the case of *Co-Reflection* [10-13], which indicates a reflection produced in and by pair interaction during group discussion.

- 1 Irene: We have used a rule of three, if for one row there are eight pine trees, for n there will be x orange trees. Oh! What a mess! x pine trees.
- 2 Gabriel: We have found directly that if we multiply eight times the number of rows it gives us the number of fir trees.
- 3 Jose: Of pine trees.
- 4 Gabriel: That's it. Of pine trees. First we have seen this observing the first and the second case. And then we have seen why.
- 5 Jose: Yes. Later we have seen why. We have seen that multiplying times two the number of rows, we have the number of pine trees that make a side of the square, this one. But not one. We already count one as being from the other.
- 6 Gabriel: The one on the corner.
- 7 Jose: Minus the one on the corner that we already count for the other side. Then, if it has three rows, three times two are six, so that here there are six pine trees, here six more, here six more, and here another six. Therefore, the number of rows times two gives you the number on one side and then you multiply times four that are the sides of the square.
- 8 Gabriel: Then if you multiply $2n$ times four it gives you $8n$, which is the x .
- 9 Jose: That it is what we had seen before and we did not know why.
- 10 Óscar: It is more direct, is the developed formula.
- 11 Irene: It is like a simplification of ours if you do it.
- 12 Óscar: Ok... Theirs is thoughtful, we have been trying.
- 13 Irene: This is true. Theirs has a reason to be. Ours just worked.

The excerpt starts when Irene introduces the algebraic expression [$1/8 = n/x$] based on inductive reasoning co-constructed with Óscar during pair work. Gabriel reacts by exposing a generalization based on multiplicative reasoning co-constructed with Jose during pair time [2]. Jose interrupts

Gabriel to suggest the use of the word "pines"-written on the wording problem- instead of "first" [3] and Gabriel accepts the suggestion [4]. Later, Gabriel points out the meaning of "one", *the one on the corner* [6], that Jose validates by including this linguistic expression in his explanation [7]. Gabriel's first explanation is based on the linguistic expression of the general rule $x=8n$, expressing the letters by referring to their meaning in the context [2]. Then Jose explains the counting strategy underlying the general rule as a commonality that can be applied in all terms of the sequence [5]. To name the variables, both students use the expressions "the number of rows" and "the number of pines", that is, linguistic generic expressions that can be applied in whatever term you may want to consider [2, 5]. Jose continues his own explanation of the counting strategy, making gestures on the pattern drawing to show how the general rule works in a particular term of the sequence. Gabriel follows-up by expressing the counting strategy and the final general rule using symbolic language [8]. In short, Jose and Gabriel share the responsibility of constructing a comprehensible discourse about a symbolic generalization that they have negotiated. The communication between them helps to make more explicit the language used and to connect linguistic expressions with different degrees of formality of the same generalization.

By the end of the excerpt, the direct communication between Irene and Óscar produce *co-reflection* on their discourse on generalization. First, they recognize the equivalence between the two symbolic expressions of the general rule, appreciating the syntactic simplification of the symbolic expression constructed by Gabriel and Jose [10-11]. Then, they reflect on their discourse as opposed to Gabriel and Jose's [12-13]. Although both pairs find and explain a general rule to solve the problem and use symbolic language to represent it, the heuristics of their discourse on generalization are different. Irene and Óscar's discourse is based on an inductive reasoning and using a trial and error strategy, they propose to apply a rule of three in a few particular cases. Gabriel and Jose's discourse points out what seems to be general in the common features of the given drawings. Irene and Óscar value the generalization discourse over the inductive because the generalization is "thoughtful" or "has a reason to be" and the inductive "just worked" by "trying" [12-13]. This suggests a qualitative modification of Irene and Óscar's discourse on the meaning of generalization mediated by the discourse constructed in the interaction between Jose and Gabriel.

From arithmetic to symbolic generalization discourse

In the second excerpt the conversation is focused on another resolution to the second question of the problem in Figure 1. Cristina and Maria *co-initiate* the discussion by taking turns speaking to construct a generalization developed together during pair work [14-18]. Maria explains the meaning of the linguistic expression "the result" used by Cristina in the previous intervention [15-16]. This student validates and tests in case 5 what was said by Maria, who also incorporates the mathematical information given by Cristina [15]. Finally, Cristina synthesizes and orders the mathematical information of the previous turns to explain a counting strategy that depends on visual perception and does not contemplate the functional relationship between variables [18]. Thus, the interaction between these two students has a positive effect on the cohesion of the discourse that makes Cristina's explanation more comprehensible. The introduction of this approach in group discussion and the implicit request for help by Cristina [18] focus the subsequent conversation on the representation of this generalization in a symbolic language. This action was coded as *Requesting*. This code is a key

and repeated action that refers to the demand for clarification or help regarding an exposed mathematical reasoning. Gabriel and Irene request clarifications that lead to connecting the perceptual dependence of the counting strategy with the lack of references to the independent variable in the context [21-22]. Cristina implicitly asks for help in [23] and Irene identifies the independent variable [24], which is crucial to represent Cristina's resolution in a symbolic language. Irene connects the linguistic expression of the variable, "the rows", with the symbolic expression, n . Then Jose refers to the algebraic expression $2n$ used in his resolution to represent the pine trees on one side minus one (see the previous excerpt) [25]. Although he does not explain the meaning of $2n$ in the context of the problem, Maria represents the counting strategy in a symbolic language [26].

- 14 Cristina: I said, if you multiplied... you subtracted four from the result, the ones on the corners... I don't know...
- 15 Maria: You count one more in each side, the one on the corner. If there are four sides, four vertices...
- 16 Cristina: That is it! Four times eleven... adding the two corners in each side...
- 17 Maria: You add all and then subtract four, the ones on the corners.
- 18 Cristina: What you do is, from every side you count how many pine trees there are with the two corners. Then you multiply by four and then you must subtract four because you have counted the corners twice. But I am not able to write it down.
- 19 Óscar: Like in a formula?
- 20 Cristina: Yes.
- 21 Gabriel: But the number of sides, I mean, the number of pine trees, you cannot know it, right?
- 22 Irene: That's right, how could you know the number of pine trees if you do not have a drawing of it?
- 23 Cristina: But you guys knew it, right?
- 24 Irene: Sure! With the rows. The n .
- 25 Jose: Right with the rows, it is $2n$.
- 26 Maria: Then it will be $2n$. No! $2n$ plus one, we multiply all times four and then we subtract the four vertices.
- 27 Cristina: And that is the number of pine trees, right? That is what we weren't able to do. We didn't find the relationship which holds, we have been trying, but we haven't found it.
- 28 Maria: Because this was the number of rows, not the number of orange trees... We haven't done it with the number of rows.
- 29 Cristina: Right, because of that we didn't find that those 11 were the $2n$ plus one.

The excerpt finishes with *co-reflection* between Cristina and Maria on their discourse [26-29]. Cristina's initial discourse points to what is general in the particular. It can be said that it is a discourse about generalizing in the mathematics classroom, but not so much about generalizing algebraically. The development of algebraic thinking through the generalization of patterns implies representing the general case through the language of algebra in order to be able to later use a symbolic expression as a structural object (Kieran, 1989). This step is not trivial and involves identifying and representing variables symbolically as well as thinking about algebraic generalization as a functional relationship.

The modification of Cristina and Maria's discourse lies not only in the use of symbolic language to express a pattern, but in the recognition of the need to identify which are the variables to represent a functional relationship.

Discussion

I have shown changes in students' mathematical languages along with the interactions involved in co-construction of processes of generalization. Results indicate that some forms of interaction have a special impact on the development of languages of mathematics and students' mathematical discourse on generalization. This is the case of *Co-Initiating*. The direct communication between students who were involved in the co-construction of a resolution have a positive effect on the explicitness of the students' language used and the cohesion of the discourse on generalization constructed. Peers of a pair share the responsibility to produce a comprehensible discourse to explain a resolution to the rest of the group. Students respond to, and build upon, the peer mathematical contributions in some appropriate way according to the classroom culture. Linguistic expressions with different degrees of formality to represent the same mathematical object are connected in the discourse co-produced by a pair in the group discussion. This fact mediates in discourse changes on generalization of other students as it was argued in the first excerpt. *Requesting* is also crucial to achieve changes in discourses on generalization. In the second excerpt, the identification along with the linguistic and symbolic expressions of the independent variable is influenced by *Requesting* and helps Maria and Cristina to move from arithmetic generalization to symbolic generalization discourse. These qualitative changes on generalization discourses are reflected again in the communication between students who were working together during pair time after they confront other discourses. Although these conversations have a private nature and are addressed to specific interlocutors, they are publicly produced and constitute a learning opportunity for the whole group. Under the assumption that the form of the students' participation in the classroom is determinant to mathematical learning, the role of the pair in the group has an important impact in the production of school mathematical languages used to construct discourses on generalization. Restructuring and connecting mathematical meanings in the group discussion represents a learning opportunity for all participants who, regardless of their participation in the construction of the certain discourse, are potential receivers of the mathematical information and are susceptible to experience conceptual changes on generalization.

Acknowledgment

Thanks to the team of the research group GIPEAM, SGR2017-101. This study was funded by Project EDU2015-65378-P, MINECO/FEDER.

References

- Blumer, H. (1969). *Symbolic interactionism: Perspective and method*. Berkeley, CA: University of California Press.
- Carraher, D. W., & Schliemann, A. D. (2007). Early algebra and algebraic reasoning. In F. K. Lester (Ed.), *Second handbook of research on mathematics teaching and learning* (Vol. 2, pp. 669–705). Charlotte, NC: IAP.

- Chico, J. (2014). *Impacto de la interacción en grupo en la construcción de argumentación colectiva en clase de matemáticas* (Unpublished doctoral dissertation). Autonomous University of Barcelona, Catalonia-Spain.
- Chico, J., & Planas, N. (2011). Interpretación de indicadores discursivos en situaciones de aprendizaje matemático en pareja. In M. Marín, G. Fernández, L. J. Blanco & M. Palarea (Eds.), *Investigación en Educación Matemática XV* (pp. 319–328). Ciudad Real, Spain: SEIEM.
- Drouhard, J. P., & Teppo, A. (2004). Symbols and language. In K. Stacey, H. Chick & M. Kendal (Eds.), *The future of the teaching and learning of algebra – The 12th ICMI Study* (pp. 225–264). New York, NY: Springer.
- Glaser, B. G. (1969). The constant comparative method of qualitative analysis. In G. J. McCall, & J. L. Simmons (Eds.), *Issues in participant observation: a text and reader* (pp. 216–228). Reading, England: Addison-Wesley.
- Kieran, C. (1989). A perspective on algebraic thinking. In G. Vernand, J., Rogalski, & M. Artigue (Eds.), *Proceedings of the 13th International Conference for the Psychology of Mathematics Education* (Vol. 2, pp. 163–171). Paris, France: Laboratoire PSYDEE.
- Krummheuer, G. (1995). The ethnography of argumentation. In P. Cobb & H. Bauersfeld (Eds.), *The emergence of mathematical meaning: interaction in classroom cultures* (pp. 229–270). Hillsdale, NJ: Lawrence Erlbaum.
- Morgan, C. (2005). Word, definitions and concepts in discourses of mathematics, teaching and learning. *Language and Education*, 19(2), 102-116. doi: 10.1080/09500780508668666
- Planas, N. (2014). One speaker, two languages: Learning opportunities in the mathematics classroom. *Educational Studies in Mathematics*, 87(1), 51-66. doi: 10.1007/s10649-014-9553-3
- Planas, N. (2018). Language as resource: A key notion for understanding the complexity of mathematics learning. *Educational Studies in Mathematics*, 98, 215-229. doi: 10.1007/s10649-018-9810-y
- Planas, N. & Chico, J. (2013). The productive role of interaction: students' algebraic thinking in whole group discussion. In B. Ubuz, C. Haser & M. A. Mariotti (Eds.), *Proceedings of the 8th Conference of the European Society for Research in Mathematics Education* (pp. 1586–1595). Antalya, Turkey: Middle East Technical University and ERME.
- Radford, L. (2010). Layers of generality and types of generalization in pattern activities. *PNA*, 4(2), 37-62.
- Solares, A., & Kieran, C. (2013). Articulating syntactic and numeric perspectives on equivalence: The case of rational expressions. *Educational Studies in Mathematics*, 84, 115-148. doi: 10.1007/s10649-013-9473-7
- Ursini, S., & Trigueros, M. (2006). ¿Mejora la comprensión del concepto de variable cuando los estudiantes cursan matemáticas avanzadas? *Educación Matemática*, 18(3), 5–38.

Metacognitive and discursive activities – an intellectual kernel of classroom discussions in learning mathematics

Elmar Cohors-Fresenborg

University of Osnabrueck, Department of Mathematics, Osnabrueck, Germany; cohors@uos.de

Keywords: Classroom discussions, instructional quality, metacognition.

Theoretical background

Although metacognition is widely regarded as a promoter of sustainable learning processes (Dignath & Büttner, 2009), little is known about the implementation of metacognition and the mode of its functioning in classroom communications (Lingel, Neuenhaus, Artelt, & Schneider, 2014). When metacognition during classroom discussions is in the scope of interest, its conceptualization must refer to a broader scope of activities than in the case of problem solving. It cannot be restricted to metacognitive processes understood as cognition about one's own or others cognition, but should take into account also cognition about the inputs, subjects and results of cognition (calculation, verbal or written information, argumentations, questions). According to this conceptualization, the objectives of metacognition in learning mathematics are, for example, to *plan* the use of mathematical tools, methods, and representations to justify an argumentation or to explain an idea; to *control and evaluate* the accurateness of argumentations, the adequateness of external (e.g. formal) or internal representations of mathematical concepts, the correctness of the use of tools and procedures; to *reflect* on the ways of reasoning, defining or proving, and on similarities and differences in conceptions and arguments. The learning process in a class can lead to a deep understanding of concepts, representations and tools only if the planning, monitoring and reflection related to them are elaborated, take students' ways of thinking into consideration, and build a coherent discourse. Therefore, the class discussion must feature discursivity. *Discursivity* means activities carried out to support the coherence and precision of a discussion. On the contrary, *negative discursivity* means activities with a negative influence on understanding what is meant (Cohors-Fresenborg & Kaune, 2007).

A rating system for evaluating metacognitive-discursive instructional quality

During the last three years¹, we worked on the design of a rating system for evaluating metacognitive-discursive instructional quality in different school subjects. The rating procedure consists of two levels: first an extended version of the *category system* developed by Cohors-Fresenborg and Kaune (2007) is used to categorize metacognitive and discursive activities in students' and teacher's utterances; then, seven high inference *rating scales* are used for a global rating of the instructional quality of these activities in the given lesson (Nowińska, 2016). Each scale consists of an item (guiding question) focusing rater's attention on aspects to be evaluated, and of 3-5 answers describing in detail how these aspects are reflected in the discussion. The two-level rating procedure was tested and evaluated in the DFG-project, based on 24 videotaped lessons (6 teachers/classes à 4 lessons, grade 6 and 7). For 6 out of 7 rating scales, the generalizability studies indicate a high inter-rater reliability and a

¹ A research project supported by the DFG (German Science Foundation) under the reference CO 96/8-1.

relatively high stability of the evaluated aspects across lessons (g-coefficients >0.78); only 3 lessons per class/teacher would be needed to get reliable and generalizable (over the lessons) assessments of the 6 aspects of the instructional quality (Nowińska & Praetorius, 2017).

Some Insights from the Qualitative Lessons Analysis

When analyzing lessons an interesting type was observed in the case of some teachers/classes: there are many metacognitive, discursive, and only few negative discursive activities; but the class discussions are only on the surface of the underlying problems. If the mathematical content becomes a little bit more substantial, then the inability of the teacher and the students for elaborate metacognitive mathematical activities breaks through, and indicates the lack of metacognitive-discursive education of this class. Now, the classroom discussion shows a lot of metacognitive activities, but also lots of negative discursivity. Consequently, the global rating of the metacognitive-discursive instructional quality leads to many low marks: the metacognitive activities are not elaborate, do not build a coherent discourse, and therefore the students do not learn something substantial in this class. This observation is contrary to our hidden theory underlying the invention and use of the primary version of the category system (Cohors-Fresenborg & Kaune, 2007), as it was represented in this paper. The new observation can explain the low correlations between observed metacognition and learning achievements as sometimes reported in the literature. We assume that high ratings achieved with the two-level rating system are needed for a deep understanding of mathematics, and that such ratings can be regarded as an indicator for an intellectual kernel of classroom discussions in learning mathematics.

References

- Cohors-Fresenborg, E., & Kaune, C. (2007). Modelling classroom discussions and categorising discursive and metacognitive activities. In D. Pitta-Pantazi & G. Philippou (Eds.), *Proceedings of the Fifth Congress of the European Society for Research in Mathematics Education* (pp. 1180–1189). Larnaca, Cyprus: University of Cyprus and ERME.
- Dignath, C., & Büttner, G. (2009). Components of fostering self-regulated learning among students: A meta-analysis on intervention studies at primary and secondary school level. *Metacognition and Learning*, 3, 231–264.
- Lingel, K., Neuenhaus, N., Artelt, C., & Schneider, W. (2014). Der Einfluss des metakognitiven Wissens auf die Entwicklung der Mathematikleistung am Beginn der Sekundarstufe I [The influence of metacognitive knowledge on the development of mathematical performance at the beginning of lower secondary education]. *Journal für Mathematikdidaktik*, 35, 49–77.
- Nowińska, E. (2016). The design of a high inference rating system for an evaluation of metacognitive-discursive teaching and learning quality. In S. Zehetmeier, B. Rösken-Winter, D. Potari, & M. Ribeiro (Eds.), *Proceedings of the ERME Topic Conference on Mathematics Teaching, Resources and Teacher Professional Development* (pp. 46–55) Berlin, Germany: ERME.
- Nowińska, E. & Praetorius, A.-K. (2017). Evaluation of a rating system for the assessment of metacognitive-discursive instructional quality. In T. Dooley & G. Gueudet (Eds.), *Proceedings of the Tenth Congress of the European Society for Research in Mathematics Education* (pp. 3121–3128). Dublin, Ireland: DCU Institute of Education and ERME.

Explorative study on language means for talking about enlarging figures in group work

Kirstin Erath

TU Dortmund University, Germany; kirstin.erath@math.tu-dortmund.de

This paper presents a first step for designing language support for Grade 9 students working collaboratively on the topic of similarity, more precisely an adaptation of Brousseau's tangram task. The qualitative study identifies (topic specific) language means which students use for talking about their ideas on how to enlarge figures, combining geometrical and arithmetical ideas. Furthermore, a textbook analysis shows the target language that students should use and understand at the end of the teaching unit. The identified difference between both repertoires of identified language means calls for developing language-responsive teaching-learning arrangements in the future in which both language repertoires can be bridged systematically by macro-scaffolding trajectories.

Keywords: Language means, language repertoire of the learner, macro scaffolding, design research.

Background: Need for supporting language means for rich discursive practices

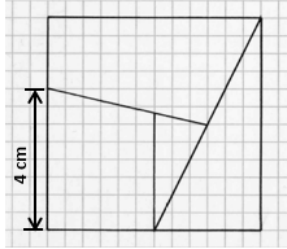
Students' participation is pointed out as crucial for learning mathematics by many researchers (e.g., Sfard, 2008) and is seen as “a process of enculturation into mathematical practices, including discursive practices (e.g., ways of explaining, proving, or defining mathematical concepts)” (Barwell, 2014, p. 332). Qualitative studies identify sequences of explaining and arguing as especially important for students' conceptual learning, in whole class discussions as well as in small group work (e.g., Mercer, Wegerif, & Dawes, 1999; Erath, 2017). However, especially for students with low language proficiency, participating in discursive practices that allow talking about conceptual knowledge is challenging (Erath, Prediger, Quasthoff, & Heller, 2018). Since language acts as a medium of thinking (Vygotsky, 1987) and following Interactional Discourse Analysis (Erath et al., 2018), this calls for supporting students in accomplishing demanding discursive practices in order to provide access to mathematical learning opportunities. Whereas in whole-class discussions, overcoming language-related obstacles can be spontaneously supported by the teacher, group work requires a prepared support when the teacher is absent. One dimension of prepared support refers to the establishment of norms about the ways students talk to each other, such as the “ground rules” proposed by Mercer (e.g., Mercer et al., 1999), emphasizing activities such as sharing relevant information and discussing alternatives. Students with low language proficiency often need additional support for accomplishing these norms, when lexical means or syntactical structures are required for explaining and arguing in the mathematical topic. Thus, referring to Gibbons' (2002) approach of macro scaffolding, these language means can be provided in prepared ways.

As Prediger & Zindel (2017) emphasize, the identification of mathematically relevant lexical and syntactical means for a specific mathematical topic is an *empirical task*; it can be conducted by analyzing textbooks and teaching-learning processes. Following the research approach of empirically identifying relevant language means, this study investigates a textbook and empirical video data for identifying the language means students initially use, the target language means, and for exploring possibilities of bridging between them.

Research context: Exploring similarity in the Tangram Task

Especially teaching-learning arrangements that activate students' individual ideas and allow processes of solving problems and discovering mathematics have the potential to elicit vivid discussions about mathematics (e.g., Brousseau, 1997) and make demanding discursive practices necessary. For identifying students' initially used language means, the presented study focuses on the first task in a teaching unit on similarity using an adaption for four students of Brousseau's (1997, p. 177ff.) tangram task (see Figure 1; translated from German by the author). The task follows a more dynamic perspective on similarity since it leads to an understanding of similarity as the result of the process of enlarging figures true to scale: Hölzl (2018) terms approaches to similarity as *dynamic* if they relate to transformation geometry and as *static* if they refer to Euklid and define similar figures by identical angles and aspect ratios.

a) We would like to have a larger version of this figure.
In doing so, a length of 4 cm should become a length of 7 cm.



(1) Each chooses a part of the figure.
(2) Execute on the following steps in individual work:

- Draw the enlarged version on squared paper
- Cut the figure out

b) Check in your group if the enlarged pieces fit together again.
What could be the reason?

Figure 1: Task 1 of the teaching-learning arrangement of enlarging figures

Thus, this paper empirically investigates students' initial language means in group work related to a task on enlarging figures true to scale and compares this repertoire to the target language means as identified in a widely used textbook by following these two research questions:

RQ1: Which language means can be identified in students' talk and in textbooks?

RQ2: Do some of these means have the potential to bridge between the identified repertoires?

Methods: Qualitative analysis of students' interactions solving the tangram task

The presented analysis is part of the larger project MAGENTA that is conducted in the tradition of design research (Gravemeijer & Cobb, 2006). It aims at developing a language-responsive teaching-learning arrangement for the topic of similarity in German Grade 9 classrooms as well as building local theories on the students' learning processes.

Methods of data collection

This paper reports research from the second cycle of collecting video data. The design experiments were conducted by two preservice mathematics teachers for their master thesis. Altogether, 6 groups of two or three students each (at the end of Grade 8 or 9; aged 14 to 16; all from the same lower

secondary school in an urban quarter in the Ruhr area) worked for 3 lessons on similarity. For all students, the design experiment was the first lesson on the mathematical concept of similarity. Following the idea of establishing ground rules, the importance of explaining and arguing and the way of working together was discussed with the students. For this paper, video data and written documents of the first task of the teaching-learning arrangement (Figure 1) were analyzed for investigating students' initial language means by making collections of the original expressions that were later on group by the used language means. The textbook analysis was conducted along the most sold textbook for comprehensive schools in North Rhine-Westphalia "mathe live" focusing on the pages introducing the topic of similarity until the summary (Böer et al., 2008, p. 20f.).

Methods of data analysis

First, all sequences were collected in which students were working independently on Task 1, until students proceeded with another task or until the teacher started to intervene. Second, these sequences were transcribed and enriched by students' written products. The third step followed inductive category formation (Mayring, 2015) and coded all utterances by generalized versions of the language means that were used (i.e. language means using variables instead of numbers) in order to gain a repertoire of students' lexical and syntactical means. For the presented analysis, only categories related to talking about changing the sides of figures are considered due to space restrictions. The textbook analysis collected all language means in tasks related to enlarging figures and in the summary.

Empirical results: language means for talking about enlarging figures

First, students' initially used language means and the target language means in textbooks are identified. Afterwards, the idea of bridging between these identified repertoires is discussed.

Students' language means for talking about enlarging figures

Task 1 proved highly suited for eliciting discursive group work, especially if students had different strategies for enlarging their parts, like in the group of Julian, Lara, and Nitika. Julian is the only student in the data of the presented research that utters the mathematically sound idea of *multiplying* each side with a constant factor that he calculates by using the rule of three (in German "Dreisatz" is a term for the rule of proportion) and that he furthermore connects with the idea of scale: "I don't know if this is correct now, but this 4 cm (...) this is like such a scale thing, right? So if 4 cm are 7 cm and 4 cm it is asked for two, the half, and the half of 7 is 3.5. Do you know what I mean?" (F1_V1_T1_G1, line 53). All other students with multiplicative ideas think of enlarging a figure as *doubling* the lengths of the sides (which is only correct in special cases). Most students have *additive* ideas for enlarging figures. Hamsa, Jussuf, and Younis serve as an example for students talking about additive ideas, especially representing students struggling with expressing their mathematical ideas. The extract (F1_F2_V1_T1_G6; translated from German by the author) starts after the boys discover that their enlarged pieces do not fit together as a square:

- 72 Hamsa: [holds up Jussuf's enlarged piece] What's that? [all laughing]
 73 Younis: This is much too small!
 ...
 78 Younis: Eh, mine is also a bit too large after all...

- 79 Hamsa: *[towards Jussuf]* Make new again!
- 80 Jussuf: Why? This is 7 cm, I think.
- 81 Hamsa well you have to- look, if 4 cm become 7 cm, you have to make larger by 3
- 82 Jussuf: There's from 4 to 7 after all...
- 83 Hamsa: You should do this one, right? *[points to the drawing in the task]* That are 6 cm here. They become 9. *[unclear]*
- 84 Jussuf: *[also points to the drawing]* I see, we should use from THESE data. I see. Well then. *[starts to draw]* [...]

Like all groups, the boys first describe quite broadly that somehow the size of the figures or some sides of them are too small or large (lines 73 to 78). Afterwards, Hamsa explains Jussuf how to additively enlarge the sides of the figure using the language means “if... (then)...” (line 81), “x cm become y cm” (lines 81 and 83), and “making larger by x” (line 81). The mathematically inadequate idea of enlarging the sides by adding 3 cm to all or some sides occurs in nearly all groups of the study. An overview on students’ language means for talking about enlarging figures is printed in Table 1, sorted by the related mathematical ideas.

Language means	Examples from students’ talk
<i>Students’ language means for talking about additive ideas</i>	
to make x cm	Did you also make everything 3 cm, Leonie?
(to calculate) x plus y / plus x	Yes, I did everything plus 3. / So then you calculated 6 plus 3?
x become y	That are 6 cm here. They become 9.
x longer / larger / higher / more / ...	Yes, I though 3 cm longer. / Everything 3 cm larger. / Um, maybe it’s just always 3 cm higher [...] to be 3 cm more?
x more / longer than	You have to be 3 cm more than true to scale. / You have to write 3 cm more than normal.
x on top	There was written that there are already 4 cm that you should enlarge on 7 cm in that I just calculate 3 cm on top.
to make larger by	look, if 4 cm become 7 cm, you have to make larger by 3
to enlarge on	There was written that there are already 4 cm that you should enlarge on 7 cm in that I just calculate 3 cm on top.
difference between x and y	I think 10.5, because 9 is only calculated plus 3. And that’s just the difference between 4 and 7.
<i>Students’ language means for talking about the idea of doubling</i>	
to take / make the double / to double	And eh it says 4 cm. And then I just took the double. Thus 8. And then this is enlarged. And quasi doubled.
<i>Students’ language means for talking about multiplicative ideas</i>	
x corresponds to y / x are y	So, 4.5 are 7.875. So, this side is 4 cm long eh 4.5. But to begin with let’s put away the 0.5. So, if we then calculate 0.5 corresponds to 0.875.
x times y	Just take the 6 cm and then 1.75 times 6. Simply just calculate times.
to calculate with the rule of three	Ehm, I did calculate with the rule of three for 1 cm 1.75 times 6, because it was 6 cm, that makes 10.5
on x cm	I have the rule of three, thus on 1 cm. To 3 cm because my side, well two were 3 cm, I think at least [...]
from x to ...	From 100 to .. And then from 1 times 3 and 1.75 times 3 are 5.25.

Table 1: Students’ language means for talking about enlarging figures identified in 6 groups

Like Hamsa in line 81, students with additive ideas often initially use language means related to visual impressions of larger, more, higher, huger and related verbs. Furthermore, they often describe processes (instead of e.g. talking about characteristics or relations). Some groups also use the phrase “x cm become y cm” (like Hamsa in lines 81 and 83) that is also offered in the text of the task.

Another interesting inside refers to the line “x more/longer than” in Table 1 (not printed in the transcript but from this group): Jussuf’s utterance “You have to be 3 cm more than true to scale” (F1_F2_V1_T1_G6, line 249) combines two ideas in one sentence: the inadequate idea of additively enlarging the sides and the concept of scale which usually refers to the mathematically sound multiplicative idea of scaling with a magnification factor. Here, Jussuf seems to use “true to scale” for referring to the length in the original figure and/or for expressing that the shape is conserved. The phrase “true to scale” is taken up by the group and later on even used in their written general instruction for enlarging figures (Figure 2). But, since it is not discussed regarding its mathematical meaning, the term stays vague and is still used in connection with additive ideas.

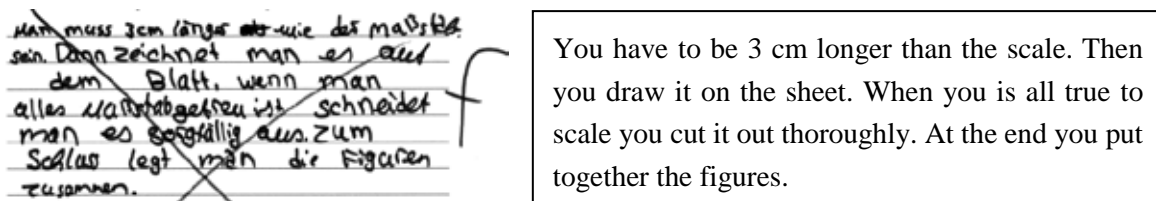


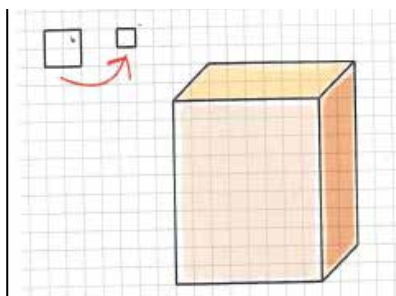
Figure 2: General instruction on enlarging figures from Hamsa, Jussuf, and Younis

The analysis of further language means related to multiplicative ideas reveals two important points. First, talking about the rule of three makes it necessary to talk about corresponding numbers, for example by the means “x corresponds to y” or “x are y” (see Table 1). These language means are relatable to a static perspective on similarity since they do not only describe a process but also relations. For example, the static perspective also talks about ‘constant length ratios of corresponding sides’. The expression “x corresponds to y” could also work with additive ideas but is not observed in this way in the analyzed data. Instead, only the expression “x becomes y” is identified which is very close to the formulation of the task and also has another meaning than “x corresponds to y”. Particularly, “x becomes y” (as a lot of the language means related to additive ideas) describes a process and not a relation and is thus more related to a dynamic perspective on similarity. Second, calculating with the rule of three makes it necessary to talk about calculating “on 1”. Mathematically this parallels the idea of calculating the magnification factor which is introduced in most German textbooks as the constant result of dividing the lengths of corresponding sides (see next Section).

Language means identified in a textbook

The analyzed textbook starts with a page headed “Enlarging and Reducing” and introduces the new topic by referring to the dynamic perspective on similarity: several tasks ask students to draw enlarged/reduced pictures without giving any instruction. Task 5 is the only one talking about the process of reducing by “merging several boxes” (Böer et al., 2008, p. 20; see Figure 3 on the left side). The second page has the caption “Similarity” and starts with the questions “Which data does the drawer need to draw an enlarged version of the house? How do the line segments change, how do the angles change during enlarging?” next to a small and a larger drawing of a house, directly followed by the summary printed on the right side of Figure 3. Whereas the first question refers to a dynamic perspective on similarity, the second question is unclear but might be intended as a transition to the static perspective. In the summary, the first sentence refers to a dynamic perspective without talking about the corresponding processes, the remaining text to a static perspective.

5 Drawings in squared grid can be reduced by merging several small boxes. Merge four boxes each for reducing in your notebook.



Übrigens

Der Maßstab k wird auch **Ähnlichkeitsfaktor** genannt. Er kann verschieden angegeben werden:
 $3:4 = \frac{3}{4} = 0,75 = 75\%$

Wird eine Originalfigur maßstäblich vergrößert oder verkleinert, so sind Bildfigur und Originalfigur zueinander **ähnlich**. Das Längenverhältnis zwischen den Strecken der Bild- und der Originalfigur wird durch den **Maßstab k** festgelegt.

$$k = \frac{\text{Länge der Bildstrecke}}{\text{Länge der Originalstrecke}}$$

Jeder Winkel der Bildfigur ist genauso groß wie der entsprechende Winkel der Originalfigur.

Is an original figure enlarged or reduced true to scale, the picture figure and the original figure are similar to each other. The length ratio between the line segments of the picture and original figure is determined by the scale k . [...]

Each angle of the picture figure is just as big as the corresponding angle of the original figure.

Figure 3: Extracts from the textbook (Böer et al., 2008, p. 20f.), translated by the author

On the one hand, it was to be expected that the book does not offer a general instruction for enlarging figures on the first pages, since it follows the tradition of taking up students' ideas. Thus, except for "merging boxes", there are no language means for the dynamic perspective identified. On the other hand, the summary focuses on the static perspective on similarity with a strong emphasis on the concept of scale (most textbooks use the term 'magnification factor' which is here only mentioned as marginalia). The more mathematical perspective of this lack of transition between the perspectives will be discussed elsewhere. The analysis of language means shows, that "enlarging true to scale", "being similar to each other", "length ration" and "scale" (not as the concept scale but as the name for the quotient of length of the line segment in the picture and in the original) are language means that are of importance but not used in the tasks or texts before. The expression "corresponding" is used in this example only in connection to the angles. Other textbooks use this mean more prominent and especially for corresponding sides. A short review of more textbooks shows that starting with a dynamic perspective on similarity is quite common. After these first tasks of investigating how to enlarge figures, there is often a cut towards the summaries which are written from a static perspective on similarity, i.e. about "length ratios", "magnification factors", etc. which coincides with a change in the used language means from describing processes towards talking about relations. The comparison of students' initially used language means and the target language identified in textbooks shows that there is a gap: On the one side students talk about processes and visual impressions, especially if they refer to additive ideas. On the other side, textbooks initiate thinking and talking about this dynamic perspective on similarity (without offering related target language) but focus often exclusively on the static perspective in the printed summaries which is connected to talking about relations. Thus, even though using different tasks, the challenge of leading over from a more dynamic to a more static perspective on similarity can be identified in the textbook itself as well as by comparing the task from the project and the textbook.

Bridges from students' language means to the language means of textbooks

Of course, it is not possible to compare students' oral language in the process of understanding with the written language of textbooks that display the already understood version of mathematics. Nevertheless, students need to be able to relate their language and the corresponding mathematical ideas from the phase of discovering mathematics with the counterpart from the textbook that is often the

basis for all other lesson phases (e.g., also as an idea in Gibbons 2002). Exploring possible bridges between students' initial language means and textbooks, three points appeared central: First, the textbook analysis revealed a cut between the use of the dynamic perspective in the first tasks and the use of the static perspective in the summaries which is paralleled in the used language means. Since the textbook does not offer language means for talking about the process of enlarging, it can be assumed that students in classrooms speak quite similar to the students in this study. This emphasizes the need of developing tasks that explicitly work on this transition of mathematical ideas along with supporting the corresponding language means in small groups or teacher guided whole-class discussion. Second, the notion of scale is used by Jussuf and Julian as well as in the presented textbook. But, this notion seems problematic since it is tied to a specific mathematical concept that needs to be understood in order to be used properly. Third and most important, the identification of language means used for talking about similarity in a dynamic perspective shows that students with additive ideas often use language means related to the visual change of sides and their language is very tied to describing processes. This also holds for the most cases in which students talk about their idea of doubling. In contrast, if students talk about the multiplicative idea, they tend not to use language means related to visual change. Especially Julian uses the language mean "x corresponds to y" which is close to "corresponding angles/sides" used in textbooks and also displays a more static perspective. Thus, the language means around "corresponding" can be identified as possible bridges between students' language and the language in textbooks since it can be used to describe parts of the process of enlarging as well as to talk about relations between features of figures. This could also hold for the expression "calculate on 1" which refers to the rule of three used in the process of enlarging but can be also interpreted as talking about the magnification factor which describes a relation.

Conclusion and outlook

The study is limited in the small size of student groups that were observed. Thus, it is planned to extend the analysis to more groups and to enrich the data with more textbooks. Nevertheless, the presented research points to important directions: On the one hand, the study shows that students mainly talk about processes and refer to visually observable change, often staying a bit diffuse and not using mathematical wording (like adding, plus, etc.). On the other hand, textbooks often talk about similarity by means of characteristics and relations. This gap between students' initial language means and the target language parallels the difference between talking about similarity from a dynamic or static perspective. This highlights the need for developing a task that explicitly picks out this transition as a central theme and supports students by offering language related support. This especially holds for students with low language proficiency that are still acquiring language and discourse practices that allow talking about characteristics and relations of figures. The analysis points to two language means that have the potential to bridge between students initial language means and the target language: "x corresponds to y" and "calculate on 1" can be used for talking about similarity from a dynamic perspective and static perspective. Nevertheless, there is a need of further research for developing language-responsive teaching-learning arrangements in the future in which both language repertoires can be bridged systematically by macro-scaffolding trajectories as well as for teacher moves for supporting the group work and following whole class discussions.

Acknowledgment

The Deutsche Telekom Stiftung funds ‘MAGENTA–Explaining mathematics, discovering geometry, and participating in small group processes. Design research study on supporting mathematical explanations of language learners in grade 9’ (Senior Fellowship Fachdidaktik MINT to K. Erath).

References

- Barwell, R. (2014). Language background in mathematics education. In S. Lerman (Ed.), *Encyclopedia of mathematics education* (pp. 331-336). Dordrecht, the Netherlands: Springer.
- Böer, H., Kliemann, S., Puscher, R., Segelken, S., Schmidt, W., Trapp, M., & Vernay, R. (2008). *mathe live Erweiterungskurs 9. Mathematik für die Sekundarstufe I*. Stuttgart, Germany: Klett
- Brousseau, G. (1997). *Theory of didactical situations in mathematics*. Dordrecht, the Netherlands: Kluwer Academic Publishers.
- Erath, K. (2017). Talking about conceptual knowledge. Case study on challenges for students with low language proficiency. In B. Kaur, W. K. Ho, T. L. Toh, & B. H. Choy (Eds.), *Proceedings of the 41st Conference of the International Group for the Psychology of Mathematics Education* (Vol. 2, pp. 321-328). Singapore: PME.
- Erath, K., Prediger, S., Quasthoff U., & Heller, V. (2018). Discourse competence as important part of academic language proficiency in mathematics classrooms. *Educational Studies in Mathematics*, 99(2), 161-179. doi: 10.1007/s10649-018-9830-7
- Gibbons, P. (2002). *Scaffolding language, scaffolding learning. Teaching second language learners in the mainstream classroom*. Portsmouth, NH: Heinemann.
- Gravemeijer, K., & Cobb, P. (2006). Design research from a learning design perspective. In J. van den Akker, K. Gravemeijer, S. McKenney, & N. Nieveen (Eds.), *Educational design research* (pp. 17-51). London, England: Routledge.
- Hölzl, R. (2108). Ähnlichkeit. In H.-G. Weigand et al., *Didaktik der Geometrie für die Sekundarstufe I* (pp. 203–225). Berlin, Germany: Springer Spektrum.
- Mayring, P. (2015). Qualitative content analysis. Theoretical background and procedures. In A. Bikner-Ahsbahs, C. Knipping, & N. Presmeg (Eds.), *Approaches to qualitative research in mathematics education* (S. 365–380). Dordrecht, the Netherlands: Springer.
- Mercer, N., Wegerif, R., & Dawes, L. (1999). Children’s talk and the development of reasoning in the classroom. *British Educational Research Journal*, 25(1), 95-111.
- Prediger, S. & Zindel, C. (2017). School academic language demands for understanding functional relationships. A design research project on the role of language in reading and learning. *Eurasia Journal of Mathematics Science and Technology Education*, 13(7b), 4157-4188. doi: 10.12973/eurasia.2017.00804a
- Sfard, A. (2008). *Thinking as communicating*. Cambridge, England: University Press.
- Vygotsky, L. S. (1978). *Mind in society*. Cambridge, MA: Harvard University Press.

Young children's mathematising during free play with 'loose parts'

Marie Therese Farrugia

University of Malta, Faculty of Education, Malta; marie.t.farrugia@um.edu.mt

'Learning through play' is an oft-quoted maxim for Early Years education. I was interested in investigating how free play with 'loose parts' (blocks, acorns, pebbles, etc.) might support children's experiences of mathematics. In this paper I discuss the first part of a study carried out with four 4-year-old children in Malta. The children were presented with various loose parts and allowed to play freely without adult intervention. I noted whether the children gave mathematical interpretations as they played; my main interest was numerical/quantitative interpretations. As a theoretical framework I drew on Vygotsky's theory of play and on the notion of 'mathematising' (Sfard), or participation in mathematical discourse. I considered this in terms of the relations set up by way of terminology (Walkerdine). My data showed that spontaneous mathematising during the free play was limited.

Keywords: Mathematics and play, early childhood education, mathematising; loose parts.

Introduction

As part of the recent Maltese National Curriculum Framework (Ministry for Education and Employment, 2012), the 'Early Years' (ages 3–7) has been recognised as a key period of education. The document emphasizes that the pedagogy to be used during this time should be distinguished from the more structured pedagogy used in the Primary years. In Malta, non-compulsory kindergarten education has been offered within State school settings since the mid-1970s, although, as Sollars (2018) explains, staff training, qualifications, recruitment and retention have posed challenges over the years. With the recent introduction of undergraduate training for kindergarten teachers, the hope is that over time, informal pedagogy will counter the established practices of formal literacy and numeracy sessions commonly carried out in kindergartens. My involvement in the new degree programme prompted me to carry out a study, in which I considered one type of play situation, namely invitations to engage with 'loose parts' (sets of items such as blocks, acorns, pebbles). My first research question was whether children would spontaneously give mathematical interpretations when playing freely with loose parts; I also asked if, and how, interpretations would be influenced when numbers were added to the sets of items available. A third question was how an adult's (myself) contributions could influence the children's apparent 'mathematising'. In this paper, I report on the first two questions.

Mathematics and play

Björklund (2016) conjectures that there is hardly any early childhood educator or researcher who would not argue for the value of children's play. However, May (2016) reflects on what 'learning through play' means, highlighting that early years educators are pulled between two 'poles' (p. 21), namely construction and instruction. While 'construction' emphasizes more freedom for the child to discover and create meanings independently, 'instruction' assumes a greater role for the adult in the learning process. Several studies that have been carried out in Early Childhood settings focus on contexts wherein adult guidance is involved (e.g., Brandt, 2013; Sayers, Andrews & Björklund

Boistrup, 2016). It is less common to find studies on children playing freely. One notable exception is Helenius et al. (2016), who use free play situations to theorize what renders play ‘mathematical’. Helenius et al. (2016) suggest that play is rendered mathematical if it is creative, participatory and if it includes rule negotiation. They thus place social processes in the forefront of their analysis and used these criteria to describe episodes of 6-year-olds’ play as being mathematical or otherwise. They distinguish their method from a more common approach to associate the mathematics of young children with school topics such as number, geometry, pattern or measurement. I myself have taken the latter stance in my study for three reasons: First, I was interested in quantitative dimensions of reality (van Oers, 2014) from the perspective of the child; second, ‘Numbers’ are stressed in our kindergartens, and third, I wished to focus on the use of subject terminology to complement my research in primary classrooms (e.g., Farrugia, 2017).

Helenius, Johansson, Lange, Meaney and Wernberg (2016) explain that the acknowledgment of the importance of the educator in Early Childhood education has led to questions about the kind of learning that children gain when ‘left to their own devices’ (p. 7). Indeed, Lee and Ginsburg (2009) note that early childhood mathematics is broad in scope and doubt that much of it will emerge in free play. Similarly, Clements and Sarama (2018) argue that ‘mathematical centres’ (classroom areas set up with materials that might encourage mathematical tasks) might promote some incidental learning, but rarely build one mathematical idea on the next, which is a key characteristic of this content area. My interest in studying free play is founded on my knowledge that such periods are common in Maltese kindergartens. Sollars (2013, and works in progress discussed in personal communications) studied a large number of local early childhood settings, and has noted a common pattern of adult-guided structured activities interspersed with ‘free play’ at various times of the day. Structured activities (hence, ‘instruction’ time) include painting and crafts, storytelling, and also worksheets aimed to fulfil school and parental expectations for learning to recognize and write numbers and letters. Free play (presumably ‘construction’ time) might involve the home corner, table-top toys, coloured dough, wooden puzzles and sets of ‘loose parts’ (e.g., blocks, sticks, pebbles).

My interest in focusing on play with loose parts in particular derives from the assumption that such items, being open ended, are intended to invite interaction and creativity. With regard to mathematics, Tucker (2010) suggests that they offer opportunities for counting, sorting, pattern making, operations, investigations into weight and length, and problem solving. I am aware of only one project that (in part) focused on mathematics and loose parts. This was carried out by Novakowski (2015), who worked with teachers to provide children with ‘Reggio Approach’ inspired provocations. However, most of the activities were set up with an intention in mind (e.g., a pattern with gems is displayed, prompting the children to explore patterns of their own, or the children are challenged to try stacking five pebbles). It is not my intention to argue that this type of play is necessarily more/less suitable than other types of play for prompting mathematical interpretations. Rather, my intention is to offer an original focus by reflecting on young children’s mathematising during free play with loose parts.

Theoretical framework

Vygotsky (1967) held that imaginary play had an enormous role in a child’s development, in that it is a transitional stage through which a child can ‘sever thought from an object’ (p. 12). The liberating

of thought and meaning from their origin in the perceptual field, provides the foundation for the further development of speech and its role in advanced forms of thinking. This liberation of meaning from object is facilitated by means of what Vygotsky referred to as ‘pivots’. If a child uses a stick as a horse, the stick acts as a pivot to transition to the child from a real situation to an imaginary one. Vygotsky (1978) further explains that when using a stick as a horse, the child retains the property of the thing, but changes its meaning. It is the meaning, in play, that now becomes the central point and objects are moved from a dominant to a subordinate position. Indeed, Vygotsky believes that a key characteristic of play is that it is a stage between, on one hand, the purely situational constraints of early childhood and, on the other hand, adult thought which can be totally free of real situation. Just as Vygotsky recognised play items as pivots for more abstract and imaginative thought, in this study I view the ‘loose parts’ as pivots that offer potential opportunities for mathematical interpretation.

Working within a Vygotskian perspective, van Oers (2010) explains that an unintentional, or spontaneous, action/utterance by a child may be taken as a cultural form [e.g. mathematics] and reacted to accordingly by an adult; in time, through participation in such interactions, the child him/herself may acknowledge the [mathematical] meaning of the adult reaction, and finally, of his/her own actions as well. The mastery of new language develops through communications with other people, even in play contexts (Van Oers, 2010). Sfard (2008) refers to the participation in mathematical discourse as ‘mathematising’. In her classic book, Walkerdine (1988) posits that a shift to mathematical discourse is a shift from one practice/system of signification (e.g. an ‘everyday’ activity) to another practice/system of signification (e.g. mathematics), wherein new relations are set up. For my analysis, I planned to focus on the children’s utterance of words that indicated a mathematical idea, and also on apparent relations expressed through these words. Relations may have been expressed by way of language alone, or with reference to the play items. I believed that the expression of such relations would allow me to discuss (a) whether the children engaged with mathematics ‘spontaneously’ in their play (first part of study); (b) if, and how, my prompts ‘pushed’ the children in the direction of considering the play items from a mathematical perspective (second part). My main interest was number and counting, although other ideas may also have been noted.

Research design

The choice of school and classroom was opportunistic. I was acquainted professionally with the Head of School, who then put me in touch with a volunteer teacher who allowed me to work with her 4-year olds. I sat in the class a few times in order that the children and I become familiar with each other. Since the 14 children in the class came from varying language groups, the teacher used English as a lingua franca. This is a common language strategy used in Malta, where English is the country’s second language. The four children who participated in my study were chosen by the teacher such that they would feel comfortable playing together. Parental consent and the children’s own assent were also necessary. Mario and Sarah were Maltese, Dorina was Hungarian and Ling was Chinese. All four children understood English; they could also speak English, with Sarah and Dorina being the more fluent. During the study sessions, I used English, although switched to Maltese if Mario chose to speak to me in Maltese. Their teacher reported that they all ‘liked mathematics and numbers’.

Eight 30 minute video-recorded sessions were carried out in the school library. Sets of ‘loose parts’ were prepared in boxes/dishes and the children were free to choose items to play with; a selection of the following items were provided on various days: acorns, small tree slices, sea shells, plastic coloured blocks, plastic coloured connecting camels, white and black river pebbles, gemstones, coloured foam dice. Numerals in various forms were introduced in Session 5. My main interest was number/quantity, but I was open to note other mathematical ideas that might arise. The children generally played around a table, sometimes moving to other parts of the room. For the first five sessions, children played freely, with minimal interaction from my part. Although the intention was not to intervene at all, in practice I found that simply watching without saying a word was unnatural; some interaction was inevitable. However, for Sessions 6–8, I interacted much more, and with purpose, as they played. In this paper I report on the first part, Sessions 1 - 5.

Analysis of the data was done by viewing the videos and noting where ‘mathematical’ vocabulary was used by the children. Short transcripts were produced of these excerpts in order to trace interaction (for example, to document if, and how, a child’s comment was reacted to by the others).

Results

The children played with the items eagerly. For much of the time each child was focused on their own task, albeit communicating with the others, and being influenced by the play going on around them. For example, if Dorina made a ‘necklace’ with connecting camels, the others picked up the idea and made their own necklaces, bracelets and crowns. At times Sarah and Ling played together. A lot of the play was imaginative and centred on the idea of birthday parties, an idea originated by Sarah. An element that persisted throughout all the sessions was making ‘cakes’ by filling the plastic dishes with pebbles and the other items. Pictures of children or monsters were sometimes placed in the dish to represent party guests; the table was sometimes decorated in various ways and the children sang ‘Jingle Bells’. The most popular items were the sea shells, gemstones and connecting camels. Figure 1 shows two cakes and a necklace.



Figure 1: Examples of children’s play creations

There were a number of comments relating to size and shape, and a high proportion of these were stated in the first session, when the children first saw the sets of items, for example “Oh! Tiny little shell!” (Dorina); “This is a pointy one” (Sarah); “This small one” (Ling). Not enough was said here for me to be able to conclude that the children were operating beyond an everyday use of qualitative descriptions (Walkerdine, 1988), although Mario did express direct comparison, a first step to the quantitative aspect of measurement (“Mine is going to be bigger than yours”). In relation to shape, Dorina once said that her camel arrangement was a rectangle, and Mario commented “it’s oval” in relation to a shell. Hence, they applied names of geometric shapes to their play items, even if the

labelling was imprecise. Occasions when *numbers* were mentioned were few. When the children first saw the monster pictures, and prompted by Dorina, they started commenting on the number of eyes (“One eye”, “two eyes” etc.); on two of the days, Dorina also selected monsters according to their eyes. In the first session, Ling pointed to the cameras saying “One, two.” At another point in the same session, Mario asked me why I had two cameras. These spontaneous uses of numbers were clear examples of quantification, and hence of these three children’s participation in the cultural practice of using numbers for expressing cardinality. It was interesting that quantity was alluded to more when a problem of limited number of each type of resource arose. Comments like “I don’t have enough of these” (Dorina), “But I need one of those!” (Mario) and other similar comments were heard, as children vied for the items they wanted/needed. The first time the problem arose this happened since we had limited space to work in, so I had to cut down on resources; then, the following day I limited the number of items purposely in order to confirm my observation. Mario and Sarah spontaneously indicated ‘emerging’ mathematical ideas relating to million as a large number, and half as part of a whole: “It was my birthday; it was a million birthdays” (Mario), “Hey Ling! You took half them!” (Sarah, referring to the gems) and “**Ghax jinkiser bil-half**” [**Because it will break with half**] (Mario, in relation to a delicate shell). On the other hand, I had included a set of foam dice to offer an opportunity for the children to focus on the dot arrangement, perhaps to subitise. However, the children used the dice as part of the cake decoration, or to construct a tower. Dorina mentioned that she had once had ‘one like this’ (a die), had lost it, and now had a new one. Although generally I was not intervening in the sessions, I pointed to the spots and asked Dorina if she knew what they were, to which she answered, “Yes, spots”. Thus she gave an everyday interpretation of the spot pattern, and did not spontaneously subitise.

On the fifth day I introduced numerals (1–10): a set of large red/blue/yellow plastic numbers, a set of magnetic numbers and cards with pictures of balloons printed on them. Dorina showed an interest in them immediately, crying: “Numbers!!!” She took magnetic numbers and laid them out in order on a metal sheet pointing to each one and naming them: “one, two, three ...” The relation between the positioning of the tangible numbers and the recitation of the names illustrated that Dorina could engage in the practice of counting using the one-to-one and stable order principles (Gelman & Gallistel, 1986). She proudly showed up the display to the others, but they showed no interest, continuing with their own activities. Dorina then moved on to making a necklace with the camels. Similarly, Mario started the session by looking through the large numbers, naming some of the them as he did, thus giving evidence that he could ‘name’ the items appropriately; however he very quickly lost interest and turned to the box of camels instead to make a crown and other things. Ling showed evidence of being familiar with the cultural practice of putting a number candle on a birthday cake: she placed a number 4 on her cake, stating “I’m four year”, then placed other different numbers on the other cakes. I consider this to be evidence of an ‘emerging’ mathematical idea, since although the symbol was used appropriately in relation with the ‘cake’, it is unlikely that such a young child would have a conception of the time measurement of ‘4 years’.

Other uses of the number items were non mathematical, for example as when Dorina grouped them by colour, placed them in different dishes and stated “I am making pies of the same colour”; Ling and Sarah used the magnetic numbers as they did the pebbles, acorns, etc., that is, to fill a dish to create

a cake. When I asked Ling why she had put ‘these new ones [items]’ on top of her cake, she answered “because this number cake”; in previous sessions she had made a ‘birthday cake’ and a ‘rainbow cake’. Sarah used the large plastic numbers as decorations around the cakes, as she had used the children/monster/balloon cards. At the end of the session, having exhausted all the items except the magnetic numbers, Ling and Sarah turned to these items and used them to ‘draw’ what they called a number castle (that is, a castle drawn with the numbers).

Discussion and conclusion

Prior to the study, I had anticipated that the children might spontaneously engage with mathematics in general, and number in particular. This assumption was based partly on the fact that at school they were systematically learning the numbers and their values, and partly on research and pedagogy texts (for example, Seo & Ginsburg, 2004; Charlesworth, 2012 respectively) that mention how children ‘spontaneously’ engage with mathematical ideas. However, in my small study I noted limited spontaneous focus on ideas that I might classify as ‘mathematical’. That is, mathematical terminology was used only a little, and not necessarily in a way that implied mathematical relations (Walkerdine, 1988). In the absence of certain relations, one cannot conclude that the children were ‘mathematising’. Even when prompted with numbers, the children’s attention to the quantities related to these numbers was limited. Since I had seen large dice in the classroom, one with numerals and one with the spot pattern, I introduced the dice to prompt subitising, but these were used as blocks or decorations. Hence, following Helenius, Johansson, Lange, Meaney and Wernberg (2016) and others, I too query the amount of mathematics that children engage with when left to play freely, although it is worth noting that restricting the number of resources increased talk related to quantity/number. There was some evidence of ‘emerging’ mathematical ideas, such as when the children used discipline-related words in an approximate or referential manner. This is similar to when the children use grammar rules in an inappropriate way. Examples of the latter are when Ling said to Dorina “You broke-ed them” or Mario said “Ajma, subajji” [Ow, my finger]. In both cases the child was applying a general grammar rule (shown here underlined) which did not actually apply to the word being used. Still, as an adult I recognized the emergence of language rules that, presumably, the child was appropriating through social interaction over time. From the perspective of mathematising, ‘emergent mathematics’ might be viewed as the crossing of boundaries (Walkerdine, 1988) from one practice (everyday experiences and ways of expression) to another (school mathematics).

One possible explanation for the limited mathematising might be found in the children’s classroom experiences. The class teacher had explained that she targeted mathematics (mainly numbers) through daily routines (e.g. counting children present) and storytelling (e.g. counting the fruit the hungry caterpillar ate) and also through worksheets focusing on number recognition and quantities which were expected to be carried out. While the children were regularly given periods of free play (house corner, table top toys, puzzles, sets of loose parts and so on), the teacher admitted that during such time she did not interact with the children but tended to use the time to catch up with required paper work, to set up an activity, disinfect toys or to sit with individuals to help them through a worksheet (numbers / letters). It seems that the mathematics they were learning in the structured curriculum remained distinct from their play. Another reason may have been that from the children’s perspective, there was no ‘need’ or interest to count items or to engage with the numbers provided in a

mathematical sense. Rather, the tasks of (mainly) making cakes and joining up camels took over the children's attention almost completely. Although the children initially admired the pebbles, etc. and the numbers, ultimately, the use of all items appeared to be subordinated to the main task of interest, e.g. filling a dish to make a cake, 'drawing' a picture and so on. This may have been compounded by the fact that many of the items provided were novel and caught the children's attention/imagination.

Vygotsky (1967) has written about the development of abstract thought through free play; he theorises how meaning becomes central, while objects themselves are moved to a subordinate position. There is still much to be done in exploring the transition from a play situation to one where play items are given an abstract 'mathematical' interpretation. That is, focusing on the numerical/quantitative aspect rather than, for example, on the item's potential use in the creation of a cake. In the second part of my study, I made a systematic attempt at using the play items as 'pivots' for mathematising. My initial analysis (still to be reported) supports the argument that purposeful intervention can be effective for prompting a focus on mathematics. According to Walkerdine (1988), this focus involves creating new relations, even when using lexical elements already familiar from 'everyday' (hence different) experiences. In the context of free play - where children rightly assume a freedom to play as they please - the process is a challenging one.

References

- Björklund, C. (2016). Playing with patterns: Conclusions from a learning study with toddlers. In T. Meaney, O. Helenius, M. L. Johansson, T. Lange, & A. Wernberg (Eds.), *Mathematics education in the early years* (pp. 269–287). Dordrecht, Netherlands: Springer.
- Brandt, B. (2013). Everyday pedagogical practices in mathematical play situations in German 'kindergarten'. *Educational Studies in Mathematics*, 84, 227–248.
- Charlesworth, R. (2012). *Experiences in math for young children* (6th ed.). Boston, MA: Cengage Learning.
- Clements, D. H., & Sarama, J. (2018). Myths of early math. *Education Sciences*, 8(2), 71.
- Farrugia, M.T. (2017). Bilingual classrooms in Malta: Teaching mathematics content and language. *Education et Sociétés Plurilingues*, 42, 61–72.
- Gelman, R., & Gallistel, C.R. (1986). *The child's understanding of number*. Cambridge, MA: Harvard University Press.
- Helenius, O., Johansson, M. L., Lange, T., Meaney, T., Riesbeck, E., & Wernberg, A. (2016). When is young children's play mathematical? In T. Meaney, O. Helenius, M. L. Johansson, T. Lange, & A. Wernberg (Eds.), *Mathematics education in the early years* (pp. 139–156). Dordrecht, Netherlands: Springer.
- Helenius, O., Johansson, M. L., Lange, T., Meaney, T., & Wernberg, A. (2016). Introduction. In T. Meaney, O. Helenius, M. L. Johansson, T. Lange, & A. Wernberg (Eds.), *Mathematics education in the early years* (pp. 3–17). Dordrecht, Netherlands: Springer.

- Lee, J. S., & Ginsburg, H. P. (2009). Early childhood teachers' misconceptions about mathematics education for young children in the United States. *Australasian Journal of Early Childhood*, 34(4), 37–45.
- May, H. (2016). A historical overview of early education policy and pedagogy: Global perspectives and particular examples. In T. Meaney, O. Helenius, M. L. Johansson, T. Lange, & A. Wernberg (Eds.), *Mathematics education in the early years* (pp. 19–56). Dordrecht, Netherlands: Springer.
- Ministry for Education and Employment (2012). A national curriculum framework for all. Retrieved from <https://education.gov.mt/en/Documents/A%20National%20Curriculum%20Framework%20for%20All%20-%202012.pdf>
- Novakowski, J. (2015). *Reggio-inspired mathematics: A professional inquiry project in the Richmond school district*. Richmond, BC: Richmond School District.
- Sayers, J., Andrews, P., & Björklund Boistrup, L. (2016). The role of conceptual subitising in the development of foundational number sense. In T. Meaney, O. Helenius, M. L. Johansson, T. Lange, & A. Wernberg (Eds.), *Mathematics education in the early years* (pp. 371–394). Dordrecht, Netherlands: Springer.
- Seo, K.-H., & Ginsburg, H. P. (2004). What is developmentally appropriate in early childhood mathematics education? Lessons from new research. In D. H. Clements & J. Sarama (Eds.), *Engaging young children in mathematics* (pp. 91–104). Mahwah, NJ: Lawrence Erlbaum Associates.
- Sfard, A. (2008). *Thinking as communicating: Human development, the growth of discourses, and mathematising*. Cambridge, MA: University Press.
- Sollars, V. (2013). *Early childhood education and care in Malta: The way forward*. Floriana, Malta: Ministry for Education and Employment.
- Sollars, V. (2018). Shaping early childhood education services in Malta: Historical events, current affairs, future challenges. *Early Years*, 38(4), 337–350.
- Tucker, K. (2010). *Mathematics through play in the early years* (2nd ed.). London, England: SAGE.
- Van Oers, B. (2010). Emergent mathematical thinking in the context of play. *Educational Studies in Mathematics*, 74, 23–37.
- Van Oers, B. (2014). The roots of mathematising in young children's play. In U. Kortenkamp, B. Brandt, C. Benz, G. Krummheuer, S. Ladel, & R. Vogel (Eds.), *Early mathematics learning: Selected papers of the POEM 2012 conference* (pp. 111–123). Dordrecht, Netherlands: Springer.
- Vygotsky, L. V. (1967). Play and its role in the mental development of the child. *Soviet Psychology*, 5(3), 6–18.
- Vygotsky, L.V. (1978). *Mind in society: The development of higher psychological processes*. Cambridge, MA: Harvard University Press.
- Walkerdine, V. (1988). *The mastery of reason*. London, England: Routledge.

High school teachers' evaluation of argumentative texts in mathematics

Giovannina Albano¹, Cristina Coppola¹ and Pier Luigi Ferrari²

¹Università di Salerno; galbano@unisa.it; ccoppola@unisa.it

²Università del Piemonte Orientale; pierluigi.ferrari@uniupo.it

The goal of this paper is to start an investigation on how high school teachers evaluate students' argumentative texts. In particular, as an argumentation requires dealing with some mathematical content, to produce a verbal text, possibly equipped with diagrams and formulas, and to make clear the links between premises and conclusion, we are interested in finding out whether teachers focus on all of the three aspects or on one or two of them only. We have gathered the comments of 12 high school teachers on five argumentations written by university science students in order to justify their answers to a problem involving formulas and graphs.

Keywords: Argumentation, language, evaluation, teachers, mathematics education.

Introduction

The importance of argumentative practices in mathematics teaching at all levels has been increasingly highlighted in the last years. In the transition from high school to university these practices are especially important. This holds also for the mathematics classes for science undergraduates, as it is often necessary to teach some basic concepts to large numbers of first-year university students with assorted levels of competence and motivation, in a short span of time. In this context, it might happen that some students try to learn some content by heart or to solve problems through strategies not based on some interpretation of the meanings involved. The practice of asking for argumentations to explain and justify their solution procedures when dealing with mathematical problems has proved effective both to assess students' competence and to help them to adjust their learning processes. Still, a number of students seem not to be acquainted with argumentative practices, regard them as abnormal and cannot tell the difference between a correct and justified procedure and a correct but unjustified one. These remarks induce us to guess that there are some problems about the development of argumentative skills in high school. So we decided to start a study about how high school teachers interpret and assess argumentative text produced by students, in order to see which aspects are, in their opinion, relevant. Throughout the paper we use some terms (such as 'proof', 'argumentation', 'argument', 'explanation', 'justification') in a broad sense, without referring to some distinctions proposed in literature, such as, for example, Duval's distinction between proof and argumentation (2007), or Johnson's distinction between 'argumentation' and 'explanation' (2000), or the distinctions between 'argumentation' and 'argument' proposed in literature (e.g., Johnson, 2000, p. 105; Bermejo-Luque, 2011, p. 68). We regard the proof of a theorem, as well as the justification of a resolution procedure of a mathematical problem, as texts that, in some way, describe and make

explicit instances of the semantic relation of *logical consequence*¹. We shall try to make this point clear in the a priori analysis.

Theoretical framework

The evaluation of an argumentation involves at least three main aspects: the analysis of the ideas related to the semantic domain of the discourse, in our case mathematics; the linguistic analysis of the text produced and the analysis of how the links between the premises and the conclusion are made explicit. These three aspects are to some extent autonomous, since an argument might happen to be appropriate related to one or two of them and not to the other(s). As remarked by many authors, such as Bermejo-Luque (2011), an argument is, first of all, a piece of text. So language is to be regarded as a relevant factor in the analysis of arguments. We adopt a functional-linguistic perspective according to Halliday (1985) and Hasan (2005). This perspective fits well with frameworks assuming that language plays a major role in the development of thought, and also with a sociocultural, non-platonistic view of mathematics. In particular, we assume Hasan's description of the central role of verbal language (2005) and Halliday's definition of the three metafunctions of language, ideational, interpersonal and textual (1985). In short, the ideational metafunction is related to the representational meaning, i.e. what the text is about. The interpersonal metafunction is concerned with interactional meaning, i.e. what the text is doing as a verbal exchange between people. The textual metafunction regards the organization of the message, i.e., how the text relates to the surrounding discourse, and to the context of situation in which it is produced. We believe that in a context of communication like a classroom, all of these components are involved and so are to be taken into account. In particular, the textual metafunction is closely related to argumentation, since explaining the links between premises and conclusion requires a well-organized text. The debate on argumentation theory is widely complex and involves a number of stances. In our opinion both the specific features of the semantic domain of mathematics and the fact that an argumentation is essentially a text are to be taken into account.

Goals

The main goal of this study is to begin to understand how high school teachers of different subjects evaluate the written argumentations produced by students, and in particular what weight they assign to each of the three aspects mentioned above, and how. This is important in order to reflect on the transition from a model of learning based on the acquisition of content only to a model aimed at developing the competencies required to take part in a discourse on such content. Arguing on a subject requires a different and somewhat deeper understanding of the subject itself.

More specifically, our main research question is: do the teachers involved also take into account the logical structure of the arguments they are evaluating (i.e., how the parts of the argumentative text are linked each other)?


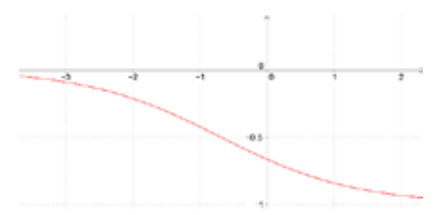
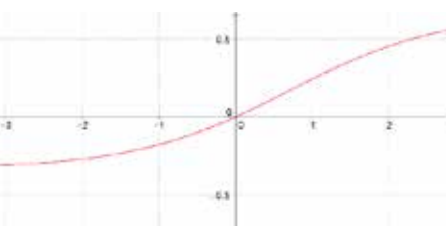

Methodology

We asked a group of 12 high school teachers of different subjects (9 Mathematics, 2 Philosophy, 1 Science) to evaluate the argumentations proposed by 5 first year science undergraduate students to

¹ A sentence P is a *logical consequence* of a set G of sentences if any interpretation satisfying all of the sentences of G satisfies P as well.

justify their answers to a problem administered during a tutorial session. The teachers were involved in a long-term in-service training course focused on transversal competences. We asked them to write down their evaluation of the arguments and any comments they felt appropriate. In particular we asked them to state if they regarded the arguments acceptable for students at the end of high school, with regard to mathematical correctness, linguistic adequacy and explicitation of the links between the parts of the argument. Afterwards we interviewed them. The aim of the interviews was not to elicit further information but to be sure of our interpretation of what they meant in their written evaluations, as it was possible that teachers of different subjects might use some words with different meanings. One example of such a word is ‘formal’ [‘formale’], which can be associated to a range of different meanings, such as ‘independent from content’ or ‘conformed to a given pattern’ or even ‘related to structure rather than to function’. The problem under discussion is shown below.

Let f be the function defined on real numbers by: $f(x) = -\frac{2}{e^x + 2}$. Among the following graphs one is associated to f . Mark it and explain in detail.

<p>A</p> 	<p>B</p> 
<p>C</p> 	<p>D</p> 

A good translation from one language to another, which is usually based on grammar, often succeeds in rendering the ideational meaning of a text. With interpersonal and textual meanings there are sometimes problems. In particular, the textual organization of Italian is quite different from English. For example, in the text of Student 1 some subjects are missing. In English this is both a grammatical and a textual error, whereas in Italian it is textually inappropriate but not grammatically wrong. In the translation, if we put the subjects, as we have been taught at school, we hide the textual inadequacy of the text, if we do not, we add a grammatical error (which affects the ideational meaning) to a text which was just textually inappropriate. So we have added the Italian original version.

Student 1: I exclude the graphs A and B because we have calculated $f'(0)=2/9$ and $2/9$ is the slope of the tangent line to $f(x)$ in x_0 . As is positive, the function is increasing, but in A and B we see that decreases \Rightarrow I exclude them. Moreover, doing the sign of the function $-2/(e^x+2)>0$ we notice that the function is always negative, because of $f'(0)=2/9$ he

minus in front of the function (otherwise positive). Then we exclude the graph *C*, since from 0 onwards it is positive. The choice then falls on graph *D*, correct.

[Escludo i grafici A e B poiché abbiamo calcolato $2/9$ è la pendenza della retta tangente a $f(x)$ in x_0 . Essendo positiva la funzione è crescente, ma in A e B notiamo che decresce \Rightarrow li escludo. Inoltre facendo il segno della funzione $-2/(e^x+2) > 0$ notiamo che la funzione è sempre negativa, per via del meno davanti alla funzione (altrimenti positiva). Allora possiamo escludere il grafico C, poiché da 0 in poi è positiva. La scelta ricade allora sul grafico D, corretto.]

Student 2: The exact graph is *D* since by computing $f(0) = -2/3$ I found the point where the function cuts the y axis, that is $-2/3$. Furthermore, by computing $f'(0) = 2/9$ I see that the function in zero is increasing because the derivative in 0 is positive.

[Il grafico esatto è il D poiché calcolando $f(0) = -2/3$ ho trovato il punto in cui la funzione interseca l'asse y cioè $-2/3$. Inoltre calcolando $f'(0) = 2/9$ noto che la funzione in zero è crescente poiché la derivata in zero è positiva.]

Student 3: Surely graph C does not correspond to $f(x)$ as it passes through the origin. Graph A does not correspond to $f(x)$ since it is decreasing in $x=0$ whereas $f'(0) = 9/2$ which is positive, so $f(x)$ for $x=0$ is increasing. Graph B does not correspond to $f(x)$ since it is decreasing in $x=0$ whereas $f'(0) = 9/2$ which is positive, so $f(x)$ for $x=0$ is increasing. The graph that most likely represents $f(x)$ is *D*.

[Il grafico C sicuramente non corrisponde a $f(x)$ in quanto passa per l'origine. Il grafico A non corrisponde a $f(x)$ in quanto è decrescente in $x=0$ mentre $f'(0) = 9/2$ che è positivo quindi $f(x)$ per $x=0$ è crescente. Il grafico B non corrisponde a $f(x)$ in quanto è decrescente per $x=0$ mentre $f'(0) = 9/2$ che è positivo quindi $f(x)$ per $x=0$ è crescente. Il grafico che più probabilmente rappresenta $f(x)$ è il D.]

Student 4: Graph C does not correspond to f as it passes through the origin. I know that in $f'(0)$ the derivative is positive, so its function must be increasing in that point. In A and B this does not happen. So the graph of the function is letter *D*.

[Il grafico C non corrisponde a f in quanto passa per l'origine. So che in $f'(0)$ la derivata è positiva, quindi la sua funzione deve essere crescente in quel punto. In A e B ciò non avviene. Quindi il grafico della funzione è la lettera D.]

Student 5: We exclude letter C at once since for $x=0$ it passes through point $(0; 0)$ while $f(0) \neq 0$. If we consider that $f'(0) > 0$ holds, the function is increasing in 0 so I exclude letters A and B, as they represent functions decreasing in 0 and a differentiable function decreasing in a point has a non-positive derivative in that point.

[Escludiamo subito la lettera C perché per $x=0$ passa nel punto $(0; 0)$ mentre $f(0) \neq 0$. Considerando che vale $f'(0) > 0$ la funzione f è crescente in 0 quindi escludo le lettere A e B, in quanto rappresentano funzioni decrescenti in 0 e una funzione derivabile decrescente in un punto ha la derivata non positiva in quel punto.]

A priori analysis

Students are requested to find which graph out of a set of four corresponds to f and to justify their answer. Teachers are requested to evaluate those explanations. The relation linking the answer to the data is that of logical consequence: the fact that graph D corresponds to f is a logical consequence of the data. In other words, students have to illustrate a mathematical, semantic relation by means of a verbal text, with the option of adding symbolic expressions and other signs. Basically students had at least three kinds of data: (1) those available from the definition of f ; (2) those available from the four graphs; (3) the ‘closure’ condition “Among the following graphs one corresponds to f ”. The sentences that are logical consequence of the definition of f (in the context of classical mathematics) are of course a countable infinity. Of course we expect that students will focus on a small choice of them, such as, for example, $f(0) = -2/3$ or $f(0) < 0$ or $f'(0) = 2/9$. As regards graphs, the sentences obtainable are infinite too. The process is a bit more complex as the interpretation of graphs anyway requires some conventions. Properties like domain, continuity, differentiability and passage through given points cannot be inferred from the graph alone. At any rate, it is crucial for science students mastering multiple representations. The competencies required to devise counterexamples showing that properties of the kind mentioned above cannot be inferred by the graphs are not included in mathematics curricula for science undergraduates. So there is no alternative to compromise, in relation to the teaching goals. In our classes we usually accept that students, when dealing with a graph, adopt naive interpretations of properties like domain, continuity and differentiability. We usually require a more critical attitude towards properties such as the behavior of the function out of the range represented and the choice of the units of the axes. All of these aspects can be explained by means of examples, problems and activities that are within the reach of our students. So we expect that from the graphs the following properties are inferred.

Graph A: the function associated (f_A) is negative and decreasing in $(-3, 0)$; $-1 < f_A(0) < -0.5$

Graph B: f_B is negative in $(-3, 2)$; $-1 < f_B(0) < -0.5$

Graph C: f_C is negative in $(-3, -1)$, positive in $(1, 3)$, increasing in $(-3, 3)$; $f_C(0) > -0.5$

Graph D: f_D is negative in $(-3, 3)$ and increasing in $(-3, 3)$; $-1 < f_D(0) < -0.5$

The closure condition (see above) is perhaps the most important piece of information, as it makes reasoning by exclusion possible. Without this piece of information the problem would not be solvable. As a matter of fact, in many cases (even though not in all) it is possible to decide that a given graph does not correspond to a given formula, but it is never possible to be sure that a graph corresponds to a given formula. A Cartesian graph, for example, represents a function only in a limited range and in an approximate way. For any graph given in a real interval, there are infinite functions that might be associated to it. In a wide range of school problems, and in particular in many of real world ones, data are almost never usable at once, but they need anyway to be identified and extracted and afterwards they require some basic competencies in order to be used. Also, a seemingly primitive property like $f(0) = -2/3$ requires to operate a replacement and apply some arithmetic operations, which implicitly involve a number of properties (and competencies). Even the recognition that the function f_D is negative in the range displayed requires some acquaintance with the conventions usually adopted to draw graphs, and some linguistic competence to master the meaning of words like ‘negative’ without

confusing it with ‘decreasing’ or with other words. In the same way, recognizing f_D as ‘increasing’ requires some knowledge of the appropriate definition.

Criteria

In order to analyze teachers’ comments, we have taken into account the following aspects.

1. The aspect of the argumentation they have focused on (e.g., mathematical, linguistic or logical correctness, communicative adequacy, explicitation level of logical relationships).
2. The overall evaluation of each argumentation, with special care to contrasting evaluations.
3. Any other specific remarks about mathematical, linguistic and argumentative aspects.

Outcomes

Of the 9 mathematics teachers only one (Flavia) considered the texts from the viewpoint of argumentation, while 7 of them almost exclusively focused on mathematical content. One of them focused on both mathematical content and language. Also Maria, the Science teacher, and Alberto, one of the Philosophy teachers, considered aspects related to argumentation. In particular Maria took into account the *explicitation* of the links among the parts of the texts produced by the students. Sara, the other Philosophy teacher appeared more interested in language. As far as mathematical content is concerned, the two Philosophy teachers did not make any remarks.

The teachers provided different and even contradictory evaluations of the argumentations, especially as far as Student 2 is concerned. Ada, Franca, Oriana and Sara place it among the best, whereas Aldo, Carlo, Fabia, Giulio, Lisa and Maria place it among the worst ones. Claudia and Giorgio considered the five texts substantially equivalent. The first group of teachers appreciated the conciseness of the argumentation of student 2. On the contrary, some of the other teachers found the argumentation incomplete. Giulio commented on this text in a different way compared to the other teachers. He claimed that “it is impossible to find $-2/3$ on the graph, unless the unit is given divided into three parts, which is not the case, since on the y -axis there are multiples of 0,5 only”. He also claimed that, even this would be possible, “it would not be enough to exclude graphs A and B ”.² From the interview, we gathered that Giulio thought that student 2 had stated two relevant facts but had failed to relate them with the goal of the argument. The text of student 3 has been criticized by some teachers as “redundant”. As a matter of fact, the student has explicitly excluded three cases to select the fourth. The structure of his argument is logically much more acceptable than explanation 2, which is compatible with wrong interpretations of logical consequence.

The most common objection raised by some mathematics teachers concerns the association of the sign of the derivative at a point to the monotonicity of the function at that point, whereas speaking of intervals would have been more correct. For example, Lisa, commenting on explanation 4, writes: “Once more we find confusion between pointwise derivative and monotonicity of the function in an interval”. Nonetheless, the same teacher, when summing up, states: “The reference to pointwise derivative, which is common to all explanations, could be accepted if one assumes that the students mean to refer to a neighborhood of the point”.³

² From $f(0) = -2/3$ one can exclude graph C only. To exclude graphs A and B more information is needed, such as $f'(0)$.

³ This difference is not relevant to this problem as all of the functions involved are continuously differentiable.

Some of the criticism involves aspects related to style, such as the use of plural forms (“We exclude ...”, “... we consider ...”) or of expressions like “letter D ” in place of “graph D ”. For example Ada comments: “In the conclusion expressions like ‘the graph of the function is letter D ’ do not sound well”. Some other remarks involve the (linguistic) confusion between “graph” and “function” or between a point and its y -coordinate, labelled as “imprecisions”. On the other hand, Aldo, Fabia and Maria spot problems that severely affect the understandability of the text, such as the lack of subjects or of connectives. Fabia speaks of explanations “linguistically inadequate for undergraduates”. Student 3 has been criticized for the use of “probably”, even though with different motivations. Giorgio thinks it is a mathematical error, for in classical mathematics a sentence is either true or false. Oriana claims that “it cannot be accepted in any case”. On the other hand, Ada, Fabia and Lisa interpret it as lack of confidence. For example, Lisa writes “the student is not fully convinced that the others can be excluded”.

The specific issue of argumentation has not been dealt with much. Aldo is the only one who explicitly analyzes the structure of arguments, in a classical way, in terms of premises-conclusions, possibly related to the model of Aristotle’s syllogisms. In his opinion “In no argumentation are premises and conclusion properly identified”, although he regards the arguments overall acceptable. Fabia, Giorgio and Maria underline the topic of the explicitation of the links among statements and remark that the argument of student 3 is the most explicit of the lot.

Final remarks

Most of the mathematics teachers involved have focused on mathematical content. It seems that their view of mathematics is still oriented to knowledge rather than to competence or reasoning. In other words, their view seems sharply acquisitional rather than discursive. Moreover, some of the objections raised involve aspects (such as the questions related to pointwise differentiability) that are not crucial for students who need a basic mathematical education only. The same teachers seem not regard argumentation as a relevant part of mathematical instruction. This suggests to teacher educators that there is still much attention to pay to teachers’ interpretation of mathematics education and to familiarise them with the learning potential of argumentation. It suggests also that teacher formation should focus on argumentation as a component of mathematical competence, rather than as an additional subject to be taught. A nice discussion, at the educational level, of these topics, has been provided by Freudenthal (1988), who clearly related the logical topics in mathematics education to language. The interdisciplinary character of argumentation is damaged if it is narrowly interpreted according to the schemes of some content domain, such as mathematical logic, philosophy or law. Most of them seem to regard linguistic competence as conformity to some pattern rather than adequacy to some functions or goal. This is the case of teachers criticizing the use of plural forms or of expressions like ‘letter D ’. These may not correspond to some stylistic patterns but surely do not severely damage the readability of the text. Moreover, some teachers seem to give value to concise texts rather than to more extensive ones. It is possible that high school teachers’ expectations of undergraduates’ linguistic competence are too high and that they assume that undergraduates can fluently use literate registers, i.e. the more educated varieties of language. This unfortunately does not often happen. The use of plural forms and of ‘probably’, which has been criticized by some teachers, seem to be related to the interpersonal metafunction of language rather than to the ideational

one. In other words the students using such wordings did not mean to express some specific content but to position themselves in relation to the instructors or even to the other students. On the other hand, only three teachers notice some more substantial weaknesses of the texts, such as the lack of subjects or of connectives, which severely damages the accessibility of the text. In our experience of undergraduate teaching, this is a major problem with a number of students. This is not just matter of style, but, in a framework assuming that language plays a major role in the development of thought, it is a major obstacle for students, who lack the means for effectively representing and compacting information and verbally expressing the organization of their thinking process. It seems that some teachers do not recognize the importance of the language demands of a formal proof and do not relate them to the field of mathematical instruction. Verbally expressing argumentation can allow students to become aware of its logical structure, but the language means to do that, such as connectives and their combination within sentences, are crucial (Prediger & Hein, 2017). We have a feeling that some of the teachers involved had too high expectations about the mathematical competence of the students involved, as far as they were at university rather than at high school. In the future we need to improve the methodology to reduce the bias caused by the teachers' view of undergraduate studies, for example by asking them to evaluate argumentations produced by high school students of their or other schools. We propose also to expand the number of teachers involved (including both mathematics and other subject teachers) and to use these results in teacher education activities.

References

- Bermejo-Luque, L. (2011). *Giving reasons. A linguistic-pragmatic approach to argumentation theory* [Kindle DX version].
- Duval, R. (2007). Cognitive functioning and the understanding of mathematical processes of proof. In P. Boero (Ed.), *Theorems in school – From history, epistemology and cognition to classroom practice* (pp. 137-161). Rotterdam, Netherlands: Sense Publishers.
- Freudenthal, H. (1988). Logic as a subject or as an attitude? In M. Barra, & A. Zanardo (Eds.), *Atti XII Incontro di Logica Matematica, La logica matematica nella didattica* (pp. 27-38). Siena, Italy: Scuola di specializzazione in logica matematica, Dipartimento di matematica, Università Siena.
- Halliday, M.A.K. (1985). *An introduction to functional grammar*. London, England: Arnold.
- Hasan, R. (2005). *Language, society and consciousness - The Collected Works of Ruqaiya Hasan*. Vol. 1 (J. J. Webster, Ed.). London, England: Equinox.
- Johnson, R.H. (2000). *Manifest rationality: A pragmatic theory of argument* [Kindle DX version].
- Prediger, S. & Hein, K. (2017). Learning to meet language demands in multi-step mathematical argumentations: Design Research on a subject-specific genre. *European Journal of Applied Linguistics*, 5(2), 309-335. doi: 10.1515/eujal-2017-0010

The role of writing in the process of learning to speak mathematically

Marei Fetzer

Goethe University, Frankfurt, Germany; fetzer@math.uni-frankfurt.de

A lot of research is being done on the interplay of mathematical learning and language skills. However, graphic aspects have been met with little response so far. What role does writing play in the process of improving language proficiency? This paper empirically reconstructs how language use develops within one lesson that provides manifold opportunities for students to negotiate and discuss. Special attention is paid to the role pupil's written notes play within that development.

Keywords: Language skills, writing processes, mathematical learning.

Introduction

We know that language plays an important role in mathematical learning. Consequently, mathematics education is not only about teaching and learning mathematical ideas and concepts, but also about the development of a language that reaches the demands of describing mathematical activities and expressing fundamental ideas. Mathematical and language learning accompany each other. One approach to improve mathematical and language skills in an interconnected way is to initiate interactive learning situations. Such discursive situations are meant to encourage language use *and* mathematical learning. Why should that work? First, language serves a communicative function. So it appears to be a platitude that learning language requires using language and interacting with others. Second, language fulfills a cognitive function. The challenge to develop mental mathematical objects is strongly linked to the availability of appropriate means of expression and language skills. Not only theories on language support the assumption that interactive learning situations are beneficial for cross-linked mathematical and language learning. However, the conceptualization of learning as a social process backs that idea. Learning takes place in the process of participating in interactive situations (Miller, 1986; Fetzer, 2007a). Referring to social frameworks of learning, all participating students should benefit from such a proceeding. Those who actively contribute to a mathematical discourse improve their language skills by developing an appropriate language that has the potential to convey their idea. Those who rather receptively attend the situation might profit by being part of a mathematical discourse. They might not only catch up mathematical ideas, but also ways to express them. But how does language use develop in classroom interaction? Graphic aspects seem to play an important role in settings that challenge mathematical language development; taking notes on solving processes, recording explanations and accounting for answers in a written way are constituent elements of cooperative classroom settings. Consequently, when studying processes of learning to *speak* mathematically, the role of *writing* should be taken into account. What role do graphic aspects play within that development? This paper provides a closer look at the two essential situations concerning these research questions: the phase of writing, and the phase of presenting on the basis of graphic notes.

Development in language use

In order to describe developments in language use, we need to specify. Koch and Oesterreicher (1985; Oesterreicher, 1997) offer a distinction in two dimensions of language: the medial and the conceptual.

The medial dimension is dichotomic: language can be either specified as phonic, when something is said and can be heard, or, it is assigned to graphic forms like writing. In contrast, the conceptual dimension is gradual. Language can be conceptually rather oral or rather written. It stretches between the poles of communicative nearness (oral) and communicative distance (written). This specification applies for both, medially graphic and medially phonic, forms of language. Talking with a good friend for example is closer to the conceptually oral pole than a presentation at a conference. A newspaper article is ‘more’ written than a twitter post. If we talk to our child when having breakfast, we might use short and incomplete sentences and combine them with gestures. As we are in a face-to-face situation, we can react directly to our counterpart and spontaneously negotiate our roles. Koch and Oesterreicher call this a language of nearness. The strategies of communication belong to the pole of orality. In contrast, conceptually written language refers to the pole of literacy and language of distance. It is used when the interlocutors are not necessarily in direct relation and the processes of speech production and speech reception might be separated from each other. Thus, aspects of the situational and cultural context have to be made explicit. Consequently, sentences are more complex, main clauses and subordinate clauses are formulated. Specific terms come into play to be precise and explicit. Koch and Oesterreicher call this a language of distance. Examples are a text of law (graphic) or a scientific lecture (phonic).

Koch and Oesterreicher help to classify the registers of everyday language and academic language (Cummins, 2008). Halliday describes a register as “a variety of language, corresponding to a variety of situation” (1985, p. 29). According to him, the term register points to the detection that individuals adapt their use of language to a given situation. Thus, the register of everyday language is rather conceptually oral, no matter which medium is realized. It has to fulfil the function of a fast and unproblematic communication in our everyday life. As such, the oral language may be supported by gestures or by reference to a context. Words do not have to be clearly defined and sentences may be short or even incomplete. In contrast, the register of academic language is conceptually written, again irrespective of its medium. In academic contexts, language should be as explicit and precise as possible and intelligible without any reference to a specific situation. For that reason, words have to be well defined. Sentences might be complex in order to reflect relations.

Eventually, there is the register of mathematical language. It is an academic register related to a certain field; mathematics. Technical terms like probability, multiplication or subtracting, as well as specific sentence structures, are constituent elements of mathematical language. Especially on the medially graphic level, very short and decontextualized sentences or graphic representations are characteristic for that register.

In mathematics classes, we face the challenge to develop individual language use from orality towards literacy, from everyday language in the direction of learning to speak and write mathematically. The learning and teaching situation remains the same: students and teacher know each other and interact face-to-face. Nevertheless, a development towards precise and decontextualized academic, respectively mathematic, language has to be initiated. Fetzer (2007a; b) proves empirically that writing in mathematical classes and mathematical discourse on the basis of students’ written works fundamentally support *mathematical* learning. In this paper, special focus is put on *language*

development, and the way in which the implementation of medially graphic elements helps to provoke a move in the direction of literacy is reconstructed.

Data and methodological aspects

The examples analyzed in this paper are taken from the empirical study MitMaL (**M**iteinander **M**athe **L**ernen) (Co-operative Mathematical Learning). In this study, cooperative and individual learning settings are compared to each other. Two math classes were observed and video-recorded for a couple of weeks. Both groups dealt with the same mathematical subject, but implemented different methodical approaches. In one class (group i), individual learning situations dominated. In contrast, the other teacher predominantly initiated cooperative group work and provided the opportunity for mathematical whole class discussion (group c). Pre-test, post-test and follow-up-test constitute the quantitative part of the study. Analyses on the transcripts of the videos account for the qualitative part of the study. They are conducted in a reconstructive manner applying analyses of interaction (Cobb & Bauersfeld, 1995). This method refers to the interactional theory of learning and is based on the ethnomethodological conversation analysis. In contrast to conversation analysis, it focuses on the thematic development of a given face-to-face interaction rather than on its structural development.

The videos for this paper are taken from group c, who worked in a cooperative manner. In order to reconstruct the development of language use, the paper concentrates on one single math lesson on probability in grade four. Debora is accompanied throughout the whole lesson. In this way, her individual performance and development can be reconstructed from the beginning until the end of the lesson. Special attention is paid to the role the notes taken in the group work play in the presentation. How do they influence the verbal language skills?

Empirical example

The empirical example is taken from a math lesson on probability. 24 students of grade four try to find out which of the four given rules is the best to win when turning a colored wheel of fortune. The wheel of fortune is equally divided into eight sections, numbered 1 to 8. Two fields are red, two are blue, three are green, and one is white. The rules are: (1) *You win with 1, 2 or 3*; (2) *You win with red*; (3) *You win with white or blue*; (4) *You win with 2, 4, 6 or 8*. Card four is the most probable to win.

The lesson starts with a thematic introduction in a whole-class situation. The tutor presents the wheel of fortune, and some students go for a first attempt. Afterwards, the children work in groups of four. They are equipped with a wheel of fortune, one set of cards with rules, and with a task sheet: *Work together and find out which rule is likely to be the best to win. Why do you think so?* The challenge is to work on the tasks, take notes and give reasons in written form. At the end of the lesson, children and tutor come together. They discuss their findings with their written notes at hand.

Language use in the context of probability: Talking about probability requires mathematical terms like probable, improbable and equiprobable. In German, ‘probable’ sounds familiar to children. The expression is used in everyday language and is applied in the sense of ‘perhaps’ or ‘might be’. In contrast, ‘improbable’ and ‘equiprobable’ sound rather strange to young students. These expressions belong to the academic, respectively mathematical, register. However, talking and writing mathematically requires more than academic expressions and mathematical terms. Describing,

explaining and giving reasons require academic language proficiency on the sentence level. In this particular task, the students first have to describe their selection in written form. This is possible using a main clause. Conceptually spoken language in everyday register meets the demands. In addition, an explanatory statement on their selection is required. This is much more challenging, as German language demands subordinate clauses in order to formulate causal connections. In contrast to main clauses that are structured subject – predicate – object, subordinate clauses are put together in an inverted structure: subject – object – predicate. This inversion does not necessarily belong to the everyday register. The outstanding challenge in the context of probability is the fact that we do not only need a causal conjunction followed by a subordinate clause with inverted sentence structure, but also an infinitive clause as a third component. This last aspect clearly belongs to academic language. To put it in other words: in order to compliment the decision with reasons and justification, not only mathematical terms, but academic registers and complex sentence structures are especially necessary.

Material for the group work: The rules rely on conceptually spoken language. They address the students directly and refer to the concrete given context of turning the wheel here and now. Mathematically spoken, it rather aims at a situational or context-bound understanding of probability and representativeness of personal attempts rather than at abstraction. The rules provide for a strong link to the students' experience on the one hand, and to their everyday language on the other hand.

The tasks (see above) apply conceptually rather spoken language as well. Again, the students are addressed directly. None of the mathematical terms of probability is used. Instead, the children are asked to choose one of the cards. A second sentence aims at an explanation. Interestingly enough, these colloquial questions can hardly be answered on a conceptually spoken level: if you work on the task in the order of appearance, you first have to determine the selection. That is easy. Afterwards, you need a causal subordinate clause and the infinitive clause, which is grammatically complex. In principle, conditional connections could be a solution: "If you choose..., you are likely to win. That is because..." This structure is much easier in German than the causal connection. Nevertheless, it clearly belongs to the academic register. However, such an answer is only possible if the students have already reached a rather high level of abstraction at this time. Condensed: if students work on the tasks and provide answers, they either have to fulfil a move on the conceptual level from spoken to written language, or they have to develop an abstract understanding that enables them to choose a slightly less complex language use.

Beginning of the lesson (phonic): Children and tutor are sitting in a circle around a colored wheel of fortune ready to be spun. Debora does not contribute to this opening. The tutor starts the lesson referring to the students' experiences with wheels of fortune: "Perhaps you know something like this. Such a wheel of fortune has something to do with winning or not. This is why it's called wheel of fortune, cause if you win, you are lucky". (Wheel of fortune is '*Glücksrad*' in German, and being lucky is '*Glückhaben*'). In the first introduction to the theme, the tutor links not only the context of own experiences with the mathematical context of probability, but also different language registers. She plays on the fact that *Glück* bridges both registers. Pointing at the paper wheel of fortune, she moves her finger around in circles and says: "Today we have a closer look at the wheel of fortune." Repeatedly in this introduction, she moves her finger in this manner as if she spun the wheel. By doing this, she might strengthen an activity-orientated representative understanding of probability:

Rule X wins because my own (little) random sample ‘proves’ it. This understanding does not claim for decontextualized academic language.

The tutor’s language changes within the introduction. First, she seems to pick the students up and see them through by applying the everyday register. She distinguishes “good rules” you are likely to win with, rules you might “not necessarily” win with and rules that make it “quite impossible” to win. When explaining the task, she even grades further down and speaks of “a good way to win” and “stupid cards”. This colloquial language is accompanied by the turning gesture. Acting and speaking like this, the tutor marks the concrete situation as the starting point of the experiment on probability. Not before her last sentences, she uses the mathematical expressions: “For example, with this card, you will most probably win; with these two cards, it is perhaps equiprobable to win; and with this one, it is rather improbable.” This is the only time these terms are quoted in the introduction scene.

Group work (phonic and graphic): For a closer look at the group work, Debora’s group is chosen exemplarily. Three phases of language use can be reconstructed within the working process: (1) conceptually spoken language, (2) everyday language with scattered mathematical terms, (3) everyday language with specifications and conjunctions.

(1): Debora is the girl to take the initiative in the group. She suggests cutting the wheel out. While doing this, she lays the foundations for an activity-orientated approach and context-specific experiences. This first phase is dominated by the register of everyday and conceptually spoken language. Sentences remain incomplete; gestures play an important role for understanding. The challenge of writing is no issue of negotiating yet. The following scene emerges as soon as the girls have read out the rules. It illustrates the register of everyday language the girls apply.

Debora: *Points at Dalya That’s best*

Sara: Yes

Debora: *to Dalya say it again reaches for the wheel and takes it*

Dalya: *I got reads out her card you win with 2/ 4/ 6/ or 8*

Debora: *puts her fingers on the wheel it’s the majority- all fields but three-*

Sara: *points at one field*

Debora: *I see- moves her fingers on the wheel five as well/*

Sara: no

Debora: *looking at the wheel, fingers still fixed on fields makes no difference- it’s equal*

However, they work straightforward on the task and find a first solution that is mathematically correct. The choice is formulated using conceptually spoken, deictic and context-bound language: “That’s best.” No mathematical term is applied. A first approach to explanation might be the physical detection (by touching) of four (out of eight) ‘lucky’ fields.

(2): The second phase can be characterized by conceptually spoken language with scattered mathematical terms. Graphic aspects still do not come into play. In this scene, one can reconstruct one example of how mathematical language works its way into the discourse: Debora picks up a comment from a neighbouring group “Red is the most improbable.” She spontaneously integrates the

term in her active language use and confirms with a look on the wheel: “Yes, red is the most improbable.” In the following, this term remains a constituent part of the interactive process. All four girls stick to conceptually spoken language using the register of everyday language. Their sentences remain incomplete with scattered mathematical expressions. For example, Debora sums their findings up as follows: “Red is the most improbable. One, two or three is same, and Dalya’s is best.”

(3): As soon as it comes to *writing*, there is no way of supporting words by pointing or showing. Written language has to carry the whole meaning. Accordingly, writing mathematically arises the necessity to develop language use. Debora’s group works sequentially. First, they answer the first part of the task: *Work together and find out which rule is likely to be the best to win*. They choose the conceptually spoken wording of their verbal formulation from the beginning “That’s best” and elaborate on it: “Best is card four which says you win with 2, 4, 6 or 8.” The deictic component of the face-to-face interaction is replaced by naming the card “card four”. The necessity to write results in specifying the concrete situation. The rule is taken from the card and copied word by word. This appears to be an appropriate strategy to create an answer that is socially accepted as ‘good mathematical language’. At the same time, the sentence structure remains conceptually oral. The elements ‘specification by concreteness’ and ‘copying phrases’ are put together one after the other. Though the subordinate clause is introduced with the appropriate conjunction, it is not conducted in the right grammatical arrangement.

Later in the group work, the tutor reminds them to provide reasons for their decision. Subsequently, Dalya picks up the pencil.

Julia: Because they are well spread\

Dalya: *holding the pen* Yes-

Julia: *points her finger to the paper* Well- because they are well spread on the turntable\

Dalya: *yes writes*

Julia: Wheel of fortune – write wheel of fortune\

Dalya: Well- we’ve found a because- uhm I’ve written *reads out* best is card four which says you win with 2 4 6 or 8 because they are well spread on the wheel of fortune.

Debora: spread *thumb up*

In this short scene, the justification is graphically recorded. The aspect of the winning fields being evenly or well spread on the wheel of fortune was mentioned earlier only once by Julia. At that time, her idea would not come through in the interactional process. Why is she successful now? The tutor directly addresses the group and asks them to find a justification. The girls are running out of time. In this situation, Julia starts her suggestion with “because”. Her first utterance is rather vague. Perhaps feeling supported by Dalya’s “yes”, she then elaborates “the turntable”. As a third move towards improved language, she implements a mathematical term “wheel of fortune.” Summing up, her suggestion is put forward at the right time within the solving process. Julia is working with the elements of *specification* and *integrating mathematical terms*. The *conjunction* ‘because’ indicates a justification. That was the task. The sentence structure itself still reminds of spoken language. This form of speaking mathematically appears to be convincing to the group members. Debora seems to

try that wording on her own by repeating it. Her thumb up can be understood as acceptance. Again, she picks up an expression and integrates it spontaneously in her active vocabulary.

End of the lesson (phonic and graphic): Gathering for the end of the lesson, the students have their sheets with their written works at hand. Debora is the first child to contribute in the presentation. As she hesitates and starts over twice, it seems as if she has to orientate herself first. In this situation, her group's notes appear to be helpful. After a quick glance at the paper, she performs much more fluently: "*Best* we found out is card four." In German, this is an example of conceptually spoken language: her word order is irritating. Precisely, 'best' is used as an adverb referring to 'to find out'. Taking into account the given context, it appears to be more reasonable that she uses 'best' to characterize card four. Thus, her sentence structure is grammatically incorrect. Instead, it might reveal her order of remembering: we had to select ("best"), we had to work ("we found out"), we made a decision ("card four"). Here, the notes appear to support the memory: what did we do? In the following, her language develops. "Cause best is card four". This is, in fact, only half a sentence. But, in contrast to the first attempt, it is in the right German word order. Then, she reads from the notes, probably in order to make sure to get the correct wording: "which says you win with 2 4 6 or 8". Turning her eyes away from the notes and looking to the tutor, she proceeds: "Cause they are quite well spread on the wheel of fortune." On the notes, the subordinate clause is in the wrong word order. Speaking aloud, she corrects the sentence structure. This can be interpreted as a step towards abstraction and language of distance. Her language develops towards academic register. Summing up, the notes warrant three aspects: orientation, reminder and thematic reassurance that helps to develop language skills.

Analysing the other contributions in this presentation confirms these findings. Every single contribution is thematically on point. Obviously, graphic notes help to *orientate*. Moreover, the students supply their comments with phrases that structure the whole presentation process: "We found out the same" or "Not as the others". That provides for orientation and structure not only within individual understanding processes, but also within the interactional discourse. The aspect of *reminding* of the own working process appears to take affect strongly. Every single student who contributes to the whole class presentation thematically closely links his or her comment to the notes. The quick glance at the paper is to be reconstructed in each sequence. Especially the observation that medially verbal language use improves compared to the graphic version in the notes confirms as an empirical result. For example, in one group, the notes say: "Weil Gewinnkarte vier das halbe Glücksrad einnimmt." (Cause winning card four takes half the wheel of fortune.). Contributing in the class, the presenting boy turns 'half' into a noun and combines it with a genitive construction ("nimmt die Hälfte des Rades ein"). Using substantives and genitive constructions is a German speciality, which is especially characteristic for academic register. Accordingly, this is understood as *development in language skills*.

Conclusions

How does language use develop in cooperative classroom settings? What role do graphic aspects play? This paper provides a closer look at the two essential situations concerning these research questions: the phase of wiring, and the phase of presenting on the basis of graphic notes.

The necessity to *write* mathematically activates a development in language move at the conceptual level. Mathematical terms are embedded in rather spoken sentence structures; a first move towards mathematical language. Specification on the concrete context serves for more precision in descriptions. Even at the level of sentence structure, first developments can be reconstructed. On the one hand, students implement phrases that were socially accepted earlier as mathematically elaborated. On the other hand, they implement conjunctions. If-clauses and causal-clauses are characteristic elements of academic and especially mathematical register.

Presenting is eventually a medially verbal action. But, in the given case, graphic aspects work their way into interaction. They contribute fundamentally to orientation, structuring and reminding both individual learning processes, and the interactional process. Particularly the graphic notes thematically reassure students and thus provide capacity to develop language skills.

References

- Cobb, P., & Bauersfeld, H. (Eds.) (1995). *The emergence of mathematical meaning: Interaction in classroom cultures*. Hillsdale, NJ: Lawrence Erlbaum.
- Cummins, J. (2008). BICS and CALP – Empirical and theoretical status of the distinction. In B. Street & N. H. Hornberger (Eds.), *Encyclopedia of language and education* (pp. 71–83). New York, NY: Springer Science + Business Media.
- Fetzer, M. (2007a). *Interaktion am Werk. Eine Interaktionstheorie fachlichen Lernens, entwickelt am Beispiel von Schreibenlässen im Mathematikunterricht der Grundschule* [Interaction at work. An interaction theory of subject learning, developed using the example of writing events in primary school mathematics lessons]. Bad Heilbrunn, Germany: Klinkhardt.
- Fetzer, M. (2007b). “Why should I implement writing in my classes?” An empirical study on mathematical writing. In D. Pitta-Pantazi & G. Phillipou, (Eds.), *Proceedings of the Fifth Congress of the European Society for Research in Mathematics Education* (pp. 1210–1219). Larnaca, Cyprus: ERME.
- Halliday, M. A. K. (1985). Part A. In M. A. K. Halliday & R. Hasan (Eds.), *Language, context, and text: Aspects of language in a social-semiotic perspective* (pp. 3–51). Oxford, England: Oxford University Press.
- Koch, P. & Oesterreicher, W. (1985). Sprache der Nähe – Sprache der Distanz [Language of proximity - language of distance]. *Romanistisches Jahrbuch*, 36, 15–43.
- Miller, M. (1986). *Kollektive Lernprozesse. Studien zur Grundlegung einer soziologischen Lerntheorie* [Collective learning processes. Studies on the foundation of a sociological learning theory]. Frankfurt, Germany: Suhrkamp.
- Oesterreicher, W. (1997). Types of orality in text. In E. Bakker & A. Kahane (Eds.), *Written voices, spoken signs: Tradition, performance, and the epic text* (pp. 190–214), Cambridge, MA: Harvard University Press.

Solving problems collaboratively in multi-age classes – a possibility for learning?

Rachel-Ann Friesen, Marcus Schütte, Judith Jung

Technische Universität Dresden, Faculty of Education, Dresden, Germany

rachel-ann.friesen@tu-dresden.de; marcus.schütte@tu-dresden.de; judith.jung1@tu-dresden.de

From an interactionist perspective, interaction is seen as a foundational constituent of mathematical learning, as it creates the possibility for students to negotiate meaning, which then can lead to the construction and/or modulation of meanings which outlast the situation - framings. According to Krummheuer (1992), this is seen as learning. In multi-age classes, students have even more diverse framings than in single-age classes and when they are given the opportunity to learn collaboratively, an increased need to coordinate their framings might lead to an optimised possibility for learning. This research project has the objective of identifying how students participate in processes of collective negotiation of meaning and therefore how possibilities for learning mathematics emerge. First analyses show that the possibilities for learning emerging in the interaction vary depending on whether differences in framings can be coordinated and a taken-as-shared meaning is brought forth.

Keywords: Multi-age education, collaborative learning, interactional analysis.

Multi-age education

No matter the school, students in a classroom are never homogeneous, also in relation to their learning preconditions. Each individual is unique and therefore has differing abilities and experiences. Using age as the distinguishing factor for placing students in specific classes is the norm, because it is seen as a possibility to make classes as homogeneous as possible. But even in learning groups which are homogeneous in age, the differences in students' preconditions for learning can be up to five years at the time they enter into school (Lorenz, 2000, p. 22). One concept with the aim to purposefully value and meet this existing diversity is merging students of different ages and grades in one class deliberately (Prengel, 2007, p. 69), which can be referred to as *multi-age classes*. The benefit in making learning groups heterogeneous in age is e.g. seen in that, because the diversity of learning preconditions increases, the necessity for differentiation increases also. However, mathematics is often presumed to be a subject built up rectilinear whose content can only be learned following a specific order (Lorenz, 2000, p. 19). Nührenbörger and Pust (2006) found that because of this common assumption students in multi-aged classes are rarely given the opportunity to learn from and with others in mathematics classrooms. Instead, this often causes extremely individualised and separated learning to take place as teachers either feel they need to separate the learners back into the different age groups or they need to let each student learn individually at their own pace in order to meet the increased diversity of the students. However, both of these waste the opportunity seen in collaborative learning (Nührenbörger & Pust, 2006, p. 17), especially from an interactionist perspective on mathematics learning.

Besides overarching concepts, which have been developed for collaborative learning within multi-age mathematics teaching (e.g., Nührenbörger & Pust, 2006), interactions between learners who are

heterogeneous in age have been examined within multi-age mathematics education research. These studies predominantly focus on dialogues between two students from different grade levels and concentrate either on how knowledge is constructed in the interaction (Nührenbörger & Steinbring, 2007) or on when interactions are beneficial for learning in these settings (Gysin, 2018). Our focus is also on possible benefits for students' learning conditions when children with diverse preconditions interact with each other while solving problems collaboratively. However, we base our study on the interaction theory of learning, which will be described below, and include analyses of group settings of three students working together.

Interaction theory of (mathematical) learning

From an interactionist perspective, the individual process of learning is constituted in the social process of the negotiation of meaning. The social interaction, therefore, holds the potential to generate meanings new to the individual. Especially for young learners, interaction is seen as a foundational constituent of learning. In this context, Miller (1986) creates a sociological theory of learning of at least two individuals – the theory of collective learning processes – in contrast to psychological theories of learning which predominantly focus on isolated individuals. Hereby, he does not, on principle, question that learning is also an individual process, but rather that, when learning fundamentally in the early stages of a child's development, an interactive collective process precedes or determines this process of learning something new (Jung & Schütte, 2018). In this sociological theory of learning, the concept of argumentation is essential and Miller (1986, p. 37) differentiates it from “communicative action.” Argumentation, and hereinafter more specifically collective argumentation, is mainly characterized by the aspect of rationality, whereas communicative action is based on something uncontroversial. Mathematical learning, therefore, takes place when two or more people negotiate what is viewed from a mathematical perspective as rational. Krummheuer and Brandt (2001) draw on this aspect of learning in collective argumentation and create an interaction theory of mathematical learning. For them, it is of great importance that students participate in collective argumentation within classroom interaction in which meaning is collectively negotiated (Krummheuer & Brandt, 2001, p. 20). This, at best, will lead to learning to occur which is seen as the construction and/or modulation of meanings which outlast the situation – also called framings (see below) (Krummheuer, 1992; Jung & Schütte, 2018, p. 1091) and can be reconstructed in the increasingly autonomous participation in these collective argumentations (Krummheuer & Brandt, 2001). Based on this understanding of learning and the significance of interaction in mathematics learning, diverse theories with rich empirical content have been developed in recent years from a foundation of “sensitizing concepts” (Blumer, 1954, p. 7) – a kind of theoretical skeleton for the interaction theory of learning, which will be described below.

At the beginning of an interaction, the participants develop preliminary interpretations of the situation on the basis of their individual experiences and knowledge – called *definitions of the situation* (Krummheuer, 1992). Furthermore, participants in the interaction attempt to attune their definitions of the situation to each other, ideally leading to the production of *taken-as-shared meaning* (Voigt, 1995, p. 172), a working consensus. The participants' interpretations of a situation can never be exactly the same, however, by creating an understanding between them concerning the objects, ideas and rules of the interaction, the participants are enabled to work together. The result of the

participants' negotiation only is something "temporarily" which serves as a basis for further processes of negotiation but might also be rejected or transformed as the interaction unfolds (Bauersfeld, Krummheuer, & Voigt, 1988; Voigt, 1995). The taken-as-shared meaning – *the working consensus* (Goffmann, 1959, p. 9) – is on the one hand socially constituted and, on the other, potentially novel for the individual if it pushes systematically beyond his or her interpretive capacities. The working consensus represents the 'stimulation potential' of individual cognitive restructuring processes. When taken-as-shared meanings are brought forth repeatedly in the interaction, the participants' individual definitions of situations can become standardized and routinized and can therefore be produced by the individual in similar situations. Drawing on Goffmann (1974), Bauersfeld et al. (1988) call these definitions *framings*. Thus, ideally, mathematical ascriptions of meaning which sustain beyond the situation (framings) are constructed, or the working consensuses, which are repeatedly collectively negotiated, 'converge' in individual mathematical framings.

However, it often happens that the framings produced by young learners either among themselves or in interaction with individuals with advanced skills are not in alignment with each other (Krummheuer, 1992). Students, for example, each interpret situations based on framings from the environments they have experienced outside of school and in their previous school career. In order to maintain the progressive mutual negotiation of content relating to a particular theme, the *differences in framing* between the participants need to be coordinated. This coordination should be done by an individual who is advanced in the subject-specific interaction. While these differences in framing can make it more difficult for the participating individuals to adjust their definitions of the situations to fit each other, they also provide the "motor" of learning" (Schütte, 2014, p. 927) since, on the interactional level, they generate a certain necessity for negotiation.

Analysing students' participation in processes of negotiation of meaning

One of the unique characteristics of multi-age education is that learners most likely have even more diverse framings than in single-age classes. We believe that this can provide an optimized opportunity for learners when working collaboratively, as there is an increased need to coordinate their differences in framing by negotiating meaning. In order to coordinate the differences in framings, the students have to bring forth a working consensus collectively. This can then lead to the construction and/or modulation of framings which is seen as learning. Based on this interaction theory of learning, the overall question this research seeks to address is: How do students participate in processes of collective negotiation of meaning within multi-age mathematics education and do possibilities for learning mathematics emerge.

Interactionist approaches of classroom research

Methodologically, this work can be located within qualitative methods of social research which follow a reconstructive-interpretative qualitative approach and have the aim to 'understand' the actions of the individuals participating in class and develop local theories (Schütte, 2011, p. 776). More specifically, this work is located within interactionist approaches of mathematics educational classroom research (e.g., Krummheuer, 2011). For this study, the classes are filmed several times over a period of one to two years in order to reconstruct possible age-specific changes concerning the participation in collective argumentation of the children. The interactions of the students are then

transcribed and analysed using the interactional analysis, which was first deployed in the area of interpretive classroom research in mathematics education in studies by Bauersfeld et al. (1988). The interactional analysis allows to reconstruct the ways in which negotiations of mathematical meaning are interactively constituted by individuals. Furthermore, it can help to reconstruct patterns and structures of verbal actions of the teacher and the students. Overall, this research seeks to describe how mathematical learning takes place collaboratively in multi-age education and will use the sensitizing concepts in order to describe these processes.

Collective argumentation of students in multi-age education

The group works analysed in this paper are from a mathematics lesson in a multi-age class including 24 children from first, second and third grade. At the beginning of the lesson, the students are divided into groups of three which mostly contain one student of every grade level. The students are given this task: “Tina and her family want to decorate their Christmas tree with hand painted Christmas ball ornaments¹. They want every ornament to look different. To paint the ornaments, they have the colours red, green and blue. With these colours, they can paint dots or stripes. For each ornament they want to use two colours and one pattern at the most. Which possibilities do they have when painting their ornaments?” To solve this task, the students have material on their tables which includes circles, stripes and dots of each colour to try out different combinations without painting them. The interactions of two groups of three students, including a student from every grade level, working on this task were analysed and the summaries of these analyses will be presented below. Afterwards, the analyses will be compared to each other and a conclusion will be drawn.

Analysis of the first group work

The first group includes Isabella (1st grade), Hans (2nd grade) and Elias (3rd grade). During the first part of this group work, the students start by creating two green circles, one with red stripes and one with blue dots. Then the following interaction emerges.

Transcript 1: Excerpt of the first group work

1		Isabella	I wouldn't just use green now but (if we) also the other two colors [<i>points to the blue and red circle</i>]
2		Elias	on red wait [<i>takes a big red circle from the pile</i>] on red we could [<i>picks up a small blue dot</i>]
3		Hans	no now now [<i>touches red dots</i>] now green dots [<i>picks up two small green dots</i>]
4		Elias	no we already have green dots . twice [<i>first points to a big green circle and then with two fingers to the two green circles with patterns on them</i>]
5	<	Elias	now we have to
6	<	Hans	but green dots [<i>places his two green dots on the red circle in front of Elias</i>]
7		Elias	yes okay . that that yes

In this excerpt, Isabella argues that they should not only use green circles but also the two other colours because they should not only use the same colour <1>. Elias then picks up this idea and starts

¹ In Germany, Christmas trees are often decorated with different kinds of ornaments (e.g. ball ornaments) which can be in one or more colors. Therefore, children in Germany are usually familiar with ball ornaments.

suggesting to put blue dots on a red circle <2>. Hans also follows up on Isabella's idea and suggests to put green dots on a red circle <3>. Elias seems to misunderstand Hans' utterance and reiterates Isabella's idea <4>. Then Hans repeats his idea to clarify it <6> and Hans and Elias agree on creating a red circle with green dots <7>. Hans and Elias then briefly disagree on the number of dots they should use but both seem to implicitly agree that for the differentiation of the possibilities the number of dots is not relevant. After settling for three, they also disagree on which background colour they should continue with. Elias now suggests to use a blue circle but Hans disagrees and suggests to create a second red one using the other colour left for the pattern (blue). They then agree on using a red circle and add two blue stripes. Isabella says that she has found another possibility and points to a blue circle with one green stripe. Contrary to Elias who then says he wants to create another red circle with a pattern, Hans explains that they have created two green and two red ones so far and suggests to now create blue circles. All three quickly agree that they will first use a blue circle with red dots.

In this part and in the continuation of this group work, one can see that all three children participate in the creation of the possibilities. All of them contribute suggestions but also disagree with each other directly. However, before they continue working on the next possibility, they always come to an agreement concerning a possibility. In doing so, they collectively negotiate their suggestions. In the arguments, which are brought forth in the processes of reaching agreements on the procedure and correctness of the specific possibilities, various strategies of the children can be reconstructed (even usage of all colours; maximum difference in the materials used; alternating colours and patterns at the same time; aesthetic reasons such as using the same or deliberately different number of dots and stripes; conservative usage of materials to avoid wasting materials). The two strategies which prevail – even usage of all colours, as well as the variation of the number of dots and stripes for aesthetic reasons – are both introduced by Isabella first and then picked up by Elias and Hans. It is noticeable that Isabella contributes a lot of ideas but does not implement them directly but rather formulates them in the subjunctive. Because she mainly relies on verbal suggestions without using the material, whereas Hans and Elias often directly use the material while bringing forth a suggestion (e.g. <3, 4>), her suggestions and arguments are often very explicit. Elias, in particular, takes up Isabella's suggestions over and over again and implements these as well as his own suggestions. Hans primarily takes up Elias' suggestions but often also contradicts them and starts acting directly on his own. However, in these contradictions - at the beginning especially between Elias and Hans – no competition develops for who prevails, instead the contradictions are used for finding the best possible strategies and methods for solving the given task. Elias, in particular, involves everyone in the process of solving the task by asking for their approval. Therefore, a working consensus seems to establish that all three participants should agree on a suggestion (or at least no longer disagree on a suggestion) before moving to the next possibility. This leads to the group bringing forth collective argumentations in order to solve the emerging differences in framing. Throughout this entire task, they all continue to work collaboratively because, even though they briefly start working alongside each other once in a while, they always agree collectively on a possibility before moving forward.

In this group work, the differences in framings seem to be coordinated as the children bring forth a working consensus through collective argumentations. Therefore the possibility for learning can be reconstructed as this working consensus can lead to the students constructing new or modulating

existing framings. In further analyses, different roles of the individual students within these negotiations could be reconstructed more specifically. Elias, for example, seems to act as one who coordinates the differences in framings and therefore seems to help them come to a working consensus as a group.

Analysis of the second group work

The second group includes Kim (1st grade), Erich (2nd grade) and Hannes (3rd grade). In this group, we can also see that all three children participate in the creation of the possibilities by making suggestions, responding to the suggestions of others, but also by acting immediately on their own suggestions. As a group, however, they only agree on a possibility briefly before revising it again. At the beginning, they start by working on one possibility collectively, however Erich's proposal is rejected by Kim and Hannes without giving clear reasons. Kim only says „no I believe I don't know if that will work with red dots I don't believe [*takes the red dots off the blue circle*]“ <78> and after Erich moves the blue circle Hannes says „no Erich red needs to go [*takes the blue circle which Erich moved and puts it in front of himself*] <82>. From then on Erich withdraws from working collaboratively. The disagreements between the children are often solved by exercising authority and rarely by giving arguments and if an argument is given, this is not taken up by the others. This is also reflected in the fact that from the start Hannes repeatedly contradicts suggestions by referring to the task – only two colours may be used – but then does not comply with it himself. Therefore, a pattern is established in which all three children work side by side. Kim and Hannes seem to interpret this situation as aimlessly trying out various possibilities, as Kim, for example, repeatedly rejects or reverses possibilities and never leaves a possibility permanently. Erich, on the other hand, seems to be looking for possibilities in a more structured way. His structured approach can also be reconstructed by him letting his suggestions remain visible and not taking them apart again like the other two. At different times during the group work, Kim looks at other tables and then introduces new suggestions for strategies for solving the task (using the sheet of paper; gluing the patterns onto the circles; using a more structured approach) but her suggestions are not taken up or even rejected by Hannes and Erich. All in all, it can be seen that all three act very autonomously right from the start but do not find a working consensus about how to solve the task. They then start working side by side, presenting their own suggestions to each other but when contradictions arise they neither bring forth arguments (other than aesthetics), nor agree on possibilities and secure their results as a group.

In this second group work, the few attempts of the participating children to coordinate the differences in framing, which emerge, fail and therefore no working consensus seems to emerge. This may be due to the fact that they bring forth separate arguments but no collective argumentation is brought forth. From an interactionist perspective, the possibility for learning in this group work is therefore limited as without bringing forth a taken-as-shared meaning the possibility for constructing new or modifying existing framings is impeded.

Conclusion

When comparing the interactions of the two groups, even though all children participate in solving the task, from an interactionist perspective, only in the first group an optimized possibility for learning can be reconstructed. Therefore, solving problems collaboratively in multi-age classes can vary in the

way it enables possibilities for learning to emerge. In further analyses, collective argumentations seems to be initiated e.g. when learners explicitly verbalize disagreements or ask questions about the correctness of a solution as this seems to put the other learner(s) – often the more advanced ones – into an interactive obligation to bring forth arguments. In the process of the students then bringing forth the argumentation collectively, both the advanced and the less advanced student seem to have the possibility for learning even though these may be different (cf. Friesen, forthcoming). However, as seen in the two group works presented in this paper, this interactive obligation does not always lead to a collective argumentation in which a taken-as shared meaning is produced. In both groups, there are arguments that are brought forth but only in the first group these are brought forth collectively as can be seen in the excerpt. In the second group, the students do sometimes give an argument when a disagreement is verbalized, however, these are not taken up by the others and therefore no argumentation is brought forth collectively. In the future, these analyses will be compared with analyses of further group work in order to more clearly describe the patterns that enable children to bring forth and participate in collective argumentation.

Acknowledgment

The project “Collaborative Learning in Multigrade Mathematics Education at Primary Level” is part of a greater project called Sylber (Synergistic teacher education in an excellent framework) at the Technical University of Dresden, which is funded by the German Federal Ministry of Education and Research in the framework of the joint state and federal “Teacher Education Quality Offensive.”

References

- Bauersfeld, H., Krummheuer, G., & Voigt, J. (1988). Interactional theory of learning and teaching mathematics and related microethnographical studies. In H.-G. Steiner & A. Vermandel (Eds.), *Foundations and methodology of the discipline mathematics education* (pp. 174–188). Antwerp, Belgium: University of Antwerp.
- Blumer, H. (1954). What is wrong with social theory? *American Sociological Review*, 19(1), 3–10.
- Friesen, R. (forthcoming). “Hatten wir das schon?”- Kinder initiieren kollektive Argumentationen in jahrgangsgemischten Lerngruppen ["Did we already have that?"- Children initiate collective argumentation in multi-age learning groups]. In *Beiträge zum Mathematikunterricht 2019*. Münster, Germany: WTM-Verlag.
- Goffmann, E. (1959). *The presentation of self in everyday life*. New York, NY: Doubleday.
- Goffmann, E. (1974). *Frame analysis. An essay on the organization of experience*. Cambridge, MA: Harvard University Press.
- Gysin, B. (2018). *Lerndialoge von Kindern in einem jahrgangsgemischtem Anfangsunterricht Mathematik. Chancen für eine mathematische Grundbildung* [Children’s learning dialogues in a multi-age mathematics education. Chances for a mathematical basic education]. Münster, Germany: Waxmann.
- Jung, J., & Schütte, M. (2018). An interactionist perspective on mathematics learning: Conditions of learning opportunities in mixed-ability groups within linguistic negotiation processes. *ZDM*,

50(6), 1089–1099.

- Krummheuer, G. (1992). *Lernen mit "Format". Elemente einer interaktionistischen Lerntheorie* [Learning with "format". Elements of an interactional theory of learning]. Weinheim, Germany: Deutscher Studien-Verlag.
- Krummheuer, G. (2011). Representation of the notion 'learning-as-participation' in everyday situations of mathematics classes. *ZDM*, 43(1), 81–90.
- Krummheuer, G., & Brandt, B. (2001). *Paraphrase und Traduktion. Partizipationstheoretische Elemente einer Interaktionstheorie des Mathematiklernens in der Grundschule* [Paraphrasing and traducing: Participation theory elements of an interactional theory of learning mathematics in primary school]. Basel, Switzerland: Beltz Verlag.
- Lorenz, J. H. (2000). Aus Fehlern wird man... Irrtümer in der Mathematikdidaktik des 20. Jahrhunderts [From mistakes you will... Fallacies of mathematics education of the 20th century]. *Grundschule*, 32(1), 19–22.
- Miller, M. (1986). *Kollektive Lernprozesse: Studien zur Grundlage einer soziologischen Lerntheorie* [Collective learning processes: studies on the basis of a sociological learning theory]. Frankfurt am Main, Germany: Suhrkamp.
- Nührenbörger, M., & Pust, S. (2006). *Mit Unterschieden rechnen. Lernumgebungen und Materialien für einen differenzierten Anfangsunterricht Mathematik* [Expect differences. Learning environments and materials for a differentiated mathematics education]. Seelze, Germany: Kallmeyer.
- Nührenbörger, M., & Steinbring, H. (2007). Students' mathematical interactions and teachers' reflections on their own interventions. Part 1: Epistemological analysis of students' mathematical communication. In D. Pitta-Pantazi & G. Philippou (Eds.), *Proceedings of the Fifth Congress of the European Society for Research in Mathematics Education* (pp. 1250–1259). Larnaca, Cyprus: ERME.
- Prenzel, A. (2007). Heterogenität als Chance [Heterogeneity as a chance]. In H. de Boer, K. Burk, & F. Heinzl (Eds.), *Lehren und Lernen in jahrgangsgemischten Klassen* (pp. 66–75). Frankfurt am Main, Germany: Grundschulverband - Arbeitskreis Grundschule.
- Schütte, M. (2011). Theorieentwicklung in der Interpretativen Unterrichtsforschung am Beispiel der Impliziten Pädagogik [Theory development in interpretative classroom research using the example of implicit pedagogy]. In R. Haug & L. Holzäpfel (Eds.), *Beiträge zum Mathematikunterricht 2011* (pp. 775–778). Münster, Germany: WTM-Verlag.
- Schütte, M. (2014). Language-related learning of mathematics: A comparison of kindergarten and primary school as places of learning. *ZDM*, 46(6), 923–938.
- Voigt, J. (1995). Thematic patterns of interaction and sociomathematical norms. In H. Bauersfeld & P. Cobb (Eds.), *The emergence of mathematical meaning. Interaction in classroom cultures* (pp. 163–201). Hillsdale, NJ: Lawrence Erlbaum.

Exploration of *patterns* in different contexts

Anne Birgitte Fyhn¹ and Lisbet Hansen²

¹UiT-The Arctic University of Norway, Department of Education, Tromsø, Norway; anne.fyhn@uit.no

² Unjárgga oahppogáldu/Nesseby oppvekstsenter/ Unjárgga center of education, Unjárgga /Nesseby, Norway; Lisbet.Hansen@nesseby.kommune.no

As part of a research project focusing on investigative approaches to mathematics, a teacher in a Sámi school created an interdisciplinary teaching unit about patterns: skiing- mathematics- Sámi language. The 1–2 grade students painted their own patterns and they created patterns using their skis and poles in the snow. The analysis shows that the students developed their rules for what constitutes a pattern when the context changed from classroom work to skis on snow. One more aspect of pattern is focused: Sámi languages do not use any overarching term for pattern. At least three words are needed to cover the meaning of pattern in the mathematics curriculum.

Keywords: Pattern, hearva, language, Sámi upbringing, skiing.

Introduction

This paper presents an analysis of an investigative teaching unit, which focuses on *patterns* related mainly to the students' local culture and some physical activities. Regarding *pattern* as mathematical concept(s), two aspects of language are highlighted, a) relations between Indigenous (Sámi) language and majority (English and Norwegian) language and b) how students express their conceptions of *hearvvat* (patterns) in paintings and through their physical activities. Unjárgga oahppogáldu/Nesseby oppvekstsenter/Unjárgga centre of education is a mixed age school where the students have either Sámi or Norwegian as their first language.¹ Sámi is the first language of the teacher and the students in this paper. Sámi schools, like Unjárgga oahppogáldu, have to provide an education that is based on Sámi culture, language and social life (Sámediggi, 2017). As part of the research project SUM (Coherence through inquiry based mathematics teaching), the school develops investigative teaching units in mathematics from kindergarten to grade 10. Outdoor schooling is on the school's regular program. During a SUM meeting with teachers and the researcher, Anne, Lisbet got the idea of an open task where the students investigate skiing patterns they create in snow. She argued, "... I could work with patterns with skis. They could investigate patterns, because that is an open task..." (Transcript from conversation, 18.06.2018). In January 2018, students in grades one and two carried out an interdisciplinary teaching unit skiing - mathematics - Sámi. Lisbeth teaches mathematics and Sámi language for grades 1–2, so she often works interdisciplinarily with these subjects.

Trinick, Meaney and Fairhall (2016) point out that revitalization and maintenance of Indigenous language, including the teaching of mathematics, is insufficient unless cultural knowledge is also revitalized and maintained. The teaching unit considers their point, and thus mathematics, language and culture are intertwined in the teaching unit. According to Vorren (1995), there are several findings

¹ Sámi and Norwegian languages are equal in the Norwegian municipalities governed by the Sámi language act.

of ancient Sámi skis from the Unjárga area. One of these, the Mortensnes ski, is two thousand years old, so skiing has strong roots in the students' local culture.

Zazkis and Liljedahl (2002) point out, that patterns are the heart and soul of mathematics, but the exploration of patterns does not always stand on its own as a curricular topic or activity. According to the national mathematics curriculum's competence aim for grade 2, the students shall be able to "make and explore geometric patterns... and describe them orally" (Ministry of Education and Research, 2013). The teaching unit in this paper is about students' understanding of geometrical patterns. The teacher and the researcher communicate in Norwegian, while the teaching unit's language is North Sámi. Sámi culture and languages has a variety of pattern concepts, related to meaning and context. There is no overarching concept of pattern. Germanic languages, on the other hand, like English and Norwegian, use *pattern* and *mønster*, respectively, as overarching concepts.

Students' exploration of patterns/*hearvvat* in snow is the teaching unit's main mission. *Hearvvat* is a new concept for many of the students and the teaching unit opens with *hearvvat* in contexts related to clothes and fabrics. One goal is to provide the students with experiences of investigative approaches to mathematics, related to local culture. An additional goal is for students to develop their understanding of *hearvvat* through oral reasoning and reflections. The research question is; how can students' investigations of patterns in different contexts contribute to their conception of pattern? The data is a) an audio recording of teacher Lisbet's narrative about the teaching unit and b) posters with the students' work. The teaching unit includes five steps in total; two preparatory lessons that focus on patterns in fabrics, on clothes and in students' paintings, two outdoor skiing lessons and one reflection lesson in the classroom. The preparatory lessons intend to provide the teacher with an overview of the students' previous knowledge and to create a common idea of *hearvvat*.

Sámi languages and Sámi upbringing

Fishman, Gertner, Lowy and Milán (1985) point out that language itself is a part of culture and every language becomes symbolic to the culture with which it is intimately associated. The Sámi is an Indigenous people who live in northern Scandinavia and in the Kola Peninsula of Russia. There are ten different Sámi languages and Sámi culture can be described as diverse. This paper refers to North Sámi language. Sámi handicraft, *duodji*, is a powerful identity marker and generator of many traditions, such as language, social relationships, customary rules etcetera (Helander-Renvall & Markkula, 2017). The traditional Sámi livelihood of hunting, fishing, trapping and reindeer husbandry are important for sustaining Sámi culture and language (Keskitalo & Määttä, 2011). Skiing is an old Sámi tradition and the art of skiing originates from the ancient Sámi hunting, fishing and trapping culture (Birkely, 1994; Vorren, 1995). Skis are among the eldest relics of culture from Sámi settlements, and variations in landscapes and snow conditions caused the development of a variety of skis and sleds, for which the Sámi languages developed a wide nomenclature of expressions (Vorren, 1995). Due to the Norwegianization process (Heidemann, 2007) many of these words are not in daily use any more. In Unjárga today, Norwegian terms for skiing are commonly used in the students' Sámi language. The teaching unit introduces students to Sámi skiing concepts.

The main goal of traditional Sámi child rearing is to develop independent individuals who can survive in a given environment; and to give the children self-esteem and zest for life and joy (Balto, 2005).

The focus is on the learning process and less on teaching, so evidently experience-oriented learning is favoured. Trial and error is important for the learning process. As for skiing, knowing how to ski uphill and downhill is learned through trial and error and from the support of grown-ups and the older children. Keskitalo and Määttä (2011) developed a framework for Sámi pedagogy, where Balto's (2005) work has the central position. Upbringing is based on story-telling, connection with nature, and independence. Sámi pedagogy is based on a holistic and constructivist idea of learning. Strengthening the Sámi language is a core factor in the framework of Sámi pedagogy (Keskitalo & Määttä, 2011). All students should have the possibility to develop as language users at their own pace.

According to Balto (2005) as well as Keskitalo and Määttä (2011), autonomous students is a central theme in Sámi upbringing; the role of the teacher is to be advising, guiding, and trusting, while the students' role is to be active, flexible, and autonomous. Children should be provided with opportunities to find information and learn in nature and other places outside the classroom. Skovsmose (2001) underlines the importance of leaving the traditional mathematics textbook-based lessons when the teacher aims to support the students' autonomy. A move towards more investigative approaches can cause the students to be acting subjects in their learning process. The teaching unit allows the students to learn at their own pace and to develop as autonomous individuals.

Mathematisation of hearvvat or patterns

To mathematise phenomena from a non-mathematical or insufficiently mathematical matter, like skiing, means learning to organize it into a structure that is accessible to mathematical refinements (Freudenthal, 1991). Mathematising patterns in cloth, gloves, and skiing involves representing phenomena from these contexts by mathematics, for instance as drawings and geometrical figures, or representations by more or less mathematical concepts, expressed in different languages. However, topics related to Sámi culture exist because they are intertwined with cultural context; they cannot just be mathematised as if they exist independently from context. This is an important issue to consider for researchers and teachers with non-Indigenous backgrounds. Lakoff and Núñez (2000) point out, that mathematical symbols are just symbols and not ideas. The intellectual content of mathematics lies in its ideas, not in the symbols themselves. Symbols are representations of ideas that often can be expressed in more than one way. In this paper, we present students' descriptions of mathematical ideas; students' own *hearvvat*, patterns, with a focus on their drawings and their words.

Context plays an important role when translating the English word *pattern* into Sámi. Repeating patterns in woven bands and around gloves' wrists, like in Figure 1, are called *hearvvat* in Sámi. According to Nielsen's (1932/1979) dictionary, *hearva* means finery, adornment, and ornamentation. He presents two more Sámi words for pattern; *minsttar*, which means pattern, model or template, and *girje*, which has two meanings. *Girje* means a spot of another colour (on an animal). In plural form, it means coloured ornamental patterns, like *girjefáhccat*; gloves that are patterned all over. However, the word *girje*'s second meaning is *book*. According to a more recent dictionary (Kåven, Jernsletten, Nordahl, Eira & Solbakk, 1995), *hearva* means decoration, trimming, or embroidery, while *minsttar* means pattern or formula, and *girji* means book, letter, or spot. So, in total there are three different North Sámi words that can mean *pattern* in English. The North Sámi version of the mathematics curriculum (Ministry of Education and Research, 2013) consequently uses *minsttar* for pattern

(Norwegian: *mønster*). *Minsttar* may work for number patterns, but not for the geometrical patterns in the teaching unit. Lisbet uses the word *hearva* in the teaching unit. She discussed the question of using *minsttar* or *hearva* with Harald Gaski who is a professor in Sámi culture and literature. He too found *hearva* to be more appropriate for *pattern* in the teaching unit's contexts. Gaski (1998) describes the lyrics in the traditional Sámi song, *luohti*, as something that follows a pattern. In that context, he uses the Sámi word *girji* for pattern. *Pattern* is a central concept in mathematics, but the literature has not problematized the Sámi translations of it.



Figure 1. Example of *hearvafáhcca*: The patterned Unjárgga/Nesseby glove (photo: Lisbet Hansen)

Sámi languages do not use overarching terms to the same extent as Norwegian and English do, they have chosen different ways of expression (Fyhn, Eira, Hætta, Juuso, Nordkild & Skum, 2018). This should be an important issue to consider for mathematics education in Scandinavia. Bishop (1990) warns that it is very difficult for anyone conditioned to the western way of naming and classification to imagine that there exists other ways of conceptualizing and using language. McMurchy-Pilkington, Trinick and Meaney (2013) point at the importance of debating standardization of terms and the place of dialectical differences, in the development of Indigenous mathematics curricula. It could be that *hearva* and *minsttar* are used differently in eastern and western parts of the North Sámi area.

The teaching unit's preparatory steps

The first step of the teaching unit was based on a collection of patterns that the teacher brought to her classroom; Unjárgga gloves as shown in Figure 1, pieces of fabric like the examples in Figure 2a and 2b, an apron, homemade woollen socks, and a *holbi* from an Unjárgga *gákti* (the bottom part of the local Sámi dress) as shown in Figure 2c. Stars and candles in Figure 2a were the first items the

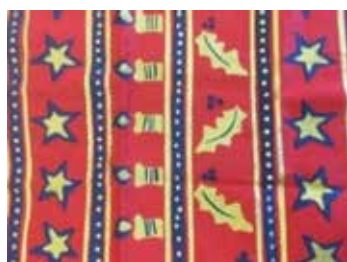


Figure 2a. Stars and candles



Figure 2b. Stripes



Figure 2c. Holbi from Unjárga

students managed to recognize and name here. The students' discussions lead to a common rule for what counts as a *hearva*; it has to be a system of colours. When asked to search for repetitions, everyone found something; for example red-green-red-green ..., square-rectangle-square-rectangle ... and star-candle-leaf-star-candle-leaf... After a while, one student pointed at two fabrics, claiming that one has *hearva* while the other has not. This student distinguished between what is *hearva* and what is not by a counterexample; that something is not *hearva*.

In Step 2, most of the students' work was autonomous. This is in accordance with Keskitalo and Määttä's (2011) description of Sámi pedagogy and with Balto's (2005) description of traditional Sámi child rearing. The students' task was to create and paint their own *hearvvat* and the teacher had no control of their choices. Every student created multiple paintings. The paintings in Figure 3 show how three students represent their ideas of *hearva*, pattern. Each painting shows a system of colours. Each painting also shows repetitions of something. The three paintings show repeating dots. The leftmost painting shows repetitions of blue dots; some dots are only blue and some dots have a brown circumference. The two other paintings also show zigzag patterns, this could be related to the zigzag pattern in Figure 2c, which is named *njunnesuorránat*. Considering that the Sámi word *hearva* means *finery*, *adornment* and *ornamentation* in English, it is reasonable to expect that the students include colours as a property of *hearva*. The other paintings also showed systems of colours and repeating items.

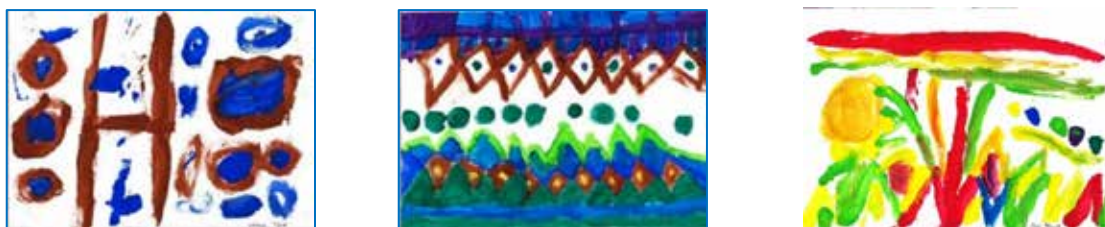


Figure 3. Three painted *hearvvat*

Work with *hearvvat*, patterns, in snow

Step 3 took place outdoor. When the teacher asked if the students could make any *hearvvat*, patterns, in the snow with their skis and poles, the answer was no. Then Lisbet skied around the schoolyard with the students following her trail. Pointing at the fresh ski trail, she asked if there were any *hearvvat*. This is interpreted to be a leading question, a support for those who had ideas they did not dare to present the first time they were asked. Several students answered no and no one objected. This is interpreted to mean that the students' conceptions of *hearvvat* did not include patterns in snow. Most likely it was limited to coloured patterns on clothes, fabric and paper. The students' rules for *hearva* included a system of colours. The white snow is just white; there is no system of colours. The teacher's aim was that the students developed their ideas of what constitutes a *hearva* to something independent of colours.

The teacher offered the students time for thinking. After a while, one student suggested that maybe the poles create *hearvvat* in the snow. Lisbet then asked whether the skis make any *hearva*. One student replied that the skis make lines, like the stripes in the fabric in Figure 2b. When you go skiing, you usually move forwards while the patterns and marks from your skis and poles appear behind you. One student expressed this as "Ovddes guvlui go čuigen šadde sárgát" [when you skied forwards, there appeared some lines] (Lisbet, transcript from conversation, 18.06.2018). In order to see what you have created, you have to look behind you. Children at school age are familiar with what ski trails look like. Students' investigations of skiing patterns also include investigations of how they move their entire bodies; they learn at their own pace, "In one way they investigate the *hearva* as well as the skiing technique... they have to try things out to see what happens", (Lisbet, transcript from

conversation, 18.06.2018). “They have to try things out”, means that the students are acting subjects in their learning process, as Skovsmose (2001) underlines. This is in accordance with Sámi traditional upbringing (Balto, 2005) and Sámi pedagogy (Keskitalo & Määttä, 2011).



Figure 4a. *Spiehččut*



Figure 4b. *Duolbmá*



Figure 4c. *Guolli*

Step 4 took place at the school’s soccer field. The students were asked to create their own *hearva* in the snow. They explained their *hearvvat* to the others, and Lisbet captured photos of their work. Usually, the students use Norwegian skiing concepts when they speak Sámi, but now they have started using Sámi concepts like *spiehččut* (herringbone skiing) as shown in Figure 4a, and *duolbmat* (sideways uphill tramping) as shown in Figure 4b. When you perform skiing techniques like in Figure 4a and 4b, the outcomes are patterns in the snow. These patterns are named by the technique; by the way you move your body. So, the students’ ideas of *hearvvat* were represented by how they moved and by the marks made by their skis and poles. At the end of the lesson, the teacher and the students looked at all the patterns. The students explained in their own words. The two students in Figure 4c first made a *dávgehápmi* (curved shape) and *njuolga sárggá* (straight line) and then *rieggát* (rings). The result was *guolli* (a fish). One student said, “When I skied forwards, the result was straight lines.” In order to bridge the students’ daily Sámi language and their mathematical language, Lisbet supplied their choice of words with mathematical terms like *circle*.

The drawings and texts in Figures 4a–c present outcomes from Step 5; a reflection lesson that took place in the classroom. The students were presented to A4 photos of their snow *hearvvat*, and they recognized the photos and discussed their *hearvvat*. Each student chose one photo, made a drawing of the *hearva* and wrote a text for that drawing. The teacher had no control of the students’ choices. Some of them needed assistance in writing down their words related to the photo; they asked how to spell some of the words and the teacher then showed them before they wrote on their own. The students were active and autonomous, while the teacher’s role was supporting and trusting; this lesson was in line with Sámi pedagogy. The first graders needed more assistance in writing than the elder ones.

Closing words

The conversation between the teacher and the researcher revealed that the teaching unit provided the students multiple experiences with investigative approaches to mathematics related to their local culture. Students were acting subjects in their learning process by creating their own *hearvvat*, patterns in different contexts. Their development of rules for what is a pattern was guided by the teacher. The students' first rules for what is *hearva*, pattern, was related to clothes, fabrics and paintings; it had to be a system of colours and it had to be repetitions of something. When the context changed to skiing, the students at first found no *hearva*. Maybe that is because there were no contrasting colours or maybe that is just because the context changed. The teaching unit caused a development of the students' concept of *hearva* such that it does not have to include different colours. The teaching unit highlights the challenge students meet when they move from one context to another; students do not automatically transfer knowledge into a new context. The analysis also revealed a need for discussing the mathematics curriculum's choice of Sámi terms for *pattern*. It turned out that the three different Sámi words *hearva*, *girji* and *minsttar* all can be translated to pattern. These words are related to different cultural contexts. This may have influenced the students' ideas when they made up their rules for what a *hearva* is. More research is needed on the meaning of these words in order to prevent misunderstandings between teachers, students, and parents, not to mention those who write textbooks and curriculum texts. The teaching unit also appreciates and strengthens local Sámi language; the students used Sámi concepts for skiing techniques that they usually refer to with Norwegian concepts in their daily Sámi language. An interesting follow-up study would be to interview Lisbet's students one year later in order to see what words they use, when describing what is meant by *hearva*, and what is meant by *minsttar*, the curriculum's word for pattern.

Acknowledgements

The work in this paper is part of the SUM project, which is supported by the Norwegian Research Council's program FINNUT - Research and Innovation in the Educational Sector. The work is also supported by Unjárgga gieldda/Nesseby municipality.

References

- Balto, A. (2005). Traditional Sámi child-rearing in transition: Shaping a new pedagogical platform, *Alter Native - An International Journal of Indigenous People*, 1, 90–113.
- Birkely, H. (1994). *I Norge har lapperne først indført skierne*. Iggaldas, Norway: Idut.
- Bishop, A. J. (1990). Western mathematics: The secret weapon of cultural imperialism. *Race & Class*, 32(2), 51–65.
- Fishman, J. A., Gertner, M. H., Lowy, E. G., & Milán, W. G. (1985). *The rise and fall of the ethnic revival: Perspectives on language and ethnicity*. Boston, MA: De Gruyter.
- Freudenthal, H. (1991). *Revisiting mathematics education. China lectures*. Dordrecht, Netherlands: Kluwer Academic Publishers.
- Fyhn, A. B., Eira, E. J. S., Hætta, O. E., Juuso, I. A. M., Nordkild, S. I., & Skum, E. M. (2018). Bishop Sámegeillii – utfordringer ved oversetting av matematikdidaktisk fagterminologi [Bishop

- into Sámi language – challenges with translation of terminology from mathematics education]. *Nordic Studies in Mathematics Education*, 23(3–4), 163–184.
- Gaski, H. (1998). Den hemmelighetsfulle teksten. Joikelyrikken som litteratur og tradisjon [The secretive text. Joik poetry as literature and tradition]. *Vinduet*, 52(3), 33–39.
- Heidemann, K. (2007). The Process of Norwegianization in Saami Communities: A critical exploration of language, education and nationalism. In D. Witkosky, & K. Schuster (Eds.), *Languages of the land: Policy, politics, identity* (pp. 165–168). Charlotte, NC: IAP.
- Helander-Renvall, E., & Markkula, I. (2017). On transfer of Sámi traditional knowledge: Scientification, traditionalization, secrecy, and equality. In A. Xanthaki, S. Valkonen, L. Heinämäki, & P. Nuorgam (Eds.), *Indigenous peoples' cultural heritage: Rights, debates and challenges* (pp. 104–129). Leiden, Netherlands: Brill Nijhoff.
- Keskitalo, P. & Määttä, K. (2011). *The basics of Sámi pedagogy*. Rovaniemi, Finland: Lapland University Press.
- Kåven, B., Jernsletten, J., Nordal, I., Eira, J. H., & Solbakk A. (1995). *Sámi-dáru sátnegirji. Samisk-norsk ordbok* [Sámi-Norwegian dictionary]. Kárášjohka, Norway: Davvi girji o. s.
- Lakoff, G., & Núñez, R. (2000). *Where mathematics comes from. How the embodied mind brings mathematics into being*. New York, NY: Basic Books.
- McMurphy-Pilkington, C., Trinick, T., & Meaney, T. (2013). Mathematics curriculum development and indigenous language revitalization: Contested spaces. *Mathematics Education Research Journal*, 25(3), 341–360.
- Ministry of Education and Research (2013). *Curriculum for the common core subject of mathematics*. Retrieved from <https://www.udir.no/kl06/MAT1-04?lplang=http://data.udir.no/kl06/eng>
- Nielsen, K. (1979). *Lapp Dictionary. Based on the dialects of Polmak, Karasjok and Kautokeino* (2nd ed., Vol. 2). Oslo, Norway: Universitetsforlaget.
- Sámediggi [The Sámi Parliament] /2017). *Prinsipper for opplæring – Samisk* [Education Principles - Sámi] Retrieved from <https://www.sametinget.no/Tjenester/Opplaering-og-laeremidler>
- Skovsmose, O. (2001). Landscapes of investigation. *ZDM - Mathematics Education*, 33(4), 123–132.
- Trinick, T., Meaney, T., & Fairhall, U. (2016). The relationship between language, culture and ethnomathematics. *Journal of Mathematics and Culture*, 10(2), 175–191.
- Zazkis, R., & Liljedahl, P. (2002). Generalization of patterns: The tension between algebraic thinking and algebraic notation. *Educational Studies in Mathematics*, 49, 379–402.
- Vorren, Ø. (1995). *Samiske oldski. Funn i Nord-Norge fra 300 f.Kr. til 1500 e.Kr.* [Ancient Sámi skis. Findings in Northern Norway 300 BC – 1500AD] Stonglandseidet, Norway: Nordkalott-Forlaget.

Centripetal and centrifugal forces in teacher-class dialogues in inquiry-based mathematics

Ingólfur Gíslason

University of Iceland, Iceland; ingolfug@hi.is

In this report I examine classroom dialogue in the practice of a teacher who is explicitly committed to a dialogical, inquiry-based approach to teaching mathematics. Of primary interest are the ways in which the dialogues on the mathematical tasks are in continual tension, alternately being pulled towards and pushed away from a proper mathematical discourse, as seen from my perspective as a mathematics educator and an observer of the lessons in the classroom.

Keywords: Classroom communication, discourse analysis, inquiry-based learning, dialogism.

Introduction

If students are to gain a command over mathematical discourse, they need to practice talking mathematics. It is well documented that in traditional classrooms it is predominantly the teacher that talks mathematics, and the IRE (initiation- (short) response-evaluation) format of teacher-student interaction is ubiquitous. Many studies show the meaning making potential of inquiry-based teaching-learning, where the students do more of the mathematical talk (e.g., Boaler, 2002; Goos, 2004; Lampert, 1990) but there is little research on mathematical discourse in inquiry-focused classrooms on the upper-secondary level. I report here on my longitudinal case study of inquiry-based teaching-learning in the practice of an upper-secondary level mathematics teacher working in a challenging classroom in Iceland. I analyse teacher-class dialogue on realistic tasks from a dialogical perspective, showing how the concepts of the centripetal and centrifugal forces (Bakhtin, 1981) may be used to describe and understand the dynamics of the dialogue.

Theoretical perspectives and prior research

In line with discursively focused research, I consider mathematics learning as the increased command of mathematical discourse, a progress from discourse confined to informal everyday language towards the command of a more advanced and formal mathematical discourse – the culturally specific, tool-mediated, historically established ways of communicating that competent users of mathematics use (e.g., Sfard, 2008; Chapman, 1997; Barwell, 2016; Roth & Radford, 2011). Dialogues are the primary objects and units of analysis, and I consider dialogue, following Linell (1998, p. 13) as “interaction through language (or other symbolic means) between two or several individuals who are mutually co-present”. A dialogue is a chain of utterances, which are the complete meaningful contributions persons make to the dialogue. An utterance is always a response to what has gone before, addressed to someone(s) in anticipation and expectation of future responses. Utterances contain intentions, emotions, evaluations, which are dependent on context, and sometimes conveyed through means such as tone and gestures. From a dialogical viewpoint, utterances do not have fixed meaning but they do have partly open meaning potentials rooted in culture, history and ideology and the specific speech genres and social languages they belong to. Communication does

not presuppose or produce total shared-ness of meaning; rather it consists in people's continued and on-going attempts to expose and test their understandings (Linell, 1998).

In the inevitable difference of two or more perspectives inherent in each utterance Bakhtin identifies a tension between a centripetal force towards uniformity, a shared and common meaning, and a centrifugal force towards diversity of discourse, the meanings made in particular situations by particular persons (Bakhtin, 1981). These forces are depicted in Figure 1 as opposite directed arrows, as we imagine the dialogue happening on a boundary surrounding a shared meaning.

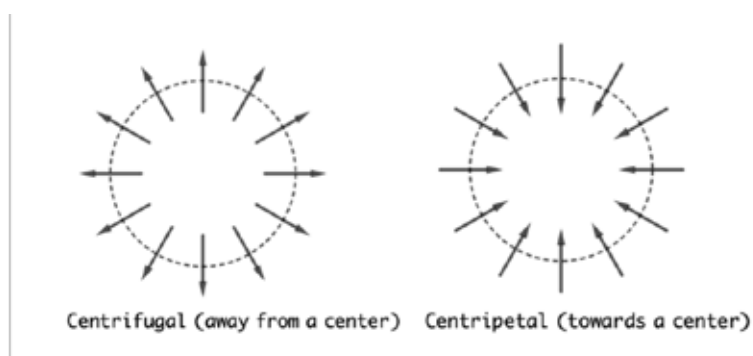


Figure 1: Forces in dialogue

From this Bakhtinian viewpoint I consider the mathematics teacher as working towards the (relative) uniformity of mathematical discourse, while the students make and express more diverse meanings, as they are imbued with language, values and views from their social worlds. When people attend mathematics classes and sense it as a painful, or even meaningless experience, this is because the words of the teacher and the textbooks do not resonate with them and do not move them. Following Bakhtin (1981) we say that the discourse lacks inner persuasiveness. In this all too familiar case, students do not make the discourse their own, it is alien to them. They behave as factory workers although they are not producing things of value for capitalist owners. Rather, they are producing strings of symbols, that are as such of no market value, in order to prove their own value (as good students and future productive citizens). Research published on mathematics in secondary school in Iceland points to a dominance of this kind of alienated form of mathematics work: an emphasis on symbolic manipulations but little emphasis on meaning and no, or very little, exploratory work; the textbook dominates and the class sessions are characterized by teacher transmission and students sitting at desks solving exercises individually (Bjarnadóttir, 2011; Gunnarsdóttir and Pálsdóttir, 2015; Jónsdóttir et al. 2014).

Research method

The setting of the study is an upper-secondary school classroom in which most of the students have a history of very low achievement in mathematics. In order for me to make sense of the classroom dialogues I was present in the classroom the whole semester-long course as a mostly passive observer, concentrating on capturing audio and video of the speaker(s) who have the floor at a given time. I attended the class with a videorecorder in 32 of the 39 classrooms sessions of the course which lasted from late August to December 2012. Although my role was mostly passive, I did interact with students, discussed the situation of me being present in the classroom, asking for permissions to record a pair or small group conversation and sometimes responding (usually rather minimally) to

questions about the mathematics tasks. For the purposes of this paper I focus only on the three lessons where there was a public whole-class discussion about realistic mathematics tasks. The tasks are all teacher translations of tasks from Swan, Pitts, Eraser, and Burkhardt (1985). A video analysis tool, Transana, (Fassnacht & Woods, 2012) was used to transcribe video segments synchronously.

I coded the teacher-student dialogues using open coding, drawing on a grounded theory approach (Charmaz, 2006) aided by the dialogical principle that it is the participants' responses that provide evidence for the meaning of a prior utterance. Still, it should be borne in mind, as Bakhtin argues, that “understanding a dialogue as a researcher implies participating in that dialogue as a ‘third voice’.” (Wegerif, 2007, p. 21). This means that I, as the researcher, make sense as the other participants, anticipating, responding, and creating tentative sense in my own way, based on my cultural background and personal history. After a few iterations, recurrent themes emerged that seemed to capture the different ways the participants responded to the tasks presented, thus contributing to different types of dialogue. In the following I present purposefully selected short sequences of dialogue to illustrate the types. These fragments are then analysed in more detail in order to bring further attention to the centripetal and centrifugal effects of the contributions to the dialogue.

In order to make the reading of the fragments feel natural, the students have all been given unique pseudonyms.

Results and discussion

Inspired by Bakhtin's ideas of learning as adopting words (and gestures, phrases, drawings and all means of communication) of others and using them with one's own intentions with varying degrees of “our-own-ness”, and his notions of centripetal and centrifugal forces operating in a dialogue, I classified four types of dialogue. Two of the types refer to distancing in dialogue: *the alien word* (11) and *irony* (29) and two are types of accepting dialogue: *authentic real world* (123) and *emerging mathematical* dialogue (48). The numbers in brackets indicate a count of utterances contributing to a types' appearance to give some indication of their relative frequencies, although an utterance does not always contribute clearly to only a single type of dialogue. The first three types function more centrifugally than centripetally.

To illustrate the most frequent type, *authentic real-world* dialogue, I present a fragment of a dialogue on the question of the nature of a general relationship between the weight of a person and her high-jump ability. The task text states: “Suppose you were to choose, at random, 100 people and measure how heavy they are. You then ask them to perform in 3 sports; High Jumping, Weight Lifting and Darts. Sketch scattergraphs to show how you would expect the results to appear, and explain each graph, underneath. Clearly state any assumptions you make.” The following sequence of utterances starts after the teacher has drawn positive coordinate axes on the whiteboard and has exchanged a few turns with students about the nature of the task.

Ari: Like, like, the body weight shouldn't matter crucially, like in high jump. [Eagerly]

Teacher: What.

Ari: Like the guy who is one ninety and a guy who is one sixty. A guy who is one ninety could be heavier than the guy who is one sixty, isn't that right?

- Teacher: But if you have two guys that are one ninety and one is heavier and the other is lighter, who
- Ari: The lighter guy.
- Teacher: What do you think about that? [Addressing the class]
- Bjarni: Not necessarily.
- Ari: It depends on the technique and where he is muscular.

The request for a relationship immediately provokes a comment from Ari that a functional relationship between body weight and height jumped is not appropriate, body weight is not the most important thing to consider in this context. He also introduces the theme of the height of the imagined people and the relations between those and their body weights. This is not at all mentioned in the task but may be related to the general knowledge that taller people usually are better at the sport of high jump and because the heights of people were a theme of a task these students worked on earlier. In their apparently sincere discussion about the context, they pull the theme of the dialogue from mathematical representations to sports and body types which I understand as a centrifugal force away from the core of mathematical discourse. Ari and the other students are perhaps understandably confused by the realism of the task. They do not know that they are expected to focus on an abstract (and arbitrary) relationship and that for the mathematics teacher it is not important what is important for success in high-jumping. The teacher attempts to pull the dialogue back, trying a what-if question where the real-world factors are controlled, trying to bring the attention to the variables of mathematical interest. The students seem unaffected by the centripetal force of the teacher's utterance and go off on a further tangent. There followed an animated discussion about important factors relating to the sport of high jump, while the intended task of representing a statistical functional relationship by a scatter graph receded from the dialogue. It is open to question whether some amount of this type of dialogue could actually be a necessary precursor to emerging mathematical dialogue. It can be seen as building emotional connections between teacher and students, showing that their thinking and perspectives are valued and not brushed aside.

The *alien word* was infrequent as a type of sustained dialogue. This is because usually when students experience mathematics as alien to them, they are simply silent, or show their alienation indirectly. They might for example choose to look at irrelevant computer programs, play with their phones, or talk with peers about social matters. Only rarely does the theme of the alien word become explicit in dialogue.

- Teacher: Are you all following what we are doing? (...) Do you think this is mathematics?
- Einar: I think this is unnecessary bother.
- Teacher: Unnecessary bother?
- Einar: Yeah.
- Gunnar: It's philosophical mathematics.

Anna: If you think about it in that way, see, that this is the weight plus the weight, but like in weightlifting, I don't feel we are talking about mathematics, rather talking about sports than mathematics.

The first utterance in this sequence was a response of the teacher to the situation that the majority of the student group seemed to be confused by the discussion and had ceased to participate in the dialogue. He tries to pull the class into a meta-discussion about the nature of mathematics and mathematics class, but Einar rejects the question on the grounds that it is unnecessary and a bother. Mathematics to him does not include students' own consideration of real-world complexities. His contribution also indicates that what is important is the amount of bother expected of him. He evaluates bother negatively. Gunnar partially supports Einar in that this is a special type of mathematics. These contributions are centrifugal. Anna makes an interesting comment that resonated with me, as she expressed what I was thinking about the dialogue up till then. It was about sports and not about mathematics. In a way this contribution is centripetal in two ways. She gives a reasonable answer to the teachers' question (she is affected by his pull) and criticizes the discussion on grounds that (in my theoretical terms) it is an authentic real-world dialogue, which she considers (again, in my theoretical terms) to be centrifugal and not conducive to mathematical discourse.

Irony means saying one thing and meaning another. To illustrate irony as a type of dialogue, there follows a dialogue on a task the point of which is to investigate the relationship between the number of workers and the time it would take them to finish a task. The task text asks the student to sketch a graph describing the time it would take to harvest a field of potatoes, depending on the number of potato pickers. The task is presented with unmarked axes in the positive direction, with the label "Total time it will take to finish the job" on the y-axis, and "Number of people picking potatoes" on the x-axis. The students were asked to work on this in their seats, the task being in their text. One student soon exclaims: "I don't understand" and the teacher goes to the whiteboard in front of the class.

Teacher: We are going to think about ... can we maybe assume. What are we going to say that one person would take long to harvest this field?

Siggi: How big is this field?

Teacher: Well, you just decide.

Siggi: Okay, it's just one meter.

Teacher: One meter. [Disbelief in the voice]

Siggi does not answer the teacher's initial question but asks a different one, and I assume he thinks this is an important question to answer in order to finish the task (in fact in the abstract mathematical model this is completely irrelevant and does not need to be answered). The teacher does completely shut down this line of inquiry but indicates a choice available for the student even if it does not really matter what the choice is. Siggi then responds with an extreme example that does not make sense if interpreted in the context of the real-world. Double-voiced discourse is a discourse that has "a twofold direction" (Bakhtin, 1984, p.184); it is directed toward someone else's discourse or toward someone else's position. One interpretation of the student's response is that that the task does not make sense

to him or that he is not committed to make sense of it, that the question (and therefore the teacher) is silly and his answer is going to be silly; that the question is too open, and he will test its boundary. It contains an evaluation of the whole situation; it is an ironic rejection to engage authentically in dialogue. The teacher's final utterance in this sequence is an echo, a repetition of the prior utterance, but in a falling tone, with a different pattern of stress on the syllables. I interpret this as an expression of disbelief, and as if to say, "that is ridiculous, you know it, reconsider your suggestion". An alternative interpretation could have been possible: in mathematics it can be informative to specialize (try out specific values in a general expression) with extreme values (not infrequently 1 or 0). The student's ironic assumption could have been taken as an attempt to specialize to see what happens in an extreme instance. However, in light of the effect of the utterance on the teacher and the dialogue closing up at this point, it seems clear that the teacher takes Siggi's contribution to be ironic, and some form of rejection to take the task seriously.

To illustrate the *emerging mathematical* type of dialogue I present a fragment where students are working further on the potato picking task. They have been asked to draw a graph of the relationship between the number of workers (x-axis) and time it takes to harvest a potato field. The teacher has circulated and comes to the whiteboard and says that he has seen "a lot of these" and draws a straight line segment with y-intercept at 100 and a negative slope, but not touching the x-axis. The students' drawings are consistent with the fact that they have not had much (or any) experience with other kinds of graphs in their mathematics in school. Their repertoire of graphs consists of straight lines, as this is what a graph means to them, and they use it to express increasing or decreasing functions. After some students confirm that this is how it is and the teacher acknowledging "in a way, approximately" expecting something more, there follows:

- Katie: You need to know how many people you want at the end.
- Teacher: Do we?
- Katie: Yes.
- Teacher: Can't we just...
- Katie: If you have the time, you know, the maximum time ... how many people are you going to have in the end.
- Siggi: We're going to have thirty people.
- Katie: Okay, if you are going to have thirty people you just do a hundred divided in thirty, then you have the time a single person has.
- Teacher: Okay, you gave us some, what, four hundred eighty minutes? But can we do this like ... in mathematics we can add people infinitely. Although there might not be enough room in the field for everyone.

First, Katie expresses that for the task to make sense and be solvable we need to know the maximum number of people. This is reasonable from a real-world perspective, as it would be impossible to have an infinite number of workers, or even a too large number of people. After a contribution from Siggi, Katie tries to express the relationship time divided by number of workers, getting the "time a single

person has” where it would be correct to say that this is the total time it takes, but indeed this is also the time each single worker would have to work. My interpretation is that Katie’s answer confused the teacher or that the teacher interpreted her as thinking that the workers would work in succession, one at a time. Therefore, he does not build directly on her contribution but returns to a particular number (480) of minutes mentioned long before in the dialogue, and to the question of whether we need to know the maximum number of workers. He indicates that they could be infinitely many, because such is mathematics, even if not realistic.

After the sequence above, there follow over a hundred turns where the teacher and the students slowly clarify the meaning of the graphical representation, the role of the axes, and what the points refer to, they discuss the assumptions needed to make a model, and then gradually move away from a linear model towards a reciprocal one, and at last some students articulated this by themselves, incorporating the model into their own discourse. Here then, the teacher and the student group continually exposed and tested their understandings and perspectives against each other, and the centripetal force was strong enough to keep the dialogue mathematical, bringing students closer and closer to shared mathematical discourse.

Concluding remarks

The students seem to orbit around mathematical concepts while the teacher tries to pull them into a more mathematical discourse. This is the dominating feature of the first three types of dialogue above. The authentic real-world type of dialogue is of particular importance. The students show sincere interest and enthusiasm for the real-world situations in which they recognise important features of the situation. Unfortunately, these features are tangential to the mathematical discourse the teacher tried to draw them into and may result in the dialogue drifting away from mathematical discourse.

To make sense of a mathematical task, the students need to attend to the context and not suspend sense making, while at the same time it also demands that the context is downplayed and not taken too seriously. In that way, the official mathematical discourse itself is double voiced and ironic. It does not really care about the high-jumping ability of people and what factors are most important to consider when estimating or predicting these abilities. It only cares about using graphs and functions to represent idealized phenomena. The teacher needs to convey this and then slowly lead students to productive ways to make mathematical sense, building on the sense made previously. For example, he suggests particular numbers (specializing) to think about or gently challenges the students’ answers while often recognizing that they are onto something. In this way the mathematical discourse becomes internally persuasive, at least for some students. We saw how the teacher and the students slowly achieve a more shared understanding in the dialogue in the last example, as it slowly approaches a more mathematical discourse, through constant exposure and testing of understandings.

References

- Bakhtin, M. M. (1981). *The dialogic imagination: Four essays*. Austin, TX: University of Texas Press.
- Bakhtin, M. M. (1984). *Problems of Dostoevsky’s poetics*. Minneapolis, MN: University of Minnesota Press.

- Barwell, R. (2016) Formal and informal mathematical discourses: Bakhtin and Vygotsky, dialogue and dialectic. *Educational Studies in Mathematics* 92(3), 331–345.
- Bjarnadóttir, K. (2011, December 30). *Stærðfræði 102 í fjölbrautaskóla: Vandí og ávinningur* [Mathematics 102 in upper-secondary: Challenges and benefits] *Netla - veftímarit um uppeldi og menntun*. Retrieved from <http://netla.hi.is/greinar/2011/ryn/008.pdf>
- Boaler, J. (2002). *Experiencing school mathematics: Traditional and reform approaches to teaching and their impact on student learning*. Mahwah, NJ: Lawrence Erlbaum Associates.
- Chapman, A. (1997). Towards a model of language shifts in mathematics learning. *Mathematics Education Research Journal*, 9(2), 152–173.
- Charmaz, K. (2006). *Constructing grounded theory: A practical guide through qualitative analysis*. London, England: SAGE.
- Fassnacht, C., & Woods, D. (2012). *Transana v2.52*. Madison, WI: The Board of Regents of the University of Wisconsin System. Retrieved from <https://www.transana.org>.
- Goos, M. (2004). Learning mathematics in a classroom community of inquiry. *Journal for Research in Mathematics Education*, 35(4), 258–291.
- Gunnarsdóttir, G. H., & Pálsdóttir, G. (2015). Instructional practices in mathematics classrooms. In K. Krainer, & N. Vondrová (Eds.), *Proceedings of the Ninth Congress of the European Society for Research in Mathematics Education* (pp. 3036–3042). Prague, Czech Republic: Charles University, Prague & ERME.
- Jónsdóttir, A. H., Briem, E., Hreinsdóttir, F., Þórarinnsson, F., Magnússon, J. I., & Möller, R.G. (2014). *Úttekt á stærðfræðikennslu í framhaldsskólum*. [A report on mathematics teaching in upper-secondary schools] Reykjavík, Iceland: Ministry of Education, Science and Culture.
- Lampert, M. (1990). When the problem is not the question and the solution is not the answer: Mathematical knowing and teaching. *American Educational Research Journal*, 27(1), 29–63.
- Linell, P. (1998). *Approaching dialogue: Talk, interaction and contexts in dialogical perspectives*. Amsterdam, Netherlands: John Benjamins.
- Roth, W.M., & Radford, L. (2011) *A cultural-historical perspective on mathematics teaching and learning*. Rotterdam, Netherlands: Sense Publishers.
- Sfard, A. (2008). *Thinking as communicating: Human development, the growth of discourses, and mathematizing*. New York, NY: Cambridge University Press.
- Swan, M., Pitts, J., Eraser, R., & Burkhardt, H, with the Shell Centre team (1985). *The language of functions and graphs*. Manchester, England: Joint Matriculation Board.
- Wegerif, R. (2007). *Dialogic education and technology: Expanding the space of learning*. New York, NY: Springer.

The importance of a meaning-related language for understanding multiplication

Daniela Götze

Technical University Dortmund, Germany; daniela.goetze@tu-dortmund.de

Multiplicative thinking is much more than recalling number facts. Furthermore, it is much more than repeated addition. It is about links and relationships and knowing how multiplicative ideas are connected and why multiplicative grouping processes work as they do. Supporting this conceptual understanding of multiplication among underachieving primary school children is the goal of a single-case intervention study presented in this paper. These children were fostered in a language sensitive way placing emphasis on the relationship of different multiplicative representations and a meaning-related vocabulary associated with this operation. The in-depth analysis of an individual learning trajectory of a low-achieving child shows that the progress may depend on whether and to what extent the meaning-related vocabulary becomes the vocabulary of thinking for these children.

Keywords: Multiplication, mathematical concepts, verbal learning, low achievers.

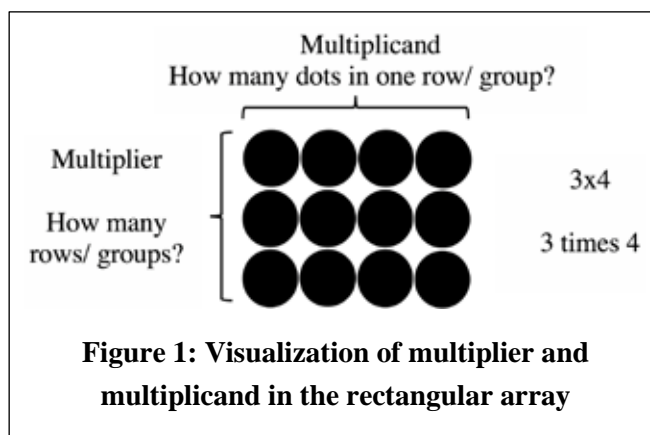
During their first years of school, children should not just be able to execute multiplication tasks, but more than anything else, should also understand them in terms of content as well. For primary school children who have not acquired a multiplication concept it is much more difficult to achieve higher learning targets (e.g. Downton & Sullivan, 2017; Moser Opitz, 2013). This is particularly the case because an understanding of multiplication represents a fundamental requirement for understanding further learning contents such as proportionality, algebra, fractions, decimal numbers, percentages... (Downton & Sullivan, 2017). In this respect, it is by now accepted that the development of a conceptual understanding for the multiplication is of far greater importance than learning the times tables off by heart (Gaidoschik, Deweis, & Guggenbichler, 2018; Moser Opitz, 2013).

Theoretical background: Fostering a conceptual understanding of multiplication

Kilpatrick, Swafford and Findel (2001) define the conceptual understanding as an understanding of mathematical concepts, operations and relationships. A mathematical concept is said to be understood when it constitutes a part of the mental knowledge and is said to reach a higher level if it is interconnected with existing knowledge and can be used to solve diverse mathematical tasks (Kilpatrick et al., 2001). What this means for the multiplication specifically is that children need to understand that cardinal quantities are combined with each other, wherein, formally speaking, the multiplier represents the frequency of the cardinal quantities and the multiplicand represents the size of the cardinal quantity (Figure 1). Both factors are therefore not equal (Downton & Sullivan, 2017). However, multiplication is often introduced in the form of repeated addition, which is the preferred strategy used to solve the multiplication tasks particularly in low-achieving children (Moser Opitz, 2013). But this equating of multiplication with repeated addition leads to an incorrect understanding of multiplication (Downton & Sullivan, 2017), in the case of addition, both numbers represent a respective quantity, which can be cardinally translated and merged. Multiplication, however, means to coordinate interrelated units.

If children tend to equate the multiplication with repeated addition or with count-by sequences (“four, eight, twelve”) – as another typical strategy of low-achieving children – this differentiation between multiplier and multiplicand does not become clear. Furthermore, the knowledge in relation to associative and distributive contexts is not accessible to them. Additionally, those solution strategies are very limited and cannot, for example, be used when it comes to fractions or decimal numbers (Downton & Sullivan, 2017).

In this respect, many researches have shown that a conceptual understanding of multiplication instead of automaticity needs to be fostered in the first place. Many of these studies take a strategy-training approach (e.g. Gaidoschik et al., 2018; Woodward, 2006). Particularly remarkable is that predominantly low-achieving children – even after a strategy-training – seldom use derived-fact strategies compared with normal-achieving children (Zhang, Xin, Harris, & Ding, 2014) or have difficulties in deriving (Gaidoschik et al., 2018). On the one hand, this can be traced back to the fact that the use of decomposition strategies is very working-memory demanding and low-achieving children are characterised by their limited working memory (Zhang et al., 2014). On the other hand, the cause can be seen in an insufficient conceptual understanding of multiplication (Downton & Sullivan, 2017). These children do not seem to have fully understood what phrases such as “three times four” or “four multiplied with three” actually mean. This means that perhaps the differentiation between multiplier and multiplicand needs to become more obvious for these children as a central basis for developing derived-fact strategies. However, current research projects have repeatedly shown that the transition from the repeated addition or count-by strategies to the understanding of multiplication is a – if not *the* – critical obstacle to the conceptual understanding of multiplication especially in the case of low-achieving children (e.g. Zhang et al., 2014). Therefore, in future research, this should be the starting point to identify which steps could help children overcome this critical obstacle. But if phrases like “three times four” or “four multiplied by three” are initially of no meaning to these children other phrases such as “three groups of four”, “the four three times”, “three rows of four columns each” may support the development of a conceptual understanding. It has still not been researched sufficiently whether and to what extent this “basic meaning-related vocabulary” (Prediger & Wessel, 2013; Pöhler & Prediger, 2015) supports a conceptual understanding of multiplication in low-achieving students. In terms of increasing a conceptual understanding of division among low-achieving children, it has been shown that the understanding of division can be fostered with the help of meaningful verbalisations such as, for example, “12 divided by 4 means how many fours fit into 12” (Götze, 2018). Whether or not students benefit from such support seems to primarily depend on whether this meaning-related vocabulary will become the students’ language of thinking (Pöhler & Prediger, 2015). This means that in the course of such fostering, it might primarily depend on if and to what extent the students are able to internalise these verbalisations and how they can contribute to the forming of mental models. In this respect, the single-case research project presented in this paper focuses on the following research question:



How does a language sensitive support of multiplicative grouping promote a conceptual understanding of multiplication in low-achieving children?

Methodology of the study

The study presented in this paper pursues the goal of conducting a detailed in-depth analysis of the learning processes for the development of a conceptual understanding of multiplication among low-achieving children. Therefore, the study is structured as a single-case didactical design research (Pöhler & Prediger, 2015). The data presented are from the first circle.

A total of ten pairs, consisting of one normal- and one low-achieving child, were assisted by one trained preservice elementary teacher. The cooperative setting was selected because the discursive negotiation of meaning among heterogeneous children has proven itself to be very beneficial for learning in other studies as well (Götze, 2018; Zhang et al., 2014). The pairs of children were provided with fostering help on a total of four remedial lessons. Each of these remedial lessons lasted approximately 25 to 30 minutes. They were provided by three pre-service teachers who had been intensively trained beforehand.

At the time of the study, the participating children were in the third grade in a German primary school and had already learnt multiplication in their second year in school. As a side note, in Germany the rows of times tables are determined by the second factor. So, 1×2 , 2×2 , 3×2 , 4×2 ... are second-row tasks, 1×5 , 2×5 , 3×5 , 4×5 ... are tasks from the fifth row. For these children, the tasks 3×4 , 3×6 , 3×9 belong to different rows.

Based on the review of the current research, these children were fostered in a language sensitive way placing emphasis in the relationship of different multiplicative representations (concrete, iconic and symbolic representations) and a meaning-related multiplicative (not additive) vocabulary associated with this operation. For doing this, the following central learning and diagnosis steps were applied in order to foster a conceptual understanding (based on Pöhler & Prediger, 2015):

- Step 1: Informal thinking starting from students' resources.
- Step 2: Focusing meaning-related vocabulary for understanding multiplicative grouping and connecting this vocabulary with concrete, iconic and symbolic representations.
- Step 3: Independent use of the meaning-related vocabulary.
- Step 4: Use of meaning-related vocabulary in order to initiate decomposition strategies.

Especially in the second support unit (step 2) the children had to find reasons for the assignment of iconic rectangular arrays and symbolic terms. At the same time, the multiplicative understanding was addressed directly: "three times four" means that there are three fours or there are three groups, each of which has four in one group. The children should always explain this relationship: Where do you see the number of the groups? Where do you see the group size? Subsequently, during the third support unit (step 3), this understanding was deepened further through more game-based assignments (for example pairs card games). The children were furthermore required to name the matching terms for orally described rectangular arrays. In the case of difficulties, they were allowed to lay the rectangle. Then, the children should lay rectangular arrays selected by themselves with manipulatives and describe these in a similar fashion. The children were repeatedly asked to interpret the group

number (the multiplier) and the group size (multiplicand) in terms of content. The constant alteration between language reception and language production was intended to form mental models. During the transition to the decomposition strategies in the fourth support unit, the children needed to think about which arrays could be laid next to each other and which overall term would match. They were given some rectangular arrays, which they could distributively combine in sometimes different ways. What was important here once again was the fact that the children had to explain why, for example, 3×4 and 2×4 together make 5×4 , but also why 3×4 and 3×1 together make 3×5 . This required them to pay attention to the differentiation between multiplier and multiplicand, as well as to verbally describe their meaning and importance. This makes it absolutely necessary to have mentally understood the previous actions carried out on the rectangular arrays or to be able to fall back on these once again.

Therefore, the following section gives an insight into the learning pathway of the low-achieving child Ilay. The goal of the analysis is to ascertain under which conditions the use of meaning-related vocabulary fosters learning for the development of a conceptual understanding of multiplication and as a basis for developing derived-fact strategies. For a deeper insight and a comparison between different children's development see Götze (under review).

The individual learning trajectory of Ilay

Ilay (I) worked together with his normal-achieving classmate Nelli (N) during the fostering course. Ilay is a very communicative child who likes to contribute to class discussions and really likes to explain how he arrived at his solution. This is less the case with Nelli.

During the first support unit Ilay knew many multiplication tasks from the times tables off by heart. Otherwise he used the strategy of repeated addition or count-by sequences. While doing so he usually started to recite the times tables from one, something which was very time consuming. For instance, he needed a total of 45 seconds until he could provide the correct solution to the problem 6×7 . While reciting, he raised individual fingers one after another sometimes even two at once, which would indicate additive calculation. He explained how he arrived at the solution as follows.

- 56 Ilay: Because when you now, when you now... aahmmm... then that's 7 (points to his thumb) plus 7 (points to his index finger) are then 14. And then you work out these 2 (points to his middle finger and his ring finger) are also 14. There are 28 in total. And then you only need to add this 14 (holds up the next two fingers). In total around 42.
- 57 Teacher: And what comes out at the end of this problem? (points to the task 7×7)
- 58 Ilay: Around... 48 (he starts to count his fingers forward once again, whispers) 14, 28, 42. So... (after 25 seconds) 49.

Ilay worked out the result by availing of additive references (turn 56 and 58). For him it appeared that being asked to multiply was more a request to count up. In doing this, Ilay displayed typical one-sided additive ideas with respect to multiplication and little strategic knowledge (Gaidoschik et al., 2018). Furthermore, he was not able to derive the solution for the new task 7×7 from the previous task 6×7 .

In order to emphasise the differentiation of multipliers and multiplicands for Ilay, during the second support unit the meaning-related vocabulary for the same groupings was introduced (step 2). In the following scene, approximately ten different rectangular arrays were laid out in front of the children, which also included the correct array for the task 3×5 (for Ilay and Nelli a task from the fifth row).

- 7 Teacher: I will now give you the problem. Do you know the game, “I spy with my little eye”? We will now play using the cards: I spy with my little eye lots of 3 groups of 5 each (places the note “3 groups of 5 each” in front of the children).
- 8 Nelli: 3 groups of 5 each?
- 9 Teacher: Do you have any idea which dot image I mean?
- 10 Ilay: (points uncertainly at the card containing the dot image relating to 3×5)
- 11 Teacher: Why could that match?
- 12 Ilay: Yes, because here are 5 (points to the uppermost row)
- 13 Nelli: ... because there are 5 in each row.
- 14 Ilay: ... because there are 5 in each row, so...
- 15 Nelli: ... 15.
- 16 Ilay: So when you now calculate (takes the card with the rectangular array 3×5), 1, 2, 3 (tips each of the respective first dots of the first column), there are 3 below and here, calculate 1, 2, 3, 4, 5 (tips each of the respective dots of the first line), then these are 15 and here are 3 groups of 5 each (points to the note with the same sentence).
- 17 Teacher: Okay, so where are the 3 groups of 5 each?
- 18 Ilay: 3?
- 19 Teacher: You have already said that these are 3 and 5. But where are the groups of 5?
- 20 Nelli: Here at the top (moves along the top line).
- 21 Ilay: Exactly, and we then have a group of 5 here (moves along the top row), two groups of 5 together, three groups of 5 together (moves along the other rows).

It can be seen that the children initially react in an uncertain manner to this unknown vocabulary (turn 8, turn 10). Even when Ilay directly found the requested dot image (turn 10), he was still not able to immediately explain why the description “three groups of five” matched this dot image. He pointed to the first column and the first row (turn 12, turn 16). This focus can be seen in many low-achieving children and indicates a limited conceptual understanding (Moser Opitz, 2013). Nelli, on the other hand, seemed to understand the content immediately, which can often be seen in the case of normal-achieving children (Götze, 2018). She emphasised that in each row there must be five dots (turn 13), which Ilay then repeated word-for-word (turn 14). Thus, Ilay had not yet understood the content of this formulation because he could not answer the follow-up question of the teacher (turn 17, turn 18). The teacher correctly recognised that although Ilay pointed to the numbers three and five of the term in the rectangular array in his customary manner, he had not yet started to think of cardinal groups of always five dots. It was only when Nelli pointed out the group of five in the dot image to him that Ilay rethought (turn 21) and recognised this new perspective.

The overall evaluation of the data from the support units of all ten low-achieving fostered children demonstrated that this scene appeared to be a key scene in the learning process for low-achieving

children such as İlay. If they were to understand the grouping concept, they had to be given a new way of looking at the rectangular arrays by means of the new language being offered. In order to ensure that the children did in fact understand the content of the subject matter, substantial repetition was needed in order for the children to make this new way of looking at rectangular arrays a part of their own mental models.

In this respect, in the third support unit İlay showed that he began to integrate the meaning-related vocabulary into his own mental thought patterns (step 3). It was astounding that already in the third support unit he seemed to give up on his additive viewpoint that he had so strongly been focussed upon up to that point. He explained why the term 6×6 matched to the corresponding rectangular array without having to be asked to do so by the teacher.

- 123 İlay: So, I took this one here because that is 6, so 6 is here (moves along the left column with his finger) and there are 6 groups (moves his finger from left to right several times) ... And here 1, 2, 3, 4, 5, 6 (taps on each of the respective points in the first row), there are 6 in a group, and when you count down (moves the finger from top to bottom), then 1, 2, 3, 4, 5, 6 (taps on each of the respective points in the first points), that's actually really easy.

First, he addressed the groups number, in other words the multiplier, by pointing to the six groups in the right corner ("there are 6 groups"). Subsequently, he described the meaning of the second six in the term ("there are 6 in a group"). Drawing on the meaning-related vocabulary he had learnt, he completely independently explained the differentiation of both sixes in the term 6×6 : one indicates the number of groups, the other the group size.

In order to obtain first indications about a possible further development of derived-fact strategies, in the fourth support unit, the children were supposed to try to make deductions between the tasks. In the following scene, İlay was asked to think about why 7×5 is always seven more than 7×6 .

- 47 İlay: Because, that (points to the multiplier) stays the same and that (points to the multiplicand), that should, if you jump over one, then that should now also be 7s.
- 48 Teacher: I don't quite understand that. What do you mean, if you jump over one?
- 49 İlay: If you count one to here (points to the multiplicands 5 and 6), then that will, then it is, if you, a 7, if you (points to both multiplicands) count up to 7.
- 50 Teacher: So, if we have 7 times 5 and 7 times 6. Why is it 7 more?
- 51 İlay: Nelli, you count it.
- 52 Teacher: That's right. But I am not convinced yet. 5s become 6s.
- 53 İlay: Oh! Because here, here, you have 6. And then one always comes in here, (points to both multiplicands), it only comes, if we do that with the dots, it only comes, so one, so one, so one row, so one dot always becomes more.

At the beginning of the scene, İlay initially tried to explain the correlations with his own linguistical means and using lots of pointing gestures (turn 47). Indeed, he also occasionally used meaning-related vocabulary such as "sevens" but could not yet use it to explain the content-related correlation of 7×5 and 7×6 . Only the direct reference of the teacher in turn 52 ("fives turn into sixes") seemed to activate the meaning-related vocabulary for him. He was then able to use it to explain the multiplicative (not

additive!) correlations very independently (turn 53). In contrast to the first support unit, he did not use his finger to count the rows but thought purely in terms of content. This content-related thinking in multiplicative structures was shown several times in the fourth support unit.

It can be seen in the above analysis that Ilay completed the intended four learning steps. After the introduction of the basic meaning related vocabulary, he first needed some time for practice and networking with concrete representations (step 2), before this vocabulary slowly became Ilay's own vocabulary of multiplicative thinking (Pöhler & Prediger, 2015; step 3). Perhaps this newly formed content related multiplicative thinking provided the basis for using derived-fact strategies. Repeated addition was a dead end for him in multiplicative understanding. With this respect, the meaning related vocabulary fulfilled a cognitive and epistemic function for him. Expressions such as "3 times 5" were no longer a "secret language", and the multiplication in rectangular arrays was really perceived in a multiplicative way via these expressions.

Discussion and limitation

Ilay's learning trajectory stands representative for other fruitful learning trajectories of other children. All these learning trajectories have in common that the children start to *think in groups of the same size*. The fostered vocabulary seems to support the development of a mental model in all these children. The meaning-related verbalizations become the language of thinking and therefore, the children can understand how to decompose or derive multiplication tasks. This multiplicative point of view has apparently not been obvious to the children in their previous learning biography through formal expressions such as "3 times 4" or "3 multiplied with 4" or "4 multiplied by 3". However, basic meaning-related phrases such as "3 groups always with 4 (dots) in a group" or "3 groups of 4" illustrate thinking in multiplied groups of equal sizes. This vocabulary then fulfils *epistemic functions* in the learning process and contributes to conceptual understanding. The problem with this is repeatedly having to detach low-achieving children from using their old, supposedly safer strategy of repeated addition. Throughout, the children use both additive and multiplicative ideas at the same time. The in-depth analysis of children such as Ilay therefore shows how central it is to continue to promote this new multiplicative point of view. Furthermore, the in-depth analysis demonstrates that the multiplicative thinking seems to be a good basis for the development of decomposition strategies. If children can think in a content-related way they can also derive tasks from each other and recognise correlations between tasks.

Despite that, not all supported children show these learning developments (for details see Götze, under review). The most striking factor however is that these children do not start to think multiplicatively. The meaning-related vocabulary does not become the vocabulary of thinking for these children. This is mostly caused by the teacher who starts to retrieve facts and vocabulary (for example "Where are the groups in this term? Where are the number of groups in the rectangular array?") instead of supporting multiplicative thinking. Especially in this paper only one single-case study can be presented. For a comparative analysis it would be helpful to contrast Ilay's individual learning trajectory with those of other children (see Götze, submitted). But that would go far beyond the scope of this paper.

This study is laid out as qualitative Didactical Design Research (Pöhler & Prediger, 2015). First of all, the aim was to derive hypotheses about the effectiveness of the support and not to operationalize them. Therefore, the duration of the fostering was very short, with just four support units. Yet, the study provides first indications that the conceptual understanding of multiplication can be promoted in a language sensitive manner when we can achieve that the children use the meaning-related vocabulary as their vocabulary of thinking. How long the fostering should actually last for the supported children to be able to independently think in a content-related way, remains unanswered. Future research must therefore check the hypotheses made in this paper.

References

- Downton, A., & Sullivan, P. (2017). Posing complex problems requiring multiplicative thinking prompts students to use sophisticated strategies and build mathematical connections. *Educational Studies in Mathematics*, 95(3), 303–328.
- Gaidoschik, M., Deweis, K. M., & Guggenbichler, S. (2018). Do lower-achieving children profit from derived facts-based teaching of basic multiplication: Findings from a design research study. In T. Dooley & G. Gueudet (Eds.), *Proceedings of the Tenth Congress of the European Society for Research in Mathematics Education* (pp. 346–353). Dublin, Ireland: DCU Institute of Education & ERME.
- Götze, D. (2018). Fostering a conceptual understanding of division: Results of a language and mathematics integrated project in primary school. In N. Planas & M. Schütte (Eds.), *Proceedings of the Fourth ERME Topic Conference ‘Classroom-based research on mathematics and language’* (pp. 73–80). Dresden, Germany: Technical University of Dresden & ERME.
- Götze, D. (submitted). Language sensitive support of multiplication concepts among at-risk children. *Learning Disabilities: A Contemporary Journal*. Manuscript submitted for publication.
- Kilpatrick, J., Swafford, J., & Findel, B. (2001). *Adding it up: Helping children learn mathematics*. Washington, DC: National Academy Press.
- Moser Opitz, E. (2013). *Rechenschwäche / Dyskalkulie. Theoretische Klärungen und empirische Studien an betroffenen Schülerinnen und Schülern* [Weakness in arithmetics/dyscalculia. Theoretical clarification and empirical studies with affected pupils]. Bern, Switzerland: Haupt.
- Pöhler, B., & Prediger, S. (2015). Intertwining lexical and conceptual learning trajectories - A design research study on dual macro-scaffolding towards percentages. *Eurasia Journal of Mathematics, Science & Technology Education*, 11(6), 1697–1722.
- Prediger, S., & Wessel, L. (2013). Fostering German language learners' constructions of meanings for fractions - Design and effects of a language- and mathematics-integrated intervention. *Mathematics Education Research Journal*, 25(3), 435–456.
- Woodward, J. (2006). Developing automaticity in multiplication facts: Integrating strategy instruction with timed practice drills. *Learning Disability Quarterly*, 29(4), 269–289.
- Zhang, D., Xin, Y. P., Harris, K., & Ding, Y. (2014). Improving multiplication strategic development in children with math difficulties. *Learning Disability Quarterly*, 37(1), 15–30.

Claims and demonstrations of understanding in whole class interactions

Jenni Ingram and Nick Andrews

University of Oxford, Department of Education, England; Jenni.Ingram@education.ox.ac.uk

One aim of teaching mathematics is to develop students' understanding of mathematics. In this paper we examine how teachers and students do understanding in interaction, and how this understanding is handled interactively during whole class interactions. Taking a Conversation Analytic approach, we look at interactions between teachers and students where there is claim of understanding and where there is a demonstration of understanding. We show how these two situations are handled differently, by the teacher and the students, with only the latter situation being concerned with students' understanding.

Keywords: Conversation Analysis, classroom interaction, understanding.

Introduction

One aim of mathematics teaching is to both develop students' understanding of key ideas, concepts and methods, and to respond to difficulties students encounter in understanding mathematics. Studying understanding in mathematics education is not original, but the existing research largely treats understanding as something real, as something that students do or do not have. However, understanding is also used by teachers and students in interaction for practical purposes, and this use or display of understanding is observable and analysable. The aim of the analysis in this paper is to investigate what the uses of words like 'understand', 'sense' or 'mean' do in interaction, focusing on how teachers and students are using these words to achieve different things. We use Sack's notions of claiming and demonstrating understanding as is observable in the interaction, rather than making any claims as to whether students actually understand or not, which is not directly observable in interaction.

Pedagogic interactions, and in particular teacher-student classroom interactions, are dominated by the IRE interactional structure. The IRE (or IRF) sequence, teacher initiation-student response-teacher evaluation, has been written about extensively (e.g. Hellermann, 2003; Mehan, 1979; Sinclair & Coulthard, 1975; Wells, 1993). This characterisation, however, only focuses on the broad structure of the interaction, rather than the multiple activities being done within it. The third turn, the evaluation turn, in particular does more than evaluate a student's answer as correct or not, but also comments on its adequacy as a response to the initiation, and its appropriateness for the broader interactional and pedagogical purposes of the interaction (Macbeth, 2003), and influences the interaction that follows. What is being assessed or evaluated by the teacher in this third turn is not necessarily focused on the content of the student's response, but could also, or alternatively, focus on how the response enables the interaction to progress, they are task-oriented rather than content-oriented (Antaki, Houtkoop-Steenstra, & Rapley, 2000). Koole (2012) also showed that teacher assessments in this third turn can focus on students' knowing, students' doing or students' understanding. However, positive assessments largely focused on students' knowing, treating their

response as shared knowledge on which to build on, but negative assessments largely focused on students' doing or understanding.

In this paper we focus on IRE sequences where the content focus includes understanding, or not understanding. In particular, we examine instances where evidence of understanding (or not understanding) is displayed by teachers or students in whole class interactions. These instances can include situations where the teacher-initiation requests students to claim or demonstrate understanding, which might include teachers themselves claiming or demonstrating understanding or not understanding, or situations where it is the students who make claims or demonstrations of understanding relevant in their response turn, or finally situations where the teacher's evaluation turn treats the student's turn as a claim or demonstration of understanding. Our analysis of these sequences takes a Conversation Analytic approach drawing upon Sacks' discussions of 'how understanding is shown' (1992:II:140). We make use of Sacks' distinction between *claiming* and *demonstrating* understanding and show that the teachers in these interactions treat claims and demonstrations differently, being content-oriented when there are demonstrations of understanding but task-oriented when there are solely claims of understanding.

Methodology

This analysis was carried out on a video corpus collected in fifteen mathematics teachers' classrooms in ten schools in England of secondary educations (students aged 11-18). All names used are pseudonyms. These videos were transcribed using Jefferson transcription (Jefferson, 1984) and the analysis focused on these transcripts, but they are presented here in a simplified form for ease of reading. The transcripts of all whole class interactions in a total of 39 lessons were analysed using Conversation Analysis (CA) (Sidnell & Stivers, 2012). The CA approach was used to develop a collection of cases (Sidnell, 2010) examining how the topics of understanding and sense-making are treated by the teachers and students as they interact. These cases include 299 interactions where the teacher explicitly talks about understanding and 58 where a student explicitly talks about understanding (including interactions about making sense, getting it, and finding meaning). In this paper we focus on those interactions that broadly follow the IRE structure in that they involve both the teacher and the students, rather than those that occur during a teacher explanation for example.

From a CA perspective understanding does not refer to a cognitive state but to an interactional object where teachers and students do understanding as they interact. For example a student saying 'I don't know' is often used to request help from the teacher, or to initiate a complaint about an explanation (Lindwall & Lymer, 2011). As such, we are not making any claims about what teachers or students understand, instead focusing on how they use understanding in interaction to achieve particular things. Within CA research a distinction is made between demonstrating and claiming understanding (Sacks, 1992). For example, a teacher can *demonstrate* understanding of what a student has said by responding with an alternative formulation as in the following extract:

- 25 Teacher: ... what is the difference then, what makes a histogram a histogram. Jin?
 26 Student: because the bars can be wider
 27 Teacher: exactly in a histogram, you can have different width um bars...

Extract 1: Tom's lesson on statistical diagrams

Alternatively, the teacher or student could just respond ‘yes’ or ‘good’ which would merely *claim* understanding.

In classrooms teachers generally ask questions that they already know the answer to, and as such student responses are demonstrations that they also know the answer. However, students can respond in a way that shows *that* they have understood, or in a way that shows *what* they have understood (Koole, 2010). Whilst showing *that* they have understood can involve either a claim or a demonstration of understanding, showing *what* they have understood requires a demonstration of understanding. Koole (2010) also showed that teacher questions of the form “do you understand” are usually followed by a *claim* of understanding and not a *demonstration* of understanding.

Results

In the data we present here we will demonstrate that *claims* of understanding support the smooth progression of interaction (Stivers & Robinson, 2006) that is underpinned by shared understanding (Weatherall & Keevallik, 2016). That is, *claims* of understanding are affiliative joint accomplishments that enable the interaction, and the lesson, to continue, but tell us nothing about what students understand. On the other hand, *demonstrations* of understanding tell us something about what students do or do not understand, but also lead to more extended interactions that focus on the content of these demonstrations, rather than moving the interaction on.

Claims of Understanding

Claims of understanding usually follow an understanding check by the teacher, such as “do you understand?” or “does that make sense”.

- 70 Teacher: is (.) does that make sense?
 71 Students: yeah
 72 Teacher: okay Simone did you do it exactly the same. (.) no slightly different. thank you Steve. er Simone could you (.) explain what you did. was it-

Extract 2: Becca’s lesson on multiplying fractions

Here the students have made a *claim* of understanding in their answer yeah in turn 71, but there is no evidence of what they understand or the nature of their understanding within the interaction. The teacher acknowledges this claim in turn 72 before moving on to a different student and asking them to explain their method.

Another situation where there is a *claim* of understanding but without a *demonstration* of understanding is given in extract 3.

- 173 Teacher: numbers pick one of the numbers as a value for n. work out the missing numbers, using the same shape, apply that rule to somewhere else, see if you can add them up to be um using this rule like this one if I draw that C anywhere else I should find that I get er five n add two will tell me, if I draw a C in here, er draw this c in one two three four five. five times thirty-two is a hundred and sixty, add two makes a hundred and sixty-two. SNAME
 174 Student: I don't understand

175 Teacher: okay I'll come and see you. it will be seven minutes, to have a go, starting now.

Extract 3: Ryan's lesson on a hundred square investigation

In turn 173 Ryan is describing how to draw a letter C on a hundred square and then sum the numbers in the letter C by treating one of the squares as n . In turn 174 a student makes a *claim* of not understanding but does not add anything that would indicate what they do not understand, so no *demonstration* of understanding or not understanding. This claim is requesting help from the teacher. Ryan acknowledges this request but defers dealing with the issue before continuing to talk to the rest of the class.

These teacher turns that include understanding checks are not always followed by student responses as in extract 4:

178 Teacher: ...but if I drew another rectangle and had that as two and four, that isn't similar to that cus they're not in the same proportions, yeah? does that kind of make sense? It's a bit of a weird mathematical word. right? but we have to get used to it in a mathematical thing, so it doesn't quite but congruent certainly is going to come up. okay. so we're going to start with reflections, but...

Extract 4: Imogen's lesson on transformations

Here Imogen asks "does that kind of make sense?" but without pausing and without any students responding continues here turn before moving on to a new topic at the end of the extract.

Where there is a *claim* of understanding (or not understanding) but no demonstration of understanding, the interaction continues without any reference to what has, or has not, been understood. Where the teacher has invited a claim of understanding but no student response is given, again the interaction continues without any reference to what has, or has not, been understood. Since 'do you understand' or 'does that make sense?' questions prefer a *claim* of understanding rather than a *demonstration* of understanding (Koole, 2010), when no response is given it is a *claim* of understanding that is 'noticeably absent' (Bilmes, 1988) and in every case in this data where there is no response, the interaction continues in the same way as if there had been a positive *claim* of understanding. In contrast, as we will show in the next section, when there is a *demonstration* of understanding, or not understanding, the following interaction focuses on the content of the understanding and extends the IRE sequence (Schegloff, 2007).

Demonstrations of Understanding

Teachers can explicitly ask students a question that requires them to *demonstrate* their understanding. In extract 5, Fiona asks the student to explain so that she and the other students can understand, and the student gives an explanation in turn 188. In the turn that follows Fiona focuses on one part of the student's explanation and asks a follow up question.

187 Teacher: right explain it to me so that I understand but also so that people that haven't done this one understand 'cause I know that there's quite a few people who haven't done it

- 188 Student: is it because Rio is forty degrees and I've worked out that Khartoum is thirty-five degrees you just add five
- 189 Teacher: right where did you get thirty-five from for Khartoum, was that one of the ones that we've worked out

Extract 5: Fiona's lesson on negative numbers

In extract 6, Tom is asking why it makes sense to take a moving average over four points when dealing with quarterly sales of ice cream. The student, Sayed, gives an explanation which Tom then follows with a prompt to be more specific in turn 70, to which the student responds with more detail.

- 68 Teacher: yeah it is because of that so why, why does that make sense, can you say so why does that makes sense to use four in the numbers. it is something to do with the fact that it's quarterly. Sayed?
- 69 Sayed: because there's four quarters
- 70 Teacher: where
- 71 Sayed: in the end, in a year
- 72 Teacher: yeah there's four quarters in a year but, so, you know so ...

Extract 6: Tom's lesson on moving averages

One of the most common ways that teachers ask about students' understanding is in relation to the meaning of mathematical vocabulary.

- 11 Teacher: ah that's a good word isn't it isosceles. what do you understand by isosceles
- 12 Student: erm two lines that are perpendicular they're straight lines and then they have two of the same angles
- 13 Teacher: we're getting lots of different mathematical words aren't we. um two lines are perpendicular what do you mean perpendicular.

Extract 7: Dave's revision lesson

In turn 10, before the transcript begins, a student has given a justification for an angle having a particular value as being because the triangle is isosceles. Dave follows this up in turn 11 by asking this student what he understands by isosceles, which he explains in turn 12, (inappropriately) introducing the word perpendicular to describe the two sides with equal length. Dave then follows up on this and returns the turn to the student to explain what he means by perpendicular.

In these three extracts the teacher's initiation includes an explicit request for a *demonstration* of understanding, which the student gives in their response, and which is followed by the teacher asking a follow-up question focused on the content of the students' demonstration which returns the turn to the student. Demonstrations of understanding can also occur when a student is indicating that they do not understand something. In extract 8, a student has given the equation of a straight line using the gradient and the y-intercept which Dave repeats in turn 71. Dave then opens up the floor to invite questions from the students at which point a student asks how to find the equation and states that he does not understand. This is both a *claim* of not understanding and a *demonstration* of what it is that

is not understood¹. The teacher follows this with an explanation for how the class found the equations of straight lines in previous lessons as well as giving a rule.

- 71 Teacher: ...yes three x plus one. um okay that's fine. who wants to ask anything about the first side, you do. go on
- 72 Student: um how do you find out the um equation I don't understand it
- 73 Teacher: no okay. this three I remember we went to the computer room and drew some things didn't we this three turned out to be the gradient and this one turned out to be where it goes through the y axis. so once you've found out the gradient is three you can just stick it in there um that requires quite a bit of thought doesn't it um at this stage with the exams coming up just stick it in there in front of the x and you put plus one on the end because of that and it all fits in with the pattern we saw when we drew lots and lots and lots of these in the computer room ...

Extract 8: Dave's revision lesson

Furthermore, whilst the student in turn 72 treats the issue as one of understanding, the teacher's following turn treats it as an issue of remembering (Koole, 2012).

In each of these cases where there is a demonstration of understanding, or not understanding, the teacher's follow up turn focuses on the content of the students' responses. This is in contrast to the situations where there was only a *claim* of understanding where the teacher's follow up turn moved the interaction on. This arises both in situations where the teacher has asked students about their understanding as well as where students indicate that they do not understand. However, this second situation is rare in whole class interactions. Also, where the teacher has requested the demonstration of understanding in their initiation, the teacher's third turn also returns the turn to the same student. The preference for moving the interaction on following *claims* of understanding is reinforced by the numerous occasions where teachers ask "do you understand" but does not wait for an answer before moving on to the next topic (as illustrated in extract 4), which occurred in just over 40% of cases of understanding checks in this data (in contrast to Koole (2010) where the students always responded).

Conclusion

In this paper we have focused on how *claims* and *demonstrations* of understanding are dealt with by teachers and students in their interactions. Within the IRE structure, teachers can invite either *claims* of understanding or *demonstrations* of understanding in their initiation, and this distinction is further supported by the students who in their responses give either a *claim* or a *demonstration* as required by the teacher's initiation. However, teachers and students are doing different things when they invite or give *claims* to when they invite or give *demonstrations*. Claims of understanding are treated as ways of supporting the progressivity of the interaction (Stivers & Robinson, 2006) and do not deal with the content or issues of what is or is not understood. In contrast, *demonstrations* of

¹ Whilst the student utterance of "how do you find out the um equation" could be interpreted as an issue of knowledge or knowing, the student treats it as an issue of understanding by following it with "I don't understand it" rather than "I don't know".

understanding lead to the interaction focusing on the content of these demonstrations and an expansion of the IRE structure.

Transcript Notation (Jefferson, 1984)

[text]	Brackets	Indicates the start and end points of overlapping speech.
(.)	Micropause	A brief pause, usually less than 0.2 seconds.
.	Period	Indicates falling pitch or intonation.
?	Question Mark	Indicates rising pitch or intonation.
,	Comma	Indicates a temporary rise or fall in intonation.

References

- Antaki, C., Houtkoop-Steenstra, H., & Rapley, M. (2000). "Brilliant. Next question. ...": High-grade assessment sequences in the completion of interactional units. *Research on Language & Social Interaction*, 33(3), 235–262. https://doi.org/10.1207/s15327973rlsi3303_1
- Bilmes, J. (1988). The concept of preference in conversation analysis. *Language in Society*, 17(2), 161–181.
- Hellermann, J. (2003). The interactive work of prosody in the IRF exchange: Teacher repetition in feedback moves. *Language in Society*, 32(1), 79–104. <https://doi.org/10.1017/S0047404503321049>
- Jefferson, G. (1984). Transcript Notation. In J. Atkinson & J. Heritage (Eds.), *Structures of social action: Studies in conversation analysis*. (pp. ix-xv). New York, NY: Cambridge University Press.
- Koole, T. (2010). Displays of epistemic access: Student responses to teacher explanations. *Research on Language and Social Interaction*, 43(2), 183–209. <https://doi.org/10.1080/08351811003737846>
- Koole, T. (2012). Teacher evaluations: Assessing "knowing", "understanding", and "doing." In G. Rasmussen, C. E. Brouwer, & D. Day (Eds.), *Evaluating cognitive competences in interaction*. (pp. 43–66). Philadelphia, PA John Benjamins Publishing Company.
- Lindwall, O., & Lymer, G. (2011). Uses of "understand" in science education. *Journal of Pragmatics*, 43, 452–474.
- Macbeth, D. (2003). Hugh Mehan's learning lessons reconsidered: On the differences between the naturalistic and critical analysis of classroom discourse. *American Educational Research Journal*, 40(1), 239–280. <https://doi.org/10.3102/00028312040001239>
- Mehan, H. (1979). *Learning lessons: Social organization in the classroom*. Cambridge, Mass: Harvard University Press.
- Sacks, H. (1992). *Lectures on conversation*. (G. Jefferson, Ed.). Oxford, England: Blackwell.
- Schegloff, E. A. (2007). *Sequence organization in interaction: A primer in conversation analysis*.

Cambridge, England: Cambridge University Press.

Sidnell, J. (2010). *Conversation analysis: An introduction*. Chichester, England: Wiley-Blackwell.

Sidnell, J., & Stivers, T. (2012). *The handbook of conversation analysis*. Oxford, England: Wiley-Blackwell.

Sinclair, J. M. H., & Coulthard, M. (1975). *Towards an analysis of discourse: The English used by teachers and pupils*. London, England: Oxford University Press.

Stivers, T., & Robinson, J. D. (2006). A preference for progressivity in interaction. *Language in Society*, 35(6), 367–392. <https://doi.org/10.1017/S0047404506060179>

Weatherall, A., & Keevallik, L. (2016). When claims of understanding are less than affiliative. *Research on Language and Social Interaction*, 49(3), 167–182. <https://doi.org/10.1080/08351813.2016.1196544>

Wells, G. (1993). Reevaluating the IRF sequence: A proposal for the articulation of theories of activity and discourse for the analysis of teaching and learning in the classroom. *Linguistics and Education*, 5(1), 1–37. [https://doi.org/10.1016/S0898-5898\(05\)80001-4](https://doi.org/10.1016/S0898-5898(05)80001-4)

Talking about standardized units in preschool – supporting language and mathematical learning

Sarah Keuch and Birgit Brandt

Technical University Chemnitz, Germany; Sarah.Keuch@zlb.tu-chemnitz.de

Today, the important role of language use for successful (early) mathematical learning processes is widely accepted and researched. Starting from the preschool teacher as an influencing variable for language learning and the mathematical content of measuring, this paper reconstructs opportunities for supporting conceptual as well as language learning in small group interactions planned for mathematical learning in preschool. The way preschool teachers talk about units ranges between a linguistically rich ‘language bath’ and an action-oriented ‘activity bath’ and thus offers different learning opportunities.

Keywords: Early mathematics education, measuring, linguistic competence, oral language.

Introduction

Despite the fact that large-scale studies have shown the impact language has on mathematical learning processes, the German school system is still in need of concepts to support children with disadvantageous starting conditions, for example migration background, low socio-economic background or developmental speech disorders. These children are still not provided with equal chances to take part in (mathematical) educational processes (Gogolin & Lange, 2011). Ensuing from these observations, for example, Prediger (2015) claims that academic language education processes should start as early as possible. While most research on language-sensitive teaching in Germany focusses on primary or secondary schools (Gogolin & Lange, 2011; Leisen, 2015), fostering academic language in preschool could contribute to improving educational injustices. Further, academic language education processes should be designed age-appropriately and oriented towards a specific content. Prediger and Zindel (2017) ask for more topic specific research in order to specify the concrete linguistic demands for mathematical contexts. Studies show that preschool teachers possess only insufficient knowledge concerning basic linguistic terminology, language acquisition and effective interventions (Michel, Ofner, & Thoma, 2014). These results are especially alarming if one takes into account that even preschool children who speak only one language are still language learners (Volmert, 2005). Hence, there is not only a lack of concrete concepts for integrated mathematical and language learning, but also for professionalizing preschool teachers in order to be able to implement such concepts. With the analysis of language usage in interactions during mathematical activities, we try to address this gap.

Our overall aim is to raise preschool teachers’ language awareness and practical knowledge for fostering academic language proficiency (Isler, Künzli, & Wiesner, 2014) and mathematical learning. In a first step, we specify this aim by looking at the use of language in kindergarten interactions concerning magnitudes. On a linguistic as well as mathematical level, units are a crucial part of measuring. Since we found measuring of children’s body length and the accompanying measured values as a recurring theme, we take a deeper look at the verbalization of units and indications of size.

After elaborating on linear measuring, the topic of our content-specific research, we present the empirical data, some results and a preliminary discussion.

Linear measuring in preschool

Measuring is not only one of Bishop's (1988) six basic mathematical activities, but is also seen as a basis for the development of mathematics as a science in all cultures and many curricula for early mathematics education in Germany put emphasis on measuring. Further, it represents a link between mathematically abstract concepts and everyday life, and comprises multiple inner-mathematical relations, especially with numbers and geometry. Beyond, the concept of measuring can be seen as a basis for further concepts, for example fractions and rational numbers (Barrett et al., 2011). While we take research on children's acquisition of a (geometric) concept of magnitudes, milestones and difficulties (Sarama, Clements, Barrett, van Dine, & McDonel, 2011) as a background for our linguistic analysis, we will not discuss it in detail. Although an integrated approach for different spatial magnitudes, especially in early education, is seen as reasonable in order to understand the differences and the fundamental idea of measuring as comparison with a unit (Barrett et al., 2011), here we only concentrate our linguistic analysis on length. Length and area are more easily perceivable and accessible for young children than other magnitudes, although they might be difficult to distinguish (Skoumpourdi, 2015). The activity of measuring length concentrates on the determination of a linear expansion. Therefore, you have to distinguish between objects with a rather clear linear characteristic, for example sticks or distances, and those objects with more than one dimension that can be measured (width, height, depth) (Nührenbörger, 2002; Skoumpourdi, 2015). Consequently, it becomes obvious that speaking about length comes along with specific linguistic challenges, for example concerning the characteristic of linearity and the differentiation from area. In order to obtain a profound concept of measuring, children need to understand the act of *iteration*. In order to obtain a measure, a subdivision of a certain length is translated. Each of these subdivisions has to be equal, the concept of *identical unit*. With these identical units, you fill out a certain space, the so-called *tiling*. In order to fill out a space completely, it might be necessary to *partition* units. Lastly, measures can be added so that a measure of eight units can be thought of as a composition of five and three suggests the concept of *additivity* (Lehrer, Jaslow, & Curtis, 2003). While some research suggests starting with non-standardized units and only introducing units like centimeter and meter later in the process, this rarely meets the children's reality. Based on this theoretical background, we focus on the following research questions:

- Which linguistic resources are at preschool teachers' disposal when talking about standard linear units?
- How are the acquisition of (academic) language and mathematical application supported in these interactions?

In order to answer the research questions, we follow methods from interactional linguistics (Couper-Kuhlen & Selting, 2000). Interactional linguistics takes an interdisciplinary and cross-linguistic perspective on language. It looks at the structure and use of language, capturing it in its natural environment, the social interaction. Based on the linguistic element used in the utterance, we look at their role in the conversation. In our context, these linguistic elements are utterances containing

standardized units to describe or accompany measuring processes. We are interested in situations in which units are used in ways which might lead to meanings within the child's and the kindergarten teacher's mind. Apart from that, we are interested in structures that deviate from a normatively correct way and which might therefore inhibit the construction of measuring concepts or at least make it harder for children to understand the concept of length. If applicable, the central concepts in linear measuring that might be transmitted through the preschool teachers' utterances are pointed out. These questions are part of a larger project which also looks at the language used with other magnitudes, older children at primary school and syntactical, lexical and semantic aspects, because "developing measurement sense can be conceptualized as learning the language of measurement, with attention paid to the semantics, syntax, grammar and pragmatics of measurement" (Joram, 2003, p. 65).

Empirical data and results

The data basis for our analysis consists of videotaped mathematical situations designed by preschool teachers from the project erStMaL (early Steps in Mathematical Learning) (Acar Bayraktar, Hümmer, Huth, & Münz, 2011). From this data basis, seventeen situations are concerned with magnitude and measuring, which are the corpus of our project (for detailed information on these situations see Brandt and Keuch (2017)). These small group interactions with one preschool teacher and two to five children were transcribed and annotated using the transcription and annotation tool EXMARALDA (Schmidt, 2002). Ten of these seventeen situations deal with the magnitude length. In order to be included into the following analysis, the utterance has to include some kind of standardized linear unit. In a first step, we differentiated between units that accompany numbers (indication of size) or that appear on their own. Indications of size are further analyzed according to which units are used and how they are combined with the respective number(s). The following utterance by one of our preschool teachers serves as an illustration for the different types of using units in indications of size:

Sabine: You are one meter and nineteen centimeters. Look, that's what the number looks like. One hundred nineteen centimeters are one meter nineteen.

For the first indication of size in her utterance, Sabine uses a number (one), then the unit (meter), the conjunction 'and', then another number (nineteen) and another unit (centimeter). So this part of her utterance is annotated as 'x m and y cm'. In the second part of her utterance she uses centimeters only, so this would be coded as 'x cm', and then she uses a shortened, colloquial form without 'and' and without 'centimeters'. This would count as 'x m y'. Preschool teachers use units more than four times more often than children (see Table 1) do. Moreover, only three children produced utterances containing units. In most cases, preschool teachers use units within indications of size. Teachers talk four times more often about centimeters than about meters. If they use mixed forms, they tend to use a shortened, colloquial version. In contrast, children never use mixed forms (but they use numbers without units to indicate size, which are not included in this analysis). Preschool teachers use units without numbers to list the different units that exist in different countries, but without giving further explanations as in the following example: "You can measure in meter or in centimeter and in America I think you measure with inch. We measure here with meter and centimeter". The following table shows how numbers and units are combined within indications of size and how often each variation is used in all ten situations dealing with length:

	<i>Units total</i>	<i>without numbers</i>	<i>x cm</i>	<i>x m</i>	<i>x m and y cm</i>	<i>x m y</i>	<i>x inch</i>
<i>Preschool Teacher</i>	88	13	41	10	4	19	1
<i>Children</i>	19	5	11	3	0	0	0
<i>Total</i>	107	19	52	13	4	19	1

Table 1: Use of units in all ten situations dealing with length

After this global view on the general usage of units, we now look at explanations that preschool teachers give for the meaning of units. Only two of them, Berna and Sabine¹, try to explain what a unit (in their cases centimeter) is, hence we concentrate our following analysis on them.

Sabine: Every number is a centimeter. That means such a small piece is a centimeter. You see that also on the ruler, don't you?

Berna: From one long line to the next, so just this little box yes? That's a ... that's a centimeter there.

In the first part of her utterance, Sabine compares the numbers on the folding stick with centimeters, the numbers equal the centimeters. With this explanation, she might want to address the concept of identical units. Barrett, Jones, Thornton, and Dickson (2003) warn that focusing on the numbers or marks on a measuring device might impede seeing length as an aggregation of segments or units. Berna, however, hints at the distance between two-centimeter marks on a tape measure, which she calls 'little box'. This expression can be (mis-)interpreted as a two-dimensional square (for example on graph paper) or as a three-dimensional object. In any case, defining linear units by using two- or three-dimensional objects like 'piece' or 'little box' might lead to confusions with area measuring (Keuch & Brandt, 2018). Starting from the former defined centimeter, Sabine tries to explain the need for other units like meter and hint to the concept of partitioning: "But when we now uhm calculate everything in centimeters, then the numbers must be much too big". Sabine hints to the inverse relationship between the number of units and the size of the unit (Grant & Kline, 2003). However, she never explains what exactly a meter is (or its relationship with centimeters), but puts a folding rule on the floor, folded in a way that it is one meter long, claims that 'that' is a meter and goes on with the next activity: "Look! And that's a meeeter! Do you now want to know how tall you are?"

Berna explains the relationship between meter and centimeter (partition) in two steps. First, she elaborates on ten centimeters and finally she draws the link to one meter, hinting at the decadal structure. However, the children's job in the second step is simply to read out the number hundred:

Berna: That's a meter. And in one meter, from the beginning to the end are? Which number is this?

Friedel: Mhm hundred.

¹ The children in these two situations are 6;0 – 6;2 (Berna) and 4;11 – 5;11 (Sabine) years old.

Berna: Hundred centimeters. So that means that in such a meter are hundred ... little boxes.

Berna tries to initiate a number of tasks that hint at the idea of iteration, identical units and tiling while referring to different measuring devices: “So, from the beginning to the seven are how many centimeters then Can?”² When she notices the children’s difficulties, she refers back to her explanation of *little boxes* and rather focuses on counting discrete little boxes (although there are no clear visible boxes on the folding stick) instead of continuous units:

Berna: One little box is always one centimeter and now count the little boxes up to seven.

Berna: Look, it is ... the numbers don’t play any role now. From one to the other mark, only one little box, is always one centimeter. Yes?

With this statement, she indirectly hints to the concept of identical units and also to the fact that every point on a measuring device can be used as a zero point. No such utterances that contain the idea of identical units, iteration or tiling were found in any other situation. Moreover, one has to consider that the children in the interaction with Berna are the oldest children in the corpus of our project. Sabine as well as Berna hint to the concept of additivity. While Sabine, in an indirect way, puts emphasis on the difference between the heights of two children, Berna takes two measuring results and adds them up in order to get a result, which equals one of the children’s height.

Sabine: And you are one meter twelve tall (...) one centimeter bigger than Theresa!

Berna: So we have now twenty-five and hundred centimeters. So, one meter are hundred centimeter, plus the twenty-five to that. Then now I can tell you that Can is one meter and twenty-five centimeters long.

Interestingly, Berna first transfers one meter into hundred centimeters and then adds more centimeters. Her result however is a mixed indication of size consisting of meter and centimeter. Sabine seems to immerse the children in a kind of ‘language bath’ to offer them a linguistically rich environment and she might hint to the concept of partitioning and additivity. In this situation, units accompany the measuring process. She never asks the children questions about units but rather integrates them as ‘silent’ participants into the measuring process. When measuring the children’s body length, Sabine uses units in various ways to express their size, also using adjectives or reading out the single digits to make those numbers that exceed the children’s actively mastered number range more comprehensible:

Sabine: Oh you’ve got a funny number. You are one meter eleven tall. Look! One meter eleven is a one, a one and another one.

Berna makes the children participate mentally and physically by posing different questions or asking the children to show her a centimeter with their fingers on a measuring device but also limits her talk on units to these devices. When she determines the children’s body length, mainly non-standardized units like building blocks are used, except when she calculates Can’s body length. However, she asks

² In German (“So, vom Anfang bis zu der sieben sind wie viele Zentimeter dann, Can?”) the utterance is not completely grammatical and the author tried to stay as close as possible to the original.

many questions concerning units so that the children get a chance to test and apply their mathematical and language knowledge:

Berna: From one long to the other long mark it's a...?

Friedel: Meter!

Berna: Noo one centimeter, but you were really close. Well done Friedel!

While we were able to show that Berna tends to correct lexical mistakes very often and very directly (Brandt & Keuch, 2018), she seems to have a quite relaxed attitude towards the difference between meter and centimeter. While from a linguistic perspective, there really is just one prefix that differentiates the two words, mathematically there are ninety-nine centimeters in between.

Conclusion

In this paper, we looked at the use of standard units in small group interactions in preschool. It became obvious that preschool teachers used units more often than children did. The children rarely spoke about units. This might have to do with limited elicitations by the preschool teachers. They, on the contrary, used units and indications of size in various ways, with the latter most often expressed in mixed and incomplete structures. When the context is clear, leaving out units in everyday settings would not inhibit the understanding, but it contradicts the idea of fostering academic language. Focusing on Berna and Sabine, both preschool teachers seem to possess pedagogical as well as didactical knowledge. Yet, we could only observe limited language awareness regarding the introduction of standard units. Central concepts of linear measuring like iteration, identical units, tiling, partition, and additivity are addressed rarely and mostly indirectly. In both situations, it is not clear which (if any) conceptual understanding of units and scale values the children develop beyond the actual context. The negotiation process related to the mathematical content stayed at the surface especially for linguistically less competent children since some explanations might not have been accessible for them and therefore they did not get a chance to improve their mathematical and (active) linguistic competences. Berna almost completely restricted units to the scales of measuring devices. Nevertheless, the children might have gotten a better idea of the actual size of a centimeter (although it might interfere with area) because of her multiple questions and tasks. It remains unclear how far the children were able to transfer their knowledge to the actual measuring activities in the situation and beyond. Because of Sabine's lack of questions and tasks concerning units, the actual concept and size might have stayed unclear. Following her rich 'language bath' concerning body sizes, the children in this situation might get a feel for expressing indications of size, even beyond this situation. This 'language bath' was integrated in the cultural practice of measuring with standard units. Through this subjective-bodily involvement, she might enable more indirect learning which can leave marks and offer connectivity options for later (direct) mathematical and language learning opportunities.

References

Acar Bayraktar, E., Hümmer, A.-M., Huth, M., & Münz, M. (2011). Forschungsmethodischer Rahmen der Projekte erStMaL und MaKreKi [Research methodological framework of the projects erStMaL and MaKreKi]. In B. Brandt, R. Vogel, & G. Krummheuer (Eds.), *Die Projekte erStMaL*

- und MaKreKi: *Mathematikdidaktische Forschung am Center for Individual Development (IDeA)* (pp. 11–24). Münster, Germany: Waxmann.
- Barrett, J., Cullen, C., Sarama, J., Clements, D., Klanderma, D., Miller, A., & Rumsey, C. (2011). Children's unit concepts in measurement: A teaching experiment spanning grades 2 through 5. *ZDM*, 43(5), 637–650.
- Barrett, J., Jones, G., Thornton, C., & Dickson, S. (2003). Understanding children's developing strategies and concepts for length. In D. Clements & G. Bright (Eds.), *Learning and teaching measurement: 2003 yearbook* (pp. 17–30). Reston, VA: NCTM.
- Bishop, A. J. (1988). *Mathematical enculturation: A cultural perspective on mathematics education*. Dordrecht, Netherlands: Kluwer Academic Publishers.
- Brandt, B., & Keuch, S. (2017). The duck is the biggest – kindergartners talking about measurement and magnitudes. In Dooley, T. & Gueudet, G. (Eds.), *Proceedings of the Tenth Congress of the European Society for Research in Mathematics Education* (pp. 1243–1251). Dublin, Ireland: Dublin City University and ERME.
- Brandt, B., & Keuch, S. (2018). Talking about measurement in the kindergarten - linguistic means in small group interactions. In C. Benz, A. Steinweg, H. Gasteiger, P. Schöner, H. Vollmuth, & J. Zöllner (Eds.), *Mathematics education in the early years - Results from the POEM3 Conference 2016* (pp. 207–230). New York, NY: Springer.
- Couper-Kuhlen, E., & Selting, M. (2000). Argumente für die Entwicklung einer ,interaktionalen Linguistik' [Arguments for the development of 'interactional linguistics']. *Gesprächsforschung – Online-Zeitschrift Zur Verbalen Interaktion*, 1, 76–95.
- Gogolin, I., & Lange, I. (2011). Bildungssprache und durchgängige Sprachbildung [Academic language and continuous language education]. In S. Fürstenau & M. Gomolla (Eds.), *Migration und schulischer Wandel: Mehrsprachigkeit*. Wiesbaden, Germany: Verlag für Sozialwissenschaften Springer Fachmedien.
- Grant, T., & Kline, K. (2003). Developing the building blocks of measurement with young children. In D. Clements & G. Bright (Eds.), *Learning and teaching measurement: 2003 yearbook* (pp. 46–56). Reston, VA: NCTM.
- Isler, D., Künzli, S., & Wiesner, E. (2014). Alltagsgespräche im Kindergarten: Gelegenheitsstrukturen für den Erwerb bildungssprachlicher Fähigkeiten [Everyday talks in kindergarten: Opportunity structures for the acquisition of academic language skills]. *Schweizerische Zeitschrift Für Bildungswissenschaften*, 36(3), 459–479.
- Joram, E. (2003). Benchmarks as tools for developing measurement sense. In D. Clements & G. Bright (Eds.), *Learning and teaching measurement: 2003 yearbook* (pp. 57–67). Reston, VA: NCTM.
- Keuch, S., & Brandt, B. (2018). Language hurdles on the way to an understanding of length in early mathematics education. In N. Planas & M. Schütte (Eds.), *Proceedings of the Fourth ERME Topic*

Conference 'Classroom-based research on mathematics and language' (pp. 89–95). Dresden, Germany: Technical University of Dresden and ERME.

- Lehrer, R., Jaslow, L., & Curtis, C. (2003). Developing an understanding of measurement in the elementary grades. In D. Clements & G. Bright (Eds.), *Learning and teaching measurement: 2003 yearbook* (pp. 100–121). Reston, VA: NCTM.
- Leisen, J. (2015). *Handbuch Sprachförderung im Fach - Sprachsensibler Fachunterricht in der Praxis* [Manual for subject specific language support – practical language sensitive subject teaching]. Stuttgart, Germany: Klett.
- Michel, M., Ofner, D., & Thoma, D. (2014). Early childhood educators' competences for supporting children's academic language skills in Germany. *Language Awareness*, 23(1–2), 138–156.
- Nührenbörger, M. (2002). *Denk- und Lernwege von Kindern beim Messen von Längen: Theoretische Grundlegung und Fallstudien kindlicher Längenskonzepte im Laufe des 2. Schuljahres. Texte zur mathematischen Forschung & Lehre: Vol. 17* [Thinking and learning paths of children measuring lengths: Theoretical foundations and case studies of childlike length concepts during the second school year. Texts for mathematical research and teaching]. Hildesheim, Germany: Franzbecker.
- Prediger, S. (2015). „Die Aufgaben sind leicht, weil ... die leicht sind.“ Sprachbildung im Fachunterricht – am Beispiel Mathematikunterricht [“The tasks are easy, because ... they are easy.” Language education in subject-based education - using mathematics as an example]. In W. Ostermann, T. Helmig, N. Schadt, & J. Boesten (Eds.), *Sprache bildet! Auf dem Weg zu einer durchgängigen Sprachbildung in der Metropole Ruhr* (pp. 185–196). Mülheim, Germany: Verlag an der Ruhr.
- Prediger, S., & Zindel, C. (2017). School academic language demands for understanding functional relationships - A design research project on the role of language in reading and learning. *Eurasia Journal of Mathematics Science and Technology Education*, 13(7), 4157–4188.
- Sarama, J., Clements, D., Barrett, J., van Dine, D., & McDonel, J. (2011). Evaluating of a learning trajectory for length in the early years. *ZDM*, 43(5), 617–620.
- Schmidt, T. (2002). Gesprächstranskription auf dem Computer: Das System EXMARaLDA. [Talk transcription on the computer: the system EXMARaLDA] *Gesprächsforschung*, 3, 1–23.
- Skoumpourdi, C. (2015). Kindergartners measuring length. In K. Krainer & N. Vondrová (Eds.), *Proceedings of the Ninth Congress of the European Society for Research in Mathematics Education* (pp. 1989–1995). Prague, Czech Republic: Charles University of Prague and ERME.
- Volmert, J. (2005). Primärer Spracherwerb: Wie der Mensch zur Sprache kommt [Primary language acquisition: how the human being comes to speech]. In J. Volmert (Ed.), *Grundkurs Sprachwissenschaft: Eine Einführung in die Sprachwissenschaft für Lehramtsstudiengänge* (pp. 207–232). Stuttgart, Germany: UTB.

Mathematical reasoning as a classroom discourse

Farran Mackay, Marieke Thurlings, Alexander Schueler-Meyer, and Birgit Pepin

Eindhoven University of Technology, Eindhoven School of Education, Eindhoven, The Netherlands; f.e.mackay@tue.nl, m.c.g.thurlings@tue.nl, a.k.schuelermeyer@tue.nl, b.e.u.pepin@tue.nl

Keywords: Mathematical reasoning, mathematical discourse, classroom practice.

Introduction

Mathematical reasoning is recognised as an essential means for promoting students' mathematical understanding and is central to students' mathematical proficiency (e.g., Kilpatrick, Swafford, & Findell, 2001). However, the teaching and learning of mathematical reasoning – here understood as a discursive practice – remains challenging in secondary school classrooms, with students often relying on mathematically superficial reasoning (e.g., Sidenvall, Lithner, & Jäder, 2015). Teachers need to have at their disposal effective discursive teaching practices to foster students in developing their ways of mathematical reasoning. This raises the question of how teachers can be supported in developing such discursive teaching practices with respect to mathematical reasoning. This question is addressed in the PhD-project of the first author. The intention of this poster is to elicit feedback concerning the inferences made from the analysis of mathematical reasoning teaching practices, within a discursive framework.

Theoretical framework

Sfard (2008) argues that 'doing mathematics' is a *discourse*, that is, the use of specific, well-defined communication. As such, mathematical reasoning can be considered as the line of thought, both the inter- and intrapersonal discourse, that is utilised to produce statements and reach conclusions while solving a task. Mathematical discourses are framed as a type of communication that is distinct to others through the permissible "vocabularies, visual mediators, routines and endorsed narratives" (Sfard, 2008, p. 297). *Routines* are a set of rules defining a discursive pattern that repeats itself in certain situations. For example, the use of the quadratic formula is a routine. *Endorsed narratives* are an ordered sequence of expressions which are labeled as *true*. They describe mathematical objects (e.g. numbers, functions, and formulae), relationships between objects, and the processes through which the objects are constructed. Examples of narratives endorsed by the mathematical community (e.g., mathematicians and teachers) include definitions, axioms, and theorems as well as acceptable forms of presenting solutions to specific tasks (e.g., answer models within state exams).

The completion of a mathematical (school) task can be considered as the production of an endorsable narrative from existing narratives (Sfard, 2008). The activity of choosing which previously endorsed narratives are relevant to the task at hand and how these narratives are to be manipulated to create a new (endorsable) narrative is fundamentally what mathematical reasoning is. In this process, students need to adhere to well-defined rules within the mathematics community. Fostering mathematical reasoning thus requires the teacher to explain the rules and mechanisms of endorsing narratives in classroom conversations. Such a meta-discourse about rules and mechanisms can be considered as a

mathematical discourse in itself because it has its own vocabulary, visual mediators, routines and endorsed narratives. This discourse is coined *mathematical reasoning discourse*.

Methodology

As part of a larger project, the present study is conceived to examine the mathematical reasoning discourse that teachers employ in their classrooms. At the time of CERME11, the present study was in the data collection phase. The results of this exploratory study will be used as one of the inputs, in the following study, for the design and evaluation of a professional development module in relation to advancing teachers' mathematical reasoning discourse.

The exploratory study consists of ten lesson (video) observations and stimulated recall interviews with five Dutch mathematics teachers at the upper secondary level. The interviews consist of non-evaluative questions asked while watching pre-selected video-scenes of their classroom routines. The questions are designed to stimulate the participant to relive the lesson, and, through this, to reflect on his/her routines (Geiger, Muir, & Lamb, 2016), to identify the conditions influencing their choice of routines and the types of routines they employed (Cooper & McIntyre, 1996), and what they deem as a successful implementation of their routines (cf. closing conditions of routines, Sfard, 2008).

The planned approach to the data analysis is the following:

1. Video sightings for identifying teacher routines in the mathematical reasoning discourse (also used as stimulated recall)
2. Qualitative discourse analysis of the (video) observations to examine the discursive means (narratives, keywords, visual mediators) for fostering the students reasoning
3. Qualitative discourse analysis of the stimulated recall interviews to uncover teachers' intentions behind their routines and as such meta-rules for mathematical reasoning discourse

From the design of the exploratory study, the expected output would include (successful/promising) routines that teachers use, and the associated meta-rules in relation to mathematical reasoning discourse. However, this raises the following question for discussion in the context of TWG09: how can inferences be made from the here presented exploratory study to a broader teacher community in order to inform the design of the professional development module?

References

- Geiger, V., Muir, T., & Lamb, J. (2016). Video-stimulated recall as a catalyst for teacher professional learning. *Journal of Mathematics Teacher Education*, 19(5), 457-475. doi: 10.1007/s10857-015-9306-y
- Kilpatrick, J., Swafford, J., & Findell, B. (Eds.). (2001). *Adding it up: Helping children learn mathematics*. Washington, DC: National Academy Press.
- Sfard, A. (2008). *Thinking as communicating: Human development, the growth of discourses, and mathematizing*. London, England: Cambridge University Press.
- Sidenvall, J., Lithner, J., & Jäder, J. (2015). Students' reasoning in mathematics textbook task-solving. *International Journal of Mathematical Education in Science and Technology*, 46(4), 533-552. doi: 10.1080/0020739X.2014.992986

Researching translanguaging: Functions of first and second languages in Maltese mathematics classrooms

Angel Mizzi

University of Duisburg-Essen, Faculty of Mathematics, Essen, Germany; angel.mizzi@uni-due.de

This paper presents a research study about the different functions of languages in teachers' translanguaging practices at primary level in the Maltese islands. Translanguaging denotes learning environments which support individuals to activate different languages in the learning or teaching process for facilitating interaction between individuals for constructing and communicating knowledge cross-linguistically. Bilingual primary teachers, Maltese and English-speaking, were accompanied during the introduction of mathematical concepts in order to identify the different functions of both languages in their discourse when teaching mathematical concepts.

Keywords: Language, multilingualism, translanguaging, primary mathematics education.

Introduction

Language plays an important role in mathematics learning, not only to communicate mathematical knowledge to each other, but also to construct mathematical knowledge cognitively (Maier & Schweiger, 1999). Several studies highlighted the importance of integrating content and language learning in mathematics learning environments, wherein, along with the content itself, language development is also a learning goal (Wessel, 2015; Farrugia, 2017). Other studies about multilingualism in learning environments state how important it is to consider the students' first language in contexts where the second language is the language of education (Cummins, 1981). However, more research is needed to investigate the different functions which two languages have in multilingual mathematics classrooms, especially when teachers use both languages to teach mathematical concepts bilingually.

The ongoing research project focuses on how two languages, which are both used by teachers and students in Maltese mathematics classrooms, influence mathematics teaching and learning at primary level. The use of both languages by teachers will be observed during the introduction of mathematical concepts in order to achieve insights into the functions of both languages. The main research question is: What are the functions of two languages used by bilingual primary teachers when translanguaging in their mathematics teaching?

Theoretical background

A quite common notion in linguistics research about multilingualism is the concept of codeswitching. Codeswitching denotes the process of switching from one language to another at discourse level for a more effective communication between bilingual speakers. In contrast to codeswitching, translanguaging denotes teaching methodologies which incorporate the use of one language for supporting the development of the second language for facilitating student understanding (Lewis, Jones & Baker, 2012). Lewis et al. (2012) emphasize that the use of two languages is cognitively high-demanding for students and this process should not be merely considered as translation:

The process of translanguaging uses various cognitive processing skills in listening and reading, the assimilation and accommodation of information, choosing and selecting from brain storage to communicate in speaking and writing. Thus, translanguaging requires a deeper understanding than just translating as it moves from finding parallel words to processing and relating meaning and understanding. (Lewis et al., 2012, p. 644)

Similarly, Baker describes translanguaging as "the process of making meaning, shaping experiences, understandings and knowledge through the use of two languages" (Baker, 2011, p. 288). According to Baker (2001) advantages of using translanguaging includes a deeper understanding of the content and support of the weaker language in the learning process. Hence, translanguaging focuses on the cognitive processes during learning and does not only emphasize the external mode of communication when switching from one language to another (as in the case of codeswitching). Nevertheless, codeswitching is a prerequisite in order to get insights into the cognitive processes in translanguaging teaching and learning environments.

The use of two languages for teaching and learning of mathematics leads to multidimensional symbolic representations of mathematical knowledge in the context of translanguaging, as it has been illustrated by a model about the different representations of mathematical knowledge under consideration of multilingualism by Prediger and Wessel (2011). This model emphasizes that different registers can be realized using different languages, e.g., first language on the level of everyday language and second language for mathematical language.

Research design, methods and implementation

In order to qualitatively research the functions of two languages when teaching mathematical concepts, a case study with different teachers was designed. It was important to find a scenario where teachers and students speak both languages, where both languages have roughly the same status in the society, and where translanguaging is the norm in the educational context. Due to these prerequisites the case study was conducted in Malta, where both Maltese and English are used for teaching and learning at primary and secondary level. Maltese primary teachers are allowed to use both languages for teaching mathematics and in order to support mathematical learning independently from the language chosen in the classroom, as stated in the Maltese primary mathematics curriculum:

The class teacher, in accordance with the school strategy, is to decide what language must be used to facilitate the development and acquisition of mathematical concepts. Once, this objective is achieved, however, it is essential that children are exposed to the mathematical ideas in English (...) However, on no account should the use of either language (Maltese or English) impede upon the children's learning of mathematics. (Department of Curriculum Malta, 2014, p. 10)

The research study was conducted in a fourth and sixth grade at a primary school in Gozo, an island in the Maltese archipelago. Two teachers were observed during the introduction of several mathematical concepts. The fourth-grade teacher introduced the concepts of fractions and their equivalency and weight and mass in two different lesson units. The sixth-grade teacher introduced the concept of percentages. Nearly all students in the observed classes have Maltese, a Semitic language and first language for the majority of the Maltese population, as their first language, and English, the language of the former colonizers, as the second language. Both languages are taught at

school starting from first grade in primary schools. The same language conditions apply for the participating teachers, who additionally studied educational studies in English at university in Malta.

The lessons of the teachers in the units were audio-recorded and observed in the classroom in order to note the different materials (e.g., books, smartboard, hands-on, etc...) used by the teachers when introducing the mathematical concepts. The recordings were transcribed and analyzed qualitatively in order to investigate the use of translanguaging, in particular, the different functions both languages fulfill during the teaching of mathematical concepts.

Results

Preliminary analyses of the recorded data show that teachers use translanguaging intensively when introducing mathematical concepts in both classrooms and that language choice also tends to depend on materials used (e.g., hands-on). Three main functions of the first and second language during the introduction of the concepts were identified and are described in the upcoming subsections.

First language as oral and second language for the fixation of the mathematical language

A particular remarkable observation is the different functions of the two languages regarding oral and written modes. The first language, Maltese, was used by both teachers only orally, whilst the written form of mathematics was only realized using English. Maltese was often used for communicating mathematical phenomena orally, and English was used to capture the mathematical insights written, as it can be observed in Transcript 1 (T stands for teacher and S for student):

Transcript 1

	Original in Maltese and English	Translation
T1	(...) <i>ħa naraw bejn wieħed u ieħor kemm jiżnu l-affarijiet. Aħna rajna li one packet of flour, li tffisser dqiq, f-l-o-u-r jiżen one kilogram. (...) Biex nkunu kapaċi nagħmlu estimate. Inqabblu bejn il-ħaġa li tiżen iktar jew inqas minn pakkett dqiq. Iktar jew inqas minn one kilogram? Rajna li around five oranges weigh one kilogram. Għadkom tiftakru kemm jiżen baby tat-twelid?</i>	(...) we are going to see how much things weigh approximately. We saw that one packet of flour, which means flour, f-l-o-u-r weighs one kilogram. (...) So that are able to estimate. Comparing whether one thing weighs more or less than the packet of flour. More or less than one kilogram? We saw that around five oranges weigh one kilogram. Do you remember how much a newborn baby weighs?
Choir	Three or four.	Three or four.

1 packet of flour = 1 kg.

Around 5 oranges weigh 1 kg.

A newborn baby weighs around 3 1/2 kg.

Figure 1: Whiteboard inscriptions accompanying Transcript 1

The scene in Transcript 1 originates from the introduction of weight and mass in grade 4, after the students (S) had learnt how to read the weight using different scales. This transcript shows an extract from the introduction to comparison and estimate of objects' weight. In this scene the first or second language is not merely used for translation purposes. The lesson goal is formulated by the 4th-grade teacher (T1) in Maltese but summarized using the concept estimate in English. The knowledge about objects, especially their weight, e.g. “around five oranges weigh one kilogram”, is formulated and written down in English (see Figure 1). English is the textbook language in Maltese mathematics classes, and this is reflected in the choice of writing mathematical phenomena in English. In contrast, Maltese is used for the oral description of the mathematical phenomena, especially the action of comparing the weight of objects. In other instances, Maltese is used for activating learnt knowledge, e.g. “Rajna li...” (We saw that...) or “Għadkom tiftakru...” (Do you remember...) in Transcript 1.

First language for concrete experiences and second language for the abstraction of mathematical phenomena

The use of two languages in mathematics classrooms was noticed during the teaching of mathematical phenomena which are first based on concrete representations and becoming more abstract in further learning processes. The first language seems to be more used for activating everyday knowledge, and the second language is used for abstracting the underlying processes, as it can be observed in Transcript 2, in which the 4th-grade teacher (T1) introduces equivalent fractions using hands-on:

Transcript 2

T1	Illum, we have twenty-four small squares, (...) if I want to eat one fourth of the chocolate, if one, two, three, four (pointing to four students) are going to share the chocolate, ha naqsmu ċ-chocolate bejn one, two, three, four, (...) kemm se tiehdu kull wiehed?	Today we have twenty-four small squares, (...) if I want to eat one fourth of the chocolate, if one, two, three, four (pointing to four students) are going to share the chocolate, we are going to break down the chocolate among one, two, three, four, (...) how much will each get?
S1	Two?	Two?
T1	Two? (pointing at the squares of the bar) One two, one two, one two, u one two, jibqa' din il-biċċa. (...)	Two? (pointing at the squares of the bar) One two, one two, one two, and one two, this piece remains. (...)
S2	Six.	Six.
T1	Nistgħu npinguha u naqsmuha f'erbgħa. One, naqsmu waħda minn nofs, u waħda minn nofs hawn (uses gestures to show how to break the bar into half and then each into halves). (...)	We can draw it and break it down into four. One, we break down one in half, and one in half here (uses gestures to show how to break the bar into half and then each into halves). (...)
S3	Teacher, jew taqşam hekk. One, two, three... (points along the rows)	Teacher, or we break it like this. One, two, three... (points along the rows)

T1	That's another method, very good. (...) K'naqsmuha f'erbgħa, one, two, three, four, dawk ir-rows, kull wieħed kemm jieħu? Għoddu!	That's another method, very good. (...) If we break it down in four, one, two, three, four, these rows, how many does each get? Count!
Choir	Six. (...)	Six. (...)
T1	What fraction? (...) How many pieces? Six. (...) What fraction?	What fraction? (...) How many pieces? Six. (...) What fraction?
S4	Six from four. (...)	Six from four. (...)
T1	Six on? Out of how many?	Six on? Out of how many?
S4	Four.	Four.
T1	Ara, are there only four in all? How many in all?	Look, are there only four in all? How many in all?
S4	Six times four.	Six times four.
T1	Six out of twenty-four. (...) Kieku naqsmu ċ-ċikkulata hekk, u kull wieħed se jieħu one fourth, kemm hemm squares?	Six out of twenty-four. (...) If we break down the chocolate like this, and each gets one fourth, how many squares are there?
Choir	Six.	Six.
T1	Six. Mela, what is another fraction? What can I say instead of six on twenty-four? (...)	Six. So, what is another fraction? What can I say instead of six on twenty-four? (...)
S2	One fourth.	One fourth.
T1	(...) So what can you tell me about these two fractions? Six on twenty-four and one fourth. What can you tell me about them? Jekk jiena rrid niekol ħafna ċikkulata, liema nagħżel din jew din (shows on the two fractions)?	(...) So what can you tell me about these two fractions? Six on twenty-four and one fourth. What can you tell me about them? If I want to eat a lot of chocolate, which one do I choose, this or this? (shows on the two fractions)?

In Transcript 2, the 4th-grade teacher activates the concept image of distributing parts of a whole using a (six times four) chocolate bar to be shared among the students. The teacher states the number of subgroups (four students), the fraction, and poses the question, “How many pieces per child?”. Although more English is used in the teacher's discourse, both languages are used to fulfill different functions at concrete and abstract level. Although the lesson goal is stated in both Maltese and English separately, the focus is on the act of sharing or breaking down the chocolate and on how much each child shall receive, which is often emphasized in Maltese by the teacher: “ħa naqsmu ċ-chocolate” (We are going to break down the chocolate) and “Kemm se jieħu kull wieħed?” (How much does each get?). English is used to denote the fraction, “one fourth of the chocolate”, and to represent the

underlying information. The more the transcript progresses, the more Maltese is used to denote the action of breaking down or sharing, whereby at a certain point even the Maltese numbers accompany this action, in “K'naqsumha f'erbgħa” (if we break it down into four), in order to denote the break down number. However, the parts broken down into are named using English numbers, the ordinal aspect of natural numbers. The English numbers are also used to describe the denominator and numerator of the intended fraction, and at the end of Transcript 2, the teacher uses mainly English to encourage the students to compare both fractions (see Figure 2), however, at a certain point, she uses Maltese again for activating student everyday knowledge (the act of eating chocolate) at the end of Transcript 2. Overall this episode shows that whereas the first language, Maltese, was more used in contextual situations of mathematics learning, English became more dominant when representing abstract mathematical objects, which were introduced concretely.

$$\frac{6}{24} \quad \frac{1}{4}$$

Figure 2: Whiteboard inscriptions accompanying Transcript 2

First language for action-based processes and second language for static concepts in mathematics classroom

The third distinction regarding the functions of the first and second language in translanguaging in mathematics lessons is between the static and dynamic processes of mathematical knowledge. Analyses of the previous transcripts led to the hypothesis that Maltese tends to be used more for action-based processes, e.g. comparing weights in Transcript 1 or breaking down objects in Transcript 2, whereas English is more used for representing static concepts, e.g. estimate, square, numbers, etc. The next transcript from Grade 6 shows how the first language is primarily used for dynamic process, whereas the second language is used more for static contexts of mathematics knowledge.

Transcript 3

T2	(...) ġo dan is-sejf għandna sixty euro w l-mami tgħidlek: ara, tista' tonfoq ten percent minnhom kull xahar. U kif se nsir naf jien kemm nista' nonfoq? Ten percent xi tfisser? (...)	(...) in this safe we have sixty euro and mum tells you: look, you can spend ten percent of it monthly. And how can I find out how much I can spend? What does ten percent mean? (...)
Choir	Ten minn hundred.	Ten from hundred.
T2	Ten out of hundred. Ten percent ta' xiex nista nonfoq jien?	Ten out of hundred. Ten percent of what can I spend?
Choir	Tas-six...	From the six...
T2	Ta' sixty. Mela kif se naħdimha? Ten percent of?	Of sixty. So how can I calculate it? Ten percent of?
Choir	Sixty. (...) Sixty division hundred.	Sixty. (...) Sixty division hundred.
T2	(...) Li tiġi? Fejn hu l-point bħalissa?	(...) Which is? Where is the point now?

Choir	Wara.	Behind.
S1	Wara zero point six.	Behind zero point six.
T2	Kemm se jaqbeż?	How much will it jump?
S1	Tnejn.	Two.
T2	Lil fejn?	Where to?
Choir	‘1 hemm. (lifting their hands and pointing to their left)	There. (lifting their hands and pointing to their left)
T2	Għaliex?	Why?
Choir	Għax division.	Because it's division.
T2	Għax ħa jiċkien. Wiehed. Tnejn. (...) X'iktar? lesta? (...)	Because it will decrease One. Two. (...) What else? Am I finished? (...)
Choir	Times ten.	Times ten.
T2	‘1 fejn se jaqbeż il-point?	Where will the point jump to?
Choir	‘1 hemm. (pointing to their right)	There. (pointing to their right)

In the above transcript, Transcript 3, the 6th-grade teacher introduces the exercise 10% of 60 Euros in percentages using the everyday register. In order to solve “ten out of sixty”, the students start using division, sixty division by hundred, however the underlying processes in the division exercise are perceived and hence also verbalized using the first language. Such processes include the identification of the decimal point, how many steps and in which direction the decimal point must be moved and whether the number value increases or decreases. Similar to Transcript 2, numbers (in contextual situations) associated with actions or movements, such as moving the decimal point, are represented using the first language, e.g. “Għax ħa jiċkien. Wiehed. Tnejn” (Because it will decrease. One. Two) in Transcript 3. English is more used for static insights on mathematical concepts, for concept names, e.g., Division or Multiplication (“times” in Transcript 3) or for number names (e.g., ordinal aspect).

Conclusion

The above transcript and their analyses in the results section show how two languages can have different functions in translanguaging mathematical classrooms and they are not merely used for translation purposes. The teachers participating in this study used one language for oral explanations and communication of mathematical phenomena and the second language for ‘fixiating’ the mathematical language and learnt knowledge. Findings showed how the first language is more used for verbalizing concrete representations of mathematical knowledge, since it is dominant in the students' everyday life. For instance, actions on objects are more likely to be communicated using the first language. The second language is required to abstract the mathematical phenomena, especially when the context is no longer in focus; For example, during the introduction of equivalent fractions in Transcript 2 the teacher tended to use Maltese for expressing actions on hands-on, whilst English was used for denoting the fractions and their comparison. Further findings showed that the first language was more used when mathematical actions were verbalized, whilst the second language was

high used for static mathematical concepts. Hence, languages can fulfill different functions in a translanguaging mathematics classroom in order to enhance language and content learning. Similar to the thesis that the development of the mathematical language requires the use of everyday language as a basis (Wessel, 2015), the use of the first language (especially in the introductory phase) is crucial in order to develop, learn and use the abstract mathematical language in multilingual classrooms.

Acknowledgment

I wish to thank the dedicated teachers participating in this study, the head mistress and Dr. Marie Therese Farrugia from University of Malta for the fruitful discussions about translanguaging.

References

- Baker, C. (2011). *Foundations of bilingual education and bilingualism* (5th Ed.). Bristol, England: Multilingual Matters.
- Cummins, J. (1981). The role of primary language development in promoting education success for language minority students. In California State Department of Education (Eds.), *Schooling and language minority students. A theoretical framework* (pp. 3-49). Los Angeles, CA: National Dissemination and Assessment Center.
- Department of Curriculum Management Malta (2014). *Mathematics. A revised syllabus for primary schools*. La Valletta, Malta: Ministry for Education and Employment.
- Farrugia, M. T. (2017). Bilingual classrooms in Malta. Teaching mathematics content and language. *Éducation et Sociétés Plurilingues* 42, 61-72. doi: 10.4000/esp.1114
- Lewis, G., Jones, B., & Baker, C. (2012). Translanguaging. Origins and development from school to street and beyond. *An International Journal on Theory and Practice* 18(7), 641-654. doi: 10.1080/13803611.2012.718488
- Maier, H., & Schweiger, F. (1999). *Mathematik und Sprache* [Mathematics and language]. Vienna, Austria: Öbv & Hpt.
- Prediger, S., & Wessel, L. (2011). Darstellen - Deuten -Darstellungen vernetzen. Ein fach- und sprachintegrierter Förderansatz für mehrsprachige Lernende im Mathematikunterricht [Representing - Interpreting - Linking representations. A content and language integrated support approach for multilingual learners in mathematics]. In S. Prediger, & E. Özdil (Eds.), *Mathematiklernen unter Bedingungen der Mehrsprachigkeit. Stand und Perspektiven der Forschung und Entwicklung* (pp. 163-184). Münster, Germany: Waxmann.
- Wessel, L. (2015). *Fach- und sprachintegrierte Förderung durch Darstellungsvernetzung und Scaffolding. Ein Entwicklungsforschungsprojekt zum Anteilbegriff* [Content and language integrated support by linking representations and through scaffolding]. Heidelberg, Germany: Springer Spektrum.

Adopting a discursive lens to examine functions learning and language use by bilingual undergraduate students

Máire Ní Ríordáin¹ and Eilis Flanagan²

¹University College Cork, Ireland; maire.niriordain@ucc.ie

²Letterkenny Institute of Technology, Ireland; eilis.flanagan@lyit.ie

This study examines the use of languages by bilingual undergraduate mathematics learners. It adopts a commognitive lens to examine whether language use by bilingual undergraduate mathematics learners impacts upon meta-level mathematical processes of learners, in particular in relation to functions. The findings suggest that there was a lack of code switching between languages when engaged in mathematical tasks and completing the mathematical tasks individually or in pairs impacted on the choice of language employed in the discourse. There was greater evidence of meta-level thinking through the medium of Irish than in English.

Keywords: Commognitive approach, language use, functions, bilingual students.

Introduction

An evaluation of the Irish and English languages demonstrates that differences exist in relation to syntax and semantics and that this may impact on the processing of mathematical text, and advantage those learning through the medium of Irish (Ní Ríordáin, 2013). Specifically, this paper examines two first year undergraduate students' (approx. age 18 years) thinking about functions and which language(s) (Irish and English) are used to facilitate their thinking. These students were participating in a bilingual first year Calculus module. In particular, we focus on concepts relating to functions, which are fundamental to mathematics learning across all levels of education, inclusive of university-level education (Gücler, 2016). We adapt Sfard's (2008) commognitive framework as an analytical lens to support our investigation of bilingual mathematics learners. This framework is adopted for a number of reasons including: to enable an examination of participants' discourses relating to functions; to facilitate a comparison of object-level and meta-level developments of functions in both English and Irish languages; and accordingly, to examine when participants are utilising their languages when engaged in mathematical thinking.

Therefore, considering object-level and meta-level level thinking and requirements in relation to functions, this research aims to make a contribution to the field by examining how languages (Irish and English) are utilised by bilingual undergraduate learners when engaged with functions discourse. Utilising Sfard's (2008) commognitive perspective, mathematical thinking is viewed as a form of communication, and that learning mathematics entails extending one's discourse from object-level to meta-level constructs. Adopting this perspective on thinking and considering that discourse is language dependent, the authors contend that discourses may differ between languages (Kim, Ferrini-Mundy & Sfard, 2012). In particular, the authors propose that there are variances between different linguistic forms of "the same discourse" (Kim et al., 2012, p.2) and accordingly it may impact on how bilingual students utilise their language(s) when engaged in mathematical thinking.

Planas and Setati (2009) argue that bilinguals switching between their languages is not just dependent on their proficiency in the languages but also due to the social situations and contexts. It is important that we study bilingual learners and their diverse contexts in order to gain a better understanding of the complexity of the issue and the influence of language(s) on mathematical thinking. It is well established that the ‘choice’ and use of language(s) may differ depending on the context (e.g., Planas & Setati, 2009). Research suggests that the type of mathematical tasks students encounter as well as the situated learning experiences facilitated, can influence language use and code switching (Moschkovich, 2007). Moschkovich asserts that some students may opt to use their first language when working on a task individually and code switch as necessary when engaged in interactive discourse concerning the same mathematical problem. Alternatively, if students associated mathematics with a particular language, it is reasonable that the students would then communicate their thinking in that language, i.e. their second language. Another alternative is that students might opt to code switch throughout the mathematical discursive processes. For example, Planas and Setati (2009) established differences in the ways that immigrant bilinguals utilised their languages whilst completing mathematical tasks. Switching between languages (Catalan and Spanish) occurred with changes in the complexity of the mathematical tasks required by the teacher. In general, they found that the students used their languages for different purposes and was dependent on the social context set up within the classroom (*ibid*). Ultimately, research suggests that that primary influencers of how students use their languages for learning mathematics are (1) the mathematical discursive competencies in a given language, (2) the social context, and (3) relative experience of mathematics (Moschkovich, 2007).

Theoretical frame

Gee’s (1996) concept of discourse as encompassing, verbal, written, technical and physical modes of language use informed the close analysis of mathematical discourse in this study. The authors were cognizant of the social aspect of language use in learning and required a framework that allowed for the examination of discourse as a complex form of communicating while paying close attention to the cognitive processes of mathematical thinking. Therefore, the authors adopt Sfard’s (2008) commognitive approach to analysing mathematical discourse in order to provide for the particular methodological considerations and central constructs of the study (mathematics discourse, bilingualism and language use). Sfard expresses thinking as comprising both personal and interpersonal communication and outlines four unique features of mathematical discourse, which this study explores as a process of socialisation into a mathematical community of practice. These discourse tenets are: 1) words use, 2) visual mediators, 3) routines, and 3) endorsed narratives. For the purpose of this paper the authors focus on word use and routines.

Word use is characterised by Sfard (2008) in terms of *passive-driven* (recognition or memorisation), *routine-driven* (using phrases or definitions), *phrase-driven* (task association) and *object-driven* (meaning-making) usage. Objectification is a feature of word use in mathematical discourse, which occurs through a process of reification (structural thinking) and alienation (impersonal presentation of phenomena). Therefore, this research was interested in whether participants engaged in objectified talk and in which language(s) this occurred. To this end, word use was categorised as above and considered in line with the routines feature of mathematics discourse. Sfard categorises routines as

deeds (a change in the environment), *rituals* (cooperative acts of learning) and *explorations* (producing an endorsed narrative). Of particular significance to this study was the course of action employed by learners to solve mathematical problems (*deeds*) and the mathematical reasoning provided (*explorations*). A particular emphasis was placed on the language(s) in which each routine was discussed or employed. The practice of learners alternating between their languages is referred to as code switching in this paper.

The authors align with Gee's (1996) concept of discourse as a sense-making process, comprising modes of communication and participation in communities of practice. Comprised of both talk and non-talk forms of communication, Gee (1996) describes discourse as 'stretches of language that "hang together"' and are embedded in the situated and sociocultural practices of its use' (p.115). Further, the authors define meta-level developments in mathematical thinking as a process of endorsing the rules that govern the particular mathematics discourse, while object-level mathematical thinking refers to familiarisation with the objects of the discourse (Sfard, 2008). In terms of mathematics as discourse, the authors view mathematics as a complex register comprising subject content conveyed through the interchangeable use of everyday (colloquial) and mathematical (literate) discourses. As such, developing an advanced mathematics discourse culminates in a shift from a colloquial to a literate use of mathematical language, which signifies conceptual (meta-level) knowledge.

Methodology

At the National University of Ireland, Galway (NUI Galway), first year undergraduate mathematics students are afforded the opportunity to study honours mathematics through a bilingual approach. Modules offered bilingually are Calculus and Algebra. Four weekly lectures are provided through the medium of Irish, with all mathematics terminology offered bilingually (Irish and English). In addition, lecturers may opt to describe more complex concepts (such as the limit of a function) bilingually. The lectures are supplemented by the provision of a weekly tutorial in English in addition to an Irish-medium tutorial. Participants were comprised of two students, Val and Jean. Two Irish-medium education contexts exist – Irish-immersion education in English-speaking communities and schools located in Gaeltacht (Irish-speaking) regions. Val was from a Gaeltacht region and attended primary and secondary schools in that region, and therefore Irish was his dominant language. Jean attended immersion primary and secondary education, with English her dominant language. Accordingly, both Val and Jean learned Mathematics through Irish but in different contexts in terms of the dominance of the English and Irish languages. At university, the dominant language of informal communication for both participants was English.

The study adopted a mixed methods approach to data collection. This study identified the plausible mathematical discourse trajectories in relation to functions for both the English and Irish languages. The purpose of these discourse trajectories is to examine object-level and meta-level developments in the both languages, and consequently identify which language(s) are used and how, as related to functions (Kim et al., 2012). Participants also completed a questionnaire. The purpose of the first part of the questionnaire was to gather participants' background data. The second part of the questionnaire engaged participants in functions discourse through the use of mathematical questions appertaining

to graphing and limits of functions. All questions were presented bilingually, providing participants with the option of utilising English or Irish or both languages. Jean and Val were invited to think-aloud their thought processes as they recalled prior knowledge and experiences of mathematical discourses while answering the questions (Desimone & Carlson Le Floch, 2004). Finally, cognitive interview methods were employed in which both students were provided with the same mathematical problems as they had solved individually in the questionnaire (one week later). Students were invited to discuss their understandings, processes and thinking about how they approached the various questions and to negotiate their respective thinking towards substantiating the narrative of the particular mathematical constructs in question (functions). This method was employed to acquire comprehensive knowledge about what students' discursive patterns revealed about their comprehension of the specific mathematics functions concepts central to the study (Desimone & Carlson Le Floch, 2004).

Qualitative data analysis included a synthesis of thematic, framework, video and discourse analysis procedures. Sfard's (2008) Commognitive Framework for analysing mathematics discourse was employed to analyse students' meta-level mathematical thinking and related language use. The data was coded, recording both data-driven and concept-driven codes (Gibbs, 2007). Concept driven codes were the discourse tenets: word use, visual mediators; routines and endorsed narratives (Sfard, 2008). Meta-level discursive statements and linguistic patterns were gathered at this stage. Cross coding was employed to code a piece of data for more than one code. Three rounds of coding allowed for similar codes to be grouped and re-characterised and redundant codes were set aside. Parent and Child themes (Gibbs, 2007) were employed to further categorise the data and all codes, categories and themes were considered in terms of English, Irish or both languages, as well as object or meta –level learning.

Findings

A learning example is provided in Figure 1 which details students' mathematical problem solving routines and their language use. Both the individual explanations and the paired discussions are provided. Val and Jean mostly utilised Irish in the individual interview and English in the paired interview. In the example provided, the students' answers are provided in the language in which they spoke/wrote, with English translations provided for those instances where Irish was utilised.

Questions: (i) What is the natural domain of a function $f(x) = x^2$? (ii) Explain to your friend how the domain for f must change if the inverse of f is to exist. (iii) Explain what the inverse function f^{-1} is when $f(x) = x^2$ (with suitable domain).

Val's Individual Answer:

Original text: Anseo $f(x)$, tá sé os cionn, mar síos anseo [pointing to the third quadrant] tá uimhreacha diúltacha ar fad, so abair lúide a haon, lúide a dó. Mar x cearnaithe [x^2] níl ann ach dá uimhir, [pauses] an uimhir x fá [meadaithe fá] é féin, so lúide a haon fá lúide a haon sin a haon. So chuile dá uimhir diúltach beith siad, em deimhneach. So, caithfidh gach páirt a bheith anseo [pointing to the region within the u-shape line drawn on the graph]. So sin é an graif. Maidir leis an inbhéarta ní, níor, like, ní cuimhin liom é a dhéanamh. Tá a fhios agam go ndearna muid é ach ní cuimhin liom and ábhar sin sa rang.

English translation: Here $f(x)$, it is above [the x axis], because down here [pointing to the third and fourth quadrants] the numbers are all negative. So let's say minus one, minus two. Because x^2 , it is just a number [pauses], it is the number x multiplied by itself, so minus one multiplied by minus one is one [$-1 \times -1 = 1$]. So every second negative number would be positive. So, every part has to be here [pointing to the region within the u-shape line drawn on the graph]. So that's the graph. With regards to the inverse, I don't remember how to do it. I know we did it but I don't remember that topic from class.


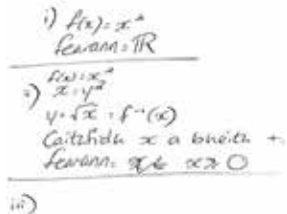

	
<p>Jean's Individual Answer:</p> <p>Original text: So an céad piosa ann, tá an fearann na réaduimhreacha go léir mar níl aon, níl aon fadhb leis. Mar shampla an ceann eile [referring to the previous question] bhí roinnt ar naid. Agus anseo, an inbhéarta, caithfidh an fearann a bheith x níos mó ná, nó cothrom le naid, mar nuair a déanainn tú amach an inbhéarta, an chaoi a déanann mise é, 'swapáil' mé an x is an y agus cuireann mé x ar y, like, leis féin. So faigheann tú préamh x, agus chun préamh x a ríomh, caithfidh x a bheith deimhneach, nó naid.</p> <p>English translation: So for the first part, the domain is all the real numbers because there is no problem with it. For example, the other one [referring to Q1] it was to divide by zero. And here, the inverse, the domain must be x more than or equal to zero, because when you do the inverse, how I do it is, I swap the x and the y and I put x on y, like, on it's own. So you get the root of x. And to calculate the root of x, x has to be positive or zero. [does not complete (iii)]</p> <div style="text-align: right;">  </div>	
<p>Paired answer (original text was in English):</p> <ol style="list-style-type: none"> 1. Val: [reads Q.2) Can that be Z? 2. Jean: Which one is Z again? 3. Val: \mathbb{R}, isn't \mathbb{R} like from 1 up and Z is like all the negative numbers and all the positive numbers? 4. Jean: Isn't N, N from 1 up, I think? I'm not sure, I was never really any good at this. 5. Val: And then, yeah, yeah, and \mathbb{R} then is N and Z, isn't it? 6. Jean: Is it? OK. 7. Val: That makes more sense, I think so. [reads Q.2 part (ii)]. 8. Jean: I don't remember what I did here [in relation to Q.2(ii)]. [Writes the answer on answer sheet] 9. Oh yeah [shows her answer sheet to Val]. See like, the way in secondary school how I learned to get the inverse was change the x and the y 10. around, like say the original one is like that [writes $y = x^2$]. And then put y instead of x and x instead of y, and then get y on it's own to get 11. like, the inverse [circles x on answer sheet]. 12. Val: Oh yeah, OK, OK.[Reads part (iii) and says:] I don't have a clue for that one. 13. Jean: Yeah, to be honest I didn't know either. 	<p>Val's written answer:</p> <p style="text-align: center;">\mathbb{R}</p> <p>Jean's written answer</p> <div style="text-align: center;">  </div>

Figure 1: Learning example

Word use

In his explanation Val utilises Irish and employs a combination of deictic language with colloquial and some literate discourse. Deictic language, such as 'os cionn' (above), 'anseo' (here) and 'síos anseo' (down here) (in reference to the Cartesian plane), is combined with gestures (pointing to the associated quadrants on the graph) to highlight where the domain on the Cartesian plane is for function $f(x) = x^2$. There are elements of routine-driven words being employed since Val is describing the graph. There is little evidence of flexibility in Val's word use and objectified talk about the global features of the graph is not evidenced. In general, Val does not address the domain in this question and the mathematical explanation remains at an object-level of understanding. In contrast,

Jean uses routine-driven mathematical words such as ‘fearann’ (domain), ‘réaduimhreacha’ (real numbers), ‘inbhéarta’ (inverse), and the phrase ‘níos mó ná, nó cothrom le’ (more than or equal to), which signifies familiarity with the subject content and related procedures and ease of use of the mathematical discourse in the Irish language. However, even when utilising Irish, Jean does not fully explain what \mathbb{R} is or why in fact there is no problem with it in this instance, indicating that word use here is routine-driven and procedural. In their discussion of this same mathematics questions, Val opens this interaction in English and despite both students utilising Irish in their respective individual interviews, neither Val nor Jean negotiate their preferred language use for mathematics learning (which is Irish, as indicated in the questionnaire). When both students discuss in English the natural domain of function $f(x) = x^2$, they employ passive-driven words such as ‘positive numbers’ and ‘negative numbers’, and expressions such as ‘from 1 up’. Their word use in English does not progress from passive-driven towards more object-driven usage as it tended to when the students utilised Irish.

Routines

In Figure 1, explaining the natural domain of a function $f(x) = x^2$, Jean explores the inverse of a function in the individual interview by first explaining (in Irish) that the domain must be x more than or equal to zero in order for the inverse of f to exist. Jean then clarifies that this reasoning is related to the routine of “doing” the inverse: ‘an chaoi a déanann mise é, ‘swapáil’ mé an x is an y agus cuireann mé x ar y , like, leis féin. So faigheann tú préamh x , agus chun préamh x a ríomh, caithfidh x a bheith deimhneach, nó naid.’ (I swap the x and the y and I put x on y , like, on it’s own. So you get the root of x . And to get the root of x , x has to be positive or zero). There is an attempt at reification with the use of the word ‘inbhearta’ (inverse) as a verb. However, overall Jean’s rituals (routines utilised for social rewards) define the repetitive discursive action or metarules for “doing the inverse” but there is little evidence of routine flexibility or explanations of why these rituals constitute an appropriate series of steps (meta-level thinking). Instead, there is a focus on pre-learned associations and repetitive patterns or routines (the domain of the function is \mathbb{R} but does not explain what \mathbb{R} is) and rote practices (learning how to swap the x and y).

Discussion and conclusion

There was a lack of language negotiation and code switching engaged in by both students throughout the learning process. Therefore, as Planas and Setati suggest (2009) the social situations and context of the learning scenario play a role in how the learner utilise their language for engaging in mathematics discourse. Both students employed Irish mostly when engaged individually in mathematics discourse but employed English when communicating with one another about the same mathematics topic. This is similar to Moschkovich (2007) who affirms that some students may opt to use their first language when working on a task individually. However, code switching was not evident in our study, even though the same mathematical problem was utilised in both the individual and paired tasks. Since there were two students only undertaking the bilingual stream of this undergraduate program, the whole group discussion was limited and group work was not facilitated. Hence, there were very few opportunities for social interactions within the learning context and as a result the opportunities for language choice and negotiations were also limited. Within the lectures, students conformed to the classroom linguistic norm of speaking Irish and carried this through to

individual interviews. However, the language of paired communication was English, which is the dominant language within the Irish third level education setting. This study has found that the choice of language used by bilingual undergraduate students in this context was influenced by their views of language use in given situations (Caldas & Caron-Caldas, 2002). The impact of the social context is a key consideration for future studies relating to bilingual undergraduate mathematics learners.

Overall the learners demonstrated a combined use of colloquial and literate words and tended towards more colloquial word use when communicating together and through English. There are perceptible determinations from learners, especially Jean, to shift their discourse from colloquial to literate, particularly in Irish. Also, considering learners' word use in English remains mainly passive-driven, it appears that their word use tends towards literate and phrase-driven when communicating about functions individually through Irish. This discursive shift in word use is an indicator of meta-level thinking (Sfard, 2008; Moschkovich, 2002). However, although a shift from colloquial to literate discourse is evident, there is little evidence of objectified talk, even when Irish is utilised as the primary language of communication.

This study demonstrates that students utilised their languages in different ways when engaged in the same discourse (Kim et al., 2012), with greater evidence of meta-level thinking evident through the medium of Irish. Interestingly, both students show more competency and mathematical skills when using Irish in their individual explanations of the routines they employ to solve the problems and begin to shift towards a more literate and less colloquial discourse. In contrast, when engaged in conversation in English about the mathematics problems, they remained at a colloquial level of word use. In both instances, Irish was the preferred language utilised in the individual interview, whereas English was the language utilised during the paired interview. Although Jean displayed more dominance in mathematical discourse in the individual interview in Irish, this is not shown in the paired interaction. Jean does not use the same words nor employ the same visual mediators to explain the domain of function f . This might suggest a gap in Jean's discourse perhaps pertaining to meta-level understanding of the question, mathematical competency, or linguistic ability to discuss mathematics through English. Although learners displayed competence in terms of ritual-based routines from previous learning, either at university or school, reliance on such processual thinking resulted in occasional errors, or highlighted a lack of meta-level thinking when endeavouring to substantiate a particular narrative, in either language. This study demonstrates the importance of studying bilingual learners in diverse contexts in order to gain a better understanding of the intricacy and impact of their languages on mathematical thinking (Planas & Setati, 2009).

Overall, these students' mathematics discourse followed a basic language trajectory when engaged in functions discourse in English and collaboratively, whereas their mathematics discourse tended towards a more advanced mathematics discourse trajectory when engaged in functions discourse in Irish and individually. However, despite their mathematical language use progressing in Irish, this does not equate to progressing towards meta-level thinking, in either language. This insight raises additional questions relating to bilingual mathematics students' learning, in particular the role of the teacher in developing students' discourses and if there is value in explicitly teaching meta-level thinking/rules (Gücler, 2016) as related to language use by bilingual learners in undergraduate education. In addition, the social setting impacted on students' language choice in this study and

raises the more general question of how the context of bilingual undergraduate mathematics learning influences choices relating to language use in bilingual mathematical discourse.

Acknowledgment

This paper is dedicated to the memory of our wonderful participant and dedicated student, Val. The project is funded by the Irish Research Council–New Horizon’s Research Grant (REPRO/2015/53).

References

- Caldas, S. J., & Caron-Caldas, S. (2002). A sociolinguistic analysis of the language preferences of adolescent bilinguals: Shifting allegiances and developing identities. *Applied Linguistics*, 23(4), 490-514. doi: 10.1093/applin/23.4.515
- Desimone, L. M., & Carlson Le Floch, K. (2004). Are we asking the right questions? Using cognitive interviews to improve surveys in education research. *Educational Evaluation and Policy Analysis*, 26(1), 1-22. doi: 10.3102/01623737026001001
- Gee, J. (1996). *Social linguistics and literacies: Ideology in discourses* (3rd ed.). London, England: The Falmer Press.
- Gibbs, G. R. (2007). *Analyzing qualitative data*. London, England: SAGE Publications Ltd.
- Gücler, B. (2016). Making implicit metalevel rules of the discourse on functions explicit topics of reflection in the classroom to foster student learning. *Educational Studies in Mathematics*, 91(3), 375-393. doi: 10.1007/s10649-015-9636-9.
- Kim, D. J., Ferrini-Mundy, J., & Sfard, A. (2012). How does language impact the learning of mathematics? Comparison of English and Korean speaking university students’ discourses on infinity. *International Journal of Educational Research*, 51-52(3), 86-108. doi: 10.1016/j.ijer.2012.01.004
- Moschkovich, J. (2002). A situated and sociocultural perspective on bilingual mathematics learners. *Mathematical Thinking and Learning*, 4(2-3), 189-212. doi: 10.1207/S15327833MTL04023_5
- Moschkovich, J. (2007). Using two languages when learning mathematics. *Educational Studies in Mathematics*, 64(2), 121-144. doi: 10.1007/s10649-005-9005-1
- Ní Ríordáin, M. (2013). A comparison of Irish and English language features and the potential impact on mathematical processing. In B. Ubuz, C. Haser, & M. A. Mariotti (Eds.), *Proceedings of the 8th Congress of the European Society for Research in Mathematics Education* (pp. 1576-1585). Antalya, Turkey: METU.
- Planas, N., & Setati, M. (2009). Bilingual students using their languages in the learning of mathematics. *Mathematics Education Research Journal*, 21(3), 36-59. doi: 10.1007/BF03217552
- Sfard, A. (2008). *Thinking as communicating: Human development, the growth of discourses, and mathematizing*. Cambridge, England: Cambridge University Press.

Specialized language support in mathematics education through the use of radio resources

Franziska Peters

Justus Liebig University, Department of Mathematics Education, Giessen, Germany

franziska.peters@math.uni-giessen.de

This paper offers insight into my pilot study on the use of radio features for specialised language support in mathematics education at the primary school level. With the help of design research, various possible applications of radio resources as auditory learning material are developed and analyzed. One example is described in this paper. The aim of this research is not only to investigate the effects of auditory material on the learning procedure in general, but also to investigate how auditory material can serve as a supportive language example and as a provided language model. First results show that auditory material can indeed be effectively implemented in teaching practice and reveal just how these effects look like.

Keywords: Auditory learning, radio resources, design science, language support.

Background: Cooperation with a radio station

In 2015, the Department of Mathematics Education at the University of Giessen started a project in cooperation with a regional radio station “hr2 – Hessen Radio for Culture”. This radio station developed, inter alia, a series of radio broadcasts on mathematical topics for the primary school level, collected in the multimedia offering “Kinderfunkkolleg Mathematik” (www.kinderfunkkolleg-mathematik.de). Within this collaboration project, future mathematics teachers developed auditory material for use in mathematics education at the primary level. More information about this first project can be found in the proceedings of the ERME topic conference 2018 (Peters, 2018). In a second project, future mathematics teachers planned teaching units for performance in schools, using auditory educational material as a central element. It was important to interrupt longer listening phases and repeat the segments while giving listening tasks in between. The auditory material could be used as preparation of a topic or as a base for discussions, as well as for explaining and deepening new content or repeating previously covered topics. The units were realised in different schools, reflected on in the seminar, optimized and then turned in. After being corrected and edited, the units were then allocated for the download center of the “Kinderfunkkolleg Mathematik,” as accompanying material. Based on this project, I started developing research aims and the design of my pilot study to further research on the effects of radio resources as auditory learning material. The material, used in this study is developed and owned by professional radio authors and producers who received help from experts in our university department.

Auditory learning

In order to research the effects and the use of auditory material, one has to understand how auditory learning is working. According to Baddeley (2007), in the working memory visual and auditory information are processed in different sensory channels. Auditory learning reduces sensory impressions on the visual channel, so that the auditory channel is required and therefore trained more.

Acoustic information is processed through various memory processes. The echo memory saves mostly unprocessed sensory impressions for a short period of time. In a next step, the working memory with its limited capacity decodes and processes the acoustic information. It can also build temporal connections that are necessary for remembering the beginning of a sentence while hearing its end (Leuders, 2011). According to Leuders, an increase in efficiency of the working memory is a training effect. Since the processing of auditory information takes place in the working memory, one can assume that the increase in auditory learning efficiency is a training effect. This is a fundamental trigger for my interest in research on auditory learning materials in mathematics education.

Another important aspect is the Cognitive Load Theory by Sweller (1994), more recently taken up by Rink (2014) for the research on digital media in mathematics education. The Cognitive Load Theory says that the capacities of the working memory are limited and should not be exhausted by extrinsic factors. One of those extrinsic factors is reading. Reading difficulties can exhaust the working memory and lead to not understanding mathematical content as well as not being able to solve mathematical tasks. Keeping mathematical concerns in the center of learning processes while reducing extrinsic factors, is one important approach for auditory learning. That's why Rink (2014) uses audio recordings as a support for solving written tasks.

Auditory learning material

As a first function, it can be stated that auditory support can aid children with reading difficulties to understand mathematical contents and tasks without the need of having to read coherently and extract the meaning. This, however, does not mean that reading should be replaced by hearing. Auditory support should only be provided if needed.

Another function of the use of auditory material is the development of active listening skills. Such competence is a primary requirement for education, but it is seldom supported or even trained (Pimm, 1987). In Germany, education standards for the subject of German language make it very clear: These require, not only the competences of reading and writing, but also speaking and listening. Speaking is required to be consciously organized, while terminology is to be trained and (the use of) language is to be examined. Regarding listening, children are to listen attentively and perceptively, while registering others' statements and constructively dealing with them. Of course, listening also takes place in the form of frontal teaching, but this kind of listening is difficult for most students. This is why supportive elements for auditory learning are necessary – both in frontal teaching and by means of group work.

Mathematics register acquisition

The mathematics register can be seen as “consisting of technical terms, diagrams, and grammatical constructions, such as logical connectives” (Meaney, Trinick, & Fairhall, 2012, p. 199). These elements are learned throughout the entire school process and students are constantly “introduced to further layers of meaning for the terms and expressions they already know” (Meaney et al., 2012, p. 199). Leung (2005) points out that learning vocabulary in mathematics means learning both formal and semantic features of words in various contexts, and involves thinking with and through the concepts. She calls it an “incremental activity” (ibid.), stating that meanings can develop and expand.

The model for mathematics register acquisition (MRA) was developed to categorize teachers' strategies in teaching the mathematical register and is divided into four stages (Meaney et al., 2012). The first stage is "Noticing". In this stage, teachers introduce new terms or expressions, use them frequently and then encourage students to use them as well. The second stage, "Intake", describes the process of understanding. Students start to explore and work with the new terms. In the next stage titled "Integration", testing, feedback and modification takes place. Students have a good understanding of the new term and are responsible for using it, but might be supported or reminded of their knowledge. In the last stage, "Output", there is a fluent use of the new terms. Teachers do not need to support, but should provide activities where the use of these terms would arise naturally. The control of teachers and support through scaffolding is only necessary in the first two stages; in the final two stages, students gain control. The teacher only needs to provide opportunities to use the new terms. Regarding auditory material, we can see that it can be of use in the first two stages. It can be used to introduce new terms and to repeat them frequently in the stage "Notice". In the stage "Intake", it can serve as a language model with which students can work.

Specialized language support through auditory material

As already mentioned, the learning of a language can be supported by training listening competence. Active processing is important for meaningful processing and for memorization of what has been heard. Reasonable and profitable use of auditory material is needed for these processes, e.g., good embedding, listening tasks or segmenting principle. With this in mind, teaching concepts can be developed, in which radio features or other auditory material serves as impulse in the sense of didactical reduction. As acoustic representations are volatilely, there is the need of adding opportunities to document the content of the heard and results of the related tasks within the teaching units. By these means, specialized language support can be ensured. Following these ideas, my research can be focused on the evaluation of auditory educational material in various settings, particularly regarding possible learning effects. The main interest of this research is the use of radio features in mathematics education for specialized language support at the primary level.

Prediger and Krägeloh (2016) refer to a model of three registers relevant for mathematical learning (everyday register, school register and technical register). This model illustrates different levels of verbal representation and how they are connected or built onto each other. Particularly interesting for my research is the question of how children can be led from everyday register to school or even technical register.

School register is an important and necessary factor for successful learning in mathematics. It is a shared language basis and helps with explaining, describing and justifying (Götze, 2015). However, children do not bring this type of language to school with them. It must be learned, like registering a new language. This applies not only to children with special needs in language development but to every other child. That is the reason why they need linguistic models to develop educational language and to fill terms with representations. These linguistic models are scaffoldings onto which children can lean (Gibbons, 2002). Lexical storages, which only include words, are not sufficient, as new terms must be used in whole phrases and sentences. According to Götze (2015), language acquisition is, in practice, merely a continuous learning process. There can be setbacks and sometimes children express

themselves better in written than in spoken language. This is because everyday register is predominant in spoken language and, oftentimes, deictic expressions are used. This is valid for children as well as for teachers – even if they do so unaware and unintentionally. At this point, auditory educational material could be a useful and profitable addition.

Research questions

The aim of my research is to find out in what way auditory learning material could be of use for language support in mathematics education. For this cause, I want to ask how auditory material, as a language model, can stimulate the development of the school register and how auditory material can support listening competence. In a second step, I want to research what a profitable use of such material could look like.

Methodological approach

Regarding the data collection, I decided to use the design research, based on Wittmann's Design Science (1995). Subject of the Design Science is the construction and research of teaching concepts, including accompanying theories. According to Wittmann (1995), this science is a practice-oriented core area for mathematical education, since it refers to the construction of artificial objects (teaching concepts, curricula etc.) and the research on possible effects in different educational settings.

Based on the Design Science, Prediger et al. (2012) developed the model of design research. The aim of this method is to effectively implement innovations for educational development in teaching practice and empirical research, carried out under realistic conditions. In order to do this, one has to undergo a cycle as pictured in the following illustration.

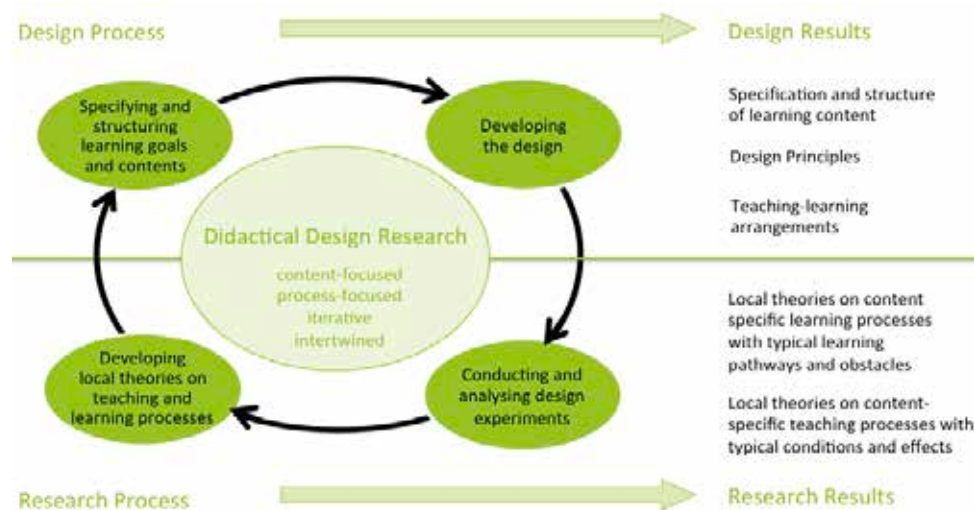


Figure 1: Model for didactical design research (Prediger & Krägeloh, 2016, p. 95)

The cycle starts at the upper left side of the illustration with the specification and structuring of the learning subject. In my case, this would be the mathematical content of the used auditory material, which will be specified later in the explanations of the pilot tests. Learning goals have to be developed and the content has to be structured matching those goals. This also means, that important sequences of the feature have to be chosen and cut as the whole feature is far too long (10-12 min) for a profitable use in classroom. Based on this preparatory work, a design is to be developed for the specific learning

topic of the used auditory material. In a third step, the developed design is to be performed by means of a design-experiment. In this phase, the concept was tested in teaching practice, data was collected by filming and said data was evaluated. To analyze the student's utterances, the analysis of interaction is used (Krummheuer & Naujok, 1999). Based on the analysis of this data, local theories about the learning subject and the teaching concept can be developed in the last phase. The local theories are the starting point for next rounds of the cycle, in which they can help to optimize the learning goals and concept. Later on, they can be developed to or lead to new local theories itself. Thus, more experiments, data collections and evaluations are to follow, along with new local theories. In this way, after a few cycles, we will not have a perfect teaching concept or representative research results, but rather new and tested theories on the use of auditory media for specialized language support. By now, I finished the first cycle and am currently using my initial experiences to develop local theories, as well as structure the learning goals and teaching concepts anew for the second cycle.

Pilot testing

For the pilot testing, I designed a teaching unit in the form of a project day in a fourth-grade classroom with four 45-minute classes. The class is made up of 16 children, all of whom participated in this project day. A teacher, who was specially trained for this project, instructed the unit. The topic of the unit was "Probability and Random Experiments", as it was developed based on the radio feature "Wann ist ein Spiel fair?" (When is a game fair?) from the Kinderfunkkolleg Mathematik (<https://www.kinderfunkkolleg-mathematik.de/themen/wann-ist-ein-spiel-fair>). In this feature, four students are planning to play a game in order to make a decision. They realize the need to test the fairness of the game, start an experiment to do so and find out that the game is unfair, since they don't have equal chances. While testing the game and talking about the mathematical problem, they use school register and mathematical terms. Thus, the students in the class that was observed and filmed were confronted with new terms in a playful way. The overall aim of the unit was the conceptual development of "fairness" (through language) while the linguistic aim was the understanding of the following terms which were presented in the radio feature: double, street (as the subject of the feature was a dice game with the winning options "double" and "street"), probable, option, coincidence, fair, unfair, unsafe, unlikely, likely and safe. Those aims work together: language development can help to develop the concept. Throughout the entire day, both the class situation as well as the working phases in smaller groups were filmed. This way, enough data was gathered referring to the individual processes of the children's speech development, while at the same time it was possible to research on what a profitable use of this material could look like. For the second testing, these experiences can be used to improve the unit and the use of auditory material.

The first lesson began by listening to the first part of the radio feature in which two children were arguing about the fairness of a dice game. In class conversation, the students repeated the content of the heard, reviewed the game and tested the fairness of that game in various steps that built on one another. In between those steps, more parts of the radio feature were presented, and a lexical memory was collectively developed based on the content of these features. In the second part of the day, the students verified the chances of winning and determined the fairness of various other games during learning stations. Hereby, they had to transfer their acquired knowledge whilst using the structures of language and reasoning they had been offered and trained through the radio feature. In Figure 2, you

see two exemplary stations referring to game fairness. Other stations were about dicing with different winning numbers and about dicing with six- or ten-sided dice, about throwing different amounts of reversible tiles and about picking different colored balls from an urn.



Figure 2: Exemplary stations of the learning stations

In groups of two, students chose a game for which they would be experts. Each group had to test every game, but they only had to work on a worksheet for their expert station. On that worksheet they had to describe and to reason whether or not that specific game was fair or unfair. If the game was unfair (which all of them were), they also had to explain why the game is unfair and how one could make this game fair i.e. how to increase the chances of winning for the losing card, colour etc. so that the chances become equal. After the learning stations, students ended the unit with the presentation of their “expert stations”. Each group presented their station, outlined how they examined the game and shared their results. They also presented a solution on how to make the game fair.

Initial experiences

Initial observations showed that students were highly concentrated while listening to the radio features. Due to the fact that students know audio-plays from their everyday life and free time, this proved to be highly motivational and made the mathematical content more exciting. The feature and its “story” involving mathematical content served as an effective conversation starter for the students’ discussion. It can already be reported that the method is currently being adjusted for the second cycle of the design research by designing the testing more as a laboratory situation and less of a whole teaching experiment. In that way, it is possible to research more about the individual processes of the speech development of the children. Still, it can already be stated that nearly every student was able to correctly repeat what he or she had heard. If anything was unclear, it was easy to repeat a certain part of the radio feature individually or in front of the whole class. In this way, auditory material can counteract transitory learning through possible repetition. Through the combination of listening, repetition (if needed) and conversation, the use of radio features successfully aided the development of lexical memory and was helpful when introducing new terms. In the beginning of the unit, the students were only able to explain abstract terms such as “fair” with help of examples:

Teacher: So what actually is fair?

Student 1: Uhm fair is.. mh.. when you say for example if t w o uhm for example o n e gets a gummi bear and the other one not then they find this unfair and fair is if the other one also gets a gummi bear.

This explanation could be considered a form of everyday register, as the speaker describes an everyday example using everyday register. However, this changed throughout the four hours of the project. During the final presentation of their investigated games, the students were allowed to look at their worksheet and their written answers for support. Interestingly, they did in fact use the new mathematical terms and phrases while arguing about the game's fairness.

Student 1: Uhm it's unfair because uhm the game is unfair because there are eight of blue, one of red, red of two uhm.. red two of them.

Student 2: No there's only one of red.

Student 1: Yes. Two of green and four of orange. Because you have more chances with blue and the others have less.. (reads the next question) *If the game is unfair, what would you have to do to make it fair?* You'd have to change the game so that everybody had equal amounts of uhm cards of every colour then everyone would have equal chances and the game would be un uhm fair.

Teacher: Very good, thank you.

Here we see that the speaker uses school as well as technical register. Mathematical terms and phrases, such as, "It's unfair because...", "more chances", "equal amounts of..." and "equal chances" – that appeared in the radio feature when the protagonists were examining their dice game – are not only used by the students, but also used correctly. Referring to the MRA model explained above, there has been a development from the stage "Noticing" – where new terms or expressions are introduced – to the second stage "Intake" – which describes the process of understanding. There are also first elements of the third stage "Integration", as there is testing, feedback and modification in the investigation of the game's fairness. To reach the last stage "Output", the children would need to be able to use the new terms fluently without support. In this case, the children still have the support of their written answers on their worksheets while presenting their results, so we are unable to tell for sure if they reached this stage. However, it is clear that there is a development from stage one to three – from noticing to integration. This indicates that there is an apparent improvement in the students' mathematical expression throughout the teaching unit. Children are offered professional language and are thus challenged to intake and use it. The absence of visuals, gestures and deictics in auditory material (unlike YouTube videos etc.) is a big challenge and opportunity for language development which worked out in my pilot testing quite well. Thus, as a first conclusion, it can be stated that radio features or auditory material in general can indeed serve as verbal language support in mathematics education. The goal of my main study is to verify and specify this statement for other mathematical topics, to further research on the use of the features in laboratory situations and to develop various possible applications of radio resources as auditory learning material.

References

- Baddeley, A. (2007). *Working memory, thought, and action*. Oxford, England: Oxford University Press.
- Gibbons, P. (2002). *Scaffolding language, scaffolding learning: Teaching second language learners in the mainstream classroom*. Portsmouth, England: Heinemann.
- Götze, D. (2015). *Sprachförderung im Mathematikunterricht* [Language support in mathematics lessons]. Berlin, Germany: Cornelsen.
- Krummheuer, G., & Naujok, N. (1999). *Grundlagen und Beispiele Interpretativer Unterrichtsforschung* [Foundations and examples of interpretive teaching research]. Opladen, Germany: Leske und Budrich.
- Leuders, J. (2011). Auditive Lernmaterialien im Mathematikunterricht [Auditory learning materials in mathematics education]. In R. Haug & L. Holzäpfel (Eds.), *Beiträge zum Mathematikunterricht* (pp. 543–546). Münster, Germany: WTM.
- Leung, C. (2005). Mathematical vocabulary: Fixers of knowledge or points of exploration. *Language and Education*, 19(2), 1227–1135.
- Meaney, T., Trinick T., & Fairhall, U. (2012). *Collaborating to meet language challenges in indigenous mathematics classrooms*. New York: Springer.
- Peters, F. (2018). Auditory material for specialised language support in mathematics education. In H. Weigand, A. Clark-Wilson, A. Donevska-Todorova, E. Faggiano, E., N. Grønbaek, & J. Trgalova- (Eds.), *Proceedings of the 5th ERME Topic Conference MEDA 2018* (pp. 195–200). Copenhagen, Denmark: University of Copenhagen.
- Pimm, D. (1987). *Speaking mathematically: Communication in mathematics classrooms*. New York: Routledge.
- Prediger, S., Link, M., Hinz, R., Hußmann, S., Thiele, J., & Ralle, B. (2012). Lehr- Lernprozesse initiieren und erforschen – Fachdidaktische Entwicklungsforschung im Dortmunder Modell. *Der mathematische und naturwissenschaftliche Unterricht*, 65(8), 452–457.
- Prediger, S., & Krägeloh, N. (2016). “X-arbitrary means any number, but you do not know which one”. In A. Halai, & P. Clarkson (Eds.), *Teaching and learning mathematics in multilingual classrooms* (pp. 89–108). Rotterdam, Netherlands: Sense Publishers.
- Rink, R. (2014). „Lass´ dir die Aufgabe doch vorlesen!“ - mit digitalen Medien Schwierigkeiten beim Sachrechnen begegnen. In S. Ladel, & C. Schreiber, (Eds.). *PriMaMedien - Lernen, Lehren und Forschen mit digitalen Medien im Mathematikunterricht* (pp. 61–78). Band 2. Münster, Germany: WTM.
- Sweller, J. (1994). Cognitive load theory, learning difficulty and instructional design. *Learning and Instruction*, 4(4), 295–312.
- Wittmann, C. E. (1995). Mathematics education as a ‘Design Science’. *Educational Studies in Mathematics*, 29(4), 355–374.

Classroom communication: Defining and characterizing perpendicular lines in high school algebra

Valentina Postelnicu

Texas A&M University-Corpus Christi, USA; Valentina.Postelnicu@tamucc.edu

A study was conducted with a high school algebra teacher and her students with the purpose of gaining insight into the students' difficulties with perpendicular lines. The study reported here focuses on the communication between the teacher and her students, and the nature of their messages. Classroom observations were conducted, and a written task was administered to students. The communication was analyzed using constructs from Hall's theory of culture. The analysis revealed that the teacher's messages were not received by her students in the way intended by the teacher. The students had difficulties defining perpendicular lines, representing graphically and characterizing them algebraically, and connecting between representations.

Keywords: Classroom communication, perpendicular lines, high school algebra.

Introduction

Research on students' difficulties with perpendicular lines and linear equations in the context of high school algebra is scarce (Postelnicu, 2017). Some studies point to students' difficulties with graphical representations and connecting among various representations (Arcavi, 2003; Knuth, 2000), and teachers' failure to identify the nature of their students' difficulties in geometric context (Gal & Vinner, 1997). The purpose of this study is to gain insight into the students' difficulties with perpendicular lines and their equations in the context of high school algebra, as it is taught and learned in a public school in the United States. The focus is on the mathematical knowledge constructed during the classroom interaction (Steinbring, 2005), i.e., on the communication between the teacher and her students, the nature of their messages, and their different interpretations of those messages. Nührenbörger and Steinbring (2009) studied the different interpretations by the teacher and two students of a mathematical statement, and pointed to the dominance of the teacher's ideas during the observed interaction. In the study reported here, the relations between the teacher's language (her messages), the language of the learners (students' messages), and the language of mathematics (textbook's messages) (Planas, Morgan, & Schütte, 2018; Planas & Schütte, 2018) are studied using Hall's (1959) theory of culture.

Theoretical framework: Hall's theory of culture

The teaching and learning of mathematics are cultural activities that take place in various institutions (e.g., the classroom from this study). The theoretical framework used to analyze the classroom culture abides by several principles (Hall, 1959):

i) Culture is equivalent with communication. "Culture is communication and communication is culture" (Hall, 1959, p. 217). This principle of equivalence between classroom culture and classroom communication, allowed us to account for the teaching and learning of mathematics in the observed

classroom by analyzing the communication between the teacher and her students. The idea of equivalence between doing mathematics and communicating mathematically is also found in Sfard (2008).

ii) We communicate through messages. A message is constituted by *sets* communicated in *patterns*. *Sets* are constituted by *isolates*. When one communicates using a language, one uses words (*sets*) that are made of sounds (*isolates*). The words are communicated in some context using a specific syntax (*pattern*) “in order to give them meaning.” (Hall, 1959, p. 124). Old words, communicated using a *pattern*, are used to give meaning to new words. When we learn a new language, the words (*sets*) are perceived first. It takes time to understand the *pattern* of communication in a new language and construct meaningful sentences. As well, it may take a long time to master the sounds (*isolates*) of the new language and pronounce them without the accent from the old language. At the academic level, the mathematical knowledge is communicated in statements like axioms, definitions, or theorems. These statements constitute the *sets*. Examples of such *sets* are the definition of perpendicular lines, or the theorem of algebraic characterization of two perpendicular lines. The *isolates* are the mathematical objects and their properties - like line, slope of a line, lines that intersect to form a right angle. In scholarly mathematics, the *pattern* of communication is the formal proof; it gives meaning to statements/theorems. Old statements, already accepted as true, are used to logically derive new statements, using the accepted rules of inference. Oftentimes, when validating a new statement, the steps of the argument are expressed in natural language and employ previously validated statements (e.g., see Postelnicu (2017) for an example of a proof of the theorem of algebraic characterization of two perpendicular lines described as a “Key Concept” in Table 1, below). The communication *pattern* changes with the cultural context/institution. In school mathematics, the *pattern* of communication may be a justification (e.g., see Wallace-Gomez & Miller (2011) for a visual justification of the “Key Concept” from Table 1, below). In United States high schools, researchers point out that proofs are found mainly in geometry courses, and are almost non-existent in algebra courses (Martinez & Superfine, 2012). In the study reported here, the participants used an Algebra 1¹ textbook (Larson et al., 2007) that contains mathematical statements (e.g., “key concepts”) without proofs. The *pattern* of communication consists of stating the “key concepts” and providing examples of algorithms to execute tasks.

iii) We can only observe a message at one level of communication at a time. When a message is communicated from one cultural context to another, its meaning may change. As observed in this study, the message changes when the level of communication changes (from textbook to teacher, and from teacher to students). Consequently, it is imperative to account for the way the textbook message (with its *pattern* of communication, *sets*, and *isolates*) changes into the teacher’s message, and then into the students’ message.

Methods

The study reported here is part of a larger study with an Algebra 1 high school teacher and her students from a public high school in the United States. The study lasted four weeks and included a teaching

¹ In the United States, students take the first algebra course before the geometry course.

experiment with multiple episodes, with the author as a witness (Steffe & Thompson, 2000), classroom observations carried out by the author (Erickson, 1985), and the administration of various written tasks to students. Only 58 students out of 137 agreed to have their answers reported in this study. The focus is on the classroom communication, as observed by the author, the day after the teacher communicated to her students the definition of perpendicular lines and the “Key Concept” about the slopes of perpendicular lines (described in Table 1, below). The author observed all six classes taught by the teacher in one day, took observation notes, and collected copies after the students’ written answers to the following task administered by the teacher, **Task 1**:

- “a) Sketch the graph of the line that is perpendicular to $y = \frac{3}{4}x - 2$ and goes through the point (2, -6). What is the equation of the new line you created?
 b) How did you determine this?
 c) A fellow student does not understand what perpendicular lines are. Explain to them in as much detail as possible what perpendicular lines are and how you find them.”

Before administering Task 1, the teacher assigned a warm-up task on parallel lines, similar to Task 1a², and solved it on the whiteboard. She also included in her the post warm-up communication a review of the knowledge on perpendicular lines, necessary to execute Task 1a. Students’ written answers to Task 1 were collected. Due to space constraints, I analyze only Task 1c. In my analysis I refer to the connections between Tasks 1a, 1b, and 1c.

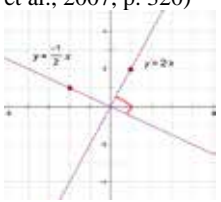
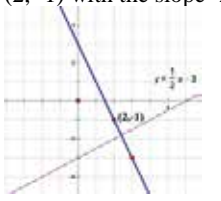
Analysis and results

Table 1, below, represents the levels of communication taken from the Algebra 1 textbook (Larson et al., 2007), the author’s observation notes on the teacher’s communication with her students, and the students’ written answers to Task 1c. The analysis considers the messages at each level, as well as the changes in message from one level to another. The messages are decomposed in *sets* (titled in bold, for example **Statements 1-4**, at the student level), and the *isolates* are presented with bullets. The textbook messages are presented in the first column from Table 1, followed by the teacher’s messages, preceded by “**T**”. The teacher’s messages were subsets of the textbook messages, hence the presentation in the same column from Table 1. The Venn diagrams and the arrows illustrate the change in message from the teacher level to the student level. Table 2, following Table 1, presents examples from the students’ written answers on Task 1c. Each of the **Statements 1-4** is accompanied by **Examples** from the students’ answers. For continuity of presentation, Table 2 restates in its first columns the student messages (*sets* with their *isolates*), exactly like in Table 1. The analysis follows each message (*set* and its *isolates*) horizontally in Tables 1 and 2, respectively. As mentioned before, when one encounters a new language, the words (*sets*) are perceived first, therefore the analysis was conducted at the level of *sets*.

It can be seen in Table 1 that in the context of Task 1c, three *sets* were communicated at the textbook and teacher level: the definition of perpendicular lines, the “key concept” stating the theorem of algebraic

² Sketch the graph of the line that is parallel to $y = \frac{1}{2}x - 3$ and goes through (2, -1).

characterization of two perpendicular lines, and the first step of the algorithm for executing Task 1a, the step referring to identifying the slope of a line perpendicular to a given line. Each of those *sets* are analyzed at the textbook, teacher, and student level. It can be observed in Table 1 that the *sets* at the student level were constituted from the *isolates* at the textbook and teacher level.

Communication at the textbook and teacher level (T)		Communication at the student level	
<i>Sets</i>	<i>Isolates</i>	<i>Sets</i>	<i>Isolates</i>
<p>“Perpendicular Lines: Two lines in the same plane are perpendicular if they intersect to form a right angle.” (Larson et al., 2007, p. 320)</p>  <p>T: “Perpendicular lines intersect and form a right (90°) angle.”</p>	<ul style="list-style-type: none"> two lines that intersect to form a right angle* two lines in the same plane 	<p>Statement 1 about intersecting lines: Perpendicular lines are lines that intersect. (N=35)*</p>	<ul style="list-style-type: none"> line two lines two lines that intersect
		<p>Statement 2 about intersecting lines forming a right angle: Perpendicular lines are two lines that intersect to form a right (90°) angle. (N=6)</p>	<ul style="list-style-type: none"> two lines that intersect angle right angle
<p>“Key Concept: If two nonvertical lines in the same plane have slopes that are negative reciprocals, then the lines are perpendicular. If two nonvertical lines in the same plane are perpendicular, then the slopes are negative reciprocals.” (Larson et al., 2007, p. 320)</p> <p>T: “Perpendicular lines have slopes negative (opposite) reciprocals.”</p> <p>Algorithm for Task 1a (Step 1): Identify the slope m of the new line based on the “key concept” (perpendicular lines have slopes negative reciprocals). (Larson et al., 2007, p. 321)</p> <p>T: “You take the slope of the original line, a/b, that is $1/2$, flip it, b/a, that is $2/1$, and change its sign, $-2/1$.” (Note: Given the line and the point from the warm-up activity, the teacher drew the line through $(2, -1)$ with the slope $-2/1$.)</p> 	<ul style="list-style-type: none"> perpendicular lines lines with slopes that are negative reciprocals slope of the given line slope of the perpendicular line is the opposite reciprocal of the slope of the given line nonvertical lines 	<p>Statement 3 about the slopes of perpendicular lines: Perpendicular lines have slopes that are negative reciprocals. (N=8)</p>	<ul style="list-style-type: none"> two perpendicular lines slope negative reciprocals
		<p>Statement 4 about finding the slope of a perpendicular line: To find the slope of a line perpendicular to a given line, you find i) the slope of the given line, and ii) the negative/opposite reciprocal of the slope of the given line. (N=28)</p>	<ul style="list-style-type: none"> given line slope of the given line the negative/opposite reciprocal of the slope of the given line perpendicular line

* (N=35), after Statement 1, represents the number of students who communicated that statement.

Table 1: Representation of levels of communication

The first *set* in Table 1 (column 1) defines perpendicular lines. The textbook marks one of the right angles formed by two perpendicular lines in a graphical representation similar to the one from Table 1 and points to the “Key Concept” necessary to execute Task 1a (a 90° rotation of a line generates a perpendicular line, and the two lines have slopes that are opposite reciprocals). At the textbook level, the definition contains *isolates* like “two lines in the same plane” and lines that “intersect to form a right angle” (Table 1, column 2). At the teacher’s level, the *isolate* “two lines in the same plane” was omitted, and the right angle was sometimes referred to as a “ 90° angle.” As noticed in Table 1 (columns 2 and 3) at the student level, the teacher’s *isolate* referring to two lines that “intersect to form a right angle” changed into two *sets*, **Statements 1** and **2**, the first referring to intersecting lines and the second referring to intersecting lines that form a right angle. Consequently, more than half of the students ($N=35$) defined perpendicular lines as lines that intersect. The *isolate* “line” was not problematic for students with respect to their graphical representations (all students graphed lines), but the other *isolates* from **Statement 1**, “two lines” and “two intersecting lines” posed difficulties. The examples accompanying **Statement 1** in Table 2 suggest the following difficulties: i) conceiving of the second line, given one line (**Example 1**, “a perpendicular line is a line that intersects with something”); ii) connecting between representations (parallel lines were represented in **Example 2**, but described as “lines that intersect, they both share the same point,” and parallel lines that “do not ever touch” were described in **Example 3**, where intersecting lines were graphed); iii) conceiving of the intersecting point (the point of intersection was mentioned in three of the students’ answers but was not marked in any of the students’ answers, making questionable the meaning of “intersecting lines” in answers like in **Example 4** where intersecting lines were described as “touching or crossing over each other”).

Continuing with the **Statement 2** in Table 2, only six students mentioned “lines that intersect to form a right (or 90°) angle, three of them did not have matching graphical representations (see **Example 5**, where the lines intersect but do not form right angles), and three of them had matching graphical representations like in **Example 6**. The analysis of the students’ answers including **Statement 2** indicates that while the *isolate* “two intersecting lines” did not pose difficulties, the *isolate* “right angle” was problematic. This issue raised the question if the difficulty was limited only to the measure of the angle or if it extended to the concept of angle itself.

To execute Task 1a, one needs the theorem of algebraic characterization of two perpendicular lines in a Cartesian system of coordinates (see the “**Key Concept**” in Table 1, column 1), and the algorithm to apply it (see also the **Algorithm for Task 1a (Step 1)**). At the teacher level, the theorem was stated “Perpendicular lines have slopes negative reciprocals,” and sometimes “negative” was replaced by “opposite” to emphasize that the slopes of perpendicular lines have opposite signs. The *isolate* “nonvertical lines” was not mentioned by the teacher during classroom observations. As mentioned in **Methods**, the teacher reminded her students how to determine the slope of the line perpendicular to the given line $y = (1/2)x - 3$, by finding the opposite reciprocal of the slope of the given line: “You take the slope of the original line, a/b , that is $1/2$, flip it, b/a , that is $2/1$, and change its sign, $-2/1$.”

The teacher matched the algebraic and graphical representations (see the last figure in Table 1, column 1). The students used the *isolates* from the teacher level (Table 1, column 2) to constitute their *sets*,

Statements 3 and 4 (see Table 1, column 3). **Statement 3** refers to a characteristic property used by students to define two perpendicular lines, while **Statement 4** refers to the algorithm of finding the slope of a line perpendicular to a given line, $y = mx + b$. None of the students who stated the property from **Statement 3** used it correctly in the algorithm described in **Statement 4**. Although the students mentioned “slope” and “negative reciprocals,” they failed to identify the slope of the given line or its negative reciprocal. Therefore, the students’ answers were reported separately for **Statements 3 and 4**.


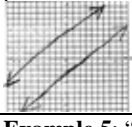
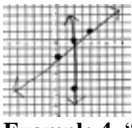
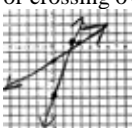
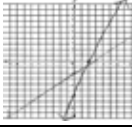
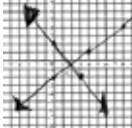
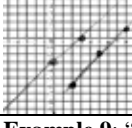
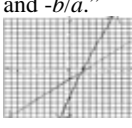
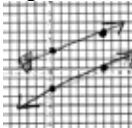

Communication at the student level		Examples from the students’ written answers	
Sets	Isolates		
<p>Statement 1 about intersecting lines: Perpendicular lines are lines that intersect. (N=35)</p>	<ul style="list-style-type: none"> line two lines two lines that intersect 	<p>Example 1: “A perpendicular line is a line that intersects with something.”</p>  <p>Example 2: “Perpendicular lines are lines that intersect, they both share the same point.”</p> 	<p>Example 3: “Perpendicular lines are lines that are side by side and do not ever touch each other.”</p>  <p>Example 4: “Perpendicular lines are lines that are straight but are touching or crossing over each other.”</p> 
<p>Statement 2 about intersecting lines forming a right angle: Perpendicular lines are two lines that intersect to form a right (90°) angle. (N=6)</p>	<ul style="list-style-type: none"> two lines that intersect angle right angle 	<p>Example 5: “Perpendicular lines [...], the intersection of the lines form 90° angles.”</p> 	<p>Example 6: “Perpendicular lines- lines that intersect with a 90° angle.”</p> 
<p>Statement 3 about the slopes of perpendicular lines: Perpendicular lines have slopes that are negative reciprocals. (N=8)</p>	<ul style="list-style-type: none"> perpendicular lines slope negative reciprocals 	<p>Example 7: “A perpendicular line are 2 nonvertical lines that have negative reciprocals.”</p> 	<p>Example 8: “Perpendicular lines are two nonvertical lines that have negative reciprocals. Slopes are a/b and $-b/a$.”</p> 
<p>Statement 4 about finding the slope of a perpendicular line: To find the slope of a line perpendicular to a given line, you find i) the slope of the given line, and ii) the negative/ opposite reciprocal of the slope of the given line. (N=28)</p>	<ul style="list-style-type: none"> given line slope of the given line the negative/ opposite reciprocal of the slope of the given line perpendicular line 	<p>Example 9: “Perpendicular lines touch, you must flip the sign and make it a negative.”</p> 	<p>Example 10: “Perpendicular lines- lines that intersect with a 90° angle. In order to find them you need to plot the original $y = \frac{1}{2}x + 3$, then make everything opposite of that, $y = -2x + 3$, then graph.”</p> 

Table 2: Representation of the communication at the student level

Only one of the eight students who referred to **Statement 3** in their answers had a graphical representation of perpendicular lines. The other answers had graphical representations of parallel lines and non-perpendicular, intersecting lines (see **Examples 7** and **8**, respectively, accompanying **Statement 3** in Table 2). In **Examples 7** and **8** perpendicular lines were described as “lines that have negative reciprocals,” and in **Example 7** “slope” was omitted. The *isolate* “perpendicular lines” remained problematic for students. Likewise, the *isolate* “slope” posed great difficulty, especially in the graphical representation. The *isolate* “negative reciprocals” or “opposite reciprocals” was used by 28 students (see Table 2, **Statement 4** and **Examples 9-10**). However, *isolates* like “perpendicular line” and “given line” and its “slope” posed difficulties for students, as shown in their graphical representations (see **Example 9** with parallel lines). In **Example 10**, the slopes of the two lines are those from the teacher’s example used in the post warm-up communication, the student wrote “make everything opposite,” although the *y*-intercept of the lines was not changed, and the graphical and algebraic representations did not match. Only 14 students determined correctly the slope of the perpendicular line in Task 1a, but they failed to find the correct *y*-intercept. Notwithstanding a minor sign error, two students found the equation of the perpendicular line from Task 1a, but their algebraic and graphical representations did not match.

Conclusions

The communication between the teacher and her students, analyzed at the level of *sets*, showed the following features:

- 1) The lessons observed in this study were “ritualistic” and abided by the following “routine” (Lavie, Steiner, & Sfard, 2019): like in the textbook, the teacher stated the “key concepts” and presented a “model” for executing a task, then asked the students to execute a similar task. The *pattern* of communication lacked justifications or proofs.
- 2) The teacher’s messages were not understood by the students in the way the teacher intended. The teacher communicated using *sets* like those from the Algebra 1 textbook (Larson et al., 2007), but only some of the *isolates* of those *sets* were received by students. The students communicated using *sets* that were constituted from the teacher’s *isolates*, with a *pattern* lacking justification or proofs.

To overcome the effects of the “ritualization,” Lavie et al. (2019) recommend turning rituals into explorations. In our case, another way to think about teaching about perpendicularity would have been to look for *patterns* of *isolates* within each *set*. For example, in the case of the *isolate* “right angle,” one such *pattern* might have been constituting all four right angles that are formed by two perpendicular lines, pointing to their vertex and sides (to constitute the *isolate* “angle”), describing them (their measure), giving counterexamples (acute and obtuse angles), and connecting the verbal and graphical representations. An example of an exploration to justify the “**Key Concept**” (see Table 1, column 1) is described by Wallace-Gomez and Miller (2011).

References

- Arcavi, A. (2003). The role of visual representations in the teaching and learning of mathematics. *Educational Studies in Mathematics*, 52(3), 215-241. doi: 10.1023/A:1024312321077

- Erickson, F. (1985). *Qualitative methods in research on teaching*. Occasional Paper No. 81. East Lansing, MI: The Institute for Research on Teaching, Michigan State University.
- Gal, H., & Vinner, S. (1997). Perpendicular lines - What is the problem? Pre-Service teachers' lack of knowledge on how to cope with students' difficulties. In E. Pehkonen (Ed.), *Proceedings of PME21* (Vol. 2, pp. 281-288). Lahti, Finland: PME.
- Hall, E. T. (1959). *The silent language*. Garden City, NY: Doubleday.
- Knuth, E. J. (2000). Student understanding of the Cartesian connection: An exploratory study. *Journal for Research in Mathematics Education*, 31(4), 500-508. doi: 10.2307/749655
- Larson, R., Boswell, L., Kanold, T., & Stiff, L. (2007). *Algebra I*. Evanston, IL: McDougal Littell.
- Lavie, I., Steiner, A., & Sfard, A. (2019). Routines we live by: From ritual to exploration. *Educational Studies in Mathematics*, 101(2), 153-176. doi: 10.1007/s10649-018-9817-4.
- Martinez, M. V., & Superfine, A. C. (2012). Integrating algebra and proof in high school: Students' work with multiple variables and a single parameter in a proof context. *Mathematical Thinking and Learning*, 14(2), 120-148. doi: 10.1080/10986065.2012.657956
- Nührenbörger, M., & Steinbring, H. (2009). Forms of mathematical interaction in different social settings: Examples from students', teachers' and teacher-students' communication about mathematics. *Journal of Mathematics Teacher Education*, 12(2), 111-132. doi: 10.1007/s10857-009-9100-9
- Planas, N., Morgan, C., & Schütte, M. (2018). Mathematics and language: Lessons and directions from two decades of research. In T. Dreyfus, M. Artigue, D. Potari, S. Prediger, & K. Ruthven (Eds.), *Developing research in mathematics education: Twenty years of communication, cooperation and collaboration in Europe* (pp. 196-210). New York: Routledge.
- Planas, N., & Schütte, M. (2018). Research frameworks for the study of language in mathematics education. *ZDM*, 50(6), 965-974. doi: 10.1007/s11858-018-0997-2
- Postelnicu, V. (2017). Didactic transposition in school algebra: The case of writing equations of parallel and perpendicular lines. In T. Dooley & G. Gueudet (Eds.), *Proceedings CERME10* (pp. 480-487). Dublin, Ireland: Dublin City University, Institute of Education and ERME.
- Sfard, A. (2008). *Thinking as communicating. Human development, the growth of discourses and mathematizing*. New York: Cambridge University Press.
- Steffe, L. P., & Thompson, P. W. (2000). Teaching experiment methodology: Underlying principles and essential elements. In A. E. Kelly, & R. A. Lesh (Eds.), *Handbook of research design in mathematics and science education* (pp. 267-307). Mahwah, NJ: Lawrence Erlbaum Associates.
- Steinbring, H. (2005). *The construction of new mathematical knowledge in classroom interaction –An epistemological perspective*. New York: Springer.
- Wallace-Gomez, P., & Miller, J. (2011). Slopes of parallel and perpendicular lines: A visual justification. *The Mathematics Teacher*, 104(9), 728-728.

Disentangling students' personal repertoires for meaning-making: The case of newly arrived emergent multilingual students

Susanne Prediger, Ángela Uribe, and Taha Kuzu

TU Dortmund University, Germany

prediger@math.uni-dortmund.de & angela.uribe@math.uni-dortmund.de

Empowering multilingual students for mathematics learning requires building on their multilingual repertoires. Although this claim has often been repeated, the students' repertoires and the interplay of their components have so far only been partly understood. The repertoire comprises different state languages but also different registers and representations serving as multimodal sources for meaning-making. This paper contributes to unpacking students' personal repertoires for meaning-making of mathematical concepts (comparing fractions). A qualitative study of three newly arrived Syrian immigrants' learning processes identifies (re)sources that the study subjects have that are different from those of native residents that had been found in former studies. These results show that teaching-learning arrangements should connect the registers and representations in more flexible trajectories.

Keywords: Multilingual repertoires, language, qualitative case study, newly arrived multilinguals.

Background: Disentangling personal multilingual repertoires as a research gap

Theoretical background: Multilingual repertoire as a resource for mathematics learning

Academic and pedagogical discourses on multilingual mathematics classrooms have undergone several shifts, not only from language-as-problem and language-as-right to language-as-resource (Planas & Setati-Phakeng, 2014), but also from focusing on students' resources in different national languages from quite static perspectives to more dynamic conceptualizations carried by the construct of a person's *language repertoire* (Barwell, 2018; Planas, 2018). Blackledge, Creese, and Kaur Takhi (2014) define a person's communicative repertoire as "the collection of ways individuals use language and ... other means of communication to function in the multiple communities in which they participate" (p. 487) and emphasize its dynamic character. Disentangling these personal repertoires is crucial for teaching approaches that build upon these resources. In order to do this, we need to focus on the *communicative* role of personal repertoires but also on their *epistemic* role in the interactive construction of meanings for mathematical concepts (Prediger & Wessel, 2013). When personal repertoires are conceptualized as sources for meaning-making (Barwell, 2018), it is even more crucial that they contain different national languages as well as overlapping registers (i.e., the functional varieties of language use) tied to social practices (Halliday, 1978) and social languages (Planas, 2018). Besides these language registers, other multimodal sources such as graphical or symbolic representations, gestures, and prosody must also be taken into account as sources for meaning-making (Prediger, Clarkson, & Bose, 2016). This paper contributes to disentangling relevant sources of meanings in the personal repertoires of multilingual students with diverse immigrant backgrounds.

Relating registers and representations as a teaching approach for building upon students' personal repertoires

Dynamic, multimodal conceptualizations of multilingual repertoires resonate with teaching approaches that outline the didactical potentials of relating registers and representations for meaning

making (see Figure 1 from Prediger, Clarkson, & Bose, 2016; similarly, Moschkovich, 2013). In many teaching approaches, teaching-learning arrangements start by activating students' informal experiences in concrete and graphical representations or familiar contexts and mobilizing their everyday languages, all of which are later systematically related to the target formal registers and representations. For multilingual students, this approach is extended to home languages (Moschkovich, 2013; Planas & Setati-Phakeng, 2014): Informal experiences and everyday language resources in home languages can be activated in multilingual mathematical discourses. Still, "meaning-making is relational" (Barwell, 2018), that is, it takes place by relating languages, registers, and representations to each other across all languages of the learners.

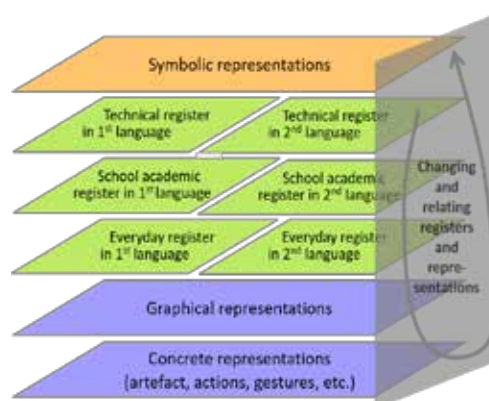


Figure 1: Relating registers and representations

Previously, based on this teaching approach, a bilingual German/Turkish teaching intervention on conceptual understanding of fractions was designed for multilingual seventh graders (native residents whose parents or grandparents born in Turkey). The study of this intervention provided quantitative evidence for the efficacy of the intervention despite the students' limited experience with the technical register in Turkish and qualitative insights into the functioning of relating languages, registers, and representations along the sketched learning trajectory from informal resources to formal learning content (Schüler-Meyer, Prediger, Kuzu, Wessel, & Redder, 2019).

In the current step of this research, the qualitative study has been extended to newly arrived immigrants from Syria. The analysis of Syrian textbooks and interviews with Syrian teachers gave indications that Syrian math classrooms prioritize the formal register and symbolic representation over the meaning-related register and the contextual and graphical representations. Thus, empirical research is required to investigate whether these different mathematical practices might influence the students' use of their multimodal repertoires.

Research gap: Disentangling the repertoires for newly arrived students from Syria

In order to adapt the main ideas of the teaching approach of relating registers and representations to multilingual repertoires of newly arrived students, it is therefore crucial to identify these personal repertoires and their activation empirically. Therefore, the learning-process study in this paper pursues the following research question: *Which personal repertoires do newly arrived students activate for meaning-making in the subject of comparing fractions?*

Methodological framework for the learning-process study

The research question was pursued in a learning-process study that was part of the larger mixed-methods project, MuM-Multi (Schüler-Meyer, Prediger, Kuzu, Wessel, & Redder, 2019), based on a teaching-learning arrangement developed by Prediger and Wessel (2013).

Methods of data gathering

Intervention. The project investigates a bilingual teaching intervention for developing multilingual students' conceptual understanding of fractions (especially organized for the research project). The

intervention was conducted in small groups of 2-5 students each, and all groups were videotaped. The teaching material was provided in German and Arabic (or Turkish in the previous study), teachers spoke both languages.

Sample. The intervention addressed newly arrived Syrian students ($n = 18$, 12-15 years old) who are emergent German speakers (abbreviated as emergent multilinguals). Their prior formal education in Syria (5-8 years) took place in their Arabic. We present a case study of three students, Manal, Malik, and Zarah, who have learned German for 1.5-2.5 years and reached a German proficiency level of A2.2 in the Common European Framework of Reference for Languages. Among the three, Malik has the strongest mathematics achievements in the pre-test, and Zarah is slightly more proficient in German language than the others. The data was later compared to findings from the first intervention with native residents who spoke both German and Turkish ($n = 41$, 12-14 years old) who had grown up in Germany with no prior experience in activating their home language, Turkish, for institutionalized mathematics learning situations.

Selected task for the case study. While many episodes from the video data corpus were analyzed in order to identify the students' repertoires, the case study presented here is focused on the task in Figure 2. It stems from the second session of the intervention, when students had already worked on the part-whole concept. The task aims at consolidating the students' part-whole concept by addressing shares for different wholes (10 GB and 5GB) and at preparing the comparison of fractions. Subtask C follows the variation principle: Students usually solve it by either lengthening the bar in the graphical representation (the teacher then asks them to also relate this to the symbolic representation, e.g., articulating that $7/10$ is less than $8/10$ or that $7/10$ must be added by $1/10$ to reach $8/10$) or starting in the symbolic representation and formally adding $1/10$ (the teacher then asks them to also show what this means in the graphical representation). The relation of meaning-related, formal language registers and different representations is at the core of developing conceptual understanding.

Methods of qualitative data analysis

The transcripts of the selected videos were qualitatively analyzed in two steps with respect to students' conceptual development across languages, registers, and representations:

- In Step 1, teachers' questions and students' answers were analyzed turn by turn with respect to the uttered individual theorems- and concepts-in-action (Vergnaud, 2016) on the part-whole concept and the students' emergent ideas for comparing fractions.
- In Step 2, each utterance was coded by the register and/or representation the speaker refers to and with a "+" if two registers/representations were related within the utterance or between two

Finding equal-sized parts in the fraction bars

Badr has already downloaded 7 GB of a 10 GB film.
Aziza has downloaded 4 GB of a 5 GB film.

- A Draw Aziza's and Badr's parts into the fractions bars and write down the fractions for their shares.

7 Gleich große Anteile in Streifen finden

a) Male Azizas und Badrs Anteile vom Ganzen aus Aufgabe 6 in die Streifen und schreibe die Brüche links neben die Streifen.

b) Wer hat den größeren Anteil vom Ganzen geladen? Wovon steht du das im Streifen?

c) Was musst du ändern, damit die Anteile gleich groß werden?

- B Who has loaded the larger part of the whole?
How do you see that in the bar?

- C What do you have to modify so that the parts become equal size?

Figure 2: Fraction tasks in the case study and its preliminary solution by Zarah

utterances. For example, “multiply,” “denominator,” and “times” are coded as terms from the technical register, “part of whole,” “colored bar,” and “equally long” as terms from the meaning-related academic register (Prediger & Wessel, 2013). Although some terms appear in different registers, their use is specific to the different registers, for example, “equally large” as a technical term vs. “equal” as an everyday term. As some English translations of terms do not exactly reflect the register character of the German or Arabic original, the original language was focused.

Insights into learning processes of newly arrived emergent multilinguals: Case study of Manal, Malik, and Zarah and equal-sized parts of the bars

In the episode in view from the first session, the newly arrived students Manal, Malik, and Zarah work with a German- and Arabic-speaking native resident bilingual pre-service teacher (TeaA) and a German-speaking teacher (TeaG) on the comparison of fractions (tasks printed in Figure 2). In earlier tasks, the fraction bars were introduced in the download context. Prior to seeing the printed part of the transcript, the students solved Task A (see Figure 2 for Zarah’s solution), drew the colored parts of the bars and wrote down the fractions. They then discussed Task B with TeaA in Arabic: Which child has downloaded a larger part of the whole, Badr’s share of $7/10$ or Aziza’s share of $4/5$. Although the graphical representation was drawn, their discussion with TeaA in Task B mainly refers to the technical Arabic register and the symbolic representation and less to the download context and related everyday language. In contrast, neither the graphical representation nor any meaning-related term, such as “share,” “part,” or “whole,” are explicitly addressed. TeaG takes over when students arrive at Task C.

45	TeaG	Now, we want to think about, how can we make this equal [<i>points at the end of the colored parts of the bars</i>]? How can we make $7/10$ and $4/5$ equally large? Do you have an idea?	T	graphical repr. + technical reg. + everyday reg.
46	Zarah	Five times two and four times two.	Z	symbolic repr.
47	TeaG	Yeah, you have an idea how to do this by [symbolic] calculations. But then, they are not yet equal, I think, because there is $8/10$ [<i>points at the bar of 4/5</i>] and $7/10$ [<i>points at the shorter bar</i>]. Do you have an idea, perhaps, when you look at the picture? Manal, you look as if you have an idea.	T	(<i>explicit</i>): not symb., but graphical repr.
48	Manal	Aziza is very, pretty large [<i>points at the 4/5 bar of Aziza</i>]	Mn	graphical repr.

In Turn 45, the teacher asks how to modify $7/10$ so that the colored part of the bar becomes equally long as the colored part in the $4/5$ bar. He uses the everyday terms “make equal” and the technical term “equally large” while pointing at the graphical representation, intending to connect these three registers and representations. But his plans are not fulfilled: Zarah (in Turn 46) does not refer to the graphical representation but only to the verbalized symbolic representation. In Turn 47, the teacher acknowledges that her procedure for finding an equally large fraction for $4/5$ is mathematically correct. He continues asking her to explain also how to modify $7/10$ so that it reaches $8/10$, and makes explicit that he wants her to refer also to the graphical representation. This repeated hint leads Manal to refer to the expected representation: Manal uses the graphical representation as the source for the comparison of fractions for the first time in Turn 48. Although she visibly struggles while searching for adequate German terms (“pretty great”) and does not complete the sentence in a grammatically correct form, her German is still sufficient to express her meaning-related ideas on the comparison, together with gestures. In contrast, Malik stays in the more familiar technical register:

49	TeaG	Exactly, Aziza is larger and what can we do so that Badr is equally large?	T	graphical repr.
----	------	--	---	-----------------

50	Malik	Simple, Simplify [...] 10 gigabytes.	Mk context lang. + symb repr.
...			
55	TeaG	How can you do it in the picture? [<i>hints to graphical representation</i>] [...]	T graphical repr.
56	Malik	The ten divided by two becomes five [<i>points at the longer and shorter bars</i>].	Mk technical register, hints to graph. repr

Although Malik receives several prompts to refer to the graphical representation (Turns 49, 51, 53, 55), he talks in the technical register (Turns 50-56). His interpretation of “equally large” seems to be “of same denominator,” without satisfying the teachers’ (perhaps unusual) expectation of adding $1/10$ to the bar. In Turn 56, he finally gestures to the graphical representation. The teacher tries once more to focus students’ attention to the elongation of the colored part of the bar:

57	TeaG	[...] Then [...], but this would be until here and for Aziza this would be until here [<i>hints again to the ending points of both bars of unequal length</i>] What would we have to do so that both shares become equally large We have seen, $7/10$ is less than $4/5$. But do you have an idea how to modify $7/10$?	T graphical repr.
58	Zarah	Well, we can change this [<i>points at the eighth piece in the 7/10-bar</i>]. And then, five times two and four times two becomes eight, like that?	Z graphical + symb repr.
59	TeaG	Hmm, exactly, but what you said first, this was a very good idea. What did you say?	T strengthens graphical repr.
60	Zarah	We can here [<i>imitates the coloring of the eighth piece</i>]	Z graphical repr.
61	TeaG	Do it, actually. Because, what happens if you color this piece?	T graphical repr.
62	Zarah	That becomes equally long [<i>points at the ending points of the colored bars</i>]	Z graphical repr.
63	TeaG	Then, the shares are also equally large.	T graphical repr.
64	Zarah	Then I do this? [<i>all students now color the eighth piece in the 8/10-bar</i>]	Z graphical repr.

The teacher’s repeated prompt to focus on the graphical representation finally leads to Zarah’s idea to relate the graphical and the symbolic representations in Turn 58 (“change this”). Again, she uses a minimal set of words to address her meaning-related ideas with gestures, deictic means, and prosody, but without explicitly articulating meaning-related terms. Once she has expressed her meaning-related ideas of modifying the part of the fraction bar, she can make explicit the meaning of “equally large” in the meaning-related register describing the graphical representation: “That becomes equally long” (in Turn 62). Here, the graphical representation is used to solve the task for the first time, not only as a diagram to read off numbers. In her solution, she considers both colored bars and their relation, as originally intended by the task. After this, the teacher asks for a justification:

65	TeaG	Yes, exactly, and why are the shares equally large, then? [...]	T graphical repr.
66	Zarah	Five times two and four times two #	Z symbolic repr.
67	Malik	#Eight	Mk symbolic repr.

The teacher’s “why” question in Turn 65 brings Zarah back to the technical register and the symbolic representations (Turn 66), and Malik joins her (Turn 67). Based on her experience with mathematical practices, justification in mathematics requires symbolic representation, as she formulates in another part of the transcript. However, this time, the symbolic procedure is related to the graphical shift from one bar to the next. Thus, Turns 58-67 indicate an activity of relating registers and representations.

Some turns later, the Arabic-speaking teacher talks to the students again and they switch to Arabic. Manal admits to have not yet understood (grey letters mark Arabic parts of the transcript):

79	TeaA	[...] You do not know how to write it?	
80	Manal	No, I have not understood it.	

...			
83	TeaA	[to Malik] [...] Can you explain to her [<i>points at Manal</i>] how you found the result, why you have drawn one more?	T graphical repr., meaning-rel. reg.
84	Malik	Because they are equally large.	Mk graphical repr.
85	TeaA	First, this is longer and that is why she got the idea to add one.	T + technical reg.

The Arabic discourse gives Manal the space to admit that she has not understood (Turn 80). The teacher makes sure that she constructs the meaning of the graphical representation (Turns 81, 83, and 85). Malik explains in the technical register what the graphical representation means (Turn 84), and then the teacher explains the graphical modification, also, remarkably, in technical terms (“add one”). During the whole discussion of Task C, the Arabic terms for “whole bar,” “colored part of the bar,” and “share” are not formulated by either the students or by the teacher.

In total, this episode shows that students and teachers activate different sources for meaning-making: Whereas the German teacher intends to construct meanings for the symbolic $7/10 + 1/10 = 8/10 = 4/5$ by working within the graphical representation and the meaning-related register, the students show a huge distance from the graphical representation, but a familiarity with the symbolic representation and a preference for the technical register. After longer negotiations, the teacher and the students jointly construct the meaning for the graphical representations by means of the context (not shown here) and by means of the symbolic representation. This huge difference in the students’ sources of meaning-making and felt need for meaning-making for unfamiliar representations are more influential to the situation than the missing meaning-related vocabulary, which the students compensate for by gesturing and other multimodal sources.

Contrasting the learning processes of native resident multilingual students and newly arrived emergent multilinguals

To contrast the presented case of Manal, Malik, and Zarah with native resident multilingual students, we draw upon findings in earlier publications (e.g., Schüler-Meyer et al. 2019) from native resident students who spoke both German and Turkish. The case study of Manal, Malik, and Zarah suggests drawing the emergent multilinguals’ repertoires in a different way: not in hierarchical levels of successive abstraction from bottom to top, as shown in Figure 1, but in three columns, where the symbolic, graphical, and contextual representations serve as mediators between the home language and German language in each of the registers, as shown in Figure 3.

Although theoretically the languages and registers could be related in different combinations, Figure 3 shows the combinations that were empirically identified. Native resident multilingual students in previous studies have often appeared to feel alienated from symbolic representation and prefer the everyday register and contextual representations, from which they access the graphical representation and the meaning-related academic register in both languages and, in the end (with teacher’s support), also the technical register and the symbolic representation. In their processes, travelling between both languages in bilingual connective modes was a major resource for their meaning-making processes (Schüler-Meyer et al., 2019; similarly in Moschkovich, 2013; Barwell, 2018).

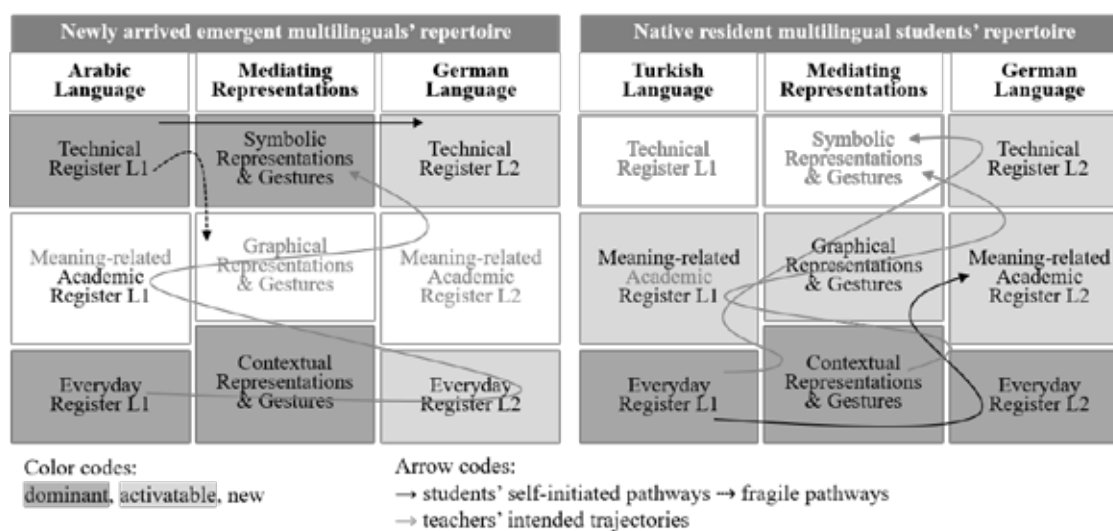


Figure 3: Contrasting the multilingual repertoires in parallel episodes

In contrast, for the three newly arrived students in the current case study, connecting both languages in either of the registers rarely occurred, mainly because they strictly reserved German for the German-speaking teacher and Arabic among themselves and for the bilingual teacher. The fact that they adopted only a dual monolingual mode with rare exceptions might be traced back to the teachers' languages (Planas & Setati-Phakeng, 2014, emphasize the language context as a crucial influence) and also to the fact that their German was not yet fluent, which shows why the term *emergent bilingual* applies. Furthermore, newly arrived students who are familiar with the symbolic representation can easily transfer the basic technical terms from their home language to German. With some teacher support, they can unpack the meaning of the symbolic elements by using implicit meaning-related references to the graphical register. In our video material, all newly arrived students were acquainted to verbalizing the symbolic representations in German, and they activated this resource to construct meanings for a more unfamiliar representation.

Hence, for the investigated students, the different prioritization of representations in Syrian and German lessons appeared to have a direct impact on different uses of students' repertoires. Those who grew up in classrooms where the technical register and the symbolic representation were more valued developed other learning pathways through their individual resources for meaning making. These pathways have not yet been considered, in either the international theoretical discourse (Barwell, 2018; Planas, 2018; Planas & Setati-Phakheng, 2018) or in classroom practices in Germany.

Discussion and outlook

As this case study has shown, students' personal multilingual repertoires can be very diverse. Whereas native resident students in Germany usually refer to contexts, graphical representations, and everyday registers as their sources for meaning-making (Moschkovich, 2013; Planas, 2013; Barwell, 2018), some of the newly arrived immigrants have strong resources in symbolic representations and thereby more quickly acquire the German technical register that their resident peers have to first get to know. In contrast, they can be unfamiliar with an emphasis on graphical representation, which is a typical shared practice in German classrooms, but not all over the world.

Although the case study is far too selective and limited in sample and scope to generalize these patterns, it already contributes to theorizing the dynamic conceptualizations of personal repertoires: repertoires are diverse and include registers and representations, beyond state languages (Barwell, 2018; Planas, 2018). We add that it should also take into account different mathematical practices in dealing with representations and registers. These theoretical extensions also have practical consequences for classrooms: Rather than planning only one learning trajectory that starts from the everyday register and concrete representations towards the formal and symbolic (Prediger & Wessel, 2013), more flexible learning trajectories should be planned. Here, we can add that for newly arrived students, it can even be beneficial to start from symbolic representations and technical registers and then continue towards graphical representations and meaning-related registers.

Acknowledgement. This paper was developed in the “MuM-Multi: Fostering Language in multilingual mathematics classrooms” project, funded from 2014-2020 by the German ministry BMBF (grant 01JM1403A to S. Prediger & A. Redder). We thank the colleagues for the interdisciplinary collaboration.

References

- Barwell, R. (2018). From language as a resource to sources of meaning in multilingual mathematics classrooms. *Journal of Mathematical Behavior*, 50, 155-168. doi: 10.1016/j.jmathb.2018.02.007
- Blackledge, A., Creese, A., & Kaur Takhi, J. (2014). Voice, register and social position. *Multilingua*, 33(5-6), 485-504.
- Halliday, M. A. K. (1978). *Language as social semiotic: The social interpretation of language and meaning*. Baltimore, MD: University Park Press.
- Moschkovich, J. (2013). Principles and guidelines for equitable mathematics teaching practices and materials for English Language Learners. *Journal of Urban Mathematics Education*, 6(1), 45-57.
- Planas, N. (2018). Language as resource: A key notion for understanding the complexity of mathematics learning. *Educational Studies in Mathematics*, 98(3), 215-229. doi: 10.1007/s10649-018-9810-y
- Planas, N., & Setati-Phakeng, M. (2014). On the process of gaining language as a resource in mathematics education. *ZDM*, 46(6), 883-893. doi: 10.1007/s11858-014-0610-2
- Prediger, S., & Wessel, L. (2013). Fostering German language learners’ constructions of meanings for fractions *Mathematics Education Research Journal*, 25(3), 435-456. doi: 10.1007/s13394-013-0079-2
- Prediger, S., Clarkson, P., & Bose, A. (2016). Purposefully relating multilingual registers. In R. Barwell et al. (Eds.), *Mathematics education and language diversity. The ICMI 21 Study* (pp. 193-215). Dordrecht, Netherlands: Springer.
- Schüler-Meyer, A., Prediger, S., Kuzu, T., Wessel, L., & Redder, A. (2019). Is formal language proficiency in the home language required to profit from a bilingual teaching intervention in mathematics? *International Journal of Science and Mathematics Education*, 17(2), 317-399. doi: 10.1007/s10763-017-9857-8
- Vergnaud, G. (1996). The Theory of Conceptual Fields. In L. P. Steffe & P. Nesher (Eds.), *Theories of mathematical learning* (pp. 219-239). Mahwah, NJ: Lawrence Erlbaum.

Preservice teachers' reflections on language diversity

Toril Eskeland Rangnes and Andrea Synnøve Blomsø Eikset

Western Norway University of Applied Sciences, Faculty of Education, Arts and Sports,
Norway; tera@hvl.no and anei@hvl.no

In this paper, we investigate how preservice teachers (PTs) express their awareness about language diversity in mathematics classrooms. We use “language as resource” and “language as a problem” as theoretical constructs. The data is taken from PTs’ group assignments, including transcriptions of dialogues between the PTs and multilingual students, and from PTs’ written reflections about teaching in multilingual classrooms. We found that in the dialogues, PTs and multilingual students produced meanings together through negotiating a shared repertoire from out-of-school and in-school mathematics context. Nevertheless, the students’ home languages were not evident as resources in PT’s dialogues and reflections. A deficit perspective was present in their reflections. These findings lead us to rethink our teacher education courses so that language as a resource becomes more prominent.

Keywords: Language as resource, language as problem, preservice teachers.

Background

In this paper, we explore preservice teachers (PTs) understandings of how to teach mathematics in multilingual classrooms. In particular, we consider if, and how, they used the construct of “language as a resource” in their interactions with multilingual students and in their written reflections about teaching in multilingual classrooms.

The construct of “language as resource” has been developed as a framework to understand how languages are used and perceived in multilingual mathematics classrooms (Planas, 2018; Planas & Setati-Phakeng, 2014). Planas and her co-authors build on Ruiz’s (1984) policy planning concepts of language as a right, as a problem, and as a resource. Ruiz focused on the resource perspective. This inspired Planas (2018) to develop a theoretical framework for exploring and theorizing how language can be seen as a resource in mathematics education. The focus on “language as a resource” has the potential to contribute to a shift away from seeing home languages, which differ from the instruction language, from a deficit perspective. This shift is also identified in CERME’S 20-year history (Planas, Morgan, & Schütte, 2018).

Nevertheless, how to understand and operationalize “language as resource” in multilingual classrooms can be challenging in teacher education, schools and in research. One attempt to do this is to use ideas about *translanguaging* in mathematics lessons. Planas (2018) described the focus of translanguaging as being on what learners do to convey meaning, on how they use all their languages, and not on the normative performance of the language of instruction. This includes “situations in which multiple mathematical sign systems, iconic representations of mathematical objects, and narratives of mathematical ideas co-exist” (p. 218). According to Planas, the concept of translanguaging supports a move from a focus on correct language to a more deliberate use of language resources in the participants’ meaning making so that they develop mathematical ideas together. This is seen as deeply connected to equality in the

classroom, as multilingual students often find themselves being viewed as lacking because their home languages are suppressed (Barwell, 2018).

Teacher education context in Norway and in former research

The “ordinary” mathematics classroom in Norway has changed in the last 20 years from being monolingual to multilingual. In Norway, there are three official languages, Norwegian, Sami and sign language. Norwegian dominates as the language of instruction in most municipalities. In some classrooms with language diversity, there can be many different languages, spoken by refugees and immigrants. Often there will be students who will not have any classmates or teachers who can understand their home language. The discourse around classrooms with language diversity seems to be dominated by a “Norwegian only” attitude (Naustdal, 2017), similar to what has been identified in neighbouring Sweden, where the described discourse is “Swedish only” (Norén, 2016).

In teacher education in Norway, there has been little focus on language diversity in mathematics education. For example, in the former *National Guidelines for Teacher Education*, language diversity is mentioned once in the chapter about mathematics and then only as something the PTs should learn to take into consideration. In the new *National Guidelines* (Universities Norway, 2016), the resource aspect is added: “the students’ different needs, where cultural, linguistic and social backgrounds must both be taken into consideration and seen as a resource in the teaching” (p. 23). Our study is situated in this change, as we re-focus our teacher education to incorporate the view that all students’ languages can be a resource in the learning and teaching of mathematics. Through a four years long research project *Learning about teaching Argumentation for Critical mathematics Education in Multilingual classrooms [LATAcME]*, our research group aims to develop both tools for teaching and theories about this development through an educational design research program. The aim in this paper is to identify our starting point, namely, how preservice teachers are currently aware of, and interpret, multilingual diversity in mathematics teaching and learning as resource, which will be the basis for subsequent interventions.

Internationally we find few studies on how teacher education can develop understandings of language diversity in mathematics classrooms. For instance, McLeman, Fernandes and McNulty’s (2012) study from the USA revealed that issues about mathematics education of English learners needed to have more prominence and to be integrated into teacher education to hinder the development of a deficit perspective among PTs. They explicitly suggested that PTs would need to be provided with experiences within the context of mathematics to help them better understand the interconnection between language and mathematics.

Based on three different contexts (South Africa, Malawi, and Spain/Catalonia), Essien, Chitera and Planas (2016) found that even though the mathematics teacher educators are aware of the linguistically diverse contexts, the “teacher education institutions rarely attend to the complexity of teaching mathematics to linguistically diverse mathematics student teachers in a structured way in their programs” (p. 107). Yet even when there is such awareness, it is challenging to change discourses (Eikset & Meaney, 2018). In their analysis of their conversations about preparing PTs for teaching in multilingual classrooms, Eikset and Meaney

found that other competing discourses, such as the PTs' expressed needs for learning more mathematics, gained priority.

The data for this paper is collected from a mandatory group assignment in the first compulsory mathematics course for those who will become teachers in Grades 1-7. The PTs were asked to write 8-10 pages about number sense connected to children's language and to link this to theory and experiences from their practicum. As part of the process, they had supervision with the second author. The PTs had to include a research question and transcriptions of dialogues between themselves and students. These PTs were in language diverse classrooms, and their interpretation of teaching in the multilingual classroom became an important part of their text. The PTs were encouraged to use their own home language as resource in their problem solving during their teacher education program and were aware of the concept of language as resource. Consequently, our research question is: *How do PT express their awareness and understanding of the construct "language as resource" through written dialogues and reflections?*

Theoretical framework

Planas (2018) described "language as a resource" in mathematics education research as being used more as a metaphor than as a defined concept in the last decade. She demonstrated that "language as resource is not about the unproblematic functioning of language as producer of meaning taken as mathematical and shared" (p. 226). From her perspective, language contributes to the realization of normative meaning in the culture of schooling and school mathematics and does so by reproducing discourses connected to these cultures. In addition, knowledge of language enables learners to influence the process of gaining meaning through interaction. Therefore, language can be a resource both for meaning making and for the relocation of culture in learning situations in mathematics classrooms. From this perspective, mathematical language cannot be separated from the learning gained from other languages or be given priority. Instead, there is a need for language from different contexts, both in and out of school, to be combined in meaning production. In Bakhtin's dialogism, learning can occur in the tension between different forces (Bakhtin, 1981). Tension can occur between voices where different opinions, understanding and linguistics settings are expressed. For example, demands to use the correct language can be one force, while focus on solving a mathematical problem can be another. Tensions might occur in the mathematics classroom between the stratified and formal mathematical language and the language of instruction on one side and the more informal and diverse multivoicedness on the other side (see for example Barwell, 2018; Planas, 2018). However, tensions provide opportunities to negotiate meaning and in multilingual classrooms to learn both language and mathematics.

In their investigations of what happens in classrooms, both Barwell and Planas have focused on translanguaging. Barwell (2018) emphasized the view of students and teachers as languaging, where they use "a repertoire of language practices that draws on students' varied experiences of communication in multiple contexts to make meaning in mathematics" (p. 161), whereas Planas (2018) stated, "translanguaging refers to what people actually do with language to convey meaning" (p. 218). This is a change of focus, from the language systems and the mix between them, to what students and teachers do with language. This includes the use of different representations and mathematical signs to make sense and convey meaning.

Methodology

The data was collected during the autumn of 2017 when groups of PTs completed a written assignment about mathematics, in particular number sense, connected to children's language, conceptual knowledge and representations in mathematics. The PTs were in their second year of a course to become teachers of Grades 1-7 and were in their first of two semesters of mathematics education. During this semester, teaching mathematics in a multilingual classroom was one of several topics. In their assignment, they were asked to take into consideration how they could adapt their teaching. Two groups chose to include language diversity as an issue in their assignment, and one of these will be analysed in this paper. It was mandatory for the PTs to obtain data that included oral responses from students, where the PTs' role was not to evaluate or judge their students. They were asked not to collect any personal data about the students. The assessment was completed before the PTs received a written request about whether this material could be analysed for research purposes. The dialogues presented in the group's assignment were between a PT and a student in grade 6 in a classroom setting (18 students). The PTs had given the students some tasks, provided them with individual help and in some cases asked the students to explain their thinking.

We analyse two excerpts containing dialogues between a PT and a multilingual, primary-school student and the PTs' reflections on the dialogues and their comments about language and multilingual students. We use a two-layered analysis. First, we sought to identify what PTs and students did to convey meaning, how they used languages, and which repertoire they used, in order to identify instances of translanguaging. Second, we sought to identify language as a resource or as a problem in PTs reflections. To do this, we searched for tensions between voices and the potential for learning that they can create (Planas, 2018; Barwell, 2018).

The original dialogues were in Norwegian and have been translated into English as faithful as we could to retain the original sense. Where the PTs have transcribed incorrect words that the student used, we place the word [incorrect Norwegian] in brackets.

Result and discussions

The PTs' aim in the activity was for the students to discover the connection between multiplication and division. Although this was the headline on the student work sheet, the PTs claimed that the student, Laban, whose home language is not Norwegian, did not read it. The task was $98/7=$

PT: Can you explain for us how you were thinking here?

Laban: Here I took 7, but the 9 is bigger. We minus [minuse] only with the nine, nine minus 7 is 2. Then we take the eight and wait... 14... so we took only 1 here (points to the second digit for tens) with 2 which is 28, then we take 7 up to 28 so that is 4, so that is 28 minus 28, which is zero. You should all the time, when it's 7 just you should just insert 1 up here, then it becomes 7 and if you take up till 9. Then it's 14, it can't be that, so we just take 7 times 9 then minusing [minuse] the 9. I can do it all in my headed [hoden].

PT: Oh yeah! That is so cool, have you worked a lot with the timetable [gangetabell] before?

Laban: No, division.

PT: That is sort of times, multiplication. It's kind of, the twin of division.

Together with his written solution, Laban managed to explain to the PT how he was thinking. Laban demonstrated that he saw the connection between multiplication and division when, for instance, he said “which is 28 then we take 7 up to 28 so that is 4 so that is 28 minus 28 which is zero”. He was switching constantly between multiplying up (7 up to 28) and reversing by subtracting so he could check if there would have been zero left to divide.

In the PT's response to Laban's explanation, s/he amplified Laban's explanation by exclaiming “Oh yeah! That is so cool”. The PT also asked Laban if he had worked a lot with times tables (gangetabell) which is an informal word for the multiplication table in Norwegian. Laban denied this by saying, “No, division”. His “No, division” is an interesting change as division is a more formal expression, even if the PT uses an informal expression “times” (gange) instead of multiplication. The PT then followed up with “that is sort of times” before s/he changed the wording to “multiplication”, “It's kind of, the twin of division”. The introduction of “multiplication” as “the twin of division” seems to be a new language construction, perhaps to support Laban to be more aware of the connection between multiplication and division, even though he already demonstrated this in his explanation. As the student and PT used resources from their informal and formal language to make meaning together, they were languaging (Barwell, 2018). The student's idiosyncratic language of “minuse” (subtract), and his conjugation of a noun into a verb as in “headed” (hoden) was in the transcription in the group assignment. However, the PTs did not highlight these examples. In this case the tension in language use was apparent in the juggling between formal and informal mathematical language, rather than between a home language and the language of instruction.

When Laban explained and requested time to think, indicated by his “wait”, he used informal words and sentence construction. While he was answering the PT's question, he began to use formal mathematical words, such as division, which belong to the school mathematical vocabulary. The dialogue between PT and Laban is characterized as a mutual willingness to make sense together. It seems that the student affected the language choices of the PT.

The group of PTs reflected on the dialog in their assignment:

He explained his way of thinking and led us through his calculations. This gave us the impression that it was not his number sense that was the challenge for Laban. He is a student we can clearly see has gained much practice in mathematics.

By mentioning that Laban explained his thinking and led them through his calculation, they recognized his skills to communicate and his number sense. However, they indicated that there was still something which was a challenge for Laban, without specifying what this was. By including his language errors, one interpretation is that the PTs saw language as a problem even as they recognized his communication skills. In the summary, the PTs repeated their belief in Laban's and another multilingual student's number sense and their explanation skills:

The students could also explain their way of thinking, the different types of calculations and how they could use this in their daily lives without much difficulty. ... Thus, we will say that it is not the numerical understanding or the number concept that hinders the students from dealing with mathematics, but rather that it is insufficient understanding of the concepts.

By stating that the students can “explain their way of thinking” and that “numerical understanding or number concept” is not the problem, they recognized the skills the students had, and implicitly that the students were able to use language in Norwegian as a resource to make others understand their thinking. However, they also mentioned what hinders the students from “dealing with mathematics”; the multilingual students had “insufficient understanding of concepts”. In this way they saw the student in a deficit perspective and the lack of concepts in Norwegian as a problem.

As an example of the problem that a multilingual child had with understanding mathematical concepts, they included this conversation with another multilingual student, Ahmed:

- Ahmed: What is “even” [jevent] I don’t understand...
- PT: You play soccer Ahmed, don’t you?
- Ahmed: Yes, Tuesday and Thursday
- P.T: Then you divide into two teams and play against each other, don’t you?
- Ahmed: Yes!
- PT: When you divide into teams, what is important?
- Ahmed: That it’s fair. That there are equally many on each team.
- PT: YES! That is another way of explaining “even”.

The PT used an example from a familiar situation for Ahmed, soccer, to explain what “even” means in mathematics. By using language repertoires that they had in common from outside of school mathematics, they had made sense and gained a shared understanding of the mathematical concept. In their assignment, they explained how they used the example of soccer as a translational link to help the student understand the concept of “even”. The PTs used the conversation as an example of where language can cause a problem, as they write “the student does not have an understanding of Norwegian term for the concept of even”. At the same time, they demonstrated how they used language as a resource in the dialogue by drawing on the example from soccer as translation link. They used repertoires from different contexts, formal and informal school mathematics, and out of school activities as soccer, to make sense together.

A question arises about whether the students’ and PTs’ use of languages from different situations, can be considered translanguaging (Planas, 2018). In the Norwegian context, it was repertoire from formal and informal Norwegian which were being transformed as meaning is being made. The PTs’ understanding of language in multilingual classrooms also reflected a tension between how they made use of theirs and the students’ language resources from different contexts, and seeing their student from a deficit perspective where language is a problem:

During the practicum, we learned that there is a connection between being able to master mathematics and to master the language. Minority-speaking students may have limited vocabulary and little understanding of Norwegian terms. This may be because the student speaks little Norwegian at home, in his immediate social environment, or never experiences situations where the terms are used.

The PTs recognized the connection between language and mathematics learning. It is clear from their perspective, that it could be a disadvantage for a student to not have Norwegian as their home language, which could cause limited understanding of Norwegian terms. The PTs only mentioned the Norwegian language. The home language and mathematical concepts that the students may have in this language were not discussed. There was no evidence that the PTs saw the students using their home languages in mathematics. This suggests that it may be difficult for PTs to know how to use the students' language and cultural background as resource and this pedagogical practice remains more an idea than an experienced reality in primary schools.

Concluding remarks

In this study, we identify tensions in more than one sense. There is a tension between “language as resource” captured in the transcribed dialogues and “language as problem” in the PTs' reflections. This tension could provide opportunities for learning if this tension become topics for discussion. In addition, we find a tension between students' and PTs' language use with informal and formal mathematical terms. Together they were languaging by using experiences of communication in multiple contexts to make meaning (Barwell, 2018, p. 161), as when they used soccer to explain even, and in the PTs' effort to connect concepts, when making the new language construction, multiplication as “twin to division”.

Planas' (2018) conceptualisation of language as resource has given us the opportunity to see how PTs use a repertoire from different contexts in their meaning making. The opposite metaphor, language as problem, made us aware of where PTs see language diversity in the mathematics classroom as a problem and how the students' home languages are neglected.

If language as resource, which includes translanguaging, is going to be valuable in PTs' teaching in the future, they need to be exposed to broader understandings about multilingual teaching both in teacher education and in the practicum, as McLeman, et al. (2012) suggested. How can different languages be present in Norwegian schools where there can be so many different languages in one classroom and when the “Norwegian only” discourse is so strong? There is a need to develop a common understanding of what language as resource can be together with the teachers in the schools where students do their practicums. As the PTs' dialogues demonstrated, repertoires from different contexts, informal and formal, and the students' culture, such as soccer, can be resources in teachers' mathematical dialogues with students. Identifying these potential resources in shared repertoires of experience can be developed further to include students' home language. Teacher educators need to engage in open discussions with PTs about which discourses dominate and which discourses should be developed to avoid language being viewed from a deficit perspective. Our next step is to develop an intervention in which practicum teachers, PTs and teacher educators explicitly

discuss tensions between language as resource and language as problem. Working together to change our discourses may help us to explore how different languages can be present.

Acknowledgment

This research project is supported by the Research Council of Norway – program FINNUT.

References

- Bakhtin, M. M. (1981). *The dialogic imagination: Four essays* (M. Holquist, Ed.; C. Emerson & M. Holquist, Trans.). Austin, TX: University of Texas Press.
- Barwell, R. (2018). From language as a resource to sources of meaning in multilingual mathematics classrooms. *The Journal of Mathematical Behavior*, 50, 155-168. doi: 10.1016/j.jmathb.2018.02.007
- Eikset, A. & Meaney, T. (2018). When does a difference make a difference? Teaching about language diversity in mathematics teacher education. *Nordic Studies in Mathematics Education*, 23(3-4), 225-246.
- Essien, A. A., Chitera, N., & Planas, N. (2016). Language diversity in mathematics teacher education: Challenges across three countries. In R. Barwell, P. Clarkson, A. Halai, M. Kazima, J. Moschkovich, N. Planas, M. Phakeng, P. Valero, & M. Villavicencio (Eds.), *Mathematics education and language diversity: The 21st ICMI Study* (pp. 103-119). Cham, Switzerland: Springer.
- McLeman, L., Fernandes, A., & McNulty, M. (2012). Regarding the mathematics education of English learners: Clustering the conceptions of preservice teachers. *Journal of Urban Mathematics Education*, 5(2), 112-132.
- Naustdal, M. (2017). *Diskursar om bruk av språk og omgrepslæring i matematikklasserom med språkleg mangfald - eit lærarperspektiv* (Unpublished master's thesis). Høgskulen på Vestlandet, Bergen.
- Norén, E. (2010). *Flerspråkiga matematikklassrum: Diskurser i grundskolans matematikundervisning* (Unpublished doctoral dissertation). Stockholms Universitet.
- Planas, N. (2018). Language as resource: A key notion for understanding the complexity of mathematics learning. *Educational Studies in Mathematics*, 98(3), 215-229. doi: 10.1007/s10649-018-9810-y
- Planas, N., & Civil, M. (2013). Language-as-resource and language-as-political: Tensions in the bilingual mathematics classroom. *Mathematics Education Research Journal*, 25(3), 361-378. doi: 10.1007/s13394-013-0075-6
- Planas, N., Morgan, C., & Schütte, M. (2018). Mathematics education and language. In T. Dreyfus, M. Artigue, P. Despina, S. Prediger, & K. Ruthven (Eds.), *Developing research in mathematics education* (pp. 196-210). London, England: Routledge.
- Planas, N., & Setati-Phakeng, M. (2014). On the process of gaining language as a resource in mathematics education. *ZDM*, 46(6), 883-893. doi: 10.1007/s11858-014-0610-2
- Ruiz, R. (1984). Orientations in language planning. *NABE Journal*, 8(2), 15-34.
- Universities Norway (UR). (2016). *National guidelines for the primary and lower secondary teacher education programme for years 1-7*. Retrieved from https://www.uhr.no/_f/p1/i9667e583-aa3b-4f25-a8fe-64af8b199072/national_guidelines_for_the_primary_and_lower_secondary_teacher_education_programme_for_years_1_7.pdf

Sense and reference of signifiers for elements of polygons

Frode Rønning and Heidi Strømskag

Norwegian University of Science and Technology, Trondheim, Norway;

frode.ronning@ntnu.no heidi.stromskag@ntnu.no

This paper is based mainly on a planning meeting involving teachers and researchers before classroom sessions in a Norwegian school where 7-8-year-old children are working with concepts connected to geometrical shapes. During the planning meeting different conjectures were made about possible confusion that might occur concerning the names of the parts (elements) of a polygon (edges and vertices). Comparing these conjectures to what actually happened in the classroom, it turns out that the group of experienced teachers and teacher educators were not able to foresee all the nuances in the children's sense and reference concerning concepts connected to polygons. The findings suggest that these concepts may be more challenging than previously assumed. The classroom sessions are designed using principles from Brousseau's Theory of didactical situations (TDS).

Keywords: Register, sense and reference, polygons, milieu.

Introduction

The project Language Use and Development in the Mathematics Classroom (LaUDiM) is an intervention study carried out in collaboration between researchers at the Norwegian University of Science and Technology and two local primary schools in the period 2014-2018. A central part of the project is to design and implement teaching sequences. The design process takes place in close collaboration between researchers and teachers. The teachers are responsible for the implementation in their respective classes, with researchers present in the classroom. The core of the project is twofold: to study pupils' development and use of mathematical language to express their ideas, and their use of language in arguing and justification; as well as to study and develop teachers' mathematics teaching practices. The design of each teaching sequence is guided by principles from *The theory of didactical situations, TDS* (Brousseau, 1997). A teaching sequence typically consists of a planning meeting between teachers and researchers followed by two or three classroom sessions. Between the classroom sessions there are reflection sessions to discuss what happened in the classroom and, if necessary, revise the plans.

This paper is mainly based on data from the planning meeting preceding one particular sequence of teaching sessions where the main aim is pupils' development of a precise mathematical language for describing elements and properties of polygons. The actual classroom sessions were reported on in (Rønning & Strømskag, 2017). In the present paper, some of the findings from the first classroom session are mentioned in order to be able to reflect on what happened in the planning meeting. Also the reflection session after the first classroom session will be mentioned. The paper will shed light on the importance of the planning session and how different discourses influence the planning, as well as deepen the knowledge about the complexity regarding the, apparently simple, concepts involved. We will in particular compare teachers and researchers' conjectures about pupils' language use about polygons to what actually happened in the classroom.

Theoretical framework

In this paper we see a word as a sign, or signifier, and, in the language of Frege (1892) we connect the sign with its *Sinn* and its *Bedeutung*. The German words *Sinn* and *Bedeutung* can be seen translated into English in different ways. We shall follow the translation in (Geach & Black, 1960), using the words *sense* and *reference*, respectively. Here, the reference is the object that the sign refers to and the sense comprises all thoughts and ideas connected to the sign. In his work, Frege gives examples to show that two different signs may have the same reference but different sense. One example used by Frege is the following, from Euclidian geometry. Let a , b and c be the medians of a Euclidian triangle. Let A be the intersection point between a and b , and B be the intersection point between b and c . Then A and B have different sense but from a theorem in Euclidian geometry the points A and B coincide, so A and B have the same reference (see e.g., Geach & Black, 1960, p. 57).

A distinction similar to Frege's sense vs. reference is made by Peirce in his definition of a sign: "A sign is a thing which serves to convey knowledge of some other thing, which it is said to *stand for* or *represent*. This thing is called the *object* of the sign; the idea in the mind that the sign excites, which is a mental sign of the same object, is called the *interpretant* of the sign" (Peirce, 1998, p. 13). Also Ogden and Richards (1923/1948) describe a similar model when they talk about a *symbol* as being connected to a *referent* via a *thought* or *reference*. They state that "[b]etween the *symbol* and the *referent* there is no relevant relation other than the indirect one, which consists in its being used by someone to stand for a referent" (p. 11). They further state that "[a] true symbol = one which correctly records an adequate reference. ... [W]hen it will cause a similar reference to occur in a suitable interpreter" (p. 102). A given word is therefore a true symbol if it causes the same reference in different interpreters. Successful communication in a mathematics classroom depends on symbols causing the same reference in the actors involved, usually teachers and pupils.

Halliday (1979) defines the term register as "a set of meanings that is appropriate to a particular function of language, together with the words and structures which express these meanings" (p. 195). So, changing between registers can mean that the same word gets both a different sense and a different reference. The mathematical register is characterised by the property that words have very precise sense and reference. Sometimes the same word may be used both in the mathematical register and in the register of everyday language but with different sense and reference. This feature is language specific so that for a given word it can be part of both the mathematical and the everyday register in one language but translating into another language may lead to different words in different registers. When the same word is used in both the mathematical and the everyday register in a language, it is of particular importance to be aware of possible discrepancies in sense and reference because such a word may not be seen as a challenge in the learning process.

Design and research question

Each teaching sequence in the project starts with a planning meeting where teachers and researchers work together to plan the activities for two or, in this case three, classroom sessions. In this planning meeting TDS plays an important role. TDS provides a model for instructional design, where a didactical situation is designed with a problem that has the target piece of knowledge as an optimal solution (Brousseau, 1997). The didactical situation consists of four phases—action, formulation,

validation, and institutionalisation—designed with milieus so as to make the knowledge (necessary to solve the given problem) progress from informal knowledge to increasingly formal (mathematical) knowledge. More precisely, in action, the pupils use an *implicit strategy* to solve the problem given to them; in formulation, they need an *explicit strategy* because they are supposed to use the knowledge to make another pupil solve the problem; in validation, the knowledge needs to be *mathematical knowledge* in order to justify that the solution is valid in general; and, in institutionalisation, the teacher decontextualises the knowledge reached to become *scholarly knowledge*. For a more detailed account, and exemplification, of the evolution of knowledge and the teacher's role in the different phases, see (Strømskag, 2017).

A teaching sequence was designed according to the teachers' and researchers' expectations regarding pupils' sense and reference of words connected to polygons (see Rønning & Strømskag, 2017). However, the data collected during implementation of the sequence gave us insight into the pupils' *actual* sense and reference of the words in question. This design was instrumental for creating opportunities for revealing the challenges of the learning process. For this paper however, the concepts from Brousseau's theory will not play a significant role.

Between the first and the second classroom session follows a reflection session, where adjustments are made for the second session. Researchers present in the classroom interact with the pupils but are not directly involved in the teaching. The planning meeting and classroom activities are video recorded, and the reflection meeting is audio recorded. After completing a cycle of planning, reflection and classroom sessions, teachers and researchers meet to watch parts of the video recordings from the classroom. This is also video recorded, but is not used as data for this paper.

The topic of polygons turned out to be interesting for several reasons. It demonstrated how the phenomenon that words (signs) may have different reference in the mathematical and everyday registers constrained pupils' conceptual development and although parts of this phenomenon could be foreseen in the planning meeting, unexpected observations were made, showing that there are challenges involved in the apparently simple concepts involved when talking about polygons.

This paper is addressing the following research question: *To what extent do teachers' and researchers' expectations regarding pupils' sense and reference of words connected to polygons fit with actual experiences from the classroom?*

The main data are the transcribed video recordings from the planning meeting. In a line by line analysis of the transcription, we look for evidence of contributions from the different participants in the meeting. Then these contributions are compared to what actually happened in the classroom at one of the schools. Here we will refer to findings in (Rønning & Strømskag, 2017).

The Norwegian language and the mathematical terms involved

The relevance of the work with the topic of polygons is connected to particular features of the Norwegian language. In Norwegian, polygons are named after the number of edges, using ordinary number words. That is, an "*n-gon*" is called an "*n-edge*", where *n* can be three, four, The Norwegian word for *edge* is *kant*. For $n \geq 5$ this is in line with English, except that the English words are based in Greek (e.g. pentagon), and therefore they have no obvious meaning for young children.

In the paper, we will use the Norwegian word *kant* (plural *kanter*) and whenever this word occurs, it is written in italics. In everyday language, the word is used in expressions like “falling off the *kant* of the cliff”, “walking along the *kant* of the road”, “sitting on the *kant* of the table”. *Edge* is also a word in English everyday language but *vertex* is a mathematical term, not used in everyday language. The Norwegian language does not have a strictly mathematical term for vertex. The word *hjørne* is used (*corner* in English). In the sequel, we will use *hjørne* (plural *hjørner*), written in italics. Since the names for the figures are made up of everyday terms, it is generally believed that learning the names of and distinguishing between different polygons is an easy task. In German, the situation is very much like in Norwegian, except there the focus is not on the edges but on the vertices, i.e. a *firkant* (four edge) is referred to as a *Viereck*, meaning “four corner”. Since the number of edges is equal to the number of vertices ($V = E$) it does not matter whether the edges or the corners are referred to, the number word connected to the figure will be the same.

Another feature is that the edges may be referred to by different words depending on the situation. For instance, when stating the formula for the area of a square, it is often said “*side* times *side*”. Then the word “*side*” (or “*sidekant*”) is seen as a variable denoting the length of the line segment making up the edge. The word *side* corresponds to the English word ‘side’.

The planning meeting

A starting point for the discussion is that the participants (teachers and researchers) present their experiences with the topic and also some evidence of confusion regarding language. Present at the planning meeting were the teachers Ruth and Pam, and the researchers Anne, Becky and Cathy.

- Ruth: We mostly talk about *kanter* so far. There is not so much talking about *hjørner*.
- Anne.: Or they do not agree on what a *kant* really is. Is this the *kant* (strikes along the side of the table), or is this the *kant* (marks the transition between the table top and the side).
- Ruth: We have discussed this a little in the staff room. Is it *side* or is it *kant*? Because when you talk about the area of a square, for instance, then it is like *side* times *side*, and why is it then called *side* when it is called *trekant* [triangle] and *firkant* [quadrilateral] and how many *kanter* has a ... ? But when you come to three dimensional figures, then the *kant* is in a way, when you see from one side, then it is one of the sides.
- Pam: *Sidekant* I think it is called.
- Ruth: Yes, because you also have the concept *sideflate* [face], and that is on a three-dimensional figure. And that is the *side*, that is what we call the *side*. So, I think it is best that the line in a two-dimensional figure is called a *kant*.

Ruth has observed that the same object in a geometric figure may be given different names in different contexts. When talking about the line segments making up a polygon, the word *kant* is used but when the length of the line segment is referred to, e.g. for calculating the area of a square, the word *side* is used, as in the formula *side* times *side*. This indicates that the words *kant* and *side* have different sense, although they refer to the same element of the polygon, i.e. they have the same reference. It could be argued that in the formula *side* times *side* the reference is not the actual line segment itself,

but a number representing the length of the line segment. In the beginning, Ruth also admits that they have not talked so much about *hjørner*, mostly about *kanter*. This may be because it is the word *kant* that appears in the names of the polygons. Ruth also refers to the three-dimensional situation where the word *sideflate* is used for the face (F) but also sometimes just *side*, for short. She finds this confusing and suggests to stick to the word *kant*.

- Anne: A *hjørne* is where two *kanter* meet.
 Becky: Yes, so then at least we agree.
 Ruth: This is a much simpler definition.
 Anne: Yes, but it isn't. When we discuss this with student teachers, they do not agree on what a *kant* is. Some envisage, yes, a *trekant*, it has three *kanter*, yes, what I would call *kanter*, and like you Pam, call *sidekanter*, but it also has three *hjørner*. So if you say *trekant* and think about *hjørner*, there is no mismatch.
 Pam: And I heard a mother asking, when we had about *hjørner* and *kanter* on the working plan; *hjørner* AND *kanter*, but isn't that the same? That is the same, so why?
 Cathy: I have not at all thought like this. I have thought like you, a *hjørne* is a *hjørne*.
 Pam: Yes, and that is correct. But I think many have a wrong opinion about this.

Anne gives a precise mathematical definition of the term *hjørne*, and both Becky and Ruth seem to be happy about this, recognising it as a simple definition. However, Anne claims that it may not be that simple because she has evidence from student teachers not agreeing on what a *kant* actually is. They say *kant* and mean *hjørne*, and because of the relation $V = E$ for polygons they get away with it. This is supported by Pam who has evidence from a mother of one of the pupils claiming that *hjørne* and *kant* are two words for the same thing. Cathy has not reflected on this being an issue. This conversation shows evidence that the word *kant* may be used by different people with different sense and different reference and also that some people think that the two words are two different signs with both the same sense and reference. The fact that the group discussing this is a group consisting of experienced teachers and teacher educators indicates that the topic may not be as simple as it may seem at a first glance.

There is agreement that one should stick to the concepts *kant* and *hjørne*, and that it is important to stick to one word in the beginning, and Ruth says that *kant* seems to be the most precise word.

The reflection session

The reflection session is based on experiences from the first classroom session and took place immediately after the classroom session. The classroom session is discussed in (Rønning & Strømskag, 2017). These are some of the observations made:

- Most pupils used the word *kanter* to refer to the vertices but there were also some who used it correctly, to refer to the edges.
- Some pupils refer to a vertex as a *hjørne* when they approach it from the inside and as a *kant* when they approach it from the outside.
- In a quadrilateral with one reflex angle and three acute angles, the vertex at the reflex angle is sometimes referred to as a *hjørne* and a vertex at an acute angle is referred to as a *kant*.

The classroom session revealed that for most of the pupils the sense of the word *kant* was something sharp. This was emphasised when they talked about *kanter* as “the pointed parts [spissene]”. The word *hjørne* was not often in use but when used, it had the sense of a space, something one can stay in, corresponding to the expression “stand in the corner” [stå i hjørnet]. It can therefore be said that the pupils use two different words for the same reference but each word has its own sense which is connected to the size of the angle at the vertex, or whether they see the vertex from the inside or from the outside.

Pam was surprised that they did not use the words correctly. They mainly used the word *kant* with the reference expected of the word *hjørne* and paid very little attention to the actual *kanter*, i.e. the edges. Diana, a researcher who was not present at the planning meeting, suggests to use *sidekant* about what they call *strek* [line]. Then there is a discussion about how the words *kant* and *hjørne* could be connected to everyday settings. Diana had observed in the classroom that some pupils talked about a “soft *kant*”, and said that that is a *hjørne* (with reference to a part of a local shopping centre), but a “real *kant*” is sharp. For 3D objects it makes sense to talk about an edge (*kant*) as being sharp. This may transfer to 2D objects. One of the tasks for the pupils was that they should write the name of a given geometrical figure and explain why it had this name. Based on the pupils’ workings it seemed that they used the words in a correct way. They could draw e.g. a quadrilateral and write “this is a *firkant* because it has four *kanter*”. Here the reference of the word *firkant* is the drawing of a quadrilateral, as it should be, and the sense of the word is that the figure has four *kanter*. This is also correct, and the written statement will not reveal the misconceptions.

In the reflection session, it is discussed how the activity could be developed to overcome the misconception. In the first classroom session, it turned out that using the abstract geometrical figures as reference context was inadequate to stimulate the correct concepts connected to the words *kant* and *hjørne*. Therefore, the teacher suggested to use a mini-pitch as a reference context. This was assumed to be a context from the pupils’ everyday experience and at the same time a context with properties sufficiently similar to an abstract geometrical figure, in this case a rectangle. Then the idea was presented to take the pupils out into the mini-pitch in the school yard and give commands like “go to the *hjørne*”, “walk along the *kant*” and similar expressions.

Discussion

The target knowledge of the teaching sequence was that the pupils should develop the scientific language for naming 2D shapes and become aware that these names are based on the number of edges (*kanter*) in the shape. To know the difference between edges (*kanter*) and corners/vertices (*hjørner*) will then also be part of the target knowledge.

The planning session revealed certain conjectures about the use of the words *kant* and *hjørne*. The different participants in the session had different expectations, based on different experiences. The teachers had experienced confusion based on previous work with pupils and also based on conversations with parents. Teacher educators in mathematics had experienced confusion among student teachers, whereas the general educators were not necessarily aware that these words could be a source of confusion. For most adults, at least adults with some mathematical background, it is so obvious what is a *hjørne* and what is a *kant* that they do not envisage any problems with this. And

also, the connection $V = E$, ensures that the naming of geometrical figures will be consistent even if there is confusion about what is what. But when the sign is broken down into components, *tre* = three and *kanter* = edges, we see that the sense and reference are not as desired.

<i>Kant</i>	Sense	Reference
Mathematical discourse	A straight line segment	E.g. AB , BC , CD and AD in quadrilateral $ABCD$.
Pupils' discourse	Something sharp A real <i>kant</i> is sharp The pointed parts	E.g. A , B , C and D in a convex quadrilateral $ABCD$, when seen from the outside.

Table 1: Sense and reference of *kant*

<i>Hjørne</i>	Sense	Reference
Mathematical discourse	A point where two <i>kanter</i> meet	E.g. A , B , C and D in quadrilateral $ABCD$.
Pupils' discourse	A spacious area A soft <i>kant</i>	E.g. A , B , C and D in a convex quadrilateral $ABCD$, when seen from the inside. A non-convex vertex.

Table 2: Sense and reference of *hjørne*

Even if some confusion was expected, the classroom sessions brought new knowledge to the sense and reference of the words *kant* and *hjørne*. This means that even for such seemingly simple mathematical concepts as here, the group of experienced teachers and teacher educators could not fully forecast how the terms would be handled by the pupils. Using the terms from Ogden and Richards (1923/1948) we may say that the words *kant* and *hjørne* did not function as true symbols because they did not cause the same reference in all persons involved.

The insight we got during the classroom sessions was used to redesign the didactical situation with respect to the conventional sense and reference of the words *kant* and *hjørne*. The desired statuses of knowledge in formulation and validation, as described above, were decisive for the team in designing a material milieu and a game (for acting on the milieu) with didactical potential regarding the target knowledge, so the pupils could know whether their responses were adequate or not. The new material milieu is shown in Figure 1. It consists of 12 tiles, where on one side of the tile was depicted a polygon where the edges had one colour and the vertices were marked with another colour. On the reverse of the tile was written descriptions like e.g. "*firkant* (quadrilateral) with blue *sidekanter*". This game was played in pairs of pupils both having the full set of tiles. One pupil reads the text and the other one is supposed to pick the correct shape. After picking he/she can turn the tile and read the text to see if the correct shape has been picked.

The conditions described in this paper indicate that there is a need to address the concepts *hjørne* and *kant* in Norwegian schools. The naming of figures by counting the *kanter* using ordinary Norwegian number words, like in *firkant*, may indicate that there is no need to go further into the topic. Also, the books that are used for the pupils seem to take the concepts for granted, there is never any indication of what is actually *hjørne* and what is *kant*. The discussion in the planning session also shows that

there is varying consciousness about the topic among teachers and researchers. And those that are conscious about it are so because they have previous experiences indicating that there may be some confusion.

Distinguishing between edges and vertices can also be seen to be important for future learning, e.g. about polyhedra, where the number of edges and the number of vertices are not the same.

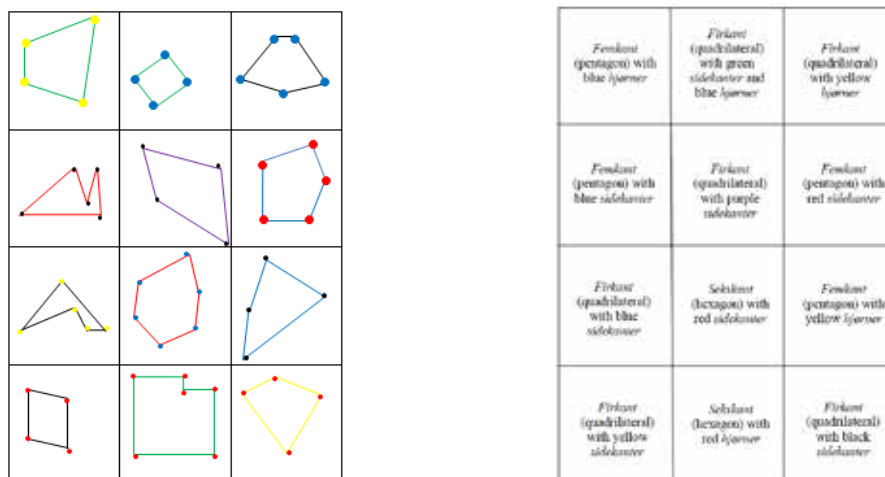


Figure 1: Material milieu for classification of polygons

References

- Brousseau, G. (1997). *The theory of didactical situations in mathematics: Didactique des mathématiques, 1970-1990* (N. Balacheff, M. Cooper, R. Sutherland, & V. Warfield, Eds. & Trans.). Dordrecht, Netherlands: Kluwer.
- Frege, G. (1892). Über Sinn und Bedeutung [On sense and reference]. *Zeitschrift für Philosophie und philosophische Kritik*, 100(1), 25–50.
- Geach, P., & Black, M. (Eds.) (1960). *Translations from the philosophical writings of Gottlob Frege*. Oxford, England: Basil Blackwell.
- Halliday, M. A. K. (1979). *Language as social semiotic. The social interpretation of language and meaning*. Baltimore, MD: University Park Press.
- Ogden, C. K., & Richards, I. A. (1948). *The meaning of meaning: A study of the influence of language upon thought and the science of symbolism* (8th ed.). New York, NY: Harcourt, Brace and Company. (1st ed. published in 1923).
- Peirce, C. S. (1998). *The essential Peirce. Selected philosophical writings. Vol. 2 (1893–1913)*. Bloomington, IN: Indiana University Press.
- Rønning, F., & Strømskag, H. (2017). Entering the mathematical register through evolution of the material milieu for classification of polygons. In T. Dooley & G. Gueudet (Eds.), *Proceedings of the Tenth Congress of the European Society for Research in Mathematics Education* (pp. 1348–1355). Dublin, Ireland: Dublin City University and ERME.
- Strømskag, H. (2017). A methodology for instructional design in mathematics—with the generic and epistemic student at the centre. *ZDM - Mathematics Education*, 49, 909–921.

Abstract thinking and bilingualism: Impact on learning mathematics

Leila Salekhova¹ and Nail Tuktamishov²

¹Kazan Federal University, Russia; salekhova2009@gmail.com

²Kazan State University of Architecture and Engineering, Russia; nail1954@gmail.com

Studies on the impact of bilingualism on academic performance in mathematics generally focus on potential problems faced by bilingual students rather than potentials and opportunities. The current research took an alternative approach and explored whether learning advantages for bilinguals may reveal themselves in solving difficult mathematical tasks that require abstract reasoning. Sixty-two bilingual and monolingual first-year students of Kazan Federal University participated in the experiment. No differences were found between bilingual and monolingual samples in solving easy and medium mathematical tasks; however, an advantage on the side of the bilingual students was observed with some of the most difficult tasks. The results from this study therefore show that bilingualism may be related to abstract thinking abilities and mathematics learning.

Keywords: Abstract thinking, learning mathematics, bilingualism.

Abstract thinking and bilingualism

Abstract thinking is a type of cognitive activity when a person moves away from specific details and begins to reason in general, using concepts, judgments and conclusions, among other structures. Moreover, abstract thinking allows us to find new things and create something new, to deviate from the rules and dogmas and to consider the phenomenon or process from different sides. The formation and development of the pupil's abstract thinking - the ability to use symbolic representation or logic - is an actual task of mathematical education.

There are many kinds of research on the relationship between mathematics and bilingualism, but only a few papers, which suggest that bilingualism may improve a person's ability to engage in more abstract or symbolic thinking processes. For example, in her work Planas (2014) argues that bilingualism can actually create opportunities for learners to deal more deeply with mathematical concepts. She observed a small sample of Catalan language learners interacting with dominant Catalan speakers while solving algebra problems in groups. The Catalan language learners used different problem-solving strategies (e.g., using a geometric approach to understand an algebraic expression) to overcome the lack of specific mathematical terminology in the academic language of instruction. The Catalan language learners also focused more on the meaning of mathematical terms than dominant Catalan speakers did because they were unfamiliar with the required terminology.

In recent years, more and more research studies have focused on the potential cognitive benefits of bilingualism. Several studies confirm that the experience of using more than one language can create unique opportunities in the bilingual brain, leading to cognitive benefits for bilinguals (Adesope, Lavin, Thomson, & Ungerleider, 2010). However, the exact nature of these benefits has proved difficult to determine in relation to specific subject contents.

On the other hand, the bilingual experience may provide other cognitive benefits. A number of researchers have supported the hypothesis that the constant switching of bilinguals from one language

to another leads to an increase in executive functions (Bialystok, Craik, & Luk, 2012). Other scientists have not found any advantages for bilinguals over monolinguals in executive functioning (Paap & Greenberg, 2013). Cummins (1991) have shown that bilinguals can learn new rules more effectively than monolinguals and have an advantage in meta-linguistic awareness.

Specific research by Gentner and Goldin-Meadow (2003) confirms that knowledge representation depends on the language of instruction; hence, there may be negative consequences when knowledge is transferred from one representative system to another. In other words, negative effects are observed when the languages of learning mathematics and knowledge extraction differ. This was confirmed by Spelke and Tsivkin (2001), Campbell, Davis and Adams (2007), but also in work from our context developed by Salekhova (2016, 2018).

A bilingual student may have problems understanding the essence of a mathematical problem if he or she is not familiar with the terms used, which are associated with abstract mathematical concepts. Conversely, there may be a positive cognitive effect due to multiple transpositions. They arise whenever an abstract concept is used and transferred from one representative system to another, when there are two different language terms in the language repertoire of a person. A number of studies have shown that the linguistic complexity of texts in mathematical achievement tests can negatively affect the performance of bilinguals for whom the language of instruction and the language of testing is not their mother tongue (Haag, Heppt, Stanat, Kuhl, & Pant, 2013). However, it is unclear which specific features of language complexity contribute to this deficiency.

The present study explores whether bilingualism can potentially influence the development of abstract thinking that plays a crucial role in learning mathematics. The study's research question derives from the assumption made by the Russian psychologist Lev Vygotsky (1962). He believed that bilingualism could have positive consequences for the flexibility of human thought. He argued that the ability to express the same thought in different languages allows us to understand the symbolic function of words, to consider words in more abstract, semantic terms and to see that any particular language is only one semiotic system among many. Vygotsky studied issues concerning the relationship between bilingualism and flexibility of thinking following the awareness that bilinguals can be (dis)advantaged in traditional learning environments of Russia at that time.

Research context - bilingualism in Russia and Tatarstan

A large number of ethnic groups living within the boundaries of the Russian Federation is evidence of a complicated history of migrations, wars, and revolutions. In the process of its historical development, Russia has emerged as a multinational, multicultural and multilingual state. About 150 languages are spoken in the territory of Russia. This ethnic diversity has had a strong influence on the state education policy. The Russian Constitution guarantees all ethnic groups the right to maintain their mother tongues. Although Russian is the official language, some ethnic republics have the right to establish their own official languages besides Russian. The use of an ethnic language in education depends on the development of its written forms and literary standards.

Tatarstan is one of the ethnic republics of Russia, and Tatars constitute 53% of its population. There are two official languages – Russian and Tatar in Tatarstan. They are used for teaching almost all school subjects and the choice of the language of instruction depends on the school location (rural or

urban) or the model of bilingual education (immersion, partial immersion, CLIL). Tatar is spoken by most of the people in Tatarstan as either a dominant or a second language. It plays a strong role in the construction of the Tatar cultural identity. Russian–Tatar, and Tatar–Russian bilingualism is widespread in Tatarstan if we consider bilingualism as the ability to speak two languages.

Experiment and materials

The present experiment sought to address the research question of whether bilinguals would outperform monolinguals on solving difficult symbolic math tasks. Algebra typically represents the students' first encounter with abstract mathematical reasoning and it therefore causes significant difficulties for students. Symbolic abstraction is a significant component of algebraic thinking. Algebra is a fundamental discipline in higher mathematics and plays a major role in the field of STEM education. The transition from arithmetic to algebra is a challenging task for learners, as algebraic thinking requires a shift from calculating exact values to considering relationships between quantities and operations with unknown values and variables.

One of the important topics of algebra is the study of functions, and many researchers favor teaching other algebraic topics, such as the solution of equations and inequalities based on functions. Students usually perceive functions as a tool to get answers but not as a mechanism to express the relationship between variables presented as symbolic abstractions.

Since abstract thinking represents the ability to process information, special symbolic algebraic tasks were developed in order to test for possible bilingual advantages in symbolic abstraction. Images and symbols are often used in abstract thinking, and their meaning derives solely from the thinking process. Algebraic functions are presented in an unconventional form; a new symbol is used to represent a certain sequence of basic mathematical operations. The task in our study has the following form: $x \&y = xy + x - y$. What is $5 \& 3$? The solution of this task requires an abstract-symbolic approach and the understanding that the new symbol indicates the relationship between the variables and a certain set of mathematical operations (see Table 1).

Sample tasks		
The first task with its solution is given as an example. The answers are provided for the remaining tasks.		
1.	$x \infty y = xy + x - y$ Solution: $4 \infty 5 = 4 \times 5 + 4 - 5 = 19$	What is $4 \infty 5$? Answer: 19
2.	$x \text{ } y = x/y + y - 3$	What is $6 \text{ } 2$? Answer: 2
3.	$x \neq y = 7x - 2y$	What is $5 \neq 3$? Answer: 29
4.	$x \alpha y = (3y - 4x) + 5$	What is $1 \alpha 4$? Answer: 13
Easy tasks		
1.	$x @ y = (x - y) + (2x + 3y)$	What is $4 @ 2$?
2.	$x \S y = (xy) (x + y)$	What is $5 \S 3$?
3.	$x \text{ } y = (x + y)^2 / (x - y)$	What is $4 \text{ } 2$?
4.	$x \# y = x^3 - y + 2x + 3y$	What is $1 \# 7$?
Medium tasks		
1.	$x \rightarrow y = (xy) (x + y)$	What is $(4 \rightarrow 2) \rightarrow 3$?
2.	$x \odot y = y^2 + xy$	What is $5 \odot (3 \odot 2)$?

3.	$x \leq y = xy$	$x \geq y = x/y$	What is $(9 \leq 2) \geq 3$?
4.	$[x] = x^2 / 2$	$\{y\} = y + 2$	What is $[7] / \{7\}$?
Difficult tasks			
1.	$\langle x \rangle = 4x - 2$	$2 - \langle x \rangle = x - 1$	What is x ?
2.	$x ? y = 11x/y$	$z ? 7 = 200$	What is z ?
3.	$x \bullet y = (x - 2y)/y$	$4 \bullet 5 = z \bullet 10$	What is z ?
4.	$(x) = x^2 - x$	$(y) = (y - 2)$	What is y ?

Table 1: Symbolic mathematical tasks

Mielicki, Kacinik and Wiley (2017) introduced the types of tasks in Table 1 for school pupils. We modified them to suit our adult participants in the research. The tasks in the current study were designed to test the development of participants' abstract thinking in a way that is intended not to depend on their previous academic experiences dealing with algebraic functions.

Participants

Sixty-two bilingual and monolingual first-year students of The Institute of Philology and Intercultural Communication of Kazan Federal University (Russia) aged 18 to 20 years participated in this experiment. They perceived this kind of symbolic problems as new because they were not familiar with the concept of binary algebraic operation.

Participants were categorized as early bilinguals (N=29) and monolinguals (N=33). Bilinguals who have had a prolonged exposure to more than one language before the age of 7 are called early bilinguals. Prolonged exposure is when both parents in the family speak a language other than Russian or when the individual attended a school in which he or she did not study in Russian. We selected only early bilinguals to identify and test positive effects based on previous studies examining the cognitive benefits associated with early bilingualism (Bialystok, Craik, & Luk, 2012). Native speakers of Russian, who did not experience prolonged exposure to another language from early childhood, were considered monolinguals.

The language history of the participants was compiled with the help of interviews. In the sample of bilingual respondents, 57% indicated Tatar as their dominant language. Other dominant languages were Russian (18%), Mari (7%), Udmurt (6%), Bashkir (4%), Tajik (3%), Uzbek (2%), Kazakh (1%), Azerbaijani (1%), and Chinese (1%).

Researchers have tried to measure dominance for many years. Some scientists use such criteria as pronunciation and vocabulary to evaluate a bilingual's languages. Others apply various tests such as naming images, recognizing words, executing a command, or translating sentences from one language to another. Based on these, the experts rate the dominant language of the participant. However, these different approaches are criticized for primitivism in the analysis of language knowledge and bilingual behavior, as the two languages are evaluated independently. We preferred an approach in which bilinguals themselves assess their level of bilingualism. We defined the dominant language as one in which the bilingual has reached an overall higher level of proficiency at a given age, and/or the language used more frequently, and in a wider range of domains.

Bilingual participants were asked to describe their level of proficiency in the dominant and the second language on a scale of 0 to 10 (0=no, 10=perfect) for “speech activity” and “understanding”. Bilinguals reported similar levels of proficiency in the dominant language ($M=8.36$; $SD=1.48$) and in the second language ($M=8.49$; $SD=1.24$) for “speech activity”. Similar levels were reported in the dominant ($M=8.66$; $SD=1.34$) and second languages ($M=8.88$; $SD=1.03$) for “understanding”.

Russian was the dominant language of all the monolinguals. The average age of onset for second language acquisition was 7.13 ($SD=1.53$). Unlike bilinguals, monolinguals reported a higher level of proficiency in speaking Russian ($M=9.61$; $SD=0.93$), and a lower level in their second language ($M=2.23$; $SD=1.16$). Monolingual participants also described their level of understanding in Russian ($M=9.65$; $SD=0.76$) as higher than their second language ($M=2.97$; $SD=1.57$).

Procedures and results

Subsequently, the participants were offered to solve symbolic mathematical tasks (see Table 1): four types of symbolic math tasks of increasing complexity, consisting of four items. The solution to the first problem in each variant was given as an example. After completing each of the remaining three tasks, participants were informed whether they had answered correctly or incorrectly. Then the participants solved 12 more tasks of three levels of difficulty (easy, medium and difficult). The level of difficulty was determined by the number of new characters in the problem, as well as the number of operations required to solve the problem.

The tasks were presented in increasing complexity, and all participants performed the same tasks in the same sequence. Tasks were shown on the computer screen; the participants recorded the answers on a special worksheet. They were asked to make as many transformations and calculations as possible mentally but also had a pencil and paper, which they could use if necessary. Participants performed the tasks at their own pace and received one point for each correct answer.

Figure 1 shows the distribution of the number of correctly solved symbolic math tasks at each level of complexity by monolinguals and bilinguals. It signals minor differences between bilinguals and monolinguals in favor of the latter in solving easy and medium level problems. However, significant differences emerge in the other sense in solving symbolic math tasks of high complexity.

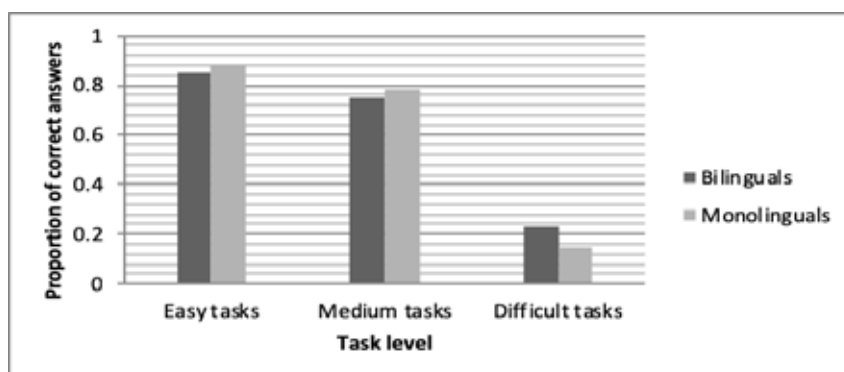


Figure 1: Performance of bilinguals and monolinguals on symbolic math tasks

A paired-samples t-test was conducted to determine the effect of bilingualism on solving symbolic math tasks. There was no significant difference between monolinguals ($M=0.97$; $SD=0.18$) and bilinguals in easier tasks ($M=0.79$; $SD=0.41$); $t(60)=2$, $p=0.05$. No evidence exists that bilingualism

has an effect on solving easy symbolic math tasks that require abstract reasoning. Similarly, there was no significant difference between monolinguals ($M=0.75$; $SD=0.44$) and bilinguals in medium tasks ($M=0.83$; $SD=0.38$); $t(60)=2$, $p=0.05$. Thus, no evidence exists that bilingualism has an effect on solving medium symbolic math tasks. However, there was a significant difference between the group of monolinguals ($M=0.1$; $SD=0.034$) and the group of bilinguals in the solution of difficult math tasks ($M=0.22$; $SD=0.041$); $t(60)=2$, $p=0.05$. Hence, we concluded that bilingualism influences the ability to solve difficult symbolic math tasks requiring advanced abstract thinking.

Bilinguals in our study performed better, particularly with the difficult problems. The advantages observed here illustrate that bilinguals may be faster to adapt to the demands of novel math tasks. Higher performance suggests that bilinguals may have some advantage in implementing the understanding of new symbolic rules in a new context. These results show that bilinguals can have superior skills in flexible selection and application of new procedures compared to monolinguals.

Discussion

Most prior research focuses on the problems encountered while learning mathematics and teaching mathematics to bilinguals and students whose home language is not the language of instruction. However, as the current study shows, bilingualism can facilitate the development of abstract thinking, which is consistent with Planas (2014). Since our sample was small, we cannot make global conclusions about the advantage of bilingualism in abstract reasoning. However, our research confirms to some extent the results obtained by Mielicki, Kacinik and Wiley (2017) for USA college students that bilinguals solve better difficult mathematical problems that require advanced abstract thinking. Our study found that bilingual students coped better with difficult abstract mathematical problems. This is how the synergetic effect of bilingualism and experience in abstract thinking manifested itself; it became obvious in those tasks that contained more ambiguity.

It is believed that executive functioning plays a crucial role in solving problems and previous studies have shown the benefits of executive functioning among bilinguals (Adesope, & Ungerleider, 2010; Bialystok, Craik, & Luk, 2012). The advantage of bilinguals in the development of executive functions could also explain the results obtained in this experiment, because memory, inhibitory control, fluid intelligence, mental flexibility and selective attention are involved in the abstract reasoning process while solving abstract math tasks.

One of the drawbacks of our investigation is the assumption that the monolingual and bilingual groups used in the study were truly comparable in every aspect, except for their linguistic skills. Paap and Greenberg (2013) expressed concern that some previously identified differences between monolinguals and bilinguals might actually be the result of differences in socioeconomic status between samples. Since socioeconomic status is known to be associated with different cognitive skills, it is important to ensure that monolingual and bilingual samples come from the same socio-economic background and share other important family characteristics (e.g., parents' education). This fact should be noted, thus an alternative explanation based on the status differences among the bilingual and monolingual participants cannot be ruled out.

Teachers and educators need to be aware of the strengths and weaknesses of bilingual students and teach them accordingly. The differences between bilinguals and monolinguals, if any, are specific to

a particular task and can be quite subtle. Further research can explain our experimental results, which enrich the growing research on the complex picture of the existing effects of the bilingual experience and the strategic intellectual resource of bilingualism when learning mathematics.

Acknowledgement

Our work was done in accordance with the Russian Government Program for Competitive Growth of Kazan Federal University.

References

- Adesope O. O., Lavin T., Thompson N., & Ungerleider C. (2010). A systematic review and meta-analysis of the cognitive correlates of bilingualism. *Review of Educational Research*, 80(2), 207-245. doi: 10.3102/0034654310368803
- Bialystok E., Craik F., & Luk G. (2012). Bilingualism: consequences for mind and brain. *Trends in Cognitive Sciences*, 16(4), 240-250
- Campbell A. E., Adams V. M., & Davis G. E. (2007). Cognitive demands and second language learners: a framework for analyzing mathematic instructional contexts. *Mathematical Thinking and Learning*, 9(1), 3-30. doi: 10.1207/s15327833mtl0901_2
- Cummins J. (1991). Interdependence of first- and second-language proficiency in bilingual children. In E. Bilyastok (Ed.), *Language processing in bilingual children* (pp. 70-89). New York: Cambridge University Press.
- Gentner, D., & Goldin-Meadow, S. (2003). Whither whorf. In D. Gentner, & S. Goldin-Meadow (Eds.), *Language in mind: Advances in the study of language and cognition* (pp. 3-14). Cambridge, MA: MIT Press.
- Haag N., Heppt B., Stanat P., Kuhl P., & Pant H. A. (2013). Second language learners' performance in mathematics: disentangling the effects of academic language features. *Learning and Instruction*, 28, 24-34. doi: 10.1016/j.learninstruc.2013.04.001
- Mielicki M. K., Kacirik N.A., & Wiley J. (2017). Bilingualism and symbolic abstraction: implications for algebra learning. *Learning and Instruction*, 49, 242-250. doi: 10.1016/j.learninstruc.2017.03
- Paap K. R., & Greenberg Z. I. (2013). There is no coherent evidence for a bilingual advantage in executive processing. *Cognitive Psychology*, 66(2), 232-258. doi: 10.1016/j.cogpsych.2012.12.002
- Planas N. (2014). One speaker, two languages: Learning opportunities in the mathematic classroom. *Educational Studies in Mathematics*, 87(1), 51-66. doi: 10.1007/s10649-014-9553-3
- Salekhova L. L., & Danilov A. V. (2016). Cognitive costs of bilingual education: theoretical and empirical research. In G. Chova (Ed.), *Proceedings of the 8th International Conference on Education and New Learning Technologies* (pp. 6340-6344). Barcelona: IATED.
- Salekhova L. L., Spiridonova N. I. (2018). The basic conditions for development of mathematical speech of students in the process of bilingual education. *The Education and Science Journal*, 2(20), 60-87.

- Spelke E. S., & Tsivkin S. (2001). Language and number: A bilingual training study. *Cognition*, 1(78), 46-88.
- Vygotsky L. S. (1962). *Studies in communication: Thought and language* (E. Hanfman & G. Vakar, Eds.). Cambridge, MA: MIT Press.

Teaching mathematics in an international class: Designing a path towards productive disposition

Marc Sauerwein

Rheinische Friedrich-Wilhelms-Universität, Bonn, Germany; sauerwein@math.uni-bonn.de

How can we design a teaching environment for an international class of refugees seizing its natural variety to encourage a path towards productive disposition? The article discusses and evaluates a potential answer by sketching a multiply implemented teaching approach to algebraic expressions and their manipulation via figurate numbers. The intended goal of that approach is twofold: On the one hand challenging pupils' beliefs of mathematics and its teaching, and on the other hand providing a suitable substantial learning environment for the introduction to elementary algebra. As multicultural classrooms, where the language of education differs from the learners' mother tongue, ask for special, language-sensitive teaching approaches, this approach considers the linguistic accessibility and tends to serve as a catalyst for further linguistic and mathematical development.

Keywords: Elementary algebra, refugees, genetic principle, figurate numbers, heterogeneity.

Introduction

In Germany, IVKs (German abbreviation for International Preparation Class) have been established since 2015 to structure the education of foreign pupils who migrated to Germany. Most pupils are refugees from conflict and war zones all over the world, with medium to non-existent German language skills. In general, pupils can attend these classes for up to two years (depending on the state), and the goals of these classes can be very diverse: different school degrees, transition into the regular educational system or qualifying for the start of an apprenticeship. As in every class there is a natural diversity with respect to the pupils' mathematical giftedness and abilities. However, this natural heterogeneity is intensified by a larger age spectrum (of at least 8 years) and previous experiences in the pupils' various homelands and the conditions of their flight to Germany.

Modelling strands of heterogeneity

In the tradition of Wittmann's view of mathematics education as a 'design science' (Wittmann, 1995), I identified, in cooperation with various experienced teachers, different strands of heterogeneity in a design research project with multiple implementation cycles (Sauerwein, 2020). A few of these (provisional) strands serve as a basic framework for the reasoning in the article to emphasise the crucial differences between teaching the IVK and regular classes:

- *Communicative strand:* There is no common daily language - neither for informal communication nor for discussions in the classroom. Learning German as a foreign language thus is not only restricted to the classrooms: It encompasses the complete daily routine. The pupils' knowledge of the German language is in-between the levels A1 and B2 (with respect to the CEFRL); some do not even cover A1.
- *Emotional strand:* The linguistic problems are not separated from daily life. This can contribute to an overwhelming frustration of feeling inadequate in nearly every respect of everyday life. Even prior to our project, we observed many pupils approaching mathematics with more courage than other subjects, where they remained passive or even missed lessons.

- *Mathematical strand:* The prior knowledge of mathematics is very individual and reaches from a rudimentary number sense in the number range 1–10 up to twelve years of mathematics education. Moreover, the primary focus in the pupils' previous mathematical education seems to lie on the symbolic languages of arithmetic and algebra.
- *Cultural strand:* Regular school attendance is not part of every culture. In some countries, the pupils are expected to contribute to their families' income. Nevertheless, all pupils had a positive attitude towards school and were grateful for every help. However, for some pupils, a structured week with a time schedule and the learning commitments were new and resulted in an overextension. Rapid changes between gratitude and frustration were observable.
- *Institutional strand:* The school system in Germany probably differs from the pupils' experiences in their respective homelands. According to what some pupils tell me, teaching here is less authoritarian and contains more independent working phases; learning by heart is less dominating. This implies that lessons for these pupils are more demanding as they ask for creativity, self-initiative or mathematical discourse.

Problematic consequences

Although these strands are not explicitly addressed in class, they influence teaching in many subtle ways. For example, different beliefs of mathematics and its teaching seemed to appear in the IVK. These expressed themselves in the following observed misconceptions in practice:

- In mathematics, there is only one correct solution and it's either the teacher's or the calculator's job to decide.
- Mathematics is a finished product and consists mainly of mimicking the teacher's solutions in a formal way with no deeper insights or discussions (in class).

This experience cannot certainly be generalised towards a statement about non-European school systems. These attitudes towards school in general and views on mathematics can prevent the pupils from building sustainable mathematical concepts. On top of that, they can cause challenges with respect to the integration into regular classes.

Research question

The description of different strands of heterogeneity does not imply that these could be addressed separately, as posed in Gorgorió and Planas (2001, p. 28): "It is very difficult to disentangle the social and cultural conflicts of a multiethnic mathematics classroom from the language issues."

As argued before, the above-mentioned intertwined strands influence the teaching. For simplicity we assume that they characterise the heterogeneity in the IVK. The context of an IVK is fundamentally different to bilingual classrooms (e.g., in Malta, Farrugia, 2017; in Catalonia-Spain, Planas & Setati, 2009; in Germany Schüler-Meyer, 2017). In general, one cannot expect to have a common language. The broad research question from the beginning can be rephrased to: Can figurate numbers help to address the special situation within an IVK in a *holistic way* to stimulate a meaningful learning of elementary algebra? In the next section, I address the topic of figurate numbers by building partly on data and findings of my doctoral dissertation (Sauerwein, 2020).

Figurate numbers

“If human actors invite the object to be a part of the discourse, objects can challenge the students to find a new language [...]. This aspect is of special interest from a didactical point of view. Objects cannot only relieve students on the language level, but also challenge them. They can be ‘supporters’ in the development of mathematical thinking and of a precise mathematical language.” (Fetzer & Tiedemann, 2015, p. 1392)

Inspired by typical generalising approaches to algebra (e.g. Mason, 1996) we define a *figurate number* as a sequence of dot patterns including the corresponding integer sequence:



Figure 1: "3, 6, 9, ..."

As the definition is based on sequences and thus incorporating the (hidden) rule of construction, Figurate numbers demand naturally for a pursuit to find this rule. In keeping with Bruner's (1966) three modes of representation of knowledge, enactive – iconic – symbolic, figurate numbers possess iconic and symbolic components. The iconic nature allows the pupils of the IVK to find linguistically more accessible common ground for mathematical discussions and development.

Such workshop languages [or intermediate languages] which are characterised by a high vividness, situatedness and grammatical looseness, which are often supported by gestures and which may hardly be comprehensible to non-participants, will emerge inevitably from themselves and their communicative importance must be highly appreciated. (Winter, 1978, p. 13, my translation)

It should be noted that, although the language is more accessible, it does not result in a cutback with respect to the richness of its mathematical content. Similarly, Moschkovich (1999) implicitly criticises some teaching practices which limit the pupils' opportunities by the early introduction of compulsory mathematical vocabulary:

“[...] [L]anguage learners can and do participate in discussions where they grapple with important mathematical content. [...] But it is only possible to uncover the mathematical content in what students say if students have the opportunity to participate in a discussion and if this discussion is a mathematical one.” (Moschkovich, 1999, pp. 18-19)

Practical perspective

Each of the four implementations of the learning environment *Figurate Numbers* started with the dot pattern in Figure 1 which was easily continued by all pupils in an iconic way. In almost all cases – with one interesting exception mentioned below – the resulting dot pattern was a 3 · 4-rectangle. Since not all pupils knew the word for rectangle, they used gestures to distinguish between columns and rows while saying a number, meaning the number of dots in that particular part of the dot pattern. In this way, they were eventually able to describe the pattern and its underlying rule of construction:

- The next dot pattern consists of three horizontal rows with four dots each.
- The next dot pattern consists of four of these columns.
- One always adds the first dot pattern.

- The right dot pattern consists of the preceding two.

The first three descriptions imply that the next dot pattern consists of 12 dots. From there on, many pupils continued the number sequences in a symbolic mode, thus identifying it with the multiples of 3. Although this change of mode of representation seems to be economic, one loses some structure: The expressions $3 \cdot 4$, $3 + 3 + 3 + 3$ and $9 + 3$ all yield 12, but each of them also encodes a certain perspective onto the iconic representation, namely how it is structured and consequently counted.

What is the meaning of the fourth description? The pupil's idea incorporates the triple Fibonacci-Numbers. Cutting the dot pattern horizontally it is easily seen that the pupil's construction is the law of construction of the Fibonacci-Numbers 1, 1, 2, 3, 5, Pupils were confronted with the fact, that different views on the given data permitted different and equally legitimate solutions; while the multiples of three later offered an obvious description as a closed term the pupils discovered the essential truth that mathematical observation, if taken seriously, might lead to open ends which cannot be immediately tied up on the basis of available knowledge. Therefore, it is fair to say that this insight was achievable due to the different perspective on the innocent looking figurate number.

Consider now the *filling glass*:



Figure 2: "6, 10, 14, ..."

The filling glass with its richer iconic structure allows more different approaches to counting. Pupils introduced the notion of "negative points" (the missing points in the lowest row) to arrive at "recipes" like $4 \cdot 4 - 2$, they observed symmetry (arriving at $2 \cdot (2 \cdot 3 + 1)$). To communicate these ideas the pupils used gestures and inscriptions into the dot patterns, thus enriching them – as diagrams - with a basis for socially accepted reasoning (in the sense of Dörfler, 2006). All these views are potential starting points for generalisations. When changing the iconic pattern is allowed too (for instance changing the position of the two points to a position below the first two columns), more terms can be found, and the observation of equivalence can be generalised to consider terms as objects for further studies and in this context understanding equality among terms on a level beyond syntactical limits.

When in a later state, pupils manipulate terms according to algebraic rules they can, if necessary, find in adapted iconic representations and the study of their geometric transformability into each other a reliable basis for their mathematical discourse.

Meta perspective

In the beginning of each implementation of our project we were met with the pupils' objection that these dot patterns were nothing but a puzzle for children and no mathematics at all. This pupils' prejudice, which can well be understood from the mathematical and institutional strands explained above, in the course of our project changed into a qualified appreciation of the subject.

Presenting patterns of small dots (i.e. the iconic representation of the first few elements of a figurate number) proved to offer several possibilities and – referring to our intentions – advantages, which are closely related to their "simplicity":

- Each pupil can count the dots; hence the figurate numbers create a productive entry for different levels. Since in our project every pupil had a certain fluency in counting activities and basic arithmetic (even if limited to a certain range of numbers) the low-threshold accessibility of our project could be taken for granted.
- No tools such as calculators or other digital tools are needed. Only a piece of paper, a pencil and a rubber are needed to gain access to the dot patterns. Taking up on Mason's (1996) distinction of *looking at* vs. *looking through*, the plainness combined with a thorough investigation offers the chance to look through the particular pattern and grasp the general rule. Thus, the picture becomes literally a "diagram" (Dörfler, 2006) and a tool for new insights.
- All but one pattern which we used in our design project corresponded to linear counting expressions. From a mathematical viewpoint these expressions are rather elementary. As this form of representation is new to the pupils, they have to accept and discover the iconic representations as worthwhile objects of further studies and later the possibility to switch between different representations, for example between the dot pattern and the number (maybe written as sum or product) as a tool to prove the validity of an algebraic argument.

This outlined simplicity yields a situation where pupils can express their own ideas even though their skills of the German language would not allow them to do so. The stimulated discussions between the pupils were making use of a certain *intermediate language* (Winter, 1978): The iconic representation becomes the basis for discussion enriched with gestures and rudimental symbolic notations. Winter emphasises the necessity of this intermediate language as a foundation for the symbolic language. Thus, he argues, one should not rush through this stage.

Epistemological perspective

An historical and epistemological analysis of Kvasz (2008) suggests that figurate numbers were a crucial step for the development of the symbolic language of algebra. Kvasz points out that there was no direct development from arithmetic to algebra as Frege proposed (1891). Instead, there were two instances of a certain *pattern of change* which he calls *re-coding*:

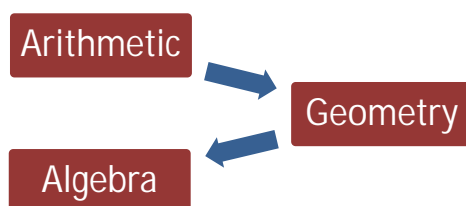


Figure 3: The *Re-coding* Arithmetic – Geometry – Algebra

Considering arithmetic and algebra as symbolic languages and geometry as an iconic language, *re-coding* can simplistically be seen as change of the mode of representation. The first *re-coding* is strongly related to the Pythagoreans who invented figurate numbers by using $\psi\eta\phi\omicron\iota$ (calculi). A first detailed account on figurate numbers can be found in Nikomachos' *Introduction to Arithmetic* (D'Ooge, 1926) where he introduces polygonal and polyhedral numbers apart from the two fundamental sequences of quadratic and oblong numbers (Figure 4). By the inscribed gnomons it is

easily possible to continue each sequence. The second *re-coding* is the symbolisation of the notion of a variable which was only implicitly used as a line segment of indefinite length, thus freeing the variable from three-dimensional space. The analysis of Kvasz and his view on the language of mathematics with its different stratifications where each layer has its own *potentials* (or *cognitive aspects*), yield the necessity to widen the definition of algebra as calculating with letters – it is more than just arithmetic with letters. The introduction of the symbol notation is only the first step to a new symbolic language (Kvasz, 2012). It also involves new ways of operating with the newly introduced symbols. Therefore, one can conclude that typical mathematical activities such as generalising, conjecturing, proving, etc. are part of the use of the language of algebra.



Figure 4: The quadratic and the oblong numbers

Communicative and linguistic connotations of figurate numbers

The notion of language occurs in different contexts within this report. These contexts are strongly related to different aspects of figurate numbers. On the one hand, there is language as a medium of communication. According to the communicative strand this function influences all teaching in the IVK. In this sense of language, figurate numbers serve as a tool for discussion of pupils without a common language. On the other hand, they act as a vehicle in a process of conceptualisation, that is, the conceptualisation of the iconic manipulations which lead to language of elementary integer algebra in the sense of Kvasz (2008).

In contrast to the perspective of Kvasz which describes the development of mathematics, the individual process of learning algebra is not linear and straightforward. From a didactical point of view, the pattern of re-coding should be used in both ways. Consequently, figurate numbers become a mediating tool between the languages. In particular, the interplay between the iconic and symbolic components of a figurate number turned out to be fruitful. Figurate numbers opened a context where pupils could conjecture, generalise, prove, discuss, etc.

Résumé

The aforementioned examples from practice showed that figurate numbers can address the special situation in an IVK by seizing the mathematical and communicative strands: The appearance of different counting strategies led to different counting expressions for the quantity of dots and ultimately to the quest to prove equivalence of different solutions on a legitimate and more concise basis than merely counting dots in examples. The iconic form of the figurate numbers served as a sustainable and workable representation compensating the lack of a common language in the class.

Furthermore, the other strands of heterogeneity were confronted: The pupils in the IVK were not familiar with the possibility that there could exist various correct solutions and that mathematics could consist of more than numbers and symbols. Thus, the opportunity arose to tackle the mentioned misconceptions. Moreover, the correctness of a solution was not judged by the teacher; it followed from a consistent argument based on different perspectives of the structure of figurate numbers. It could be observed that the sketched approach to figurate numbers was not only addressing the strands

of heterogeneity and some of their consequences but also contributing to the ambitious goal of the pupils' empowerment.

The strands of heterogeneity cannot be treated separately as they are strongly intertwined. Nevertheless, the initially observed positive attitude within the IVK towards mathematics seemed to be an appropriate starting point: This inclination of the pupils encouraged me to develop it into a “productive disposition” (NRC, 2001, p. 116).

The figurate numbers here act as a generic example for the context of elementary algebra. It could be worthwhile looking for other subject matters with similar potential with respect to mathematical and linguistic development in this social and cultural context of an international class for refugees.

Acknowledgments

I want to thank the pupils of the IVK for their cooperativeness and the Otto-Kühne Schule in Bonn for all the support and opportunities to conduct the research. Moreover, I would like to express my gratitude for the long discussions with Carl-Peter Fitting leading to the report in its present form.

References

- Bruner, J. (1966). *Towards a theory of instruction*. Cambridge, MA: Harvard University Press.
- Dörfler, W. (2006). Diagramme und Mathematikunterricht [Diagrams and mathematics lessons]. *Journal für Mathematik-Didaktik* 27(3-4), 200-219.
- D’Ooge, M.L. (1926). *Nicomachus of Gerasa. Introduction to Arithmetic*. London, England: The Macmillan Company.
- Farrugia, M. T. (2017). Young children’s appropriation of mathematical discourse: Learning subtraction in a plurilingual classroom. In T. Dooley, & G. Gueudet (Eds.), *Proceedings of the Tenth Congress of the European Society for Research in Mathematics Education* (pp. 1268-1275). Dublin, Ireland: DCU Institute of Education and ERME.
- Fetzer, M., & Tiedemann, K. (2015). The interplay of language and objects in the mathematics classroom. In K. Krainer, & N. Vondrová (Eds.), *Proceedings of the Ninth Congress of the European Society for Research in Mathematics Education* (pp. 1387-1392). Prague, Czech Republic: Charles University and ERME.
- Frege, G. (1891). *Function und Begriff – Vortrag gehalten in der Sitzung vom 9. Januar 1891 der Jenaischen Gesellschaft für Medizin und Naturwissenschaft* [Function and term – lecture given at the meeting of the Jena Society for Medicine and Science, 9th January 1891]. Jena, Germany: Verlag Hermann Pohle.
- Gorgorió, N., & Planas, N. (2001). Teaching mathematics in multilingual classrooms. *Educational Studies in Mathematics*, 47(1), 7-33. doi: 10.1023/A:1017980828943
- Kvasz, L. (2008). *Patterns of change: Linguistic innovations in the development of classical mathematics*. Basel, Switzerland: Birkhäuser.
- Kvasz, L. (2012). *Language in Change. Fernando Gil International Prize 2010*. Lisbon, Portugal: Fundacao Calouste Gulbenkian.

- Mason, J. (1996). Expressing generality and roots of algebra. In N. Bednarz, C. Kieran, & L. Lee (Eds.), *Approaches to Algebra. Perspectives for research and teaching* (pp. 65-86). Dordrecht, Netherlands: Kluwer.
- Moschkovich, J. (1999). Supporting the participation of English language learners in mathematical discussions. *For the Learning of Mathematics* 19(1), 11-19.
- National Research Council (2001). *Adding it up: Helping children learn mathematics*. Washington, DC: The National Academy Press.
- Planas, N., & Setati, M. (2009). Bilingual students using their languages in the learning of mathematics. *Mathematics Education Research Journal*, 21(3), 36-59. doi: 10.1007/BF03217552
- Sauerwein, M. (2020). *Figurierte Zahlen als produktiver Weg in die Mathematik. Ein Entwicklungsforschungsprojekt im Kontext einer Internationalen Vorbereitungsklasse* [Figurate numbers as a productive way into mathematics. A design research project in the context of an international preparatory class]. Wiesbaden, Germany: Springer Spektrum.
- Schüler-Meyer, A. (2017). Multilingual learners' opportunities for productive engagement in a bilingual German-Turkish teaching intervention on fractions. In T. Dooley, & G. Gueudet (Eds.), *Proceedings of the Tenth Congress of the European Society for Research in Mathematics Education* (pp. 1372-1379). Dublin, Ireland: DCU Institute of Education and ERME.
- Winter, H. (1978). Umgangssprache – Fachsprache im Mathematikunterricht [Colloquial language – specialized language in mathematics education]. *Schriftenreihe des IDM* 18, 5-56.
- Wittmann, E. C. (1995). Mathematics education as a 'design science'. *Educational Studies in Mathematics* 29(4), 355-374. doi: 10.1007/BF01273911

Which factors coincide with mathematical learning gains in bilingual classrooms? German language proficiency and mixed language use

Alexander Schüler-Meyer¹, Susanne Prediger², and Henrike Weinert²

¹TU Eindhoven, The Netherlands, a.k.schuelermeyer@tue.nl

²TU Dortmund University, Germany

Although bilingual mathematical learning opportunities have often been requested for multilingual students, little quantitative evidence has been provided that activating two languages has measurable effects on learning gains. This study uses data from a bilingual teaching intervention to investigate which factors coincide most with the mathematical learning gains in conceptual understanding of fractions. Students' individual and family characteristics have been assessed and participation and language use have been coded in ~95h videotaped teaching-learning processes. A regression analysis shows that students' learning gains can best be explained by students' German language proficiency and their use of Turkish and mixed mode, while talking time did not coincide with learning gains. Thus, the connection of languages seems to be even more important for mathematical learning gains than the isolated use of home languages or active participation.

Keywords: Multilingual math learning, teaching intervention, supply-use-model, learning gains.

Research gap on factors for effective multilingual mathematics learning

Many qualitative case studies illustrate benefits of activating multiple languages in mathematics classrooms (Planas, 2014). Multilingual resources have been shown to support mathematics learning and engaging students in discursive practices of problem solving, when drawing on multilingual everyday experiences (Domínguez, 2011). In fact, multilingual resources can support problem solving processes in general (Wagner, Redder, Kuzu, & Prediger, 2018), especially when students are highly proficient in their languages (Clarkson, 2006). Furthermore, the activation or acknowledgement of students' multiple languages can have a positive effect on students' agency (Norén, 2015). Summing up, multiple positive effects have been qualitatively identified. However, little *quantitative* evidence could so far be provided that bilingual interventions have *measurable* effects on the mathematical learning gains (Reljić, Ferring, & Martin, 2015).

In order to close this research gap on quantitative evidence, the project MuM-Multi conducted a randomized control trial with Turkish-German seventh graders comparing a bilingual and a monolingual German intervention aiming at conceptual understanding of fractions in small group teaching (Schüler-Meyer, Prediger, Kuzu, Wessel, & Redder, 2019a). The analysis showed that on average, mathematical learning gains in the bilingual intervention were comparable to the corresponding monolingual intervention. The differential analysis of learning gains shows that they were significantly higher for the students with high Turkish language proficiency (ANOVA: $F_{(\text{group} \times \text{time})} = 4.49$, $p < .01$, $h^2 = .16$). Additionally, a strong variance in learning gains was found for the different small groups (for which Cohens d varied between -0.12 and 2.22). A first hypothesis was that these differences might be traced back to different intensity in Turkish modes.

Hence, this study systematically investigates the factors contributing to the effective use of multiple languages in mathematics classrooms. For this, a video analysis was conducted to capture students' language use (Schüler-Meyer, Prediger, Wagner, & Weinert, 2019b) with this research question:

Which factors in individual and family characteristics and students' language use significantly coincide with students' learning gains in the bilingual teaching intervention?

This research is framed by the supply-use-model (Brühwiler & Blatchford, 2011; Helmke, 2009), which is outlined in the next section, before the methods of the study and its results are presented.

Research framework: Supply-use-model for quantitatively capturing potentially relevant factors for bilingual interventions

The supply-use model (Brühwiler & Blatchford, 2011; Helmke, 2009) has often proven to be powerful in quantitative classroom research for modelling the factors that influence whether a *supplied* learning opportunity is really *used* to its full potential by students in a classroom and how this impacts the learning outcome. The assumption is that the relations between supply, use and outcomes (learning gains) can be influenced by context factors or students' individual or family characteristics. Figure 1 shows the general model and its adaptation for the current research (justified in detail in Schüler-Meyer et al., 2019b).

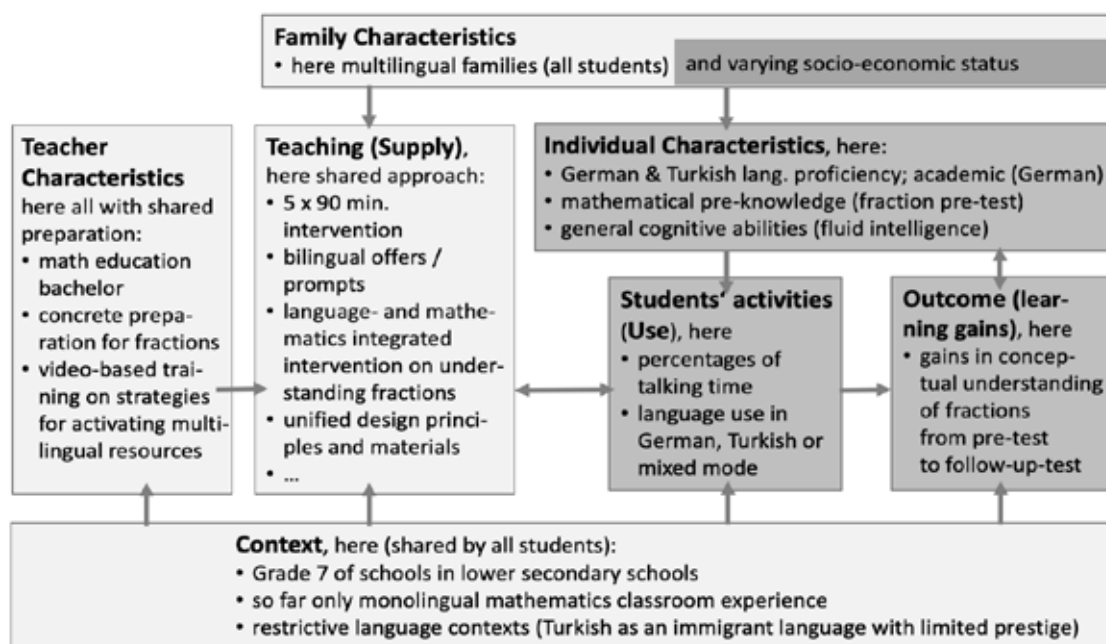


Figure 1: Supply-Use-Model adapted from Helmke (2009) by Schüler-Meyer et al. (2019b) (factors held constant are colored in light grey, varying factors in dark grey)

Following the research question, we investigate the learning processes of multilingual seventh graders with equal conditions in the language context (cf. Schüler-Meyer et al., 2019a): All students stem from multilingual Turkish-German families (all factors held constant are colored in light grey in Figure 1), their shared language context is shaped by only monolingual math classroom experiences and the limited prestige of their home language Turkish. All small groups are taught by teachers which share many characteristics and preparations. They follow the same bilingual intervention with

equal design principles and teaching materials, thus the *supplied* learning opportunities are held constant in the bilingual intervention on fractions.

The research question focuses on the individual *use* of supplied bilingual learning opportunities (in terms of percentage of individual talking time and language use) and students' *characteristics*. 'Percentage of individual talking time' was chosen as a use factor because active participation has often been qualitatively described as influencing learning gains (Gresalfi, Martin, Hand, & Greeno, 2009). The second *use factor concerns individual language use*: As all prior math experience was monolingual German, it was crucial to control whether students really use both of their languages. Like for most multilinguals, the bilingual modes are expected to be characterizable by mixed modes (e.g. various forms of Code-switching between German and Turkish), also for the second- and third-generation Turkish immigrant students (Auer, 2010).

Methodology of the study in the supply-use-model

Design of the bilingual teaching intervention

The investigated bilingual Turkish-German teaching intervention was designed to foster the conceptual understanding of fractions, which encompasses the part-of-whole concept, equivalence, and order of fractions. The intervention consists of five 90-minute weekly sessions and builds on three principles for fostering multilingual learning (cf. Schüler-Meyer et al., 2019a): (1) Providing rich contexts and problem tasks for language production (Domínguez, 2011); (2) macro-scaf-folding, which included encouraging the use of Turkish with bilingual teaching material, bilingual teaching practices (e.g. revoicing), explicitly addressing and developing the Turkish and German academic language, and (3) systematically relating registers (Prediger, Clarkson, & Bose, 2016).

Design of the overarching project MuM-Multi and video corpus for the current study

The randomized control trial (Schüler-Meyer et al., 2019a) was conducted in a pre-post-follow-up design with conceptual understanding of fractions as dependent variable. The family and individual characteristics mentioned in Fig. 1 served as control variables and the contrast between mono- and bilingual intervention served as the independent variable. The groups in the bilingual intervention were taught by trained Turkish-German speaking preservice teachers in small groups of 2-5 students, for 5 sessions of 90 minutes. This study focuses only on the bilingual intervention, for this 13 x 90 minutes video material of the third session was coded from 13 small groups. The third session in the middle of the intervention was chosen because teachers had developed their routines, and the students had a chance to overcome first barriers of using Turkish in the classroom.

Measures for data collection for the individual and family characteristics

At three measurement time points, several measures were administered:

- *Measures for students' conceptual understanding of fractions.* The test has 28 items to test for the understanding of the part-of-whole concept, equivalence, and order of fractions. The test has a satisfactory internal consistency with Cronbach's $\alpha=.83$ (28 Items, $N=1120$).
- *Measures for students' socioeconomic status and general cognitive abilities.* Students' socioeconomic status was measured with the economic and reliable book scale ($r=0.80$). The students'

fluid intelligence was measured using an adapted matrix test BEFKI 7 (with Cronbach's $\alpha=.763$ in the initial full sample of $N=1124$).

- *Measures for German and Turkish language proficiency.* Students' language proficiencies were measured by C-tests, which provide an economic and valid measure based on cloze texts. The C-tests are highly reliable: the Turkish C-Test with $\alpha=.874$ ($N=254$) and the German C-Test with $\alpha=.774$ ($N=1122$). Students' German academic language proficiency is measured with a test which assesses the use of nominalizations and other academic language features (BiSpra).

Initial sample and sample of the bilingual teaching intervention

The initial full sample encompasses $N=1124$ seventh-grade students from twelve secondary schools (48% female and 52% male). From the 303 Turkish speaking students, a subsample of 254 students self-selected themselves by accepting to work on the Turkish C-test (Table 1). For the intervention, students with a low conceptual understanding of fractions were selected (Cut-off of 28 points in the fraction test). This group consisted of $N=128$ students who were then stratified along the control variables and randomly assigned to the intervention groups. The sample of this study consisted of $n=35$ students who participated in the third sessions of the bilingual teaching intervention on fractions. Due to missing follow-up data, the statistical analysis has a sample of $n=33$ students.

	Initial sample ($N=1124$)	Bilingual subsample ($N=254$)	Sample of this study ($n=35$)
Family characteristics			
Percentage of German-Turkish speaking students	27%	100%	100%
Socio-economic status (low, medium, high SES)	35%, 33%, 31%	38%, 30%, 31%	40%, 20%, 40%
Individual student characteristics			
Mathematics achievement by fraction pre-test, $m(SD)$	10.31 (4.73)	9.81 (4.69)	8.03 (2.70)
General cognitive ability by BEFKI, $m(SD)$	7.94 (3.41)	7.25 (3.23)	7.49 (2.72)
Turkish language proficiency by C-Test, $m(SD)$		23.95 (13.17)	25.97 (13.07)
German language proficiency by C-Test, $m(SD)$	35.27 (9.17)	33.18 (8.34)	32.77 (5.52)
German academic language prof. by BiSpra-Test, $m(SD)$	19.06 (5.34)	17.03 (4.92)	17.20 (4.35)
Age by self-report, $m(SD)$	12.76 (0.70)	12.79 (0.78)	12.77 (0.65)

Table 1: Descriptive data for the full sample, the bilingual subsample, and the sample of this study

Methods of data analysis I: Coding the video corpus of the third intervention sessions

All utterances of the students (S1-S4) and teachers (T) were categorized turn-wise with respect to (a) speaker and starting / ending time of the utterance, and (b) language use (Turkish, German, mixed mode). Utterances with one switch from one language to the other were splitted and each part categorized. Utterances with borrowings or multiple code-switchings were coded as mixed mode. This categorization captures lexical aspects of language, while grammatical mixes are left out. The duration of the utterances is used for operationalizing the two use factors.

- *Percentages of talking time:* The operationalization of participation has to account for the fact that students in differently sized groups have different allotted talking times. Two students and a teacher theoretically have 30 min. of talking time each, while four students would only have 18

min. Hence, the allotted talking time is the theoretical talking time per group member with x group members, hence $90/x$. The individual percentages of talking time is the share of actual talking time from the allotted talking time (which can be bigger than 100%). Students on average participated 90,45% of the allotted talking time. The averages in the groups are between 72% and 110%, and the individual participation varies between 20% and 210%.

- *Modes of language use:* The individual language use is operationalized as the share of Turkish, German and mixed modes from the total individual talking time. Table 2 shows the descriptive data for the modes of language use.

Methods of data analysis II: Hypotheses and model for the statistical data analysis

For statistically investigating the research question, the following hypotheses were validated by correlations: The learning gains of the bilingual intervention is connected to **H1** the percentage of talking time; **H2** the Turkish language use; **H3** the language proficiency in Turkish and German. For comparing the influences of factors, a regression analysis was conducted with the software R (<https://cran.r-project.org/>) for validating Hypothesis **H4**: Among the different factors, some exist which coincide significantly with the learning gains. If a Shapiro-Wilk test confirms the normal distribution, Pearson's Product-moment correlations r were determined, if not, Kendall's Tau τ was used. To rule out an effect of the groups on the investigated variables, the intra class correlation ICC was determined and tested for significance with boot-strapping.

Results

Descriptive findings for the modes of language use

Table 2 shows that both, teachers and students, participated in bilingual modes, i.e. in a mixed mode or in Turkish. On average, 52% of the overall talk time was Turkish or mixed (72% teachers, 30% students). Hence, there is a high degree of productive and receptive use of Turkish. Furthermore, a large percentage of the talk time is in mixed mode, so that both teachers and students seem to use every-day bilingual practices of code-switching and -mixing. However, individually, there are substantial differences in the language use. The group averages between teachers and students also vary strongly. This suggests that individual preferences of language use might in part be a result of group-specific practices of activating multiple languages. Nevertheless, in a teaching intervention in which teachers consequently invest in the use of Turkish and mixed language, these numbers show that students can nevertheless be engaged in bilingual learning processes, compensating the low prestige of Turkish and the previous monolingual education.

	German mode	Mixed mode	Turkish mode
Teachers' average use of languages	27.5%	34.6%	37.4%
Students' average language use (all groups)	68.9%	13.6%	16.2%
Teachers' span of language use (min. – max. of the groups)	9.2% – 53.5%	15.7% – 56.4%	12.7% – 72.0%
Students' span of group average (min. –max. of the groups)	51.3% – 85.2%	4.9% – 26.5%	2.5% – 36.1%
Students' span of language use (min. – max. of all students)	16.1% – 96.8%	0% – 32.3%	1.5% – 56.1%

Table 2: Distribution of modes of language use for teachers and students (n=37 students)

Findings of influences of different factors

For investigating Hypotheses **H1–H3**, correlations were determined between the learning gains (difference between pre-test and follow-up-test) and the potential factors: The correlation with the German language proficiency is $r = 0.38$, with the Turkish and mixed modes in language use it is $r = 0.32$, these are two relatively high correlations. For the language use of only Turkish modes, the correlation is low with $r = 0.14$. No correlation exists with the percentage of individual talking time where $r = -0.03$. Thus, the hypothesis on relevance of active participation must be refuted.

To investigate the joint effects of the different factors on the learning gains (H4), a regression analysis with a stepwise model selection was performed (Table 3). As the learning gains of the small groups provide a non-significant ICC-value of 0.29 ($p > .05$), a multiple linear regression model is adequate.

	Regression coefficient b	Standard error (b)	Standardized regression coefficient
Model 1: All variables ($R^2 = 0.35$, $R^2(\text{korr.}) = 0.14$, $F(7,22) = 1.68$, $p > .05$)			
Intercept	-9.45	6.2	
German language proficiency (C-Test)	0.32	0.17	0.40
Fluid intelligence (Befki)	-0.0007	0.33	-0.0004
German academic language proficiency (BiSpra)	-0.05	0.26	-0.05
Turkish language proficiency (C-Test)	0.034	0.09	0.10
Socio-economic Status (Book index)	0.79	0.82	0.20
Use of Turkish and mixed mode	5.25	4.88	0.23
Percentages of talking time	-0.91	1.91	-0.092
Model 2: After systematic model reduction ($R^2 = 0.35$, $R^2(\text{korr.}) = 0.30$, $F(2,30) = 7.973$, $p < .01$)			
Intercept	-9.90 *	4.17	
German language proficiency (C-Test)	0.34 *	0.13	0.41
Use of Turkish and mixed mode	6.90	3.64	0.30
Model 3: Only German language proficiency as variable ($R^2 = 0.27$, $R^2(\text{korr.}) = 0.25$, $F(1,31) = 11.39$, $p < .01$)			
Intercept	-10.63 *	4.32	
Proficiency in German	0.44 **	0.13	0.52
Model 4: Only Turkish and mixed modes as variable ($R^2 = 0.20$, $R^2(\text{korr.}) = 0.18$, $F(1,31) = 7.873$, $p < .01$)			
Intercept	0.28	1.45	
Use of Turkish and mixed mode	10.33**	3.68	0.45

Table 3: Results of the regression analysis with stepwise model selection

Model 1 with all variables, while being complete, is not significant. A stepwise model selection results in a significant Model 2 ($F(2,30)=7.973$, $p < .01$), which includes German language proficiency as significant factor for learning gains ($p < .05$). In comparison, Model 3 and 4 are models with single variables, namely German language proficiency and the use of Turkish and mixed mode, respectively. Overall, Model 2 has the best model accuracy with $R^2(\text{korr.})=0.30$. This model shows that a higher German language proficiency leads to higher learning gains: One additional point in the C-test leads to higher learning gains of 0.34. Also, the use of Turkish and mixed language is a relevant factor: 10% more use of Turkish and mixed language leads to 0.69 more points in the learning gains.

In sum, the learning gains in the bilingual teaching intervention coincide with the German language proficiency, but not the Turkish language proficiency or the German academic register. This student

characteristic is combined with the use factor ‘use of Turkish and mixed mode’, which also shows a strong connection to learning gains.

Summary and discussion

This study contributes to the research discourse on multilingual mathematics learning as follows:

- Within usual language policies of monolingualism, the percentage of the mixed-language mode used by teachers and students is remarkable (Norén, 2015). By implementing certain principles for activating multiple languages, multilingual students can be fostered to activate their multiple languages in mathematical teaching learning situations, despite a language context which devalues the immigrant language Turkish.
- The finding that the share of Turkish and mixed language use in students’ utterances best explains the learning gains in the bilingual teaching intervention (together with German language proficiency) is a quantitative evidence for many qualitative results which show how multilinguality can be a resource in learning processes (Planas, 2014; Norén, 2015).
- The students’ percentage of individual talking time is not correlated to the learning gains. This confirms skepticism on too simple conceptualizations of active participation as talking time.
- In light of studies illustrating how conceptual tasks involving problem solving are especially accessible to multilingual students by means of certain discursive practices like discussing (e.g. Dominguez, 2011), the finding that students’ German language proficiency significantly coincides with the growth of conceptual understandings may hint at a more complex relation between conceptual tasks and their utilization in discursive practices, and the languages used.

Interestingly, not the share of Turkish from an individual student’s talk time, but the share of Turkish and mixed mode *together* have the second strongest influence on the long term achievement (Table 3). This is in line with Auer (2011) who identifies the mixed mode as the norm for Turkish-German multilinguals, and not the “pure” use of Turkish. This suggests that in bilingual classrooms the multilingual register and mixed mode are central pillars of the classroom discourse. Furthermore, it may suggest that a mixed mode allows deeper conceptual understanding (Wagner et al., 2018). Hence, in spite of its methodological limitations, this study confirms research which hints at the relevance of activating multiple languages in learning processes.

Acknowledgment

“MuM-Multi: Fostering Language in multilingual mathematics classrooms effects and conditions of a content- and language integrated intervention” was funded by the German ministry BMBF (01JM1403A, grant holders S. Prediger, J. Rehbein & A. Redder). We thank T. Kuzu, A. Redder, J. Rehbein, J. Wagner, and M. Çelikkol.

References

Auer, P. (2010). Code-switching/mixing. In R. Wodak, B. Jonstone, & P. E. Kerswill (Eds.), *The SAGE handbook of sociolinguistics* (pp. 460-478). London, England: Sage.

- Brühwiler, C., & Blatchford, P. (2011). Effects of class size and adaptive teaching competency on classroom processes and academic outcome. *Learning and Instruction*, 21(1), 95-108. doi: 10.1016/j.learninstruc.2009.11.004
- Clarkson, P. C. (2006). Australian Vietnamese students learning mathematics: High ability bilinguals and their use of their languages. *Educational Studies in Mathematics*, 64(2), 191-215. doi: 10.1007/s10649-006-4696-5
- Domínguez, H. (2011). Using what matters to students in bilingual mathematics problems. *Educational Studies in Mathematics*, 76(3), 305-328. doi: 10.1007/s10649-010-9284-z
- Gresalfi, M., Martin, T., Hand, V., & Greeno, J. (2009). Constructing competence: An analysis of student participation in the activity systems of mathematics classrooms. *Educational Studies in Mathematics*, 70(1), 49-70. doi: 10.1007/s10649-008-9141-5
- Helmke, A. (2009). *Unterrichtsqualität und Lehrerprofessionalität* [Teaching quality and teacher professionalism]. Seelze, Germany: Kallmeyer.
- Norén, E. (2015). Agency and positioning in a multilingual mathematics classroom. *Educational Studies in Mathematics*, 89(2), 167-184. doi: 10.1007/s10649-015-9603-5
- Planas, N. (2014). One speaker, two languages: Learning opportunities in the mathematics classroom. *Educational Studies in Mathematics*, 87(1), 51-66. doi: 10.1007/s10649-014-9553-3
- Prediger, S., Clarkson, P., & Bose, A. (2016). Purposefully relating multilingual registers: Building theory and teaching strategies for bilingual learners based on an integration of three traditions. In R. Barwell, P. Clarkson, A. Halai, M. Kazima, J. Moschkovich, ... M. Villavicencio (Eds.), *Mathematics education and language diversity. The ICMI 21 Study* (pp. 193-215). Cham, Switzerland: Springer International.
- Reljić, G., Ferring, D., & Martin, R. (2015). A meta-analysis on the effectiveness of bilingual programs in Europe. *Review of Educational Research*, 85(1), 92-128. doi: 10.3102/0034654314548514
- Schüler-Meyer, A., Prediger, S., Kuzu, T., Wessel, L., & Redder, A. (2019a). Is formal language proficiency in the home language required to profit from a bilingual teaching intervention in mathematics? *International Journal of Science & Mathematics Education* 17(2), 317-339. doi: 10.1007/s10763-017-9857-8
- Schüler-Meyer, A., Prediger, S., Wagner, J., & Weinert, H. (2019b). Bedingungen für zweisprachige Lernangebote – Videobasierte Analysen zu Nutzung und Wirksamkeit einer Förderung zu Brüchen [Conditions for bilingual learning opportunities – video-based analyses of usage and efficacy of an intervention on fractions]. *Psychologie in Erziehung und Unterricht* 66(3), 161-175. doi: 10.2378/peu2019.art09d
- Wagner, J., Kuzu, T., Redder, A., & Prediger, S. (2018). Vernetzung von Sprachen und Darstellungen in einer mehrsprachigen Matheförderung [Relating languages and representations in a supportive multilingual teaching intervention on fractions]. *Fachsprache - International Journal of Specialized Communication*, 40(1-2), 2-23. doi: 10.24989/fs.v40i1-2.1600

Publishing as an English non dominant language author. First results from a survey of support offered by mathematics education journals

Rudolf Sträßer (Straesser)

Justus-Liebig-University, Giessen, Germany & Australian Catholic University, Brisbane, Australia

rudolf.straesser@math.uni-giessen.de

With English as the language of the vast majority of highly regarded international journals in Didactics of Mathematics (research in mathematics education), authors who do not have English as their dominant language face the challenge of producing a text in a target language different from their working language (source language). The paper presents first results of a survey on how a number of highly recognised international journals in Didactics of Mathematics handle this issue and identifies some of the related challenges. Some challenges are linked to specific customs and norms related to the generation and credentialing of new knowledge within communities of research practice. Others are connected to semantic and pragmatic characteristics of transforming thoughts and texts from a source to a target language. The paper also provides insight into types of support offered by major journals to English non-dominant language authors.

Keywords: Translation, heteroglossia, centripetal versus centrifugal forces, journal survey.

Coming to the issue

This paper started in the experience of the author when publishing in journals of Didactics of Mathematics where the English language was obligatory. As I am not a native nor dominant¹ English speaking author, I had to express my ideas in English, which I had developed in a German speaking scientific community. My way out of this dilemma was asking a friend (Vince Geiger) to help me with transforming my texts from German English to Australian English. After some experiences with this simple arrangement, we came to reflect on this practice – what ended up in a presentation at a conference and later in a journal publication (see Geiger & Straesser, 2015). This publication was very well received and encouraged us to continue work on publishing about the issue of English non dominant language (EndL) authors in scientific journals of Didactics of Mathematics (see Geiger & Straesser 2017; Geiger, Margolinas, & Sträßer, 2018). In this paper I aim to progress this line of research inquiry by examining the ways in which major journals in mathematics education provide support for non-dominant English language authors.

Helpful concepts and ideas

In addressing the issue of the challenges faced by EndL authors when attempting to publish in major international journals in mathematics education, two major issues stand out: the transformation from a source language into a target language, and heteroglossic considerations. Publishing as an English

¹ The word “dominant” is used deliberately, because it best covers the situation to be analysed. The Merriam-Webster Dictionary offers two major explanations for “dominant”: “more important, powerful, or successful than most or all others” or “most common”. As can be seen for some colleagues, the dominant language is not always the language with which a person has grown up. “Dominant” also captures the power relation inherent in the dominance of a language.

non dominant language author in scientific journals inevitably invokes the challenge of transforming one's own dominant language, the *source language*, into English as the dominant language of international scientific discourse and of majors journals, which, at least in Didactics of Mathematics, is into the *target language* English – see section 3 for typical pitfalls as identified in the German/French/English context.

There are also challenges related to issues within a single language – normally discussed inside linguistics under the concept of *heteroglossia*. Heteroglossia was coined as a concept by translators of Bakhtin and provides a perspective relevant to learning a language different from a dominant language. The concept refers to the diverse, multiple layers of meaning and understanding embedded within speech and speech types (Barwell, 2014). In this respect, Busch (2014) distinguishes “between ... the multiplicity of (social-ideological) speech types or discourses, ... the diversity of (individual) voices, and [the] linguistic variation or the diversity of languages”, in distinguishing between multidiscursivity, multivoicedness and linguistic diversity (see Geiger & Straesser, 2015, p. 37). In particular, Bakhtin’s concepts of “*centripetal*” and “*centrifugal*” forces account for the tension that exists between a variety of languages or language types co-existing in communication within one language (Barwell, 2014). Centripetal forces place pressure on speakers or authors to adopt a single standardised linguistic code - an “official” language that must be adopted to gain full acceptance into a professional community or other social system. Working against this influence are centrifugal forces that push the language used by speakers and authors towards more diverse expression. Centrifugal forces arise because of differences between people, due to multivoicedness, and the multidiscursivity of linguistic diversity associated with geography, culture or membership of specific social groups. Such forces are seen at work within mathematics education through the diversity of its focuses and endeavours.

Challenges and pitfalls

This section can be read as a summary of a number of types of challenges identified in previous research and draws primarily on work within English, German and French language contexts.

The question of the name of the discipline

At least for researchers from French or German speaking communities, translating into English first starts with a choice of an adequate name of the researcher's “home discipline”. Is it *Didactique des Mathématiques*, *Mathematikdidaktik* or ... (Research in) Mathematics Education – as expected by anglophone communities? A loophole to this dilemma may be the rarely used *Science of Mathematics Education/Sciences de l'Éducation Mathématique / Wissenschaft vom Mathematik-unterricht*. However, this solution is a marker of a major problem. Different language-based communities of practice of a discipline have chosen to use names for their research activity, now well established and deeply rooted historically, that carry “baggage” when used in other languages. From the European perspective, *Didactique/Didaktik*, for example, has wide acceptance because of the famous *Didactica Magna* by Comenius (1896/1907), often cited as foundational publication from the early days of the discipline. However, for the anglophone researcher *Didactique des Mathématiques/Mathematikdidaktik*, has an undesirable association with “didactic” approaches to teaching and learning (e.g. teacher directed modes of instruction), while *Mathematics Education* for the French

and German speaking researcher is too wide and also covers the day-to-day practice in school, and does not focus on research.

Shared and non-shared references and respective theoretical frames

When developing an annotated translation of the English language article by Geiger & Straesser (2015) into French, we became aware of another major difficulty of EndL authors. Research papers across the disciplines must demonstrate that they take into account existing research on the topic at hand and that they provide a contribution to new knowledge. Translating a paper into another language, however, usually requires additional work because an initial publication in one language tends to have extensive references to research originating from the source language and the tradition within a (national) discipline. Often these lists include few, if any, references from the target language – this holds true even for journals with an international reach and readership, for example, *Recherches en Didactique des Mathématiques* (RDM) or *Educational Studies in Mathematics* (ESM). Unsurprisingly, reviewers tend to look for references in the dominant language of the journal, which for the author/translator may imply a longer search for appropriate papers to be referenced. In the worst-case scenario, this requires a literature search from scratch to have the basic seminal papers of the target language cited. This shift from papers in one language group to another within mathematics education can also require a revised reflection on the results and the re-writing of the results/conclusion section(s) in order to situate findings in a different theoretical landscape.

Type of ‘acceptable’ research reports

Communities of research practice do not only have sets of seminal reference points but often a very clear perspective on how to report on research activities. This is especially true for US-American research in mathematics education with an accepted structure around introduction, methodology, results, discussion and conclusion (Geiger & Straesser, 2015, p. 36). Such a tendency towards prescriptiveness can also be seen in other mathematics education research communities. For example, it is only for some five years that the International Group for the Psychology of Mathematics Education (PME) has accepted not only “Reports of empirical studies”, but also “Theoretical and philosophical essays”. For researchers from the French community, the dominant reporting structure for journals publishing in English, typified by PME, is highly problematic for reports on empirical investigations. For the French researcher, the expected structure requires a description of the theoretical framework that includes an extensive introduction to situate and justify the investigation and the precise methodological choices (the so-called a priori analysis). Further, the PME distinction of results and conclusions hinders an integrated presentation of empirical and often epistemological facets of a research, which would be common in a publication in French. There are also difficulties for German speaking researchers who adhere to the 'German' approach to Didactics of Mathematics called *Stoffdidaktik* when trying to follow the traditional PME structure (for this approach see Straesser, 2014 or Hußmann et al. 2016). The focus of research according to *Stoffdidaktik* is on disciplinary mathematics and so scientific progress is often recognised through identifying possible approaches to a specific mathematical topic (i.e. obtained with mathematical, not primarily empirical analysis) and will seldom fit with the definition of empirical investigations prioritised in empirical English language publications.

Semantic differences in scientific debates in different languages

Translating from a source language to a target language often implies the challenge of “false friends”, i.e. the fact that using a word from the source language in the target language produces incorrect, if not misleading associations. Using the French word (and in French didactics: theoretical concept, see Brousseau 1997, p. 56f and p. 214) *milieu* in English will hide the theoretical role of *milieu* in the French *Théorie de Situation* (TDS), where the concept also includes material aspects of an environment, whereas in English, *milieu* is only designating the social and cultural environment, not its material aspects. As a consequence and from the point of view of semantics, *milieu* has a broader sense in French than in English and so should not be used for a translation from French into English without qualification. If authors, especially those drawing from the French TSD, do not change the term when publishing in English and continue to use *milieu*, they widen the signification of the word in English. Thus, in theoretical terms, they exercise a centrifugal force in the sense of Bakhtin. If authors accept the difficulty of Anglo-phone researchers with the narrow understanding of *milieu* and – in contrast to its use in the TSD – only apply it in the narrow, dominant sense of *social milieu*, they surrender to the centripetal forces of the English language community.

Another challenge may be the absence of two different words from the source language in the target language. Geiger et al. (2018, p. 36f), discusses this case with the example of an adequate translation of the concepts of *savoir* and *connaissance* from French into English. The terminological problems (already existing) in French are exacerbated by the complexity associated with finding an appropriate word in English. The English language does not have the same depth, the granularity for the semantic field, for the term *knowledge*; this limit in vocabulary implies different solutions for the translation of the two French nouns *connaissance* and *savoir*, for example, to use the noun *knowing* for *connaissance* and reserve *knowledge* for *savoir*. Given these difficulties, an author would first require a very clear idea about the differences between these two terms within the Theory of Didactical Situation (TSD) and would then have to find a way to describe and explain this difference in English. By linking *connaissance* and *situation* on one hand and *institution* and *savoir* on the other (see Margolinas, 2014), a linguistic solution may be possible when attempting to communicate with English as dominant language speakers. Adding two adjectives to differentiate the only available noun *knowledge* instead of creating one or two new noun(s) has been used in a course about Brousseau’s work in English commissioned by ICME – with Margolinas and Bessot introducing the terms *situational knowledge* and *institutional knowledge* to deal with this situation.

The situation can be even worse for a translation. What if there is no word in the target language that can convey the meaning of an expression in the source language? In Didactics of Mathematics, the translation of *Bildung* from German into English is simply not possible. While there is a widespread debate in Germany of the relationship of *Bildung* to mathematics education, a number of publications on the topic (e.g., Winter, 1975) and a special topic study group on *Bildung* in the German research association *Gesellschaft für Didaktik der Mathematik* (GDM), this activity has not produced an adequate translation of the term *Bildung* in either English or French. An attempt to translate texts that refer to *Bildung* and its ramifications for mathematics education in German schools, would need an extensive description of the cultural history of the concept *Bildung*, which itself would only be a faint

echo of discussions in the pedagogical and didactical debate in Germany after world-war II (for the respective seminal book in pedagogy see Klafki 1985).

How journals in Didactics of Mathematics handle the issue – a survey

In order to gain insight into the support of EndL authors from major international journals in Didactics of Mathematics / Mathematics Education, a survey of the seven most highly recognised journals in the field was conducted. Journals were identified via the list in a study by Leatham and Williams (2017, especially the list on page 390) into those journals. After trialling the survey with the editor of the journal ranked 8th, the editors of the top 7 ranked journals were invited to respond to a survey. The survey was based on questions on the support offered by the journal for EndL authors before, during and/or after the processes of submission, review, proofing and publication. To date, there are five complete responses. Preliminary results of this survey are presented below.

The responses represent a wide spectrum of handling manuscripts from EndL authors. One extreme is the tendency to place all of the responsibility for conforming to a journal's expectations of language usage on the author, clearly communicated in the following response.

We expect language-edited papers for authors, whose mother tongue is not English, but many manuscripts still have strong deficits, when they reach us. We have language editing at the end by NN [name cancelled], but that comprises only a check of correct usage of terminology and correct academic writing.

At the other end of the spectrum, there are comments such as:

Thank you for investigating this important issue. Around 40% of articles published in NN [name of the journal] come from countries where English is not the dominant language, but the proportion of EndL authors is higher than this when one considers all submitted manuscripts. However, some caution is needed in looking for causes of manuscript rejection – language is not the only reason, and perhaps not even the main reason. Many authors struggle to frame and communicate their research so that it is relevant and accessible to an international audience, and this can be a consequence of differences in the significance of research questions across cultural contexts. So language diversity is part of a bigger global challenge in understanding culturally inflected ways of framing and communicating research.

None of the journals that have provided responses to date have a formal, institutionalised provision or special procedure for manuscripts submitted by EndL authors, but at least two of the editors-in-chief, indicated they take special care with such manuscripts. One of them tries:

... where possible, to align the language expertise [of handling editors] with the dominant language of the corresponding author [and tends] to support several rounds of major revisions to help the EndL author produce a publishable article. (Only one or at most two major revisions would be the norm for other manuscripts.) [In addition, the editor-in-chief spends]...many hours on language editing of the penultimate version of each EndL-authored manuscript that I handle. I aim to not only achieve an acceptable standard of academic English but also preserve some of the distinctive linguistic features of the author's first language (lexical choices, syntactic structures, etc.). I want

readers to “hear” the traces of the author’s first language rather than obliterate it and produce a bland and rather boring set of articles in each journal issue.

Another Editor-in-Chief states that

... after a submission is accepted the Editor works with the author(s) to improve the presentation of the article. Depending on the situation this can range from offering advice on rewriting, to offering suggested rephrasings.

In total, in two of the responses, language editing by the editors-in-chief is mentioned. At least one journal Editor indicated it was actively encouraging EndL authors to submit to their journal.

As Editor I actively seek contributions from non-English speaking researchers. ... This includes requesting members of our Advisory Board, which includes researchers from around the world, to suggest possible authors, and approaching potential authors at conference, etc. When a submission is received the evaluation of it is carried out on the basis of its content, and the editors are experienced in reading work by authors writing in a language other than their mother tongue, and so we are able in most cases to evaluate the content independently of the presentation. Some of our reviewers offer corrections at the grammatical level when commenting on a submission but not all. It is chiefly my responsibility as Editor to address any remaining language issues once an article has been accepted. That is, it is possible for an article to be accepted with ‘heavily accented’ writing. I then work with authors to ensure that their ideas are presented as clearly as possible to ... readers. An approach I have discussed with some potential authors, but which has not yet been implemented, is the submission of articles in a language other than French or English. Our Advisory Board includes researchers who are able to read many languages and so the first stage of our reviewing process (the internal review) could occur in another language.

In addition to this, the same journal even provides complimentary subscriptions to:

...national organizations, or research teams, in countries from which we rarely receive submissions ... on the theory that if more people in that country read [name of the journal], more people will submit articles to it.

Other responses indicate some journals manage the handling of manuscripts by EndL authors via the identification of appropriate reviewers, for example,

Selection of reviewers would take into account multiple factors, including familiarity with the theoretical and methodological approaches and often the local research context, in addition to the author’s language and cultural background.

By looking through the lens of centripetal / centrifugal forces within the major journals, the “standard” position in the answers is “There is no preferred form of English, but there does need to be consistency in using either US or English spelling within an article.” Thus, consistency is generally seen as the vital principle of English language usage. By contrast, the response of one Editor-in-Chief stands out by stating

Our instructions to authors state 'Contributions may be submitted in English or French. (The English may be American, British, or hybrid.)' How exactly this is interpreted has varied from

editor to editor. As I am not personally familiar with many dialects of English, and I find [...] English quirky and inconsistent, I tend to edit submissions to either US or UK spelling. NN style includes a mix of punctuation rules from US, UK and [...] sources, and some that have simply evolved as ‘the way NN does things’. As Editor I take responsibility for making sure the style of each article is close enough to NN style that most readers notice no inconsistencies.

This approach appears to be a special form of centripetal action in that while some diversity is allowed, expression is limited to only three forms of English.

Conclusion

Two conclusions can be drawn from the previous study of the challenges faced by EndL authors and their opportunities to publish in highly recognised journals. English (in the form of the UK, USA and other dialects or a mixture of them) is the “lingua franca” of international research in mathematics education / Didactics of Mathematics. At the same time, fruitful and innovative research in the field depends on the healthy life of “local” research communities, which need opportunities of publishing ideas and results in the individual dominant language of their “own”. The initial findings of the survey indicate that the support offered to EndL authors attempting to publish in highly recognised journals varies considerably. The spectrum of support ranges from an almost non-interventionist approach through to significant editorial support before publication in journals targeting the broad mathematics education / Didactics of Mathematics community.

Acknowledgement

I thank Vince Geiger, ACU Brisbane, for his continuous support and advice with writing this report.

References

- Barwell, R. (2014). Centripetal and centrifugal language forces in one elementary school second language mathematics classroom. *ZDM*, 46(6), 911-922. doi: 10.1007/s11858-014-0611-1
- Brousseau, G. (1997). *Theory of didactical situations in mathematics* (Translators: N. Balacheff, R. Sutherland, V. Warfield. Editors: N. Balacheff, M. Cooper, R. Sutherland, V. Warfield). Dordrecht, Netherlands: Kluwer.
- Busch, B. (2014). Building on heteroglossia and heterogeneity: The experience of a multilingual classroom. In A. Blackledge & A. Creese (Eds.), *Heteroglossia as practice and pedagogy* (pp. 21-40). New York: Springer Science+Business Media.
- Comenius, J. A. (1896/1907). The great didactic. The whole art of teaching all things to all men. URL: <https://ia600204.us.archive.org/21/items/cu31924031053709/cu31924031053709.pdf>
- Geiger, V., Margolinas, C., & Straesser, R. (2017). On the challenge of multi-linguisme in mathematics education research. *For the Learning of Mathematics*, 37(2), 16-18.
- Geiger, V., Margolinas, C., & Sträßer, R. (2018). Le défi de la publication en contexte anglophone de didacticiens des mathématiques dont la langue n'est pas l'anglais - version française commentée [The challenge of publishing in English-speaking contexts for mathematics educators whose

- language is not English – French version]. *Recherches en Didactique des Mathématiques*, 38(1), 15-42.
- Geiger, V., & Straesser, R. (2015). The challenge of publication for English non-dominant-language authors in mathematics education. *For the Learning of Mathematics*, 35(3), 35-41.
- Hußmann, S., Rezat, S., & Sträßer, R. (2016). Subject matter didactics in mathematics education. *Journal für Mathematik-Didaktik*, 37(Supplement 1), 1-9.
- Klafki, W. (1985). *Neue Studien zur Bildungstheorie und Didaktik. Beiträge zur kritisch konstruktiven Didaktik* [New studies on educational theory and didactics. Contributions to critically constructive didactics]. Weinheim, Germany: Beltz.
- Margolinas, C. (2014). Connaissance et savoir. Concepts didactiques et perspectives sociologiques? [Knowing and knowledge. Didactic concepts and sociological perspectives?]. *Revue Française de Pédagogie*, 188, 13-22.
- Sträßer, R. (2013). Stoffdidaktik in mathematics education. In S. Lerman (Ed.), *Encyclopedia of Mathematics Education*: Dordrecht, Netherlands: Springer.
- Williams, S. R., & Leatham, K. R. (2017). Journal quality in mathematics education. *Journal for Research in Mathematics Education*, 48(4), 369-396. doi: 10.5951/jresmetheduc.48.4.0369
- Winter, H. (1975). Allgemeine Lernziele für den Mathematikunterricht? [General learning objectives for mathematics education]. *Zentralblatt für Didaktik der Mathematik*, 7(3), 106-116.

Variations in students' reading process when working on mathematics tasks with high demand of reading ability

Frithjof Theens

Umeå University, Department of Science and Mathematics Education, Sweden
frithjof.theens@umu.se

The purpose of this study is to deepen the understanding of the relation between features of the text of mathematics tasks and the tasks' demand of reading ability. Variations in students' reading processes when they work with PISA mathematics tasks with high demand of reading ability are identified and analyzed. These variations can be related to linguistic features of words, phrases, or sentences in the tasks, which in turn can be possible sources for the high demand of reading ability.

Keywords: Mathematics tasks, reading comprehension, reading process, PISA.

Introduction

Mathematics tasks are a common way to assess students' mathematical knowledge. They are used in examinations, nationwide tests, and also in international assessments like the Programme for International Students Assessment (PISA). They are meant to assess mathematical ability, that is, acquired proficiency in mathematics, but a written task usually also requires that the student can read natural language in the task text, which can make the task also assess reading ability. Some reading ability can be seen as a necessary part of mathematical communication which is an aspect of mastering mathematics (NCTM, 2000). However, to ensure that the task assesses what it is intended to assess and nothing else, *unnecessary* demand of reading ability not connected to mathematical ability should be avoided. This unnecessary demand of reading ability can be caused by linguistic features of the task text which may be avoidable if they are not connected to mathematics (e.g., use of uncommon words not belonging to mathematical vocabulary or complex sentence structure). Therefore, it is important to identify which linguistic features of mathematics tasks are related to an unnecessary demand of reading ability. This demand may become apparent in variations in students' reading process when working with mathematics tasks (e.g., stumbling at a word or rereading a sentence). Analyzing these variations, and identifying the units of the text where they occur, makes it possible to determine features of the task text potentially causing an unnecessary demand of reading ability.

This study thus detects and analyses variations in students' reading processes when working with mathematics PISA tasks identified as having high unnecessary demand of reading ability. Also, features of the tasks' text and their possible impact on the tasks' demand of reading ability are discussed.

Background

This section presents the theories about reading comprehension and reading of mathematical texts that are used in this study to characterize the variation in the students' reading processes. It will also give a short overview of earlier research concerning sources of (unnecessary) demand of reading ability in mathematics tasks.

Reading comprehension

A simple description of reading comprehension is given by Hoover and Gough (1990) who describe *decoding* and *linguistic comprehension* as necessary for successful reading. Decoding means the ability to recognize words, that is, being able to connect written words to mental lexical information. Linguistic comprehension is the ability to derive meaning out of lexical information. In the concept of *reading comprehension*, these two are combined into the ability to derive meaning out of written information. In addition, Österholm, Bergqvist and Dyrvold (2016) identify three aspects of reading comprehension that can be related to reading difficulties. These are *phonological*, *syntactic*, and *semantic* aspects. The phonological aspect concerns sound and the flow of reading, since phonological memory supports listening comprehension and thus, indirectly, reading comprehension (Perfetti, Landi, & Oakhill, 2005, p. 238). The syntactic aspect concerns the decoding of grammatical structures at the sentence level. Finally, the semantic aspect refers to the depth and breadth of knowledge of word meaning (Nation, 2005, p. 254).

The different parts and aspects of reading comprehension are used in this study to identify possible sources for issues students encounter when reading mathematics texts.

Reading mathematics text

This study concerns reading of mathematics tasks. It is therefore relevant that there exist features that are typical for mathematics texts, like special mathematical words (e.g., differentiate), words that have a different meaning in mathematical context than in everyday language (e.g., product), or the use of numbers and formulas (see, e.g., Schleppegrell, 2007). In this study, an assumption is therefore that reading and understanding a mathematical text requires a certain kind of reading ability that is part of the mathematical ability that a mathematics task intends to assess. But a mathematics task text can also contain features unconnected to mathematical ability, for instance, long or unusual “non-mathematical” words or complex sentences with subordinate clauses. These features might cause an unnecessary demand of reading ability that is unconnected to mathematical ability. In this case, a student needs, besides mathematical ability (including the aforementioned mathematics-specific reading ability), also a reading ability not connected to mathematics to solve the task. Therefore, it is important to separate necessary and unnecessary demands of reading ability of a mathematics task.

Österholm and Bergqvist (2012a) developed and confirmed the reliability and validity of the statistical measure for the unnecessary demand of reading ability (DRA) of a mathematics task used in this study. A principal component analysis of students’ results on both mathematics and reading tasks extracts two main and partly overlapping components; a mathematics and a reading component. Mathematics tasks are loading mostly on the mathematics component, but are also, to varying degree, loading on the reading component. The loading on the reading component excludes the effects from the overlap between the components, and can therefore be interpreted as a measure of DRA.

In a mathematics task that is supposed to measure mathematical ability only, DRA should be avoided as far as possible. To be able to avoid DRA, it is necessary to identify not only tasks with high DRA, but also which features of a mathematics task are related to high DRA.

Sources of DRA

Since DRA measures a task's demand of reading ability that is not part of mathematical ability, it is plausible that linguistic features of the task text can be sources of DRA. These could be features connected to readability in general, such as long words (e.g., Lenzner, 2014), unfamiliar words (e.g., Abedi & Lord, 2001), or complex sentence structure (e.g., Dempster & Reddy, 2007). In an earlier study, Österholm and Bergqvist (2012b) found correlations between DRA and both word length and information density for the Swedish mathematics tasks of PISA 2003 and 2006. In a more recent study, Bergqvist, Theens, and Österholm (2018) identified tasks in the Swedish version of the PISA 2012 mathematics assessment having high DRA. In that study, however, the DRA was not correlated to any of the investigated features (word length, sentence length, task length, and information density). Identifying possible sources of DRA in mathematics tasks might help task constructors and teachers to avoid DRA or, at least, to make them aware of these issues.

Purpose of the study

The purpose of this study is to deepen the understanding of the relation between features of the text of mathematics tasks and the tasks' demand of reading ability. Therefore, this study identifies and analyzes variations in students' reading processes when they work with PISA mathematics tasks with high demand of reading ability (DRA) and then relates these variations to the linguistic features of the task texts. Thus, the research question is: Which kinds of variations appear in students' process of reading Swedish mathematics PISA tasks with high DRA?

After having identified the variations, by examining the units of the text where they occurred, I attempt to identify and discuss which features of the text can be possible sources for the DRA

Research Method

To investigate the variations in students' reading process, I collected and analyzed think-aloud-protocols (TAP) of students reading and solving mathematics PISA tasks in Swedish. These TAPs are part of a bigger data collection including students from both Sweden and Germany, several PISA-tasks, and follow-up interviews. In this study, I used the part of the TAPs where Swedish students read the tasks. The different steps of data collection and analysis are described in more detail below.

Task selection

For this study, I chose two tasks from the Swedish version of the 2012 PISA assessment that were identified having high DRA in an earlier study (Bergqvist et al., 2018). Since these PISA-tasks are confidential they cannot be reproduced here. The two tasks differ in several properties: Task 800Q01 (Dataspel/Computer Game) is a single task without subtasks and contains relatively little text. It is a selected-response (multiple choice) task made up of two shorter sentences and a table with numbers. Task 446Q01 (Termometersyrans/The Thermometer Cricket) is the first subtask of two in a longer task. It contains more text than 800Q01 - three long and two shorter sentences - and a photo showing the insect. It is a closed constructed-response item, that is, the students have to calculate an answer and write it down. They do not need to show their calculations.

Selection of participants and data collection

The students were recruited from three different schools, two from rural areas and one from a bigger city. They voluntarily agreed to participate when their teachers asked the classes. All twelve students spoke Swedish fluently and gave their informed consent to take part in the study. Six students were working with task 446Q01 and seven students with task 800Q01. One of the students worked with both tasks. The eight girls and four boys were between 14 years and 6 months and 16 years and 1 month old, that is, about the age of 15, which is the age for which the PISA tasks are designed.

The students were told to read and think aloud during their attempt to solve the tasks. Everything the students said was recorded with a Livescribe Echo® smartpen, which also recorded everything the students wrote and connected it to the audio data. If the students were silent for a while they were encouraged to continue talking.

Think-aloud-protocols have the advantage that it is possible to follow the students' reading process and to get to know in which order they are reading the task text. Even if reading aloud is a somewhat unnatural way of reading mathematics tasks, it makes visible which words, phrases, or sentences may be problematic for the students, since oral reading fluency is an indicator for reading competence in general (Fuchs, Fuchs, Hosp, & Jenkins, 2001).

Data analysis

To find the variations in students' reading process when solving the tasks, I performed an analysis in two steps. In step 1, I analyzed the TAPs to identify all variations and sorted them in different categories of types of variations. In step 2, I analyzed the categories found in step 1 to find patterns in the variations. The steps are described in more detail below.

Step 1: While listening to the TAPs, I made a note every time a student made any deviation from a "straight-on" reading process. This straight-on process is understood as starting to read at the beginning and reading all text once to the end without any interruptions. The straight-on process is not assumed to be an ideal way of reading, but used as a guiding norm to highlight variations. I also noticed if a student did not make any deviations from the straight-on process. Each time a variation occurred, I labeled it with a category. When this type of variation occurred for the first time, a new category was defined. When a variation of the same category had occurred before, this existing category was used. Examples for the categories are *stumbling*, *misreading*, or *rereading*.

Step 2: To get a clear picture of the nature of the categories of variations, I sorted the categories in two dimensions. The first dimension referred to which kind of unit of the text the category concerned. That is, whether the variations occurred at a single word, a phrase consisting of several words, or a whole clause or sentence. This division facilitated the identification of text features that might trigger variations in the reading process, since, for example, syntactic aspects of reading comprehension concern decoding at the sentence level, whereas phonological aspects concern word level. Some of the categories of variations can occur at several different units, for instance, a student could stumble at a single word or a longer phrase. For other categories, it is more difficult to determine which unit they concern. If a student, for example, makes a filler sound (like "er") in the beginning of a sentence, this variation could be categorized as being at word level (the first word of the sentence) or at sentence

level. In cases like this, I had to interpret within the context which unit the variation concerned, as described in the results paragraph below.

The second dimension referred to which aspect of reading the variation concerns. That is, whether it deals with the accuracy, the flow, or the order of reading. The accuracy of reading concerned what is read, that is, if the student reads exactly what is written in the text, or if he/she leaves out anything, reads anything wrong, or adds words to the text. The flow of reading concerned interruptions in the reading, for example, stumbling or hesitating. It also included repeating a word or phrase directly when reading it, which is a form of stammering. The order of reading concerned which order the student reads the text in, that is, if he/she starts at the beginning or, for example, by reading the question, and if he/she rereads any parts of the text.

Results

The analysis of the think-aloud-protocols (TAPs) revealed several different categories of variations in students' reading process when solving mathematical PISA tasks with high DRA. A very common category was reading words and phrases correctly and with flow. On the other hand, there was only one student who read a whole task (Computer Game, 800Q01) straight-on, that is, read all text just once from beginning to end without any interruptions. In Table 1, the categories of variations that deviated from straight-on reading are sorted by the two dimensions mentioned above. Some of the categories are described in more detail below and exemplified in the discussion.

Variations at word level

Many of the observed variations in the students' reading process were connected to a single word, like the ones categorized as *hesitating* or *stumbling*. Hesitating means that the student paused within a sentence before reading a certain word, interrupting the flow of reading. Stumbling also occurred in relation to phrases but the students mostly stumbled at single words, that is, they started to read the word, eventually read wrong, stopped in the middle of the word, and started over. Other types of variations concerning single words were *reading slowly* and different types of *misreading*. These variations occurred for example in task 800Q01 for the word “kriterium” (English: criterion) and in task 446Q01 for the words “snöträdssyrsan”, “termometersyrsan”, and “temperatursyrsan” (different names for the thermometer cricket), and “Fahrenheit”.

Variations at sentence/clause level

At the sentence/clause level the observed variations concerned *rereading* or making *filler sounds* like “er” or “um” in the beginning of a sentence or clause. Filler sounds almost only occurred in the beginning of a sentence or clause and not within sentences. Therefore, this variation was categorized as sentence/clause level when occurring at the beginning of a sentence or clause.

There was no type of variation where the students changed the order of reading when they were reading the task for the first time. All students started reading the tasks at the beginning and read them until the end, that is, none of them started by reading the question written in the end. For task 446Q01, all students but one reread some part of the text task at some point after having read the complete text first — either before or after having solved the task, or both. For task 800Q01, four of seven students who worked on the task did not reread any clause or sentence of the task text.

	Word	Phrase	Sentence/clause
Accuracy of reading	<ul style="list-style-type: none"> · misreading, becomes a different word · misreading, becomes meaningless · misreading, becomes a synonym · misreading a number · skipping a word · adding a word · wrong pronunciation · mumbling 	<ul style="list-style-type: none"> · mumbling 	
Flow of reading	<ul style="list-style-type: none"> · hesitating · filler sounds · stumbling · pausing within a word · reading slowly · repeating 	<ul style="list-style-type: none"> · stumbling · repeating 	<ul style="list-style-type: none"> · filler sounds
Order of reading			<ul style="list-style-type: none"> · rereading after having read everything · rereading after having solved the task

Table 1: Categories of variations in the students' reading process deviating from straight-on reading

Discussion

Some of the observed variations in students' reading processes may indicate problems for the students when reading the tasks' text. These reading problems can relate to different aspects of reading comprehension (phonological, semantic, or syntactic) depending on features of the word, phrase, or sentence/clause that was problematic. In this section, I discuss some of the variations that may indicate sources of unnecessary demand of reading ability (DRA).

Variations at word level

Several types of variations occurred in relation to the different Swedish words for "the thermometer cricket" ("snöträdssyrans", "termometersyrans", "temperatursyrans") in task 446Q01. Some students were stumbling or hesitating when reading these words. These expressions are long compounds of shorter and more common words such as "snö" (English: snow) or "syrans" (cricket), which can make it difficult for the students when they read them for the first time. Since the observed categories of variations concern decoding of written text into sound, they relate to the phonological aspect of reading comprehension (Hoover & Gough, 1990; Perfetti et al., 2005). Two other types of variation occurring for these words are related to semantic aspects of reading comprehension, since they refer to the meaning of the words. One type of variation was that some students read "...syrans" (acid) instead of "...syrans" (cricket) the first time they read the word. A possible explanation is that reading the context and seeing the photo of the cricket eventually helped them realize that the text was about an

insect, and they did not make this mistake any more. The other type of variation was that some students read simply “syrsan” (cricket) instead of “thermometersyrsan” (thermometer cricket) when they reread the sentences. A possible explanation is that they had understood that the text was about some kind of cricket and realized that the exact name was less important. Since DRA for a task concerns a demand of reading ability that is not part of mathematical ability, and since knowing and reading these names for the cricket cannot be seen as a part of mathematical competence, the use of these long compound words in this task may be a source of high DRA.

Another word in task 446Q01 where the variations *hesitating*, *stumbling*, and *reading slowly* occurred was “Fahrenheit”. For Swedish students, this is not a common word in their everyday language since temperature is measured in degrees Celsius in Sweden. The use of different units can be seen as being a part of mathematical language and, thus, a part of mathematical competence. In this case, the use of “Fahrenheit” is not likely to be connected to high DRA, since DRA concerns the part of reading ability that is *not* included in mathematical ability. In task 800Q01, some students were hesitating and reading slowly the word “kriterium” (English: criterion). This is a shorter word than, for example, “snöträdsyrsan” but not a compound of shorter common words and not common in the students’ everyday language either. Since it does not belong to the vocabulary that is necessary or common when communicating mathematics at these students’ school level (year 8-9), it might contribute to DRA of the task.

Variations at sentence/clause level

At the sentence/clause level, one variation was that students reread sentences or clauses after having read the whole text first. At task 446Q01, this occurred most frequently at sentence 3, which was a long sentence presenting the way to calculate. It also occurred at sentences 4 and 5, where the question was posed, but never at sentence 1 and 2 that contained general information about the cricket. At task 800Q01, it occurred mostly for sentence 2 that contained the question and more seldom for the first sentence that presented the situation. The same pattern occurred when students were reading sentences or clauses again after having solved the task. I see two aspects as possible explanations for this, either individually or in combination of both. After having read the text once, it is possible that the students had figured out in which sentences the information necessary to solve the task was presented. Based on this conclusion, they could have deemed it unnecessary to reread, for example, the first two sentences in task 446Q01, since these only presented general information about the cricket. This behavior would be an indication that the students mastered the semantic aspect of reading comprehension, which refers to meaning (Nation, 2005).

Another possible explanation for these variations, in particular the common rereading of sentence three in task 446Q01, can be syntactic issues. This sentence is long (37 words) and contains three subordinate clauses. Such sentence complexity could cause DRA, that is, a demand of reading ability, not connected to mathematical competence.

Conclusions

This study has shown that there are different kinds of variations in students’ process of reading when they are working with mathematics tasks that have a high demand of reading ability (DRA) not connected to mathematical ability. These variations occur both at single words, longer phrases, and whole

sentences and may be of different types. Some of the variations, such as stumbling or hesitating, can indicate reading problems that the students encounter. In this study, I found some examples in the two tasks investigated that may be related to these issues. Further research with more students and tasks can help to identify more text features that may cause DRA.

References

- Abedi, J., & Lord, C. (2001). The language factor in mathematics tests. *Applied Measurement in Education, 14*(3), 219–234.
- Bergqvist, E., Theens, F., & Österholm, M. (2018). The role of linguistic features when reading and solving mathematics tasks in different languages. *The Journal of Mathematical Behavior, 51*, 41–55.
- Dempster, E. R., & Reddy, V. (2007). Item readability and science achievement in TIMSS 2003 in South Africa. *Science Education, 91*(6), 906–925.
- Fuchs, L. S., Fuchs, D., Hosp, M. K., & Jenkins, J. R. (2001). Oral reading fluency as an indicator of reading competence: A theoretical, empirical, and historical analysis. *Scientific Studies of Reading, 5*(3), 239–256.
- Hoover, W. A., & Gough, P. B. (1990). The simple view of reading. *Reading and Writing, 2*(2), 127–160.
- Lenzner, T. (2014). Are readability formulas valid tools for assessing survey question difficulty? *Sociological Methods & Research, 43*(4), 677–698.
- Nation, K. (2005). Children's reading comprehension difficulties. In M. J. Snowling & C. Hulme (Eds.), *The science of reading: A handbook* (pp. 248–265). Malden, MA: Blackwell Publishing.
- NCTM (2000). *Principles and standards for school mathematics* (Vol. 1). Reston, VA: NCTM.
- Perfetti, C. A., Landi, N., & Oakhill, J. (2005). The acquisition of reading comprehension skill. In M. J. Snowling & C. Hulme (Eds.), *The science of reading: A handbook* (pp. 227–247). Malden, MA: Blackwell Publishing.
- Schleppegrell, M. J. (2007). The linguistic challenges of mathematics teaching and learning: A research review. *Reading & Writing Quarterly, 23*(2), 139–159.
- Österholm, M., & Bergqvist, E. (2012a). Methodological issues when studying the relationship between reading and solving mathematical tasks. *Nordic Studies in Mathematics Education, 17*(1), 5–30.
- Österholm, M., & Bergqvist, E. (2012b). What mathematical task properties can cause an unnecessary demand of reading ability? In G. H. Gunnarsdóttir, F. Hreinsdóttir, G. Pálsdóttir, M. Hannula, M. Hannula-Sormunen, E. Jablonka, ... K. Wæge (Eds.), *Proceedings of Norma 11: The Sixth Nordic Conference on Mathematics Education in Reykjavik, May 11-14, 2011* (pp. 661–670). Reykjavík, Iceland: University of Iceland Press.
- Österholm, M., Bergqvist, E., & Dyrvold, A. (2016). The study of difficult vocabulary in mathematics tasks: a framework and a literature review. In A. Dyrvold (Ed.), *Difficult to read or difficult to solve?* Umeå, Sweden: Umeå University.

Generalizing distributive structures in primary school

Annika Umierski and Kerstin Tiedemann

Bielefeld University, Germany; annika.umierski@uni-bielefeld.de

In the reported project, the focus is put on the process of generalizing distributive structures: How do primary school children use different communicative resources in order to express their generalizations? Thereby, the use and function of language is of particular importance. When analyzing the interview data, the central questions are: How does the interplay of different resources vary? What does that consequently mean for the level of generalization? In this paper, we present first results from a pilot study. They suggest, among other things, that language and manipulatives can fulfill quite contrasting functions when they are used in combination.

Keywords: Generalizing, distributive structures, resources, language.

Introduction

“Generalization is the heartbeat of mathematics, and appears in many forms” (Mason, 1996, p. 65). According to Mason (1996), generalizing can be described as one of the basic skills in mathematics. The ability to notice a local commonality in patterns or terms and to distinguish between different aspects (Radford, 2006) enables learners to generalize this across all terms. Then this identified generality can be used as a basis to develop strategies (Lannin, 2005).

It becomes apparent that generalizing is not only important from a propaedeutic point of view, but is already important in primary school itself. In accordance with Lannin (2005), in some contexts using a strategy means using a general rule, for example generalized distributive structures can be used to derive multiplication tasks. Therefore, instead of investigating generalizations of patterns, like it is commonly done, this study will focus on how primary school children generalize distributive structures. In primary school, different resources, such as images or mathematical signs, are available. Primary school children can use these resources for generalizing as well. Language as one resource stands out, because it enables students to detach from concrete objects and to make mathematical structures visible (Radford, 2003). Moreover, if students can express complex structures in a more condensed way with language, it indicates a bigger availability of those structures (Caspi & Sfard, 2012). Therefore, the way how structures are expressed with language can be used as an estimation of the level of generality (Caspi & Sfard, 2012). This is why - concerning generalization - language seems to be an important aspect. Hence, the interplay between language and other resources and its function and role are to be investigated in this study.

In this paper, at first generalizing is defined, the meaning of generalizing in context of distributive structures and the students usage of combinations of resources are outlined. According to the current theoretical framework, our research interest and results of the pilot study are presented.

Theoretical framework

Generalizing in mathematics

Generalizing as a process consists of multiple parts with different focuses. Hence, the term generalization is not used consistently. Nevertheless, most definitions refer to the ability of “seeing a generality through the particular” (Mason, 1996, p. 65). When generalizing, commonalities across different cases have to be identified and regularities have to be derived and extended to other cases (Ellis, 2007; Fischer, Hefendehl-Hebeker, & Prediger, 2010; Harel & Tall, 1991)

The biggest difference between the definitions is the prioritization within the process of generalizing. While Harel and Tall (1991) emphasize that in generalizing the scope of a mathematical object is extended and transmitted, Fischer et al. (2010) highlight the understanding of commonalities in a general context. Furthermore, Ellis (2007) distinguishes between generalizing *actions* and *reflections*. On the contrary, Radford (2003, 2006) distinguishes between the *comprehension* and the *expression* of a generality. The formal way in which generalizations are expressed is not overly important for Ellis, while it is crucial for Radford. Nonetheless, for both researchers the grasping of a general structure is the first step of generalizing. Average primary school children are not able to refer to algebraic language such as variables (Britt & Irwin, 2008). This is why the focus on how primary school children expressing generalizations, becomes especially interesting.

Students can use different ways to express a generalization, for example gestures or colloquial means (Radford, 2003). According to Radford (2003, p. 65) “language allowed the students to carve and give shape to an experience out of which new general objects emerged”. Additional resources, like manipulatives, are available in primary schools. Usage of and switching between representations, which can be used as resources (Greeno & Hall, 1997), support the development of mathematical understanding (Duval, 2006). The expressions themselves may differ in their degree of generality. In particular, the usage of language to express a generality can indicate the level of generality (Caspi & Sfard, 2012). According to that, three levels can be claimed within the process of generalizing. At the first level, *processual description*, language is used to express and describe a calculation. The calculation is presented in the order of its execution. Generalizations at the second level, *granular description*, still include description of a process but also (linguistic) parts that transform procedural elements into an object, like ‘the product of...’. This change from an operational conception (process) to a structural conception (object) is called reification (Sfard, 2008). At the third level, *objectified description*, all processes are reified and students use them as fully fledged objects, for example ‘if two products have a common divider, they can be combined into one fact’. General expressions “will now be used in alienated (depersonalized) descriptions of relations between objects” (Caspi & Sfard, 2012, p. 51).

While Radford (2003) emphasizes the importance of natural language, Caspi and Sfard (2012) focus on the meaning and level of generality of language and Duval (2006) classifies language as one of four equally important representations. With the help of these different perspectives on language, various expressions and the associated interplay of different resources and its consequences for generalization are to be investigated.

Generalizing distributive structures

It should be noted that many studies refer to the generalizations of pattern sequences (Akinwumni, 2012; Blanton & Kaput, 2005). However, Ellis, Lockwood, Moore, and Tillema (2017, p. 677) are correct to point out, that “there remains a need to understand how students construct generality in more varied and more advanced mathematical domains”. Our interview study aims to investigate how primary school children express their generalizations of distributive structures. Since generalizing as a form of algebraic thinking represents a general capability, results from previous studies serve as a first empirical basis and should be compared with results of this study.

The skillful use of arithmetic laws supports students to develop strategies for solving arithmetic problems (Lannin, 2005). In order to be able to use arithmetic laws skillfully, students have to grasp structures in concrete tasks and generalize them. Only if general regularities are extended beyond a case (Harel & Tall, 1991), they can be related to other contexts and used to the student’s advantage. According to Mason (1996), generalizing can be described as the identification of a general rule through particular tasks. This generalized rule in combination with fact based knowledge can serve as a strategic tool. Therefore, in the context of multiplication, generalizing means the recognition of the systematic construction of multiplication and the classification of separated facts in its construction.

In primary school, the distributive law is often implicitly used. Primary school children do not learn to automate multiplication task by learning the times table off by heart. Instead they learn to acquire an understanding of the multiplicative operation and to automate facts that are easier to remember in order to derive facts that are more difficult to remember (Gaidoschik, 2016). Students do not have to acquire and automate all 100 multiplication facts, merely the facts of the one, two, five and ten times tables. If students have insights into distributivity, they can systematically derive all further facts of multiplication (Gaidoschik, 2016). Therefore, individual cases do not always have to be treated as new phenomena but are assigned to a certain structure, so that the memory of students who automated a lot of structures is much less stressed (Fischer et al., 2010). In summary, from this perspective the use of deriving strategies includes a form of generalization of distributive structures.

Expressing generalizations: Language and other used resources

According to Radford similarities and differences of structures are grasped and expressed through and with linguistic expressions (2003, 2006). Language is particularly suitable in this process, because it turns experience into knowledge (Halliday, 1993). “With [...] speech, words become signs capable of being used with a certain autonomy regarding the objects they denote” (Radford, 2003, p. 63). Since generalizing means to abstract from the particular to the general (Mason, 1996), language is particularly suitable as a resource. Therefore, it is assumed that regardless of its level or function, language takes part in expressing generality.

However, language is assumed to be especially challenging for some students (Fetzer & Tiedemann, 2015) and in primary school students use other resources, such as manipulatives, in addition to language to acquire and communicate mathematical understanding. Therefore, instructions “should include how students use the situation, the everyday register, and their first language as resources as well as how they make comparisons [...] and use mathematical representations” (Moschkovich, 2002,

p. 208). In this study, the term *resource* refers to all representations, such as language or manipulatives, which students can use in order to express generalizations. Figure 1 provides an overview of these possibly used resources. The structure of the figure is based on the distinction between different representations (e.g., Duval, 2006) and the assumption that language always plays a role in generalization. Therefore, a distinction is made between three different types of combinations of representation *language and mathematical signs*, *language and actions* and *language and images* and the representation *language*. These (combinations of) representations are available resources that can potentially be used for generalizing. In previous studies, particular resources are identified as appropriate for the process of generalizing (Akinwumni, 2012; Britt & Irwin, 2008) are consequently relevant for our study, too. These resources have been assigned to the combinations of representations (Figure 1).

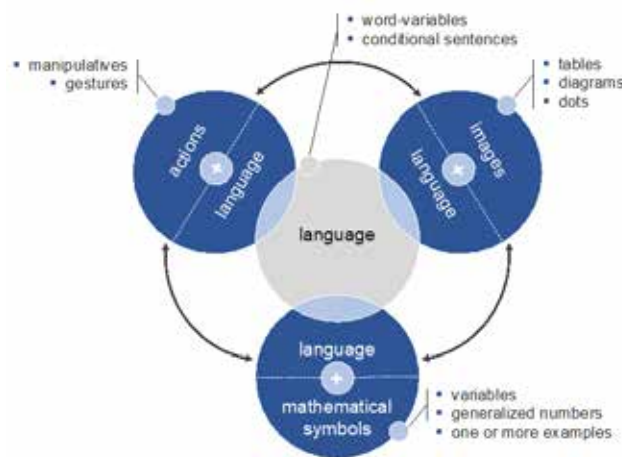


Figure 1: Combinations of resources in generalizing

As figure 1 shows, it is assumed that resources are not used separately but mutually in relation to each other. Language can have different functions within these combinations. While the use of language in form of word-variables can refer to grasped structures, *reified objects* as Sfard (2008) calls them, language can serve to describe generalized numbers (Akinwumni, 2012), relations and other resources as well. In conclusion, language has a functional character for all available resources and the interplay within the combinations can vary according to the individual use. Moreover, the switch between two or more combinations of representations, like *language and actions* and *language and mathematical signs* is possible as well. According to Duval (2006), the process of switching between different representations reveals whether a given mathematical structure has been understood. Thus, generalizing can be understood as a form of understanding: A child that is expressing a given structure in two different representations, in this context two different combinations of representations, is generalizing this particular structure. Moreover, “forms of representations are *tools* that students can learn to use as resources in thinking and communicating” (Greeno & Hall, 1997, p. 362). Therefore, various resources should be made available for primary school children should be used.

Research interest

According to the theoretical assumptions, we are looking for answers to the following questions: (How) do children use language in order to generalize distributive structures? And can language, as a consequence, be regarded as the essential resource for the purpose of expressing generality? Correspondingly, we want to learn more about language and other used resources of the children while generalizing distributive structures. This focus touches two aspects, the interplay within the combinations of resources on an interactional level and the switch between different combinations and its respective consequences on a content level. To describe the use of resources and combinations, we refer to children’s multi-resource statements and at first focus on the following two questions:

- How do students use different combinations of resources in the process of generalizing?
- How do two resources interplay within a combination in the context of generalizing?

Research design

Our study is designed as an interview study. In order to pursue the research interest, the interview questions and tasks are in accordance with the classification (see Figure 1) of the interplay within and between the combinations of resources. It refers to the assumption that language always takes a part

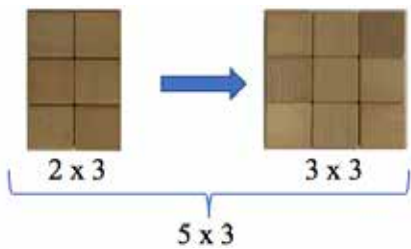


Figure 2: Multiplication blocks

and its function is determined in relation to other resources. Based on a guideline, children are asked to decide whether they can identify a distributive structure in different resources. In this paper, the use of one resource, the multiplication blocks, is presented as an example. Those blocks are manipulatives like given blocks that are composed of different amounts of cubes (see Figure 2). These blocks are fixed, glued together wooden cubes, which cannot be attached but laid against each other.

Therefore, the interviews are designed according to the different resources. In addition, the interview differentiates between the two “directions” of the distributive law: One interview part focuses on decomposing one multiplication fact and the other interview part focuses on combining two multiplication facts. Within the part of combining, two different types of tasks serve as basis. In the first type of task, two multiplication facts may be combined to one multiplication fact, e.g. $2 \times 3 + 3 \times 3 = 5 \times 3$. In the second type of task two multiplication facts cannot be combined to one multiplication fact, e.g. 2×3 and 1×4 . Table 1 illustrates an extract of the second type of task of the pilot study guideline. In order to emphasize the relation to the mathematical context of the distributive law, a section of the interview talks about concrete facts in the form of mathematical symbols. The relation to mathematics is also established by naming the blocks according to their respective facts.



Resource	Questions	Research interest
 2x3-block 1x4-block <hr/>  2x4-block	<ul style="list-style-type: none"> Can you combine these two facts to one fact? Why yes or no? And what about this fact? Why can I now combine two facts? 	<ul style="list-style-type: none"> What aspects are the learners focusing on? How and with which resources do they generalize? How do these interplay? Does the generalization change? How do they talk about the new situation?

Table 1: Interview guideline and associated research interest

The interview is conducted with second- and third-grade students of different primary schools. One of the schools is supposed to be a language school, a school for children with language disorders. These two types are chosen because, on the one hand, the difference between children with and without language disorders should be emphasized. On the other hand, the difficulties of children with language disorders may point to general aspects of the relation between language and generalizing.

In order to reconstruct the processes of generalizing distributive structures, we transcribe the recorded interviews and subsequently use the analysis of interaction (Cobb & Bauersfeld, 1995). This method serves to reconstruct the processes of negotiation between the child and the interviewer and reveals the content-related ideas which emerge in the interaction. This allows us to determine levels of generalization (Caspi & Sfard, 2012) with a special focus on the interplay of resources.

First results

To give an impression of the results from our pilot study, some illustrative examples are presented in the following. In May 2018, six second-grade students of a primary school for children with language disorders, were interviewed. Reference was made only to the combination of *action (blocks) and language*. First results indicate that depending on the type of task (two multiplication facts can be linked distributively or not), students generalize on different levels. According to Caspi and Sfard (2012) *generalizing is distinguished regarding to the level of generality*. In tasks of the first type students used language to generalize in form of chronological description, for example: “first there was 3×3 , then 2×3 was added and then it is 5×3 ”. Relating to Caspi and Sfard (2012), these descriptions comply with the first level *processual description*. On contrary during completion of the second type of task, students used vocabulary like “here is always one more” or “because now this has two and this has two, too”. These terms correspond to the second level *granular description*. Parts of their generalizations such as the “two” are objectified, as it stands for the second times table and hereby for the general distributive structure. In conclusion, the two types of tasks could be used to induce various level of generality when generalizing distributive structures.

Further results can be seen when *generalizing is distinguished regarding to its expressions* (following Radford 2003, 2006). According to the theoretical framework of resources, the interplay of resources have been analyzed. The participating children with language disorders used the offered manipulative combined with language. Their generalizations were quite often grammatically incomplete and incorrect. In addition, they tended to use gestures and linguistic references, such as pronouns like “it does not fit, here (1×4 -block), to that (2×3 -block) two more”. In this example, the student compensated missing language with the help of provided material and used place deictic words. According to Fetzer and Tiedemann (2015), manipulatives are used to relief language. Thus, the scope how to interpret the expression extents. At this point it is assumed that the manipulatives function as generic example, because the example is used to explain conditions of a general structure (Harel & Tall, 1991). The function of language is to emphasize the aspect that is being referred to.

Similar interviews were conducted at another primary school with no particular specialization on children with language disorders. These students used considerably more nouns, conditional sentences, and explained their processes in a more detailed way. The example “this stone (single cube of 1×4 -block) must go, then we would have 3×3 ” shows a combination of manipulative and language as well, but the manipulative does not relief language. Language is used to structure the process and to construct an example, which includes parts of a generic example, such as the use of a conditional statement. The use of language makes it possible to construct relations that are not visible. Nevertheless, the description is close to the concrete example, like “must go”. Because of this, the utterance is interpreted as an example with the potential to be generalized.

The comparison between both participating student groups indicate a difference in expressing generalizations of distributive structures. Both examples refer to the same mathematical content and in both cases a *granular description* (Caspi & Sfard, 2012) is given. Both children describe a process combined with facts (2x3, 3x3), which are used as reificated objects (Sfard, 2008). Furthermore, the same resources are involved. However, the interplay within the combination of the resources *language* and *manipulative* differs. Two different types of resource interplay in the process of generalizing have been identified. While in the first example the manipulative enriches the linguistic expression, linguistic expressions enrich the manipulative in the second example. Consequently, we can see that children express comparable generalizations by using resources differently.

Outlook

These first results indicate different functions of language in the process of generalizing. According to the interplay of resources, it further will be analyzed how the other resources (images and mathematical signs) interplay with language. To figure out how language and the other resources interplay in detail and its consequences for generalizations is one of the main goals of the further research project. In addition, the objective of the study is to analyze how an interviewer or another child interprets expressions within an interaction. Both examples provide potential that can be identified as generalization. Regarding to the two different types of resource interplay, it will be worked out how expressions will be grasped and how the types influence the generalization of distributive structures. In addition to the resources, it will be investigated, how and if the consequences through the two types of tasks can be confirmed and which conclusions arise regarding generalizing. The analysis of the pilot study also shows that new impulses must be developed to facilitate generalization. For example, we should no longer talk about concrete facts, but about a rule.

References

- Akinwumni, K. (2012). *Zur Entwicklung von Variablenkonzepten beim Verallgemeinern mathematischer Muster* [On the development of the concept of variables through generalization of mathematical patterns]. Wiesbaden, Germany: Springer Spektrum.
- Blanton, M. L., & Kaput, J. J. (2005). Helping elementary teachers build mathematical generality into curriculum and instruction. *ZDM - Mathematics Education*, 37(1), 34–42.
- Britt, M. S., & Irwin, K. C. (2008). Algebraic thinking with and without algebraic representation: A pathway for algebraic thinking. *ZDM - Mathematics Education*, 40, 39–53.
- Caspi, S., & Sfard, A. (2012). Spontaneous meta-arithmetic as a first step toward school algebra. *International Journal of Educational Research*, 51/52, 45–65.
- Cobb, P., & Bauersfeld, H. (1995). Introduction: The coordination of psychological and sociological perspectives in mathematics education. In P. Cobb & H. Bauersfeld (Eds.), *The emergence of mathematical meaning: Interaction in classroom cultures* (pp. 1–16). Hillsdale, NJ: Lawrence Erlbaum Associates.
- Duval, R. (2006). A cognitive analysis of problems of comprehension in a learning of mathematics. *Educational studies in mathematics*, 61(1–2), 103–131.

- Ellis, A. (2007). A taxonomy for categorizing generalizations: Generalizing actions and reflection generalizations. *Journal of the Learning Sciences*, 16(2), 221–262.
- Ellis, A., Lockwood, E., Moore, K., & Tillema, E. (2017). Generalization across domains: The relating-forming-extending generalization framework. In E. Galindo & J. Newton (Eds.), *Proceedings of the 39PME-NA* (pp. 677–684). Indianapolis, IN: PME-NA.
- Fetzer, M., & Tiedemann, K. (2015). The interplay of language and objects in the mathematics classroom. In K. Krainer & N. Vondrová (Eds.), *Proceedings of the ninth congress of the European Society for Research in Mathematics Education* (pp. 1387–1392). Prague, Czech Republic: Charles University of Prague and ERME.
- Fischer, A., Hefendehl-Hebeker, L., & Prediger, S. (2010). Mehr als Umformen: Reichhaltige algebraische Denkhandlungen im Lernprozess sichtbar machen [More than transforming: Making rich algebraic thinking visible in the learning process]. *Praxis der Mathematik in der Grundschule*, 52(33), 1–7.
- Gaidoschik, M. (2016). *Einmaleins verstehen, vernetzen, merken. Strategien gegen Lernschwierigkeiten* [Multiplication tables: understanding, connecting, remembering. Strategies towards learning difficulties] (3rd ed.). Seelze, Germany: Klett and Kallmeyer.
- Greeno, J. G., & Hall, R. P. (1997). Practicing representations: Learning with and about representational forms. *The Phi Delta Kappan*, 78(5), 361–367.
- Halliday, M. (1993). Towards a language-based theory of learning. *Linguistics and Education*, 5(2), 93–116.
- Harel, G., & Tall, D. (1991). The general, the abstract and the generic in advanced mathematics. *For the Learning of Mathematics*, 11(1), 38–42.
- Lannin, J. (2005). Generalization and justification: The challenge of introducing algebraic reasoning through patterning activities. *Mathematical Thinking and Learning*, 7(3), 231–258.
- Mason, J. (1996). Expressing generality and roots of algebra. In N. Berdnarz, C. Kieran, & L. Lee (Eds.), *Approaches to algebra: Perspectives for research and teaching* (pp. 65–86). Dordrecht, Netherlands: Kluwer.
- Moschkovich, J. (2002). A situated and sociocultural perspective on bilingual mathematics learners. *Mathematical Thinking and Learning*, 4(2–3), 189–212.
- Radford, L. (2003). Gestures, speech, and the sprouting of signs: A semiotic-cultural approach to students' types of generalization. *Mathematical Thinking and Learning*, 5(1), 37–70.
- Radford, L. (2006). Algebraic thinking and the generalization of patterns: A semiotic perspective. In Alatorre, S., Cortina, J.L., Sáiz, M., and Méndez, A. (Eds.) (2006). *Proceedings of the 28th annual meeting of the North American Chapter of the International Group for the Psychology of Mathematics Education*. Mérida, México: Universidad Pedagógica Nacional.
- Sfard, A. (2008). *Thinking as communicating. Human development, the growth of discourses, and mathematizing*. New York, NY: Cambridge University Press.

TWG10: Diversity and Mathematics Education: Social, Cultural and Political Challenges

Introduction to the work of TWG10: Diversity and Mathematics Education: Social, Cultural and Political Challenges

Hauke Straehler-Pohl¹, Anette Bagger², Laura Black³, Anna Chronaki⁴ and David Kollosche⁵

¹Freie Universität Berlin, Germany; h.straehler-pohl@fu-berlin.de

²Örebro Universitet, Sweden; anette.bagger@oru.se

³University of Manchester, United Kingdom; laura.black@manchester.ac.uk

⁴University of Thessaly, Greece; chronaki@uth.gr

⁵Pädagogische Hochschule Vorarlberg, Austria; david.kollosche@ph-vorarlberg.ac.at

Scope and Focus

Thematic working group 10 is interested in discussing mathematics education within the realms of *culture, society and the political*. TWG10 builds on the premise that mathematics education is always more than the encounter between an individual and an object. Such encounters are embedded within wider contexts than just classroom settings. They are shaped by the social, cultural and political contexts in which they take place. Being social, cultural and political encounters themselves, they reflexively contribute to constituting the wider context in which they are embedded. Research in this group is characterized by an effort to reflect its own double-role in not only analysing but also shaping the possibilities of seeing and inventing mathematics education practices.

The call for papers invited participants to address how *diversity* affects possibilities in mathematics education. The group's work was based on a broad understanding of diversity, including: 1) Diversity as expressed in terms of attributes of people, such as gender, ethnicity, language, socio-economic status, social class, (dis)abilities, needs, achievement, life opportunities; 2) diversity as expressed in terms of ways of perceiving the world and giving structure to it, such as aspirations, worldviews, ideologies, school systems, and governance structures; 3) diversity in relation to the variety of sites where mathematics education takes place, such as schools, homes, workplaces, after-school organisations, communities; and finally, 4) diversity in relation to who is doing the research and who is being researched, posing methodological issues of an ethical nature. Diversity thus also refers to the wide variety of doing mathematics education research within the realms of culture, society and the political. As all these multiple diversities intersect, the group made an effort to develop reflexive approaches. The group invited to explore, deconstruct and even reinvent the concept of diversity.

Organisation of TWG 10's work

Understanding research as a practice that is situated within the realm of the cultural, the social, and the political has implications for practicing research *in situ*. We strived to organize the group to work in a way that 1) cultivates a change of perspectives and fosters reflexivity and 2) creates consciousness about the power relations underlying TWG10's work as a community of practice. The introduction in the first session gave a brief overview about the controversies that have unfolded within the TWG in previous CERMEs, highlighting that controversies do not only occur *between* (groups of) scholars but also occur *within* individuals or within allegedly homogeneous "camps". Fostering controversy was intended to counteract dichotomization and facilitate the deconstruction of binaries.

The development of reflexivity was sought by following the principle of *peer presentation*, namely that authors do not present their own paper, but give a short (5 minutes) presentation of a colleague's paper. This peer presentation included a description of the main ideas from the perspectives adopted in the paper and the formulation of questions from the presenter's own perspective that opened up subsequent whole-group discussion (15 minutes). In addition, two sessions each involved, firstly, a small group breakout discussion (30 minutes) and, secondly, a synthesis (30 minutes) to support participants in drawing connections between contributions. In an attempt to make poster contributions visible to the whole group, posters were also presented. However, since the poster presentations were not followed by discussions, this procedure did not only make visible the posters, but also visualized and potentially stabilized the hierarchical distinction between papers and posters.

The papers discussed

In order to encourage and also facilitate drawing connections between papers, they were grouped in thematic pairs before the conference. As any classification does, this grouping highlighted some connections while displacing others. In the 1st session the contributions of *Wright* and *Black et al.* critically sounded out possibilities of practicing progressive pedagogy in favour of underprivileged students. In the thematic pair on democratic experiences, *Daher* sought for ways of assessing democratic practices using a quantitative analysis of questionnaires, and *Sachdeva* took a closer look on how students experience learner autonomy in mathematics classes. In the first half of the 2nd session, *Maheux et al.* invited us to consider school mathematics as a possible reference for mathematics itself, hence disrupting traditional understandings of mathematics, where professional mathematics is often seen as the reference for school mathematics. *Salazar* reported on how students of colour developed a practice of mathematics in problem solving activities similar to the practice of professional mathematicians, thereby disrupting institutional racism in traditional school mathematics. In the second half of the session, *Cabral et al.* proposed Solidarity Assimilation Methodology not only as a way of disrupting traditional pedagogy, but also as a way of subverting the recurrent mode of capital accumulation embodied in assessment practices. *Bagger et al.* analysed how a neoliberal regime of assessment has expanded into the domain of preschool-class education in the Swedish context. The first half of the 3rd session was devoted to the connections between mathematics and life. *Aizikovitsh-Udi* reported on a teaching unit that aimed at explicitly teaching critical thinking skills. *Yolçu* problematized the forms of responsabilisation, reason and rationality in a course on “mathematical applications” in Turkey. In the second half, the contributions of *Kollosche* and of *Lüssenhop et al.* focused on language diversity, the former proposing guidelines for analysing and developing teaching materials, the latter exploring the practices of teachers in international preparatory classes for refugees. In the 4th session, *Makramalla et al.* explored the gaps between the “mathematical ideologies” of the Egyptian curriculum, of the teachers and of the teachers' practices, yielding the potential for change within the contextual power dynamics operating in Egypt. *Foyn* confronted an emerging public discourse in Norway on disadvantaging boys with data from a longitudinal study, highlighting the need to nuance the debate and not lose track of the discourses that still disadvantage girls. Critically reflecting the power relations between the researcher and her/his informants, *Lembrer* raised methodological questions concerning the use of photo-elicitation for data-collection in the context of early years mathematics education. *Kara et al.* presented their research on the relation between students' social backgrounds and their problem-solving competencies. *Nordkild et al.* reported on a culturally sensitive teaching unit in Finland. The unit was developed by students

with a Sami background to teach geometry to peers from their own culture. The first half of the 5th session was devoted to mathematics teacher education. *Povey* reflected on the potential of her own teaching practice as an embodied case of a “living education theory” to serve the aims of social justice. *Dexel et al.* showed how a course on inclusive mathematics teaching for pre-service teachers fostered a potential-related perspective on diversity within teacher-students. This potential-related perspective on diversity was further developed in the second half by *Padilla et al.* who proposed the conjunction of interdisciplinarity, culturally sustaining pedagogies and pandisability cultures as a point of departure for co-creating diverse mathematics learning contexts. The need for such co-creation was empirically consolidated by *Nieminen* who reconstructed discourses of otherness in self-reports of university students with special needs. The 6th session zoomed in on the mathematics student. Both the contributions of *Røj-Lindberg et al.* and *Doğan* reconstructed students’ perspectives. The former did so through a longitudinal study that provided insight into why some students develop negative identifications with mathematics despite the reform-related efforts of their teachers. The latter turned the focus on a popular Turkish social medium, where almost a thousand users reported on their moments of farewell to mathematics and constructed it as an individual and subject-related fate. The last thematic pair focused on students’ identities. Taking an intersectional approach, *Sabbah et al.* investigated how categories of gender, ethnicity and religion play out in the formation of agency and identity in female Arab students entering university mathematics in Israel. *Gebremichael* explored in an Ethiopian context how students perceive the relevance of mathematics and how this is closely linked to the development of identity. His analysis also sheds light on how little Ethiopian mathematics education is attuned to Ethiopian society’s needs and the possible historical reasons for this.

Common conclusions

All contributions and discussions were characterized by a strong openness to perspectives and methods that are not yet established within the field of mathematics education, but belong to the state of the art in the corresponding disciplines of reference. This interdisciplinary character was consistently appreciated. It also led participants to collectively question the “nature” of mathematics: How do we define it? What are legitimate sources of reference? Who decides what is legitimate? The group agreed that these questions must remain undecided. Another issue that found unrestricted approval was the necessity of bringing theory and practice together, not only rejecting theory for theory’s sake but in a similar manner rejecting excessively inductive empirical research. This commitment to (social) theory is related to the critical spirit that participants saw as common ground, binding the group together. Work in this group is largely concerned with a critique of the *status quo*. This critique may concern educational institutions or the societies we live in more broadly. Group members were united in the desire to change systems, whilst at the same time being aware that they are part of these systems themselves. This insight resulted in a self-critical attitude when it comes to assessing the ethical ramifications and also the generalisability of research. The self-critical attitude expressed itself in the fact that participants consensually cherished TWG work as an opportunity of “decentring oneself”, an opportunity to experience their own perspective as one among legitimate alternatives, thereby allowing a reflection about each perspective’s social, cultural, and political foundations. It was also expressed in a deep concern for the power relations that pervade instances of mathematics learning and teaching as well as research practice and the dynamics within the working group itself.

Open questions / controversy

While the participants all agreed on conceptualizing power as simultaneously having both restricting “negative” as well as empowering “positive” effects, the group remained undecided about the normative ramifications related to identifying power relations. For example, the group addressed the question of whether there is a boundary between acceptable and unacceptable values. What would a strictly horizontal organisation of values imply? If we do not privilege some values over others, how can we, then, talk back to and fight against socially accepted forms of oppression and violence? Related to the question of equality of values is the question about the role and function that we assign to schools: Is it their task to adapt to students’ backgrounds? Or is it exactly their task to treat students irrespective of their background, or at least help them to transcend their backgrounds? Reflecting the political and moral underpinnings of each of the participants’ stance certainly created tensions within the group. Some participants may identify with dissolving tensions to one side or the other, a third part of participants may identify with the contradiction inherent in the tension itself. While the group agrees that it is a collective task to deal with these contradictions and tensions, there may be different normative stances on how this *should* be done: Once power relations within the group surface, should the use of power be regulated? Can the group benefit in the future from explicit rules so that “privileged” participants develop techniques to govern themselves, re-distributing power to the “non-privileged”? Or would this suffocate the attempt to embrace controversy, finally leading to synchronization of perspectives and thereby jeopardizing the cherished opportunity of decentering oneself? Another controversial issue was the role of utopia in our research: Is utopia the generator of change that allows us to think of something in rupture with what exists? Or is utopia actually preventing change to materialize by outsourcing change into some displaced “alternative reality”? Finally, identifying all these controversies led to commonly posing the question: How much diversity can a thematic working group on “diversity” productively handle?

Future tasks

The group identified a need to ensure the productivity of diversity and saw the danger of losing depth in the discussion. Depth, here, applies both to the scientific quality as well as to the social quality of mutual intellectual engagement. Two ideas that found approval were 1) the reformulation and specification of the group’s theme and 2) a stronger focusing and specification of the group’s call for papers. Concerning the theme, the group agreed that even though *diversity* adequately described the spirit of the group, it factually did not serve anymore as the thematic pivot. It is a designated task for the future TWG-leaders to maintain this spirit of diversity. However, the contributions rarely addressed diversity explicitly. The group suggested to exclude diversity *from the title*, nevertheless making sure that the call maintains the thematic inclusion of diversity *as a theme* (among others). Further, the call should more explicitly demand authors to interrelate “the micro” and “the macro” which also implies a stronger attentiveness to social, cultural and political theory. If the next group-leaders should, however, decide to keep diversity in the title, there is a need to sharpen the call for papers in that direction. In order to develop in any of these directions, the group requires a clearer and more concise focus in order to maintain its scientific and intellectual productivity.

Construction of Critical Thinking Skills by the infusion approach in “Probability and Statistics in Daily Life”

Einav Aizikovitsh-Udi

Davidson Institute, Weizmann Institute of Science, Israel; einav.aizikovitsh@weizmann.ac.il

This paper presents a teaching experiment that combined the explicit teaching of critical thinking with the content of an existing mathematics unit called “Probability and Statistics in Daily Life”. The original unit was designed to teach probability and statistics through real-life scenarios at the high-school level. I took the original mathematical content and “infused” it with a progression of critical thinking skills, so that both the mathematics and the critical thinking competencies developed hierarchically, growing more and more complex as the unit progressed. This paper illustrates the mutual benefits of this “infusion” to both the teaching of statistics and of critical thinking. The paper discusses the problem of transfer of critical thinking skills and shows some promising elements in that sense, deriving from the analysis. Finally, it also discusses some educational implications of the work done, the limitations of the unit’s first run and the improvements that may yet be made.

Keywords: Critical thinking, probability, statistics in daily life.

Introduction

This paper reports a research project undertaken into the utilisation of the mathematics classroom for the specific development of critical thinking skills through probability instruction (Aizikovitsh-Udi, 2012). In this paper, critical thinking skills are taken as representative of the aspirations of the majority of mathematics curricula. I suggest that the mathematics education community needs to investigate why the consensus regarding the importance of higher order thinking skills in mathematics has not led to greater consistency and success in its classroom implementation. This research represents one attempt to give classroom reality to this curricular aspiration and examined the processes of construction of critical thinking skills (e.g., identifying variables, suspension of judgment, referring to sources, searching for alternatives) during the study of the “Probability in Daily Life” learning unit in an infusion approach. In particular, I closely reviewed the contents of the learning unit for connection to relevant thinking skills. The skills that were found relevant were: (a) identifying variables; (b) referring to sources; (c) identifying assumptions; (d) evaluation of statements; (e) suspending judgment; (f) offering alternatives.

Theoretical Background

The term “critical thinking” (CT) has been used in academic circles for less than a century, but evidence of the relevance of this concept in education is far older, spanning several forms of human endeavor and 2500 years of human history since the Greek Antique. The universal applicability of these “ancient” skills is perhaps more relevant than ever in today’s complex and ceaselessly changing reality, which requires independent decision-making on a daily basis. Fostering and developing students’ ability to think critically, to be capable of engaging in inquiry and evaluation based on rational considerations regarding the various messages they are exposed to in different areas of life, is therefore a particularly important part of their education (Bryan, 1987; Feuerstein, 2002; Glaser,

1972). While this need to focus on the promotion of CT skills has long been widely recognized by educators (Ku, 2009), they have not yet reached a similar consensus regarding *how best this should be done*. This on-going debate raises the question of whether critical thinking should be taught as a topic in its own right, or integrated into a topic already present in the school curriculum. This question in turn raises additional questions – for instance, if critical thinking *is* integrated, which subjects should it be integrated with? Furthermore, when teaching CT skills in conjunction with another topic, should these skills be taught *implicitly*, as a hidden component ‘immersed’ in the primary material, or should they be an *explicit* part of the learning experience, in which the students’ attention is drawn to their presence as an additional component ‘infused’ into the material through which it is being taught?

Amongst those who believe that critical thinking should be taught in conjunction with other subjects, one of the topics suggested for this purpose is mathematics. In the field of education, mathematics has traditionally been considered a branch of knowledge particularly suited to the teaching and learning of higher-order thinking skills such as critical thinking. Mathematics curricula all over the world, including Israel, identify the acquisition of these skills as one of their goals. The idea that mathematics is a discipline suited to teaching critical thinking also appears in the research literature in a more or less explicit way (Elder & Paul, 1994; Paul, Elder, & Bartell, 1997).

However, in spite of this assumption, very few empirical studies to date have engaged with the question of whether the study of school mathematics indeed develops or even requires this mode of thinking. The answer to this question is far from being clear. The study upon which this paper is based attempts an approach to teaching critical thinking through mathematics that *explicitly* integrates the topic into a learning unit designed to teach high-school level probability and statistics. This topic is, I believe, particularly well-suited for the acquisition and practical application of critical thinking skills. Our model is based on the combination of two theoretical elements: the hierarchical model of critical thinking skills presented in Ennis’ (1985, 1987a, 1987b) taxonomy and the “infusion approach” to teaching posited by Swartz & Parks (1994). To create the new learning unit, whose classroom implementation is presented in this paper, I took the mathematical content of an existing learning unit called “Probability and Statistics in Daily Life” (Lieberman & Tversky, 2001) and (in collaboration with one of this unit’s co-creators) I “infused” it with a hierarchical progression of critical thinking skills according to Ennis’ taxonomy (Ennis, 2002). In this paper, I present, in order of increasing complexity, a series of three samples from the classroom implementation of the unit. These illustrate a) how the two topics develop hierarchically together, and b) how each lesson combines them anew, calling on the students to draw on both their mathematical and their critical thinking skills to solve problems based on daily life.

Methodology

The “Probability and Statistics in Daily Life” learning unit as a basis for teaching CT

“Probability and Statistics in Daily Life” is a preexisting learning unit developed by Lieberman and Tversky (2001), which was expanded and modified for the purposes of this research. I selected this unit as a basis upon which to build the teaching experiment reported in this paper because it was designed to teach mathematical content using problems and stories from daily life, and because its

rationale already alluded to “elements of critical thinking”, citing these among the “issues relevant to daily life” that it hoped to teach (Lieberman & Tversky, 2001, p. 3).

The original unit was based on Tversky and Kahneman’s well-known work on making decisions in conditions of uncertainty (Tversky & Kahneman, 1974; Kahneman, Slovic, & Tversky, 1982). It covers topics in statistics and probability in hierarchical order, connecting each to daily-life scenarios and decisions. The purpose of the original unit was to turn students into ‘intelligent’ consumers of information by introducing them to modes of thinking that went beyond the mechanics of mathematical calculation. The use of problems from daily life exposed the students to various additional fields such as medicine, economics, and law, illustrating the practical applications of probability and statistics to these fields and showing the students the ways that statistical considerations are inextricably woven into our lives. Furthermore, the unit’s composition required them to analyze problems, raise questions and think critically about the numerical data and the information placed before them. Faced with problems that did not necessarily have one correct, clear-cut answer, the students learned not to be satisfied with arriving at a numerical solution, but to assess the validity of data, and to assess the problems before them in a qualitative – and not just a calculative – manner. I composed a revised version (Aizikovitsh-Udi, 2012). The unit combines the hierarchy of topics in probability and statistics with a corresponding hierarchy of topics in critical thinking, so that, as the students progressed in the former, they would also progress in the latter.

Setting, population and data collection

Results presented here are from a subgroup of one class taken out of a larger population of six classes (147 students in all, three experiment groups [70] and three control groups [77]). The larger population was used for deriving quantitative results regarding the experiment’s efficacy, which are not presented here. In this paper, I will present two groups: 18 students were taught by the researcher in high school 1, 20 students were also taught by the researcher in high school 2 in central Israel.

The experiment consisted of 15 sessions (90 minutes each) during the course of the academic year and served as the “probability and statistics” section of the students’ mathematics curriculum for that year. The group whose sessions are described here was the one taught by me, in my capacity as these students’ regular mathematics teacher. Data collection was conducted by way of triangulation between the following sources: (i) The students’ written products, including exams, in-class papers, and homework were collected. (ii) Sessions were recorded, transcribed and analyzed (paying special attention to their relation to CT skills). The teacher kept a log on every session. In general, data were processed by means of qualitative methods, which enabled me to follow the students’ patterns of thinking. (iii) Personal interviews: 27 students were randomly chosen (four from each of the seven experimental classes) and interviewed at the end of the first and second semesters, in the middle and at the end of the unit. Personal interviews were conducted in order to reveal changes in the students’ attitudes towards critical thinking throughout the academic year. The interviews were of two kinds: closed/structured interviews, based on questions chosen in advance, and open/semi-structured interviews, where only part of the questions chosen in advance was asked (possibly in modified form) according to the interviewees’ answers. The interview questions were: (a) What do you think about the importance of critical thinking ability? In which fields/activities is it important? (b) Can you give

an example of a situation (from school, everyday life, etc.) where critical thinking is necessary? Have you used it? Did it help you? (c) In your opinion, is it possible to develop/improve critical thinking ability? How? Do you have any suggestions for improving it? (d) In your opinion, is it possible to change dispositions for critical thinking? How? What influences the dispositions? Do you have any suggestions for improving them? (e) Did your studies in the other disciplines improve your ability for critical thinking? If yes, in what course and in what way? If not at all, why not? (f) How would you evaluate yourself in the area of critical thinking? The intended aims of the six questions were: (1) To ascertain the degree of students' awareness of the nature of critical thinking (mainly questions a, b, e, f, through the pertinence of the examples and the answers). (2) To identify students' ideas about possible fields of application for critical thinking (a, b), and in particular to identify suggested fields far from those proposed during the course (as a sign of interiorization and a premise for a possible transfer). (3) To get feedback about students' perception of which aspects/moments of the course had an impact on their CT skills and dispositions (c, d), as a way to assess students' awareness of the aims of the course.

Results

Analysing the Findings by two lessons

In what follows, I present two lessons, taken from three progressive points within the learning unit. For each, I present the daily-life topic upon which the lesson was based and show how first the mathematical content and then the thinking skills were integrated into it. In addition to exemplifying how the two topics were tied together, the succession of the lessons shows how both the mathematical content and the critical thinking skills built upon themselves hierarchically as the unit progressed, involving students in meaningful activities related to the aims of the learning unit (development of both CT and mathematical competencies). Each of the three selected samples also highlights a different element of the program. The first lesson, in which the students are sent outside of the classroom to gather data for themselves, highlights the centrality of the practical "daily life" element in the study unit. As this example shows, each daily life story or problem places the students in a position where they must draw on both the mathematics and the critical thinking skills to gather the information they need to make their decision. The second lesson is the most elaborated and detailed of the three examples, and it shows (through a long excerpt and the related analysis), how the melding working hypothesis was implemented (thus showing its feasibility). It also shows how by that point in the learning unit specific features of CT had already been interiorized by students, and how specific CT expressions entered students' language and were used by them in an appropriate way (see Discussion). The third example stresses the four-step format of each lesson, and emphasizes the function served by each: It shows how the daily life scenario triggered the students' intuitive response, which was then informed and modified by the mathematics before being rethought and adjusted a second time by further application of CT. This problem shows the unit's lessons at their final and most advanced stage, where the students see that CT can be used not only to support conclusions based in mathematics, but also to look beyond them.

Example #1: The shoe size problem as an introduction to Simpson's Paradox¹

This lesson (Aizikovitsh & Amit, 2008), taken from the point of transition between chapters one and two, introduced the mathematical concept of the “mediating factor” (see below). In terms of critical thinking, it engaged the students in: a) identification of relevant questions and variables; b) locating the source of information; c) evaluating/analyzing the validity of statements. The students were given the following dialog called “Shoes and Mathematics”:

Avi: “There is a connection between shoe size and level of mathematical knowledge.”

Beni: “Can't be.”

Avi: “Go to the school in the next building and see for yourself.”

Beni: “You are right, the kids who wear bigger shoes really know math better!”

Why is this phenomenon true? What do you think about the conclusion?

The purpose of this lesson was to show the students that while causal connections *are* predicated on the presence of statistical connections, the presence of a statistical connection does *not* necessarily mean that a causal connection exists. Most of the students had a strong initial intuition that the causal connection was impossible, but they did not yet know how to explain and support it mathematically. After the preliminary discussion of the students' intuitions, several of them were sent out to ‘gather evidence’ at the nearby elementary school, stopping random students and asking them: a) their shoe size, and b) what mathematical topics they were familiar with. This exercise introduced a critical element into the lesson, with the students validating the reliability of their source by gathering the (seemingly) corroborative data themselves. The ultimate purpose of this lesson is that the students recognize the logical fallacy in the connection suggested here between shoe size and mathematical knowledge by realizing that this connection is generated by a mediating element (the child's age). The mathematical content of the lesson consisted in the translation of the information into a mathematical format (set theory) and the use of a two-dimensional matrix. I also performed new calculations that included the mediating factor C. I found that statistical connections exist between A (shoe size) and C (age), as well as between B (mathematical knowledge) and C (age). This, I argued, is the reason for the statistical connection between A and B. By means of this process and its illustration through the real-life example of shoe size, the students were introduced to Simpson's Paradox and the concept of the mediating factor. The critical thinking portion of this lesson consisted primarily in the students learning to evaluate and question the validity of their information, even when they had obtained that information themselves, in recognizing the fallacious connection and in drawing an alternative, valid conclusion.

¹ Simpson's Paradox refers to the situation where normalizing data from different ways of partitioning the same population will provide incompatible conclusions about the associations that hold in the total population. For example, a partition by gender might indicate that both males and females fared worse when provided with a new treatment, while a partition of the same population by age indicated that patients under fifty, and patients fifty and older both fared better given the new treatment. The relevant element for this paper is the role of the mediating variable (age or gender).

Discussion & Conclusion

As the examples above show, the mathematical content of statistics and probability is well suited to being ‘infused’ with instruction in critical thinking skills. The hierarchical patterns in which both the content and the skills can be taught complement one another structurally, with more elements of critical thinking coming into play as the mathematics becomes progressively more complex. The two instructional goals (statistics and critical thinking) are also mutually beneficial in terms of content: The mathematics provides the students with a means to engage in critical thought and pursue independent challenges and confirmations to the information they are given. The “Probability in Daily Life” unit provides the mathematics with a practical ‘real-world’ context that can help the students comprehend the material more concretely as more than the abstract manipulation of numbers on a page. The various critical thinking skills could then be taught explicitly in the context of using mathematics to solve problems in the real-world situations. The addition of critical thinking provides an added reflective dimension to the mathematical treatment rendering both the approach and the results more meaningful to students.

Analyzing the findings, I have arrived at the following generalizations regarding the process of critical thinking skills construction and teaching: (1) It seems that critical thinking skills do not develop spontaneously and that even good students acquire them by means of explicit instruction. This finding is in direct opposition to Tennyson & Rasch (1988) claim that learning skills and learning strategies develop in the student spontaneously, without direct instruction. (2) To a large extent, the construction and teaching of critical thinking skills are determined by specific contents and tasks the teacher uses. In this research, the skills were chosen with respect to the contents and the increasing difficulty level of the learning unit. (3) It is possible to significantly influence and change the mathematical discourse of the classroom and the students’ language of critical thinking, by providing appropriate conditions and using appropriate instruction methods. This type of learning emphasizes the development of skills in the process of solving mathematical problems.

In much of the literature, critical thinking development is referred to as an important goal of the educational system. This research may contribute to the public discourse of the mathematical education community on this issue. It also raises the public awareness of the need to develop critical thinking in the framework of mathematical education, which may enable future examination and promotion of critical thinking development through mathematics teaching in a fuller and more informed way. To conclude, the main contribution of this research lies in revealing the connection between critical thinking and the teaching of mathematics. It should be possible to strengthen the status of the study of mathematics in imparting higher-order thinking skills, both in parallel with and beyond the formal education program. This paper has reported an investigation into the use of the infusion approach to teach critical thinking skills while also teaching conventional probability and statistics content. The students acquired critical thinking skills that they came to value.

References

Aizikovitsh-Udi, E. (2012). *Developing critical thinking through probability models, intuitive judgments and decision-making under uncertainty*. Lambert Academic.

- Aizikovitsh, E., & Amit, M. (2008). Developing critical thinking in probability lessons. In O. Figueras, J. L. Cortina, S. Alatorre, T. Rojano, & A. Sepúlveda (Eds.), *Proceedings of the Conference of the International Group for the Psychology of Mathematics Education* (Vol. 2, pp. 9–13). Morelia, México: Universidad Michoacana de San Nicolás de Hidalgo.
- Bryan, M. (1987). *The great philosophers*. New York: BBC Books.
- Elder, L. & Paul, R. (1994) Critical Thinking: Why we must transform our teaching, *Journal of Developmental Education*, 18(1), 34–35.
- Ennis, R. H. (1985). The logical basis for measuring CT skills. *Educational Leadership*, 43(2), 44–48.
- Ennis, R. H. (1987a). A conception of critical thinking – with some curriculum suggestions. *American Philosophical Association Newsletter on Teaching Philosophy*, 1–5.
- Ennis, R. H. (1987b). A taxonomy of critical thinking dispositions and abilities. In J. B. Baron & R. J. Sternberg (Eds.), *Teaching thinking skills: Theory and practice* (pp. 9–26). New York: Freeman.
- Ennis, R. H. (2002). Goals for a critical thinking curriculum and its assessment. In A. L. Costa (Ed.), *Developing minds* (3rd ed., pp. 44–46). Alexandria, VA: Association for Supervision and Curriculum Development.
- Feuerstein, M. (2002). *Media literacy in support of critical thinking* (Doctoral dissertation). University of Liverpool, United Kingdom.
- Glaser, E. (1972) *An Experiment in the development of critical thinking*. New York: AMS Press.
- Innabi, H., & Sheikh, O. (2006). The change in mathematics teachers' perceptions of critical thinking after 15 years of educational reform in Jordan. *Educational Studies in Mathematics*, 64(1), 45–68.
- Kahneman, D., Slovic, P., & Tversky, A. (Eds.). (1982). *Judgment under uncertainty: Heuristics and biases*. New York: Cambridge University Press.
- Ku, K. Y. (2009). Assessing students' critical thinking performance: Urging for measurements using multi-response format. *Thinking Skills and Creativity*, 4, 70–76.
- Lieberman, V., & Tversky, A. (1996). *Hshiva Bikortit* [Critical thinking: Statistical considerations and intuitive judgments]. Tel Aviv: Open University.
- Lieberman, V., & Tversky, A. (2001). *Hisatbroot* [Probability thinking in daily life]. Tel Aviv: Open University.
- McPeck, J. E. (1981). *Critical thinking and education*. New York: St. Martin's Press.
- Paul, R., Elder, L. and Bartell, T. (1997). *California teacher preparation for instruction in critical thinking: Research findings and policy recommendations*. Commission on Teacher Credentialing.
- Swartz, R. J., & Parks, S. (1994). *Infusing the teaching of critical and creative thinking into content instruction: A lesson design handbook for the elementary grades*. Pacific Grove, CA: Critical Thinking & Software.

Tennyson, R. D., & Rasch, M. (1988). Linking cognitive learning theory to instructional prescriptions. *Instructional Science*, *17*, 369-385.

Tversky, A., & Kahneman, D. (1974). Judgment under Uncertainty: Heuristics and Biases. *Science*, *185*, 1124–1131.

The politics of early assessment in mathematics education

Anette Bagger¹, Helena Vennberg² and Lisa Björklund Boistrup³

¹Umeå University, Sweden; anette.bagger@umu.se

²Umeå University, Sweden; helena.vennberg@umu.se

³Stockholm University and Malmö University, Sweden; lisa.bjorklund@mnd.su.se

One of the latest reforms in Sweden in order to increase equity and quality in education is making national assessment compulsory in preschool-class (age 6). The claimed political volition is all students' best possible mathematical development. In this paper, we examine the preparatory work, the assignment to the National Agency of Education, and the assessment material itself, searching for what meaning is inscribed regarding the student, mathematics and assessment. The results imply that the politics of the assessment might exaggerate a search for flaws and control instead of promoting all students learning and in addition contributing to the schoolification of preschool-class.

Keywords: Early assessment, preschool-class, development in mathematics, national assessment.

National assessment in mathematics

National and standardised assessment has been vastly criticised and described as driven by a neo-liberal logic and securing market values (Dreher, 2012; Luke 2011; Lundahl, 2016). Equality and values of social justice, diversity and democracy are shown to be threatened by these kinds of tests (Hudson, 2011; Lundahl, 2016; Peters & Olivers, 2009; Rustique-Forrester, 2005). In Sweden there are currently three national tests in compulsory school that all students have to take: in grade 3 (age 9), grade 6 (age 12), and grade 9 (age 15). National assessment in mathematics, in the form of a support material, is also compulsory in grade 1, and voluntary in grade 2. The national assessment system has recently been evaluated (Regeringen, 2016). Since autumn 2019, this has led to a supplementation with compulsory national assessment also in preschool-class (age 6), which is a separate school form within the Swedish school system. The everyday assessment discourses in the classroom of the preschool-class are characterized by an activity-specific educational culture, which is meant to stand between the pre-school's and the school's norm systems (Vennberg, 2015). Important reasons claimed for developing the system are to direct teachers' attention, use of mathematical concepts, and efforts in certain directions, and through that striving towards equity and quality. These are in other words areas that are understood as important to govern. A core issue in assessment of preschool-class students' knowledge is also to early identify students in need of support. This is considered as a prerequisite for affording equal opportunities to learn, regardless of background factors. Another argument is to diminish the decrease of measured knowledge in grade 9, and the identified differences in the quality of support given to various students and in different schools (Regeringen, 2017a).

According to Boistrup (2017), a lack of equality can be found in the context of assessment at different levels within the school as a system. Assessment in mathematics can be said to hold a gatekeeping dispositive regarding the access to success. This dispositive may play out in the immediate situation of assessment if students belonging to disadvantaged groups face obstacles in displaying knowledge.

An example is when the teacher feels that securing multi-lingual students' equity could threaten the tests validity (Bagger, 2017). These findings from earlier research indicate that it is urgent to continue to investigate how the assessment and the teacher are governed. In this paper, assessment in mathematics education is understood as an element of governing (Foucault, 1994), where purpose and how it is carried out have impact on aspects related to quality and equity. Newton (2007) stresses that if several purposes of assessment – to evaluate education, to make grounds for decisions of recourses, and assessment of knowledge – are active simultaneously, conflicts of interests are built into the assessment, and a test will work poorly for all or mainly for some of the purposes. Further, how the teacher understands the student and the teaching content will have impact on the mathematical support (Scherer, Beswick, DeBlois, Healey & Opitz, 2016). Related to this, a study by Bagger (2017) indicates that the educational segregation in the teaching and learning of mathematics might occur earlier with earlier testing. Simultaneously, there are indications that if the preschool-class teachers get skilled in assessing mathematical knowledge, students at risk in preschool-class reach similar achievements as their peers in the national test in grade 3 (Vennberg & Norqvist, 2018). Our assumption is that assessment in the preschool-class constitutes a risk for but also an opportunity to levelling disadvantage.

The purpose of this study is to increase our knowledge of how policy documents govern the implementation of national assessment in preschool-class in mathematics. This is achieved through a systematic exploration of how some central aspects are discursively constructed: the student, mathematics, and assessment.

Theory and methods

In this paper, discourse is taken as representations of power, truth and knowledge that govern individuals and society. Truth and knowledge are further understood as social constructs and as such they evoke power relations (Foucault, 1994). Popkewitz (2004) draws on Foucault's thinking and uses the concept of *fabrication* as a governing technology. Categories, for example central notions adopted in assessment practices, are conceptual constructs through which reality can be understood and is simultaneously fabricated. These fabrications communicate versions of truth, knowledge and power, and coincide with processes of exclusion and inclusion. Governing texts are regarded as *inscription devices* that attribute terms, possibilities, and characteristics (Popkewitz, 2012). In this case, the governing texts are the testing material, political preparatory work, and decisions, through which the student as a mathematician, the teaching content, and the assessment are understood as attributed with terms, possibilities and characteristics. In other words, the texts fabricate the student, the assessment and the subject, and also inscribe meaning into them. This might by extension affect how the student, subject and assessment are handled and understood in the practice and governing of national assessment in preschool-class. The governing may then concern what is considered as 'true', what counts as 'knowledge', how students' knowledge is valued, and how results should be used.

The texts selected to explore the fabrications of mathematics, the student and the assessment are preparatory work and political decisions regarding the assessment in preschool-class and the material for assessment (see Table 1). Initially, in the analytical process, statements concerning preschool-class were selected from the texts into a scheme in which each text was in its own column. After that,

all utterances depicting the student, the mathematics, or the assessment were coded in different colours. The next step was to ‘translate’ such utterances into explanatory paraphrases. The fabrications were thereafter narratively construed with regards to how terms, possibilities, characteristics, and demarcations were attributed. An example of the analysis is displayed in Table 2.

Text	Responsible author and short description
Skolverket (2016)	Comments to curriculum. Swedish National Agency of Education (SNAE). The purpose and content of mathematics in preschool-class.
Skolverket (2018)	National support for assessment in mathematics in preschool-class
Regeringen 2017a	Swedish Government (SG). The assignment to the SNAE to develop the national system for assessment including the material for assessment in preschool-class.
Regeringen (2017c)	SG. A bill guarantying support in reading, writing and counting.
Utredningen om nationella prov (2016).	SG. A bill in which the need for assessment in preschool-class is put into the context of national assessment and the quality and equity of education.

Table 1: Overview of the five documents analysed in this paper

Selected text	Explanatory paraphrases	Construed fabrication
“To observe the students’ mathematical abilities in different areas of importance for development of mathematical thinking”	The purpose of the assessment is to identify student’s mathematical thinking	Lack of mathematical thinking is fabricated as the supposed obstacle for goal achievement in grade 3. Assessment will level inequalities in teaching and grant high quality and equal support earlier. Another threat against equity is the teacher who draws wrong conclusions regarding support or the displayed knowledge. So, they also need support.
“... early identify students who show indications of not achieving the goals in learning that are set for grade 3”	This is needed in order to identify students in need / at risk of not reaching goals three years later.	
“the assessment will help teachers to know what support to possibly put in”	Teachers need help to know how to support.	
“National material might increase the equity of the quality in the support given”	There is a lack of equity in the support now – another aim with assessment.	
“... solutions should be evaluated by someone else than the teaching teacher”	The teacher should not evaluate the solutions of her/his own students.	

Table 2: Example of the analytic procedure and construction of the narrative

Findings

A narrative was constructed by depicting how mathematics, the assessment and the student were fabricated. All texts are in Swedish and quotes have been translated by the authors.

The fabrication of mathematics

One aim of mathematics, as construed from the analysed texts, is to be a caretaker of curiosity and understanding: “The teaching shall take care of students curiosity and afford them the opportunity to develop their interest in mathematics and understanding for the possible use of mathematics in different situations” (Skolverket, 2016, p. 13). Also: “students shall be challenged and stimulated to use mathematical concepts and reasoning to communicate and solve problems in different ways through different representations and to explore and describe their surroundings” (p. 13). The areas of mathematics that preschool-class is supposed to pay attention to in order to reach the aim is: “Mathematical reasoning and different ways of solving problems” (p. 20) together with “Mathematical concepts and representations” (p. 21). Mathematical reasoning is defined as a “logical mathematical argument that is used for motivating an answer or a choice” (p. 20), and mathematical problems are defined as “situations or tasks in which the students do not know beforehand how to

solve the problem” (p. 20). The mathematical contents that the students are supposed to be offered to meet are:

the characteristics of natural numbers and how they can be used to designate cardinality and ordinality.... mathematical concepts and representations in order to explore and describe space, location, shape, direction, pattern, time and change. (Skolverket, 2016, p. 21)

Mathematics is, through the above-mentioned statements, fabricated in the curriculum for preschool-class as a nurturing and caretaking assignment that will grant the student an opportunity to further develop an already existing curiosity, interest and understanding. The mathematical content is fabricated as a kind of founding building blocks needed in order to explore and investigate various problems and arguments. Problems and reasoning that could impose interest and curiosity are additionally fabricated as deriving from visuospatial elements of the student’s surroundings. We interpret the intentions of mathematics education, as described in the curricula, as a way of supporting the students in experiencing themselves in the world, appreciating diversity in ideas and recognising their own competence to deal with problems.

In the title of the material for assessment itself, mathematics is labelled as mathematical thinking: “Find the mathematics. Evaluation material in mathematical thinking in preschool-class” (Skolverket, 2018, p. 1). In other words, it is fabricated as something that resides within the student. The material encourages the teacher to promote different arguments, reasoning, examples, and not to stop or be content with just one solution from students. This approach towards exploring is in line with the curriculum’s intentions. The areas through which the mathematical thinking is supposed to be explored and evaluated are patterns, maps, counting, sorting, and volume. The focus on experiencing the world and relations in it, in both the curriculum and the material, fabricates mathematics as something concrete and visible that constitutes reality. We wish to connect this to Straehler-Pohls (2015) writings of distributive rules in relation to school mathematics;

The foundation of this distribution is a stratification of mundane and esoteric meanings. In this stratification, esoteric meanings inevitably take the dominant role, as it is these meanings that transcend the spatial and temporal materiality that bear the potentials to think yet unthinkable solutions that draw on (contextually) external frames of reference” (p. 3).

Mathematics as concrete and constituting is further interpreted as fabricating school mathematics in preschool-class as mundane, at the same time as the exchanged meaning making is supposed to take place in an esoteric form through an exchange of different understandings and reasoning. The promoted variation in reasoning and solutions connects to a fallibilist (Ernest, 2014) view on mathematics in which knowledge is considered fallible and open for revision. In the assessment material, there is an attached observation scheme in order to register the student’s knowledge. A text on this is: “date when the observation point is reached/finished” (Skolverket, 2018, p.1 in compilation form). This assumes knowledge to be possible to observe, reach and check at a certain date, fabricating mathematical knowledge as situated in an absolutist perspective (Ernest, 2014) in which knowledge is secure, fixed and objective. This is opposed to the fallibilist view, represented in the previously described encouragement in the material and curriculum; to explore and negotiate

solutions and arguments. It also fabricates the mathematical thinking, or knowledge, as something that could and should be reached – *as if* there were goals to achieve in preschool-class.

The fabrication of assessment

The title of the assessment material is: “Find the mathematics: Evaluation of mathematical thinking” (Skolverket, 2018). Assessment is thereby fabricated as needed in order to capture the inner world of the student, the thinking, or the lack thereof. The thinking is further fabricated as promoting or threatening a development of knowledge towards the goals in grade 3: “... is carried out during autumn in preschool-class so that the teacher can early identify students who show indications of not achieving the goals in learning that are set for grade 3” (p. 3). This message is also repeated in the preparatory work and the assignment to the Swedish National Agency of Education to develop this material. In addition, assessment is in these preparatory texts fabricated as something that will level inequalities in teaching and grant high quality and equal support earlier: “Nationally produced material might also increase the equity of the quality in the support given and contribute to a common terminology regarding assessment, progression and knowledge requirements which will lead to higher quality of judgements” (Regeringen, 2017a, p. 5). Teachers are fabricated as being responsible for detecting where in the development the student is and to adapt teaching so that the student can achieve the goals in third grade. This is seen in several parts of the texts and in the instructions to the material. For example: “to give teachers a clearer basis for assessment of the student’s knowledge development and more information on what support to introduce” (p. 2). Also, the material will evaluate the teaching and help teachers to correct it through “affording preschool-class teachers and teachers support in seeing how opportunities and obstacles in the teaching impacts on students learning.” (pp. 1–2). The proposition further fabricates assessment as insecure and invalid due to the teacher and relations involved: “solutions should be evaluated by someone else than the students’ teacher, and such solutions should be de-identified” (p. 1). Another statement fabricating the teachers as the ones in need of support is in the assignment to the national agency of education: “the material will be completed with a supportive material for analysing evaluations” (p. 2). The assessment is then fabricated as a tool to control and support teachers in the assessment process.

The fabrication of the student

In the curriculum, the student is fabricated as already mathematically able and interested: “Teaching shall take students curiosity into consideration and give them the opportunity to develop their interest in mathematics and their understanding of how mathematics might be used in different situations” (Skolverket, 2016, p. 13). This harmonises with statements in the instructions to the material in which the use is presented as an opportunity in itself to learn mathematics: “By allowing students to meet activities that differ in character, they can develop trust in the ability to solve problems in different situations and contexts” (Skolverket, 2018, Instruction to material, p. 4). The student is thereby fabricated as a learner, rather than a test-taker. This stands in contrast to other statements in which the students are depicted as needed to display their knowledge. Such statements occur in the preparatory work and the material itself. The curiosity and interest that was fabricated as mathematical entities within the student and as something that the school should build on in the curriculum is instead fabricated in the material as a kind of mathematical knowledge that the student

must display. “When the student shows curiosity and interest for the mathematical content, it reflects how the student participates in the activity” (p. 4). The participation is further fabricated as the notion that will inform the teacher about “where the student is in her/his development” (p. 5). In the preparatory work, the assignment, and the material, there is an overweight towards the student being fabricated as lacking or possibly missing knowledge, that those errors may grow and therefore need to be identified and corrected through adaptations of education.

Conclusions and discussion

A higher degree of goal achievement and increase of test-results have been central arguments in the evaluation of and revision of the national system for quality measuring (Regeringen, 2017b). This stands in contrast with the preschool-class’s pedagogical assignment of being a bridge between preschool and school. National and compulsory assessment in preschool-class is a new phenomenon and it is crucial that it is implemented in a manner that is in line with this educational spirit of preschool-class. Otherwise, the assessment might not present an opportunity to nurture interest, curiosity and the identity of being a mathematical learner and explorer, but instead contribute to an approach in which it is the performed interest or competencies that counts. The preschool-class could risk being colonised by the prevalent neoliberal logics of governing that exists in compulsory school including *schoolification* of the assessment practice in mathematics.

A focus on mathematics as the observed and displayed activity, and the assessment of knowledge as making achievement visible, positions the 6-year-old preschool-class student as a test-taker and the teacher as the controller and corrector of knowledge. The mathematical thinking and development were fabricated in the data as having a certain order or being a destination. To identify where the student is positioned on this map or road, is claimed as a key for giving adequate support early. A question to raise is how the teacher is supposed to position the students’ place in development through observing their displayed participation, as suggested (and we are reluctant to the idea of assigning students places in developmental ‘paths’, but that is not in focus in this text). It may be many factors that affect how and if a student participates, several of these have to do with the organisation of education and teaching. These are mentioned in the material with regard to the importance that students are allowed to express different ideas, which can also happen with other modes than spoken language. The stress laid on the freedom to communicate and try ideas indicates that it should be an explorative and playful situation. Also, knowledge can be displayed outside these situations or with other alternative and adaptive settings. These fabrications stand against the one of control and goal achievement. An adapted and creative mathematical teaching is supposed to be the possible outcome from the analysis of the material. We question how this can this happen, in a practice deriving from an assessment that is only assessing a few mathematical items. This is significant, not least since the risk of ‘teaching to the test’ is obvious. Another aspect is how the mathematical processes, selected and tested in the material, are promoted as *the* mathematics, which is limiting in itself. There is a risk that the material may contribute to the narrowing of implemented curricula, teaching to the test, and seeing students as their levels of achievement, as reported in previous research (Wrigley, 2010). Thereby, the material may unintentionally limit possibilities for development and knowledge in mathematics, which is opposed to the purpose of increasing equity and quality.

The described use of the assessment material is easy to interpret as being about a search for problems, rather than promoting education for all. The strive towards high quality and quality in equity is then becoming an issue of everyone doing the same thing, having the same focus and the same demarcation in regard to the support given and the mathematics taught. A final question is: Is this assessment material a material for teaching or a material for controlling, and if so, what is being controlled and thereby restricted, locked in, or included? What is excluded when it comes to kinds of students, kinds of mathematical knowledge and kinds of teachers' ways of teaching? Our hope is that the discursive fabrications, presented in this paper, of assessment, mathematics and who the student is, may contribute to revealing some of the underpinnings in the so-hard-to-grasp patterns or structures of disadvantage in mathematics education.

References

- Bagger, A. (2017). Quality and equity in the era of national testing. The case of Sweden. In J. Allan & A. Artiles (Eds.), *Assessment inequalities* (pp. 68–88). London: Routledge.
- Boistrup, L. B. (2017). Assessment in mathematics education: A gatekeeping dispositive. In H. Straehler-Pohl, N. Bohlmann, & A. Pais (Eds.), *The disorder of mathematics education: Challenging the sociopolitical dimensions of research* (pp. 209–230). Cham: Springer.
- Dreher, K. (2012). Tests, testing times and literacy teaching. *Australian Journal of Language and Literacy*, 35(3), 334–352.
- Ernest, P. (2014). What is mathematics, and why learn it? In P. Andrews & T. Rowland (Eds.), *Masterclass in mathematics education: International perspectives on teaching and learning* (pp. 3–14). London: Bloomsbury
- Foucault, M. (1994). *The essential works of Foucault, 1954-1984. Vol. 3, Power*. London: Penguin.
- Hudson, C. (2011). Evaluation: The (not so) softly-softly approach to governance and its consequences for compulsory education in the Nordic countries. *Education Inquiry*, 2(4), 671–687.
- Luke, A. (2011). Generalizing across borders. *Educational Researcher*, 40(8), 367–377.
- Lundahl, L. (2016). Equality, inclusion and marketization of Nordic education: Introductory notes. *Research in Comparative and International Education*, 11(1), 1–10.
- Newton, P. (2007). Clarifying the purposes of educational assessment. *Assessment in Education: Principles, Policy & Practice*, 14(2), 149–170.
- Peters, S., & Oliver, L. A. (2009). Achieving quality and equity through inclusive education in an era of high-stakes testing. *Prospects: Quarterly Review of Comparative Education*, 39(3), 265–279.
- Popkewitz, T. (2004). The alchemy of the mathematics curriculum: Inscriptions and the fabrication of the student. *American Educational Research Journal*, 41(1), 3–34.
- Popkewitz, T. (2012). Numbers in grids of intelligibility: Making sense of how educational truth is told. In H. Lauder, M. Young, H. Daniels, M. Balarin, & J. Lowe (Eds.), *Educating for the knowledge economy? Critical perspectives* (pp. 169–191). London: Routledge.

- Regeringen. (2017a). *Uppdrag att ta fram kartläggningmaterial och revidera obligatoriska bedömningsstöd och nationella prov i grundskolan, sameskolan och specialskolan* [Assignment U2017/02561/S] of June 1, 2017 (Sweden).
- Regeringen. (2017b). *Nationella prov – rättvisa, likvärdiga, digitala* [Proposition 2017/18:14] from September 14, 2017 (Sweden).
- Regeringen. (2017c). *Läsa, skriva, räkna – en åtgärdsgaranti*. [Bill 2017/18:18] from September 21, 2017 (Sweden).
- Rustique-Forrester, E. (2005). Accountability and the pressures to exclude: A cautionary tale from England. *Education Policy Analysis Archives*, 13(26), 2–41.
- Scherer, P., Beswick, K., DeBlois, L., Healey, L., & Opitz, E. M. (2016). Assistance of students with mathematical learning difficulties: How can research support practice? *ZDM Mathematics Education*, 48(5), 639–649.
- Skolverket. (2016) *Förskoleklassen – Ett kommentarmaterial till läroplanens tredje del*. Stockholm
- Skolverket. (2018). Hitta matematiken.[Assessment material]. Retrieved from skolverket.se
- Straehler-Pohl, H. (2015). Devaluing knowledge: School mathematics in a context of segregation. In P. Vitale & B. Exley (Eds.), *Pedagogic rights and democratic education: Bernsteinian explorations of curriculum, pedagogy and assessment* (pp. 103–117). Abingdon: Routledge.
- Utredningen om nationella prov (2016). [Committe report SOU 2016:25.] *Likvärdigt, rättssäkert och effektivt- ett nytt nationellt system för kunskapsbedömning*. Statens offentliga utredningar, Stockholm.
- Vennberg, H. (2015). *Förskoleklass – ett år att räkna med: Förskoleklasslärares möjligheter att följa och analysera eleverns kunskapsutveckling i matematik* [Preschool-class – a year that counts: Preschool-class teacher’s possibilities to track and analyse students’ knowledge development in mathematics] (Licentiate thesis). Umeå Universitet, Umeå, Sweden.
- Vennberg, H & Norqvist, M. (2018). Counting on – long term effects of an early intervention program. In E. Bergqvist, M. Österholm, C. Granberg & L. Sumpter (Eds.), *Proceedings of the 42nd Conference of the International Group for the Psychology of Mathematics Education* (Vol. 4, pp. 355–362). Umeå, Sweden: PME.
- Wrigley, T. (2010). The testing regime of childhood: Up against the wall. In D. Kassem, L. Murphy, & E. Taylor (Eds.), *Key issues in childhood and youth studies* (pp. 136–148). New York: Routledge.

‘Critical uses’ of knowledge and identity: Embedded mathematics as a site for/of class struggle in educational praxis

Laura Black¹, Julian Williams², David Swanson³, Sophina Choudry⁴ and Emilia Howker⁵

University of Manchester, United Kingdom;

¹laura.black@manchester.ac.uk; ²julian.williams@manchester.ac.uk;

³david.swanson@manchester.ac.uk; ⁴sophina.choudry@manchester.ac.uk;

⁵emilia.howker@postgrad.manchester.ac.uk

This paper considers what the praxis of ‘Funds of Knowledge/Identity’ (FoK/I) might offer to researchers and practitioners of mathematics education. Building on a critique of FOK/FOI as reflecting cultural capital (in Bourdieu’s sense) we posit the notion of ‘use value’ in the knowledge and practices of oppressed communities: in knowing how to live poor, how to resist capital, and how to solidarise in social movements related to class, nationality, race, gender, sexuality etc. We focus on ‘dark’ FOK - defined as difficult or challenging experiences for learners and/or communities; we reconceptualise these as related to the objective relations of oppression under capitalism whereby ‘dark funds’ are the surfacing of class contradictions in our learners’ experiences. The implications for critical mathematics education are led by these considerations: in the problems we choose to tackle, the partners we choose to work with, and the research methodologies we adopt.

Keywords: Funds of knowledge, funds of identity, social class, mathematics.

Introduction

The Funds of Knowledge (FoK) (and more recently Funds of Identity – FoI) perspective has increasingly been utilized by those interested in addressing issues of inequality and oppression in education (including mathematics education, González, Andrade, Civil, & Moll, 2001). Arguably, mathematics is a significant area of the curriculum for such work given the commonly accepted ‘gatekeeper’ role it plays in sorting and selecting who has access to high status careers/subjects and its function in excluding those from disadvantaged backgrounds (Jorgensen, Gates, & Roper, 2014). In this paper, we present a narrative review of the literature on FoK/FoI in order to demonstrate how key critiques present important implications for how we conceptualise and how we ‘do’ critical mathematics education.

Funds of Knowledge/Funds of Identity in/for Mathematics Education

The ‘Funds of Knowledge’ (FoK) approach, originally developed by Moll and colleagues at the University of Arizona working with Latino immigrant communities and schools, has sought to emphasize the rich resources children have access to and experience in the home/community environment. In order to challenge the normative assumption that children from such communities are in some way ‘deficient’, it presents home activities (and the associated knowledge) as a rich resource for developing and teaching a school curriculum orientated towards social justice which are embedded in complex/rich social networks. The premise is that building a curriculum on these ‘funds’ will establish more meaningful connections between the school curriculum and learners lives beyond school. In one example, Moll, Amanti, Neff, and Gonzalez (1992) documented the development of a

learning module around the FoK evident in the home of one child, Carlos, who engaged in buying and selling Mexican sweets to friends and relatives after visits to Mexico. This is presented as a hybrid curriculum since it initially involved bringing the home experience into the classroom (e.g., parents came into the classroom to make Mexican sweets with the children) but then incorporated formal curriculum knowledge (e.g., the ingredients of Mexican and American sweets and comparison of their nutritional value). According to Moll et al. (1992) the term ‘funds’ originated from the ‘household funds’ paradigm (in anthropology) and refers to the funds that households must juggle to make ends meet – rent, social funds, ceremonial funds – each fund entailing a wider set of activities requiring a specific body of knowledge.

The essential cultural practices and bodies of knowledge and information that households use to survive, to get ahead or to thrive [...] acquired primarily, but not exclusively, through work and participation in diverse labour markets. (p. 21)

More significantly, Moll et al. (1992) were keen to point out that a FoK approach is not merely a culturally sensitive curriculum – or rather a ‘static grab bag’ of food, dances and celebrations which prove tokenistic (here they align with studies on ethnomathematics/culturally responsive pedagogies in mathematics education which also makes a similar critique). But rather this type of knowledge is strategic to households’ or communities’ functioning, development and well-being, and particularly may relate to the social, economic and productive activities of people in a local area.

More recently, Esteban-Guitart and Moll (2014) extended their approach to include ‘Funds of Identity’ (FoI) which refers to moments where a FoK is used to make some claim to be a certain kind of person:

funds of knowledge become funds of identity when people actively internalize family and community resources to make meaning and to describe themselves. (p. 33)

In this sense, they argue that education/teaching-learning should be about identity development as well as knowledge creation since the two are interwoven. Drawing on Vygotsky’s notion of *perezhivanie* (defined as an emotional experience having developmental potential, Blunden, 2016) they emphasise the subjective significance of the situation on the persons as they consume and use FoK. More so Esteban-Guitart and Moll (2014) define ‘the term *funds of identity* ... [as] a set of resources or *box of tools and signs*’ (p. 37). The authors highlight five types of funds of identity: ‘(1) Geographical Funds of Identity..., (2) Practical Funds of Identity..., (3) Cultural Funds of Identity..., (4) Social Funds of Identity..., and (5) Institutional Funds of Identity’ (p. 38).

FoK/FoI approaches have been utilised within mathematics education (Moll et al., 2009; Gonzalez et al., 2001) and clearly there is commonality with the ethnomathematics tradition (d’Ambrosio, 1985) and Critical Mathematics Education (CME) (Gutstein, 2006; Skovsmose & Nielsen, 1996); although CME is usually viewed as perhaps more explicitly political, involving critical interpretations of the world and political engagement (see, e.g., Skovsmose, 2016). The FoK approach is largely deemed critical because it rejects a deficit point of view on the learners (typically of immigrant or otherwise disadvantaged or marginal communities) vis a vis their ‘capital’. Moll and colleagues (2009) argue, and their research findings establish this, that many children bring funds or resources that could be useful to teaching/learning, but that go unrecognized by the teachers/schools because of their

ignorance of the culture involved. In this respect, this perspective also sits well with the Vygotskian idea of the everyday/spontaneous practices of the learner as providing potential for ‘making sense’ of the formal, academic concepts of the school curriculum and its teachers.

Critiquing the ‘Funds’

Williams (2016) has offered a critique of this work, drawing on Bourdieu, which illustrates how FoK/FoI has been used to refer to the surfacing of capital in the home/community as a means to reposition the learner with ‘access’ to the school curriculum. For instance, Moll et al. (2009) describe how the teachers-researchers involved in their projects discover one Mexican family’s educational values and high aspirations for their children which were previously been unseen/unrecognised by the school. Here the identification of FoK may be to enable the redistribution of such ‘capital’ by making visible and legitimate home resources and by providing the machinery to ‘scaffold’ the movement of such capital from the home into the educational field as a means to access ‘success’ and capital growth. According to Williams (2016), in such cases, identifying FoK does not necessarily challenge the process of capital exchange, but instead serves to strengthen its orthodoxy as ‘natural’ and open to all. As Zipin (2009) notes, the very act of identifying ‘everyday’ or ‘lifeworld’ knowledge to facilitate access to more powerful or ‘elite’ cultural artefacts entails the loss of its use value (productivity) and transforms such knowledge into objects with exchange value to be mobilized for capital growth in the educational market (he defines this as an ‘asset’ perspective).

When schools operate as high-stakes competitive markets, the use values of diverse people’s cultural assets are sadly diminished in relation to ‘gold standards’ of restricted exchange value. (p. 319)

However, poor communities also have resources which may not be valued as ‘capital’ and may even function to resist capital exchange within the educational field – for example, parents who question how they are positioned by schools in terms of capital ‘deficit’ and express confusion as to why schools do not teach the ‘life skills’ they practice ‘everyday’ as a function of ‘being poor’ (Howker, 2018). Both Bourdieu and Freire – were they alive today – might argue for the need to disrupt the ‘orthodoxy’ which occurs when FoK/FoI approaches are used to merely surface capital in the home/community (thereby strengthening the process of capital exchange). For Bourdieu and Wacquant (1992), it is the reflexive sociologist who, having made visible the processes of capital production/reproduction, might support practitioners/communities in identifying with a heterodoxa in a given field (i.e., an alternative frame which challenges orthodoxy and so threatens the ‘doxa’ in place). Similarly, Freire’s (1970) *Pedagogy of the Oppressed* suggests that emphasis should *not* be placed on resources ‘latent’ in the home/community practices which are useful to a formal curriculum of some sort but rather on how such resources can be brought to consciousness in order to ‘name’ (and challenge the limits of) the systems/relations/institutions which produce/reproduce oppression/inequality. Freire also outlines a process of conscientization where collective agency/solidarity and social movements are mobilized to fight struggles of injustice pertaining to class, race, etc. Through the pedagogy of the oppressed students can “perceive the reality of oppression, not as a closed world from which there is no exit, but as a limiting situation which they can transform” (p. 85). Here the agents are students/community members/teachers/activists rather

than the social scientist (as per Bourdieu), although special status is given to the ‘educator’ whose role is to draw out the learners’ view of reality and enable him/her to question it.

All of this suggests the need to situate FoK/FoI in relation to the objective relations of oppression, which under capitalism may be understood as relations of class position (dominated/dominating, working/leisured, disowned/owning class positions in Bourdieu). In identifying the types of knowledge embedded in homes/communities and the subjective experiences they engender (FoI), it is not sufficient to relate to ‘domains’ of activity (e.g., home/community etc.) in which they arise or even the social function that such activities serve (e.g., practical/institutional etc.). But rather we need to recognize how FoK/FoI function in relation to objective structures which (re)produce ‘capital’ (either through alignment or resistance) if we wish such an approach to challenge oppression/alienation of those from disadvantaged communities.

Dark/Existential FoK/FoI

In relation to the above critique, Zipin (2009) notes the difficulty of developing a curriculum based on the ‘use-value’ of FoK and anticipates the challenges and limitations presented by institutions whose function is to mechanize capital exchange (Bourdieu, 1986). In this sense, he critiques the tendency of researchers/teachers to gravitate to what he terms ‘light’ FoK or rather positive experiences and to omit what is seen as more difficult or challenging sides of living in disadvantaged or poor communities. As such, dark FoK are conceptualised as knowledge/resources/experiences which may be painful, challenging or difficult (e.g., bullying, poverty, incarceration, mental ill-health, exploitation, or other problems with social relations) and which Zipin (2009) argues are significant if we wish to fully recognize how poverty and class position permeate the ‘habitus’ of children. More recently, Poole and Huang (2018) have made a similar argument in relation to existing accounts of FoI (Esteban-Guitart & Moll, 2014) critiquing the heavy focus on the learner’s positive experiences, rather than capturing the whole range of human subjective experience. They suggest that difficult experiences or rather ‘existential FoI’ (identified through an ‘experience as struggle’ lens) are significant since they indicate a *perezhivanie*, that is emotional experiences which are/can be developmental in that they provoke the need to work through or reflect and subsequently overcome. Thus whereas Zipin (2009) sees dark funds/difficult experiences as offering a potential FoK approach which can counter the logic of capital exchange in teaching and learning (since ‘dark funds’ are not merely a matter of identifying ‘assets’ for capital exchange), Poole and Huang (2018) suggest such potential be located at the subjective level – with difficult or challenging experiences viewed as developmental in that they may bring about ‘human growth’:

Existential funds of identity are defined as positive and negative experiences that students develop and appropriate in order to define themselves and to help them grow as human beings. Existential funds of identity are presented as an additional category of funds of identity that are designed to complement the typology consisting of geographical, social, cultural, institutional, and practical funds of identity as developed by Esteban-Guitart. (Poole & Huang, 2018, p. 126)

In the above quote we can see how Poole and Huang (2018) equate existential FoI to other categories proposed by Esteban-Guitart and Moll (2014) as if they are merely an alternative form of resource/experience which individuals encounter. However, our own work on *perezhivanie* has begun

to look at how emotional experiences (difficult/challenging or otherwise), although experienced subjectively, may also be related to objective structural conditions whereby contradictions arise. For instance, in Black, Choudry, Pickard-Smith, Ryan, and Williams (2018) we present the case of 6-year-old Nico who experiences his classroom mathematics as ‘boring’ and in contradiction with his home/community activities where he is able to ‘see’ some embedded mathematics ‘in practice’. We have highlighted in this paper how this contradiction is experienced subjectively but also how it arises objectively in social structures, that is as a manifestation of the family habitus regarding school mathematics as ‘not for them’ which contradicts the embedded mathematics used by Nico, his family and his community in their everyday practice. Thus, we propose that dark/existential FoK need to be reconceptualised as manifestations of (and so refracted through subjective experiences of) objective relations of oppression under capitalism whereby ‘dark funds’ arise from the surfacing of class contradictions in learners’ experiences. In general, the habitus of the oppressed is not well aligned with the cultural capital needed to resource the acquisition of power in the various fields and in the field of power generally. However, just as we must imagine a world beyond such arbitrary power structures, we must imagine the potential of such experiences to resource developments of new understandings and consciousness of ways to live differently. In this simple formula we may reposition Vygotsky’s conception of *perezhivanie* in a critical class context, as the potential of experiences for development of newer and bolder class consciousness.

Implications for Critical Mathematics Education

Our critique of Poole and Huang’s (2018) conceptualisation therefore suggests that ‘dark’ experiences, if they are understood in the way we outline above, can give insight into how we might relate productively to them, and how they might be made to become developmental in a critical sense. This may entail finding ‘uses’ of mathematics in the home/community and in class struggles which can be mobilised to fight real issues of poverty or oppression in the way Freire (1970) envisaged. See, for example, Gutstein (2016) for a course designed with this explicit orientation. Examples where such an orientation integrates with actual struggles and campaigns are far rarer, however. Williams, Bertholt, Nardi, Jornet-Gil, and Vadeboncouer (2018) have more recently made the distinction between ‘critical’ and ‘domesticated’ forms of CH-AT in educational praxis: Our remarks in the previous paragraph suggest a critical perspective on *perezhivanie* to balance the more domesticated, personalized one attached to psychotherapy (i.e., that ‘development’ is a purely personal, therapeutic one rather than an emergence of class consciousness). The critical perspective may involve working with the experiential ‘resources’ that capital is not interested in, but that allows or encourages a different ‘knowledge/know-how’. Zipin, Sellar, and Hattam (2012) refer to such resources as ‘knowledge that has use’ as opposed to knowledge that ‘has market-exchange value’ thus:

knowledge that has uses for social life in those settings – not abstracted from living social use by a logic of accumulation of knowledge that, due to its scarcity, has ‘market-exchange value’ which can be parlayed by either individual ‘entrepreneurs of the self’ or networked collectives of ‘social capitalists’. (p. 181)

We should add to this ‘knowledge that has use’ in the struggles of the oppressed. Most obviously such ‘resources’ relate to how to ‘live poor’, but we also argue, following Freire, the need to recognize

and legitimate practices and know how involved in sharing/mobilising solidarity with others who are oppressed and also how to engage in collective action, for example through social movements and community, union or party activity. One might also see how such resources can challenge the ‘limits’ Freire refers to in the education-industry, for example in asserting the need to overcome the disciplinary boundaries (in curriculum and pedagogy), spatial and temporal structures in educational institutions, and above all assessment and qualification structures (Williams et al., 2016).

References

- Bourdieu, P., & Wacquant, L. (1992). *An invitation to reflexive sociology*. Cambridge, UK: Polity Press.
- Bourdieu, P. (1986). Forms of capital. In J. Richardson (Ed) *Handbook of theory and research for the sociology of education* (pp. 241–258). New York, USA: Greenwood.
- Black, L., Williams, J., Choudry, S., Pickard-Smith, K., & Ryan, B. (2018). Identification with early primary school mathematics: A home–school activity theory conceptualisation and methodology. *Cambridge Journal of Education*, 49(3), 349–368. <https://doi.org/10.1080/0305764X.2018.1533523>
- Blunden, A. (2016). Translating *perezhivanie* into English. *Mind, Culture, and Activity*, 23(4), 274–283.
- d’Ambrosio, U. (1985). Ethnomathematics and its place in the history of mathematics. *For the Learning of Mathematics*, 5(1), 44–48.
- Esteban-Guitart, M., & Moll, L. C. (2014). Lived experience, funds of identity and education. *Culture & Psychology*, 20(1), 70–81.
- Freire, P. (1970). *Pedagogy of the oppressed* (M. B. Ramos, Trans.). New York, USA: Seabury Press.
- González, N., Andrade, R., Civil, M., & Moll, L. (2001). Bridging funds of distributed knowledge: Creating zones of practices in mathematics. *Journal of education for students placed at risk*, 6(1-2), 115–132.
- Gutstein, E. (2006) *Reading and writing the world with mathematics: Towards a pedagogy for social justice*. New York, USA: Routledge.
- Gutstein, E. R. (2016). “Our issues, our people—math as our weapon”: Critical mathematics in a Chicago neighborhood high school. *Journal of Research in Mathematics Education*, 47(5), 454–504.
- Howker, E. (2018) *Investigate the role mathematics plays in the alienation of working class parents in the educational field*. Unpublished Masters Dissertation: University of Manchester.
- Jorgensen, R., Gates, P., & Roper, V. (2014). Structural exclusion through school mathematics: Using Bourdieu to understand mathematics as a social practice. *Educational Studies in Mathematics*, 87(2), 221–239.
- Moll, L. C., Amanti, C., Neff, D., & Gonzalez, N. (1992). Funds of knowledge for teaching: Using a qualitative approach to connect homes and classrooms. *Theory Into Practice*, 31(2), 132–141.

- Poole, A., & Huang, J. (2018). Resituating Funds of Identity within contemporary interpretations of *perezhivanie*. *Mind, Culture, and Activity*, 25(2), 125–137.
- Skovsmose, O. (2016). What could critical mathematics education mean for different groups of students? *For the Learning of Mathematics*, 36(1), 2–7.
- Skovsmose, O., & Nielsen, L. (1996). Critical mathematics education. In A. Bishop, K. Clements, C. Keitel, & J. Kilpatrick (Eds.) *International handbook of mathematics education* (pp. 1257–1288). Dordrecht: Springer.
- Williams, J. (2016). Alienation in mathematics education: Critique and development of neo-Vygotskian perspectives. *Educational Studies in Mathematics*, 92(1), 59–73.
- Williams, J., Bertholt, B., Nardi, B., Jornet-Gil, A., & Vadeboncouer, J. (2018). Development: The dialectics of transgression and social transformation. *Mind, Culture, and Activity*, 25(3), 187–191.
- Williams, J., Roth, W-M., Swanson, D., Doig, B., Groves, S., Omuvwie, M., & Mousoulides, N. (2016). *Interdisciplinary mathematics education: A state of the art*. Dordrecht: Springer.
- Zipin, L. (2009). Dark funds of knowledge, deep funds of pedagogy: Exploring boundaries between lifeworlds and schools. *Discourse*, 30(3), 317–331.
- Zipin, L., Sellar, S., & Hattam, R. (2012). Countering and exceeding “capital”: A “funds of knowledge” approach to re-imagining community. *Discourse*, 33(2), 179–192.

Mathematics education's solidarity assimilation methodology

Tânia Cabral¹, Alexandre Pais² and Roberto Baldino³

¹State University of Rio Grande do Sul and Pontifical Catholic University of Rio Grande do Sul, Brazil; cabral.taniacb@gmail.com

²Manchester Metropolitan University, Faculty of Education, Manchester, United Kingdom; a.pais@mmu.ac.uk

³State University of Rio Grande do Sul, Brazil; rrbaldino@terra.com.br

This paper discusses the solidarity assimilation methodology (SAM) under the critical scrutiny of the community, as a strategy of intervention in an inherently exclusionary school system. This intervention has been operating for almost 40 years in direct contact with the classroom and in the context of institutional obstacles faced by the authors. The core principles of SAM is to distinguish promotion from evaluation and to conflate rewarding effort with content progress as promotional criterion leading to credit. SAM adopts the motto “we teach when we listen, we learn when we talk”. We argue that this common belief in progressive pedagogies acquires a deeper meaning under a Lacanian perspective. Rewarding effort is less easy to digest because it forces us to politicise our work. The problem of universal failure will not be solved by SAM, but SAM provides an understanding-in-action of the role of failure in the resilience of school practices.

Keywords: Solidarity Assimilation, Hegel, Marx, Lacan

Introduction

Solidarity assimilation methodology (SAM) is an intervention into capitalist schooling that started in Brazil through the work of Roberto Baldino and Tânia Cabral. Contrary to other approaches in mathematics education, SAM is not a bird's-eye view on the teaching and learning of mathematics, developed by a researcher who is not teaching mathematics. Instead, it born out of the necessity to deal with the daily difficulties that Baldino experienced when trying to teach mathematics to his university students at the Federal University of Rio de Janeiro in the early seventies. Since then, other people, including Alexandre Pais, have joined in the development that is now well documented in the research literature (e.g. Baldino, 1997, 1998a, 1998b; Baldino & Cabral, 1989, 1998, 1999, 2006, 2008, 2010, 2013; Baldino & Carrera, 1999; Cabral, 1993, 1998, 2015; Gluz, Cabral, Baggio, Livi, & Mallmann, 2008; Pais, 2011; Persad, 2014; Silva, 1997). In the present article, we briefly describe the main aspects of SAM and point to a research project to be developed in the years to come. The following personal testimony of Alexandre Pais completes our introduction.

The reality of the classroom forces teachers to believe that we are all struggling for “mathematics for all”, at the same time making it difficult to sustain the illusion that a complete pedagogy can be achieved. This led Alexandre – at the time a mathematics teacher in a Portuguese school – to find in the work of Baldino and Tânia elements to understand his everyday reality. For the first time Alexandre saw a lucid account of the sociopolitical problems he was experiencing as a teacher. While mathematics education research was roughly divided between a ‘didactical’ approach, with no social or political concerns whatsoever, and a ‘postmodern’ approach, with its emphasis on discourse and

power relations, Baldino and Cabral were using old Marxist categories to analyze their work as mathematics teachers at the university (e.g., Baldino, 1998a, 1998b; Baldino & Cabral, 2006).

Their research spoke to Alexandre because he felt in their work an attempt to show the “shit” (Pais, 2015) involved in schooling, instead of trying to disguise it through the report of successful experiences which teachers find difficult to associate with their practice. Indeed, the reader will have to search hard to find in Baldino and Tânia’s research one example of a successful experience. This is because they are not talking from above to an arranged classroom (where someone else is doing the work of teaching). They are researching their own teaching and, as such, cannot afford to play the narcissistic game that so often populates mathematics education research (see, for instance, Pais, 2017).

One can say that Baldino and Tânia anticipated what is now known as the “social turn” in mathematics education. Studies within this vein emphasize the importance of considering how what is happening in a classroom depends on the entire social, cultural and political frame. These studies highlight the importance of “social interactions” and the role of “culture” when learning mathematics; they also raise broader issues of equity and social justice in accessing mathematics education (Gutiérrez, 2013; Sriramann & English, 2010). A problem with these studies however, is their disavowal of the *economy* when addressing the question of failure in school mathematics (Pais, 2014).

Despite the diversity of studies animating the social turn, what binds them is the rejection of a central organizing principle, which takes into account how schools manifest the totality that capitalism is today. In a postmodern research-world, it is not easy for researchers to posit capital as the “concrete universal” of our times (Baldino & Cabral, 2018). To do so, will imply a questioning of not only the structures and actors that exercise damaging influence on school mathematics (governmental policies, discourses, etc.) but also a questioning of our own role worsening what we intend to improve (Pais, 2015). In what follows we briefly present what can be considered the main principles of SAM.

SAM’s birth scenario

Here, we briefly describe the political context where SAM was born so that the reader can understand why we say that this methodology is an intervention in an elitist undergraduate teaching context and how it is an understanding-in-action of a system which is inherently thwarted.

In 1972, under the military dictatorship, the Brazilian economy was growing steeply, an illusion that did not last long. In that scenario, students’ meetings were strictly forbidden, many professors had been expelled from universities, some students were killed in demonstrations, others disappeared, the press was under control and observers disguised as students watched every classroom. In 1969, a university reform had opened access to underprivileged students to higher education. A radical elite expected that failure, especially in calculus courses, would push these newcomers out. Most teachers developed personal strategies to accommodate the situation. People engaged in SAM¹ called the prevailing exclusionary pedagogy, *current traditional teaching* (CTT).

¹ Mainly, Charles Guimarães and his group.

According to the military, teachers were supposed to speak for the entirety of the class, and the students should listen quietly. Teachers of CTT dedicated their attention to stimulating stronger students while passing the weaker ones who had not learned enough, based on criteria tinted with social and ethnical prejudice; for instance, manners and speech associated with those of the upper class counted as hidden subsidiary criteria. As a consequence, CTT stimulated rote learning and enabled students' to gain credit without learning.

Implementing an alternative pedagogy became an urgent political issue to those who opposed the regime. Baldino tried to approach the students who were repeatedly failing in the two mid-terms and one final exam each semester. However, the prompt answers of the academically successful elite presented an obstacle when he tried to address the difficulties of these students, e.g. by offering simpler questions during class. Extra class activities were monopolized by questions from the mathematically stronger students. His attempts to reduce the number of students per class had little support from the administration and faced considerable opposition from the leading students.

SAM's pedagogy

There is much literature on pedagogy and didactics but the meaning of these terms is not always clear. In order to develop SAM as a pedagogy of intervention, we must say that, by pedagogy we refer to the institutional conditions designed to engage the students with the learning task, mostly through what Vinner (1997) called the *credit system*. We acted on these conditions introducing rules to get credit in group work. These so-called norms of SAM were developed over a decade. Each semester began with a description of the rules adopted in the previous one, followed by a report of defective results. Then, a modification of the rules was suggested and a question was made: does anyone have a better idea? We finally arrived at a stable set of norms to include assessment of classroom work as a promotional criterion leading to credit, thereby distinguishing SAM from other pedagogies based on assessment. These norms provided us with the necessary empowerment to face the disruptive elite. They allowed contact with weaker students during classes, without harm to stronger students, and with all students separated into ability groups. In this way, SAM became an efficient instrument to rebuff disruption or the monopolization of classes by the radical elite. SAM intervened in CTT by, on the one hand, culturally rewarding underprivileged students according to what they could give, namely work and, on the other hand, constraining the white-male elite to submit to the classroom organization.

Basically SAM conflates effort-based with content-based promotional criteria. The class is organized into groups of four; the students are expected to engage in the task of solving *and understanding* the solution of assigned exercises. SAM norms, under the form of a work contract, are presented in the first class; after a two or three weak clearance trial they are put to a vote, against CTT. Generally the supporters of SAM prevail. Before asking for help, the group must decide what they are going to ask. In case of divergence in the group, each student must report the point of view of the other. The group must work together on each exercise and never pass to the next without showing understanding of the solution of the former. If everything goes well, the group receives credit points proportional to the duration of the work. *Only effort, not content progress counts at this moment.* These points count as a bonus to be added to the grades obtained in the classical CTT summative assessment represented

by individual exams. Individual disruption of the norms, count negatively *to the whole group*; group disruption of general classwork, such as failure to be silent at collective moments, count negatively *to the whole class*. Cases of disruption are reported in the fifteen-minute final plenary session occurring after each one-hundred minute class.

Difficulties with implementing this strategy in the classroom can be addressed, provided that we recognize the differential progress of different ability groups and adjust our help accordingly, formulating different questions to different groups. The organization of the SAM classroom is further discussed in Baldino (1998a), and Baldino and Cabral (1999, 2010). The content progress made in each class, is what we call *understanding* and how operational and preferential this understanding will be in the next class, is what we call *learning*. SAM was developed under the supposition that understanding implies learning. However, along the way we have found out that this is not necessarily so (Baldino & Cabral, 2005). We tell the students that we can assure understanding, but learning is a result of their attitude with respect to the discipline, the university and, in general, to life.

It soon became clear that opposition to SAM was not only an “educational” questioning, but a truly *political* one. We are not advancing *effort-based promotion* as the solution to the segregation problem, but these questions force us to examine the promotional criteria used in CTT—how do we, as teachers, arrive at a “grade” that is supposed to condense everything that the student did during a certain period of time? Once we take up such political questions, new ones emerge. What criteria do we have to impart credit to some students and deny it to others? What are the consequences of our denial to the life of a particular student? Should we base our promotional criterion exclusively on assessment of content progress? Are we allowed to take our own classrooms as objects of research, introducing unexpected changes? SAM has been considering such question since the 1980s (e.g., Baldino & Cabral, 1989).

SAM’s psychoanalytical slant

From first pioneering report (Baldino, 1997) to the recent presentation in MES 10 (Cabral & Baldino, 2019a), our work (see below) reports the results of our classroom practice based on SAM, and is mainly concerned with economy and psychoanalysis. Here, we only have space for a brief discussion.

“You teach when you listen, and you learn when you talk.” This motto calls up the vast literature that posits the student as constructor of her own learning and holds that the teacher’s role is to formulate questions, not to give answers. Relying on Lacanian psychoanalysis, SAM reformulates some meanings of progressive pedagogy. Within SAM, ‘making questions’ in a situation of individual tutoring, means driving the student into *contradiction*. ‘Listening’ means to let oneself be hypnotized by what the student says, in an “upside-down hypnosis” (Lacan, 1973, p. 245). ‘Not giving answers’ means to follow up the student’s saying with new questions, to keep the focus of the initial contradiction until she perceives what irreducible signifier she was attached to. Finally, ‘talking’ refers to the student’s expression of her new understanding.

SAM adapts the directives of the clinic to the classroom through the concept of *pedagogical transference* (Cabral, 1998), where the teacher controls the level of anxiety by opening and closing the lack of understanding that the student perceives with respect to mathematics. The teacher assumes a special position, called the *Other’s position*, in such a way as to suggest that she may also have a

mathematical lack. When the teacher listens, the student cannot figure out whether he is just trying to understand what she says or whether he is trying to take time to think. SAM seeks to assure the student that she will not find in this Other, the fulfillment of the lack that would allow her to pass (gain credit) using rote learning. The teacher endeavors to keep the student's fault open, leading her to ask herself: *Did I understand? What do I really want?*

In fact, anxiety emerges when the student presupposes that this lack may lack, that is, when she evaluates that she has actually understood; in this case she becomes vulnerable: what if in her next answer the lack is filled with a negative teacher's verdict? The teachers' listening is selective, but sufficient to detect signs of anxiety in the student's gestures and speech. Negative individual verdicts should be avoided and replaced by further questions, otherwise they may cause unbearable anguish. The organization of the classroom into ability groups is fundamental in SAM: a negative verdict which addresses a common mistake made by the whole group, produces coalition and positive excitement instead of anxiety.

If, on the contrary, the teacher hides his own lack behind a position of *subject supposed to know* and provides ready-made explanations, he obliterates both lacks, his and the student's. From this position, he produces the illusion that the student understood and he denies the student the opportunity to face her ghosts and develop her own *savoir* about her learning process. She has no chance to come to "love maths anxiety" (Baldino & Cabral, 2008).

SAM is a way of sustaining the student's lack and accepting her initial position of not wanting to know about a *savoir* that she actually detains. She asks *may I do this? We answer if it is right you may, if it is wrong you may not; let us check it.* This is how SAM allows the student to learn by speaking and the teacher to teach by listening. The word has a high value for the speaker; it is important to the student to be sure that she will be listened carefully. SAM has allowed us to approach the student's ignorance regarding his preferential ways of justifying mathematics that expose her cognitive difficulties.

The economic issue: school opposition and resilience

A discussion of the valorization of effort instead of content is virtually absent from mathematics education research. Typing <"reward effort" "mathematics education" calculus> into Google shows 70 entries, none of which thoroughly discusses, much less advocates rewarding effort. Summative assessment is highly underrepresented in the literature (Cabral & Baldino, 2019b), not even in the Routledge yearbook 2017: Assessment inequalities. As an exception, the possibility of rewarding effort appears *en passant* in Jablonka (2017) as though in a devaluated rise. The system demands that measuring achievement be the only promotional criterion. SAM provides a way to teach inside the system, but not "according" to the system. It is bound to face opposition.

We assign the reason for the absence of effort rewarding studies in mathematics education to the need to *cover up that school is an economic enterprise where the production of qualified-labor-power threatens to become evident* (Baldino & Cabral, 2013). In this sense, the usual requirement of reviewing literature in this eight-page article would cut the space for presenting the new and would corroborate the cover up.

Although a student can spend an entire year in school, going to classes, participating in all the regular activities, if after everything she does not get a certificate, she will not receive anything for all the work she did. On the contrary, those who get the diploma may vaunt their merit of having superseded those who failed. As a commodity, qualified-labor-power has to be sold in the market for higher salaries, otherwise the investment would not be worthwhile. From this perspective, failure is necessary for school functioning, as argued by Baldino and Cabral (1998, 2013). It is because some of us fail that others can achieve higher positions in social hierarchies. The value produced by the ones who flunk is appropriated by the ones who pass. This is the scandal that SAM-in-action threatens to reveal.

The years to come

The dialectical movement that has generated SAM and CTT as opposite poles goes on today in a wide scenario. The hippy movement of the sixties was the first sample. Not only does capitalism penetrate all pores of private life, but it also offers advance role scripts for its eventual opponents (Baldino & Cabral, 2018). What this sort of late capitalism cannot admit to is the demonstration of the dialectical movement from which it emerges as one of the poles. It has to present itself as the only natural truth. In particular, it cannot admit that school is an economic enterprise producing qualified-labor-power. It must hide its truth under a thick layer of priestly teaching and ‘helpful’ mathematics education research that we call CTT.

Therefore, research in SAM for the years to come should aim at eliciting such dialectical movement. SAM is an intervention into capitalist schooling that defines itself in opposition to CTT. Nevertheless, it is not a cosmology or a formula on how school should be. We are not implying that literature on assessment must move beyond content progress evaluations. SAM is not intended to replace CTT; insofar as this could happen, SAM would lose its *raison d’être*. Contrarily to globalized liberal capitalism, SAM recognizes itself as one of the poles generated by the same dialectical socio-historical movement.

Acknowledgement: We thank our colleagues Laura Black and David Kolloche for the superb and detailed review work with comments that improved the manuscript.

References

- Baldino, R. R. (1997). Students strategies in solidarity assimilation groups. In V. Zack, J. Mousley, & C. Breen (Eds), *Developing Practice: Teacher’s inquiry and educational change* (pp. 123–134). Geelong: Deakin University.
- Baldino, R. R. (1998a). Escola, mais-valia e consciência cínica. *Educação em Foco*, 3(1), 39–65.
- Baldino, R. (1998b). School and surplus-value: Contribution from a third-world country. In P. Gates (Ed.), *Proceedings of the First International Conference on Mathematics Education and Society* (pp. 73–81). Nottingham: Centre for the Study of Mathematics Education.
- Baldino, R. R., & Cabral, T. C. B. (1989). O professor de matemática e a seleção chamada avaliação. *Boletim do GEPEM*, 24, 41–54.

- Baldino, R. R., & Cabral, T. C. B. (1998). Lacan and the school credit system. In A. Olivier & K. Newstead (Eds.), *Proceedings of the 22nd Conference of the International Group for the Psychology of Mathematics Education* (Vol. 2, pp. 56–63). Stellenbosch: University of Stellenbosch.
- Baldino, R. R., & Cabral, T. C. B. (1999). Lacan's four discourses and mathematics education. In O. Zaslavsky (Ed.), *Proceedings of the 23rd Conference of the International Group for the Psychology of Mathematics Education* (Vol. 2, pp. 57–64). Haifa: Technion.
- Baldino, R. R., & Cabral, T. C. B. (2005). Situations of psychological cognitive no-growth. In H. L. Chick & J. L. Vincent (Eds.), *Proceedings of the 29th Conference of the International Group for the Psychology of Mathematics Education* (Vol. 2, pp. 105–112). Melbourne: University of Melbourne.
- Baldino, R. R., & Cabral, T. C. B. (2006). Inclusion and diversity from Hegel-Lacan point of view: Do we desire our desire for change? *International Journal of Science and Mathematics Education*, 4(1), 19–43.
- Baldino, R. R., & Cabral, T. C. B. (2008). I love maths anxiety. In T. Brown (Ed.), *The psychology of mathematics education: A psychoanalytical displacement* (pp. 61–92). Rotterdam: Sense.
- Baldino, R. R., & Cabral, T. C. B. (2013). The productivity of students' schoolwork: An exercise in Marxist rigour. *The Journal for Critical Educational Policy Studies*, 11(4), 70–84.
- Baldino, R. R., & Cabral, T. C. B. (2018) Mathematics education and the juggernaut of capitalism. *The Mathematics Enthusiast*, 15(1), 178–200.
- Baldino, R. R., & Carrera, A. C. (1999). Action research: Commitment to change, personal identity and memory. In O. Zaslavsky (Ed.), *Proceedings of the 23rd Conference of the International Group for the Psychology of Mathematics Education* (Vol. 2, pp. 65–72). Haifa: Technion.
- Cabral, T. C. B. (1993) *Vicissitudes da aprendizagem em um curso de cálculo* (Master's thesis). Universidade Estadual Paulista, Rio Claro, Brazil.
- Cabral, T. C. B. (1998) *Contribuições da psicanálise à educação matemática. A lógica da intervenção didática em processos de aprendizagem* (Doctoral dissertation). University of São Paulo, São Paulo, Brazil.
- Cabral, T. C. B. & Baldino, R. R. (2010). Educação matemática conversando com psicanálise. *ZETETIKÉ*, 18, 621–652.
- Cabral, T. C. B. (2015). Metodologias alternativas e suas vicissitudes: Ensino de matemática para engenharias. *Perspectivas da Educação Matemática*, 8(17), 208–245.
- Cabral, T. C. B., & Baldino, R. R. (2019a). The social turn and its big enemy: A leap forward. In J. Subramanian (Ed.), *Proceedings of the Tenth International Mathematics Education and Society Conference* (pp. 32–46). Hyderabad: MES10.
- Cabral, T. C. B., Baldino, R. R., (2019b). The credit system and the summative assessment splitting moment. Unpublished manuscript.
- Gluz, J. C., Cabral, T. C. B., Baggio, P. E., Livi, P. F. C., & Mallmann, R. M. (2008). Pedagogical negotiation and solidarity assimilation group in action: The combined efforts of E-M@T and Leibniz

- to aid calculus students. In R. M. Viccari, P. A. Jaques, & R. Verdin (Eds.), *Agent-based tutoring systems by cognitive and affective modeling* (pp. 260–291). Hershey: Information Science Reference.
- Gutiérrez, R. (2013). The sociopolitical turn in mathematics education. *Journal for Research in Mathematics Education*, 44(1), 37–68.
- Jablonka, E. (2017). Gamification, standards and surveillance in mathematics education: An illustrative example. In A. Chronaki (Ed.), *Mathematics education and life at times of crisis: Proceedings of the Ninth International Mathematics Education and Society Conference* (Vol. 2, pp. 544–553). Volos: MES9.
- Lacan, J. (1973). *Le séminaire, livre XI : Les quatre concepts fondamentaux de la psychanalyse, 1964*. Paris: Éditions du Seuil.
- Pais, A. (2011). *Mathematics education and the political: An ideology critique of an educational research field* (Doctoral dissertation). Aalborg University, Denmark.
- Pais, A. (2014). Economy: The absent centre of mathematics education. *ZDM Mathematics Education*, 46(7), 1085–1093.
- Pais, A. (2015). Symbolising the real of mathematics education. *Educational Studies in Mathematics*, 89(3), 375–391.
- Pais, A. (2017). The narcissism of mathematics education. In H. Straehler-Pohl, N. Bohlmann, & A. Pais (Eds.), *The disorder of mathematics education* (pp. 53–63). Cham: Springer.
- Persad, V. R. (2014). *Mathematics, mathematicians, and desire* (Doctoral dissertation). Simon Fraser University, Burnaby, United States.
- Silva, M. R. G. d. (1997). *Avaliação e trabalho em grupo em Assimilação Solidária: Análise de uma intervenção* (Doctoral dissertation). São Paulo State University, Rio Claro, Brazil.
- Sriraman, B. & L. English (Eds.). (2010). *Theories of mathematics education: Seeking new frontiers*. Berlin: Springer.
- Vinner, S. (1997). From intuition to inhibition: Mathematics education and other endangered species. In E. Pehkonen (Ed.), *Proceedings of the 21th Conference of the International Group for Psychology of Mathematics Education* (Vol. 1, pp. 63–78). Helsinki: Lahti Research and Training Centre.

Assessing students' perceptions of democratic practices in the mathematics classroom

Wajeih Daher

An-Najah National University, Faculty of Educational Sciences, Nablus, Palestine;

wajeihdaher@gmail.com

Though there exists considerable literature exploring the connections between mathematics education and democratic society, much of this literature is theoretical about what could or should occur. This situation has led some researchers to call for the development of empirical research regarding democratic practices in the mathematics classroom. This paper attempts to advance quantitative empirical research in this area by presenting a questionnaire that examines students' perceptions of four democratic factors: freedom, engagement, equality and justice. The proposed questionnaire is factorable and explains 58.72% of the variance of a more general democracy score. The questionnaire was distributed to 398 ninth grade students, and the data collected was analyzed by computing a one sample t-test to assess participants' scores in relation to the four democratic factors. The results indicated scores are 'less than the good'.

Keywords: Democratic practices, mathematics classroom, questionnaire

Introduction

Democratic teaching practices may have a positive influence on students' learning outcomes in the mathematics classroom. This may be because successful democratic teaching and learning is conceived as situations where individuals are able to think for themselves, judge independently, and discriminate between good and bad information (Dewey as in Orrill, 2001). Therefore, it is desirable or necessary to enact democratic practices in the mathematics classroom. In addition, such democratic practices need to be assessed to ensure they are appropriately implemented, and to see if they influence specific variables of students' mathematics learning positively (e.g. emotions). One way to assess democratic teaching and learning practices and their relation with other variables is through quantitative methods, with a questionnaire as the main tool. The present research tries to do this and presents a questionnaire to assesses four democratic practices: freedom, equality, engagement and justice in the mathematics classroom.

Research goals and rationale

Vithal (1999) argues that the literature exploring connections between mathematics education and democratic society is generally theoretical, which indicates the need for research that studies what happens actually in the mathematics classroom regarding this link. Aguilar and Zavaleta (2012) agree with Vithal and point to the need for empirical studies to test and expand such theoretical ideas. The present research offers one step towards providing such empirical research, in that it offers a questionnaire to assess students' perceptions of democratic practices relating to four democracy components: Freedom, engagement, equality and justice. It does so in the context of the Palestinian ninth grade mathematics classroom.

Literature review

Democracy in general is described as consisting of distinct components. Kesici (2008) found that teachers, who adopted democratic practices, talked about democratic classrooms where fair behaviors are demonstrated towards students, students' range of personal freedom is enlarged, and students are provided with equality of opportunity. Thus, Kesici (2008) presents three categories of democracy: fairness, freedom and equality, where fairness can be related to justice and freedom and equality can be related to equity which includes the consideration of individual needs. Regarding equality, Kesici (2008) emphasizes that equality does not mean that teachers should treat all students the same way, but they should give equal opportunity to all students, so to meet their needs.

Democracy in the mathematics classroom

Aguilar and Zavaleta (2012) identified three links between mathematics education and democracy. Firstly, mathematics education can provide students with the skills to analyze critically real life phenomena. Second, the mathematics classroom can encourage values and attitudes essential to building and sustaining democratic societies. Third, mathematics education can function as a social filter that restricts students' opportunities for development and civic participation.

The possible links between mathematics education and democracy have attracted the attention of mathematics education researchers for at least three decades, where different aspects of teaching and learning practices have been studied in the mathematics classroom. Some of these aspects are: authority (Amit & Fried, 2005), students' voice (Daher, 2017; Kaur, Anthony, Ohtani, & Clarke, 2013), the right to equal access to mathematical ideas (Allen, 2011; Ellis & Malloy, 2009), promoting equality (Croom, 1997), promoting democracy (Allen, 2011; Ellis & Malloy, 2009), diversity of curriculum and classroom (Ellis & Malloy, 2009), revisiting old ideas in new ways (Ellis & Malloy, 2009), dialogue (Ball, Goffney, & Bass, 2005; Skovsmose, 1998), proving (Almeida, 2010; Skovsmose, 1998), and engaging in ethnomathematics (Ball et al., 2005; Skovsmose, 1998). This literature has indicated the complexity of the construct of 'democratic practice' in teaching and learning mathematics, which indicates the need for an assessment tool to better understand this construct.

Assessing democratic practices in the classroom

Educational researchers have offered various questionnaires to assess democratic practices in the classroom (Daher & Saifi, 2018; Kubow & Kinney, 2000). For instance, Ahmad, Said, and Jusoh (2015) designed a questionnaire to assess the relationship between democratic classroom practices and students' social skills development. In addition, the tools used to collect data related to democracy in the mathematics classroom have included open ended questions (Daher, 2012) and questionnaires with Likert items (Bulut & Yilmaz, 2014). The questionnaire suggested by Bulut and Yilmaz (2014) consists of a single scale to assess democratic practice. In the present research we suggest a questionnaire that offers multiple factors relating to democratic teaching and learning practices described in the literature.

Methodology

Research context and sample

398 Grade 9 students participated in the research. The distribution of these students according to gender and level in math is described in Table 1.

		Level in math					Total
		Poor	acceptable	good	very good	Excellent	
Gender	male	41	34	33	22	10	140
	female	59	65	76	52	6	258
Total		100	99	109	74	16	398

Table 1: The distribution of the sample according to gender and level in math

The descriptive statistics of the questionnaire items are given in Table 2.

Item	M	SD	Skew
We can express ourselves freely in the mathematics lesson.	2.84	1.35	.19
We can express our opinion regarding the teacher's presentation.	2.67	1.30	.32
We can express our opinion regarding the teacher's solution methods.	2.70	1.29	.32
We can give different solution methods for a mathematical problem.	2.55	1.47	.281
We can give a faulty solution method for a mathematical problem.	2.46	1.30	.77
The mathematics teacher does not give additional time for solving problems.	3.62	1.34	-.66
The mathematics teacher ignores some students' discussions.	3.39	1.46	-.37
The mathematics teacher does not give the same time to all students to answer questions.	3.08	1.40	-.01
The mathematics teacher does not give the same time to all students during discussions.	3.16	1.31	-.07
The mathematics teacher does not give different solutions to accommodate differences between individual students.	2.92	1.53	.11
The mathematics teacher ignores some students' solutions.	3.41	1.41	-.35
The mathematics teacher encourages us to give new mathematical ideas.	2.58	1.29	.48
The mathematics teacher encourages us to justify our mathematical ideas.	2.48	1.29	.45
The mathematics teacher encourages us to give different answers to a mathematical question.	2.50	1.46	.52
The mathematics teacher encourages us to engage in mathematical discussions.	2.30	1.26	.73
The mathematics teacher encourages us to ask questions.	2.25	1.24	.62
The mathematics teacher does not clarify the reasons for giving marks on the mathematics exam.	3.34	1.20	-.14
I cannot have explanations in the mathematics classroom on the issues that I have not understood.	3.69	1.25	-.61

Table 2: Means, standard deviations and skewness of the questionnaire items (N=398)

Analysis method of the level of democratic behavior scores in the Palestinian ninth grade

To calculate democracy mean scores for the students participating in the research, we computed first grouped frequency distributions (Stockburger, 1998). Then we compared the resulting democracy mean scores with a 'good democracy score' and a 'normal democracy score'. We computed the normal democracy score by dividing 4 by 5 (4 items divided by 5 possible scores where 1 is the lowest score of any item, and 5 is the highest). This resulted in 0.8 which was used to calculate intervals on a scale presented in Figure 1. We considered point (1.8) to be a 'low democracy score', (2.6) to be a 'normal democracy score' and (3.4) to be a 'good democracy score' on this scale. Thus, the scores between 1 and 1.8 were considered 'very low democracy scores', the scores between 1.8 and 2.6 'low democracy scores', the scores between 2.6 and 3.4 'normal democracy scores', the scores between 3.4 and 4.2 'good democracy scores', and the scores between 4.2 and 5 'very good democracy scores'.

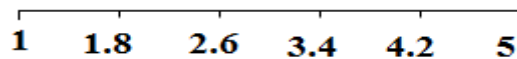


Figure 1: Intervals related to the democracy scores of any item

To compare the students' mean scores with the 'normal democracy score' and the 'good democracy score' we used a one-sample t-test and compared with the appropriate democracy value.

Results

Initially, the factorability of the 18 democracy items was examined. Several well recognized criteria for the factorability of a correlation were used. Firstly, it was observed that all the items correlated at least .3 with at least one other item, suggesting reasonable factorability. Secondly, the Kaiser-Meyer-Olkin measure of sampling adequacy was .89, above the commonly recommended value of .6, and Bartlett's test of sphericity was significant ($\chi^2(153) = 2562.90, p < .001$). The diagonals of the anti-image correlation matrix were also all over .5. Finally, the communalities were all above .4, further confirming that each item shared some common variance with other items. Given these overall indicators, factor analysis was deemed to be suitable with all 18 items.

Table 3 presents factor loadings based on rotated principal components analysis with Oblimin rotation for 18 items from the above scale (N = 218).

Principal component analysis was used because the primary purpose was to identify and compute composite scores for the factors underlying the scale. Initial eigenvalues indicated that the first four factors explained 33.56%, 9.96%, 7.81% and 7.39% of the variance respectively. The fifth factor had an eigenvalue 5.02, while the other factors (from the sixth to the eighteenth) explained less than 4% of the variance.

Our adoption of the four-factor model depended on the results of the principal factor analysis, including the total-variance-explained table and the scree plot (see Figure 2 below). There was little difference between the four-factor Varimax and Oblimin solutions, thus both solutions were examined in subsequent analyses before deciding to use a Varimax rotation for the final solution. According to this solution, the four factors explained 58.724% of the variance in the democracy scores.

Item	Component			
	F	En	Eq	J
We can express our opinion regarding teacher's presentation.	.78			
We can express our opinion regarding the teacher's solution methods.	.75			
We can express ourselves freely in the mathematics lesson.	.74			
We can give different solution methods for a mathematical problem.	.74			
We can even give a faulty solution method for a mathematical problem.	.47			
The mathematics teacher encourages us to justify our mathematical ideas.		.75		
The mathematics teacher encourages us to engage in mathematical discussions.		.73		
The mathematics teacher encourages us to ask questions.		.72		
The mathematics teacher encourages us to give new mathematical ideas.		.71		
The mathematics teacher encourages us to give different answers to a mathematical question.		.68		
The mathematics teacher does not give the same time to all students to answer questions.			.77	
The mathematics teacher does not give the same time to all students during discussions.			.77	
The mathematics teacher does not give different solutions to accommodate differences between individual students.	-.45		.63	
The mathematics teacher ignores some students' discussion.			.60	
The mathematics teacher ignores some students' solutions.			.54	
The mathematics teacher does not clarify the reasons for giving marks on the mathematics exam.				.77
I cannot have explanations in the mathematics classroom on the issues that I have not understood.				.72
The teacher gives additional time for solving.				-.49

Table 3: Factor loadings based on Oblimin-rotated principal components analysis (N=398), F=Freedom, En=Engagement, Eq=Equality, J=Justice

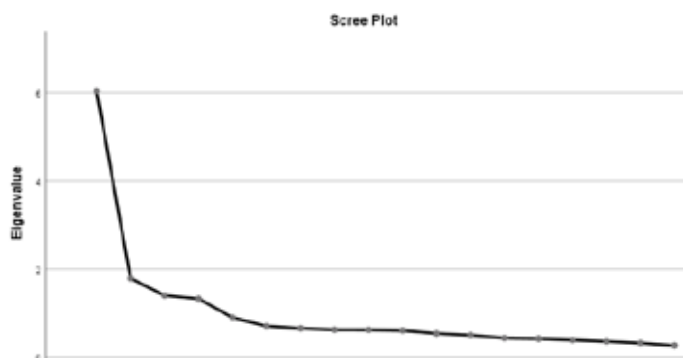


Figure 2: Scree Plot of the items factorization

Validity and reliability analysis

Validity and reliability analyses were performed for the four factors. To ensure validity, the first-version of the questionnaire was presented to experts in mathematics education or in the social aspect of learning to analyze it and thus verify its validity for data collection. After this analysis, the necessary corrections were made to the scale in accordance with their comments, which gave the present 18-item 5-point Likert type rating scale. To ensure reliability, Cronbach's Alpha was computed for each of the four democratic factors. This computation gave .81 for Freedom, .82 for Engagement, .78 for Equality, and .54 for Justice. These reliability results indicate good reliability for the constructs: freedom, engagement, and equality (Field, 2009) because these reliabilities are around .80. However, the reliability of justice is not sufficient, and we suggest the need to add additional items to the questionnaire in order to improve the reliability of this construct (Field, 2009). The Cronbach Alpha computation for the whole questionnaire is .88 which indicates high reliability.

Level of democratic practices in Palestinian middle schools

To assess the level of democratic practices in the Palestinian mathematics classrooms, we computed means and standard deviations for the four factors: freedom, engagement, equality, justice s. We also conducted a one-sample t test to assess the statistical significance of the variation of each factor with a low, normal and good level of democratic practice (see Table 4).

Component	M (SD)	T value		
		Low	Normal	Good
Freedom	2.64 (1.01)	16.60**	0.87	
Engagement	2.42 (1.00)	12.34**	-3.58**	
Equality	2.81 (2.04)		3.97**	-11.40**
Justice	2.45 (0.91)	14.22**	-3.26**	
General democracy	2.59 (0.77)	20.54**	-.135	

Table 4: Level of democratic practices in the Palestinian mathematics classrooms (N=398), ** p<.000

Discussion and conclusions

Empirical research regarding democratic practices in the mathematics classroom is still in its infancy. One way to develop such empirical research is to develop quantitative tools, such as questionnaires, to assess the level of democratic practice in mathematics classroom. The present research offers a questionnaire that assesses four democratic factors: freedom, engagement, equality and justice. These four constructs/factors explain 58.72% of the variance in the overall democracy score across our sample. Previous research, using questionnaires to assess democratic practice has suggested one scale consisting of only one factor that explains 47.701% of the variance of an overall democratic score. I argue that a scale with four factors addresses the concerns regarding scales with only one or two factors, which may not provide an accurate representation of the construct (Pett, Lackey & Sullivan, 2003). Also, further democracy constructs, such as autonomy and decision making, could also be assessed in future research.

The questionnaire suggested in the present research may help researchers study the level of democratic practice in mathematics classrooms. Here, I used the suggested questionnaire to examine the democratic practices in Palestinian ninth grade mathematics classrooms. The results indicate that the level of democratic practice in this context is less than good. There may be various reasons that explain this level of democratic practice, such as authoritarian styles of teaching by teachers (Ramahi, 2015). These authoritarian styles cannot foster critical or independent thinking, which may impact negatively the future functioning of students. In addition, the ‘less than good’ level of democratic practice may be a result of students’ and teachers’ limited awareness of the student’s right to a democratic space in the mathematics classroom.

The present research indicates the need to improve the level of democratic practice in the Palestinian mathematics classroom. This could be done by different means. First, by holding workshops for mathematics teachers with the goal to increase their awareness of democracy factors and discuss with them ways to increase democracy in their classrooms. These workshops need to be based on pedagogic approaches that enhance student agency and voice, foster creative and critical thinking, and enable students to collaborate, share their mathematical ideas, and negotiate their decisions regarding their mathematical learning (Daher, 2017; Ramahi, 2015). Moreover, these workshops need to be supported by the ministry of education as it calls for inclusive education in the schools (Ministry of Education & Higher Education, 2015). Second, special emphasis needs to be put on enhancing students’ awareness of their democratic rights. These workshops to advance democratic practices in the Palestinian context could benefit from similar attempts around the world (see, e.g., Varnham, Evers, Booth, & Avgoustinos, 2014).

References

- Aguilar, M. S., & Zavaleta, J. G. M. (2012). On the links between mathematics education and democracy: A literature review. *Pythagoras*, 33(2), Art. 164.
- Ahmad, I., Said, H. & Jusoh, A. (2015). Empirical evidence on the relationship between democratic classroom and social skills development of students. *Mediterranean Journal of Social Sciences*, 6(2), 18–27.
- Allen, K. (2011). Mathematics as thinking: A response to ‘Democracy and school math’. *Democracy & Education*, 19(2), 1–7.
- Almeida, D. F. (2010). Are there viable connections between mathematics, mathematical proof and democracy? *Philosophy of Mathematics Education Journal*, 25.
- Amit, M., & Fried, M. (2005). Authority and authority relations in mathematics education: A view from an 8th grade classroom. *Educational Studies in Mathematics*, 58(2), 145–168.
- Ball, D. L., Goffney, I. M., & Bass, H. (2005). The role of mathematics instruction in building a socially just and diverse democracy. *The Mathematics Educator*, 15(1), 2–6.
- Bulut, I., & Yilmaz, F. (2014). The relationship between mathematics teachers’ democratic behavior and students’ mathematic success. *International Online Journal of Educational Sciences*, 6(3), 626–637.

- Croom, L. (1997). Mathematics for all students: Access, excellence, and equity. In J. Trentacosta (Ed.), *Multicultural and gender equity in the classroom* (pp. 1–9). Reston, VA: NCTM.
- Daher, W. (2012). Student teachers' perceptions of democracy in the mathematics classroom: Freedom, equality and dialogue. *Pythagoras*, 33(2), Art. 158.
- Daher, W. (2017). Student voice in the mobile phone environment. *International Journal of Mobile and Blended Learning*, 9(3), 12–23.
- Daher, W., & Saifi, A. (2018). Democratic practices in a constructivist science classroom. *International Journal of Science and Mathematics Education*, 16(2), 221–236.
- Ellis, M. & Malloy, C. E. (2009). Preparing teachers for democratic mathematics education. In D. Pugalee, A. Rigerson, & A. Schinck (Eds.), *Proceedings of the Mathematics Education in a Global Community Ninth International Conference* (pp. 160–164).
- Field, A. (2009). *Discovering statistics using SPSS*. London: Sage.
- Kaur, B., Anthony, G., Ohtani, M., & Clarke, D. J. (Eds.) (2013). *Student voice in mathematics classrooms around the world*. Rotterdam: Sense.
- Kesici, Ş. (2008). Teachers' opinions about building a democratic classroom. *Journal of Instructional Psychology*, 35(2), 192–203.
- Kubow, P. K., & Kinney, M. B. (2000). Fostering democracy in middle school classrooms: Insights from a democratic institute in Hungary. *The Social Studies*, 91(6), 265–271.
- Ministry of Education & Higher Education (2015). *Palestine inclusive education policy*. Ramallah, Palestine.
- Orrill, R. (2001). Mathematics, numeracy, and democracy. In L. A. Steen (Ed.), *Mathematics and democracy* (xiii–xx). Princeton, NJ: National Council on Education and the Disciplines.
- Pett, M., Lackey, N., & Sullivan, J. (2003). *Making sense of factor analysis*. Thousand Oaks: Sage.
- Ramahi, H. (2015). *Education in Palestine: Current challenges and emancipatory alternatives*. Ramallah, Palestine: Rosa-Luxemburg-Stiftung.
- Skovsmose, O. (1998). Linking mathematics education and democracy: Citizenship, mathematical archaeology, mathemacy and deliberative interaction. *ZDM*, 98(6), 195–203.
- Stockburger, D. W. (1998). *Introductory Statistics: Concepts, Models, and Applications*. Retrieved from <http://www.psychstat.missouristate.edu/introbook/sbk09m.htm>
- Varnham, S., Evers, M., Booth, T., & Avgoustinos, C. (2014). Democracy in schools: Encouraging responsibility and citizenship through student participation in school decision making. *International Journal of Law and Education*, 19(1), 23–41.
- Vithal, R. (1999). Democracy and authority: A complementarity in mathematics education? *ZDM*, 31(1), 27–36.

Diversity, inclusion and the question of mathematics teacher education – How do student teachers reflect a potential-related view?

Timo Dixel¹, [Ralf Benölken](mailto:Ralf.Benolken@uni-wuppertal.de)² and Marcel Veber³

¹University of Münster, Germany; t.dixel@wwu.de

²University of Wuppertal, Germany; benoelken@uni-wuppertal.de

³University of Osnabrück, Germany; marcel.veber@uni-osnabrueck.de

Diversity raises different questions such as how an adequate education of student teachers can be organized in this context. Against the background of a potential-related view, this paper outlines an exemplary concept of an interdisciplinary seminar and an evaluation study about possible impacts reflected by student teachers as barriers in inclusive mathematics teaching. Qualitative data were generated by learning maps in a pre-post-design and analyzed by a reconstructive pedagogic- iconological interpretation. The results indicate that the foundation of the seminar leads to a more complex reflection of student teachers' individual educational paths.

Keywords: Diversity, inclusive mathematics education, teacher education.

Introduction

According to Ainscow (2007), inclusion is seen “as a reform that supports and welcomes diversity amongst all learners” (p. 3). Its aim is to analyze barriers to participation and learning experienced by students within school systems. In some countries, inclusive education is seen as teaching children with disabilities within general education, traditionally by special educators. Slee and Allan (2001), who express their skepticism about inclusion as co-location of pupils, criticized this understanding earlier. There is a similar discourse in Germany: Hinz (2013) states that inclusion moved from ignorance to being unrecognizable, reminding us that inclusion had been ignored by educational science and politics, and now the scientific discourse shifts its attention from inclusion to de-segregation: Instead of focusing on barriers, the individual problems of pupils with special needs and their location in regular schools are discussed. This causes consequences for teacher education: Mathematics teacher education for inclusion is often realized by implementing elements of special education (Werner, 2017), or inclusive mathematics education is reduced to the question of how pupils with special needs learn and what can be done to compensate for their deficits (Krause, 2017). Three problems can be found in this approach: Empirical research showed that marking pupils with special needs is highly influenced by socio-economic status or migration, leading to negative consequences for further schooling and to the potential danger of stigmatization (Sturm, 2016). Secondly, a focus on categories might neglect other children who do not belong in a predetermined category and, therefore, become marginalized (Messiou, 2017). Finally, concentrating on pupils' individual deficits ignores the role of the social and political environment in mathematics education and individualizes failure (Veber & Fischer, 2016). An alternative approach and the framework of this paper is given by viewing inclusion not limited to deficits or categories like gender or social class, but by perceiving individuals' differences as an advantage. We will outline that addressing pupils' differences in this sense of diversity, which we call potential-related, understanding inclusion as a

concept welcoming diversity, and a focus on barriers to participation are suitable frames for mathematics teachers' education (Benölken, Berlinger, & Veber, 2018). In this paper, we address the learning and reflection of student teachers in the context of inclusive mathematics education. Therefore, we do not only describe our attempts on inclusive teacher education but focus on the students attending these courses. The following questions will be investigated: *How can a seminar for student teachers be conceptualized into inclusive mathematics education from a potential-related perspective? How do student teachers reflect on barriers in inclusive mathematics teaching before and after taking part in the seminar?* First, brief overviews of the theoretical frameworks will be given. On these bases, the seminar concept will be outlined. Finally, the design and results of an exploratory study analyzing learning-maps in a pre-post-comparison by applying methods of pedagogic-iconological image interpretation will be subsumed and discussed.

Theoretical framework: A brief overview

Inclusive education demands a positioning in the understanding of 'inclusive'. While most of German mathematics education research regards the concept in the sense of special education, an alternative approach is a potential-related view. Benölken, Berlinger and Veber (2018) identified three axioms of inclusion: (1) The rejection of labels such as 'disabled' or 'dyscalculia' for pedagogical actions is an inherent part of inclusive approaches. It means that differences are produced in contexts and not determined in a static way. Most pedagogical categories emphasize negative aspects and, therefore, reduce people to one dimension of their individuality. Vice versa, a potential-related view focuses on the resources of learners. (2) The traditional German school-system is based on homogeneity, assuming pupils learn better if they visit schools for their specific needs. For example, the *Gymnasium* for supposedly 'intelligent' children or the *Förderschule* for 'disabled' children. Inherent is the assumption that heterogeneity poses an obstacle for successful learning. In contrast, a potential-related view demands to accept and to appreciate differences, which is represented in the term *diversity*. (3) Inclusion has a political approach. It is based on human rights, and it demands for changes in society (Slee & Allan, 2001). The research status on inclusion in German mathematics education is characterized by proposals for inclusive lessons (Häsel-Weide & Nührenbörger, 2017), often using the concept of natural differentiation. There are few concepts that include other aspects such as co-teaching, diagnostics and beliefs (Käpnick, 2016). There tends to be a lack of a theoretical discussion about the principles of inclusive mathematics education. Often, the needs of pupils with difficulties in learning mathematics are discussed to design learning environments; the role of mathematics education itself as a producer of inequality is hereby neglected. The international research on inequality and exclusion has given useful suggestions on reflecting discriminating structures and the influence of mathematics education and its teachers (e.g., Bishop, Tan, & Barkatsas, 2015). Consequently, we think that it is not sufficient to add special needs courses to mathematics teacher education. We suggest *reflexive inclusion* as a promising theoretical construct (Budde & Hummrich, 2013). Reflexive inclusion means both to perceive differences when it is needed and to make discrimination visible, but at the same time a rejection of implicit norms and institutional categorization. In this understanding, reflexive inclusion is an interdisciplinary task of mathematics education, special education and pedagogy. In contrast to other concepts, it is not reduced to the dimension of disability, but framed intersectionally, that is, several dimensions of

diversity act in combination. This understanding meets our axioms and provides the theoretical background of a potential-related view. Thus, it is relevant for student teachers to learn that differences need to be deconstructed when possible, and to recognize discrimination. Furthermore, specific knowledge about pedagogical diagnostics and categories of social inequality such as disability, gender, milieu and such is necessary. Therefore, it is of interest to scrutinize seminar designs, and to explore the development of student teachers' reflection, knowledge or perhaps beliefs on, for example, ex- and including factors.

Survey of a seminar conception

We will outline an exemplary teaching concept (for further details see Benölken, Berlinger, & Veber, 2018). It has proven itself in implementations at the Universities of Münster, Osnabrück, Halle and Kassel as well as at the Pedagogical University Tyrol. It aims at students who have already acquired their first subject-didactic and subject-scientific knowledge. Thus, it requires a level of ambition that enables students to expand and network knowledge already acquired with a focus on the organization of inclusive mathematics lessons. Against the background of interdisciplinary networks, the aim of the seminar is to enable students to plan, reflect and analyze inclusive mathematics lessons. The overarching questions of the seminar sessions can be identified as follows: Which influencing factors must be considered in the design of inclusive mathematics lessons? How can concrete mathematics didactic implementations be identified, and, conversely, do they meet the requirements of inclusive education? The seminar concept approaches these questions with a potential-related understanding of inclusive education. Consequently, various facets that are discussed in the relevant literature concerning the realization of lessons for all children without exclusion are taken into account: Attitudes and experiences, professional competencies in relation to various diversity facets (including facets relevant to special education), diagnostic and methodical spectra, educational framework conditions, social relationships as well as cooperative forms of teaching. In summary, the complex of all presented aspects mirrors a holistic approach to student teachers' education, and they explore single facets of the complex as well as interrelated patterns by research-based learning, that is, by raising relevant questions, developing corresponding concepts and sometimes examining them in greater depth in bachelor and master theses. The organization of the seminar combines usual demands of higher education didactic such as different methods and both traditional and digital media, multifaceted combinations of theoretical contents and authentic practical examples. Additionally, there are supplements of expert lectures (often as 'best practice' information), school visits and workshops, in which student teachers can network and deepen their knowledge. A recurring highlight are discussions about both potentials and possibilities of implementing developed ideas, concepts and findings in inclusive mathematics teaching. In each case it is scrutinized whether work products meet both mathematics educational and inclusive pedagogical postulates of organizing teaching-learning processes.

The study

The study focuses on the *question* how student teachers reflect on barriers in inclusive mathematics teaching before and after taking part in the seminar. The sample consisted of 124 *participants* (101 f., 23 m.), who were primary and secondary student teachers and took part in the study during the

semester in which they attended the seminar. The data originated from implementations of the seminar concept in Münster (between the winter semester 2015/2016 and the summer semester 2017), Osnabrück, and Innsbruck (each in the summer semester 2018). Mostly, the participants were in their first year of undergraduate studies. The study has an explorative character, that is, generalizations were not intended, but existential propositions (Lamnek, 2010). Thus, a qualitative *design* was advisable. As to the *method*, qualitative data were generated by applying learning maps in a pre-post-comparison, which were anonymized by codes to ensure unbiased interpretations. In the maps' header, the student teachers were given the impulse to craft their way between their current status and their future work at schools: "Inclusive education is currently considered as the greatest challenge for teachers. The question arises as to how teachers can structure their specialized instruction in such a way that (really) all children can learn together in order to reach their respective zone of proximal development. This joint learning of all children without exclusion might arise opportunities, challenges, stumbling obstacles and much more. What does this mean to you personally? Which way have you covered or which way will you have to cover in the future? Please lay out your way" (translated from German). All participants designed the maps for the first time, and the maps were created at the beginning of a semester and its end. As to the *analysis*, the pre- and post-maps were compared by a reconstructive pedagogic-iconological image interpretation, following its characteristic steps: (1) Discussion of previous history and selection of key motives, (2) image description and analysis (with regard to the factual, expressive and form-related sense), (3) context analysis, and (4) comparative analysis (Schulze, 2013). The evaluation procedure was piloted in a research workshop with student teachers in the summer semester 2016; afterwards, the analyses were conducted in a research group.

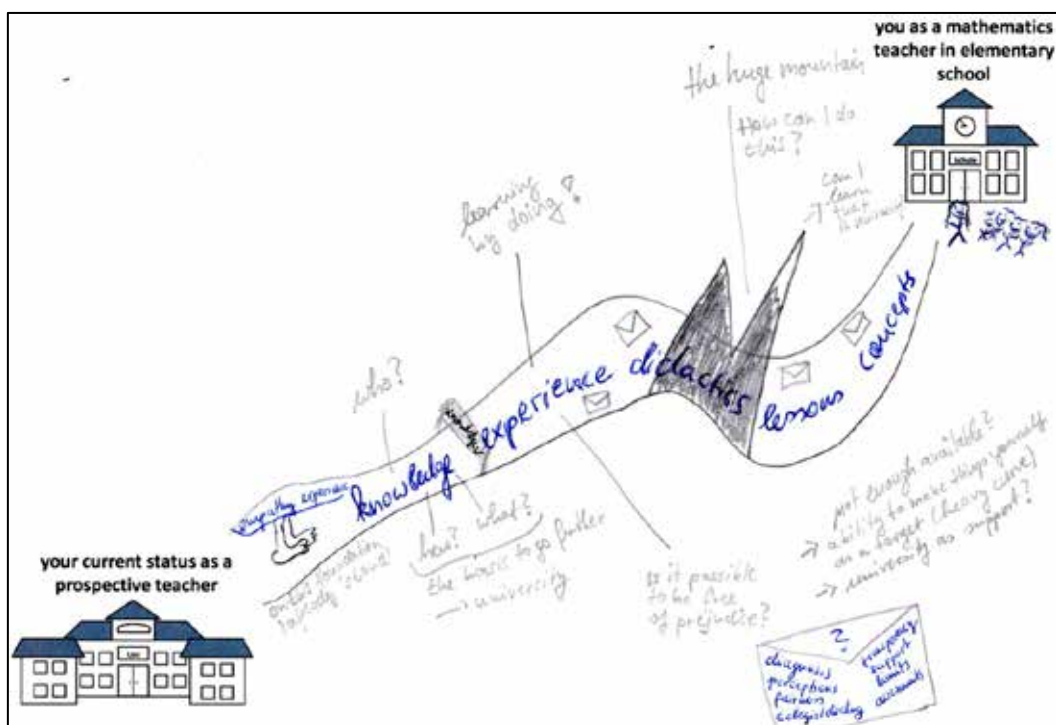


Figure 1: Example of a pre-map

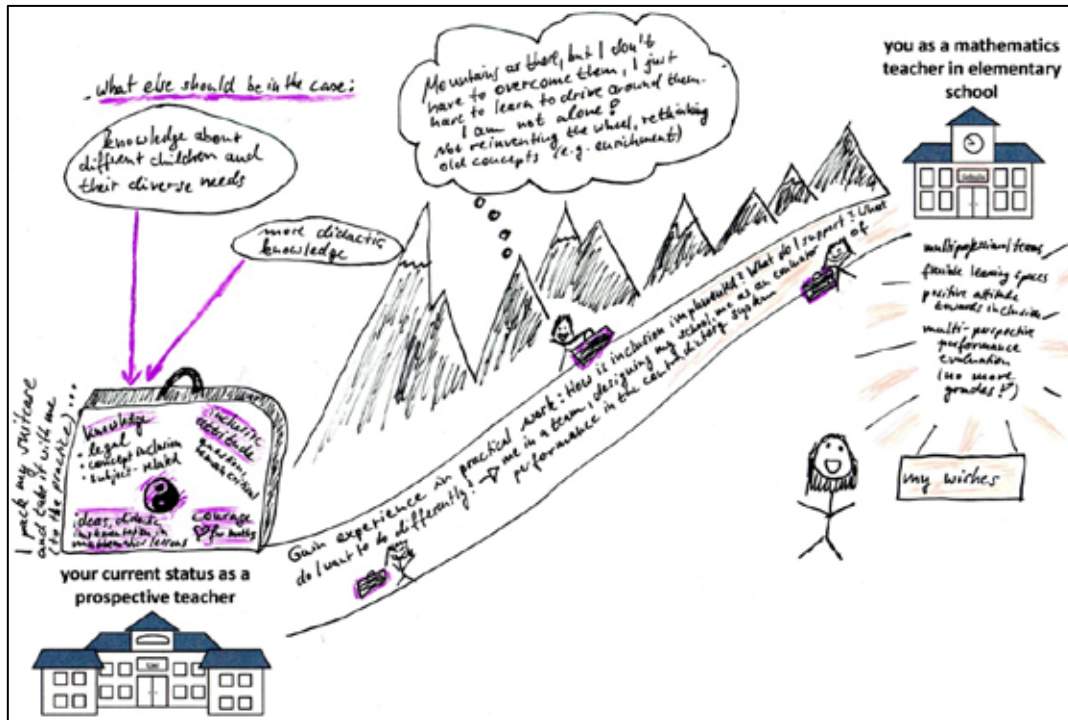


Figure 2: Corresponding post-map to Figure 1

Results

As to the map's *previous history*, the reflections' interpretations must be seen in the context of the seminar, which attempts to combine school requirements in dealing with diversity and university teaching. For example, led by theory, the student teachers develop concrete task formats in the seminar, which provides one of the topics in the context of methodical spectra. This framing implies that the student teachers receive a view of school practice from the university perspective between the pre- and post-drawings, which produces impacts on the post-maps' design. Additionally, the seminar's evaluation was conducted in a mixed-method design, where the maps provide one constituent. Regarding *key motives* and their *description*, main types were drawing both (1) paths (or a systems of paths), and (2) obstacles. Subsequently, we focus on spotlights of the reconstructions of one example shown by the Figures 1 and 2, which reflect typical features (the figures show facsimiles with translations from German; the original data can be requested from us).

As to the factual sense of the pre-map (Figure 1), the most important symbols are a path and a mountain. With regard to the sense of form, the path begins and ends relatively narrow, and it winds directly before the finish. The mountain is on the path. Additionally, some persons at the end of the path smile and stretch their arms into the air. As to the sense of expression, another noteworthy detail is that the remarks are often written in questions. The expression is rather sober. As to the factual sense of the post-map (Figure 2), the spotlights are basically repeated. Additionally, at the beginning of the path is a large suitcase, which is taken along: Small suitcases are carried by a person walking on the path. With regard to the sense of form, the path is not winding, but it leads straight to the destination without detours. The suitcase is swung back and forth by the person. The mountains stand beside the path in the background. As to the sense of expression, most of the remarks do not represent

questions, but statements. The bigger person smiles and stretches the arms upwards. Colors are used to highlight single aspects.

As to a *context analysis* of the pair of maps, the feet drawn in the pre-map (Figure 1) seem to indicate that the creator of the map reflects that he or she has started the journey to inclusive teaching, but there are several aspects showing ambiguity like the real starting line is not reached yet or the annotations are phrased as questions. The creator still seems to expect to gain experience, knowledge and the like as shown by both the words on the path and the envelopes, especially the big one with the question mark, but his or her bases are “empathy” and “experience” (which is not explained in detail here). With regard to the central symbol ‘mountain’, an ambivalence must be noted: On the one hand, mountains can block the view, can be a hurdle. On the other hand, mountains represent challenges that require effort but offer opportunities in relation to the goal being achieved, and both the ‘path is the goal’ and the ‘goal is the goal’; climbing and reaching the summit can cause a ‘flow’. The latter can justify the previous effort. Mountaineering can also be influenced by different weather conditions and the like, that is, different conditions that require special equipment. Thus, the symbol ‘mountain’ can stand for different chances but also challenges and dangers (on the part of the teachers, but not only there) and this requires a specific preparation. As indicated, in the pre-map, the mountain is drawn on the path, which seems to reflect that the creator can imagine to cope with inclusive teaching at school in principle (which is also indicated by the cheerful group of people at the school), but he or she still perceives barriers that will be difficult and challenging to overcome. This interpretation is confirmed by the fact that a curve is drawn between the mountain and the school. The comparison with the post-map (Figure 2) suggests that the creator now reflects to perceive a direct access to inclusive teaching: The big suitcase seems to indicate that he or she can classify own experiences in a more differentiated way. Experiences and likeness are reflected to be more comprehensive than it was the case in the pre-map. The potential-related perspective can be assumed as an essential impulse for this fundamental change (e.g., “knowledge about different children and their diverse needs”). Questions posed in the pre-map (e.g., “who?”, “how?”, “what?”) turned to concrete intentions and planning steps (as expressed by the phrasings on the path or the “wishes” of the bigger person on the right). Especially, as to the central symbol ‘mountain’, in the pre-post comparison two aspects appear central: the position of the mountains in relation to the path and their number. As to the position of the mountains, it should be noted that, at the beginning, the mountain stands in the way as a hurdle and it makes it necessary to overcome it. Those who want to walk the path cannot avoid overcoming the mountain. In the end, the position of the mountains has shifted significantly, as the path now leads less curvy in front of the mountains: climbing changes from a compulsory to an optional experience. In connection with the altered position, the increasing number of mountains indicates that in the end the ambivalence of mountains is perceived to a much greater and more intensive extent. However, these opportunities and risks no longer appear to be hurdles that cannot be circumvented. Thus, the symbol ‘mountain’ allows exemplary illustrations of a deeper interpretation of the observable changes considering the previous history of the maps: The student teacher experiences a paradoxical situation, since a synchronization of university theory and school practice provokes numerous difficulties (mountain peaks) within the framework of inclusion. However, the mountains are no longer obstacles (i.e., a key motive was reinterpreted). This interpretation is confirmed by the facts that the path is drawn continuously and no longer winding.

Furthermore, there are different impressions reflecting a higher level of confidence like the swinging of the small suitcases, the use of colors (e.g., the ‘sun’ on the right) or the big person, whom one may assume to be the creator him- or herself. The synthesis of his or her size and his or her cheerful expression might be interpreted as a symbol of prospective knowledge and experience, that is, he or she can now well imagine coping with diversity at school and experiences him- or herself better equipped for the journey (e.g., by the suitcases).

Based on these typical examples, a *comparative analysis* of all pre- and post-maps suggests that both the paths of student teachers and their experience of walking on the paths, thus, the reflections of barriers in inclusive mathematics teaching, changed to more confident characteristics. In sum, these changes can be described by three reflexively connected levels: key motives, lines of development, and their antitheses or contrasts. For example, the symbol ‘mountains’ clearly shows that the student teachers change their image of inclusive mathematics teaching in the course of the seminar. On the one hand, it becomes more differentiated and extensive, since in their opinion it is no longer sufficient to simply overcome a hurdle and the goal is already in front of their eyes. It rather seems that inclusion in mathematics teaching offers numerous challenges. These offer opportunities, but also dangers for teachers. The given pre-post-map-example represents a main type of all pairs of maps, the ‘expectant expert’. A feature of this type is that knowledge about inclusion increases and the person develops confidence in inclusive teaching. Another type shows similar characteristics, but in a lower level of contrast, which we named the ‘optimistic novice’. In both cases, we reconstructed an increase of knowledge and reflection, so we assumed deeper understanding of – or at least insight in – the possibilities and challenges of inclusive education. Finally, the type ‘interested layman’ was reconstructed showing much lower levels of confidence’s increase (forming the subtypes ‘positively stagnating’ and ‘no process’), but it was rarely found.

Discussion

The results indicate that participating in a seminar which takes a potential-related perspective on inclusive education and which considers the idea of research-based learning as well as intertwining theory and practice in a university context contributes sustainably to student teachers’ reflections of removing barriers in inclusive mathematics teaching. Thus, beyond the context of mathematics education, the results suggest the hypothesis that the seminar’s foundation provides an appropriate approach to student teachers’ education in the field of diversity, which is, for example, reflected by the main type ‘expectant expert’. Of course, the study’s character is explorative and it has obvious limitations, for example, the reconstructions were conducted within a group of researchers, but it remains uncertain if a consensus view is the right one (Lamnek, 2010). The interpretations reported in this article focus on the most important spotlights, especially regarding the characterization of the previous history of the images’ geneses, the connection between motives emerging from the previous history and the central symbols applied in the maps’ drawings, or the introduction of different types. As to the sample, all data collected between 2015 and 2018 were included in the analyses in order to get both various and sustainable impressions, although single conceptual improvements were conducted during this period because of feedbacks from the single evaluations. However, the basic principle of a potential-related perspective always remained the same. Subsequent research might focus on a deeper clarification of the evaluation of the seminar’s theoretical framework in the context

of both mathematics education and education in different subjects. Another step could be adapting contents of the seminar to different types of learners we found in the comparative analysis.

References

- Ainscow, M. (2007). Taking an inclusive turn. *Journal of Research in Special Educational Needs*, 7(1), 3–7.
- Benölken, R., Berlinger, N., & Veber, M. (2018). Das Projekt ‚Inklusiver Mathematikunterricht‘: Konzeptuelle Ansätze für Unterricht und Lehrerbildung. *MNU Journal*, 5, 340–345.
- Bishop, A., Tan, H., & Barkatsas, T. N. (Ed.). (2015). *Diversity in mathematics education: Towards inclusive practices*. Cham: Springer.
- Budde, J., & Hummrich, M. (2013). Reflexive Inklusion. *Zeitschrift Für Inklusion*, 4. Retrieved from <http://www.inklusion-online.net/index.php/inklusion-online/article/view/193/199>
- Häsel-Weide, U., & Nührenbörger, M. (Eds.). (2017). *Gemeinsam Mathematik lernen: Mit allen Kindern rechnen*. Frankfurt am Main: Grundschulverband e.V.
- Hinz, A. (2013). Inklusion: Von der Unkenntnis zur Unkenntlichkeit!? *Zeitschrift Für Inklusion*, 1. Retrieved from <http://www.inklusion-online.net/index.php/inklusion/article/view/201/182>
- Käpnick, F. (Ed.). (2016). *Verschieden verschiedene Kinder*. Seelze: Klett Kallmeyer.
- Krause, C. (2017). Diagnose im Fach inklusive. *Mathematik Lehren*, 201, 42–45.
- Lamnek, S. (2010). *Qualitative Sozialforschung* (5th ed.). Weinheim and Basel: Beltz.
- Messiou, K. (2017). Research in the field of inclusive education. Time for a rethink? *International Journal of Inclusive Education*, 21(2), 146–159.
- Schulze, T. (2013). Bildinterpretation in der Erziehungswissenschaft. In B. Friebertshäuser, A. Langer & A. Prengel (Eds.), *Handbuch Qualitative Forschungsmethoden in der Erziehungswissenschaft* (4th ed.) (pp. 529–546). Weinheim: Beltz Juventa.
- Slee, R., & Allan, J. (2001). Excluding the included: A reconsideration of inclusive education. *International Studies in Sociology of Education*, 11(2), 173–192.
- Sturm, T. (2016). *Lehrbuch Heterogenität in der Schule* (2nd ed.). München: Ernst Reinhardt.
- Veber, M., & Fischer, C. (2016). Individuelle Förderung in inklusiver Bildung: Eine potenzialorientierte Verortung. In B. Amrhein (Ed.), *Diagnostik im Kontext inklusiver Bildung: Theorien, Ambivalenzen, Akteure, Konzepte* (pp. 98–117). Bad Heilbrunn: Klinkhardt.
- Werner, B. (2017). Inklusiver Mathematikunterricht aus sonderpädagogischer Perspektive. Konsequenzen für die Lehrerbildung. In J. Leuders, T. Leuders, S. Prediger, & S. Ruwisch (Eds.), *Mit Heterogenität im Mathematikunterricht umgehen lernen: Konzepte und Perspektiven für eine zentrale Anforderung an die Lehrerbildung* (pp. 211–220). Wiesbaden: Springer Spektrum.

A farewell to mathematics: A personal choice or social exclusion?

Oğuzhan Doğan

Yeditepe University, Faculty of Education, İstanbul, Turkey; oguzhan.dogan@yeditepe.edu.tr

One of the dimensions that the socio-political understanding of mathematics education brings to mathematics education research is the study of how students are excluded from mathematics education. Social media could be a fruitful site to examine students' exclusion from mathematics. Therefore, the purpose of this study is to analyze how some social media users describe the moments of their farewell to mathematics and discuss what these moments imply to mathematics education researchers, specifically to the critical ones. Content analysis was utilized to analyze social media users' description of their own farewell moments to mathematics. From the analysis of these descriptions, it was concluded that almost all stages of the formal education system from the beginning of elementary school to the very last day of university, and almost all mathematics topics from multiplication to differential equations could be the moments of farewell to mathematics.

Keywords: Mathematics education, farewell to mathematics, exclusion, social media, ekşisözlük.

Introduction

Understanding mathematics education as socio-political construct has been finding increasingly more place in the mathematics education research community in the last 20 years. Straehler-Pohl, Pais, and Bohlmann (2017) portrayed this increase prominently:

Established conferences like ICME and CERME now incorporate in their programmes working groups exclusively dedicated to sociopolitical studies; the “Mathematics Education and Society” conference series has become an inherent part of the field; on a regular basis, themes like “equity”, “diversity”, “social justice” and “critical education” are problematized in edited collections and special issues of the most renowned journals; and one of the four sections that compound the very recent Third International Handbook of Mathematics Education is dedicated to “Social, Political and Cultural Dimensions in Mathematics Education”. (p. 2)

Although educational conferences, journals, edited collections or handbooks provide particular spaces for the social and political dimension of mathematics education, it is questionable whether or not such understanding reflects on educational policies and public opinion. For example, for the case of Turkey, ‘equity’ is still only a mathematics topic but not a policy identifier (Doğan & Haser, 2014).

One of the dimensions that this socio-political understanding of mathematics education brings to mathematics education research is the study of how students are excluded from mathematics education. The social, cultural, class-, gender- and race-based explanations of this exclusion are clearly presented in critical mathematics education literature (Jablonka, Wagner, & Walshaw, 2013; Jorgensen, Gates, & Roper, 2014; Kolloosche, 2017). However, we still have limited knowledge of how this exclusion is explained by the excluded themselves.

In the last decade social media has become one of the important places that individuals use to communicate with each other, explain their point of view, share their ideas, discuss different perspectives and so help the construction of public opinion. With the awareness of the common

popularity of social media and its growing potential, it could be fruitful to examine social media shares to understand their relations with mathematics. Considering this potential, this paper will examine a popular social media site (eksisozluk.com/sourtimes.org) in Turkey in terms of how social media users describe their exclusion from mathematics education.

Exclusion in Mathematics Education

Similar to what Marx and Engels (1848) indicated about the written history of mankind, “the history of all hitherto existing society is the history of class struggles” (p. 14), it could be argued that the history of all hitherto existing mathematics classrooms is the history of exclusion. In the first handbook of research on mathematics teaching and learning, Secada (1992) highlighted this history as such:

For over 40 years, we have been confronted with an ever-growing body of research documenting that the American educational system is differentially effective for students depending on their social class, race, ethnicity, language background, gender and other demographic characteristics. This differential effectiveness has been found in mathematics as well as in many other academic subjects. (p. 623)

Following comprehensive reviews on mathematics education research (Jablonka, Wagner & Walshaw, 2013; Bishop & Forgasz, 2007) also emphasized that a wide range of students (from different racial, ethnic and religious minorities, working-class students, female students and students with disabilities) had suffered from conflicts with mainstream mathematics education. It can be concluded from this consistent body of literature that disadvantaged groups of students are excluded from mathematics education on both micro level (in mathematics classrooms) and macro level (national tests, higher education entrance, job preference etc.). Mathematics has an important role in the intellectual selection, preparation and guidance of students to enter higher education studies and has used to help select those who will occupy different social positions. Thereby it serves as a critical filter. Understanding these exclusion processes can help us to understand the role of mathematics education in the reproduction of social inequalities.

These exclusion processes or moments are investigated under the roof of different theoretical frameworks. Within a traditional Marxist perspective, it can be argued that working class children have fewer resources (economic opportunities, family support etc.) to be successful in mathematics and are subjected to be a member of future working-class thorough education/schools (Bowles & Gintis, 1976). With a Žižekian contribution to this perspective, it can be argued that failure or exclusion in mathematics education is not an observed singularity that can be solved through better mathematics classrooms with hard-working mathematics teachers, but a necessary feature of existing schooling and mathematics education (Pais, 2012; Straehler-Pohl & Pais, 2014). As Pais (2012) influentially stated “the ‘slogan’ or ‘motto’ ‘mathematics for all’ is used as an exemplary case for the social fantasy that is concealing the crude reality that, as any mathematics teacher knows, mathematics is not for all” (p. 58).

In addition, in a Bourdieusian sense, it can be argued that working class students or students with limited cultural baggage do not have the necessary cultural capital to ‘play the game’ that is involved in the learning of mathematics and are less likely to understand the mechanisms required to succeed

in mathematics (Lareau & Horvat, 1999; Doğan and Haser, 2014). Similarly, based on Bernstein's theory of the language and codes used in educational settings, it could be argued that some context or language use in mathematics lessons can result in mathematical exclusion (Helenius, Johansson, Lange, Meaney, & Wernberg, 2015).

Moreover, from a Foucauldian perspective, the concept of 'power' can be an expressive tool to understand moments of exclusion. For example, Valero (2007, p. 226) indicated that viewing power as a "capacity to participate by taking and defining the positions and conditions for engaging in social practice" offers investigation of the microphysics of power in mathematics education practices. According to her, such an analysis clarifies the mechanisms through which different actors get positioned as more or less influential participants and thereby get included and excluded.

These perspectives can provide mathematics education researchers a supplementary toolbox for understanding and portraying the processes and moments of exclusion. On the other hand, how these processes and moments were interpreted by the excluded themselves needs to be clarified. Therefore, the purpose of this study is to analyze how some social media users describe the moments of their farewell to (or exclusion from) mathematics and discuss what these moments imply to mathematics education researchers, specifically to the critical ones.

Methodology

In line with the purpose of the study, the research questions are: (i) How do social media users describe the moments of their farewell to mathematics? (ii) What are the themes that emerge as a portrayal of these farewell moments? and (iii) What are the implications of these farewell moments for mathematics education researchers?

To answer these questions, one of the most popular social media sites in Turkey, Ekşisözlük (Sour Dictionary) was analyzed. Ekşisözlük can be considered a unique website, somewhat similar to Wikipedia, in which each member of the dictionary writes their own definition/description of a specific concept, people, event etc. For example, you can find users' own definitions of lasagna, Deep Purple, Utrecht or the latest comments of political figures. In 2018, there are almost 500.000 active members writing in Ekşisözlük and it (www.eksisozluk.com) is the 15th most visited website in Turkey.

The research methodology was content analysis. The content of the users' definitions (entries) of 'the moments of farewell to mathematics' was investigated in this study. There were 945 different entries under this heading (<https://eksisozluk.com/matematige-veda-edilen-an--4614088>), which means that 945 different users describe their own farewell moments to mathematics. As an example, the last entry was "In the second year of university, when I passed the differential equations. I got rid of mathematics, but then I faced more terrible things".

The 945 entries under the heading 'the moments of farewell to mathematics' were retrieved from the website in June 2018 with the help of NVivo 11 (NCapture for NVivo 11). Each entry was read in the beginning of data analysis. 236 of the entries were not related with the title and did not include any meaningful definition, so they were omitted in the further analysis. After this first reading, the possible themes for the farewell moments were constructed, such as the year of the farewell and the

specific reason of the farewell. Each entry was coded according to these initial themes with the help of NVivo 11, and through the analysis the themes were combined, separated or re-constructed. Finally, the data (709 entries) were re-coded with the final version of themes, sub-themes and codes.

Findings

To clarify how I examined Ekşisözlük users' description of their farewell moments, I will present some of the representative entries and try to explain how I interpreted these entries. One of the entries under the heading 'the moments of farewell to mathematics' was this:

Entry 1: I think, for everyone, there is a moment when they say goodbye to mathematics. Some go away when they see 'x' or 'y', some wait for the derivatives. The moment that I feel I did not understand mathematics at all was the first grade where we saw the multiplication with 7. I am still mad at this multiplication table.

As it can be seen, the user pointed out the first grade of primary school and multiplication table as the moment of farewell. S/he did not identify any specific reason for the farewell but only indicated the mathematics topic (multiplication with 7). There were a lot of similar entries indicating specific mathematics topics and grade levels, for example:

Entry 2: Math was my favorite lesson in primary school. However, when the letters came into stage I fell out of love with mathematics.

Entry 3: My body was fumbling with functions, and the last blow was trigonometry.

The writer of Entry 2 pointed out the 'letters' as the farewell moments, so it can be inferred that the mathematics topic was algebra and the time was elementary school (although there is no specific grade level, algebra is one of the main mathematical concepts of elementary schools (5th to 8th grade) in Turkey). Entry 3 pointed out two mathematics concepts (functions and trigonometry) from high school as the farewell moments.

In addition, some of the entries gave further reference to the users' reasons of farewell. For instance:

Entry 4: With the start of limit-derivative-integral and because of the teachers who cannot explain what these topics mean.

While the user specifically indicated the topic (calculus) and so also the grade level (High school, 12th grade), s/he also pointed out the teachers and their lack of explanation as the reason of farewell.

On the other hand, some of the entries did not specify any mathematics topics or reasons of farewell but indicated a national exam. As an example:

Entry 5: It is the moment that you give up hope from KPSS (Exam for Civil Servant Selection).

Five main themes have emerged as a result of content analysis of the farewell moments; the grade level of the farewell, the specific mathematics topic of the farewell, the specific national exam of the farewell, the reasons of the farewell and no farewell. The number of entries that have specific reference to these main themes is presented in Table 1.

Theme	Code	# of entries
Grade Level		232
	High School (Grade 9-12)	70
	University	53
	Primary School (Grade 1-4)	41
	Elementary School (Grade 5-8)	40
	Passing the University Entrance Exam	19
	Graduation	9
Mathematics Topic		167
	Calculus	43
	Algebra	31
	Trigonometry	20
	Functions	15
	Advanced Calculus/Mathematics	11
	Multiplication Table	11
	Equations	5
	Negative Numbers	5
	Others (Sets, Logic, Fractions, etc.)	26
Reasons		64
	Teachers	42
	Poor grades	20
	Friends	2
National Exams		24
	ÖSS (University Entrance Exam)	17
	ALES (Exam for Graduate Study)	4
	KPSS (Exam for Civil Servant Selection)	3
No Farewell		47

Table 1. The number of entries that have specific reference to main themes

When the grade level theme was examined, it can be seen that the users identify all stages of education from elementary school to university graduation as a farewell moment. While high school and university grades were the most referenced grades, a significant number of users emphasizes the

farewell moments almost at the start of their education career, primary school (41; 18% of grade level references).

In addition, when the mathematics topic theme is examined, it is understood that the users have highlighted a variety of mathematics topics from multiplication table to calculus as a farewell moment. Calculus (43; 26% of mathematics topic references) and algebra (31; 18% of mathematics topic references) were the most referenced mathematics topics.

Moreover, when the reasons of the farewell are examined, two main reasons emerge: the teacher and poor grades. In addition, it should be noticed that most of the entries did not include any specific reason of farewell: only 64 entries (9%) of 709 entries pointed out a specific reason.

Lastly, 47 (7%) of the entries indicated that it is not possible to say goodbye to mathematics and so there can be no such farewell moment. Two examples were these:

Entry 6: I think there is no such moment, math is life.

Entry 7: Only death can separate us.

To sum up the findings of this content analysis, it can be argued that Ekşisözlük users portrayed their moments of farewell by drawing mostly on specific mathematics topics and grade level but do not identify socio-political reasons of these farewells. When they indicated a specific reason, it was either the teacher or their poor grades.

Conclusion and Discussion

From the analysis of the Ekşisözlük users' description, it can be concluded that almost all stages of the formal education system from the beginning of elementary school to the very last day of university, and almost all mathematics topics from multiplication to differential equations could be the moments of farewell to mathematics. It could be re-stated after these findings that the history of all hitherto existing mathematics classrooms is the history of exclusion. Additionally, when the grade level and mathematics topics are considered together, it can be concluded that multiplication table in primary school, algebra in elementary school, functions and trigonometry in high school and calculus in university emerged as the key moments of farewell to mathematics.

Furthermore, another conclusion can be drawn from what was absent in these descriptions. Although Ekşisözlük users identified (i) mathematics itself (they mostly identify specific mathematics topics as the farewell moments), or (ii) the difficulty of mathematics (poor grades as the farewell moments), or (iii) teachers as the reasons their farewell, they did not give any reference to social, cultural, political, gender- or class-based reasons for their farewell. While identifying the reasons of their farewell, social media users did not cross the wall of mathematics classrooms, therefore they oscillated between their teachers and themselves.

From this absence of socio-political reasons among the reasons of farewell, it can be inferred that although understanding mathematics education as socio-political construct finds increasingly more space in the mathematics education research community, it seems that this understanding could not get across through the walls of mathematics education research to reach public opinion. While we, as (critical) researchers in mathematics education, examine and emphasize that one of the most

important variables affecting mathematics education is socio-economic status, that gender is both a factor in achieving mathematics and in selecting mathematics-based studies/jobs, that cultural capital is responsible for mathematics scores, our students mostly emphasize the individual or mathematics-specific factors as the reason of their farewell to mathematics.

Following these conclusions, the implications for mathematics educators and researchers are two-fold; firstly, there are strong personal reasons for farewell to mathematics, such as mathematics being perceived as difficult and unachievable (reference to poor grades), complex and meaningless (referenced the specific mathematics concepts). Therefore, the inside of the classroom should be organized to make mathematics more meaningful and achievable for students. Additionally, as Kollosche (2017) emphasized “auto-exclusion is not merely the result of psychological dispositions of the individual, which could then be changed by pedagogical intervention, but that auto-exclusion is created in the interplay of the individual and the social environment” (p. 2). So, counter-acting auto-exclusion from mathematics is as much an issue of changing the social environment outside the classroom as it is an issue of changing the mathematics classroom itself.

Secondly, social, cultural, political and gender- and class-based factors that divorce students from mathematics need to get more reference in the public sphere. In spite of the socio-political turn within mathematics education, specific working groups in educational conferences and special issues in high stake journals, it could be argued that the social, cultural, political and class-based exclusion in mathematics education is not publicly echoed adequately. Therefore, as critical mathematics educators, it would be better to demand more to get more public spaces so as to not confine ourselves to special issues or handbook chapters.

References

- Bishop, A. J., & Forgasz, H. J. (2007). Issues in access and equity in mathematics education. In F. K. Lester (Ed.), *Second handbook of research on mathematics teaching and learning* (pp. 1145–1168). Charlotte, NC: Information Age Publishing.
- Bowles, S., & Gintis, H. (1976). *Schooling in capitalist America*. New York: Basic Books.
- Doğan, O., & Haser, Ç. (2014). Neoliberal and nationalist discourses in Turkish elementary mathematics education. *ZDM Mathematics Education*, 46(7), 1013–1023.
- Helenius, O., Johansson, M., Lange, T., Meaney, T., & Wernberg, A. (2015). Mathematical exclusion with the every day. In K. Krainer & N. Vondrová (Eds.), *Proceedings of the Ninth Congress of the European Society for Research in Mathematics Education* (pp. 1584-1590). Prague, Czech Republic: Charles University in Prague.
- Jablonka, E., Wagner, D., & Walshaw, M. (2013). Theories for studying social, political and cultural dimensions of mathematics education. In A. Bishop, M. A. K. Clements, C. Keitel-Kreidt, J. Kilpatrick, & F. K.-S. Leung (Eds.), *Third international handbook of mathematics education* (pp. 41–67). New York: Springer.
- Jorgensen, R., Gates, P., & Roper, V. (2014). Structural exclusion through school mathematics: Using Bourdieu to understand mathematics as a social practice. *Educational Studies in Mathematics*, 87(2), 221–239.

- Kollosche, D. (2017). Auto-exclusion in mathematics education. *Revista Paranaense de Educação Matemática*, 6(12), 38–63.
- Lareau, A., & Horvat, E. M. (1999). Moments of social inclusion and exclusion: Race, class, and cultural capital in family-school relationships. *Sociology of Education*, 72(1), 37–53.
- Marx, K., & Engels, F. (1967). *The communist manifesto* (1848). Trans. Samuel Moore. London: Penguin.
- Pais, A. (2012). A critical approach to equity. In O. Skovsmose & B. Greer (Eds.), *Opening the cage: Critique and politics of mathematics education* (pp. 49–91). Rotterdam: Sense.
- Secada, W. G. (1992). Race, ethnicity, social class, language, and achievement in mathematics. In D. A. Grouws (Ed.), *Handbook of research on mathematics teaching and learning: A project of the National Council of Teachers of Mathematics* (pp. 623–660). New York, NY: Macmillan Publishing.
- Straehler-Pohl, H., & Pais, A. (2014). To participate or not to participate? That is not the question! In B. Ubuz, Ç. Haser, & M. A. Mariotti (Eds.), *Proceedings of the 8th Congress of the European Society for Research in Mathematics Education* (pp. 1794–1803). Ankara: Middle East Technical University.
- Strahler-Pohl, H., Pais, A., & Bohlman, N. (2017). Welcome to the jungle. An orientation guide to the disorder of mathematics education. In H. Straehler-Pohl, N. Bohlmann, & A. Pais (Eds.), *The disorder of mathematics education. Challenging the sociopolitical dimensions of research* (pp. 1–15). Dordrecht: Springer.
- Valero, P. (2007). A socio-political look at equity in the school organization of mathematics education. *ZDM – The International Journal on Mathematics Education*, 39(3), 225–233.

A call for nuancing the debate on gender, education and mathematics in Norway

Trine Foyn

OsloMet – Oslo Metropolitan University, Norway; trine.foyn@oslo.met.no

This paper aims to scratch beneath the surface of a domestic concern with boys' 'underperformance' in school in Norway. Focusing on mathematics, I argue that there is more to the ongoing debate on gender and education than meets the eye. Exploring the unexpected emergence of a gendered context in a 10th grade mathematics class, I show the need for revisiting the gender and mathematics debate. Characterising the current debate in Norway as a binary concern with boys struggling in the educational system versus successful girls, I argue that the current moral panic is detrimental for girls in mathematics, where challenges remain for those choosing to study at a level which enables access to further studies in the STEM field. The Norwegian debate in this field needs to be more complex and nuanced than first impressions and assumptions about gender equality suggest.

Keywords: Gender, mathematics, discursive challenges, Norway.

Introduction: Presenting two discussions in the education debate in Norway

Current debate in Norway addresses how boys are outperformed by their female peers, from the early school years onwards. Led by Camilla Stoltenberg, Director General of the Norwegian Institute of Public Health, a National Commission on Gender Equity in Education was convened to explore gender differences in school and make recommendations to address inequities. Their report, published in February 2019, concludes that there are differences in girls' favour in the Norwegian educational system (NOU, 2019). The Commission's work has gained a lot of media attention, leading to headlines such as "Girls continue to storm ahead of boys in school"¹ (Solvang, 2017). While Camilla Stoltenberg has strongly expressed her worries about boys, academics such as Harriet Bjerrum Nielsen (2017) and Kristoffer Chelsom Vogt (2018) have challenged this view in public debate, arguing that it over-simplifies complex gender relationships in current Norwegian society.

Mathematics is not a central focus in this domestic discussion, apparently because differences in test results between boys and girls are small. Girls are performing slightly better than boys in mathematics, but the gap is less noticeable in comparison with other subjects and reading (Backe-Hansen, Walhovd, Huang, 2014; Nordtvedt, 2013; Statistisk Sentralbyrå [SSB], 2017). However, Norwegian students' overall level of performance in mathematics has caused school authorities a headache since the "PISA-shock" of 2000, in which Norway did not perform well in comparison to other countries, triggering major policy-level attention on the improvement of mathematics teaching, including the introduction of National Tests in reading, English and numeracy in grades 5, 8 and 9².

¹ Translated from «Jentene fortsetter å rase fra guttene på skolen»

² These are distinct from national level examinations in mathematics in grade 10, at the end of lower secondary school.

My experience as a secondary school mathematics teacher has meant that I have frequently seen students who seem to give up on mathematics during the years in upper secondary school, or on the other hand begin to connect to mathematics. Reflecting on the issue of Norwegian students' poor results in mathematics, I have wondered why some students seem to change their attitude towards mathematics during these crucial years of early adolescence. Hence, I embarked on a longitudinal study of students in a lower secondary school mathematics class, aiming to understand their developing relationships with mathematics, whether in a positive or negative direction.

Having tracked a class for one and a half years from 8th to 10th grade, I noticed gender dimensions in the 10th grade which are not captured by the general discussion of gender and education in Norway. This unexpected emergence of gender patterns led me to look more closely at the current debate. In this paper, I describe how a longitudinal analysis of individual students' trajectories in this class provides a very different account of gender in comparison to basic test statistics. I will argue that the ongoing debate on gender, education and mathematics has to be both more nuanced and given more attention, in order to be fair to the all the students in the Norwegian educational system.

Setting the scene: “Class A”

“Class A” is a 10th grade class (age 15) in a lower secondary school in Norway, just outside Oslo. The school is situated in a high income socio-economic area with a largely well-educated population, of whom the majority are ethnic Norwegians. I have been tracking “Class A” since midterm in the 8th grade (age 13), observing classes and holding focus group interviews. These data are supplemented with information on students' test³ performance and teacher assessments. “Class A” is in general a high-achieving class with results remarkably better than the national level in mathematics, even those one grade above. The average grade in their 9th grade final test was 4,65, in comparison with national results in 10th grade examinations of between 2,9 and 3,6 in recent years⁴ (SSB, 2017).

	Average grade in 8 th grade	Average grade in 9 th grade
Boys	5,0	5,2
Girls	4,25	4,4

Table 1: Average grades for boys and girls in 8th and 9th grade

Table 1 illustrates the picture gained from the basic statistics for boys and girls in 8th and 9th grade. These give the impression that boys are performing remarkably better than girls in this class. If we go beyond average grades a more nuanced picture appears. As we can see in Table 2, at the end of 9th grade, all boys are labelled as high achievers in the terminology used in the Norwegian assessment system (students achieving grade 5 or 6). Their grades are largely stable or improving, and only one boy is an exception to this pattern. The girls not only lag behind the boys in terms of basic grades, but, as a group, their grades seem to be more unstable, either remaining static or declining. Just one

³ These are school-level tests, designed by the teachers.

⁴ The Norwegian grading scale in grades 8-10 runs from 1 to 6, with 6 as the best possible grade to achieve.

girl improved her results from 8th to 9th grade. No girls achieved the top grade in either 8th or 9th grade, although four boys did so in 8th grade and three boys in 9th grade.

Test Grade	Number of boys achieving each grade		Number of girls achieving each grade	
	8 th grade	9 th grade	8 th grade	9 th grade
6	4	3	-	-
5	3	5	6	5
4	2	1	3	4
3	1*	-	3 (2*)	1

Table 2: Overall patterns of attainment by gender (*Moved to a group for struggling students)

Given the current debate on education, gender and mathematics, this emergent gender pattern was unexpected. The apparently more unstable situation of girls in “Class A” led me to question whether gender matters or not in Norwegian mathematics classrooms. Could “Class A” be just an exception from the norm in Norway? Thinking further on this question, a contrary question presented itself: “Could it be that the binary gender debate in Norway needs further nuancing in order to bring genuine equity for both boys and girls in Norwegian mathematics classrooms?” Could it be time for a discussion of the challenges for girls as mathematics students in the Norwegian context where gender is ostensibly not an issue? The importance of scratching beneath the surface of the debate on gender, education and mathematics in Norway thus became difficult to ignore and is my aim in this paper.

The context of gender, education and mathematics in general in Norway

The current debate on education and gender in Norway emphasizes that girls outperform boys. When it comes to school results, data from the Norwegian Central Bureau of Statistics (SSB) show that girls perform better than boys in almost every subject except gymnastics. The gender gap is most significant in Norwegian and English, and least in mathematics (SSB, 2017). The high school drop-out rate is higher for boys, and the general picture in higher education is that girls are in the majority in universities and colleges (Hollås, 2007). With this established reality of gender patterns in education, there is little room for worrying about girls, while ensuring boys’ success is at stake.

However, although women may be in the overall majority in higher education, this is not the case in the STEM area, where in Norway they are in a minority (Hollås, 2007; Olofsson, 2016). International studies of this situation in the Netherlands and the Nordic countries have labelled this phenomenon “the gender-equality-paradox” (Stoet & Geary, 2018), noting the contradiction between high rates of women’s emancipation and hence gender equality in these countries and their underrepresentation in STEM higher education. Even though this pattern is also known in Norwegian statistics and has gained attention in the past (Tønnessen, 2018), it seems that it has been forgotten in the current debate.

Consideration of why women are a minority in the STEM area in Norway suggests that the years before students make their choices for higher education must be influential. It makes sense to look for traces of this pattern in the field of mathematics in the secondary school years, since mathematics

is a key subject for all students who intend to continue with study in the STEM area. Girls' situation in mathematics is in danger of becoming a blind spot in this domestic debate on gender and education.

Digging beneath the surface of gender equality issues in Norway

To move beyond a binary picture of gender in the Norwegian education context, we need to draw on different data from that provided by the SSB analysis of test results. PISA 2012 (Kjærnsli & Olsen, 2013) not only presented data on test results, but also on students' relationships with mathematics. Nordtvedt's (2013) analysis of PISA 2012 was that although girls performed slightly better than boys, there were no significant gender differences in mathematics performance in Norway; differences were more prominent in reading and in English. However, when it comes to students' relationships with mathematics, another perspective on gender and mathematics appears. Jensen and Nordtvedt (2013) reported that boys scored more positively on intrinsic motivation, stamina, assessment of their own capacity in problem solving, self-perception and self-efficacy. Focusing on extrinsic motivation and anxiety, while there were no differences in the former, girls scored more highly on the latter.

Turning to national test data from the 5th, 8th and 9th grades, 2017 data show that girls achieve better results in reading, while boys have better results in numeracy (UDIR 2017a, 2017b). These results are in line with those of previous years. Even though boys seem to be ahead of girls according to these national tests, statistics show that when it comes to the 10th grade examination in mathematics, they do not gain better grades, suggesting a decline in the last year of high school. As the SSB (2017) notes, the tests differ in terms of both form and content, but they nevertheless raise issues regarding gender which suggest that we need to understand more about students' experience of mathematics.

At the end of lower secondary school, students choose different education pathways. Bjørkeng (2011) reports that girls' participation in the more theoretical mathematical pathway for science drops from 48% in 11th grade to 40% in 13th grade, even though they perform better than boys on the same pathway. Bjørkeng (2011) argues that girls have a need for better grades than their male peers do, in order to choose this mathematics pathway. She concludes that although girls often have equally good results as boys, they have less motivation and poorer perception of their skills, corresponding to the conclusions of PISA 2012 and drawing attention to the impact of girls' relationships with mathematics on their participation in post-compulsory mathematics, in spite of their better grades.

Discursive issues in gender and mathematics in international and Scandinavian contexts

“Whether the issue is gender difference or gender equity, in the Nordic countries the underlying issue will always be equal opportunity” (Wedegge, 2007, p. 252). If equality of opportunity is the pathway towards gender equity, it is difficult to see why women are still in a minority in STEM and the mathematics pathway for science in egalitarian Norway. However, international studies have shown the impact of discursive challenges for girls who study mathematics, where mathematics is inscribed as a male domain (Mendick, 2005; Rodd & Bartholomew, 2006). In the Scandinavian context, Brandell and Staberg's (2008) research in Sweden finds that despite the country's “fairly good record concerning gender equity” (p. 495), female participation in intensive mathematics programmes is 38% in upper secondary school, dropping to 30% at undergraduate and 26% at graduate levels. They found that even in the egalitarian context of Sweden, mathematics was more likely to be perceived as

a male domain among high school students. Boys had more positive relationships towards mathematics, and while both boys and girls conceived of mathematics as difficult and unattainable, these negative qualities were seen as more applicable to girls. Szabo (2017) similarly reports that boys and girls in accelerated mathematics classes in Sweden differ in their experience of mathematics.

Foyn, Solomon and Braathe's (2018) study of high-performing 10th grade girls in Norway also reports on the discursive challenges for girls in mathematics. They document the social cost of being a "clever girl" and its effect on the dynamics between students in this group. In line with these findings, With and Solomon (2014) found that the dominant Norwegian discourse of gender equality seemed to have little impact on upper secondary school students' attitudes towards mathematics. They found that girls positioned themselves as "just" hard workers and as lacking natural ability for mathematics. These studies suggest that there are challenges for high-performing girls when making choices to study mathematics, even in the Norwegian context.

Returning to "Class A"

The importance of understanding more about students' relationships with mathematics than basic statistics can tell us is illustrated further by looking at "Class A" from another perspective. Looking beyond the impression given by the students' overall results, and instead exploring individual trajectories in mathematics in the period from the second half of 8th grade and throughout 9th grade, suggests a complex picture of gender in mathematics.

Figures 1 and 2 show individual students' trajectories in mathematics as they move through grades 8 and 9. Close inspection shows a pattern of gender differences which appear to be important. As we can see, boys show a more stable development than girls. Focusing on Figure 1, five of the boys gained better results at the end of 9th grade than at the beginning of 8th grade. One shows a drop at the beginning of 9th grade, but is back on track at the end of 9th grade. Another has lost his top mark, but he is still achieving very good results and these could be interpreted as stable with a slight dip. Turning to the girls, their individual trajectories show a more unstable situation. Figure 2 shows that there is only one girl whose results improve. The rest of the girls are in a more unstable situation, either declining or showing a dip before getting back on track. The girls' unstable situation is a potential indicator in terms of their future as mathematics students.

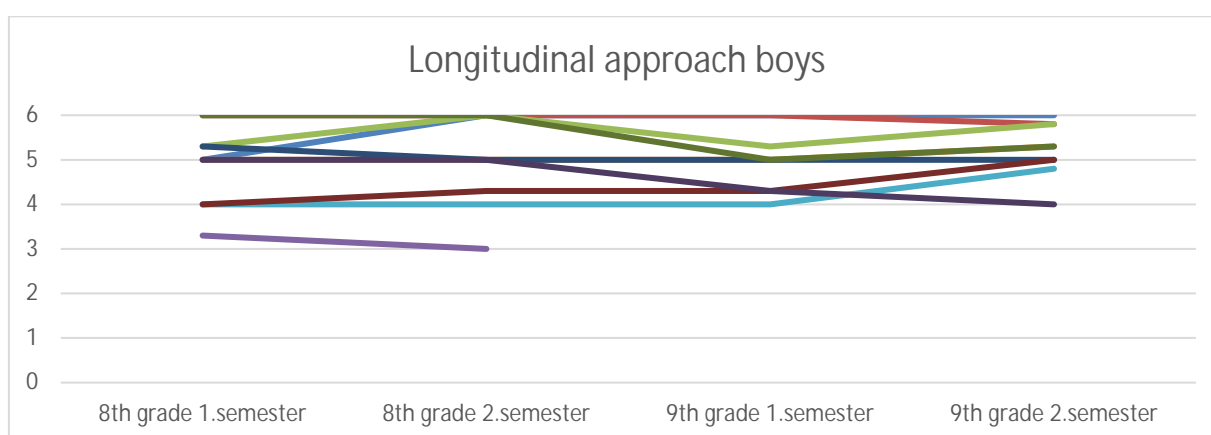


Figure 1: Boys' grades from grade 8 to 9, based on written tests and teacher assessment combined

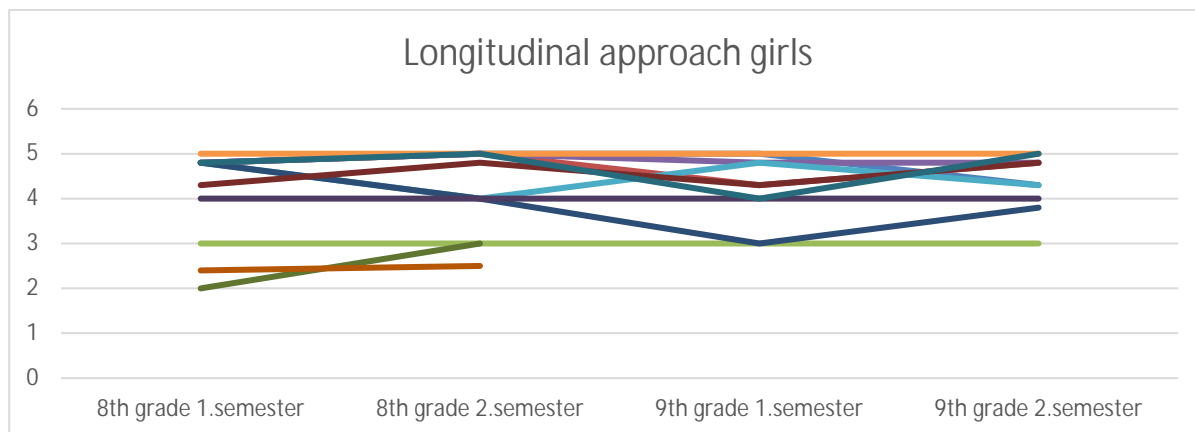


Figure 2: Girls' grades from grade 8 to 9, based on written tests and teacher assessment combined

Data from focus group interviews adds a further interesting perspective. Those girls who described themselves as enjoying working with mathematics in 8th grade did not maintain their positive attitude during 9th grade. None said that they still enjoyed working with mathematics. On the other hand, boys who expressed positive attitudes toward mathematics in 8th grade maintained this view in grade 9. The most stable higher achieving girl in the group expressed a very negative attitude towards mathematics, using expressions such as “I really don’t see the point”. A final comment worth mentioning is that, in 8th grade, the teacher named just one girl among the best students in mathematics. She was not on the teacher’s top list in 9th grade.

A need for expanding the debate of mathematics and in Norway

Having argued that the debate on gender, education and mathematics is more complex than the impression given by basic statistics and average grades, my claim is that we need to take a more nuanced view of the role of gender in mathematics. Including data on students’ attitudes and relationships to mathematics, the course of individual trajectories and the role of popular discourse and peer cultures in student choice underlines the complexity of the issue. Knowing that women are underrepresented in the STEM area, combined with knowledge of discursive challenges for girls as students in mathematics in the educational system, my conclusion is that there is a gender dimension in mathematics in Norway which we need to be aware of. Maintaining the binary picture of boys struggling while girls effortlessly succeed in school will not be fair to either boys or girls.

The problem of girls being in a minority in mathematics for science is not being treated as in need of attention in the Norwegian context. Quoting Harriet Bjerrum Nielsen (2017a), it seems as if the alarm is louder when there is a problem for boys rather than for girls. From an economic point of view, failing to give this situation further attention means that Norway will suffer from the lack of women with important skills in mathematics in the STEM area. More theoretically, there is little basis for such a binary conception of boys and girls, and it does disservice to both (Francis, 2012).

The case of Class A shows the importance of conducting longitudinal, qualitative studies of students in Norwegian schools in mathematics. Important knowledge about the situation in mathematics will get lost if we continue to rely only on basic statistics and ignore issues of relationships towards mathematics and the dynamics of the mathematics classroom. My preliminary analysis raises issues which cannot be captured by the ongoing debate, and the emerging gender pattern shows the

importance of scratching beneath the surface. Finally, these words from Harriet Bjerrum Nielsen (2017a) will highlight my conclusion: “Those who think that boys are being neglected in schools nowadays have most probably not been in a classroom for a long time”.

References

- Backe-Hansen E., Walhovd, K. B, & Huang L. (2014). *Kjønnforskjeller i skoleprestasjoner: En kunnskapsoppsummering* [Gender differences in school performance: A summary of knowledge.] Oslo: Norsk institutt for forskning om oppvekst, velferd og aldring.
- Bjørkeng, B. (2011). *Jenter og realfag i videregående opplæring* [Girls and science in secondary education]. Oslo: Statistisk sentralbyrå.
- Brandell, G., & Staberg, E.-M. (2008). Mathematics: A female, male or gender-neutral domain? A study of attitudes among students at secondary level. *Gender and Education*, 20(5), 495–509.
- Foyn, T., Solomon, Y., & Braathe, H. J. (2018). Clever girls’ stories: The girl they call a nerd. *Educational Studies in Mathematics*, 98(1), 77–93.
- Francis, B. (2012). Gender monoglossia, gender heteroglossia: The potential of Bakhtin’s work for re-conceptualising gender. *Journal of Gender Studies*, 21(1), 1–15.
- Hollås, H. A. (2007). Kvinner dominerer på nesten alle områder [Female dominance in almost all areas]. Oslo: Statistisk sentralbyrå. Retrieved from <https://www.ssb.no/utdanning/artikler-og-publikasjoner/kvinner-dominerer-paa-nesten-alle-nivaer>
- Jensen, F., & Nordtved, G. (2013). Holdninger til matematikk [Attitudes towards mathematics]. In M. Kjærnsli & R. V. Olsen (Eds.), *Fortsatt en vei å gå* (pp. 97–117). Oslo: Universitetsforlaget.
- Kjærnsli, M., & Olsen, R. V. (2013). PISA 2012: Sentrale funn [PISA 2012: Central findings]. In M. Kjærnsli & R. V. Olsen (Eds.), *Fortsatt en vei å gå* (pp. 13–40). Oslo: Universitetsforlaget
- Mendick, H. (2005). A beautiful myth? The gendering of being/doing ‘good at maths’. *Gender and Education*, 17(2), 89–105.
- Nielsen, H. B. (2017a). Når gutter fremstilles som tapere går alarmklokkene langt høyere enn når jenter er tapere [When boys are made appear as losers, the alarm is louder than when girls are losers]. Retrieved from https://www.aftenposten.no/meninger/kronikk/i/voeGj/Nar-gutter-fremstilles-som-tapere_-ringer-alarmklokkene-langt-hoyere-enn-nar-jenter-er-taperne---Harriet-Bjerrum-Nielsen
- Nielsen, H. B. (2017b). Frafall og prestisjestudier: Gutter er ikke bare gutter [Drop-out and high-status studies: Boys are not only boys]. Retrieved from <https://www.aftenposten.no/meninger/debatt/i/blkr/-Frafall-og-prestisjestudier-Gutter-er-ikke-bare-gutter--Harriet-Bjerrum-Nielsen>
- Olofsson, C. (2016). Positive trend stalled: Women still underrepresented in STEM subjects. Retrieved from <http://www.nikk.no/en/news/positive-trend-stalled-women-still-underrepresented-in-stem-subjects/>
- NOU. (2019). *Nye sjanser – bedre læring: Kjønnforskjeller i skoleprestasjoner og utdanningsløp* [New chances – better learning: Gender disparities in school achievement and education] Retrieved from <https://nettsteder.regjeringen.no/stoltenbergutvalget/files/2019/02/nou201920190003000dddpdfs.pdf>

- Nordtvedt, G. (2013). Resultater i matematikk [Results in mathematics]. In M. Kjærnsli and R. V. Olsen (Eds.), *Fortsatt en vei å gå* (pp. 67–92). Oslo: Universitetsforlaget.
- Rodd, M., & Bartholomew, H. (2006). Invisible and special: Young women's experiences as undergraduate mathematics students. *Gender and Education*, 18(1), 35–50.
- Solvang, T. M. (2017). Jenter fortsetter å rase fra guttene på skolen [Girls continue to storm ahead of boys in school]. Retrieved from <https://www.nrk.no/norge/ekspertutvalg-skal-undersoke-hvorfor-jenter-gjor-det-bedre-enn-gutter-pa-skolen-1.13706126>
- Statistisk Sentralbyrå [SSB]. (2017). Guttene havner bakpå [Boys are lagging behind]. Retrieved from <https://www.ssb.no/utdanning/artikler-og-publikasjoner/guttene-havner-bakpa>
- Stoet, G., & Geary, D. C. (2018). The gender-equality paradox in science, technology, engineering, and mathematics education. *Psychological Science*, 29(4), 581–593.
- Szabo, A. (2017). Matematikundervisning för begåvade elever – en forskningsöversikt [Mathematics education for talented students—a research overview]. *NOMAD*, 22(1), 21–44.UDIR. (2017a).
- Tønnessen, E. (2018). Fortsatt få jenter på ingeniørfag [Still a few female engineering students]. Retrieved from <https://khrono.no/ikt-norge-tekna-jenter-og-teknologi/fortsatt-fa-jenter-pa-ingeniorfag/210901>
- UDIR. (2017a). Analyse av nasjonale prøver på 8. og 9. trinn 2017 [Analysis of national tests in 8th and 9th grade]. Retrieved from <https://www.udir.no/tall-og-forskning/finn-forskning/tema/nasjonale-prover/resultater-fra-nasjonale-prover-pa-8.-og-9.-trinn/>
- UDIR. (2017b). Analyse av nasjonale prøver på 5. trinn 2017 [Analysis of national test in 5th grade]. Retrieved from <https://www.udir.no/tall-og-forskning/finn-forskning/tema/nasjonale-prover/resultater-fra-nasjonale-prover-pa-5.-trinn/>
- Vogt, K. C. (2018). Svartmaling av gutter [Catastrophising boys]. *Norsk Sosiologisk Tidsskrift*, 2(2), 177–193.
- Wedeg, T. (2007). Gender perspective in mathematics education: Intentions for research in Denmark and Norway. *ZDM – The International Journal on Mathematics Education*, 39(3), 251–260.
- With, K., & Solomon, Y. (2014). Choosing mathematics in Norway and England: Discourses of gender, equity and choice. *Philosophy of Mathematics Education Journal*, 28.

The relevance of mathematics and students' identities

Andualem Tamiru Gebremichael

Universitetet i Agder, Norway; andualemtam@yahoo.com

This paper reports on a project, which explores the relevance of mathematics to students in an Ethiopian school. The data collection, which involved group interviews, was undertaken in 2010-2011. The analysis process identified themes that captured diverse perceptions of relevance and students' identities. The focus of this paper is on diverse aspects of students' identities and their relationship with students' perceptions of the relevance of mathematics. The analytic framework is cultural historical activity theory. The results indicate that the students' perceptions of relevance and identity are dialectically related.

Keywords: relevance, identity, mathematics curriculum, dialectical relation.

Introduction

This paper reports on data collected in 2010–2011. It is part of a research project, which was launched in 2009, and had two phases: a pilot study and a main study. The participants were students of a *preparatory* school (equivalent to an upper secondary school) in Ethiopia. The study examined students' perceptions of the relevance of mathematics to their future goals, their everyday life and society. Previous studies have investigated perceptions of mathematics' relevance focusing on upper secondary school (e.g. Sealy & Noyes, 2010; Black et al., 2010) and middle school (e.g., Masingila, 2002). Sealy and Noyes (2010) identified three different categories regarding the perceived relevance of mathematics to students' future goals: usefulness, exchange value and transferable skills. They note how students' perceptions are varied across different schools, and argue that such variations are linked to differences in the social and cultural situations of students as well as differences in the social context of the schools. They assert that the mathematics curriculum and its pedagogy should be framed in accordance with these varied perceptions of relevance.

Black et al. (2010) relate students' identities to the exchange value and use value of mathematics focusing on students' aspirations to study mathematically demanding subjects and their future career plans. They argue that the exchange value and use value of mathematics frames students' motives for studying mathematics. Use value relates to how mathematics enables one to pursue a vocation, and exchange value refers to what mathematics offers, e.g. it may enable one to join the university or obtain an academic degree. Black and colleagues suggest that identity develops alongside the motive, students' identities influence their perceptions of the use value and exchange value of mathematics.

Students' perceptions of the relevance of mathematics to their everyday life has also been examined previously (Masingila, 2002). Masingila's study is about students in Kenya. Her aim is to close the gap between students' experiences of mathematics in the classroom and its use in out-of-school contexts. She identifies six mathematical categories which are consistent with Bishop (1988): counting; measuring; explaining; playing; locating; and designing. Furthermore, some studies relate mathematical identities and perceptions of relevance to students' cultural backgrounds (e.g., Nasir, 2002; Nasir & Saxe, 2003). Nasir's (2002) study highlighted how students establish a sense of identity as learners in relation to their African-American cultural backgrounds. She argued they learn better when tasks

relate to their sociocultural backgrounds, such as playing dominoes and basketball. A similar study by Nasir and Saxe (2003) reported that students experience tensions between how they are situated in school and in out-of-school cultural practices (Nasir & Saxe, 2003). This body of work highlights how identity relates to race, and its influence on power (Nasir & de Royston, 2013) supporting Gutiérrez (2013) who also calls for the sociopolitical turn in exploring racial identity in mathematics education.

The Ethiopian sociocultural context has peculiar features and its schooling has a peculiar history. Before the introduction of modern education in Ethiopia, there have been traditional education associated with Islam and Orthodox Christianity. Modern education was introduced in Ethiopia around the beginning of the 20th century (Wagaw, 1979). In 1908, a modern school was opened in Addis Ababa (Hoot, Szente, & Mebratu, 2004). It was named after the Emperor, Minilik II, who ruled the country in that period. Modern education was not in line with the country's needs in some ways, where many of the subjects were languages such as Arabic, English and French (Wagaw, 1979). Wagaw asserts that though local languages such as Amharic and Ge'ez were taught as subjects, the language of instruction was not any of the local vernaculars (the language of instruction for the participants in the current study is also English). Although education was considered as a gateway to getting a job, some parents were sceptical about 'modern education' fearing it would not maintain cultural values (Wagaw, 1979). According to Wagaw, the clerics also expressed concern about maintaining Ethiopian values, a worry shared by some scholars.

Participants of the current study were 16 to 18 years old, yet distinguished from the rest of their age group as they are considered as elites (high ability). Because they joined the preparatory school based on their success in the second of the three national examinations in the Ethiopian school system. They expect to join university after sitting the third and final national examination.

It is important to examine if students perceive that mathematics is relevant to their everyday life, society and future studies, and how students perceive the reason for learning and engaging with mathematics. Preliminary results of this study were reported earlier (Gebremichael, 2013). The purpose of the current paper is to show the relationship between perceptions of mathematics' relevance and students' mathematical identities. This introduction provides background information, which can help the reader to understand the results. In the following sections, I provide the theoretical and methodological issues before presenting the data and its analysis. I finalize the paper with my concluding remarks.

Theoretical issues

Cultural historical activity theory (CHAT) is adopted as the theoretical perspective in this study. I employed Engeström's mediational triangle (Engeström, 2001) to understand how the students spend their time at home and at school. In the current study, the school and the family-life are considered as two different activity systems (see Figure 1). In the school, students experience and use artifacts, signs and tools such as textbook, lessons, etc. while undertaking actions towards the goals of learning mathematics and the other school subjects. The students are subjects of the schooling activity, and interact with the object (Roth et al., 2004). The object of an activity system consists of material objects, the motive, and the goals (Roth, 2007). The object of the school activity system consists of the motive and the goals, including students' future goals. The school's motive could be producing students who can succeed in the national examination to attend university and become capable of

solving problems of everyday life and society. The school's goals could be providing adequate knowledge for realizing the motive.

The artifacts, rules, community and division of labor mediate this interaction (Roth, 2007). There are rules, which govern members of the community. According to the rules, students should follow the classroom norms, attend to specific topics and sit examinations. Students are members of the school community, which also interacts with the object. These relationships are also mediated by the division of labor among members of the school community; the students and the teacher have different roles. There could also be differences in the roles of students. There are authorities, who have roles in deciding who will go to preparatory school and university. These authorities are represented by the school administrators, who enforce the rules set by these authorities and form part of the community. The students are divided into social science (SS) and natural science (NS) streams. These are also communities. The mathematics teacher also classifies them in terms of achievement level. The teachers of the various school subjects are members of the school community. According to the school rules, the students are operating in a school, which implements a nationally designed curriculum. Mathematics teachers are required to follow the nationally produced textbook (Federal Democratic Republic of Ethiopia Ministry of Education, 2010). This artifact influences another school artifact, the lesson. It is from this textbook that teachers give classwork and homework.

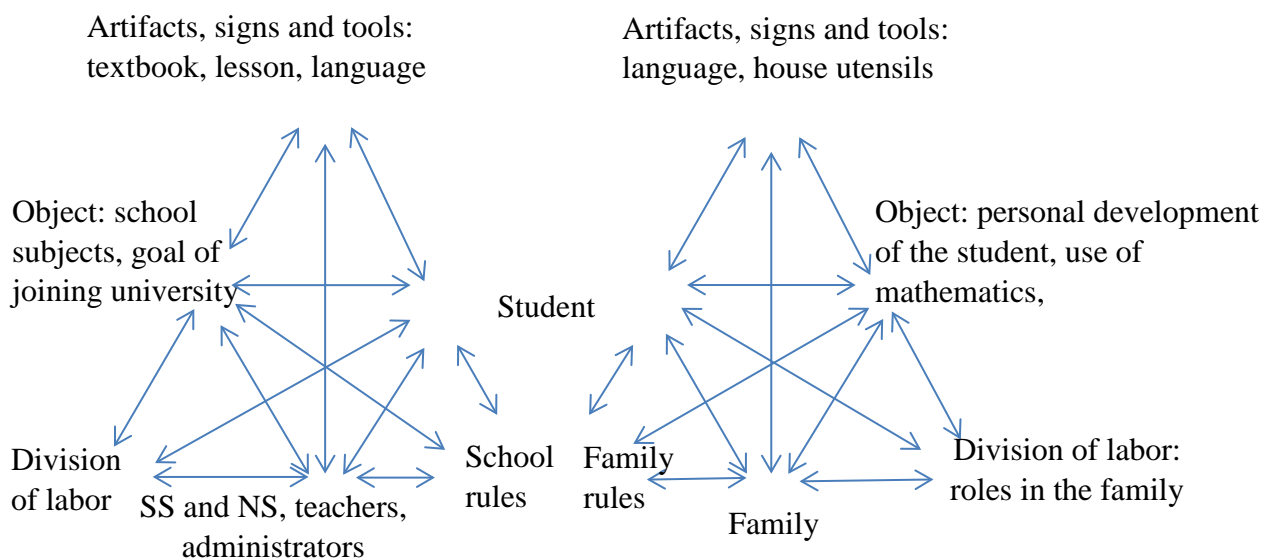


Figure 1: Network of activity systems adopted from Engeström (2001)

Figure 1 shows that the components of the activity systems are related to each other, and the double arrows represent the dialectical relationship between them. The figure represents two activity systems: school and family-life. As in the school activity, the student is subject of family-life activity, and interacts with the two objects as an actor. The object of the family-life activity system consists of material objects, home tasks, motive and goals. The motive of the family-life activity could be survival of the family, and one goal of this activity is a student's personal development. As part of this goal, the student engages in school tasks and family members provide support. Participants experience contradictions between the components of activity systems, and contradictions are considered as sources of development (Roth et al., 2004). Students may experience contradictions

between objects of the school and out-of-school activities. For example, as we will see in the data presentation, preparatory mathematics is hardly seen as useful in everyday life and society. These contradictions can be sources of development of particular perceptions of relevance and identity.

As long as there is activity, there is an acting individual, and the individual's identity is integral to the activity (Roth, 2007). Roth et al. (2004) distinguish between social and personal identity. In my study, the students seem to form aspects of identity as they participate in the school and out-of-school activities. Personal identity is where the individual student recognizes her/himself as such, and the student can also have a social identity where other members of the community recognize her/him as such (Roth et al. 2004). For example, a student is recognized by others as a high achiever. Roth and Lee (2007) suggest a third aspect of identity, collective identity, which an individual holds as a member of a group. Students are recognized as members of SS or NS streams. Collective identity is associated with the structure, which includes the components of activity systems (Roth & Lee, 2007). The national curriculum and the instruction language (which is foreign to them) are parts of the structure.

Artifacts, rules, community and division of labor mediate students' identities (Roth et al., 2004). For example, the teacher recognizes students as such based on their roles in the classroom. The division of labor also mediates the perceptions of relevance as the teacher directs students' attention to what might be of value for future studies in both the SS and NS communities. The school rules, which enforce the significance of success in examinations, can mediate the students' personal as well as social identities. The rules direct the students' attention to the importance of examination scores for recognizing themselves or others. The teacher's recognition of students as such is also based on examination scores. In addition to the rules, which enforce the adopted curriculum, the school and out-of-school artifacts mediate students' identities as Ethiopians and perceptions of mathematics' usefulness. The contradictions, which they experience between the objects of the school and out-of-school activities, can be sources of development both in relation to their national identities and in addressing doubt about mathematics' usefulness in everyday life and society.

Methodological issues

Group interviews were undertaken where each group had three students of the same sex and same class. Each group had high, medium and low achieving students. The intention of the grouping is to make students feel comfortable and remind each other of their respective experiences. Following Miles and Huberman (1994), I conducted data reduction through listening to the video-recorded interviews. This was done to simplify the data and obtain focus by deciding on which pieces of data provided the best idea of what each participant is saying. This data reduction process was influenced by the research questions and aimed to expose the students' perceptions of the relevance of mathematics. I made a table indicating the time and a description of what the interviewer and interviewees said. I transcribed the utterances of students that possibly exposed their perceptions of the relevance of mathematics and related issues. Then, I followed Miles and Huberman, and undertook coding. Miles and Huberman (1994) explain that coding of written transcripts can be undertaken based on the research questions and can employ concepts that are often used in certain theoretical perspective. The excerpts reported in the data presentation and analysis are students'

responses to the interview questions about the relevance of mathematics. After coding was completed, the next step was to examine the coded text to obtain themes (e.g., Miles & Huberman, 1994). I grouped the data segments with the same recurring topic into a particular theme.

Data presentation and analysis

This section presents examples and analysis of the interview data under two subsections as follows.

Students' personal and social identities and the relevance of mathematics to future goals

Students tell stories which relate to their identities and mathematics' relevance to future goals.

Andualem: What do you want to study in the future? Is mathematics useful for what you want to study? How do you come to know about its use?

Milkias: I want to study law. I ... do not think that it has mathematics ... Some teachers say to us, you [SS students] are not serious about mathematics because you think you do not need it in the future. [12th grade, SS, male]

Andualem: Why do you learn and engage in mathematics?

Beliyu: Primarily, to get a higher rank in the class. I derive pleasure from it [getting a higher rank] to get some knowledge because I have a target to meet.... The reason for coming to school is that I have a target that I hope to meet. In order to meet that target, I have to work now.... My target is to learn well and become someone in a field of study I like. ... I want to study medicine. [11th grade, NS, female]

Sofia: It is joyful answering about something you know. It tells who you are. Let us say I graduated [from the university] and someone asked for help, how could I explain to him, if I do not know about it? However, if I know it, I can explain it without feeling ashamed. Therefore, I enjoy knowing it, even though I do not benefit from it.

Andualem: Do you have such experience of helping others in mathematics?

Sofia: I have little brothers and sisters and I help them ... My brother used to help me and advise me using his own experiences. Now, he is studying at the university. [11th grade, SS, female]

Identities and perceptions of relevance seem to emerge as students participate in school and out-of-school activities (e.g., Sofia's story). They emerge in the interactions between the subject, the communities and the objects of the activities (Milkias's story). The rules and the division of labor mediate students' identities as well as their perceptions of relevance (Beliyu and Milkias's stories). The school rules, which enforce that students should master certain mathematics topics and are ranked in the class based on examination scores, direct their attention to the relevance of mathematics to their future goals and to recognize themselves as such (see Beliyu's story). The division of labor also mediates their identities; for instance, their teachers recognize Beliyu and Sofia as high-achieving students. In the family-life activity, there is interaction between the community and the object, in which members of the family have roles in the student's personal development (e.g., Sofia's story).

The rules in family-life activity enforce that students should follow what their elders tell them to do and that elders should care for the younger. Members of the family recognize each other as such. The rules and the division of labor in family-life activity direct students' attention to recognize themselves as such in connection with mathematics. The division of labor also determines their perceptions of relevance as the teacher directs the students' attention to the relevance of mathematics with respect to their current community and their future study (Milkias's story). The students also perceive that mathematics has exchange value (e.g., Beliyu's story). The school rules, which mediate the students' identity, mediate this perception of relevance.

Other members of the community such as the mathematics teacher, recognizes the individual student as such (e.g., Beliyu and Sofia). This could be their social identities (e.g., Roth et al., 2004). There is a distinction between the areas of study, which students of SS and NS streams can progress to at university. There is also evidence of a collective identity (e.g., Roth & Lee, 2007). Based on their membership of either SS or NS streams, students recognize themselves or others recognize them as members of these communities, particularly, in connection with the implications this membership has for the use of mathematics in future studies (e.g., Milkias's story).

Students' national identities and the relevance of mathematics to the nation

Students tell stories relating to national identity and mathematics' use in everyday life and society.

Andualem: Is preparatory mathematics useful in everyday life? In the society?

Akalu: I think that is the difference between the others [other countries/ societies] and us. They are more practical, but we grasp the theory and we get confused where to apply it. That is the problem. [11th grade, NS, male]

Haleluya: We learn to change our situations in a scientific way. Therefore, what we learn has to be related to our everyday life ... After consuming two or three pages, you get ... numbers. ..., what is its importance in my life? Or something related to ... society. Our country might not have a need for mathematics. However, in economics, many people want to know ..., and about business, about alleviating unemployment ... How we can use our resources. [12th grade, SS, male]

The students perceive that preparatory mathematics is hardly useful in everyday life and society. The lessons and the textbooks mediate the perceptions of relevance by offering mathematics topics with hardly any usefulness in everyday life and in Ethiopian society (e.g., Haleluya's story). These artifacts direct students' attention to recognize themselves in connection with their attending of a national mathematics curriculum. The rules and artifacts, which enforce the content of school subjects for SS and NS communities, mediate students' identities by directing the students' attentions to the available gaps (e.g., Haleluya's story). The division of labor, which gives students the role of grasping the theory and does not allow students to have a clear idea of where to apply it, directs students' attention to recognition of themselves as such (e.g., Akalu's story). In addition, participants experience contradiction between the objects of the school and out-of-school activities in Ethiopian society (e.g., Akalu's story). The experiencing of this conflicting situation can be a source of the development of national identity. The students belong to a society, which uses artifacts and has a cultural heritage that

are Ethiopian, though diverse. They operate in an Ethiopian school system, which enforces Ethiopian education policy. Students are experiencing a national mathematics curriculum, which hardly embraces the situation in Ethiopian society (e.g., Haleluya's story). They learn in a foreign language. These national features form the structure in which national identity emerges.

Concluding remarks

The different aspects of students' identities and their perceptions of relevance are dialectically related (one presupposes the other). They recognize themselves as preparatory students, who have a future goal of joining university. Then, they perceive that preparatory mathematics has an exchange value in giving access to this future goal. Thus, an exposition of students' perceptions of relevance presupposes their identities. In addition, students' expositions of identities presupposes their perceptions of mathematics' relevance as having exchange value in giving access to university study, as well as in being ranked high in examinations. The teacher's recognition of students as SS and NS students presupposes the relevance of mathematics to these students' future study, which influences their perceptions of relevance. The students' perceptions of relevance also presupposes their identities as SS and NS students as well as their identities as future students of certain disciplines. The exposition of perceptions of mathematics' relevance to everyday life and society appears to presuppose who they are as mathematics learners in this Ethiopian situation. On the other hand, their expositions of national identities are based on perceptions of mathematics' relevance to Ethiopian society and everyday life.

The current study exposed national identity, which is different from ethnic or racial identity (e.g., Gutiérrez, 2013; Nasir, 2002; Nasir & de Royston, 2013; Nasir & Saxe, 2003). These works attempt to examine identity of particular minority groups within a larger national culture (e.g., American culture, American school system where school rules enforce the American curriculum). But each national context has peculiar features. The sociocultural situations, including out-of-school activities, and the artifacts students experience in the school and outside of the school are likely to be different in various national contexts. National identity is a collective identity, and consistent with Roth and Lee (2007) the focus is on the structure. It is important to examine this identity in national contexts with peculiar features of the structure including adopted curriculum, use of language foreign to them, etc.

Therefore, mathematics education in Ethiopia must consider the sociocultural situation in which it sits. The situations that separated parents from students, in the introduction of modern education, still appear to prevail in the students' learning of mathematics. Students feel detached from their society with respect to the usefulness of mathematics. Further investigations need to be undertaken in this direction.

References

- Bishop, A. J. (1988). Mathematics education in its cultural context. *Educational Studies in Mathematics*, 19(2), 179–191.
- Black, L., Williams, J., Hernandez-Martinez, P., Davis, P., Pampaka, M., & Wake, G. (2010). Developing a 'leading identity': The relationship between students' mathematical identities and their career and higher education aspirations. *Educational Studies in Mathematics*, 73(1), 55–72.

- Engeström, Y. (2001). Expansive learning at work: Toward an activity theoretical reconceptualization. *Journal of Education and Work, 14*(1), 133–156.
- Federal Democratic Republic of Ethiopia Ministry of Education (2010). *Mathematics: Student textbook grade 11*. Addis Ababa, Ethiopia: Aster Nega Publishing Enterprise.
- Hoot, J. L., Szente, J., & Mebratu, B. (2004). Early education in Ethiopia: Progress and prospects. *Early Childhood Education Journal, 32*(1), 3–8.
- Gebremichael, A. T. (2013). Ethiopian preparatory students' perceptions of the relevance of mathematics to learning goals. In B. Ubuz, Ç. Haser, & M. A. Mariotti (Eds.), *Proceedings of the Eighth Congress of the European Society for Research in Mathematics Education* (pp. 1359–1368). Ankara, Turkey: Middle East Technical University.
- Gutiérrez, R. (2013). The sociopolitical turn in mathematics education. *Journal for Research in Mathematics Education, 44*(1), 37–68.
- Masingila, J. O. (2002). Examining students' perceptions of their everyday mathematics practice. *Journal for Research in Mathematics Education, 11*, 30–39.
- Miles, M. B., & Huberman, A. M. (1994). *Qualitative data analysis: An expanded sourcebook*. Thousand Oaks, CA: Sage Publications.
- Nasir, N. S. (2002). Identity, goals, and learning: Mathematics in cultural practice. *Mathematical Thinking and Learning, 4*(2-3), 213–247.
- Nasir, N. S., & de Royston, M. M. (2013). Power, identity, and mathematical practices outside and inside school. *Journal for Research in Mathematics Education, 44*(1), 264–287.
- Nasir, N. S., & Saxe, G. B. (2003). Ethnic and academic identities: A cultural practice perspective on emerging tensions and their management in the lives of minority students. *Educational Researcher, 32*(5), 14–18.
- Roth, W.-M. (2007). Emotion at work: A contribution to third generation cultural-historical activity theory. *Mind, Culture, and Activity, 14*(1-2), 40–63.
- Roth, W.-M., & Lee, Y.-J. (2007). “Vygotsky’s neglected legacy”: Cultural-historical activity theory. *Review of Educational Research, 77*(2), 186–232.
- Roth, W.-M., Tobin, K., Elmesky, R., Carambo, C., McKnight, Y.-M., & Beers, J. (2004). Re/Making identities in the praxis of urban schooling: A cultural historical perspective. *Mind, Culture, and Activity, 11*(1), 48–69.
- Sealy, P., & Noyes, A. (2010). On the relevance of the mathematics curriculum to young people. *The Curriculum Journal, 21*(3), 239–253.
- Wagaw, T. G. (1979). *Education in Ethiopia: Retrospect and prospect*. Ann Arbor: The University of Michigan Press.

Social inequalities in mathematics from a socialization theoretical point of view – Analysis of problem-solving processes of students

Belgüzar Kara¹, Bärbel Barzel²

¹University of Duisburg-Essen, Germany; belguezar.kara@uni-due.de

²University of Duisburg-Essen, Germany; baerbel.barzel@uni-due.de

Keywords: Problem-solving, diversity, inequality, habitus

Theoretical background

In the recent German school curriculum, mathematical problem solving is anchored obligatorily as an important competence for mathematics learning. Since 2008, competence expectations for problem solving have explicitly indicated what the pupils are supposed to have acquired at the end of grade 4 (Ministerium für Schule und Weiterbildung des Landes Nordrhein-Westfalen, 2008). But empirical research results indicate that the demands can generate inequalities with regard to social origin (Cooper & Dunne, 2000; Lubienski, 2000). Achievement studies confirm the impact of socio-economic status on mathematic achievement (Stubbe, Schwippert, & Wendt, 2016). Research in mathematics education on social inequalities in the acquisition of mathematical competences observes different achievement in dealing with problem solving tasks specific to social class (Cooper & Dunne, 2000; Piel & Schuchart 2014). The study by Lubienski (2000) shows differences between students with different socioeconomic status (SES) dealing with problem-centered materials. The analyses show, for example, that,

In general, lower-SES students focused more on giving the right answer to a question (...), whereas higher-SES students were more inclined to discuss a method or an idea. (...) lower-SES students were more likely to use language in “common-sense” reasoning that was closely tied to the context of the problems. (...) Higher-SES students were more likely to contribute in relation to abstract, strictly mathematical contexts and to use generalized language and reasoning. (p. 369)

Based on the theories of Bourdieu (1987) and the research work of Lareau (2011), in the study presented here, the problem-solving process is analyzed from a perspective of socialization. The theory of habitus (Bourdieu, 1987) is used as an analytical tool for the mediation between the individual problem-solving process and the structural conditions of the social background. Lareau (2011) identified two milieu-specific child-rearing approaches and characteristic practices associated with the two educational styles: Middle-class families concerted child rearing on cultivation, working-class families concerted child rearing on accomplishment of natural growth. In particular, Lareau (2011) describes the two approaches as differently beneficial learning environments and socialization conditions for school practice. For example, while the discussion and argumentation between child and parents is an essential feature in the child-rearing approach of concerted cultivation of the middle classes, the child-rearing approach of accomplishment of natural growth of the working class is characterized by direct instructions. If the characteristics of child-rearing approaches are considered in competence expectations and the inherent structure of problem-solving, origin-related differences in competence development can be expected through habitual dispositions. The danger

that mathematical competence expectations have undesired impacts for less privileged students, which in turn can have the consequence that accessibility to mathematical contexts and the intended learning processes become more difficult or blocked, is subject of this investigation.

Design and methods of the study

The praxeological approach theory establishes dialectical relationship between objective structures and structured dispositions of the acting actors and serves as the epistemological fundamentals for the investigation. A mathematics performance test and student and parent questionnaires were used to select and classify pupils according to mathematical achievement level and social background. Data was then collected within the framework of individual clinical interviews during the processing of a total of three mathematical problem-solving tasks to get an insight into possible differences in the process.

Results

The preliminary analysis according to the phases model of Schoenfeld (1985) gives an indication of milieu-specific ways of acting through the phenomenon of the abridged analysis and exploration of mathematical problem-solving tasks of students from families of less privileged origin. The focus on a direct approach like one-word-answers without complete comprehension of the task has so far only been observed in students of less privileged origin. The correct answer seems to be more important than the understanding or discussion of the task which is unfavorably supported by the abridged analysis and exploration.

References

- Bourdieu, P. (1987). *Distinction: A social critique of the judgement of taste*. London: Routledge.
- Cooper, B., & Dunne, M. (2000). *Assessing children's mathematical knowledge: Social class, sex and problem-solving*. Buckingham: Open University Press.
- Lareau, A. (2011). *Unequal childhoods: Class, race, and family life* (2nd ed.). Berkeley: University of California Press.
- Lubienski, S. T. (2000). A clash of social class cultures? Students' experiences in a discussion-intensive seventh-grade mathematics classroom. *The Elementary School Journal*, 100(4), 377–403.
- Ministerium für Schule und Weiterbildung des Landes Nordrhein-Westfalen (Ed.) (2008). *Richtlinien und Lehrpläne für die Grundschule in Nordrhein-Westfalen*. Frechen: Ritterbach.
- Piel, S., & Schuchart, C. (2014). Social origin and success in answering mathematical word problems. The role of everyday knowledge. *International Journal of Educational Research*, 66, 22–34.
- Schoenfeld, A. H. (1985). *Mathematical problem solving*. Orlando: Academic Press.
- Stubbe, T. C., Schwippert, K. & Wendt, H. (2016). Soziale Disparitäten der Schülerleistungen in Mathematik und Naturwissenschaften. H. Wendt, W. Bos, C. Selter, O. Köller, K. Schwippert, & D. Kasper (Eds.), *TIMSS 2015: Mathematische und naturwissenschaftliche Kompetenzen von Grundschulkindern in Deutschland im internationalen Vergleich* (S. 299–316). Münster: Waxmann.

Towards guidelines for the analysis of teaching materials in linguistically and culturally diverse mathematics classrooms

David Kollosche

Pädagogische Hochschule Vorarlberg, Austria; david.kollosche@ph-vorarlberg.ac.at

An ongoing research project aims at analysing and improving materials for teaching mathematics at German community colleges to non-native speakers of German. This paper first gives details on the circumstances of the study. Because of a lack of empirical research on the analysis and design of appropriate teaching materials for multilingual mathematics classrooms, this paper then discusses research findings from socio-political, linguistic and socio-linguistic perspectives and theoretically deduces guidelines for the analysis and improvement of the teaching materials.

Keywords: Multilingualism, learning problems, instructional materials, sociolinguistics, community colleges.

Analysing teaching materials for multilingual mathematics teaching in Germany

As a basis for teaching elementary mathematics to adults who experienced difficulties with mathematics, the German Community College Association had both a curriculum and teaching materials developed for corresponding courses (Deutscher Volkshochschul-Verband, 2017). Course contents are organised in three different entry levels, beginning with a therapeutic approach to dyscalculia, covering basic arithmetic operations with bigger numbers, and arriving at secondary school mathematics contents which are considered useful in private and vocational environments. The development was pursued on the basis of empirically founded theories of learning mathematics but the materials were not themselves tested in practice. In a follow-up project, which is headed by the author of this paper, the practical usefulness of the materials is to be evaluated theoretically and empirically with the aim to guide and implement improvements. It is paramount to understand that the teaching materials constitute the central manifestation of the idea of the course, for teachers in German community colleges, even those teaching mathematics, are usually laypersons in mathematics who orient their teaching by the materials available. Apart from the questions in how far the available materials mirror the educational philosophy of the curriculum and whether they are practical to use with students who experienced difficulties with mathematics, the evaluation project lays a special focus on the suitability of the materials for learners whose first language is not German. Irrespective of the other goals of the project, this paper will illuminate *how teaching materials in mathematics can be analysed for their suitability for non-native speakers of German.*

Despite a substantial increase in research publications on multilingual mathematics classrooms during the last two decades (e.g., see the edited volumes of Barwell, 2009; Barwell et al., 2016; Halai & Clarkson, 2016; or, for the German case, Prediger & Özdil, 2011), insights on suitable material is still scarce. In her recent meta-study of all 51 anglophone journal articles on mathematics education in multilingual classrooms published between 1970 and 2012, Setati Phakeng (2016) found only six articles that explicitly discuss didactical and methodological aspects of teaching in such environments, whereas the majority of the publications focusses on linguistic explanations for critical moments in the learning process. As Prediger and Wessel (2011) argue, the same is the case for the German

research community, “for up to now there are relatively few empirically founded insights on the question what constitutes special linguistic and subject-related obstacles for multilingual learners of mathematics and with which support (of empirically tested efficacy) such obstacles can be overcome” (p. 163, my translation). Clearly, the question of material-use in multilingual mathematics classrooms has yet to be studied, a task that cannot be achieved in this project. As the goal of this project is to analyse available teaching materials from the perspectives of multilingual learners, *the following discussion sets out to synthesise the results from previous studies on multilingual mathematics classrooms and to deduce guidelines for the analysis of teaching materials*. Accordingly, it can be understood as an early theorisation of material use in multilingual classrooms.

The specific situation of Germany and its community colleges

As this project is located at community colleges in Germany, some information on the local circumstances is required to interpret the following discussion from an international perspective. Although Germany knows some autochthonous languages other than German, some of which are accepted as official languages in small regions of Germany (e.g., Danish and Sorbian), plus some regional languages (e.g., Low Saxon) and a large variety of regional dialects of High German, Germany constructs its national identity as a monolingual country. Immigrants are expected to learn German and school education is almost exclusively organised in German. In most cases, multilingualism is based on immigration. Nearly every fourth German citizen has an immigration background (i.e. at least one parent born with a nationality other than German). Many immigrants, mostly but not exclusively of Turkish descent, were invited to West Germany in the 50s and 60s as so-called guest workers, stayed and founded families. In addition, people with German ancestors resettled to Germany in the last decades, mostly from the former Soviet Union. Germany has also welcomed a large variety of refugees with an especially large population from Syria, Iraq and Afghanistan arriving in the last years. Consequently, education in Germany faces a wide variety of cultural backgrounds and proficiency in the German language, with many students of immigrant background being born and educated in Germany, some speaking mostly German with their parents, and some having been learning German for a few years only. Nevertheless, the German situation differs a lot from the situations in bilingual communities (as on Malte, in French Canada or in Spanish-speaking communities in the USA), in classrooms with different regional languages (as in South Africa or India), and in classrooms with revitalised a language (as in Ireland). Therefore, it has to be checked carefully in how far research results from these socio-cultural settings can be transferred to the German situation.

The German educational system appears to be ill-equipped to face the challenges of multilingual classrooms, given that, irrespective of intellectual capability, an immigration background is highly correlated with under-average achievement in national assessment (OECD, 2007). As a lack of proficiency in the German language has been shown to influence learning negatively, the perceived achievement gap is mainly being associated with language deficits (Herwartz-Emden, 2003). Indeed, a recent study with 766 pupils of Turkish descent attending a German primary school labelled about a half of this population as not competent in German, seeing their chances to participate in the German-speaking classroom substantially limited (Dollmann & Kristen, 2010). All in all, estimates assume the proportion of students who did not learn German as a first language to lie around 20%,

thus identifying a large proportion of the student population in risk of being disadvantaged by the German school system (Chlosta & Ostermann, 2008). In regard to mathematics education, studies suggest that the under-achievement of multilingual learners can partly or even totally be explained by language deficits (e.g., Heinze, Herwartz-Emden, Braun, & Reiss, 2011). For example, differences in achievement between first and second language speakers of German disappeared when problems were presented symbolically instead of verbally (Heinze et al., 2011). Some authors go as far as claiming that “subject learning can essentially be understood as language learning”, thereby accentuating the focus on linguistic obstacles towards the learning of mathematics (Gellert, 2011, p. 98, my translation). Consequently, research in the last two decades has aimed at explaining how multilingual students in German mathematics classrooms are systematically disadvantaged and at exploring how education can create a supportive and inclusive environment for such students.

However, the situation of students in German community colleges differs from the situation of students in regular schools and has not yet been studied in relation to mathematics education: Students in mathematics courses at community college attend these courses voluntarily, as adults they have more extensive life and work experiences, and they assume to have problems with mathematics. As a consequence, different to the situation in the regular school system, mathematics courses at community college are first and foremost concerned with learning mathematics in a supportive environment rather than with simultaneously improving the mastery of German.

On the politics of multilingualism in mathematics classrooms

Discourses on language use in public education are usually ideologically biased as they closely interfere with national language, minority and immigration policies. Such bias has also been found in research. For example, Leung, Harris and Rampton (1997) revealed that the anglophone discourse on multilingual classrooms implicitly assumed that multilingual students do not use English at home, primarily learn English in school and thereby face comparable problems, altogether assumptions that do not withstand any closer analysis. Nevertheless, they constitute the group of those whose first language is not the language of instruction as a distinct group of others, sharing specific problems and needing the same kind of support. It is in such ways that the multilingual student is constructed as a deficient learner in spite of the fact that multilingual students differ a lot in their abilities and needs (Halai, Muzaffar, & Valero, 2016). As will be explained later, an alternative explanation resting on the distinction of certain language registers allows to analyse a wide range of linguistic difficulties of first and second language speakers simultaneously, leading the focus away from first language status and towards language proficiency in general.

Linguistic obstacles for multilingual learners are partly created by the classroom policy of promoting German as the only language of communication in school (except in foreign language classes). This limitation means that often students cannot use all of their language resources, not even when they work in pairs or groups with their language peers, thus denying them options of participation that have proven highly beneficial (Meyer, 2016). Instead, students learn not to use their first language for their learning endeavours, a process that leads to a devaluation of immigrant languages (which, in an act of resistance, might be used as a solidary signs of a specific ethnic affiliation) and to the installation of German as the hegemonic language in science and politics (Setati, 2005). This

attribution of social status to the different languages spoken by the students leaves its traces in the micro-structure of education. For example, Schütte (2009) revealed that mathematics teachers communicate the meaning of mathematical language almost exclusively in an implicit form, thereby systematically leaving behind many multilingual learners who rather require explicit explanations (Tshabalala & Clarkson, 2016, provide similar results from English-speaking classrooms).

In an attempt to discuss the situation of multilingual mathematics learners from a perspective that does not construct under-average achievements as an issue of individual deficits, recent studies have promoted the ideas to valorise multilingualism as a resource (Barwell, 2018). Indeed, several studies prove that competent multilingualism is closely related to achievement in mathematics, probably because of meta-cognitive abilities either pre-existent or acquired by the learning of multiple languages (e.g., Clarkson, 1992). In German mathematics classrooms with students of Turkish background and a policy of free language use, code-switching between German and Turkish has proven beneficial for the understanding of mathematics (Meyer, 2016; Özdil, 2011). However, Swain und Cummins (1979) found that positive effects of the use of multiple languages in class depend on a language-friendly atmosphere where the learners' first languages share the same privileges as the language of instruction. In this respect, Meyer (2016) reports that he needed to have students teach him how to count in Turkish before they would feel comfortable to use Turkish in classroom conversation.

The impact of differences in language proficiency

Instead of focussing solely on the traditional categories of lexicon and grammar, a considerable part of differences in languages proficiency can more appropriately be explained by the analysis of different language registers. Already in the 50s, Bernstein (1996) started to analyse how the English language is used rather differently in different discursive situations and among different groups of society. He found that speakers of the working class often use a “horizontal code” which uses a particular set of vocabulary, rather easy grammatical constructs, and organises knowledge along personal stories and shared experience, while middle class speakers rather use a “vertical code” which uses more loanwords and nominalisations, more complex grammatical structures and an organisation of knowledge along universal logics. Above all, Bernstein also showed that students often lack the means to recognise the structure of the meaning-making process in the code they are not used to. This phenomenon results in substantial disadvantages for the participation of horizontal speakers in the primarily vertically organised discourse of school and mathematics education (Cooper & Dunne, 2000). In an adaption to the German situation, Gogolin (1988) differentiated between everyday language (*Alltagssprache*), erudite language (*Bildungssprache*) and subject-specific language (*Fachsprache*, in our case mathematical language), with each of them differing in their use of vocabulary, grammar and knowledge-organisation. For example, “if and only if” is a phrase that is typical for mathematical language but hardly used in everyday and erudite language.

While proficiency in everyday language can be obtained in about two years (Cummins, 2010), erudite and subject-specific German language takes four to eight years to learn for second language learners (August & Shanahan, 2006), creating a barrier for understanding and participation in the mathematics classroom (Gellert, 2011; Özdil, 2011). Vertical discourses in German can be extraordinarily difficult to decipher because of its synthetic grammar and extensive use of nominalisations, compounds,

dependent clauses, prepositional phrases and participial attributes – at times even causing German native speakers to pose linguistically problematic tasks as teachers (Rösch & Paetsch, 2011). Deseniss (2015) could show that students in Germany can much more easily describe the characteristics of erudite and mathematical language if their first language is German instead of any other language. However, proficiency in the vertical registers of the first language has been shown to support the acquisition of the vertical registers in the language of instruction (Celedón-Pattichis, 2004). It becomes clear that language-related learning barriers are not only a matter of immigrant background but to a large extent a question of a learner's socio-economic background. *En passant*, the same holds true for the learners' familiarity with situational context which might differ tremendously between learners of different socio-economic conditions, for example when it comes to planning a bicycle trip or reading the bicycle's speedometer (Rösch & Paetsch, 2011). So, while it is true that everyday vocabulary might pose a barrier for non-native speakers of German, for example when words such as "to remove", "to spend" or "to disappear" are used to explain subtraction, large parts of the mathematical language are equally unknown to speakers of the language of instruction, starting already with the quantity-based conception of words such as "more" and "less" (Walkerdine, 1988). The same is certainly true for the understanding and use of register-specific grammar. Consequently, a language-sensitive teaching of mathematics education should explicitly address the characteristics of the vocabulary, phrases and grammatical structures involved in erudite and mathematical language, for the sake of both non-native and native speakers of German (Gellert, 2011).

Finally, another problem arises from linguistic interferences, that is from the confusion of seemingly similar but functionally different linguistic structures in two languages. Confusion begins at the pre-verbal level, for example with different number symbols or with differences in marking bundles of thousands and the beginning of decimals (for "3,835.4" Germans write "3.825,4"), and extend to verbal constructions of numbers (Germans literally say "seven-and-fifty" instead of "fifty-seven") and other mathematical objects ("three-fifth" literally translates to "in five three" in Turkish) (Frenzel, 2017).

Consequences for the analysis and design of teaching materials

Instead of a summary of the ideas discussed above, the last section of this paper will deduce guiding questions for the analysis and design of teaching materials in multilingual mathematics classrooms. The underlying assumption is that, especially in educational environments where teachers are usually laypersons in mathematics, materials and the comments provided on them can provoke or hinder certain activities in the classroom and thus influence teaching substantially. In this sense, the question is in how far materials can constitute or induce new barriers for multilingual learners and in how far materials can be designed to include and support multilingual learners. The guiding questions are:

(1) *Does the text of the material include everyday language words of German which are used to clarify the meaning of mathematical content but might be unfamiliar to some learners?* Research in language-sensitive education proposes to collect and discuss the relevant vocabulary, to illustrate it in labelled pictures, to document it in various forms of word lists and to train its use by filling word puzzles or writing mathematics-related texts (Leisen, 2011).

(2) *Does the text of the material feature unnecessarily complex grammatical forms?* While such grammatical features can be understood as attempts to introduce learners to vertical registers of the

language of instruction, they pose a barrier for the understanding of mathematics for many students. Often such text can be reformulated into more comprehensible versions (see, e.g., Griebhaber, 2011).

(3) *Does the material allow or provoke an explicit discussion of the new mathematical vocabulary and phrases that come with the covered mathematical content?* If not, materials such as mind-maps with appropriate words and phrases or building sets with chunks of mathematical phrases can help (Leisen, 2011). Mathematical writing appears to be an activity that strongly supports learners in building up competence in vertical registers (Morgan, 1998), probably because it grants students more time and chances for revisions for the struggle with the language than verbal communication does. Reports from an unexpectedly successful Latino classroom in the United States, where a culture of mathematical writing was cultivated, support this assumption (Chval & Licón Khisty, 2009).

(4) *Does the material encourage learners to compare German formulations and notations with other languages in order to identify possible misunderstandings based on linguistic interference?* Even monolingual students may profit from an explicit comparison of different possibilities of expressing mathematical ideas. Such a comparison may be introduced by easy prompts: “If you speak any other language than German, do you know how to say this in the other language? Which way do you prefer?”

(5) *Does the material allow or provoke the use of other languages in the learning process?* As Meyer (2016) discovered that students have often internalised the German-only policy of the classroom and are inhibited from the use of other languages, more or less detailed prompts to provoke the use of other languages seem necessary if the resources of other languages are to be used in the classroom.

(6) *Does the material build on situational contexts which might not be well-known to some students, especially because of cultural and socio-economic differences?* If it does, it would be worth to check if the context can be changed to one all students are familiar with, or if the situational contexts can be clarified before proceeding with the mathematical analysis of the situation.

These theoretically deduced guidelines do only constitute a first approach towards the research-based analysis and design of teaching materials for multilingual mathematics classrooms. They refer more closely to the situation in German community colleges than to other localities of mathematics education. Its usefulness will be tested when the available teaching materials of the German Community College Association are analysed first on-the-paper and then in practice. For reasons of word limitations, this paper could not include a closer discussion of ethno-cultural obstacles towards the learning of mathematics, which Setati Phakeng (2016) sees in danger of being neglected in the mostly language-focussed discourse in academia. For example, Deseniss (2015) could identify different beliefs about the usefulness of mathematics and mathematics education between native and non-native speakers of German and even between different groups of non-native speakers. More research will be needed to apply the insights from cultural, linguistic, sociolinguistic and socio-political perspectives on multilingual classrooms to the analysis and design of appropriate teaching materials.

References

- August, D., & Shanahan, T. (2006). *Developing literacy in second-language learners: Report of the National Literacy Panel on Language-Minority Children and Youth*. Mahwah, NJ: Erlbaum.
- Barwell, R. (Ed.). (2009). *Multilingualism in mathematics classrooms*. Bristol: Multilingual Matters.

- Barwell, R. (2018). From language as a resource to sources of meaning in multilingual mathematics classrooms. *The Journal of Mathematical Behavior*. <https://doi.org/10.1016/j.jmathb.2018.02.007>
- Barwell, R., Clarkson, P., Halai, A., Kazima, M., Moschkovich, J., Planas, N., ... Villavicencio Ubillús, M. (Eds.). (2016). *Mathematics education and language diversity*. Cham: Springer.
- Bernstein, B. (1996). *Pedagogy, symbolic control and identity*. London: Taylor & Francis.
- Celedón-Pattichis, S. (2004). Alternative secondary mathematics programs for migrant students: Cultural and linguistic considerations. In C. Salinas & M. E. Fránquiz (Eds.), *Scholars in the field: The challenges of migrant education* (pp. 197–210). Charleston, WV: ERIC.
- Chlosta, C., & Ostermann, T. (2008). Grunddaten zur Mehrsprachigkeit im deutschen Bildungssystem. In B. Ahrenholz (Ed.), *Deutsch als Zweitsprache* (pp. 17–30). Freiburg: Fillibach.
- Chval, K. B., & Licón Khisty, L. (2009). Bilingual Latino students, writing and mathematics. In R. Barwell (Ed.), *Multilingualism in mathematics classrooms* (pp. 128–144). Bristol: Multilingual Matters.
- Clarkson, P. C. (1992). Language and mathematics: A comparison of bilingual and monolingual students of mathematics. *Educational Studies in Mathematics*, 23(4), 417–429.
- Cooper, B., & Dunne, M. (2000). *Assessing children's mathematical knowledge: Social class, sex, and problem-solving*. Buckingham: Open University.
- Cummins, J. (2010). *Language, power, and pedagogy*. Clevedon, England: Multilingual Matters.
- Deseniss, A. (2015). *Schulmathematik im Kontext von Migration*. Wiesbaden: Springer Spektrum.
- Deutscher Volkshochschul-Verband (Ed.). (2017). *DVV-Rahmencurriculum: Rechnen*. Bonn: DVV. Retrieved from <https://www.grundbildung.de/projekte/rahmencurriculum-transfer/material>
- Dollmann, J., & Kristen, C. (2010). Herkunftssprache als Ressource für den Schulerfolg? Das Beispiel türkischer Grundschulkiner. *Zeitschrift für Pädagogik*, 56(Suppl. 55), 123–146.
- Frenzel, B. (2017). Sensibel für Mehrsprachigkeit: Mathematikunterricht für neu zugewanderte Schülerinnen und Schüler. *mathematik lehren* 201, 39–41.
- Gellert, U. (2011). Mediale Mündlichkeit und Dekontextualisierung. In S. Prediger & E. Özdil (Eds.), *Mathematiklernen unter Bedingungen der Mehrsprachigkeit* (pp. 97–116). Münster: Waxmann.
- Gogolin, I. (1988). *Erziehungsziel Zweisprachigkeit*. Hamburg: Bergmann + Helbig.
- Grießhaber, W. (2011). Zur Rolle der Sprache im zweitsprachlichen Mathematikunterricht. In S. Prediger & E. Özdil (Eds.), *Mathematiklernen unter Bedingungen der Mehrsprachigkeit* (pp. 77–96). Münster: Waxmann.
- Halai, A., & Clarkson, P. C. (Eds.). (2016). *Teaching and learning mathematics in multilingual classrooms: Issues for policy, practice and teacher education*. Rotterdam: Sense.
- Halai, A., Muzaffar, I., & Valero, P. (2016). Research rationalities and the construction of the deficient multilingual mathematics learner. In R. Barwell et al. (Eds.), *Mathematics education and language diversity* (pp. 279–295). Cham: Springer.

- Heinze, A., Herwartz-Emden, L., Braun, C., & Reiss, K. (2011). Die Rolle von Kenntnissen der Unterrichtssprache beim Mathematiklernen. In S. Prediger & E. Özdil (Eds.), *Mathematiklernen unter Bedingungen der Mehrsprachigkeit* (pp. 11–33). Münster: Waxmann.
- Herwartz-Emden, L. (2003). Einwandererkinder im deutschen Bildungswesen. In K. S. Cortina, J. Baumert, A. Leschinsky, K. U. Mayer, & L. Trommer (Eds.), *Das Bildungswesen in der Bundesrepublik Deutschland* (pp. 661–709). Reinbek: Rowohlt.
- Leisen, J. (2011). Sprachsensibler Fachunterricht. In S. Prediger & E. Özdil (Eds.), *Mathematiklernen unter Bedingungen der Mehrsprachigkeit* (pp. 143–162). Münster: Waxmann.
- Leung, C., Harris, R., & Rampton, B. (1997). The idealised native speaker, reified ethnicities, and classroom realities. *TESOL Quarterly*, 31(3), 543.
- Meyer, M. (2016). Productivity and flexibility of (first) language use. In A. Halai & P. C. Clarkson (Eds.), *Teaching and learning mathematics in multilingual classrooms* (pp. 143–156). Rotterdam: Sense.
- Morgan, C. (1998). *Writing mathematically: The discourse of investigation*. Bristol, PA: Falmer.
- OECD. (2007). *PISA 2006: Science competencies for tomorrow's world*. Volume 2: Data. Paris: OECD.
- Özdil, E. (2011). Zur linguistischen Analyse mathematikdidaktischer diagnostischer Interviews. In S. Prediger & E. Özdil (Eds.), *Mathematiklernen unter Bedingungen der Mehrsprachigkeit* (pp. 117–142). Münster: Waxmann.
- Prediger, S., & Özdil, E. (Eds.). (2011). *Mathematiklernen unter Bedingungen der Mehrsprachigkeit: Stand und Perspektiven der Forschung und Entwicklung in Deutschland*. Münster: Waxmann.
- Prediger, S., & Wessel, L. (2011). Ein fach- und sprachintegrierter Förderansatz für mehrsprachige Lernende im Mathematikunterricht. In S. Prediger & E. Özdil (Eds.), *Mathematiklernen unter Bedingungen der Mehrsprachigkeit* (pp. 163–184). Münster: Waxmann.
- Rösch, H., & Paetsch, J. (2011). Sach- und Textaufgaben im Mathematikunterricht als Herausforderung für mehrsprachige Kinder. In S. Prediger & E. Özdil (Eds.), *Mathematiklernen unter Bedingungen der Mehrsprachigkeit* (pp. 55–76). Münster: Waxmann.
- Schütte, M. (2009). *Sprache und Interaktion im Mathematikunterricht der Grundschule*. Münster: Waxmann.
- Setati, M. (2005). Teaching mathematics in a primary multilingual classroom. *Journal for Research in Mathematics Education*, 36(5), 447–466.
- Setati Phakeng, M. (2016). Mathematics education and language diversity. In A. Halai & P. C. Clarkson (Eds.), *Teaching and learning mathematics in multilingual classrooms* (pp. 11–23). Rotterdam: Sense.
- Swain, M., & Cummins, J. (1979). Bilingualism, cognitive functioning and education. *Language Teaching*, 12(1), 4–18.
- Tshabalala, L., & Clarkson, P. (2016). Mathematics teacher's language practices in a grade 4 multilingual class. In A. Halai & P. C. Clarkson (Eds.), *Teaching and learning mathematics in multilingual classrooms* (pp. 211–225). Rotterdam: Sense.
- Walkerdine, V. (1988). *The mastery of reason*. London: Routledge.

How do we teach mathematics to refugee students? A qualitative study of the teaching and learning of mathematics in International Preparatory Classes

Maike Lüssenhop¹ and Gabriele Kaiser²

¹University of Hamburg, Germany; maike.luessenhop@uni-hamburg.de

²University of Hamburg, Germany, gabriele.kaiser@uni-hamburg.de

Although migration itself is not a new phenomenon, the rising numbers of refugees in Germany and Europe are influencing the population composition leading to greater diversity within our society. This particularly affects school systems, as a great number of refugees are of school age and have to be provided with adequate schooling. In this paper, we discuss how the German education system, in particular in the city of Hamburg, deals with the schooling and integration of refugee students in what are called International Preparatory Classes. We describe a research study, which is examining what aspects influence teaching practices in mathematics lessons in these classes for refugees. The study investigates how teachers in these classes design their lessons from a mathematical and a linguistic perspective, how they deal with the task of providing refugee students with adequate instruction and how students experience mathematics.

Keywords: Refugee students, teaching practices, mathematics classroom, diversity, mathematics education and language.

Introduction

[H]ow school systems respond to migration has an enormous impact on the economic and social well-being of all members of the communities they serve, whether they have an immigrant background or not. Some systems need to integrate large numbers of school-age migrants and asylum seekers quickly; some need to accommodate students whose mother tongue is different from the language spoken in the host community or whose families are socio-economically disadvantaged; some systems are confronted with all three challenges at once. (OECD, 2015a, p.1)

Indeed, it is a major challenge for the German school system to teach refugee students with limited knowledge of the German language and to provide them with adequate support. Refugee children and young adults are perceived as a vulnerable group with a diverse range of special needs. In Hamburg, refugees and other immigrant students attend International Preparatory Classes (IPCs). IPCs prepare them for admission into German mainstream classes. Currently, scarcely any research studies how mathematics teachers work with students in these particular IPCs. Moreover, little is known about how they design lessons while they are confronted with linguistic, cultural and performance-related heterogeneity (Benholz, Magnus, & Niederhaus, 2016). Supporting refugee students' development in general, and specifically in mathematics, is crucial for their participation in society and their ability to contribute to the society as a whole. Our study aims at contributing to close the existing gap in research but will also allow others (e.g., authorities) to use the knowledge gained for educational changes on several levels (Cornely Harboe, Mainzer-Murrenhoff, & Heine, 2016). In this paper, we present two case studies from two different mathematics classrooms. Sharing ideas and best practice examples in order to improve the schooling of refugees in the European Union and worldwide is of great importance for the international community as recognized by the OECD report (OECD, 2015b).

In the following, we introduce the current state of research on IPCs from a German perspective and present first results of our ongoing research.

National frameworks for IPCs

Although German federal states implement different school-organizational models of teaching children and adolescents from refugee families, three basic models can be recognized:

- Integrative model: In this model, the students of refugee families are taught in regular classes with additional language support in German.
- Parallel model: In this model, children and adolescents from refugee families are taught in separate classes that are set up for them. The greatest amount of teaching is dedicated to the acquisition of the German language.
- Semi-integrative models constitute a transition between these two models: Students who are taught in IPCs can already take part in regular classes, depending on the level of subject-specific competences in individual subjects (Massumi & Dewitz, 2015).

The three models outlined here are also prevalent internationally (OECD, 2015a). Countries deal very differently with the schooling of refugee students. Some countries such as Iceland and Norway follow the integrative model (Ragnarsdóttir, Berman, & Hansen, 2017), others such as Spain follow the parallel model (Gorgorió & Planas, 2001).

The framework for IPCs of the local education authorities in Hamburg provides insight into the current situation of schooling of refugees in Hamburg and Germany, since each year school-aged refugee children and adolescents move to Hamburg with little to no knowledge of the German language. According to the Geneva Convention, all children are guaranteed the right to education. The Geneva Refugee Conventions (Article 21), the UN Universal Declaration on Human Rights (Article 26) and the UN Convention on the Rights of the Child (Article 28) as well as the German Basic Law (Article 3) explicitly encourage compliance with this right (El-Mafaalani & Kemper, 2017). In IPCs at different types of schools (primary/middle/high school etc.), refugee students are prepared for entry into mainstream classes.¹ The objective of IPCs is to enable children and adolescents to learn the German language and thus to facilitate their integration into the German-speaking environment as smoothly as possible. Students that are able to write in the Latin script, start in IPCs that focus on learning the German language and basic knowledge of other subjects. Students who are illiterate² or literate in a different script – such as Arabic – gain German reading and writing skills in literacy classes. These classes focus on reading and writing in the Latin script and on basic German skills. IPCs aim at providing a quick transition to an age-appropriate class, suiting students' individual education level at general or vocational schools (mainstream classes). Refugee students can be admitted into IPCs at any time of the year and stay in them for a period of twelve months. The number of students in each class is around 15. The language learning process in all different forms of IPCs is divided into two phases in the first year of schooling. In the first phase (basic level), students acquire basic knowledge in German and receive guidance in dealing with, and acting within, the

¹ Immigrant students from EU-countries or other countries are also schooled in IPCs. In our study, however, we focus on refugee students who recently and forcibly fled from their country of origin.

² By illiterate, we mean that these students can neither read nor write.

German-speaking world. This first phase should not be longer than 6 months. At the end of this phase, the parents receive information about the performance and learning development of their children in learning development talks organized by the teachers. These meetings advise parents on further schooling and acts as an exchange on how best to support the development of their children.

The second phase (advanced level) focuses on the preparation of the students for classroom communication and the use of subject-specific language in different subjects. After six months, students receive a transition certificate. At the end of the second phase, students transfer into mainstream classes and receive additional language tutoring for another year.

The basis for teaching in IPCs are the frameworks and curricula of German as a Second Language in IPCs at each school level, in which minimum requirements and assessment for performance are set. The level of difficulty of teaching is oriented towards the Common European Framework of Reference for Languages. Subject-specific instruction, such as mathematics, is based on the minimum requirements laid down in the curricula offered in each grade. The framework for IPCs in Hamburg focuses more on the macro level of the regulation of the schooling process than on the micro level of actually teaching the subject. It recommends, however, that teachers orient themselves towards the minimal requirements of the mathematics curricula for mainstream classes.

Current state of research on IPCs

In empirical educational research (in general), there are numerous and comprehensive analyses of the educational opportunities of various groups of refugees. In particular, the research field covers studies on participation in education, educational transitions, acquisition of competencies, and school success. In-depth analyses focus especially on social background, gender and ethnic background and/or migration background. Despite this highly differentiated field of research, the long history and increased presence of refugees, it is surprising that the educational opportunities and conditions of refugee students have not been steadily researched (El-Mafaalani & Kemper, 2017). Unsurprisingly, however, since Germany had a high influx of refugees in 2015, interest in education policy and research into the education of refugees has increased. This interest is also reflected in the literature and more recent research publications (Kleist, 2017).

Nevertheless, a paucity of research is still especially obvious when the focus turns to subject-specific instruction in IPCs, including mathematics education. Some studies use ‘wordless methods’ of teaching mathematics to circumvent possible language barriers. In his study, (Oswald, 2017) used ‘wordless methods’ with adolescent refugees and found that it had a positive impact on the motivation of the students and the teachers. Furthermore, Mink & Sauerwein (2017) conducted a teaching project in one IPC on figured numbers and proofs without words. They found that only after intensive study of the material the mathematics could be understood, and it remained questionable whether students who see a visualization for the first time can use this to carry out complex proofs, since they are still unfamiliar with elementary mathematical activities. Despite the intention of these ‘wordless methods’, it is not possible to avoid oral explanations, which were difficult for participating students to understand. Most of the respective research projects implemented so far focus on language and mathematics (Prediger & Schüler-Meyer, 2018), or mathematics in the context of migration (Deseniss, 2015). In other words, this research does not consider mathematics lessons with refugee students and their teachers. Exceptions are the studies by Oswald (2017) and Mink and Sauerwein

(2017), which focus on new teaching methods for IPCs. However, there currently exists no research on the actual classroom practices of teachers in IPCs. Although an increasing number of textbooks and teaching materials for refugee students are published by publishers all over Germany, there is clearly a gap in scientific research concerning the needs and challenges of teachers and students in IPCs.

Apart from the German state of research, there exists an extensive discussion on the teaching and learning of mathematics in multilingual classrooms that highlights social, cultural and linguistic aspects of mathematics teaching and learning (Gorgorió & Planas, 2001; Moschkovich, Wagner, Bose, Rodrigues Mendes, & Schütte, 2018). As most of these studies focus bilingual or multilingual classrooms and not classrooms with only refugee or immigrant students, we can only draw partially on these studies. For example, Barwell et al. (2016) stress that situations of language diversity have been extensively examined, such as bilingual and multilingual context. They underline that there is a need in researching trilingual contexts where learners are exposed to home languages, a national and an official language. However, they do not focus on students that are second languages learners (sometimes referred to as minority learners, immigrant students) with different native languages. Furthermore, refugee students might come from countries with multiple national languages, which equals bilingual students, but most of them have no knowledge of the academic language, in this case German, at all, when they enter IPCs. However, Barwell et al. focus partly on second language learners. Gorgorió & Planas (2001) conducted research on language and socio-cultural aspects of mathematics education in a classroom with a high percentage of immigrant students and they are particularly convinced of the importance of continuing to study the teaching and learning of mathematics in multiethnic and multilingual situations. Moreover, they emphasize the need for continuing studies not only in terms of equity and social justice, but also in terms of the richness of the research ground.

Overall, these studies and the above-mentioned gaps in the research highlight the need for a deeper understanding of what is happening in the IPC mathematics classrooms, what affects the (teaching) practices of teachers and the challenges they face when it comes to teaching materials, previous knowledge of refugee students etc. This research project aims at narrowing this research gap.

Research questions and aims of the study

Overall, it can be stated that the framework for IPCs does not offer advice for teachers on how to teach mathematics to refugee students except to focus on the minimum requirements of the same or similar grade of general schools. Furthermore, the analysis of the current state of research on IPCs in the previous section shows that there is a research gap in the field of mathematics in the context of IPCs relating to best practices, teaching materials and theoretical approaches. Hence, our study highlights findings from research that explores mathematical teaching practices and aims at researching mathematical teaching approaches and mathematical practices within the IPC mathematics classrooms.

Our research project investigates the following research questions:

How do teachers deal with the task of designing and implementing mathematics lessons for refugee students? What kind of practices and which materials do they use, and how do social, cultural and linguistic aspects influence the learning and teaching of mathematics in IPCs?

Overall, the aim of this study is to generate knowledge about how teachers design lessons, which theories from other subjects their lessons are based on, and whether these fit the needs of the students they teach. More insight is necessary on the challenges mathematics teachers are encountering in IPCs, and how they deal with them within the mathematics lessons in order to develop supportive learning environments for refugee students.

Design of the study

The study is embedded in the project “Mathematics and refugees” at the University of Hamburg, a subproject of the state-funded research network “Everyday Mathematics as Part of Basic Adult Education”, the so-called “Hamburg Numeracy Project”. The research network focuses on (adult) numeracy practices and their use of everyday mathematics, focusing on particularly vulnerable groups, for example refugees and asylum seekers, over-indebted, and disabled persons. The presented study is qualitatively oriented and focuses on the IPC mathematics classroom and the practices of mathematics teacher and their students. The sample of the study consists of teachers and students from three comprehensive schools at lower and higher secondary level in Hamburg. For the data collection, we use different methods such as classroom observation, guideline-based interviews with the mathematics teachers and narrative interviews with 3-4 students from each class.

The study has been conducted in the last 6 months of 2018 and this paper emerges from a larger research project which we described above. At first, informal talks to gain a first impression of the research field have been carried out with teachers outside of the classroom. After that, participatory observations of four lessons each lasting 45 minutes have been conducted. From these observations and the literature we draw on, we generated questions for the guideline-based interviews. Each IPC-teacher has been interviewed for approximately one hour. The interviews focused on the question how teachers design mathematics lessons in IPCs, for example how they deal with the particular heterogeneity of the learning group, how they proceed methodically and didactically, which challenges occur and how they deal with them, and so forth. Moreover, we conducted narrative interviews with refugee students from each class. The interviews focused on the experiences of the students inside the mathematics classroom of their country of origin and in their new school in Germany. The data collection and analysis has been based the coding paradigm of Grounded Theory (Corbin & Strauss, 2015). All interviews conducted have been recorded and transcribed. Furthermore, the data collected has been or will be evaluated with MAXQDA.

Preliminary results

In the following, we focus on two IPCs at two different comprehensive schools in Hamburg, which were selected as paradigmatic cases reflecting general characteristics of the whole database. We summarize selected aspects of the observation of four lessons in the mathematics classroom and informal conversations with teachers and students. In this paper, we name these classes IPC A and IPC B to distinguish certain aspects of the observation. Both IPCs are linked to grade 7/8 teaching groups (inter-year groups) situated in parts of Hamburg with a low social index.

Both classes consisted of approximately 12-15 students at the age of 12-16 years. The majority of the students came from Syria, Afghanistan and Iraq. According to both mathematics teachers, the students were very heterogeneous in terms of their mathematical competences and educational biography. Some students from Afghanistan had never gone to school before having fled to Germany,

others had finished primary or secondary school in Syria and directly joined the German system, and again others had not gone to school for many years. In addition, both classes had students from Eastern European countries, for example from Bulgaria, or students from countries such as Thailand, Turkey, Ghana and Togo.

Teachers' mathematics and teaching experiences

The mathematics teachers of both IPCs had a very different educational biography but both were class teachers of the observed classes, meaning that they taught most of the subjects and lessons of their IPC. The teacher of IPC A completed her teacher education, worked and researched abroad, had a PhD and worked as a lecturer at university level in educational science, particular in multilingualism, migration and education. It was her first year teaching an IPC and the first time teaching mathematics to students. She emphasized that she did not study mathematics as a subject in her studies, but she had a very good knowledge of the didactics of German and German as a Second Language and carried out extensive research in the field of migration. The teacher of IPC B has completed his teacher education and taught mathematics in IPCs for seven years. He did not study mathematics as a subject at university but completed an additional course in mathematics some years ago. At that time, there was no specific teacher education program for IPC classes. Since the increase of new immigrant students in recent years, many teachers who have been employed for the newly created school classes have completed a German as a Second Language degree. Often these teachers have to teach mathematics lessons in their IPCs, also due to the existing lack of teachers of mathematics. This means that many teachers lack the didactic and mathematical knowledge of mathematics. In some cases, underqualified teachers were also recruited because the positions in the IPCs could not be filled otherwise. This highlights the fact that apparently many teachers have very different experience with IPCs and teaching mathematics as a subject.

Linguistic aspects

Teacher A paid significant attention to the native languages of the students, which is in line with the accepted research results. A table with important German sentences hang on one of the walls of the classroom, such as “What does that mean in German?”, “Good Morning”, “Can you help me?”. Students added a translation of these sentences in their own mother tongue. Throughout the school year, the teacher studied all sentences of the languages of her students herself. At the beginning of each week, students were allowed to test her language skills. Apart from this, language comparisons between German and the native language of the students were an integral part of the lessons. In addition, two of the weekly lessons in mathematics focused on subject specific vocabulary. With teacher B the picture was contrary. Even if some posters with German grammar were hanging on the walls of the classroom and some dictionaries were available, a set of rules was attached to the teachers table forbidding or avoiding the usage of native languages of students. This seemed to be a general rule for the IPCs of this school. This handling of the native language of the students contradicts findings from language teaching research and general pedagogy, and yet seems to be widespread.

Mathematical Aspects

In IPC A, students were taught in cross-class teaching two hours per week in homogenous groups regarding their performance in mathematics, and the other two-hour classes on subject-based mathematical language in their original classes. Some students sat in groups according to mother

tongue, topics or performance. There were chalk-and-talk phases within the lesson and reflections on mathematical vocabulary. Work sheets with topics such as addition, subtraction, multiplication of fractions and subtraction of fractions with different denominators, text problems etc. mainly focused on basic mathematics. Students were working on different worksheets with diverse topics. After each lesson, the teacher collected the sheets, corrected them and handed them back during the next lesson. Furthermore, the teacher offered some enactive materials such as wooden fraction models. In IPC B, each student worked on his/her own work plan. The teacher talked to each student for 5-10 minutes and gave personal support, no chalk and talk phases occurred. Topics were similar to IPC A and focused on basic mathematics such as subtraction, addition, fractions and so on. In both classes, some students worked with the mathematics textbook that was being used in the mainstream classes they are supposed to transfer to after completing IPC.

Discussion and looking ahead

The two case studies presented here emphasize the great diversity of the design of the lessons in IPCs and the learning opportunities provided by the two teachers based on the heterogeneous group that they were teaching. Socio-cultural aspects played a crucial role, as students seem to have very different backgrounds according to their previous educational development and different linguistic background (and possibly experiences with flight, conflict and/or war). The role of the linguistic aspects in the observed lessons was handled very differently by the two teachers and led to different learning environments. Drawing on the research results of Prediger and Schüler-Meyer (2017) and other scholars, who emphasize that the appreciation of the students' native language has positive effects on students' motivation and confidence, we find it a concern that only one of the two teachers was drawing on these findings. This might indicate that there is a need of further education in terms of the inclusion of the native language of the students.

Furthermore, the initial results of the study point out that the two teachers design their mathematics lessons very differently. Nevertheless, both of them tried to adapt their classes to the need of the students, in a way that they think is best for them. Earlier on, we demonstrated that there is no official curriculum for mathematics in IPCs and few adequate teaching materials that have been developed in the last years. This is also reflected in the initial results, as both teachers' lessons are mostly based on self-developed materials. Overall the two case study presented in this paper provide first insights into how teachers deal with the task of carrying out mathematics lessons to refugee students. The research seems to suggest that the educational background of the teachers influences the way in which they carry out this task, especially concerning linguistic aspects and the role of mathematical content and the kind of its inclusion, but also how external factors influence the learning and teaching of mathematics, such as socio-political and socio-cultural aspects.

References

- Barwell, R., Clarkson, P., Halai, A., Kazima, M., Moschkovich, J., Planas, N., ... Ubillús, M. V. (2016). *Mathematics education and language diversity: The 21st ICMI Study*. Cham: Springer.
- Benholz, C., Magnus, F. K., & Niederhaus, C. (2016). *Neu zugewanderte Schülerinnen und Schüler – eine Gruppe mit besonderen Potentialen: Beiträge aus Forschung und Schulpraxis*. Münster, New York: Waxmann.

- Corbin, J. M., & Strauss, A. L. (2015). *Basics of qualitative research: Techniques and procedures for developing grounded theory* (4th ed.). Los Angeles: SAGE.
- Cornely Harboe, V., Mainzer-Murrenhoff, M., & Heine, L. (Eds.) (2016). *Unterricht mit neu zugewanderten Kindern und Jugendlichen: Interdisziplinäre Impulse für DaF/DaZ in der Schule*. Münster, New York: Waxmann.
- Deseniss, A. (2015). *Schulmathematik im Kontext von Migration*. Wiesbaden: Springer Spektrum.
- El-Mafaalani, A., & Kemper, T. (2017). Bildungsteilnahme geflüchteter Kinder und Jugendlicher im regionalen Vergleich: Quantitative Annäherungen an ein neues Forschungsfeld. *Z'Flucht: Zeitschrift für Flüchtlingsforschung*, 1(2), 173–217.
- Gorgorió, N., & Planas, N. (2001). Teaching mathematics in multilingual classrooms. *Educational Studies in Mathematics*, 47(1), 7–33.
- Kleist, O. (2017). *Flucht- und Flüchtlingsforschung in Deutschland: Bestandsaufnahme und Vorschläge zur zukünftigen Gestaltung*, from Institut für Migrationsforschung und Interkulturelle Studien (IMIS) & Bonn International Center for Conversion (bicc).
- Massumi, M., & Dewitz, N. v. (2015). *Neu zugewanderte Kinder und Jugendliche im deutschen Schulsystem*. Köln. Retrieved from https://www.portal.uni-koeln.de/sites/international/aaa/92/92pdf/92pdf_REFUGEEES_PUBL_MI_ZfL_Studie_Zugewanderte_im_deutschen_Schulsystem_final_screen.pdf
- Mink, M., & Sauerwein, M. (2017). Mathematikunterricht in einer Internationalen Vorbereitungsklasse. *GDM-Mitteilungen*, 103, 16–20.
- Moschkovich, J. N., Wagner, D., Bose, A., Rodrigues Mendes, J., & Schütte, M. (2018). *Language and Communication in Mathematics Education: International Perspectives*. Cham: Springer.
- OECD (2015a). *Helping immigrant students to succeed at school – and beyond*. Retrieved from <https://www.oecd.org/education/Helping-immigrant-students-to-succeed-at-school-and-beyond.pdf>
- OECD (2015b). *Immigrant students at school: Easing the journey towards integration. OECD reviews of migrant education*. Paris: OECD.
- Oswald, N. M. R. (2017). Beweise ohne Worte mit jugendlichen Geflüchteten. *GDM-Mitteilungen*, 102, 5–11.
- Prediger, S., & Schüler-Meyer, A. (2018). Mathematikunterricht: Interkulturelle Perspektiven auf Mathematikunterricht – Ein Überblick zum Diskussionsstand. In I. Gogolin, V. B. Georgi, M. Krüger-Potratz, D. Lengyel, & U. Sandfuchs (Eds.), *Handbuch interkulturelle Pädagogik* (pp. 518–525). Bad Heilbrunn: Verlag Julius Klinkhardt.
- Ragnarsdóttir, H., Berman, R., & Hansen, B. (2017). *Successful educational contexts in Iceland for immigrant students: Case studies of nine Icelandic schools*. SAGE Research Methods Cases. <https://dx.doi.org/10.4135/9781473981676>

Using photo-elicitation in early years mathematics research

Dorota Lembrér

Western Norway University of Applied Sciences, Bergen, Norway, dorota.lembrier@hvl.no

In this paper, I examined the use of photo elicitation interviews as a method for gathering data from parents, whose views are not often investigated in research in early childhood mathematics education. The parents shared and discussed photos of their children engaged in mathematics. This method for gathering parents' views is investigated using Bourdieu's theoretical lens of the field. The findings suggest both advantages and disadvantages that established rules of the field which could interfere with or enhance relationships. Photo-elicited interviews can provide insights into parents' knowledge, experiences and views, revealing broader perspectives on mathematics activities at home. However, the choice of photos influenced the interview, limiting or silencing parents if they were unable to recognise any mathematics in what the children were doing in a photo.

Keywords: Home environment, parents, photo elicitation interview, research methodology

Introduction

In this paper, I discuss the advantages and disadvantages of using photo elicitation focus group interviews to gain insights from nine parents, who have children in preschools in Norway, about mathematics education at home. In a photo elicitation interview (PEI), a single photo or a set of photos are used as stimuli during a research interview (Hurworth, 2004).

Vasilyeva, Laski, Veraksa, Weber, and Bukhalenkova (2018) concluded that parents' involvement in school and preschool practices has a significant impact on children's development and learning. Studies have shown that there is generally a positive association between parents' engagement in their children's education and students' academic outcomes (e.g., Galindo & Sheldon, 2012). These studies concluded that parents and family members have a role in children's achievement in preschool and school. Therefore, it is not surprising to find that parents' funds of knowledge when interacting with children at home have been recognised by researchers (Björklund & Pramling, 2017), with parents and families being acknowledged as children's first educators (Phillipson, Gervasoni, & Sullivan, 2017). The relationships between parents, teachers and children has consequences for children's engagement with mathematics.

Nevertheless, issues remain about the kind of role parents are expected to have. Most research focuses on parents' limited ability to support their children's mathematics learning at home. Although parents might feel welcome at preschool (Hujala, Turja, Gaspar, Veisson, & Waniganayake, 2009), Whyte and Karabon (2016) suggested the communication is typically one-way, from preschool to home. Although parents, such as immigrant parents, can have different views (Civil, Bratton, & Quintos, 2005), their views about mathematics done at home are often marginalized or absent in mathematics education research (Milner-Bolotin & Marotto, 2018). It is the teachers' expertise which is expected to enhance parents' awareness of their children's learning of mathematics (Streit-Lehmann, 2017). Consequently, some researchers, such as Anderson and Anderson (2018), have stressed the need for more understanding of the mathematical experiences of young children that adults mediate at home. To conduct research which values parents' views about mathematics education for young children at home there is a need for an appropriate methodology.

To better understand the views of parents about the mathematics that their children engage with at home, I wanted to use photo elicitation interviews. PEIs are considered more effective in gaining insider views than information gained through exclusively verbal methods (Hurworth, 2004). In PEI, participants are asked to take photos on a topic (Epstein, Stevens, McKeever, & Baruchel, 2006). Using the photos as stimuli in interviews supports participants to reflect on a moment or an action (Torre & Murphy, 2015). Frith and Harcourt (2007) stated, “We saw the photographs as a reference point to be used in conversation rather than an objective representation of reality that has a meaning independent of these conversations” (p. 1342). Conversations around photos of everyday life can provide understandings how both the photographer and the viewer construct meaning. Thus, PEI are considered to facilitate dialogues that participants find enjoyable (Pain, 2012) and which enhance collaborative and participatory forms of data collecting.

In early childhood studies, photo elicitation has been used in several ways to try to gain participants’ views on particular issues. Clarke and Robbins (2004) stated that discussions between parents and teachers when sharing photos taken by the parents created opportunities for a better understanding of aspects of activities captured in these photos: “The nature of these and the parents’ ability to articulate them was a surprise to many of the teachers in the project” (p. 181).

In this paper, I examine photo elicitation interviews as a methodology for gathering data from parents about their views on mathematics. The paper is divided into three further sections. First, I outline Bourdieu’s notion of a field as the theoretical framework for identifying the advantages and disadvantages for gathering data in this way. Secondly, I describe my study of parents’ views, before, finally, I use examples from my study to discuss PEI’s advantages and disadvantages.

Theoretical framework

Parents’ involvement in and preparations for PEI occur within power relationships, as they are influenced by the knowledge they have about the subject of mathematics and how this knowledge is then described by the researcher. As well, within a social situation such as the group interview, there is a negotiation of power and this determines which parents’ views are heard. Thus, I have used Bourdieu’s notion of a *field* to consider how parents and their social positions are located (Bourdieu & Wacquant, 1992). Social positions refer to the knowledge, skills, resources and dispositions that parents take into their discussions with other parents and myself as the researcher. These inform the types of relationships that parents have in society and with the institution of preschool.

Key aspects of Bourdieu’s notion of a field are production and the material resources of power and capital. Capital refers to the variety of resources, noticeable and hidden, through which agents can further their aspirations and achieve “success” in the field (Bourdieu, 1975). A social position arises from an interaction between the rules of the field, the parent’s habitus and the parents’ capital (social, cultural and economic). The field is the social arena in which positions are available for agents, each with a different habitus (behaviour, dispositions to act in the social world), and which are constructed by relations between agents in this field. These relations are bound by rules, which are dynamic in that they can differ within the field and be changed and adjusted by circumstances. Additionally, understanding the impact of capital can help to unpack and explain what is hidden, for example, in the parents’ photos as it determines what is valued as mathematics activity. Identifying the capital

that parents make use of within PEIs provides an opportunity to see how this affects their sharing of views.

Habitus can also help to unpack the set of dispositions parents use to identify the mathematics in their children's activities, as these are rooted in their experiences of schooling (Grenfell & James, 1998). Habitus includes a sense of parents' place in a social situation and the status they bring, such as how comfortable they feel in an interview and their views about what is expected of them to say or do.

The data in my study

Using Bourdieu's notions, I discuss the advantages and disadvantages of photo elicitation interviews by using examples from my study of nine Norwegian parents' (4 males, 5 females) views on mathematics activities their children engage in at home. This is a typical sample size for photo-elicited research involving both the production of visual data (photos) and participants' discussions and reflections of the photos (e.g., Clark-Ibáñez, 2004; Miller, 2015). Participants received guidelines in a letter about what to photograph (children engaged in mathematics), how many photos to take (10), time to complete this task (one week) and where to send the photos after completing the task. No data that could identify participants, such as income, education and family structure, and demographic details, were collected. The parents were asked to attend focus group interviews in which some of the photographs were used as stimuli. In group one, there were four parents, in group two five. During the interviews, the parents used their photo and those of others as a basis for sharing their views about children's mathematics activities.

In reflecting on my use of PEI, I was able to identify both advantages and disadvantages associated with gaining an insider view on parents' understanding about their children's mathematics activities. In the reflection, I also need to consider how my position as the researcher and facilitator of PEI may have affected my understanding. I come from a working-class background, was a preschool teacher in a low-income household area, and am a mother of two children. My research focuses on mathematics education in preschool and at home. These personal characteristics and experiences influence my position in the field and affect my habitus and doxa (organising the rules of PEI in the field of social situation to discuss photos). Reflecting on PEI supports me to understand how my own background can hinder or support me making sense of parents' views.

Discussion

Reflecting on PEI contributed to identifying advantages and disadvantages in generating data from it. In particular, the parents' cultural capital seemed to affect their sharing of views about their children engaging with mathematics.

Disadvantages of PEI

Drawing on Bourdieu's theoretical notion of the field, I could identify some of the parents' available positions which were affected by parents' habitus and dispositions to discuss mathematics activities and the status they brought to the situation. Although earlier research suggested that PEI is an effective strategy to gather data for investigating parents' views, it has some challenges.

PEI requires participants to be provided with more or less detailed instructions about what to photograph. However, the field in which these instructions are given in my study is that of research, a field in which not all participants can determine the implicit rules. For example, the participants

needed to understand how the photos would be used, including ethical, privacy and sampling issues, but this information was not provided. It was clear that their interpretation of these issues shaped how and what they took photos of in their home environments. This sometimes resulted in the parents not being able to describe their views on the mathematics young children could engage in. For example, a parent stated, “I think he shows fingers too, but I did not manage to take a picture to capture that”. For a researcher, knowing the context of the discussion stimuli is important. However, like this parent, it did not always occur to the participants to take notes about the circumstances of a photo. This lack of knowledge about the research field affected how much each photo contributed to the discussions. If the parent who had taken the photo could not remember why they had taken it, then it was often difficult to provoke a discussion amongst the other participants. Thus, it seems that I needed to be more aware of the habitus and dispositions that the participants brought to the task.

Although it is stated that PEI offers insights that might not be achieved through verbal-only methods, the usefulness of the data is still dependent on the interviewing skills of the researcher. Within the field of research, the researcher is accepted as being more knowledgeable about how to do the research than participants are. This power dynamic can affect participants’ willingness to discuss the topic if I, as the researcher, impose my own view, as occurred in the following example:

Researcher: Is Yahtzee a game that you play a lot in Norway?

Parent 1: It is a (holiday) cottage phenomenon.

Parent 2: Yes, yes, yes!

Researcher: Okay.

Parent 1: Yes, everybody plays Yahtzee.

Parent 2: All Norwegians that have respect for themselves have Yahtzee in their (holiday) cottages.

Researcher: So, you can claim that all children know Yahtzee in Norway?

Parent 2: Yes, I think so. They probably have the same in preschool too.

Researcher: But I mean, do you have it at home?

Parent 2: Yes, it’s quite common to have it at home.

Parent 3: Yes, it’s a regular game to have a home. Yes!

The rules of PEI used by myself, as the researcher to construct or, as Bourdieu stated, to produce, circulate and exchange knowledge, pushed the conversation in a particular direction through my follow-up questions. Although I was seeking clarification, the parents’ responses suggest that the conversation was somewhat awkward as they are not entirely sure what was being clarified and why. The parents’ answers suggest that they assumed that I as the researcher would have the same knowledge (cultural capital) about what would occur in holiday cottages, and as this was an experience shared by all Norwegians, it appeared not need elaboration. They seemed confused as to why I continued to question them about the presence of Yahtzee in Norwegian homes. The status they brought was not embedded in my habitus for understanding parents’ embodied views.

In the Yahtzee, example parents were placed in a position of having to convince me, which could affect their behaviour in later discussions, hence limiting their possibilities to develop a sense of trust in how I would make sense of the information they were providing. In another example, the angle of the photo of the outdoor game “stone skipping” did not provide an immediately recognisable mathematical situation for myself or other parents.

Parent 4: I think of distance, but I am unsure if this is correct.

Researcher: What are you doing?

Parent 4: My son will throw stones in the lake and has two stones, one in each hand. I do not know if you see here (pointing on the photo). No, you cannot see his hands!

Researcher: What you are thinking about this situation?

Parent 4: I think distance, but he does not. I do not know, maybe how far he should throw the stone?

The lack of response by other parents suggests that they perhaps did not share the social capital hidden in Parent 4’s photo, and thus did not “see” the potential mathematics that the child was engaging with. Whereas Parent 4’s habitus could be explained as a disposition to act in this activity, for the researcher to see a possible identification of mathematics in “stone skipping” to some degree was uncertain.

As well, differences in social capital between parents and the researcher can interfere with providing recollections about the content of the photo and its social context. For example, after a father spoke about playing an app on a tablet, a mother asked me, as a researcher, for an opinion about children playing apps. That parent seemed to consider that I had a form of cultural capital that gave me the possibility to evaluate the value of another parent’s point of view.

In summary, PEIs have some disadvantages, related to how parents’ positions are located in the field. As the facilitator of the PEIs, I, as the researcher, had more status and the social capital that I brought with me seemed to be considered more relevant for this research field. This unacknowledged valuing could limit the possibilities for parents’ views to be valued appropriately in the discussions. As a researcher, I needed to be aware of how I could overcome these disadvantages.

Advantages of PEI

Bourdieu’s notion of field situates parents’ positions (knowledge, skills and relationships) in interactions in which their habitus (behaviours and dispositions) is evident. From this notion, I could identify opportunities for gaining insights into parent’s views about mathematics activities at home for young children in the PEIs. In my project, 23 coloured photos were used to stimulate discussions. Parents used the photographs to discuss the mathematics they considered their children engaged with. Parents’ positions were constituted by the system of the relationships they had to each other as parents and having an interest in discussing and presenting their views on children’s mathematics activities at home.

Sharing photos engaged parents in discussions about their children engaging in a variety of mathematics situations at home (e.g., gaming, cooking, playing, building etc.). Some situations, such as playing the board games Ludo or Yahtzee, were recognized in the photos by many parents, suggesting that they shared social capital that allowed them to relate to these activities. This then

allowed them to share their understanding about their family resources to describe different strategies the family used to play these games with children. Within the social field of the group interview context, there were possibilities to uncover what parents had in common as the first educators of young children. The similar strategies for supporting children in the games, such as manipulating the game so that younger siblings had a chance to win or participate, suggested that the parents could “read” each other’s habitus and confirmed each other’s views on these situations being mathematical. The parents supported each other in a confident manner when discussing their children’s actions, for example, when they were using dice. In the field, there are different positions available for persons with different habitus, and they are equipped with different capitals. Their capitals can be valued differently and also in different ways (Bourdieu, 1975). Bourdieu stated that what is valued is important as what it is, and different ways of being engaged in mathematics at home may also be given different values. This is an example of a condition for being qualified as a capital.

For some parents, the sharing provided them with new ways to think about everyday activities. For example, a parent stated:

In a busy day at home, it is a bit difficult to think about mathematics, it’s not easy at all. You are not thinking about it. But once you are aware of it, you are going to find it, you’ll find it all over the place.

From the everyday activities, these parents could identify and discuss mathematics and its possible relevance in home environments. As considered with cultural capital, parents’ views about mathematics activities can be gained through PEI and it becomes relevant to reflect on mathematics from their point of view.

The photos taken in environments well known by the parents supported them to express their point of view. The parents’ photos had been taken because the parents believed that they showed their children engaging with mathematics, based on their knowledge of what could be labelled mathematical. As parents’ participation in PEI includes a system of power relations between positions, the parents seemed to share cultural capital by recognising that they also engaged in similar situations, which meant they were able to take powerful positions as experts within the research field. This was in contrast to situations where PEI did not support the sharing of views – a result of one person, often me as the researcher, being seen as having more valuable knowledge or by acting as though that was the case.

Conclusion

Drawing on Bourdieu’s notion of the field to reflect on the impact of using PEIs in early years mathematics research, habitus was a tool for understanding parents’ dispositions and had to do with conditions that are set up in the field. The way in which the parents understood the structure of PEI and how this knowledge was incorporated in their habitus was influenced by the new experiences of discussing photos with others. The condition of PEI was structured internally in terms of power relations between parents and researcher and had an impact on gaining insights into parents’ views about mathematics activities of young children. Parents views are embedded between structure, their habitus and capitals and are representations of implicit relations that affect what is considered as mathematics activities. In the field of research, parents struggle over the unequal distribution of and

definition of what are the most valued views. Therefore, it is a matter of distinguishing the most worthwhile efforts and methodology where parents' views can be carried out.

A field can be considered as a social arena of the positions available for persons, each person with a different habitus. In a certain field different capitals are valued (Bourdieu, 1975). As a method for gathering data, PEI includes certain kinds of rules which made a limited set of positions available for those who participated in a study. PEIs are described as enabling participants to record and reflect on their own perspectives and concerns, by promoting dialogue about issues and views through discussions about photos (Miller, 2015). When initiating PEI, I had no doubt that parents' dispositions to take an active position in discussion required me to be reflective. As the parents had already identified mathematics activities at home when they decided to take specific photographs, they came into the interviews situated as experts. In the parts of the interviews in which they could situate themselves as experts, parents were able to discuss the different photographs by talking about the mathematics that they saw their children engaged with at home.

However, there were challenges in using PEIs which hindered the parents in retaining the position of expert in those interviews. As a researcher, I was located within the research field, where I organized the rules and guidelines for PEI. Although the formal rules were sent out with the information letter, there were invisible rules connected to the field of research that the parents were unaware of such as keeping notes about the photos they had taken, which affected the data which was produced.

The PEI methodology is a social activity, where parents could contribute with a certain kind of knowledge, based on their capitals and habitus. Parents suggested that taking photos gave them new views on the activities their children engage in at home. They also found the task to be of interest and helpful to unpack their own views about mathematics education for young children at home. As a researcher, reflecting on the use of PEI to gather data has helped me understand how my actions can support or limit parents providing their views about the mathematics that their children engaged with at home. This is important if I am to be able to evaluate my own research questions as well as give information back to the preschool sector about the expertise that parents could have about mathematics activities that could be used as a basis for activities in preschool.

References

- Anderson, A., & Anderson, J. (2018). Instruction and construction of mathematics at home: An exploratory study. In C. Benz, A. S. Steinweg, H. Gasteiger, P. Schöner, H. Vollmuth, & J. Zöllner (Eds.), *Mathematics education in the early years: Results from the POEM3 conference, 2016* (pp. 281–298). Cham: Springer International Publishing.
- Björklund, C., & Pramling, N. (2017). Discerning and supporting the development of mathematical fundamentals in early years. In S. Phillipson, A. Gervasoni, & P. Sullivan (Eds.), *Engaging families as children's first mathematics educators* (pp. 65–80). Singapore: Springer.
- Bourdieu, P. (1975). The specificity of the scientific field and the social conditions of the progress of reason. *Information (International Social Science Council)*, 14(6), 19–47.
- Bourdieu, P., & Wacquant, L. J. D. (1992). *An invitation to reflexive sociology*. Cambridge: Polity.
- Civil, M., Bratton, J., & Quintos, B. (2005). Parents and mathematics education in a Latino community: Redefining parental participation. *Multicultural Education*, 13(2), 60–64.

- Clark-Ibáñez, M. (2004). Framing the social world with photo-elicitation interviews. *American Behavioral Scientist*, 47(12), 1507–1527.
- Clarke, B., & Robbins, J. (2004). Numeracy enacted: Preschool families conceptions of their children's engagements with numeracy. In I. Putt, R. Faragher, & M. McLean (Eds.), *Mathematics education for the third millennium, towards 2010: Proceedings of the 27th annual conference of the Mathematics Education Research Group of Australia* (pp. 175–182). Sydney: MERGA.
- Epstein, I., Stevens, B., McKeever, P., & Baruchel, S. (2006). Photo elicitation interview (PEI): Using photos to elicit children's perspectives. *International Journal of Qualitative Methods*, 5(3), 1–11.
- Frith, H., & Harcourt, D. (2007). Using photographs to capture women's experiences of chemotherapy: Reflecting on the method. *Qualitative Health Research*, 17(10), 1340–1350.
- Galindo, C., & Sheldon, S. B. (2012). School and home connections and children's kindergarten achievement gains: The mediating role of family involvement. *Early Childhood Research Quarterly*, 27(1), 90–103.
- Grenfell, M., & James, D. (1998). *Bourdieu and education: Acts of practical theory*. London: Psychology.
- Hujala, E., Turja, L., Gaspar, M. F., Veisson, M., & Waniganayake, M. (2009). Perspectives of early childhood teachers on parent–teacher partnerships in five European countries. *European Early Childhood Education Research Journal*, 17(1), 57–76.
- Hurworth, R. (2004). Photo-interviewing for research. *Qualitative research journal*, 4(1), 73–79.
- Miller, K. E. (2015). Dear critics: Addressing concerns and justifying the benefits of photography as a research method. *Forum Qualitative Social Research*, 16(3), Art. 27.
- Milner-Bolotin, M., & Marotto, C. C. (2018). Parental engagement in children's STEM education: Part I: Meta-analysis of the literature. *LUMAT: International Journal on Math, Science and Technology Education*, 6(1), 41–59.
- Pain, H. (2012). A literature review to evaluate the choice and use of visual methods. *International Journal of Qualitative Methods*, 11(4), 303–319.
- Phillipson, S., Gervasoni, A., & Sullivan, P. (Eds.). (2017). *Engaging families as children's first mathematics educators: International perspectives*. Singapore: Springer.
- Streit-Lehmann, J. (2017). Involving parents in games and picture books. In S. Phillipson, A. Gervasoni, & P. Sullivan (Eds.), *Engaging families as children's first mathematics educators* (pp. 147–163). Singapore: Springer.
- Torre, D., & Murphy, J. (2015). A different lens: Changing perspectives using Photo-Elicitation Interviews. *Education Policy Analysis Archives*, 23(111), 1–26.
- Vasilyeva, M., Laski, E., Veraksa, A., Weber, L., & Bukhalenkova, D. (2018). Distinct pathways from parental beliefs and practices to children's numeric skills. *Journal of Cognition and Development*, 19(4), 345–366.
- Whyte, K. L., & Karabon, A. (2016). Transforming teacher–family relationships: Shifting roles and perceptions of home visits through the funds of knowledge approach. *Early Years*, 36(2), 207–221.

Referring and proffering: An unusual take on what school mathematics is about

Jean-François Maheux¹, Jérôme Proulx², Rox-Anne L'Italien-Bruneau³ and Marie-Line Lavallée-Lamarche⁴

Laboratoire Épistémologie et Activité Mathématique, Université du Québec à Montréal, Canada;

¹maheux.jean-francois@uqam.ca; ²proulx.jerome@uqam.ca;

³litalien-bruneau.rox-anne@courrier.uqam.ca; ⁴lavallee-lamarche.marie-line@courrier.uqam.ca

When it comes to appreciating school mathematics, there is a strong tendency to turn to the work of professional mathematicians as a reference. Although we see good reasons to do so, in this paper we question that reference to professional mathematicians as a “standard” for school mathematics and pay more attention to what the practice of mathematics in school itself has to offer. This raises significant political and cultural issues for school and research practices. The concept of doing/mathematics is discussed for this purpose, along with that of proffering.

Keywords: School mathematics, mathematicians’ practices, reference, doing/mathematics.

Introduction

Historically and culturally, learning mathematics has often, if not always, been closely associated with the work of professional mathematicians. Evidence of this, for example, can be found in ancient Babylonian and Egyptian traditions, where training seems to mingle formal education and apprenticeship (Karp & Schubring, 2014). Closer to us, when the French decided to establish widespread public education after the 1789 Revolution, they naturally turned to mathematicians like Monge, Laplace, Lagrange, and Carnot to design and teach mathematical curricula to young people. One also thinks of Klein, who supervised the publication in Germany of many volumes on teaching mathematics at all levels. This turn toward mathematicians appears quite natural, because, after all, professional mathematicians are said to be the experts of the discipline: They spend their days doing mathematics and so they probably know better than anybody what mathematics is really about and what one needs to do in order to know about mathematics and practice it (Hersh, 1997).

Hence, we could say we have good reasons to refer to what mathematicians do to think about what is going on in schools. For one, paying attention to how mathematicians work helps us see the difference between doing mathematics and learning about mathematics (Papert, 1972). We also realize how much asking questions and trying out ideas is central to this practice (e.g., Brown & Walter, 2005; Lockhart, 2009). Also, we understand why problem-solving or mathematical modeling cannot be reduced to linear 4- or 5-steps procedures (Schoenfeld, 1985). Looking at what it means to do mathematics for a professional mathematician thus provides us with good grounds to challenge the simplistic idea of direct instruction and the possible overemphasis on the procedural part of school mathematics. Attending actual professional mathematicians’ work is also important to humanize the discipline: mathematics is often seen as cold, uncreative, abstracted from real-life, homogeneous, and indubitable: all aspects that a close account of professional struggles and enjoyment of mathematicians can help transform (Burton, 2004).

This being said, we are, however, also familiar with the disastrous political upshot of the “new math” movement started in the 1960s, when governments tried to include “up to date” topics such

as modular arithmetic, matrices, symbolic logic, and Boolean and abstract algebra in elementary and secondary school. This was also the case in the vivid discussions we know as the 1990 “math wars” in the US and elsewhere. The political role that mathematicians played in school mathematics was then talked about in relation to so-called traditional and reform mathematics philosophy and curricula; these ideas were often criticized as being conceived in an isolated way and disconnected with the everyday reality of the classroom. Nevertheless, it is still common today to hear mathematicians comment on how school mathematics “should” be: One thinks of Wolfram (2010) in the US, of Liu (2000) in Canada, and of Villani and Torossian (2018) in France.

Mathematicians undoubtedly have something to contribute to school systems, but the nature of that contribution might be interesting to discuss and not left unquestioned. Thus, in this paper, we raise a number of these questions, and in turn raise cultural and political issues, by reflecting on the issue of *referring* to mathematicians’ practices. Through drawing on the concept of *doing/mathematics* (Maheux & Proulx, 2015, 2018), we consider what the practice of mathematics in schools offers, and even *proffers*, as we call it, to mathematics itself as a discipline.

Referring to mathematicians’ practices

One way of examining how mathematicians’ work relates to school mathematics is to think about how we use this work to talk about what is, or needs to be, happening in schools. As mentioned above, it is quite common to refer to mathematics as practiced by professional mathematicians to express or orient what students ought to be doing in a mathematics classroom. Schoenfeld (1994), for example, describes true mathematics as the science of patterns and thus suggests that curricula be organized in the form of mathematical inquiry resembling what mathematicians do. The idea of being “authentic” to what mathematics is really about is also often used to critique didactical approaches to teaching mathematics in schools in order to promote a variety of practices that are said to be better aligned with what mathematicians really do: for example, problem solving (Borasi, 1992; Lampert, 1990), modeling-driven curricula (English & Gainsburg, 2016; Lesh & Zawojewsky, 2007), and classroom culture (Bauersfeld, 1998; Papert, 1996).

This notion of referent, when considered in relation to mathematicians’ practices for school practice, is multifaceted. One of the facets consists of referring to mathematicians’ practice as what ought to be happening in the classrooms. This would entail tailoring students’ mathematical experiences to what doing mathematics represents for a mathematician and try to have them experience this. So, if much of what mathematicians do is read papers, ask questions, try to find answers to these, and eventually change the questions based on the answers they find, this is also what students ought to be doing in classrooms. Of course, we do not see this often, but *some* parts of it are easily selected from what mathematicians do as we decide what to ask of students.

A second facet is referring to mathematicians’ practices as considering them as an objective to attain, that is, as the finality of school mathematics work, and the end goal to achieve. In that sense, students are not expected to reproduce the mathematicians’ activity, but to prepare themselves to perform it. From this perspective, one could say that although students might need to start learning how to ask good mathematical questions, they might mostly need to “learn the basis” (or the basics) so they can later engage in mathematicians’ practices. This is a common view, especially in undergraduate mathematics. However, there is no easy agreement on what exactly students most

need as preparation to become mathematicians. For some, the answer to this question might be exactly what is suggested in the first facet.

A third facet is related to referring to mathematicians' practices as a means of devising classroom practices. In analyzing what mathematicians do, we can identify key elements around which educational practices or activities can exist. For example, one could draw on mathematicians' ways of discussing during conferences to organize classroom debates or boil down peer-review processes to students through checking one another's work in writing, or again transform mathematicians' lab interactions as small-group talk. Hence the activities considered are not necessarily direct examples of mathematicians' practices, nor are they done to prepare students to be mathematicians, but are mostly inspirations from which to guide the design of specific activities. That is, the starting point could even be any given school practice (like testing, lecturing, note-taking, homework) into which some of the "essence" of mathematicians' practices has been injected.

A fourth way of referring, more at a meta-level, is for mathematicians' practices to be used, referred to, as a source of justification of practices attempted in schools. For example, the idea of changing a mathematics classroom's ethos to make it more engaging for girls because we do not see enough of them in the professional community would be one example. Arguing in favor of introducing the history of mathematics because of its importance to the discipline itself could be another. Here, it is about mathematics as a practice, but more as an authority for justifying actions. Obviously, the three facets mentioned above can also be seen as a way of doing just that.

Although all these make sense for taking the mathematicians' practice as a referent, one can wonder if they are legitimate for thinking of school mathematics. Hence, aside from the habits of doing things like this culturally, aside from political agendas related to curriculum aimed at reproducing societies' current goals, one can wonder: is this reference to mathematicians' practices, in all their possible facets well aligned with school mathematics' practices?

Questioning professional mathematics as a referent

If only to make more transparent the choices we make, the reference to mathematicians' practices is something to be examined. Indeed, a number of possible questions could be raised in relation to this reference. For example, who are the mathematicians to whom we are referring? Squalli (2010) answers this question, first by wishing to include all people who have a university mathematical background, but then arguing that we should be more inclusive and consider any person who uses or produces mathematics. This would include not only engineers, economists and many artists, for example, but also teachers of mathematics and even students who do mathematics every day. For Squalli, all these persons can be considered mathematicians because they are all engaged in activities that produce¹ mathematics at various levels, for diverse uses and needs. From this angle, the concept of mathematicians' practices as a referent no longer makes much sense: If everybody engaged with mathematics is a mathematician, then everybody acts as its own referent! Albeit lightly, this raises questions about the relevance of mathematicians' practices for school purposes. And many other questions can be raised on the matter, each leading to different viewpoints on the

¹ In the sense of making mathematics happen, causing it to take place, to come into existence. It thus includes both the invention of some "new" mathematics and realization of any mathematical work, since both are based on the occurrence of some mathematical activity, or, again, as one mathematician in Burton's (2004) study argues, re/creation for oneself.

use of professional mathematics as a referent for the classroom. We offer here a sample of these questions, as a range of reflections frequently heard of when discussing mathematics education matters. This list is obviously not exhaustive, nor does it raise all possible matters on the issue.

- It is said that mathematics is everywhere around us, that we use it all the time. Would it not be more relevant to use everyday life mathematics skills as a referent?
- Mathematics is an evolving domain, as are mathematicians' practices. How can we use mathematicians' practices as a referent for school if they are not fixed and established?
- Most teachers have not been trained as mathematicians. Is it reasonable to expect teachers to have mathematicians' practice as a referent if they have not experienced it themselves?
- For many, school mathematics should prepare for citizenship, for example, by reproducing values that society deems relevant. How is mathematicians' practice of any help for this, especially if mathematicians' work is seen as lodged in a space where relevance to society is rarely desired, or even cumbersome?
- We often assert that mathematicians have a tendency to conceive mathematics as a platonist/absolutist domain. Is this a reference aimed at for school mathematics?
- Mathematicians are not homogeneous and are widely oriented (topologists, algebraist, logicians, etc.) by diverse (kinds of) problems, expectations, goals, and so forth. When we refer to mathematicians' practices, to whom are we referring?
- Mathematicians engage in the solving and posing of problems never solved or encountered before. How is this a valid referent for school when most problems, if not all, already have the answers at the end of the textbook?
- Mathematicians do not gather in a room to solve, in a given time frame, problems imposed by someone else. How close can school be to professional mathematicians' context?
- We might generously estimate the number of mathematicians on earth at 100 000. This contrasts with millions of kids doing mathematics in schools. Is it fair to impose the view of a few on the many?
- Most (previous and current) mathematicians are white occidental males living in privileged countries. How equitable is it to aim at reproducing their practices in schools?
- We know that pure and applied mathematicians, as well as engineers and other professionals, do not use the same mathematics and do not do mathematics in the same way. How is this to be taken into account as a referent for school practices?
- Almost all mathematicians learned their mathematics in school and use that knowledge to create new mathematics. Would not professional mathematics then be considered as a form of applied school mathematics? Which would be the referent of which?
- Studies have shown that even in the university, classes taught by mathematicians do not align with mathematicians' practices. Hence, how is this "project" doable for schools if it cannot even be achieved in the university by the mathematicians themselves?

Each one of these questions could also be examined closely as a way to clarify why and how we think or not about mathematicians' practices as a reference for schools. These questions highlight how using mathematicians' practices as a referent for school mathematics is not trivial and hides diverse interpretations or outcomes, as well as agendas. But, while we see how the reference to mathematicians can be questioned, the notion of "referent" in itself can also be scrutinized.

Doing away with the referent? From referring to proffering

Desiring a referent for school mathematics comes with a prescriptive attitude. Why do we wish to look at the classroom mathematical activity from the outside, if not to "judge" it, one way or another, in relation to something else? A question we might ask is: what does it mean to *refer* to something? The verb *refer* comes from the Latin *referre* meaning "carry back", from *re-* "back" + *ferre* "bring". We refer to professional mathematicians' work when we turn back to it in order to appreciate what is going on in school, to describe either what it is, what it is not, or what it can be.

Reference is a relation in which one object designates another. As such, it suggests the defined, rather static existence of these objects in themselves. Searle (1983) explains that descriptive content of the sentence "Aristotle was a philosopher" does not define the name (what is "Aristotle") but establish the name's reference. There is something called "a philosopher", there was someone called "Aristotle", and by saying "Aristotle was a philosopher" we do not at all fix or change who Aristotle was and what a philosopher is: we simply state an assignation relationship. This view on language is challenged by other linguists (e.g., Bakhtin, Wittgenstein) for that very reason: thinking that a word can actually represent something is too restricting in regard to how words live in actual languaging (where their signification changes with the intonation, the context, the intention, the response, and so on), and the continually evolving nature of meanings (across time or cultures, for example). "Carrying back" school mathematics to professional mathematicians' work can certainly be unsatisfactory in this sense. What we mean by being a mathematician or doing mathematics is something open, fluid, and so is school mathematics. The designation relationship is problematic once we accept the dynamic, irreducible complexity *evoked* by the words "school mathematics" or "professional mathematician's practices".

One way to go around this tension is to think in terms of self-reference: an approach developed in many fields of studies, such as language, biology, philosophy and others. In mathematics, for example, self-reference is fundamental to the notion of fractals: mathematical objects exhibiting similar patterns at various scales. The specific nature of a given fractal is expressed in how it recursively reproduces its structure. Looking at coherence and similarity at various scales of mathematical activity (in and out of school) could be one way to further examine and develop it without having to make continual comparison with some externally posited entity. We offered elsewhere such conceptualization of mathematical activity (Roth & Maheux, 2015), contrasting the idea of defining mathematics "in itself" (i.e., as a fixed, independent, objective thing) with a dynamical approach in which mathematics is a way of making difference "in its own terms". Coherently, these terms are themselves observer-dependent and evolve under their own movement.

We have explicitly discussed this idea through the use of the dialectical expression *doing/mathematics* (Maheux & Proulx, 2015, 2018). *Doing/mathematics* is both *doing* something (some thing) recognizable as *mathematics*, but also producing *mathematics* as this thing that we

are *doing* when what we do is mathematics. The Sheffer stroke between “doing” and “mathematics” serves here to emphasize the dialectical relationship between the two terms. *Doing/mathematics*, as an activity that produces mathematics in its production, represents as much the activity of mathematics than the mathematics produced: it is an act of meaning-making, where meaning is made through it. Thus, in this view, it is *doing/mathematics*, its activity and its product, which constitutes the landscape that we call Mathematics. That landscape is a “reference” for any mathematical idea or activity, but it is also something to which all contribute by nourishing, complexifying, defining and developing this very landscape of “reference”. The two processes are inherently tied, dynamically: As we contribute to the mathematics landscape, this landscape influences us, and as it influences us, we contribute back to it. This also means that students, university professors, statisticians, teachers, and so on, in their ways and time, all indirectly but inescapably influence one another through this evolving landscape.

What is suggested here is *also* to consider school mathematics more like a *response*, a dialogue with mathematicians’ professional activity, and not merely something that exists *in reference* to it. In this sense, school mathematics as an instance of *doing/mathematics*, is an act of *proffering*: offering itself as an answer to what it means to do mathematics. If mathematicians are seen as producers of mathematics, it is precisely because they engage in an activity that we identify as mathematics. They do mathematics in order to produce what we recognize as mathematical, while that very product of their activity also affects how we conceive of mathematics. It is the same for mathematics in schools, or in any other places where mathematics happens: workplace, street, institutes, etc. Mathematics in schools affects itself and contributes to itself while being influenced by the mathematical landscape with/in which it occurs and evolves. From such perspective, school mathematics legitimately has a life of its own (something often called for, see Hart & Johnson, 1984; Watson, 2008). But like just any other living entity, it is in constant interaction with other life forms (as non-living material).

Focusing on school, we could say that classroom mathematics dialogues with professional mathematician’s practices; not to see what ought to be, but in terms of possibilities that they both embody. Thinking about what might happen is very different from setting something as an objective. Enabling students to further engage in mathematics can mean many things. Similarly, if school mathematics is seen as contributing in its own terms to the landscape, that is, to understandings of what it means to do mathematics, thinking of how students might experience things similar or different to what mathematician do is not merely justifying or reducing the later to the former, but exploring the very nature of those experiences. Considering how similar or different mathematical experiences might occur outside school or professional practices simply adds to these possibilities and enriches their very nature and essence. To some extent, this is at the core of ethnomathematical research (e.g., Powell & Frankenstein 1997), leading to wonder what really are “mainstream” mathematics practices. These are, of course, only very general orientations: something to be discussed, worked on, and engaged with more deeply.

Coda: On mathematics education research

The term *proffering* is provocative. It suggests turning the tables and thinking about what school mathematics actually offers to our understandings of mathematics as a practice. The idea that professional mathematicians could learn from schoolchildren does have a revolutionary twist.

Taken more generally, the proposition is less aggressive: we can learn about what is mathematics and mathematical activity from both lay and professional mathematicians. Following such an assertion, one might ask: what is the role of mathematics education research in relation to this?

Evolutionary epistemology (Campbell, 1974) teaches us that by paying attention and studying a concept (or phenomenon) in order to understand it, that very concept (or phenomenon) is transformed. Studying professionals' or schools' mathematical practices also has this effect. By reifying, deconstructing and explicating them, we affect those practices. Analyzing a phenomenon renders some elements (more) salient; it imposes an interpretation that changes how we view things (regardless of how we acted on them or not). Observing always disturbs the observed, and discourse always shape how we do things. From this perspective, we can see mathematics education research as also contributing to the development of mathematics in a broad sense. If research investigates mathematical practices in schools and elsewhere, it not only makes these mathematical practices available to one another, but it also contributes in its own ways to them, affecting them in the process, and thereby also contributing to the mathematical landscape through it. So, coherently, whatever comes out of mathematics education research is not to be taken as *the* reference for mathematical activity. Proffering is also something mathematics education research does.

References

- Bauersfeld, H. (1998). Remarks on the education of elementary teachers. In M. Larochelle, N. Bednarz & J. Garrison (Eds.), *Constructivism and education* (pp. 213–232). Cambridge: Cambridge University Press.
- Borasi, R. (1992). *Teaching mathematics through inquiry*. Portsmouth: Heineman.
- Brown, S. I., & Walter, M. I. (2005). *The art of problem posing*. Mahwah: Erlbaum.
- Burton, L. (2004). *Mathematicians as enquirers*. Dordrecht: Springer.
- Campbell, D. T. (1974). Evolutionary epistemology. In P. A. Schlipp (Ed.), *The philosophy of Karl Popper* (pp. 413–463). LaSalle: Open Court.
- English, L. D., & Gainsburg, J. (2016). Problem solving in a 21st century mathematics curriculum. In L. D. English & D. Kirshner (Eds.), *Handbook of international research in mathematics education* (pp. 313–335). New York: Routledge.
- Hart, K. M., & Johnson, D. (1984). *Ratio: Children's strategies and errors*. Windsor: NFER-Nelson.
- Hersh, R. (1997). *What is mathematics, really?* Oxford University Press.
- Karp, A., & Schubring, G. (Eds.). (2014). *Handbook on the history of mathematics education*. New York: Springer.
- Lampert, M. (1990). When the problem is not the question and the solution is not the answer: Mathematical knowing and teaching. *American Educational Research Journal*, 27(1), 29–63.
- Lesh, R., & Zawojewski, J. S. (2007). Problem solving and modelling. In F. K. Lester (Ed.), *Second handbook of research on mathematics teaching and learning* (pp. 763–804). Charlotte, US: IAP.

- Liu, A. (2000). The high-school teacher upgrade program. Retrieved from <http://www.math.ualberta.ca/Newsletter/Newsletter.htm>
- Lockhart, P. (2009). *A mathematician's lament*. New York: Bellevue Literary Press.
- Maheux, J.-F., & Proulx, J. (2015). Doing|mathematics: Analysing data with/in an enactivist-inspired approach. *ZDM Mathematics Education*, 47, 211–221.
- Maheux, J.-F., & Proulx, J. (2018). Mathematics education (research) liberated from teaching and learning: Towards (the future of) *doing|mathematics*. *The Mathematics Enthusiast*, 15, 78–99.
- Papert, S. (1972). Teaching children to be mathematicians versus teaching about mathematics. *International Journal of Mathematics Education, Sciences and Technology*, 3, 249–262.
- Papert, S. (1996). An exploration in the space of mathematics education. *International Journal of Computers for Mathematical Learning*, 1, 95–123.
- Powell, A., Frankenstein, M. (1997). Introduction. In A. Powell & M. Frankenstein (Eds.), *Ethnomathematics: Challenging eurocentrism in mathematics education*. Albany: SUNY.
- Roth, W.-M., & Maheux, J.-F. (2015). The stakes of movement: A dynamic approach to mathematical thinking. *Curriculum Inquiry*, 45, 266–284.
- Schoenfeld, A. (1985). *Mathematical problem solving*. Orlando, US: Academic Press.
- Schoenfeld, A. (1994). Reflections on doing and teaching mathematics. In A. Schoenfeld & A. Sloane (Eds.), *Mathematical thinking and problem solving* (pp. 53–70). Hillsdale: LEA.
- Searle, J. (1983). *Intentionality*. Cambridge, UK: Cambridge University Press.
- Squalli, H. (2010). Quelle articulation entre formation mathématique, formation didactique et formation pratique dans la formation des maîtres? In J. Proulx & L. Gattuso (Eds.), *Formation des enseignants en mathématiques* (pp. 153–158). Sherbrooke, Canada: Éditions du CRP.
- Villani, C., & Torossian, C. (2018, February 12). *21 mesures pour l'enseignement des mathématiques*. Retrieved from <http://www.education.gouv.fr/cid126423/21-mesures-pour-l-enseignement-des-mathematiques.html>
- Watson, A. (2008). School mathematics as a special kind of mathematics. *For the Learning of Mathematics*, 28(3), 3–7.
- Wolfram, C. (2010, November 15). *Teaching kids real math with computers* [Video file]. <https://youtu.be/60OVlfAUPJg>

The contextual power dynamics in defining and utilising problem solving tasks: A case study at an Egyptian private school

Mariam Makramalla¹ and Andreas J. Stylianides²

¹University of Cambridge, Faculty of Education, United Kingdom; mmmm2@cam.ac.uk

²University of Cambridge, Faculty of Education, United Kingdom; as899@cam.ac.uk

This paper builds on Ernest's five ideologies for mathematics education in order to explore the socio-cultural buy-in of mathematical problem solving tasks within the context of private schools that are governed by the Egyptian national mathematics curriculum. The research contributes to the contextual understanding of teacher beliefs and school power dynamics that affect the adoption or rejection of a culturally foreign teaching ideology of problem solving. Findings from one teacher focus group revealed that the teachers had a good understanding of the features that align with a literature-based classification of problem solving tasks. Yet, a disparity was found between desired and existing best practices for classroom implementation of problem solving tasks. This disparity is argued to be a function of power tensions between inner and outer circles of contextual influence.

Keywords: problem solving, socio-cultural power tensions, educational ideologies, teacher beliefs

Introduction

Literature argues against school education being viewed as a neutral enterprise (Apple, 2004). The skill and knowledge dissimilation process in schools is arguably better understood when viewed from the perspective of the schools' position in a dynamic and turbulent context that incorporates complex social and cultural power relations (Bernstein, 1971). This study explores the specific context of mathematics instruction at Egyptian private schools that teach the national curriculum. As will be elaborated further in the upcoming sections, this context is particularly interesting as it embodies – at the private school level – a teaching culture that appreciates an inquiry-based enactment (Apple, 2004) of the mathematics curriculum. This culture is however situated and controlled by an imposed national curriculum agenda that is rather stagnant and one-sided in nature (Hargreaves, 1997; Naguib, 2006). The study aims to unravel the mentioned inner and outer circles of influence and how these play a role in shaping mathematics teachers' beliefs and practices, particularly in relation to their teaching of mathematical problem solving.

Literature Review

Literature claims that social and cultural configurations govern the outcome of schooling in order to ensure the reproduction of an existing culture of stratified social class relations (Apple, 2004). In line with that view, Alexander (2000) unpacks the term 'education' and focuses on three particular aspects, namely curriculum, assessment and inspection. He claims that the formation of those is bound by different forms of policy and power. Our study focuses on the first element and argues that, since education cannot be viewed as a neutral enterprise, similarly curriculum design and knowledge distribution schemes cannot be viewed as neutral. According to Apple (2004), curriculum design and enactment which govern the process of skills formation and cultural capital distribution (Bourdieu, 1986) are controlled by power dynamics that relate to a given context's social class hierarchy.

Particularly in relation to science and mathematics curricula, literature suggests that the general tendency to move towards a curriculum design where students are taught to become independent inquirers is often quenched by a culturally selective curriculum enactment tradition where educators may choose to teach certain skills or forms of knowledge in order to re-enforce certain configurations of social power. This selective tradition, which in turn is governed by social and cultural power dynamics, can be better understood when considering the historical roots that led to its formation (Apple, 2004; Bourdieu, 1986).

Scholars (e.g., Alexander, 2000; Apple, 2004) have added to the discussion about forces affecting curriculum design and enactment the dimension of political control. In his comparative study on primary education in five different cultures, Alexander (2000) claims that the national constitutional identity plays a vital role in prescribing curriculum outlines and elevating certain forms of knowledge and skill transfer over others. According to scholarship, to better understand the question of political control, the question of centralizing (or de-centralizing) systems of curriculum design and enactment is crucial to consider (Alexander, 2000).

In light of that understanding, we intend to map the situation of primary stage mathematics curriculum enactment and design in Egypt. A wider study from which this work is derived has elaborately addressed, drawing on relevant literature (Heyworth-Dunne, 1968; Sika, 2010), the historical evolution of education in modern Egypt. It sought to map out social and cultural configurations and power tensions against educational outcomes of skills and cultural capital distribution. While it is beyond the scope of this work to elaborately address the overall historical mapping of education in modern Egypt, we consider it as important to use sections of that mapping, particularly to better understand political and social control forces governing the purpose and identity of curriculum enactment and formation. In light of Alexander's (2000) views about political control, it is worth mentioning that, since the republic of Egypt was formed in 1953, curriculum design and enactment agendas have been standardized. A centralized system that is governed and tightly controlled by the Ministry of Education (MOE) strategically selects the forms of knowledge acquisition and skill transfer that are to be enacted by the national curriculum to all schools of Egypt. Literature (Naguib, 2006) shows that for the case of the mathematics curriculum the focus is on factual knowledge and the transmission of a one-sided set of facts that are not to be questioned or debated. Mathematics instruction is meant to take on the form of a procedural, teacher-led, exam-oriented structure (Sika, 2010). The national curriculum in Egypt is taught in all public schools and also in the so-called 'national curriculum private schools'. Both forms of schooling stem from different social, cultural and historical roots (Heyworth-Dunne, 1968). The historical plotting, referred to earlier, indicates a so-called cultural migration (Alexander, 2000) of educational values which governed the original institution of foreign private schooling, even before the republic of Egypt was formed. Those values are centered around a more multi-façade, student-centered scheme for curriculum enactment. Nevertheless, being under the governance of the MOE, a centralized system ensures that the curriculum enactment follows the same format across all types of national schools in Egypt (Hargreaves, 1997; Naguib, 2006; Sika, 2010).

Alexander (2000) claims that schools are micro-cultures mediating imposed curricula in such a way that reflects some of the school's own flavor. It is true that, despite the fact that the same mathematics

curriculum is meant to be applied across the mentioned wide base of schooling, curriculum enactment remains quite a complex process (Remillard & Heck, 2014). This paper presents a case study that addresses the interplay between a centrally governed curriculum and its contextual enactment in the culture of a private school. More specifically, we will focus on how the factual nature of the national mathematics curriculum translates into the formation of teacher beliefs about problem solving and how in turn these beliefs affect, according to the teachers, their curriculum enactment decisions in the classroom. The research questions to be addressed are the following:

- (1) Within the context of a private school in Egypt that is bound to follow the national curriculum, how do school mathematics teachers perceive features of problem solving tasks?
- (2) Within this same context, how do school mathematics teachers view the contextual suitability of adopting their perceived problem solving tasks into their local teaching setting?

Theoretical Framework

In his model of educational ideology for mathematics, Ernest (1995) situates the wider aims of mathematics education along with the specific function of school mathematics teaching, learning and assessment within a context that is bound by the theory of society, the theory of the child and the moral ideologies attached to a given society. Ernest (1995) differentiates between five educational ideologies in viewing teaching and learning mathematics and maps those out against cultural power configurations in society. He views these ideologies from various social and pedagogical perspectives. Three of those perspectives form the theoretical grounding of this paper (Figure 1).

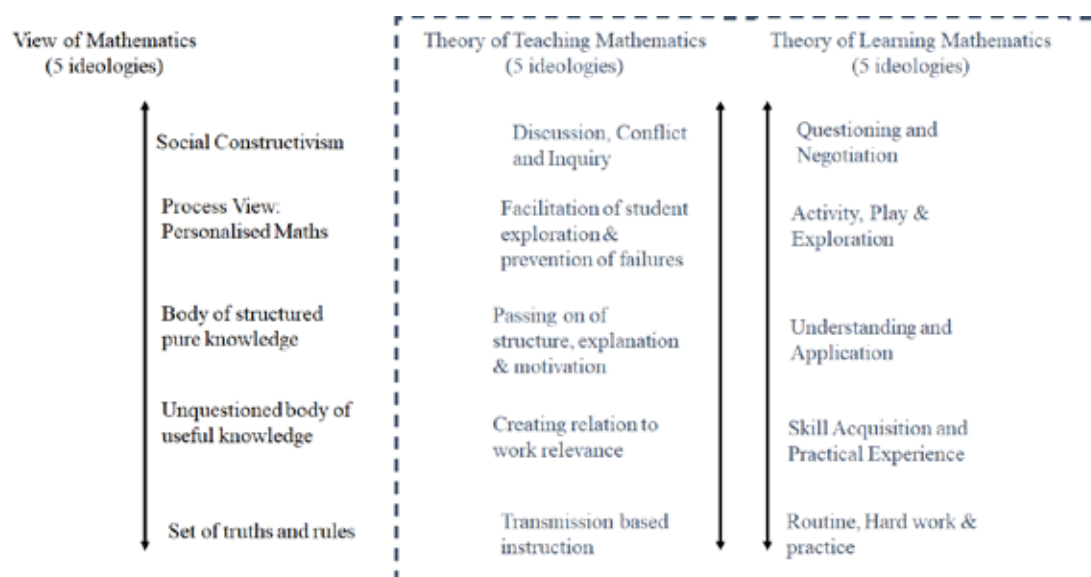


Figure 1: Mathematical ideologies: Three perspectives (adapted from Ernest, 1995)

As illustrated in Figure 1, it is not possible to dissociate a teacher's perception of mathematics, which in turn translates into a teaching and learning theory, from the student's experience when learning mathematics and from the wider nature of viewing and experiencing mathematics both by the teacher and by the student. Figure 1 shows how five different mathematical ideologies manifest themselves in the experience of the teacher and the learner. These ideologies extend all the way from viewing mathematics as a set of fixed truths and teaching it in a rather authoritarian and transmission-based

mechanism all the way to viewing mathematics as a subject of constructive nature and the teaching of it as being rather more inquiry- and discussion-based. In turn, the learning of mathematics is viewed as lying on a spectrum that extends from the mastery of formulas and procedures on the one end to the learning of inquiry skills and negotiation on the other end. Ernest's (1995) discussion of the latter features align broadly with our understanding of problem solving skills as discussed in the literature (Schoenfeld, 1992; Stein, Smith, Henningsen, & Silver, 2000).

Various scholars (Polya, 1945; Schoenfeld, 1992) have sought to conceptualize mathematical problem solving as a construct and apply that understanding in the formulation of mathematical tasks. As an extension of the scholarly view that perceives mathematics as ranging from the pure application of rules on the one side of the spectrum to problem solving on the other (Schoenfeld, 1992), Stein et al. (2000) identified four types of mathematical tasks: memorisation tasks, procedures without connections tasks, procedures with connections tasks, and doing mathematics tasks. While we acknowledge that the term "problem solving" has been used in different ways in the literature (Schoenfeld, 1992; Reiss & Törner, 2007), for the purpose of this work we have adopted Stein et al.'s (2000) perspective on problem solving which, at the task level, has been conceptualized by the authors as "doing mathematics tasks" (p. 16). According to the authors, doing mathematics (or problem solving) tasks are unique in that they invoke student analysis based on conceptual understanding of the underlying mathematical principles, their solution process has an unpredictable nature and a high level of ambiguity, they place on the solvers high cognitive demands and they require solvers to self-regulate their thought process. The broad understanding of the ideologies that formulate a teacher's and a learner's view of mathematics along with the specific unfolding of that view in the form of mathematical tasks constitute the foundation to conceptualizing the upcoming analysis.

Methodology

As part of the larger project exploring contextual power dynamics in relation to framing teacher perceptions of mathematical problem solving, this research adopts the methodology of a multiple case study, conducting various focus groups across a wide range of private schools in Egypt. It is worth mentioning that, in Egypt, private schools annually serve a wide base of students (approximately two million) from various sociocultural family backgrounds (CAPMAS Yearly Report, 2017). The case studies have been carefully selected to represent the high end, the low end, and the middle of the socio-cultural map of private schooling. Each case study represents findings of two focus groups conducted at different schools that are both classified within the same socio-cultural cluster of schooling. In the following, we present findings from one focus group that has been classified by local partners as lying on the high end of the private schooling spectrum. This classification has been also confirmed based on an assessment of the school location, the school fee and the selection criteria of both students and teachers. The sample comprised a group of six mathematics teachers.

Being a contextual study, it was important that the method selected was locally fitting. Researchers have investigated the suitability of using focus groups as a research method in the Arab context and have argued that focus groups are well received by participants (Thomas, 2008). Being a collective culture (Thomas, 2008), teachers' choices and practices are governed and influenced by each other's perceptions making it unlikely for a teacher to adopt a practice in their classroom if it is not

collectively perceived as best practice by most other teachers. Hence group power dynamics represented a cultural reality that needed to be taken into consideration.

The data collection protocol was framed around prompts of a Task Sorting Activity (Friedrichsen & Dana, 2003) followed by a more holistic focus group discussion. For the Task Sorting Activity, eight tasks were put together ranging across Stein et al.'s (2000) mathematical task spectrum. The tasks showed an interesting variation in terms of their presentation, including numerical tasks, word problems, and visual integration tasks. The participating teachers were unaware of the existing task pre-classification and were prompted to classify the eight tasks according to (a) which tasks they considered to be problem solving tasks (cf. RQ1) and (b) which tasks they would be more likely to use in their classrooms (cf. RQ2). Each of the sorting prompts was followed by a more elaborate focus group discussion about teachers' task sorting choices.

The data analysis followed an inductive data-driven approach. Incidents in the data demonstrating task features that were associated by teachers to problem solving tasks (cf. RQ1) were grouped together to form codes and clusters. Based on the constant comparative method (Glaser, 1965), the coding scheme was developed over three levels of analysis. First, incidents in the data were compared to each other. More specifically, three different focus group transcripts were chosen representing low, high and middle socio-cultural levels. Incidents in those three transcripts were cross-compared and clustered to create a preliminary coding scheme representative of all three sets of data. Secondly, the created code was compared to another set of incidents, represented by three other focus group transcripts also varying across socio-cultural standings. Resulting from that was a more elaborate coding scheme. Finally, created codes were compared against each other, yielding a saturated format of codes and clusters. This saturated code was then utilized for the frequency count analysis of all focus group transcripts. Occurrences in the transcripts that aligned with the codes in the saturated coding scheme were counted in order to trace the popularity of certain task features. Following the same method, a separate set of codes was created to represent task features that teachers perceived to be suitable for their local classroom practices (cf. RQ2) given the constraints of the national curriculum framework. Contrasting the findings obtained from these two sets of codes cast some light on the power tensions between teacher perceptions and the contextual reality.

Findings

Results of the analysis revealed the following task features to be most popularly associated by teachers with problem solving tasks:

Nature of the task: The task layout has to be relevant to students' everyday lives. Also, the task needs to be approachable by a range of different methods, thereby giving space for a wide audience of learners to address the task, each in their own way.

Teaching the task: Students need to independently tackle the task, thereby exploring new and often unfamiliar territories. However, the teacher needs to be in tight control of that exploration process.

Learning from the task: In order to solve the task, students would need to go through an inductive process, to develop a yet unknown formula or solution procedure, that can then be adopted to find the solution to the problem. This creative process of invention was said to be cognitively demanding and was argued to naturally trigger student enjoyment.

These results show a high degree of alignment of teacher perceptions of problem solving task features with Stein et al.'s (2000) conceptualization of problem solving tasks (referred to as “doing mathematics tasks” in their classification). Indeed, teachers seem to agree with the literature about the knowledge creation process that ought to be triggered in students’ minds as they engage in problem solving tasks.

When asked about the suitability of adopting such tasks in the classroom, teachers admitted that these tasks would not naturally align with the national curriculum agenda. Yet, they also made it clear that they would favor adopting this type of tasks over the tasks that fulfil the national curriculum textbook requirements. The teachers described the latter kind of tasks as follows:

Nature of the task: The task layout has to be tangible and relevant to students’ everyday lives. Its formulation needs to be straightforward and needs to align with the formulation of expected examination questions.

Teaching the task: The teacher presents to the students the task solution process. This is often coupled with a more elaborate explanation of the concepts that relate to that solution process. Students are encouraged to follow teacher explanations and ask questions.

Learning from the task: The task needs to be quickly and easily solvable by an average student.

When contrasting the two descriptions of task features, we see a gap between (1) the kind of tasks that align with the curriculum requirements and that the teachers perceived to be suitable for local adoption and (2) the kind of tasks that the teachers perceived to be problem solving tasks and would rather enact in their classrooms if they were given the choice. Figure 2 maps our classification of the two aforementioned task types on to the framework developed in Figure 1. The symbols (x) and (*) have been used to mark the position of the first and second kind of tasks, respectively.

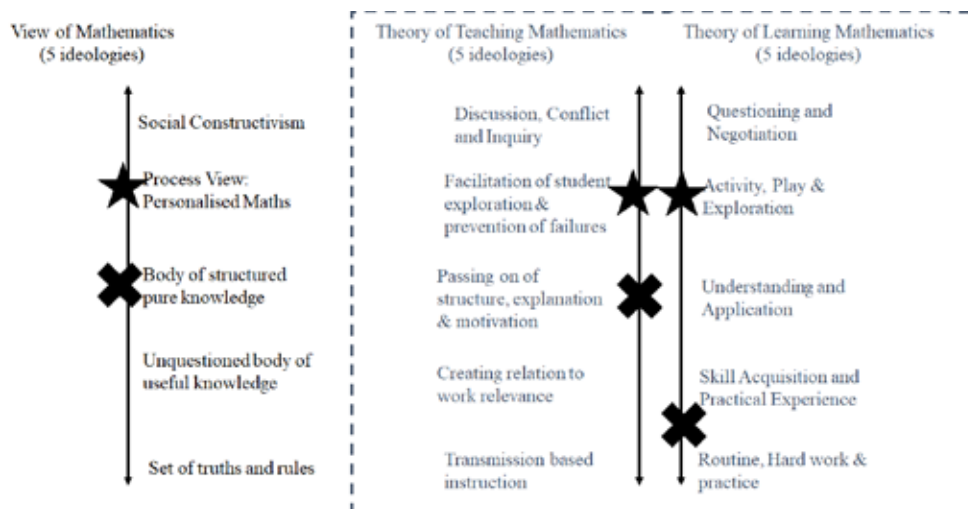


Figure 2. Mapping of findings

As illustrated in Figure 2, there seems to be a variation between the ideology that the curriculum dictates and the mathematical ideology that would rather be implemented by the teachers and that in their view relates to problem solving. In their focus groups, teachers commented about them being governed by a one-size-fits-all curriculum model that does not align with their own views about mathematics. They also argued to be bound by a narrow time schedule that is dictated by the national

curriculum requirements which results in them mostly having to enact a rather more procedure-based (Stein et al., 2000) mathematics view in their teaching.

Nevertheless, the discussion still revealed traces of teachers attempting to enact their own mathematical ideology in the classroom despite being bound by a different curriculum ideology. Teachers expressed their belief in the importance and relevance of integrating into their teaching the tasks that they defined to be problem solving tasks. Being foreign to the national curriculum, it would be difficult to integrate this type of tasks as a student-led activity. Nevertheless, teachers claimed that those tasks could still be useful as a pedagogical tool to introduce students to new mathematical concepts and to involve them in the development of formulae and procedures in relation to those. In that way, the teachers' definition of a problem solving task experience would be partially fulfilled. The task would trigger knowledge construction, yet it would only serve as a teacher explanation tool.

Discussion

In response to the research questions about teacher perception and enactment of problem solving within the context of the mathematics national curriculum, the following can be stated:

- (1) Teacher perceptions about mathematical problem solving seem to align more with the ideology that is found in literature (Stein et al., 2000) rather than with the ideology that is dictated by the curriculum (Naguib, 2006; Sika, 2010).
- (2) In view of curriculum enactment, the ideology dictated by the national curriculum seems to have superiority on classroom enactment choices when compared to teachers' ideological preferences. Nevertheless, there is some evidence of a partial realization of problem solving task integration in the classroom, which aligns more with teachers' preferred ideology.

These results re-emphasize the indicated gap between the inner and outer circles of culture and contextual influence. In line with the plotting at the onset of this paper, the historical roots of cultural migration that led to the formation of a different cultural footprint of foreign private schooling in Egypt seem to still have an impact on teacher belief formation and desired curriculum enactment practices. As the results indicate, teachers seem to be more oriented towards inquiry-orientated curriculum enactment practices. Despite the fact that the mathematics curriculum in Egypt is meant to be centralized around schemes dictated by the MOE and that its enactment is meant to be unified across all national Egyptian schooling types, the investigation of the actual enactment seems to offer more variety and complexity. Findings of this study indicate some traces that re-emphasize Alexander's (2000) views of schools being microcultures transferring their own cultural flavor. As the findings indicate, teachers seem to find it important to integrate problem solving tasks into their daily instruction, even if those do not align with requirements of the national curriculum. Results also indicate an apparent power dynamic that gives superiority to the influence of the national curriculum ideology, resulting in teachers' mathematical ideologies being trapped and only being partially realized in terms of practical enactment in the classroom. This superiority seems to only influence the practical enactment, yet it seems not to affect the formation of teacher beliefs about mathematical problem solving. Findings reported in Figure 2 also indicate a disparity between the national curriculum's views of teaching and those of learning mathematics. While teaching mathematics seems to be associated with the teaching of structures, the learning of mathematics was associated by

teachers as a routine process of recalling knowledge. According to Ernest's (1995) framework there seems to be a mismatch between both views that is worth investigating in future research.

References

- Alexander, R. (2000). *Culture and pedagogy: International comparisons in primary education*. Malden: Blackwell.
- Apple, M. W. (2004). *Ideology and curriculum*. Abingdon, Oxon: Taylor & Francis.
- Bernstein, B. (1971). *Class, codes and control: Towards a theory of educational transmission*. London: Routledge & Kegan Paul.
- Bourdieu, P. (1986). The forms of capital. In I. S. Kaposy (Ed.), *Cultural theory: An anthology* (pp. 81–93). West Sussex: Wiley-Blackwell.
- CAPMAS Yearly Report. (2017). *Statistics of educational measures*. Cairo: Ministry of Planning.
- Ernest, P. (1995). *The philosophy of mathematics education*. London: Falmer.
- Friedrichsen, P. J., & Dana, T. M. (2003). Using a card-sorting task to elicit and clarify science-teaching orientations. *Journal of Science Teacher Education*, 14(4), 291–309.
- Glaser, B. G. (1965). The constant comparative method of qualitative analysis. *Social Problems*, 12(4), 436–445.
- Hargreaves, E. (1997). The diploma disease in Egypt: learning, teaching and the monster of the secondary leaving certificate. *Assessment in Education: Principles, Policy & Practice*, 4(1), 161–176.
- Heyworth-Dunne, J. (1968). *An introduction to the history of education in modern Egypt*. Bristol: Burleigh.
- Naguib, K. (2006). The production and reproduction of culture in Egyptian schools. In C. A. Torres (Ed.), *Cultures of Arab schooling* (pp. 25–53). New York: State University of New York Press.
- Polya, G. (1945). *How to solve it*. Princeton: Princeton University Press.
- Reiss, K., & Törner, G. (2007). Problem solving in the mathematics classroom: The German perspective. *ZDM International Journal on Mathematics Education*, 39(5–6), 431–441.
- Remillard, J. T., & Heck, D. J. (2014). Conceptualizing the curriculum enactment process in mathematics education. *ZDM Mathematics Education*, 46(1), 705–718.
- Schoenfeld, A. H. (1992). Learning to think mathematically: Problem solving, metacognition, and sense making in mathematics. In D. Grouws (Ed.), *Handbook for research on mathematics teaching and learning*, (pp. 334–370). New York: MacMillan.
- Sika, N. (2010). *Educational reform in Egyptian primary schools since the 1990s: A study of the political values and behavior of sixth grade students*. Lewiston: Edwin Mellen.
- Stein, M. K., Smith, M. S., Henningsen, M. A., & Silver, E. A. (2000). *Implementing standards-based mathematics instruction: A casebook for professional development*. Reston: Teachers College.
- Thomas, A. (2008). Focus groups in qualitative research: Culturally sensitive methodology for the Arabian Gulf? *International Journal of Research & Method in Education*, 31(1), 77–88.

Discourse of otherness in a Universally Designed undergraduate mathematics course

Juuso Henrik Nieminen

University of Helsinki, Finland; juuso.h.nieminen@helsinki.fi

To meet the needs of student diversity, universities have often implemented the principles of Universal Design in their instruction. However, previous literature knows little about the effectivity of these practices. In this study, two students with special needs are given a voice to share their experiences about a Universally Designed undergraduate mathematics course. The study uses the view of a Foucauldian discourse analysis in order to investigate how these students construct discourses on their position in the context of the course. According to the results, the students positioned themselves as the Others, constructing a discourse of “different learners”. The study implicates that there is a need to shift the existing discourses to open up alternative subjectivities.

Keywords: Discourse analysis, otherness, special needs, university mathematics, Universal Design.

Little is known about disabled students' perceptions of their studies in the field of postsecondary mathematics. Indeed, disabled students are often marginalized in mathematics educational research. These students are rarely seen as mathematical thinkers and doers rather than focusing on cognitive deficits (for a review see Tan & Kastberg, 2017). What is known about disabled mathematics students is that they are not encouraged in their studies (Feigenbaum, 2000) and that university staff might also be reluctant to change their teaching methods in order to take these students into account (Thurston, Shuman, Middendorf, & Johnson, 2017). It is also known that especially dyslexic students are shown to struggle in studying tertiary mathematics because of environmental barriers for learning (Perkin & Croft, 2007). In general, it is known that disabled students often struggle while participating in higher education. These students are less likely than others to persist until completing their educational program (Mamiseishvili & Koch, 2012). According to Weeber (2004) students might see their disability status as an undesirable factor in how they perceive themselves as the campus environment does not provide enough support. In a Finnish report, it was found that accessibility was rarely thought about when learning environments were designed (Laaksonen, 2005). However, in this study it was the staff who assessed the level of accessibility, and the disabled students themselves were never given a voice. I argue that there is a critical silence, in terms of Seale (2014), when it comes to researching disabled students in the field of postsecondary mathematics.

In this study, an undergraduate mathematics course was designed to be more accessible. By using Foucauldian discourse analysis on power, the voices of the students with special needs themselves were heard. The aim of this study is to examine how these students positioned themselves in this course that tried to promote inclusion for all through the framework of Universal Design.

Background of the study

Discourse and power as theoretical frameworks

This article draws on Foucauldian discourse analysis. Discourse analysis is not used simply as a research method; it serves as a broad theoretical framework for understanding discourse and its

importance in social life. According to Foucault, discourses are “practices that systematically form the objects of which they speak ... [they] are not about objects, they constitute them and in the practice of doing so conceal their own invention” (Foucault, 1977, p. 49). Discourses, therefore, produce normality by constructing what can be taken as granted. By studying discourse, we can gather information on social organizations and identities, since they are constructed by rules about what is *normal*. The way language is used shapes reality. Observing the ways in which social constructions form our world are the core of discourse analysis and form the theoretical base for this study.

Discourses produce meaning and knowledge, and these Foucault (1977) connected with power. Foucault (1977) proposed that in modern societies, we must move forward from analyzing dyadic relations of a ruler and a subject, and instead focus on finding these power relations in institutions that are so often labeled as ‘humane’. He defined the concept of disciplinary power, a form of power that is understood to be the body of knowledge and those discourses takes as the ‘truth’. According to Foucault (1982), personal identities are only produced through institutional or societal power and knowledge. In other words, subjectivity is constructed through the productive power of discursive practices. Various scholars have also emphasized the socially constructed nature of mathematical identity – how discourses construct mathematical identities and agency (Alderton & Gifford, 2018). Because discourses truly produce our social reality, they are all about power. Some voices are heard as meaningful and authoritative, while some others are not. When power and knowledge are combined, *hegemonic discourses* are constructed (Dant, 1991). By this, Dant means that certain socially constructed discourses are considered as facts.

Universal Design

Inclusive pedagogy has often been introduced as a way to promote positive discourses of students with special needs by promoting a view of disability as a social construction. While the traditional, medical model views disability as an abnormality that has to be cured and assisted, the social model emphasizes the idea that disability is constructed when the environment cannot account to the needs of the disabled (Seale, 2014). The social model is often fostered in higher education by using Universal Design (UD), an environmental design that is accessible for everyone (Burgstahler, 2015). According to Burgstahler, the learning environments create barriers for learning, and UD aims to reduce these by taking into account the needs of the diversity of students. Often, UD is fostered by using the guidelines by the Center for Applied Special Technology: 1) engagement 2) representation 3) action & expression (CAST, 2018). These guidelines are tied to brain research on how people learn. Another common and practical way to enhance inclusion in higher education is to implement the Principles of UD of Instruction (UDI) into learning environments: 1) equitable use 2) flexibility in use 3) simple and intuitive 4) perceptible information 5) tolerance for error 6) low physical effort 7) size and space for approach and use (Burgstahler, 2015). Often, two additional principles are used: 8) community of learners and 9) instructional climate (Shaw, Scott, & McGuire, 2001).

Although UD has been used as a base for legislation (e.g., the USA; Higher Education Opportunity Act 2008), we know surprisingly little about whether it works in higher education (for a review, see Roberts, Park, Brown, & Cook, 2011). The warm-hearted idea of supporting inclusion through UD is not to be judged, but there is a need for more research-based evidence. Also, the voice of disabled

students themselves is usually not heard in the research on UD in higher education (Seale, 2014; Griful-Freixenet, Struyven, Verstichele, & Andries, 2017). Griful-Freixenet and colleagues underline the fact that it is impossible to “tackle the need of all learners” and calls for a need of responsiveness. I argue that there is need for studies that would, at the same time, break the silence surrounding UD and also examine the power structures surrounding it. This study examines whether the framework of UD, aimed to promote the socially constructed view of disability, was able to promote discourses that would see students with special needs as an equal part of the learning community.

Aims of the study

In this study, the power relations in a Universally Designed university mathematics course are brought into light through students’ own voices. The objective of this study is to examine the subjective positions that the students with special needs have constructed during the course.

Methodology

Context of the study

The study was conducted on a proof-based undergraduate mathematics course with over 400 participants that lasted for 7 weeks. The course arrangements reflected the principles of UD: All of the three principles of CAST (2018) and the nine principles of Burgstahler (2015) and Shaw, Scott and McGuire (2001) were implemented in the course examined in this study. Each week, students were given a set of problems to solve, both pen-and-paper and digital. After that, they received various feedback on the tasks (peer feedback, automatic feedback, feedback from the teacher and the teacher assistants) and participated in mathematical conversation during active lectures. There was no exam, and the final course grade was self-assessed. Table 1 shows an overview of the course components.

Engagement	Representation	Action and learning
Applied tasks relevant to different majors	Course material been developed for years to be simple and intuitive ²	Various options for returning the tasks (LaTex, drawing...) ²
Accepting and supportive classroom climate ^{8,9}	Materials in Finnish and in Swedish ²	Digital WhatsApp groups for group discussion ^{8,9}
Active lectures based on discussion; minimizing the social demands ^{7,8}	Mathematical discussion was one of the learning objectives ^{8,9}	Anonymous discussion forum ^{8,9}
Learning objective matrix	Concept maps about the relationship of concepts	Digital GeoGebra tasks
Formative assessment used to value process and effort ⁵	A guide for producing clear mathematical text was provided ³	Digital polls during lectures ⁸
An open learning space with tutor students offering support when needed ^{2,4,6,7}		Digital Moodle environment as a “base” for the course ^{1,3}
		Social interaction in the open learning space; students are guided to tutor each others ^{5,8,9}

Peer-assessment ⁵ Formative and summative self-assessment ⁵ Flipped learning approach ^{5, 8}	Dynamic geometry (GeoGebra) offering multiple representations Progressive information releasing; first simple, then more advanced tasks	Personal goal-setting through formative self-assessment Various kinds of digital feedback; automatic, from tutors ^{5, 8, 9} Octave software for computing
--	--	--

Table 1: The course components through the lense of the principles of UD (CAST, 2018), linked with the elements of UDI (with superscript; Burgstahler, 2015; Shaw, Scott, & McGuire, 2001)

Participants

All of the participants of the course were emailed an advertisement about the study. Six students, self-reporting as having some kinds of special needs during the course, were interviewed. Because of the page limit, only two of these six interviews were used in this study, the ones of Jesse and Nico; these two interviews were chosen as representative examples of the phenomenon. Jesse, aged 20, had been studying for two years and self-reported having difficulties with dyslexia. Nico, aged 23, was also studying in their second year and stated to have been diagnosed with ADHD. Both of the participants could explain as much about their diagnosis as they wanted to, and their choice was respected. Self-report about the diagnosis was needed; no diagnostic documents were collected for this study. Jesse and Nico were both majoring in mathematics or related science. Both of the names are gender-neutral pseudonyms – gender of the participants is not reported in order to provide anonymization. Gender neutral pronouns *they/them* are used throughout the text. “Special needs” is the term used in this study to describe the participants. The purpose is not to label these students as one group and contribute in constructing a discourse of “students with special needs” as one subject. Instead, this label is used to underline that the students, usually neglected in studies, are given a voice here (Seale, 2014), even though mediated by the researcher.

Data collection and analytical process

Data was collected after the course using semi-structured interviews, with the questions concerning perceptions of the course components. The students were able to give feedback on the course arrangements and therefore participate in the development process of the course.

The first cycle of analysis consisted of careful familiarization with the data. The transcripts of the interviews were read through multiple times to gather a general understanding of the discourses of the students. The focus on the first cycle was on the position that the students created for themselves. Foucauldian concepts of discourse and power were used in order to unpack the ways students described themselves as participants of the course. This first part of the analysis was led by the question “Do the students position themselves as included or excluded in the learning community, and how is that inclusion or exclusion created?”. The analysis was guided by identifying hegemonic discourses.

The second analysis changed the view towards examining *how* the students constructed the discourses on their subjective position and *how* they contributed in building hegemonic discourses. The data was read through the lens on *simplifications*: When did the students choose to rely on simplifications over

complexity and contradictions? How were these simplifications made seem convincing (Dant, 1991)? The concept of *naturalization* (Fairclough, 1989) was used in the analysis as an ultimate form of simplification; this kind of a process happens when socially constructed discourses and practices are taken as natural and are even connected to the nature itself. The analysis of simplifications reconstituted as follows: when do the students see social orders arranged by nature and not by people, and how are these discourses justified? During the analysis it was noted that there is a need for an analytical tool that would frame the asymmetrical power constructed through naturalization. This is why the theory of otherness was implemented; as a part of the reliability of this study, I describe this process as it chronologically happened in my findings.

Findings

The first analysis cycle: The discourse of ‘a different kind of a learner’

The first notice, after getting familiar with the data, was that both of the students described a very lonely learning process. This loneliness was connected with the difficulties the students faced in this course. An evident part of this loneliness was that throughout the data, the students spoke almost entirely in the first-person point of view as is evident through all the citations used in this article. In the entire data, there were no references to *us*.

Jesse: When I am doing an exercise, the exercise number one. Everyone else has started that exercise at the same time as me but they are already doing the task number five when I’m moving forward to task number two. I just progress so much slower. – – I realized a long time ago that for me it is better to work on my own.

The clear, choiceless segregations made between *me* and *them* were seen as building blocks of the discourse about *difference*. The discourse was named by the researcher as ‘the discourse of a different kind of a learner’ after Nico’s feedback on the course:

Nico: I think it is good if there is a will to map out the needs of different kinds of learners.

One way of constructing difference between these students and the others was the *discourse of different kinds of study methods*. The students did not want to lean on to the ready-made methods, built for them by the teacher. On the contrary, they created their own study strategies by themselves, because they could not make use of the *normal* ways of studying. This smaller discourse was seen as a legitimator for the stronger discourse of difference. Even these kinds of *helper discourses* might have some serious real life consequences.

Jesse: Well. I have been to small groups or so. Where you need to do group work with other people. These kinds of situations have always been very bad for me since. I mean, goodness. You have to write very fast, just whatever comes to your head. And the answers to the tasks, they are what they are.

Nico: I tried to study in a way everyone else is studying and. In the end of the year I realized that I wasn’t even getting grades from my courses. Now then, I built this learning strategy. So, maybe I don’t learn like other people, so I’ll just have to learn completely in my own way. – – I was using a timer with these exercises. For example, I decided that at 5 pm I’ll start doing these exercises.

The discourse of difference was also identified when the students gave feedback on the course. This was most clear with Nico, who told that they almost did not use any of the social course components, yet still they praised the existence of these arrangements. They told that they did not attend the lectures nor the open learning space, and neither wanted to take part on the digital discussion groups of the course. According to Nico, there was nothing wrong with the course components, designed with the principles of UD; they were just meant for someone else.

Nico: I would say that compared to last year. Well, this is. A hundred times better arranged, this course. So, keep going like this and it'll be very good.

As shown, there was a hegemonic discourse of 'a different kind of a learner', a strong discourse that was obviously constructed way before attending this course. But how was this kind of a hegemony legitimised? For further analysis, a new tool was needed: the concept of *otherness*.

A plunge back to the theory: Otherness and power

Individual subjects construct their reality and identity under the supervisory of normalizing practices that impose homogeneity and build discourses on *norms* (Foucault, 1977). This leads to monitoring one's behavior, a process that is constantly judged. Fenwick (2003) uses the concept of *internalisation* to describe the process where identities are produced through following norms, thus leading to being dependent on the disciplinary power the subjects have directed on themselves.

When norms produce inclusion and exclusion through disciplinary power, they produce *otherness*. Staszak (2008) conceptualizes otherness as a discursive process which is produced by a dominant group by stigmatizing a difference. The creation of otherness thus constructs two different group: *them* and *us*. Asymmetry of power is the key feature in constructing otherness: Only the more powerful group of *them* and *us* is able to maintain hegemonies and construct their own identity, while the identity of *the other* is only constructed in a relation to these powerful discourses. Discipline power is found when the others define themselves in relation to the dominant group, not having equal power to define themselves by their own means. When otherness is seen in a negative way through dominant discourse, the results tend to be very real and reflect the power structures (Okolie, 2003).

The second analysis cycle: The discourse of otherness

Because of the asymmetrical power structure that was found at the first cycle of analysis, the 'discourse of a different kind of a learner' was renamed as the 'discourse of otherness'. It was kept up with simplifications; strong discourses that left no room for seeing things from different angles. Internalisation of norms created otherness when the students saw their differences as something that could not be taken account by the course or the university staff. The students positioned themselves as the others that cannot and therefore should not be *helped* by the course. This is a strong hegemonic discourse: This learning environment of university mathematics is not meant for *them*, even if it is constructed with the principles of UD. This is an obvious simplification, since the learning environments could, of course, be adjusted for these students too.

Jesse: It would have been nice if I would have bought the physical copy. And not just read the material from the screen of my computer, since there is that backlight. I always become so confused about the line I'm reading. -- It costs money. So no thank you.

Nico: I would say that if you are a different kind of a learner, then the most important thing you should do immediately after you start your university studies is to find out how you learn.

Naturalization was the key element in constructing otherness. This kind of a process was most evident in Nico's interview. Nico referred to themselves as an 'ADHD person' and constructed otherness through neurology. Also, Jesse made references of dyslexia as a biological state that prevented them of studying in a *normal* way. These kinds of discourses can be seen as ultimate ways of asymmetrical power between *them* and *me*.

Jesse: Well. Always, it would be nice to get. Some kind of an assistance. When it comes to dyslexia. Which means more hours to a day, but that just isn't possible.

Discussion

This study examined how students with special needs position themselves in a Universally Designed undergraduate mathematics course. Even though the theories of UD and UDI were reflected in the course design, it was found that the two students interviewed constructed a discourse of otherness (Staszak, 2008; Okolie, 2003). Asymmetrical power structures were found in the way they distanced themselves from the *other* students.

Mathematical identities are known to be formed through institutional power. As educators and researchers, we need to see our responsibility in how we create discourses – or silence. There is a growing need to admit there are students with special needs in undergraduate mathematics, both in research and practice. What we can do is to transform the experiences and possibilities of students with special needs (Alderton, & Gifford, 2018). This study showed how naturalization helped to build the discourse of otherness. If we normalize this kind of inequity, we are constructing a hegemonic discourse that legitimizes subordination through asymmetrical disciplinary power.

UD offers a way to change our view towards more equal mathematics teaching in higher education by challenging the medical model of disability. However, implementing the principles of UD into a course is not enough if discourses of otherness in mathematics are not shifted. The study suggests that that designing inclusive environments *for* disabled students is not enough, since, in the end, that would reflect the medical model of disability and not social. Seale (2014) sees participation, both in research and practice, as a way to truly foster inclusion. Maybe this would be a way to shift the discourse of otherness and truly include disabled students in the mathematical learning environments. In university mathematics, the first thing to do would be to *listen* to these students.

References

- Alderton, J., & Gifford, S. (2018). Teaching mathematics to lower attainers: Dilemmas and discourses. *Research in Mathematics Education*, 20(1), 53–69.
- Burgstahler, S. E. (Eds.). (2015). *Universal design in higher education: From principles to practice*. Cambridge, MA: Harvard Education.
- CAST (2018). Universal Design for Learning guidelines version 2.2. Retrieved from <http://udlguidelines.cast.org>.

- Dant, T. (1991). *Knowledge, ideology and discourse*. London and New York: Routledge.
- Fairclough, N. (1989). *Language and power*. London: Longman.
- Feigenbaum, R. (2000). Algebra for students with learning disabilities. *The Mathematics Teacher*, 93(4), 270.
- Fenwick, T. J. (2003). The ‘good’ teacher in a neo-liberal risk society: A Foucaultian analysis of professional growth plans. *Journal of Curriculum Studies*, 35(3), 335–354.
- Foucault, M. (1977). *Discipline and punish: The birth of the prison*. New York: Vintage.
- Foucault, M. (1982). The subject and power. *Critical inquiry*, 8(4), 777–795.
- Griful-Freixenet, J., Struyven, K., Verstichele, M., & Andries, C. (2017). Higher education students with disabilities speaking out: Perceived barriers and opportunities of the universal design for learning framework. *Disability & Society*, 32(10), 1627–1649.
- Mamiseishvili, K., & Koch, L. C. (2012). Students with disabilities at 2-year institutions in the United States: Factors related to success. *Community College Review*, 40(4), 320–339.
- Laaksonen, E. (2005). *Esteetön opiskelu yliopistoissa*. Ministry of Education, Helsinki.
- Okolie, A. C. (2003). Introduction to the special issue. Identity: Now you don’t see it; now you do. *Identity: An International Journal of Theory and Research*, 3(1), 1–7.
- Perkin, G., & Croft, T. (2007). The dyslexic student and mathematics in higher education. *Dyslexia*, 13(3), 193–210.
- Roberts, K. D., Park, H. J., Brown, S., & Cook, B. (2011). Universal design for instruction in postsecondary education: A systematic review of empirically based articles. *Journal of Postsecondary Education and Disability*, 24(1), 5–15.
- Seale, J. (2014). *E-learning and disability in higher education: accessibility research and practice*. London and New York: Routledge.
- Shaw, S. F., Scott, S. S., & McGuire, J. M. (2001). Teaching college students with learning disabilities. ERIC Digest. Retrieved from <https://eric.ed.gov/?id=ED459548>.
- Staszak, J.-F. (2008). Other/otherness. In R. Kitchin & N. Thrift (Eds.), *International Encyclopaedia of Human Geography*, (pp. 43–47). Oxford: Elsevier.
- Tan, P., & Kastberg, S. (2017). Calling for research collaborations and the use of dis/ability studies in mathematics education. *Journal of Urban Mathematics Education*, 10(2), 25–38.
- Thurston, L. P., Shuman, C., Middendorf, B. J., & Johnson, C. (2017). Postsecondary STEM education for students with disabilities: Lessons learned from a decade of NSF funding. *Journal of Postsecondary Education and Disability*, 30(1), 49–60.
- Weeber, J. E. (2004). *Disability community leaders’ disability identity development: A journey of integration and expansion* (Doctoral dissertation). North Carolina State University, Raleigh, NC, United States. Retrieved from <http://www.lib.ncsu.edu/resolver/1840.16/5952>.

Lávvu and mathematics

Siv Ingrid Nordkild¹ and Ole Einar Hætta²

¹UiT The Arctic University of Norway, Faculty of Humanities, Social Sciences and Education, Tromsø, Norway; siv.i.nordkild@uit.no

²Guovdageainnu nuoraidskuvla—Guovdageaidnu Lower Secondary School, Guovdageaidnu, Norway; ole.einar.heatta@kautokeino.kommune.no

Keywords: Lávvu, ethnomathematics, sámi and indigenous education.

Introduction

Sápmi is the Sámi term for the Sámi homeland and society, the land area extends from Central Norway, Sweden and Finland to the Kola Peninsula in Russia. In Norway, the Sámi as a population has status as an indigenous people, which means that the Sámi have the right to develop their own culture and language on their own premises. Traditionally the Sámi people has lived as hunters and gatherers and in connection with this, they lived a nomadic life. The *lávvu* is a temporary dwelling, and the design of it reflects the Sámi culture as a community. Families travel in small groups, and the *lávvu* is designed so that even one person could quickly set it up with little effort.

Teachers at a Sámi school in northern part of *Sápmi* in Norway have for several years developed teaching units for all grades in lower secondary school with *lávvu* as an overall theme. When students attend their last year at lower secondary school, they develop their own teaching unit in mathematics with the *lávvu*. This study builds on research by Fyhn et al. (2016), Fyhn, Meaney, Nystad, and Jannok Nutti (2017), and Jannok Nutti et al. (2015), where the Sámi culture founds basis for mathematics in school. The research question investigated here is: How do students use the *lávvu* in mathematics teaching?

Theoretical framework

The Sámi pedagogy reflects the Sámi culture, and the culture has a holistic conception of knowledge (Balto, 2005; Keskitalo & Määttä, 2011; Siri & Hermansen, 2018). The holistic view is also central in the upbringing of the Sámi children. Culturally-responsive teaching is about teaching that founds basis in cultural knowledge and insight (Gay, 2013). It is essential that this teaching must not take cultural phenomena out of its context, because the student can experience that the teacher and the school simplify the students own culture (Fyhn et al., 2017).

Method

The analysis of the data in this study can be characterized as abductive, and the data material has been analyzed towards Sámi pedagogy and culturally-responsive teaching. The data is based on observation, audio recordings of the teaching activity and conversation between authors. Ole Einar was the teaching students' supervisor in the development and performance of the teaching. Siv participated in the teaching as a participating observer following one group of learners.

Findings

There were five *lávvu*s in the schoolyard. Each of them had different themes in which it was taught. These topics were cooking in the *lávvu*, building a traditional *lávvu*, storytelling and *luohti* (Sámi traditional song), the history of the *lávvu* and mathematics in *lávvu*. In addition, each lesson in the *lávvu* lasted for approximately 30 minutes. The students who were taught were divided into four groups, and each group of learners were visiting all *lávvu*s. In Sámi pedagogy the place where teaching happens does not necessarily need to be situated in the traditional classroom (Keskitalo & Määttä, 2011). This teaching is literally situated outside the classroom. It takes place in *lávvu*s in the schoolyard. The teaching combines the Sámi culture and the Norwegian upper primary school level curriculum. Four of the *lávvu*s addressed phenomena and activities in relation to the Sámi culture. The fifth *lávvu*, where mathematics was taught, stands out in such a way that it was based on *lávvu*, but it related to geometry. All the *lávvu*s had to be included in the teaching because this gave a holistic perspective and cultural-responsive teaching, even though the mathematics teaching could be characterized as deductive.

References

- Balto, A. (2005). Traditional Sámi child rearing in transition: Shaping a new pedagogical platform. *AlterNative: An International Journal of Indigenous Peoples*, 1, 85–105.
- Fyhn, A. B., Eira, E. J. S., Hætta, O. E., Juuso, I. A. M., Skum, E. M., Hætta, S. I., . . . Siri, M.-T. (2016). Med kultur i fokus: Eksemplet *lávvu*. *Tangenten*, 27(3), 2–14.
- Fyhn, A. B., Meaney, T., Nystad, K., & Jannok Nutti, Y. (2017). How Sámi teachers' development of a teaching unit influences their self-determination. In T. Dooley & G. Gneudet (Eds.), *Proceedings of the Tenth Congress of the European Society for Research in Mathematics Education* (pp. 1481–1488). Dublin, Ireland: DCU Institute of Education.
- Gay, G. (2013). Teaching to and through cultural diversity. *Curriculum Inquiry*, 43(1), 48–70.
- Jannok Nutti, Y., Fyhn, A. B., Eira, E. J. S., Sandvik, S. O., Børresen, T., Hætta, O. E., . . . Gaup, K. M. (2015). Call your mothers! Sámi culture-based curriculum development based on mathematics teachers, students and mothers in joint research actions. *International Journal about Parents in Education*, 9(1), 10–23.
- Keskitalo, P., & Määttä, K. (2011). *Sámi pedagogihka iešvuodat = Saamelaispedagogiikan perusteet = The basics of Sámi pedagogy = Grunderna i samisk pedagogik = Osnovy Saamskoj pedagogiki*. Rovaniemi, Finland: Lapland University Press.
- Siri, K. K. M. N., & Hermansen, J. O. K. (2018). Suonjir og luovvi: Lokal samisk tradisjon. *Tangenten*, 4, 13–18.

Interdisciplinarity, culturally sustaining pedagogies, and the problem of pandisability as culture: Co-creating diverse mathematics learning contexts

Alexis Padilla¹ and Paulo Tan²

¹University of New Mexico, Department of Language Literacy and Sociocultural Studies, Albuquerque, United States; m3689@unm.edu

²University of Hawaii, Mānoa, Institute for Teacher Education, Honolulu, United States; paulotan@hawaii.edu

We argue for the need to reframe interdisciplinarity to encompass pandisability. Such reframing enhances cultural experiences and genuine diversity through collaborative creation of mathematics learning contexts and culturally sustaining pedagogies. We explore ways to undo vertical hierarchy patterns of relationality that hinder exchanges across differences. In these equity-driven pedagogical interventions, we call for conflating multiple disciplinary fields within and around mathematics as well as diverse layers of practice, namely in research, teaching, teacher education, disability advocacy, parenting, youth self-determination, rehabilitative sciences, and so forth. We recognize that these practices relate to multiple disability experiences and identity formation trajectories that enrich mathematics as a collaborative space for all and of all within and outside schooling.

Keywords: Mathematics education, disability culture, radical interdisciplinarity, pandisability.

Introduction

The present paper highlights the need to reframe interdisciplinarity in conjunction to pandisability cultural experiences to enhance genuine diversity in the collaborative creation of mathematics learning contexts inside and outside schooling. Pandisability refers to the full scope of disability categories, including disability modes of identity not yet labeled as such by system actors or not fully accepted by recipients of disability labels. The unique knowledges afforded by this sense of difference must be deliberately incorporated into mathematics learning pedagogical interventions, competency assessment, and process standards in meaningful ways. Doing so enriches not only the collective experiences of students with disabilities but most especially those imbued with privileged status as expressions of embodied normalcy (Davis, 1995, 2002, 2013; Goodley, 2003; Hughes, 2007). In this introductory section we touch on interdisciplinary knowledges as typically conceived in ways that marginalize experiential spaces such as those afforded by pandisability culture. In the next section, we tackle the link between pandisability cultural knowledges and mathematics learning. The section that follows dives into the theoretical and practical implications of using culturally sustaining pedagogies (CSP) in conjunction with interdisciplinarity. We conclude by drawing a few critical notes on ways to enhance CSP as it becomes part of the everyday practices of disability studies in mathematics education (DSME). To this end, we use the example of the braille literacy crisis, showing how expansive views on pandisability culture can help CSP and mathematics education practices transcend typical interdisciplinary boundaries and knowledge creation pre-conceptions. Importantly, the reader should note that DSME's pedagogical and learner-centered practices are radically distinct from special and mathematics education approaches that rest on medical and

behaviorist models with their fixing, deficit-driven attitude toward students with disabilities (see, for example, the DSME-centered meta-analysis of recent mathematics education empirical work carried out by Tan, Lambert, Padilla, & Wieman, 2018).

Interdisciplinarity is portrayed as a set of practices designed to bridge multiple knowledges. Unfortunately, by its very definition, the implementation of interdisciplinarity privileges disciplinary knowledges (Bhasker & Danermark, 2006). Therefore, the experiential wealth of knowledges such as those afforded by disability identity and alterity tends to be neglected and/or marginalized as external to the making of interdisciplinarity. Likewise, parallel knowledges of interdependence actors, for example, families or friends of learners with disabilities tend to be discarded as insignificant or completely ignored.

We are appealing to an international audience. Our positionality is grounded in DSME research and practice contextually based in the United States. As such, through the present paper we aspire to engender an invitational dialogue which revolves around the need to explore ways to articulate a new, much more embracing conceptualization of interdisciplinarity that transforms the way everyday mathematics education practices inside and outside the classroom are conceived and enacted. The aim is to incorporate disability difference and the knowledges it affords into why and how things are approached and learned by students with and without disabilities. Our purpose is to capture the multiple layers of diversity associated with disability knowledges and ways of knowing in the making of mathematics as their equity-centered learning space for belonging and reciprocal interactions of collaborative creativity. Such creativity is nurtured by special modes of disability-centered multicultural difference and parallel spheres of intersectionality with identity areas such as gender, class, race/ethnicity, multi-lingual richness, and so on.

Why pandisability?

Disability is a social category of culture in action. It flows in reciprocal interaction with institutionalized settings (Blanton, Pugach, & Bóveda, 2018; Kupperts, 2011). Each disability category constitutes a sub-cultural sphere. Disability's unique difference-based sense of richness can enhance collective contexts for mathematics learning in special ways. Take for example the meaning of musical silences as a mathematical unit susceptible to rhythmic and trans-melodic embodiments. How many of our readers have ever wondered if or how deaf learners and their interdependence partners would contribute to enriching our understanding of the mathematical depth of musical silences? The absence of questions such as these in mathematics learning circles is quite telling. Yet, answering these questions is only viable by unleashing the power of true belonging in co-learning spaces for sharing. Those knowledges are already brewing within the vitality of deaf learner experiences and those of their interdependent partners. Excluding them, we are also depriving the contextual whole from one of its core learning parts.

Now consider visual mathematics dimensions as they get experienced by blind and/or visually impaired individuals and their interdependent partners. To what extent do stereotypical conceptions of visuality prevent us from dialoguing with these kinds of learners?

An example outside mathematics may help us appreciate the power of non-visual knowledges and ways of knowing in terms of their intuitional relationality. We allude to an essay by critical

anthropologist Michael Taussig (1991) who builds on Walter Benjamin's (1969) suggestion that one should place the sense of sight under the guidance of tactility for the sake of aesthetic interpretation. From this idea, Taussig implies that tactility can guide everyday interpretations to an extent non-realized by actors. Taussig (1991) states:

Surely this sense includes much that is not sense so much as sensuousness, an embodied and somewhat automatic 'knowledge' that functions like peripheral vision, not studied contemplation, a knowledge that is imageric and sensate rather than ideational and as such not only challenges practically all critical practice across the board of academic disciplines but is a knowledge that lies as much in the objects and spaces of observation as in the body and mind of the observer. What's more, this sense has an activist, constructivist, bent; not so much contemplative as it is caught in *media res* working on, making anew, amalgamating, acting and reacting. We are thus mindful of Nietzsche's notion of the senses as bound to their object as much as their organs of reception, a fluid bond to be sure in which ... 'seeing becomes seeing *something*'. (pp. 147-148)

Taussig is talking here about the interpretative processes and intuitional knowledges experienced and created by sighted individuals. If he had developed statements like these in relation to experiences of blind students or scholars, the depth of what he was saying would immediately vanish. This vanishing is the byproduct of ableist readings of blindness as mere impairment or as an incapacitating/paralyzing state.

What if pedagogically one takes Taussig's idea of tactility and asks blind students to become teachers of sighted students and perhaps prospective teachers on how they enact and embody tactility as students of disciplines like mathematics and the arts? In doing so, one should be prepared for all kinds of outcomes. For instance, thinkers with visual impairments such as David Bolt (2014) criticize the over-representation of haptic constructions in relation to the blind. In Bolt's view, this haptic over-emphasis is an expression of ocularcentrism, that is, the belief that knowledge is only possible under sighted guidance, under the "light" of wisdom and proper directionality, which contrasts with the frightening darkness and vacillation inherently associated with tactility. What if there is a culture of resistance toward tactility among these teaching blind students? What if there is more cultural plurality among them than initially anticipated by non-blind audiences? Ultimately, only these teaching individuals could show us the lights and shadows of tactility as a dynamic knowledge-creating tool and as a multifaceted expression of cultures of blindness.

Exploring interdisciplinarity along with culturally sustaining pedagogies and dialogicality

A great part of the problem with narrow conceptualizations of interdisciplinarity stems from a dualist split between thinking and doing, and knowing and experiencing. Disciplinary knowledges, if they do something, the doing is conceptually framed as encapsulated within abstract thinking. This is a Cartesian legacy. Our mind is always "in interaction with others, that is, with individuals, groups, institutions, cultures, and with the past, present and future" (Marková, 2016, p. 91).

It is precisely with our mind's interaction with, within and beyond the boundaries of disability cultures that we are concerned with as we reframe the dialogical enactment of interdisciplinarity to encompass experiential knowledges typically excluded from its purview. Our invitation engages the

special implications of these culturally contextualized interactions for the making and re-making of mathematics as a learning space for all and of all. Therefore, the value of CSP as a core component of this process becomes paramount.

Paris (2012) suggests the use of CSP terminology as a much more accurate conceptualization of the dynamics pursued as one engages with cultural contexts of diversity that are threatened by their systematic marginalization within learning spaces. It does not suffice to keep talking of culturally relevant or culturally responsive pedagogies (as has been done in United States educational contexts of critical multiculturalism for at least three decades, but especially with the publication of Ladon-Billings, 1995; along with this terminology there are other less diffused similar terms that have been used in the literature such as culturally congruent pedagogy, Au & Kawakami, 1994, culturally compatible pedagogy, Jacob & Jordan, 1987, engaged pedagogy, hooks, 1994, everyday pedagogies, Nasir, 2008, and critical care praxis, Rolón-Dow, 2005)

The next logical step is to grapple with another core question: What are the concrete areas of cultural practice one is trying to sustain and why? Paris and Alim (2014) interrogate this dimension. They argue that important as it is to employ asset-based pedagogies, it is paramount to dynamize their applicability to keep up with the evolving transformations of youth cultural processes at the local level and throughout the globe, as well as counteract the myriad of institutionalizing practices that aim at stifling this relational learning dynamicity. The latter is of crucial significance for youth and adults with disabilities in their mathematics of all experiences inside and outside schooling contexts. Paris and Alim (2014) point out their own sense of responsibility in the areas of practice they criticize:

[S]ome of our own research and teaching has uncritically taken up and built on previous notions of asset pedagogies, has at times reified traditional relationships between race/ ethnicity and cultural practice, and has not directly and generatively enough taken up problematic elements of youth culture. ... we live, research, and write with the understanding that our languages, literacies, histories, and cultural ways of being as people of color are not pathological. Beginning with this understanding ... allows us to see the fallacy of measuring ourselves and the young people in our communities solely against the White middle-class norms of knowing and being that continue to dominate notions of educational achievement. Du Bois ... of course, theorized this over a century ago with his conceptualization of double consciousness... (p. 86)¹.

Double consciousness means a state in which people of color, students with disabilities, gendered and lower-class subaltern individuals reject their own selves, adopting a stance that favors dominant cultural patterns. For students with disabilities this might entail rejecting sign language, in the case of deaf youths, or, in the case of blind individuals, rejecting braille or wanting to continue driving motor vehicles at the onset of visual impairments to deny any pandisability linkages. All of these self-isolation and self-rejecting behaviors are likely to impact negatively the enactment of edifying mathematics learning habits as well as collaborative learning prospects grounded on pandisability culture and interdependence.

¹ see also, Du Bois (1965).

Let us transpose this to the field of DSME. In terms of teaching and research practices, the plight of students with intellectual disabilities illustrates quite well what happens. There is a dualism that tries to transform deficit-centered scenarios but falls into rather ritualistic mathematics learning attempts. Many modalities of direct teaching with their repetitious behaviorist exercises guided by deficit-centered conceptions of intellectual disabilities seldom involve youth with disabilities themselves as drivers of their own transformational mathematics learning as well as that of the institutional environments where their education takes place. Our own review of the specialized mathematics education literature for the past decade (Tan, Lambert, Padilla, & Wieman, 2018) makes evident a minoritarian status for those instances of research where DSME principles are explored. Sadly, this exploration is often timid and, in none of the studies we found are students with disability involved as co-designers of their learning or the mathematics education research that pertains to them. Of course, we know that this very prospect would alarm many mathematics education researchers for whom the very configuration of research studies is a continuous exercise that corroborates their self-fulfilling prophecy: that these students are not capable of complex operations. Thus, it would be temerity to leave their learning destiny in their disabled hands or pretend that one can have a meaningful collaboration toward pedagogical ends and processes with them as responsive agents. Double consciousness acquires an internalized status in the lives of these students with disabilities. Learned helplessness, learned hopelessness are not an unlikely outcome for them. After all, the symbolic exposure to exclusion messages in classroom settings for years at times is taken to heart (Ayres, Lowrey, Douglas, & Sievers, 2011; Baglieri, 2017; Connor, 2008a, 2008b; Connor & Ferri, 2007; Connor, Ferri & Annamma, 2016; Duckworth, 1995; Erevelles, 2000, 2005; Gallagher, 2004; Graham & Slee, 2008; Paris & Alim, 2017).

Concluding Remarks

One example of possible interdisciplinary applications of CSP and disability-centered double consciousness examinations is the so-called braille literacy crisis faced by students with visual impairments in the United States. This is a crisis that indirectly impacts mathematical inclusivity practices. It involves youth self-advocates, families and blind membership organizations. Teaching institutions and researchers could design collaborative research models aimed at tackling culturally sustaining ways to approach the crisis and transform it creatively into a broad, long-term co-learning opportunity. This collaborative research approach would build momentum. It would allow multiple layers of collaborating partners to discover, discuss critically and undo from the inside out those youth cultural practices collectively identified as detrimental and alienating, instead of assuming a priori things about which researchers only have very tenuous knowledge. Most significantly, it would avoid blaming the victim and perpetuating the very top-down systemic practices that originated the braille literacy crisis in the first place (teacher certification requirements, limited incorporation of blind teachers, distancing from youth needs, downplaying of braille, special mathematics coding tools developed with and for the blind, etc.), letting it deepen as years went by.

There are many other innovative paths of interdisciplinary applications of CSP and disability-centered double consciousness examinations which are in their own right interdisciplinary and desperately needed in order to change the lives of individuals with disabilities in and out of mathematics classrooms. Yet, one problem in tackling these explorations is that CSP in its original design has

ignored disability issues. Waitoller and Thorius (2016) suggest remedying this by combining CSP with Universal Design for Learning (UDL) techniques. This solution only addresses the problem in part. Both UDL and CSP lack a genuinely global/international approach for dealing with educational contingencies and are too circumscribed to narrowly conceived schooling dynamics. Therefore, we hope that our CERME discussions will help elucidate innovative ways to correct these deficiencies particularly in relation to how disability studies and mathematics education can embody a true sense of interdisciplinary collaboration.

References

- Au, K., & Kawakami, A. (1994). Cultural congruence in instruction. In E. Hollins, J. King, & W. Hayman (Eds.), *Teaching diverse populations: Formulating knowledge base* (pp. 5–23). Albany, NY: SUNY Press.
- Ayres, K. M., Lowrey, K. A., Douglas, K. H., & Sievers, C. (2011). I can identify Saturn but I can't brush my teeth: What happens when the curricular focus for students with severe disabilities shifts. *Education and Training in Autism and Developmental Disabilities*, 46(1), 11–21.
- Baglieri, S. (with Shapiro, A.). (2017). *Disability studies and the inclusive classroom: Critical practices for embracing diversity in education* (2nd ed.). New York: Routledge.
- Benjamin, W. (1969). The work of art in the age of mechanical reproduction. In W. Benjamin, *Illuminations* (pp. 217–252). New York: Schocken Books.
- Bhasker, R., & Danermark, B. (2006). Metatheory, interdisciplinarity and disability research: A critical realist perspective. *Scandinavian Journal of Disability Research*, 8(4), 278–297.
- Blanton, L. P., Pugach, M. C., & Bóveda, M. (2018). Interrogating the intersections between general and special education. *Journal of Teacher Education*, 69(4), 354–366.
- Bolt, D. (2014). *The metanarrative of blindness: A re-reading of twentieth-century Anglophone writing*. Ann Arbor, MI: The University of Michigan Press.
- Connor, D. J. (2008a). Not so strange bedfellows: The promise of disability studies and Critical Race Theory. In S. L. (Eds.), *Disability and the politics of education: An international reader* (pp. 451–476). New York: Peter Lang.
- Connor, D. J. (2008b). *Urban narratives: Portraits-in-progress—Life at the intersections of learning disability, race, and social class*. New York: Peter Lang.
- Connor, D. J., & Ferri, B. A. (2007). The conflict within: Resistance to inclusion and other paradoxes in special education. *Disability & Society*, 22(1), 63–77.
- Connor, D. J., Ferri, B. A., & Annamma, S. A. (Eds.). (2016). *DisCrit-disability studies and critical race theory in education*. New York: Teachers College Press.
- Davis, L. J. (1995). *Enforcing normalcy: Disability, deafness and the body*. London: Verso.
- Davis, L. J. (2002). *Bending over backwards: Disability, dismodernism and other difficult positions*. New York: New York University Press.

- Davis, L. J. (2013). The end of identity politics: On disability as an unstable category. In L. J. Davis (Ed.), *The disability studies reader* (pp. 263–277). New York: Routledge.
- Du Bois, W. E. B. (1965). *The souls of black folk*. New York: Avon Books. (Original work published 1903)
- Duckworth, E. (1995). *“The having of wonderful ideas” and other essays on teaching and learning*. New York: Teachers College Press.
- Erevelles, N. (2000). Educating unruly bodies: Critical pedagogy, disability studies, and the politics of schooling. *Educational Theory*, 50(1), 25–47.
- Erevelles, N. (2005). Understanding curriculum as normalizing text: Disability studies meet curriculum theory. *Journal of Curriculum Studies*, 37(4), 421–439.
- Gallagher, D. J. (2004). The importance of constructivism and constructivist pedagogy for disability studies in education. *Disability Studies Quarterly*, 24(2), 1–20.
- Goodley, D. (2003). Against a politics of victimisation: Disability culture and selfadvocates with learning difficulties. In N. Watson & S. Riddell (Eds.), *Disability, culture and identity* (pp. 105–130). London: Routledge.
- Graham, L. J., & Slee, R. (2008). An illusory interiority: Interrogating the discourse/s of inclusion. *Educational Philosophy and Theory*, 40(2), 277–293.
- hooks, b. (1994). *Teaching to transgress*. New York: Routledge.
- Hughes, B. (2007). Being disabled: Towards a critical social ontology for disability studies. *Disability & Society*, 22(7), 673–684.
- Jacob, E., & Jordan, C. (1987). Moving to dialogue. *Anthropology and Education Quarterly*, 18(4), 259–261.
- Kuppers, P. (2011). *Disability culture and community performance*. New York: Palgrave Macmillan.
- Ladson-Billings, G. (1995). Toward a theory of culturally relevant pedagogy. *American Educational Research Journal*, 32(3), 465–491.
- Marková, I. (2016). *The dialogical mind: Common sense and ethics*. Cambridge, England: Cambridge University Press.
- Nasir, N. (2008). Everyday pedagogy: Lessons from basketball, track, and dominoes. *Phi Delta Kappan*, 89(7), 529–532.
- Paris, D. (2012). Culturally sustaining pedagogy: A needed change in stance, terminology, and practice. *Educational Researcher*, 41(3), 93–97.
- Paris, D., & Alim, H. S. (2014). What are we seeking to sustain through culturally sustaining pedagogy? A loving critique forward. *Harvard Educational Review*, 84(1), 85–100.
- Paris, D., & Alim, H. S. (2017). *Culturally sustaining pedagogies: Teaching and learning for justice in a changing world*. New York: Teachers College Press.

- Rolón-Dow, C. (2005). Critical care: A color(full) analysis of care narratives in the schooling experiences of Puerto Rican girls. *American Educational Research Journal*, 42(1), 77–111.
- Tan, P., Lambert, R., Padilla, A., & Wieman, R. (2018). A disability studies in mathematics education review of intellectual disabilities: Directions for future inquiry and practice. *The Journal of Mathematical Behavior*. <https://doi.org/10.1016/j.jmathb.2018.09.001>
- Taussig, M. (1991). Tactility and distraction. *Cultural Anthropology*, 6(2), 147–153.
- Waitoller, F. R., & Thorius, K. K. (2016). Cross-pollinating culturally sustaining pedagogy and universal design for learning: Toward an inclusive pedagogy that accounts for dis/ability. *Harvard Educational Review*, 86(3), 366–389.

The teaching of higher education mathematics by pre-service mathematics teacher educators: How might this contribute to social justice? A consideration of a possible approach

Hilary Povey

Sheffield Hallam University, England, h.povey@shu.ac.uk

This paper considers the teaching of higher education mathematics as part of pre-service teacher education and the potential for it to contribute to social justice. In it I ask and seek to offer one possible answer to the following question: By enacting within their own higher education mathematics teaching an enquiry-based pedagogy informed by considerations of fairness and equality, can mathematics education tutors open up possibilities for their students to engage more deeply with such practices and the attendant commitment to social justice? A set of exemplar practices drawn from my own teaching is briefly described and discussed and responses from a cohort of students considered.

Keywords: Neo-liberalism, mathematics education, pre-service teacher education, activism.

Introduction

Socio-political researchers in mathematics education have connected active, engaged, meaning-making pedagogies with the possibilities for social justice in school mathematics classrooms (Skovsmose, 1994; Gutstein, 2006; Boaler, 2008). Although there is a rich literature about innovative and critical approaches to other aspects of pre-service teaching (for example, Cochran-Smith, 1991; Nolan, 2012), there has been comparatively little written about the impact of such pedagogies on those teacher education students who study academic mathematics as an undergraduate subject in its own right. We know that talking about and recommending practices that go against the grain (Cochran-Smith, 1991), whilst essential, have, in themselves, comparatively little effect in teacher education (Nolan, 2012) – but that, in other educational contexts, *enacting* recommended practice may do so (Alexander, 2008).

In England, over the last three decades, neo-liberalism has been successful in colonising educational discourse to such an extent that we are left with just “the rubble of words” (Berger, 2016, p. 7)¹. It becomes almost impossible to think outside neo-liberalism’s world view and, therefore, to think how things could be otherwise (Llewellyn, 2017): Our human priorities have been “systematically sprayed, not with pesticides, but with ethicides – agents that kill ethics and therefore any notion of ... justice” (Berger, 2016, p. 83). Education has been marketised as a consumer good and no longer understood as a moral enterprise, leading to relentless managerial auditing ruthlessly imposed and internalised by practitioners who have to constantly remake themselves as neo-liberal individuals (Povey, Adams, & Everley, 2017). I argue that offering the experience of countervailing ways of being in the world (often momentarily) can open up other ways of *thinking about* and *acting in* the

¹ Space allows for only a brief statement of these ideas here and in the next paragraph. See Povey & Adams (2018) for a fuller argument.

world: “Revolutions are about little things. Little things which happen to you all the time, every day, wherever you go, all your life” (Rowbotham, 2000, p. 211). Routine preservice classroom practices are part of this everydayness.

In this study, I largely bracket, for the time being, whilst accepting them as always already essential for critique, a set of difficulties and dilemmas present in any critical engagement in socio-political mathematics education research. In capitalist societies, inequity and exclusion are consubstantial with the acts of teaching and learning mathematics (Pais, 2017). Mathematics itself creates pernicious collateral damage (summarised in Povey & Adams, 2018, and developed in some detail in Ernest, 2016, and Skovsmose, 2016). Nevertheless, as well as critiquing existing patterns of inequality, I intend my research and writing to contribute to the struggle for a more just, democratic and socialist mathematics education, to enable us to act in the world, however necessarily unstable and temporary that positioning and analysis may be. My project is an activist one, not functioning as we are supposed to do as researchers (Straehler-Pohl, Pais, & Bohlmann, 2017, p. 13) but otherwise and utopian in seeking to catch an occasional, penumbrian glimpse of “the speculative could” (p. 3).

This paper asks: *Can teacher educators, by enacting the approach considered here, open up possibilities for their students to engage more deeply with (and therefore perhaps adopt) such practices and the attendant commitment to social justice?* Neo-liberal discourses regulate practices (Nolan, 2012), reproduce existing class relations and valorising being “strong and selfish” (p. 210). Can we enable our students to reassert in education a moral landscape of autonomy and trust (Stronach, Corbin, McNamara, Stark, & Warne, 2002, p. 130), an interpersonal enterprise contributing to understanding how we should live and challenging hegemonic neo-liberalism?

My practice

There is a categorical difficulty in trying to represent practice given its “dense, continuous, expressive nature” (Coldron, 2013, np.). Practice, a set of “socially produced, culturally constructed activities” (Holland, Lachicotte, Skinner, & Cain, 1998, p. 41), can probably only be properly conveyed by the practice itself. Nevertheless, it is expressed and mediated by spoken discourse, materiality and embodied practices: It is opened by and entered through *artefacts* (Holland et al., 1998, p. 251) which assume and express *intentionality*. In this case, the mediating artefacts include:

- *my language and the implicit and explicit rules I set up for classroom talk* – for example, discussing and disallowing talk about people as ‘clever’ or ‘able’ or, including about oneself, as ‘useless’, ‘thick’ or ‘stupid’, encouraging talk which is collective, supportive and reciprocal; welcoming mistakes and queries as prompts for thinking rather than worrying about being wrong;
- *the physical space for studying* – for example, preparing the room with mathematical posters and frequently taking in eye catching and intriguing objects to promote inter-cultural respect and the awareness of possibilities of communicating mathematics outside a common vernacular; arranging tables in groups of about six;
- *promoting collaboration across the whole class* – for example, putting students in heterogeneous groups chosen by me; restructuring each time a new topic is introduced; discussing my research-

evidenced conviction that this supports building a learning community; requiring that everybody in a table group must understand before the group moves on;

- *questions or other responses where answers might be expected* - for example, developing a sense of themselves as being sources of authoritative knowing when they look to me for conventional 'help' and it is not forthcoming and offering instead, say, 'Can you apply that reasoning to this one?', 'How does what he is saying connect with what we were discussing last week?', 'You two don't agree - excellent - an opportunity for mathematical argument!'
- *the tasks set* - for example, ensuring that they are group-worthy; adapting the curriculum according to students' responses;
- *the pattern of attendance* - for example, making some sessions explicitly optional and others justified as essential, required for honouring and contributing to the learning community; allowing extended periods for an enquiry;
- *the physical objects used* - large, colourful physical models, shared task recording sheets, cards to be flexibly sorted and organised rather than static texts, erasable short-term responses to group questions;
- *characteristics of the final assessment* - for example, open book where students can take in anything except things that connect with the internet; more marks available than needed so that any work submitted can be rewarded.²

For almost all of the students, the effect of these mediating practices in mathematics education is “a totally new experience” (interview data).

The study

This action research case study offers a “serious example” (Skovsmose, 1994, p. 9) of practice, that bundling together of “co-dependent (mutually constitutive) sayings, doings, understandings, physical arrangements, purposes, feelings, roles and identities” (Coldron, 2013, np.). It is framed within my “living education theory” (Whitehead, 1989, p.41), undertaking research as thoughtful practice. I have been teaching very similar mathematical content with very similar intentions to very similar students for many years and the theory which guides my practice has become embodied and enacted with increasing complexity over time. McNiff and Whitehead (2010) describe the process thus:

Because you are a living person, you are changing every day; and because you are reflecting consciously on what you are doing, and making adjustments as you go, your theory is also developing with you. Your theory is part of your thinking and living, which is continuously transforming. So your theory, as part of your own thinking, is living... In living educational theories the explanations are produced ... in the practice of enquiries of the kind, ‘How do I improve what I am doing?’. (pp. 252–253)

² For much greater detail and exemplars see Povey (2017).

I used interview data from students to explore their experience of and reaction to my practice. The participants were from a class of 40 who were following an undergraduate pure mathematics module comprising a third of their final year study taught within a mathematics education centre by staff who had been school teachers (Povey & Angier, 2007).

The group interviews, each of which lasted about an hour, were conducted by a researcher unknown to the participants using a very open, semi-structured protocol. I explained the purpose of the enquiry in writing, making it clear that they were under no obligation to take part and could withdraw from the study at any time. I assured them that all data would be reported anonymously unless they specifically requested otherwise. I guaranteed that the data would not be viewed by me until I had finished teaching and assessing them, hoping in this way to address the ethical issues involved. Everyone in the class agreed to be interviewed but logistical constraints during a pressurised time of year meant that only eighteen ended up being able to participate. Overall, the groups were heterogeneous and not composed of friendship subgroups from the class.

The interviews were all transcribed by an independent transcriber (with occasional editing for clarity and brevity). The initial analysis, despite being careful and systematic, was iterative and somewhat ‘messy’. I worked with the transcription texts, reading and re-reading them many times, tentatively extracting what seemed to me to be interesting and coherent passages of dialogue. I printed each of these onto a separate sheet of paper and physically grouped, de-grouped and re-grouped the sheets, searching them and annotating emergent themes. I did not identify the individual participants in the transcripts at this stage in order to gain a little distance from the texts. I then listened to all the tape recordings more than twice, attempting “radical listening” (Clough & Nutbrown, 2012, p. 99), immersing myself in the full data set to gain a sense of how the emerging themes were, or were not, grounded in the data. I then repeated the initial process of working with the transcripts, checking out and supplementing the existing themes and looking for new ones. No new themes emerged but some were modified and/or enriched. Finally, I referred to my record of which students had participated in which group interview and listened carefully to the tapes for a final time in order to identify the participants in the extracted passages.

Analysis

The interviews were cultural spaces where the students, through improvisation, articulated an understanding of their experiences of the module. In analysing them, I asked to what extent and in what way (i) my “living theory” was visible to them and (ii) they were willing to experiment with embracing aspects of it in their sense of who they were becoming. All but one suggested some such identification. After interrogating the data, I identified a number of themes which there is no space here to discuss. Rather, I present extracts from the data which link to just one aspect of working for social justice in and through mathematics education, that of experiencing solidarity.

Solidarity involves *challenging the discourse of ‘ability’* (Marks, 2013) and destabilising attendant hierarchies, offering equal value and equal respect towards each other.

Anna: I think we’re all on kind of a level as well. Like we all have obviously our strengths and weaknesses in certain areas, but they’re all different so we can actually get that collaborative kind of thing that everyone’s talking about.

Matt: There's one example where the vast majority of all the groups thought one particular answer was correct and then one person disagreed and that person was the one that got it right... that's kind of a bit of an indicator... It's not the fact that 95% have got it wrong. It's the fact that one person got it... it's almost like reverse psychology... instead of feeling left out because you're the one that hasn't got it right, it's like everybody else thought 'we can do it as well' ...Does anyone know what I'm trying to say there?

Rach: ... Because you've got a group mentality you sort of think 'One of us has got it so between us we've managed it and with a little bit of work it's not out of reach for us all'.

Developing links *in a learning community* expressed metaphorically as being a family (comp. Angier & Povey, 1999) becomes a shared preference and brings *pleasure*:

Anna: It encourages a different way of working... you don't get the chance to work in a group very often normally for maths. It's seen as a very solitary subject, but I think it makes it a lot more interesting and a lot more enjoyable when you can sit and work with people on a subject and on a problem particularly.

Will: I do like it a lot better ...It's more like a little family, ain't it?

Rach: There's a lot of us who will come into uni when we haven't got set lectures... because we want to sit and work as a group of us rather than sitting at home doing the work...

Int: Would you have done that before?

Rs: [*several*] No, no never.

They appreciated that the nature of their tasks supported this. These group-worthy tasks and the discourse of collaboration are used by the students to position themselves as agentic in the face of doubt or difficulty. Such a sense of *agency and authority* has been found to be a central characteristic of those mathematics teachers who were able to interrogate taken-for-granted practices in schooling and work for progressive change (Povey, 1997). The approach to answers plays a part in developing their shared conviction and authority.

Dora: I think a lot of the tasks though because they're quite open-ended, it's not stuff you can do individually. You have to do it with other people's inputs, so you're using other people's ability... at first it got us kind of gelling together and then we just naturally did it afterwards.

Sally: I think it's a lot more open to ask questions...

Beth: Yeah, I think it definitely encouraged me to keep going with problems when I've been stuck... when you're in a group and you see that other people have understood it, you know that it is possible and it just pushes you to keep going that bit further.

Julia: She asks us to convince each other what the right answer is... she rarely actually gives us answers. You know, we have to work to the answers between us until we're all happy that we have got the answer...

Dora: I feel it almost takes away that kind of elitist side of maths where somebody'll be like 'I have the answer. You don't have the answer', because it doesn't particularly work like that because we've all been discussing. Nobody really knows who's got what, but we've all gained.

Working together and supporting each other is expressed through *an ethic of caring* (Collins, 2000) where the experience of being left behind is turned around to be an opportunity to demonstrate solidarity with each other.

Sue: I think maybe if everyone on the table understands it and... [you're the one] left behind... I'm not always the one [*laughter and cross talking*]... times like that it's not fantastic, but it's very rare that actually happens anyway because everyone tends to help everyone in our group.

Sally: ... there's always somebody in the group... they'll go through it again and again if need be and I've been in the situation where I've understood something and somebody else hasn't and they've been getting a bit stressed out and I've been able to explain to them, like taking it back a step and going through things.

Rach: Yeah, people are very good at giving you the time if they can see something's bothering you... helping you through... getting everybody to the same level before everyone moves on.

Conclusion

In order for hegemony to be questioned, students have to be able to gain a critical and reflective distance from the taken-for-granted. This cannot be accomplished without theoretical engagement with the workings of power and our own complicity in perpetuating and reproducing hegemonic discursive practices (Nolan, 2012). Here, however, I have foregrounded the significance also of *experience* in shaping our understanding of what it is possible to be and to do, of who we are and who we might become and of how we might act in and on the world. This springs from a conviction that inhabiting "potentiary" (Holland et al., 1998, p. 250) imaginative spaces defies the corruption of the capacity for hope that neo-liberalism engenders (Berger, 2007).

The interview data suggest that the students distanced themselves from neo-liberal discourses and experimented with other ways of constructing themselves and others, enacting new selves-in-practice, engaged, confident, authoritative, agentic and participatory selves, selves which allow for a commitment to social justice. Mathematics is *par excellence* the discipline that is used to separate learners from each other, to valorise individuals, to rank them and to place them in hierarchies in order to justify fundamental inequalities as appropriate and merited. In addition, it epitomises a separated, de-personalised, moral-free epistemology. Combatting these ways of using and understanding mathematics with the experience of solidarity – challenging 'ability' hierarchies, experiencing pleasure and caring within a learning community and developing agency and both

personal and shared epistemological authority – has the potential to support the fight for social justice in mathematics education.

References

- Alexander, R. J. (2008). *Towards dialogic teaching: Rethinking classroom talk* (4th ed.). York: Dialogos.
- Angier, C., & Povey, H. (1999). One teacher and a class of school students: Their perceptions of the culture of their mathematics classroom and its construction, *Educational Review*, 51(2), 147–160.
- Boaler, J. (2008). Promoting ‘relational equity’ and high mathematics achievement through an innovative mixed-ability approach. *British Educational Research Journal*, 34(2), 167–194.
- Berger, J. (2016). *Hold everything dear: Despatches on survival and resistance*. London, UK: Verso.
- Clough, P., & Nutbrown, C. (2012). *A student’s guide to methodology*. London, UK: Sage.
- Cochran-Smith, M. (1991). Learning to teach against the grain. *Harvard Educational Review*, 61(3), 279–310.
- Coldron, J. (2013). Reflections on the connections between research and practice. Unpublished manuscript.
- Collins, P. H. (2000). *Black feminist thought: Knowledge, consciousness, and the politics of empowerment*. New York, USA: Routledge.
- Ernest, P. (2016) The collateral damage of learning mathematics. *Philosophy of Mathematics Education Journal*, 31.
- Gutstein, E. (2006). *Reading and writing the world with mathematics: Toward a pedagogy for social justice*. New York, USA: Routledge.
- Holland, D., Lachicotte, W., Skinner, D., & Cain, C. (1998). *Identity and agency in cultural worlds*. Cambridge, USA: Harvard University Press.
- Llewellyn, A. (2017). Technologies of (re)production in mathematics education research: Performance of progress. In H. Straehler-Pohl, N. Bohlmann, & A. Pais (Eds.) *The disorder of mathematics education: Challenging the sociopolitical dimensions of research* (pp. 153-169). Cham, Switzerland: Springer.
- Marks, R. (2013) ‘The blue table means you don’t have a clue’: The persistence of fixed-ability thinking and practices in primary mathematics in English schools. *Forum*, 55(1), pp. 31–44.
- McNiff, J., & Whitehead, J. (2010). *You and your action research project*. London, UK: Routledge.
- Nolan, K. (2012). Dispositions in the field: Viewing mathematics teacher education through the lens of Bourdieu’s social field theory. *Educational Studies in Mathematics*, 80(1-2), 201–215.
- Pais, A. (2017) The narcissism of mathematics education. In H. Straehler-Pohl, N. Bohlmann and A. Pais (Eds.) *The disorder of mathematics education: Challenging the sociopolitical dimensions of research* (pp. 53–63). Cham, Switzerland: Springer.

- Povey, H. (2017). *Engaging (with) mathematics and learning to teach: An integrated approach to mathematics preservice education*. Münster, Germany: WTM-Verlag.
- Povey, H. (1997). Beginning mathematics teachers' ways of knowing: The link with working for emancipatory change. *Curriculum Studies*, 5(3), 329–342.
- Povey, H., & Adams, G. (2018) Possibilities for mathematics education? Aphoristic fragments from the past. *The Mathematical Enthusiast*, 15(1), 159–177.
- Povey, H., Adams, G., & Everley, R. (2017) “Its influence taints all”: Urban mathematics teachers resisting performativity through engagement with the past. *Journal for Urban Mathematics Education*, 10(2), 52–65.
- Povey, H., & Angier, C. (2007). Creating opportunities for authoritative knowing: Some undergraduate experiences of mathematics assessment. *Philosophy of Mathematics Education Journal*, 21.
- Rowbotham, S. (2000) *Promise of a dream: Remembering the sixties*. Harmondsworth. UK: Penguin Books.
- Skovsmose, O. (2016). Politics of meaning in mathematics education. *Philosophy of Mathematics Education Journal*, 31.
- Skovsmose, O. (1994). *Towards a philosophy of critical mathematics education*. Dordrecht, Netherlands: Kluwer.
- Straehler-Pohl, H., Pais, A., & Bohlmann, N. (2017). Welcome to the jungle: An orientation guide to the disorder of mathematics education. In H. Straehler-Pohl, N. Bohlmann, & A. Pais (Eds.) *The disorder of mathematics education: Challenging the sociopolitical dimensions of research* (pp. 1–15). Cham, Switzerland: Springer.
- Stronach, I., Corbin, B., McNamara, O., Stark, S., & Warne, T. (2002). Towards an uncertain politics of professionalism: Teacher and nurse identities. *Education Policy*, 17(1), 109–138.
- Whitehead, J. (1989). Creating a living educational theory from questions of the kind: “How do I improve my practice?” *Cambridge Journal of Education*, 19(1), 41–52.

The student's perspective on school mathematics – a case study

Ann-Sofi Røj-Lindberg¹ and Kirsti Hemmi^{1,2}

¹Åbo Akademi University, Vasa, Finland; aroj@abo.fi

²Uppsala University, Sweden; khemmi@abo.fi

This paper is based on a long-term case study of students' experiences of reform mathematics classrooms in Finland. Specifically, it focuses on emerging school mathematical actions and activities experienced by three committed and engaged students. Students described their experiences in interviews during and ten years after lower secondary school. The paper asks why taking part in certain practices makes some students learn to like and others to dislike school mathematics, despite high attainment concerning reform-related objectives on achievement and responsibility. The case study showed the importance of making classrooms places where all students belong to communities in which mathematical knowledge is negotiated.

Keywords: Habits of the mathematics classroom, long-term case study, spaces for participation, student perspective.

Introduction

In mathematics education, it is challenging to develop classroom cultures in which students maintain positive relationships towards mathematics after their first school years (Sullivan, Tobias, & McDonough, 2006). Although Finnish students have performed well in mathematics in international comparisons, especially in the Programme for International Student Assessment (PISA), many Finnish students' attitudes, self-confidence and engagement are poor in comparison to other countries. Based on PISA 2003, Viking Brunell (2007) found that only one third of the students in Swedish-speaking classrooms in Finland looked forward to mathematics lessons, and one half did not express any interest in mathematics whatsoever. Later, the 2015 Trends in International Mathematics and Science Study showed that Grade 4 Finnish students had a less positive attitude towards school mathematics than those in other European countries (Mullis, Martin, Foy, & Hooper, 2016). This was especially the case with girls, who chose to invest in subjects other than mathematics quite early on (Metsämuuronen, 2017). While much research has confirmed some students' negative relationship with mathematics (cf. Brunell, 2007; Lewis, 2016), very few studies have focused on why engaged and committed students develop negative attitudes and abandon mathematics by neglecting to study advanced courses in the subject at upper secondary level. The aim of this paper was to contribute to our understanding of the reasons behind these choices.

For some decades, attempts have been made in many countries to improve/reform school mathematics to make it more meaningful for all students (Fennema & Scott Nelson, 1997). This has also been the case in Finland. This paper was situated in a reform context in a Swedish-speaking lower secondary school in Finland. The reform emerged in connection with a three-year action research project that focused on learning processes and assessment, especially those involving problem-solving and investigative project work. The national core curriculum declared that solving problems and attending to the internal logic of mathematics were the two most important principles for mathematics teaching (Finnish National Board of Education, 1994). By probing and assessing the mathematical thinking of

students, teachers wanted to encourage the discovery of useful and viable mathematical ideas that they described as ‘active’ knowledge and to support individual students’ emerging sense of control over and responsibility for learning to a greater degree than was possible through ‘ordinary’ classroom practices.

Few studies have investigated school mathematics from students’ perspectives, and we have not come across any studies that involved students as legitimate participants in an interpretive research methodology that relates to teachers’ reform work during lower secondary school and beyond. In the doctoral study on which this paper was based (Røj-Lindberg, 2017), participating students were interviewed several times from the age of 13 to approximately 25. In this paper, we aimed to answer the following question, “Why do some committed and engaged students develop a negative identity concerning mathematics during lower secondary school?”

School mathematics from the student’s perspective

About thirty years ago, Alan Schoenfeld (1988) argued that school mathematics might unintentionally produce “disasters” even though most actions and activities in mathematics classrooms proceed as envisaged by teachers in terms of the curriculum and teaching practices. As a result of his inquiry, Schoenfeld called for broad research agendas that should aim “to understand the world from the student’s point of view” (p. 165). His message was that if learning could be perceived as much more than what can be inferred from observing students in classrooms, including their mathematical performance, different forms of assessments, and so on, then the voices of students really should start to matter in school mathematics and educational research. Since then, the same type of request has been formulated repeatedly both outside and within mathematics education (Berinderjeet, Anthony, Ohtani, & Clarke, 2013).

Jo Boaler (2003) defined classroom practices as the recurrent activities and norms that develop in classrooms over time. We argue here that even if researchers are strongly focused on changing classroom practices, they have tended to apply a top-down perspective, looking at students and processes of learning from the outside. Classroom practices have been studied in isolation from students themselves, though they have been conceptualized as methods of teaching¹ that provide a social context that influences and allows the experiences and expectations of students. From an observer’s perspective in a classroom, it may be possible to describe and conceptualize regularities within observable actions and activities. But such a stance does not take into account the notion that activities and actions in the classroom are complex when seen from the perspectives of students who are the immediate participants.

Here, we have taken reflexivity as a premise of the research and argue that students’ accounts of what happens or is expected to happen in mathematics classrooms are socio-cultural in their very nature. We have accepted that social situatedness should be taken as a premise when students’ perspectives are the focus of interest. Whatever else might be innate, students’ expectations concerning school

¹ In the literature, teaching methods have been described in different ways, for instance, as open, progressive, traditional, constructivist and discussion oriented.

mathematics are not; these are formed over the years, largely through students' interactions with their parents, peer group and teachers. Based on such a premise, we interpreted the experiential accounts given by students in interviews as having a social and cultural origin. Interpretations can be created through "zooming in" (Lerman, 1998) on the complex territory of classroom practices through accounts given by students and by looking at classroom actions and activities through students' 'eyes'. On the other hand, one must "zoom out" to view individual students' experiential accounts without losing contact with the actions and activities that constitute school mathematics in their individual classrooms.

The study was embedded in social practice theory and focused specifically on students' alignment and their development of identities and imagination in relation to classroom practices in which they took part. Learning was defined as increasing participation in classroom practices, which were understood as social processes where meanings are negotiated and students become or avoid becoming persons for whom mathematics is important (Wenger, 1998).

Methodology

This paper was based on a case study (Røj-Lindberg, 2017) within the context of teacher-initiated action research and reform work. The main case record material (see Bassey, 1999) was semi-structured interviews with four to five students from each reform classroom, in total 120 interviews with 27 students. Four to five interviews were done with each of them during the three lower secondary school years. Students were asked to describe and comment on their experiences of school mathematics, including their wishes and expectations, for instance, in relation to recent mathematics lessons. Students were also probed about their views on problem-solving activities and other reform-related activities, for instance, on being asked to explain one's thinking publicly. Interviews with three committed and engaged classmates, Joakim (male), Kristina and Nette (females), were selected for further analysis for the case study. These three students, who had experienced the same classroom context, were also invited to look back on their experiences as adults. Adult interviews were conducted when the three students had finished university and focused not only on lower secondary school classroom practices but also on mathematical practices more widely. The first author's preliminary interpretations of the lower secondary school interviews were used as inputs in the adult interviews, which were conducted to deepen the researcher's understanding of school mathematics from a student's point of view, not for fact-finding.

The analysis of the interviews, which were conducted in Swedish, was first inductive and then deepened through holistic interpretations of each interview (see Merriam & Tisdell, 2016). The researcher's responsiveness to emic issues appearing in students' accounts was high. Important emic issues were *structure and closure* emerging from the lower secondary school interviews and experiences of *identity work* from the adult interviews (see Røj-Lindberg, 2011, 2015). Emic issues were theoretically connected to Wenger's social practice theories. In the final analysis, they were connected to other theoretical constructs from this theory, such as communities of practice (applied to school mathematics), negotiation of meaning, modes of belonging and students' trajectories within a specific practice. These were applied during the interpretation of interview accounts. It is beyond the scope of this paper to give a thorough explanation of the use of these constructs. It is also

impossible to give an exhaustive account of the extent to which the reform influenced activities in the classrooms (for detailed information, see Røj-Lindberg, 2017). Yet, when presenting the results we connected the issues brought forth by students to relevant classroom events. The quotes have been translated into English by the first author. Results presented here do not intend to generalise but to understand school mathematics as it emerged in one reform classroom from students' perspectives.

Results

In the following section, we have introduced the students, Joakim, Kristina and Nette, and their trajectories (Wenger, 1998) in mathematical practices. Next, we have reported two reasons that we claim to be of crucial importance to students who make negative choices concerning the role of mathematics in their lives. These reasons are neither mutually exclusive nor exhaustive. They are more like what can be seen in a kaleidoscope; each turn gives a new view of school mathematics from the student's perspective.

Student trajectories

As newcomers in the seventh grade, Joakim, Kristina and Nette were highly engaged students. Nette's engagement clearly related to an imagined future as a veterinarian, while Joakim and Kristina were generally confident about the significance of learning mathematics. During lower secondary school, they were responsible students who were evaluated by the teacher as skilful/capable in different types of assessment. They wanted to take part in actions and activities in school mathematics communities, and they appreciated the problem-solving activities that were introduced within the reform. In short, we can describe them as successful students who expressed strong alignments in relation to reform objectives. Nevertheless, their trajectories and identifications related to school mathematics were constituted very differently over the following school years, which strongly affected their futures. Joakim's trajectory continued to be structured by positive choices concerning mathematics. He passed the advanced mathematics courses he had selected in upper secondary school² with success and chose a mathematics-intensive university program to obtain a MSc in engineering. The trajectories of Kristina and Nette differed significantly from Joakim's. Both of them chose basic mathematics courses at secondary level and neither of them chose university programs that included mathematics. Nette's dream of becoming a veterinarian turned into a claim that mathematics was not for her, and she chose a university program in psychology. Kristina described school mathematics as a more or less alienating experience, but in contrast to Nette, she continued to be very accepting. However, she dropped her plan of studying science, because she did not want to align with the workings of the mathematics classrooms she had experienced in school. Instead, she chose a university program in pedagogy.

The dominant habits of the mathematics classroom

From a student perspective, the actions and activities in a mathematics classroom are complex. A characteristic that supports participation in the case of a student at one moment in time might not be

² The upper secondary mathematics curriculum is divided into basic and advanced level courses. Only students who select advanced courses must take mathematics in the matriculation examination.

supportive for all students and might not continue to be supportive for that student over time. However, our analysis of students' interview accounts showed recurrent patterns in mathematics classrooms that we described as dominant habits. As the space of the paper does not allow us to thoroughly account for all habits, we have chosen those that most likely led to the development of non-participation (Wenger, 1998) of Kristina and Nette in the long run. Two dominant habits that appeared in all student interviews in the case study were as follows:

(1) The “all-look-alike” structure of lessons, which contributed to the sense that mathematics was a monotonous subject and led to a kind of meaninglessness for students who did not accept non-participation as an adventure (see the work of imagination, Wenger, 1998, pp. 185–186):

All lessons look alike, we have theory and write down the things we are doing. The teacher asks different things. Then, we may count at our own pace from the book. The last lesson we did x times x and such. (Nette, Grade 7)

I don't think there have been any changes. It just continues from year seven to year eight and then, to year nine. In my opinion, nothing has changed. It has been fairly similar all the time. Of course, they follow and teach by the book. (Nette, Grade 9)

(2) The general mode of working individually during lessons, which meant that students were mostly left by themselves to struggle for coherence regarding mathematical structures. Hence, there were limited opportunities to develop a sense of belonging to any community where mathematical knowledge was negotiated in the classroom:

We do work alone all of us. It is like that anyhow, the teacher has to come to everybody, so it is the fastest way to ask the one you sit next to, so you talk to everybody. (Kristina, Grade 9)

Joakim continued to take part in communities that included the teacher and students he described as “smart”. Moreover, the support he received from his teacher reminded him repeatedly of his membership in communities of mathematically-able people.

The textbook continued to be the main pedagogical artefact during the reform, and teachers continued to structure the tempo of student learning with the textbook. The habit of working alone with textbook tasks may have added to some students' sense of enjoyment. But as Kristina stated, the positive effect emerged only “when you succeed and keep up with new things”. In the long run, both Kristina and Nette expressed a sense of not keeping up with the tempo. Hence, the way the textbook was used in the classroom may have contributed to their developing identities of non-participation.

All students who took part in the case study welcomed reform-related activities, such as investigative project work, which “did show a little what mathematics can be”, as Joakim stated as an adult. However, some students considered investigative project work to have a marginal role in their learning of mathematics even if their accounts clearly described the opposite:

You learn things that don't have so much to do with mathematics. I did learn about unemployment rates in Finland. But this has nothing to do with mathematics. I think that I haven't learned anything that has to do with mathematics. I mean, like what we are doing in the book for (math) theory. I don't learn in that way when I do investigative work. (Kristina, Grade 9)

In general, reform-related activities had the potential to increase participation for all students. Yet, as the extract above shows, students did not always see the connection between these activities and their development of mathematical knowledge. Therefore, the activities did not necessarily enhance students' participation.

The character of spaces for participation in classroom practices

We defined learning as increasing participation in classroom practices. Thus, it is natural to consider the character of mathematical spaces where meanings were negotiated in the classroom (Wenger, 1998). We have attended here to the most obvious characteristics that seem to have contributed to some students becoming persons for whom mathematics was not important.

The most important aspect was that “right or wrong” classroom practices limited the possibilities for constructing mathematical knowledge for all students. Nette succinctly captured this aspect and her perspective on one of its side effects, which was that questioning might be interpreted by the teacher as a lack of responsibility for learning and not as comments from students striving for understanding:

You cannot dispute lower secondary school mathematics, because it is right-or-wrong mathematics. If you start questioning it, the teacher thinks you are trying to escape. (Nette, adult)

Within “right-or-wrong” practices, there was little room for social, playful and investigative mathematics. Aligning to the practice meant individually struggling for coherence and understanding by listening to the teacher. The struggle for understanding was accompanied by feelings of insecurity, because the act of giving a wrong answer in public was shameful.

When students are supposed to answer in public, I get fairly nervous. I think what if I give the wrong answer. (Nette, Grade 7)

You have to listen all the time to what the teacher is saying and you get so tired. As soon as you talk just a little bit with your friend then it goes, oh, now I do not understand anything again. It is rather strenuous. You should have a better ability to concentrate. (Kristina, Grade 9)

Reaching the right answers rapidly was, from the students' perspective, a sign of understanding and often meant immediate rewards, such as praise from the teacher or not being constrained by homework. The case study showed that tentativeness, wrong answers, misinterpretations or extended interpretations of textbook tasks were not considered by students to be characteristics of a space where every student could belong and participate. For some students such as Nette and Kristina, this situation contributed to the development of negative identifications towards mathematics, which strongly affected their futures.

Discussion

We argue that a main concern for reforms in mathematics education should be a critical focus on the reality of the classroom, which from students' perspectives is even more complex than interviews can reveal (see Berinderjeet et al., 2013). Also, dimensions that extend the classroom level had an impact on students' relationship to mathematics. According to Gregg (1995), reformers should encourage teachers to think in new ways by implementing new ‘idioms’ into their stories and explanations. This is, however, exactly what teachers who were involved in this case study did; they were supported by

the scholarly community to integrate new idioms based on constructivism (see, for example, Black & Atkins, 1996) into their talk about classroom practices. Idioms such as active learning, discovery processes and responsibility for knowledge construction were strongly present when teachers talked about reforming their practice. Yet, they did not oppose the epistemological hegemony of academe by asking, “What if we lift our gaze from the student as a ‘constructing individual’ to zoom out and include the ‘socio-cultural whole of the student and ourselves?’” They attended to the practice-in-individual but not to the individual-in-practice (Lerman, 1998). The latter perspective confronts us with the question “What is the nature of school mathematics practices in which all students should become qualified in order to develop positive identifications and to enhance the role of mathematics in their lives?” This question must be the starting point whenever we want new curriculum ideas to change classroom culture in a direction that makes participation an inclusive experience for as many students as possible. This is an issue to which hardly any research attends.

Several factors interacting in a complex manner influence students’ choices and relationships to mathematics, and, therefore, it is valuable to explore some cases deeply to understand them. In this study, Wenger’s (1998) theoretical constructs proved fruitful for revealing hidden regularities behind the development of students’ negative identifications concerning mathematics. According to Wenger, learning is so much more than gaining skills and knowledge, it is a process of becoming that transforms both who the learner is and what the learner can do (p. 215). Concerning the results presented here, this a very strong statement. When students, regardless of gender or school mathematical practices, learn disengagement (e.g., Sullivan, Tobias, & McDonough, 2006) or explicitly refuse mathematics in school (e.g., Chronaki & Kolloosche, 2019), their lives as adults, and especially their possibilities to partake in the working life, might be diminished.

References

- Bassey, M. (1999). *Case study research*. Maidenhead: Open University Press.
- Berinderjeet, K., Anthony, G., Ohtani, M., & Clarke, D. (2013). *Student voice in mathematics classrooms around the world*. Rotterdam: Sense Publishers.
- Black, P., & Atkin, J. M. (Eds.). (1996). *Changing the subject. Innovations in science, mathematics and technology education*. London: Routledge.
- Boaler, J. (2003). Studying and capturing the complexity of practice: the case of the dance of agency. In N. Pateman, B. Dougherty, & J. Zillox (Eds.), *Proceedings of the 27th Conference of the International Group for the Psychology of Mathematics Education*, (Vol. 1, pp. 3–16). Honolulu: Center for Research and Development Group, University of Hawaii.
- Brunell, V. (2007). *Klimat och resultat i den finlandssvenska grundskolan: En fördjupad analys av PISA 2003* [Climate and achievement in the Finland-Swedish comprehensive school: An in-depth study of PISA 2003]. Helsingfors: Svenska Kulturfonden.
- Chronaki, A., & Kolloosche, D. (2019). Refusing mathematics: A discourse theory approach on the politics of identity work. *ZDM Mathematics Education*. <https://doi.org/10.1007/s11858-019-01028-w>
- Fennema, E., & Scott Nelson, B. (Eds.). (1997). *Mathematics teachers in transition*. Mahwah: Lawrence Erlbaum.

- Finnish National Board of Education. (1994). *National core curriculum for comprehensive school*. Helsinki: Finnish National Board of Education.
- Gregg, J. (1995). The tensions and contradictions of the school mathematics tradition. *Journal for Research in Mathematics Education*, 26(5), 442–465.
- Lerman, S. (1998). A moment in the zoom of a lens: Towards a discursive psychology of mathematics teaching and learning. In A. Olivier & K. Newstead (Eds.), *Proceedings of the 22th Conference of the International Group for the Psychology of Mathematics Education* (Vol. 1, pp. 66–81). Stellenbosch: University of Stellenbosch.
- Lewis, G. (2016). *Disaffection with school mathematics*. Rotterdam: Sense Publishers.
- Merriam, S., & Tisdell, E. (2016). *Qualitative research*. San Francisco: Jossey-Bass.
- Metsämuuronen, J. (2017). *Oppia ikä kaikki: Matemaattinen osaaminen toisen asteen koulutuksen lopussa 2015* [Lifelong learning: Mathematical knowing at the end of secondary level 2015]. Tampere: Painatus Juvenes Print.
- Mullis, I. V. S., Martin, M. O., Foy, P., & Hooper, M. (2016). TIMSS 2015 international results in mathematics. Retrieved from <http://timssandpirls.bc.edu/timss2015/international-results/>
- Røj-Lindberg, A.-S. (2011). Structure and closure of school mathematical practice: The experiences of Kristina. *Philosophy of Mathematics Education Journal*, 26.
- Røj-Lindberg, A.-S. (2015). School mathematical practices as experiences of identity work: The learning journeys of three students. *Nordic Studies in Mathematics Education*, 20(2), 5–26.
- Røj-Lindberg, A.-S. (2017). *Skolmatematisk praktik i förändring: En fallstudie* [School mathematical practice in the process of change: A case study] (Doctoral dissertation). Åbo Akademi University, Åbo, Finland. Retrieved from <http://urn.fi/URN:ISBN:978-952-12-3618-1>.
- Schoenfeld, A. (1988). When good teaching leads to bad results: The disasters of “well-taught” mathematics courses. *Educational Psychologist*, 23(2), 145–166.
- Sullivan, P., Tobias, S., & McDonough, A. (2006). Perhaps the decision of some students not to engage in learning mathematics in school is deliberate. *Educational Studies in Mathematics*, 62(1), 81–99.
- Wenger, E. (1998). *Communities of practice*. Cambridge: Cambridge University Press.

Agency and identity of female Arab students entering a technological university

Soryna Sabbah¹ and Einat Heyd-Metzuyanin²

¹Technion, Israel Institute of Technology, Israel; sorynas86@gmail.com

²Technion, Israel Institute of Technology, Israel; einat.metz@gmail.com

This report studies the progression of cultural and mathematical identities of female Arab students during their first semester of engineering studies in a technological university in Israel. The report focuses on the cases of two students, Mira and Lena, who demonstrated remarkably different trajectories of identity development. Data was analyzed by closely examining narratives in students' Space of Authorship related to gender and ethnicity. Findings show that Mira's Space of Authorship included multiple narratives relating to ethnic and religious conflicts, upon which Mira enacted agency by debating and choosing specific courses of action both in social life and in mathematics learning. In contrast, Lena's Space of Authorship drew upon psychological discourse to explain her difficulties in ways that did not afford her agency to act back on the challenges she was facing.

Keywords: Agency, identity, gender, Arab students, undergraduate education

Introduction and theoretical framework

The Arab minority in Israel is an involuntary minority (dependent on their collective identities in relation to the dominant group) (Flum & Kaplan, 2016) which consist of 20.5% of the general population. There are long standing tensions between the Jewish majority and the Arab minority in Israel, which have encouraged geographical, political and social separation between them (Flum & Kaplan, 2016; Kaplan, Abu-Sa'ad, & Yonah, 2001). This separation also exists in the education system, where the K-12 education systems of the two populations are completely separated. Thus, universities are usually the first multicultural encounter between Arab and Jewish students. University courses are taught in Hebrew, while in school Arab students study mostly in Arabic. In addition, Arab students have multiple challenges connected with their minority status and the political and ethnic conflicts it entails. For female students, these are compounded by difficulties relating to changing gender roles in this relatively traditional society (Arar & Masry-Herzalah, 2014). As female students enter the predominantly Jewish university, they are exposed to social narratives that question their ability to succeed (similar to Jewish female students). Yet, for Arab females, university studies are often the first occasion to leave their home-village and be exposed to Western, secular culture. This is a transition that often causes "culture shock" (Arar & Haj-Yahia, 2016).

The report is a part of a large study whose goal was to explore the process that Arab female students' identities undergo through their entry into a predominantly Jewish university, both in relation to these students' academic and mathematical learning, and in relation to their sense of ethnic and cultural belonging. Data shows high rates of failure of this particular minority on entry-level mathematics courses at the Technion. We employ a socio-cultural lens on the activity of mathematics learning to study the relation between cultural transitions and the development of a student's mathematical and learning identity (Sfard & Prusak, 2005; Wenger, 1998). In particular, we rely on a sociocultural view of learning as becoming a participant in a certain community (Lave & Wenger, 1991; Sfard & Prusak,

2005). Communities are characterized by shared values, forms of action and interpretative schemes. These have been defined by Holland, Lachicotte, Skinner, and Cane (1998) as “figured worlds”, where a figured world is defined as “a socially and culturally constructed realm of interpretation in which particular characters and actors are recognized, significance is assigned to certain acts, and particular outcomes are valued by others” (p. 52). In the case of Arab students, the home, family and village figured world is extremely different from the predominantly Jewish, technological and western figured world of the university.

In our work, we rely on Holland and colleagues’ (1998) concept of “space of authorship”, which links between figured worlds and the identity participants author for themselves within these figured worlds. Holland et al. point out that the space of authoring, in which people figure their identity, is always a contested space. We link these ideas with Sfard & Prusak’s (2005) definition of identity as a set of reifying, significant and endorsable narratives about a person. Space of authorship, for us, is the realm of narratives from which identity narratives are picked up, contested against and negotiated. Agency, defined by Holland and colleagues (1998) as “the realized capacity of people to act upon their world” (p. 42), is enacted through the orchestration “arranging the identifiable social discourses/practices that are one’s resources” and form his/her space of authorship (p. 272). Thus, the question of this study is: How do cultural and mathematical identities of female Arab students develop during the initial phase of their college level mathematics studies and in what ways do these students enact agency in relation to the narratives regarding ethnicity and gender in their space of authorship?

Method

The cases of Mira and Lena were taken from a larger study in which we followed 13 female Israeli Arab undergraduate students during their first semester at the Technion, a technological university in Israel. All of the participants were studying in either the Computer Science faculty or the Electrical Engineering faculty, where 40-50% of the courses taken in the first semester are mathematics courses (usually Calculus I and Algebra I), both of which are among the most coveted faculties in this institute and have very high entrance qualifications. The students’ ages ranged between 18 and 19.5 years. They were recruited voluntarily, during the first week of the semester, through an institutional mentoring project for Arab students in which senior students mentor the incoming students. Students were promised complete confidentiality and signed informed consent forms. The study was approved by the Institutional Review Board of the Technion.

All the students were interviewed at the beginning and at the end of their first semester. Interviews were semi-structured and conducted by the first author in Arabic. They lasted between 30 and 90 minutes. Students also completed two midterm diaries, which included answers to questions sent to them by email. The final interview consisted of questions eliciting reflections about the past semester. In addition, students were requested to reflect upon and answer some of the questions from their final calculus exam. Data was analyzed using a combination of inductive and deductive codes (Saldana, 2016). Inductive coding searched for recurring themes in students’ interviews. For example, a common conflict described by the students regarded social encounters, whether to “hang out” with certain people and with whom to study. Deductive codes were based on the theoretical orientation of figured worlds. In particular, we searched in the interviews’ transcripts for valued actions, valued

outcomes, significant actors and roles in the home vs. Technion figured worlds. The main themes arising in all the interviews in relation to conflicts between the home figured world and the Technion figured world related to narratives about ethnicity and gender. In relation to these conflicts, we searched for indications of agency both in the actions described by participants (e.g., “I try to study hard”), or lack thereof (“I feel I am not focused” – with no mention of possible action to become focus). We also searched for agency in the manner in which interviewees spoke about the conflicts – as a given situation or as something that can be acted upon.

Findings

Mira and Lena were chosen for this report since they exemplified very different trajectories of acclimation to the figured world of the Technion. While Mira ended the first semester with passing grades and relative success, Lena failed several courses and was quite discontented with herself at the end of the semester. The different trajectories afforded opportunities to view and contrast different processes of change in identity narratives and the ways in which these changes drew upon certain spaces of authorship. We first explore the figured world of Mira and Lena, as seen through the collective narratives told by them. We pay attention here to what they say about gender/ethnicity and their positioning with relation to the conflicts they talk about.

Mira’s stories about her family and village drew a figured world that is mono-ethnic and mono-religious. She reported in her first interview that she was having trouble living in a multi-cultural environment. She also identified herself as a “non-social person by nature”, perhaps to minimize the potential conflicts that could arise as result of the multi-cultural environment at the Technion. Mira also reported being the first in her family to attend university and that she felt pressure from her family to succeed:

I’m the first one [from my family] to ever attend a high academic institution. Everyone at home has expectations (from me) and that’s a bit stressful. (Mira, 1st interview)

Positioning her academic skills in relation to her family seemed to be important to her:

I have four older brothers and they were not strong at school, and a sister (who is) a year older than me. I’m better than her academically. She has not yet begun her academic studies. (Mira, 1st interview)

Although Mira authored herself as “strong” academically, she confessed in her first interview that mathematics was not a subject she preferred: “to tell (you) the truth, I do not like mathematics”. Her goal was to study computer science and mathematics was seen only as a means towards that cause.

Unlike her academic identity, which included narratives of relative strength and did not include many conflicts in its space of authorship, regarding her ethnic identity as an Arab student Mira’s space of authorship was much more conflictual. In the initial interview, Mira reported that she had not encountered people from other religions before she started studying at the Technion. Her first close encounter with someone of a different religion occurred when she entered the dorms:

I live with a Christian student in the dorms; she is from a different religion. At first, I worried about the idea of living with her, because I am a Muslim and she is Christian. I was worried I would feel restricted and not able to behave freely. (Mira, 1st interview)

Mira's justification of her worries as based on the fact that the student was "Christian" while she was "a Muslim" indicated that, in her space of authorship, the mere religious identity of a person could cause problems while living together and "not behaving freely". Notably, the fact that the Christian student was also Arab was not mentioned but taken for granted, and the possibility of living with a Jewish student was not mentioned at all. Yet, like in many other instances, where Mira only reported about conflicts in retrospect, this encounter was already authored as resolved. She ended the story by:

Later I discovered that if I give her the space to behave according to her beliefs and religion, she will give me back the same space I need. (Mira, 1st interview)

Her agency in relation to this conflict could be seen in the actions she described ("give her space") that resulted in what she needed ("the same space I need"). As the semester progressed, Mira repeatedly recounted encounters with students of other religions and gave them significance. Although Mira expressed an acceptance of students from different religions, her diary entries clarified that she was engaged with conflictual narratives around ethnicity and religion and that these were entering her space of authorship:

Every day and all the time, I face differences. First, the atmosphere at the Technion is not like the atmosphere at home at all. Here everyone is independent and each person is responsible for himself and his own decisions. There are people from different places, different religion[s], different thoughts and different values and cultures. For example, I came from a village where everyone is Arab and we all belong to the same religion, whereas at the institute I meet people from all over the world and from different religions. I see people behaving in a way that goes against my values and that is a new atmosphere for me, I am constantly trying to stay on the side and not get involved with anyone. (Mira, 1st diary)

Several issues relating to this excerpt are worth mentioning. First, Mira is explicitly talking about "differences" between the "Technion" and "home". In other words, it is clear that she is constructing the two locations as different figured worlds. The differences mainly point to differences in relations between the individual and the social community ("here everyone is independent"), hinting that in her home figured world, people are interdependent and not responsible for their own decisions. The interdependence is linked in Mira's words to the Arab ethnicity and to the religious homogeneity of her home village. Thus, it is clear from Mira's words that she is able to locate the conflict, the values that are at stake, and her positionality with relation to this conflict. Notably, there are signs of agency in this story too. Mira writes about the conflict and immediately states her actions in relation to it ("I try to stay on the side and not get involved"). Later in the semester, this action of "staying on the side" seems to mature into a more nuanced positioning and identification of herself with relation to the "others":

I came from a traditional and relatively conservative family, where I grew up with values that I believe are correct. However, at the Technion, I encounter many people who behave against my beliefs, and it makes me feel that I am an extreme person or something like that. Yet I continue to believe in my tradition as they continue to believe in theirs. (Mira, 2nd diary)

This excerpt hints at several processes that Mira underwent during the semester. First, there are beginnings of separation from "her beliefs". Whereas these beliefs were stated in the first diary as

simply “her values” (“I see people behave against *my* values”), here, these beliefs are located in time and space (“I came from a traditional ... family”, “I *grew up* with values”). Moreover, the statement about values “that I believe are correct” shows hints of voices that position these beliefs as “incorrect”. These voices are later located in people “who behave against my beliefs” and that, whether directly or indirectly, make Mira feel she is “an extreme person”. The taken-for-granted “beliefs” and “values” have thus been questioned and contested for Mira, and this has raised a conflict with regard to identity narratives concerning religion and ethnicity. In the face of these conflicts, Mira enacts agency in choosing to adhere to her home values.

With relation to her mathematical identity, Mira reported finding her mathematics studies to be surprisingly satisfying. In her first diary, she wrote:

The most interesting lecture in my weekly schedule is a Calculus lecture, because I learn mathematics differently... I learn how to learn mathematics, how to think outside the box and how to find ideas or solutions for different mathematics problems. It is a hard course but the lecturer is a wonderful person and he makes it an enjoyable course. (Mira, 1st diary)

Her satisfaction with her mathematical studies continued throughout the semester despite hurdles and setbacks. In the last interview Mira reported failing in the first take of the calculus exam because of being “unprepared unlike I should have been”, then studying better and passing the second take with a satisfying result.

To summarize, Mira retold her identity at the end of the semester as stronger in mathematics than at the beginning, despite recounting many stories of conflicts with relation to her ethnic and religious identity in a foreign figured world. With relation to almost all the descriptions of conflict, Mira’s talk was full of agency, whether it was related to decisions she made to adhere to her religious values, or with regard to changing her methods of study. Along with that, some changes in the space of authorship of her ethnic and religious identity occurred. These could be detected mainly in how she narrated her “values” and “beliefs” – from being inherently “hers” to being a result of her “upbringing” and her home figured world. In addition, the space of authorship came to include also third person narratives about her being identified as an “extreme” person by others, something which forced Mira to reexamine her beliefs and values and to make choices regarding them.

Unlike Mira, who was hesitant about her connection with mathematics in the first interview, Lena’s first person mathematical identity was authored in the interview as highly successful. To signify her success, she narrated the following story:

I don’t know if you know the Elkasmi competitions? (Interviewer nods.) I participated in this competition from fourth till ninth grade, almost I won the first place, once I won second place and once third place... that means it (mathematics) was for me. (Lena, 1st interview)

Elkasmi is a competition for gifted students in mathematics in the Arab community. Lena was signifying her strength in mathematics by drawing on the significance that participating and winning these competitions has in her community, a significance she made sure was shared by her interviewer.

Apart of the Elkasmi story, Lena relied, similarly to Mira, on her family’s narratives when authoring her first person academic and mathematical identity. She reported that her family thought of her as a

strong student, who could achieve anything she wanted. These expectations were talked about both as a reassuring element and as a stress factor:

They (parents and family) always remind you that you have potential. So I somehow try to turn this potential (to reality) ... So that's my parents' expectations in particular, and my sisters think that I'm 'Rambo'. That I could do anything and get along. Most people expect so. (Lena, 1st interview)

Unlike Mira, Lena was not a first generation university student in her family. Her parents both had academic degrees. Yet similarly to Mira, she also reported feeling stress from her family's high expectations. Again, it was clear from her talk that she was highly accountable to her family and community with relation to her academic choices and achievements. Yet unlike Mira, Lena's talk about her studies was mostly devoid of agency. Her authoring of herself as successful was based on the diagnosis that "math is for me", justified by her winning math competitions during her childhood. Also in revoicing the voices of parents and significant narrators ("they always remind you"), these voices narrated her as "having potential" and "turning this potential into reality". This diagnostical discourse was most noticeable in the main conflict Lena talked about from her first interview – that relating to her gender:

I will not begin now by saying that boys are smarter than girls, but I believe that boys have more self-confidence in the science field than girls. They (boys) always think that the science field is for them, and girls think that they are less ... that is what I read and see around me. Here I see the difference between boys and girls, but that does not mean anything about the final results because sometimes the way the girl thinks help her beat all her competitors. (Lena, 1st interview)

Notably, already at this initial phase of her studies, Lena was contesting voices that were saying "boys are smarter than girls". She was negating them, yet endorsing the narrative that "boys have more self-confidence than girls", which she justified based on what she "read and saw around her". Again, there were no signs of agency in Lena's talk. Her talk was diagnostic ("here I see the difference between boys and girls"), but there was no mention of her own actions in relation to this conflict.

As the semester progressed, the gender related narratives turned into first person identity narratives. In her first diary, she wrote:

Despite all the faith I have in myself, I feel that I'm not confident enough, in comparison with boys, at least with a boy who I study with. I think it comes from old stereotypes about the composition of the boy's brain versus the girl's brain. Sometimes I fear that these stereotypes are true and that my mental ability is not enough. (Lena, 1st diary)

Again, Lena's authoring of the narratives about gender and mathematics/technological studies was solely diagnostic and devoid of agentic descriptions. She was examining her "beliefs in herself" and her "self-confidence" against "old stereotypes", indicating at least a partial endorsement ("sometimes I fear these stereotypes are true") of these narratives about "the composition of the boy's brain versus the girl's brain". Importantly, these "stereotypes" were about "brains" of males and females, something that was clearly beyond Lena's agency to change. Lena was examining and identifying herself within this figured world of fixed-ability gender-related narratives, without any indication that

she had a choice to accept or reject them. The gender-related narratives evolved in the second diary into a mini-theory of the relation between her “self-confidence” and her actions:

When a person is less confident, I don't know how (to explain this) ... But sometimes you do not believe in yourself, sometimes you do not want to meet anyone. That (decision), not wanting to meet anyone, is not the best decision in the world. You have to be with people who you see every day and share with them what you solved, and what you did not (solve). So that it helps you keep going. Sometimes it made me stop or slow down. (Lena, 2nd diary)

This quote exemplifies well the psychological discourse that Lena drew upon to explain her perceived failure during the first semester. Explanations about her failure (which is not mentioned here explicitly, only hinted at) use psychological keywords (“self-confidence”, “belief in oneself”) to justify her decision “not to meet anyone”. The self-diagnostic statements are written about as pre-given and beyond Lena’s control. Further, these psychological states have led Lena, according to her narrative, to certain decisions that she regrets (“you have to be with people”), yet there is no indication that Lena had a choice regarding these decisions. They were a direct result of her low “self-confidence”. In the final interview at the end of the semester, Lena’s discourse was full of such regrets:

I started the semester as a little girl, I was not focused ... I was very nervous about people around me so I did not study in the library and stayed at the dorms. Everyone asks you ‘what’s going on?’, ‘Did you solve the homework?’ Why should they ask me? I felt pressure. (Lena, 2nd interview)

Again, this quote is full of psychological terms relating to maturity, cognitive and emotional functioning (“a little girl”, “not focused”, “very nervous”). As was common in all her interviews and diary entries, there is no mention of any difficulties relating to her ethnic or cultural status.

The final interview also had indications that Lena was re-authoring her identity as a high-school student (at least to the audience of the interviewer). She said: “I have never been in a place like this, even in high school there were difficulties but it isn’t like here.” This narrative was different than those authored in the first interview, where Lena talked about herself as successful and being “made for” mathematics. She now talked about her high-school career as containing difficulties too, yet not as extreme as in the Technion. The lack of agency with relation to these difficulties was consistent. Lena talked about wrong decisions that she made during the semester (such as not asking for help) but always in retrospect, and always with relation to how these decisions were unhelpful.

Summary and Discussion

Multiple studies have discussed the relationship between being part of a minority group and success in school or academic studies (Arar & Haj-Yahia, 2016; Flum & Kaplan, 2016; Nasir & Saxe, 2003). According to these studies, higher education allows minority students to move from the margins of society closer to its centers of power. Yet, at the same time, institutions of higher education pose significant barriers and conflicts for minority students. In the case of the Arab minority in Israel, and in particular, female students, these barriers are only starting to be understood. In this study, we shed light on two contrasting cases of first semester acclimation. These two cases hint that agency may be a crucial aspect of such acclimation, in the face of complex social and political conflicts. Mira’s story

demonstrates a case of high agency, along with very explicit positioning of herself in relation to ethnic and religious conflicts. This agency seems to have helped her overcome difficulties in the social, as well as the academic and mathematical aspects of the Technion's figured world. In contrast, Lena's story demonstrates a case of very little agency, along with a total neglect of her positionality with regard to ethnic and religious conflicts. Paradoxically, although Lena seemed to start the semester as better acclimated to the figured world of the Technion, her lack of awareness of the constraints imposed on her by her minority status may have led to lack of agency. The significance of our study lies in turning attention to the importance of Arab female students' awareness of the social and ethnic conflicts they face upon entering a foreign figured world. This awareness may cultivate choice, which is the necessary condition for these students' agency to cope with challenges.

References

- Arar, K. H., & Masry-Herzalah, A. (2014). Cultural pluralism increases difficulties in learning experiences yet advances identity formation for Muslim Arab female students at higher education institutions in Israel. *Journal of Applied Research in Higher Education*, 6(2), 325–341.
- Arar, K., & Haj-Yahia, K. (2016). *Higher education and the Palestinian Arab minority in Israel*. New York, NY: Palgrave Macmillan.
- Flum, H., & Kaplan, A. (2016). Higher education in a transforming society: The case of Arabs in Israel. *International Journal of Educational Research*, 76, 89–95.
- Holland, D., Lachicotte, W., Skinner, D., & Cain, C. (1998). *Identity and agency in cultural worlds*. Cambridge: Harvard University Press.
- Kaplan, A., Abu-Sa'ad, I., & Yonah, Y. (2001). Jewish-Arab relations in Israel: Perceptions, emotions, and attitudes of university students of education. *Intercultural Education*, 12(3), 289–307.
- Lave, J., & Wenger, E. (1991). *Situated learning and legitimate peripheral participation*. New York: Cambridge University Press.
- Nasir, N. S., & Saxe, G. B. (2003). Ethnic and academic identities: A cultural practice perspective on emerging tensions and their management in the lives of minority students. *Educational Researcher*, 32(5), 14–18.
- Saldana, J. (2016). *The coding manual for qualitative researchers* (3rd ed.). London: Sage.
- Sfard, A., & Prusak, A. (2005). Telling identities: In search of an analytic tool for investigating learning as a culturally shaped activity. *Educational Researcher*, 34(4), 14–22.
- Wenger, E. (1998). *Communities of practice: Learning, meaning and identity*. Cambridge: Cambridge University Press.

Students' experiences of learner autonomy in mathematics classes

Shipra Sachdeva

Norwegian University of Science and Technology (NTNU), Norway; shipra.sachdeva@ntnu.no

This paper presents representative excerpts from post-project interviews conducted with 8th and 9th grade students from a Norwegian countryside school. Interviews attempt to explore students' experiences of learner autonomy in mathematics classes. These students participated in a larger study where they responded to a pre-project questionnaire followed by solving practical group projects using mathematics and science knowledge and post-project interviews. Preliminary interview analysis reveals that students' experiences with learner autonomy in mathematics classes are limited to opportunities provided by their teachers together with an insecurity in perceiving themselves as responsible autonomous learners. However, these learners clearly exhibit a desire to acquire autonomy, the potential to suggest changes, and participate in discussions and decisions concerning their mathematics teaching-learning process, together with their teachers.

Keywords: Student experience, learner autonomy, classroom environment and mathematics instruction.

Introduction

Developing autonomy in learners has been emphasized as a goal of mathematics education (Ben-Zvi & Sfard, 2007; Yackel & Cobb, 1996). Learner-centered teaching strategies such as mathematics teaching based on real-life contexts, inquiry-based and problem-centered learning (Wheatley, 1992; Yackel & Cobb, 1996) have been discussed to increase learners' autonomy in learning mathematics. However, discussions related to autonomy in mathematics education literature have mostly depicted it as an *intellectual* attribute to be acquired while working with mathematical problems in order to identify, enquire and develop alternative solutions, and/or as the ability to scaffold mathematical algorithms and procedures in a better way (McConney & Perry, 2011; Mueller, Yankelewitz, & Maher, 2014; Wood, 2016; Yackel & Cobb, 1996). Specifically, intellectual autonomy has been defined as, "students' awareness of and willingness to draw on their own intellectual capabilities when making mathematical decisions and judgements" (Cobb & Yackel, 1998, p. 170). However, less researched aspects of autonomy in mathematics classes are the ones in which learners themselves "develop a particular kind of psychological relation to the process and content of [their mathematics] learning" (Little, 1991, p. 4). Developing such a *psychological* relationship with their mathematics learning can help students better understand, intervene and improve the ways *they* learn mathematics.

The first section of chapter one of the Norwegian Education Act (NEA), states that "[through education] students and apprentices must learn to think critically, and act in an ethically and environmentally conscious way. They *must have co-responsibility and the right to influence* [their education]" (Opplæringsloven, 1998/2018, italics added). For pupils to have the responsibility and right to influence their mathematics education, they need to take charge of their own learning in mathematics, that is become autonomous, at least partially. Further, if learners are supposed to apply their mathematical knowledge toolkit effectively in order to solve real-life problems after finishing formal education, they should be autonomous learners. Not only to solve their own real-life problems using mathematics, but also to participate as critical, responsible and active future citizens of society,

learners need to have experience and training in understanding and thinking over their current situations along with taking right decisions and actions to reach desired outcomes. This would require learners to acquire and practice both, the *intellectual* (i.e., the capability to take reasoned decisions), and the *psychological* aspects (i.e., a perception and an experience in exercising) of their autonomy. Although each learner is autonomous and possesses some decision-making skills, these should be nourished by getting an experience of exercising them within their immediate community and own peer-group (in the mathematics class). By learning how to balance power, authority, freedom and co-responsibility among themselves, students would effectively use their autonomy to take charge of their own lives, decisions and their consequences, and benefit society. Consequently, researching psychological aspect of *learner autonomy* in mathematics classes, in addition to its intellectual aspect, is equally significant if learners are to be motivated to succeed in mathematics (George, 2012).

By *learner autonomy* in this paper, I mean learners' ability to develop a psychological relation with, and freedom to take *responsibility* of their own mathematics learning process. This *responsibility* includes learners taking initiatives, participating in discussions, planning and executing self-beneficial mathematics learning activities, making decisions about what one wants to learn, how one likes to learn, at what pace and why together with their teachers, and simultaneously reflecting on these choices. Learner autonomy is a widely researched concept and is considered to be an essential attribute for learners of any second/foreign language because of its positive correlation with language learning (Little, 2003). However, the positive influence of acquiring learner autonomy may not be limited only to second/foreign language learning. Therefore, in this paper, I explore the research question "What can young learners' descriptions communicate about their experiences of learner autonomy in their mathematics classes?" in order to explore young learners' experiences with learner autonomy in mathematics classes as per the aim of NEA.

Background of the study

This study is a part of a bigger research project called Local Culture for Understanding Mathematics and Science (LOCUMS, 2016). This project explores if using practical activities rooted in *learners' own culture* can benefit them in learning mathematics and science in lower secondary classes. Building on experiences from a former research project where solving practical tasks rooted in students' local culture in discipline design and technology promoted their school engagement (Lysne & Hoveid, 2013), LOCUMS intends to research if similar approach can increase students' interests in learning mathematics and science. While reviewing the literature, I observed that learner-centered intervention studies carried out in mathematics classrooms are often planned either by the researchers or the teachers, and learners' choices remain un(der)stated. For designing practical activities rooted in students' local culture for learning mathematics and science, it was important to get informed about learners' interests. Therefore, I designed a pre-intervention questionnaire consisting open and closed ended questions about themes such as: learner's general views about education, perceptions about mathematics and science education, their activities of interest, what they desire to learn about at the school, their thoughts on culture etc. The purpose of these questionnaires was two-fold – to design a learner-centered teaching approach voicing learners' opinions, choices and interests which acted as an input for designing practical activities; and to explore learners' potential of taking reflected decisions and responsibility of learning mathematics. It was while analyzing students' questionnaire responses such as "I don't know what I want to learn in mathematics", "I do not know what [content]

is useful to learn in mathematics”, “I am not interested in learning mathematics, yet learning mathematics is important”, to open-ended questions concerning mathematics that the notion of *learner autonomy* in mathematics classes emerged as my research interest. Therefore, learners’ autonomy was investigated further through semi-structured interviews. Data gathered for LOCUMS was directed towards both mathematics and science, and consisted of a cycle of pre-project student questionnaires, practical group tasks, followed by individual semi-structured interviews with selected students. Group tasks required knowledge of mathematics and science to be solved. Semi-structured interviews were focused to probe learners’ experiences of autonomy in mathematics classrooms among broader themes such as getting a vision of learners’ experience on project day, their general outlook towards learning mathematics and science, the extent of activities used in the mathematics and science teaching and its relevance etc. Learners’ responses about experiences of learner autonomy in mathematics classes collected in the first ten semi-structured interviews are presented in this paper.

Theoretical framework

Learner autonomy was first defined as “the ability to take charge of one’s own learning” (Holec, 1981). The rationale of fostering autonomy in learners “... is quite simply that a teacher may not always be available to assist. Learners need to be able to learn on their own because they do not always have access to the kind or amount of individual instruction they need ...” (Cotterall, 1995, p. 220). The first definition of learner autonomy was later elaborated by Little (1991) as, “a capacity – for detachment, critical reflection, decision-making, and independent action” (p. 4). Further, Little (2003) mentions that, “... *autonomous learners* understand the purpose of their learning program ..., take initiatives in planning and executing learning activities, and regularly review their learning and evaluate its effectiveness” (p. 4, italics added). Therefore, learner autonomy entails more than intellectual autonomy, meaning the learners can “act freely with a sense of volition and choice” (Deci & Flaste, 1996, p. 89) and involves an activating psychological process in order to attain autonomy in relation to one’s learning processes. Little (1991) moreover reminds of the difference between an autonomous learner and an independent learner. Being an autonomous learner does not mean that one is an independent learner and is able to learn without any assistance of the teacher, but it means taking a partial control of one’s own learning process. By having a partial control, the learner should her/himself understand and reflect upon one’s learning curve in order to figure out what strategies work best for her/himself. Resultantly, a learner can comprehend how one learns better and design, plan, execute and analyze self-beneficial mathematics learning strategies.

Students’ intellectual autonomy has been discussed, but, I found fewer studies devoted to promoting learners’ autonomy among students in mathematics education research literature. Research initiatives in directions such as *critical mathematics education* (Skovsmose, 2014), *culturally-responsive mathematics education* (Greer, Mukhopadhyay, Nelson-Barber, & Powell, 2009), *mathematics education for social justice* (Gutstein, 2003), and *sociocultural and sociopolitical awareness* (Sriraman & Knott, 2009) have illuminated social implications of learning mathematics for the learners and our future society. These research areas address concerns to acknowledge learners’ interests, promoting pupils’ critical awareness towards sociocultural and sociopolitical issues involving mathematical calculations, and engage students in struggle for social justice through mathematics education. For learners to become mathematically literate critical citizens of society, they should be able to understand their responsibility of learning mathematics, comprehend the role

mathematics plays in their lives and society, and make decisions involving mathematical calculation. These capabilities require students to understand and take charge of their own learning in mathematics. Skovsmose (2014) mentions that, “It is a preoccupation of critical mathematics education ... to develop a mathematics education that might provide new possibilities for the students” (p. 117). This study tries to enhance research concerning learner autonomy in mathematics education by providing the learners with an opportunity to express their experiences regarding learner autonomy in mathematics classes. The focus is to explore if learners are aware of their responsibility and can suggest changes to improve the quality of mathematics classes, provided they can assume more control of their mathematics teaching-learning process, as NEA expects from them.

Method and study participants

Qualitative research design using semi-structured interviews with students was adopted as a method to learn about students’ experiences. Since I wanted to know individual opinions, perceptions and thoughts of the learners participating in mathematics classes, interviewing seemed as an optimal way to proceed. Semi-structured interviews provided me with the opportunity to engage the learners in a free conversation with occasional follow-ups, without the restrictions of time limitations and a strict structure. In this way, participants could also, to some extent, control the direction of the interview, so that I avoided being the steering authority in the interview, and could gather authentic and trustworthy information.

Learners of age 13 to 14 years, studying in 8th and 9th grade in a countryside school located in central Norway were informants of this study. One learner per group was chosen from 4 or 5 groups in each class, based on the level of their activity on the project day. Keeping in mind the principal of representativeness, an attempt was made to select students with different interests, level of activity (high, medium and low), achievement in mathematics (high, moderate and low achievers) etc. so that various experiences could be gathered. Here, I present representative excerpts from interviews with 5 girls (one of them with Sámi background) and 5 boys (one of them with Eritrean background). Most of these students’ parents were working or driving farms, holding an average socio-economic status.

Results and discussion

The interviews were conducted in Norwegian, translated to English and interview transcripts were analyzed in order to identify learners’ experiences regarding learner autonomy in mathematics classes. Interview questions were designed so that learners had to reflect on their mathematics teaching, make choices, take decisions and suggest changes in it; and were analyzed to find learner responses involving words such as *control*, *decision*, *responsibility* etc. concerning their mathematics education. This section presents selected interview excerpts followed by the *descriptive analysis* of learners’ responses from the first ten informants. In the following transcripts, *I* indicates the interviewer and *L_{number}* indicates which of the ten learners is responding. Interviews were conducted after practical group activities and hence in the first extract presented below, the interviewer is asking how in the learners’ experience the learning situation on the day of project was different from the learning situation in their usual mathematics classroom. The following snippet illustrates the learners’ experience:

I: eh... do you think this way to repeat mathematics and science content was different from the usual teaching?

L₃: yes...

- I: how would you describe that why was it different from usual teaching? ... how would you describe that the situation was different then? what was the difference?
- L₃: ... we did not sit in the classroom and raised our hands and talked like... we do not calculate like we discuss so much and find it together...
- I: but is it then different form usual teaching or would you say that it's also you who controls there as well?
- L₃: no... there it's the teacher who has more control
- I: but do you get it [the responsibility] usually like in mathematics and science classes?
- L₆: or... like we don't get to decide everything on our own because then it's like they have already decided what we should do from beforehand but also...

Both of the learners' responded that the learning situation they experienced on the day of project was different in terms of having control and responsibility. These experiences of learners about usual mathematics classroom exhibit limited experience with self-control and self-decision where the teacher is usually the one who manages the class and everything that is to happen in the classroom is decided beforehand. These classroom experiences, where learners are not exposed to the responsibility of their own learning, may inhibit learners' potential to understand, reflect, analyze and make decisions to improve their own learning processes for their self-benefit. Therefore, only when provoked a bit to assume autonomy, most of the learners suggested probable improvements in mathematics classroom:

- I: are you satisfied with the way teachers teach you?
- L₄: yes...
- I: why do you think that this way to be taught is alright?
- L₄: because... eh... I don't know maybe I'm used to having it like that like this so...I have done it all these years so, I think it's a fine way to learn...
- I: but if you had a chance... would you change the teaching in mathematics ...?
- L₄: no...
- I: nothing?
- L₄: maybe a bit more activities in mathematics but otherwise I don't think so of anything...
- I: would you have included any other activities like some practical activities in mathematics teaching?
- L₈: eh... I would have done it because what we've done in the whole 8th grade is just to write, write and write and solve the task and then it becomes quite boring and you lose the interest and you sit there just to write and when the class is over so you think "oh yes, finally finished...".

In the first snippet, learner L₄ expresses being *used to have been taught like this* as the reason of being satisfied with the teaching. Consequently, thinking about some other way of being taught or suggesting a change to the *usual* way sounds like a difficult task to him/her. However, when asked

again in a way where she/he could choose, she/he suggested an improvement in the mode of mathematics instruction. Similarly, the frustration of mathematics classes lacking practical activities and a suggestion to include the same if given the opportunity is evident in L₈'s response. The next excerpt shows that given the possibility to suggest changes and design their mathematics teaching themselves, learners can acquire autonomy in mathematics learning.

- I: hmmm... now when you have a suggestion about that you could have learnt to set up a budget... have you also thought of how would you have liked to learn it? In what way?
- L₅: eh... if we could have got a realistic situation... and then we could have got a task about it so it would have... for example set up a budget for a whole family for a month and you get different expenses and the teacher and you get the income and you have to pay the tax and you have to pay different and you should have a bit sum as saving if you sometimes get into a trouble and such things... like which are important to learn like you don't need to take a loan and you don't have a lot of debt because you just got into a trouble which you never expected in your budget... so we learn how one should use his money because I mean that mathematics... we use a lot of mathematics in society like money and much is controlled by money and money gives power so... because people should not use up... because of people should have better like I don't have any concept of... like I don't know what 1 million kroner is... it's a lot and lot but you can't manage to buy a house for one million kroners... so we should learn more about the value like how much 1000 kroner is worth ... and such...

The learner (with Sámi background) not only mentions what he/she desires to learn but also suggests how the lesson could be planned and what kind of tasks they could have worked on. This segment shows that learners have a potential of developing autonomy and co-responsibility in mathematics learning. Further, the extract below presents learners' response to the question of sharing responsibility of their learning with the teacher:

- I: what is the difference between if it's only me [who, as a teacher] decided everything and if you are also with me when I decide?
- L₉: it becomes more fun if both decide... then... I think it could have happened that people would have liked to come to school more often...
- I: when they are asked...?
- L₉: yes... when they get to decide a bit what they do at the school...

As indicated in the response of L₉ (Eritrean immigrant, in Norway since three years), the thought of gaining a little bit charge over one's own learning can not only encourage their autonomy but also that they would have liked to come to school more often, exhibiting the importance of listening to student voices.

Conclusion

Learners' responses concerning autonomy in their mathematics classroom exhibit limited experience with self-control and self-decision. This indicates that decisions regarding what will happen in mathematics classroom are usually made in advance by school authorities and the teachers, which

can act as a constraint for learners' autonomy to emerge and being practiced. Consequently, learners *get used to* mathematics classes, trust decisions of their school and teachers, and consequently see the *traditional way* to be the only way of mathematics education. This can leave learners unfamiliar with assuming autonomy to comprehend their learning processes in depth and limit their creative potential to experiment with better and self-beneficial ways of learning mathematics. Moreover, if concerns for social justice, adopting a critical stance towards mathematics' role in society and learners' personal lives, and raising consciousness towards sociopolitical and socio-economic issues through mathematics education are to be fulfilled; learners need to experience autonomy in their mathematics education. This way they can feel confident to put forward their argument, discuss and design better learning opportunities in mathematics with their teachers and, moreover, get engaged in, discuss and debate about social issues and initiate social changes in wider society.

Moreover, enthusiasm of learners to experience a partnership and co-responsibility of their own mathematics learning is the same regardless of their ethnic background. Interview excerpts from learners L₅ and L₉ depict similar experiences in mathematics classrooms and they desire similar changes (i.e., *a culture of promoting learner autonomy*) in mathematics learning as their Norwegian classmates. Similar responses from learners having diverse backgrounds complemented my focus on *youth culture* instead of ethnic backgrounds in this study.

Observing learners' potential to suggest, design, co-operate and improve teaching-learning strategies in mathematics, I conclude that learners should be *heard*, encouraged to be critical, take responsibility and decisions regarding their mathematics education to make them autonomous, cooperative and responsible mathematics learners fulfilling the aim of NEA, and become mathematically literate critically aware citizens to deal with challenges of our future society. For encouraging learners to be autonomous, they should be provided with time and space to plan and execute their own learning strategies together with their teachers, and approaches promoting autonomous behavior (Deci & Ryan, 1987) should be adopted. Moreover, to make learners think critically, decide, have more control and co-responsibility of their learning with teachers, just asking them simple questions (Croninger & Croninger, 2016) can be the first step of an interaction leading them to assume autonomy. Learner autonomy can make learners aware of their right to social justice by balancing the power relations between students and teachers. Autonomous learners can build a personal relationship with mathematics and gain experience of participation and authority of understanding mathematics' role in his/her personal (i.e., their home, classroom, school etc.) and wider society (as visible in L₅'s response).

Acknowledgment

LOCUMS is supported by the Norges forskningsråd (The Research Council of Norway). I wish to extend my gratitude to my supervisor Per-Odd Eggen for his co-operation in data collection and valuable discussions regarding observations derived from data analysis, and to the reviewers' feedback.

References

- Ben-Zvi, D., & Sfard, A. (2007). Ariadne's thread, Daedalus' wings and the learners autonomy. *Education & Didactique*, 1(3), 117–134.
- Cobb, P., & Yackel, E. (1998). A constructivist perspective on the culture of the mathematics classroom'. In F. Seeger, J. Voigt, & U. Waschescio (Eds.), *The culture of the mathematics classroom* (pp. 158–190). Cambridge: Cambridge University Press.

- Cotterall, S. (1995). Developing a course strategy for learner autonomy. *English Language Teaching Journal*, 49(3), 219–227.
- Croninger, R. G., & Croninger, R. M. V. (2016). Just ask! What prompts elementary school students to engage in critical thinking in reading and mathematics classes in the United States? *Turkish Online Journal of Educational Technology*, (November Special Issue), 1369–1376.
- Deci, E. L., & Flaste, R. (1996). *Why we do what we do: Understanding self-motivation*. New York: Penguin.
- Deci, E. L., & Ryan, R. M. (1987). The support of autonomy and the control of behavior. *Journal of personality and social psychology*, 53(6), 1024–1037.
- George, M. (2012). Autonomy and motivation in remedial mathematics. *Primus*, 22(4), 255–264.
- Greer, B., Mukhopadhyay, S., Nelson-Barber, S., & Powell, A. B. (Eds.). (2009). *Culturally responsive mathematics education*. New York: Routledge.
- Gutstein, E. (2003). Teaching and learning mathematics for social justice in an urban, Latino school. *Journal for research in mathematics education*, 34(1), 37–73.
- Holec, H. (1981). *Autonomy and foreign language learning*. Strasbourg: Council of Europe.
- Little, D. (1991). *Definitions, issues and problems* (Vol. 1). Dublin: Authentik.
- Little, D. (2003). Learner autonomy and second/foreign language learning. Good Practice Guide. Retrieved from <https://www.llas.ac.uk/resources/gpg/1409>
- LOCUMS. (2016). Local culture for understanding mathematics and science. Retrieved from <https://www.ntnu.edu/locums>
- Lysne, D. A., & Hoveid, H. (2013). A practical approach in technology and design in a school for all. In M. H. Hoveid & P. Gray (Eds.), *Inquiry in science education and science teacher education* (pp. 237–259). Trondheim: Akademika Forlag.
- McConney, M., & Perry, M. (2011). A change in questioning tactics: Prompting student autonomy. *Investigations in Mathematics Learning*, 3(3), 26–45.
- Mueller, M., Yankelewitz, D., & Maher, C. (2014). Teachers promoting student mathematical reasoning. *Investigations in Mathematics Learning*, 7(2), 1–20.
- Opplæringsloven. (1998/2018). Retrieved from <https://lovdata.no/dokument/NL/lov/1998-07-17-61>
- Skovsmose, O. (2014). Critical mathematics education. In S. Lerman (Ed.), *Encyclopedia of mathematics education* (pp. 116–120). Dordrecht: Springer Netherlands.
- Sriraman, B., & Knott, L. (2009). The mathematics of estimation: Possibilities for interdisciplinary pedagogy and social consciousness. *Interchange*, 40(2), 205–223.
- Wheatley, G. H. (1992). The role of reflection in mathematics learning. *Educational Studies in Mathematics*, 23(5), 529–541.
- Wood, M. B. (2016). Rituals and right answers. *Educational Studies in Mathematics*, 91(3), 327–348.
- Yackel, E., & Cobb, P. (1996). Sociomathematical norms, argumentation, and autonomy in mathematics. *Journal for research in mathematics education*, 27(4), 458–477.

Locally disrupting institutional racism by enacting mathematics in a U. S. laboratory classroom

Sabrina Bobsin Salazar

Universidade Federal de Pelotas, Brazil; University of Michigan, United States;

sabrina.salazar@ufpel.edu.br

In this study I investigate whether mathematical knowledge inherently carries fragments of its socio-political-historical development or if mathematics itself is value-free and can only get a political dimension attached to it by how it is used in society. I empirically approached the problem by studying a laboratory classroom collectively solving a problem. This classroom served as a proxy for a community of practicing mathematicians and I particularly investigated how conceptions of mathematics endorsed in this classroom could support (local) disruption of racism. Theories guiding this study include critical realism and critical race theory and analyzed data includes video records of instruction in this laboratory classroom. Results show that creating opportunities for students to engage in more authentic mathematical practices can support (local) disruption of racism.

Keywords: Mathematical knowledge, institutional racism, normativity.

The problem I am addressing and how I am doing it

Mathematics often enjoys a distinctive status among the sciences. Such highly regard status comes from the idea accepted by most practicing mathematicians that mathematics is universal, objective, and certain (Ernest, 1999), or, in other words, mathematics is an *a priori* knowledge that deals with truths that are true by virtue of necessity, and with objects that are abstract (Linnebo, 2017). These ideas however, are not unanimous, and disagreement about such assumptions can be traced back to the work of Plato and Aristoteles (Machado, 2013). Whereas refined arguments were developed to support one or another claims, the debate is still open. The work of Kitcher (1984) and Ernest (1998) are relatively recent work supporting an *a posteriori* view of mathematics that is intrinsically dependent of human activity in society, but introductory texts on philosophy of mathematics such as George and Velleman (2002) still presuppose that mathematical knowledge can be philosophically investigated disregarding its social and historical construction.

Mathematics education researchers that are concerned with socio-political dimensions of mathematics education have been interested in these philosophical disputes. Such scholars have a long-term commitment in understanding the relationships between mathematics education and society, particularly relationships involved in social inequality and injustice. To these scholars it is important to understand if mathematics inherently carries fragments of its socio-political-historical development or if mathematics itself is value-free and can only get a political dimension attached to it by how it is used in society. It is clear for socio-political researchers that mathematics and mathematics education are deeply connected with our contemporary social structure that privileges a group of people over others. What is not so clear is whether this connection comes from pure mathematical knowledge itself or not.

So far, many philosophers have argued in favor of one option or the other employing a variety of philosophical techniques to support their claims. I am adopting a different strategy. To investigate whether mathematical knowledge is independent of the human activity that produced or discovered it, I study a small community solving a mathematical problem together. This small community is an elementary mathematics laboratory classroom and it serves as a proxy for a broader community of practicing mathematicians. There are striking differences between both communities, and yet many similarities I expect to be helpful in illuminating the problem I am investigating. For example, in this classroom, the teacher functions as a permanent knowledge authority, being responsible for, ultimately, legitimating a mathematical claim in this environment, while in a community of practicing mathematicians, there is an institutionalized peer-reviewing system responsible for legitimating mathematical claims. The discussions the students participate in, however, are very comparable with mathematics seminars run by mathematics departments. There are discussions about whether a mathematical idea is true and arguments are laid out so other participants can be convinced of the validity of mathematical claims.

Moreover, I will look to a specific social dimension, namely institutional racism, so I can investigate it in depth and gather a better understanding of the connection of mathematical knowledge and the (re)production or disruption of racism. A pilot study showed that, in this classroom, there are instructional practices that support local disruption of racism (Salazar, 2018), the question now is if these practices were the only ones responsible for promoting such disruption or if the mathematics itself was also important in promoting local disruption of racism in this classroom. The research question I want to answer in this study is: *What conception of mathematics is endorsed in this laboratory classroom and how can it support (local) disruption of racism?*

Conceptual framework

Critical race theory

Critical race theory (CRT) is a theoretical framework for research that foregrounds race, racism, and racialized experiences. To critical race scholars, race is a complex social construct that goes beyond the color of skin and citizenship (Ladson-Billings, 1999), and brings real consequences to people once they are identified as member of a particular racial group (Bonilla-Silva, 2006). The kind of racism CRT is interested in exposing and challenging is institutionalized racism that permeates daily social interactions as opposed to individual blatant acts of racial prejudice. Finally, CRT posits that people of color experience racial oppression differently based on their individual background and multiple identities and insists in a non-essentialist approach (Delgado & Stefanic, 2001).

Critical realism

Critical realism (CR) is a philosophy of science that starts from a realist conception of the world, and *the real things* that make the world are then structures and mechanisms, or, in other words, causal laws (Bhaskar, 2008). In this perspective, in spite of being socially constructed, race is real because it has causal powers; race brings real consequences for the lives of people (Bonilla-Silva, 2006). In CR phenomena cannot be completely determined by scientific laws, they are only influenced by them. When I say that race causes segregation within schools through tracking, I am describing a tendency of over-representing White and Asian students while under-representing African American and

Latinx students in advanced classes, and over-representing African American and Latinx while under-representing Whites and Asian in lower tracks (Oakes, 1995). Race influences but does not completely determine what is going to be a student placement.

In CR the real things in the world can be combined in a way that, because of their structure and not only its individual properties put together, a new thing emerges in the world. This new thing, also called “entity” or whole, possesses “properties or capabilities that are not possessed by its parts” (Elder-Vass, 2010, p. 4). The whole is then not just the sum of its parts, but something else, with a new causal power that is, of course, derived from the individual properties of its parts. But not only this, the way the parts interact and relate with each other is also responsible for the emergence of the new thing.

The concept of emergence forms the laminated view of the world. A particular whole is said to be in a higher level than its parts. The same whole, however, can be a part of another emergent structure; in this case the whole is in a lower level than the new emergent structure. Individuals are seen as the lowest level of the social world, the whole society as the highest level, with many intermediate levels in between, such as social institutions. The immediate higher level to an individual is, according to Elder-Vass’s (2010) definition, a *norm circle*. The norm circle is defined by the group of individuals who hold a normative belief of *endorsing* a social norm or, in other words, each individual in the norm circle acts to reinforce the norm and discourage behavior that does not conform to the norm. Elder-Vass’s argument is that the norm circle is actually an emergent structure rather than only a group of people because it has a new causal power: to increase conformity to the norm.

The content within instruction

In this work, I view instruction as defined by Cohen, Raudenbush, and Ball (2003) as “interactions among teachers and students around content, in environments” (p. 122). Figure 1 shows a representation of this definition. I am looking to social normativity as a particular environment, and to classroom interactions as individual actions in light of norms enforced by norm circles when some or most of these norms are oppressive and perpetuate institutional racism. In this study, I am narrowing my gaze to the role of the content in these relationships.

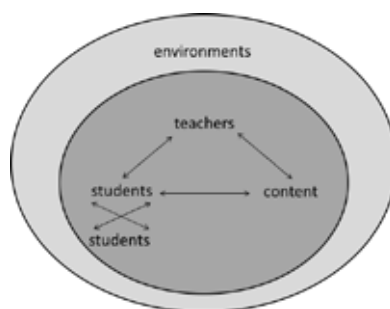


Figure 1: Representation of instruction from Cohen, Raudenbush, and Ball (2003, p. 124)

Methods

The laboratory setting and collection of data

In this study I analyzed episodes of instruction from a mathematics elementary laboratory classroom. This classroom is the main part of a summer program held each summer at a large research university in the United States. In this program, an experienced White teacher teaches lessons to a group of

rising fifth grade students (students going to start fifth grade at the subsequent fall) in public—that is, while over 70 other educators observe. Because this summer program is a site of research for student learning and teaching practices, different types of data are collected by the research team. The data set includes video records of instruction, video records of pre-brief and de-brief meetings with learning teachers, copies of students' notebooks, pictures of classroom records such as charts, lesson plans, class materials such as handouts for students, etc. The majority are African American and most come from low-income households. Only a few of them are White. The students have different levels of English proficiency and their mathematical performance in school is homogenously low.

The train problem

At this edition of the summer program, the students worked on collectively solving the train problem (Figure 2) over the span of the entire two weeks of the program. Students worked on this problem every day since the second day of the program at the second half of class that lasted about one hour each day. In this study, I focus on data related with students working on this problem, so video records of classroom, detailed lesson plans for each class, copies of student work (notebooks, homework, and assessments), photos of every collective record produced in classroom (such as charts and white board records). I am focusing on this problem because it is unusual to work in problems of this kind at this level, but some of its characteristics are very common in the field of mathematics, which makes it interesting to investigate practices of doing mathematics in a community. The solution of part 1 is that the SP company can build trains that hold 1 to 15 passengers. Part 2 actually does not have a solution and, in this case, solving the problem means mathematically explaining why it is not possible to find a train that meet all the conditions of the problem.

<p><u>The Train Problem</u></p> <p>The SP Train Company has five different-sized train cars: a 1-passenger car, a 2-passenger car, a 3-passenger car, a 4-passenger car, and a 5-passenger car. These cars can be connected to form trains that hold different numbers of people.</p> <div style="display: flex; align-items: center; margin-top: 10px;"> <div style="margin-right: 10px;"> <input type="checkbox"/> </div> <div>1-passenger car</div> </div> <div style="display: flex; align-items: center; margin-top: 5px;"> <div style="width: 15px; height: 10px; background-color: red; margin-right: 5px;"></div> <div>2-passenger car</div> </div> <div style="display: flex; align-items: center; margin-top: 5px;"> <div style="width: 15px; height: 10px; background-color: green; margin-right: 5px;"></div> <div>3-passenger car</div> </div> <div style="display: flex; align-items: center; margin-top: 5px;"> <div style="width: 15px; height: 10px; background-color: purple; margin-right: 5px;"></div> <div>4-passenger car</div> </div> <div style="display: flex; align-items: center; margin-top: 5px;"> <div style="width: 15px; height: 10px; background-color: yellow; margin-right: 5px;"></div> <div>5-passenger car</div> </div>	<p><u>Part 1</u></p> <p>You can use <u>only</u> these five types of cars to build trains, and you can use <u>at most one</u> of each type of car in each train. What are the different numbers of people that the SP Train Company can build trains to hold?</p> <p><u>Part 2</u></p> <p>Ms. McDuff wants to order a special 5-car train that uses exactly one of each of the different-sized cars. Ms. McDuff wants to be able to break apart the 5-car train to form smaller trains that hold exactly each number of people from 1 to 15. The customer wants to be able to build these smaller trains using cars that are next to each other in the 5-car train. Can the SP Train Company build Ms. McDuff's order? Explain how you know.</p>
---	---

Figure 2: Summer program train problem

Analysis

I watched and wrote fieldnotes from all video records. From the fieldnotes, I wrote a description of how the class solved the train problem. Then I selected episodes from interactions of the teacher and the students that showed students working and discussing pieces of the solution of the train problem. Each episode was then re-watched and a more detailed description was written. In each episode I investigated mathematical normative practices that could illuminate the nature of the knowledge produced in this laboratory classroom. I also look for schooling normative practices that could intersect with mathematical practices. Additional data from student work and detailed lesson plans were used to check and refine hypotheses.

Enacting math: Collectively solving the train problem

The class worked to find the solution of the train problem. The process started in class 2 and involved individual and small group work, as well as whole class discussions. To solve part 1, the strategy consisted in finding the smallest train that the SP company could build, then the greatest, then find trains “in between”.¹ In this initial discussion, La’Rayne² (*La-rain*)³ said wr ⁴, which holds 3 passengers, is the smallest possible train because $w=1$ and $r=2$. Other students loudly say “no”, disagreeing. La’Rayne immediately revised her thinking, saying that you could use just the red or the white, unless no train would be made at all. They agreed 1 (or zero) was the smallest train. The class did not reach a consensus about the greatest train as quickly, so they worked independently or in small groups on this question. During this work, the teacher discussed with La’Rayne about the train she was testing. She first thought her train held 19 passengers, but after discussing with the teacher she realized it actually held 15. Then she and the teacher had a very dynamic interaction, with questions and answers being said immediately on top of each other. In this interaction, La’Rayne explained that the biggest train held 15 passengers because it used all the rods, and that it was not possible to build a train for 19 because there would be no rod left to add to the train. The class continued their collective work and concluded that the company could build trains of size 1 to 15 by the end of class 3.

The solution of the part 2 spanned across the remaining 7 classes. They started doing some exploratory work to understand the problem and make sense of the conditions. During this part of the work they build collectively one train that holds 15 passengers, namely *yrpwg*, and broke it apart in different ways, trying to understand how they could break it, how they could not, and what were smaller trains they could built from it. They agreed that this train did not work because they could not build 9, 13, or 14. Then they started testing out other trains of size 15 and begun making records of all the trains they were testing that did not work. In this work, the teacher talked with the pair Layla and Olivia who said they were done, meaning they found a train. As a result of this interaction, teacher and girls realized they “were moving” things around, or, in other words, they were violating the condition that the cars had to be next to each other to form the smaller trains. Many students had

¹ I am using the idea of size to talk about the number of passengers a train holds. So, a train of size 7 holds seven passengers, a train of size 7 is smaller than a train of size 11, and the greatest train is a term used to refer to the train who holds the greatest number of passengers.

² The research consents and IRB approval permit us to use the children’s real first names. Other identifying information (e.g., last names) are not used.

³ Names of African Americans in the U. S. often have unusual spellings. Additionally, their names are frequently misspelled or mispronounced. In this work, I am trying to use their first names with correct spelling and pronunciation as a sign of respect. When I cite a name with an unusual spelling and/or pronunciation, I will write the pronunciation in parenthesis with emphasis after the first time I write the name, so La’Rayne is pronounced *La-rain*’.

⁴ The letters used here are a reference to the first letter of the name of the color of the train cars. So the train *wr* is the train white-red which holds $1+2=3$ passengers. Similarly, *yrpwg* is the train yellow-red-purple-white-green which holds $5+2+4+1+3=15$ passengers.

similar confusion and interactions with the teacher. With practice and interactions with the teacher, the students seemed to overcome such difficulty, and also progressed to make more organized records of their attempts. They continued the exploratory work of testing out trains for about three days.

On class 7 they made some important progress with respect to understanding the mathematical work they were doing: they discussed why it is always possible to make trains for 1 to 5 (only one car is needed to build these trains) and for 15 (all cars are needed), how to decide a train did not work (only one number that does not work is enough), and started to think what are the numbers that are difficult to make and why it that so (“big” numbers, such as 11, 12, 13, and 14).

On day 8, the students received the red and white clue: “If there is a train that can be made for Ms. McDuff, it will have to have the red car (2) on one end and the white car (1) on the other end.” This clue contains a logic implication that was not easy for the students to understand. Moreover, the clue was given to the students with the idea that it could be a “wrong” clue, so before they could use it, they would need to find out whether the clue was valid. Students were confused in the beginning, they thought the clue was wrong because they were testing trains with the red and white cars in the ends of the trains and still could not find a train that works. It was only on class 9 that the students agreed the clue was right, meaning that if they were to find a train that works, they needed to build trains for 13 and 14, and that was only possible with red and white in the ends. Then using the clue, they arrived at the conclusion that they only needed to test six trains: wgypr, wgypr, wpygr, wygpr, and wygpr. On class 10, the students were divided into six groups, so each group were to test one of the six possible trains. After a final discussion in which each group reported their train did not work, the class seemed convinced there was no train that could fulfill Ms. McDuff’s request.

When school norms intersect with mathematical norms

There were often school norms and mathematical norms shaping the interactions observed in this laboratory classroom, and in some instances such norms were conflicting. In other words, in some cases, a school norm assigned a behavior for a particular situation, while a mathematical norm assigned a different behavior for the same situation. For example, this interaction occurred after the brief discussion described above on day 7 about what numbers need to be checked in each train. After talking about not needing to test one to five, the teacher asked if he needed to check 15. He answered:

Kassim: No.

The teacher asked why not, which seemed to be interpreted as a wrong answer, so Kassim changed it:

Kassim: Oh, yes.

Teacher again immediately asked why. Then Kassim presents a full explanation:

Kassim: No, because all of these is equal to fifteen. [Pointing to the rods.]

In this interaction between the teacher and Kassim, the boy tried to guess what would be the answer the teacher was expecting. He answered, waited for the teacher’s response to his question, and quickly changed his first answer after the teacher’s reaction was not confirming. This behavior can support school success given the role teachers have in assigning grades often based in students correct responses to questions. In this classroom, however, the teacher tried to promote mathematical

reasoning. Thus, frequently her responses to students' answers were follow-up questions asking for more explanation. In the end, to answer in a way that aligned with teacher expectations, Kassim would need to do a mathematical explanation, and so did he.

Another issue generated by the conflict between school norms and mathematical norms arises when students are “solving” a problem that has no solution. It is common in school, even more at this grade level, that mathematical problems always have a solution, often a unique one. Problems with no solutions, or with multiple solutions will most likely only appear in algebra in secondary school mathematics. Moreover, even when students deal with this kind of problems in algebra, it is not always discussed how this kind of problems are “solved” by mathematicians. In the field of mathematics, “solving” a problem with no solutions means to prove the problem is unsolvable. In this laboratory class, the students had to negotiate between a school norm, in which they had to find a solution to the problem, and a mathematical norm, in which they had to prove there was no solution to be found. On day 7, Luiz commented when testing one train:

Luiz: I was so close, I needed two more, 13 and 10.

He expressed the frustration of not finding a solution. Later, on day 10, the class received the visit of Ms. McDuff and they had to report how her request cannot be fulfilled. They had discussed before she arrived how they were going to report it to her. They were all sure there was no solution, and they discussed how they were going to talk about the red and white clue, how they tested all the “possible trains” and none works. But when she arrived, they struggled to say it. Even Olivia who had said before very clearly “there is no train” was speaking more quietly, seemed ashamed of not having a train to report, saying “we couldn't figure out a train”. The discussion proceeded and the teacher supported students in reporting what they had actually discovered. Eventually, Miah (*Maya*) said very clearly that her train was impossible, and Chandler spoke loudly, raising her hand to her front with the palm upwards when Ms. McDuff asked what that meant:

Chandler: Your train is impossible, we can't make it.

And Jerone added:

Jerone: So what we're saying is that your train could never be made.

Ms. McDuff replied that she will have to find another company and students responded loudly at the same time “no no no”.

They continued a brief discussion afterwards, and students talked to her about the red and white clue and how they tested all the “possible trains” and none works. They were then able to convince Ms. McDuff her train could not be made and she did not need to keep requesting it from any other company.

Discussion

In this classroom, students engaged in doing mathematics in similar ways mathematicians do. They explained their reasoning mathematically, why some trains always worked, so they did not need to test them; why they did not need to find all small trains they could not build from the whole train to be sure the whole train did not work; why the red and white clue was right and how to use it to solve the problem. They used strategies to solve problems frequently used in mathematics, such as finding

the small and greatest possible train for part 1, then look for trains “in between”. When engaging in these practices of doing mathematics, the students took an active role in producing mathematical knowledge in their community. The active enactment of mathematics by these students was crucial to support local disruption of racism. When the students described in this report, mostly African Americans, one Latinx, boys and girls, performed mathematics they countered the idea that mathematics intelligence is a function of being White (and male). In this classroom, mathematics is something you do, rather than know, and they could all do it. In spite of the intersection between school normativity and mathematical norms, creating the opportunity for students to engage in more authentic mathematical activity opened up the classroom space for students, specially students in this classroom, to participate in mathematical discussion they usually cannot, and that is disruptive.

References

- Bhaskar, R. (2008). *A realist theory of science*. Abington: Routledge.
- Bonilla-Silva, B. (2006). *Race with racists: Color-blind persistence of racial inequality in the United States*. Oxford: Rowman & Littlefield.
- Cohen, D. K., Raudenbush, S. W., & Ball, D. L. (2003). Resources, instruction, and research. *Educational Evaluation and Policy Analysis*, 25(2), 119–142.
- Delgado, R., & Stefanic, J. (2013) *Critical race theory: The cutting edge* (3rd ed.). Philadelphia, PA: Temple University Press.
- Elder-Vass, D. (2010). *The causal power of social structures: Emergence, structure and agency*. New York: Cambridge University Press.
- Ernest, P. (1998). *Social Constructivism as a philosophy of mathematics*. Albany: State University of New York Press.
- Ernest, P. (1999). Is mathematics discovered or invented. *Philosophy of Mathematics Education Journal*, 12, 9–13.
- George, A. L., & Velleman, D. (2002). *Philosophies of mathematics*. Malden: Blackwell Publishers.
- Kitcher, P. (1984). *The nature of mathematical knowledge*. New York: Oxford University Press.
- Ladson-Billings, G. (1999). Just what is critical race theory and what’s it doing in a nice field like education? In L. Parker, D. Deyhle, & S. Villenas (Eds.), *Race is... race isn’t: Critical race theory and qualitative studies in education* (pp. 7–27). Boulder, CO: Westview Press.
- Linnebo, Ø. (2017). *Philosophy of mathematics*. Princeton: Princeton University Press.
- Machado, N. J., (2013). *Matemática e realidade: Das concepções às ações docentes*. São Paulo: Cortez.
- Oakes, J. (1995). Two cities’ tracking and within-school segregation. *Teachers College Record*, 96(4), 681–690.
- Salazar, S. B. (2018). *Explaining how racism can be locally disrupted in a mathematics classroom*. Manuscript submitted for publication.

Visible pedagogy and challenging inequity in school mathematics

Pete Wright

UCL Institute of Education, United Kingdom; pete.wright@ucl.ac.uk

This paper reports on the initial findings of a research project aiming to explore ways of addressing concerns regarding the persistent gap in mathematics achievement between children from different socio-economic backgrounds and low levels of engagement of significant numbers of students with school mathematics. It argues that such concerns can be addressed without the need to abandon a commitment towards progressive teaching approaches. It highlights the potential of adopting a critical model of participatory action research for challenging existing classroom practices that contribute towards reproducing inequities in mathematics education. It demonstrates how developing strategies for making progressive pedagogies more visible offers students the chance to become more aware of the intentions of the teacher and what they need to do to be successful in school mathematics.

Keywords: Inequity, participatory action research, school mathematics, visible pedagogy.

Introduction

This paper reports on the initial findings of a research project which aimed to develop strategies to address the large gaps in mathematics achievement existing in schools between children from different socio-economic groups. Evidence suggests that ‘progressive’ teaching approaches, which involve providing opportunities for students to work independently and collaboratively on solving open-ended problems, can lead to higher levels of engagement and more equitable outcomes amongst mathematics students. However, there is also a danger that their relatively unstructured character can further disadvantage children from less wealthy backgrounds who are more likely to misinterpret the intentions of the teacher or to miss the point of the lesson. The project aimed to develop strategies teachers can use to make their pedagogy more visible, so that all students are able to recognise their intentions as teachers, and to identify research processes and methods that enable this to happen.

Background

Wide gaps in achievement in school mathematics persist worldwide between children from different socio-economic backgrounds. There is evidence of a strong and persistent correlation between students’ attainment and participation in school mathematics and their family income (Boaler, Altendorf, & Kent, 2011). Whilst other differences in achievement (e.g., between boys and girls) have narrowed, socio-economic disadvantage remains the most decisive factor in determining success in school mathematics (Jorgensen, 2016). This is the case in England despite recent government policies aimed at highlighting and reporting differences in attainment and, since the introduction in 2011 of the ‘pupil premium’ (based on eligibility for free school meals), targeting resources at poorer students. Since mathematics qualifications play a critical role in regulating access to higher-paid employment, under-performance in school mathematics restricts the social mobility of disadvantaged children and contributes towards the reproduction of inequality from one generation to the next (Jorgensen, 2016).

Concerns have also been expressed for a number of years over the quality of mathematics teaching. Traditional teacher-led approaches, based on routine use of repetitive closed tasks, have been blamed

for an alarming decline in students' attitudes towards mathematics as they progress through secondary school, causing them to opt out of further study (Williams & Choudhury, 2016). Learning of mathematics is too often limited to memorising and practising procedures with little understanding of their application, purpose or underlying concepts (OFSTED, 2012; Foster, 2013), resulting in many children (and adults) continuing to exhibit alienation from mathematics (Nardi & Steward, 2003). In contrast, more 'progressive' teaching approaches, characterised by open-ended activities, collaboration between learners and an emphasis on developing problem-solving and reasoning skills, can lead to more equitable outcomes and greater levels of engagement amongst all students (Boaler, 2008; Wright, 2017). There is a growing consensus amongst the mathematics education community that a more relevant and engaging mathematics curriculum is needed, with a greater focus on open-ended tasks, problem-solving and conceptual understanding (ACME, 2011; Hodgen, Foster, Marks, & Brown, 2018; NCETM, 2008; OFSTED, 2012). This is reflected in the renewed focus on reasoning and problem solving in the revised National Curriculum in England (DFE, 2013).

However, some researchers have highlighted a formidable challenge for mathematics teachers concerned with issues of equity who wish to adopt progressive teaching approaches. Barrett (2017) warns of the danger of denying students access to 'powerful knowledge' in an attempt to widen access to school mathematics by emphasising 'everyday knowledge'. In a study in the United States, Lubienski (2004) describes how the relatively unstructured nature of progressive teaching approaches resulted in disadvantaged children being less likely than others to recognise the intentions of the teacher, for example by failing to notice hints and clues and by missing the point of class discussions. Bernstein (2000) argues that children from disadvantaged backgrounds, because of their upbringing, are generally less able to decipher the 'rules of the game', that is the 'recognition rules' (identifying relevant meaning from tasks) and 'realisation rules' (formulating appropriate and legitimate responses). This poses something of a dilemma for mathematics teachers committed to addressing inequity in their classrooms: should they avoid progressive approaches altogether or explore ways to make pedagogical rationale more explicit to learners? Classroom-based studies exploring whether making pedagogies more visible can address issues of inequity have been mostly limited to science education (Morais & Neves, 2017) and literacy (Bourne, 2004). This project focuses on developing strategies for making teachers' pedagogy more visible to learners in mathematics classrooms, to help all students recognise their intentions when adopting progressive approaches to teaching. It seeks ways to enable all students to be successful in mathematics, whilst embracing progressive pedagogies.

Methodology

The project adopts a Participatory Action Research (PAR) methodology, that is a collaborative approach to research in which academics aim to carry out research 'with', rather than 'on', research participants. PAR recognises how 'academic researchers', with their expertise in conducting research, and 'teacher researchers', with their detailed knowledge of the classroom, each have a distinct, but essential, role to play. It seeks positive social change, through generating knowledge that is of greater relevance to practitioners, whilst developing a deeper understanding of 'theory-in-practice' amongst teachers (Brydon-Miller & Maguire, 2009). In contrast to conventional mathematics educational research, which is often conducted in artificial situations (Skovsmose, 2011), PAR pays closer attention to challenges, constraints and opportunities teachers experience on a day-to-day basis. It can offer a

systematic and critical approach to research based on clearly-defined processes including: reflecting critically on current practice in relation to research literature; articulating an alternative vision; trying out new approaches whilst taking account of realities and practical constraints; analysing outcomes of these trials to evaluate the feasibility of the alternative vision (Andersson & Valero, 2016).

Practitioner-led research is often criticised as lacking rigour and being limited in scale (Myhill, 2015). In a recent review of practitioner-led collaborative research in mathematics education, Robutti et al. (2016) reported how most studies failed to theorise ‘collaboration’, relying instead on theories relating to a ‘community’ in which it is assumed to take place. Much practitioner-led research has been criticised for lacking a critical element, either because it involves general agreement in advance of the intended outcomes, or because the focus is left open for practitioners to decide, without questioning the legitimacy of existing modes of practice (Kemmis, 2009). Critical reflection requires teachers to view their own practice as problematic, and to question the consequences of their actions, in relation to wider historical, cultural and political values and beliefs (Hatton & Smith, 1995; Liu, 2015). It is driven by external support and stimulus, which is seen as essential for challenging existing practice and without which collaborative inquiry is likely to perpetuate existing practice through the process of ‘alignment’ with accepted norms (Jaworski, 2006). Critical action research involves partners working together to “change their social world collectively, by thinking about it differently, acting differently, and relating to one another differently” (Kemmis, 2009, p. 471).

This project aimed to develop, refine and evaluate research processes and methods that facilitate effective collaboration and critical reflection amongst academic and teacher researchers. This is seen as particularly important when applying PAR to the mathematics classroom situation where existing practice has proved otherwise resistant to change. Research methods employed during the project include the joint design of student surveys and interviews (to be implemented by the teachers themselves), carrying out peer observations, and making use of video-stimulated reflection to evaluate lessons (Geiger, Muir, & Lamb, 2016). The project was innovative in that it sought to make the collaborative and critical characteristics of such methods and processes explicit.

Research design

The research project was situated in a comprehensive secondary (age 11 to 18) school in North London with an above-average proportion of disadvantaged students (approximately 30% of students qualified for the ‘pupil premium grant’ in 2016-17 compared with a national average of 27%). The two-year project was initiated in November 2017. This paper reports on initial findings from the first year of the project. The project was a collaboration between myself, as academic researcher, and two teacher researchers, Tiago and Alba, who shared an interest in developing progressive teaching approaches and exploring issues of equity in mathematics classrooms. (I will refer to the three of us collectively as the ‘research group’.) The school’s mathematics department had recently incorporated a series of problem-solving activities into its scheme of work and was gradually moving away from a rigid setting structure towards mixed attainment grouping in the lower years. There was a whole-school focus on developing ‘oracy’, which in the mathematics department included encouraging students to articulate and communicate their reasoning through ‘think-pair-share’ strategies (thinking about a problem as an individual, before sharing with a partner and then the whole class).

The focus of the study was to explore strategies teacher researchers could use to make their pedagogy more visible, that is to help all pupils recognise their intentions as teachers when adopting progressive approaches to teaching secondary mathematics. In so doing, it was hoped to develop strategies that might be effective in reducing the large gaps in mathematics achievement existing between children from different socio-economic groups within the school. The research questions were:

1. Which teaching strategies are successful in helping students develop their ability to decipher the recognition and realisation rules of the mathematics classroom?
2. What impact do these strategies have on students' mathematical achievement and engagement, particularly for those from disadvantaged backgrounds?
3. What characteristics of PAR enable academic and teacher researchers to work collaboratively to bring about transformations in mathematics classroom practice?

A series of nine research group meetings were held at the school during the first year. At the first meeting, I provided Alba and Tiago with journals in which they were encouraged to reflect on their experiences and write a commentary on the development of their thinking and classroom practice over the course of the project. The initial meetings included jointly agreeing the research design and a focus on critical reflection on existing practice in relation to the research literature. The teacher researchers read and presented for discussion key research papers (identified by me) during these meetings. We decided that Alba and Tiago would work with two similar Year 7 (age 11-12) groups that they taught, making use of teaching materials that already existed within the department. This enabled them to focus on developing strategies to make their pedagogy more visible, alongside the progressive approaches to teaching mathematics already in use. Two 'plan-teach-evaluate' action research cycles were carried out in order to try out strategies devised during meetings. We jointly designed a survey to give students after the first cycle in order to evaluate the impact of these strategies. We also discussed and agreed the questions that were asked and the protocols that were adopted during semi-structured interviews conducted by Alba and Tiago after the second cycle with six disadvantaged students (identified on the basis that they qualified for the 'pupil premium grant').

The focus of the surveys and interviews was on assessing the impact of the strategies on students' success in, and engagement with mathematics, their dispositions towards learning, and their awareness of the pedagogical rationale employed by the teacher. We arranged for four of the lessons (two for each teacher) to be video-recorded and observed by either myself or the other teacher researcher. The observer created a time line of key events during the lesson so that these could be quickly located in the video recording during subsequent meetings. We carried out detailed evaluations of the strategies through reflective discussions during research group meetings. These discussions were prompted by watching back extracts from the video recordings and relating these to survey and interview responses and notes kept by Alba and Tiago in their reflective journals.

Data was collected through making audio-recordings of discussions held during research group meetings and audio-recordings of interviews conducted with the six students. These recordings were transcribed and fully anonymised, with pseudonyms being used throughout the data analysis for students and any third parties mentioned. During the thematic analysis, categories were assigned to extracts of text from the transcripts using a combination of deductive and inductive coding. Since the

project involves applying theory to pedagogical practice, an initial coding structure was derived from the theoretical framework. This structure was developed through a process of repeatedly reading the transcripts to allow familiarization with the data and to interrogate the relevance of the categories. Further amendments and additions were made during the coding process to increase the relevance of the categories to the data. The categories included in the coding structure fell into four broad groups: 1) students' understanding of recognition/realization rules; 2) students' recognition of educational disadvantage and relational equity; 3) teachers' pedagogical strategies; 4) students' dispositions towards learning. NVivo software was used to facilitate the comparison of extracts of text which had been assigned similar categories, and to explore 'commonalities', 'differences' and 'relationships' between these and other categories, enabling themes to emerge from the data (Gibson & Brown, 2009). These themes were then related back to the research questions and underlying theoretical framework in order to generate meaning (Kvale & Brinkmann, 2009).

Initial findings

The findings reported below are based on an initial analysis of the interview and survey data only, from the first year of the project. Further analysis is currently being undertaken of the data from the research group meetings, which will enable a fuller discussion of the research methodology and the collaborative and critical nature of the research design to be reported in due course.

It was noticeable from the responses to the surveys completed at the end of the first cycle that students often did not fully appreciate the intentions of the teacher in adopting progressive teaching pedagogies, resonating with Lubienski's (2004) conclusions described earlier in this paper. Many students misread the rationale behind teaching approaches aimed at enhancing mathematical learning, often perceiving them as being designed to enforce compliance. One example that illustrated this tendency was an open-ended problem given to students that involved calculating the area of different sections of a flag. There were several alternative methods that could have been used to solve this problem. There was nothing remarkable about this open-ended, problem-solving task, or about the 'think-pair-share' approach that was used to introduce it, both of which were employed routinely by Alba and Tiago in their teaching practice prior to their involvement in the project. However, they developed strategies to use alongside the task that had not previously been a focus of their practice. In this case students were asked first to think about the problem on their own, discuss it in pairs, and then to explain their partner's thinking to the rest of the class (rather than explaining their own thinking). The completion of the task was followed by a whole class discussion prompted by teacher researchers asking: "Why do you think I asked you to present your partner's ideas rather than your own?" Students were encouraged to put forward suggestions which were then discussed with the teacher enabling her/him to help students appreciate how the teaching approach adopted was designed to facilitate deeper mathematical understanding. Prompting students to present their partner's ideas and the follow-up discussion of the pedagogical rationale represented a change in teachers' practice.

In the survey administered at the end of the lesson, students were asked the following question: "Why do you think the teacher asked you to explain your partner's thinking and not your own?" The responses of some students suggested they had correctly interpreted the teacher's intentions, for example "So that we understand other's point [of] view", "So you can share everyone's methods", "Because it

helps you to understand different opinions on the maths problems and different paths to the answer”, “Because you can get two different perspective[s] and it may help you finalise your idea”. However, a majority of responses suggested most students misinterpreted the strategy as simply an implicit way of enforcing listening, for example “To make sure you listen”, “To see if you’re listening to your friend.”

The strategy described above was aimed at making pedagogies visible that would otherwise remain implicit (and often not at all transparent) to learners. The intentions of the teacher thus become an explicit focus for discussion and consideration by learners. Another strategy employed during the second cycle was to scribe students’ responses to questions verbatim, that is to write down exactly what they said regardless of whether they were correct or incorrect. This was followed up with a discussion with students around the rationale for doing so, in this case to draw out ambiguity in language used by students and to enable students to identify errors and misconceptions for themselves.

It appeared, from interview responses at the end of the second cycle, that disadvantaged students were developing a greater awareness of some (but not all) of the primary reasons for teachers’ pedagogical choices. Four of the six students interviewed, Marcus, Sophia, Mary and Keira (all pseudonyms), appeared to recognise the primary purpose of identifying and addressing errors and misconceptions when they were asked why they thought the teacher wrote down exactly what students said:

To maybe see like where we go ... because it’s better if you say it out than keep it in because the teacher could help you and try and improve from wrong to right. (Marcus, interview)

Cos then you can compare the correct and incorrect answers together and see, like, where you went wrong, and how you, you know, changed the answer to get the correct one. (Sophia, interview)

It was nice to like write down it, and then look at our mistakes. ... Because of, then we can, like, fix the mistakes. ... But usually people will like ... if we make a mistake, and then they just change it. They just tell you it’s this, but they don’t tell you why ... and then next time they do the same mistake. (Mary, interview)

It will be showing us that you think we’ve gone wrong a little bit. And by writing everything we’ve said, that will help, not just like the person, it will show everyone like where it went wrong. Instead of like you telling us, and that, we can learn from our mistakes. (Keira, interview)

However, Ennis demonstrated only a partial appreciation of the primary purpose, identifying a reason that might be valid in a different situation, whilst Neal was not able to articulate a valid purpose:

So other people can know how to do it. And so everyone could like ... everyone can understand from it, and see what they’ve done wrong, if they’ve got it wrong, and see what they’ve done correct, if they’ve got it correct. (Ennis, interview)

Maybe they never got it right, but then someone worked out the same way but still got it right. And then you will show the person who did it how ... they should do it correctly. (Neal, interview)

There was a similar pattern for other strategies that Alba and Tiago tried out for making pedagogy more visible, with most students recognising at least one purpose identified as primary by the teachers during research group meetings. However, students also articulated other purposes, some considered potentially valid in other situations but not primary for these strategies, and others considered invalid.

Conclusion

From an initial analysis of the data from the early stages of the research project, it appears that developing strategies for making teachers' pedagogical rationale more visible to learners has the potential to increase students' appreciation of the intentions of the teacher, although some misinterpretation is likely to persist. This offers the promise of eliciting more appropriate responses from a wider range of students, including those from poorer backgrounds, when less-structured teaching approaches are employed. This in turn suggests ways of developing classroom practice that can begin to address issues of inequity in mathematics classrooms without the need to abandon progressive pedagogies. It offers a positive way forward for teachers who are committed towards closing the gap in achievement between advantaged and disadvantaged students and who also believe that adopting collaborative and problem-solving teaching approaches promotes greater mathematical understanding. It highlights the need for further research to explore, refine and disseminate strategies, that can be adopted alongside progressive pedagogies, to help all students recognise the intentions of the teacher and hence to respond appropriately and achieve greater success in mathematics.

References

- ACME. (2011). *Mathematical needs: Summary*. London: Advisory Committee on Mathematics Education.
- Andersson, A., & Valero, P. (2016). Negotiating critical pedagogical discourses: Stories of contexts, mathematics, and agency. In P. Ernest, & B. Sriraman (Eds.), *Critical mathematics education: Theory, praxis, and reality* (pp. 199–226). Charlotte, NC: Information Age.
- Barrett, B. (2017). Bernstein in the urban classroom: A case study. *British Journal of Sociology of Education*, 38(8), 1258–1272.
- Bernstein, B. (2000). *Pedagogy, symbolic control and identity: Theory, research, critique*. Lanham: Rowman & Littlefield.
- Boaler, J. (2008). Promoting 'relational equity' and high mathematics achievement through an innovative mixed-ability approach. *British Educational Research Journal*, 34(2), 167–194.
- Boaler, J., Altendorf, L., & Kent, G. (2011). Mathematics and science inequalities in the United Kingdom: When elitism, sexism and culture collide. *Oxford Review of Education*, 37(4), 457–484.
- Bourne, J. (2004). Framing talk: Towards a 'radical visible pedagogy'. In J. Muller, B. Davies, & A. Morais (Eds.), *Reading Bernstein, researching Bernstein* (pp. 91–122). London: Routledge.
- Brydon-Miller, M., & Maguire, P. (2009). Participatory action research: Contributions to the development of practitioner inquiry in education. *Educational Action Research*, 16(1), 79–93.
- DFE. (2013). *Mathematics programmes of study: Key stage 3*. London: Department for Education.
- Foster, C. (2013). Resisting reductionism in mathematics pedagogy. *The Curriculum Journal*, 24(4), 565–585.
- Geiger, V., Muir, T., & Lamb, J. (2016). Video-stimulated recall as a catalyst for teacher professional learning. *Journal of Mathematics Teacher Education*, 19(5), 457–475.
- Gibson, W. J., & Brown, A. (2009). *Working with qualitative data*. London: Sage.

- Hatton, N., & Smith, D. (1995). Reflection in teacher education: Towards definition and implementation. *Teaching and teacher education*, 11(1), 33–49.
- Hodgen, J., Foster, C., Marks, R., & Brown, M. (2018). *Evidence for review of mathematics teaching: Improving mathematics in key stages 2 and 3*. London: Education Endowment Fund.
- Jaworski, B. (2006). Theory and practice in mathematics teaching development: Critical inquiry as a mode of learning in teaching. *Journal of Mathematics Teacher Education*, 9(2), 187–211.
- Jorgensen, R. (2016). The elephant in the room: Equity, social class, and mathematics. In P. Ernest, B. Sriraman, & N. Ernest (Eds.), *Critical mathematics education: Theory, practice and reality* (pp. 127–146). Charlotte, NC: Information Age Publishing.
- Kemmis, S. (2009). Action research as a practice-based practice. *Educational Action Research*, 17(3), 463–474.
- Kvale, S., & Brinkmann, S. (2009). *InterViews: Learning the craft of qualitative research interviewing*. London: Sage Publications.
- Liu, K. (2015). Critical reflection as a framework for transformative learning in teacher education. *Educational review*, 67(2), 135–157.
- Lubienski, S. (2004). Decoding mathematics instruction: A critical examination of an invisible pedagogy. In J. Muller, B. Davies, & A. Morais (Eds.), *Reading Bernstein, researching Bernstein* (pp. 91–122). London: Routledge.
- Morais, A., & Neves, I. (2017). The quest for high-level knowledge in schools: Revisiting the concepts of classification and framing. *British Journal of Sociology of Education*, 39(3), 1–19.
- Myhill, D. (2015). A self-improving system. *Research Intelligence*, 126, 20–21.
- Nardi, E., & Steward, S. (2003). Is mathematics T.I.R.E.D.? A profile of quiet disaffection in the secondary mathematics classroom. *British Educational Research Journal*, 29(3), 345–367.
- NCETM. (2008). *Mathematics matters: Final report*. London: National Centre for Excellence in Teaching Mathematics.
- OFSTED. (2012). *Mathematics: Made to measure*. Manchester: The Office for Standards in Education, Children’s Services and Skills.
- Robutti, O., Cusi, A., Clark-Wilson, A., Jaworski, B., Chapman, O., Esteley, C., . . . Joubert, M. (2016). ICME international survey on teachers working and learning through collaboration: June 2016. *ZDM Mathematics Education*, 48(5), 651–690.
- Skovsmose, O. (2011). *An invitation to critical mathematics education*. Rotterdam: Sense Publishers.
- Williams, J., & Choudhury, S. (2016). Mathematics capital in the educational field: Beyond Bourdieu. *Research in Mathematics Education*, 18(1), 3–21.
- Wright, P. (2017). Critical relationships between teachers and learners of school mathematics. *Pedagogy, Culture and Society*, 25(4), 515–530.

Real-life mathematics: Politicization of natural life and rethinking the sovereign

Ayşe Yolcu

Hacettepe University, Turkey; ayseyolcu@hacettepe.edu.tr

The aim of this paper is to examine the connections made between real life and school mathematics as politics of mathematics education. The analysis focuses on an elective course, “mathematics applications”, offered for middle graders in Turkey. I explore, first, how mathematics education discourses authorize responsabilization, reason and rationality for the administrative needs of a society. Second, my analysis focuses on how the natural lives of humans lie at the center of the political calculations where sovereign decisions are taken. The connection between natural life and life as a citizen offers alternative ways to think about modern sovereignties.

Keywords: Discourse analysis, equity, mathematical applications, politics of education

Introduction

Mathematics is considered as central to young people’s preparation for life in contemporary societies (e.g., see, OECD, 2013). The will to teach and learn mathematics for better lives, however, has a political dimension where it conceives mathematics as having a positive role to cultivate the new generations into that knowledge and to the related values (Valero, 2004). In these processes, desire for a “better” life in/through mathematics education discourses constitutes particular subjectivities and differences (e.g., Diaz, 2017). Parallel with the aim of preparing youth for “better” lives, an elective course, “mathematics applications”, is offered for middle school students in Turkey to make the school mathematics more real and relevant to life. This course has been the most elected course by students since its initiation (Karagözoğlu, 2015). The course is less about teaching mathematical content (i.e., fractions, triangles or equations); rather, instructional material consists of problems, games and interdisciplinary tasks that include the real life of the child (MNE, 2013). This paper does not treat the “inclusion” of real life in the curricular and instructional materials as natural, but it rather problematizes the processes of associating real life and mathematics as a politicization of natural life. Specifically, I analyze *how* mathematics is associated with “better” life. In doing so, my aim is, first, to explore how connection processes produce administrative tools to govern people at a distance without domination, and second, to examine how these processes make biological life as object of sovereign decisions (i.e., who is allowed to live/die) in today’s politics.

Research has already spent some time examining how school mathematics embodies a set of practices that govern students’ being and acting as future citizens (see, e.g., Diaz, 2017; Valero, 2004; Yolcu & Popkewtiz, 2018). These studies provide important insights about the way in which particular subjectivities and their differences are made in/through school mathematics to configure (im)proper modes of life as citizens. For example, it is argued that calculations inscribe a bureaucratic mode of thought among students in modern states where mathematics functions as a technology of trust (Kollosche, 2014). Nevertheless, in today’s societies, calculations are not merely used for bureaucratic-administrative purposes, but become the politics of life itself (Rose, 2001).

That is, the biological existence of humans becomes the object of politics within narratives of security, health or any kind of crisis. Chronaki (2018), in this vein, uses a fictional environmental crisis to argue how a totalitarian mathematical ban may also function as a form of sovereign power that can penetrate the bodies, locate traces of biological lives and decide who is allowed to live. This provides an insight in how life becomes the object of sovereign decisions. In today's societies, nonetheless, connection between mathematics and life is made without domination, but through an inevitable "need" of mathematics for "better" lives. This vanishing point between sovereignty and productive power relations (i.e., relationship between natural life and life as citizen) necessitates further analysis to grasp the nature of contemporary politics.

Contemporary Political Paradigms and Life

For Agamben (1998), there were two different meanings for the word "life" in the classical world. First one is *zoē*, which is the natural life that is common to all living beings. The other one is *bios*, which is the form of life that is proper to a group (i.e., citizens). The distinction between the two had constituted the "city", consisting of people with a proper form of life, until Foucault (1990) makes visible how natural life is included in political calculations. For Foucault, modern power is exercised through different political rationalities and governmental technologies than the sovereign power – those in monarchies, kingdoms or empires. For instance, contemporary government forms administer lives of self and others in the light of conceptions of what is good, healthy, normal, virtuous, efficient or profitable in order to ensure maximal functioning in civil life and to secure the best possible future for its subjects (Rose & Miller, 1992). In this way, power is exercised through a set of practices that make up citizens as a particular kind of human (Hacking, 2007; Rose, 1999). According to Foucault (1990), this has not always been the case. While "sovereignty took life and let live" in societies ruled by monarchs or religious authorities, he points out the emergence of practices that tend to make lives and let them die (p. 247). In the realm of modernization processes, such practices form human life as the object of politics that authorizes particular action and social participation. He calls them "biopolitics of the population" as they focus on human life as species to maximize its well-being, health and security (Rabinow & Rose, 2006).

Nevertheless, according to Agamben (1998), there remain several questions that relate to the original activity of sovereign: If governmental practices are no longer "taking the life" but rather they are "making the life," how can we understand the explosion of numerous and meticulous techniques to control populations at the level of biological/natural life, which are the ones closest to death? If power is exercised at the level of human's biological life, how are its practices and strategies different from domination and repression? To deal with these questions, one should account for the hidden yet converging point between the juridical-institutional and the biopolitical models of power since the inclusion of human's natural life in political strategies points to the original activity of sovereignty:

Placing biological life at the center of its calculations, the modern State therefore does nothing other than bring to light the secret tie uniting power and bare life, thereby reaffirming the bond between the modern power and the most immemorial of the *arcana imperii*. (Agamben, 1998, p. 6, emphasis original)

In those converging points or in the bonds, the body becomes a vital living system where “real” life become molecularized and organized with the gaze of biological and natural sciences, their institutions, procedures, instruments and spaces of operations (Rose, 2001). Health, for example, provides a transactional zone between political concerns of modern states and personal techniques for the care of the self. It is usually offered as a universal human right to protect persons and as a dignity for their living vital bodies. Here, subjects are rendered responsible for their own biological or natural lives, which previously was the duty of sovereign. This does not mean the disappearance of the sovereign, but refers to modification of practices, operating in the horizon of a natural life.

Within the scope of this paper, I take these changes as a historical continuity rather than a threshold of modernity. Following Agamben’s (1998) works and Foucault’s (2007) lectures on biopolitics, my aim is to make visible the modifications of how governmental technologies constitute a complex network of practices that blur the distinctions between sovereign, disciplinary and control relations in the field of school mathematics and in the society as well. Affirmation of bare life offers new and more dreadful rationales and foundations for sovereign decisions (i.e., who is allowed to live), not the sovereign himself, because natural life and its needs become politically decisive facts. Mathematics education is part of those rationalities and technologies since one of the concerns in the field is the inclusion of real or natural lives in order to make mathematics relevant for “all”. The issue, here, is not merely providing equitable access to mathematics because the discourse of “all” is already proven to produce exclusions (see, e.g., Diaz, 2017; Yolcu & Popkewitz, 2018). A fundamental activity of these processes is the production of bare life through the politicization of natural lives in its calculations so that any decision for those “excluded” can be taken. In this way, sovereign logic is normalized and made permanent with notions of security, health, and biological productivity.

This paper offers alternative ways to think about sovereignty in modern societies. Rather than treating natural life and life-as-citizen as separate entities, the examples presented in the paper make visible the indeterminate relationship between the two as the political paradigm of modern sovereignties. In this way, the politics becomes a set of techniques and strategies that legitimize the connection of natural life and life-as-citizen as paradoxes of inclusion and exclusion such as deciding who is going to live and die. I deal with specific ways and techniques of school mathematics that operate at the level of natural lives, the very biological making of humans. To do this, curricular documents and teacher guidebooks of a “mathematics application” course are analyzed. The reason why the focus is on this elective course is to make visible political rationalities and technologies that are far from domination but similar to sovereignty. I have purposefully selected examples from the textbooks that relate biological processes of life. A numerical analysis of the problems indicates that the examples that relate to natural life constitute approximately twenty percent of the total (n=132) across the middle school grades (5th–8th). The rest of the problems are mental games, strategy development tasks, market relations that are concerned with informed shopping or budgeting, and geometry-measurement problems. Analysis of curricular and instructional texts does not assume that they are the same with teacher practice itself. Nonetheless, discourses are results of practices and, at the same time, they produce further practices (Popkewitz, 2013). This reciprocal relation shows possibilities of change without assuming a pre-existing subject (e.g., teacher) as an agent of change.

“Adolescent” as an object of school math: Cultivating reason and rationality

The child in the curricular statements of the mathematics application course is configured as a particular kind of human who is “in transition” and needs math to realize their potentials:

These ages are sensitive transition periods in the life of the students, since the rapid changes are the periods of adolescence. [...] The perceptions of what they get from these ages shape their attitudes towards the course in the coming years and affect their achievements in mathematics [...]. If students challenge the limits of knowledge and skills in mathematics courses in the school, and if they receive the support they need, they will have the best chance of achieving their mathematical potential (MNE, 2013, p. 1, all originally Turkish texts translated by me).

Here, the adolescent is the object of teaching and the target population. Students are configured as “adolescents” who are to learn particular skills to find reasonable and rational solutions to the problems of real life. Adolescent, here, is not merely a label, but a particular kind of human and a fictional construction that comes to being by generating ideas about how one lives or should live (see, e.g., Lesko, 2012). They are to take responsibility in the process so that they would be able to show their agency or “mathematical potentials” in their future lives when they become adults.

The emphasis of the course is not at the end products but the processes of connecting real-life and mathematics in group settings. In this way, students, as future adults, are to learn to find not merely the correct answer but reasonable and rational solutions: “In this course, students need to look for rational and reasonable solutions with their classmates through collaboration rather than finding correct answers” (p. 1). These statements cannot be interpreted as purely domination; rather they are technologies of automation and responsibility that enable the ‘proper’ life as citizens (Rose, 1999).

Let us take one of the problems, connecting the life as citizen and natural lives of humans. It is related to energy saving through using energy-efficient bulbs. Students are expected to learn about the “importance of energy saving” and “calculating the possible saving” for this particular problem (MNE, 2012, p. 45). Energy saving, here, is neither a personal issue nor about saving money for personal interest. Rather, the mathematical task is contextualized around concerns for human life since energy usage is correlated with CO₂ emission that has a negative impact on earth where we, human beings, live. The image in Figure 1 illustrates how the problem is situated in wider world issues with implications on human’s biological lives. Of course, the issue is important and the problem relevant. Nevertheless, the specific questions that are addressed by students through mathematical task assemble with particular processes of making responsible citizens. As stated: “You can also contribute to energy saving. What are your responsibilities for this? In which areas can you save money?” (p. 44).



Figure 1

The mathematical part of the problem is the calculation of the energy saving amount if energy-efficient light bulbs are used or if one avoids unnecessary usage of electricity. In this regard, the emphasis of the questions is on everyday habits of people, not on the mathematics itself. Asking questions such as “How many bulbs do you use at home?”, “How many hours are the lights turned on in the living room?” or “How much savings do you get when you turn unused bulbs off?” (p. 44)

bring the everyday life into a calculation practice. However, these are not merely prompting questions that push students into the mathematics, but become specific practices that order (im)proper lives in order to socialize ‘adolescents’ in effective ways. When students denote the correct amount of saving following the calculations, they learn energy-efficient ways of living not just mathematics.

The processes that connect real-life and mathematics do not only regulate human conduct, but also connect with biological lives. The link between the two makes a kind of human who is committed to science, humanity and the world through taking care of nature, life of self and humanity.

There is a release of 1.5 kilograms of CO₂ into the air for 1 kilowatt of energy production from fossil fuels. Calculate how many kilograms of CO₂ emission you prevented with your energy savings. Show the results you find with tables and graphs. (p. 44)

As the above text shows, energy saving is both a personal and social problem, an issue that the whole society should be “accountable” for. Individual efforts are to take care for the natural life, which is a concern for everyone. In addition to this, the ability to “show the results” is not the domination of mathematics but a specific technology that mathematics education offers for taking ownership in the processes of finding reasonable solution for their own lives. In this way, the truth is not imposed upon student’s mind. Individual contribution is valued, but calculations, tables and graphs, simultaneously, create boundaries of rationality in their own solutions and so in their “natural” lives: “All these processes will enable students to take ownership of mathematics and solutions by allowing them to make personal contributions and take responsibility instead of trying to find the “right” solution in the teacher’s mind” (MNE, 2013, p. 7).

Students, aged between eleven and fifteen, are regarded as people-in-transition who are to become future citizens. The real-life application of mathematics is the technology to make them part of the society with a sense of belonging so that there would not be any noise, social disorganization or natural disorder in the unknown future. Practices that make the people responsible are embedded in the connection processes in order to ensure the integration would happen in a harmony neither by force nor through domination. In this way, “freedom” is ensured but it is regulated with reason and rationality for their own well-being and natural lives.

Calculations of real life: Irreversible clock time and progressive human nature

Some problems in the mathematics application textbooks are directly contextualized with biological processes of human beings when making the connection between mathematics and real life. See, for instance, how a problem is introduced in a 5th grade teacher guidebook:

The heart is a marvel of biological engineering with its general structure and function. Even the hearts of people who do not do sports are very strong in terms of durability. Our heart, which has a high-density vessel structure, has about 2000 capillaries per square millimeter. This allows oxygen to reach the heart muscle continuously and safely at a sufficient level (MNE, 2012, p. 12).

Here, heart as a vital biological character of living human beings, including its health and durability, is the main context that drives the problem. It is described as a “marvel of biological engineering” and a natural mechanism that allows oxygen circulation throughout the body. The mathematical part of the problem is counting and calculation of the frequency of heart rate at a given time, including a

minute, an hour, a day, a week, a month and a year. At the end, students present their heart rate frequencies with peers or the whole class and discuss results aiming to learn the relationships between second, minute and hour but also between day, week, month and year (p. 13).

Such practices are not simply mathematical tasks but activities that engage students in a process where they learn the irreversible time that provides qualities of growth, development and progress to human nature. That is to say, the linear time is being made and associated with the accumulated heart rate counts, biological productivity and developmental clock-time. This association generates the “nature” of human life as a linear experience similar to the forms of civilization, evolution, development, acculturation, and modernization (Fabian, 2014). The temporal yet accumulated view of human nature is accompanied with the construction of the child as “adolescent” and, thus, it authorizes proper life as a citizen in companion with the processes of making up their natural lives.

As students count heart rates, they are also encouraged to see and discuss different measurements from different groups. Specifically, students evaluate the different results in terms of “physically active bodies”, “other personal characteristics” or “gender” (MNE, 2012, p. 13). Here, numbers become the agents to see and differentiate the modes of life through vital processes of human nature, such as heart rates. However, more is required to secure the best possible future with “healthy” bodies in addition to the comparing different kinds of people in terms of their heart rate measurements. In the 7th grade guidebook, for instance, a similar heart rate context is offered. This time, a caution for possible health problems is presented with algebraic equations for the “recommended maximum heart rate” (i.e., $y = 208 - (0,7 \times \text{age})$): “Due to health problems, people have to obey certain limits when doing sports activities. For example, if a certain heart rate is passed while doing sports, this can cause health problems for people” (MNE, 2017, p. 27).

In this way, students are to calculate the recommended heart rate and how the results change with respect to age. The issue, here, is not simply a matter of comparison. Bodies are calculated with appropriate heart rate at a given age and associated with the kinds of people who do physical activities or who smoke. Techniques of making “normal” bodies also employ rationales to act on those deviate from those normal lines. With numbers revealed from algebraic equations, doing physical activity or quitting smoke become self-authorizations for “adolescents” to “correct” their life, to improve themselves biologically as part of human species and to adapt their bodies in line with the proper modes of life as a citizen. There is no elimination of unhealthy or foreign bodies that are disruptive to progressive human nature; rather, it is a matter of classifying and correcting in the face of death.

Politicization of natural life, life as citizen, and school mathematics

This paper has examined some mathematics education discourses within the scope of contemporary political paradigms. In connecting mathematics and real life, the body is subjugated in a double sense. First, the child is constituted as an object, which is to be made a future citizen, embodying a particular form-of-life through socio-cultural integration. Second, natural life emerges at the center of calculations that make the child a subject who decides for his/her own well-being in that political zone. In other words, biological processes of human life are located at the center of the connections made between mathematics and real life and enabling self-authoritative techniques to maximize health, biological productivity or well-being of their own bodies and also themselves as human

species. In these linked ways, people seek for better, healthier or secure options through a continuous “need” for mathematics since the issue becomes natural life and survival, not only framed in economic but also in biological terms.

The specific case of the “mathematics application” course is important to consider since those students taking the course, in fact, are outside of regular mathematics classes. Taking the elective course is considered as extra mathematics support by themselves or their parents (Çoban & Erdoğan, 2013) or as a mean to reduce mathematics anxiety and to develop positive attitudes towards mathematics (MNE, 2013; Keşan, Coşar & Erkuş, 2016). Although those students are excluded, they are still in the system in paradoxical ways, through an “inclusive exclusion” (Agamben, 1998). The student body for this particular course does not actually fit to the regular classes but is simultaneously engaged with additional mathematics through the “need” for mathematics for their well-being and future survival. This generates topological relations of inclusion/exclusion rather than a polarization.

Instead of immobilizing with the unquestionable need of mathematics to make the individual’s lives better, healthier or more productive, reading mathematics education discourses through contemporary political philosophy makes visible how the logic of sovereignty circulates along the modern life, which is configured as citizen life. That is, as discourses connect natural/biological life and life as citizen, the sovereign decisions become possible. The analysis, here, allows us to rethink the tactics, tools and governmental technologies of modern sovereignties such as affirmation of real-life in mathematics problems. Rethinking makes visible the possibilities as well. We could reconsider questions that seek to discover whose lives are properly represented because the political issue discussed here is less about authentic representation of real life but it is the representation itself. Each of us has a heart rate and we all are exposed to CO₂ emission.

Political potentialities, which need further explorations, could start with contesting the representational paradigms that seeks to emancipate, live or survive with the mathematics. Or more generally, they could challenge and problematize identity politics that “liberate” people within given and historically polarized populational categories. This is partly because exclusions are being generated through inclusion of real life in mathematical practices. Sovereign logic circulates in these processes where life itself becomes the object of politics that organize its survival and death.

References

- Agamben, G. (1998). *Homo sacer: Sovereign power and bare life*. Stanford, CA: Stanford University.
- Chronaki, A. (2018). The unbearable lightness of dis|appearing mathematics: Or, life and reason for the citizen at times of crisis. *The Mathematics Enthusiast*, 15(1), 8–35.
- Çoban, F. N. & Erdoğan, A. (2013). Ortaokul öğretmenlerinin matematik uygulamaları dersinde karsılaştıkları sorunlar [Difficulties encountered by middle school teachers in mathematics application]. *Turkish Journal of Computer and Mathematics Education*, 4(3), 242–258.
- Diaz, J. (2017). *The paradox of making in/equality. A cultural history of reforming math for all*. New York: Routledge.
- Fabian, J. (2014). *Time and the other: How anthropology makes its object*. New York: Columbia University.

- Foucault, M. (1990). *The history of sexuality*. New York: Vintage.
- Foucault, M. (2007). *Society must be defended: Lectures at College de France, 1975–76*. New York: Picador.
- Hacking, I. (2007). Kinds of people. *Proceedings of the British Academy*, 151, 285–318.
- Karagözoğlu, N. (2015). Ortaokul 5. sınıflarda tercih edilen seçmeli dersler ve tercih nedenlerinin öğrenci ve veli görüşlerine göre değerlendirilmesi [Evaluation of elective courses and reasons in the 5th grade according to students and parents' opinions]. *Pegem Eğitim ve Öğretim Dergisi*, 5(1), 69–94.
- Keşan, C., Coşar, M. Ç., & Erkuş, Y. (2016). Matematik uygulamaları dersini seçen ortaokul öğrencilerinin derse ilişkin görüşleri [Views of secondary school students for mathematics applications]. *Batı Anadolu Eğitim Bilimleri Dergisi*, 7(14), 33–44.
- Kollosche, D. (2014). Mathematics and power: An alliance in the foundations of mathematics and its teaching. *ZDM Mathematics Education*, 46(7), 1061–1072.
- Lesko, N. (2012). *Act your age! A cultural construction of adolescence*. New York: Routledge
- Ministry of National Education [MNE]. (2012), *Matematik uygulamaları 5. Sınıf: Öğretmenler için öğretim materyali (Mathematics application 5th grade: Teaching material)*. Ankara: MEB.
- Ministry of National Education [MNE]. (2013), *Ortaokul ve imam hatip ortaokulu matematik uygulamaları dersi öğretim programı (Middle and imam hatip middle school mathematics application course program)*. Ankara: MEB.
- Ministry of National Education [MNE]. (2017), *Matematik uygulamaları 7. Sınıf: Öğretmenler için öğretim materyali (Mathematics application 7th grade: Teaching material)*. Ankara: MEB.
- Organization for Economic Co-operation and Development [OECD]. (2013). *PISA 2012 assessment and analytical framework: Mathematics, reading, science, problem solving and financial literacy*. Paris: OECD Publishing.
- Popkewitz, T. S. (2013). The impracticality of practical knowledge and lived experience in educational research. *Nordic Studies in Education*, 33(02), 124–139.
- Rabinow, P., & Rose, N. (2006). Biopower today. *BioSocieties*, 1(2), 195–217.
- Rose, N. (1999). *Powers of freedom: Reframing political thought*. Cambridge University.
- Rose, N. (2001). The politics of life itself. *Theory, culture & society*, 18(6), 1–30.
- Rose, N., & Miller, P. (1992). Political power beyond the state: Problematics of government. *The British journal of sociology*, 61, 271–303.
- Valero, P. (2004). Socio-political perspectives on mathematics education. In P. Valero & R. Zevenbergen (Eds.), *Researching the socio-political dimensions of mathematics education: Issues of power in theory and methodology* (pp. 5–23). Dordrecht: Springer.
- Yolcu, A., & Popkewitz, T. (2018). Making the able body: School mathematics as a cultural practice. *ZDM Mathematics Education*. <https://doi.org/10.1007/s11858-018-1003-8>

TWG11: Comparative studies in mathematics education

Thematic working group 11: Comparative studies in mathematics education

Paul Andrews¹, Eva Jablonka², and Constantinos Xenofontos³

¹Stockholm University, Sweden, paul.andrews@mnd.su.se

²The Free University of Berlin, Germany, eva.jablonka@fu-berlin.de

³University of Stirling, Scotland, constantinos.xenofontos@stir.ac.uk

Introduction

As with earlier CERMEs, TWG 11 adopted an eclectic perspective in its interpretation of comparison as referring to any study that documents, analyses, contrasts or juxtaposes cross-cultural or cross-contextual similarities and differences across all aspects and levels of mathematics education. In this way the TWG aimed to encourage critical but supportive discussions around a number of themes, some of which were predetermined by the papers received by the group, while others emerged from them.

A recurrent but very productive aspect of this working group has been the relatively small number of paper presentations, although this has also led to the group being constantly on the verge of extinction. This year, thirteen papers and one poster were received. Unfortunately, for various reasons, two papers were withdrawn, leaving eleven papers and a single poster. This created space not only for colleagues to share their research in detail but for everyone to engage in lengthy and inclusive discussions on the nature of comparative mathematics education research and the means by which it can be meaningfully and rigorously undertaken. In particular, as is discussed in more detail below, the group came to realise that concepts like ‘unit of analysis’ meant different things to different people according to the research traditions from which they derive. The various contributions fell naturally into five themes that framed the different working group sessions.

Theme 1: Assessment in mathematics education

The first theme drew on two papers with very different foci and methodological conceptualisations focused on assessment in comparative mathematics education research. On the one hand, Cascella and Giberti’s paper, drawing on Italian national test data, highlighted significant gender differences in the ways in which students respond to different presentations of the same arithmetical task. Such findings remind us that the debate concerning gender differences in mathematical understanding are by no means resolved. On the other hand, Simsek, Jones, Xenidou-Dervou and Dowens’ study, framed by the important assertion that if “the same instrument is used in different cultures, no bias should arise from the particular characteristics of an instrument or its administration, focused on children’s understanding of mathematical equivalence. Their use of an extant American scale with English and Turkish students yielded a different factor structure from the original, highlighting the difficulties of assuming the validity of a test developed in one cultural context for use in another.

Theme 2: Mathematics teacher education

The second theme, drawing on three papers, dealt with issues concerning mathematics teacher education. The first of these papers, presented by Clivaz and Miyakawa, reported on how two groups of students, one Swiss and one Japanese, collaborated, both at a distance and face-to-face, on the planning of the same problem-solving lesson. After planning, each group of students taught the lesson repeatedly in their own cultural contexts. Analyses of the two sets of plans and their respective lessons highlighted well the cultural norms that underpin beginning teachers' practices. The second paper, presented by Gorgorió, Albarracín and Laine and written with the aim of evaluating admissions policies, examined the impact of recent changes to the admission requirements for primary teacher education programmes in Barcelona and Helsinki. The study found that such tools are too contextually situated to facilitate genuine comparison and argue for a better theorisation of the expected knowledge of such students and a measure appropriate for cross-cultural application. Finally, in this session, the paper by Zhang and Wray examined similarities and differences in the sequences and patterns of teachers' questioning practices in secondary mathematics classrooms in the UK and China. Drawing on observations of a dozen teachers in each country, the authors' discourse analyses identified clear distinctions between the collectively-focused questioning of the Chinese teachers and the individually-focused questioning of the English.

Theme 3: The analysis of mathematics textbooks

The third theme, based on two papers and a poster, focused on the analysis of mathematics textbooks. The first paper, presented by Hemmi, Lepik, Madej, Bråting and Smedlund, examined the presentation of material focused on expressions, equations, inequalities, and the meaning of the equal sign in textbooks in grades 1-3 in Estonia, Finland and Sweden. They found considerable variation in the presentation of such material, with concomitant opportunities for the later learning of algebra, both between countries and between different language groups within countries. The second paper, presented by Xenofontos, examined the use of the word 'problem' in the state mandated upper primary and lower secondary textbooks of the Republic of Cyprus. He found, with inevitable consequences for the coherence of children's learning of mathematics, that while the word was used frequently and consistently in the primary books, it was used rarely and less consistently in the secondary. Finally, Palm Kaplan presented her poster comparison of the algebra tasks found in year 8 Swedish textbooks and the TIMSS 2003 assessments. Her discourse analytic approach showed considerable differences in the privileged content of the two sets of data.

Theme 4: Curriculum

The fourth theme, comprising two papers, focused on curriculum. The first paper from a multinational group of scholars, Van Steenbrugge, Krzywacki, Remillard, Koljonen, Machalow and Hemmi, examined recent mathematics curriculum reform efforts in the US, Finland, Sweden, and Flanders. Drawing on a range of data sources they showed that curriculum reform that is both region-wide and supported by teachers is a major challenge, not least in systems where teachers enjoy autonomy and textbooks are largely unregulated. Jablonka's study, the second in this theme and initiated by international tests of achievement, found that the mathematics taught in Germany

was intellectually more challenging than that taught in China. However, bringing to the group a concept that provoked much discussion, Chinese teachers experienced greater discretionary space than their German colleagues. That is, they had more adaptive freedom in the planning of their teaching.

Theme 5: Methodology

The final theme, drawing on two papers, differed from the others in its explicit focus on methodology. The first of these, Petersson, Sayers and Andrews, presented an analysis of textbooks based on the use of moving averages to highlight the location and extent of different content emphases. Such an approach, which facilitates comparison between textbooks, offers an important visual support to conventional frequency analyses. The second, Chan and Clarke, alerted group members to the importance, particularly for comparative research, of identifying an appropriate unit of analysis. This particular presentation, despite the issue having been discussed in previous CERMEs, provoked a long discussion, which is revisited below, on how the expression ‘unit of analysis’ is construed differently by different cultural groups.

Discussion

As with previous CERMEs, the variety of topics and methodologies brought to the group highlighted well the diversity of work undertaken within the broader field. All papers offered insights to remind us that comparative research, which includes much mainstream work undertaken in single cultural contexts, is a messy and complex undertaking reliant on strong theoretical foundations and clearly-defined constructs. In this latter respect, the group’s discussion on unit of analysis was particularly interesting as it became increasingly clear that colleagues were not talking about the same thing. On the one hand, colleagues working in a theory-driven tradition tended to construe the unit of analysis as the theoretical framework within which they worked. On the other hand, colleagues working in a problem-driven tradition, typically Anglophone, saw the unit of analysis as the individual piece of data to be analysed. These very different conceptions of the phrase highlighted well the difficulties faced by all researchers and the dangers of assuming a common understanding of what one might typically expect to be unproblematic. Of equal interest, as indicated, was the notion of discretionary space. Here, colleagues were able to see the methodological advantage such a simple yet powerfully evocative concept brings to analyses of curricula and teachers’ engagement with them.

As always, the various contributions brought to the group reflected not only cultural diversity but also methodological pluralism. For example, studies included those that were informed by a priori theoretical assertions and those that were not. There were equal numbers of qualitative and quantitative studies focused on a range of aspects of children’s and teacher education students’ learning of mathematics. All studies confirmed the extent to which mathematics and its teaching and learning are culturally normative.

Order of factors in multiplying decimal numbers and gender differences: a comparison of tasks

Cascella Clelia¹ and Giberti Chiara²

¹Manchester University, UK; clelia.cascella@manchester.ac.uk

²Free University of Bozen, Italy; chiara.giberti@unibz.it

Differential Item Functioning (DIF) analysis carried out within the framework of the Rasch model has been used to compare scholastic performance in sub-groups of students matched on ability and clustered by some features (such as, for example, gender). In this paper, we use DIF to understand if misconceptions about multiplication with decimal numbers act on boys and girls differently, i.e. if this can lead boys and girls to approach a mathematics item differently and, in some cases, to encounter it not successfully. We present empirical evidences revealed on a sample of 1647 students attending grade 8 of lower intermediate school. Results highlighted that misconception about multiplication of decimal numbers strongly disadvantages girls relative to boys and pose new research questions about mechanisms causing these results.

Keywords: Mathematics achievement test, Misconceptions, Gender gap, Rasch model, Differential item functioning.

Introduction.

Italian National standardized assessments, called INVALSI test, are administered every year to all Italian students in different grades from primary to secondary school. In recent years the importance given to these tests has increased and researchers in mathematics education are starting to use the INVALSI results.

Results of national and international surveys have highlighted that in many countries there is a strong gender gap in mathematics in favour of males and Italy is one of the countries in which this gap is more remarkable (Mullis et al., 2016; OECD, 2016; INVALSI, 2017). This phenomenon has been deeply studied in mathematics education research. Recent works overcome the idea that the main causes of gender gap are related to biological differences (Hill, Corbett & St Rose, 2010): the main reasons of this gap must be sought considering factors related to the social and cultural context in which the students live, such as the level of gender inequality which is strictly related to the gap in mathematics (Guiso, Monte, Sapienza & Zingales, 2008). Furthermore, the beliefs of teachers and parents on students' ability and differences in metacognitive aspects such as self perception, self concept and anxiety related to mathematics are fundamental to explain the reason of the observed gender gap (Fredericks & Eccles, 2002; Cargnelutti, Tomasetto, & Passolunghi, 2016; OECD, 2016; Pajares, 2005). Finally, recent research has revealed that factors related to classroom practices, learning strategies and curriculum variables have a strong influence on gender differences in mathematics (Leder & Forgasz, 2008; Giberti, Zivelonghi, & Bolondi, 2016; OECD, 2016). Moreover, in previous studies we have shown the influence on gender differences of micro-social factors, strictly related to the *milieu* habits (Brousseau, 1988) and to the interrelation between the student and the teacher. From this perspective we highlighted that misconceptions, as a product of

classroom practices, have a stronger impact on females rather than males (Bolondi, Cascella & Giberti, 2017) and our aim is to investigate more in depth this issue.

In this paper we propose the analysis of a specific item, which is part of a wider research program called “Variazioni 2” and financed by INVALSI, aimed at exploring the relationship between variations in item formulation and in its psychometric functionality. Much research in mathematics education has studied the impact of a variation in item formulation with a particular attention to ‘word problems’. An updated literature review has been proposed by Daroczy and colleagues (2015). Literature considers the influence of linguistic variations as well as other kinds of minor changes on students’ responses and solving strategies (e.g. Nesher, 1982; De Corte, Verschaffel & Van Coillie, 1988; D’Amore, 2000). Duval in 1991 defines all these modifications as “redactional variables”, and Laborde in 1995 uses this term to include also non-verbal changes, e.g. introduction or modification of pictures. Using a specific statistical strategy, in this paper we analyze data collected in the project “Variazioni 2” to understand if and how a specific variation might affect differently male and female solving strategies to solve a mathematics item. In particular, we analyze an item included into a mathematics achievement tests to explore a specific didactical issue concerning misconceptions in multiplying decimal numbers (Fischbein, Deri, Nello, & Marino, 1985; Sbaragli, 2012).

Research questions.

The term misconception is widely used in research in education and takes different meanings; in this research, following D’Amore & Sbaragli (2005), we define a misconception as a concept momentarily incorrect, standing by for a more critical and developed cognitive arrangement. A typical misconception (D’Amore & Sbaragli, 2005; Hart et al., 1981) is due to the premature formation of a conceptual model of multiplication when students operate exclusively with natural numbers. Students learn multiplication with natural numbers and, observing that the product of two numbers is always greater than its factors, they are led to believe that “multiplication always increases”. This is true for natural numbers (excluding 0 and 1), but this is not always true for decimal numbers. This misconception, thus, leads students to make mistakes when they operate with decimal numbers, and, for instance, D’Amore and Sbaragli (2005) explain that the answer of many students of different grades to the question “What is the result of 4×0.5 ?” is 8. In order to explore this phenomenon, we compared two versions of the same item (Table 1).

Booklet F1 and F2	Booklet F3 and F4
D9. Which is the result of 4×0.5 ? Choose one of the following options. A. <input type="checkbox"/> 8 B. <input type="checkbox"/> 4 C. <input type="checkbox"/> 2 D. <input type="checkbox"/> 20	D9. Which is the result of 0.5×4 ? Choose one of the following options. A. <input type="checkbox"/> 8 B. <input type="checkbox"/> 4 C. <input type="checkbox"/> 2 D. <input type="checkbox"/> 20

Table 1: Different formulations of the item D9

The two formulations differ only in factor order. This allows us to understand if the idea that “multiplication always increases” is related to both factors of the multiplication or mostly to one of the two factors. In particular, our hypothesis is that the intuitive model (Fischbein, Deri, Nello & Marino, 1985; Mulligan & Mitchelmore, 1997) of multiplication as a repeated sum is easier to apply

in the second version (0.5×4) and this strategy led students to overcome easier the misconception. This is of course also related to the language used: in Italian we read the multiplication 4×0.5 as “4 repeated 0.5 times” while in English and in many other languages it is “4 times 0.5”.

This only one of several misconception related to the transition between natural numbers and decimals and, in previous studies focused on misconception in comparing decimal numbers (Bolondi, Cascella & Giberti, 2017; Giberti, 2018) we observed that females have more difficulties than males. For this reason, we decided to investigate if this misconception and the variation carried out, affects differently boys and girls. Therefore, our research questions are: 1) Does the misconception here analyzed act on boys and girls differently? In other words, does this misconception cause different item functioning in male relative to female subgroup? 2) What is the impact of the inversion of factors into a multiplication (e.g., 4×0.5 in place of 0.5×4) on students’ answers? What is its impact on item functionality? Does the inversion of factors have different effects on boys and girls?

Participants and measures.

Starting from a mathematics achievement test developed by INVALSI for students attending grade 8 (lower intermediate school), in the project ‘Variazioni2’, we developed three further mathematics achievement tests, complete in terms of mathematical content and level of difficulty. These four forms (F1, F2, F3 and F4) were administered to a probabilistic sample of 1647 students attending grade 8.

Analytic strategy.

Our four mathematics achievement tests were administered by means of a spiraling process (according to which different forms are administered to different students within each classroom) in order to randomly assign forms, in this way each form was administered to approximately 400 students. When using this design, differences between group-level performance on administered forms are taken as direct indications of the differences in difficulty between forms (Kolen & Brennan, 2004) and it is particularly adequate to make comparable answers given by different subgroups of students. In addition, all achievement tests were equated to make estimations directly comparable. Both item and person parameters estimated via the Rasch model (Rasch, 1960) were scaled in an empirical range equal to $[-4; +4]$ logits, where 0.00 logit does not mean absence of ability but it is the ability-difficulty level in relation to which students have a probability equal to 0.5 of encountering an item successfully.

In the result section, we provided a summary of psychometric characteristics of the item D9 in F1, F2, F3, and F4. In order to compare, male and female performances, we provided a visual display of the set of observed means for each person factors level (i.e., for boys and girls) across each of the class interval present in the item-trait test-of-fit specifications. Each level is plotted in relation to the Item Characteristic Curve, i.e. the theoretical curve estimated by the Rasch model according to which no factor other than students’ intrinsic ability can explain the probability of a correct answer. At the bottom of the table, we reported the distractor plots drawn for males and female, separately, in order to explore their answer behavior in relation to each answer option.

Results.

The table below (Table 1) reports on differences in item functionality in F1, F2, F3, and F4. For each of them, in addition to information about fit (i.e., Weighted MNSQ) always close to 1 and thus good, the distribution of correct and wrong answers provided by students is available in order to provide a first glance on the differences between booklets.

Booklet F1							Booklet F2						
item:19(D9) Weighted_MNSQ 0.87							item:18(D9) Weighted_MNSQ 1.02						
Label	Score	% of tot	Pt Bis	t (p)	PV1Avg:1	PV1 SD:1	Label	Score	% of tot	Pt Bis	t (p)	PV1Avg:1	PV1 SD:1
A	0.00	3.83	-0.07	-1.40(.161)	-0.12	0.85	A	0.00	4.90	-0.17	-3.47(.001)	-0.67	0.49
B	0.00	4.31	-0.18	-3.68(.000)	-0.77	0.67	B	0.00	4.66	-0.19	-3.83(.000)	-0.81	0.74
C	1.00	75.36	0.49	11.41(.000)	0.27	0.84	C	1.00	69.85	0.51	11.94(.000)	0.19	0.81
D	0.00	15.55	-0.41	-9.23(.000)	-0.68	0.68	D	0.00	19.36	-0.35	-7.61(.000)	-0.65	0.60
Miss	0.00	0.96	-0.12	-2.49(.013)	-0.88	0.41	Miss	0.00	1.23	-0.17	-3.42(.001)	-1.27	0.64
Booklet F3							Booklet F4						
item:19(D9) Weighted_MNSQ 0.89							item:19(D9) Weighted_MNSQ 0.88						
Label	Score	% of tot	Pt Bis	t (p)	PV1Avg:1	PV1 SD:1	Label	Score	% of tot	Pt Bis	t (p)	PV1Avg:1	PV1 SD:1
A	0.00	1.95	-0.08	-1.54(.124)	-0.60	0.63	A	0.00	4.03	-0.19	-3.98(.000)	-0.75	0.93
B	0.00	2.19	-0.10	-2.13(.034)	-0.64	0.67	B	0.00	2.68	-0.19	-3.99(.000)	-0.94	0.65
C	1.00	81.51	0.45	10.24(.000)	0.18	0.92	C	1.00	80.31	0.47	11.30(.000)	0.23	0.93
D	0.00	13.38	-0.39	-8.66(.000)	-1.01	0.62	D	0.00	12.08	-0.33	-7.46(.000)	-0.91	0.79
Miss	0.00	0.97	-0.16	-3.25(.001)	-1.37	0.95	Miss	0.00	0.89	-0.13	-2.87(.004)	-2.07	1.34

Table 1. Item functionality in F1, F2, F3 and F4

Item formulation shows little variation comparing booklets F1 and F2 and it's the same also comparing booklets F3 and F4. As already explained, in both versions the question intent is the same but the inversion of factors into the multiplication might change the influence of the misconception on decimal numbers and the answering strategy activated by students to solve the item might change. Indeed, we observe a lower percentage of correct answers (Table 1) in the first version, included in booklet F1 and F2, than in the second one, included in F3 and F4.

To analyze gender differences, we provided a visual display of the set of observed means for each person factors level (i.e., for boys and girls) across each of the class interval present in the item-trait test-of-fit specifications. Each level is plotted in relation to the Item Characteristic Curve, i.e. the theoretical curve estimated by the Rasch model according to which no factor other than students' intrinsic ability can explain the probability of a correct answer. Distractor plots drawn for males and female, separately, showed differences in answer behavior between boys and girls in relation to each answer option (Table 2). In particular, option B is more attractive for low-ability male students relative to females with the same ability level. Instead, it is evident that females are more attracted by option D, which is strictly related to the misconception, since they give the result of 4×5 instead of 4×0.5 . Little differences can be disclosed also in relation to option A, more attractive for low-ability girls and all these evidences are confirmed also by percentage reported in Table 2. Most of these differences are more remarkable in F2 (Table 3), with a clear advantage of males relative to females. Nevertheless, by exploring Distractor Response Curves drawn by gender, response patterns for the set of distractors associated with D9 presented in F1 and D9 presented in F2 are similar. The main difference between them can be disclosed into the distractor plot drawn for males in Table 3: high-ability boys are not attracted by any distractors, while distractor D is attractive also for high-ability females.

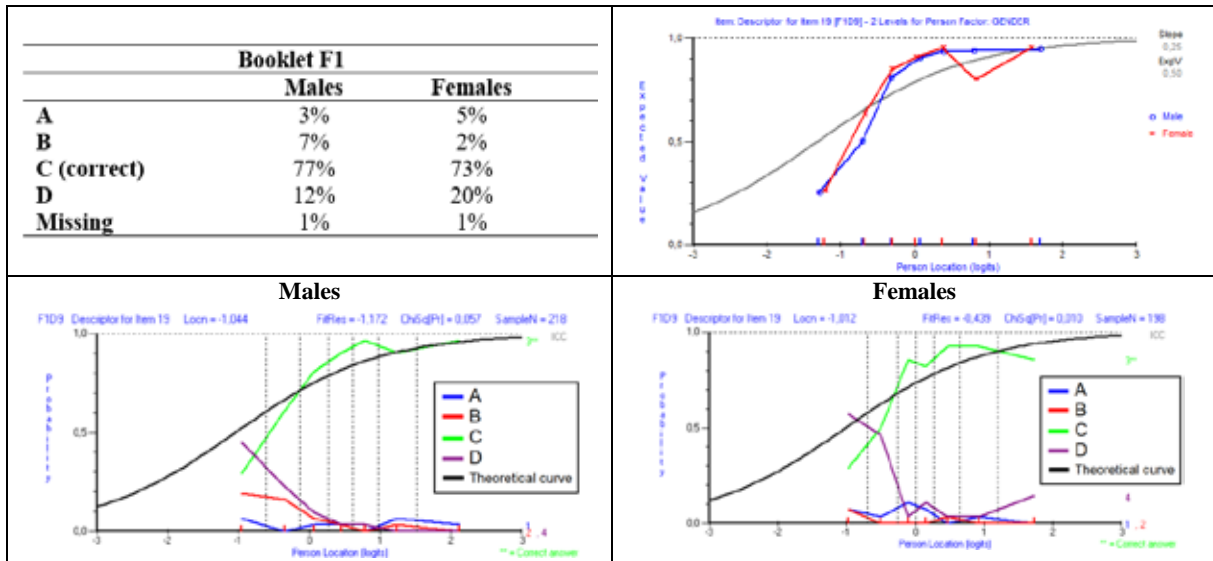


Table 2: Responses by gender and Analysis of Variance by Gender for item D9 administered in booklet F1 (top-left) - DIF-plot (top-right) - Distractor Plot of males (bottom-left) and females (bottom-right)

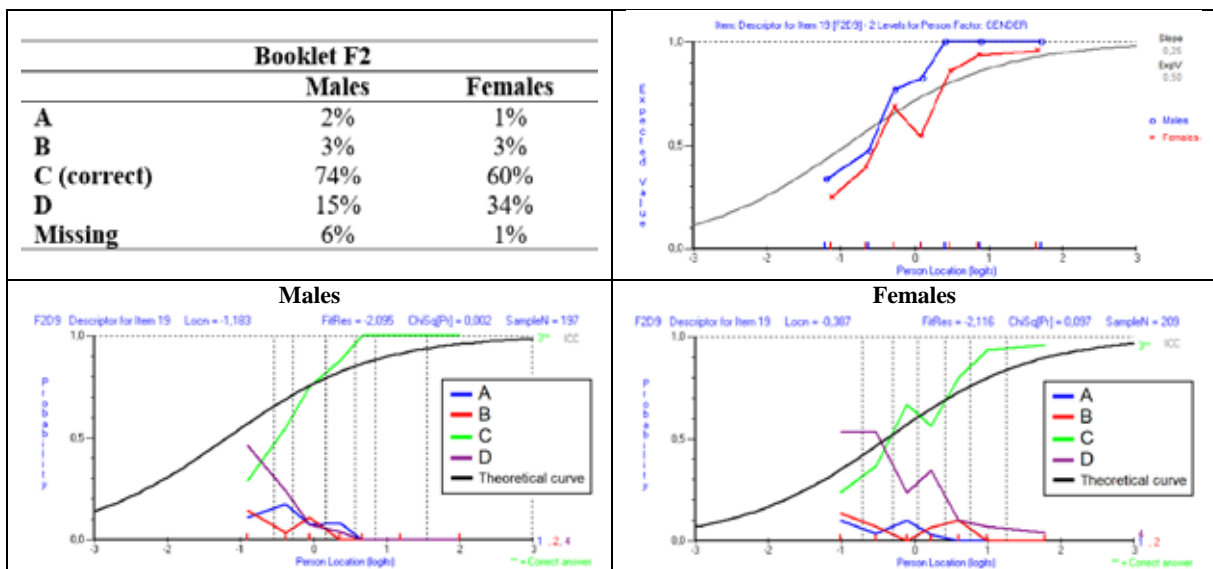


Table 3: Responses by gender and Analysis of Variance by Gender for item D9 administered in booklet F2 (top-left) - DIF-plot (top-right) - Distractor Plot of males (bottom-left) and females (bottom-right)

Both in booklet F3 and F4 (Table 4 and 5), the item D9 proposes the inversion of factors, i.e. 0.5×4 in place of 4×0.5 . The analysis of answers to the item D9 in booklet F3 confirms an overall advantage of males. Differently from previous cases, higher differences are observable especially at medium-ability level along the latent trait (around 0.0 logit). Nevertheless, differences observed for low ability students are the most result of this analysis: from -1.5 to -0.5 logit all differences are in favor of females. This evidence is strongly confirmed by analyzing F4 data: the probability of a correct answer is 20% higher in female than in male group, from -1.50 to -0.5 along the latent trait. In both cases, distractor analysis shows interesting dissimilarities. The most interesting differences between boys and girls can be observed in F4. In particular, option B is attractive for males and not attractive for

females, while option D is more attractive for girls especially at the lower level of the latent trait, confirming the evidences emerged in F1 and F2.

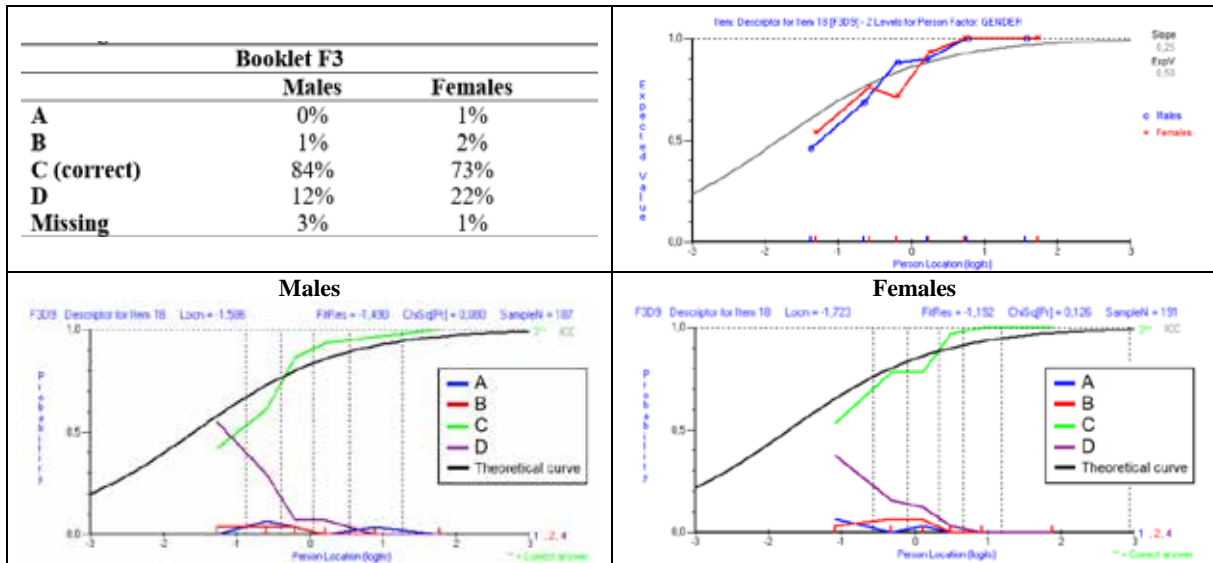


Table 4: Responses by gender and Analysis of Variance by Gender for item D9 administered in booklet F3 (top-left) - DIF-plot (top-right) - Distractor Plot of males (bottom-left) and females (bottom-right)

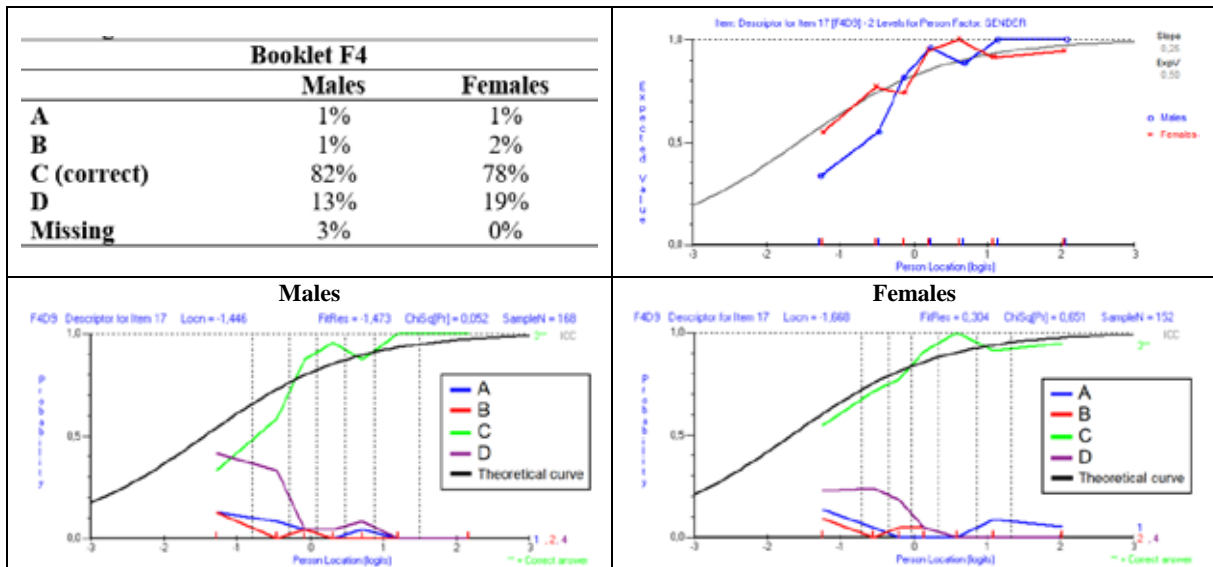


Table 5: Responses by gender and Analysis of Variance by Gender for item D9 administered in booklet F4 (top-left) - DIF-plot (top-right) - Distractor Plot of males (bottom-left) and females (bottom-right)

Conclusions.

In this paper, we compared two versions of the same item with the purpose of analyzing a specific misconception concerning multiplication with decimal numbers. The results showed interesting evidence that will be investigated in further studies from a qualitative point of view. The analysis showed that our new formulation (0.5×4) is simpler (in terms of item difficulty) than the first one (4×0.5) and this is particularly due to the improvement of the performances of girls. This result is

coherent to the model of multiplication as a repeated sum proposed by Fischbein, Deri, Nello, & Marino (1985) or by Sbaragli (2012). In particular, our new formulation seemed to affect low-ability girls positively suggesting that they are more prone than boys to the effect of misconception. Moreover, empirical findings showed a sharper difference between boys and girls at the higher ability level, unless boys confirmed their superiority in encountering this task independently on its formulation at the top level of the ability distribution. Furthermore, in both versions, distractor D (i.e., product equal to 20) which is strictly related to the misconception, is always preferred by females. In particular, we observed that the inversion of the two terms of a multiplication has a huge impact on students' answering behavior especially on females: strong gender gap emerges in favor of males in the first version (4×0.5) for students scaling at the upper-tail of the latent trait and in favor of females in the second version (0.5×4), especially at the lower tail of the ability distribution. In the second form the influence of the misconception appears lower and (probably for this reason) the item is easier since students can calculate the product by using the implicit model of multiplication as repeated addition and this particularly helps low-ability girls.

References

- Bolondi, G., Cascella, C., & Giberti, C. (2017). Highlights on gender gap from Italian standardized assessment in mathematics. In J. Novotná & H. Moravà (Eds.), *Diversity in Mathematics Education. Proceedings of the International Symposium Elementary Maths Teaching*. Prague: Università Karlova Press.
- Brousseau, G. (1988). Le contrat didactique: le milieu. *Recherches en Didactique des Mathématiques*, 9 (3), 309-336.
- Cargnelutti, E., Tomasetto, C., & Passolunghi, M. C. (2016). How is anxiety related to math performance in young students? A longitudinal study of Grade 2 to Grade 3 children. *Cognition & Emotion*, 31, 755-764.
- D'Amore, B. (2000). Lingua, matematica e didattica. *La matematica e la sua didattica*, 1, 28-47.
- D'Amore B., Sbaragli, S. (2005). Analisi semantica e didattica dell'idea di "misconcezione". *La matematica e la sua didattica*, 2, 139-163.
- Daroczy, G., Wolska, M., Meurers, W. D., Nuerk, H-C. (2015) Word problems: a review of linguistic and numerical factors contributing to their difficulty. *Frontiers in Psychology*, 6, 348. doi: 10.3389/fpsyg.2015.00348
- De Corte E., Verschaffel L., & Van Coillie V. (1988). Influence of number size, problem structure, and response mode on children's solutions of multiplication word problems. *Journal of Mathematical Behaviour*, 7, 197-216.
- Duval, R. (1991). Interaction des différents niveaux de représentation dans la compréhension de textes. *Annales de Didactique et de sciences cognitives*, 136-193.
- Fischbein, E., Deri, M., Nello, M. S., & Marino, M. S. (1985). The role of implicit models in solving verbal problems in multiplication and division. *Journal for Research in Mathematics Education*, 3-17.
- Fredricks, J. A., & Eccles, J. S. (2002). Children's competence and value beliefs from childhood through adolescence: Growth trajectories in two male-sextyped domains. *Developmental Psychology*, 38(4), 519.

- Guiso, L., Monte, F., Sapienza, P., & Zingales, L. (2008). Culture, gender, and math. *Science*, New York Then Washington, 320(5880), 1164.
- Giberti, C. (2018). Differenze di genere e misconcezioni nell'operare con le percentuali: evidenze dalle prove INVALSI. *CADMO*, 2018 (2), 97-114.
- Giberti, C., Zivelonghi, A., & Bolondi, G. (2016). Gender differences and didactic contract: analysis of two INVALSI tasks on powers properties. In C. Csikos, A. Rausch & J. Szitanyi (Eds.), *Proceedings of the 40th Conference of the International Group for the Psychology of Mathematics Education* (p. 275). Szeged: IGPME.
- Hart, K. M., Brown, M. L., Kuchemann, D. E., Kerslake, D., Ruddock, G., & McCartney, M. (1981). *Children's understanding of mathematics: 11-16*. London: John Murray.
- Hill, C., Corbett, C., & Rose, A. (2010). *Why So Few? Women in Science, Technology, Engineering, and Mathematics*. Washington: American Association of University Women.
- INVALSI, (2017). Rilevazione nazionale degli apprendimenti 2016-2017. Le rilevazioni degli apprendimenti. Retrieved in January 2019 from http://www.invalsi.it/invalsi/doc_eventi/2017/Rapporto_Prove_INVALSI_2017.pdf
- Kolen, M. J., & Brennan, R. L. (2004). *Test equating, scaling, and linking*. Springer: New York.
- Laborde, C. (1995). Occorre apprendere a leggere e scrivere in matematica. *La matematica e la sua didattica*, 9(2), 121-135.
- Leder, G., & Forgasz, H. (2008). Mathematics education: new perspectives on gender. *ZDM – The International Journal on Mathematics Education*, 40(4), 513-518.
- Mulligan, J. T., & Mitchelmore, M. C. (1997). Young children's intuitive models of multiplication and division. *Journal for research in Mathematics Education*, 309-330.
- Mullis, I. V. S., Martin, M. O., Foy, P., & Hooper, M. (2016). *TIMSS 2015 International Results in Mathematics*. Boston: TIMSS & PIRLS International Study Center.
- Nesher, P. (1982). Levels of description in the analysis of addition and subtraction word problems. *Addition and subtraction: A cognitive perspective*, 25-38.
- OECD (2016). *PISA 2015 – Results (Volume I): Excellence and equity in education*. Paris: OECD Publishing.
- Pajares, F. (2005). Gender differences in mathematics self-efficacy beliefs. In A. M. Gallagher & J. C. Kaufman (Eds.), *Gender differences in mathematics: An integrative psychological approach*, pp. 294-315. New York: Cambridge University Press.
- Rasch, G. (1960). Probabilistic models for some intelligence and attainment tests. Copenhagen: Denmark's Paedagogiske Institut.
- Sbaragli, S. (2012). Il ruolo delle misconcezioni nella didattica della matematica. In Bolondi B., Fandiño Pinilla M.I. (Eds), *I quaderni della didattica. Metodi e strumenti per l'insegnamento e l'apprendimento della matematica*, 121-139.

The centrality of the unit of analysis in comparative research in mathematics education: comparing analytical accounts of student collaborative activity in different social groups

David Clarke¹ and Man Ching Esther Chan²

¹The University of Melbourne, Australia; d.clarke@unimelb.edu.au

²The University of Melbourne, Australia; mc.chan@unimelb.edu.au

Multi-theoretic research designs are increasingly seen as a useful approach to connect and compare multiple theories employed in the in-depth investigation of specific research settings or specific phenomena. Central to multi-theoretic designs is the comparison of the analytical accounts arising from the application of different theoretical lenses to data relating to the same research setting. We argue that the selection of a suitable unit of analysis is critical to the legitimacy of these acts of comparison. This paper discusses the issues arising from consideration of the unit of analysis in multi-theoretic research designs and illustrates these issues with examples drawn from the Social Unit of Learning project. The degree of correspondence between the units of analysis employed in the different analyses has implications for the connections that might be made between the parallel analyses.

Keywords: Classroom research, research design, research methodology, social interaction.

Introduction

Multi-theoretic research designs are increasingly seen as a useful approach to connect and contrast multiple theoretical perspectives on the same research settings or in relation to the same phenomena (Bikner-Ahsbals & Prediger, 2014; Clarke et al., 2012). Such research designs generally involve the parallel application of multiple theories and associated research methodologies and methods within a single research design for analysing data relating to the same setting or situation in order to investigate the phenomenon and the theories of interest. Although many educational researchers over the years have drawn from multiple perspectives in their work (cf. Cobb, 2007), the meta discussion of the issues, contradictions, and affordances of such research designs is an emerging discourse in the field of educational research, resembling the discourse concerning mixed methods research designs in the early 2000s (Johnson & Onwuegbuzie, 2004). This paper particularly addresses the issues arise from the consideration of the unit of analysis in multi-theoretic research designs.

Multi-theoretic research studies (e.g., Clarke et al., 2012; Even & Schwarz, 2003) create a need for researchers to consider more carefully the epistemological, theoretical and practical implications for juxtaposing multiple theoretical perspectives within a single research study. As argued elsewhere (Chan & Clarke, 2017a), we posit that theories can be complementary in their conceptual totality (having different epistemological and ontological bases) but nonetheless invoke operationalised versions of specific constructs common to both theories, which could be used to interrogate the setting, and form the basis for interpretive accounts which can then be juxtaposed with respect to their implications for practice. Commensurability was suggested as a possible important

consideration in multi-theoretic research, as it obliges researchers to articulate the nature of the comparability between theoretically-grounded interpretive accounts when juxtaposing theories. We argue that the commensurability between separate analyses can be examined in terms of: (a) what constitutes evidence within the realm of an analytical framework, (b) the unit of analysis, and (c) the conclusions that can be drawn from the analyses (Chan & Clarke, 2017a).

The unit of analysis

Central to multi-theoretic designs is the need to compare and connect the analytical accounts arising from the application of different theoretical lenses to data relating to the same research setting. We argue that the selection of a suitable unit of analysis is critical to the legitimacy of these acts of comparison. Säljö (2009) suggested that in the area of learning theories, there is a need to recognise the differences and possible incompatibilities in ontologies and epistemologies between different research traditions (e.g., behavioural, cognitive, and socio-cultural theories) through dialogues regarding what counts as evidence of learning in these different traditions. This paper argues that the discussion of the unit of analysis can serve such an important dialogic function because the unit of analysis reflects “the choice of a conceptualisation of a phenomenon that corresponds to a theoretical perspective or framework” (Säljö, 2009, p. 206). We take the position that the unit of analysis also operationalises the focal construct in terms of specific empirical data.

According to Neuman (2003), unit of analysis refers to “the type of unit a researcher uses when measuring” (p. 156). The unit of analysis employed in a study can differ depending on the field of research (e.g., psychology or sociology), research techniques (e.g., survey or content analysis), and research topics and questions. Although the concept of the unit of analysis seems to have come from quantitative research, the concept appears to be a useful research consideration in other forms of research (e.g., qualitative research) for examining the internal coherence of a study (Neuman, 2003) and the commensurability between studies (Chan & Clarke, 2017a). In order to expand the concept of unit of analysis to go beyond quantitative studies in terms of measurement, we define unit of analysis as the unit of empirical data a researcher uses to make distinction in relation to a focal construct. This definition is further elaborated.

As will be argued in this paper, the choice of the unit of analysis also affects the meaningful comparison between theoretical perspectives and between interpretive accounts (Chan & Clarke, 2017a). The next section provides an overview of a research project which utilised a multi-camera technology to generate a rich source of classroom data for multi-theoretic analyses. Three parallel analyses that were employed using the same data set are used in this paper as illustrative and contrasting examples. The paper addresses the questions, “What was the decision-making process involved, relating to the selection of the units of analysis in the project?” and “What are the possible consequences where the units of analysis employed in parallel analyses are the same or different?”

Method

The Social Unit of Learning Project used the Science of Learning Research Classroom (SLRC) at the University of Melbourne to examine individual, dyadic, small group (four to six students) and whole class problem solving in mathematics and the associated/consequent learning. The project

aimed to distinguish the social aspects of learning and, particularly, those for which “the social” represents a fundamental and useful level of explanation, modelling and instructional intervention.

Data generation

The SLRC laboratory classroom is equipped with 10 built-in video cameras and up to 32 audio channels. Intact Year 7 classes were recruited with their usual teacher in order to exploit existing student-student and teacher-student interactive norms. Two classes of Year 7 students (12 to 13 years old; 50 students in total) provide the focus for this report. Each of the classes participated in a 60-minute session in the laboratory classroom involving three separate problem solving tasks (e.g., Sullivan & Clarke, 1991) that required them to produce written solutions. The students attempted the first task individually (10 minutes), the second task in pairs (15 minutes), and the third task in groups of four to six students (20 minutes). The resulting data collected in the project included: all written material produced by the students; instructional material used by the teacher; video footage of all of the students during the session; video footage of the teacher tracked throughout the session; transcripts of teacher and student speech; and pre- and post-lesson teacher interviews.

Parallel data analyses

As an entry point for analysing the project data, the written solutions, transcripts, and video record were used to understand the social process that took place to produce the written solution. The instructional material and teacher pre- and post-lesson interviews provided insights about the class capabilities and social relationships that the researchers would not otherwise be able to access.

In this project, a theory was recruited for its capacity to address constructs, artefacts or situations distinct from those addressed in other theories being employed – that is, for its capacity to complement those already selected. Several parallel analyses were undertaken, drawing on the established research expertise of classroom research communities in multiple countries. This paper particularly focuses on three of the analyses as illustrative examples of different definitions of units of analysis:

- 1) Student negotiative foci led by Chan and Clarke;
- 2) The sophistication in mathematical exchange led by Tran; and
- 3) Student motivating desires led by Tuohilampi.

Chan and Clarke (2017b) conducted an analysis that identified the negotiative foci of the students’ social interactions during collaborative problem solving, taking the social negotiation of meaning as a key constitutive element of learning (e.g., Clarke, 1997). Tran (Tran & Chan, 2017) examined the sophistication of the mathematical exchange between students by applying the frameworks of cognitive demand (Stein & Lane, 1996) and mathematical practices (Common Core State Standards Initiative [CCSSI], 2010). While the cognitive demand framework assumes a hierarchy of skills, the mathematical practices framework does not assume a hierarchy and suggests possible co-occurrence and interrelation between each type of mathematical practice. Tuohilampi (2018) carried out an investigation of the affective enablers and disablers of student participation in collaborative group work, drawing on the work of motivating desires (Goldin, Epstein, Schorr, & Warner, 2011) to explore the extent to which a group of students established a productive affective micro-culture.

These three analyses offer distinct perspectives and approaches for examining the data in the project. Initially, attempts were made to standardise the unit of all the analyses applied in this study in order to make “fair” comparisons between the coding. However, we soon realised that such standardisation would create a mismatch between the theories underpinning some of the analyses and the coding or categorisation that these different theories required to be applied to the data (cf. Säljö, 2009). Several analytical approaches were considered, including: coding using a fixed, common transcript unit as the unit of analysis (e.g., negotiative events or speaker turns); the interpretive annotation of interactions; or the narrative reconstruction of interactive sequences. In each of these analytical approaches, the degree of researcher interpretation and reconstruction of the data is different. However, some of the particular analyses undertaken in this project (e.g., negotiative focus and mathematical sophistication) could be carried out using the same or very similar units of analysis, while some (e.g., student motivating desires) required a different unit of analysis entirely. The degree of correspondence between the different units of analysis has implications for the connections that might be made between the parallel analyses.

The analysis of negotiative foci by Chan and Clarke (2017b) employed the negotiative event as the unit of analysis for analysing the transcripts. In this analysis, a negotiative event is defined as “an utterance sequence constituting a social interaction with a single identifiable purpose” (Clarke, 2001). For example, consider the following excerpt during the discussion of the Task 2 pair activity between Pandit and Anna (the number within the square brackets denotes speaker turn):

- [28] Pandit: ... The average.
 [29] Anna: No. The average age is 25.
 [30] Pandit: I know. So 25 times five is average.
 [31] Anna: No.
 [32] Pandit: What do you mean? Do you know average?
 [33] Anna: You know what average is?
 [34] Pandit: Yes. Do you know what average is?
 [35] Anna: Yes.
 [36] Pandit: (Laughs) Okay. What's an average (laughs)?
 [37] Anna: So one of them is Year 7, right?
 [38] Pandit: Yeah. One of them is Year 7.
 [39] Anna: Yeah.
 [40] Pandit: So there's one dude that's 13 years old. Year 7 is 13 years old.

The excerpt began with Pandit and Anna trying to clarify each other’s understanding of average. When Pandit persisted and requested an answer from Anna (Turn 36), Anna changed the subject (Turn 37) and revisited the task instructions in terms of the Year 7 student that they had to take into account as part of the task. Turns 28 to 36 can be considered a single negotiative event related to clarifying each other’s understanding of average (a goal that is not really achieved), while Turns 37 to 39 constitute a separate negotiative event. In the negotiative foci analysis, the full transcript was partitioned into negotiative events and then subsequently coded according to the negotiative focus of each event (mathematical, sociomathematical, or other social focus).

In the case of Tran's analysis (Tran & Chan, 2017), he initially considered an overall rating of each group of students in terms of the mathematical sophistication of the students' exchange. However, an overall rating of the entire interaction was deemed too coarse grained, as it overlooked the dynamics of the student reasoning as the conversation progressed. Tran's later analytical approach involved interpretive annotation of student interactions looking for demonstration of a particular level of thinking process (e.g., unsystematic or non-productive exploration; memorisation; use of procedures without connections to concepts, meaning, and/or understanding; or use of procedures with connections to concepts, meaning, and/or understanding) (see Stein & Lane, 1996) or a particular set of mathematical practices (e.g., making sense of problems and persevering in solving them; reasoning abstractly and quantitatively; constructing viable arguments and critiquing the reasoning of others; model with mathematics; etc.) (CCSSI, 2010, pp. 6–8). Also applying negotiative events as the unit of analysis (Clarke, 2001), Tran summarised the student interactions in terms of the highest level of cognitive demand attached and types of mathematics practices displayed by the student pair within each negotiative event. Different from Chan and Clarke (2017b), only verbal exchange between students with a mathematical focus was considered in the coding. The definition of "negotiative focus" was also re-defined in his analysis in terms of mathematical reasoning resulting in generally larger "event chunks" than that in the analysis conducted by Chan and Clarke. In addition, employing an entirely different unit of analysis, Tran also created storylines to trace the reasoning of the students individually and as a cognising student pair and a small group unit.

The analysis of motivating desires by Tuohilampi (2018) focused on the key affective events (Goldin, 2017) of student interactions. Her analysis involved reconstructing the interactive sequences between the students during video episodes of half a minute to one minute each. For example, Tuohilampi (2018) described a one-minute episode (Episode 0) involving Anna, Pandit, John, and Arman during the group task (Task 3). During that episode, the motivating desire of John appeared to be Commitment, where he was pondering about the task on his own without a lot of interaction with the other three people in the group. However, when the previous half-minute episode (Episode -1) was taken into consideration, the interpretation of John's motivating desires in the initial episode had to be revised to account for his apparent difficulty with communicating with the other people in the group due to language difficulties (Avoidance). Yet, when another half-minute episode (Episode -2) which took place one minute before the initial episode (Episode 0) was considered, John's language difficulty did not seem to have affected his friendly interaction with Arman. The researcher's interpretation of the students' motivating desires therefore could change as more episodes and more background information about the students were considered.

Discussion

Using unit of analysis as a connecting construct, we can begin to examine the commensurability (Chan & Clarke, 2017a) between the various analytical approaches reported in this paper. Consistent with Säljö (2009), central to the decision-making process involved relating to the selection of the units of analysis in the project, is consideration of the correspondence between the unit of analysis, the conceptualisation of the phenomenon of interest, and the theoretical perspective employed. The above examples of parallel analyses applied in the Social Unit of Learning Project

illustrate the close connection between the unit of analysis and the conceptualisation of the phenomenon of interest, which in turn corresponds to the theoretical perspective or framework. In the case of the negotiative focus analysis, the social negotiation of meaning was taken as a key constitutive element of learning (e.g., Clarke, 1997). The application of negotiative events as unit of analysis (Clarke, 2001) helps the researchers to focus on the purpose and content of the student exchange.

The multiple analytical approaches used by Tran (Tran & Chan, 2017) highlighted the variety of possibilities for examining the mathematical sophistication of student exchanges. When the goal of the analysis of the mathematical sophistication level of the student exchange was set at the characterisation of the overall individual, student pair, or student group level, this focus on “mathematical sophistication” as a generalised attribute true of a particular social unit (individual, pair, group), demonstrated throughout a particular episode, reflected a theory of competency of learning, where a person’s behaviours are a reflection of the skills or knowledge that the person holds (cf. Gagné, 1962). Despite the re-conception of the unit of analysis as indicative of levels of thinking processes displayed throughout the student exchange, the approach still assumes a hierarchy of behaviours consistent with a competency view of learning. The application of the mathematical practices framework (CCSSI, 2010), on the other hand, appears to assume a process model where students may call upon or generate different skills and knowledge as they interact with each other during a collaborative task.

Tuohilampi’s (2018) analysis suggests that a fixed unit of analysis such as negotiative events employed in the negotiative focus analysis (Chan & Clarke, 2017b) and the analysis of the mathematical sophistication of student exchange (Tran & Chan, 2017) is unsuitable for the analysis of motivating desires. A negotiative event based on the transcript appears to be too restrictive to interpret a person’s affective responses and ascertain the person’s motivating desire. The analysis of motivating desire requires interpreting the intention(s) of the actor, where the intention(s) are fluid and can be defined and re-defined depending on how the situation perceived by the researcher, taking in to account the prior and subsequent behaviours of the people involved, and the consequence(s) of the interactions.

The second question that this paper addresses is: “What are the possible consequences where the units of analysis employed in parallel analyses are the same or different?” The multi-theoretic research design of this study makes possible the comparison and contrasting of multiple analytical approaches. While the use of a standardised unit of analysis may suggest that it is possible to directly compare the results of the parallel analyses in terms of their application to a specific “piece” of data, the validity of individual analyses could be compromised in terms of their correspondence to the theoretical perspective and the phenomenon of interest. In order to preserve the coherence of individual analyses, the standardisation possible between analytical approaches is limited. Nevertheless, the common data source and setting that the separate analyses draw upon provide important points of connection between the analyses.

In the past, our capacity to connect analyses of the learning process employing different theoretical perspectives has been limited to comparison of the reports of research undertaken in relation to

different individuals interacting in different learning environments. The inevitable internal alignment of data with the choice of analytical lens within each separate report has made the comparison and connection of these separate analytical accounts difficult. Multi-theoretic research designs afford the comparison and connection of analytical accounts in relation to the same setting and data source. This represents a significant advance in our capacity to deal with the complexity of a particular social setting, through the combination of perspectives offered by multi-theoretical designs. This also affords the delineation of the zone of applicability of each of the theoretical lenses applied. These advantages remain whether or not the different analytical accounts employ the same unit of analysis.

The use of multiple theories is motivated by two goals: understanding of the setting and delineation of the field of feasible application of the theory. Careful attention to the unit of analysis is required, if these two goals are to be met. It is through analytical accounts grounded in the designated units of analysis that comparisons are made and whether comparison of these accounts can serve as an adequate surrogate for the comparison of the related theories will depend on the coherence with which each unit of analysis is connected to the relevant superordinate construct and the theory from which it was drawn.

Conclusion

Acts of comparison are fundamental to all forms of research, and are dependent on the careful selection of the units of analysis by which these acts of comparison are undertaken. Our use of multiple theories serves to highlight this critical consideration. It is not surprising that analyses informed by different theories should require different units of analysis. We would like to emphasise, however, that strategic consideration of the units of analysis can facilitate the identification of connection and distinction between multiple theories and therefore enhance our understanding of both the theories and the phenomenon of interest. With the emerging meta-discourse about multi-theoretic research, it is hoped that the explication of the issues concerning units of analysis provided in this paper will contribute to the further theorisation of multi-theoretical research approaches.

Acknowledgment

This research is supported under Australian Research Council's Discovery Projects funding scheme (Project number DP170102541).

References

- Bikner-Ahsbabs, A., & Prediger, S. (Eds.). (2014). *Networking of theories as a research practice in mathematics education*. Cham, Switzerland: Springer.
- Chan, M. C. E., & Clarke, D. J. (2017a). Learning research in a laboratory classroom: Complementarity and commensurability in juxtaposing multiple interpretive accounts. In T. Dooley & G. Gueudet (Eds.), *Proceedings of CERME10, Dublin, Ireland* (pp. 2713–2720).
- Chan, M. C. E., & Clarke, D. J. (2017b). Structured affordances in the use of open-ended tasks to facilitate collaborative problem solving. *ZDM-The International Journal on Mathematics Education*, 49, 951–963. doi: 10.1007/s11858-017-0876-2

- Clarke, D. J. (1997). Studying the classroom negotiation of meaning: Complementary accounts methodology. *Journal for Research in Mathematics Education, Monograph No. 9*, 98–111. doi:10.2307/749949
- Clarke, D. J. (2001). Untangling uncertainty, negotiation and intersubjectivity. In D. Clarke (Ed.), *Perspectives on practice and meaning in mathematics and science classrooms* (pp. 33–52). Dordrecht, The Netherlands: Kluwer Academic Publishers.
- Clarke, D. J., Xu, L. H., Arnold, J., Seah, L. H., Hart, C., Tytler, R., & Prain, V. (2012). Multi-theoretic approaches to understanding the science classroom. In C. Bruguière, A. Tiberghien & P. Clément (Eds.), *E-Book proceedings of the ESERA 2011 biennial conference: Part 3* (pp. 26–40). Lyon, France: European Science Education Research Association.
- Cobb, P. (2007). Putting philosophy to work: Coping with multiple theoretical perspectives. In F. K. Lester (Ed.), *Second handbook of research on mathematics teaching and learning* (Vol. 1, pp. 3–38). Charlotte, NC: Information Age Publishing.
- Common Core State Standards Initiative. (2010). *Common Core State Standards for mathematics*. Washington DC: Authors. Retrieved from <http://www.corestandards.org/Math/>
- Even, R., & Schwarz, B. B. (2003). Implications of competing interpretations of practice for research and theory in mathematics education. *Educational Studies in Mathematics, 54*(2/3), 283–313.
- Gagné, R. M. (1962). The acquisition of knowledge. *Psychological Review, 69*(4), 355–365. doi:10.1037/h0042650
- Goldin, G. A. (2017). Motivating desires for classroom engagement in the learning of mathematics. In C. Andrà, D. Brunetto, E. Levenson & P. Liljedahl (Eds.), *Teaching and learning in maths classrooms: Emerging themes in affect-related research: Teachers' beliefs, students' engagement and social interaction* (pp. 219–229). Cham, Switzerland: Springer International Publishing.
- Goldin, G. A., Epstein, Y. M., Schorr, R. Y., & Warner, L. B. (2011). Beliefs and engagement structures: Behind the affective dimension of mathematical learning. *ZDM-The International Journal on Mathematics Education, 43*(4), 547–560. doi:10.1007/s11858-011-0348-z
- Johnson, R. B., & Onwuegbuzie, A. J. (2004). Mixed methods research: A research paradigm whose time has come. *Educational Researcher, 33*(7), 14–26.
- Neuman, W. L. (2003). *Social research methods: Qualitative and quantitative approaches* (5th ed.). Boston: Allyn and Bacon.
- Säljö, R. (2009). Learning, theories of learning, and units of analysis in research. *Educational Psychologist, 44*(3), 202–208. doi:10.1080/00461520903029030
- Stein, M. K., & Lane, S. (1996). Instructional tasks and the development of student capacity to think and reason: An analysis of the relationship between teaching and learning in a reform mathematics project. *Educational Research and Evaluation, 2*(1), 50–80. doi:10.1080/1380361960020103
- Sullivan, P., & Clarke, D. J. (1991). Catering to all abilities through "good" questions. *The Arithmetic Teacher, 39*(2), 14–18. doi:10.2307/41194944
- Tran, D., & Chan, M. C. E. (2017). Examining mathematical sophistications in collaborative problem solving. In B. Kaur, W. K. Ho, T. L. Toh & B. H. Choy (Eds.), *Proceedings of the 41st Annual Meeting of the International Group for the Psychology of Mathematics Education, Singapore, Vol. 4* (pp. 281–288).
- Tuohilampi, L. (2018). Analyzing engagement in mathematical collaboration: What can we say with confidence? In E. Bergqvist, M. Österholm, C. Granberg & L. Sumpter (Eds.), *Proceedings of the 42nd Annual Meeting of the International Group for the Psychology of Mathematics Education, Umeå, Sweden, Vol. 1* (pp. 235–242).

Impact of access requirements on the mathematical knowledge of students admitted to Primary Teaching programs: a micro-comparative study

Núria Gorgorió¹, Lluís Albarracín², and Anu Laine³

¹Universitat Autònoma de Barcelona, Spain; nuria.gorgorio@uab.cat

²Universitat Autònoma de Barcelona, Spain; lluis.albarracin@uab.cat

³Helsingin Yliopisto, Finland; anu.laine@helsinki.fi

We present a comparative micro-study analyzing whether the changes made to the admission requirements to the primary teacher training programs of the Universitat Autònoma de Barcelona and the University of Helsinki in the academic year 2017-18 have had an impact on the background mathematical knowledge of those admitted to the programs. We are interested in finding elements that provide information for university admission policies. Our results show that significant changes only took place in Barcelona and these were a consequence of the variations in the academic profile of the students admitted. We conclude that working with a context-bound instrument, while making comparison difficult, directs the researchers' attention to the need for an in-depth theoretical discussion about the mathematical knowledge of candidates to initial teacher education programs and a methodological discussion on how to evaluate this knowledge.

Keywords: University access requirements, primary teaching degree, background mathematical knowledge.

Introduction

Our study is among those that attempt to determine what factors influence the development of mathematical knowledge for teaching during teacher education. According to Blömeke and Delaney (2012), some of these variables are the institutional characteristics of each program, the idiosyncrasies of the national and social context, and the individual characteristics of the students attending the programs. The survey we present here is a small part of an emerging comparative study that aims to contribute to the discussion of university policies regarding access to primary teacher education programs while promoting a theoretical debate about what the desirable mathematical knowledge of students admitted to these programs would be (for more details about the project, see e.g. Albarracín, Gorgorió, Laine, & Llinares, 2018; and Gorgorió et al., 2017). We understand that the admissibility criteria and the requirements for access to educational programs, as institutional particularities, contribute to defining the individual characteristics of their students. We assume that the mathematical knowledge with which students access primary teaching programs – henceforth, background mathematical knowledge – influences the development of the knowledge needed to teach mathematics during their education.

As educators of primary school teachers, we are interested in finding elements that provide information for university admission policies so that requirements can be established to ensure a minimum of mathematical knowledge among admitted students. Comparative studies between

different national realities that evaluate the mathematical knowledge of the candidates in relation to the admission criteria can help to explain the success differences between the different training programs, thus identifying variables that may otherwise remain hidden in national studies and hence remain unquestioned.

Since 2014, at the Universitat Autònoma de Barcelona, Catalonia – henceforth BCN – we have been evaluating the background mathematical knowledge of students admitted to the primary teaching program through a specific test. In the 2016-17 academic year, we decided to also administer the test to the students admitted to the Master of Education degree at the University of Helsinki, Finland – henceforth HEL – to study the results comparatively, taking the entrance requirements into account. We then observed that students at HEL performed significantly better than students at BCN.

In this paper, we present a comparative micro-study analyzing whether the changes introduced in the 2017-18 academic year regarding requirements for admission to the primary teacher training programs in Catalonia and at the University of Helsinki have had an impact on the background mathematical knowledge of those admitted to the programs. The changes are of a very different nature and have to do with the idiosyncrasies of the respective university and school systems. For the students admitted to a teaching degree in Catalonia, and in particular to BCN, September 2017 was the first time they had to pass a specific mathematics test. At HEL the change consisted in increasing the proportion of candidates for whom not only the VAKAVA-test and suitability test but also the mathematics and Finnish grades of the matriculation examination were considered for admission.

We exploited quantitative data collected in the academic years of 2016-17 and 2017-2018, i.e. before and after changes took place in the admission criteria both at BCN and HEL. Here we discuss how the changes introduced have impacted students' performance on the test, comparing the performance across years, both within and between universities. We are especially interested in seeing whether the differences occur as result of the changes in the academic profile of the admitted students prior to their University studies.

Admission to a primary teaching degree at BCN and HEL

The recent introduction of the requirement to pass a specific mathematics test for admission to the primary teaching degrees in Catalonia justifies the presence of BCN in the research study. Since the results of the first PISA Study were published in 2000, there has been widespread international recognition of the success of Finland's educational model. Even though this success is due to many factors, the most important aspect is believed to be the quality and competence of its teachers (Salhberg, 2011). For this reason, it seemed logical to include a Finnish program in this study. In addition, since the policies and admission requirements to the primary teaching program in Helsinki are very different from the Spanish ones, we consider it interesting to compare HEL and BCN.

Since 1979, primary teachers in Finland need to have completed a Master of Education degree (300 ECTS). After compulsory education, youngsters can enter the job market directly or instead attend either university-preparatory Upper Secondary School or Vocational School. At Upper secondary school, students can choose to do either intermediate mathematics or advanced mathematics. At the end of Upper Secondary School, students take the Finnish Matriculation Examination, *Ylioppilastutkinto* in Finnish (henceforth YLIO), which is the only national-level test in Finland. Each

examinee is required to complete at least four exam papers, only one of them (mother tongue) being mandatory. The remaining three are chosen by the student and may include one in mathematics, either intermediate or advanced. Graduates of Vocational School may also gain admission to university. In Finland, students interested in becoming primary teachers, after passing the YLIO, must go through a special two-stage application process. The first stage involves taking an exam (the so-called *VAKAVA testi*) based on a set of education-related readings. Those who perform well on this exam go on to the second stage, a suitability test that assesses their motivation to study and suitability to work as teachers. Universities in Finland agree on the number of new admissions in cooperation with the Ministry of Education. At HEL, fewer than 10% of applicants are accepted annually for the primary teacher education program. In 2016-17, 48 students (40%) were selected based on the suitability test alone and 72 students (60%) were selected based on the suitability test and their grades in the YLIO in 4 subjects – Finnish and 3 optional subjects. In 2017-18, only 24 students (20%) were selected based on the suitability test alone, and 96 students (80%) based on the suitability test and the grades in the YLIO in Finnish and mathematics. Thus, the number of students at HEL who took a mathematics test in the YLIO increased by at least 20 percentage points.

In Spain, primary teachers are required to have completed a Degree in Primary Teaching (240 ECTS). Access to primary teaching degrees can be gained via the Baccalaureate (2 years of non-compulsory education) or through a vocationally-oriented Professional Cycle. Those who study Baccalaureate may choose a track containing mathematics – either mathematics or mathematics for social sciences – but some tracks do not contain any mathematics subjects. The professional cycles from which students gain access to the primary teaching programs do not have mathematics courses. Those that have completed the baccalaureate have to pass the *Pruebas de Acceso a la Universidad* (henceforth PAU) to be admitted to any university program. Four of the exam papers of the PAU are universal for all students across Spain, but this is not the case for mathematics, which is an optional subject. Students who have completed a Professional Cycle may also gain access to university. Therefore, applicants to teacher education programs in Spain will not have taken any mathematics courses in post-compulsory education unless they have taken one of the two tracks of the Baccalaureate that include mathematics. It is important to point out that the number of student places in primary teaching degrees in Spain bears no relationship to the actual number of teaching jobs in the market. At BCN, around two thirds of the applicants were admitted for the academic years 2016-17 and 2017-18¹. In the academic year 2016-17, there was no specific requirement for admission to Primary Teaching programs in Spain outside the universal procedure described above. However, in Catalonia, starting in the 2017-2018 academic year, a specific complementary entrance examination – which includes a mathematics test – was implemented.

Data collection

Instrument

The instrument we used to collect our data was the mathematics test that had been designed and used to pilot the specific complementary entrance examination in Catalonia mentioned above that had the

¹ http://universitats.gencat.cat/ca/altres_pagines/informe_i_estadistiques/informes_i_estad_pre/

administrative purpose of regulating access to primary teaching degrees in Catalan universities. The mathematics test was intended to ensure a minimum mathematical content knowledge of admitted candidates (for a detailed description of how the test was created and validated see Albarracín et al., 2018). The test evaluated disciplinary knowledge of a conceptual and procedural nature.

The test had 25 questions, with an open-answer format, related to the prescribed curriculum of Spanish compulsory education – Numbers and Arithmetic, Space and Shape, Relations and Change, Magnitude and Measure, and Statistics and Randomness. The weight given to each content area was related to the actual presence of said contents in the school practice. Thus, there were 7 items on numbers and arithmetic (procedural and conceptual exercises with natural, integer, fraction and decimal numbers), 5 items on magnitude and measure (concepts of length and area, calculation of perimeter and area, and units change, in both decimal and sexagesimal systems), 5 items on relations and change (3 items on proportionality, 1 patterns, and 1 graph interpretation), 4 items on space and shape (2 conceptual on plane geometry, 1 visualization, 1 representation) and 4 items on statistics (1 reading and 1 construction of bar charts, 1 interpretation of a pie chart, all of them procedural, and 1 on conceptual measures of central tendency). Students had 90 minutes to answer the test and no calculators were allowed.

The following are examples of the items in the test:

- *4- A product is on sale. According to the label, the normal Price is £125. The sale price is £100. What percentage of discount has been applied?*
- *7- Which prime number can be made by subtracting two multiples of 7?*
- *14- What is the surface area of a square with a perimeter of 32 cm?*
- *16- Which of the following figures must have equal diagonals? a) square; b) rhombus; c) rectangle; d) trapezium*
- *18- How many cm are in 7.8 km?*
- *24- What number would we add to the list in order for the mean to equal 7? {2, 6, 6, 6, 8, 8, 9}*

From the beginning we were aware that the test, as it had been defined, was going to be culturally context-bound to the idiosyncrasies of the educational system in which it had arisen. Although the curricula in Finland and Spain are not so different, the emphasis placed on each of the subjects and the way they are taught in class is. We have purposely included some of the items of the questionnaire as examples that will serve to illustrate how the questionnaire was bound to the context. For example, it was already expected that item 7 shown above would harm students' results in HEL, since, although they work on divisibility, the term “prime number” is not as familiar to them. Another example would be item 16 since it includes the idea of a rhombus, which is rarely used in Finland – it is not a category in itself in the classification of quadrilaterals that schoolchildren learn, contrary to what happens in Spanish school mathematics lessons, where the rhombus gives rise to a category in itself. A full discussion of how the test was context-bound can be found in Albarracín et al. (2018).

Participants and data collection

In HEL, the test was taken by the 116 students starting their primary teaching education program in 2016-17 and 2017-18, at the very beginning of their courses in August. In BCN, the 254 students that initiated their teaching education in 2016-17, and the 276 that did so in 2017-18, took their test in

February, at the beginning of the second semester. Neither in HEL nor in BCN had students taken any university class on mathematics or mathematics education at the time of the test.

Students had to answer the test on a worksheet, without using a calculator and in a maximum time of 90 minutes. The answers were marked, assigning 1 point when the answer was completely correct (meanings, calculations, units, etc.) and 0 points if it was not. The students' grades in the exam are part of our data, the other group being the information they gave us about their previous academic trajectory, allowing us to gain information on which (if any) mathematics courses they had taken as part of their pre-university education.

Results

Reliability of the instrument

First, to test the reliability of the data obtained in the test, we calculated the Cronbach's alpha, both overall and for each campus, as an internal consistency estimate of the reliability of the test scores. The results that we obtained (α BCN·16·17 = 0.8157; α HEL·16·17 = 0.8106; α BCN·17·18 = 0.7963; α HEL·17·18 = 0.7579; α Overall = 0.7985), in all cases higher than the reference value of 0.7, were a suitable indicator of the internal consistency of the instrument, meaning that the different questions of the test evaluate the mathematical knowledge with which students arrive at the teacher education programs, in a coherent way and from a disciplinary perspective. In this way, we consider that the instrument sufficiently and consistently approaches our idea of background mathematical knowledge.

Differences in performance

Table 1 presents the basic statistics that describe the centrality and distribution of the scores in the test by the students in HEL and BCN in 2016-17 and 2017-18 academic years.

Variable	HEL·16·17	HEL·17·18	BCN·16·17	BCN·17·18
N	116	116	254	276
Mean	17.233	17.595	15.996	17.750
SE Mean	0.405	0.368	0.302	0.264
StDev	4.363	3.963	4.812	4.389
Minimum	7.000	6.000	3.000	4.000
Q1	14.000	15.000	12.000	15.000
Median	17.500	18.000	16.000	18.000
Q3	21.000	21.000	20.000	21.000
Maximum	25.000	24.000	25.000	25.000

Table 1: Centrality and distribution of marks

A series of mean comparison t-tests allows us to establish the significance of differences (Table 2)

	Estimate for Difference	Confidence Interval for difference (95%)	p-value
HEL·17·18 vs. HEL·16·17	0.362	(-0.716; 1.440)	0.509
BCN·17·18 vs. BCN·16·17	1.754	(2.539; 0.969)	0.000
HEL·16·17 vs. BCN·16·17	1.237	(0.242; 2.232)	0.015
HEL·17·18 vs. BCN·17·18	-0.155	(-1.084; 0.773)	0.743

Table 2: T- tests comparison of score means across universities

As can be seen in Table 2 for 2016-17, students at HEL obtained significantly better results than students at BCN. It also shows that at HEL there was no significant change in performance between 2016-17 and 2017-18. However, results at BCN were significantly better in 2017-18, to the extent that such results cannot be statistically distinguished from the results in HEL of the same year.

Impact on the academic profile of students admitted to BCN

We note that there are only significant differences between the results before and after the implementation of a new requirement at BCN, this being the only change affecting entry conditions at BCN. In Albarraçin et al. (2018) we had found that the academic profile of students prior to entering university generated different results. Therefore, it is interesting to explore what aspects have changed in the profile of admitted students – we have no information about those who applied for admission but were not admitted.

We labelled BCN students who had only taken the compulsory mathematics BCN·COM and those who had followed the Baccalaureate track containing mathematics BCN·BAC. Table 3 shows the proportion of students and the mean of the scores obtained in the test by the students in each subgroup, as well as the standard deviations. Table 4 shows the results of the T-tests comparing the mean scores of the subgroups.

	Percentage of students in each subgroup	Mean score (max. 25)	Standard deviation
BCN·COM·16·17	42.52%	13.611	4.488
BCN·BAC·16·17	57.48%	17.760	4.263
BCN·COM·17·18	32.61%	15.967	4.348
BCN·BAC·17·18	67.39%	18.613	4.153

Table 3: Proportion of students that had taken mathematics after compulsory education, and the mean scores of each subgroup, with standard deviations

	Estimate for difference	Confidence interval for difference (95%)	p-value
BCN·COM·16·17 vs. BCN·BAC·16·17	-4.033	(-5.175; -2.891)	0.000
BCN·COM·17·18 vs. BCN·BAC·17·18	-2,646	(-1.580; -3.712)	0.000
BCN·COM.1718· vs. BCN.COM.1617	2.356	(3.601; 1.110)	0.000
BCN.BAC.1718 vs. BCN.BAC.1617	0.853	(1.766; -0.061)	0.067

Table 4: Results of the T-tests comparing the mean scores of the subgroups depending on whether they had taken mathematics after compulsory school

In both the 2016-17 and 2017-18 academic years, students who had studied mathematics during Baccalaureate obtained better test results than those who had not. In addition, the 2017-18 academic year increased the number of students in the first group by 10 percentage points. In the 2017-18 academic year, students who had studied mathematics during Baccalaureate obtained better results than the same group in the previous academic year, but by a few thousandths we cannot say that this difference is significant. However, the difference is significant between 2016-17 and 2017-18 for those who had not studied mathematics during their post-compulsory education.

Discussion

In our contribution we analyzed the impact of changing the criteria and requirements for admission to the teacher education programs of the Universitat Autònoma de Barcelona and the University of Helsinki. In both cases, the change implies a greater demand in relation to mathematics. However, we see that while in Barcelona the impact is significant, in Helsinki it is not so.

The results from BCN show that the introduction of the mandatory requirement to pass a mathematics test in order to gain access to the teachers' education program has generated a change in the academic profile of admitted students and their mathematical background knowledge has improved significantly compared to the previous academic year. We found that the number of students who continued to study mathematics after completing their compulsory schooling has increased by 10 percentage points. Our knowledge of the Catalan university system allows us to state that the only variable that could have generated this change in the academic profile of the students is the introduction of this new requisite. In addition, those who dropped out of mathematics at the end of compulsory schooling have also proven to have a better background mathematical knowledge than those in the same group the previous year. From informal conversations with the students, we dare to say that they have prepared for the new specific mathematics test that was part of the new entrance requirements.

However, we did not observe any significant changes in Helsinki. We believe that this is essentially due to the fact that the instrument used to collect our data was bound to the Catalan context. Although access to the primary teaching program in Helsinki had increased its mathematical demands, the terminology and formalism of the test that we used are still elements that have little weight on the education of Finnish students. In Hel, the new entrance requirement implies that a greater number of admitted students have studied secondary mathematics. However, the mathematics of intermediate or

advanced courses of upper-secondary in Finland are of little help to answer test questions linked to an approach that is characteristic of another national context.

We find it interesting to compare data from two cultural realities as different as the university systems of Finland and Catalonia. These results provide us with ideas that a study restricted to only one country would not generate, and these ideas can contribute to decision making. In particular, the changes introduced in Helsinki in the 2017-18 academic year are a consequence of the analysis of the results obtained by its students in the 2016-17 academic year. In Catalonia, our study can help to support the changes introduced that are beginning to be questioned by the media. We plan to incorporate data from other European universities into our study in the near future.

We are aware that working with a context-bound data collection instrument generates dilemmas, such as those suggested by Clarke (2013), that appear when an international comparative study is carried out. In spite of this, researchers working together who are outsiders with respect to each other's data, cultural contexts and national realities leads to richer and more nuanced interpretations. In addition, working with a context-bound instrument, while it makes comparison difficult, directs the researchers' attention to the need for an in-depth theoretical discussion about what the desirable mathematical knowledge would be for candidates to initial teacher education programs. An agreement on the theoretical level on what basic knowledge an entrance examination should evaluate would help to agree on the characteristics of the examination on the methodological level, to avoid it being strictly tied to a context.

Acknowledgment

The research presented has been developed under the auspices of the research grants EDU2013-4683-R and EDU2017-84427-R –Spanish Ministry of Science, Innovation and Universities.

References

- Albarracín, L., Gorgorió, N., Laine, A., & Llinares, S. (2018). The mathematical knowledge of students entering primary teaching degrees and its relationship with university admission criteria and requirements. Submitted to *PLOS ONE*.
- Blömeke, S., & Delaney, S. (2012). Assessment of teacher knowledge across countries: a review of the state of research. *ZDM. Mathematics Education*, 44(3), 223–247.
- Clarke, D. J. (2013). The validity-comparability compromise in cross-cultural studies in mathematics education. *CERME8* (pp. 1855-1864)
- Gorgorió, N., Albarracín, L., Ärlebäck, J., Laine, A., Newton, R., & Villareal, A. (2017, June). *Fundamental Mathematical Knowledge: progressing on its definition and concretization*. Paper presented at the VIII Nordic conference on Mathematics Education, NORMA17, Stockholm, Sweden.
- Sahlberg, P. (2011). *Finnish lessons: what can the world learn from educational change in Finland?* New York: Teachers College, 2011

Introduction to early algebra in Estonia, Finland and Sweden – some distinctive features identified in textbooks for Grades 1-3

Kirsti Hemmi^{1,2}, Madis Lepik³, Lars Madej¹, Kajsa Bråting¹ and Joakim Smedlund²

¹Uppsala University, Sweden; kirsti.hemmi@edu.uu.se; lars.madej@edu.uu.se
kajsa.brating@edu.uu.se

²Åbo Akademi University, Finland; khemmi@abo.fi; joakim.smedlund@abo.fi

³University of Tallinn, Estonia; mleplik@tlu.ee

This cross-cultural study focuses on specific features concerning the introduction to early algebra in three neighbouring countries – Estonia, Finland and Sweden – that, despite having relatively similar school systems, have different student results in international evaluations. The data consists of commonly used mathematics textbooks for Grades 1-3, and the focus of analysis is particularly on the treatment of expressions, equations, inequalities, and the meaning of the equal sign. The results show differences not only between the countries but also between different language groups within the same country, and similarities between the same language groups in different countries. We exemplify the most significant characteristics identified in different contexts in relation to various approaches to early algebra described in research literature, and discuss the implications of the findings for our research field.

Keywords: early algebra, comparative analysis, mathematics curriculum, primary education

Background

Early introduction to algebra has been in focus in recent research, and several researchers point out that it is beneficial to start working with important ideas within algebra already in primary school (e.g. Blanton, Stephens, Knuth, Murphy Gardiner, Isler & Kim, 2015). For example, an intervention study by Blanton et al. (2015) shows that students can improve their understanding of so-called big ideas of algebra with an appropriate teaching approach and relevant material. International comparisons show that there are great differences between approaches to the teaching and learning of algebra in different countries (e.g. Cai, Lew, Morris, Moyer, Ng & Schmittau, 2005; Leung, Park, Holton & Clarke, 2014). These comparisons have mainly concerned countries with significantly different cultures and school systems. In contrast, the present study investigates the early introduction to algebra in the three neighbouring countries of Estonia, Finland and Sweden, where the school systems are quite similar. For example, all three have nine years of compulsory school with no tracking. Moreover, national steering in the three countries is relatively weak, with no approval process for curriculum materials that are commercially produced. We deem that the similarity of the school systems facilitates the identification of specific features concerning the views on early progression in algebra in these countries. In international evaluations, there are differences between the countries in students' learning outcomes, making it interesting to discuss different approaches to early algebra in relation to this variation. While Estonian and Finnish students' results in international comparisons have been relatively good, algebra has not been the strongest area in Finland (Yang Hansen et al., 2011). In Sweden, students' results in algebra have

been low since the 1960s regardless of the variation in other mathematical topics (Hemmi et al., 2018).

Curriculum materials are produced within certain educational traditions, and may therefore be shaped by national perspectives on the specific school subjects (cf. Andrews, 2007). In all three countries, mathematics textbooks are an important part of classroom work. Therefore, in this paper, we exemplify and discuss typical characteristics of the approaches to early algebra in Estonia, Finland and Sweden as identified in our textbook analysis concerning Grades 1-3 (ages 7-9 years). We have also included textbooks produced by Finnish Swedish¹ authors in the analysis, as there are differences between the two language groups in Finland when it comes to students' learning outcomes, as well as teachers' relation to mathematics textbooks (e.g. Pehkonen, Hemmi, Krzywacki & Laine, 2018). We acknowledge that the textbooks can be used by teachers in various ways when designing and enacting mathematics lessons (e.g. Lepik et al., 2015; Røj-Lindberg, Partanen & Hemmi, 2017; Kilhamn, 2014). However, we deem these kinds of studies important as we learn how textbook authors interpret the introduction of early algebra in different cultural-educational contexts. The following research question guides the study: *What are the specific characteristics of early algebra in textbooks series produced in four different contexts?*

Relevant research and theories

Few comparative studies address the progression of algebra in different countries' curricula. Cai, Lew, Morris, Moyer, Ng and Schmittau (2005) study how algebraic concepts are developed and represented in the curricula of the US (Investigations curriculum), China, Singapore, South Korea and Russia (Davydov curriculum). The study by Cai et al. (2005) shows that the three Asian countries build informal equation solving on the use of inverse operations and the related doing-undoing. In the Russian Davydov curriculum for Grades 1-3, children develop algebraic thinking by exploring and comparing quantities before the study of arithmetic and, in contrast to the US Investigations curriculum, letters are used from the very beginning (Cai et al., 2005). Both the Russian and the US curricula address real-life problems, but in fundamentally different manners. In the former, they are carefully planned and sequenced to help students develop a theoretical understanding of mathematical concepts and an ability to analyse problem situations (Cai et al., 2005). Rather than proceeding inductively from the concrete to the abstract as Investigations does, the Davydov curriculum develops students' ability to see the same abstract relationships across different concrete contexts. Investigations engages students in mathematical problems embedded in authentic contexts and these applied problem-solving activities require US students to explore problems in depth, construct their own strategies and approaches utilizing a variety of tools (e.g., manipulatives, computers, calculators), and communicate their mathematical reasoning through drawing, writing, and talking (Cai et al., 2005).

Based on recent research on early algebra and the language of learning progression, Blanton et al. (2015) have identified five so-called big ideas connected to algebraic thinking. These big ideas

¹ About 5% of the Finnish population has Swedish as their mother tongue, and have the right to receive education in Swedish.

consist of: 1) equivalence, expressions, equations and inequalities; 2) generalized arithmetic; 3) functional thinking; 4) proportional reasoning; and 5) variables. In a recent study, we used the big ideas as the basis for an analytical tool in order to analyse the algebraic content in the current Swedish curriculum for mathematics as well as two Swedish textbook series for Grades 1-6 (Bråting, Madej & Hemmi, 2019). In the study reported in this paper, we look more in-depth at Grades 1-3 and the first two big ideas. The first – equivalence, expressions, equations and inequalities – includes relational understanding of the equal sign; representing and reasoning with expressions, equations, and inequalities; as well as relationships between and among generalized quantities. The second big idea – generalized arithmetic – involves reasoning about structures of arithmetic expressions (rather than their computational value) as well as generalizations of arithmetical relationships, which include fundamental properties of numbers and operations (e.g., the commutative property of addition) and inverse properties of operations (Blanton et al., 2015).

Method

We chose the textbooks to be analysed based on our knowledge of their popularity in each region. In order to examine the variation within different contexts, we chose two textbook series each in Estonia (*Matemaatika* by Koolibri and *Matemaatika* by Avita), Finnish Finland (hereafter FinFin) (*Kymppi* and *Tuhattaituri*), and Sweden (*Eldorado* and *Matte Safari*). Only one series has been produced in the Finnish Swedish context (hereafter FinSwe), *Lyckotal*. In the data analysis, we identified the sections connected to the big ideas of equivalence, expressions, equations, and inequalities as well as generalized arithmetic. The insider(s) in each region conducted the analysis according to our collective interpretation of the categories based on our thorough discussions, and the analyses were then discussed by the whole research team. The analysis was qualitative, identifying the character of the texts and their order/place of appearance throughout the three grades in order to understand the progression of this big idea within various topics. The only quantification that took place in the analysis was connected to the identification of possible dominating topics. For example, if a certain kind of task occupied a great number of pages in a textbook or occurred regularly throughout the grades, it was marked in the analysis protocol. While it is not possible to report the results of the entire study within the scope of this paper, in the following we will describe, exemplify, and discuss the most striking differences and similarities displayed in the textbooks from the four regions.

The results with illustrative examples

Estonia

Addition and subtraction are introduced simultaneously in Grade 1, with subtraction introduced as the inverse of addition. In Grade 2, multiplication and division using whole numbers are introduced in a similar manner. Students are to find missing values using the inverse property of the operations (Figure 1). They should learn the names of the components and results of the four arithmetic operations in order to be able to reason about informal equation solving using the inverse property of the operation at a more general level. In addition, the trial and error strategy is introduced for searching the value of an unknown. At this stage, various symbols (box, blank, letter) are widely used in the textbooks to represent a variable or an unknown. Children are expected to learn to use

letters to express the relationships between quantities and determine the correct order of operations in expressions (parentheses, multiplication/division and addition/subtraction) from Grade 2. The notions of equivalence and inequality of two expressions (incl. letter expressions) are introduced and practiced using the formal signs ($=$, $<$, $>$) from the beginning.

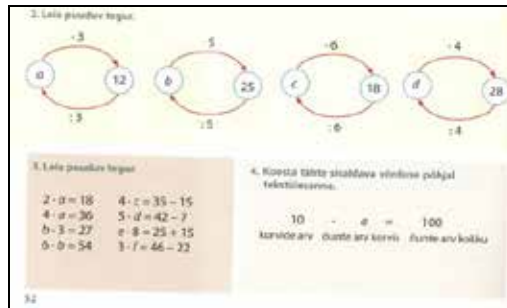


Figure 1. Division as the reverse of multiplication in Estonian Grade 2 textbook, (*Matemaatika by Koolibri*)

Rather than seeing equations as simply objects to manipulate, in Estonian primary textbooks from Grade 2 the equations describe relationships between varying quantities that arise from contextualized situations. Children are required to schematically represent the internal quantitative relationships in word problems and to write expressions of these relationships (Figure 2). This process is sequenced by the authors so that the same abstract relationship appears in different concrete contexts. Textbooks also systematically guide students in composing their own word problems for given expressions.



Figure 2. Modelling word problems in Estonian Grade 2 textbook (*Matemaatika by Koolibri*)

Finland

In the FinFin textbooks, equalities and inequalities are presented with formal signs ($>$, $<$, $=$) in parallel from the very beginning of Grade 1 and are used consistently throughout the three grades. First, only numbers are compared, and later during Grade 1, expressions are compared. This approach is different from the FinSwe style, in which the equal sign is introduced in Grade 1 while the signs for inequalities are only briefly introduced and practiced. Similar to the Estonian textbooks, one of the FinFin textbooks (*Tuhattaituri*) introduces the inverse property of addition and subtraction and guides students in using it in informal equation solving during Grade 1. The same is done with multiplication and division in Grade 2. This is not the case in the FinSwe textbooks, however, where equations start to appear at the beginning of Grade 1 in connection with the partition of specific numbers, for example with the number 5 in Figure 3.

The inverse property of addition and subtraction is introduced very briefly in the FinSwe textbooks during the first school year using so-called *number families*, whereby the student is tasked with writing out different expressions with the numbers 10, 3 and 7 in the shape of a triangle with + and – signs included. Hence, the students are expected to see how the members of this “family” are connected to each other via the operations. No explicit connections are made to guide students in using the inverse properties in equation solving. In the FinFin textbooks, the informal equation solving proceeds step-by-step by first focusing only on equations in which the same term of the operations is missing, while in the FinSwe books, diverse and sometimes open equations start appearing quite early in Grade 1. For example, students are asked to create two different expressions that are equal to each other during the first school term by filling out empty spaces (e.g. $_ + _ = _ + _$), or with expressions in which the operations are missing (e.g. $4 _ 3 = 5 _ 2$).

$1 + _ = 5$
$2 + _ = 5$
$3 + _ = 5$
...

Figure 3. Partition of the number 5 in the FinSwe textbook (*Lyckotal*)

Contrary to the FinFin textbooks, at no point during Grade 1 are students asked to check their solutions by using the inverse operation. Neither the FinFin nor the FinSwe textbooks use letters for variables or unknown quantities during Grades 1-3; instead, they use gaps or pictures such as flowers and hearts. Thus, in the textbooks from the two language contexts students are expected to write the expressions of operations based on pictures or real-world problems from the beginning. The FinSwe textbooks also guide students in finding real-world problems for expressions, which we do not find in the FinFin textbooks.

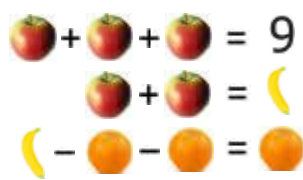
<p>a) $16: 4 + 15: 5$ $= 4 + 15: 5$ $= 4+3$</p>	<p>b) </p>
--	--

Figure 4. Handling of expressions (a) and informal equation systems (b) in the FinFin mathematics textbooks

In the FinFin context, the priority rules are presented in Grade 2 and students learn to systematically calculate the value of expressions with two operations, stepwise marking every new phase below the previous expression. In Grade 3, students are to handle expressions with three operations in a similar matter, as in Figure 4a, where the first line includes two divisions and one addition. For Grade 3 the FinSwe textbooks state that the multiplicative operation is done before the additive, but all calculations are done in a straight line, i.e., not each below the previous as in the Finnish textbook *Kympy*, shown in Figure 4a. The commutative properties of operations are presented during Grade 1 (addition) and Grade 2 (multiplication) in the FinFin textbooks. The formal names

of the operations are used from the beginning, and in Grade 3 students are to choose the correct expressions for sentences, for instance “Subtract from the quotient of 18 and 2 the product of 2 and 3.” A special feature of the Finnish textbook is its repeated exercises from the very beginning in solving systems of equations in an informal manner (see Figure 4b).

Sweden

What characterizes the Swedish textbook series, especially *Matte Safari*, is the emphasis on open number sentences (see Figure 5). Inverse expressions occur in the context of number families, but the connection between addition and subtraction is barely visible in practice. As in the FinSwe textbooks, no explicit connections are used to guide students in applying the inverse properties in equation solving. We found only one example in a single textbook (*Eldorado*) in which students were to check their solutions using the inverse property.

$32 + \underline{\quad} = 36$	$51 + \underline{\quad} = 58$	$75 + \underline{\quad} = 80$
$34 + \underline{\quad} = 39$	$43 + \underline{\quad} = 47$	$22 + \underline{\quad} = 30$
$36 + \underline{\quad} = 38$	$84 + \underline{\quad} = 85$	$53 + \underline{\quad} = 60$

Figure 5. Practicing of open number sequences (*Matte Safari*)

Both textbook series present the commutative property of addition and state that subtraction is not commutative. Multiplication is introduced in Grade 2, and the commutative property of multiplication is shown in both textbook series. The inverse relation between multiplication and division is only presented in *Eldorado*. Expressions are addressed in both textbook series, but more often in *Eldorado*. In both series, the expressions go “both directions”, i.e. students are expected to write an expression from a real-world problem or a picture, but also to create their own text problem for a given expression. This is similar to the Estonian and FinSwe textbook series. An example of this is the task “Draw and write text problems” in Grade 1, in which students are to create text problems for the expressions $5+3+2$ and $12-5$.

<p>Symbolen x Symbolen x har ett värde så att likheten stämmer. $3 + x = 5$ $x = 2$</p>	<p>$40 + x = 48$ $x = \underline{\quad}$ $x + 70 = 71$ $x = \underline{\quad}$</p>
---	--

Figure 6. Examples of equations in the Swedish Grade 1 textbook (*Eldorado*)

Priority rules are not considered in either of the two Swedish textbook series; and neither are inequalities, even though one of the textbooks guides students in using the symbols for “greater than” and “less than” to express which of two numbers is larger or smaller. However, this appears only one single time and in the other textbook these symbols are not used at all. The relational meaning of the equal sign is emphasized in both textbook series, especially *Matte Safari*. For example, students are asked to write $=$ or \neq between expressions like $9 - 2$ and $4 + 4$ or $7 + 3$ and $2 + 8$. There are also fully open number sentences, such as $_ + _ = _ + _$, in line with the FinSwe

textbooks. Neither of the textbook series introduces formal equation solving. Yet, one of the textbooks introduces “the symbol x ” as a placeholder in Grade 1, using the sentence “The symbol x has a value which makes the equality true”, and lets students find the value of x through inspection (Figure 6). However, this is not followed up in Grade 2 or 3.

Discussion and conclusion

Our analysis reveals both differences and similarities between the four regions. Next, this will be discussed in light of relevant research.

The Estonian textbooks and one of the Finnish textbook series frequently use inverse properties of operations in connection with informal equation solving, which is similar to how informal equation solving is prescribed in the Singaporean and Chinese curriculum documents (Cai et al., 2005). Meanwhile, the Finnish Swedish and the Swedish textbook series use inverse properties of operations in the context of “number families” (Figure 3), but not explicitly in connection with informal equation solving. Instead, they both frequently use open number sentences to introduce students to equation solving. In Sweden, this approach might be connected to the emphasis on the meaning of the equal sign, which is explicitly pointed out in the current Swedish mathematics curriculum for Grades 1-3 (Bråting, Madej & Hemmi, 2019). In all textbook series from the four regions, the handling of expressions appears to varying degrees and students are expected to write expressions based on real-world problems. However, it is only in the Estonian textbooks that students are expected to create letter expressions and equations, which is in conformity with the Russian Davydov curriculum in which letters are used from the very beginning (Cai et al., 2005). The Swedish and the FinSwe series guide the students in finding real-world problems for expressions by means of writing and drawing. This approach is analogous to the US Investigations curriculum, in which students are required to explore problems in depth and construct their own strategies using a variety of tools (Cai et al., 2005).

We know that both Estonian and Finnish students have had outstanding results on PISA (Programme for International Student Assessment), in which concrete real-life problems are solved. Both Estonian and FinFin textbooks focus on the creation of quite complicated expressions in Grades 1-3, which might enhance students’ structural understanding of problems. This is something to delve into more deeply in further studies. Perhaps the most striking result is the difference we found between the Finnish language contexts. Although they follow the same national curriculum, the FinFin textbooks contain elements similar to the Estonian textbooks, while the FinSwe textbooks seem to have been influenced by Swedish traditions or vice versa. In fact, there seems to be a greater difference between the two Swedish textbook series than between one of the Swedish series and the Finnish Swedish textbook series. There is no government auditing of the textbooks in the three countries, and we are seeing an increased exchange of curriculum material between countries (e.g. Hemmi, Krzywacki & Liljekvist, 2018). In addition, some publishing companies have emerged across the countries. This might lead to greater variation between textbook series within single contexts, but also similarities across various contexts, making our understanding of the connections between curriculum materials and student outcome within a certain context more difficult.

Acknowledgment

This work was supported by the Swedish Research Council [Grant number 2015–02043].

References

- Andrews, P. (2007). The curricular importance of mathematics: A comparison of English and Hungarian teachers' espoused beliefs. *Journal of Curriculum Studies*, 39, 317-338.
- Blanton, M., Stephens, A., Knuth, E., Murphy Gardiner, A., Isler, I., & Kim, J-S. (2015). The development of children's algebraic thinking: The impact of a comprehensive early algebra intervention in third grade. *Journal for Research in Mathematics Education*, 46(1), 39-87.
- Bråting, K., Madej, L., & Hemmi, K. (2019). Development of algebraic thinking: opportunities offered by the Swedish curriculum and elementary mathematics textbooks. *Nordic Studies in Mathematics Education*, 24(1), 27-49.
- Cai, J., Lew, H., Morris, A., Moyer, J., Ng, S.F., & Schmittau, J. (2005). The development of students' algebraic thinking in earlier grades. *ZDM – The International Journal on Mathematics Education*, 37(1), 5-15.
- Hemmi, K., Krzywacki, H., & Liljekvist, Y. (2018). Challenging traditional classroom practices: Swedish teachers' interplay with Finnish curriculum materials. *Journal of Curriculum Studies*, 1-20.
- Hemmi, K., Bråting, K., Liljekvist, Y., Prytz, J., Madej, L., Pejlare, J., & Palm Kaplan, K. (2018). Characterizing Swedish school algebra – initial findings from analyses of steering documents, textbooks and teachers' discourses. In E. Norén, H. Palmér & A. Cooke (Eds.), *Nordic research in mathematics education. Papers of NORMA 17* (pp. 299–308). Gothenburg: SMDF.
- Kilhamn, C. (2014). When does a variable vary? Identifying mathematical content knowledge for teaching variables. *Nordic Studies in Mathematics Education*, 19(3-4), 83-100.
- Leung, F. K. S., Park, K., Holton, D., & Clarke, D. (Eds). 2014. *Algebra Teaching around the World*. Rotterdam: SensePublishers.
- Lepik, M.; Grevholm, B.; Viholainen, A. (2015). Using textbooks in the mathematics classroom - the teachers's view. *Nordic Studies in Mathematics Education*, 20, 129–156.
- Pehkonen, L., Hemmi, K., Krzywacki, H., & Laine, A. (in press). A cross-cultural study of teachers' relation to curriculum materials. In E. Norén, H. Palmér & A. Cooke (Eds.), *Nordic research in mathematics education. Papers of NORMA 17* (pp. 299–308). Gothenburg: SMDF
- Röj-Lindberg, A-S., Partanen, A-M, & Hemmi, K., (2017). Introduction to equation solving for a new generation of algebra learners. In Dooley, T. & Gueudet, G. (Eds.). *Proceedings of the Tenth Congress of the European Society for Research in Mathematics Education (CERME10, February 1-5, 2017)*. Dublin, Ireland: DCU Institute of Education and ERME.
- Yang Hansen, K., Gustafsson, J-E., Rosén, M., Sulkunen S., Nissinen, K., Kupari, P., ... Hole, A. (2014). *Northern lights on TIMSS and PIRLS 2011: differences and similarities in the Nordic countries*. Copenhagen: Nordic Council of Ministers.

A preliminary comparison of Chinese and German state mandated curricula for mathematics education (years 1 to 6)

Eva Jablonka

Freie Universität Berlin, Department of Education and Psychology, Germany;
Eva.jablonka@fu-berlin.de

The paper presents a preliminary analysis of official state-mandated curriculum documents for compulsory school mathematics education in China and Germany with a focus on years one to six. Both documents were issued in the context of relatively recent reform initiatives. In the context of these reforms some have observed an international harmonization of curriculum goals via the educational discourse disseminated by the OECD. This trend motivates the comparison. The preliminary comparison presented in this paper is part of a larger upcoming project that investigates how curriculum objectives are interpreted by actors at different levels of governance in systems with differing policies for controlling curriculum implementation. As a starting point for investigating the discretionary space granted to schools and teachers in their micro-curricular planning, the comparison presented here identifies the level of detail in the content standards.

Keywords: Mathematics curriculum, curriculum research, cross cultural studies, educational goals.

China and Germany – comparing the incomparable?

In China, after an incipient period in the 1950s where Soviet mathematics education was investigated and “sinocised” through translating and adapting Soviet textbooks (Ye, 2018), subsequent explorations of other systems appear much more diverse and critical. At a national forum convened by the Ministry of Education of the P.R.C. in 1959, investigations of Eastern European curriculum reforms were initiated; in the 1960s comparisons included the German Democratic Republic, the Soviet Union as well as the United States and Japan. In the late 1970s and the 1980s, the People’s Education Press investigated textbooks from Germany (along with some from England, France, Japan and the United States) in order to look at the structuring of mathematical knowledge and arrangement of topics (Xu, 2013). Some dimensions of the recent Chinese curriculum reform were originally initiated by investigations of trends in mathematics education in a range of countries, including Germany, Hong Kong, the United States and Taiwan in the 2000s (Lv & Cao, 2018; Ye, 2018).

In the context of incipient reforms in the 1950s, classroom pedagogy in some regions in northern China was found to draw on a five-step formal sequencing model for instruction (preparing; prompting; making comparisons; summarizing; applying) developed by the German philosopher Friedrich Herbart (who held Emmanuel Kant’s chair in Königsberg) and his followers; the model was imported during the New Culture Movement. According to Ruan and Zheng (2012) this sequencing of instruction is still seen in many classrooms in China at the beginning of the 21st century.

Over the last decade the Chinese mathematics curriculum has been subjected to continuous reforms. Some shift in focus is according to Zhang (2018, p. 480) motivated by the needs created in an era of “knowledge-based economies and information-based societies, the fierce international competition and challenges”, which require a capability for “knowledge innovation and scientific innovation, to

be able to collect, sort and express information using mathematical methods, establish models, solve problems, and create value for society.” The resulting revised compulsory mathematics curriculum standards (issued in 2011; implemented in autumn 2012) stress the importance of mathematical thinking and problem solving, including problems in real-world settings, in addition to the traditional emphasis on developing basic mathematical knowledge and skills (Wang et al., 2018). Further, aspects of what often is associated with allegedly ‘Western’ pedagogies, including ‘student-centered’ activities such as experimenting and conjecturing, argumentation and discussion have found their way into official Chinese recommendations for curriculum implementation (Li & Li, 2018). The changes in China also entailed a de-centralizing of educational administration and textbook production in order to allow for more diversity (Cai & Nie, 2007). In comparison to the previous policy for controlling curriculum implementation via textbooks, this entails a shift towards proposing the use of a range of resources, only harmonized by the national standards, which consequently (compared with the old syllabus) expanded in scope and depth (Xu, 2013; Wang et al., 2018).

In Germany, the unexpectedly low national performance in the OECD’s PISA as well in the IEA’s TIMSS-tests at the turn of the millennium stimulated a major debate on the quality of schooling and resulted in a new focus in educational policy. The Federal Ministry of Education and Research (BMBF) *inter alia* justified the need for developing outcome-oriented national educational standards by comparisons with some more successful education systems in the PISA-ranking. As a matter of fact, the selected comparator countries not only had adopted national curriculum standards, but also engaged in regular external evaluations of student achievement-outcomes. As Ertl (2006) points out, this new attempt of curriculum alignment across the Länder of the Federal Republic of Germany was conceptually different from earlier approaches of the Standing Conference of the Ministers of Education and Cultural Affairs (KMK) to reaching agreement on shared national standards since the late 1990s. The initiative not only aimed at modernizing and homogenizing local curricula, but also at alignment of educational aims and assessment. According to an expertise commissioned by the BMBF, the new national curriculum should describe competencies at a level of detail that not only affords conversion into learning tasks for students but in principle also into test items so that it becomes “possible to check whether the desired competencies have actually been acquired.” And further, “This will determine the extent to which the education system has fulfilled its mandate (educational monitoring), and schools will receive feedback on the results of their work (school evaluation)” (Klieme et al., 2003, p. 10, transl. EJ). At the same time the expertise recommended that standards should determine competency outcomes (instead of listing topics to be covered) and so leave sufficient freedom for schools and teachers for micro-curricular planning.

The resulting national curriculum document bears some similarities with the US National Council of Teachers of Mathematics (NCTM, 2000) standards in its descriptions of general (topic- and context-independent) processes and the structuring of mathematical topics in broader areas. All Länder have agreed to use the national standards as a basis for developing new local curricula as well as in teacher education. In parallel they also founded institutes responsible for the control and the improvement of the quality of schooling. These institutes not only employ assessment for educational monitoring and school evaluation, but also aim at developing teachers’ professional practices by exemplary operationalization of the curriculum standards in the form of assessment tasks (Blum et al., 2006).

The above sketch of diverse reform movements, in the context of which the Chinese and German mathematics curriculum documents have been produced, suggests that the texts under scrutiny represent hybrids of a range of pedagogic discourses from antecedent national curricula and other educational policy texts, international curricula as well as national recontextualisations of policy texts produced by supra-national institutions. The stated curriculum objectives in both systems reflect international mathematics education discourses that frame the outcomes as not only relevant for developing disciplinary knowledge, but stress applications ('mathematical literacy', 'practical mathematics', 'numeracy') (Jablonka, 2015). Consequently, these curricula can be expected to share some objectives and so have sufficient in common to make an investigation of their differences meaningful. Further, while in both systems there are centralized education regulations, there are differences in modes of governance that shape the decisions of actors (schools, teachers, textbook writers etc.). The production of textbooks in the two systems certainly recontextualises official pedagogic discourse in different spheres, with more or less intersections with the economic field.

Goals and methodology

In addition to other curriculum control instruments, such as officially sanctioned textbooks, external assessments, school inspections and other measures of evaluation, an investigation of curriculum documents provides a starting point for investigating how much interpretive action is granted to teachers. Depending on the level of detail in prescriptions of curriculum standards, teachers might perceive greater or lesser freedom to decide upon what content to bring into focus and how to adapt their instructional strategies in line with their school ethos, their professional identities, and personal values. In turn, such curriculum adaptations might either mitigate or (unintentionally) reinforce unequal access to mathematical knowledge: on the one hand, access to the generative principles and styles of mathematical reasoning that underpin disciplinary knowledge, and on the other, to more skill-based forms (e.g., Dowling, 1998; Jablonka & Gellert, 2012). This concern has been raised in the context of curriculum reforms in both systems: in China particularly with respect to increasing social inequality (Cai & Nie, 2011); in Germany with a focus on the challenges for teachers in finding ways to address the needs of heterogeneous groups of students (Siller & Roth, 2016).

Based on the general research interest stated above, this preliminary comparison explores at which level of detail the prescriptions operate and which forms of mathematical knowledge and skills they privilege. It is part of a larger upcoming project that investigates how curriculum objectives are interpreted by actors at different levels of governance in systems with differing policies for controlling curriculum implementation. The larger project will investigate the articulation of curriculum objectives at three levels, which are commonly conceptualized as macro-, meso- and micro-levels, and will include case studies of classroom practice. While conceptualising the relation between these levels as "recontextualisation" of pedagogic discourses (Bernstein, 1996), in the project this is not interpreted as constituting a hierarchical relation.

The focus of the comparison are the state mandated curricula for mathematics education for years 1 to 6. For Germany, the recently issued common mathematics curriculum standards for Berlin and Brandenburg (Senatsverwaltung für [...], 2015; henceforth the "G-BBM") has been chosen as an example. The document has been developed in order to align the local with the statewide standards.

In the two Länder primary school comprises 6 grades (instead of the usual four). The Chinese national curriculum standards for compulsory mathematics education (Ministry of Education P. R. C., 2012; henceforth the “C-NCM”) are grouped into three stages, grades 1-3, grades 4-6, and grades 7-9. Only the first two stages are of interest for the comparison. The G-BBM is for grades 1-10. It is structured in levels A-H within topics. For years 1-6, “as a rule” the levels A-D are to be reached and so these have been chosen for the comparison. One shared feature of the two documents is the coherent structuring of the mathematical topics beyond grade six, which affords useful comparison.

The most obvious challenge of this comparison is language. The Chinese document was subjected to a machine translation into English as well as into German. In some instances, these versions complemented each other and lead to improvements. The draft was further edited with the aid of an online German-Chinese dictionary. In many cases only knowledge of school mathematics helped to edit the translation. In addition, a semi-official English translation of an early trial-version has been consulted along with translations of key concepts in publications authored by insiders. Still, there remained quite some nonsensical portions of text.

Both the C-NCM and the G-BBM contain sections with mathematical topics (entitled “Content Standards” and “Topics and Content”, respectively). These sections contain short statements with some thematic coherence under one or two levels of headings and subheadings with names for school mathematical areas and specific topics. In the texts, these statements are clearly separated by lay-out (paragraph spacing, arrangement in table cells, numbering). For the analysis, each visually separated portion of text has been counted as one statement. While simply counting statements admittedly does not provide deep insights about the authority relations established by the state-author with the teacher-reader, this simple comparison of content standards might reveal differences to be explored further.

A difference that emerged when reading the content statements concerns the “discursive saturation” of the suggested student activity; the notion here is used in the sense of Dowling (2009). While interpreting the translated curriculum statements has been aided by an explanation of “action verbs” used in the curriculum document found in the Appendix of the C-NCM, an in-depth analysis of envisaged student learning activities clearly is not possible with the machine translation. However, Bernstein’s (1996) notion of “classification” can be applied to the structuring of the content in the documents, as his notion does not differentiate between forms of expression and content.

Outcomes

The C-NCM has four main sections: “Section I: Preamble”; “Section II: Curriculum Objectives”; “Section III: Content Standards”; “Section IV: Recommendations” (including suggested pedagogic strategies, evaluation recommendations, guidance on textbook development, development and usage of resources). If from Section III only the text for grades 1-6 is taken (which is relevant here), the proportions of the sections (pages of the English version) are very roughly as follows: One fifth for sections I and II together; one fifth for section III; three fifths for section IV. Obviously, the section that describes content standards is comparatively short.

The German G-BBM has three main sections: “1. Development of Competencies in Mathematics”, “2. Competencies and Standards”, “3. Topics and contents”. If from Section 3 only the text for levels A-D is taken, the proportions of the sections (pages) are very roughly as follows: Five eighths for

sections 1 and 2 together; three eighths for section 3. Obviously, the section that describes “topics and content” is also comparatively short, but fills a larger proportion of the document than in the C-NCM.

Table 1 depicts the number of statements for each stage by topics and subtopics in “Section III: Content Standards” of the C-NCM. The abbreviations are explained under the table. Topics and subtopics are enlisted in rows and columns in the order of appearance in the text. “Practical and integrated applications” (in some publications the English term is “Practice and Synthesis Application”), aims at providing opportunities for cross-disciplinary work as well as for inner-disciplinary connections, and so guide “students to focus on practice and application” and “making the abstract mathematical concepts deeply rooted in children’s real lives” (Wang et al., 2018 p. 67). The standards for statistics and probability obviously are less detailed than for the other topics.

	First Stage (Grades 1-3)				Second Stage (Grades 4-6)					Sum
	NA ₁	NA ₂	NA ₃	NA ₄	NA ₁	NA ₂	NA ₅	NA ₆	NA ₄	
<i>Numbers and Algebra</i>	7	8	5	1	9	10	4	4	1	49
<i>Graphics and Geometry</i>	GG ₁	GG ₂	GG ₃	GG ₄	GG ₁	GG ₂	GG ₃	GG ₄		43
<i>Statistics and Probability</i>	no sub-division				SP ₁	SP ₂				
	3				6	2				11
<i>Practical and Integrated Applications</i>	no sub-division				no sub-division					
	3				4					7
Sum Total										110

Table 1: Number of statements in “Section II: Content” (First Stage and Second Stage) of the C-NCM.

Abbreviations used for subtopics in Table 1 are as follow: **NA₁** *Knowing Numbers*; **NA₂** *Number Operations*; **NA₃** *Common Quantities*; **NA₄** *Exploring Patterns*; **NA₅** *Expressions and Equations*; **NA₆** *Direct and Inverse Proportion*; **GG₁** *Knowing Figures*; **GG₂** *Measurement*; **GG₃** *Figures and their Transformation*; **GG₄** *Figures and their Positions*; **SP₁** *Simple Statistical Data Processing*; **SP₂** *Random Phenomena*.

Table 2 (next page) depicts the number of statements for the levels A-D by topics and subtopics in the section “3. Topics and contents” of the G-BBM.

A comparison of the two tables suggests that the German content standards (Berlin-Brandenburg) provide more detailed descriptions than the Chinese. There are three levels in structuring the content in G-BBM, while in the C-NCM there are only two. As to the content, the school mathematical area *Quantities and Measuring* of the G-BBM, a topic that only appears in the German document, is in the C-NCM integrated into *Numbers and Algebra* in the subtopic *Common Quantities* (NA₃), and into *Graphics and Geometry* in the subtopic *Measurement* (GG₂). Here the classification of the C-NCM is stronger as it reflects classificatory principles of academic mathematics. The other extra topic in the G-BBM, namely *Equations and Functions*, is in the C-NCM largely contained in the topic *Numbers and Algebra*. The German G-BBM does not include an extra cross-topic field (such as *Practical and Integrated Applications* in the C-NCM), but outlines six mathematical “process

standards” (generic skills or key competencies), which are described in the section “1. Development of Competencies in Mathematics” and “2. Competencies and Standards”.

	Level B (End of grade 2)					Level C (End of grade 4)					Level D (End of grade 6)					Sum
<i>Numbers and Operations</i>	Na			Nb		Na			Nb		Na			Nb		
	Na ₁	Na ₂	Na ₃	Nb ₁	Nb ₂	Na ₁	Na ₂	Na ₃	Nb ₁	Nb ₂	Na ₁	Na ₂	Na ₃	Nb ₁	Nb ₂	
	8	5	5	4	6	4	4	4	4	7	5	5	6	5	7	79
<i>Quantities and Measuring</i>	Qa		Qb			Qa			Qb		Qa		Qb			
	Qa ₁	Qa ₂	Qb ₁			Qa ₁	Qa ₂	Qb ₁			Qa ₁	Qa ₂	Qb ₁			
	7	5	3			7	4	4			8	8	6			52
<i>Space and Shape</i>	Sa			Sb		Sa			Sb		Sa			Sb		
	Sa ₁	Sa ₂	Sa ₃	Sb ₁	Sb ₂	Sa ₁	Sa ₂	Sa ₃	Sb ₁	Sb ₂	Sa ₁	Sa ₂	Sa ₃	Sb ₁	Sb ₂	
	6	3	9	4	4	4	5	7	3	4	3	5	4	2	2	65
<i>Equations and Functions</i>	Ea		Eb			Ea		Eb			Ea		Eb			
	Ea ₁	Ea ₂	Eb ₁	Eb ₂	Eb ₃	Ea ₁	Ea ₂	Eb ₁	Eb ₂	Eb ₃	Ea ₁	Ea ₂	Eb ₁	Eb ₂	Eb ₃	
	3	6	3	2	1	4	5	2	2	2	3	3	2	2	1	41
<i>Data and Chance</i>	Da			Db		Da			Db		Da			Db		
	Da ₁	Da ₂	Da ₃	Db ₁	Db ₂	Da ₁	Da ₂	Da ₃	Db ₁	Db ₂	Da ₁	Da ₂	Da ₃	Db ₁	Db ₂	
	2	3	3	3	3	2	2	3	2	5	1	2	1	1	2	35
Sum Total															272	

Table 2: Number of statements in section “3. Topics and Contents” (levels A to D) of the G-BBM.

Abbreviations used for subtopics in Table 2 are as follow: **Na** *Conceptions of Number*: **Na₁** Perceiving and representing numbers; **Na₂** Ordering numbers; **Na₃** Describing number relationships; **Nb** *Conceptions of Operations and Calculation Strategies*: **Nb₁** Developing conceptions of operations; **Nb₂** Using calculation procedures and strategies; **Qa** *Conceptions of Quantities and Measuring*: **Qa₁** Utilizing conceptions of quantities and their units; **Qa₂** Determining expressions for quantities; **Qb** *Calculating with Quantities*: **Qb₁** Calculating quantities in contexts; **Sa** *Geometrical Objects*: **Sa₁** Describing geometrical objects; **Sa₂** Describing relationships between geometrical objects; **Sa₃** Representing geometrical objects; **Sb** *Geometrical Transformations*: **Sb₁** Utilizing geometrical transformations and their properties; **Sb₂** Carrying out geometrical transformations; **Ea** *Terms and Equations*: **Ea₁** Representing terms and equations; **Ea₂** Solving equations; **Eb** *Mappings and Functions*: **Eb₁** Exploring mappings and functions; **Eb₂** Representing mappings and functions; **Eb₃** Utilizing properties of functional relationships; **Da** *Data*: **Da₁** Collecting data; **Da₂** Representing data; **Da₃** Evaluating statistical investigations; **Db** *Counting strategies and probabilities*: **Db₁** Using counting strategies; **Db₂** Determining probabilities of events.

Concluding comments

Contrary to what might have been expected, the German content standards (Berlin-Brandenburg) describe learning outcomes at a much higher level of detail than the Chinese. This conflicts with the

official policy discourse which preceded their development. According to Klieme et al. (2003), the new standards should describe broader competency outcomes. The similarities in the main structuring of the topics in both documents suggests some cross-system harmonization of objectives in the 2000s (see Lv & Cao, 2018; Ye, 2018). The Chinese content standards, however, appears to leave more discretionary space to teachers and schools for making micro-curricular decisions. In both contexts, the role of accountability measures vis-à-vis the standardization of the curriculum needs to be investigated. Regarding the naming of the topics and sub-topics, the Chinese appears to be more specialized, but complemented by the topic *Practical and Integrated Applications*. If Bernstein's (1996) concept of "classification" is applied here, this interpretation suggests an intended move towards weakening (internal and external) classification by establishing more relations with other school subjects as well as with everyday practice. This might be one of the reasons for the opposition against the reform from mathematicians reported by Yin (2013).

One conspicuity that emerged in the course of the investigation concerns the use of verbs that refer to students' competencies in terms of "experiencing", "developing a feeling for" or "grasping". Examples of such statements are, "[Students are] able to feel the meaning of large numbers when associated with realistic material, as well as to make estimations." (First Stage, "Numbers and Algebra: Knowing Numbers"), "Experience that amongst all lines connecting two points the segment is the shortest." (Second Stage, "Graphics and Geometry: Knowing Figures"). The German document does not contain similar statements. A consistent investigation of this observation has been hampered by the low-quality machine translation. However, it can be taken as an indication for a greater focus on non-discursive dimensions of mathematical practice. A systematic investigation of differences in curriculum statements with regard to privileged forms of knowledge and skills will have to include an analysis of stated overall objectives as well as pedagogic recommendations or examples of student activities that are given to exemplify the envisaged classroom practice. An important follow up question then is whether the documents aim at providing insights into the principles on the basis of which the curriculum has been developed.

References

- Bernstein, B. (1996). *Pedagogy, symbolic control and identity: Theory, research, critique*. London: Taylor & Francis.
- Blum, W., Dürke-Noe, C., Hartung, R., & Köller, O. (Eds.) (2006). *Bildungsstandards Mathematik: konkret*. Berlin: Cornelsen.
- Cai, J., & Nie, B. (2007). Problem solving in Chinese mathematics education: Research and practice. *ZDM International Journal on Mathematics Education*, 39(5-6), 459-473.
- Dowling, P. (1998). *The sociology of mathematics education: Mathematical myths/pedagogic texts*. London: Routledge.
- Dowling P. (2009). *Sociology as method: Departures from the forensics of culture, text and knowledge*. Rotterdam: Sense.
- Ertl, H. (2006). Educational standards and the changing discourse on education: the reception and consequences of the PISA Study in Germany. *Oxford Review of Education*, 32(5), 619-634.

- Jablonka, E. (2015). The evolvement of numeracy and mathematical literacy curricula and the construction of hierarchies of numerate or mathematically literate subjects. *ZDM Mathematics Education*, 47(4), 599-609.
- Jablonka, E., & Gellert, U. (2012). Potentials, pitfalls and discriminations: Curriculum conceptions revisited. In O. Skovsmose & B. Greer (Eds.), *Opening the cage: Critique and politics of mathematics education* (pp. 287-308). Rotterdam: Sense.
- Klieme, E., Avenarius, H., Blum, W., Döbrich, P., Gruber, H., Prenzel, M., ... Vollmer, H. J. (2003). *Zur Entwicklung nationaler Bildungsstandards. Expertise*. Bonn: BMBF.
- Li, H., & Li, N. (2018). Features and characteristics of Chinese new century mathematics textbooks. In Y. Cao & F. K. S. Leung (Eds.), *The 21st Century Mathematics Education in China* (pp. 171-192). Berlin: Springer.
- Lv, S., & Cao, C. (2018). The evolution of mathematics curriculum and teaching materials in secondary schools in the twenty-first century. In Y. Cao & F. K. S. Leung (Eds.), *The 21st century mathematics education in China* (pp. 147-169). Berlin: Springer.
- Ministry of Education P. R. C. (2012). *Mathematics curriculum standards for compulsory education (2011 version)* [in Chinese]. Beijing: Beijing Normal University Publishing Group.
- National Council of Teachers of Mathematics (NCTM) (2000): *Principles and standards for school mathematics*. Reston, VA: NCTM.
- Ruan, J., & Zheng, G. (2012). High school Chinese language and literacy curriculum reforms. In C. Leung & J. Ruan (Eds.), *Perspectives on teaching and learning Chinese literacy in China* (pp. 141-156). Dordrecht: Springer.
- Senatsverwaltung für Bildung, Jugend und Wissenschaft Berlin, Ministerium für Bildung, Jugend und Sport des Landes Brandenburg (2015). *Rahmenlehrplan für die Jahrgangsstufen 1 - 10 der Berliner und Brandenburger Schulen*. Berlin & Potsdam: Author.
- Siller, H.-S., & Roth, J. (2016). Herausforderung Heterogenität. Grundvorstellungen als Basis und Bezugsnorm – das Beispiel Terme. *Praxis der Mathematik in der Schule*, 70(August), 2-8.
- Wang, L., Liu, Q., Du, X., & Liu, J. (2018). Chinese mathematics curriculum reform in the twenty-first century. In Y. Cao & F. K. S. Leung (Eds.), *The 21st century mathematics education in China* (pp. 53-72). Berlin: Springer.
- Xu, B. (2013). The development of school mathematics textbooks in China since 1950. *ZDM Mathematics Education*, 45(4), 725-736.
- Ye, B. (2018). Developments and changes in the primary school mathematics curriculum and teaching material in China. In Y. Cao & F. K. S. Leung (Eds.), *The 21st century mathematics education in China* (pp. 107-125). Berlin: Springer.
- Yin, H. B. (2013). Implementing the national curriculum reform in China: A review of the decade. *Frontiers of Education in China*, 8(3), 331-359.
- Zhang, C. (2018). Practice and theoretical thinking in constructing a developmental assessment system for mathematics ability. In Y. Cao & F. K. S. Leung (Eds.), *The 21st century mathematics education in China* (pp. 479-493). Berlin: Springer.

Reform on a shaky ground? A comparison of algebra tasks from TIMSS and Swedish textbooks

Kristina Palm Kaplan

Uppsala University, Department of Education, Sweden; Kristina.Palm.Kaplan@edu.uu.se

Keywords: Algebra, curriculum reform, large-scale assessment, textbooks.

URL: <http://dx.doi.org/10.13140/RG.2.2.30727.65448>

Background

In the Swedish curriculum reform of 2011, TIMSS and PISA were explicitly mentioned as a point of departure (Skolverket, 2011). More precisely, algebra was singled out as a topic where students needed to improve their knowledge. Given the large influence of international large-scale assessments, ILSAs, the items of these tests should be further investigated (Säljö & Radišić, 2018).

Comparative studies using data from ILSAs have concentrated on their results, not their tasks (Jablonka, Andrews, Clarke, & Xenofontos, 2018). Moreover, while textbook tasks are common in comparative studies, these often focus on how the learning of a specific topic is presented in textbooks from different countries (Jablonka et al., 2018). They are not considered in relation to curriculum reforms.

The aim of this study is to problematize the role of ILSAs in national curriculum reforms. It builds on results from a previous study of textbook tasks by Palm Kaplan and Prytz (submitted) and is a part of a thesis project which problematizes the role of ILSAs and textbooks in curricular reform, by looking at the algebra in TIMSS 2003–2015 and algebra chapters in Swedish textbooks. This study focuses the case of Swedish school algebra and the 2011 curriculum reform through looking at algebra items from TIMSS 2003, compared to changes in year 8 algebra tasks in three Swedish textbook series. The research question is

- To what extent is the algebra in TIMSS consistent or in conflict with algebra chapters in Swedish textbooks?

Theory and method

The algebra items in TIMSS 2003 are studied to understand what the student is expected to engage with, when solving the items. To get a detailed picture of the items, discourse analysis is combined with an analysis of the algebra offered. These two aspects are discussed in terms of *school algebra discourses* and *algebraic activities* respectively. The school algebra discourses are constructions in linguistic resources (Luke, 1995), steering what choices are possible to express different ideas while the algebraic activities mainly builds on Blanton et al.'s (Blanton et al., 2015) 'big ideas' in algebra. One of these is *functional thinking*, which is the activity to investigate, represent and generalize relationships between co-varying entities (Blanton et al., 2015), e. g. number patterns. The analytic frameworks are further developed on the poster and in Palm Kaplan and Prytz (submitted).

The analysis is conducted in several steps. The two aspects mentioned above are analyzed in the items to obtain the distribution of the algebraic activities in the school algebra discourses. The distribution is then compared to the results of the Palm Kaplan and Prytz (submitted) textbook analysis of 1557

algebra tasks from algebra chapters in six Swedish textbooks. These books come from three textbook series which were on the market before and after the 2011 curriculum reform. TIMSS 2003 entail 45 valid algebra items out of 47. Two trend items are left out since in TIMSS 2007, they are coded by TIMSS as data and chance instead of algebra. Items including more than one activity or more than one discourse are also left aside in this study, for reasons concerning statistical analysis in the thesis. All items are used with permission from the Swedish National Agency of Education. They are chosen as a starting point for further analysis, which will also include the algebra items from TIMSS 2007, 2011 and 2015 in order to understand the development of TIMSS' algebra.

Results

The distributions of the algebraic activities in the school algebra discourses are reasonably corresponding when TIMSS-items are compared to Swedish algebra chapters. However, there are differences between the proportions in the distributions: Swedish algebra chapters concentrate on mainly two algebraic activities while TIMSS 2003 entail other algebraic activities to a larger extent. For example, functional thinking is more stressed in TIMSS. The proportions of the school algebra discourses also differ in the TIMSS-items from the Swedish algebra chapters, and a whole new discourse, the *Relational discourse*, was identified in the TIMSS-items. This discourse constructs algebra as relationships between variables in graphs, tables and symbols; whereas the other discourses, identified in the algebra chapters, do not use graphs as a resource and only occasionally use tables. In Swedish textbooks though, chapters on functions and relations are often saved for year 9, which is the year after the TIMSS-test is taken. Though it is difficult to assess since there are few algebra items in one TIMSS-test compared to in textbooks, these results make one of the points of departure for the Swedish curriculum reform in 2011 questionable.

References

- Blanton, M., Stephens, A., Knuth, E., Gardiner, A. M., Isler, I., & Jee-Seon, K. (2015). The Development of Children's Algebraic Thinking: The Impact of a Comprehensive Early Algebra Intervention in Third Grade. *Journal for Research in Mathematics Education*, 46(1), 39–87.
- Jablonka, E., Andrews, P., Clarke, D., & Xenofontos, C. (2018). Comparative studies in Mathematics Education. In T. Dreyfus, M. Artigue, D. Potari, S. Prediger, & K. Ruthven (Eds.), *Developing Research in Mathematics Education. Twenty Years of Communication, Cooperation and Collaboration in Europe* (pp. 223–238). London, UNITED KINGDOM: Routledge.
- Luke, A. (1995). Text and Discourse in Education: An Introduction to Critical Discourse Analysis. *Review of Research in Education*, 21, 3–48.
- Palm Kaplan, K., & Prytz, J. (submitted). The role of textbooks in a curriculum reform process. The case of Swedish school algebra, 1995 - 2015.
- Säljö, R., & Radišić, J. (2018). Promoting teaching, learning and informed decision-making through the lenses of international large-scale assessment: looking beyond numbers. *European Journal of Psychology of Education*, 33(3), 419–426. <https://doi.org/10.1007/s10212-018-0388-7>
- Skolverket. (2011). *Kommentarmaterial till kursplanen i matematik*. Stockholm: Fritzes offentliga publikationer.

Time series analysis: Moving averages as an approach to analysing textbooks

Jöran Petersson², Judy Sayers¹ and Paul Andrews²

¹Leeds University, England; ²Stockholm University, Department of Mathematics and Science Education, Stockholm, Sweden; joran.petersson@mnd.su.se

In this study we introduce time series analysis, specifically moving averages, as a novel strategy for analysing mathematics textbooks. Such analyses show how different topics or mathematical processes are emphasised over different time periods, whether at the level of the lesson, the week, the month or year. In this paper, by way of example, we show how one of the eight categories of foundational number sense (Andrews & Sayers, 2015), namely simple addition and subtraction, is distributed and sequenced across three English, year one, textbooks. The analyses are compared empirically with four other methods found in the literature to show how time series analysis using moving averages helps address the shortcomings of these different approaches.

Keywords: comparative textbook analysis, foundational number sense, moving average, time series.

Introduction

For many teachers of mathematics, irrespective of where they work, the textbook they use is not only the major resource for lesson planning and the provision of tasks for students but also the means by which the curriculum within which they work is realised (Stein & Kim, 2009; Tarr, Chaves, Reys & Reys, 2006; Stacey & Vincent, 2009). However, textbook analysis is in some way probabilistic in the sense that teachers make decisions as to how they use any book, leaving the analytical question “what would students learn if their mathematics classes were to cover all the textbook sections in the order given? What would students learn if they had to solve all the exercises in the textbook?” (Mesa, 2004, pp. 255–256). That is, researchers are typically interested in understanding the “likely impact of the text on the users (teachers and students)” (Stacey & Vincent, 2009, p.276). Moreover, in those cultures in which textbooks are unregulated, often leading to a plethora of choice for teachers, students may receive very different opportunities to learn (Charalambous, Delaney, Hsu & Mesa, 2010; Huntley & Terrell, 2014; Tarr et al., 2006).

Much of the world’s textbook-related research has employed some form of qualitative description, typically aligned with an analytical framework related to the topic under scrutiny, supplemented by frequency analyses. That is, researchers often count and compare the number of occurrences of particular forms of task in different textbooks. Such studies usually focus on either mathematical content knowledge or mathematical processes, although there are exceptions such as Borba and Selva’s (2013) study of calculator use in Brazilian primary school textbooks. Research focused on mathematical content knowledge has included, for example, studies of primary school textbooks’ treatment of fractions in Kuwait, Japan, and the USA (Alajmi, 2012), Cyprus, Ireland, and Taiwan (Charalambous et al., 2010), division of fractions in grades six and seven in Chinese, Japanese and US textbooks (Li, Chen & An, 2009), multiplication and division of fractions in grades five and six in the textbooks of the USA and Korea (Son & Senk, 2010), inverse relations in US and Chinese primary textbooks (Ding, 2016), functions in the middle school textbooks of 15 countries (Mesa,

2004); geometry in English and Japanese grade eight textbooks (Jones & Fujita, 2013), number sense in year one textbooks in England and Sweden (Löwenhielm, Marshall, Sayers & Andrews, 2017) the distributive property (Ding & Li, 2010) and so on.

Textbook-related studies on mathematical processes has included, for example, examinations of mathematical problem solving (Brehmer, Ryve & Van Stenbrugge, 2016; Fan & Zhu, 2007), mathematical problem posing (Cai & Jiang, 2017), general perspectives on reasoning and proof in Australia (Stacey & Vincent, 2009) and the USA (Stylianides, 2009), geometry-related proof for students in the grades 6-9 in the USA (Otten, Gilbertson, Males, & Clark, 2014) and France and Japan (Miyakawa, 2017), calculus-related reasoning and proof for upper secondary students in Finland and Sweden (Bergwall & Hemmi, 2017).

Other studies have attempted to identify and demonstrate the different emphases within a textbook by going beyond simple quantification. For example, Tarr et al., (2006), in their analysis of American teachers' use of different types of textbooks, introduced what they called the emphasis index, which was defined as the number of lessons taught by a teacher on a topic divided by the number of lessons in the textbook on the same topic. Interestingly, a similar procedure could be applied uniquely to a textbook, where the emphasis index would be the number of lessons on a particular topic in the book divided by the total number of lessons.

However, while frequency analyses have the potential to offer insight into the topics privileged by a textbook's authors they typically offer little with respect to how mathematical ideas are sequenced. Indeed, even though some scholars have conceded that they "examined only proportions of various types of opportunities and did not attend to the sequencing of activities, which may be important with regard to students' learning" (Otten et al., 2014, p.75), few have examined the distribution of codes within a text. Of those studies that have attempted explicitly to examine the distribution of codes, four methods stand out. Firstly, method 1, researchers have identified, in the sequence of all tasks, the position of the first task of interest (Fujita, 2001). Secondly, method 2, researchers have analysed the proportion of a textbook covered before an occurrence of interest (Alajmi, 2012; Li et al., 2009). Thirdly, method 3, studies, particularly those analysing series of textbooks that cross several grade boundaries, have displayed relative percentages across grades (Borba & Selva, 2013; Ding, 2016). Moreover, Ding displayed results in a line diagram, where the distribution of a code per grade level in one book series could be compared with the distribution of the same code per grade level in another book series. This takes us to our final method and the inspiration for our contribution. Fourthly, method 4, studies have exploited timeline analyses, whereby coded observations were presented as dots on a horizontal axis representing the sequence of all tasks through the textbooks. With such an approach, "large swaths of these textbooks were not coded", allowing the reader to see, at a glance, how topics under scrutiny are both located and emphasised (Huntley & Terrell, 2014, p. 758). One advantage of such diagrams is that they give a picture that is fine-grained down to occurrence of individual codes. However, this is also its draw-back. For larger data sets, the graphic in the time-line diagram might get too jammed making it difficult to discern any useful information in the diagram. In this paper we present a comparison of several of these methods before offering a novel methodological perspective on the analysis of textbooks that goes beyond what others have achieved.

In so doing, we aim to make a meaningful contribution to the methods of comparative textbook analysis.

The context of this study

This paper is a preliminary account of textbook analyses conducted as part of the Foundational Number Sense (FoNS) project, which is an ongoing Swedish Research Council-funded study of how FoNS, a set of eight core number-related competences, is acquired by year one children in England and Sweden. These core competences, which research has shown to be essential for later mathematical success, derived from a constant comparison analysis of literature from mathematics education, psychology, special educational needs and generic education (Andrews & Sayers, 2015). While it is important to understand how textbooks structure opportunities for learning, England and Sweden are of particular interest as both systems, due to perceptions of systemic failure on international tests of achievement like TIMSS and PISA, have begun importing and adapting textbooks used in high-achieving countries. In Sweden, textbooks from Finland and Singapore have been imported, while in England, textbooks from Singapore and Shanghai.

In the study presented here, which is principally a methodological contribution, we examine aspects of three textbooks used with English grade 1 classes, Abacus, Inspire Maths (hereafter, Inspire), and Maths - No Problem (hereafter, MNP). These were chosen because Abacus is a long-standing series written by a well-known primary mathematics education researcher. The other two, drawing on societal perceptions that English mathematics teaching would be improved by the adoption of Singaporean practices, were English-authored adaptations of Singapore textbook series.

Comparing different display methods on the same data

Many educational research analyses yield codes of zeros and ones for the absence or presence of specific phenomena, particularly analyses of the tasks found in textbooks. Thus, depending on whether analysed properties are present in each task, one outcome of this process might be a sequence $\{0, 0, 1, 0, 1, 1, \dots\}$ of ones and zeros. The manner in which the results from such analyses are displayed necessarily depends on the research question and could be the presentation of frequencies or the distribution of such codes throughout the data. When comparing textbooks, differences in the frequencies of particular codes can be compared by means of, say, χ^2 tests. However, when the research goal is to focus on the sequential distribution of codes, the focus of this paper, other methods are needed. In this paper, as a response to this, we offer time series analysis as a novel method for comparing the sequential distribution of particular task properties in textbooks. In so doing, we compare this novel approach with others found in the literature.

In the following, as indicated above, we draw on FoNS-related analyses of three English year one textbook series, in which every task that explicitly expected a student response was coded for its FoNS-related opportunities. Thus, every task could be represented as set of eight ones and zeros ranging from $(0, 0, 0, 0, 0, 0, 0, 0)$, in which no FoNS-related codes were identified, to $(1, 1, 1, 1, 1, 1, 1, 1)$, in which all FoNS codes were identified (Löwenhielm et al., 2017). However, with the objective of comparing methodologies, space prevents an analysis of all eight FoNS categories, so we restrict this presentation to just one, in order to exemplify the advantages and disadvantages of different analytical approaches. Thus, the following focuses solely on FoNS category seven, simple

addition and subtraction within the number range 0 – 20 due, in part, to the significance of such competence in later mathematical learning.

The figures of table 1 show the results of the two methods employed by Fujita (2001) and Alajmi (2012) respectively. The first, based on the position of the first occurrence of the code in question (Fujita, 2001), shows substantial differences in the number of tasks completed before simple arithmetical operations are introduced. However, due to differences in the total number of tasks in each series, it is not necessarily straightforward, without additional calculation, to discern whether the positions of the first occurrence are comparable across the three books. In this respect, the second method, based on the percentage of all tasks presented before the first occurrence (Alajmi, 2012), gives a better indication of how deep into the book the first occurrence of each code occurs and, of course, their relative positions. Thus, it can be seen that the introduction of simple arithmetic in the two textbooks based on the Singaporean tradition, Inspire and MNP, occurs not only substantially later than in the English textbook, Abacus, but also in different positions relative to each other.

Book	FoNS category	Position of first occurrence	Percentage of tasks before first occurrence
Abacus	7	22nd of 1522	1%
Inspire	7	168th of 907	18%
MNP	7	175th of 1955	9%

Table 1. Method 1 (1st occurrence) and method 2 (% tasks before first occurrence)

The third method, represented in Table 2, shows the relative percentages across the various workbooks in each series (Borba & Selva, 2013). Here, each series is partitioned into a different number of booklets; Abacus is in three booklets, Inspire in four and MNP in two. What is clear, interestingly, is the variation in the distribution of tasks focused on code 7, simple addition or subtraction, across the three sets of workbooks; Abacus incorporates substantial proportions of such material across all three booklets, while both Inspire and MNP incorporate such tasks only in the first half of their respective series. Of course, presenting the same data as line diagrams in the manner of Ding (2016) may have offered a clearer picture, but little by way of additional insight into the actual sequencing of the tasks.

The fourth method, Figure 1, shows a timeline with the position of each task coded for simple addition or subtraction, code 7, shown as a dot (Huntley & Terrell, 2014). As with method 3, this highlights well differences between Abacus and the two Singapore-based books, Inspire and MNP. The former shows simple arithmetic tasks distributed throughout the workbooks, while the latter confirms that such tasks only occur within the first half of the series. They also show a not dissimilar pattern within the two Singapore-based books, with periods of extended opportunity, followed by a gap with occasional revisitations before a second extended opportunity. That being said, such graphs offer

insight only into the sequencing of activities within a textbook and not necessarily an indication how children’s day-to-day learning may be structured.

Abacus (3 booklets)	Inspire (4 booklets)	MNP (2 booklets)
56%	55%	40%
24%	35%	0%
35%	0%	0%

Table 2. Method 3 (% occurrences per booklet) for code 7

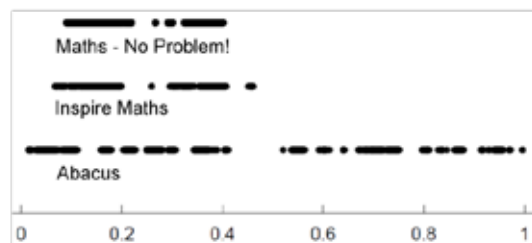


Figure 1. Method 4 (timeline dot plot) for code 7

Moving averages

The fifth method, which is our contribution to the debate, involves moving averages as an approach to time series analysis in which data are logged at equally spaced points in time. Typically, these are undertaken to “understand the underlying dynamics, forecast future events, and control future events via intervention” of stochastic processes (Fan & Yao, 2003, p. 9). Now, while a school mathematics textbook is not stochastic, the use of time series, whereby data are successive tasks, should offer a clear indication of a textbook’s sequential emphases over time. However, the graphs yielded by time series analyses are typically extremely noisy, as with daily records of air temperature (Wakaura & Ogata, 2007), a problem that can be overcome by means of moving averages. Here, rather than report single data points, moving averages are based on a sequence of overlapping sets of data or moving windows. This process smoothes out short-term fluctuations in time series so that longer-term patterns become more visible and the influence of outliers is eliminated. Mathematically, a moving average means substituting a single data point (t_k, y_k) with (t_k, \hat{y}_k) , where \hat{y}_k is the arithmetic mean of its neighbouring data points y_j as in equation 1.

$$\text{(Equation 1)} \quad \hat{y}_k = \sum_{j=k-n}^{k+n} \frac{1}{2n+1} y_j$$

Of interest here, is the size of the divisor, $2n + 1$, which represents the total number of data points included in the calculation and is dependent on the time period chosen for the calculation. That is, $2n + 1$ refers to the original point, y_k , and its $2n$ neighbouring data points, n before and n after. In the context of a mathematics textbook, the width $2n + 1$ of this window could be the number of tasks

that an average student is expected to cover each day, or each week or each month and this choice depends on the research question. Thus, one choice of the width of the moving average window could be $\frac{\text{all items in a book series for one year}}{40 \text{ school weeks}}$, roughly corresponding to a single week's workload across the year. This means that wherever the moving average diagram shows 'above zero', then the pupil would have met that coded property during that week. Figure 2 shows the results, for code 7, simple addition or subtraction, for different time periods. The vertical axis refers to the average code score, taking values from 0 to 1, for any given time interval, and the horizontal axis the year for which the textbook is intended for use. The solid line refers to MNP, the dotted line to Inspire and the dashed line to Abacus.

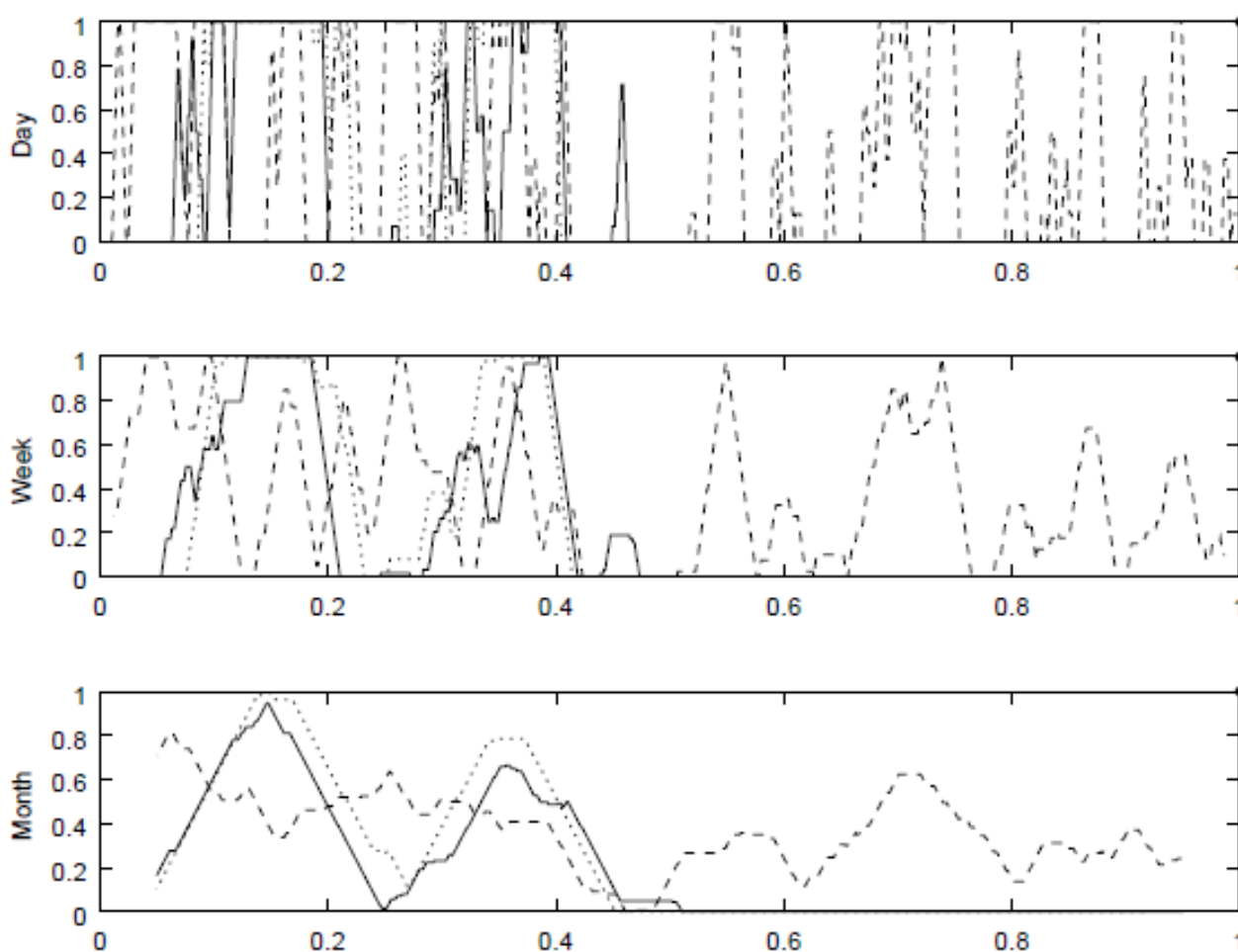


Figure 2. Method 5 (moving average) for code 7

As can be seen, analysing the daily opportunities for code 7 produces a noisy diagram that is difficult to interpret, particularly with the three textbooks are presented together. However, as seen in the weekly graphs, a longer time period begins to smooth out much of this short-term variation and expose patterns of emphasis. Therefore, in such analyses it is important to select a window that is sensitive to the context of the data source in to obtain a graph that shows neither too little nor too much of the data's details. In the context of this study, the monthly graph is probably the most illuminating. The two Singapore books are virtually indistinguishable but Abacus, shows continued exposure, albeit at different levels of intensity, to tasks focused on simple addition and subtraction,

opportunities, we know from several of the analyses above, missing in the second half of the two Singapore-inspired series.

In conclusion, we believe that graphs presenting moving averages offer a novel but methodologically important tool in the analysis of textbooks. In fact, it can be argued that it represents a generalisation of the four methods compared above, albeit dependent on the choice of time interval. For example, where the moving average curve in figure 2 rises above zero, it shows where the first occurrence of a code occurs, which is the information provided by methods 1 and 2 in table 1. Moreover, it shows where in a series of books a code occurs, as yielded by method 3 in table 2, corresponding to a non-overlapping (disjoint) average, while moving averages do overlap. Finally, moving averages offer a direct generalisation of strategy 4, since a moving average with a window of length one would reproduce the diagram in Figure 1.

Acknowledgment

The authors gratefully acknowledge the support of the Swedish Research Council (Vetenskapsrådet), project grant 2015-01066, without which the work reported here would not have been possible.

References

- Alajmi, A. (2012). How do elementary textbooks address fractions? A review of mathematics textbooks in the USA, Japan, and Kuwait. *Educational Studies in Mathematics*, 79(2), 239–261.
- Andrews, P., & Sayers, J. (2015). Identifying opportunities for grade one children to acquire foundational number sense: Developing a framework for cross cultural classroom analyses. *Early Childhood Education Journal*, 43(4), 257–267.
- Bergwall, A., & Hemmi, K. (2017). The state of proof in Finnish and Swedish mathematics Textbooks—Capturing differences in approaches to upper-secondary integral calculus. *Mathematical Thinking and Learning*, 19(1), 1–18.
- Borba, R., & Selva, A. (2013). Analysis of the role of the calculator in Brazilian textbooks. *ZDM*, 45(5), 737–750.
- Brehmer, D., Ryve, A., & Van Steenbrugge, H. (2016). Problem solving in Swedish mathematics textbooks for upper secondary school. *Scandinavian Journal of Educational Research*, 60(6), 577–593.
- Cai, J., & Jiang, C. (2017). An analysis of problem-posing tasks in Chinese and US elementary mathematics textbooks. *International Journal of Science and Mathematics Education*, 15(8), 1521-1540
- Charalambous, C., Delaney, S., Hsu, H., & Mesa, V. (2010). A comparative analysis of the addition and subtraction of fractions in textbooks from three countries. *Mathematical Thinking and Learning*, 12(2), 117–151.
- Ding, M. (2016). Opportunities to learn: Inverse relations in U.S. and Chinese textbooks. *Mathematical Thinking and Learning*, 18(1), 45–68.
- Ding, M., & Li, X. (2010). A comparative analysis of the distributive property in U.S. and Chinese elementary mathematics textbooks. *Cognition and Instruction*, 28(2), 146-180.

- Fan, J., & Yao, Q. (2003). *Nonlinear time series: Nonparametric and parametric methods*. New York: Springer.
- Fan, L., & Zhu, Y. (2007). Representation of problem-solving procedures: A comparative look at China, Singapore, and US mathematics textbooks. *Educational Studies in Mathematics*, 66(1), 61–75.
- Fujita, T. (2001). The order of theorems in the teaching of Euclidean geometry: Learning from developments in textbooks in the early 20th century. *ZDM*, 33(6), 196–203.
- Huntley, M., & Terrell, M. (2014). One-step and multi-step linear equations: A content analysis of five textbook series. *ZDM*, 46(5), 751–766.
- Jones, K., & Fujita, T. (2013). Interpretations of national curricula: The case of geometry in textbooks from England and Japan. *ZDM*, 45(5), 671–683.
- Li, Y., Chen, X., & An, S. (2009). Conceptualizing and organizing content for teaching and learning in selected Chinese, Japanese and US mathematics textbooks: The case of fraction division. *ZDM*, 41(6), 809–826.
- Löwenhielm, A., Marschall, G., Sayers, J., & Andrews, P. (2017). Opportunities to acquire foundational number sense: A quantitative comparison of popular English and Swedish textbooks. In T. Dooley & G. Gueudet (Eds.), *Proceedings of the Tenth Congress of the European Society for Research in Mathematics Education* (pp. 371–378). Dublin: Dublin City University.
- Mesa, V. (2004). Characterizing practices associated with functions in middle school textbooks: An empirical approach. *Educational Studies in Mathematics*, 56(2), 255–286.
- Miyakawa, T. (2017). Comparative analysis on the nature of proof to be taught in geometry: The cases of French and Japanese lower secondary schools. *Educational Studies in Mathematics*, 94(1), 37–54.
- Otten, S., Gilbertson, N., Males, L., & Clark, D. (2014). The mathematical nature of reasoning-and-proving opportunities in geometry textbooks. *Mathematical Thinking and Learning*, 16(1), 51–79.
- Son, J., & Senk, S. (2010). How reform curricula in the USA and Korea present multiplication and division of fractions. *Educational Studies in Mathematics*, 74(2), 117–142.
- Stacey, K., & Vincent, J. (2009). Modes of reasoning in explanations in Australian eighth-grade mathematics textbooks. *Educational Studies in Mathematics*, 72(3), 271–288.
- Stein, M., & Kim, G. (2009). The role of mathematics curriculum materials in large-scale urban reform. In J. Remillard, B. Herbel-Eisenmann & G. Lloyd (Eds.), *Mathematics teachers at work: Connecting curriculum materials and classroom instruction* (pp. 37–55). New York: Routledge.
- Stylianides, G. J. (2009). Reasoning-and-proving in school mathematics textbooks. *Mathematical Thinking and Learning*, 11(4), 258–288.
- Tarr, J., Chávez, Ó., Reys, R., & Reys, B. (2006). From the written to the enacted curricula: The intermediary role of middle school mathematics teachers in shaping students' opportunity to learn. *School Science and Mathematics*, 106(4), 191–201.
- Wakaura, M., & Ogata, Y. (2007). A time series analysis on the seasonality of air temperature anomalies. *Meteorological Applications*, 14(4), 425–434.

A cross-cultural study of curriculum systems: mathematics curriculum reform in the U.S., Finland, Sweden, and Flanders¹

Hendrik Van Steenbrugge¹, Heidi Krzywacki², Janine Remillard³, Tuula Koljonen⁴, Rowan Machalow⁵ and Kirsti Hemmi⁶

¹Mälardalen University, Sweden; hendrik.van.steenbrugge@mdh.se

²University of Helsinki, Finland; heidi.krzywacki@helsinki.fi

³University of Pennsylvania, USA; janiner@upenn.edu

⁴Mälardalen University, Sweden; tuula.koljonen@mdh.se

⁵University of Pennsylvania, USA; machalow@gse.upenn.edu

⁶Åbo Akademi University, Finland; kirsti.hemmi@edu.uu.se

This paper relates to the mathematics curriculum systems of the United States, Finland, Sweden, and Flanders (Belgium). These four regions are in the midst of curriculum reform, which provides interesting grounds for cross-cultural comparison. Our analysis builds on a framework that focuses on curriculum policy, design and enactment in each of these regions and draws on interview data with teachers in all four regions, sample cases of curriculum use, context descriptions, and available descriptions of mathematics education in these four regions. This leads to a more nuanced understanding of the particular curriculum systems through which reform manifests, and sheds light on a challenging balance concerning a curriculum reform that is both coherent across a region and supported by teachers.

Keywords: Cross-cultural study, Curriculum reform, Mathematics education

Mathematics curriculum reform: a delicate process

Curriculum reform is a delicate process because multiple factors influence implementation, and, ultimately, student performance. If a curriculum is to promote region-wide reform, it should be coherent across that region. Further, there is evidence that the teacher has a crucial role, in that teachers should embrace the underlying vision (e.g., Tarr et al., 2008). Also crucial for educational change is to understand the educational system to which the reform applies (Andrews, 2007; Miyakawa & Winsløw, 2017; Stigler & Hiebert, 1999). This paper aims to add to a better understanding of the mathematics curriculum systems in the U.S., Finland, Sweden, and Flanders (Belgium). All four regions have recently undergone mathematics reform, or are in the midst of reform, which makes them interesting sites for comparison of curriculum systems. The paper's central goal is to describe the curriculum systems of these four regions, and to consider consequences for teacher involvement in, and region-wide coherence of the region.

¹ This study is funded by the Swedish Research Council (2016-04616).

Curriculum policy, design, and enactment framework

Because we understand teachers' use of resources to be situated in a broader school system, we draw on the curriculum enactment process as conceptualized in Remillard and Heck (2014) (See Figure 1). Remillard and Heck differentiate between an official and operational curriculum. The official curriculum, authorized by governing agencies includes curricular aims and objectives; assessments; and the designated curriculum – a set of instructional plans specified by a governing agency. The operational curriculum captures the enactment process. It acknowledges the central role that teachers have in interpreting and mobilizing curriculum resources and differentiates between a teacher-intended and enacted curriculum and student outcomes. The location of instructional resources outside of the official and operational curriculum allows to fit both (centralized) systems in which the instructional resources are part of the official curriculum, and other systems in which they are not.

The framework assumes a definition of curriculum, which we also subscribe to: “a plan for the experiences that learners will encounter, as well as the actual experiences they do encounter, that are designed to help them reach specified mathematics objectives” (Remillard & Heck, 2014, p. 707). We use the term instructional resources to refer to the resources used to support curriculum enactment. These resources include curriculum resources that sequence a particular content such as student textbooks and teacher's guides, but also other resources such as digital (online) applications.

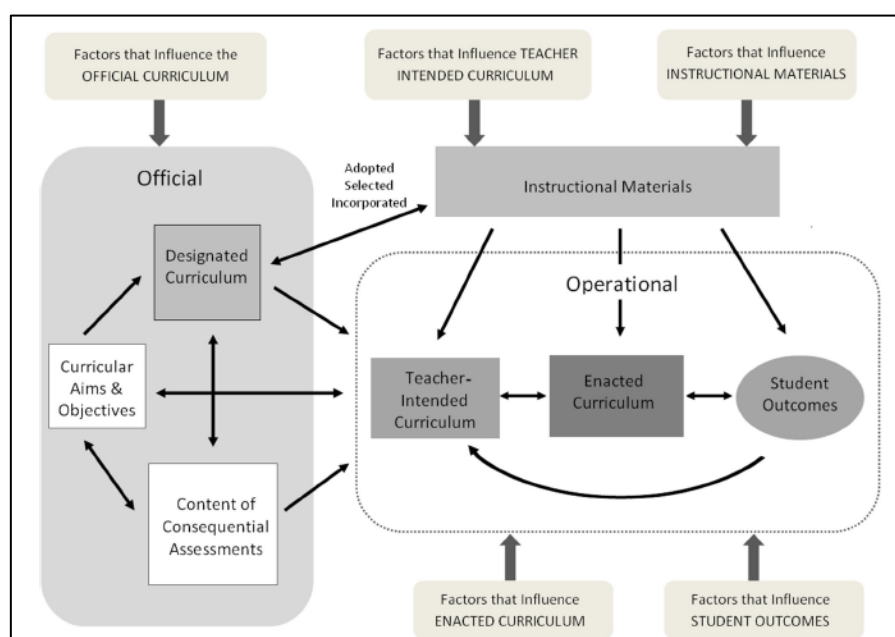


Figure 1. Visual model of the curriculum policy, design, and enactment system (Source: Remillard & Heck, 2014, p. 709)

Context and method of study

This study is part of a larger cross-cultural study on elementary school teachers' use of printed and digital instructional resources in the U.S., Finland, Sweden, and Flanders (the northern part of Belgium, which has its own educational system). Although largely an opportunity sample, the selection of these four regions addresses both constants and contexts (Osborn, 2004) comprising a sound rationale for comparison. Talking to the constants, all four regions value local educational authority, emphasize similar aspects as to the mathematical curriculum, and teachers rely on (printed) curriculum resources when teaching mathematics. Our previous analyses of printed curriculum

resources also shed light on differences in provided teacher support, surfacing context-specific assumptions of teaching and learning mathematics (e.g., Remillard, Van Steenbrugge, & Bergqvist, 2016).

When designing and analyzing interviews on resource use in the four regions, we were faced with challenges of equivalence, validity, and comparability (Clarke, 2013; Osborn, 2004), and with challenges related to the undertake of such a study in a cross-cultural team of researchers. To develop the team's prerequisite intersubjectivity (Andrews, 2007) needed to fully understand the completed interviews as situated in their specific context, we developed case descriptions illustrating curriculum use for one teacher per context, and context descriptions. This paper draws primarily on these four case and context descriptions, but also on interview data specifically relating to the selection of instructional resources and additional readings on mathematics curricula in these four regions (i.e., Hemmi, Krzywacki, & Partanen, 2017; Remillard & Reinke, 2017; Van Steenbrugge & Ryve, 2018; Verschaffel, 2004).

Ten teachers in Finland, the U.S., Flanders, and Sweden were interviewed in fall 2017 and again in spring 2018 on their use of resources when planning and teaching mathematics (Note: In Sweden and the U.S., one teacher was unavailable for the second interview; in Finland, nine instead of ten teachers have been interviewed so far). The first interview was more general and addressed teacher and school backgrounds, what resources teachers used, teachers' views on the curriculum resources being used, and teachers' general beliefs on teaching and learning mathematics. The second interview focused in more detail on teachers' actual use of both print and digital resources, centered around a walk-through of planning, decisions, and enactment of a lesson that the teacher taught recently. Input for Interview 1 initially came from team members' previous related research on curriculum use and was modified during subsequent team meetings. Interview 2 was also developed collaboratively, based on findings and experiences from Interview 1 and our knowledge of each of the contexts.

Each case description was prepared by a team member who is a cultural insider, written in English for shared use. We first applied low-inference codes to the interviews to index excerpts of the interviews. These codes identified, for instance, teachers' descriptions of resources, how they were used, reasons for use, background information on the teacher and school, and teacher beliefs on curriculum use and teaching and learning mathematics. The process of coding was tried out individually, discussed in, and refined by the team. Having coded two interviews for one teacher per region, we gathered similarly-coded statements and applied the following structure to the cases: a) teacher education and teaching background, b) information about school and class, c) selection process of the resources, d) use of resources and purposes for use, e) teacher beliefs and conceptions, f) changes in resource use.

The process of writing and reading cases made us aware that significant insider knowledge was necessary to make sense of them, which is why we also developed context descriptions. Context descriptions are organized according to the following structure: a) school system-structure, b) pathways into teaching elementary mathematics, c) school environment, d) financial resources for organizing education, e) decision-making mechanisms in schools in relation to mathematics education (including the selection of instructional resources), f) student assessment, and g) monitoring and quality assurance of education.

An important step in the process of developing the cases and context descriptions was full-team review and discussion of them. In fact, we arrived at a common structure and approach through incremental development, review, and discussion.

Building on the curriculum policy, design, and enactment framework (Remillard & Heck, 2014), we came to the following analytical structure to compare the four educational systems, based on case and context descriptions, interview data, and the abovementioned additional readings:

- Educational jurisdiction and school funding;
- Most recent central mathematics curriculum, including name and launching date, initiators, structure, novel aspects, requirement of adoption;
- Role of assessments;
- Curriculum specification in addition to central curricular aims and objectives;
- Instructional resources and influential factors, including resource market, designers of curriculum resources, embedment of a digital platform, selection of resources, acceptance criteria.

Curriculum systems in the U.S., Finland, Sweden, and Flanders

Table 1 includes our descriptions of the curriculum systems of the U.S., Finland, Sweden, and Flanders. Looking across the table helps to attain a more nuanced understanding of these curriculum systems, which, from the outset share similarities such as local authority, use of a primary (usually printed) curriculum resource available from a commercial publishing market, and the raise of digital resources. Surfaced similarities and differences relate to a) regulations and incentives to steer local authority, b) role of curriculum resources in curriculum reform, and c) curriculum interpretation. We discuss these aspects below and relate them in a final section to two crucial aspects of curriculum reform: coherence and embracement of the reform by teachers.

	U.S.	Finland	Sweden	Flanders
Educational jurisdiction and school funding				
Jurisdiction	School districts with oversight from states	Finnish government	Swedish government	Flemish government
School funding	State and local taxes	National and local funding	Government to municipalities to schools	Government; also targeted funding
Most recent central mathematics curriculum				
Name & launching date	Common Core State Standards (CCSS), 2010	National Core Curriculum (NCC), 2016	Läroplan (LGR 11), 2011 – revised 2018	Attainment targets; 1998/under development
Initiative	State governors & educational leaders, private foundations	Finnish National Board of Education commissioned expert group	Swedish government commissioned the National	Flemish government commissioned an entity

		(about every 10 years)	Agency of Education	
Structure	Grade-by-grade content and practice standards	Content, competences, learning environment descriptions, assessment criteria; grades 1-2, 3-6, 7-9	Core content, mathematical abilities, knowledge requirements; grades 1-3, 4-6, 7-9	Required knowledge, skills, attitudes by end of grade 6
Novel aspects	Emphasis on visual models and conceptual understanding	Cross-curricular competences (e.g., digital competence)	Mathematical competences, digital competence	Structured around 16 key competences (e.g., digital competence)
Adoption	Not required; Federal government incentivizes states toward CCSS & assessment adoption	Required, but not checked	A nationwide professional development program was launched (2012-2016) to support adoption; checked by school inspectorate	Required, checked by school inspectorates
Assessments				
Grades & aim	Grades 3-8: annual standardized tests, often consequential for student promotion, teacher employment, school funding	Schools are not monitored by national assessments; Teachers are responsible for assessment	Grades 3, 6, 9: Mandatory national tests support equality & check performance on school and population level	Tests assess mastery of attainment targets on student population level (since 2002 and on a 7-year interval)
Continued curriculum specification				
Level & content	Districts and schools often specify instructional resources to be	National board of education hosts a website that lists available	/	Three umbrella organizations issue learning plans, which break down

	used, and issue pacing guidelines	instructional resources; School teams and/or local authorities concretize NCC into a central school-level curriculum		attainment targets per grades, add goals and didactical suggestions
Instructional resources and factors that influence resources and use				
Instructional resource market	Commercial enterprise, limited number of publishers	Commercial enterprise, limited number of publishers	Commercial enterprise, limited number of publishers	Commercial enterprise, limited number of publishers
Designers (printed) curriculum resources	Mathematicians, prior teachers, researchers	Teacher educators, researchers, teachers	Teacher educators, teachers (during their free time)	Teacher educators, teachers, members of inspectorates, representatives umbrella organizations
New curriculum resources accompanied by digital platform?	Yes	Yes	Yes	Yes
Selection instructional resources	Main curriculum resources & larger digital platforms: districts & schools; Digital resources: teachers	Main curriculum resource & digital resources: teachers	Main curriculum resource: schools; Digital resources: teachers	Main curriculum resource: schools; Digital resources: teachers, schools, school groups, umbrella organizations
Acceptance criteria	By some states/districts	No	No	No

Table 1. The curriculum systems of the U.S., Finland, Sweden, and Flanders

Regulations and incentives to steer local authority are present to different extents. The curriculum systems of the U.S. and Flanders have the most explicit mechanisms to steer local authority. In the U.S., states possess authority in relation to educational policy and, sometimes, delegate policy to school districts, but the Government by means of applying specific funding mechanisms influences policy and curriculum use at state, district, and school level. In Flanders, schools are in principle free to determine how to work toward the attainment targets, but the Government, through regulations such as school inspectorates and the requirement to adopt a learning plan, and through targeted funding, sets the framework of the curriculum system and influences curriculum policy and use at the local school level. In Sweden, the Government also sets the framework of the curriculum system, but influences curriculum use at a more implicit level, through rolling out a nation-wide professional development program following the curriculum reform. From our study, it appears that central regulation is the least well manifested in Finland. The Finnish National Board of Education commissions on regular interval-base an expert group to develop a new curriculum. Schools and teachers are provided with guiding documents and regulations, but are not checked upon application of the guidelines and regulations.

Across the four regions, curriculum resources served as interpreters of the official curriculum, hereby serving as mediators between the intended curriculum and the classroom (Valverde, Bianchi, Wolfe, Schmidt, & Houang, 2002). Additionally, and talking to the systems of Finland and Flanders, curriculum resources can also potentially influence curriculum making. In Finland, teachers at times rely on the learning sequence in commercial curriculum resources to design their crucial school-level curriculum. Currently in Flanders, new curriculum resources, often complemented with digital applications, are published before the actual launch of the new attainment targets, hereby possibly influencing the novel aspects of the mathematics reform related to digital competence.

Following the curriculum policy, design, and enactment framework (Remillard & Heck, 2014), we allocate teachers to have a central role in interpreting and mobilizing the curriculum. Indeed, we find related evidence in our interview data. Our comparative analysis also reveals differing levels where significant curriculum interpretation happens to reside. In Sweden, the bulk of interpretation happens at the individual teacher level. In Finland, significant interpretation is applied to compose a school-level curriculum, whereas in Flanders, major interpretation of the attainment targets is located above the school-level, by the umbrella organizations issuing learning plans. In the U.S., significant curriculum interpretation resides in the assessments.

Curriculum reform: a delicate balance between region-wide coherence and teacher approval

Our study of the mathematics curriculum systems of the U.S., Finland, Sweden, and Flanders, suggests that a curriculum reform that is both region-wide and supported by teachers, is a challenging balance. Both Flanders and the U.S., through their layered curriculum infrastructure, succeed most toward a region-wide curriculum coherence, but this goes at the cost of teacher involvement in the reform process. In Finland, teachers are most involved in reform through the design of a school-level curriculum, but this goes at the cost of a nation-wide curriculum-coherence. Sweden stands out in that teachers were asking for reform and that the Government answered the call by means of rolling out a nationwide professional development program. It still has to be seen to what extent that results in curriculum coherence. In all four regions, commercially published curriculum resources are a central aspect in a region-wide curriculum reform. Given this significant position, it is remarkable that only in the U.S., sometimes quality criteria are issued that curriculum resources have to pass.

References

- Andrews, P. (2007). Negotiating meaning in cross-national studies of mathematics teaching: Kissing frogs to find princes. *Comparative Education*, 43(4), 489-509.
- Clarke, D. (2013). *The validity-comparability compromise in crosscultural studies in mathematics education*. Paper presented at the Proceedings of the Eighth Congress of the European Society for Research in Mathematics Education.
- Hemmi, K., Krzywacki, H., & Partanen, A. (2017). Mathematics Curriculum: The Case of Finland. In D. R. Thompson, M. A. Huntly, & C. Suurtamm (Eds.), *International Perspectives on Mathematics Curriculum* (pp. 71-102). Greenwich, CT: Information Age Publishing.
- Miyakawa, T., & Winsløw, C. (2017). Paradidactic infrastructure for sharing and documenting mathematics teacher knowledge: a case study of “practice research” in Japan. *Journal of Mathematics Teacher Education*. doi:10.1007/s10857-017-9394-y
- Osborn, M. (2004). New methodologies for comparative research? Establishing ‘constants’ and ‘contexts’ in educational experience. *Oxford Review of Education*, 30(2), 265-285.
- Remillard, J. T., & Heck, D. J. (2014). Conceptualizing the curriculum enactment process in mathematics education. *ZDM*, 46(5), 705-718.
- Remillard, J. T., & Reinke, L. (2017). Mathematics Curriculum in the United States: New Challenges and Opportunities. In D. R. Thompson, M. A. Huntly, & C. Suurtamm (Eds.), *International Perspectives on Mathematics Curriculum* (pp. 131-162). Greenwich, CT: Information Age Publishing.
- Remillard, J. T., Van Steenbrugge, H., & Bergqvist, T. (2016). *A cross-cultural analysis of the voice of six teacher's guides from three cultural contexts*. Paper presented at the AERA annual meeting, Washington, DC.
- Stigler, J., & Hiebert, J. (1999). *The teaching gap: Best ideas from the world’s teachers for improving education in the classroom*. New York: The free press.
- Tarr, J. E., Reys, R. E., Reys, B. J., Chavez, O., Shih, J., & Osterlind, S. J. (2008). The impact of middle-grades mathematics curricula and the classroom learning environment on student achievement. *Journal for Research in Mathematics Education*, 39(3), 247-280.
- Valverde, G. A., Bianchi, L. J., Wolfe, R. G., Schmidt, W. H., & Houang, R. T. (2002). *According to the book: Using TIMSS to investigate the translation of policy into practice through the world of textbooks*. Dordrecht, the Netherlands: Kluwer.
- Van Steenbrugge, H., & Ryve, A. (2018). Developing a reform mathematics curriculum program in Sweden: relating international research and the local context. *ZDM*. doi:10.1007/s11858-018-0972-y
- Verschaffel, L. (2004). All you wanted to know about mathematics education in Flanders, but were afraid to ask. In R. Keijzer & E. de Goeij (Eds.), *Rekenen-wiskunde als rijke bron [Mathematics education as a gold mine]* (pp. 65-86). Utrecht, The Netherlands: Freudenthal Instituut.

The use of *problem* in upper-primary and lower-secondary textbooks of the Republic of Cyprus

Constantinos Xenofontos

University of Stirling, United Kingdom, constantinos.xenofontos@stir.ac.uk

Research suggests that transitions from primary to secondary education typically have negative influences on pupils' mathematical performance, motivation, and self-efficacy. In acknowledgement of these issues, I examine how the term 'problem' is used in the upper-primary and lower-secondary national maths textbooks in the Republic of Cyprus, in an attempt to explore the coherence between the instructional materials pupils are exposed to in the two school levels. More specifically, all tasks explicitly labelled as 'problems' in the two textbook series were identified. For analysing the tasks, an adapted version of Borasi's (1986) framework about the structural characteristics of problems was utilised. Findings conclude that coherence between the two textbook series is limited, as in the primary series the term 'problem' is extensively used in a particular way, while in the secondary series, a significant decline of the number of tasks labelled as problems is observed.

Keywords: Transitions, mathematical problem, textbooks, primary, secondary

Transitioning from primary to secondary school

Many pupils preparing to transition from primary to secondary school appear to have predetermined ideas about the challenges and difficulties of mathematics at the next school level (Attard, 2010). As a consequence, there is a general decline of pupils' engagement with mathematics as they move from primary to secondary education (Martin, Way, Bobis, & Anderson, 2015), a decline of their self-efficacy beliefs, motivation, and performance (Bouffard, Boileau, & Vezeau, 2001), and the reinforcement of stereotypes regarding gender and mathematics performance (Denner, Laursen, Dickson, & Hartl, 2018). While research evidence suggests that the observed differences could partly be attributed to teachers' self-efficacy beliefs (Midgley, Feldlaufer, & Eccles, 1989), as well as to teachers' and parents' emphases on goal (Friedel, Cortina, Turner, Midgley, 2010) across the two school levels, little is known about the impact of the use of instructional materials by primary and secondary mathematics teachers (Howard, Perry, & Tracey, 1997), and more specifically, how similarly or differently textbooks are used at these two school levels (Fan, Zhu, & Miao, 2013).

Here, I focus on the national textbooks of a highly centralised educational system, that of the Republic of Cyprus. The mathematics curriculum of Cyprus (as with all school subjects) is prescribed centrally by the Ministry of Education and Culture - MoEC (Mullis, Martin, Goh, & Cotter, 2016). In order to bridge the gap between the previous primary and secondary mathematics curriculum, the curriculum in effect, introduced in 2010, is built around the same five general topics, from pre-primary education up to the last year of upper-secondary education (MoEC, 2010). These five topics are numbers, algebra, geometry, measurement, and statistics-probability. Furthermore, this unified mathematics curriculum claims to be built on four principles, with principle 2 stating that the curriculum places emphasis on problem solving (MoEC, 2010). Yet, no further clarifications are provided as to what a problem is, what problem solving means, and what kind of related skills are desirable.

Both in primary and secondary education, the vast majority of mathematics teachers' instruction methodology depends on the respective national textbooks, prepared by the MoEC (Xenofontos, 2014; Xenofontos & Papadopoulos, 2015). Although I do not, in this study, examine textbook use by teachers, I do explore how the concept of *problem* is presented in the upper-primary (grade 6) and lower-secondary (grade 7) textbooks, which were introduced after the initiation of the reform in 2010. Such an approach sees textbooks as a *potentially implemented curriculum* (Schmidt, McKnight, & Raizen, 1997), or, as Mesa (2004, p. 255–256) puts it, “a hypothetical enterprise: What would students learn if their mathematics classes were to cover all the textbook sections in the order given? What would students learn if they had to solve all the exercises in the textbook?”

Why *problem*?

In the mathematics education literature, the term *problem* is one of the most widely used; yet, there does not seem to be an agreement as to what it means. In general, my views coincide with Schoenfeld's (1985, p. 74) statement that “being a ‘problem’ is not a property inherent in a mathematical task. It is a particular relationship between the individual and the task that makes it a problem for that person”. For the purposes of this study, however, I do not want to use any particular definition of the term, as my goal is to examine how *problem* is conceptualised and formed in the national textbooks of Cyprus. Such a deliberate choice may serve as a proxy to how problems and problem solving are conceptualised at the level of policy-making, that is, the intended curriculum (Mullis et al., 2016; Schmidt et al., 1997). Also, I acknowledge that a number of comparative studies have concluded that *problem* and *problem-solving* are perceived differently across educational systems (Cai, 1995; Xenofontos & Andrews, 2014).

In attempts to analyse the types of problems found in mathematics textbooks, various colleagues have used well-defined frameworks. For instance, in their work with two widely used textbook series in Singapore, Fan and Zhu (2000) distinguish between routine and non-routine problems, with various other categories falling under the latter (namely problem-posing problem, puzzle problem, project, journal task). In subsequent work, Fan and Zhu (2007) identified various similarities and differences in the promotion of problem-solving strategies in Chinese, Singaporean, and US textbooks, again, using a very structured, predetermined framework related to how the researchers understood the concepts of problem and problem-solving. In the same spirit, Xin (2007) examined the distribution of seven types of word problems (namely: multiplicative comparison-compared, multiplicative comparison-referent, multiplicative comparison-scalar, rate times a quantity, fair share or measurement division, and proportion problem type) in Chinese and US middle school textbooks, noting a more balanced distribution in the former than the latter. In turn, Son & Kim (2015) investigated how teachers select problems from textbooks and present them in class; however, the researchers “use problems and tasks interchangeably” (p. 493), meaning that they did not utilise a specific definition of what a *problem* might be.

Methodology

This study is based on the following research question:

How similar/different are the characteristics of the tasks explicitly labelled as problems in the upper-primary and the lower-secondary national textbooks of Cyprus?

This question is of particular significance, mainly because in its rhetoric the MoEC declares that the new unified curriculum aspires to promote a smooth transition from one school level to another (MoEC, 2010).

Instead of utilising a predetermined definition of the term *problem*, I chose to focus only on those tasks explicitly labelled as problems in the two textbook series. By *explicitly*, I refer to a presentation of the term ‘problem’ in the instructions provided, i.e. “solve the following problems”. Nonetheless, to enable comparisons to be made, I used an adapted framework based on Borasi’s (1986) ideas about the structural characteristics of problems. In her work, Borasi acknowledges the difficulties in deciding whether a specific task *is* a problem or not, the same way Schoenfeld (1985) recognises the role of the individual solver in the labeling of a task as a problem. Borasi, therefore, proposes four structural characteristics of tasks, which are independent of the solver. The first is the *formulation*, and refers to how instructions about what needs to be done are presented. These can take three forms: a question, a statement, or no presentation of instructions at all (open for the solver to decide). The second is the *context* in which the task is presented, and can take two forms: purely mathematical or applied (Blum & Niss, 1991). The third is the *set of the acceptable solutions*. There may be no acceptable solution to a problem, one and only solution, or more than one. Finally, the fourth characteristic has to do with the *methods of approach*. In respect to this, Polya (1981) classified problems in four categories: *one rule under your nose* (when the problem can be solved by simply applying an algorithm just presented), *application with some choice* (when the suitable algorithm must be selected among others previously studied), *choice of a combination* (when in order to reach the solution some of the algorithms previously learnt must be suitably combined), and *approaching research level* (when the elaboration of a new algorithm is required or when the task cannot be solved algorithmically). The term ‘approaching research level’ is used by Polya himself to refer to tasks that are genuinely problematic, and perhaps is closer to Schoenfeld’s (1985) views about what a problem is.

As explained earlier, this paper focuses on the tasks explicitly labelled as problems in the upper-primary (grade 6) and lower-secondary (grade 7) national mathematics textbooks of Cyprus. Each task was described in terms of the four structural characteristics (formulation, context, set of acceptable solutions, methods of approach). For grade 6, the textbooks are organised in six parts, while for grade 7 they are organised in two parts.

Findings

In grade 6 textbooks, 228 tasks were identified as being explicitly labeled as *problems*, while in grade 7 textbooks, only two tasks were identified. Although the total number of tasks (labelled as problems or not) in the two series was not counted, a quick scan through the textbooks shows that in each grade (6 and 7) there are more than 1000 tasks.

Below, figure 1 presents an example from grade 6, and how it was coded with the use of Borasi’s (1986) four structural characteristics. Figure 2 demonstrates another example from the textbooks of grade 6, which, contrary to the algorithmic task of figure 1, was identified as approaching research level, as there is no standard algorithm that could be applied for its resolution. In figure 3, one of the two tasks identified in grade 7 textbooks is presented. In fact, both tasks were coded under

“approaching research level”, due to their high complexity and lack of any particular algorithm to be applied.

Table 1 illustrates the distribution of these tasks for each form of a structural characteristic.

The Grade 6 pupils are $\frac{1}{6}$ of the total pupil population in a school. There are 258 pupils in total. Find how many pupils are in Grade 6.

(α) Οι μαθητές της ΣΤ' τάξης αποτελούν το $\frac{1}{6}$ των μαθητών ενός σχολείου. Όλοι οι μαθητές του σχολείου είναι 258. Να υπολογίσετε τον αριθμό των μαθητών της ΣΤ' τάξης.

formulation: statement
context: applied
acceptable solutions: one
methods of approach: one rule under your nose

Figure 1: An example of a task (grade 6, part B, page 89)

24. Να επιλύσετε τα προβλήματα.

(α) Η Μαργαρίτα ξεκίνησε να περπατά από το σημείο Α. Περπάτησε $\frac{1}{2}$ km νότια, μετά $\frac{3}{4}$ km ανατολικά, μετά $\frac{2}{5}$ km βόρεια και στο τέλος $\frac{3}{4}$ km δυτικά και έφτασε στο σημείο Β. Να βρείτε πόσα χιλιόμετρα απέχει (σε ευθεία γραμμή) το σημείο Α από το σημείο Β.

Margarita began to walk from point A. She walked $\frac{1}{2}$ km south, then $\frac{3}{4}$ km east, then $\frac{2}{5}$ km north, and finally $\frac{3}{4}$ west, and she reached point B. Find the distance between point A and point B in kilometres (in a straight line).

formulation: statement
context: applied
acceptable solutions: one
methods of approach: approaching research level

Figure 2: An example of a task (grade 6, part B, page 106)

In both grades' textbooks, certain tasks were identified, in which the term problem appeared in the instructions. However, these were classified as problem-posing tasks, as they invited pupils to write a problem that would meet particular criteria (i.e. ‘translate’ a symbolic expression/representation into a real world situation). In the textbooks of grade 6, eleven such tasks were identified, while in the textbooks of grade 7, there were four tasks of this type. Below, figures 4 and 5 demonstrate an example from the primary and secondary textbooks, respectively.

One of the problems in number theory says:

11. Ένα από τα προβλήματα της θεωρίας αριθμών λέει:
 Μετά από πολλά χρόνια συναντούνται δύο συμμαθητές, ο Πυθαγόρας και η Υπατία, που είχαν ιδιαίτερη αγάπη στα μαθηματικά και διεξάγεται ο πιο κάτω διάλογος:

Π: Παντρεμένος; Έχεις παιδιά; Πόσα; Πόσες ηλικίες;
 Υ: Ναι, τρία και το γινόμενο των ηλικιών τους είναι 36.
 Π: (Ίστερα από σκέψη) Δεν μπορώ να βρω τις ηλικίες τους, τα στοιχεία που μου έδωσες δεν είναι αρκετά.
 Υ: Σωστά, και αν σου πω ότι το άθροισμα των ηλικιών των παιδιών μου είναι το ίδιο με τον αριθμό του σπιτιού σου.
 Π: Ούτε και τώρα μπορώ να βρω τις τρεις ηλικίες. Θέλω και άλλη βοήθεια...
 Υ: Σωστά! Και αν σου πω πως το μεγαλύτερο παιδί έχει ξανθά μαλλιά...
 Π: Τώρα ναι! Μπορώ να σου πω τις ηλικίες των παιδιών σου, χωρίς καμιά αμφιβολία!

Ποιες είναι οι ηλικίες των παιδιών και τι σκέψεις έκανε ο Πυθαγόρας, για να φτάσει στην απάντηση;

After many years, two old friends, Pythagoras and Hypatia, met. They both loved mathematics. Below, is presented the discussion between them:

P: Are you married? Do you have kids? How many? How old are they?
 H: Yes, I have three, and the product of their ages is 36.
 P: (after some thought) I can't find their ages, the information you gave me isn't sufficient.
 H: You're right, but what if I tell you that the sum of their ages is the same as the number of your house?
 P: I still can't find the age of each. I need another clue...
 H: You're right! What if I tell you that the eldest has blond hair?
 P: Oh, yes! I can tell you the ages of your kids, without a doubt!

formulation: question
 context: applied
 acceptable solutions: one
 methods of approach: approaching research level

What are the children's ages and what thoughts did Pythagoras have to reach the answer?

Figure 3: An example of a task (grade 7, part A, page 94)

Structural characteristic	Forms of each structural characteristic	Upper-primary (grade 6)	Lower-secondary (grade7)
<i>Formulation</i>	Question	166	2
	Statement	62	0
	Open	0	0
<i>Context</i>	Purely mathematical	5	0
	Applied	223	2
<i>Acceptable solutions</i>	None	0	0
	One	228	1
	More than one	0	1
<i>Methods of approach</i>	One rule under your nose	110	0
	Application with some choice	37	0
	Choice of a combination	73	0
	Approaching research level	8	2

Table 1: The identified tasks and their structural characteristics

Write a problem for each of the following mathematical propositions (sic). Work in your exercise book.

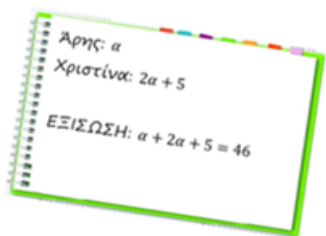
7. Να γράψετε ένα πρόβλημα για καθεμιά από τις πιο κάτω μαθηματικές προτάσεις. Να εργαστείτε στο τετράδιό σας.

(α) $5 \cdot \frac{3}{8}$

(β) $\frac{3}{8} \cdot 5$

Figure 4: A problem-posing task (grade 6, part D, page 21)

19. Ποιο πρόβλημα μπορεί να διάβασε η Αννίτα, αν ξεκίνησε να το λύει ως εξής:



Which problem might Annita have read, if she began solving it as follows:

Aris: a
Christina: 2a + 5
EQUATION: a + 2a + 5 = 46

Figure 5: A problem-posing task (grade 7, part A, page 80)

Discussion

When approached from different perspectives, the findings of this study offer insight into at least two matters. Firstly, regarding transition from primary to secondary education, this paper suggests that pupils in grade 6 (upper primary) are significantly exposed to the term *problem* when interacting with their mathematics textbooks, compared to grade 7 (lower secondary). There appears to be a change of discourse, as we move from grade 6 to grade 7. This does not necessarily mean that children in grade 7 are exposed to less tasks that, according to Polya (1981), *approach research level*. Nonetheless, an abrupt disappearance of the term *problem* as children move from primary to secondary education is apparent. Although the latest educational reform intends to bridge the gap between the mathematics curricula at various transition points (MoEC, 2010), this does not seem to be happening in an effective manner. In fact, questions are raised about the extent to which the intended “cohesive and coherent curriculum from pre-primary to upper secondary education” (MoEC, 2010, p. 15) is, in reality, cohesive and coherent. Secondly, when these findings are taken as a whole, and especially when the problem-posing tasks in the two series are added to the equation, the study echoes my previous work examining pre-service teachers’ problem-solving related beliefs (Xenofontos, 2014; Xenofontos & Andrews, 2014). In the Republic of Cyprus, there seems to be a very particular, perhaps culturally specific, understanding of what a mathematical problem *is*:

A ‘problem’, for the educational system of Cyprus, seems to be a real-world task, in which the instructions regarding what needs to be done are mainly presented in the form of question, or, sometimes, with a statement. There is always one (and only) acceptable solution to this task, which can either be solved by applying a straight-forward method/algorithm or a combination of methods/algorithms, which in any case, are already known.

Such a cultural perception of mathematical problems is, I think, extremely problematic, especially when the new curricula claim, in their rhetoric, to be placing emphasis on problem solving (MoEC, 2010). Nevertheless, I do acknowledge that this study, as all studies, carries a set of limitations that has the potential to introduce new research avenues. As explained, in this paper I only examine those tasks explicitly labelled as problems. There appear to be other tasks in the textbooks that are not labelled as problems, the methods of approach of which, in Polya's (1981) terminology, approach research level. Furthermore, even though teachers in Cyprus seem to rely heavily on textbooks (Xenofontos, 2014; Xenofontos & Papadopoulos, 2015), what we don't know is *how* they use textbooks and other instructional materials in the classroom. Finally, future research could examine and compare primary and secondary in-service teachers' beliefs and practices in relation to problem-solving, so that we can have a complete picture of how to make the transition, as smoothly as possible, from one school level to another.

References

- Attard, C. (2010). *Students' experiences of mathematics during the transition from primary to secondary school*. Paper presented at the 33rd annual conference of the Mathematics Education Research Group of Australasia, Fremantle, Perth.
- Blum, W. & Niss, M. (1991). Applied mathematical problem solving, modeling, applications, and links to other subjects: state, trends and issues in mathematics education. *Educational Studies in Mathematics*, 22, 37-68.
- Borasi, R. (1986). On the nature of problems *Educational Studies in Mathematics*, 17, 125-141.
- Bouffard, T., Boileau, L., & Vezeau, C. (2001). Students' transition from elementary to high school and changes of the relationship between motivation and academic performance. *European Journal of Psychology of Education*, 16, 589-604.
- Cai, J. (1995). *Cognitive analysis of U.S. and Chinese students' mathematical performance on tasks involving computation, simple problem solving, and complex problem solving* (Monograph 7, Journal for Research in Mathematics Education). Reston, VA: National Council of Teachers of Mathematics.
- Denner, J., Laursen, B., Dickson, D., & Hartl, A. C. (2018). Latino children's math confidence: The role of mothers' gender stereotypes and involvement across the transition to middle school. *Journal of Early Adolescence*, 38(4), 513-529.
- Fan, L. & Zhu, Y. (2000). Problem solving in Singaporean secondary school mathematics textbooks. *The Mathematics Educator*, 5(1), 117-141.
- Fan, L. & Zhu, Y. (2007). Representation of problem-solving procedures: A comparative look at China, Singapore, and US mathematics textbooks. *Educational Studies in Mathematics*, 66(1), 61-75.
- Fan, L., Zhu, Y., & Miao, Z. (2013). Textbook research in mathematics education: development status and directions. *ZDM*, 45(5), 633-646.

- Friedel, J., Cortina, K. S., Turner, J. C., & Midgley, C. (2010). Changes in efficacy beliefs in mathematics across the transition to middle school: Examining the effects of perceived teacher and parent goal emphases. *Journal of Educational Psychology*, *102*(1), 102-114.
- Howard, P., Perry, B., & Tracey, D. (1997). *Mathematics and manipulatives: Comparing primary and secondary teachers' views*. Paper presented at the annual conference of the Australian Association for Research in Education, Brisbane.
- Martin, A.J., Way, J., Bobis, J. & Anderson, J. (2015). Exploring the ups and downs of mathematics engagement in the middle years of school. *Journal of Early Adolescence*, *35*, 199-244.
- Mesa, V. (2004). Characterizing practices associated with functions in middle school textbooks: An empirical approach. *Educational Studies in Mathematics*, *56*, 255-286.
- Midgley, C, Feldlaufer, H., & Eccles, J. (1989). Change in teacher efficacy and student self- and task-related beliefs in mathematics during the transition to junior high school. *Journal of Educational Psychology*, *81*, 247-258.
- MoEC [Ministry of Education and Culture] (2010). *National curriculum for the state schools of the Republic of Cyprus* (in Greek). Nicosia: Pedagogical Institute, Ministry of Education and Culture.
- Mullis, I. V. S., Martin, M. O., Goh, S., & Cotter, K. (Eds.) (2016). *TIMSS 2015 Encyclopedia: Education Policy and Curriculum in Mathematics and Science*. Retrieved from Boston College, TIMSS & PIRLS International Study Center website: <http://timssandpirls.bc.edu/timss2015/encyclopedia/>
- Polya, G. (1981). *Mathematical discovery: On understanding, learning and teaching problem solving*. New York: John Wiley and Sons.
- Schmidt, W. H., C. C. McKnight, & S. A. Raizen. (1997). *A splintered vision: An investigation of U.S. science and mathematics education*. Boston: Kluwer Academic Publishers.
- Schoenfeld, A. H. (1985). *Mathematical problem solving*. Orlando, FL: Academic Press.
- Son, J. & Kim, O. (2015). Teachers' selection and enactment of mathematical problems from textbooks. *Mathematics Education Research Journal*, *27*(4), 491-518.
- Xenofontos, C. (2014). The cultural dimensions of prospective mathematics teachers' beliefs: Insights from Cyprus and England. *Preschool & Primary Education*, *2*(1), 3-16
- Xenofontos, C. & Andrews, P. (2014). Defining mathematical problems and problem solving: Prospective primary teachers' beliefs in Cyprus and England. *Mathematics Education Research Journal*, *26*(2), 279-299.
- Xenofontos, C. & Papadopoulos, C. E. (2015). Opportunities of learning through the history of mathematics: the example of national textbooks in Cyprus and Greece. *International Journal for Mathematics Teaching and Learning*. Available online at <http://www.cimt.plymouth.ac.uk/journal/>
- Xin, P. Y. (2007). Word problem solving tasks in textbooks and their relation to student performance. *The Journal of Educational Research*, *100*(6), 347-359.

A cross-cultural comparative study into teachers' questioning patterns in lower secondary mathematics lessons in the UK and China

Wenping Zhang¹ and David Wray²

¹University of Warwick, The Centre for Education Studies; United Kingdom;
w.p.zhang@warwick.ac.uk

²University of Warwick, The Centre for Education Studies, United Kingdom;
david.wray@warwick.ac.uk

Teacher questioning has been extensively studied in countries such as the UK since 1980s, however, such study within the specific context of mathematics classrooms has not received much attention. Moreover, there does not exist a direct comparative study between the UK and China with a focus on teachers' questioning in secondary mathematics classrooms. Therefore, this article aims to fill the gap in the literature. This paper looks for similarities and differences in the sequences and patterns of teachers' questioning practices in secondary mathematics classrooms in the UK and China. By making a comparison between the two countries, it is possible to examine the perceived cultural differences and similarities underpinning the use of teachers' questioning.

Keywords: Teacher questioning; Secondary mathematics classrooms; the UK; China

Introduction

The UK government launched a project called 'The Mathematics Teacher Exchange' in 2014, which involved secondary mathematics teacher exchange between schools in England and Shanghai (Boylan et al., 2017). Its intention is to improve students' achievement through copying the Chinese education model. This programme is believed to be successful (ibid) and has been extended to 2020. However, despite the fact that Chinese students have repeatedly outperformed their UK counterparts in school mathematics in various international comparative assessments, there is little comparative research into teacher questioning between the UK and China. Alexander (2009) further suggests a deliberate ignorance of comparative studies of pedagogy in the UK. To address this gap, this exploratory study aims to direct comparative studies of pedagogy in the UK and China, with a focus on teachers' questioning in secondary mathematics classrooms in the hope of providing some explanations from a social-cultural perspective.

There has been a long history of research investigating teacher questioning in the UK context. Extensive research into teacher questioning has witnessed a radical shift in focus from exploring the relationships between teacher questioning and student achievement based on the process-product paradigm in studies conducted before the 1980s (e.g. Mehan, 1979), towards examining questioning from social constructivist perspectives (Chin, 2007). This has followed the educational reform from a traditional transmissive teacher-centred teaching to an inquiry-based teaching that emphasises the social and linguistic nature of knowledge construction in UK classrooms. However, very few studies of teacher questioning have been carried out in

places like China (Ma & Zhao, 2015), where cultural values are different from the UK (Leung, 2001) and where teachers may be constrained by having to deal with larger classes (Chin, 2007) or high-stake examinations (Wong et al., 2012). Traditionally, Confucianism was first and foremost a distinctly Chinese teaching, but it then spread into many East Asian countries such as Japan, Korea, and as well as territories with predominantly Chinese populations such as Hong Kong and Singapore. Confucianism defines much of these East Asian countries' identity, especially in relation to philosophical thoughts and practice (ibid). Wu (1993) studies teachers' questioning patterns in Hong Kong and discovers that students generally have a habit of waiting to be called up before answering teachers' questions. Such student passiveness and reluctance may be explained from a cultural perspective. Chin (2007) carries out several investigations of teacher questioning in science classrooms in Singapore and goes on to suggest that, given the predominant Confucian views of teaching and learning, teachers typically are perceived as expert role models for students, which makes them relatively active in lessons compared to students. Such activeness of a teacher in a lesson can manifest in the form of teacher monologue. Lending support to such findings, Ma & Zhao (2015) have observed 13 primary mathematics lessons in China, and found question-answer exchanges to be the most dominant dialogic form between teachers and students, in which almost all mathematical questions are raised by the teachers.

Teacher questioning is a frequent component of classroom talk. The use of questioning in the West can be traced back to Plato and Socrates, and contemporaneously teachers use questions to stimulate students' thinking (Chin, 2007). Research examining teacher questioning has shown the importance of the kinds of questions teachers ask. Open-ended questions that are not limited within a set of answers can encourage more meaningful responses from students and further stimulate students' logical thinking; whereas closed questions which often refer to those with predetermined answers, tend to limit students' responses into a few simple words and produce merely recall of facts and concepts (Chin, 2007). Thinking about the questions teachers ask is vital, but equally important is thinking about the questioning patterns or sequences that they employ. It is therefore necessary to understand more deeply what happens in classroom exchanges after an initial question is posed, or in other words, what questioning patterns or sequences can occur. Franke et al. (2009) examine teachers' questioning sequences following students' explanations and find that students tend to produce fully complete and correct explanations of their mathematics when asked by teachers' sequential probing questions. Therefore, the focus of this paper is to explore teachers' questioning sequences and patterns employed by two groups of teachers in the UK and China in order to investigate the following research questions:

What are the similarities and differences in UK and Chinese teachers' questioning sequences and patterns in practice?

Methods

A combination of both classroom observation and individual interview were employed, with a group of 11 mathematics teachers of Key Stage 3 pupils (aged 11-14 years) in the UK and a group of 12 mathematics teachers of Year 7 and Year 8 students (aged 11-14 years) in China. Four lower-secondary schools (two from Beijing and Hangzhou, two from Coventry and

Birmingham) were selected, all of which were national-run, state schools. The teachers were teaching various different topics from multiplying decimals to equations with algebraic fractions, and with a wide range of years of teaching experience from newly qualified to very experienced (e.g. some teachers had been teaching for nearly 40 years). The class size ranged from 8-55 students (50 students on average in China, 30 in the UK). Classroom observation was undertaken to answer the research question, focusing on identifying questioning strategies that the teachers might adopt in practice. These were carried out in naturalistic settings in the hope that they could provide rich descriptions of classroom settings to examine naturally occurring teacher questions and to understand the underlying silent social norms and cultural values behind the teachers' behaviours. The individual follow-up interviews were semi-structured and conducted as a supplement to observation to further understand and justify certain patterns of teachers' questions from their own perspectives, which may differ from the researchers' interpretations. Through this, it was hoped that some interesting themes would be uncovered which may not otherwise have been accessible to the researcher. All data were audio-recorded and transcribed and analysed in original languages. Thematic analysis was adopted in this study as it is the most widely used method for identifying themes and patterns of meaning with a clear set of procedures in qualitative research (Braun & Clarke, 2006).

To consider a teacher's question, the research focused on a teacher's utterance that had the grammatical and intonation form of a question, whether it was for the purpose of eliciting information about students' knowledge or thinking or was social act for keeping students' attention. Questions in whole class settings were selected from each observation to analyse. The research attempted to use a discourse analysis approach to analyse the teachers' questioning. The main unit of analysis here was of content units (Hsu, 2001). "A content unit is a piece of discourse that consists of a main question and all the verbal moves made by classroom participants that are directly related to that question in content" (ibid, p. 62). A content unit may not only include a question-answer exchange but might go beyond into the sequences of connected talk associated with a main question. The following extract offers a good example of a content unit:

Excerpt 1 (example from a Chinese lesson)

- Teacher: It is what of the previous call? What exactly?
- Student: The cost of a call.
- Teacher: What? Is it the cost of a previous call?
- Students: Length of a call.
- Teacher: It is it call cost or length of a call?
- Students: Length of a call.
- Teacher: S3, is it the call cost or length of a call?
- Student: Length of a call.

In the process of analysing interview data, both an inductive and deductive approach were used, which included some of the themes taken from the classroom observation. During the analysis,

new issues emerged from the data, therefore, the researcher worked to refine the codes and sub-codes back and forth in a process of inductive and deductive coding.

Results

Individualised vs. collective questioning

One distinct difference lay in the number of students involved in teachers' questioning, which illustrated two opposite questioning patterns. The questioning patterns used by Chinese teachers often took the form of collective questioning, whereas British teachers' questioning patterns were more likely to involve individualised questioning. Specifically, the Chinese teachers frequently posed their questions to the entire class and often involved verbal interaction more than one student. The excerpts above (Excerpt 1) and below (Excerpt 2) are respectively typical examples of questioning to the entire class and questioning to individuals that also involves the rest of the class. The following distinct pattern was only found in the Chinese classrooms. Every single teacher observed adopted this questioning strategy, and used it multiple times in their lessons. A teacher asked students to solve a practical mathematical issue in choosing from three sampling strategies in the textbook.

Excerpt 2

In order to know the eye health of all students from secondary schools across the nation, someone presented the following three sampling methods:

1. To get eye tests for all secondary school students
2. To get eye tests for students from one secondary school
3. On the country level, firstly, divide the country into five areas: east, west, south, north, and middle. Secondly, pick three secondary schools from each area. Thirdly, carry out eye tests for all students from the 15 secondary schools picked.
Which sampling method do you think is the most appropriate?

Teacher: So, someone presented these three sampling methods in order to understand the vision situation of all secondary school students across the country. Li, which one do you think is best?

Li: The third one.

...

Teacher: ... what kinds of issues would rise if we get eye tests for the entire country?

Students: Waste of time.

Teacher: Waste of time. Some students are right. What do we waste?

Students: Waste of energy, waste of people and waste of money...

T&S: Waste of money.

In this excerpt, the teacher asked questions to an individual student Li, but his questions were not individual-centred, because when the teacher continued questioning Li, he set his eyes on the rest of the class, welcoming others to join in this process. Along with the question-answer

exchanges, his follow-up questions with Li were shared and answered among all students in the class, and eventually the teacher and students answer the questions all together.

In contrast, UK teachers asked their questions mostly at an individual level, sticking to one individual student, and keeping eye contact with that individual student until they finished answering the questions or came to the correct understanding. In the process, no other students were allowed to interrupt the interaction between that individual student and the teacher, even when the individual student's solution was incorrect. A classic example can be seen below in Excerpt 3. In one lesson on grouping different cubes and a list of numbers to make a square, rectangle and stick, a teacher had given each group a set of different tasks to complete. As they were looking at square 4 on the board, the following conversation ensued.

Excerpt 3

Teacher: Hannah, how's that 4 made up on the board? How many rows?

Students: (Inaudible)

Hannah: (Inaudible)

Teacher: No, it's Hannah I'm talking to. The 4, Hannah, how many rows has it got?

Hannah: 2.

...

Teacher: 5, well done.

Moreover, the UK teachers often began by asking questions based on the tasks for all the students, but soon followed this with individual students. Depending on how well they answered the questions, their follow-up questions were frequently modified according to the student's response. In one lesson on Trigonometry's problems, a teacher asked Jane to give solutions to question 2, as shown below.

Excerpt 4

Question 2: $\angle C = 71^\circ$, $BC = 8$ cm, get y .

Teacher: ...means the hypotenuse on this side. (*Pointing to line BC*) What is 8? (*Using SOHCAHTOA approach*)

Jane: Opposite.

Teacher: Why Opposite?

Jane: Because it's the shortest one.

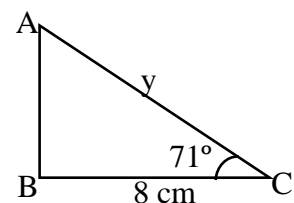
Teacher: No... Is the 8 opposite the given angle?

Jane: No it's the other one.

Teacher: Okay so what's the 8?

Jane: Adjacent.

...



Teacher: Which one has got the adjacent and the hypotenuse in? Is it sin, cos or tan?

Jane: The middle one.

Teacher: The middle one which is what?

Jane: I don't know.

Teacher: The middle one which is what? Sin, cos or tan?

Jane: Cos.

Teacher: Cos, lovely.

In the excerpt above, the teacher insisted on questioning Jane alone until she came to the final correct answer. Every time when she replied with 'I do not know', the teacher asked more followed up questions that probed or guided her understanding.

The findings from interviews reveal that class size has always been a challenge for Chinese teachers. In order to accomplish lesson objectives in such a short, limited time, it was very hard to ask individualised questions. The UK teachers, in contrast, tried to question every student during the lesson. The lower the ability of the group, the smaller the group size would be: a higher ability group tended to be bigger in class size, but no bigger than 30 students. Classroom management was also seen as a concern by the Chinese teachers. They were not as interested in their students' answers but instead on keeping the lesson going and keeping students all focused. Furthermore, it is believed that most mathematics questions were shared by all students. Instead of questioning one student alone, it would be best to ask the entire class, so that everyone could benefit. Their lesson objectives took priority, the lesson pace was fixed and set to get 2/3 of their students to understand their lessons. In contrast, the UK teachers believed that individualised questioning worked best for their individual students' needs. Each student has their own capacity in learning mathematics, and they should work at the pace of their individual students. When a child fell behind, they would increase questioning specifically to that child.

Discussion

The Chinese questioning pattern has been described by Alexander (2017, p. 28) as "teachers and children address learning tasks together, whether as a group or as a class, rather than in isolation". In the Chinese classrooms observed, teachers and students were facing each other during the whole lesson, and maintained eye contact as much as possible between one adult and a class. These teachers indicated an orientation towards learning together, also called collective orientation (Leung, 2001), and the questioning pattern in their classrooms became a rather collective form of questioning. This collective questioning has been found in other studies investigating Chinese classrooms (Ma & Zhao, 2015). Most of the teachers' questions were answered by all students in unison, echoing the notion of social harmony and the 'obligation of the individual to fit into the social structure' (Leung, 2001, p. 44). In contrast, the UK teachers' questioning pattern demonstrates an orientation towards individualised learning described as individual orientation (ibid), illustrating a relatively individualised questioning pattern. The UK teachers observed firstly started questioning with a task-driven

purpose, but soon followed this conversation with individual students and assessed how well they answered the questions. Their follow-up questions were frequently modified to accommodate the individual student's response, in a much more student-centred approach, which fits the description of Western culture seeing the individual as being of prime importance (Leung, 2001). The difference in the two groups of teachers' questioning patterns is in line with Alexander's (2017) conclusions of collectivism- individualism in Western and Eastern countries. The collectivism-individualism concept refers to "the extent to which the individuals of a society are perceived as autonomous" (Kaiser & Blömeke, 2014, p. 406). The underlying assumptions are about the relations between individuals and the community. Collectivism emphasises "human interdependence, caring for others, and sharing and collaborating, but only in as it serves the larger needs of society, or the state, as a whole" (Alexander, 2003, p. 25). Individualism as its counterpoint, puts "the self above others and personal rights before collective responsibilities". This may create different joint identities for students and teachers in China and the UK, which may then explain their classroom questioning behaviours and their explanations for choosing certain questioning patterns. Most of the time, the Chinese teachers questioned students as a group, rarely as isolated individuals, as they emphasised learning common mathematical knowledge together and sharing uniform learning outcomes, following a single curriculum for all. On the contrary, the UK teachers' student-centred questioning strategy viewed "knowledge as being personal and unique", embracing "individual intellectual differentiation and divergent learning outcomes" (Alexander, 2009, p. 936).

Another issue pertinent difference is class size. Consistent findings concerning class size effects on classroom processes show that small class size is strongly related to the individualisation of teaching, whilst large class size is associated with classroom management and classroom control (Blatchford et al., 2011). Specifically, class size seems to alter the proportion of time spent questioning the whole class, or with individuals. With a large class size of over 50 students, the collective questioning pattern may be adopted in the interest of maximising participation by as many students as possible, encouraging them all as a whole to contribute to the answers. In the smaller class sizes of the UK classrooms, the teachers may be able to offer more personalised questioning to their students who are more often the focus of the teachers' attention (Blatchford et al., 2011). It further reveals that the UK teachers and individual students were often engaged in a sequence of several question-answer exchanges. This may suggest that small class size can sustain teacher-student interactions, whereas large class size tends to cut teacher-student interaction short. The Chinese teachers favoured content-based questioning, the remaining third of their students often comprising the least able students may be potentially left out. In contrast, in the UK, students' abilities are strongly linked to the size of a class. This has given teachers the possibility to challenge and extend all students at their own levels of understanding in mathematics.

To conclude, this study suggests that teacher questioning is a cultural-based pedagogy. Thus, it is hoped that policy makers such as the Department for Education in the UK or the Ministry of Education in China can be openly looking at and learning from other education systems, and incorporating parts in a culturally appropriate way.

Reference

- Alexander, R. J. (2003). Oracy, Literacy and Pedagogy: International Perspectives. In E. Bearne, H. Dombey, & T. Grainger (Eds.), *Classroom Interactions in Literacy*, (pp. 23–35). McGraw-Hill Education (UK).
- Alexander, R. J. (2009). Towards A Comparative Pedagogy. In R. Cowen & A. M. Kazamias (Eds.), *International Handbook of Comparative Education* (pp. 923–942). Springer Science & Business Media.
- Alexander, R. J. (2017). *Towards dialogic teaching: Rethinking classroom talk*. (5th Edition). Cambridge.
- Blatchford, P., Bassett, P., & Brown, P. (2011). Examining the Effect of Class Size on Classroom Engagement and Teacher–pupil Interaction: Differences in Relation to Pupil Prior Attainment and Primary vs. Secondary Schools. *Learning and Instruction*, 21(6), 715–730.
- Boylan, M., Maxwell, B., Wolstenholme, C., & Jay, T. (2017). Longitudinal Evaluation of the Mathematics Teacher Exchange: China–England. *Interim Research Report*. Sheffield Hallam University.
- Braun, V., & Clarke, V. (2006). Using Thematic Analysis in Psychology. *Qualitative Research in Psychology*, 3(2), 77–101.
- Chin, C. (2007). Teacher questioning in science classrooms: Approaches that stimulate productive thinking. *Journal of Research in Science Teaching*, 44(6), 815–843.
- Franke, M. L., Webb, N. M., Chan, A. G., Ing, M., Freund, D., & Battey, D. (2009). Teacher questioning to elicit students’ mathematical thinking in elementary school classrooms. *Journal of Teacher Education*, 60(4), 380–392.
- Hsu, W. (2001). *How Classroom Questioning Influences Second Language Acquisition*. Ph.D. Thesis, University of Illinois at Urbana–Champaign.
- Kaiser, G., & Blömeke, S. (2014). Learning from the Eastern and the Western Debate—the Case of Mathematics Teacher Education. In S. Blömeke, F-J. Hsieh, G. Kaiser, & W. H. Schmidt (Eds.), *International Perspectives on Teacher Knowledge, Beliefs and Opportunities to Learn* (pp. 517–539). TEDS–M Results, Springer, Dordrecht.
- Leung, F. K. S. (2001). In Search of An East Asian Identity in Mathematics Education. *Educational Studies in Mathematics*, 47(1), 35–51.
- Ma, Y., & Zhao, D. (2015). Features of exemplary lessons under the curriculum reform in China: a case study on thirteen elementary mathematics Lessons. In S. J. Cho (Ed), *Selected Regular Lectures from the 12th International Congress on Mathematical Education* (pp. 507–525). Springer, Cham.
- Wong, N. Y., Wong, W. Y., & Wong, E. W. Y. (2012). What do the Chinese value in (mathematics) education? *ZDM*, 44(1), 9–19.
- Wu, K. Y. (1993). Classroom interaction and teacher questions revisited. *RELC journal*, 24(2), 49–68.

TWG12: History in Mathematics Education

Introduction to the papers of TWG12: History in Mathematics Education

Renaud Chorlay¹; Aline Bernardes²; Tanja Hamann³; Antonio Oler-Marcén⁴

¹ESPE de l'académie de Paris (France) & LDAR ((EA 4434), UA, UCP, UPD, UPEC, URN; France). renaud.chorlay@espe-paris.fr

²Federal University of the State of Rio de Janeiro (Brazil). aline.bernardes@uniriotec.br

³Universität Hildesheim (Germany). hamann@imai.uni-hildesheim.de

⁴Centro Universitario de la Defensa de Zaragoza (Spain). oller@unizar.es

Introduction

History of mathematics in mathematics education, and history of mathematics education continue to receive much attention. However, empirical research and coherent theoretical/conceptual frameworks within this area have emerged relatively recently. The purpose of this CERME TWG is to provide a forum to approach mathematics education in connection with history and epistemology.

TWG12 welcomes both empirical and theoretical research papers, and poster proposals related to one or more of the following issues:

1. Design and/or assessment of teaching/learning materials using the history of mathematics, preferably with conclusions based on empirical data; all levels can be considered, from early-age mathematics to tertiary education and teacher training.
2. Surveys on the existing uses of history or epistemology in curricula, textbooks, and/or classrooms in primary, secondary or tertiary levels, and in teacher training;
3. History of mathematics education;
4. Relationships between, on the one hand frameworks for and empirical studies on history in mathematics education and, on the other hand, theories, frameworks and studies in other parts of mathematics education research.

Even though the inception of this TWG is fairly recent – it started in CERME6 (2009) – it has deeper institutional roots within the maths education research community. Indeed, the *HPM* study-group (*History and Pedagogy of Mathematics*) was created at the 1972 ICME conference; it has been organizing satellite conferences to the ICME meetings since 1984, and has several active regional branches (HPM-Americas, European Summer Universities). In CERME11, 13 papers and 3 posters were presented in TWG12, with participants coming from a large range of European countries and beyond (Brazil, Tunisia). The topics covered by TWG12 were also reflected in Kathy Clark's plenary address on *History and pedagogy of mathematics in mathematics education: History of the field, the potential of current examples, and directions for the future*.

Before going into any details, it should be stressed that this TWG has four general but distinctive features which give these meetings their specific flavour. Firstly, its topic lies at the intersection of different fields of research – maths education research and history of mathematics – which requires versatility and methodological vigilance (Fried, 2001; Chorlay & Hosson, 2016). Secondly, the

strength of the historical and the HPM community varies greatly among countries, and these meetings play a crucial role for researchers working in relative isolation, and with difficult access to resources in the field. Thirdly, the scope of TWG covers both history in mathematics education and history of mathematics education, which are two significantly different research topics (TSG 24 and 25 in ICME13); connecting the two lines of investigations is a constant challenge. Fourthly, since the topic of TWG12 is neither specific to one level of the educational system (from primary education to teacher-training) nor to any single mathematical topic (be it fraction concepts, algebra, proof, etc.), the work in TWG12 intersects that of most other TWGs. It should be noted that, for this edition, there was little intersection with what was covered in TWG8 (Affects and the teaching and learning of mathematics), TWG10 (Diversity and maths education), in spite of the fact that it is not uncommon for outsiders of the HPM research community – among which most policy-makers and curriculum-designers – to ascribe such goals to the historical perspective in teaching.

These four features made this meeting not only useful but also challenging and exciting. As the final discussion made clear, the general feeling among the participants was that one of the main outcomes of this meeting is that we actually *learned* a lot from the one another, both from their papers and from the lively discussions.

Some significant features of the 2019 conference

A large share of the papers bore on teacher training, either for prospective or in-service maths teachers. Two case studies, one presented by Barreras and Oller-Marcén, and one by Bernardes and Bruna-Correa, showed how confronting teachers with mathematical documents from the past can be a tool both for research into teachers' content knowledge, and for the professional development of teachers. From another perspective, van den Bogaart and Schorcht focused on teachers' beliefs, either when studying some history of maths as part as their per-service training, or when assessing the didactical potential of classroom activities with some historical content.

By contrast, few papers were dedicated to what has long been a central line of research in the HPM community, namely the use of historical documents in the classroom. However, these few papers point to fresh research directions. For instance, the poster of Olsen and Thomsen aimed to connect the studies on history of maths in the classroom with those on the use of ICT. Chorlay's paper bore on primary school mathematics and argumentation, thus illustrating the new approach in the French IREM community, with its greater emphasis on the actual teaching effects of experimental sessions and its rather new involvement with pre-secondary mathematics. This new approach led to the publication of a textbook (Moyon & Tournès, 2018), which was awarded the 2019 prize for best science teaching resource by the Paris Academy of science.

On a par with teacher-training, a significant share of the papers bore on the history of mathematical education; a fact which bears witness to the vitality of this research field at the international level. We are pleased that TWG12 of CERME provides opportunities for researchers working in different fields – mathematics education research, history of mathematics, and history of mathematics education – to interact fruitfully. The papers on topics from history of maths education presented in this CERME conference gave food for thought for mathematics education researchers working on textbooks (Hatami and Pejlare), resources for teaching and the professional development of teachers

(Krüger), testing and assessing (Smestad & Fossum). Several papers (Zwaneveld & De Bock, Weiss & Känders) bore on fairly recent historical developments, thus shedding a new (and occasionally critical) light on current trends. History of education was complemented with inputs from sociology in Hamann's work, in order to sketch a general model for education reform.

References

- Chorlay R., & de Hosson C. (2016) History of Science, Epistemology and Mathematics Education Research. In B. Hodgson, A. Kuzniak, J.-B. Lagrange *The Didactics of Mathematics: Approaches and Issues. A Homage to Michèle Artigue* (pp. 155-189). Springer International Publishing Switzerland.
- Fried M. (2001). Can Mathematics Education and History of Mathematics Coexist? *Science and Education* 10, 391-408.
- Moyon, M., & Tournès, D. (Eds.) (2018). *Passerelles : enseigner les mathématiques par leur histoire au cycle 3*. Paris : ARPEME.

Generalizing a 16th century arithmetic problem with prospective Secondary education teachers

Álvaro Barreras¹ and Antonio M. Oller-Marcén²

¹Universidad Internacional de La Rioja, Logroño, Spain; alvaro.barreras@unir.net

²Centro Universitario de la Defensa de Zaragoza, Spain; oller@unizar.es

The use of history of mathematics and, in particular, of historical problems is a very useful tool for teacher training. In this work we present some partial results obtained after the design and implementation of an activity based upon an arithmetic problem from the “Conpusicion de la arte de la arismetica y juntamente de geometria” by the Spanish 16th century Dominican friar Juan de Ortega. This activity was conducted with 48 prospective Secondary education teachers enrolled on an on-line Masters’ degree. We focus on the part of the activity related to generalization and, more particularly, on the relation between generalization and use of algebraic language. Our results show that there exists a positive significant relation between generalization and the use of algebraic language. However, we also found out that many students were able to provide correct and satisfactory generalizations using just natural language.

Keywords: History of mathematics, word problems, teacher training, generalization, algebraic language.

Introduction and objectives.

The use of history of mathematics in mathematics education can be approached in many different ways and with many different motivations and objectives (Jankvist, 2009). Regarding the classroom implementation, one interesting possibility is the use of historical problems and, in particular of problems “having clever, alternative, or exemplary solutions” (Tzanakis et al., 2000, p. 224).

In the context of teacher training, Mosvold, Jakobsen and Jankvist (2014) show how all the different domains of teachers’ Mathematical Knowledge for Teaching (MKT) might profit from the use of history of mathematics. In particular, the analysis of historical problems and their solutions can be a very interesting task for prospective teachers (Meavilla-Seguí & Oller-Marcén, 2015).

Generalization belongs to the two main domains of the MKT model described by Ball, Thames and Phelps (2008): Subject Matter Knowledge (SMK) and Pedagogical Content Knowledge (PCK). From the point of view of SMK it is clear that generalizing is one of the main components of mathematical activity (Harel & Tall, 1991). Regarding PCK, Ellis (2007, p. 221–222) points out that “one of the primary aims of educational practice is to help students to develop robust, generalizable knowledge that will support their abilities to create generalizations in the classroom”. Generalizing and specializing are two key aspects of one possible approach to algebra (Lee, 1996) and the use of symbolic algebraic language is strongly related to the generalization of arithmetic properties or to the modelization of different situations (Usiskin, 1988).

Even in the absence of symbolic algebraic language, the search for some kind of balance between generalization and specialization can be clearly seen in many ancient mathematical texts. These texts included very long collections of problems possibly hoping that the reader would be able to

infer the general rules used to solve the seemingly different problems. In the *Zhou bi suan jing*, a Chinese text from the 3rd century, this idea was even explicitly stated in a dialogue between a master and a student:

Illuminating knowledge of categories [is shown] when words are simple but their application is wide-ranging. When you ask about one category and are thus able to comprehend a myriad matters, I call that understanding [my] Way. (Cullen, 1996, p. 15)

This underlying philosophy can still be found in Fibonacci's *Liber Abaci* (Sigler, 2002), for example, about one thousand years later. In fact, many mathematical texts written during the 16th and 17th centuries contained series of problems whose solutions were just the description of the operations that had to be performed with the given data.

In this work, we analyze part of an activity designed for and implemented with prospective Secondary school teachers which is based on an arithmetic problem excerpted from a 16th century Spanish arithmetic textbook. Our main objective is to explore if and how the participants are able to provide generalizations of the statement and the solution of the problem. More particularly, we focus on the interplay between generalization and the use of algebraic language. In other words, we focus on two ways to generalize, according to which semiotic register is used: algebraic language or natural language.

The source.

The only known biographical facts about friar Juan de Ortega is that he was born in Palencia, that he was a Dominican and that he taught mathematics in Spain and Italy both publicly and privately (Madrid, 2016).

As far as we know, he only wrote one book, the *Conpusicion de la arte de la arismetica y juntamente de geometria* (Ortega, 1512). Ortega's book was rather popular and it was reedited several times in different countries during the 16th century (Rey Pastor, 1926). In fact, it was reprinted (sometimes with slightly different titles) and translated at least in Roma and Lyon (in 1515), Messina (in 1522), Sevilla (in 1534, 1537, 1542 and 1552) and Granada (in 1563). Some authors (Carabias, 2012) point out that the 1515 translation published in Lyon was the first text on commercial arithmetic written in French. Marquant (2016) presents an interesting discussion on the authorship of some of these translations.

Regarding its content, the book consists of 204 folios organized according to 36 chapters and it covers the usual topics in a Renaissance commercial arithmetic text: elementary operations with natural and fractional numbers, progressions, square and cubic roots, rule of three and its applications and some elements of geometry. The editions of 1534, 1537 and 1542 included a method to approximate square roots that improved the known methods at his time, on this issue we refer the reader to the classical works by Rey Pastor (1926, pp. 72–81) and Barinaga (1932). Finally, the 1552 edition included a collection of 13 problems solved using algebraic techniques that was inserted by Gonzalo Busto, the editor of this probably posthumous edition. This is an interesting feature of the text, since the first book with a systematic introduction to algebraic

language written in Spanish, the *Libro Primero de Arithmetica Algebraica* (Aurel, 1552) was published that very same year (Puig & Fernández, 2013).

In addition to many classical problems (Métin, 2018), in chapters 14 through 17, Ortega provides a collection of 34 examples of what he calls “extraordinary rules” and that he defines (Ortega, 1512, fol. 60r) as “rules outside the usual way of adding, subtracting, multiplying and dividing and that involve hidden ways to apprise those who know little”. They are, in fact, a collection of arithmetic problems and their solutions presented in a merely descriptive fashion. For example, the eleventh example from chapter 14 goes as follows (our translation):

If you wanted to know, or if it was asked to you, which are those three numbers such that two fifths of the first one is the same as three sevenths of the second one and the same as four ninths of the third one, you will do the following. Put the numbers as you see here: $\frac{2}{5} \frac{3}{7} \frac{4}{9}$. Then, multiply the 5 below the 2 by the 3 above the seven to get a 15. Multiply this 15 again by the 4 above the 9 and you will get 60, which is the first number. After that, multiply the 7 below the 3 by the 4 above the 9 to get a 28, which you shall multiply by the 2 above the 5 in order to get a 56, which is the second number. After that, multiply again the 9 below the 4 by the 2 above the 5 and you will get an 18 which you shall multiply again by the 3 above the 7 to get 54. This is the third number. If you want to check that it is true, look for the two fifths of 60 and you will see that it is 24. In the same way you will see that three sevenths of 56 is 24 and that four ninths of 54 is 24, as you see in the example. (Ortega, 1512, fols. 63r–63v)

Activity and participants.

The experiment was carried out in the context of the subject “Didactics of arithmetic and algebra” during the academic year 2017-2018 with 48 students of the online Master’s degree in Didactic of Mathematics in Secondary education from the International University of La Rioja. The age of the participants ranged from 25 to 56 (with a mean of 37.7 and a standard deviation of 7.9) and most of them (91.7%) had at least six months of prior experience teaching mathematics at secondary level. Even though background of the students was diverse, most of them had prior teaching experience or a degree on a STEM or education discipline and hence a good knowledge of mathematics could be assumed. Table 1 provides further information about the participants.

Gender		Nationality				Degree		
<i>Male</i>	<i>Female</i>	<i>Spain</i>	<i>Colombia</i>	<i>Ecuador</i>	<i>Mexico</i>	<i>STEM</i>	<i>Education</i>	<i>Other</i>
52%	48%	17%	44%	37%	2%	61%	35%	4%

Table 1: Some data about the sample

The designed activity was based upon the problem transcribed above. It consisted of three exercises, each of them addressing to a different issue. Being an online Master’s degree, the students had to complete this activity at their homes and they were given a two-week deadline in order to obtain as many answers as possible.

- In exercise 1, a short version of the original problem was presented using modern natural language and the students were asked to solve it using whichever method they wanted.

- In exercise 2, a short version of the original solution was presented using modern natural language and the students were asked to:
 - § Give their opinion about this solution.
 - § Compare this solution with their own solution from exercise 1.
 - § Explain which of the two solutions is “better” and in which sense.
- In exercise 3, the students were asked to provide a general version of the statement of the problem from exercise 1 and a general solution based on the solution from exercise 2.

As we see, exercises 1 and 3 mostly deal with purely mathematical aspects so they are more related to SMK. Exercise 2, on the other hand, is more focused on PCK because it involves the analysis of different solutions to the same problem, their comparison and the reflection about the advantages and disadvantages of each of them. In this work, we will present the results of the analysis of exercise 3. In particular, we will focus on two variables: generalization and language. For the first one we will focus on its correctness (correct or incorrect) and on its completeness (partial or full) while for the second one we will consider the attributes natural and algebraic.

Results.

Although in this work we focus only on exercise 3, it is interesting to point out that almost all the students (46 out of 48) were able to solve the problem in exercise 1 at some extent. However, not all the answers were equally complete. For example, very few students mention that the problem has an infinite number of solutions. In any case, we conclude that the students were able to understand the problem

Exercise 3 was answered by 47 out of the 48 participants. Only 28 of them (about 60%) were able to provide some kind of correct generalization for the statement and the solution of the problem. In Table 2 we see that those participants that used algebraic language were more capable to provide a correct generalization of the situation. In fact, performing a χ^2 test of independence, we obtain a statistically significant relationship between both variables (significance level of about 95%).

	Algebraic language	Natural language
Correct generalization	18	10
Incorrect generalization	7	12

Table 2: Correctness versus use of algebraic language

Most of the wrong answers that tried to generalize the problem using only natural language simply provided incomplete statements. One student’s answer, for example, was: “Do the following exercise, multiplying one denominator by the remaining numerators”, which is a just simple explanation of the method rather than a generalization.

General rule

$$\frac{a}{b} = \frac{c}{d} = \frac{e}{f}$$

- $b \cdot c \cdot e$
- $d \cdot e \cdot a$
- $f \cdot a \cdot c$

Figure 1: Incorrect generalization

The incorrect generalizations that used algebraic language mostly looked like the example in Figure 1. The statement of the problem (top of the figure) is expressed incorrectly and, at the bottom, we just find the required operations expressed symbolically.

It is noteworthy that some students seem to identify the process of generalization just with the use of symbols. Figure 2 is an interesting example of this phenomenon. There is no generalization in the student's answer, just the use of the letters X, Y and Z to denote the unknown numbers.

Being three quantities X; Y; Z proportional to each other, such that:
 $2/5 X = 3/7 Y = 4/9 Z$
 It is possible to find those quantities multiplying the denominator of each fraction by the numerators of the other two fractions

Figure 2: Use of symbols that does not imply generalization

We recall that 28 students provided a correct generalization of the original problem and its solution. However, not all of them provided a full generalization of the situation. In Table 3 we analyze the relation between the use of algebraic language and the degree of generalization of the answer.

	Algebraic language	Natural language
Full generalization	4	7
Partial generalization	14	3

Table 3: Degree of generalization versus use of algebraic language

We obtain again a statistically significant relationship between both variables (significance level of about 95%) showing that the students that were able to correctly generalize the original situation using natural language provided full generalizations more often than their partners. The following transcription is a good example of full generalization that essentially uses only natural language:

If in a set of n numbers that are proportional to each other in a rational way, we multiply the denominator of one of them by the $(n - 1)$ remaining numerators, we obtain that number. If we successively proceed in this way, we will obtain the n numbers of the solution. Since it is a compatible and indeterminate system with $(n - 1)$ equations and n unknowns, the system has infinitely many solutions...

a.- General statement.

Given the following n fractions $\frac{a_i}{b_i}$ $i \in \{1, 2, \dots, n\}$

find n natural numbers x_i $i \in \{1, 2, \dots, n\}$

such that $\frac{a_i}{b_i} x_i = \frac{a_{i+1}}{b_{i+1}} x_{i+1}$ $\forall i \in \{1, 2, \dots, n-1\}$

b.- General solution.

$$x_i = b_i \cdot \prod_{j=1}^i a_j \quad \forall i \in \{1, 2, \dots, n\}$$

Figure 3: Full generalization using only algebraic language

Regarding the 4 answers that fully generalized the problem using algebraic language, three of them combined algebraic and natural language and only one (Figure 3) could be described as “completely algebraic”. Only one of these 4 answers stated that the problem has infinitely many solutions.

Now, 17 students provided correct generalizations that were only partial generalizations. In particular, they only considered a situation with three unknown numbers as in Figure 4.

<p>To find three numbers such that a/b of the first one is the same as c/d of the second and as e/f of the third</p> $\frac{a}{b}x = \frac{c}{d}y = \frac{e}{f}z$
--

Figure 4: Partial generalization using algebraic language

Even if most of these 17 answers were very similar to that in Figure 4 (only varying in the degree of use of algebraic language), two of them were particularly incomplete generalizations. For example, in Figure 5, a student considers arbitrary fractions in the statement of the problem but imposes a very particular relation between numerators and denominators inspired by the particular numbers of the original problem.

<p>To find three natural numbers a, b and c such that the $x/(x+3)$ of the first one, a, is the same as the $(x+1)/(x+5)$ of the second, b, and as the $(x+2)/(x+7)$ of the third, c</p>

Figure 5: A very restricted generalization

The other restricted generalization imposed the additional conditions that the numerators (n_i) of the three fractions are consecutive numbers and the denominators are of the form $2n_i + 1$.

Discussion and final remarks.

From the purely mathematical point of view, it was somewhat surprising that about 40% of the students were not able to provide a correct generalization of the given situation. This might be caused in some cases just by some lack of SMK (Figures 1 or 2) while in other cases it might be related to a misconception about generalization that identifies it with the mere use of symbols in any way (see Figure 2). Regarding the completeness of the generalizations we see that, in terms of Ellis (2007, p. 235), many students generalize just by *removing particulars* (what we called partial generalization, like in Figure 4) rather than by *expanding the range of applicability* (what we called full generalization, like in Figure 3). It is also noteworthy that some students show a different behavior between the statement and the solution. For example, in Figure 2, the student does not generalize the statement at all (he only introduces letters for the unknown quantities) but in the solution he refers to “each fraction” instead of to particular values. This fact probably deserves more attention.

Throughout the students’ responses there is a varying degree in the use of algebraic language. From those using only natural language to those using only algebraic language. Nevertheless, most of the students lie in between showing in their answers a mixture of algebraic and natural language. The results of our work suggest that the use of algebraic language facilitates the process of generalization of the considered problem, illustrating, as Usiskin (1988) points out, that one of the main uses of variables is as “pattern generalizers”. However, and somewhat paradoxically, this use

of algebraic language seems to constitute some kind of obstacle in order to fully generalize the considered situation. There can be several explanations for this phenomenon. One reason can be the context of the exercise, since the answer that was provided to the students only used natural language. Another reason can be related to SMK, because some students might be uncomfortable using algebraic language. Finally, the beliefs, conceptions and expectations of the students about the notion of generalization (Strachota, 2015) might play an important role in their performance.

Zazkis and Liljedahl (2002, p. 400) reached similar conclusions finding out that “there is a gap between students’ ability to express generality verbally and their ability to employ algebraic notation comfortably”. Nevertheless, it must be noted that they worked with preservice elementary school teachers in a context of pattern generalization, while we have worked in a purely arithmetic setting with Secondary education teachers. Either way, there exist contradictory results in the literature. For example, in (Richardson, Berenson & Staley, 2009) most of the elementary prospective elementary teachers participating in the study expressed their explicit generalizations using algebraic notation.

The designed activity, an example of using history as a tool (Jankvist, 2009), involved other exercises. We have already mentioned that most of the students solved the problem correctly. However, after a preliminary and incomplete analysis, we have observed different solving methods some of which involve the use of other semiotic registers besides algebraic or natural language. For example, a few students solved the problem using diagrams. It would be interesting to analyze the influence of different aspects of the students’ solution to the problem over their ulterior process of generalization.

Acknowledgment

This work has been partially funded by the Government of Aragón and the European Social Fund via the research group S36_17D “Investigación en Educación Matemática”.

References

- Aurel, M. (1552). *Libro primero, de Arithmetica Algebratica*. Valencia, Spain: Ioan de Mey.
- Ball, D. L., Thames, M. H., & Phelps, G. (2008). Content knowledge for teaching: What makes it special? *Journal of teacher education*, 59(5), 389–407.
- Barinaga, J. (1932). Sobre los ejemplos de Fr. Juan de Ortega, *Revista Matemática Hispano-Americana*, 7, 194–207.
- Carabias, A. M. (2012). *Salamanca y la medida del tiempo*. Salamanca, Spain: Ediciones Universidad de Salamanca.
- Cullen, C. (1996). *Astronomy and mathematics in ancient China: the Zhou bi suan jing*. New York, USA: Cambridge University Press.
- Ellis A. B. (2007). A Taxonomy for Categorizing Generalizations: Generalizing Actions and Reflection Generalizations. *Journal of the Learning Sciences*, 16(2), 221–262.
- Harel, G. & Tall, D. (1991). The general, the abstract, and the generic in advanced mathematics. *For the learning of mathematics*, 11(1), 38–42.
- Jankvist, U. T. (2009). A categorization of the “whys” and “hows” of using history in mathematics education. *Educational Studies in Mathematics*, 71, 235–261.

- Lee, L. (1996). An initiation into algebraic culture through generalization activities. In N. Bednarz, C. Kieran & L. Lee (Eds.), *Approaches to algebra* (pp. 87–106). Dordrecht, Netherlands: Kluwer.
- Madrid, M. J. (2016). *Los Libros de Aritmética en España a lo Largo del Siglo XVI* (Doctoral dissertation, University of Salamanca, Spain). Retrieved from <http://hdl.handle.net/10366/131718>.
- Marquant, H. (2016). Juan de Ortega (¿1480-1568?) (OP) y la autotraducción al italiano (1515) de su Arte de la Aritmética y juntamente de Geometría (1512). In A. Bueno, D. Pérez & E. Serrano (Eds.), *Dominicos 800 años. Labor intelectual, lingüística y cultural* (pp. 325–341). Valladolid, Spain: Universidad de Valladolid.
- Meavilla Seguí, V. & Oller Marcén, A. M. (2015). Problemas de Relojes. Ejemplos Históricos y Consideraciones Didácticas. *Boletim de Educação Matemática*, 29(51), 110–122.
- Métin, F. (2018). The arithmetic of Juan de Ortega: equations without algebra. In E. Barbin et al. (Eds.), *Let History into the Mathematics Classroom* (pp. 59–73). Cham, Switzerland: Springer.
- Mosvold, R., Jakobsen, A., & Jankvist, U. T. (2014). How mathematical knowledge for teaching may profit from the study of history of mathematics. *Science & Education*, 23, 47–60.
- Ortega, J. de (1512). *Conpusicion de la arte de la arismetica y juntamente de geometría*. León, Spain: Joannes Trinxer.
- Puig, L. & Fernández, A. (2013). La Arithmetica Algebratica de Marco Aurel, primer álgebra impresa escrita en español. Preliminares para su estudio. In L. Rico, M. C. Cañadas, J. Gutiérrez, M. Molina & I. Segovia (Eds.), *Investigación en Didáctica de la Matemática. Homenaje a Encarnación Castro* (pp. 143–150). Granada, Spain: Editorial Comares.
- Rey Pastor, J. (1926). *Los matemáticos españoles del siglo XVI*. Madrid, Spain: A. Medina.
- Richardson, K., Berenson, S., & Staley, K. (2009). Prospective elementary teachers use of representation to reason algebraically. *The Journal of Mathematical Behavior*, 28, 188–199.
- Sigler, L. E. (2002). *Fibonacci's Liber Abaci. A translation into modern English of Leonardo Pisano's Book of Calculation*. New York, USA: Springer.
- Strachota, S. (2015). Conceptualizing generalization. *IMVI Open Mathematical Education Notes*, 6, 41–55.
- Tzanakis, C., Arcavi, A., de Sa, C. C., Isoda, M., Lit, C-K., Niss, M., Carvalho, J. P., Rodriguez, M., & Siu, M-K. (2000). Integrating history of mathematics in the classroom: an analytic survey. In J. Fauvel & J. van Maanen (Eds.), *History in mathematics education. The ICMI study* (pp. 201–240). Dordrecht, Netherlands: Kluwer.
- Usiskin, Z. (1988). Conceptions of School Algebra and Uses of Variables. In A. Coxford (Ed.), *The Ideas of Algebra K–12* (pp. 8–19). Reston, USA: NCTM.
- Zazkis, R. & Liljedahl, P. (2002). Generalization of patterns: the tension between algebraic thinking and algebraic notation. *Educational Studies in Mathematics*, 49, 379–402.

On the didactical function of some items from the history of calculus

Stephan Berendonk¹

¹Universität Duisburg-Essen, Germany; stephan.berendonk@uni-due.de

The article draws attention to some individual results from the history of calculus and explains their appearance in a course on the didactics of analysis for future high school mathematics teachers. Specifically it is shown how these results may serve as a vehicle to address and reflect on three major didactical challenges: determining the meaning of a result, concept or topic to be taught, teaching mathematics as a coherent subject and understanding the source of misconceptions.

Keywords: *Didactics of analysis, meaning, coherence, misconceptions.*

Why do we have to learn this *historical* stuff, although this is a course on *didactics*? This is a question frequently posed by future high school mathematics teachers taking my third semester course on the didactics of analysis at the university of Duisburg-Essen. In this course we consider and compare several different approaches to differentiation and integration, uncover some of the relationships of analysis with other mathematical subdomains and try to settle the role and meaning of analysis within the high school curriculum. Although the students have mastered a typical first semester university course on real analysis before taking my course on the didactics, I feel obliged to incorporate several mathematical digressions into this course. These digressions especially include some episodes from the history of calculus that weren't discussed in the course on real analysis. I teach these episodes, however, not as an end in itself or as an introduction to the history of mathematics, but as a means in order to be able to seriously address the didactical issues at stake. In the following article I will mention some of those episodes and I will try to point out their relevance and value from a didactical point of view.

Three didactical challenges – meaning, coherence and misconceptions

Let us consider a typical first semester university course on real analysis. With such a course we may associate the following keywords: axioms for the real numbers, convergence of sequences and series, Heine-Borel, Bolzano-Weierstrass, differentiability, monotony, continuity, integrability, intermediate value theorem, mean value theorem, fundamental theorem of calculus and epsilon-delta proofs. This course has a lot to offer to its students. It introduces them to the mathematical quest for rigor, generality and structural results. It shows that the knowledge about differentiation and integration learned at school can be embedded into a beautiful large-scale deductive system, and thereby exemplifies the architectural nature of mathematics.

One might believe that this course would form a sufficient background regarding the mathematical content knowledge with respect to analysis for a future high school mathematics teacher. However, teaching analysis at school may serve quite different aims than the university course we considered. For instance one might want to teach analysis as a tool to formulate and understand some Newtonian physics or more generally speaking, one might want to teach analysis as an example showing the applicability of mathematics and its role for the other sciences. In any case, in contrast to the university course, analysis nowadays usually isn't taught architecturally at school and

according to Freudenthal (1973) and his legacy it wouldn't be a good idea to do so either. One should be acquainted with a subject, with local orderings of its results and concepts before one should work on or be confronted with a global ordering of that subject. From this situation, namely teaching analysis in a different way, a didactical challenge arises: Find the role and meaning of the concepts and results to be taught with respect to the overall approach chosen, e.g. genetic, applicational or problem-oriented. In the axiomatic approach the concepts and results receive their meaning from their place within the system. The mean value theorem for instance occupies a central position within the system. It can be seen as the linchpin of the theory. Continuity is treated as a central concept. In a different approach, however, the roles and meanings of the concepts and results might be completely different.

A central concept developed and used by the German-speaking educational sciences in order to direct the discussion of school curricula is called 'Allgemeinbildung'. The concept elaborates on the functions of school and thereby it serves as a framework and a benchmark for the development and analysis of curricula. Each school subject is then requested to determine its individual contribution to the Allgemeinbildung. In Heymann's (1997, p.2) version of the concept, which is especially prominent in mathematics education, one major task of school is to teach the subjects in such a way as to endow cultural coherence, meaning not only the relationship between past, presence and future, which Heymann would rather have called 'cultural continuity', but also the interrelations of different subcultures. Analysis seems the perfect choice when trying to reveal the interrelations of mathematics and physics. However, even in mathematics itself there are subcultures or rather subdomains, whose relationship one should uncover. The didactical challenge, therefore, consists in discussing the unity of mathematics and asks the following questions: How is analysis related to geometry, how is it related to algebra? The first semester course on real analysis imagined hardly addresses this issue, since it rather focuses on presenting analysis as a self-contained subject.

Teacher students are usually keen to learn about pupils' misconceptions and the best recipes on how to treat them. It is important for them to notice, however, that the instruction itself may cause some of those misconceptions and that a different instruction, using for instance a different approach, may again cause quite different misconceptions. Thus, some misconceptions may be 'typical' in general, whereas some of them may only be 'typical' relative to a given instruction. It is an important didactical challenge to determine the misconceptions belonging to a certain instruction. Since every mathematics teacher student shares the experience of roughly the same first semester course on real analysis, it appears to be a good exercise to think about misconceptions that this course might favor.

In the preceding passages I have formulated three didactical challenges ('meaning', 'coherence' and 'misconceptions') and I have tried to indicate their importance for mathematics teacher students. These challenges form an integral part of my course on the didactics of analysis. My students, when confronted with these issues in the beginning of the course, have a hard time dealing with them. This is understandable, considering that their analytical background consists solely of a first semester course on real analysis. However, teaching a few episodes from the history of calculus, already helps them to handle the challenges in a much more appropriate and satisfying way. I will now, for each challenge separately, mention the results from the history of calculus that I teach and I will explain how they may contribute to the discussion on the respective challenge.

Meaning – the integral integrates, the calculus calculates

What is the meaning of the integral? What is the meaning of the calculus in general? What is the meaning of the fundamental theorem of calculus? A mathematics teacher needs to be able to answer these questions in a satisfying way, since ‘how’ he teaches a certain subject or course should of course highly depend on ‘why’ he regards the content as being worth to be taught in the first place. In my view, the best way to approach these questions is to look at the prehistory of the calculus. Let us consider Roberval’s determination of the area (see Whitman, 1943) under the cycloid (Figure 1) and his comparison of the length (see Pedersen, 1971) of an Archimedean spiral with that of a certain parabola (Figure 2).

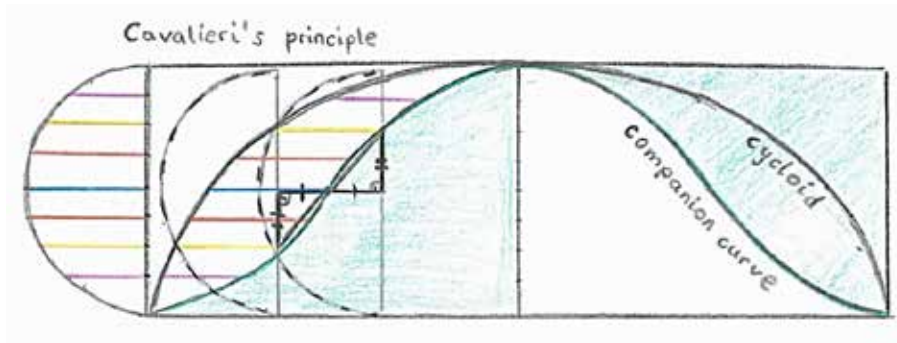


Figure 1: Roberval – The area of the cycloid

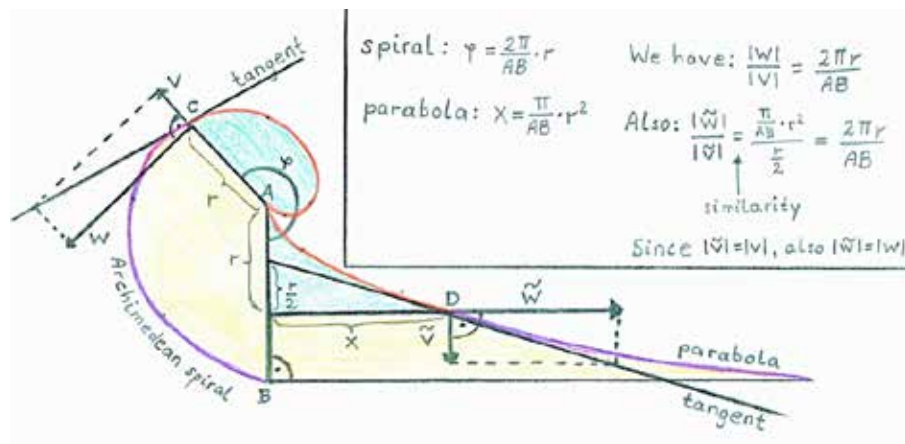


Figure 2: Roberval – The length of the Archimedean spiral

To solve the ‘area’ problem Roberval uses Cavalieri’s principle. To solve the ‘length’ problem he employs his kinematic approach to tangents (see Pedersen, 1969). Thus, the two solutions are based on two completely different methods. This is interesting, since in the world of calculus both, the length problem and the area problem, have become one and the same, in the sense that both ask you to compute some integral. Apparently the integral does what it promises. It integrates the two basic problems associated with a curve. Determine its length and its area. Of course the concept of the integral incorporates ‘volumes’, ‘centers of gravity’ and many other things as well. Wouldn’t this be one possible meaning of the integral that we might wish to convey to learners of mathematics? After all Poincaré once said (see Verhulst, 2012):

Mathematics is the art of giving the same name to different things. (Poincaré, 1914, p.23)

Let us now think about the meaning of calculus and its fundamental theorem. To this end, let us in addition to Roberval's two results consider Archimedes' quadrature of the parabola (see Dörrie, 1965, p.239) and Huygens' determination of the area (see Maanen van, 2003) between the cissoid of Diocles and its asymptote (Figure 3). After looking at these four problems and their solutions one might get the impression that before calculus every curve was treated individually, that at that time people were extremely well acquainted with the geometrical properties of these curves and that one had to come up with a new ingenious idea for every other curve. Today, on the other hand, it needs no ingenuity to solve these questions. With the calculus at hand, these problems have become more or less straightforward routine exercises. The routine goes like this: Formulate the problem in terms of an integral and apply the fundamental theorem, that is, look for an antiderivative and plug in the limits of integration. Finding an antiderivative might be a problem, but that is where the calculus with its powerful tools, integration by parts or by substitution, sets in. We could therefore view the calculus as a facilitation of a major part of mathematics. With calculus everyone has the chance to learn how to handle areas under curves. It seems to be exactly this meaning that Leibniz himself saw in his calculus:

For what I love most in this calculus is that it gives us the same advantage over the ancients in the geometry of Archimedes as Viète and Descartes gave us in the geometry of Euclid and Apollonius; by relieving us of working with the imagination. (as cited in Blåsjö, 2016, p.17)

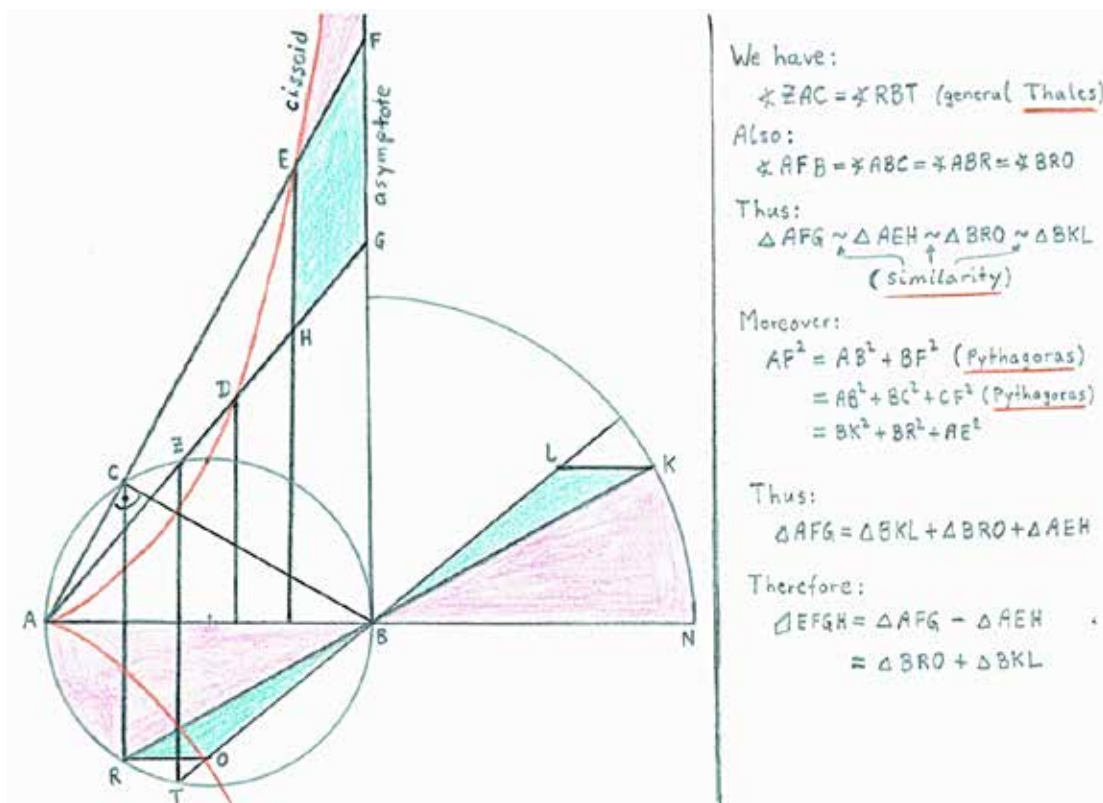


Figure 3: Huygens – The area of Diocles' cissoid

Coherence – calculus seen as the algebra for transcendental curves

Which of the following terms does not fit with the others?

‘Similarity of triangles’, ‘Thales’ theorem’, ‘Pythagoras’ theorem’, ‘differential equation’.

Of course the last term does not fit, since the first three terms belong to geometry, whereas the last term belongs to calculus. Huygens’ determination of the area of the cissoid, however, may cast some doubts about this decision. To the modern eye his problem might appear as a ‘calculus problem’. His method, on the other hand, is purely geometrical. Thales, Pythagoras and similarity (compare Figure 3), these are exactly the tools that Huygens employs. Calculus and geometry, this is the morale of Huygens’ result, are not as divorced from each other as the typical courses on these subjects might let one think. By looking for instance at Johann Bernoulli’s lectures on the calculus (Bernoulli, 1924) one realizes that differentials and their equations were just an additional tool incorporated into the old game of geometry. Thales, Pythagoras, similarity and a differential equation, in Bernoulli’s determination of the tangents to a cycloid (Figure 4) we have all this at one place.

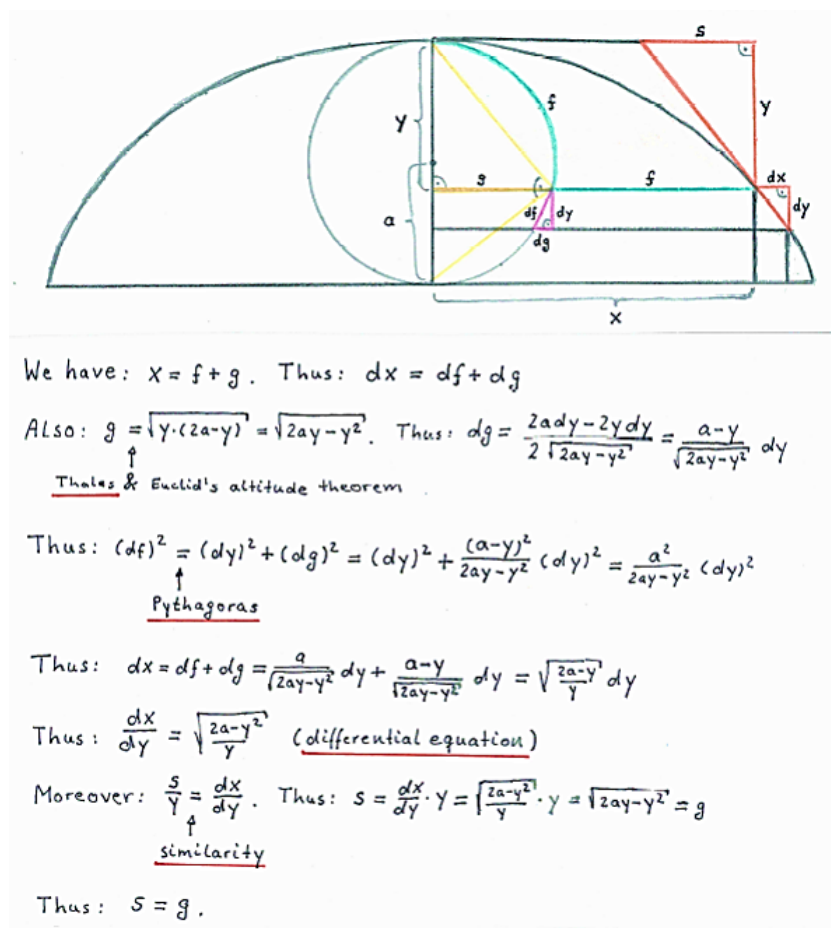


Figure 4: Bernoulli – The tangent of the cycloid

We now turn to the relationship between calculus and algebra. A major challenge in teaching these two subjects coherently is to show where the algebra ends and where the calculus begins, that is, to

reveal their line of demarcation. At least according to Leibniz the line runs precisely between the algebraic curves and the transcendental curves:

As far as the differential calculus is concerned, I admit that there is much in common between it and the things which were explored by both you [Wallis] and Fermat and others, indeed already by Archimedes himself. Yet now the matter is perhaps carried much further, so that now those things can be accomplished which in the past seemed closed even to the greatest geometers as Huygens himself recognized. The matter is almost the same in the analytical calculus applied to conical curves or higher: Who does not consider Apollonius and other ancients to have had theorems which present material for the equations by which Descartes later preferred to designate curves. In the meantime the matter has been reduced to calculation by the method of Descartes, so that now conveniently and without trouble that can be done which formerly required much effort of contemplation and imagination. In the same way, by our differential calculus, transcendentals too, which Descartes himself excluded in the past, are subjected to analytical operations. (as cited in Blåsjö, 2016, pp.16-17)

In this picture the relationship between geometry, algebra and calculus is beautifully simple. At first we have the Euclidean geometry with compass and ruler only. Then Descartes allows some other kinds of construction tools, which on the side of the equations correspond exactly with the algebraic curves. This world can be studied by means of algebra. Leibniz, finally, goes even further and includes modes of constructions that allow also transcendental curves to enter geometry. Algebra falls short of these curves and calculus is needed. A good way to experience this situation is by starting with Descartes' double-root method for finding normals and tangents and by trying to get as far as possible with this method. This is performed in detail in (Range, 2011). One first of all shows that there is a unique line through each point of the graph which intersects the graph at that point with multiplicity at least 2. Then one generalizes this fact to rational functions and finally to algebraic functions. When it comes to transcendental functions, of course, one gets stuck. It is at that point, that one has to generalize one's definition of tangent. It is at that point, where the 'limits' come into play.

Misconceptions – tangents require limits, areas require rectangles

Instead of Descartes' double-root method we might also consider the notion of tangent that Euclid employed in his third book when dealing with the circle:

A straight line is said to *touch* a circle which, meeting the circle and being produced, does not cut the circle. (Euclid, 1956, p.1)

How far can we get with this notion? If we take the notion literally, it already fails when confronted with a parabola, since through each point of a parabola there are two different lines that have only one point in common with the parabola, one of them being a line parallel to the axis of symmetry of the parabola. We can, however, rule out these parallels by requiring the tangents to stay on one side of the parabola. This leads to the following modification of Euclid's definition: A line, which has a common point with a curve, is called *tangent* to that curve, if the curve lies on one side of the line and if it is the only line through the common point with that property. Huygens, for instance,

worked with this notion, as one can see in his work on the cycloid (see Aarts, 2015, pp.3-4). For convex curves this notion works fine, but already in the case of such a simple non-convex curve as the cubical parabola ($f(x) = x^3$) not one single point would have a tangent according to this notion. However, for all but one point on the cubical parabola, the problem is easily resolved by only requiring the curve to stay locally on one side of the line. The point not covered by this extended notion is the inflection point. It seems that we have to give up on Euclid's notion of tangents ultimately when it comes to inflection points. Arnold Kirsch, however, has shown in (Kirsch, 1960a) how to overcome this obstacle. After defining *smoothness* of convex functions by means of the modified version of Euclid's notion of tangent, he goes on to define smoothness of functions in general essentially as follows: A function is *smooth* in some point, if the function lies locally between two smooth convex functions that both go through that point and that share a common tangent at that point. In (Kirsch, 1960b), Arnold Kirsch shows that this notion of *smoothness* is equivalent to our usual notion of differentiability. This is certainly an interesting result, since it clashes with the widespread belief that one needs the concept of *limit* in order to define differentiability and tangents in general.

Another major misconception I come across among teacher students more often than one might imagine is the belief that one can determine areas associated with curves only by means of the Riemann integral or rather by exhausting the relevant area with rectangles. This conception seems to consolidate itself in the course of the received instruction, since children, which have not yet been 'enlightened' by a course on calculus, apparently still use all kinds of figures, triangles, trapezoids, squares or whatever suits, in order to cover the area in question. Against this background it seems important to elaborately discuss examples such as Archimedes' quadrature of the parabola (see Dörrie, 1965, p.239), which uses triangles, or Huygens' determination of the area of the cissoid (see Maanen van, 2003), which uses trapezoids and triangles instead of the notorious rectangles.

Summary and discussion

In this article I have shared my approach on how to address three major challenges ('meaning', 'coherence' and 'misconceptions') in a course on the didactics of calculus for future high school mathematics teachers. In order to discuss the meaning of the calculus I provided the students with results from Roberval and Huygens, which show firstly, what can be done even without calculus and secondly, how much insight is needed for this. In this way the students may see and appreciate the calculus, just as Leibniz apparently does, as a 'mechanization' of geometry. It should be critically noted that the historical episodes chosen play within geometry and due to this we have left the meaning of calculus for other branches of mathematics and especially its role in Newtonian physics completely untouched. In order to show the coherence between calculus and geometry I offered some examples from Bernoulli's lectures on the differential calculus. To this end it is also worthwhile to consider two different rather recent geometrical approaches (Apostol & Mnatsakanian, 2002 and Kaenders & Kirfel, 2017) to the integration of the basic functions, treated in high school. Both of them, the sweeping-tangent approach by Apostol and Mnatsakanian and the approach using geometrical transformations by Kaenders and Kirfel link calculus and geometry each in their own way. To show the coherence between calculus and algebra I focused on the

difference between algebraic and transcendental curves, especially by maxing out Descartes' double-root method. Finally, regarding the misconceptions, I tried to point out that some of them might be 'instruction-generated'. For example, I showed that generalizing Euclid's notion of tangent can lead to a 'limit-free' general notion of tangent, a fact that seems to clash with the calculus related beliefs of many students. By way of the three didactical challenges I tried to show that and to indicate how courses on the didactics of mathematics may benefit from a selective and targeted recourse to the history of mathematics.

References

- Aarts, J. (2015). *Christian Huygens: Het Slingeruurwerk – Een studie*. Amsterdam, Epsilon Uitgaven.
- Apostol, T. M. & Mnatsakanian, M. A. (2002), Tangents and Subtangents Used to Calculate Areas, *The American Mathematical Monthly*, 109(10), 900-908.
- Bernoulli, J. (1924). *Die Differentialrechnung*. Ostwald's Klassiker der exakten Wissenschaften Nr. 211. Leipzig, Akademische Verlagsgesellschaft M.B.H.
- Bläsjö, V. (2016). *Transcendental Curves in the Leibnizian Calculus* (Doctoral Dissertation, University of Utrecht, Netherlands), Academic Press.
- Dörrie, H. (1965). *100 Great Problems of Elementary Mathematics*. New York, Dover Publications.
- Freudenthal, H. (1973). *Mathematics as an Educational Task*. Dordrecht, Springer Netherlands.
- Euclid (1956). *The Thirteen Books of the Elements*. Vol. 2 Book: 3-9 (trans. T. Heath). New York: Dover Publications.
- Heymann, H. W. (1997). Allgemeinbildung als Aufgabe der Schule und als Maßstab für Fachunterricht. *Pädagogik*, 49(2), 42-45.
- Kaenders, R. & Kirfel, C. (2017), Flächenbestimmung bei Basisfunktionen der Schule mit Elementargeometrie, *Mathematische Semesterberichte*, 64(2), 199-220.
- Kirsch, A. (1960a). Eine geometrische Charakterisierung der "Differenzierbarkeit" einer Funktion. *Mathematisch-Physikalische Semesterberichte*, 7, 96-100.
- Kirsch, A. (1960b). Ein geometrischer Zugang zu den Grundbegriffen der Differenzialrechnung. *Der Mathematikunterricht*, 8(2), 5-21.
- Maanen van, J. (2003). Precursors of Differentiation and Integration. In Jahnke, H.N. (Ed.), *A History of Analysis*, 41-72.
- Pedersen, K. M. (1969). Roberval's Method of Tangents. *Centaurus*, 13(2), 151-182.
- Pedersen, K. M. (1971). Roberval's Comparison of the Arclength of a Spiral and a Parabola. *Centaurus*, 15(1), 26-43.
- Poincaré, H. (1914). *Wissenschaft und Methode*. Leipzig, B.G. Teubner.
- Range, M. (2011). Where are Limits needed in Calculus? *The American Mathematical Monthly*, 118(5), 404-417.
- Verhulst, F. (2012). An interview with Henri Poincaré - Mathematics is the art of giving the same name to different things. *Nieuw Archief voor Wiskunde*, 5(13), 154-158.
- Whitman, E. A. (1943). Some Historical Notes on the Cycloid. *The American Mathematical Monthly*, 50(5), 309-315.

Justifying a calculation technique in years 3 and 6

Renaud Chorlay

Laboratoire de didactique André Revuz (EA 4434), UA, UCP, UPD, UPEC, URN; France

renaud.chorlay@espe-paris.fr

In this progress report, we present the outline and the first results of a research project which aims to study the argumentative capacity of year 3 (age 8) to year 6 (age 11) students, in a numerical context involving natural and decimal numbers. This project centers on a technique for dividing natural numbers by two, a technique which appears in Al-Khwarizmi's Kitāb al-ḥisāb al-Hind.

Keywords: Al-Khwarizmi, primary school, operations, place value, proof.

Preliminary remark: This paper is a progress report on an ongoing project. In Chorlay (forthcoming), which was written before the first classroom experiments were carried out, we presented in some detail the historical background, the general motivation, and elements on the *a priori* analysis; these will only be sketched here. Our main goal is to present some of the empirical data gathered, and discuss the theoretical tools which can help us analyze them.

Rationale.

Historical background.

Although Al-Khwarizmi is usually remembered for his treatise on algebra and quadratic equations, he also wrote several other books for which the oldest manuscripts available now are Latin translations. In particular, in his *Book on Indian Reckoning (Kitāb al-ḥisāb al-Hind)*, he introduced into the Arabic-speaking scientific community a technique to write whole numbers (the decimal place value system), and written calculating techniques relying on this conveniently uniform coding system; techniques for addition, subtraction (with the borrowing method), *mediation* and duplication (i.e. division and multiplication by 2), multiplication, division, and square root extraction (with mediation as one of its steps). Although he found these in the Indian mathematical and astronomical traditions, it should be noted that they were also in use in Chinese mathematics.

Both the book on algebra and that on Indian reckoning were first translated into Latin in the 12th and 13th centuries, more often than not by scientists working in Andalusia with a prime interest in astronomy. For a recent study on these treatises, we refer the reader to Allard's edition and French translation of the three oldest extant Latin translations/adaptations of the lost Arabic text (Al-Khwarizmi, 1992).

General didactical motivation.

For reasons which we will spell out below, we thought the algorithm for *mediation* (i.e. division by 2) could be used in mathematics education research, in order to study phenomena which have no direct connections to the use of history of mathematics in the classroom. In a general report on the future of mathematics education published in 2003, a French study-group headed by Pr. Kahane stressed that:

(...) Most of the reckoning algorithms whose teaching and learning took so much school-time are now available in the most basic calculator. By contrast, new questions emerge, in particular about the digital representation of the mathematical objects on which they bear (such as numbers), and about the efficiency of algorithms (beyond their correctness) ... question which were not issues in teaching until now. The calculating power of the new tools (...) calls for renewed investigations into the connections between calculation and reasoning, and fosters exploration, simulation and experimentation. (quoted in (Charnay, 2007, p. 204). Our free trans.)

On this basis, Roland Charnay suggested that the main interest of studying written calculating techniques was that they provide

opportunities to work on the properties of numbers and operations by focusing the greater part of the effort on understanding and justifying these algorithms (...). This requires that we do not content ourselves with a *technicist* teaching (bearing on the *how*), but endeavour to justify the various steps and their connections (the *why*) ... and actually *do* mathematics! (Charnay, 2007, p. 206. Our free trans.).

Of course, these statements call for qualification: on the one hand, it would not be fair to say that the justification of numerical algorithms played no part in teaching, even in elementary school (for instance, see Clivaz (2016) and Constantin (2017) for recent investigations into teacher practices and mathematical-knowledge-for-teaching with regard to the justification of reckoning techniques). On the other hand, it is likely that some familiarity with calculation routines is a prerequisite to entrust students with *meta*-tasks – “*meta*” in so far as do not bear on specific numbers or numerical problems, but on mathematical procedures; procedures which are to be described, reformulated, compared with others, assessed, or justified (Chorlay, 2016). In this context, the procedures change status: from epistemic tools (i.e. answer-generating tools, which can, in themselves, be black-boxes) to epistemic objects (i.e. question-generating objects). It should be pointed out that, as stressed in Chorlay (2016), this change of status allows for the insertion of justification tasks in the larger set of meta-tasks. One of the underlying macro-hypothesis is that enculturation of the students into the class of meta-task could be a viable pathway to the teaching of the specific and highly demanding meta-task “prove”.

Al-Khwarizmi’s technique.

The three oldest Latin texts expound variants of the same technique. The *Dixit Algorismi* reads¹:

To divide any number by two, begin with the first place and divide it by two. If its number is odd, divide the pairs [or: the even one] in two halves, and there will remain one to be divided by two – that is, to be divided in two halves – and you shall set one half, which is a fraction of thirty

¹ *Cum volueris mediare aliquem numerum, accipe a prima differentia et media eam. In qua si fuerit numerus impar, media pares, et remanebit unum quod mediabis, idest divides in duas medietates, constituesque medietatem unam triginta partem ex sexaginta (...). Deinde mediabis sequentem differentiam, si fuerit numerum eius par. Et si fueris impar, accipe medietatem paris et pone eam in loco eius, et constitue medietatem unius residui quinque, et pone eos in differentia que est ante ipsam. (...) et similiter operare in universis differentiis.* (Al-Khwarizmi, 1992)

out of sixty (...). Then, you shall divide by two the next place, if its number is even. If it's odd, take half of the even one and put it in its place; set 5 as half of the remaining unit and put it in the place before. (...) Operate the same way for all places. (Al-Kwarizmi, 1992. Our trans. based on Allard's translation into French).

No justification for this specific technique is given, but the three manuscripts provide justifications for most of the others and probably consider this one to be self-explanatory. Even though the meaning of “first place” is ambiguous in this excerpt, it is not in the treatises: it denotes the units; so, if we write the number in today's standard form, the algorithm works from right to left, from units to tens, then to hundreds etc. When applying the technique to 92, one can display the successive states of the slate as the shown in the boxes below:

$\boxed{92}$ [2 @ 1] $\boxed{91}$ [9 = 8+1; 8@ 4] $\boxed{41}$ [carry 5 to the right, 1 @ 6] $\boxed{46}$

In square brackets, we described the operations to be carried out either on the slate (@ for “erase and replace”) or mentally (decompose², carry).

From a purely mathematical viewpoint, the validity of this algorithm rests of the fact that halving a sum is the same as summing the halves (which can be seen as a special case of the distributivity of \cdot over $+$, if we agree to count “one half” as a number), on the multiplicative linearity of the “halving” and, eventually, on the canonical decomposition of whole numbers in a place value system. The fact that we are working in base ten is reflected in the “carry 5 to the right” rule: a “1” digit in the second place stands for “ten”, so its half is 5 units; a “1” digit in the third place represents one hundred, which is 10 tens, so its half is 5 tens etc. If numbers were written in base 4, the technique would be the same except for a “carry 2 to the right” step. Resting on the same mathematical bases, this algorithm is structurally similar to the other “Indian” algorithms: you don't need to consider the number as a whole; rather, you iteratively apply the same procedure to every digit, which means that you can process any whole number as long as you can process 1-digit numbers. A more detailed analysis can be found in Chorlay (forthcoming).

First report on the experiments.

Outline of the experiments and theoretical background.

The fact that this technique is not known to French students, but rests only on the basic principles of the decimal place-value system (namely: place value, and the “exchange rate” of 10 between two adjacent places³) led us to assume that it was fit to be used to investigate whether or not *meta*-tasks – including “justify” – could be entrusted to young students. In school year 2017-2018, we designed teaching experiments based on this material and tried it out in a year 6 class (1st year of middle-

² Or “subtract one”, or “consider the predecessor”, or “take the greatest even number less than (or contained in) 9”.

³ The validity of the algorithm also rests on the distributive property, a property which is not taught explicitly before year 7 in France. However, the distributive property is used *in act* at very early stages in the study of multiplication, either in mental calculation, or in the standard written techniques. We assumed that the distributive property of “halving” would “go without saying” for students, that is, would neither be mentioned nor questioned explicitly.

school in France, students aged 11) and in a year 3 class (students aged 8). A key difference lies in the fact that year 6 students know decimal numbers, whereas year 3 students do not. Indeed, in the experiments, year 3 students typically said that halving 3 is impossible – or cannot be carried out completely accurately – whereas all year 6 students said that half 3 is 1.5.

For the researchers to gather data, students were asked to produce written traces of their individual reflection. These worksheets were collected, and the collective phases were video-recorded. The experiment took place in ordinary classes of about 25 students each. The class was taught by the regular teacher (or maths-teacher in year 6); the teachers had been associated to the design of the sessions from the outset. The researcher was present but played no active part in the sessions.

We have no room here to present the specifics of the teaching sessions, which differed for year 3 and year 6 students. To put it in a nutshell, the starting point was a silent performance – on the blackboard, by the teacher – of a few instances of mediations along Al-Khwarizmi's technique, with even whole numbers, some with even digits only, some with odd digits as well. Over the course of the sessions, the various tasks entrusted to students were:

1. Make hypotheses as to the function performed by the algorithm (that is: division by 2).
2. Emulate the technique with new even numbers (with or without odd digits).
3. Write (for year 6 students) or describe orally (for year 3 students) the method shown.
4. Justify its correctness.

Before we focus on points 3 and 4 (which, as we will see, were not treated independently by most students), let us mention a few empirical results regarding points 1 and 2. Regarding point 1, even year 3 students guess very quickly that it is a halving technique. When asked how they could test this conjecture, they suggested the following three correct techniques: add the output with itself and compare with the input; multiply the output by 2 and compare with the input; subtract the output from the input and compare with the output; they had not yet studied Euclidean division. By contrast, few students managed to identify the procedure for the treatment of odd digits (that is: subtract one, halve the result⁴, and add a carry of five to the digit of the output immediately to the right). Thus, tasks 2 turned out to be significantly more difficult than task 1.

As far as points 3 and 4 are concerned, we wanted to investigate:

- A. What – if any – knowledge about the decimal place value system was used by students to describe, then make sense of or justify the algorithm.
- B. What forms of justification – if any – did students supply.

In our investigation into A, we relied on the work of Frédéric Tempier (2016) who, after Christine Chambris, regards “tens”, “hundreds” etc. as a system of (non-independent) units. In his analysis of the work of students at the end of primary school he identified four interpretations of numbers written in standard form: 1. Juxtaposition of identical units (584 seen as 5 units, 8 units and 5 units); 2. Place-value juxtaposition (the student is able to read in terms of “hundreds”, “tens”, and “units” but with no functional connection between these terms); 3. Simple units (584 seen as 500 units plus

⁴ Or: halve the greatest even number contained in (less than) the odd number; halve the number before/the predecessor.

80 units plus 5 units); 4. System of units (“units”, “tens”, “hundreds” are seen as units, and relationships such as $1 \text{ hundred} = 10 \text{ tens} = 100 \text{ units}$ are available). Of course, when dealing with numbers (either in rewriting tasks, as studied by Tempier, or to justify mediation), interpretations 1 and 2 are not functional, whereas interpretations 3 and 4 are. A key aspect is that many students tend to regard written calculation as a black-box operating *only* on number *signs*, and indeed, the strength of place value systems lies in the fact that the algorithms can be described (and applied) as series of graphic operations bearing on written signs; of course, applying these techniques rests on properties of one-digit numbers, properties which are usually to be learnt by heart for an efficient and routine use of the technique. In the following, we will not consider the use of memorized numerical facts bearing on one-digit numbers to be indicative of an engagement in justification.

As far as argumentation is concerned, our starting point is the seminal work of Nicolas Balacheff (1987). He distinguished between two forms of “proof”: pragmatic proof (by actually performing and checking) *vs* intellectual proof (through a discourse bearing on object, thus dependent on means of representation of the objects). He also considered a hierarchy of forms of argumentation: naïve empiricism (check on a few cases), *experimentum crucis* (the generality issue is considered, and addressed by checking a specially difficult or large case), generic proof (where the actions are performed on a specific object which is used as a representative for a class of objects, and one claims that arguments – or moves – hold – or can be performed – for all other cases “just as well”; see (Yopp & Ely, 2016) for a recent survey), the thought experiment (the action is described without being performed on a specific case, and the general properties are indicated in some other way than by the result of their use), and formal proof. This framework has since proved inspirational for many at an international level, also in works bearing on primary school mathematics (Stylianides, 2007). In recent years, Balacheff also suggested that we should distinguish between *explanation* (which strives for coherence) and *demonstration* (striving for a type of proof).

A sample of results.

We will focus on the results for year 6, with occasional asides about year 3. After silently carrying out several mediations on the blackboard, the teacher staged a first collective discussion on the nature of the results. Once a consensus had been reached on the fact that it worked out halves (or divided by two) the teacher asked students to work on individual worksheets for 5 minutes. The two questions were: 1. “A schoolmate of yours has not seen the teacher carry out this operation and would like to divide by two as he did. Write down the method for him.” 2. “Justify each step of the method”.

One student – we will call him K – gave a remarkable answer; an answer which is actually quite close to that of the medieval treatises:

1. First write down the number that you want to divide by 2. Consider the number of units⁵, if it’s even write down its half, if it’s odd take away 1, write down its half. You add “.5”. Move on

⁵ Strictly speaking this is incorrect, at least for numbers greater than 9. The correct version would read: the unit digit.

to the number of the tens, if it's even write down its half under it⁶, if it's odd we take away 1 from the number; write down its half under it, and add five to the number that came before. Do the same for the hundreds, the thousands, the millions.

2. It works because even numbers are divisible by 2, and odd numbers are even numbers +1, so we work out the half + 0.5. $1:2 = 0.5$

Beyond its thoroughness and clarity, this answer differs from all the others in the sample in three significant ways. First, K is the only one who gave separate and clearly distinct answers to questions 1 and 2, thus distinguishing between the algorithmic-imperative and the justificatory genres of text. As we will see below, all the other students gave a single answer, and inserted elements of “justification” as they described the technique. Second, he is the only student who anticipated the adaptation of the technique to odd numbers. Third, we claim that the numerical facts he relied on put him in Tempier’s category 4. In the written worksheet, he resorted to decimals to make sense of the role of “5”, but in the second session, while commenting on a mediation of 256 on the occasion of which another student claimed that “half of 5 is 2.5” but was unable to explain why a “5” should be added to the 3, he explained that “duh! In fact it’s simple, because, for real, it’s not 2.5 but 2.5 *tens*, so5 is for units”. The recordings show that, when the teacher asked the class if they agreed that “2.5 tens” was equal to 25 (which had been suggested by another student to clarify K’s remark), he stirred puzzlement in many, even disbelief in some students.

By contrast, the written work of other students shows no distinction between the expression of the algorithm and attempts at accounting for / explaining / justifying the steps; on the basis of the written traces, we hypothesize that the approach of most students was: 1/ endeavour to devise a technique to divide by two (without using Euclidean division), 2/ check whether or not it gives the correct results, and 3/ compare it with the teacher’s technique. In year 6, for lack of a preliminary phase enabling us to assess whether or not students were able to emulate the technique for new even inputs, we cannot say whether they regarded looking for their own technique as the only possibility, or as something which they took to address the “justify” question. The low level of identification of the technique in year 3 (where it was tested independently of its written description), and the absence of a divide between the “describe” and the “justify” answers suggest that the first alternative holds for a large majority of students. In year 6, besides K, only two students clearly stated the “add five to the right” step in their description, without any justification though.

Some students tried to devise a written technique for mediation by adapting steps or moves they were familiar with in other calculating techniques. In year 6, 3 out of 24 students tried to use the “bridge-trick” from their technique for Euclidean division; for instance, in order to divide say 345 by 4, you start from the left and try to divide 3 by 4; since you can’t, you try to divide 34 by 4 etc. Unfortunately, in mediation, this trick works in cases such as 834 (one half of 4 is 2, one half of 3 – stop, one half of 34 is 17 [probably from mental calculation], one half of 8 is 4, so half of 834 is 417), but not so well with several consecutive odd digits. This can be seen in some students’ worksheets, for example when dealing with 334. In year 3, student G suggested a mediation

⁶ On the blackboard, the output of the algorithm was written under the input.

technique which used the “borrowing” trick from the subtraction technique he knew: to divide 9014 by two, starting from the left, write 4 (half of 8), and in 9014 write 10 instead of 0 (“because we took away 1 from 9”), so the half is 5 etc. This is a correct and efficient techniques, but not Al-Khwarizmi’s. We did not investigate whether G was able to justify this “trick” on the basis of numerical properties, or just performed a graphic operation which he considered legitimate because 1. It was already in use in class (in another context, however), 2. It worked.

Let us finally compare two other suggestions. To do this, we will use the notion of *unfolding* of a numerical algorithm. We will call an unfolding of algorithm X, the description of another algorithm X’ along with: 1. A (possibly crude) description of how its steps are related to that of X, and 2. Indications that its connection to X’ *accounts* for X; as we will see below (analysis of C’s unfolding), we consider that accounts *can* but *need not* be justificatory. This notion emerged from our analysis of Liu Hui’s first justification of the correctness of the technique for fraction multiplication in the *Nine Chapters* (Chorlay, 2017): he described a longer algorithm than the one actually performed, but which necessarily gives the same results (the extra-steps it involves neutralize one another) and whose correctness rests on explicit general properties of multiplication.

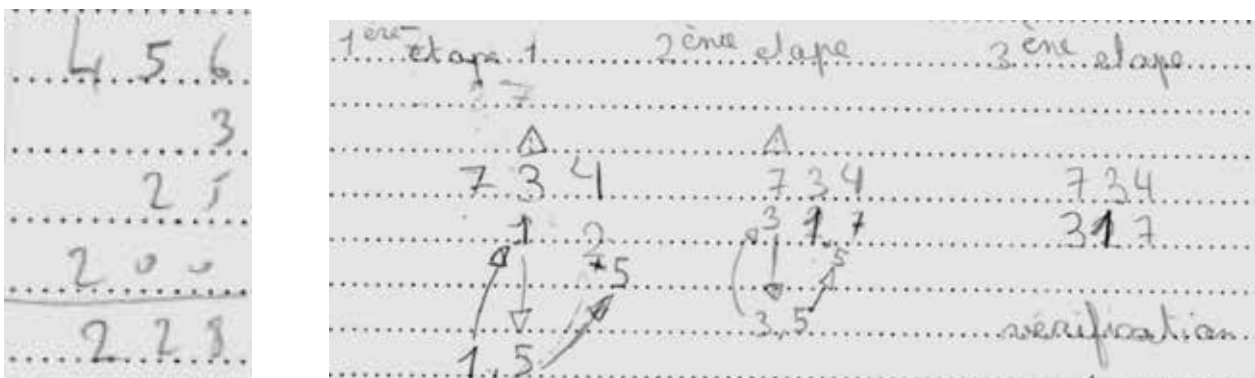


Figure 1: Worksheets of students L (left) and C (right)

L’s method (fig. 1 left) rests on a type 3 decomposition (in Tempier’s framework), as his oral explanations in session 2 showed: “3 is the half of 6, 25 is the half of 50, and 200 is the half of 400”. So he devised a correct technique for mediation and was able to justify it by mentioning valid and relevant properties of the numbers involved, which we take to be indicative of a proof by generic example. We have no way to say if he only looked for a mediation technique (which he managed to justify), or actually considered this to be an unfolding of the teacher’s technique.

The technique used by C (fig.1 right) is correct in so far as it leads to correct halves, and is clearly an unfolding of Al-Khwarizmi’s technique, embedding it in a larger algorithm involving calculations (with decimal numbers) and a “carry five to the right” step. She described her diagram as something which shows what she “did in her head” when applying Al-Khwarizmi’s technique. However, we do not take C’s correct unfolding to be of a justificatory nature, since, when asked why the .5 in 1.5 and 3.5 could be used as a “+5 to the right”, she mentioned no numerical properties. She justified her moves by saying that writing 1.5 under 3 was “impossible” (meaning: this is not a proper standard form), so she just wrote 1; and the fact that the output had extra “5”s (although in the “.5” form) could account for the move she had identified in the technique: “carry

five to the right”. So she unfolded the technique as a graphic algorithm dealing with number signs, and her unfolding achieves *coherence* (between what she knows about halves of one-digit numbers, and the steps of Al-Khwarizmi’s technique), without providing proof.

Perspectives.

Let us mention three alterations considered for a new round of classroom experiments in 2018-2019:

- Since a large share of students (even in year 6), fail to identify the “carry 5 to the right”-step, it should be made explicit before any attempts to entrust students with description or justification tasks.
- Asking for written traces helps the researcher gather data, but has several drawbacks: 1. Many students are not willing or able to engage in this writing tasks, which results from a combination of cognitive (in particular when comparing students of different ages) and social factors (Bautier & Goigoux, 2004). 2. As the cases of L and C show, the extent to which written traces testify to an actual engagement in justification is difficult to assess without a follow-up interview.
- We would like to study how students assess the various “arguments”.

References

- Al-Khwarizmi (1992). *Le calcul indien (algorismus)*. Edition critique, traduction et commentaires de André Allard. Paris : Librairie A. Blanchard, et Namur : Société des Etudes Classiques.
- Balacheff, N. (1987). Processus de preuve et situations de validation. *Educational Studies in Mathematics* 18, 147–176.
- Charnay, R. (2007). La division, le plus tôt possible ? La division, le mieux possible ! *Bulletin de l'APMEP* 469, 202–212.
- Bautier, E., & Goigoux, R. (2004). Difficultés d’apprentissage, processus de secondarisation et pratiques enseignantes: une hypothèse relationnelle. *Revue française de pédagogie* 148, 89–100.
- Chorlay, R. (2016). *Historical sources in the classroom and their educational effects*. In L. Radford, F. Furinghetti & T. Hausberger (Eds.), *Proceedings of HPM 2016* (pp.5–23). Montpellier (France): IREM de Montpellier.
- Chorlay R. (2017). Mathematical analysis of informal arguments: a case-study in teacher-training context. In Dooley, T., & Gueudet, G. (Eds.) *Proceedings of CERME 10* (pp. 1701–1708). Dublin, Ireland: DCU Institute of Education and ERME.
- Chorlay R. (forthcoming). Justifier une technique opératoire au cycle 3 : le cas de la division par 2. *Proceedings of EMF 2018* (oct. 22-26, Paris).
- Clivaz, S. (2016). Connaissance mathématique des enseignants et enseignement de l’algorithme de la multiplication. *Recherche en didactique des mathématiques* 36(2), 231–261.
- Constantin, C. (2017). La distributivité : quelles connaissances pour enseigner la multiplication à l’école primaire ? *Grand N* 100, 105–130.
- Stylianides, A. (2007). The notion of proof in the context of elementary school mathematics. *Educational Studies in Mathematics* 65, 1–20.
- Tempier, F. (2016). Composer et décomposer : un révélateur de la compréhension de la numération chez les élèves. *Grand N* 98, 67–90.
- Yopp D., & Ely R. (2016). When does an argument use a generic example? *Educational Studies in Mathematics* 91, 37–53.

New Math at primary schools in West Germany – a theoretical framework for the description of educational reforms

Tanja Hamann

Universität Hildesheim, Germany; hamann@imai.uni-hildesheim.de

To describe the implementation of New Math in West German primary schools (known as “Mengenlehre”/”set theory” up to today) in the 1970s, a framework model is developed. The model shows an educational reform as a two-dimensional process, characterized by a chronological as well as an institutional dimension wherein for the latter the educational system is divided into four layers. The model is introduced and specified when used for the description of New Math. Suitability of the framework for this suggests that it might be well transferable to the historical description of further educational reforms.

Elementary school mathematics, elementary school curriculum, history of mathematics education, New Math.

Initial questions and aim

In West Germany the New Math movement had a massive impact on mathematics education at primary schools from 1972 on, especially regarding the curricular contents and classroom methods of elementary instruction. The most remarkable innovation was the introduction of concepts from naïve set theory to young children and the use of materials such as colored blocks (the most famous being the *Logic Blocks* credited to Z. P. Dienes) in the classroom. However, there is still a broad consensus within a considerable part of German society that the reform failed miserably. A subsequent valuation whether the reform, its concepts and implementations were “any good” cannot be accomplished nowadays as there exists hardly any empirical data from back then. A statement whether “*Mengenlehre*” must be considered a failed experiment from the historical point of view, though, would require a thorough definition of the concept of “failure”, which – as far as the author of this paper is aware – does not exist in this context. An estimation of the historical significance of New Math within the development of primary mathematical education in Germany is yet to be given.

Hitherto, existing analyses of the reform in the Federal Republic are widely limited to works by contemporary witnesses, naturally lacking historical distance (Damerow, 1977; Zumpe, 1984; Keitel, 1980, 1996), and short summaries as part of general overviews of the historical development of primary education (e. g. Padberg, 2011). The need for a broader account that allows a historical grading of the “*Mengenlehre*” reform and a well-founded verdict on its historical impact and role within German mathematics education is obvious. Any judgement from a historical point of view requires a comparative integration of the event into a broader context, and this again requires a description of the historical event first. The challenges one meets when taking up the description of the introduction and implementation of New Math in West German primary schools must be considered typical, as they are inherent in any reform within a public educational system. The aim of this paper is to introduce a theoretical model, which provides a framework that has proven

suitable for describing the case of “*Mengenlehre*” reform. It will then be shown how the model has been used for this purpose.

A framework model for the description of educational reforms

A reform is never an isolated event, but a process bound in a multitude of influences (general cultural and societal conditions as well as current developments) and outcomes, and for describing it numerous aspects and directions – or dimensions, as will be the term used in this paper – must be taken into consideration and be structured in a sensible way. The obvious dimension is the chronological one as a reform does not happen in an instant but in a certain timeframe. Not only is there an initial situation as well as an aftermath, but the reform period itself takes time and in the course of events ideas, conditions and actions might be subjects to change. But especially in the case of governmental reforms there is another, non-chronological dimension, which might be called the institutional one. Numerous protagonists act on diverse institutional levels and layers and thereby take an active part in the course of reform. These institutional layers do not function independently, but they influence each other in a certain way. So altogether, the description of a public educational reform must consider multi-dimensionality of reforms. In order to allow describing the institutional dimension a model is needed, which identifies separate layers and their respective protagonists.

H. Fend (2008, pp. 30-33) has developed a model for the educational system consisting of four (more or less) separate layers that influence each other from top to bottom. In his model Fend assumes that the protagonists on each of the levels interpret the ideas, that are covered in products from the respective level above, from their very own point of view, in their own specific contexts, and that this re-interpretation always necessarily leads to substantial changes, shortenings and adjustments. He denotes these changes and adaptations as “recontextualizations” (p. 13). The four layers in Fend’s model are the following:

1. the layer of **culture**: within each cultural sphere certain ideals of education exist and from these educational objectives are generated
2. the layer of **curriculum**: educational aims serve as starting point, from which subjects and contents are deduced that seem suitable to meet the aims; products on this layer are curricula as well as textbooks etc.
3. the layer of **practical schooling**: this is the layer where teachers plan and perform their lessons regarding the specific nature of their students
4. the layer of **reception**: pupils (and their parents) comprehend and assimilate contents in their specific, subjective way and make sense of it

Fend has generated his model in the context of his studies in educational sociology, it is therefore not fully applicable to the history of mathematics education. It serves as a suitable starting point but needs to be adjusted to the subject of educational reform.

As the model considers the educational system as one, the subjects play a minor role. Educational research institutions appear as part of the layer of curriculum where their function is limited to a descriptive one, whereas their normative function in designing educational concepts is not

mentioned. Looking upon the educational system from a subject didactical point of view the scientific discipline as well as didactical research and design need an evident place within the model, and regarding New Math this applies even more, as on the one hand the reform has been grounded on subject science to a high degree and on the other hand mathematics educationalists were widely responsible for designing practical concepts, courses and textbooks. Hence, it is obvious that (despite some overlappings) there is a considerable difference between the protagonists responsible for writing curricula (mainly personnel in politics and administration) and those writing textbooks. Due to their importance for classroom practice mathematics didactics is given a layer of their own.

Science in general is part of culture putting it on the layer of culture. However, it belongs to a global kind of culture, that is not limited by a community's borders. Undoubtedly, national culture and traditions in general are highly relevant for any educational reform within a nation's borders but they comprise such a vast number of aspects that they cannot be described in detail within the frame of a work like this and are therefore neglected. Mathematics as a theoretical discipline is different from didactical science regarding the latter's practical implementations and the former's function in providing a basis for the latter's work. That is why the two scientific branches must belong to different layers. Of course, the scientific subject is not the only discipline educationalists refer to when designing their concepts, educational sciences like pedagogy and the psychology of learning play an important role, as well.

As mentioned before, when it comes to New Math contemporary empirical data is scarce and gathering an amount of data to be able to describe the layer of reception in a satisfying way (e. g. by interviewing former pupils) is certainly a desideratum in due research, but as it cannot be part of this work either the layer is integrated in the layer of school practice in this case.

From all these specifications in consideration of an educational reform derive the following adapted layers of the educational system:

1. the layer of **theoretical scientific discipline**: institutions and protagonists on this layer are scientists from subject and educational science; their products are subject-specific foundations, scientific theories for example on the development of knowledge etc.
2. the layer of **curriculum**: institutions and protagonists are personnel from politics (e. g. from the ministry of education) and administration, sometimes educationalists as far as they contribute to decisions concerning curricula; their products are curricula, syllabi, decrees etc.
3. the layer of **classroom concept**: institutions and protagonists are subject didactics, textbook authors (these can be teachers, as well), editors and publishers of schoolbooks etc.; their products are textbooks, workbooks, teacher's handbooks, manipulatives, suggestions for instruction etc.
4. the layer of **practical schooling**: institutions and protagonists are schools, teachers in classroom, pupils, parents; their products are lessons, learning progress, knowledge as well as tests, written tasks, exercise books, portfolios, reports and so on

As for personal overlaps between the layers (i. e. someone acts on more than one level) it is assumed that the actor's function is a different one on each layer and that they must recontextualize their own ideas in another context, as well.

On each of these layers the chronological dimension additionally comes to effect. If we stick to the top-down model developed by Fend, the adapted model can be visualized as follows, the arrows meaning "recontextualized by".

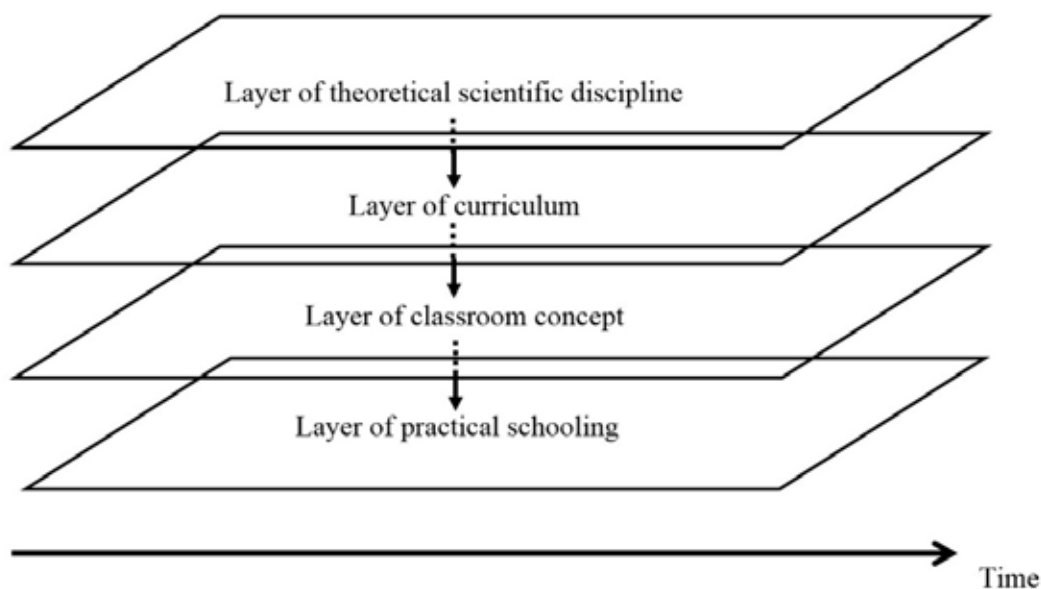


Figure 1: Adjusted layer model

This framework model now allows concretization dependent on the specific reform that is about to be described, the sources that have been selected and the focus chosen. Guiding questions that are implicitly suggested by the model are:

1. What central aims and/or ideas (on content, didactical principles, methods, curriculum concept...) can be deduced from the products of each layer?
2. How can one characterize the process(es) of recontextualization between the different layers?
3. How did ideas and concepts develop and change over time?

New Math in West German primary schools – sources, focus and findings

Choice of sources and focus

We are already dealing with a model naturally underlying diverse reductions. Nevertheless, further reductions become mandatory when one chooses exemplary sources for each layer and decides on a focus.

It has been mentioned before that sources for pupils' (and parents') reception of "*Mengenlehre*" courses are scarce, the same is true for the whole layer of practical schooling, therefore this part of the educational system will not be the focus. From a subject didactical point of view the layers on

which scientific personnel is most active – that are the layer of theoretical scientific discipline and, at least in the case of New Math, the layer of classroom concepts – seem the most relevant, that is why the emphasis will be laid on these. By this, the layer of curriculum gets assigned the role of an intermediary, which is relevant, if one wishes to describe the recontextualization that has been taking place between the other two layers, so that it must be looked at, as well.

In this case however, analysis of curricular documents leads to a specific difficulty, based on the German federal system, which involves that issue of curricular documents belongs to the federal states' field of responsibility. Hence, the number of syllabi that has been generated during the time of reform cannot be surveyed at once, and there is no work yet giving the due overview of primary school curricula in the way Damerow (1977) has provided of secondary school curricula. There are few nationwide documents, though, which must be taken into consideration. Explicitly concerning mathematics as a school subject, there are two directives on behalf of the *Kultusministerkonferenz* (the common conference of the federal states' ministers of education, referred to in figure 2 as KMK), the first one from 1968, which at the same time is seen as the starting point of reform in Germany, and the second one from 1976. In order to get an impression of at least one example of federal state curricula (*Rahmenrichtlinien*, referred to in figure 2 as RRL), those of Lower Saxony were chosen. The latest of these syllabi shows a massive decrease of the concept of “*Mengenlehre*” and therefore, its year of release, 1984, marks the terminal of the time axis.

Of course, the sources for classroom concepts are numerous, as well. Due to the facts that during the New Math reform primary school textbooks were written by mathematics educationalists and that they were widely accompanied by teachers' handbooks giving explicit insight into aims, concepts, didactical foundations and methods intended, samples from textbook series provide adequate sources for the layer of classroom concept. Here, the sample that has been chosen for thorough analysis of conceptual elements comprises 1st grade materials from three textbook series.

The textbook series are *alef* by H. Bauersfeld et. al. (1970), *Wir lernen Mathematik* (“We learn mathematics”, referred to in figure 2 as N & S) by W. Neunzig and P. Sorger (1968) and *Mathematik in der Grundschule* (“Mathematics in primary school”, referred to in figure 2 as F & B) by A. Fricke and H. Besuden (1972). *Alef* is a textbook series that derived from the only large-scale empirical project in the history of New Math in Germany, namely the *Frankfurter Projekt*, in the course of which children were educated with specially designed all new materials throughout their elementary school years. *Wir lernen Mathematik* was the earliest textbook containing “*Mengenlehre*” to be released in West Germany, even earlier than the first *Kultusministerkonferenz* directive, and thus it holds a special role in the process of the reform. *Mathematik in der Grundschule* has been chosen because it initially appeared in pre-reform times and has then been adapted to the reform standards. Of all three textbook series several editions exist, which are compared and thus contribute to the question how concepts developed and changed along the time axis.

As for the layer of theoretical scientific discipline, pedagogy has usually not been a point of reference for “*Mengenlehre*” concepts, so there is no need to consider the subject of pedagogy any further. Scientific mathematics, especially the Bourbaki work, is said to have had a big impact on

the global New Math movement but going into the scientific subject any further would lead astray. A major impulse to the start of reform activities within Europe is attributed to the seminar, which was organized by the OEEC (precursor of the OECD) and took place in Royaumont, France, in 1959. The seminar was attended by high school teachers and university mathematicians, who put a strong focus on how modern scientific mathematics could find its way into school, turning them into protagonists from the layer of theoretical scientific discipline. So, the report from the Royaumont seminar (OEEC, 1961) serves as source for the influence of scientific mathematics and according to the impact of the event, the date of the seminar serves as starting point of the time axis.

Another discipline the authors of textbooks have constantly referred to is the psychology of learning. Especially the landmark findings and theories by J. Piaget (e. g. Piaget & Szeminska, 1965) were most prominent. J. S. Bruner on the other hand has had a big influence even on modern day German curricula and his theories, which emerged in pre-“*Mengenlehre*” time, as well, were well-known. One of the biggest influences on primary school math certainly was Z. P. Dienes. Dienes is not easily allocated to one of the layers as he provided a vast amount of concrete classroom examples. As he never created a complete course, though, but rather provided theoretical foundations for German courses which partly arose from his own psychological research, Dienes is assigned to the scientific layer, as well.

From the above the general model can now be specified as it is filled with names of the documents that serve as sources for the description of New Math in West German primary schools. The arrow indicates the focus on the process of recontextualization from basic ideas and concepts as they can be derived from the layer of theoretical science to their concretization in textbooks on the layer of classroom concepts.

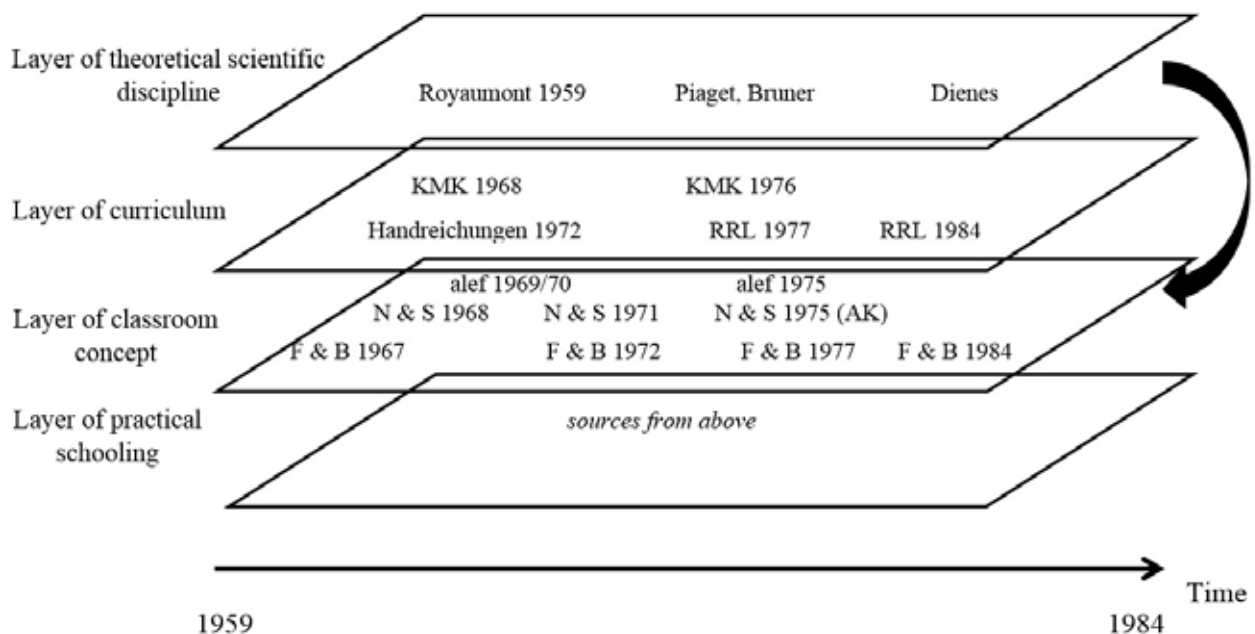


Figure 2: Layer model filled with sources used for the description of “*Mengenlehre*” in West Germany

Findings¹

Regarding the focal question for recontextualization of the scientific roots of reform it becomes obvious that the extent to which original ideas have been implemented differs. Altogether they have not been fully transferred to textbooks, but the authors of each course have selected a certain part and by this, shortened the original concept towards their own respective purpose. Bauersfeld comes closest to the ideas from the scientific layer but in this case, he was forced by decisions coming out of the curriculum layer to apply changes to his concept. The shortcomings that are caused by the incomplete transfer of the original concept altogether lead to diverse inconsistencies in the implementation of “*Mengenlehre*”. Independently of what happened on the layer of practical schooling, this finding even allows us to state that New Math at West German primary schools has indeed been a failure, and as educational reforms never go without recontextualization processes there is a high probability for extensive innovations in the classroom to fail according to this definition of failure.

Another finding concerns the influence of the layer of practical schooling. The sources suggest that teachers’ customs, beliefs and attitudes, along with an education that did not meet the demands presented by New Math, proved as an obstacle in classroom. Many parents are said to have had reservations towards reform, anyway, and these most probably increased as soon as things were not implemented according to plan. Presumably, one political reaction to this was a change in curricula, which in turn led to a change in textbooks and therefore, regarding recontextualization processes along the time axis, one finds that the process of reform cannot be described using a top-down-model. Instead, within the framework model, mutual influences rather must be pictured the following way:

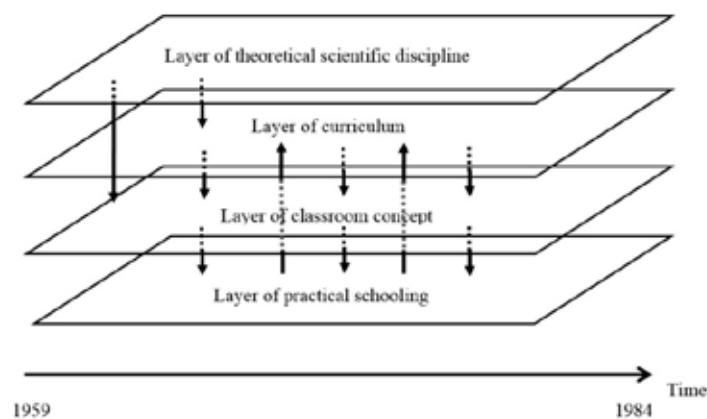


Figure 3: Layer model showing the process of reform

In this case, even though the original model did not prove fully suitable for a description of New Math in West German primary schools, it still served as a useful device for illustrating the process of reform.

¹ This paper presents an extract from a bigger research project. Due to the focus that has been set here findings can only be displayed in a strongly abridged way. For details and a complete account of the sources see Hamann, 2018.

Conclusion

It was the aim of this paper to introduce a framework model for description of complex educational reforms from a historical point of view. As for the example of New Math in West German primary schools, the model proved suitable for providing a restricting frame, a helpful device for structuring the work and a starting point that could be adjusted according to the process of the reform. It therefore allowed relevant findings which may function as a ground on further research on the topic. All of this suggests that the model of recontextualization might be suitable for historical studies on other educational reforms, as well.

References

- Bauersfeld, H., Gnirk, H., Görner, U., Homann, G., Lubeseder, U., Radatz, H., & Rickmeyer, K. (1970). *Alef 1: Wege zur Mathematik, Handbuch zum Lehrgang*. Hannover, Germany: Schroedel.
- Damerow, P. (1977). *Die Reform des Mathematikunterrichts in der Sekundarstufe I: Eine Fallstudie zum Einfluß gesellschaftlicher Rahmenbedingungen auf den Prozeß der Curriculum-Reform, Bd. 1: Reformziele, Reform der Lehrpläne*. Stuttgart, Germany: Klett-Cotta.
- Fend, H. (2008). *Schule gestalten: Systemsteuerung, Schulentwicklung und Unterrichtsqualität*. Wiesbaden, Germany: VS Verl. für Sozialwissenschaften.
- Fricke, A., & Besuden, H. (1972). *Mathematik in der Grundschule 1: Ausgabe B Lehrerband*. Stuttgart, Germany: Klett.
- Hamann, T. (2018). *Die „Mengenlehre“ im Anfangsunterricht: historische Darstellung einer gescheiterten Unterrichtsreform in der Bundesrepublik Deutschland*. Siegen, Germany: universi.
- Keitel, C. (1980). Entwicklungen im Mathematikunterricht. In *Institut für Bildungsforschung (Ed.), Bildung in der Bundesrepublik Deutschland: Daten und Analysen, Bd. 1: Entwicklungen seit 1950* (pp. 447–500). Stuttgart, Germany: Klett.
- Keitel, C. (1996). Réformes et développements de l'enseignement mathématique en R.F.A. depuis 1950. In B. Belhoste (Ed.), *Les sciences au lycée: un siècle de réformes des mathématiques et de la physique en France et à l'étranger* (pp. 303–310). Paris, France: Librairie Vuiber.
- Neunzig, W., & Sorger, P. (1968). *Wir lernen Mathematik I: Erstes Schuljahr*. Freiburg, Germany: Herder.
- OEEC (1961). *New thinking in school mathematics*. Paris, France: OEEC.
- Padberg, F., & Benz, C. (2011). *Didaktik der Arithmetik: für Lehrerbildung und Lehrerfortbildung*. Heidelberg, Germany: Spektrum Akad. Verl.
- Piaget, J., & Szeminska, A. (1965). *Die Entwicklung des Zahlbegriffs beim Kinde*. Stuttgart, Germany: Klett.
- Zumpe, S. (1984). *Der neue Mathematikunterricht in der Grundschule: eine kritische Analyse auf dem Hintergrund bildungspolitischer Zielsetzungen Anfang der 70er Jahre*. Berlin, Germany: FU Berlin, Zentralinstitut für Unterrichtswissenschaften und Curriculumentwicklung.

Relevance of mathematics journals for Dutch teachers in the 18th and 19th century

Jenneke Krüger

Utrecht University, Freudenthal Institute, Utrecht, Netherlands; j.h.j.kruger@uu.nl

Mathematics teaching took place long before the formation of teacher education institutes and university courses for mathematics teachers. Very little is known about the ways teachers acquired the necessary knowledge and skills before the mid-19th century. In the Netherlands, from the late 16th century on, a tendency is noticeable to have all children taught reading, writing and increasingly often some arithmetic. Moreover, as was the case in England, there was an expanding group of mathematical practitioners who needed some knowledge of the relevant mathematics. Consequently there were many small schools with lowly paid primary teachers, and there were many private mathematics teachers and small private schools where some mathematics was taught. In the 18th and 19th century many journals were published in the Netherlands, including mathematics journals for teachers. In this paper the relevance of such journals for teachers' improvement of their mathematical skills and position in society is discussed.

History of mathematics education, mathematics journals for teachers, primary schools, teacher examinations.

Introduction

In the process of teaching and learning mathematics, the mathematics teacher is an important actor; consequently his/her skills, Mathematical Content Knowledge (MCK) and Pedagogical Content Knowledge (PCK) are the subject of a body of research. Analysis of three historical Dutch cases of mathematics education shows, that already in 1600 the relevant mathematical knowledge and pedagogical qualities of the mathematics teacher were considered very important for the successful implementation of mathematics curricula (Krüger & van Maanen, 2013; Krüger, 2014, pp. 463-474). The question arises how mathematics teachers in the past acquired the necessary knowledge and skills to be successful. Recent research on this topic is often concerned with the present educational structures, restricting itself to the late 19th and the 20th century, e.g. (Candeias, 2017; Menghini, 2017). However, in Europe as elsewhere, mathematics was taught for centuries before the creation of the present stable educational structures, with its formal teacher education institutes. The Netherlands form a rich case for several reasons:

- Starting in the late 16th century, a drive to teach all children reading, writing and gradually also some arithmetic, in combination with a complete absence of central regulation of education, until 1806. There were no teacher training institutes until the 19th century, very few until the 20th century.
- A relatively high demand for mathematics teaching, due to the growing number of mathematical practitioners (navigators, geometers, wine gaugers, engineers, etc.), who one way or another, had to learn the relevant type of mathematics.
- An abundance of publishers of journals, from the late 17th century onwards. Many printers and editors were active in the Netherlands, not only in the larger cities, but also in the smaller towns.

Thus journals, relatively low priced and flexible, could play a role in the dispersal of knowledge for teachers. The first mathematics journal for teachers was published in 1754, probably the first journal for this specific group in Europe (Gispert, 2018). On the topic of mathematics journals for teachers, recent publications mainly concern the second half of the 19th century or later, when teacher education institutes were established, e.g. (Furinghetti, 2009; Oller-Marcén, 2017). Preveraud (2015) published a paper on mathematical journals, published during the first half of the 19th century in the USA and instrumental in the transmission of French mathematical education to American higher and secondary education. The present paper concerns mathematics journals for teachers in primary and advanced primary education, in the 18th and early 19th century. Secondary education was not formally part of the educational system until 1863 (Boekholt & De Booy, 1987; Krüger, 2014).

The number of mathematical journals aimed at teachers increased during the first half of the 19th century. With regards to the question “How did Dutch teachers of mathematics acquire their knowledge before there was formal teacher education?” the focal question of this paper narrows to “*Which role did mathematics journals have in the acquisition of knowledge by Dutch teachers in the 18th and early 19th century?*”

The main method of research is analysis of a limited number of journals from the period (1754-1835), with regards to the occupation of the subscribers, the topics treated and the style of treatment. These journals are included in the database of Cirmath¹.

Mathematics: a boost for the teacher’s career, 1750-1800

In the 18th century nearly every village and each town in the Netherlands had at least one primary school, a so-called ‘Dutch’ school, supervised by the local council and the local reformed church, in which children could learn the catechism, reading, writing, and usually arithmetic. There were also many private schools with often more advanced primary education, with a few more mathematical subjects, so-called ‘French’ schools, and there were private schools for specialized mathematical instruction. Subjects taught in these small mathematics schools depended on the specialization of the instructor: algebra, geometry, geography, surveying, navigation, bookkeeping, fortification, astronomy, architecture, etc..

Being knowledgeable in mathematics had several advantages for teachers in primary schools: improved results in the comparative exams for the better paid teaching posts, the possibility to give private lessons to students or to start a French school or even a specialized mathematics school and thus to improve one’s income in several ways (Krüger, 2018, 2). One could also combine working as a mathematical practitioner with teaching. Most aspiring teachers lacked the financial means and the required knowledge of Latin to study at a university. So their main means to learn mathematics were private lessons and self-instruction.

A teacher at a Dutch school usually had a very low salary, supplemented by the fees parents paid for each subject or part of subject taught to their child, by chores for the church and other jobs, e.g. gravedigger. As parents were encouraged, but not obliged, to send their children to school, the

¹ *Circulation des mathématiques dans et par les journaux*: <https://cirmath.hypotheses.org/>

income varied through the year, with in rural areas a severely diminished income in the summer months. In the more expensive French schools the pupils were also taught French and other subjects, such as advanced arithmetic, bookkeeping, geometry, algebra, geography and drawing and the fees were paid for longer periods. A consequence of the lack of a national curriculum and of national teacher qualifications was a large variation with regards to the level and quality of instruction between the various Dutch schools and also between French schools.

The teachers and their journal

Working as an assistant-teacher was the usual way to start a teaching career. When there was a vacancy in a Dutch school, local councils usually required a comparative examination, in writing, reading from the Bible, singing hymns and increasingly often in mathematics. Mostly arithmetic, but by the mid-eighteenth century in the western part of the country there were also exams covering several mathematical subjects (Krüger, 2018). Those exams were often set by a teacher, either the departing teacher or from a school in the vicinity. Examples of such examinations, with different levels of mathematics (*Mathematische Liefhebberye*, 1754, 1755):

- On 24 November 1754 in Lopiker-Kapel, a small village in the province of Utrecht (in the middle of the country), the exam consisted only of reading from the Bible and singing a hymn. It was not a well paid position, only assistant-teachers applied.
- On 8 December 1754 in Oost-Zaan, a small town in Holland, near Amsterdam, 4 teachers took part in the examination, which included ten arithmetic problems.
- In 1751 in Purmerend, a slightly more important town in the same area as Oost-Zaan, a new town's schoolmaster and cantor was appointed after a strenuous exam, consisting of fourteen questions on arithmetic, twelve questions from geometry (plane and solid), ten problems on navigation and six problems on spherical trigonometry.

From 1754-1769 Pieter Jordaan, librarian in Purmerend, published the first Dutch mathematics journal for teachers, a monthly with news of primary schools (vacancies, examinations, etc.) and a section on mathematics, *Mathematische Liefhebberye* [Mathematical Pastimes]. Each month mathematical problems, from the editor and the readers, were published, as were solutions to problems published in previous months, also from the readers, sometimes discussed by the editor. The mathematics editor until 1765 was Jacob Oostwoud, teacher in Oost-Zaandam, surveyor, mapmaker and author; he was succeeded by Louis Schut, also a teacher. A specific goal of the editors was support for teachers who were inexperienced in mathematics, by more experienced teachers and practitioners. In total 3000 problems were published, apart from the questions of the local examinations for teaching posts, also published frequently. There was some theory, on topics such as arithmetic theorems, series and probability. More than 100 subscribers, amongst whom a few women, were active in sending questions and even more sent solutions. The problems mainly came from existing publications, recent ones, but often from the 17th century as well. German authors were a favourite source; later on English journals were mentioned as origin of some problems. Over the years a wide range of topics was addressed, arithmetic and algebra, but also geometry (calculations and constructions), both plane and solid geometry, simple problems in probability, navigation problems (spherical trigonometry) and maximum-minimum problems, solved by means of a new technique, differentiation. Obviously arithmetic and algebra were important subjects for all teachers, and there is a large range of topics which may be put under these

headings. Simple questions, for beginners, modelling of a situation, resulting in equations or systems of equations from linear up to the fifth power, series, proportionality, also in mechanics, mixtures of substances, distances travelled (Krüger, 2018).

The journal may be seen as an example of informal teacher training, by experienced teachers and practitioners. It gives the impression of eagerness and a combination of learning and recreation. The journal offered problems from elementary mathematics to fairly advanced mathematics and the editors positively encouraged readers at all levels to join in.

Mathematics: obligatory for primary teachers

From 1795, with the proclamation of the 'Bataafse Republiek' [Batavian Republic], a process of centralization was set off, also for education. The first Dutch constitution (1798) mentioned 'national education', there was mention of responsibility of the national government for education and in 1806 the first national law on primary education was accepted. The law and its regulations specified amongst many other matters the subjects which had to be taught (reading, writing, arithmetic and Dutch language), the required content knowledge for primary teachers and the obligation to pass an examination, also in mathematics, as a prerequisite for a teaching post. Primary school teacher was on its way to become a profession.

The teaching certificate recognized four ranks of male teachers; there was only one rank for women. For the lowest rank (4) one had to show reasonable skills in reading, writing and basic arithmetic, with whole numbers up to and including simple proportions (rule of three). For the third rank the candidate had to show for mathematics also skills in calculations with fractions and in use of calculations in problems from daily life. For the second rank the candidate should also have theoretical knowledge of arithmetic; for the first and highest rank, one had to show proficiency in mathematics and science, amongst other things. For each rank there were other requirements as well, for example level of teaching skills, knowledge of geography, etc. The mathematics exam always had a section on theory and practice of arithmetic, in whole numbers, fractions and decimal fractions and problems pertaining to daily life (for rank 1-3). As an addition one could take exams in specialist subjects, such as languages or advanced mathematics. The primary schools were ranked as well, with the salary in accordance to the rank of the school. A teaching rank 1 or 2 gave the right to be appointed at the highest ranked and best paid schools. So any primary teacher with ambition tried to reach at least second rank. The first rank was rather sparingly handed out by the regional examiners (Boekholt & de Booy, 1987, pp.109-110).

So this law put in place formal requirements on a national level for primary teachers, male and female, in order to improve education for all children. The teachers would get payment from the council and classroom teaching to groups of similar abilities was introduced. Regional school inspectors, appointed by the national government, would see to enforcement of legislation; they encouraged modern teaching methods and actively strove to improve the quality of teachers. However, it took a long time before the changes became reality in all parts of the country.

Secondary education continued to be privately organised with French schools and specialist schools. Latin schools, also called gymnasia, where mainly the classics were taught as a preparation for university, were from 1826 obliged to provide instruction in mathematics, following at least a minimal curriculum (Smid, 1997). At some gymnasia a primary teacher of first rank was engaged to

teach mathematics, as often the professors at the Latin schools looked down on mathematics and/or didn't know enough to teach the subject.

The teachers and their journals

In order to become a teacher in primary education, the usual way still was to find a teacher with whom one could work as an apprentice, while in the evenings studying for the examinations. The assistant-teacher was now called 'kwekeling' or 'secondant'. To improve the content knowledge and pedagogical knowledge of primary school teachers, the government promoted the formation of local teacher societies [onderwijzers gezelschappen], whose members were inexperienced teachers as well as experienced teachers and school directors. They had regularly meetings to discuss the subjects and teaching methods (Boekholt & de Booy, 1987, p.111) and practiced for the teacher's exams. The teacher societies started small libraries, with textbooks and journals. Mathematics journals, which had as explicit aims improving the mathematical and pedagogical knowledge of teachers in primary and advanced education, were published from the 1820's. They can be classified into four categories: journals on general mathematics; on arithmetic; on arithmetic, algebra and geometry; on mathematics and sciences. Only the first three categories will be discussed in this paper (Table 1).

Table 1: Dutch mathematics journals for teachers, 1820–1850

<i>Tijdschrift ter Bevordering der Mathematische Wetenschappen (TBMW)</i> [Journal for the Improvement of Mathematical Sciences]	1823–1828
<i>Magazijn voor de rekenkunst (MR)</i> [Magazine for the arithmetic art]	1828–1835
<i>Bijdragen tot de beoefening der zuivere wiskunde (BBZW)</i> [Contributions to the practice of pure mathematics]	1829–1833
<i>Magazijn voor stel- en meetkunst (MSM)</i> [Magazine for algebra and geometry]	1830–1835
<i>Bijdragen tot de beoefening der gewone cijferkunst (BBGC)</i> [Contributions for the practice of simple arithmetic]	1831–1840
<i>Tijdschrift voor reken-, stel- en meetkunst (TRSM)</i> [Journal for arithmetic, algebra and geometry]	1839–1842
<i>Nieuw tijdschrift voor reken-, stel- en meetkunst (NTRSM)</i> [New journal for arithmetic, algebra and geometry]	1843–1847
<i>Tijdschrift der toegepaste rekenkunst voor onderwijzers en gevorderde leerlingen (TTR)</i> [Journal of applied arithmetic for teachers and advanced pupils]	1850–1852

These journals existed usually between four and ten years; often with a change of editor(s) a journal got a new or slightly different name and so became a new but very similar journal as its predecessor. For example one of the first journals in the 19th century with many teachers among its subscribers, was the Journal for the Promotion of Mathematical Sciences, or TBMW for short², on general mathematics. It was published by J.P. Bromstring in Purmerend; the editor was Jacob (Jan)

² In this paper the abbreviations, introduced in Table 1, will be used, to save space.

van Cleeff, mathematics teacher at the Academy for Drawing, Architecture and Navigation in Groningen (Beckers, 2003, p.77). In 1823 there were 250 subscribers listed. In the last volume the readers were informed that Mr van Cleeff had decided to discontinue as an editor, due to his workload, however there would be a new journal with Hendrik Strootman, subscriber and contributor to TBMW, as editor. This new journal was BBZW, also on general mathematics; the number of subscribers had increased to about 420. Hendrik Strootman taught mathematics at the Royal Military Academy, since 1828 situated in Breda. From 1830 this journal was published in Breda. Another example is the succession of TRSM by NTRSM. The editors are unknown, but the publisher and format were the same for both journals.

All journals in Table 1 were quarterlies; they all published problems and their solutions, usually also other forms of content, such as articles and reviews of books and they encouraged subscribers to send solutions and new problems. The subscribers, usually listed in the first volume, are differentiated in four categories: educators (teachers, assistant-teachers, mathematics teachers, teacher societies and school inspectors), other occupations, including military, no occupation mentioned and booksellers. The two journals on general mathematics, TBMW and BBZW, treated similar topics as are found in the 18th century journal for teachers. However, in the 18th century the journal was aimed at teachers (and other practitioners) who were also ‘lovers of mathematics’; presenting mathematics as both useful and a pleasant pastime was usual in the 18th century in the Netherlands. This attitude shows in the interactions with the readers, which is lively and frequent. In the 19th century mathematics was less seen as a pastime, it was, for teachers, military and other practitioners, a serious requirement for their profession. All teachers had to learn at least some mathematics, whether they liked it or not, and the more the better from the point of view of career. The style of the journals was modern; the solutions of problems were clear and well formulated, the theoretical articles, if present, were usually well written. If sources were mentioned by the editors, they were from recent authors, such as De Gelder, Lacroix, Floryn and Prinsen, who were comfortable with the new, more exact style of mathematics and with modern teaching methods.

Another difference was the absence of women. In 18th century journals on mathematics most subscribers were males, but there were a few subscribers recognisable as women who occasionally sent problems and also solutions. Though the law on primary education stated that ‘primary education is taught by teachers of both genders’³, the lists of subscribers was invariably titled: ‘the gentlemen subscribers’. Mathematics was by now a very serious and consequently male business, women who wished to subscribe may have done so through a bookseller, remaining invisible.

Between 40% and 50% of subscriptions was ordered by booksellers, it is as yet not clear why so many ordered their copy through a bookseller. Of the personal subscriptions TBMW and TRSM both had around 70% working in education. TBMW aimed at practitioners and teachers, TRSM aimed at inexperienced and experienced teachers of Dutch and French primary schools. For the other journals this percentage was between 44% and 61%. It is remarkable that for all journals, irrespective whether they aimed specifically at teachers, up to 16% of the personal subscriptions was taken by other professionals (military, skippers, farmers, bookkeepers, shopkeepers, notaries,

³ Reglement voor het Lager Schoolwezen en Onderwijs binnen de Bataafsche Republiek 1806, art. 4

etc.). The first journal on arithmetic only (MR) was very popular. It was meant for student-teachers and advanced pupils in primary schools, as was BBGC. The journals on algebra and geometry, MSM, TRSM, NTRSM, were aimed at the teachers of French schools and the advanced classes of Dutch schools, with older pupils. They also served the teachers who studied for a higher certificate. Evidently, even if there was some specialization among the journals for teachers of primary schools. TTR was slightly different: it was meant for ‘teachers, advanced pupils, farmers, builders, stonemasons, carpenters, painters, shipbuilders, etc.’ It contrasted the ‘high level of accuracy, the rigour of calculations in school’ with the situation in the professional life, in which one had to be able to give a quick approximation, to work fast and to produce useful answers in calculations. Again, both teachers (presumably of older pupils) and professionals subscribed to this journal.

Concluding remarks

From the mid-18th century mathematics journals, primarily meant for teachers, but subscribed to by other practitioners as well, were published in the Netherlands. In the 18th century mathematics was both a respectable pastime and a means to improve the situation of those teachers, who were prepared to learn mathematics; learning mathematics was each teacher’s individual choice. *Mathematische Liefhebberye* set out to disperse and enhance mathematical knowledge among teachers in the 18th century. It meant to be a support for those inexperienced in mathematics by more knowledgeable colleagues, while also offering interesting mathematics for the experienced readers. From the early years of the 19th century, one consequence of efforts by the government to improve the quality and standing of primary school teachers was the obligation for all teachers to learn at least some mathematics and preferably more. Mathematical knowledge and pedagogical skills formed from 1806 on part of the requirements for all teachers. All journals discussed above had as their aim to further mathematical knowledge and skills among their readers, primarily through encouraging them to solve problems and send new ones, just like was the case with *Mathematische Liefhebberye*. In this way the emergence of an informal learning community was facilitated, with experienced and less experienced teachers. The very diverse and active group of readers with a wide range of mathematical topics of the 18th century made place for a more narrowly defined group of readers (though still with practitioners amongst them) less topics, more specialization, in the first half of the 19th century. A common focus of the whole period discussed is the driving force of mathematics exams. In the 18th century occasionally, for some vacancies and differing very much between towns; in the 19th century compulsory for all primary teachers, probably not that different from region to region, but with increasing demands for higher ranks. All journals provided material which could be used for teaching and catered for those who practised for exams. We conclude that these journals played an important role in the professional development of teachers.

References

- Beckers, D. (2003). *"Het despotisme der Mathesis." Opkomst van de propedeutische functie van de wiskunde in Nederland, 1750 -1850*. Hilversum: Verloren.
- Bijdragen tot de Beoefening der Zuivere Wiskunde (1829-1833)*. Purmerend: J.P. Bromstring.
- Boekholt, P.Th.M. & Booy, E.P. de (1987). *Geschiedenis van de school in Nederland*. Assen: van Gorcum.

- Candeias, R. (2017). Mathematics in the initial pre-service education of primary school teachers in Portugal. In Dooley, T., & Gueudet, G. (Eds.). (2017). *Proceedings of the Tenth Congress of the European Society for Research in Mathematics Education (CERME10, February 1-5, 2017)* (pp. 1693-1700). Dublin, Ireland: DCU Institute of Education and ERME.
- Furinghetti, F. (2009). The evolution of the journal *L'Enseignement Mathématique* from its initial aims to new trends. In K. Bjarnadóttir, F. Furinghetti, & G. Schubring (Eds.). "*Dig where you stand*". (pp.31-46). Reykjavik: University of Iceland, School of Education.
- Gispert, H. (2018). Journaux mathématiques et publics enseignants (18e-20e siècles). Le rôle heuristique de l'hétérogénéité des mondes de l'enseignement des mathématiques. *Revue suisse des sciences de l'éducation*, 40 (1), 133-152
- Krüger, J. & Maanen, J. van (2013). Evaluation and design of mathematics curricula: Lessons from three historical cases. In B. Ubuz, Ç. Haser, & M. A. Mariotti (Eds.), *Proceedings of the eight Congress of the European Society for Research in Mathematics Education* (pp. 2030-2039). Ankara, Turkey: Middle East Technical University, European Society for Research in Mathematics Education.
- Krüger, J. (2014). *Actoren en factoren achter het wiskundecurriculum sinds 1600*. Utrecht: PhD thesis University of Utrecht.
- Krüger, J. (2018). *Un journal mathématique néerlandais au XVIIIe siècle - Le Passe-Temps mathématique (1754-1769)*. Images des Mathématiques. Digital publication. <http://images.math.cnrs.fr/Un-journal-mathematique-neerlandais-au-XVIIIe-siecle-Le-Passe-Temps?lang=fr>
- Magazijn voor de Rekenkunst* (1828-1835). Breda: Broese & Comp.
- Mathematische Liefhebberye* (1754-1769). Purmerend: P. Jordaan
- Menghini, M. (2015). Emma Castelnuovo's commitment to creating a new generation of mathematics teachers. In K. Bjarnadóttir, F. Furinghetti, J. Prytz, G. Schubring (Eds.). "*Dig where you stand*"3. (pp. 263–278). Uppsala: Department of Education, Uppsala University.
- Oller-Marcén, A.M. (2017). The problem section of *El Progreso Matemático*, In K. Bjarnadóttir, F. Furinghetti, M. Menghini, J. Prytz, G. Schubring (Eds.), "*Dig where you stand*" 4. *Proceedings of the fourth International Conference on the History of Mathematics Education* (pp. 235-246). Roma: Edizioni Nuova Cultura.
- Preveraud, T. (2015). American mathematical journals and the transmission on French textbooks to the USA. In K. Bjarnadóttir, F. Furinghetti, J. Prytz, G. Schubring (Eds.). "*Dig where you stand*"3. (pp. 293–308). Uppsala: Department of Education, Uppsala University.
- Smid, H.J. (1997). *Een onbekookte nieuwigheid? Invoering, omvang, inhoud en betekenis van het wiskundeonderwijs op de Franse en Latijnse scholen 1815 – 1863*. PhD thesis: Technische Universiteit Delft.
- Tijdschrift ter Bevordering der Mathematische Wetenschappen* (1823-1828). Purmerend: J.P. Bromstring.

Semiotic potential of a tractional machine: a first analysis

Michela Maschietto¹, Pietro Milici² and Dominique Tournès³

¹Università degli Studi di Modena e Reggio Emilia, Italy; michela.maschietto@unimore.it

²Université de Bretagne Occidentale, Brest, France; p.milici@google.com

³Université de la Réunion, Saint-Denis, France; dominique.tournes@univ-reunion.fr

Tractional motion is an almost forgotten theory involving machines to geometrically solve inverse tangent problems. It was at the basis of Leibniz's development of calculus and interested many important mathematicians (e.g. Euler) mainly in the 17th and 18th centuries, before its disappearance because of the decrease of importance of geometric constructions. In this work, we analyse the exploration of a tractional motion machine using the framework of Theory of Semiotic Mediation. This is just a very first work in the perspective of introducing this kind of machine to students in order to mediate the meanings of transcendental curves and infinitesimal analysis.

Keywords: History of mathematics, tangent, mathematical machines, tractional motion, semiotic potential.

Introduction.

The use of historic machines is a well-established practice to mediate mathematical meaning (Maschietto & Bartolini Bussi, 2011). Specifically, many studies have been published about the construction of geometric curves as traces of both ideal and practical machines, but most of such studies focus on algebraic curves. In this work, we deal with an approach to transcendental curves with machines, that is *new*¹ in mathematics education. Such an approach, called “tractional motion,” was so relevant to the conception of infinitesimal analysis (e.g. for Leibniz, who designed in 1693 a material instrument to practically solve quadrature problems). As deepened in Tournès (2009), tractional motion mixed theoretical developments and concrete constructions of artefacts for the resolution of the inverse tangent problem. Those artefacts could be interesting for STEM education. In our approach, before proposing them to students, the analysis of cognitive processes of exploration by experts is necessary. In the paper, we aim to present the first elements of this analysis for a particular tractional machine.

Brief history of tractional motion.

As clearly exposed in Bos (2001), in 17th century Descartes proposed a class of machines tracing algebraic curves as synthetic part of his method, and polynomial algebra as an analytical tool in order to simplify the problems. That determined a dualism between “geometric” and “mechanic” curves (in modern terms, algebraic and transcendental curves), being only the first one considered acceptable in the Cartesian setting. Soon after the spreading of Descartes' canon, mathematicians got habituated to polynomials, that became no longer an extremely important step for the problem solving, but directly the solution. In that period, there were only a few curves that were considered

¹Such approach is not in use today, but it was already adopted in Italy by Giovanni Poleni in Padua (first half of the 18th century) and Ernesto Pascal in Naples (beginning of the 20th century).

“mechanic” (e.g. the quadratrix or the cycloid), but a new general method to generate curves beyond Cartesian limits was going to emerge. The main idea underlying behind such constructions was given by a problem proposed by the architect Claude Perrault in Paris in the 1670s. The problem was easily described: *if we move the end of a chain watch along a line slowly enough to avoid inertia, what curve does the watch describe?* Cartesian tools appeared powerless to answer.

In the case of Perrault’s watch, the motion is given by the traction of a cord: that gave the name to such constructions by “tractional motion.” The described curve (called “tractrix”) is constructed given its tangents: while the watch moves, the tangent to the obtained curve is given by the direction of the chain in traction. This is a new kind of tangent problem: instead of the classical tangent problem (given a curve, finding its tangent that satisfies certain properties), known at least since classical Greek period, this time the tangent properties are given, and the curve has to be determined as the solution. That’s the rise of “inverse tangent problems.”

But how can inverse tangent problems be concretely implemented? The reference to a heavy load having friction on a plane (as the watch) involved physical problems that should be kept away from the domain of pure geometry, e.g. the unwanted role of velocity (because of the inertia that the load acquires) or the non-perfect horizontality of the plane. It was missing a clear instrumental embodiment of the theoretical concept “driving the direction of a curve” (as a pair of compasses embeds the concept of equidistance): mathematicians as Huygens and Leibniz worked on it.

To sum up, after the habituation of mathematicians to consider polynomials as solutions, which brought to a loss of interest to machines for algebraic curves, at the end of 17th-century machines got a new importance; this time to justify the construction of transcendental curves (Bos, 1988).

In the 18th century, it was particularly interesting the role of Giovanni Poleni. Mathematician, physician, astronomer and also interested in engineering studies, Poleni (1729) proposed machines for the tractrix and the logarithmic curve, that were also built and used in cabinets for exhibitions and in teaching. In 1739, he obtained the creation, at the University of Padua, of a laboratory of experimental physics (“*Teatro di filosofia sperimentale*”) which was unanimously praised by his contemporaries. He took the opportunity to set up one of the first university courses based on laboratory experiments (previously, he had students coming to his home in his personal scientific cabinet). For this reason, Poleni got a particular attention to the design of his tractional machines: they were no longer only theoretical machines but also practical instruments guaranteeing an adequate usability and accuracy. In this period, curves like the tractrix or the logarithmic were well known and generally accepted, thus it was no longer necessary to justify their introduction as solutions to certain problems, but it became important to give them concreteness (something similar to the possible needs in today classrooms). The main component behind such machine was the introduction of the “wheel” to drive the direction of the curve (as in the front wheel of a bike). Poleni’s publication (1729) made a strong impression on the geometers of his time. Leonhard Euler (1736) read it and found in it an interesting mode of construction to address the differential equations that he could not integrate in finite form by algebraic methods. Among other results using tractional motion, Euler succeeded in integrating the famous Riccati equation, which had remained unsolved for a long time. From there, an epistolary dialogue continued between Euler and Poleni for

more than four years, revealing interesting interactions between theoretical and practical concerns (Tournès 2009, p. 95-96): in particular, at Euler's request, Poleni gave the description of an instrument for drawing the tractrix of a circle.

Following on from Euler's work, Vincenzo Riccati (1752) published in Bologna a treatise in which he demonstrates that it is possible to exactly integrate any differential equation using tractional motion. From a theoretical point of view, Riccati's work is the culmination of the ancient tradition of problem-solving through the construction of curves. Descartes had shown the construction of algebraic curves by a simple continuous motion using linkages. Riccati, for his part, established that transcendental curves can also be constructed by a simple continuous motion from the differential equations that define them.

After the middle of the 18th century, the theory and the practice of the tractional motion got rapidly lost. The geometric paradigm was no longer dominant, and new mathematicians were interested in exploring only the analytical counterpart of infinitesimal analysis. However, in the late 19th and early 20th centuries, a new generation of mathematicians and engineers reinvented essentially the same solutions of Poleni, increasing just the complexity of these instruments (the "integrators").

The tractional machine of our study.

One of the most interesting features of tractional motion is the deep link between its instrumental and theoretical components. Specifically, the possibility of introducing some transcendental constructions from history to classroom might be mediated by the exploration of a machine.

Out of the tractrix, the most famous construction easily given by tractional motion is for the logarithmic (or exponential) curve. As visible in Figure 1 (left and centre), for tracing this curve, a machine can implement the property of having a constant subtangent². Poleni, who designed and build a machine tracing the exponential, also evinced that one tractional machine could generate both algebraic and transcendental curves. That was a fundamental idea while conceiving our machine: according to the notation of Figure 1, if we change the direction of the wheel in the machine for the exponential (i.e. we put the wheel direction perpendicular to the segment QS), the machine traces a parabola (Figure 1, right).

More specifically, according to Figure 2, the machine³ proposed in this study is made up by a horizontal wooden table with two parallel fixed wooden guides in which a wooden frame can slide. A brass cylinder is forced to remain within the frame, free to rotate and to slide perpendicularly to the two fixed guides. Inside the cylinder, there is a wheel perpendicular to the plane. The cylinder rotation is determined by a rod that is constrained to pass through a pin fixed on the frame.

²In a Cartesian plane, given a curve C passing through the point (x,y) , the subtangent to C in (x,y) is the segment between $(x,0)$ and the intersection of the line tangent to C in (x,y) with the x -axis. Referring to the Figure 1, the subtangent in S is the segment QP.

³Simulations of this machine are available online: <https://www.geogebra.org/m/zrMyFGdd> (for the parabola) and <https://www.geogebra.org/m/LXugImiH> (for the exponential). This machine was introduced by Milici & Di Paola (2012) and described with more details in Salvi & Milici (2013).

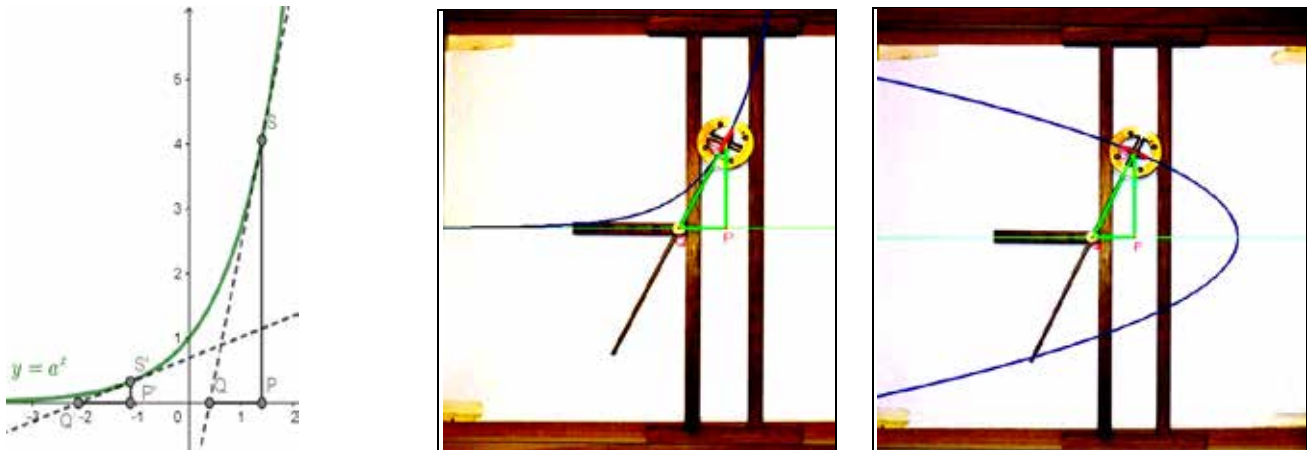
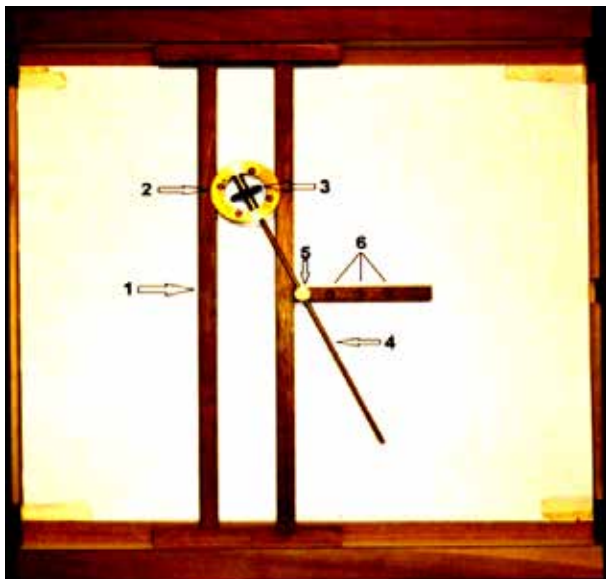


Figure 1:[Left] The exponential $y=a^x$ has constant subtangent QP ; [Centre] machine for exponentials; [Right] machine for parabolas



Components:

1. wood translating frame
2. brass hollow cylinder
3. tyred wheel that rotates inside the cylinder (2)
4. rod giving the direction of the cylinder (2)
5. pin with a hole where the rod (4) slides
6. holes where to put the pin (5)

Figure 2: The various components of the proposed machine

Artefacts in mathematics education.

Basing on previous works on the use of artefacts in mathematics education (for instance, the mathematical machines in Maschietto & Bartolini Bussi, 2011; www.mmlab.unimore.it and macchinematematiche.org), the analysis of the machine proposed in this paper is carried out within the framework of the Theory of Semiotic Mediation (TSM) developed by Bartolini Bussi & Mariotti (2008) in a Vygotskian perspective. In this, a teacher uses an artefact as a tool of semiotic mediation for mediating mathematical meaning to students by managing didactical cycles (composed of small group work, collective mathematical discussion and individual work). The first proposed activity is a small group work with the artefact, because its use solicits a certain semiotic activity (where the signs can be language, gestures, drawings, ...) that is the base for the teacher's intervention. The exploration of the chosen artefact related to the educational objectives is carried out following four questions (Bartolini Bussi, Garuti, Martignone & Maschietto, 2011, p.128): "How is the machine made?", "What does the machine make?", "Why does it make it?", "What

could happen if ...?”. Within this framework, the choice and the educational use of an artefact is based on the analysis of its semiotic potential. In the TSM, the distinction between meanings emerging from the practice (use of artefact) and the mathematics knowledge evoked in the expert’s mind is very important. Mariotti & Maracci (2012) specify the notion of the semiotic potential of an artefact to make that distinction explicit:

By semiotic potential of an artefact we mean the double semiotic link which may occur between an artefact and the personal meanings emerging from its use to accomplish a task and at the same time the mathematical meanings evoked by its use and recognizable as mathematics by an expert. (Mariotti & Maracci, 2012, p. 61)

Our research questions are about if and how we could use the machine as an instrument of semiotic mediation with secondary school and/or university students. As in other research on mathematical machines, we intend to propose first a material machine rather than its simulation in a DGS, because we assume the relevance of the exploration by the hand (allowing touching, decomposing the machine, perceiving the resistance to movement or not, ...). In order to answer to those questions, the first step is the analysis of the semiotic potential of the machine, considering the description of the machine by an expert that already knows it on the one hand, and the exploration of the machine by other subjects, experts in other kinds of machines or university students in mathematics. In this way, we aim to analyse what kind of semiotic activity can emerge from the exploration and use of the machine. In particular, we focus on: which are the processes of exploration of the machine? Do people identify the role and the meaning of the wheel? How?

Methods.

We have videotaped two exploration processes of the machine. We chose three people that knew the mathematical machines and the TSM, and were experts in mathematics but without any knowledge of tractional motion. The first exploration was carried out by two secondary teachers, following the structure of four questions that they knew very well. In the exploration, the researcher had to often put the attention on the wheel and its way of use, thus, for the second case, we began proposing only some components of the machine. The second exploration was performed by a postgraduate student in mathematics that studied mathematical machines during a university course. In this case, the machine has been disassembled and gradually reassembled by the researcher: first the cylinder with inside the rolling wheel (cf. Figure 2, (2) and (3)) is given free to move on the table; then the rod (cf. Figure 2,(4)) is added, in the two positions (parallel and perpendicular to the wheel direction); finally, the cylinder is put into the wood frame (cf. Figure 2, (1)).

Findings and discussion.

The analysis is based on videotapes and drawings produced by the people exploring the machine. More specifically, we analyse the part of the two explorations in which people detect the movement and constraints of the wheel and identify the link between wheel and the line tangent to the curve.

First exploration: Alberto and Bianca.

During the first moments of the exploration of the machine (corresponding to the first question, “how is it made?”), Bianca describes the machine but she does not seem to pay particular attention

to the presence of the wheel, even if she considers it as a component of the machine. When the machine is then used to trace (intentionally, the ways of use are not suggested to her), this lack of attention is evident by how Bianca acts on the frame and on the wheel: sometimes the wheel rolls and sometimes it slips, tracing a curve or a straight line. The resistance to the slipping of the wheel is not noticed by Bianca, who raises doubts on how to use the machine until the researcher intervenes by asking it explicitly (“Don’t you feel resistance?”), by specifying the principle of operation (“[the machine] works when the wheel turns”) and by explaining the relationship between the resistance and the constraint of the machine (“you’re forcing a constraint of the machine”).

The machine doesn’t seem to offer feedback sufficiently strong to actions that force the constraints; while forcing the wheel not to follow its direction, the resistance of the tyre is mixed with friction by other structural parts, such as the frame. This certainly is an important point to take into account for paying attention to the wheel as a new element, compared to other curve drawers (such as the ones using taut threads). To foster the identification of the role of the wheel in tracing the curve, the researcher asks to specify the physical constraints of the machine allowing that tracing; he also suggests a comparison with a tracer (which corresponds to the point of a pen) (“If, instead of the wheel, there had been a tracer, would it have been the same?”). The question corresponds to “What could happen if ...?” of our educational framework. However, it is a question that can be asked to expert people. Here are some excerpts of exchanges with Bianca, Alberto and the researcher.

- Alberto: It would have been different.
- Bianca: That is ...
- Alberto: Then, the wheel...
- Bianca: Yes, it would have been different.
- Bianca: If there is a point... that is a wheel...
- Alberto: It would slip, ... it would move randomly.
- Researcher: And, so, what must the wheel do?
- Bianca: It turns [laughter]
- Bianca: It must not slip, because if it slips ...
- Alberto: Turning without slipping.

Then, they turn their attention to the geometrical property of the machine. The relationship between the wheel and the tangent to the curve appears in terms of “direction.”

- Alberto: [The properties] of the tangent line, isn’t it? But physically ... I don’t know why it is physically ... that is, the small wheel gives the direction [*gesture by the hand*] that is not ... any direction to the curve.
- Researcher: And then, what do we know ... having the small wheel this direction? ... at the drawn point.
- Alberto: The curve must have that direction.

These excerpts show that the exploration is in discontinuity with the explorations of the curves drawers that Alberto and Bianca are familiar with. This seems to confirm the deep change quoted above from the epistemological point of view. The emergence of the link between the wheel and the tangent line to the curve is fostered by the researcher. However, some questions are not immediately understood by Alberto and Bianca, as they do not link the task and their personal meanings on curve and machine. The difference between rolling and crawling seems to emphasize such a change.

Second exploration: Corrado.

According to researchers' queries, Corrado moves the cylinder with inside the rolling wheel (cf. Figure 2, pieces 2 and 3) on the plane and defines some properties of the traced curve with consciousness ("It is not constrained to stay on a straight line or a circumference or a parabola or a branch of hyperbole, if we let it free it can go up and down in every place. ... It traces a continuous line, [...] can do edges but without jumps"). When asked to describe more precisely his interactions to make the machine move, he immediately defines the two degrees of freedom. In terms of the analysis of the semiotic potential, we could affirm that the task links the manipulation to Corrado's personal meanings of the curve.

Unlike Bianca, when Corrado is asked to explore the fully reassembled machine, he seems aware of the mechanical resistance to certain motions, and he is able to interpret it in relation with the constraints of the instrument. Specifically, when the wheel is put in the vertex of the parabola, Corrado notices that the machine "resists" when he tries to move along the direction of the axis of the parabola. To explain such behavior, he puts his attention on the idea of direction: "[the machine cannot move that way] because it cannot [with a gesture indicates to move along the axis direction], it is constrained here [indicates the pin, component 5 of Figure 2], it cannot invert, get comfortable [with a gesture of the hand: change the direction] and trace, it has to stay this way and it is unnatural to draw [gesture: in the direction of the axis], it cannot rotate this way [gesture of the rotation of the wheel perpendicularly to the direction of the wheel]. It [the wheel] draws only while rotating and in the direction of its rotation." Later on, he is asked to characterize the traced curve that he identified as a parabola. Corrado is able to find independently the role of the tangent for the wheel: "if we hypothesize that this [with the hand indicates the direction of the wheel] gives the direction of the tangent, the wheel is always perpendicular to this rod and so ... [he looks for a conjecture on the tangent perpendicular to something, but doesn't find any]."

Therefore, as a very early conclusion, we can suppose that disassembling the machine eases the understanding of the constraints of the machine. However, we cannot affirm that disassembling can also ease the characterization of the curve because Corrado tried to verify that the traced curve was a parabola focusing on the points traced on the plan and neglecting tangent properties. This corresponds to another aspect of the epistemological change that characterizes the machine.

Concluding remarks.

At our knowledge, this is the first empirical work aimed at analysing the semiotic potential of a tractional machine. As a first result, we can evince that the passage from algebraic to transcendental constructions, so groundbreaking from a historical and epistemological perspective, recalls also

very different abilities in the exploration (the explorations were not trivial even for experts of mathematical machines). In particular, the relation between the wheel and the tangent did not appear immediately, but the idea of disassembling the machine in order to investigate simpler components appeared quite fruitful (even though it requires to be much more deepened). This suggests a possible task, but this is not enough sufficient for constructing worksheet for students. What done is only a very first step in this direction. We need other experimentations to clearly define the mathematical contents to be mediated (tangents, derivatives, integrals, differential equations) and the level of the exploration (high school, university).

References

- Bartolini Bussi, M.G., Garuti, R., Martignone, F., & Maschietto, M. (2011). Tasks for teachers in the MMLAB-ER Project. In B. Ubuz (Ed.), *Proceedings of the 35th Conference of the IGPME* (Vol. 1, pp. 127–130). Ankara, Turkey: PME.
- Bartolini Bussi, M.G., & Mariotti, M.A. (2008). Semiotic mediation in the mathematics classroom: Artifacts and signs after a Vygotskian perspective. In L. English & al. (Eds.), *Handbook of International Research in Math. Educ.* (II edition, pp. 746–783). New York, NY: Routledge.
- Bos, H.J.M. (1988). Tractional motion and the legitimation of transcendental curves. *Centaurus*, 31(1), 9–62.
- Bos, H.J.M. (2001). *Redefining geometrical exactness: Descartes' transformation of the early modern concept of construction*. New York: Springer.
- Euler, L. (1736). De constructione æquationum ope motus tractorii aliisque ad methodum tangentium inversam pertinentibus. *Commentarii academiae scientiarum Petropolitanae*, 8, 66–85.
- Mariotti, M.A., & Maracci, M. (2012). Resources for the Teacher from a Semiotic Mediation Perspective. In G. Gueudet, B. Pepin, & L. Trouche (Eds.), *From Text to 'Lived' Resources, Mathematics Teacher Education* (Vol. 7, pp. 59–75). New York: Springer.
- Maschietto, M., & Bartolini Bussi, M.G. (2011). Mathematical Machines: from History to the Mathematics Classroom. In P. Sullivan and O. Zaslavsky (Eds.), *Constructing knowledge for teaching secondary mathematics: Tasks to enhance prospective and practicing teacher learning* (Vol. 6, pp. 227–245). New York: Springer.
- Milici, P., & Di Paola, B. (2012). Geometrical–mechanical artefacts for managing tangent concept. *International Journal for Mathematics in Education*, 4, 486–492.
- Poleni, J. (1729). *Epistolarum mathematicarum fasciculus*. Patavii: Typographia Seminarii.
- Riccati, V. (1752). *De usu motus tractorii in constructione æquationum differentialium commentarius*. Bononiæ: Ex typographia Lælii a Vulpe.
- Salvi, M., & Milici, P. (2013). Laboratorio di matematica in classe: due nuove macchine per problemi nel continuo e nel discreto. *Quaderni di Ricerca in Didattica (Mathematics)* 23, 15–24.
- Tournès, D. (2009). *La construction tractionnelle des équations différentielles*. Paris: Blanchard.

On the historical development of algorithms - hidden in technical devices?

Regina Möller¹ and Peter Collignon²

¹University of Erfurt, Faculty of Education, Germany; regina.moeller@uni-erfurt.de

²University of Erfurt, Faculty of Education, Germany; peter.collignon@uni-erfurt.de

The content of Adam Ries' book (1574) with the instructions to written arithmetic fostered an enlightening for citizens at this time since they learned how to calculate themselves making it obsolete to pay a "Rechenmeister" for this task. In the early modern times algorithms entered the industrial world by mechanical automatisms intended to take away the routines from people. Nowadays algorithms hidden in many technical devices have become a part of our daily procedures often staying unaware for people. The paper discusses the historical development of the concept of algorithm and its potential for mathematics and general education today.

Keywords: Algorithms, enlightening, fundamental ideas, mathematics education

A historical view on the mathematical aspects of algorithms

The history of algorithms as part of mathematics started in the very early days since the systematic solving of mathematical problems is part of doing mathematics. For example, during the Old Greek times Euclid (300 v. Chr.) gave a rule to calculate the greatest common divisor of two given natural numbers. Another well-known algorithm is the sieve of Eratosthenes, a step-by-step procedure giving prime numbers up to a certain given natural number. Several hundred years later it was Al-Khwarizmi who presented a number of mathematical applications for traders. These were translated into Latin with the title "Algorithmi" containing the artificial word "arithmos" that is derived from "number" and the name of the mathematician (cf. Chabert, 1999).

Hundreds of years later Adam Ries (1574) wrote a booklet on basic arithmetic operations which had great influence on the German citizenship at that time. In the year 1614 the Scottish John Napier published a book on logarithms which made him look like the inventor of logarithms. Leonardo da Vinci (1452-1519) as another significant personality of the Renaissance era demonstrated with the "Vitruvian Man" his understanding of proportions blending geometric descriptions with the Renaissance art. Another hundred years later Leibniz (1646-1716) used the binary code and algorithms on that basis.

In 1815 Augusta Ada Lovelace was the first woman to program for the (technologically underdeveloped) calculator of Charles Babbage (1791-1871). 1931 Gödel destroyed the dream of many mathematicians that all mathematical theorems can be proved by algorithms by his Incompleteness Theorems:

They imply that there is no algorithm with a finite number of steps that can decide if an arithmetic statement is true or false in all cases imaginable.

Furthermore, it is impossible to prove consistency for a formal system whose complexity is the same as that of the natural numbers.

In this context we also must accept an incompleteness of arithmetic:

There is no (finite) algorithm that proves the valid statements of arithmetic on the whole. (Ziegenbalg, 2010; translated by the authors).

Later on during the 20th century von Neumann and Turing provided the mathematical basis for computing with which they started the new era of computer science (Chabert, 1999, p. 457).

During the last decades the development of “artificial intelligence” progressed so rapidly that the nature of algorithms became in immense multiple ways complex (e.g. voice recognition, decision making systems). This development was possible because of rapidly advanced technical conditions which as a consequence offered an improvement in calculating speed and storage space. As an organizational form cloud computing brought enhancements.

Concluding this very short historical view on the successive appearances of algorithms through the centuries it becomes apparent that in former days they were documented in a written form by books with the aim of becoming public to scientists and citizens. Even in the case of military purposes, namely cryptography, the secrecy of the underlying algorithm was not considered appropriate. Only the "key" that gives details of a general – even public – encryption process had to be hidden, which is the subject of Kerckhoff's principle (Kerckhoff, 1883, p. 12). Nowadays the algorithms behind apps and programs often stay hidden because they are part of a business secret often with the idea to gain money. The question arises when exactly the balance turned from transparency to its opposite and how we can deal with this new situation. One can expect insight from sociological and historical analyses that are not yet been finally concluded.

Today's mathematical exactification and its impact on education

During centuries an algorithm was understood as a series of instructions. The development algorithm's understanding led to distinguished properties.

Steps towards formalization

For the longest algorithms consist of a finite series of instructions to solve a given problem like it was apparent with the sieve of Eratosthenes. Generally accepted are also the following properties which led to a general view and that can be understood as postulates for algorithms (Saake et al., 2010):

- (1) The algorithmic procedure must end up with the same outcome in case of the same preliminaries.
- (2) Any next step to take is uniquely determined.
- (3) The description of an algorithm implies a finite length of the source text which needs to consist of a limited number of signs.
- (4) An algorithm is requested to have a limited storage space at any time during its procedure.
- (5) An algorithm stops after a finite number of steps.

For didactical purposes it is therefore clear what solving procedures fall under the concept of an algorithm. Like with the concept of sets there is a naïve version of it. And after being confronted with logical difficulties (Russell, 1903) the need of exactification became apparent and was solved in form of axiomatization. The naïve perception of algorithms has its limits, exactified by the work of Turing and especially of Gödel's Incompleteness Theorems. Both topics, sets and algorithms, finally lead to questions of cardinality and self-reference.

Didactical perspectives for math classes

The idea of an algorithm appears several times in school in mathematics classes. On the elementary level the four basic written arithmetic calculations have algorithmic nature and are named as such in mathematics literature. In our daily practice we do not observe a very detailed reflective attitude; neither teachers nor pupils seem to reflect on their algorithmic nature. At the beginning of the secondary I level the well-known Euclidean algorithm is subject matter in class. Very often this is the first time that pupils get aware of the concept of an algorithm. It is regarded as a prototype of an algorithm since it is named like it.

Following the spiral principle other examples of algorithms occur on the secondary I level (in the German system meaning classes 5 – 10: the methods used to solve linear and quadratic equations as well as systems of linear equations. Typical examples on the secondary II level occur with curve sketching, finding extrema, points of inflection and other properties of functions. At this stage the systems of linear equations are again subject matter with an even more algorithmic procedure (Gauß algorithm).

In school algorithms also occur using a calculator or tablets including software for educational purposes. That is for example the dynamic geometry software (DGS; GeoGebra, Cinderella) and Computer Algebra systems (CAS). Nowadays Witzke (2018) uses 3D-Plotters in math classes on different levels to not only visualize mathematical objects but to materialize graphs and geometric solids. This means that algorithms generate didactical tools not only iconical, but even haptical.

Comparing all the mentioned school examples above very few are labeled explicitly as algorithms through the names as the Euclidean and the Gauß algorithm and are therefore more obvious to the pupils. The algorithmic character of other parts of the curriculum is also not easily recognized by the pupils. Even with algorithms whose names prove to be programmatic the teaching normally emphasizes the arithmetic acting and often fails to reflect upon the concept and the meaning of an algorithm. Furthermore, the use of the recently introduced tools in mathematics classes serve didactically as technical devices to manage some type of mathematical problems. However, several of them create some kind of didactical bubble. Some calculators for the secondary level are meaningful only for math classes.

Algorithms as fundamental ideas – alibi or truth?

In 1905 Felix Klein (1849-1925) claimed functional thinking as a guiding principle for mathematics education which was implemented in the German curriculum through the last decades. Already in the seventies of the last century the importance of algorithmic thinking was claimed (Engel, 1977, p. 5). This was expressed in the light of the situation 40 years ago. Nowadays, there should be no

doubt that the situation became much more prominent. The fact that the relevance of algorithms is still not in the center of educational issues is apparent with the “German Bildungsstandards” (Ständige Konferenz der Kultusminister der Länder in der Bundesrepublik Deutschland 2004, 2012): On the primary level algorithms are not mentioned at all and on the secondary I and II levels some of the well-known procedures are classified as algorithms but mostly because of their repetitive character and not in terms of their entire meaning.

We observe a simplified and shortened understanding of the notion on the part of the pupils and teachers as well, in particular relating to its potential in science, society, economy and culture in general. The latter is only recently a subject of scientific research. In the last decades algorithms and their different mechanical realizations have infiltrated our whole life in various and subtle ways. They are omnipresent in every angle of our daily routines. Social networks (like Facebook) and search engines (like Google or Yahoo) are selecting, ordering and evaluating our data, our inputs and their results. Especially the selecting part based on evaluation is a sensitive issue that the companies and institutions have not made transparent, let alone to make an enlightening out of it. On the contrary, many companies admit that they hide the conditions of their procedures, and one often gets the impression of a conscious deception of the public. Advertisements are individualized simulating or pretending that some kind of care plays a vital role. However the companies gain money by using or selling our data and neutrality and objectivity became illusions.

The role of algorithms for general (math) education

Since our daily life is influenced by algorithms in the ways described above the question arises whether mathematics education can play an enlightening role. The aim here is not only the listing of typical, historically well-known examples, but the task is to elucidate about the significance of the impact on all facets of society. Heymann (2013) emphasized general education in the light of fundamental mathematical ideas. He aimed at showing that the fundamental ideas indicate the universality of mathematics and their relevance for the “entire culture” (Heymann, 2013, p. 158) and this needs to become apparent for the pupils during their school life.

Here we follow the structure of Heymann’s frame of reference. The criteria include their relevance for the mathematical development and show the essential nature of mathematics:

- (1) Preparation of life;
- (2) cultural coherence;
- (3) global orientation;
- (4) critical use of reason;
- (5) sense of responsibility;
- (6) communication and cooperation.

There can be no doubt that algorithms affect our daily life in an increasing manner. Therefore, school and especially math classes need to prepare for this fact. Although it is apparent that different countries answer with different attitudes: Europe, primarily the European Union, looks for governmental regulations while the USA care less about rules. The Far East, that is predominantly

China, responds to the situation with even stronger governmental rules. In this light cultural coherence as an aim seems to be out-of-date, and, at the same time, the developed global view is an inevitable consequence of it. Hence the critical use of reason becomes more urgent than ever before. The sense of responsibility needs to be revised and also discussed and reflected in school. And this even more since the situation became much more complex and it is not easily apparent what is for the benefit of humanity and what will harm. Of course communication and cooperation stay important in this light.

Towards an implementation of algorithms in math classes

Both concepts, the set and the algorithm, are simple enough to be presented on the primary level: a set as a Venn diagram (as understood within naïve set theory) and an algorithm as a series of instructions as in a cooking recipe. Therefore both can be represented on the enactive level (Bruner 1974) and are accessible for the iconic one. Their difference lies in the fact that sets can be regarded foremost as a static phenomenon simultaneously due to time, while temporal processing is in the nature of algorithms. In this sense they are complementary. On top of it the concept of sets plays a vital role in the succession of math classes (spiral principle) as the notion of algorithms could and should also (Bruner, 1976).

Closely connected is a theory of conceptual progression of mathematical concepts (Vollrath, 1987). Vollrath presents a didactical theory of learning and teaching mathematical terms. He outlines in general what kind of various steps lead to a certain understanding of mathematical notions:

- (1) Intuitive level;
- (2) content level;
- (3) integrated level;
- (4) formal level.

On the intuitive level the pupils have an idea of a series of steps as a first access to algorithms. This may be represented by game rules or cooking recipes. On the second level they explore typical properties of algorithms. Actually on the third level a network should be recognized on the part of the pupils. In the case of an algorithm we observe that the notion itself provides a conceptual network. We distinguish two levels of formulation: Firstly, there is an exact description of certain mathematical issues through algorithms represented by flow charts or simple programming languages. Secondly, the notion of the concept of an algorithm itself is to be formulized.

It is apparent that the exactification makes the idea of an algorithm accessible for pupils already during early schooling. It became apparent that the idea of an algorithm is rich enough to be taught on all levels with a shifting emphasis. Therefore mathematics education is obliged to prove again its self-established claim for general education. This needs to be done on the conditions of the presence and how they have developed.

Analysis on consequences for the teaching and learning of algorithms

In early historical times algorithms started as a scientific insight on a mathematical problem and additionally gave information for a systemized solving procedure. Paul Ernest (2004, p. 5) describes it like this:

An example is provided by algorithms. These denote precisely specified sequences of actions, procedures which are as concrete as the terms they operate on. They establish connections between the objects they operate on, and their products. They are a part of the rich structure that interconnects, and thus helps to implicitly define, the terms, and hence the objects of mathematics. This must be relativized to the solver, for what is routine for one person may require a novel approach from another. It is also relative to a mathematics curriculum, which specifies a set of routines and algorithms.

At the very end of the middle ages when Adam Ries, standing at the brink of the abacus using concrete tokens and the decimal number system using symbols on paper, the arithmetic operations in form of a booklet had an enlightening impact on the citizens; an enlightening event that is surely not often recognized in history (Deschauer, 1992). It is an example of a practice through all these times when it was mostly the aim to inform, to get insight and to support people's solution practices.

In order to simplify the solving practices and to avoid mistakes, Babbage, for instance, designed a mechanical machine (1923). And, as soon as machines came into place, the questions also involved avoiding counting errors. Later on the development continued with electronic devices aiming at more and better efficiency which first was the storages place and later the shortening of time.

We observe that the chances of an enlightening process in today's society got at least diminished as soon as commercial ambitions entered the global scene and the hiding of information was part of the business practices. And now our so called informational society is confronted with many different "black boxes".

Here, mathematics and its didactics have a long enough history to feel responsible to undertake the task to clarify the situations and to offer enlightening insights. A view into history confirms once again that we do not observe totally new phenomena. Babbage dealt with a similar situation during the early 19th century. In his "Reflections on the Decline of Science in England", first published in 1830 (Babbage, 2013), he complained about scientific mishaps: He observed that scientific results were whitewashed: by trimming (levelling of irregularities), cooking (quoting of results which fit to a theory, omitting results that contradict) and forging (inventing of scientific results which fit a conventional meaning or can be fitting to a desired doctrine).

Concluding our observations on the development of algorithms and our analyses on their position today we notice that they bear only minor enlightening character anymore compared to former times. In order to answer to this situation there needs to be a focus in math classes on prototypes of today's computers. These elementary simplifications could make apparent that the programmed algorithms are combined with money-making commercial ambitions which have to do with

evaluating, selecting and, as a result, manipulating. This goes along with Freudenthal's idea of a guided reinvention within his concept of "mathematics as a human activity" (Freudenthal, 1983).

We do not favour teaching algorithms as it developed chronologically. This might be an interesting experiment, but would be naïve to push the analogies between ontogenesis and history of science to the limit. Instead of it we support a refinement of historical awareness and instruct students to pay attention to the conditions that caused today's appearance of algorithms – one of several possible implementations of a few fundamental ideas of mankind. This is what Paul Ernest (2015) calls the "postmodern perspective". According to Lyotard (1984), postmodernism can be narrowed to scepticism towards meta-narratives. Since different fields focus on and deal with unlike sometimes divergent ideas and phenomena, their historically developed metanarratives differ enormously among each other. Therefore analysing (deconstructing) metanarratives means to retrace historical developments and the decisions made on the way. This endeavour reveals choices which were taken along the historical evolution within each field.

References

- Babbage, Charles (2013). *Reflections on the Decline of Science in England*. Cambridge: Cambridge University Press.
- Russell, Bertrand (1903). *The principles of Mathematics*. Cambridge 1903. (Chapter X online: <http://fair-use.org/bertrand-russell/the-principles-of-mathematics/s106>)
- Bruner, Jerome (1974). *Entwurf einer Unterrichtstheorie (Toward a theory of instruction)*. Berlin: Berlin Verlag.
- Bruner, Jerome (1976). *The process of education*. Harvard: Harvard University Press.
- Chabert, Jean-Luc (1999). Algorithms for arithmetic operations. In Chabert, Jean-Luc (Ed.) (1999): *A history of algorithms. From the pebble to the microchip*. Berlin, Heidelberg: Springer, 7-48.
- Deschauer, Stefan (1992). *Das zweite Rechenbuch von Adam Ries*. Braunschweig, Wiesbaden: Vieweg.
- Engel, Arthur (1977). *Elementarmathematik vom algorithmischen Standpunkt*. Stuttgart: Klett.
- Ernest, Paul (2004). *The Philosophy of Mathematics Education*. London: Taylor & Francis.
- Ernest, Paul (2015). Postmodern Mathematics. In *The Proceedings of the 12th International Congress on Mathematical Education*. Heidelberg, New York, Dordrecht, London: Springer, 605-608.
- Freudenthal, Hans (1983). *Didactical Phenomenology of Mathematical Structures*. Dordrecht: D. Reidel Publishing Company.
- Heymann, Hans Werner (2013). *Allgemeinbildung und Mathematik*. Weinheim, Basel: Belz.
- Kerckhoff, Auguste (1883): *La cryptographie militaire*. In *Journal des sciences militaires*, Volume 9, 5-38.
- Lyotard, Jean-François (1984). *The postmodern condition: A report on knowledge*. Manchester: Manchester University Press (French original published by Les Editions de Minuit, 1979).
- Napier, John (1614). *Mirifici logarithmorum canonis descriptio ejusque usus in utraque trigonometria etc*. Edinburgh 1614. (Online: <https://archive.org/details/mirificilogarit00napi>)

- Roberge, Jonathan & Seyfert, Robert (2017). Was sind Algorithmenkulturen? In Seyfert, Robert & Roberge, Jonathan (Eds.), *Algorithmenkulturen. Über die rechnerische Konstruktion der Wirklichkeit* (pp. 7-40). Bielefeld: Transcript Verlag.
- Saake, Gunter & Sattler, Kai-Uwe (2010). *Algorithmen und Datenstrukturen*. Heidelberg: dpunkt.verlag.
- Ständige Konferenz der Kultusminister der Länder in der Bundesrepublik Deutschland (Ed.) (2004). Beschlüsse der Kultusministerkonferenz: Bildungsstandards im Fach Mathematik für den Mittleren Bildungsabschluss. Beschluss vom 04.12.2003.
https://www.kmk.org/fileadmin/veroeffentlichungen_beschluesse/2003/2003_12_04-Bildungsstandards-Mathe-Mittleren-SA.pdf
- Ständige Konferenz der Kultusminister der Länder in der Bundesrepublik Deutschland (Ed.) (2004). Beschlüsse der Kultusministerkonferenz: Bildungsstandards im Fach Mathematik für den Primarbereich. Beschluss vom 15.10.2004.
https://www.kmk.org/fileadmin/veroeffentlichungen_beschluesse/2004/2004_10_15-Bildungsstandards-Mathe-Primar.pdf
- Ständige Konferenz der Kultusminister der Länder in der Bundesrepublik Deutschland (Ed.) (2012). Beschlüsse der Kultusministerkonferenz: Bildungsstandards im Fach Mathematik für die Allgemeine Hochschulreife. Beschluss vom 18.10.2012.
https://www.kmk.org/fileadmin/veroeffentlichungen_beschluesse/2012/2012_10_18-Bildungsstandards-Mathe-Abi.pdf
- Vollrath, Hans-Joachim (1987). Begriffsbildung als schöpferisches Tun im Mathematikunterricht. In *Zentralblatt für Didaktik der Mathematik* 19, 123-127.
- Winter, Heinrich (1996). Mathematikunterricht und Allgemeinbildung. In *Mitteilungen der Gesellschaft für Didaktik der Mathematik*, 61, 37-46.
- Witzke, Ingo & Hoffart, Eva (2018). 3D-Drucker: Eine Idee für den Mathematikunterricht? Mathematikdidaktische Perspektiven auf ein neues Medium für den Unterricht (Preprint).
- Ziegenbalg, Jochen & Ziegenbalg, Oliver & Ziegenbalg, Bernd (2010). *Algorithmen von Hamurapi bis Gödel*. Wiesbaden: Springer Spektrum.

Historical tasks to foster problematization

Bruna Moustapha-Corrêa¹ Aline Bernardes² Victor Giraldo³

¹Federal University of the State of Rio de Janeiro (UNIRIO) and Federal University of Rio de Janeiro (UFRJ), Brazil, bruna.correa@uniriotec.br

²UNIRIO, Brazil, aline.bernardes@uniriotec.br

³ UFRJ, victor.giraldo@ufrj.br

In this paper, we present a proposal for problematizing activities organized in task rounds, each one consisting of three stages: a triggering task, a historical task, and reflections on teaching. This model is part of a doctoral research project and it is being tested in a module of a professional master's program for mathematics teachers. We draw from the commognition framework (Sfard, 2008), combining the mathtask model (Biza, Nardi, & Zachariades, 2007) and Kjeldsen & Petersen's approaches (2014). More specifically, we discuss how we used history to design the historical task of the first task round, based on the so-called Aha problems from Ahmes' Papyrus. History of mathematics is used in the problematizing activities to move teachers out of their comfort zone and to legitimate different ways of producing mathematical knowledge. Some episodes are presented only to illustrate our discussion.

Keywords: Commognitive conflict, history in teacher education, mathtask, Ahmes' Papyrus.

Introduction

How do teachers deal with their students' unexpected solutions? We believe that acknowledging and legitimating different kinds of mathematical reasoning in all educational levels is a crucial aspect of teachers' knowledge and professional activity, and, therefore, this discussion cannot be put aside in teacher education programs. With this motivation, we have investigated how teachers deal with students' different solutions for mathematical problems in lower and upper secondary schools.

The experience reported in this paper is part of the doctoral research of the first author, jointly supervised by the other two authors. The aim is to design activities to problematize teachers' understandings of mathematical knowledge production, in particular their own mathematical knowledge production, and how they legitimate (or not) students' mathematical knowledge production. We understand problematizing as considering different alternatives for something that is usually taken for granted, which opens ways to explore questions that are usually not even regarded as relevant. In this paper, we focus on the use of historical problems and contexts to trigger problematization. For this, we consider recent trends of the historiography of mathematics, which builds upon the perspective of social and cultural contexts within which mathematical practices are produced. Our research combines frameworks on the integration between history of mathematics and teaching of mathematics and on teachers' education.

From the historical framework, we draw from Kjeldsen and colleagues' (e.g Kjeldsen & Petersen, 2014) work, which suggests that the history of mathematics is a source of discourses governed by

different metarules. We believe that history can be used to legitimate unusual practices in specific contexts. From the teacher education framework, we consider the importance of a kind of knowledge which is developed through school practice (Tardif, 2000). For this reason, the participants in our study are experienced teachers, who were taking a professional master's program¹. Our field work took place in a module, which was part of their degree. In the sessions, participants were invited to analyse solutions for mathematical problems from Brazilian school syllabuses, including students' strategies and historical approaches. This was done by combining tasks inspired by Biza et al. (2007) and Kjeldsen and Petersen's history approach (2014). The field work's methodology was designed in the light of commognitive framework (Sfard, 2008), which will also be used in data analysis. The aim of this paper is to discuss the use of history in the design of these tasks. Episodes from the sessions are reported only to illustrate our task design.

Theoretical Background

According to Sfard, learning is understood as participating in a discourse and mathematics is a kind of discourse. For the author, discourse is a "special type of communication [...] distinguishable by their vocabularies, visual mediators, routines, and endorsed narratives" (Sfard, 2008, p. 297). She adds: "In mathematics, endorsed narratives are those that constitute mathematical theories." (idem, p. 298) However, Sfard does not reduce narratives to formal written texts. For her, narratives correspond to a series of spoken or written utterances, whilst routines grasp a set of metarules. These rules are related to the actions of *discursants* and are historically established, changing through the different discourses. Sfard (2008, p. 260) also points out that commognitive conflict

appears when one encounters a discourse incommensurable with one's own – when familiar routines are confronted with other people's alternative ways of implementing the same discursive tasks, grounded in different metarules.

Commognitive conflicts are at the core of our research. Thus, to lead participants to discuss and reflect on different ways that mathematics can be produced, we expose them to different discourses in two ways: using historical sources, and through tasks inspired by *mathtasks* (Biza et al., 2007). Biza et al. (2007) propose *mathtask* as a situation-specific task designed to engage teachers with classroom situations, to which they are invited to discuss attitudes they would take in the actual classroom. These situations are usually hypothetical, yet data grounded and likely to occur in the actual practice. The connection between history of mathematics and the commognitive framework is inspired by Kjeldsen's work. Since history is a source of discourses governed by different metarules (e.g. Kjeldsen & Petersen, 2014), it provides different ways of approaching problems and their solutions.

Arcavi and Isoda (2007, p. 112) highlight the importance of teachers' listening capabilities, that is, "giving careful attention to hearing what students say (and to see what they do), trying to understand it and its possible sources and entailments". This is close to our goal, since we aim to problematize teachers' criteria to legitimate (or not) students' production of mathematical

¹ In Brazil, legal certification to teach at school is granted by an undergraduate degree. So, this master program is a professional development and is also a way to increase public school teachers' income.

knowledge. In our work, history is used to reach this problematization by discussing historical solutions to mathematical problems, which may differ from the usual strategies teachers are familiar with. Thus, the *problematizing activities* we propose are designed to use historical sources that move teachers out of their comfort zones, by revealing consistent practices within specific social contexts.

The Problematizing Activities Design

The *problematizing activities* we propose are organized in *task rounds*, each one consisting of three stages: *triggering task*, *historical task*, and *reflections on teaching*. Our field work was conducted in a module of a professional master's program for mathematics teachers. Participants were 12 mathematics experienced teachers (who teach students with ages range from 11 to 18) who were taking this module. The module comprised thirteen 3-hour sessions (organized in three task rounds), including students' assessment. In this paper, we discuss how we used history, in articulation with frameworks on teachers' education, to design the activities, with a special focus on the historical task. We address the case of one of the three task rounds – based on the so-called *Aha* problems from Ahmes' Papyrus. Some episodes are presented, in order to illustrate our discussion. It is not an aim of this paper to rigorously analyse this empirical data.

The task rounds' structure

Each round starts with a *triggering task*, in which participants are given hypothetical student solutions to a mathematical problem. The aim is to bring about the ways they deal with students' responses, and to which extent they are open to unusual solutions. This is followed by a *historical task*, in which participants are presented to excerpts from original sources. The aim is to shake participants' comfort zones formed by the kind of solutions they are familiar with, since the historical discourses are usually different from the ones used in the classroom. In the last stage of each round, *reflections on teaching*, participants are again given hypothetical student solutions, which now also draw upon historical solutions.

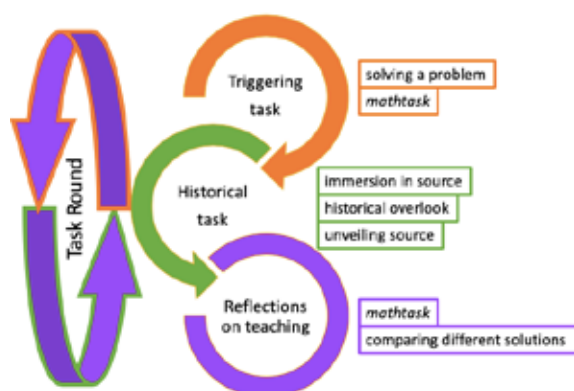


Figure 1: Structure of task rounds

The structure of the *triggering task* and the *reflections on teaching* stages are inspired by Biza et al. (2007) *mathtask* model, namely: firstly, participants are asked to solve a mathematical problem; then they are asked to analyse student solutions to this problem, and to describe the feedback they would give to students in an actual classroom situation. In each of the three stages, participants are

first asked to write down individual responses, and then invited to collective discussion. Either by bringing historical excerpts, or by using *mathtasks*, we try to promote a commognitive conflict (Sfard, 2008). Our goal is to encourage the participants to reflect and discuss on: i) their own *routines* regarding their classroom practices, ii) how they understand mathematics, and also iii) the criteria they apply when judging their students' mathematical solutions and reasonings. For the choice of each task round's topic we take into account: potential to allow different solutions; relevance to the participants' practice; and availability of primary and secondary historical sources.

The first task round: context and structure

Our first task round is built around the *simple false position rule*, according to which the solution is reached by using an “experimental number” that is adjusted by a factor. Thus, the process of finding the solution is not based on a representation for the solution, as in the case in the contemporary algebraic methods. We choose the context of the ancient Egyptian *Aha* problems (e.g. Roque, 2012; Chace et al., 1927) from Ahmes Papyrus to explore different solutions to problems modelled by linear equations nowadays, as a potential trigger of commognitive conflicts. We could consider many metarules regarding the discourse from *Aha* problems (e.g. the ones related to the Egyptian symbols, the ones related to the structure of the *Aha* problems, the ones related to the Egyptian mathematical practices), but we focus on the metarule related to the assumption of an “experimental number” to start the *Aha* problem – which considerably differs from representing the unknown quantity by a letter and operating with it. Thus, we use the simple false position rule as a means of problematizing algebraic solutions commonly used at school. The choice of this activity is also justified by the fact that the false position rule is grounded in the notion of proportionality. Despite this is a key concept in school mathematics, it is sometimes underestimated in the teacher education programs (at least in the Brazilian context). The *triggering task* consists of a *mathtask* with two hypothetical solutions to the following problem:

Marina likes to make problems for her father inspired from what she learns at school. One night she said: “Dad, find out how many Reais² I have! The tip is: if I add a quarter of what I have to what I have, I'll get R\$15,00.”

Ten participants attended this session, all of which presented an algebraic solution, as expected. A *mathtask* with two students' solutions to the problem was then discussed. The *mathtask's* context was an introductory lecture on algebra at elementary school for 12/13 years old students. The first solution uses a diagram to split the whole in 4 parts, and then add a fourth one. So, 15 is divided by 5, and the result is multiplied by 4. The second solution is a “trial and error” strategy. Aiming to set up commognitive conflicts, both student solutions were designed considering *routines* different from the algebraic solutions. The metarules behind the first solution's routine are related to the use of fraction bars, whilst the ones in the second solution routine are related to the use of a trial and error strategy.

² Brazilian currency.

Designing the historical task: our methodological option

The historical task concerns two well defined moments: an immersion in original sources and a historical overlook. These approach were inspired by Arcavi and Isoda (2007)'s hermeneutic method. The authors propose a sequence of tasks aiming to

parsing the source, posing questions to oneself (or to a peer) around it, paraphrasing parts of the text in our words and notations, summarizing partial understandings, locating and verbalizing what is still to be clarified, and contrasting different pieces for coherence. (Arcavi & Isoda, 2007, p.116)

Thus, immerging in a source is the opportunity to analyse and understand different mathematical practices, contrasting them with the participants' own ones. In the historical overlook, we discuss (mathematical and cultural) contexts of the source and some aspects of the Egyptian mathematics. We adopt this approach as a means to lead participants to experiencing "other perspectives", as Arcavi and Isoda (2007) posit, which, in the context of the history of mathematics, may be the ones from the primary sources, as we used in this research. As these authors suggest, in the context of the classroom, the "other perspective" is the students' ones. So, they argue that trying to understand historical sources may lead teacher to be more receptive to students' productions, specially the unexpected ones.

The aim of the first round was to explore Problem 25 of the Ahmes' Papyrus, which states: "*A quantity whose half is added to it becomes 16.*" Firstly, we invited participants to analyse Problem 25 in Hieratic and Hieroglyphic (Figure 2), as it appears in the Ahmes' Papyrus (Chace et al., 1927). Next, they were presented to Problem 25, as it appears in Figure 3, with translation to English and to (our) Portuguese. After presenting a brief contextualization on Ancient Egypt, the role of the scribes in the society organization, and what Ahmes' Papyrus and, particularly, the *Aha* problems are about, we presented Problem 25 again as it appears in Figure 3, and invited participants to explore it. We then proposed tasks from Arcavi and Isoda's work, including: the elaboration of a dictionary of Egyptian symbols, especially numbers; a problem with Egyptian multiplication; and a set of tasks exploring Problem 24³ (Arcavi & Isoda, 2007) in stages. Finally, we discussed Ancient Egyptian mathematics, especially number system, fractions and operations, using Roque (2012) as the main reference.

³ Problem 24 is quite similar to Problem 25 and states "*A quantity whose seventh is added to it becomes 19.*"



Figure 2: Hieratic and Hieroglyphic solutions of Problem 25

Problem 25

A quantity, $\frac{1}{2}$ of it added to it, becomes it : 16. [Uma quantidade, 1/2 dela adicionada a ela, torna-se 16.]

b	$2 + f$	bpr	$bpr \cdot f = 16$
1	2	2	4
2	3	3	6
4	6	6	24
8	12	12	96
16	24	24	384

Let my bpr
The doing as it occurs. [O fazer como ocorre.]

The quantity [A quantidade]

b	10
$2 + f$	5
bpr	16
Total [Total]	

Figure 3: Modern translation of the Problem 25

We then resumed Problem 24's solution and encouraged the participants to understand the solution as a whole. As Arcavi and Isoda suggest, we asked them to try to present a solution using a different experimental number. Moreover, we invited them to try to compare the solutions for Problems 24 and 25. The solution was written in modern terms and the expression "false position rule" was presented. Finally, the questions (inspired by Winicki, 2000) were posed to guide the discussion: 1) In modern terms, to which kind of equations do the *Aha* problems correspond? 2) Present a justification for the false position rule. 3) In the false position rule, does the result depend on the experimental number? 4) Does the false position rule work for all kinds of *Aha* problems? Why? 5) Why do you think such a rule was invented? 6) Why is it anachronistic to claim that the Egyptian "solved equations"?

To conclude the historical part, we asked the teachers about simple false-position-rule rationale, that is, to explain why the method is valid. After a brief discussion, we presented a modern justification, using a linear function's graphic in order to show the proportionality between the experimental number (false position) and the solution. The *reflections on teaching* stage was guided by a *mathtask* presenting a situation in which a 12-year-old boy that doesn't know algebra yet solves Problem 25 by trial. His father wants to convince him that it is easier to solve the problem through the use of an equation. The boy tells the story to his teacher and asks her why does his dad insist on the equation. The participants were asked to explain how they would answer the boy, if they were his teacher. By the end of the task round, we had 5 different types of solutions for a linear equation: i) algebraic one, ii) using diagrams (fraction bars), iii) trial and error, iv) simple false position, and v) another one by trial presented by the boy (i.e., 3 solutions by trial). We invited the participants to compare these solutions.

During the whole first task round, we tried to promote commognitive conflicts, since the discourse of the historical Egyptian source, the discourse of the solutions presented in the *mathtasks* are modelled by different metarules (Sfard, 2008; Kjeldsen & Petersen, 2014) and are (supposed to be) different from the teachers own's discourses. This strategy aimed to stimulate the participants to reflect about the way they deal with their students' different solutions and reasonings.

The first task round: what happened

The first task round took a bit more than two sessions, guided by the first two authors, and with the participation of 12 teachers (four of which attended all of the three meetings). During the sessions, we repeatedly asked the participants about how they deal with different reasonings and solutions brought by their students. Almost all participants have long-term experience in teaching mathematics at public and private schools. The sessions were audio and video recorded. There were separated audio recordings for each small group of 3 or 4 teachers, that discussed each task. The individual written answers to the *mathstasks* and to the historical task were collected. After each session, the participants were asked to write individual reflective diaries, in which they recorded their impressions of the session. Those data will be analysed in a next stage of the doctoral research project.

Impressions from the first activity's round implementation

In general, the participants engaged with the tasks and discussions conducted in the first task round. We could discuss the approaches to equations and algebra teaching they use in classroom. When asked about how they deal with unusual solutions brought by their students, they acknowledge that they recognize them, sometimes sharing them with the rest of the class. However, although we tried to relativize the supremacy of algebra over other approaches, their discourses suggest that their main goal is to develop students' algebraic reasoning and writing. That is, even though they recognized some value on other approaches, they kept pursuing their goal, namely to lead students to understand that algebra makes solutions faster. For example, when we discussed solutions by trial, they repeatedly highlighted that if the numbers were bigger, they would have spent much more time, whilst algebraic solutions take the same amount of time regardless of how big the numbers are. None of them seemed to consider that experimenting with some examples could lead to an understanding of the problem, in such a way that testing all numbers would not be needed. One of the reasons for the teachers keep pursuing the algebra in classrooms might be the important role played by the algebra in the school syllabus in Brazil.

One of the participants, who we will refer to by the pseudonym Ulisses (who were present in all sessions) caught our attention in two different ways. Firstly, he told us that he used Ancient Egyptian multiplication algorithm (which had been discussed in the task round) with his students. He reported that, as his students were facing difficulties with the standard multiplication algorithm, he decided to show the Ancient Egyptian method. The students understood it and claimed that it was easier. We remark that we did not make any suggestions for the participants to apply specific approaches in their classrooms, and Ulisses did so by his own initiative. This kind of attitude is relevant to our work, since this teacher allowed himself to experiment in his own classroom with historical practices discussed during the sessions. During the discussion about Problem 25's solution, Ulisses once more surprised us: he thought of non algebraic solutions. Even though he wrote down the equation, he tried out different values. He noted that $10+5=15$ and $12+6=18$. Looking to $10+5=15$, he noticed that 1 more was necessary, so he split 1 in three pieces $1/3$, $1/3$ and $1/3$, of which two should be with 10 and one with 5 – and he reached the solution.

Arcavi and Isoda (2007, p. 125) posit that

the intention to nurture attentive listening by creating a gap between our method and the Egyptian had a slightly counterproductive effect for some: the symbolic method is so powerful and efficient why bother to even consider a complicated alternative so difficult to understand.

Contrary to this, in our case, the teachers considered all methods – of simple false position and the ones that were used in the *mathtasks* – correct and valid.

Final Remarks

The continuation of our field work included two more task rounds. The second one explores Euclid's approach to areas without numbers (quadratures) and the role of the Pythagorean Theorem's in Euclidian tradition. The aim is to problematize the teaching of areas, which is mainly based on formulas in Brazil. The third task round is designed around the development of the concept of function, and some of its historical definitions, aiming to foster the reflection of image of mathematics as an immutable science.

The episodes reported above indicate that our proposal combining *mathtasks* and historical tasks seems to be a promising way to problematize teachers' understandings of mathematical knowledge production, in particular their students' mathematical knowledge production. When data analysis from our field work is completed, we will have more evidence to deepen the understanding of our proposal's potential. Nevertheless, the episodes from the first task round indicate that at least this group have been receptive to the use of the history of mathematics. We highlight that Ulisses spontaneously tried the Egyptian multiplication out in one of his classrooms. This indicates that he problematized, at least to some extent, not only his own and his students' mathematical knowledge productions, but also his teaching practices.

Acknowledgments

We acknowledge CAPES for the scholarship for a doctoral internship at Rutgers University under the supervision of Prof. Arthur Powell. We are grateful to Prof Arthur Powell for the partnership, especially in the design of the field work methodology and to Prof. Elena Nardi and Dr. Irene Biza for the opportunity of working together and exchanging experience through the MathTASK project.

References

- Arcavi, A., & Isoda, M. (2007). Learning to listen: From historical sources to classroom practice [Special Issue]. *Educational Studies in Mathematics*, 66, 111–129. doi: 10.1007/s10649-006-9075-8.
- Biza, I., Nardi, E., & Zachariades, T. (2007). Using tasks to explore teacher knowledge in situation-specific contexts. *Journal of Mathematics Teacher Education*, 10(4–6), 301-309.
- Imhausen, A. (2007). Egyptian Mathematics. In V. Katz (Ed.), *The Mathematics Egypt, Mesopotamia, China, India, and Islam: A Sourcebook* (pp. 7–56). New Jersey: Princeton University Press.
- Chace, A.B., Manning, H.P., & Archibald, R.C. (1927). *The Rhind Mathematical Papyrus: British Museum 10057 and 10058* (Vol. 1). Oberlin, OH: Mathematical Association of America.

- Chace, A.B., Bull, L., Manning, H.P., & Archibald, R.C. (1929). *The Rhind Mathematical Papyrus: British Museum 10057 and 10058* (Vol. 2). Oberlin, OH: Mathematical Association of America.
- Kjeldsen, T.H., & Petersen, P. H. (2014). Bridging history of the concept of a function with learning of mathematics: Students' metadiscursive rules, concept formation and historical awareness. *Science & Education*, 23, 29–45.
- Miatelo, L. (2008). The difference $5\frac{1}{2}$ in a problem of rations from the Thind Mathematical Papyrus. *Historia Mathematica*, 35 (4), 277–284.
- Roque, T. (2012). *História da Matemática: Uma visão crítica, desfazendo mitos e lendas*. Rio de Janeiro: Zahar.
- Sfard, A. (2008). *Thinking as Communicating: Human development, the growth of discourses, and mathematizing*. Cambridge: Cambridge University Press.
- Tardif, M. (2000). Saberes profissionais dos professores e conhecimentos universitários: elementos para uma epistemologia da prática profissional dos professores e suas consequências em relação à formação para o magistério. *Revista Brasileira de Educação*, 13. Retrieved from http://www.anped.org.br/sites/default/files/rbe/files/rbe_13.pdf.
- Winicki G. (2000). The Abalysis of Regula Falsi as an Instance for Professional Development of Elementary School Teachers. In V. Katz (Ed.), *Using history to teach mathematics—an international perspective*, MAA notes (Vol. 51, pp. 129–133). Washington, DC: MAA.

The development of Thales theorem throughout history

Slim MRABET

Carthage University, Tunisia; mrabet_slim@yahoo.fr

Keywords: Thales theorem, similar triangles, transformation.

Thales theorem may have different functionalities when using distances, algebraic measurements, or vectors. In addition to that, the utilization of a figure formed of secant lines and parallels or a figure relating to two similar triangles.

The aim of this work is to categorize different formulations of Thales theorem and explain why in teaching we must know the appropriate mathematical environment related to each Thales Theorem statement. The analysis of many geometry books in history makes it possible to distinguish two points of view according to different forms, demonstrations and applications of this concept.

The Euclidean point of view

The general statement of Thales theorem shows us the idea to move from one triangle to another, moreover, the link with similar triangles (immediately following it and generally with similar figures) is a characteristic of this point of view.

Proposal 2 of Book VI states that:

"If a straight line be drawn parallel to one on the sides of a triangle, it will cut the sides of the triangle proportionally; and, if the sides of a triangle be cut proportionally, the line joining the

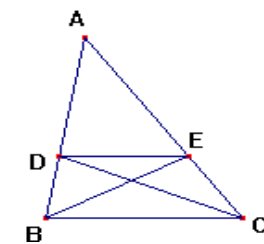


Figure 1 : figure of Euclid

points of section will be parallel to the remaining side of the triangle". (Heath, 1956).

The demonstration is based on the surfaces method; using equalities of triangles cases and making cuts and re-compositions in order to compare surfaces.

The point of view of transformations

This point of view is characterized by the disappearance of the link between Thales theorem and similar triangles, and, a passage from one line to another by projection appears in a figure of type: "parallels and secants".

In the seventeenth century, Euclidean treaty did not seem to satisfy some researchers. In fact, the latter prefer not to prove a result on lines using surfaces. In Thales theorem proof, Arnold rejects the detour by the surfaces made by Euclid.

For Arnold (1667), the statement of Thales theorem uses several parallels cut by secants:

"If several lines, being differently inclined in the same parallel space, are all cut by parallel lines to this space, they are cut proportionally"

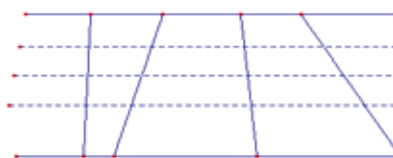


Figure 2 : Figure of Arnold

When applying the Thales theorem, we find essentially the search of 4th proportional, and the division of a segment with a given ratio.

This type of statement is also found in Hadamard (1928) where the study of figures marks the appearance of transformations that coexist with traditional objects of geometry.

The homothety, introduced with distances, consolidates for Hadamard dynamic aspect of geometric figures. It also provides the possibility to use similarity of polygons by decomposing them into triangles.

Note that starting from the 20th century, new conceptions of geometry appeared and benefit from linear algebra. The traditional methods of Euclid and his successors were eventually set aside.

With Choquet (1964), Dieudonné (1964) and other renowned researchers, geometry is evolving in each century. For Choquet, Thales theorem allows proving the relation $a(u+v) = au + av$, in order to study the linearity of an oblique projection.

Conclusion

In Thales theorem proof, Euclid uses surfaces method to avoid problems of irrational numbers. In majority of perused publications, Thales theorem proofs often use commensurable segments, thus, the transition to immeasurable segments is admitted.

In teaching, it is important for instructors to conceive the real line without holes. We also think that the two points of view of Thales theorem have their efficacy and both should have enough time to reach the students. We recommend set each one of them in the appropriate mathematical environment that can result in a better understanding of geometric themes introduced in class.

References

- Arnould, A. (1667). *Nouveaux éléments de géométrie*. Paris: Charles Savreux.
- Choquet, G. (1964). *L'enseignement de la géométrie*. Paris: Hermann.
- Dieudonné, J. (1964). *Algèbre linéaire et géométrie élémentaire*. Paris: Hermann.
- Euclid. (1956) *The Thirteen Books of the Elements*. Translated with introduction and commentary by T. L. Heath. Second edition. New-York: Dover.
- Hadamard, J. (1928). *Leçons de géométrie élémentaires*, 10th edition. Paris: Armand Colin.

Original sources, ICT and mathemacy

Marianne Thomsen¹ and Inge Marie Olsen²

¹ PhD student, Aarhus University & University College Copenhagen, Denmark; mtho@au.edu.dk

² Mariendal Friskole, Copenhagen, Denmark; ingemarieolsen@hotmail.com

Keywords: ICT, original sources, hidden mathematics, mathemacy.

The focus of our master's thesis in Mathematics Education was on how 4th grade students (10-11 years old) connect working with ICT and reading original mathematical sources in ways that support the development of a competency, *mathemacy*, "which may help students to reinterpret their reality and to pursue a different reality" (Skovsmose & Nielsen, 1996, p. 1263). Our study indicated that ICT and original sources complement each other in terms of the students' learning activities. The students' experimental activities in ICT supported their understanding of the original source. Their work with the original source supported a development of a mathematical consciousness and sharpened their awareness of hidden mathematics (Jankvist & Toldbod, 2007) and black box situations (Buchberger, 2002), which means that the students didn't just accept the results of a computer – they also questioned the mathematics behind when using ICT. Furthermore, the students' awareness of differences between working with contemporary ICT and original sources seemed to increase a balanced and critical stance towards mathematics as a universally given thing – making them see both mathematics and ICT as something that develops and changes over time.

Our research design was inspired by Skovsmose's (2006) description of critical research based on three situations: The *current*, the *imagined* and the *arranged*, as well as three processes: *Pedagogical imagination*, *pedagogical experimentation* and *explorative analysis*. The three situations and processes were used in our planning, implementation and analysis of the 3 x 90 minutes teaching session we conducted. The students were asked to carry out a final individual evaluation. We performed three types of data collection: 1) Focus group interviews prior to the first teaching session, 2) Teaching session observations, and 3) students' products from each teaching session. Data category 2 and 3 we regarded as pedagogical experimentation data helping us describe the current situation. We used this situation and our pedagogical imagination to prepare the next imagined situation. Based on the collected data we performed an explorative analysis and planned the next arranged situation and so on. The first current situation was based on data type 1. In our planning and analyses of the learning activities we were among other inspired by Jankvist's (2009) framework concerning the use of history in mathematical education as a goal (meta-issues) or as a tool (in-issues). Our study focused on history both as a goal *and* as a tool. We extended Jankvist's categorization also to deal with the students' work with ICT. The mathematical content was kept relatively simple letting the students work with only Euclid's Proposition 1, book I, *To construct an equilateral triangle on a given finite straight line* and equilateral triangles in *GeoGebra*. For the meta-issues we focused especially on hidden mathematics in software (Jankvist & Toldbod, 2007) and the fact that mathematics develops over time (Jankvist, 2009). Inspired by Jankvist and Kjeldsen (2011) and Kjeldsen and Blomhøj (2012), we used Sfard's (2008) theory of discourse and commognitive conflicts. We considered Euclid's proposition 1, book I, and *GeoGebra* as two

different discourses. Within these two discourses we saw meta-issues and in-issues as two different discourses. During the teaching sessions, we made a common ‘discourse-poster’ on which we gathered the students’ statements they agreed to during the classroom discussions. The students worked with the construction part and the proof part in relation to Euclid’s Proposition 1, book I, and equilateral triangles in *GeoGebra*. This gave rise to common discussions about the difference between proof; in terms of Euclid’s proposition and in terms of working with *GeoGebra*. One student for example compared Euclid’s proof to a game; he found one circle, then the next and so on. The students were asked to construct as many equilateral triangles as possible in *GeoGebra* and formulate their own proofs for these. The outcome of this assignment was what they called three different types of ‘proofs’ for equilateral triangles: *Measuring, the computer outcome as a proof in itself and the Euclidian way*. There were different opinions among the students about which type of ‘proof’ they found most credible, which we regarded as an in-issue discussion; understandings of different kinds of proofs within the two discourses were to some extent generating commognitive conflicts. Furthermore, the students discussed whether the computer always tells the truth and if mathematic will change in the future as well – a meta-issue discussion based on their experiences by working within the two different discourses. In addition to this, we arranged special learning activities, which focused on the meta-issues, for example asking students to write and discuss pros and cons of using Euclid’s proposition and the use of *GeoGebra* in mathematical education. Several students found that working with both Euclid’s proposition and *GeoGebra* was a good idea and had increased their learning. The students became aware of that computer outcome may contain a lot of hidden mathematics. Hopefully, this will support their reflexive use of ICT and also later in life qualify their critical stance towards the outcome of mathematical modelling.

References

- Buchberger, B. (2002). Computer algebra: The end of mathematics? *ACM SIGSAM Bulletin*, 36(1), 3–9.
- Jankvist, U. T. (2009). A categorization of the ‘whys’ and ‘hows’ of using history in mathematics education. *Educational Studies in Mathematics*, 71(3), 235–261.
- Jankvist, U. T. & Toldbod, B. (2007). The hidden mathematics of the mars exploration rover mission. *The Mathematical Intelligencer*, 29(1), 8–15.
- Jankvist, U. T. & Kjeldsen, T. H. (2011). New avenues for history in mathematics education – mathematical competencies and anchoring. *Science & Education*, 20(9), 831–862.
- Kjeldsen, T. H. & Blomhøj, M. (2012). Beyond motivation: history as a method for learning meta-discursive rules in mathematics. *Educational Studies in Mathematics*, 80(3), 327–349.
- Sfard, A. (2008). *Thinking as communicating*. New York: Cambridge University Press.
- Skovsmose, O. (2006). Kritisk forskning - pædagogisk udforskning. In O. Skovsmose & M. Blomhøj (Eds.), *Kunne det tænkes? - om matematiklæring* (pp. 255–272). Copenhagen: Malling Beck
- Skovsmose, O. & Nielsen, L. (1996). Critical mathematics education. In A. J. Bishop, K. Clements, C. Kietel, J. Kilpatrick & C. Laborde (Eds.), *International Handbook of Mathematics Education*, (pp. 1257–1288). Dordrecht: Kluwer Academic Publishers.

Rizanesander's *Recknekonsten* or “The art of arithmetic” – the oldest known textbook of mathematics in Swedish

Reza Russell Hatami¹ and Johanna Pejlare²

¹Østfold University College, Faculty of Education, Halden, Norway; russell.hatami@hiof.no

²Chalmers University of Technology and University of Gothenburg, Gothenburg, Sweden; pejlare@chalmers.se

The present paper considers an important cultural treasure in the early Swedish history of mathematics education. After the reformation in the 16th century it became possible to study mathematics in Sweden. The first printed textbook in Swedish on arithmetic appeared in 1614, but already in 1601, the oldest known manuscript in Swedish on arithmetic was written by Hans Larsson Rizanesander. In this paper we investigate Rizanesander's manuscript in its historical context.

Keywords: Mathematics history, history of education, arithmetic, mathematics education.

Introduction

Swedish school mathematics has a history of about four centuries. During recent years there has been an increased research interest in the history of Swedish mathematics education (see, for example, Hatami (2007), Lundin (2008), Pejlare (2017), and Prytz (2007)). However, not much research has been conducted on the early history of Swedish mathematics education. The first printed textbook on arithmetic in Swedish was written by Aegidius Aurelius (c.1580–1648) in 1614 (Aurelius & Johansson, 1994). However, the oldest known manuscript in Swedish of a mathematics textbook was written in 1601 by Hans Larsson Rizanesander (1574–1646); this manuscript is the focus of the present paper. The manuscript, entitled *Recknekonsten (The art of arithmetic)*, constitutes a significant part of the history of Swedish mathematics education. There seems to be a pedagogical idea behind the structure of the text, and it contains numerous examples with solutions. Even though it was never printed, and it is not known to what extent it was used, it can give us insights into the early history of Swedish mathematics education. Hatami and Schéele have interpreted the handwritten manuscript, and in 2018 it was, after more than 400 years, finally printed (Rizanesander, 2018). Hultman (1868–1871, 1874) wrote on the Swedish history of arithmetic, but he was probably not aware of Rizanesander's manuscript, since it was not mentioned. In his dissertation on the Swedish history of mathematics up to 1679, Dahlin (1875) summarized parts of Rizanesander's manuscript, but he did not consider it in the context of the Swedish history of mathematics education. The present paper is part of the outcome from a larger project aiming to contribute to the understanding of the early history of mathematics education in Sweden. The aim of this paper is to investigate Rizanesander's manuscript as well as possible influence on him by other authors. We conduct a content analysis on relevant parts of the manuscript and perform comparisons to other textbooks on arithmetic that he may have had access to. In order to better understand the context in which Rizanesander wrote his manuscript, we will first give an overview of the Swedish history of mathematics education (13th to 17th century).

Swedish history of mathematics education

To better understand the cultural value of Rizanesander's manuscript and its importance for mathematics education, we will first give a summary of the history of Swedish mathematics education until the 17th century. The Swedish education has its origin in the 13th century, when education was committed at cathedral schools, convent schools and provincial schools. Through the Fourth Council of the Lateran, convoked by Pope Innocentius III in 1215, each cathedral was committed to have a school where future priests could get free education. In 1237 the Dominican Order established the first Swedish convent school in Åbo. The convent schools were oriented towards theology, but gave a higher education than the cathedral schools. In particular, those belonging to the higher states had the possibility to get educated. However, many nobles on the continent could not read or write and possibly it was the same in Sweden. During the reformation in the 16th century the convent schools were closed and the opportunity of higher education disappeared. King Gustav Vasa (1496–1560) took over the management of the cathedral schools and provincial schools, but there was no particular interest of education among the people. Not until 1842 there was a Royal decision to implement a public-school system in Sweden (Lundgren, 2015).

The oldest university in the Nordic countries is Uppsala University, which was founded in 1477, and it was the only university in Sweden until King Gustav II Adolf in 1632 founded the university of Dorpat, which today is the University of Tartu in Estonia. During the Reformation there was very little activity at Uppsala University, but during the synod of the Lutheran Church of Sweden in 1593 the Duke Charles (later King Charles IX) gave new privileges to the university, which reopened in 1595 (Pejlare & Rodhe, 2016). Until the reformation the traces of mathematical knowledge in Sweden are few; only at the end of the 13th century the Arabic numerals became known (Dahlin, 1875). At the beginning of the 14th century there probably were a few that were skilled in using the Arabic numerals in simple calculations, but at the beginning of the 16th century there were most likely very few Swedes who could perform calculations except with finger calculations or with an abacus.

The first Swede mentioned to own mathematical literature is the canon Hemming from Uppsala, who testamentated his mathematics books to a relative when he died in 1299. Among these books we find those written by two of the most well-known mathematicians of that time: Campanus of Novara (c. 1220–1296) and Johannes de Sacrobosco (John of Halifax, c.1195–1256) (Dahlin, 1875). The oldest Swedish mathematical work known is a short overview of the calendar with the title *Tabula cerei paschalis*, written in Uppsala in 1344. The first Swedish mathematician mentioned to have been relatively knowledgeable of mathematics and astronomy is King Charles VIII (c. 1408–1470), but some details of what kind of knowledge he had is not known.

When Uppsala University was given new privileges in 1593, Ericus Jacobi Skinnerus (deceased 1597), became the first Swedish professor of mathematics (Rodhe, 2002). No mathematical works by Skinnerus have been encountered. Nevertheless, he was an avid supporter of the French philosopher Petrus Ramus' (1515–1572) controversial ideas (Rodhe, 2002): Ramus questioned the Aristotelian theories that were then dominating in the academic world. Even if we cannot see any clear traces of mathematical activity during the time of Skinnerus, his interest of ramism should have provided a basis for a positive development of education.

The first Swedish professor of mathematics whose activity we know somewhat well is Laurentius Paulinus Gothus (1565–1646). He was a professor at Uppsala University from 1594 to 1601 where

he lectured on arithmetic, algebra, logic, geometry and philosophy (Dahlin, 1875). He also studied the mathematical works by Ramus, and in his spirit Paulinus struggled for the Aristotelian theories to be removed from school. Ramus preached on the usefulness of science, which for mathematics implies the search for applications to other subjects. The followers of Ramism in particular fought the mysterious and superstitious features found in the Aristotelian scholastics (Rodhe, 2002). In 1637 Paulinus became arch bishop and promulgated a program for students of theology: the demand for becoming a priest would be to have good knowledge of arithmetic, Euclid's *Elements*, Ramus' physics and in astronomy, in particular the *doctrina sphaerica* and the calendar (Dahlin, 1875).

During the end of the 16th century it became possible to teach mathematics at the cathedral schools as long as the teaching did not have a negative influence on other subjects. In the curricula from 1611, *Skolordningen 1611*, we can read that in school the children should be educated in Buscherus' arithmetic and in "*Sphaera Johannis de Sacro busto*" with the condition that no other subjects would be neglected (Dahlin, 1875). Buscherus, or Heizo Buscher (1564–1598), was a German philosopher. His book on arithmetic, *Arithmeticae logica methodo conscriptae libri duo* (1590), was an important textbook in Sweden during the early 17th century (Vanäs, 1955) and was later reedited by the Swedish bishop Johannes Bothvidi (1575–1635). *Johannis de Sacro busto* most likely refers to Johannes de Sacrobosco, who wrote a book on astronomy, *Libellus de sphaera*, that was widely used at universities during the middle ages.

The first known mathematics book on arithmetic in Sweden is a handwritten manuscript in Latin on the rule of three, by Peder Månsson (c.1465–1534), written in the early 16th century (Hultman 1870). In 1609 Olof Bures' (1578–1655) book on arithmetic, *Arithmetica instrumentalis abacus*, was printed. The first printed textbook on arithmetic in Swedish is Aegidius Aurelius' *Arithmetica eller Räknebook, medh heele och brutne Taal (Arithmetica or arithmetic textbook, with integers and fractions)*, which was published in eleven editions between 1614 and 1705. But already in 1601, the first Swedish textbook on arithmetic was written: *Recknekonsten* by Hans Larsson Rizanesander. It is written in Swedish at a time when education was reserved for privileged boys with knowledge of Latin, and when mathematics education still was not generally in question.

Rizanesander and *Recknekonsten*

Not much is known about Hans Larsson Rizanesander (1574–1646). He studied at Vasa Akademi in Gävle – a school that had been founded by King Gustav Vasa in 1557 – and became a judge in Gästrikland, a province north of Uppsala, in 1605. Originally, he came from Rotskär in Älvkarleby. The linguistic origin of the name Rizanesander is a Greek translation of the Swedish word Rot-skärman (in English: Root-skerry-man), i.e., *Rhiza-nes-ander*.

Rizanesander wrote his manuscript in Tallinn, which during this time was a dominion of Sweden called Räfte or Reval. Today the manuscript is kept at the university library *Carolina Rediviva* at Uppsala University; to our knowledge it only exists in one copy. The manuscript is dated the 21st of August 1601. It does not have a title, but since the word *Recknekonsten* (*The art of arithmetic*) is used in the dedication this is how we will refer to the book. The manuscript consists of 147 pages, including twelve pages that may have been written by Rizanesander's son Lars Hansson. It is divided into 20 chapters: The first two chapters contain definitions and explanations of the hindu-arabic positional notation (4 pages), as well as a description of the abacus (4 pages). The following

four chapters deal with addition (11 pages), subtraction (7 pages), multiplication (10 pages) and division (12 pages), both on the abacus and with numerals. Chapters VII and VIII deal with the greatest common divisor (1 page) and the least common multiple (4 pages). Chapters IX to XIII deal with fractions (3 pages) and the four basic mathematical operations with fractions (5, 4, 3, and 4 pages, respectively). Chapter XIV deals with arithmetic and geometric series (10 pages), and chapters XV and XVI deal with the rule of three (14 pages) and reversed rule of three (2 pages). The last four chapters deal with general counting (3 pages), square roots and cubic roots (19 pages), *regula cecis* (also called *regula virginum*, 7 pages), and the rule of false position (8 pages).

The manuscript is dedicated (4 pages) to Duke John (1589–1618), son of King John III of Sweden. At this time Duke John was 12 years old. In the introduction Rizanesander claims that the art of arithmetic is indeed a glorious and useful art, since God herself used arithmetic. He also refers to Plato, who demanded that kings and princes should have the acquirement of the art of arithmetic. At the end of the introduction Rizanesander asks Duke John for financial support in order to have the manuscript printed. It is not known if there was any contact between Rizanesander and Duke John, but apparently Rizanesander never got any funding, since the manuscript was not printed. It is not known if Duke John ever mastered the art of arithmetic. However, he never became king; twice he gave up the throne and he died only 28 years old.

Recknekonsten or The Art of Arithmetic

Rizanesander begins the first chapter of *Recknekonsten* by stating that “The art of arithmetic is a knowledge of calculating well”¹. He uses nine *significant* digits (1–9) and one *insignificant* (0) called *Nulla* or *Ziphra*.² The insignificant is explained to “do nothing by itself”³ but it fills up the space where there is no significant digit. This means that the zero only has a meaning as an empty place indicator in the place value number system; the zero does not yet have a meaning in itself. These ten significant and insignificant digits are explained to be “the wood of the art of arithmetic of which it is built in the same way as a house is built by timber, stones, lime, clay and sand”⁴. It is further explained how numbers should be pronounced. Rizanesander does not have a word for numbers greater than 1000. To pronounce a great number, he uses a dot on each thousand to indicate how many multiples of thousand the digits represent. The example he gives, 13̇45̇6̇79̇8̇65̇4321̇06̇2489, should be pronounced as follows:

Thirteen thousand, thousand thousand, thousand thousand times thousand
 Four hundred fiftysix thousand thousand thousand, thousand times thousand
 [...]
 four hundred eighty nine⁵

¹ “Recknekonsten ähr een lärdom till att wäll Reckna” (Rizanesander, 1601, p. 3 r).

² In modern Swedish the word for *zero* is *noll* and the word for *numerical digit* is *siffra*.

³ “förmå inthett vthi sig sielfff” (ibid, p. 3 r).

⁴ “wirkin till Reckne konsten af hwilken hon warder vpbygd medh Lijka såsom till itt hus att vpbyggia hörer Stocker, Stenar, Kalck, Leer och Sandh” (ibid, p. 3 r).

⁵ Thretton tusendh, tusend tusend, tusend tusend gånger tusend fyre hundrade femtiyosex tusend tusend tusend, tusend gånger tusend [...] fyre hundrade ottotiye niyo (ibid, p. 4 v).

This method is not very efficient, but any great number can be pronounced with it. In Christopher Clavius' (1537–1612) *Epitome arithmeticae practicae* from 1583 great numbers were also marked with dots and described to be pronounced in the same way.

After presenting numbers and how to pronounce them, Ryzanesander continues to give a description of the abacus (see Figure 1) and the meaning of the lines and their spacing on it. A coin on the lines represents, from below, a unit, a tenth, a hundredth and so on. A coin in the spaces between the lines represents five, fifty, five hundred, and so on. His abacus resembles a traditional abacus but with the supplement that a coin below the bottom line represents half a unit. This is interesting, considering that Ryzanesander has not yet introduced fractions.

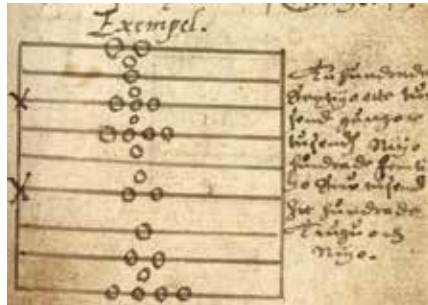


Figure 1: Ryzanesander's abacus representing the number 268,957,129 (Ryzanesander, 1601, p. 6 r).

Ryzanesander proceeds through the following four chapters by explaining the four basic operations addition, subtraction, multiplication and division, both with the abacus, and with algorithms. The abacus will only be used in these chapters; in later chapters numerical methods, only, will be considered. The chapters on the four basic operations with numbers include many examples. Most of the examples concern money, but there are also some numerical examples without a context where it is explained how to carry through the algorithms.

The algorithm for the addition of numbers is the same as the standard addition algorithm that we use today, starting from the right. However, when Ryzanesander describes subtraction with numbers, he starts the algorithm from the left, which forces him at each step to look at the position to the right in order to decide whether he has to decompose and recompose the numbers or not. For example:

One asks how many years there has been since we wrote 1574 and now write 1601? *Reliquus* 27.

Put $\begin{array}{r} 1601 \\ 1574 \end{array}$. Say 1 from 1 is nothing left. Draw a line through them both. Say again 5 from 6

Reliquus is 1, which should be written above. But the next number, 7 could not be taken from 0.

Therefore, write under :| less than one is 0 |: and keep this. Draw a line through 6 and 5. Say

again from 10 :| Since you had it in memory to do so |: *Reliquus* is 3. But write less that is 2

above, the same reason as before, draw a line through 0 and 7, and again keep one in memory;

Thereafter take four from 11 *Reliquus* is 7 which can complete be written above. Draw a line

27

through 1 and 4 and now the example is thus: $\begin{array}{r} 1601 \\ 1574 \end{array}$.⁶

$\begin{array}{r} 1601 \\ 1574 \end{array}$

⁶ Een frågar huru många år, ähre sedan thz skreffz 1574 och nu skriffwes 1601? *Reliquus* 27. Sätt såledhes. $\begin{array}{r} 1601 \\ 1574 \end{array}$
Sågh 1 ifrå 1 år inthz öffwer. Dragh så en linie igenom them bådhen. Sågh åther 5 ifrå 6 *Reliquus* år 1, hwilkett skulle

Ramus used the same algorithm for subtraction in his *Arithmeticae libri* from 1555, but Clavius in 1583 used the same subtraction algorithm as we do today.

Chapter V deals with multiplication, and this chapter Ryzanesander begins by presenting the Pythagorean table (see Figure 2), which he states has to be learned by heart.

Figure 2: Ryzanesander's table of multiplication (Ryzanesander, 1601, p. 16 r).

Interesting is that Ryzanesander uses a triangular table, where the commutative law implicitly has to be considered. This means that from the table of multiplication with 2 to the table of multiplication with 9 the length of the tables successively gets shorter. Also, other mathematicians active during the 17th and first half of the 18th century, such as for example Aurelius, but also Nils Buddaeus (1595–1653), Nicolaus Petri Agrelius (c. 1625–1681) and Anders Celsius (1701–1744), have taken the commutative law into account when they designed their multiplication tables, which makes the table triangular and compact. However, Swedish mathematics textbook authors during the end of the 18th century, such as Nils Petter Beckmarck (1753–1815), Olof Hansson Forsell (1762–1853) and Per Anton Zweigbergk (1811–1862) used quadratic multiplication tables and do not focus on the commutative law. Clavius (1583) also used a quadratic multiplication table, but Ramus (1555) only presented a multiplication algorithm and not a multiplication table.

Ryzanesander refers to the Pythagorean table when he describes division with numbers. The division algorithm with numbers he uses is a scratch method, or *divisione per galea*, which was a common method in the middle ages (Vanäs, 1955). Characteristic for this method is that the divisor is written under the dividend and is moved one position for every new quotient digit, and the quotient is written to the right. As the computation is performed, the digits belonging to the same number does not have to be written next to each other on the same line and the remainder is written above the dividend. Also, the partial products are computed from the left to the right and are subtracted as they are computed.

After the chapters on the four basic mathematical operations, Ryzanesander proceeds with finding the greatest common divisor, and the least common multiple, of two numbers. He needs this in his rendering of fractions and the four basic mathematical operations with fractions in the following chapters. Compared to the presentation of the four basic operations with numbers, the presentation of the four basic operations with fractions is different. Both presentations contain numerous

skriffwas offwanföre. Men her till nest föliande taal, icke kunna 7 tages vthaf 0. Derföre skriff ret vnnder :| mindre ähn eett ähr 0 |: och beholtt thz. Dragh een linie igenom 6 och 5. Säggh åther ifrå 10 :| Ty war thu i sinnett hadhe gör thz så |: *Reliquus* ähr 3. Men skriff i mindre som ähr 2 offwanföre, för förne orsackz skuldh; dragh een linie igenom 0. Och 7, och beholtt åther eet i sinnett; Tagh sidhan fyra ifrå 11 *Reliquus* ähr 7 hwilken kan fulkommeligen schriffwas offwan före.

2 7

Dragh och een Linie igenom 1 och 4 och ståår nu hele Exemplet såledhes. $\frac{1601}{1574}$ (Ryzanesander, 1601, p. 14 v–15 r).

$\frac{1601}{1574}$

examples, but when the examples with numbers often are in a context there is, with only one exception (unit weights), no context in the examples with fractions. Also, there is no explanation of how the fractions should be interpreted: focus lies instead on how the algorithm should be carried through. However, in the following chapter XIV on arithmetic and geometric series we find examples where fractions are used in a context. One example of an arithmetic series is the following:

I would like to know how many times the bell rang since it rang at one during the night until it rang at 12 during the day.⁷

Many of the examples use a context with money. The money used in Sweden at this time was thaler, mark, öre and penningar (pg). The thaler was an international silver coin used throughout Europe. One thaler is four mark, one mark is eight öre, and one öre is 24 penningar. One example of a geometric series in the context of money, which resembles an example we also find in Buscherus' *Arithmetica* (1590), is the following:

One buys a horse that is shod with 32 nails and give 1 pg for the first nail, 2 pg for the second nail, 4 pg for the third nail and 8 for the fourth and so on doubling. How expensive is the horse? Answer: 4294967295 pg, that is 5592405 thaler 1 mark 6 öre 19 pg. That was an expensive horse.⁸

This was indeed an expensive horse. But Rizanesander has actually made an arithmetical mistake when he changes his money: the correct answer should be 5,592,405 thaler, 1 mark, 2 öre and 15 penningar.

Concluding remarks

Being the oldest mathematics textbook in Swedish, Rizanesander's manuscript is an important source through which we can learn more on the early Swedish history of mathematics education. The manuscript includes a rich repertoire of examples, giving students the possibility to master the art of arithmetic. However, explanations to, for example, why certain algorithms work, are not given. Regarding the algorithms, we see some similarities with both Ramus' and Clavius' books, indicating that Rizanesander was influenced by them. Also, it is indicated that he was influenced by Buscherus' book. We suggest that further investigations of Rizanesander's manuscript should be done; in particular it would be valuable to consider not only the algorithms, but also the contextualization of the examples in order to further investigate in what way he was influenced by Ramus, Clavius and Buscherus.

Acknowledgement

This work was partly supported by the Swedish Research Council [Grant no. 2015-02043].

References

⁷ Jagh will gerna weeta huru många slagh Klockan haffwer slagitt ifrå thz hon slogh 1 om natten och in till hon slogh 12 om daghen: Summa 78 slagh (Rizanesander, 1601, p. 41 r).

⁸ Een köper een hest som ähr skodd med 32 söm och giffwer för then förste sö 1 pg^r för then andre 2 pg^r för then tridie 4 pg^r för then fierde 8. Och så aitt dubbelt vp huru dyr ähr thå samme hest Facit. 4294967295 pg^r. Thz ähr 5592405 daler 1 mk 6 öre 19 pg^r thz war een dyr heest (Rizanesander, 1601, p. 42 v).

- Aurelius, A.M. & Johansson, B. (Ed.) (1994). *Minnen och dokument. 5, Aurelius' räknelära från 1614: nyutgåva av den första tryckta läroboken i matematik som skrivits på svenska*. Uppsala: Fören. för svensk undervisningshistoria.
- Dahlin, E.M. (1875). *Bidrag till de matematiska vetenskapernas historia i Sverige före 1679*. (Doctoral dissertation, Uppsala University, Department of Mathematics, Uppsala, Sweden).
- Hatami, R. (2007). *Reguladetri: en retorisk räknemetod speglad i svenska läromedel från 1600-talet till början av 1900-talet*. (Licentiate thesis, Växjö University, School of Mathematics and Systems Eng., Växjö, Sweden). Retrieved from <http://urn.kb.se/resolve?urn=urn:nbn:se:vxu:diva-1407>
- Hultman, F.V. (1868–1871, 1874). Svenska aritmetikens historia. *Tidskrift för matematik och fysik*. 1868: pp. 1–11, 53–67, 149–164, 245–256; 1869: pp. 57–63, 105–113; 1870: pp. 7–11, 49–95, 241–249; 1871: pp. 5–12, 97–101, 209–225; 1874: pp. 1–10, 145–162, 225–240.
- Lundgren, U.P. (2015). When curriculum theory came to Sweden. *Nordic Journal of Studies in Educational Policy*, 2015(1), 5–13.
- Lundin, S. (2008). *Skolans matematik: en kritisk analys av den svenska skolmatematikens förhistoria, uppkomst och utveckling*. (Doctoral dissertation, Uppsala University, Department of Studies in Edu., Uppsala, Sweden). Retrieved from <http://urn.kb.se/resolve?urn=urn:nbn:se:uu:diva-9395>
- Pejlare, J. & Rodhe, S. (2016). On the relations between geometry and algebra in Gestrinius' edition of Euclid's Elements. In L. Radford, F. Furinghetti, & T. Hausberger (Eds.), *Proceedings of the 2016 ICME Satellite Meeting of the International Study Group on the Relations Between the History and Pedagogy of Mathematics* (pp. 513–523). Montpellier. France: IREM de Montpellier.
- Pejlare, J. (2017). On the relationships between the geometric and the algebraic ideas in Duhre's textbooks of mathematics, as reflected via Book II of Euclid's Elements. In K. Bjarnadóttir, F. Furinghetti, M. Menghini, J. Prytz & G. Schubring (Eds.), *"Dig Where You Stand" 4 Proceedings of the Fourth International Conference on the History of Mathematics Education* (pp. 263–273). Turin. Italy: Edizioni Nuova Cultura.
- Prytz, J. (2007). *Speaking of Geometry: a study of geometry textbooks and literature on geometry instruction for elementary and lower secondary levels in Sweden, 1905–1962, with a special focus on professional debates*. (Doctoral dissertation, Uppsala University, Department of Mathematics, Uppsala, Sweden). Retrieved from <http://urn.kb.se/resolve?urn=urn:nbn:se:uu:diva-7902>
- Rizanesander, H.L. (1601). *Aritmetik, skriven i Reval den 21 augusti 1601, dedicerad till hertig Johan af Östergötland*. Manuscript. Uppsala universitet, Carolina Rediviva, Celsiska samlingen. urn:nbn:se:alvin:portal:record-54163.
- Rizanesander, H.L. (2018). *Recknekonsten – Tolkad av Reza Russell Hatami & Adam von Schéele*. NCM: Göteborg.
- Rodhe, S. (2002). *Matematikens utveckling i Sverige fram till 1731*. (Doctoral dissertation, Uppsala University, Department of Mathematics, Uppsala, Sweden).
- Vanäs, E. (1955). Divisionens historia i Sverige, *Lychnos* (1954–1955), pp. 141–164.

I Spy with my Little Eye – Teachers’ linkages about historical snippets in textbooks

Sebastian Schorcht

Justus-Liebig-University Giessen, Germany; sebastian.schorcht@math.uni-giessen.de

The aim of this explorative survey is to identify teachers’ beliefs about tasks concerning the history of mathematics. This poster proposal will give an insightful view on a pilot study on teachers’ beliefs about historical snippets in textbooks. First results of these pilot study can be discussed at CERME11 and may help to develop the main study.

Keywords: History of mathematics, beliefs, textbook.

Research topic

Textbooks play a crucial role in most mathematical lessons (Hiebert et al., 2003). Interactions between teachers and textbooks are an active process of re-sourcing the resource (Adler, 2000, p. 207) and have an impact on mathematical lessons (Brown, 2009). If we consider that tasks concerning the history of mathematics are included in textbooks and that teachers use their pedagogical design capacity to interact with these tasks, the following research questions are formed: Which connotations do the teachers have over these textbooks’ tasks? Do teachers identify the same benefits on history of mathematics in education like researchers do?

Theoretical framework

The presented pilot study uses historical snippets to stimulate prospective teachers’ linkages, due to the fact that historical snippets are the most founded tasks in German textbooks (Schorcht, 2018). Tzanakis and Arcavi shaped the concept of “historical snippets” (Tzanakis & Arcavi, 2002, p. 214): A Historical snippet informs students or stimulates students’ activity. The detailedness ranges from simple dates into specifics about the history of mathematics. The possible content of a historical snippet could be, for example, biographical dates, photographs, introduction into topics, etc.

The international overview shows only small variations on types of tasks over different countries. For example, Xenofontos and Papadopoulos (2015) identify two types of tasks in Greek and Cyprus textbooks: those which inform students about the history of mathematics and those which lead to students’ mathematical activity. In German textbooks Schorcht (2018) identifies similar types of tasks. In comparison with the results of the studies, the presented survey determines three types of tasks: informative type, acting type and personalization type.

Method and Sample

The pilot study shows participants three historical snippets in an online instrument¹. These tasks are selected to represent one of the three types of tasks: one informative type, one acting type, and one personalization type. The topics are Pounds and Hundredweights, Egyptian Fractions, and Sofia

¹ For a closer look into the online instrument, use the following link: <https://surveys.hrz.uni-giessen.de/limesurvey/index.php/794939?lang=de> (online available until CERME11 and in German).

Kowalewskaja's biography. All tasks are from German textbooks of grade 3, 4 and 6. The participants are German mathematics pre-service teachers studying for primary level at University of Giessen. During the online survey, the participants should name similarities of two tasks and describe a third task in a different way. For example, the first two tasks (Pounds and Hundredweights, Egyptian Fractions) deals with mathematics, the third task shows a biography of Sofia Kowalewskaja. In this way, pairs of attributes of tasks emerge by the participants (for example: "deals with mathematics" and "shows a biography"). Afterwards, the participants define their pairs of attributes (for example: "deals with mathematics" = "the task request students to do math"). This kind of method is named as Repertory grid method (Kelly, 1955). The outcome of this online instrument will be a table, where each task can be assigned to one or more attributes. These attributes allow an insight into teachers' connotations about these tasks.

Conclusion

The poster will show some tables from participants and figures of the used tasks. The Repertory grid method may give an overview on teachers' linkages about historical snippets. The results presented at CERME11 should initiate a discussion about the research questions and the developed pilot study. The hypothesis is, teachers didn't realize the benefits of history of mathematics in education and therefore integrate historical snippets without any idea how they should exhaust the benefits for the students.

References

- Adler, J. (2000). Conceptualising resources as a theme for teacher education. *Journal of Mathematics Teacher Education*, 3, 205–224. doi:10.1023/A:1009903206236.
- Brown, M. W. (2009). The teacher–tool relationship: Theorizing the design and use of curriculum materials. In J. T. Remillard, B. A. Herbel-Eisenmann, & G. M. Lloyd (Eds.), *Mathematics teachers at work: Connecting curriculum materials and classroom instruction* (pp. 17–36). New York, NY: Routledge.
- Hiebert, J., Gallimore, R., Garnier, H., Givvin, K. B., Hollingsworth, H., Jacobs, J., et al. (2003). *Teaching mathematics in seven countries: Results from the TIMSS 1999 video study*. Washington, DC: NCES.
- Kelly, G. A. (1955): *The psychology of personal constructs*. New York, NY: Norton.
- Schorcht, S. (2018). *Typisierung mathemathikhistorischer Beispiele in deutschen Mathematikschulbüchern der Klassenstufe 1 bis 7*. Münster, Germany: WTM-Verlag.
- Tzanakis, C. & Arcavi, A. (2002). Integrating history of mathematics in the classroom: an analytic survey. In J. Fauvel & J. van Maanen (Eds.), *History in mathematics education: the ICMI study* (pp. 201–240). Dordrecht, Netherland: Kluwer.
- Xenofontos, C., & Papadopoulos, C. E. (2015). Opportunities of learning through the history of mathematics: the example of national textbooks in Cyprus and Greece. *International Journal for Mathematics Teaching and Learning*, 1–18. Retrieved from <http://www.cimt.org.uk/journal/xenofontos.pdf>

Exams in calculations/mathematics in Norway 1946–2017 – content and form

Bjørn Smestad¹ and Aina Fossum²

¹OsloMet – Oslo Metropolitan University, Oslo, Norway; bjorsme@oslomet.no

²OsloMet – Oslo Metropolitan University, Oslo, Norway; aifos@oslomet.no

Mathematics has been a constant part of Norwegian primary schooling. This impression of constancy is misleading, however. In the period from 1946 to 2017, the subject ‘regning’ (calculations) had its name changed to mathematics and has gone through a long series of reforms. The goals of the subject have changed with each reform.

Based on content analyses of a selection of school leaving exams, we will describe how the content of mathematics has changed over time. As the demands on pupils’ language have increased, so have the demands on their ability to use different tools and handle different task formats and information presented in different ways. In summary, the knowledge and skills that pupils need to complete the exams today are very different from the skills they needed in 1946.

Keywords: Mathematics Education, history, exit examinations, language.

Background

Mathematics as a school subject has been evolving over time, and this development can be studied through the examination of curriculum documents, exams and other sources. In this paper, we will study the school subject in Norway through its exams. While this is interesting in itself, we also hope that this study may be built upon to study trends in different countries.

In 1889, ‘folkeskolen’ (‘folk school’) was established by law in Norway. Pupils would enter school at age 7 and finish at age 14. There was a difference between the urban schools (byskoler) with 40 weeks of schooling per year and the rural schools with mostly 12 weeks per year at the program’s inception (Thune, 2017). In 1890, the first ‘normal plan’ for folkeskolen was put forward; it was revised in 1922/25.¹

The law was again revised in 1936 (with new ‘normal plans’ in 1939). At this time, most children aged 7–14 did attend school. In 1959, a common law for both urban and rural areas was introduced, making schooling compulsory for everyone for 7 years. It even became possible to expand compulsory schooling to 9 years (this was to be decided locally). A new curriculum for the trials with 9-year schooling was published in 1960. By law, in 1969, school was extended to 9 years for everyone. It was extended to 10 years in 1997. New curriculum documents went into effect in 1974 (M74), 1987 (M87), 1997 (L97) and again in 2006 (LK06) (Thune, 2017). The next curriculum document is expected to go into effect in 2020.

The subject was called ‘regning’ (calculation) until 1959 but was renamed ‘matematikk’ (mathematics) in the curriculum documents from 1960 onwards. The different curricula had

¹ The normal plan for rural areas was revised in 1922, the one for urban areas in 1925.

different focuses, but Table 1 suggests a clear trend: new subjects have regularly been included, but rarely have subjects been removed. The subject ‘datalære’ (computer technology) was first a subject on its own in the 1987 curriculum, and computer technology has remained part of the curriculum in some form (although not in the original form with the intention of working on algorithms). However, according to the preliminary versions of the 2020 curriculum, it seems that it will be coming back.

	1939	1974	1987	1997	2006
Numbers and calculation	x	x	x	x	x
Geometry	x	x	x	x	x
Measurement	x	x	x	x	x
Algebra and equations		x	x	x	x
Functions		x	x	x	x
Application: private economy		x	x	x	x
Problem solving			x	x	x
Statistics			x	x	x
Probability and combinatorics				x	x
IT (‘Datalære’)			x		

Table 1: Subjects in the curriculum documents

Such a classification can never convey the full scope of the curriculum documents; there will be nuances in which parts of these subjects are included and how they are described. For instance, in the 1997 curriculum documents, the history of mathematics was explicitly included in the description of what pupils should learn, but not as a subject on its own.

By 1939, the plan stressed the active pupil, in the sense that the pupils should ‘do as much independent work as possible’ (Mosvold, 2002, p. 12, our translation). This was adhered to in the 1960 plan. In a temporary plan in 1971, this idea was gone, and the plan was based on the New Math and on teaching the correct definitions and rules. However, by 1974, heavy criticism led to the return to the concept of the active pupil, and most of the New Math ideas were removed (Mosvold, 2002). Throughout the 1987, 1997 and 2006 documents, the focus on active pupils has remained important, even though the latest curriculum documents have been more concerned with teachers’ autonomy in choosing their own teaching methods.

Theory and earlier research

The development and implementation of curriculum happens on several levels: societal, institutional and instructional (Goodlad, 1979). The development of the exam in Norway is currently done on the institutional level by an ‘eksamensnemnd’ (‘exam committee’) appointed by the directorate of education. The exam and the results are important for the pupils, and the results

on the school level are published and influence the standing of the schools in the community. Exams play an important part in what pupils and teachers do – what is tested influences what is considered important (Au, 2007; Niss & Jensen, 2002; Wideen, O’Shea, Pye, & Ivany, 1997). Teachers also use earlier exams in their teaching (Andresen et al., 2017). Therefore, exams are an important object of study used to investigate the implementations of the curriculum over time.

In an evaluation of the 2017 exam (Andresen et al., 2017), comparisons with the 2009 exam show that, even in such a short time, there are important developments in terms of the content tested and the language, illustrations, question formats and so on.

Andresen et al. (2017) include a summary of international research on language traits that make mathematics tasks difficult to understand. These traits can exist on the word level (long words, infrequent words etc.), on the sentence level (for instance, long noun clauses) and on the text level (such as lack of connection between sentences). They can make tasks more difficult on their own or when combined with other traits, but difficult language can also be partially offset by helpful illustrations.

Our research question is this: How has the content and form of primary school exams in calculations/mathematics in Norway changed in the period from 1946–2017?

The choice of the particular period to study is governed by the availability of full sets of exams. We would like to stress that we do not study the difficulty of the exams, as the difficulty depends on the content of the education that has been presented. Neither will this article include an analysis of the contexts used in the tasks.

Method

To answer the research question, we performed content analysis of the selected exams. The analyses considered several different aspects of the exams: the subjects, the answer formats, the language and the illustrations. In the analyses of language, the same method and operationalization are used as in the evaluation of the 2017 exam (Andresen et al., 2017).² This means that we analyse language features that are known to contribute to making understanding mathematics tasks more difficult: the number of words, long words (>6 letters), compound words and general academic words.³ In the analyses of illustrations, we are inspired by Van Den Heuvel-Panhuizen (2005) and the different roles illustrations can have, but we use a simpler categorization: illustrations that are necessary to solve the task, illustrations that are helpful and illustrations that are simply decorative.

The choice of exams has been somewhat convenience-based, as not all exams are easily available in complete versions suitable for the different analyses we plan to do. Also, we have chosen exams from different time periods. For this paper, we include the exams from 1946, 1960, 1979, 1985, 1995, 2006 and 2017.

² Indeed, some of the results of the analyses of the 2017 exam have been used here directly.

³ According to Academic Wordlist: <http://www.tekstlab.uio.no:4000/>

The 1946 and 1960 exams were made locally, and the ones we include are from Oslo, the capital of Norway, for the entire period. The remainder of the exams are national.

Year	School	Grade	Hours
1946	Oslo Folkeskole	7 th	4h
1960	Oslo Folkeskole	7 th	4h
1979	Grunnskolen	9 th	5h
1985	Grunnskolen	9 th	5h
1995	Grunnskolen	9 th	5h
2006	Grunnskolen	10 th	5h
2017	Grunnskolen	10 th	5h

Table 2: Exams chosen for analysis

In some of the exams, there are tasks that not everyone is supposed to do in the same way. The 1946 exam included one task that girls could choose not to do, as they had less teaching than boys. We have included that task in our analyses. The 1985 exam was in two parts: part 1 was to be done without a calculator, but part 2 came in two versions, one for use with a calculator and one without. We have analysed the version where the calculator was allowed. In 2006, there was a considerable number of tasks (62) of which pupils were supposed to choose only some (39). While we have analysed all 62 tasks in tables and graphs, here we include only numbers based on 39 tasks.⁴ In 1960, 1979, 1995 and 2017, every pupil was supposed to do all the tasks included in the exam. It is an interesting finding on its own that the scope of choices has varied so much through the years.

For most of the exams, it was not apparent whether all subtasks counted the same towards the result. Therefore, in these analyses, we use unweighted counts of the subtasks.

Results and discussion

The analysis of the content of the tasks is in accordance with the general goals of the curricula. While numbers and calculations were part of all sub-questions in the 1960 exam, today they comprise about half of the tasks. There appear to be two reasons for this: partly because new topics are included in the curriculum and partly because the tasks seem to be ‘purer’, in that there are more examples of tasks that test only one topic.

⁴ To be precise, we calculate the average of the numbers that would be right if the students always chose the first available option and the numbers if the students always chose the last available option.

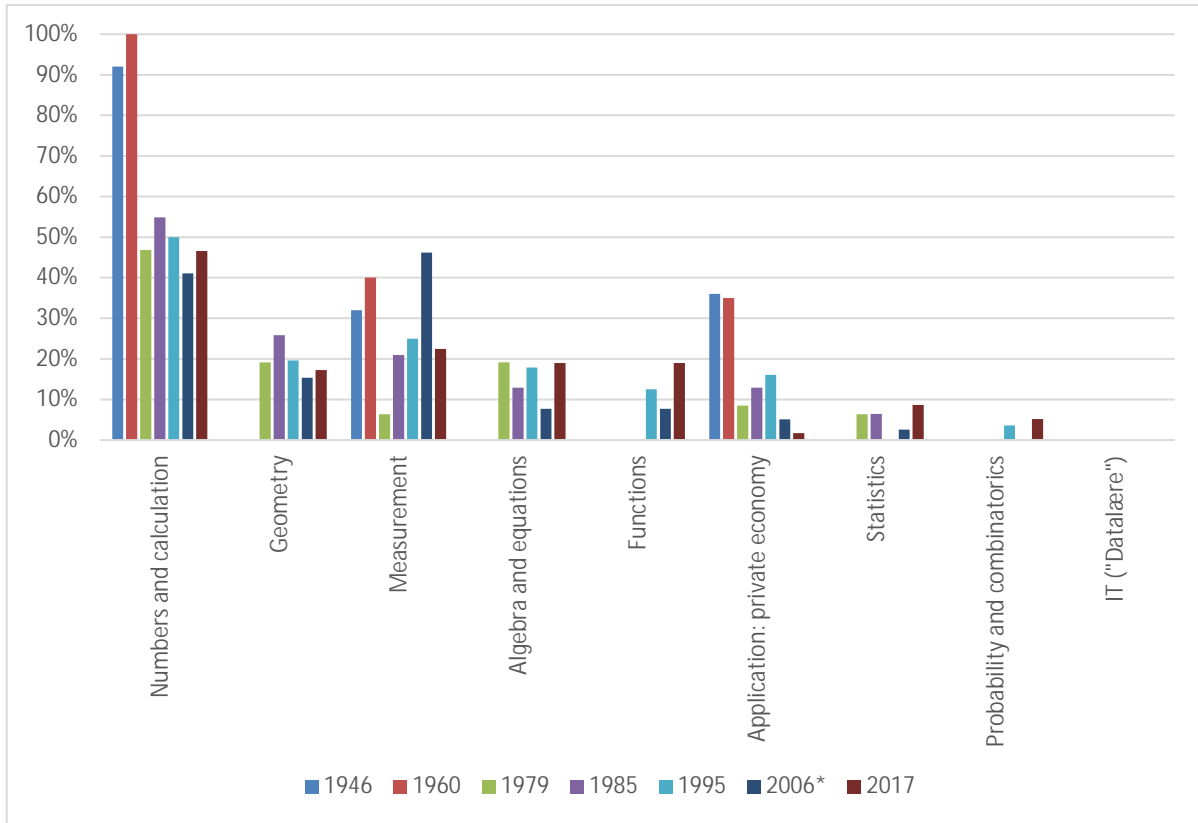


Figure 1: Percentage of tasks testing different topics, 1946–2017

In addition, the answer formats have also become more diverse. In 1946 and in 1960, all exam tasks were answered with a short calculation and an answer (called ‘open’ here). In 2017, 24% of the tasks were multiple-choice items. In addition, some tasks are to be answered using a spreadsheet, some using a graphing program (Geogebra, for instance) and some (17%) were to be answered with the answer only.

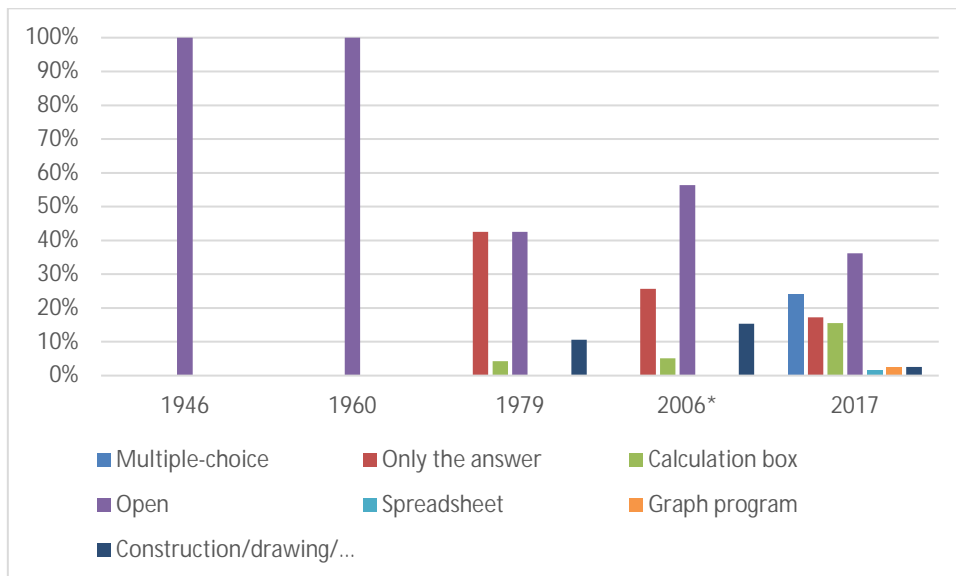


Figure 2: Answer formats in exams

The tools that pupils have available and are supposed to master have changed through the years. In 1946, the pupils probably had no other tools than pen or pencil and paper. In 2017, pupils are supposed to use graphing software (such as Geogebra) and spreadsheets in addition to more traditional tools, such as calculators, compasses and rulers. Today, computer algebra systems (CAS) are also allowed.

Table 3 shows the number of sentences and the number of words in the exams. The amount of language has varied, with a decrease from 1946 to 1960. However, the main tendency is that the amount of language has been increasing since 1960 and that it was higher in 2017 than in any other year in our sample.

	1946	1960	1979	1985	1995	2006	2017
Number of sentences	95	62	63	113	143	111	158
Number of words	756	464	456	896	945	924	1240

Table 3: Number of sentences and words in the exams

In this table, the number of sentences and words that the pupils in 2006 were exposed to is understated. If we suppose that many pupils read all 62 tasks in order to choose which 39 to do, they would have to read 164 sentences with a total of 1,434 words, making the 2006 exam the most voluminous of all of these exams. Additionally, there was a 539-word information booklet which the pupils were supposed to have read in advance of the test.

More challenging than simply evaluating the number of words is trying to say something concrete about how the language has changed. In analyses of language traits that make tasks difficult to read, long words, compound words and general academic words are of interest.

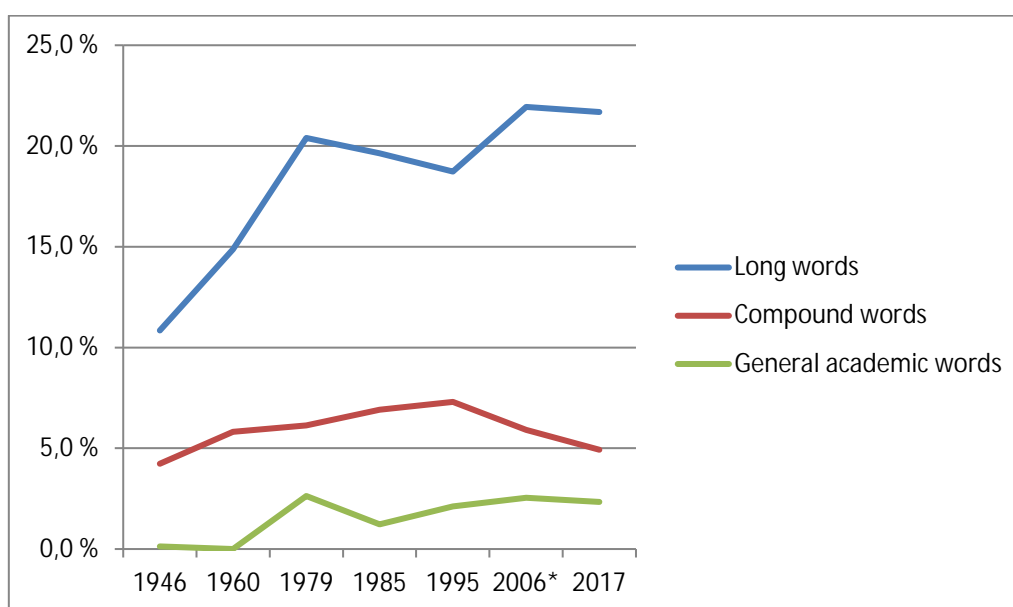


Figure 3: The ratio of long words, compound words and general academic words in exams

In Figure 3, we see a clear tendency throughout the period of a higher proportion of long words and general academic words, while there has been no significant increase in the number of compound

words. The general academic words are noteworthy – examples of these are ‘describe’, ‘function’, ‘example’ and ‘explanation’. While pupils in 1946 were mostly asked to do something (calculate, usually), in 2017 they were asked to compare, describe and explain, which may be more demanding.

In addition to pupils having to deal with more tools and a more academic language, the exams are also visually different: there is a large number of illustrations in modern tasks. We look at which illustrations are necessary to solve the task, which are helpful, and which are only decorative.

	1946	1960	1979	1985	1995	2006	2017
Necessary	0	0	2 (2)	4 (3)	8 (8)	14 (13)	17 (15)
Helpful	0	0	2 (1)	0	0	3	7 (1)
Decorative	0	0	0	0	0	10	9

Table 4: Illustrations in exams: necessary, helpful or decorative. In parenthesis are the numbers of illustrations that are explicitly mentioned in the text of the task

Table 4 shows that, in our material, illustrations were not included until 1979, and at that time only as illustrations that were necessary or helpful to solve the task. In the 21st century, there have also been more illustrations that are simply decorative, and even illustrations that are necessary to solve the task are not necessarily mentioned explicitly in the text. Even though illustrations can make the tasks easier to understand, at the same time, they make more demands on the pupils – in 2017 there were 33 illustrations, and for each, the pupils had to decide if they needed to use them to solve the tasks.

While it is important to consider that the 1946 and 1960 exams were for 14-year-olds, while the rest of the tests are for 16-year-olds, most of the development noted seems to have been independent of that change.

Conclusion

The overall picture is complex. Thematically, mathematics as a subject has become more diverse. While the exams in ‘folkeskolen’ consisted mainly of calculations, often involving measuring units and everyday economics, today they involve more topics. However, at the same time, the connections among different topics seem to be included less often – fewer tasks now include more subjects at once.

More tasks are multiple-choice, making it possible to get through more tasks in the same amount of time. Also, there is a need for speed because in the five hours allotted, pupils must demonstrate their skills with more tools than previously, including spreadsheet and graphing software and CAS.

The demands on the pupils’ language skills have also increased. The number of words has increased, and the proportion of long words and general academic words has increased as well. There are far more illustrations than before, and the illustrations serve several different functions.

Consequently, although we cannot say whether the difficulty level of the mathematics has increased or decreased, the complexity of the exams – a greater variety of topics, answer formats, tools and

greater language difficulty – means that there are many more factors that pupils must deal with than previously. At the same time, the number of questions has increased substantially, meaning that the students have far less time to consider each sub-question while handling the different complexities. Thus, speed is implicitly seen as an important value in mathematics, and while this is rarely questioned by teachers, it is often questioned by mathematics education researchers.

In conclusion, such an analysis of exams may give a clear picture of the development of mathematics as a school subject which can complement the results of curriculum analyses. To the extent that exams do not develop in the same direction as the curriculum documents, it is an open question as to whose concept of mathematics will prevail. International comparative studies would be an interesting next step to see how trends in exams are similar or different across borders.

References

- Andresen, S., Fossum, A., Rogstad, J., & Smestad, B. (2017). *På prøve. Evaluering av matematikksamen på 10. trinn våren 2017 [To the test. Evaluation of the tenth grade mathematics examination in the spring of 2017]*. (Fafo-rapport 36/2017). Oslo, Norway: Fafo.
- Au, W. (2007). High-stakes testing and curricular control: A qualitative metasynthesis. *Educational Researcher*, 36(5), 258–267.
- Goodlad, J. I. (1979). *Curriculum inquiry: The study of curriculum practice*. New York, US: McGraw-Hill.
- Mosvold, R. (2002). *Læreplanutvikling i historisk perspektiv: med fokus på «hverdagsmatematikk i dagliglivet» [Curriculum development in a historical perspective: with focus on ‘everyday mathematics in the daily life’]*. Notodden, Norway: Telemarksforskning.
- Niss, M., & Jensen, T. H. (2002) *Kompetencer og matematiklæring – ideer og inspiration til utvikling af matematikundervisning i Danmark [Competences and mathematics learning – ideas and inspiration for development of mathematics education in Denmark]*. Danmark: Undervisningsministeriet, Uddannelsesstyrelsen.
- Thune, Taran. (2017, November 5th). Norsk Utdanningshistorie [Norwegian history of education]. In *Store norske leksikon*. Retrieved from https://snl.no/Norsk_utdanningshistorie.
- Van Den Heuvel-Panhuizen, M. (2005). The role of contexts in assessment problems in mathematics. *For the Learning of Mathematics*, 25(2), 2–9.
- Wideen, M. F., O’Shea, T., Pye, I., & Ivany, G. (1997). High-stakes testing and the teaching of science. *Canadian Journal of Education/Revue Canadienne de l’éducation*, 22(4), 428–444.

Curriculum documents

- Normalplan 1939: https://urn.nb.no/URN:NBN:no-nb_digibok_2017062307152
- Læreplan forsøk 1960: https://urn.nb.no/URN:NBN:no-nb_digibok_2008051904019
- Mønsterplan 1974: https://urn.nb.no/URN:NBN:no-nb_digibok_2008052804017
- Mønsterplan 1987: https://urn.nb.no/URN:NBN:no-nb_digibok_2007080200101
- L97: https://urn.nb.no/URN:NBN:no-nb_digibok_2008080100096
- LK06: <https://www.udir.no/laring-og-trivsel/lareplanverket/>

History of mathematics in Dutch teacher training

Desiree van den Bogaart-Agterberg

University of Applied Sciences of Amsterdam, Faculty of Education, Amsterdam, The Netherlands;
d.a.van.den.bogaart@hva.nl

In most teacher training programs for Dutch mathematics teachers, history of mathematics is a required part of the curriculum. The courses provide historical background knowledge of certain mathematical developments to the students. This knowledge could also affect prospective teachers' views on the nature of mathematics and the pedagogical choices they make for their classrooms. These effects have been examined in a small qualitative research project with two different groups of students from a teacher-training program in Amsterdam. The results are discussed in this paper and can be useful in describing and evaluating the relation between knowledge of history of mathematics and classroom activities.

Keywords: History of mathematics, teacher training, empirical study.

Introduction.

I have been teaching history of mathematics courses at the University of Applied Sciences in Amsterdam (in Dutch: Hogeschool van Amsterdam, in short: HvA) for the last eight years. Over time, the goals of the courses I designed have shifted from providing background knowledge of history of mathematics, to demonstrating what this could mean in terms of pedagogical choices and classroom activities. This assumes that there actually is a relation between the two. In my research I want to focus on this relation, in part to describe it and in part to evaluate it.

Organization of the paper.

This paper is organized in three sections. First the Dutch system of teacher training is briefly described; in particular the way history of mathematics is incorporated. In the first section I will also focus on the situation at HvA, the context in which the empirical part of the study took place. Next, the aim of the study and the research method are described in the second section. Finally, the results are presented and discussed. Acknowledgements and references will conclude this paper.

History of mathematics in Dutch teacher training.

To become a mathematics teacher in the Netherlands, there are two main options. There is the university program, which consists of a three-year undergraduate program in mathematics, followed by a two-year master's program in science education. This route leads to a teaching qualification for all secondary levels in mathematics, for pupils aged 12 to 18. This is called a first degree qualification, or a master's degree in teaching. However, in this paper the focus is on the other option, chosen by the large majority of (future) Dutch mathematics teachers. (Van den Bogaart et al., 2018)

The alternative route consists of a four-year program at a university of applied sciences. This leads to a teaching qualification for the lower secondary levels in mathematics (pupils aged 12 to 15). This is called a second degree qualification, or a bachelor's degree in teaching. Once these four years are successfully finished, teachers have the opportunity to advance in another three-year program at a university of applied sciences. This finally leads to the full first degree qualification for all secondary levels, or a master's degree in teaching.

Institutions for teacher education have autonomy in designing their curriculum, but the programs are grounded on formal 'knowledge bases' (Kennisbasis in Dutch, KB in short). Since the Dutch system recognizes two degrees of teaching, there is a separate KB Mathematics Bachelor for second degree teachers and another KB Mathematics Master for first degree teachers in programs at universities of applied sciences. I will refer to the two KBs in Mathematics as KBM2 and KBM1. In both KBM1 and KBM2, history of mathematics can be found as a specific subdomain.

The subdomain history of mathematics in KBM2 consists of eight learning outcomes, for instance "The teacher can give examples of the development of mathematics in relation to cultural and historical contexts". History of mathematics is also mentioned explicitly in the last domain of KBM2, which deals with pedagogy. "The teacher can use history of mathematics to enrich his/her pedagogical skills". (Kennisbasis Wiskunde Bachelor, 2017, p. 19)

History of mathematics is not an obligatory subdomain in KBM1, but it can be chosen as extra or can be integrated in the rest of the curriculum. For instance the history of non-Euclidean geometry can be integrated in a geometry course, (Kennisbasis Wiskunde Master, 2012). History of mathematics is not explicitly mentioned in the pedagogical domain of KBM1.

The curriculum at HvA.

In the second degree mathematics teacher training program at HvA a course on history of mathematics is programmed in the first semester of the third year. The course is equivalent to 3 ECTS. Over a period of seven weeks, the students receive an overview of history of mathematics from the early ages until the beginning of the seventeenth century. There is a 100 minutes lecture once a week. Students are provided with texts (a textbook, additional articles, some primary sources), videos and exercises. To pass, students complete a written exam.

In the first degree mathematics teacher training program at HvA a course on history of mathematics is programmed in the second semester of either the first or the second year. The course is equivalent to 5 ECTS. Students learn about the history of mathematics, starting with the seventeenth century and finishing in the early 20th century. Over the course of an entire semester there are six lectures of 150 minutes each. Students are provided with texts (two textbooks, additional articles, some primary sources), videos and exercises. They are expected to perform a bit of historical research themselves on a mathematical subject of their choice. To pass, they must hand in several written assignments (individually) and a research report (group work). In both the research project and one of the other assignments they have to design a classroom activity. One of the criteria for the research report is that there has to be explicit mentioning of the implication(s) of the research project for their practices as teachers. Finally, they present the research to their classmates.

The subjects that are dealt with in both courses, either discussed in the lectures or explored in the provided materials, are chosen by me and my colleagues at HvA, with the future teaching practice of our students in mind. The subjects are closely related to subjects that they will discuss themselves with their pupils (such as preliminary algebra and Euclidean geometry in the second degree training and calculus and analytical geometry in the first degree training). Some of the exercises we do in the course are exercises that can be done in the students' own classrooms, without any modification. However, most of the texts and problems that are discussed in the course are on a more advanced level. The purposes of these activities can be different, such as: demonstrate the level of sophistication of the mathematicians and cultures of the past (and by doing so testing the level of mathematical knowledge of the students), discuss what conceptual obstacles were overcome, illustrate the circumstances under which discoveries took place and the human factor in all that. The two instructors of the courses (myself and a different colleague on either first and second degree training) both emphasize the importance of the historical knowledge for mathematics teachers on a regular basis.

Description of the research.

The starting point of this research was the evaluation of the courses on history of mathematics at HvA with special interest to their effects on the beliefs and teaching skills of the students. Did the course on history of mathematics affect students' views and is there some form of transfer to their classroom activities? If the students could not identify any effects, or mainly describe the personal gain of the course they took as simply historical background knowledge with little relation to their teaching, this could serve as input for redesigning the courses.

There is very little empirical data on effects of integrating history of mathematics in mathematics education (Jankvist, 2009). The amount of empirical information on the effects of this integration in teacher training is even less. Although this research is partially set up in a quantitative way, its main goal is to gain qualitative information, as input for further research.

One can think of a number of ways in which information about the history of mathematics can have an effect on students, in particular student teachers. Literature on the use of history of mathematics in the context of teacher training provided a list of possible effects/influences, stated below.

- a) Influence on attitude and beliefs on the nature of mathematics as a subject (Schubring et al., 2000), (Charamboulous et al., 2009)
- b) Insight in the development of mathematics and its curricula (Schubring et al., 2000)
- c) Acknowledgement of processes and obstacles that can occur in developing mathematics, and thereby enhancing one's own comprehension of mathematics (Schubring et al., 2000)
- d) History is an inspirer of strategies of teaching (Furinghetti, 2007)
- e) Learning to use history of mathematics in own teacher practices (Schubring et al., 2000)
- f) Influence on self-efficacy (the degree to which a teacher considers himself as capable of affecting student learning) (Charamboulous et al., 2009)

These six possible effects were reformulated into six statements (in Dutch), to which the students were asked to react (see Table 1). Do they (partially) agree with the statement or not? Students were asked to react to the statements on a five-point Likert-scale from completely disagree (1) to completely agree (5). Statement A corresponds to effect (a), statement B to effect (b), etc.

Following the course on history of mathematics has...	1	2	3	4	5
A) affected my view on the nature of mathematics					
B) enhanced my own comprehension of certain mathematical concepts					
C) made me more aware of conceptual- or process-related obstacles that my pupils have					
D) expanded my pedagogical repertoire					
E) taught me how to use history of mathematics with my own pupils					
F) enhanced my self-efficacy as a math teacher					

Table 1: Statements in questionnaire (transcription)

In addition to reacting to these six statements, students were invited to comment on each statement separately. It was not required to comment on every statement, but in the instructions given by the researcher to the students upon filling out the questionnaire, the value of their additionally provided explanations, examples and/or information was amplified. For each statement there was a separate question added, to be able to connect the comments to the right statement and also provoke sufficient reactions. For instance, the additional question to statement A was: “Can you comment on the way in which your view has changed? How was it before and how is it now?”.

The group of students of the first degree training, who took the course on history of mathematics from January until July 2017, was asked to fill out the questionnaire in September. Almost the entire group had finished the course by then (some still had to hand in an assignment or do some revision work on the research project). Some students had left the teacher training program altogether, or simply were not present at the time the questionnaire was taken. Approximately 60% of the students who took the course participated in this research. In November and December 2017 the course on history of mathematics in the second degree training took place. Over 70% of the students who took this course filled out the questionnaire in March 2018.

The questionnaire was filled out in class, on paper, at the start of a lecture of another course that most students were expected to take. I chose not to combine filling out the questionnaire with the written test or peer presentations at the end of the course. This way the complete course, assessment included, could be taken into account by the participants, after the entire course had finished.

The results were imported to a spreadsheet to calculate the mean of the reactions to the statements. The open responses to the questionnaire were qualitatively categorized. The categories used were not defined in advance, but were a work-in-progress. Some categories turned out to be useful for

open responses on several statements, which show interesting relations between some of the statements. I discuss these relations in the next section.

Results.

The results of both questionnaires are presented separately, since the students took separate courses and have different backgrounds and teaching practices. I first summarize the quantitative results on the statements, and then I address the reactions to the statements (open responses). Finally, I provide some remarks on similarities and differences between the results of the two groups.

First degree training questionnaire.

Twenty-three students filled out the questionnaire. Table 2 shows the mean value of student reactions to the six statements and also the number of students who commented on each statement.

Statement	A	B	C	D	E	F
Mean	3.35	3.35	3.22	3.61	3.57	2.70
Comments on statement	13	12	8	15	13	7

Table 2: Reaction to statements by first degree training group

The calculated means were not meant to be interpreted separately, but can be used to arrange the statements from strongest agreement to weakest agreement. The statements on pedagogy and classroom activity (D and E) resonated most strongly with these students, while the statement on self-efficacy (F) received the weakest agreement. As for the comments, in what follows I briefly review the statements, specify the categories used to label them, and give examples of statements made by the students.

Comments on statement A were arranged into five separate categories. They are presented here in order of declining frequency. The majority of responding students mentioned they gained more background information (i), some started seeing mathematics more as a dynamic subject rather as a fixed set of techniques (ii), some started seeing mathematics more as a human activity (iii), some discovered more coherence within mathematics itself (iv), and finally one student realized that mathematics can be ambiguous and debated (v).

Sample student comments on statement A:

Student #M17: From abstract science to human activity.

Student #M20: I see mathematics now more as a process rather than a result (toolkit).

On statement B, most of the responses listed mathematical topics or concepts that were understood better due to the gained knowledge of their history, but some also specifically mentioned the increased insights in coherence (see also category (iv) from statement A). When asked to comment on statement C, half of the responses described in some way that their pupils should also experience mathematics as a process rather than a product, so that can be seen as a form of transfer of category (ii) to the learning process of their own pupils.

Additional remarks to statements D and E on the possible expansion of their own pedagogical repertoire and use in their own classrooms produced mostly broad topics of school mathematics such as geometry or algebra. Some students made general remarks on using history of mathematics as a way to introduce new mathematical concepts or create more variation in lesson activities.

Statement F (on self-efficacy) had the lowest average on the Likert-scale and also produced the lowest number of reactions. A number of students explicitly stated that there was no relation between their knowledge of history of mathematics and their self-efficacy as a teacher. They almost seemed offended by the suggestion. On other statements they would simply leave a blank space if they disagreed. Students who did see a positive influence formulated it in a general way, e.g., more background knowledge gives me more insights in mathematics and therefore enhances my self-confidence as a teacher. This seems equivalent to category (i) in the first statement.

Second degree training questionnaire.

Seventeen students completed the questionnaire. Table 3 shows the mean of student reactions to the six statements and the number of students who commented on each statement.

Statement	A	B	C	D	E	F
Mean	3.65	3.88	3.53	3.76	3.29	2.88
Comments on statement	13	10	9	10	9	5

Table 3: Reaction to statements by second degree training group

When statements are ordered by calculated means of the Likert-scale of agreement, statement B (on their own understanding of mathematics) appears first. This seems logical, since the mathematical knowledge of this group of students in the bachelor program is obviously much less than that of the students in the master program, so there is more room for growth. Statement F also scores lowest in this group, the same as in the first degree training group, with similar comments that explicitly deny the relation. The statement on the use of history of mathematics in their own classrooms comes in second to last, which can be explained by the fact that this group consists of less-experienced teachers, which might be holding back on this type of activity in their teaching.

Comments on statement A were divided into five separate categories, which mostly correspond to the categories in the other group. Again the order is by declining frequency. Students mentioned they gained more background information (i), recognized, in particular, more different cultural contributions in the history of mathematics (ii), started seeing mathematics more as a dynamic subject rather as a fixed set of techniques (iii), saw more coherence within mathematics itself (iv), and made connections with the learning of their own students (v). The new category (ii) seems appropriate, since this course explicitly pays attention to the contribution of non-Western cultures to the development of mathematics.

Statements B and C were commented on in a rather similar way. Almost all comments contained examples of specific topics or concepts of school mathematics. Amongst those topics the concept of number (e.g., negative numbers, fractions, square roots, and zero) was mentioned frequently, as well as solving linear and quadratic equations.

Sample student comments on statement D:

Student #B3: For instance to visualize equations with geometry.

Student #B14: Introducing variables with “The thing plus the root of the thing.”

Although statement D scored rather high quantitatively and the comments on this statement produced plenty of concrete examples (like the ones on statement B and C), the use of history of mathematics in students’ own classrooms (statement E) mostly resulted in general ways of using history of mathematics, such as introduction or variation.

Overall remarks.

It was surprising to see students describe effects that taking the course on history of mathematics had on them with such detail, especially in the first degree training group. Without any concrete examples mentioned by the researcher, students were able to mention words like coherence, human activity, and ambiguity. This can indicate advanced personal reflection skills on the part of students, or this may have been provoked successfully by the course.

Some of the differences in reactions between the two groups seem naturally connected to the level of their knowledge of mathematics and teaching experience. Students in the second degree training group were better at specifying the relation to the topics in school mathematics, which seems logical considering the contents of their course. Early developments of mathematics can actually be found in the curriculum for 12 to 15-year-olds, until the coordinate system of Viète and Descartes in the early 17th century, but when we discuss Weierstrass and Cantor with students in the first degree training, this has much more distance to the concepts they teach in their own classrooms.

Both groups were rather firm in their rejection to influence on their self-efficacy. One could argue that the gained knowledge, both mathematically and pedagogically, should be rather closely connected to the confidence of a teacher, but for the students who took these courses and completed the questionnaire this was a bridge too far.

Discussion.

The obvious point of discussion here is the design of the courses. This was not aligned with the six effects of the use of history of mathematics in the context of teacher training which were obtained from literature. Further research is necessary to focus on one or more effects, which must be attended to beforehand in the design of the courses. In particular, the way the courses are assessed should be taken into account. Still the results of this research give us valuable information on what effects take place, by courses designed in the described manner, at least as reflected by the students themselves. This leads to another point of discussion.

It is important to note that the results are purely based on self-reported opinions of the students themselves, on their self-assessment of their knowledge, and their views ‘at the desk.’ That means: this is what they think of themselves, their views and skills, outside the classroom. To get a better picture of the effects there should be some form of ‘in action’ research in their classrooms.

The results of this pilot empirical study indicate an added value of knowledge of history of mathematics for teachers. The results can be used as input for the redesign of these courses and other activities involving history of mathematics in teacher training. They may also be useful for further research on the partnership between mathematics, history and education.

Acknowledgements.

This research project has been made possible by the financial support of both the Research Center and the Department of Science teacher training of the Faculty of Education of the HvA. Thank you to Ron Oostdam, Monique Pijls and Andrea Haker for their support. The courses on history of mathematics that I taught in 2017, which were the context for the research in this paper, were taught together with two wonderful colleagues: Lidy Wesker-Elzinga (first degree training) and Peter Lanser (second degree training).

References.

- Charalambous, C. Y., Panaoura, A., & Philippou, G. (2009). Using the history of mathematics to induce changes in preservice teachers' beliefs and attitudes: Insights from evaluating a teacher education program. *Educational Studies in Mathematics*, 71(2), 161-180.
- Furinghetti, F. (2007). Teacher education through the history of mathematics. *Educational Studies in Mathematics*, 66(2), 131-143.
- Jankvist, U.T. (2009). A categorization of the 'whys' and 'hows' of using history in mathematics education. *Educational Studies in Mathematics*, 71(3), 235-261.
- Kennisbasis Wiskunde Bachelor (2017). *Kennisbasis docent wiskunde bachelor*. 10 voor de leraar. Retrieved from <https://10voordeleraar.nl/publicaties>
- Kennisbasis Wiskunde Master (2012). *Kennisbasis docent wiskunde master*. 10 voor de leraar. Retrieved from <https://10voordeleraar.nl/publicaties>
- Schubring, G., Cousquer, É., Fung, C.-I., El Idrissi, A., Gispert, H., Heiede, T., et al. (2000). History of mathematics for trainee teachers. In J. Fauvel & J. van Maanen (Eds), *History in mathematics education – The ICMI study* (pp. 91-142). Dordrecht, The Netherlands: Kluwer.
- Van den Bogaart, T., Daemen, J., & Konings, T. (2018). Secondary mathematics teacher education in the Netherlands. In M. van den Heuvel-Panhuizen, P. Drijvers, M. Doorman, & M. van Zanten (Eds.), *Reflections from inside on the Netherlands didactic tradition in mathematics education*. Utrecht, The Netherlands.

History of mathematics and current developments in education

Ysette Weiss¹ and Rainer Kaenders²

¹Johannes Gutenberg-University, Institute of Mathematics, Mainz, Germany; yweiss@uni-mainz.de

²University of Bonn, Hausdorff Center for Mathematics, Germany; R.Kaenders@uni-bonn.de

With the introduction of so-called educational standards, the German government has mandated by law that German schools, universities and teacher training colleges use the language of competences as a universal language to describe, plan, test and develop teaching and learning processes. This shift to output orientation resulted in a break with the formerly internationally recognized educational tradition of the Enlightenment. In order to understand and highlight the magnitude of this, we look at different historical perspectives regarding these reforms.

Keywords: Democracy, history of mathematics, educational reforms.

Introduction

The present paper responds to a desire that several of our colleagues had expressed at the International Conference on the History of Mathematics Education (ICHME) in Utrecht in the Netherlands in 2017: To place current developments in German mathematics education in a historical context. The reasons for this request were that these colleagues realised similar developments sometimes, possibly with a time shift, in other European countries, such as output and competence orientation, the introduction of educational standards, central tests and global assessments, or the economization, centralization and digitalization of the education system. The study of the history of mathematics and mathematics education seems to support a critical view of these developments. It was pleasant to find congeniality. However, it immediately rose questions which of these issues constitute a common concern. What precisely is going on with these developments? Another aspect of this debate inspired by our lively discussions was whether and how the study of history can support the teaching of critical judgement and the safeguarding of democracy and human values in pedagogy.

In the meantime, some new perspectives such as a better understanding of the origins of competence orientation in psychology (cf. Ryan & Deci, 2000 or Gelhard, 2011) emerged from the study of the developments in mathematics education at the end of the last millennium, and from the authors' attempts to incorporate them into seminars on mathematics education. The reforms and changes we are going to discuss are, however, not specific to mathematics education. Therefore, this discourse should be relevant to the history of education, pedagogy, sociology and psychology.

However, the changes in German education policy at the beginning of our millennium were accompanied by a shift in the subjects and theoretical foundations of educational sciences towards applied psychology, empirical research and the notions of evidence and measurability. The latter had an impact on school development and beliefs and convictions about the superior importance of factors that contribute to good teaching and "effective" learning. Still, if there were to be a lecture about the history of current reforms in education, it would probably be attended by only a few people. Most students put educational sciences on a par with a general methodology (cf. Jahnke,

2008), and therefore, above all, want to receive the latest and empirically proven approaches in these subjects in order to be able to adapt themselves to the requirements of their future working situation. Here the economization of the university system and the new role of students as customers and future employees plays its part.

Why should the *history of mathematics education* be taught to future teachers and in which form can it be incorporated in mathematics education?

Learning from history does not automatically mean that history prevents us from repeating mistakes. Politicians are not supposed to be historians: Historical situations never completely recur, and therefore the future cannot be predicted from even the most profound knowledge of the past. However, on a small scale with limited demands, it is quite possible to learn from history (Geiss, 2019). The recognition of constellations and gradient patterns occurring over time plays an essential role in this. Even though it is not possible to transfer causal connections, the study of structural components, which recur and make up these constellations and patterns, can certainly contribute to sharpening political judgement. However, the tightrope between showing such patterns and indoctrination through the political or even ideologically influenced production of time references is extremely narrow (Bergmann, 2002).

Because of this, and the highly political significance of the reforms, we are going to work backwards: We start with a description of the current situation and ask the students to find differences with the practices, school subjects and events of the past, which look at first sight very similar or carry similar names to those of today. Thus, the formation of analogies does not arise through our study of historical sources, but is rather questioned by these sources.

In the implementation of educational policy requirements, teachers in Germany have a great deal of freedom in the design and application of these requirements through the legally guaranteed freedom of methods (Gasser, 1982). Dealing with the history of mathematical teaching can help to appreciate existing structures, to include experiences from the history in change processes and to relativize so-called “new approaches”.

Through taking a historical perspective on the development of mathematics education and related educational policy, our goal is to support our students’ need to question the reasonableness and necessity of political reforms and to shape them as responsible future teachers.

Some features of educational reforms

The study of the history of educational reforms and their theoretical foundations is particularly relevant today. German students have experienced several reforms during their school time. The theoretical foundation of these reforms has not yet taken place. Keywords for these reforms are *output* and *competence orientation*, the introduction of educational standards and central tests, the abolition of the orientation classes and pre-school education, the reduction of upper secondary classes by one year, the digitalization of learning environments, the restructuring of secondary schools, and the overall present *inclusion*¹.

¹ Political activities of the Government to implement the *UN Convention on the Rights of Persons with Disabilities*.

In particular, these political reforms have been pushed through with tremendous pace. Therefore, it is certainly worthwhile to engage in reforms, which had been prepared and installed during half a century; e.g. the *Meraner Reform* was discussed widely and implemented in small steps (Schubring, 2007). However, the current reforms have a different character. The abolition of the *orientation level*² and pre-school education, the reduction of upper secondary classes by one year, the restructuring of secondary schools, the shift from special schools for specific disabilities to integrated/ inclusive forms of schooling, the shift from the three-tier school system towards a comprehensive school: All these can be seen as structural reforms of the school *system*. Looking back at the history of German schools, it strikes us that every of the former changes in the education system was related to just one type of school and perhaps their related types, and was prepared for and carried out over a period of 200 years. The current reforms, however, took place almost simultaneously in a period of just 20 years and involved all school forms at once.

It is worth studying the history of different school types and of preschool education separately and to investigate their links to teacher training and assessment development for teachers and students (Leschinsky & Roeder, 1983). There is a large body of literature now starting from original sources like school archives, commission reports and resolutions, as well as secondary literature, which studies these reforms from the point of view of institutional history (Müller et al., 1987). Of course, the study of these sources relates institutional aspects to the biography of its main actors and of the study of political and economic contexts. It is noteworthy that it is often difficult to find historical sources with plans, programs and resolutions, but if one does find them, one knows the names of the main institutional actors. This is not the case with the present documentation of reforms. Here, the authors hide behind huge organizations and their programs. It is hard to find out who is responsible.

Another approach when looking at the history of reforms is to see the teaching community as a *community of practice*. When doing so, the importance of associations, societies, clubs, unions etc. should also be taken into account. One can also study reforms as the history of concepts, ideas and value systems as they develop in communities.

In order to describe the current changes in mathematics education as a change of value systems from input³ to output orientation in terms of economization with a measurable and an only functional notion of education, we here give a short historical overview of where the notion of *competences* comes from.

What is the dispute about competence orientation all about?

The concept of *education systems*, which is based entirely on economic aspects, has a long tradition in the OECD. The conference documents and the results of the discussion at the “OECD

² Grade 5 and 6 of secondary school were supposed to be an orientation period in order to decide about the type of school.

³ Input orientation is often misleadingly referred to as the lack of qualification goals and results as well as interpreted evaluations see (Ladenthin, 2011, p.1).

Conference in Washington”, which was also decisive for the entire public discussion of educational and educational issues, showed unequivocally in 1961 the limited economic and technical view of human development and progress:

“It goes without saying that the educational system must be an aggregate of the economy, it is just as necessary to prepare people for the economy as real assets and machines. The educational system is now equal to highways, steel works and chemical fertilizers’. Thus the claim can be made ‘without blushing and with good economic conscience that the accumulation of intellectual capital is comparable to the accumulation of real capital – and in the long range may outmatch it.’” (Graupe & Krautz, 2014, p. 3)

Earlier, Graupe and Krautz explicated:

“The same conference volume states that, with regard to developing countries, it would be ‘nothing short of cutting a million people loose from a way of life that has constituted their living environment for hundreds or thousands of years. Everything achieved by these countries’ schools and education until now has served social and religious aims which have primarily allowed for resignation and spiritual comfort; things that completely go against any economic sense of progress. Changing these century-old approaches may perhaps be the most difficult yet also most important task for education to accomplish in developing countries.’” (loc. cit., p. 2)

Here, human development is reduced to economic growth and technical progress. Socio-historical, cultural and educational aspects are not only ignored, but also presented as disturbing and negative. In essence, the views expressed by the OECD have not fundamentally changed since then, but the causes of the need for unifying reforms are now general concerns, such as the growing globalization of the economy and the new requirements of a technological society.

50 years on, the OECD has in its own words, “become central, providing indicators of educational performance that not only evaluate but also help shape public policy.” (Gurría, 2011, p.318). The introduction of competence orientation is not a particularly German phenomenon. However, it seems that in Germany it leads to more radical changes in the educational system than elsewhere. The pretext for a radical change in education policy was the “moderate performance” of German students in the PISA test 2003, which was not in line with social expectations. In the media and by politicians it is referred to as the “PISA shock”.

Although the OECD had already tested in mathematics decades before, and the TIMS study had already taken place (since 1995), the second PISA test in 2003 was suddenly taken as “the truth” by German politicians and media about the German educational system and as an indicator of what students “really” know. The political goal became to improve the result of tests such as PISA or the TIMS study. Competence orientation promises, among other things, to be able to do this and turn education into a manageable system:

“Educational standards with their reference to student competences are explicitly formulated in a way that allows them to be checked with the help of corresponding questions or tests. This measurability characterizes them nationally and internationally, and with all due modesty, it is this characteristic that makes it possible to determine at certain points in time whether and to

what extent students are adequately prepared for life or whether there is a need for optimization.”
[Blum et al. 2006, p. 9, translation by the authors]

As a measure against the PISA shock, in 2004 the German Conference of Ministers of Education adopted the so-called “educational standards” (*Bildungsstandards*) and reorganized the curricula on the basis of competence orientation.

However, is ‘competences’ really just a new word for something akin to learning goals? Has that not always been around? And, who can object to schools and universities at least formulating the goal of ensuring that graduates are fully competent when leaving? Would anyone not want them to apply this knowledge meaningfully and use it to solve “inner-mathematical problems” as well as real-world ones? Do the practitioners and theoreticians of mathematical doctrine focus on an enemy who is not actually a threat? Is it not good that requirements are standardized so that they can be taught systematically? This critical discourse may appear to large parts of a general mathematical audience as splitting hairs. The introduction of competence orientation as a universal and legally prescribed paradigm for the description and design of learning processes, however, has a very specific impact on the mathematical culture in teaching and research. The definition, which is based on the German competency orientation, goes back to Weinert:

Competences in this context are the cognitive abilities and skills available to or learnable by individuals in order to solve specific problems and the associated motivational, volitional and social readiness and ability to successfully and responsibly use the solutions in variable situations. (Weinert, 2002, pp. 27-28, translation by the authors)

The introduction to this definition in the above-cited text is rarely added:

In this context, the OECD has repeatedly suggested that the ambiguous concept of performance should generally be replaced with the concept of competence.

It is vital for mathematics teachers in schools and universities to understand these developments more thoroughly and to engage in a humanities discourse with pragmatic consequences that cannot be fundamentally clarified by empiricism and that only partially takes place within the mathematical culture. In competence orientation, we are dealing with a fundamental change in our understanding of learning. Is it about learning to understand something, or is it about convincing others on the basis of measurable output that I have understood something?

The conceptual system of competence orientation derives from applied psychology (Gelhard, 2011). For a long time it was used for the selection and adaptation of workers who were meant to meet specially defined psychological requirements in the workplace, such as patience, accuracy, speed, etc. Although competence orientation with regard to teaching was promoted on the initiative of the OECD (cf. Weinert, 2002, p. 27) and by pedagogical psychologists and educationalists working predominantly on a quantitative empirical basis, there is still no unequivocal empirical evidence to date that suggests that the competence orientation currently implemented by the state has a positive effect on the knowledge and skills of high school graduates or new students.

As of now the concept of competence, the credo of the testing industry, based on a definition by Franz Weinert, has become the central concept of the transformation of our entire education system.

It has evolved from a psychological selection tool into the guiding principle for quality control of industrial production of human capital, as the OECD has promoted for decades. After all - and this cannot be emphasized enough - competences are a psychological instrument. Modeling, collaborating, arguing and even moral competences (Weinert 2002, p. 28) etc. are elevated to context-free problem-solving activities. As they do not have to do justice to any context, they become observable and measurable psychological categories.

Are there developments in the past akin to competence orientation and educational standards?

If we look at competence orientation as a promise of salvation, as a concept of being able to acquire skills applicable to any subject without learning to be an expert in that subject, then we cannot find similar developments during the last 200 years: Skills and knowledge are traditionally closely related to content, either from the perspective of vocational training or from the perspective of humanistic education.

The existence of very general concepts guiding educational reforms leads us to the reform of school geometry, driven by the slogans such as “Neue Geometrie” (new geometry) or “Los von Euklid” (away from Euclid), both in the 19th century. We may also think of the Meraner Reform and its motto of “Erziehung des funktionalen Denkens” (Education of functional thinking) or the “Neue Mathematik” (New Maths movement) (Schubring, 2014, pp. 241-257). In all these cases, the principles for the reforms were inspired by developments in mathematics such as projective and other non-euclidian geometries, descriptive and analytic geometry in the 19th century and functional analysis, algebra, logic and set theory, and probability theory at the turn of the last century.

If we think about the pretext of the reform the so-called “PISA shock”, it sounds quite similar to the “Sputnik shock” on the eve of the New Maths reforms. The Sputnik shock however, was part of world affairs whereas PISA was enacted especially to get an influence on national educational systems.

We traced the development of the notion of competences back to its original use as a psychological selection tool and its modern use to limit the notion of “Bildung” to practical usefulness and functionality. The discourses about role, extent and place of applications and modeling in today's mathematical education have also a history and can be retraced to discussions during the twenties, fifties and eighties. The current so-called modeling problems in A level tests became part of German school mathematics in the context of the PISA shock and its subsequent reforms to improve the poor performance of students in the field of modeling competences.

As we can see, there are various ways to explore the history of mathematics education: On the one hand, we went back to the roots of current educational reforms; on the other, we looked for similar patterns in the past.

Conclusion

We did not answer the question of how to continue the discourse, which started at ICHME, but it inspired us to look for ways to include the history of mathematics education in teacher education. The current gradual shift in the fundamental principles of the German education system make reflecting on these foundations even more important.

Notably the *von Humboldt Bildungsideal* is built on two notions: the *autonomous individual* and the *cosmopolitan or Universalist (Weltbürger)* – that is, a universally interested person who cares about the important questions of humankind. The university should be – both for students and professors – a place for autonomous individuals to become such a *Weltbürger*. Student teachers, who are about to become responsible experts for *Bildung* at school, not only need to come in contact with these ideas, but should also be given opportunities to work on their own *Bildung* and personal development.

Acknowledgment

Type any acknowledgment here.

References

- Bergmann, K. (2002): Geschichte als Steinbruch? Anmerkungen zum Gegenwartsbezug im Geschichtsunterricht. *Zeitschrift für Geschichtsdidaktik* 1, S. 138-150.
- Blum, W., Drüke-Noe, C., Hartung, R. & Koller, O. (ed.) (2006): Vorwort der Herausgeber. *Bildungsstandards Mathematik: konkret Sekundarstufe I: Aufgabenbeispiele, Unterrichtsanregungen, Fortbildungsideen*. IQB, Cornelsen Verlag Scriptor, Berlin.
- Ryan, R. M. & Deci, E. L. (2000): Intrinsic and Extrinsic Motivations: Classic Definitions and New Directions. *Contemporary Educational Psychology*, 25, 54-67.
- Gasser, P. (1982): *Methodenfreiheit – Theoretische Grundlagen zu einem Aspekt des Professionalisierungsproblems der Volksschullehre*. Graphische Anstalt Schüler Biel.
- Geiss, P. (2019): War da was? – Historische Bildung im Output-Zeitalter. pp.133-150 in: Stomporowski S. & Redecker A., & Kaenders, R. (Eds.): *Bildung – noch immer ein wertvoller Begriff ?!*, Wissenschaft und Lehrerbildung, 5, Bonn University Press, Geiss P. & Ißler, R. (Eds.), V&R unipress, Göttingen.
- Gelhard, A. (2011): *Kritik der Kompetenz*. 2. Aufl., Zürich, Diaphanes-Verlag.
- Gurría, A. (2011): The OECD at 50: Past achievements, present challenges and future directions. *Global Policy*, 2(3), 318-321.
- Graupe, S., & Krautz, J. (2014): Die Macht der Messung. Wie die OECD mit PISA ein neues Bildungskonzept durchsetzt. COINCIDENTA. *Zeitschrift für europäische Geistesgeschichte*. Beiheft, 4. (English translation by the authors: From Yardstick to Hegemony – How the OECD uses PISA to enforce a new concept of education, <https://bildung-wissen.eu/fachbeitraege/from-yardstick-to-hegemony.html> [24.11.2018]).

- Jahnke, T. (2008). Rede an die Hörerinnen und Hörer der Vorlesung, Einführung in die Mathematikdidaktik, Universität Potsdam im SS 2008. *Mitteilungen der Gesellschaft für Didaktik der Mathematik*, 34(85), 15-19.
- Kaenders, R. & Weiss, Y. (2017): Mathematische Schneeschmelze. *Mitteilungen der Deutschen Mathematiker-Vereinigung*, 25(2), pp. 82-89.
- Ladenthin, V. (2011). *Kompetenzorientierung als Indiz pädagogischer Orientierungslosigkeit*. Profil, Mitgliederzeitung des Deutschen Philologenverbandes, 9, 1-6.
- Leschinsky, A., & Roeder, P. M. (1983): *Schule im historischen Prozess: zum Wechselverhältnis von institutioneller Erziehung und gesellschaftlicher Entwicklung (Vol. 39055)*. Ullstein.
- Müller, D. K., Zymek, B., & Herrmann, U. (1987): *Sozialgeschichte und Statistik des Schulsystems in den Staaten des deutschen Reiches, 1800-1945 (Vol. 2)*. Vandenhoeck & Ruprecht.
- Schubring, G. (2007). Der Aufbruch zum „funktionalen Denken“: Geschichte des Mathematikunterrichts im Kaiserreich. *NTM International Journal of History & Ethics of Natural Sciences, Technology & Medicine*, 15(1), 1-17.
- Schubring, G. (2014) Mathematics Education in Germany (Modern Times). in Karp, A., & Schubring, G. (Eds.). *Handbook on the history of mathematics education*. New York, NY: Springer.
- Organisation for Economic Co-operation and Development, OECD (2004): *The PISA 2003 assessment framework: Mathematics, reading, science and problem solving knowledge and skills*. Paris: PISA, OECD Publishing.
- Weinert, F. E. (Ed.) (2002): *Leistungsmessungen in Schulen*. Weinheim/Basel: Beltz Verlag.

Lucas Bunt and the rise of statistics education in the Netherlands

Bert Zwaneveld¹ and Dirk De Bock²

¹Open Universiteit, Welten Institute, The Netherlands; zwane013@planet.nl

²Katholieke Universiteit Leuven, Belgium; dirk.debock@kuleuven.be

We describe the role of Lucas Bunt at the start of the teaching of probability and statistics in the last two years of Dutch secondary schools in the early 1950s. Together with his co-authors, Bunt developed an experimental text which, from the mid-1950s on, became a regular textbook. We further sketch Bunt's other – mostly international – activities with respect to the curriculum reform movement initiated at the Royaumont Seminar in 1959. Bunt's experiment can be seen as one of the initiatives related to this reform. Finally, we present what happened with statistics teaching in the Netherlands "after Bunt".

Keywords: Mathematics curriculum, Probability, Secondary school mathematics, Statistics.

Introduction

The attention to statistics in Dutch secondary school mathematics arose in the early 1950s when a student text about statistics was developed by a group of mathematics teachers led by Lucas Bunt. The text was used in experiments in the last two years of secondary schools that prepare students for the university, initially only for the non-exact streams of these schools. Bunt's reason to develop this text was a proposal made by *Liwenagel*, one of the two associations of teachers of mathematics at that time¹, to include statistics into the curriculum for these students. The proposal cannot be seen independently from the worldwide trend after World War II to include applications of mathematics into the secondary school curricula (De Bock & Zwaneveld, in press). During the 1950s the call for curriculum change was so strong that the OECD took the initiative to organize, in 1959, the Royaumont Seminar with representatives from different western countries to initiate the reform. Bunt attended "Royaumont" and many other international meetings related to this reform movement.

Although Bunt's pioneering role in statistics education is well-known in the Netherlands, a proper scientific review of his work is still missing. Moreover, his acting at the international math educational scene was not given appropriate attention so far, especially in the debates about a possible introduction of statistics at the secondary school level.

We present Bunt's role in the Dutch curriculum reform movement of the 1950s, more specifically, his activities related to the development of a statistics program as a part of it. Based on written historical sources and a few oral testimonies of contemporaries, we first provide some elements of Bunt's professional career. We then report about his experiment with the teaching of statistics in secondary school classrooms and about the actions he took to ensure that his ideas became

¹ The other organization of teachers of mathematics was *Wimecos*. Both organizations, *Liwenagel* and *Wimecos*, were the predecessors of the *Nederlandse Vereniging van Wiskundeleraren* [Dutch Association of Mathematics Teachers].

consolidated. Finally, we report what happened with statistics in Dutch secondary mathematics curricula “after Bunt” and we present some conclusions.

Lucas Bunt

Lucas Nicolaas Hendrik Bunt (Figure 1) was born in 1905 in Edam, a small village north of Amsterdam. He studied mathematics at the University of Amsterdam where he also defended, in 1934, his PhD thesis, entitled *Bijdrage tot de theorie der convexe puntverzamelingen* [Contribution to the theory of convex point sets]. In the early 1930s, Bunt started his career as a mathematics teacher in Leeuwarden where he likely met his wife, a chemistry teacher at the same school. In the late 1940s Bunt became mathematics teacher trainer at the University of Groningen. From 1948 to 1969 he was appointed as a full-time mathematics teacher trainer at Utrecht University, a position that he combined with that in Groningen. In 1968, immediately after the retirement of his wife, he and his family migrated to Arizona (US) where Bunt became a professor of mathematics at Arizona State University. We assume that Bunt had already developed strong professional ties with the US in the early 1960s to secure this appointment, but could not verify this any further. Bunt died in 1984 in the US.



Figure 1: Lucas Bunt (left: detail of a picture of the *Mathematics Working Group*, 1948; right: attending the public defense of the PhD thesis of his son Harry at the University of Amsterdam, 1981)

Bunt became active at the math educational scene in the Netherlands shortly after World War II as a member of the *Mathematics Working Group*, a group that critically reflected on the existing secondary school curricula and developed proposals for new curricula (La Bastide-van Gemert, 2015). Bunt’s international career started in 1959. Recommended by Hans Freudenthal to the Dutch Ministry of Education, Bunt was one of the three representatives for the Netherlands at the famous Royaumont Seminar and he co-edited the Seminar’s Proceedings with Howard F. Fehr (OEEC, 1961). In the late 1960s, Bunt translated and adapted, in cooperation with Harrie Broekman, a series of booklets that were developed by the *School Mathematics Study Group* in the US. This resulted in a six-volume programmed instruction course for Dutch secondary school students.

Bunt was primarily a mathematician who explained mathematics to a non-mathematically schooled audience. We mention his textbook *Statistiek voor het voorbereidend hoger en middelbaar onderwijs* [Statistics for preparatory higher and secondary education] (1956), intended for Dutch students, aged 16 to 18 years, who prepared themselves for university studies in social sciences,

economics, geography, etc., based on an experiment of which Bunt published the report (Bunt, 1957). For an international audience, Bunt (co-)authored *An introduction to sets, probability and hypothesis testing* (with Howard F. Fehr and George Grossman) (1964) and *Probability and hypothesis testing* (1968).

First experiments with statistic education at the secondary level

Bunt took the initiative to develop an experimental text about statistics in some gymnasia A². The text was initially mimeographed, in 1956 it was printed as a textbook (Bunt, 1956). As mentioned before, one of the reasons for Bunt to start with an experiment about the teaching of statistics was a proposal of a commission established by the organization of mathematics teachers *Liwenagel*, intended to study the opportunities and possibilities of “a re-organization of mathematics education in the A-streams of the gymnasia and the gymnasium sections of the lyceums” (1950). Bunt was a member of that commission and, although it is not mentioned, likely the main author of the commission’s report.

It is worth mentioning that Bunt did not develop the experimental text and the textbook on his own, although this was a common practice in the Netherlands at that time, but in cooperation with a team of teachers. In the *Preface* of the textbook Bunt wrote (translated from Dutch):

... was an educational experiment in statistics, organized by the Department of Didactics of the Pedagogical Institute of the State University of Utrecht. The following teachers cooperated: Dr. Cath. Faber-Gouwentak, Barlaeus-Gymnasium, Amsterdam; Sr. E. A. de Jong, *Rectrix* [Headmistress] St.-Theresia-Lyceum³, Tilburg; D. Leujes, Grotius-Gymnasium, Delft; Dr. H. Mooy, Barlaeus-Gymnasium, Amsterdam; Dr. P. G. J. Vredenduin, *Co-rector* [Vice Headmaster] *Stedelijk* [Municipal] Gymnasium, Arnhem. (Bunt 1956, p. v)

At that time in the Netherlands, statistics was not a part of the official curriculum that only included algebra and geometry, topics that were also part of the final exams, organized centrally by the government. However, based on an exception rule, the Inspection of Education could allow teachers to change parts of the exam program. Such exception was obtained for the statistics experiment.

In 1957, Bunt published the report in which he describes the experiment with the student text that was used during the years 1951-1955 (Bunt, 1957). The reason why the textbook was published before this report was, as Bunt wrote in the textbook’s *Preface*: “The recent proposals of the mathematics teachers associations *Wimecos* and *Liwenagel* about the curriculum change for mathematics in the B-stream of the secondary schools, in which statistics is included as a new topic, made it desirable to make, as soon as possible, the text public” (Bunt, 1956, p. v). Bunt’s report has two parts: part A includes the motivation and explanation about the selected topics, and the way they are treated; part B is the student text (it is not included in the printed version of the report).

² At that time, the gymnasia in the Netherlands had two study streams: The A-stream, preparing students for university studies such as languages, economics, psychology, sociology, history, and geography, and the B-stream, preparing students for university studies in mathematics, science and technology.

³ A lyceum was a school for secondary education with two sections: gymnasium and *Hogere Burger School (HBS)* [Higher Citizens School], similar to gymnasium but without Latin or Greek.

We focus on some highlights of part A. Bunt motivated the reasons for choosing statistics as follows: to students in university disciplines such as economy, psychology and sociology, an extensive study of algebra is less useful than a well-balanced treatment of the first concepts and principles of statistics. Statistics in university turns out to be very difficult and uncommon to these students. Moreover, they have to learn it in a rather short period of time. Statistics in secondary school is not only useful for the aforementioned students, but for all citizens in modern society. By reducing the algebra content, Bunt found the necessary 35 classroom hours for his statistics course. After that, he justified the chosen topics. In the first experimental text, these topics were: frequency distribution, histogram, frequency curve, cumulative frequency, average, median, quartiles, range, mean deviation, standard deviation, quartile distance, permutations, variations (without repetitions), combinations, Pascal's triangle, Newton's binomial formula, some simple theorems from probability calculus, the binomial distribution for $p = 0.5$, the normal curve as a limit of the histogram of the binomial distribution (graphical, not with formulae). At the end of the course, some applications of the normal curve for calculating probabilities were presented. Linear regression and correlation were left out, because of being too time-consuming. Especially on the insistence of his cooperators, Bunt drastically changed the end by including a final chapter on hypothesis testing: estimating some characteristics of a population on the basis of a sample.

Bunt extensively deals with the principles of probability calculus for which he presents an axiomatic approach. Probability is a function that assigns to an event a number in the interval $[0,1]$. He starts from the following two axioms: (1) If $p \rightarrow \neg q$, then $P(p \text{ or } q) = P(p) + P(q)$; (2) If p is the sure event, then $P(p) = 1$. From these axioms Bunt derives the complement and product rule. He illustrates these rules with examples about rolling dice. In the textbook, however, Bunt introduces the concept of probability differently. There he starts with the definition of Laplace: the probability of an event is the number of outcomes favorable for that event, divided by the total number of outcomes (under the condition of mutually exclusive and equally likely outcomes). After having dealt with the complement, the sum and the product rule, he introduces "another" definition: if it turns out that in a large number of repetitions of an experiment, n , an event happens k times, then we are convinced that every time we repeat this experiment a sufficient number of times, this event will happen in k/n part of this number. We then state that the probability of that event equals k/n . For probabilities derived from that "new" definition, the complement, sum and product rule keep their validity. We note that Bunt's approach contrasts sharply with that of his contemporary Gustave Choquet, then president of the *International Commission for the Study and Improvement of Mathematics Teaching* (CIEAEM), who proposed at the 9th meeting of the CIEAEM a definition of probability based on the mathematical concept of measure (translated from French):

In a set U , one chooses a family F of subsets E , to each of which we attach a number $m(E)$, called the measure of E . These subsets have the following properties: their union and their intersection are again part of F , even if the number of E 's is infinite. In the case of probabilities, the set U has measure $m(U) = 1$. Each element of U represents a possible event: all favourable events constitute a subset E with measure $m(E)$. The probability of the favourable event is given by $m(E)/m(U)$. (Carleer, 1955-6, pp. 63-64)

The difference between Bunt's and Choquet's approaches illustrates the debate during the mid-1950s between the mathematics-didacticians and the mathematics-structuralists on how statistics should be introduced at the secondary school level.

Because of its innovative character, we discuss in some detail how Bunt explained the concept and procedure of hypothesis testing. He wrote about this:

On the basis of a sample of 10 marbles out of a box with 5000 white and 5000 red marbles the probabilities of 0, 1, 2, ..., 8, 9, 10 red marbles in that sample are 0.001, 0.010, 0.044, 0.117, 0.205, 0.246, 0.205, 0.117, 0.044, 0.010, 0.001. It follows that in 1.1% of all samples of 10 marbles there are 0 or 1 red marbles, and even so, in 5.5%, there are 0, 1 or 2 red marbles. And, in 5.5% of all samples there are 8, 9 or 10 red marbles. And moreover, in 1.1% of all samples there are 9 or 10 red marbles. Now suppose that the fraction p of red marbles is unknown and we take a sample of 10 marbles. We shall agree that if $p = 0.5$ and there are 0, 1, 9 or 10 red marbles in the sample, we shall reject the hypothesis $p = 0.5$. If the hypothesis $p = 0.5$ is right we have a risk of $1.1\% + 1.1\% = 2.2\%$ that we, in spite of this, reject the hypothesis. More precisely, there is a probability of 1.1% that we reject the hypothesis $p = 0.5$ on the strength of too small (or too large) a number of red marbles. Because, in this connection, we, for the time being, do not want to risk a greater probability than 2.5%, we stick to the mentioned agreement. This agreement, therefore, conforms to the following conditions: (a) if $p = 0.5$, we risk, both for too small and for too large a number of red marbles in the sample, a probability of not more than 2.5% that we reject the hypothesis $p = 0.5$; (b) both for too small and for too large a number of red marbles this probability lies as close to 2.5% as possible. When we reject the hypothesis $p = 0.5$, we say the hypothesis $p = 0.5$ is rejected with an unreliability of not more than 5%. (Bunt, 1957, p. 12)

The fraction v is introduced as the number of red marbles divided by the number of marbles in the sample and its values which are or are not thought contradictory to $p = 0.5$ are represented by, respectively, dots and circles on an axis (Figure 2).

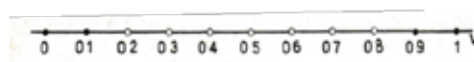


Figure 2: Axis representing values of v with dots and circles

Repeating this procedure for different values of p , one gets the two-dimensional scheme (Figure 3):

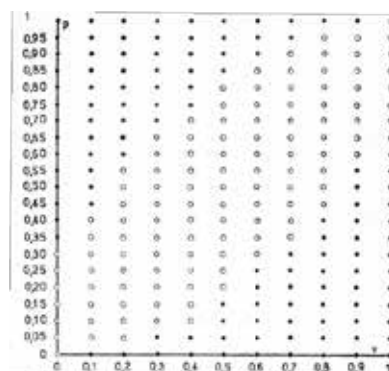


Figure 3: v -axes for different values of p

By making the values of v and p “continuous”, one gets a figure on which the different boundary lines refer to different sample sizes (Figure 4). The textbook contains two of these, corresponding to unreliabilities of 5% and 10%, called by Bunt “nomograms”. From these nomograms, the student can observe that the probability of rejecting a false hypothesis increases with the sample size.

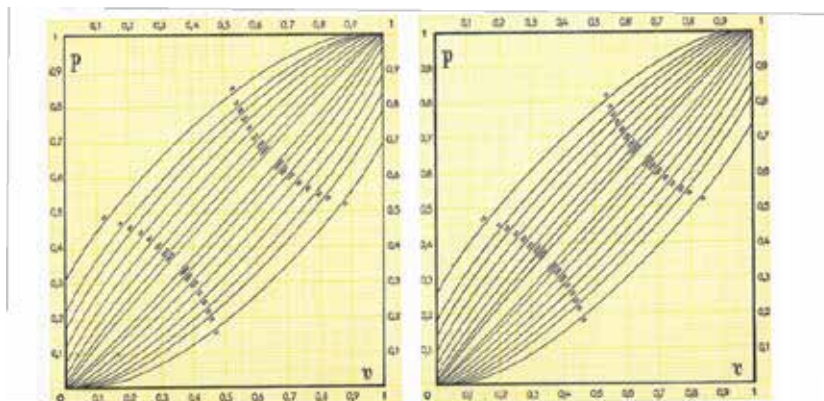


Figure 4: Nomograms for different sample sizes (left, the unreliability is 5%, right 10%)

Consolidation and internationalization

In 1954-1955 a curricular commission of *Wimecos* published a report including a draft curriculum and central examination program for mathematics in HBS-B. Bunt had been a member of that commission representing the Dutch mathematics didacticians and mathematics teacher trainers. In the commission’s report, it is stated that statistics had been important sources for the commission. The commission basically confirmed the conclusions of the report of *Liwenagel* (Liwenagel, 1950-1951), but now generalized to all students who prepared themselves for university studies. In 1958, the new curriculum was actually implemented, but, although it entailed a considerable change, statistics only became an optional subject for gymnasium A.

The fifth edition of Bunt’s textbook (Bunt, 1968) had a slightly different title, a consequence of the curriculum reform consolidated in 1968 by a new law for secondary education. The subtitle, statistics for preparatory higher and secondary education, was changed into: statistics for preparatory scientific education. This new curriculum reform was prepared and supervised by the *Commissie Modernisering Leerplan Wiskunde* (CMLW) [Commission for Modernization of the Mathematics Curriculum]. The task of that commission was to prepare the mathematics curriculum reform in line with the ideas of Royaumont Seminar. Bunt was a member of the CMLW. The commission was officially set up in June 1961 by the Ministry of Education, Arts and Science, but already in January 1961, Bunt had proposed to the Ministry to establish such commission. However, the Inspection of Education had given a negative advice to the Ministry because the commission as proposed by Bunt was too small. In 1968 the new curriculum for mathematics, in which statistics played a clear role, was implemented in all schools for secondary education in the Netherlands: Bunt had achieved what he had started working on in 1951.

During the late 1950s and early 1960s, Bunt disseminated his ideas about the teaching of statistics. Already on May 24, 1959, he was invited to report on his experiment about the teaching of statistics at the annual meeting of the *Société Belge de Professeurs de Mathématiques* [Belgian Association

of Mathematics Teachers] and the *Société Belge de Statistique* [Belgian Association of Statistics], held in Brussels on May 24, 1959 (Bunt, 1959). The manner in which statistics became a part of the secondary-school curriculum in the Netherlands was also the topic of Bunt's paper at the Royaumont Seminar (OECE, 1961). In the period after Royaumont, Bunt had the opportunity to actively participate in meetings held in order to coordinate, monitor and refine the implementation of the Royaumont recommendations (Aarhus, 1960; Athens, 1963, Echternach, 1965).

More recent developments

According to the law for secondary education of 1968, two types of schools could prepare students to higher education: *Voorbereidend Wetenschappelijk Onderwijs* (VWO, six grades for students from age 12 to 18) [preparatory scientific education], preparing for university studies, and *Hoger Algemeen Voortgezet Onderwijs* (HAVO, five grades for students from age 12 to 17) [higher general continued education]. The mathematics curricula of these school types were prepared by the CMLW. The curriculum of VWO included probability theory and statistics, that of HAVO only included descriptive statistics. These topics were meant to be taught in the last two years of these school types. We restrict ourselves to statistics teaching at VWO. Although Bunt's textbook was available, CMLW judged that it was better to not implement statistics immediately, but first to develop a new text and conduct an experiment with a restricted number of schools. The argument was that Bunt's textbook was only intended for students in the "old" gymnasia A, whereas statistics now had become a compulsory subject for all students. A statistics development team started in 1970, first under the supervision of the CMLW, from 1971 under the supervision of the then started IOWO, the predecessor of the Freudenthal Institute.

After a first draft the team developed the textbook (Nijdam et al., 1973) including the following content: Introduction, Probability rules, Probability distributions, Hypothesis testing and reliability intervals, Parameters of a distribution, Use of the normal distribution. The introduction contained an example with a prognosis of the number of students of VWO that should follow science or mathematics at the university, based on data of the Dutch *Central Bureau of Statistics*. From that example, terms as sample, population, random, representative, testing – for instance with respect to the quality of the production of certain items – were introduced. In this textbook the students themselves started with a probability experiment. There was a box with 1000 small marbles, 600 red and 400 black. With a kind of spoon with 20 wholes, they drew a random sample of 20 marbles. This box with the "spoon" was used to simulate various probability experiments.

Conclusions

The mathematician Lucas Bunt played a crucial role in promoting and developing materials for statistics education at the secondary level, in the Netherlands but also at the international level. Indeed, in the post-Royaumont era, probability and statistics were seen as valuable elements of a worldwide reform of the mathematics curricula. Although Bunt explained his approach in a rather classical way, starting with some probability axioms (in pure *New Math* style), the approach in his textbook was very pragmatic. Bunt did not emphasize "theoretical aspects", accepted properties without proof and provided many clarifying examples. This pragmatic style enabled Bunt to explain the basic principles of hypothesis testing at the end of his course, in a limited number of lessons.

Nowadays in the Netherlands and in several other countries, probability and statistics are included in the mathematics programs, at least for some streams at the secondary level, but in the 1950s and 1960s, it was quite revolutionary to propose to teach these topics at that school level.

Because of his didactical work in general and more specifically on statistics, Bunt was important in Dutch mathematical education in the post-WWII period. Due to his participation to Royaumont and other international conferences, and his textbooks in English, Bunt may also have played a role in debates about the gradual introduction of statistical curricula for the secondary school level in other countries. However, this role has not yet been clarified and is a topic for follow-up research.

Acknowledgements

We thank Bunt's son Harry for the biographical information about his father, Danny Beckers for the information about the start of the CMLW, and Harrie Broekman for his information about Bunt in the years he was Bunt's colleague at Utrecht University.

References

- De Bock, D., & Zwaneveld, B. (in press). From Royaumont to Lyon: Applications and modelling during the sixties. In G. A. Stillman, G. Kaiser, & C. E. Lampen (Eds.), *Mathematical modelling education and sense making*. New York: Springer.
- Bunt, L. H. N. (1956). *Statistiek voor het VHMO*. Groningen: Wolters-Noordhoff.
- Bunt, L. H. N. (1957). *Statistiek als onderwerp voor het gymnasium A: verslag van een proefneming*. Utrecht: Paedagogisch Instituut der Rijksuniversiteit te Utrecht.
- Bunt, L. N. H. (1959). L'enseignement de la statistique dans les écoles secondaires des Pays-Bas. *Mathematica & Paedagogia*, 17, 35–48.
- Bunt, L. N. H. (1968). *Statistiek voor het VWO*. Groningen: Wolters-Noordhoff.
- Carleer, L. (1955-1956). IX^e rencontre internationale de professeurs de mathématiques. *Mathematica & Paedagogia*, 7, 63–66.
- La Bastide-van Gemert (2015). *All positive action starts with criticism. Hans Freudenthal and the didactics of mathematics*. New York: Springer.
- Liwenagel (1950-1951). Rapport van de commissie ter bestudering van een reorganisatie van het wiskundeonderwijs in de A-afdelingen van de gymnasia en de gymnasiale afdelingen der lycea. *Euclides*, 26(2), 49–55.
- Nijdam, B., Van Daal, J., Sloff, J., Wouters, J., Yntema A. (successor of Wouters, J.), & Zwaneveld, B. (1973). *Statistiek en kansrekening voor het VWO*. Utrecht: IOWO.
- OEEC (1961). *New thinking in school mathematics*. Paris: OEEC.

TWG13: Early Years Mathematics

Early Years Mathematics: Introduction to TWG 13

Ingvald Erfjord¹, Bozena Maj-Tatsis², Esther Levenson³, Priska Sprenger⁴ and Marianna Tzekaki⁵

¹University of Agder, Norway; ingvald.erfjord@uia.no,

² University of Rzeszow, Poland; bmaj@ur.edu.pl

³Tel Aviv University, Israel; levenso@tauex.tau.ac.il

⁴ University of Education Karlsruhe, Germany; priska.sprenger@ph-karlsruhe.de

⁵Aristotle University of Thessaloniki, Greece; tzekaki@auth.gr

Introduction

The Early Years Mathematics working group shares scholarly research revolving around mathematics for children aged 2-8. This includes different areas of mathematics and attention to how mathematics is approached implicitly and explicitly by children and teachers alike. The broad age range affords attention to several transitions within preschool, and from preschool to the early grades of primary school. At each CERME-conference (since CERME 6), the working group on early years mathematics has spent time considering differences in Europe (and outside Europe) regarding the organization of preschool and the cultural approaches of different countries to education at this young age. Some countries have one preschool curriculum for children aged 1-5 (6), while others distinguish between nursery and preschool. The number of children attending preschool in different countries also differs greatly, with consequences for transitions. As an example, Norway has one preschool curriculum and 91.8 % (ages 1-5) and 97.1 % (ages 3-5) of children attended kindergarten in 2018¹.

Prior to the conference in Utrecht, paper and poster authors were requested to prepare and send to the leaders a brief text outlining the main points of their contribution. This helped the leaders plan the discussions and presentations, and served as a basis for this introduction. Each of the 22 papers were allocated 30 minutes for presentation and discussion. For each paper, an author of a different paper was requested in advance to prepare questions and comments for the paper presenters. The seven posters were also briefly presented in a group session, followed by a group discussion in a one-hour session.

The number of participants in TWG13 in Utrecht was greater than the number of participants in previous years. In addition to participants from Europe, there were also stimulating contributions from outside of Europe (Japan, Canada, and Malawi). In total, 38 participants from thirteen different countries attended the working group (see table below).

¹ Published on the website by The Norwegian Directorate for Education and Training <https://www.udir.no/tall-og-forskning/statistikk/statistikk-barnehage/tall-og-analyse-av-barnehager-2018/barnehager/> (the website is currently written only in the Norwegian language)

Country	Number of papers	Number of posters	Number of Participants
Canada	1		1
Germany	5	3	10
Greece	2		2
Israel	1		1
Italy	1		1
Japan	1		1
Malawi		2	2
The Netherlands			1
Norway	6		10
Poland	1		1
Sweden	3	1	5
Spain	1		1
UK		1	2
TOTAL	22	7	38

A variety of topics

Several contributions to TWG13 concern classical, but indeed crucial areas in early years mathematics, such as numbers and arithmetic skills. Björklund and Runesson consider children's way of experiencing numbers, and found evidence of six different ways children can experience numbers. Bjørnebye investigates children's ability to synchronize multiple representations of numerosity in the embodiment of a counting-on-strategy. He argues that bodily experiences could support early appropriation of a counting-on strategy. Lüken highlights the role of finger use during numerical considerations, and considers how the role and use changes over time. Sprenger and Benz consider children's ability to perceive and use structures in sets. They argue that eye-tracking, as a data collection instrument, together with observations, provide strong insight into the two processes of perception and determination of the cardinality of sets of objects. Bakos and Sinclair consider the role of a digital app on the development of children's multiplicative awareness. In particular, they consider the relation between bodily movement and mathematical meaning-making. Bakos and Sinclair found two primary gestures used by children which they discuss. Müller and Tiedemann report from an ongoing study which focuses on children's development of conceptual subitizing, while Bruhn looks at first graders' creative processes when working on arithmetical open-ended problems. Tzekaki and Papadopoulou consider different levels of generalization that children can

develop in arithmetic learning by systematically adopting teaching approaches with relevant tasks and discussion.

Another branch of studies considers approaches that facilitate children's learning of mathematics during the early years. Grimeland and Sikko study children's development of mathematical literacy in a second-grade classroom working with play-coins in an inquiry-based setting. Inquiry-based settings are also the frame for the study by Skoumpourdi. However, her study is related to another area of mathematics – plane geometrical shapes. Skoumpourdi found that cooperative exploration, discussion, and justification processes were fostered in the inquiry-based setting. Pettersen and Volden look at the transition from mathematics in kindergarten to school mathematics. They argue that inquiry-based mathematics education was found to be helpful for children's ability to remember and recognize mathematical activities across the transition.

A study of Matsuo and Nakawa consider whether preschool children can improve their understanding of length and area measurement. In particular, their concern is on direct and indirect measurement, as well as measurement by an arbitrary unit. Their findings pinpoint that area measurement is found hardest to grasp, but partly in play-based settings, while direct comparison is easiest. Vanegas, Prat and Rubio characterize the learning trajectory of children aged six to eight years old when acquiring the notion of length measurement. The group also had a contribution by Bräuning that look at children's development of strategies for a combinatorial task and argues for a process-oriented view.

Palmér and Björklund focus on 2-3 years-old toddlers' ability to explore structural elements while playing "hide the toy-dragon", and pinpoint indications of emergent structural awareness among the small children. The inclusion of toddlers, as young as 2 years, within the scope of focus for TWG13 came as a result of the CERME10 conference and as an overall desire to increase insight into children's learning of mathematics (Levenson, Bartolini Bussi, & Erfjord, 2018). Nordemann and Rottmann look at how children's repeating pattern competencies can be fostered by physical activity, and report that development can be found especially for children with learning difficulties in mathematics. Nergård studies five-years-olds children's use of mathematical concepts, and found evidence of such use when they compare, explain and argue about natural phenomena.

Erfjord, Hundeland, and Carlsen characterise the mathematical discourse evolving as a teacher facilitates a mathematical activity for five-year-old children in kindergarten. Their findings indicate that mathematical discourse was characterised by engaging only one or two of the six children in longer periods and children's contributions were often of a non-mathematical nature. Gifford and Thouless address how teachers develop young children's pattern awareness.

Maffia and Mancarella consider children's interpretation of equalities represented through images, and found evidence that relational thinking can be supported when children work with number sentences containing equivalence. Maj-Tatsis and Tatsis look at characteristics of tasks that promote mathematical reasoning among young children. Tasks that required a shift from geometrical structures to numerical ones were found most difficult for children. Wernicke et al. look at social

training of spatial perception and spatial cognition in an ongoing study based on a training program of children in a day-care centre.

In two studies situated in Malawi, Gobede investigates mediation strategies used by early years mathematics teachers and Mandala explores how primary teacher education prepares pre-service teachers to teach early years mathematics. Svensson focuses on pre-school teacher students' ability to capture children's learning of mathematics in activities in preschool while Johansson, Tossavainen, Faarinen, and Tossavainen analyse student-teachers' perceptions regarding teaching mathematics for young children. Johansson et al. found evidence of different pedagogical beliefs and expectations regarding what mathematics teaching in preschool should be. Breive considers the balance between freedom and structure in kindergarten teachers' orchestration of mathematical learning activities. Tsamir, Tirosh, Levenson and Barkai investigated preschool teachers' self-efficacy for teaching patterning, with attention to why teachers report high self-efficacy before the professional program involved. Finally, Vogler focuses on the indirect processes of learning in preschool situations, which may be considered as an opportunity for children to participate and learn in what may be denoted as a "double layer structure" of every day meanings and abstract mathematical meaning".

Methodological approaches

In TWG13, there has been an ongoing discussion regarding methodological approaches to investigating early mathematics learning. These approaches often reflect the culture of educational settings for children. In some countries in Europe, all kinds of testing and even organised activities are considered problematic when it comes to preschool. The role of play, from (total) children initiated free play to strong teacher guided play is another important discussion that has been ongoing in the group (Levenson, Bartolini Bussi, & Erfjord, 2018). In CERME 11, this discussion again arose and emphasised e.g., by Breive, who considered the balance between freedom and structure in mathematical activities for five-year-old children in kindergarten.

Most of the research reported in TWG13 follows a qualitative data collection approach, with interviews or observations, or lesson observations and video data. However, a variety of ways for analyzing the data were adopted such as: cross-case, process oriented, interpretative, and hermeneutical approaches. There are also reports from a few experiments or design research studies, with pre and post examination of children, mainly with interviews and qualitative analysis. There are also a few quantitative approaches, utilizing tests or questionnaires, and one mixed study. These differences reflect the scope of that area of research, and that different kinds of research can contribute differently.

Reference

Levenson, E. S., Bartolini Bussi, M. G., & Erfjord, I. (2018). Early years mathematics. In T. Dreyfus, M. Artigue, D. Potari, S. Prediger, & K. Ruthven (Eds.), *Developing research in mathematics education: Twenty years of communication, cooperation and collaboration in Europe* (pp. 106–114). New York, USA: Routledge.

Pips (times) Pods: Dancing towards multiplicative thinking

Sandy Bakos and Nathalie Sinclair

Simon Fraser University, Canada; sbakos@sfu.ca; nathsinc@sfu.ca

This paper examines the design of an iPad touchscreen application (TouchTimes), that provides children with the opportunity for direct mathematical/multiplicative mediation through fingers and gestures. We describe the explorations of a pair of third-grade students with this technology, in which engagement with number in a multiplicative sense draws on a singular interaction between the eyes and both hands. Using a theoretical perspective informed by tool use and by embodiment in mathematical thinking and learning, we seek to gain insight into the affordances of the TouchTimes app in the development of multiplicative awareness in young children, with a specific focus on the multimodal nature of their mathematical interactions.

Keywords: Touchscreen technology, multiplicative reasoning, primary, tangible.

Introduction

Multiplicative reasoning is the ability to work flexibly and efficiently with “the concepts, strategies and representations of multiplication (and division) as they occur in a wide range of contexts” (Siemon, Breed & Virgona, 2005, p. 2), concepts that include direct and indirect proportion. Among other things, such reasoning involves learners viewing situations of comparison in a multiplicative rather than an additive sense. As students progress to larger whole numbers – and then to decimals, fractions, percentages, ratios and proportions – multiplicative reasoning becomes key to a large number of mathematical situations found in upper elementary and middle school (Brown, Küchemann & Hodgen, 2010).

In the primary grades (K–3), however, the action of repeated addition is commonly used as the initial (and, for some, the sole) means for introducing and working with multiplication, and it tends to become firmly entrenched as the dominant perception of multiplicative situations, both for students *and* for primary teachers (Askew, 2018). This becomes problematic when students begin to engage with mathematics that requires a direct capacity to think multiplicatively (e.g. Siemon et al., 2005). Consequently, multiplication may prove a crucial turning point in student learning, possibly a turnstile for mathematical competence. Rather than rely exclusively on repeated addition, approaches need to be developed and implemented in the early grades that highlight the function aspect of multiplicative reasoning that can be so critical to future success with mathematics.

Since Vergnaud (1983) wrote about the conceptual field of multiplicative structures, considerable attention has been given to the comparison of quantities using multiplicative thinking. Extensive research has documented difficulties students have with employing it in middle school and beyond, which Brown, Küchemann & Hodgen (2010) claim has not improved since the 1970s. Limited student experience with different multiplicative situations is proposed as a contributing factor to this significant challenge (e.g. Downton & Sullivan, 2017). Furthermore, Askew (2018) contends that the lack of development of multiplicative reasoning in the primary grades is “a consequence of predominant approaches to teaching multiplication limiting access to opportunities through which thinking functionally can emerge” (p. 1).

Multiplicative reasoning and digital technology

Digital technology is providing new resources and means that show promise in supporting the mathematical learning of young children (e.g. Sedaghatjou & Campbell, 2017). In particular, the multi-touch affordances of *TouchCounts* (hereafter TC) allow children to produce and transform objects directly on an iPad screen using fingers and contact gestures, providing new counting and early arithmetic opportunities that are enabled by the app's visible, audible and tangible design. Sinclair and de Freitas (2014) show how the interaction in TC between fingers and eyes—between the tangible and the visual—enables new ways of thinking about number.

TouchTimes (TT), a novel extension of TC, is a gesture-based, multi-touch environment for multiplication designed to improve children's flexible and relational understanding of multiplication. Multiplicative rather than additive, TT allows children to create the “visual images of composite unit structures in multiplicative situations” (p. 306) that Downton and Sullivan (2017) argue are fundamental to developing multiplicative reasoning directly. Children can produce and transform objects directly on an iPad screen, using new gestural experiences of multiplication that provide direct feedback through both symbolic and visual representations. Our research focus involves exploring the influence of TT as a gesture-based modality for conceptualizing, visualizing, experimenting with and communicating about multiplicative relationships with students in primary grades (2–4).

Brief description of *TouchTimes*

TouchTimes is an iPad application, which when initially opened displays a blank screen that is split in half by a vertical bar (Figure 1a). A user can place and hold her fingers on one side of the screen to create coloured discs, which we call “pips”. (In what follows, we presume that the user has chosen the left side of the screen, but the description is also symmetric for the right side of the screen.) Each finger that maintains continuous contact with the left side (LS) produces a different coloured pip (Figure 1b). When the user taps her finger(s) on the right side (RS) of the screen, a unit of coloured discs appears. These units, which we call “pods”, are comprised of the coloured pips that correspond to those pips being created by the user's fingers in contact on the LS (Figure 1c). As each tap creates a new pod, *TouchTimes* displays the number sentence that corresponds with the pips and pods created by the user. When a finger is taken off a pod, it remains on the screen, but becomes slightly smaller, so that users can create numerous pods. As long as at least one finger remains in contact with the LS, the pips are maintained within the pods, but when the user removes all fingers, the pods disappear (“multiplying by 0”). Contact with the screen can be made either one finger at a time or several fingers simultaneously. Pods can be dragged into the trash, at the bottom of the screen.

Pimm and Sinclair (2015) note that *TouchCounts* ‘takes care of the counting’ through both symbolic and auditory means in response to the user's fingered requests. Although done in a different manner, TT ‘takes care of the multiplying’, both in terms of making sure that the pods on the RS are reflective of the number of pips on the left, and in terms of ensuring that the equation on the screen corresponds to the pips and pods that are displayed in response to the fingered requests of the user.

Downton and Sullivan (2017) argue “that the co-ordination of composite units is the core of multiplication, and that young children's (8 year-olds) concept of multiplication is based on the meaning they give to the composite units they construct” (p. 306). Thinking multiplicatively involves

the ability to simultaneously think about units of one and units of more than one. TT embodies a multiplicative model that involves the co-ordination of two quantities similar to Figure 1d below (Boulet, 1998, p. 13). One way to conceptualise this action is to see the LS touches as the number of pips which are then unitised into pods, with the pods then unitised into the product, as in the Davydovian approach (see Boulet, *ibid.*). In this view, the sentence $3 \times 4 = 12$ is read as the multiplicand times the multiplier equals the product, which reverses the typical North American approach $(3)(4x)$. Of course, it is also possible to see the pods as being groups of pips, which can be understood in terms of repeated addition. However, the simultaneity of the two-handed touching retains less of the temporal, sequential sense of repeated addition. Part of the research goal is to develop tasks that promote a more multiplicative sense of multiplication.

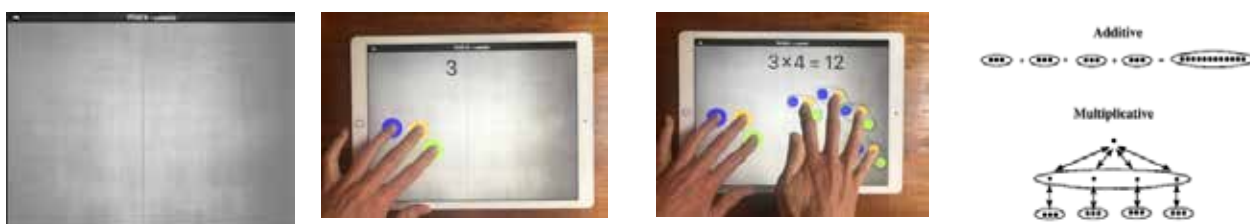


Figure 1: (a) Initial screen of TT; (b) Creating pips; (c) Creating pods; (d) Multiplicative model

Theoretical Framing

The theoretical orientation of this study draws principally on theories of embodiment and the relation between bodily movement and mathematical meaning-making (see Nemirovsky et al., 2013; Radford, 2009). We take the monist, ontological position found in inclusive materialism (de Freitas & Sinclair, 2014) on the nature of body and mind, which does not subordinate sensorimotor actions to thinking, but instead recognizes the way in which new ways of moving one's body *are* new ways of thinking. For this reason, we are less interested in studying TT as a manipulative involving acts of moving structures and are more interested in the *structured acts of moving* that TT modulates. Given this orientation, and the gesture-rich design of TT, our focus will include not only verbal explanations but also gesture-based actions, as we are particularly interested in the structured acts of gesturing that arise through the use of the app. The epistemic and communicative nature of gestures has been well documented in the literature (see Sinclair & de Freitas, 2014) and warrants our attention to gestures as particularly relevant structured acts of moving. Since the multitouch environment also enables children to work together, we will also focus on jointly structured acts of moving. Therefore, we will be investigating how a pair of students' interactions with TT prompts new gestures and how these new structured acts of moving are related to multiplicative thinking.

Methods

The data for this paper comes from an exploratory conversation conducted by one of the authors as part of an iterative design experiment aimed at refining the TT prototype and developing appropriate tasks for use with grade two and three children. After the researcher requested a pair of students who had not yet used TT (three pairs of children had already participated), the two girls, whom we refer to as Jacy and Kyra, were selected by their classroom teacher to explore TT with the researcher. This interaction occurred in an elementary school in a culturally diverse and affluent neighbourhood in

British Columbia, where the interviewer worked for approximately 30 minutes with the pair. A video-recording of this interaction was created, and the drawings produced by the girls were kept. The children were initially given time to become familiar with TT through independent exploration prior to any specific requests or questions from the interviewer. Given that this was the pair's first encounter with TT, it provided an opportunity to observe how they made sense of the app and if their interactions with TT would lead to an ability to identify certain multiplicative aspects with distinct handedness. After a period of free exploration that lasted about seven minutes, the interviewer began to use prompts to focus the attention of the children on certain features of their creations on the iPad screen. Using TT, in conjunction with the significant presence of an adult, the initial aim of this research was to understand better the impact of the affordances of TT on young children's multiplicative thinking, with a particular focus on the multimodal and joint nature of the mathematical activity of two girls working together on a single iPad.

Data analysis

In order to account for the multimodal, distributed nature of the phenomenon seen in the video-recordings, following our theoretical tenets, we produced an *orchestral transcription* of ten-second increments involving three separate, but interacting modalities: voices, hands and the iPad screen itself (Figure 2). The top three rows were designated for the voices of each child and the interviewer, thus providing a way to sequence the speaking visually in a manner that would effectively display overlapping voices. Descriptions of what the children's hands were doing on both sides of the iPad screen, were sequenced in time with the voices transcribed in the section above.

As the importance of the iPad screen itself became apparent, additional rows were created to reflect what could be seen on the top, left and right sides of the iPad screen, supplemented by screen shots to illustrate these ideas. The orchestral transcription enabled us easily to identify patterns of structured acts of moving throughout the course of the interaction, by comparing the images.


Voices	Jacy	Laughs.....		
	Kyra	Wait, now I'll make a three.	And then... laughs They're dancing! Laughs	
	Interviewer			
Hands	Left Screen	3-finger simultaneous touch (RH)	3 sequential finger touches	
	Right Screen	Pointer finger touch (RH)	Hold two fingers	
iPad Screen	Top of Screen	3	3x1=3	2x1, 2x2, 2x3
				
	Left Screen	3 pips		
	Right Screen	1 pod	1, 2, 3 pods	

Figure 2: Orchestral transcription

Results

From the orchestral transcript we chose two intervals that illuminate some of the gestures made by the girls during their exploration of TT that we see as being relevant to multiplicative thinking. Prior

to presenting these two intervals, however, we describe the pair's initial interactions with TT, which began with the researcher giving the pair permission to "play a little bit". Each girl placed and removed her pointer finger on and off the screen in what appeared to be random motions. After approximately fifteen seconds, Jacy placed her thumb on the screen in addition to her pointer finger, creating two pips. Kyra next touched the screen, creating a pod composed of two pips (Figure 3a). Jacy then began to use both hands. It is shortly thereafter that Jacy said, "How do you get those mini ones?", thus marking a transition from random tapping to more intentional actions on the iPad screen.

Disappearing pips and 'dancing' pods

Approximately five minutes into the exploration, Jacy instructed Kyra to "Wait, just press a lot. Press your whole hand." Kyra responded by placing all five RH fingers simultaneously on the LS and waited while Jacy created pods on the RS one at a time with her index finger. The top of the iPad screen read 5×1 , 5×2 , 5×3 , 5×4 , 5×5 , 5×6 until Kyra abruptly removed her hand from the screen, causing both girls to laugh. At this point, Jacy began directing the creation of pips through the placement and removal of Kyra's fingers on the LS: when Kyra returned her five fingers to the iPad, Jacy physically removed her partner's pinky and thumb from the screen, causing some confusion. Jacy tried again, telling Kyra to "Wait. Put those [indicating Kyra's RH fingers] and then take up your pinky and thumb." Kyra placed three fingers on the LS, while Jacy created one pod on the RS. This was clearly not what Jacy was after, and she further instructed Kyra to "Press your pinky and thumb away. No wait. Put your pinky and thumb down [Jacy physically presses Kyra's pinky and thumb down (Figure 3b)] and now take them away." Each time Kyra's pinky and thumb touched the screen, the resulting pips changed colour, and the composition of the pod that Jacy was 'holding' changed from three pips to five pips and back to three pips as Kyra alternated rhythmically, making the pod appear to be swinging back and forth (Figure 3c). Jacy created a second pod and at this point Kyra pointed to the pods with her free hand and declared with a laugh that "They're dancing!".



Figure 3: (a) Two fingers; (b) Pinky and thumb down; (c) Pinky and thumb up

Throughout this brief episode, Jacy became interested in exploring how the creation and deletion of pips on the LS affected the shape and colour of the pods on the RS, as demonstrated by both her comments and her actions. This complex interplay between the girls and TT involved a coordination of two pairs of hands, which resulted in a *joint holding and repetitive-tapping gesture*. The appeal of the 'dancing' pod seemed to draw the girls' attention to the relation between the RS and LS finger touches, which we see as significant in terms of multiplicative thinking. It involved the intentional co-ordination of two quantities: the multiplicand (three or five pips) and the multiplier (the one pod). The girls' joint gestures expressed their attention to the way in which the pods on the RS are directly affected by changes related to the number of pips controlled by the finger actions on the LS.

Counting by fours and fives

After seven minutes of exploration, the interviewer asked Kyra to put four fingers down, which she did with a simultaneous four-finger gesture, creating four pips on the LS. Without prompting, Jacy created a single pod on the RS with her index finger (Figure 4a). When questioned about what she noticed, Jacy replied, “Four times one equals four”. She then created additional pods with her thumb while maintaining her index finger on the original pod (Figure 4b). When asked how Jacy could make five with one finger on the RS, Kyra’s thumb touched the screen to create five pips, while Jacy continued to add pods on the RS (Figure 4c). After a pause, the interviewer asked, “Are you making a five now?” At this point Jacy, who had been creating additional pods with her thumb, glanced towards the top of the screen which displayed $5 \times 10 = 50$, then $5 \times 11 = 55$. She said, “Fifty-five, sixty...” and with excitement, “Wait! It’s counting up by fives! Sixty-five, seventy, seventy-five, eighty, eighty-five, ninety, ninety-five...”. The pair were then asked what they could do to count by fours. Kyra removed one of her five fingers from the screen. Jacy said, “Count up by fours?” and physically moved closer to the left side of the screen, causing Kyra to remove her hands. While placing her thumb and all fingers except her pinky on the screen, Jacy explained that you would “Put four fingers down”. Meanwhile, Kyra used her index finger on the RS (reaching over Jacy’s arm) to create pods (Figure 4d). Jacy then said, “Two, four, six, eight, twelve” then “wait, what?” after she noticed the product displayed on the iPad screen go from eight to twelve. She silently observed the next product and then began to count aloud again: “Twenty, twenty-four, twenty-eight... We’re counting by fours.”



Figure 4: (a) First pod of 4; (b) Second pod of 4; (c) Many pods of 5; (d) Crossover pod making

The girls had transitioned away from single touches and were now making a *simultaneous touch gesture*, as in the four-finger gesture described above. The interviewer’s first question was meant to draw attention to the number/colour of pips in the 4-pod they had created, but Jacy described the multiplication statement instead. The interviewer then hoped to elicit the making of a 5-pod in order to prompt the unitising of five pips into one pod. With Kyra’s additional finger on the LS, Jacy did indeed begin creating 5-pods, but she did not seem to be aware of the shift from 4-pods until she noticed the multiplication statements, and that the product was increasing by five with each RS touch. This induced a particular kind of *joint skip-counting gesture* in which one girl was responsible for holding pips while the other girl’s sequential touches created pods. The pair then switched roles to skip-count by four, with Jacy holding pips and Kyra sequentially making pods. Unlike the skip-counting that occurs in many classrooms, where children count intransitively by the unit (“four, eight, twelve”, etc.), the skip-counting in TT explicitly involves gesturally expressing the unit (the pips) *and* the number of units (the pods).

Jacy’s counting self-correction seems to indicate a shift from rote counting to co-ordinating the *joint skip-counting gesture* (tangible expression) with the products (symbolic expression) that she could

see on the iPad screen. When asked how Jacy could create a 5-pod, Kyra who was in control of creating the pips, immediately added a finger to the screen and later removed a finger when prompted to count by fours. Kyra was controlling the effects of the multiplier (the pips) on the multiplicand (the pods) with her fingers. Jacy, however, did not attend to the effects of each added pod on the product until after she noticed the product changing in the equation at the top of the iPad screen. Skip-counting in TT using the *joint skip-counting gesture* involves co-ordinating two quantities (instead of one) and is therefore more multiplicative than additive.

Discussion

The intent of the TT design was for learners to notice the relation between the number and colour of pips, and the shape and content of the pods, as this is the basis for the multiplicative operation. Although the girls created numerous pips and pods, it was not until the *joint holding and repetitive-tapping* gesture that they seemed to co-ordinate this relation. Indeed, it appeared to be the shifting pod shape, and then the changing pip colour, that initially drew their attention. The *joint holding and repetitive-tapping* gesture, which arose from manipulating the screen in exploratory ways, became a gesture for expressing the relation between pips and pods. The girls were able to make visible the effect of changing the unit through the tapping on and releasing of pips, which resulted in the changing size, shape and colour of the pods. When there was more than one pod on the screen (as in Figure 4c), the *joint holding and repetitive-tapping* gesture produced the multiplicative effect in which one new tap produced a new pip in *every* pod *simultaneously*.

In the previous section, we outlined how the joint skip-counting gesture can be viewed as more multiplicative than additive. However, we think that a gestural shift from tapping one finger at a time to create new pods, to tapping several fingers simultaneously would provide an even stronger multiplicative effect. We know from prior *TouchCounts* research that sequential tapping was more frequent than simultaneous tapping, during children's initial interactions. Since the girls rarely created several pods simultaneously, we hypothesise that such a gesture involves a more difficult co-ordination and may need to be prompted by a particular task.

Another significant aspect of the actions described throughout this paper involves the joint nature of the girls' interactions. In both of the gestures identified, the pair must co-ordinate their hand movements and there were a few instances during the 30-minute exploration in which one of the girls "took over" TT. We wonder how a situation with two children co-ordinating multiple hands would differ from one in which a single child coordinates only her own hands.

Conclusion

Designed to support the development of multiplicative thinking, TT provides young learners with ways of thinking about multiplication that are not solely dependent upon the use of repeated addition. Two intervals were described in the 30-minute episode reported above, in which the girls created and sustained particular structured ways of moving their hands that we hypothesise as being relevant to the development of multiplicative thinking. The two primary gestures discussed were the *joint holding and repetitive-tapping* and the *joint skip-counting* gestures. The former prompted and enabled the girls to attend to the relation between the number/colour of pips and the pods, and thus the co-ordination of the two quantities. The latter enabled the girls to produce multiples of a number

determined by the number of pips. Attention to the symbolic expression on the screen was particularly salient in the second interval. We highlight that the girls primarily engaged in free exploration throughout this experiment, with few prompts from the interviewer. In future explorations, we intend to build upon the insights gathered here to design tasks that can effectively prompt and support similar types of gestures, and to link these gestures to other off-line and TT-based actions.

References

- Askew, M. (2018). Multiplicative reasoning: Teaching primary pupils in ways that focus on functional relationships. *The Curriculum Journal*, 29(3), 406–423.
- Boulet, G. (1998). On the essence of multiplication. *For the Learning of Mathematics*, 18(3), 12–19.
- Brown, M., Küchemann, D. & Hodgen, J. (2010). The struggle to achieve multiplicative reasoning 11–14. In M. Joubert & P. Andrews (Eds), *Proceedings of the Seventh British Congress for Mathematics Education (BCME7)*, (30)1, pp. 49–56. University of Manchester, UK: BSRLM.
- de Freitas, E. & Sinclair, N. (2014). *Mathematics and the body: Material entanglements in the classroom*. New York, NY: Cambridge University Press.
- Downton, A. & Sullivan, P. (2017). Posing complex problems requiring multiplicative thinking prompts students to use sophisticated strategies and build mathematical connections. *Educational Studies in Mathematics*, 95(3), 303–328.
- Nemirovsky, R., Kelton, M. & Rhodehamel, B. (2013). Playing mathematical instruments: Emerging perceptuomotor integration with an interactive mathematics exhibit. *Journal for Research in Mathematics Education*, 44(2), 372–415.
- Pimm, D. & Sinclair, N. (2015) “How do you make numbers?” In K. Krainer & N. Vondrová (Eds), *Proceedings of the Ninth Congress of the European Society for Research in Mathematics Education* (pp. 1961–1967). Prague, CZ: Charles University in Prague and ERME.
- Radford, L. (2009). Why do gestures matter? Sensuous cognition and the palpability of mathematical meanings. *Educational Studies in Mathematics*, 70(2), 111–126.
- Sedaghatjou, M. & Campbell, S. (2017). Exploring cardinality in the era of touchscreen-based technology. *International Journal of Mathematical Education in Science and Technology*, 48(8), 1225–1239.
- Siemon, D., Breed, M. & Virgona, J. (2005). From additive to multiplicative thinking. In J. Mousley, L. Bragg & C. Campbell (Eds), *Proceedings of the 42nd Conference of the Mathematical Association of Victoria* (pp. 278–286). Bundoora, Australia: MAV.
- Sinclair, N. & de Freitas, E. (2014). The haptic nature of gesture: Rethinking gesture with new multitouch digital technologies. *Gesture*, 14(3), 351–374.
- Vergnaud, G. (1983). Multiplicative structures. In R. Lesh & M. Landau (Eds), *Acquisition of mathematics concepts and processes* (pp. 127–174). New York, NY: Academic Press.

Framework for analysing children's ways of experiencing numbers

Camilla Björklund¹ and Ulla Runesson Kempe²

¹University of Gothenburg, Faculty of Education, Gothenburg, Sweden;
camilla.bjorklund@ped.gu.se

²Jönköping University, School of Education and Communication, Jönköping, Sweden;
ulla.runesson@ju.se

This study contributes to the field of arithmetic learning a framework based on a conjecture that learning is a change in ways of experiencing numbers – decisive for what is possible to do with numbers in arithmetic tasks. 309 task-based interviews with 5-6-year-old children were used to develop the framework. To validate its use for studies on arithmetic skills development we selected 7 children who between two interview occasions developed from scoring 0 in the first interview to >75% correct answers in the second interview. Based on the results of these children's changing ways of experiencing numbers, we conclude that arithmetic skills development can be found empirically related to changes in the children's ways of experiencing numbers, which validates the framework as being a useful tool to follow and describe children's arithmetic skills over time.

Keywords: Arithmetic skills, early childhood education, mathematical development, variation theory of learning.

Background and aim

Early arithmetic development has raised an increasing interest during the last decades, providing the mathematics education field with observations of children's counting strategies (Carpenter, Moser & Romberg, 1982) and learning trajectories (Clements & Sarama, 2009; Cross, Woods & Schweingruber, 2009). Multiple studies within this knowledge area have proven that learning arithmetic is complex but most children do in fact learn to solve simple arithmetic problems during their preschool years. Nevertheless, the development of arithmetic skills is a challenge to study, not least because arithmetic computation includes knowledge and awareness of several aspects of numbers and principles (Baroody, 2016). Even if children have strategies to solve a task, their strategies may not be based on conceptual understanding of relationship between and within numbers and arithmetical principles, but rather on procedural knowledge (see Fuson, 1992). Relying on procedural knowledge alone has not shown to facilitate further learning and may even induce mathematics difficulties when encountering more advanced arithmetic tasks (Gray, 1991; Gray & Tall, 1994; Neuman, 1987). Of educational and scientific interest is thereby to be able to interpret the way a child understands numbers and what s/he can do with numbers in arithmetic tasks.

Our approach to learning and development is experiential, based on Variation theory of learning (Marton, 2015), meaning that how a child acts when trying to solve an arithmetic task depends on the child's way of experiencing numbers in the task. Variation theory explains learning failures in a specific way and spells out the conditions of learning; when learners fail to learn what was intended, they have not discerned aspects that are necessary to discern. So, the very core idea of Variation

theory is that discernment is a necessary condition of learning. Furthermore, the way a learner is experiencing numbers is expressed in the way the learner is acting in solving arithmetic tasks. This approach adds to the field of research an alternative approach to understanding development and learning as changes in ways of experiencing numbers in arithmetic tasks, that is what is discerned by the learner and what is yet to be discerned, rather than learning to use more sophisticated strategies.

The aim of this paper is to describe a framework of children's ways of experiencing numbers. To validate its use for studying arithmetic skills, we used empirical data of children's acts and utterances in interviews from a smaller sample of the whole data set and discuss to what extent these children's increased arithmetical skills can be explained in terms of different ways of experiencing numbers.

The study

This particular study is part of a larger project (FASSETT) in which a pedagogical program to enhance children's number knowledge and arithmetic skills was developed. To assess this project we needed a framework to consolidate our conjecture of how children develop arithmetic skills that would allow us to study children's development and find theoretically and empirically sound explanations for their learning and possible impact of implemented teaching programs.

103 preschool children participated in researcher-designed interviews based on addition and subtraction tasks (number range 1–10). The interviews were conducted at three occasions: in the beginning of the last preschool year (5-year-olds), in the end of the last preschool year (8 months later) and after another year in pre-primary school (3 x 103 children = 309 interviews). Each interview was video-recorded, with the legal representatives' permission, to ensure repeated analyses. Ethical clearance has been provided to collect personal data for the longitudinal investigations of the children. Furthermore, we chose one group of children (n=7) who made substantial improvements in their interview scores between interview 1 and 2 (from 0 to >75% correct answers on arithmetic tasks) for thorough analyses of their answers in the interviews.

Developing a theoretically informed framework

The interview data, consisting of 3 x 103 interviews (0% falling-off), was used as empirical basis for developing a framework of the outcome space of different ways of experiencing numbers. The children's acts and utterances regarding eight items were the unit of analyses. Several researchers participated in this thorough work, both individually and collectively to fine-tune the characteristics for each category. Six different ways of experiencing numbers have been found. They are distinct in that each category forms a qualitatively different way of seeing and thus understanding what is possible to do with numbers in an arithmetic task. The framework is generated from the analysis of answers to each task, not as a general expression of a specific child. The ways of experiencing numbers are thus analysed as unique observations of each item in the interviews, which gives us a sample of approximately 2400 observations (309 interviews x 8 items).

Validating the framework

The purpose of this paper is furthermore to validate the framework as a tool for studying children's arithmetic skills development. We thereby compared a group of children (n=7) who in the first interview scored low concerning correct answers (0 of 8 possible) and high in the second interview

(>75%), eight months later. Our concern is to what extent the improvement can be explained by their different ways of experiencing numbers. These children's ways of experiencing numbers are, in line with the framework, analysed as unique observations of each item in the interviews, which gives us a sample of 56 observations (7 children x 8 items).

The framework

The result from analysing the interviews constitutes six distinct ways of experiencing numbers (Table 1, left column). These are described in terms of criteria for inclusion (Table 1, middle column).

<i>Ways of experiencing numbers</i>	<i>Criteria for category inclusion</i>	<i>Strategies enacted when experiencing numbers in respective ways</i>
As words	<ul style="list-style-type: none"> - Number words are used in quantitative contexts but without numerical meaning 	<ul style="list-style-type: none"> - Random number words are used solely or as a sequence, <i>or</i> - Number words from the given task are repeated
As names	<ul style="list-style-type: none"> - Numbers are ordered in a sequence - Number words describe “the nth” object, no cardinal meaning - Names cannot be added or subtracted from other names, because they lack cardinal meaning 	<ul style="list-style-type: none"> - Ascribing number names to objects - Saying the following number word in the counting sequence as an answer to an arithmetic task - Static way of representing a number with fingers
As extent	<ul style="list-style-type: none"> - Numbers are approximate with a cardinal meaning - Some sense of plausible quantities related to the task 	<ul style="list-style-type: none"> - No attempts to count single units - Numbers are used to give a plausible description or comparison of quantities (however not exact)
As countables	<ul style="list-style-type: none"> - Strong influence of the ordinal aspect of number - Added units of ‘ones’ 	<ul style="list-style-type: none"> - Counting all parts and the whole - Exceeding the subitizing range imposes counting to determine a set
As structure	<ul style="list-style-type: none"> - Numbers are composite sets - The part-part-whole relation is constituted in the act 	<ul style="list-style-type: none"> - Using finger patterns to structure numbers’ parts and whole - Operating on the relation between parts and/or the whole
As known number facts	<ul style="list-style-type: none"> - Numbers are instantly recognized as a part-whole relation 	<ul style="list-style-type: none"> - Giving an instant (correct) answer - Retrieving from known facts

Table 1. Overview of the criteria for category inclusion and empirical expressions

Furthermore, the way to experience numbers is conjectured to be related to what is possible to do with numbers, which means that how children use numbers and express their understanding in words and in gestures are keys to interpreting their ways of experiencing numbers (Table 1, right column).

In the following these different ways of experiencing numbers and the implications for solving arithmetic tasks will be described with examples from the interviews.

Numbers as words

Children expressing their experiencing numbers as words say random numbers, either solely as an answer to a task, or as a sequence of words (not in an orderly fashion). This category includes instances when a child repeats one of the number words appearing in the task. Thus, numbers are words used in certain contexts but there is nothing you can *do* with numbers to solve the task at hand.

- Task: Seven marbles are hidden in two hands. How many could be in each hand?
 Child: Five, eight, nine [taps her finger at the right hand of the interviewer, once for each number word], ten [points at both hands], six [points at the right hand] and seven [points at the left hand]. (PFÅ09-1)

Number words are said as an answer to a question with a numerical content, but as shown in the excerpt above, there is hardly a numerical reasoning guiding the child's way of using numbers. Number words are in this sense experienced as a type of word in a certain context. They refer to quantitative situations, but the child does not know *what* numbers they refer to (Wynn, 1992).

Numbers as names

Children seeing numbers as names have been observed by Neuman (1987), and described as a procedure of 'word tagging' by Brissiaud (1992). The child considers number words as names given to a counted item and the last uttered word denotes only that single object.

- Task: You have ten candies and eat six of them. How many are left?
 Child: [shows all the fingers on the left hand and the thumb on the right raised] Ate six. This is six. And then I took the thumb away. So, it's five. (ASJ10-1)

Numbers as names means that each item within a group is given a specific number name. Taking away one (the thumb) of the six fingers and answering "five" to this specific task, is a reasonable answer if the thumb is seen as "the six". Such named items cannot be added to or subtracted from anything in a true sense, since they do not have a cardinal meaning. What characterizes this way of experiencing numbers is thus the ordinal aspect, which means that for example when fingers are used to count on, each finger is given a specific number name and this name cannot be altered because the other fingers are given their unique number names. The lack of cardinal meaning of these number names is also expressed when children answer with the following number word in the counting sequence. This makes sense to the child since the order of the number words implies that the addition of a quantity will include (at least) the next word in the sequence (the n^{th} item).

Numbers as extent

Experiencing numbers as extent means that children have an awareness of numbers in that they use quantities as approximate (Neuman, 1987).

- Task: Seven marbles are divided in two closed hands, how may the marbles be divided?
 Child: [points on the closed right hand] One in that one [points at the closed left hand] five in that one.

Interviewer: How did you figure that out?

Child: [points at the left hand] Eight in that one and two in that one [points at the right hand]. (PLS05-1)

To experience numbers as extent are in a sense cardinal: children give plausible approximations of smaller and larger numbers that together are close to the correct answer. The lack of ordinality means that children do not make any attempts to count in order to determine the quantity of a set. This also makes it impossible to add or subtract in other ways than giving an approximate estimation of more or less than the given numbers in the task. The answer may though be quite close to the correct answer.

Numbers as countables

Experiencing numbers as countables is strongly influenced by the ordinal aspect of numbers, as children count to make a number, often using their fingers to count on. Numbers are thus seen as added units of ‘ones’ which may be difficult to coordinate in an arithmetic task.

Task: You have two shells and your friend five. How many do you have together?

Child: One, two [points at his little and ring finger] wait, I have to start over, 1, 2, 3, 4, 5 [pointing at fingers starting from long finger, index, thumb and thumb, index on the other hand. Then starts again from the little finger] 1, 2, 3, 4, 5. Five! (AVT09-1)

This child knows how to count fingers as representations for the items mentioned in the task. However, he does not seem to discern any structure that would help him solve the task in an easier way – he is able to create parts but has trouble coordinating them (c.f. Steffe, Thompson & Richards, 1982). Numbers as countables further implies that numbers are not comprehended as a composite set, they are created by adding ‘ones’. This becomes visible when using the strategy “counting all”. Some children do however experience small sets by subitizing for example three fingers (that will not be counted), but when the quantity exceeds the subitizing range the numbers have to be counted in ones.

Numbers as structure

A structural approach in arithmetic problem solving is assumed to promote children in developing their conceptual knowledge of numbers (Davydov, 1982; Lüken, 2012; Schmittau, 2004).

Task: You have two shells and your friend five. How many do you have together?

Child: [puts her left hand with all fingers unfolded on the table, then the right hand with thumb and index finger unfolded, looks at her hand shortly] Seven! [with a confident smile] (HNV02-2)

The child knows the finger pattern for five and two, but needs to create the whole by seeing the parts simultaneously both as parts and as a whole, related to each other. This means that some parts may need to be counted, while other parts are experienced for example as finger patterns, but the parts and the whole are experienced as related to each other and are thus possible to handle as a triad (see Baroody, 2016). The difference, compared to experiencing numbers as countables, is the way children experience the parts as composite sets that relate to another set and/or the whole. This opens up for a different way of handling arithmetic tasks, for example in “seeing the five in the eight”. This has also shown to be a key feature of some young children’s spontaneous ways of successfully solving arithmetic problems (Björklund, Kullberg, & Runesson Kempe, 2019).

Numbers as known facts

The last category of experiencing numbers reflects an advanced understanding of number relations. Either, the number relations are known to the child and s/he does not need to calculate, or s/he has an advanced way of reasoning and using retrieved facts to come up with the answer.

- Task: Seven marbles are divided in two closed hands, how may the marbles be divided?
 Child: Four in that one and three in that one. ‘Cause, if you have three and one more it makes four. You have three in that one [points at the left closed hand] and three in that one and one more, makes seven [points at the right closed hand]. (HRM01-2)

In this example the child knows how three, four (seen as ‘three and one more’) and seven are related and is able to retrieve from memory known facts (‘three and three makes six’) that he can operate with to find a plausible solution. The difference between numbers as structure and numbers as known facts lies in the child’s approach to the arithmetic task. The former is focused on structuring numbers in that the missing addend will be possible to discern (it appears in the structure), while this latter category means that the child sees number relations instantly and is often able to describe how s/he retrieves the answer from known number relations.

Validating the framework

The categories outlined above derives from the 309 interviews and 8 tasks given in each interview. Our theoretical conjecture has a pedagogical purpose, which directs our attention towards the extent to which the framework can be used to understand children’s developing arithmetic skills. Thus, we analysed the target group who made substantial improvements during an eight months period. Table 2 shows the number of observations within each category in the first and the second interview.

words	names	extent	countables	structure	known facts
10 / 0	11 / 0	10 / 6	1 / 9	0 / 22	0 / 16

Table 2: Occurrences of ways of experiencing numbers, interview 1 / interview 2

In Table 2 we can see that children in the first interview are with only one exception found in the three first categories: *Numbers as words*, *Numbers as names* and *Numbers as extent*. From earlier research we know that a simultaneous awareness of numbers’ cardinal and ordinal aspects are important for the child’s ability to operate with numbers. Without these aspects coordinated in the arithmetic problem solving process it is not possible to use any counting strategies or arithmetic principles (Davydov, 1982; Fuson, 1982). Experiencing numbers in these ways do not include this crucial aspect of arithmetic skills and the children’s low achievement on the arithmetic tasks in interview 1 is thereby no surprise.

The second interview includes most observations within the categories *Numbers as countables*, *Numbers as structure* and *Numbers as known facts*. Children’s way of experiencing numbers change, in this group, towards ways that allow them to handle numbers in prosperous ways in arithmetic problem solving. However, there are differences in these categories concerning what they enable the children to do with numbers. In some addition tasks the children who experience numbers as

countables manage to solve the problems by ‘counting all’ and thus working with added ‘ones’. This way of experiencing numbers stand in bright contrast to numbers as structure or as known facts, in which the parts to be added or taken away already from the beginning are seen as related to each other as composite sets. Because of this latter relational approach to a task, the child usually avoids cumbersome strategies such as working with one unit at a time. In other words, they can handle arithmetic tasks in a more prosperous way when numbers are experienced as structure.

Discussion

The framework was developed first through qualitative interpretations of a large sample of children’s different ways of experiencing numbers in simple arithmetic tasks. In this study, we then used the six categories derived from the large data, to test the extent to which it was possible to use the framework to explain differences in arithmetic skills. The results suggest a confirmation of basic principles of Variation theory that failing to solve a task is due to the learner not being able to discern necessary aspects within the task and the strategies children use reflect what aspects they discern. Consequently, the children who score 0 on their initial interview have not discerned necessary aspects of numbers. This is also shown in our definition of the different ways of experiencing numbers. The validation of the framework further shows a hierarchical structure of the categories: when more necessary aspects are discerned there is also an advancement in what the child can do with the numbers in the tasks.

When analysing children’s ways of experiencing numbers, their strategies for solving arithmetic tasks become possible to understand, what works and why? Their ways of experiencing numbers change in most cases from primitive ways (that do not enable them to operate with arithmetic tasks) to quite advanced ways of experiencing numbers (that allow them to solve arithmetic tasks as part-part-whole relations). The framework opens for interpreting how new experiences may advance children’s arithmetic skills that does not depend on correct answers, or learnt strategies, instead it offers an alternative: what it means to learn about numbers and how to do simple addition and subtraction.

The analysis of the changes in ways of experiencing numbers seems to be solid enough to explain why some children have difficulties solving arithmetic tasks. Since our target group contained children who scored 0 points and improved to almost perfect score, we would suggest that changes in ways of experiencing numbers are possible over time and the ways to experience numbers have significant impact for children’s possibilities to solve arithmetic tasks. We would argue that more attention should be directed towards what children are able to discern in arithmetic situations, than strategies to come up with a correct answer. However, more research on a larger sample is needed to confirm our statement.

Acknowledgment

This study was funded by the Swedish Research Council (grant no. 721-2014-1791).

References

- Baroody, A. J. (2016). Curricular approaches to connecting subtraction to addition and fostering fluency with basic differences in grade 1. *PNA*, *10*(3), 161–190.
- Björklund, C., Kullberg, A., & Runesson Kempe, U. (2019). Structuring versus counting: critical ways of using fingers in subtraction. *ZDM Mathematics Education*, *51*(1), 13–24.

- Brissiaud, R., (1992). A tool for number construction: Finger symbol sets. (Trans.) In J. Bideaud, C. Meljac, & J.-P. Fischer (Eds.), *Pathways to number: Children's developing numerical abilities*. (pp. 41–65). Hillsdale, NJ: Lawrence Erlbaum.
- Carpenter, T.P., Moser, J.M., & Romberg, T.A. (Eds.)(1982). *Addition and subtraction: A cognitive perspective*. Hillsdale, NY: Lawrence Erlbaum.
- Clements, D.H. & Sarama, J. (2009). *Learning and teaching early math: The learning trajectories approach*. New York, NY: Routledge.
- Cross, C., Woods, T., & Schweingruber, H. (Eds.). (2009). *Mathematics learning in early childhood. Paths towards excellence and equity*. Washington, DC: The National Academies Press.
- Davydov, V.V. (1982). The psychological characteristics of the formation of elementary mathematical operations in children. In T.P. Carpenter, J.M. Moser, & T.A. Romberg (Eds.), *Addition and subtraction: A cognitive perspective*. Hillsdale, NY: Lawrence Erlbaum.
- Fuson, K. (1982). An analysis of the counting-on solution procedure in addition. In T.P. Carpenter, J.M. Moser, & T.A. Romberg (Eds.), *Addition and subtraction: A cognitive perspective*. (pp. 67–81). Hillsdale, NY: Lawrence Erlbaum Associates.
- Fuson, K. (1992). Research on whole number addition and subtraction. In D. Grouws (Ed.), *Handbook of research on mathematics teaching and learning*. (pp. 243–275). New York, NY: Macmillan Library Reference.
- Gray, E. (1991). An analysis of diverging approaches to simple arithmetic: Preference and its consequences. *Educational Studies in Mathematics* 22(6), 551–574.
- Gray, E., & Tall, D. (1994). Duality, ambiguity, and flexibility: A “proceptual” view of simple arithmetic. *Journal for research in mathematics education*, 25(2), 116–140.
- Lüken, M. (2012). Young Children’s Structure Sense. *Journal of Mathematics Didaktik*, 33(2), 263–285. Doi:10.1007/s13138-012-0036-8
- Marton, F. (2015). *Necessary conditions of learning*. New York, NY: Routledge.
- Neuman, D. (1987). *The origin of arithmetic skills: A phenomenographic approach*. Göteborg, Sweden: Acta
- Schmittau, J. (2004). Vygotskian theory and mathematics education: Resolving the conceptual-procedural dichotomy. *European Journal of Psychology of Education*, 19(1), 19–43.
- Steffe, L., Thompson, P.W., & Richards, J. (1982). Children’s counting in arithmetical problem solving. In T.P. Carpenter, J.M. Moser, & T.A. Romberg (Eds.), *Addition and subtraction: A cognitive perspective*. (pp. 83–89). Hillsdale, NY: Lawrence Erlbaum.
- Wynn, K. (1992). Children's acquisition of the number words and the counting system. *Cognitive Psychology* 24(2), 220–251.

Pre-schoolers' ability to synchronise multiple representations of numerosity in embodiment of a counting-on-strategy

Morten Bjørnebye

Inland Norway University of Applied Sciences, Norway; Morten.Bjornebye@inn.no

Based on an outdoors intervention where 4- and 5-year olds were guided in articulated physical mapping of a counting-on-strategy, this study aims to examine their ability to embody a min-strategy in terms of using and cohering to multiple representations of numerosity. Video of individual post-tests of the child's interaction with the affordances are from an interpretive stance analysed from the perspective of embodied cognitive theory. Pattern analysis shows that the activity might support early appropriation of a counting-on-strategy, and the cross-case analysis reveals diversities in use and synchronisation of bodily affordances with verbalised number-space mappings. In particular, it demonstrates quality differences in the children's ability to integrate the kinaesthetic and semantic modalities with respectively tactile, visual and mental based representations of numerosity in terms of supporting fluency and solving proficiency in counting-based addition.

Keywords: Embodied cognition, multimodal, addition, counting, strategies

Introduction

Mastery of counting based addition is an important stepping-stone to the development of more mature, efficient and fluent arithmetic that involves retrieval and decomposition strategies, and the counting-on strategy is thus a critical competence in early arithmetic (Clements & Sarama, 2013). A conceptual shift occurs when the child refines informal use of a counting-all-strategy (e.g. count both addends in $3+2$) into a counting-on-strategy and starts to count from the smallest or largest addend, which are termed respectively as the max- and min-strategy. The min-strategy involves stating the largest integer and count on the number of times equal to the smallest addend.

Several developmental theories (e.g. Vygotsky & Piaget) and an extensive research literature (e.g. Howison et al., 2011; Lakoff & Núñez, 2000; Seitz, 2000) suggest that children learn best through play and bodily activities, which underlines a whole-child approach that stimulates cognitive, motor and social development. Moreover, there is a rapidly growing literature within the multimodal and embodied domain which highlights the use of fingers and gestures as mediating tools for the development of arithmetic skills and concepts (e.g. Crollen & Noël, 2015). Yet, little is known about how children's informal motor skills and the use of other bodily semiotic resources might be integrated in multimodal interaction for the development of proficiency in addition. Hence, in order to address this gap, 10 pre-schoolers were engaged in a 5 weeks guided intervention. They used their body to physically map a counting-on-strategy on a 100-dotted matrix. Based on individual post-tests, this study examines the participants' ability to use and integrate multiple representations of numerosity into coherently structured articulated body-spatial mappings of an additive min-strategy. By coherence we mean the ability to integrate multimodal representations (e.g. kinaesthetic, tactile, auditory, visual, semantic) of numerosity according to the structure of the min-strategy (cf. Zmigrod & Hommel, 2013) as outlined below.

Theoretical framework

The view that mathematical knowledge is embodied seems to meet a growing acceptance in the research domain of mathematical education (Thom & Roth, 2011). Stevens (2012) uses the notions “embodiment as conceptualist” and “embodiment as interactionist” as two complementary theoretical understandings of embodied cognition. The conceptualist stand provides a profound understanding of the nature of human thoughts and how they are organised in vast unconscious and conscious conceptual systems that are grounded in everyday activities, motion and physical experiences. An interactionist perspective of embodiment acknowledges that the body produces meaning and actions in diverse modalities. These often happen in combination and include the use of supporting means and tools such as movement, gestures, pointing, physical position and speech (Stevens, 2012). Moreover, embodied cognition holds that basic arithmetic is closely related to physical and embodied experiences (Lakoff et al., 2000). Hence, embodied actions and use of tools might follow basic laws of arithmetic and therefore possess the potential to be an integrated part of mathematical cognition that might subserve mental calculations (Johansen, 2010).

Clements et al. (2013) suggest that the understanding of counting-on strategies rests on the integration of the learning trajectories’ counting, subitising and addition. The first trajectory might be elaborated by Gelman and Gallistel’s (1978) five counting principles, which form a skeleton structure for children’s early development of counting. Applied on a multimodal scene, the one-to-one-correspondence between items of sets requires the child to relate countable units across modalities (e.g. kinaesthetic and visual tags). In counting-based addition, a prerequisite skill which addresses the stable order principle is verbal enumeration from a given number-word (e.g. “four, five, six” in $4+2$). This requires the child to understand the relation between the semantic expression of the addend and the quantity (Fuson, 1988), which reflects the core of the cardinal principle. The abstraction principle is mediated via knowledge of the relations between countable items of sets with various abstract or physical modalities; for example, visual and mental units might be included in a count and in use of numerical equivalence for comparing sets across modalities. The next trajectory, subitising, refers to the immediate perception of the numerosity of small sets of items (Clements, 1999). Moreover, the term pattern recognition, which refers to direct visual perception of the numerosity of a learnt configuration (e.g. dice), is complementary and dialectical to subitising in early conceptualising of cardinality. Finally and central to the learning trajectory of addition is parts-whole relations of numbers that comprise an understanding of cardinality as an invariant property across any partitioning of a set (e.g. part-part- or part-ordinal-structure). Hence, mental fluency in additive manipulation might be mediated across modalities in the form of direct retrieval or decomposition strategies (e.g. $2+3=5$ and $2+3=2+2+1=4+1=5$, respectively), whereas counting-on-strategies build on both ordinal and cardinal properties of numbers.

Methodology

Participants, intervention and qualitative analysis

Ten 4- and 5 year olds (4 girls, 6 boys; mean age at point of post-test 4:9) participated in a 5 weeks intervention programme, which included seven 1-hour sessions outdoors in the vicinity of their kindergarten (mean participation 6.4 sessions). Give-N-post-tests assessing knower-level of

cardinality (Lee & Sarnecka, 2010) showed that nine participants were Cardinal Principle-knowers (CP-knowers) as they mastered the use of verbal counting for exact enumeration. Moreover, one child showed consistency in the production of the maximum four objects on request and was accordingly classified as a C4-knower.

Each session integrated the min-activity as a guided part of a free construction activity. In order to get a piece for their design, they had to role two dice (e.g. 3 and 5), and outside a 100-dotted matrix ($d = 4$ m, see Figure 1) verbalise and physically express the largest integer in a simultaneous manner (i.e. use the feet to “tag” the dice and say “Five”). Then, inside the matrix and informed by the other dice, they had to verbalise and physically tag the smallest addend in a sequential order (i.e. “six, seven, eight”). In mapping the sum, they had to hold a one-legged body-pose.

Based on an interpretive stance, a mix of pattern and cross-case analyses (Yin, 2009) were adapted to our objective to examine the participants ability to integrate multimodal representations of numerosity according to the min-strategy. First, we examined coherence in each participant’s interaction and the use of cross-modal representations of numbers across trials. Then, in order to identify differences and similarities in use and integration of modalities, a cross-case analysis was conducted. Based on this, categories of task-solution emerged and were synthesised.

Procedure of the min-task

Individual post-testing in the 100-dotted matrix (see Figure 1) was conducted by a researcher and recorded on video. First, the participants were introduced to the min-task: “You are to do as we did in the game earlier (cf. the min-activity described above). Can you toss the dice? Which dice should you pick up? What do you do with the other dice?” If necessary, the child was guided via a practice trial. Next, in order to ensure variation in numbers to add, at least three tasks were given at each level 1 to 3: Level 1 – two dice 1 to 4; Level 2 – one dice 1 to 4, one 1 to 6; and Level 3 – one dice 1 to 6, the other set to 3, 5 and 6, respectively. During task-solution, the researcher could ask: “What did you get?”, “What do you say/do?” and “How many did you get?”

Results



Figure 1: A small circle outside the 100-dotted matrix

Figure 2: Tagging the largest addend (Stage 2)

Figure 3: Touch-counting (Stage 3)

Figure 4: Visual counting (Stage 3)

Figure 5: Physical expression of the final tag (Stage 4)

The results show that five participants solved all tasks, two had one tagging error while one child developed solving abilities across trials after three errors on the first two levels. This adds up to a solution rate of 94 % (i.e. 82/87) for the eight participants who showed solving proficiency. The two remaining children, C4-knower Garth and CP-knower Hans, failed to solve the tasks (i.e. 0/19). With the exception of one-more-tasks (e.g. 6+1, 3+1), most participants showed consistency in strategy

usage. However, some children used different representations depending on whether the smallest integer exceeded the subitising range 1 to 4 or not. Basically, the children's cross-modal representations of numerosity in the min-task involved four steps or stages: 1) Place the dice with the largest addend in the small circle, pick up the other dice; 2) Articulate and physically tag the largest integer simultaneously as a whole (see Figure 2); 3) Enter into the matrix and sequentially physically tag dots and verbally count the number of units equal to the smallest addend (see Figures 3 and 4); and 4) Verbalise the sum and physically gestalt the final tag (see Figure 5). Guided by this framework, the next section provides an elaborated presentation of the general results.

Stage 1: Most CP-knowers used subitising or pattern recognition to determine the outcome of the dice. However, one CP-knower had to count dice with numerosity 6, and C4-knower Garth used verbal touch counting to perceive the numerical value of dice from 4 to 6. Regarding the more-and-less-relation, all participants shared the ability to distinguish between the two dice according to size. However, in contrast to Garth who picked up the dice with the largest addend, the rest of the children placed the dice with the largest integer in the small circle.

Stage 2: While the CP-knowers verbalised and body-tagged the largest addend in the little circle, C4-knower Garth ignored the dice on the ground. Physically, some stated the largest integer in the form of a two-legged tagging, while others integrated the tagging in gait or jumped into the circle to perform a distinct one-legged pose in parallel with an exaggerated articulation of the number word.

Stage 3: Inside the matrix, the CP-knowers mapped only one physically tagging of a dot onto one semantic expression of a number word (cf. the one-to-one principle). This transformation of units from the hand-held-dice was based on visual, tactile or mental representations of numerosity. Except for Hans who linguistically treated the two addends as separate parts, the CP-knowers showed verbal skills in counting on from the largest addend (cf. the stable order principle). C4-knower Garth also started to count from "One", but he kept on counting past the cardinality of the hand-held dice. Regarding the spatial and temporal features of the kinaesthetic modality, some participants walked in a delayed mode while others combined jumping and rhythmic moves in a rapid, precise and flexible appropriation of the spatial layout of the dots.

Stage 4: Regarding the final body-spatial tagging that stated the sum, a recurring kinaesthetic pattern for the CP-knowers was to halt in a one-legged body-pose. Some also attributed an auditory dimension as the final step was expressed in a more physically distinct way. This behaviour was often accompanied with an accentuated and prolonged articulation of the sum. Some children also attributed personal gestalts, bodily rotations and aesthetic moves to the physical tagging of the cardinal value. In contrast, C4-knower Garth continued to count and walk past the numerosity of the hand-held-dice without assigning a final tag to any physical or semantic significance. Regarding conceptualisation of the sum, participants with solving proficiency either stated the cardinal value unasked, repeated the last articulated number-word by request or via the counting-all-strategy.

The results show that major differences across solution proficiency were mediated in their multimodal use and synthesis of numerosity in the counting-on part of the min-task (cf. Stage 3). In particular, four children showed a preference for the use of tactile support, two for visual and two for mental based representations of numerosity, while two showed flexibility in a varied use of these forms of

representations in the integration with the semantic and kinaesthetic modalities. Based on this, the next section presents examples and rich description for each of these categories.

Preference in tactile based representations of numerosity: A shared feature for this group is the use of fingers for touch-counting the dots on the dice (cf. Stage 3, see Figure 3). Hence, tactile sensory information supported the synchronisation of articulation, visual perception and physical tagging of the configuration of the dice and the spatial layout in the matrix.

Preference in visual based representations of numerosity: A core feature of the “visual counters” is their use of the eyes to coordinate visual pointing and tagging of dots in the transformation of numerical information to the counting-on part of the min-task (cf. Stage 3, see Figure 4). Rich descriptions of Jon’s task solution aim to illustrate this group’s proficiency: A recurring pattern was to physically tag the largest addend as a whole, then slowly walk into the matrix and, supported by visual examination of the dice in between each tagging, continue to map the numerosity onto the semantic and kinaesthetic domain to produce the sum. However, in the following excerpt, which starts after the dice show 6 and 6, he deviates from his normal pattern:

Jon: Six and six [Jon uses a finger to touch-count the dots on both dice] One, two ... 11, 12. [He picks up a dice and tags the other using his right leg] Six. [He jumps into the matrix and without looking at the dice he continues in direct physical tagging in synchronisation with verbalising] Seven, eight ... 11, 12 [In a one-legged pose, he articulates the sum in an extended manner]

C4-knower Garth is also categorised as a “visual counter”, although incompletely compared to the proficiency described above. For example, in the 5+3- and 6+5-tasks, he counted to 10 and 22 respectively and only partially based his actions on what seemed to be “visual tagging”. Moreover, in these sequences, he lost control over the feet-dot mapping.



Figure 6: Multimodal mapping of the largest addend (Stage 2)



Figure 7: Rhythmic mapping (Stage 3)



Figure 8: Rapid, fluent and precise physical mapping (Stage 3)



Figure 9: Bodily rotation in expressing the sum (Stage 4)

Preference in mental-based representations: Shared features for this group comprise the use of subitising or pattern recognition to perceive numerical information from the dice (cf. Stage 1), articulated one-legged body-pose in mapping of the largest addend (cf. Stage 2) and mentally maintaining and retrieving numerical information to support the counting-on part of the min-strategy (cf. Stage 3). The smallest addends within the subitising range were most often mapped directly. However, when the smallest integer was larger than three, they could also perceive visual information from the dice one time during the process. Additional recurring patterns were in the form of precise and rapidly articulated body-spatial mapping, which was mediated as rhythmic verbalisations and

steps in between dots in expressing the ordinal structure of the counting based addition (cf. Stage 3, see Figures 7 and 8). Moreover, they often attributed an exaggerated verbalised and prolonged physical mediation of the sum with creative moves and aesthetic body-poses (cf. Stage 4, see Figures 5 and 9). Below, rich description of Oda's task solution illustrates this group's proficiency. In tasks where the smallest addend is less than and sometimes equal to four (e.g. $5+2$, $5+3$, $6+3$ and $6+4$), Oda showed mental fluency in the numerical mapping, as she did not look at the dice after entering the matrix (cf. Stage 3). The following excerpt exemplifies her behaviour when the smallest addend was larger and it starts after the dice show 6 and 6:

Oda: [Oda picks up one dice and tags the other with her left foot] Six. [She briefly holds the gestalt, jumps into the matrix and tags dots in a rapid motion in synchronisation with articulating] Seven, eight, nine, 10 [She halts and quickly looks at the dice before she continues in rhythmic tagging] 11, 12 [The articulation of the sum is extensive as she performs a one-legged bodily rotation]

Cross-modal variations in use of representations: Two participants showed flexibility across tasks in terms of a varied use of mental, tactile and visual support for modulation of numerical information in the counting-on part (cf. Stage 3). This is exemplified by Viola, who applied retrieval of mental magnitudes when the smallest addend was within subitising range and varied between using visual- and tactile based representations to solve other tasks (e.g. $6+5$ and $5+5$).

Discussion

Based on the shared experiences of 4- and 5-year olds in a matrix to support early appropriation of the min-strategy, this study investigates the participants use and coherence of multimodal representations of numerosity in task-solution. The post-tests show that eight of the participants mastered the min-task, while two of the children lacked solving proficiency. Beyond this dichotomy, the preference for touch-counting, visual-counting or mental based representations of numerosity reflects major categories concerning the integration of modalities in the min-task.

A core signature for children with a preference to the retrieval of numerical information to support embodiment of the ordinal structure of the min-strategy is a fluent numerical interaction between the semantic and kinaesthetic modalities. This is exemplified by Oda in the $5+3$ -task, where she projects a visual pattern recognition of the largest addend and the subitising of the smallest integer into a two-staged coherent motion in parallel with the articulation "five" and then "six, seven, eight" (cf. Stage 2 and 3, respectively). This group's ability to maintain mental magnitudes and modulate cognition of addition into compound body movements is further exemplified in the $6+6$ -task. Based on visual pattern recognition of the numerosity, Oda's interaction suggests that she mentally decomposes the additive structure into three parts (i.e. 6, 4, 2), which are perceived and retrieved one at a time and holistically expressed as a three-staged movement trajectory reflecting a part-part-part-structure of the whole (i.e. 12). Moreover, this group's preference in mental retrieval seems to support motor creativity and verbal manipulation across the four stages of task solution. This is mediated in the form of a louder articulation and a harder physical tagging of the largest addend and the sum, rhythmic mappings of the smallest addend and in the integration of personal gestalts and bodily rotations in expressing the sum (cf. Figures 5 to 9).

The “eye- and touch-counters” are characterised by the use of visual or tactile based representations of numerosity in a resource demanding integration with the kinaesthetic and semantic modalities. Shared features include the use of the hand-held dice for cross-modal transformation of one unit at a time and this ordinal structure seems to be projected in a stiff body-spatial mapping. However, in the 6+6-task “visual counter” Jon deviates from this pattern as a pre-count enables him to mentally maintain the sum of the addition during action. Hence, he replaces visual counting and a delayed gait with a fluent multimodal mapping of the counting-on-strategy.

Regarding the children who do not solve any of the tasks, Garth is not able to follow the rules of the min-strategy, nor is he able to recognise or enact the multimodal correspondence between the spatial information of the affordances and the kinaesthetic and semantic domains. Moreover, his proficiency in exact enumeration as a C4-knower might explain his lack of the necessary abilities to embody the parts and the whole of the additive structure. By contrast, Hans demonstrates proficiency in coherent mappings of numerosity across modalities, but he is not able to use verbal skills to combine the two addends into a whole. Thus, this suggests that his mastery of the min-tasks is a linguistic matter in terms of a flexible use of the stable order principle (Gelman et al., 1978).

To sum up: The findings show cross-modal variations in the participants’ mediation of partitioning, boundaries and the interior of the additive structures. The results also suggest that the ability to apply the abstraction principle in terms of storage and retrieval of mental magnitudes supports fluency in the semantic and physical modalities of numerosity. In contrast, participants that mapped information from the dice in between each mapping seem to use their cognitive and motor resources with the complex synchronisation of eye, dice, finger, feet and matrix. These variation in strategy usage might be explained in individual differences in working-memory capacity (Noel et al., 2003), the participants’ competences in applying bodily semiotic resources and their proficiency in the learning trajectories counting, subitising and addition (Clements et al., 2013).

Summary and concluding remarks

Countering a view of cognition which sees mathematics as a fixed disembodied phenomenon, this study presupposes that arithmetic structures must be embodied by each child, as the body with its motor system is an integrated part of thinking that works dialectically with and under the guidance of both external factors and cognitive processes (Seitz, 2000). Thus, by grounding the additive structure in the body language of 4- and 5-year olds, we examine their use and coherence of multimodal representations of numerosity in counting-based addition. The findings show that mediation of the min-strategy rests on the children’s ability to structure and synchronise cross-modal and mental based partitioning of numbers and manipulation of the interior and the boundaries of sets. Hence, this study contributes to embodied cognitive theory, which regards the body as an open and available resource for thinking, learning and social activity (Stevens, 2012). In particular, it demonstrates how embodied experiences in ecological rich milieus might conflate with arithmetic structures (Lakoff et al., 2000). However, the study is limited in the sense that we cannot make any claims of strategy generalisation (Siegler & Jenkins, 1989). Yet, even though some participants have problems to discern the additive structure embedded in the complex scene, our overall results suggest that the min-activity might

facilitate 4- and 5-year olds ability of to synchronise multimodal representations of numerosity in a manner that reflects coherence of the min-strategy.

References

- Clements, D. H. (1999). Subitizing: What is it? Why teach it? *Teaching Children Mathematics*, 5(7), 400-405.
- Clements, D. H., & Sarama, J. (2013). Rethinking early mathematics: What is research-based curriculum for young children? *Reconceptualizing early mathematics learning* (pp. 121–147). Dordrecht, The Netherlands: Springer.
- Crollen, V., & Noël, M.-P. (2015). The role of fingers in the development of counting and arithmetic skills. *Acta Psychologica*, 156, 37–44.
- Fuson, K. C. (1988). *Children's counting and concepts of number*. New York, NY: Springer.
- Gelman, R., & Gallistel, C. R. (1978). *The child's understanding of number*. Cambridge, MA: Harvard University Press.
- Howison, M., Trninic, D., Reinholz, D., & Abrahamson, D. (2011). *The mathematical imagery trainer: From embodied interaction to conceptual learning*. Paper presented at the Proceedings of the SIGCHI Conference on Human Factors in Computing Systems.
- Johansen, M. W. (2010). Embodied strategies in mathematical cognition. In B. Löwe, & T. Müller (Eds.), *PhMSAMP Philosophy of mathematics: Sociological aspects and mathematical practices* (pp. 179–196). London, England: College Publications.
- Lakoff, G., & Núñez, R. (2000). *Where mathematics comes from: How the embodied mind brings mathematics into being*. New York, NY: Basic Books.
- Lee, M. D., & Sarnecka, B. W. (2010). A model of knower-level behavior in number concept development. *Cognitive Science*, 34(1), 51–67.
- Noel, M.-P., Seron, X., & Trovarelli, F. (2003). Working memory as a predictor of addition skills and addition strategies in children. *Current Psychology of Cognition*, 22(1), 3–24.
- Seitz, J. A. (2000). The bodily basis of thought. *New Ideas in Psychology*, 18(1), 23–40. doi: [http://dx.doi.org/10.1016/S0732-118X\(99\)00035-5](http://dx.doi.org/10.1016/S0732-118X(99)00035-5)
- Siegler, R., & Jenkins, E. (1989). *How children discover strategies*. Hillsdale, NY: Erlbaum.
- Stevens, R. (2012). The missing bodies of mathematical thinking and learning have been found. *Journal of the Learning Sciences*, 21(2), 337–346.
- Thom, J. S., & Roth, W.-M. (2011). Radical embodiment and semiotics: Toward a theory of mathematics in the flesh. *Educational Studies in Mathematics*, 77(2-3), 267–284.
- Yin, R. K. (2009). *Case study research: Design and methods*. (4th ed.). Thousand Oaks, CA: Sage Publications.
- Zmigrod, S., & Hommel, B. (2013). Feature integration across multimodal perception and action: A review. *Multisensory Research*, 26(1-2), 143-157.

Development of strategies for a combinatorial task by a 5 year old child

Kerstin Bräuning

University of Halle-Wittenberg, Germany; braeuning.kerstin@gmail.com

The transition from kindergarten to first grade is a very special time for children. In a longitudinal research project over two years, we interviewed children up to 6 times individually. They solved several tasks from different mathematical areas. In this study, I will present one combinatorial problem and analyze approaches to solve it by one child over two years as a case study using the strategies of Hoffmann (2003). How does this child solve the combinatorial problem before school, just after the school start and at the end of grade 1? What kind of different information do we get if we analyze the data product-oriented or process-oriented? Observing and analyzing the child's approaches and development over time will be at the heart of this paper.

Keywords: combinatorics, combinatorial reasoning, Piaget, preschool education, elementary school

Introduction

The domain of combinatorics is a very interesting and fertile field for research in mathematics education. Even young children can discover the rich mathematical structure and can become acquainted with mathematics as the art and science of patterns (Devlin 1995). Still this topic is not the best recognized one in elementary school, as English (1991, p. 451), almost 30 years ago mentioned. Hoffmann (2003, p. 3) indicates that combinatorial problems are interesting because previous knowledge is not necessary. It is possible to solve combinatorial problems in an activity-oriented and material-oriented fashion; it is easy to build analogous problems on a higher level; one can choose different ways to arrive at the solution. Furthermore, problem-solving approaches can become apparent and children are encouraged to mathematical communication and argumentation skills.

Theoretical background

Piaget and Inhelder (1975) investigated in their studies the development of a combinatorial system connected to the Piagetian developmental stages. They find out that children in the preoperational stage search without a system, in the concrete operational stage they search for a system and in the formal-operational stage, they search systematically and use the odometer strategy. Their ability to reason and argument is increasing similar to their search for a system. Combinatorial problems play not only an important role in cognitive development but mathematics education researchers like Piaget and Inhelder (1975) found that they may promote students' reasoning and generalization processes. Further research showed that there are first steps to a systematical search and that the task should be in a more suitable and meaningful context and material should be more child appropriate (English 1991, p. 453).

Further studies investigated the strategies of the children when solving a combinatorial task. I refer to two studies explicitly because in my study I deal with almost the same age range and videotapes like English (2005) and with a case study like Martino (1992). English (2005, p. 129) videotaped 50

children between 4.5 and 9 years, solving combinatorial tasks. She analyzed the video material without transcripts. In comparison to English, I observe the children several times over two years. I use transcripts to reconstruct the approach of the child when solving the combinatorial task. Martino (1992) dealt with the understanding and development of mathematical ideas using combinatorial tasks as one example. She looked at three case studies. She observed children in grades 2, 3 and 4 in pairs or a group of three without the intervention of a teacher. I observe children from 5 to 7 years old in one-to-one-interviews with an interviewer, as an observer, and so I examine a younger group of children. Looking at younger children is especially interesting because combinatorial problems also “facilitate the development of enumeration processes, as well as conjectures, generalisations, and systematic thinking” (English 2005, p. 122) and these are key components of mathematical understanding.

Hoffmann (2003), based on the two studies mentioned above, worked out that there are macro and micro strategies. Macro strategies are guiding actions for a structured finding of all combinations. One strategy is the odometer strategy, “holding one item constant while systematically varying each of the other items” (English 1991, p. 451). Other strategies are, the entire counterpart construction, and looking for the solution in phases. Micro strategies describe patterns of action to find the next combination or find some of the combinations. For my study, only the following seem relevant: 1- and 2-constant-principle, stair formation, counterpart construction and turn around. In the analysis part, I will describe them on more detail.

The study reported here made use of two levels of manipulative materials. The concrete external representation enables the children to handle the material and keep their focus on the solving process without representing their solution on paper. English (1991, p. 453) stressed that young children would display more sophisticated combinatorial approaches than suggested by the Piagetian studies. Further on English (2005, p. 128) assumes that preoperational children (like the children in my study) “generate combinations only in an empirical manner by randomly associating elements” and her conclusion is that “there is a lack of systematic method”. This study addressed this assumption in the course of a longitudinal study over two years where each child solved the same combinatorial task up to six times in a one-to-one-interview. The idea of repeating always the same task without teaching is that the children need time to become acquainted with this task. In addition, the verbalization competence is restricted with young children, but they have the possibility to show their thinking by using materials, gestures, deictic expressions (Werner 2018) and also by us observing their actions in process. Previous studies looked at the products children developed when they solved combinatorial tasks and because of the young children, I take a process-oriented view on the children’s actions. Even more, I could not find any studies, which had a longitudinal view on the solving of combinatorial tasks of young children. English (2005, p. 130) observed the learning across the set of tasks dealing with combinatorics at one interview point.

The present report examines the following research questions focused on one case study for a first small analysis of all collected data:

What kind of approaches does a child, aged 5 to 7 years, use in solving the same combinatorial problem several times over two years?

To what extent does the analysis method, product-oriented or process-oriented, show a different view on the way of finding all combinations for a combinatorial task of one child (5-7 years)?

Research project

Sample

The study is called “mathematics and first day at school – talking with children in the transition from kindergarten to primary school” (MaScha). The key aspect of this study is to investigate the (re)interpretation and strategy diversity of children from the last year of kindergarten (preschool) to the end of grade one in several different mathematical areas. It includes finger patterns, one problem solving task, one combinatorial task and the attitudes of children to mathematics teaching and mathematics as a teaching content. In this paper, I will only focus on the combinatorial problem.

The study involved 14 children (8 boys, 6 girls) from a rural area. They all attended the same kindergarten and the same class in primary school. At the beginning of the study, they are all in their last year of kindergarten (5 or 6 years old). The end of the study is at the end of first grade and they are almost all 7 years old. Surveys were conducted every three months in the last year of kindergarten (December 2015, February 2016, May 2016) and every 5 months at the beginning, in the middle and at the end of the first school year (September 2016, February 2017, June 2017). Each child is interviewed for about 30 minutes in a one-to-one-interview. The interviews are all video documented and interesting parts are transcribed for analysis. The interviews take place during school time but are additional to teaching. The interviewer is either a pre-service teacher who attended a seminar on talking with children about mathematics or the researcher. It follows a semi-structured interview guide, which is competence-oriented and can be widened with questions to better understand the comprehension of the child and with additional analogous tasks if necessary. The semi-structured interview guide remains the same over the two years because I can only recognize changes or process of development in the (re)interpretation and strategy use of the children when they were familiar with the task and knew what to do. Especially the assisted problem solving with the interviewer could help the children, and like Freudenthal (1973, p. 110) said, “the best way to learn an activity is to perform it”. On the other side, the tasks have to be sufficiently challenging so the children have to solve the tasks every time from scratch and cannot remember the solution like an easy calculating task.

The competence of the interviewer influences the results of the interviews with the children. Therefore, the same interviewer interviews most of the children over the two years to keep the influence constant. The interviewer sometimes gives instructions or intervenes (Bräuning & Steinbring 2011) to establish a “common base of understanding” (Bräuning & Steinbring 2010) between the child and the interviewer and to give the children the chance to deal with unfamiliar tasks. The kindergarten teacher and the primary teacher were only told that the interviewer is talking with the child about mathematics for around 30 minutes. They were not given the tasks so that the teacher is not able to train the children and cannot intervene.

The combinatorial task called bears task is: “You have three bears, a yellow, a blue and a green bear. They move into a tower. Each bear lives on one level. How many different ways can they live in the tower?”. The children were given eight towers (without a roof to avoid confusion) drawn on paper and several yellow, blue and green plastic bears (more than 20 bears).



Figure 1: Solution of the bears task interview 1 with Lena final product

We offered the children more material than needed so that they have to decide if they found all combinations on their own. Similar to the bears task the problem is often presented with blocks which the child puts together. The advantage for the bears task is that through the tower on paper and the placing bears, two dimensions for representing the child's approach are available. Especially if a very detailed process-oriented view on the approach is taken the researcher can identify on which level at what time the child is placing a bear and where the child is looking at to find a new combination. Through the video documents and the transcripts, eye and head movements are observed. This would be easier using eye tracking, but it probably would be an artificial situation for the child, therefore we did not use it.

Realization of the interview

When the child solved the task with material there was preferably no inquiry. At the end the question, "How many ways did you find" is posed. If the child found the same combinations several times, or less than three combinations the interviewer asked: "Can you find double combinations in how you have bears living in towers? Can you find additional combinations? How often can you find yellow (blue, green) on the lower (middle, upper) level?" I think these questions are very important because during the analysis there occurred the phenomena that some children had a lot of trouble with understanding equality. Some of them interpreted equal as identical so that every tower constellation even with the same order of colors was a new combination for the child.

In the reflection phase, the children were asked: "What can you notice if there is yellow twice on the lower, middle and upper level? Are you sure you found all combinations? Please explain". Hoffmann (2003, p. 260) observed that her youngest participants (7-9 years old) could not justify repositioning their combinations. As this challenge was too much for them, I decided for the 5 to 7 years old children not to pose this demand. Instead, we asked them to explain why they think that they completed the task. Some of the children developed their argumentation skills and were able to explain their approach. By means of these explanations, the macro strategy can probably be identified.

Analysis of one case study

I will present as a case study Lena. She is interviewed six times. I chose her because five interviews were conducted by the same interviewer, and only the fifth interview was by another interviewer. Therefore, the influence of the interviewer is kept almost constant. This is especially important because the interviewer posed different questions, which I distinguish in subject-specific questions and non-subject-specific questions. In another paper, I will analyze the influence of these two types of questions for the explorative investigation of the child's thinking. I will present the analysis of three interviews of three specific moments. The analysis of her first interview represents the first contact of Lena with this task. Her fourth interview is just one month after the first day of school and

so she is still getting used to this new institution. At the end of first grade, the sixth interview shows the end of development in her approaches because it is the final interview of this study.

In the product-oriented analysis, I always present the final product of the solving process in the interview and in the process-oriented analysis I describe each change and the whole process precisely in order the child placed the bears in the tower and the order of the towers. The eight towers on paper are represented in two rows of four towers. The researcher when transcribing the video document writes down the order. In the coding table, you will find the order of towers with T1, T2, etc. and the order of placed bears in an extra column for each tower. The researcher and his team watch the video several times to identify each hand and eye movement and analyse the transcript qualitatively.

The following micro strategies referring to Hoffmann (2003) are identified in the previous analysis:

1-constant-principle: the color of one level will be fixed. For three-dimensional combinatorial tasks, an implicit 1-constant-principle occurred in the process-oriented analysis where at first two colors will change places and then the constant will be placed implicitly or automatically the third color keeps constant.

Stair formation: the colors “walk” through the levels (entire or single stair formation)

Counterpart construction: changing the two possible colors between two combinations (only for multiples of two-dimensional combinatorial tasks). With three-dimensional combinatorial tasks, this corresponds to the 1-constant-principle or the implicit 1-constant-principle.

Turn around: two combinations are the same when rotated 180°.

The macro strategy is reconstructed out of the most frequent occurrence of micro strategies and the verbal justification of the child.

In the first interview with Lena in December 2015, she found six combinations. Tower 6-4 means that Lena found this combination after rejecting three other possibilities. I present the solution in this table because I want to compare Lena’s solutions at different interview points and to give more consistency (you can see the real picture in Figure 1).

T5 Blue Yellow Green	T6-4 Yellow Blue Green		
T4 Green Yellow Blue	T3 Yellow Green Blue	T2 Green Blue Yellow	T1 Blue Green Yellow

Table 1: Solution of the bears task interview 1 with Lena final product

From T1 to T2 yellow remains constant and so the 1-constant-principle can be identified. The 1-constant-principle also occurs as from T3 to T4 blue is constant and from T5 to T6-4 green is fixed. T2 to T3 is an entire stair formation. T4 to T5 is a “turn around” or a 1-constant-principle where yellow remains in the middle. In consideration of the identified micro strategies, a kind of odometer principle is inherent, because Lena uses a lot the 1-constant-principle. Analyzing the same approach with a process-oriented view provides another insight into strategies Lena used.

T5 Blue Yellow Green	3 2 1	T6-4 Yellow Blue Green	10 9 8 (I)				
T4 Green Yellow Blue	3 1 2	T3 Yellow Green Blue	2 3 1	T2 Green Blue Yellow	3 1 2	T1 Blue Green Yellow	1 2 3
		T6-1 Blue Green Yellow	3 1 2	T6-2 Green Blue Yellow	5 4 -	T6-3 Green Yellow Blue	- 7 6

Table 2: Solution of the bears task interview 1 with Lena process

From T1 to T3 there is a single stair formation and between T2 and T3 even an entire stair formation. T3 to T4 is not identified and T4 to T5 is a “turn around”. T5 to T6-1 is an implicit 1-constant-principle and T6-1 to T6-2 a 1-constant-principle where Lena detect the identity to T2 and rejects this combination. T6-2 to T6-3 is also the 1-constant-principle and identical to T4; Lena also rejects this combination. From T6-3 to T6-4, there is an implicit 1-constant-principle. In consideration of the identified micro strategies we can recognize that Lena’s’ approach is very inconsistent and cannot identify a macro strategy. English (1991, p. 458) named this strategy trial-and-error-procedure with random item selection and rejection of inappropriate items whereupon in this study the interviewer asked the child if there are identical combinations. In addition, I present some of the interviewer’s questions posed to Lena. “Are they all different (the towers) which you posed here?”, “How often does a yellow bear live in the lower level?”, “Compare these two (towers)”, ... These questions influenced of course the way of Lena’s solving process, but these affects occur in the product-oriented and process-oriented analysis and nevertheless there is a difference. Even more the interviewer wanted to give stimuli to deepen the mathematical thinking of the child.

	Product	Process
Micro strategies	T1/T2: <i>1-constant-principle</i> T2/T3: <i>entire stair formation</i> T3/T4: <i>1-constant-principle</i> T4/T5: <i>turn around or 1-constant-principle</i> T5/T6-4: <i>1-constant-principle</i>	T1-T3 <i>single stair formation</i> T2/T3 <i>entire stair formation</i> T3/T4 ? T4/T5 <i>turn around</i> T5/T6-1 <i>implicit 1-constant-principle</i> T6-1/T6-2 <i>1-constant-principle, identical to T2</i> T6-2/T6-3 <i>1-constant-principle</i> T6-4 <i>implicit 1-constant-principle</i>
Macro strategies	Mainly <i>1-constant-principle</i> -> <i>odometer principle</i>	???

Table 3: Comparison of the product-oriented vs. process-oriented analysis of Lena’s solution 1

I will only present the comparison of the product-oriented vs. process-oriented analysis of Lena’s solution 4 and 6.

	Product	Process
Micro strategies	T1-T3: <i>entire stair formation</i> T4-T5: <i>entire stair formation</i>	T2/T4 <i>1-constant-principle, yellow remains in the middle, blue and green change</i> T3/T5 <i>1-constant-principle, yellow remains in the lower, blue and green change</i>

	T6/T7 identical to T3 T8 identical to T1	T4/T6 <i>1-constant-principle</i> , green remains in the middle then see identical to T1 T5/T6 <i>1-constant-principle</i> , yellow remains in the lower, then blue and green change T6/T7 identical to T3 T8 identical to T1
Macro strategies	Mainly stair formation -> odometer principle	Mainly 1-constant-principle -> odometer principle

Table 4: Comparison of the product-oriented vs. process-oriented analysis of Lena's solution 4

In September 2016 some weeks after the first day of school, Lena had her fourth interview. She already used an emerging pattern in item selection. Interesting is that it is the same micro strategy for the whole solution process but a different one for product-oriented or process-oriented analysis. Lena did not identify the identical ones and she could not justify her approach.

	Product	Process
Micro strategies	T1/T2 turn around T2/T3 stair formation T3/T4 1-constant-principle, yellow remains in the upper level, green and red change T4/T5 stair formation T5/T6 1-constant-principle	T1/T2 implicit <i>1-constant-principle</i> T1/T2/T3 green in every level, <i>single stair formation</i> T3/T4 <i>1-constant-principle</i> T5/T3 <i>1-constant-principle</i> T6/T1 <i>1-constant-principle</i>
Macro strategies	???	Mainly 1-constant-principle -> odometer principle

Table 5: Comparison of the product-oriented vs. process-oriented analysis of Lena's solution 6

In the sixth interview with Lena in June 2017, the product-oriented analysis cannot find a macro strategy but if we look at the process-oriented analysis, there is evidence that Lena uses the odometer principle without rejecting any combination. She does not use the odometer principle visibly from the beginning but if she checks her solutions, one can observe it. Even more she justifies her approach after the question “how can you quickly check that they are all different?” with “these two have to change all the time (points to T6 and T1) and these also (points to T5 and T2) and also those (points to T3 and T4)”. Looking at Lena's progression from the first to the sixth interview, she developed a more efficient solution procedure, which is only observable with the process-oriented analysis and is confirmed by Lena's verbal justification of her approach.

Closing remarks and outlook

To answer the posed research questions, I refer to the studies of English (1991, 2005). English (2005, p. 128) assumes that preoperational children (like the children in my study) “generate combinations only in an empirical manner by randomly associating elements” and her conclusion is that “there is a lack of systematic method”. Looking at the analysis of the case study, Lena uses quite different strategies when analyzing her approaches product-oriented or process-oriented. In her first interview in the product-oriented interview, it seems that Lena is already “emerging pattern in item selection, with rejection of inappropriate items” (English 1991, p. 458). This could be traced back to the interviewer's questions. If you compare it to the process-oriented analysis you can see that Lena uses the trial-and-error-procedure with random item selection and rejection of inappropriate items. In the sixth interview the interviewer does not pose any questions and in the process-oriented analysis it

seems evident that she uses the “odometer principle without rejecting any combination” (English 1991, p. 461). There is an obvious development in Lena’s solving approaches when using the process-oriented analysis. It seems that the process-oriented analysis method is more appropriate to this young child and probably to all young children with restricted verbalization possibilities. So probably preoperational children are already able to evolve strategies from dealing several times with the same task and an explorative supervision of the interviewer. In the sixth interview, Lena is able to justify her conclusion by making the following statement: “these two have to change all the time (points to T6 and T1) and these also (points to T5 and T2) and also those (points to T3 and T4)”. Hoffmann (2003, p. 260) observed that her youngest participants (7-9 years old) could not reposition their combinations with justification. There will be further analysis of the children’s development over two years especially qualitative interpretative analysis of the communication and interaction between child and interviewer (Bräuning & Steinbring 2011). The possibilities of young children to express their mathematical thinking is quite different to that of older children and adults. Looking at the approaches of young children, researchers should seek methods to observe and to analyze strategies of children who have limited possibilities to verbalize their thinking.

References

- Bräuning, K., & Steinbring, H. (2010). Bedingungen praxisbezogener Professionalisierung von Mathematiklehrkräften. In B. Brandt, M. Fetzner, & M. Schütte (Eds.), *Auf den Spuren Interpretativer Unterrichtsforschung in der Mathematikdidaktik* (pp. 291–317). Münster, Germany: Waxmann.
- Bräuning, K. & Steinbring, H. (2011). Communicative characteristics of teachers’ mathematical talk with children. From knowledge transfer to knowledge investigation. *ZDM–The International Journal of Mathematics Education*, 43, 927–939.
- Devlin, K. (1996). *Mathematics: The Science of Patterns*. New York, NY: Freeman.
- English, L. D. (1991). Young children’s combinatoric strategies. *Educational Studies in Mathematics*, 22(5), 451–474.
- English, L. D. (2005). Combinatorics and the development of children's combinatorial reasoning. In G. A. Jones (Ed.), *Exploring probability in school: Challenges for teaching and learning* (pp. 121–141). New York, NY: Springer.
- Freudenthal, H. (1973). *Mathematics as an educational task*. Dordrecht, The Netherlands: Reidel.
- Hoffmann, A. (2003). *Elementare Bausteine der kombinatorischen Problemlösefähigkeit*. Hildesheim, Germany: Franzbecker.
- Martino, A.M. (1992). *Elementary students’ construction of mathematical knowledge: Analysis by profile*. Unpublished doctoral dissertation, Rutgers, the State University of New Jersey, New Brunswick, NJ.
- Piaget, J. & Inhelder, B. (1975). *The origin of the idea of chance in children*. New York, NY: Norton.
- Werner, B. (2018). *Mathematik inklusive. Grundriss einer inklusiven Fachdidaktik*. Stuttgart, Germany: Kohlhammer.

Kindergarten teachers' orchestration of mathematical learning activities: the balance between freedom and structure

Svanhild Breive¹

¹University of Agder, Norway; svanhild.breive@uia.no

This paper reports on a multiple-case study which focuses on four kindergarten teachers' orchestration of mathematical learning activities with respect to the degree of freedom, and what impact their orchestration has for children's mathematical learning possibilities. The study draws on Valsiner's (1987) zone theory to investigate the relationship between zone of free movement (ZFM) and zone of promoted action (ZPA) which the kindergarten teachers set up to canalise children's actions and thinking and thus development. The results show that in the kindergarten where the ZFM is gently set up and limited to mathematics, and where the kindergarten teacher sensitively sets up the ZPA and promotes children to share, argue for and explain their mathematical ideas, and explicitly promotes the children to collaborate, is where most problem-solving interaction occur and thus facilitate children's learning possibilities the most.

Keywords: Kindergarten, mathematics, orchestration, zone of free movement, zone of promoted action.

Introduction

This paper reports on a multiple-case study which aims to investigate four kindergarten teachers' (KTs') orchestration of pre-designed mathematical learning activities and what impact their orchestration has for children's learning possibilities. The current debate about mathematics in kindergarten is seldom about whether or not mathematics should be part of the curricula in kindergarten, rather on how mathematical activities in kindergarten should be orchestrated¹ (Gasteiger, 2012; Hirsh-Pasek, Golinkoff, Berk, & Singer, 2009; van Oers, 2010). Children's opportunities to take part in mathematical discourses are important in learning mathematics, but in activities where the kindergarten teacher has a pedagogical aim, it may be difficult to balance teacher-talk and child-talk (Dovigo, 2016). The study reported here focuses on four KT's orchestration of mathematical learning activities with respect to the degree of freedom² and aims to:

- Investigate the characteristics of four kindergarten teachers' orchestration of pre-designed mathematical activities with respect to the degree of freedom, and;
- Investigate what impact the four kindergarten teachers' orchestration of the mathematical activities has for children's mathematical learning possibilities.

¹ The term 'orchestration' is used in accordance with Kennewell (2001), as a broad metaphor for how the KT's structure or organise the activity through use of questions, cues, prompts, information, demonstrations etc.

² The term 'degree of freedom' is used in accordance with van Oers (2014) as a characteristic of the way an activity (in cultural-historical activity theory) is carried out and refers to the "degrees of freedom allowed to the actor in the choice of goals, tools, or rules" (p. 113, emphasis in origin), which in turn initiates the actor's choices of actions.

Theoretical framework

The study reported here draws on Valsiner's (1987) zone theory to investigate the relationship between freedom and structure in four KT's orchestration of mathematical learning activities. The balance between freedom and structure is the main focus when Hirsh-Pasek et al. (2009) and Weisberg, Kittredge, Hirsh-Pasek, Golinkoff, and Klahr (2015) discuss 'playful learning' as an educational approach in kindergarten. Playful learning captures both 'free play' where children play without interference from adults, and 'guided play' where the KT organises the learning environment and guides the play in desired directions with respect to a learning aim. Weisberg et al. (2015) argues that, although the KTs initiate and guide the activity in guided play, the KTs must make room for children's self-directed exploration, and it is this balance between freedom and structure that makes guided play such an effective teaching tool. Similar van Oers (2014) argues that playful learning activities should contain some elements of instruction. "The nature of the actions embedded in play can vary with respect to their degree of freedom allowed, as long as the activity as a whole remains a playful activity" (van Oers, 2014, p. 121). The learning activity must be engaging and give possibilities for the players freedom to explore the (mathematical) objects in their own manner.

In his study on preschool children's argumentation, Dovigo (2016) investigates children's learning opportunities in different types of conversations (peer-talk and child-teacher talk). Dovigo found that children had richer opportunities to participate and asked more questions in peer-talk than in child-teacher talk. It was a clear tendency that in child-teacher talk, the KT talked more than the children. However, the children's abilities to build arguments were limited in peer-talk and were facilitated in child-teacher talk. The KTs facilitated children's explanations and helped them to elaborate their argumentations, which again improved children's critical thinking and abilities to collaborate.

Through his zone-theory, Valsiner (1987) explores the development of children's actions and thinking through organisation of person-environment relationships. The physical environment of the child is the cultural frame which the child is acting within and thus develop its thinking. Valsiner's theory emphasises that both the developing child and the environment are structurally organised, however the structuring nature of the child and the environment is continuously and dynamically transformed. Valsiner (1987) uses three zone concepts to conceptualise the dynamic environmental structures that organise the child's development: Zone of Free Movement (ZFM); Zone of Promoted Action (ZPA); and Zone of Proximal Development (ZPD). The ZFM is co-constructed by the child and the adult and organises the "child's (1) access to different areas in the environment, (2) availability of different objects within an accessible area, and (3) ways of acting with available objects in the accessible area" (p. 97). Within the ZPA there may be activities or objects which the child is promoted to engage with. An important characteristic of the ZPA is its non-binding nature: The child does not need to follow the ZPA and can act with other objects (in other ways) within the ZFM. The child cannot be 'forced' to accept the ZPA unless the ZPA is turned into ZFM. The ZFM and ZPA must be considered as a unit and Valsiner (1987) labels it the 'ZFM/ZPA complex'. The ZFM/ZPA-complex work as a mechanism to canalise the child's actions and thinking and thus development in culturally accepted ways. In addition, Valsiner (1987) discusses how ZPD relates to the ZFM/ZPA-complex, but due to space limitations, this study focuses primarily on the relationship between ZFM and ZPA in four kindergartens with respect to mathematics.

Methodology

The study reported here is a multiple-case study (Yin, 2014), which aims to characterise four KT's orchestration of pre-designed mathematical activities and its impact for children's mathematical learning possibilities. It is part of a larger study on mathematical teaching and learning in kindergarten and situated within a Norwegian research and development project called the Agder Project³ (AP). The intervention of the AP was based on mathematical activities which were pre-designed in collaboration between researchers (including myself) and the KTs in the focus groups of AP. The mathematical activities suggest how to organise learning sessions, what materials to use and suitable questions to ask etc. in order to promote a playful and inquiry-based approach to the teaching and learning of mathematics. The activities were meant as suggestions not as scripts which the KTs needed to follow to the letter and this was communicated both verbally and in written form to the KTs before the intervention. The activities are described in Størksen et al. (2018), a book containing one-page outlines of the activities. This study takes a qualitative approach to data collection and data analysis and the empirical material was collected over two observation periods (autumn 2016 and spring 2017) during the intervention of the AP. Observations were conducted of approximately 40 minutes sessions where the four KTs, who were part of the focus groups of the project, implemented the pre-designed activities. Interviews were conducted in each kindergarten after each observation period. Overview over data sets (observations and interviews) in each kindergarten is illustrated in Table 1 below. All four KTs have at least 15-years working experience.

	KT1	KT2	KT3	KT4
Autumn 2016	5 obs. + 1 interv.	4 obs. + 1 interv.	5 obs. + 1 interv.	3 obs. + 1 interv.
Spring 2017	6 obs. + 1 interv.	7 obs. + 1 interv.	0 obs. + 0 interv.	4 obs. + 1 interv.

Table 1: Overview over data sets (observations and interviews) in the four kindergartens

The empirical material was collected through ethnographic field notes (Emerson, Fretz, & Shaw, 2011) from observations and interviews. Field notes were written during and/or straight after each observed session and were supplemented when having conversations with the KTs after each session. Field notes from the interviews were made straight after the interviews and were extended when the video-recordings of the interviews later were watched. Field notes should not, ideally, include interpretations of the observed interaction (Emerson et al., 2011). However, as Emerson et al. (2011) argues, when the fieldworker starts to work with the field notes, he/she orders patterns of interactions and decides what to include and leave out from the field notes. In this research study the research questions were made before conducting the field work, which guided what I was especially looking for and thus what I included and left out from the field notes. The field notes must therefore, to a certain extent, be regarded as interpretative or analytical.

³ The Agder project is funded by the Research Council of Norway (NFR no. 237973), The Sørlandet Knowledge Foundation, The Development and Competence Fund of Aust Agder, Vest Agder County, Aust Agder County, University of Agder and University of Stavanger.

Processing and analysing data went through an iterative process. Instead of using the field notes as ‘raw material’ from which I started a coding process, I worked directly with the field notes and carefully contracted them into profiles of the KT’s orchestration and their interaction with the children. Since the field notes were already to some extent analytical, they served as a useful starting point for this purpose. The profiles concern four key points: (1) Children’s access to different areas in the environment; (2) children’s freedom to act (physically) within the accessible area; (3) children’s freedom to contribute with questions, mathematical ideas and argumentations etc.; and (4) the degree to which problem-solving interaction was promoted (that is the degree to which the children were promoted to ask questions and explain and argue for their ideas to solve mathematical problems). Key points 1-3 concern the KT’s orchestration of the mathematical activities with respect to the degree of freedom and intends the ZFM. Since the ZFM is co-constructed by the child and the adult, children’s eagerness to participate and take initiative are also used to identify ZFM. Key point 4 concerns how the KT’s promote children to ask questions, explain and argue for mathematical ideas to solve mathematical problems, which intends the ZPA. As Valsiner (1987) argues, ZFM and ZPA are related and work as a unit to canalise children’s development, and in this case, learning and development related to mathematics. In this study I identify learning possibilities whenever the KT’s and the children together solve mathematical problems through questions, explanations and argumentations.

The profiles, which will be presented below, are of course tendencies not absolute characteristics. The KT’s orchestration with respect to the degree of freedom changes dynamically during each session and from session to session. In addition, the profiles are relative, which means that the degree of freedom in one kindergarten is relative to the three other kindergartens and cannot provide an indication for how it relates to other KT’s orchestration in other contexts.

Profiles of four kindergarten teachers’ orchestrations

Kindergarten teacher 1

KT1 orchestrated the mathematical activities with a relatively high degree of freedom, which is based on the way that the children were allowed to move around in the room (and even walk out of the room) and to talk about almost whatever they wanted, like birthday parties or their parents’ occupation etc. The KT never told the children to sit down and pay attention, instead she promoted the children to do so by the way she enthusiastically presented the activities, which captured the children’s attention. For example, in an activity about reflection symmetry, the KT introduced the activity having diverse reflection symmetrical objects in a plastic bag without telling what was inside. She shook the bag and whispered, “Listen!”, which made the children curious and created joint attention. Another characteristic of the KT’s orchestration was that the KT listened to almost every child’s contribution (not only related to mathematics). In one of the conversations with the KT, she expressed that her desire to listen to and appreciate every child’s contribution could be a hinderance for her, because her attention became very shifty. She rapidly turned her attention from one child to another. The children eagerly participated in the activities, however, as mentioned above, they often contributed with other ideas than mathematics. The KT expressed that she had a challenging group of children but their ability to pay attention to mathematics grew during the intervention. There were a lot of ‘golden moments’ for problem-solving interaction. The KT and the children initiated a lot of

interesting ‘topics’ for investigation, but very few ideas were thoroughly discussed. Mathematical questions were often (not always) considered briefly, and the children seldom had to ponder about problems and to express mathematical ideas, argue for and explain their ideas in order to solve the problem. Because the KT gave the children a lot of freedom to talk and payed attention to almost every contribution, the conversations moved very quickly from one topic to another.

Kindergarten teacher 2

KT2 gave the children a relatively high degree of freedom to talk, however she often restricted children’s talk to mathematics by ignoring some of the contributions that were about the children’s everyday experiences. The KT also restricted the children’s freedom to act (physically) to areas or with objects relevant to the mathematical activity. Although the KT for the most part focused attention to mathematics, she gave the children freedom to suggest other mathematical issues than what she initially introduced. Similar as KT1, the KT2 presented the activities in an exciting way, by use of for example excited face expressions and whispering, which captured the children’s attention and promoted the children to contribute. But sometimes she also asked questions directly to children to capture their attention. For example, when Carl was distracted by something else, she said: “Carl, do you know how many building blocks there are in the red tower?” When Carl said that he didn’t know, the KT further asked “Would you like to help me count?” This helped Carl, who often had difficulties paying attention, to focus his attention on mathematics. The conversations between the KT and the children were almost always mathematical, and sometimes the KT and the children had longer conversations about mathematical problems. The children had to argue for and explain their ideas in order to solve the problems, and the children eagerly participated with mathematical ideas and explanations. In addition, the KT seemed to focus on collaboration. For example, the KT had a conversation with the children about the meaning of collaboration, and the KT promoted the children to help each other if needed. She also promoted the children to listen to each other by for example asking the group of children: “Did you hear what Ada suggested?”.

Kindergarten teacher 3

KT3 was a football trainer in his spare time, which was somehow recognisable from his orchestration of the activities. He gave the children a relatively high degree of freedom to act (physically) and focused on ‘doing’ mathematics, which for him was when the children got opportunities to use their hands, their body and various artifacts to solve mathematical tasks. In one of the conversations with the KT he expressed that ‘doing’ mathematics was for him an important feature of mathematics in kindergarten and therefore he especially liked physical outdoor activities. In addition, he was giving short ‘missions’ for the children to perform. For example, in the ‘Sorting Shoes’ activity, when the children had to figure out how many shoes there were in each category, the KT gave each child a ‘mission’ to draw equally many lines in the bottom of the diagram as there were shoes in each category. The KT expressed several times that it was important to give the children challenging but manageable tasks, so they felt they succeeded. He often encouraged the children, in an enthusiastic manner, with comments like “good” or “great” etc. It seemed that the children enjoyed the activities and the way that the KT encouraged them. The children eagerly participated and seemed to have fun. There was relatively little problem-solving interaction and the children often solved tasks without

having to explain or argue for their ideas. For example, in the activity called ‘Tripp, Trapp’, where the children should count stairs in a staircase and find out what number each stair had, the KT made A4 papers with numbers from 1-24 on and the children, one by one, had to pick an A4 sheet and place it on the correct stair. (Stair number 15 should have the A4 sheet with the number 15 on). The children just performed the tasks, without having to explain what they did, and why they did what they did. Sometimes the KT promoted the children to reflect on their solution strategies in retrospect, however the children’s explanations were seldom helping them to solve problems in the first place.

Kindergarten teacher 4

KT4 gave the children relatively little freedom to act (physically) or talk which is based on the way that she, to a large degree, controlled who was going to talk (or ‘do’ something) and when. For example, in an activity called ‘The Farm’ the children were, at one point in the activity, supposed to find how many animals there were on the farm. First the KT asked a girl, “Helene, can you figure out how many animals there are all together?”. After Helene had counted and answered the KT asked a boy, “John, can you find how many different animals there are?”. The KT continued to give similar ‘missions’ to each child. The KT made sure that each child got the opportunity to answer or ‘do’ something mathematically, and she appreciated children’s contributions by comments like ‘that’s correct’, ‘very good’ etc. The KT expressed in one of the conversations that it was important that the children learnt to respect the other children and to wait for their turn in an activity. The KT also expressed that some activities were difficult to implement as outdoor activities, because the children often got disturbed by other things. These characteristics are of course tendencies, and sometimes the activities were a lot more open where the children had a lot more freedom to act. But, as she also expressed in one of the interviews, she thought it was difficult to ‘hold back’ and give room for the children to figure out the problems themselves without too much interference. It is difficult to state how ‘eager’ the children were to participate, because they seldom answered or did something without being asked. They accepted the KT’s request to sit and wait for their turn. In some activities, like when they measured how much water there was room for in a tank, the children laughed and were having fun and showed eagerness to participate. Still they were asked to wait for their turn and respect that each child got the same opportunity to fill water. There were few incidents where the children together solved problems by expressing ideas and arguing for solutions. The children were waiting for their turn to answer or to perform ‘missions’. The KT sometimes asked the children to explain what they did when they solved a task, but this explanation did not help the children to solve the problem, but to reflect on their strategy in retrospect.

Discussion

From the results above, it seems that KT1 is very concerned about freedom, and the ZFM is relatively wide compared with the ZFM the other KTs set up, both with respect to what the children are allowed to talk about and what they are allowed to do (physically). The children are even allowed to walk out of the room if they want to, and they can talk about whatever they want. KT2 restricts the ZFM to mathematics, both what the children can physically do and what the children are allowed to talk about. However, KT2 gives the children freedom to talk about and work with other mathematical objects than what she initially promotes. KT3 restricts the mathematical talk to specific mathematical areas,

however the ZFM is relatively wide when it comes to what the children are allowed to do (physically). The KT3 gives the children freedom to move physically and to make loud voices when they solve the mathematical tasks. KT4 is the most controlling of the four KTs, and the ZFM is relatively narrow both with respect to what the children are allowed to do (physically) and what the children are allowed to talk about. KT4 decides, to a large degree, who is allowed to talk (or 'do' something), when the children are allowed to talk (or 'do' something) and what the children are allowed to talk about.

Considering the ZPA, the results illustrate how the KTs promote children to ask questions, explain and argue for their ideas in order to solve mathematical problems. The children do not need to accept the ZPA set up by the KT, but instead of turning the ZPA into ZFM the KT may, I hold, 'advertise' for the ZPA to promote the child to act in a desired manner. In K1 the KT promotes children to act mathematically by acting in an exciting way, and by introducing the activities in a manner which makes the children curious. The children sometimes accept the ZPA, but sometimes they do not. The KT1 is carefully promoting the children to think mathematically, but the ZPA (related to mathematics) is never turned into ZFM. The KT2 also promotes children to think mathematically by acting in an exciting way. The ZPA is related to specific mathematical areas, however the ZFM is related to mathematics in general. Sometimes, especially related to some children, the KT2 carefully turns the ZPA into ZFM, that is the KT limits the ZFM to specific mathematical tasks whenever the children do not pay attention. In addition, the KT explicitly promotes the children to help each other and to collaborate which, I hold, is important for the way that the children solve problems together. KT3 promotes children to think mathematically or 'do' mathematics by a quite tight ZFM related to mathematics. The ZPA is often turned into ZFM by asking the children to perform 'missions'. However, the ZFM is relatively wide related to physical actions. KT4 almost always turns the ZPA into ZFM. What the KT promotes the children to do is also what the KT allows the children to do.

Considering the characteristics of ZFM/ZPA complex in each kindergarten which according to Valsiner (1987; 1997) canalise children's actions and thinking and thus development, it seems that the KTs who limit children's actions to mathematics, but where the children's freedom is relatively wide related to what the children may talk about within mathematics and who is allowed to speak, promotes most problem-solving situations (KT2), and thus children's opportunities for learning. How the ZFM/ZPA complex canalise children's development is not only related to the boundaries of the zones itself, but *how* the ZFM and ZPA are set up. The KT2 is relatively mild in her way of setting up the ZFM, and instead of turning the ZPA into ZFM she acts in an exciting way which promotes the children to accept the ZPA. The KT2 'advertise' for the ZPA by the way she presents the mathematical problems and makes the children want to pay attention and accept the ZPA. The KT4 is not that enthusiastic, and perhaps that is why she must turn the ZPA into ZFM to make the children pay attention and to accept the ZPA. The KT1 is also enthusiastic in setting up the ZPA, but since the ZFM is relatively wide, the children often choose to act in other ways than what the KT promotes. The results support Hirsh-Pasek et al. (2009), Weisberg et al. (2015) and van Oers (2014) who emphasise that playful learning activities should have some structure as long as the activity as a whole remains a playful activity and as long as the KTs gives freedom for children's self-directed play, so they may explore the content in their own manner. The results also supports Dovigo's (2016) results in the sense that whenever the KT is structuring the environment around mathematics, but opens up

for children's own exploration around mathematical ideas, the children are canalised into more problem-solving activity and thus create possibilities for children's mathematical learning.

The results indicate that instruction which structures children's actions around mathematics but introduces the mathematics in an 'exciting' way and allows and promotes children to contribute with various mathematical ideas not necessarily related to the aimed subject area, captures children's attention and promotes their voluntarily participation in the problem-solving activity and thus facilitates children's possibilities for mathematical learning.

Limitations of the study

This study focuses on the KT's orchestration and its consequences for children's learning possibilities and does not consider how the children, in light of for example their background, influence the KT's orchestrations and the nature of interaction in each kindergarten. Moreover, in this study the ZFM/ZPA complex is considered on a group level. It would be interesting to investigate the ZFM/ZPA related to each child in the groups, to see which children benefitted the most from the KT's different orchestrations.

References

- Dovigo, F. (2016). Argumentation in preschool: a common ground for collaborative learning in early childhood. *European Early Childhood Education Research Journal*, 24(6), 818–840.
- Emerson, R. M., Fretz, R. I., & Shaw, L. L. (2011). *Writing ethnographic fieldnotes*. Chicago, IL: University of Chicago Press.
- Gasteiger, H. (2012). Fostering early mathematical competencies in natural learning situations—foundation and challenges of a competence-oriented concept of mathematics education in kindergarten. *Journal für Mathematik-Didaktik*, 33(2), 181–201.
- Hirsh-Pasek, K., Golinkoff, R. M., Berk, L. E., & Singer, D. (2009). *A mandate for playful learning in preschool: Presenting the evidence*. New York, NY: Oxford University Press.
- Størksen, I., ten Braak, D., Breive, S., Lenes, R., Lunde, S., Carlsen, M., . . . Rege, M. (2018). *Lekbasert læring – et forskningsbasert førskoleopplegg fra Agderprosjektet*. Oslo, Norway: GAN Aschehoug.
- Valsiner, J. (1987). *Culture and the development of children's action: A cultural-historical theory of developmental psychology*. Chichester, UK: John Wiley & Sons.
- van Oers, B. (2010). Emergent mathematical thinking in the context of play. *Educational Studies in Mathematics*, 74(1), 23–37.
- van Oers, B. (2014). The roots of mathematising in young children's play. In U. Kortenkamp, B. Brandt, C. Benz, G. Krummheuer, S. Ladel, & R. Vogel (Eds.), *Early mathematics learning: Selected papers of the POEM 2012 conference* (pp. 111–123). New York, NY: Springer.
- Weisberg, D. S., Kittredge, A. K., Hirsh-Pasek, K., Golinkoff, R. M., & Klahr, D. (2015). Making play work for education. *Phi Delta Kappan*, 96(8), 8–13.
- Yin, R. K. (2014). *Case study research: Design and methods*. Thousand Oaks, CA: Sage publications.

Creative processes of one primary school child working on an open-ended task

Svenja Bruhn

Bielefeld University, Germany; svenja.bruhn@uni-bielefeld.de

A lot of mathematical tasks challenge primary school children to be mathematically creative. But how exactly is mathematical creativity embedded in primary school education? And: How are the mathematical creative processes of one first grader working on an open-ended task displayed? Therefore, two creativity patterns are analyzed. The first illustrates the flexibility within the free working process. The second depicts the child's ability to structure and describe her solutions during the elaboration process. Purposeful and adaptive prompts support the child in both creative processes. The results of this pilot study show, that the child develops a qualitative new structure of her solutions and, therefore, is able to expand her solution space.

Keywords: Mathematical creativity, primary school children, open-ended tasks.

Introduction

In most standards for mathematics education (e.g. MSB NRW 2008; NCTM 2003) creativity is part of the competences children from the early years onwards have to exercise and develop in their mathematical education. However, the construct of creativity is often sparsely characterized but rather all process-oriented abilities in mathematics implicate creative behavior as a fundamental competence. Already Vygotsky (1930/1998) described creativity as “one of the basic mechanisms that facilitate development of new knowledge” (Leikin & Pitta-Pantanzi, 2013, p. 162) Therefore, it is necessary to define creativity more precisely in a content-specific way to make this term more adaptable for mathematics instruction.

In this paper, I present my research project on the creative processes of primary school children in Germany. I illustrate my working definition of mathematical creativity at school based on various studies within the psychological and mathematical research sphere. Additionally, a case study of one child at the end of the first grade from the pilot study I have realized so far is presented. Therefore, my greater research question is: How are creative processes of a primary school child displayed?

Theoretical Background

Mathematical creativity

Creativity is nothing mystical (Sternberg & Lubart, 1999) but rather a construct that is being researched not only in psychology but also in various other disciplines like e.g. arts, language, mathematics, and pedagogy (Torrance, 1966). Logically, there is no coherent definition of creativity in general. Also in the particular field of mathematics education “the word creativity is ‘fuzzy’ and lends itself to a variety of interpretations” (Sriraman, 2005, p. 20). Thus, there is a large body of research discussing the different approaches on defining mathematical creativity (e.g. Leikin & Pitta-Pantanzi, 2013).

Kwon, Park, and Park (2006) state that, when analyzing all different approaches, there are overall only two main positions: The first one is the definition of mathematical creativity as “the creation of new knowledge” (Kwon et al., 2006, p. 52). The moment, a student finds a new, adequate, and – more important – insight-based and therefore mathematically adaptive solution to a mathematical problem, the person acts creatively (Liljedahl & Sriraman, 2006; Silver, 1997). In contrast, the second position focuses on the “flexible problem-solving abilities” (Kwon et al., 2006, p. 52) that every child is supposed to develop at school (NCTM, 2003). Children show flexible competences by finding not only one but various differing solutions to a task (also called *divergent thinking* (Guilford, 1967)). In doing so the children act creatively. Therefore, the definitions of mathematical creativity referring to the first position mainly focus on the creative product, while the ones referring to the second position analyze the individual creative processes that students show. I locate my research at the second one because my motivation is to observe, illustrate, and appreciate the creative process of primary school children in detail.

Creative person, product, process, and press

When talking about creativity there are four creative domains which constitute the specific mathematical creativity: *person*, *product*, *process*, and *press* (Leikin & Pitta-Pantanzi, 2013). Every domain has an overlap to the other three so that complex connections within these aspects occur. Haylock (1987) postulates that in many research studies product and process are focused and connected. This connection results from reconstructing the creative process by analyzing the child’s creative product as well as the child’s procedure in finding the solutions. I follow Haylock’s assumption in this pilot study and focus on the creative process, while analyzing the creative product.

To think of the other two domains, the situation in which the child solves the task marks the creative press. However, I do not concentrate on details of the creative environment or person itself. In contrast to many definitions that link mathematical creativity to giftedness (e.g. Sriraman, 2005) or advanced mathematical thinking (e.g. Ervynck, 1991), I assume that every primary school child has the ability to be a creative person. It has to be considered, though, that “creativity in school mathematics differs from that of professional mathematicians” (Leikin, 2009, p. 131). Referring to Vygotsky’s “division into subjective and objective imagination” (Vygotsky, 1930/1998, p. 164), the term of *relative creativity* in contrast to *absolute creativity* in the work with children is suggested. Relativistic creativity means that the creativity level is not compared to the ability of a professional mathematician. Instead, a person’s creativity is compared within a specific peer group. That is why every student can be creative and thus shows a creative process (Liljedahl & Sriraman, 2006).

Characteristics of the mathematical creative process

There are as many different approaches to characterizing the creative process as well as definitions of mathematic creativity itself. Due to the assignment of this study to the second definition position presented before, the characterization of the creative process is based on the student’s ability to think divergent. Following Guilford (1967), Torrance (1966) defines for his psychological test four categories of creativity: *fluency*, *flexibility*, *originality*, and *elaboration*. These “characterize students’ creative process” (Leikin & Pitta-Pantanzi, 2013, p. 163). Many recent studies on mathematical

creativity use these characteristics for their research, whereas the most of them only use the first three concepts, excluding elaboration, and investigating on students grade 6 and higher (e.g. Leikin, 2009).

Leikin's (2009) and Silver's (1997) concept on creativity are based on Torrance's categories but fit to mathematical tasks: Fluency means the total number of solutions and thus, focus on the quantity. In contrast, to depict the quality of a creative process, flexibility measures the number of solution strategies which are "based on different representations, properties (theorems, definitions, or auxiliary constructions), or branches of mathematics" (Leikin, 2009, p. 137). Hence, if the child finds a vast number of solution this does not automatically mean that he/she shows a high flexibility score. Originality in Leikin's understanding evaluates the relativistic singularity and novelty of an idea. Leikin showed in her study on mathematical creativity that only a few children had higher originality scores. Based on her results, she attributes originality to gifted students (Leikin, 2009). In contrast, Silver (1997) defines originality (or novelty) as the ability to explore many given solutions to a mathematical task and then generating a new, different one. The production of a novel solution refers to Leikin's concept of original ideas, because the child has to find a solution, which was not stated in the solution space before. While exploring the given solutions the child has to describe, illuminate, and generalize the solution strategies, which relates to Torrance's (1966) characterization of the category elaboration: The elaboration displays the amount of detail in the responses and shows the ability to describe, illuminate, and generalize the responses.

I aspire to illustrate the quality of the creative process of primary school children in a neutral, not judging way. In contrast, many studies aim to evaluate the mathematical creativity of children or adults (e.g. Leikin, 2009). This is why I mainly and directly focus on the aspects of flexibility and elaboration, and only indirectly on fluency and originality:

Flexibility, in my research, means that children find solutions by different changes of ideas. An idea either can be structurally inferred from the idea before or is newly generated. The concept of fluency is considered by the total number of the solutions.

Elaboration means the children's ability to describe and structure their own solutions to find additional solutions, and thus to expand their solution space. The new found solutions could be considered as original following Silver's definition, and therefore the concept of originality is implicitly included.

Open-ended tasks

Hashimoto (1997) outlines that at today's schools children do not have to be creative, because most tasks prompt the students to find only one correct solution. He states that a good mathematical education needs appropriate tasks to allow children to explore and develop their creativity. There are many notations in the international references, which describe these tasks: e.g. multiple solution tasks (Leikin, 2009) or open-ended problems (Silver, 1997). It is essential that in my study the creativity fostering tasks have to allow the students to demonstrate their fluency, flexibility, originality, and elaboration abilities. Therefore, I characterize an *open-ended task* as a task that invites the children to find various solutions and has no verbalizations like "Find all solutions...". In addition, the task has no limited number of solutions and challenges every student. Most important, the tasks entail quantitative and especially qualitative differences of the solution spaces.

Prompts

Fostering children's ability to show creative processes working on open-ended tasks, the children can be supported by instructional prompts. Prompts are "recall and/or performance aids, which vary from general questions to explicit execution instructions" (Bannert, 2009, p. 139). Based on the research results on instructional prompts, the combination of *cognitive prompts* (explanation) and *metacognitive prompts* (regulation) has a high effectiveness on supporting children's self-regulated learning (Wichmann & Leutner, 2009). Cognitive prompts "directly support a student's processing of information for example by stimulating memorizing/rehearsal, [or] elaboration" (Bannert, 2009, p. 140). This relates to the two in this study primarily focused characteristics of creativity: flexibility and elaboration. Metacognitive prompts in general tend to support children's monitoring and controlling when working on specific tasks like mathematical open-ended tasks (Bannert, 2009).

Research questions

My research aim is to illustrate the individual creative processes of a primary school child working on open-ended tasks. Considering the theoretical background, I attempt to answer the following detailed questions in the case study:

1. How is the child's individual flexibility displayed in her solutions?
2. How does the elaboration and the prompts support the child to find additional solutions?

Method

The intention of my first pilot study was to try out various ideas concerning the tasks, interview design, procedure and material, the interview guideline, and the instructional prompts. Below these decisions are illustrated and the results of the presented case study are discussed.

Participants

In July 2018, I realized a first pilot study with three children at the end of first grade (age: 6;11, 7;0, and 7;9). They are primary school children of a municipal primary school in a large German town. The children were chosen because I expect first graders to be more open-minded and less affected from in school thought mathematical structures and strategies than older school children. Thereby, it is more likely to accurately reconstruct the creative processes of these children. The primary school teacher selected these three children due to their current mathematical development. In this paper, I present as a case study the creative processes of Maria (7;9 years), who shows an age-based mathematical development.

Design, materials, and procedure

During an individual interview, the first grader worked on the following arithmetical open-ended task, because arithmetical ideas can explicitly be categorized and thus, flexibility can be analyzed:

Find different tasks with the number 4. [Finde verschiedene Aufgaben mit der Rechenzahl 4.]

The interview was divided into two creative working phases that built on each other and used different sort of materials:

1. *Free working process*: The child found as many different solutions as he/she could and, at the same time, produced his/her own documentation of the solutions. I offered the first graders blank filling cards to write down each solution and arrange them on the table.
2. *Elaboration working process*: Afterwards I asked the children to explain their solutions and the process of generating them. Then I invited them to restructure their solutions and explain this arrangement of the written cards for me. This procedure was supposed to help the children in finding additional solutions and adding them to the arrangement.

Furthermore, I gave adaptively cognitive and metacognitive “just-in-time-prompts” (Bannert, 2009, p. 142) during the elaboration working process to support the child in his/her creative processes. The used metacognitive prompts tended the first grader to follow the open-ended task in the working processes. The explicit questions was e.g. “Can you find further solutions?”. For cognitive prompts, I used to write a new solution on a card and asked the child to explain, whether this solution match to his/her solutions, and if so, if he/she can find further solutions. Thus, children with a very systematic approach might be encouraged to admit new ideas and conversely, children who found many new ideas might be motivated through a prompt to structure their solutions in a systematic way.

Analytical tool

To illustrate the flexibility and elaboration in the two working processes I conducted a category-lead analysis for each child. I deductively constituted a catalogue of categories for the changes of ideas children can use in their solutions. There are three main categories of changes of ideas: *new*, *inspired*, or *structured ideas*. A new idea has no connection to the idea before (e.g. $3 + 4 = 7$ followed by $20 - 16 = 4$). A structured idea connects two consecutive ideas by a mathematical structure like the sub-category law of constancy (e.g. $3 + 1 = 4$ followed by $2 + 2 = 4$) or the complement principle (e.g. $3 + 1 = 4$ followed by $4 - 3 = 1$). An idea is inspired either if it was used in a former structure and is picked up again in another structure (e.g. $3 + 1 = 4$ followed by $2 + 2 = 4$ (law of constancy) and by $4 - 3 = 1$ (complement principle)), or if a previously used structure is resumed.

Thus, I got two *individual creativity patterns (ICP's)* which I represented graphically in a sort of a sequential tree diagram. Afterwards I contrasted the two patterns to show how they differ and how the new structure extends the solution space. Due to the lack of space in this paper, I present the ICP's in a reduced schema only concentrating on the main categories – new (green), inspired (orange), and structured (red) ideas – but categorizing them in detail in the description.

Results

Maria generated 13 solutions during her free working process on the open-ended task “*Find different tasks with the number 4*”. She wrote every solution on a single card and placed them randomly on the table. She did not look back on the inscribed cards but only on the blank cards in front of her. I was not able to see any system in the arrangement of the cards. Moreover, her ICP illustrates that she found her solutions by generating mainly new ideas. I analyzed ten new and two structured ideas. First, Maria produced six different tasks, which differed in the used operation – addition or subtraction – and in the placement of the number 4 either as the first summand or as the result. Afterwards she showed one of the two structured ideas by inferring a solution from the one before by the law of constancy: $8 - 4 = 4$ followed by $9 - 5 = 4$. Maria generated the second structured idea in the same

way but with the operation of addition: $1 + 3 = 4$ followed by $2 + 2 = 4$. In between and after these structured ideas Maria produced constantly new ideas with the number 4 as the result of the task. The following schema illustrates Maria's complete first ICP (see figure 1):

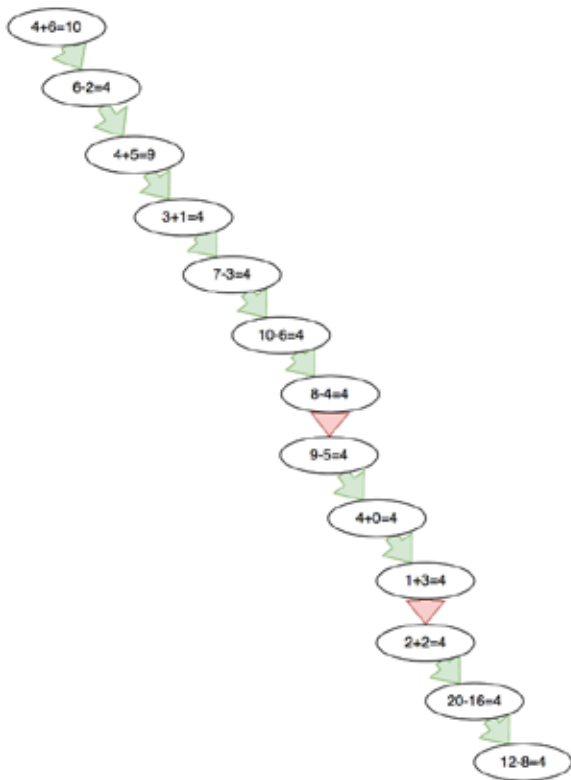


Figure 1: Maria's ICP of the free working process

Figure 2 shows the schema of Maria's second ICP. The red lined tasks are the tasks, which Maria produced in addition to her free working process. The dotted arrows symbolize that she produced more solutions in the prior pattern.

Maria's second ICP, illustrating her elaboration process, differed widely from her first one. She expanded her first solution space from 13 to now 31 solutions consisting of two new, four inspired and 18 structured ideas. First, she picked up her two written cards $1 + 3 = 4$ and $3 + 1 = 4$, arranged them side by side and labeled them *turn arounds* [Tauschaufgaben]. This structured idea is based on the additive commutative law. She then displayed a new structured idea – the complement principle – by connecting the two cards $4 + 5 = 9$ and

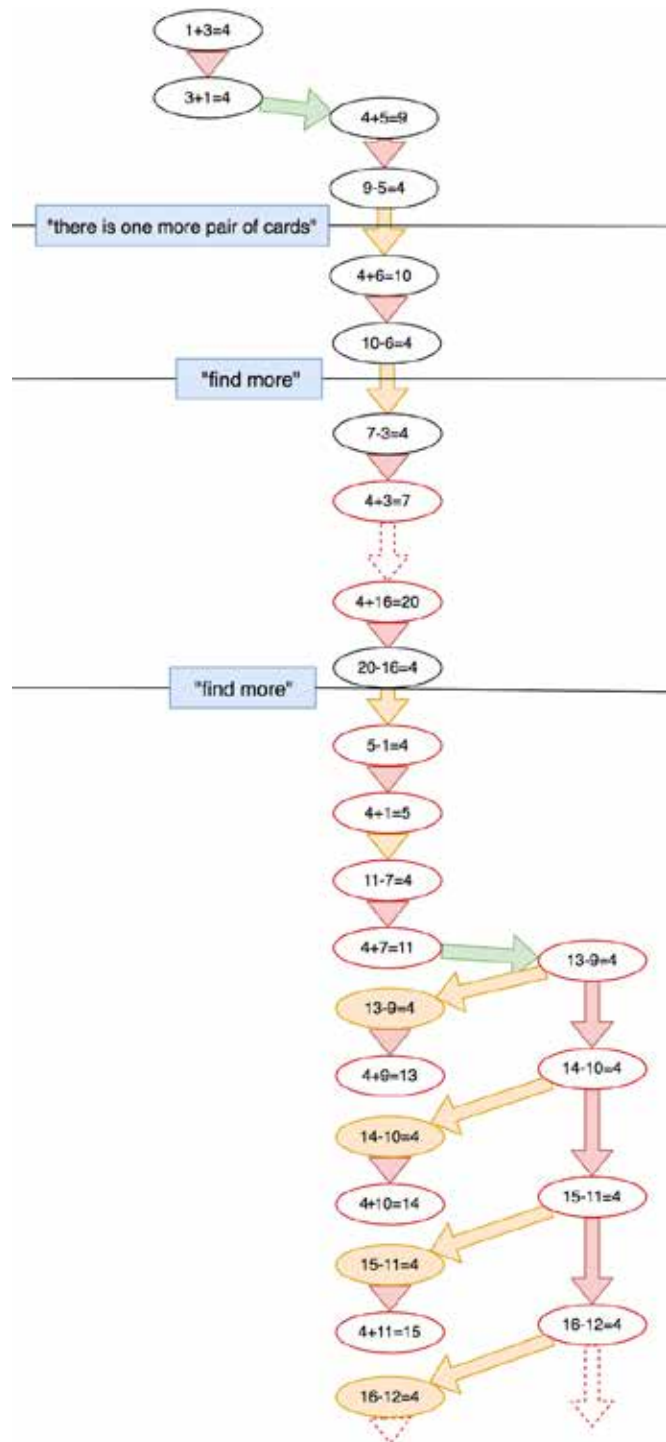


Figure 2: Maria's ICP of the elaboration working process

$9 - 5 = 4$. I gave her a metacognitive prompt by saying that there is one more pair of matching cards based on the complement principle. She found them and placed them near the first pair. Hence, Maria reconsidered the previously used structured idea and thus, showed an inspired idea connecting the task $9 - 5 = 4$ with the tasks $4 + 6 = 10$ and $10 - 6 = 4$. Subsequently, she thought for a while and after a metacognitive prompt, if she could write more solutions, she wrote the matching tasks within the complement principle to all previously found solutions. This means that Maria was able to respond to the given prompt and produce seven additional solutions by following a structured idea. After one more metacognitive prompt, if she could find further solutions, she generated in the previous used focus four new solutions, thus, two additional pairs. Finally, and without a prompt, she showed a new idea by writing the solution $13 - 9 = 4$. For this solution she combined two different structural ideas. Primarily, Maria interpreted her solution in the previously used structure based on the complement principle, and wrote $4 + 9 = 13$, and thus, showed an inspired idea. Then she focused on the law of constancy and derived $13 - 9 = 4$ from the solution $14 - 10 = 4$. Maria repeated this pattern twice with the tasks $14 - 10 = 4$ and $16 - 12 = 4$. Then she stopped the production but was able to explain how she could find further solutions in this way.

Discussion and Outlook

The case study gives an insight into the potential of a high-resolution view on the first graders' creative processes when working on arithmetical open-ended problems.

Referring to the first research question the analyzed processes of the first grader Maria exhibit that there are interesting differences in the flexibility (and fluency) of the two ICP's from the two processes themselves and in the transformation. She first produced mainly new ideas and then completely changed her ICP when elaborating and expanding her own solution space. Especially her last composition, the combination of the complement principle and law of constancy, is stunning. Thus, a qualitative view at and analysis of the four characteristic of mathematical creativity seems to be necessary to define this term more precisely in a content-specific way. The second research question tended on the expanding of the child's solution space through elaboration and prompts. In the case study, Maria was able to react to the given prompts, and thus, the level of support of the metacognitive prompts themselves were high. Maria did not need any sort of cognitive prompts to expand her solution space. Thus, the following assumption can be made: The higher the ability of elaboration (and originality) of the child, the lower the need for various instructional prompts.

Following the previous presented insights of this case study from the pilot study, there have to be two implication for my future main study from March to July 2019:

First, an interview design needs to be developed in which all characteristics of mathematical creativity – still focused on flexibility and elaboration – can be analyzed in one first grader's creative process working on an arithmetical open-ended task. Looking at more such creative processes may lead to additional and complex ICP's.

Second, the prior stated assumption about the relationship between the elaboration abilities and the reaction to the instructional prompts has to be researched precisely. Furthermore, the effectiveness of the prompts itself must be considered in more detail. Therefore, all participants in my main study will be interviewed twice with two arithmetical open-ended tasks but the same instructional prompts.

References

- Bannert, M. (2009). Promoting Self-Regulated Learning Through Prompts. *Zeitschrift Für Pädagogische Psychologie*, 23(2), 139–145.
- Ervynck, G. (1991). Mathematical creativity. In D. Tall (Ed.), *Mathematics education library: Vol. 11. Advanced mathematical thinking* (pp. 42–52). Dordrecht, The Netherlands: Kluwer.
- Guilford, J. P. (1967). *The nature of human intelligence*. New York, NY: McGraw-Hill.
- Hashimoto, Y. (1997). The methods of fostering creativity through mathematical problem solving. *ZDM Mathematics Education*, 29(3), 86–87.
- Haylock, D. W. (1987). A Framework for Assessing Mathematical Creativity in Schoolchildren. *Educational Studies in Mathematics*, 18(1), 59–74.
- Kwon, O. N., Park, J. S., & Park, J. H. (2006). Cultivating divergent thinking in mathematics through an open-ended approach. *Asia Pacific Education Review*, 7(1), 51–61.
- Leikin, R. (2009). Exploring mathematical creativity using multiple solution tasks. In R. Leikin (Ed.), *Creativity in mathematics and the education of gifted students* (pp. 129–145). Rotterdam, The Netherlands: Sense Publ.
- Leikin, R., & Pitta-Pantanzi, D. (2013). Creativity and mathematics education: the state of the art. *ZDM Mathematics Education*, 45(2), 159–166.
- Liljedahl, P., & Sriraman, B. (2006). Musing in mathematical creativity. *For the Learning of Mathematics*, 26(1), 20–23.
- MSB NRW. (2008). *Richtlinien und Lehrpläne für die Grundschule in Nordrhein-Westfalen: Mathematik* (Vol. 2008). Frechen, Germany: Ritterbach.
- National Council of Teachers of Mathematics. (2003). *Principles and standards for school mathematics* (3. print). Reston, VA: National Council of Teachers of Mathematics.
- Silver, E. A. (1997). Fostering creativity through instruction rich in mathematical problem solving and problem posing. *ZDM Mathematics Education*, 29(3), 75–80.
- Sriraman, B. (2005). Are Giftedness and Creativity Synonyms in Mathematics? *The Journal of Secondary Gifted Education*, 17(1), 20–36.
- Sternberg, R. J., & Lubart, T. I. (1999). The concept of creativity: Prospects and Paradigms. In R. J. Sternberg (Ed.), *Handbook of creativity* (pp. 3–16). Cambridge, UK: Cambridge University Press.
- Torrance, E. P. (1966). *Torrance tests of creative thinking: Norm-technical Manual* (Research edition). Princeton, NJ: Personal Press Inc.
- Vygotsky, L. S. (1930/1998). Imagination and creativity in adolescent. In R. W. Rieber (Ed.), *Child Psychology. The Collected Works of L. S. Vygotsky* (pp. 151–166). Boston, MA: Springer US.
- Wichmann, A., & Leutner, D. (2009). Inquiry learning: Multi-level support with respect to inquiry, explanations and regulation during an inquiry cycle. *Zeitschrift Für Pädagogische Psychologie*, 23(2), 117–127.

Characterising the mathematical discourse in a kindergarten

Ingvald Erfjord, Martin Carlsen, and Per Sigurd Hundeland

University of Agder, Norway; ingvald.erfjord@uia.no, martin.carlsen@uia.no,
per.s.hundeland@uia.no

In this study we investigate the mathematical discourse in a kindergarten. The mathematical learning activity engaged with was initially designed by researchers for 5-year-olds, and the kindergarten teacher orchestrated the mathematical activity. Observational data was quantitatively analysed by measuring how time and talk were distributed between the kindergarten teacher and the children. We also analysed whether the talk was focused on mathematics or not. Our analysis shows that the time elapsed during the activity was distributed unequally, the nature of the participants' utterances shared both similarities and differences, while the engagement nurtured upon the kindergarten teacher's request varied from each of the requests. Based on these results we characterise the mathematical discourse and hypothesise about the children's potentials for mathematics learning.

Keywords: Discourse, inquiry, kindergarten, mathematics, playful learning.

Introduction

Researching teaching and learning of mathematics in a kindergarten setting has been gaining improved focus over the last decade. Since the establishment of the early years mathematics research group at the 6th Congress of the European Society for Research in Mathematics Education in Lyon in 2009, a multitude of research foci have been launched and 50-100 research studies have been conducted (see CERME proceedings, www.mathematik.uni-dortmund.de/~erme). This is not to neglect journal articles published in the same period as well as before 2009. Early years mathematics has gained its place as a research field with mathematics education research also due to the four POEM conferences we have seen so far (POEM - A Mathematics Education Perspective on early Mathematics Learning). A huge portion of the conducted studies have been qualitative in nature, as case studies have been conducted, observations and interviews have been made (Levenson, Bartolini Bussi, & Erfjord, 2018). This study is an attempt to broaden the qualitative research scope and include quantitative aspects of mathematics discourse in a kindergarten context.

The aim of the analyses made in the current study is thus to quantitatively characterise the mathematical discourse evolving as a kindergarten teacher (KT) orchestrates a mathematical activity for her five-year-olds. In the analysis we seek to develop an analytical approach which quantifies the collected qualitative data. We use the term mathematical discourse in line with Sfard (2007), as a type of communication featuring mathematical words that “bring some people together while excluding some others” (p. 573). According to Sfard, a mathematical discourse has the features called visual mediators, narratives, and routines as well. However, in the current study we focus at the verbalisations made by the KTs and the participating children. The results of our analysis will be discussed in light of the framework of mathematics discourse in instruction (MDI), developed by Adler and Ronda (2015), which heavily build on Sfard's (2007, 2008) work. For the present study we have formulated the following research question:

What characterises the mathematical discourse in a kindergarten in which a kindergarten teacher and five-years-old children engage with a planned mathematical learning activity?

In our analysis we have particularly focused at three dimensions: (1) the distribution of time in the activity; (2) the nature of the participating persons' utterances; and (3) the engagement nurtured through the KT's initiatives, requests, and prompts. Our focus at adult-child interactions has been studied elsewhere (e.g. Carlsen, Erfjord, & Hundeland, 2010; Dovigo, 2016; Vogel & Jung, 2013). Dovigo (2016) studied argumentation as a basis for collaborative learning and problem solving in a preschool setting. Dovigo adopted a sociocultural approach in his analysis, compared teacher-children talk and peer-talk, and investigated the role of argumentation in empowering children's collaboration and problem solving through discursive practices. Results from quantitative and qualitative analyses show that argumentation is effective in cultivating shared and critical thinking amongst the children.

The mathematical activity that was orchestrated by the KT (one of many) was designed by researchers in mathematics education (the authors of this paper among others) in collaboration with the KT (among others), as part of the research and development project called "The Agder project"¹ (AP). This is why we use the term planned mathematical learning activity in the research question.

These planned mathematical activities were designed based on the principles of playful learning and inquiry approach to the learning of mathematics. Playful learning as a construct comprises free play (child-initiated and child-directed play) and guided play (adult-initiated and child-directed play). In AP we drew on the principle of guided play as the KTs were empowered to orchestrate and guide the children's play in the mathematical activities in purposeful directions in order to plausibly reach aims for the activities. Furthermore, The KTs functioned as catalyst for the interest, curiosity, engagement, and mathematical sense-making of the children (cf. Weisberg, Kittredge, Hirsh-Pasek, Golinkoff, & Klahr, 2015). Adopting inquiry as an approach to the learning of mathematics is in accordance with Jaworski's (2005) inquiry as "a way of being in practice" (p. 103). Inquiry as a way of being is empowering when five-year-olds and their KT interact to achieve insights in mathematics. By seeking answers to mathematical prompts and questions, the children's curiosity and excitement are nurtured and met.

Mathematical Discourse in Instruction

Adler and Ronda (2015) developed the MDI framework to analyse the mathematics made available for students to learn in the classroom. The framework was developed for a South African classroom setting, deviating from a Norwegian kindergarten context. We have thus slightly adapted the framework in order for us to purposefully employ this framework in our analyses of orchestrations of mathematics activities. However, the main components are adopted in our use of the framework. But as will be seen, we have adapted the definitions of these components to also encompass a Norwegian kindergarten context.

According to Adler and Ronda (2015), it is important to focus on what mathematics students are supposed to learn, when analysing teaching. Thus, the object of learning, e.g. a concept, procedure,

¹ The Agder project is funded by the Research Council of Norway (NFR no. 237973), The Sørlandet Knowledge Foundation, The Development and Competence Fund of Aust Agder, Vest Agder County, Aust Agder County, University of Agder and University of Stavanger.

algorithm, is the starting point for the MDI framework. In our context and analysis, acknowledging and accommodating the social pedagogy tradition of Norwegian kindergartens' enterprise, we use the concept of intention to address what the children are supposed to meet and make experiences of in the mathematical activities. Further, Adler and Ronda (2015) argue that the mediational means used in teaching to reach the object of learning, are exemplification (examples and tasks), explanatory talk (naming and legitimations), and student participation. We believe learning takes place in social, communicative settings, in which children and adult(s) actively participate, engage, and argue in interaction. Hence, it is of importance to consider children's possibilities to talk in the orchestrations, their opportunities to "speak mathematically and to verbally display mathematical reasoning" (Adler & Ronda, 2015, p. 245).

The mediational means of exemplification manifests itself as examples and tasks. Examples used in mathematics teaching/orchestration serve the purpose of being a representative of a larger class, one particular case of that class from which it is possible to generalise (Zodiak & Zaslavsky, 2008). Deliberate use of examples is important to reach the intention/object of learning. Tasks are also commonplace constituents of mathematics teaching/orchestration. Tasks are given by the teacher/KT to bring to the fore certain mathematical properties, actions etc. Tasks are thus what the children are supposed to do with the examples given (Adler & Ronda, 2015).

The mediational means of explanatory talk comprise what is to be done and known, that is to name and legitimate the focus and content of the talk between the teacher/KT and the children. To address this, Adler and Ronda (2015) coin the terms naming and legitimation. Naming is "the use of words to refer to other words, symbols, images, procedures or relationships" (p. 244). Naming may be either colloquial, non-mathematical everyday language, or mathematical, either mathematical words used or reading strings of symbols (Ms) or formal mathematical language used (Ma). Legitimation comprises four domains: mathematical, non-mathematical, curriculum and teacher. Within the mathematical domain there are local (L) criteria (specific case, convention) and general criteria (partial (GP) and full (GF) that give authority. Within the non-mathematical domain there are also criteria that give authority, called visual (V), positional (P), assigning the authority to the speaker, and everyday (E) knowledge and experience. The significance of addressing all these criteria is, according to Adler and Ronda (2015), "the opportunities they open and close for learning" (p. 244).

The KT's utterances will be analysed according to the levels in the MDI framework (cf. Adler & Ronda, 2015), where level 1 is a type of mathematical discourse in which the children contribute with answers to yes/no questions or single words to the KT's unfinished utterances. Level 2 is a type of mathematical discourse in which the children contribute with answers to what/how questions in phrases/sentences. Level 3 is a type of mathematical discourse in which children contribute with answers to why questions and present ideas and where the KT revoices/confirms/asks questions (cf. Adler & Ronda, 2015).

In our discussion we adapt the MDI framework in order to analyse the KT's orchestration of mathematical activities. Thus, not all facets of the MDI framework will be used in the discussion. The reason for our adaptation is that the MDI framework is developed to analyse mathematics teaching in (South African) schools. The Norwegian kindergarten context differs significantly from that school context. As will be seen in the analysis, to approach the intention/object of learning of the mathematical activity, the KT exemplifies by the use of examples, use of tasks made explicit

through questioning, and explanatory talk. The children participate in the interaction with the KT, question and argue for their opinion(s).

Our analytical approach

In this study we collected video data from the orchestration of a mathematics activity by one kindergarten teacher. The activity involved five five-years-old children in this kindergarten who participated in AP, selected by the KT. The studied KT and children were chosen out of convenience, based on the consideration that the only criterion for selection was that the observed KT and children had to participate in AP and voluntarily participate in this specific study.

In order to analyse the mathematical discourse emerging from the KT's orchestration of a mathematical activity, we developed an analytical tool that fitted our purpose of quantifying qualitative data. Quantification of qualitative video data has also been studied by Vogel and Jung (2013), however from a slightly different perspective. The first step of our analytical process was that we agreed upon making 'quantification of qualitative' data the main focus of our analysis. With this idea in mind, the second step of our analysis continued as two of the researchers met and discussed ways of making this quantification. These two researchers agreed that use of time was a critical element in the orchestration, who had the floor? Were any questions asked, and by whom? Were the questions mathematical ones or not? What other comments were made, and by whom? Were these comments mathematical or not? etc.

The result of that meeting was submitted to the third researcher, who had not been taking part in the discussions so far, comprising a third step in our analysis. This researcher critically scrutinised the preliminary analytical tool, asked critical questions and made modifications to the tool.

All three researchers met for the fourth step of our analysis as we refined the analytical approach, agreed upon the various dimensions necessary to scrutinise in order to analyse the mathematical discourse in the kindergarten, as well as pinpointed sub-categories within the three dimensions. The idea behind our analytical approach is to steadily funnel down to the core of our analysis. The distribution of time is seen as a first attempt to separate the various elements of the activity. Secondly, we discriminate between what we call verbal mathematical contributions and non-mathematical or colloquial contributions. Thirdly, we have chosen to make a deeper analysis of those verbal contributions in which mathematics is focus, what Sfard (2008) would label a mathematical discourse. Our analytical approach is summarised in the following table (Table 1):

Distribution of time between the KT and the children		
Who	Number of minutes	Description of category
KT active		Informing, Demonstrating, Explaining, Exemplifying
Dialogic communication		Questions and prompts from KT and answers from children
Children active (KT interference tolerated)		The children work with concrete materials, explore mathematical relationships «on their own»
Verbal utterances		
Who	Mathematical (#)	Non-mathematical (#)
KT		
Children		

Mathematical engagement nurtured					
Initiatives from KT	Child 1	Child 2	Child 3	Child 4	Child 5
1					
2					
...					
N					

Table 1: The analytical approach to quantification of qualitative data

Analysis of the mathematical discourse associated with ‘The secret bag’

The mathematical activity called ‘The secret bag’ was orchestrated by the KT Tone (pseudonym). The activity addresses geometrical shapes of both two and three dimensions and an in-transparent fabric bag. The KT and the children talked about and discussed the various geometrical shapes, and they talked about the connections between two-dimensional shapes and three-dimensional shapes, as some two-dimensional shapes may be turned into three-dimensional ones and vice versa. Continuing from this, the KT put all the shapes in the in-transparent bag, and let one child at a time, hold his/her hand into the bag, pick one of them and tactilely reason what shape the picked one has. As seen in Table 2, the KT holds the floor for approximately 1/3 of the total time used, the children are active discussing more or less on their own for about 15 % of the time. About 50 % of the time was used for dialogic communication between the KT and the children.

Category	Distribution of time
KT active	00:07:16
Dialogic communication	00:10:54
Children active (KT interference tolerated)	00:04:11

Table 2: Distribution of time between the KT and the children

Concerning the verbal communication going on in the activity, we found that the KT made 125 mathematical utterances and 99 non-mathematical utterances. The children contributed with 103 mathematical utterances and 86 non-mathematical utterances. An utterance is here viewed as an instance of speech. However, the non-mathematical utterances enable the mathematical utterances to emerge. Thus, all utterances contribute to the ongoing mathematical discourse (cf. Sfard, 2007, 2008).

Verbal utterances			
Who	Mathematical (#)	Non-mathematical (#)	Sum
KT	125	99	224
Children	103	86	189

Table 3: Categorisation of utterances

In this study we are occupied with the KT’s utterances that we characterise as mathematical and the verbal engagement nurtured amongst the 5 children involved. Upon the KT’s verbal utterances, we counted the number of contributions of the various children, see Table 4.

	Erik	Ivar	Ida	Mari	Nina	>1	Sum
Number	62	29	23	24	22	29	189

Table 4: Number of verbal contributions distributed over the children

We further registered the number of children responding to the KT's questions and prompts, thus we see this number as a measure of the mathematical engagement nurtured, see Table 5. Three questions from the KT were not responded to at all, and none of questions/prompts engaged all five children. At 46 occasions it was only one child responding to the KT's question/prompt. However, each child might contribute with several responses to the initial question/prompt. Thus, the total number of responses in Table 5 (120 responses) is less than the 189 verbal contributions mentioned above.

# of children engaged	0	1	2	3	4	5	Sum
Frequency	3	46	23	4	4	0	77
# of children responding in total	0	46	46	12	16	0	120

Table 5: Children responding to the KT's questions/prompts

Adopting an inquiry approach to the orchestration of mathematical activities in kindergarten, will plausibly create mathematical engagement amongst the children. We thus further scrutinised each of the 77 contributions of the KT that engaged the children mathematically, and we analysed the mathematical discourse that these contributions initiated according to the levels of discourse in the MDI framework (cf. Adler and Ronda, 2015). From this analysis we found that 49 mathematical discourses were at level 1, 24 of the discourses were at level 2 and four discourses were at level 3, see the right-hand column of Table 6.

# of children engaged	1	2	3	4	Sum
# of mathematical discourses at Level 1	31	14	2	2	49
# of mathematical discourses at Level 2	14	8	0	2	24
# of mathematical discourses at Level 3	1	1	2	0	4
Total	46	23	4	4	77

Table 6: Number of children involved versus the levels of mathematical discourse

Amongst the 49 mathematical discourses at level 1, 31 engaged only one child, 14 of those 49 discourses at level 1 engaged two children, 2 discourses engaged 3 children and 2 discourses engaged four children. From Table 6 we also observe that approximately 64 % of the mathematical discourses were at level 1, and 36 % were at level 2 & 3. We also observe that rarely more than 2 children were engaged by the KT's questions and prompts, 69 (46 + 23) out of the 77 mathematical discourses, and in those occasions 45 were at level 1 and 22 at level 2 and only two discourses were at level 3.

Examples of the KT's questions and prompts that we analysed as initiating a mathematical discourse at level 1 were: "Are all the edges (of the rectangle) of equal length?" and "Is it (the rectangle) two dimensional?" Examples of the KT's questions and prompts that we analysed as initiating a mathematical discourse at level 2 were: "What is this (a sphere)?" and "What is your thinking with respect to that one (a cone)?" Examples of the KT's questions and prompts that we analysed as initiating a mathematical discourse at level 3 were: "Why is that a rectangle?" and "Why does this quadrilateral (a square) have another name?"

Discussion

We have addressed the question: What characterises the mathematical discourse in a kindergarten in which a kindergarten teacher and five-years-old children engage with a planned mathematical activity? *Firstly*, the mathematical discourse analysed is dominated by the KT. She holds the floor

on individual basis for about 1/3 of the elapsed time for the whole activity. She is also dominating the dialogic communication going on, a category comprising approximately 50 % of the elapsed time. This result is also documented by Dovigo (2016). *Secondly*, we observe that the distribution of verbal utterances amongst the KT and the children is fairly equal, both regarding utterances categorised as mathematical and utterances categorised as non-mathematical. However, we also observe that the children do not contribute equally to the mathematical discourse. Erik is dominating and the other four children are contributing approximately at the same level. *Thirdly*, the mathematical discourse is characterised by engaging only one or two children. Additionally, 64 % of the mathematical discourses were at level 1 and 36 % at level 2 and 3 according to Adler and Ronda (2015).

The sparsity of occasions where three or four children were engaged, and at the same time engaged in a mathematical discourse at level 2 and 3, we hypothesise has consequences for the mathematical learning potential in this orchestrated mathematical activity. According to Sfard (2007), “Learning mathematics may now be defined as individualizing mathematical discourse, that is, as the process of becoming able to have mathematical communication not only with others, but also with oneself” (p. 573). We thus hypothesise that the children in this activity have limited opportunities to individualise the mathematical discourse occurring.

We took the KT’s questions and prompts as point of departure in our analysis, and scrutinised the mathematical discourse associated with these various questions and prompts. The mathematical discourse was then analysed according to the levels of Adler and Ronda (2015) regarding children’s participation. From this analysis, we came to the result communicated in Table 6 above. Our initial hypothesis was that it seems reasonable to argue that the levels of children participation comprise an increasing opportunity for learning. Thus, the potential of learning associated with a level 3 mathematical discourse is more promising than mathematical discourses at level 2 and level 1 respectively. Our analysis shows that most of the mathematical discourse was at level 1 (64 %). From the analysis we argue that the KT often initiated a mathematical discourse at level 1 through asking a yes/no question. However, these mathematical discourses evolved into mathematical discourses at level 2 and level 3 in several occasions. Thus, mathematical discourses that from the outset may seem to have a limited learning potential evidently may improve into mathematical discourses at levels comprising a higher mathematical learning potential.

We also find that the KT adopts an inquiry approach to mathematics teaching and learning (cf. Jaworski, 2005), due to her mathematical questions and prompts. However, how to engage the children in mathematical inquiries is a different matter. An implication from our study is thus how to empower the children’s inquiry by discussing more between themselves. More research regarding what characterises mathematical activities that empower children’s own inquiry into mathematics is needed.

References

- Adler, J., & Ronda, E. (2015). A framework for describing mathematics discourse in instruction and interpreting differences in teaching. *African Journal of Research in Mathematics, Science and Technology Education*, 19(3), 237–254. doi: 10.1080/10288457.2015.1089677
- Carlsen, M., Erfjord, I., & Hundeland, P. S. (2010). Orchestration of mathematical activities in the kindergarten: The role of questions. In V. Durand-Guerrier, S. Soury-Lavergne, & F. Arzarello (Eds.), *Proceedings of the Sixth Congress of the European Society for Research in Mathematics*

Education. January 28th - February 1st 2009 (pp. 2567–2576). Lyon, France: Institut National De Recherche Pédagogique.

Dovigo, F. (2016). Argumentation in preschool: A common ground for collaborative learning in early childhood. *European Early Childhood Education Research Journal*, 24(6), 818–840. doi: 10.1080/1350293X2016.1239327

Jaworski, B. (2005). Learning communities in mathematics: Creating an inquiry community between teachers and didacticians. *Research in Mathematics Education*, 7(1), 101–119. doi: 10.1080/14794800008520148

Levenson, E. S., Bartolini Bussi, M. G., & Erfjord, I. (2018). Early years mathematics. In T. Dreyfus, M. Artigue, D. Potari, S. Prediger, & K. Ruthven (Eds.), *Developing research in mathematics education: Twenty years of communication, cooperation and collaboration in Europe* (pp. 106–114). New York, USA: Routledge.

Sfard, A. (2007). When the rules of discourse change, but nobody tells you: Making sense of mathematics learning from a commognitive standpoint. *Journal of the Learning Sciences*, 16(4), 565–613. doi: 10.1080/10508400701525253

Sfard, A. (2008). *Thinking as communicating: Human development, development of discourses, and mathematizing*. Cambridge, United Kingdom: Cambridge University Press.

Vogel, R., & Jung, J. (2013). Videocoding – A methodological research approach to mathematical activities of kindergarten children. In B. Ubuz, Ç. Haser, & M. A. Mariotti (Eds.), *Proceedings of the Eighth Congress of the European Society for Research in Mathematics Education* (pp. 2248–2257). Ankara, Turkey: Middle East Technical University.

Weisberg, D. S., Kittredge, A. K., Hirsh-Pasek, K., Golinkoff, R. M., & Klahr, D. (2015). Making play work for education. *Phi Delta Kappan*, 96(8), 8–13.

Zodiak, I., & Zaslavsky, O. (2008). Characteristics of teachers' choice of examples in and for the mathematics classroom. *Educational Studies in Mathematics*, 69(2), 165–182. Doi: 10.1007/s10649-008-9140-6

Paper plate patterns: teachers developing patterning in pre-school

Sue Gifford¹ and Helen Thouless²

¹University of Roehampton, United Kingdom; S.Gifford@roehampton.ac.uk

²UCL-Institute of Education, United Kingdom; h.thouless@ucl.ac.uk

Keywords: Early childhood education, cooperative learning, mathematical activities.

Introduction

Young children's patterning, defined as "finding a predictable sequence", has been identified as significant for later mathematical achievement, with promising intervention research (Rittle-Johnson, Fyfe, Hofer & Farran, 2017, p. 3). Two years ago we began a collaborative project with English teachers of three to five year olds, drawing on the work of Papić, Mulligan and Mitchelmore (2011) and Mulligan and Mitchelmore (2016). Our research question is: How do teachers develop young children's pattern awareness? We analyse our findings as learning in a 'community of practice' (Wenger, 1998), focusing on a teacher innovation of paper plate patterns.

Methodology

Wenger (1998) identifies a community of practice as a group whose members have a joint enterprise, are mutually engaged in an activity and have a shared repertoire of customs of practice. Accordingly, learning is defined as a change in participation in the community of practice. Bannister (2018) identifies benefits of teacher communities of practice as providing better outcomes for teachers in terms of opportunities to learn and improved working conditions. Our group was formed of 12 experienced nursery and reception teachers who volunteered to trial teaching patterning, working in six socially diverse state-funded schools in London, UK. We offered number and pattern assessment activities, and a core teaching sequence, which we encouraged teachers to adapt for their children and settings. In total we held 14 after-school meetings, where we introduced the next month's topic and teachers shared how they had been teaching pattern, with photos and accounts. We visited three times to assess focus children with teachers and three times to conduct informal interviews about teachers' work, discuss records of children's progress and once to observe teaching and learning. The data reported here derive mainly from three sources: field notes from teachers' reports at project meetings and informal interviews, our observations of teaching and learning and semi-structured group exit interviews. We analysed notes and transcriptions to identify common themes in relation to our focus on learning in a community of practice.

Findings

As a community of practice, the teachers developed convergent pedagogical approaches, such as integrating patterning into whole class routines and encouraging children's independent 'co-working', including challenging each other to continue patterns or spot errors. In Bannister's (2018) terms, teachers reported benefits for themselves in increased subject knowledge of patterning progression and in improved working conditions through peer support for 'marginalised' early years teachers in primary schools. One example of learning was a teacher's innovation of circular repeating patterns as an interim stage before Papić et al.'s (2011) border patterns. The latter present the

challenges of making a continuous pattern, turning corners (by rotating the frame or carrying the pattern mentally through a rotation) and fitting the unit of repeat into a fixed number of squares. During the second year, Sam reported that paper plates enabled children to make continuous patterns by adjusting the size of the unit to fit, which allowed discussions about whether a pattern ‘worked’. The other teachers took up this idea in their practice and in subsequent meetings Tess and Pam agreed that their children found it easier to make a pattern around a circular border than a square one since this avoided turning a corner. Several teachers noted disadvantages in using plates and made adaptations: for example, Pam said, “Dave wanted to put another circle inside the first one, maybe because he thought that he had to fill in the plate. He wanted to match the inside and outside circle but didn’t realise that the numbers couldn’t match. So I coloured the inside of the circle so that the children didn’t feel like they had to fill in the middle.” Two other teachers developed a further interim stage of making a border around the outside of rectangular shapes, which involved turning corners, without a fixed number of squares. We observed two children fitting pom-poms around a rectangular border by changing the pattern unit from “white, white, white, yellow, yellow, blue” to what they jointly described as “white, white, white, 3 whites” and “yellow, blue and start over and over”. The refinements made by the teachers seem to enable these children to analyse and identify the unit of repeat in a continuous pattern.

Conclusion

The teachers’ learning in this community of practice was evident in changes in their participation as they took up the research and applied it to their teaching, developing new activities based on children’s responses and mutually engaging in sharing and refining each other’s ideas. The strength of this community of practice lay in participants’ willingness to share and develop their pedagogy, which resulted in the teachers creating significant interim stages in the trajectory of developing pattern awareness.

Acknowledgement

We are grateful for the contribution of the teachers and children in our participating schools.

References

- Bannister, N. (2018). Theorizing collaborative mathematics teacher learning in communities of practice. *Journal for Research in Mathematics Education*, 49 (2), 125–139.
- Mulligan, J.T., & Mitchelmore, M. (2016). *Pattern and structure mathematics awareness programme (F-1)*. Victoria, Australia: Australian Council for Educational Research.
- Papic, M., Mulligan, J., & Mitchelmore, M. (2011). Assessing the development of pre-schoolers’ mathematical patterning. *Journal for Research in Mathematics Education*, 42(3), 237–268.
- Rittle-Johnson, B., Fyfe, E.R., Hofer, K.G., & Farran, D.C. (2017). Early math trajectories: Low-income children’s mathematics knowledge from ages 4 to 11. *Child Development*, 88(5), 1727–1742.
- Wenger, E. (1998). *Communities of practice: Learning, meaning, and identity*. Cambridge, England: Cambridge University Press.

Investigating mediation strategies used by early years mathematics teachers in Malawi

Fraser Gobede

University of Malawi, Malawi; fgobede@cc.ac.mw

Keywords: Early years mathematics, mediation, Malawi

Introduction

Teaching mathematics to children in their early years of primary schooling is a very challenging undertaking. Teachers usually find it difficult to design tasks that can keep young minds engaged and motivated throughout the lesson. In Malawi, the task is even more difficult considering that 60% of learners do not have the opportunity of attending some form of pre-school education; hence most children are formally introduced to concept of number in grade 1 at the age of six, or more (Robertson, Cassity, & Kunkwenzu, 2017). If number sense is not properly introduced to learners, the result might be a wide gulf between school mathematics and their everyday experiences of actual mathematics, making them disengage their minds in the subject despite efforts of the teacher (Boaler, 2016). For children in Malawi, the problem of lack of understanding Mathematics is often observed from the perpetual low scores attained by learners during standardised national examinations and international assessments in mathematics and numeracy. As such, this study seeks to understand ways in which early years mathematics is taught in Malawi and assess the opportunities of learning offered through their approaches. The study will seek to answer the question: How do Malawian teachers mediate mathematics during lessons in the early years of primary school? The main question will be answered through the following subsidiary questions: How do teachers in early years work with tasks and examples during lessons? How do mathematics teachers use artifacts during early years of primary school? In what ways do teachers use inscriptions to represent mathematical processes in early years? What talk/gestures do teachers use to generate solutions to problems, make mathematical connection, and advance learning connections?

Theoretical Framework

This study is guided by the Mediating Primary Mathematics (MPM) framework developed by Venkat and Askew (2018). The framework focuses on the nature of the mathematics that is made available to learn and enables a detailed exploration of the quality of primary mathematics instruction. The MPM framework applies variation theory to understand teachers' use of example spaces during instruction (Kullberg, Kempe, & Marton, 2017). It is grounded on Vygotskian concept of mediation as the major requirement for learning and adopts sociocultural theory to understand the teacher's role as the sole mediating agent in the classroom, determine the goals in mathematical instruction, and determine sociocultural materials and practices for mediation. The framework identifies four overarching means of mediation (called strands), which are: Tasks/examples, artifacts, inscriptions, and talk/gesture.

Research Design and Methodology

The research will adopt a qualitative exploratory case study design. One rural primary school in a remote village will be purposively selected as a paradigmatic case of exemplary performance during standardised national examinations, despite having limited teaching and learning resources. Lessons will be observed from four outstanding mathematics teachers (one in each of the first four early years classes), identified by the school authorities. The classroom observations will be followed by video-stimulated recall interviews (VSRI) with each teacher to elicit their thinking behind the choices made during the lesson. Document analysis will also be done on learners' notebooks, textbooks, mathematics syllabi, teachers' guides, lesson plans, schemes and records of work. Recorded videos of lessons will be analysed using MPM's tool for lesson analysis (Venkat & Askew, 2018).

Pilot Findings

The study was piloted with a grade 2 teacher at another well performing rural primary school. The findings from the pilot study indicated substantial use of artifacts to explain new concepts during lessons. Single-use artifacts were mainly developed by the teacher while multiple-use artifacts, such as counters, were brought by children in collaboration with their parents. Chalkboard inscriptions were also used to reify the artifacts when representing concepts during lessons. Highest levels of abstraction were achieved with talk and gesture that corresponded with the tangible artifacts and the written inscriptions. This shows that highest opportunities for learning are afforded when artifacts, inscriptions, talk and gestures are used concurrently to represent a single concept.

Acknowledgment

This study will be carried out with support from Norwegian Programme for Capacity Development in Higher Education and Research for Development (NORHED) programme through the *Strengthening Numeracy in Early Years through Capacity Development of Teachers* project based at the University of Malawi in collaboration with the University of Stavanger.

References

- Boaler, J. (2016). *Mathematical Mindsets: Unleashing students' potential through creative math, inspiring messages and innovative teaching*. San Francisco, CA: Jossey-Bass.
- Kullberg, A., Kempe, U. R., & Marton, F. (2017). What is made possible to learn when using the variation theory of learning in teaching mathematics? *ZDM*, 49(4), 559–569. <https://doi.org/10.1007/s11858-017-0858-4>
- Robertson, S., Cassity, E., & Kunkwenzu, E. (2017). *Girls' primary and secondary education in Malawi: Sector review*. Camberwell, Australia: Australian Council for Educational Research (ACER).
- Venkat, H., & Askew, M. (2018). Mediating primary mathematics: theory, concepts, and a framework for studying practice. *Educational Studies in Mathematics*, 97(1), 71–92. <https://doi.org/10.1007/s10649-017-9776-1>

Developing mathematical literacy in an inquiry-based setting working with play-coins in a second-grade classroom

Benedikte Grimeland and Svein Arne Sikko

Norwegian University of Science and Technology (NTNU), Norway;

benedikte.grimeland@ntnu.no , svein.a.sikko@ntnu.no

In this paper we discuss how focusing on inquiry-based learning may contribute to the development of mathematical literacy in the early grades. We analyze a grade 2 lesson with play-coins with a particular view on what it means for students to have a critical orientation.

Keywords: Mathematical literacy, Numeracy, Elementary school mathematics, Number concepts, Inquiry-based learning

Introduction

The work reported in this paper is part of a longitudinal study on mathematical and scientific literacy and inquiry-based learning in two Norwegian primary schools. The project group consisted of university didacticians from both the mathematics and the science sections of the teacher education department working together with teachers at the two schools. At the start of the project, the students were in grade 1. The data analyzed in this paper was collected when the students were at the start of second grade, at ages 6- and 7-years old. Using data from an IBL-inspired lesson with students at their start of second grade, we explore affordances for students' critical meeting with mathematics in a 'realistic' context. While a lot has been said and written about literacy in general and also the particular topic of mathematical literacy, what mathematical literacy constitutes in the earlier grades has been less discussed (e.g., Askew, 2015, p. 708). In this paper our research question is: Which opportunities do students have to be critical in mathematics in a second-grade classroom, and how can an IBL approach foster this?

Literature review

The use of more inquiry-based learning has been launched as a way to make mathematics and science more relevant to students, preparing them for an uncertain future where the ability to ask questions, to reason, explore, explain and develop a creative and critical mind is seen as essential (e.g., Maaß & Artigue, 2013). Also for early years mathematics inquiry-based activities has been launched as beneficial to develop critical and creative thinking (e.g. Skoumpourdi, 2017). Through working inquiry-based, teachers will expand their teaching repertoire and will also be better able to meet different types of students, including students who struggle with mathematics. Inquiry-based learning has been shown to be effective in rich and real-life contexts and may have a positive effect on students who otherwise perform poorly (Kogan & Laursen, 2013). Through context-based approaches, students gain insight into meaningful use of mathematics and this results in improving students' motivation and attitudes towards learning, which in turn affects academic achievement (Bruder & Prescott, 2013). In this way, IBL appears as a framework that is productive in terms of building mathematical literacy. There is no universally agreed upon definition of inquiry-based learning. Core elements of IBL include developing a questioning mind and a scientific attitude. In the EU funded

Primas project (Maaß & Reitz-Koncebovski, 2013), aspects related to students, teachers, classroom culture, valued outcomes and learning environment were identified and summarized, see Figure 1.

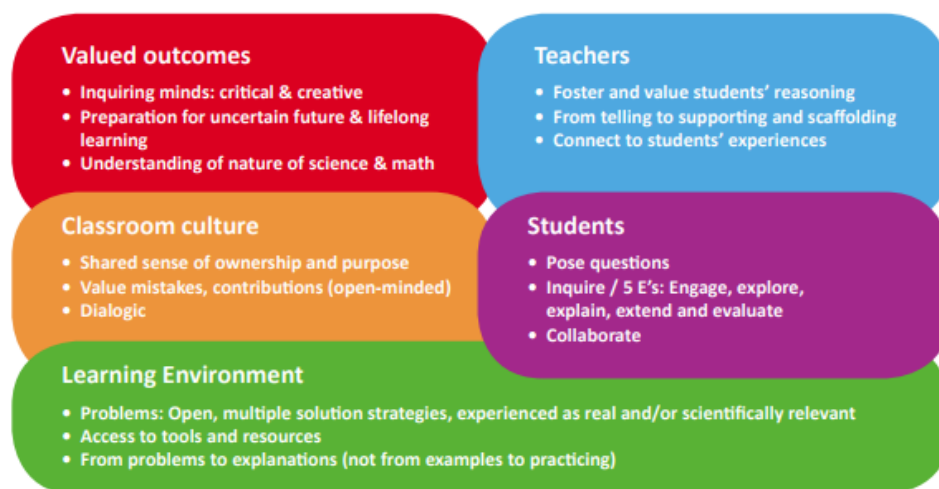


Figure 1. The multifaceted understanding of IBL (Maaß & Reitz-Koncebovski, 2013, p. 8)

Whereas mathematical literacy has been propagated by policy makers and educational authorities, the term is not well defined within the scientific literature. Terms like numeracy and quantitative literacy have been used, more or less synonymously with mathematical literacy, without any determinate definition of what the term entails (Geiger, Goos, & Forgasz, 2015). Niss and Jablonka (2014) pointed out that researchers from non-English speaking countries may have reservations towards the use of the term based on the fact that it is not easily translated and lack counterparts in many languages, including German and the Scandinavian languages. For the PISA assessments, OECD made a working definition that has been slightly amended through the years. In its latest version it reads

Mathematical literacy is an individual's capacity to formulate, employ and interpret mathematics in a variety of contexts. It includes reasoning mathematically and using mathematical concepts, procedures, facts and tools to describe, explain and predict phenomena. It assists individuals to recognize the role that mathematics plays in the world and to make the well-founded judgements and decisions needed by constructive, engaged and reflective citizens. (OECD, 2017, p. 4)

An aspect that is downplayed by this definition is the critical aspect. Some authors see the development of a critical disposition as a primary aspect of mathematical literacy. In the model developed by Goos, Geiger and Dole (2014) a critical orientation is seen as an overarching element. D'Ambrosio (2003) used the term matheracy along with literacy and technoracy as essential for the "providing, in a critical way, the communication, analytical, and technological instruments necessary for life in the twenty-first century" (p. 237). Matheracy is not about counting or measurements, but about thinking and philosophy, about the ability to derive, suggest hypotheses and draw conclusions from data. Literacy, according to D'Ambrosio, is the ability to process information, such as the use of spoken and written languages, of characters and gestures, of codes and numbers. Ole Skovsmose (1998) introduced the term mathemacy as a parallel to the way Paulo Freire has used literacy, namely by linking it to being able to function in society, and thus not only to number sense or basic skills in arithmetic (p. 199). To Skovsmose, mathemacy is about the competence to be able to function in

society structured by mathematics. Against this we can ask to what extent mathematics education educates students to become critical citizens who can challenge the authorities. Askew (2015, p. 708) argued that being critical can be addressed in at least three ways: 1) being critical within a particular mathematical model; 2) being critical of the choice between mathematical models; and 3) being critical of what is modelled mathematically. Askew emphasized that these three forms of being critical are not to be seen as separate to each other or mutually exclusive, but rather “co-construct each other” (p. 709). Being critical within a particular mathematical model is the approach in most papers about young students, this is about reflecting on the chosen methods/approaches used by the students towards finding the required answers or results. It is less clear what being critical to the choice of mathematical model or being critical to what is being modelled may constitute in the lower grades. Does being critical presuppose mathematical knowledge to a certain degree? And which comes first, Askew asked, the mathematical knowledge that enables you to be critical, or the critical orientation towards practice? The problems posed in mathematics classes has a long tradition of being ‘made up’ to look like real problems, and posed to be solved by the algorithms of mathematics. On the other hand, “real-life problem solving is pragmatic and seeks effective solutions to particular problems, rather than the generality and abstraction sought in formal mathematics” (Askew, 2015, p. 709). There are, however, no quick fixes according to Geiger et al. (2015): “The question of how to best promote numeracy capabilities remains an open question. (...) there appears to be little research that outlines the characteristics of effective numeracy tasks or how these tasks promote student learning” (p. 544).

Methodology

The data was collected as part of a seven-year longitudinal study where four groups/classes in two different primary schools and their teachers partake in lesson study cycles focusing on inquiry-based approaches to mathematics and science. Each group of children with their teachers partake in two lesson study cycles each year, in science or mathematics, starting with the children’s first year in school and until they leave primary school after 7th grade. At the time of the lessons reported on here the students were at start of their second year at school. Skoumpourdi (2017) pointed out that “it is not easy for teachers to design inquiry-based activities and implement them in the classroom” (p. 1906). To implement new pedagogical and didactical ideas, it is beneficial for teachers to work collaboratively and with support from outside ‘experts’. Lesson studies in the form of planning lessons together and observing each other’s teaching in cyclic processes of design and redesign is a particular efficient way of professional development (e.g., Yang & Ricks, 2013). In our project, each lesson study cycle is initiated by the in-service teachers choosing a topic or teaching goal, building on the national curriculum, in either mathematics or science. The research group and the teachers meet to develop a detailed lesson plan for the teaching. The planning meeting is audio-recorded. One of the in service-teachers then conducts the lesson, which is video-taped, while the other teachers and researchers observe the lesson, using observation sheets that have been developed as part of the planning sessions. In addition, the teacher wears an audio-recorder, and additional audio-recorders are placed among selected groups of students. After the lesson the researchers and the in-service teachers meet to reflect on the lesson and redesign it. A (possibly different) teacher conducts a new lesson with the new redesigned lesson plan in another group/class. A new reflection and redesign

meeting is held after this second run-through. This is also audio-recorded. In addition, annual interviews are conducted. Students are interviewed in groups of 3-4, while teachers are interviewed individually and respond to questionnaires. For this paper the data analyzed comes from two lessons in the lesson study cycle. The first group of students comprised 16 students and the second 14 students. The same teacher, who is one of the two regular teachers sharing these two groups, conducted both lessons. The underlying mathematical goal concerned addition with natural numbers up to twenty. The mathematics was introduced in a context that involved Norwegian coins (values 1, 5, and 10 kroner), bringing the ‘real’ world into play. We use the word ‘play’ here deliberately to emphasize that the real world for children is as much a world of playing games and not only the real adult world. At the same time, using coins relates to the adult world and prepares students for meetings with, and they may already relate to, money in the real world. Thus, the tasks were partly presented as small ‘mysteries’ where the students were supposed to find solutions, as if solutions to real problems and not pure mathematical tasks. A particular aim in the design of the tasks was to focus on the different types of number of solutions a mathematical problem may have: one unique solution, several or infinitely many solutions, or no solution at all. For the students, working collaboratively, in pairs, was an explicit goal for the lesson. Students had access to number lines, play coins similar to Norwegian 1, 5 and 10 kroner coins, and A3-size sheets of paper, pencils and crayons. Each lesson was divided in three parts: 1) plenary gathering around the smartboard, where the topic was introduced; 2) students working in pairs with up to five different tasks. The tasks were printed on laminated A5-size paper sheets and handed to the students as they asked for it. 3) plenary session where students were asked to present their findings. Data sources used for the analysis in this paper are the audio- and video-recordings and transcripts of the lessons, observation sheets filled in by the authors during the lessons, and copies of the A3 sheets filled in by the students. The multiple data sources enhances the construct validity (Yin, 2018, p. 43). Data analysis started by the two of us watching the video recordings together. Whenever anything in the video was unclear, the audio recordings were consulted, and sometimes also copies of the student work sheets. Together with the lesson plan and the observation sheets this gave us an overview of the lessons. Subsequently, the transcripts were analyzed by each of the authors with respect to two lines of inquiry: 1) are any of the aspects of IBL as identified by Maaß and Reitz-Koncebovski (2013) apparent? and 2) are any of the three ways of being critical as identified by Askew (2015) apparent? We then sat together to exchange scripts and discuss our findings to enhance inter-rater reliability. Part of this also included consulting the video- or audio recordings or the students work sheets whenever anything needed to be clarified.

Findings

All together there were six available tasks for students to work on, labelled 1a, 1b, 1c, 2a, 2b, 2c. All students were able to work with at least the two first ones, and some students were able to finish all tasks. We arrange our findings according to the tasks, with an analysis of student answers to the first four tasks. The students started out on task 1a), that had a unique solution, namely: *Jens has four coins in his pocket. The value of the coins are 17 kroner. Which coins is it?* In the conversation below we see an example where the students have already solved the mathematical problem by representing the answer with play-coins but without writing or drawing. The teacher asks them to write and draw the answer, and the calculation. They found a short plenary talk where the teacher reminded the class

that they should collaborate and use the available resources when needed, as something that disturbed them:

24 Student 2: We are already finished with these coins. We managed to find out before you began with your talking-thing

30 Teacher: But, you, can't you say how you were thinking, and write it? Draw coins, write the addition? Write the answer!

In this interaction with the teacher the students have a solution, and rather than giving the students an opportunity to explain their thinking with the play coins, they are encouraged to make a written record on paper. The teacher does ask them to draw the coins, while in the video it is clear that the students have used the play-coins to solve the problem. We see here that there is some discrepancy between the students' and the teacher's ideas about how to solve the problem. This can be interpreted as the students being critical within the mathematical model, the first of Askew's (2015) three ways of being critical.

Task 1b): Jens has 17 kroner in his pocket. Which coins can that be? This task has several solutions, however only a finite number using Norwegian coins.

66 Student 1: OK. 17 kroner. OK. One ten, one five, plus two. Like that. You can write it.

Student 2 asks whether to write the same answer as in 1a), but Student 1 says

70 Student 1: No, no, no. You do different ways.

The students explore different ways to make a sum of 17 kroner from the Norwegian coins, realizing that there are lots of solutions.

104 Student 2: Maybe we can fill the whole sheet only with b).

This type of task, with several solutions, is not very common in Norwegian text-books and classrooms. In their conversation, Student 1 sees only one possible solution, however Student 2 points out that there are in fact many solutions, and they continue to explore this together.

Task 1c): There are 4 coins in the bag. Which coins can it be and how many kroner? This task poses the same challenges as the previous one, as there are several solutions, though only a finite number using Norwegian coins. Many of the students did not realize that the coins did not need to hold the same value in this task. Several were happy with the solution $1+1+1+1$, and needed prompting from the teacher to realize that there were other possible solutions. Two of the students found several possibilities and started discussing whether there are more than already discovered. Further in the discussion a question arises:

416 Student 2: Is it allowed with minus? Because there are no more numbers.

This can be interpreted as the student questioning the choice of model in this setting, which is the second way of being critical according to Askew (2015). It is not within the model or given context natural to consider that you add some of the coins in the pocket and subtract any. These students are in the early stages of learning addition and subtraction and so it is natural to also question which mathematical operation that is valid in a given situation. And indeed, considered as a purely mathematical problem, subtraction is also part of the additive context.

Task 2a): Kari has 5 coins in her pocket, in total 20 kroner. Which coins does Kari have in her pocket? This task does not have any solutions using Norwegian coins. The students' first reaction was

468 Student 1: OK, that is easy. No, what?

The two students discussed it, trying out possible solutions.

511 Student 1: We need one ... It doesn't work

513 Student 2: Yes, but it has to work, Hm ...

515 Student 1: This also does not work. Definitely not this. Kari has five in her pocket ...

527 Student 1: It would have worked if there was a 2-coin.

529 Student 2: OK. Oi, oi, oi. This is totally ... Hm ... Five ..

537 Teacher: What are you doing?

539 Student 2: We are working with this one, with 5 coins, it is not possible to divide in twenty or something. Ones, too few. All of them, too little. And fivers, too much, and tens, too much.

567 Student 2: Four. If we need, then,... If it was supposed to be 19, then we would have found the answer immediately. There should have existed 2-coins.

Not all mathematical tasks have a solution, and quite a few mathematical tasks do not have a solutions within the number set you are working with; e.g. $3 - 5$ does not have a solution in the natural numbers, $3 : 5$ does not have a solution in the integers, a set of linear equations represented by non-identical parallel lines does not have a solution; etc. In this case this fact is discovered by the students, when they realize that if you had a coin with value 2 kroner then the problem could be solved. Two other students, Student 3 and Student 4, also working with 2a), turned critical to the idea of having this type of tasks. Their relationship with the teacher is one of confidence and trust, allowing expression of honest opinions of frustration without being interpreted as rude or angry.

445 Student 3: So this is a nonsense task?

447 Teacher: Or an impossible task?

449 Student 3: Did you make this so that we should not be able to solve it, just sit there struggling and struggling?

These students questions the teachers motivation for choosing a task that does not have a solution. This can be seen as the students being critical to what is being modelled mathematically, the third way of being critical as identified by Askew (2015).

Discussion

The multi-faceted understanding of IBL consisting of five related areas displayed in Figure 1 was used as a guiding map during the planning of the lesson, and the analysis shows that several characteristic aspects of IBL could be discerned in the lessons. The learning environment was characterized by problems that afforded diverse possible solution strategies, and apart from task 1a) they all had a number of possible solutions. Furthermore, the problems could be experienced as real for the students, and there was access to tools such as play-coins, number lines, paper and pencils. Explanation of solutions were encouraged, as made clear by the teacher both at the start of the lesson and during the students' problem solving. The realistic restrictions to the coin-problems by using only

Norwegian coins afforded the students opportunities to discover firstly that not all problems are solvable with these restrictions, secondly that if there were other coins such as a coin with value 2 kroner the problem could be solved, and thirdly, in the real world there is actually no coin in Norway with value 2 kroner. Understanding what a solution means, under what circumstances and limitations solutions can be found, and being able to see that changing conditions may lead to other solutions, is an important part of learning mathematics, and in particular an important part of developing a critical orientation in mathematics, e.g. as identified by Goos et al. (2014) and Askew (2015). Additionally, it is certainly also an important part of being able to solve problems in the society. This brings us closer to those aspects of learning mathematics that are proposed by D'Ambrosio (2003), Skovsmose (1998) and which are some of the underlying ideas and valued outcomes of IBL (Maaß & Reitz-Koncebovski, 2013). For some students, such as students 1 and 2, we observed that they had to be encouraged specifically to do writing and drawing by the teacher. They had already solved the problem using play-coins but not made a written record. Learning to communicate your solution, making your thinking visible to others in a multitude of ways, is an important part of building mathematical literacy. At the same time, forcing children to represent their answers in particular ways may distract from their learning of the mathematical content, and prevent them from going into deeper thinking. One risks, as D'Ambrosio (2003) pointed out, to emphasize manipulation of numbers and symbols rather than developing matheracy. We believe that this tension between steering children towards particular representations and letting them explore more freely, is something we have to live with. By emphasizing the importance of writing or drawing as representations and as means for communicating results, one risks downplaying the importance of other, for instance oral communication (which is also something one would like to foster). From the empirical data we also see that the students engaged in the inquiry cycle with the five E's, engage, explore, explain, extend and evaluate while working collaboratively in pairs. The teacher encouraged students' reasoning by asking students about their ways of thinking, both in plenary and when students were working in pairs. From the data it is evident that it was necessary for the teacher to prompt students to collaborate and inquire, even if this prompting when done in plenary was seen as 'disturbing' for some students, as evident from transcript line 24 above. Developing a classroom culture that values questioning, exploration and where mistakes are seen as a necessary part of learning mathematics is emphasized as important in IBL (Maaß & Reitz-Koncebovski, 2013) and is essential for students to develop a critical disposition that is essential in being mathematically literate. In our data it is evident how the teacher tried to achieve this, both by her innate experience as a teacher and by using the IBL oriented lesson plan. The start of the lesson with the students all gathered around a smart-board where the coins and the problems were introduced, was used to create a classroom culture of shared ownership and purpose, and where the students were encouraged to explore and work together. Valued outcomes in an IBL setting include developing critical and creative inquiring minds. This echoes some of the ideas proposed by D'Ambrosio (2003) and Skovsmose (1998) and also the critical orientation underlined by Goos et al. (2014). It is not straight forward to answer the question about what it means to be critical in a mathematics lesson, in particular at the lower grades of primary school. Our data shows that it is possible to identify the three ways of being critical (Askew, 2015) even in 2nd grade, if the setting and atmosphere in the classroom is encouraging, e.g. the classroom culture and learning

environment are as described in the IBL model. Planning a lesson using an IBL model like the one used here may help fostering mathematical literacy, including developing a critical disposition.

Acknowledgement

The authors would like to thank participating teachers, the schools and our colleagues from NTNU.

References

- Askew, M. (2015). Numeracy for the 21st century: a commentary. *ZDM*, 47(4), 707–712.
- Bruder, R., & Prescott, A. (2013). Research evidence on the benefits of IBL. *ZDM*, 45(6), 811–822.
- D’Ambrosio, U. (2003). The role of mathematics in building a democratic society. I B. L. Madison & L. A. Steen (Eds.), *Quantitative literacy: why numeracy matters for schools and colleges* (pp. 235–238). Princeton, NJ: National Council on Education and the Disciplines.
- Geiger, V., Goos, M., & Forgasz, H. (2015). A rich interpretation of numeracy for the 21st century: a survey of the state of the field. *ZDM*, 47(4), 531–548.
- Goos, M., Geiger, V., & Dole, S. (2014). Transforming professional practice in numeracy teaching. In Y. Li, E. A. Silver, & S. Li (Eds.), *Transforming Mathematics Instruction: Multiple Approaches and Practices* (pp. 81–102). Heidelberg, Germany: Springer.
- Kogan, M., & Laursen, S. L. (2013). Assessing long-term effects of inquiry-based learning: a case study from college mathematics. *Innovative Higher Education*, 39(3), 183–199.
- Maaß, K. & Artigue, M. (2013). Implementation of inquiry-based learning in day-to-day teaching: a synthesis. *ZDM*, 45(6), 779–795.
- Maaß, K., & Reitz-Koncebovski, K. (Eds.) (2013). *Inquiry-based learning in maths and science classes*. Freiburg, Germany: Pädagogische Hochschule Freiburg.
- Niss, M., & Jablonka, E. (2014). Mathematical literacy. In S. Lerman (Ed.), *Encyclopedia of Mathematics Education* (pp. 391–396). Dordrecht, The Netherlands: Springer.
- OECD (2017). *PISA 2015 Assessment and Analytical Framework: Science, Reading, Mathematic, Financial Literacy and Collaborative Problem Solving*. Paris, France: OECD Publishing.
- Skoumpourdi, C. (2017). A framework for designing inquiry-based activities (FIBA) for early childhood mathematics. In T. Dooley, & G. Gueudet (Eds.), *Proceedings CERME10* (pp. 1901–1908). Dublin, Ireland: DCU Institute of Education and ERME.
- Skovsmose, O. (1998). Linking mathematics education and democracy: citizenship, mathematical archaeology, mathemacy and deliberate interaction. *ZDM*, 30(6), 195–203.
- Yang, Y., & Ricks, T. E. (2013). Chinese lesson study: Developing classroom instruction through collaboration in school-based Teaching Research Group activities. In Y. Li & R. Huang (Eds.), *How Chinese teach mathematics and improve teaching* (pp. 51–65). New York, NY: Routledge.
- Yin, R. K. (2018). *Case Study Research and Applications. Design and Methods* (6th ed.). Los Angeles, CA: Sage.

Student teachers' definitions of the concept “teaching mathematics in preschool”

Maria Johansson, Timo Tossavainen, Ewa-Charlotte Faarinen, and Anne Tossavainen

Luleå University of Technology, Sweden; maria.L.johansson@ltu.se ; timo.tossavainen@ltu.se ;
ewa-charlotte.faarinen@ltu.se ; anne.tossavainen@ltu.se

This article reports on how a group of preschool and primary student teachers define the concept “teaching mathematics in preschool” in the beginning of their studies. The background for this pilot-study is the recent change in the Swedish curriculum, which means a shift from play-based to more teaching oriented activities, and the actual Swedish debate on the role of teaching in preschool.

Keywords: Young children, Teaching, Learning, Mathematics, student teachers, preschool.

Introduction.

In 2011, a new national curriculum for Swedish preschool was implemented. In this text, and also in the previous curricula for preschool, the concept of teaching is not discussed. Instead of that, the guidelines for preschool teachers highlight the learning opportunities that should be provided to children, and these indicate indirectly what kind of mathematics preschools should provide to children (Swedish National Agency for Education, 2011). The concept of teaching is however used in the Swedish educational act (SFS, 2010:800). According to Öqvist and Cervantes (2017), this was the first time the concept of teaching was used in a steering document for preschools in Sweden. On the other hand, it seems to be important for preschool teachers not to work in the school-like way and, hence, they tend to avoid using the word “teaching” to describe their professional work (Hedefalk, Almqvist, & Lundqvist, 2015).

In Sweden, there is an ongoing discussion about what teaching in preschool means (Rosenqvist, 2000; Doverborg, Pramling, & Pramling Samuelsson, 2013; Hedefalk, Almqvist, & Lundqvist, 2015; Jonsson, Williams, & Pramling Samuelsson, 2017). Palmér and Björklund (2016) provide an overview of eight Nordic articles which show a large diversity of aims and goals within preschool mathematics. There is not a common understanding or view of what teaching in preschool is, could or should be. Quite recently, this question was raised when the Swedish National Agency for Inspection (2017) reported that there is a lack of teaching in the Swedish preschools and that there is uncertainty about what the concept teaching in preschools is. This debate is our primary motivation for the present study.

Secondly, according to Clarke, Clarke and Cheeseman (2006), the research into mathematics in preschools has often been driven by the school curriculum with its emphasis on number knowledge. Researchers have investigated various aspects of children’s learning of mathematics and numerous theories concerning children’s mathematical learning exist. Yet the everyday of the teaching of early mathematics has received much less attention in Nordic countries (Saebbe and Mosvold, 2016; Vallberg Roth, 2018).

A third motivation for this study is the fact that the views and beliefs of student teachers (and teachers) affect the way they plan their teaching, what kind of materials they use, and their performance in mathematics during their teacher studies (Wilson & Cooney, 2002; Tossavainen, Väisänen, Merikoski, Lukin, & Suomalainen, 2015). Hannula (2002) emphasises, in his widely applied framework for analysing individuals' attitude towards mathematics, the role of expected consequences and relating the attitudes to personal values. So, by surveying prospective preschool and primary teachers' views of the teaching of mathematics for small children we hope to get knowledge about their personal values and what they expect the outcome of their own mathematics education during teacher education and mathematics education in preschool will be.

Theoretical perspective

Benz (2016) synthesised the professional competences needed for supporting children's early mathematical thinking. These competences are also important for teacher education and hence can contribute to the understanding and the impact of beliefs on the teaching of mathematics. She specified three categories of competences found in previous research: (a) content knowledge, pedagogical content knowledge, and knowledge of children's development, (b) action competencies, and (c) attitudes and beliefs. In this article, we will focus on the third point, the attitudes and beliefs. These play an important role when it comes to providing learning opportunities for children in mathematics in preschools. Indeed, teachers' view of what counts as mathematics and what mathematics teaching for young children is have a remarkable effect on their everyday practice.

Hannula (2002, p. 30) defines attitude as a category of behaviour that is produced by different evaluative processes which concern emotions, values and expectations. These processes are influenced by the social setting and former experiences. In the present paper, we are interested especially in students' values and expectations.

Concerning the beliefs, we use the following definition: "...teachers' pedagogical beliefs refer to pedagogical attitudes and values such as educational goals and norms, the definition of their own pedagogical role, beliefs about developmentally appropriate practices, as well as the educational goals of preschools" (Anders and Rossbach, 2015, p.308). More specifically "mathematics-related beliefs, which include the implicitly and explicitly held subjective conceptions about mathematics education, the self as a mathematician, and the social context, i.e., the class-context" (Op't Eynde et.al. 2002, p.14). In this paper, we focus on the explicitly held subjective conceptions about teaching in mathematics education.

Our research questions are:

- (i) *How do student teachers describe mathematics teaching in preschool in the beginning of their university studies?*
- (ii) *Are there differences between the different groups of students, and if there is, how can they be described?*

The study

This study aims to investigate student teachers' beliefs about the concept of teaching in mathematics education for young children, specifically in preschool. In order to do that, we collected data from three different groups of students by using a printed questionnaire. The participants of the study (N=94) represent Swedish university students from three different teacher education programs. The first group studies (N=27) to become preschool teachers, the second (N=42) to lower primary teachers (Swedish classes F-3) and the third group (N=25) to upper primary (Swedish classes 4-6) teachers. All of the respondents were in the beginning of their university studies and had therefore not yet taken any mathematics courses contained in their university program.

The motivation for including these three different groups is the fact that the primary teachers continue the work of the preschool teachers, so, it is important to see if they share the same ideas and goals related to mathematical education. Another reason for the three groups is that we want to see whether students' views on teaching arise during the teaching education programme or are they based on their earlier beliefs. Therefore, we need to examine whether or how these groups' views differ from one another already in the beginning of university studies.

The first part of the questionnaire surveyed the participants' educational background concerning mathematics. In the second part, the participants were asked to make a concept map of their definition of mathematics education in the Swedish preschool. The third part contained a set of statements related to teaching of mathematics for young children with the seven-point Likert-type scales. In this article, we focus on the participants' concept maps i.e. the second part of the survey. The task was presented in the questionnaire as follows: "The definition of mathematics teaching in preschool: Spend a few minutes on reflecting teaching mathematics to young children and what it brings to your mind. Then, using a concept map, define what mathematical teaching in preschool education in Sweden should in your opinion be. Focus on the essential features, more detailed questions follow on the next page."

The students then provided concept maps where they had a centre of the map and then added essential features of the question around this centre. Using a concept map may provide other information about teachers' views and beliefs than open questions and Likert-type scale questions. This method is mostly used for investigation concept understanding (Rosas & Kane, 2012) and, hence, we found that it might be a way also to investigate beliefs and views on the concept of teaching mathematics in preschool since this is in line with the definition and focus of the paper, the conceptions about teaching of mathematics. When analysing the students' concept maps we realised that they often had more features of a mind map than a concept map. According to Davies (2011), one important difference between a mind map and a concept map is that a concept map has a hierarchical structure with several levels. This was not the case with these students, most of their maps had only one level.

We used content analysis in order to find the essential categories of sub-concepts that occur in the students' concept maps. The analysis focused on qualitative differences in students' values and expectations. It did not however take into account at what levels in the concept maps these sub-concepts were mentioned. The categories were derived purely from the data, i.e., the words found in

the maps are grouped and after the grouping the categories are defined. When it comes to the written answers (a few students gave a written response instead of drawing a concept map), they were added to the categories after the grouping of the words.

Result

In this section, we first present the categories found in the concept maps and then give examples of different categories and their content. Secondly, we discuss the differences or similarities that can be seen between the three different groups.

The following categories were found in the concept maps: Motivation, Methods for teaching, Children-centred, Everyday, and Content.

Motivation is the first one of these categories. Here we have words like fun, enjoyable, meaningful, play based, play, inspiring, interesting and creative. We interpret these words as describing how mathematics teaching should be for young children. They focus on feelings as a tool for motivation. We also attached play and play-based to this category even though they could be placed also in the category methods for teaching.

The category *Methods for teaching* also answers the question how mathematics teaching should be for young children, but with a focus on the organization of the teaching or learning rather than the motivational aspects. Here we find words like practical, concrete, concrete materials, games, digital tools, mathematics in all activities, variation, exploration and group work.

The next category can also be seen to answer the question how, but it focuses on children and their world. Therefore, we call it *Children-centred*. Here we find words like draw on children experiences, on the child's level, and suitable level.

Everyday is another category putting a child in the centre. In this category, we find words like everyday situations, connect to the everyday, connected to reality and use the everyday.

Content is the last of the categories and here the students have given examples of mathematical content that the children should meet in the preschool. Here are words like numbers, counting, shapes, develop concepts, space, symmetry, geometry, arithmetic, problem-solving and sorting. This category is not analysed in detail here due to limited space but it is of interest for further investigations.

	Motivation	Children-centred	Everyday	Methods for teaching	Content
Preschool N=27	17 64%	12 44%	4 15%	5 19%	17 63%
Lower Primary N=42	26 62%	7 17%	9 21%	16 38%	18 45%
Upper Primary N=25	7 28%	1 4%	3 12%	11 44%	21 84%

Table 1: Distribution of the categories for each group

In Motivation, we have few (7) response from upper primary student teachers, and of these seven, six mentions play. On the other hand, play is not mentioned at all by the preschool student teachers, this is surprising given that play as a base for learning is a foundation for the Swedish curriculum for preschool. For the preschool student teachers, we have 17 responses and for the lower primary student teachers we have 26 responses in this category. To conclude this category seems to be important for preschool student teachers and for lower primary student teachers.

The category Children-centred seems to be important for the preschool student teachers but not so important for the other groups, only one of the upper primary student teachers has a word in this category, and there are only few words from the lower primary student teachers and then even less for the upper primary student teachers.

Surprisingly, Everyday does not have that pattern. Here the lower primary student teachers have the mode while preschool student teachers and upper primary student teachers only have 4 and 3 responses, respectively.

In Methods for teaching, the preschool student teachers have few words in this category and they all say variation. This is in contrast to lower primary student teachers group where they have 16 and upper primary student teachers have 11 and gives a variety of methods.

Content is the largest category overall and seems to be important for all the groups, and it will be a subject to a separated analysis later on. It is the only category that is almost the same in all three groups and almost all student teachers have words in this category.

One important thing that was noticed in the analysis was the fact that the students had different words in the centre of their concept maps. The formulation of the task mentioned explicitly “The definition of mathematics teaching in preschool” and from this expression the students had chosen different centre words for their maps. This may have had an impact on the concept maps and, hence, it is important to present the different centerwords as well. They are: mathematics, mathematics learning, mathematics teaching and mathematics in preschool. The remaining 19 students either does not have a centre word, have written a short text describing, or it is not obvious what the centre word is.

	Mathematics	Mathematics in preschool	Mathematics learning	Mathematics teaching
Preschool N=27	7 26%	3 11%	9 33%	1 4%
Lower Primary N=42	8 18%	17 39%	0	14 32%
Upper Primary N=25	9 39%	6 26%	0	1 4%

Table 2: Concept map centres across the student groups

As we can see in Table 2, only one of the student teachers for preschool has written about mathematics

teaching. This is not surprising since we know from previous research that this is typical for in-service preschool teachers (Hedefalk, Almqvist, & Lundqvist, 2015). So, the fact that the same pattern appears for upper primary student teachers is more interesting. On the other hand, none of the primary student teachers has used the mathematics learning in their centre. The lower primary student teachers have focused on mathematics in preschool or mathematics teaching and the upper primary student teachers on mathematics and mathematics in preschool. The difference between the groups is noticeable and can only partly be explained by the fact that they have started their studies. They are, as mentioned before, in the beginning of their studies and have not yet taken the mathematics course.

Discussion

As mentioned above, this is just a pilot study with a relatively small group of students, and the results discussed in this article are only due to an analysis of one of the parts of the survey. The next step would be to investigate how these results are connected to the students' responses to the statements measures on a Likert-type scale; some preliminary results have been reported by Tossavainen, Johansson, Faarinen, Klisinska and Tossavainen (2018). Nevertheless, the above results give us an overview of what prospective preschool and primary teachers expect mathematics education in preschool to be and what they value in the teaching of mathematics for small children.

One point that needs to be addressed here is that the students had chosen different words in the middle of their concept maps. The formulation of the task mentioned explicitly “The definition of the teaching of mathematics in preschool” and it seems that, from this expression, the students have chosen different centre words for their maps. This may have impacted the concept maps and, hence, it is important to present the different subcategories as well. They are: mathematics, mathematics learning, mathematics teaching and mathematics in preschool. The fact that most students have mathematics learning as the concept centre is compatible with previous research (Hedefalk, Almqvist, & Lundqvist, 2015) but a new finding is that this view is already present when they start their studies at university. Similarly, it is surprising that their concept centres differ already at this stage.

The lack of the word *play* in the preschool student teachers' concept maps is another point is worth more investigations. One way to interpret this is that, for this group of students, play is so obvious that it does not have to be mentioned, yet this is not self-evidently supported by our data.

The fact that the lower primary student teachers seem to have a broader view than the other groups would be even more evident if we studied the students' concept maps at individual level.

To answer our research questions, the three groups of students give different descriptions about what teaching in mathematics in preschool is, and they focus on different parts of the teaching of mathematics. We can say that they in fact have different pedagogical beliefs and expectations regarding at least what mathematics teaching should be in preschool, how it should be provided, and also which focus the teachers should have. The category Content gives us some indications of attitudes and values regarding their educational goals. Since this category is shared by all groups and is the largest one, we can conclude that this is an important base for all the teachers' pedagogical beliefs. The categories Everyday and Children-centred give information regarding expectations and

values concerning the teachers' pedagogical role. Here the focus for the preschool student teachers is on the child and the focus for the lower primary student teachers is on the everyday. These are not so important for the upper primary student teachers, and this could possibly be explained by the fact that they have not thought about the pedagogical role of the teacher since they will not teach themselves. Methods for teaching and Motivation give information about attitudes and values about appreciated practices. These can be found in all the groups but with different focus. For the preschool student teachers, the focus is on motivational issues and, for the primary student teachers, on the methods. This is one of our main results since it gives us information about the preschool student teachers' beliefs that teaching in preschool is not their main interest but they prefer to focus on other parts of the educational practice.

Acknowledgment

We thank Anna Öqvist for the assistance with collecting the data.

References

- Anders, Y., & Rossbach, H. G. (2015). Preschool teachers' sensitivity to mathematics in children's play: The influence of math-related school experiences, emotional attitudes, and pedagogical beliefs. *Journal of Research in Childhood Education*, 29(3), 305–322.
- Benz C. (2016) Reflection: An opportunity to address different aspects of professional competencies in mathematics education. In: Meaney T., Helenius O., Johansson M., Lange T., & Wernberg A. (Eds.) *Mathematics Education in the Early Years*. (pp. 419–435) Cham, Switzerland: Springer.
- Clarke, B., Clarke, D. M., & Cheeseman, J. (2006). The mathematical knowledge and understanding young children bring to school. *Mathematics Education Research Journal*, 18(1), 78–102.
- Davies, M. (2011). Concept mapping, mind mapping and argument mapping: what are the differences and do they matter? *Higher education*, 62(3), 279–301.
- Doverborg, E., Pramling, N., & Pramling Samuelsson, I. (2013). *Att undervisa barn i förskolan*. Stockholm, Sweden: Liber.
- Hannula, M. (2002). Attitude towards mathematics: emotions, expectations and values. *Educational Studies in Mathematics*, 49(1), 25–46.
- Hedefalk, M., Almqvist, J., & Lundqvist, E. (2015). Teaching in preschool. *Nordic Studies in Education*, 35(1), 20–36.
- Jonsson, A., Williams, P., & Pramling Samuelsson, I. (2017). Behöver de yngsta barnen undervisas i förskolan? Undervisningsbegreppet och dess innebörder uttryckta av förskolans lärare. *Forskning om undervisning & lärande*, 1(5), 90–109.
- Op't Eynde P., De Corte E., & Verschaffel L. (2002) Framing students' mathematics-related beliefs. In: Leder G.C., Pehkonen E., Törner G. (Eds.) *Beliefs: A Hidden Variable in Mathematics Education?* Mathematics Education Library, vol 31. Dordrecht, The Netherlands: Springer.

- Palmér, H., & Björklund, C. (2016). Different perspectives on possible–desirable–plausible mathematics learning in preschool. *Nordisk matematikdidaktik*, 21(4), 177–191.
- Rosas, S. R., & Kane, M. (2012). Quality and rigor of the concept mapping methodology: a pooled study analysis. *Evaluation and program planning*, 35(2), 236–245.
- Rosenqvist, M. M. (2000). *Undervisning i förskolan? En studie av förskollärarstuderandes föreställningar*. Doktorsavhandling. Stockholm, Sweden: HLS Förlag.
- SFS. (2010:800). *The Educational Act*. Stockholm, Sweden: The ministry of education.
- Swedish National Agency for Education. (2011). *Curriculum for the Preschool Lpfö 98: Revised 2010*. Stockholm, Sweden.
- Swedish National Agency for Education. (2017). *Måluppfyllelse i förskolan. Skolverkets allmänna råd och kommentarer*. Stockholm, Sweden.
- Sæbbe, P. E., & Mosvold, R. (2016). Initiating a conceptualization of the professional work of teaching mathematics in kindergarten in terms of discourse. *Nordic Studies in Mathematics Education*, 21(4), 79–93.
- Tossavainen, T., Väisänen, P., Merikoski, J.K., Lukin, T., & Suomalainen, H. (2015). A survey on the permanence of Finnish students' arithmetical skills and the role of motivation. *Education Research International*, Vol. 2015, Article ID 213429, <http://dx.doi.org/10.1155/2015/213429>.
- Tossavainen, T., Johansson, M., Faarinen, E. C., Klisinska, A., & Tossavainen, A. (2018). Swedish primary and preprimary student teachers' views of using digital tools in preprimary mathematics education. *Journal of Technology and Information Education*, 10(2), 16–23.
- Vallberg Roth, A. C. (2018). What may characterise teaching in preschool? The written descriptions of Swedish preschool teachers and managers in 2016. *Scandinavian Journal of Educational Research*, DOI: 10.1080/00313831.2018.1479301
- Wilson, M. & Cooney, T. (2002). Mathematics teacher change and developments. In G. C. Leder, E. Pehkonen, & G. Törner (Eds.), *Beliefs: A hidden variable in mathematics education?* (pp. 127–147). Dordrecht, The Netherlands: Springer.
- Öqvist, A., & Cervantes, S. (2017). Teaching in preschool: heads of preschools governance throughout the systematic quality work. *Nordic Journal of Studies in Educational Policy*, 4(1), 38–47.

Using finger patterns – the case of communicating age

Miriam M. Lüken

Bielefeld University, Germany; miriam.lueken@uni-bielefeld.de

Young children spontaneously use their fingers to represent numerosities. However, there has been relatively little research on how and in what contexts young children use finger patterns, which is critical to understanding the role fingers play in early numerical development. This study examines a very common situation in which young children use finger patterns: answering the question “How old are you?” In one-on-one interviews 158 children age three to five were asked their age; additional tasks to measure the child’s early number development were administered. Results show a decrease in the spontaneous use of finger patterns for older children. Interestingly, all finger patterns for four and five were shown canonically and produced statically. This hints at the fact that finger patterns might function symbolically. Furthermore, older children who spontaneously used finger patterns vs. verbally said their age differed according to their early number development.

Keywords: Finger pattern, numeracy development, number representation.

Introduction

The use of fingers during numerical considerations is a frequently and cross-culturally observed action in early childhood. Children use their fingers in different ways and for various purposes: Fingers are used to point at objects that are being counted (*pointing gestures*; Gelman & Gallistel, 1978). Fingers themselves are counted or rather raised consecutively to accompany the recital of number words (*finger counting*; Wasner, Moeller, Fischer, & Nuerk, 2014). Over the last couple of years, a growing body of research has shown that the ability to represent one’s fingers mentally is correlated with math skills (*finger gnosis*; Noël, 2005). Later, fingers are used in solving arithmetic problems (*finger arithmetic*; Butterworth, 1999). The research presented in this paper focuses on yet another purpose of fingers in early mathematical development: Like number words and written numerals, fingers can be used to represent numbers, for example holding up a certain number of fingers to represent a set size. Various terms like *finger pattern* (Butterworth, 1999), *finger montring* (Di Luca & Pesenti, 2008), *finger numeral configuration* (Di Luca & Pesenti, 2008), *cardinal number gesture* (Gunderson, Spaepen, Gibson, Goldin-Meadow, & Levine, 2015), or *finger symbol set* (Brissiaud, 1992) are used in this context. Coming from mathematics education, in particular a pattern and structure background, I use the term *finger pattern* throughout this paper.

Children from most cultures spontaneously use their fingers to represent numerosities, and, on some occasions, adults still use their fingers to communicate with other people about numerosities (Di Luca & Pesenti, 2008). Despite their ubiquity across cultures, there has been relatively little research on how and in which contexts young children use finger patterns, which is critical to understanding the role fingers play in early numerical development (Gunderson et al., 2015). And, although I personally have observed children spontaneously produce finger patterns as early as two years of age, most of the existing research has focused on adults’ use of finger patterns (e.g., Di Luca & Pesenti, 2008). This research, therefore, specifically looks at how young children use finger patterns. To start with, a very common case was chosen: children communicating their age by showing a finger pattern.

Theoretical Background

“Finger dialects” and canonical configurations of finger patterns

Although the use of finger patterns to show numerosities can be found in most cultures (Ifrah, 1981) there are no universal finger patterns; instead, they differ by culture. Butterworth (1999, p. 221) calls this phenomenon “finger dialect”. The finger pattern that represents *three* would be for most Germans and Southern Europeans the raised thumb, index, and middle finger, for most Northern Americans and Northern Europeans it would be the raised index, middle, and ring finger (Butterworth, 1999; Pika, Nicoladis, & Marentette, 2009). For these kinds of finger patterns the term *conventional gesture* is used to emphasize that their form and meaning are established by the conventions of specific communities (McNeill, 1998). Di Luca and Pesenti (2008) used the term *canonical finger numeral configurations* in their study with young adults when evaluating the understanding of canonical and non-canonical finger patterns. Subjects were instructed to say as fast and as accurately as possible how many fingers they saw. Canonical finger patterns included only those that would occur during cardinal finger pointing (showing a finger pattern to others), whereas non-canonical finger patterns showed an assembly of random fingers (e.g., index, ring, and pinkie finger raised to mean *three*). Results showed that subjects were better in naming the correct number when a (for the individual) canonical (and not a random non-canonical) finger pattern was presented. Furthermore, canonical finger patterns, but not non-canonical, prime nearby numbers based on their proximity to the target in the same way that Arabic numerals do (Di Luca, Lefèvre, & Pesenti, 2010). These findings suggest that adults’ finger patterns function symbolically and possess semantic meaning based on their canonical configuration, rather than deriving their meaning merely from the number of raised fingers. Using finger patterns might even be a form of pattern recognition in which well-known patterns are recognized and employed, similar to the dot-patterns on dice.

In the context of mathematics education it is important to look at the way, i.e. *how* a finger pattern is produced. Finger patterns can either be constructed by raising the fingers successively (by counting) or simultaneously (Gaidoschik, 2007). The first would be called a dynamic, the second a static finger pattern (Lorenz, 1992). If a child produces a static finger pattern it might be supposed that it has the pattern for the specific number memorized and does not need to count up to the specific number (pattern recognition). However, it possibly might be that lacking fine-motor skills hinders a child to simultaneously raise his/her fingers and instead the child raises the fingers one by one until the produced finger pattern matches the one he/she has memorized for the specific number. In this case, the dynamically produced finger pattern is not a result of a counting process.

Finger patterns as number representations

Fingers are an easily accessible, concrete, and always available device that can aid children in the development of number concepts. Fayol and Seron (2005) see finger-based representations and finger use as a link between concrete numerosity and abstract number. Fingers themselves are concrete but at the same time, “finger representations exhibit an iconic relation to numerosities, since they preserve the one-to-one matching relation between the represented set and the fingers used to represent it” (p. 29). Furthermore, fingers have an additional abstract dimension. Similar to number words they can stand for various different objects: “[...] the same pattern of raised fingers can equally well represent

three giraffes, three toys, or three elements in an argument.” (p. 29). By this dual capacity, fingers moderate the transition from an understanding of concrete numerosities to an understanding of abstract number (Rösch, 2016). The use of specifically *finger patterns* has a lot of theoretical potential to support children’s development of number concept, namely the cardinal principle, subitizing, part-whole concept (Resnick, 1983), and the concept of base (Fayol & Seron, 2005). As the first two are relevant for this research, they are explicated further in the following. One of the basic number concepts, young children acquire, is that numbers are not only represented as sequences of single units (e.g., fingers, finger counting; *ordinality*) but that number also corresponds to the whole set of fingers (finger pattern; *cardinality*). Finger patterns directly reflect the cardinal aspect, i.e. the quantity of number; a specific finger pattern is associated with a particular number. Thereby, each number between 1 and 10 has its own culture-specific finger pattern. Considering fingers as manipulatives they can be used for exercises in quickly and simultaneously determining quantities (*subitizing*; Schipper, 2005). Because of their base-five structure it is possible to conceptually subitize quantities bigger than four (Butterworth, 1999). Closely connected with subitizing is the pattern recognition of canonical finger patterns. Similar to dice-pattern, the specific arrangement is recognized and connected to the corresponding number word.

Research on young children’s competencies for labeling set sizes with finger patterns

Current research with young children on their use of finger patterns when labeling sets shows somewhat contrary results. Nicoladis, Pika, and Marentette (2010) assessed the correctness of 44 preschoolers’ (aged two to five) answers in determining set sizes when using number words vs. finger patterns. They found that children perform better on verbal than on gestural (finger pattern) number tasks. They conclude that children’s early understanding of number words is not aided by finger patterns. Gunderson and colleagues (2015) examined the number words and finger patterns 3- to 5-year olds (n = 155) used to label set sizes. They found that young children who had not yet mastered the cardinal meaning of number words performed significantly more accurate in labeling set sizes when giving a gesture response (finger pattern) than a speech response. They conclude that finger patterns may play a functional role in young children’s development of number concepts.

Understanding of number and the use of finger patterns do not only occur in situations in which set sizes are labeled. Therefore, when trying to assess finger patterns contribution to young children’s development of number concepts, study designs should take alternative contexts into account.

Research questions

This research aims at contributing to our understanding of the role, finger patterns play in children’s development of (cardinal) number concept. Therefore, I take a closer look at children’s use of fingers in a common, everyday situation, namely young children conveying their age. I specifically address the following questions:

How do 3-, 4-, and 5-year old children spontaneously communicate their age?

- If children show finger patterns, do they use a canonical or a non-canonical pattern? How do they produce the finger pattern (dynamic vs. static)?

Does the way in which children convey their age relate to their early number development?

Method

Participants

Consent was obtained for 158 children attending 14 kindergartens¹ in a metropolitan area in the northwestern part of Germany. The kindergartens were chosen to cover a broad range of socio-economic backgrounds. The sample consisted of 54 children aged 3 (30 girls, $M_{\text{age}} = 3$ years 6 months, $SD = 2.7$ months, range = 2 years 11 months – 3 years 11 months, 43% with a migration background², 76% speaking German as family language), 64 children aged 4 (33 girls, $M_{\text{age}} = 4$ years 5 months, $SD = 3.2$ months, range = 4 years 0 months – 4 years 11 months, 36% with a migration background, 81% speaking German as family language) and 40 children aged 5 (15 girls, $M_{\text{age}} = 5$ years 4 months, $SD = 3.9$ months, range = 5 years 0 months – 5 years 11 months, 58% with a migration background, 80% speaking German as family language). Children participated voluntarily and with informed consent of their parents.

Design, Materials, and Procedure

Using a clinical format, individual interviews with each participant were conducted. After being asked for their age, children completed several patterning tasks, followed by tasks on early number development. The patterning tasks are not object of this paper. Interviews were conducted by four members of the research team and were videotaped.

Task on finger pattern (asking for age). Right at the beginning of the interview the child was asked “How old are you?”. If the child indicated his/her age by showing a finger pattern the child was then asked if he/she could also tell the age using a number word (“Please, also tell me with words how old you are!”). If the child used a number word in the first place the child was prompted to also show his/her age with fingers (“Please, also show me your age with your fingers!”).

Tasks on early number development. To explore a possible relation between children’s use of finger patterns and their number development in early childhood, children’s rote counting, enumeration, and subitizing skills were measured. I adapted the tasks from the Australian “Early Years Numeracy Interview” (DEET, 2001). They included counting forward from 1 (total possible score was 5 points), counting onward from 4 and 8 (max. 4 points), counting backward from 7 (max. 3 points), and identifying the number before/after 4 and 8 (max. 4 points). For enumeration the children were asked to enumerate 4, 7 and 12 object sets (max. 7 points), counting out 3 objects (max. 1 point), and compare sets of 3 and 4 objects (max. 1 point). Materials were red, yellow, and blue little plastic bears (see DEET, 2001). During enumeration children’s abilities regarding the counting principles were observed (Gelman & Gallistel, 1978), including the one-one principle, the stable-order principle, the cardinal principle, and the order-irrelevance principle (max. 5 points). For subitizing children were presented with seven 9x9cm cards with sets of 2, 5, 4, 1, 9, 3, and 6 dots placed regularly on each

¹ German kindergarten comprises the three years before school entry, i.e. children start kindergarten when they are three years old.

² Migration Background is defined here as: the child or one parent or both parents not born in Germany.

card. The cards were displayed for two seconds each in the above order (max. 7 points). The total possible score for all items on early number development was 37 points.

Analysis

Children's initial reactions to the question "How old are you" were inductively categorized according to their way of communication. Furthermore, the correspondence of finger pattern and number word was assessed. I also looked at how the finger pattern was produced (dynamic vs. static) and at the produced finger pattern itself in terms of canonical vs. non-canonical use. For Germany (see German Math textbooks and finger pattern based intervention programs, e.g., Claus & Peter, 2005), a canonical finger pattern would be for *three* the raised thumb, index, and middle finger. For *four* two different versions are common. Depending on the children's fine motor abilities they would either raise thumb, index, middle, and ring finger (pinkie finger folded) or raise index, middle, ring, and pinkie finger (thumb folded). The canonical finger pattern for *five* is the raised fingers of one complete hand. The answers to every task on early number development were coded by correctness; the scores were added for each child.

Results

The three main ways children communicated their age was by either naming a number word (category 1), showing a finger pattern (2) or doing both, i.e. uttering a number word and showing a finger pattern simultaneously (3). Only three 3-year olds were not able to convey their age at all. As number words only whole numbers of years were used by all children. The distribution of frequencies (see Table 1, left) shows a distinct pattern: the older the children, the more frequently they used verbal number words and less frequently their fingers to spontaneously indicate their age. Comparing the children's mean scores for the number tasks regarding their way of communicating their age revealed some significant differences. The 4-year olds who answered by saying the number word (1) scored significantly higher on average for the number tasks than the 4-year olds who were showing their fingers (2) ($t(48) = 2.43$; $p < 0.05$; $d = 0.7$). This difference did not apply for the 3-year olds. As the sample size for the 5-year olds who were showing a finger pattern was too small ($n = 5$) a t-test was not executed. For comparison purposes it has to be said though that the difference between the 5-year olds answering by number word (1) and the 5-year olds doing both (3) was significant ($t(33) = 2.49$; $p < 0.05$; $d = 0.87$), with the former scoring higher on average. As the sample sizes of the sub-groups are quite small these results should be treated carefully.

All 4- and 5-year olds (except one) who communicated their age by spontaneously showing a finger pattern were able to verbalize their age when asked to do so, and vice versa. This was different with the 3-year olds. Additional to the three who were not able to communicate their age at all, four were merely able to show a finger pattern and not name the number word, and three could not show the finger pattern for their age (plus one missing data: one 3-year old was not asked the second question). When children were able to use both ways in communicating their age, the finger pattern matched the spoken number word in 63% of the cases for the 3-year olds. With 94% for the 4-year and 98% for the 5-year olds the percentage of concordant number word and finger pattern was much higher (see Table 1, right). The children with whom the finger pattern and number word did not match were distributed quite evenly over the categories 1 to 3 for the initial question.

%	first reaction to the question “How old are you?” [<i>number tasks mean scores</i>]				accordance of number word and finger pattern	
	number word (1)	finger pattern (2)	number word and finger p. simult. (3)	not able to tell/ show age (4)	accordance	no accordance or not able to tell/ show age
3	28 [10.4]	50 [9.9]	17 [10.4]	5 [4.0]	63	37
4	56 [19.3]	22 [14.5]	22 [17.9]	0	94	6
5	60 [24.8]	12 [18.4]	28 [20.8]	0	98	2

Table 1: Relative frequencies for children’s reactions to the question “How old are you?”; mean scores for number tasks (in brackets); accordance of number word and finger pattern

In looking at the way children produced their finger pattern (see Table 2, left) it is striking to see that (nearly) 100% of the 4- and 5-year olds raised their fingers simultaneously (static finger pattern) and not as an end-product of a counting process. Most of the 3-year olds (67%) did the same, still over a fifth (22%) raised their fingers one by one. A similar pattern can be found for the type of finger patterns (see Table 2, right). Nearly 100% of all 4- and 5-year olds showed canonical finger patterns. Over half of the 3-year olds showed canonical, but one third showed non-canonical finger patterns.

%	production of finger pattern			finger pattern		
	static	dynamic	shows no fingers at all	canonical	non-canonical	shows no fingers at all
3	67	22	11	56	33	11
4	98	2	0	98	2	0
5	100	0	0	100	0	0

Table 2: Relative frequencies for way of production and type of children’s finger patterns

Discussion

This study examined young children’s use of finger patterns in a very common, everyday situation, and, furthermore, related children’s number development to it. Results show that 3- to 5-year olds spontaneously communicated their age by either showing a finger pattern, saying a number word, or simultaneously doing both. The frequencies in which they did so, however, changed over the years with the younger children signing, the older children using number words most frequently. The increase in verbal answers might be due to the general language development during early childhood. Children might also adapt their reactions to the adults’ way of verbally talking numbers.

Comparison of children’s number development with regard to their initial reaction showed no significant differences for the 3-year olds but for the 4-year olds. The direction, though not significant due to low power, was the same for the 5-year olds, suggesting that older children who told their age by saying the number word have developed a deeper understanding of number concepts than their

peers who showed a finger pattern. This does not mean that early mathematical educators should aim to quickly and early detach children from using finger patterns. In my opinion it rather shows the relevance and potential of finger patterns as an aid in the acquisition of number concepts from concrete to abstract number representation. A finger pattern, therefore, may be one of the concrete foundations that is needed at the beginning and is left behind when a mental concept of the particular number is developed. These findings contribute to Gunderson and colleagues (2015) results that children who had not yet mastered the cardinal principle performed significantly more accurate in labeling set sizes when responding by finger pattern than by number word. Together they strengthen the evidence for taking age and specific number knowledge into account as factors for finger patterns' relevance in early numerical development. For further studies it seems reasonable to differentiate between very young (2 to 3 years) and young children (4 years and older) and specifically look at the number concepts these children already have or have not acquired.

This study adds to previous research because it explicitly looks at the way young children produced their finger patterns. All finger patterns for *four* and *five* were presented canonically. This is not surprising as the finger pattern for *five* equals simply holding up one hand. The only alternative would have been to produce different hand shapes with each hand, a difficult task at this age. As I considered *four* with the folded thumb as well as with the folded pinkie finger as canonical, all produced finger patterns for *four* and *five* were canonical for the children's countries of origin. Together with the fact that nearly all patterns for *four* and *five* were produced statically, I conclude that the 4- and 5-year olds have the respective finger pattern memorized like a familiar pattern. They use it as a symbol, similar to the verbal number word. As there are more possibilities to produce a non-canonical finger pattern for *three*, it is not surprising that a third produced a non-canonical and just above half of the 3-year olds a canonical finger pattern. This fact can only partly be explained by the children's migration background. Over half of the non-canonical showers were German children. The younger children also differed from the two older groups in the way they produced the finger pattern. With over a fifth unfolding three fingers one by one (dynamically) until three fingers were reached and still a tenth not being able to produce a finger pattern for *three* at all, it might be suggested that the utilization of fingers in order to represent age develops in early childhood (possibly starting between the age of two and three). Further research, therefore, should look at 2-year olds' ways of communicating their age and in general their knowledge and utilization of finger patterns. In summary, the presented study results show that finger patterns are an important preverbal way of experiencing and communicating numbers for many young children.

References

- Brissiaud, R. (1992). A toll for number construction: Finger symbol sets. In J. Bideaud, C. Meljac & J.-P. Fischer (Eds.), *Pathways to number. Children's developing numerical abilities* (pp. 41–65). Hillsdale, NJ: Lawrence Erlbaum Associates.
- Butterworth, B. (1999). *The Mathematical Brain*. London, England: Macmillan.
- Claus, H., & Peter, J. (2005). *Finger, Bilder, Rechnen. Förderung des Zahlverständnisses im Zahlenraum bis 10*. Göttingen, Germany: Vandenhoeck & Ruprecht.

- DEET (Department of Education, Employment and Training). (2001). *Early numeracy interview booklet*. Melbourne, Australia: DEET.
- Di Luca, S., Lefèvre, N., & Pesenti, M. (2010). Place and summation coding for canonical and non-canonical finger numeral representations. *Cognition*, *117*(1), 95–100.
- Di Luca, S., & Pesenti, M. (2008). Masked priming effect with canonical finger numeral configurations. *Experimental Brain Research*, *185*(1), 27–39.
- Fayol, M., & Seron, X. (2005). About numerical representations: insights from neuropsychological, experimental and developmental studies. In J. I. D. Campbell (Ed.), *Handbook of mathematical cognition* (pp. 3–22). New York, NY: Psychology Press.
- Gaidoschik, M. (2007). *Rechenschwäche vorbeugen: Das Handbuch für LehrerInnen und Eltern*. Wien: öbv & htp.
- Gelman, R., & Gallistel, C. R. (1978). *The child's understanding of number*. Cambridge, MA: Harvard University Press.
- Gunderson, E. A., Spaepen, E., Gibson, D., Goldin-Meadow, S., & Levine, S. C. (2015). Gesture as a window onto children's number knowledge, *Cognition*, *144*, 14–28.
- Ifrah, G. (1981). *Histoire universelle des chiffres*. Paris, France: Robert LaVont.
- Lorenz, J. H. (1992). *Anschauung und Veranschaulichungsmittel im Mathematikunterricht*. Göttingen, Germany: Hogrefe.
- McNeill, D. (1998). Speech and gesture integration. In J. M. Iverson & S. Golding-Meadow (Eds.), *The nature and functions of gestures in children's communication* (pp. 11–27). San Francisco, CA: Jossey-Bass.
- Nicoladis, E., Pika, S., & Marentette, P. (2010). Are number gestures easier than number words for preschoolers? *Cognitive Development*, *25*(3), 247–261.
- Noël, M.-P. (2005). Finger gnosia: A predictor of numerical abilities in children? *Child Neuropsychology*, *11*(5), 413–430.
- Pika, S., Nicoladis, E., & Marentette, P. (2009). How to order a beer. Cultural Differences in the Use of Conventional Gestures for Numbers. *Journal of Cross-Cultural Psychology*, *40*(1), 70–80.
- Resnick, L. (1983). A Developmental Theory of Number Understanding. In H. P. Ginsburg (Ed.), *The Development of Mathematical Thinking* (pp. 109–151). London, England: Academic Press.
- Rösch, S. (2016). *Förderung früher numerischer Kompetenzen im Vorschulalter unter Berücksichtigung des Einflusses der Finger*. Doctoral Thesis: Tübingen.
- Schipper, W. (2005). *Modul G 4: Lernschwierigkeiten erkennen – verständnisvolles Lernen fördern*. Kiel, Germany: SINUS-Transfer Grundschule.
- Wasner, M., Moeller, K., Fischer, M. H., & Nuerk, H.-C. (2014). Aspects of situated cognition in embodied numerosity: the case of finger counting, *Cognitive Processing*, *15*(3), 317–328.

Evidence of relational thinking at kindergarten level

Andrea Maffia¹ and Simona Mancarella²

¹ University of Pavia, Italy; andrea.maffia@unipv.it

²University of Bologna, Italy; simona.mancarella@studio.unibo.it

Taking inspiration from recent literature about algebraic thinking at early grades, we wonder if and how we can prompt and recognize relational thinking at the kindergarten level. Adopting a design-based research approach, we analyze students' answers to a task, both with the aim of developing its potential in prompting relational thinking and the aim of getting clues about how to recognize relational thinking at the kindergarten level. Analyzing students' behavior while facing our task, we find evidence of relational thinking in students aged 5, even if at different stages. The task proves to be effective in stimulating children relational thinking and in making distinguishable their answers.

Keywords: Kindergarten, Relational Thinking, Number sentence

Introduction

The distinction between instrumental and relational understanding of mathematics has been originally defined as, respectively, knowing just how mathematical procedures work and knowing both the how and the why (Skemp, 1976). Such definition found application in the field of arithmetic: several researchers paid attention on prompting students in understanding operations' properties standing behind calculation algorithms. A commonly proposed task consists in finding the missing number in an equality between two arithmetical operations like $39 + 52 = \dots + 55$. Usually, it is assumed that relational thinking is shown if students do not resort to calculation of the results on the two sides of the equality, but they find a solution by compensation or other strategies based on operations' properties and numbers decomposition (Carpenter, Franke, & Levi, 2003; Stephens & Wang, 2008).

According to Mason (2018), "recognizing that $87 + 54 = 84 + 57$ without doing any calculation contributes to and is part of algebraic thinking" (p. 343) and it is never too early to let children thinking in this way. He claims that "the use of natural powers which, when expressed in words and symbols is recognizable as algebra, is called upon from birth if not before" (Mason, 2018, p. 347). Such claim is a starting point for us in wondering if and how we can prompt and recognize relational thinking at the kindergarten level. Adopting a design-based research approach, we analyze students' answers to a task, both with the aim of developing its potential in prompting relational thinking and the aim of getting clues about how to recognize relational thinking at the kindergarten level.

Number sentences written with arithmetical symbols could be inaccessible to students aged 5. This same issue was dealt by Steinweg and colleagues (2018) and Lenz (in press). They developed a suitable task to let kindergarten students approach unknowns. In their task, there are two fictitious characters playing with marbles. They both have the same amount of marbles, but some of them are visible and others are inside colored boxes. Boxes of the same color contain the same amount of marbles. The student is asked to understand how many marbles are in the boxes. Figure 1 schematizes a possible instance of the task by Steinweg et al. They administered the task to students aged from 5 to 10.

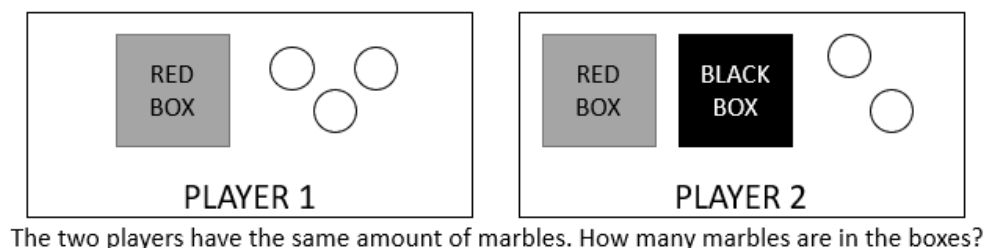


Figure 1: Schematization of the task by Steinweg and colleagues (2018)

Steinweg et al. (2018) observe that many fourth graders show relational thinking while facing this task. However, according to their data, it seems that younger students have difficulties in dealing with it relationally: “While the majority of kindergarten children indicate numerical values, some children in grades 2 and 4 are already able to describe relationships or dependencies” (Lenz, in press). Kindergarten students “neither describe a relation nor display the dependency between the amounts of marbles in the boxes” (Steinweg et al., 2018, p. 19). We modified the task: In our modified version, students know that there are two characters having the same number of marbles. The first character’s marbles are completely visible, while part of the marbles of the second character are in a box. Children have to figure out how many marbles are in the box. Differently than the original task, the amount of marbles in the box is fixed. An example of our task is obtainable taking away the red boxes from Figure 1. We analyzed students’ behavior in solving this task assuming the perspective described in the following section.

Theoretical framework

When analyzing their data, Steinweg et al. (2018) consider as evidence of relational thinking those cases in which a student can express verbally a relation between the quantities of marbles in the boxes: according to them, sentence like “In the green box is always one marble more, than in the orange box” (p. 19) can be considered as relational, because there is an explicit connection between the amounts of marbles in the boxes. Those cases in which students just tell the number of marbles that are in a box were interpreted by them as evidence of the fact that children see the amounts as fixed. We are convinced that some of these cases could be applications of relational thinking. We believe that this can be unveiled by analyzing the process that is enacted by the student to find such results.

Carpenter et al. (2003) describe four different benchmarks in the interpretation of number sentences containing the equal sign.

- First benchmark: a very first step in interpreting the equal sign is the student’s ability to express his/her own interpretation of the equal sign.
- Second benchmark is achieved when students accept equivalences that are not in the standard form $a+b=c$, for instance $c=a+b$ or $a+b=c+d$.
- Students at third benchmark compare the two sides of the equal signs carrying out the calculations on each side of the equal sign.
- Fourth benchmark is achieved when students can compare the sides of the equality without performing calculations. According to the definitions above, this is relational thinking.

We must stress that, in this paper, we are analyzing a task that is not the same that was used by Carpenter and colleagues to describe these benchmarks. Numbers, operations and equality are not expressed symbolically, but by means of boxes, marbles and verbally. Furthermore, our version of the task does not require calculation on both sides of the equality: the number of marbles on the left side is visible. The algebraic structure of our task is $a=x+b$ with known a and b (number of visible marbles) and unknown x (number of marbles in the box).

We reinterpret benchmarks by Carpenter et al. (2003) in the context of our task. According to our interpretation the first benchmark is reached when children can explain that the number of marbles on the two sides must be the same. Literature shows that understanding the property of ‘being the same in quantity’ is not granted at kindergarten level (Sfard & Lavie, 2005).

Second benchmark is achieved if students recognize the structure of the equivalence $a=x+b$. This is not the case if the student gives a as value for x , interpreting the first part of the equivalence as $a=x$. This is not reached even if the student counts all the marbles, interpreting the equivalence as $a+b=x$. Evidence of the reaching this benchmark could be guessing a value for x that is smaller than a . When the third benchmark is reached, students use counting to determine the value of x . They can count-on starting from b until they reach a , or they count backward from a to b . We can say that a student reaches the second benchmark, but not the third, when s/he tries to guess a number for x but s/he cannot use counting as a checking strategy. Students at the fourth benchmark can find the number of marbles in the box without a counting procedure, but decomposing numbers, hence showing relational thinking. For instance, they can split a marbles in a group of b marbles and consider that the remaining marbles are as much as those in the box.

We analyzed students answers to the task coding them according to the reached benchmark. The aim is that of answering the following research question: Administering the task, which benchmarks can we observe, distinguish and describe at the kindergarten level?

Methods

Kindergarten children may not be aware of what an adult means while saying that two quantities are “the same” (Sfard & Lavie, 2005). For this reason, we organized a first session in which the task was implemented with concrete objects. A group of 21 Italian kindergarten students (aged 5) was divided in small groups of four or five. They seated in front of two paper-characters, one of them holding a box (Figure 2a). Plastic balls were used as marbles. A certain quantity of balls was put in front of the character without box (Marco). The interviewer said that the character with the box (Penelope) had the same quantity of marbles. Some of them were onto the box and some of them were inside. Children were asked to say how many marbles were inside the box. After they said a number, they could actually check by opening the box. We will refer to this first session as training session.

In a second session, the students were again divided in groups of four or five. The task was administered showing images on an interactive whiteboard (Figure 2b), so this time they did not have the chance to open the box to check the number of marbles inside it. The interviewer asked them to say how many marbles are in the box. She also interacted with them asking how they figured it out. In this paper, we analyze video-data from this second session, that we call testing session. Both the training and testing sessions were completely video-reordered and fully transcribed. While

transcribing, texts were enriched with screenshots from the video when gestures were performed. Students interventions have been coded with the benchmarks described in the previous section. Both authors discussed together to decide on such coding.

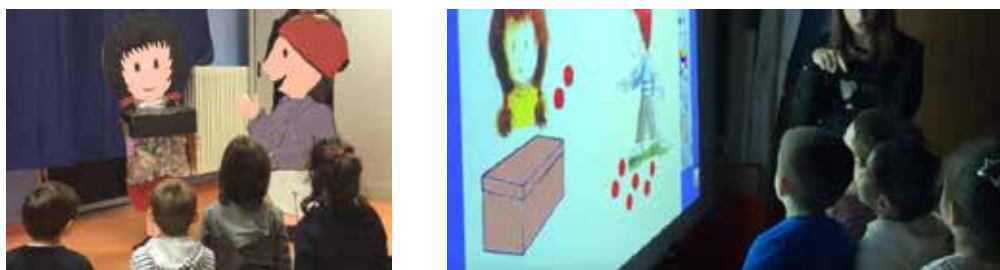


Figure 2: Settings during training session (left side) and testing session (right side)

Data analysis

Due to the limit of space, we are not able to show here the complete data analysis. We selected some examples of the different benchmarks that we were able to detect and interpret in our data.

The first benchmark is not reached by all children: When asked to explain the situation, few of them are not able to express in words that the two characters must have the same number of marbles. Apparently, they do not understand what is asked to them and they remain in silence or they change the topic. The following is an example in which we consider that the first benchmark is reached:

Interviewer: Do you remember what we did the last time?

Sofia: Because they always took the balls in the same number, so if he... if Marco took seven, Penelope could take seven because they became friends at the end of the story.

Here the interviewer prompts the child to recall the training session. The student uses the expression ‘the same number’ to refer to the fact that the two characters have the same amount of balls. According to Sofia, the two sets of balls must have the same property of being seven. Similar explanations are found in other children. They never talk about a correspondence between the two sets of marbles; in other words, they never refer to the fact that for each marble of Marco there is one of Penelope. Statements like that by Sofia, with different numbers as example, are common.

Concerning the second benchmark, we have several examples of children who did not achieve it. For instance, the following excerpt reports the discussion of a group while facing the task in the case in which Marco has six marbles and Penelope has just two marbles outside her box.

Interviewer: What is going on there?

Martina: Penelope has just two balls.

Interviewer: Just two balls? [...]

Martina: No, because the others are inside the box.

Interviewer: And where are those two? [...] I heard ‘outside’. Is it right?

Emma: The two balls are outside, but the others are inside.

Interviewer: How many are inside?

Asia: Eight!

Asia answers to the interviewers' question naming the number eight, that is the total amount of marbles that are shown in the image (two belonging to Penelope and six belonging to Marco). Even if the question is specifically referring to the marbles inside the box, the student is interpreting the equivalence differently than expected. She is not considering the situation in the form $6=x+2$ but as if it were $6+2=x$. According to our interpretation, the second benchmark is not yet reached. This happens again in the same little group of students when they face the situation of Marco having five balls and Penelope with four balls outside the box. The students suddenly state that they have the same number, so the interviewer invites them to check by counting; they react counting all the marbles that are shown in the figure. We can notice that reaching the first benchmark is necessary to achieve the second one, but it is not enough. This is shown clearly in the following excerpt.

Luca: They must have the same number.

Interviewer: They must have the same number; Marco has seven and Penelope has three, how many has she got in the box?

Luca: She must have...

Emma: Seven balls?

Luca: Seven.

Luca can state that the two character must have the same number of marbles, however he interprets this sentence relating the number of Marco's marbles with those in Penelope's box. Emma and Luca seem to interpret the equivalence $7=x+3$ as if it were $7=x$, ignoring the role of the '+3', and so they give the number seven as answer. This is like some cases documented by Carpenter et al. (2003), who found children justifying the presence of an additional number after the equal sign with statements like "it is there just to trick you".

In our data, we do not have cases of students who reached the second benchmark but not the third. Indeed, all those who interpreted correctly the equivalence, then used some counting strategy.

Leonardo: If Penelope has two outside...

Ginevra: The other four are inside the box.

Leonardo: Because two plus four...

Ginevra: Here she has two [she points the two marbles that are drawn outside the box] so here she has four [she points the box].

Leonardo: Two [he raises two fingers of his right hand] plus four [he raises four fingers of his left hand], how much is it? Count! [he faces Ginevra, Figure 3a]

Ginevra: One, two, three, four, five, six.

Giulia: Indeed, they are six.

In this last excerpt, we can see that Leonardo do not determine the sum $4+2$ by himself, but he involves his peers in calculating it to check if the result of such operation is the number of marbles owned by Marco. It is not clear how Ginevra determined that the number of marbles in the box is four. One possibility is that she guessed. Indeed, we have evidence of tentative numbers that are put aside after checking that they are not correct.

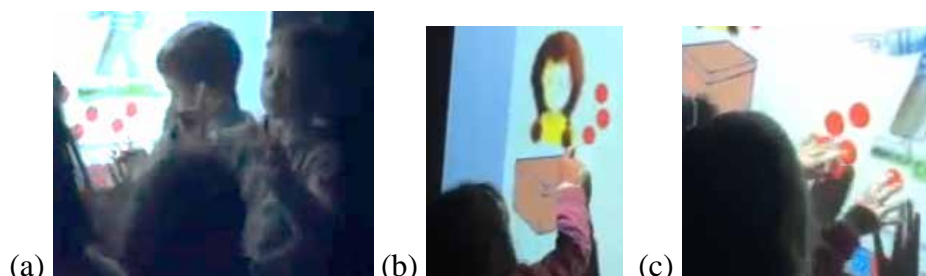


Figure 3: Leonardo's and Ginevra's gestures

Interviewer: Who wants to tell me what he sees?

Rebecca: Penelope now has two balls while Marco has many.

Interviewer: How many?

Rebecca: Six.

Interviewer: So, Marco has six balls. And what about Penelope? Does she have just two balls?

Sofia: Penelope has got two outside. Like the last time. Marco has got six, so if she has two outside, it could be that she has... that she has two inside. [...]

Emma: If there are two balls outside and other two inside it makes four and Marco has six, so it is not the same number.

Apparently, Sofia is trying to guess the number of marbles in the box, she tries with the number two. Emma follows Sofia's reasoning and she confutes it by summing the supposed amount of marbles with the number of visible marbles owned by Penelope. She realizes that the total amount is different than the number of Marco's marbles and so she rejects Sofia's hypothesis. This kind of guessing and testing strategy could appear not sophisticated but, as Mason notices, "*Guess & Test* is not only good mathematics, but it can develop over time into more sophisticated versions: *Try & Improve*, in which the guess is modified according to some principle rather than being essentially random" (Mason, 2008, p. 85). It cannot be considered as relational thinking, but it constitutes a preliminary step for it.

Counting as strategy to determine a sum is frequently used to check the correctness of suggested amounts for marbles in the box. Determining the right number of marbles in the box with different processes appears less frequently. The following excerpt shows one of the few examples. The children are facing the task in the case of Marco having seven marbles and Penelope with three marbles outside the box. They are discussing about the number of marbles that are inside Penelope's box.

Leonardo: They aren't four.

Emma: Yes, four! Because there are seven there.

Ginevra: Look! Here she has three [she moves her finger along the three marbles that are outside the box, Figure 3b]. Look: here he has three [she moves her finger along three of Marco's marbles] and he has four [she points with both hands to the remaining four Marco's marbles, as she were grasping them, Figure 3c]. So here she has three [she repeats the gesture in Figure 3b pointing to marbles that are outside the box] and here [she repeats the 'grasping gesture' on Penelope's box] she has four.

Interpreting Ginevra's gestures, we can notice that she creates a correspondence between Marco's marbles and Penelope's one. She selects three marbles among Marco's one and she isolates them from the remaining four. Then she notices that Penelope's marbles can be divided again in a group of three (that is shown) and a group of four that is inside the box. The correspondence is made evident by the use of the same gesture (moving the finger along the balls) to point to the groups of three, and a different gesture (grasping the balls with both hands) to point the groups of four. Ginevra is decomposing the number 7 has the sum $4+3$ and so she finds the amount of marbles in the box making use of such decomposition. We consider this as an evidence of reaching the fourth benchmark.

Discussion and conclusion

Developing suitable task to let kindergarten students think relationally appears as an important objective if we believe that it is never too early to start thinking algebraically (Mason, 2018). In this paper, we try to develop such kind of task basing our work on that made by others before. We have modified the task proposed by Steinweg, Akinwunmi and Lenz (2018) because we were not convinced by the fact that they could not observe evidence of relational thinking in children at kindergarten level. Mutuating benchmarks by the work by Carpenter et al. (2003), in our data we can observe different levels of interpretation of a number sentence containing an equivalence. In particular, most of students reach the first benchmark, being able to state what they mean while saying that two amounts are the same in number. We noticed that there are children that are not achieving the second benchmark: they interpret the equivalence $a=x+b$ as if it were $a+b=x$ or $a=x$. Apparently, they reinterpret the equivalence according to schemes that are more familiar to them.

We do not have evidence of students reaching the second benchmark without reaching also the third one. Using counting to add numbers is used to check the correctness of the amount of marbles in the box. It is not clear if they are using a *guess and test* method (Mason, 2008), or if there are other mental processes leading students to suppose a number for the unknown marbles in the box. Evidence of the fourth benchmark are rare, but there are some. Eventually, we can answer to our research question stating that we find distinguishable evidence of all the four benchmarks.

This result appears in contrast with that by Steinweg et al. (2018), however we must notice that it is not easy to directly compare their work with ours. Indeed, even if we are both speaking about relational thinking, it is not sure that we are speaking about the same thing. We used the benchmarks by Carpenter et al. (2003) who consider relational thinking equivalent to the fourth benchmark. We interpreted students' utterances, but also their gestures, as evidence of the process enacted to solve the task. Steinweg and colleagues (2018) use just the words as data and so it is possible that they interpreted differently some cases that we would interpret as relational thinking.

We are aware that there are limitations in this study. Our theoretical framework is modified for this situation, adapting it from the original one that was thought for primary school level. This was necessary because we do not have frameworks for relational thinking at kindergarten level. The framework works well here in describing differences between the behaviors, however it should be tested in other contexts.

We are convinced that the task proved to be effective in terms of eliciting students' processes in determining an unknown quantity in a simple number sentence. Taking the perspective of the designers, we can notice that the task is effective both in stimulating children and in making distinguishable their answers. However, there is still a problem in evidencing those cases in which the second benchmark is reached while the third one is not. Modifications to the task could solve this problem. We can also notice that in our data we have interesting examples of kindergarten students' arguments; it seems that the task could be suitable also to solicit argumentation.

References

- Carpenter, T. P., Franke, M., & Levi, L. (2003). *Thinking mathematically: Integrating arithmetic and algebra in elementary school*. Portsmouth, NH: Heinemann.
- Lenz, D. (in press). Relational thinking and operating on unknown quantities. A study with 5 to 10-years old children. In: U. T. Jankvist, M. van den Heuvel-Panhuizen, & M. Veldhuis (Eds.), *Proceedings of the Eleventh Congress of the European Society for Research in Mathematics Education*, (pp. xxxx-yyyy). Utrecht, the Netherlands: Freudenthal Group & Freudenthal Institute, Utrecht University and ERME.
- Mason, J. (2008). Making use of children's powers to produce algebraic thinking. In J. J. Kaput, D. W. Carraher, & M. L. Blanton (Eds.) *Algebra in the early grades* (pp. 79–116). New York, NY: Routledge.
- Mason, J. (2018). How Early Is Too Early for Thinking Algebraically? In C. Kieran (Ed.) *Teaching and Learning Algebraic Thinking with 5-to 12-Year-Olds* (pp. 329–350). Cham, Switzerland: Springer.
- Sfard, A., & Lavie, I. (2005). Why cannot children see as the same what grown-ups cannot see as different? — Early numerical thinking revisited. *Cognition and Instruction*, 23(2), 237–309.
- Skemp, R. R. (1976). Relational Understanding and Instrumental Understanding. *Mathematics Teaching*, 77, 20–26.
- Steinweg, A. S., Akinwunmi, K., & Lenz, D. (2018). Making Implicit Algebraic Thinking Explicit: Exploiting National Characteristics of German Approaches. In C. Kieran (Ed.) *Teaching and Learning Algebraic Thinking with 5- to 12-Year-Olds* (pp. 283–307). Cham, Switzerland: Springer.
- Stephens, M., & Wang, X. (2008). Investigating some junctures in relational thinking: a study of year 6 and year 7 students from Australia and China. *Journal of Mathematics Education*, 1(1), 28–39.

Task characteristics that promote mathematical reasoning among young students: An exploratory case study

Bozena Maj-Tatsis¹ and Konstantinos Tatsis²

¹ University of Rzeszow, Poland; bmaj@ur.edu.pl

² University of Ioannina, Greece; ktatsis@uoi.gr

In the paper we examine possible factors that enhance young students' mathematical reasoning. Particularly, we present the characteristics of seven mathematical tasks, which were chosen based on an a priori analysis, in order to elicit reasoning among a pair of young students. Additionally, we examine the reasoning processes that were manifested during the students' interactions while solving the tasks. Our results show how particular task characteristics affect reasoning processes.

Keywords: Task design, mathematical reasoning, task characteristics.

Introduction

Algebra constitutes one of the most significant elements of mathematics, and children, even at a small age, have access to mathematical ideas such as mathematisation, connections, argumentation, number sense and mental computation, algebraic reasoning, spatial and geometric thinking, data and probability sense (Perry & Dockett, 2002). This has led to the “Early Algebra” movement, which has been the background of a number of studies (see, e.g., Kieran, Pang, Schifter & Ng, 2016). The main process involved in algebraic thinking – and in all mathematical activities – is undoubtedly generalisation (Mason, 2005), which therefore has been the focus of the majority of studies in early algebra. However, other significant processes are also involved in algebraic thinking: Blanton et al. (2011) (as cited in Kieran et al., 2016, p. 12, our emphasis) refer to “the processes of generalizing, representing, justifying, and *reasoning with mathematical structure and relationships*”. One of the questions that may then arise is whether it is possible to design and propose mathematical tasks that enhance reasoning among young students. Having this question in mind we designed a case study aiming to examine how particular task characteristics relate to the reasoning processes of two eight-year-old students. Thus, our main research question is what are the characteristics of the tasks which promote mathematical reasoning. Particularly, we aim to examine how specific factors of the tasks are related to reasoning processes.

Algebraic reasoning and task design

Algebraic thinking is defined as “a process in which students generalize mathematical ideas from a set of particular instances, establish those generalizations through the discourse of argumentation, and express them in increasingly formal and age-appropriate ways” (Kaput & Blanton, 2005, p. 99). This is in line with “Early Algebra”, which can be characterised by the following shift:

... from a traditional content-centered characterization of algebra to that of the mathematical reasoning processes and representations that would seem appropriate for young children, as well as to the nature of the early algebra activities that might promote the development of these processes and representations (Kieran et al., 2016, p. 5).

The above statement leads us to the importance of engaging young students in activities that promote reasoning. But how should such activities look like? This question might prove misleading, since there are various factors that contribute to a learning situation: besides the task itself, we may refer to the teacher and the students participating and interacting. This list is not exhaustive; one could also consider the wider social and classroom context, the available resources and artefacts, the histories of the students and their interactions, etc.

In our research paper, we focus on the teacher (as a task designer), as well as on the students (their reasoning activities as they manifest during their interactions). The importance of task design in enhancing students' engagement and promoting mathematical reasoning has been stressed in research focused on reasoning (Francisco & Maher, 2005) as well as assessment (van den Heuvel-Panhuizen, 2005). These studies have provided comprehensive suggestions on task characteristics, including the expected teacher and students' roles. They can be summarised as follows:

- “the problems must be accessible, inviting and worthwhile to solve” and “the students must have the opportunity to give their own answers in their own words” (van den Heuvel-Panhuizen, 2005, p. 3); moreover, pictures play an important role as context-bearers and they serve multiple functions (van den Heuvel-Panhuizen, 2005);
- “the development of a sense of ownership of the mathematical activity enhances the building of personally meaningful mathematical understanding and students' confidence in their abilities” and working collaboratively and discussing “helps the students become flexible in problem comprehension and adaptive rather [than] routine experts at solving problems” (Francisco & Maher, 2005, p. 371).

Context of the study and methodology

Based on the type of our research questions we have adopted an exploratory case study approach (Yin, 2014). The participants were two eight-year-old female students studying together in the 2nd grade of a public primary school in an urban area in Poland. They both had good marks in mathematics and volunteered to participate in the research. The session took place in one of the students' house, lasted for two hours and was videotaped, after the parents' consent was obtained. Both authors of the paper were present in the session and both were familiar to the students, who worked together for solving the tasks. The role of the first author of the paper consisted of the following: challenge pupils, support pupils, evaluate their progress, think mathematically in order to pose challenging and interesting mathematical questions, supply and recall information and promote pupils' reflection (da Ponte, 2001).

A priori analysis of the tasks

Task design was based on the assumptions mentioned in the previous section. Seven tasks were chosen from two sources (Lankiewicz, Sawicka & Swoboda, 2012; Treffers, 2008), based on: their potential to stimulate students' interest, be solvable, or at least approachable, in more than one way and without the use of tricks, illustrate important mathematical ideas, serve as first steps towards mathematical explorations and be extensible and generalisable (Schoenfeld, 1994). Table 1 below presents all tasks, except Tasks 3 and 5, which will be presented and analysed later.


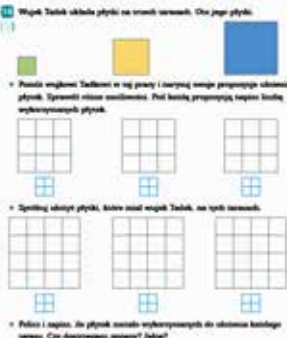
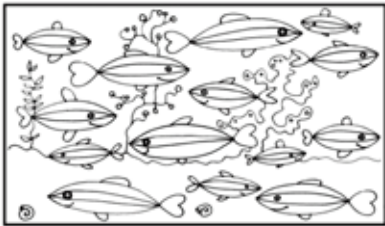



<p>Task 1: Chairs</p> <p>Jak możesz rozdzielić krzesła na dwóch zbiorów po cztery?</p>  <p>How you can divide the chairs into 2 sets of 4 chairs in each?</p>	<p>Task 4: Tiles</p> <p>Uncle Ted tiles three terraces. Here are the tiles he uses.</p>  <ul style="list-style-type: none"> • Pomóż wujkowi Tedowi w jego pracy i narysuj swoje propozycje ułożenia płytek. Spróbuj różne możliwości. Pod każdą propozycją napisz liczbę użytych płytek. • Spróbuj ułożyć płytki, które miał wujek Ted, ale tylni terraced. • Półoś i napisz, ile płytek zostało użytych w każdym z ułożonych kształtów teras. Czy obserwujesz zmiany? Jak? <ul style="list-style-type: none"> • Help uncle Ted in his work and draw your propositions for the tiling. Check different possibilities. Write under every proposition the number of used tiles. • Try to tile the following terraces by using the tiles of uncle Ted. • Count and write how many tiles you used for every terrace. Do you notice any changes? Which ones?
<p>Task 2: Fish</p> <p>Je rybak ma trzy polkolorewalne trawki koloremzi tak, aby każda była inna? Masz trzy kolory: zielony, pomarańczowy, niebieski.</p>  <p>How many fish can you colour by three colours so that every fish is different? You have three colours: green, orange and blue.</p>	<p>Task 7: Caterpillar</p> <p>You choose two numbers less than 100. Each successive number is the sum of the previous two. For example:</p>  <p>Try to make a 5-part caterpillar with 100 as the last number.</p> 
<p>Task 6: The parrot Waku-Waku</p>  <p>This is a talking parrot; his name is Waku-Waku. Unfortunately, he can say only one word: five. You want to show your friends how clever parrot you have. Ask him some questions, for which the answer is “five”.</p>	

Table 1: Five of the given tasks

Our a priori analysis of the tasks initiated by identifying the mathematical concepts and processes involved in the tasks' solutions as anticipated by us and, wherever applicable, by the original task designers. The mathematical fields contained in the tasks correspond to those included in the Polish curriculum for the particular age group. All tasks contained a written description, but in our a priori analysis we also analysed the role of the accompanying images, according to van den Heuvel-Panhuizen's (2005) pictures' functions: motivator (M: making the task more attractive), situation describer (S: describing the context of the task), information provider (I: providing necessary information), action indicator (A: an action is elicited that has the potential of a strategy that leads to a solution), model supplier (MS: the picture structuring possibilities that can be used to solve the problem), and solution and solution-strategy communicator (SC: the picture contains the solution and aspects of the applied strategies). The analysis of the tasks' contexts was based on de Lange's (1999) assessment framework: zero-order (0): fake context, not considered for the solution (to this category we also inserted mathematical contexts, e.g. Task 5, which will be analysed later); first-order (1): relevant context, needed for the solution; second-order (2): relevant context, mathematisation needed for the solution; third-order (3): the context serves for constructing or reinventing mathematical

concepts. Finally, each task was categorised as open or closed. As shown in Table 2, all tasks but one were open.

Task	Field	Concepts	Image	Context	Type
1	set theory	categorisation	I	1	open
2	combinatorics	combinations	I	0	closed
3	geometry & arithmetic	dimensions, shapes, areas, multiplication & properties	S & MS	2	open
4	geometry & combinatorics	areas, tiling, combinations	I & A	2	open
5	arithmetic	addition & properties	I	0	open
6	arithmetic & algebra	numbers, operations, equations	M	0	open
7	arithmetic	addition, subtraction & properties	I	0	open

Table 2: Task characteristics

A posteriori analysis of the tasks

In our a posteriori analysis, we focused on the interactions that took place among the students and the researcher, during the research session. For this analysis we have adopted Lannin, Ellis and Elliot's (2011) manifestations of essential understandings related to mathematical reasoning: developing conjectures, generalizing to identify commonalities, generalizing by application, conjecturing and generalizing using terms, symbols, and representations, investigating why, justifying based on already-understood ideas, refuting a statement as false, justifying and refuting the validity of arguments and validating justifications. To these we added: reformulating conjectures or justifications, monitoring each other (a form of collaborative reasoning), concluding and explaining (a form of informal justification). After identifying the above understandings, we made a cross-analysis of all tasks, in order to identify commonalities and differences among them.

Results

As we see in Table 3, the reasoning processes which persevered were: developing conjectures and reformulating conjectures or justifications.

	Reasoning processes / Tasks	1	2	3	4	5	6	7
R1	developing conjectures		ü		ü	ü		ü
R2	identifying commonalities	ü					ü	
R3	generalizing by application					ü		
R4	investigating why		ü					ü
R5	justifying based on already-understood ideas		ü	ü	ü			
R6	refuting a statement as false				ü	ü		ü
R7	justifying and refuting the validity of arguments					ü		
R8	validating justifications					ü		
R9	reformulating conjectures or justifications		ü	ü		ü		ü
R10	monitoring each other				ü	ü		ü
R11	concluding							ü
R12	explaining	ü				ü	ü	

Table 3: Tasks and reasoning processes

Next, we present the analyses of Tasks 3 and 5; these tasks are chosen because they demonstrate the range of reasoning processes that we have encountered.

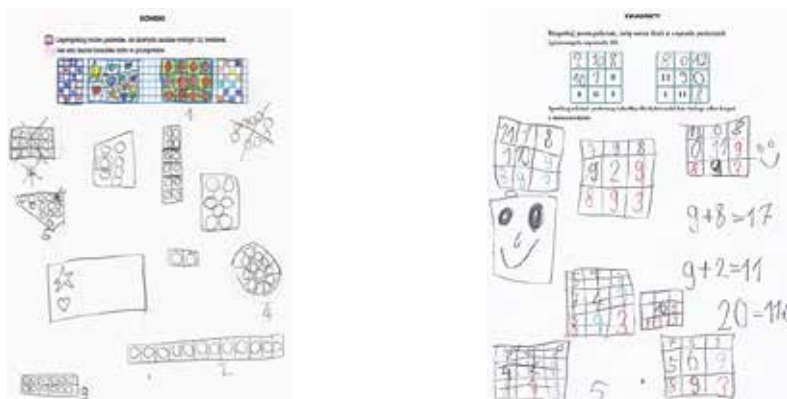


Figure 1: Task 3 and Task 5, containing students' work

Task 3: Christmas baubles

In Figure 1, on the left, we read: “Design different boxes in which you can put 12 Christmas baubles in such a way that every bauble is in one compartment.” The mathematical concepts come from geometry (shapes, dimensions, area) as well as arithmetic (numbers and multiplication); we anticipated that students will shift from the geometrical representation of the problem to an arithmetic one. The image of the grid can be categorised as a situation describer and a model supplier. The students – signified by A and M, while R stands for the researcher (the first author of the paper) – started by drawing a 4×6 rectangle on the grid and placing their drawn baubles in every second compartment. Initially, it was hard for them to imagine how the baubles can be arranged. Later, they discovered that the box they designed can contain more baubles than they thought, and they justified it. However, they were not able to use this knowledge for the design of boxes of different sizes; they were more focused on the shape, the colours and the sizes of the baubles. In the following excerpts our notes are in brackets and (...) signifies an omitted part of the discussion. The number(s) of the reasoning processes (as they appear in Table 3) are put in brackets at the end of the respective lines.

R: Could we put more baubles to this box? [the box on the right edge of the grid]. For example, could we put one more bauble?

A: I guess not.

R: If I had one more bauble and I would tell you: girls, put that bauble to your box...

M: I would pack it in such a square. (...)

R: (...) then how many could we pack here?

A [immediately]: More, 24.

R: How do you know that 24? You didn't count.

A: Because there are 12 baubles and 12 empty places. [R5]

R: And how do you know that there are 12 empty places?

A: Because here in the 4 squares there are 4 places and in 2 of them there are baubles and those 2 are left. And in the same way you can count to the bottom so it will be 24. [R9]

M: Or 4×6 [showing the dimensions of the rectangle]. (...) [R9]

R: Are those boxes different? [showing the four boxes drawn on the grid]

A: Uhm.

R: By what? [A and M thinking]

A: Here are bigger baubles [the second and third box] and here smaller [the first box].

M: And these are medium ones [the fourth box].

During the whole interaction only two aspects of mathematical reasoning were manifested: justification and reformulating the justification. The students eventually discovered different arrangements of the baubles (in different boxes) but they could not find any relations between them, neither geometric nor arithmetic.

Task 5: Magic squares

In Figure 1, on the right, we read: “Complete the empty fields so that the sum of the numbers in rows and columns is 20”; and then: “Try to create a similar table for your friend or somebody from your family”. The main mathematical concept is addition and its properties: identity, commutative and associative. The images of the task are information providers. An extensive analysis of the students’ interactions (Maj-Tatsis & Tatsis, 2015) has led to the following understandings related to mathematical reasoning: developing conjectures, generalizing by application, refuting a statement as false, justifying and refuting the validity of arguments, validating justifications, reformulating conjectures, monitoring each other and explaining. Thus, this task has proved fruitful for mathematical reasoning among our students. In the following excerpt the students have completed working on the first magic square and are discussing on the second. It is interesting that student M started filling the square by number 9 (which means that then one has to put 0 in the third square) which was the extreme case in the first square, and it took them some time to accept it.

M: Here for example 8 [in the centre] and put 1 here [above 8] [R1]

R: Aha (...) What if here we put 7 [in the centre], then what will be here? [above]

M: 2

R: And what if 6?

A & M: [loudly] 3!

R: How do you know it’s 3?

A: Because when it was 7 then it was 2. And if we decrease it more then it will be 3. [R1, R12]

R: What if we put 5?

M: Then 4 (...)

R: What’s the biggest number we can put in the centre? (...)

M: For me 9, because $10+11$ would be already 21. [R1, R7]

The differences between this task and the Christmas baubles task lie not only in the extent of reasoning processes, but also in their depth. Although in this task the students were able to articulate, justify and validate mathematical conjectures in order to support their mathematical reasoning, in the baubles task they did not manage to cross the boundaries between arithmetic and geometry; this has resulted in limited opportunities for extensive mathematical reasoning.

Cross-analysis of the tasks

We have seen the greatest extent of reasoning processes in Tasks 5 and 7 (followed by Tasks 2 and 4), while Tasks 1, 3 and 6 proved the poorest concerning the manifested reasoning processes by the students. The common characteristic of Tasks 1 and 6 is that they both required the identification of commonalities and explanations; furthermore, the students' interactions have shown that there was no explicit need for justification or generalisation. Tasks 5 and 7 were similar concerning the mathematical concepts involved (addition and its properties); additionally, they were both open, but with a finite number of solutions (unlike Task 6). At the same time, the only task with a single solution (Task 2) allowed for a considerable extent of mathematical reasoning; this was probably due to the many ways of solution. Task 3 was the one that demonstrated the influence of context: the students were engaged in a non-mathematical investigation concerning the size and the type of baubles, which in turn minimised the reasoning processes and hindered a thorough investigation of the task. It might be also the influence of the geometrical nature of the task that had created obstacles in its generalisation.

Discussion

The fact that reasoning processes were manifested in all tasks goes in line with relevant studies of the "Early Algebra" movement and strengthens the claim that students at a young age are able to reason mathematically. The variety of our tasks has proved that young students, even with a minimum help, can develop, justify, validate and refute mathematical conjectures.

Our main research question was what are the characteristics of the tasks which promote mathematical reasoning. Firstly, we have not seen any influence of the images that accompanied the tasks; however, we have seen that context might move students away from reasoning (Task 3). Some tasks have proven more fruitful than others concerning the reasoning processes they evoked. It seems that open tasks do not pose any difficulties to the students, when they have a finite number of solutions (Tasks 5, 7). The same is the case with closed tasks that can be solved in many different ways (Task 2). On the contrary, our students experienced difficulties when faced with a task that required a shift from geometrical structures to numerical ones (Task 3). At the same time, they manifested a variety of reasoning processes during another geometrical task (Task 4), which did not require an explicit shift to numerical properties. Based on all the above, although our exploratory study has not led to conclusive results, we believe that it may assist the design of mathematical tasks aiming to promote reasoning among young students.

References

- Blanton, M., Levi, L., Crites, T., & Dougherty, B. J. (2011). *Developing essential understandings of algebraic thinking for teaching mathematics in grades 3–5*. Reston, VA: NCTM.
- Da Ponte, J. P. (2001). Investigating in mathematics and in learning to teach mathematics. In F. L. Lin & T. J. Cooney (Eds.), *Making sense of mathematics teacher education* (pp. 53–72). Dordrecht, The Netherlands: Kluwer.
- De Lange, J. (1999). *Framework for classroom assessment in mathematics*. Utrecht, The Netherlands: Freudenthal Institute & National Centre for Improving Student Learning and Achievement in Mathematics and Science.
- Francisco, J. M., & Maher, C. A. (2005). Conditions for promoting reasoning in problem solving: Insights from a longitudinal study. *Journal of Mathematical Behavior*, 24(3), 361–372.
- Kaput, J. J., & Blanton, M. (2005). Algebrafying the elementary mathematics experience in a teacher-centered, systemic way. In T. Romberg & T. Carpenter (Eds.), *Understanding mathematics and science matters* (pp. 99–125). Mahwah, NJ: Lawrence Erlbaum Associates.
- Kieran, C., Pang, J., Schifter, D., & Ng, S. F. (2016). *Early algebra: Research into its nature, its learning, its teaching*. New York, NY: Springer.
- Lankiewicz, B., Sawicka, K., & Swoboda, E. (2012). *Matematyka [Plus] 1, ćwiczenia rozwijające zainteresowania [Mathematics [Plus] 1, exercises developing interest]*. Warsaw: Nowa Era.
- Lannin, J., Ellis, A. B., & Elliot, R. (2011). *Developing essential understanding of mathematical reasoning: Pre-K-Grade 8*. Reston, VA: NCTM.
- Maj-Tatsis, B., & Tatsis, K. (2015). Investigations in magic squares: a case study with two eight-year-old girls. In K. Krainer & N. Vondrová (Eds.), *Proceedings CERME 9* (pp. 1954–1960). Prague, Czech Republic: Charles University in Prague.
- Mason, J. (with Graham, A. & Johnston-Wilder, S.). (2005). *Developing thinking in algebra*. London, England: Sage.
- Perry, B., & Dockett, S. (2002). Young children's access to powerful mathematical ideas. In L. D. English (Ed.), *Handbook of international research in mathematics education* (pp. 81–112). Mahwah, NJ: Lawrence Erlbaum Associates.
- Schoenfeld, A. H. (1994). Reflections on doing and teaching mathematics. In A. H. Schoenfeld (Ed.), *Mathematical thinking and problem solving* (pp. 53–70). Hillsdale, NJ: Lawrence Erlbaum Associates.
- Treffers, A. (2008). Grade 1 (and 2). Calculation up to 20. In M. van den Heuvel-Panhuizen (Ed.), *Children learn mathematics. A learning-teaching trajectory with intermediate attainment targets for calculation with whole numbers in primary school* (pp. 43–60). Rotterdam, The Netherlands: Sense Publishers.
- Van den Huevel-Panhuizen, M. (2005). The role of contexts in assessment problems in mathematics. *For the Learning of Mathematics*, 25(2), 2–9.
- Yin, R. K. (2014). *Case Study Research Design and Methods* (5th ed.). Thousand Oaks, CA: Sage.

Exploring how primary teacher education prepares pre-service teachers to teach early years Mathematics

Justina Longwe Mandala

University of Malawi, Chancellor College, Malawi; jlongwe@cc.ac.mw

Keywords: Teacher education, Malawi, early years mathematics, pre-service teachers.

Introduction

Learner underachievement in mathematics still remains an issue of concern in primary schools in Malawi. Analysis of Early Grade Mathematics Assessment (EGMA) indicates that learners in the early grades continue to perform poorly and experience mathematics as memorization of facts and procedures to determine the correct answer to questions, instead of experiencing it as a meaningful, sense-making, problem-solving activity (MTPDS, 2010). This may mean that the teaching of mathematics in early years is not being effective. Teachers tend to approach mathematics as facts that need to be learned through practice and speed drill (Boaler, 2016). This approach to teaching mathematics to beginning learners raises questions on how teachers are trained to teach mathematics in early years, bearing in mind that pre-service teacher education is the principal source of teacher knowledge (Shulman, 1986). Ball & Forzani (2011) recognize that there are different factors that affect educational outcomes, such as curriculum, assessment, parents; however, they argue that learner success basically depends on skilful teaching which is largely a result of well trained teachers. They claim that if teachers fail to help learners learn, it is possibly because, among other reasons, they do not receive enough preparation during training. Scherrf & Singer (2012) argue that pre-service teachers enter training programs with their own perspectives of mathematics teaching from their learning experiences. Thus, their pre-service training should help them refine their perspectives. If they receive insufficient preparation, they may likely be compelled to teach according to their own experiences of learning.

In Malawi, to the best of my knowledge, research is silent on preparation of pre-service teachers to handle mathematics in early years. It is against this gap in knowledge that this study seeks to gain an understanding of how primary teacher education prepares pre-service teachers to teach mathematics in early years, which include standards (grades) 1 to 4. The study seeks to answer the following question: How does primary teacher education prepare pre-service teachers to teach early years mathematics? And the following are the specific questions: What examples, tasks and explanations do mathematics teacher educators use when teaching the concept of number and operations to student teachers? How do mathematics teacher educators involve student teachers in their lessons on early years mathematics? How do student teachers use knowledge obtained from teacher training to teach mathematics in early years during teaching practice?

Theoretical framework

The study is guided by Adler & Ronda's (2015) Mathematical Discourse in Instruction (MDI) framework. MDI is theoretically grounded in the sociocultural theories and empirically grounded in mathematics teaching practices. The framework was chosen because it specifically targets mathematics teaching practices and constitutes interrelated elements that are encouraged in

mathematics teacher education, which include object of learning, exemplification, explanatory talk and learner participation. The study focuses on how mathematics teacher educators encourage the use of these elements as they teach pre-service teachers.

Research Methodology

This is a qualitative case study in which 4 mathematics teacher educators from one public teacher training college will be observed teaching and then interviewed. Pre-service teachers practicing their teaching in any 4 teaching practice schools belonging to the participating college will be involved in focus group discussions. Document analysis on mathematics schemes of work, lesson notes, lecturers' and students' handbooks will be done to supplement information on where teacher educators get examples and tasks. Participants were purposively sampled based on mathematics teaching experience at college level for teacher educators and accessibility for teaching practice schools. FGD participants are all student teachers teaching mathematics in lower classes in the sample schools. Data will be analyzed thematically. Transcribed data will be read carefully, coded, and then sorted into potential themes.

Piloting

Piloting was done on one mathematics teacher educator. Preliminary pilot results show that in terms of exemplification, mostly, one or two examples were used in the lessons. In all the lessons, there was more emphasis on what resources to use when teaching a concept. In student participation, student teachers were invited to participate by mostly answering yes/no questions, finishing teacher's sentences, group discussions, and demonstrating how an activity is done.

Acknowledgement

This study is kindly funded by the Norwegian Programme for Capacity Building in Higher Education and Research for Development (NORHED) through the Strengthening Numeracy in Early Years of Primary Education Through Professional Development of Teachers project (Ref: QZA-0498 MWI 16/0020)

References

- Adler, J., & Rhonda, E. (2015). A framework for describing mathematics discourse in instruction and interpreting differences in teaching. *African Journal of Research in Mathematics, Science and Technology Education*, 19(3), 237–254.
- Ball, D.L., & Forzani, F.M. (2011). Building a common core for learning to teach, and connecting professional learning to practice. *American Educator*, 35(2), 17–21.
- Boaler, J. (2016). *Mathematical Mindsets. Unleashing students' potential through creative math, inspiring messages and innovative teaching*. San Francisco, CA: Jossey-Bass.
- Malawi Teacher Professional Development Support (MTPDS) (2010). Malawi Early Grade Mathematics Assessment: National Baseline Report.
- Scherrf, L. & Singer, N. R. (2012). The pre-service teachers are watching: Framing and reframing the field experience. *Teaching and Teacher Education*, 28(2), 263–272.
- Shulman, L. S. (1986). Those who understand: Knowledge growth in teaching. *Educational Researcher*, 15(2), 4–14.

Preschool children's understanding of length and area measurement in Japan

Nanae Matsuo¹ and Nagisa Nakawa²

¹Chiba University, Faculty of Education, Chiba, Japan; matsuo@faculty.chiba-u.jp

²Kanto-gakuin University, Japan; nagisa@kanto-gakuin.ac.jp

This study assesses preschool children's understanding of length and area measurement through the activities of a mathematics program in Japan. Japanese preschool children do not formally learn mathematics; thus, we designed mathematical measurement activities for young, less-experienced preschool teachers to implement for nine five- to six-year-old children. We conducted structured clinical interviews with the children individually, both before and after the measurement activities, and qualitatively analyzed the results by comparing their answers and connecting them to the activity contents. Results indicate that children learn to understand direct comparison through activities; however, it is more difficult to establish understanding of measurement by non-universal units.

Keywords: Preschool children, mathematical activity, length measurement, area measurement

Research on measurement in preschool

Much of the current research focuses on elementary mathematics education for preschool children and younger elementary school students (e.g., Brandt, 2013); however, measurement has not been sufficiently included in these studies (Sarama, Clements, Barrett, Van Dine, & McDonel, 2011; Smith, van den Heuvel-Panhuizen, & Teppo, 2011), even though it is an important real-world area of mathematics used in everyday life. In addition, Hachey (2013) states that mathematical conceptual change in young children is as effective as a substantial change in early childhood mathematical teaching practice, as a large body of developmental research advocates that young children are born mathematicians, and therefore, early childhood mathematics education is vital.

It is known that the development of children's understanding is related to foundational or key ideas of measurement such as comparison, unit iteration, number assignment, and proportionality (Lehrer, Jaslow, & Curtis, 2003; Wilson & Osborne, 1992), and several kinds of teaching methods for measurement have been developed (Battista, 2006; Kamii, 2006). Although Piaget (1968) assumed that children up to seven years old are unable to consider more than one stimulus dimension in their judgments, subsequent research has demonstrated that preschoolers can consider two dimensions; for example, they can consider the width and length of rectangles to estimate their area (Wilkening, 1979). Further, Ebersbach (2009) addressed the question of whether children can also take three stimulus dimensions into account and showed that preschoolers have the cognitive competencies required for multidimensional reasoning. There have also been numerous other important studies on preschool children's understanding of measurement. Sarama et al. (2011) proposed a learning trajectory for length and area in the early years and evaluated it. Zöllner and Benz (2013) concluded that four- to six-year-old children could compare directly and indirectly, but cannot measure using a non-standardized unit. Tzekaki (2017) indicated that a seven-month intervention helped preschoolers improve their abilities to reflect on their own activities and express their ideas regarding measurement. Skoumpourdi (2015) verified that preschoolers do have some strategies for length

measurement, but confuse the concept of length with perimeter and area. Finally, Kotsopoulos (2015) showed that a free exploration approach in the context of a play-based learning environment is more effective in teaching length measurement than guided instruction and center-based learning.

This article examines whether preschool children can improve their understanding of length and area measurement, especially direct and indirect measurement, as well as measurement by non-universal units. It does so with an elementary mathematics play-based program, which can even be implemented by young, less-experienced teachers who have not been trained in mathematics instruction, thereby fostering children's understanding of measurement. These play-based activities are intended as a further contribution to the existing research. The article also seeks to explain the specific reasons the program is effective. First, we compare pre- and post-interview results for five- to six-year-old children. Next, we intentionally choose two children with different degrees of change between their pre- and post-interview results. Finally, we discuss the reason the change occurred, scrutinizing each child's actions and attitude during the activities, as well as his/her post-interview.

The early childhood mathematics program in Japan

Elsewhere, we have proposed a framework for constructing an early childhood mathematical curriculum (Matsuo, 2016). The theoretical and methodological underpinnings of our program are social constructivism (Ernest, 1994), mathematical guided-play (Weisberg et al., 2013), and the Structure of the Observed Learning Outcome (SOLO) taxonomy (Biggs, 1982). This program presents a scope for the content of preschoolers' activities, while the learning process of those activities are explained from the viewpoint of sequence, based on the relationship between age and modes of representation and focusing on activities for five- to six-year-old children to create a program tailored to these concerns. Based on this framework, we have proposed a mathematical education program to enable a smooth transition from preschool to elementary school mathematical education (Matsuo, 2017). Less-experienced preschool teachers should be able to use these activities to better incorporate mathematical content into children's play and recognize activities that will make children think and act mathematically. This practical program was designed for preschools and elementary schools.

Methodology

Research participants

The preschool kindergarten in an urban area of Kanagawa Prefecture of Japan participated in our pilot study. This article focuses on nine five- to six-year-old children in the oldest classes. The children are all Japanese, coming from middle- and upper-middle-class families in Japan. There were six boys and three girls. The school's focus was on physical activities, as well as entrance to candidate schools for the International Baccalaureate (IB). Children started to learn Japanese letters and English to prepare themselves for primary education in September 2017.

The oldest classes of the preschool had two teachers: Teacher A, a male teacher with three years of experience teaching preschool, and Teacher B, a female teacher with two years of experience teaching preschool. Teacher A taught the first three sessions of measurement activities in the first cycle of the program and Teacher B taught the latter three sessions in the second cycle. For the analysis, we intentionally chose two children, T1 and T7, based on the results of pre- and post- interviews, to

intensively examine their outcomes and learning processes, as well as to determine the relations between the interview results, their actions, and the detailed observations of the teachers during the activities. T1 was actively engaged in the activities, but provided incorrect answers in the post-interview. T7 was not actively engaged in the activities, but made correct observations and provided correct answers in the post-interview. To compare the two children's understanding, we discuss the level of understanding of direct and indirect measurement, as well as measurement with non-universal units, in connection with the young teachers' instruction.

Data collection and analysis

In the project, we developed six play-based activities related to numbers, measurement, and shapes. Among these activities, we carefully chose those that were better tailored to relate to numbers, shapes, and measurements, things that are necessary for our curriculum to focus on and develop. To evaluate the improvement of children's mathematical skills after these activities, we developed pre- and post-interview questions. Pre-interviews were conducted in June 2017 and all six activities were implemented twice; therefore, twelve activities were implemented after the pre-interview. After all activities had been completed, a post-interview was conducted with each child in February 2018. Sixteen questions were developed for the pre-/post-interviews, corresponding with the planned activities and previous research by the author (Matsuo, 2016), as well as the SOLO taxonomy. Four of the sixteen questions were in the area of measurement, as shown in Table 1.



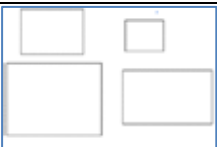

Q12	Prepare four different pencils, each of a different length, as shown in the diagram, and ask, "Which do you think is the longest pencil of the four? And tell me the order of the length, from longest to shortest."	
Q13	Show four different pencils, each of slightly different length as shown in the diagram, and ask, "Which do you think is the longest pencil of the four? And tell me the order of the length, from longest to shortest."	
Q14	Prepare four different rectangles as shown in the diagram, and ask, "What do you think is the biggest rectangle of the four? And tell me the order of the area, from biggest to smallest."	
Q15	Prepare four different rectangles as shown in the diagram, and ask, "What do you think is the biggest rectangle of the four? And tell me the order of the area, from biggest to smallest."	

Table 1: Description of the interview questions and the problem contexts

Methodologically, the authors conducted structured clinical interviews (Goldin, 1998). To alleviate children's anxiety, the teachers conducted the interview themselves, while one of the authors sat next to the child to record. The assigned teachers rehearsed the interviews to be consistent with mathematical words and expressions. During the implementation, each child came to the room randomly and the teacher sat in front of the child. The pre-interviews took fifteen to twenty-five

minutes, and the post-interviews took ten to fifteen minutes. During the interview, the children could use a ruler, transparent paper, grid paper, and clips to answer questions 12 to 15. The results were qualitatively analyzed.

Description of measurement activities in the intervention

Teacher A taught the children the first course in how to measure the length of something carefully using clips as non-universal units. They measured assorted items by connecting clips (e.g., measuring the edge of the desk, the mat, the height of the teacher). Teacher B taught the second course, in which the children tried to connect eight clips in order to use them to measure shorter objects than the ones measured in the first course. After the children used the connected clips to measure a building block or a box, the teacher asked the children to find objects with lengths equivalent to eight clips. Next, they looked for objects with lengths equivalent to sixteen clips. They lined up sixteen red magnets and set out to measure them using the clips.

In the area measurement activity, the children employed indirect comparison and measured using non-universal units, such as length measurement. The activity was implemented like a code-breaking game, and when the code was solved, figures whose areas were objects for measurement were supposed to be arranged in descending order. A teacher directed the children to count the square grids covered in rectangular paper to measure the total area. First, the children copied the target onto plain paper, put this paper on grid paper, and counted the number of squares as non-universal units. The sizes of the three kinds of rectangles (thirty-two, forty, and forty-eight squares) were relatively large, and the children had been actively counting quite carefully. Finally, the paper with a number written on it was matched with a corresponding letter, which enabled them to solve the code. Letters with meaning were arranged in order so that the numbers became larger.

Results and Discussion

Table 2 shows that there is not a significant difference of the correctness toward questions between length and area measurement.

Child No.	Gender	Birthday	Q12		Q13		Q14		Q15	
			Pre	Post	Pre	Post	Pre	Post	Pre	Post
T1	F	MAY	1	1	0	0	1	1	1	0
T2	M	JULY	1	1	1	1	1	1	1	1
T3	M	NOVEMBER	1	1	0	1	1	1	0	1
T4	F	NOVEMBER	1	1	0	1	1	1	0	1
T5	F	AUGUST	1	1	1	0	1	1	1	0
T6	M	JUNE	1	1	0	1	1	1	1	0
T7	M	DECEMBER	0	1	0	1	0	1	0	1
T9	M	JULY	1	1	1	1	1	1	0	1

Table 2: Pre- and post-interview results for measurement of length and area

* 1 means correct, 0 means incorrect

Looking at the transition of the results from the pre- to post-interview, problems whose answers are incorrect in both pre- and post-interview cannot be seen except for T1. In the case of Q12 and Q14,

children got the correct answers in the pre- and post-interview, excluding T7. Since the edges of some part of the figures in these problems are aligned, it is possible to judge the difference in size from the difference in other parts by visual observation. Children were thought to be mature, developable, and able to maintain natural demeanor. Regarding Q13 and Q15, about half of the children answered correctly in the pre-interview, but they had incorrect answers in the post-interview. T2 had correct answers for everything both pre- and post-interviews. T9 also had correct answers, except for Q15, in the pre-interview. T8, who was absent from the length and area measurement activity of the second course, was excluded from analysis.

Comprehensive analysis of eight children's understanding of measurement

Table 2 indicates that every child understood direct measurement in Q12 and Q14 in the post-interview, though in Q13 and Q15, a few children did not understand indirect measurement nor measurement by non-universal units. An erroneous view prevails that the area measurement is harder to understand than length measurement, as the number of dimensions is higher. As Ebersbach (2009) stated, not only length and area but also volume can be estimated by a young child, and the rate of correct answers does not change much between children and adults. It is possible for preschoolers to tackle activities that are not limited to length, area, and volume measurement, as we inferred from the results of our survey; however, even though children were working well on the measurement activities, most of them gave incorrect answers for area measurement.

T3, T4, and T7 answered incorrectly in the pre-interview but correctly in the post-interview for Q13 and Q15. Although they answered visually for Q13 and Q15, they were correct. We infer the program implemented had a positive effect, especially because the measurement using non-universal units is not commonly done at home or in preschools. While there were scenes in which they could not be regarded as proactively working on the program activities, in many cases, it is mentioned that they were working on collaborative and individual work well and could observe other subjects' behavior.

Conversely, T1, T5, and T6 had incorrect answers in the post-interview even if they were correct in the pre-interview, revealing that the influence exerted by the activities of the mathematics program are strongly related to this fact. Let us consider why they did not have correct answers for Q15, even if they were trying to answer based on measurements in non-universal units using tools and enjoyed it in the post-interview. It is probably because children could not distinguish between the measurement of length and area and did not associate the numerical value measured in non-universal units with the results of the comparison of length and area, or because they could not understand the meaning of the work and retain this understanding even if they acquired skills related to measurement. This can be judged from the state of the post-interview.

Qualitative analysis for two children who had different results and processes of playing

We will now compare and examine the results of two children, T7 and T1, their post-interview responses, and the teacher's findings regarding them in Table 3.

T1 was engaged in acting as a group leader in length measurement. After the clip-connecting activity, she was looking for various items to measure, like building blocks, etc. She was highly interested in the length-measurement activity. Further, in the area-measurement activity, she actively worked on counting. She did the measurement work again, but her answer was not correct. She did not seem to have an opportunity to objectively review the meaning of the work after she had concentrated on it.

It can be surmised that because the meaning of the work was unclear, she confused length and area. The result of this study is consistent with previous studies (e.g., Skoumpourdi, 2015). The length and the area are different in dimension, and in daily life, for a child, the length comparison is familiar and more understandable than the area comparison.

T1	Q12	She replied visually, pointing with her finger.
	Q13	She took the fine-grid tracing paper, and after a little measuring, she answered, "Oh, I understood it."
	Q14	She replied visually.
	Q15	She laughed and took the clips first, and asked, "Can I measure them sideways?" She joined the clips, measured the length of the rectangle sideways, adjusting the length of the joined clips. Next, using the tracing sheet (with a grid), she aligned the edges and measured the length of the rectangle.
	Post-test state	She said, "I was looking forward to it today," and "It's fun to find different lengths in measuring activities."
	Teachers' findings	She is not good at detailed work. She is good at drawing. She loves playing football and moving her body. She would rather move her body than sit and work. She is interested in the alphabet.
T7	Q12	He pointed in a sequential order visually.
	Q13	He pointed in the descending order visually and quickly without using tools.
	Q14	He pointed in the descending order visually and quickly.
	Q15	He pointed in the descending order visually and quickly.
	Post-test state	He worked silently. He did not use any tools at all in the measurement, and answered quickly and visually. He enjoyed the math activities and especially enjoyed using the clips to measure the room. He did not seem to be an noteworthy type.
	Teachers' findings	He is good at fine work and studying. Currently, he is learning division and fractions progressively. He is shy and not good at speaking in front of people.

Table 3: Results of T1 and T7 for Q12-15, post-interview results and teachers' findings

Conversely, T7 did not do much work and wandered around. He did not work as actively as the other children, though he observed the other children's activities well. During area measurement, everyone was absorbed in drawing figures and counting the squares, while he also worked and looked around. It is highly likely that his reply was affected by this behavior. As a result, T7 who did not actively work, gave the correct answer by visual observation. It can be inferred that this is due to the child's rich sense of length and area, fostered during the activities (Schoenfeld, 2016). Through these activities, it seems that the sense of long/short, wide/narrow is more sharpened. Preschool children may not have this vocabulary, but instead use "big" or "small" to express differences in quantity. Since children who observed better than doing their own work seemed to grasp the size correctly by visual observation in the post-interview, rather than just doing work, by sharing the work process of early mathematical activities, it can be said that the sense of quantity has been enhanced.

Further, even when it seems that a child is not actively working on a problem, or appears not to be thinking too much, we must accept the fact that the child considers silently and may still answer correctly. According to Shinohara (1942), since observation is an educationally effective activity, like experiments, it is important for children to observe others' behavior and imitate it. In the case of

young children, it is often difficult for them to express in words; therefore, it is important for the teacher to observe the situation and guess from the usual activities or the activities with other children. From the countereffect by the program, it appears that by depending on teachers' questioning, summary, etc., children concentrate on the work without thinking about its meaning.

Conclusion

Children in this study showed different outcomes of learning in measurement. The children continued to understand direct comparison in all activities; however, it was difficult to establish understanding of measurement by non-universal units. The intervention activities seemed to affect their learning outcomes, although we only focused on how two children's actions related to their interview results. Play-based activities offered by the young teachers influenced children's understanding in both positive and negative ways. This suggests that play-based activities are effective, but should be meaningful and substantial mathematical activities, not superficial. This study only analyzed a small number of children's understanding of measurement, and therefore cannot be generalized further. Future research should analyze a larger number of children.

Acknowledgment

This research was supported by a Grant-in-Aid for Science Research (B) (15H02911) in Japan.

References

- Battista, M. T. (2006). Understanding the development of students' thinking about length. *Teaching Children Mathematics*, 13(3), 140–146.
- Biggs, J., & Collis, K. (1982). *Evaluating the quality of learning: SOLO taxonomy*. New York, NY: Academic Press.
- Brandt, B. (2013). Everyday pedagogical practices in mathematical play situations in German "kindergarten." *Educational Studies in Mathematics*, 84(2), 227–248.
- Ebersbach, M. (2009). Achieving a new dimension: Children integrate three stimulus dimensions in volume estimations. *Developmental Psychology*, 45(3), 877–883.
- Ernest, P. (1994). Social constructivism and the psychology of mathematics education. In P. Ernest (Ed.), *Constructing mathematics knowledge: Epistemology and mathematical education* (pp. 68–79). Bristol, PA: Falmer.
- Goldin, G. A. (1998). Observing mathematical problem solving through task-based interviews. In A. R. Teppo (Ed.), *Qualitative research methods in mathematics education. Monograph 9, Journal for Research in Mathematics Education* (pp. 40–62). Reston, VA: NCTM.
- Hachey, A. C. (2013). Early childhood mathematics education: The critical issue is change. *Early Education and Development*, 24(4), 443–445.
- Kamii, C. (2006). Measurement of length: How can we teach it better? *Teaching Children Mathematics*, 13(3), 154–158.
- Kotsopoulos, D., Makosz, S., Zambrzycka, J., & McCarthy, K. (2015). The effects of different pedagogical approaches on the learning of length measurement in kindergarten. *Early Childhood Educational Journal*, 43(6), 531–539.

- Lehrer, R., Jaslow, L., & Curtis, C. (2003). Developing an understanding of measurement in the elementary grades. In D. H. Clements & G. W. Bright (Eds.), *Learning and teaching measurement: yearbook of the national council of teachers of mathematics* (pp. 100–121). Reston, VA: NCTM.
- Matsuo, N. (2016). Framework for an early mathematical preschool curriculum in Japan. In C. Csíkós, A. Rausch, & J. Sztányi (Eds.), *Proceedings of the 40th International Conference for the Psychology of Mathematics Education, 3*, 299–306.
- Matsuo, N. (2017). *Shugakuzen sansu kyoiku puroguram no teian: Hirosa kurabe/zukei no hamekomi katsudou ni tsuite. [The preschool mathematical education program: Focus on the domains of area measurement and embedding of geometric figures]*. *Tokyo Gakugei Journal of Mathematics Education*, 29, 63–72. (In Japanese).
- Piaget, J. (1968). Quantification, conservation, and nativism. *Science*, 162, 976–979.
- Sarama, J., Clements, D. H., Barrett, J., Van Dine, D. W., & McDonel, S. (2011). Evaluation of a learning trajectory for length in the early years. *ZDM*, 43(5), 667–680.
- Schoenfeld, A. H. (2016). Learning to think mathematically: Problem solving, metacognition, and sense making in mathematics (reprint). *Journal of Education*, 196(2), 1–38.
- Shinohara, S. (1942). *Kyojyu genron [Teaching principle]*. Tokyo, Japan: Iwanamisyoten. (In Japanese).
- Skoumpourdi, C. (2015). Kindergartners measuring length. In K. Krainer and N. Vondrová (Eds.), *Proceedings of the Ninth Congress of the European Society for Research in Mathematics Education* (pp. 1989–1995). Prague, Czech Republic: Charles University in Prague and ERME.
- Smith, J., van den Heuvel-Panhuizen, M., & Teppo, A. (2011). Learning, teaching, and using measurement: Introduction to the issue. *ZDM*, 43(5), 617–620.
- Tzekaki, M., & Papadopoulou, E. (2017). Teaching intervention for developing generalization in early childhood: the case of measurement. In T. Dooley and G. Gueudet (Eds.), *Proceedings of the Tenth Congress of the European Society for Research in Mathematics Education* (pp. 1925–1932). Dublin, Ireland: Institute of Education, Dublin City University and ERME.
- Weisberg, D. S., Hirsh-Pasek, K., and Golinkoff, M. R. (2013) Guided play: Where curricular goals meet a playful pedagogy. *Mind, Brain, and Education*, 7(2), 104–112.
- Wilkening, F. (1979). Combining of stimulus dimensions in children's judgments of area: An information integration analysis. *Developmental Psychology*, 15, 25–33.
- Wilson, P. A., & Osborne, A. (1992). Foundational ideas in teaching about measure. In T. R. Post (Ed), *Teaching mathematics in grades K-8: Research-based methods* (pp. 89–121). Needham Heights, MA: Allyn & Bacon.
- Zöllner, J., & Benz, C. (2013). How four to six year old children compare length indirectly. In B. Ubuz, Ç. Haser, and M. Alessandra Mariotti (Eds.), *Proceedings of the Eighth Congress of European Research in Mathematics Education (CERME 8)* (pp. 2258–2267). Ankara, Turkey: Middle East Technical University.

The use of structure as a matter of language

Lara Müller¹ and Kerstin Tiedemann¹

¹ Bielefeld University, Bielefeld, Faculty of Mathematics, Germany; lara.mueller@uni-bielefeld.de;
kerstin.tiedemann@uni-bielefeld.de

Keywords: Subitizing, use of structure, language.

Introduction

Recent research shows that structure plays an important role for the arithmetical development and the development of number sense (Lüken, 2012; van Nes, 2009). In this context, using structure for identifying the cardinality of a set of objects is a main achievement of children's competence in the early years (Clements, 1999; Schöner & Benz, 2018). The ongoing study presented in this poster focuses on language to foster children's structure abilities. The aim is to explore which language children (can) use to talk about structures when determining the cardinality of sets.

Theoretical Background

The use of structure to determine the cardinality of a set of objects is defined as *conceptual subitizing* (Clements, 1999; Sarama & Clements, 2009). Structuring a set of concrete objects into subsets which can be determined easily and used to determine the cardinality of the whole set of objects is an important mathematical ability and should be learned and fostered during the early years (Clements, 1999). In a recent study Schöner and Benz outline that many children aged between 5 and 6, who are able to perceive and use structure to determine the cardinality of a set, "often lack the words to describe their constructions and approaches" (2018, p. 141). The most common way to describe their approaches is counting (Schöner & Benz, 2018). It seems like children are missing language to describe structure and their use of it. In order to be able to foster conceptual subitizing in the everyday interaction in kindergarten, we want to explore which language children (can) use to talk about structures in sets of objects and their use of this structures when determining the cardinality of sets. This is an important issue, because language and communication play an important role in the learning process of children. Communicating about mathematical concepts can foster the insight into the abstract mathematical notion (Maier & Schweiger, 1999). Furthermore communication can facilitate a deeper reflection on the mathematical structures and structures that may still be implicit can become explicit (Maier & Schweiger, 1999). Thus, talking about structures in sets of objects possibly helps children to interpret numbers as wholes which can be composed to larger wholes.

In order to analyze the specific language requirements for describing the process of conceptual subitizing, we refer to Sfard's (2008) approach of reification. With a view to mathematical discourses, she distinguishes between two types of discursive entities: mathematical processes and mathematical objects. According to Sfard (2008, p. 47), mathematical objects can be understood as reified processes: In a discursive transformation mathematical processes can be reified into mathematical objects. We can use this approach for analyzing how children describe structures in sets of objects and their use of this structures. Thus, one example of the distinction between processes and objects is that of natural number. We can talk about numbers by talking about the process of counting (e.g. "one, two, three,...") or we can talk about numbers as static objects which can be manipulated as

wholes in new processes (e.g. “four times three”) (Sfard, 1991, 2008). In terms of determining a set of concrete objects the *talk about numbers as objects* is prerequisite for describing conceptual subitizing. Children who subdivide the whole set in structured subsets which can be recognized and manipulated as wholes (e.g. *three* and *four*) and composed to a larger whole (e.g. *seven*) need a specific kind of language: In order to describe conceptual subitizing in discourse, they need *language for talking about numbers (subsets) as objects* and *language for the new process “linking”*. Thus, they talk about numbers as objects which can be used and manipulated in a new process.

Method

This theoretical analysis of the language requirements leads to two distinct questions:

How do children talk about objects and processes while they determine the cardinality of a set of objects? How do children adopt ways of describing from the discourse with an adult?

To answer this questions, preschoolers, aged 5 to 6, will be interviewed individually. The interview will be divided in to two parts: At the beginning of the interview, the child will constantly be encouraged to describe his or her process of determining the cardinality of a set of concrete objects. Depending on the child’s talk about the objects and processes, the interviewer will make adaptive offers of language.

References

- Clements, D. H. (1999). Subitizing: What is it? Why teach it? *Teaching Children Mathematics*, 5(7), 400–405.
- Lüken, M. (2012). Young children’s structure sense. *Journal für Mathematik-Didaktik*, 33(2), 263–285.
- Maier, H. & Schweiger, F. (1999). Mathematik und Sprache: Zum Verstehen und Verwenden von Fachsprache im Mathematikunterricht. *Mathematik für Schule und Praxis*, 4 (1 ed.). Wien, Austria: Öbv & hpt.
- Sarama, J. & Clements, D. H. (2009). *Early childhood mathematics education research: Learning trajectories for young children* (1 ed.). New York, NY: Routledge.
- Schöner, P. & Benz, C. (2018). Visual structuring processes of children when determining the cardinality of sets: The contribution of eye-tracking. In C. Benz, A. S. Steinweg, H. Gasteiger, P. Schöner, H. Vollmuth, & J. Zöllner (Eds.), *Mathematics education in the early years. Results from the POEM3 conference 2016* (pp. 123–143). Cham, Switzerland: Springer.
- Sfard, A. (1991). On the dual nature of mathematical conceptions: Reflections on processes and objects as different sides of the same coin. *Educational Studies in Mathematics*, 22(1), 1–36.
- Sfard, A. (2008). *Thinking as communicating: Human development, the growth of discourses, and mathematizing*. New York, NY: Cambridge university press.
- van Nes, F. (2009). *Young children’s spatial structuring ability and emerging number sense*. Utrecht, The Netherlands: All Print.

Children's use of mathematical language

Beate Nergård

Queen Maud University College of Early Childhood Education, Trondheim, Norway;

bne@dmmh.no

Sixteen assemblies in a Norwegian kindergarten have been studied to identify characteristics pointing to when and how 5-year-old children use mathematical language when expressing their thoughts. When participating in an assembly the children are in a situated social context where communication is an important part of the context. The analysis shows that children use mathematical language when they compare, explain and argue. This paper links the way children use mathematical language in interaction with others through verbal language, body language and body movements.

Keywords: Kindergarten, Mathematical language, Comparing, Explaining.

Introduction

In all mathematical activities and play, language and the use of concepts are an important part of learning (Riccomini, Smith, Hughes, & Fries, 2015). According to Clements (2001), we may look at mathematics as a language based on structure and logic, where rich interaction with mathematical concepts is important for the development of children's mathematical knowledge (Purpura, Napoli, Wehrspann, & Gold, 2016). Even though research shows connections between children's linguistic understanding and their mathematical achievements, the causal relationship between mathematical language and mathematical knowledge has not been fully investigated (Purpura et al., 2016). By examining patterns in dialogues and interactions between adults and children it may be possible to gain a better understanding of which linguistic elements are important for the child's mathematical thinking and understanding (Trawick-Smith, Swaminathan, & Liu, 2016).

Children's development of mathematical vocabulary cannot be ignored as it is of great importance for their further learning of mathematics in school (Monroe & Orme, 2002). The article will focus on the use of mathematical language in a kindergarten. The study, exploring the use of mathematical language, is relevant both in relation to the increasing interest in the learning aspect and the increasing focus on language and mathematics in Nordic kindergartens (Hammer, 2012).

To contribute to the discussion about mathematics and the place of mathematical language in Norwegian kindergarten this article has the following research question: How do some five-year-olds use mathematical language when they express their thoughts about natural phenomena?

The research methods involved studying 16 assemblies in a Norwegian kindergarten. The Nordic kindergarten tradition is placed in what the OECD (2006) calls a "social pedagogical tradition", with a broad and open view of learning where children are seen to learn by playing and through their everyday activities. An activity which is often a regular feature in the kindergarten is the assembly. Assemblies in a Norwegian kindergarten involve typically 12 – 32 children. One characteristic of the assembly tradition is that it is organised and planned in advance by the adults and is probably the most structured and adult-led activity in the kindergarten. Children and adults come together to take

part in various activities focusing on a topic for the assembly. Assembly may be considered a social situated practice where learning can take place. This then is a particular, pedagogic and social context where the child uses language as a tool in interaction with others to explain and find words for his or her thoughts.

Mathematics in the kindergarten

Bishop (1989) divides children's experience with mathematics into six fundamental mathematical activities: 1) explanation, 2) locating, 3) measuring, 4) counting, 5) design and 6) playing. He states that these mathematical activities are independent of culture and are reflected in children's everyday lives. Bishop (1989) claims that the number of activities is not important. What is important is how these six mathematical activities might help us gain a broader and more nuanced perception of what mathematics is and can be for children in kindergarten (Bishop, 1989).

Counting and measuring are both related to numbers, but in different ways. Counting relates to the perception of numbers and ways of determining numbers, while measuring refers to describing a magnitude by means of a system of numbers. In kindergarten, children gain experiences of counting using numerals, they count and experience that the numerals describe different amounts, where language becomes a tool for explaining how much of something they have. When measuring, children use numbers to compare and when put things in order to indicate how much there is of something or how big something is. When children measure, the need arises to sort things so that they can compare the objects they measure to find similarities and differences in their magnitudes rather than in their attributes.

According to Bishop (1989), locating and design are two important ways of developing mathematical thoughts based on the need to order space. Locating refers to the ability to describe where objects are placed in space, while design is about describing the form of a shape or how it is created. Bishop states that locating is a description of how several objects are placed in relation to each other and refers to how the children use language to say something about direction and placement, to orient themselves and to find their way in the three-dimensional space they are in. Design basically refers to the language children use to describe the characteristics of an object independent of location.

Explanation is used by children to express their experiences through language and action, while playing are the methods or activities through which children may experience mathematics. Bishop maintains that while counting, measuring, locating and design are related to our physical environment, play and explanation are also connected to our social environment. Through explanation and argumentation the child is challenged to give grounds and explain, find words for thoughts and tell about his or her reasoning. The child's power of explanation depends on his or her linguistic ability to express logical conclusions (Bishop, 1989).

Mathematics and language

Children who do not master the mathematical language or understand the mathematical concepts may experience that they do not understand the mathematics required of them when they enter school. Mathematical language is used to describe structures, and language plays an important part when children develop their understanding of mathematical concepts. In mathematics, a mathematical

language is a verbal and written linguistic expression, body language, such as looks, gestures and movements, and also characters, words and number symbols (Clements, Baroody, & Sarama, 2014). Understanding a concept is nevertheless much more than merely recognising the word designating the concept. The children need to hear the word used in different contexts and with different meanings, and to understand not only the concept but also the changed meaning of the particular word. Understanding mathematical vocabulary allows children to understand the meaning of mathematical discussions with others as well within instructional learning activities (Purpura et al., 2016).

There are two specific aspects of mathematical language which turn out to have an important role in early learning of mathematics: quantitative language and spatial language. Quantitative language, referring to amounts includes concepts such as fewer, less than, more than and many. Understanding quantitative concepts helps children to make and describe comparisons between numbers and amounts. The magnitude of amounts (cardinality) and order of numbers (ordinality) comprises a language which may be particularly difficult for many, as teaching often uses explanations which rely on one's understanding of verbal language, for example concepts such as big, little, more, few, before, after or next (Barner, Chow, & Yang, 2009).

Spatial language includes concepts such as above, before, near and over. Some spatial words, such as after and before, indicate magnitude as well, as they are often connected to the number sequence and indicate decrease and increase in quantity (Purpura et al., 2016). Understanding of the spatial language is related to children's spatial thinking, where the concepts help the children to talk about relations between objects and numbers, and not least help children to develop spatial skills that are important for mathematical development. Also, children with rich spatial language may be able to decrease the cognitive load involved in mentally transforming and describing a shape (Pruden, Levine, & Huttenlocher, 2011). Mental rotation and spatial visualization are related to geometric problem-solving, and in order to describe spatial relationship and create mental images of geometric shapes the children need to use spatial concepts such as top and bottom (Ferrara, Hirsh-Pasek, Newcombe, Golinkoff, & Lam, 2011).

The process goals in the Framework Plan for Kindergartens in Norway (Ministry of Education, 2017) states that pre-school teachers must support the mathematical development of children through everyday activities in the kindergarten. Pre-school teachers must encourage children to undertake systematic reflection and thinking and make mathematical relationships visible for them. Moreover, pre-school teachers must actively use mathematical language in a reflective manner so that the children develop understanding of basic mathematical concepts and are inspired to undertake mathematical thinking. By enriching the play the pre-school teachers will help children to experience the joy of mathematics. In such an educational practice it is important that learning in kindergarten is based on play (Björklund, 2014). The Nordic kindergarten didactics is child-centred and based on the pedagogical idea that children are playing and learning individuals in a socio-cultural society (Doverborg, Pramling, Pramling Samuelsson, & Haukeland, 2015). From a socio-cultural perspective, communication and the use of language are very important and are the link between the child and his or her environment. Socio-cultural theory is based on the thoughts and ideas of Vygotsky (1978). Language has a key role in Vygotsky's theory, where all thinking is based on language. To

understand this view the concept of language must be expanded to include other ways of expression, such as drawings, body language and gestures. Ehrlich, Levine and Goldin-Meadow (2006) suggest that using gesture to instruct children may have a profound and positive impact on the development of early spatial skills. Gesture provides children with a second, complementary problem-solving strategy that can be integrated with spoken language and lead to better understanding of the principles of mathematical equivalence (Wakefield, Novack, Congdon, Franconeri, & Goldin-Meadow, 2018).

Methodology

Design, data and participants

The data used in this article is a part of a larger data set collected for my PhD. Video observations of everyday activities in a Norwegian kindergarten were collected over a period of seven weeks spread over one year in a privately-operated kindergarten, in a city in southern Norway. This kindergarten is special in the way it focuses on natural science activities. The participants are adults and 25 five-year-old children in this kindergarten.

This paper reports from the study of 16 assemblies. The examples in this paper are from two of the 16 assemblies. In these two assemblies mathematical language was most utilized. The structure and topics of the 16 assemblies differed. However, the adults used a particular method when they were working on experimentations with natural phenomena. The adults explained and demonstrated a natural phenomenon, and asked questions like; “What does this look like?”, “Why do you think this happens?” and “Why would this one sink?” The children participated by answering, describing, asking questions and experimented in different ways with the natural phenomena.

Analytical approach

The analytical approach used was the constant comparison method (Corbin & Strauss, 2008), where comparisons are made in a socially situated context and regularities or patterns in when and how adults and children used mathematical language are identified. Coding the videos directly allowed for both verbal and visual cues to be considered, such as gesturing, movements and the use of artefacts. Six salient categories emerged from the data 1) children compare, 2) children explain and argue, 3) children respond to questions, 4) adults describe, 5) adults ask question and 6) adults respond.

This paper focuses on two of the six categories: 1) children compare and 2) children explain and argue. Bishop’s (1989) six fundamental mathematical activities are used to illuminate the findings and to describe which mathematical activity the children are relating to when they use mathematical language.

Findings

Comparison

During the assemblies the children were asked to observe and compare objects. When the children observed, they would often respond that “it looks like” or “it is similar to”. They observed and explained the similarities and dissimilarities of the objects, familiar objects and activities presented to them. Features used by the children to describe the similarities and dissimilarities were aspects of color, shape, size and function.

One assembly presented the planets and the adults showed a model of each planet in the solar system. During this assembly, the children used many verbal comparison expressions. They compared the shape using expressions such as “it looks like a ball” and “they’re all round”. Measurements were used when comparing the size of the planets, with such terms as “it’s the smallest”, “it’s bigger than Earth” and “Jupiter is the biggest”. One child also used comparison in the description of how hot the sun is. He stated, “It’s just as hot as the asphalt is in summer”. This child uses measurement and describes a quality using his experiences of the concept “hot”.

When the children describe qualities of objects and phenomena this can be seen in conjunction with their nascent learning of mathematics, where it is important to distinguish between similarities and dissimilarities to be able to sort and classify. Sorting and classification are about creating order, structure and having an overview. Ordering the object by size helps the children to use quantitative language, which is important in early mathematics (Barner et al., 2009).

The children often used gestures in the comparison given of what things look like and what they resemble, and when they explained themselves. In the assembly where they were to describe the planets and what characterized them, size and shape were expressed by gestures. The children would draw a circle in the air while saying “the planet is round”. Here the concept of circle is supported by a physical gesture. When comparing the size differences of the planets they demonstrated it by drawing circles in the air, either smaller or bigger than the last circle. One child supported the non-verbal language by saying “it’s sooo big”, drawing a big circle in the air. Body movements can be seen as a physical comparison of the size of a circle. When using the body in making comparisons between the planets, the non-verbal language helps the children to visualize what they are thinking and comparing. Children would often measure verbally while demonstrating with their body, testing out language in their comparison. I observed this in several cases where the children described height by lifting their hands up, width by stretching out their hands to the side, and little by holding two fingers close together. Such gestures complemented the children’s verbal expression to visualize their understanding of different sizes (Wakefield et al., 2018).

Explanation and argumentation

During the assemblies the children got opportunity to explain and argue what they thought. By explaining verbally, the children expressed what they were thinking; they gave reasons for their thoughts and explained relationships.

An example of this is from an assembly exploring if objects float or sink. Each child was given an object to feel its mass in their hand before describing its property and state whether they believed it would float or sink. For each object to be explored, the child was allowed to describe the object to the others and give reasons why he or she believed it would float or sink. In children’s explanations about whether objects would float or sink they argue according to previous observations or what has taken place earlier in the assembly. Different explanations, such as “this is as heavy as an rock so I know it will sink”, “it’ll sink because it’s bigger than the other one we put in”, “this will float because it has the same material as a sponge” and “it’ll float because it’s only plastic” show that the children base their argumentation on different experiences. The children emphasized different

arguments for what was going to happen based on the size, weight, mass and characteristics of earlier known objects.

Explanation and argumentation by the children in this assembly were often supported by using their sensory impressions. The children used their tactile sense by holding two objects, each in one hand. They begin discussing the weight of the two objects by lowering the hand where they felt the most heavy object, this to determine whether the object would float or sink. In doing so, these children were able to compare whether the object had more or less mass. No measuring instruments were used and so no specific quantification was mentioned. Instead, the comparisons were described using terms about heavy and light (Helenius, Meaney, Lange, Wernberg, & Johansson, 2016).

Some children were **still** unable to explain verbally why they meant an object would float or sink and would use the objects in their explanation. One boy experienced that a small object sank and a big one floated, despite that he had predicted otherwise. To explain why he had predicted that the small object would float and the big one would sink, he took the two objects out of the water and held them close together, while saying “this is why I think this one would sink, because it’s bigger than this one”. Then he held up the smallest object and said “this one have the same size as another who floated”.

The children’s explanations in this assembly helped them to use mathematical language related to their understanding of the aspect of measurement, and they described what they meant by heavy and light, by both using spoken language, body language and the artefacts. The children gained experience with measuring and explaining mass in different ways.

Discussion

The analysis shows that when children compare what they see, hear or touch, they deal with mathematical language, which in particular can be seen in relation to Bishop’s measuring, design and counting mathematical activities. By identifying similarities and differences in objects relating to measuring and design, the children use mathematical language, which become tools for classifying and ordering objects according to size and quantity, and they used a quantitative language to compare (Barner et al., 2009). When children were asked to explain their thoughts about an object or phenomena, the analyses show that the children used mathematical language in relation to Bishop’s locating, design and measuring.

The mathematical topics shape and size were mostly explained by using both words and gestures. By supporting their verbal language with physical movements, the children demonstrated visually with their bodies how they believed the shape appeared. In the situations where the children used non-verbal language in their comparisons, the analyses show that design was also present in their communication.

If the children did not have the language to give a verbal comparison or explanation they would show what they meant by using body language. Non-verbal responses – such as pointing, shaking their head and moving objects – were frequently prominent. The children showed their solution strategies by using their body language or the artefact as a support for the spatial language (Pruden et al., 2011). When the children explained and argued by using the artefact they supported their body-language

with mathematical words related to locating and size, they expressed their spatial movement while they moved their body or the artefacts.

In the social interaction and ongoing dialogues in the assemblies, the children encounter mathematics, which is related to locating, measuring, counting and design. The analysis shows that the children used mathematical language to make sense of the situation and their experience, to clarify their thinking and to communicate their understanding to others. The mathematical language in the informal talk around a natural phenomenon might help the children to gain a better understanding of the situation, and rich interaction with mathematical concepts in the communication might contribute to the children's mathematical development.

The analyses of the children's comparing, explanations and argumentation show that they classify and sort what they see, hear or touch during the assemblies. Despite the fact that the topic in the assemblies was on natural science phenomena, my analysis shows that the children were, in a large extent, using mathematical language to express their thoughts about natural phenomena. By acting and thinking freely they were given the opportunity to discover mathematical relationships. Descriptions of what the children do, see and think help them to use mathematical language they need if they are to talk about their actions. Mathematics then becomes a way of thinking and a language used to solve problems (Björklund, 2014). An identification of when children use a mathematical language shows a multifaceted opportunity for speaking about mathematics in kindergarten.

References

- Barner, D., Chow, K., & Yang, S. J. (2009). Finding one's meaning: a test of the relation between quantifiers and integers in language development. *Cognitive Psychology*, 58(2), 195–219.
doi:10.1016/j.cogpsych.2008.07.001
- Bishop, A. J. (1989). Mathematical enculturation: A cultural perspective on mathematics education. *Journal for Research in Mathematics Education*, 20(4), 367–370.
- Björklund, C. (2014). Powerful teaching in preschool – a study of goal-oriented activities for conceptual learning. *International Journal of Early Years Education*, 22(4), 380–394.
doi:10.1080/09669760.2014.988603
- Clements, D. H., Baroody, A., & Sarama, J. (2013). *Background research on early mathematics*. Washington, DC: National Governors Association.
- Clements, D. H. (2001). Mathematics in the preschool. *Teaching Children Mathematics*, 7(5), 270–275.
- Corbin, J. M., & Strauss, A. L. (2008). *Basics of qualitative research : techniques and procedures for developing grounded theory* (4rd ed. ed.). Thousand Oaks, CA: Sage.
- Doverborg, E., Pramling, N., Pramling Samuelsson, I., & Haukeland, E. (2015). *Å undervise barn i barnehagen*. Oslo, Norway: Gyldendal akademisk.
- Ferrara, K., Hirsh-Pasek, K., Newcombe, N. S., Golinkoff, R. M., & Lam, W. S. (2011). Block talk: Spatial language during block play. *Mind, Brain, and Education*, 5(3), 143–151.
doi:doi:10.1111/j.1751-228X.2011.01122.x

- Hammer, A. S. E. (2012). *Undervisning i barnehagen?* (pp. 223–244). Bergen, Norway: Fagbokforlaget.
- Helenius, O., Meaney, T., Lange, T., Wernberg, A., & Johansson, M. (2016). Measuring temperature within the didactic space of preschool. *Nordic Studies in Mathematics Education*, 21(4), 155–176.
- Ministry of Education. (2017). *Framework Plan for Kindergartens*. Oslo, Norway.
- Monroe, E. E., & Orme, M. P. (2002). Developing mathematical vocabulary. *Preventing School Failure: Alternative Education for Children and Youth*, 46(3), 139–142. doi:10.1080/10459880209603359
- OECD. (2006). *Starting Strong II*.
- Pruden, S. M., Levine, S. C., & Huttenlocher, J. (2011). Children’s spatial thinking: does talk about the spatial world matter? *Developmental Science*, 14(6), 1417–1430. doi:10.1111/j.1467-7687.2011.01088.x
- Purpura, D. J., Napoli, A. R., Wehrspann, E. A., & Gold, Z. S. (2016). Causal connections between mathematical language and mathematical knowledge: A dialogic reading intervention. *Journal of Research on Educational Effectiveness*, 10(1), 116–137. doi:10.1080/19345747.2016.1204639
- Riccomini, P. J., Smith, G. W., Hughes, E. M., & Fries, K. M. (2015). The language of mathematics: The importance of teaching and learning mathematical vocabulary. *Reading & Writing Quarterly*, 31(3), 235–252. doi:10.1080/10573569.2015.1030995
- Trawick-Smith, J., Swaminathan, S., & Liu, X. (2016). The relationship of teacher–child play interactions to mathematics learning in preschool. *Early Child Development and Care*, 186(5), 716–733. doi:10.1080/03004430.2015.1054818
- Vygotsky, L. S. (1978). *Mind in society: the development of higher psychological processes*. Cambridge, MA: Harvard University Press.
- Wakefield, E., Novack, M. A., Congdon, E. L., Franconeri, S., & Goldin-Meadow, S. (2018). Gesture helps learners learn, but not merely by guiding their visual attention. *Developmental Science*, 21(6), e12664. doi:10.1111/desc.12664

Fostering children's repeating pattern competencies by physical activity

Kathrin Nordemann¹ and Thomas Rottmann¹

¹Bielefeld University, Faculty of Mathematics, Bielefeld, Germany

kathrin.nordemann@uni-bielefeld.de, thomas.rottmann@uni-bielefeld.de

Keywords: Early years mathematics, pattern competencies, physical activity.

Introduction

Studies on early pattern competencies in the primary grades show a close relationship between children's competencies in this domain and their general mathematical competencies. Furthermore, several studies suggest that children's pattern competencies can be fostered by implementing patterning activities in intervention programs or in regular mathematics lessons (Lüken & Kampmann, 2018). Those interventions usually involve concrete objects or iconic representations. In contrast, the exploratory study presented in this poster focuses on physical activity to foster children's patterning abilities. This pilot study aims to develop, implement and evaluate movement games dealing with a variety of activities concerning repeating patterns.

Theoretical Background

In accordance with Lüken and Kampmann (2018) a mathematical pattern can be defined as any predictable regularity. One of the types of patterns relevant for the primary grades are *repeating patterns* with a cyclic structure, consisting of a sequence of elements (the *unit of repeat*) that is repeated indefinitely (e.g., ABAB...). A longitudinal study reported by Lüken et al. (2014) reveal a significant effect of children's repeating patterning abilities one year prior to school on their mathematical competencies at the end of grade 1. Furthermore, elaborated repeating patterning abilities are also relevant for further mathematical developments, e.g. in algebraic thinking (Warren & Cooper, 2006). Tasks and interventions are frequently based on a variety of activities, such as conceiving, reproducing, and extending repeating patterns (Warren & Cooper, 2006), often involving concrete materials. While dealing with materials solely involve fine motor activities, a higher level of motoric engagement is realised by whole-body movements. In this domain, two approaches can be distinguished: either the movement accompanies the learning process only in time, or it is directly related to the content (Bayer & Rottmann, 2018). While there is evidence of positive effects of physical activity for the learning process in general, research investigating the added value of connecting the movement to the specific content is largely missing. One of the few exceptions is the exploratory study by Bayer and Rottmann (2018), which shows an improvement of first and second graders understanding of multiplication in an intervention based on movement games.

Methodology

The exploratory study (09-10/2017) reported in this poster aimed to answer the following research question: To what extent can children's repeating pattern competencies be fostered by physical activity? Therefore, a diagnostic tool and three movement games directly related to repeating patterns have been developed and trialed in a German primary school with 19 first graders. The trial included

seven teaching units. The diagnostic tool was conducted as a paper-pencil-test in the first and the last unit in a pre- and post-test-design. It contained tasks to reproduce and extend repeating patterns with various units of repeat as well as tasks demanding to identify the unit of repeat, extrapolate a pattern and create a new one. Typical movement games from physical education (e.g. “Reversal Relay Race”) were implemented in the remaining five lessons. Each movement game focused on different activities relating to the learning content. For example, to extend a repeating pattern by physical activity in the Reversal Relay Race, children had to rerun a unit of repeat consisting of single whole-body movements like *jumping with one’s legs apart – jumping with one’s legs tightly* to move on in the gym. A reflection phase to direct children’s attention to the unit of repeat in the pattern was integrated into each game. Apart from playing the games in physical education lessons once a week, further teaching of repeating patterns did not take place.

Results and Outlook

The results of the pre- and post-test indicate a positive development of children’s repeating pattern competencies. In the pre-test, an average of 9.2 tasks (from 16 tasks in total; 58% of tasks) is answered correctly, whereas the number of successfully solved tasks increases to an average of 12.7 tasks (79% of tasks) in the post-test. It is conspicuous that there are considerable differences within the sample regarding students’ mathematical competence level. Compared to the pre-test, the group of four students with difficulties in learning mathematics demonstrated an increase of 5.25 tasks solved correctly in the post-test. Progress was related with identifying the unit of repeat, continuing and completing repeating patterns. These first results indicate a positive influence of physical activity on children’s repeating pattern competencies. However, it is still an open question to what extent this positive effect was caused by the physical activity itself, or by the respective (linguistic) reflection of the activity induced in the reflection phases following each movement game. A subsequent research project is in preparation to further investigate this question.

References

- Bayer, F. & Rottmann, T. (2018). Physical activity in mathematics education. *Learning Tech - Tidsskrift for læremidler, didaktik og teknologi*, 1(4), 66-93.
- Lüken, M.M., Peter-Koop, A., & Kollhoff, S. (2014). Influence of early repeating patterning ability on school mathematics learning. In P. Liljedahl, C. Nicol, S. Oesterle, & D. Allan (Eds.), *Proceedings of the 38th Conference of the International Group for the Psychology of Mathematics Education and the 36th Conference of the North American Chapter of the Psychology of Mathematics Education*. Vol. 4 (pp. 137–144). Vancouver, Canada: PME.
- Lüken, M.M., & Kampmann, R. (2018). The influence of fostering children's patterning abilities on their arithmetic skills in grade 1. In I. Elia, J. Mulligan, A. Anderson, A. Baccaglini-Frank & C. Benz (Eds.), *Contemporary Research and Perspectives on Early Childhood Mathematics Education. ICME-13 Monographs*. (pp. 55–66). Cham, Schweiz: Springer 55-66.
- Warren, E., & Cooper, T. (2006). Using repeating patterns to explore functional thinking. *Australian Primary Mathematics Classroom*, 11(1), 9–14.

Toddlers exploring structural elements in play

Hanna Palmér¹ and Camilla Björklund²

¹Linnaeus University & Dalarna University, Sweden; hanna.palmer@lnu.se

²University of Gothenburg, Sweden; camilla.bjorklund@ped.gu.se

The focus of this paper is on possibilities for children to discern elements of structure and to develop structural awareness through play. In Sweden, preschool is part of the education system why teaching is to be conducted. At the same time, play is to be promoted and consciously used. In this paper, we explore possibilities for the youngest preschool children (2-3-yearolds) to discern structural elements in a rule-based play. In the example, discerning structural elements becomes of importance for being able to participate proficiently in the play. As such, the example shows that a conscious use of play may promote toddlers' development of structural awareness which in turn is of importance for further mathematical learning and for their participating in the play.

Keywords: mathematizing, play, structural awareness, toddlers

Introduction

Studies show that early mathematics has positive effects on later school performance (Duncan et al. 2007; Ginsburg, 2009) but there is no consensus when it comes to *how* early mathematics is to be conducted (Palmér & Björklund, 2016). A long-time debated question is if teaching is to be integrated with or separated from children's play (Bennet, 2005) and similar to other countries there is a discussion in Sweden regarding the relation between play and teaching. In this discussion, play-oriented activities withholding mathematical content sometimes are set as a counter-pole to systematic teaching of a content. At the same time as there are researchers emphasizing a consolidation of play and teaching (Pramling & Pramling Samuelsson, 2011) there are traditions that uphold children's right to play, undisturbed by adults, for the sake of play itself (Sundsdal & Øksnes, 2015).

In this paper we will not immerse in this debate but instead focus on an example where children need to mathematize the idea of structure, to be able to participate proficiently in an ongoing play. Structural awareness has been researched by Mulligan and Mitchelmore (2013a,b) and been shown to be both salient and critical to children's mathematical learning. Mulligan and Mitchelmore (2013b) have made interventions to promote children's structural awareness. These interventions showed that teachers can plan and direct children's attention towards patterns and structures in a developmentally suitable way. In this paper we analyze an example where young children (2–3-yearolds), to be able to participate in an ongoing play, need to discern the elements of the structure of the play. Thus, the children in this example are younger than the children in the studies by Mulligan and Mitchelmore (2013b) and the setting is very different. The aim of this paper is to explore *if* the research on structural awareness by Mulligan and Mitchelmore (2013b) is applicable in this context and *how* these young children with support of their preschool teacher may discern structural elements in the ongoing play. This is of interest since such a discernment would be of value both for their possibility to participate proficiently in the ongoing play and for their further mathematical learning, as suggested by Mulligan and Mitchelmore (2013a,b).

Teaching and play

In Sweden, preschool is a non-mandatory pedagogical practice available to all children aged one to six years. Preschool is part of the education system why teaching is to be conducted (Education Act 2010:800). At the same time, play is to be promoted and consciously used in relation to children's learning (National Agency for Education, 2010). In the national curriculum it is however not expressed or exemplified *how* play is to be incorporated with children's learning.

According to van Oers (1996), the relation between teaching, mathematics and play can be seen as either "mathematics made playful" or "mathematizing elements of play" (p.74). Games in which counting, sorting and different mathematical operations are prominent are examples of mathematics made playful while mathematizing elements of play implies that the primary act is play but a teacher introduces mathematical concepts or operations into the play. The teacher's way of acting towards children's play thus have implications for how mathematics is introduced and thereby made meaningful to the children. Walsh, McGuinness and Sproule (2017) have found three different approaches towards children's play that are considered to be based on the teacher's views on play, learning and teaching. Some teachers do not participate in children's play as they think children learn and develop naturally through play why the participation of preschool teachers would primarily destroy a natural process. An opposite to this is teachers that continually interrupt children's play by asking questions, questions that seldom are meaningful in relation to the play but rather connect to different curriculum content. The third approach includes a balanced commitment to participation in children's play: not entirely child-centered or teacher-led but a balanced mix of reciprocity and listening to children's initiatives and need for support. This third approach was shown to be most successful for children's learning in the study of Walsh et al. A similar approach based on empirical studies is found in so called Developmental Education (van Oers, 2012) which has been further developed and theorized as play-responsive teaching in a recent study by Pramling et al. (in press). Both these theoretical stances emphasize a starting point in children's meaning making and a collaborative structuring (between children and teacher) of activities (for example play) that are enriched with cultural meanings (for example mathematics) in interactive processes.

Teachers who actively take part in children's play with pedagogical intentions may however do this in distinctly different ways which has been observed by Björklund, Magnusson and Palmér (2018). Some *confirm children's direction of interest*, which implies that the teacher responds to and confirms the children's initiatives and ideas. A teacher may also contribute by *providing strategies*, which is a more goal-oriented act of directing the child towards skills or tools that will help him/her master a challenge. Thus, providing strategies can be understood as the teacher providing the child with new strategies to facilitate the activity the child is involved in. If a teacher is *situating known concepts*, this implies that the teacher is applying a mathematical concept known from another situation into the play, enabling generalization of the concept. Finally, when *challenging concept meaning*, the teacher highlights or introduces a mathematical problem or concept within the play context where the child/ren need to work together in an intellectual way to solve the problem or to clarify the concept. All of these different ways to actively take part in children's play can be considered as a balanced commitment of participation (c.f. Walsh, McGuinness & Sproule, 2017) that may extend the child/ren's knowledge and may also add new value to their play.

Pattern and Structure

It is well known that preschool children can both note and construct different kind of patterns. However, it is only more recently that research has shown that children's exploration and construction of patterns may have positive influence on their general learning of mathematics (Cross, Woods & Schweingruber 2009; Mulligan, Mitchelmore, Kemp, Marston & Highfield, 2008). For example, exploration and construction of patterns offer children opportunities to discover and understand repeating structures, which in turn is fundamental for later understanding of variables, functions and algebra (Moss & Beatty, 2006).

According to Mulligan and Mitchelmore (2013a) awareness of mathematical pattern and structure is both salient and critical to mathematical learning, since effective mathematical reasoning involves the ability to note patterns and structure. They define *pattern* as involving a predictable regularity and *structure* as the way in which various elements (for example in a pattern) are organized and related. Based on studies on children aged 4-8 Mulligan and Mitchelmore (a.a) divide children's development of structural awareness into four levels. *Prestructural awareness* implies children taking notice of properties or features that appeal to them but often the properties or features are not relevant to the underlying mathematical concept. *Emergent structural awareness* implies that children start to distinguish some regularities and/or structures but they are unable to organize them appropriately. *Partial structural awareness* implies that children distinguish several patterns and/or structures but they still struggle with organizing and representing them as a whole. The forth level is *structural awareness*, which implies that the children correctly organize and represent a given structure. In the studies by Mulligan and Mitchelmore (a.a) the children's structural awareness were consistent across tasks and the level of structural awareness correlated with the children's mathematical performance. In later studies, Mulligan and Mitchelmore (a.a) added a fifth level, *advanced structural awareness*, implying children being able to generalize underlying features between contexts.

Based on the above, Mulligan and Mitchelmore (2013b) have made interventions to promote children's structural awareness. These interventions show that teachers can plan and direct children's attention towards patterns and structures in a developmentally suitable way. When children in their interventions had developed structural awareness they learned basic properties of number, space and measurement more easily and they also made more connections between numerical, measurement and spatial mathematical ideas. There are few studies on structural awareness among preschool children below three years but there are examples of an emerging senses of structure and internal relations expressed when children are allowed to explore materials and activities in play-based manners or with guidance (Björklund, 2016), relationships that however may not always be based on logic but on the child's own experiences and intuitions (Björklund, 2014).

The Study

The empirical material in this paper stems from a larger research project [1] aiming to investigate the teaching-play relation in Swedish preschool practice. Data for analysis consists of teachers' self-collected video-documentations where the teachers together with their preschool children are engaged in different kinds of play. Only children with written consent from their legal guardians (in accordance with ethical guidelines from the Swedish Research Council, 2017) participate in the video-documented activities. For this particular study, one video-documentation is chosen as it

contains a teacher initiated rule-based play where certain acts and roles are necessary to comprise. To participate proficiently in the play it becomes important to discern certain structural elements. Because the play contains repeated parts of actions, it is possible to gain a comprehensive understanding of the complexity of the play and the necessary skills that are needed to conduct the play. Thus, the example is information-orientated aiming to maximize the utility of information from small selection (Flyvbjerg, 2006). In the analysis we explore how the youngest preschool children (2-3-year-olds) discern structural elements in the play. We also explore if Mulligan and Mitchelmore's (2013a) four levels of structural awareness is possible to apply on a situation quite different from the situations in their studies. In their studies, the analysis is based on children's written documentations and the level of structural awareness is set in relation to different mathematical concepts. In this paper the analysis will be based on children's actions in the play and the level of structural awareness is set in relation to children's discernment of the structural elements in the play.

In the following section the example will first be presented divided into 7 episodes. Each episode constitutes a part of the play where the teacher and the children initiate an act and follow it through. These episodes are then analysed through thematic analysis (Braun & Clarke, 2006) to identify themes or patterns in the observed activity that are interpreted in accordance with a theoretical framework; in this case the levels of structural awareness (Mulligan and Mitchelmore, 2013a).

Discerning elements of structure – an example

Three boys and one girl, aged 2 and 3, are to play *hide the key* with their preschool teacher. Instead of a key they have a green toy dragon that is to be hidden. It is a new play for the children and to be able to participate proficiently in the play the children need to discern the elements of structure in the play. The video-documentation is ten minutes long and will be presented and discussed through 7 episodes where the children are called boy 1, boy 2, boy 3 and girl 1.



Figure 1: Picture of the room where the play is conducted. The door is in the upper corner.

Episode 1: The children are standing outside the room while the teacher hides the dragon behind a basket standing under a shelf. She opens the door, sits down and says that she has hidden the toy dragon *far down, not high up*. She emphasizes *down* and *high* by movements with her hand. The children are then encouraged to start looking for the toy dragon. Boy 1 finds the toy dragon before the others have even started their search.

Episode 2: The teacher says that now the child who found the toy dragon is to hide it, that he can hide it *far down* or *high up* but he should wait until the others are outside the room. Boy 1 who is to hide the toy dragon is left alone in the room. He is standing in the middle of the room holding the toy dragon in his hand up towards the ceiling. He says “high up”. After a little while the teacher opens the door to ask if he is finished.

Teacher: Can I help you?

Boy 1: I hide it up. (stretches his hand with the dragon towards the ceiling) I hide it head.
 Teacher: In the ceiling?

The teacher takes the toy dragon and hides it high up (not visible where in the video). The boy opens the door and the other three children instantly run to the previous hiding place. The teacher says to the boy who has hidden the toy dragon not to tell where it is hidden but to tell if it is hidden far down or high up. Boy 1 then looks up and points towards the hiding place.

Episode 3: Boy 2 is in turn to hide the toy dragon and he shows with his hands that he wants to hide it far down. The teacher helps him to find a hiding place behind some big pillows under a table (to the right in Figure 1). After he has opened the door to let the other children in he himself directly walks to the hiding place and points towards the toy dragon. The girl follows him and takes the toy dragon but then boy 2 gets angry. Boy 3 does not take notice of them but instead searches at the first hiding place. While the teacher explains to boy 2 that it is now the girls turn to hide the toy dragon the girl walks out and closes the door. The teacher goes after her telling that she should stay inside because it is now her turn to hide the toy dragon. Then the girl takes the toy dragon and before the other children has had time to leave the room she puts it on same shelf as the first hiding place. Boy 1 and 2 leave the room by themselves and the teacher walks boy 3 out of the room.

Episode 4 When all three boys are outside the room, the girl again hides the toy dragon on the same shelf as the first hiding place. Then she walks to the door. It seems like she is going to go out and close the door but the teacher stops her and asks her to let the other children in and tell them that the toy dragon is hidden *quite far down*.

Episode 5: Boy 3 is to hide the toy dragon and he chooses the same hiding place as in episode 1 and 4. He himself also “finds” the toy dragon immediately afterwards, before letting the other children into the room. The teacher explains that he instead should let the other children into the room. When he does, they go directly to the hiding place.

Episode 6: Boy 1 says that it is now his turn to hide the toy dragon. The girl immediately goes out of the room and the other two boys follow her. The teacher tells boy 1 that he is to hide the toy dragon in a new place and she emphasizes *far down* and *high up*. She also tells him not to tell the others where it is hidden. He hides the toy dragon at a new place under a box standing on the floor. When he lets the other three children into the room they directly run to the previous hiding place. When the toy dragon is not there they seem to get a little confused. They start to look at other places but find the toy dragon first after some guidance from the teacher.

Episode 7: Boy 2 is about to hide the toy dragon and he chooses the same hiding place as in episode 1, 4 and 5. The teacher tells him not to tell the others where it is hidden but to tell them if they should look *far down* or *high up*. When the children are let into the room the boy himself runs to the hiding place and “finds” the toy dragon. As the teacher tries to explain for him that it was the others who were to search for the toy dragon the girl walks outside the door.

Analysis - structural awareness in the play

According to Mulligan and Mitchelmore (2013a) *structure* is the way in which various elements are organized and related. To make use of a structure the child needs to recognize the internal relationship

between the elements. In the “hide the toy dragon play” there are various elements that form the structure of the play that the child has to discern and relate to other necessary elements:

- choose between two options of hiding positions: far down or high up
- all but one should leave the room and close the door when the toy dragon is to be hidden
- only the one who is to hide the toy dragon can stay in the room
- the hiding place should be different from the previous turn
- after hiding the toy dragon the door is to be opened and all children gather inside the room
- when being let into the room you are to search for the toy dragon
- if you have hidden the toy dragon you are not to tell where it is hidden but indicate with spatial instructions “high up” or “down low”
- the one who finds the toy dragon is in turn to hide it the next time
- all children are to hide the toy dragon once which is not an element of the play but connected to fairness

During the play the children successively distinguish some of the elements above but they are unable to organize them appropriately which is labeled as *emergent structural awareness* by Mulligan and Mitchelmore (2013a). For example, all children know that they should search for the toy dragon when they enter the room (observed in all episodes). However, mostly they start to search at the same hiding place as the previous turn (episode 2, 3, 5, 6) and boy 3 “finds” the dragon when he is “the hider” (episode 5). Often they also hide the toy dragon at almost the exact same place as the teacher did in episode 1 (episode 3, 4, 5). The element of leaving the room after the toy dragon has been found is not discerned by boy 3. Instead, the teacher takes his hand and walks him to the door each time (for example episode 3). This element is however immediately discerned by the girl who very quickly leaves the room each time the dragon has been found. On the other hand, she does not recognize the specific circumstances of being the “hider” to which this element does not apply, which is shown as she leaves the room when she is the one who found the dragon and thus in turn to enact the hiding element (episode 3). The girl has discerned that one is to leave the room after the toy dragon has been found but has not yet discerned the internal relationship of being a hider and a searcher, a role that in turn is determined by who found the dragon. Thus, one issue that increases the difficulty in discerning the elements of the structure in the play is that the structure’s internal relationships change when you are the one who finds the toy dragon. Another expression of this complex relationship is shown when the boys in episode 3 and 7 “finds” the toy dragon they themselves have hidden.

Discussion

Mulligan’s and Mitchelmore’s (2013b) interventions showed that teachers can plan and direct children’s attention towards patterns and structures. The children in our study are younger and the setting is very different why we in the analysis explored possibilities for the youngest preschool children (2-3-yearolds) to discern structural elements based on an ongoing play. We also explored if the four levels of structural awareness is possible to use when analysing a play situation. Even though the teacher’s mathematical focus initially seems to be on *far down* and *high up* she *provides strategies* (c.f. Björklund et al., 2018) for the children to discern elements of structure. The example illustrates that elements of structure is possible for children to discern within play if a teacher provides strategies for this. The example also indicates that *emergent structural awareness* starts to develop among children younger than those in the studies by Mulligan and Mitchelmore. The notion of *mathematizing*

implies a process where mathematics becomes of importance when children explore different phenomena (Freudenthal, 1968). The example in this paper can be seen as mathematizing structural elements of play (van Oers, 1996), not in the sense that the teacher tries to introduce mathematical concepts or operations into the play but instead in the sense the teacher tries to make visible mathematical elements of the play. By repeating the play several times children's discernment of important features becomes visible. It also becomes visible how the teacher has an important role in this discernment process. The teacher shows a balanced commitment in the play (Walsh, McGuinness & Sproule, 2017), with a mix of reciprocity and listening to children's initiatives and need for support. Considering the emphasis in the Swedish curriculum on play as a way to teach and learn in preschool, this study broadens our knowledge of how discerning structural elements becomes of importance for children to be able to participate proficiently in rule-based play. While Mulligan's and Mitchelmore (2013a,b) have shown that structural awareness is both salient and critical to children's mathematical learning the analysis in this paper indicates that structural awareness may start to develop among children even younger than previously thought and in situations not obviously labelled as mathematical.

[1] The study is funded by the Swedish Institute for Educational Research, grant no. 2016/112.

References

- Björklund, C. (2014). Klassificering och mönster – förskollärares intentioner och småbarns initiativ. *Tangenten*, 3, 35–43.
- Björklund, C. (2016). Playing with patterns – conclusions from a learning study with toddlers. In T. Meaney, O. Helenius, M. Johansson, T. Lange & A. Wernberg (Eds.), *Mathematics Education in the Early Years. Results from the POEM2 Conference*. (pp. 269–287). Cham, Switzerland: Springer.
- Björklund, C., Magnusson, M., & Palmér, H. (2018). Teachers' involvement in children's mathematizing – Beyond dichotomization between play and teaching. *European Early Childhood Education Research Journal. Special issue 'Mathematics in the EY'*, 26(4), 469–480. DOI: 10.1080/1350293X.2018.1487162
- Braun, V. & Clarke, V. (2006). Using thematic analysis in psychology. *Qualitative Research in Psychology*, 3(2), 77–101. DOI: 10.1191/1478088706qp063oa
- Cross, C.T., Woods, T.A., & Schweingruber, H. (2009). *Mathematics learning in early childhood: Paths toward excellence and equity*. Washington, DC: The National Academies Press.
- Duncan, G.J., Dowsett, C.J., Claessens, A., Magnuson, K., Huston, A.C., Klebanov, P., Pagani, L. S., Feinstein, L., Engel, M., Brooks-Gunn, J., Sexton, H., Duckworth, K., & Japel, C. (2007). School readiness and later achievement. *Developmental Psychology*, 43(6), 1428–1446.
- Education Act* (2010:800). Stockholm: Ministry of Education and Research.
- Flyvbjerg, B. (2006). Five misunderstandings about case-study research. *Qualitative inquiry*, 12(2), 219–245. DOI: 10.1177/1077800405284363

- Freudenthal, H. (1968). Why to teach mathematics as to be useful? *Educational Studies in Mathematics*, 1(1), 3–8.
- Ginsburg, H.P. (2009). Early mathematics education and how to do it. In O.A. Barbarin & B.H. Wasik (Eds.), *Handbook of child development and early education: Research to practice*. (pp. 403–428). New York, NY: The Guilford Press.
- Moss, J. & Beatty, R. (2006). Knowledge building in mathematics: Supporting collaborative learning in pattern problems. *International Journal of Computer-Supported Collaborative Learning*, 1(4), 441–465. DOI: 10.1007/s11412-006-9003-z
- Mulligan, J. & Mitchelmore, M. (2013a). Early awareness of mathematical pattern and structure. In L.D. English & J.T. Mulligan (Eds.), *Reconceptualizing early mathematics learning*. (pp. 29–45). New York, NY: Springer.
- Mulligan, J. & Mitchelmore, M. (2013b). Reconceptualizing early mathematics learning. The role of pattern and structure. In L.D. English & J.T. Mulligan (Eds.), *Reconceptualizing early mathematics learning*. (pp. 47–66). New York, NY: Springer.
- Mulligan, J., Mitchelmore, M., Kemp, C., Marston, J., & Highfield, K. (2008). Encouraging mathematical thinking through pattern and structure. An Intervention in the first year of schooling. *APMC, Australian Primary Mathematics Classroom*, 13(1), 10–15.
- National Agency for Education (2010). *Curriculum for the Preschool Lpfö98*. [Revised 2010.] Stockholm, Sweden: National Agency for Education.
- Palmér, H. & Björklund, C. (2016). Different perspectives on possible – desirable – plausible mathematics learning in preschool. *Nordic Studies in Mathematics Education*, 21(4), 177–191.
- Pramling, N., Wallerstedt, C., Lagerlöf, P., Björklund, C., Kultti, A., Palmér, H., Magnusson, M., Thulin, S., Jonsson, A. & Pramling Samuelsson, I. (in press). *Play-responsive teaching in early childhood education*. Springer.
- Pramling, N. & Pramling Samuelsson, I. (Eds.) (2011). *Educational encounters: Nordic studies in early childhood didactics*. Dordrecht, The Netherlands: Springer.
- Sundsdal, E., & Øksnes, M. (2015). Til forsvar for barns spontane lek. *Nordisk tidskrift for pedagogikk og kritikk*, 1, 1–11. DOI: 10.17585/ntpk.v1.89
- Swedish Research Council (2017). *God Forskningssed. [Good research practice]* Stockholm, Sweden: Vetenskapsrådet.
- van Oers, B. (1996). Are you sure? Stimulating mathematical thinking during young children's play, *European Early Childhood Education Research Journal*, 4(1), 71–87.
- van Oers, B. (2012). Developmental education: Foundations of a play-based curriculum. In B. van Oers (Ed.), *Developmental education for young children. Concepts, practice and implementation* (pp. 16–26). Dordrecht, The Netherlands: Springer. DOI: 10.1007/978-94-007-4617-6
- Walsh, G., McGuinness, C., & Sproule, L. (2017). It's teaching ... but not as we know it': Using participatory learning theories to resolve the dilemma of teaching in play-based practice. *Early Child Development and Care*. [pre-publ. online] DOI: 10.1080/03004430.2017.1369977

What can five-, six- and seven-year-olds tell us about the transition from mathematics in kindergarten to that in school in Norway?

Geir Olaf Pettersen and Monica Volden

UiT The Arctic University of Norway, Norway; geir.olaf.pettersen@uit.no, monica.volden@uit.no

As we grow from small children to adults, we experience several transitions. This paper focuses on children's voices on the transition from mathematics in kindergarten to that in school. What are their thoughts on going from one institution to another with a different curriculum, culture and values regarding mathematical learning? This paper reports answers from focus group interviews with children, ages five, six and seven, about mathematical learning. The study was situated within a research and development project SUM at UiT The Arctic University of Norway. The findings show that even though the transition is clear for teachers, both in kindergarten and school, we need to discuss how to present mathematical activities to children such that these activities help to ease the transition from one level of education to another.

Keywords: Mathematics, kindergarten, transitions, school.

Introduction

The transition to school is one of many transitions that children experience during childhood, youth and adolescence. First, they undergo the transition from home to kindergarten. In Norway, we use the term kindergarten for institutions providing early childhood education and care for children from ages one to five years. Next, they experience the transition from kindergarten to school and therefore go from one institution to another, which have different curricula. Finally, the transition to higher education and/or work occurs.

This study was situated within a research and development project called SUM (Blomhøj, 2016) – the acronym for the Norwegian title of the project, *Sammenheng gjennom Undersøkende Matematikkundervisning*. SUM focus on five transitions in the educational system. These are Kindergarten => Primary school => Middle school => Lower secondary => Upper secondary => University. At all five transitions students typically experience a discontinuity in their mathematics teaching. For each transition, a group of teachers and researchers will design, test and evaluate inquiry based mathematical activities. One assumption in SUM is that inquiry based mathematics education (IBME) can help students to explore the transitions as more continuous and transparent. IBME can be seen as a way to motivate students to learn mathematics through investigation in and with mathematics (Artigue & Blomhøj, 2013). Consequently, it is necessary to listen to the students voices on both mathematical activities and how they explore the transitions.

This paper presents children's descriptions of mathematics and mathematical activities in kindergarten versus school, and their thoughts about the differences going from kindergarten to school. Do we as professional teachers take some aspect of the transition for granted? Accordingly, our research question was as follows: *What can children, ages five, six and seven, tell us about mathematics in kindergarten and in school and the transition between these institutions?*

Theoretical background

Transitions have been recognised as a challenge for children. Einarsdóttir (2007) reports that children characterise preschool and first grade in similar ways. They expect a change from more free play in preschool to more academic work in primary school. According to Hogsnes and Moser (2014), kindergarten teachers and schoolteachers agree on the importance of children experiencing a connection in the transition to school and it being well-defined. However, Hogsnes and Moser also stress that the transition will have to represent some changes. The children also expect this distinction, as Einarsdóttir (2007) finds. Further, Hogsnes and Moser (2014) argue that one way of making the connection is to allow children to present in school something in which they were involved in kindergarten. Almost 70% of the kindergarten teachers in their study see this presentation as important, whereas 60% of the schoolteachers find it somewhat important or unimportant.

The Framework Plan for Kindergartens (Kunnskapsdepartementet, 2017) defines the content and tasks for kindergarten in Norway. The core values of kindergarten shall be “promulgated, practised and manifest in every aspect of a kindergartens pedagogical practices” (p. 7). This means that play and the children’s initiative are important parts of the curriculum. The framework is structured on the basis of learning areas instead of traditional subjects. For mathematics, the learning area is called *quantities, spaces and shapes* and is based on Bishop’s six mathematical activities. Regarding the transition, the Framework Plan states that “working in partnership with the parents, the kindergarten shall ensure that the child has a safe and good transition from kindergarten to school” (p. 33).

Bishop (1988) defines six universal mathematical activities – namely, *counting, locating, measuring, designing, playing* and *explaining*. For these six activities to provide a useful structure to help children experience a successful transition into formal mathematics, he argues that it is necessary to embed them in the value-laden frameworks of the classroom (Bishop, 2016). Bishop presents six value clusters, grouped into three sets of complementary pairs. The first pair is *ideology: rationalism and objectism*. Argument, reasoning, logical analysis and explanation are all aspects of *rationalism*. Encouraging students to search for different ways to symbolise and represent ideas falls under the value of *objectism*, as does appreciating and creating mathematical objects. The second pair is *sentiment: control and progress*. *Control* involves rules and prediction. Valuing control means emphasising not just the correct answer but also the checking of answers and explaining why other answers are not correct. *Progress* concerns how mathematical ideas grow and finding alternative and non-routine solutions. This value also contains individual liberty and creativity. The third and last pair is *sociology: openness and mystery*. Valuing *openness* means appreciating sharing and defending answers in class. A good practice is asking students to explain their ideas to the whole class. Valuing *mystery* means promoting thinking about the origin and nature of knowledge. This can be done by telling stories about old mathematical puzzles and searches for negative numbers and zero. Bishop (2016) concludes that values in preschool and school are not the same and we must be conscious of the differences.

In the curriculum for the common core school subject of mathematics (Kunnskapsdepartementet, 2013), the focus in years 1–4 is on numbers, geometry, measurements and statistics. After years 2 and 4, competency goals are formulated. Regarding the curricula for school and the Framework Plan

for Kindergartens, there are some important differences to note. The most obvious difference is between the competency goals in school and more process-oriented goals in kindergarten. This also means that there are cultural and value differences between these Norwegian institutions. However, both plans emphasise the importance of explorative, playful, creative and problem-solving activities, which is also the aim for the SUM project.

Developing the IBME theoretical framework in order to address challenges in transitions is the focus in the SUM project (Blomhøj, 2016). The teachers and researchers jointly designed two inquiry based mathematical activities. Both activities followed the phases from inquiry-based mathematics education (Artigue & Blomhøj, 2013). However, since this was the first year of the SUM project, the emphasis was on phases one, *setting the scene*, and two, *students' investigative work*. The teachers in school and kindergarten tested the activities. The aim of the activities in SUM is to investigate if and how they can contribute to a transparent transition.

The first activity involved a tangram. The given introduction was the story about how Tan wanted to impress the emperor. Then the children had to conduct the investigative work of determining ways of putting the tangram into different figures. The progress differences from kindergarten to school were visible through the focus on visualisation in kindergarten and on properties and counting edges in school. The second activity involved word problems and early arithmetic. Here, the introduction was aimed at creating a story that could make room for word problems. The jointly developed story was about a bus, and the focus was passengers who got either on or off the bus at bus stops or stories from inside the bus. An example is as follows: “There are seven seats in the bus. Three are taken. How many are free?” One group of kindergarteners created a story about a human-like creature from Sami folklore, Stallo, who likes to eat people.

Data collection and analysis methods

Data were collected using focus group interviews with eight groups from kindergarten and elementary school (Cohen, Morrison, & Manion, 2007). There were four groups from two different kindergartens (age 5), two groups from year 1 of school (age 6) and two groups from year 2 of school (age 7). In total, 13 children from kindergarten and 12 schoolchildren participated. We used convenient sampling for selecting the participating children. All interviewed children are participants in the SUM project. The argument for including also second graders (age 7) was that they in general have more developed language. The interviews were semi-structured and the questions were based on different aspects of mathematics from the SUM project. Each interview began with the same question: “What is mathematics (about)?” Subsequent questions concerned what they do when they do mathematics; whether we need mathematics (and for what); whether they find mathematics interesting; and how to be good at mathematics. Some questions differed for children in kindergarten and those in school. The kindergarteners were asked what they thought mathematics would be like in school. Conversely, the schoolchildren were asked what mathematics they had done in kindergarten. In addition, we brought tangrams to the kindergarten interviews to help the children remember the activities from SUM. The schoolchildren were asked to show examples of mathematics on paper.

The interviews were video-recorded and transcribed to the written Norwegian standard bokmål, and then translated into English. NVivo 12 was used to analyse the data. For each question in the

interview, we coded the answers and created categories. E.g. for the first question “What are mathematics about?” the categories were counting, calculating, numbers, shapes, measurement and others, like homework. The presented excerpts are to be seen as anchor examples of the categories.

Interviewing children can be challenging also due to which term to use. The term mathematics was challenging because the children did not seem to use the term themselves or have a full understanding of it. However, we clarified the term together with the children. We therefor used the term in the rest of the interview.

Results

This section will present and discuss our findings from the interviews. The section is structured according to the interview questions.

What is mathematics about?

When asked what mathematics is about, most of the kindergarteners were silent or said that they did not know. After some consideration, two children answered that mathematics is about counting and adding things together. Some children also answered making movies, reading and homework.

To move the interview along, the interviewer proposed that mathematics could be about doing arithmetic. In the curriculum in Norway the term calculate is used as a synonym for doing arithmetic. The children then said that they knew about calculation. John said, “Calculation is about doing homework”. However, what he meant by “calculation” was unclear, because he later said he added letters. Olivia said that she had heard about mathematics because her older sister was doing mathematics; however, she did not clarify what she meant by “doing mathematics”.

The picture gleaned from the schoolchildren’s interviews is more diverse. Some of the six-year-olds were not familiar with the term mathematics, but the most common answers were counting and calculating numbers, followed by shapes and measurements.

In terms of children’s understanding of mathematics, some differences between the children in kindergarten and the schoolchildren are evident. The children in kindergarten gave in addition examples of activities like making movies, reading and colouring. These are not typically mathematical activities but can include and give children experience with mathematics.

Do we need mathematics?

When asked if we need mathematics, most kindergarteners and schoolchildren answered yes, but their answers differed somewhat. One group of kindergarteners said that there was no need for mathematics in kindergarten because they were so young. The following example is from an interview in a kindergarten:

John	Because we then know what to do in school.
Interviewer	Do we need mathematics outside of school?
John	Maybe
Olivia	Yes

Interviewer When do we need mathematics?

John Because we try to learn all the things we are going to do at school.

Interviewer What do you think, Olivia? When we are not at school, you said we need mathematics. When do we need it?

Olivia I do not know. I am not thinking about it. I am just thinking about butterflies.

John said, “Because we then know what to do in school”. Then the interviewer asked if we need mathematics outside of school. John did not really answer this question; instead, he returned to his original statement about knowing what to do at school. When Olivia was directly asked about mathematics outside of school, she replied, “I am just thinking about butterflies”. This may indicate a lack of interest in mathematics, at least in the interview situation.

The schoolchildren agreed with the kindergarteners that mathematics is not necessarily required in kindergarten. However, they gave more examples of situations where we need mathematics – namely, shopping, readiness for work and to carry out mathematical tasks. The following excerpt is from an interview with seven-year-olds.

Interviewer Why is it wise?

Lucy Because it is easier to go shopping

Kate and, if someone gives you a math task

Lucy It is wise to know.

Lucy argued that we need to know mathematics because it is wise to know in order to go shopping. According to the schoolchildren, this is the most common situation where we need mathematics. Kate’s statement, “and, if someone gives you a math task”, may indicate that mathematics is something you only need in school.

How to be good at mathematics

In general, the kindergarteners and schoolchildren said that practising and working with mathematics can make you good at mathematics. They also considered homework as a significant factor.

Interviewer How can you be good at mathematics?

Lucy We have to practise and make mistakes

Kate Yes

Sarah You can learn from your mistakes

...

Interviewer In what way can you learn from others?

Lucy If you have an older brother or sister, you can learn mathematics.

Interviewer Can you learn from students in your class?

Lucy Yes

Lucy (age 7) started by stating that you need to practise, but also that you can learn from your mistakes. Sarah and Kate agreed with that statement. Learning from mistakes places the focus on finding one right answer, but also that a wrong answer can lead to an opportunity to learn. Instead of focusing on correct answers, the children in kindergarten were more focused on doing mathematics.

What do you do in kindergarten and how do you expect it will be in school?

The kindergarteners said that the mathematics they were doing was mostly about counting, arithmetic and shapes. They also mentioned making movies and baking as mathematical activities.

In the interviews, we asked the children directly about the activities in SUM.

Interviewer Do you remember what you have been doing? Have you done *Formjakt* (an activity that entails looking for different shapes)?

Audrey No, we did the bus

Interviewer What was that about?

Audrey It was about counting.

“We did the bus” is a reference to the word problem activity in SUM. The children remembered the activity and clarified that it was about counting.

Audrey and we have put shapes together

Audrey and we remember the man who made a nice gift and...

Leah ... then he fell on the steps. And then...

Audrey ... we had to build it up again.

Audrey But it was just a story.

Audrey and Leah showed that they remembered the story about Tan. Even though their initial response was that they did not remember, without help from the interviewer they recalled important actions from the story. They also remembered that they had to put it all together. We can identify both the setting of the scene and investigative work components of the activity from SUM. In the last statement, Audrey clarified that overall, it was just a story.

In the kindergarten where the setting of the scene was about the Sami creature Stallo, we wanted to see if the children remembered the activity. They confirmed with “mm”, meaning yes.

Interviewer Maybe I could create a word problem

Sophie I can make one. Once upon a time there were three bears sliding down a hill. And at the bottom of the hill, there was Stallo.

This is a clear reference to the activity. Sophie could recall the situation and was able to create the beginning of a word problem. The reason why she referred to bears instead of children is most likely that we had introduced counting bears in the interview. It is quite challenging to create a word problem on the fly and in an interview like this. We recognised this as a sign that they had remembered the activity and had gained experience from the first two phases. Regarding the children’s expectations

of what mathematics would entail in school, they emphasised learning about numbers and doing arithmetic.

What do you do in school and how is it compared to kindergarten?

Concerning this question about mathematics in school, it became apparent that the schoolchildren could name more mathematical activities, including discussions and playing games. However, they still mostly brought up activities like calculating numbers, working with shapes and using textbooks or worksheets.

They did not remember much about their experience of mathematics during kindergarten. As Lucy said, “No, I think maybe in the last year. Sometimes, maybe once. We gathered to do worksheets – math worksheets – very easy tasks”. Several children mentioned easy tasks in kindergarten as things they remembered. For example, Ryan (7 years old) said the following:

Interviewer Do you find the mathematics in kindergarten simple?

Ryan Yes

Interviewer Do you find the mathematics in school hard?

Ryan It was not so easy in kindergarten either, because we were much younger. Then it was the same as we have it now, in kindergarten.

First, he claimed that mathematics in kindergarten is easy. After the interviewer followed up this statement, he did not directly answer the question, but gave a reflection on learning.

Discussion and implications

First, we wish to discuss the content of, and the need for, mathematics as children see it. Our data show that children in kindergarten, in general, are not familiar with the term mathematics. Sæbbe and Samuelsson (2017) offer a possible explanation: most kindergarten teachers avoid using the term mathematics when they engage children in mathematical activities. According to the kindergarten teachers, they are afraid that the activities could be regarded as boring and “schoolish”.

In the curricula for both kindergarten and school, mathematics is about helping children understand the world. Although the aim is to prepare the children for developing a broader understanding of mathematics, our data show that the kindergarteners and schoolchildren had a narrow understanding of mathematics, viewing it mostly as being about doing something with numbers, shapes and counting. The schoolchildren, however, also talked about subjects in mathematics.

Significantly, according to Bishop (2016), the values in school and kindergarten are different. Lucy said that you can learn from your mistakes. This could indicate a focus on checking answers and knowing why an answer is not right, similar to Bishop’s *control* value. At the same time, children in kindergarten have a strong focus on doing – hence, *progress*. This could be an indication of the distinction between the process aim in the kindergarten curriculum and the competence aim in the school curriculum.

When we asked about doing mathematical activities, the kindergarteners and schoolchildren gave more detailed examples. It is clear from our data that the children remembered activities from SUM,

but did not necessarily see them as mathematical. This raises some new questions regarding the transition to school. Is mathematics a Trojan horse, as Fosse et al. (2018) claims? Does the term mathematics scaffold the transition or is it an obstacle? One way to investigate this further would be through projects like SUM. In SUM, the goal is to develop enquiry-based activities that follow the curricula and cultures of both kindergarten and school. Our data suggest that activities may be the missing link in order to make the transition more transparent. Our findings also imply a need for a discussion on how to present activities so that children have the opportunity to discover the mathematical ideas regardless of whether the term mathematics is used.

References

- Artigue, M. & Blomhøj, M. (2013). Conceptualizing inquiry-based education in mathematics. *ZDM*, 45(6), 797–810.
- Blomhøj, M. (2016). *SUM: Coherence through inquiry based mathematics teaching – project description*. Retrieved from <http://site.uit.no/sum>
- Bishop, A. J. (1988). Mathematics education in its cultural context. *Educational Studies in Mathematics*, 19(2), 179–191.
- Bishop, A. J. (2016). Can values awareness help teachers and parents transition preschool learners into mathematics learning? In T. Meaney, O. Helenius, M. Johansson, T. Lange, & A. Werberg (Eds.), *Mathematics education in the early years* (pp. 43–56). Cham, Switzerland: Springer international Publishing.
- Cohen, L., Morrison, K., & Manion, L. (2007). *Research methods in education*. London, England: Routledge.
- Einarsdóttir, J. (2007). Children's voices on the transition from preschool to primary school. In A.-W. Dunlop & H. Fabian (Eds.), *Informing transitions in the early years* (pp. 74–91). Maidenhead, England: Open University Press.
- Fosse, T., Lange, T., Lossius, M. H., & Meaney, T. (2018). Mathematics as the Trojan horse in Norwegian early childhood policy? *Research in Mathematics Education*, 20(2), 1–17.
- Hogsnes, H. & Moser, T. (2014). Forståelser av gode overganger og opplevelse av sammenheng mellom barnehage, skole og sfo. *Tidsskrift for Nordisk Barnehageforskning*, 7(6), 1–24. <https://doi.org/10.7577/nbf.625>
- Kunnskapsdepartementet. (2013). Curriculum for the common core subject of mathematics (Mat1-04). Oslo, Norway: Utdanningsdirektoratet. <https://www.udir.no/kl06/MAT1-04?lplang=http://data.udir.no/kl06/eng>
- Kunnskapsdepartementet. (2017). *Rammeplan for barnehagens innhold og oppgaver* [Framework plan for Kindergartens – contents and tasks]. Oslo, Norway: Utdanningsdirektoratet. <https://www.udir.no/globalassets/filer/barnehage/rammeplan/framework-plan-for-kindergartens2-2017.pdf>
- Sæbbe, P. E. & Samuelsson, I. P. (2017). Hvordan underviser barnehagelærere? Eller gjør man ikke det i barnehagen? *Tidsskrift for Nordisk barnehageforskning*, 14, 1–15.

Inquiry-based implementation of a mathematical activity in a kindergarten classroom

Chrysanthi Skoumpourdi

University of the Aegean, Rhodes, Greece; kara@aegean.gr

Although inquiry-based education is an approach that supports student-centered ways of teaching involving students in the development of their own learning, it seems that inquiry-based instruction has not been employed broadly in the subject area of mathematics and the few studies that have been conducted are not focused on very young children. In this paper an inquiry-based implementation of a mathematical activity in a kindergarten classroom is presented investigating the way it was applied by the teacher and the way students participated into it. The activity was related with plane geometrical shapes as a mathematical construct that cause difficulties to young students. From the results it emerged that even though the inquiry-based implementation is a demanding approach it had many benefits for both teacher and students.

Keywords: Inquiry-based education, early childhood education, mathematical activity, plane geometrical shapes.

Introduction

A mathematical construct that cause difficulties to young students is the plane geometrical shapes. It is a concept that needs to be communicated multimodally (Clements & Sarama, 2007), because their iconic representations need ‘observation’, ‘reading’ and parallel ‘description of this reading’ in order to be understood (Skoumpourdi, 2016). The ‘observation’ factor has to do with shape’s visual perception. The ‘reading’ factor is focused on shape’s figural properties. The ‘description of this reading’ factor requires the description/communication of the above. The above three factors can help students face their difficulties, so as, to develop gradually the shape’s concept, but through the appropriate teaching method, since, geometrical thinking is main influenced by instruction.

Inquiry-based teaching is a theoretical approach that supports more student-centered ways of teaching. It is an approach that actively involves students in the development of their own learning supporting their active participation to the teaching/learning process. But, the effects of inquiry-based teaching remain limited and the inquiry-based education has been slow in mathematics due to several reasons such as the very low attention that has been paid to that approach, the imprecise definition of the approach, as well as, the peculiarities and the demands that are required for its adoption and promotion.

Taking the above into consideration an educational design research study is conducted, aiming to investigate how teachers and students adopt and apply the inquiry-based approach in the mathematics classrooms. In this paper an inquiry-based implementation of a mathematical activity related with plane geometrical shapes in a kindergarten classroom is presented investigating the benefits and the demands of such an implementation in order to design the gradual adoption of the approach in the subsequent educational levels. The research questions were the following: 1. How the teacher implements a mathematical activity related to plane geometrical shapes, in a kindergarten classroom,

grounded on the inquiry-based approach? 2. How the students participate in the inquiry-based implementation of a mathematical activity related to plane geometrical shapes?

Geometrical Shapes in the Kindergarten

Kindergarten children identify and describe shapes through levels. The first one is the pre-recognition level (Clements & Sarama, 2007), in which children may recognize only a subset of a shape's visual characteristics. In this level, children cannot distinguish the basic shapes from their counterexamples. The other levels are the first two of Van Hiele's levels of thought (Yin, 2003). At the first one, 'visualization', children identify shapes according to appearance and cannot form mental images of them. At the second level, 'analysis', children start analyzing and naming properties of geometric figures. They use shapes' properties to recognize and characterize shapes.

Circle, square, triangle and rectangle, when represented in a prototype way can be recognized and named by kindergarten children. Shape's features and whether they can be defined (closeness, straight sides and exact number of sides) or not (orientation, position, sides' length and angles' size) influence the accuracy of children recognitions (Satlow & Newcombe, 1998). Young children identify circles accurately, they are less accurate in identifying triangles and their average accuracy for rectangles is low (Clements & Sarama, 2007).

Children in the age of five-years-old have a difficulty in describing shapes. The language that children use to describe shapes is gradually developed (Clements & Sarama, 2007). Initially they answer the question "what shape?" with the use of just a word, the shape's name. Then they match this word with specific shape examples. After that, they combine the correct shapes' names with the prototypical examples of the shapes. When children are asked to explain their decision, they are induced to describe shapes' features, using, initially, a subset of the shape's visual characteristics, such as the quantity and the size of sides (Yin, 2003). Although children's primary descriptions may include various terms and attributes they usually base these descriptions in the comparison with the specific shape's representation. Later, children become more capable of distinguishing attributes and adding to their descriptions other visual-spatial elements like right angles.

Children's written schematisation for a circle is something closed and 'rounded', for a square something closed with almost equal sides and nearly right angles, for triangle something closed and 'pointy' and for a rectangle something closed with 'long' like-parallel sides (Clements & Sarama, 2007).

Instruction influences the development of geometric thinking more than age does (Van Hiele, 1986). But in traditional geometry programs, during formal and informal instruction, little emphasis is given on understanding plane shapes, incorrect statements and terminology are used, no new content is added (Clements & Sarama, 2007) and inappropriate examples of geometric shapes are used. On the other hand, in contexts such as team games, that teacher's guidance is limited, it seemed that kindergartners recognized shapes in different types, sizes and orientations and could describe some of the shapes' basic attributes such as sides and angles (Skoumpourdi, 2016). But children did not use more sophisticated descriptions related to shapes' specific characteristics like the equality of shapes' sides, and the schematisations they used in the game, to describe an atypical shape, were not accurate. Thus, it was hypothesized that inquiry-based approach could be an effective method of

teaching plane geometrical shapes in the kindergarten.

Inquiry-Based Mathematics Education

Inquiry-based mathematics education, is one of the main aspirations of innovation in the field of mathematics education focusing more on cooperative problem solving, on understanding, on learning processes and strategies, on posing and answering questions and on cultivating exploratory practices, than learning mathematical skills only (Calder, 2015). Students in that approach are in the center of the learning process. They are actively involved in explorations and discussions, in posing questions, in making assumptions, in expressing, explaining and communicating their opinions, presenting their solutions to a problem, justifying them in a way that is understood both by the other students and the teacher (Eckhoff, 2017). Teachers create opportunities to students and work cooperatively with them to facilitate and support their mathematical constructions. They transfer the problem-solving responsibility to the students by posing questions linked with the inquiry-based activity, giving meaning to student's actions and developing their understanding without, at least initially, intervening and suggesting ways of thinking.

Research results highlight the benefits and demands of inquiry-based method on teaching practices. When analyzing a teacher's practice following an inquiry-based program, it emerged that although the teacher at the beginning of the program had very limited knowledge of the subject, after the program he was able to apply inquiry-based practices (Towers, 2010). Also, in a research program, it came out that although the process brought uncertainties and tensions within the teachers' practice and between the practices of teachers and didacticians, the value of the approach for the learning emerged by the knowledge gained by participants (Goodchild, Fuglestad, & Jaworski, 2013). In a study on how prospective teachers adopt inquiry-based approach in their professional development it seemed that they: 1. resisted to the adoption of the inquiry approach, 2. partially adopted the inquiry approach, or 3. fully adopted the inquiry approach. At the end of the course all students stated that they built a theoretical understanding of the inquiry teaching and they felt a bit more able to design and implement inquiry-based activities (Σκουμπουρδή, 2017). Teachers' difficulties to adopt inquiry-based pedagogies, to develop and manage collaborative cultures within the classroom and plan lessons that adapt to the emerging needs of learners (Swan, Pead, Doorman, & Mooldijk, 2013) are mentioned in research. Other obstacles and difficulties that the teachers face in adopting the inquiry-based method for teaching are the lack of experience and of complete understanding of the method, the lack of enough allocated teaching hours, as well as the lack of believe that students can be prepared for succeeding in tests with that method (Chin & Lin, 2013). The lack of teachers' familiarity with the method and the need of advanced professional development, which will equip them with multiple teaching strategies to create an adaptive and enriched learning environment is also indicated in research (Wu & Lin, 2016). In sum, active teachers lack knowledge of the inquiry-based approach, they have difficulty in adopting and applying this approach in practice, as well as they have difficulty in designing inquiry-based activities. These obstacles might cause the lack of inquiry-based instruction being employed broadly in the subject area of mathematics and the lack of studies being conducted with a focus on very young children.

Taking into consideration the above results an 'inquiry-based implementation' of an activity related

to plane geometrical shapes, was conducted in a kindergarten, investigating the way it was realized by the teacher as well as the way that kindergartners participated in such an intervention.

Method

For the main research study, which aims to investigate how teachers and students adopt and apply the inquiry-based approach in the mathematics classrooms, the design-based research is used, as the methodology to develop learning theories and tools designed to support learning (Cobb, Confrey, diSessa, Lehrer, & Schauble, 2003). Through this method, which is intrusive in nature, changes and revisions are taken place, in every stage of the main research which enables the simultaneous development and testing of the inquiry-based approach as an innovative learning environment, giving an insight into whether, how and under which circumstances this approach can work. In this paper the benefits and the demands of the approach in a kindergarten classroom is presented.

The kindergarten classroom and the mathematical activity

The kindergarten classroom, where the intervention took place, had 25 students divided by the teacher in four teams and was chosen because the teacher uses student-centered methods, cultivating the conditions for math discussion. She is also positive to innovations.

The author explained to the teacher the basic characteristics of the inquiry-based approach and encouraged her to use it through the Framework for Inquiry-Based implementation of Activities (FIBA) (Skoumpourdi, 2017). The FIBA consists of seven stages: 1. Task: A problem-based task is invented and presented. 2. Exploration: Children use their own problem-solving strategies to explore the problem. 3. Presentation: Children share their explorations with the whole class by presenting their solutions. 4. Connection: Teacher, in cooperation with students, connect the presented solutions with each other, with the task that was explored and with the mathematical aims. 5. Generalization: Teacher is generalizing students' solutions. 6. Translation: Students translate their solutions through different modes—verbalizing, gesturally and schematizing. 7. Expansion: Expanded problems are posed. For the implementation of the mathematical activity by the teacher the FIBA was used.

The mathematical activity, designed by the author, was developed in such a way as to problematize and incite children, engaging them in a problem solving and posing process. The problem to be solved was a non-standard, unfamiliar, a bit complex and novel situation in order not to be solved just by applying existing knowledge and already-known strategies, but through exploration and discussion.

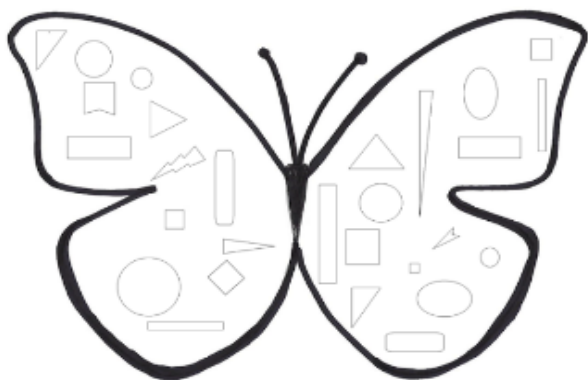


Figure 1: The 'Enchanted butterfly'



Figure 2: Students shapes' schematizations

The scenario of the task was the following: "Once upon a time, a strange magician, who envied the happiness of the Shape-Town, captured with his spells its inhabitants (shapes) on the wings of butterflies flying around his enchanted forest. This strange magician would be good enough to solve the spells only if the children would help the inhabitants-shapes to liberate. The spells would be solved only if the children managed to recognize the shapes hidden in the butterflies' wings". The butterfly had in its wings the four-basic plane geometrical shapes (circle, square, rectangle and triangle) in various types and orientations, as well as counterexamples of them (Figure, 1).

Results

In the beginning, the problem-based task was presented by the teacher through the context of the 'Enchanted Butterfly' (FIBA's 1st stage: Task). The teacher in this stage asked each team of children to mark one kind of shape. The 1st team had to mark the shapes they thought to be circles, the 2nd team the squares, the 3rd team the rectangles and the 4th team the triangles.

Each team independently explored the shapes on the Butterfly, posing questions to each other and to the teacher in order to identify and mark the correct shapes giving a right answer to the problem (FIBA's 2nd stage: Exploration). Although, in general, each child thought about the problem on their own and marked a shape, each in turn, there were instances in which wrong shapes were marked and thus interesting discussions between children of each team and with the teacher took place regarding the identity of the shapes. Debates of whether a shape is a triangle or not, is a square or not, is a rectangle or not, is a circle or not, took place. An example is described in the following dialogue [The letter T refers to the teacher and S1, S2 etc. refer to the young students. The symbol () is used when many children speak simultaneously and our notes are in brackets]:

S1: Is this a circle?

T: You will discuss with your team and you will find out.

(): It is circle, it is not, it is circle, it is not, it is circle but is a small circle [a girl tried to mark it but the other girl pushes her hand away], it is not a circle, is an oval.

S3: These are the ovals: one, two [a boy counted by showing the oval shapes].

S2: Mrs, is that correct [shows the marked circle that created a debate in the first stage]?

T: What shape is it?

S2: It is circle.

T: Yes, it is.

S2: I was telling you ... [said to her classmate that she insisted that the shape was oval]

Similar debates were also carried out for the other shapes and especially for the non-prototypical examples and the counterexamples. The identity of the triangles, the squares and the rectangles were justified, by the children, by counting shapes' angles. But this strategy was not always effective. For example, when a girl showed a counterexample as a triangle, another child told her: "No, this is a 'square' because it has four angles" and the other team members disagreed by saying "No, it is not, it is a shuttle". The orientation of the shapes did not seem to confuse the children. This might have

occurred due to the way the team members sat around the table, allowing them to have different perspectives of the shapes. Once they explored the shapes and discussed about them each team marked ‘their shapes’.

After that, each team shared their explorations with the whole class by presenting/describing their shapes (FIBA’s 3rd stage: Presentation). The teacher, in that stage, observed and organized each team’s presentation, posing questions to help children describe, explain and open out their explorations, as well as to ensure effective and understandable presentations. For example, during the ‘circle team’ presentation the following discussion took place:

- T: How did you understand that all these shapes are circles?
- S2: Because it is round, and this is round, and this is round ...
- T: I think that this is also round [showed an oval, placed horizontally].
- S3: No, this is like an egg.
- T: So, is not a circle?
- () : No.
- T: Is that shape circle [showed an oval placed vertically]?
- () : No, this is not a circle.
- T: But in my opinion is round, why it is not a circle?
- S2: Because it is oblong [showed with her hands] and the circle is not oblong.
- T: Why are these shapes circles?
- S3: Because they do not have angles.
- S2: And because circles are thicker than ovals

For the other shapes, children’s answers in the question ‘why these shapes are triangles (squares/rectangles)?’ were focused on the amount of their angles as well as the amount of their sides, with the usual answer being that: “It is triangle because it has 3 angles and 3 lines/sides”.

The teacher posed advanced questions to the members of each team. For instance, when a boy presented his teams’ shapes and said that “this shape is rectangle because it has four sides”, the teacher continued, by showing a square near it, asking “So I can assume that this shape is also a rectangle because of its four sides?” and vice versa. Or, she was addressing to the children supposing that “this shape (showing counterexamples) is e.g. triangle (rectangle)” calling them to reflect on that statement. Children, in general, had answers to those questions, justifying them by relying on the specific iconic representation. Their answers were as follows: “It is not a rectangle because it has different height”, “It is not a square because it is thin”, “It is not a triangle because this shape has seven lines”. When children had difficulty in their justifications they used gestures in order to present their solution: “It is not a rectangle because it is like that ... (trying to show the curvature sides by gestures)”.

After the presentations, teacher, in cooperation with all the students, orchestrated a mathematical discussion trying to connect presentations with each other, with the ‘Enchanted Butterfly’ task, as

well as with plane geometrical shapes concept so that a shared meaning to emerge (FIBA's 4th stage: Connection). She also tried to generalize plane geometrical shapes concept connecting it with students' previous knowledge (FIBA's 5th stage: Generalization). She posed combining questions to the students, bringing back, for negotiation, issues that were discussed such as: "Does the circle looks like the triangle?" or "Does the square looks like the rectangle?". In the first question, children' one-word answers, through the re-questions of the teacher, were transformed into 'documentations', such as "Circle does not look like triangle because circle does not have angles", "the triangle is pointed ... the circle is not". Teacher's second question seemed to confuse children and their answers differed, claiming that they look like, but the rectangle is bigger or that they do not resemble because they are different shapes with different sizes. These issues, such as the similarities and differences of shapes (circle and oval, square and rectangle), expanded the activity and could be the context of new activity in order to be discussed more thoroughly (FIBA's 7th stage: Expansion). At the end of the activity, students were asked to make a painting in order to explain to their parents what they had done in that activity (FIBA's 6th stage: Translation). Children's schematizations looked like the visual prototypes except the rectangle which was placed vertically (Figure 2).

Conclusions-Discussion

An inquiry-based implementation of a mathematical activity is a complex situation, that requires from the teacher time, effort and deep knowledge of both the approach and the subject matter and from the students to develop various skills, abilities and capabilities to be actively involved in their own learning, constructing mathematics concepts and ideas. From the results of the implementation it seemed that the FIBA, as a readymade framework, helped the teacher to adopt and realize an inquiry-based teaching process encouraging exploration, presentation, connection, generalization, translation and expansion, cultivating cooperation, communication and justification, through a child-centered approach. In all the FIBA's stages, teacher activated students' questions, ideas, actions and comments and tried to turn them into learning opportunities. She also successfully scaffolded the mathematical discussion between the students and herself, guided team work and the whole classroom as a community of learning. Inquiry-based approach helped students to develop their cooperation, communication and justification capabilities. It also helped them to construct the idea of plane geometrical shapes.

The research results about young children' abilities for plane geometrical shapes were confirmed in this paper. But it also became obvious that although there were children in the pre-recognition level, recognizing only some of shape's visual characteristics, they moved on the visualization and the analysis level using shapes' properties to recognize and to characterize typical and atypical shapes through the cooperative exploration, discussion and justification process. Children, initially, described or compared the shapes using specific shapes' representation features. All shape's features either defined or undefined were recognized by children because of the way the activity presented and implemented. Students had identified and named plane geometrical shapes in various forms and orientations, recognized them among counterexamples, communicating their descriptions, discussing about their characteristics and particularities. They had also translated their solutions and constructions to schematic representations that looked like the visual prototype but there were also variations.

References

- Calder, N.S. (2015). Student wonderings: scaffolding student understanding within student-centred inquiry learning. *ZDM-The International Journal on Mathematics Education*, 47(7), 1121–1131.
- Chin, E.-T. & Lin, F.-L. (2013). A survey of the practice of a large-scale implementation of inquiry-based Mathematics Teaching - from Taiwan's perspective. *ZDM-The International Journal on Mathematics Education*, 45(6), 919–923.
- Clements, D. & Sarama, J. (2007). Early childhood mathematics learning. In F. Lester (ed.), *Second handbook of research on mathematics teaching and learning a project of the National Council of Teachers of Mathematics* (pp. 461–555). New York, NY: Information Age Publishing, USA.
- Cobb, P., Confrey, J., diSessa, A., Lehrer, R., & Schauble L. (2003). Design experiments in educational research. *Educational Researcher*, 32(1), 9–13.
- Eckhoff, A. (2017). Partners in inquiry: A collaborative life science investigation with preservice teachers and kindergarten students. *Early Childhood Education Journal*, 45(2), 219–227.
- Goodchild, S., Fuglestad, A.B., & Jaworski, B. (2013). Critical alignment in inquiry-based practice in developing mathematics teaching. *Educational Studies in Mathematics*, 84(3), 393–412.
- Satlow, E. & Newcombe, N. (1998). When is a triangle not a triangle? Young children's developing concepts of geometric shape. *Cognitive Development*, 13(4), 547–559.
- Skoumpourdi, C. (2016). Different modes of communicating geometric shapes, through a game, in kindergarten. *International Journal for Mathematics Teaching and Learning*, 17(2), 1–23.
- Skoumpourdi, C. (2017). A framework for designing inquiry-based activities (FIBA) for early childhood mathematics. In T. Dooley, & G. Gueudet, G. (Eds.) *10th Congress of the European Society for Research in Mathematics Education (CERME10)* (pp. 1901–1908). Dublin, Ireland: DCU Institute of Education and ERME.
- Σκουμπουρδή, Χ. (2017). Δραστηριότητες για τα μαθηματικά των μικρών παιδιών βασισμένες στη διερεύνηση: Σχεδιαστικοί προβληματισμοί. (Inquiry based mathematical activities for young children: Considerations on their design). *ENEAIM 7*, (σελ. 246–255), Αθήνα.
- Swan, M., Pead, D., Doorman, M., & Mooldijk, A. (2013). Designing and using professional development resources for inquiry-based learning. *ZDM-The International Journal on Mathematics Education*, 45(7), 945–957.
- Towers, J. (2010). Learning to teach mathematics through inquiry: a focus on the relationship between describing and enacting inquiry-oriented teaching. *Journal of Mathematics Teacher Education*, 13(3), 243–263.
- Wu, S.-C. & Lin, F.-L. (2016). Inquiry-based mathematics curriculum design for young children-teaching experiment and reflection. *Eurasia Journal of Mathematics, Science & Technology Education*, 12(4), 843–860.
- Yin, H. S. (2003). Young children's concept of shape: van Hiele visualization level of geometric thinking. *The Mathematics Educator*, 7(2), 71–85.

Perceiving and using structures in sets – the contribution of eye-tracking in a three-level evaluation process

Priska Sprenger¹ and Christiane Benz²

¹University of Education Karlsruhe, Germany; priska.sprenger@ph-karlsruhe.de

²University of Education Karlsruhe, Germany; benz@ph-karlsruhe.de

The investigation of children's perception of structure gains in importance in research of mathematics education. In this article we discuss a three-level evaluation process to generate hypotheses about the way preschool children perceive structures and how they use them to determine the cardinality of sets. Eye-tracking data can help to get some deeper insights into these processes of perception and determination. In sum it is shown that the interaction of three different types of data (observation aspects, explanation and eye-tracking data) are important to generate some final hypotheses about the two processes.

Keywords: Perceiving structures, structural use, eye-tracking, preschool education, early mathematics education.

Introduction

Structures play an important role both in the daily life of children and also in mathematics and therefore in mathematics in early childhood education (Schöner & Benz, 2018). Looking on children's mathematical development, structures are obviously essential e.g. for geometrical and arithmetical patterns, for learning the number sequence from twelve onwards but also for identifying quantities. Mulligan & Mitchelmore (2013, p. 31) point out that structure “has been also a growing theme in the past two decades of research on students' development of numerical concepts.”

Theoretical background

Hunting (2003) describes very clearly the importance of perceiving structures for numerical development by emphasizing the ability to change the focus of counting every single item to perceiving and identifying structures of parts in sets. If children are able to identify structures in sets they have the chance to develop a mental image of a number which does not only exist of many single items but also of parts. A mental image of a set consisting of parts is equivalent to the part whole understanding of numbers. Studies confirm the connection between the ability to perceive structures and part-whole understanding (e.g. Young Loveridge, 2002) and also general arithmetical abilities (Lüken, 2012, Mulligan et al., 2004; Obersteiner, 2012).

Because perceiving is an individual and invisible act it is not easy to investigate how and if children perceive structures. Eye-tracking can help to get some insights. Eye tracking data “draws on the so-called “eye-mind” hypothesis (Just & Carpenter, 1976) meaning that what a person looks at is in the focus of the person's cognitive processes and that a person's eye-movements are tightly related to their cognitive processes (Jang et al., 2014)” (Schindler & Lilienthal, 2017, p. 47). Still, using eye-tracking with young children is quite new in the field of mathematics education and data has to be interpreted carefully (Schöner & Benz, 2018). Especially concerning young children's perception of structures in sets there is no comparable eye-tracking data available. Therefore, the aim of the study

reported in this paper is to investigate if and how children perceive structures in sets and if and how they use it for identifying the cardinality of sets. When children determine the cardinality of a set, observations such as audible counting can indicate how a child has determined the number. Subsequently, the child can also be questioned how the number was determined. But, in order to get insights into the perception process, in this paper it is examined how the research tool eye-tracking can help to give insights into this invisible act of perception. In order to analyze the data a theoretic model is used, in which it is distinguished between the process of perceiving a set and determining cardinality. These processes can be subsequent or coincide e.g. as it is the case by (structural) subitizing (Schöner & Benz, 2018).

Research question

In this paper we aim to answer the research question regarding the way of investigation visual structuring abilities of preschool children:

What can the eye-tracking data contribute to the analysis approach of children's perceiving and determination processes concerning the use of structures?

Design

The presented study has a pre-, post-, follow-up-design. 95 children were interviewed individually at three times. The children were between five and six years old and they attended the last year of kindergarten. They were divided in a treatment group ($n=55$) and a control group ($n=40$). The first interview took place at the beginning of the kindergarten year, the second after an implementation phase for four months and the third at the end of the kindergarten year. The treatment group got a box with different materials and games which offer the opportunity to discover and facilitate perceiving structures in sets and using the structures to determine the cardinality. The control group didn't get these materials and games. All the three interviews with the children described above consist of different parts. In this paper we focus only on the part with photos of egg cartons of ten eggs. This is the usual package for eggs children usually know from daily life. Different numbers of eggs were presented on a monitor. With the help of an eye-tracking camera the eye-movements of the children were recorded. In the presented evaluation, the six items with the cardinality of five, seven and nine were used (cf. Figure 1).



Figure 1: Items that have been evaluated

Before the interview started, the children had been told that the interviewer always wants to know "how many eggs" there are and that they should say the number as soon as they know it. The children were given no time restrictions. As soon as the child said a number, the interviewer asked for example: "How do you know that there are n eggs?" In addition to the eye-tracking camera, there were two more cameras. Activities such as finger pointing or lip movements could be observed through an external camera positioned diagonally behind the child and through a webcam. These gestures are considered when evaluating the processes of perception and determination.

Task

Each child was shown photos of egg cartons on a monitor. On the photos different numbers of eggs were presented at the same position on the monitor. Each item started with the presentation of a closed egg carton. Then an open egg carton with eggs appeared. The child said a number, the interviewer asked how it came to the result, the child explained and then a closed carton was presented again.

Aspects of analyzing

The basis of the analysis consists of qualitative categorization processes. Based on a theoretical model (cf. Schöner & Benz, 2018) the analysis of the data is divided in two processes: the process of perception (PP) and the process of determination (DP) (cf. Figure 2). Hypotheses about these processes are generated on three different types of data. There are *observation aspects* generated during the time the child sees the egg carton until it says the number of eggs such as gestures, sounds or promptness of the answers. Additional information by *eye tracking data* is gained recording the eye tracking movements until the child says the number of eggs. The eye-tracking data provides insights into the children's process of perception. After the child said the number there is also data of children's *explanation* (cf. Figure 2).

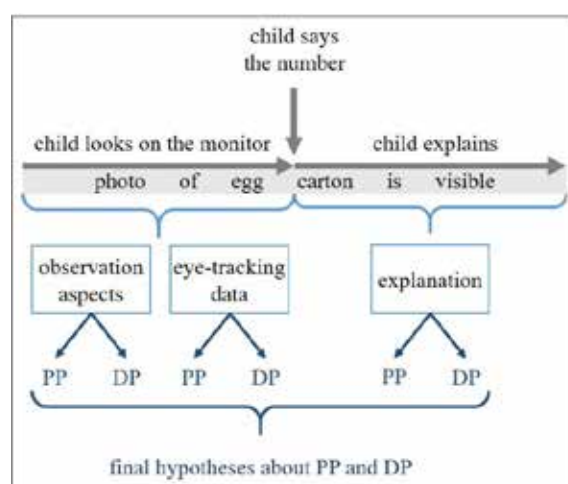


Figure 2: Scheme of evaluation process

Based on these three kinds of data, hypotheses about perceiving structures in sets and structure-using strategies to determine the cardinality can be formed. These three kind of data lead to a final hypothesis about the perception process (PP) and the determination process (DP). Because of the limitation of the number of pages the way coming to these final hypotheses cannot be presented in detail here (see Schöner & Benz, 2018). So the evaluations are based on a hypothesis-generating process. In the following, the frequencies are given for perceiving structure or perceiving no structure during the PP and using structure or using no structure for the DP. Only hypotheses which could be assigned to these categories are included, all other categories are here not taken into account.

Results and first interpretations

In the following tables the arithmetic average of strategies solving the five described items is given. In this paper, the focus is not on significant differences between points of investigation or groups, the percentages are rather used to show how the three types of data can help to give insights into the

analysis process. The percentage frequencies given in Table 1 are based on the observation aspects. They are divided in the two processes the PP and the DP. The range for structure perception and structural use for determination is between 2% and 9% for both groups. Perception is very difficult to observe because it is actually an invisible act (cf. Schöner & Benz, 2018). This fact could be one possible interpretation for these low percentages. An observation aspect which could be assigned to the category structure for example is, when a child uses his hands to show a structure or verbally names a structure. As shown in Table 1 observation aspects which indicate that a child does not perceive a structure (cf. Table 1) could not be found. On the other hand, for the non-structural use in the determination process for both groups, the range of the percentage frequencies is between 30% and 58%. Nodding, pointing with the finger or audibly counting are aspects which can be observed easily. Therefore counting every single item, which means using no structure to determine the cardinality is more obvious to observe. Here, both groups show a different decrease: 16% for the control group and approximately 28% for the treatment group. An assumption for the decreasing frequencies of counting every single item from t1 to t3 is that perhaps the children start to use more and more structures to determine the cardinality.

	Perception Process (PP)						Determination Process (DP)					
	structure			no structure			structure			no structure		
	t1	t2	t3	t1	t2	t3	t1	t2	t3	t1	t2	t3
treatment	8.5	5.2	4.5	0.0	0.0	0.0	4.2	2.4	3.9	57.6	37.3	29.7
control	5.4	7.5	5.4	0.0	0.0	0.0	3.3	5.4	4.2	47.8	40.4	32.1

Table 1: Arithmetic mean of percentage frequencies based on observation aspects

Table 2 shows the percentages of structural and non-structural perceiving as well as the use for determination based on the child's explanation after saying the number (cf. Figure 2). Such an explanation could be, for example, the naming of subsets or the statement "I have counted". Based on the explaining, more structural perceiving and structural use could be observed than based on the observation (cf. Table 1). The variation in (not) perceiving structures and (not) using structures are very similar in both groups and for both processes. Both in terms of perceiving structures and using structures to determine the cardinality, an increase of approximately 36% from t1 to t3 can be observed. In addition, the non-structural use to determine the cardinality decreases from t1 to t3 in both groups.

	Perception Process (PP)						Determination Process (DP)					
	structure			no structure			structure			no structure		
	t1	t2	t3	t1	t2	t3	t1	t2	t3	t1	t2	t3
treatment	31.2	49.4	66.7	0.3	0.3	0.0	27.0	45.2	63.6	13.0	9.1	2.4
control	29.2	42.9	67.1	4.6	7.9	0.0	32.9	48.8	66.3	18.3	7.9	2.1

Table 2: Arithmetic mean of percentage frequencies based on explanation

In Table 3 the arithmetic mean of percentage frequencies of structural and non-structural perceiving and using based on the eye-tracking data is shown. The eye-tracking data shows in which order and how long the child has fixed the (individual) eggs. An illustration of Table 3 is presented in the diagram in Figure 3.

	Perception Process (PP)						Determination Process (DP)					
	structure			no structure			structure			no structure		
	t1	t2	t3	t1	t2	t3	t1	t2	t3	t1	t2	t3
treatment	31.2	47.6	60.6	30.9	21.2	17.9	26.1	40.0	54.5	30.6	26.4	23.0
control	50.4	48.8	54.6	18.3	22.9	19.6	37.1	40.0	48.3	24.6	29.6	24.6

Table 3: Arithmetic mean of percentage frequencies based on eye-tracking data

For all categories the range based on eye tracking data is between 18% and 61% for both groups. The range for the structural perceiving and using is between 26% and 61%, the range for the non-structural perceiving and using is between 18% and 31%. In the determination process an increase for the use of structures could be observed for both groups. In sum, a lot of hypotheses could be built. Looking on the PP there are differences between the groups. An increase of approximately 30% is observed in perceiving structures of the treatment group (from 31% (t1) to 61% (t3)). The control group starts at t1 at a higher frequency, and increases in total from t1 to t3 only by about 4% (from 50% (t1) to 55% (t3)). Also a decrease from t2 to t3 is observable (cf. Table 3). The frequencies of perceiving structures in the treatment group at t3 are higher than those of the control group. In the DP, a similar tendency can be seen. An increase of approximately 30% is observed in the structural use of the treatment group (from 26% (t1) to 55% (t3)). The control group starts at t1 again with higher percentages, but increases in total from t1 to t3 by about 10% (from 37% (t1) to 48% (t3)) (cf. Table 3 and Figure 3).

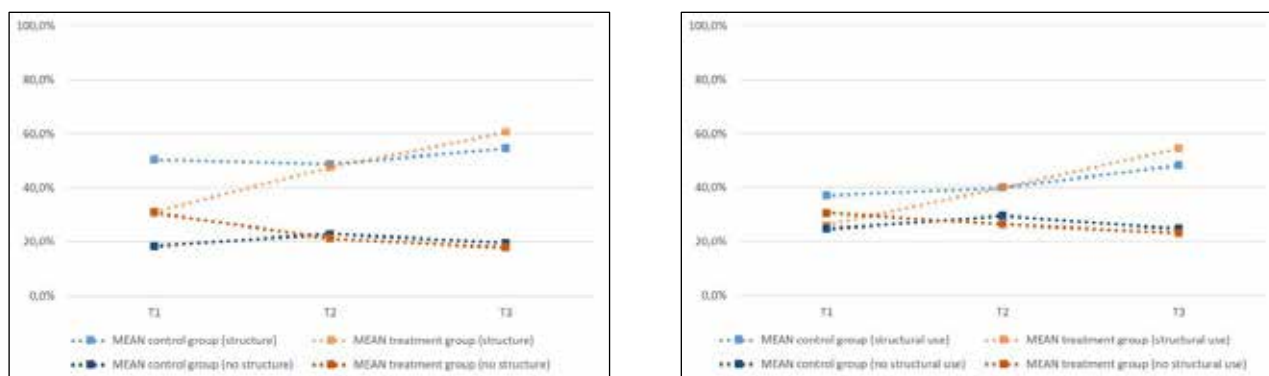


Figure 3: Arithmetic mean of percentage frequencies based on eye-tracking data

The percentage frequencies given in Table 4 are based on all three types of data: observation, explanation and eye-tracking data. These frequencies correspond to the final hypotheses briefly mentioned above.

Perception Process (PP)		Determination Process (DP)	
structure	no structure	structure	no structure

	t1	t2	t3	t1	t2	t3	t1	t2	t3	t1	t2	t3
treatment	40.9	57.0	67.0	27.9	17.0	13.3	30.6	44.5	57.0	60.9	45.8	35.5
control	56.3	55.4	63.8	14.2	17.1	15.0	40.0	45.0	55.4	49.6	49.2	38.8

Table 4: Arithmetic mean of percentage frequencies based on observation aspects, explanation and eye-tracking data

An illustration of the frequencies of Table 4 can be seen in Figure 4. Here similar tendencies can be seen as in the data based only on the eye-tracker (cf. Figure 3).

The frequencies of the structural perceiving and using both for the PP and DP of the control group are also higher at t1 than of the treatment group. Nevertheless, the percentages of the treatment group increased both for the PP and DP, so that the percentages of structural perceiving and use at t3 are higher than those of the control group. In the determination process an increase for the structural use could also be observed for both groups. For the frequencies of non-structural perceiving and use an opposite tendency can be noticed for the treatment group. The more structures are in the PP and DT, the less non-structural can be seen or vice versa (cf. Figure 4). In the control group a similar tendency can be observed. It's remarkable that in the PP there is a decrease from t2 to t3 and overall, a smaller increase can be seen compared to the treatment group (cf. Table 4).

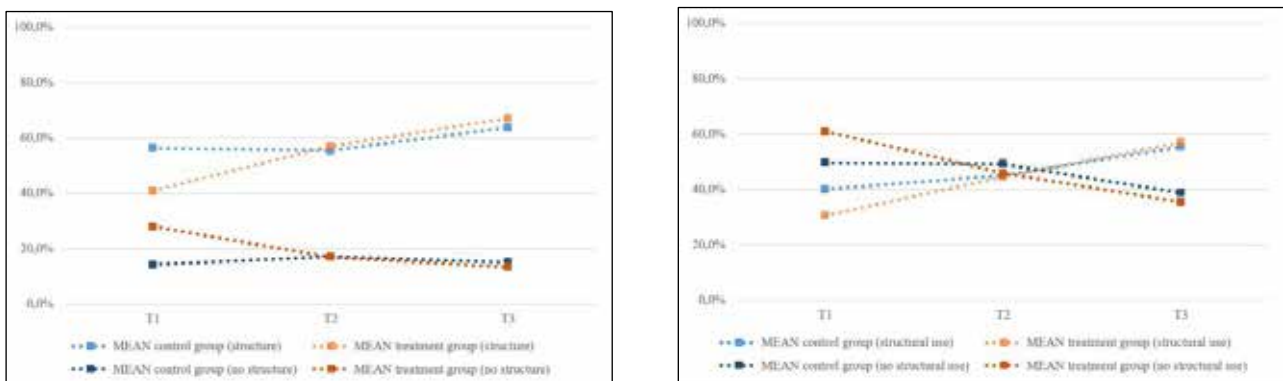


Figure 4: Arithmetic mean of percentage frequencies based on observation aspects, explanation and eye-tracking data

Summary of the results

Observation aspects only provide few data (range: 0-9%) for perceiving and using structures. For the development of perceiving and using structures to determine the cardinality only few hypotheses can be derived. The sole exception is found in the DP concerning non-structural use. In the DP, a decrease is observed in non-structural use in both groups (control group: 16% from t1 to t3, treatment group: about 28% from t1 to t3). A possible interpretation would be that non-structural use decreases but perceiving structures increases. The latter case could not be seen in the observation aspects but nevertheless the conclusion about an increase in perceiving structures becomes possible.

Data based on *explanation* provide more information about structural use in DP and PP (range: 27%-67%). There are very similar tendencies: In each group, an increase of approximately 36% in perceiving structures and structural use is observable. Similar to data based on observation aspects

no information can be gained for non-structural use in the PP. In the DP there is less information available than for data collected with observation aspects.

Data based on *eye-tracking* (cf. Table 3) provide more information than data based on observation aspects and explanation. The data show an increase in perceiving and using structures to determine the cardinality (Treatment group: PP: 30% from t1 to t3, DP: 30% from t1 to t3 / Control group: PP: 4% from t1 to t3, DP: 10% from t1 to t3). In both cases (PP and DP) the control group starts at t1 at a higher frequency and the frequencies of perceiving structures in the treatment group at t3 are higher than those of the control group. In sum, a lot of hypotheses could be generated.

Hypotheses based on all *three kinds of data* (observation aspects, explanation, eye-tracking) show similar tendencies as the eye-tracking data. The frequencies show nearly the same increase of perceiving and using structures to determine the cardinality in the treatment group (PP: 26% from t1 to t3, DP: 26% from t1 to t3). In comparison to this a very small increase is also observable in the control group (PP: 8% from t1 to t3, DP: 15%) (cf. Figure 3 and Figure 4). Also the frequencies for no structural perceiving and using are similar. In sum, the changes in perceiving and using structures for determining the cardinality are almost identical to the changes shown by the eye-tracking data (cf. Table 3 and 4).

Discussion and Conclusion

The following tendencies about perceiving and using structures to determine the cardinality are generated only from the observation aspects and the explanation (without eye-tracking data): The data from the observation aspects show a decrease of the non-structural use which leads to the interpretation that there is a simultaneous increase of using structures to determine the cardinality. In the data of explanation an increase of perceiving and using structures can be observed and also a decrease in non-structural use. This leads to the conclusions that there is a consensus in the increase for using structures to determine the cardinality and also for perceiving structures. Both groups nearly have the same frequencies and ranges.

Coming back to the research question: What can the eye-tracking data contribute to the analysis approach of children's perception and determination processes concerning the use of structures? One advantage of the eye-tracking is to get some deeper insights in the invisible perceiving process when making it visible. This could for example be interesting if children have a lack of words to describe how they perceived a structure. These linguistic difficulties may be due to the linguistic development (because of the age of the children) or to another native language. The eye-tracking data leads to additional information especially for the PP. The data also show that in the treatment group a clearer development in perceiving structures and using structures to determine the cardinality has taken place than in the control group. In a next step, the significance for these frequencies are checked.

However, eye-tracking data has to be interpreted. So far, there are no comparative data from children in this age from other studies that could help or give some directions. In order to come to an interpretation of the recorded eye-movements, the explanations and the observation aspects of the children are often important. So an inductive approach to generate hypotheses from the eye-tracking data is necessary about how children perceive structures in sets.

In the first step of analysing data most of the eye tracking data only could be interpreted because of the additional information from the observation aspects and the explanation. Due to this data, categories could be generated in order to analyse the eye-tracking data. In a second step of analysing the data it could be referred to these categories of eye-tracking data, especially in cases where no additional data exists. For this reason, all three types of data are important not only for the interpretation of the eye-tracking data but also for generating the final hypotheses. Thus, in this study the three-level evaluation turned out to be viable, because the observation aspects, the explanation and the eye-tracking data complement each other and interdepend.

References

- Hunting, R. (2003). Part-whole number knowledge in preschool children. *Journal of Mathematical Behavior*, 22(3), 217–235.
- Jang, Y.-M., Mallipeddi, R., & Lee, M. (2014). Identification of human implicit visual search intention based on eye movement and pupillary analysis. *User Modeling and User-Adapted Interaction*, 24(4), 315–344. doi: 10.1007/s11257-013-9142-7
- Just, M.A. & Carpenter, P.A. (1976). Eye fixations and cognitive processes. *Cognitive Psychology*, 8, 441–480.
- Lüken, M. (2012). *Muster und Strukturen im mathematischen Anfangsunterricht: Grundlegung und empirische Forschung zum Struktursinn von Schulanfängern*. Münster, Germany: Waxmann.
- Mulligan, J. T., Prescott, A., & Mitchelmore, M. (2004). Children's development of structure in early mathematics. In M. J. Høines & A. B. Fuglestad (Eds.), *Proceedings of the 28th conference of the international group for the psychology of mathematics education*, 2, 393–400. Bergen, Norway: PME.
- Mulligan, J. T. & Mitchelmore, M. (2013). Early awareness of pattern and structure. In L. English, & J. T. Mulligan (Eds.), *Reconceptualizing Early Mathematics* (pp. 29–46). New York, NY: Springer.
- Obersteiner, A. (2012). *Mentale Repräsentationen von Zahlen und der Erwerb arithmetischer Fähigkeiten*. Münster, Germany: Waxmann.
- Schindler, M. & Lilienthal, A. (2017). Eye-tracking as a tool for investigating mathematical creativity. In M. Schindler, & A. J. Lilienthal (Eds.), *The 10th Mathematical Creativity and Giftedness International Conference: Proceedings* (pp. 45-50). Nicosia, Cyprus: Department of Education, University of Cyprus. Retrieved from <http://urn.kb.se/resolve?urn=urn:nbn:se:oru:diva-64766>
- Schöner, P. & Benz, C. (2018). Visual structuring processes of children when determining the cardinality of sets – The contribution of eye-tracking. In C. Benz, H. Gasteiger, A. S. Steinweg, P. Schöner, H. Vollmuth, & J. Zöllner (Eds.), *Early Mathematics Learning – Selected Papers of the POEM Conference 2016* (pp. 123–143). New York, NY: Springer.
- Young-Loveridge, J. (2002). Early childhood numeracy: Building an understanding of part-whole relationships. *Australian Journal of Early Childhood*, 27(4), 36–42.

Construction of scientific basis for pre-school teacher education

Christina Svensson

Malmö University, Sweden; christina.svensson@mau.se

Keywords: Teacher education, mathematics education, variation theory, preschool

In university education, students are prepared for a future that is both known and unknown (Marton, 2014). Educators try to prepare the students in the unknown by raising the known. The best and most powerful way is to try to develop and contribute tools that can support students for new situations in future professions as a teacher (Marton, 2014). Investments in teacher education indirectly affect what opportunities for education future students have. In Sweden, several studies have made it clear that students' skills are not enough internationally. This has increased focus on preschool opportunities to contribute to higher goal achievement later on in school. Furthermore, discussions about higher goal achievement can be discussed in relation to how pre-school teacher education contributes to the opportunities for students in future enable success in the subject of mathematics. Niss (2001) argues that the term mathematics constitutes five different "faces", each face representing mathematics in a certain context. A mathematical content can thus be interpreted differently depending on the face or context from which it is considered. For example, teacher education can be taken into account as both a very important element as very different in the fourth face. Furthermore, Alrø and Johnsen-Høines (2010) argue how communication between educator and child affects the quality of mathematics learning. They consider that teachers in the early ages rather use an evaluation strategy of mathematic knowledge than investigative methods in their mathematic teaching. This teaching strategy could impede a more exploratory approach to mathematics education (Alrø & Johnsen-Høines, 2010). A strategy that can be related to Marton's (2014) argument for the development of deep understanding. It can be put in context in the sense of deepening their own mathematical understanding in order to identify others' understanding of the subject. In order to highlight the complexity it means to visualise understanding of a subject and thus the understanding of others, by using more theoretical frameworks (a.a). Several arguments arise in relation to the teacher's importance in creating a structure for the learning in mathematics in preschool. Research in mathematics teacher education is therefore of great importance because the quality of education affects the quality of future teacher training, which in turn affects the quality of student performance. In this study teacher students are challenged during an intervention study based on theoretical knowledge input consisting of Bishop's six mathematical activities (1988) and variation theory (Marton, 2014). This leads to the following question: In what way does theoretical knowledge input contribute pre-school teacher students to identify children's mathematical understanding in different learning activities in preschool?

Theory

Within the variation theory, the purpose of learning is the ability to do something with something (Marton, 2014). In order to understand learning, especially what is crucial for learning, it is necessary to take into account what is actually learned in different learning activities (Marton, 2014). Further in variation theory, the differences in which aspects are perceived at the same time are significant for learning. In order to experience or understand something in a certain way, certain aspects must be perceived. It is the perception of these aspects that are crucial to learning (Marton, 2014). From an

educational point of view, aspects that are considered important on the basis of the learning of a chosen learning object. Marton (2014) describes how a difference in how the same phenomenon is experienced has to do with differences in discernment. Discernment based on variation theory which focuses on learning activity (Marton, 2014). Furthermore, learning is also a question of being able to distinguish and differentiate which aspects are considered critical to a specific group in a specific situation based on a chosen learning object. It is thus through increased understanding of what is critical to distinguish that increases knowledge and conditions for learning in relation to the goals.

Method

A pre and post -test has been constructed consisting of eleven learning activities in preschool based on Bishop's (1988) activities. The empirical data consists of data from the respondents' written reflections of the pre-and post -test. Data collection has taken place three times before, between and after they have participated in teaching with different designs. The two different designs within the course consist in offering two groups (73 students) of six more opportunities for teacher supervision by teacher educators, who are involved in both theories, based on their completed documented field studies that integrate theory and practice. All six groups have been taught in the two theoretical elements but individually. Analysis of the collected empirical data consists based on variation theory, focusing on identifying differences in how students in the different groups distinguish the object of learning for the children and the opportunity for the children`s understanding on the same.

Results and Conclusion

Preliminary results indicate that the teacher students who are offered more support into the two theoretical elements at the same time, identify more mathematical learning objects in the constructed pre- and post-test. Which leads to discussion of what in the theoretical input contribute and support meta-reflection in relation to deeper understanding of other mathematical understanding. A contribution to the development of the student's profound understanding through theoretical input at the same time as a mathematical content and structure of teaching in pre-school, focusing on the actual learning of learning ability. The latter as an important element in preparing the teacher student to identify others' mathematical understanding of the learning ability. The poster will visualize and discuss the students' understanding of the intentional learning object for the children in the designed pre and post-test, based on the different teaching design the teacher students were included in the intervention.

References

- Alrø, H., & Johnsen-Høines, M. (2010). Critical dialogue in mathematics education. In H. Alrø, O. Ravn, & P. Valero (Eds.), *Critical mathematics education: Past, present and future* (pp. 11–22). Rotterdam, The Netherlands: Sense Publishers
- Bishop, A. J. (1988). Mathematics education in its cultural context. *Educational Studies in Mathematics*, 19(2), 179–191.
- Marton, F (2014). *Necessary conditions of learning*. New York, NY: Routledge.
- Niss, M. (2001). *Matematikken og verden*. København, Denmark: Fremad.

Shedding light on preschool teachers' self-efficacy for teaching patterning

Pessia Tsamir¹, Dina Tirosh¹, Esther Levenson², Ruthi Barkai²

¹Tel Aviv University, School of Education, Tel Aviv, Israel; pessia@post.tau.ac.il;
dina@post.tau.ac.il

²Kibbutzim College of Education and Tel Aviv University, Israel; levenso@post.tau.ac.il;
ruthibar@post.tau.ac.il

As teacher educators, we recognize the importance of considering teachers' self-efficacy for teaching mathematics. In this study, we investigate preschool teachers' self-efficacy for teaching repeating patterns, both before and after participating in a professional development program. Findings from questionnaires indicated that self-efficacy related to subject-matter knowledge changed little, while self-efficacy related to pedagogical-content knowledge, increased. Interviews with teachers shed light on these findings.

Keywords: Repeating patterns, self-efficacy, preschool teachers, professional development

Introduction

Recently, several countries have introduced specific guidelines for introducing mathematical concepts during the early years. Along with new guidelines comes a need for enhancing preschool teachers' knowledge for teaching mathematics. Knowledge, however, may not be sufficient. Teacher self-efficacy is another factor which may impact on teachers' classrooms interactions and student achievement (e.g., Guo, Piasta, Justice, & Kaderavek, 2010). Teacher self-efficacy may be conceptualized as "a teacher's individual beliefs in their capabilities to perform specific teaching tasks at a specified level of quality in a specified situation" (Dellinger et al. 2008, p. 752). With regard to mathematics, Hackett and Betz (1989) defined mathematics self-efficacy as, "a situational or problem-specific assessment of an individual's confidence in her or his ability to successfully perform or accomplish a particular [mathematics] task or problem" (p.262).

This paper focuses on preschool teachers' self-efficacy for engaging young children with repeating pattern activities. Repeating patterns are patterns with a cyclical repetition of an identifiable 'unit of repeat' (Zazkis & Liljedahl, 2002). For example, the pattern ABBABBABB... has a minimal unit of repeat of length three. According to the Israel National Mathematics Preschool Curriculum (INMPC) (2008), "patterning activities provide the basis for high-order thinking, requiring the child to generalize, to proceed from a given unit, to a pattern in which the unit is repeated in a precise way" (p. 23). In this paper we take a close look at a group of preschool teachers who attended the Repeating Patterns professional development Program (RPP) aimed at enhancing their knowledge and self-efficacy for teaching repeating patterns. We examine their self-efficacy before and after the program, and through interviews, we attempt to untangle variations in their self-efficacy beliefs.

Background

For the past several years, we have been employing the Cognitive Affective Mathematics Teacher Education (CAMTE) framework for investigating preschool teachers' knowledge and self-efficacy

for teaching mathematics, as well as planning for professional development with preschool teachers (Tirosh, Tsamir, Barkai, & Levenson, 2017). The framework is based on Shulman's (1986) recognition of teachers' subject-matter knowledge (SMK) and pedagogical-content knowledge (PCK), as well as Ball, Thames, and Phelps's (2008) refinement of these elements.

	Subject-matter		Pedagogical-content	
	Solving	Evaluating	Students	Tasks
Knowledge	Cell 1: Defining, drawing, extending repeating patterns	Cell 2: Identifying examples of repeating patterns	Cell 3: Knowledge of students' ways for drawing, extending, and comparing repeating patterns	Cell 4: Designing and choosing tasks for promoting and evaluating children's knowledge of repeating patterns
	Cell 5: Mathematics self-efficacy related to Defining, drawing, extending repeating patterns	Cell 6: Mathematics self-efficacy related to evaluating solutions	Cell 7: Pedagogical-mathematics self-efficacy related to children's conceptions	Cell 8: Pedagogical-mathematics self-efficacy related to designing and evaluating tasks

Table 1: The CAMTE framework illustrated within the context of repeating patterns

Regarding teachers' knowledge of patterning, several studies pointed out the need to promote teachers' knowledge of the language of patterns. For example, Waters (2004), described how one preschool teacher showed the children dress materials with, what she called, patterns. Some of the materials contained a mixture of shapes, colors, hearts, and stars, and demonstrated random designs without any regularities. The teacher did mention the need for repetitions, but did not focus on what exactly is repeated. Similarly, in our study of preschool teachers' patterning knowledge (Tirosh, Tsamir, Levenson, Barkai, & Tabach, 2018), we found that teachers have difficulties verbalizing what exactly is repeated, although most referred in some way to the unit of repeat and to the notion of repetition. We also found that when asked to draw or continue repeating patterns, teachers mostly drew repeating patterns that have three cycles of the unit of repeat and a unit length of three. In addition, teachers' continuations of given patterns indicated a strong tendency to end patterns with a complete unit of repeat.

For each knowledge cell in the framework, there is a related self-efficacy cell, emphasizing teachers' mathematics self-efficacy as well as their pedagogical-mathematics self-efficacy, i.e. their self-efficacy related to the pedagogy of teaching mathematics (see Table 1). This differentiation was also pointed out by Bates et al. (2011), who investigated the relationship between early childhood (pre-K to third grade) preservice teachers' mathematics self-efficacy and their mathematics teaching self-efficacy. Results of that study showed that teachers who reported higher mathematics self-efficacy were more confident in their ability to teach mathematics than teachers with a lower mathematics

self-efficacy. However, participants with a high mathematics teaching self-efficacy did not necessarily perform well on the mathematics skills test. Some teachers who scored low on the skills test still felt confident to teach mathematics. We also note that self-efficacy beliefs are not only domain-specific (e.g. mathematics, history, science) and content-specific (e.g., within the domain of mathematics there is numeracy, patterns, geometry, etc.), but also task-specific (e.g., extending patterns, duplicating patterns, etc.) (Zimmerman 2000).

The aim of this paper is to report on preschool teachers' mathematics self-efficacy as well as their pedagogical-mathematics self-efficacy, before and after the Repeating Patterns Program (RPP). The teachers in this study met seven times (21 hours in total) over a period of about four months. All lessons were planned by the four authors of this paper. The fourth author did the actual teaching. The program revolved around patterning tasks that we designed, which teachers could implement with children, but could also be used to engage teachers with the mathematics involved in patterning, and promote their knowledge of patterning tasks and children's ways of solving those tasks. Towards the end of the program, teachers implemented patterning tasks with children in their classes, video-taped their implementations, and then brought those recordings to the program for discussion. (See Tirosh et al. (2017) for additional information regarding this program.) Specifically, we ask: (1) Was there a change in teachers' self-efficacy from before to after the program, and if so, what was the nature of this change? (2) When reflecting on self-efficacy, how do teachers explain their self-efficacy beliefs?

Methodology

Participants in this study were 18 preschool teachers enrolled in the RPP. All had a first degree in education, between 1 and 38 years of teaching experience in preschools, and were currently teaching children ages 4-6 years in municipal kindergartens. All sessions were videotaped and transcribed.

Before the program began, and again during the last session, teachers were asked to fill out a questionnaire which began with the following self-efficacy statements: I am able to say what a repeating pattern is; if shown a repeating pattern along with several suggestions for continuing the pattern, I am able to choose appropriate continuations; I am able to point out repeating patterns that most preschool children are able to continue appropriately; I am able to choose tasks for investigating children's patterning knowledge. A four-point Likert scale was used to rate participants' agreements with self-efficacy statements: 1 – I do not agree that I am capable; 2 – I somewhat agree that I am capable; 3 – I agree that I am capable; 4 – I strongly agree that I am capable.

Approximately one month after the program was over, seven teachers, chosen to reflect a variety of responses (e.g., no change in self-efficacy, increased self-efficacy, decreased self-efficacy) were interviewed individually. The aim of the interview was to further investigate teachers' self-efficacy beliefs for teaching patterning by evoking their reflections on these beliefs, and focusing on changes that may have occurred with regard to self-efficacy. In general, the interview questions were of the form: "Before the program began, you wrote that you strongly agree (somewhat agree/agree/do not agree) that you are capable of _____. At the end of the program you wrote _____. Can you tell me more about this?" The blanks were filled in with the different tasks taken from the questionnaire and teachers' self-efficacy assessments in the pre- and posttests. In addition, teachers were encouraged to freely reflect on their self-efficacy beliefs. Interviews were recorded and transcribed.

Findings

Results from the questionnaires

Table 2 shows the mean values for teachers' self-efficacy scores before and after the program (on a scale from 1-4). As can be seen, teachers had a rather high regard, both before and after the program, in their ability to define a pattern and to choose appropriate continuations for a given pattern, with their self-efficacy rising slightly after the program. Teachers also had a high self-efficacy for identifying patterns that children could continue, with seemingly no change between before and after the program. The greatest change was noted in the last question. Before the program, teachers were not so confident in their ability to choose appropriate pattern tasks for investigating children's pattern knowledge, whereas after the program, their self-efficacy was noticeably higher.

	Self-efficacy statement	Pre		Post	
		Mean	SD	Mean	SD
SMK	I can say what a pattern is.	3.3	.59	3.8	.44
	I can choose appropriate continuations for a repeating pattern.	3.6	.62	3.8	.38
PCK	I can point out patterns that most preschool children can continue.	3.2	.56	3.3	.69
	I can choose appropriate tasks for investigating children's patterning knowledge.	2.2	.79	3.4	.72

Table 2: Means and SD per self-efficacy statement before and after the program (N=18)

Taking a closer look at the distribution of self-efficacy scores, Table 3 presents the frequencies of teachers whose self-efficacy scores increased, stayed the same, or decreased.

	Self-efficacy Statement	Increased	No change	Decreased
SMK	I can say what a pattern is.	6	12	-
	I can choose appropriate continuations for a repeating pattern.	5	13	-
PCK	I can point out patterns that most preschool children can continue.*	4	9	4
	I can choose appropriate tasks for investigating children's patterning knowledge.**	12	4	-

*One teacher did not respond. **Two teachers did not respond.

Table 3: Changes in self-efficacy beliefs between pre and posttests (N=18)

In general, approximately two-thirds of the teachers did not feel a change in their self-efficacy related to SMK, while the rest of the teachers' self-efficacy increased. However, when it came to PCK-related

self-efficacy beliefs, findings were more complex. With regard to knowledge of students, approximately half of the teachers did not feel any change, but 25% of the teachers felt a rise in their self-efficacy and 25% reported a decrease. With regard to knowledge of tasks, approximately 75% of the teachers' self-efficacy scores increased, with the rest showing no change.

Interviews: Reflecting on self-efficacy

As seen in the previous section, most teachers' SMK-related self-efficacy beliefs were high and did not seem to change. When asked to comment on her SMK-related self-efficacy, Michelle (this and all other names are pseudonyms), who rated her self-efficacy both before and after the course at level 4, said, "Before the course, I don't think I knew how to define a pattern. I'm trying to remember when I learned this topic. But after we studied this in depth during the program...I know a lot more now." While Michelle does not explain why in the beginning of the course she had such a high self-efficacy, thinking back, she realizes that her SMK regarding defining a pattern actually increased.

With regard to being able to choose appropriate continuations to a pattern, Anne explains why she rated her self-efficacy as very high before the course, "Before the course, I knew that a pattern could be continued in several ways." However, she adds, "But now, I understand the reasoning behind these options, and I can explain it better to the children." In other words, although her self-efficacy rating has not changed, she feels that her knowledge has increased. Rina, who also had rated her self-efficacy as 4 both before and after the course, had a different reason for why no change was reported:

In the beginning of the course, when they asked me these questions, I think I didn't really know what they [repeating patterns] meant. At the end of the course, now, I understand what is meant by a repeating pattern, that it can end in the middle [with a partial unit of repeat]. Now, the question is clear. I don't remember what I wrote in the beginning.

In other words, Rina reflects back on before the course, and can now say that before the program, she did not really know what was meant by a repeating pattern, and was not aware that patterns do not have to end with a complete unit of repeat. This is similar to Michelle. Both teachers seem to acknowledge that their self-efficacy ratings in the beginning of the course were incorrectly high. In fact, when Rina was asked what score she should have given herself in the beginning of the course, she answered, "Now, I'm a 3-4. Then, maybe a 2, because I did know a little."

When it came to reflecting on their PCK self-efficacy beliefs related to knowing children's patterning abilities, teachers again had varied responses. Prior to the program, Anne had evaluated her self-efficacy at level 3, and at the end she reported level 4. She told the interviewer that her self-efficacy increased and explained, "Today, I can define it [a repeating pattern] better. I know that there is a minimal unit of repeat, and that it is made up of elements. This definition organizes my thoughts and adds to my self-efficacy." Although Anne was asked to relate to her ability to point out patterns that most preschool children can continue, her response focused on her ability to define a repeating pattern. It could be that for Anne, her knowledge of the centrality of the minimal unit of repeat, affected her belief in her ability to assess children's knowledge.

Rina, who consistently rated her self-efficacy to assess children's knowledge at 4, said, "If, in the beginning of the course, I didn't really understand about repeating patterns, then of course, I couldn't

really know about the children.” Rina is acknowledging her over-confidence in the beginning of the course. Moreover, she connects her SMK with her PCK, by connecting her knowledge of patterns to her knowledge of students. Sharon, who consistently rated her self-efficacy at level 3 said, “I’m not so sure of myself here. I think I need more experience working with children to feel more sure of myself in this area.” This explains why currently, her self-efficacy is a 3 and not a 4. When asked to reflect back, she adds, “Before (the course), I would give myself a 2. I didn’t engage with patterns as much as I do now, and so I’m more self-confident now that I can do things better.” She now acknowledges that her self-efficacy in the beginning of the course was too high.

Lottie’s self-efficacy for assessing children’s patterning knowledge decreased from a 4 to a 3. During her interview, she stated the following:

For me, before the course, I would have children make patterns by giving them a red sticker, and then a yellow sticker, and so on. This course was a wake-up call. Patterns can be made with different materials... I was stuck on one type. There is also the pattern ABB. Before, I engaged the children with patterns, but without reflecting on what I did.

Lottie states that before the program, she engaged children with patterning tasks. This could be the reason that in the beginning, she felt very strongly that she could say which patterns children would be able to complete. After the course, Lottie acknowledges that her previous patterning knowledge was limited. Perhaps, this causes her now to be unsure regarding her knowledge of children.

Finally, we review teachers’ reflections regarding their self-efficacy for choosing appropriate tasks. Recall that most teachers’ self-efficacy for choosing tasks increased. Rina, who increased her self-efficacy from a 3 to a 4, commented, “I did work with repeating patterns with children, but they were not so varied, they did not end in the middle (with a partial unit of repeat).” Sharon, who went from level 2 to 4, said, “The program gave me lots of tools, and also self-confidence.” However, she qualifies her response by adding, “I think I still need more experience.” Similarly, Anne, who also went from a self-efficacy of 2 to 4, said, “The patterns that Ruthi (the program instructor) gave us in the course, really helped me to organize my thoughts and implement them in the kindergarten. I know that another teacher also uses them, and even when in the yard she uses sound patterns, because it’s very nice, and we really liked it.”

Summary and discussion

This study examined preschool teachers’ mathematics self-efficacy as well as their pedagogical-mathematics self-efficacy, related to teaching repeating patterns, as well as teachers’ reflections on these beliefs. Regarding teachers’ SMK-related self-efficacy beliefs, results indicated that no significant change was felt. That teachers reported high SMK-related self-efficacy beliefs at the end of the program, was satisfying. However, we are left with two questions: How is it that teachers had such a high self-efficacy before the program began? In addition, even though the reported self-efficacy beliefs did not change, did teachers feel some change?

Regarding the first question, it could simply be that teachers indeed knew how to complete these tasks in the beginning, although to a lesser extent than they did in the end. In a previous study (Tirosh et al., 2018), we found that most preschool teachers did recognize that a repeating pattern must have

unit of repeat, but missed stating that the unit must be structured. On the other hand, they could all construct and extend given repeating patterns. Regarding the task of choosing an appropriate continuation for a given repeating pattern, in general, teachers were able to choose appropriate continuations, although they had greater success in choosing appropriate continuations for the patterns which ended with a complete unit, than for the pattern which ended in a partial unit.

Teachers' interviews shed additional light on the issue of their self-efficacy. During the interviews, some teachers acknowledged that their first self-efficacy reports were higher than they should have been. They explained these initial high self-efficacy reports by saying that the topic of repeating patterns was not new to them. Thus, it might be that teachers did feel a change in their knowledge, but that this change was not reflected in the questionnaires. This finding raises the complexity of investigating self-efficacy beliefs. First, it could be that a scale of 1-4 was not sensitive enough to capture changes. In addition, this study, like most self-efficacy studies (e.g., Bates et al., 2011), relied on Likert-scales. It was the addition of interviews that revealed teachers' changes in their beliefs. Thus, we encourage the use of interviews when investigating self-efficacy.

Regarding teachers' PCK-related self-efficacy beliefs, from the questionnaires, it seemed that teachers did not feel a change in their self-efficacy related to knowing children's patterning abilities. Taking a closer look, we found that some teachers' self-efficacy increased, some stayed the same, and some teachers' self-efficacy decreased. As one aim of the course was to support teachers' self-efficacy beliefs, this result is surprising. One explanation is that after the program, teachers realized how much more there is to learn. They also mentioned feeling the need for more experience engaging children with patterning activities. Thus, this may actually be positive outcome of the program.

Regarding teachers' self-efficacy for choosing patterning tasks that can investigate children's knowledge, we ask, why is it that before the course this particular self-efficacy belief was relatively low? One possibility is that we asked teachers if they could choose tasks for the purpose of investigating children's pattern knowledge. It could be that if they were asked to choose tasks that had the potential to promote, rather than assess knowledge, their self-efficacy might have been greater. In a previous study of preschool teachers' knowledge and self-efficacy for teaching three-dimensional figures (Tsamir, Tirosh, Levenson, Tabach, & Barkai, 2015), we found that teachers' self-efficacy related to designing tasks for promoting knowledge was greater than their self-efficacy related to designing evaluation tasks.

Finally, this study highlighted the connection between teachers' SMK-related self-efficacy and their PCK-related self-efficacy. When asked about her self-efficacy for knowing children's pattern abilities, Anne referred to her improved ability to define a repeating pattern. Rina and Lottie also connected their knowledge of repeating patterns, including that a repeating pattern does not have to end a complete unit of repeat, to their knowledge of children and patterns. While previous educators (e.g., Ball, Thames, & Phelps, 2008; Shulman, 1986) connected teachers' SMK to PCK, this finding connects teachers' SMK-related self-efficacy to their PCK-related self-efficacy, and suggests that if we wish to promote positive self-efficacy for teaching mathematics, we should also consider teachers' self-efficacy for solving mathematical tasks.

Acknowledgment

This research was supported by The Israel Science Foundation (grant No. 1270/14).

References

- Ball, D. L., Thames, M. H., & Phelps, G. (2008). Content knowledge for teaching what makes it special?. *Journal of Teacher Education*, 59(5), 389–407.
- Bates, A. B., Latham, N., & Kim, J. (2011). Linking preservice teachers' mathematics self-efficacy and mathematics teaching efficacy to their mathematical performance. *School Science and Mathematics*, 111(7), 325–333.
- Dellinger, A., Bobbett, J., Livier, D., & Ellett, C. (2008). Measuring teachers' self-efficacy beliefs: development and use of the TEBS-Self. *Teaching and Teacher Education*, 24(3), 751–766.
- Guo, Y., Piasta, S. B., Justice, L. M., & Kaderavek, J. N. (2010). Relations among preschool teachers' self-efficacy, classroom quality, and children's language and literacy gains. *Teaching and Teacher Education*, 26(4), 1094–1103.
- Hackett, G., & Betz, N. (1989). An exploration of the mathematics self-efficacy/mathematics performance correspondence. *Journal for Research in Mathematics Education*, 20(3), 261–273.
- Israel national mathematics preschool curriculum (INMPC) (2008). Retrieved April 7, 2009, from http://meyda.education.gov.il/files/Tochniyot_Limudim/KdamYesodi/Math1.pdf
- Shulman, L. S. (1986). Those who understand: knowledge growth in teaching. *Educational Researcher*, 15(2), 4–14.
- Tirosh, D., Tsamir, P., Barkai, R., & Levenson, E. (2017). Using children's patterning tasks for professional development for preschool teachers. In C. Benz, H. Gasteiger, A. S. Steinweg, P. Schöner, H. Vollmuth, and J. Zöllner (Eds.), *Mathematics Education in the Early Years - Results from the POEM3 Conference, 2016* (pp. 47–67). New York: Springer.
- Tirosh, D., Tsamir, P., Levenson, E., Barkai, R. & Tabach, M. (2019). Preschool teachers' knowledge of repeating patterns: Focusing on structure and the unit of repeat. *Journal of Mathematics Teacher Education*, 22(3), 305–325. DOI 10.1007/s10857-017-9395-x
- Tsamir, P., Tirosh, D., Levenson, E., Tabach, M., & Barkai, R. (2015). Preschool teachers' knowledge and self-efficacy needed for teaching geometry: Are they related? In B. Pepin and B. Rösken-Winter (Eds.), *From beliefs to dynamic affect systems- (exploring) a mosaic of relationships and interactions* (pp. 319–337). Cham, Switzerland: Springer International Publishing.
- Waters, J. (2004). Mathematical patterning in early childhood settings. In I. Putt & M. McLean (Eds.), *Mathematics education for the third millennium* (pp. 565–572). Townsville, Australia: Mathematics Education Research Group of Australia.
- Zazkis, R., & Liljedahl, P. (2002). Generalization of patterns: The tension between algebraic thinking and algebraic notation. *Educational Studies in Mathematics*, 49(3), 379–402.
- Zimmerman, B. J. (2000). Attainment of self-regulation: a social cognitive perspective. In M. Boekaerts, P.R. Pintrich & M. Zeidner (Eds.), *Handbook of self-regulation* (pp. 13–39). San Diego, CA: Academic Press.

Generalization in early arithmetic

Marianna Tzekaki¹ and Evaggelia Papadopoulou¹

¹ Aristotle University of Thessaloniki, tzekaki@auth.gr

Research in the field of early arithmetic and relevant international educational programs present a variety of approaches (activities, tasks and material) that aim at teaching children from early age to count verbally or count quantities or to recognize and compare without counting, etc. However, a deeper insight into underlying arithmetic thinking, reasoning and early generalization always remains required. In our study, 23 preschoolers (of 5 to 6 years) participated in a program focusing on generalizing in early arithmetic. Task-based interviews before and after this program were conducted to examine children's improvement in conceptual development and generalization related to numbers. Findings indicate that appropriated teaching approaches with relevant tasks and discussion supported children to extract more general ideas about numbers, their properties and interrelations.

Keywords: arithmetic learning, number sense, generalization

INTRODUCTION

Arithmetic learning is one of the most well-known and recognized mathematical field of teaching and learning in early years, thereby, there is an extensive related literature with different approaches and views. Programs around the world suggest a wide variety of projects, tasks and materials aimed at effective numerical learning. Thus, children from early age learn to recognize and compare quantities without counting, recite the arithmetic sequence, count objects, etc. What is though genuine arithmetic learning and how can we ensure it? Researchers have long ago pointed out that daily numerical activities or involvement with arithmetical elements with numbers and operations could not assure the development of numerical meaning. First references regarding this issue started with Brownell (1947) who attempted to distinguish 'meaning of' from 'meaning for' that essentially differentiates the use of numbers in real life from generalizations that lead to mathematical conceptualization.

Long ago also, researchers highlighted the gap between everyday use of numbers and development of mathematical number concepts in education (Carragher et al., 1985). The value of spontaneous or informal use of mathematics by students or practitioners is generally recognized and studied, but this use does not automatically link mathematical elements to relevant mathematical concepts. It could be supported that counting quantities or realizing other numerical tasks in everyday situations keep a 'concrete' aspect that is not simply transferred out of its context. Thus, the development of number sense towards the correspondent mathematical meaning demands a shift from the specific situation and content in which it functions to a broaden level through systematic generalization processes. As it was recently underlined by many researchers related to the learning and teaching of arithmetic in early years "...our knowledge of how children develop accurate and general understanding of basic arithmetic principles and make use of them as strategies for arithmetic problem solving remains incomplete..." (Björklund et al., 2018, p. 126)".

In this paper, we will attempt to highlight different levels of generalization that pre-schoolers can achieve in arithmetic learning when they are systematically encouraged by relevant teaching approaches.

Arithmetic Learning

Research in the field of early arithmetic and consequent educational programs presents a variety of supplementary or complementary approaches, activities, tasks and material, emphasizing their importance for later mathematical proficiency. However, while all these advances support the need of meaningful arithmetic knowledge and the development of number sense, cognitive expectations and educational outcomes remain to be clarified by teachers and educators. Moving away from the (initial) Piagetian logical operations related to arithmetic learning and from other relevant psychological research, newer approaches such as subitizing and counting-based arithmetic appear to focus more on quantity and number sense (e.g. Clements & Sarama, 2014). Current suggestions orient also their interest to number structure and connections (Venkat & Askew, 2017).

Researchers who emphasized the importance of counting as a base upon which number concepts could be developed, supported that counting connects knowledge coming from outside with in-school understanding (Fuson, 1988). However, when children count quantities by reciting a sequence of number names and pointing out one by one different objects (even respecting the relevant principles: ordered names, one-to-one and cardinal principle, Carpenter et al., 2016) follow a rather procedural than conceptual understanding (LeFevre et al, 2005). Studies have revealed that while young students, knowing in general object counting, attempted to complete a simple task of change (e.g. 4 to 8 or 8 to 5) stayed more depended on counting or perceptual information (use of fingers or blocks) than on numerical facts. Subsequently later, research in early arithmetic learning (e.g. Baroody, 2004; Clements, 1999, etc.) studied the representational flexibility of subitizing that reinforced children to interconnect and generalize numerical concepts, maintaining however the importance of counting and recognition of number interrelations for arithmetic learning.

In this brief presentation, we attempted to justify why, despite the volume of research related to early arithmetic, a deeper insight into underlying arithmetic thinking, reasoning and early generalization remains always required.

Generalizing in early arithmetic

Generalization is an important prerequisite for arithmetic learning, similarly to every other mathematical learning. As presented in an earlier paper, generalization (Tzekaki & Papadopoulou, 2017, p. 1926) “...could be firstly identified as the level at which students, starting from specific situations, proceed to more general ideas and conclusions, identifying patterns, structures, relationships etc.” (see, e.g. Döfler, 1991; Kaput, 1999), with fundamental elements the “*reflection over actions*” and the “*expression of more generalized ideas or rules*”. Despite its importance in the mathematical development, research in early childhood generalization is mainly limited to patterns.

On the other hand, research and proposals in early arithmetic place its focal points on counting, subitizing, ordering and connecting quantities and numbers. Relevant proposals underline the need of pupil’s shift from ‘*quantity sense*’ to ‘*number sense*’, by first perceiving the magnitude of numbers,

then understanding their multiple interrelations and finally operating on them (Wagner & Davis, 2010), thus, moving beyond perceptual or procedural practices, both in counting and subitizing or in operating with other means such as fingers or relevant material (Dehaene, 1997).

Combining views on generalization with proposals for early arithmetic we attempted to examine whether young children were able to overcome perceptual subitizing or verbally object counting in a concrete content and apprehend numbers in a more generalized level. Thus, in our study we examined whether preschoolers managed to approach and verbally express more global ideas about quantities, numbers and their interrelations, beyond perceptual or procedural practices in the four strands of early arithmetic (1) verbal counting up to 10, (2) subitizing, (3) analyzing and combining quantities and numbers, (4) relating and ordering quantities and numbers (Clements & Sarama, 2014). Moreover, we investigated whether these ideas could be evolved when working in teaching approaches that systematically encouraged generalizations.

Methodology

23 preschoolers aged 5 to 6 years (selected by classroom teachers on the basis of their common age and attendance in the same school and school area) participated in an 8-month teaching program focusing on generalization related to all fields of early mathematics education (shapes, patterns, measurement and numbers, Tzekaki & Papadopoulou, 2017), with the number module to be the last, from late April to late May. Task-based interviews were conducted to examine pre-schoolers' arithmetic achievement and levels of generalization before and after the teaching program (following a design study). The content of the task-based interviews followed the strands mentioned earlier: counting quantities up to 10 (4 cases), subitizing quantities up to 10 (3 cards), combining numbers (1 task with quantities in dot cards) and transforming numbers (2 tasks of change, see tasks in Table 1). The interviews' questions aimed at examining statements related to children's conceptualization of numbers concerning their way of acting (e.g. *what did you do to ...*, *how did you do it...*), children's thinking (e.g. *what did you think to ...*, *what did you notice to...*), children's justification (e.g. *why did you do it...*) and finally children's more general ideas (e.g. *Is it always the same or it may be different...*, *how can we find that...*) (Dougherty et al., 2015). The interviews were conducted individually, recorded and transcribed.

To approach children's ideas about numbers, we analyzed their utterances in the transcribed interviews and categorized them in a three-stage generalization model, following current literature. Preschoolers' explanations at a *first stage* do not present any characteristics or properties or relationships related to quantities or numbers, as children remain verbally reciting the number sequence (see, e.g. Baroody, 2004). Children's explanations at a *second stage* show a perceptual or procedural approach of characteristics, properties or relationships related to quantities, as children order or combine quantities mainly by counting or by subitizing small quantities and recognize only a part of interrelations (see, e.g. Clements, 1999). Children's expressions at a *third stage* start presenting a certain awareness of characteristics, properties or interrelations of numbers, as children conceptually subitize and stabilize number facts (see, e.g. Clements & Sarama, 2014; due to space restrictions examples of each stage will be presented along with the results). After their initial examination and categorization, these 23 pre-schoolers, individually or in teams, dealt in their

classroom with rather usual arithmetic tasks, materials and games for four weeks (e.g. games for verbal counting quantities forward and backward, games for subitizing dot cards with different configurations, tasks for comparing, ordering or analyzing quantities, recognizing numbers in numbers cards, etc., see Clements & Sarama, 2014). During this program, they were systematically encouraged by their teacher to discuss about their actions, strategies, methods, decisions, reasoning and to proceed to verbal formulations regarding more general ideas related to their outcomes of their activity. Thus, they were reinforced to move from a *local level* with conclusions made out of a specific task or activity (e.g. way of doing it) *to a broader level* with assumptions about mathematical ideas (e.g. number 4) and finally *formulation of rules or propositions* (e.g. numbers' relations) (Dougherty, et al., 2015) and they were reexamined in similar tasks. After working for several months on other mathematical fields, these children improved, in general, their flexibility to find common elements in different contents, to reflect on their actions and produce more general conclusions deriving from specific situations.

Results

The table below (Table 1) shows differences between the initial and final examination of the children as they appear in the transcripts of their interviews. These results provide an overview about preschoolers' achievement and progress in relevant tasks after a rather short teaching period.

Items	Quantities or Numbers	Initial	Final
Verbal counting	Up to 10, one by one or by twos, forward and backward	6	18
Subitizing	Dot-cards with 5, 7, 8 dots	3	15
Combining	Quantities with dot-cards to form 6	8	17
Transforming	7 to 4 and 2 to 6 (in numbers)	3	15

Table 1. Number of correct answers before and after teaching period in numbers.

Correct answers in this table concern: for *verbal counting*, correctly counting in all four cases (one by one or by twos, forward and backward), for *subitizing*, correctly recognizing all dot cards with 5, 7 and 8 dots without counting, for *combining*, putting together dot cards in all possible combinations (5+1, 3+3, 4+2 and 2+2+1) and for *transforming* from 7 to 4 and 2 to 6, correctly completing both changes.

Seeking for a deeper insight into preschoolers' number conceptualization and, thus, their underlying more *generalized ideas about numbers and interrelations*, we analyzed their explanations in the interviews according to the three-stage generalization model, presented earlier (in brief: reciting the number sequence, perceptually subitizing or procedurally approaching relationships, conceptually subitizing and stabilizing number facts). In general, there were no children at the first stage.

- In the initial examination of verbal counting (Baroody, 2004), all 23 children were able to recite the arithmetic sequence one by one forward, but did not show the same stability in all counting tasks (by twos or backward, by ones or twos). Seven children who were identified as being at the *second stage (mostly procedural)* were able to count one by one, but could not do it backward, hesitating especially

for numbers after 7, missing one or two numbers in the sequence or starting counting with their fingers. They had greater difficulties in counting forward or backward by twos, not being, thus, able to realize that number sequence was stable (e.g. 5,7... so backwards 7, 5...) or to perceive relationships between numbers. For example, a child said, “*It may be something else...*” and another one “*10, 8, 6, 2, 0, ... there must be some numbers missing*”. Eleven children, who were considered as being *at the third stage* (more advanced procedural), recited the arithmetic sequence fluently, but did not have the same fluency in counting backward or counting by twos, while the rest (5) with the same procedural approach were able to count by using the one by one correspondence and to explain based on it, e.g. “*0, 2, 4 (plus 1), 5, (plus 1), 6, ...*”, showing, thus, an awareness of stability and simple relationships between numbers (see Table 2).

In *the final examination of verbal counting*, 22 children verbally counted correctly in all cases and, furthermore, declared that the order of number sequence was stable, being identified thus *at the third stage*. However, their explanations regarding this order might be indicative of different levels of generalization, as 6 of them who recognized certain relationships (e.g. 8 and 1 is 9 or 3 and 2 is 5) could not generalize them throughout the whole number succession, or other 5 children who had stabilized knowledge of succession one by one, were not in the same state when counting by twos. Finally, with more or less complete understanding, 11 children seemed to be aware of numbers’ interrelations that generate the number sequence, appearing to be at a more advanced level (see Table 2).

- In *subitizing dot cards* (Clements, 1999), *initially* most of the children (15) could not recognize quantities or explain how to do it by perceiving subgroups of quantities and interrelations between them, being thus *at the second stage*. Very few children (3) could recognize quantities with more than 3 dots and, except one, they said that they counted silently. Some other also (5) used the combinations they knew, e.g. “*I saw 3+3 that is 6 and then 7...*” (partly recognizing and partly counting). These 8 children were identified as being *at the third stage*. In *the final examination*, after working with relevant tasks and discussing on number characteristics and relationships, 15 children declared that they recognized subgroups and did not use counting, e.g. a child said “*No, I didn’t count, I did 3+3 and plus 2...*”. Some children (6) made use of patterns of previous cards and said “*this was 7, then this is 8*”. Some other still (2) combined subitizing small quantities and counting. These different approaches (some procedural and some conceptually subitizing) show also different kinds of generalization *at the third stage* (see Table 2).

- While *combining dot cards to form the number 6* (Clements & Sarama, 2014), 15 children *initially* presented only the combination 5+1 of one 5-dot card and one 1-dot card. The children (8 in total) who provided all the right combinations were divided into two groups: in the first group 3 preschoolers mainly used a ‘trial and error’ method and counted the dots one by one, without knowing if always 4 plus 2 was equal to 6. For example, a child started with a 5-dot card and put it together with a 2-dot card and counted all the dots, as the result was 7 s/he changed with a smaller card. In the second group, 5 children put cards together using the relationships they already knew, but they checked the result by counting. This group of children remained mainly at a procedural and, thus, *second stage*.

In the final examination, 15 children were able to present all the combinations for 6 (third stage) while 8 remained in 1 or 2 -3 of them (second stage). Eleven of the 15 pupils did not use the method of “trial and error” or of counting, but, in general, they were able to put together groups of quantities, showing, thus, an awareness of relationships of quantities and numbers. They could be considered being in a course of a conceptual understanding, as they were competent to explain with numbers e.g. “*I said 3+2 makes 5, plus 1, 6...*” and “*...then 3+3 makes 6*”. For the other four pupils of this stage, the interrelations between quantities and numbers were generally less developed, as they verified every suggestion by counting, showing that they remained at a procedural stage.

- Finally, *in the task of transforming 7 to 4 or 2 to 6*, initially all the children were at the second stage. Twelve of them counted in different ways, e.g. a child said “*I counted with my fingers and (showing) if I put out 3 remains 4 fingers*”, or, more generally, they did it with number sequence, “*I put out 1, 6 and then 5, so we get 4*”, while 11 children were not able to find a way of doing it (see Table 2).

But in the *final examination*, 12 children were identified as being at the third stage, but in different levels of conceptualization. Thereby, a group of 5 children explained the changes with numbers in a more general way e.g. “*3 and 3 and 1 equals 7, if you keep 4 you have 3...*” showing a conceptual understanding, while 7 others did the same without being sure about the results (between conceptual and procedural). E.g. for 7 to 4, a child said “*I can see a group with 3 and a group with 4... so (hesitates)... then 3...*” or they put groups together and counted (in a procedural stage). The rest 11 children were still not able to do it correctly. This analysis is summarized in the Table 2 in which the initial three-stage model was analyzed in more details, as there was no child in stage 1 but, as it was previously presented, differences were revealed in other stages.

Pre-schoolers’ explanations of stage 2 are divided in three sub-stages: 2a, in which their utterances revealed a procedural recognition of quantities and basic relationships, with no specific awareness; 2b, in which they presented a wider procedural recognition of quantities and relationships and 2c, in which they showed children mainly able to manage procedurally quantities and numbers. For example, in the task of combining dot cards to form a quantity of 6 dots, children of 2a put together cards with 5 and 1 (basic) dots, without being able to present other combinations, while children of 2b started putting together more cards by counting them and children in 2c were able to find cards and in case of errors (e.g. 4-dot card and 3- dot card) to directly change with other dot cards but also count for checking.

Pre-schoolers’ explanations of stage 3 were also divided in three sub stages: 3a, in which their utterances revealed recognition of a part of groups/subgroups of quantities and numbers or their interrelations, 3b, in which they presented a wider recognition of interrelations of quantities or numbers but without consolidation and (a final) 3c, in which children recognized numbers, their order and their interrelations. For example, in the task of subitizing, children of 3a started by recognizing small quantities and continuing by counting, while children of 3b recognized some of the proposed cards and explained e.g. for a 5- dot card “*I saw these 4 and this 1*”, but still misjudged a 7-dot card, finally 3c children recognized all cards and explained e.g. “*2 plus 2 and 1 equals 5*” or “*3 plus 3 plus 2 equals 8*” showing the relevant groups in the cards.

		Stage 2: perceptual and procedural approach			Stage 3: procedural and conceptual approach		
		Stage 2a	Stage 2b	Stage 2c	Stage 3a	Stage 3b	Stage 3c
Reciting	Initial	4	3	0	11	5	0
	Final	0	0	1	6	5	11
Subitizing	Initial	8	5	2	5	2	1
	Final	0	0	0	2	6	15
Combining	Initial	15	3	5	0	0	0
	Final	4	4	0	3	1	11
Transforming	Initial	11	9	3	0	0	0
	Final	4	4	3	7	3	2

Table 2. Number of children in different generalization stages in the initial and final examination

This table provides an overview of these children's improvement in approaching and verbally expressing more global ideas about quantities, numbers and interrelations indicating, thus, a more substantial conceptual understanding.

Discussion

The results presented indicate in brief that the participating children were initially able to count verbally up to 10, but they did not recognize more generalized interrelations between quantities or numbers, remaining mainly in this procedural counting. Conversely, after working in the teaching program that systematically encouraged them to reflect over this counting and express more generalized ideas related to quantities and numbers, most of these children (almost 19 out of 23) started developing flexibility in combining quantities and numbers, in realizing numbers' relationships and consolidating several numbers' facts. Despite the small sample that does not allow wider conclusions, these outcomes suggest that guiding young children to focus on dynamic and relational aspects of numbers and express more general ideas related to their numerical tasks could support decisive numerical understanding and more generalized arithmetic knowledge.

Arithmetical learning has many approaches, but the dominance of counting tasks does not often make apparent whether children develop number sense, structural numerical elements or relationships, as this study attempted to show. Many deficiencies in the first arithmetic learning prove to cause difficulties to students to conceptualize the multiplicative, relational and repetitive structure of numerical system. Teaching approaches that encourage children to generalize seem to be required for numbers as they are for any other mathematical concept, since learning mathematics is not only to practice in situations with material, but also to reflect and draw more general ideas out of this practice

References

Baroody, A. J. (2004). The developmental bases for early childhood number and operations standards. In D. H. Clements, J. Sarama & A.-M. DiBiase (Eds.), *Engaging young children in mathematics* (pp. 173–219). Mahwah, NJ: Erlbaum.

- Björklund, C., Clements, C., Sarama, J., Levenson, E., Barkai, R., Tirosh, D., Tsamir, P., Askew, M., Venkat, H., & Hannula-Sormunen, M. (2018). Learning and teaching of arithmetic skills in early years. In Bergqvist, E., Österholm, M., Granberg, C. & Sumpter, L. (Eds.), *Proceedings of the 42nd Conference of PME* (Vol. 1, pp. 125–154). Umeå, Sweden: PME.
- Brownell, W. A. (1947). The place of meaning in the teaching of arithmetic. *The Elementary School Journal*, 47(1), 256–265.
- Carraher, T. N., Carraher, D. W., & Schliemann, A. D. (1985). Mathematics in the streets and in schools. *British Journal of Developmental Psychology*, 3(1), 21–29.
- Carpenter, T. P., Franke, M. L., Johnson, N. C., Turrou, A. C., & Wager, A. A. (2016). *Young children's mathematics: Cognitively guided instruction in early childhood education*. Portsmouth, NH: Heinemann Educational Books.
- Clements, D. H. & Sarama, J. (2014). *Learning and teaching early math: The learning trajectories approach* (2nd ed.). New York, NY: Routledge.
- Clements, D. H. (1999). Subitizing: What is it? *Teaching children mathematics*, 5(7), 400–405.
- Dehaene, S. (1997). *The number sense: How the mind creates mathematics*. New York: Oxford Press.
- Dörfler, W. (1991). Forms and means of generalization in mathematics. In A. Bishop, S. Mellin-Olsen, & J. van Dormolen (Eds.), *Mathematical knowledge: Its growth through teaching* (pp. 61–85). Dordrecht, The Netherlands: Kluwer.
- Dougherty, B., Bryant, D., Bryant, B., Darrough, R., & Phannestiel, H. K. (2015). Developing concepts and generalization to build algebraic thinking: The reversibility, flexibility and generalization approach. *Intervention in School and Clinic*, 50(5), 273–281.
- Fuson, K. (1988). *Children's counting and concepts of number*. New York, NY: Springer.
- Kaput, J. J. (1999). Teaching and learning a new algebra. In E. Fennema T. & Romberg (Eds.), *Mathematics classrooms that promote understanding* (pp. 133–155). Mahwah, NJ: Lawrence Erlbaum.
- LeFevre, J. A., Smith-Chant, B. L., Fast, L., Skwarchuk, S. L., Sargla, E., Arnup, J. S., & Kamawar, D. (2006). What counts as knowing? The development of conceptual and procedural knowledge of counting from kindergarten through Grade 2. *Journal of experimental child psychology*, 93(4), 285–303.
- Tzekaki, M., & Papadopoulou, E. (2017). Teaching intervention for developing generalization in early childhood: the case of measurement. In T. Dooley, & G. Gueudet (Eds), *Proceedings of the Tenth Congress of the European Society for Research in Mathematics Education* (pp. 1925–1932). Dublin: Dublin City University and ERME.
- Venkat, H., & Askew, M. (2017). Mediating primary mathematics: theory, concepts, and a framework for studying practice. *Educational Studies in Mathematics*, 97(1), 71–92.
- Wagner, D., & Davis, B. (2010). Feeling number: grounding number sense in a sense of quantity. *Educational studies in Mathematics*, 74(1), 39–51.

Characterisation of the learning trajectory of children aged six to eight years old when acquiring the notion of length measurement

Yuly Vanegas¹, Montserrat Prat² and Alba Rubio³

¹Universitat de Barcelona, Spain; ymvanegas@ub.edu

²Universitat Autònoma de Barcelona, Spain; montserrat.prat@uab.cat

³Fundació Escoles Garbí, Spain; arubio@escolesgarbi.cat

The goal of this study is to identify the learning trajectories that students aged 6 to 8 years old follow during the construction of the notion of length measurement. An instrument based on the construct of a hypothetical learning trajectory was designed to ascertain the different levels of understanding of this notion among the children. The implementation of the said instrument and the subsequent analysis are described. The results obtained from the study were used to situate the children on their predominant learning trajectory level. At the same time, the results reveal what mathematical topics teachers should focus on to ensure that children can move on to the next level of their trajectory and thus consolidate their learning.

Keywords: Learning trajectories, length measurement, early years.

Introduction

From the standpoint of the pre- and primary school education mathematics curriculums, measurement is a fundamental area of content and strongly related to the mathematics used in everyday life (Battista, 2006; Clements & Sarama, 2009; Chamorro, 2003; Smith, van der Heuvel-Panhuizen, & Teppo, 2011; Antonopoulos, Zacharos & Ravanis, 2009). Nonetheless, sometimes not enough effort is invested in teaching length measurement formally because it is considered social knowledge that will be acquired by students outside school (Chamorro, 2003).

Length measurement has the potential to connect different mathematical domains such as numeracy and geometry (Clements & Sarama, 2009; Smith, van der Heuvel-Panhuizen, & Teppo, 2011). It is also a tool without which many descriptions of a spatial type would be vague and imprecise (Battista, 2006) and it provides a practical skill that is important in everyday life (Buys & De Moor, 2005).

On the other hand, like Sarama, Clements, Barret, Van Dine and McDonel (2011) we believe that an understanding of the learning trajectory involved in length measurement gives us, as teachers, resources to improve teaching and learning strategies that support children's acquisition of this competence. The goal of this study is to identify the learning trajectories followed by pupils aged six to eight years old in order to construct the notion of length measurement.

Learning length measurement

Research on measurement learning at an early age shows that educators place the focus on arithmetic (counting, comparing quantities) and geometry (constructions, shapes and patterns) rather than on measurement (Benz, 2012), despite the huge presence of measurement in children's day-to-day lives. Copley (2006) expresses himself in similar terms when noting that measurement is an often-neglected

mathematics topic in the education of young children; and also, Barret et al. (2012), for whom measurement learning is little connected to its mathematical foundations, often meaning that educators miss opportunities to strengthen measurement concepts such as the idea of the unit. And as pointed out by Clements and Sarama (2009) mechanical learning of the notion of measurement should be avoided.

Piaget, Inhelder and Szeminska (1960) define the notion of length measurement as the synthesis of subdivision and change of position, which includes extracting a part of the total and iterating this unit throughout the entire object. Measurement for Clements & Sarama (2009) “can be defined as the process of assigning a number to a magnitude of some attribute of an object, such as its length, relative to a unit” (p.163). These attributes are measured in continuous quantities so that they can always be divided into smaller quantities (Clements & Sarama, 2009). For these authors “length is a characteristic of an object found by quantifying how far it is between the end points of the object” (p. 164). Thus, to determine the length it is necessary to first subdivide the object into equal units of measurement and iterate them along the object (Clements & Sarama, 2009).

According to Clements and Sarama (2007; 2009), learning of measurement, and in particular of length measurement, involves the comprehension of eight concepts: (i) understanding of the attribute (of length); (ii) conservation (of length); (iii) transitivity; (iv) equal partitioning of the object to be measured; (v) units and unit iteration; (vi) accumulation of distance and additivity (the number of iterations indicates the space covered by the units up to a specific point); (vii) origin; and, (viii) relation between number and measurement.

Hypothetical Learning Trajectories

The construct of the Hypothetical Learning Trajectory (here in after HLT) was developed by Simon (1995) as part of his teaching cycle model. According to this author, an HLT is built around three components: a) the learning goal, b) the mathematical tasks that will be used to promote learning, and c) the hypotheses about the learning process. The aim is to make a prediction of how students can learn a certain mathematical content based on their previous knowledge and experience.

Clements & Sarama (2009) state that children follow natural processes of development when learning mathematics. These developmental paths form the basis of learning trajectories. Thus, in a similar way to what was proposed by Simon (1995), these authors consider that learning trajectories involve three essential components: a) a mathematical goal; b) a developmental path; and c) a set of instructive activities or tasks typical of the levels of thinking of the path. They also suggest that the use of learning trajectories can help answer key questions concerning teaching and learning processes: the goals to be set; where to start; how to decide the direction of the next step; and how to achieve that next step.

Specifically, in the case of length measurement, Clements & Sarama (2009) propose an HLT organized at different levels of development, with some associated instructional tasks. It is assumed that these levels indicate the path taken by children while constructing meanings for length measurement. Some learning goals defined by key aspects of the curriculums of each pre and primary school class level are considered in order to specify these levels. Importance is given to the fact that children initially have to identify the attributes of measurement and compare objects using these attributes. Later they must be able to order objects according to their length. As the children advance

in their understanding of numbers, their learning should be geared towards the recognition of connections between the metric and numeral systems, making measurements that imply the use of units and counting those units. Finally, children must be able to recognize the need to have units of equal length, through the use of standard units, and be able to identify and use measurement tools.

The levels proposed by Clements and Sarama (2009) for the learning trajectory involved in length measurement are as follows: Pre-Length Quantity Recognizer (PR); Length Quantity Recognizer (R); Length Direct Comparer (DC); Indirect Length Comparer (IC); Serial Orderer to 6+; End-to-End Length Measurer (EE); Length Unit Relater and Repeater (RR).


To improve children's understanding of length measurement, it is necessary to identify how they act in the various situations that involve this notion. We see the HLTs as a construct that serves to verify this understanding and thereby provide key elements for the definition of specific actions related to the teaching and learning processes.

In this study, we use the HTL construct in order to design our instrument and also as an analytical framework. Particularly we compare the current performance of each child with the hypothetical learning trajectory about length measurement.

Methodology

Our research uses qualitative methodology. An ad-hoc data collection instrument featuring open and manipulative activities was designed to respond to the research goal. The instrument was used in interview format with 20 students aged six to eight years old. The data was recorded audio-visually. The following factors were considered when defining the sample: a) *Gender*, there were eight boys and twelve girls. b) *The time of the year when they were born*, with six participants born in the first four months of the year, six in the second four months and eight born during the last four, the children were distributed by age, which resulted in a more homogeneous sample. c) *Diversity in mathematical performance*, we find children who are able to solve different mathematical activities and others who usually have some difficulty in carrying them out.

The data collection instrument considered the components of the HLT. It consisted of seven activities related to the key concepts underlying measurement: *recognition*, *comparison*, *ordering* and *iteration*. By way of an example, Table 1 presents instrument activities 1 and 3, consisting of the goal, the task, the description and a series of questions that guide the dialogue during its implementation.

	Goal	Activity	Description	Image	Dialogue
Recognition	Find out whether the child recognizes the attribute of length in objects. Assess whether the child is on the PR or R level.	Discussion about the length of pieces of string	Four pieces of strings are handed out, with different attributes: thickness, colour, and length. The idea is children talk about the attributes of the pieces of string during the activity and that they clearly refer to the notion of length.		What differences do you observe between these pieces of string? Are the four the same? How are they different? Can you see any other features that are different? How do you say it when they are different in their "bigness"?


Comparison	Find out whether the child can make indirect comparisons between objects in order to discover which is longer. Assess whether the child is at IC level.	Comparing pencils with a piece of string.	An object is placed on the table (notebook or box) that prevents the child from seeing both pencils at the same time. A pencil is placed on one side of the notebook and the child is asked to place his/her pencil on the other side. The child can look at and touch the pencils without moving them from their place. They can use any object they have available.		Can you use the piece of string to discover which pencil is longer? Can you use another object to measure them?

Table 1: Data collection instrument activities 1 and 3

The data collected came from 20 videos, one per student, lasting between 9' 21'' and 26' 28''. Each student was tagged with a number in chronological order. The analysis focused on the actions and processes performed by the children in order to situate their level (L) on the trajectory for each activity (Act.) carried out. Using the levels proposed by Clements and Sarama (2009), some indicators associated with each of the activities are described (Table 2).

Act.	L	Indicators
1	R	The student is capable of identifying the attribute of length
2	DC	The student is capable of making a direct comparison
3	IC	The student is either capable of making an indirect comparison or does not do so properly, but he/she certainly understands the notion that two objects can be measured using a third one in order to know which is longer
4	O	The student is capable of ordering the five strips using length as a criterion.
5	EE	The student takes into account the origin and purpose of the objects when measuring them but does not show any signs of understanding that the accumulation of units of measurement serves to measure the total length. He/she overlaps the units of measurement, leaves gaps between them, or does not show an understanding of the possible subdivision of units of measurement
6	EE/RR	The student takes into account the origin and purpose of the objects when measuring them and shows some signs of understanding that the accumulation of units of measurement serves to measure the total length. He/she does not perform the procedures needed to carry out the measurement in the right way (i.e. by avoiding overlaps, gaps and unequal positioning of units of measurement)
7	RR	The student takes into account the origin and purpose of the objects when measuring them, and shows that he/she understands that the accumulation of units of measurement serves to measure a total length

Table 2: Correspondence between activities and levels

Once the videos were transcribed, the dialogues generated by each activity were established as units of analysis. The information about each student was then organized according to the following

factors: the activity, the unit of analysis, the graphic evidence and the researchers' observations. At this point the level evidenced by the children in each unit of analysis was identified (Table 3).




Act.	Unit of analysis	Evidence	Observations	L
2: Direct comparison of two pencils	<p>Student: This one.</p> <p>Tutor: This one? How do you know?</p> <p>Student: Because this is the small one and this is the big one. Because this one is longer.</p> <p>Tutor: Ok, but how do you know? What did you do with the pencils to find out?</p> <p>Student: Measure them, and I saw (pointing to where the pencils are different) that this one was longer than that one.</p>		Lining up the ends	DC
5: Measuring pencils with paperclips	<p>Tutor: Why do you put them like that, on the other side too? Can you tell me what you're doing now?</p> <p>Student: That's it.</p> <p>Tutor: That's it? How many paperclips long is it?</p> <p>Student: (counts) 6.</p> <p>Tutor: 6? Ok</p> <p>Student: 1,2,3,4,5,6.</p> <p>Tutor: And why do you do it like that? Can you tell me?</p> <p>Student: Because I put them in 3s. 1,2,3, 1,2,3 and that's how I know.</p> <p>Tutor: Ok. And why have you put them on both sides. Wasn't one side enough?</p> <p>Student: No...</p> <p>Tutor: Did you have to put them like that?</p> <p>Student: Yes, I had to put them like that.</p> <p>Tutor: (...)</p> <p>Student: I think it's 6 metres.</p> <p>Tutor: 6 metres? Or 6 paperclips?</p> <p>Student: Well, 6 metres I think</p>		<p>The student places them at an equal distance but on both sides. She always uses paperclips of the same size.</p> <p>She leaves gaps between the paperclips. The student does not take into account the beginning and the end of the pencil.</p> <p>She does not understand the accumulation of units of measurement because if she did she wouldn't measure the pencil on both sides.</p>	DC /IC /O
7: Measuring pencils with a ruler	<p>Student: It measures a 1 and a 7.</p> <p>Tutor: A 1 and a 7. Do you know what number that is? A 1 and a 7?</p> <p>Student: Twenty.... seven? Isn't it?</p> <p>Tutor: I don't know, I'm asking you....</p> <p>Student: 17.</p> <p>Tutor: 17 what?</p> <p>Student: 17 metres.</p>		<p>The student puts the pencil under the ruler. She lines up the beginning with the ruler.</p> <p>This is the only moment when we see EE.</p>	EE

Table 3: Example from analysis instrument corresponding to student A10

Results

The results of this research visualise the individual trajectory of each student and these trajectories provide a characterization that encompasses the whole sample. Thus, it can be seen in Table 3 that student A10 is capable of recognizing the attribute of length, of making direct and indirect comparisons, and ordering. To contrast the hypothetical learning trajectory with the real trajectory of each student, we drew up a two-dimensional adhoc graph that relates the activities to the levels.

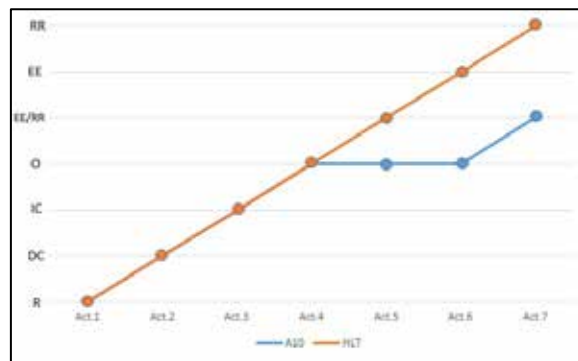


Figure 1: Real learning trajectory of student A10 in relation to the HLT

According to Figure 1, student A10 performs the first activities (Act 1 - Act4) in consonance with the HLT. However, in the activities geared towards measurement levels (Act 5 - Act 7) there is no consonance. As shown by the data collected in Table 3 and Figure 1, we can position student A10 on the IC level. At this level children are able to use rulers but often show a lack of understanding or ability. We only find student A10 performing actions on the objects on the EE level during the last activity.

It is important to clarify that the purpose of the graph contrasting the HLT with the real trajectory (Figure 1) is to provide a visual overview that shows where each child is situated during the performance of each activity. For this reason, although the transition from one level to another is not always the same, when drawing up the graph the levels have been positioned equidistantly. This makes the HLT appears to rise on a steady gradient, which is not really the case.

In Figure 2, the results obtained by the sample are presented visually, indicating in what levels the students are for the set of activities. Each point on the graph represents one student's level in each of the respective tasks of the instrument.

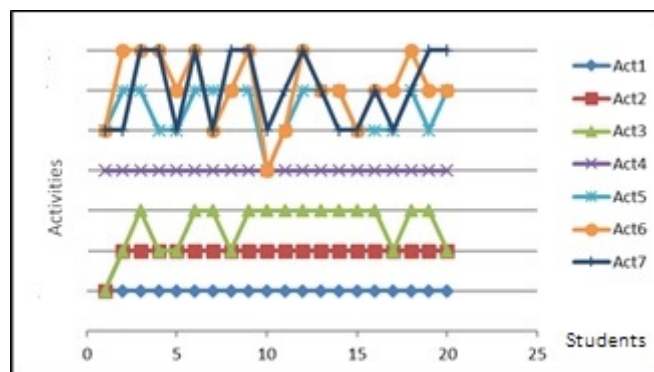


Figure 2: Learning trajectories in the sample

Once the individual trajectories of the children had been established, it was observed that 70% of the group were either moving between the EE and RR levels or on the RR level. Only 20% showed no signs of the RR level, with 15% located at the EE level and 5% at the CI level. On the other hand, we can see that in activities 5, 6 and 7 related to the levels of measurement, the students were moving between the EE, EE/RR and RR levels but they did not necessarily stay at the same level during the performance of the three activities. In activities 1 and 4 all students were situated at the corresponding HLT levels. In Activity 2, all students except one were on the DC level.

Discussion

This study provides an overview of the group on the basis of the children's levels and trajectories. All the children, except one, were situated on levels EE and RR or were moving between them. According to Clements & Sarama (2009) and Barrett et al. (2012) children reach the EE level of measurement when around six years old and the RR level when around seven. This affirmation concurs with the data generated by this study. The transition between these two levels is very subtle and for this reason we decided to divide it into two sub-levels so that we could see more clearly where the children were situated.

During the analysis of the data, it was observed that children, although they are shown to be working mostly on one of the HLT levels, apply concepts and perform actions on the objects that correspond to levels considered higher. And, of course, they also apply strategies and perform actions on objects that belong to lower HLT levels (Sarama et al., 2011).

Once the data was analysed, we noted that despite the fact that all the children except one were above the EE level, not all of them were able to cope with the challenge of transitive inference. Although we are aware that the study is limited by the performance of only one activity linked to the IC during data collection, and the fact of working with only 20 children, in our case we suggest the following explanation: the EE level is either usually reached a little before the possibility of transitive inference, or work on specific mathematical experiences related to this inference is needed prior to its development. In this respect Sarama et al., (2011) conclude in their study: "(...) children achieved the Indirect Length Comparer level of thinking just prior to the End to End measurer level" (p. 678).

In this study we found students who, despite being mostly on the RR level, were not able to make explicit transitive inferences. This finding also supports the idea that children do not need to acquire conservation, nor the concept of transitivity, in order to acquire certain notions about measurement (Hiebert, 1981; Clements, 1999, cited by Sarama et al., 2011).

It is noteworthy that in this type of study is relevant to consider the influence of the interaction between the child and the tutor, as it could make a difference in the evaluation of actions in the various activities. In some cases, this could be considered a limitation of the study. In our case, the tutor who participated is a teacher who knew the children and was involved in the research.

A knowledge of the Hypothetic Learning Trajectory and its levels can enhance the teaching of length measurement (Barrett et al., 2012). This study showed us where the six-to-eight-year-olds in our sample were situated and which mathematics topics demand greater attention to enable them to move on to the next level of the trajectory and thereby consolidate their learning.

Acknowledgement

This work is part of projects: EDU2015-65378-P and EDU2013-46083-R, MINECO/Spain

References

- Antonopoulos, K. Zacharos, K. & Ravanis, K. (2009). Measurement activities and teaching interaction in early childhood education. In M. Paramythiotou & C. Angelaki (Eds.), *European regional conference "Current Issues in Preschool Education in Europe: Shaping the Future"* (pp. 55–63), Syros, Greece: OMEP.
- Barrett, J. E., Sarama J., Clements, D. H., Cullen, C., McCool, J., Witkowski-Rumsey, C., & Klanderma, D. (2012). Evaluating and improving a learning trajectory for linear measurement in elementary grades 2 and 3: A longitudinal study. *Mathematical Thinking and Learning*, 14(1), 28–54.
- Battista, M. T. (2006). Understanding the development of students' thinking about length. *Teaching Children Mathematics*, 13(3), 140–146.
- Benz, C. (2012). Attitudes of Kindergarten Educators about Math. *Journal für Mathematik-Didaktik*, 33(2), 203–232.
- Buys, K. & de Moor, E. (2005). Domain description Measurement. In M.van den Heuvel-Panhuizen and K. Buys (Eds.), *Young Children Learn Measurement and Geometry. A Learning-Teaching Trajectory with Intermediate Attainment Targets for the Lower Grades in Primary School* (pp.15–36). Rotterdam, The Netherlands: Sense Publishers.
- Chamorro, M. C. (2003). *Didáctica de las matemáticas para primaria*. Madrid, Spain: Pearson Educación.
- Clements, D. H. & Sarama, J. (2007). Early Childhood Mathematics learning. In F. Lester (Ed.), *Second handbook of research on mathematics teaching and learning* (pp. 461–555). New York, NY: Information Age Publishing.
- Clements, D. H. & Sarama, J. (2009). *Learning and teaching early math: The learning trajectories approach*. New York, NY: Routledge.
- Copley, J. V. (2006). *The young child and mathematics*. Washington, DC: NAEYC.
- Hiebert, J. (1981). Cognitive development and learning linear measurement. *Journal for Research in Mathematics Education*, 12(3), 197–211.
- Piaget, J., Inhelder, B. & Szeminska, A. (1960). *The Child's Conception of Geometry*. London, England: Routledge & Kegan Paul.
- Sarama, J., Clements, D.H, Barrett, J., Van Dine, D. W. & McDonel J. S. (2011). Evaluation of a learning trajectory for length in the early years. *ZDM Mathematics Education*, 43, 667–680.
- Simon, M. A. (1995). Reconstructing mathematics pedagogy from a constructivist perspective. *Journal for Research in Mathematics Education*, 26(2), 114–145.
- Smith, J. P., van den Heuvel-Panhuizen, M. & Teppo, A. (2011). Learning, teaching, and using measurement: introduction to the issue. *ZDM Mathematics Education*, 43, 617–620.

Chances and obstacles of ‘indirect’ learning processes in situations with preschool teachers

Anna-Marietha Vogler

Goethe University Frankfurt, Germany; vogler@math.uni-frankfurt.de

From a co-constructive perspective, interactions are key variables for learning processes. In the context of learning preschool mathematics, these interactions are often characterized by ‘indirect’ negotiations of mathematical meaning: while, on the surface, everyday problems are discussed, ‘mathematically rich contents’ are nevertheless involved and negotiated latently in these interactions. The following paper focuses on such interactions that emerge in situations with preschool teachers and children in self-designed learning situations in German “Kindergärten”. I will point out how different forms of interactive support entail different opportunities for the children to participate in the interaction and especially in the ‘mathematically rich contents’ of the ‘indirect’ learning situations.

Keywords: preschool teacher, interaction, indirect learning processes.

Introduction

For children, entering primary school is not the first time when they learn mathematics. It is rather the preschool or the family context in which children collect first experiences with mathematics. Compared to a time when toddlers and infants were seen as mostly incapable of learning mathematics, today, the appraisal changed to the concept that mathematics is - besides the early learning of the mother tongue - an important topic to learn and that the early years are a sensitive period for learning it. In addition to the early learning at home, learning mathematics in preschool has been a field of increasing attention over the last decades. While learning at home with parents and siblings is surely a formative learning context, learning in kindergarten is also an important factor for children’s learning biographies: it is the first time of institutional learning for young children and also builds a crucial basis for future schooling (Claesens & Engel, 2013). Hence, the question arises regarding how mathematics learning can be integrated and supported in preschool to make use of this ‘potential’.

From an educational point of view, preschool teachers play an important role in supporting young children’s learning. Preschool teachers are major attachment figures as well as “more competent others” (Vygotsky, 1979) who support children in their interactive learning processes. For this reason, the following paper focuses on these interactions between preschool teachers and children. The analyzed interactions take part in the self-designed learning situations of the preschool teachers. But, while some researchers observe, analyze and evaluate teaching and the quality of preschool teachers acting and content knowledge, below, the interplay and the negotiation of meaning between the preschool teachers and the children is centered. There is a particular situation on which this paper focuses in which so-called ‘indirect’ learning processes take place and mathematical meanings are not explicitly negotiated, but rather implicitly involved within the interaction. This focus is chosen because indirect learning can be considered as characteristic for co-constructive learning processes since it conforms with ‘discovery learning’. But, missing explicitness within the process of

negotiation of meaning cannot only be seen as characteristic; from some perspectives, it can also be perceived as an obstacle for learning. On the one hand, it can be obstructive if learners are not able to interpret the ‘hidden’ meaning and, as a result, cannot participate in the learning process. On the other hand, it is also hindering if the “more competent other” is not able to recognize what the learner associates with the interaction. Hence, it seems fruitful to examine to which extent mathematical interactions between preschool teachers and children are characterized by missing explicitness and whether this form of indirect interactive learning is really an obstacle for learning. An important consideration is the kind of supportive guidance from preschool teachers that helps children to discover also ‘hidden’ meanings.

Preschool learning and curricula in Germany

In response to the low performance of German learners in international comparative studies such as PISA and the already existing curricula for preschool learning in other countries, Germany has also, since the early 2000s, established different ‘curricula’ for “Kindergärten” (meaning: preschool) and “Kindertagesstätten” (meaning: day care centers) for children 0 to 10 years in each of its states. Concerning mathematics, there is more or less concrete advice regarding how to ‘teach’ different mathematical contents. Co-constructive learning is picked out as a central theme for all contents in all these curricula. Thus, even mathematics should be learned within situations where children are actively helping to shape the interactional process. Furthermore, several studies could prove that children develop a sustainable understanding of elementary mathematics by being integrated in such co-constructive learning processes.

Theoretical Framework

Co-constructive learning processes within the preschool context

Under the co-constructive approach, interactions are ‘key variables’ for learning (mathematics). Within these interactions, children actively construct meaning by themselves in interplay with others. From this perspective, learning is conceptualized as the increasing autonomy of participation within interactional practice (Sfard, 2008). Therefore, the more or less active participation in processes of negotiation about mathematical meaning gives learners the opportunity to also recognize mathematical contents as the interactive rules for presentation and interpretation. Concerning the learning of mathematics, the children should participate in interactions that can be characterized as ‘mathematically rich’ to develop mathematical meaning that is full of relations and outlives the situational context. Especially in preschool interactions, these mathematical meanings are not necessarily negotiated directly; rather mathematics “is, as knowledge of abstract relations, not directly accessible” (Steinbring, 2015, p. 281), and mathematical meaning is developed in a process of the increasing ‘mathematization’ of situated contexts. For primary school classrooms, Maier and Voigt (1989), were able to show that, in most situations, the teacher keeps the interaction going on rather than explicitly negotiating mathematical (complex) meaning. Even in preschool situations, teachers and children seem to negotiate mainly every day meanings like how to tidy up or how to play with different materials. While, on the surface, every day meanings are discussed, mathematically rich meaning is sometimes nevertheless (latently) involved. For mathematics, this conclusion seems to be obvious because, in some cases in mathematics, the concrete and every day meaning already contains

the general and abstract mathematical meaning. Hence, the concrete meaning superimposes the abstract. The result is a ‘double layer structure’ where learners can participate on both levels of the interaction – the concrete situational and the abstract mathematical meaning. However, successful mathematical learning can be characterized as an increasing participation on the (latent) *abstract* level of meaning – only, of course, when there is mathematical content contained on this level. But, which level of meaning is accessible for the learner depends on her or his subjective interpretations.

Indirect learning mathematics in the early years

Krummheuer (1997, p. 9) calls learning processes, which are characterized by this ‘double layer structure’ of the process of negotiation of meaning, “*indirect* learning processes” (Krummheuer, 1997, p. 9). In his approach of “the narrative character of learning”, he stresses that the indirect learning processes are characteristic of early learning in primary school. Krummheuer (1997) revealed that indirect learning processes are sometimes obstructive for learning because learners and teachers must have high interpretation competences to cope with this kind of learning (Krummheuer, 1997, p. 95). For mathematics learning in secondary school, other researchers also found evidence for cumbersomeness in indirect learning processes (e.g. Strähler-Pohl, Fernández, Gellert & Figueiras, 2014). Oevermann, Allert, Kunnau and Krambeck (1979, p. 384) more generally describe that children in their early ages often do not interpret meanings which are socially constructed and latently involved in interactions; rather, they perceive the meaning of interaction as naturally undistorted, and, so to speak, affectively truthful. In this synopsis on several studies on indirect learning processes, the following questions emerge:

- (1) whether early mathematical learning in *preschool* is also characterized by mainly indirect processes of negotiation of meaning, and
- (2) whether this kind of learning is a necessary obstacle for learning because it consequently drops children out from early learning mathematics.

From the findings above, the demand also evolves to analyze how preschool teachers can support children in indirect learning processes.

Methodology

To analyze the different direct and indirect processes of negotiation of meaning, a two-step analysis is implemented. In order to analyze the explicit processes of negotiation of meaning and the included opportunities of the children to participate, (1) the interactional analysis is used (e.g. Krummheuer, 1997). For the not explicitly negotiated but latently involved meanings, an extension of this analysis is needed, because interactional analyses mainly take *situational* processes into account that generate “taken as shared meanings” (Krummheuer, 1997). Thus, mathematical concepts or processes that are not negotiated explicitly within the situation cannot be analyzed in a sophisticated manner. Therefore, (2) the interactional approach is enlarged by elements from the objective hermeneutical approach as developed by Oevermann et al. (1979). This approach focuses on the “latent rules of the interactional system” that are characteristic of the indirect learning processes on which this paper focuses. Hence, the enlargement also provides the opportunity to even reconstruct meanings that originate from individual ‘fields of experiences’ (Bauersfeld, 1983). By this means, it is possible to also reconstruct the ‘hidden’ meaning of the interaction that originates from one of the participants of the interaction.

For this purpose, (linguistic) “markers” within the interaction are taken into account. These markers are words or phrases that are used by the recipients to interpret the meaning of a communication (Heller, 2015). The final ‘product’ of that analytical process is a reconstruction of different levels of interpretational perspectives that emerge in the interactions, which are summed up in the following matrix (e.g. Figure 1). With the help of this matrix, it is possible to determine (1) meanings that are latent, which means they are not explicitly negotiated and interpreted in the interaction and only reconstructed by the so-called markers, (2) explicitly negotiated meanings, called manifest, that are interpreted by the participants in the situation, as well as (3) manifest meanings that are negotiated and that have trans-situational origins, and (4) latent meanings that can be only understood with the help of knowledge outlying the situational process and stems from a wider knowledge background.

	situational	trans-situational
latent meanings	<i>situational, latent fields of experience</i>	<i>trans-situational, latent fields of experience</i>
manifest meanings	<i>situational manifest fields of experience</i>	<i>trans-situational manifest fields of experience</i>

Figure 1: Representation of the different levels of interpretational perspectives

The situational and also trans-situational latent levels of interpretational perspective are both levels of the interaction that are more or less implicit. In the following sections, I will summarize how these levels of interpretational perspectives can be found in a situation with preschool teachers and how indirect learning processes take place in these situations.

Empirical Results - Obstacles and chances of indirect learning processes

The presented empirical data is part of the erStMaL study (*early Steps in Mathematics Learning*) at the IDeA center (*Individual Development an Adaptive Education of Children at Risk*)¹. Within the study, the research team encouraged 25 preschool teachers from different “Kindergärten” to develop and implement mathematical situations with groups of two or four children by themselves each year (from 2009 to 2012). Therefore, the teachers were asked to create the situations in reference to one of the five mathematical domains. The situations are videotaped and transcribed. One of these situations is presented below. The situation can be seen as a paradigmatic example of ‘successful’ learning situations in preschool – even if that is not directly obvious.

“Which are belonging together? ... Compare!” – Increasing autonomy through constancy of the level of latent meaning

The analyzed situation takes place with four children from a kindergarten in Germany: Hannah (3.3 years), Michael (3.7 years), Bettina (4.7 years) and Martha (5.3 years); and their preschool teacher Nicola. The materials which are used include two green paper circles with different diameters (0.5m and 1.0m) and a burlap sack which is filled with ten different yet pairwise similar objects - in each case in two different sizes. In the following described scene, two nails (3cm and 5cm) and two building blocks (15x7x4cm and approx. 5x3x2cm) are mentioned. The blocks, as well as the nails are lying together with the other, yet pairwise similar objects on the two paper circles (e.g. Figure 2).

During the time of the situation, the children are sitting on a carpet together in front of the paper circles with the teacher.



Figure 2: Arrangement of the objects on the paper circles

At the beginning of the scene, the kindergarten teacher Nicola asks the children to find two things that belong together. She asks: “And which are belonging together?”. After a girl, Bettina, pointed at two building blocks, Nicola continues with her instructions.

Scene 1

- 456 Nicola: Take a look Bettina. (.) Put two things together. Here we make a line.²
 457 *pointing with her finger in a line right beside the paper circles parallel to the edge of the carpet ...*
 459 Start right here.
 460 *pointing at one point near the edge of the carpet*

In line #456, Nicola instructs Bettina to locate (the) objects on the edge of the carpet where they are separated from the paper circles. She says that they have to be located in a line. She marks with a gesture the starting point of the array and the accompanying expression: “start right here” #459.

- 469 Bettina: *placing the bigger pin to the place that is marked second and the smaller pin to the place that is marked first by the nursery teacher*
 470 Nicola: Exactly! This way.
 471 *adjusts the pins on the carpet the way that they are lying parallel to the edge of the carpet and the heads of the pins are abreast*
 472 Who wants to search for two things that belong together now?

When Bettina lays down the nails #469 on the positions marked by Nicola in #460, the teacher corrects the arrangement by putting the nails side by side until the nails are parallel to each other and the carpet’s edge. She additionally confirms the successful ending of the task through her expression “Exactly! This way!” in #471 and asks the kids who would like to find the next objects that belong together in #472. In the next scenes, the kids position pairs of objects on the carpet in a line with the first two nails. Later on, the children compare the objects in the different lines and the teacher Nicola accompanies these interactions linguistically using phrases like ‘which is the biggest’ and other superlatives that underline the process of comparing.

Scene 2

- 583 Nicola: What **else** can we do with it? Does anybody have an idea?
 584 Martha: Compare.
 585 Nicola: Compare! How would you do that, Martha? (...)
 586 Martha: There you can see it. It is beautiful like that.
 587 Nicola: mh?

- 588 *turning to Martha*
 589 Martha: It is beautiful like that. ...
 592 Nicola: The way it is lying here or different? (..)
 593 Martha: The way it-
 594 *she squirms*
 595 Bettina: is lying there.
 596 Nicola: The way it is lying here?
 597 Martha: mh!
 598 Nicola: okay! mhhh (5 sec) now (.) which is the absolutely biggest of the things?

In that scene, Nicola asks the children about the use of the two ‘lines’ of objects lying on the carpet. Martha specifies the use as ‘comparing’ #584. But, after Nicola asks for the way to compare, the girl astonishingly replies that one can see it because it is beautiful #586. And the girl maintains her opinion, although Nicola asked again – probably to change Martha’s mind. Bettina even agrees with Martha #595. At the end of the episode, Nicola modified her question and explicitly asked for the biggest ‘size’ #598.

Reconstruction of the different levels of meaning

Nicola’s last turn, in line #598, particularly provides evidence that there is also a latent meaning involved in the interaction in Scene 2, as well as in Scene 1. On the surface, it could be interpreted that Scene 1 deals with putting nails on a carpet, but, on the latent level of the interaction, especially in Scene 2, it is understood that the preschool teacher Nicola introduces an early concept of ‘size’ by directly comparing objects of equal shapes and different sizes. The latent meanings are also revealed *within* Scene 1. This can be mainly interpreted from the marker in line #472. Based on this marker and the interpretations from the other scene (amongst others, #583-598), different levels of the negotiated meaning can be reconstructed. They are presented in the following matrix.

	situational	trans-situational
latent meanings	One big and one small pin from the paper pad should be placed on the carpet at a time	Two objects of similar shape and different size are building a pair and should be placed to visualize the exact geometrical difference in size in order to enable a direct mathematical comparison
manifest meanings	The pins are placed on the carpet Marker: <i>Nicola adjusts the pins on the carpet so that they are lying parallel to the edge of the carpet and the heads of the pins are abreast #471</i>	

Figure 3: Representation of the different levels of negotiation of meaning in Scenes #456 - 472

Three of the latent and manifest levels in Scene 1, from #456 to #472, can be reconstructed: on the manifest and situational level of interpretation, Nicola and the kids ostensibly put some objects in order, but, on the latent level, it is obvious that, within the interaction, the preschool teacher also tagged on mathematical issues concerning size. Thereby, an interpretation of these mathematical themes is possible on the situational level. Here, it is perceptible that two similar objects are belonging together because they are equal in shape and different in size. Together with the interpretations of the

second scene, from #583 to #598, the mathematical theme is additionally enlarged. The preschool teacher Nicola also addresses direct comparisons and size. This interpretation is only possible with the knowledge about the mathematical concepts.

Participation and Support

When looking at the participation of the children, it becomes apparent that the girl, Bettina, first participates on the level of manifest meaning where the (right) placement of pins is negotiated - although she could interpret the latent meaning as well. In Scene 2, it is Martha who describes the use of the lines and manifests the meaning, which is also latently involved in Scene 1. Additionally, Martha characterizes the arrangement of the objects in two lines (side by side) as beautiful. Thereby, she introduces a further aspect to the interaction that can be interpreted as profound from a mathematics perspective: one could say she described a kind of mathematical well-ordering with words of the aesthetic kind (e.g. Sinclair, 2006) when she says the lines can be compared because they are beautiful #586. As the second scene shows, the girl Martha, and maybe also Bettina, participate as a result of the 'rich' mathematical contents of the interaction and rather manifest them over time. In addition, they contribute some own mathematical ideas in the form of the aesthetic of the lines which are to be compared. It can be assumed that the increasing autonomy of the children emanates from the coherence of latent meaning throughout the situation, which is maintained by Nicola. She supports the children by consequently focusing on the size of the objects and the direct comparison. Unfortunately, she does not recognize Martha's idea #586. Further, it can be supposed that the 'double layer structure' of the indirect process of negotiation of meaning, which can be analyzed in Scene 1 in Figure 2, is supportive because it helps the children to participate over time. As does Bettina, for example, the children get the opportunity to be active on the manifest level of the interaction on which every day meanings are negotiated, while they can also interpret the latent meanings which are more abstract and maybe 'hard' to understand. In the course of the ongoing situation, a bunch of markers open several opportunities for the child to participate on more than just the every day level.

Discussion

The aim of this paper was to examine whether learning processes in preschool situations with teachers and children can be characterized as 'indirect' and whether that has to be seen as an obstacle for the participation of children. While the indirect processes of learning in the context of school are seen as repressive for learning (e.g. Strähler-Pohl et al., 2014), the analysis of the situation provides evidence that indirect learning in preschool situations can be seen as a chance for children to participate and 'learn over time'. Crucial for the success of this learning over time is a 'double layer structure' of every day meanings and abstract mathematical meaning. Thereby, especially the latent and abstract mathematical meaning has to be coherently introduced throughout the whole situation. Thus, the learners can discover the mathematics and mathematize their everyday experiences over time. By means of such a 'supportive' structure, maybe even 'struggling' learners could have the opportunity to participate (somehow) within the interaction and recognize further latent meanings later on. Of course, that structure also involves risks for the learning processes of young learners, because they can be unable to perceive the meaning of the markers that lead them to the further implicated

meanings, as many studies observe. Further analysis should show, how other interactional aspects could also support the interpretation process of young learners.

Notes

1. For more information, please visit: www.idea-frankfurt.eu
2. All characteristics of the spoken language (mistakes) are mentioned in the translation of the transcribed sequence. Pauses within the speech are coded using a dot for every second in round brackets. All names were made anonymous.

References

- Bauersfeld, H. (1983). Subjektive Erfahrungsbereiche als Grundlage einer Interaktionstheorie des Mathematiklernens und -lehrens. In H. Bauersfeld & u.a. (Hrsg.), *Lernen und Lehren von Mathematik*. Köln, Germany: Aulis.
- Claesens, A., & Engel, M. (2013). How important is where you start? Early mathematics knowledge and later school success. *Teachers College Record*, 115(6), 1–29.
- Heller, V. (2015). Academic discourse practices in action: Invoking discursive norms in mathematics and language lessons. *Linguistics and Education*, 31, 187–206.
- Krummheuer, G. (1997). *Narrativität und Lernen. Mikrosoziologische Studien zur sozialen Konstitution schulischen Lernens*. Weinheim, Germany: Deutscher Studien Verlag.
- Maier, H. & Voigt, J. (1989). Die entwickelnde Lehrerfrage im Mathematikunterricht, Teil 1. *Mathematica Didactica*, 12(1), 23–55.
- Oevermann, U., Allert, T., Konau, E. & Krambeck, J. (1979). Die Methodologie einer objektiven Hermeneutik und ihre allgemeine forschungslogische Bedeutung in den Sozialwissenschaften. In H.G. Soeffner (Ed.), *Interpretative Verfahren in den Sozial- und Textwissenschaften*, (pp. 352–434). Stuttgart, Germany: J.B. Metzlersche Verlagsbuchhandlung.
- Sfard, A. (2008). *Thinking as communicating. Human development, the growth of discourses, and mathematizing*. Cambridge, England: Cambridge University Press.
- Sinclair, N. (2006). *Mathematics and beauty: Aesthetic approaches to teaching children*. New York, NY: Teachers College Press.
- Steinbring, H. (2015). Mathematical interaction shaped by communication, epistemological constraints and enactivism. *ZDM: The International Journal on Mathematics Education*, 47(2), 281–293.
- Strähler-Pohl, H., Fernández, S., Gellert, U., & Figueiras, L. (2014). School mathematics registers in a context of low academic expectations. *Educational Studies in Mathematics*, 85(2), 175–199.
- Vygotsky, L. S. (1979). *Mind in society. The development of higher psychological processes*. Cambridge, MA: Harvard University Press.

Developing a social training of spatial perception and spatial cognition

Martina Wernicke¹, Jasmin Kizilirmak¹, Barbara Schmidt-Thieme² and Kristian Folta-Schoofs¹

¹ Neurodidactics & NeuroLab, Institute of Psychology, University of Hildesheim, Germany;
wernicke@uni-hildesheim.de; kizilirmak@uni-hildesheim.de; foltak@uni-hildesheim.de

² Institute of Mathematics and Applied Computer Science, University of Hildesheim, Germany;
bschmidt-thieme@imai.uni-hildesheim.de

Keywords: Preschool education, cognitive development, spatial ability

Introduction

Numerical magnitude understanding by young children, ways of stimulating this f.e. with intervention programs and their impact on future mathematics achievement, started in cognitive neuropsychology, is now a virulent field of research in the didactics of mathematics. Some others like pattern and structure assessment (Mulligan et al., 2015) or the role of executive functions in mathematics achievement (Van Dooren & Inglis, 2015) are getting more attention recently, linking mathematics education and neuropsychology again. Neuropsychological evidence suggests that abilities of processing spatial information play a significant role in grasping magnitudes and emphasize the potential benefit of promoting their development early on (Verdine et al., 2014). However, studies have still to attest a beneficial value of trainings for spatial abilities. The current study focuses on the development and evaluation of such a training program for preschoolers. The training was developed on the bases of two trainings designed for children with constructional apraxia (Schroeder, 2015; Muth et al. 2001). Constructional apraxia is a visuomotor disorder with deficits in perceiving the extrapersonal space and building/drawing objects (Hanser, 2000). Tasks within these trainings focus on the perception of shapes, angles, lengths and spatial axes, cognitive processes like mental changes in perspective, spatial orientation and navigation as well as the construction of 2- and 3-D objects. Materials and tasks were partially derived, adjusted in difficulty and modified to fit in a coherent 10-days training with 27 consecutive tasks. Afterwards, the training was reviewed by preschool teachers, revised and implemented for evaluative purposes.

Methods

Six daycare centers with 60 preschoolers (31 males; ages from 5.5 to 7.2 years; $M_{age} = 6.2$) participated. Thirty-seven children received the training (EG; experimental group), while 23 children resumed their normal day routine (CG; control group). Before and after the training, performance tests (sustained attention: DL-KG, numbers and magnitudes: ZAREKI-K, motor skills: M-ABC-2, intelligence: CFT) were applied to measure training effects. In addition, preschool teachers were asked to evaluate the improvements of each child during this period on targeted skills (spatial perception, spatial imagination, math skills, fine and gross motor skills, social skills) and not targeted skills (artistic skills, verbal skills) on stepless scales between “degraded” and “improved”. For further improvement of the training, teachers rated each task on stepless scales between “adverse” and “beneficial” for target skills. All stepless scales deliver values between -5.0 and +5.0. They also assessed difficulty, excitement and entertainment value of each task as indirect moderators of general learning success (e.g. via motivation and attention) on 5-point Likert scales.

Results

MANOVAs were applied to reveal training effects (EG > CG) on improvement ratings. A significant effect of the training was found for target skills, $V = .88$, $F(6,5) = 6.62$, $p = .03$. The univariate F tests showed a significant difference between EG and CG for spatial perception, $F(1,10) = 9.93$, $p = .01$, $\eta^2 = 0.49$ and spatial imagination, $F(1,10) = 6.11$, $p = .03$, $\eta^2 = 0.38$. Due to unevenly distributed missing values, pre-post improvements were contrasted between EG and CG with t -Tests, revealing benefits for intelligence (CFT; $t(42) = 1.81$, $p = .04$) and a tendency for higher improvements of sustained attention (DL-KG; $t(52) = 1.47$, $p = .07$) in the EG.

On average, the training was rated as beneficial (+2.8) by preschool teachers. Each task was considered beneficial (> +2.5) for at least one target skill. The difficulties of 9 tasks need to be increased. Ratings of excitement were mainly mediocre. The entertainment value of 19 tasks was rated positive.

Discussion

Overall, beneficial effects of the training were reported by subjective teacher ratings for spatial perception and imagination. Furthermore, intelligence increased more strongly in children with the training. Considering the relation between intelligence, working memory and mathematical abilities (Alloway & Alloway, 2010) this training-related increase might also be moderated by an increase in math skills. Developing a specific diagnostic tool for spatial abilities as well as applying follow-up tests might be promising to reveal objectively measured benefits for targeted skills. As one main goal of the current survey, feedback revealed several approaches for improving the effectivity of the training and thereby paving the way to the next phase of the evaluation.

References

- Alloway, T. P., Alloway, R. G. (2010). Investigating the predictive roles of working memory and IQ in academic attainment. *Journal of Experimental Child Psychology*, 106(1), 20–29.
- Hanser, H. (2000). *Lexikon der Neurowissenschaft*. Berlin, Germany: Spektrum.
- Mulligan, J. T., & Mitchelmore, M. C., & Stephanou, A. (2015). *Pattern and structure assessment (PASA): An assessment program for early mathematics (Years F-2) teacher guide*. Melbourne, Australia: ACER Press.
- Muth, D., Heubock, D., Petermann, F. (2001). *Training für Kinder mit räumlich-konstruktiven Störungen*. Göttingen, Germany: Hogrefe.
- Schroeder, A. (2015). *Klabauter: Neuropsychologisches Therapieprogramm für Kinder mit räumlich-konstruktiven Störungen*. Dortmund, Germany: Verlag Modernes Lernen.
- Van Dooren, W., & Inglis, M. (2015). Inhibitory control in mathematical thinking, learning and problem solving: A survey. *ZDM Mathematics Education*, 47(5), 713–721.
- Verdine, B. N., Golinkoff, R. M., Hirsh-Pasek, K., Newcombe N. S., Filipowicz, A. T., Chang, A. (2014). Deconstructing Building Blocks: Preschoolers' spatial assembly performance relates to early mathematical skills. *Child Development*, 85(3), 1062–1076.

TWG14: University Mathematics Education

Introduction to the papers of TWG14: University Mathematics Education

Alejandro S. González-Martín¹, Irene Biza², Jason Cooper³, Imène Ghedamsi⁴, Ghislaine Gueudet⁵, Vilma Mesa⁶, Alon Pinto⁷ and Olov Viirman⁸

¹Département de Didactique, Université de Montréal, Canada; a.gonzalez-martin@umontreal.ca

²School of Education and Lifelong learning, University of East Anglia, UK; i.biza@uea.ac.uk

³Department of Science Teaching, Weizmann Institute of Science, Israel;
jason.cooper@weizmann.ac.il

⁴Department of mathematics, University of Tunis, Tunisia; ighedamsi@yahoo.fr

⁵CREAD, ESPE de Bretagne, Université de Brest, France; ghislaine.gueudet@espe-bretagne.fr

⁶ School of Education University of Michigan-Ann Arbor, USA; ymesa@umich.edu

⁷ Department of Science Teaching, Weizmann Institute of Science, Israel;
alon.pinto@weizmann.ac.il

⁸Department of Electrical Engineering, Mathematics and Science, University of Gävle, Sweden;
olov.viirman@hig.se

Keywords: University mathematics education, transition to and from university, resources in university mathematics, mathematics in non-mathematics disciplines, university teachers' practices and knowledge

Introduction

The TWG14, *University Mathematics Education* (UME), was launched in CERME7 (Nardi, González-Martín, Gueudet, Iannone, & Winsløw, 2011) showcasing the fast growth of research in UME and also the specificity of the research context. In particular, the abstract, formal nature of a significant portion of the mathematical content; the absence of national curriculum guidelines, and therefore the great variations in organization and practices across institutions; the general lack of professional development or of systematic preparation for teaching; and, the volume of content to learn in a short period of time, and the degree of autonomy expected from the students and faculty. The consolidation of this research area, both outside and inside CERME, was recognized by the ERME community in inviting the first, three-time leader of this TWG to present a summary of UME research as a CERME10 plenary lecture (Nardi, 2017). Moreover, an ERME Topic Conference, *International Network for Didactic Research in University Mathematics* (INDRUM) was launched in 2015 with two successful conferences ([INDRUM2016](#) and [INDRUM2018](#)) since then, with the first one leading to a [special issue](#) in the [International Journal of Research in Undergraduate Mathematics Education](#), the new journal in the UME field. Future developments include a forthcoming book on *Research and development in University Mathematics Education* (Durand-Guerrier, Hochmuth, Nardi, & Winsløw, in preparation).

The number of papers submitted to TWG14 has been increasing since its inception. This year, we received 52 paper and 13 poster submissions, with 35 papers and 15 posters presented at the

conference and published in the proceedings. Having received the largest number of papers in CERME10 and the second largest in CERME11, the number of papers led to the decision to split TWG14 into two isomorphic groups, TWG14A (18 accepted papers) and TWG14B (17 accepted papers) that ran in parallel; we held some common sessions during the conference. Each of the groups covered the same range of areas of research pertaining to UME, therefore the isomorphic label. The decision was prompted because splitting thematically would have resulted in losing perspective on the complexity of the issues that participants wanted to address. Furthermore, because the call for papers was open to a range of themes it would be unfair to assign contributions to a new group that might not align with the authors' original aim. This introductory paper summarizes the works presented in both groups organized according to the discussed themes, as well as the common discussions.

Some themes continue work from CERME10. For instance, we received a large number of papers focusing on students' learning of specific topics (10 papers), such as calculus, reasoning, and proof. We accepted seven papers proposing interventions, whereas in CERME10 we received five papers; however, relative to CERME10, the number of papers about teachers and their practices and about mathematics for non-specialists decreased from ten to four and from seven to two, respectively. We had two new themes: one on curriculum and resources and one on transition. In the next section, we briefly present the seven themes used to organize the work this year, with examples from paper contributions. It is important to note that many papers could fit in more than just one theme; this classification helped us to structure the presentations and the discussions during the sessions.

Themes and paper contributions

Students' learning of specific topics

Ten papers were classified under this theme: Aaten, Roorda, Deprez, & Goedhard; Gabel & Dreyfus; Herrera Alva, Figueroa, & Aguirre de la Luz; Kondratieva; Kontorovich; Lankeit & Biehler; Malaspina & Torres; Bašić & Milin Šipuš; Mkhathshwa; and, Pinto & Cooper.

Calculus was prominent in several papers (Aaten et al.; Herrera Alva et al.; Lankeit & Biehler; Malaspina & Torres; Mkhathshwa), with an increasing interest in two-variable calculus (Malaspina & Torres; Mkhathshwa) and analysis (Kondratieva). Under-researched topics were also present: differential geometry and its connections with two-variable calculus (Bašić & Milin Šipuš) and the use of conventions (Kontorovich). We also received papers addressing reasoning and proof (Gabel & Dreyfus; Pinto & Cooper).

Some of the papers discussed in this theme also concerned questions related with teachers and teaching. For instance, an intervention to improve in-service teachers' comprehension of discontinuity in one or two variables was also presented (Malaspina & Torres), as well as studies about the challenges in providing feedback that is actionable by students when revising a proof (Pinto & Cooper) or when teaching proofs (Gabel & Dreyfus). These last two studies raised questions in relation to the teaching of, and communication about, proof relevant to other themes we discuss below.

Resources and curriculum

Five papers were discussed in this theme: Bosch, Hausberger, Hochmuth, & Winsløw; Howard, Meehan, & Parnell; Pepin & Kock; Sabra; and, Viirman & Jacobsson.

From a student perspective, but also in relation to lecturers' intentions, Pepin and Kock explored what type of resources first year engineering students use and how they use/orchestrate these resources for their study of mathematics. They found that students' type and use of resources varied in relation to the type of course and the lecturer's expressed expectations. In relation to assessment, Howard et al. discussed student engagement with resources and continuous assessment in a mathematics course for business students.

Some of the papers studied the relation of university mathematics instructors with resources. For instance, Viirman and Jacobsson put forward the role of the mathematical content in the didactical choices made by university mathematics lecturers in course design; they highlighted how differences in the epistemological character of the topics to be taught may have affected the course design. Similarly, Sabra showed how different teachers with different training may focus on different aspects of the content to teach using some resources.

Finally, Bosch et al. presented a study about the didactic transposition processes that lead to the creation of undergraduate mathematics programmes, which fills a gap on the rationale behind the creation of such programmes. Overall, the papers discussed in this theme show how the use of resources is related to learning and teaching practices, a question that was discussed in the other themes as well.

Transition

Four papers were discussed in this theme: Bampili, Zachariades, & Sakonidis; Bergsten & Jablonka; Doukhan & Gueudet; and, Pinkernell.

Different aspects of transition were present in these papers. For instance, Doukhan and Gueudet studied praxeologies in pre-university and university courses regarding the notion of random variable; they showed that the content learned in secondary school may not prepare students for tertiary courses. Regarding institutional support, Bampili et al. showed how institutional support (or the lack of it) at university can influence the trajectories of novice students. Furthermore, Pinkernell reported on a frame (WiGORA), founded on five characteristics of understanding mathematics, for supporting students' transition towards university mathematics.

Transition towards and within university courses has been investigated in the last years through several lenses. Bergsten and Jablonka presented a review of literature concerning the secondary-tertiary transition, referring to five theories. Their review evidenced that, while there is a move towards socio-cultural theorizing, some dimensions pertaining to social issues still appear under-researched.

Literature on transition addresses, in many cases, students' challenges. This calls for intervention, and some specific examples were discussed in the following theme.

Interventions

Seven papers were discussed in this theme: Feudel & Dietz; Florensa, Barquero, Bosch, & Gascón; Ghedamsi & Lecorre; Hochmuth, Schaub, Seifert, Bruder, & Biehler; Kuklinski et al.; Thomas, Jaworski, Hewitt, Vlaseros, & Anastasakis; and, Uysal & Clark.

A relatively recent approach to constructing interventions—framed by the Anthropological Theory of the Didactic (ATD)—is the study and research paths (SRPs); SRP is a specific form of inquiry-based intervention. Florensa et al. discussed ten years of SRPs implemented at university level, showing their utility as a methodological tool for the systematic design of interventions. Other interventions included the implementation of a coaching program to support conceptual learning in a first-year mathematics course (Feudel & Dietz) or innovative lectures that foster more social interactions and student engagement than traditional ones (Kuklinski et al.). These studies investigated the impact of the interventions on student engagement. Finally, Uysal and Clark reported on the use of history in learning mathematics and its potential to support mathematical and emotional aspects of students' transition from high school to university.

On a more theoretical level, Ghedamsi and Lecorre compared and contrasted the Theory of Didactical Situations (TSD) and ATD with the aim of combining them in the design of a teaching intervention on real numbers and sequences. Many papers presented in this theme were related to other themes. Hochmuth et al. presented the structure of a diagnostic and evaluative test that helps students decide about what bridging courses are more appropriate for them; this paper has connections to the transition theme as well. Thomas et al. presented a project involving a bridging module, and showed that student-partners in task design furthered their own understanding of the topics (complex numbers) and developed didactical insights when designing mathematical tasks for others; this paper has connections to the transversal issue of collaborations in UME.

Students' identity and experience

Three papers were discussed in this theme: Thoma & Nardi; Toor, Mgombelo, & Buteau; and, Voigt, Rasmussen, & Martínez.

Students' experiences were seen by Thoma and Nardi in relation to their participation in the mathematical discourse. They used the theory of commognition to study students' substantiation of claims in exam scripts, in a first-year course called "Sets, Numbers and Theory." They demonstrated that students' participation in mathematical discourse, at least in the exam, was mostly ritualized. On the other hand, Toor et al. studied the experiences of post-secondary mathematics students learning to use programming as a computational thinking instrument for mathematics. They argued that identity is essential to the development of productive dispositions in learning to program for mathematics investigation and modeling. The notion of identity was central in the work of Voigt et al. as well. Adopting a sociocultural perspective and the notion of *figured world*, they showed how three different variations in a calculus course can have an impact on a student's trajectory and relationship with mathematics.

Teachers and teaching

Four papers were discussed in this theme: Costa Neto, Giraldo, & Nardi; Mali, Cawley, Duranczyk, Mesa, Ström, & Watkins; Mesa, Duranczyk, Watkins, & AI@CC Research group; and, Stewart, Epstein, Troup, & McKnight.

The involvement of and the tension between different communities in relation to the teaching of mathematics was addressed by Costa Neto et al. Using a re-storying methodology, their study examined disputes between mathematicians and mathematics educators in Brazil over the curriculum of a pre-service teacher education program. Teaching at the post-secondary level is the focus of Mesa et al. who describe the development of an instrument for the evaluation of community college algebra instruction, Evaluating the Quality of Instruction in Postsecondary Mathematics (EQIPM), through the analysis of video recorded data that include codes for student-content, instructor-content and instructor-student interactions. Specifically, Mali et al presented two of the twelve characteristics of instruction included in EQIPM: *Instructors Making Sense of Procedures*, and *Student Mathematical Reasoning and Sense Making*. Although these characteristics can contribute to the quality of instruction, the authors showed that exemplary instances of instruction with these characteristics were relatively rare. Finally, Stewart et al. addressed the work of a mathematician preparing his course on eigenvalues and eigenvectors, showing how the use of some didactic constructs may be useful for the mathematician to organize content and to reflect on his practice.

Use of mathematics by non-mathematicians

Two papers were discussed in this theme: González-Martín & Hernandez-Gomes and Tetaj & Viirman.

Artigue, Batanero, and Kent (2007) stated ten years ago that the study of issues related to mathematics as a service course would certainly need the use of sociocultural approaches. This is the case of the two papers discussed in this theme. For instance, González-Martín and Hernandez-Gomes studied the teaching of mathematics to future engineers with an institutional perspective based on ATD. Using textbook analysis, they compared how the integral is taught in a calculus course and in a mechanics of solids course for engineers. The authors identified a rupture in the study of a similar task (the sketching of the graph of an antiderivative), likely to prevent students from using their calculus knowledge in professional courses. Tetaj and Viirman used the commognitive approach to analyze the mathematical discourse of undergraduate biology students. Their results showed students' tendency to develop a ritualized approach, as well as their difficulties to mathematize a biological phenomenon; their lack of familiarity with relevant construction routines may prevent them from developing abilities to deal with certain problems.

Transversal issues addressed in plenary discussions

Resources in university mathematics education

Research on resources and their use in UME is growing, with works investigating the use of textbooks (e.g., González-Martín, Nardi, & Biza, 2018; Mesa & Griffiths, 2012) and technology (e.g., Lavicza, 2010). Some authors consider a general concept of resource, as anything likely to re-

source the activity of a teacher (e.g., Gueudet, 2017) or a student (e.g., Gueudet & Pepin, 2018). Since CERME10, TWG22 has been dedicated to studies related to the use of resources in mathematics education, but, in TWG14, some papers explicitly or implicitly addressed resource use and analysis of resources. For instance, the design of interventions is linked to the design of specific resources and the teaching of mathematics for non-specialists uses particular resources. The discussions on this topic in TWG14 raised several questions. Choosing an appropriate definition of resource is a first complex step. Should this definition encompass mathematical knowledge, professional knowledge (in the case of teachers), or affect? Different definitions may be needed depending on the question studied. The question of the use of resources for the research activities of the lecturers, as well as lecturers' interactions (or absence of interactions) with resources for teaching also requires further study.

University mathematics: teachers and teaching

Relative to school settings, research on teachers and teaching is less common in UME (e.g., Speer, Smith III, & Horvath, 2010). In contrast, CERME has three groups dedicated to teachers and teaching (TWG18, TWG19, and TWG20), four if one counts assessment (TWG21). The growing interest of UME in this area is evidenced in our TWG14, which discussed some of the challenges of working at the intersection of university mathematics teaching and research in mathematics education (RME). To begin with, the conception of what it means to know mathematics at university may be quite different from conceptions that are common in pre-tertiary RME. As a result, the models of university-level teaching may not be consonant with theoretical models and frameworks that typically guide RME. This state of affairs can be particularly challenging for researchers who set out to investigate their own mathematics lecturing. Another type of challenge has to do with relationships between the two communities involved: university lecturers do not always value RME as a scientific field, while educational researchers are often critical of lecturers' approach to teaching. Thus, to support research-based professional development for university lecturers there is a need for teacher educators with expertise in both content and teaching, credentials that may be scarce. These challenges and others were addressed in TWG14 contributions, as summarized in the *Teachers and Teaching* section. Finally, many research works involving the study of practices (e.g., teaching, resource use, planning, and assessment) of mathematics lecturers and also mathematicians call for the development of fruitful collaborations.

Collaboration with mathematics lecturers, mathematicians, and other professionals in research and development in UME

Collaboration and relationships between mathematics lecturers¹ (ML) and mathematics education researchers have been addressed in UME research studies (e.g., Nardi, 2008). This collaboration can be seen from (at least) two different perspectives: (1) through the roles of each group in such collaboration (e.g., UME researchers researching the practice of ML; ML researching their own

¹ We use “mathematics lecturer” or “mathematics teacher” to refer to a person who teaches mathematics at university. This person may be active in research in mathematics or not.

practice in collaboration with UME researchers; or UME researchers and ML collaborating in UME research and development); and (2) through the contribution of research in UME to developmental projects in industry and practice (e.g., what is the ‘utility’ of research to practice?) and to mathematics teaching and curriculum development (e.g., how a research finding is transformed in order to be used as a curricular ‘product’?). Collaborations and tensions in such collaborations were addressed in contributions to this conference as we have exemplified in the themes above. The discussion on this topic had two directions: (a) theoretical and methodological tools that will help to study such collaborations and make them fruitful; and (b) the role and impact of theory in such collaborations, from the perspective of both UME researchers and ML. Indicative points raised in the discussion concerned the observation that collaborations engage communities with different practices, as a result we should work on the: need of theoretical tools to study collaborations; need for tools to study boundary crossing, even though the boundaries between the communities are not clear (e.g., ML may also be UME researchers); need of ways to identify the goals and expectations of different professionals (e.g., mathematicians, chemists, biologists, engineers, etc.) who are involved in such collaborations; and, a need for better understanding of institutional factors (e.g., institutions may or may not facilitate such collaborations).

Reflection and ways forward

We initiated the discussion in the concluding session of our work at the conference summarizing some of the main points of the chapter *Research on university mathematics education* (Winsløw, Gueudet, Hochmuth, & Nardi, 2018), published in the book celebrating twenty years of CERME. Winsløw et al. (2018) synthesize the main contributions of CERME to research in UME in terms of: (a) *what is it?*, namely research into current practices of UME (with no direct intervention), such as: mathematical content; methods and resources; transition phenomena; student experiences; and, teaching non-mathematics specialists; and (b) *what could it be?*, namely developmental or experimental research, that includes an intervention design as part of the research project (e.g., research on, and for innovation in UME; i.e., interventions in specific courses or programmes) and professionalization of UME practice (preparation of ML).

In our discussion in the concluding session we reflected on these areas as well as on the studies we discussed at the sessions and we suggested the following ways forward: 1) because many areas and topics of UME require the establishment of varied collaborations (with ML, mathematicians, engineers, school mathematics researchers) we need to develop theoretical tools to study these collaborations; 2) some papers presented an articulation or networking of different perspectives which could be a way to study complex phenomena (there were papers using “external” theories, e.g., sociology); 3) large-scale studies are needed to consolidate some results; 4) innovative methodologies are also being developed, such as those to study the use of digital textbooks; 5) most of the current studies in UME are local, and therefore, we need to develop studies and tools that help to transfer findings to other educational contexts; and 6) new topics appeared in this conference: the use of history of mathematics, curriculum design and its origin, the role of course coordinators. We predict more new topics will appear in the years to come. We anticipate that the coming CERME conferences will allow us to pursue research on the areas and questions discussed this year and to bring research on some of these areas forward.

References

- Artigue, M., Batanero, C., & Kent, P. (2007). Mathematics thinking and learning at post-secondary level. In F. K. Lester (Ed.), *Second handbook of research on mathematics teaching and learning: a project of the National Council of Teachers of Mathematics* (pp. 1011-1049). Charlotte, NC: Information Age Pub.
- Durand-Guerrier, V., Hochmuth, R., Nardi, E., & Winsløw, C. (Eds.) (in preparation) [working title *Research and development in university mathematics education*]. Routledge ERME Series: New Perspectives on Research in Mathematics Education Research.
- González-Martín, A. S., Nardi, E., & Biza, I. (2018). From resource to document: Scaffolding content and organising student learning in teachers' documentation work on the teaching of series. *Educational Studies in Mathematics*, 98(3), 231-252.
- Gueudet, G. (2017). University teachers' resources systems and documents. *International Journal of Research in Undergraduate Mathematics Education* 3(1), 198-224.
- Gueudet, G., & Pepin, B. (2018). Didactic contract at university: a focus on resources and their use. *International Journal of Research in Undergraduate Mathematics Education* 4(1), 56-73.
- Lavicza, Z. (2010). Integrating technology into mathematics teaching at the university level, *ZDM, The international journal on mathematics education*, 42(1), 105–119.
- Mesa, V., & Griffiths, B. (2012). Textbook mediation of teaching: An example from tertiary mathematics instructors. *Educational Studies in Mathematics*, 79, 85-107.
- Nardi, E. (2008). *Among mathematicians. Teaching and learning mathematics at university level*. New York: Springer.
- Nardi, E. (2017). From advanced mathematical thinking to university mathematics education: a story of emancipation and enrichment. In T. Dooley & G. Gueudet (Eds.), *Proceedings of the Tenth Congress of the European Mathematical Society for Research in Mathematics Education* (pp. 9-30). Dublin, Ireland: DCU Institute of Education and ERME.
- Nardi, E, González-Martín, A., Gueudet, G., Iannone, P., & Winsløw, C. (2011). University Mathematics Education. In M. Pytlak, T. Rowland, & E. Swoboda (Eds.), *Proceedings of the 7th Congress of European Research in Mathematics Education (CERME7)* (pp. 1923–1927). Rzeszów, Poland: ERME.
- Speer, N. M., Smith III, J. P., & Horvath, A. (2010). Collegiate mathematics teaching: An unexamined practice. *The Journal of Mathematical Behavior*, 29(2), 99-114.
- Winsløw, C., Gueudet, G., Hochmuth, R., & Nardi, E. (2018). Research on university mathematics education. In T. Dreyfus, M. Artigue, D. Potari, S. Prediger, & K. Ruthven (Eds.), *Developments in European Research in Mathematics Education - Twenty Years of Communication, Cooperation and Collaboration* (pp. 60-74). London and New York: Routledge.

How Lisa's mathematical reasoning evolved at undergraduate level – on the role of metacognition and mathematical foundation

Aaltje Berendina Aaten^{1,2}, Gerrit Roorda², Johan Deprez¹ and Martin Goedhart²

¹ KU Leuven, Belgium; aldine.aaten@kuleuven.be; johan.deprez@kuleuven.be;

² University of Groningen, the Netherlands; g.roorda@rug.nl; m.j.goedhart@rug.nl

Undergraduates' mathematical reasoning often lacks mathematical foundations and metacognition. This is worrying since it may negatively influence mathematics learning. Little is known however about whether and how undergraduates' reasoning foundations and use of metacognition evolve over time. In preparation of an educational intervention to enhance undergraduates' mathematical reasoning, we investigate the evolution of students' mathematical reasoning on calculus tasks during bachelor studies in mathematics, using a framework on mathematical reasoning we developed in an earlier stage. In this article, we discuss the case of Lisa to shed light on mathematical reasoning evolution, and on the role of mathematically founded reasoning and metacognition in this evolution.

Keywords: Mathematical reasoning, undergraduate students, calculus, metacognition.

Introduction

Since Lithner (2003, 2008) introduced his theoretical framework on mathematical reasoning, many studies have used his distinction between creative mathematically founded reasoning and imitative reasoning. Lithner (2003) showed how undergraduates' reasoning is often not mathematically founded, but instead relies on imitation of exemplary or recalled solution strategies. Jonsson, Norqvist, Liljekvist, and Lithner (2014) have investigated learning effects of tasks requiring creative mathematically founded reasoning and found that it enables students to solve the same task at a later point in time. For moderately non-routine tasks however, undergraduate mathematics students have difficulties to think of suitable strategies (Selden, Selden, Hauk, & Mason, 2000). To gain more insight into undergraduates' mathematical reasoning, also on moderately non-routine tasks, we investigated its development at undergraduate level at two research universities and used Lithner's ideas concerning creative mathematically founded reasoning as a starting point.

Framework to analyze mathematical reasoning

For our research, we used Lithner's (2008) concepts in a different manner than in the original framework, because of its limitations for characterizing any reasoning observed in students' task solving (Aaten, Deprez, Roorda, & Goedhart, 2017; Mac an Bhaird, Nolan, O'Shea, & Pfeiffer, 2017). From the single category of creative mathematically founded reasoning, we disentangled two dimensions: reasoning foundation and novelty. Furthermore, we added a third dimension: metacognition level. Building upon Lithner (2008), we define *mathematically founded reasoning* as reasoning in which decisions are based on mathematical properties that are relevant to the decision. *Superficially founded reasoning* is reasoning that is not mathematically founded. Lithner (2008, p. 266) defined *novel reasoning* in situations when "a new (to the reasoner) reasoning sequence is created, or a forgotten one is re-created". Since we encountered difficulties in discerning whether a

reasoning sequence is new or not, we choose to see novel reasoning as the opposite of recall, where *recall* means that a strategy is selected because the strategy was used before to solve similar tasks.

Metacognition levels

Since metacognition plays a central role in learning mathematics (Desoete & Veenman, 2006; Schneider & Artelt, 2010) it is important to include this aspect into our analysis. Several studies indicate that undergraduates' use of metacognition is limited (De Backer, Van Keer, & Valcke, 2012; Radmehr & Drake, 2017). However, not much research has been done on the evolution of metacognition during undergraduate mathematics courses. Since Flavell (1979) introduced the notion of metacognition, various conceptions have been developed. In this study we build upon research that distinguishes levels of metacognition explicitly, or implicitly by discerning types of metacognition or metacognitive behavior. Wilson and Clarke (2004) consider three aspects of metacognition: awareness, evaluation, and regulation, where *awareness* concerns the connection between the task at hand and past experience, *evaluation* is about the task solving actions just undertaken, and *regulation* anticipates specific task solving actions. In analyzing students' solutions, they discern regulation that builds upon awareness (e.g. retrieval of procedures) from regulation that builds upon evaluation of awareness, for instance, regulation as a "consequence of the need for a decision [...] as to how best to proceed" (Wilson & Clarke, 2004, p. 38). This distinction is similar to Koichu's (2010) distinction between circular heuristic behavior and spiral heuristic behavior. The former concerns employing strategies without building upon the intermediary outcomes, while the latter does build upon intermediary outcomes. Nunokawa (2005) similarly distinguishes initial problem analysis and knowledge application from problem solving by building upon obtained information, e.g. transforming the problem or finding new perspectives.

Based upon these models, we define two metacognition levels. *High-level* metacognition builds upon evaluation of components of the task solving situation. By task-solving components we mean the task itself, strategies that are used or considered, intermediary outcomes of strategies, and sub-goals formulated during task-solving. *Low-level* metacognition lacks such evaluation, for instance, if a student takes the decision to use a different strategy without reflecting upon what could be learned from the steps taken so far.

Research question

In the light of the above, we aim to answer the question: in what way do undergraduates' reasoning characteristics evolve over the course of bachelor studies in mathematics and what is the role of mathematical foundations and metacognition? In our larger study on undergraduates' mathematical reasoning when solving calculus tasks, we noticed how some students' reasoning barely evolved over the years, while the reasoning of other students did develop, even though the courses taken by the students, and the way the courses were taught (lectures and tutorials, a little project work), were similar. To answer the research question of this study, we focus on a student whose reasoning did evolve over the years: Lisa¹, who started off unsuccessfully but improved over the years is a bachelor

¹ Pseudonym

student in mathematics but has taken courses in econometrics before. In the first year of her mathematics studies, Lisa's average exam scores were low but sufficient to pass most exams.

Method

To investigate students' reasoning, the first author administered task-based think-aloud interviews in three different years. In each interview, Lisa solved three tasks, see Table 1. In post-interviews after each task, she explained her solutions and answered questions such as: 'How did you come to think of using this strategy?', 'How certain were you that this strategy would help you solve the task, and why?', 'Have you seen this type of task before?'. The interviews were video and audio recorded and transcribed.

	Y 1	Y2	Y3
A: $\int \frac{1}{1+e^x} dx$	X		X
B: $\int \frac{1+x^{1/2}}{1+x^{1/3}} dx$		X	
C: $\int \sqrt{9-x^2} dx$	X	X	X
D: $\int \sqrt{x^2-9} dx$	X	X	X

Table 1: Overview of tasks given to Lisa.

The tasks used are indefinite integrals that can be solved with methods from the first year course on integral calculus. We chose these tasks, because students had learned a large number of integration strategies they could choose from, and because we expected that these specific tasks would be difficult to many students. This would give rise to longer and more elaborate

CODE:	CODE ASSIGNED IF:
Mathematically founded reasoning	student explicitly gives relevant mathematical reasons for why the strategy selected will help to solve the task
Superficially founded reasoning	reasoning does not comply with the criterion for mathematically founded reasoning
Recall	student selects strategies because they have been used before to solve similar tasks
Novel reasoning	reasoning does not comply with the criterion for recall
High-level metacognition	student evaluates components of the task solving situation when selecting a strategy
Low-level metacognition	little to no evaluation takes place for selecting strategies

Table 2: Coding scheme

solutions compared to solutions of routine tasks, therewith giving more insight into students' reasoning. To be able to compare reasoning over the years, some tasks have been used each year. In order to be able to correct for a possible test-retest effect, we alternately used task A and B. Although Lisa was given task A both in year 1 and in year 3, Lisa did not seem to recognize the task.

Analysis

To analyze the interview transcripts, we used the coding scheme in Table 2. For each dimension, one code is given per task solution as a whole, based upon Lisa's on-task utterances, and upon explanations and answers during the post-interview. We made use of Lisa's own analysis of her reasoning (e.g., that she recalled a strategy) and of our impression of her reasoning inferred from Lisa's statements and actions. These various angles served to complement each other and where possible to triangulate our findings. This analysis led to nine codes for each dimension, which together give the global picture of Lisa's reasoning evolution, or more specifically, the evolution of each of the dimensions.

To determine one code per dimension per task, we chose to focus on the phase of strategy selection, since that phase is especially essential in solving difficult tasks (Selden et al. 2000). This implied in general that the initial orientation phase is left out of the analysis, just like the execution phase. While one solution often contains various strategy selection phases, we focus on the phases in which the

solution progressed, or was close to making progress. Considering these progressing task selection phases, we determined what type of reasoning was prominent.

When coding the reasoning characteristics, we deliberately ignored mathematical correctness of calculations and arguments, but we did evaluate the *success* of the solution as a separate category. This code is given somewhat indulgently: if a (lengthy) task was solved correctly almost completely, and only a minor error or lack of time appears to have been the cause of not finding the correct answer, the solution is coded as successful.

Student	Task	
Math. F.		
Superf. F.	X	
	Recall	Novel

Codes are visualized in the scheme in Figure 1. Coding of the transcripts using the framework was executed by two of the authors independently. Discussion until agreement led to minor adjustments of the coding only. In the results section we include fragments from the interview transcripts to illustrate our coding.

	low-level metacognition
	high-level metacognition
X	task not successfully solved

Figure 1: Framework visualization (with exemplary coding) and legend

Results

We first describe how Lisa’s reasoning on task A evolved over time. Due to space limitations, Lisa’s reasoning on the other tasks is not discussed in detail, but the codes are included in the overview.

Lisa’s reasoning on task A: $\int \frac{1}{1+e^x} dx$

We briefly describe and illustrate Lisa’s solutions. In year 1, Lisa used only one strategy to solve this task: she calculated the derivative of the integrand, then considered what adjustments should be made to the integrand to obtain the anti-derivative. We call this strategy derive-and-correct.

Lisa: Eh, what sometimes helps is taking the derivative of that part. I am not sure whether that will help this time. Sometimes I see a pattern that I can apply to the integral. I will try that now. $\left[\frac{1}{1+e^x}\right]' [\dots] = \frac{1+e^x-e^x}{1+e^x} = \left(\frac{1}{1+e^x}\right)^2$

She made an error here, in applying the quotient rule, but did not notice.

Lisa: Well, the only similarity I see is that both have a fraction $\frac{1}{1+e^x}$, but this is twice that fraction. $\frac{1}{1+e^x} \cdot \frac{1}{1+e^x}$. Ehm, to find the anti-derivative, I would, in one way or another $(1 + e^x)^{1/2}$, the fraction, I think. [...] Let’s see if I get the same. I’m afraid I won’t, but I can always try. (Then she calculated the derivative of $\left(\frac{1}{1+e^x}\right)^{\frac{1}{2}}$)

Here, Lisa again made an error, interchanging taking-power and taking-derivative, which are not commutative. She continued for some time, observing intermediary outcomes, considering what to infer to adjust the presupposed anti-derivative, et cetera. She did not find the correct answer.

There was no progress in solution, so we considered all strategy selection phases. Lisa did not explicate relevant mathematically founded reasons for her strategic decisions: her reasons are non-mathematical (“I can always try”) or merely superficially related to the task (“this is twice that fraction”

Lisa	Year 1	
	Task A	
Math. F.		
Superf. F.	X	
	Recall	Novel

Figure 2: Coding of Lisa’s reasoning, task A, year 1

to decide to take the square root). This latter quote illustrates how Lisa, although superficially and incorrectly, did evaluate intermediary outcomes for how to proceed, which is coded as high-level metacognition. Lisa used only one strategy, which she also used when solving the other tasks in the interview. She chose it because it ‘sometimes helps’, which we coded as recall. See figure 2.

In year 3, Lisa employed various strategies to solve task A: $\int \frac{1}{1+e^x} dx$

Lisa: Eh, I try to solve this integral by substitution. Let’s see whether that works. I take $u = e^x \rightarrow du = e^x$, so this is equal to $\int (1+u)^{-1}$. Ah wait, this is getting complicated. [...] Ehm, if I take $u = e^x$, then $\frac{du}{dx} = e^x \Rightarrow du = e^x dx$. Ehm. This is not correct.

Then Lisa attempted substituting $u = 1 + e^x$ but stopped. She then decided to derive the integrand.

Lisa: I don’t see it. Eh. I’ll check what the derivative becomes. Perhaps that will help. $\left(\frac{1}{1+e^x}\right)' = [\dots] = \frac{e^x}{(1+e^x)^2}$. (silence) [...] If I take the derivative of this, $[1 + e^x]'$, then I have $= e^x$, so that is not possible either. Hmm.

Next, Lisa modified the integrand.

Lisa: And... $\int \frac{1}{1+e^x} dx = \int \frac{e^x}{e^x(1+e^x)} dx$. If I take this u , take $u = e^x$, $du = e^x dx$. Ehm. Then it becomes $= \int \frac{1}{u(1+u)} du$. Does this help?

After some more thinking, Lisa thought of partial fractions, and solved the task correctly.

The episode in which the integrand is modified after which substitution is implemented, is the progressing phase in the solution. Here, the task is manipulated in such a way that the task is simplified. In the post-interview, Lisa explained how she came to think of this:

Lisa: I took the derivative to see whether there is a pattern [...] to see what step you can use to find the antiderivative [...] Sometimes you obtain an e^x , you see what to do to find the anti-derivative. So in the end it did help for this step. So I thought, wait, if I multiply with $\frac{e^x}{e^x}$, that is simply times 1. Then I used again $u = e^x$ for substitution. [...] And I thought, what if I put an e^x here, multiply the anti-derivative² with $\frac{e^x}{e^x}$. [...] Because I still had this substitution ($u = e^x$) in mind, and then, if you have an extra e^x , then you have $e^x dx$ and that can be replaced by du .

In this last phase, Lisa evaluated how she could use the intermediary outcome obtained by deriving the integrand and combined it with the requirements of the previously attempted substitution $u = e^x$, which indicates high-level metacognition. She did give relevant mathematical foundations for these strategic choices: “if you have an extra e^x , then you

Lisa	Year 3	
	Task A	
Math. F.		
Superf. F.		
	Recall	Novel

Figure 3: Coding of Lisa’s reasoning, task A, year 3

² Probably Lisa meant: integrand

have $e^x dx$ and that can be replaced by du ". Lisa did not make any statements that indicate she recalled the strategy to use for this type of task, but instead she considered various substitutions and task modifications, which indicates novel reasoning. The coding is visualized in Figure 3.

Lisa’s reasoning evolution

We analyzed Lisa’s reasoning on nine tasks over three years. The codes for each dimension for each task in each year are put together in Figure 4 and summed in Figure 5. We summarize the coding below and frame them based upon observations in the data. Since Lisa was given task B only once, her reasoning on task B is excluded from the analysis of reasoning evolution. However, since task A and B require the same integration strategies, we did consider them sufficiently comparable for the global analysis of Lisa’s reasoning evolution.

On task A, we see a change from superficially founded reasoning to mathematically founded reasoning, and from recall to novel. Level of metacognition is high in both years. A factor that was apparent from the data but not visible in these codes is that in year 3 Lisa used a much larger variation of strategies.

On task C, we see a change from low-level metacognition to high-level, from superficially founded reasoning to mathematically founded reasoning, and from novel to recall. In addition to these codes we remark that Lisa’s solution in year 1 was extremely brief, without any real solving attempt. After the interview in year 2, Lisa had looked up the solution to this task, which she recalled in year 3.

On task D, Lisa’s reasoning was consistently superficially founded, changed from recall to novel reasoning, and with varied level of metacognition. We add that in year 2 she used various strategies, and made several correct manipulations. In year 3, Lisa built upon her successful solution strategy used on the related task C. She modified that strategy to fit task D, which appeared somewhat mathematically founded, but her explanations were not explicit enough to code her reasoning as mathematically founded.

For each year, the number of tasks characterized by the codes of mathematically founded reasoning, novel reasoning, high-level metacognition, and success are included in Figure 5. These numbers give an overview of how Lisa’s reasoning evolved over time. The overall impression is in line with the examples described and the coding per task: at the beginning of her bachelor in mathematics, Lisa used high-level metacognition, no mathematical

Lisa	Year 1		Year 2		Year 3	
Lisa	Task A		Task B		Task A	
Math. F.						
Superf. F.	X		X			
	Task C		Task C		Task C	
Math. F.						
Superf. F.		X		X		
	Task D		Task D		Task D	
Math. F.						
Superf. F.	X			X		X
	Recall	Novel	Recall	Novel	Recall	Novel

	low-level metacognition
	high-level metacognition
X	task not successfully solved

Figure 4: Overview of codes given to Lisa's reasoning on the tasks over the years

Lisa	Year 1	Year 2	Year 3
MF	0	0	2
high MC	2	2	3
novel	1	2	2
success	0	0	2

Figure 5: Number of times each code is given per year (maximum is 3)

foundations, little novel reasoning and was not successful in solving the tasks. Over time, Lisa consistently used high-level metacognition, used more mathematically founded, some novel reasoning, and was more successful in solving the tasks.

Conclusion and discussion

The analysis of Lisa's reasoning using the framework shows how her reasoning evolved during three years of bachelor studies in mathematics, which is especially interesting given the many worrying characteristics in the first year: Lisa's reasoning was superficially founded (like often observed in undergraduate students), the solutions were full of errors and not successful. In this first year, Lisa appeared to have limited access to strategies and to be unaware of what mathematical properties are relevant in selecting a strategy. Given these rather weak characteristics, coding Lisa's reasoning as using high-level metacognition even seemed somewhat out-of-place. However, in comparison to other students who reasoned superficially founded, Lisa's metacognition level was clearly higher. The finding that Lisa's reasoning evolved towards mathematically founded (while other students' reasoning remained superficially founded) suggests that high-level metacognition may play a supportive role in developing mathematically founded reasoning.

The variety of strategies used by Lisa increased, which is captured by the 'novel' code. Thinking of suitable strategies to solve moderately non-routine tasks is difficult (Selden et al., 2000) and requires insight into what mathematical characteristics are relevant for choosing strategies (Mason, 2013), which is needed to make mathematically founded strategic decisions. In Lisa's reasoning, we see that her use of high level metacognition preceded mathematically founded strategy choices. This observation can be used as a starting point to stress the use of high-level metacognition in mathematics teaching.

Limitations

Our choice to use integration tasks has influenced the reasoning observed in this study, so we should be careful about extrapolating the findings to other contexts. However, the tasks have proven to arouse extensive reasoning of various kinds and, by using the same/similar tasks over the years, to bring to light an evolution in the way Lisa reasoned about challenging integration tasks.

Acknowledgment

We would like to thank Anke Haaksma for her help in transcribing the interviews.

References

- Aaten, A. B., Deprez, J., Roorda, G., & Goedhart, M. (2017). Undergraduates reasoning' while solving integration tasks: discussion of a research framework. In T. Dooley & G. Gueudet (Eds.), *Proceedings of the Tenth Congress of the European Society for Research in Mathematics Education* (pp. 1961–1968). Dublin, Ireland: DCU Institute of Education and ERME.
- De Backer, L., Van Keer, H., & Valcke, M. (2012). Exploring the potential impact of reciprocal peer tutoring on higher education students' metacognitive knowledge and regulation. *Instructional Science*, 40, 559–588.

- Desoete, A., & Veenman, M. (Eds.). (2006). *Metacognition in mathematics education*. Hauppauge, NY: Nova Science.
- Flavell, J. H. (1979). Metacognition and cognitive monitoring: A new area of cognitive-developmental inquiry. *American Psychologist*, *34*, 906–911.
- Jonsson, B., Norqvist, M., Liljekvist, Y., & Lithner, J. (2014). Learning mathematics through algorithmic and creative reasoning. *The Journal of Mathematical Behavior*, *36*, 20–32.
- Koichu, B. (2010). On the relationships between (relatively) advanced mathematical knowledge and (relatively) advanced problem-solving behaviours. *International Journal of Mathematical Education in Science and Technology*, *41*, 257–275.
- Lithner, J. (2003). Students' mathematical reasoning in university textbook exercises. *Educational Studies in Mathematics*, *52*, 29–55.
- Lithner, J. (2004). Mathematical reasoning in calculus textbook exercises. *The Journal of Mathematical Behavior*, *23*, 405–427.
- Lithner, J. (2008). A research framework for creative and imitative reasoning. *Educational Studies in Mathematics*, *67*, 255–276.
- Mac an Bhaird, C., Nolan, B. C., O'Shea, A., & Pfeiffer, K. (2017). A study of creative reasoning opportunities in assessments in undergraduate calculus courses. *Research in Mathematics Education*, *19*, 1–16.
- Mason, J. (2013). Having good ideas come-to-mind: Contemporary Pólya based advice for students of mathematics. In M. S. Badger, C. J. Sangwin, T. O. Hawkes, R. P. Burn, J. Mason, & S. Pope (Eds.), *Teaching problem-solving in undergraduate mathematics* (pp. 33–51). Loughborough: National HE STEM Centre.
- Nunokawa, K. (2005). Mathematical problem solving and learning mathematics: What we expect students to obtain. *The Journal of Mathematical Behavior*, *24*, 325–340.
- Radmehr, F., & Drake, M. (2017). Exploring students' mathematical performance, metacognitive experiences and skills in relation to fundamental theorem of calculus. *International Journal of Mathematical Education in Science and Technology*, *48*(7), 1043–1071.
- Schneider, W., & Artelt, C. (2010). Metacognition and mathematics education. *ZDM*, *42*, 149–161.
- Selden, A., Selden, J., Hauk, S., & Mason, A. (2000). Why can't calculus students access their knowledge to solve non-routine problems? In A. H. Schoenfeld, J. Kaput, & E. Dubinsky (Eds.), *Issues in mathematics education: Vol. 8. Research in Collegiate Mathematics Education. IV* (pp. 128–153). Providence, RI: American Mathematical Society.
- Wilson, J., & Clarke, D. (2004). Towards the modelling of mathematical metacognition. *Mathematics Education Research Journal*, *16*(2), 25–48.

Students' conceptions of the definite integral in the first year of studying science at university

Inen Akrouti

Virtual University of Tunis, ISEFC, Tunisia; akroutiinen@yahoo.fr

Keywords: Definite integral, antiderivative, area, limit of approximation, student conceptions.

Theoretical considerations and method

To explore students' interpretation of the definite integral and to deepen their understanding of its application, I draw on the works of Tall and Vinner (1981) and Sfard (1991). Tall and Vinner (1981) consider an individual's concept image for a given concept is "the total cognitive structure that is associated with the concept, which includes all the mental pictures and associated properties and processes" (p.152). They used the expression "evoked concept image" to indicate the elements of the concept image that were uncovered by their responses. According to Sfard (1991) a mathematical concept possesses two aspects: a process aspect and an object aspect. The first one identifies the operational nature when students focus their thinking on the procedure, action and algorithms contained in the concept. The second one identifies the structural nature when students conceive the mathematical concept as if it is an abstract object. Sfard notes that an individual is said to have a pseudo-structural conception when the object conception manifested by that individual does not refer to the objects of lower levels and to the processes that led to it. For the definite integral concept, the image of the area and antiderivative conceptions are usually due to insufficient abstraction of the integral image. However, the limit of approximation is due to the reification of the summation process into the symbol $\int_a^b f(x)dx$. So I consider that students of this category possess both the process and the object aspects of the evoked concept image. It is important to emphasize that students concerned by this study may possess elements that are never uncovered by their responses. Therefore, I am exploring their involved conceptions in response to given questions. Students participating in this study attended a first-semester calculus course at Bizerte University of Science. The year before this study, they had all succeeded at the baccalaureate examination with mathematics as an option. They were 18/19 years old. Eighteen students were interviewed in January 2017 and fifteen others in January 2018. The test consisted of five questions that focused on students' conception of the definite integral. The students written responses were analyzed according to Jones' categories. In this paper, I focus on the first question of the test:

Q1: Suppose $\int_a^b f(x)dx = k$, k is a real number. Explain what k means and how it was obtained.

This question was designed to explore how students interpret definite integral when asked to describe its meaning.

Preliminary results

Based on Jones' categorization (2015), my preliminary analysis of students' responses found three categories. The first category describes the definite integral in terms of anti-derivative. This category focuses on symbolic representation of integrand function. K is evaluated by manipulating the FTC: one takes an anti-derivative F of f , and substitutes b for x and a for x and finally evaluate $\int_a^b f(x)dx$ by subtracting the values of F at the endpoints of the interval $[a, b]$. The second category describes the

definite integral $\int_a^b f(x) dx$ as an area under the curve, where f is a positive function and that $a < b$, the boundary being the x-axis and the vertical lines $x = a$ and $x = b$ as illustrated in Figure 1. Finally, the third category describes integral as an approximation process. They write this type of response “ $\int_a^b f(x) dx = k$ is the area of the region that lies under the graph of the function f which represents the limit of the sum of the areas of approximating rectangles as shown in the Figure 2 below”.

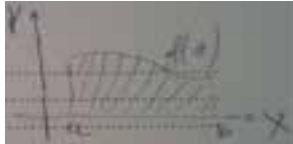


Figure 1: area conception



Figure 2: limit of approximation conception

Discussion

Preliminary results from the analysis show that most of the students (42%) interpret the definite integral as an area underneath the graph of the function and roughly, half of the remaining students (27%) describe it in terms of an antiderivative. The area conception involves the idea that an integral represents an area even though f is a negative function on $[a, b]$. It is based on generalization of a special case ($f \geq 0$). This consideration is not always evident, it produces unsatisfactory results in some situations where $f < 0$. Students of this category confuses between definite integral and area. They should be reminded that integral could be negative, zero or positive value. It is interesting that, although area conception leads to the procedural aspect of definite integral, this conception is it is necessary to develop a conceptual learning. The second category bases its reasoning on FTC. However, the response of students in this study is quite unsatisfactory since it conflicts with the formal definition of the definite integral. One of the students of this group thinks about a symbolic expression of the FTC. Even though it is a satisfactory response, it is not sufficient for structural understanding. It joins definite integral to antiderivative and limits it to algebraic representation. It is noteworthy that 15% students describe $\int_a^b f(x) dx$ as an approximation process. This conception enables the students to understand the meaning of definite integral, not only as a process but also as an object. Moreover, it brings out the epistemological aspects of integration. All students show that the definite integral represents an infinite process, however they focus only on positive functions. These preliminary results show that the large number of the students in this study evoked conceptualizations of integration that fail to emphasize the underlying structure of the definite integral. It seems to be a pseudo-structural thinking as described by Sfard (1991).

References

- Jones, S. (2015). Areas, anti-derivatives, and adding up pieces: Definite integrals in pure mathematics and applied science contexts. *Journal of Mathematical Behavior*, 38, 9–28.
- Sfard, A. (1991). On the dual nature of mathematical conceptions: reflections on process and objects as different sides of the same coin. *Educational Studies in Mathematics*, 22, 1-36.
- Tall, D. & Vinner, S. (1981). Concept image and concept definition in mathematics, with particular reference to limits and continuity. *Educational Studies in Mathematics*, 12, 151-169.

The transition from high school to university mathematics: the effect of institutional issues on students' initiation into a new practice of studying mathematics

Amalia-Christina Bampili¹, Theodossios Zachariades¹ and Charalampos Sakonidis²

¹ National and Kapodistrian University of Athens, Greece; amabab@gmail.com, tzaharia@math.uoa.gr ² Democritus University of Thrace, Greece; xsakonid@eled.duth.gr

The present paper reports on a study of the challenges faced by two first year mathematics undergraduate students during their transition from secondary to tertiary education, focusing on the institutional issues that shape the initiation into their studying university mathematics practice, through the lenses offered by the Communities of Practice framework. We consider transition as developing a new identity of studying mathematics, that is, of studying university mathematics, aiming to examine the trajectories of this development. Data were gathered over students' first two semesters of attendance predominately through interviews. The results of our analysis reveal that the students' introduction into an unknown, strongly institutionalized community of practice has a powerful effect on their initiation into the new practice of studying university mathematics.

Keywords: Transition, studying university mathematics practice, identity, institutional issues.

Introduction

The transition from high school to university mathematics is itself an exciting and often confusing experience for students. After tough examinations, the successful students have yet to adjust to new learning environments, new modes of study, and above all, higher expectations of the self. The transition from high school to university mathematics can be seen as the result of many interacting transitions: social, institutional, mathematical content transitions as well as others (Alcock & Simpson, 2002). The aim of this paper is to study how two first-year students in a Mathematics Department of a Greek University dealt with transition issues, focusing on the ways that institutional conditions, in fact the institutional support provided, affect students' studying university mathematics. For this purpose we draw on data gathered over the students' first year of attendance predominately through interviews. To situate our study within this institutional perspective on studying, we identified certain crucial elements of the Mathematics Department under consideration as an institution and of participating in this institution as a student.

Literature review

Students in transition undergo changes requiring an adjustment of learning strategies, time management skills and a shift to more independent studying. Mathematical practices at university level are distinguished from those at secondary level for reasons related to the mathematical content as well as to the participants in each of the two practices (i.e., teachers and students) (Biza, Jaworski, & Hemmi, 2014). Considering a mathematics department as a community of practice, teachers and students, as members of this community, distinguish themselves as well as they develop shared ways of doing things, forming a unique identity in the community (Hemmi, 2006).

The new environment demands a different type of critical thinking; students witness an increased emphasis on the precision and rigor of the mathematical language something for which students are

not necessarily prepared (Biza et al., 2014; Clark & Lovric, 2009). Hence, learning new mathematics via independent studying might involve developing some new skills (Alcock, 2013). Liebendörfer and Hochmuth (2015) state that students' autonomy depends on both the person (including competence) and the environment and that learning strategies and institutional norms are critical. Hernandez-Martinez et al. (2011, p.119) see the transition "as a question of identity in which persons see themselves developing due to the distinct social and academic demands that the new institution poses".

University as an institution and university mathematics are encountered as new worlds, where new communication and participation rules are required to live in, which might make the novice student feel like a foreigner (Gueudet, 2008). Winsløw, Barquero, De Vleeschouwer and Hardy (2014) claim that two viewpoints, the internal viewpoint and the viewpoint of external observers, are needed to treat in depth questions, such as: "What can be done to help my students pass the exams?" The external viewpoint focuses on the conditions and constraints for university mathematics education practices, which refer, among others, to more general constraints derived from the way our societies organize the study of mathematics.

The above suggests that students studying mathematics at university level enter a new community where the practice of being a student differs from that of the school community. Hence, the need for shifting to new ways of 'being' and 'belonging' signifies the need for developing a new identity of practicing mathematics.

Theoretical framework

We employed the Communities of Practice (CP) framework based on the work of Lave and Wenger (1991) and Wenger (1998) to explore the ways in which the subjects of the study dealt with identity issues through analysing the changing forms of their participation to the studying university mathematics practice during the transitional phase: from entrance as a newcomer, to becoming an old-timer.

Within this perspective, the person is defined by as well as defines relations, which are in part systems of relations among persons (Lave & Wenger, 1991). Activities and understandings are part of broader systems of relations in which they have meaning. In this sense, identity in practice arises out of an interaction of participation and reification. Lave and Wenger consider learning as increasing participation in CP, which concerns the whole person acting in the world:

...a community of practice is a living context that can give newcomers access to competence and also can invite a personal experience of engagement by which to incorporate that competence into an identity of participation (Wenger, 1998, p. 214)

The transition from newcomer to old-timer involves differing trajectories of identity. According to Wenger (1998), a trajectory can be seen as a continuous motion through time that connects the past, the present and the future. The characteristics of the mathematical identity of high school students 'good in mathematics' might be: ability to solve exercises following specific methodologies predetermined by the teacher, to identify if an exercise corresponds to some worked examples, to probably leave the teacher to take responsibility for deciding how much practice is needed. In other words, as Solomon (2007, p.90) states: "... students experience mathematics as something 'done to them' rather than 'done by them'". On the other hand, studying university mathematics requires a

'shift' to independent learning, thinking in productive ways, deepening in definitions and theorems, proving and focusing on conceptual understanding (Breen, O'Shea, & Pfeiffer, 2013). These features, some of which are incompatible to those of the way students were used to at school, require/signal a qualitatively different way of studying mathematics. Wenger (1998, p.154) states: "As we go through a succession of forms of participation, our identities form trajectories, both within and across communities of practice", including peripheral (never leading to full participation) and inbound (from the periphery to the centre) trajectories. Furthermore, an individual's identity is shaped by combination of participation and non-participation in the community of practice. With respect to the interaction of participation and non-participation, he distinguishes two cases: peripherality (some degree of non-participation enables a less full participation) and marginality (non-participation prevents full participation).

As far as the institutional perspective on studying is concerned, we draw on Sierpiska, Bobos and Knipping (2008) concept of institution. An institution constrains the individual behaviour of the "participants", through formal as well as informal rules and norms. Members of an institution, which participate in several communities within it, share certain values and goals and give common meaning to the actions (regularised collective actions, as well as enforced actions) of the institution. Participants' actions are adjusted to rules, norms and strategies of achieving the objectives.

The study

Greek students go through hard preparation to pass the university entry exams. During their final high school year, most of the students undergo a strictly structured life program, including many hours of daily study almost always under the guidance of school teachers and private teachers in paid courses after school. Hence, the social (family, friends-classmates) and the institutional (school and private lessons) communities are aligned: all support them with the aim of passing university entrance exams, an achievement highly valued in Greek society. On the other hand, as soon as they succeed, they are not aware of automatically entering, as students, in a centrifugal process, without strong supports. Some of them continue to flirt with the margin: not to let the centrifugal force to throw them out, because the social (friends-fellow students) and the institutional communities might not be aligned. Flirting with the margin, according to Solomon (2007), might mean alignment with the rules of the community of undergraduates emphasizing summative assessment and surface learning. In what follows, we present those features of the new institutional community which might create centrifugation with a high degree of containment difficulty for students, preventing them from completing their studies on scheduled time (8 semester's time).

The Mathematics Department under consideration has a highly demanding curriculum: a student has to pass at least 36 courses to get his/her degree, 14 of them are basic courses (mandatory). There is an indicative curriculum, but no prerequisite courses: one can take any courses he/she wants, in any of the 8 semesters required to graduate. What is there is a maximum number of courses that can be chosen in one semester, depending on the semester. The indicative curriculum suggests, for example, the following courses for the first semester: Calculus I (Axiomatic foundation of the real number system. Axiom of completeness and consequences, convergence of sequences, functions, algebraic functions, preliminary definition of the trigonometric functions, exponential function, limits and continuity, etc.), Linear Algebra I, Computer Science I (all three are mandatory courses), and to choose three at most from the elective courses Foundations of Mathematics, Combinatorics I

and Theories of Learning and Teaching. In Calculus I and Linear Algebra I, students are introduced to formal definitions, proofs of various theorems and theoretical exercises using mathematical rigor. There are three exam periods each academic year. A student can try as many times as required to pass the exams. On average, students need 13 semesters to get their degree. Students are required to deal daily and consistently with the subject. First-year students have to attend 27 hours of lectures per week, in overcrowded auditoriums. They do not often know how to make lectures work for them (i.e. how to learn in lectures, how to study after lectures), how to manage time, etc. On the other hand, no institutional support is provided for their effort to effectively attend lectures, for example, pre-university bridging courses, mathematics support centers, bridging lectures in the first semester, support systems accompanying traditional lectures, such as extra tutorials or student learning advisory. Thus, it could be argued that attending lectures and studying daily and consistently highly demanding courses with almost no institutional support are typical features of the practice of studying university mathematics. The work reported in this paper concerns the ways that the institutional support provided affects students' studying university mathematics. This is because contrary to what they had experienced as high school students, the features of the new community of practice, which first year students are invited to join, are to a large extent conflicting: high institutional expectations with reduced institutional support. Thus, the research question pursued in the study is as follows:

“How does the institutional support shape trajectories of identity related to studying university mathematics practice by first-year students”?

In October 2015 we started surveying incoming first-year students (October 2015-June 2016), collecting information. Twelve students volunteered to be interviewed individually to help us look at the interface between social, institutional and studying mathematics aspects of the transition. Four semi-structured interviews (in the beginning of the first semester, before the semester exams, in the middle of the second semester and before the second semester exams) were carried out, each lasting between 25 and 45 minutes; these were audio-recorded and fully transcribed. The questions concerned three aspects of the transition: i) social (e.g. how did they deal with the changes in their social-personal life; how did they experience relating to classmates and friends) ii) institutional (e.g. did they feel being supported in the new learning environment and to what extent; how did they experience teacher-student relationship) iii) studying mathematics (e.g. how was their experience of school mathematics different from that at the university). The analysis of students' answers to the questions related to each of the above three aspects focused on the identification of the specific ways that students experienced the aspects under consideration. Two of these students, Sonja and Paola (pseudonyms), are the focus of the work presented here: Sonja's responses during the interviews strongly indicated that she was undergoing changes (from a peripheral participant to an almost full participant) regarding studying mathematics. On the other hand Paola, from the beginning to the end of her first university year felt that she could not meet the requirements of her studies.

Results

Drawing on Sonja's and Paola's answers to questions concerning institutional issues and studying mathematics aspects, we identified that they both highlighted two features respectively: institutional

support and the difficulty of the subject matter knowledge. Some characteristic comments related to these features, as expressed in the four interviews, are presented in Tables 1 and 2 and discussed.

As far as the institutional support is concerned, Sonja had great expectations for academic staff support at the beginning. Her adjustment was getting better with great mental and spiritual effort. Regarding studying mathematics, she lost her self-confidence right at the beginning. She struggled a lot with the difficulty of the subject. As time went by, she confronted studying mathematics as a challenge: to turn her disappointment and stress to something powerful and effective (Table 1).

Sonja	1 st interview	2 nd interview	3 rd interview	4 th interview
Institutional support	IS ₁ : “I have great expectations for academic staff support, like in high school”.	IS ₂ : “I believe that professors take it for granted that students understand mathematics. They have high academic expectations from them. I am afraid to ask the professor, because he may think that I am stupid”.	IS ₃ : “I am negatively influenced by the absence of any support. Why don’t we have some tutorials?”	IS ₄ : “...Although I have to admit that some professors guided us well enough, my adjustment was getting better after a long time with great mental and spiritual effort”.
Studying mathematics	MS ₁ : “In high school, I thought that I was good in mathematics because of my good school grades and because I passed the university entrance exams also achieving good grades. When I started studying university mathematics, I was desperate. I was wondering if I had taken the right decision”.	MS ₂ : “If I could say only one thing that I still struggle with, this is the difficulty of the subject. ... I felt I turned my love to mathematics to something sick. I try to change the way of studying. I try very hard on my own to understand”.	MS ₃ : “...I realized that to do well on the first semester exams, I had to use my “simple” knowledge inductively to solve a problem, rather than knowing many things”.	MS ₄ : “I feel more confident. I passed the exams with good grades”.

Table 1: Sonja’s comments related to institutional support and studying mathematics aspects

Paola encountered difficulties of adjustment from the beginning until the end of the first year. She had encountered problems with the effectiveness of her studying even from the university entrance

exams. Studying university mathematics is harder than she expected, and until the end of the first year she could not find a way to study and learn independently (Table 2).

Paola	1 st interview	2 nd interview	3 rd interview	4 th interview
Institutional support	IP ₁ : “Students have to deal alone with their studies more than I expected”.	IP ₂ : “...professors do not make any effort to help students understand their lectures”.	IP ₃ : “I am negatively affected by the absence of any help. We do not have either a Student Learning Advisor or a Tutor”.	IP ₄ : “I need some help. I struggle alone to find out which courses to take, how to study effectively...”.
Studying mathematics	MP ₁ : “Although I have studied hard, I am negatively affected by the fact that for the university entrance exams I could not achieve the grades that I expected”.	MP ₂ : “I think it was a good decision to study mathematics, but the subject is more difficult than I expected”.	MP ₃ : “I could not pass the 1 st semester exams. I think that even if I study hard I will again fail the exams”.	MP ₄ : “I am struggling a lot. If I get my degree with a low score, how will I find a job afterwards?”

Table 2: Paola’s comments related to institutional support and studying mathematics aspects

The results indicate that the lack of studying support, which is a feature of the new institutional environment, affected Paola almost until the end of the first year. She struggled a lot to achieve necessary changes something that also affected her self-confidence as a mathematics student (IS₂, MS₁, MS₂). Her great mental and emotional effort as well as the influence of some inspiring professors (MS₄, IS₄) helped her to take the next step. After the first semester exams and more clearly near the end of the first year, it looks like she had also managed to find the needed way of studying (MS₃, MS₄). Overall it might seem that her identity was forming somehow an inbound trajectory (she was close to finding her place within her new community, which is a feature of an old-timer). With regard to Paola, the analysis of the data show that the lack of studying support also affected her until the end of the first year (IP₂, IP₃, IP₄). Although she had no doubts about her decision to study mathematics (MP₂), the fact that she could not achieve the grades that she expected for the university entrance exams (MP₁), affected her self-confidence as a math student (MP₃). It seems that it was difficult for her to find her place within the new community (forming an identity of non-participation which is close to marginality). She failed the first semester exams and almost felt losing her motivation (MP₄).

Discussion and conclusions

We consider transition to university as an opportunity to develop a new identity of studying mathematics. In CP terms, developing an identity as a student of mathematics is about negotiating

what counts as legitimate ‘being’ within various communities, in university and school, comprising shifting conceptions of what mathematics studying is or should be. The results of our analysis reveal that high institutional expectations, with insufficient institutional support, shape differing trajectories of identity. Sonja was negatively affected because of the overwhelming changes imposed in the new institutional environment that strongly influenced her studies; she even considered quitting. For the benefit of her ‘being’ within the community, she managed to overcome the institutional lack of support with great mental and spiritual effort, as well as with the guidance of some professors forming what Wenger (1998) defines as a trajectory from the periphery to the center. On the other hand, Paola’s responses indicated that she was struggling (at least to be a peripheral participant) regarding studying mathematics. She was also negatively affected by the changes imposed in the new institutional environment, but, unlike Sonja, she could not help herself to find a place into the new community: the difficulty of the subject and the lack of support was a major mismatch for Paola. She could not meet the requirements of her studies and at the end of the first year she almost felt losing her motivation. Thus, it could be argued that she was constantly flirting with the margin: not to let the centrifugal force to throw her out.

Students’ position in multiple communities of practices, in university and school, with opposing rules of engagement, implies differential experiences of identity (Solomon, 2007). Some of them, who considered themselves to be ‘good’ in mathematics at school, develop negative relationships with mathematics which might marginalize them and can turn them against further study. The implication of our analysis might be that, if we want to ensure that studying mathematics as a discipline is not only for those who are ‘talented’ and/or can show great mental and spiritual effort, it is important to take into account that studying mathematics is experienced by some students as excluding, because the features of the new community of practice, which first year students are invited to join, can be to a large extent conflicting. Sierpinska states that

institutions are difficult to change. They are based not only on conventions and rational rules of economy, but also on values that are considered "natural"... Any attempt at changing or developing an institution in certain desired direction must therefore be based on a thorough understanding of...what are the things that can be changed without jeopardizing its existence. (Sierpinska, 2006, p.127)

An interesting element in the direction of moderating the emerging contradictions might be the following: in the Mathematics Department under consideration, among the freshmen who took Calculus I exams in the first semester, 23% passed and only 2 achieved 10/10 (Sonja was one of them). In the next academic year freshmen who took Calculus I could choose to participate in 10 tests during the semester. Among those who took at least 3 tests, 84% passed the final exams and 19 achieved 10/10. This might be seen to suggest that, if high demanding institutional expectations are somehow aligned with sufficient institutional support, university mathematics students may experience transition as well as the formation of a new identity of studying mathematics as a challenge rather than a ‘problem’.

References

Alcock, L. (2013). *How to study for a mathematics degree*. Oxford, UK: Oxford University Press.

- Alcock, L., & Simpson, A. (2002). Definitions: Dealing with Categories Mathematically. *For the learning of Mathematics*, 22(2), 28–34.
- Biza, I., Jaworski, B., & Hemmi, K. (2014). Communities in university mathematics. *Research in Mathematics Education*, 16, 161–176.
- Breen, S., O’Shea, A., & Pfeiffer, K. (2013). The use of unfamiliar tasks in first year calculus courses to aid the transition from school to university mathematics. In B. Ubuz, C. Haser & M.A. Mariotti (Eds.), *Proceedings of the Eighth Congress of the European Society for Research in Mathematics Education* (pp. 2316–2325). Ankara, Turkey: Middle East Technical University and ERME.
- Clark, M., & Lovric, M. (2009). Understanding secondary-tertiary transition in mathematics. *International Journal of Mathematical Education in Science and Technology*, 40, 755–776.
- Guedet, G. (2008). Investigating the secondary-tertiary transition. *Educational Studies in Mathematics*, 67, 237–254.
- Hemmi, K. (2006). *Approaching proof in a community of mathematical practice* (Doctoral dissertation, Stockholm University, Sweden. Retrieved from <http://www.diva-portal.org/smash/get/diva2:189608/FULLTEXT01.pdf>
- Hernandez-Martinez, P., Williams, J., Black, L., Davis, P., Pampaka, M., & Wake, G. (2011). Students' views on their transition from school to college mathematics: rethinking ‘transition’ as an issue of identity. *Research in Mathematics Education*, 13, 119–130.
- Lave, J., & Wenger, E. (1991). *Situated learning. Legitimate peripheral participation*. New York, NY: Cambridge University Press.
- Liebendörfer, M., & Hochmuth, R. (2015). Perceived autonomy in the first semester of mathematics studies. In K. Krainer & N.Vondrová (Eds.), *Proceedings of the Ninth Congress of the European Society for Research in Mathematics Education* (pp. 2180–2186). Prague, Czech Republic: ERME.
- Sierpinska, A. (2006). Sources of students’ frustration in bridging mathematics courses. In J. Novotna (Ed.), *Proceedings of 30th Conference of the International Group for the Psychology of Mathematics Education* (Vol. 5, pp. 121–129). Prague, Czech Republic: PME.
- Sierpinska, A., Bobos, G., & Knipping, C. (2008). Sources of students’ frustration in pre-university level, prerequisite mathematics courses. *Instructional Science*, 36, 289–320.
- Solomon, Y. (2007). Not belonging? What makes a functional learner identity in undergraduate mathematics? *Studies in Higher Education*, 32(1), 79–96.
- Wenger, E. (1998). *Communities of practice: Learning, meaning and identity*. Cambridge: Cambridge University Press.
- Winsløw, C., Barquero, B., De Vleeschouwer, M., & Hardy, N. (2014). An institutional approach to university mathematics: from dual vector spaces to questioning the world. *Research in Mathematics Education*, 16, 95–111.

Students' understanding of the interplay between geometry and algebra in multidimensional analysis: representations of curves and surfaces

Matija Bašić¹ and Željka Milin Šipuš¹

¹University of Zagreb, Faculty of Science, Department of Mathematics, Zagreb, Croatia;
mbasic@math.hr, milin@math.hr

The aim of this study is to investigate mathematics students' understanding of geometrical objects such as curves and surfaces in space, when these objects are presented algebraically, that is, by their equations. Flexible use of different representations, in this case geometric and algebraic, as well as the ability to convert between implicit and parametric types of equations, is often assumed as a prerequisite in multivariable calculus. We have performed an in-depth analysis of students' answers to exam questions to identify types of students' difficulties in these conversions. However, our results also point to the impact of the didactic contract on students' productions which possibly prevented students to fully present their understanding.

Keywords: Transition across university mathematics, multivariable calculus, curve, representation, didactic contract

Introduction

In this paper we investigate learning difficulties that students face in the transition from the first courses in linear algebra and multivariable calculus, to more advanced mathematical courses that involve mathematical analysis of functions of several variables. As described by Kondratieva and Winsløw (2018), requests for efficiency and economy of exposition at university level often lead to narrow and disconnected teaching modules. Our teaching experiences indicate similar disparities in the transition from courses in analytical geometry, linear algebra and calculus on one side, to mathematical analysis of functions of several variables and differential geometry on the other. We noticed misconceptions and knowledge gaps in dealing with basic objects such as curves and surfaces in three-dimensional space, in using their implicit and parametric representations, and in converting from one representation to the other. These notions are essential for calculating curve integrals, applying Green-Stokes theorem, or in introductory lessons in differential geometry, for instance, the introduction of curve and surface curvature.

A curve in three-dimensional space can be presented either by a parametrization, that is, as a trace of a moving particle, or by a system of equations in three variables, that is, as an intersection of surfaces. Transitions from one representation to the other and vice versa are theoretically underpinned in multivariable calculus by implicit and inverse function theorems. However, students' work in basic examples usually happens in the domain of algebra and geometry – solving systems of (not necessarily linear) equations and giving them geometrical meaning. We noticed many students' difficulties in this process, starting from a non-meaningful manipulation of equations in a way that just leads to new equations, understanding what a solution of a system of equations is, especially when a solution is not unique, and, finally, providing a geometrical interpretation of the obtained objects. Students' difficulties in the same field but with linear objects,

in recognition of lines and planes given by their implicit (Cartesian) and parametric equation, and the presentation of these objects as sets (subsets in space satisfying the same conditions or equations) are well evidenced (Artigue, 1999; Alves-Dias; 1998; Nihoul, 2016). However, students' work related to curved objects in space is an under-researched area.

Motivation

Our study was motivated by the following question posed as one of five questions in the midterm exam for the course Introduction to differential geometry in spring semester 2017:

Question. Prove that the space curve given by $x^2 + y^2 = z$, $x^2 + y^2 + 2x + 2y = 1$ is planar and determine its osculating plane.

The question could be answered by following the procedure taught during the exercise classes (for a somewhat more complicated curve), which requires a curve to be parametrized. From the parametrization, one calculates its torsion, which should vanish for a planar curve, or determines its binormal field, which should be constant. However, in the above example the tedious calculation of a torsion (which often results in a calculation error) could have been avoided by using the definition of the planar curve emphasized during lectures. By a simple manipulation of the given equations, it is possible to eliminate the square terms to get $2x + 2y + z = 1$, which could be recognized as an equation of a plane in which the curve lies. Among 136 students who provided any answer to this question (of 172 who participated in the exam), only 7 % (10 students) solved the task using that approach, and 10 % more solved it using both approaches, that means, they obtained the equation $2x + 2y + z = 1$, and then still parametrized the curve and applied the tedious procedure. Some 27 % of students obtained the plane equation without providing an interpretation, and 30 % of students solved the question by immediately parametrizing the curve and applying the procedure only. The remaining 26 % did not obtain the equation nor a correct parametrization. This high number of students who focused only on procedure and failed to apply the definition of a planar curve, encouraged us to implement a more thought-out approach in the next year courses followed by a deeper analysis of students' work.

Theoretical framework and research questions

Mathematical concepts are identified and represented through various representations, which reflect possibly different features of a concept, but simultaneously complement each other. Treating a concept within a certain representation (representational mode or register) and successfully converting between different registers of representation, is considered as a prerequisite for conceptual understanding. Conversion processes entail recognition of the same mathematical objects through representations from different registers and therefore require coordination of registers. Many students' difficulties can be described and explained by the lack of coordination of different registers of representation (Duval, 1993, 2006). Research provides examples (Artigue, 1999; Alves-Dias, 1998; Nihoul, 2016) of students' difficulties in using the algebraic representation of lines and planes in space, and vice-versa, in recognizing straight lines and planes in space from their equations, and in converting between parametric and implicit viewpoints.

In this study we tried to answer the following research question: What are students' learning difficulties in relation to different representations of curves and surfaces in 3-dimensional space?

As observed in the motivational example, it seems that students tend to use lengthy procedures as opposed to conceptual definitions. This indicates that the work of some students does not show their complete mathematical understanding and difficulties, but rather that their answers are governed by reasons of didactical nature. We use the notion of didactic contract from the Theory of Didactic Situations (TDS) by Brousseau (1997), a framework useful to study phenomena at university level (González-Martín, Bloch, Durand-Guerrier, & Maschietto, 2014):

A core TDS conceptual tool is Brousseau's notion of the *didactic contract*, the implicit set of expectations that teacher and students have of each other regarding mathematical knowledge and regarding the distribution of responsibilities during the teaching and learning processes. ... The *didactic contract* is linked to an institution and, in particular at university level, the terms of the *didactic contract* can be quite strong. (pp. 119, 131)

Although our ultimate goal is to study the cognitive and epistemological dimensions for the concept of a curve in space, we first had to analyze the didactical constraints that govern students' answers. Hence, motivated by our students' work we wanted to trace the impact of the didactic contract on students' exam productions and investigate if students' understanding could be improved through some changes in this contract.

Methodology and mathematical context

The participants of our study in 2018 were in total 173 students at a department of mathematics in Croatia, while participating in elective course Introduction to differential geometry (students of undergraduate program in mathematics and in mathematics education). The course has 2 hours of lecture and 2 hours of exercise class per week for 13 weeks. It is naturally divided into two parts, with the first part that focuses on the use of differential calculus to study geometrical properties of curves in 2D and 3D (curvature and torsion). The second part focuses on the study of surfaces and special curves on surfaces. The emphasis of the course is on low dimensions to encourage students to use the geometrical register in interpreting and understanding the results. The second author is the lecturer, while the first author is one of three teaching assistants for the course.

In 2018, during the exercise classes, the teaching assistants led the discussion about the exam question from the year before. The aim of this discussion was to re-negotiate the didactic contract built during previous courses in which teachers assign tasks and students answer in the way they were taught. In this case, it means that students apply the lengthy procedure, not the definition of a planar curve in space, which is intuitive and, although presented during the course, not exclusively a part of differential geometry content. As learning can be accomplished, in many cases, through the ruptures of the didactic contract (Brousseau, 1997), the assistants showed both strategies and emphasized that the aim of the course is to encourage students to use the geometrical interpretation. In other words, it is the conceptual and not the lengthy approach that was expected and aimed for. It was important for the students to hear that all correct answers are acknowledged at the exam, not just those that follow procedures from the exercise classes, since their comment during the discussion on the "non-standard" approach was that "they did not know this was allowed". In

addition, the teaching assistants addressed other students' difficulties observed by the preliminary insight into students' work in 2017, like false generalizations and analogies from plane to space geometry (2D to 3D) in interpretation of equations and non-adequate conversions between implicit and parametric viewpoints of a curve.

The source of data for the in-depth analysis were midterm exam solutions. Questions were formulated in the geometric register, where curves are given as intersections of surfaces. The properties of the intersection curve can be recognized algebraically (from its equation) or geometrically (by some geometrical properties, such as its curvature). In this paper we analyze the questions presented in Figure 1.

Question 1. Determine the set of points in space given by the equations $x^2 + y^2 + z^2 = 4$, $x - y = 0$. Find its parametrization and determine its curvature. Which object does it represent geometrically?

Question 2. The curve c is given by the equations $x^2 + y^2 + z^2 = \frac{17}{2}$, $y = x + 1$. (a) Explain why c is planar. (b) Determine the curvature of c and decide what curve it is. (c) What curve is obtained by projecting c onto the xz -plane?

Figure 1: Exam questions analyzed in the study

In Question 1, the set of points satisfying both equations, the equation of a hyperboloid of one sheet and a special plane, is to be identified either from a system of transformed implicit equations, or from its obtained parametrization which enables determining the curvature. Simple calculation in the algebraic register gives the system of transformed implicit equations as $x = y$, $z = \pm 2$, therefore the intersection set consists of two parallel lines that are given as intersections of two pairs of non-parallel planes.

In Question 2, the expected solution is to state that $y = x + 1$ is an equation of a plane, so the curve is planar by definition. For the second part it is expected that the equation of the sphere is recognized, and that the curve is a circle since it is the intersection of the sphere and the plane. The radius R of the circle may be determined geometrically, so the curvature can be expressed as $1/R$.

The projection onto xz -plane is given by the equation $2(x + \frac{1}{2})^2 + z^2 = 8$, which is the equation of an ellipse. Another correct approach is to parametrize the obtained curve, and then to calculate its curvature by using the formulas from the lecture. Conclusion that the curve is a circle should follow from the fact that the curvature is a non-zero constant, and the projection curve could be recognized from the parametrization with $y = 0$.

Students' answers were processed in an iterative way. First, based on our mathematical analysis of the question, we formulated codes regarding the register in which the task was solved: algebraic (following the algebraic procedure given in the exercise class) or geometric (geometrically interpreting equations), as well as the success of the students (if the calculation was completed or the conclusion reached). Second, the codes were refined to track students' different strategies and

unexpected answers pointing to some difficulties. Next, the observed categories and special cases were discussed between the authors and an agreement was reached to cluster the codes with low frequency pointing to the same type of difficulties. As an example, in Table 1 we present the data for Question 2 (a).

Question 2 (a)			
No answer		57	33%
Recognizing the equation of the plane		46	27%
Using torsion = 0 as criterion	Showing that torsion equals 0	8	5%
	Only stating the criterion	23	13%
Wrong arguments	$y = x + 1$ is a line, and lines lie in planes	15	9%
	$x^2 + y^2 + z^2 = 17/2$ is a plane	7	4%
	Substituting and stating that the curve is an ellipse in yz -plane	17	10%

Table 1: Codes and frequencies for Question 2(a)

Results

In Question 1, approximately half of the students (51 %) noted correctly that the intersection of a doubly-curved surface (an hyperboloid of one sheet) and a plane is a pair of parallel straight lines. Most of the students (76 %) who reasoned correctly relied on parametrizing the obtained set as $c(t) = (t, t, \pm 2)$ and calculating its curvature, which turned out to be 0 in all of its points, and some (29 %) relied on recognizing the lines from the system of transformed equations, whereas 5 % of students used both approaches.

Among students who did not provide a complete solution, approximately half gave no answer at all, further 30 % successfully obtained transformed equations or calculated the curvature, but did not interpret the result geometrically and approximately 20 % misinterpreted the obtained result. Most of the errors in the last group occurred when trying to interpret a transformed implicit equation, which was seen as the requested intersection curve, and not as a new surface on which the intersection curve lies (the intersection set described as a plane, a cone, or a hyperbolic paraboloid); many errors also come from the misinterpretation of a transformed implicit equation without z -coordinate as a curve (a hyperbola instead of a hyperbolic cylinder).

In Question 2, 46 out of 173 students (27 %) noted that the given equation is an equation of a plane and successfully concluded that the curve is planar without further calculation, and a smaller number (18 %) of them went still for calculation of the torsion. More students than in 2017 successfully concluded that a curve is planar by the first approach, but still more than 70 % did not use this approach. Among the students that did not provide a solution, 9 % stated that $y = x + 1$ is an equation of a straight line in space, which is a well-evidenced false generalization in transition from 2D to 3D in linear algebra (Nihoul, 2016). Further students' false argumentation runs as follows "since this is a line, and lines belong to a certain plane, therefore the curve is planar". Furthermore, careless approach to ambient space in which a curve is given seems to generate another case of false transition from 2D to 3D, since 38 students chose the formula for curvature that is the formula for curves in \mathbb{R}^2 , not in \mathbb{R}^3 .

Among 122 students who tried to parametrize the curve, 80 students (65 %) used the local parametrization $c(t) = (t, t+1, \sqrt{17/2 - t^2 - (t+1)^2})$ of the intersection curve, which is not adequate to conclude that the (whole) curve is planar, contrary to the linear case, where the standard procedure provides a global parametrization. To determine the curvature of the curve, students predominantly (70 %) used parametrization for further calculation over geometric approach. Only 15 (9 %) of them used a geometric approach by stating that the plane intersection of a sphere is a circle, with only 4 of them even moving forward to determine geometrically the radius of a circle.

Discussion

In general, we may state that students' difficulties in *converting algebraic equations into geometrical objects* are persisting, even after the first courses in linear algebra and calculus. In the case of a planar curve identification, students predominantly focus on the known procedure, although it is burdened with calculation, over using the conceptual definition of a planar curve which involves recognizing a plane by its implicit equation. We may also say that we observed the influence of the didactic contract, as the students tried to ensure that their answers included newly learned procedures during the exercise classes. However, students' difficulties in recognizing a plane by its equation can be seen as a particular case of a more general lack of coordination between algebraic equations and spatial geometrical objects. When manipulating equations defining a spatial curve, students interpret the new implicit equation as that intersection curve, not as a new surface on which the curve lies.

The above general observations point out to several further remarks. The first remark concerns evidence on students' false generalizations and analogies in their *passage from 2D to 3D*. As already stated, this was particularly the case when they identified the equation of a special plane with a line, a circular cylinder with a circle, or a hyperbolic cylinder with a hyperbola. Similar difficulties are observed in linear algebra, e.g. in the case of a plane in space given by an equation $ax + by = c$ (Alves-Dias, 1998; Nihoul, 2016). It is a clear example of the fact that a piece of existing knowledge (a single equation represents a curve) may undergo a hasty generalization, and therefore standing in the way of full comprehension. It is not irrelevant to notice that the missing insight of different ambient (2D and 3D) is also identified in students' inappropriate use of formulas for the curvature of curves.

Our second remark concerns students' use of and conversion between *the implicit and the parametric representation (viewpoints)* of curves. Again, students' difficulties in this process in linear algebra are well evidenced (Artigue, 1999; Alves-Dias; 1998; Nihoul, 2016). In our study with curved objects, we observed that students did not invoke the need for conversion to a parametric representation, nor is the conversion found as flexible as it is assumed, already discussed in the case of linear algebra (Artigue, 1999, p. 1384):

Flexibility seems to be considered as automatically internalized once one has “understood” the notion, as if it were a simple question of homework that one can leave to the private work of the student.

Another remark is related to students' difficulty coming from *the character of non-linear problems*. Conversion from implicit equations to parametrization and vice-versa, that relies on a procedure of

“eliminating a parameter” or “substituting a variable by a parameter” from linear algebra has a local character in the non-linear case and cannot produce an instant answer as in the linear case. This conversion brings many different transformation approaches, usually non-routine ones (especially when trigonometric and hyperbolic functions are involved). For example, in Question 2, a local parametrization is not adequate to conclude that the curve is planar. A relevant explanation can be provided with the implicit and inverse function theorems, which although do not provide a recipe to change representation, should be discussed during the class to emphasize the subtleties in the non-linear case. Students’ focus on procedures suggests that their knowledge is an “amalgamation of practical blocks” (Brandes & Hardy, 2018, p. 506). Moreover, the observed absence of theoretical insight in students’ knowledge might be seen as a missing brick in Transition of type 1 (Winsløw, Barquero, De Vleeschouwer, & Hardy, 2014).

Conclusion

Different representations of curves and surfaces and their flexible conversions are essential for various mathematical courses that involve the analysis of functions of several variables. We also repeat that our study tries to see some of the students’ bad performances as a result of the impact of the didactic contract. However, students’ productions firstly point out to the existence of difficulties which were also observed in linear algebra in representations of lines and planes (Artigue, 1999; Alves-Dias; Nihoul, 2016). False generalizations from 2D to 3D appear (a line in space is represented by a single implicit linear equation, and vice-versa, single implicit linear equation with, for instance, no z -coordinate is an equation of a line in space; the same student’s reasoning appears for e.g. a circle and a circular cylinder). This observation may also point to the presence of some learning obstacles in the sense introduced by Brousseau (1997), which needs to be further explored. According to Brousseau, obstacles of various origins can stand in the way of an efficient learning of mathematics. Brousseau distinguishes between cognitive (due to the state of mental development), didactical (due to a certain way of teaching) and epistemological obstacles (due to the very nature of mathematical concepts). Clear distinction among them, due to the complex nature of human’s knowledge acquisition, is not always possible. Obstacles become evident in students’ errors which are not related to chance but persist, or in difficulties and problems that students encounter that slow down the learning process. When this becomes evident, it does not point out to the lack of knowledge, but often to the piece of knowledge that was adequate in a previous situation, but now leads to incorrect reasoning. Brousseau suggests that to overcome an obstacle, a sufficient flow of new situations challenging old knowledge is needed. Whether careful task design with different potentials for student learning would be beneficial as well (Gravesen, Grønbaek, & Winsløw, 2017), is another question to be explored in the future.

Acknowledgment

We dedicate this paper to the memory of our dear colleague doc.dr.sc. Stipe Vidak (1980-2018) and to our many fruitful joint discussions.

References

- Alves-Dias, M. (1998). *Les problèmes d'articulation entre points de vue cartésien et paramétrique dans l'enseignement de l'algèbre linéaire. Histoire et perspectives sur les mathématiques* (Unpublished doctoral dissertation). Université Denis Diderot Paris 7.
- Artigue, M. (1999). The Teaching and Learning of Mathematics at the University Level. Crucial Questions for Contemporary Research in Education. *Notices of the AMS*, 46(11), 1377- 1385.
- Brandes H., & Hardy, N. (2018). From single to multi-variable Calculus: a transition? In V. Durand-Guerrier, R. Hochmuth, S. Goodchild & N. M. Hogstad (Eds.), *Proceedings of INDRUM2018 – Second conference of the International Network for Didactic Research in University Mathematics* (pp. 498- 508), Kristiansand, Norway: University of Agder and INDRUM.
- Brousseau, G. (1997). *Theory of Didactical Situations in Mathematics: Didactique des Mathématiques*. 1970 – 1990. Dordrecht; London: Kluwer Academic Publishers.
- Duval, R. (1993). Registres de représentation sémiotique et fonctionnement cognitif de la pensée. *Annales de Didactique et de Sciences Cognitives*, 5, 37- 65.
- Duval, R. (2006). A cognitive analysis of problems of comprehension in the learning of mathematics. *Educational Studies in Mathematics*, 61(1–2), 103–131.
- González-Martín, A. S., Bloch, I., Durand-Guerrier, V., & Maschietto, M. (2014). Didactic Situations and Didactical Engineering in university mathematics: cases from the study of Calculus and proof. *Research in Mathematics Education*, 16(2), 117–134.
- Gravesen, K. F., Grønbæk, N., & Winsløw, C. (2017). Task Design for Students' Work with Basic Theory in Analysis: the Cases of Multidimensional Differentiability and Curve Integrals. *International Journal of Research in Undergraduate Mathematics Education*, 3(1), 9- 33.
- Kondratieva, M., & Winslow, C. (2018). Klein's Plan B in the Early Teaching of Analysis: Two Theoretical cases of Exploring Mathematical Links. *International Journal of Research in Undergraduate Mathematics Education*, 4(1), 119- 138.
- Nihoul, C. (2016). Quelques difficultés d'étudiants universitaires à reconnaître les objets "droites" et "plans" dans l'espace: une étude de cas. In E. Nardi, C. Winsløw, & T. Hausberger (Eds.), *Proceedings of INDRUM2016 – First conference of International Network for Didactic Research in University Mathematics*. (pp. 464- 473), Montpellier, France: Université de Montpellier and INDRUM.
- Winsløw, C., Barquero, B., De Vleeschouwer M., & Hardy, N. (2014). An institutional approach to university mathematics education: from dual vector spaces to questioning the world. *Research in Mathematics Education*, 16(2), 95- 111.

Understanding the secondary-tertiary transition in mathematics education: contribution of theories to interpreting empirical data

Christer Bergsten¹ and Eva Jablonka²

¹Linköping University, Mathematics Department, Sweden; christer.bergsten@liu.se

²Freie Universität Berlin, Education and Psychology, Germany; eva.jablonka@fu-berlin.de

The paper reports a review of studies on the secondary-tertiary transition in mathematics. With an interest in the contribution of theories, it intends to explore what insights empirical studies using new theoretical lenses have added. While there is a move towards socio-cultural theorizing, some dimensions pertaining to issues of social (re)production still appear under-researched.

Keywords: university mathematics, sector transition, theories, socio-cultural studies.

Introduction

In mathematics education, the expression ‘transition problem’ commonly refers to difficulties when students enter a new school sector, or begin a new more ‘advanced’ course. While the notion has been used also for passages between other contexts, this contribution focuses on the transition from school to university, which has long been described as particularly problematic (e.g., De Guzman, Hodgson, Robert, & Villani, 1998), *inter alia* alerting to high dropout rates. Nevertheless, a difficult transition may not only be seen as a *problem* for the students, but also “as something potentially positive for their development and future opportunities” (Jablonka, Ashjari, & Bergsten, 2017, p. 76). ‘Smoothing’ the transition may not necessarily be desirable. Conceived as problematic, the transition has attracted much attention in mathematics education over the years, and the analytical lenses employed for its study have been diverse. However, a comparison of the overviews in De Guzman et al. (1998) and Gueudet (2008) shows that new theories might contribute to deepening the understanding of the secondary-tertiary transition. While De Guzman et al. categorized ‘types’ of problems in ‘theoretical’ categories (*epistemological/cognitive; sociological/cultural; didactical*), their discussion also included under-theorized notions (e.g., type of mathematics, contact to teachers, ways of studying). Gueudet (2008) used similar categories (*thinking modes, mathematical language and communication, and didactical transposition and contract*) but in contrast to De Guzman et al. (1998) explicitly contained the discussion within a range of theoretical frameworks with reference to empirical research drawing on these frameworks. In a later “survey of the state of the art” regarding transitions in mathematics education, Gueudet, Bosch, DiSessa, Kwon and Verschaffel (2016) pointed to the diversity of theoretical orientations, but also to the importance of complementarity.

In this paper studies from the last ten years on the secondary-tertiary transition in mathematics education will be reviewed with the aim to trace the development in terms of the theoretical approaches taken and how these have contributed to new insights regarding the transition.

Method

For an initial literature search, articles published during the last ten years in major (mathematics) education research journals and conference proceedings as well as articles listed in the MathEduc database that explicitly addressed the secondary-tertiary transition were identified. From these, only

articles reporting empirical studies with an explicit theoretical approach were included in a first step of the analysis. From these around 100 articles, a final sample of around 50 articles drawing on theories *not already discussed* in Gueudet (2008) was selected for a second step; weakly theorized quantitative studies were not included. The main stated results of the studies were used to identify how theoretical approaches contribute to insights regarding the transition. For the notion of theory, the selection was guided by the discussions in Radford (2008) and Jablonka and Bergsten (2010). Certainly, some of the theoretical orientations discussed in Gueudet (2008) continued to be used and developed during the period studied; for example, in the first step of the analysis around ten articles drawing on ATD and/or TDS and five using a cognitive approach were found. These represent an important part of the theoretical development of the area but will not be included here due to space limitations. As the literature review was not based on a fully comprehensive search, some recent theoretical developments might have been omitted. The categorization made from the analysis of the sample, however, has a strong base in the articles found.

In the next section, the dominating theoretical approaches identified will be presented. These were found in 37 (of the 50) papers; single studies employing *Horizon content knowledge* (MKT) and *Three worlds* (Tall), *use-and-exchange-value*, *communities of practice*, a framework for textbook comparison, as well as a few studies using theoretically less specified notions such as *competences*, *interest*, *expectations*, *transmissionist pedagogies*, and *perspective*, will not be discussed here.

Contributions of different theoretical approaches

In the selected articles, five theoretical approaches not discussed in the review by Gueudet (2008) were identified, which unavoidably only adumbrate distinct categories: *Bourdieuian sociology*, *Bernsteinian sociology of education*, *Cultural anthropology*, *Cultural Historical Activity Theory* and *Commognition*. How these contribute to the understanding of the transition will be illustrated by way of examples of specific studies.

Bourdieuian sociology

A group of studies drew on Bourdieu's notions of *habitus* and *capital* to analyse students' struggles during the transition. Kleanthous and Williams (2013) employed the notion of habitus to develop a framework for measuring parental influence on students' inclination to pursue mathematics studies in higher education. They interpreted their findings to be consistent with a Bourdieusian view in that "family influences might inculcate a mathematical habitus that encourages choosing mathematically-advanced courses at school, which thus enhance mathematical confidence and inclination, and shapes positive dispositions to study mathematically-demanding courses in the future." (p. 64).

That also those students who find the transition hard may hang on to successfully complete the transition was illustrated in Hernandez-Martinez and Williams (2013), where these students were labelled as *resilient*, defined as a socio-cultural term. For the analysis the authors employed Bourdieu's notions of cultural and social capital, adding that "students can *develop* capital through reflection" (p. 49), a capital allowing agency for example during transition to align "their habituses with the conditions of the new field" (p. 49). Based on a narrative analysis of data from two student interviews, the authors identified biographical "narratives of resilience" (p. 50) that showed how reflexivity led to the development of a capital during schooling that eventually became valuable

during the transition, for example when experiencing risks to progression. For education practice the authors therefore suggested that “processes that encourage reflexivity in students should be incorporated in pedagogical practices at all levels” (p. 57).

Bergsten and Jablonka (2013) interviewed students at the beginning, middle and end of their first year of study in a five years engineering programme at two Swedish universities, and interpreted their data in terms of Bourdieu’s notions of *field* as well as *cultural, economic and symbolic capital*. Regarding the choice of programme at university, the outcomes corroborated those of Kleanthous and Williams (2013), showing how “the cultural capital possessed by the families influence the choice to enrol at a university” (Bergsten & Jablonka, 2013, p. 2293). Students also appeared to have acquired a cultural capital in their science- and technology programmes at secondary school that has developed into a disposition towards academic studies (many talking about “a natural continuation”). While expectations about future professions differentiated between students from different study programmes in terms of the importance of cultural and economic capital as well as the symbolic capital that multiplies their impact, the views of the role of mathematics in this context were more coherent, with a focus “less on particular mathematical skills as a form of cultural capital”, but more on “a general habituation to solve problems in a rational way” (p. 2294).

Bernsteinian sociology of education

To identify issues and operationalize notions seen as critical for the transition, some studies employed key concepts from Bernstein’s theory of pedagogic discourse, in some instances combined with other theoretical constructs. Kouvela, Hernandez-Martinez and Croft (2018) focused on the discourses that frame the changes in teaching and learning practices during the transition from school to university, and how these discourses transmit *messages* to the students that affect how they experience and handle the transition. Drawing on Bernstein the authors distinguished *strongly classified* and *strongly framed* messages. The empirical study involved first-year mathematics students and two lecturers, and included lecture observations, student questionnaires and interviews; a grounded theory approach amounted to categories of messages (what students should do during and after lectures, assessment, general study habits). These messages, transmitted by the lecturers to their students, were analysed in terms of classification and framing helping to decompose each message and “identify, through the underlying structures of power and control, in what ways the message can be influential on students’ transition” (p. 173). The general conclusion was that messages common between school and university ease the transition, while differences can “prompt action to be taken by students and can change their thinking” (p. 181).

Jablonka, Ashjari and Bergsten (2017) investigated how first year students interpreted the type of mathematics they encountered at university. To explicate the expression ‘type of mathematics’ and create a language of description for the reading of the empirical data, an analytical framework drawing on Bernstein’s notions *knowledge classification* and *recognition rules*, elements of *social semiotics* by Halliday and Hasan, Eco’s conception of a *model reader*, and Sierpiska’s idea of mathematical and didactical discourses as *mathematical* and *didactical layers* in textbooks was developed. In individual interviews, textbook excerpts were shown to 60 first year engineering students at two Swedish universities, asking them to rank the texts according to which they saw as “more

mathematical”. The framework allowed a description of students’ articulation of their recognition rules, and the authors concluded that “recognition of differences in strength of classification of different mathematical discourses emulated in a range of pedagogic practices relates to success in the examinations” (p. 87). The study thus illustrates how academic success relates to a recognition of the university mathematical discourse.

Cultural anthropology

A couple of studies used theories that can be located in the rather broad field of cultural anthropology. Four research groups referred to the idea of a phased *rite of passage*, coined by Arnold van Gennep at the beginning of the 1900s. Clark and Lovric (2008) first suggested that this is a useful model for the study of the transition to university (mathematics). The transition period is characterised through a *separation* phase (end of school, anticipating university life), *liminal* phase (from finishing school to beginning university), and *incorporation* phase (first year at university). It thus constitutes first of all a formal grid for framing the transition but does not specify what or how to approach the particular issues related to the phases.

One attempt to apply the model is found in a pilot study by Bampili, Zachariades and Sakonidis (2017), which presents data from interviews involving 12 students during their transition to mathematics studies at a Greek university. At the three phases of Clark and Lovric’s model questions were asked regarding the dynamics of the social-personal life, academic life and mathematical content dimensions to investigate how “the academic and social dimensions interact to shape the passage from the liminal to the incorporation phase regarding mathematical content” (p. 1987). In the paper, data from one student were discussed “because her responses during data collection strongly indicated that she was undergoing a rite of passage regarding mathematics” (p. 1987). Based on their findings the authors considered the study as “a good starting point for exploring specific issues considering transition more extensively” (p. 1991).

Wade, Sonnert, Sadler, Hazari and Watson (2016) conducted an online qualitative survey involving secondary and tertiary level mathematics teachers in the USA about what they conceived as good high school preparation for students for the college calculus courses. As a framework for interpreting their data they used the *rite of passage*. In particular, the separation and incorporation phases were investigated through thematic analyses that revealed five categories in which secondary and tertiary teachers “differed significantly in the relative frequency of addressing them” (p. 7). While teachers at university pointed at preparation of specific areas within algebra and precalculus as vital, teachers at secondary level highlighted “classroom environment realities of teaching in the separation phase.” (p. 7). The authors concluded that a better understanding of the “gap between the teachers’ and the professors’ outlooks” is needed and that these two groups need to “realize more clearly that they are part of one and the same rite of passage process” (p. 13).

Corriveau and Bednarz (2017) drew on *cultural theory* (referring to the work of Edward T. Hall), in particular the distinction between *formal*, *informal*, and *technical* modes of culture and on *ethnomethodology*. They sought to understand how differences in secondary and post-secondary teachers’ “ways of doing mathematics” rather than differences in formal or technical aspects of mathematics present difficulties for students. More specifically, the secondary teachers aimed at

“giving form” to symbols that “speaks” to the student, representing particular generalisations, while the post-secondary teachers worked to “give voice” to the pre-existing general symbols. The authors concluded that “the ‘informal’ mode of mathematical culture specific to each teaching level plays a key role in attempts to better grasp transition issues” (Corriveau & Bednarz, 2017, p. 1).

Cultural Historical Activity Theory

Several transition studies used Cultural Historical Activity Theory (CHAT) to frame their research. In a project in the UK on student participation in post-compulsory mathematics education, Black et al. (2010) interviewed 40 students at three occasions during the transition period. In doing so, they used a notion of *identity*, which in their reading of CHAT is “historical in origin and emerges from the subjectivities (how one views oneself) we experience in the process of doing activities” (Black, Williams, Hernandez-Martinez, Davis, & Wake, 2010, p. 58). The authors argued that what they termed *leading identity* (based on Leont’ev’s concept *leading activity*) defines a student’s motive for study and also influences the relation to mathematics. A narrative analysis of interviews with two students with different experiences and showing “contrasting aspirations in their interviews” (Black et al., 2010, p. 59) was conducted. For the analysis an operationalization of the constructs leading activity, leading identity, cultural models (such as ‘math is hard’) and troubles/obstacles used to read the data was developed. The two students were both drawing on “cultural models regarding learning mathematics and studying in general” (p. 68) which framed their leading identities; in one case to become an engineer, in the other to obtain a university degree. The authors suggested that a leading identity implying the use value of mathematics as a motive for its study has a stronger potential to “bring about a commitment to persisting with mathematics, particularly for at-risk students who may face more difficulties or challenges than others” (p. 71).

Within the same project, investigating the transition from school to college mathematics in the UK through student pre- and post-transition interviews, Hernandez-Martinez et al. (2011) categorised the transition ‘problems’ in *social dimension*, *continuity of curriculum/pedagogy*, and *individual-progression/differences*. Rather than only a discourse focusing on problems, the authors also identified “a more positive discourse on challenge, growth and achievement” (p. 119). They focused on the notion of *identity*, relying mainly on CHAT, in particular the ideas of *self in practice* and *consequential transitions*. As a result, the authors suggested it to be viable to “re-think transition as a question of identity in which persons see themselves developing due to the distinct social and academic demands that the new institution poses” (Hernandez-Martinez et al., 2011, p. 119).

Commognition

A number of studies drew on the theory of *commognition* (Sfard, 2008) to analyse the transition to university mathematics education as a *discursive shift* that may involve a *commognitive conflict*, that is “the encounter[s] between interlocutors who use the same mathematical signifiers (words or written symbols) in different ways or perform the same mathematical tasks according to differing rules” (Sfard, 2008, p. 161). This approach provides a language for describing mathematical work as discursive practices, characterized by their shared *word use*, *visual mediators*, *endorsed narratives* and *routines*. In a UK context, Thoma and Nardi (2018) investigated how a group of first year mathematics students solved closed book exam tasks, and also interviewed the two lecturers involved

in the courses. In the students' scripts four manifestations of (unresolved) commognitive conflict were observed, two of which (the numerical domains involved, and visual mediators and rules of school algebra and set theory) seen as “stemming from the use of visual mediators and rules from the school mathematics discourse” (Thoma & Nardi, 2018, p. 165). A challenge for beginning students at university is then to recognise the switch and adapt to different discursive contexts, which was not required in the arithmetic and algebra dominated school mathematics. Some further examples are found in Nardi, Ryve, Stadler and Viirman (2014) who discuss empirical studies highlighting “*commognitive conflicts* that characterise the transition to *literate* mathematics” (p. 194).

Discussion

The studies reviewed above illustrate how the framing of the secondary-tertiary transition in mathematics education has widened in scope during the last decade. With the exception of *commognition*, the theoretical approaches identified as “new” have been developed outside mathematics education; however, most of them have been imported first into other research areas in mathematics education. Many of the studies recruit a combination of different theoretical resources in order to achieve their research aims. Overall, the transition as a process has come more into focus, which is also reflected in the methodologies (e.g., interviewing students at different points in time). Referring to recent work, Gueudet et al. (2016) made a similar observation in noticing a trend towards approaches that intend to grasp transition as a process in its complexity.

Notably, all approaches discussed might be subsumed under “socio-cultural” theorizing. This is a move away from views that essentialize students' mathematical and cognitive dispositions that may (or may not) make them successful in crossing the boundary between school and university mathematics education. The new approaches illustrated above certainly have enriched the field, as transition is not only pictured as problematic but as necessarily involving discontinuities. By drawing on theoretical tools developed within coherent frameworks in the analyses of mathematics-specific practices, critical experiences of the transition as well as social and cultural (dis)continuities have been identified that otherwise would have remained hidden; some questions would not have been asked without turning to theories developed outside mathematics education. This applies not only to such issues as implicit rules for the use of mathematical symbols or modes of argumentation, but also to the organization of the content of mathematical courses, their modes of study and resources used. This development is also in alignment with the general trend in mathematics education research, including university level (cf. Inglis & Foster, 2018). However, the dominant focus here is on the “cultural” to the detriment of the “social” in “socio-cultural” theorizing. How social orders or hierarchies are (re)produced in the transition remains under-researched, despite numerous statistical reports on underrepresentation or dropout in higher (STEM) education of particular social groups. While, for example, ATD offers a precise language of description for conceptualising differences between mathematical cultures, sociological approaches, in particular if they allow a description of mathematical practices, discourse and knowledge structures in relation to mechanisms of inclusion and exclusion, are important to understand how particular social hierarchies are (re-)produced *within* particular mathematical cultures (see e.g., Bergsten, Jablonka, & Klisinska, 2010; Bergsten & Jablonka, 2013; and the review of sociological theories in mathematics education in Jablonka, Wagner, & Walshaw, 2013).

As to the cultures of doing mathematics, similarly as noted by Gueudet (2008), technology as one area relevant for the transition appears under-researched in our sample of papers. While as long as 30 years ago technology (in particular CAS) was seen as a key resource for ‘reshaping calculus’ in the USA, “the potential of technology in helping students in the ‘rite of passage’ to tertiary education has not yet been researched” (Bardelle & Di Martino, 2012, p. 787). There are however recent attempts in theorizing technology use in the transition (Gueudet & Pepin, 2018). Still, even after suspending traditional ways of doing university mathematics (e.g., through technology), going through a status of liminality will be necessary in the process of enculturation.

References

- Bampili, A-C., Zachariades, T., & Sakonidis, C. (2017). The transition from high school to university mathematics: A multidimensional process. In T. Dooley & G. Gueudet (Eds.), *Proceedings of the 10th Conference of European Research in Mathematics Education* (pp. 1985–1992). Dublin: Institute of Education, Dublin City University.
- Bardelle, C., & Di Martino, P. (2012). E-learning in secondary–tertiary transition in mathematics: for what purpose? *ZDM*, 44(6), 787–800.
- Bergsten, C., & Jablonka, E. (2013). Mathematics as “Meta-Technology” and “Mind-Power”: Views of engineering students. In B. Ubuz, C. Haser & M. A. Mariotti (Eds.), *Proceedings of the 8th Conference of European Research in Mathematics Education* (pp. 2286–2295). Antalya, Turkey: Middle East Technical University.
- Bergsten, C., Jablonka, E., & Klisinska, A. (2010). Reproduction and distribution of mathematical knowledge in higher education: constructing insiders and outsiders. In U. Gellert, E. Jablonka & C. Morgan (Eds.), *Proceedings of MES6* (pp. 150-160). Berlin: Freie Universität Berlin.
- Black, L., Williams, J., Hernandez-Martinez, P., Davis, P., & Wake, G. (2010). Developing a ‘Leading Identity’: The relationship between students’ mathematical identities and their career and Higher education aspirations. *Educational Studies in Mathematics*, 73(1), 55–72.
- Clark, M., & Lovric, M. (2008). Suggestion for a theoretical model for secondary–tertiary transition in mathematics. *Mathematics Education Research Journal*, 20(2), 25–37.
- Corriveau, C., & Bednarz, N. (2017). The secondary-tertiary transition viewed as a change in mathematical cultures: an exploration concerning symbolism and its use. *Educational Studies in Mathematics*, 95(1), 1–19.
- De Guzman, M., Hodgson, B., Robert, A., & Villani, V. (1998). Difficulties in the passage from secondary to tertiary education. *Documenta Mathematica, Extra Vol. ICMI, III* (Proceedings of ICM, Berlin 1998, August 18–27), 747–762.
- Gueudet, G. (2008). Investigating the secondary – tertiary transition. *Educational Studies in Mathematics*, 67, 237–254.
- Gueudet, G., Bosch, M., DiSessa, A., Kwon, O. N., & Verschaffel, L. (2016). *Transitions in mathematics education*. ICME-13 Topical Surveys. Springer Open.

- Gueudet, G., & Pepin, B. (2018). Didactic contract at the beginning of university: a focus on resources and their use. *Int. Journal of Research in Undergraduate Mathematics Education*, 4(1), 56–73.
- Hernandez-Martinez, P., & Williams, J. (2013). Against the odds: resilience in mathematics students in transition. *British Educational Research Journal*, 39(1), 45–59.
- Hernandez-Martinez, P., Williams, J., Black, L., Davis, P., Pampaka, M., & Wake, G. (2011). Students' views on their transition from School to College mathematics: rethinking 'transition' as an issue of identity. *Research in Mathematics Education*, 13(2), 119–130.
- Inglis, M., & Foster, C. (2018). Five decades of mathematics education research. *Journal for Research in Mathematics Education*, 49(4), 462–500.
- Jablonka, E., Ashjari, H., & Bergsten, C. (2016). "Much palaver about greater than zero and such stuff" – first year engineering students' recognition of university mathematics. *International Journal of Research in Undergraduate Mathematics Education*, 3(1), 69–107.
- Jablonka, E., & Bergsten, C. (2010). Theorising in mathematics education research: differences in modes and quality. *Nordic Studies in Mathematics Education*, 15(1), 25–52.
- Jablonka, E., Wagner, D., & Walshaw, M. (2013). Theories for studying social, political and cultural dimensions of mathematics education. In M.A.K. Clements, A. Bishop, C. Keitel, J. Kilpatrick & F. Leung (Eds.), *Third international handbook of mathematics education* (pp. 41-67). New York: Springer Science+Business Media B.V.
- Kleanthous, I., & Williams, J. (2013). Perceived parental influence and students' dispositions to study mathematically-demanding courses in Higher Education. *Res. in Math. Education*, 15(1), 50–69.
- Kouvela, E., Hernandez-Martinez, P., & Croft, T. (2018). "This is what you need to be learning": an analysis of messages received by first-year mathematics students during their transition to university. *Mathematics Education Research Journal*, 30(2), 165–183.
- Nardi, E., Ryve, A., Stadler, E., & Viirman, O. (2014). Commognitive analyses of the learning and teaching of mathematics at university level: the case of discursive shifts in the study of Calculus. *Research in Mathematics Education*, 16(2), 182-198.
- Radford, L. (2008). Connecting theories in mathematics education: challenges and possibilities. *ZDM*, 40(2), 317–327.
- Sfard, A. (2008). *Thinking as communicating: Human development, development of discourses, and mathematizing*. New York: Cambridge University Press.
- Thoma, A., & Nardi, E. (2018). Transition from school to university mathematics: Manifestations of unresolved commognitive conflict in first year students' examination scripts. *International Journal of Research in Undergraduate Mathematics Education*, 4, 161–180.
- Wade, C., Sonnert, G., Sadler, P., Hazari, Z., & Watson, C. (2016). A comparison of mathematics teachers' and professors' views on secondary preparation for tertiary calculus. *Journal of Mathematics Education at Teachers College*, 7(1), 7-16.

External Didactic Transposition in Undergraduate Mathematics

Marianna Bosch¹, Thomas Hausberger², Reinhard Hochmuth³ and Carl Winsløw⁴

¹Univ. Ramon Llull, Spain; marianna.bosch@iqs.edu

²Univ. of Montpellier, France; thomas.hausberger@umontpellier.fr

³Leibniz Univ. of Hannover, Germany; hochmuth@idmp.uni-hannover.de

⁴Univ. of Copenhagen, Denmark; winslow@ind.ku.dk

Undergraduate mathematics programmes in Europe are typically delivered in hierarchical structures of modules whose contents are in general assumed to be quite similar across universities. These programmes and the mechanisms through which they are maintained, revised and developed, have so far not been the subject of systematic research, as most research (including intervention-based research) takes the programme for granted. This paper furnishes a theoretical and methodological framework for undertaking didactic research in this area and provides some results from a first study in four universities in Denmark, France, Germany, and Spain.

Keywords: undergraduate mathematics, external didactic transposition, curricula.

Introduction

As one of the main challenges for future research on university mathematics education (UME), Artigue (2016, p. 22) noted the need to “maintain some connection between the living field of mathematics [...] and undergraduate mathematics education”. She relates this to the fact, already noted by Kahane (cited in Bass, 2005, p. 417), that “in no other discipline is the distance between the taught and the new so large”. It is an illusion that the contents of university mathematics teaching flow directly from the source of research, being continuously updated with the advances of mathematics.

Most research studies consider teaching and learning processes related to a given mathematical piece of knowledge that takes place within one or a few curriculum subjects, domains or modules. These modules seem to function as a context of the study that is not in itself submitted to research—neither at the level of the entire study programmes nor at the level of the modules and their syllabi. In some studies, this context is found to offer constraints or even obstacles to student learning and teaching innovation of the piece of knowledge considered, but the module itself—its structure and place in the curriculum—is rarely put under question. The need for research to go beyond this relationship to curricula was emphasized in the conclusion of the chapter on university mathematics education of the recent volume celebrating the 20th anniversary of ERME:

We should mention also the potential, but currently quite limited, impact [*of research on UME*] at the level of innovation of curricula and policy. Some of the more global problems identified by [*research on UME*] [...] clearly call for research and impact at this level (Winsløw, Gueudet, Hochmuth, & Nardi, 2018, p. 71).

Creating a research-based approach to the development of undergraduate mathematics programmes appears as an important challenge. Bosch and Winsløw (to appear) have started to address this

question from the perspective of university didactic transposition, using some research available on the evolution of university mathematics programmes (e.g., Huntington, 2015; Tucker, 2013). In this line of research, this paper presents the first results from a study of the structure and evolution of undergraduate mathematics curricula at selected universities in four European countries. Its main aim is to outline some theoretical and methodological directions for this line of research.

Theoretical framework and research questions

We problematize the elaboration and evolution of university curricula by using the framework of the didactic transposition (Chevallard, 1991; Chevallard & Bosch, 2014). We use this framework as a tool to investigate the precise organisation and structure of the *knowledge to be taught*. Study processes—at all levels—are defined in terms of learning goals to be reached by a given group of people under certain conditions. In the case of European university degrees, these goals are defined in terms of general competencies, materialised in *study programmes*, which are first concretised in a set of *modules* (or subjects). Modules receive a name that can correspond to a sector or domain of a discipline (Algebra, Analysis, Geometry) or to a specific selection of contents (Perspectives in Mathematics, Mathematical language and reasoning, Mathematical modelling). At a second level of concretion, modules are described through a *syllabus* where the learning goals are more precisely defined in terms of subject-based contents and often also skills, learning outcomes, textbooks, prerequisites, etc. Taking the word “knowledge” in a broad sense—to include formal knowledge but also informal practices, skills and competencies, attitudes, etc.—we can say that study programmes, modules and syllabi are the way used by universities to define the knowledge to be taught.

The notion of didactic transposition points to the fact that teaching and learning processes do not begin when teachers and students meet in a classroom. The starting point is the selection and elaboration of the *knowledge to be taught* from what is called the *scholarly knowledge*, which gives legitimacy to the knowledge to be taught. Three institutions intervene in this process: the scholarly institution of knowledge producers and users (the “experts” or scholars); the school institution where the scholarly knowledge has to be transposed (which in our case corresponds to the university); and the *noosphere* which is defined in the neighbourhood of both and includes all those who make decisions about the teaching processes at play. In the case of UME, these three institutions have a large intersection. However, even if they share many of their subjects, we should differentiate the *positions* occupied and the roles assumed by their subjects. Therefore, a mathematics researcher can act as a subject of the scholarly institution—a scholar—when she produces mathematics and acts as an expert of the discipline. She can also act as a subject of the noosphere when she makes decisions about the study programme of a given degree. And she is also the subject of the school institution—this or that university or faculty— when she teaches a module.

The process of selecting, adapting, organizing and declaring the “knowledge to be taught”—beginning from scholarly knowledge and ending with all the teaching materials that can be proposed in a given course—is called *external didactic transposition* (EDT), while the subsequent step towards the “actually taught knowledge” is called *internal didactic transposition* (Chevallard, 1991, p. 35). One can interpret almost all existing research on UME as primarily concerned with internal didactic transpositions, since (as noticed above) the programmes and syllabi are merely considered a context

of teaching and learning processes. When putting the EDT at the core of the study, we consider the following research questions: What are the main processes and rationales in the EDT processes leading to UME study programmes and modules? What are the institutional forces that influence them (from the scholarly institution, the noosphere, and the school)? What common tendencies can be found in European universities, regarding these questions?

Methodology

This paper only presents a first attempt to provide some pieces of answer to these research questions throughout an exploratory study mainly based on four one-hour interviews with experienced undergraduate mathematics teachers from Denmark (DK), France (FR), Germany (GE) and Spain (ES). Teachers were selected for their experience with recent curriculum drafting. They are all professors in mathematics departments and researchers in different areas of pure mathematics: topology, number theory, algebra, combinatorics, and functional analysis. The main selection criterion was our facility to approach them and their willingness to participate in the study. The bachelor programmes of mathematics of the four universities were analysed before preparing the interviews and used as the empirical basis of our interaction with the interviewees. They are not necessarily representative of other programmes in the same country.

The interview guide contains four sections. The first section asks a rough description of one of the latest undergraduate modules the interviewee had taught. The second section is about the history of this module, the genesis of its syllabus and possible conditions for changing it. The third section includes questions about the whole study program, compared to past programs and to programs of other universities. Finally, the fourth section refers to processes involved in the elaboration of the program, obstacles for changing it, and factors of influence within and outside the department. To support the discussion, the informants were given a copy of the course structure diagram of their faculty, showing modules with titles, ECTS credits and time organisation. In particular, the informants drew arrows on this diagram to show the dependency between modules and referred to it while commenting on the design of the study plan as a whole. Both the design of the interview guide and the choice of informants reflect our assumption that EDT in this context is closely related to the internal didactic transposition, including the daily teaching experience.

The interviews were audio-recorded and afterwards transcribed, and translated into English if not conducted in this language (one of the four was not). After a first reading of the interviews, we identified four themes, which were also to some extent built into the interview guide. Given our research questions, the themes focus on the product of EDT (themes 1 and 2) and its functioning as a dynamic process (themes 3 and 4). We scanned the interviews for utterances about these themes and then identified emerging, shared viewpoints on the EDT. These are presented in the next sections. When quoting informants, we refer to their country (DK, ES, FR, GE).

Theme 1: Form and contents of study programmes

We first note some initial observations mainly based on the documentation of the study programmes. We focused on bachelor programmes in (pure) mathematics. All four universities also offer master programmes in this area. Therefore, the bachelor programmes may not qualify students for a job in the “real world” but could mainly provide a basis for master studies, which in all four cases may lead

to a job as a secondary school teacher, among other options. All programmes offer a common core of courses on analysis, linear algebra, algebra, numerical methods, and stochastics. The programmes also include some auxiliary subjects such as programming or informatics (all), physics (France and Spain), or a secondary “minor” subject (Germany), but the interviews show that the core mathematics subjects do not rely on such auxiliary modules. Even the use of digital tools such as CAS for analysis courses is mostly optional. A quite substantial difference among the programmes is that in the Spanish and the French ones, almost all modules in the three years are fixed and mandatory, while the Danish and German programmes reserve at least 40 ECTS for elective courses. The elective courses cover many fields, some of which are mandatory in the other two programmes: geometry, topology, functional analysis, advanced algebra, stochastics or statistics, etc. The size of individual modules is also quite different: In the Spanish case all modules are 6 ECTS, the French programme contains courses from 2.5 up to 7.5 ECTS and the Danish and German programmes mostly have 10 ECTS-modules. All larger modules include lectures, and usually also tutorials, labs or problem sessions.

There seems to be a tendency to keep a core of courses that cover the same mathematical domains, with a strong consensus on these core domains:

This program gives a solid foundation for most of the mathematical directions that you would, we want to cover here. I mean you do a solid background in analysis and in algebra... (DK)

On the other hand, details, and emphases of the study programme also depend on local conditions like staff composition, established research units and so on:

If people from the staff are more, say, predominantly from applied mathematics, they tend to shift pure mathematics from the syllabus. And the reverse is true too. (ES)

In spite of differences between the programmes, the interviewees claim that the structures of modules are hard to change (DK) and that there is not very much to play with (ES).

Another common facet relates to the basic idea underlying the overall structure of the programmes and in particular the sequencing of the modules: they are organized according to the logical dependency of notions, definitions, and theorems (mathematics as a product). In the interviews, there was only the case of a discrete mathematics course where the content seems, at least partly, to be organized around problems:

[We] rather start from a concrete problem, a problem that they know, the Fibonacci numbers, and look how the method is developed in that problem you see, how to do, how to get a functional equation for the generating function and then use partial fractions. (GE)

Theme 2: Form and usage of module syllabi

The first part of the interviews centres on a recent module taught by the informant. This provides further information about one particular syllabus, and the ways it functions to structure and direct the actual teaching. Considering all four interviews, we can identify some common points, as hypotheses about how undergraduate mathematics syllabi are elaborated and used more generally. The first common point is that the syllabus consists of a short list of mathematical concepts or results that form the core of the module, while still leaving some initiative to the teacher:

There is still some flexibility, particularly how far one would go with certain topics. (GE)

Not surprisingly, more choice is left to the lecturer in the case of modules that are more “free-standing”, such as a course on order structure and social choice theory. In courses within a longer sequence, such as the first analysis course, the constraints are stronger:

The curriculum was sort of written beforehand and I basically had to stick to it [...] You do have some influence on the weight you would put on certain topics, and I think I spent more time and focus on continuous functions than was perhaps originally intended. (DK)

When the informants describe one of the undergraduate courses they have taught recently, they almost exclusively refer to their lectures, including the particular choices they make in terms of emphases, what to cover, etc. When asked, some of the informants also mention the exercises, often taught by assistants in different sessions, but without giving them crucial importance in the structure of the course. Tutorials are strongly related to the lectures, as the relevant theory should always be treated before being applied in exercises. The exercises are also related to the final exam in the module:

[Tutorials teachers] teach on the blackboard, have 100 students in front of them and they solve the exercises on the blackboard. [...] the list of exercises is a list that comes from father to son. It’s the same list that has been there for the past 10 years. [...] they are trained in the classroom with the same kind of exercises that will be at the exam. [...] the key for 60 or 70% of the students to pass is to do an exam that is not essentially different from previous ones. (ES)

All informants agree that their own activity as researchers does not directly influence their activity and choices as lecturers, because the material of the undergraduate course is very elementary:

It’s so basic, all of it. [...] I mean, I think most people would agree these are the kind of things that you would include in a course like that, so I am not sure that my particular line of research has played a significant role. (DK)

The interviewees all agreed that syllabi can be revised in reaction to experiences while taking into account the function of the module as a prerequisite for other ones. However, most changes described in the interviews seem to respond to more global changes of an administrative character, such as the passage from quarters to semesters. In two of the universities, changes were also due to the passage from a structure where some basic courses, including calculus, were shared with other study programmes, to a programme where all courses are tailored exclusively to mathematics students. The contents are mainly justified by such a collegial consensus, the needs in other courses and the preparation for the master level, and sometimes also students’ prerequisites. Two informants (GE and DK) also made passing references to the perceived needs of future teachers, but otherwise, the contents are not related to needs or factors outside of the programme. All the informants express, in various ways, that the contents of the core modules must be kept:

Changes on the content are really dangerous because either you omit things which are important for other modules or [*you add something new in relation to previous years, with the result that*] the exam, it’s going to be a full disaster. (ES)

Theme 3: Process of design of study programmes and modules

We seek to identify the main constraints of the EDT as a process conducted inside the mathematics department, seen as an institution within the university. External constraints may originate from other disciplines within the university (interrelations of programmes), the university as a whole (coherence and economy of study programmes), the ministry of education (accreditation), the European Union (the Bachelor-Master-Doctorate (BMD) structure or other aspects of the Bologna process), or the socio-economic sphere (needs for qualified labour force in specific domains).

The collected interview data gave an overall picture of EDT as a rather informal process:

There may be two or three people who go teaching this course, and I think we will (for the new accreditation) just sit together again and see what everyone agrees to. (GE)

The module descriptions are thus done by teachers who volunteer, motivated by their involvement in the teaching. The formal constraints imposed by national authorities seem weak and concern only the formal structure of the study programme:

Before the BMD reform, the size of the modules and their names were given by law. The legislation regulated the number of hours of integration theory, differential calculus, and so on, and checked on the syllabus that the study programme fulfilled the expectations of the degree. With the BMD, universities are totally autonomous. (FR)

The autonomy of institutions is indeed furthered by the Bologna Accord. In some cases, this is used as an opportunity to create more independent and pure mathematics programmes. External constraints due to other fields are limited to the few cases when modules are shared with them:

In this version of the programmes, great autonomy was given to the departments, with little constraints on the potential navigation of students between different study programmes. This choice was made by the ruling committee of the faculty of sciences and the consequence that I can see is that it leads to a disciplinary retreat. (FR)

Constraints due to the socio-economic environment were also mentioned: “Here, you have a lot of insurance companies and banks, so we lose some students in this direction” (GE). However, its impact on the EDT seems weak: “In the curriculum, you don’t see it” (GE). Again, students’ mobility was also pointed out, to justify that mathematics programmes need to be fairly similar.

Because of the overall weakness of perceived external constraints, the interviewees came to identify students as the main constraint that EDT meets as a process:

The real constraints are the students. How to build a study programme that is suitable to open to advanced studies in mathematics but also matches the level of students that we find in front of us? This is very complicated. (FR)

Theme 4: Evolution of programmes and modules

When asked about major evolutions of the study programmes over the last decades, two main changes were mentioned: the tendency to structure programmes in a higher number of (smaller) modules, and the incorporation of new modules related to computer science, programming and discrete

mathematics. All interviewees agreed that the strong compartmentalization of knowledge leads students to specific study strategies, resulting in a loss of connections among subjects:

So, it's not so much the curriculum, but what matters is how people learn. I take my exam after the end of this course right away and then I can forget about it and come to the next thing. So this was different in the diploma system. You had the oral exams after two years and you had a big exam at the end after four or five years. This makes a big difference. (GE)

Another change that can be observed is the incorporation of what we can call “propaedeutic” courses in the first semester of some universities: “Mathematical language and reasoning” (ES), “Perspectives in Mathematics” (DK). In the French case, a more unified start has been achieved by merging the modules of analysis and algebra in the first semester:

In the first years, you need to give substance to a set of mathematics, to have more possibilities of interaction between the different elements of the subject to facilitate the links. (FR)

As for the modular structure, the fragmentation seems to be reinforced by the repartition of subjects among groups of researchers:

[What introduces changes in the curriculum is] the sociological evolution of the laboratory, that is, the number of colleagues that are in this or that team, their thematic orientations. (FR)

The tendency towards disciplinary “purism” also means that subjects which are not linked to research groups in the department tend to be reduced or even disappear.

There appears to be strong stability in the core-curriculum shared by the four programmes, and we see no signs of substantial disagreement about the overall profile of the programmes.

Conclusion and outlook

Our exploratory study considers the EDT, its processes and rationales, institutional forces and common tendencies, mainly through the lens of experiences reported by lecturers and their reflections on internal didactic transposition processes—how it is framed, determined by obstacles and goals. Our main results (in fact, hypotheses of general trends) are the following:

- § Although the programme structures of the universities look quite different, they have a common core of courses (analysis, algebra, probability, and statistics, etc.), reflecting a broad consensus among mathematicians at large. The interviewees describe and justify relations between the modules in terms of inner-mathematical (logical or theoretical) dependencies.
- § A module is a lecture-based course and it is described essentially through a short list of topics, especially notions and theorems. This list outlines what the lectures should cover, leaving room for variations, but with very little reference to what the students are asked to do (types of problems, exams, etc.).
- § The process of curriculum design is very informal, with no systematic and explicit organisational principles, thus relying on a set of shared assumptions and on the dependence between faculty and teaching needs. Moreover, the interviewees experience weak external constraints (influence of the socio-economic environment, students' mobility) together with a high autonomy to make changes, which seem to reinforce disciplinary purism.

§ An increased modularisation is seen in the last 20 years with a trend towards early specialisation in mathematics. When changes are operated in a study programme, the core of the programme is preserved but some auxiliary modules may be added or replaced, to support students' learning of generic skills (e.g. mathematical reasoning), to introduce new domains (graphs, modelling, etc.) or provide new tools (computer programming).

At this stage of the research, we are far from being able to propose or support initiatives towards a more systematic and knowledge-based EDT—that is, to produce curricula and syllabi that optimize mathematics programmes in relation to institutional contexts and specific sets of constraints. One major motivation is that, if we want to pursue specific agendas—such as broader and more efficient preparation of secondary school teachers, new paradigms of “inquiry-based” teaching, and so on—, we need to understand the processes of EDT that determine the set of conditions and constraints under which such agendas are pursued.

Acknowledgments

Funded by Ministerio de Economía y Competitividad, MINECO/FEDER, EDU2015-69865-C3-1-R

References

- Artigue, M. (2016). Mathematics Education Research at University Level: Achievements and Challenges. In E. Nardi, C. Winsløw & T. Hausberger (Eds.), *Proceedings of the First INDRUM Conference* (pp. 11–27). Montpellier, France: University of Montpellier and INDRUM.
- Bass, H. (2005). Mathematics, mathematicians and mathematics education. *Bulletin of the American Mathematical Society*, 42(4), 417-430.
- Bosch, M., & Winsløw, C. (to appear). The external didactic transposition of mathematics at university level: dilemmas and challenges for research. *Educação Matemática Pesquisa*.
- Chevallard, Y. (1991). *La Transposition didactique: du savoir savant au savoir enseigné* (2nd edition). Grenoble, France: La Pensée sauvage.
- Chevallard Y. (2015) Teaching Mathematics in Tomorrow's Society: A Case for an Oncoming Counter Paradigm. In J. S. Cho (Ed.). *Selected regular lectures from the 12th International Congress on Mathematical Education* (pp. 173-187). Switzerland: Springer.
- Chevallard, Y., & Bosch, M. (2014). Didactic Transposition in Mathematics Education. In S. Lerman (Ed.), *Encyclopedia of Mathematics Education* (pp. 170-174). Netherlands: Springer.
- Huntington, H. (2015). *A historical analysis of the mathematics major requirements at six colleges in the United States from 1905 to 2005*. Ph.D.-thesis, University of Columbia.
- Tucker, A. (2013). The History of the Undergraduate Program in Mathematics in the United States. *The American Mathematical Monthly*, 120(8), 689-705.
- Winsløw, C., Gueudet, G., Hochmut, R., & Nardi, E. (2018) Research on University Mathematics Education. In T. Dreyfus, M. Artigue, D. Potari, S. Prediger & K. Ruthven (Eds.), *Developing research in mathematics education - Twenty years of communication, cooperation and collaboration in Europe* (pp. 60–74). Oxon, UK: Routledge.

Students' difficulties to learn derivatives in the Tunisian context

Rahma Bouguerra

Université virtuelle, ISEFC, Tunis, Tunisia; rahmabouguerra@gmail.com

Keywords: Concept image, formal definition, language, articulation of knowledge, non-technological environment.

Introduction and research problem

In my research, I focus on the concept of derivative at a point; this concept was selected as a means to study students' conceptions and difficulties when learning derivatives. This concept has been chosen because it poses problems to students throughout the teaching / learning process. It is known that this concept is connected to many other concepts and it can be represented in various ways. So there are many ways and different interpretations to understand it. In particular, there are many findings reported in the mathematics education literature related to my topic; these include the study of students' difficulties with tangents (Tall, 1986; Vinner, 1983) of with the understanding of derivatives at a point (Park, 2013).

Since 1957, mathematics education in Tunisia has known five reforms at the secondary level. In the current reform, derivatives are first introduced as an instantaneous speed in the third year of secondary school (17-18 years).

In this research, my goal is to identify the obstacles and constraints that prevent students from understanding the concept definition of a derivative and from having adequate concept images of it. My study is guided by the following questions:

1. Does this introduction guarantee a good conceptualization of the derivative at a point?
2. What are the difficulties that prevent secondary and university students from apprehending and visualizing this concept?

Theoretical framework

In my research, I draw on the frame of Concept Image and Concept Definition (Tall & Vinner, 1981), which is a powerful theoretical construct that allows for analyzing students' representations of derivatives. The total cognitive structure associated with a derivative in a student's mind can give us many ideas about the reasons for the misconceptions and lack of understanding that students have. In this study, I consider the interpretation of a derivative as an instantaneous rate of change, which plays an essential role to strengthen students' concept image.

Methodology

The participants in my research are third-year secondary students (17-18 years) in the mathematics section in a Tunisian public school, as well as first-year university students in the Mathematics program in a Tunisian University. I chose these participants to identify some types of difficulties that persist for University students. Sixty secondary students and twenty university students were interviewed in January 2019. They also filled a questionnaire.

Data analysis and discussion

The results show that participants learned by heart the definition of a derivative at a point and therefore give its symbolic representation without knowing that the derivative at a point is an instantaneous rate of change. We interpret this as a result of the teachers' practices (that focus on procedural understanding), as well as the absence of the term "rate of change" in the formal definition in the third-year secondary textbook. Furthermore, institutional choices do not seem to propose contextualized activities where rates of change are used.

This introduction does not help pupils / students understand the derivative at a point, because in physical sciences they have not learned that instantaneous speed is an instantaneous rate of change and in mathematics they cannot find the term "rate of change" in the formal definition. Then, students' difficulties also lie in the articulation of knowledge from physical sciences and from mathematics.

The slope of a tangent is the main representation in their concept image, and to explain their evoked concept image, they use some words referring to language difficulties because their first language is Arabic.

This traditional teaching (where technology is absent) does not allow students either to visualize the concept definition of a derivative nor to develop adequate concept images. There is much to learn and this traditional teaching (using blackboards and static images) does not allow students to see the dynamic characteristics of derivatives especially when there are interplays between settings. These traditional practices hinder our pupils from seeing the link between the slope of the secant line and the slope of the tangent line.

Acknowledgment

I would like to thank Dr. Alejandro Gonzalez-Martin who let me know about this conference, and my dear Professor Elena Nardi; without her, I would not have been able to do this poster.

References

- Park, J. (2013). Is the derivative a function? If so, how do students talk about it? *International Journal of Mathematical Education in Science and Technology*, 44(5), 624–640.
- Tall, D. O. (1986). *Building and testing a cognitive approach to the calculus using interactive computer graphics*. Ph.D. thesis. University of Warwick.
- Tall, D., & Vinner, S. (1981). Concept image and concept definition in mathematics with particular reference to limits and continuity. *Educational Studies in Mathematics*, 12(2), 151–169.
- Vinner, S. (1983). Conflicts between definitions and intuitions: the case of the tangent. *Proceedings of the Sixth International Conference for the Psychology of Mathematics Education* (pp. 24-28).

The integration of digital resources into teaching and learning practices of the derivative concept

Danilo Christo¹ and Sonia Iglioni²

¹Pontifícia Universidade Católica de São Paulo – PUC/SP, Programa de Estudos Pós-Graduados em Educação Matemática, São Paulo, Brasil; danilo.christo@gmail.com

²Pontifícia Universidade Católica de São Paulo – PUC/SP, Programa de Estudos Pós-Graduados em Educação Matemática, São Paulo, Brasil; soniaigliori@gmail.com

Keywords: Resources, document, instrument, derivative.

This paper presents elements of a preliminary research on teaching and learning of the concept of derivative in higher education to be conducted in a Brazilian university. In the research we intend to study the interactions between teachers and resources systems according to the documentational approach to didactics (Gueudet & Trouche, 2010) in order to answer the following research question: How can we develop a joint researcher / teacher actions in the design of resources and analysis of the documentational work of higher education teachers when they approach the concept of derivative?

Literature review

We conducted a literature review and found that some researches in Brazil on the teaching and learning process of the concept of derivative, for example, Leme (2016), and Almeida (2017), show that students express more satisfaction in situations that involve operative aspects than in situations that involve conceptual aspects of derivative. An analysis of didactic books, used in the teaching of differential and integral calculus, in engineering and mathematics Brazil courses, showed that most of these books privilege the use of the technique, offering a superior amount of exercises that focus the technique than in exercises that conceptual aspects.

Theoretical Framework: The Documentational Approach to Didactics

The documentational approach to didactics (Gueudet & Trouche, 2010) refers to the notions of resources, scheme, documentational work, among others that support the development of Documentational Genesis theory, an extension of Instrumental Genesis (Rabardel, 1995) to Didactics of Mathematics. There is still in this theory the proposition of the dialectic resources / documents that renew it and even give more force to the questions of the professional practice of the teachers. In the Documentational Genesis (Gueudet & Trouche, 2009), the teachers' documentation, in the action of preparing and implementing their classes, is at the core of the teachers' professional activities and development, and implies: the research of new resources, selection and creation of mathematical tasks for sequential planning and development, time management, and artefact management. For Rabardel (1995), the use of technology invokes the need for any technological artefact that should become an instrument, that is, when the artefact acquires a meaning for the subject, therefore, according to Gueudet, and Trouche (2009, p. 204), this process occurs when an "*instrument* results from a *process*, named *instrumental genesis*, through which the subject builds a *scheme* of utilization of the *artefact*, for a given class of situations". Today, digital resources have become an important part of teacher and student resources systems, and schemes of use: an integration of these resources into teaching and learning practices in mathematics; their appropriate uses within a myriad of available options,

allowing them to be tailored to the specific learning objectives in question and their orchestration¹ and use by students; student resource systems; monitor teacher preparation before and during challenging tasks; and, the role of digital resources in the evaluation performance. Resources with such schemes of use become a document for teachers.

Methodology

This research will follow a reflective methodology (Gueudet & Trouche, 2010) of the principles of: long-term follow-up, monitoring the process, extensive collection of the used resources and evidence of documentational work and reflective accounts of documentational work. The research subjects consist of six teachers who teach differential and integral calculus in the early years of a bachelor's degree in mathematics and in aeronautical engineering, computer engineering, electrical engineering, and production engineering courses. Research on teachers' documentational work, both within and outside the classroom, through the reflective methodology described above, has been extensively developed with high school teachers and even with higher education teachers. For example, Gueudet (2017) interviewed, collected resources and analyzed documents and resources systems specific to the university context of six French university teachers.

Conclusions

In the literature review carried out so far, we found a few studies on higher education with focus on teachers' resources and documents systems. We envisage that the direct observation of teacher work, including testimonials and their interactions with students, will provide important insight into their practices. We consider, as at other educational levels that documentational work is essential in the practices of university teachers and has high potential in university mathematics education research.

References

- Almeida, M. V. (2017). *Material para o Ensino do Cálculo Diferencial e Integral: referências de Tall, Gueudet e Trouche*. (Unpublished doctoral dissertation). PUC/SP, São Paulo, Brasil.
- Gueudet, G., & Trouche, L. (2009). Towards new documentation systems for teachers? *Educational Studies in Mathematics*, 71(3), 199-218.
- Gueudet, G., & Trouche, L. (Eds.). (2010). *Ressources vives. Le travail documentaire des professeurs en mathématiques*. Rennes / Lyon: Presses Universitaires de Rennes/INRP.
- Gueudet, G. (2017). University Teachers' Resources Systems and Documents. *International Journal of Research in Undergraduate Mathematics Education*, 3, 198-224.
- Leme, J. C. M. (2016) *Aprendizagem da Derivada: Uma Perspectiva De Análise Pelos Fluxos De Pensamento*. (Unpublished doctoral dissertation). PUC/SP, São Paulo, Brasil.
- Rabardel P. (1995). *Les hommes et les technologies: Une approche cognitive des instruments contemporains*. Paris. Armand Colin.
- Trouche, L. (2005). Construction et conduite des instruments dans les apprentissages mathématiques: nécessité des orchestrations. *Recherches en Didactique des Mathématiques*, 25, 91-138.

¹ An instrumental orchestration is the systematic and intentional arrangement of the elements (artefacts and human beings) of an environment carried out by an agent (teacher) in order to effect a given situation and, in general, to guide learners in the instrumental geneses and evolution and balance of their instrument systems (Trouche, 2005).

Restoried narratives on the agency and disputes of mathematicians and mathematics educators in the education of mathematics teachers

Cleber Dias da Costa Neto¹, Victor Giraldo² and Elena Nardi³

¹Universidade Federal do Rio de Janeiro, Brazil; cleberneto@gmail.com

²Universidade Federal do Rio de Janeiro, Brazil; victor.giraldo@gmail.com

³University of East Anglia, United Kingdom; e.nardi@uea.ac.uk

We address agency and disputes of mathematicians and mathematics educators over a pre-service mathematics teacher education programme. The format of these courses has been debated (and disputed) within Brazilian academic communities over decades. We use a re-storying methodology (Nardi, 2016) to construct a fictional dialogue to present and analyze data from interviews with four retired lecturers affiliated with mathematics education, who played key roles in the development of the curriculum of the teacher education undergraduate programme in a large Brazilian university. We support our discussion through a framework that articulates teacher education and curriculum theory. Our analysis indicates that these disputes and agency take place within a landscape that transcends teacher education and reaches broader and more complex political and epistemological terrains closely related to the binarism of mathematics and mathematics education.

Keywords: university mathematics education, curriculum, mathematics teacher education.

Introduction: mathematics and mathematics education communities in the preparation of teachers

Nardi (2016) comments that the “relationship between mathematicians and mathematics educators has been the focus of debate since at least the 1990s” (p. 362), and adds that this relationship has been often portrayed “as at best fragile” (ibid.). Theories in the field of *curriculum* may help to unveil possible theoretical or political disputes in the terrain of undergraduate education in general, and undergraduate mathematics teacher education in particular. These disputes (Gabriel, 2013) tend to take place mainly because there are different knowledge areas involved, with differences in agency, acknowledgement by scientific community, and affiliation to scientific domains (mathematics in the Exact and mathematics education in the Social Sciences). The complexity of these disputes is highlighted by authors affiliated to post-critical curriculum theories (e.g. Lopes, 2013) and transcend a binarism that typically permeates this discussion. Our study explores this complexity.

The research we report in this paper is part of a broader study, which is the ongoing doctoral research project of the first author supervised by the second author and aims to investigate the curriculum of the undergraduate programme for pre-service mathematics teacher education in the Mathematics Departments at the Federal University of Rio de Janeiro, Brazil (UFRJ), since the 1980s, from the perspective of the institutional and political terrain in which successive curricular versions were conceived and developed. The study focuses on: (i) the institution, and its official documents; (ii) the lecturers as actors who directly influenced these curricular versions; and, (iii) students (prospective teachers), whose professional preparation took place within this context.

In this paper, we report data and analysis from the broader study which address the disputes between Mathematicians and Mathematics Educators over the conception and development of these successive curricular versions. As previous research indicates (e.g. Nardi, 2008), teaching and management in undergraduate mathematics programmes, in particular curricula design, often involve negotiations and disputes between mathematicians and mathematics educators. This can be the case also when prospective mathematics teacher education is concerned. This is the focus of our paper in which we address the following research question: *How, and to which extent, do negotiations and disputes between Mathematicians and Mathematics Educators take place in the context of an undergraduate programme for mathematics teacher education?* We seek to answer this question through analysing the views of lecturers who are involved with this curricular design. Similarly to Nardi (2008), we characterise a participant as mathematician or mathematics educator according to their academic and professional activities, not necessarily their formal qualifications.

Research on pre-service teachers' education has been accumulating a significant theoretical corpus in the last decades, with strong influences from the field of Education, such as Shulman (1986), and Tardif (2013), and the field of Mathematics Education, such as Ball et al. (2008), and, specifically in Brazil, Moreira (2012), Moreira & Ferreira (2013) and Fiorentini & Oliveira (2013) on debates concerning the design of undergraduate programmes for mathematics teacher education. These debates are situated within broader considerations of research in university mathematics education, which, in recent years, has been consolidating significantly (Winsløw et al, 2018) and has been more attentive to institutional, disciplinary and curricular factors that, within broader political contexts, may influence the what, why and how of teacher preparation in undergraduate programmes.

In Brazil, there are separate undergraduate programmes in pure and applied mathematics (called “Bacharelado” and, in general, intended for future academic careers in Mathematics), and in mathematics teaching (called “Licenciatura”, which legally certifies school teachers). The Brazilian Mathematics Education research community (e.g. Moreira, 2012; Moreira & Ferreira, 2013) has been advocating that undergraduate programmes for mathematics teachers should take more into account a professional-oriented perspective (Tardif, 2013), which should be informed by reflections on school practice, and should integrate more explicitly mathematical knowledge for teaching (Ball et al, 2008). In the Brazilian context, this debate is evidenced in the curricular reforms of undergraduate programmes for prospective teachers, at least since the 1980's.

For instance, Moreira (2012) critiques the influence of the “Bacharelado” over the conception of the “Licenciatura” programmes. This influence is mostly expressed by the “three-plus-one” model – three years on “mathematical content”, followed by one year on “didactics” – which was dominant in “Licenciatura” programmes in Brazil until the early-1990's. In this model, pre-service teacher education consisted of two separate, non-overlapping clusters. According to Moreira, even though this organization has been progressively put aside in most Brazilian universities, its internal logic remains largely unchanged and still underlies current curricular structures, which are variations of the “three-plus-one” model. One such variation is the inclusion of a third cluster of modules, the so-called “integrating disciplines”, which focus on mathematics teaching. However, mathematics teaching is often assumed to consist of practical knowledge (that is, an ensemble of techniques on “how to teach a certain topic”), with little overlap with other curricular components. Commenting on attempts to

integrate these clusters of modules, Moreira (2012) argues that “the institutions do not manage to accomplish this task, because its accomplishment is impossible under the three-plus-one logic” (p. 1141). Fiorentini & Oliveira (2013) refer to this variation as a “quasi trichotomy”, alluding to an analogy with the dichotomic logic of types of knowledge (mathematical, pedagogical) needed for teaching. Moreira & Ferreira (2013) claim that, in teacher education in Brazil, there is an explicit clash between two strands – one that understands teachers’ knowledge to be plural in nature, with specificities emerging from school practice; and another that regards mathematical content knowledge as reference knowledge for teacher education and practice – and that in Brazil and elsewhere, there are disputes for “hegemony” over these two strands (p. 1001).

The Study

Context, aims and data production

As part of the broader research project, we conducted semi-structured interviews with four retired lecturers of the Mathematics Institute at UFRJ (IM-UFRJ), who played central roles in the curricular reforms over the last 50 years. Criteria to choose these participants included their degree of engagement with the undergraduate programme, including not only teaching but also academic administration positions during the above-mentioned timespan. The participants formally agreed with the study’s terms of confidentiality: their personal identities will be kept confidential, through the use pseudonyms, but the Institution (IM-UFRJ), which provides the context of this research, is known.

The interviewees are identified by the pseudonyms *Ana*, *Elis*, *Inês* and *Olga*. All have undergraduate and masters degrees in mathematics, and have worked as school mathematics teachers before becoming university lecturers. Ana has a doctorate degree in pure mathematics, Inês and Olga in mathematics education, and Elis does not have a doctorate degree. All have experience of research in pure mathematics, at least as masters students; and all migrated their affiliation to research in mathematics education during doctoral studies (Inês and Olga), or later, as lecturers (Ana and Elis). They are all currently retired, and were lecturers at IM-UFRJ from late 1960’s to early 2000’s (Ana from 1978 to 2017; Elis from 1964 to 1993; Inês from 1979 to 2010; Olga from 1976 to 1996). Their academic careers at UFRJ were marked by administrative positions in different levels, active participation in the design of successive curricular versions of the mathematics teacher education undergraduate programme, participation in the Projeto Fundação (a research and development programme on in-service teacher education, and development of instructional resources for the teaching of mathematics at elementary and secondary school). Furthermore, Ana and Olga participated as lecturers in the Graduate Programme in Mathematics Education since its creation in 2006; Ana until 2011 and Olga until now.

The interviews were conducted individually with each participant by the first and the second authors, and were fully transcribed. Interview questions aimed to better understand issues unclear from the analysis of the official documents of the programme (which was part of a previous phase of the study); and, to explore participants’ views on the relationships between Mathematicians and Mathematics Educators. The desing of the interviews scripts was also intended to shed light on lacunar issues that emerged from the analysis of the official documents.

In this paper, we present parts of the interviews with focus on disputes over the undergraduate programme's curriculum. Thus, we focus on participants' responses to the two questions, stated below. As the interviews were semi-structured, these questions were not necessarily made to the interviewees at the same moment, and depended on the flow of the discussion with each.

Question 1: Do you believe that there are disputes between mathematicians and mathematics educators concerning the undergraduate programme for pre-service teacher education at UFRJ? If yes, for which reason(s)? If yes, how do these disputes take place?

Question 2: Do you believe that there is room for mathematicians and mathematics educators to work jointly in the design of the undergraduate pre-service teachers education curricula? If so, how?

We present data in a dialogic format (Nardi, 2016) which provides readers with an intimate look at contradictions and convergences in the participants' statements. We wish to allow readers different interpretations of the data, but we put in evidence the complexity inherent to the disputes that characterize the curricular terrain in which these participants have worked. We stress that the first and the second authors cannot be regarded as external or neutral observers. On the contrary, both are former students and are currently lecturers at UFRJ, working in departments (Application School and Mathematics Institute, respectively) with joint responsibility for the Licenciatura programme. They are therefore deeply involved with the institution under study. However, we do not see this as a compromise of the research, but as part of the research itself. That is, the results we report here are shaped by the perspectives, (shared) experiences, alliances and divergences of the interviewees and the researchers. What we report is a *restoried narrative* (Nardi, 2016) of the agency and disputes of mathematicians and mathematics educators in the undergraduate mathematics teachers education programme at UFRJ – that is, *a possible version of this story, through the lens of its actors* (participants and researchers) which gives prominence to participants' voices.

Data analysis method: From individual interviews to fictional dialogue among four lecturers

To put in evidence the voices of the participants, and to reveal points of agreement, disagreement, and possible contradictions, we gather the voices of the four participants in a fictional dialogue among the four interviewees, grounded on raw data extracted from the transcripts. Conducting the interviews individually was important to avoid inter-participant influence. By gathering them together, we aim to grasp the gist of their responses to the questions we wish to investigate. Such methodology is consistent with the logic that “narratives constructed from testimonials of actors who collaborated in educational research can provide access to the senses and emotions evoked at the moments of data collection, opening space for several interpretations” (Barbosa, 2015, p. 359).

In order to promote this interweaving of the participants' discourses, we use elements of the “narrative approach of re-storying” (Nardi, 2016, p. 362-3), a process for constructing a story from original data, taking into account features, such as a problem, characters involved with a scenario in which they discuss and act upon the problem and its resolution. Here, we identify a common scenario evidenced in the interviews. This scenario, as presented by the interviewees, concerns the views on the relationships between Mathematicians and Mathematics Educators by the interviewees, who worked in the same institution, in a concomitant timespan, and with academic trajectories presenting similarities and distinctions. Each participant's utterances presented here correspond to their actual

responses in the respective individual interviews. However, these interviews took place separately, and the order of these utterances was reconstructed by the authors in the process of composing the fictional dialogue. The interviewer's utterances are introduced in the re-storied dialogue in order to make sense of connections between interviewees' utterances, put together as a whole conversation. Thus, we offer a *re-reading* of the original data – as we believe to be the case for any kind of data description, including those that present full original transcriptions. The order of the utterances and the connections between them in the composed, fictional dialogue and the fact that the first and the second authors are deeply involved in the institution under study produce a particular interpretation of the story, one possible narrative¹. As Nardi (2016) points out, the proximity of the authors to the raw data, the transparency of the process that makes it “accountable and replicable” (p.364), and (specifically in this work) the possibility of establishing communication between Mathematicians and Mathematics Educators are important constitutive elements of the re-storying method.

To organize and present data, we firstly separated and classified the interviewees' statements regarding agreement or not about the existence of disputes between Mathematicians and Mathematics Educators. Then, drawing on the arguments posed by the interviewees, we constructed the sequence of responses and interactions between them, to create a fictional dialogue among five characters – the Researcher and participants *Ana*, *Elis*, *Inês* and *Olga* – in which the alternation of ideas and the views of the characters on the disputes at stake are present. Thus, we mean *fictional* in the sense that it is presented as a dialogue between five individuals but it is based on four conversations conducted with each one separately. Our design includes a respondent validation phase in which the participants read and comment on the fictional dialogue (at the time of writing, a preliminary part of this phase had been conducted through scrutiny of samples of the dialogue by critical friends in our research group). Our method resonates with that of Nardi (2008, 2016), where the composition of the fictional dialogue was based on interviews with groups of participants conducted separately and choices were made in the light of the study's theoretical underpinnings, literature influences and research questions. We now present a sample of the fictional dialogue resulting from this process.

A fictional dialogue among four mathematics lecturers and a mathematics education researcher

The *Researcher* asks whether there are disputes between mathematicians and mathematics educators concerning the Licenciatura programme. *Elis* says “No”.

Inês: I agree. Mathematicians have no interest in undergraduate teacher education.

Olga: As far as the Licenciatura programme is concerned, I don't know if there are disputes. But I believe there are disputes about hiring of new lecturers.

Researcher: What are the reasons for such disputes?

Ana: They want pre-service maths teacher education out of the Mathematics Institute.

Elis: I think mathematicians do not value teacher education. They think it's just not worth

¹ In order to allow readers to judge our composition and, possibly, even produce different interpretations, the raw data is in <https://drive.google.com/file/d/1BUm5gGCUQPvuyyhyuSag09WvNgnNXI16/view>.

it, that it's a lesser thing.

Inês: But this happens because it's just not their interest. Their interest has always been the Bacharelado. It's to push good students to finish undergraduate fast, and put them in the pure maths graduate programme. It's not to prepare teachers, they never had that in mind. Their interest is to prepare researchers in pure maths.

The *Researcher* asks Olga why she thinks this dispute has to do with hiring new lecturers.

Olga: Those people with doctorates in pure and applied maths want to grab everything for them. They want all the new lecturers to them, everything to their fields, dynamical systems, algebra, differential equations. They think only that is mathematics.

The *Researcher* asks whether mathematicians from the Institute have really no interest in the curriculum of the Licenciatura programme at all.

Ana: They won't care about that. At most, they will say: "But why is there no Analysis at \mathbb{R}^n there?"; "Why is there no Calculus with Complex Variables?"

Elis: That's true. But it's funny how though they think Licenciatura has no importance, they yet believe that to be a maths teacher one needs to know a lot of maths.

Inês: People tend to keep retrograde positions: "let's not change anything". They stand against changes because they wanted Licenciatura under their own control. They stand against changes because they don't want to get involved with other programmes, only in the ones that they have interest in.

The *Researcher* asks whether there is room for mathematicians and mathematics educators to work collaboratively in the Licenciatura programme.

Olga: On the one hand, I think that it'd be very good, but I feel a little afraid of putting these lecturers with no link with mathematics education to teach modules in the first year, for example.

Elis: I think that, nowadays, maybe yes. For that, there must be more guidelines for lecturers, to try to get the mathematicians who are more committed more involved.

Ana: I think this is not possible. I'm too pessimistic, because I'm way apart from the Institute. But what I see is people with intransigent positions, which have no factual support. There'll be collaborative work in the same way there is in the Engineering: we go there, teach our lectures, some do the job very well, other put a lot of effort for students to learn, other just don't care. This kind of "collaborative" work always existed, and will keep on existing.

Inês: I have no doubt joint work between mathematicians and mathematics educators is possible. But it has to be with lecturers who do not want to transform prospective teachers into prospective mathematicians. However, I think there are few people with this kind of mentality. I have managed to have very good partnership with a colleague with a doctorate in pure maths at the Institute. But that's rare.

Commentary on the dialogue and closing remark

Our interpretation of the participants' responses to *Question 1* suggests that they do not consider that such disputes exist, since there is no interest from the mathematicians with respect to teacher education. One of the participants conjectures that such disputes do take place when hiring new lecturers. The claim is that mathematicians appear to resist changes in the curriculum of the Licenciatura programme, and intend on keeping it close to the Bacharelado. These statements confirm that there are disputes, not with respect to different conceptions of mathematics teacher education, but to keep the political territories intact. As evidence for this, we also include the purposes to prepare new undergraduate or graduate students and to hire new lecturers to their own fields.

On *Question 2*, the divergence of opinions among the participants was remarkable. Thus, concerns towards the participation of mathematicians in the first year of the undergraduate programme, the need to engage mathematicians more interested in teacher education, the polysemy and fragility of the term "collaboration", and the highlight of the need to differentiate prospective teachers and prospective mathematicians are brought about in a debate that implicitly underlines the acknowledgement of disputes between mathematicians and mathematics educators.

Our interpretation of the debate around the two questions suggests that these participants, clearly affiliated with mathematics education, acknowledge the professionalization and the orientation to school practice as constitutive aspects for the education of mathematics teachers, as per, for example, Tardif (2013) and Nóvoa (2009). In this context, disputes initially seem to be over the consideration of what constitutes mathematical knowledge for teaching (Ball et al, 2008) in pre-service mathematics teacher education, as Brazilian research literature advocates (e.g. Moreira, 2012). However, the debate among the participants indicates that these disputes are situated in more strategic goals: the preservation of political terrains, where students in the mathematics department, here prospective teachers, are background characters who suffer the side effects of someone else's quarrels. As others have noted (Lopes, 2013; Gabriel, 2013), the complexity of the disputes we discuss briefly in this paper is evidenced by a displacement of a more local terrain (undergraduate mathematics teachers programmes) to a broader one (preservation of fields and professional agency). The divergence of responses concerning possible collaborations also reinforce this complexity, since the binarism and tensions between mathematics and mathematics education (Nardi, 2008, p.257-292) was not always prominent in the participants' utterances. Such inferences were only possible because of the particular data analysis design we adopted. These utterances, which appeared initially in each individual interview, were intertwined, revealing convergences and contradictions at the same time as they produce dialogues on ideas that might not be present in a collective interview. These ideas are shaped under the authors' own standpoint, which, as we stressed earlier, is not neutral.

In the broader doctoral project, we are now collecting and analyzing data from discussion groups of former and current students of UFRJ's mathematics teachers education programme. The perspectives put forward in the overall study will therefore be enriched and complemented by our triad of analyses of institution (through analysis of official documents), lecturer and student data.

Acknowledgment

We thank UFRJ for having allowed periods of partial and full study leaves to the first author, without which the development of this doctoral research project would not have been possible.

References

- Ball, D.L., Thames, M. H., & Phelps, G. (2008). Content knowledge for teaching: what makes it special? *Journal of Teacher Education*, 59(5), 389–407.
- Barbosa, J.C. (2015). Formatos insubordinados de dissertações e teses na Educação Matemática. In B. S. D'ambrosio & C. E. Lopes (Eds). *Vertentes da subversão na produção científica em educação matemática*. Campinas: Mercado de Letras.
- Gabriel, C. T. (2013). Conhecimento Científico e Currículo: Anotações sobre uma articulação impossível e necessária. *Revista Teias*, 14(33), 44–57.
- Fiorentini, D., & Oliveira, A. T. C. C. (2013). O lugar das matemáticas na Licenciatura em Matemática: que matemáticas e que práticas formativas? *Bolema*, 27(47), 917–938.
- Lopes, A.. (2013). Teorias Pós-Críticas, Política e Currículo. *Educação, Sociedade e Culturas*, 39, 7–23.
- Moreira, P.C. (2012) 3+1 e suas (in)variantes: reflexões sobre as possibilidades de uma nova estrutura curricular na licenciatura em matemática. *Bolema*, 26, 1137–1150.
- Moreira, P.C., & Ferreira, A.C. (2013) O lugar da matemática na licenciatura em matemática. *Bolema*, 27(47), 981–1005.
- Nardi, E. (2008). [*Amongst mathematicians: Teaching and learning mathematics at university level*](#). New York: Springer.
- Nardi, E. (2016). Where form and substance meet: Using the narrative approach of re-storying to generate research findings and community rapprochement in (university) mathematics education. *Educational Studies in Mathematics*, 92(3), 361–377.
- Shulman, L. (1986). Those Who Understand: Knowledge Growth in Teaching. *Educational Researcher*, 15(2), 4–14.
- Tardif, M. (2013). A profissionalização do ensino passados trinta anos: dois passos para a frente, três para trás. *Educ. Soc. [online]*, 34(123), 551–571.
- Winsløw, C., Gueudet, G., Hochmuth, R., & Nardi, E. (2018). Research on university mathematics education. In Dreyfus, T., M. Artigue, D. Potari, D., S. Prediger, & K. Ruthven (Eds.) *Developments in European Research in Mathematics Education – Twenty Years of Communication, Cooperation and Collaboration*, (pp. 60–74). London and New York: Routledge (New Perspectives on Research in Mathematics Education, ERME series, Vol. 1).

Evaluation of a connecting teaching format in teacher education

Andreas Datzmann¹ and Matthias Brandl²

University of Passau, Faculty of Computer Science and Mathematics, Passau, Germany,

¹andreas.datzmann@uni-passau.de, ²matthias.brandl@uni-passau.de

Keywords: teacher education, geometry, conceptualisation, evaluation, concept image.

Motivation and teaching format

More than 100 years ago Felix Klein described the problem of the double discontinuity and its consequences. With his “three worlds of mathematics” model, David Tall (2008) saw the problem in the existence of different worlds in school and university, namely a conceptual-embodied respectively proceptual-symbolic world at school and an axiomatic-formal world in university. We wanted to counteract the problem of the double discontinuity by connecting the different worlds of mathematics. Therefore we designed a teaching format that should illustrate the interdependencies of mathematics taught at school and mathematics taught at university in the field of geometry. That these connections do not emerge automatically was already stated by Bauer and Partheil (2008). To aid the learning process of the students our teaching format was supported by a blended learning course and mathematical maps. Mathematical maps are a didactical tool to show interrelations between topics and development of a subject matter in time (Brandl, 2008; Schwarz et al., 2017).

Theoretical framework and empirical study

To measure the effect of our teaching format, we used the theoretical framework of concept image by Tall and Vinner (1981). The term concept image describes “the total cognitive structure that is associated with the concept, which includes all the mental pictures and associated properties and processes” (Tall & Vinner, 1981, p. 2). It is built up over time by engaging with the concept and changing as new mental connections are made or older connections are exposed as imperfect. So for us it is interesting how the concept image of the students changed after attending the teaching format and if more mental connections between aspects of the concept taught in school and aspects taught in university are observable. We focused on the concepts of line, circle, congruence and sum of interior angles for this evaluation because they are broadly discussed in school and university.

Data collection and analysis

For our exploratory pre-post-survey we used a guided interview because it allowed both students who attended the full teaching format to answer freely on the question what they connect with a certain concept and then we were able to specifically ask questions on aspects that were not addressed. In all interviews the questions were the same to provide comparability. For each of the four concepts the theoretical notion of concept image was operationalized into different subcategories to which the statements of the students were assigned. We then examined the relations between aspects taught in school and aspects taught in university in these subcategories.

Results and discussion

We want to show changes in the concept image exemplarily. For both students, we call them S1 and S2, the summed up concept image of a line in the first interview was very close to school matters.

Lines were only seen as a linear function, $y = m \cdot x + t$ (S1) and as a slanting dash upwards (S2). The line equation, the slope of a line, parallelism of lines and the number of points of intersection were correctly explained by both students. In the second interview lines were seen as an infinite set of points (S1 & S2) that satisfies the line equation, $y = m \cdot x + b$ (S2) and also from an analytical perspective as reference point and direction vector (S1 & S2). S1 even gave the axiomatic definition of a line as a set that contains at least two different points and that there is exactly one line for any two points. Contentwise you see a change in the concept image of a line. The conception of a line changed to include different aspects, a set theoretical approach of a line as an infinite set of points, which is mainly used in university and an algebraic and analytical approach which is used in school.

In the first interview S1 understood congruence as being the same shape and size, which is the graphic description from school. She also made a connection to the criteria for congruence of triangles which are taught in school. In the second interview S1 added the following excerpt.

Student 1: [Congruence means that] you can map it onto each other with a motion. And a motion is achievable with a maximum of three reflections [...].

This shows that S1 was able to connect the previously very school based knowledge with formal mathematics. The answer to the question which functions are congruence functions reinforces this.

Student 1: Well, so reflections and rotations definitely are congruence functions. Translations too, but dilation and contraction are no congruence functions.

Overall these results suggest that our teaching format positively influenced the concept image of different terms of geometry. Aspects from school were not replaced by but extended with aspects from university. Especially with the abstract concepts of congruence and sum of interior angles more mental connections between aspects of the concepts taught in school and aspects taught in university can be observed. This suggests that the students were able to establish interrelations between what they learned – and will be teaching later – at school and what is taught at university.

References

- Bauer, T., Partheil, U. (2008). Schnittstellenmodule in der Lehramtsausbildung im Fach Mathematik. *Mathematische Semesterberichte*, 56 (1), 85-103.
- Brandl, M. (2008). The vibrating string – an initial problem for modern mathematics; historical and didactical aspects. In I. Witzke (Ed.), *18th Novembertagung on the History, Philosophy & Didactics of Mathematics*, 95–114. Berlin: Logos.
- Schwarz, A-M., Brandl, M., Kaiser, T., Datzmann, A. (2017). Interactive mathematical maps for de-fragmentation. In Dooley, T., Gueudet, G. (Eds.). (2017). *Proceedings of the Tenth Congress of the European Society for Research in Mathematics Education (CERME10, February 1-5, 2017)*. Dublin, Ireland: DCU Institute of Education and ERME, 2292–2293.
- Tall, D., Vinner, S. (1981). Concept image and concept definition in mathematics with particular reference to limits and continuity, *Educational Studies in Mathematics*, 12 (2), 151–169.
- Tall, D. (2008). The Transition to Formal Thinking in Mathematics. *Mathematics Education Research Journal*, 20 (2), 5–24.

Students' difficulties at the secondary-tertiary transition: the case of random variables

Camille Doukhan and Ghislaine Gueudet

CREAD, ESPE de Bretagne, University of Brest, France; camille.doukhan1@espe-bretagne.fr,
ghislaine.gueudet@espe-bretagne.fr

The work presented here concerns the teaching and learning of random variables at the secondary-tertiary transition. Our study takes place in France, where discrete random variables are studied in grade 11 and in the first post-secondary year. Comparing textbooks, we observe that random variables are introduced as tools for the modelling of random situations at grade 11, while they are presented theoretically at the post-secondary level. The answers of first year students to a test confirm this difference: they are able to use random variables to produce interpretations in a concrete situation, but are not prepared for the learning of theoretical definitions. These results can contribute to design a teaching intervention concerning probabilities for first year students.

Keywords: Praxeologies, Probabilities, Random variables, Registers, Secondary-Tertiary transition.

Introduction

Difficulties encountered by students at the secondary-tertiary transition have been analyzed in many research studies in mathematics education, with different perspectives (Gueudet & Thomas, in press). Some of these studies focus on particular mathematical topics: calculus or linear algebra for example. The transition issues concerning probabilities have been less studied so far; yet probabilities are present in many tertiary courses, for non-specialists of mathematics in particular, like biologists or economists. Our study, taking place in France, addresses this issue with a focus on the concept of random variable. Our research questions are the following:

- How is the concept of random variable taught at secondary school, at the beginning of tertiary education? Which similarities or differences can be observed?
- What do the students know about random variables after the end of secondary school, and does this prepare them adequately for what is taught in the first year of tertiary level?

We study these questions with an institutional perspective. We present in the next section our theoretical tools, and studies about the teaching and learning of probability which inform our research. Then we expose in Section 3 the context of our study and our methods. In Section 4 we present our results, coming from a textbook study and a test proposed to first year students. We draw conclusions from these results and present them in Section 5.

Theoretical frame and related works

In our work we consider the secondary-tertiary transition as an institutional transition: the mathematics taught is shaped by the teaching institution, and is thus different at secondary school and university. We use the Anthropological Theory of Didactics (ATD, Chevallard, 2006), which introduces, in particular, the concept of praxeology. A praxeology has four components: a type of tasks, T; a technique, t to accomplish this type of tasks; a technology q which is a discourse explaining and justifying the technique; and a theory Q. Comparing the praxeologies at the end of secondary

school and at the beginning of university can illustrate different kinds of changes in the mathematics taught (see e.g., Winsløw, Barquero, De Vleeschouwer & Hardy, 2014). Some changes are very general: for a given type of tasks, a single technique is taught at secondary school, while several techniques can be expected at university; similarly, at university the theoretical block (formed by the technology and the theory $[q, Q]$) is more important than the practical block $[T, t]$. Other changes concern a particular type of task, for example in our case: “Determine the probability distribution of a random variable,” studied below.

We also use in our work the concept of semiotic registers (Duval, 2017). Mathematical concepts, in particular random variables, can be described through different semiotic registers: a text, a table, or a graph. Compared with secondary school, the institutional expectations concerning the flexible use of different registers increase at university (Gueudet & Thomas, 2018). Hence observing the registers used, in particular the need to combine several registers in the same technique for a given task, can illustrate discontinuities in the transition process.

Concerning probability, several works acknowledge the specific nature of probabilistic reasoning. Batanero et al. (2016) state for example that “probabilistic reasoning is a mode of reasoning that refers to judgments and decision-making under uncertainty and is relevant to real life” (p. 9). Such link between probability and real-life is emphasized by many authors, and in the curriculum of different countries (Batanero et al., 2016). However, some studies indicate that an important proportion of probability problems proposed to students are not related to real life situations and that the problems involve more algebraic than probabilistic reasoning (20% in entrance tests to university in Andalucía according to Batanero, López-Martín, Arteaga, & Gea, 2018). Student difficulties are observed and connected with the teaching practices; for example Burrill and Biehler (2011) claim that a formal teaching of probabilities focusing on set theory and counting techniques can hinder the understanding of the associated phenomena.

Research in mathematics education concerning random variables is scarce. At the beginning of university, Amrani and Zaki (2015) observed student difficulties, after a very formal teaching about random variables. Given a random experiment, they had difficulties proposing a model with an appropriate random variable and determining the probability distribution for a given random variable. Nevertheless these authors did not observe the impact of a less formal teaching.

Context and methods

Our research takes place in France, where probability is an important part of the official curriculum at secondary school, starting at Grade 9. We focus here on Grade 11 of the scientific track (called “S section”). Students encounter random variables for the first time at Grade 11, in the context of discrete random variables. The concepts of *probability distribution*, *expected value*, and *variance* are defined; the Bernoulli and binomial distributions are introduced. According to the official curriculum: “*The concept of probability distribution of a random variable permits the modelling of random situations and their study with the tools of probability*”. At Grade 12 students encounter continuous random variables, with the concept of density and the Gaussian distribution.

We chose to focus on “preparatory classes” in the tertiary level, selecting high-achieving students, who want to enter a “*grande école*” after two years of preparation. The classes are organized is

similarly to secondary school, hence we claim that the institutional differences mainly come from the mathematics taught. Moreover, because they are high achieving, the difficulties encountered by these students should not come from an insufficient grasp of secondary school praxeologies. The official curriculum of the first year of preparatory classes (in our case an “Economics and Commercial – Scientific, ECS,” preparatory class) concerning random variables is limited to discrete random variables (continuous random variables appear only in the second year). The curriculum revisits the notions taught at Grade 11: random variable, probability distribution, expected value, and introduces the study of pairs of random variables, and independent random variables. The official curriculum states that “Modelling simple random situations with random variables is a skill expected from students”, meaning that the preparatory classes institution is not responsible for this modelling skill.

In the study presented here, we used two kinds of methods. First, we performed a comparative analysis of a secondary school textbook, and a preparatory class textbook. The secondary school textbook (Barbazo, 2015), is used by a large number of Grade 11 teachers in France. The students in the preparatory classes did have a textbook, but they often bought books to complement the course given by their teacher. The content across books was quite similar, so we chose Gautier and Warusfel (2012). We compared the chapters concerning random variables according to five characteristics: the structure of the chapters in terms of course vs exercises (theoretical vs practical block), the definition of random variable given (considered as an important aspect of the theory), the registers of representations used, the types of tasks and associated praxeologies, and the contexts in which the exercises and examples were situated. For each chapter studied, we listed and counted the types of tasks requested in each exercise or worked example. The theoretical block appeared mainly in the content parts of the chapters (definitions, theorems, demonstrations, proposals) whereas the practical block appeared in the exercise and example parts of these chapters.

Second, we designed a test and submitted it to the students from a first year ECS class before the teaching of random variables (see Appendix). The teacher only allowed us to use 20 minutes to administer the test in class, so we had to limit its length. The test started with three questions: mathematical definition of a random variable, how to explain to a Grade 12 student what a random variable is, and give an example of random variable; then an exercise in an economical context was proposed. This exercise, taken from a website for Grade 11, was typical from what can be found in secondary school textbooks for this level. It corresponded to a random situation in a “real” context. Nevertheless the students’ responsibility for modelling was reduced: the random variable to be studied was given in the first question. The types of task were: “Determine the distribution of a random variable (described by a text)”; “Compute the expected value of this random variable and interpret it”; and “Study the influence of a change in the initial data on the expected value”. Forty-four students took the test at the beginning of a course. We analyzed the students’ answers using the following categories: for Questions 1 and 2: elements of theory and technology used, errors, ideas or elements related to randomness, and type of answer (theoretical, related to randomness, other). For the Question 3 we looked at example correct or not, if not why, in what context it was stated, and which registers were used. For the exercise, the categories were: answer correct or not, the technique used, the technology (justification of the answer), use of registers, and result correctly interpreted.

Modelling “real” situations and mastering formal definitions

Comparing secondary school and preparatory classes textbooks

We noted a large difference in the proportions of courses/exercises within the chapters studied, in terms of number of pages dedicated to each: 15% for course in the Grade 11 textbook; more than 80% in the ECS textbook. We consider this as an indicator of the much greater importance of the technological-theoretical block in higher education, compared to secondary education.

Concerning the definition of random variable, in the Grade 11 textbook the students already knew the concept of sample space W ; a random variable X was defined as “a function from W to \mathbb{R} ”. We claim that this definition was difficult for Grade 11 students, who mostly met functions from \mathbb{R} to \mathbb{R} . The definition of the probability distribution; as a function from \mathbb{R} to \mathbb{R} , followed immediately and it was more familiar. In the ECS textbook, the definition of random variable was situated at a much more general level. The definition of σ -algebra was introduced together with the notion of probability space as a triple (W, F, P) . In this context a very general definition of a random variable was given: “an application X from W to \mathbb{R} such that $\forall x \in \mathbb{R}, \{w \in W \mid X(w) \leq x\}$ belongs to F ”.

We categorized the registers of representations present in the parts of courses, in the examples of the courses and in the exercises of the chapters studied. We observed seven different registers: symbolic, natural language, and five kinds of graphical registers: tree diagrams, function graphs, tables for representing the random variable distribution, some charts representing the random situation and various illustrations (e.g., photos). The symbolic register and the register of natural language were omnipresent in both textbooks. The graphical registers were more frequent in Grade 11 (68 examples used these registers) than in ECS (18 examples). There were, in particular, many illustrations in Grade 11, and none in ECS. There were 36 tables representing the random variable distribution in Grade 11 and only six in ECS. Overall, there were very few tree diagrams. In the secondary school textbook, random situations were often represented by charts or diagrams, but relatively few by trees.

Regarding the contexts in which the examples and exercises were posed, we distinguish two categories: exercises and examples in a non-mathematical context and in a mathematical theoretical context (what Batanero, *et al.* 2018 call “problems with no context,” p. 113). This choice is governed by the claim of the secondary school curriculum, about the importance of random variables for “the modelling of random situations” (Ministère de l'Éducation Nationale, 2010, p. 5).

In the first category, *exercises and examples in a non-mathematical context*, we identified real-life situations such as the lifespan of a robot or the waiting time at a doctor, but also “artificial” situations such as a flea moving on a graduated axis or a drawing of balls from an urn. There were also situations in other scientific fields such as the study of physical uncertainty of measurement. The proportion of examples and exercises in a non-mathematical context is 78% for Grade 11 and 67% for ECS (out of a total of 108 exercises and examples, respectively 66).

In spite of this difference, we observed similarities concerning the types of tasks. For both Grade 11 and ECS, the three most frequent types of tasks were: “determining the probability distribution of a random variable,” “proving that a random variable admits an expected value and/or calculating it,” and “proving that a random variable admits a variance and/or calculating it.”

For example, for the type of task “determining the probability distribution of a random variable,” the following technique was described in the Grade 11 textbook: “(1) determine the possible values x_i for X ; (2) compute the probabilities $P(X = x_i)$; (3) summarize them in a table”. This technique was linked with the fact that in most cases, the random variable took a limited number of values (in our test for example, X takes 4 different values), that could be presented in a table. In the Barbazo textbook, 104 exercises amongst 106 were about random variables taking a limited number of values. In the ECS textbook, in 20 exercises amongst 21 the random variable took its values between 1 and an integer n . To determine the distribution, the technique is consisted of finding a formula giving $P(X=k)$ for $1 \leq k \leq n$. The associated technologies in the two institutions were provided by the definitions mentioned above. Thus the praxeologies were clearly different in each textbook.

Also the differences concerning the context lead, for similar types of tasks, to different responsibilities of the students in terms of modelling. In Grade 11, 19 exercises asked students to calculate an average payout or determine whether a game would be favorable or not to the player, with no intermediate tasks. For this type of task, the technique used was to select the appropriate random variable, and then determine its distribution in order to calculate the probability of a certain event. This modelling work is totally absent for ECS, although the proportion of exercises in the context of artificial situations is high. In these exercises, the random variable is always given and the types of tasks present are "determining the probability distribution" or "calculating its expected value".

Students responses to the test

We recall here that the test started with three questions, concerning: the mathematical definition of a random variable, the explanation for a Grade 12 student of what a random variable is, and an example of random variable. These questions were directly linked with the theoretical block $[q, Q]$. Twenty-three of 44 students (52%) answered the first question, 33 of 44 students (75%) answered the second question, and 26 of 44 students (59%) answered the third question.

The answers were very often false or incomplete. The most common errors were confusion between the random variable and the probability distribution (which we expected, considering the definitions given in the textbook) and confusion between the definition of a random variable and its properties. In the first question concerning the theory, six students confused the definition of a random variable with its properties, and five students confused the random variable with the probability distribution. In the second question (in which students are expected to produce a technological discourse), three students confused the random variable with the probability distribution. In the third question, 11 students confused the random variable with the probability distribution.

The vocabulary and mathematical notations used by the students allowed us to distinguish two types of answers: theoretical answers in which we find a symbolic register with mathematical concepts and notations, and answers in relation to randomness in which we find a vocabulary in relation to randomness. Such answers contain ideas linked to chance, for example: “randomly draw a sample,” “results of a random experiment,” or “depends on chance.”

For the first question, students mainly gave a theoretical answer (19 of 23 students); only 4 gave an answer in relation to randomness. An example of theoretical response by student S2 is:

“A random variable is a law that associates a variable entity (price, size) with X.” (our translation)

The second question generated more diversity in the registers used by the students in their responses. We distinguish for this question a new type of response, in which students responded with a specific example of the use of a random variable. Almost a fourth of the students produced such a technological discourse, explaining in their answers how a random variable can be used (see the example below). These students seem to have incorporated the perspective of the official curriculum: random variables as tools for the modelling of random situations.

An example of this type of response by student S38 is as follows:

"it will be a question of insisting on the fact that a random variable is not fixed, it will allow specially to make calculations of returns, of profits. Know through expected value if it is relevant or not to play a game of chance. In order to be able to work on its expected value for example it will be necessary to draw up the law of probability (table of values)". (our translation)

Finally, on the third question, we were interested in the contexts in which students set their example. Eight of 26 students who answered this question gave an example in a real-life situation (e.g., the price of a chocolate bar, the price of a car, the life of a light bulb or the size of a plant) while four of 26 of students gave an example in an artificial context (e.g., a betting game, a die roll, or a drawing of balls from urns).

The students were more successful with the exercise than with the three preliminary questions. Thirty-seven of 44 students answered the first question that asked them to determine the distribution of a random variable (described by a text), 38 of 44 students answered the second question that asked them to compute the expected value of this random variable and interpret it, and 29 of 44 students answered the third question that asked them to study the influence of a change in the initial data on the expected value. Students who responded to these questions often offered a correct and well-justified answer.

Concerning the first question, a fourth of the students who answered used a technique involving the representation of the probabilistic situation with a diagram or a tree diagram. Questions of interpretation were often well addressed. Almost two thirds of the students who answered the second question gave a correct interpretation of the expected value.

Finally, we note that these students (who were high-achieving at secondary school) were able to use a random variable for the modelling of a concrete random situation. They interpreted the situation to find the distribution of the random variable, used it to solve a question concerning an expected value, but were unable to produce the correct theoretical/technological discourse needed at tertiary level.

Conclusion

The questions we studied here about the concept of random variable concerned on the one hand the differences between secondary and tertiary levels; and on the other hand how well prepared students were by their secondary school for the teaching proposed at tertiary level.

The textbooks' comparative study evidenced as expected that the practical block was more important at secondary school while the theoretical block was more important in the preparatory classes. The

definition of random variable given at secondary school was less general, and immediately associated with the definition of the distribution, which is central in the exercises. Similar types of tasks were found in preparatory classes, but they corresponded to different praxeologies. For example, techniques were different because random variables met at secondary school had a limited number of values, while random variables in preparatory classes had values between 1 and n . At secondary school, random variables are introduced as tools to study situations and the focus was on the distribution, represented by a table. In preparatory classes, in contrast, the concept of random variable and the associated theory became central.

The student responses to the test are coherent with the textbook study: they were able to use a random variable for the study of a given situation but did not seem to handle well the theoretical and technological aspects. In particular they confounded random variable with its distribution. The textbook analysis suggests that secondary school teaching is probably not a sufficient preparation for what is expected at tertiary level, and our small sample of students seems to confirm this. Even if the concepts are the same, students at tertiary level are likely to meet difficulties for connecting the new theoretical aspects with their previous knowledge.

Beyond these observations, similar to the results obtained by studies about the secondary-tertiary transition for other topics (Gueudet & Thomas 2018), our work raises theoretical and methodological issues. Concerning the theory, the importance of modelling within the theme of probabilities leads to questions about “modelling praxeologies”: how can the praxeology be described? Which kind of theory is involved in it? It is necessary to answer these questions, in particular, to design a teaching intervention in which modelling plays a central role, and theory is also present. Concerning the methods, we have observed that the analysis of textbooks can contribute to identify changes of praxeologies between different institutions. Nevertheless, identifying the theoretical and the practical blocks in a textbook is not always straightforward; different textbooks can have very different structures. We consider that this is a direction open for a further methodological work, especially important for transition studies.

Naturally the study presented here remains limited. In a further work we will consider the learning of probabilities by non-specialists in the first year of university, with the aim to propose a teaching and associated resources combining the modelling of real-life situations and theoretical aspects.

References

- Amrani, H., & Zaki, M. (2015). Student’s conceptual difficulties with respect to the notion of random variable. *International Journal of Education, Learning and Development*, 3(9), 82-98.
- Barbazo, E. (Ed.). (2015). *Mathématiques Barbazo Ire S*. Paris: Hachette.
- Batanero, C., Chernoff, E. J., Engel, J., Lee, H., & Sánchez, E. (2016). *Research on teaching and learning probability*. ICME13 topical series. New York, NY: Springer.
- Batanero, C., López-Martín, M., Arteaga, P., & Gea, M. M. (2018). Characterizing probability problems posed in university entrance tests in Andalucía. In C. Batanero & E. J. Chernoff (Eds.), *Teaching and learning stochastics* (pp. 103-123). New York, NY: Springer.

- Burrill, G., & Biehler, R. (2011). Fundamental statistical ideas in the school curriculum and in training teachers. In C. Batanero, G. Burrill & C. Reading (Eds.), *Teaching statistics in school mathematics-challenges for teaching and teacher education* (pp. 57–69). Dordrecht, The Netherlands: Springer.
- Chevallard, Y. (2006). Steps towards a new epistemology in mathematics education. In M. Bosch (Ed.), *Proceedings of the Fourth Conference of the European Society for Research in Mathematics Education* (pp 22–30). Barcelona, Spain: Universitat Ramon Llull Editions.
- Duval, R. (2017). *Understanding the mathematical way of thinking – the registers of semiotic representations*. New York, NY: Springer.
- Gautier, C., & Warusfel, A. (2012). *J'intègre, Mathématiques ECS 1ère année*. Paris: Dunod.
- Gueudet, G., & Thomas, M. (in press). *Secondary-tertiary transition in mathematics education*. Encyclopedia of mathematics education. New York, NY: Springer.
- Ministère de l'Éducation Nationale (2010). *Bulletin officiel spécial n°30. Mathématiques. Cycle terminal de la série scientifique. Classe de Première*. Retrieved from: https://cache.media.education.gouv.fr/file/special_9/21/1/mathsS_155211.pdf
- Winsløw, C., Barquero, B., De Vleeschouwer, M., & Hardy, N. (2014). An institutional approach to university mathematics education: From dual vector spaces to questioning the world. *Research in Mathematics Education*, 16(2), 95-111.

Appendix: English version of the test given to the students

Please answer this little test without consulting any document: the goal is to know what you remember, at the end of high school, about random variables.

1. Give the mathematical definition of a random variable.
2. How would you explain what a random variable is to a senior student?
3. Give an example of a random variable.
4. Solve (on the back) the exercise below.

Optimization of a profit:

The cost of production of a laptop computer by the company MARBIC is 950€. This laptop may have a defect *A*, a defect *B*, or both the defect *A* and the defect *B*. The warranty allows repairs to be made at the manufacturer's expense with the following costs: 100€ for the defect *A*, 150€ for the defect *B* et 200€ for the defect *A* et *B*. We admit that 90% of the laptops produced have no defects, 4% have the only defect *A*, 2% have the only defect *B* and 4% have the defects *A* and *B*.

1. We denote X the random variable which, with each laptop randomly chosen, associates its cost price, i.e. its production cost increased by the possible repair cost. Determine the probability distribution of X .
2. Calculate the expected value $E(X)$ of this random variable. What does $E(X)$ represent for MARBIC? It's assumed that all laptops produced are sold.
3. (a) Can MARBIC hope to make a profit by selling 960€ each product?
(b) MARBIC wants to make an average profit of 100€ per laptop. Explain how to choose the selling price of the laptop produced.

Participation of female students in undergraduate Mathematics at the University of Malawi

Levis Eneya¹, Lisnet Mwadzaangati² and Mercy Kazima³

¹University of Malawi, Faculty of Science, Malawi; leneya@cc.ac.mw

²University of Malawi, Faculty of Education, Malawi; lmwadzaangati@cc.ac.mw

³University of Malawi, Faculty of Education, Malawi; mkazima@cc.ac.mw

Keywords: Undergraduate mathematics, female students, student performance, student retention.

Rationale

In line with declarations to improve the education and literacy of women, Malawi, like many other African governments, has implemented various policies and action plans to improve access and participation of girls in both primary and secondary education. Since 1994 the government has progressively promoted a policy of 50:50 for selection of girls and boys to secondary schools (Ministry of Education, Science and Technology [MoEST], 2001). This policy has been accompanied by several gender reforms and interventions by the government and Non-Governmental Organizations (NGO's) to support the participation of girls in secondary schools, including school fee waivers, cash transfers, and building of additional hostels for girls in boarding secondary schools. Furthermore, the MoEST developed a National Girls' Education Strategy aimed at strengthening and improving girls' access and participation at all levels of education (MoEST, 2014). Despite these interventions, female students' access, success and retention in mathematics and science continue to be a challenge throughout secondary and higher education (Mbano & Nolan, 2017) sectors. This might be because the interventions mainly focus on improving general performance of the girls in schools and not necessarily focusing on girls' participation in mathematics and science subjects. We have not found any studies that have been conducted to find out how these female students sustain themselves both academically and socially during tertiary education in the absence of the interventions they were offered during primary and secondary education. This is important because after access to university, retention of the girls is necessary. Therefore, the purpose of this study was to examine the participation of female students in mathematics courses at the University of Malawi, and to explore possible strategies that would support and sustain participation of female students in mathematics at university.

Methodology

The study adopted a mixed method approach using quantitative and qualitative techniques to investigate how female mathematics students cope academically. Quantitative methodology involved a desk study that analysed secondary data regarding female students' access, performance and retention in mathematics courses. Three cohorts of all students enrolled into Bachelor of Science and Bachelor of Education Science programmes in 2013, 2014 and 2015 were followed to their completion in 2016, 2017 and 2018, respectively. Qualitative methods involved interviews and focus groups discussions with 41 female mathematics students to gain in-depth insights into their views and experiences regarding access, participation and retention of female students in mathematics. Data analysis for quantitative data used Microsoft Excel to calculate frequencies and percentages. For qualitative data, responses were coded and categorised into themes that were not predetermined.

Findings

Retention

Results from desk study indicate that 15.1% of potential female mathematics majors at second year (compared with 24.7% for males) proceed to take at least two mathematics courses at years three or four due to various reasons including lack of support systems and planted fear resulting from, among other issues, negative correlation between entry grades and semester grades.

Motivating factors to continue with Mathematics

When asked about what motivated them to study mathematics, and what will compel them to continue with the subject, students gave several reasons including: scoring good grades, having role models, learning the practical use of mathematics in the industry, and wanting to be role models to other girls. However, the most prominent response was the encouragement from fellow students and lecturers.

Strategies and support that would help the learning and better performance in mathematics

When asked about strategies and the support that they think would help them in the learning of mathematics, all students (100%) mentioned tutorials for practice, while other strategies ranged from availability of teaching and learning materials (75%), conducive learning environment (50%), motivation talks (25%), and use of YouTube (10%).

Implications

The study is ongoing, such that results after interviews with male students and lecturers will be reported in a separate poster or paper. However, the following implications can be drawn from the results this far:

1. The mathematics department need to introduce support systems for female mathematics students.
2. The department need to enhance and increase frequency of mathematics tutorials.
3. The department need to work together with stakeholders for continued policy interventions for female mathematics students.

Acknowledgment

This study is kindly funded by Norwegian Programme for Capacity Building in Higher Education and Research for Development (NORHED) under the project: Improving Quality and Capacity of Mathematics Teacher Education in Malawi.

References

- Mbano, N., & Nolan, K. (2017). Increasing Access of Female Students in Science Technology, Engineering and Mathematics (STEM), in the University of Malawi (UNIMA). *Science Education International*, 28(1) 53-77.
- Ministry of Education Sports and Culture Malawi (MoEST) (2001). *Malawi Education Sector: Policy & Investment Framework (PIF)*. Malawi: SDNP. Available: <http://www.documan.net/d/Ministry-of-Education-Sports-and-Culture-Malawi.pdf>
- MoEST (2014). *National Girls Education Strategy*. MoEST, Lilongwe, Malawi.

Supporting the use of study skills in large mathematics service courses to enhance students' success – one example

Frank Feudel¹ and Hans M. Dietz²

¹Humboldt-University of Berlin, Germany; feudel@math.hu-berlin.de

²University of Paderborn, Germany; dietz@upb.de

Many university freshmen have difficulties in first year mathematics courses due to inappropriate study skills and learning strategies. In large mathematics service courses the effect of poor study skills is even worse because individual support is hardly possible. Past research shows that it is not sufficient to introduce new study skills because students often do not use these; they need first to be supported when working with them. In this paper we describe one possible support with a coaching program for a tool that aims to assist students in learning mathematical concepts. We describe the aims, the design, and the implementation of the coaching program supporting the students' work with the tool provided, as well as some evaluation results concerning reported students' benefit from the program, their attitudes towards the tool, and the frequency of use of the tool at the end of the coaching.

Keywords: Study skills, methodological support, mathematics for non-mathematics degree, coaching for study skills

Introduction and embedding of the research

Many students have problems in their first year mathematics courses at university due to insufficient study skills (Anthony, 2000). Empirical evidence suggests that promoting study skills in tertiary mathematics courses might lower students' difficulties in learning university mathematics (see, e.g., Cornick, Guy, & Beckford, 2015; Mireles, Offer, Ward, & Dochen, 2011). Teaching study skills is in particular successful if respective programs are integrated into the regular course (Hattie, Biggs, & Purdie, 1996). Hence, the second author, a mathematician, developed a methodological support program named CAT (Checklist, Ampel [=Traffic Lights], Toolbox) and, in 2010, integrated it into his course 'Mathematics for economics students' at the University of Paderborn. This program consists of several tools addressing different study skills (for details see Feudel & Dietz, 2019).

Past research, however, also showed that many students fail to use study skills and learning strategies taught to them or just do not use them at all (Anthony, 1996; Dembo & Seli, 2004). In a joint previous research project at the Centre for Higher Mathematics Education in Germany, the authors of this paper identified five additional reasons for such failure: 1) perceived time and effort required to use the methods provided, 2) difficulties in working with them, 3) perceived unhelpfulness of the methods, 4) perceived lack of benefit from them, 4) insufficient understanding of them, 5) using personal methods, and 6) no need (see Feudel & Dietz, 2019 for more details).

To address these problems, the authors developed a coaching program for one of the tools of the CAT program, the 'Concept Base' that aims to help students learn mathematical concepts. This tool was chosen because the authors conjectured that a suitable coaching program could address the two

main reasons for not using it: ‘perceived time and effort compared to the benefit’ and ‘difficulties when working with the methods’. These two reasons are also described (not verbatim but in terms of the content) as important reasons for not using study skills taught or optional resources provided in literature (Dembo & Seli, 2004; Guthrie, 2010). The ideas behind the coaching program to address these reasons for the non-use of the Concept Base can be also probably transferred to other study skills or optional resources provided in mathematics courses.

Short description of the *Concept Base* tool

The tool was conceived as a study skill that should help students learn mathematical concepts. The ‘Concept Base’ is a system of various categories that students should attend to in order to make sense of a mathematical concept. These categories include: the definition of the concept, examples, non-examples, visualizations, statements involving the concept and applications. The category system was developed by the lecturer H. Dietz of the course based on his teaching experience. But these categories are also labeled as crucial in didactic literature for gaining understanding of mathematical concepts (Tall & Vinner, 1981; Vollrath, 1984).

The lecturer H. Dietz advises the students to attend to the Concept Base categories for each mathematical concept taught in the course. He also points out that the knowledge of the categories is also required in the exam. Further, he recommends the students to write them down for important concepts, for example for the ones covered in more than one lecture. These written Concept Bases may also serve as summaries when preparing for the exam later in the semester. The students can download an empty template from the course homepage as support (Figure 1).

Keyword/ Name of the Concept: Symbol:	
Definition:	
Examples: Non-Examples: Visualization: Important statements: Applications: Further Annotations:	

Figure 1: Template of a Concept Base (scaled down from one page)

A written ‘Concept Base’ as a summary of aspects of a mathematical concept is also closely related to the idea of a ‘concept map’ by Novak and Cañas (2008) that organizes knowledge related to mathematical concepts. However, the latter focuses more on linking different concepts while the ‘Concept Base’ focuses on categories crucial for gaining an understanding of a single concept (for acquiring an adequate concept image in the sense of Tall & Vinner, 1981).

Framing of the coaching program to support the use of the Concept Base

As pointed out in the introduction, the majority of the students did not use the tool ‘Concept Base’ after its introduction in the course in 2010, although the lecturer advised them to do so. To address two of the reasons identified in prior work on reasons for not using the Concept Base (Feudel & Dietz, 2019), specifically ‘perceived time and effort required for the creation of the Concept Base compared to its benefit’ and ‘difficulties when trying to create Concept Bases’, the authors designed a coaching program addressing these problems in the winter semester of the academic year 2016-2017. Its goal was to help students overcome difficulties with the tool ‘Concept Base’ and see its benefit, so they might use it on their own.

The design of the coaching program was based on the ‘Decoding the disciplines’-model by Middendorf and Pace (2004). The model consists of seven steps that are important for a successful implementation of subject-specific study skills and working techniques into a university course. It was developed by faculty members of different disciplines at Indiana University at Bloomington on the basis of similar problems they had experienced when trying to implement study skills and learning strategies in university courses. The seven steps are:

- 1) Identification of students’ difficulties
- 2) Identification of strategies that experts of the subject (here: the lecturer as a mathematician) would use to overcome these difficulties
- 3) Demonstration of the strategies in the course
- 4) Exercise of the demonstrated strategies with the students including feedback
- 5) Motivation of the students to continuously use the strategies provided
- 6) Evaluation of the effectiveness of the strategies provided
- 7) Sharing of the knowledge acquired

In our case the recognition of the students’ difficulties by the lecturer, the development of the Concept Base and its implementation into the mathematics course were exactly steps 1-3.

Steps 4)-6) were realized in a systematic manner with the coaching program that was developed, implemented, and evaluated. Although students had practiced creating Concept Bases in the course tutorials that accompanied the lecture before 2016, the frequency and the intensity of its use varied across the tutorials because there was no mandatory guideline.

Design and implementation of the coaching program

The program consisted of two parts: I. one workshop to practice the creation of Concept Bases (Step 4 of the ‘Decoding the Disciplines’-model), and II. submitting four written Concept Bases for further practice including feedback (still Step 4) and for motivating further regular use of the Concept Base (Step 5 of the model). The workshop was carried out after the Concept Base was introduced in the lecture in December 2016 by the first author and another tutor of the course who was familiar with the Concept Base. The second phase, the submission of the Concept Bases, took place afterwards during the second half of December 2016 and during January 2017, and was also conducted by the first author.

Participants of the coaching: Due to capacity restrictions only 50 participants could take part in the program (workshop + submission phase, 48 finished both). They volunteered to take part by writing an email to the first author (a randomized design was not possible due to ethical reasons, but the participants did not receive a reward). Hence, when evaluating the coaching, one has to take into account that these students were willing to work and to invest time for their study program.

Detailed description of the two parts of the coaching program:

Part I - the workshop: The workshop had several aims:

- 1) Clarifying the benefit of the Concept Base to the students
- 2) Providing different suggestions how Concept Bases can be created
- 3) Helping students to overcome first difficulties when creating Concept Bases

It consisted of four phases:

1. Explanation of the benefit of Concept Bases by the leaders of the workshop
2. Creation of a Concept Base for the concept ‘preference relation’ on a poster in groups of 4-5 students (supported by the leaders of the workshop if questions occurred)
3. Comparison of the different Concept Bases in a poster session with discussion
4. Revision of the Concept Bases based on the discussions in Phase 3

Afterwards, pictures of the Concept Bases that had been created in the workshop, were taken and sent to the participants via email as stimuli for creating their own Concept Bases.

These activities were meant to address three problems found out in previous research causing the non-use of the Concept Base. First, the reason ‘difficulties with creating a Concept Base’ was directly addressed by helping the students during the workshop. Second, the reason ‘perceived lack of benefit’ was addressed by communicating one main benefit of the Concept Base explicitly right at the beginning: the possibility to use it as summary when preparing for the exam. And third, the reason ‘use of own methods’ was addressed. It had been found out that students felt constrained by the template in Figure 1. Hence, the adaptability of the ‘Concept Base’ according to the students’ own preferences was underlined by (1) emphasizing that the important aspect of a Concept Base is the categories and not how they are arranged on the paper, (2) by motivating the students to extend their Concept Bases by further categories if needed (e.g., by a personal concept definition, Tall & Vinner, 1981), and (3) by providing lots of different examples of Concept Bases in the workshop.

Part II: Submission of four written Concept Bases with feedback: The aim of this phase was to continuously support the students when creating Concept Bases to further reduce the difficulties with the tool. In addition, the authors wanted for the students to get more experience creating Concept Bases and become more time efficient, which could address the reason ‘time effort’ for not using the Concept Base.

This phase was implemented as follows. The students were asked to create a Concept Base for four concepts: 1) monotonicity, 2) derivative, 3) convexity, and 4) Cartesian product of sets. The first three concepts were simultaneously taught in the lecture. The Cartesian product had already been taught at the beginning of the semester. This concept was chosen to motivate the students to also create Concept Bases for the concepts taught before the introduction of the tool in the course.

The first author provided feedback to the students on each of the four Concept Bases. The feedback had one quantitative and one qualitative component. The quantitative component was a list of aspects of the concept the authors expected the students to know. If an aspect on the list was found in the student's Concept Base it was marked with a check. Otherwise it was marked with a cross. In this way students could get an idea of the scope of the concept. In the qualitative feedback the students were given methodological hints for future Concept Bases, for example to structure the Concept Base on the basis of its categories. Mathematical mistakes in the students' Concept Bases were marked as well. The feedback gave the students ideas about what to include concretely in Concept Bases, and to help them become more efficient in their creation.

Evaluation of the Concept Base coaching

For the 6th step of the 'Decoding the disciplines' framework we carried out an evaluation. In order to find out (1) to what extent the Concept Base coaching was helpful to the students, (2) to what extent they saw the benefit of the Concept Base before and after the coaching, and (3) whether the students used the Concept Base on their own in the following semester, several data was collected:

1. Data from a questionnaire administered to the coaching participants in January 2017 (N = 48)
2. The results of the final exams (in February 2017) of all students from the course (N = 821)
3. Data from one follow-up question administered in the next semester in June 2017 (N = 357)

1) Questionnaire for the coaching participants: The questionnaire comprised of two blocks of questions.

I. To find out if the coaching program and its components (workshop, submission of four Concept Bases) was helpful to the students the questionnaire contained 10 Items with statements about the perceived helpfulness of the coaching program. An example is 'The Concept Base coaching helped me to get a better understanding of the concepts, to which a Concept Base had to be submitted.' The answers format was a 1-6 Likert-scale (1='Do not at all agree' to 6='Totally agree'). The items can form a scale 'perceived helpfulness of the coaching program' ($\alpha = 0.778$). Furthermore, the survey contained two items asking if the time for the participation was well invested.

II. To find out if the students saw a benefit of the Concept Base before and after the coaching the questionnaire contained a question asking about the perceived benefit of the Concept Base before and after the coaching program. The students could choose from several options that had been identified in previous research (Feudel & Dietz, 2019). Sample options were 'better understanding of the concepts' or 'summaries for the preparation of the exam'. Multiple answers were possible.

2) Consideration of the results of the final exam: To get an idea if the coaching might have had a positive effect on the students' performance, we also looked at the exam results. To mediate the effect that the participants were probably more motivated, we generated two special groups for the comparison of the exam results by asking all students of the course the following two questions¹:

¹ These questions were administered in January 2017 and were part of a larger survey about the tool 'Concept Base' not described in detail here because the focus of the paper is on the coaching.

‘Would you participate in the coaching program if it was offered next semester again?’

‘How often do you use the Concept Base?’ (answer format was a 1-6 Likert-scale from 1=‘never’ to 6=‘every week’)

We suspected that students who would agree on the first question and did not take part in the coaching were probably as motivated as the current coaching participants. With the second question we wanted to find out if the coaching really made a difference (and not just the use of the tool alone). Finally, all students were asked for their final grades in mathematics at school to find out if better results might only be due to better initial mathematical qualification.

3) *Follow-up question in the next semester:* In the following semester all students in the subsequent lecture “Mathematics for economics students II” were again asked the question ‘How often do you use the Concept Base?’, in order to find out if the participants of the coaching continued using the Concept Base on their own.

Some results of the evaluation

Results concerning the perceived helpfulness of the coaching program by the participants: Many participants found the coaching program helpful. The parameters of the 10-item scale ‘perceived helpfulness’ mentioned above ranging from 1=‘not at all helpful’ to 6=‘very helpful’ are: $\bar{x} = 5.08$, $\tilde{x} = 5.3$, $s = 0.58$. The distribution of the answers to one sample item is shown in Table 1.

<i>The Concept Base coaching helped me to get a better understanding of the concepts, to which a Concept Base had to be submitted.</i>								
1	2	3	4	5	6	\bar{x}	\tilde{x}	s
-	-	4%	11%	40%	45%	5.26	5	0.820

Table 1: Sample item concerning the perceived helpfulness of the Concept Base coaching

Moreover, the two items concerning the time effort indicate that, on average, the participants believed that the time spent for the coaching was well invested ($\bar{x} = 4.57$, $\tilde{x} = 5.0$, $s = 0.99$), although there was more variation than in the scale ‘perceived helpfulness’.

Results concerning the perceived benefit of the Concept Base by the coaching participants: The coaching participants saw a greater benefit of the tool Concept Base after the coaching than before, in particular the benefit of the deep processing of mathematical concepts during the time consuming process of their creation (due to limited space details cannot be presented here).

Results concerning the success in the exam: The pass rate in the exam of the whole mathematics course (N = 815) was 57%, which mirrors the pass rates in former years. The pass rate among the coaching participants (N = 48) was significantly higher than of the rest: 81% versus 55% ($p < 0.01$). These differences are not necessarily due to better initial mathematical qualification of the coaching participants because the final grades in mathematics at school did not differ significantly.

The comparison with the two comparison groups can be seen in Table 2. The differences between the coaching participants and the comparison groups are again significant ($p < 0.01$).

	Participants of the coaching (N = 48)	Comparison group 1 (N = 91)	Comparison group 2 (N = 49)
Pass rate	81%	62%	55%

Table 2: Pass rates in the final exam of the participants and the two comparison groups

Assuming that students who did not take part in the coaching program but wanted to take part in the next semester (Comparison Group 1) are as similarly motivated as the current coaching participants, Table 2 suggests that the better performance of the current participants was not only due to higher motivation. The comparison with the students of the Comparison Group 2 (students who answered the question ‘*How often do you use the Concept Base*’ with 5 or 6 on a 6-point Likert-scale, but did not take part in the coaching), suggests that the coaching program and not just the tool ‘Concept Base’ were important.

Results concerning the continuous use of the Concept Base: The last important result is that most of the coaching participants continued using the Concept Base in the next semester (see Table 3). Hence, the coaching had a sustainable effect on the students’ study behavior.

	1	2	3	4	5	6	\bar{x}	\tilde{x}	s
Participants	-	-	8%	46%	8%	38%	4.77	4	1.09
Others	38%	19%	17%	17%	5%	4%	2.41	2	1.44

Table 3: Comparison of the use frequency of the Concept Base of the coaching participants (N = 14) with the others (N = 343) in the following semester. Answers ranged from 1=‘never’ to 6=‘every week’

Unfortunately, due to schedule difficulties, only 14 coaching participants took part in the mathematics course in the following semester. Hence, the result only yields a tendency; because the result is only based on one item, the interpretation also needs to be made cautiously.

Summary and Discussion

The major finding of the research presented here is that the coaching program aiming to support the students in working with the Concept Base was helpful and important so that the students could become familiar with it, see its benefit (even despite the necessary time effort), and become more successful in the course. It furthermore indicates that, as a consequence, they tended to continue to use the tool on their own in the next semester (with the caveat of the small sample size of coaching participants taking part in the subsequent course).

Besides the problem of the small sample size of coaching participants in the next semester two other limitations of the research need to be mentioned that may be a starting point for future research:

- 1) The data cannot show in which way coaching program and the tool Concept Base itself helped the students to perform better in the exam exactly. It would be important to find out if the Concept Base really helped students to acquire a solid understanding of mathematical concepts.
- 2) Even if we tried to mediate the effect of motivation by choosing two comparison groups, of which we expected that they were also willing to invest time for their studies, we should keep in

mind that our coaching participants might nevertheless have been a group with special attributes. The results in the case of less motivated students may be different. Hence, scaling up this experiment on the whole course might be another important point for further research.

A last issue concerns the tool ‘Concept Base’. Although literature like Vollrath (1984) suggests that the categories of the Concept Base are crucial for understanding a mathematical concept, we did not investigate empirically how mathematicians in general concern themselves with these categories when trying to make sense of new mathematical concepts, which would be interesting for future research as well.

References

- Anthony, G. (1996). When mathematics students fail to use appropriate learning strategies. *Mathematics Education Research Journal*, 8(1), 23-37.
- Anthony, G. (2000). Factors influencing first-year students' success in mathematics. *International Journal of Mathematical Education in Science and Technology*, 31(1), 3-14.
- Cornick, J., Guy, G. M., & Beckford, I. (2015). Integrating study skills and problem solving into remedial mathematics. *Teaching Mathematics and its Applications*, 34(2), 83-90.
- Dembo, M. H., & Seli, H. P. (2004). Students' resistance to change in learning strategies courses. *Journal of Developmental Education*, 27(3), 2-11.
- Feudel, F., & Dietz, H. M. (2019). Teaching study skills in mathematics service courses—how to cope with students' refusal? *Teaching Mathematics and its Applications*, 38(1), 20-42.
- Guthrie, C. (2010). Towards greater learner control: Web supported project-based learning. *Journal of Information Systems Education*, 21(1), 121.
- Hattie, J., Biggs, J., & Purdie, N. (1996). Effects of learning skills interventions on student learning: A meta-analysis. *Review of Educational Research*, 66(2), 99-136.
- Middendorf, J., & Pace, D. (2004). Decoding the disciplines: A model for helping students learn disciplinary ways of thinking. *New directions for teaching and learning*, (98), 1-12.
- Mireles, S. V., Offer, J., Ward, D. D., & Dochen, C. W. (2011). Incorporating study strategies in developmental mathematics/college algebra. *Journal of Developmental Education*, 34(3), 12-41.
- Novak, J. D., & Cañas, A. J. (2008). *The theory underlying concept maps and how to construct and use them*. Technical Report. Institute for Human and Machine Cognition, Pensacola.
- Tall, D., & Vinner, S. (1981). Concept image and concept definition in mathematics with particular reference to limits and continuity. *Educational Studies in Mathematics*, 12(2), 151-169.
- Vollrath (1984). *Methodik des Begriffslehrens im Mathematikunterricht* [Methodology of the teaching of concepts in mathematics classes]. Stuttgart, Germany: Klett.

Digital learning materials in traditional lectures and their evaluation at the example of a voluntary pre-university bridging course

Yael Fleischmann, Tobias Mai, Rolf Biehler and Alexander Gold

University of Paderborn, Germany;

yael.fleischmann@math.upb.de, tmai@math.upb.de, biehler@math.upb.de,
alexander.gold@math.upb.de

Keywords: transition, bridging course, evaluation design.

Description of the research topic

This contribution documents an excerpt from a conducted research study concerning the integration of digital learning materials into a voluntary, attendance-based bridging course for freshmen majoring in different engineering subjects at the University of Paderborn, Germany. The focus of the study was to evaluate the acceptance of digital learning materials by the students during the lectures and self-regulated learning days of the four-week course. Based on the use of an audience response system (ARS), we developed an instrument to collect feedback from the students immediately after elements of blended learning – such as students' usage of interactive applets and digital, self-evaluating tasks with solutions and different elements using the ARS – were implemented during the lectures of this course to obtain students' reactions as instantaneous as possible.

The digital material was provided in form of the studiVEMINT-online course, which can be found on the website www.studiport.de as free-access material (only available in German yet). This learning material was designed and implemented by our research team during the years 2014 to 2016 and was created as an independent online course in mathematics that can be used for free by any person who wishes to prepare her- or himself for university mathematics (e.g., Biehler, Fleischmann, Gold, & Mai, 2017; Colberg, Mai, Wilms, & Biehler, 2014; studiVEMINT homepage: go.upb.de/studivemint).

Additionally, we prepared work assignments for this digital course that the students were asked to work on during the self-regulated learning days with the intention to support them in repetition and deepening their knowledge.

The study was conducted to answer (among others) the following research questions:

1. Do students appreciate the integration of digital learning materials in the lecture, i.e. do they experience it as a support for their learning process and do they find pleasure in using the materials?
2. How much time do the students invest to work with the provided learning materials on the self-regulated learning days?

Theoretical background and method

ARs can support feedback from learners and provide a means to collect data for research purposes. Ebner, Haintz, Pichler, and Schön (2014) suggest a distinction between front-channel (direct feedback during lectures) and back-channel (asynchronous feedback during and out of the lecture) of those

systems. They further distinguish these into qualitative and quantitative forms of feedback. The focus of the study is the evaluation of the presented teaching scenario in mathematics with its elements of blended learning (e.g., Bernard, Borokhovski, Abrami, Schmid & Tamim, 2014) via the ARS.

We used the ARS functionality regarding quantitative front channel feedback (Ebner et al., 2014) during the lectures to collect reactions to the use of the digital elements as instantaneous as possible. Furthermore, we asked the students how much time they spent working (as they were requested to do) with the digital learning material on the self-regulated learning days in each subsequent lecture. Supplementary data was collected by a pen and paper questionnaire issued at the first and the last day of the course.

Results and discussion

The feedback concerning the integration of the digital learning materials into the lectures was largely positive. However, while looking at the results more closely, we found that more students appreciated the support of the digital materials for their learning processes than reported having pleasure while working with those materials. Another result was that the time students spent on their self-regulated learning days decreased dramatically during the four weeks of the course, even though students reported that the work on the tasks for these days was helpful for their individual learning and understanding. Further and more detailed results from the study have been presented at the conference.

Literature

- Biehler, R., Fleischmann, Y., Gold, A., & Mai, T. (2017). Mathematik online lernen mit studiVEMINT. In C. Leuchter, F. Wistuba, C. Czaplá, & C. Segerer (Eds.), *Erfolgreich studieren mit E-Learning : Online-Kurse für Mathematik und Sprach- und Textverständnis* (pp. 51–62). Aachen: RWTH Aachen University.
- Bernard, R. M., Borokhovski, E., Abrami, P. C., Schmid, R. F., & Tamim, R. M. (2014). A meta-analysis of blended learning and technology use in higher education: from the general to the applied. *Journal of Computing in Higher Education*, 26, 87–122.
- Colberg, C., Mai, T., Wilms, D., & Biehler, R. (2017). Studifinder : Developing e-learning materials for the transition from secondary school to university. In R. Göller, R. Biehler, R. Hochmuth, & H.-G. Rück (Eds.), *Didactics of Mathematics in Higher Education as a Scientific Discipline – Conference Proceedings*. (pp. 466–470). Kassel: Universität Kassel: Khdm-report 17-05.
- Ebner, M., Haintz, C., Pichler, K., & Schön, S. (2014). Technologiegestützte Echtzeit-Interaktion in Massenvorlesungen im Hörsaal. Entwicklung und Erprobung eines digitalen Backchannels während der Vorlesung. In K. Rummler (Ed.), *Lernräume gestalten - Bildungskontexte vielfältig denken*. (pp. 567–578). Münster: Waxmann.

Study and research paths at university level: managing, analysing and institutionalizing knowledge

Ignasi Florensa¹, Berta Barquero², Marianna Bosch³ and Josep Gascón⁴

¹Escola Universitària Salesiana de Sarrià, Barcelona, Spain; iflorensa@euss.es

²Universitat de Barcelona, Barcelona, Spain; bbarquero@ub.edu

³IQS School of Management Univ. Ramon Llull. Barcelona, Spain, marianna.bosch@iqs.edu

⁴Universitat Autònoma de Barcelona, Barcelona, Spain gascon@mat.uab.cat

After more than 10 years of designing, implementing and analysing study and research paths (SRP) at university level, we present a retrospective analysis of the SRP implemented in different university degrees. We focus on the main methodological tools for the SRP design and managing, together with some results about their viability at university level. We come across different SRPs and underline the methodological tools that have worked better. We also show how they have evolved to set up a more systematic methodology.

Keywords: Study and Research Paths, ATD, IBME education, didactic engineering.

Introduction

During the past two decades, Inquiry Based Mathematics Education (IBME) has spread widely. It has been promoted by governments and international organizations through specific programs and curricula reforms, such as the PRIMAS and Fibonacci projects in Europe, or the Common Core State Standards in the United States. Artigue and Blomhøj (2013, p. 802) describe how different research frameworks offer “particular perspectives on the conceptualization and implementation of IBME”. Their analysis reveals that there exists shared principles such as the “authenticity” of questions and activities; their epistemological relevance; the progression of knowledge; the development of extra-mathematical questions and the role of mathematics as a modelling tool in inquiry processes. One of the problems emerging from this diversity of approaches is that the concretion of IBME in research experiences may only rely on these general principles, lacking a clear systematic methodology to design, manage and analyse the implemented experiences, and to provide specific research tools to develop these tasks.

Study and Research Paths (SRPs) are an inquiry-based teaching formats proposed by the Anthropological Theory of the Didactic (ATD) (Chevallard, 2015). They are initiated by a *generating question* (Q_0) addressed by a community of study (a set of students X and a set of guides of the study Y) that form a *didactic system* $S(X, Y, Q_0)$. The aim of the didactic system is to generate a final answer A^\heartsuit to question Q_0 . The work of the community of study and the knowledge involved can be described as a concatenation of derived questions and their associated answers that will led to the development of A^\heartsuit . The inquiry process will combine moments of *study* of information available, with moments of *research* and creation of new questions and answers, including the adaptation of the information to the specific (initial and derived) questions addressed.

The goal of implementing an SRP is twofold. On the one hand, SRPs can be understood as a teaching device to promote a shift from the pedagogical paradigm of “visiting works” to the new paradigm of “questioning the world” (Bosch, Gascón, & Nicolás, 2018; Chevallard, 2015). On the other hand, SRPs can also be considered as a research tool to identify, modify and study *didactic phenomena*, that is, regular facts that take place in teaching and learning processes and that are specific to the content involved. The implementation of SRPs is an empirical tool to generate data to evaluate to what extent and how *didactic phenomena* can be modified and to work on the definition and design of alternative epistemological and didactic models in which the knowledge at the stake and its related teaching practices are questioned and newly organised.

The ATD framework has developed diverse subtheories enabling researchers to analyse study processes and SRPs in particular. Two of these tools are the Herbartian schema (Chevallard, 2008) (see Fig. 1) and the media-milieu dialectics. The first part of the schema represents the *didactic system* $S(X; Y; Q_0)$ that faces the task to generate an answer to an open question Q_0 . The second part of the schema describes the process of elaboration of an answer (A^\heartsuit) of the community of study to the generating question Q_0 . The hallmarked answers and works are preexisting knowledge developed in different institutions that the community of study will access in the *media*. This information obtained is then studied, deconstructed and adapted to the (sub)question addressed and incorporated to the *milieu*. This *media-milieu* dialectic that explicitly appears in the Herbartian schema allows researchers to question and analyse the external information (and its diversity) addressed by the community of study and how it is validated.

$$[S(X; Y; Q_0) \curvearrowright \{Q_1, Q_2, \dots, Q_m; A^\diamond_{m+1}, A^\diamond_{m+2}, \dots, A^\diamond_n; W_{n+1}, W_{n+2}, \dots, W_p\}] \curvearrowright A^\heartsuit$$

Figure 1 Herbartian schema

Following Artigue (2014), Barquero and Bosch (2015) have described four main phases in the design and research methodology related to Didactic Engineering: the identification of didactic phenomena; the design or a priori analysis of an SRP; the in vivo analysis of the SRP; and the evaluation or a posteriori analysis of the ecology and economy of the SRP. This is a crucial point of SRPs: including an explicit epistemological questioning differs heavily with other PBL approaches.

However, as Bosch (2018) and Florensa, Bosch and Gascón (2015) stated, this theoretical and methodological apparatus is difficult to be transposed to teacher and lecturers practice, especially when they are not at the same time familiar with the ATD framework. In fact, most of the experienced SRPs at university level have been led by researchers in the ATD or by lecturers working closely with them. In this paper, we present a retrospective analysis of previous SRP implementations at university level in order to identify the evolution of the used didactic tools. When examining this evolution, we intend to set up the foundations of a more systematic methodology for the design and managing of SRPs in university classrooms and for their viability.

The experienced SRPs

Table 1 presents a brief account of the SRPs implemented during this past decade by the ATD research team based in Spain. Details of their design and implementation can be found in the references. Let us just point out that the integration of the SRPs has adopted different modalities to

be integrated in the traditional organization of the university courses. SRP1 and SRP2 ran as workshops in parallel to the regular course, as weekly 2-hour sessions for a total of 60 hours both, thus complementing the lectures and problem sessions. SRP3 consisted in an elective workshop that lasted about 9 sessions of 2 hours at the end of the course about forecasting the Facebook users' growth. SRP4 was fully organized as an SRP lasting a whole 6 ECTS subject (17 weeks, 4 hours per week). SRP5 was implemented after 8 weeks of lectures, labs and problem sessions, for the 7 last weeks of the course, thus covering a total of 21 h.

SRP	Subject	Level and degree	Period	References
1	Mathematics	Population dynamics 1 st year Chemical engineering (groups of 30-35 students)	2005-2009	Barquero, Bosch & Gascón (2011; 2013)
2	Mathematics	Sales of products 1 st year Business administration (groups of 40-60 students)	2006-2014	Serrano (2013), Serrano, Bosch & Gascón (2010)
3	Mathematics	Evolution of Facebook users 1 st year Business administration (groups of 20 students)	2015-2017	Barquero, Monreal, Ruiz-Munzón & Serrano (2018)
4	Strength of materials	How to make a slatted bed base? 3 rd year Mechanical engineering (group of 20-25 students)	2015-2018	Bartolomé, Florensa, Bosch & Gascón (2018)
5	General elasticity	How to make a bike part? 2 nd year Mechanical engineering (groups of 30 students)	2015-2018	Florensa, Bosch, Gascón & Mata (2016) and Florensa, Bosch, Gascón & Winsløw (to appear)

Table 1. List of experienced SRPs by the ATD research team in Spain

Dealing with knowledge in an SRP: the language of modelling

The traditional “transmissive” way of knowledge dissemination at university level tends to sacralise the bodies of knowledge to be taught (Bosch, 2018). Therefore, tasks such as describing, organizing the work, collecting data, and searching well-established (and labelled) knowledge are not always part of the students' responsibility. And, when they are, they appear as non-problematic for the students, who only have to retake and at most summarize the accessed pieces of knowledge. In addition, the dominant pedagogical paradigm tends to hide the questions for which a specific knowledge is relevant, or at least leave them for the very end of the study process. These phenomena generate important constraints when implementing an SRP in a school institution. In the design and implementation of SRPs, the dialectics between the questions posed and the construction of answers is central, as well as the share of new responsibilities between teachers and students in the inquiry process. The development of tools enabling changes, especially those relating to the way “content” is described and managed, have appeared since the first implementations of SRPs.

Barquero, Bosch and Gascón (2013) present one of the first SRPs experienced at university level (SRP1). The SRP was implemented along the annual course of “Mathematical Foundations for Engineering” with students of Industrial Chemical Engineering, in the so-called “Workshop of

mathematical modelling” which was created only to develop the SRP and which ran in parallel of the regular course based on lectures and problem sessions. This three university teaching devices were easily coordinated because there was only one group of about 35 students and two lecturers, the one responsible of the theoretical sessions and the other (second author of this paper) who guided the problems sessions and the workshop. Although there was a study programme to accomplish, the lecturers-researchers had freedom to carry it out in the most convenient way. The generating question of the SRP was “How can we predict the long-term behaviour of a population size, given the size of a population over some previous periods of time? What assumptions should be made? How to forecast the population size’s evolution and how to test its validity?” The design and implementation of this SRP wanted to address the problem of teaching modelling at university level and to deal with the widespread didactic phenomena of reducing modelling activity to the simple “application” of some pre-established models and contents. Researchers designed the SRP paying special attention to the modelling process to be developed with students. The *a priori* design included a careful delimitation of the generating and derived questions that could be posed and of mathematical models and knowledge that would appear to provide answers.

One of the first necessities experienced by the lecturer guiding the modelling workshop was to share and institutionalise a new *discourse* to talk about the mathematical activity students were developing. In this occasion, most of the discourse needed was about modelling, which was quite new for the students. Introducing terms referring to systems and models, to the formulation of hypotheses, to the actions of validating the models or discussing the scope and limitations of the models, was a new *logos* for the students to describe, organise, justify and report their activities.

A second aspect highlighted by Barquero et al. (2013) is the necessity to create new didactic devices to transfer new responsibilities to the students who had “to produce their own answer [...] considering intermediate (sub)questions and write and defend a team report [...] with their temporary answers” (Barquero et al., 2013, p. 326). The main didactic devices to manage the implementation of the SRP and to institutionalize the modelling activities were the *weekly reports* that students developed and presented. From the second year on, these reports were based on an explicit fixed structure, including a description of the questions faced, the mathematical models built, the answers obtained, and the new questions proposed to follow with. Moreover, each team had to designate its own “secretary”, a student in charge of explaining and defending the team’s report at the beginning of each new workshop session. A whole class discussion followed these presentations, to state the main progress and to agree on how to continue with the inquiry. At the end of the SRP, each student individually had to write a *final report* of the entire study where she had to analyse the whole modelling process followed (Barquero et al., 2013, p. 327).

The implementation of SRP2 was initially done as a workshop that took place during the Mathematics course of a 1st year degree in Management. The workshop lasted for 5 weeks with two 2-hour sessions. The generating question of the SRP was: “A firm registers the term sales of its 7 main products during 3 years. What amount of sales can be forecasted for the next terms? Can we get a formula to estimate the forecasts? Which are its limitations and guarantees? How to explain them? What products sales are increasing more than 10% a term? Less than 12% a term?” It is important to highlight that the

lecturers established two kinds of sessions: one devoted to autonomous group work under the lecturers' supervision and another to share the results obtained and validate them by the big group.

From modelling to questions-answers maps

SRP3 was initiated by the following question: “How can we model and fit real data about the evolution of the number of Facebook users to provide our forecasts about the short-term evolution of the users of this social network?” (Barquero et al. 2018). Its implementation took place in the academic years 2015-16 and 2016-17 with first-year students of a Business Administration and Innovation Management degree, at Pompeu Fabra University. It run as a teaching device created for its implementation called the “Modelling workshop” that was independent of the mathematics courses. Students voluntarily participated in the workshop, with the possibility of adding an extra point to their final mathematics grade. The responsible of guiding the workshop was the lecturer of the mathematics course who, for the first time, was not a researcher in the ATD. The workshop run for 2 hours every week for 9 weeks, although most of the modelling work was developed by students working in groups out of the class. This SRP combined online sessions and face-to-face sessions. The workshops sessions were devoted to students' presentations and to the debate about the questions posed, new questions to inquire and the models, tools and answers found out.

When designing the SRP, a group of researchers and the lecturer participated in it. In its design, the understanding of mathematics as a modelling tool was central, but the description of the “skeleton” of the SRP in terms of questions (Q) and answers (A) took the central role for many reasons. First, there was an intensive work in the designers' team to delimit the structure of the SRP in terms of Q and A , which define the epistemological models of reference upon which they started to plan and analyse the implementation—as proposed in other research works, Florensa, Bosch, & Gascón, 2018; Winsløw, Matheron, & Mercier, 2013).

Second, the weekly reports remained to be the main communication tool and were explicitly asked to be done in terms of questions and answers. To accomplish this, the virtual platform (called a c-book unit developed in the frame of the European project MCSquared) was extremely useful to provide students with dynamic tools to structure their reports (Barquero et al., 2018, p. 20-24).

Moreover, questions and answers maps were also used by the lecturer to analyse the development of each workshop session in collaboration with the researchers. It was then decided to start a *journal of implementation* as a tool facilitating the lecturer-researcher interaction and to report on the type of knowledge appearing in the inquiry process. As the authors describe, in this journal:

[...] the researchers indicated, before a workshop session, the questions they had to present, the way to organize student participation, some indications about the gestures and strategies they could follow, and so on. After each workshop session, the lecturers and researchers met to analyse the work of students, and compared it to the a priori design. (Barquero et al., 2018, p. 20)

SRP4 (Bartolomé et al., 2018) was implemented during the 2016/17 academic year in a “Strength of Materials” course of a Mechanical Engineering degree at Univ. Autònoma de Barcelona. The generating question of the SRP was: “You are working as an engineer in a company manufacturing slatted-beds. Your company supplies beds to an American client (a chain of motels). Recently, you

have been commissioned to provide them with single slatted-beds, capable of supporting the weight of a 120 kg person”. The SRP was implemented during the whole semester in all the sessions (17 weeks, two 2-hour sessions per week). In this work the management and description of knowledge was done using question-answer maps. This tool played an important role: it allowed both students and lecturers to communicate and they were also used to describe the final answer. An important difference between previous implementation was the explicit training of participants in the use and development of this tool. During this initial training session, the students were informed that the sessions would be structured in four phases. The first part of the session was devoted to check the status of the project using a common question-answer map followed by a brainstorming session to decide the next question(s) Q_i relevant to the problem. In the second phase the group was divided in different small groups each tackling a specific question. The third phase was devoted to team work developing an answer to the assigned question. The final phase consisted on each small group presenting a specific Q-A map describing their answer to the whole group. Figure 2 exemplifies the Q-A after the two first sessions. In addition, SRP4 also included the *media - milieu* dialectic as a managing tool. During the four phases of the sessions, students described not only their work in terms of answers and new subquestions but also, they had to incorporate the *media* they used to grasp information to generate the answer. In addition, the students had also to justify their answer presenting proofs or data in order to show to what extent the acquired data and its study and modification were adequate to generate an answer to the question tackled.

SRP5 was implemented in an “Elasticity” course in the same engineering degree than SRP4. In contrast, this SRP was implemented during the last 7 weeks of the semester, keeping the traditional structure along the 10 first weeks. In this implementation students were organized in small groups (3-4 students) and each group was in charge of designing and validating part of a machine (a bike for the first edition and a formula student car in the second edition). The assessment and management of the SRP was done using weekly reports in where Q-A maps become the main content. In contrast to the previous SRPs, the final report took the form of a technical report addressed to the company that commissioned the design work.

Conclusions

The revision of different SRP implementations shows the evolutions that have occurred concerning the different didactic tools used in the design and managing of SRPs in university classrooms. We have focused on showing how, along the different investigations, these tools have been made available to the participants (students and lecturers) to deal with the knowledge and to organize the study processes. In addition, our retrospective study reveals that the tools needed by lecturers and students to manage and experience SRPs are diverse. We have identified aspects related to the language level: participants in SRP1 had to develop a specific terminology concerning modelling that was absent in the institution of study.

Another aspect relates to the need to describe and communicate how knowledge evolves during the inquiry process. Q-A maps have been satisfactorily adopted in different implementations helping teachers and lecturers to overcome this problem. Another useful aspect in one of the implementations is the transposition of the *media-milieu* dialectics—a research tool of ATD—to help teachers and

students organise their work. Making the search for information in the media and its confrontation with or integration into the milieu explicit helped to assign tasks.

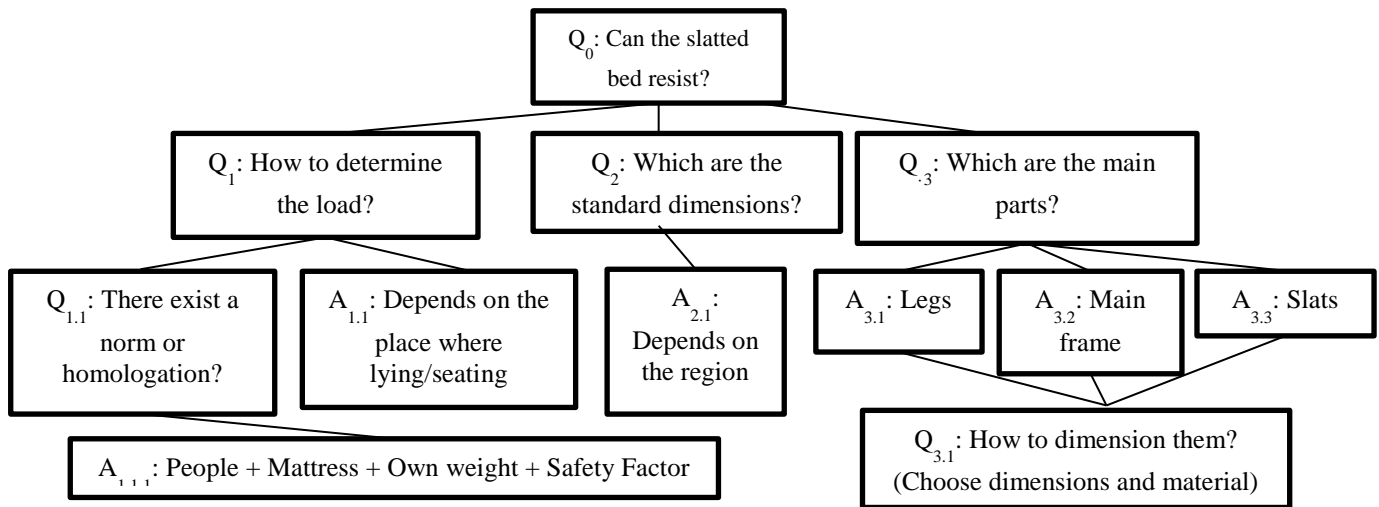


Figure 2: Initial Q-A maps generated during the SRP concerning the dimension of a slatted bed (Bartolomé et al., 2018)

Another aspect that our study has identified is that the degree of explicitness of the implemented tools is increasing in each implementation. In the last editions of the SRPs, working with lecturers that were not researchers in didactics required a presentation of the ATD tools used. Finally, it is important to highlight that these tools (Q-A maps, media-milieu dialectics) come from the research and have been transposed to the community of study level for its use. We consider that these findings should encourage the community of researchers to more systematically use these tools in further SRP implementations. It seems to be a promising way to deal with some of the institutional constraints that have been found to hinder the dissemination of SRPs in university education, especially those related to the lack of epistemological terms to deal with inquiry processes.

Acknowledgments

Funded by Ministerio de Economía y Competitividad, MINECO/FEDER, EDU2015-69865-C3-1-R

References

- Artigue, M. (2014). Didactic engineering in mathematics education. In S. Lerman (Ed.), *Encyclopedia of Mathematics Education* (pp. 159–162). Netherlands: Springer.
- Artigue, M., & Blomhøj, M. (2013). Conceptualizing inquiry-based education in mathematics. *ZDM - International Journal on Mathematics Education*, 45(6), 797–810.
- Barquero, B., & Bosch, M. (2015). Didactic Engineering as a Research Methodology: From Fundamental Situations to Study and Research Paths. In A. Watson & M. Ohtani (Eds.), *Task Design in Mathematics Education- ICMI Study 22* (pp. 249–273). Springer.
- Barquero, B., Bosch, M., & Gascon, J. (2011). ‘Applicationism’ as the dominant epistemology at university level. In M. Pytlak, T. Rowland, & E. Swoboda (Eds.), *Proceedings of CERME7* (pp. 1938-1948). Rzeszów, Poland: University of Rzeszów and ERME.

- Barquero, B., Bosch, M., & Gascón, J. (2013). The ecological dimension in teaching of mathematical modelling at university. *Recherches en Didactique des Mathématiques*, 33, 307–338.
- Barquero, B., Monreal, N., Ruiz-Munzon, N., & Serrano, L. (2018). Linking Transmission with Inquiry at University Level through Study and Research Paths : the Case of Forecasting Facebook User Growth. *Int. Journal of Research in Undergraduate Math. Ed.*, 4(1), 8–22.
- Bartolomé, E., Florensa, I., Bosch, M., & Gascón, J. (2018). A ‘study and research path’ enriching the learning of mechanical engineering. *European Journal of Engineering Education*, 1–17.
- Bosch, M. (2018). Study and Research Paths: a model for inquiry. In B. Sirakov, P. N. de Souza, & M. Viana (Eds.), *International congress of Mathematicians* (Vol. 3, pp. 4001–4022). Rio de Janeiro: World Scientific Publishing Co. Pte. Ltd.
- Bosch, M., Gascón, J., & Nicolás, P. (2018). Questioning Mathematical Knowledge in Different Didactic Paradigms: the Case of Group Theory. *International Journal of Research in Undergraduate Mathematics Education*, 4(1), 23–37.
- Chevallard, Y. (2008). Afterthoughts on a seeming didactic paradox. In J. Lederman, N. Lederman, & P. Wickman (Eds.), *Efficacité & Équité en Éducation* (pp. 1–6). Rennes.
- Chevallard, Y. (2015). Teaching mathematics in tomorrow’s society: a case for an oncoming counter paradigm. In S. Cho (Ed.), *Proceedings of the 12th International Congress on Mathematical Education* (pp. 173–187). Seoul: Springer International Publishing.
- Florensa, I., Bosch, M., & Gascón, J. (2015). The epistemological dimension in didactics : Two problematic issues. In K. Krainer & N. Vondrova (Eds.), *Proceedings of CERME9* (pp. 2635-2641). Prague, Czech Republic: Charles Univ. in Prague, Faculty of Education and ERME.
- Florensa, I., Bosch, M., & Gascón, J. (2018). Reference epistemological model : what form and function in school institutions ? In H. Chaachoua & M. Bosch (Eds.), *6th International Conference on the Anthropological Theory of the Didactic* (pp. 22–26). Autrans.
- Florensa, I., Bosch, M., Gascón, J., & Mata, M. (2016). SRP design in an Elasticity course : the role of mathematic modelling. In Nardi, E., Winsløw, C., & Hausberger, T. (Eds.) *Proceedings of INDRUM 2016* (pp. 191-200). Montpellier, France: Univ. of Montpellier and INDRUM.
- Florensa, I., Bosch, M., Gascón, J., & Winsløw, C. (2018). Study and Research Paths: A New tool for Design and Management of Project Based Learning in Engineering. *International Journal of Engineering Education*, 34(6), 1848–1862.
- Serrano, L. (2013). *La modelización matemática en los estudios universitarios de economía y empresa: análisis ecológico y propuesta didáctica*. Doctoral dissertation. Univ. Ramon Llull.
- Serrano, L., Bosch, M., & Gascón, J. (2010). Fitting models to data: the mathematising step in the modelling process. In V. Durand-Guerrier, S. Soury-Lavergne, & F. Arzarello (Eds.), *Proceedings of CERME6* (pp. 2186–2195). Lyon: Institut National de Recherche Pédagogique and ERME.
- Winsløw, C., Matheron, Y., & Mercier, A. (2013). Study and research courses as an epistemological model for didactics. *Educational Studies in Mathematics*, 83(2), 267–284.

Two situations for working key properties of \mathbf{R}

Macarena Flores González¹, Alain Kuzniak¹, Elizabeth Montoya Delgadillo² and Laurent Vivier¹

¹Université Paris Diderot, France; prof.macarena.flores@gmail.com, alain.kuzniak@univ-paris-diderot.fr, laurent.vivier@univ-paris-diderot.fr

²Pontificia Universidad Católica de Valparaíso, Chile; elizabeth.montoya@pucv.cl

Keywords: Completeness, real numbers, mathematical analysis, algebra, transition to university.

Introduction

Teaching and learning real numbers is not an easy topic, and it is probably for this reason that most secondary school curricula do not develop it, even if they are used. Several studies have been conducted on this subject, but often focusing on the double decimal representation of decimal numbers or on irrationality (Oktaç & Vivier, 2016) made a recension of researches on these theme). More recently, the emphasis has been placed on the completeness of \mathbf{R} , for the topology of the order, as one of the key characteristic properties to be achieved (e.g. Bergé, 2010; Durand-Guerrier, 2016). It has been hypothesized that these properties of \mathbf{R} are important for understanding real analysis. We are in line with this hypothesis with a positioning in favour of an algebraic approach, but how to develop the simultaneous study of algebraic and topological properties of \mathbf{R} ? In particular, we have built situations that may introduce the completeness of \mathbf{R} , on the basis of the algebraic properties of \mathbf{R} . In the two preliminary studies we present here, we analysed the students' mathematical work using the Mathematical Working Space theory – MWS- (Kuzniak, Tanguay, & Elia, 2016).

Calculations with real numbers

This situation presents the basic algebraic operations in relation to the completeness of \mathbf{R} . In fact, the definitions of the sum and the product in \mathbf{R} are based on the completeness of \mathbf{R} . They are rarely worked at the secondary level, as if these definitions were trivial.

We asked the students to find the roots x_1, x_2, x_3 of the polynomial $P(x) = x^3 - 60x^2 + 980x - 4700$ using adjacent sequences of decimal numbers. At this educational level, it is only possible to calculate approximate values of these roots since exact values need more advanced mathematics (unless using an algebra calculator). We, then, asked them to calculate the results of the basic operations on the three real roots, such as $x_1 + x_2 + x_3$, that is actually 980 with the root properties of a polynomial. The visualization process is based on increasingly precise approximations (of the adjacent sequences) defining *small* nested intervals, and the signs (such as the tables of values), are used to support these processes. The main goal was to encourage work of visualization to conjecture the limits of each adjacent sequence, to recognize the polynomial coefficients.

This situation has been proposed to 6 grade 12 students by pairs, in France in 2018. The data are made on the student's dialogues and their written productions. Finally, the visualization of the limits did not take place, but this did not prevent elements of completeness from appearing spontaneously, as for the convergence and the intersection of the nested intervals, or from students confronting the epistemological obstacle of the potential infinite and the actual infinite.

Functional equation of the real exponential

The fact that it is hard to distinguish the density and completeness of \mathbf{R} by graphical representation (especially in technological tools). In this sense, we propose to construct algebraically a function that allows a visualization of the discrepancy between density and completeness. This situation is attractive because it allows using and connecting of a wide range of academic knowledge.

The mathematical task consists in searching for the functions f defined on E , where E is the usual numbers sets \mathbf{N} , \mathbf{Z} , \mathbf{D} and/or \mathbf{Q} and \mathbf{R} , with values in \mathbf{R} , which satisfy the conditions: (a) $f(1) = 2$ and (b) $\forall x \forall y$ on E $f(x+y) = f(x) \cdot f(y)$. The first question proved that $f > 0$ and that $f(0) = 1$. Then, there is a unique function (the exponential) in \mathbf{N} , \mathbf{Z} , \mathbf{D} and \mathbf{Q} but this is not the case in \mathbf{R} . More specifically, we ask for certain values and graphical representations. The functional equation is used as an artifact by calculating the values of f algebraically, and a graph is drawn for each set.

A first study in Chile with 6 students by pairs was conducted in 2017. The data are made of written students' answers and direct observation. For sets \mathbf{N} and \mathbf{Z} , there were some technical problems in using (b) to compute values and some students drew a continuous line but quickly realize that the context is discreet. For \mathbf{D} and \mathbf{Q} , the discussion is based on the line drawn and the density: do we represent a continuous line? Finally, a significant obstacle arose for \mathbf{R} because of the need of topological arguments. We think that asking more explicitly to build a function f on \mathbf{Q} (additive subgroup of \mathbf{R} - $1.a \in \mathbf{Q}, b \in \mathbf{Q}$) with $f(a) = 1$ could help, and so do the use of a technological software like Geogebra.

Conclusion and discussion

We presented two preliminary studies with these situations that have a great potential. Nevertheless, it seems that the introduction of an algebraic work allows to clearly show the topological jump made when "passing" from \mathbf{Q} (or \mathbf{D}) to \mathbf{R} . Moreover, \mathbf{R} cannot be reduced to its sole property of completeness: the uniqueness of \mathbf{R} is based on several other properties, like its algebraic structure.

MWS theory has allowed us to design these situations and interpret the results obtained. Thus, the three dimensions of MWS has been activated: the work is done on the visualized signs (semiotic dimension), on the mathematical knowledge itself (discursive dimension) and on the technological tools to produce signs (instrumental dimension).

REFERENCES

- Bergé, A. (2010). Students' perceptions of the completeness property of the set of real numbers, *International Journal of Mathematical Education in Science and Technology*, 41(2), 217–227.
- Durand-Guerrier, V. (2016). Conceptualization of the Continuum, an Educational Challenge for Undergraduate Students. *International Journal on Undergraduate Mathematics Education*, 2, 338-361.
- Kuzniak, A., Tanguay, D., & Elia, I. (2016). Mathematical working spaces in schooling: An introduction. *ZDM*, 48(6), 721-737.
- Oktaç, A. & Vivier, L. (2016). Conversion, change, transition... In B.R. Hodgson, A. Kuzniak, & J.-B. Lagrange (Eds.), *The Didactics of Mathematics: Approaches and Issues. A Hommage to Michèle Artigue*, (pp. 87-122). Switzerland: Springer.

To whom do we speak when we teach proofs?

Mika Gabel^{1,2} and Tommy Dreyfus²

¹Afeka - Tel Aviv Academic College of Engineering, Tel Aviv, Israel; mikag@afeka.ac.il

²Tel Aviv University, Tel Aviv, Israel; tommyd@post.tau.ac.il

We assess rhetorical aspects of the flow of proof, a notion that encapsulates various aspects of classroom presentation of proof, proposing Perelman's New Rhetoric (PNR) as a theoretical framework. We present findings from semi-structured interviews conducted with experienced mathematics lecturers, who were asked to reflect about general features and pedagogical considerations of mathematical proofs by relating to two proofs of the 'Two Pancakes theorem'. We focus on PNR's concept of audience and argue that lecturers generally address two types of audience, particular and universal, when teaching proofs and need to balance between the requirements of each audience. We conclude that PNR is suitable to capture this inherent tension in teaching proofs.

Keywords: Proof teaching, flow of proof, Perelman's New Rhetoric, mathematical argumentation

Reconnecting mathematics and rhetoric

The notion 'flow of a proof' has been used by Gabel and Dreyfus (2017) to examine different aspects of classroom presentation of proof: the way that the lecturer chooses to present the logical structure of the proof, to incorporate informal features into the presentation and to account for various mathematical and instructional contextual factors. The analysis of the informal and contextual features requires a theoretical lens that can account for rhetorical features of the presentation. However, traditionally, scholars perceive rhetoric and mathematics as antithetical disciplines (Reyes, 2014), two banks of a river. On one bank - mathematics, dealing with the establishment of unequivocal truths based on the rigorous laws of formal logic, and on the other bank - rhetoric, mostly related to the study of style, expression and ornamental aspects of discourse.

Yet, scholars have been gradually building bridges between the two banks by using rhetorical concepts to gain better understanding of mathematics and mathematical education. Davis and Hersh (1987), for example, challenged the then prevailing opinion that "mathematical truth is established by a unique mode of argumentation, which consists of passing from hypothesis to conclusion by means of a sequence of small logical steps, each of which is in principle mechanizable..." (pp. 59-60) and claimed that "mathematical proof has its rhetorical moments and its rhetorical elements" (p. 60). Ernest (1999) related to other scholars who share that approach and stated that in education this approach is less controversial than in mathematical and philosophical circles. Reyes (2014) adds that mathematics, as a practice of writing, thinking, and arguing, should be studied by rhetorical scholars, and that rhetorical scholars should explore mathematics discourse as its importance is constantly increasing. In this work, we analyse rhetorical features of mathematical proof presentation through the lens of an argumentation theory called 'The New Rhetoric' (PNR, Perelman and Olbrechts-Tyteca, 1969). PNR is a comprehensive theory that allows the considerations of a varied range of argument aspects within a single unifying theory and ties these different aspects to the adaptability to the audience for whom the argumentation is intended. Therefore, it enabled us to relate to different aspects of the flow as well as to the ways these aspects are intertwined.

Perelman's new rhetoric (PNR)

PNR assumes a speaker addressing an audience and studies techniques that aim to increase audience adherence to the theses presented by the speaker. It concerns the effective use of informal reasoning, i.e. reasoning that promotes audience adherence. PNR was initially designed to complement formal logic and to show how choices, decisions, and actions can be justified on rational grounds; thus, it relates to dialectical, rhetorical and contextual features. It asserts that form is subordinated to content and to the effort to persuade, and that reducing an argument to its formal features undermines the rhetoric features that support its meaning. PNR offers a description of various aspects of argumentation: (i) *scope and organization*, which is a result of the lecturer's need to take into account a complicated, at times contradictory, set of considerations in the proof presentation; (ii) the constitution of a shared *basis of agreement* between the speaker and the audience (iii) the manner by which the lecturer uses rhetorical figures to endow elements with *presence* and to focus audience's attention on them; and (iv) different *argumentation techniques*. Moreover, PNR stresses that an effective argument must be adapted to the audience. In Gabel and Dreyfus (2017) we explained our adaptation of PNR for analysing mathematical proof teaching and how we use PNR to account for different aspects of the flow of a proof; we also discussed aspects (i) and (iii). In the current paper, we focus on PNR's notion of *audience* and examine its relation to inherent tensions in the teaching of mathematical proofs.

The universal audience and the particular audience in Perelman's new rhetoric (PNR)

The audience plays a pivotal role in PNR. Perelman and Olbrechts-Tyteca (1969) make a distinction between argumentation aimed to persuade the *particular audience* addressed by the speaker, which is the actual, physical audience (and therefore the argumentation needs to be adjusted to particular knowledge, experiences, expectations, opinions and norms), and argumentation that transcends particularity and is aimed to convince what is called a *universal audience*. The universal audience is a mental construct of the speaker, composed of all normally reasonable and competent people, where competence is specific to a discipline or culture, and consists of a series of beliefs, agreements and language that are typical for this discipline, whether it is of scientific, juridical or other nature. Such agreements may be the result of certain conventions that characterize audiences, usually distinguishable by their use of a technical language of their own (van Eemeren et al., 2013). While every argument is directed to a specific individual or group, the speaker decides what information and approaches will be convincing according to the universal audience that s/he has in mind. Thus, some arguments appeal only to particular groups in a particular context and some arguments attempt to have a broader appeal. By addressing differences between universal and particular audiences, Perelman believes he can better distinguish between a merely effective argumentation that persuades a particular audience, and a genuinely valid argumentation that convinces the universal audience. In that sense, a universal audience may be used as a standard of relevance (Crosswhite, 1989).

Rationale and goals

This work is situated within the growing research field concerned with different styles that mathematical lecturers employ (e.g., Hemmi; 2010) and the various pedagogical considerations they apply while teaching proof (e.g., Dawkins & Weber, 2017; Lai & Weber, 2014).

The goals of this paper are firstly to present different pedagogical dilemmas that mathematicians have when teaching proof at the undergraduate level and secondly to demonstrate how these dilemmas can be interpreted by using PNR's notion of two audiences. We show how the tension between the universal and particular audiences can explain decisions taken by mathematics lecturers and focus on conflicts that emerge during proof teaching between the lecturers' own views of mathematics and the characteristics of their students.

Method

We present findings from interviews conducted with five experienced mathematics lecturers (10-40 years of experience), teaching a variety of tertiary level mathematics courses to diverse student populations (engineering students in college or university, mathematics students, prospective teachers, computer science students, high-school students). They volunteered to be interviewed and were asked about features of mathematical proofs and considerations for proof teaching by relating to the 'Two Pancakes theorem' and its two proofs (Davis and Hersh, 1983) outlined below:

Theorem: Given two arbitrary closed and bounded areas in the plane, A and B, there exists a line that simultaneously bisects the two areas.

Proof 1 uses an arbitrary point O and a directed line ℓ rotating through O (Figure 1); one defines functions $p(\theta)$, $q(\theta)$: the coordinates on ℓ of the lines perpendicular to ℓ that bisect areas A, B. If $r(\theta)=p(\theta)-q(\theta)$ is positive for some θ , then it is negative for $\theta+180^\circ$. Hence, there exists θ_0 for which $r(\theta_0)=0$, i.e. $p(\theta_0)=q(\theta_0)$, according to the intermediate value theorem (IVT).

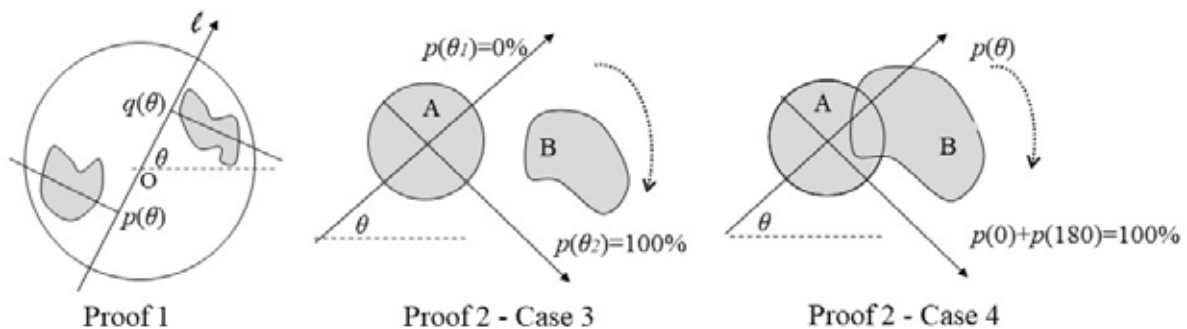


Figure 1: Drawings for Proof 1 and Proof 2 (Case 3, Case 4)

Proof 2 is based on five successively more general cases. Cases 1-2 are trivial: If A and B are circles (concentric in Case 1, non-concentric in Case 2) then the line through their centres bisects both. Case 3 (Figure 1): A is a circle, B does not overlap A; when rotating the diameter of A, the part of the area of B that lies on one side of the diameter, $p(\theta)$, changes from 0 to 1; the existence of θ_0 for which $p(\theta_0)=0.5$ follows from the IVT. Case 4 (Figure 1): A is a circle and B partially overlaps A; now $p(0^\circ)+p(180^\circ)=1$, and the claim follows from the IVT on $0^\circ \leq \theta \leq 180^\circ$. Case 5: Two arbitrary areas; the same argument as in Case 4 applies with the diameter of A replaced by a line that halves the area of A.

The interviews were semi-structured. Most questions related to features of mathematical proofs in general and pedagogical considerations for teaching proof. The interview began with questions relating to the proofs of the above theorem and proceeded to more general questions. The interviews

were audio-recorded, transcribed and analysed using principles of verbal analysis (Chi, 1997). The analysis was carried out in five steps: (1) Segmenting and reducing: Segmenting the transcriptions into modules that contain an answer to a specific question. Each module was reduced by selecting significant utterances; (2) Coding and organizing: Most categories were created naturally by the interview questions and some were created when reading the reduced data. The relevant utterances were summarized and placed in the appropriate category; (3) Operationalizing evidence: A collection of utterances that constitute evidence for each category was created; (4) Seeking for patterns in the organized data. When such patterns emerged, they were validated by looking for further evidence; (5) Repeating the procedure in order to verify the coding and alter it if necessary.

In this paper, we focus on the lecturer's answers to the following three questions:

1. Which of the two proofs would you use for teaching this theorem, and why?
2. What aspects of the proof do you emphasize when teaching a proof?
3. What language (formal/informal) do you use when teaching a proof?

Findings

We start by presenting the interviewees' answers to the first question: which of the two proofs they would teach and why. Proof 1 was chosen by three interviewees: Sally, Dana and Max. Max claimed that Proof 1 is more correct and properly built: “[it] is built as a proof: you start at the beginning and reach the end. [In Proof 2] I am told: take a case and prove it... What would happen if there were 79 cases?! ... It's more elegant to find one proof that does not require the separation into cases”; he also stated that “students should learn the proper way to prove claims” and that the many cases of Proof 2 might “drive the student crazy”. Dana stated that the division into cases makes “Proof 2 hard to remember” and Sally stated that it worries her: “...I am always concerned that a case is missing, it's stressful...”. Proof 2 was chosen by Tara and Anne who stated that it is more intuitive and less ‘tricky’. Tara said: “I relate better to the idea of halving the first domain and then the second one, than to the idea of the perpendicular lines”. Anne said that “it enables to teach students how to ‘play’” and that the gradual increase in complexity allows students to fully understand each case before proceeding.

The lecturers also suggested how to improve the proofs. Sally, Dana and Max preferred teaching Proof 1 but were aware of its difficulties, mainly the ‘Deus ex Machina’ nature of the function $r(\theta)$. Sally suggested to “divide the board, write down the stages and finally ... fill in the details. First the ‘how’ then ... the ‘what’... define a-priori where [you are] heading”, because “...completing the details is [only] half of the work...”. Max suggested using Cases 1-2 of Proof 2 to increase students' intuition regarding the meaning of the claim. Dana suggested emphasizing one central idea: the construction of the distances. These lecturers chose Proof 1 because it agrees with their beliefs about what a “good, proper mathematical proof” is, but contemplated how to improve its communication to their students. Tara and Anne preferred teaching Proof 2; they felt its intuitive nature is better adapted to their students. The division into cases, a disadvantage for others, is an advantage for Anne, who believes that the gradual increase in complexity improves students' learning experience. Tara said that Proof 2 is more intuitive to her than the perpendicular lines of Proof 1; She said: “...I don't like it when proofs are based on an idea that I would not spontaneously think about... if it can be done... without ‘tricks’, I prefer it”. Yet she suggested shortening the proof by omitting Cases 1-2.

Although these findings indicate different lecturer choices, there were noticeable commonalities in their answers. Firstly, Tara and Max chose different proofs, but were both bothered with the imprecise way of using the IVT and stated that one should explicitly define functions and justify their continuity before applying the IVT. For them, some standard of mathematical rigor is important. Secondly, several lecturers refer to meta-proof issues. For example, Sally refers to a proof plan, Anne to pre-proof activities ('play') and Max to the pedagogical value of using precise language. Thirdly, the lecturers address affective aspects, and subjectivity is demonstrated by the opposite attributes that different lecturers relate to the same proof feature. Whereas Sally and Max feel that the division into cases might disturb the students, Anne sees the gradual increase in complexity as giving students a sense of understanding and stability. Thus, the lecturers' choice of proof is highly influenced by their perception of the students attending the lesson. Moreover, earlier in the interview, when asked about their proof preference some lecturers stated that the choice mostly depends on the intended audience. Sally, for example, stated that Proof 1 is clearer in her opinion but that Proof 2 is better for her students. Then, when asked to choose which proof to teach she chose Proof 1 and described pedagogical ways to improve its presentation. The choice of proof appears to be an amalgam of mathematical and pedagogical considerations, personal preferences and convictions.

In the second question, the interviewees were asked what aspects they emphasize while teaching proofs. They all stated that their answer is population dependent. Table 1 summarizes their answers and reveals that lecturers invest a lot of effort in communicating the proof, and raising students' awareness of meta-proof and rhetorical aspects (e.g., aesthetics, and significance). Tara tries "...to look for... the significance, why this conclusion... [and] the way [it] was derived is important...". Anne focuses on pre-proof activities and states that she partly "... wants to teach them how to transform a 'game' into a proof...how to produce... the simplest example that still maintains the features of a problem, ... [how] to try to prove or refute when you still don't have a clue if the claim is true or false...". Max adds that his verbal explanations are what "really explains it to students".

Highlighted aspects	Suppressed aspects
1. Ideas that are: (i) repeated in future proofs or (ii) related to the current content {A, S, D} 2. The thoughts and intuitions that led to the proof {M} 3. What was proved and what "skipped" {T, D} 4. Beauty, aesthetics {T} 5. Intermediate summaries {S} 6. Proof structure, proof type (e.g., proof by induction) {A}; dividing the proof into stages/ parts {M} 7. Flow; one thing arises from another, like a chain {A} 8. Completely justifying each passage {A} 9. Useful "pre-proof" activities: how to formulate an effective example; how to approach the proof when it is still not known if the claim is true or false {A} 10. Difficult points in the proof {M} 11. Significance and relevance of the theorem {T, D}	1. Repetitive stages that do not contain new ideas or new calculations {D, S} 2. Details that are not directly relevant to the work of the students {S} 3. Stages that are too difficult to the current level of the students {S} 4. Sometimes – formality, if the proofs are trivial enough and the concepts have been thoroughly exercised {A}

Table 1: Proof features that are highlighted or suppressed while teaching

In the third question, four were explicitly asked about their use of formal language (the fifth interviewee referred to the use of formal language throughout the interview). Sally used an analogy to explain the importance of using formal language: "... lawyers use words that have meaning only in the context of the law discipline. It's not the same meaning as their dictionary definition..." She says that similarly, students should master the proper way of writing proofs, using the necessary symbols and language. Tara and Anne demonstrate flexibility regarding the use of formality in places where it might obstruct student's learning. For example, Tara states: "in one classroom I might describe the concept of a limit very informally... as a sequence of values getting nearer some value; in a different classroom, I have to use the epsilon-delta definition with extreme formality". Anne admits that "...somewhat reducing the formality" might harm students' understanding but supports her choice by stating that otherwise students may "... lose their grasp of 'the whole'... they need to deal with parts... [and] sub-parts that are not well constructed yet..." Dana's approach marks the other end of the range, for she speaks of 'gluing' things in a non-formal way and clearly expresses her preference to emphasize central ideas rather than to dwell on technical steps. Dana advises students to concentrate on the main, less technical, proof ideas. Thus, the lecturers' answers to the third question reflect a range of attitudes: from a strict use of formal language, via compromises between formality and audience, to an entirely context dependent attitude. They balance between helping the students to be sufficiently acquainted with the customary mathematical language on one hand, and not getting lost in the rigidity and details of extreme formality on the other hand. At the same time, the proof presented to the students should reasonably satisfy some standard of the mathematical community, the same way a legal document should accept approval of law experts.

To summarize, the interviewees discussed a rich collection of proof features, constantly referring to pedagogical considerations. Two themes, subjectivity and context-dependent value of proof features, particularly the type of student population, were prominent throughout the interview.

Discussion of the findings within PNR framework

The findings show that the interviewed lecturers have a clear vision of different mathematical ideas and features of the two proofs, combined with a rich collection of pedagogical considerations. These findings are consistent with the literature (e.g., Hemmi, 2010; Lai and Weber, 2014). However, we wish to focus on the manner in which the lecturers consider their students, i.e. the audience, while teaching proofs. Lai and Weber (2014) explored factors that mathematicians claim to consider when preparing a pedagogical proof and found that audience diversity influenced mathematicians in four aspects: (a) the assumed previous knowledge; (b) the actions that need to be taken to avoid potential student difficulties; (c) using techniques students find familiar or comfortable; (d) what mathematical ideas are emphasized by the proof. Indeed, most of these issues were also raised by our interviewees.

Our data show that when mathematicians teach proofs a tension between two poles arises: the first pole is the wish to present the proofs in a rigorous manner acceptable to professional mathematicians (as Max said "the proper way to prove"); the second pole is the wish to accommodate students' cognitive and affective needs so that they will gain adequate understanding and a rewarding learning experience. This tension is widely found in the literature (e.g., Dawkins and Weber, 2017; Lai and Weber, 2014). Dawkins and Weber (2017), for example, investigate values and norms of

mathematicians regarding proof and acknowledge that sometimes the needs of the mathematical community differ from those of the classroom community, which cannot perfectly mimic practices of professional mathematicians. They claim that expecting students to adopt mathematicians' proof norms without perceiving the underlining values might cause a dissonance between the mathematicians' and the students' communication culture. They also state that one outcome is that "researchers... have sensibly advocated loosening various norms for the purpose of encouraging students' genuine insights" (p. 133). Within PNR, this dilemma is an inherent feature of simultaneously addressing the universal and particular audiences. It is not about "compromising" but about adjusting the argument and creating a shared basis of agreement with the students while maintaining a proof presentation that would still be acceptable by professional mathematicians (possibly imagined as sitting at the back of the class). Moreover, PNR not only relates to the difference between the lecturer's and the students' norms and values but also to other rhetorical and informal features of the proof classroom presentation (Gabel and Dreyfus, 2017), as well as to other types of lecturer-student gaps in the argumentation and their sources.

This may also explain why during the interview, the lecturers frequently answered interview questions focused on mathematical proofs in general by raising pedagogical considerations related to the particular audience, constantly shifting between two perspectives: mathematician and teacher. We give three examples. Sally stated that as a mathematician, she prefers Proof 1, but Proof 2 better fits her students. Nevertheless, when asked to choose a proof to teach she chose Proof 1, suggesting pedagogical ways to improve its presentation. Sally also stressed the importance of formal language in class, but admitted skipping repetitive stages of proofs, and suppressing details that might currently be too difficult for her students. A similar tension can be found in the suggestion Max made regarding the improvement of Proof 1. Max declared the importance of proof formality and preciseness and chose Proof 1 both as his personal preference and as the better proof to teach. However, he suggested improving the presentation of Proof 1 by adding Cases 1–2 of Proof 2, in order to enhance students' intuition regarding the claim's meaning. A similar tension appeared when Anne, who chose to teach Proof 2 for the feeling of understanding it provides referred to formal language by saying that "...one can skip formality if one has the ability to reconstruct it ... but [students] don't know how to do that, so it's a kind of 'pretence' understanding".

Mathematics lecturers address two audiences when teaching proofs: particular and universal. The particular audience is the actual group of students attending the lesson, who bring with them their previous knowledge, attitudes, learning habits, beliefs and cultural conventions. The lecturer needs to address the needs of the particular audience, to maintain a shared basis of agreement with the students and persuade them that the claim was truly proved. In parallel, the lecturer needs to convince the universal audience, which is a mental construct of the lecturer; it may include professional mathematicians, experts of the taught material or admired lecturers. Convincing the universal audience requires different standards of formality, preciseness and rigor. Whenever mathematics lecturers teach proofs, they need to balance between the different requirements of both audiences. The need for this balance is demonstrated, for example, by Dana, who admits that in class she prefers to emphasize important ideas rather than to dwell on technical steps "in an attempt not to give up on classroom proving altogether because then understanding drops to a very low level".

Thus, PNR is a unifying and comprehensive theoretical framework that can be used to interpret a major challenge of proof teaching. Within PNR this challenge is considered an inherent tension that always exists between the need to present a proof that is convincing to the universal audience, in our context a complete, flawless proof accepted by expert mathematicians, and between the need to persuade the particular audience, in our context the students actually attending class. PNR also relates to other rhetorical and informal features of classroom presentation of proof, such as means to endow proof elements with presence (Gabel and Dreyfus, 2017) as well as to lecturer-student gaps in the argumentation and their sources. Therefore, PNR may be used not only to describe mathematicians' proof presentations but also to evaluate the presentations and to provide practical suggestions of how to improve them.

References

- Chi, M. T. H. (1997). Quantifying Qualitative Analyses of Verbal Data: A Practical Guide. *The Journal of the Learning Sciences*, 6(3), 271–315.
- Crosswhite, J. (1989). Universality in Rhetoric: Perelman's Universal Audience. *Philosophy & Rhetoric*, 22(3), 157–173.
- Davis, P. J., & Hersh, R. (1983). *The mathematical experience*. Boston, MA: Houghton Mifflin Company.
- Davis, P. J., & Hersh, R. (1987). Rhetoric and Mathematics. In J. Nelson, A. Megill, & D. McCloskey (Eds.), *The rhetoric of the human sciences: language and argument in scholarship and public affairs* (pp. 54–68). Madison, WI: University of Wisconsin Press.
- Dawkins, P.C., & Weber, K. (2017). Values and norms of proof for mathematicians and students. *Educational Studies in Mathematics*, 95, 123–142.
- Ernest, P. (1999). Forms of knowledge in mathematics and mathematics education: Philosophical and rhetorical perspectives. *Educational Studies in Mathematics*, 38, 67–83.
- Gabel, M., & Dreyfus, T. (2017). Affecting the flow of a proof by creating presence – a case study in Number Theory. *Educational Studies in Mathematics*, 96, 187–205.
- Hemmi, K. (2010). Three styles characterising mathematicians' pedagogical perspectives on proof. *Educational Studies in Mathematics*, 75, 271–291.
- Lai, Y., & Weber, K. (2014). Factors mathematicians profess to consider when presenting pedagogical proofs. *Educational Studies in Mathematics*, 85, 93–108.
- Perelman, C., & Olbrechts-Tyteca, L. (1969). *The new rhetoric: A treatise on argumentation* (J. Wilkinson & P. Weaver, Trans.). Notre Dame, IN: University of Notre Dame Press.
- Reyes, G. M. (2014). Stranger relations: The case for rebuilding commonplaces between rhetoric and mathematics. *Rhetoric Society Quarterly*, 44, 470–491.
- Van Eemeren, F. H., Garssen, B., Krabbe, E. C. W., Snoeck Henkemans, A. F., Verheij, B., & Wagemans, J. H. M. (2013). The new rhetoric. In *Handbook of argumentation theory* (pp. 257–299). Dordrecht, the Netherlands: Springer.

Towards an interplay between TDS and ATD in a Design-Based Research project at the entrance to the university

Imène Ghedamsi¹ and Thomas Lecorre²

¹University of Tunis, Tunisia; ighedamsi@yahoo.fr

²University of Cergy Pontoise, Paris, France; Thomas.lecorre@u-cergy.fr

It is often said that understanding the complex teaching and learning issues at university level requires the networking of several theories. In this paper, we study how the Theory of Didactic Situations and the Anthropological Theory of the Didactic can be combined to address a developmental research issue at university level. We refer to criteria provided by Design-Based Research to compare and contrast the two theories. This preliminary study should allow us to design a teaching intervention related to Calculus at university.

Keywords: Calculus, hypothetical learning trajectory, Theory of Didactic Situations, Anthropological Theory of the Didactic, Design-Based Research.

Delimitation of the project's context

The final aim of our research is to design a teaching intervention in relation to real numbers and numerical sequences at university. At the entrance to university, real numbers and numerical sequences represent an important part of the real analysis curriculum in the mathematical sciences and pre-engineering in France and Tunisia where our experiment will take place. The goal of this chapter is to establish rigorously the properties of real numbers and their interpretation by means of numerical sequences, and its structure is generally founded (as requested by the curriculum) on the continuity principle of the set of real numbers: *Any non-empty subset bounded from above has a least upper bound*. This principle in conjunction with the ordered field properties achieves the implicit axiomatic construction of the theory of real numbers and other properties follow: Archimedean property, density of rational numbers and sequence's interpretation, sequence's interpretation of the continuity principle (monotone convergence theorem), adjacent sequences theorem, Bolzano-Weierstrass theorem and Cauchy completeness theorem. In line with Winsløw, Gueudet, Hochmut and Nardi's claim (2018) about the stability of the mathematical contents (including Calculus) at the first year of university, this chapter requires typical practices involving logical reasoning about the formal existence of real numbers or the aforementioned properties. Relying on different paradigms (e.g., cognitive, socio-cultural, semiotics), research on the secondary-tertiary Calculus transition has highlighted over the years students' difficulties to engage in these practices at the entrance to university and beyond (e.g., Bressoud, Ghedamsi, Martinez-Luaces & Törner, 2016; Winsløw et al., 2018). We decided to use a Design-Based Research approach (Anderson & Shattuck 2012) with the aim of designing a teaching intervention for learning real numbers and sequences that provides details about what is likely to happen and why. The DBR approach leaves an open choice concerning the theories involved in the design. Moreover, comparing and contrasting theories can contribute to improve these theories (Prediger, Bikner-Ahsbabs & Arzarello 2008). Here we have chosen to network the Theory of Didactic Situations (TDS, Brousseau 2008) and the Anthropological Theory of the Didactics (ATD, Chevallard 2015). TDS and ATD are indeed two neighboring theories with

strong epistemological concerns and with the same research program, so that: "[...] *each one reinterprets and reformulates the problems raised by the other.*" (Artigue, Bosch, Gascón & Lenfant 2010, p. 1535). In this paper, we firstly focus on basic variables for comparing and contrasting TDS and ATD by means of the DBR methodology. We secondly present our preliminary thoughts on the elaboration of the Hypothetical Learning Trajectory (HLT) of Calculus at the entrance to university (related to the interconnected properties of real numbers and sequences). The HLT is a fundamental component of DBR. It mainly contains mathematical learning goals, mathematical problems and specific learning and teaching assumptions in the context of these problems; it has a dynamic character and can change during the different phases of the research. The interaction between the HLT and the empirical results is the cornerstone element for developing the teaching intervention.

Design-Based Research as a methodological research

Reports on what is DBR are numerous. In this paper we retain Anderson and Shattuck claim (2012): "Design-based research (DBR) evolved near the beginning of the 21st century and was heralded as a practical research methodology that could effectively bridge the chasm between research and practice in formal education." (p. 16). We focus our description of DBR on its main methodological components: 1) iterative cyclic process; 2) deciding on orienting theory and design guidelines framework; 3) HLT; and 4) selection of research instruments and techniques. The DBR methodology classically consists of intertwined cycles of three phases each: elaboration of the intervention (design); teaching experiments and analysis on the fly; and retrospective analysis. The collaboration between researchers and practitioners (teachers) is the key feature of the quality of the iterative adjustment and refinement of the intervention. This collaboration is carried out through prospective and reflective processes before, during and after each teaching experiment. The results of the retrospective analysis phase mostly supply a new cycle of three phases. Concretely, the research's aim (i.e. the development of an empirically and theoretically grounded teaching intervention for specific mathematics education aims) has to be firstly transformed into research questions and subquestions with the help of the orienting theory and of the design guidelines framework. The design guidelines framework is a theoretical construct describing how to design the intended learning and teaching environment. For an illustration of these choices, see for example the DBR project for statistics education of Bakker and Van Eerde (2015) where a semiotic approach is combined to the Realistic Mathematics Education framework. These theoretical frames guide the development of the HLT through the different phases of the research. In the first cycle, the design phase involves the reflection on what students should learn about the targeted mathematical topics and how this should be done. This first identification leads to the formulation of temporary mathematical learning goals which initiates the design of mathematical problems, identification of learning processes and teacher management of these processes. Informed by concrete mathematical tasks, the HLT is progressively shaped during this phase. An elaborated HLT contains: "[...] *mathematical learning goals, students' starting points with information on relevant pre-knowledge, mathematical problems and assumptions about students' potential learning processes and about how the teacher could support these processes.*" (Bakker & Van Eerde, 2015, p. 446). In the teaching experiment phase, the HLT is used by both teachers and researchers and could be adjusted or changed on the fly (i.e. during the lessons linked to one teaching experiment phase) sometimes by using additional theoretical considerations.

In the retrospective analysis phase, the evolving HLTs are the researcher's guideline to generate conjectures about students' learning and thus to create the teaching intervention. Reciprocally, the teaching intervention is progressively enriched by the evolving HLTs. The DBR methodology involves several instruments and techniques that connect theoretical concerns and concrete experiences in the form of testable hypothesis (potential HLT). For instance, task oriented analysis and longitudinal cyclic approach are useful to test and refine the HLT in the retrospective phase. Researchers who are familiar with TDS can quickly see similarities between Didactical Engineering (DE) as the research methodology of TDS (Artigue, 2000; Brousseau, 2008) and DBR methodology. The specialists of ATD may possibly connect DBR methodology with the theoretical construct of Study and Research Path (SRP) (Chevallard, 2015; Winsløw Barquero, De Vleeschouwer & Hardy 2014). Nevertheless, designing teaching experiments drawing on DE or SRP, specifically in the case of university mathematics education (UME), remains a challenging issue that requires further investigation. We claim that DBR can contribute to this investigation.

TDS and ATD from the DBR perspective

Variables of the networking

We draw here on the methodological components of DBR to generate appropriate variables for comparing and contrasting TDS and ATD. The selection of these variables is conducted with respect to the strategies that have been discussed and adopted by the researchers in the field of networking theories (e.g., Kidron et al., 2018). For the sake of clarity, we find helpful to firstly reorganize the whole DBR methodology through three stages according to the developmental process of HLTs: 1) the upstream stage; 2) the ongoing stage; 3) the downstream stage. In the following description of each stage, the role of both teachers and researchers and their potential collaboration, if any, are carefully stated. The instruments and techniques (questionnaires, interview, methods of analysis, etc.) used are a main issue that we cannot discuss here. The upstream stage is substantially linked to the chosen theoretical approach and leads to the formulation of the research question or problem by means of the epistemological and cognitive assumptions of this approach. At this stage, researchers need to carefully reflect on the (educational) aim of their project/intervention, by using two questions: V1: how to model the mathematics to be learnt and to be taught? V2: how to model mathematics learning and teaching processes? These questions represent the two first variables V1 and V2. The ongoing stage involves the development of series of HLTs and should be carried out by both the researchers and the teachers mainly at the experimental step. The potential variables are then: V3: the design guidelines; V4: the process of implementation. The downstream stage is related to the evolving HLTs and the improvement of the intervention, and it is supposed to be conducted by the researchers. The last two variables are: V5: the potency of the elaborated HLT and V6: transferability of the teaching intervention in other contexts.

Primary interpretations of the variables for TDS and ATD

Starting from a concrete phenomenon or a set of data, the problem of the questions formulated by theories on them, was raised from the beginning by the researchers working on networking theories (Kidron et al., 2018). In the case of our project, the research question refers to the design and implementation of a replicable teaching intervention that focuses on transition issues and enhances

students' learning of Calculus at the beginning of the university. A more general question forms the basic goal of the *research program* of both TDS and ATD: 1) TDS's formulation: "*how to design, regulate and make controlled observations of experimental situations where mathematical content appear as the optimal way to address a mathematical problem?*" (González-Martin, Bloch, Durand-Guerrier & Maschietto, 2014, p. 120- slightly adapted); 2) ATD's formulation: "*how to design a didactic organization that places central questions at the starting point of mathematical activity, making mathematical content appear as models constructed to provide answers to these questions? And what is the ecology of these didactic organizations?*" (Winsløw et al., 2014, p. 106). In the case of our study, the refinement of our research question depends primarily and mostly on the values of each of the following variables.

V1. The ATD models mathematics through the construct of Epistemological Reference Model (ERM) which is formulated by taking into account all the institutions involved in the process of didactic transposition (i.e. the adaptation of mathematical scholarly objects to mathematical objects to be taught and learnt). The construct of Fundamental Situation (FS) models mathematics in the TDS approach. Its formulation takes into account the sources of the meanings of mathematical objects and defines the conditions for saving these meanings when they are concerned by didactic transposition.

V2. In TDS, the process of learning and teaching mathematics is modeled under the central construct of Situation: the system of relationships between the students, the teacher and a mathematical milieu (Ghedamsi, & Lecorre, 2018). Situation is defined by means of two levels: didactic (situation of institutionalization) and a-didactic (situation of action, situation of formulation, and situation of validation). In the didactic level, the use by the teacher of knowledge developed by the students in a-didactic level improves learning and its link to the teaching goal. In the case of ATD, this process is modeled into didactical organization (a set of didactical praxeologies modeling teaching and learning activities) which is strongly connected to the mathematical organization (a set of mathematical praxeologies) that this didactical organization aims to implement. The different didactical organizations are defined by means of the notion of moment of study: exploratory moment, technical moment and technological moment (Bosch & Gascón, 2001).

V3. In the case of TDS, the design guidelines are divided into two steps. In the preliminary step, the researchers conduct an epistemological, cognitive and didactical analysis in order to identify specific characteristics of the targeted mathematical objects, the complexity of the potential cognitive process for students and the actual teaching environment. These analyses aimed to identify the didactical variables (namely the parameters that influence students' learning of the targeted mathematical object(s)) that structure the whole design. In the second step, the construct of the milieu which structures the interactions between students, the teacher and the mathematical milieu in the a-didactic level is used to test several values of these variables. The researchers deploying ATD analyze all the steps in the didactic transposition process linked to the targeted mathematical objects or domain of objects: their origin, their relation with other objects, their integration in mathematical praxeologies, etc. in order to elaborate the related ERM and then to establish the generating question. This question should go over the school level (see the notion of scale of levels of determination (Bosch & Gascón 2006)) and be linked to specific subjects raised by the society. The study of this question will lead to new questions that make the study open and the learning goal not determined in advance. However,

in the rare case where the analysis must guarantee that students meet specific praxeologies, the learning goal should be clearly defined. Otherwise, it is the responsibility of students and teachers, during the study, to choose the trajectory which will determine the praxeologies they encounter.

V4. The implementation with ATD follows at least three criteria: a) the distribution of responsibility between teacher and students is continuously renegotiated, b) the access to intermediate answers is mediated by media (books, journals, TV, internet, etc.) and validated with regards to the didactical milieu, c) the final answer, if any, must include a learning goal. In the case of TDS, the improvement of the interactions among students is ensured by the teacher's enrichment of the mathematical milieu. Depending on the complexity of the mathematical objects, especially at the entrance to university, the teacher can manage the values of the didactical variables without minimizing students' responsibility in generating knowledge. The experimental situation evolves according to the rules of the didactic contract: "*the implicit set of expectations that teacher and students have of each other regarding mathematical knowledge and regarding the distribution of responsibilities during the teaching and learning processes.*" (González-Martin et al., 2014). The teacher should support the change in the didactic contract by strengthening the link between the outcomes of the a-didactic level and the institutionalization level. Due to space constraints, we will not say more about the remaining variables. Figure 1 synthesizes the values of these variables for TDS and ATD.

	TDS	ATD
Global Vision	Socio-constructivist vision of learning and teaching mathematics.	Socio-cultural vision of learning and teaching mathematics.
V1	Fundamental situation of a mathematical object: Mathematical game (or problem). The problem should satisfy the same criteria as those developed in mathematical games theory. The object targeted by the problem should not be explicitly referenced and must provide an optimal method for solving it.	Epistemological Reference Model (ERM) related to mathematical object or domain of objects: Organization of local and regional mathematical praxeologies through sequences of connected praxeologies. Praxeologies (composed of two interrelated blocks: practical and theoretical) model human activity (including mathematical).
V2	Situation at two levels didactic and a-didactic	Didactical organization and moments of study
V3	Preliminary design	
	Researchers: Identification of didactical variables to determine global and local organizations of the design.	Researchers: Identification of a question with generating power for praxeologies and with significance in the context of students' life.
	A priori design	
	Researchers/Teachers: set the variables at certain values to achieve the learning goal.	Researchers/Teachers: the question is rarely accompanied by a learning goal.

V4	Teachers: a) more active role of teachers at the university (manage the values of didactical variables that are already decided), b) gradual change of didactic contract.	Teachers: a) distribution of responsibilities between teacher and students, b) dialectic media/milieu (Chevallard, 2008), c) final answer, if any, with a learning goal.
V5	Researchers: Testing the learning goal and the validity of the theoretical assumptions of TDS through the actual teaching and learning process	Researchers: Testing the actual teaching and learning process.
V6	Reproducibility and paradigmatic didactic contracts	Ecological issues (institutional conditions and constraints; scale of levels of determination)

Figure 1: TDS and ATD from the DBR perspective

This comparison enables the discussion on the potential of each theory by means of DBR methodology. In our case, this discussion will be developed through the project of elaborating a teaching intervention for real numbers and sequences at the entrance to the university. Among the DE studies on the transition towards university Calculus, Ghedamsi (2008) (see also González-Martin et al., 2014) discussed ways of designing a milieu that helps students deepening their understandings of the interrelated properties of real numbers and sequences at the entrance to the university. The epistemological hypothesis of the design is formulated as follows: numerical approximation methods connect the practical and theoretical existence of the mathematical objects stated in the interrelated properties of real numbers and sequences (see first section). These properties become the arguments to validate the used methods. The elaboration and the experimentation of the design have been undertaken through TDS constructs where the epistemological hypothesis has been cognitively formulated so that it can be verified or falsified. In the last section, we use the choices made in this DE as a filter to start a brief discussion on how to elaborate the HLT of the present research.

First steps towards the elaboration of the HLT

This paper presents a theory networking study which is a preliminary step required to design the HLT. The succinct comparison above highlights the necessity to keep the coherence of the whole theoretical foundations when engaging in an intervention project. We retain three fundamental results from this study: 1) the two theories complement each other to address transition issues; 2) the implementation of the design in the context of university mathematics needs the planning of an ad-hoc didactical milieu; 3) the study of the replicability of the intervention necessitates the identification of paradigmatic university expectations about learning and teaching mathematics. We will not develop more the conclusion of this study; we have chosen to end this paper by presenting the first step towards the elaboration of the HLT. The process of modeling the mathematical contents related to the interconnected properties of real numbers and sequences is a fundamental step towards the elaboration of the HLT. The epistemological aspect constitutes the starting point for engaging the elaboration of the design for both theories i.e.: 1) the design of a collection of mathematical problem(s) where the interconnected properties of real numbers and sequences appear as providing the optimal solution, according to TDS; 2) the design of central questions where the interrelated properties of real numbers and sequences appear as models (mathematical praxeologies) constructed

to provide answers to these questions, from the ATD point of view. As claimed by TDS, the construction of mathematical problems, that create the need for these properties, requires firstly investigating the mathematical meaning of their relationship and its fundamental significance. This investigation should be done by using fundamental mathematical sources (i.e. the several theorizations of the set of real numbers) and by deepening insights on their historical growth. As researchers involved in TDS approach know, designing a collection of problems that connects rationally these properties remains a real challenge. The main reason seems to be that the didactical variables that may emerge must preserve the meaning of the relationship between these properties at the moment of their transformation into mathematics to be learned. For instance, the DE experimented by Ghedamsi (2008) shows that the mathematical organization related to the interconnected properties built upon the expectations of the curriculum (i.e. start with the self-evidence of the continuity principle) does not fit cognitive requirements. The fundamental reason was that during the teaching experiments, the students employed spontaneously the nested intervals theorem which is closely linked to the adjacent sequences theorem. However, the nested intervals theorem, in conjunction with the Archimedean property, generates all the targeted properties and leads to another foundation for real numbers theory. So, this theorem deserves more attention in the elaboration of the HLT. ATD materializes a mathematical organization by a set of connected mathematical praxeologies. In the case of the properties of real numbers and sequences, each set of praxeologies, including the one proposed by the official curriculum, is grounded on a specific theory of real numbers. Thus, the theoretical components of each set achieve a fundamental significance (in the terms of TDS) of the relationship between these properties. In the case of our project, the mathematical problems of the HLT must include in particular the theoretical aspects of the mathematics involved. At least two questions may guide the elaboration of these problems: what are the mathematical meanings produced by each set of praxeologies? How should several sets of praxeologies be combined to support learning? These comments provide some information to start thinking about the development of the HLT but to go further supplementary analysis is needed, in particular for formulating the learning goals.

References

- Anderson, T., & Shattuck, J. (2012). Design-based research: A decade of progress in education research? *Educational Researcher*, *41*, 16-25.
- Artigue, M. (2000). Didactic engineering and the complexity of learning processes in classroom situations. In C. Bergsten, G. Dahland, & B. Grevholm (Eds.), *Proceedings of the MADIF 2 Conference* (pp. 5–20). Gothenburg: Swedish Society for Research in Mathematics Education.
- Artigue, M., Bosch, M., Gascón, J. & Lenfant, A. (2010). Research problems emerging from a teaching episode: a dialogue between TDS and ATD. In V. Durand-Guerrier, S. Soury-Lavergne & F. Arzarello (Eds.), *Proceedings of the Sixth Congress of the European Society for Research in Mathematics Education* (pp. 1535-1544). Lyon, France: INRP.
- Bakker, A., & Van Eerde, D. (2015). An introduction to design based research with an example from statistics education. In A. Bikner-Ahsbals, C. Knipping & N. Presmeg (Eds.), *Doing qualitative research: Methodology and methods in mathematics education* (pp. 429-466). NY: Springer.

- Bosch, M., & Gascón, J. (2001). Théories & Empiries. In J.-L. Dorier, M. Artaud, M. Artigue, R. Berthelot & R. Floris (Eds.), *Actes de la 11ème école d'été de didactique des mathématiques* (pp. 23–40). Grenoble : La Pensée Sauvage.
- Bosch, M., & Gascón, J. (2006). 25 years of the didactic transposition. *ICMI Bulletin*, 58, 51-63.
- Bressoud, D., Ghedamsi, I., Martinez-Luaces, V., & Törner, G. (2016). *Teaching and Learning of Calculus*. Cham: Springer International Publishing.
- Brousseau, G. (2008). Research in mathematics education. In M. Niss (Eds.), *Proceedings of the 10th International Congress on Mathematical Education* (pp. 244–254). Denmark: IMFUFA.
- Chevallard, Y. (2008). Un concept en émergence : La dialectique des médias et des milieux. In G. Gueudet & Y. Matheron (Eds.), *Actes du séminaire national de didactique des mathématiques 2007* (pp. 344–366). Paris: IREM de Paris 7 et ARDM. Brest, France.
- Chevallard, Y. (2015). Teaching mathematics in tomorrow's society: A case for an oncoming counter paradigm. In S. Cho (Ed.), *Proceedings of the 12th International Congress on Mathematical Education* (pp. 173–188). Cham: Springer.
- Ghedamsi, I., & Lecorre, T. (2018). Students' understanding of ε -statements involving equality and limit. In V. Durand-Guerrier, R. Hochmuth, S. Goodchild & N.M. Hogstad (Eds.), *Proceedings of the Second conference of the International Network for Didactic Research in University Mathematics, INDRUM2018* (pp. 34-43) Kristiansand, Norway: University of Agder.
- Ghedamsi, I. (2008). *Enseignement du début de l'analyse réelle à l'entrée à l'université* [Teaching of the bases of real Analysis at the entrance to the university] (PhDThesis). Bordeaux University.
- González-Martín, A., Bloch, I., Durand-Guerrier, V., & Maschietto, M. (2014). Didactic Situations and Didactical Engineering in University mathematics: cases from the study of Calculus and proof. *Research in Mathematics Education*, 16(2), 117-134.
- Kidron I., Bosch, M., Monaghan, J., & Palmér, H. (2018). Theoretical perspectives and approaches in mathematics education research. In T. Dreyfus, M. Artigue, D. Potari, S. Prediger & K. Ruthven (Eds.), *Developing Research in Mathematics Education* (pp. 254-268). Oxon: Routledge.
- Prediger, S., Bikner-Ahsbahs, A., & Arzarello, F. (2008). Networking strategies and methods for connecting theoretical approaches – First steps towards a conceptual framework. *ZDM - The International Journal on Mathematics Education*, 40(2), 165-178.
- Winsløw, C., Gueudet, G., Hochmuth, R. & Nardi, E. (2018). Research in university mathematics. In T. Dreyfus, M. Artigue, D. Potari, S. Prediger & K. Ruthven (Eds.), *Developing Research in Mathematics Education* (pp. 66-74). Oxon: Routledge.
- Winsløw, C., Barquero, B., De Vleeschouwer, M., & Hardy, N. (2014). An institutional approach to university mathematics education: from dual vector spaces to questioning the world. *Research in Mathematics Education*, 16(2), 95-111.

The graph of a function and its antiderivative: a praxeological analysis in the context of Mechanics of Solids for engineering

Alejandro S. González-Martín¹ and Gisela Hernandes-Gomes²

¹Université de Montréal, Canada; a.gonzalez-martin@umontreal.ca

²Université de Montréal, Canada; gisela.hernandes.gomes@umontreal.ca

The notion of integral is usually first introduced to engineering students in their calculus courses before later being used in their professional engineering courses. In this paper we analyse the textbooks used as main references in two engineering courses: a calculus course and a mechanics of solids course. Specifically, we compare how each textbook presents the task of sketching the graph of an antiderivative in the context of kinematics. Our results indicate that the mechanics of solids course presents this task by emphasising the notion of area and basic geometric calculations, using different notation and rationale than in the calculus course. We discuss the possible impact of these differences on the training of engineers.

Keywords: Mathematics for engineers, teaching and learning of calculus, textbook analysis, anthropological theory of the didactic, antiderivative.

Introduction

The mathematical education of engineering students is a topic of increasing concern for mathematics education researchers, university mathematics teachers and professional associations (Bingolbali, Monaghan, & Roper, 2007, p. 764). In particular, calculus is considered an important component of basic engineering curriculum, providing notions, skills, and competences that are deemed necessary for the following professional courses. Nonetheless, the difficulties that calculus courses pose for students are not restricted to engineering programs (Rasmussen, Marrongelle, & Borba, 2014), and they may become a factor leading to the abandonment of STEM degrees (Ellis, Kelton, & Rasmussen, 2014).

In the case of engineering, there is still a lack of understanding about how calculus notions are used in professional engineering courses; and by better understanding this use, some changes could be made to the content of calculus programmes. For instance, our previous research (González-Martín & Hernandes Gomes, 2017, 2018) indicates that the notions of bending moment and first moment of an area (used in civil engineering) are used in tasks that are not present in calculus courses, despite these notions being defined as integrals. Nor does their use require techniques that are explicitly derived from practices introduced in calculus courses. In the case of the notion of bending moment (González-Martín & Hernandes Gomes, 2017), some professional engineering textbook tasks require students to sketch the graph of the antiderivative of a given function. For this reason, we are currently interested in the connections between functions and antiderivatives, as well as their graphic interpretation, in professional engineering courses.

Some difficulties that students encounter in interpreting the graph of a function and the graph of its derivative are well known. For instance, Borgen and Manu (2002) identified that some students may be able to perform the necessary calculations to find the stationary points of a function, but that the

same students would not see these points as a part of the graph. In addition, Ubuz (2007) identified several difficulties students encounter in sketching the graph of the derivative of a function by looking at the graph of this function. In the same vein, some studies point out students' difficulties relating the graphs of a function and its antiderivative. Swidan and Yerushalmy (2014) found that some students try to guess the shape of the antiderivative function based on the position of the function graph, instead of correlating the y -value of the function graph with the tangent slope value of the antiderivative function graph. Finally, Marrongelle (2004) investigated how undergraduate students in an integrated calculus and physics curriculum used physics to help them solve calculus problems. The circumstantial evidence exposed in this study "supports the view that students come to understand graphs, as well as other mathematical representations, by recalling or imagining physical events" (p. 271).

Because we are interested in the training of engineering students and how they use mathematics in their professional courses, we examine whether the ability to visualise and interpret graphs of antiderivatives is required in professional engineering courses (besides the notion of bending moment) and how this relates to practices taught in calculus courses. Our research program's first step is to analyse textbooks used in these courses. In the next sections, we present the theoretical tools we used in our study, as well as our methods and main results.

Theoretical framework

To analyse the use of visualisation and the production of graphs in professional engineering textbooks, we use tools from the anthropological theory of the didactic (ATD – Chevallard, 1999). ATD considers human activities, as well as the production of knowledge, as institutionally situated; this means that knowledge about these activities and why they are important (or why we need to learn them) is also institutionally situated (Castela, 2016, p. 420).

One key element of ATD, essential in our analyses, is the notion of praxeology (in the case of the study of mathematical activity, mathematical organisation or mathematical praxeology – MO hereinafter). A praxeology $[T/\tau/\theta/\Theta]$ is formed by four elements: a type of task T to perform, a technique τ which allows the task to be completed, a rationale (technology) θ that explains and justifies the technique, and a theory Θ that includes the rationale. These elements are grouped in the practical block $[T/\tau]$ (or know-how), and the knowledge block $[\theta/\Theta]$ which describes, explains and justifies what is done. To describe mathematical knowledge (including its production, its use, and its learning), these two blocks permit an analysis of what needs to be done, how it is done, and the justifications for this. ATD distinguishes different types of MO: punctual, which are associated with a specific type of task; local, which integrate multiple punctual MOs that can be explained using the same technological rationale; and regional, which integrate local MOs that accept the same theoretical rationale (Barbé, Bosch, Espinoza, & Gascón, 2005).

Knowledge (and also praxeologies) can be used in institutions other than where it was created, which implies transpositional effects on the concerned praxeologies (Chevallard, 1999), causing some (or all) elements of the original praxeology to evolve. Although these changes may have little impact on experts, they may make it difficult for students to recognise "the same" knowledge used in another institution. Therefore, it is important to analyse the types of tasks and techniques as well

as the rationales employed (for instance, in different courses) to identify the challenges these transpositional effects pose for students. To that end, our research identifies specific local MOs present in professional courses; we analyse how calculus notions are used (practical block) and the explanations given (knowledge block) in relation to the way the notions are usually presented in calculus courses.

Methodology

As we have noted, the study presented in this paper continues our previous work examining how calculus notions are used in professional engineering courses. Our latest work focuses on future engineers' use of integrals (first, to define shear forces and bending moments, and second, to define the first moment of an area – see, respectively, González-Martín & Hernandez Gomes, 2017, 2018), which is why we are pursuing the current study along these lines. As in all our studies concerning future engineers' use of calculus notions, we worked with teachers of professional engineering courses (all of them holding engineering degrees, some of them active engineers), who guided us in identifying key notions of engineering that are based on calculus notions and helped us grasp the important elements of these notions. Our current study focuses on two courses at a Brazilian university (although the textbooks we analysed are distributed internationally): Calculus (I and II), and Mechanics of Solids for Engineers. In the latter course, students need to work with functions, interpreting their graph and constructing their antiderivative graph to solve problems related to motion. At this stage of our research, we chose to work with the reference texts for each course. Guided by our collaborating engineering teachers, we examined the following books: *Calculus*, by Stewart (2012) and *Vector Mechanics for Engineers: Statics and Dynamics* (Beer, Johnston, Mazurek, & Cornwell, 2013), an international book used in the discipline of mechanics of solids. We consider the courses to be two different institutions, since practices vary greatly between them.

At this university, calculus is taught in the first year of the engineering program over two semesters, in two courses: Calculus I and Calculus II. Integrals appear towards the end of the first course and are the main topic in the second course (the second author of this paper has taught Calculus I for 15 years and Calculus II at this same university for two years). Both courses follow the structure of Stewart (2012) fairly closely, but it is worth mentioning that the Brazilian version of this textbook is divided in two volumes: volume 1 (Calculus I - chapters 1 to 6 of the international edition) and volume 2 (Calculus II - chapters 7 to 10 of the international edition). Mechanics of Solids is taught during the third semester of the program (second year), and, as stated above, the main reference for this course is Beer et al. (2013). We identified the pages in Stewart (2012) covering the introduction of integrals, and identified the pages in Beer et al. (2013) where content related to kinematics of particles in one dimension is taught. Within these pages, we then pinpointed tasks related to sketching the graph of an antiderivative and the proposed technique(s), paying attention to the use of given definitions and properties. We also identified each task's rationales (technologies) and whether they are implicit or explicit. Therefore, for each book, the identification of common rationales allowed us to recognize local MOs, which enabled us to propose an overall organisation for the content related to sketching the graphs of antiderivatives for each book. The next section provides specific details of our analysis.

Data analysis and discussion

Organisation of Stewart (2012)

The content concerning integrals in volume 1 of the Brazilian version of Stewart (2012) is distributed among chapter 5 (integrals), 6 (applications of integration), 7 (techniques of integration), and 8 (further applications of integration). In these chapters, content is basically structured using two local MOs. The first, MO_{M1} , presents notions and results justified by the definition of integral, the use of limits, and some theorems. It informally introduces Riemann sums to define definite integrals, interpreting them as areas, and leads to the Fundamental Theorem of Calculus (FTC) and the calculation of definite integrals using Barrow's rule; this then leads to some applications of the integral (area, volume, etc.). The tasks involve the use of the sigma notation, calculating integrals using series, calculating areas, proving some properties, and so on. The second, MO_{M2} , although it requires knowledge of the notion of integral, makes use of many algebraic properties of functions. It introduces techniques for calculating indefinite integrals (immediate integration to begin with, followed by various integration techniques). Many of the techniques used in MO_{M2} are derived from MO_{M1} .

The word antiderivative appears in the book for the first time in chapter 4 to introduce its definition: "A function F is called an antiderivative of f on an interval I if $F'(x) = f(x)$ for all x in I ." (Stewart, 2012, p. 344). The connections between the graph of a function and its antiderivative are explained only in chapter 5, as a part of MO_{M1} , among other tasks of this MO. Section 5.3 presents the FTC, which is followed by an application to sketch the graph of the antiderivative of a function ($g(x) = \int_0^x f(t) dt$) knowing the graph of $f(x)$. The technique consists of estimating the area under the curve up to certain points (based on the technology that an integral represents an area). For instance, for the graph of Figure 1a, the value of $g(1)$ corresponds to the area of a triangle; the value of $g(2)$ corresponds to the area of the triangle and the rectangle; for $g(4)$ we can estimate that: $g(4) = g(3) + \int_3^4 f(t) dt \approx 4.3 + (-1.3) = 3.0$ (Figure 1b). Students are given five exercises to practice this technique. A second technique to validate the sketch of the graph of $g(x)$ is based on the fact that it is an antiderivative, and by estimating the slopes of tangents at different points we should get the graph of $f(x)$ (Figure 1c). Note that this technique could be seen by students as coming from another MO_{M3} (developed in the chapters on derivatives – section 4.3. *How derivatives affect the shape of a graph* – and using the relation between the sign of the derivative and the shape of the graph as technology). Tasks involving the connection between the graph of a function and its antiderivative appear spread out until chapter 7, but in all these cases the technique calls for validation using notions from derivatives exclusively (increase, decrease, maxima, and minima). We find, for instance, arguments such as: "Notice that $g(x)$ decreases when $f(x)$ is negative and increases when $f(x)$ is positive, and has its minimum value when $f(x) = 0$. So, it seems reasonable, from the graphical evidence, that g is an antiderivative of f " (Stewart, 2012, p. 409).

The number of exercises in which students are asked to relate the graphs of a function and its antiderivative is quite limited: seven exercises in section 5.3 (only five require students to sketch the graph of the antiderivative by hand), four exercises in section 5.5, five exercises in the summary of

chapter 5, four exercises in section 7.1, six exercises in section 7.2, and two exercises in section 7.4. None of them has a context of motion.

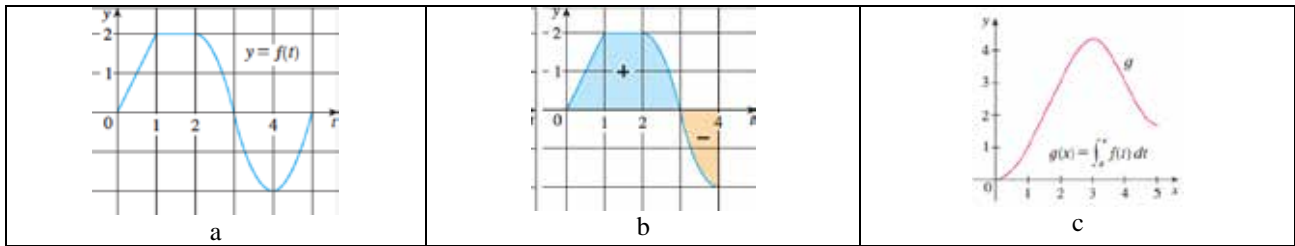


Figure 1. Solved example showing how to sketch the graph of a antiderivative (Stewart, 2012, p. 387)

Organisation of Beer et al. (2013)

In Beer et al. (2013), chapters 1 to 10 are devoted to statics. The study of dynamics begins in chapter 11, where the graphic interpretation of antiderivatives appears. This chapter deals with particles in rectilinear motion; that is, the position, velocity, and acceleration of a particle. This chapter presents an MO_{E1} with the main goal of studying kinematics problems. It uses several elements from MO_{M3} to introduce the notions of average and instantaneous velocity and acceleration. The task of sketching graphic solutions is introduced at the end of the chapter, section 11.7 (pp. 632-634), as a complimentary technique to the analytical approach. We focus our analyses on this part, comparing with the approach to solve graphic tasks in Stewart (2012). A first graphic interpretation of these elements appears on page 606, relating the graphs of a particle's position ($x = 6t^2 + t^3$), velocity, and acceleration (Figure 2). Note that the notation used in MO_{E1} is different from that used in the calculus textbook, particularly the use of x as a dependent variable (compare Figures 1 and 2).

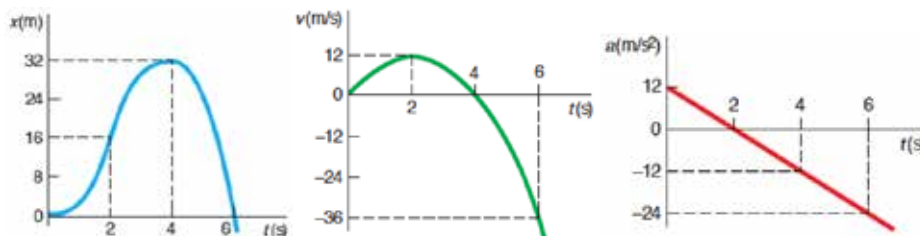


Figure 2. Graphs of position, velocity, and acceleration (Beer et al., 2013, p. 606)

On page 632 we find the type of tasks in which we are interested: the introduction of graphic techniques to solve problems involving rectilinear motion. The book states that both $v = dx/dt$ and $a = dv/dt$ have a geometrical significance and that v and a can be seen, respectively, as the slope of x and v (p. 632). This fact, sustained by elements from MO_{M3}, leads to the introduction of the backwards process to sketch the $x-t$ and $v-t$ graphs given the $a-t$ curve (Figure 3). This technique is based on elements from MO_{M1}. We note, however, that in MO_{M1}, elements related to this visual interpretation are rather marginal. There is also no physical interpretation, and different notation is used. In particular, after presenting cases where a is constant and linear, the following technique is given: “In general, if the acceleration is a polynomial of degree n in t , the velocity will be a polynomial of degree $n + 1$ and the position coordinate a polynomial of degree $n + 2$; these

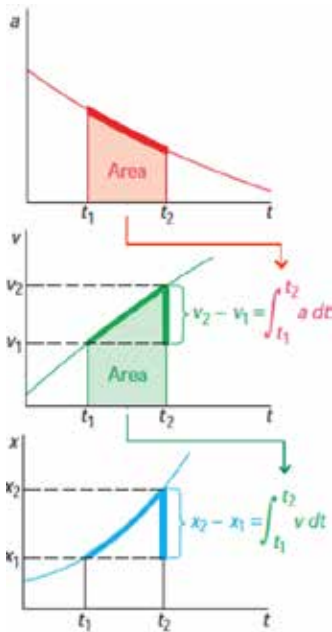


Figure 3. Backwards process
(Beer et al., 2013, p. 632)

polynomials are represented by motion curves of a corresponding degree.” (Beer et al., 2013, pp. 632-633)

We note that this technique is introduced almost as a mnemotechnic rule, without any explicit connections to elements of MO_{M1} or MO_{M2} (where techniques of integration are studied). We also observe that it is written using terms from MO_{E1} , and not explicitly relating to the language used in calculus. These elements are used to solve problems such as the one in Figure 4. The application of the given technique, as well as basic geometric considerations, leads to the solution in Figure 5.

Two main observations can be made: 1) the sketching of the antiderivative is based mostly on explicit elements from MO_{E1} , which are implicitly related to elements of MO_{M1} and MO_{M3} ; 2) however, we note that the technique in MO_{E1} calls attention more directly to the analysis of the area under the curve and to geometric considerations, whereas the tasks of sketching an antiderivative graph introduced in MO_{M1} shift mostly to properties of the derivative

(from MO_{M3}). Moreover, this section of the book groups together 28 exercises for students to practice this type of task. One factor that may hinder students’ appropriation of this type of task is that the technique presented relies more heavily on basic geometric considerations, does not make explicit connections with the rationale from the calculus book, uses many interpretations based on area and kinematic ideas, and uses sensibly different notation.

SAMPLE PROBLEM 11.6

A subway car leaves station A; it gains speed at the rate of 4 ft/s² for 6 s and then at the rate of 6 ft/s² until it has reached the speed of 48 ft/s. The car maintains the same speed until it approaches station B; brakes are then applied, giving the car a constant deceleration and bringing it to a stop in 6 s. The total running time from A to B is 40 s. Draw the a-t, v-t, and x-t curves, and determine the distance between stations A and B.

Figure 4. A kinematic problem (Beer et al., 2013, p. 634)

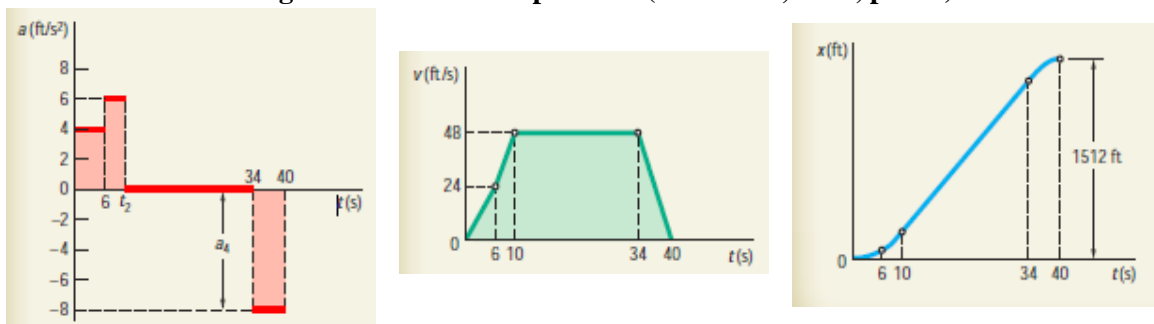


Figure 5. Solution of sample problem 11.6 (Beer et al., 2013, p. 634)

Final considerations

Our results indicate that there is an important rupture in the study of a similar task (sketching the graph of an antiderivative) as presented in two different textbooks used in two different courses. In the calculus book, the task is presented marginally, with a first technique practised in only five exercises and a second technique that emphasises properties of derivatives without taking into account students' known difficulties with the graphic interpretation of the derivative. On the other hand, the engineering book emphasises interpretations using the notions of area and kinematics, which seems to be a way of helping students better grasp antiderivatives graphs (Marrongelle, 2004). An important element to take into account is that the presentation of the task in the mechanics of solids book (through MO_{E1}) does not make explicit connections to the content and techniques of the calculus book (mostly, through MO_{M1} and MO_{M3}).

These findings are coherent with our earlier results concerning other engineering notions (González-Martín & Hernandez Gomes, 2017, 2018). Our previous research indicates that in professional engineering courses, although integrals are used to define certain engineering notions, tasks and techniques are presented without an explicit connection to the language and rationale of calculus, and the many techniques learned in calculus courses are not called upon to solve engineering tasks. We believe that an important element of students' difficulties in seeing the connection between calculus and their professional courses may be due to the following: although the "same" notions are used in both courses, they are used with different techniques and rationales, which may hinder students' ability to recognise these notions. Our results also indicate that a task such as the graphic sketching of an antiderivative (and its interpretation) is performed in at least two engineering courses: strength of materials (bending moments) and mechanics of solids (kinematics). More research is needed to identify whether this type of task is performed in other courses, which may justify spending more time on it in calculus courses.

Finally, we highlight the fact that the books analysed in our previous papers and in this one are of international distribution, so our analyses, although restricted to two different books, may be representative of a general situation in engineering programs. Moreover, the results regarding different topics seem to go in the same direction. We believe that more research is needed to better understand the real use of calculus notions in professional engineering courses, as well as teachers' practices and whether these practices reproduce what is presented in the reference books, to have a more precise idea of how these notions are actually introduced and used. Research on these issues will help advance an international discussion about the content traditionally taught in calculus courses and its adequacy in training engineers (especially in light of the fact many students abandon their programs due to their failing of calculus courses). Our research program intends to contribute to this discussion and our results will be the topic of future publications.

References

Barbé, J., Bosch, M., Espinoza, L., & Gascón, J. (2005). Didactic restrictions on the teacher's practice: the case of limits of functions in Spanish high schools. *Educational Studies in Mathematics*, 59(1), 235–268.

- Beer, F. P., Johnston, E. R., Mazurek, D. F., & Cornwell, P. J. (2013). *Vector Mechanics for Engineers: Statics and Dynamics* (10th edition). New York: McGraw-Hill.
- Bingolbali, E., Monaghan, J., & Roper, T. (2007). Engineering students' conceptions of the derivative and some implications for their mathematical education. *International Journal of Mathematical Education in Science and Technology*, 38(6), 763–777.
- Borgen, K. L., & Manu, S. S. (2002). What do students really understand? *The Journal of Mathematical Behavior*, 21(2), 151–165.
- Castela, C. (2016). When praxeologies move from an institution to another: an epistemological approach to boundary crossing. In R. Göller, R. Biehler, R. Hochmuth & H.-G. Rück (Eds.), *Proceedings of the KHDM Conference: Didactics of Mathematics in Higher Education as a Scientific Discipline* (pp. 153–161). Kassel, Germany: Universitätsbibliothek Kassel.
- Chevallard, Y. (1999). L'analyse des pratiques enseignantes en théorie anthropologique du didactique. *Recherches en Didactique des Mathématiques*, 19(2), 221–266.
- Ellis, J., Kelton, M. L., & Rasmussen, C. (2014). Student perceptions of pedagogy and associated persistence in calculus. *ZDM – The Int. Journal on Mathematics Education*, 46(4), 661–673.
- González-Martín, A. S., & Hernandez Gomes, G. (2017). How are calculus notions used in engineering? An example with integrals and bending moments. In T. Dooley & G. Gueudet (Eds.), *Proceedings of the Tenth Congress of the European Society for Research in Mathematics Education* (pp. 2073–2080). Dublin, Ireland: DCU Institute of Education and ERME.
- González-Martín, A. S., & Hernandez-Gomes, G. (2018). The use of integrals in Mechanics of Materials textbooks for engineering students: the case of the first moment of an area. In V. Durand-Guerrier, R. Hochmuth, S. Goodchild & N. M. Hogstad (Eds.), *Proceedings of INDRUM2018 – Second conference of the International Network for Didactic Research in University Mathematics* (pp. 115-124). Kristiansand, Norway: Univ. of Agder and INDRUM.
- Marrongelle, K. A. (2004). How students use physics to reason about calculus tasks. *School Science and Mathematics*, 104(6), 258–272.
- Rasmussen, C., Marrongelle, K., & Borba, M. C. (2014). Research on calculus: what do we know and where do we need to go? *ZDM – The Int. Journal on Math. Education*, 46(4), 507–515.
- Stewart, J. (2012). *Calculus* (7th edition). Belmont, CA: Cengage Learning.
- Swidan, O., & Yerushalmy, M. (2014). Learning the indefinite integral in a dynamic and interactive technological environment. *ZDM – The Int. Journal on Mathematics Education*, 46(4), 517–531.
- Ubuz, B. (2007). Interpreting a graph and constructing its derivative graph: stability and change in students' conceptions. *International Journal of Mathematical Education in Science and Technology*, 38(5), 609–637.

Calculus students' difficulties with logical reasoning

Gabriel Herrera Alva¹, Antonio Rivera Figueroa¹ and Kinrha Aguirre-De la Luz²

¹Center of Research and Advanced Studies IPN, Mexico; jgherrera@cinvestav.mx

¹Center of Research and Advanced Studies IPN, Mexico; arivera@cinvestav.mx

²Universidad Autónoma Metropolitana, Mexico; kaguirre@uam.mx

In this paper, we examine the conditional reasoning of 14 undergraduate Mathematics students. The used instrument consisted of four questions in the context of the essential contents of Calculus. The analysis was based on the written answers given by students and five semi-structured interviews. We found two important logical flaws that prevailed among students' reasoning: 1) use of the invalid inference denial of the antecedent, and 2) incorrect use of negations of conjunctions involved in a structure of the type $P \rightarrow Q$.

Keywords: Calculus, advanced mathematical thinking, logical reasoning.

Introduction

In an undergraduate degree, a first course in Calculus is actually a course about its foundations. In this type of course, students are required to develop their mathematical and logical reasoning, specifically their conditional reasoning. Students' difficulties in conditional reasoning tasks have been demonstrated in several investigations (Hoyles & Küchemann, 2002). Some of them consisting of obtaining valid inferences from a rule given in the form $P \rightarrow Q$, and a minor premise, for example to assume Q or not P (Evans, Handley, Neilens, & Over, 2007; Inglis & Simpson, 2008). In general, given a statement $P \rightarrow Q$ there are four commonly drawn types inference, two are valid and two are invalid. The valid inferences are modus ponens (MP) ($P \rightarrow Q$) and modus tollens (MT) ($\text{not } Q \rightarrow \text{not } P$); the invalid inferences are the denial of the antecedent (DA) ($\text{not } P \rightarrow \text{not } Q$) and affirmation of the consequent (AC) ($Q \rightarrow P$). There are three types of contexts where tasks of this kind can be made: verbal and mathematical contexts (Stylianides, Stylianides & Philippou, 2004), and abstract context (Evans et al., 2007; Inglis & Simpson, 2008; Attridge & Inglis, 2013). Specialized literature reported that verbal and mathematical contexts can influence when a logical inference is made (see, for instance, a study carried out by Stylianides (2004) on the use of MT inference in a verbal and mathematical contexts). In this paper, we use Toulmin's scheme to study the following question: can invalid inferences be identified from a conditional mathematical proposition by students who have completed a first course of university Calculus?

Theoretical Framework

In this work we used the term difficulty as Gueudet (2008), that is: "the association of an inadequate mathematical production and of various levels of factors likely to have caused this production" (p. 239). On the other hand, we will understand conditional reasoning as

those inferences that can be made from a rule –major premise– of the form “ $P \rightarrow Q$ ” and a given minor premise, for example, suppose Q or not P . In general, the statement “ $P \rightarrow Q$ ” lead to four types of inferences summarized in Table 1.

Inference	Premise	Conclusion	Legitimacy
MP	P	Q	Valid
DA	Not P	Not Q	Not valid
AC	Q	P	Not valid
MT	Not Q	Not P	Valid

Table 1: Model of logical inferences

In our research we examined the performance of 14 students –who had successfully completed a first course in university Calculus– through a task that included DA inference in the context of Calculus. Two questions were proposed (P1 and P2) in which the students were to use fundamental concepts of Calculus already learned with in their previous course, and two auxiliary questions written in two versions (P1a and P1b) with the purpose of minimizing the possible influence of context on the students' reasoning.

We used Toulmin's argument pattern (TAP), to analyze arguments students provided to support their written answers. This scheme was designed to analyze arguments from different scientific and philosophical areas, and it has become an important instrument in mathematics education researches as a way to analyze arguments (Pedemonte, 2007; Simpson, 2015; Zazkis, Weber & Mejía, 2016). The scheme focuses on the content of the arguments and not on their logical structure. According to Simpson (2015), many authors adapt the Toulmin's scheme to their data and intentions for analysis. Toulmin identifies six elements in his model: Data (D), the available information which the claim is based; Conclusion (C) what is stated; Warranty (W) that justifies the transition of data to conclusion; the support (S) where warranty backs, for instance, a law, a theorem or a theory; a modal qualifier that assigns the degree of certainty in the conclusion, words such as probably, always, sometimes, never are examples of modal qualifiers; finally, Toulmin incorporates into his model the conditions of rebuttal (R) that show the possible invalidity of the conclusion (Toulmin, 2003; Simpson, 2015).

Toulmin's argument pattern and the logical inferences model were appropriate to analyze the students' written answers. By mean of the use of these two tools, we were able to specify and analyze both the structure and the content of the arguments.

Methodology

The research instrument is composed of two questions (P1 and P2) that involved the use of fundamental concepts of Calculus studied in the first semester in Mathematics; and one auxiliary questions, written in two version (P1a and P1b), whose purpose were to minimize

the possible influence of the context in students' reasoning. Invalid DA inference has been considered within P1 and P2 answers options.

P1 (Weierstrass Theorem) If f is continuous in interval I , which is closed and bounded, then f is bounded and has a maximum in I . What would you say if interval I is not bounded? Indicate which of the following statements are true.

a) The theorem states that, if the three conditions are fulfilled, then f is bounded and has a maximum. Since I is not bounded, then f has not maximum; b) The theorem does not establish anything, if any of the hypothesis is not fulfilled; c) Since I is not bounded, then f is not bounded in I ; d) Although I is not bounded, f can be bounded and have a maximum.

P2. (Quotient Law of Convergent Sequences) Let (a_n) and (b_n) be two sequences of real numbers. If they fulfill: 1) $\lim_{n \rightarrow \infty} a_n$ exists, 2) $\lim_{n \rightarrow \infty} b_n$ exists, and 3) $\lim_{n \rightarrow \infty} b_n \neq 0$. Then,

$\lim_{n \rightarrow \infty} \left(\frac{a_n}{b_n}\right)$ exists and $\lim_{n \rightarrow \infty} \left(\frac{a_n}{b_n}\right) = \frac{\lim_{n \rightarrow \infty} a_n}{\lim_{n \rightarrow \infty} b_n}$. Based on this theorem, indicate which options are true and which are false:

a) If $\lim_{n \rightarrow \infty} b_n = 0$, then $\frac{\lim_{n \rightarrow \infty} a_n}{\lim_{n \rightarrow \infty} b_n}$ is not defined; b) Theorem states that if the three conditions are fulfilled, then $\lim_{n \rightarrow \infty} \left(\frac{a_n}{b_n}\right)$ exists. Therefore, if $\lim_{n \rightarrow \infty} b_n = 0$, we can affirm that necessarily $\lim_{n \rightarrow \infty} \left(\frac{a_n}{b_n}\right)$ does not exist; c) Theorem does not state anything if any of the hypotheses is not met; d) Even when $\lim_{n \rightarrow \infty} b_n = 0$ occurs, the $\lim_{n \rightarrow \infty} \left(\frac{a_n}{b_n}\right)$ may exist.

In relation to the P2 question, we assumed that the prohibition on the division by zero would influence the inferences of the students (Tsamir & Sheffer, 2000; Kajander & Lovric, 2018). To minimize the impact of this prior knowledge, we opted to include an auxiliary question in our research instrument, which refers to the definition of the derivative of a function in its two versions: $\lim_{h \rightarrow 0} \frac{f(x+h)-f(x)}{h}$ (P1a) and $\lim_{x \rightarrow a} \frac{f(x)-f(a)}{x-a}$ (P1b). The purpose of considering two versions of the definition of the derivative of a function was to investigate if students would accept some quotients, whose denominator tends to zero for its popularity as consolidated topics in Mathematics, for example, P1a; or whether they actually apply the concept of limit. In addition, we considered both expressions thinking in the possibility of some students would know the definition of derivative in one or another version.

The research instrument was applied to 14 students who had completed their first university course in Calculus at the Facultad de Ciencias de la Universidad Nacional Autónoma de México (UNAM). Due to the incorporation of the auxiliary question (in its two versions), we decided to apply the research instrument in two sessions so that, it would not immediately influence the students' answers to P2. In the first session, students formed two groups: we applied (P1 and P1a) to one group and (P1 and P1b) to the other. After two days, the second session took place. Question P2 was applied to both groups at the same time. Experimentation

lasted 35 minutes. To deepen the arguments that students provided to support some of their answers, we carried out five semi-structured short interviews of 15 minutes.

Questions P1 and P2 have the same logic structure, see Figure 1.



Figure 1: Logic structure of questions P1 and P2

Question P1 has two correct answer options b) and d), the first makes clear the impossibility of decision of the theorem if any of the three hypotheses A , B or C are not satisfied; and the second, i.e. d), alludes to the possibility that when hypothesis C is not satisfied, there are particular cases in which statements D and E are fulfilled. The answer options a) and c) are incorrect and contemplate the DA inference.

Question P2 has three correct answer choices: a) it is a distractor, b) it refers to the impossibility of deciding the theorem when one of the hypotheses is not satisfied; and option d) again opens the possibility that even when $A \wedge B \wedge \neg C$ occurs, D and E can happen.

Discussion and analysis of results

We provide the analysis and discussion for each question P1 and P2. Due to space restrictions, we will present only one TAP referring to P2, which reflect the general reasoning of most of the students.

About Question P1

Only three of the fourteen students chose options b) or d), which are the correct answers. It should be noted that none of these 3 students chose b) and d) simultaneously. Most of the rest of the students chose c), they argued: “if it is a continuous function in an interval that is not bounded, then function is not bounded”; “all hypothesis must be met so we can say that a function is bounded in a closed interval I ”. In some cases, students that chose a), confused the maximum of a function with the maximum of the interval: “in order an interval has a maximum, it must be in the set, that is, it has to be closed and bounded”.

We highlight the logical flaw in the reasoning of these students; they think that the falsehood of the premise of a proposition necessarily implies the falsehood of what is stated in the conclusion (DA inference). Figure 2 shows the logical structure of the reasoning of most of them.



Figure 2: Logical structure of students' reasoning in Question P1

In terms of Gueudet (2008), this inadequate mathematical production was caused by factors of logical and mathematical type, that is, both the lack of knowledge of logical structures and the misuse of the concepts of Calculus, determined this inadequate production.

About Question P2

The results reveal that 10 of the 14 students did not answer this question correctly. Before beginning the analysis of P2, we will briefly comment on what happened in the answers to the auxiliary question (P1a and P1b). Most students expressed that the existence of the limit in both P1a and P1b depended on the nature of the function. More precisely, in the case of P1a, most students identified this limit with the derivative of a function, and still two students stated that such a limit did not exist because the denominator tended to zero. In the case of P1b, although no student directly related it to the derivative, none said that this limit was indeterminate, even two students argued that this limit was equal to 1. Regarding P2, it might seem strange that most students failed in this question a few days after having faced a similar situation with the definition of derivative of a function, since the expressions in P1a and P1b, and $\lim_{n \rightarrow \infty} \left(\frac{a_n}{b_n} \right)$ share the same structure of a quotient where the denominator tends to zero. However, the analysis of the students' responses and the interviews revealed the cause of this problem.

Figure 3 shows student A's TAP. The answer provided in the instrument by this student was incorrect and reflect the general reasoning of most of the students. However, the student identified the type of incorrect reasoning during the interview. As the initial data (D), the student considered (Quotient Law of Convergent Sequences) and $\lim_{n \rightarrow \infty} b_n = 0$, and his conclusion (C) was that the limit of the quotient $\lim_{n \rightarrow \infty} \left(\frac{a_n}{b_n} \right)$ does not exist. The student chose the word “always” as the modal qualifier (Q), and used as warrants (W) the flawed reasoning “the negation of the premise implies the negation of the conclusion”, the prohibition of dividing by zero, the impossibility to calculate $\frac{\lim_{n \rightarrow \infty} a_n}{\lim_{n \rightarrow \infty} b_n}$ and the equality $\lim_{n \rightarrow \infty} \left(\frac{a_n}{b_n} \right) = \frac{\lim_{n \rightarrow \infty} a_n}{\lim_{n \rightarrow \infty} b_n}$.

Notice that the warrants (W) of student A were also justified by support (S) that consisted of the properties of real numbers, the theory of limits, and the DA inference. The rebuttal conditions (R) were considered during the interview with student. Student A was presented with some examples of quotients of sequences where the sequence in the denominator was convergent to zero.

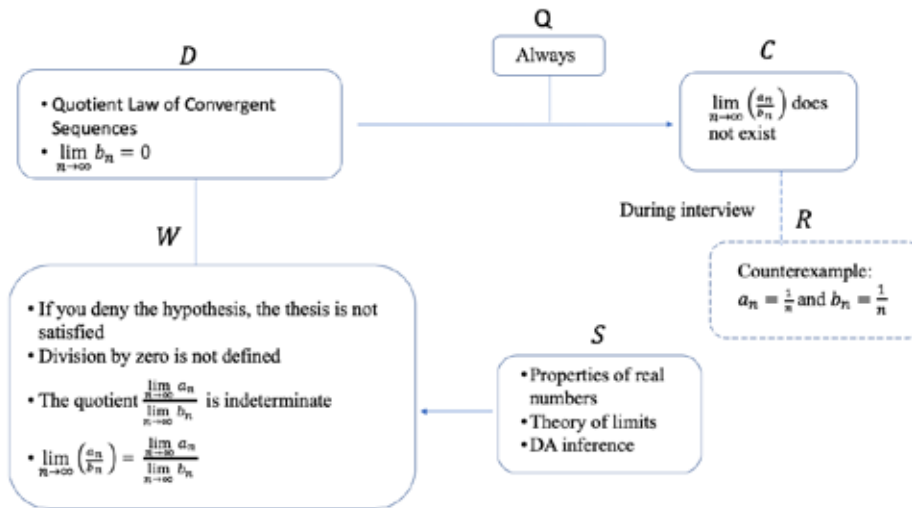


Figure 3: TAP of student A, who identified the incorrect type of reasoning

The interview

During the interview, student A was asked to calculate $\lim_{n \rightarrow \infty} \frac{a_n}{b_n}$, where $a_n = b_n = \frac{1}{n}$.

Teacher: Please find the limit of the quotient.

Student A: But, that limit does not exist.

Teacher: Why do you think that the limit does not exist.

Student A: Well, mmm... because, $\frac{\lim_{n \rightarrow \infty} a_n}{\lim_{n \rightarrow \infty} b_n}$ is indeterminate, and $\lim_{n \rightarrow \infty} \left(\frac{a_n}{b_n} \right) = \frac{\lim_{n \rightarrow \infty} a_n}{\lim_{n \rightarrow \infty} b_n}$.

At first, student A was reluctant to calculate the limit because he was convinced that the limit did not exist (C) and (Q).

Teacher: Please try to calculate it.

Student A: Ok! oh! the limit is 1! Is the theorem wrong? Let me see...

When the student finished the calculations, he was surprised to find the existence of this one (R) and, for a moment, questioned the validity of the theorem. After the interview, the student managed to modify his reasoning and obtained the correct answer.

The main obstacle to correct reasoning was the impossibility of calculating $\frac{\lim_{n \rightarrow \infty} a_n}{\lim_{n \rightarrow \infty} b_n}$ when $\lim_{n \rightarrow \infty} b_n = 0$. That is, The student A could not distinguish between the existence of $\lim_{n \rightarrow \infty} \left(\frac{a_n}{b_n} \right)$ and the validity of the formula $\lim_{n \rightarrow \infty} \left(\frac{a_n}{b_n} \right) = \frac{\lim_{n \rightarrow \infty} a_n}{\lim_{n \rightarrow \infty} b_n}$, because he considered these expressions as equivalents.

In general, the reasoning of the majority of the students was: since $\lim_{n \rightarrow \infty} b_n = 0$, necessarily the quotient $\frac{\lim_{n \rightarrow \infty} a_n}{\lim_{n \rightarrow \infty} b_n}$ is not defined (which is correct), and therefore $\lim_{n \rightarrow \infty} \left(\frac{a_n}{b_n} \right)$ does not exist, see Figure 4.



Figure 4: Scheme of reasoning for P2

There are two flaws that stand out in the logic used by these students:

- 1) Accept the DA inference in considering certain: if $\lim_{n \rightarrow \infty} b_n = 0$, then necessarily $\lim_{n \rightarrow \infty} \left(\frac{a_n}{b_n} \right)$ does not exist.
- 2) They did not become aware that the conclusion of the theorem is a conjunction of two statements: one about the existence of $\lim_{n \rightarrow \infty} \left(\frac{a_n}{b_n} \right)$ and the other about equality $\lim_{n \rightarrow \infty} \left(\frac{a_n}{b_n} \right) = \frac{\lim_{n \rightarrow \infty} a_n}{\lim_{n \rightarrow \infty} b_n}$. Both mistakes came from the impossibility to calculate $\frac{\lim_{n \rightarrow \infty} a_n}{\lim_{n \rightarrow \infty} b_n}$, when $\lim_{n \rightarrow \infty} b_n = 0$, because students know that division by 0 is not allowed.

In terms of Guedet (2008), the acceptance of DA inference, the impossibility to calculate the quotient $\frac{\lim_{n \rightarrow \infty} a_n}{\lim_{n \rightarrow \infty} b_n}$ and the failure to identify that the conclusion of the theorem is a conjunction of two statements were the associated factors for an inadequate mathematical production.

Final considerations

Our study suggests the importance of understanding the logical structure of mathematical statements; not being aware of it can cause additional difficulties for students, especially novice students who are barely getting involved in conceptual Calculus. Not knowing such structures can lead the student to false conclusions, for example, accepting invalid DA inference, or misapplying certain theorems, i.e., inadequate mathematical production.

The types of logical inferences (MP, MT, DA and AC) have been studied extensively, especially in abstract contexts, and are known to be difficult to assimilate. Our research focused solely on DA inference and revealed that this problem is further increased when conjunctions are involved in the premise and conclusion of a conditional-type structure in a mathematical context, particularly Calculus. Although the participants were students who had successfully completed their first course in Calculus of the Mathematics career and therefore already knew and had worked on the concept of derivative, the theorem of Weierstrass and the theorem of the limit of the quotient of sequences, even after all this, it is observed that these difficulties in the management of logical structures persist in a significant number of them.

Our study suggests that, in order to promote a better understanding of the students in the contents of Calculus, it would be very useful to pay special attention to the type of logical difficulties reported here, to insist on the structures of mathematical statements, to make them explicit and to point out their scope.

References

- Attridge, N., & Inglis, M. (2013). Advanced Mathematical Study and the Development of Conditional Reasoning Skills. *PLoS ONE*, 8(7). doi.org/10.1371/journal.pone.0069399
- Evans, J. St. B. T., Handley, S. J., Neilens, H., & Over, D. E. (2007). Thinking about conditionals: A study of individual differences. *Memory & Cognition*, 35(7), 1772–1784.
- Gueudet, G. (2008). Investigating the secondary–tertiary transition. *Educational Studies in Mathematics*, 67(3), 237–254.
- Hoyles, C., & Küchemann, D. (2002). Students’ understanding of logical implication. *Educational Studies in Mathematics*, 51(3), 193–223.
- Inglis, M., & Simpson, A. (2008). Conditional inference and advanced mathematical study. *Educational Studies in Mathematics*, 67, 187–204.
- Kajander, A., & Lovric, M. (2018). “It Does Not Exist”: Infinity and Division by Zero in the Ontario Mathematics Curriculum. *Canadian Journal of Science, Mathematics and Technology Education*, 18(2), 154–163. <https://doi.org/10.1007/s42330-018-0012-5>
- Pedemonte, B. (2007). How can the relationship between argumentation and proof be analysed? *Educational Studies in Mathematics*, 66, 23–4. doi: 10.1007/s10649-006-9057-x
- Simpson, A. (2015). The anatomy of a mathematical proof: Implications for analyses with Toulmin’s scheme. *Educational Studies in Mathematics*, 90, 1–17. doi: 10.1007/s10649-015-9616-0
- Stylianides, A. J., Stylianides, G. J., & Philippou, G. N. (2004). Undergraduate Students’ understanding of the contraposition equivalence rule in symbolic and verbal contexts. *Educational Studies in Mathematics*, 55, 133–162.
- Toulmin, S. E. (2003). *The Uses of Argument*. Cambridge, U.K.: Cambridge University Press.
- Tsamir, P., & Sheffer, R. (2000). Concrete and Formal Arguments: The Case of Division by Zero. *Mathematics Education Research Journal*, 12(2), 92–106. doi:10.1007/BF03217078
- Zazkis, D., Weber, K., & Mejía-Ramos, J. (2016). Bridging the gap between graphical arguments and verbal-symbolic proofs in a real analysis context. *Educational Studies in Mathematics*, 93(2), 155–173. doi: 10.1007/s10649-016-9698-3

The VEMINT-Test: Underlying Design Principles and Empirical Validation

Reinhard Hochmuth¹, Marcel Schaub², Andreas Seifert³, Regina Bruder² and Rolf Biehler³

¹Leibniz University Hannover, Germany ²Technical University of Darmstadt, Germany ³University of Paderborn, Germany; hochmuth@idmp.uni-hannover.de

VEMINT (Virtual Entrance Tutorial for the STEM subjects), a joint project by researchers from the universities of Darmstadt, Kassel, Paderborn and Hannover, has worked on material and course-designs for bridging courses for more than 15 years. In recent years, VEMINT has focused on the development of a psychometrically validated test to provide students with appropriate hints for the use of material and to evaluate the impact of teaching and learning activities. In this paper, we present elements of the test, which are based on ideas from Feldt-Caesar (2017), who combined cognitive activity and action control theoretical approaches in the development of a three-dimensional competence structure model, and on Anthropological Theory of Didactics, to explain content-related differences between dimensions of the model. Validating Rasch-analyses show that, in accordance with the design ideas, a three-dimensional Rasch-model fits with empirical data.

Keywords: Bridging course, diagnosis, transition, calculus, Rasch-Analysis

Introduction

The average dropout rates of mathematics and engineering programs in universities in Germany are 47% and 36%, respectively (Bildungsberichterstattung, 2014). These rates are higher than the overall average drop-out rate which is 33% for all study programs at German universities. In addition to the lack of acquisition of key competences such as the ability and willingness for self-reflection and self-motivation (Hilgert, 2016), the literature (e.g., Cramer & Walcher, 2010) highlights that the lack of prior mathematical school knowledge is one of the major reasons for the high proportion of dropouts.

As a measure to reduce the number of dropouts, most universities and higher education institutes have offered mathematical remedial activities in the form of bridging courses to support students' learning of university mathematics in recent years. The idea is to reduce the gap between school and university mathematics while maintaining the standards of the programs. One of the major challenges is to design remedial bridging courses that are sensitive to individual needs. For example, while some of the students need more support in simplifications of algebraic expressions, other students may need support in elementary calculus. It is also important for the students to know what prior knowledge is needed to take the courses at the university. To support students in deciding which of the modules of the bridging course to take, it is desirable to have an appropriate diagnostic tool available. Such tool should also measure the impact of bridging courses. A substantial content analysis is essential in order to provide detailed feedback to individual learners and advice to lecturers in choosing topics and in deciding how intensely topics should be taught in transition courses (Biehler & Hochmuth, 2017; Hochmuth, 2018). For more than 15 years, the universities of Darmstadt, and recently also Hannover, Kassel, and Paderborn, have been offering bridging courses in the cooperative project Virtual Entrance Tutorial for STEM subjects (VEMINT,

STEM in German is MINT) for students who wish to pursue mathematics-related programs (Bausch et al., 2014; Fischer, 2014). In recent years, the authors have also worked on developing a diagnostic test, the VEMINT-test, which is the focus of this paper.

The structure of the paper is as follows. After sketching the main goals of the VEMINT-test, we outline basic ideas of the competence structure model that underlies our test design and provide a briefpraxeological content analysis of tasks assigned to the dimensions of the model. Finally, we present results from a Rasch-Analysis empirically validating the three dimensions of the competence structure model.

The Development of the VEMINT-Test

The development of the VEMINT-test follows two partly opposing, goals: While working as a diagnostic test to understand better students' prior knowledge and gaps, it should also help to evaluate the impact of bridging courses. In addition, the pre-test needs to give information in a short time so students can decide what modules they need to take in the bridging course. In recent years, the diagnostic test has been refined several times based on both empirical and theoretical findings. Thereby, our main aim was to develop a standardized diagnostic instrument in two essentially equivalent versions (Form A and Form B), which can be used every year at the beginning and at the end of a bridging course. An expert rating determined the particular content of the test, which focused on analysis and elementary algebra and took into account the German minimum standard requirements (see, Cooperation Schule Hochschule, 2014). The items were adjusted according to quality criteria for tests and technical possibilities (e.g., the use of the Moodle STACK plug-in, Sangwin, 2007).

The final test in two forms (A and B) was designed for 60 minutes and comprised 22 tasks from secondary levels I and II in German schools. The examined topics are algebraic terms, equations, functions and calculus (differentiation and integration). The test was developed using a three-dimensional competence structure model that will be described next. Afterwards we present results from a Rasch-Analysis, considering data that has been collected in the winter semester of 2017/2018. These results empirically reproduce the three-dimensional structure, thus validating our test-design in this respect.

A Competence Structure Model and its Dimensions

The competence structure model is based on the idea of “Basic Mathematical Knowledge” (BMK), which has been introduced by Feldt-Caesar (2017) as follows:

Basic mathematical knowledge and skills refer to the mathematical knowledge, skills and abilities which are to be retrievable to all pupils at the end of the two secondary levels in the form of mathematical terms, theorems and procedures in the long term and independently of the situation, i.e. in particular without the use of aids. (Our translation, p. 182)

BMK serves “as a prerequisite for successful further learning, especially in a course of study” (our translation, p. 180), which requires that knowledge be sustainable and connected in the sense of “intelligent knowledge” (Feldt-Caesar, 2017; Weinert, 2000) and, furthermore, transferable and connectable with new content (Feldt-Caesar, 2017; Nitsch Bruder & Kelava, 2016). For related

diagnostic and feedback goals these ideas imply that items of a test should cover not only calculus-oriented tasks but should also aim at “intelligent knowledge” and “understanding oriented knowledge” where the latter is not the same as “understanding.” We agree with Skemp (1976) that no “understanding,” neither instrumental nor relational understanding, is validly testable without additional intersubjective interactions. On the other hand, “understanding oriented knowledge” including knowledge necessary for “relational understanding” beyond knowledge necessary for “instrumental knowledge” is an important basis for further learning (Bruder, Feldt-Caesar, Pallack, Pinkernell & Wynands, 2015; Skemp, 1976). These general underlying goals call for a sample of tasks which cover various qualitative facets of knowledge and associated mental activities. Moreover the sample should be helpful both in regards to diagnostic and evaluation goals as well as for providing appropriate feedback. To cover and operationalize the idea of such different qualitative facets we have developed a three-dimensional competence structure model on the basis of ideas from Feldt-Caesar (2017) and applied Anthropological Theory of Didactics (ATD, Chevallard, 1992)) for the content analysis of tasks.

In Feldt-Caesar (2017), cognitive, activity and action control theoretical approaches are combined to describe and analyze mental activities with respect to five conceptual levels. Within our context, the levels “elementary actions,” including identification and realization, and “basic actions,” including recognizing, describing, linking, applying and justifying, are important. In Feldt-Caesar (2017), both types of actions have been related to the so-called “content elements” that are conceptualized in terms, theorems, and procedures. In view of our focus on analyzing test tasks within the institutional context of the transition from school to university mathematics, it turned out that a praxeological view on “content elements” was probably more appropriate for the current project.

Accordingly, in the following we apply a few basic praxeological notions from ATD: The simplified [P, L]-model with P representing the praxeological block (i.e., the technical aspect(s) connected to a type of task and) with L representing the technological-theoretical block. The latter covers in particular: describing a technique, validating (e.g., proving or justifying how and that a technique works), knowledge about the efficiency and motives of a technique as well as knowledge about variants and simplifications, and finally, knowledge required or useful for controlling the application of a technique, which is particularly relevant for connecting practices and praxeologies. Our starting point for the identification of P and L lies in the single tasks of the test, curricula school books and in the VEMINT group consented experiences concerning the actual implementation and institutionalization of praxeologies and corresponding technical and technological aspects of school mathematics. There are, of course, further relations between above mentioned cognitive notions like “instrumental” and “relational understanding”: From the viewpoint of knowledge and meaning structures, they can be referred to qualitative differences in relationships between practical and technological-theoretical blocks of one or several praxeologies. A more detailed analysis of such issues, however, lies beyond the scope of this paper. Here, the praxeological notions mainly serve as a tool for describing and analyzing qualitative aspects of “content elements” with regard to the three dimensions of the competence structure model.

Dimension I (which is associated to instrumental understanding) is characterized by elementary

actions and cognitive operations such as identification and realization, and usually refer to a content element that does not have to be transferred to other content elements. The actions to be taken consist of a single step and are related to a “first elementary level” of mental activities in Feldt-Caesar (2017). Content-wise and in praxeological terms, Dimension I covers tasks from school that can be solved by techniques without especially taking into account technological aspects like supporting argumentations, proofs, or contextual embedding, etc. The techniques in Dimension I tasks are more or less extensively institutionalized in school mathematics, represent typical tasks of school examinations, and, at least partly, also appear in final exams (e.g., baccalaureates). A characteristic task in the test is the calculation of the derivative of $\sqrt{(3 - x^2)^6}$. It can be calculated by algebraic operations that can be executed without referring to basic rules and notions. This kind of tasks, focusing on techniques without links to technologies and supporting mathematical organizations, seems to be dominant in school internationally (e.g., Barbé, Bosch, Espinoza & Gascón, 2005).

In Dimension II, the one-step approach is maintained but a linking to content elements of the same

A polynomial function f fulfils the following properties: f'' is negative for $x < 4$ and positive for $x > 4$. Which of the graphs belongs to f ?

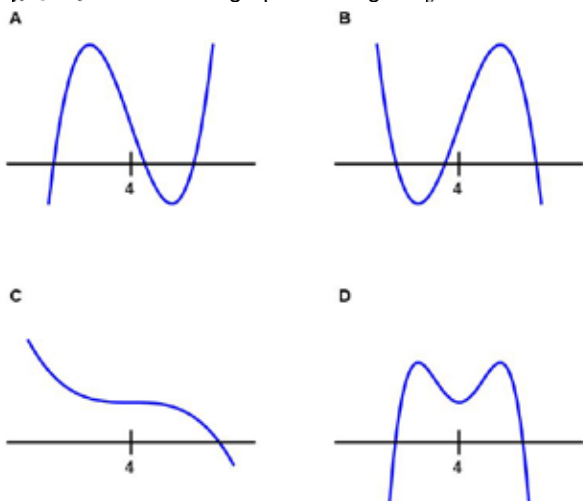


Figure 1: Example for a task of dimension II

Moreover, in the school context, this type of tasks typically demands verbal descriptions or even verbal justifications. A further common aspect of Dimension II tasks is that the technological aspects need no additional validation, for example by linking to technological aspects of praxeologies living in other domains; hence they are of a local nature. Figure 1 presents an example for a Dimension II task. It is expected that to solve this task students use relationships between verbal, graphical, and symbolic representations and switch across those representations. In order to solve the task, the second derivative is to be interpreted as the curvature of the function f . What is unusual about this task is that the values of the second derivative are given and, conversely, a function f must be reconstructed based on the given information.

Dimension III tasks are multi-step tasks, and characterized by several elementary actions and cognitive operations (associated to “intelligent knowledge”). The tasks refer to content elements

from at least two different content areas. Thus, solving of Dimension III tasks combines techniques from different praxeologies; the techniques involved are often more complex, or the technological aspects relevant for the combination of the techniques are either weakly established or combine aspects of different praxeologies. A task of this type, that combines techniques and is well-established in school, looks as follows (Feldt-Caesar, 2017): “The function f is given by $f(x) = x^2 - 7$. Determine the equation of the tangent t , which touches the graph of the function f at the point $P(-2, 1)$.” In this task, content elements of differential calculus must be linked and the results of the differential calculus must be used to establish a linear function (equation of a tangent). Thus, both content from secondary level I and secondary level II must be applied. Another task (item 13) of Dimension III is the following: “Simplify the following expression and collect the variables $\left[\frac{x^{k-n}}{y^{2n}} : \frac{x^{2k-n}}{y^{n-1}} (x, y \neq 0) \right]$.” In this task, the required combination of techniques from division of fractions and power calculations is nested; in addition, related technological aspects have to be combined in an appropriate way. This means that it is not enough to apply simple and local techniques from different domains. Content-wise, the main characteristic of Dimension III tasks is the link of different techniques and technologies, which is as such not well-institutionalized in school mathematics.¹

Rasch-Analysis

Roughly one half of 362 students from three German universities who participated in bridging-courses (29% female) filled out test-form A before and test-form B after the courses. The other half took the opposite order. No sequence effects were found. Each participant received each test-form only once, and, although pre- and posttest samples were related (both samples consisted of the same participants), the occurrence of test-effects is not plausible. Using pre- and posttest samples in one analysis reduces the probability of the occurrence (respectively the effect) of a possible limitation of variance, which can lead to a possible underestimation of all correlational measures and possibly limiting the information value of assertions regarding validity. Participants were tested before and after a bridging course and therefore were not on the same performance level at both times of measurement.

To scale the data, we first estimated two one-dimensional Rasch-models, one for each measurement point. A Rasch-model is a probabilistic psychometrical model for generating measurements from categorical data (e.g., right/wrong-answers in a performance test) as a function

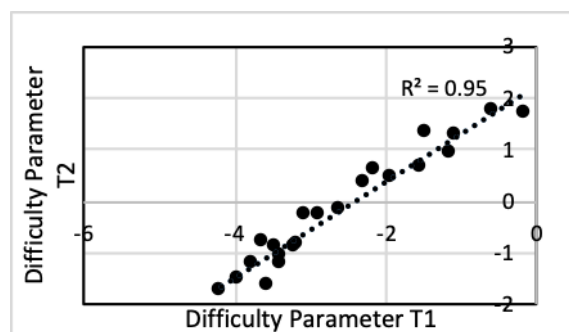


Figure 2: Scatterplot of the rank of difficulty

measurements from categorical data (e.g., right/wrong-answers in a performance test) as a function

¹ It should be noted that assigning tasks to a single of the dimensions is not always possible due to different possible solutions of a task. For the classification, several possible solutions were anticipated and the most probable one was used to determine the dimension. Analyses of some of our test tasks can be found in Feldt-Caesar (2017), which investigates validation issues.

of the relation between the ability of the respondents and the item difficulty (Rasch, 1980). EAP/PV-reliabilities were suitable, $R = .868$ (resp. $.865$ for Model 2), as well as the variances, $V = 2.256$ (resp. 1.967 for Model 2). Figure 2 shows the

scatterplot of the rank of the difficulty parameters. Most importantly, the correlation of the difficulty parameters is high, $R^2 = .95$. For this reason, measurement invariance can be assumed.

Because of the high correlation between both measurement points, the approach of virtual cases could be applied (see Hartig & Kühnbach, 2005; Rost, 1996). If a participant took part at both measurement points, he or she represents two cases in the data. This approach has two advantages: Firstly, resulting scores are in a consistent metric and secondly, the appearance of the problem of constrained variance is less likely (see above). With this approach, a data set of 724 cases resulted. Again, a one-dimensional model was calculated but also a three-dimensional model consisting of the three performance levels described before. Results are shown in Table 1. Both models show good variances and EAP/PV-reliabilities as well as discrimination indices.. The three-dimensional model shows significantly less deviance than the one-dimensional model ($p < .001$), so it fits the data better.² Figure 3 shows the wright-map of the three-dimensional model. Thus, the Rasch-analysis empirically confirmed the three-dimensional structure of the test.

Dimensionality	One-dimensional	Three-dimensional		
		I	II	III
Performance Level				
Number of tasks	22	8	10	4
Variance	2.216	2.346	1.963	3.661
EAP-PV-Reliability	.872	.868	.856	.842
Weighted MNSQ	.86-1.32	.92-1.12	.83-1.24	.93-1.06
Discrimination Indices	.36-.69	.52-.68	.39-.71	.69-.73
Deviance	16293.17612	16258.04687		
Estimated Parameters	44	31		
Difference Deviance	35.12925			
Difference Parameters	5			
Sig. (χ^2 -Difference-Test)	< .001			

Note: EAP/PV-Reliability – Expected-A-Priori / Plausible-Values-Reliability (see Rost, 1996)

Table 1: Results of the Rasch-Analysis

The order of tasks within the dimensions could be understood as a consequence of how intensively and how often (regarding different classes, schools etc.) the tasks are practiced; the order could hardly be deduced by theoretical considerations alone. In accordance with our content analysis, Dimension II in fact includes tasks which need conversions between different representations of a function, even if these tasks are not unfamiliar. The task in Figure 1 is even rated as a rather difficult one within Dimension II in the Rasch model. Within Dimension III, besides the degree of institutionalization and the time of treatment of indicated techniques in school,

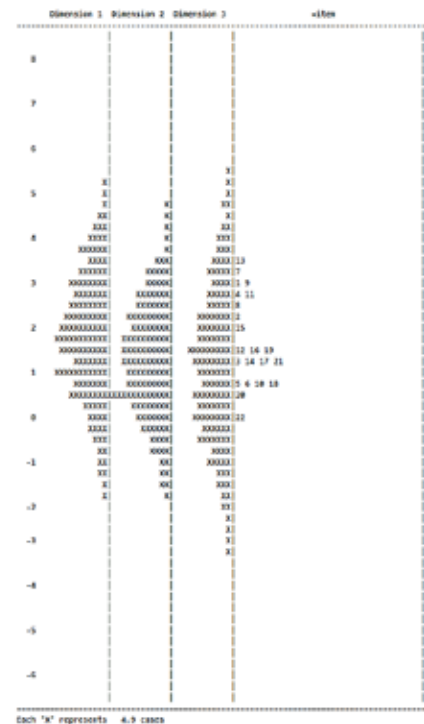


Figure 3: Wright-map of the 3D

² One item (Item 3) shows a weighted MNSQ larger than 1.2 (values should lie in the range of $0.8 < \text{MNSQ} < 1.2$). This is not too problematic for all other indices perform very well.

the praxeological interconnectedness seems to be reflected in the order of tasks (items 3, 7, 10, 11, 12, 13, 15, 18, 20, 22). It is perhaps a little bit surprising that the complex term transformation task (item 13) turned out to be the most challenging task of Dimension III.

Discussion

The main aim of bridging courses is to support students by providing learning materials and samples of tasks for their self-evaluation. From the design of material and courses as well as the point of view of teaching, specific test instruments are required for a possibly objective evaluation of the impact of support measures. The test instruments should be most sensitive for specific mathematical knowledge domains and should allow relating pre-post-comparisons to specifics of bridging courses in order to adopt courses in view of actual pre-test results. Our results show that our test takes into account qualitatively different knowledge dimensions and might be a valuable tool for reaching these goals, which, of course, needs further investigations.

References

- Barbé, J., Bosch, M., Espinoza, L., & Gascón, J. (2005). Didactic restrictions on the teacher's practice: The case of limits of functions in Spanish High Schools. *Educational Studies in Mathematics*, 59 (1/3), 235–268.
- Bausch, I., Biehler, R., Bruder, R., Hochmuth, R., Koepf, W., Fischer, P.R., & Wassong, T. (2014). VEMINT– Interaktives Lernmaterial für mathematische Vor- und Brückenkurse [Interactive learning material for mathematics pre- and bridging-courses]. In I. Bausch, R. Biehler, R. Bruder, P.R. Fischer, R. Hochmuth, W. Koepf, S. Schreiber, & T. Wassong (Eds.), *Mathematische Vor- und Brückenkurse* [Mathematics pre- and bridging-courses] (pp. 261-276). Wiesbaden: Springer Spektrum.
- Biehler, R., & Hochmuth, R. (2017). Relating different mathematical praxeologies as a challenge for designing mathematical content for bridging courses. In R. Göller, R. Biehler, R. Hochmuth, H.-G. Rück (Eds.), *Didactics of mathematics in higher education as a scientific discipline Conference proceedings. Khdm-Report 17-05* (pp. 14-20). Kassel: Universität Kassel.
- Bruder, R., Feldt-Caesar, N., Pallack, A., Pinkernell, G., & Wynands, A. (2015). Mathematisches Grundwissen und Grundkönnen in der Sekundarstufe II [Basics in mathematics in secondary education]. In W. Blum (Eds.), *Bildungsstandards aktuell: Mathematik in der Sekundarstufe II* [Education standards: Mathematics in secondary education] (pp. 108–124). Braunschweig: Schrödel.
- Bildungsberichterstattung (2014). *Bildung in Deutschland 2014* [Education in Germany 2014]. Bielefeld: W. Bertelsmann Verlag.
- Chevallard, Y. (1992). Fundamental concepts in didactics: Perspectives provided by an anthropological approach. In R. Douady & A. Mercier (Eds.), *Research in didactic of mathematics, selected papers* (pp. 131–167). Grenoble: La Pensée Sauvage.
- Cooperation Schule Hochschule (2014). *Mindestanforderungskatalog Mathematik* [Minimum requirements of mathematics] (version 2.0). Retrieved from: https://www.hs-karlsruhe.de/fileadmin/hska/SCSL/Lehre/mak V2.0B_ohne_Leerseiten.pdf.
- Cramer, E., & Walcher, S. (2010). Schulmathematik und Studierfähigkeit [School mathematics and

- academic achievement]. *Mitteilungen der DMV*, 18(2), 110-114.
- Feldt-Caesar, N. (2017). *Konzeptualisierung und Diagnose von mathematischem Grundwissen und Grundkönnen. Eine theoretische Betrachtung und exemplarische Konkretisierung am Ende der Sekundarstufe II* [Concepts and diagnosis of basics in mathematics. A theoretical perspective and specification at the end of secondary education]. Wiesbaden: Springer.
- Fischer, P. R. (2014). *Mathematische Vorkurse im Blended-Learning-Format: Konstruktion, Implementation und wissenschaftliche Evaluation* [Mathematics preparation courses in blended-learning-format: construction, implementation and scientific evaluation]. Wiesbaden: Springer.
- Hartig, J., & Kühnbach, O. (2006). Schätzung von Veränderung mit „plausible values“ in mehrdimensionalen Rasch-Modellen [Estimation of variables with “plausible values“ in multidimensional Rasch-models]. In A. Ittel & H. Merckens (Eds.), *Veränderungsmessung und Längsschnittstudien in der empirischen Erziehungswissenschaft* [Measurement of change and longitudinal studies in empirical educational studies] (pp. 27-44). VS Verlag für Sozialwissenschaften.
- Hilgert, J. (2016). Schwierigkeiten beim Übergang von Schule zu Hochschule im zeitlichen Vergleich—Ein Blick auf Defizite beim Erwerb von Schlüsselkompetenzen [Difficulties in the transition from school to high school in a time comparison—a view to deficits of acquisition of key-competences]. In A. Hoppenbrock, R. Biehler, R. Hochmuth, & H.-G. Rück (Eds.), *Lehren und Lernen von Mathematik in der Studieneingangsphase* [Teaching and learning of mathematics during the introductory phase] (pp. 695-709). Wiesbaden: Springer.
- Hochmuth, R. (2018). *A general scheme for a heterogeneous manifold of transitions*. Paper presented at the 6th International Congress of Anthropological Theory of Didactics, Grenoble (22nd -26th Jan. 2018).
- Neumann, I., Pigge, C., & Heinze, A. (2017). *Welche mathematischen Lernvoraussetzungen erwarten Hochschullehrende für ein MINT-Studium* [Which mathematical learning requirements do university lecturers expect for STEM-courses]? Institut für die Pädagogik der Naturwissenschaften Kiel. Retrieved from https://www.telekom-stiftung.de/sites/default/files/malemint_broschure_langfassung2.pdf
- Nitsch, R., Bruder, R., & Kelava, A. (2016). Schülerhandlungen als Elemente fachdidaktisch motivierter Kompetenzmodellierungen [Student's performance as elements of didactically motivated competence modelling]. *Journal für Mathematik-Didaktik*, 37(2), 289-317.
- Rasch, G. (1980). *Probabilistic models for some intelligence and attainment tests* (expanded edition). Chicago: The University of Chicago Press.
- Rost, J. (1996). *Lehrbuch Testtheorie, Testkonstruktion* [Textbook test theory, test construction]. Bern: H. Huber.
- Sangwin, C. (2007). *Computer aided assessment of mathematics*. Oxford: Oxford University Press.
- Skemp, R. R. (1976). Relational understanding and instrumental understanding. *Mathematics Teaching*, 77 (1), 20-26.
- Weinert, F. E. (2000). Lehren und Lernen für die Zukunft-Ansprüche an das Lernen in der Schule [Teaching and learning for future requirements to learning in school]. *Rheinland-Pfälzische Schule*, 12, 240-246.

An exploration of the relationship between continuous assessment and resource use in a service mathematics module

Emma Howard¹, Maria Meehan¹ and Andrew Parnell^{2,3}

¹School of Mathematics and Statistics, University College Dublin, Dublin, Ireland;
emma.howard@ucdconnect.ie; maria.meehan@ucd.ie

²Hamilton Institute, Maynooth University, Ireland; andrew.parnell@mu.ie

³Insight Centre for Data Analytics, Ireland

Previous research has shown that students' use of module resources strongly relates to the timing of the module's continuous assessment. In our case study of a large first-year mathematics module for Business students, Maths for Business, we examine this relationship and the resources relied on by students for completing their continuous assessment. In Maths for Business, students have the choice of using live lectures or online videos or a combination of both. We find that students who incorporate lectures into their approach engage consistently throughout each week with module resources, while others adopt a just-in-time approach for each weekly quiz. We also show that the introduction of remediation of quizzes can boost participation with resources, in particular feedback resources.

Keywords: Continuous assessment, student participation, remediation, undergraduate mathematics, service mathematics.

Introduction

Research shows that student engagement in a module is strongly related to the timing of assessment (Rust, 2002; Marriott & Lau, 2008; Holmes, 2018). In this study, we focus on this relationship in a service mathematics module, showing that through module design which includes frequent continuous assessment, students can be encouraged to consistently access resources both prior to, and post assessment (through feedback). While this relationship seems evident, we analyse electronic data to demonstrate it. To this effect, we analyse resource usage in a large first-year undergraduate module entitled *Maths for Business* (based on the 2015/16 student cohort). Continuous assessment is an integral component of *Maths for Business*, with 40% of the final module mark designated to a student's best eight (out of ten) weekly quizzes. We investigate which resources students access when preparing for the assessment; and when specific resources (lectures, online videos, worksheets, Maths Support Centre and quiz solutions) are accessed; and, whether the approach taken relates to a surface or a deep learning approach to learning (Rust, 2002).

While some research focuses on resource usage in preparation for continuous assessment (Holmes, 2018), we also wish to investigate the relationship specifically with feedback resources. In 2016/17, we introduced a 'remediation system' whereby students who did not receive the full five marks on their weekly quiz, had the opportunity to resubmit their quiz one week later with an explanation of their error(s) and corrections for one additional mark. We examine how the introduction of the remediation system increased students use of feedback resources. Subsequently our research questions are:

1. In *Maths for Business*, what is the relationship between the timing of continuous assessment and module resource usage?
2. In *Maths for Business*, what resources do students access when preparing for their continuous assessment?
3. Is there a relationship between students' choice of resource and their learning approach?
4. Through incentivising remediation, can students be encouraged to access module resources?

Unlike our prior work on *Maths for Business* (Howard, Meehan, & Parnell, 2018; Howard, Meehan, & Parnell, 2019), this study focuses on examining resource usage in the context of the timing of continuous assessment, rather than the reason behind students' choice of module content resources (Howard et al., 2018), or, whether the remediation system benefitted students based on their end-of-semester examination (Howard et al., 2019).

Theoretical Framework and Related Literature

Engagement and participation

In educational literature (Fredricks, Blumenfeld, & Paris, 2004), student engagement is considered under three sub-themes or constructs: behavioural, cognitive and emotional. Behavioural engagement (Fredricks et al., 2004) encompasses positive student conduct and participation or on-task behaviour for example effort, persistence, concentration, attention, asking questions, and contributing to class discussion. Fredricks et al. (2004) note there is a difference between active and passive behaviour. In this study, we refer to participation as the interaction students have with resources which is measured by log or attendance data. When we consider students' participation or resource usage, we are considering a narrow, limited definition or application of behavioural engagement.

Continuous assessment and engagement

Holmes (2018) argues for the importance of student engagement owing to its relationship with student satisfaction and the quality of the student experience. Her research aims to improve the student experience by influencing the relationship between resource-use and assessment. Holmes (2018) shows that the introduction of frequent low-stakes assessment leads to a consistent increase in the use of online resources in a university geography module. This particularly benefits students with "weaker" prior knowledge in a module, as research suggests that they benefit more from participation with resources than their peers (Nordmann, Calder, Bishop, Irwin, & Comber, 2018). Marriott and Lau (2008), and the references within, argue that assessment is the main variable in accounting for how students approach their learning. Rust (2002) expands on this relationship, by noting that students will study the content or resources that they believe will be examined. Anastasakis (2018) uses activity theory to explore in detail engineering and mathematics undergraduates' resource-use. Anastasakis (2018) found that assessment rules were the main regulator of students' use of resources. Other, less significant factors included: students themselves including their learning preferences, degree and year of study; resources' usability; the level, nature and familiarity of the mathematics; and, lecturers and past members of students' community. In addition to encouraging pre-assessment resource usage, continuous assessment can also encourage engagement through the feedback provided for assessment.

Alternative to examining students' specific resource-use, one could consider whether students take a surface or deep learning approach to learning. A surface approach is often associated with rote learning and extrinsic motivation, whereas a deep approach is associated with learning for understanding and intrinsic motivation. Biggs, Kember, and Leung (2001) presents a survey to examine these approaches, the 'Revised Two Factor Study Process Questionnaire: R-SPQ-2F'. Trenholm et al. (2019) used the R-SPQ-2F to examine learning approaches in two mathematics modules where students had the option of attending lectures or/and viewing recorded lecture videos. Despite the modules being located in different universities, they found in both cases that a decrease in live lecture attendance combined with regular use of the recordings was associated with an increase in surface approaches to learning.

Module Context

Maths for Business is a large first-year undergraduate module with approximately 500 business students enrolled annually. In *Maths for Business*, students have the choice of completing the module material by attending approximately 32 live lectures or watching 67 online videos or a combination of both. Each short video (average length of 7.5 minutes) was designed and created by the lecturer – second author of the paper. These videos were created using the *Explain Everything* app (<https://explaineverything.com/>), and consisted of the lecturer writing on “skeleton” slides while explaining the topic. Students also have access to the Maths Support Centres (the university drop-in centre and a dedicated module drop-in centre). All resources in *Maths for Business* – worksheets, lectures or online videos – list the specific learning outcomes which they address. The module is examined through an end-of-semester written 2-hour examination and ten weekly quizzes. These contribute 60% and 40% respectively towards a student's final mark. Students best eight (out of ten) quizzes contribute 5% each to the continuous assessment mark of 40%. From week three of the twelve-week teaching semester, all students sit the weekly quizzes on Tuesdays under the supervision of a teaching assistant. Further detail on the module can be found in Howard et al. (2018). Between 2015/16 and 2016/17, there were no changes to the learning outcomes of the module. While the content and aims remained the same, the quizzes were changed to ensure students did not copy from the prior year's quizzes.

Date	Oral feedback by TA for quiz	Quiz completed	Quiz returned	Remediated quiz submitted	Feedback resources made available
27 th of September	-	1	-	-	-
4 th of October	1	2	1	-	Quiz 1 pdf & video solutions
11 th of October	2	3	2	1	Quiz 2 pdf & video solutions

Table 1: Example of the remediation timeframe

In *Maths for Business* in 2016/17, a 'remediation system' was introduced (Howard et al., 2019). In the remediation system, any student who did not receive the full five marks on a quiz, had the

opportunity to resubmit their quiz with corrections and an explanation of their error(s) for one additional mark. Table 1 provides an example of the remediation time-frame. Both the pdf and video solutions highlighted relevant video resources for the quiz questions. Owing to the fortnightly remediation cycle, students only had the opportunity to remediate the first eight quizzes. Students were encouraged to use the Maths Support Centre for help with their remediation, particularly students who received a low score on their quiz.

Data Collection and Analysis

We use a case study approach as we are not controlling the behavioural approaches of students and it allows for a mixed method approach. The case study approach allows for the examination of the real-life relationship between continuous assessment and resource usage in the context of *Maths for Business*. In accordance with our permission from the UCD Ethics Committee, for two years of *Maths for Business*, we collected students' lecture attendance, log data for online resources, Maths Support Centre attendance, Irish post-primary terminal mathematics examination grade (as an indicator of prior mathematics learning) and marks in the module. In total, there were 522 students in 2015/16 and 480 students in 2016/17. In addition, a survey that included the 'Revised Two Factor Study Process Questionnaire: R-SPQ-2F' (Biggs et al., 2001) was distributed to the 2015/16 cohort at the end of the teaching semester. We received 161 survey responses. For this paper, we are examining the results from the 'R-SPQ-2F' and one open-ended question from the survey, "How do you study for the weekly quiz, making specific reference to the resources you use (online videos, lecture slides, external sources, friends, worksheets, class notes, Monday drop-in session, Maths Support Centre)?" These survey results are beyond our prior research (Howard et al., 2018).

To examine the time dynamic between continuous assessment and resource usage, we use descriptive statistics in the form of graphs. We do not include resource usage data relating to the revision and examination period of the semester (prior to the end-of-semester examination) as the number of views increases substantially during this time as expected. To analyse the open-ended survey question on which resources are used in studying, we use thematic analysis (Braun & Clarke, 2006).

Results

RQ1: What is the relationship between continuous assessment and module resource usage?

Based on the 2015/16 cohort, analysis of the video views shows that students access videos prior to the weekly Tuesday continuous assessment (on Monday and Tuesday). Similarly, students mainly access the worksheets and Maths Support Centre prior to the weekly quiz. Alternatively, we could investigate the timing of resources based on a finer scale which considers students' main content resources. If we classify students according to their use of live lectures or online videos or combination of both (see Howard et al. (2018) for details of the classification by clustering analysis), we have four distinct groups: Dual-Users, Lecture-Users, Video-Users and Switchers. Switchers either start the semester predominantly using lectures and progress to predominantly using videos or choose between videos and lectures for content based on the timing of a lecture. Lecture-Users and Video-Users predominantly use lectures and videos respectively, while Dual-Users use both lectures and videos to review the same material. Figure 1 shows the standardised number of video accesses

for each cluster over the semester (views are divided by the number of students in each cluster). When examining video accesses in relation to the time in the semester for Dual-Users, Video-Users and Switchers, the distribution is of weekly peaks prior to the continuous assessment albeit with increasing peaks for Switchers as the semester progresses. However, for Lecture-Users, this pattern is not maintained initially. As the semester progresses, the limited number of videos seem to be accessed for assessment purposes. Dual-Users, and to a lesser extent Lecture-Users, use resources throughout the semester whereas Video-Users and Switchers use them on Mondays and Tuesdays. There are limited accesses of resources once their associated quiz has occurred.

RQ2: What resources do students access when studying for their continuous assessment?

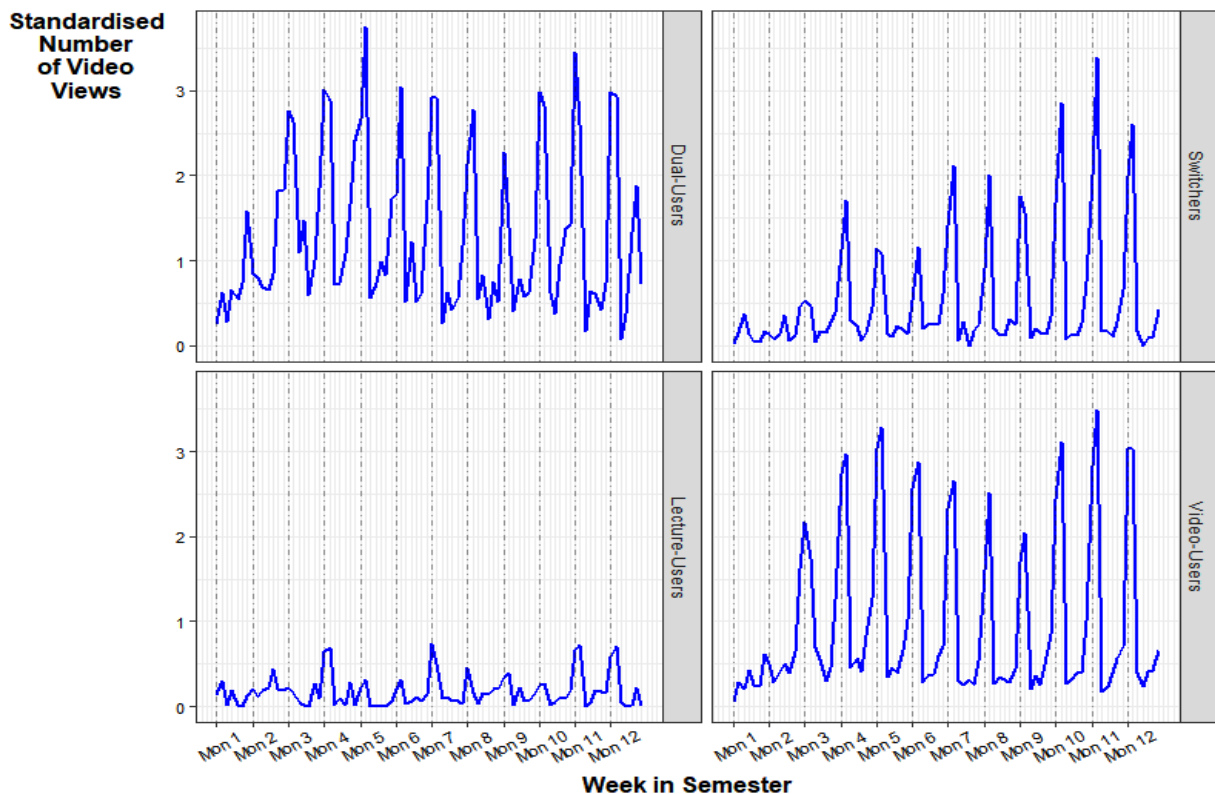


Figure 1: *Maths for Business* video accesses for 2015/16. The number of accesses for each cluster has been divided by the number of students in each cluster to allow for comparisons

Our findings from the first research question suggests a strong relationship between the time when students' access module resources and the date of the continuous assessment. After each quiz, students prepare for the next quiz rather than revising past quizzes. In order to understand the resources students use to study, towards the end of the 2015/16 semester, we asked students how they studied for the weekly quiz. From thematic analysis (Braun & Clarke, 2006) of the responses, a central and important theme identified is 'Order of Study'. Students often explained the order of their study approach using the word "then". For example, one response consisted of:

Firstly I go through all the videos and write out notes. Then I attempt the worksheet and highlight all the good examples and things that I need to remember. I then look back over the notes I took

and the completed worksheet. I went to the math support centre when I couldn't get the answer to a question.

Generally, students' study pattern for the weekly quiz fall into three stages:

Stage 1: Review the relevant module material - this is completed through videos or/and lectures. Students may also create their own notes at this stage.

Stage 2: Attempt/complete the worksheet, may refer to videos to help with the worksheet.

Stage 3: If stuck on the worksheet, seek assistance from friends and Maths Support Centre.

There are students who deviate from this, for example students who listed a single resource as their response such as worksheets or videos. Male students were more likely to list a single resource, whereas in contrast female students or Dual-Users were more likely to seek support as described in stage 3. Similarly to Figure 1, worksheets and Maths Support Centre were accessed in the days prior to the quiz. We have no data for when friends were consulted.

RQ3: Is there a relationship between student' choice of resource and their learning approach?

Using Biggs et al.'s (2001) 'R-SPQ-2F', for the 2015/16 cohort, we examined students' approaches to learning, namely surface versus deep approach. The results from the five-point Likert scale questions were summed (as outlined in Biggs et al., 2001) to extract a numerical measure for students' surface and deep approach to learning. Surprisingly, using an analysis of variance approach, there was no statistical difference between the surface and deep approach of Lecture-Users, Dual-Users, Video-Users and Switchers. Following Trenholm et al.'s (2019) methodology, we also divided users into regular or low video users using the median number of videos accessed. Upon examination, there was no difference in the learning approach of these two groups. However, Trenholm et al. (2019) measured the learning approaches of students at two points in the semester whereas we measured the learning approach at one point, the end of the semester. They found an increase in the surface approach of students who regularly used lecture-capture videos combined with lower lecture attendance. The difference in results could possibly be caused by our lack of examining learning approaches at two time points or an innate difference between lecture-capture and short-designed videos for mathematics courses or possibly owing to a difference in survey respondents as our survey respondents were biased towards higher marks in comparison to our overall population.

RQ4: Can students be encouraged to consistently use module resources?

In 2015/16 cohort, resources were accessed prior to the quizzes. In 2016/17, we introduced the remediation system where students could gain an extra mark out of five quiz marks if they resubmitted their quiz within one week of having it returned with an explanation of their error(s). While the primary motive of this was to encourage students to identify and learn from their errors in a timely manner (Howard et al., 2019), a potential side-effect was students engaging with quiz or/and feedback material post-quiz i.e. within a week after the quiz. The feedback resources provided included: the graded quizzes; oral tutor feedback; the lecturer providing a video entitled "Most Common Errors"; and, a pdf copy of the quiz solutions that also highlighted the most relevant online videos from the module. In addition, students could seek help from friends and the Maths Support Centre. We found (Howard et al., 2019) that the main resource students made use of was the pdf solutions, with limited

use of the videos and the Maths Support Centre. Upon further examination, with a focus on timing, students accessed the pdf solutions at the end of the remediation cycle i.e. prior to resubmission of their quiz. This just-in-time approach results in a similar distribution or pattern to the video accesses (Figure 1). This is in contrast to the prior year of 2015/16 as seen in Figure 2. For the teaching semester, the number of views for the pdf solutions doubled between the two cohorts (see Figure 2). Figure 2 indicates that students can be encouraged to positively participate with feedback resources.

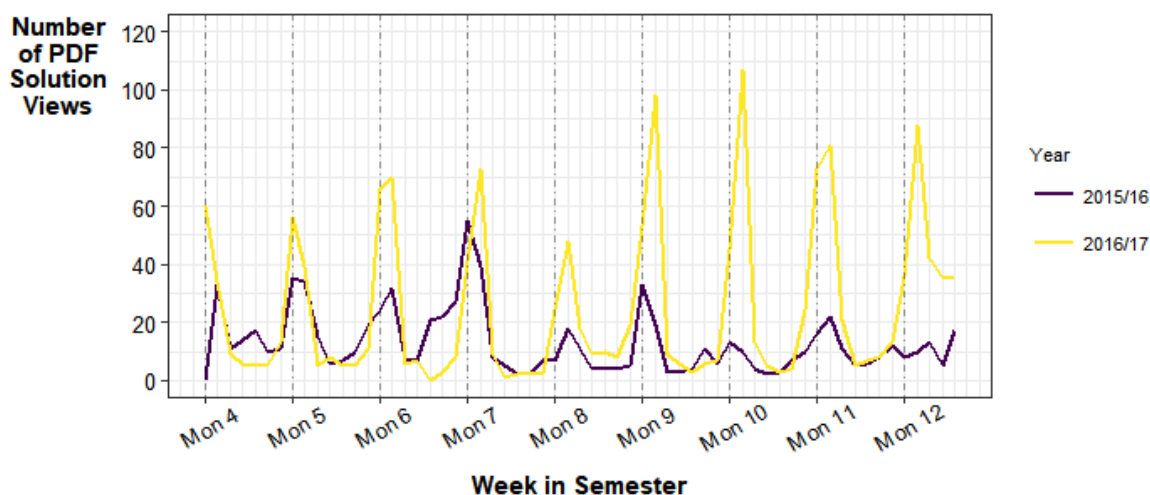


Figure 2: The number of pdf solution views for *Maths for Business* students by year and day.

Duplicate views by a student on a specific day have been removed

Discussion and Conclusion

In *Maths for Business*, we have examined resource-use in relation to its main influencer - continuous assessment. Continuous assessment is linked to students' resource use in two distinct forms: firstly, in preparation for the continuous assessment; and, secondly through students engaging with feedback on their assessment. Resources are accessed prior to the Tuesday quiz except for live lectures which are timetabled. Although the students are using a just-in-time approach, they are still accessing the resources weekly, and in that sense, consistently. The use of resources is divided into three stages or into the following order: module material review; practice questions; and, external help. While not all students will pursue each stage, females are more likely to seek external help from friends or the Maths Support Centres. For the 2016/17 cohort, a positive outcome of the remediation system was that students were encouraged to use feedback resources (pdf solutions). However, similar to preparing for the weekly quiz, a just-in-time approach was adopted for the feedback resources. As a limitation, we note that without qualitative data, we cannot confirm for what percentage of students this was the case. In comparison in 2015/16, there is no obvious distribution to viewing the pdf solutions (after the initial weeks). However, the number views are significantly lower.

In the broader context, continuous assessment can be used to encourage engagement by students and subsequently student satisfaction and the quality of the student experience (Holmes, 2018). Arguably, continuous assessment may lead to a 'study-to-the-test' approach. In Ireland, students' learning in the post-primary environment tends to be structured, leading to students struggling with the transition to becoming an independent learner at third level. *Maths for Business* is an entry-level module and the

continuous assessment within allows students to maintain some structure following the transition between education levels. Students' end-of-semester evaluations show an appreciation for the weekly quizzes and the opportunity to have module marks prior to the final examination through low-stakes assessments. This approach may not be applicable for specialist or higher-level mathematics modules. Currently, there is debate surrounding whether recorded lectures or specialised videos have a negative effect on students' learning when used as a replacement for the traditional lecture. In contrast to the current literature, we found no relationship between surface or deep learning approach and students' choice of resource. More research is needed to identify any influencing factors, for example the nature of the video, in this relationship.

References

- Anastasakis, M. (2018). *An activity theory investigation of tool-use in undergraduate mathematics*. (Doctoral dissertation, Loughborough University, United Kingdom). Retrieved from <https://dspace.lboro.ac.uk/2134/32832>.
- Biggs, J., Kember, D., & Leung, D. Y. (2001). The revised two factor study process questionnaire: R-SPQ-2F. *British Journal of Educational Psychology*, 71, 133-149.
- Braun, V., & Clarke, V. (2006). Using thematic analysis in psychology. *Qualitative Research in Psychology*, 3(2), 77-101.
- Fredricks, J. A., Blumenfeld, P. C., & Paris, A. H. (2004). School engagement: Potential of the concept, state of the evidence. *Review of Educational Research*, 74(1), 59-101.
- Holmes, N. (2018). Engaging with assessment: Increasing student engagement through continuous assessment. *Active Learning in Higher Education*, 19(1), 23-34.
- Howard, E., Meehan, M., & Parnell, A. (2018). Live lectures or online videos: Students' resource choices in a first-year university mathematics module. *International Journal of Mathematical Education in Science and Technology*, 49(4), 530-553.
- Howard, E., Meehan, M., & Parnell, A. (2019). Quantifying participation in, and the effectiveness of, remediating assessment in a university mathematics module. *Assessment and Evaluation in Higher Education*, 44(1), 97-110.
- Marriott, P., & Lau, A. (2008). The use of on-line summative assessment in an undergraduate financial accounting course. *Journal of Accounting Education*, 26, 73-90.
- Nordmann, E., Calder, C., Bishop, P., Irwin, A., & Comber, D. (2018). Turn up, tune in, don't drop out: The relationship between lecture attendance, use of lecture recordings, and achievement at different levels of study. *Higher Education*. <http://dx.doi.org/10.1007/s10734-018-0320-8>
- Rust, C. (2002). The impact of assessment on student learning. *Active Learning in Higher Education*, 3(2), 145-158.
- Trenholm, S., Hajek, B., Robinson, C. L., Chinnappan, M., Albrecht, A., & Ashman, H. (2019). Investigating undergraduate mathematics learners' cognitive engagement with recorded lecture videos. *International Journal of Mathematical Education in Science and Technology*, 50(1), 3-24.

How to assess students' learning in mathematics literacy education: An attempt to use students' comments for assessment

Mitsuru Kawazoe

Osaka Prefecture University, Japan; kawazoe@las.osakafu-u.ac.jp

Keywords: mathematics education for non-specialists, student attitude, alternative assessment

Research objective and questions.

It is increasingly important for all students, regardless of educational level, to acquire mathematical skills for use in various contexts, especially in real-world situations. An education that fosters such skills is often referred to as *mathematical literacy education*, the aim of which often includes improving students' attitudes toward mathematics and deepening their interest in the subject. This raises the question, "How can we assess the success of such courses?" Accordingly, this study focused on students' text feedback, which is a rich resource that represents students' learning and attitudes (cf. Di Martino and Zan, 2010), and examined whether students' comments could be useful in assessing their mathematical literacy learning. With this aim, this study analyzed the students' reflection comments collected during one semester. Our research questions are as follows:

(RQ1) What categories are identified in students' reflection comments?

(RQ2) Do the students' responses stem from their actual learning? Or do they instead stem from their prior learning in high school or even from their attitudes at the beginning of the course?

Two analyses on students' comments in mathematical literacy education.

A qualitative and quantitative analysis was conducted on students' comments collected during a mandatory one-semester mathematical literacy course for first-year students in social sciences and humanities majors. The course was designed as "learning mathematics through application," but the lecturer emphasized the nature of mathematical knowledge in each lesson. Students' reflections were collected over 14 weeks from an area reserved for comments on each lesson's worksheet. There were 68 first-year students in the class, and a total of 952 comments were collected. We distributed a questionnaire at the beginning of the course; before the students attended the class, we collected data on their courses in high school (science-oriented or humanities-oriented) as well as their attitude toward mathematics (good/bad at math, like/dislike math), using a five-point Likert scale.

The first analysis focused on RQ1, and an open coding method was used to determine a set of categories in order to understand how students described their learning. In the analysis, students' comments were segmented, and we assigned one code to each segment. The analysis was conducted with the help of the following three models: a three-dimensional model for attitudes toward mathematics by Di Martino and Zan (2010); the three phases of learning by Polya (1981, chapter 14); and the ICE model (Fostaty Young and Wilson, 2000), in which learning outcomes are distinguished in three levels. We found seven important categories that indicate learning progress or attitude improvement. We listed the categories with short explanations, and indicated the percentage of comments containing segments that were assigned with the codes: IA (expressing their Interest in Application, 17.1%), IM (expressing their Interest in Mathematics, 17.2%), MR (expressing their

Metacognitive Reflection, 7.9%), EL (expressing their Enjoyment of the Lesson, 7.9%), RQ (Raising Questions that extend their learning, 5.1%), MM (expressing their Motivation in using/learning Math, 8.5%), and RA (expressing their Reduced Awareness of being bad at math, 2.4%). IM and RA were regarded as being related to “vision of mathematics” and “perceived competence” in the model of Di Martino and Zan, respectively. MR was regarded as being related to a phase of “verbalization and concept” in Polya’s model and to a level of “connection” in the ICE model.

The second analysis focused on RQ2. Using statistical analysis, this study examined the codes IA, IM, and MR, and investigated whether the frequency of comments corresponding to each category per student depended on students’ courses in high school or on their attitude toward mathematics at the beginning of the course. For the second analysis, this study set the following groups based on the students’ answers for the aforementioned questionnaire: S+/S- (students who took science-oriented/humanities-oriented courses in high school), G+/G- (students who are good/bad at math), and L+/L- (students who like/dislike mathematics). The numbers of students in each group were 24 (S+), 43 (S-), 13 (G+), 38 (G-), 19 (L+), and 29 (L-). Next, the differences in the frequency of comments corresponding to each category per student between S+ and S-, between G+ and G-, and between L+ and L- were examined. A significant difference was found in the frequency of MR per student between L+ and L-. A Mann-Whitney test indicated that the frequency of comments containing descriptions corresponding to the rate of MR per student was greater for L- (Mdn=1) than for L+ (Mdn=0), $U=371.5$, $p=0.032$. No significant difference was found for other codes, and no significant difference was found between the differences in students’ courses in high school.

Discussion.

The first analysis showed that students’ comments collected from lessons in a mathematical literacy course contained multiple descriptions, including both their attitudinal change toward mathematics and their metacognitive reflections. An interesting result of the second analysis was that less-motivated students showed better results in terms of metacognitive reflection. The second analysis also suggested that students’ comments that showed their interest in mathematics or their metacognitive reflection did not stem from their prior learning in high school or their attitude toward mathematics before attending the course. These results seem to indicate that students’ comments are potentially useful to assess their mathematical literacy learning. However, more research is needed. One of future tasks is to analyze the changes in students’ comments over time.

Acknowledgment

This work was supported by the JSPS KAKENHI Grant Number JP16H03065.

References

- Di Martino, P., & Zan, R. (2010). ‘Me and maths’: Towards a definition of attitude grounded on students’ narratives. *Journal of Mathematics Teachers Education*, 13(1), 27-48.
- Fostaty Young, S., & Wilson, R. J. (2000). *Assessment & Learning: The ICE approach*. Winnipeg: Portage & Main Press.
- Polya, G. (1981). *Mathematical Discovery: On Understanding, Learning, and Teaching Problem Solving* (combined edition). New York: John Wiley & Sons.

On tasks that lead to praxeologies' formation: a case in vector calculus

Margo Kondratieva

Memorial University, Canada; mkondra@mun.ca

A praxeology comprises a type of task, a technique to accomplish it, a discourse (technology) explaining this technique and a theory supporting this discourse. We consider a situation where a praxeology was presented to students in a lecture, but they discovered an alternative one while working on a routine exercise. This exercise was then followed by a more challenging question related to immediate results obtained by the students. We analyzed this student experience in view of Chevallard's six steps of constructing a praxeology. We suggest that observing students' work on standard exercises may give some productive and innovative ideas for the design of tasks that help students deepen their understanding and encourage theoretical justifications of their solutions. We also comment about possible effects of the explicit requirement to search for the most efficient solution on the formation of praxeologies by students.

Keywords: Praxis, logos, task design, osculating plane, parametric curve.

Introduction

It has been observed that the majority of university mathematics classes are given in the format of lecture and largely employ the pedagogy of “massive scaffolding and direct telling” (Sfard, 2014, p. 202). This teaching approach has been criticized for its limited capacity to empower students in both critical reflection on given information and applying their knowledge in unfamiliar situations. In contrast, within the inquiry-based approach learners start with considering a problem, and then planning, developing and validating their own solutions (Polya, 1945). In this *adidactic* phase (Brousseau, 1997) learners construct their knowledge by working on a problem via thinking about it autonomously, studying related literature and talking to peers. In the didactic phase the teacher discusses the ideas produced by students, corrects them, validates and develops the subject further. However prolific it may sound, this approach is not fully applicable in teaching university mathematics due to the large amount of advanced material to be studied in a relatively short timeframe. Nevertheless, one can ask: to what extent is it possible to embed elements of inquiry in the lecture format courses? Where do we find questions that promote students' “intellectual needs” (Harel, 2012) for critically processing the information given in the lecture? What principles should guide the design of educational tasks that help students to progress from the direct application of given methods to the analysis and justification of them (Gravesen, Grønbaek & Winsløw, 2017)?

Perhaps the central requirement to these tasks is that they should help students to think about and reflect on their actions – what am I doing and why? – so that students can extract new knowledge directly from solving tasks. It is desirable that tasks have *adidactic* potential letting students to “find at least initial and partial answers” (Gravesen et al, 2017, p. 15). The same material can be taught with a different degree of initiative required from students. Typical examples illustrating general concepts and methods may be shown in class and then students can be assigned questions that are just a slight variation of already considered tasks. Such questions, known as *exercises*, contain little challenge but permit verifying students' initial grasp of the material, as students basically mimic

instructor's actions and adjust them according to his or her expectations. In contrast, *problems* require an adaptation or alternation of a given method or a combination of several previously discussed ideas and serve as a form of inquiry. A task that stimulates students to “construct new inferences between results or definitions, reformulate, generalize and instantiate them” is said to have a deepening potential (Gravesen et al, 2017, p. 13). Similarly, research potential of a task measures the possible degree of engagement with activities similar to ones of research mathematicians. However, even if a task is specifically designed, its potential may not be realized in a particular didactic situation. Thus, it is important to consider cases when students gain rich mathematical experience and to notice the circumstances that have a positive effect. This paper presents such a case confirming that even when a lecturer “tends to tell the learner what to do” and “rushes to present their own solutions” (Sfard, 2014, p. 200) it is possible and desirable to delegate to students some work that aims at the development of theoretical knowledge “while working on her own in the quiet of her room” (Sfard, 2014, p. 201).

Theoretical framework and research question

We work under the assumption that “mathematics is a human activity of study of types of problems” (Barbé, Bosch, Espinoza, & Gascon, 2005, p. 236) and mathematical learning (even in a lecture based course) results from solving educational tasks (e.g. problems). Each task is a system of “given-required”, where “given” includes objects and relations between them, while “required” challenges the solver to derive new facts based on the “given” and their existing knowledge. A solution to a mathematical problem can be considered from two angles: “What is done?” and “Why does it work?”. In terms of the Anthropological Theory of Didactics (ADT) proposed by Chevallard (1999), the first question belongs to the domain of praxis, which includes techniques such as formulas, algorithms and methods, while the second - to the domain of logos, which provides corresponding theory, conditions of applicability, derivations and relations to general settings. The praxis consists of the types of tasks and corresponding techniques to solve them. The logos includes technology (explanations of the techniques, proofs of related theorems) and a broader theory within which the theorems are stated. Together praxis and logos components form a praxeology, described by Chevallard (2006, p. 23) as a “basic unit in which one can analyze human activity at large”. Praxeologies can occur at different levels of generality: punctual, local, regional or global. Punctual praxeologies address a unique type of task. Several punctual praxeologies can be integrated in different local mathematical organizations each of which provides a common technological discourse (e.g. algebraic). Local technologies can be further integrated into regional ones.

In the teaching of primary and secondary mathematics there is a tendency to focus on the praxis component with very minimal exposition of the students to the related logos. Even at the university level, there exists an artificial division of courses into e.g. Calculus and Analysis, assuming significant dis-balance towards the praxis in the former and leaving the theory until the latter (see Kondratieva & Winsløw, 2018). The lack of an explanation of why and when a technique works (i.e. lack of technology) leads to incomplete praxeologies; this is a disservice to learners at all levels as it kills natural learners' curiosity and reduces the flexibility of the technique. Even if technology is given by the teacher it may not necessarily lead to formation of a praxeology by students – to the practice when the use of a technique is informed by related technology. In this paper we look at a

case when students were engaged in the formation of a praxeology; the research question being: what are the instructional conditions making this possible at the undergraduate university level?

Our discussion will refer to the following six moments of creating a praxeology (Chevallard, 1999).

- 1) The moment of *first encounter* of a certain type of problem related to a praxeology;
- 2) The *exploratory* moment of finding and elaborating techniques suitable for the problem;
- 3) The *technical* moment of using and improving the technique;
- 4) The *technological-theoretical* moment in which alternative techniques are assessed;
- 5) The *institutionalization* moment, when one is aiming to identify the elaborated praxeology;
- 6) The *evaluation* moment, when one examines the value of the constructed praxeology.

Here the *adidactic* situation leads students to propose some techniques that need to be assessed and theorized. Students react on the situation in accordance with an existing *didactic contract* (Brousseau, 1997), that is, a set of responsibilities, rules and norms of schooling behavior. In our instructional setting we encountered a slightly modified sequence of events presented below.

Instructional settings and observations

This section describes several episodes that occurred in a vector calculus course taught by the author of this paper in the Spring 2018 term at Memorial University (MUN) in Canada. The episodes had been selected in order to present the story of success. They describe a didactic contract, an error and its correction, made by students, leading to formation of a new praxeology.

The settings

The vector calculus course is the last course in the sequence of calculus courses offered by the department of Mathematics and Statistics at MUN. One-hour lectures are given three times a week for a twelve-week period (with regular homework assignments and a midterm exam) followed by a 3-hour written final exam. The course discusses such topics as parametric curves and surfaces, multiple integrals, Green's, Stokes' and the Divergence theorems with some motivations from physics. The course is usually taken by students majoring in either mathematics, physics, computer science or engineering. Similarly to preceding calculus courses it focuses mostly on computational techniques and obtaining numerical answers. Some sketches of proofs are discussed in lectures but they are not tested in exams. While the syllabus of the course is prescribed, the instructor has some freedom in composing questions for assignments and tests. In the considered case the homework assignments were marked by the instructor and consisted of the following types of questions: (1) short summary describing definitions, formulas, and conditions of their applicability as discussed in lectures; (2) exercises in direct application of formulas listed in (1); (3) problems that require minor alternations of formulas listed in (1); (4) bonus problems that may require additional reading and creative thought. Note that questions of types (1) and (4) were not typical in students' previous experience. Twenty students completed the course in Spring 2018.

The observations and interventions

Episode 1: Efficiency of solutions as a part of didactic contract. This observation took place in the very beginning of the course. The students just learned how to find the curve length given a parametric description of a curve $\mathbf{r}(t) = \{(x(t), y(t), z(t)), t \in [a, b]\}$. Using the integration formula

$\int_a^b \sqrt{(x')^2 + (y')^2 + (z')^2} dt$ they were able to find the length of some exotic curves such as a part of a helix. However the assignment also included examples of parts of a straight line and a circle. Many students still used the general method to find the length of these curves even when they had recognized them correctly. It was then pointed out to students that they should aim at the most efficient way of finding their answers or at least mention that their calculations were consistent with the obvious answer. For example, the length of a straight line $r(t) = \{(\cos(2t), 2, 1), t \in [0, \frac{\pi}{2}]\}$ connecting points $(-1, 2, 1)$ and $(1, 2, 1)$ (Figure 1, left) is obviously 2, which makes the calculation in (Figure 1, right) unnecessary. Similar situations appeared in other assignments. Some hints referred to efficiency in numerical calculations, such as

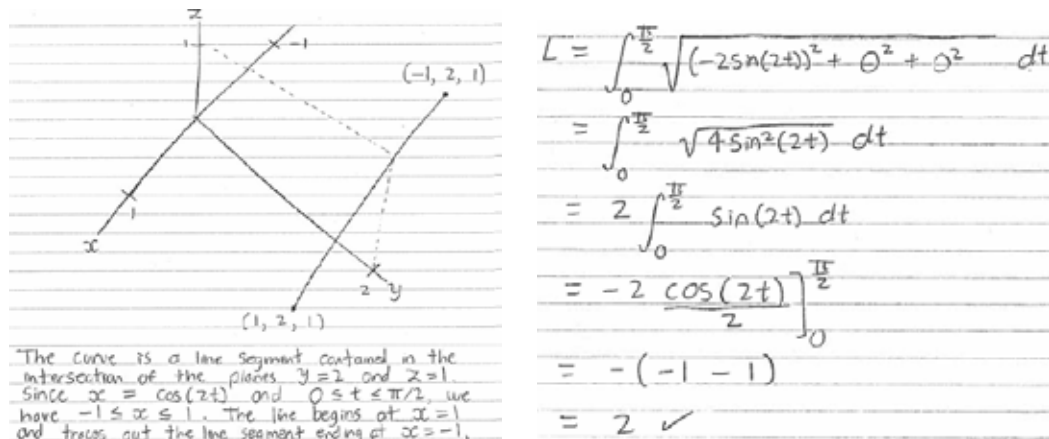


Figure 1: Student's work on curve $r(t) = \{(\cos(2t), 2, 1), t \in [0, \frac{\pi}{2}]\}$. Description and length

a suggestion to use the property $\sqrt{(ka)^2 + (kb)^2} = k\sqrt{a^2 + b^2}$ ($k \geq 0$), or warned that the simplification $\sqrt{A + B} = \sqrt{A} + \sqrt{B}$ is not valid unless $AB=0$. All in all, such systematic instructional feedback shaped the didactic contract for this group of students.

Episode 2: Accidental efficiency. Another assignment included a problem of finding an osculating plane for the curve $r(t) = (\cos t, \sin t, \cos t)$ at $t = \pi/2$. The instructor explained a method, which consisted of the following steps:

1. Find the unit tangent vector $T = \frac{r'}{\|r'\|}$ to the curve at a given point.
2. Find the unit normal vector $N = \frac{T'}{\|T'\|}$ to the curve at a given point.
3. Find the unit binormal vector $B = T \times N$ to the curve at a given point.
4. An osculating plane by definition includes vectors T and N and therefore is orthogonal to vector B . Thus the equation of the plane is $B \cdot (r - r_0) = 0$, where $r = (x, y, z)$ and r_0 is the point on the curve where the plane is required.

An example considered in class in order to illustrate this method was helix of radius α : $r(t) = (\alpha \cos t, \alpha \sin t, t)$. Note that in this case $r'(t) = (-\alpha \sin t, \alpha \cos t, 1)$ and so $\|r'\| = \sqrt{1 + \alpha^2}$ is t -independent. Consequently, the normal unit vector $N = \frac{r''}{\|r''\|}$. However, if $\|r'\|$ is a function of t , this must be taken into consideration when calculating N . When working on the assignment described above, some students ignored this circumstance and used the formula $\frac{r''}{\|r''\|}$ for N in step 2.

Nevertheless, they still got a correct answer for the proposed problem, the plane $z = x$. The mistake was pointed out by the instructor during a lecture, but the fact of accidental efficiency was surprising for students and caught their attention leading to an in-class discussion. Their first thought was that maybe the value of the parameter $t = \pi/2$ was special, but the “wrong method” still gave a correct equation of the osculating plane for $t = \pi/4$ and some other variations they tried. So, a bonus problem naturally emerged: to explain why and when the “wrong method” works.

Episode 3: A praxeology given in the lecture. The method of finding the osculating plane was not completely unexplained in the lecture. Prior to Episode 2 the students were presented with the statement that if a vector-function $f(t)$ has a t -independent norm $\|f\| \equiv \sqrt{f \cdot f} = \text{const}$ then the vector function $f'(t)$ is orthogonal to $f(t)$ for every t . Indeed, if we differentiate both sides of the equation $f \cdot f = \text{const}$ we obtain $f' \cdot f = 0$. Now, the unit tangent vector has norm $\|T\| = 1$, therefore $T'(t)$ is orthogonal to $T(t)$ by the above statement. After normalization it gives the unit normal vector $N(t)$. The cross product of two unit vectors gives a unit vector orthogonal to both initial vectors. This way the binormal unit vector $B(t)$ is obtained. These explanations presented a technology related to the praxis of finding an osculating plane. However, as it could be inferred from the error made by the students who were somehow misled by the example of helix in Episode 2, this praxeology, given by the instructor, remained external to them and the application of the method was not guided by the related theory. This revelation prompted the instructor to encourage students to develop their own explanations of the method that they had accidentally discovered.

Episode 4: Towards a new praxeology construction by students. Proving was not a well developed skill for many students, so their initial attempts naturally were flawed. We will follow the progress of a student called Sam (a pseudonym). Firstly, Sam arrived at the correct statement, but it was not very useful in the situation he needed: if $r'(t) \perp r''(t)$ for $t \in [a, b]$ then $N = \frac{r''}{\|r''\|}$. Indeed, the conclusion was desirable but the condition was not met in the problem they had. After some time Sam managed to prove algebraically that if $r'(t_0) \perp r''(t_0)$ then $N(t_0) = \frac{r''}{\|r''\|}$ (Figure 2, left). When this result was shared with others in class, it was noted by students that the statement is obvious from the geometrical point of view: if both vectors N and r'' are orthogonal to r' , they must be proportional. In this way the case $t = \pi/2$ was successfully explained. However, it was still unclear why the “wrong method” gave the correct equations of the osculating plane even in the case when N was not proportional to r'' (see e.g. calculations for case $t = \pi/4$ in Figure 2, right).

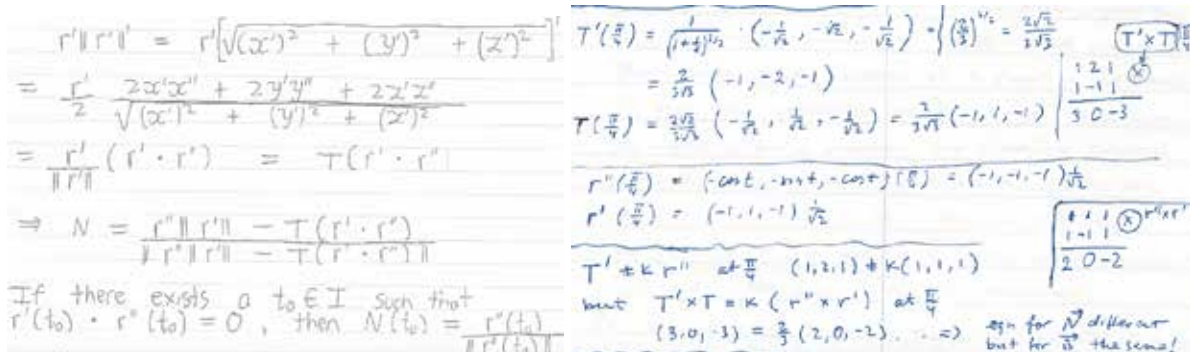


Figure 2: Student’s work on a proof for the alternative technique: cases $t = \frac{\pi}{2}$ (left) and $t = \frac{\pi}{4}$ (right)

Episode 5: The new method explained. After looking at several examples that produced a correct osculating plane by the “wrong method”, Sam started to realize that he should not try to prove that N is proportional to r'' (which in general is not so) but instead he should try to prove that the span on vectors r' and r'' forms exactly the same plane that the span of vectors T and N does. This shift of attention made Sam perceive a new property, which according to Mason (2008, p. 38) is feasible “when you are aware of a possible relationship and you are looking for elements to fit in”. Once he knew what he was looking for, a simple line sufficed: since $r' = ||r'||T$, by differentiation we obtain $r'' = v'T + vT'$, where $v = ||r'||$ and v' are scalars. Thus, vector r'' is a linear combination of vectors T and T' , or equivalently of vectors T and N . Therefore, whenever $v \neq 0$, vectors r' and r'' can be used for finding the osculating plane initially defined by vectors T and N .

Concluding discussion

In this paper we explored the possibility of imbedding an inquiry task, allowing students to construct technique-technological links and eventually to develop praxeologies by themselves, within a praxis-dominated lecture-based calculus course. Here we refer to the six moments of constructing a praxeology (listed in the Theoretical Framework section) in order to comment on two conditions that in our view had a positive effect on the successful outcome reported in Episode 5.

The first condition is the systematic attention paid by the instructor to the issue of the efficiency of students' work. This requirement for a solution of a problem is entwined with the inquiry-based methodology. In a situation when more than one approach is applicable to a problem in hand, one would naturally ask for the simplest answer, which is based on the insight about the nature of the situation and avoids unnecessary lengthy calculations. Indeed, “as mathematical thinking develops, it should become not only more powerful, but more simple” (Tall, 2013, p. 19) because “not only mathematics, but science as a whole progresses only if we understand things ... and explain [ideas] in simple terms” (interview with Sir M. Atiyah, as quoted in Tall, 2013). Episode 1 confirmed the observation that students in North America spend little time on planning their solution and jump into calculations right away (Schoenfeld, 1985). While the cognitive mechanisms for finding simple solutions in general are not clearly understood (see discussion in Koichu, 2010), it is important to establish the work habit of looking for legitimate simplifications whenever possible. Viewed as a part of didactic contract, the higher efficiency of the alternative method of finding the osculating plane prompted the students to keep trying to justify it. This efficiency gave the value to the praxeology being constructed (moment 6: evaluation).

The second condition is the fact that an additional new task emerged from the instructor's feedback on a mistake made by students while solving an exercise. Let us look at it a bit closer. The initial task in Episode 2 was to find an osculating plane for a curve at a point, which was defined in terms of the unit tangent and normal vectors -- the objects that were introduced to the students at the same time as was the osculating plane. The definitions prescribed the way of constructing all listed above objects. Thus, in the scenario of Episode 2 the first two moments (first encounter, exploration) were missing as such, and in this sense the task was an exercise in which a given technique was supposed to be used (a modified moment 3). On the other hand, the curve was chosen in such a way that it allowed a more intuitive approach in line with examples discussed in Episode 1. A “simple”, intuitive solution

was to notice that the curve belonged to the intersection of the cylinder $x^2 + y^2 = 1$ and the plane $z = x$. Therefore the entire curve lied in the plane $z = x$, which thus was the osculating plane for any value of the parameter t . Finding this solution relied on explorations and noticing specific relations between components of the vector-function $r(t)$ describing the curve. Indeed, several students had commented on this but only after they found the answer by a different method. Erroneously, they altered the method given to them attempting to (illegitimately) reduce the amount of calculations. The fact that the altered method provided an answer consistent with the “simple” intuitive approach led to a new task: to explain why it happened. It was the instructor’s role to formulate this task, but because the method appeared from the students’ own omission they claimed ownership of this task. Here the *adidactic* phase occurred later in the process and the development of praxeology by students basically started from moment 4, that is, from the assessment of the alternative technique. The successful outcome in Episode 5 was warranted by students’ reflection on the ideas related to the original praxeology with technology presented by the instructor in Episode 3, and modifying them accordingly. The institutionalization moment (5) was completed after Episode 5, when related physical motivation was also discussed in the lecture. Indeed, the observation that played the key role in the justification of the alternative method could be interpreted as follows: no matter how the object moves through the space the acceleration vector $a = r''$ always belongs to the osculating plane: $a = v'T + \kappa v^2 N$, where $\kappa = ||T'||/v$ is the curvature of the trajectory and $v = ||r'||$ is the speed of motion. Vector T gives the direction of the motion and vector N points in the direction the object is turning. So T and N describe the (osculating) plane to which the trajectory of motion locally belongs. The expressions for the tangential and normal components of the acceleration vector make sense if we think of a passenger in a car making a turn (Stewart, 2003, p. 875).

Note that the praxeology developed by students in Episodes 2, 4 and 5 is punctual as it addresses just one particular problem of constructing an osculating plane. It is a refinement of the initial praxeology given in Episodes 2 and 3, and we conjecture that due to students’ involvement in its justification it will be more readily integrated in the future in local and regional types.

In sum, our case involved a routine exercise and a lot of “direct telling” as in a typical calculus course. This setup presumes that the two steps (first encounter, exploration) in the construction of a praxeology could be missing. Instead, through working on exercises using given information and techniques, the groundwork for developing alternative techniques and raising new questions is established. This situation gives us a clue about possible sources of questions that appeal to students and are perceived as important or meaningful, questions that help them to critically process given information and eventually develop praxeologies. We conclude that innovative ideas for task design can come from observing and analyzing students’ mistaken work with practice exercises. Sometimes the instructor can predict or even provoke those mistakes. Reshaping standard exercises so that they have multiple ways to solve them, like in our case above, may enrich the possibilities for the tasks that follow. If these tasks “aim directly to develop and refine knowledge in progress” (Gravesen *et al.*, 2017, p. 28), or explain certain puzzling phenomena, they will have the deepening potential and perhaps the research potential, helping students to work with new material in a meaningful way and gain richer experience of mathematical work. Because of their origin such tasks (compare to *a priori*

designed ones) may have a stronger and more personalized effect on learners when used in a didactic setting.

References

- Barbé, J., Bosch, M., Espinoza, L., & Gascón, J. (2005). Didactic restrictions on teachers' practice - the case of limits of functions at Spanish high schools. *Educational Studies in Mathematics*, 59(1-3), 235–268.
- Brousseau, G. (1997). *Theory of didactical situations in mathematics 1970–1990*. Dordrecht; London: Kluwer Academic Publishers.
- Chevallard, Y. (1999). L'analyse des pratiques enseignantes en théorie anthropologique du didactique. *Recherches en Didactique des Mathématiques*, 19(2), 221–266.
- Chevallard, Y. (2006). Steps towards a new epistemology in mathematics education. In M. Bosch (Ed.), *Proceedings of the 4th Conference of the European Society for Research in Mathematics Education (CERME 4)* (pp. 21–30). Barcelona: Universitat Ramon Llull Editions.
- Gravesen, K.F., Grønbaek, N., & Winsløw, C (2017). Task Design for Students' Work with Basic Theory in Analysis: the Cases of Multidimensional Differentiability and Curve Integrals. *International Journal of Research in Undergraduate Mathematics Education*, 3(1), 9–33.
- Harel, G. (2012). Intellectual need. In K. Leatham, (Ed.) *Vital Direction for Research in Mathematics Education*. New York: Springer.
- Koichu, B. (2010). On the relationships between (relatively) advanced mathematical knowledge and (relatively) advanced problem-solving behaviours. *International Journal of Mathematical Education in Science and Technology*, 41(2), 257–275.
- Kondratieva, M. & Winsløw, C. (2018). Klein's plan B in the early teaching of Analysis: two theoretical cases exploring mathematical links. *International Journal of Research in Undergraduate Mathematics Education*, 4(1), 119–138.
- Mason, J. (2008). Being mathematical with and in front of learners: Attention, awareness, and attitude as sources of differences between teacher educators, teachers and learners. In B. Jaworski & T. Wood (Eds.), *The mathematics teacher educator as a developing professional* (pp. 31–56). Rotterdam/Taipei: Sense Publishers.
- Polya, G. (1945). *How to solve it* (First edition). Princeton: Princeton university press.
- Schoenfeld, A. (1985). *Mathematical Problem Solving*. New York: Academic Press.
- Stewart, J. (2003). *Calculus*. Fifth edition. Toronto: Nelson.
- Sfard, A. (2014). University mathematics as a discourse - why, how, and what for? *Research in Mathematics Education*, 16(2), 199–203.
- Tall, D. (2013). *How Humans Learn to Think Mathematically: Exploring the Three Worlds of Mathematics*. New York: Cambridge University Press.

What can be ‘annoying’ about mathematical conventions? Analysing post-exchanges of mathematically competent discursants

Igor’ Kontorovich

The University of Auckland, New Zealand; i.kontorovich@auckland.ac.nz

The study reported in this paper is concerned with mathematical conventions, a discussion on which unfolded among mathematically competent discursants. The data came from a rich online thread, where practicing mathematicians, mathematics lecturers, graduate students and undergraduates at advanced stages of their studies were asked to share mathematical conventions “that are annoying, those that nobody likes but it’s too late to cancel”. Grounded in the commognitive framework, the study aims to delineate some rules that this discussion abided. Two discursive rules are presented herein: one rule calls for the use of the same symbols in different discourse communities to denote the same objects. The second rule appeals to a goodness-of-fit between mathematical objects and their conventional symbols. Some affordances that a discussion on conventions can bring to educational research and teaching practice are sketched.

Keywords: Conventions, commognition, mathematicians, mathematical symbols, online forums.

Introduction and background

Accepting established mathematical conventions – for instance, definitions of concepts, their names and symbols – is necessary for participating in a literate mathematical discourse (cf. Hewitt, 1999). However, research offers colorful instances of students and teachers grappling with some broadly accepted conventions. For example, in Kontorovich and Zazkis (2017), we asked pre-service teachers to propose arguments for denoting reciprocals and inverse functions with the same superscript ‘-1’. One of the teachers rejected the possibility that the two may have something in common beyond the symbol. After a comprehensive classroom discussion that revolved around the notion of closure under operation, the teacher amended his position and started using the terms “multiplicative inverse” and “inverse function”. Yet, he still refused to use “inverses” for referring to reciprocals and inverse functions together. The rest of the class, myself included, remained rather defeatist about the abstract algebra argument being not convincing enough for the teacher. These communicational clashes resonate with Sfard’s (2008) definition of a *discourse* as a type of communication “that draw[s] some individuals together while excluding some others” (p. 91); in the described episode, this feature could be ascribed to a *discourse on mathematical conventions* (DoMC).

At least two features distinguish DoMC from its mathematical congeners. First, it is substantially less deductive. While sequences of apodictic moves lead from a problem to a solution or from a theorem to a proof, the above episode illustrates that it might be difficult to justify a convention to a critical interlocutor (cf. Hewitt, 1999). Thus, familiar ways of mathematical communication might turn to be not transferable to DoMC. Second, DoMC mostly occurs among professional mathematicians (e.g., Kontorovich, 2016a; Knuth, 1992) and, in my experience, it rarely unfolds in regular mathematics lessons at school and university. Furthermore, a handful of studies show that teachers might intentionally avoid engaging in such a discourse with their students. Fukawa-Connelly (2015) reports on a lecturer in abstract algebra who wanted his students to engage in inquiry-based learning. He was

more successful, however, in delegating the responsibility for proving to the students – i.e. making conventional moves, rather than for developing definitions – i.e. introducing conventions. In Kontorovich (2016b), I show how thoroughly three mathematicians promoted particular conventions in their teaching, while being fully aware that they contradict the conventions promoted by their colleagues. Thus, little seems to be known about discursive practices that can be considered as characteristic of DoMC.

The study at hand is interested in drawing attention of the mathematics education community to DoMC as it unfolds in mathematics classrooms and professional mathematics communities. Research has repeatedly shown that a disciplinary inquiry into experts' thinking and doing can benefit the mathematics education community practically and theoretically (e.g., Poincaré, 1909/1952). This gives reason to believe that exploring the participation of mathematically competent discursants in DoMC might be insightful as well.

Theoretical framework

This study is grounded in the *commognitive framework* (Sfard, 2008), whose usage in mathematics education in general and in university mathematics education in particular has been on the rise (e.g., Nardi, Ryve, Stadler & Viirman, 2014). Commognition posits that mathematical discourses are distinguishable through characteristic *words* (e.g., “reciprocal”, “inverse function”) and their use; *visual mediators* (e.g., the superscript ‘-1’ symbol) and their use; generally endorsed narratives (e.g., conventions); and *routines*, which are repetitive sets of metadiscursive rules (or *metarules*) that attest to actions and re-actions of the discursants. *Object-level rules*, in turn, “are narratives about regularities in the behavior of [usually mathematical] objects of the discourse” (Sfard, 2008, p. 201).

Sfard (2008) posits that “object-level rules of mathematics, [...] once formulated, remain more or less immutable” (p. 202), which might explain her main interest in discursant-centered metarules. The discourse of interest in this study revolves around mathematical conventions, a discourse the rules of which are said to be less known. Accordingly, the aim of this study is to discern some object-level rules that emerge from participation of mathematically competent discursants in DoMC.

The notion of object has an operational definition within the commognitive framework. Sfard (2008) argues that when communicating, we operate with perceptually accessible *signifiers* (e.g., words, symbols) that are realized into other signifiers. For instance, “inverse” can be realized into “ \blacksquare^{-1} ”, which can be realized even further forming a *realization tree*. In this way, “[t]he discursive object signified by S in a given discourse on S is the realization tree of S within this discourse” (ibid, p. 166). This definition turns discursive objects into personalized and contextualized structures. However, our occasional success in coming up with mathematical narratives that are endorsed by our interlocutors show that there is room for expanding the notion beyond a particular person. In this study, some mathematical objects are ascribed to discourse communities in the sense that their object-names/symbols and corresponding realizations and narratives are shared by people who are recognized as community experts in mathematics.

Method

This is exploratory research, the data for which comes from an online mathematical forum hosted on a popular social network. The forum communication occurs in Hebrew and it is far from sporadic. The forum has a clearly stated scope and descriptions of topics that are welcome for discussion. These include challenging theorems and problems in post-graduate mathematics, historical developments, and career paths in the discipline. Consequently, the forum brings together practicing mathematicians, university lecturers, graduate students, and undergraduates at the final stages of their studies. The forum activity is overviewed by a group of moderators who make sure that the posts are within the forum's scope. Posting in the forum requires registration, and the posts appear next to full and real names of their creators. This rather rigid frame of communication allows arguing that the forum discursants are committed to the ideas that they share in the forum at least to some degree.

As part of regular forum activity, one of the forum participants (FPs) raised the question, "*Which conventions do you know in mathematics that are annoying, those that nobody likes but it's too late to cancel?*" While this forum participant (FP1) did not elaborate any further on the meaning of the word 'annoying', the responses of FPs allowed to operationalize it as a tension between one's reconciliation with a particular mathematical convention and their awareness to its normative status in a broader mathematics community. The request for 'annoying' conventions was especially fortunate for this study, as it served as a methodological tool for illuminating discursive rules through breaching them (see Herbst & Chazan, 2011 for the use of breaching experiments in mathematics education).

FP1's call grew into a rich thread where 36 FPs enthusiastically engaged in a discussion on conventions and generated 132 telling posts. The thread constituted the data corpus for this study¹. The sought discursive rules were inductively developed through an iterative analytical procedure (Glaser & Strauss, 1967). At the first stage, the posts were divided into mathematical conventions around which they revolved. Then, the conventions were grouped according to their similarities in the 'annoyance' that they raised for FPs. This categorization identified a potentially confusing use of words and symbols, which instigated me to engage reflexively with the commognitive framework in a search for the underlying tenets that these situations violated. This step yielded initial rules that were reapplied to the whole data corpus aiming to check whether the commognitive logic concurs with FPs' posts. Such systematic alternations between the framework and data resulted in four rules; two of them, the ones that accounted for the majority of discussed conventions, are presented next.

Two discursive rules that 'annoying' conventions violate

"Same object-symbol – same object" rule

To illustrate the first rule, let us consider Figure 1 for two narratives that FPs posted at FP1's request. Both narratives are concerned with conventional signifiers that feature in discourses that differ in their use of words and symbols, which results in conflicting narratives. In the first narrative, the 'C'-

¹The study abided the recommendations of the University of Auckland Human Participants Ethics Committee for research with data collected from the public sphere.

symbol characteristic to set theory is used for signifying subsets by some and proper subsets by others. Figure 2 illustrates the second narrative with excerpts from popular textbooks that reflect discourses on vector decomposition in physics and mathematics. The same symbols ϕ and θ are used in both discourses, but their realizations are inverted: in the physics textbooks, we can see that ϕ signifies the angle on the xy -plane and θ denotes the angle with z -axis; in the mathematics textbooks, ϕ signifies the angle with z -axis and θ is used for the angle on the xy -plane.

FP31

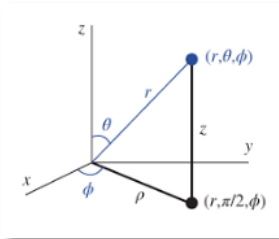
If $A \subset B$ then the sets are necessarily different? (My approach: in the first two years of first degree yes, later no.)

FP17

The immortal confusion between ϕ and θ in spherical coordinates among physicists and mathematicians. Not only what is signified how but also whether one of them is the angle with the plane xy or with z -axis.

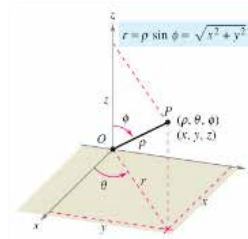
Figure 1: Example of the violation of the rule “same object-word/symbol – same object”

The presented narratives exemplify a wider set of conventions that FPs shared, all violating the rule stating that in different communities of discourse, *the same object-symbol should stand for the same discursive object*. To put it more precisely (and more mathematically), I suggest determining the sameness of discursive objects S_1 and S_2 through an existence of a relation preserving one-to-one mapping between the realization trees of S_1 and S_2 . The presented examples illustrate that the mapping might require conversion of signifiers, which is what Sfard (2008) coins as discursive attuning – interlocutors reaching a consensus around their usage of particular words and symbols. Indeed, physicists and mathematicians do not disagree on how to decompose a vector, they disagree on how these components should be labeled.



Felder and Felder (2016, p. 232)

Mathematical methods in engineering and physics



Larson and Edwards (2010, p. 825)

Multivariable calculus

Figure 2: Incommensurable approaches to spherical coordinates in physics and mathematics textbooks

In turn, the sameness of object-symbols goes beyond their written and pronounced identity as it pertains to whether the signifiers are perceived as the same by the interlocutors. For instance, one FP shared that when studying probability and statistics, he often confused between visually similar symbols ‘ χ ’, ‘ X ’ and ‘ x ’, which led to multiple misunderstandings. When the difference between the symbols was clarified, many misunderstandings faded because the narratives that conflicted when assigned to the same object were distributed between different ones.

“The goodness-of-fit” rule

The second discursive rule is concerned with a *goodness-of-fit between mathematical objects and their symbols*. In statistics, a goodness-of-fit is used for capturing the quality of a match between the factual data and the one that was predicted with some quantitative model. I discern a reflection of this idea among FPs, who were ‘annoyed’ when some key properties of a mathematical object were misrepresented in its conventional symbol. Figure 3 illustrates this rule violation with ‘|’ – a conventional symbol of divisibility.

<p>FP26 [1] $n m$, n divides m. Who uses a symmetrical sign $$ for a non-symmetrical relation?!</p>
<p>FP24 [2] The sign of “divisible by” is asymmetrical. But the fact that there are two signs for “divides at” and “divisible by” just illustrates your claim. [3] (In an internet search in English I haven’t found evidence for existence of a sign for “divisible by”. But I know one. Very strange.)</p>
<p>FP26 [4] What is the sign for divisible by?</p>
<p>FP27 [5] Three dots that are written vertically is a standard sign for “divisible by”</p>
<p>FP24 [6] I am familiar with the diagonal, not vertical (and then it is asymmetrical). However the direction of a diagonal is not always consistent. Do you have a reference in Russian for this?</p>
<p>FP10 [7] And if we are already talking about this then why n is to the left of m and not to the right? If m is divisible by n then we get an integer when we divide m by n, and suddenly n jumps to the left side. So it is confusing. This is so annoying.</p>
<p>FP24 [8] You can just write $n m$, and then it remains on the right 😊</p>
<p>FP10 [9] Correct but this is not accepted and I have never encountered such a sign in the context of numbers. [...]</p>
<p>FP10 [10] Besides the accepted signs m/n align with the accepted way to say that “m divided by n” [...].</p>
<p>FP14 [11] Agree. The relation should be $x//y$ for x “divisible” by y.</p>

Figure 3: Example of violation of the goodness-of-fit rule

In the presented exchange, the discursive object of divisibility is separated from its conventional symbol ‘|’ and the attention is drawn to the mismatch between the two. In [1], FP26 addressed the mismatch in terms of symmetry: a visual symmetry that the symbol has and a symmetrical relation

that divisibility does not satisfy. In [7], FP10 focused on the inconsistency of equivalent realizations “ m is divisible by n ”, “ $m/n = \text{integer}$ ” and “ $n|m$ ”: while in the two former realizations m appears to the left of n , the order is inversed in the third realization. The participants of the exchange seem to endorse the badness of the symbol’s fit since the exchange quickly refocuses on possible alternatives.

Figure 3 demonstrates two criteria of the goodness-of-fit that FPs recurrently praised in their narratives. The first criterion pertains to visual similarities between symbols of related objects. Indeed, FP14’s ‘//’-symbol in [11] is closely linked to ‘/’ – a conventional symbol of division. The second criterion suggests that the symbol should be accepted in some literate mathematics community, which can be shown through references (see [3] and [6]). More often than not, a promotion of unfamiliar symbols was criticized (see [8-9] as an example). Figure 3 also illustrates that it is not always easy to satisfy both criteria with the same symbol.

Discussion

This study has been concerned with DoMC and the rules that this discourse abides. While the mathematics community tends to be explicit about object-level rules of discourses on well-defined mathematical objects (e.g., numbers, functions, triangles), this is not the case of DoMC. Metaphorically speaking, this discourse mostly unfolds in “corporate mathematical kitchens”, whose doors are firmly closed for outsiders. An online space though seems like a spectacular arena for observing how DoMC can unfold almost in the real-time (Kontorovich, 2016a). This being said, it seems worthwhile to highlight that the scarcity of our research knowledge on mathematicians’ communication about conventions should not tempt us to generalize discursive patterns emerging from a particular subcommunity to the mathematics community as a whole.

Two discursive rules were reported in this paper: same object-symbol – same object and goodness-of-fit between objects and their symbols. The first rule, stating that the same *objects* should be denoted with the same object-symbol in different discourse communities bears resemblance to the renowned intuitive rule “same A – same B” (e.g., Tirosh & Stavy, 1999). With “same A – same B”, Tirosh and Stavy refer to a reasoning principle, according to which the sameness in one property of two *objects* is often conceived as sufficient for deriving their sameness in another property. The FPs of this study would probably classify the resemblance between the discursive and intuitive rules as ‘annoying’ because the overlap of the italicized terms conceals the incommensurability of their epistemological origins. Building on the work of Fischbein and Piaget, Tirosh and Stavy concentrate on perceptual objects (e.g., geometrical figures) and their properties (e.g., length, perimeter). The study at hand, however, leveraged commognition for indicating regularities between discursive objects and their leading signifiers (i.e. names and symbols). Therefore, it would be more accurate to acknowledge that the intuitive and discursive rules agree on the “transition of sameness”, when the cognitive and commognitive foundations offer substantially different answers to “sameness of what?” and “transition to where?” Another similarity between the two rules is in the ways they are enacted. Tirosh and Stavy (1999) refer to their rule as “intuitive” since it is accepted as true without a need for any further justification. In a similar manner, the FPs of this study neither offered nor sought explanations for the nature of the ‘annoyance’ that they or their peers experienced when the

corresponding discursive rule was violated. This might suggest that the emotional disturbance was self-evident in these cases.

The goodness-of-fit rule emerged from the exchanges where FPs discussed how some key realizations of mathematical objects are poorly reflected in their symbols and what alternatives may ensure a better fit. Commognitively speaking, such a discussion requires a separation between a ‘root’ – conventional object-word or symbol – and the rest of the realization tree. This discursive move cannot be taken for granted. Sfard (2008) associates one’s understanding of a mathematical object with a particular form of talk, where mathematical intangibles are discussed in a manner that is similar to the physical congeners. Such a talk could not be possible without tightened connections between a leading signifier and the rest of the realization tree. In this way, the study shows that some mathematically competent discursants are capable of separating and contrasting between the two for judging the quality of the fit. Further research may explore the relations between this capability and one’s proficiency in a mathematical discourse.

Teaching-oriented remarks

The interest in conventions that was identified in this study among mathematically competent discursants, begs us to consider the affordances that DoMC could offer to the educational research and the teaching practice. Three affordances are sketched next.

First, this study shows that mathematically competent discursants can be ‘annoyed’ with conventions featuring in a variety of mathematical areas. The nature of some of their ‘annoyances’ is not very different from the one identified in Kontorovich and Zazkis (2017) with pre-service teachers and some other studies with school and university students. This rare similarity between substantially different cohorts allows me to propose that the endorsement of some conventions requires exceptional discursive leaps. In other words, newcomers’ struggles with conventions might be interpreted in some cases as an expert-like sensitivity to a radical discursive change rather than a knowledge deficiency or a result of infelicitous teaching.

Second, all discursants in this study lamented over conventions that are often positioned as “well-established” and advocated for their less-celebrated alternatives (e.g., ‘|’ as a symbol of divisibility). In an educational context, this result delineates a barely explored teaching practice of *choosing* conventions for architecting classroom discourses (Kontorovich, 2016b). This conceptual delineation invites research on whether teachers are aware of the status of conventions in mathematics, how they choose between mathematically incommensurable alternatives, and how these choices impact discourses that students develop. I hope that the rules identified in this study will instigate teachers to make more informed and thought-through choices. Indeed, if mathematically competent discursants complain about some signifiers standing for different objects and the badness of symbols’ fit, then it seems reasonable to predict that students might struggle with such conventions as well.

Lastly, the discursants in this study transitioned between objects that are characteristic of different mathematical areas; they referred to definitions, symbols, and theorems; and they reasoned and communicated with each other. These desirable practices raise the question of whether students should also be given a space to actively participate in DoMC. The debate on this issue is ongoing (see Hewitt, 1999 and Kontorovich & Zazkis, 2017 for opposite views). I believe that opening this space

for students will also open a research space for articulating and challenging conventions that we, mathematics educators, hold about teaching and learning.

References

- Felder, G. N., & Felder, K. M. (2016). *Mathematical methods in engineering and physics*. Hoboken, NJ: John Wiley & Sons, Inc.
- Fukawa-Connelly, T. (2015). Responsibility for proving and defining in abstract algebra class. *International Journal of Mathematics Education in Science and Technology*, 47(5), 733–749.
- Glaser, B. G., & Strauss, A. L. (1967). *The discovery of grounded theory*. Chicago: Aldine.
- Herbst, P., & Chazan, D. (2011). Research on practical rationality: Studying the justification of actions in mathematics teaching. *The Mathematics Enthusiast*, 8(3), 404–462.
- Hewitt, D. (1999). Arbitrary and necessary part 1: A way of viewing the mathematics curriculum. *For the Learning of Mathematics*, 19(3), 1–9.
- Knuth, D. E. (1992). Two notions on conventions. *The American Mathematical Monthly*, 99(5), 403–422.
- Kontorovich, I. (2016a). [We all know that \$a^0=1\$, but can you explain why?](#) *Canadian Journal of Science, Mathematics and Technology Education*, 16(3), 237–246.
- Kontorovich, I. (2016b). [\$\sqrt{9}=?\$ The answer depends on your lecturer.](#) *Research in Mathematics Education*, 18(3), 284–299.
- Kontorovich, I., & Zazkis, R. (2017). [Mathematical conventions: Revisiting arbitrary and necessary.](#) *For the Learning of Mathematics*, 37(1), 29–34.
- Larson, R., & Edwards, B. H. (2010). *Multivariable calculus*. Belmont, CA: Brooks/Cole, Cengage Learning.
- Nardi, E., Ryve, A., Stadler, E., & Viirman, O. (2014). Commognitive analyses of the learning and teaching of mathematics at university level: the case of discursive shifts in the study of Calculus. *Research in Mathematics Education*, 16(2), 182–98.
- Poincaré, H. (1909/1952). The future of mathematics. *General Journal of Pure and Applied Science*, 19, 930–939.
- Sfard, A. (2008). *Thinking as Communicating: Human development, the growth of discourses, and mathematizing*. Cambridge: Cambridge University Press.
- Tirosh, D., & Stavy, R. (1999). Intuitive rules: A way to explain and predict students' reasoning. *Educational Studies in Mathematics*, 38, 51–66.

Beliefs about learning attributed to recognized college mathematics instructors

Valentin A. B. Kuechle¹ and Shiv S. Karunakaran²

¹Michigan State University, East Lansing, USA; kuechlev@msu.edu

²Michigan State University, East Lansing, USA; karunak3@msu.edu

Keywords: Beliefs, learning, teaching, college mathematics.

The study of teachers' beliefs has a rich tradition (Calderhead, 1996), and several key categories of beliefs have been identified: teachers' beliefs about mathematics and the learning and teaching thereof (Ernest, 1989). Although the study of beliefs has largely focused on K–12 teachers, researchers have sought to extend this work to instructors of collegiate mathematics (e.g., Speer, 2008). Our study adds to this body of literature by focusing on a particular subset of college mathematics instructors, namely those who have been recognized with teaching awards. Although we do not equate winning a teaching award with teaching excellence, we note that recognized instructors are nominated by fellow colleagues and/or students, have had cause to reflect on their own teaching, and by winning the award have had their teaching explicitly commended by their department and college. Such an award adds weight to their voices in matters of teaching and makes them teaching role models. Thus, we seek to explore recognized instructors' beliefs about mathematics and the learning and teaching thereof.

Below, we present our study's preliminary findings from a series of interviews we conducted with recognized college mathematics instructors. We align with Ernest's (1989) conceptualization of beliefs and mirror his focus on beliefs about mathematics and the teaching and learning thereof. Furthermore, we espouse Speer's (2005) view that researchers attribute beliefs to participants and concur that interviews alone do not do justice to our participants' beliefs. Thus, we see our interviews as forming the first step of a larger study including detailed classroom observations.

Method

At a large US institution, six mathematics instructors who had won at least one teaching award each were randomly chosen—from the set of thirteen mathematicians who had won a teaching award within the last five years—and individually interviewed for around one hour using a semi-structured interview protocol. Two of the participants were non-PhD mathematicians, the other four held PhDs in mathematics. One of the non-PhD mathematicians was male (Aleph), the other female (Beth), whereas the four PhD mathematicians were all male (Gimel, Dalet, Waw, and Zayn).

All interviews were transcribed and coded with the help of MAXQDA, a qualitative data analysis software. A coding scheme was iteratively developed by the two authors with four top-level domains (*Learning, Teaching, Mathematics, Miscellaneous*) and several subcodes allowing for more nuanced coding. Separately from this coding scheme, declarative statements were highlighted.

Results

Thus far, we have identified three interesting findings. First, the interviews with the non-PhD and the PhD instructors took markedly different turns. For the non-PhD mathematicians, who had typically

taught incoming undergraduate students, students' motivation was perhaps the most dominant issue. Both Aleph and Beth agreed that students require intrinsic motivation for true learning, which their students lacked. As a result, both had embraced efficiency in their teaching, for instance via course handouts containing most of the lectures' content. For the PhD mathematicians, motivation was hardly a topic of concern: They took intrinsic motivation for granted—perhaps because they were teaching mainly upper-division courses.

Second, the beliefs of the PhD mathematicians varied widely: Beliefs ranged from learning is solitary to learning is collaborative. Whereas Gimel believed that learning happened when one was working alone on a problem, Dalet took a more moderate approach and stated that learning could be both a solitary and a social activity. In opposition to Gimel's belief, Waw asserted that learning is social. The last PhD mathematician, Zayn, noted that he did not want to impose his own learning experiences onto others and that there are as many ways of learning as there are students. Thus, even among this small number of PhD mathematicians, beliefs varied widely, and no dominant view emerged.

Last, PhD mathematicians' own learning experiences aligned with how they spoke about their teaching. Gimel, Dalet, and Waw all taught in a way that reflected how they themselves had learned. Even Zayn, aware of the possible differences between his and his students' learning, realized during the interview: “[The course] *is* made in my image, now that I think about it. I went through all that trouble of saying I don't want them to learn the way I learned, but now that you're making me say it ...” Thus, the PhD instructors' teaching mirrored their learning experiences.

Discussion

Our results lead us to ponder several issues. First, we wonder whether college mathematics is too broad a term. Perhaps a more fine-grained view that distinguishes between lower- and upper-division courses might be beneficial for untangling college instructors' beliefs. Second, we note that instructors holding a wide variety of beliefs were able to win teaching awards at this institution. Lastly, the interview with Zayn demonstrated that one's teaching may be in-line with one's learning preferences even when one is aware of differences between one's own and others' learning experiences and wishes to be considerate of these differences.

References

- Calderhead, J. (1996). Teachers: Beliefs and knowledge. In D. C. Berliner & R. C. Calfee (Eds.), *Handbook of educational psychology* (pp. 709–725). New York, NY: Macmillan Library Reference USA, Simon & Schuster Macmillan.
- Ernest, P. (1989). The impact of beliefs on the teaching of mathematics. In P. Ernest (Ed.), *Mathematics teaching: The state of the art* (pp. 249–254). London, UK: Falmer Press.
- Speer, N. M. (2005). Issues of methods and theory in the study of mathematics teachers' professed and attributed beliefs. *Educational Studies in Mathematics*, 58(3), 361–391.
- Speer, N. M. (2008). Connecting beliefs and practices: A fine-grained analysis of a college mathematics teacher's collections of beliefs and their relationship to his instructional practices. *Cognition and Instruction*, 26(2), 218–267.

Features of innovative lectures that distinguish them from traditional lectures and their evaluation by attending students

Christiane Kuklinski¹, Michael Liebendörfer¹, Reinhard Hochmuth¹, Rolf Biehler², Niclas Schaper²,
Elisa Lankeit², Elena Leis¹ and Mirko Schürmann²

¹University of Hannover, Germany ²University of Paderborn, Germany

kuklinski@idmp.uni-hannover.de

To support students at the often-times difficult transition from high school to university mathematics, some universities in Germany have introduced innovative lectures. The WiGeMath project evaluated to what extent these measures fulfill their self-set goals. During the evaluations, specific questionnaire items and lecture observations were applied to investigate which characteristics made these lectures different from traditional ones and in how far students valued these features in achieving the courses' learning objectives. The results show that students in the redesigned lectures value guidance and clarification rather than abstractions and that redesigned lectures include more social interactions and student engagement than traditional lectures.

Keywords: Mathematics Education, Novel approaches to teaching, Observation, Secondary-Tertiary Transition, Higher Education

Background and aim of the paper

Many students face difficulties at the transition from high school to university mathematics (Gueudet, 2008). Some universities give support by establishing redesigned lectures, by which we mean lectures that are usually held during the first semester and, unlike traditional lectures, do not focus on university mathematics content. They may, for instance, rather help students who have already failed certain tests to revise the necessary foundations for their further studies or they focus on study techniques like problem solving. Good experiences with lectures or courses that do not focus on the presentation of new theory have been documented in the UK with focus on problem-based learning of analysis (Alcock & Simpson, 2002) or problem solving activities (Tall & Yusof, 1998). Meanwhile, traditional lectures are still both widespread and criticized for neither promoting students' active learning nor exploiting their potential in drawing students into higher mathematical thinking (Pritchard, 2015). Promoting innovative support is the goal of the WiGeMath project (german for Effects and success conditions of mathematics learning support in the introductory study phase), which is a joint research project of the Universities of Hannover and Paderborn (Colberg et al., 2016). It evaluates diverse support measures including redesigned lectures. First, the project developed a taxonomy that serves to categorize features and goals of support measures (Liebendörfer et al., 2017; Kuklinski et al., 2018). This taxonomy was then used to lead guided interviews with the lecturers about the courses' goals. Previous research showed that redesigned lectures were successful in meeting at least some of their goals (Kuklinski et al., 2018). Students' mathematical self-concept and self-efficacy did not decline significantly in these lectures unlike in traditional lectures (Rach & Heinze, 2017), and toolbox beliefs decreased. Our research questions are (1) which course features named by lecturers did students find helpful in reaching learning goals and (2) which observable characteristics distinguish these courses from traditional ones.

Method

With regard to research question (1), we will first report on a questionnaire survey and then, for research question (2), on lecture observations. After we had interviewed the lecturers about their concepts of the redesigned lectures, covering their envisioned teaching strategies, the learning goals they wanted students to achieve and which activities they hoped the students would engage in to reach the goals, we developed questionnaires that aimed at evaluating if attending students felt the lecturers succeeded in meeting their own goals. We applied a special concept for lecture course evaluations called the Bielefelder Lernzielorientierte Evaluation (BiLOE, Frank & Kaduk, 2017) which serves to investigate to what extent students feel they have reached certain learning objectives, which activities they found helpful in achieving those they feel confident they achieved and what reasons they see for not reaching the others. The items looked as displayed in Figure 1.

Question: To what extent have you achieved the following learning objectives?				
	Achieved entirely	Rather achieved	Rather not achieved	Not achieved at all
I can handle various strategies for problem solving.	<input type="checkbox"/>	<input type="checkbox"/>	<input type="checkbox"/>	<input type="checkbox"/>
...	<input type="checkbox"/>	<input type="checkbox"/>	<input type="checkbox"/>	<input type="checkbox"/>

Question: To what extent did you find the following activities helpful in achieving the learning objectives? → Please fill this out only for those learning objectives that you achieved entirely or rather achieved.									
	I did not do this.	Learning objective 1: I can handle various strategies for problem solving.				Learning objective 2: ...			
		Very helpful	Rather helpful	Less helpful	Not helpful at all	Very helpful	Rather helpful	Less helpful	Not helpful at all
I worked on problems of various types in the lecture.	<input type="checkbox"/>	<input type="checkbox"/>	<input type="checkbox"/>	<input type="checkbox"/>	<input type="checkbox"/>	<input type="checkbox"/>	<input type="checkbox"/>	<input type="checkbox"/>	<input type="checkbox"/>
...	<input type="checkbox"/>	<input type="checkbox"/>	<input type="checkbox"/>	<input type="checkbox"/>	<input type="checkbox"/>	<input type="checkbox"/>	<input type="checkbox"/>	<input type="checkbox"/>	<input type="checkbox"/>

Figure 1: Example items of the BiLOE

This questionnaire was given to the students towards the end of the term. The students were asked only to fill out the part of the helpful activities for those goals they felt they had reached or rather reached. An overview of our samples is given in table 1.

Cohort	Engineering students		Pre-service teachers			
Location	Kassel	Stuttgart	Kassel	Oldenburg	Paderborn	Würzburg
<i>n</i> (f/m)	13 (0/13)	55 (11/44)	12 (6/6)	102 (54/48)	45 (18/27)	41 (20/21)
Method	Paper-pencil		Online	Paper-pencil		

Table 1: Overview of the sample size (*n*) and the numbers of female (*f*) and male (*m*) participants

Moreover, we conducted lecture observations. We used the WiGeMath taxonomy to develop a guideline to observe the redesigned lectures and created an observation sheet where the observer has to mark different categories as they apply during five-minute-sections that we split the whole session into. The observation sheets for the non-participating observation contained a series of tables like in figure 2. As to the categories of jargon of mathematics and memorizing, these were coded if the lecturer explained the use of a mathematical formula/ character or named a character like \in or if he asked students to learn a definition, proof scheme or calculation rule by heart, respectively.

		<u>Jargon of mathematics</u>	<u>Memorizing</u>	<u>Media</u>	<u>Form of interactions</u>	<u>Problem solving/ task solving</u>
<u>Time:</u> 0.00 Min.- 5.00 Min.	<u>Themes:</u>	<input type="checkbox"/> Explanation:	<input type="checkbox"/> Definition:	<input type="checkbox"/> Board <input type="checkbox"/> OHP <input type="checkbox"/> Power-point	<input type="checkbox"/> Lecturer presenting, facing the board <input type="checkbox"/> Lecturer presenting, facing the students	<input type="checkbox"/> Students look for an answer <input type="checkbox"/> Lecturer helps during the solving process → kind of help:
<u>Explicit reference to school</u>			<input type="checkbox"/> Proof scheme:	<input type="checkbox"/> PC-Simulation <input type="checkbox"/> Work-sheet <input type="checkbox"/> Calculator <input type="checkbox"/> Tablet-PC	<input type="checkbox"/> Lecturer asks questions <input type="checkbox"/> Students answer <input type="checkbox"/> Student asks, lecturer responds <input type="checkbox"/> Student asks, student responds	<input type="checkbox"/> Students present their results <input type="checkbox"/> Lecturer presents the solution <input type="checkbox"/> Wrong approaches to the solution are discussed
<u>Explicit reference to profession</u>		<input type="checkbox"/> Translation:	<input type="checkbox"/> Calculation rule:		<input type="checkbox"/> Discussion <input type="checkbox"/> Individual work <input type="checkbox"/> Partner work <input type="checkbox"/> Group work	
<u>Explicit reference to university</u>						

Figure 2: Extract from the observation sheet

For each of the evaluated lecture courses, we employed two student assistants to observe the lecture course at three times during the semester, once in November, once in December and once in January (the semester lasts from October to January). The observers studied mathematics but were not regularly taking part in the lecture courses observed. They had been given the observation sheet and a manual including examples and they had been trained using a short video episode of a lecture to make sure they had understood the categories and their handling in the way we had intended them. The students were advised not to communicate so we would get independent results from them which led to a few disagreements in their codings but their overall assessments matched. To have a reference point as to the deviation that the evaluated lecture courses showed from traditional lecture courses, we also had two students evaluate a traditional linear algebra section and a traditional analysis section for first semester students.

Results

We will first look at the results of the BiLOE and then analyze the lecture observations. For the BiLOE, the lecturers named some activities that they expected students to engage in, which did not seem to deviate from traditional lectures. These included attending the lecture sessions, working on homework alone or in groups or revising the lecture notes.

Yet, there were other activities that seemed to be of a more innovative and supportive kind. These activities very much appealed to the students as can be seen from the percentage of students that found them to be rather helpful or very helpful in achieving the lectures' learning objectives. Although the lecturers were free to name any activities they wanted without having been given categories or guidelines, the activities they named could be grouped into five different classes, namely reflection, testing oneself in a safe place, work with examples, work with prototypes and social interactions, see table 2.

With regard to research question (1), the categories of reflection and work with prototypes seemed to be the most helpful ones in the eyes of the students as more than 60% (for some of the activities a lot more than that) found them rather helpful or very helpful for all given learning objectives. All categories seem to reflect a learning atmosphere that is closer to school life than to university life. The categories of reflection, work with examples and work with prototypes all suggest that students hope for guidance and clarification rather than abstractions. Moreover, they do not like the feeling that they have to prove themselves, they rather want to work without pressure or in cooperation with others.

Reflection	Paying deeper attention to common mistakes	76% - 92%
	Reflecting on every step while solving problems	67% - 83%
	After solving a problem, reflecting which solution techniques were used	74% - 90%
	Reflecting the preconditions and the steps in every proof of the lecture	75% - 85%
	Looking for common patterns in proofs	67% - 96%
Testing oneself in a safe place	Writing mathematical texts myself	42% - 59%
	Doing smaller proofs myself	77% - 100%
	Working on difficult problems in an easier form at first	68% - 80%
Work with examples	Revising the examples from the lecture	40% - 77%
	Having the lecturer demonstrate how to prove	82% - 92%
	Having the lecturer explain different proof methods in detail	63% - 86%
Work with prototypes	Getting to know problems with many different facets	78% - 85%
	Working with very appealing proofs	60% - 100%
Social interactions	Asking the lecturer for help when I got stuck	59% - 79%
	Asking the lecturer for feedback even where my solutions were correct	54% - 72%
	Working on content together with others	40% - 88%

Table 2: Activity categories and percentages of students who found the activity rather helpful or very helpful for all given learning objectives

With question (2) in mind, we will now focus on the observation results. Although the predominant media used was limited to the blackboard almost exclusively, just as in traditional mathematics lectures, we found some interesting deviations in the social interactions that took place as well as in the way that students were engaged in problem and task solving processes. In all lectures, we observed various instances where the lecturer asked questions and students answered, indicating that interactions took place regularly. Besides, students also asked questions repeatedly. This suggests that the learning atmosphere in the lectures made students comfortable to openly express their comprehension difficulties. Yet, we did not encounter instances where a student asked a question and another then answered. In consequence, discussions did not take place and neither did typical teaching conversations. Although we observed a few phases of single, partner or group work, these stayed an exception which also indicates that the lecture atmosphere stayed distinct from a typical school classroom. Rather, the format of a lecture remained central and the two forms of interaction that were predominant in all courses were the lecturer talk facing the blackboard and the lecturer talk facing the students. But the fact that other forms of interactions did occur is enough to make the lectures distinct from traditional ones. In fact, phases where the students were actively engaged in problem or task solving processes did not occur in the traditional lectures we observed (Analysis I in Figure 3). In contrast, such phases were observed in all redesigned lectures and there was even one observation where students were active to this effect in 95% of the time (cf. Figure 3).

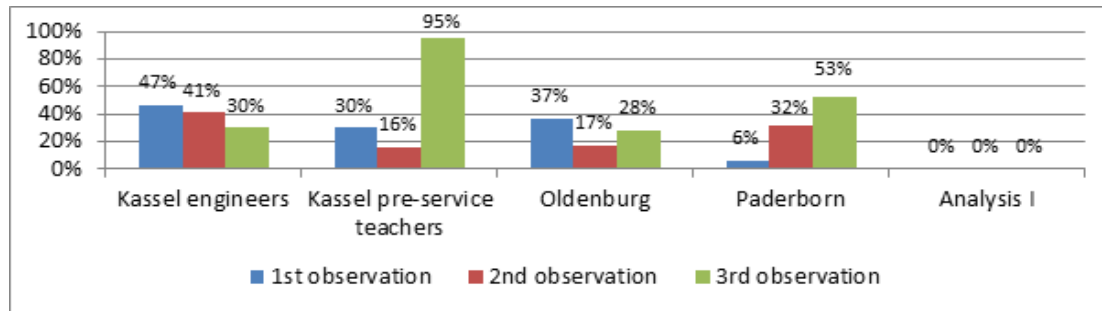


Figure 3: Engagement of students in problem solving in some of the lectures

As students rated the category of testing themselves in a safe place as helpful in the BiLOE, it seems like they profited from these periods of student task solving.

Discussion

Methodological discussion

To examine the features of redesigned lecture courses and in how far students find them helpful, we decided to make use of an established evaluation instrument called the BiLOE and to hire students who observed lecture sessions focusing on certain categories based on the WiGeMath taxonomy which we provided them with. To be precise, in applying the BiLOE we used an established evaluation method that we connected to the WiGeMath taxonomy and we developed an observation instrument that is easy to use with small training effort of the observers. Moreover, we did not rely on single observations but employed two raters.

The results of the BiLOE must be interpreted as personal estimates only. Though the students indicated how helpful they found the given activities to be in achieving the learning goals, we cannot say whether they actually did achieve these goals. Other indicators like exam results or homework assignments would have had to be examined to make a qualified statement in this respect. It would also be possible to use a pre- and post-test design to measure the students' understanding of the content. Moreover, the results we got from the BiLOE may be biased as we only surveyed those students that attended the lectures. Had we questioned all registered students of the course, results might have been different.

Concerning the observations, the two student observers did not always agree in their codings. However, we could not calculate inter-rater reliabilities due to unmatched timings by the observers. We recommend parallel timing for both observers in future research and maybe a more elaborate training. Yet, our results show that the use of simple methods can reveal important lecture features.

Discussion of the results

The data show that successful, innovative lectures may benefit from the five elements of reflection, testing oneself in a safe place, work with examples, work with prototypes and social interactions. It is possible to implement such elements in traditional settings and students value these elements.

According to Slomson (2010) the format of lectures remains the dominant way of teaching for university mathematics students at the beginning of their studies and he claims that they have hardly changed for 40 years. Our results show, that changes are possible. They contradict the text of Wood

et al. (2007) referring to Gibbs et al. (1992) who claim that university lectures are more or less uninterrupted monologues by lecturers where student activity was limited to listening and note-taking. The innovative approach of the projects in WiGeMath is visible as in the traditional lectures we only encountered lecturer talk and no problem solving by the students during the lecture. In fact, Slomson (2010) gives four characteristics of lectures and one of them is that there is scarce interaction between the lecturer and his audience and the focus of the lecturer lies in transmitting a set amount of material. Moreover, Wainwright et al. (2004) also observed traditional mathematics lectures and did not encounter any instances where students collaborated or interacted with other students or the lecturer. Yet, students do seem to be interested in being more engaged during lectures just as we found in our research. In fact, Willcoxson (1998) found that students value teacher-student and student-student interactions in the lectures they attend and as Cavanagh (2011) makes clear lectures that engages students in more than just note-taking have positive effects in students' approaches to learning and their long-term understanding.

That students found social interactions and the work with examples helpful in achieving the learning goals goes hand in hand with the findings by Slomson (2010) that students prefer lectures with exactly these features and by Anthony (2000) that students believe that availability of support helps to lead to students' academic success. Moreover, Wood et al. (2007) explain the lasting percentage of students attending lectures where they could easily access the material online by the importance that these students must place on human contact in their university learning experience.

In another study that evaluated the success of so-called lectorials which blend traditional lecturing with more engaging activities where students learn cooperatively also found that most of the students valued these activities as they helped them in deeper understanding the content and in staying interested (Cavanagh, 2011).

While students in our surveys found the work with prototypes and examples helpful in achieving the learning goals, Anthony (2010) found that students did not allocate an important role to the practice with examples for achieving academic success. Yet, Anthony (2010) refers to the self-directed study of examples rather than the work with examples during lecture time. Conversely, Cavanagh (2011) found that students valued an abundance of examples in the lectorials he surveyed as they increased motivation and interest in the tasks.

An important question is, however, what caveats lecturers see in these innovative formats. A major concern might be the pressure they feel to cover all the contents (Johnson, Ellis, and Rasmussen, 2016). We should then discuss extending the time given for such lectures as well as the sustainability of students' learning.

Implications for research, policy and teaching

Our results indicate that lecturers should consider restructuring their lectures so that students feel more secure to engage with the contents as well as with the lecturer and other students. Where possible, an abundance in examples might help students in understanding and then feeling more confident in the lecture content. So even though the traditional format of the lecture cannot be said to be useless in transmitting mathematical knowledge, our results indicate that students value social interactions and more lively formats which make the content illustrative by means of examples.

The lecture courses we evaluated differ from traditional lecture courses in more respects than the ones we focused on in this paper. In the categorization of the WiGeMath taxonomy, their focus on revisions of content and on study techniques or mathematical working techniques rather than on mathematical content would be differences in the individual and system-related goals of the measures. Yet, the measures also show specificities in their frame conditions and their characteristics. For example, the measures for engineering students in Kassel and Stuttgart are set out with small groups where the students work in an atmosphere that resembles school lessons. The lecture courses in Kassel and Oldenburg, where we focused on the pre-service teachers, indeed address this group predominantly rather than traditional lecture courses which mathematics majors and pre-service teachers attend together. The lecture course in Paderborn uses two tests in the course of the semester to prepare the students for the final exam and the structure of university mathematics exams in general whereas the lecture course in Würzburg does not include any examination at all. In this text, we looked at some further aspects of the lecture courses' learning culture and didactical features but to evaluate in how far students find these other features helpful in their learning process might be an endeavor worth undertaking in the future.

Acknowledgment

The WiGeMath project is funded by the German Federal Ministry of Education and Research (BMBF), grant identifiers 01PB14015A, 01PB18015A, 01PB14015B and 01PB18015B.

References

- Alcock, L., & Simpson, A. (2002). The Warwick analysis project: Practice and theory. In D. A. Holton (Ed.), *The Teaching and Learning of Mathematics at University Level* (pp. 99–111). Dordrecht: Springer.
- Anthony, G. (2000). Factors influencing first-year students' success in mathematics. *International Journal of Mathematical Education in Science and Technology*, 31(1), 3-14. doi: 10.1080/002073900287336
- Cavanagh, M. (2011). Students' experiences of active engagement through cooperative learning activities in lectures. *Active Learning in Higher Education*, 12(1), 23-33. doi: 10.1177/1469787410387724
- Colberg, C., Biehler, R., Hochmuth, R., Schaper, N., Liebendörfer, M., & Schürmann, M. (2016). Wirkung und Gelingensbedingungen von Unterstützungsmaßnahmen für mathematikbezogenes Lernen in der Studieneingangsphase. *BzMU* 2016. Heidelberg.
- Frank, A., & Kaduk, S. (2017). Lehrveranstaltungsevaluation als Ausgangspunkt für Reflexion und Veränderung. Teaching Analysis Poll (TAP) und Bielefelder Lernzielorientierte Evaluation (BiLOE). In Arbeitskreis Evaluation und Qualitätssicherung Berliner und Brandenburger Hochschule (Ed.), *QM-Systeme in Entwicklung: Change (or) Management? 15. Jahrestagung des Arbeitskreises Evaluation und Qualitätssicherung der Berliner und Brandenburger Hochschulen* (pp. 39-51). Berlin: FU Berlin.

- Gibbs, G., Habeshaw, S. & Habeshaw, T. (1992). *53 Interesting Things to do in your Lectures*. Bristol: Technical and Education Services Ltd.
- Gueudet, G. (2008). Investigating the secondary–tertiary transition. *Educational Studies in Mathematics*, 67(3), 237–254. <https://doi.org/10.1007/s10649-007-9100-6>
- Johnson, E., Ellis, J., & Rasmussen, C. (2016). It's about time: the relationships between coverage and instructional practices in college calculus. *International Journal of Mathematical Education in Science and Technology*, 47(4), 491–504. <https://doi.org/10.1080/0020739X.2015.1091516>
- Kuklinski, C., Leis, E., Liebendörfer, M., Hochmuth, R., Biehler, R., Lankeit, E., Neuhaus, S., Schaper, N. & Schürmann, M. (2018). Evaluating Innovative Measures in University Mathematics – The Case of Affective Outcomes in a Lecture focused on Problem-Solving. In V. Durand-Guerrier, R. Hochmuth, S. Goodchild & N. Hogstad (Eds.), *Proceedings of the Second conference of the International Network for Didactic Research in University Mathematics (INDRUM2018)* (pp. 527-536). Kristiansand, Norway: University of Agder and INDRUM.
- Liebendörfer, M., Hochmuth, R., Biehler, R., Schaper, N., Kuklinski, C., Khellaf, S., ... Rothe, L. (2017). A framework for goal dimensions of mathematics learning support in universities. In T. Dooley & G. Gueudet (Eds.), *Proceedings of the Tenth Congress of the European Society for Research in Mathematics Education (CERME10)* (pp. 2177-2184). Dublin, Ireland: DCU Institute of Education and ERME.
- Pritchard, D. (2015). Lectures and transition: from bottles to bonfires? In M. Grove, T. Croft, J. Kyle & D. Lawson (Eds.), *Transitions in undergraduate mathematics education* (pp. 57–69). Birmingham: University of Birmingham.
- Rach, S., & Heinze, A. (2017). The Transition from School to University in Mathematics: Which Influence Do School-Related Variables Have? *International Journal of Science and Mathematics Education*, 15(7), 1343–1363. <https://doi.org/10.1007/s10763-016-9744-8>
- Slomson, A. (2010). What makes a good maths lecture? *MSOR Connections*, 10(3), 17-20. Retrieved from <https://www.heacademy.ac.uk/system/files/msor.10.3e.pdf>
- Tall, D., & Yusof, Y. B. M. (1998). Changing attitudes to university mathematics through problem solving. *Educational Studies in Mathematics*, 37(1), 67–82.
- Wainwright, C., Morrell, P., Flick, L. & Schepige, A. (2004). Observation of Reform Teaching in Undergraduate Level Mathematics and Science Courses. *School Science and Mathematics*, 104(7), 322-335. <https://doi.org/10.1111/j.1949-8594.2004.tb18251.x>
- Willcoxson, L. (1998). The impact of academics' learning and teaching preferences on their teaching practices: A pilot study. *Studies in Higher Education*, 23(1), 59-70. doi: 10.1080/03075079812331380492
- Wood, L., Joyce, S., Petocz, P. & Rodd, M. (2007). Learning in lectures: multiple representations. *International Journal of Mathematical Education in Science and Technology*, 38(7), 907-915. doi: 10.1080/00207390701561496

Students' work with a task about logical relations between various concepts of multidimensional differentiability

Elisa Lankeit and Rolf Biehler

Universität Paderborn, Germany; elankeit@math.upb.de, biehler@math.upb.de

The purpose of this study is to identify student difficulties concerning the linkage of various concepts of differentiability in \mathbb{R}^n . For that reason, we designed a task where students are encouraged to explore the logical relations between these concepts and analyse how university students work with this task. Based on a detailed a priori analysis of the task building on TDS, we present results of an analysis of students' written work on the task, produced in tutorial group meetings. We identify different types of reasoning and compare difficulty levels of the different relations.

Keywords: College mathematics, multidimensional analysis, task design, tutorial groups.

Introduction and literature review

Differentiability and derivatives are essential topics in school and university mathematics and have been studied for many years (e.g., Orton, 1983; Zandieh, 1997). However, as Rasmussen, Marrongelle, and Borba (2014) point out, studies looking beyond first topics of calculus, for instance in multivariable calculus, are rare. From informal discussions with students and lecturers, and from our own teaching experience, we know that multivariable differentiation, an exciting and essential topic covered at the university level, is not an easy topic for many students. The transition from the one-dimensional into the multidimensional case is far from trivial, especially since there are inequivalent concepts of differentiability in \mathbb{R}^n . Nevertheless, the literature on the difficulties of students working with these different concepts and relating them to differentiability in the one-dimensional case is scarce. Martínez-Planell, Gaisman, and McGee (2015) studied students' understanding of the differential calculus of functions of two variables using APOS theory and found out that the geometric interpretation of functions in two variables and especially of their partial derivatives and total differential are problematic for students. However, they focused on the geometric understanding and did not define the total differential as a linear function and especially did not look at the students' understanding of the relationships of the different concepts. Since we could not find any literature concerning students' understanding of the relationship between the different concepts of differentiability in \mathbb{R}^n as such, we had to refer back to the one-dimensional case. Of course, there exists only one concept of differentiability (with different interpretations), and the concept of left- or right-hand differentiability usually plays no important role, whereas directional differentiability becomes an important notion in the multidimensional case. Students' knowledge and difficulties in linking differentiability, continuity and integrability in the one-dimensional case could provide helpful insights. Juter (2012) and Duru, Köklü, and Jakubowski (2010) found that many students believed continuity implied differentiability in the one-dimensional case. Additionally, students who found the correct relations between these concepts were often not able to give sufficient justifications. When looking at the relations between differentiability, continuity and integrability, success rates are even lower (Sevimli, 2018). In some

cases, students used the teaching sequence as an argument for the stated relations. Generalising from this, we expect even more difficulties in the multidimensional case, which may exacerbate, if the knowledge on the one-dimensional case is still fragile. A further challenge for the students is the linkage of the one-dimensional to the multidimensional case. This linkage requires that the students have acquired the interpretation of the derivative as the best linear approximation and not just the interpretation of it as a tangent line, as a local rate of change or as the limit of the difference quotient (for these different interpretations, see Greefrath et al., 2016).

In this article, we are especially interested in the way students work with different concepts of differentiability in \mathbb{R}^n . We designed a task asking to explore the logical relations between these. The task was given to students in their weekly tutorial group meetings in an Analysis II class (which is, from an international perspective, more on the level of upper-division proof-oriented Real Analysis courses in the US than typical lower-division Calculus courses). We will present the task and selected results from our study examining how students in their second or higher semester worked on the designed task, showing success rates for rating and justifying the validity of different relationships and selected ways of argumentation. Thereby we want to improve understanding of students' knowledge and learning of differentiability concepts and hopefully contribute to designing suitable learning environments regarding this subject area in the future.

Theoretical framework

We base our task design and analysis on Brousseau's Theory of Didactical Situations (TDS) (Brousseau, 2006). A *situation* describes the circumstances in which students find themselves concerning their *milieu* (the set of objects on hand, available knowledge and interaction with others). The distinction between didactical and adidactical situations is essential. A situation is of adidactic nature if the teacher does not instruct, but students work autonomously and learn by adapting to the milieu whereas, in a didactical situation, acculturation happens through institutionalisation and devolution. For a more detailed description and a well-presented introduction of TDS, see for example Artigue, Haspekian, and Corblin-Lenfant (2014).

According to Gravesen, Grønbæk, and Winsløw (2016, p. 10), "exercises are the cores of situations of learning". They developed a framework for task design and analysis, based on TDS and focusing on four specific "potentials" of tasks. The *adidactic potential* of a task describes the possibilities of a task to be used in an adidactical situation: Which possibilities does a student have to engage with the task and develop new knowledge independently without additional interactions with the teacher? A task's *research potential* is measured by the possibilities to engage with one or more research like activities formulated by Gravesen et al. (2016). *Linkage potential* represents the possibilities for students to connect "old" and "new" knowledge. At last, *deepening potential* means the task's potential to intensify and elaborate the students' knowledge regarding results, notations and methods.

Research questions

We designed a task with adidactical, research, linkage and deepening potential and put the students into an adidactical situation of working on that task. We investigate how the students link the different concepts of differentiability in \mathbb{R}^n and want to identify students' difficulties in this subject

area. In this paper, we want to answer the following research questions: **RQ 1:** Which of the logical relations seem to be more difficult for the students? Is the order of difficulty levels the same for the decision of validity and the associated argumentation? **RQ 2:** What kind of reasoning do the students use when explaining the relationships? **RQ 3:** How is this reasoning related to the reasoning and identified problems that we anticipated in the a priori analysis? In this paper we focus on students' work on the two questions "Does partial differentiability imply differentiability?" and "Does continuity imply the existence of all directional derivatives?".

Methodology and study design

The method of didactical engineering (Artigue, 1994), evolved from TDS, provides the link between the theoretical framework of TDS and the practical implementation in this study to answer our research questions. It is composed of a preliminary analysis of epistemological, cognitive and didactical dimensions of the mathematical knowledge that is to be learned in the situation. It includes the design of the situation including an a priori analysis with the students' expected behaviour based on the choice of the didactic variables, the experimentation (usually a classroom implementation of the situation) and an a posteriori analysis with evaluation and comparison of a priori and a posteriori analyses. Guided by these steps, we will now provide a short description of our approach.

Step 1: Designing a task that supports our research interests. We used the described method of didactical engineering and conducted a preliminary analysis at first (not shown here). For this, we analysed some broadly established Analysis II books used in German universities (e.g., Heuser, 1992) concerning the essence of the concept of multidimensional differentiability. When designing the task, we oriented ourselves by the four "potentials" according to Gravesen et al.'s framework. The task analysed in this article aims at supporting the students in gaining an overview of how the different concepts of differentiability are connected. After working on this task, students should be able to explain how the concepts are connected and to give counterexamples of functions having only some of the properties. The task discussed in this paper was preceded by a prompt to recapitulate which of the connections the lecture had already covered. The discussed task was given to the students after they completed this. In the task, students are asked to examine whether different implications (called "T1" to "T15") are valid or not. The diagram used in the task can be seen in Figure 1 together with the success rates. We created the visual representation of the logical relations (similar to a concept map) in order to support students' reasoning. In particular, the diagram is to support an abstract knowledge network, which students can use as an abstract reasoning tool that some implications are true / cannot be true because other logical relations have already been proven. We were interested in how the students would use this network vs try to proof or refute a particular implication by specific arguments.

Step 2: Conducting an a priori analysis of the task. The a priori analysis of two implications (T10 and T15) can be found in the next section. It was conducted before the implementation of the task.

Step 3: Task milieu and data collection. The situation of working on the task is characterized by the task itself and the milieu in which the students found themselves. The task, which was

coordinated with the teacher and teaching assistant, was given to the students of an Analysis II course in their weekly tutorial group meeting. Most of the students worked in pairs or small groups and discussed the task. They also used their lecture notes and could ask the tutor if they needed help. For this particular meeting, particular instructions for the tutors were developed: They were asked to only give strategic hints and mostly just let the students work on their own. The written work the students ($n=31$) produced during the tutorial group meetings was collected anonymously, scanned and then handed back to the students (without comment or marking).

Step 4: Analysis of data. We analysed the students' written solutions concerning two aspects: the correctness of students' solutions and their ways of argumentation. At first, we used a normative approach by rating the solutions: For every implication arrow, there are two separate tasks: A. deciding whether the implication is true or false, and B. stating a correct justification which could be a counterexample or a proof. Two types of missing values are coded: If there are none of the boxes checked (A) or nothing was written down (B), but subsequent subtasks were worked on, we coded it as a "missing, but attempted", i. e. we believe the lack of written work was not due to time. If nothing is written down but none of the subsequent tasks was worked on, we coded it as "missing". For the last subtask, we decided to count as attempts every work where one of the boxes for T5 or T15 was checked, or anything was written down for B. The correct decision of A is rated one point if correct and 0 if wrong. B is rated as follows: a (nearly) right justification (i.e. correct with a minor formal error) is rated two points. We give one point for a meaningful attempt for a justification, including argumentations containing consequential errors or correct counterexamples without arguments why these are counterexamples. Wrong or incomprehensible justifications, including wrong counterexamples, are rated zero points. Two total solution rates for A and B were calculated. Here, we defined the success rate per task as the sum of the scores divided by the number of students who attempted the subtask multiplied by the maximum score (1 for A and 2 for B). For analysing the students' ways of argumentation, we used qualitative content analysis (Schreier, 2012) with categories deducted from the a priori analysis complemented with inductively found categories.

A priori analyses

The a priori analysis is the first result and serves as a research tool in the data analysis as well since the results will be compared to our expectations.

A priori analysis of "Does partial differentiability imply differentiability?" (T10)

Most students will probably state correctly that this implication is not true. A hint for this could be that if it were true, it would have probably been covered in the lecture when the other direction was discussed. Moreover, why should the lecturer introduce two different concepts if they turn out to be equivalent? We call these reasons "didactical-contract reasons". They are not mathematical reasons but based on assumptions on what constitutes the didactical contract (Brousseau 2006) of the lecture. For proof, there are several options. Since the students are in their second semester or higher and are used to using counterexamples, we expected that they would look for an example of a partially differentiable function that is not differentiable. The function used in the lecture to show that partial differentiability did not imply continuity (Example VII.1.5, see Figure 1) and stated in

part b) of this task, which is such an example, should come to mind quickly. Some students will probably only give the counterexample without explaining why it contradicts the implication. Others will explain why the function is not differentiable by calculating the error term φ and showing that $\frac{\varphi(h)}{\|h\|}$ does not converge to 0 as $h \rightarrow 0$. Another possibility is that students will argue on the abstract level of logical relations and might take advantage of the argumentation that f is not continuous and therefore cannot be differentiable due to the contraposition of T3. However, it may also occur that students think the implication is true in the first place or that they have difficulties to construct own counterexamples. Based on this analysis, we expected that most students would solve task T10 successfully.

A priori analysis of “Does continuity imply the existence of all directional derivatives?” (T15)

It is important to note that the lecturer defined directional derivatives as one-sided limits in this lecture. Students could have developed a general sense of what we may call “levels or degrees of smoothness” in \mathbb{R}^1 . These students might quickly come to the conjecture that this implication is probably not true by making the courageous generalisation from \mathbb{R}^1 that only continuity will not imply any differentiability whatsoever. A strategy may also be to check the meaning of this implication in \mathbb{R}^1 . Students may know that \mathbb{R}^n -continuity for $n = 1$ is the same as one-dimensional continuity. Moreover, the existence of directional derivatives for $n = 1$ means that the function has a left- and a right-hand derivative (which need not be the same). With this clear picture, they remember that $x \mapsto |x|$ is continuous and has both left- and right-hand derivatives, so the question is whether there is an \mathbb{R}^1 -example that is continuous but has no left- and right-hand derivatives. Alternatively, students may initially think that $x \mapsto |x|$ is a counterexample but then discover with a closer look that this is not the case. Some students might take this as a hint that the implication is, in fact, true, mainly because the only examples for continuous but non-differentiable functions coming to their minds might be jagged functions. Another example for a non-differentiable but continuous function that the students could know is the square root function $\mathbb{R} \rightarrow \mathbb{R}, x \mapsto \sqrt{|x|}$ in 0, which will provide a valid counterexample for T15, having a “vertical tangent” in $x = 0$. If they do not know this example, it might be tough for them to construct a counterexample themselves. It could also happen that students look for counterexamples not in \mathbb{R}^1 but in \mathbb{R}^2 or higher dimensions, but we did not expect that they would be successful with that. Students might also try to use the logical network, but this will not be rewarding.

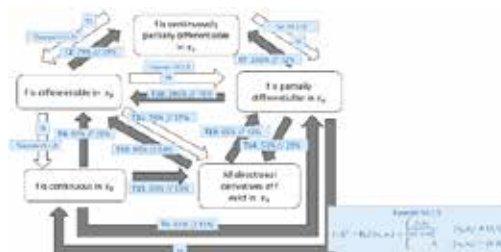


Figure 1: The two success rates for each implication. The first number per arrow depicts the success rate for A (correctness of decision); the second number is the B success rate (correctness and quality of argumentation). We marked correct implications white, wrong implications dark grey. The implications without success rates had been covered in the lecture before.

Description of selected results

Our expectation that the implication T10 would be one of the most straightforward tasks was correct (see Figure 1). A success rate of 100% for A (decision what is correct) is notable and satisfying. We credited 72% of the attempts in T10B with 2 points, 10% got 1 point, 7% 0 points and 10% of the attempts did not contain any written work concerning this task. The success rates in A for the recognition of the correctness of the implication T15 are lower than we expected. We expected low success rates in B for the justification in T15, but the fact that the rates lower than the rate for T2 (where the counterexample is not intuitive at all) is somewhat surprising to us. None of the students received 2 points for their reasoning, 35% of the attempts got 1 point, whereas 26% of the attempts got 0 points and 39% was coded as missing but attempted.

Results of the qualitative analysis of the written reasoning (B) in subtasks T10 and T15

For T10, we found the following categories from the a priori analysis and the data. We assigned two points for stating the function from Example VII.1.5 in the lecture as a counterexample and showing “by hand” that it is not differentiable by calculating the error term (coded “B1”) or the argumentation that it cannot be differentiable because it is not continuous (“B2”). Another argumentation assigned two points was working logically with the diagram saying that if T10 were true, together with T3, it would imply T6 which is wrong without stating a counterexample (“A”). A different correct counterexample with appropriate argumentation (“E1”) would be assigned two points as well. We assigned one point for stating the function from Example VII.1.5 as a counterexample without an explanation (“B0”). Giving a wrong counterexample (“E0”) resulted in 0 points. Typical examples for the two most common argumentations for T10, “A” and “B2”, can be found in Figure 2.

<p>“Partial differentiability does <u>not</u> imply differentiability Counterexample: f as in part b) is partially differentiable in $x_0 = 0$. If f were differentiable in $x_0 = 0$, continuity would be implied (‡) Thus, f is not differentiable in $x_0 = 0$”</p>	<p>“If partially differentiable and differentiable in x_0 were equiv- alent, T6 would have to be true because T3 is valid. ‡ ⇒ T10 is not true.”</p>
--	---

Figure 2: Typical examples for “B2” (left) and “A” (right) (translated by the first author)

Concerning T15, we assigned two points for stating a correct counterexample with appropriate reasoning. We expected the square root function as a counterexample, with different possible explanations: stating that it is continuous but not all directional derivatives exist (“W1”), this explanation with specifying the point of interest $x = 0$ (“W2”) or a calculation that the directional derivatives in $x = 0$ don't exist (“W3”). We gave one point for stating the square root function as a counterexample without an explanation (“W0”). The statement that the absolute value function is not a valid counterexample (“Bx”) was also rated one point. Additionally, some students gave explanations using the logical structure and wrong implications they thought were true in preceding tasks to argue without a counterexample, namely T12 and the fact that T4 is not true (“Z1”) or T13 and the fact that T5 is not true (“Z2”). Stating the absolute value function as a counterexample resulted in 0 points. For both implications, other argumentations were coded as “X”. The number of students who used these different kinds of argumentation can be found in Table 1 (T10) and Table 2 (T15). It can be seen that we could not assign some of the categories to any student, e.g., “B1” for T10.

Points (10 B)	Code	Number of students
2	B1	0
	B2	13
	A	8
	E1	0
1	B0	1
	X	2
0	E0	1
	X	1

Table 1: Student answers for T10

Points (15 B)	Code	Number of students
2	W1/W2/W3	0
1	W0	1
	Bx	1
	Z1	2
	Z2	1
	X	2
0	B	5
	X	1

Table 2: Student answers for T15

Discussion of results

RQ 1: Most of the students were able to decide correctly for most of the implications whether they were true or not. The calculated success rates give hints concerning the level of difficulty of the implications. We can conclude that deciding whether an implication is true and stating the right reason are not the same, as illustrated by T15. It corroborates findings from studies reviewed in the introduction that students often cannot give correct justifications for relationships between different concepts in the one-dimensional case. However, students in our study were in general more successful than in some of the described studies. That could indicate that working with logical relations between new concepts becomes more accessible for students as they pursue their studies.

RQ 2: When they could, nearly all students used the logical structure of the diagram for answering whether a new implication is true, instead of constructing a new proof or a counterexample. In some cases, properties of examples were established by reference to the logical structure instead of verifying the property with calculations with the example itself (for example in T10). When they could, students traced the question back to one-dimensional cases and tried to find counterexamples there (which was possible for many of the implications and was our purpose in the design, utilising the task's linkage potential). The teaching sequence was not given as an argument (as was the case in Sevimli, 2018), which could be either because students knew from experience that this is not true, or because these concepts (except continuity) were introduced in a short period after another.

RQ 3: The a priori analysis was based mostly on our intuition because we could not find literature concerning didactics of multidimensional calculus, which is something we want to contribute to in the future. There were some lines of argument we did not anticipate, especially concerning incorrect reasoning. We found it surprising that a not negligible part of the students incorrectly considered the absolute value function as a counterexample in T15 although it was proven a week before that all directional derivatives of the absolute value function exist. There were some lines of argument we expected some of the students to use that were not used at all (like showing that the error term in T10 does not have the required property). This fact might, however, also be due to the rather small sample of only 31 students. Our estimates of the subtasks' difficulty were most often appropriate.

For further investigation, including what leads students to their decision, we additionally filmed eight pairs of students while working on the task. The analysis of these is expected to provide more

insights concerning the questions where the students got stuck and why. This analysis will be especially interesting because often students who made the wrong decision did not explain why they thought that (e.g., in T15). Our data will be analysed more thoroughly in the next months.

References

- Artigue, M. (1994). Didactical engineering as a framework for the conception of teaching products. *Didactics of mathematics as a scientific discipline*, 13, 27-39.
- Artigue, M., Haspekian, M., & Corblin-Lenfant, A. (2014). Introduction to the Theory of Didactical Situations (TDS). In A. Bikner-Ahsbahs, & S. Prediger (Eds.), *Networking of Theories as a Research Practice in Mathematics Education* (pp. 47-66): Springer.
- Brousseau, G. (2006). *Theory of Didactical Situations in Mathematics* (Vol. 19): Kluwer.
- Duru, A., Köklü, Ö., & Jakubowski, E. (2010). Pre-service mathematics teachers' conceptions about the relationship between continuity and differentiability of a function. *Scientific Research and Essays*, 5(12), 1519-1529.
- Gravesen, K. F., Grønbaek, N., & Winsløw, C. (2016). Task Design for Students' Work with Basic Theory in Analysis: the Cases of Multidimensional Differentiability and Curve Integrals. *International Journal of Research in Undergraduate Mathematics Education*, 3(1), 9-33.
- Greefrath, G., Oldenburg, R., Siller, H.-S., Ulm, V., & Weigand, H.-G. (2016). Aspects and "Grundvorstellungen" of the Concepts of Derivative and Integral. *Journal für Mathematik-Didaktik*, 37(1), 99-129.
- Heuser, H. (1992). *Lehrbuch der Analysis* (Vol. 2). Stuttgart: Teubner.
- Juter, K. (2012). *The validity of students' conceptions of differentiability and continuity*. Paper presented at the MADIF 8.
- Martínez-Planell, R., Gaisman, M. T., & McGee, D. (2015). On students' understanding of the differential calculus of functions of two variables. *The Journal of Mathematical Behavior*, 38, 57-86.
- Orton, A. (1983). Students' understanding of differentiation. *Educational Studies in Mathematics*, 14(3), 235-250.
- Rasmussen, C., Marrongelle, K., & Borba, M. C. (2014). Research on calculus: what do we know and where do we need to go? *ZDM – The International Journal on Mathematics Education*, 46(4), 507-515.
- Schreier, M. (2012). *Qualitative Content Analysis in Practice*. London: SAGE.
- Sevimli, E. (2018). Understanding students' hierarchical thinking: a view from continuity, differentiability and integrability. *Teaching Mathematics and its Applications: An International Journal of the IMA*, 37(1), 1-16.
- Zandieh, M. J. (1997). *The evolution of student understanding of the concept of derivative*. (Doctor of Philosophy (PhD)), Oregon State University, Corvallis.

Teaching of discontinuous functions of one or two variables: A didactic experience using problem posing and levels of cognitive demand

Uldarico Malaspina and Carlos Torres

Pontificia Universidad Católica del Perú, Lima, Perú; umalasp@pucp.pe

This paper is a part of an ongoing research that seeks to propose sequences of problem-posing and problem-solving tasks that will help students to develop deeper comprehension of jump discontinuity of functions. We present a teaching experience focused on problem-posing in the context of discontinuous functions of one or two real variables, and analyze the cognitive demand that underlie the posed problems. We developed this experience in a real analysis course for in-service teachers. The teaching experience shows that it is possible to design a sequence of didactic tasks of problem-posing grounded in daily life situations, which facilitate the perception and intuitive comprehension of jump discontinuity of real functions. This experience suggests also to delve into the relationship between problem posing and cognitive demand.

Keywords: Problem solving, problem posing, discontinuous functions, cognitive demand, university mathematics.

Introduction

The concept of function has been considered for a long time as the most important in the whole development of mathematics. However, in mathematics education research, there are few publications related to discontinuity of functions at the university level. In one of them, Hitt (1994) claims that “when teachers came to construct functions they showed a marked tendency to think in terms of continuous functions. [...] Even if they had learned about discontinuous functions, the concept has not become an active element of their mathematical thinking” (p.19). Furthermore, Jayakody and Zazkis (2015) state that the type of definition that is used on continuity of functions is important for the teaching of this mathematical object. Thus, according to these researchers, students must face different definitions and representations, depending on the context. Based on our previous researches, we claim problem posing (PP) tasks help to deep into definitions and representations of a mathematical object previously chosen. Certainly, this innovation should be addressed by a teacher who should have the competence for analyzing his/her mathematical practices (didactic analysis competence) (Torres & Malaspina, 2018).

In our research, we are developing PP tasks with emphasis on the observation of the discontinuity of functions. Even more, with the purpose of contributing to the improvement of in-service teachers' didactic analysis competence around this topic, we analyze the levels of cognitive demand (LCD) of the posed problems. With this feedback, the future similar sequences of tasks to be proposed could have more possibilities of adaptation to different groups of students. As Georgius (2013) says, “Teachers need to learn to differentiate between tasks of high and low cognitive demand and select tasks that require students to make deep mathematical connections.” (p. 9).

Our main research goals are: (i) To examine the cognitive demand of the problems posed by in-service teachers, from daily life situations, in the mathematical environment of the functions with jump

discontinuities; (ii) to propose a didactic sequence for the teaching of functions with jump discontinuities.

Theoretical framework

Problem posing and mathematical teacher's competence

It is worth mentioning that there are different positions in terms of what researchers understand by engaging in problem posing activities (Cai, Hwang, Jiang, & Silber, 2015). In this study, we adopt the proposal from Malaspina, Mallart and Font (2015), according to which problem posing is a process through which a new problem is obtained. If the new problem is obtained by modifying a given problem, it is said that the new problem was obtained by *variation*. If the new problem is obtained from a given situation or from a specific requirement, whether mathematical or didactic, it is said that the new problem was obtained by *elaboration*. These scholars also consider that problems have four fundamental elements: information, requirement, context (intra-mathematical or extra-mathematical) and mathematical environment; in that approach, problem posing by variation entails quantitative or qualitative modifications of one or more of these elements in a given problem; and problem posing by elaboration can be done specifying these four elements from the given situation.

Usually, in order to develop and assess students' mathematical knowledge and skills, instructional strategies mainly focus on problem solving. We consider that a teacher must not only have the ability to solve mathematical problems, but also choose, modify and pose problems with educational purposes, which means to facilitate or delve into his students' learning and stimulate their mathematical thinking (Tichá & Hošpesová, 2013; Torres & Malaspina, 2018). Moreover, we consider that the teachers' experiences, both in the problem posing and in the determination of their LCD, will contribute to the quality of the problem posing tasks when they design mathematical units of study, including the assessment of the learnings; i.e., such experiences will contribute to improving their didactic analysis competence.

Cognitive demand to discontinuous functions

As one can imagine, conducting research regarding cognitive demand of mathematical problems is a wide endeavor. Most of the studies related to these topics apply quantitative research, which means to describe the LCD based on psychometrical methods. In our study, we want to go deep into cognitive demand from a qualitative perspective, because as Wilhelm (2014) claims "there is evidence suggesting that mathematical knowledge for teaching and conceptions of teaching and learning mathematics are likely to be related to the enactment of cognitively demanding tasks and that they might be interrelated in complex ways". In this sense, the cognitive demand of mathematical tasks as a research topic has been of interest for mathematics education researchers (Gutiérrez, Benedicto, Jaime, & Arbona, 2018; Smith & Stein, 1998).

The Cognitive Demand model proposed by Smith and Stein (1998), characterizes the mathematical tasks according to their *potential to engage students in high-level thinking*. It includes four levels of cognitive demand that assess the cognitive effort required from students to solve a mathematical task. Moreover, they argue the importance to examine the cognitive demand required by tasks because of their influence on student's learning.

Certainly, the proposal developed by Smith and Stein (1998) has been a seminal reference at this time. These researchers gave us a set of criteria to classify mathematical tasks or problems into four levels of cognitive demand corresponding to different grades of cognitive effort required to solve them. However, if we want to determine a LCD to the posed problems on discontinuous functions, we consider necessary to make adjustments to the characteristics of these LCD (Table 1). It is worth mentioning that there are already studies taking this approach. For example, Gutiérrez et al. (2018) made a particularization for pre-algebra problems.

Taking into account the importance of the LCD, expressed by mathematics education researchers, and considering cognitive demand as a characterization of the complexity of the reasoning required for solving a mathematical task, we think that having criteria and examples to assign levels of cognitive demand to problems on real discontinuous functions, will serve as a basis for assigning tasks on this mathematical object; even more, if the purpose is to work with non-routine problems, such as those proposed by the teachers themselves, based on situations from daily life.

We use the LCD proposed by Smith and Stein (1998) as a reference for our purposes. In Table 1 we describe these four LCD that we have adjusted to problems posed by variation or elaboration on discontinuous real functions. We take into account that in the given problem or in the given situation, a discontinuous function could be implicit or explicit. Each level is exemplified and some of the examples come from problems 1 to 7, which emerged in this didactic experience and are shown in the results and discussion section.

Levels of cognitive demand		Some characteristics of posed problems (by variation or by elaboration) on discontinuous functions
Low-level	Routine procedures (A)	Calculating values of a given function near, by left and right, to a point of jump discontinuity. (e. g. calculate $f(1.5)$ and $f(2.5)$, where f is the greatest integer function; See Problem 1)
	Procedures without connections to concepts or meaning (B)	Non evident values of an implicit discontinuous function of one or two variables in a given situation are calculated. (e.g., Suppose that for each kilo of rice you pay 3 dollars, but if you buy 4 kilos or more, you have a total discount of 10%. How much will you pay for 3.5 kilos of rice? And for 4 kilos of rice? See Problem 4 and Problem 6)
High-level	Procedures with connections to concepts and meaning (C)	Tasks focused on discovering the underlying contents and gaining mathematical understanding. (e.g. Make a graphic representation of the greatest integer function; See Problem 2 and Problem 5.)
	Doing mathematics (D)	Specify algebraically a discontinuous function of one or two variables, given implicitly in a situation. (e.g. Find the algebraic expression and its graphic of the pay function given as example in level B; See Problem 3 and Problem 7)

Table 1: Characterization of the LCD to problems posed on discontinuous functions

The study methodology

This study is based on an experimental case study, exploratory and descriptive, taking as unit of analysis the problems posed by the teachers participating in the workshop. We use the LCD stated in Table 1 to analyze problems posed by the participants. They developed a sequence of tasks of PP aimed at guiding them in understanding the basic ideas related to functions with jump discontinuities. To determine the LCD of each problem, we examined the link between its information and its requirement, the solutions presented by the participants and the solutions we developed. Finally, we compared the characteristics found in our analysis with the characteristics given in Table 1.

Sample and experimental setting

The sample for this study comprises of 22 in-service teachers who were enrolled in the *Analysis in the real line* course and *Analysis in several real variables* course from the Master's Program in Mathematics Education at Pontificia Universidad Católica del Perú. Most of them are in-service teachers, and some of them are engineers. None of them has had previous experience neither in PP whose objective is to facilitate learnings nor in studying discontinuous functions in daily life contexts.

We developed the experience in 6 phases: *Phase 1*: Become familiar with PP as part of the topics of the class; for example, given a daily life situation related to shopping in a convenience store, pose and solve a problem in the mathematical environment of affine functions. *Phase 2*: Choose a real situation corresponding to a single variable real function, discontinuous at points of integer abscissa, and ask for questions related to the given situation. *Phase 3*: Present the definition of continuous single variable real function at a point of accumulation of the domain of the function by using limits. Analyze the definition and jump discontinuity at a point using the questions and answers to Phase 2. *Phase 4*: Present a daily life situation and ask to use it to pose problems that illustrate cases of continuity and discontinuity of a single variable real function. *Phase 5*: Propose daily life situations favorable for graphic representations of subsets of the plane related to points of discontinuity of a two-variable real function. *Phase 6*: Use the results from the previous phase to formally define a two-real variable function with discontinuities. Analyze the definition and jump discontinuity at a point.

Results and discussion

In this section, we analyze the results from the didactic experience, focusing on the LCD of the problems posed and solved by the participants, following the specifications given for each level in Table 1. We analyzed the cognitive demand of all the problems posed by the participants, but due to space limitations, we will show only some of them.

In Phase 1, we focused on what happened when students were asked to pose a problem based on the following situation: *A convenience store sells a specific brand of juice in one-liter bottles at 6 dollars each, and offers 3 bottles for the price of 2*. The problems posed were of different LCD, but due to space limitations we don't refer explicitly to them as we do for other phases, directly related to discontinuous functions with real variables.

We worked on Phase 2 with a common daily life situation, such as paying for a parking space. There are fees such as: *"4 dollars hourly or less"*. Students were asked to write problem-questions that could

be posed in the mathematical environment of real functions of a real variable. We chose some of the questions, considering the different LCD they entail:

Problem 1: *How much will you pay for parking for 1 hour and 15 minutes?*

Problem 2: *What is the graph like of the payment function for parking for x hours?*

Problem 3: *What is the algebraic expression of the payment function for parking for x hours?*

Students worked in pairs and some of them came to the correct graph of function $P = P(x)$: ‘the payment of $P(x)$ dollars for parking for x hours’, as the one shown in Figure 1. After sharing this graph, we asked the following question: *If Mary says she parked her car for about 2 hours, can we know how much Mary paid for parking?*

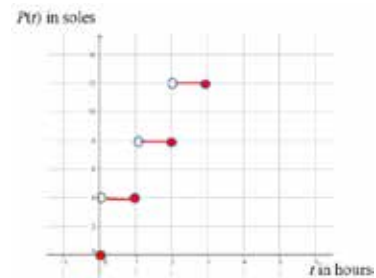


Figure 1: Graph of the payment for parking function

With the graph (Figure 1) and the question, participants intervened saying expressions like ‘discontinuity’, ‘left-hand limit’ and ‘right-hand limit’.

All of this we used for formally introducing the concept of continuity at a point of the domain of a real function of a real variable by using limits, when that point is a point of accumulation of its domain; that is, for developing Phase 3. We used the following definition: If f is a real function of a real variable, a is a point of domain and a point of accumulation of f ; then f is continuous for $x = a$ if and only if $\lim_{x \rightarrow a} f(x) = f(a)$. We analyzed the meaning of this definition using the representations made by the participants.

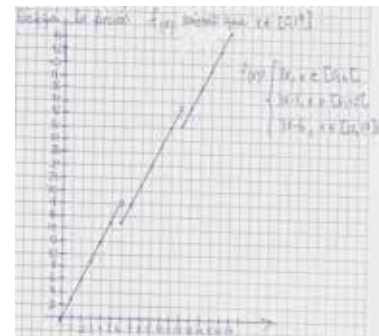


Figure 2: Graph of the payment function using the offer. Problem 2

We can see that Problem 1 requires a direct calculation, so we place it in Level A. Problem 2 explicitly requires the graph of a function, so we place it in Level C. Problem 3 requires complex and non-algorithmic thinking of the solver, so we place it in Level D.

For Phase 4, we proposed the following: *Use the following situation to pose a problem whose solution shows cases of continuity and discontinuity of a function in the interval $[0; 17]$. In a convenience store there is a sign with the following offer: 6 kg bag of rice for 15 dollars. Price per kilogram: 3 dollars*

Most of the participants proposed using the situation to define a function and represent it graphic and algebraically, as shown in Figure 2.

For Phase 5, we proposed the following situation:

At a market, rice and sugar are sold for 3 and 2.40 dollars per kilogram, respectively. Also, as a special offer, 3-kg-rice and 2-kg-sugar packages are sold for 10 dollars.

The idea was to use the situation so that, assuming the quantities of rice and sugar bought can vary in intervals of real numbers, it is perceived that by taking the offer it is possible to find points near each other, whose corresponding payments are not near. Finding the function f of two variables, which expresses paying $f(x; y)$ dollars for x kg of rice and y kg of sugar by taking the offer as long as it is possible, and assuming variables x, y can take every non-negative real number, it is a problem requiring high cognitive demand. We didactically consider it is important and necessary to pose problems

that facilitate the comprehension and solution of this problem; in other words, *pre-problems*, which is the term used in our PP approach (Malaspina, Mallart, & Font, 2015). The basic idea for such pre-problems was to identify points and regions of the plane where the convenience store's offer cannot be taken up on. Thus, we proposed participants to pose problems by using the given situation and different possibilities in relation to taking the convenience store's offer. Some of the problems were:

Problem 4. *How much should you pay if you take up on the offer for 4 kilos of rice and 3 kilos of sugar?*

Problem 5. *How much should you pay if you take up on the offer – when possible - for the following cases? 2.95 kilos of rice and 8 kilos of sugar; 3 kilos of rice and 8 of sugar; and 3.05 kilos of rice and 8 of sugar?*

Problem 6: *How much should you pay if you take up on the offer for 7 kilos of rice and 5 kilos of sugar?*

Problem 7: *When buying what quantities of rice and sugar is it not possible to use the offer?*

We invited the authors of problems 4, 5 and 6 to socialize their problems and solutions. Some doubts were clarified after a short discussion.

Due to the simplicity of these problems, we will stop at Problem 7, which is the one that implies the greatest cognitive demand. Its complexity requires restrictions and graphic representations of the corresponding regions. We asked all participants to solve it, telling them to use x as the variable representing kilograms of rice and y as the variable representing kilograms of sugar, both of which can take non-negative real numbers.

Something particularly important in this context is to consider strips of points where the offer cannot be taken up on since $x < 3$ or $y < 2$. After examining this observation, participants stated that they understood the solution presented by their colleague A3 (Figure 3).

The problems posed by the participants and the solutions they analyzed – specially Problem 7 – created favorable conditions to go to Phase 6: define a function f whose variables x and y have the meanings already assigned, so that $f(x; y)$ expresses the payment made to buy x kilos of rice and y kilos of sugar by taking the offer, as long as it is possible. To simplify, the purchase was restricted to 5 kilos of rice and 4 kilos of sugar maximum, and we asked to examine how much should one pay

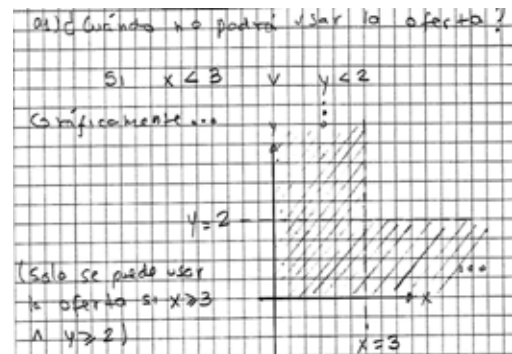


Figure 3: Solution of the Problem 7 presented by participant A3 (set L)

for several $(x; y)$ points in which the offer cannot be taken up on. After some rich mathematical and didactic discussion, it was agreed to name the given set as L in Figure 4, and the set of all possible purchases as A , considering the given restriction.

$A = [0; 5] \times [0; 4]$ and $L = ([0; 3[\times R) \cup (R \times [0; 2[)$. $A \cap L$ is shown in Figure 4.

Using these sets and calculating values such as $f(3; 2)$; $f(2.9; 1.8)$; $f(2.9; 2.1)$; $f(3.25; 3)$; $f(2.9; 4)$; $f(5; 1.9)$ we came to the following function:

$$f(x, y) = \begin{cases} 3x + 2.40y, & \text{if } (x; y) \in A \cap L \\ 10 + 3(x - 3) + 2.40(y - 2), & \text{if } (x; y) \in A - A \cap L \end{cases}$$

It became evident that f values for points near $(3; 2)$ were not necessarily near $f(3; 2)$, and that is how the discontinuity of this function was perceived at point $(3; 2)$. It is worth mentioning that f is a discontinuous function not only at $(3; 2)$ and that it was obtained by PP, considering an extra-mathematical context taken from a daily life situation. Following this discussion, the formal definition of continuous function at point $a = (a_1; a_2)$ of its domain was given, when the function is real of two real variables and a is an accumulation point of its domain, similar to what was done for single variable functions in Phase 3.

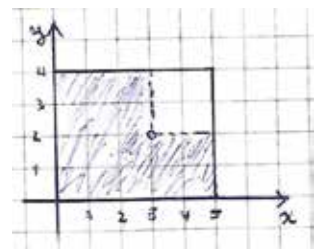


Figure 4: $A \cap L$ shaded

We placed problems 4 and 6 in Level B because they were basically calculations that were not straightforward. Problem 5, by proposing calculate values of the implicit function corresponding to points with non-whole abscise, and near to the point $(3; 8)$, contributed to the perception that the values of the function at a point of its domain are not necessarily near the value of the function near that point. Furthermore, that $(3; 2)$ is not the only point with that characteristic (point of discontinuity), but there are many other points of discontinuity on the line with equation $x = 3$. Thus, we place it in Level C. Problem 7 is placed in Level D. It requires the perception of a subset of the plane that do not contain its boundary, precisely because at some boundary points the offer can be used.

Final considerations

Based on the previous section, as well as on the results of the examination made at the end of the course, we consider that the didactic sequence, with the above described phases, to pose problems of different LCD, facilitate perception and intuitive comprehension of single and two-variable real functions, which have jump discontinuities at one or more points of their domains and which are related to daily life situations. Moreover, it allowed us to introduce and analyze definitions and representations of continuity and discontinuity of functions as Jayakody and Zazkis (2015) claimed to be helpful for understanding theses mathematical objects.

The adjustments that we propose of Smith and Stein's model of cognitive demand levels for analyzing problems on discontinuous functions and their examples emerged from the experience, give us elements for new proposals oriented to the improvement of teachers' didactic analysis competence. It could be useful as a starting point for similar experiences and deepening the research of teaching and learning single or two-variable discontinuous real functions, including LCD analysis. We consider it important that teacher educators and researchers of university mathematics education have examples

of problems about discontinuous functions created from daily life situations and characterized with specific LCD. It is also worth mentioning the students' positive comments about the tasks that they developed. Moreover, they value the links shown between daily life situations and the university mathematics, which are usually dealt only in intra-mathematical contexts. This experience, which links university mathematics, PP and cognitive demand, suggests research should be done to delve into these links that are not so present in the researches in these fields.

Acknowledgment

This study was carried out as part of two projects: EDU2015-64646-P, Ministry of Economy and Competitiveness, Spain; and IREM-PUCP 2019, Peru.

References

- Cai, J., Hwang, S., Jiang, C., & Silber, S. (2015). Problem-Posing research in mathematics education: some answered and unanswered questions. In F. M. Singer, N. F. Ellerton, & J. Cai (Eds.), *Mathematical problem posing: From research to effective practice* (pp. 141-174). NY: Springer.
- Georgius, K. (2014). *Planning and enacting mathematical tasks of high cognitive demand in the primary classroom* (Unpublished doctoral dissertation). University of Nebraska, Lincoln.
- Gutierrez A., Benedicto C., Jaime A., & Arbona E. (2018) The Cognitive Demand of a Gifted Student's Answers to Geometric Pattern Problems. In F. Singer (Ed.), *Mathematical Creativity and Mathematical Giftedness* (pp. 169-198). ICME-13 Monographs. Springer, Cham.
- Hitt, F. (1994). Teachers' difficulties with the construction of continuous and discontinuous functions. *Focus on Learning Problems in Mathematics*, 16, 10-10.
- Jayakody, G., & Zazkis, R. (2015). Continuous problem of function continuity. *For the Learning of Mathematics*, 35(1), 8-14.
- Malaspina, U., Mallart, A. & Font, V. (2015). Development of teachers' mathematical and didactic competencies by means of problem posing. K. Krainer & N. Vondrová (Eds.), *Proceedings of the 9th Conference of the European Society for Research in Mathematics Education* (pp. 2861-2866). Czech Republic: Charles University in Prague, Fac. Educ. and ERME.
- Smith, M. S., & Stein, M. K. (1998). Selecting and creating mathematical tasks: From research to practice. *Mathematics Teaching in the Middle School*, 3(5), 344–350.
- Tichá, M., & Hošpesová, A. (2013). Developing teachers' subject didactic competence through problem posing. *Educational Studies in Mathematics*, 83(1), 133-143.
- Torres, C. & Malaspina, U. (2018). Improving in-service teachers' problem posing skill by means of didactic reflection. In E. Berqvist, M. Österholm, C. Granberg, & L. Sumpter (Eds). *Proceedings of the 42nd Conference International Group for the Psychology of Mathematics Education* (Vol. 5, p. 176). Umeå, Sweden: PME.
- Wilhelm, A. G. (2014). Mathematics teachers' enactment of cognitively demanding tasks: Investigation links to teachers' knowledge and conceptions. *Journal for Research in Mathematics Education*, 45(5), 636- 674.

Identifying sense-making in algebra instruction at U.S. post-secondary colleges

Angeliki Mali¹, Anne Cawley², Irene Duranczyk³, Vilma Mesa⁴, April Ström⁵ and Laura Watkins⁶

¹University of Groningen, The Netherlands; a.mali@rug.nl

²California Polytechnic State University, Pomona, United States; acawley@cpp.edu

³University of Minnesota, United States; duran026@umn.edu

⁴University of Michigan, United States, vmesa@umich.edu

⁵Chandler-Gilbert Community College, United States; april.strom@cgc.edu

⁶Glendale Community College, Glendale, AZ, United States, laura.watkins@gccaz.edu

As part of a large-scale study of algebra instruction at two-year post-secondary institutions in the United States, we have developed a qualitative video analysis framework, Evaluating the Quality of Instruction in Post-secondary Mathematics (EQIPM). In this paper, we present two of twelve characteristics used to describe instruction (Instructors Making Sense of Procedures, and Student Mathematical Reasoning and Sense Making), which describe students and instructors engaging with mathematics so their ideas or ways of thinking are evident. We use examples taken from our corpus of videos to exemplify these two characteristics of instruction and how they contribute to its quality. We also offer suggestions for professional development activities.

Keywords: Instruction, College mathematics, Postsecondary education, Community colleges, Instructional quality.

In the United States, 43% of all undergraduate students enroll in public post-secondary institutions that offer courses for the first two years of their undergraduate degree. These institutions, hereafter called community colleges, provide students with many options to further their educational goals, some of which include remediation, transfer to university undergraduate programs, vocational training, general education, continuing education, and workforce development (Blair, Kirkman, & Maxwell, 2018). Community colleges target diverse students who are mostly non-traditional (e.g., older, working, or with family responsibilities), offer flexible schedules, and charge very low tuition compared to universities. Because of the wider range of students who enroll, these colleges offer a broad range of mathematics courses, from developmental mathematics (designed to prepare students for collegiate level study of mathematics) to mathematics courses taught in the first two years of an undergraduate major. The failure rates in algebra courses at community colleges range from 30% to 70% (Bahr, 2010). Because algebra skills are of paramount importance for advancing into higher level mathematics, investigating algebra instruction at community colleges becomes important; however, community colleges are largely under-researched (Mesa, 2017).

In *Algebra Instruction at Community Colleges: An Exploration of its Relationship with Student Success (AI@CC, Watkins et al., 2016)*, we seek to investigate the relationship between the quality of characteristics of algebra instruction and student learning as evidenced by student grade as a percent. In this paper, we exemplify two characteristics of algebra instruction at community colleges,

Instructors Making Sense of Procedures, and Student Mathematical Reasoning and Sense Making. We focus on observed instances that evidence mathematical sense-making¹, to start addressing the wider question: What is the nature of sense-making evidenced in algebra instruction at the community college level of post-secondary mathematics education?

Background and supporting literature

We used the instructional triangle to define algebra instruction as the interactions between instructors, students, and the content studied in community college environments (Figure 1, Cohen, Raudenbush, & Ball, 2003). To characterise algebra instruction, we drew on two frameworks that analyse the quality of instruction created for school-level mathematics education (Mathematical Quality of Instruction (MQI), Hill, 2014; Quality of Instructional Practices in Algebra (QIPA), Litke, 2015). These frameworks describe and code (with ratings from 1 to 5)

instructional practices from video-recorded class sessions by rating consecutive 7.5-minute segments. Although the two frameworks provided useful language to describe the characteristics of instruction, the actual descriptions were tied to elementary or high-school content and interactions that bore little resemblance to instructional practices at community colleges. We retained some of their characteristics, but modified the descriptions for our purposes, through multiple iterations that involved the use of video recordings of 15 class sessions in Fall 2016, ranging between 45 and 120 minutes (see Cawley et al., 2018). From this work we developed the video-coding framework called Evaluating the Quality of Instruction in Post-secondary Mathematics (EQIPM). This paper includes two EQIPM characteristics, Instructors Making Sense of Procedures and Student Mathematical Reasoning and Sense Making, which emphasise ways in which instructors or students engage in algebraic sense-making in community colleges. Version 3.0 of EQIPM is presented in Figure 2².

The definition of ambitious mathematics instruction (NGA, 2010) supports 11 of 12 characteristics of instruction in EQIPM. In ambitious instruction, the instructor engages students in challenging tasks, observing and listening while they work on those tasks providing an appropriate level of support to diverse learners. The instructional goal is to ensure that all students do high quality work instead of only expecting fast and correct execution of mathematical procedures. Classroom Environment emerged from our observations of community college lessons. This characteristic is informed by Danielson (2015) who advocated that in a respectful and open environment, student opinions are encouraged, and student contributions are validated in ways that make them feel safe.

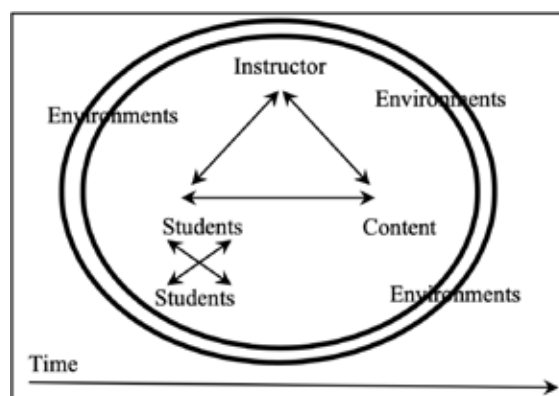


Figure 1: Instructional Triangle (Cohen, Raudenbush, & Ball, 2003)

¹ We use the NCTM (2009) definition of sense-making which accounts for students discovering coherence across mathematical domains and seeing connections between new concepts and their existing knowledge.

² The development of EQIPM is ongoing. See Mesa et al. (2019) for the most recent changes in the code structure.

EQIPM: Evaluating Quality of Instruction in Postsecondary Mathematics			
Features of Segment	Quality of Student-Content Interaction	Quality of Instructor-Content Interaction	Quality of Instructor-Student Interaction
Mathematics is Focus of Segment	Student Mathematical Reasoning and Sense-Making	Instructors Making Sense of Procedures	Instructor-Student Continuum of Instruction
Procedure Taught	Connecting across Representations	Supporting Procedural Flexibility	Classroom Environment
Modes of Instruction	Situating the Mathematics	Organization in the Presentation of Procedures	Remediation of Student Errors and Difficulties
Technology Use	Mathematical Errors and Imprecisions in Content and Language		Mathematical Explanations

Figure 2: Dimensions and characteristics of instruction in EQIPM

The American Mathematical Association of Two-Year Colleges' IMPACT³ guide (2018) presents a vision to improve mathematics education in the first two years of college. The IMPACT guide concludes that for students to achieve proficiency in mathematics it is necessary

for them to, among other things, (1) know mathematics procedures and execute core computations fluently, (2) make sense of and solve problems, and (3) demonstrate evidence of mathematical understanding (AMATYC, 2018, p. 25). Research by Star (2005) provides additional evidence of the importance of linking conceptual understanding with procedural skills.

Methods

The data for this paper were collected in the Fall of 2017. Trained observers video-recorded all class sessions on two of three topics from 40 instructors: linear, rational, or exponential equations and functions. The instructors, who volunteered to be observed, were at six diverse community colleges, which represent a range of institution size, degree of urbanicity, region (Southwest, Midwest, and Central in the U.S.), and student background. This round of data collection resulted in 131 class sessions, which ranged in duration between 45 and 150 minutes. Fifty-four percent of these sessions were solely in a lecture context and 85% included some elements of a lecture.

Starting in the Summer 2018, 17 trained coders used EQIPM to rate the characteristics of instruction that appeared in each segment⁴ ($n = 1,576$ coded segments of which 1,236 are full 7.5-minute segments) of every class session. For each segment, the quality of each characteristic was coded along the 12 characteristics using a rating from 1 to 5. The coders provided a justification for their rating, including the specific time stamp in which the coder noticed evidence that justified that rating, and a brief explanation of the quality of the characteristic based on specific guidelines of EQIPM. For the most part, a rating of 1 was reserved for "no evidence" except for the Mathematical Errors and Imprecisions in Content and Language in which the ratings are reversed. A rating of 3 was considered an acceptable quality, usually indicating a modal rating. A rating of 5 was reserved for exemplary cases; cases we interpreted as best examples of that characteristic against EQIPM. Ratings of 2 and 4 were reserved for 'in between' cases. When some features were present but they were of less quality

³ Improving Mathematical Prowess and College Teaching (IMPACT)

⁴ Hill et al. (2012) used a segment length of 7.5-minutes after several comparisons of coding using various lengths. All lessons were parsed into 7.5-minute segments; the last segments of the lessons were usually shorter than 7.5 minutes.

than what a rating of 3 would have been, a 2 was assigned. When the quality was better than a rating of 3, but not truly illustrative of an exemplary quality, a 4 was assigned.

Instructors Making Sense of Procedures refers to instructor work that fosters students' sense-making about how a procedure moves from one step to the other, rather than merely reproducing the steps of the procedure (Star, 2005). For this code, the coder is trained to assess the extent to which instructor practices of using mathematical definitions, symbols, properties, structures, examples, and interpretations of solutions motivate understanding of a mathematical procedure. Examples of such instructor practices include, but are not limited to attending to the type of solution generated by a procedure and its interpretation, using a series of examples of an abstract formula to extract key features, and clarifying symbols of definitions. For a 7.5-minute segment, an exemplary 5 rating of the characteristic is assigned in the event that the coder interprets that the practices identified motivate mathematical understanding and belong to either a range of instances or a sustained, prolonged instance with instructor practices for fostering student sense-making. A rating of a 5 only indicates that sense-making happened in an exemplary way, attending to elements of a procedure or the algebraic concepts in a procedure. Other codes in the framework will pick up additional elements of instruction that together may allow one to determine high-quality instruction.

Student Mathematical Reasoning and Sense Making entails the components of reasoning and sense-making for students. Mathematical reasoning includes student practices such as drawing logical conclusions from patterns identified, providing conjectures, offering counter-claims in response to a proposed mathematical idea, and mentioning the mathematical properties that underlie a procedure. Evidence for sense-making includes student practices such as asking mathematically motivated questions while requesting explanations, leveraging previous mathematical ideas while responding to a question, and interpreting the solution generated by a procedure. A 5 rating includes either a combination of instances that meet these criteria or a sustained instance that saturates the 7.5-minute segment with student reasoning or sense-making so that student ideas are evident and contribute to the development of the mathematics.

Coders adhered to three additional rules when coding: (a) assigning a higher rating rather than a lower rating when in doubt, (b) rating each segment in isolation from other segments within the same class session, and (c) focusing on evidence that was seen and said in the video, rather than what coders thought should be in the video. Following Hill (personal communication, September 2017), 10% of randomly selected class sessions were double-coded; the coders held calibration meetings to discuss discrepancies in ratings and agree upon final ratings. The data used for the analysis reported in this paper came from the coding of 903 segments.

Findings

EQIPM offers a close and granular examination of the quality of algebra instruction at community colleges, but no element of EQIPM can stand alone to suggest high-quality instruction. Breaking down instruction into parts is a first important step towards efforts to understand the current status of instruction at community colleges, and a valuable activity that may help instructors develop their teaching skills. Qualities we interpreted as exemplary included cases of algebra instruction identified with a 5 rating. Only 89 out of 920 segments (10%) were identified as exemplary in at least one of

the 12 codes. There were 398 segments (43%) with a rating of 4 and 5. We identified 29 exemplary segments (5,3%) where instructors supported students in making sense of procedures and seven segments (1%) where students demonstrated exemplary mathematical reasoning and sense-making in class. Examining instances with a rating of 4 or 5, the cases increase to 95 (10%) and 37 (4%) respectively. In light of these percentages in the community college setting, we think that there is much room for improving instruction, and existing practices of exceptional quality can act as resources for improving instruction and student outcomes.

Instructors making sense of procedures

In a lesson on rational expressions, Instructor 110 discussed with the students the procedure of finding domain restrictions. She started her lecture by asking what is $\frac{0}{5}$ and why $\frac{7}{0}$ is undefined, gradually moving student attention to rational expressions and the denominator of $\frac{x+5}{x-7}$. She asked students to find x -values for which the aforementioned rational expression is undefined, and students suggested $x = 7$. After the instructor made the calculations for the suggested value and confirmed that the outcome is $\frac{12}{0}$, which is undefined, she asked whether there were suggestions for other values for which the rational expression is undefined. She waited for 11 seconds for a response, and suggested $x = -5$ for which the expression becomes $\frac{0}{-12}$. The students recalled this fraction equals zero so the rational expression is defined for $x = -5$. The instructor then gave the students time to find domain restrictions for a series of more complicated examples of rational expressions with denominators that are binomials, trinomials, and other polynomials (e.g., $\frac{x+4}{x^2-3x-10}$ and $\frac{x^2-x-2}{x^2-25}$). The use of instructor practices was rated as an exemplary case for this characteristic, because the instructor attended to the type of solution (i.e., denominator equals zero) generated by the procedure of finding domain restrictions, first using integers, which the students are familiar with in this level of education, then interpreting increasingly complicated examples of rational expressions. The students successfully suggested -7 for $\frac{12}{0}$ and related $\frac{0}{-12}$ back to the information in the beginning of the lecture.

In a lesson on exponential functions, Instructor 102 discussed the reason behind the growth pattern of exponential functions. He created tables of values of a linear function, a quadratic function, and an exponential function in which the x -values started at 0 and increased by 1. He calculated the difference of consecutive y -values of each of the three functions, and found that for the linear function the difference was always 2, but for the quadratic function the difference each time increased by 2. He generalised the finding about the differences by saying for both functions that “It doesn’t matter it is a 2, it could be any constant.” He then found that for the exponential function the difference of consecutive y -values, even the difference of the difference of consecutive y -values, would never become constant or increase by a constant value; rather, the difference of consecutive y -values will repeat the growth of the exponential function. The instructor’s use of the structure of three kinds of functions—a linear, quadratic, and exponential—to clarify the meaning of exponential growth was rated as an exemplary case for this characteristic. In particular, he used various numerical y -values of the functions and their differences to find patterns and exemplify the exponential growth. Later in the lesson, all students went to the board to determine the type of growth of various types of functions and they were asked to classify the growth of functions as either exponential or linear.

Student mathematical reasoning and sense making

In a lesson on rational expressions, Instructor 610 worked with the students on simplifying rational expressions. After the first half hour of the 150-minute lecture, the instructor asked students to tell her what simplifications she should carry out for the expression $\frac{3y}{y^2+3y-10} - \frac{6}{y^2+3y-10}$. A student correctly suggested the instructor to write $\frac{3y-6}{y^2+3y-10}$, to factor the polynomial in the numerator and denominator, and to simplify the rational expression. Another student correctly suggested for the expression $\frac{5}{7} + \frac{4}{21}$ that the instructor could multiply both the numerator and the denominator of $\frac{5}{7}$ by 3 and perform all calculations needed. A third student correctly suggested for the expression $\frac{1}{5} - \frac{2}{3}$ that the instructor multiply the numerator and the denominator of $\frac{1}{5}$ by 3, the numerator and denominator of $\frac{2}{3}$ by 5, and perform all calculations needed. This instance where different students contributed to the lecture by leveraging the mathematical idea of Least Common Denominator (LCD) in various cases (e.g., the LCD is the same as or different from both of the denominators) while simplifying expressions lasts for about two of the 7.5 minutes of the segment. A follow-up instance in the same segment lasted for about four and a half minutes. It included a fourth student who orally provided the calculations he performed to find the LCD for the expression $\frac{19x+5}{4x-12} + \frac{3}{2x^2-12x+18}$. By factoring the latter expression, it becomes $\frac{19x+5}{4(x-3)} + \frac{3}{2(x-3)^2}$. The student reasoned the LCD was $4(x-3)^2$ because the LCD included the highest exponent from all multiples of the factors of the denominators. Two other students found the LCD for each of two different rational expressions, using their fellow student's reasoning. The combination of two prolonged instances that saturate the segment with student reasoning and sense-making so that student inputs contributed to the development of the meaning of the LCD was rated as an exemplary case for this code.

A rule for deciding on the rating of Student Mathematical Reasoning and Sense Making was that there must be clear evidence of students engaging in mathematical reasoning or sense-making through verbal utterance(s) and/or through written work. A limitation for finding such evidence was that despite the premium quality of our audio-visual equipment, the recordings sometimes did not capture clearly student voices or written work. Although we found instances that saturated the 7.5-minute segments with student reasoning or sense-making, the audible or visible evidence found within a segment could not qualify for an exemplary case. That resulted into lowering the quantity of exemplary cases found for this characteristic of instruction in the community college classes.

Discussion

This paper described two characteristics of instruction captured in EQIPM, Instructors Making Sense of Procedures and Student Mathematical Reasoning and Sense Making. The common theme in the three examples given can be summarized as 1) a sustained effort to provide sense-making behind procedures by use of a variety of examples in varying complexity while 2) prompting students to provide solutions to the examples with an explanation of their reasoning. The instructors' approach paved the way for students to develop proficiency in mathematical procedures; this is a new insight into community college instruction because educational research in this context is still rather limited. Rules were not given to simply be followed but ideas were presented with concrete examples to apply

sense-making. We currently work on improving the codes and ratings of EQIPM. In recent iterations for the development of EQIPM, we widened the mathematical content of the codes of the dimension Instructor-Content interaction. Instructor Making Sense of Procedures, for example, includes sense-making whether it occurred while supporting a procedure, a mathematical idea or ways of thinking.

In Instructors Making Sense of Procedures, instructor practices that motivated sense-making included the search for patterns, the use of integers or numerical y -values of functions which were familiar to students, and the careful selection of examples with increasing rigor. The latter can help students build their own understanding of rate of change, and later connect this idea to the concept of derivative in calculus. In Student Mathematical Reasoning and Sense Making, the instructor offered different students the opportunity to suggest how they would simplify rational expressions and to justify their choices, sometimes using their peers' language and reasoning. This practice also provides the instructor with the opportunity to overlay student discussion with more precise language and connect student ideas. Such video-recorded instances of exceptional qualities of algebra instruction at community colleges can be leverage points to discuss with instructors, compare, and build up the current instructional practices that are in place. EQIPM nevertheless is not intended to become a score system to evaluate teachers. It is created to understand what the characteristics are that constitute instruction at community colleges and what features make that instruction of high quality.

The AMATYC IMPACT guide provides a vision for mathematics instruction in the first two years of college and identifies key attributes that point to the importance of students making sense of mathematics and demonstrating evidence of mathematical understanding (AMATYC, 2018). The opportunities for students to develop these attributes, as evidenced by our video analysis, is not common practice at community colleges. Our findings indicate that exemplary implementation of Instructors Making Sense of Procedures, and Student Mathematical Reasoning and Sense Making occurred in only a small number of cases. Professional development using instances of exemplary practices that support high quality algebra instruction can help change the landscape of mathematics instruction at community colleges by helping instructors provide opportunities for their students to develop key attributes tied to mathematical proficiency. In the next phase, we will work to identify ways for instructors to support students to develop mathematical proficiency and to subsequently improve student performance and preparation for higher mathematics.

Acknowledgment

Funding for this work was provided by the National Science Foundation Award EHR #1561436. Any opinions, findings, and conclusions or recommendations expressed in this material are those of the authors and do not necessarily reflect the views of the National Science Foundation. We also wish to thank the community college faculty who participated in this study. Without them, this investigation would not have been possible.

References

American Mathematical Association of Two-Year Colleges (2018). *AMATYC IMPACT: Improving mathematical prowess and college teaching*. Retrieved from: https://c.ymcdn.com/sites/amatyc.site-ym.com/resource/resmgr/impact/AMATYC_IMPACT.pdf

- Bahr, P. R. (2010). Revisiting the efficacy of postsecondary remediation: The moderating effects of depth/breadth of deficiency. *Review of Higher Education, 33*, 177-205.
- Blair, R., Kirkman, E. E., & Maxwell, J. W. (2018). *Statistical abstract of undergraduate programs in the mathematical sciences in the United States*. Fall 2015 CBMS Survey. Washington D.C.: American Mathematical Society.
- Cawley, A., Duranczyk, I., Mali, A., Mesa, V., Ström, A., Watkins, L., Kimani, P., & Lim, D. (2018). An innovative qualitative video analysis instrument to assess the quality of post-secondary algebra instruction. In E. Bergqvist, M. Österholm, C. Granberg, & L. Sumpter. (Eds.). *Proceedings of the 42nd Conference of the International Group for the Psychology of Mathematics Education* (Vol. 2, pp. 227-234). Umeå, Sweden: PME.
- Cohen, D. K., Raudenbush, S. W., & Ball, D. L. (2003). Resources, instruction, and research. *Educational Evaluation and Policy Analysis, 25*, 119-142.
- Danielson, C. (2015). Danielson 2014-15 Rubric: Adapted to New York Department of Education Framework for Teaching Components. Retrieved from: https://www.cfn107.org/uploads/6/1/9/2/6192492/danielson_2014-2015_rubric.pdf.
- Hill, H. C. (2014). *Mathematical Quality of Instruction (MQI)*. Harvard, MA. Retrieved from <https://hu.sharepoint.com/sites/GSE-CEPR/MQI-Training/Shared Documents/MQI 4-Point.pdf>.
- Litke, E. G. (2015). The state of the gate: A description of instructional practice in algebra in five urban districts, (Unpublished doctoral dissertation). Harvard University, Cambridge, MA.
- Mesa, V., Duranczyk, I, Watkins, L., & the AI@CC Research group. (2019). The structure of EQIPM, a video coding protocol to assess the quality of community college algebra instruction. In U.T. Jankvist, M. Van den Heuvel-Panhuizen, & M. Veldhuis (Eds.). *Proceeding of the Eleventh Congress of the European Society for Research in Mathematics Education* (pp. XXX-YYY). Utrecht, the Netherlands: Freudenthal Group & Freudenthal Institute, Utrecht University.
- Mesa, V. (2017). Mathematics education at public two-year colleges. In J. Cai (Ed.), *First compendium for research in mathematics education* (pp. 949-967). Reston, VA: National Council of Teachers of Mathematics.
- National Council of Teachers of Mathematics. (2009). *A teacher's guide to reasoning and sense making*. Reston, VA: Author.
- Rasmussen, C. L., & Ellis, J. (2013). Who is switching out of calculus and why. In M. Lindmeier & A. Heinze (Eds.), *Proceedings of the 37th Conference of the International Group for the Psychology of Mathematics Education*, Vol. 4 (pp. 73-80). Kiel, Germany: PME.
- Star, J. R. (2005). Reconceptualizing procedural knowledge. *Journal for Research in Mathematics Education, 36*(5), 404-411.
- Watkins, L., Duranczyk, I., Mesa, V., Ström, A., & Kohli, N. (2016). *Algebra instruction at community colleges: Exploration of its relationship with student success*: National Science Foundation (EHR #1561436).

From university mathematics students to postsecondary teachers

Sarah Mathieu-Soucy¹, Claudia Corriveau² and Nadia Hardy³

¹Concordia University, Montreal, Canada; sarah.msoucy@gmail.com

²Laval University, Quebec, Canada; claudia.corriveau@fse.ulaval.ca

³Concordia University, Montreal, Canada; nadia.hardy@concordia.ca

Keywords: Postsecondary teaching, becoming a teacher, narrative inquiry.

Introduction

Little is known about the transition from being a university mathematics student to being a postsecondary teacher (e.g. Speer & Hald, 2008), particularly in cegep institutions (general and vocational colleges), the first step in postsecondary education in the province of Quebec, Canada. The program in those institutions covers, notably, calculus and linear algebra. Our goal is to explore that transition into being a teacher, while focusing on the (past and present) experiences of new teachers in relation to mathematics, and its teaching and learning. We do so by conducting a narrative inquiry with 5 new teachers with less than 5 years of experience, with whom we have met individually seven times over a semester. We *lived* alongside them and heard about their stories, their lives and their experiences.

In our work, we speak of “being a teacher” in the sense of *acting and thinking as a teacher*, rather than holding a teaching job. We see it as a “process of becoming” (Beisiegel, 2007, p. 23) that starts before the first teaching job and that will continue long after. It is supported by the idea that mathematics students receive implicit teacher training during their time as students, where their life experiences in a mathematics department shape their “views of the discipline and its teaching” (Beisiegel, 2009, p. 42). We see “being a mathematics teacher” as involving, among other things, thinking about mathematical concepts, with teaching and learning in mind, in a way that reminds us of Shulman’s (1986) pedagogical content knowledge. It also involves thinking, to various degrees, about the role of a teacher, presentation, assessment and the creation of material.

As we analyzed all the stories these 5 new teachers shared with us, we came to the realization that 4 out of the 5 participants were not “being teachers” during their studies in mathematics; for them, this “being a teacher” only happened when they actually held a teaching position, even if some of them were aiming for a teaching career. This triggered two reflections for us.

Firstly, we identified essential differences between what they need to emphasize to be successful students versus what they need to emphasize to be successful teachers. On a daily basis, to succeed as a mathematics student, they needed to create and validate proofs a professor deemed important, figure out what is expected from them to succeed in assessments and researching for proofs that may not even exist. To be teachers, instead, they would need to think about what is important for their students to learn while keeping it at a level that is adequate, what work would represent a passing grade in a particular course and choosing problems that would be interesting to solve, not for them, but for their students. The gap between these two needs suggests that there was no time or space during their studies in mathematics to “be a teacher.” This reflection shows us one way in which the

transition to post-secondary teaching could be different than the transition to school teaching since such time and space is probably not lacking in university teacher training.

Secondly, too often, mathematics faculty who focus on teaching are perceived by their colleagues as weak mathematicians who could not succeed as researchers; these “second-class” mathematicians are not good enough to participate in the very competitive mathematical community (Kline, 1977, cited in Beisiegel, 2009). Beisiegel (2009) showed the influence of this culture for graduate students, saying that “as [they] attended to the existing practices of the department, there were suggestions and rites of passage which revealed that only [...] becoming a mathematician, really counts” (p. 287). Also, Beisiegel (2007) states that “many dichotomies exist in mathematics and, in [the mathematics] community, you either are or you are not a mathematician” (p. 23); if you are a mathematics teacher, you are not a mathematician. Again, we can briefly underline how different this situation is from university teacher training, where students are not, most likely, torn between two different identities, as becoming a teacher is the goal of their education.

One of the participants in our study, however, seemed to have been successfully a mathematician and a mathematics teacher during her degree in mathematics. Indeed, as a student, while keeping up with the highest standard of performance in her classes, she would constantly look at how the class was presented, thinking how she would do it when she would get to stand in front of a classroom, collecting great explanations of things as models and always asked herself, “why?” and “what if?” specifically so that she would be more prepared to teach certain pieces of mathematics. We believe that those two differences put her in a similar position than a student in a teacher training program (Lee & Shallert, 2016). Our research explores why it is that she was “being a teacher,” according to our definition above, in the midst of a mathematician’s training, while the others did not.

This research goes into detail of some stories shared by the participants about their transition from mathematics student to teacher. Because we found that it is possible to do both, “be a mathematician” and “be a teacher,” during a mathematicians’ training, we ask how we can help mathematics students to “be teachers” while in their mathematics training and to help them use this time to their advantage.

References

- Beisiegel, M. (2007). A process of becoming. *For the Learning of Mathematics*, 24(3), 23-24.
- Beisiegel, M. (2009). *Being (Almost) a Mathematician: Teacher Identity Formation in Post-Secondary Mathematics*. Doctoral thesis, University of Alberta.
- Kline, M. (1977). *Why the Professor Can't Teach: Mathematics and the Dilemma of University Education*. New York, NY: St. Martin's Press.
- Lee, S., & Shallert, D. (2016). Becoming a teacher: Coordinating past, present, and future selves with perspectival understandings about teaching. *Teaching and Teacher Education*, 56, 72-83.
- Shulman, L. S. (1986) Those Who Understand: Knowledge Growth in Teaching. *Educational Researcher*, 15(2). 4-14.
- Speer, N. M., & Hald, O. (2008). How do mathematicians learn to teach? Implications from research on teachers and teaching for graduate student professional development. In M. Carlson & C. L. Rasmussen (Eds.), *Making the Connection: Research to Practice in Undergraduate Mathematics Education* (pp. 305-317). Washington: Mathematical Association of America.

The structure of EQIPM, a video coding protocol to assess the quality of community college algebra instruction

Vilma Mesa¹, Irene Duranczyk², Laura Watkins³ and the AI@CC Research group

¹University of Michigan, Ann Arbor MI United States; vmesa@umich.edu

²University of Minnesota, Minneapolis MN, United States, duran026@umn.edu

³Glendale Community College, Glendale, AZ, United States, laura.watkins@gccaz.edu

Evaluating the Quality of Instruction in Post-secondary Mathematics (EQIPM) is a video coding instrument that provides indicators of the quality of instruction in community college algebra lessons (AI@CC Research Group, 2017)¹. It grew out of two instruments that assess the quality of instruction in K-12 settings—the Mathematical Quality of Instruction (MQI) instrument (Hill, 2014) and the Quality of Instructional Practices in Algebra (QIPA) instrument (Litke, 2015). We present a revision of EQIPM prompted by results of factor analyses performed with preliminary data, then discuss next steps and research implications.

Keywords: Algebra, instruction, video coding, community colleges.

Various reports have established an indirect connection between students leaving science, technology, engineering, and mathematics (STEM) majors because of their poor experiences in their STEM classes (Herzig, 2004; Rasmussen & Ellis, 2013). Most of these reports, however, are based on participants' descriptions of their experiences in the classes, rather than on evidence collected from large scale observations of classroom teaching (Seymour & Hewitt, 1997). When such observations have been made, they usually focus on superficial aspects of the interaction (e.g., how many questions instructors ask, how many students participate, or who is called to respond, Mesa, 2010) or their organization (e.g., time devoted to problems on the board, or lecturing, Hora & Ferrare, 2013; Mesa, Celis, & Lande, 2014). Undeniably, these are important aspects of instruction, yet these elements are insufficient to provide a characterization of such a complex activity as instruction.

A key concern in post-secondary mathematics education is the lack of preparation that mathematics instructors receive in their graduate education (Ellis, 2015; Grubb, 1999). We argue that the lack of a reliable and valid method to fully describe how instruction occurs hinders our understanding of the complexity of instructors' work in post-secondary settings and therefore limits the richness of preparation and professional development opportunities focused on the faculty-student-content interactions (Bryk, Gomez, Grunow, & LeMahieu, 2015). As part of a larger project that investigates

¹ The AI@CC Research group includes: Megan Breit-Goodwin, Anoka-Ramsey Community College; Anne Cawley, California State University, Pomona; April Ström, Chandler-Gilbert Community College; Randy Nichols, Delta College; Anna Bright, Patrick Kimani, Fern Van Vliet and Laura Watkins, Glendale Community College; Angeliki Mali, University of Groningen; David Tannor, Indiana Wesleyan University; Jon Oaks, Macomb Community College; Nicole Lang, North Hennepin Community College; Carla Stroud, and Judy Sutor, Scottsdale Community College; Saba Gerami, and Vilma Mesa, University of Michigan; Irene Duranczyk, Dexter Lim, and Nidhi Kohli, University of Minnesota. Colleges and authors are listed alphabetically.

the connection between the quality of instruction and student learning in community college algebra courses, we have developed an instrument, EQIPM (Evaluating Quality of Instruction in Postsecondary Mathematics), that seeks to characterize instruction. This paper focuses on the instrument and its validation, and to this effect we present the fourth revision prompted after results from exploratory and confirmatory factor analyses and a discussion with our advisory board suggesting several areas that needed refinement.

Theoretical Perspective

We assume that teaching and learning are phenomena that occur among people enacting different roles—those of instructor or student—aided by resources of different types (e.g., classroom environment, technology, knowledge) and constrained by specific institutional requirements (e.g., covering preset mathematical content, having instructional periods of 50 minutes, see Chazan, Herbst, & Clark, 2016; Cohen, Raudenbush, & Ball, 2003). We focus on instruction, one of many activities that can be encompassed within teaching (Chazan et al., 2016) and define instruction as the interactions that occur between instructors and students with the mathematical content (Cohen et al., 2003). These interactions are influenced by the environment where they happen and can change over time. Empirical evidence from K-5 classrooms (5-11 year olds) indicates that ambitious instruction (Boston, 2012) is positively correlated with student performance on standardized tests (Hill, Rowan, & Ball, 2005). Understanding mathematics instruction requires attention to the disciplinary content and the mathematical knowledge for teaching and learning. Therefore, we assume, first, that quality instruction is illustrated through the experiences of instructors and students while interacting with mathematical content that have a significant impact on what students are ultimately able to demonstrate in terms of knowledge and understanding, and second, that it is possible to identify latent constructs that might account for the observed quality of instruction. We seek to corroborate findings from Hill et al. (2005) in the community college context.

Instruction is central to EQIPM. EQIPM (see Figure 1) was designed to assess the three main interactions that Cohen and colleagues (2003) used to define instruction: (1) Quality of Instructor-Student interaction, (2) Quality of Instructor-Content Interaction, and (3) Quality of Student-Content Interaction, which are hypothesized by our framework for instruction (Cohen et al., 2003, see Figure 1). An additional aspect, *Mathematical Errors and Imprecisions in Content and Language*, is also hypothesized to be an indicator of the quality underlying all the interactions (Hill, personal communication, 2017). The *Mathematical Errors and Imprecisions in Content and Language* code is intended to capture all *uncorrected* errors or imprecisions that may occur within a segment; including those advanced by students. This code is the only code that attends to errors and imprecisions within the segment. Within each quality construct we propose codes adapted from existing rubrics (Hill, 2014; Litke, 2015) in order to capture specific observable behaviors that can be used as a proxy for the construct. Thus, the *Student Mathematical Reasoning and Sense-Making* code is a proxy for the quality of student interaction with content as it seeks to describe and qualify instances in which students make their thinking evident. Likewise, the codes *Connecting Across Representations* and *Situating the Mathematics* provide evidence for such interaction (Leinwand, 2014). In a similar way we chose four codes under the instructor content interaction, *Instructors*

EQIPM: Evaluating Quality of Instruction in Postsecondary Mathematics			
Features of Segment	Qual. Student-Content Interaction	Qual. Instructor-Content Interaction	Qual. Instructor-Student Interaction
Nature of Mathematics in Segment	Mathematical Reasoning and Sense-Making (S)	Making Sense of Mathematics (I)	Instructor-Student Continuum of Instruction
Modes of Instruction	Connecting across Representations (S)	Connecting across Representations (I)	Classroom Environment
Technology Use	Situating the Mathematics (S)	Situating the Mathematics (I)	Inquiry/Exploration
		Supporting Procedural Flexibility	Remediation of Student Errors and Difficulties
		Organization in the Presentation	
		Mathematical Explanations	
Mathematical Errors and Imprecisions in Content and Language			

Figure 1: Dimensions and codes for the EQIPM 4.0 instrument

Making Sense of Mathematics a code that seeks to assess the extent to which instructors assist students in making sense of the mathematics they are teaching. This code is related, but different from, *Mathematical Explanations*, which attends primarily to the quality of the mathematical argumentation and justifications that instructors provide for any particular mathematical process or idea. While sense making might use informal language or everyday contexts, explanations require in

addition that definitions or proofs be used in sound mathematical arguments. *Supporting Procedural Flexibility* was included in order to account for the quality of the teaching of procedures, an important component of the teaching of algebra (Litke, 2015; Star, 2005; Star & Newton, 2009). The last code in this dimension, *Organization in the Presentation*, originally from Litke's (2015) instrument, was included because there is evidence that such organization contributes to student performance (Cabrera, Colbeck, & Terenzini, 2001). Finally, the codes under the third dimension seek to capture the way in which instructors and students negotiate the work in the classroom, the extent to which their contributions are taken up to shape the direction of the lesson (*Continuum of Instruction*), how instructors respond to and seek to understand student misconceptions (*Remediation of Student Errors and Imprecisions*), and how the interactions produce a class environment that is conducive to learning (*Classroom Environment*). These codes directly reveal the quality of the student and instructor interactions. The codes under Features of Segment help characterize the activity in the segment without qualification (e.g., *Nature of math*: procedures, applications, etc.; *Modes of instruction*: lecture, group work, etc.; *Technology use*: graphing calculators, etc.). These codes are not assessed on quality, only on presence and are used to describe the lessons.

Understanding how the instrument works

In the Fall 2017 semester, we video-recorded 131 lessons in intermediate and college algebra classes from six different community colleges in three different states. These lessons ranged in duration between 45 and 150 minutes, and were taught by 40 different instructors (44 different unique courses video-recorded; 4 instructors taught 2 sections of a course). The majority of the lessons covered one of three topics: linear equations/functions, rational equations/functions, or exponential equations/functions. These topics were chosen because they offered opportunities to observe instruction on key mathematical concepts (e.g., transformations of functions, algebra of functions) and to attend to key ways of thinking about equations and functions (e.g., preservation of solutions after transformations, covariational reasoning), which are foundational algebraic ideas that support more advanced mathematical understanding (Breidenbach, Dubinsky, Hawks, & Nichols, 1992; Carlson, Jacobs, Coe, Larsen, & Hsu, 2002). The development of EQIPM was iterative process similar to that used by Hill and colleagues (2008) and by Litke (2015). Their instruments subdivided video-taped lessons into 7.5-minute segments, after testing the efficacy of 3 to 15-minute segments,

they found that 7.5-minutes provided coders with a segment long enough to capture mathematical practices and events in a cohesive way when rating all segments within a lesson without compromising quality of coding that is experienced in long segments. In the Spring 2018 semester, our iterative process produced the EQIPM version 3a which was used in the first round of coding (AI@CC Research Group, 2017). Coders were given up to four consecutive 7.5-minute segments to reduce bias due to familiarity with the previous work. Coders recorded their ratings and justifications in a spreadsheet developed for this purpose after watching each segment. Each segment was rated on each of the codes on a 1 to 5 scale (see Mali et al., 2019 for more information on rating and exemplification of codes). Ten percent of segments were randomly chosen for double-coding. Each pair of coders held calibration meetings to discuss codes with ratings with a discrepancy greater than one point; the pairs reconciled their new rating by consensus.

Following an exploratory factor analysis [EFA] using 169 segments (Mesa, Duranczyk, Bardelli, & AI@CC Research Group, 2018) we identified a three-factor structure that corresponded to our hypothesized dimensions (see Figure 2a). This analysis also identified two problematic codes (*Remediation of Student Errors and Imprecisions* and *Mathematical Errors and Imprecisions in Content and Language*). A subsequent confirmatory factor analysis [CFA] with 306 coded segments, suggested instead a two-factor structure (Instructor-Content interaction and Student-Instructor interaction) and four problematic codes (one had poor loading, *Connecting Across Representations*, and three could not be used in the analysis, *Mathematical Errors and Imprecisions in Content and*

Exploratory Factor Analysis				Confirmatory Factor Analysis		
Codes	Factor 1	Factor 2	Factor 3	Codes	Factor 1	Factor 2
St. Mathematical Reasoning	0.790*	-0.001	-0.028	St. Mathematical Reasoning...	0.844*	
Instructor-Student Continuum	1.055*	-0.182	0.012	Instructor-Student Continuum...	0.878*	
Inquiry/Exploration	0.594*	0.039	-0.016	Inquiry/Exploration	0.656*	
Remediation Student Errors	0.281*	0.187	-0.057	Remediation of St. Errors...	0.392*	
Instr. Making Sense Procedures	-0.179	0.661*	0.022	Instr. Making Sense Proc.		0.667*
Supporting Proc. Flexibility	0.051	0.307*	-0.283*	Mathematical Explanations		0.561*
Organization Pres. of Procedures	0.072	0.454*	0.297	Situating the Mathematics		0.480*
Math. Err & Imprecision	0.023	-0.224*	-0.156	Supporting Procedural Flexibility		0.409*
Math. Explanations	-0.001	0.954*	-0.792*	Conn. across Representations		0.289*
Connect across Representations	0.036	-0.053	0.300*			
Situating the Mathematics	-0.05	0.222	0.325*			
Class Environment	0.374	0.011	0.530*			

The 3-factor solution had an adequate to good fit to the data: $\chi^2 = 47.466$, $p = 0.049$, RMSEA = 0.051, 90% CI = [0.003, 0.082], CFI = 0.972, TLI = 0.944, SRMR = 0.065 (Hu & Bentler, 1999). Significant loadings at the 95% level. The three factors are weakly and positively correlated: corr Factor 1-Factor 2 = 0.184, corr Factor 1-Factor 3 = 0.245, and corr Factor 2-Factor 3 = 0.391. * Significant loadings at the 95% level. a. Loading patterns suggest to exclude item in the EFA solution (Worthington & Whittaker, 2006). Factor 1: Quality of Instructor-Student Interaction; Factor 2: Quality of Instructor-Content Interaction; Factor 3: Quality of Student-Content Interaction.

The two-factor solution had a good fit to the data: RMSEA = 0.061, 90% CI = [0.039, 0.083], CFI = 0.958, TLI = 0.942, SRMR = 0.065. These two factors are weakly and positively correlated: corr Factor 1-Factor 2 = 0.351 ($p < 0.001$) indicating that the two factors are correlated, but significantly distinguishable. * Significant loadings at the 95% level. In CFA loadings are only estimated for the hypothesized factors. Factor 1: Quality of Instructor-Student Interaction; Factor 2: Quality of Instructor-Content Interaction.

Figure 2: (a) Loadings for the EFA 3-factor solution; (b) Loadings for the CFA 2-factor solution

Language, Organization in the Presentation of the Procedure, and Classroom Environment, see Figure 2b). In addition, in both analyses, some codes did not load into the hypothesized dimensions (e.g., *Situating the Mathematics, Connecting Across Representations, Student Mathematical Reasoning and Sense Making*). We called a meeting with our advisory board to discuss the conflicting results. Their review of the instrument and the findings helped us identify two issues that required

substantial revision of the instrument (EQIPM 4.0, see Appendix for the revised definitions of the codes) to better describe the ratings and de-confound: 1) quality with quantifiable elements and 2) low quality with absence. We discuss these next.

Confounding quality with quantifiable elements

For some of the codes we had assigned low or high ratings depending on either the time span in which the behavior was observed (or not observed) or other visible quantifiable aspects of the observed behavior. For example, for the code *Student Mathematical Reasoning and Sense Making* we were assigning a high rating to cases in which the work was “sustained” over the duration of the segment; if an instance was observed but it was “not sustained” or “not the focus” of instruction in the segment, the instrument directed coders to lower the rating. In another case, in the *Connecting Across Representations* code we accounted for number of representations that were visible in the segment in addition to the quality of the connections made; a high rating would be assigned only to lessons in which the instructor used 3 or more representations. Such approach resulted in lower ratings for segments in which instructors made really good connections but only used two representations; these segments were rated as a 3. We believe that this attending to number of representations possibly over quality of the connection might explain why this particular code had low loadings in both factor analyses. In EQIPM 4.0 we have eliminated language across all codes that refers to quantity or duration, and instead focused strictly on quality.

Confounding low quality with absence

The rating system that we chose, a 1 through 5 scale, was adopted following prior work by Hill (2008) and Litke (2015). Our instrument included similar language in describing a rating of 1 which was assigned to two scenarios. For example, a 1 rating for *Mathematical Explanations* read as follows: “No mathematical explanations provided by instructor or student. **OR** Explanations do not include mathematical reasoning or justification; instructor or students provide only steps of a procedure.” This way of defining a 1 was problematic, because in some codes a rating of 1 meant not present (e.g., *Situating the Mathematics*), in others (e.g., *Classroom Environment*) it represented the lowest quality, and yet in others it meant both (e.g., *Mathematical Explanations*, the example above). Our advisory board pointed out that the ambiguity makes it difficult to interpret what a low score in a scale would represent. In EQIPM 4.0, the revision of the meaning of a rating of 1 also required a decision about the scale for assessing quality. We had followed Litke’s practice of using a rating of 3 to be “modal practice,” meaning practices that could be expected in many instances or that would not be extraordinary (in terms of both high and low quality). Ratings of 2 and 4 were defined as “in between” levels, less than or better than 3, without being the extremes. Defining the scale in this way was problematic for several codes, especially for those in which 1 could mean not present. In those codes the change from 1 to 2 was not commensurable to a change from 2 to 3, 3 to 4, or 4 to 5 on our rating scale. The recommendation was to use a four-point scale in order to force the coders into differentiating four levels of quality, with 1 being the lowest and 4 being the highest. We assigned a rating of 0 for “not present” which will facilitate their exclusion as needed.

The revised EQIPM 4.0 instrument

The current version of EQIPM is presented in Figure 1. Once the data are recoded we will run a split sample EFA/CFA to understand the revised instrument's factor structure. The preliminary analyses with the previous instrument lend support to the structure underlying the instrument. One issue we face is the high number of segments in which lecture is the main mode of instruction (75%, 688 of 920 segments coded as of this writing had lecture combined with other modes of instruction, e.g., group work, and 487 of those used only lecture). We believe that with the revised instrument we will be able to differentiate interactions that are solely led by the student. If there are enough segments in which students lead the interactions, we will run an analysis to see whether the three-factor structure holds.

As we move forward we will account for (1) the multi-level structure of our data, specifically, segments within lessons, lessons within instructors, and instructors within colleges, which will address the possible non-independence of some of these codes, (2) lesson duration (e.g., in some lessons, student work individually at the end) and (3) coder bias. We anticipate that the structure will be stable in these cases as well and that as lecture diminishes as consequence of exposure to professional development, we may see that data will fit with three distinct factors as student interaction with content increases.

Acknowledgment

Funding for this work was provided by the National Science Foundation award EHR #1561436. Any opinions, findings, and conclusions or recommendations expressed in this material are those of the author(s) and do not necessarily reflect the views of the National Science Foundation. We thank Emanuele Bardelli and Inah Ko for analytical assistance and Saba Gerami for comments to earlier versions of the proposal. We thank the faculty who participated in the project. Without them this work would not have been possible.

References

- AI@CC Research Group. (2017). *Evaluating the Quality of Instruction in Postsecondary Mathematics. Instrument for video coding*. Glendale Community College, Scottsdale Community College, University of Michigan, University of Minnesota. Phoenix, AZ; Scottsdale, AZ; Ann Arbor, MI; Minneapolis, MN.
- Boston, M. (2012). Assessing instructional quality in mathematics. *Elementary School Journal*, 113(1), 76-104.
- Breidenbach, D., Dubinsky, E., Hawks, J., & Nichols, D. (1992). Development of the process conception of function. *Educational Studies in Mathematics*, 23, 247-285.
- Bryk, A. S., Gomez, L. M., Grunow, A., & LeMahieu, P. G. (2015). *Learning to improve: How America's schools can get better at getting better*. Cambridge, MA: Harvard Education Press.
- Cabrera, A. F., Colbeck, C. L., & Terenzini, P. T. (2001). Developing performance indicators for assessing classroom teaching practices and student learning. *Research in Higher Education*, 42(3), 327-352.

- Carlson, M., Jacobs, S., Coe, E., Larsen, S., & Hsu, E. (2002). Applying covariational reasoning while modeling dynamic events: A framework and a study. *Journal for Research in Mathematics Education*, 33, 352-378.
- Chazan, D., Herbst, P., & Clark, L. (2016). Research on the teaching of mathematics: A call to theorize the role of society and schooling in mathematics instruction. In D. H. Gitomer & C. A. Bell (Eds.), *Handbook of research on teaching* (5th ed., pp. 1039-1097). Washington DC: American Educational Research Association.
- Cohen, D. K., Raudenbush, S. W., & Ball, D. L. (2003). Resources, instruction, and research. *Educational Evaluation and Policy Analysis*, 25, 119-142.
- Ellis, J. (2015). Three models of graduate student teaching preparation and development. In D. M. Bressoud, V. Mesa, & C. L. Rasmussen (Eds.), *Insights and recommendations from the MAA National Study of College Calculus* (pp. 117-122). Washington, DC.
- Grubb, N. W. (1999). *Honored but invisible: An inside look at teaching in community colleges*. New York: Routledge.
- Herzig, A. (2004). Becoming mathematicians: Women and students of color choosing and leaving doctoral mathematics. *Review of Educational Research*, 74, 171-214.
- Hill, H. C. (2014). *Mathematical Quality of Instruction (MQI)*. Retrieved from Harvard, MA: <https://hu.sharepoint.com/sites/GSE-CEPR/MQI-Training/Shared%20Documents/MQI%204-Point.pdf>
- Hill, H. C., Blunk, M., Charalambous, C., Lewis, J., Phelps, G., Sleep, L., & Ball, D. L. (2008). Mathematical Knowledge for Teaching and the Mathematical Quality of Instruction: An exploratory study. *Cognition and Instruction*, 26(4), 430-511.
- Hill, H. C., Rowan, B., & Ball, D. L. (2005). Effects of teachers' mathematical knowledge for teaching on student achievement. *American Educational Research Journal*, 42, 371-406.
- Hora, M. T., & Ferrare, J. J. (2013). Instructional systems of practice: A multidimensional analysis of math and science undergraduate course planning and classroom teaching. *Journal of the Learning Sciences*, 22(2), 212-257.
- Hu, L., & Bentler, P. M. (1999). Cutoff criteria for fit indexes in covariance structure analysis: Conventional criteria versus new alternatives. *Structural Equation Modeling: A Multidisciplinary Journal*, 6(1), 1-55.
- Leinwand, S. (2014). *Principles to action: Ensuring mathematical success for all*. Reston, VA: National Council of Teachers of Mathematics.
- Litke, E. G. (2015). *The state of the gate: A description of instructional practice in algebra in five urban districts*, (PhD). Harvard University, Cambridge, MA.
- Mali, A., Cawley, A., Duranczyk, I., Mesa, V., Ström, A., & Watkins, L. (2019). Identifying sense-making in algebra instruction at U.S. post-secondary colleges. In U.T. Jankvist, M. Van den Heuvel-Panhuizen, & M. Veldhuis (Eds.), *Proceeding of the Eleventh Congress of the European Society for Research in Mathematics Education* (pp. XXX-YYY). Utrecht, the Netherlands: Freudenthal Group & Freudenthal Institute, Utrecht University.
- Mesa, V. (2010). Student participation in mathematics lessons taught by seven successful community college instructors. *Adults Learning Mathematics*, 5, 64-88.

- Mesa, V., Celis, S., & Lande, E. (2014). Teaching approaches of community college mathematics faculty: Do they relate to classroom practices? *American Educational Research Journal*, *51*, 117-151.
- Mesa, V., Duranczyk, I., Bardelli, E., & AI@CC Research Group. (2018). *An exploratory factor analysis of EQIPM, a video coding protocol to assess the quality of community college algebra instruction*. Ann Arbor MI.
- Rasmussen, C. L., & Ellis, J. (2013). Who is switching out of calculus and why. In A. M. Lindmeier & A. Heinze (Eds.), *37th Conference of the International Group for the Psychology of Mathematics Education* (Vol. 4, pp. 73-80). Kiel, Germany.
- Seymour, E., & Hewitt, N. (1997). *Talking about leaving: Why undergraduates leave the sciences*. Westview Press: Boulder CO.
- Star, J. R. (2005). Reconceptualizing procedural knowledge. *Journal for Research in Mathematics Education*, *36*, 404-411.
- Star, J. R., & Newton, K. J. (2009). The nature and development of experts' strategy flexibility for solving equations. *ZDM*, *41*(5), 557-567.
- Worthington, R. L., & Whittaker, T. A. (2006). Scale development research: A content analysis and recommendations for best practices. *The Counseling Psychologist*, *34*(6), 806-838.

Appendix: Revised Definition of the Codes

Code	Revised Definition: The following codes assess...
Student Mathematical Reasoning and Sense-Making:	student utterances that showcase reasoning and sense-making about mathematical ideas (e.g. drawing logical conclusions, providing conjectures, counter-claims, reasoning and engaging cognitively in problem solving)
Connecting Across Representations:	the connections that instructors or students make between and across representations of the same mathematical problems, ideas, and concepts
Situating the Mathematics:	how instructors or students make connections to other aspects of the algebra curriculum, related topics, or the broader domain of mathematics, situating and motivating the current area under study within a broader context.
Instructors Making Sense of Mathematics:	how instructors attend to specific aspects of mathematics (e.g., solution, symbols, conditions) to clarify their nature
Mathematical Explanations:	how mathematical reasons and justification for why something is done are provided
Supporting Procedural Flexibility:	how instructors identify what procedure can be applied, and when and where to apply them, or makes connections across procedures
Organization in the Presentation:	how complete, detailed, and organized the instructor's or students' presentation (either verbal or written) of content is when outlining or describing the mathematics at hand.
Instructor-Student Continuum of Instruction:	how the investment that students make in their own learning and development of mathematical understanding by expressing thoughtful ideas that advance their learning.
Classroom Environment:	how instructor and students create a respectful and open environment in their classroom conducive to learning; high quality mathematical work is the norm.
Inquiry / Exploration:	the amount of exploration and inquiry of the mathematics that students do in the classroom
Remediation of Student Errors and Difficulties:	how remediation in which student misconceptions and difficulties with the content are addressed
Mathematical Errors and Imprecisions in Content or Language:	mathematically incorrect or problematic use of mathematical ideas, language, or notation.

University Student Use of Dynamic Textbooks: An Exploratory Analysis

Vilma Mesa¹, Angeliki Mali² and Elena Castro-Rodríguez³

¹University of Michigan, Ann Arbor, MI, USA; vmesa@umich.edu

¹University of Groningen, Groningen, The Netherlands, a.mali@rug.nl

³Universidad de Granada, Granada, Spain; elenacastro@ugr.es

Keywords: Textbook research, instruction, educational resources, didactical tetrahedron, linear algebra

Within the array of resources for teaching and learning, the textbook continues to be the most prevalent one for instructors and students. Textbook formats have been changing from paper to digital, open source formats, including sophisticated tools such as computing cells, annotation tools, and powerful search engines, easing access at relatively low cost. Importantly, open source textbooks never expire or go out of print and can be distributed at no cost to students, making them practically fully accessible. The main study seeks to describe how instructors and students use two open-source, technologically enhanced textbooks (linear algebra and abstract algebra for math majors). We use Rezat and Strässer's (2012) didactical tetrahedron to investigate how resources support instruction (Cohen, Raudenbush, & Ball, 2003). The tetrahedron suggests a relationship between textbooks, students, instructors, and the content at stake and suggests that instructors, and the nature of linear algebra, can influence the interactions between the students and their textbooks. We investigate the use of the textbook by the students (student-textbook interaction, arrow *a* in Figure 1) and how linear algebra chapters of the textbook and instructor planning influence such use of the textbook by the students (arrows *b* and *c*, respectively, in Figure 1.)

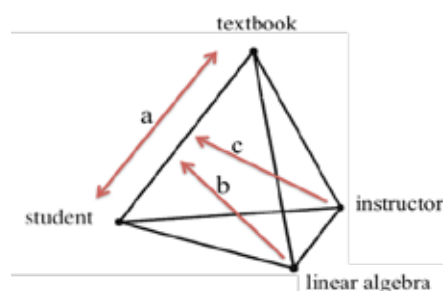


Figure 1: Relationships studied in the didactical tetrahedron (adapted from Rezat & Strässer, 2012, p. 241)

We analyzed bi-weekly log¹ data from 102 students from four instructors in four different states who were using a dynamic linear algebra textbook (Beezer, 2017). The textbook can be accessed on any device with any commonly available browser. It is online, free, open-source, enhanced with computational cells.² It includes standard linear algebra chapters (e.g., systems of linear equations, matrices, vector spaces, etc.) and is written in a definition-theorem-proof format, with exercises and some solutions towards the end of each chapter. The textbooks used in the project have a tracking system that allows to identify which sections of the textbook are being viewed and for how long.

¹ A log was an online survey that contained between four and seven questions about the use of the textbook during the past two weeks. We used thematic analysis to group log responses regarding student use of the textbooks.

² Students did not use the open-source feature, and infrequently used computational cells.

The analysis of the viewing data revealed, unsurprisingly, that viewing tended to occur during the days when the classes were offered (mostly during class sessions), close to exams days, or when homework was due. The students mainly used solutions of exercises—in 17,405 viewings, 81% of the viewing time was for solutions of exercises, 15% for examples, and 5% for all the other elements. In the log responses students reported that they checked the textbook the day before class or the last day of their break; they also used it to study for the upcoming class, or when they were stuck, missed class, or had not understood their instructor's explanation. Students reported using mainly problems, exercises, and examples as they were preparing for class. When asked about their use of theorems, definitions, and examples, students said those were mainly used when producing notes for later use because they wanted to make sure they were connecting ideas and knew the basic definitions. In addition, students created class notes, homework documents or solutions, and textbook notes in order to improve their understanding, for practice, and reminders or memorization, and used many other resources (classmates, Internet, Google, YouTube, Chegg, Khan Academy, and class lecture videos).

We have been tracing how the various uses students reported relate to the specific content covered in the courses and to decisions instructors had made about the course. We noticed that students did not use features that were not required by their instructors; in general, the students (and their instructors) seemed reluctant to take full advantage of novel features (such as the programming cells). We speculated that by itself, the design of the textbooks was insufficient for pushing users into adopting different ways of using these textbooks in teaching and learning linear algebra. Instructors might need training, perhaps in the form of conversations with designers and authors or in authorship that takes advantage of the open nature of the textbooks, so that they can envision new ways in which these textbooks can be used for teaching and learning. Textbook production is expensive, and thus, research that documents how open access textbooks can be made widely available is important. Yet, without knowing how to best take advantage of the new technologies, we might not realize their potential within mathematics classrooms.

Acknowledgment

Funding has been provided by the National Science Foundation (IUSE 1624634). Any opinions, findings, and conclusions or recommendations expressed in this material are those of the author(s) and do not necessarily reflect the views of the National Science Foundation. We thank David Farmer, the American Institute of Mathematics, and Diana Curtis for their research support.

References

- Beezer, R. (2017). *First course in linear algebra*. Gig Harbour, WA: Congruent Press. Available at <http://linear.pugetsound.edu>. HTML available at <http://linear.ups.edu/html/fcla.html>.
- Cohen, D. K., Raudenbush, S. W., & Ball, D. L. (2003). Resources, instruction, and research. *Educational Evaluation and Policy Analysis*, 25, 119-142.
- Rezat, S., & Strässer, R. (2012). From the didactical triangle to the socio-didactical tetrahedron: Artifacts as fundamental constituents of the didactical situation. *ZDM Mathematics Education*, 44, 641-651. doi:10.1007/s11858-012-0448-4

An exploratory study of calculus students' understanding of multivariable optimization problems

Thembinkosi P. Mkhathshwa

Miami University, USA; mkhatstp@miamioh.edu

Contributing to the growing body of research on students' quantitative reasoning at the undergraduate level, this study reports on students' reasoning about a multivariable optimization problem that involves finding the dimensions of the largest volume bag a passenger can carry on an American Airlines flight. Analysis of verbal responses and work written by 11 students when solving the problem revealed that finding the required dimensions was easy for nearly all the students. However, showing that these are the dimensions of the largest volume bag was problematic for a majority of the students. Implications for instruction and directions for future research are discussed.

Keywords: Optimization problems, quantitative reasoning, problem solving, calculus education.

Introduction

Optimization problems form an essential part of the study of differential calculus at the undergraduate level in the United States. Findings of a comprehensive review of literature on students' understanding of various topics in university calculus by Speer and Kung (2016) indicate that research on students' reasoning about optimization problems is lacking. A growing body of research (e.g., Borgen & Manu, 2002; Dominguez, 2010; LaRue & Infante, 2015) has examined students' reasoning about univariate optimization problems (UOPs). We define UOPs as optimization problems where the objective function, that is, the function whose minimum/maximum value(s) is to be found is a real-valued function of a single variable. Only one study (Heid, 1988) has reported on students' understanding of multivariable optimization problems (MOPs), that is, optimization problems where the objective function is a real-valued function of two variables. Heid found that determining minimum/maximum values of objective functions when solving MOPs where algebraic forms of the objective functions were given was problematic for a majority of the 135 students who participated in her study. We remark that the focus of Heid's study was more on the impact of resequencing skills and concepts on students' understanding of fundamental concepts in calculus, and less on students' understanding of MOPs.

While Heid's study has provided beneficial information about how students calculate minimum/maximum values when solving MOPs, there is still much to be explored about how students set up and solve MOPs in situations where an algebraic form of the objective function is not given, which is the motivation for this study. Thus, to build on Heid's study, we intend to explicitly examine students' understanding of the key steps (e.g., setting up the objective function, finding critical points of the objective function, and using the critical points to find the minimum/maximum value(s) of the objective function) that are generally involved in the process of solving MOPs algebraically.

Research on students' understanding of UOPs

While the focus of this study is on students' understanding of MOPs, it is important to discuss the research literature on students' understanding of UOPs for comparison. Specifically, we use the

literature base on students' understanding of UOPs to identify trends in students' reasoning about UOPs that may be comparable to the results found in this study. There are three themes that emerge from the research that has looked at students' understanding of UOPs: (1) students' difficulties with setting up the objective function, (2) students' difficulties with determining and interpreting critical numbers and/or extrema, and (3) students' difficulties with justifying/verifying extrema (the minimum/maximum value(s) of the objective function). Following is a brief discussion of each of the aforementioned themes.

In the first theme, several researchers have found that setting up the objective function is problematic for high school and undergraduate students (e.g., LaRue & Infante, 2015; Swanagan, 2012). Swanagan (2012) reported on a high school student who used the equation of the parabola, $y = x^2$, as the objective function in a task about finding a point on the parabola closest to the point (1,0). In the same study, another high school student used the perimeter function as the objective function in a task about minimizing the cost of fencing a rectangular plot of land. LaRue and Infante (2015) found that formulating the objective function when solving contextualized optimization problems is problematic for undergraduate students even if the objective function is simple and the context of the problem is familiar to the students.

In the second theme, evidence from research (e.g., Dominguez, 2010; Mkhathshwa, 2018; Swanagan, 2012) shows that determining and interpreting critical numbers and/or extrema when solving optimization problems that have real-world contexts is problematic for high school and undergraduate students. Two of the five high school students in Swanagan's (2012) study occasionally relied on guesswork to determine extrema in a cost minimization context. Interpreting extrema in a profit maximization context was problematic for a majority of the 94 undergraduate calculus students who participated in Dominguez's (2010) study. In another profit maximization context, Mkhathshwa (2018) reported on three undergraduate business calculus students who conflated extrema (maximum profit) with a critical number (profit maximizing quantity).

In the third theme, research by Borgen and Manu (2002) and Mkhathshwa (2018) shows that justifying/verifying extrema is problematic for undergraduate students. Borgen and Manu (2002) reported on a student who presented a perfect solution to the problem of finding the minimum value of the function $y = 2x^2 - x + 1$. However, when asked for a justification on why the function has a minimum value and not a maximum value, the student incorrectly claimed that since the coefficient of the linear term of the function is negative, the function must have a minimum value. Mkhathshwa (2018) found that 16 of the 24 students who participated in his study had difficulty verifying extrema (maximum profit) while reasoning about a profit maximization task.

Relationship between UOPs and MOPs

Solving MOPs algebraically may be more difficult for students than solving UOPs for several reasons. First, setting up the objective function for a MOP is more difficult than for a UOP. Part of the difficulty stems from the fact that in the case of a MOP the objective function is a real-valued function of two variables, whereas in the case of a UOP the objective function is a real-valued function of a single variable. Second, the algebra involved when solving a MOP may be more challenging than the algebra involved when solving a UOP. In particular, to find a critical point(s) for a MOP, students

have to simultaneously solve a system of equations, where as in the case of a UPO, they only have to solve a single equation (the derivative of the objective function) to find a critical number(s). Third, algebraic procedures such as the Second Derivative Test (Stewart, 2016) for verifying extrema when solving a MOP are much more complex than algebraic procedures for verifying extrema in the case of a UOP. Thus, one can expect the aforementioned students' difficulties with UOPs to carry over to MOPs.

Theoretical perspective

This study draws on the theory of quantitative reasoning (Thompson, 1993; Thompson, 1994b; Thompson, 2011). Quantitative reasoning (hereafter, QR) is the act of analyzing a problem situation in terms of the quantities and relationships among the quantities involved in the situation (Thompson, 1993). In this study, QR refers to how students: (1) constructed formulas for quantities, (2) how they evaluated these formulas to determine numeric measures for quantities, (3) how they interpreted quantities, and (4) and how they reasoned about relationships between or among quantities while solving a MOP situated in a volume maximization context. Thompson (2011) identified several tenets that are central to the theory of QR. We describe three of those tenets that are related to the study reported in this paper. These tenets are: a quantity, a quantitative operation, and quantification. A quantity is a measurable attribute of an object. Examples of quantities (i.e., measurable attributes) in this study include the volume, length, width, and height of the carry-on bag (i.e., the object) mentioned in the task that appears in the methods section. Thompson (1993) distinguished between a quantity and a numerical value: A quantity has a unit of measurement but a numerical value does not.

A quantitative operation is the process of creating a new quantity from other quantities (Thompson, 1994b). The task used in this study provided a number of opportunities for students to create new quantities (partial derivatives) through the process of differentiation, that is, to perform quantitative operations. More precisely, one way students could use to solve this task successfully is to find a model (algebraic formula) that relates the quantities in the task. In this task, an appropriate model would be the formula for calculating the volume of the carry-on bag (hereafter, bag), i.e., $V = lwh$ where V is the volume of the bag, l is the length of the bag, w is the width of the bag, and h is the height of the bag. Multiplying the length, width, and height of the bag would result in the creation of a formula for the quantity of volume for the bag. In addition, differentiating this model (preferably, after first writing it as a function of two variables by taking into consideration the constraint on the dimensions of the bag given in the task) partially with respect to two of the dimensions (e.g., width and height) of the bag will result in the creation of new quantities (partial derivatives). Quantification is the process of assigning numerical values to quantities (Thompson, 2011). The task used in this study provided several opportunities for students to engage in the process of quantification. For example, evaluating the formula for the quantity of volume, $V = lwh$, after the dimensions of the length, width, and height that will maximize the volume of the bag have been found would lead to the determination of a numerical value for the quantity V . Our study was guided by the following research question: How can we interpret the theory of quantitative reasoning in the context of students solving MOPs?

Methods

This qualitative study used task-based interviews (Goldin, 2000) with 11 students. The interviews lasted for about 34 minutes, on average, and contained two tasks. In this paper, we report on how the students reasoned quantitatively about one of the tasks:

American Airlines requires that the total outside dimensions (*length + width + height*) of a carry-on bag not exceed 45 inches. What are the dimensions of the largest volume bag that a passenger can carry on an American Airlines flight?

The students worked through the task while the interviewer asked clarifying questions about their work. After the student concluded their work on the task, the interviewer asked the following questions about the task and the content of their solutions: (a) Have you seen a problem like this before? (b) What did you do to solve the problem? (c) What does your answer tell you? (d) What does each quantity you used throughout your solution mean? (e) What are the units of each quantity that you used in your solution? (f) What was the easiest part when solving this problem? (g) What was the challenging part when solving this problem? Eight students acknowledged having seen or even solved a similar task prior to participating in this study.

Setting, participants, and data collection

The study participants were undergraduate students at a research university in the United States. These students represented most of the high-performing students who were enrolled in two sections of a traditional calculus III course taught in the spring semester of 2018. The students were chosen based on their willingness to participate in the study, and on their ability to explain their thinking when engaged in problem solving. In addition, drawing on my my past experience with inviting students to participate in research studies similar to the one reported in this paper, high-performing students are more likely to accept the invitation than average or low-performing students. The students were familiar with formal techniques (e.g., the Lagrange multiplier method) that can be used to solve the problem posed in the task from course lectures and the course textbook (Stewart, 2016). We state as a remark that the students in this study had limited exposure to optimization problems that are situated in real-world contexts through classroom instruction and/or homework assignments. At the time of the study, four students were mathematics majors, another four students were engineering majors, two students were physics majors, and one student was an economics major. We note that this is a required course for mathematics, engineering, and physics majors, and that students outside the aforementioned disciplines rarely take this course as an elective. Eight students were freshmen, and the other three students were sophomores. Data for the study consisted of transcriptions of audio-recordings of the task-based interviews and work written by the 11 students during each task-based interview session.

Data analysis

Data analysis was done in two stages. In the first stage, we used a priori codes that consisted of the themes on students' difficulties when solving UOPs discussed earlier. Specifically, we carefully read through each interview transcript and coded: (1) instances where students reasoned about the objective function, (2) instances where students reasoned about finding and interpreting critical points

and/or extrema, and (3) instances where students reasoned about justifying/verifying extrema. In the second stage of the analysis, we looked for patterns in each of the codes identified in the first stage of the analysis. These patterns included trends in the students' understandings, or difficulties they had in connection with each of the a priori codes identified in the first stage. The common understandings or difficulties in students' reasoning found in the second stage of our analysis provided answers to our research question.

Results

There are three main findings from this study. First, setting up the objective function was easy for nearly all the students. Second, most of the students successfully determined and correctly interpreted critical points and extrema. Third, verifying extrema was problematic for a majority of the students.

Setting up the objective function

Ten students were successful in setting up the objective function (i.e., the volume function) for the problem posed in the task. These students performed a quantitative operation by conceptualizing a measure of the quantity of volume as a quantitative product, i.e., volume as the product of the length, width, and height of the bag. The following excerpt illustrates how Sally, whose reasoning is representative of these students, thought about the objective function and constraint function.

Researcher: What was the first thing you did when solving the problem?

Sally: I wrote down the equations for the volume [$V = lwh$], which is what we are trying to solve for and maximize, and our constraint [$l + w + h = 45$] that we have, in terms of the variables we have, which is length, width, and height of the carry-on bag.

Researcher: What are the units of the l , w , and h ?

Sally: They will be in inches.

Researcher: How about the units of V ?

Sally: Cubic inches.

After reading the problem statement, Sally recognized that the volume of the bag is the product of the length, width, and height of the bag, and that to maximize the volume of the bag, the sum of the dimensions of the bag will have to be 45 inches. She quickly turned these recognitions to algebraic equations for the objective function and constraint function. Sally also recognized the volume, length, width, and height of the bag as quantities (and not as unit-less variables) when she assigned units of measure to the variables l , w , h , and V . Only one student, Andy, had difficulty setting up the objective function. This student conflated the objective function with the constraint on the dimensions of the bag given in the task. Consequently, he incorrectly claimed that the volume function would be $f(x) = xyz = 45$, where $f(x)$ represents "the volume of the bag" and x , y , and z represents the length, width, and height of the bag respectively. Andy's notation for the volume function suggest that this student either did not know how to write the correct function notation for a real-valued function of three variables or that he treated the variables y and z as constants.

Determining and interpreting critical points and/or extrema

Eight students correctly determined the critical point of the objective function using algebraic methods. The following excerpt illustrates how Ronda, who is representative of how six of these students used the Lagrange multiplier method (hereafter, LMM) to find the critical point of the objective function.

Researcher: What did you do next [after finding the objective function and constraint function]?

Ronda: I found the partial derivatives for the volume equation [$f(x, y, z) = xyz$ in Figure 1], and I did the same thing for the other equation [$g(x, y, z) = x + y + z$ in Figure 1]. From there, I tried solving. I used the Lagrange multipliers [method] but I don't know if that is what I was supposed to do but that's what I ended up doing. I ended up getting that the length, the width, and the height will equal each other, and I got $45/3$ or 15 inches for all of those [length, width, and height].

Handwritten work showing the solution to a Lagrange multiplier problem. The student defines variables l, w, h, V and g . They calculate partial derivatives f_x, f_y, f_z and g_x, g_y, g_z . They set up equations for the Lagrange multiplier method and solve for x, y, z , finding that they are all equal to 15. Finally, they calculate the volume $V = 3375$.

Figure 1: Ronda's solution

Ronda correctly used the LMM as presented during classroom instruction and in the course textbook to find the critical point of the objective function. When asked about the meaning and units of the quantities she used in her solution, Ronda stated that the variables $V, x, y,$ and z represent the volume, length, width, and height of the bag respectively and that the units of the variable V are “inches cubed” while those of $x, y,$ and z are “inches.” In the process of using the LMM to find the critical point of the objective function, Ronda created new quantities (i.e., performed quantitative operations). Three of the quantities she created are the partial derivatives $f_x = yz, f_y = xz,$ and $f_z = xy$. When asked about the meaning of the partial derivative $f_x = yz$, Ronda said, “that would be saying like the width and the height would both be constant, so they wouldn't be changing at all, x is the only variable.” While Ronda's interpretation of the partial derivative f_x shows that she clearly understood that only x is allowed to vary while y and z are held constant, it does not show that she understood the partial derivative to be a “rate” quantity. She stated that the units of the partial derivative $f_x = yz$ would be “inches cubed,” suggesting that she conflated a “rate” quantity with an “amount” quantity, i.e., volume. Ronda gave similar interpretations and units for the other two partial derivatives, namely f_y and f_z . Ronda and three other students (Sally, Austin, and Tim) went on to engage in quantification by evaluating the volume function at the critical point they found (i.e., 15 inches for the length, width, and height respectively) to determine the volume of the bag.

Two other students (Noel and Paul) used another algebraic method to find the critical point of the objective function. Because of space limitations, we will not show student work that illustrates the method used by these students. Two other students (Tom and Austin) drew on their prior experiences with calculating volumes of rectangular prisms and correctly determined the critical point of the objective function. Another student (Andy) incorrectly assumed that the length, width, and height of the bag will each be $\sqrt[3]{45}$ inches long.

Verifying extrema

Eight students had difficulty verifying that the dimensions of the bag they found would result in a bag of largest volume. For example, when asked how they can convince someone that the dimensions of the bag they found are the dimensions of the largest volume bag a passenger can carry on an American Airlines flight, Ronda commented, “honestly, I am not sure” while Garry said “I would probably google Lagrange multipliers to refresh myself. Lagrange multipliers would sort of be my proof.” In response to the same question, one of the students who gave an acceptable response, stated that he could use a numerical approach that involves randomly trying other numeric values for the quantities of length, width, and volume besides 15 inches and showing that these values would result in a smaller volume than when each side of the bag is 15 inches long. He also stated that the Second Derivative Test, discussed during classroom instruction and in the course textbook, could be used. The student correctly explained how this test could be used, in addition to using it correctly to verify extrema in another task not reported in this paper.

Discussion and conclusions

Although previous research (e.g., LaRue & Infante, 2015) has reported on students’ difficulties with setting up the objective function when solving UOPs, this was not the case for most of the students in this study. To some extent, findings of this study suggest that students’ difficulties when solving MOPs are similar to students’ difficulties when solving UOPs. In particular, verifying that the dimensions of the bag the students found (correct or incorrect) were the dimensions of the largest volume bag a passenger can carry on an American Airlines flight was problematic for eight of the 11 students who participated in this study. Similar results have been reported among students when solving UOPs (Borgen & Manu, 2002; Mkhathshwa, 2018). One student (Ronda) interpreted a “rate” quantity represented by a partial derivative as an “amount” quantity with units of volume (i.e., inches cubed). Similar results have been reported in other studies that have examined students’ reasoning about “rate” and “amount” quantities in real-world contexts (e.g., Mkhathshwa & Doerr, 2018). As noted earlier, the students in this study had limited exposure to solving MOPs that have real-world contexts. The presentation of optimization problems during course lectures closely followed the presentation of optimization problems in the course textbook. In particular, verifying extrema using informal and formal techniques such as the Second Derivative Test received minimal attention during course lectures. Hence, we argue that the students’ difficulties with verifying that the dimensions they found would result in a bag of largest volume may be directly related to the limited opportunities they had to verify extrema via examples that were given during course lectures. Calculus instructors may have to supplement examples given in course textbooks in order to maximize students’ opportunity to learn about MOPs. Future research might examine whether or not there are gaps in students’ prior

knowledge that impact them in understanding MOPs and the use of technology (especially graphs and spreadsheets) during classroom instruction to help students understand MOPs.

References

- Borgen, K. L., & Manu, S. S. (2002). What do students really understand? *The Journal of Mathematical Behavior*, 21(2), 151-165.
- Dominguez, A. (2010). Single Solution, Multiple Perspectives. In R. Lesh, P. L. Galbraith, C. R. Haines, & A. Hurford (Eds.), *Modeling Students' Mathematical Modeling Competencies: ICTMA 13* (pp. 223-233). New York: Springer.
- Goldin, G. A. (2000). A scientific perspective on structured, task-based interviews in mathematics education research. In A. E. Kelly, & R. A. Lesh (Eds.), *Handbook of research design in mathematics and science education* (pp. 517-545). Mahwah, NJ: Laurence Erlbaum Associates.
- Heid, M. K. (1988). Resequencing skills and concepts in applied calculus using the computer as a tool. *Journal for Research in Mathematics Education*, 19(1), 3-25.
- LaRue, R., & Infante, N. E. (2015). Optimization in first semester calculus: a look at a classic problem. *International Journal of Mathematical Education in Science and Technology*, 46(7), 1021-1031.
- Mkhatshwa, T. P. (2018). Students' quantitative reasoning about an absolute extrema optimization problem in a profit maximization context. *International Journal of Mathematical Education in Science and Technology*, 50(8) 1105-1127.
- Mkhatshwa, T. P., & Doerr, H. M. (2018). Undergraduate students' quantitative reasoning in economic contexts. *Mathematical Thinking and Learning*, 20(2), 142-161.
- Speer, N., & Kung, D. (2016). The complement of RUME: What's missing from our research? In T. Fukawa-Connelly, N. Infante, M. Wawro, & S. Brown (Eds.), *Proceedings of the 19th Meeting of the MAA Special Interest Group on Research in Undergraduate Mathematics Education* (pp. 1288-1295). Pittsburgh, Pennsylvania.
- Stewart, J. (2016). *Calculus: Early transcendentals* (8th ed.). Boston, MA: Cengage Learning.
- Swanagan, B. S. (2012). *The impact of students' understanding of derivatives on their performance while solving optimization problems* (Doctoral dissertation). University of Georgia, Georgia.
- Thompson, P. W. (1993). Quantitative reasoning, complexity, and additive structures. *Educational Studies in Mathematics*, 25(3), 165–208.
- Thompson, P. W. (1994b). Images of rate and operational understanding of the fundamental theorem of calculus. *Educational Studies in Mathematics*, 26(2), 229-274.
- Thompson, P. W. (2011). Quantitative reasoning and mathematical modeling. In L. L. Hatfield, S. Chamberlain, & S. Belbase (Eds.), *New perspectives and directions for collaborative research in mathematics education*. WISDOMe Monographs (Vol. 1, pp. 33- 57). Laramie, WY: University of Wyoming.

Towards a better understanding of engineering students' use and orchestration of resources: Actual Student Study Paths

Birgit Pepin and Zeger-Jan Kock

Eindhoven University of Technology, Eindhoven School of Education, The Netherlands;

b.e.u.pepin@tue.nl, z.d.q.p.kock@tue.nl

In this study we explore (1) which kinds of 'resources' engineering students use in selected first year university mathematics courses (Calculus, Linear Algebra); and (2) how they use/orchestrate them for their study of mathematics. Using a case study and mixed methods approach, we found that in the large Calculus course students followed various study paths. Moreover, it appeared that in such courses students used/included human and social resources extensively. In the smaller Linear Algebra course students could follow the study path established by the lecturer/course designer, with all resources provided for students to pass their examinations. At the theoretical level, we coined the term Actual Student Study Path to describe their self-reported ways of how they identified and orchestrated their chosen resources for their study of the mathematics.

Keywords: Student use of resources, university mathematics education, actual student study path/s.

Introduction

In most western (engineering) universities students now have access to a plethora of resources, both digital/online resources and 'traditional' curriculum resources, such as textbooks, readers (course textbook/set of materials prepared by the lecturer), worksheets, provided by the university and by lecturers. In particular in large first year courses (e.g., Calculus), students are typically expected to use and blend the available resources according to their individual needs, to support their learning. The rationale for our study is that, in times where students have access to almost limitless learning resources online, it becomes increasingly important to understand which resources are preferably (and beneficially) used by students from the ones on offer, and how they orchestrate them for their study of mathematics. This, in turn, is likely to inform the designers and teachers/lecturers of mathematics courses in their efforts to enhance their courses.

The use of particular curriculum resources by teachers and students in higher education mathematics has been subject of current research. In a recent review study (Biza, Giraldo, Hochmuth, Khakbaz, & Rasmussen, 2016), the opportunities afforded by introductory university mathematics textbooks and the actual use made of these curriculum materials by students are described. Anastasakis, Robinson, and Lerman (2017) investigated the different types of tools ('external' to the university, and 'internally' provided resources) that a cohort of second year engineering undergraduates used. Their results showed that although to some extent students used resources external to their university, their practices were dominated by tools that their institution provided. The students in their sample chose certain tools mainly because these enabled them to pursue their examination-driven goals. Specifically, the use of visual resources (e.g. online lectures) has been studied by Inglis, Palipana, and Ward (2011). Using the Documentational Approach to Didactics, Gueudet (2017) investigated mathematics teachers' interactions with resources at university, and Gueudet and Pepin (2018) explored how Brousseau's (1986) Didactic Contract can be seen through the lens of the use of

curriculum resources. Whilst the learning of Calculus (CS) has been studied extensively (e.g. Bressoud, Mesa, & Rassmussen 2015), Linear Algebra (LA) learning has had less attention (e.g. Grenier-Boley 2014).

However, we note here that relatively little research is available on the broad range of resources available to first year university students to learn the mathematics, and moreover how students actually orchestrate the resources in order to study mathematics. Typically, studies include the curriculum resources made available or recommended as part of mathematics courses (e.g., textbooks), but there are also *social resources* (e.g. lecturers, tutors, peers) that students tap into, and digital and other resources mobilized by students themselves. Inglis et al. (2011) suggest that students might need explicit guidance on how to combine the use of various resources into an effective learning strategy. Before this guidance can be given, more in-depth information on students' actual use of resources is needed. Hence, we ask the following research question:

How do first year engineering students identify and use the available resources for their study of Calculus and Linear Algebra in their first year at university, and what kinds of paths do students describe?

Theoretical frames/literature review

The lens of resources

Leaning on the Documentational Approach to Didactics (e.g. Trouche, Gueudet, & Pepin, 2018), in this study we use the notion of *re-source/s* that students have access to and interact with in and for their learning. We assume that the ways university students learn the mathematics is influenced/shaped by their use of the various resources at their disposal. By *use of resources* we denote, for example, which resources students choose (amongst the many on offer) and for what purpose (e.g. revision); the ways they align and orchestrate them (e.g. first lecture then checking the textbook); which ones seem central to achieve particular learning goals (e.g. for weekly course work, for examinations, for their engineering topic area). However, we do not address the specific learning of CS and LA, that is how students interact with particular (e.g. cognitive) resources to learn particular topic areas in CS and/or in LA.

Gueudet and Pepin (2018) have coined student resources as anything likely to re-source (“to source again or differently”) students' mathematical practice, leaning on Adler's (2000) definition of mathematics re-resources, in Adler's case used by teachers. In this study, following Pepin and Gueudet (2018), we distinguish between (1) material/traditional text/curriculum resource (including digital resources); and (2) human/social resources. As to (1) material/traditional text/curriculum resources: a further distinction has been made between (a) curriculum resources (those resources proposed to students and aligned with the course curriculum), and (b) general resources (which students might find/access randomly on the web). Curriculum resources are developed, proposed by teachers and used by students for the learning of the course mathematics, inside and outside the classroom. They may include text resources, such as textbooks, readers, websites and computer software, to name but a few. General resources are the non-curricular material resources mobilized by students, such as general websites (e.g. Wikipedia, YouTube). (2) In terms of social resources, we refer to formal or casual human interactions, such as conversations with friends, peers or tutors/lecturers.

Actual student study paths

The research literature in mathematics and science education shows many different terms and concepts linking to student study paths, often associated with instructional theory and curriculum design, such as Hypothetical Learning Trajectory (HLT) (Simon, 1995); Learning Trajectories/Progressions (Lobato & Walters, 2017); or, Learning Trajectories in mathematics education (Weber, Walkington, & Mc Galliard, 2015). Whereas some of the approaches focus primarily on learners (e.g. Lobator & Walters, 2017), Simon's (1995) HLT approach includes instructional supports for learning and was originally conceived as part of a model of teachers' decision making. Simon and Tzur (2004) later highlighted the importance of and principles for selecting tasks that promote students' development of more sophisticated mathematical concepts. Building on this work, Clements and Sarama (2004) define learning trajectories as

descriptions of children's thinking and learning in a specific mathematical domain and a related, conjectured route through a set of instructional tasks designed to engender those mental processes or actions hypothesized to move children through a developmental progression of levels of thinking, created with the intent of supporting children's achievement of specific goals in that mathematical domain. (p. 83)

Whilst recognizing this important work, it is clear that we have to define what we mean by student study paths for our purpose: first, when using the lens of resources to investigate students' study paths, we look at the alignment and orchestration of resources, and not at the actual tasks or activities and how students develop understandings of mathematical concepts; second, we view this from the students' perspective, how they actually orchestrate and align the resources for their own learning, and how they give meaning to these self-reported paths. We call these *Actual Student Study Paths*.

The study

Using a case study approach, we explored two first year mathematics courses in a Dutch engineering university: Calculus (CS) and Linear Algebra (LA), as our cases.

LA was taught to one group of approximately 130 students, mainly mathematics and physics students. The LA course was organized with four hours of lectures per week, and four hours of tutorials (in groups of approximately 30 students). The learning aims were described as the acquisition of mathematical skills, and to help students develop the skills and appreciate the importance of correct mathematical communication, including writing formal proofs. Completing a mathematical writing assignment was part of the course requirements to reach this aim. According to lecturers, the purpose of LA was to prepare students for higher mathematics (used in the mathematics and physics courses).

CS was taught as an obligatory subject to approximately 2000 students, in 6-7 groups of 300 students each (all types of engineering). The CS course was organized with six hours of lectures and one hour of tutorials (in small groups of approximately eight students). It was also differentiated at three levels (A, B, and C), according to perceived level of difficulty and with varying level of emphasis on formal aspects of mathematics (e.g. proof). The aim of the CS course (according to lecturers) was to provide students with a basic set of mathematical/computational tools they could subsequently use in their engineering studies and in their future work as engineers.

In terms of participants, in total 24 students participated in the study; all of them ‘opted in’ after a general mail to all CS and LA students: 18 CS students, involved in nine different engineering programs and all taking the B level CS course; 1 CS student who dropped out of university; 5 LA students, all studying for the applied mathematics engineering course. In terms of background, of the interviewed CS students 15 came from secondary schools in the Netherlands, three came from other educational systems.

For this paper we used data from the following data collection strategies:

- Individual and focus group interviews with students (24): 19 CS + 5 LA. The CS students were interviewed in four focus groups, and one individual interview. The LA students were interviewed in two groups of two, and one individual interview.
- CS students’ drawings (see example Figure 1): students were asked to draw Schematic Representation of Resource System (SRRS - see Pepin, Xu, Trouche, & Wang, 2017) during the interviews, to illustrate the particular resources each student used, and how. During the interviews students were asked to explain their resource use based on their SRRSs. The SRRSs were a methodological tool, to help the researchers better understand student use of resources.
- Interviews with course designers/lecturers and tutors (of the CS and LA courses): 3CS + 2LA.
- Selected observations of CS and LA lectures and tutorials, and examination of documents/curriculum materials provided by the university for the students, such as syllabi, textbook/s, reader/s, and lecture videos (mainly to understand the context in which students were working).

In terms of analysis, the interviews were first transcribed and interview quotes were coded using ATLAS-ti software. The codes were based on our knowledge from the literature (e.g. concerning the different curriculum resources and their use) and on our knowledge about student approaches to learning mathematics. Second, student drawings were compared with their explanations (within case comparison): how they explained their identification of (for them) suitable resources and the orchestration of these resources; this resulted in self-reported study paths. Third, these self-reported study paths were compared (across case comparison), and this resulted in particular types of study paths. In another step, the findings from CS and LA were compared, also taking into account our knowledge of the context and course organization.

Results

Overall, students used different/additional resources in the two courses, and they used the available resources differently for LA than for CS: (1) Basically, all LA curriculum resources offered/provided were used, and students worked with them according to the lecturer’s guidance. (2) The CS resources seemed to be a large bag of ‘tools’, a ‘pile of bricks’, that the students could pick from (according to their needs) and use for their learning. However, how students could orchestrate and align the resources for the learning of CS was not clear. These differences appeared to be related to (a) the size and student audience of the courses (130 students in LA; 2000 in calculus), and this, in turn, was connected to different organizations of the courses (4 hours lecture and 3 hours tutorials in LA; 6 hours lecture and 1 hour of tutorial in calculus); and (b) the organization and alignment of the resources with the assessment/tests. For example, there was a clear intended (by the lecturer) learning

trajectory in LA, with exercises aligned with the examinations. Students mentioned that if they worked according to/with the reader and did “all exercises in the reader”, and the obligatory weekly assignments, they could expect to pass the examination. In the CS course, many support tools were proposed (e.g. on the web, in print), with many exercises and tasks that, according to the students, were not always clearly aligned with the examinations. Students said that it was not possible to do all exercises, read all materials provided, and they often had considerable difficulties choosing from the immensity of resources provided.

From the interviews based on students’ drawings of their resource system, we could identify several study paths, which were the paths students perceived/drew when we asked them which resources they used, the importance of those resources (their role with respect to their perceived study paths), and how they orchestrated them for their learning. The study path of the LA course appeared to be relatively traditional and most students followed it: students could identify core resources (e.g. the lecture, the reader, past examinations, weekly tests), and a particular blending of the different resources was recommended by the lecturer. This would help students to understand the weekly coursework and to pass the final examinations. In addition, students had time to work together (in tutorials), and they also used human resources (e.g. peers, tutor/s, lecturer) during that time. In this course the number of tutorials was balanced as compared to the number of lectures (4 + 4).

In contrast, the students on the CS course outlined several study paths, based on their individual preferences and experiences, and for each path different resources came into play, and different core resources were described. For example, in the interviews based on their drawings, only two students put the lecture as a center point for their learning. For others, it appeared that the lecture was for information only of what students had to learn: “If I hear them talk about it, it’s easier for me to revise/practice when I’ve already seen it, heard about it” (see Joanna’s¹ drawing in Figure 1).

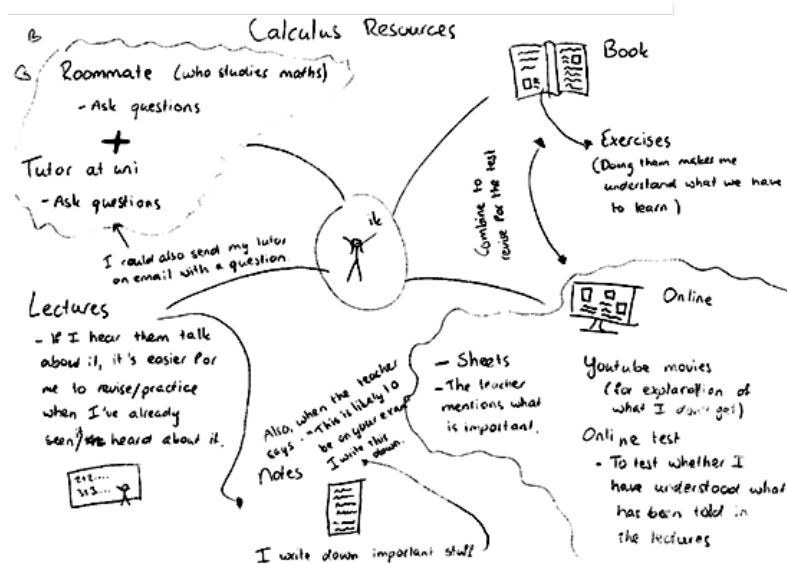


Figure 1: Joanna’s drawing of her resource system

¹ All names are pseudonyms

At the same time, either the lecture or lecture notes were mentioned by all students as a supporting resource for their learning of CS. Interestingly, a large number of students pointed to human resources, in particular their friends and peers, and the tutor, as resources they often used. As perhaps expected, books and tests/quizzes/exercises were mentioned as a huge help, and the digital resources (e.g. YouTube; Khan Academy) seemed to gain importance compared to high school. Altogether, the CS study paths showed a complex picture of students using a mixture and ever-increasing number of external resources, in particular of human and digital nature. Due to the interviews based on the SRRSs, we could identify a small number of (for students) ‘productive’ study paths that students self-reported upon. What made a study path ‘productive’ was that it allowed the students to orchestrate the different resources around a particular focus, in such a way that the students felt the demands of the course could be met.

The study paths we present here had different foci: (1) tests and examinations, weekly homework; (2) lecture; (3) friends and social media; and (4) understanding.

- (1) For most students the *weekly homework, tests and examinations* were the focal point, hence they described the resources that helped them to solve the associated tasks (e.g. “last resort professor”). Some students described a real trajectory of how they prepared for solving particular tasks or homework, and for passing tests and examinations.

- (2) Selected students chose the *lecture* as focus:

Dirk’s path: from lecture → tests → tutor hour & old exams → YouTube/Khan academy → homework (“reading text” & “do it”)

Naomi’s path: from lecture (every week) → tutor time → homework every week → on-course extra questions & weekly quiz → discussion with friends → “my own comments” /writings to prepare for exam.

- (3) Example of *human resources and social media* as focus:

Rebecca’s path: from “human resources” (at center) - first friends & summary chapters (book)/exercises & weekly homework → lecture “for orientation & overview, not in depth” (video lecture “only if I missed an essential”) → Matlab “own curiosity & personal interest” → Tutor hour (falling asleep).

Jop’s path: social media at the center

- (4) Example of students who differentiated between resources used for different kinds of learning:

Melissa’s path: she made a distinction between (a) procedural understanding: solving exercises/passing exams (resource/s: e.g. tutor, weekly quiz, online practice test), and (b) conceptual understanding: “if you do not understand underlying thought/concept” (resource: YouTube).

Conclusions

From our findings, it can be seen that students’ use and orchestration of resources were largely shaped by the course organizations. In one case (LA), the lecturer/course designer provided a ‘home-made’ reader (no other textbook was needed) which provided all necessary and important information in

terms of the mathematics (e.g. concept explanation) and the most relevant exercises. All other curriculum resources were aligned with the reader, and in line with the learning objectives/course aims (as described in the course guide booklet). In addition, the lecture and tutor hours afforded opportunities to discuss problems and ask for help from the lecturer/tutors, or indeed from peers. In the case of CS (at the B level), a commercially produced textbook was used, and several lecturers and tutors were involved. Moreover, in terms of opportunities for learning, the lectures were foregrounded (6 hours), with only one hour of tutor support. In addition, several resources had been prepared and were provided within the course web environment, as a support for students. However, it appeared that in this environment students looked for their own ways to use the affordances of the resources on offer (e.g. opportunities offered by textbooks and other resources, see Biza et al., 2016). They sometimes had difficulties navigating their ways around the different resources, benefitting from the quality of the resources on offer, with little (time and) guidance from the tutors. There were many (and new) resources to choose from, and the “didactic contract” (Gueudet & Pepin, 2018) was not clear to them; hence, students created their own actual study paths.

Based on our results we claim that it is not sufficient to provide a plethora of curriculum resources, may they be digital, traditional text or human resources, but that serious consideration should be given to how students might work with these resources, and orchestrate them into productive *Actual Student Study Paths*. In addition, it is advisable to help, perhaps even to train students how to develop such study paths, and these might be different from one subject to another (even from one mathematics course to another). This, we claim, is the responsibility of the lecturer/teacher/course designer. Such course design would involve purposeful design, including the development of particular (intended) study paths, and the design of particular resources supporting such paths. Simply providing access to curriculum resources does not seem to help students to orchestrate the resources on offer, neither to develop their individual study or learning strategies, but may rather confuse and overwhelm them (due to the immensity of resources on offer), and drive them towards “learning for the test”. As Anastasakis et al. (2017) claim, under such conditions “students use the most popular resources [and] they aim mostly for exam-related goals” and use “certain tools because these enable them to pursue their exam-driven goals” (p. 67).

References

- Adler, J. (2000). Conceptualising resources as a theme for teacher education. *Journal of Mathematics Teacher Education*, 3, 205–224.
- Anastasakis, M., Robinson, C.L., & Lerman, S. (2017). Links between students’ goals and their choice of educational resources in undergraduate mathematics. *Teaching Mathematics and Its Applications*, 36, 67-80.
- Biza I., Giraldo V., Hochmuth R., Khakbaz A., & Rasmussen C. (2016). *Research on Teaching and Learning Mathematics at the Tertiary Level: State-of-the-Art and Looking Ahead*. ICME-13 Topical Surveys. Cham: Springer.
- Bressoud, D., Mesa, V., & Rasmussen, C. (Eds.) (2015). *Insights and recommendations from the MAA National Study of College Calculus*. Washington, DC: Mathematical Association of America.

- Brousseau, G. (1986) Fondements et méthodes de la didactique. *Recherches en Didactique des Mathématiques*, 7(2), 35–115.
- Clements, D. H., & Sarama, J. (2004). Learning trajectories in mathematics education. *Mathematical Thinking and Learning*, 6(2), 81–89.
- Grenier-Boley, N. (2014). Some issues about the introduction of first concepts in linear algebra during tutorial sessions at the beginning of university. *Educational Studies in Mathematics*, 87(3), 439–461.
- Gueudet, G. (2017). University teachers' resources systems and documents. *International Journal of Research in Undergraduate Mathematics Education*, 3(1), 198–224.
- Gueudet, G., & Pepin, B. (2018). Didactic contract at university: a focus on resources and their use. *International Journal of Research in Undergraduate Mathematics Education*, 4(1), 56-73.
- Inglis, M., Palipana, A., Trenholm, S., & Ward, J. (2011). Individual differences in students' use of optional learning resources. *Journal of Computer Assisted Learning*, 27, 490-502.
- Lobato, J., & Walters, C.D. (2017). A taxonomy of approaches to learning trajectories and progressions. In Cai, J. (ed.) *The Compendium for Research in Mathematics Education* (pp. 74–101). National Council of Teachers of Mathematics (NCTM).
- Pepin, B., & Gueudet, G. (2018). Curricular resources and textbooks. In S. Lerman (Ed.), *Encyclopedia of mathematics education*. Cham: Springer.
- Pepin, B., Xu, B., Trouche, L., & Wang, C. (2017). Developing a deeper understanding of mathematics teaching expertise: an examination of three Chinese mathematics teachers' resource systems as windows into their work and expertise. *Educational Studies in Mathematics*, 94(3), 257-274.
- Simon, M. A. (1995). Reconstructing mathematics pedagogy from a constructivist perspective. *Journal for Research in Mathematics Education*, 26(2), 114–145.
- Simon, M. A., & Tzur, R. (2004). Explicating the role of mathematical tasks in conceptual learning: An elaboration of the hypothetical learning trajectory. *Mathematical Thinking and Learning*, 6(2), 91–104.
- Trouche, L., Gueudet, G., & Pepin, B. (2018). Documentational approach to didactics. In S. Lerman (Ed.), *Encyclopedia of Mathematics Education*. Cham: Springer.
- Weber, E., Walkington, C., & McGalliard, W. (2015). Expanding notions of “learning trajectories” in mathematics education. *Mathematical Thinking and Learning*, 17(4), 253–272.

Conceptualising knowledge of mathematical concepts or procedures for diagnostic and supporting measures at university entry level

Guido Pinkernell

University of Education Heidelberg, Germany; pinkernell@ph-heidelberg.de

At the 10th CERME in Dublin, Pinkernell, Düsi and Vogel (2017) introduced a model of proficiency in elementary algebra that serves as a frame of reference for analysing and constructing material for diagnostic and supporting measures for students at the entry level of university. One basis of this model was a systematic analysis of the mathematical concepts and procedures of elementary algebra with regard to five aspects of understanding mathematics. This paper introduces this framework in detail, thus contributing to a genuine mathematics educational conceptualisation of content oriented knowledge for STEM subjects at university entry.

Keywords: STEM Education, Secondary Education, Assessment, Knowledge, Understanding.

Conceptualisations of knowledge at university level

The recent years have shown a growing interest of mathematics educators for the transition from secondary to tertiary phase, which is mainly being characterised as a gap between mathematical levels and institutional cultures. In her analysis Gueudet (2008) describes differences with regard to modes of conceptualising mathematical objects, also different levels of rigour in communication or reasoning, and institutional differences, e.g. concerning the didactics of teaching and learning mathematics. Thomas, de Freitas Druck, Huillet, Ju, Nardi, Rasmussen and Xie (2015) come to similar findings when they analyse the transition from four different theoretical perspectives. One aspect that adds to these cognitive, didactical and institutional differences, however, is the content orientation that appears to dominate discussions about the demands and deficits of students in STEM subjects at university entry. This becomes manifest, for example, in catalogues of minimum mathematical requirements (e.g. cosh, 2014) or in a large-scale delphi study with mathematics teachers in the tertiary sector (Neumann, Pigge, & Heinze, 2017). Yet when it comes to devising diagnostic and supporting measures, what students need to know can only be made clear when there is a notion of what knowing means.

Among the frameworks for conceptualising knowledge that are familiar at university level is the so-called Bloom taxonomy, which in a revised version by Anderson and Krathwohl (2001) differs between various categories of knowledge about subject matter content as well as various forms of cognitive activities on that subject matter content. According to Krathwohl (2002) the reasons for revision were to update to new psychological models of knowledge as well as to meet with terminology use among teachers or educators. This resulted, e. g., in formulating four categories of knowledge, which are factual, procedural, conceptual and metacognitive knowledge. This framework had been designed for trans-disciplinary purposes (Krathwohl, 2002), which is seen as an advantage since it seems suitable for interdisciplinary use (Maier, Kleinknecht, Metz, & Bohl, 2010). While the procedural-conceptual dichotomy is not only part of many models of general knowledge but of mathematical knowledge as well (e.g. Hiebert & LeFevre, 1986; de Jong & Ferguson-Hessler, 1996; Rittle-Johnson & Alibali, 1999), it appears that for analysing mathematical content knowledge, the

four categories do not quite fit to how the knowledge of mathematical concepts or procedures is seen from within mathematics education. Firstly, Star and Stylianides (2013) have shown that while psychologists see procedural and conceptual knowledge as merely two different types of knowledge, in mathematics education these two are regarded as of different quality. For many school teachers, conceptual knowledge is preferable over procedural knowledge which is seen as simply recalling facts or applying algorithms “without significant thought.” (Star & Stylianides, 2013, p. 178) Secondly, this again seems to be in contrast to how many university teachers view procedural knowledge. They see procedural proficiency as a necessary basis for following or performing symbolic mathematical reasoning. In fact, since the process of learning abstract mathematical concepts can be described as a progression from procedures to concepts (Tall, 1991; Sfard, 1994), the procedural-conceptual dichotomy does not quite grasp the nature of knowledge in mathematics where concepts and processes are seen as part of the very same knowledge entities (see also Kieran, 2013). In fact, Star and Stylianides (2013) suggest “abandon[ing] the conceptual/procedural framework entirely and select new words or phrases to describe knowledge outcomes of interest.” (p. 179)

This paper proposes a genuine mathematics educational approach to conceptualising mathematical knowledge at the transition from the secondary to the tertiary level. While procedural and conceptual knowledge is still implicitly present, it addresses specific forms of accessing or understanding a mathematical object, thus acknowledging the content orientation and other characteristics of mathematical knowledge as it is seen at university level.

Content orientation from perspective of mathematics education

The following ideas are rooted in the German Stoffdidaktik (subject-matter didactics) tradition. It shares the conviction that student oriented approaches to abstract mathematical objects are possible without compromising on the mathematical validity. At the centre of didactical efforts of Stoffdidaktik is a thorough analysis of the mathematical concept. In the past this took on the form of mathematical rigour that seemed unsuitable for the use in learning situations (Hußmann, Rezat & Sträßer, 2016). While subject of an ongoing dispute, the ideas of Stoffdidaktik are still present in German mathematics education. Prediger and Hußmann (2016) for example plead for a combination of a thorough content analysis and empirical evaluation, for which they describe four phases: 1. a formal analysis of mathematical conceptualisations of the teaching object, 2. a semantic analysis of meaningful interpretations of the teaching object, 3. a structural orchestration of the findings in the form of a teaching unit, and 4. constant empirical evaluation and subsequent modifications of steps 2 and 3 to adapt to students' needs. Especially the first two phases indicate that formal conceptualisations and meaningful interpretations of mathematical objects can be part of one didactical framework, which seems suitable for purposes at the transition from school to university where formal and educational perspectives meet.

The WiGORA frame of reference

Before going into details, this section starts with an outline of necessary a priori settings that reflect the area where the framework is being used, which is the transition from secondary to tertiary maths: First, it is a concise and summative view on what facets of knowledge of a given mathematical object a student needs to have at his or her disposal once it has been taught, not a formative view on how

knowledge should be developed during school-time. Further, the facets of knowledge are considered normative, that is they are meant to cover mathematically sound ways of accessing a mathematical object which include, e.g. explanatory models or visualizations that are structurally equivalent to the object. Moreover, considering the formal level at which mathematics is being taught at university (Gueudet, 2008; Thomas et al., 2015), a correct use of terminology and definition based access to mathematical objects will be addressed explicitly. Simultaneously, since formal and abstract nature of mathematical objects requires a flexible use of representations (Duval, 1999), this aspect will be addressed explicitly, too. And last, this framework is for conceptualising an “intelligent content knowledge base” (Klieme et al., 2007) for developing higher level competencies, it is not a framework for higher level competencies itself.

The acronym WiGORA derives from the German labels for the five facets of knowledge that make up the frame of reference. In the following each facet will be introduced and illustrated by tasks that address the concept of integral.

- Declarative knowledge (“Wissen”) refers to the ability to recall or identify correct definitions, rules or characteristic properties of a mathematical concept or procedure as well as the necessary terminology associated with it. Declarative knowledge basically is knowledge about facts and information (Anderson, 1976). It seems rather less present in conceptualisations of mathematical knowledge as compared to procedural or conceptual knowledge. While in its strictest sense it does not allow for weighting knowledge regarding significance, declarative knowledge here also comprises prototypical knowledge that characterises, but not necessarily defines, the object (Rosch, 1983; Tall & Bakar, 1992; Weigand, 2004). The following task asks for prototypical knowledge that differs between definite and indefinite integrals.

Which of the four statements are correct?

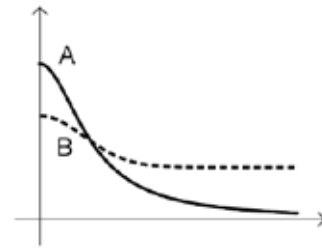
$\int_a^b f(x) dx$ is a number. $\int_a^b f(x) dx$ is a function.

$\int f(x) dx$ is a number. $\int f(x) dx$ is a function.

- Explanatory models (“Grundvorstellungen” or GV for short) refers to the ability to recall or identify conceptualisations of a mathematical object that “make sense” (vom Hofe & Blum, 2016; Greefrath et al., 2016; Weber, 2017). The concept of GV is one of the key concepts of German Stoffdidaktik, which “should be able to, on the one hand, accurately fit to the cognitive qualifications of students and, on the other hand, also capture the substance of the mathematical content at hand” (vom Hofe & Blum, 2016, p. 227). In international context, GV are also being referred to as “basic ideas”, “basic notions” or “conceptual metaphors” (Soto-Andrade & Reyes-Santander, 2011). In its broadest sense, GV comprise normative, descriptive and constructive aspects. Here, at the transition from school to university, the notion of GV is restricted to its normative aspect. As such, a GV could result from a semantic analysis of a mathematical object (Hußmann & Prediger, 2016). For example, “reconstruction” of rates or speed is one of the GV for the concept of the definite integral (Greefrath et al., 2016) and is subject of the following task.

The graph shows for any point of time the current fuel consumption for each of two vehicles A and B.

Which of the vehicles has a higher consumption overall over the period shown?



- Operational flexibility (“Operationale Flexibilität”) refers to the ability to apply, adapt and modify mathematical procedures for situational needs. Going beyond simply reproducing step-by-step instructions this facet refers to the cognitive construct of operations in the sense of Piaget and Aebli. Characterised for example by reversibility or transitivity of the mental operations involved (Fricke, 1970), corresponding tasks would require reversing procedures or selecting efficient over routine procedures (“strategic flexibility”: Rittle-Johnson & Star, 2007). Here, procedures are not restricted to algorithms for calculating numbers or transforming algebraic expressions. A procedure can be any method for solving a mathematical task, which e.g. could also involve switching representation forms. The following example shows a reverse task which can be answered by mentally visualising a graph and/or recalling prototypical information about the periodicity of trigonometric functions.

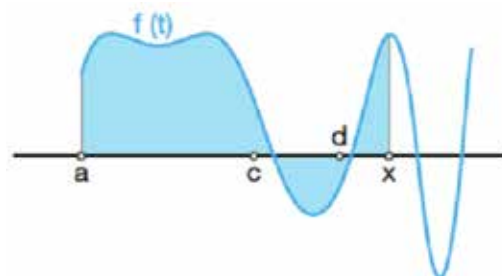
Specify as many $a \neq b$ as you can find

$$\text{such that } \int_a^b \sin(x) dx = 0.$$

- Representational flexibility (“Repräsentationale Flexibilität”) refers to the ability to switch within and between representational forms or registers of a mathematical object. Following Duval (1999), this ability is specific to understanding higher level mathematics since a mathematical concept, being essentially abstract, can not be addressed otherwise: “From a didactical point of view, only students who can perform register change do not confuse a mathematical object with its representation.” (Duval, 1999, p. 318). As to the many possible forms in which a mathematical object can be represented, this framework is restricted to those that are conventionally used in mathematics such as numerical, algebraical, geometrical representations, or verbal paraphrasing.

Order by value:

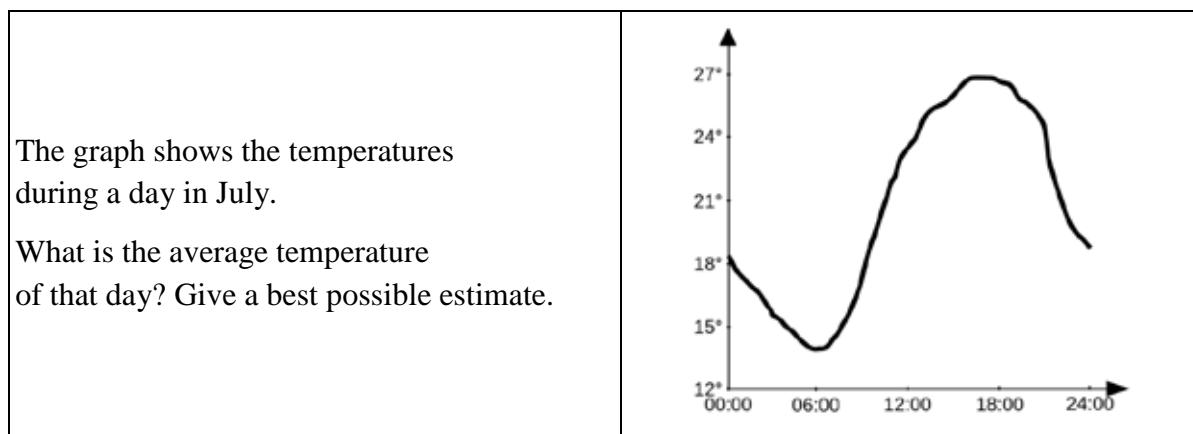
$$\int_a^a f(t) dt, \int_a^c f(t) dt, \int_a^d f(t) dt, 0, \int_c^d f(t) dt$$



by H. Körner (in Pinkernell et al. 2015)

- Knowledge application (“Anwendung”) refers to the ability to identify a mathematical concept or procedure as suitable for solving a problem. Here, the given concept or procedure

is considered as a potential model for mathematising situations within or outside mathematics (“Mathematisierungsmuster”: Tietze, Förster, Klika & Wolpers, 2000). This facet, as all five facets do, focusses on meaning and use of a given mathematical object. It does not refer to the modelling process or parts of it, but it addresses the content knowledge base of modelling. The following example asks for the average of values of a continuous function over an interval $\frac{1}{b-a} \int_a^b f(x) dx$ which here is determined by graphical estimation.



Discussion

With WiGORA, this paper proposes a framework for conceptualising mathematical knowledge at the university entry level. With focussing on single concepts or procedures WiGORA follows a similar approach as the familiar taxonomies of Bloom or Anderson and Krauthwohl, yet with a genuine theoretical base from mathematics education. When compared with Anderson and Krauthwohl (2001), the most significant difference is that the well-known dichotomy of procedural and conceptual knowledge has been abandoned. It has been replaced by facets of knowledge that take specific aspects of objects from formal mathematics into account, which roughly can be characterised as being abstract “by definition”. The facet “Grundvorstellungen” (GV) asks for the activation of explanatory models for the abstract mathematical object at hand. Such models can be hands-on activities on real or virtual material or situational interpretations within or outside mathematics. Equally, the facet “Repräsentationale Flexibilität” reflects the abstract nature of mathematical objects by asking for a flexible use of representations of this object. Also, the facet “Operationale Flexibilität” derives from the cognitive nature of mental operations as being abstractions from step-by-step procedures when it asks for heuristic flexibility in adapting mathematical procedures to situational needs. Among these facets, procedural and conceptual aspects of knowledge are still present though not explicitly. From the two other facets, “Wissen” corresponds to the category “factual knowledge” from Anderson and Krauthwohl (2001).

The five facets of the WiGORA framework all stand for viewing the same mathematical concept or procedure from different perspectives. Although the perspectives are different, the tasks that result from operationalisations following the framework are not necessarily disjunct. In fact, the very same task could address several facets. E.g., among the five examples above, three require representation change. And since GV are often associated with actions and concepts from everyday life, they identify

obvious applications for the mathematical objects. For example, the GV “average value” (Greefrath et al., 2016) points to applying the integral for measuring the average of a continuous function, as shown in the fifth task. Hence, WiGORA has its main use for analysing or devising test material that is based on a list of given concepts or procedures. It is meant to serve as a model of reference for checking whether the five facets are being covered in a diagnostic tool.

With focussing on single objects, WiGORA does not allow for analysing a whole network of knowledge of a mathematical field, which from an educational perspective is characterised by a meaningful use of the specific language or the mastery of key concepts from that field. In the field of elementary algebra, these would be various aspects of knowledge specific to the structuring, transforming and interpreting of algebraic expressions (Pinkernell et al., 2017), as e.g. aspects of giving meaning to expressions (structure sense: Hoch & Dreyfus, 2006; systemic vs. surface structure: Kieran, 1989), or aspects of interpreting the equation sign (operational vs. relational meaning: Baroody & Ginsburg, 1983). Hence, the object related facets of knowledge from WiGORA would need to be integrated into a larger educational conceptualisation of the knowledge of that area. Presently, as part of the German optes+ project (Mechelke-Schwede, Wörler, Hübl, Küstermann, & Weigand, 2018), this is being done for the areas secondary arithmetic, functions and geometry.

References

- Anderson, J. R. (1976). *Language, memory and thought*. Hillsdale: Lawrence Erlbaum Associates.
- Anderson, L. W., & Krathwohl, D. R. (2001). *A taxonomy for learning, teaching, and assessing: a revision of Bloom's taxonomy of educational objectives*. New York: Longman.
- cosh: cooperation schule:hochschule. (2014). *Mindestanforderungskatalog Mathematik*. www.cosh-mathe.de/materialien > 2018-09-10
- de Jong, T., & Ferguson-Hessler, M. G. M. (1996). Types and qualities of knowledge. *Educational Psychologist*, 31(2), 105–113.
- Baroody, A. J., & Ginsburg, H. P. (1983). The effects of instruction on children's understanding of the “equals” sign. *The Elementary School Journal*, 84(2), 199–212.
- Duval, R. (1999). Representation, Vision and Visualization: Cognitive Functions in Mathematical Thinking. Basic Issues for Learning. In F. Hitt, & M. Santos (Eds.), *Proceedings of the Twenty-first Annual Meeting of the North American Chapter of the International Group for the Psychology of Mathematics Education (Vol. I, pp. 3–26)*. Mexico.
- Fricke, A. (1970). Operative Lernprinzipien im Mathematikunterricht der Grundschule. In A. Fricke & H. Besuden (Ed.), *Elemente einer Didaktik und Methodik* (pp. 79–116). Stuttgart: Klett.
- Greefrath, G., Oldenburg, R., Siller, H.-S., Ulm, V., & Weigand, H.-G. (2016). Aspects and “Grundvorstellungen” of the Concepts of Derivative and Integral: Subject Matter-related Didactical Perspectives of Concept Formation. *Journal Für Mathematik-Didaktik*, 37(1), 99–129.
- Gueudet, G. (2008). Investigating the secondary–tertiary transition. *Educational Studies in*

Mathematics, 67(3), 237–254.

- Hiebert, J., & LeFevre, P. (1986). Conceptual and procedural knowledge in mathematics: An introductory analysis. In J. Hiebert (Ed.), *Conceptual and procedural knowledge: The case of mathematics* (pp. 1–27). Hillsdale, NJ: Lawrence Erlbaum Associates.
- Hoch, M., & Dreyfus, T. (2006). Structure sense versus manipulation skills. In J. Novotná, M. Moraová, M. Krátká, & N. Stehlíková (Eds.), *Proceedings of the 30th Conference of the Group of Psychology and Mathematics Education* (vol 3, pp. 305–312).
- Hußmann, S., Rezat, S., & Sträßer, R. (2016). Subject Matter Didactics in Mathematics Education. *Journal Für Mathematik-Didaktik*, 37(1), 1–9.
- Hußmann, S., & Prediger, S. (2016). Specifying and Structuring Mathematical Topics: A Four-Level Approach for Combining Formal, Semantic, Concrete, and Empirical Levels Exemplified for Exponential Growth. *Journal Für Mathematik-Didaktik*, 37(1), 33–67.
- Kieran, C. (1989). The early learning of algebra: a structural perspective. In S. Wagner, & C. Kieran (Eds.), *Research issues in the learning and teaching of algebra* (pp. 33–56). Hillsdale: Erlbaum.
- Kieran, C. (2013). The false dichotomy in mathematics education between conceptual understanding and procedural skills: An example from algebra. In K. R. Leatham (Ed.), *Vital directions for mathematics education research* (pp. 153–171). New York: Springer.
- Klieme, E., Avenarius, H., Blum, W., Döbrich, P., Gruber, H., Prenzel, M., ..., & Vollmer, H. J. (2007). *Zur Entwicklung nationaler Bildungsstandards. Eine Expertise*. Bundesministerium für Bildung und Forschung (BMBF), Referat Bildungsforschung.
- Krathwohl, D. R. (2002). A revision of Bloom's taxonomy: An overview. *Theory into practice*, 41(4), 212–218.
- Maier, U., Kleinknecht, M., Metz, K., & Bohl, T. (2010). Ein allgemeindidaktisches Kategoriensystem zur Analyse des kognitiven Potenzials von Aufgaben, 14.
- Mechelke-Schwede, E., Wörler, J., Hübl, R., Küstermann, R., & Weigand, H-G. (2018). Das Verbundprojekt optes – Optimierung der Selbststudiumsphase: Konzepte, Inhalte & Ideen. *Beiträge zum Mathematikunterricht*.
- Neumann, I., Pigge, C., & Heinze, A. (2017). *Welche mathematischen Lernvoraussetzungen erwarten Hochschullehrende für ein MINT-Studium?* (IPN. Leibniz-Institut für die Pädagogik der Naturwissenschaften und Mathematik, Ed.). Kiel.
- Pinkernell, G., Düsi, C., & Vogel, M. (2017). Aspects of proficiency in elementary algebra. In T. Dooley & G. Gueudet (Eds.), *Proceedings of the Tenth Congress of the European Mathematical Society for Research in Mathematics Education* (pp. 464–471). Dublin, Ireland: DCU Institute of Education and ERME.
- Pinkernell, G., Elschenbroich, H.-J., Heintz, G., Körner, H., Langlotz, H., & Pallack, A. (2015). *Grundlegendes Wissen und Können am Ende der Sekundarstufe II: Zentrale Begriffe und Verfahren beherrschen und verstehen* (MNU Themenreihe Bildungsstandards). Deutscher Verein

zur Förderung des mathematischen und naturwissenschaftlichen Unterrichts e. V.

- Rittle-Johnson, B., & Alibali, M. W. (1999). Conceptual and procedural knowledge of mathematics: Does one lead to the other? *Journal of Educational Psychology*, *91*(1), 175–189.
- Rittle-Johnson, B., & Star, J. R. (2007). Does comparing solution methods facilitate conceptual and procedural knowledge? An experimental study on learning to solve equations. *Journal of Educational Psychology*, *99*(3), 561–574.
- Rosch, E. (1983). Prototype Classification and Logical Classification: The Two Systems. In E. K. Scholnick (Ed.), *New trends in conceptual representation: challenges to Piaget's theory?* (pp. 73–86). Hillsdale, N.J: L. Erlbaum Associates.
- Sfard, A. (1994). Reification as the birth of metaphor. *For the Learning of Mathematics*, *14*(1), 44–55.
- Soto-Andrade, J., & Reyes-Santander, P. (2011). Conceptual metaphors and Grundvorstellungen: A case of convergence. In M. Pytlak, T. Rowland, & E. Swoboda (Eds.), *Proceedings of the Seventh Congress of the European Mathematical Society for Research in Mathematics Education* (pp. 1625–1635). Rzeszów, Poland: University of Rzeszów and ERME
- Star, J. R., & Stylianides, G. J. (2013). Procedural and conceptual knowledge: exploring the gap between knowledge type and knowledge quality. *Canadian Journal of Science, Mathematics and Technology education*, *13*(2), 169–181.
- Tall, D. (Ed.). (1991). *Advanced Mathematical Thinking*. Dordrecht: Springer Netherlands.
- Tall, D., & Bakar, M. (1992). Students' mental prototypes for functions and graphs. *International Journal of Mathematical Education in Science and Technology*, *23*(1), 39–50.
- Thomas, M. O. J., de Freitas Druck, I., Huillet, D., Ju, M.-K., Nardi, E., Rasmussen, C., & Xie, J. (2015). Key Mathematical Concepts in the Transition from Secondary School to University. In J. Cho (Ed.), *The Proceedings of the 12th International Congress on Mathematical Education* (pp. 265–284). Cham: Springer International Publishing.
- Tietze, U.-P., Förster, F., Klika, M., & Wolpers, H. (2000). *Mathematikunterricht in der Sekundarstufe II*. Braunschweig: Vieweg.
- vom Hofe, R., & Blum, W. (2016). “Grundvorstellungen” as a Category of Subject-Matter Didactics. *Journal Für Mathematik-Didaktik*, *37*(1), 225–254.
- Weber, C. (2017). Graphing logarithmic functions: Multiple interpretations of logarithms as a basis for understanding. In T. Dooley & G. Gueudet (Eds.), *Proceedings of the Tenth Congress of the European Mathematical Society for Research in Mathematics Education* (pp. 537-544). Dublin, Ireland: DCU Institute of Education and ERME.
- Weigand, H.-G. (2004). Funktionales Denken. *Der Mathematikunterricht*, *50*(6), 4–10.

Formative assessment of proof comprehension in undergraduate mathematics: Affordances of iterative lecturer feedback

Alon Pinto and Jason Cooper

Weizmann Institute of Science, Israel; alon.pinto@weizmann.ac.il; jasonc2107@gmail.com

Research shows that lecturer feedback on students' proofs is crucial for developing proof-comprehension in advanced mathematics courses, yet students often fail to comprehend lecturer feedback, and only rarely receive further feedback on their revisions. In this study we investigate the affordance of a novel formative-assessment scheme, designed and enacted by a mathematics professor, which employed multiple rounds of lecturer-feedback / student-revision. We analyze one such round, focusing on various facets of proof comprehension that underlie the lecturer's feedback and the student's subsequent revisions. On the basis of this analysis we discuss various ways in which lecturers can leverage feedback/revision cycles, not only for gaining insight into students' comprehension, but also for fostering meta-level ideas, and affording opportunities for students to develop agency and holistic proof comprehension.

Keywords: Undergraduate mathematics education, proof comprehension, formative assessment.

Introduction

One of the most prominent learning activities in advanced mathematical courses is proof reading. Students listen to their professors as they present proofs in lectures, and are expected to continue studying these proofs extensively after class, using their lecture notes or the course textbook (Weber, 2012). However, reading, validating and comprehending mathematical proofs are not easy tasks. It involves not only strategic knowledge in specific content areas, but also knowledge and norms specific to proof and reasoning (Knapp, 2005). In a study of students' proof validation practices, Alcock and Weber (2005) found that students focused on superficial features of proofs, while failing to develop a holistic view of the proof and neglecting arguments' explicit or implicit warrants. In spite of these difficulties, instructors rarely attend directly to proof reading in their teaching, presumably because knowledge related to proof reading strategies is largely tacit (Weber, 2012). Weber (2012) concludes that the mathematicians he interviewed provided "little guidance to students on how to engage in the complicated process of reading and comprehension of proofs and, by their own admission, lacked adequate methods for assessing students' understanding of a proof" (p. 478).

Lecturer feedback is an important aspect of assessment practice. Moore (2016) has argued that lecturer feedback is instrumental not only for proof comprehension, but also for developing the notion of proof and the ability to write proofs. Yet, relatively little empirical research has been conducted on how proofs are assessed in undergraduate mathematics courses, particularly in relation to lecturer feedback. Moore, Byrne, Hanusch, and Fukawa-Connelly (2016) have investigated students' comprehension of written lecturer feedback, and found that students "were generally quite capable of writing revised proofs that remediated the issues indicated by the professor's marks and comments, even when they could not fully explain the rationale for the comments" (p. 320). Consequently, students' written proofs were found to be insufficient for distinguishing between different levels of comprehension. These findings highlight that when students do not resubmit their revised proofs,

neither the students nor the lecturers have a way of knowing whether students have interpreted the feedback and respond to it in ways that promote proof comprehension.

One way to address this limitation is by having students' work iteratively critiqued and resubmitted until deemed acceptable by the lecturer. Our research goal is to investigate how multiple rounds of lecturer feedback and student revision can be used effectively for formative assessment of proof comprehension. We use the term *formative* for assessment that is integrated with teaching to contribute, through feedback, to student learning. Mejia-Ramos, Fuller, Weber, Rhoads, and Samkoff (2012) have proposed a conceptual framework for proof comprehension based on an extensive literature review and on interviews with mathematicians. Based on this framework, they have proposed an assessment model that comprises questions for probing various facets of proof comprehension. They suggest that this model can be used by researchers "to examine how proof comprehension develops in students and to evaluate different means of improving it" (p. 4), and by lecturers to "inform what specific aspects of a given proof students understand and what aspects they do not understand" (p. 4). In this study we draw on Mejia-Ramos et al.'s work in order to scrutinize the affordances for formative assessment of proof comprehension of a novel assessment scheme that includes cycles of feedback/revision, which was designed and enacted by a mathematics professor.

Setting

The assessment scheme examined in this paper was used in a proof-oriented Real-Analysis course at a large public research university in the United States. The key aspect of the assessment scheme was the instructor's decision to replace the "traditional" problem sets (weekly homework assignments; exams) with a term-paper assignment: Students were required to produce and submit weekly 'lecture notes' that would present selected proofs taught in the lecture in the students' own words. The instructor, whom we will call Mike, is a research mathematician who had been teaching proof-oriented courses for more than two decades. In the term under investigation he invested a great deal of time and effort in this novel assessment scheme, planning his lectures accordingly, redesigning the assignments for the course, and providing extensive written feedback on student submissions. Assessment of the students' proofs proceeded in cycles of feedback and revision until the instructor was satisfied. These submissions were a passing requirement for the course.

Prior research of Mike's goals and expectations for the term-paper assignment revealed that it was meant to promote students' proof comprehension by scaffolding their independent proof reading (Pinto & Karsenty, 2018). Thus, the term paper assignment can be seen as part of a formative assessment scheme for proof comprehension. Though this assessment scheme was not designed by educational researchers, it nevertheless seemed to address some of the key limitations for formative assessment of traditional assessment practices (e.g., Moore et al., 2016). Many of the students' initial submissions contained numerous flaws. Mike's assessment scheme gave him more flexibility when facing feedback related challenges, for example:

- **Prioritizing comments:** Indicating all of the deficiencies in a proof can be overwhelming for students, while selective feedback may be misconstrued as endorsement of unmarked errors.
- **Diagnosing student (mis)comprehension:** Deficiencies in a proof can be linked to different kinds of miscomprehension. Has the instructor correctly diagnosed them?

- Providing effective feedback: What will students learn or mis-learn from the instructor's comments? Will they be able to leverage the feedback to produce a satisfactory proof?

In this paper we describe how Mike addressed these challenges in one feedback/revision cycle and present an in-depth analysis of its affordances for formative assessment, thus shedding light on ways lecturer and students can leverage feedback/revision cycles to promote proof comprehension.

Methodology

The main source of data for our analysis is iterations of students' proofs, along with Mike's comments on each iteration. Additional background data include: video-documentation of lectures; field notes; informal discussions; and two 90-minute interviews with Mike, one conducted at the beginning of the course and the other after its conclusion. The interviews focused on the course design and aimed at eliciting Mike's goals and expectations (for further detail, see Pinto & Karsenty, 2017).

For the study reported herein we chose to analyze a particularly long cycle: six submissions of a student, whom we will call Ben, for a proof of the theorem, *a non-empty subset of the real numbers bounded above has a least upper bound*. The 6th submission was accepted without comment. Mike defined the real numbers as the set of all decimals and proved the theorem in class by constructing the least upper bound, digit after digit in an infinite iterative process. In his first submission, Ben tried a different approach for proving the theorem. This submission had numerous deficiencies, including a structural flaw, as Ben relied on a corollary of the theorem he was attempting to prove. The number of iterations and the variety of flaws in Ben's first submission, which intensify the dilemmas discussed in the previous section, made this cycle particularly suitable for our investigation.

We view students' submission of a proof "in their own words" as an opportunity for assessing their comprehension of the proof presented during the lecture. Such assessment is formative when the instructor, in his feedback, invites students to reflect on and develop their comprehension of the proof. We characterize opportunities for formative assessment through analysis of the instructor's feedback (i.e., which aspects of proof-comprehension he stresses) and of the students' subsequent revisions (i.e., how they attend to the feedback). For this analysis we draw on the seven facets of proof comprehension proposed by Mejia-Ramos et al. (2012, see Figure 1), which were grouped into *local* – discerned by studying a few related statements within the proof – and *holistic* – ascertained by inferring the ideas or methods that motivate a major part of the proof or the proof in its entirety.

These seven facets were operationalized in terms of 19 assessment items (pp. 5–6). In coding Mike's feedback, we asked ourselves: "to which of the 19 assessment items is Mike implicitly asking students to attend?" For example, the feedback "one can only prove a statement, not a bound" (Figure 1) was coded as *meaning of terms and statements*, because Mike appears to want Ben to notice that the statement should have been "to prove *the existence of* an upper bound," and therefore his feedback could have been rephrased as "explain the meaning of the term *prove a bound*." In coding Ben's submissions, we listed all the deficiencies that we found in his proof, and for each we asked ourselves: "Which of the 19 assessment items can we conclude that Ben has responded to inadequately?" For example, if a statement was correct but did not serve a logical purpose in the proof sequence, we coded for *logical status*, because Ben would apparently not have had an adequate response to the implicit question "identify the purpose of the sentence."

Local Facets (<i>example</i>)	Holistic Facets (<i>example</i>)
<ul style="list-style-type: none"> • Meaning of terms and statements (<i>state the definition of a term</i>) • Logical status of statements and proof framework (<i>identify the purpose of a sentence</i>) • Justification of claims (<i>identify the specific data supporting a given claim</i>) 	<ul style="list-style-type: none"> • (Summary of) high level ideas (<i>provide a good summary of the proof</i>) • Transferring general ideas or methods to another context (<i>appreciate the scope of the method</i>) • Modular structure (<i>identify the logical relation between modules of a proof</i>) • Illustrate with examples (<i>illustrate a sequence of inferences with a specific example</i>)

Figure 1: Seven facets of local and holistic proof comprehension (Mejia-Ramos et al., 2012)

The coding was conducted in three stages. In the first stage, each author individually coded local facets of each of Ben's submissions, as a backdrop against which to consider the instructor's feedback. We refrained from coding holistic facets, which would have been highly speculative. In the second stage, each author individually coded Mike's feedback on Ben's submissions. Some feedback addressing normative mathematical writing (e.g., inadequate notation) did not align with the framework, and was excluded from the analysis. Disagreements in coding were discussed and resolved. In the third stage, we located Ben's responses to Mike's comments, and coded them according to the deficiencies that they did or did not address. Our analysis of the coding had three foci: 1. Ben's initial submission, reflecting the range of issues from which Mike could choose what to attend to; 2. Subsequent interplay of feedback and revision; 3. Ben's final submission and overall appraisal of the assessment process.

Analysis

1. **Ben's first submission:** In Ben's first submission (see Figure 2, only the highlighted text was added in the second submission) we recognized substantial flaws: Ben relied on a corollary of the theorem he was attempting to prove; this is a case of cyclic reasoning, which we coded as *logical status of statements and proof framework*, because we assume he might have responded inadequately to the question "identify the purpose of the sentence within the proof framework." Furthermore, the proof of this corollary that was presented in the lecture relied on properties of the construction of \mathbb{R} ,

Theorem 4.1: A non-empty set $E \subset \mathbb{R}$ bounded above has the least upper bound (denoted $\sup E$). Why? It might be clear to you, but not to me. *To prove an upper bound? One can only prove a statement, not a bound.

Proof 4.1: Let A be the set of real numbers as follows: $\alpha \in A$ if and only if there is some $x \in E$ such that $\alpha < x$. We denote B as the set of all real numbers not in A . It is clear that no member of A is an upper bound of E , and it is also clear that every member of B is an upper bound of E . Thus, to prove a least upper bound of E , it must be proved that B contains a smallest number. It must be verified that A and B satisfy the following hypotheses:

(a) Every real number is either in A or in B . I've already voiced my objections to this argument last time. If you don't understand my comments, you should ask. The reason why it cannot be correct is because you never use the definition of real numbers, and so the argument applies verbatim for rational numbers. But in this case the statement is false: in \mathbb{Q} , the set E of rational numbers x with $x^2 < 2$ do not have the least upper bound.

(b) No real number is in A and in B

(c) Neither A nor B is empty:

(d) If $\alpha \in A$ and $\beta \in B$, then $\alpha < \beta$:

Given these hypotheses are true, then there is one and only one real number γ such that $\alpha \leq \gamma$ for all $\alpha \in A$ and $\gamma \leq \beta$ for all $\beta \in B$.

(a) and (b) hold by contradiction. Suppose there are two numbers: γ_1 and γ_2 , and $\gamma_1 < \gamma_2$. Choose γ_3 such that $\gamma_1 < \gamma_3 < \gamma_2$. Then, $\gamma_3 < \gamma_2$ means γ_3 must lie in A , but $\gamma_1 < \gamma_3$ implied γ_3 must lie in B . Thus, there is only one such γ that lies in either A or B . (c) must hold because since E is not empty, there is some $\alpha < x$, so A is not empty. Since E is bounded above by B , there is a y such that $x \leq y$ for $x \in E$, thus there is a $y \in B$ so B is not empty. (d) must hold since it has been shown that $\alpha < x$. If there is some $\beta \in B$, $x \leq \beta$. Then, $\alpha < \beta$. Counterexample in \mathbb{Q} : Let A and B be rationals respectively smaller and greater than $\sqrt{2}$.

There exists a corollary such that if the above 4 hypotheses are satisfied, then either A contains some largest number or B contains some smallest number. But, A cannot contain some largest number: let us choose an α' such that $\alpha < \alpha' < x$. Then, $\alpha' \in x$ and α cannot be the largest number of A .

Figure 2: Ben's 2nd submission; revisions of the 1st submission are highlighted; Mike's feedback appears in red

a crucial point that Ben did not mention in the proof. We coded this oversight as *justification of claims*, because Ben would presumably have failed to answer the question “make explicit an implicit warrant in the proof.” We coded Ben’s use of the phrase “it is clear that” as another case of *justification of claims*, because in our judgment what followed required elaboration, suggesting that Ben had not appreciated how subtle the justification of this claim might be. The phrase “it must be proved that” was coded as *logical status of statements*, because in fact it is not *necessary* to prove the claim that followed, but rather it is *sufficient*.

2. Interplay of feedback/revisions: Mike’s feedback on the 1st submission referred only to the holistic structure of the proof, without explicitly drawing attention to the issue of cyclic reasoning: “Your argument cannot be correct because you are not using the definition of real numbers and therefore your argument equally applies to rational numbers [where] the statement [...] is false.” We note that the course definition of the real numbers had a central role in the lecture proof of the existence of least upper bounds in the domain of real numbers. Thus, Mike’s feedback underlined a key idea that was absent in Ben’s 1st submission, and was therefore coded *Holistic: High-level ideas*. In response to this feedback, in his 2nd submission, Ben made two changes (Figure 2, highlighted text): he added the full statement of the corollary that he was relying on (*Local: Meaning of statements*) and he added justifications as to why the corollary’s conditions are satisfied (*Local: Justification of statements*). The remainder of the proof was unchanged. Therefore, there is a discrepancy between Mike’s holistic feedback and Ben’s local revisions. Seeing that the structural flaw was not resolved, Mike reiterated his criticism in his feedback on Ben’s 2nd submission: “I’ve already voiced my objection to this argument last time...” (*Holistic: high-level ideas*) and added an example of how the corollary does not hold for rational numbers (*Holistic: illustrate with examples*). Mike also commented on local issues that were already present in Ben’s 1st submission, criticizing Ben’s use of the phrase “it is clear that...” (*Local: Justification of claims*) and drawing attention to his misuse of the word “prove” (*Local: Meaning of terms*). There were several additional indicators of possible comprehension issues that we identified in Ben’s 2nd submission that Mike did not comment on. For example, it is *sufficient* and not *necessary* to verify the conditions of the corollary (*Local: Logical status of statements*).

Synopsis of submissions 3-6: In his 3rd submission, Ben reverted to the proof that had been presented in a lecture, though it is not clear to what extent he appreciated the structural problem in his initial approach. In his 3rd feedback, Mike implicitly endorsed Ben’s new approach, and his feedback addressed issues of local comprehension as well as providing structural hints (e.g., “Now prove that b^* is an upper bound, and is smaller than any other upper bound,” *Local: proof framework*). The 4th feedback included a mix of local and holistic comments; the 5th and final feedback was strictly local. In both the 4th and 5th feedbacks, Mike focused on notational issues. Our analysis—comparing successive submissions—highlighted improvements in Ben’s proofs, yet Mike did not comment on this, limiting his feedback to errors and deficiencies. Our analysis also highlighted that in many cases, Ben’s revisions, while attending to Mike’s feedback, introduced new local issues, some of which were commented on and subsequently revised.

3. Ben’s final submission: While most of Mike’s comments were resolved by the 6th submission, our analysis reveals some unresolved issues. Nevertheless, it was implicitly endorsed when accepted without comment.

In spite of several apparent *local* issues in Ben's 1st submission, Mike chose to focus his first feedback on big ideas, attending to them in a *holistic* manner, stressing that as long as there is no use of properties of real numbers the proof cannot be correct, because it would apply to rational numbers where the claim does not hold. He illustrated this through a counter-example: The set of rational numbers less than $\sqrt{2}$ does not have a rational least upper bound. Ben's revisions generally attended to Mike's comments, yet he did not always attend to them immediately. For example, in his 4th feedback, Mike criticized local aspects of Ben's definition of a sequence of nested sets: "here there needs to be a condition on a ." Ben's 5th submission did not address this problem, so Mike commented again in his 5th feedback, and Ben eventually addressed it in his 6th and final submission.

Discussion

Our analysis highlights potential affordances of multiple cycles of feedback and revision for formative assessment of proof comprehension, which we now turn to discuss while keeping in mind the three feedback-related challenges discussed in the Setting section: prioritizing comments, diagnosing student (mis)comprehension, and providing effective feedback.

Our analysis of Ben's 1st submission highlighted various deficiencies. In a traditional assessment model, providing only one opportunity to provide feedback, Mike might have responded to Ben's 1st submission by commenting on all deficiencies, which could have been overwhelming for Ben. Alternatively, Mike could have picked one or two issues that he considers most crucial. He would need to be quite explicit in his feedback, because he would not have the opportunity to clarify subtle points that Ben could not make sense of on his own. Instead, in the cycle we have analyzed, Mike's feedback began with holistic structural issues, later moving to local issues of notation, terms, and logical status and justification of claims. Mike did not need to be exhaustive in his feedback, knowing he would have opportunities to return to unattended issues later on. This transition suggests lecturers can leverage multiple cycles of feedback for prioritizing feedback according to a didactic agenda. Postponing feedback related to local issues until resolving issues related to structure and big ideas of a proof does not only support students' development of proof comprehension, but also signals which aspects of comprehension are most valued. For example, in his feedback to Ben's first two submissions, Mike highlighted a meta-level idea related to proof and proving—does the proof make use of all the assumed conditions, and how would it fail without them? This is a central theme in university mathematics, where the domain of a result is of interest, and reflects a "mathematical habits of mind" of *tinkering* (Cuoco, Goldenberg, & Mark, 1997).

In the cycle we examined, there were deficiencies that Mike highlighted in his feedback that were not resolved in Ben's next submission, and deficiencies that emerged during the revision process. While an analysis of Ben's proof comprehension is beyond the scope of this paper, we note that these additional data provide valuable insights into Ben's comprehension that were not salient in the 1st submission, which suggests that multiple rounds of feedback and revision could support lecturers' diagnosis of their students' proof comprehension. In addition, we found discrepancies between the facets of proof comprehension that Mike and Ben addressed in their respective feedback and revision. In particular, we found that in some cases Ben responded to holistic-oriented feedback with local-oriented revisions, and responded holistically only after Mike reiterated his comment. Thus, our

analysis indicates that multiple rounds of feedback and revision could support lecturers in providing feedback that students could leverage to produce a proof that the lecturers would find acceptable.

This case study also illustrates that it may be necessary to support students in harnessing lecturer feedback to develop their holistic proof comprehension. Research indicates that it is difficult for students to develop holistic comprehension of proofs even when instructors' explicitly highlight holistic aspects of proofs in their lectures (Lew, Fukawa-Connelly, Mejía-Ramos, & Weber, 2016). Cycles of feedback and revision may offer affordances for holistic comprehension. Mike's first feedback on Ben's alternate proof scheme was not prescriptive—he did not tell Ben how to correct his proof. Providing open questions as feedback is a risky move in a traditional single-round assessment, as students may fail to answer these questions and revise the proof, as Ben's second submission illustrates. However, because Mike was able to monitor Ben's revisions and provide further feedback, he was able to provide Ben the opportunity not only to reflect on the inadequacies of his own submissions, but also on the ways in which they are addressed in the lecture-proof that he eventually reproduced (e.g., the role of the definition of real numbers in the proof). The discrepancies between Mike's holistic feedback and Ben's local revisions, along with Mike's comments on these discrepancies, highlighted gaps in instructor-student communication that were likely to remain hidden in a traditional single-round assessment of Ben's first submission.

We now turn to discuss a potential affordance of multiple cycles of feedback and revision from the student perspective. In his first submission, Ben attempted a proof scheme different from the one presented in class. In his re-submissions, Ben postponed attending to some feedback, splitting his responses to Mike's 4th feedback over his 5th and 6th submissions. While we can only speculate on Ben's considerations, we recognize in his readiness to submit an original proof and to prioritize his revisions an indication of agency that in our experience is not common in undergraduate mathematics courses, particularly in relation to proof writing. A consequence of instructors' tendency to grade proofs by reducing points for deficiencies rather than assigning points for merit is that students might avoid taking risks and constructing original arguments that expose their thinking and (mis)comprehensions. In contrast, if students know they will have the opportunity to resubmit their work, and that their work will be graded on the quality of their final submission, then they have little to lose and something to gain from constructing an original argument. Thus, students can leverage multiple cycles of feedback and revisions as an invitation to explore and take risks in their proving.

Concluding thoughts

We have discussed various potential affordances of an assessment scheme that include multiple rounds of feedback/revision for formative assessment of students' comprehension of mathematical proof. We note an advantage of such a scheme in relation to the scheme proposed by Mejía-Ramos et al. (2012); whereas Mejía-Ramos et al. propose designing sets of questions to probe various facets of student comprehension, multiple rounds of feedback and revision seem more compatible with traditional practices of assessment grounded in proof validation, and thus may be more accessible and appealing for some instructors. We acknowledge that multiple rounds of feedback and revision are demanding for both instructors and students, because each new homework assignment entails reviewing/revising any number of prior assignments. Furthermore, it is not clear when the process

should end. Ben's 6th and final submission included several substantial deficiencies. Did Mike deem it "pedagogically acceptable"? Did he decide that in spite of its flaws, his time and effort would be better spent commenting on Ben's submissions of more recent assignments? Or did he simply tire of the process? Cutting the feedback process short could have serious consequences, because refraining from comment on a student's proof could be misconstrued as implicit endorsement of its correctness. It is also important to recognize that although multiple iterations of feedback and revision may provide invaluable opportunities to engage students with the various facets of proof comprehension, lecturers and students will not necessarily capitalize on these opportunities. Mike noted, in retrospect, that in some cases students ended up copying proofs from the textbook. In the final interview, he mentioned several examples where students' revisions of their proofs, in light of his comments, revealed that "they did not understand what they were talking about."

Thus, there is still much we need to learn about enacting assessment schemes based on multiple rounds of feedback and revision effectively. We call for further research that will develop and validate various formative assessment schemes, towards promoting student proof comprehension.

References

- Alcock, L., & Weber, K. (2005). Proof validation in real analysis: Inferring and evaluating warrants. *Journal of Mathematical Behavior*, 24(2), 125–134.
- Cuoco, A., Goldenberg, P. E., & Mark, J. (1996). Habits of mind: An organizing principle for mathematics curriculum. *The Journal of Mathematical Behavior*, 15(4), 375–402.
- Knapp, J. (2005). Learning to prove in order to prove to learn. https://mathpost.asu.edu/~sjgm/issues/2005_spring/SJGM_knapp.pdf.
- Lew, K., Fukawa-Connelly, T. P., Mejía-Ramos, J. P., & Weber, K. (2016). Lectures in advanced mathematics: Why students might not understand what the mathematics professor is trying to convey. *Journal for Research in Mathematics Education*, 47(2), 162–98.
- Mejia-Ramos, J. P., Fuller, E., Weber, K., Rhoads, K., & Samkoff, A. (2012). An assessment model for proof comprehension in undergraduate mathematics. *Educational Studies in Mathematics*, 79(1), 3–18.
- Moore, R. C. (2016). Mathematics professors' evaluations of students' proofs: A complex teaching process. *International Journal of Research in Undergraduate Mathematics Education*, 2(2), 246–278.
- Moore, R. C., Byrne, M., Hanusch, S., & Fukawa-Connelly, T. (2016). When we grade students' proofs, do they understand our feedback? <https://digitalcommons.andrews.edu/pubs/422>.
- Pinto, A. & Karsenty, R. (2018). From course design to presentations of proofs: How mathematics professors attend to student independent proof reading. *Journal of Mathematics Behavior*, 49, 129–144.
- Weber, K. (2012). Mathematicians' perspectives on their pedagogical practice with respect to proof. *International Journal of Mathematics Education in Science and Technology*, 43, 463–482.

Relations between academic knowledge and knowledge taught in secondary education: Klein's second discontinuity in the case of the integral

Gaëtan Planchon

IMAG –Université de Montpellier, France; gaetan.planchon@umontpellier.fr

Keywords: Klein double discontinuity, teacher training, integrals in mathematics, Anthropological Theory of the Didactics

Felix Klein (1872) put forward a double *discontinuity*: in addition to the secondary-tertiary transition, a second discontinuity occurs at the end of university studies when a student who obtains a teaching position is appointed to teach mathematics in high-school. This discontinuity is observed through the difficulties faced by postgraduate students in France to perceive the links between the knowledge of mathematics learned at university and the knowledge acquired in high school (for example between the integral as a measurement of an area and the Lebesgue integral, even with the Riemann Integral). These postgraduate students are therefore often reluctant to work on advanced mathematics (e.g. upper division undergraduate courses) as part of their teacher training.

Winsløw and Grønbaek (2014) formalized this double discontinuity in the language of the Anthropological Theory of The Didactics (ATD), using the notion of personal relationship R to an object of knowledge within an institution, introduced by Chevallard (2007). Let us consider: the institution, which here will be either high school (L) or university (U); an individual x who occupies different kinds of positions in his path through the institutions: first as a student in high school (s), then as a student at university (σ) and then back again in high school as school teacher (t); an object of knowledge, that lives in the institutions and noted o in high school and ω when considered at university level. Klein's double discontinuity may be expressed as the following diagram:

$$R_L(s, o) \longrightarrow R_U(\sigma, \omega) \longrightarrow R_L(t, o)$$

The purpose of my research project (PhD thesis) is to study the second transition between $R_U(\sigma, \omega)$ and $R_L(t, o)$ by choosing an object of knowledge from the field of analysis: the integral. Students meet integrals in different institutions and in different theories (Newton Integral in high school, Riemann and Lebesgue integrals, and Measure Theory at university). So a first research question is: *how does a math teacher in high school mobilize his knowledge of university mathematics to teach integrals in high school?* To study this question, we formulate sub-questions: *What links are put forward by the institutions between the different integration theories? Conversely, which gaps can be observed in the curricula? How are the continuities and discontinuities perceived by teacher students? What training courses may be proposed to help students draw connections?* The poster presents the overall methodology of my study and some preliminary results obtained so far.

The methods used are of a qualitative nature. *Epistemological Models of Reference* (EMR; Florensa, Bosch, & Gascón, 2016) are built in order to describe the relationships to knowledge, beginning with $R_U(\sigma, \omega)$ and $R_L(s, o)$. The EMR is a tool for the researcher who operates a reconstruction of knowledge. The elaboration of the EMR is based on epistemological analyses related to historical

epistemology (supplemented if necessary by a study of contemporary epistemology by means of interviews with mathematicians) and the analysis of official syllabi and curricula, teaching materials and textbooks. This model is constructed both to analyze continuities, discontinuities and gaps in the path of the learner through institutions and to identify possible entry points for the design of a didactic engineering.

A first study (conducted in the context of my Master's degree thesis) consisted of comparing EMRs between the logos block of praxeologies related to the Riemann integral at university and the integral in high school. The main results and their consequences for learning (in the form of hypotheses for further research) are as follows: on the one hand, the praxeologies related to the measurement of areas at high school contain an implicit logos that a teacher student will probably have difficulties to relate to academic knowledge on the integral (a substantial mathematical work would be necessary to link the notion of area from high school with Measure Theory, taught as a highly abstract subject at university); on the other hand, the academic praxeologies involving Riemann's integral focus on computational techniques for antiderivatives rather than working on the corresponding logos, apart from abstract questions on integrability (probably out of reach for a majority of students). As a result, it is likely that students will draw little connections between the block of the logos of Riemann praxeologies and the methods for approximate computation of integrals at high school since they will not grasp the conceptual scope of Riemann sums.

In order to study Klein's second transition and to propose training courses for future teachers, didactic praxeologies of the teacher need to be investigated: indeed, the tasks of the teacher are not limited to solving problems, but also to elaborate problems that promote adequate conceptualization and learning, make pertinent choices of didactic variables, and provide adequate feedback to students. The development of a model to describe these praxeologies will be based on observations of classroom practices and teacher interviews, in order to determine the role and then explore the possibility of strengthening the use of academic knowledge in didactic organizations of the teacher.

References

- Chevallard, Y. (2007). Passé et présent de la théorie anthropologique du didactique. In L. Ruiz-Higueras, A. Estepa, & F. Javier García (Éds.), *Sociedad, Escuela y Matemáticas: Aportaciones de la Teoría Antropológica de la Didáctica* (pp. 705-746). Jaén: Universidad de Jaén.
- Florensa, I., Bosch, B., & Gascón, J. (2016). The epistemological dimension in didactics: Two problematic issues. In K. Krainer & N. Vondrová (Eds.), *Proceedings of the Ninth Congress of the European Society for Research in Mathematics Education* (pp. 2635-2641). Prague, Czech Republic: Charles University in Prague, Faculty of Education and ERME.
- Klein, F. (1872). *Vergleichende Betrachtungen über neuere geometrische Forschungen. Program zum Eintritt in die philosophische Fakultät und den Senat der k. Friedrich-Alexanders-Universität zu Erlangen*. Erlangen: Deichert.
- Winsløw, C., & Grønbaek, N. (2014). Klein's double discontinuity revisited: contemporary challenges for universities preparing teachers to teach calculus. *Recherches en Didactique des Mathématiques*, 34(1), 59-86.

Theorizing coordination and the role of course coordinators

Chris Rasmussen¹, Jessica E. Hagman² and Naneh Apkarian³

¹San Diego State University, USA; crasmussen@sdsu.edu

²Colorado State University, USA; jess.ellis@colostate.edu

³Western Michigan University, USA; naneh.apkarian@gmail.com

Keywords: Coordination, calculus, community of practice.

In the United States (US) improvement efforts at the school level have a long history of bringing teachers together to plan lessons, discuss issues of student learning, create assessments, etc. For example, lesson study has been implemented across American schools as one way to create community among teachers and improve teaching and learning (e.g., Lewis & Takahashi, 2013). Professional learning communities are another way of building community among teachers to improve instruction. At the university level, coordination of high enrolment introductory courses provides a similar opportunity for bringing faculty at the same institution together to improve student success. Coordination systems are particularly popular as a response to the large numbers of students enrolled in calculus courses and the wide range of instructors teaching them. Robust coordination systems, led by one or more coordinators (who are typically ladder rank faculty) consist of two major elements: uniform course elements (e.g., common text; exams) and regular instructor meetings. Regular meetings convened by course coordinators are important because they provide opportunities to bring faculty together to discuss issues of learning, assessment, pacing, etc. Robust coordination systems can, therefore, have the effect of turning calculus instruction into a joint enterprise, engendering a community of practice (Rasmussen & Ellis, 2015).

While coordination systems are widely used in the US, such systems are under-theorized. In this report, we draw on case study data from five universities to begin theorizing about coordination systems more broadly and the role of the coordinator in particular. More specifically, we address the following research goal: *How might we characterize coordination systems and the role of coordinators in these systems?* A better theoretical understanding of these phenomena will contribute to pragmatic efforts aimed at improving the teaching and learning of high enrolment, coordinated, undergraduate mathematics courses. The 2-3 day case study site visits we conducted were part of a larger national study of successful calculus programs in the US (Bressoud, Mesa, & Rasmussen, 2015). We employed thematic analysis (Braun & Clarke, 2006) of the data corpus, which included interviews with faculty, administrators, classroom observations, and student focus groups.

Our theoretical framing of coordination systems and coordinators draws on work in behavioral economics, thus bringing a novel point of view to university mathematics instructional systems. In particular, we draw on the work of Thaler and Sunstein (2008), who offer an insightful perspective on how libertarian views of free choice can be profitably combined with paternalistic structuring of choices for others in the marketplace. A central construct in their thesis of libertarian-paternalism is that of *choice architect*. A choice architect is someone who is responsible for organizing the context in which people make decisions. For example, the person responsible for arranging the way in which school cafeteria food is displayed has the potential to influence the food choices that kids make. What

should be placed at eye level, cookies or green beans? The power of a choice architect lies in focusing peoples' attention in a certain direction, and "nudging" them to make particular choices, rather than making the choice for them. Similarly, we argue, this is what effective course coordinators can do.

In our analysis of the five case studies, we came to see the coordination systems more broadly as an example of *coordinated independence*. The notion of coordinated independence, much like that of libertarian-paternalism, embraces the oxymoron that individuals can be part of a system that directs their choices, but maintains a certain level of autonomy. Our retrospective search of the literature for use of the term coordinated independence revealed the original coining of this phrase to describe the premier jazz drummer "Cozy" Cole in the late 30's. Cozy Cole was renowned for the way in which his hands and feet acted independently yet produced a harmonious sound that was highly coordinated. In a similar way, we theorize that effective course coordinators allow for instructor independence yet result in a harmonious calculus instructional system.

Drilling down into the particulars of what the course coordinator does to promote this culture of coordinated independence, we posit that the coordinator functions much like a choice architect as described by Thaler and Sunstein (2008). In our analysis we identified the following overlaps in the roles of a choice architect in the market place and the various roles of the coordinator in an educational setting: makes life easier by setting default options; provides feedback to users; makes mappings easy to understand; and provides information about what others are doing. For example, Thaler and Sunstein describe how a computer manufacturer functions as a choice architect by making life easier for users by pre-setting screen-saver default settings. A user can change the default options but doing so takes time and requires taking some action. We found that the calculus coordinator similarly sets a number of "default" options for instructors, including homework problems, exams, class activities, syllabus, and rubrics for exam grading. In our interviews with instructors we learned that the vast majority of instructors very much appreciated the coordinator taking care of these decisions, while still allowing for pedagogical autonomy and some choice within these default setting. Our poster presentation gives illustrative examples of this and other roles of coordinator as choice architect.

References

- Braun, V., & Clarke, V. (2006). Using thematic analysis in psychology. *Qualitative Research in Psychology*, 3(2), 77–101.
- Bressoud, D., Mesa, V., & Rasmussen, C. (Eds.). (2015). *Insights and recommendations from the MAA national study of college calculus*. Washington, DC: The Math. Association of America.
- Lewis, C, & Takahashi, A. (2013). Facilitating curriculum reforms through lesson study. *International Journal for Lesson and Learning Studies*, 2(3), 207-217.
- Rasmussen, C., & Ellis, J. (2015). Calculus coordination at PhD-granting universities: More than just using the same syllabus, textbook, and final exam. In D. Bressoud, V. Mesa, & C. Rasmussen (Eds.), *Insights and recommendations from the MAA national study of college calculus* (pp. 107–116). Washington, DC: The Mathematical Association of America.
- Thaler, R. H., & Sunstein, C. R. (2008). *Nudge: Improving decisions about health, wealth, and happiness*. Yale University Press.

OPTES+ – A Mathematical Bridging Course for Engineers

Anna-Katharina Roos¹, Gerhard Götz², Hans-Georg Weigand³ and Jan Franz Wörler³

¹University of Würzburg, Germany; anna-katharina.roos@mathematik.uni-wuerzburg.de

²DHBW Mosbach, Germany; gerhard.goetz@mosbach.dhbw.de

³University of Würzburg, Germany; weigand@mathematik.uni-wuerzburg.de;
woerler@mathematik.uni-wuerzburg.de

Keywords: Bridging course, engineers, competencies.

Introduction

Many students perceive the transition from school to university mathematics as problematic. Existing studies not only discuss difficulties broadly but promise that so-called bridging courses can help to reduce the gap between school and higher education. Also for students studying science, technology, or engineering (STE), mathematics is an important prerequisite for successful studies. For them, mathematics is mainly used as a tool for other subjects. We focus on these STE-students, who have a high heterogeneity with regard to their mathematical knowledge before entering university. Taking this phenomenon into account, creating a bridging course in mathematics especially for this group of students is important in order to build a common level of mathematical knowledge, which professors can take for granted and rely upon when students enter university.

The OPTES+-project – optimizing the self-study phase

OPTES+ is a project funded by the BMBF (Ministry of Education and Research) that includes several universities in Germany working together to reduce the drop-out rate in STE-related subjects. The heart of the project is an online mathematics course, similar to a traditional mathematics book, but enriched with additional interactive elements. The whole course is implemented in the open source learning management system ILIAS. All the material offered by OPTES+ will be accessible for universities and other educational institutions in the future. The contents of the course are based on the experience of the involved lecturers and the cosh-catalogue (Cosh group, 2014), a catalogue written by representatives of schools and universities to list the minimum requirements in mathematics that students should have when starting their studies in economy or a STE-related subject at university. Moreover, as engineering per se often requires the application of mathematics, not only mathematical knowledge is important, but also the development of mathematical competencies. Weinert defines mathematical competencies as an individual's available or learnable cognitive abilities and skills to solve certain exercises, as well as the connected willingness and ability to use the solutions in variable situations in a successful and responsible way (Weinert, 2001). For that reason, apart from the mathematical contents, the bridging course should also concentrate on mathematical competencies, which leads to the following questions.

Research Questions

(Q1) Which model can be used to describe the learners' mathematical competencies and simultaneously provide a basis for differentiation within the course?

(Q2) How can the chosen competency model be implemented into the online course?

(Q3) How could, after the construction and implementation of the model, an evaluation and reflection of it take place as a step of design-based research?

The Ability Matrix

We decided to take the HarmoS-model (Huber, Späni, Schmellentin, & Criblez, 2006; Schweizerische Konferenz der kantonalen Erziehungsdirektoren [EDK], 2011) as foundation for constructing our own model – the so-called Ability Matrix (AM), as the aspects of action used in the HarmoS-model seem to fit well the competencies the future engineer students should acquire. Figure 1 illustrates the AM.

content fields	LOC 1: arithmetic					
	LOC 2: equations/inequalities					
	LOC 3: powers/roots/logarithms					
	LOC 4: functions					
	LOC 5: geometry					
	LOC 6: trigonometry					
		knowing and describing	operating and calculating	using representations	mathematizing	reasoning
		aspects of action				

Figure 1: The Ability Matrix

Outlook

While (Q1) and (Q2) concentrate on theoretical considerations that are answered by the construction and usage of the Ability Matrix, we plan to run a pilot study in January and February 2019 to answer (Q3) and to investigate if the chosen competency model and its implementation are suitable for our setting. To do so, we will compare the measured competencies before and after the course to see if the attendance of the course (including the feedback the students get by the visualization of the Ability Matrix) brings any improvement of the students' competencies. Based on the results of this pilot study we will evaluate the used competency model and reflect on possibilities of adjusting it.

References

- Cosh group (2014). *Mindestanforderungskatalog Mathematik (Version 2.0)*. Retrieved September 1, 2018 from https://lehrerfortbildungbw.de/u_matnatech/mathematik/bs/bk/cosh/katalog/.
- Hubner, C., Späni, M., Schmellentin, C., & Criblez, L. (2006). *Bildungsstandards in Deutschland, Österreich, England, Australien, Neuseeland und Südostasien – Literaturbericht zu Entwicklung, Implementation und Gebrauch von Standards in nationalen Schulsystemen*. Aarau, Switzerland: Fachhochschule Nordwestschweiz.
- Schweizerische Konferenz der kantonalen Erziehungsdirektoren (2011). *Grundkompetenzen für die Mathematik – Nationale Bildungsstandards*. Retrieved September 1, 2018 from <http://www.edk.ch/dyn/12930.php>.
- Weinert, F. (2001). Vergleichende Leistungsmessung in Schulen – eine umstrittene Selbstverständlichkeit. In F. Weinert (Ed.), *Leistungsmessungen in Schulen*, (pp 17–32). Weinheim: Beltz.

The connectivity in resources for student-engineers: the case of resources for teaching sequences

Hussein Sabra¹

¹University of Reims Champagne-Ardenne, Cérep EA4692, France

This paper concerns the teaching of mathematics for student-engineers. We focus on the theme of sequences in the first year of engineering education. We claim that teaching sequences in the first year of engineering education requires different kinds of connections: connecting different topic areas, different concepts, and different registers. We use here the concept of connectivity, to analyze resources in the case of an engineering school in France. We provide elements from interviews showing that the teachers can strengthen some forms of connections during their use of resources.

Keywords: connectivity, resources in engineering education, mathematics for engineers, sequences.

Context of the research

The present paper concerns the teaching of mathematics in the context of engineering. We present an analysis of resources collectively designed by teachers in a French Engineering School (undergraduate education). We address the issue of the connections made in mathematics for student-engineers. We focus on the theme “sequences”.

The textbook is a crucial artifact for university teachers (González-Martín, Nardi, & Biza, 2018). However, the appropriateness of the content offered by textbooks in some academic paths remains a controversial issue; Randahl (2016) shows that student-engineers do not perceive the mathematics offered by the textbook as relevant for the engineering context. She considers that the issue of how the textbook is combined with the context of lectures and task solving sessions might “provide learning opportunities with meaningful use of the textbook” (Randahl, 2016, p.67).

Research literature highlights the gap between the mathematics taught in mathematics courses and the use of them in engineering courses (Biehler, Kortemeyer, & Schaper, 2015). Minding this gap supposes to understand the reasons behind it. Research evidences also the necessity of making explicit connections between theory and practice to make the mathematical content in engineering education relevant to students (Flegg, Mallet, & Lupton, 2012). According to Gueudet and Quéré (2018), engineers in the workplace identify missing links in the mathematics taught during their studies: links between mathematics and the real world, and between different mathematical contents.

All these sources suggest that the teaching of mathematics in engineering education should propose specific “connections”. The main question we address here is: what type of connections is present in the resources used and in teaching practices regarding mathematics for engineering students?

Connectivity in resources: topic areas, concepts and semiotic representations

“Connections” can be related with (at least) three issues that could influence the teaching of mathematics; some of them are specific to the context of engineering education.

(1) Within mathematics, the networking between mathematical objects and their representations (Hiebert & Carpenter, 1992), identified as essential for the understanding of mathematical facts.

(2) The need to build links between mathematics courses and engineering courses.

(3) The modifications of learning processes in the digital era prompted Siemens (2005) to introduce the concept of *connectivism*. He considers learning as an “actionable knowledge” that can reside outside ourselves. The learning in this case depends on the ability to build a network of connections between, and across, the available resources (or databases) and users of these resources.

Based on these works, we have proposed the concept of *connectivity* (Gueudet, Pepin, Restrepo, Sabra, & Trouche, 2018) developed in the frame of e-textbooks analysis. This connectivity has two components: “macro-level connectivity” that refers to the potential of linking to and between users and resources outside the textbook (practical aspect); and “micro-level connectivity”, where the focus is on a particular mathematical topic within the e-textbook to look for connections in, between, and across individuals’ cognitive/learning tasks and activities. We define therefore *connectivity* in a set of resources for teaching a mathematical theme as a linking potential for a given user (student or teacher) both practically as well as cognitively. We only use here micro-level connectivity. We indeed consider, in the case of sequences, the connections present in resources between different topic areas or mathematics fields, between different concepts, and between different semiotic representations.

For Duval (2006), semiotic representations are productions constituted by the use of signs belonging to the same “register” (natural language, formalism, algebraic formula, graph, figure, etc.). A register of semiotic representation allows the following activities: to represent a concept; to treat representations within the same register; to convert representations from a given register into another. According to Duval (2006), the conceptual acquisition of a mathematical object necessarily passes through the acquisition of one or several semiotic representations. However, the connection between different representations, seems absent in engineering programs. Quéré (2017) interviewed French engineers about their mathematical needs in the workplace. They declared that the teaching of mathematics they received during their studies “did not make enough connections” particularly connections between different mathematical contents and between different representations.

From the institutional point of view, the mathematics taught are shaped by the institution where they are taught (Chevallard, 2003; González-Martín et al., 2018). We consider, as Quéré (2017), that in engineering education, mathematics courses constitute an institution different from engineering courses. Different institutions could shape the teaching of mathematical topics in different ways. Moreover, teachers’ *personal relationship* with those topics, which results from their experiences in different institutions (Chevallard, 2003; González-Martín et al., 2018), could shape the mathematics taught. Indeed, the teaching actually implemented by a teacher using a given resource can offer more connections than this resource. Teachers might develop an “unexpected” connectivity in practice, by their discourse, examples produced “on-the-spot”, and how they show proofs, etc. Here, there is the issue of the combination between *potential connectivity* and *effective connectivity* developed in use, which could be also related to the teacher’s perception of students’ needs and difficulties.

Our aim here is to consider the connectivity in the case of teaching sequences in the first-year in a French Engineering School. Therefore, we reformulate our general question as follow:

Q1: Which connections concerning sequences appear in resources for a mathematical engineering course?

Q2: Which is the effective connectivity of the curriculum implemented by different teachers using these resources?

Sequences in the French curriculum and in the engineering education

Our choice of to focus on sequences is related to its importance in some engineering paths. Within mathematics courses, sequences constitute an entry for other concepts (single and double integrals, series, etc.). They are also essential for studying Fourier series. In engineering courses, sequences are needed in a different way: in the study of some processes of discretization (transferring of continuous models into discrete models), in numerical analysis (numerical resolution of differential equations or heat equations, etc.), and in the “signal processing” course.

In France, the first encounter of students with sequences happens in grade 11. The curriculum recommends that the teaching of sequences in grade 11 goes through the modelling of real-life situations. Connections in terms of registers are recommended. For instance, the curriculum requests using the spreadsheet (numerical representation) or the calculator (algorithms) to compare the evolution of arithmetic and geometric sequences, as well as to represent the term of a sequence graphically. According to the curriculum, in grade 12 the concept of “limit of a sequence” should be studied in order to prepare the introduction of “limit of a function”.

In different engineering education paths, the introduction of sequences usually appears in the calculus courses. Randahl (2016) notices that calculus is part of the basic mathematics courses for engineering students, and it has many formal aspects. Compared to the secondary level, more time is dedicated for mathematical reasoning and the use of formal representations. Research literature on the teaching and learning of sequences acknowledges the existence of strong links between both concepts “limit” and “sequences” (Alcock & Simpson, 2004; Roh, 2008). Regarding the concept of “convergence”, studies highlight the importance of the graphical representation to make sense of it, as well as to facilitate the appropriation of its formal representation (Alcock & Simpson, 2004).

Context of the study and methodology

The context of our study is a French Engineering School. It is one of the three technological universities in France. Mathematics teachers in this Engineering School have different statuses (teacher-researcher, full-time teacher, etc.) and various specialties (mathematicians, engineers, physicists, etc.). Four semesters structure the first and second academic years, where there are “basic science courses”, including mathematics, physics and chemistry. There are four mathematics courses. Each of them followed in consecutive semesters. Sequences are introduced in the first chapter of the mathematics course of the second semester. In this context, our methodology consists in two parts: 1) collection and analysis of resources on sequences; 2) interviews with 3 teachers and their analysis.

The resources collected are collectively designed and used by teachers. They contain the textbook’s lesson distributed to students; the slideshow projected during the lecture sessions; the tutorial that contains tasks to solve and problems; and the Practical Work tutorial (PW) composed of online exercises on a moodle platform.

To analyze the resources, in terms of micro-level connectivity, we used the grid developed by Gueudet et al. (2018). We adapted it to our case, according to the definition of connectivity we

discussed above. We then analyzed the resources following four steps. In the first step, we identified concepts used in the resources, we mentioned the connected concepts and the way they are connected by definitions, propositions, theorems, examples, and/or exercises. Within this step, we studied the connections that concern “progression” chosen by the designers (connections with previous knowledge and further knowledge). In the second step, for each concept (or connected concepts), we characterized the different moments of their appropriation (lesson, examples, exercises, problem solving, or practical tasks); we considered also the context of this appropriation (different topic areas within mathematics, different disciplines, real-life situations, etc.). In the third step, for each concept (or connected concepts), we identified the registers of semiotic representation used or that can be used in solving tasks; we characterized them in terms of the three cognitive activities “to represent”, “to treat”, or “to convert” (Duval, 2006). In this step, we determine, where appropriate, the connections made with particular tools (software, calculator, etc.). The fourth step concerns particularly the exercises; we determined the different strategies to solve them, and the variations of the same exercises. The fourth step allowed us to understand the connections that the designers emphasize between concepts, registers and mathematics topic areas.

We also conducted interviews with three teachers. We chose teachers with contrasting profiles in terms of their specialties and academic education, and in terms of their status. T1 is a physicist, he has a PhD in theoretical physics and modeling, he teaches mathematics, modeling and physics; T2 is an engineer, he has a PhD in Engineering, he teaches mathematics and engineering courses; T3 is a mathematics teacher, he has an “agrégation” in mathematics (French competitive examination that must be passed to teach at university). We hypothesize that the contrasted profiles can inform us on different forms of connectivity developed in implementation of mathematics resources.

The interview grid covers four axes, according to which we analyzed the teachers’ declarations. The first concerns the connections to make across the different mathematics topic areas, across different disciplines, or with real-life problems. The second axis concerns the teachers’ point of view on students’ difficulties, which influences the connectivity they could emphasize in their use of resources. The third axis concerns the place of the examples they add, which allows to make connections between concepts or to use the registers of semiotic representation. The fourth axis concerns the place of mathematics proofs in engineering education, and their role in enhancing connectivity. We aim by the analysis of the interviews to identify elements on the effective connectivity of the curriculum implemented by different teachers using the same resources. Nevertheless, we are limited here to what teachers declare about the use of resources.

Potential connectivity in resources for teaching sequences

We identified in the resources for teaching sequences: 7 definitions, 10 theorems, 29 exercises, and 9 examples. The PW contains three exercises, where the use of Wiris CAS calculator is requested.

In terms of previous knowledge, some basic concepts from secondary school are reintroduced but in a formal register (convergence and limit of sequences). We note that continuity and limits of functions are taught in the first semester. We also note that the sequential definition of limits of functions is not taught. The order used to teach the concepts of “limit of sequences” and “limit of functions” is different from the choice made in the curriculum of secondary school (see above).

The connections between both concepts “limit of sequences” and “convergence” are emphasized. The resources also emphasize, in the properties and exercises, the connections between “convergence”, “variation of sequences” and “bounded sequences”. For instance, there is in the tutorial an exercise with nine different sequences; students are asked to study the convergence of sequences and calculate their limits when it is possible. The sequences given need different strategies to solve the proposed tasks (a sequence bounded by another one that tends to 0; a decreasing sequence and bounded from below by 0; a task that needs the use of properties about the quotient of convergent sequences; etc.). Recursive sequences are particularly emphasized in the different components of the resources. The exercises related to recursive sequences allow students to establish connections with “upper bound”, “lower bound” and functions.

There is no connection between different topic areas within mathematics. In terms of different semiotic representations, the resources contain particularly one semiotic representation, the formal representation. In general, the treatment of tasks remains within the same representation. The resources contain rarely tasks where students are asked to represent mathematical objects in a given register. The PW constitutes an opportunity to make new connections between mathematics topic areas as well as between semiotic representations. Nevertheless, it is restricted to three exercises. The connections between semiotic representations are strengthened; there are, for example, tasks that need the graphical study of the given sequences. Besides, the algorithmic topic area changes to study the behavior of recursive sequences by dynamic representations (Figure 1). The use of Wiris CAS software offers the potential to make connections between algorithms and the graphical register.

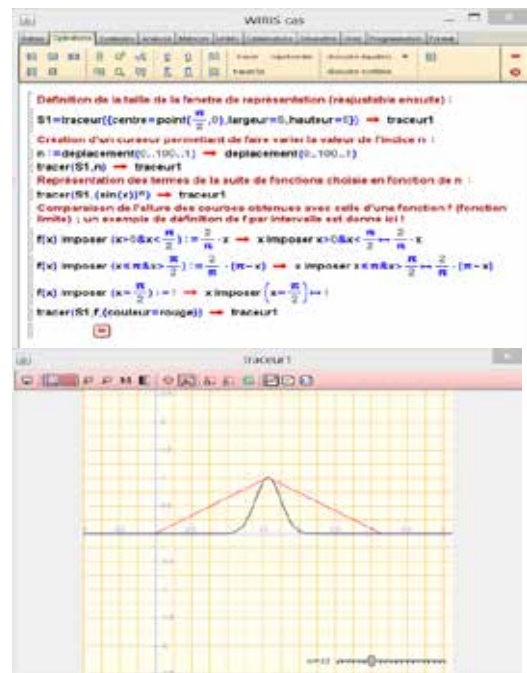


Figure 1. It is required to act on the cursor “n” to relate the two dynamic representations (Wiris CAS).

In the analyzed resources, sequences constitute a theme where the mathematical materials are mainly limited to the calculus topic area. This is very similar to the content presented to mathematics majors. There are strong connections between concepts (convergence/divergence, limit of a sequence, function, upper/lower bound, recursive sequences). The tasks and activities propose mainly treatments within the formal register. In addition, there are no authentic situations, real life problems, or problems referring to other disciplines. All the examples, exercises and applications are intra-mathematical, which could strengthen a possible gap with the institution of engineering courses.

Analysis of interviews: towards effective connectivity in the enacted curriculum

Concerning the characteristics of a mathematics teaching well suited to engineering education, we identify three different trends in the answers of the interviewed teachers: T1 emphasizes the need for “contextualization”; T2 perceives his profile as interesting for teaching mathematics in engineering

education; T3 perceives himself as a teacher who applies the mathematics as are “recognized in the university institution”. T1 notices that teachers who are mathematicians have a reluctance to integrate problems referring to other disciplines. He supposes that they need some support in the design and the implementation of this kind of problems. T2 states he has “ability” to make connections between contents to ensure a continuum of learning between mathematics courses and engineering courses. He sees himself as a “specialist in mathematics for engineers”. He says:

T2: Specialist of mathematics no, I am not a mathematician. Otherwise, am I a specialist in mathematics for engineers? I think I have a lot of experience to know how math tools are used in the workplace. [Our translation]

He presents mathematics content as tools that have utility in the workplace of engineers:

T2: We try often to remind students that later on they will need mathematical tools and they have to build them. They have to be able to manipulate them properly. [Our translation]

T3 only considers the mathematics courses in terms of utility within mathematics.

In their answers about students’ difficulties, the teachers referred to: 1) reasoning (T1, T2, T3); 2) treatment of tasks within the formal representation (T2, T3); 3) the capacity of abstraction (T1, T3). It seems that the emphasis on formal representations in resources accentuates these difficulties.

According to their declarations in the interviews, the examples they add during the classroom sessions appear as revealing their will to support connectivity in different ways. Each teacher, in his preparation of the course, designs his own examples. T1 says that the examples he designs should enhance the meaning of the concepts at stake. He presents examples referring to other disciplines. T2 says that he gives examples particularly during the introduction of concepts, “intra and extra-mathematical examples”. According to T1 and T2, examples referring to other disciplines of real life situations are opportunities to make sense of the contents. T3 says that he gives examples after having stated a theorem. He uses examples to illustrate the “operability of the theorem”.

Concerning proofs, all interviewed teachers stated that they do not do, in the classroom sessions, all the proofs given in the resources. The reasons they gave could be interpreted in terms of personal relationship with calculus [our translation]:

T1: the proofs I like are usually the useful proofs. I do not like for instance the “trapping” proofs for which if you do not have the right intuition, you cannot start.

T2: When you look at the theorem and the proof does not come to your mind right away, and you finally find out that the proof is based on tricks, I think this proof should be replaced by examples.

T3: If the proof requires little effort and seems important to me, I do it. I do not do it if I think we can understand the theorem without the proof, sometimes the proofs help to understand.

T1 and T2 show in class the proofs that can support the learning of a form of reasoning, which is, according to them, essential for future engineers. T3 shows the proofs that can help to understand theorems and properties, even if they sometimes require fastidious techniques. However, the interviews allowed us to identify criteria the teachers consider for choosing the proofs to do in the

mathematics courses in engineering education: they can help improve the understanding of theorems; they allow highlighting the importance of a given theorem; they can help – during the proof – implement a mathematical reasoning. Each of these criteria could promote a specific form of connection between concepts.

The additional resources that the teachers design individually can strengthen specific connectivity in their teaching. T2, for instance, prepares examples to motivate the introduction of a given concept or to replace “tricky” proofs. T1 designs resources to show situations from other disciplines. T3 designs additional resources (exercises and examples) to strengthen links between mathematics concepts.

Discussion and conclusion

We present in this paper the issue of connectivity concerning a mathematics course in engineering education. We analyze the potential connectivity of resources, collectively designed, for teaching sequences theme. We highlight elements on effective connectivity that teachers, as users of these resources, could develop in their implementation.

The potential connectivity in resources for teaching sequences appears as restricted to the calculus topic area. The register of formal representation occupies an important space. According to two of the interviewed teachers (T1 and T2), making connections with engineering contexts, real-life problems or other disciplines “remains a dimension to enhance”.

It appears by the interviews that the way the teachers use resources is likely to lead to an effective connectivity different from the potential connectivity, and this could be related to their personal relationship with the topic at stake. The teachers stated that students struggle with making sense of formal properties. Hence they attempt to support students by designing additional resources. They add examples and select separately the proofs to show in lectures sessions. These individual teachers’ choices could strengthen some forms of connections. The physicist (T1) tries to enhance the connections in terms of other disciplines; the engineer (T2) constructs mathematical tools and tries to make connections with the engineering courses; the mathematics teacher (T3) tries to maintain connections within mathematics.

The analysis of the interviews draws our attention to the need to take into consideration the macro-level connectivity (Gueudet et al. 2018), especially connectivity across disciplines, in terms of teachers’ own resources, as well as in terms of teachers’ and students’ joint work. Besides, based on the analysis of the interviews, we highlight the necessity to observe how the teachers select and implement proofs in their sessions, which could tell us more about the effective connectivity built.

The issue of connectivity in resources and the connectivity developed by their use seems to be relevant in the context of engineering education, where the connectivity between theory and practice is crucial. Each of these elements requires further study with a larger sample of teachers, considering different mathematical topics and articulating the analysis of resources and classroom observations.

References

Alcock, L., & Simpson, A. (2004). Convergence of sequences and series: Interactions between visual reasoning and the learner’s beliefs about their own role. *Educational Studies in Mathematics*, 57(1), 1–32.

- Biehler, R., Kortemeyer, J., & Schaper, N. (2015). Conceptualizing and studying students' processes of solving typical problems in introductory engineering courses requiring mathematical competences. In K. Krainer & N. Vondrova (Eds.), *Proceedings of the Ninth Congress of the European Mathematical Society for Research in Mathematics Education* (pp. 2060-2066). Prague, Czech Republic: Charles University in Prague, Faculty of Education and ERME.
- Chevallard, Y. (2003). Approche anthropologique du rapport au savoir et didactique des mathématiques. In S. Maury & M. Caillot (Eds.), *Rapport au savoir et didactiques* (pp. 81–104). Paris: Fabert.
- Duval, R. (2006). A cognitive analysis of problems of comprehension in a learning of mathematics. *Educational Studies in Mathematics*, 61(1-2), 103-131.
- Flegg, J., Mallet, D., & Lupton, M. (2012). Students' perceptions of the relevance of mathematics in engineering. *International Journal of Mathematical Education in Science and Technology*, 43(6), 717–732.
- González-Martín, A., Nardi, E., & Biza, I. (2018). From resource to document: scaffolding content and organising student learning in teachers' documentation work on the teaching of series. *Educational Studies in Mathematics*, 98(3), 231-252.
- Gueudet, G., Pepin, B., Restrepo, A., Sabra, H., & Trouche, L. (2018). E-textbooks and connectivity: proposing an analytical framework. *International Journal for Science and Mathematics Education*, 16(3), 539-558.
- Gueudet, G., & Quéré, P.-V. (2018). “Making connections” in the mathematics courses for engineers: the example of online resources for trigonometry. In V. Durand-Guerrier, R. Hochmuth, S. Goodchild, & N. M. Hogstad (Eds.), *Proceedings of the Second conference of the International Network for Didactic Research in University Mathematics, INDRUM2018* (pp. 135-144). Kristiansand, Norway: University of Agder and INDRUM.
- Hiebert, J., & Carpenter, T. (1992). Learning and teaching with understanding. In D.A. Grouws (Ed.), *Handbook of Research on Mathematics Teaching and Learning* (pp. 65-97). New York, NY: Macmillan.
- Quéré, P.-V. (2017). French engineers' training and their mathematical needs in the workplace: interlinking tools and reasoning. In T. Dooley & G. Gueudet (Eds.), *Proceedings of the Tenth Conference of the European Society for Research in Mathematics Education* (pp. 2233-2240). Dublin, Ireland: DCU Institute of Education and ERME.
- Randahl, M. (2016). *Engineering students approaching the mathematics textbook as a potential learning tool - opportunities and constraints*. PhD. University of Agder, Norway.
- Roh, K. (2008). Students images and their understanding of definitions of the limit of a sequence. *Educational Studies in Mathematics*, 69, 217–233.
- Siemens, G. (2005). Connectivism: a learning theory for the digital age. *International Journal of Instructional Technology & Distance Learning*, 2(1). Retrieved May 2019 from http://itdl.org/Journal/Jan_05/article01.htm

TWG15: Teaching Mathematics with Technology and Other Resources

Introduction to the papers of TWG15: Teaching Mathematics with Technology and Other Resources

Alison Clark-Wilson¹, Ornella Robutti², Melih Turgut³ and Iveta Kohanová⁴

¹University College London, London, United Kingdom; a.clark-wilson@ucl.ac.uk

²University of Turin, Italy; ornella.robutti@unito.it

³Eskişehir Osmangazi University, Turkey; mturgut@ogu.edu.tr

⁴Norwegian University of Science and Technology, Norway; iveta.kohanova@ntnu.no

Keywords: Technology uses in education, teaching mathematics, teacher competencies, teacher behavior, teacher professional development.

Introduction

At CERME11 two groups addressed mathematics education research concerning technology. TWG15 focused on issues related to teaching, teacher education and professional development, whereas TWG16 focused on students' learning with technologies, alongside software and task design issues (see Introduction to TWG16 in this volume).

The TWG15 work was stimulated by contributions in the form of 12 research papers and 8 posters that had responded to the call that had highlighted the following themes:

- The specific knowledge, skills and attributes required for efficient/effective/equitable mathematics teaching with generic and mathematics-specific technologies and resources.
- The design and evaluation of initial teacher education and teacher professional development programmes (to include MOOCs) that embed the above knowledge, skills and attributes.
- Theoretical and methodological approaches to describe the identification/evolution of teachers' practices (and of 'best' practices) in the design and use of technology and resources.
- Theory and practice relating to the formative/summative assessment of mathematical knowledge in technological environments.

The work of TWG15 drew upon research from 13 countries: Austria, Brazil, Denmark, England, France, Iceland, Israel, Germany, Greece, Norway, Portugal, Sweden and Turkey.

Organisation of the TWG15 at the conference

During the conference the TWG15 convenors piloted a new format for the 30-minute paper presentations. Two weeks in advance of the conference, each lead paper author was paired with another participant in the group, their *partner*, and it was this partner who was invited to present the paper. She or he was asked to share their presentation slides, which were required to include some questions to the author. In reality, this led to email exchanges, online calls and face-to-face meetings, most of them before the conference, and some during the early days of the conference. The resulting presentations enabled the ideas in the submitted papers to be explored in much more depth than at previous CERMEs - often requiring the author(s) to show examples of tasks, resources and functionalities from within their selected technologies. Alongside this, the TWG15 poster submissions were thematically aligned with the TWG session programme and the poster authors were

invited to give a brief overview of their research. Following these paper and poster presentations, small group discussions were instigated within the TWG that focused on understanding the presented work in its cultural context. In particular, we probed the terminologies and contexts within the reported research that related to technological, pedagogical, mathematical, theoretical and methodological ideas. The TWG leaders supported the analytic and synthetic processes of the group by capturing the comments and questions made by participants as an ongoing process. We reflect on participants' perspectives of this approach later in the TWG15 introduction.

The emergence of TWG15 sub-themes

During the final two TWG sessions, the group spent time to discuss and agree the emergent sub-themes, which were: teachers' uses of students' (digital) productions; sorting and organising digital content such as: simulations, applets, Open Educational Resources (OERs); the teaching of computing/programming in, and through, mathematics; teachers' choices and beliefs concerning technology use; and the group's ongoing grappling with theory. The TWG sub-divided into smaller groups, each of which then contributed text to the summaries that follow.

Teachers' uses of students' productions

A number of papers and posters described research that featured teachers' practices when using students' work as a basis for discussion in the mathematics classroom. In these projects different technologies were employed, e.g. *c-book* units (Diamantidis, Kynigos & Papadopoulos), videos (Kristinsdóttir, Hreinsdóttir & Lavicza; Fidje & Erfjord), connected classroom technologies (Fahlgren & Brunström), and mini-whiteboards (Eidissen, Hreinsdóttir & Lavicza). These technologies served to both make students' thinking visible and to stimulate classroom discussions based on students' own work/solutions, which are known to be important formative assessment practices (Black & Wiliam 1996).

However, orchestrating class discussion based on students' contributions was reported to be challenging for teachers for which the selection, deliberate grouping and sequencing of student productions are useful strategies. When it comes to sequencing, the role of teacher preparation was considered important, however sometimes students' responses opened opportunities for discussion that could not have been realistically predicted by the teacher. Such opportunities can contribute to the classroom discussion, if the teacher has both the flexibility to take it up and it aligns with the teacher's goals for the lesson. As such, this relates to the existing framework of instrumental orchestration (Trouche, 2004) within the socio-mathematical norms where students' various personal meanings of concepts are valued and 'up for discussion' as a crucial factor to foster classroom discourse. The TWG group agreed that the aforementioned technologies might aid teachers in this endeavour.

The use of students' productions in education was exploited by Diamantidis et al., who focused on the role of students as co-designers - with teachers - of digital resources for learning mathematics. Their project design involves collaboration between students and teachers, who used digital tools for mathematics education for the design and production of *c-books*, a set of narrative units blended with digital artefacts. The research, which was framed by the *documentational approach* (Gueudet & Trouche, 2010), aims to research the design phase as a learning process for the students as they search

for new mathematical meanings that emerge around the concept of co-variation (in the sense of Thompson, 2002).

Kristindóttir et al. presented a poster on the use of silent videos to the whole class in Iceland, with the possibility for the students to view them as often as they want. The students, divided in pairs, were asked to plan and to record their voice-over for the video. The role of the teacher is of facilitator, encouraging students in many ways, for example by reminding them that their voice-overs might help their classroom peers to gain access to the mathematics shown in the video. The research is highlighting how the use of silent video in this way is particularly helpful to teachers as a form of formative assessment, because data about students' knowledge can be collected in an indirect way.

Fidje and Erfjord's research also focused on videos produced by students, this time in Norway, which are used to stimulate discussions that are coordinated by the teacher. Their project *Digital Interactive Mathematics Teaching*, explores the use of digital tools in three lower secondary mathematics classes. The student-produced videos are presented as a tool for the students to show strategies related to inquiry-based tasks given by the teacher (in this case, relating to similar triangles). The idea emerged from the teachers as they wanted to explore different uses of videos in teaching, both teacher- and student-produced. The three-part lesson sequence used in the analysed lesson was developed by both teachers and researchers in a workshop. The aim for both teachers and researchers was to develop an approach for eliciting student talk in full-class mathematics discussions. The results show that the teachers adopt different 'teacher moves' to steer the discussion towards both didactical and mathematical goals.

The final two research studies that relate to this sub-theme are those of Fahlgren and Brunström and Eidissen et al.. Both sets of authors presented posters of work in progress. Fahlgren and Brunström's study concerns research into the impact of *connected classroom technology*, a networked system of personal computers or handheld devices specifically designed to be used in a classroom for interactive teaching and learning, through a design-based study with Swedish mathematics teachers to establish design principles for its use for formative assessment purposes. The contribution by Eidissen et al., notable by its absence of digital technology, proved to be a significant one for the TWG as it challenged the group to consider how theories such as instrumental genesis and orchestration (Trouche 2004, and Drijvers' plenary paper in this volume) might be applied for classroom practices involving non-digital resources.

Sorting, organising, and increasing quality of mathematical digital content

The current diversity, complexity and potential of mathematical digital content demands research studies to support better understanding and communication of the main characteristics, constraints, didactical value, and quality. The abundance of digital resources for the teaching and learning of mathematics highlights the need to provide teachers with guidance and support to make discerning choices. In the previous CERME, a paper was addressed specifically on discerning quality issues of web materials useful for teaching mathematics with technologies (Kimeswenger, 2017). In this CERME, TWG15 included several contributions that had adopted both empirical and theory-driven research approaches to address the challenges to sort, organise and make judgments about the quality of mathematical digital content.

Wörler focused on finding central features of digital simulations for learning mathematics, and articulate the underlying traits that can be derived within the context of mathematical modelling. The resulting research question concerned how these features and traits might enable an a priori classifications of mathematical simulations. This question, and the results of the study give some order within the field of modelling and simulation for teaching mathematics and enable comparisons between the products used in different countries and contexts. Considering the importance of variation in the field of simulation, the author introduced a classification based on the kind of variation, number and possibilities of varying elements in a simulation model, and kind of representation used. In this way, different simulation applications are classified with a quantitative scale based on different levels of manipulation, and the classification is useful to both researchers and teachers.

Alongside simulations, applets are also widely (and increasingly) available for the teaching and learning of mathematics and it is widely evidenced that teachers find it challenging to select which ones to use, highlighting a need for some related quality criteria (Nakash-Stern & Cohen). The authors reported research that concluded teachers' choices, which were classified by the intended mathematical learning goals, the role of the applet in the planned lesson and the nature of its planned use. Nakash-Stern and Cohen's research aims to support teachers to cope with the propensity of such OER by offering a methodological tool (a meta-data map, as shown in Figure 1) to link a teacher's pedagogical-content considerations with the didactical aims.

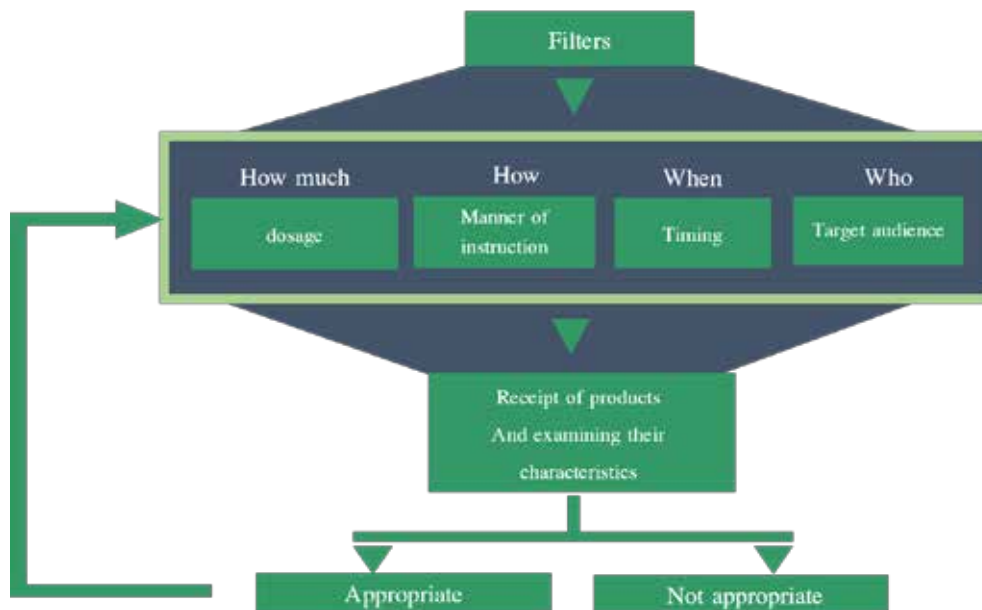


Figure 1. A Map for applets integration in teaching sequence (Nakash-Stern & Cohen)

The specific case of gamification within mathematics is addressed by Russo, whose research has reviewed the features of existing gamification platforms for mathematical learning to develop a framework for the evaluation of their motivational aspects. This is to be used to inform the development of a gamification editing platform that will be explicitly designed for teachers' uses.

Braukmüller, Bikner-Ahsbahs and Wenderoth offer a publisher's perspective to the same challenge in their consideration of teachers' needs whilst developing a digital tool for learning algebra in the German *multimodal algebra learning* (MAL) project. They argue that, as textbooks are the dominant media in mathematics teaching, research with textbook authors is necessary to derive principles for integrating the MAL digital tool within textbook authoring.

These different approaches all address the aim to facilitate teachers' choices, uses and evaluation of all manner of digital tools in classroom practice. The collaborative work of the TWG resulted in new ideas for future research focusing on some aspects that are considered useful when evaluating a tool, for instance motivational features, authoring systems, types of use and levels of interaction/activity. Basically, two different approaches arose: platforms that suggest some tools according to teacher needs (using filters) and the provision of frameworks to evaluate a specific tool for a special use case.

Teaching computing/programming in and through mathematics

Discussions in the group revealed that several of the represented countries are now implementing computing curriculum in schools (England) and/or mandating compulsory technology usage (Denmark, Sweden). The legacy of Seymour Papert (1980) and his seminal work that resulted in the computer programming language LOGO stimulated the TWG discussions on this sub-theme.

The ScratchMaths project (Clark-Wilson, Noss, Hoyles, Saunders & Benton), a large-scale evaluation project in English primary schools focused on making the mathematics explicit by focusing on an explicit pedagogical framework, the *5 Es* (Explore, Explain, Envisage, Exchange, bridgeE). The research reports the important methodological considerations in relation to the teachers' adoption and adaptation of the pedagogical ideas as a means to assess the fidelity of classroom implementations of the computing curriculum.

In Norway, Munthe is undertaking design-based research with upper secondary students on an elected science and mathematics pathway in which they are presented with mathematical problems to investigate how the use of programming can facilitate their learning of mathematics in the classroom. His poster is a good example of how the mathematics explored was explicit, within the problem of solving quadratic functions with no real roots.

This idea is researched from the teachers' perspective in the paper by Misfeldt, Szabo and Helenius, in Sweden, where teachers' perceptions of the relationship between mathematics and programming is explored within the context where teachers are expected to integrate compulsory programming within the mathematics curriculum, without deep thought about its value.

There is a diversity in the perspectives of the different papers in relation to both the definition and positioning of computational thinking within the school mathematics curriculum, which lead to differing approaches to curriculum and teacher development. Critical to this were the questions, *where is the mathematics?* and *how is the mathematics transformed (in terms of syntax, representation and meaning) through the use of different programming tools?* - and the implications of these approaches on teachers' roles and actions.

Teachers' choices, beliefs and practices with technology

A number of TWG15 contributions addressed issues related to mathematics teachers' attitudes to, and uptake of, digital technological tools. The paper by Thurm and Barzel adopts a quantitative approach to explore the link between teachers' self-efficacy and their use of *mathematical analysis software* (MAS). They adopt Bandura's definition of *self-efficacy*, 'a judgement of one's ability to organize and execute the courses of action required to produce given attainments' (1997, p. 3), to develop and validate a scale that concludes that teachers with high self-efficacy tend to use MAS more frequently. Furthermore, high teacher self-efficacy is less well-correlated with the teachers' level of experience with technology. A different methodological approach to explore teachers' perceptions of their technology use is evident in the work of Bang et al., who use a stimulated interview task to research how Danish teachers are integrating computer algebra software (CAS) into their teaching.

In his presentation of ongoing doctoral work, Dreyøe declares the integration of digital tools by teachers of mathematics to be a *wicked problem*, a phrase first coined by Rittel and Webber for problems with many interdependent factors making them seem impossible to solve (Rittel & Webber, 1973). Dreyøe's study explores the impact of participatory design with mathematics teachers as a means to create shared understanding of their declared intentions and practices with digital tools.

Focusing more on mathematics teachers' particular practices with digital tools, research by Rocha and Yemen-Karpuzcu & Isiksal-Bostan adopt a micro approach with respect to particular mathematical content. Rocha's study explores Portuguese teachers' representational fluency when teaching functions at high school level and the impact of their choices of representations within their practice, concluding hierarchies in algebraic, graphical and tabular forms. Yemen-Karpuzcu & Isiksal-Bostan research Turkish teachers' mathematical practices as they taught a sequence of lessons addressing the concept of slope that used both concrete and technology-based resources. Their findings highlight the nuances of teachers' practices, which vary by: the mathematical construct, their own understanding of it; and their knowledge of their students' understandings of the same construct.

The use and application of theories within TWG15

Over the years, and especially this year, the TWG15 papers have shown a strong appreciation of theory, which is used to inform hypotheses, research questions and research methodologies. During TWG15, this work continued as we discussed theories in relation to: individual papers; by making links with other papers in the group; the CERME plenaries; or other papers in the literature. One theory that continues to be present has been *instrumental genesis*, with its origins in French cognitive ergonomics (Verillon & Rabardel, 1995) and its applications in mathematics education (Artigue, 2002; Guin & Trouche, 2002). One discussion point was the complexity of two key components: *instrumentation* and *instrumentalisation*. In particular: how (and whether) to interpret these from a user perspective or an instrument perspective; their meaning in digital and non-digital contexts; and whether to consider each separately or in a more dialectic relationship. However, as addressed by Paul Drijvers in his plenary, instrumental genesis or, in other words, the emergence of utilisation schemes, emerges from the intertwinement of mathematical concepts and the employed techniques for the proposed task. In this process the *tools* have a central role but such tools 'come with [their

own] affordances and constraints, with opportunities and obstacles'. Our discussion, and resulting consensus was that instrumental genesis is a *long* and *continuing* process (as exemplified by Paul Drijvers' piano recital in the Dom church), in which the user continually and spontaneously shapes his/her techniques and associated cognition. Consequently, the separation of instrumentation and instrumentalization as distinct processes is not an easy task and may not be observable. The paper by Bozkurt et al. prompted rich debate on the process of instrumentalization as, in their research, they had particularly 'focused on a stage of discovery' of a specific tool and how this related to the instrumentation of other tools.

Moreover, to describe the design of material in a technological context, Diamantidis et al. used the *documentational approach* (derived from the instrumental approach, Gueudet & Trouche, 2010). The interesting and new perspective introduced in this study is the involvement of students alongside with teachers in the phases of design.

An emergent phenomenon in the TWG15 contributions is the increasing number of studies that report the involvement of teachers in mathematical, technological contexts as active protagonists, not only as consumers of professional development made by researchers. The engagement of teachers in working, not only learning, is the novelty coming to the fore of the theme in the last years, over the world: teachers as designers, with researchers or with students, teachers involved in the research, teachers aware of the materials produced, of their role, of their choices.

And, for the future, it seems increasingly important to research situations where teachers are working more collaboratively with each other and more knowledgeable others for the purpose of developing knowledge of, and practice with, digital mathematical tools. For that reason, theoretical approaches that take care of praxeologies of the teacher both in the activity of teaching (i.e. didactical), as well as in the activity of working and learning (i.e. meta-didactical), can be used to describe possible evolution and improvement of teachers in their learning and working trajectories. The recently announced 25th ICMI Study: *Teachers of mathematics working and learning in collaborative groups* will be an opportunity to explore the role of technology in this respect.

Areas for further research

Following the conference, the group created a ResearchGate¹ project page to enable the community to share, and comment upon research projects, articles and conference presentations that align with the TWG15 focus.

The group identified the following emergent research themes that might be included in future TWG calls for proposals:

- Teachers' decision-making for the selection and use of digital tools for teaching and learning mathematics.
- Quality criteria for digital tools that enable the teaching and learning of valuable and meaningful mathematics.

¹ <https://www.researchgate.net/project/CERME10-TWG15-Teaching-Mathematics-with-Technology-and-Resources>

- Developing collaborative groups to scale digital mathematical implementation – How to implement different technologies in schools? What are the challenges and barriers? What makes a successful implementation?
- The implications of the emergence of ‘big data’ in mathematics education and its impact on how mathematics is assessed.
- Teachers’ appropriations of emerging technologies, for example virtual and augmented reality, artificially intelligent digital tools etc.

References

- Artigue, M. (2002). Learning mathematics in a CAS environment: The genesis of a reflection about instrumentation and the dialectics between technical and conceptual work. *International Journal of Computers for Mathematical Learning*, 7(3), 245–274.
- Bandura, A. (1997). *Self-Efficacy. The exercise of control*. New York: Prentice-Hall.
- Black, P., & Wiliam, D. (1996). *Inside the black box*. London: King’s College.
- Gueudet, G., & Trouche, L. (2010). Teaching resources and teachers' professional development: towards a documental approach of didactics. In V. Durand-Guerrier, S. Soury-Lavergne, & F. Arzarello (Eds.), *Proceedings of the Sixth Congress of the European Society for Research in Mathematics Education* (pp. 1359–1368). Lyon, France: Institut National de Recherche Pédagogique and ERME.
- Guin, D., & Trouche, L. (2002). Mastering by the teacher of the instrumental genesis in CAS environments: necessity of instrumental orchestrations. *ZDM Mathematics Education*, 34(5), 204–211.
- Kimeswenger, B. (2017). Identifying and assessing quality criteria for dynamic mathematics materials on platforms. Proceedings of the Tenth Congress of the European Society for Research in Mathematics Education (CERME10). Dublin, Ireland.
- Papert, S. (1980). *Mindstorms: Children, computers, and powerful ideas*. New York: Basic Books.
- Rittel, H. W., & Webber, M. M. (1973). "Dilemmas in a General Theory of Planning." *Policy Sciences*, 4(2), 155–169.
- Thompson, P. W. (2002). Didactic objects and didactic models in radical constructivism. In K. Gravemeijer, R. Lehrer, B. v. Oers, & L. Verschaffel (Eds.), *Symbolizing and Modeling in Mathematics Education* (pp. 197–220). Dordrecht, The Netherlands: Kluwer.
- Trouche, L. (2004). Managing the complexity of human/machine interactions in computerized learning environments: Guiding students' command process through instrumental orchestrations. *International Journal of Computers for Mathematical Learning*, 9, pp. 281–307
- Verillon, P., & Rabardel, P. (1995). Cognition and artefacts: A contribution to the study of thought in relation to instrumented activity. *European Journal of Psychology of Education*, 10(1), 77–102.

Teachers' strategic choices when implementing technology

Henrik P. Bang¹, Niels Grønbaek² and Claus R. Larsen¹

¹Christianshavns Gymnasium, Denmark; hb@cg-gym.dk

²Dept. of Mathematical Sciences, University of Copenhagen, Denmark; gronbaek@math.ku.dk

Keywords: Tools, technology, tasks, technics, teachers' choices.

Background

Teachers in Danish upper secondary schools are expected to independently plan and implement teaching, basing content and didactic approach on their own preferences - customized to student level, useful teaching materials, time spent etc. Use of technology - especially CAS – is extensive and reflected in tasks and techniques, in the sense of Artigue (2002), in both the classroom and within final examinations. The technological dimension changes the conditions for organizing teaching, which makes continued in-service teachers training an urgent need.

CMU has met these challenges by establishing a community of teachers and offering coaching to smaller groups or individuals, allowing for a dialogue that respects the teachers' wishes and needs while providing solid support in the process (Bang, Grønbaek, & Larsen, 2017a). Among the issues that we have identified during the coaching process are:

- The teachers' own mastery of the instruments – technically as well as educationally.
- Questioning how much the students themselves can do with the instrument in terms of time consumption, classes and student types, software for which the school has access, etc.
- The relationship between doing tasks with CAS and (also) doing without, expressing itself in many ways, e.g. which procedures you want to teach, what non-CAS assumptions you should have in terms of using CAS, and how work with CAS supports non-CAS work.
- Teachers' awareness of the relationship between procedural and conceptual development in a technological context, while respecting mathematical content in a longitudinal perspective.
- Standards for CAS responses opposed to non-CAS. The latter having a long tradition, while the first may depend on software, instrumentation, etc.
- Students' motivation - not least the motivation triggered by final exams.

Fruitful aspects of the outsourcing metaphor.

The complexity of these interlaced issues involves many approaches, imposing a lot of theory on teachers not being one of them. We therefore need pragmatic ideas that can form a basis for dialogue with the participants and among the teachers themselves. Outsourcing (to technology/CAS) is to some extent used as a metaphor for how procedures that have been time-consuming maybe/may be advantageous with CAS. We have explored the concept, and its dual partner, insourcing, covering procedures and approaches done with or without technology, promoted in teaching (Bang, Grønbaek, & Larsen, 2017b). We are especially drawn to the control aspect, e.g. a company outsourcing procedures and thus losing control of them e.g. product quality, how the product fits in with the company's other production. Conversely, insourcing allows for control in the sense that you have clarity about qualities, resources, etc. Out-/insourcing can take place with or without technology.

Interviewing teachers posting tasks for students on maps.

Based on the interviewee's generic teaching experiences e.g. 2nd degree polynomial, initial differential calculation, we asked her to post different tasks on a two-dimensional map (fig.1). The teachers quickly connected to the idea and although placing specific topics gave rise to discussion, e.g. possible placement in several places, there was rarely doubt about the general idea^a.

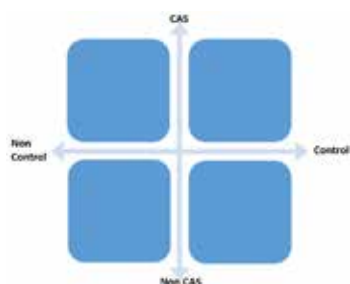


Fig.1

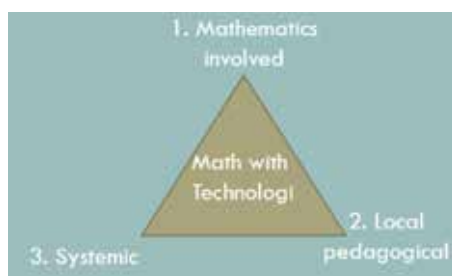


Fig.2

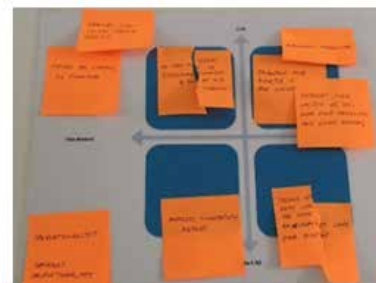


Fig. 3

Identifying choices and research questions.

We have tentatively placed teachers' reasons for their choice in three interrelated categories (Fig.2):

1. Mathematics involved -derived from what promotes mathematics in a longitudinal perspective
2. Local pedagogical - approaches, that work in a specific class setting.
3. Systemic - approaches derived from e.g. requirements for examinations or grades.

Our RQs: How can analyses of teachers' choices promote better understanding of relations between (in-sourced) procedures and objects. What kind of activities with technology could stimulate interest in realistic mathematics? What kind of technology use at upper secondary mathematics is fruitful in a transitional perspective?

References

- Artigue, M. (2002). Learning of mathematics in a CAS environment: the genesis of a reflection about instrumentation and the dialectics between technical and conceptual work. *International Journal of Computers for Mathematical Learning*, 7, 245–274.
- Bang, H., Grønbaek, N., & Larsen, C. (2017a). Coaching and engaging. Developing teaching with CAS in High School. *CERME 10 Proceedings*. Dublin. Retrieved from https://keynote.conference-services.net/resources/444/5118/pdf/CERME10_0218.pdf
- Bang, H., Grønbaek, N., & Larsen, C. (2017b). Out- and insourcing, an analysis model for use of instrumented techniques. *CERME 10 Proceedings, TWG15*. Dublin. Retrieved from https://keynote.conference-services.net/resources/444/5118/pdf/CERME10_0039.pdf

^a One of the many tasks in question was the parallel shift of a parabola, e.g. to display formula for vertex. You can choose completely to outsource the procedure, but also choose to insource parallel shift of absolute value and do it by hand, or you can choose to look at Geogebra etc. to enhance students control of the procedure. A large part of the interview would be the teacher elaborating on their choice.

Turning dilate from point tool into part of an instrument: an example of a preservice mathematics teacher working on a dynamic geometry system

Gulay Bozkurt^{1,2}, Candas Uygan¹ and Melih Turgut¹

1- Eskisehir Osmangazi University, Faculty of Education, Eskisehir, Turkey,

2- Charles University, Faculty of Education, Prague, Czech Republic;

E-mail: gbozkurt@ogu.edu.tr

The aim of this paper is to investigate a preservice mathematics teacher's instrumental genesis of 'dilate from point' tool in a dynamic geometry system. Data is collected through a series of task-based interviews including seven specific construction tasks regarding the use of dilate from point tool with a Turkish preservice mathematics teacher. Video-recorded interviews and screen recorder software productions were triangulated and analysed within the theoretical lens of instrumental genesis. According to the findings, the participant firstly explored the properties of the dilation transformation and its relation to other geometrical concepts and transformations. Secondly, the participant developed instrumented schemes related to the dilate from point tool for applying appropriate strategies in the construction tasks.

Keywords: Preservice mathematics teachers, Dynamic geometry system, Construction tasks, Instrumental genesis.

Introduction

Geometric similarity is regarded as a crucial concept in most school geometry curriculum. Likewise, in Turkish secondary school mathematics (MoNE, 2018a; MoNE, 2018b) this concept has its place focusing on making connections between measurement of angles and side lengths of two polygons through reasoning about the concepts of ratio and proportion. Considering the similarity related terms and concepts, the importance of dilation and scale factor has been emphasised in the related literature (e.g. Cox, 2013) since the deep understanding of these concepts do not only enable learners to solve similarity problems but also help them to involve in ratio-related problems. However, these concepts do not take place in the Turkish mathematics curriculums as a geometrical transformation. Instead, the focus is on investigating similar polygons in different sizes by focusing on the ratio between side lengths through paper folding tasks or drawing activities on a plotting paper (MoNE, 2018a). Also, tasks based on the basic proportionality theorem (MoNE, 2018b) are addressed without mentioning the concepts of scale factor or centre of dilation. Starting from this point, we focus on teachers learning of dilation as a geometrical transformation. This is particularly crucial in teacher education as it is essential for preservice mathematics teachers to have a wide and deep understanding of geometric similarity before their actual teaching in classrooms.

Focusing on these concepts, dynamic geometry systems (DGSs) in particular measurement and dragging facilities are considered as having a critical role to support learners' reasoning processes on the ratio and proportional relationships between two figures (Denton, 2017). In this regard, we focus on a preservice mathematics teacher learning dilation and scale factor concepts in a DGS as Simsek and Clark-Wilson (2018) in their review stated that there is a need to know about how dynamic technology tools shape teachers knowledge on geometric similarity related concepts. Considering the geometrical transformation tools in a DGS, it has become apparent that dilate from point tool is an unfamiliar tool for Turkish preservice mathematics teachers in its practical use as well as in its mathematical content. Along this direction, we focus on encouraging a preservice mathematics teacher to explore dilate from

point tool as a geometrical transformation tool in which she first had a difficulty in making the mathematical meaning of the tool.

Theoretical Framework

Instrumental genesis offering a model to describe the process of learning to use technological tools is chosen as a theoretical perspective in this study (Artigue, 2002). This is derived from the instrumental approach issuing from cognitive ergonomics (Vérillon & Rabardel, 1995) pointing out the difference between the terms ‘artefact’ and ‘instrument’ and the fact that using a tool is a dialectic between the user and the instrument. In this approach, the process through which an artefact becomes part of an instrument is called instrumental genesis ‘involving the construction of personal schemes or, more generally, the appropriation of social pre-existing schemes’ (Artigue, 2002, p. 250). The instrument is used in a psychological sense, which is developed by the user through mental schemes in order to use it for specific tasks. Instrumental genesis consists of two interrelated processes *instrumentalisation* and *instrumentation*. The former is directed towards the artefact and concerns the way in which the artefact is shaped by the user. The latter is directed towards the user and concerns ‘the emergence and evolution of schemes of a subject for the execution of a given task’ (Guin & Trouche, 2002, p. 205).

For the aim of this study, both instrumentalisation and instrumentation processes are of crucial importance. For the instrumentalisation process, we will focus on a stage of discovery of dilate from point tool and a process of differentiation of this tool itself in which instrumentation of the other DGS tools can emerge (Guin & Trouche, 2002). For the instrumentation process, we will focus on instrumented schemes for working on dilation and scale factor related tasks in a DGS. Hence, the research question addressed in this study is: How does instrumental genesis process of a preservice mathematics teacher occur in utilisation of dilate from point tool while solving enlargement/reduction and scale factor related construction tasks in a DGS?

Research Context and Methods

This paper is part of an ongoing research project that is designed as a case study focusing on instrumental genesis of preservice mathematics teachers while they commence GeoGebra. For the sake of page constraints, this particular study reports the case of one preservice mathematics teacher, Selin’s (pseudonym) appropriation of dilate from point tool in GeoGebra while working on construction tasks. She enrolled in a secondary mathematics teacher education program at a state university in Turkey. She took several courses (e.g. abstract and discrete mathematics, calculus, geometry and linear algebra) before the interviews were completed. She was selected mainly because she had no previous experience with GeoGebra in particular while solving construction tasks. Also, we considered her performance on geometry course since she achieved A from geometry for the grades F (fail) to A (excellent). In addition, her communication skills especially in terms of expressing her thinking clearly has been taken into account.

Data was collected from three task-based interviews, during which the participant talked/explained her solutions while working on a mathematical task. These interviews were recorded through a video-camera filming the participant’s working environment, which included a laptop with GeoGebra installed in front of her. Screen recorder software was also used to capture the techniques she employed during the tasks in detail. All the collected data were triangulated and analysed through thematic analysis techniques. Codes and themes were assigned by researchers according to the participant’s solutions for each task, and the tools

utilised by the participant and her reasoning behind it with reference to the used techniques during her solutions.

The Tasks

For exploring the process of instrumental genesis of dilate from point tool, we prepared seven different construction tasks. Since the participant initially had no insight into how dilate from point tool worked, the first task consisted of the analysis of this tool. The interviewer showed Selin the icon of dilate from point tool in GeoGebra and the task was proposed as: explore this tool and explain its mathematical feature. Then she was asked three different construction tasks focusing on enlargement/reduction concepts without the use of this tool:

- Dilate a circle by scale factors of 2 and 3 (without using dilate from point tool),
- Dilate a triangle by scale factors of 2 and 3 (without using dilate from point and reflect object in point tools),
- Dilate the given QRS triangle from the centre point T by the scale factor of $-1/3$ (without using dilate from point tool).

By this way the participant was encouraged to think about possible ways to obtain dilation transformation by using other GeoGebra tools. These three tasks were proposed in order for her to become familiar with the use of dilate from point tool and elaborate its mathematical meaning, hence the focus was on the instrumentalisation process. Finally in order to explore the participants' instrumented schemes for this specific tool, three more tasks were asked:

- Construct the centre of gravity point in a given triangle (without using line construction tools),
- Divide a line segment into two parts by a certain ratio (without using parallel line construction tool),
- Construct a trapezoid with a given triangle (without using parallel line construction tool)

During these tasks, the participant was asked to develop strategies without the use of some tools in order to encourage her to think indirect ways of constructing a figure which aimed to give deeper insight into the extent of the participant's knowledge.

Findings

Initial analysis of the 'dilate from point' tool

Task 1: Explore the dilate from point tool and explain its mathematical feature

Selin started her analysis by selecting the tool, respectively clicking on point *A* (as object) and point *B* (as centre of dilation), and entered the number 5 as a scale factor. As a result, she assumed that the distance between the two points (*A* and *B*) on the screen would be five (the image of the point *A* was not seen on the screen). After making use of distance or length tool, she found the distance *AB* 3.1 (Figure 1) and refuted her initial conjecture. She then said: "I would like to say that there is a certain proportion between points but I don't see a third point so I am confused".



Figure 1

Selin applied the dilate from point tool again for C as object and D as centre of dilation. Then she used the zoom out tool to look for a third point, to her, which was possible to emerge on the screen as the image of C (Figure 2). When she found the point C' (image of the original point) on the screen, she said: ‘aha, now it is OK’.



Figure 2

She stated that the tool constructed a bigger triangle which was constructed by the ratio that was entered as 5.

She also worked on the two triangles and explained the similarity between them based on the basic proportionality theorem (Figure 3).

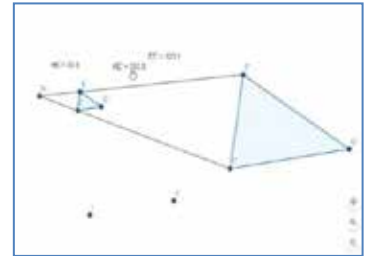


Figure 3

Selin then applied the dilate from point tool on various other figures (a triangle and a circle) and examined the relationships between the original figures and their images. She suggested that the scale factor affected each point of the original figures and made an assumption that the original shapes and their images were similar.

In order to support her assumption, she used the distance or length and area tools and justified it with proportional relational facts. Based on this, she explained the similarity of figures and ratios.

In the second step of the analysis process, she examined the simple fractions and negative numbers as scale factors. After examining the new shapes that appear as a result of her operations, she stated that for fractions the smaller versions of the original shape occurred as its images, whereas for negative numbers, the similar versions of the original shape occurred at the opposite side of the centre of dilation.

Elaboration of the ‘dilation’ by the use of other types of transformations

Task 2: Dilate a circle by scale factors 2 and 3 respectively without the use of dilate from point tool.

During this task, she, by following the steps below:

- drew a circle with the centre P through point Q and chose a point called R as centre of dilation,
- reflected the point R in the point Q and also in the point P by using *reflect object in point* tool,
- obtained two new points R' and R_1' ,
- constructed the new circle with these points by using *circle with centre through point* tool, which was a dilation image of the original circle by scale factor 2 (Figure 4),
- reflected the point Q in the point R' and reflected the point P in the point R_1' for the dilation image by scale factor 3 (Figure 4).

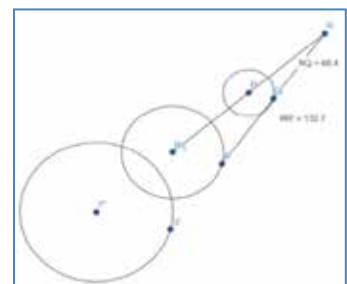


Figure 4

The reasoning behind this instrumented action was notions of extending a segment by projecting it by its own length.

Task 3: Dilate a given triangle by scale factors 2 and 3 respectively without the use of dilate from point or reflect object in point tools.

At this step, Selin focused on the use of translate by vector tool. She, by following the steps below:

- drew a vector from the centre of dilation V to one of the vertices of the given triangle,
- translated the triangle by the vector (Figure 5).

After this operation, she noticed that while there was a ratio of 2 between V and one vertex of the constructed image, this ratio was not preserved for the other two vertices of the image and she concluded: “I now translated the whole triangle by the same vector”. Then, she, by changing her operations as follows:

- translated each vertices of the original triangle by vector (similar with the use of ‘reflect object in point’ in the previous instrumented action),
- drew three different vectors from the centre of dilation V to the three vertices of the given triangle and translated each vertex by the corresponding vector,
- obtained three vertices of the dilated image of the original triangle by scale factor 2 (Figure 6),
- did the same operation for scale factor 3.

The reasoning was again related to extending a segment by projecting it by its own length.

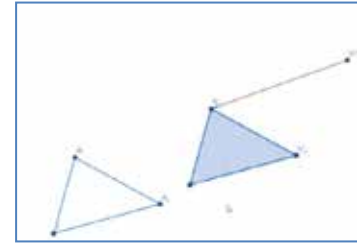


Figure 5

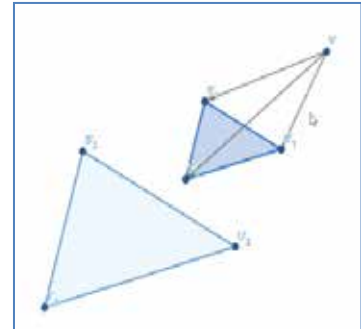


Figure 6

Task 4: Dilate the given QRS triangle with a centre of dilation T by a scale factor of $-1/3$ without using the dilate from point tool.

Selin initially said: “the image should be on the right side of the dilation centre and needed to be smaller than the object. How can I do that? For instance, the image of point Q needs to be somewhere on the line QT (collinear) and its distance from the centre should be one third of the line QT . So then if I divide QT line segment into three parts and reflect the point in the dilation centre I think that I could obtain its image by $-1/3$ ”.

In this sense, her initial aim was to divide line segment QT into three equal parts. At this point she, by following the steps below:

- drew two lines (QT and RQ),
- constructed three equal line segments on the line RQ through constructing three new points called R' , Q' and R'' by using the reflect object in point tool (e.g. reflected R in Q , then reflected Q in R' , and reflected R' in Q'),
- drew the line segment TR'' ,
- constructed parallel lines passing other two points (R' and Q') to the line segment TR'' ,
- constructed three equal line segments on the line segment QT based on the basic proportionality theorem (Figure 7),
- specified the point U on the line segment QT , which was the intersection point of the parallel line passing Q' and QT (Figure 8),

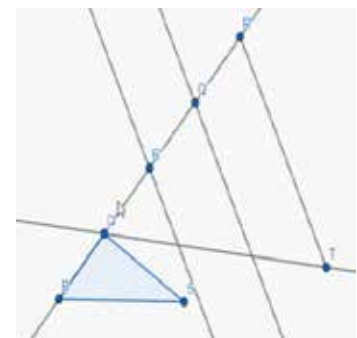


Figure 7

- applied the same division method on the other two lines (RT and ST),
- constructed the vertices of a new triangle (UZW) which was the image of QRS triangle by a scale factor of $1/3$,
- reflected the points U , Z , and W in the centre of dilation T and constructed $U'Z'W'$ triangle, which was the reduction image of QRS triangle by a scale factor of $-1/3$ (Figure 8).

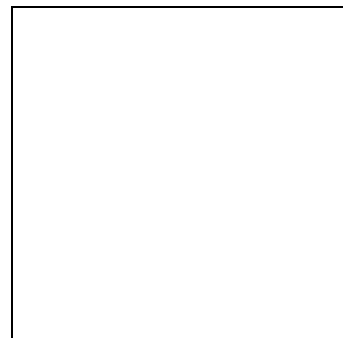


Figure 8

In this task, she developed an instrumented scheme in which she related the reduction with division of line segments and negative scale factors with reflect object in point.

Construction of the centre of gravity point in a given triangle

Task 5: Construct the centre of gravity point in a triangle without the use of line tools.

In the solution process, she, by following the steps below:

- firstly constructed the midpoints (D_1 , E_1 , F_1) of the sides of a triangle ($A_1B_1C_1$) with the use of ‘midpoint or centre’ tool (Figure 9),
- and then reasoned on the ratio between the parts of median that separated by the gravity point.

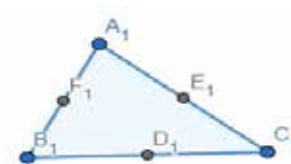


Figure 9

In order to obtain the ratio between the parts as $1/3$, she decided to use dilate from point tool and thought about what value should be entered in the scale factor window by considering the procedural features of the tool. As a result, she chose B_1 as object and E_1 as the centre of dilation. She said: “since the image should be on the left side of centre of dilation, the scale factor should be positive and since the ratio is $1/3$, the scale factor should be $1/3$ ”. Therefore, she put the value $1/3$ as a scale factor and completed the task.

Division of a line segment into two parts by a certain ratio

Task 6: Selin was given two different line segments (called RS and UV). The line segment RS was divided into two parts from the point T (Figure 10). The task was to divide the line segment UV into two parts with the same ratio of $|RT|/|TS|$ without the use of parallel lines.

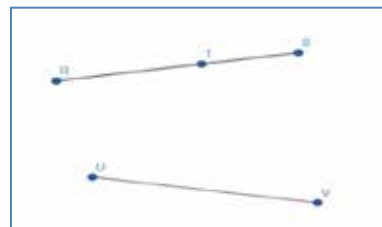


Figure 10

She started considering the ratio concept and the use of dilate from point tool. She, by following the steps below:

- constructed a line segment F_1G_1 which was equal length to the ratio of $|RS| / |TS|$ with the use of segment with given length tool (Figure 11),
- used dilate from point tool by choosing U as object, V as centre of dilation and the distance F_1G_1 as a scale factor.

However, she noticed that the point, which she wanted to construct, appeared outside of the UV (Figure 11).

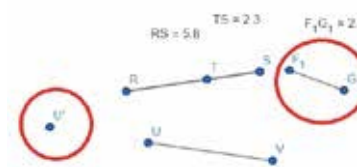


Figure 11

Then she said: “the image should be between object and the centre of dilation therefore I need to use a fraction as a scale factor”. Finally she changed the scale factor as $1/\text{distance}F_1G_1$ and repeated the operation again and finished her construction. She concluded that she could also use $\text{distance}TS/\text{distance}RS$ as a scale factor which would have done the same operation.

Construction of a trapezoid with a given triangle as part of the trapezoid

Selin was firstly asked to examine the properties of the given quadrilateral in Figure 12 ($M_1N_1L_1K_1$) focusing on its variants and invariants through dragging. At this step, she stated that the given quadrilateral was a trapezoid for the reason that two opposed sides were always parallel within the quadrilateral. After her explanations, she was ensured to remember the diagonal based definition of trapezoid.

Task 7: A triangle ($P_1Q_1R_1$) was given to her and she was asked to reason on how a trapezoid can be constructed if the given triangle was formed by the diagonals of the trapezoid (Figure 12) without the use of parallel line tool.

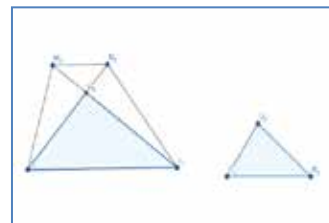


Figure 12

Selin focused on using dilate from point tool by considering the fact that the diagonals of a trapezoid divide each other into two parts by the same ratio. Then, she, by following the steps below:

- extended one of edges of the triangle by using the line tool and marked a random point on this line as third vertex of the trapezoid (point S_1) (Figure 13),
- examined the ratio of the distances of the opposed vertices (S_1 and R_1) from the intersection point of the diagonals Q_1 by using the length measurement tool (Figure 13),
- selected the dilate from point tool and chose Q_1 as object, P_1 as the centre of dilation, and distance S_1R_1 /distance Q_1R_1 as a scale factor,
- constructed U_1 as the fourth vertex of the trapezoid (Figure 14) and completed the task by using the segment tool.

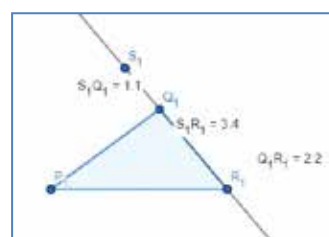


Figure 13

As a second solution to the same task, she dilated the given triangle ($P_1Q_1R_1$) as a whole, by choosing the given triangle as object, the intersection point of the diagonals Q_1 as a centre of dilation and $-\text{distance}S_1Q_1/\text{distance}Q_1R_1$ as a scale factor.

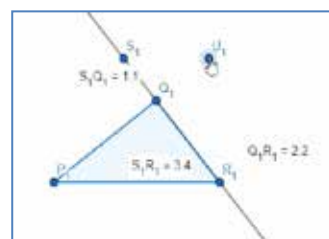


Figure 14

Discussion and Conclusion

This study focuses on instrumental genesis of a preservice mathematics teacher's use of dilate from point tool working on enlargement/reduction and scale factor related construction tasks in GeoGebra. For the initial analysis and elaboration of the tool, the participant discovered and understood the use of dilate from point tool particularly by engaging in thinking of the use of other tools to perform dilation. After that, she developed a number of instrumented schemes regarding the dilate from point tool while working on construction tasks related to proportional relationships.

During the initial analysis and elaboration of the tool, on the one hand, she differentiated the properties of the dilation from other geometric transformations (e.g enlarging the given triangle by the use of translate by vector). On the other hand, she made connections between the properties of dilation and other transformations, which enabled her to develop a deeper understanding of dilation concept. For instance, in the example of dilating the given triangle by a scale factor of $-1/3$, it was seen that she mainly engaged in geometric thinking and used other concepts/transformations (e.g. division of line segments for reduction, the use of reflect object in point for negative scale factors) to complete the task. By this way, she extended and supported her understanding of the dilate from point tool regarding its underlying mathematical meaning and its practical use.

Considering the instrumentation process of the dilate from point tool, it was observed that she developed different schemes for positive/negative scale factors as well as for integer/fractional scale factors. For the former, she referred to the direction of the image from the centre of dilation (i.e. when the value of scale factor is negative, the dilation takes place in the opposite direction from the center of dilation). For the latter, she considered the size of the image whether it would be bigger or smaller than the original object and also the proportional relationships between the distances of the points of object and its image. In addition, she developed schemes related to the concept of dilation as a geometrical transformation in which centre point and scale factor are considered as parameters. These schemes about dilation and scale factors in a DGS indicated also some connections between algebraic and geometric strategies of the participant (Cox, 2013).

To conclude, this study focused on the learning process of dilation transformation in a DGS in the context of the instrumental genesis of the dilate from point tool. The results of this research indicated that the instrumental genesis process for a DGS tool provided scaffolding in the construction and understanding of the dilation and scale factor related concepts. However, this study examined one specific preservice mathematics teacher's solution processes of different construction tasks, which needs to be borne in mind.

Acknowledgment

This research has been carried out through the support of Eskisehir Osmangazi University Scientific Research Projects Council (grant no: 2017–1682).

References

- Artigue, M. (2002). Learning mathematics in a CAS environment: the genesis of a reflection about instrumentation and the dialectics between technical and conceptual work. *International Journal of Computers for Mathematical Learning*, 7(3), 245–274.
- Cox, D. C. (2013). Similarity in middle school mathematics: At the crossroads of geometry and number. *Mathematical Thinking and Learning*, 15(1), 3–23.
- Denton, J. (2017). Transforming mathematics: Using dynamic geometry software to strengthen understanding of enlargement and similarity. *Warwick Journal of Education*, 1(1), 69–84
- Guin, D., & Trouche, L. (2002). Mastering by the teacher of the instrumental genesis in CAS environments: necessity of instrumental orchestrations. *Zentralblatt Für Didaktik Der Mathematik*, 34(5), 204–211.
- Ministry of National Education (MoNE) (2018a). *İlkokul ve Ortaokul Matematik Öğretim Programı [Mathematics Curricula for 1.-8. Grades]*. Ankara: Talim Terbiye Kurulu Başkanlığı.
- Ministry of National Education (MoNE) (2018b). *Ortaöğretim Matematik Öğretim Programı [Mathematics Curricula for 9.-12. Grades]*. Ankara: Talim Terbiye Kurulu Başkanlığı.
- Simsek, A., & Clark-Wilson, A. (2018). Teacher knowledge for teaching geometric similarity with technology: A review of literature. In H.-G. Weigand et al. (Eds.). *Proceedings of the Fifth ERME Topic Conference (ETC 5) on Mathematics Education in the Digital Age (MEDA)* (pp. 249–256). Copenhagen, Denmark: University of Copenhagen.
- Vérillon, P., & Rabardel, P. (1995). Cognition and artifacts: A contribution to the study of thought in relation to instrumented activity. *European Journal of Psychology of Education*, 10(1), 77–101.

Towards linking teaching, technology and textbooks

Maike Braukmüller¹, Angelika Bikner-Ahsbahs² and Dirk F. Wenderoth¹

¹Westermann Gruppe, Braunschweig, Germany; maike.braukmueller@westermanngruppe.de

²University of Bremen, Germany; bikner@math.uni-bremen.de

The aim of the research project MAL (multimodal algebra learning) is to develop a digital algebra learning system (MAL-system) that provides an accessible approach for teaching and learning algebra. The subproject MAL textbook conducts an expert study with secondary school teachers who are also textbook authors to identify current teaching practices and needs. These are reconstructed by three iterations combining group discussions and questionnaires. The results are considered in the design of the MAL-system and lead to principles for integrating the MAL-system into textbooks. This paper shows how the surprisingly high commitment to the balance model is extracted from the data and its impact on the design of the MAL-system.

Keywords: Delphi technique, textbooks, digital tools, anthropological theory of the didactic.

Introduction

Although digital tools are available for everyday classroom practice, researchers as well as teachers are questioning how the use of digital tools can improve teaching and learning (Hillmayr, Reinhold, Ziernwald, & Reiss, 2017). Despite from the digital tool itself, two main factors are responsible for students' success: the teachers' integration of digital tools into classroom practice and a supplementary use of digital and traditional resources (Hillmayr et al., 2017). Teachers' integration requires change or innovation of current teaching practices. Research on innovation of teaching and learning shows that teachers are more likely to use digital tools if they address teachers' needs. Moreover, fruitful innovation in schools should rather be an incremental process building on current teaching practices than a revolutionary break (Bikner-Ahsbahs & Doff, 2019). These teaching practices are highly influenced by textbooks: on the one hand, textbooks specify the mathematical content; on the other hand, they shape the didactic style that teachers apply in their teaching (Valverde, Bianchi, Wolfe, Schmidt, & Houang, 2002). Thus, textbooks represent teaching practices as well as traditional resources. Taking this into consideration, to provide the potential for integrating a digital tool for learning in classroom practice, already the development of the tool should follow a user oriented design that supports students' learning and furthermore takes into account the textbook and teachers' practices and needs.

In the research and development project Multimodal Algebra Learning (MAL), the overall goal is to develop a digital algebra learning system (MAL-system) that supports the students' transition from arithmetic to algebra, however, this paper is restricted to linear equations. With the design of the MAL-system we want to overcome the disadvantages of using either digital or physical manipulatives by integrating physical manipulatives in a digital environment (Reinschlüssel et al., 2018). The subproject MAL textbook focuses on (A) integrating teachers' perspectives into the

design process of the MAL-system and (B) providing strategies for using the MAL-system facilitated by textbooks. This will be achieved by answering the following research questions:

- (1) What kind of teaching practices do teachers consider when confronted with the concept of the MAL-system?
- (2) What kind of needs for teaching do teachers address for the design of the MAL-system?
- (3) What kind of criteria for accepting or rejecting the MAL-system do teachers express?
- (4) Which principles for integrating the MAL-system into textbooks can be extracted from (1)-(3)?

This paper focuses on the methodical design of the MAL textbook study based on a Delphi study. It will show that this choice is fruitful to inform research and development of digital tools with teachers' practices. These practices are conceptualized in the subsequent theoretical framework.

Theoretical Framework

In order to consider established teaching practices in the design of the MAL-system and, beyond that, to develop guidelines to include the MAL-system into established textbooks, the theoretical framework should address institutionalized forms of teaching and learning. This is possible by considering a theory that captures these teaching practices, the Anthropological Theory of the Didactic (ATD). The ATD (Bosch & Gascón, 2014) models human activities by the concept of *praxeology*. According to ATD, human activity splits up into a *practical* and a *theoretical component*. The former is broken down into a set of *types of tasks* and a *technique* that tells how these tasks are or might be carried out; the latter is broken down into *technology* and *theory*. The technology explains how and why a technique works. The theory comprises basic assumptions and views supporting and justifying the technology. In many cases, it is hard to reveal the theory because it is usually taken for granted. The practical component is often referred to as the know-how, whereas the theoretical component is the knowledge behind, in the sense of *raison d'être*. The set of all praxeologies of one person is called her *praxeological equipment*. In general a person's praxeological equipment emerges out of previous and current institutional settings including the people surrounding her.

Algebra tiles and the MAL-system

The MAL-System is developed based on algebra tiles (Dietiker, Kysh, Sallee, & Hoey, 2010). Algebra tiles can be used for modeling linear and quadratic expressions and equations with integers. A small square represents the number one, a big square represents x^2 , and a rectangle with the side lengths of the two squares represents the variable x . The three types of tiles usually have three different colors on one side and are all red on the other side. The red side indicates a "negative sign" (Figure 1 a). For modeling a linear equation a so-called equation mat with two distinct sides, left and right, is needed. By laying out the appropriate tiles, an equation is modeled (Figure 1 b). The equation can be solved by taking away or adding the same tiles on both sides and dividing both sides into the same number of equal sets. A subtraction zone – an area where all the tiles within are supposed to be subtracted – can be introduced; either to mark the difference of sign and arithmetic operator or to express subtraction without negative Tiles (Figure 1 c).

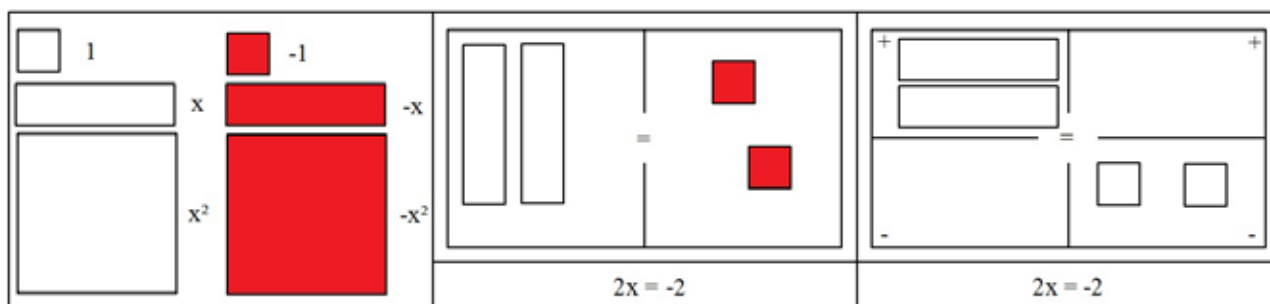


Figure 1 a: algebra tiles; b: equation with negative tiles; c: equation with subtraction zone

As the focus in this paper is on linear equations only, x^2 -tiles are not addressed in this paper.

Methodology and Method

In Germany, textbook authors are primarily in-service teachers. Therefore, they are familiar with established teaching practices in their schools and many of the teachers' needs for teaching. As these teachers author a certain textbook series in a team, they are also influenced by the teaching practices provided by this textbook series. Hence, their praxeological equipments are affected by their experience as teachers as well as textbook authors. This awareness of relevant praxeologies makes these teachers experts for the MAL textbook study to inform the design of the MAL-system through established teaching practices and relevant needs for teaching algebra. In order to gain main directions of consensus for adapting the MAL-system to these practices and needs, an expert study in the style of a Delphi study is conducted.

According to various definitions, any Delphi study comprises an expert group communication with several iterations and guided feedback to achieve consensus on a given question (Linstone & Turoff, 1975). The MAL textbook study conducts three iterations combining group discussions and questionnaires building on one another (Figure 2). Three groups of authors, working on books for three different performance levels are involved (*Math Alpha*: comprehensive school (covers and combines lower secondary education, secondary education and high school education); *Math Beta*: special school; *Math Gamma*: high school). These groups are selected because they cover a wide range of school types at different performance levels in Germany. The first iteration includes group discussions of the teams Math Alpha and Math Beta. Due to organisational reasons the team of Math Gamma did not participate. The topics are algebra learning, digital learning, gamified learning, and the MAL-system, introduced by a concept video. The second iteration includes all experts to answer an online questionnaire readdressing the topics from the first iteration by open and closed items. For example, the high relevance of the balance model to the experts came up in both discussions. As this was unexpected, the questionnaire asked for advantages and disadvantages of it within the whole expert group. In the third iteration, comprised statements based on the answers in the second iteration are evaluated by the experts. According to the example with the balance model, this iteration reveals tendencies on the central advantages and shows the willingness to make compromises concerning disadvantages.

The group discussions are audio taped, transcribed and analysed in a sequential way (Przyborski, 2004) based on ATD concepts to reconstruct the textbooks' and teachers' praxeologies, identify

teachers' needs and principles for textbook integration. The data set of the second iteration is analysed by theory-driven content analysis (Mayring, 2015) to capture individual praxeologies and needs based on the authors' experiences in school. The final data set is analysed by descriptive statistics to identify quantified relevancies of the praxeological elements from the iterations before.

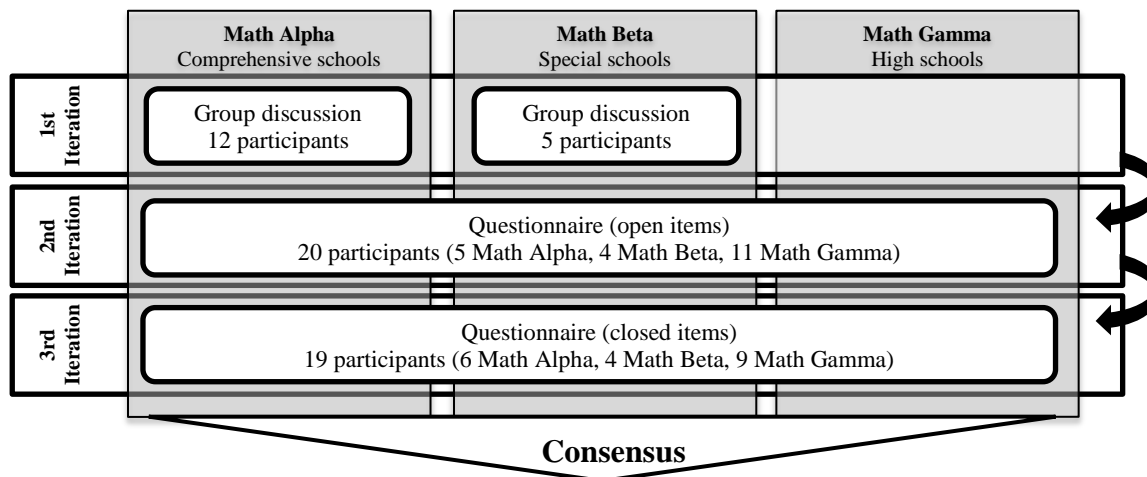


Figure 2: Procedure of the MAL textbook study

Results

This section shows the three steps of data analysis applied to reconstruct the praxeological equipment of the expert authors. Presenting the results, we focus specifically on the balance model since the teachers have shown a strong commitment to it throughout the three iterations. Praxeological elements that came up while comparing algebra tiles and the balance model in the first iteration are presented. As the experts could hardly detach from the balance model while judging algebra tiles, the second iteration asked separately for advantages and disadvantages of the two models. The categorized range of experts' opinions extracted from data analysis is then presented. From the third iteration, the final evaluation of selected (dis-) advantages is presented.

The first iteration

In the first iteration, the teams Math Alpha (12 participants) and Math Beta (5 participants) took part in a group discussion each. The researcher gave an introduction on algebra tiles and the experts were invited to work with them. Afterwards, the experts were asked if they can imagine using algebra tiles in class. Both groups immediately refused to do so, giving the same *technological*¹ arguments. Similar to expert A10²: “[the balance model] is just easier for the kids to understand” (#236-237)³, teacher expert B2 said: “the balance model is much easier” (#76-77) and narrowed to “more illustrative” (#78) by B3. Another *technological* argument that came up in both groups in the beginning is that algebra tiles are “too abstract” (A10, #238) or rather “very abstract” (B3, #82).

¹ The reconstructed praxeological elements are highlighted in italics.

² The experts from Math Alpha are named AXX and those from Math Beta BXX.

³ (#236-237) refers to the lines in the original transcript that is not shown here due to the limited space.

In the discussion of the Math Alpha team, A1 then mentioned that “the problem of the balance model is clearly that I cannot express negative numbers with it” (#239). This was a turning point in the discussion towards algebra tiles, validated by three more experts. A1 continued to point at a *technique* based on algebra tiles: “one can slide the [...] x s that cancel out each other together” (#242-243). This was justified by the *technology* that “this [...] also always helps” (#243). At this point, the Math Alpha group stopped comparing algebra tiles and the balance model.

The process in the Math Beta group was slightly different. B6 presented a “counter *technology*” concerning two different *techniques*. One was working with the balance model on the iconic level; the other was working with algebra tiles on the enactive level. Based on the *technological* argument that the enactive helps in real life and the iconic does not, B6 saw an advantage of algebra tiles versus the balance model. Based on that, B5 suggested a didactic technique combining the two models. She started with the core *technology*: “the equal sign [...] means the balance” (#125-126) that was substantiated by the *technology* that the pupils should interpret the equal sign as a relational and not as an arithmetical sign. Based on that, her *didactic technique* related to the balance model began with using it, “this [equal sign] could maybe be introduced with the balance” (#126-127). But then B5 suggested to use algebra tiles “in the beginning really only using additive elements” (#128-129), before involving the subtraction zone or negative tiles. This was justified by the *didactic technologies* that the concrete action of laying out tiles is helpful and the subtraction zone “is a demanding conception” (#132).

This analysis shows that the experts’ praxeological equipments on teaching linear equations is highly bound to the use of the balance model. The experts could hardly think of *didactic techniques* involving algebra tiles that fit to their *theoretical arguments* and moreover they could hardly detach their *theoretical arguments* from the balance model. Even the positive statements on algebra tiles were mostly connected to weaknesses of the balance model. To reveal *theoretical arguments* detached from comparing the two models we asked for advantages and disadvantages of the two models separately in the second iteration.

Second iteration

In the second iteration a questionnaire was sent to 37 experts. 20 of them answered (5 Math Alpha, 4 Math Beta, 11 Math Gamma) the questionnaire. The answers on the advantages and disadvantages of the balance model are summed up in categories in Table 1.

	Advantages	Disadvantages
Balance model	<ul style="list-style-type: none"> • illustrative • intuitively accessible • enactive and iconic working • builds on students’ knowledge • prepares new knowledge • illustrates equivalence (transformations) 	<ul style="list-style-type: none"> • no negative numbers or quadratic equations • hard to illustrate fractions • more enactive working needed • transition to symbolic level problematic • students do not know the balance
Algebra tiles	<ul style="list-style-type: none"> • illustrative • negative numbers and quadratic equations 	<ul style="list-style-type: none"> • abstract • linking of area and term is difficult

<ul style="list-style-type: none"> · explain more than the balance model · link algebra and geometry · combinable with balance model · enactive and iconic working 	<ul style="list-style-type: none"> · explanation takes much time · do not illustrate equivalence (transformations) · not intuitive for students
--	--

Table 1: Categorized results of (dis-) advantages of balance model and algebra tiles

We focus on the complementary findings in this iteration. As expected, the experts mentioned the core *technology* from the first iteration as an advantage: the balance model illustrates equivalence very well. In contrast, this is a disadvantage of algebra tiles, e. g. one expert from Math Alpha stated “[the] equivalence is taken for granted [...]”. This *technology* is connected to the *technological argument*: the balance model is intuitive for the students whereas algebra tiles are not.

The other way round, an advantage of algebra tiles is that negative numbers and quadratic equations can be illustrated. In particular, the lack of expressing negative numbers was mentioned as a disadvantage of the balance model several times. This also already occurred in the discussion of Math Alpha in the first iteration as a *technique* to favor algebra tiles.

The third iteration offers further clarity about the experts’ preferences by rating the findings above.

Third iteration

In the third iteration, the 37 experts were again asked to answer a questionnaire. We received 19 answers (6 Math Alpha, 4 Math Beta, and 9 Math Gamma). Figure 3 shows the evaluation of the four complementary statements: (1) The balance model enriches my teaching because it illustrates the equivalence very well. (2) The algebra tiles are insufficient for my teaching because they do not illustrate the equivalence. (3) The use of algebra tiles would enrich my teaching because it can represent negative numbers. (4) The balance model is insufficient for my teaching because it cannot represent negative numbers.

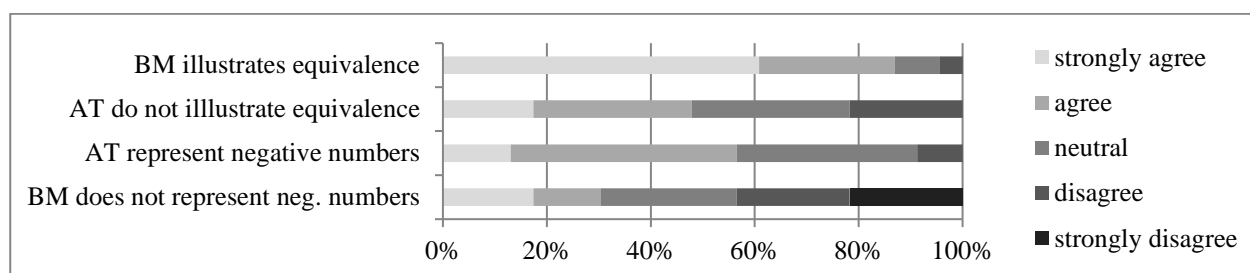


Figure 3: Ratings on complementary statements (BM: balance model; AT: algebra tiles)

These results emphasize the importance of the core *technology* substantiating the use of the balance model. More than 80% of the experts agreed that the balance model enriches teaching because it illustrates the equivalence very well. In contrast to that, about 50% of the experts rated algebra tiles as insufficient for their teaching because the intuitive access to equivalence is missing. Only 20% did not take this as a barrier for classroom teaching.

The strongest advantage of the algebra tiles over the balance model is the possibility to represent negative numbers. More than 50% of the experts evaluated this feature as enriching for their

teaching, and only 10% disagreed on that. However, only one third of the experts evaluated the balance model as insufficient due the lack of negative numbers and as one half of them disagreed, the balance model was still rated positive on average.

All in all, the results show that the balance model is indispensable in current teaching practices, however, the lacking representation of negative numbers gives space for the algebra tiles to enter classroom practice.

Discussion

The *didactic technique* - teaching linear equations with the balance model - reconstructed in the previous section reveals insight into current teaching practices. Independent of the type of school, the balance model turned out to be the most relevant model for teachers when teaching linear equations. However, the experts were aware of the problems and limitations of the model, e. g. no negative numbers, special kind of balance is unknown to kids, limited possibilities to explore equations concretely, aspects also discussed in the literature (e.g. Vlassis, 2002). Especially the missing representation of negative numbers points to a need in current teaching. The results from the third iteration suggest a complementary use of the two models allowing to address strengths of both models in a complementary way. We suggest introducing equations with the balance model by working enactively with the balance in class to make the students experience the equal sign as a relational sign of keeping two collections of weights in balance. The balance may then be readdressed in the MAL-system as a feedback symbol for equality when the students begin to work with algebra tiles. Starting only with positive tiles and additive equations, a balance in the middle, that is balanced or not (depending on the correctness of the actions carried out) instead of the equal or unequal sign is used.

As the authors *theoretical and technological arguments* on teaching linear equations are highly influenced using the balance model, it should not be replaced by the MAL-system. The balance model seems to be very fruitful for teaching in all the three types of schools in Germany since it provides intuitive access to the equal sign of equations and the equivalence relation. Addressing a current need like the representation of negative numbers which is missing in the balance model turns out to be a criterion for accepting the MAL-system. In addition, a careful integration of the MAL-system into textbooks could compensate the teachers' judgement of algebra tiles as being abstract. This could be done by creating a context that makes algebra tiles more accessible to students, for example by gamification or as an expanded digital environment for exploring problems. An important issue for increasing acceptance of the MAL-system is its correspondence to textbook praxeologies, as well.

Looking back to the methodology, the Delphi study with the three iterations has proven to be fruitful for investigating teachers' needs for teaching, their praxeologies and textbook praxeologies. The discussions have led to three important insights: the teachers' strong commitment to the balance model; contrasting the balance model with Algebra Tiles has made the teachers sensitive to disadvantages of a given technique that is normally not questioned; it has shown that a negotiation process is needed to disclose hidden needs for teaching underlying the praxeologies. The second iteration has provided the possibility to readdress aspects not considered before like the balance

model. The final questionnaire supplies a quantitative overview, showing possible differences according to the types of schools. In conclusion, the three steps of the Delphi study exactly fit the purpose of the MAL textbook study. As they are not tied to the topic of algebra, they unlock potential for further research on the role of textbooks in reform processes with a wider scope.

Acknowledgment

The research reported on in this paper is part of the ongoing project “Multimodal Algebra lernen” (MAL), which is funded by the German Federal Ministry for Education and Research in the grant program “Erfahrbares Lernen” (experienceable learning) (grant number: 16SV7550K).

References

- Bikner-Ahsbahr, A., & Peters, M. (2019). How does change happen? Ein Modell zur Innovation im Fachunterricht. [A model for innovation in subject teaching]. In A. Bikner-Ahsbahr & M. Peters (Eds.), *Unterrichtsentwicklung macht Schule. Fachdidaktische Forschung und Innovation im Fachunterricht [Development of teaching catches on. Subject educational research and innovation in subject teaching]*(pp. 309–330). Wiesbaden: Springer VS.
- Bosch, M., & Gascón, J. (2014). Introduction to the Anthropological Theory of the Didactic (ATD). In A. Bikner-Ahsbahr, & S. Prediger (Eds.), *Networking Theories as a Research Practice in Mathematics Education* (pp. 67–83). Springer Int. Publishing Switzerland.
- Dietiker, L., Kysh, J., Sallee, T., & Hoey, B. (2010). *Making Connections: Foundations for Algebra, Course 1*. Sacramento, CA: CPM Educational Program.
- Hillmayr, D., Reinhold, F., Ziernwald, L., Reiss, K. (2017). *Digitale Medien im mathematisch-naturwissenschaftlichen Unterricht der Sekundarstufe. [Digital media in mathematics and science education in secondary education]*. Münster: Waxmann.
- Linstone, H. A., & Turoff, M. (1975). *The Delphi Method - Techniques and Applications*. Addison-Wesley Publishing Company, Advanced Book Program.
- Mayring, P. (2015). Qualitative Content Analysis: Theoretical Background and Procedures. In A. Bikner-Ahsbahr, C. Knipping, & N. Presmeg (Eds.), *Approaches to research in mathematics education* (pp. 365–399). New York: Springer.
- Przyborski, A. (2004). *Gesprächsanalyse und dokumentarische Methode. [Conversation analysis and documentary method]*. Wiesbaden: Springer Fachmedien.
- Reinschlüssel, A., Alexandrovsky, D., Döring, T., Kraft, A., Braukmüller, M., Janßen, T., Reid, D., Vallejo, E., Bikner-Ahsbahr, A., & Malaka, R. (2018). Multimodal Algebra Learning: From Math Manipulatives to Tangible User Interfaces. *i-com. Journal of Interactive Media*, 17(3), 201–209.
- Valverde, G. A., Bianchi, L. J., Wolfe, R. G., Schmidt, W. H., & Houang, R. T. (2002). *According to the Book*. New York: Springer Science + Business Media.
- Vlassis, J. (2002). The Balance Model: Hindrance or support for the solving of linear equations with one unknown. *Educational Studies in Mathematics*, 49(3), 341–359.

Project in preparation - Connected classroom technology (CCT) to enhance formative assessment in mathematics education

Mats Brunström and [Maria Fahlgren](#)

Karlstad University, Department of Mathematics and Computer Science, Sweden;

mats.brunstrom@kau.se and maria.fahlgren@kau.se

Keywords: Connected classroom technology, formative assessment.

Background

It is well established that formative classroom practice in mathematics has a positive impact on students' learning and development. The widely used theoretical framework for formative assessment (FA) by Black and Wiliam (2009) identifies five key strategies and three agents (teacher, learner, peer). The strategies are:

1. clarifying and sharing learning intentions and criteria for success;
2. engineering effective classroom discussions and other learning tasks that elicit evidence of student understanding;
3. providing feedback that moves learners forward;
4. activating students as instructional resources for one another; and
5. activating students as the owners of their own learning (p. 8)

The literature on formative assessment has emphasized the potential of technology to enhance FA strategies in mathematics education (Clark-Wilson, 2010). The European project *Formative Assessment in Science and Mathematics Education* (FaSMEd) investigated different aspects of the use of digital technology to promote formative assessment. Besides the five key strategies and the three agents introduced above, the FaSMEd framework identifies a third dimension consisting of three technological functionalities: (a) sending and displaying, (b) processing and analysing, and (c) providing an interactive environment. Interactive environment refers to a learning environment in which interactions, both between user and machine and between classroom participants, are based on mathematical exploration activities (Cusi, Morselli, & Sabena, 2017).

In the planned study, we will investigate educational use of the type of technology referred to as Connected Classroom Technology (CCT). Irving (2006) defines CCT as "... a networked system of personal computers or handheld devices specifically designed to be used in a classroom for interactive teaching and learning." (p. 16). To date, several studies, primarily conducted in the US, have demonstrated that CCT facilitates several FA strategies. This literature emphasizes how the 'sending and displaying' functionality of CCT can be used. For example, teachers could use CCT to access more comprehensive information about students' mathematical thinking which could be used to guide immediate adaptation of subsequent instructions (Shirley & Irving, 2015). Moreover, by facilitating the display of different student solutions, CCT can support the teacher in engaging students in whole-class discussions in which they receive feedback, both from the teacher and their peers (Cusi et al., 2017), providing a forum for reflection on their own responses in comparison to their peers. These activities relate to the third, fourth, and fifth FA strategy. Cusi et al. (2017) argue that this could also be a way to activate the first FA strategy by focusing on criteria for success when discussing different

solution strategies. Concerning the functionality, ‘processing and analysing’, CCT often includes a classroom response system (CRS) which processes student responses and presents statistics, e.g. in the form of charts (e.g. Clark-Wilson, 2010). In relation to the ‘providing an interactive environment’, Shirley and Irving (2015) describe how teachers have used CCT to collect and analyze student data received by laboratory-based investigations.

Aim and study design

The aim of the proposed research and development activity is to develop design principles to guide formative teaching activities using CCT:

- principles for designing tasks that have good potential to make use of CCT facilities
- guiding principles for teachers in monitoring, selecting and displaying student solution(s) to use as a base for dialogues
- guiding principles for teachers in their choice of interaction type (e.g. group discussion, student presentation, whole-class discussion) in different situations
- guiding principles for teachers in the orchestration of various digital resources to enhance an interactive classroom in which all students are engaged

These principles will be refined through successive cycles of design-based experimentation, across a range of teaching contexts. In each cycle, the current version of the principles will be made operational in curriculum materials and teacher guides designed to support the use of formative teaching processes within a particular course unit. Through testing across a range of contexts in each cycle, and across a range of topic units over successive cycles, the principles – and classroom techniques through which they can be operationalised – will be refined.

The intervention to be developed and evaluated, then, consists of (a) the system of design principles to guide formative teaching activities using CCT, and (b) the operationalisations of these principles in the curriculum materials and teacher guidance for the (different) topic-specific course units designed in each cycle.

References

- Black, P., & Wiliam, D. (2009). Developing the theory of formative assessment. *Educational Assessment, Evaluation and Accountability*, 21(1), 5-31. doi:<https://doi.org/10.1007/s11092-008-9068-5>
- Clark-Wilson, A. (2010). Emergent pedagogies and the changing role of the teacher in the TI-Nspire Navigator-networked mathematics classroom. *ZDM*, 42(7), 747-761. doi:<https://doi.org/10.1007/s11858-010-0279-0>
- Cusi, A., Morselli, F., & Sabena, C. (2017). Promoting formative assessment in a connected classroom environment: design and implementation of digital resources. *ZDM*, 49(5), 755-767. doi:<https://doi.org/10.1007/s11858-017-0878-0>
- Irving, K. E. (2006). The impact of educational technology on student achievement: Assessment of and for learning. *Science Educator*, 15(1), 13-20.
- Shirley, M. L., & Irving, K. E. (2015). Connected classroom technology facilitates multiple components of formative assessment practice. *Journal of Science Education and Technology*, 24(1), 56-68. doi:<https://doi.org/10.1007/s10956-014-9520-x>

Key Factors for Successfully Embedding a Programming Approach to the Primary Maths Curriculum at Scale

Alison Clark-Wilson, Richard Noss, Celia Hoyles, Piers Saunders and Laura Benton

UCL Institute of Education, University College London; a.clark-wilson@ucl.ac.uk

The ScratchMaths (SM) intervention was designed in response to changes in the primary curriculum in England to incorporate mandatory computer science - aiming to exploit this change in the interests of mathematics learning. In this paper we describe SM and its critical components for implementation with fidelity. We present preliminary case studies of two high-fidelity schools, which point to variation in fidelity of implementation. We conclude with a derivation of quantifiable measures for the identification of high, middle- and low-fidelity schools (O'Donnell, 2008).

Keywords: Primary mathematics, computer science, teacher professional development, coding, programme evaluation.

Introduction

In 2014 in England, the previous information and communications technology (ICT) primary curriculum was replaced by a new computing curriculum specifying mandatory content (but no pedagogical guidance) for the teaching of computer programming to all pupils (Department for Education, 2013). Some factors that contributed to Logo and other early programming initiatives not fulfilling their potential have been described in earlier work (Benton, Hoyles, Kalas, & Noss, 2016), a key factor being identified by Noss and Hoyles (1996) as the importance of fostering a sense of teacher understanding and ownership of any programming innovation.

There have been significant technological developments since this early teaching of computer programming, with a number of block-based languages such as Scratch now freely available and widely used. These environments have helped to address some of the difficulties of mastering programming syntax, but there remains the challenge of ensuring that teachers first appreciate why they are introducing programming as part of mathematics - and then have opportunities to develop appropriate skills to teach programming.

The ScratchMaths (SM) 2-year intervention¹ aimed to develop the mathematical knowledge of pupils (aged 9-11 years) through programming. The SM approach was to select and design activities around core computational ideas that would then be used as vehicles to explore specific mathematical concepts and promote mathematical reasoning. For example, the concept of variable is developed by enabling pupils to first explore the *Answer* block, initially on its own, but then in association with its companion block *Ask* in the context of a short script that draws polygons. Pupils encounter the limitations of the *Answer* block when confronted by a situation that needs the answer to contain two

¹ <https://www.ucl.ac.uk/ioe/research/projects/scratchmaths>

different values simultaneously, stimulating a need to introduce the new idea of **Variable**. This approach enables parts of computing to be taught within, or as a supplement, to mathematics lessons.

SM initially adopted a design research methodology to produce pupil and teacher materials along with professional development (PD) to support the teachers to exploit the powerful ideas of computational thinking as a way to engage pupils in mathematical thinking (see Benton, Hoyles, Kalas, & Noss, 2017 for a detailed account of the design of the study). SM is also being independently evaluated by another university through a randomized control trial (RCT, see Education Endowment Fund, 2016 for the detailed research design of the RCT). The first year's content (Y5 in England) focuses primarily on the computing curriculum and developing pupils' programming skills. In the second year (Y6), pupils utilise these programming skills to explore key mathematical ideas within the primary mathematics curriculum (place value, polygons and ratio and proportion). 111 English primary schools (6300 pupils) were recruited to the project by open invitation through networks such as the National Association for Advisers in Computing Education (NAACE) and regional information events. The schools were randomly assigned to the control and treatment groups at the school level. Schools did not pay to participate in the project and the teaching materials are freely available from the ScratchMaths website under creative commons licensing (www.ucl.ac.uk/scratchmaths).

The primary research question for the RCT conducted by the external evaluators was "What has been the effect of the intervention on the development of pupils' mathematical skills as measured by a randomised control trial?" However, in parallel to this the authors of this paper sought to research how the curriculum materials were used by teachers to seek to understand its effects. The research reported here concerns the latter study.

Theoretical background of ScratchMaths and its pedagogical design

The SM design was framed by constructionist theory whereby pupils would engage with the mathematical ideas by building programs to explore them. (See Noss & Hoyles, 2017). This constructionist approach was operationalized in a pedagogical approach structured by five key ideas, called the '5Es framework' derived from the theoretical underpinning of constructionism (Papert, 1980) and described in Noss & Hoyles (2017), see also Benton et al. (2016). These five unordered constructs are:

Explore: Pupils learn from computer feedback. Pupils should have opportunities to explore different ways of dealing with constraints and ambiguity as well as investigating their own and others' ideas and debugging different types of errors. Through this exploration pupils should be encouraged to take control of their own learning and understand the reasons behind different outcomes.

Explain: Pupils use different modes of communication to articulate learning and the reasoning behind choices of approach. Pupils should have opportunities to explain their own ideas as well as answer and discuss reflective questions from the teacher and peers. Pupils should be encouraged to use the programming language as a 'tool to think with' and to support explanations of key mathematical ideas.

Envisage: Pupils predict outcomes of their own and others' programs with specific goals prior to testing out on the computer. Pupils should be given opportunities to consider program goals and the

outcomes of different strategies before conducting their own exploration in Scratch. This should be balanced with activities which allow discovery through exploration.

Exchange: Pupils develop ideas through interacting and comparing with others. Pupils should have opportunities to share and build on others' ideas as well as being encouraged to both justify their own solutions and understand another's perspective on a problem.

bridgE: Pupils make links between contexts beyond the Scratch programming environment and the mathematics domain by explicit re-contextualization and reconstruction within the language of mathematics.

Our overall aim in developing this framework was to chart a course for pupils in which they could begin to express mathematical ideas in Scratch and to provide guidance for teachers on the pedagogical strategies (which the English National Curriculum does not stipulate) that could lead to successful implementation of the SM intervention.

Professional Development

Prior to teaching each year of the SM intervention, teachers were offered two full days of professional development, spaced a few months apart. During these sessions, the teachers were introduced to Scratch and the SM curriculum content. The 5Es framework guided the design of these highly interactive sessions, with teachers given the opportunity to participate in activities that incorporated exemplars of these different pedagogical strategies. After experiencing for themselves the pedagogical approach, as modelled by the PD leaders, teachers were also explicitly introduced to the approach and the definitions of each of the constructs.

Curriculum Materials

The learning objectives of all activities within the SM curriculum are focused towards one or more of the 5Es. The connection with the different constructs is made explicit within the teacher materials, with a range of activities such as Scratch-based tasks that require pupils to explore within the Scratch environment and then subsequently explain and exchange their programs with the rest of the class as well as 'unplugged' tasks (away from the computer) which require pupils to envisage outcomes of particular programs and bridgE to their existing mathematical knowledge to calculate the correct inputs.

Findings

Measurable constructs for the fidelity of ScratchMaths

Fidelity of implementation within an education context has been defined as "the determination of how well an intervention is implemented in comparison with the original program design during an efficacy and/or effectiveness study" (O'Donnell, 2008). Using the criteria of program differentiation, the SM team evolved some critical components for implementation with fidelity of the SM intervention, leading to the derivation of quantifiable measures for the identification of high-, middle- and low- fidelity implementation. There is a tension between a high-fidelity implementation of the original designed intervention and the potential for the intervention to be adaptable and flexible enough to fit within a range of contexts, which could lead to higher rates of adoption and sustainability

(O'Donnell, 2008). Therefore, finding an appropriate measure of fidelity that identifies the critical components of an intervention that must remain unchanged but allows for appropriation to local context was important.

The fidelity of implementation was defined in terms of five school-level measures as: days of professional development attended; availability of computer technology; curriculum coverage; the amount of time spent teaching SM and the sequence of progression followed through the materials. The criteria are given in Table 1.

Fidelity criteria	High	Medium	Low
Days of professional development	Y5 and Y6 teachers each attended at least two days of PD.	Y5 and Y6 teachers each attended at least one day of PD.	Y5 and/or Y6 teacher had limited PD from a more experienced person away from the organised sessions.
Technology	Computers running Scratch 2.0 online or offline. Minimum 2:1 pupil to computer ratio.	<i>No classification</i>	Computers running Scratch 2.0 online or offline. Minimum 3:1 pupil to computer ratio.
SM curriculum coverage	Pupils taught at least some of the core activities across 5 different modules.	Pupils taught at least some of the core activities across 4 different modules.	Pupils taught at least some of the core activities across 3 or fewer different modules.
Curriculum time	Time spent teaching SM is at least 20 hours in Year 5 and at least 12 hours in Year 6.	Time spent teaching SM is at least 12 hours in each year.	Time spent teaching SM is fewer than 12 hours per year.
Progression	The order of modules and order of activities are mostly followed in general.	The order of modules and order of investigations are mostly followed in general.	The order of modules is mostly followed in general.

Table 1: The ScratchMaths fidelity criteria

All schools participating in the trial received online surveys to complete at the end of the 2015-16 and 2016-17 school years to collect information about SM implementation. 28 of the 55 'treatment schools' provided data to both surveys and are included in our analysis presented below. Whilst a

more complete set of research data would have increased the validity and reliability of our findings, we could only work with the data that we received. Indeed, it is a finding that, despite their initial enthusiasm to participate in the project, with institutional participation agreed by the headteacher, approximately half of the schools did not respond to project communications. Hence the survey results of these 28 schools, alongside data triangulation by follow-up communications and school visits, were then used to classify the schools according to their fidelity.

School level fidelity

The spread of fidelity scores for the 28 schools is shown in Figure 1.

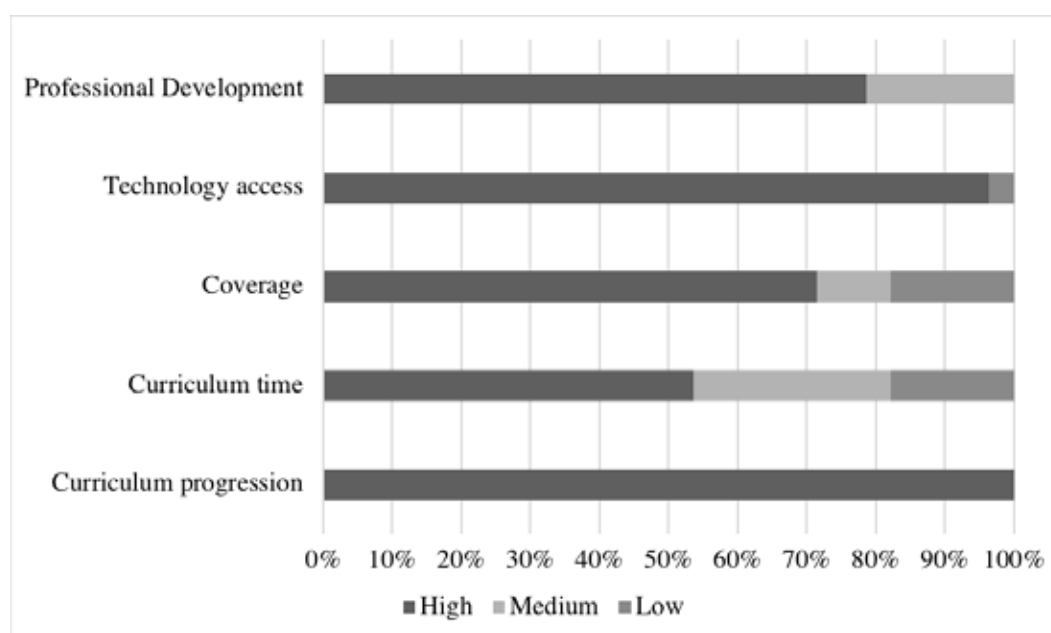


Figure 1: Spread of fidelity measures (n=28 schools)

Probing the survey and interview data further revealed a number of findings.

Professional development: The school-level fidelity measure reveals high commitment to the PD. However, probing the data further revealed that 43% of schools were hampered by internal staff changes and teacher movement in and out of the schools (teacher ‘churn’). So, in fact the teachers who were trained did not necessarily match with the actual classes being taught SM.

Technology access: Only one school was unable to provide the pupil:computer ratio of at least 2:1, which resonates with recent OECD data on the high levels of computer access in UK schools (OECD, 2015).

Coverage: Three quarters of the schools reported that they had struggled to cover the SM curriculum. This was particularly evident in Y6 where the demands of the high-stakes National tests are great, with the result that a huge proportion of class time was spent ‘teaching to the test’ and associated revision activities.

Curriculum time: The allocation of curriculum time was challenging for about half of the schools, again more evident in Y6 due to pressures of the National test.

Curriculum progression: All of the schools were high fidelity in that they followed the order of the teaching modules and the activities within them. (In lower fidelity schools, teachers reported that they varied the sequencing or skipped activities).

This analysis identified 15 schools that were high fidelity for all five criteria. From this group, an opportunity sample of 2 schools was selected for follow-up visits and semi-structured interviews with teachers and headteachers during the 2017-18 school year, focusing on three general questions to elicit respondent's experiences and perceptions of the SM curriculum: How and why they got involved in the SM project? How they implemented SM, and what were their impressions of SM? Both schools were in the same geographical (rural) area about one mile apart. The resulting data was used firstly, to triangulate the fidelity judgement for each school and secondly, it was coded in relation to the 5 Es as a means to establish a deeper understanding of the quality of the implementation. Arriving at a school level judgement for a project that had spanned two years proved to be complex due to the differing experiences, perceptions and memories of the people involved.

The demographic information for the two schools is given in Table 2.

School	Number of pupils on roll	Scaled score in mathematics (100 = National expected score)	School progress in maths score ²	% of pupils eligible for free school meals (Measure of socio-economic status)
School A	420	102	Average (-0.9)	28.9%
School B	424	101	Below average (-3.1)	3.6%

Table 2: Overview of the schools³

Although similar in overall size, the pupil demographic and attainment measures were notably different; one might have expected School A to achieve rather lower progress given the social background of the pupils. This difference is highlighted in School B's lower 'progress score', a comparative measure of pupil progress in similar schools. Both schools taught the SM curriculum in the teaching time allocated for the teaching of computing and none of the teachers in either school also taught mathematics to the same pupils. We now highlight aspects of the quality of delivery that were discernible from the research data, to provide deeper insight in relation to school-level implementations.

² A government-defined measure of school progress with respect to pupils' mathematical outcomes at age 11. https://assets.publishing.service.gov.uk/government/uploads/system/uploads/attachment_data/file/560969/Primary_school_accountability_summary.pdf

³ 2017 data taken from <https://www.compare-school-performance.service.gov.uk>

School A was confirmed as a high-fidelity school as it became clear that the two teachers involved (Peter and Carol) had worked in a highly collaborative way and had both embraced the SM curriculum, dedicating their planning and preparation time to becoming familiar with all of the pupil activities in advance of the lessons, as highlighted by the following response:

Peter: You couldn't just pick it up and follow it, and then expect the children to understand. And, then we thought, 'Well, if we have got to spend this amount of time getting our heads around it, it is a big ask for the children to do it in the same time'.

Concerning the 5Es, Carol referred to the ways in which she encouraged children to *Explain*,

Carol: Once they got it, we kind of said, 'Well, try to show the person next to you, if they haven't,' and then sometimes, if they showed them one little bit, they were alright then...

Peter highlighted how the pupils *Exchanged* their ideas,

Peter: And, I make a point at the end of sessions now, I leave 15 minutes before the end so that anyone who has done what I have asked them to do, essentially gets to share their work. And, they absolutely love it, whether they have not quite got it, or they have done more... .. I put it up on the big screen for them.

In addition, School A had made the SM materials locally accessible and created files of exemplar student work, which had supported alignment between the two teachers' pedagogic approaches.

The overall fidelity criteria for school B was also confirmed to be high as the two teachers described how one of them (David) had taught the Y5 curriculum to both classes and the second teacher (Tim) had done the same in Y6. During interview, Tim described his pedagogic approach thus,

Tim: We sort of gave them the option to explore the bits and for them to ... trying to link it to the real world, to explain the steps behind it... why they have done what they have done, why they think it is may be more efficient or whatever. And as I say, I think we did the envisioning with a lot of the debugging ones [activities].

David commented on his use of the unplugged activities, highlighting how he encouraged pupils to *Envisage*, *Explain* and *Exchange* their ideas,

David: I would put up, for example, one of the algorithms and I say, "Well, what would this algorithm do if we clicked on it," and they would talk it through with a partner and then... I could pop one up on the board and say, "Right, what would this do?" And, "If we changed this bit, how would that change the outcomes?" and things like that.

Final comments

It is hard to assess in such a large-scale study how far the implementation of SM was faithful to the designers' goals (Fullan, 2001). Many of these goals were generic, and we make no claim to originality on this score. For example, teacher 'churn' was both ubiquitous and destructive - quite

frequently SM teachers had not engaged fully with the PD. However, where we saw specific variation in fidelity, it tended to be related to the particularities of attempting a novel and demanding curriculum based on a somewhat daunting field of knowledge – programming – where teachers had little or no background. In such circumstances, the curtailment of teaching time due to the pressures of national testing was a strong impediment.

Clearly, some factors supported SM implementation: local access to the resources, exemplar student work and pre-written computer models. The excellent collaborative practice of School A that enabled them to overcome the challenges is noteworthy and echoed in other high-fidelity schools.

We noted little teacher adaptation at this first stage of implementation, but with more fluency and familiarity with the SM approach, this is likely to grow, leading, we conjecture to less emphasis on ‘curriculum coverage’ and more time to explore the mathematical ideas.

Acknowledgment

This research was funded by the Education Endowment Foundation.

References

- Benton, L., Hoyles, C., Kalas, I., & Noss, R. (2016). *Building mathematical knowledge with programming: insights from the ScratchMaths project*. Paper presented at the Constructionism Conference 2016, Bangkok, Thailand.
- Benton, L., Hoyles, C., Kalas, I., & Noss, R. (2017). Bridging Primary Programming and Mathematics: Some Findings of Design Research in England. *Digital Experiences in Mathematics Education*, 1–24. doi:10.1007/s40751-017-0028-x
- Department for Education. (2013). *Statutory guidance: National curriculum in England: Computing programmes of study*. Retrieved from <https://www.gov.uk/government/publications/national-curriculum-in-england-computing-programmes-of-study/national-curriculum-in-england-computing-programmes-of-study>
- Education Endowment Foundation. (2016). Evaluation protocol: ScratchMaths (revised May 2016) Retrieved from https://educationendowmentfoundation.org.uk/public/files/Projects/Evaluation_Protocols/Round_6-Scratch_maths_amended.pdf
- Fullan, M. (2001). *The meaning of educational change*. New York: Teachers College Press.
- Noss, R., & Hoyles, C. (1996). *Windows on mathematical meanings: Learning cultures and computers*. Dordrecht: Kluwer Academic.
- O’Donnell, C. L. (2008). Defining, Conceptualizing, and Measuring Fidelity of Implementation and Its Relationship to Outcomes in K–12 Curriculum Intervention Research. *Review of Educational Research*, 78(1), 33–84.
- OECD (2015), *Students, Computers and Learning: Making the Connection*, OECD Publishing, Paris. <http://dx.doi.org/10.1787/9789264239555-en>
- Papert, S. (1980). *Mindstorms: Children, computers, and powerful ideas*. New York: Basic Books.

The co-design of a c-book by students and teachers as a process of meaning generation: The case of co-variation

Dimitris Diamantidis¹, Chronis Kynigos¹, Ioannis Papadopoulos²

¹University of Athens, Educational Technology Lab, dimitrd@ppp.uoa.gr ; kynigos@ppp.uoa.gr ;

²Aristotle University of Thessaloniki, ypapadop@eled.auth.gr

In this study we focus on the role of students as co-designers of digital resources for learning mathematics. Students with the use of c-book technology construct in collaboration with their teachers units of narrative blended with artifacts and constructions designed with digital tools for mathematics education, acting as designers. We see the design phase as a learning process for students, searching for new mathematical meanings that emerge around the concept of co-variation. For our analysis we use the lens of Documentational Approach as a means of a deeper understanding of the learning process.

Keywords: c-book, Documentational Approach, design of digital tools, co-variation

Introduction

Proposing answers on how to create didactic objects that may provoke reflective mathematical discourse in the classroom, fostering students to make significant mathematical advances and transforming grounded conceptual understandings about certain mathematical concepts constitute a generic aim of instructional design research (Thompson, 2002). The design of didactic objects entails making assumptions on students' and teachers' way of participating in this discourse. However, there is a productive tension between teachers' intentions and actions when they design tasks and the students' activity when they are involved in them (Johnson, Coles & Clarke, 2017), that could be studied in more detail. Research into the design and use of mathematical tasks accommodating students' intentions, actions and interpretations to the same extent as those of teachers' is fragmented. Focusing on the use of digital media in mathematics education, the students' agency during the learning process and its confluence on instructional design could become more visible; students along with mathematics teachers may share the role of co-designers of digital resources that can be used as didactic objects. In this report we build on previous research about students' activity with a 'c-book' technology, a new digital environment where storytelling is blended with mathematical tasks (Papadopoulos, Diamantidis & Kynigos, 2016). But, now we make a step further, using c-book technology to put students in the role of the co-designer (the 'narrator') in the sense of building on the notion of design as a learning process and as a means to intervene in educational practice (Kynigos, 2015a). We focus on the question: How does the students' role as co-designer affect the mathematical meanings they make through the design process? In our research, we employed the Documentational Approach (DA) a framework hitherto used to understand and support teachers as they iteratively design and use resources in the classroom (Gueudet & Trouche, 2009), in order to understand classroom practice and student meaning making.

Theoretical Framework

The focus of this research is on the design of a digital medium as a learning process; a group of teachers and students jointly design such a resource for learning mathematics through the pages of a

digital narrative. Assuming that the element of storytelling may provoke students' initiative, the design process could be a field of dense interaction between students and teachers. It could yield a series of digital artefacts (i.e. narrative meshed with constructionist digital 'widgets') as foregoing versions of the end product, along with discussion among the members of the group that refers mostly to argumentation about them, reconstruction and exchange of different versions of artifacts. From the constructionist point of view, this communication between teacher and students results to a learning collective where meaning making process occurs naturally (Papert & Harel, 1991). In this sense, the digital medium to be designed is more than a product for the designers' group; it may be an object-to-think-with (Brennan, 2015; Kynigos, 2015b). Especially for students, the design process of this kind of medium could foster the generation of new meanings around mathematics.

To investigate this aspect in detail we have chosen the approach of DA (Gueudet & Trouche 2009; Guin & Trouche, 1999) that describes the creation of new resources. Taking into account that DA has been used to study teacher's role as a designer of digital resources, we adopted it to study the students as they co-design resources with the teacher being part of the mathematics course. According to Documentational Genesis (DG) (Gueudet & Trouche 2009; Guin & Trouche, 1999), a 'document' is the set of the existing resources the designer uses together with the scheme of use for these resources in a certain class of situation; i.e. when a mathematics teacher constructs a certain task for teaching functions with a digital medium (this is the class of situation), he/she attaches a scheme of use for a set of resources (the curriculum, another related task, a discussion with other teachers etc), shaping a document. In parallel, this task can be a new resource for him/her or others. In this study, we have students collaborating with teachers in the design of new resources, shaping new documents about mathematics blended with the element of narrative, which might affect the set of the existing resources. Teachers, at the same time have their own teaching agenda. Thus, in terms of instructional design, the documents that teacher and students jointly create can be seen as didactic objects, as well. Thus, we found DA useful to help us enhance our understanding of a process through which new mathematical meanings for students may emerge.

In this paper, we present instances of students as they generate meanings around the concept of co-variation. Following Thompson and Carlson (2017) approach of co-variational thinking we build on the hypothesis that co-variation emerges when students conceptualize a situation envisioning two quantities varying simultaneously and dynamically. Quantity refers to students' conceptualization of an object's attribute that can be measured. A quantity is varying in the sense that students envision the object having momentary states, thus its attribute has momentary values (Thompson, 2002).

The Digital Medium

The c-book technology

C-book technology affords the design and use of modules named c-book units. Each c-book unit consists of a narrative blended with diverse "widgets"; hyperlinks, videos and mostly instances of digital tools like GeoGebra, DME (Digital Mathematics Environment) and MaLT2 (Kynigos, 2015b). DME provides also an authoring tool for the teacher to design new modules, while MaLT2 is a web-based Turtle Geometry environment which affords the design through Logo programming along with dynamic manipulation of 3D geometrical objects using sliders. GeoGebra and MaLT2 allow

customization and personal construction of tools (Healy & Kynigos, 2010) in the form of microworlds, fostering the meaning making process. The end users (mostly students) of a c-book unit can explore the narrative, experiment with the “widgets between the lines” and be involved in mathematical tasks. C-book environment also includes the “Workspace”, a tool that affords asynchronous discussions between the designers or the users of a c-book unit organized in ‘trees’ (Fig.1).

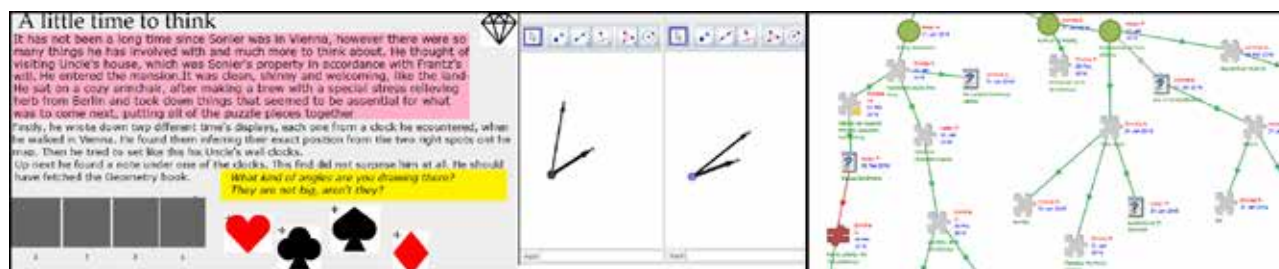


Figure 1: A c-book unit page on left hand side. The Workspace on right hand side.

The Design of the Study

Jewelry c-book unit was jointly designed from scratch by a group of students and teachers, for the purposes of this study. The storyline in this c-book unit is about a dinky merchant named Sonier back in 1820 who got an inheritance after his uncle's death. However, the size of the uncle's assets was not clear, so Sonier got in a quest to detect the inherited goods. His adventure - full of math related riddles and playing cards - involved a trip from Berlin to his uncle's house in Vienna. His uncle's passion for gambling -in contrast to his love for mathematics- was well-known. Widgets were used by the designers' group to make up challenging tasks as parts of a riddle. A riddle was formed either by one task alone, or by a sequence of tasks, and the answer of each task was prerequisite for solving the next one and moving forward with the story. The plot was narrated through comic frames and text giving hints that might help the readers to solve the riddles (Fig. 1).

The group of designers consisted of three Grade-9 students in a public Experimental School in Athens (where teachers follow the same curriculum with other schools, adopting innovative teaching methods and/or conducting teaching experiments in collaboration with the University) and two teachers of mathematics. One of the teachers was the school teacher of the students and he additionally shared the role of the “participant observer”. The communication between students and teachers while making the c-book unit, took place exclusively in a shared digital Workspace. The whole process lasted almost two months. Students and teachers were exchanging ideas and widget drafts in the Workspace in order to discuss and decide their inclusion to the c-book unit. Whilst the students were akin to the use of digital media, they did not have the competence to make changes in an already designed widget, so when they wanted to suggest a modification of an existing widget, they used to “draw a picture” to inform their teachers. The 68 posts uploaded in the Workspace and the produced c-book unit constituted our data. The analysis of the collected data took place on the level of identifying and analyzing critical episodes defined as selected segments of (discourse) activity with a single theme as a focus in the discussion among the design group members in the Workspace (Kynigos & Kolovou, 2018). The focus in these episodes lies on instances that show how the storytelling affected the emergence of new mathematical meanings around co-variation.

Results

The theme of “Jewelry” was used by the teachers as a spark for the content of the c-book unit from the very first moment. As a result, one student posted in the Workspace a short story that triggered the whole group to make a decision about the main idea of the plot: The heir of a probably great but mysterious fortune. From the beginning of the discussion among students and teachers, the question “what kind of task should be constructed to be included in the c-book unit?” became the epicentre. Teachers (T1 & T2) proposed a couple of tasks, and posted them on the Workspace. The main issue for the reader was to fix a buggy-by-design diamond constructed in MaLT2 (Figure 2). The teachers’ aim was to underpin learning through tinkering. Students (S1 & S2) expressed a discontent, saying that this could be boring. Instead, they made a suggestion:

- 1 S1: I think this could be a little boring. It seems better if we had riddles,
 2 not pure math problems; like an orientation game we recently played.
 3 S2: Yes! And the riddles could be connected to each other; you must solve one
 4 riddle before moving to the next, and go on with the story.

This was the designers’ first goal, to construct a ‘chain of riddles’ connected to each other in a way that the narrative would be garbled if one or more riddles remained unsolved. The teachers posted suggestions on possible twists of the narrative, including clues about riddles, as an effort to find out what a proper riddle might be for students, while students made their own suggestions. Soon, it was obvious that riddles’ selection would leave its mark on the narrative or vice versa:

- 5 S1: The uncle could have hidden a different diamond in each room at his house.
 6 Sonier should replicate the correct diamond using MaLT2. The challenging
 7 thing is that Sonier should find the correct room number, by solving an
 8 equation, or by calculating a value of a variable x (Figure 2).
 9 T2: Why is it challenging?
 10 S1: It is more difficult to make these calculations, than having a number
 11 ready to be used.

In the previous extract, S1 uses the word “variable” referring to a numeric expression (Fig. 2), maybe just because the value of x is not obvious or easy to calculate. Students made a suggestion about a riddle, where the challenge was to unlock a room, by calculating x ’s value which was the door’s ‘key’. In the next couple of days students reflected on their design, inferred with frustration that if someone solves the door’ riddle once, then he/she had no interest in reading the c-book unit again, since he/she knows the answer:

- 12 S2: The value of x must be different every time someone opens the c-book unit.
 13 T1: We could use a slider in GeoGebra.
 14 S1: T1, in which way? S2’s idea reminds me of a book I read. The story
 15 had many different endings. We could also do the same; the flow of
 16 the narrative can vary in relation to the value of the variable x .

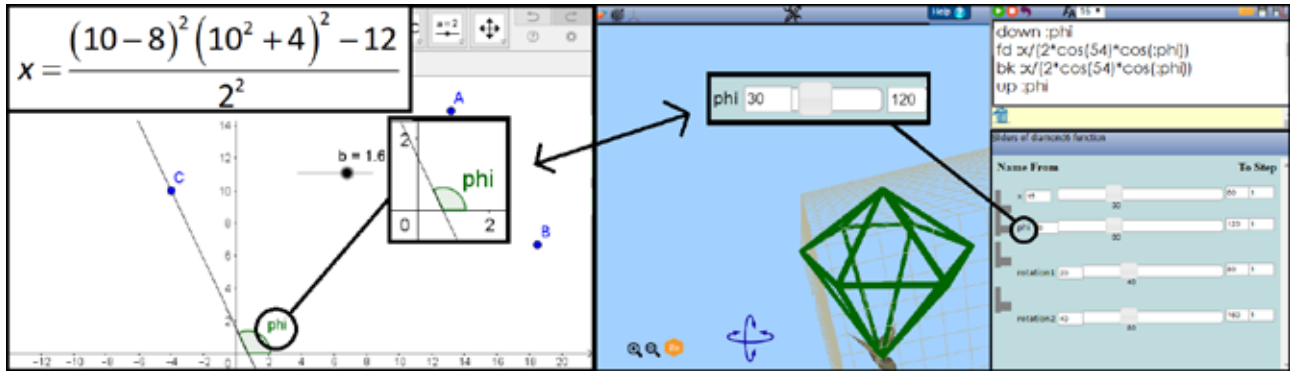


Figure 2: The GeoGebra widget-riddle on left hand side. The ‘diamond’-riddle in MaLT2 on right hand side. Designers used these artifacts in the c-book unit to form a narrative with alternate endings.

On top left hand side: the ‘x’ of line 8.

This might be considered the ultimate aim of the designers; A c-book unit that would be interesting to be read repeatedly. Soon, they realized that it was not feasible to have a different answer for the riddle every time someone opens the c-book unit. Hence, there was a shift in the group’s effort. They turned to the connection between the readers’ choices and the alternate versions of the narrative. Teachers made up a microworld that afforded the variation of a line’s position on the Cartesian plane, by the use of two sliders in GeoGebra, as a sparker for students to make a riddle. Therefore, the use of the slider came up again, as an option (Workspace):

- 17 T1: See the graph in GeoGebra. What changes when you move the sliders?
 18 S1: The position of the line.
 19 S2: We can relate the diamond’s shape that Sonier asks for, with the line.
 20 T1: To what characteristic of the line?
 21 S2: The sliders change the angle between the line and x-axis. We could imply
 22 through the narrative that this angle should be equal to diamond’s angle.

It seems that the designers came up with the idea of using the notion of angle as an element that would give a potential relation between two riddles. Thus, students made up a story in GeoGebra as the first riddle. There was a map of Vienna on a Cartesian plane with a line on it. The position of the line was determined by two sliders. The reader should put the line in a position of his/her choice, in order to make a path. Then, using the size of the angle between the line and x axis in degrees, as a hint, the reader should fix the buggy diamond in MaLT2 (Fig. 2) that had been proposed by the teachers at the beginning; this was the second riddle. The twist of the narrative was depended on the diamond that was constructed, since its shape was crucial for the storyline. It seems that the designers used the answer of the first riddle as an output magnitude necessary for solving the second one. When the content (microworlds and narrative) was ready to be used, students suggested making a trial on how it works focusing on the use of constructions:

- 23 S1: We should play a couple of times, maybe more, to see how it works.
 24 S2: Yes, we should draw a line that changes smoothly and normally in order to
 25 coordinate its angle with the angle of the diamond.

So, the students tested the two microworlds many times, to observe if the variation of the line's position in GeoGebra had an elegant effect on the diamond's shape in MaLT2, through the common angle measure. Finally, they decided to use the same name 'phi' as the name of the variable for both the diamond's angle in MaLT2 and the angle in GeoGebra, too (the angles mentioned in line 25).

Discussion

For the analysis of the Jewelry's design, under the lens of DA we have distinguished four phases. In the first phase, although they shared the same class of situation, i.e. to design a c-book-unit, students and teachers seemed to have their own separate agendas. Teachers suggested an instance with a buggy-by-design figure of diamond in MaLT2 which mostly promoted the added value of learning mathematics through tinkering, while students overrated the amusement of the reader. Furthermore, students at first almost rejected the microworld as 'pure mathematics' (line 2), suggesting to use riddles 'like in a game they recently played' instead of mathematical problems. This reaction may be in line with the hypothesis that students' set of resources was mostly related to storytelling, than to the design of mathematical tasks. This became more evident in the second phase, where the designers tried to make up riddles linked to each other, which probably is a good description of the new class of situation for the group. Despite the consensus on that, there was no common understanding of what kind of riddles should be used. Students made up an intriguing story about hidden diamonds in locked rooms, trying in the same time to involve a variable x as the 'key number' to unlock the door. We assume that they made an effort to use resources with mathematical content, such as a narrative based on the use of a variable, representing it with x (line 8). However, this effort was fruitless, since they did not manage to operate the variation of x . In the sense of co-variational thinking, the dysfunctional use of x seems to be congruent to Thompson's view (2002); although a person operates successfully on algebraic representations, it is hard to talk about the represented relationship. In the third phase, the aim of the design was more apparent. The riddles should be constructed in a way to provoke the reader to read the c-book-unit many times, which as a class of situation was more specific. To construct this kind of riddles, teachers proposed an instance in GeoGebra where a line changed position through the use of sliders (line 13). The core idea was to relate each time the 'key number' of the locked door to a different position of the line; Unfortunately, this did not work. It seems that the relation between sliders' manipulation and the line's changing position was not a usable case of co-variation for the students, since the varying attributes of the line might not be clear in the momentary states of its variation (Thompson, 2002). Using this kind of instance as a design unit might not be feasible for the students according to their scheme of use for their set of resources. However, students made a contribution which determined the final product, the c-book-unit as a 'document'. They proposed that the c-book-unit should have alternate endings, in order to be provoking. This idea, came up from a resource related with storytelling, (i.e. a book read by S1, line 14), and was soon adapted by the rest of the designers as the main goal of their efforts, during the fourth phase. Therefore, the role of instances-riddles was to give to the narrative the characteristic of different twists of the plot. To achieve this goal students and teachers used the instance in GeoGebra, along with buggy diamond in MaLT2, trying to 'link' them. Thus, it seems that they conceptualized this linking as a situation of two objects (the diamond and the line) varying simultaneously and dynamically. This became clearer, when students tried to coordinate the manipulation of the line in GeoGebra with the

diamond in MaLT2 (lines 23-25), so that a move of the sliders in GeoGebra should correspond to an ‘elegant’ and ‘normal’ change of shape of the diamond. This action seems to be in line with Thompson’s (2002) view of co-variation that points out the importance of coordinating actions among two attributes with an ‘operative image’ of their co-variation so that one can act out how the two are related. In phase four, students’ goal was to conceptualize and define a ‘co-variational relationship’ between two attributes; the position of the line in GeoGebra and the diamond’s shape in MaLT2. It seems that students, by making use of the two sliders that represented angles’ measures (one related to the line and another related to the diamond), they envisioned these two attributes’ momentary states varying simultaneously (lines 17-22). Thus, they decided to use a common variable ‘phi’ related with both angles as an operative image of the co-variation between line’s position and diamond’s shape, linking the two riddles. According to Johnson, McClintock, Hornbein, Gardner and Grieser (2017) students are facing fewer difficulties to discern co-variation among quantities (in the sense of Thompson) that can be measured with linear units. Building on this position, we assume that, in our case, students employed such a quantity ‘phi’ (that represented an angle’s measure) to define and use a ‘co-variational relationship’ among two objects/attributes (the position of the line and the shape of the diamond) that could not directly be measured.

Conclusions

In this study, the focus was on the role of students as co-designers of a digital medium, a c-book-unit, i.e. a digital narrative blended with tasks and constructions with mathematical content. We used the DA theory to understand in detail the way new meaning around co-variation during the design process emerged. During the four phases of the design process the students’ set of resources and their scheme of use seemed to be in flux. In the beginning, the use of resources had mostly to do with storytelling. This changed progressively, and in the last phase a combination of narrative with mathematical resources was used. It was in this phase when, according to our analysis, students made meanings around the concept of co-variation, while ‘building’ a relationship for the needs of the storyline. It is remarkable that, after building this relationship, students tried to attune the mathematical content to the narrative, referring to the line in GeoGebra, as a path on a map. It seemed that initially, the differentiation between students’ and teachers’ resources and their schemes of use, worked as a barrier to the design process. However, from the analysis of the ‘document’ is evident that when resources were related to both narration and available mathematical tools, this led to the emergence of new meanings. From this point of view, it seems that when students act as designers using this kind of media, they take the role of both the storyteller and learner. Given the lack of research in this field, we believe that such enquiries should come up, assuming that these two roles -of storyteller and learner- should not be seen as separated, since the interaction between different kinds of resources was crucial for the design as a learning process.

References

- Brennan, K. (2015). Objects to think with. *Constructivist Foundations*, 10(3), 313–314.
- Gueudet, G. & Trouche, L. (2009). Towards new documentation systems for mathematics teachers? *Educational Studies in Mathematics*, 71(3), 199–218.

- Guin, D. & Trouche, L. (1999). The complex process of converting tools into mathematical instruments: The case of calculators. *The International Journal of Computers for Mathematical Learning*, 6(2), 143–165 .
- Healy, L. & Kynigos, C. (2010). Charting the microworld territory over time: design and construction in mathematics education. *ZDM Mathematics Education*, 42(1), 63–76.
- Johnson, H. L., McClintock, E., Hornbein, P., Gardner, A. & Grieser, D. (2017). When a critical aspect is a conception: Using multiple theories to design dynamic computer environments and task to promote secondary students' discernment of co-variation. In T. Dooley, & G. Gueudet (Ed.), *Proceeding of the 10th Congress of European Research in Mathematics Education* (pp. 2738–2745). Dublin, Ireland: DCU Institute of Education & ERME.
- Johnson, H. L., Coles, A. & Clarke, D. (2017). Mathematical tasks and the student: navigating “tensions of intentions” between designers, teachers, and students. *ZDM Mathematics Education*, 49, 813–822.
- Kynigos, C. (2015a). Constructionism: Theory of Learning or Theory of Design? In S. J. Cho (Ed.), *Selected Regular Lectures from the 12th International Congress on Mathematical Education* (pp. 417–438). Cham, Switzerland: Springer.
- Kynigos, C. (2015b). Designing Constructionist E-Books: New Mediations for Creative Mathematical Thinking? *Constructivist Foundations*, 10(3), 305–313.
- Kynigos, C. & Kolovou, A. (2018). Teachers as designers of digital educational resources for creative mathematical thinking. In L. Fan, L. Trouche, C. Qi, S. Rezat, & J. Visnovska (Eds.), *Research on Mathematics Textbooks and Teachers' Resources: Advances and issues ICME-13*. Cham, Switzerland: Springer.
- Papadopoulos, I., Diamantidis, D., & Kynigos, C. (2016). Meanings around Angle with Digital Media Designed to Support Creative Mathematical Thinking. In C. Csikos, R. A., & J. Szitanyi (Eds.), *Proceedings of the 40th Conference of the International Group for the Psychology of Mathematics Education*. 4, (pp. 35–42). Szeged, Hungary: PME.
- Papert, S. & Harel, I. (1991). Situating Constructionism. In I. Harel & S. Papert (Eds.), *Constructionism*. Norwood, NJ: Ablex Publishing.
- Thompson, P. W. (2002). Didactic objects and didactic models in radical constructivism. In K. Gravemeijer, R. Lehrer, B. v. Oers, & L. Verschaffe (Eds.), *Symbolizing and Modeling In Mathematics Education* (pp. 191–212). Dordrecht, The Netherlands: Kluwer.
- Thompson, P. W. & Carlson, M. P. (2017). Variation, co-variation, and functions: Foundational ways of thinking mathematically. In J. Cai (Ed.), *Compendium for research in mathematics education* (pp. 421–456). Reston, VA: National Council of Teachers of Mathematics.

Addressing the problem of digital tools with digital methods

Jonas Dreyøe

Aalborg University, Department of learning and Philosophy, jmd@learning.aau.dk

Keywords: Digital tools, wicked problem, capacity building, data handling, digital methods.

Introduction

This poster presents a research design on how mathematics teachers can be involved in creating a shared understanding of their declared intentions and practices with digital tools in their mathematics teaching. The context of this poster is an ongoing PhD project with two strands. On one hand it aims to investigate and map the reasoning for mathematics teachers' use or non-use of digital tools (CAS, Spreadsheets, Dynamic geometry) in their practice. On the other hand, it aims to explore a method of high practitioner participation with data and digital methods. The project's research question is: How can the utilization of the workshop format inspired by participatory data design involve mathematics teachers in creating a shared understanding of their declared intentions and practices with digital tools in their mathematics teaching?

Digital tools in mathematics teaching as a wicked problem

Digital tools heavily influence mathematics teaching on many levels. The presence of tools amounts to a more complex teaching situation, because the tools themselves affect the teaching (Tabach, 2013). On one hand the process of learning mathematics is different when the tools are used because they transform mathematical actions and goals. These transformations can certainly amount to new ways of learning mathematics, they also cause a series of problems and difficulties as the key mathematical operations can be accomplished without the students understanding the underlying mathematical processes (Jankvist & Misfeldt, 2015).

In this way, digital tools can amount to barriers in learning mathematics as a metacognitive shift towards the tool can occur instead of focusing on the mathematical concepts in question. On the other hand, it is also known that digital tools can increase children's mathematical horizon and competence. The mathematics teacher is thus situated in a dilemma; if digital tools are included without critique/blindly it can lead to learning difficulties. If they are not included the students' mathematical competence can be subverted. The usage of digital tools, that is the object of inquiry, in the Danish primary and lower secondary school can by this be viewed as a *wicked problem* – a problem, which does not have a single solution, but only more or less appropriate solutions. To handle a wicked problem, it is needed to create a shared understanding of the problem and consider concrete dilemmas (Rittel, 1972). Pedagogical research highlights collaboration as a valuable impetus for professional development of teachers. The aim of this project is to support capacity building of teachers by teacher collaboration and dialogue concerning their didactical practices and intentions with digital tools.

Addressing and understanding the wicked problem by using digital methods

Collaboration and discussions among teachers can be improved and qualified if data about teaching and learning is included. It is especially recommended by the learning analytics field, which has shown that data can be utilized in facilitating well-informed decision-making processes. This project

thus aims at developing an approach where the collection and visualization of data is utilized to qualify teacher collaboration. Currently, there are different approaches to use data in supporting teacher work such as databased best-practice, as Hattie's visible learning project is an example of and using data to inform local development in improving professional judgment which Qvortrup's project about professional judgment is an example of. I aim to involve teachers even more in the handling of data. In facilitating such a process, I take my point of departure in Participatory Data Design, which involves stakeholders in the development and structuring of data that are used to describe, valuate, guide and develop the stakeholders' own work (Jensen et al., 2017).

	Provisioning	Selecting data	Visualizing data	Interpreting	Implementation
Participatory Data Design (Jensen et al., 2017)	E	P	P	P	P
Datainformed local change (Qvortrup et al., 2017)	E	E	E	P	P
Databased best-practice (Hattie, 2009)	E	E	E	E	P

Practitioner participation in data handling; E = only Experts, P = Practitioners involved

Handling of data in research projects can be described to work in five iterative phases. 1) A provisioning of data which entails in, figuring out what data is possible to obtain and cleaning the data for the intended use 2) Selecting the appropriate data for the concrete research purpose. 3) Visualization of the data to be able to see patterns. 4) Interpreting the data and visualizations at hand. 5) Implementing the decisions from the interpretations into practice. I propose a model to depict practitioner participation in data handling, where I have placed the three different approaches.

The ongoing PhD project will thus involve practitioners in as many phases as possible in data handling. And thus, provides a frame for investigating their declared intentions and practices in a way that both support data from their own classrooms as well as more generic data. This data will be interpreted and visualized in workshops with teachers, researchers and data-visualization experts collaborating. In this collaboration they will investigate the problem of digital tools in small groups and propose answers to why teachers would choose to use or not-use digital technology. These answers will inform the mapping of declared intentions and practices of teachers using technology.

References

- Jankvist, U. T., & Misfeldt, M. (2015). CAS-induced difficulties in learning Mathematics. *For the Learning of Mathematics*, 35(6), 15-20.
- Jensen, T. E., Madsen, A. K., Misfeldt, M., Munk, A. K., & Tamborg, A. L. (2017). *Participatorisk Data Design: En ressource for Capacity Building*. In H. K. Krogstrup (ed.), *Samskabelse og Capacity Building i den offentlige sektor* (p. 171-195). Hans Reitzel.
- Rittel, H. (1972). *On the planning crisis: systems analysis of the "first and second generations"*. Reprint. Nr. 107, Berkeley: Institute of Urban and Regional Development, University of California
- Tabach, M. (2013). Developing a General Framework for Instrumental Orchestration. In: *The Eighth Congress of the European Society for Research in Mathematics Education*. CERME 8. 2744-2753.

The forgotten technology. Teachers use of mini white-boards to engage students

Thomas F. Eidissen¹, Karen Bjerkeli², and Ove Gunnar Drageset³

¹UiT, The Arctic University of Norway, Norway; thomas.f.eidissen@uit.no

²Norwegian University of Science and Technology, Norway; karen.bjerkli@gmail.com

³UiT, The Arctic University of Norway, Norway; ove.gunnar.drageset@uit.no

Keywords: Classroom techniques, discussion, learner engagement, peer teaching, problem-based learning.

This day and age, the focus in education is for the most part on how we can use technology to make it easier for children to learn. While there is a lot of amazing technology that aims at this, we want to make the case that we should not throw away all the tools that are not part of the new wave. This poster focuses on the use of mini white-boards to engage students in their learning of mathematics. There might be things to learn from this forgotten technology when designing and implementing new technology into mathematics. This project arose from observations of an exceptionally talented teacher. The observation focused primarily on discourse, structure, and tools used. We were intrigued by the way this relatively young teacher utilized an old tool in the lessons to a seemingly great effect.

The structured use of mini white-boards

Gathering the students

The teacher gathered the students around the Smartboard at the beginning of the class. Here, the students sit tightly together on benches without desks, where they spend most of a typical lesson. The teacher uses a PowerPoint presentation on the Smartboard, where definitions, assignments, videos, and students answer to homework assignments are presented for discussion. A main tool in these gatherings was the mini white-board, where they solved tasks and shared methods and thoughts. Hiebert & Grouws (2007) writes that the way a teacher chooses to organize their students, and in what way time is prioritized, plays a role in the students' opportunity to learn. By gathering the students around the Smartboard, the teacher signals that conversation is a priority. According to Lee (2006), such organizing will make the students more included in the conversation and increases the probability of conversation. By using a substantial part of the lesson for a gathering, the teacher prioritizes conversation and sharing of methods.

The mini white-boards

This mini white-board was a simple A4 sized white-board, which the students were handed at the beginning of the lesson. The students were given one to three minutes to solve the different tasks the teacher presented on the Smartboard. For example, the students could be asked to find the volume of different figures shown on the Smartboard, where the solution method was the teacher's primary goal. The teacher made it clear to the students that they had to write down their answers and how they came by them. They could also be asked to write their own definition of mathematical terms or more open tasks such as drawing three-dimensional shapes. Whichever task the students were given, the white-

boards gave them the opportunity to work by themselves for a short time, which in turn gave them the time to consider the given task. This method is henceforth called *individual work time*. The typical tasks were to do calculations, write definitions and draw explanations.

In one instance, the teacher told the students to write the answer right after the task was given, for then to show their answer to the rest of the group immediately. This direct approach makes the students give an answer fast, without time to think and without checking it against other students' answers. Making this approach is what Wiliam (2007) calls an *all-student response system*, as opposed to a *single student response system*, which gives the teacher an overview over which of the students got it right and which did not. This method is henceforth called *direct use* and might be used to fast check fluency and understanding of concepts.

After *individual time* and *direct use*, the white-boards were used in three different ways, which all started with the students showing their solutions or explanations. One way was to ask a student to explain their own method. A second way was to ask a student to explain another student's method. A third way was that the teacher selected a solution and explained the method. All this means that the teacher orchestrated the conversation by selecting student work and then constantly probing and pressing for information. The result is a practice with a strong focus on sharing and understanding student thinking.

Individual use		Plenary use		
Work time	Direct use	Students explain their own method	Students explain another's method	The teacher explains a student's method

Table 1: The use of mini white-boards

The way forward

This work is part of a project (SUM) which purpose is to look at how inquiry-based learning can contribute to coherence in the students' motivation for and learning of mathematics at the transitions in the system of mathematics education. By utilizing these mini white-boards together with tasks where there is more time for inquiry, maybe we can involve the students more fully in the tasks given in the lessons in SUM. The findings in this poster will be used together with teachers to take a closer look at how this forgotten technology can help improve learning and understanding in mathematics. In addition, we have a long-term goal of using the insights from this forgotten technology to make our mathematics teaching with ICT more productive.

References

- Hiebert, J., & Grouws, D. A. (2007). *The effects of classroom mathematics teaching on students' learning*. In F. K. Lester, Jr. (Ed.), *Second handbook of research on mathematics teaching and learning: Vol. 1* (pp. 371- 404). Charlotte, N.C: Information Age.
- Lee, C. (2006). *Language for Learning Mathematics: Assessment for Learning in Practice*. Berkshire: Berkshire, GBR: Open University Press.
- Wiliam, D. (2007). *Keeping learning on track*. In F. K. Lester, Jr. (Ed.), *Second handbook of research on mathematics teaching and learning: Vol. 1* (pp. 1053- 1098). Charlotte, N.C: Information Age.

Investigating similar triangles using student-produced videos

Anders Støle Fidje¹ and Ingvald Erfjord¹

¹University of Agder, Faculty of Engineering and Science, Kristiansand, Norway;
anders.s.fidje@uia.no; ingvald.erfjord@uia.no

The task of eliciting student talk in mathematics teaching can be daunting for teachers. An approach to this is using student work actively in teaching. In this paper, the teacher moves in a lower secondary full class discussion regarding similar triangles is investigated. The results show that the teacher utilised different teacher moves to steer the discussion towards both didactical and mathematical goals.

Keywords: Student-produced videos, inquiry-based teaching, mathematical discussions

Introduction

The DIM-project (Digital Interactive Mathematics Teaching) is a developmental research project exploring the use of digital tools in three lower secondary mathematics classrooms in Norway. One such innovation is the use of student-produced videos (later termed SPVs) as a medium for presenting strategies related to inquiry-based tasks. This idea emerged from the teachers as they wanted to explore different uses of videos in teaching, both teacher- and student-produced. The three-part lesson sequence used in the analysed lesson was developed by both teachers and researchers in a workshop. The aim for both teachers and researchers was to develop an approach for eliciting student talk in full-class mathematics discussions.

The transcripts originated from a follow-up discussion related to similar triangles and the use of this idea to measure the heights of objects, the task and lesson sequence is presented in detail in the methodology section. While planning the discussion, the teacher viewed SPVs to identify aspects of interest in the students' work. The teacher also used videos while enacting the discussion. As such, the paper addresses the topic of using student thinking in mathematics teaching. The paper aims to characterise how the teacher used the SPVs in teaching to promote students' active engagement in a full-class discussion. Our analysis is based solely on video recordings of the teaching, as the authors sought to investigate how looking through the lens of teacher moves can inform how the teacher is positioning the students in the discussion.

Key concepts

Research has demonstrated that effective instructional practices demand students' mathematical talk (Walshaw & Anthony, 2008). To achieve this, teachers need approaches to elicit students' thinking and promote mathematical discussion. An area of interest for the teachers and researchers in the DIM-project is to foster what Goos defines as a community of inquiry; a classroom "...where students learn to talk and work mathematically by participating in mathematical discussions and solving new or unfamiliar problems" (Goos, 2004, p. 259). This moves beyond being mathematically correct as the students are "...expected to propose and defend mathematical ideas and conjectures and to respond thoughtfully to the mathematical arguments of their peers" (Goos, 2004, p. 259). An approach to studying such discussions is analysing the moves used by the teacher

to facilitate students' active engagement. Krussel, Edwards and Springer define a teacher move as "a deliberate action taken by a teacher to participate in or influence the discourse in the mathematics classroom" (Krussel, Edwards, & Springer, 2004, p. 309). In the following paragraphs, we introduce frameworks of teacher moves and actions used as guidance for the research presented in this paper.

Scherrer (2013) classifies twelve types of moves to investigate teaching practices in relation to theoretical notions of effective teaching. Scoring guidelines are used to code and evaluate the effectiveness of teachers' discussions, where each move is scored according to the surrounding moves. In this framework, the teacher moves that are prompted by student thinking generally receive positive scores. Scherrer refers to five such teacher moves, categorised as rejoinders, used to elicit and use student thinking rather than evaluate it. The moves categorised as rejoinders are uptake, collect, connect, lot and repeat. Uptake is an open-ended question that invites student thinking while using a student response to extend, clarify, or elaborate the discussion. Collect is a move aiming to provide different student responses to the same question. Connect is a question related to different responses and how they may be connected. Lot are occurrences where the teacher acknowledges a student's response and indicates that the topic will be revisited in the future. Repeat is a move related to echoing a student's response.

Mueller, Yankelewitz, and Maher (2014) perceive teacher interventions as crucial to introduce the students to the mathematical discourse. The authors state that "[t]houghtful interventions, implemented according to students' developing ideas, allow students to take ownership of their learning and solutions" (Mueller et al., 2014, p. 2). In order to investigate teacher moves, they present three categories which encompass student thinking; making ideas public, eliciting student ideas, and encouraging justification and explanations. In this paper, we use these categories as an initial coding scheme for the interactions. We expand the categories to incorporate the elements needed to investigate the use of SPVs to promote a community of mathematical inquiry.

We view the investigated episodes to involve a *didactical performance* in accordance with how the term is outlined in the framework of instrumental orchestration (Drijvers, Doorman, Boon, Reed, & Gravemeijer, 2010). This performance is the ad-hoc decisions made by the teacher within the orchestration. Teacher moves can be planned, but they also involve some aspect of improvisation from the teacher, as the teacher must manage the feedback provided by the students. The teacher's moves are related to specific didactical intentions. Such intentions are typically implicit rather than explicit. As such, the didactical intentions referenced in this paper are deduced by the authors based on observed patterns in the data. The teacher moves are integral in this process as they are used by the teacher to benefit the didactical intentions. In the transcripts analysed for this paper, the teacher is asking the students to explain why a solution "makes sense". Thus, the perceived didactical intention is "a discussion using a SPV to validate a strategy for solving similar triangles problems".

Methodology

The lesson analysed for this paper was number two of in all four lessons the teacher enacted using SPVs in plenary discussions over a six-month period. Four lessons were video recorded from three

different teachers' classrooms totalling twelve lessons of about 45 minutes. All these lessons utilised a fixed three-part sequence. Part one is a group investigation of an inquiry-based task in school (see an example of such a task below). Part two is to present the work of the group in a video, this serves as homework, and every student produces one video and sends it to the teacher. Part three is a full class discussion related to the topic investigated in part one and two. The discussion is based on the presentations in the SPVs, and the teacher watches all the videos while planning the full class discussion. The transcripts used in this paper is from one such discussion. One of the aims of this paper is to pilot an analytical approach to investigate the discourse in these discussions. As such, one lesson was selected at random and analysed for this paper. The process of selecting a lesson was done by double-clicking a random folder.

23 tenth grade students and one teacher attended the 43-minute lesson analysed for this paper. The mathematical topic was similar triangles, and the lesson was a follow-up discussion at the end of this topic. One of the teachers in the DIM-project designed the task below after a brainstorming session at a workshop where both teachers and researchers attended.

The task investigated and solved in the SPVs was (the authors' translation from Norwegian):

Look at the drawing (Figure 1). There is a mark on the wall (green dot). Nils has placed a mirror in front of him and placed himself so that he sees the mark in the mirror.

He can measure the following lengths; from the ground to his eyes, from himself to the mirror, and from the mirror to the wall. Can he, by using these measurements, find the final measure (from the ground to the green dot)?

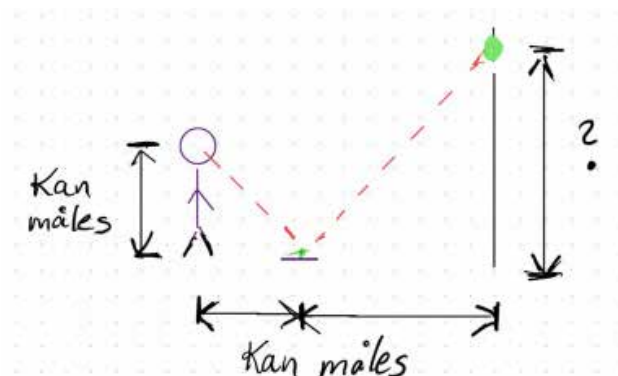


Figure 1: Drawing provided to the students (“Kan måles” translates to “Can be measured”)

Record a video where you show your measurements and explain how you can find the height of the building. Also, show generally how you can find the sides of similar figures if you know measurements of some of the sides. Maximum 5 minutes.

Data was collected using a video camera. The SPVs and the google presentation used in the lesson were shared with the first author before the lesson. The data was transcribed and translated by the first author.

The data was analysed using the approach presented in Powell, Francisco, and Maher (2003, p. 413). The authors perceive the process of analysis in seven non-linear phases (comments related to

our process in brackets); Viewing attentively the video data, describing the video data (data reduction), identifying critical events (identifying instructional episodes where student thinking is central), transcribing (selected episodes of interest for the topic of this paper), coding (using the codes presented in this paper and constructing new codes if needed), constructing storyline (looking at the context of the code), and composing a narrative.

The transcripts presented in this paper are from one specific episode within the lesson. The notion of an episode is to be understood as a sequence within a lesson related to a specific goal, with a specific didactical intent. There were six episodes in the lesson. The time-span of the episodes were from three to ten minutes. The episodes with titles indicating the content were:

1. Discussion related to misconceptions and issues identified in the SPVs
2. Introduction to figures often used in similar triangle problems
3. Discussion related to validating a strategy for solving similar triangles problems
4. Discussion related to validating a similar strategy for solving similar triangles problems
5. Discussion related to a different strategy for solving similar triangles
6. Discussion related to solving similar triangle problems using GeoGebra

The third episode was selected to be analysed for this paper based on; a SPV being shown in the episode, the narrative being constructed by both teacher and students, and being an episode of length fitting for the page constraints of this paper. The episode is mainly a conversation between the teacher and one student (Harald). The transcript also presents the narrative from the video (SPV) as it is central to the dialogue which emerges. Additional information is in square brackets. (..) is used to indicate a short pause in the narrative.

Results and analysis

At the start of the lesson, the teacher elaborated on two issues emerging from the videos. The first issue was the definition of similar triangles, as some students stressed that all the angles *and* the shape had to be the same, not recognising that they are the same criteria. The second issue was a lack of explanation of why the two triangles used to solve the task were similar. This issue can be identified in the transcript below, from Svein's video.

SPV (Svein): Okay, if we have (..) for example (..) two triangles and all the angles are the same, and they have the same shape. They do not necessarily need to have the same size, but (..) We can see that all the angles are the same in both figures. Therefore, these are similar. Okay, we measured from the feet to the eyes.

Teacher: And the measurements are here [pointing to the measurements on the screen].

SPV (Svein): It was 165 cm, and from the feet to the mirror, which is from here to here [points with the mouse on the video], it was 178 cm. And (..) we want to find the ratio between these, so we divide (..) 165 by 178 and get 0,926966 and so on. And then we measure from the mirror, which was here (..) to the church [points with the mouse on the video], because we wanted to find the height of the church. Eh (..) and we got 1448 cm. Eh (..) then we calculated 1448 times 0,9269 and so on. And

we got 1342,247 cm. And that is 13,42 m. So, from the church (..) up to here [points to the top of the church in their figure] it is about 13,42 m.

Teacher: And we will stop Svein there. Eh (..) we will look further later with. That is good. If you look at the drawing here, (..) the height of Svein or Harald, I do not know who is measuring, it is 165 from the ground to the eyes. And from the ground to the mirror it is 178 cm, and 1448 from the mirror to the church. And then he calculates that the church wall is 1342 cm or 13,42 m. My question to you; does this make sense?

The transcript above illustrates how the teacher guides the students towards his didactical intent. It appears as if the purpose for showing the video was an introduction to the task and one approach to solve it. The teacher interacts with the video to highlight the measurements used in the calculation, adding emphasis to the presentation in the video. We consider this a parallel to a pushback rejoinder move, to add emphasis to important aspects of the presentation through intervention. Pushback is usually done through a question, as in “could you point to the measurement?”. However, as the presentation is through a pre-produced video, the teacher elects to point to the measurements himself. It appears as if the objective is to make students reflect on how to validate that the strategy works; if this calculation makes sense. This is to be explored through a discussion, hence the didactical intent appears to be a discussion using a SPV to validate a strategy for solving similar triangles problems.

The teacher sets the scene to further the student’s presentation, all the while emphasising that this is the student’s work. Furthermore, it is not clear from the context of the question what kind of validation the teacher wants, as such; the request is an open-ended Uptake. As the question is also directly related to student thinking (presented in the video), the teacher is requesting the students to make their ideas public. In the following transcript, the teacher further establishes what such a validation entail.

Student: Yes.

Teacher: Why does it make sense?

Student: Because the church is about 13 meters.

Teacher: You know that, but I did not know that. But why does it make sense? It could be about 14 m. Why does it make sense? [awaits response]. If they had done it like this, divided 178 by 165, and found another solution. They chose to do 165 divided by 178, but if they had changed these numbers they would have gotten 1,079. And if they had taken the length to the church [14,48] and multiplied by 1,079 the answer would be (..) eh (..) they would have [looks in his notes]. I have not calculated it, but they would have about 1500. That is another answer. Why is one of them correct? You need to know the height [of the church] to say that it is 13 m. Harald, why does what you did make sense?

In this section, the teacher's idea of a validation becomes clearer. It would appear as if, in his view, the validation should result from the information at hand, not from prior knowledge. This might explain the decision to repeat the measurements from the students' work in the prior section, and not to go into detail about the calculations they used. Such negotiation of what the argumentation should entail is important in understanding what mathematical discourse is (Cazden, 2001). The teacher's statements exemplify the complex relationship between the planned teacher moves and the didactical performance of the teacher, used to bring the discussion towards a validation. At first, there is a rebuttal; the student knows that the church is about 13 meters, but this is not the kind of validation the teacher expects. This move must be ad-hoc as the teacher did not know the student's validation strategy before the question was asked. As the reinitiation of the original uptake is left unanswered, the teacher provides a starting point towards a validation, by changing the ratio and finding an alternative solution. The level of planning in this "thinking aloud" move is unclear, but one would assume that this is a pre-planned move being enacted. In this process, the teacher is limiting the cognitive demands from the initial "find a strategy to validate this calculation" to "find a strategy to determine which calculation is correct". The initial request to make ideas public is limited to following through with the specific strategy initiated by the teacher, by encouraging an explanation from one of the students with ownership of the work. The following extract shows the reply from Harald and the teacher's response.

- Harald: Because, if you divide 165 by 178 you get 0,9 and so on, (..) and if you multiply that by 178 you get the height of the person. But if you had divided the opposite way, and multiplied 178 by 1,078, you would have 180 and so on. That is not the height we measured. So, we have the ratio between the bottom and the height. Then we can multiply with the other height to find the height [of the church].
- Teacher: I will repeat what I perceive he said. He divided this by this [points to the ratio calculation] and got 0,9. And then he is saying that if you use that number, the bottom [178], and multiply by 0,9 you get 1,65. And then I understand you said that if you then take the other bottom and multiply by 0,9 you get this [points to the church height]. Did I understand you correctly?
- Harald: Yes.

In this exchange, the teacher obtains what appears to be a satisfactory validation in his view and confirms this through his comments. The teacher's moves are interesting, as the aim of the initial and follow-up moves was to get the validation. However, the rephrasing from the teacher does not stress the validation presented by the student. The student explained that the ratio calculated by the teacher would provide the wrong height for the person. As such, the ratio used by the group must be the right calculation in this situation, as it provides the correct height of the person. The teacher's rephrasing is mostly related to the overall strategy used and does not highlight the validation, *why* it provides the correct solution. This may be regarded as a missed opportunity to zoom out of the computational perspective and connect the task to the general proportional relationship, which underpins similar

triangles problems. While the teacher does acknowledge the backwards calculation to get the height of the person, it is not clear from the extract that this is the student's validation of the strategy.

Teacher: So, we must think about which numbers to multiply. Not just choose freely. But, there is also something logically correct with these numbers. Can you look at the numbers, why is it logically correct? You can keep going Harald.

Harald: Because the height is less than the bottom.

Teacher: Yes, do you see that the height is a bit smaller than the bottom here? [points to the smaller triangle]. Then it makes sense that this [points to the church's height] is a bit smaller than here (..) to the church [from the mirror to the church]. So it makes sense. Okey, now there is some red text [in the teacher's notes]. You get two minutes to write. What was Svein and Harald's strategy?

The student's affirmation regarding the teachers rephrasing is followed by two statements, or "words of warning", to conclude Harald's validation. The statement "...think about which numbers to multiply" is the key to the deduced goal of the episode, to validate why the initial strategy worked. The student's idea of backwards calculation showed this, but as the teacher did not highlight this during his rephrasing, it might get lost on the students. Rather than generalising or expanding the idea, the teacher moves on to another strategy, by relating the question directly towards the measurements and visual information. It appears as if this is what the teacher was working towards the entire episode. Evidence of this is the emphasis on measurements at the start of the episode, and the need to introduce two approaches to validate the strategy provided in the SPV.

Concluding remarks

To encourage students' active engagement in mathematical discourse is instrumental in establishing a community of mathematical inquiry. In the transcripts provided, the process of negotiating what a validation entail is directly related to student work. By addressing the students and narrowing the initial uptake to steer the discussion towards the goal, the teacher appears to get a satisfactory validation. Still, the analysis illustrates the need to dig deeper than codes, exemplified by the teacher's rephrasing of Harald's idea of backwards calculation. The teacher validates the student's response. However, he de-emphasises what we perceive to be an important contribution to the discussion. Furthermore, the teacher keeps a computational perspective throughout the episode, not zooming out to connect the discussion (and initial task) to the concept of similar triangles in general. To account for such instances, we emphasise the need to analyse transcripts qualitatively as oppose to quantitatively to understand the potential of the moves throughout the discussion fully.

The three-part sequence presented in this paper might unlock possibilities for more active engagement from the students. More work is needed to understand the potential of this model. In future work, we aim to incorporate the teacher's perspective and to investigate the design process of the individual teachers in the main study. We made a conscious decision to only use the video recordings as data for the analysis in this paper as one of the aims was to investigate the potential of using the lens of teacher moves to analyse mathematical discussions. The analysis showed that the teacher utilised teacher moves to steer the discussion towards the didactical intent, and the goal of

the episode. In the future, we hope to contribute to the understanding of both the intention and impact of teacher moves in a classroom discussion.

In the context of the Norwegian school system, digital tools are on the rise. Such tools are integral in the framework presented in this paper. Throughout the discussion, the teacher utilised the interactive blackboard in varying ways. To play videos, pause at desirable moments and show actual student work are integral elements in the design of the lesson. These elements enable the teacher to use students' own voices extensively throughout. However, the implementation of such ideas does require a lot from the teacher. In the analysis presented, we realise the importance of both being alert and open towards student ideas and being conscious about the goals of the episodes. The episode investigated is illustrative of this dialectic relationship. Although it would appear as if the teacher had a specific validation strategy in mind when the episode starts, he does not avert from Harald's strategy of backwards calculation. Not only does he confirm that the student's idea is usable to validate the strategy, he also repeats the idea while acknowledging that this is the student's work and not his own.

References

- Cazden, C. B. (2001). *Classroom Discourse: The Language of Teaching and Learning*. Portsmouth: Heinemann.
- Drijvers, P., Doorman, M., Boon, P., Reed, H., & Gravemeijer, K. (2010). The teacher and the tool: instrumental orchestrations in the technology-rich mathematics classroom. *Educational Studies in Mathematics*, 75(2), 213-234. doi:10.1007/s10649-010-9254-5
- Goos, M. (2004). Learning mathematics in a classroom community of inquiry. *Journal for Research in Mathematics Education*, 35(4), 258-291. doi:10.2307/30034810
- Krussel, L., Edwards, B., & Springer, G. (2004). The teacher's discourse moves: A framework for analyzing discourse in mathematics classrooms. *School Science and Mathematics*, 104(7), 307-312.
- Mueller, M., Yankelewitz, D., & Maher, C. (2014). Teachers promoting student mathematical reasoning. *Investigations in Mathematics Learning*, 7(2), 1-20.
- Powell, A. B., Francisco, J. M., & Maher, C. A. (2003). An analytical model for studying the development of learners' mathematical ideas and reasoning using videotape data. *The Journal of Mathematical Behavior*, 22(4), 405-435. doi:<https://doi.org/10.1016/j.jmathb.2003.09.002>
- Scherrer, J. (2013). *Investigating the relationship between "effective" teachers and theoretical notions of effective teaching: An analysis of whole-group discussions*. (Doctoral thesis), University of Pittsburgh, Pittsburgh, PA.
- Walshaw, M., & Anthony, G. (2008). The teacher's role in classroom discourse: A review of recent research into mathematics classrooms. *Review of educational research*, 78(3), 516-551.

Silent video tasks: Towards a definition

Bjarnheiður (Bea) Kristinsdóttir¹, Freyja Hreinsdóttir¹ and Zsolt Lavicza²

¹University of Iceland, School of Education, Reykjavík, Iceland; bjarnheidur@gmail.com

²Johannes Kepler University, Linz School of Education, Linz, Austria

Keywords: Silent video task, formative assessment, task design.

Introduction

This poster presents the development process of assigning silent video tasks and the criteria a video must fulfill to be eligible to be used as a silent video task. Some preliminary results regarding the use of silent video tasks in four different Icelandic upper secondary school mathematics classrooms were presented at PME42 in Umeå, Sweden and at the 5th ERME topic conference MEDA in Copenhagen, Denmark in 2018. These presentations were focused on teachers' role in assigning tasks and using technology in mathematics classrooms; teachers' expectations and experiences with using the silent video task in their classes (Kristinsdóttir et al., 2018). During the discussion at these conferences, it became clear that a more precise definition of the silent videos and the silent video tasks was needed. This poster presents results of further work towards such definitions.

Using silent video tasks in the classroom

The process of assigning a silent video task involves selecting a silent video; showing this video to the whole class; giving students the link to the video to watch as often as they want; dividing them into groups of two; and asking each group to prepare and record their voice-over for the video. The teacher acts as a facilitator, encouraging students e.g. by asking them to bear in mind that their solution might help their peers to gain access to the mathematics shown in the video. In order not to restrict this open task in any way, no list of concepts for students to address should be handed out. In case students find it hard to start recording, a suggestion for them to draft a script might be helpful.

By only assigning the task something might be gained, but to reach the full potential of the task, discussing the solutions in a follow-up lesson is key. By listening to the students' solutions, the teacher prepares a whole-group discussion for the follow-up lesson. Usually the range of solutions shows how differently students think about what is presented in the video. Either the teacher selects some solutions to show in the follow-up lesson (e.g. if there is a sequence of solutions ranging from everyday language to a more formal mathematical language) or asks students to volunteer for presenting some example solutions. The preparation involves listening for topics to address in the follow-up lesson discussions, e.g. different levels of conceptual understanding and precision in language use. After the whole group discussion, students can be asked to write about their experiences.

The goal is, on the one hand, to encourage students to engage in discussion about the mathematics shown in the video. On the other hand, the goal is to make misunderstandings and imprecise word use accessible to the teacher so that they can be discussed. In this process, students might get aware of that explaining mathematics to others can bring them to understanding it better themselves.

Potentials of the silent video tasks as a tool for formative assessment.

Improving students' learning should be at the forefront of assessment practices (Suurtamm et al., 2016). In silent video tasks, students get the opportunity to explain to others and to receive explanations from their classmates. Students' discourse is encouraged both in the process of preparing students' solutions and in a whole class discussion in the follow-up lesson (Kristinsdóttir et al., 2018).

Even in mathematics classrooms where discussion was seldom or never practiced, silent video tasks showed to be easily implemented, and students put their thoughts into words as they explained the mathematics shown in the video. In the process, they may become aware of aspects of the mathematics that they have not yet fully understood. Also, misunderstandings and imprecise word use can be addressed explicitly by the teacher with reference to the student solutions in the follow-up lesson.

After the follow up lesson, decisions about the next steps in instruction are likely to be better founded and the process could fulfil Wiliam's definition (2011, p. 43) of formative assessment. Wright et al. (2018) list six potentials that technology-based formative assessment strategies have to support learning: providing immediate feedback, encouraging discussion, providing a meaningful way to represent problems and misunderstandings, giving opportunities to use preferred strategies in new ways, help raising issues that were previously not transparent for teachers, and providing different outcomes feedback (Wright et al., 2018, p. 219) and the silent video supports all but the first one.

Requirements for videos used in silent video tasks

To be used in a silent video task, a video should be short (less than 2-3 minutes in total), with no text or sound, and show mathematics dynamically. The theme should be as clear and focused as possible (not try to squeeze in too many things) and the video should offer different descriptions, aiming at exposing the students' different levels of conceptual understanding. Some proofs without words (e.g. <https://ggbm.at/jFFERBdd>) might serve as an example but the video themes are not only restricted to proof. They can also include definitions such as the general definition of the sine and cosine functions using a unit circle (e.g. <https://ggbm.at/BfRqGSKq>) or rules like how the area of a triangle can be calculated (e.g. <https://youtu.be/xnPworcoGcM>). These ideas will be presented in the poster with additional details.

References

- Kristinsdóttir, B., Hreinsdóttir, F., & Lavicza, Z. (2018). Realizing students' ability to use technology with silent video tasks. In H.-G. Weigand, A. Clark-Wilson, A. Donevska-Todorova, E. Faggiano, N. Grønæk, & J. Trgalova (Eds.), *Proceedings of the 5th ERME topic conference MEDA* (pp. 155–162). Sept. 5-7 2018 Copenhagen, Denmark.
- Suurtamm, C., Thompson, D. R., Kim, R. Y., Moreno, L. D., Sayac, N., Schukajlow, S., Silver, E., Ufer, S., & Vos, P. (2016). *Assessment in Mathematics Education*. Springer International Publishing. https://doi.org/10.1007/978-3-319-32394-7_1
- Wiliam, D. (2011). *Embedded Formative Assessment*. Bloomington, IN: Solution Tree Press.
- Wright, D., Clark, J., & Tiplady, L. (2018). Designing for formative assessment: A toolkit for teachers. In D.R. Thompson, M. Burton, A. Cusi, & D. Wright (Eds.), *Classroom assessment in mathematics: Perspectives from around the globe* (pp. 207–228). Cham, Switzerland: Springer.

A new era of manipulatives: making your own resources with 3D printing and other technologies

Diego Lieban¹, Eva Ulbrich², Marina Menna Barreto³ and Zsolt Lavicza⁴

¹Federal Institute of Education, Science and Technology, Bento Gonçalves, Brazil;
diegolieban@yahoo.es

²Johannes Kepler University, Linz, Austria; eva.ulbrich@gmx.at

³Renert School, Calgary, Canada; marinambarreto@gmail.com

⁴Johannes Kepler University, Linz, Austria; lavicza@gmail.com

Keywords: 3D printing, manipulatives, student-centered learning.

Introduction

Understanding three-dimensional representations on a two-dimensional representation system can be challenging. It mainly means to be able to understand around a virtual dimension additionally to the representation of two dimensions. With the advent of production technologies that can quickly generate three-dimensional objects, being able to construct in three dimensions is becoming a key skill. Especially, since 3D printers have become widely available due to declining costs. Being affordable by schools, a 3D printer can help teachers to explore mathematical concepts with their students by printing their own materials. Knill and Slavkovsky (2013) claim that while models in the real world do not help much to prove mathematics, they do very much help in understanding the results of mathematics. In this poster, we intend to share with the Mathematics Education community how teachers can use 3D printing examples to trigger students' internal needs to develop mathematical proofs. In other words, through the manipulation of models students could feel the necessity to prove their observations or conjectures from their interaction with 3D printing. We feel that often students are "forced" to prove theorems that they don't have internal connections, but in this case, if students ask themselves whether or not it is sufficient to use a particular case to generalize cases they could be motivated for proving.

These daily life demands can also trigger fruitful discussions to mathematical ideas, particularly in 3D environment. Due to that, we consider the importance of sharing new approaches among teachers and exchange perspectives in how these initiatives with upcoming technologies can contribute for mathematics teaching.

3D printer at schools

The use of manipulatives in the classroom has been advocated for a long time. In his work, Post (1981) brings perspectives from Lesh, Piaget, and Dienes, who emphasize the importance in applying concrete materials with students, especially the young ones. The increasing application of 3D printing in different areas led us to discuss possibilities for using it in education settings, as creating, adapting and printing such manipulatives. Lieban et al. (2018) discuss ideas, and describe activities that make use of 3D printing in the school context. Some of the objects explored were logical games. They were developed in GeoGebra and Tinkercad, and then printed in a 3D printer.

These two resources were chosen due to their intuitive interface for educational purposes, and friendly connections with 3D printers.

Besides enhancing modeling competencies, these approaches with 3D printing can be a good opportunity to promote a student-centered learning environment. Students increase their motivation when working on activities that they create themselves (Nussbaum, 2013). In addition, moving from playing to making games, teachers and students develop skills that go beyond mathematics, like communication, creativity, collaboration and critical-thinking, the 4C's for 21st century demands.



Figure 1: Game that already exists were adapted and explored by students and teachers

Perspectives in using 3D printing

The feedback from both experiences we had using 3D printing, which includes a school in Canada and a teacher-training program in Israel, opened our minds and booster our desire to explore further this powerful tool. We are now focusing in manipulatives that foster mathematical explorations, either to facilitate spatial reasoning or to open questions and discussions from them. Our first step in that direction is to evaluate a range of materials that are already available online in collaborative platforms (e.g. Thingiverse, GeoGebra, Tinkercad, ...), and from which users can easily download a printable file. We are collecting, adapting, and testing many of these materials and evaluating their perspectives for using them in different levels of education.

Proposal

The digital poster will present some perspectives in using 3D printing for mathematics teaching in different educational levels as well as how can these physical manipulatives be integrated with other digital tools. Some examples will be shown and explained, even as printouts in 3D.

References

- Knill, O., & Slavkovsky, E. (2013). *Illustrating Mathematics using 3D Printers*. ArXiv.org
- Nussbaum, B. (2013). *Creative Intelligence: Harnessing the Power to Create, Connect, and Inspire*. Harper Collins Publishers.
- Lieban, D., Barreto, M.M., Reichenberger, S., Lavicza, Z., & Schneider, R.M. (2018). Developing Mathematical and Technological Competencies of Students Through Remodeling Games and Puzzles. In *Bridges 2018 proceedings*. Retrieved September 2, 2018, from <http://archive.bridgesmathart.org/2018/bridges2018-379.pdf>
- Post, T. (1981). The Role of Manipulative Materials in the Learning of Mathematical Concepts. In *Selected Issues in Mathematics Education*, 109–131.

Surveying teachers' conception of programming as a mathematics topic following the implementation of a new mathematics curriculum

Morten Misfeldt¹, [Attila Szabo](#)² and Ola Helenius³

¹Aalborg University, Department of Learning and Philosophy; misfeldt@learning.aau.dk

²Stockholm University, Stockholm Education Administration; attila.szabo@stockholm.se

³University of Gothenburg, National Center of Mathematics Education, ola.helenius@ncm.gu.se

In this paper, we investigate mathematics teachers' conception of the relationship between mathematics and programming. The context of the investigation is a recent curriculum reform in Sweden that makes programming a compulsory element of the national mathematics standards. Following up on an in-service training initiative, we conducted a pilot survey (N = 133) exploring – among other things – the teachers' conception of the relationship between mathematics and programming. The results suggest that the teachers, on average, feel that there is a strong, but not very strong, relationship between the two subjects. Furthermore, the results suggest that mathematics teachers are interested in working with programming but that they do not feel well prepared for taking on that task. These results are used to discuss the mathematical potential of the different ways in which compulsory programming can be introduced in schools.

Keywords: Programming, mathematics, computational thinking, curricular changes.

Introduction: Programming as a new element in compulsory school

Programming, computing, computational thinking (Wing, 2006), technology as a subject, and similar topic formulations are currently being included in the curriculum of compulsory schools in many countries. The purpose of these changes is ostensibly to support students in becoming technologically literate and able to participate in the society of the future, as well as to promote STEM careers. Different countries are taking different routes to implement this change. In Great Britain, the main idea has been to develop a computer science curriculum as a new topic, whereas other countries such as France, programming is included in the mathematics curriculum. European approaches to computing in schools differs (Vahrenhold et al., 2017) but most countries have technological skills and literacy as increasingly important objectives of K–12 teaching students, and they share the challenge of building the necessary teacher capacity (Wilson et al., 2010).

The specific relationship between mathematics and programming have been explored by scholars such as Papert (1980) and Dubinsky and Harel (1992) and we know that the potential for learning mathematics through programming depends on a number of other contextual factors (Misfeldt & Ejsing-Dunn, 2015). Investigations of the relation between programming and mathematics, have typically taken aim at the potential of using programming as a vehicle for developing mathematical competence. The current situation is almost the converse; programming is included in the national curricula and standards and mathematics, is in some cases used as a vehicle to meet that goal.

In Sweden programming became a compulsory part of mathematics (and science) in autumn 2018. Therefore, several in-service activities have been developed and were already started in spring 2018 and all three authors of this paper have been involved in the development. As part of this work, we

decided to conduct a survey of how Swedish mathematics teachers have experienced the introduction of programming as a topic in their teaching. This paper is our first report on the data from this survey¹, and we will continue by describing the Swedish situation and then go on to the theoretical understanding that underpins our work, as well as our method. In the last part of the paper, we present descriptive statistics on the teacher's conception of the relationship between mathematics and programming in his/her class. We end the paper by discussing how to implement programming in relation to mathematics in light of the presented results.

An in-service professional development program in Sweden

The structure of the Swedish national curricula of both primary and secondary mathematics (grades 1–9) as well as upper secondary school builds on certain special “central content,” such as algebra, numbers, statistics, and geometry as well as five to seven competencies (e.g. problem solving, reasoning and communication). The grading criteria mostly relate to these competencies. Programming has been included in school mathematics through the revision of the curricula, in which it is referred to in connection with the specified central content.

The Swedish National Agency of Education is responsible for the implementation of programming in grades 1–12, while Swedish schools are governed by municipalities, companies, or nonprofit organizations. The National Agency has arranged courses in programming for teachers. These courses are not related to mathematics teaching but are simply oriented towards developing the teachers' own programming competency. To attend to the didactical question of how to include programming in mathematics teaching, the National Agency also decided that specific professional development (PD) modules should be designed².

The context for the creation of these modules is that Sweden has recently carried out a large-scale PD program involving all teachers of mathematics in grades 1–9 and in upper secondary school. Boesen, Helenius and Johansson (2015), describes the program and effect and Lindvall, Helenius and Wiberg (2018) describes the program theory that was used in the initial design. Briefly, the program consists of several different PD modules that teachers may choose among. These modules were designed by researchers and teacher educators. Each part of the module follows a cycle in which teachers first study the PD material individually (60 minutes per part), then meet in groups and discuss the PD material and plan lessons together (90 minutes), after which they carry out those lessons with their regular classes (one lesson), and then again discuss the material and the lessons (60 minutes). Schools are monetarily compensated for teachers to attend two such modules, but the modules are free to use for teachers or schools that want to do more PD. As support for the implementation of programming in school mathematics, the National Agency decided that a special programming module should be designed. The first and third author of this paper were part of the

¹Since the data collection is ongoing, this paper can be regarded as a pilot study. More results and insights will be explored further in the continuing work.

²The digital material supporting the professional development program can be found here: <https://larportalen.skolverket.se/#/moduler/0-digitalisering/alla/alla>

design team. We describe the conceptual framework underlying this module below, but one interesting difficulty was that the level of programming competency among teachers was unknown. From reviewing teacher education, based simply on our background knowledge of Swedish teachers, we knew that their programming knowledge and experience were probably rather basic and probably lower the earlier in the school system that the teachers taught. However, at the time, the time frame available for the design of the module did not allow more research into this question. The future effects of such a large-scale programming reform will be interesting to follow up, and as an aid to better understand such effects, we carried out a survey among 133 teachers. The intent of this survey was to establish a knowledge base for understanding the situation among teachers now and to form a basis for further longitudinal investigations. The present paper describes the design of this survey by relating it to some of the ideas we developed when constructing the PD module and presents some preliminary survey results.

Conceptual framework and ideas about the relationship between programming and mathematics

When designing the PD module, a view of mathematics that we found helpful was the Piagetian-based work by Vergnaud, in particular his work on representations (1998). Briefly, mathematical ideas (concepts, theorems, etc.) are, on one hand, related to situations where some particular mathematics makes sense and, on the other hand, related to representations, such as language or other semiotic systems used to signify mathematical matters. Vergnaud's reasoning can be extended to programming, but here, situational phenomena are instead represented in terms of programming code. A real-world situation hence can be modelled either by programming code or by mathematical concepts. Moreover, for understanding, analyzing, or improving the code, it may often make sense to use mathematics, and conversely, if a mathematical model of a situation already exists, that can often be translated into code. This creates an interesting and quite complex dynamic among real-world situations, the world of code and the world of mathematics.

This prompted us to consider two different programming situations in relation to mathematics. Type 1 is where the programming concerns some concrete phenomenon – to take a classic example, a model of a turtle moving in some particular pattern. For type 1, mathematics is not necessarily a part of the modelling of, for example, the turtle's movements. This modelling can be done purely in programming code. Therefore, for mathematics lessons based on type 1 programming, the teacher must assume the responsibility of extracting or inserting mathematics into the lesson. Using the work of Misfeldt and Ejsing-Dunn (2015) on programming and mathematics, we described three intersecting points or potentials: (1) viewing students as producers of code; (2) supporting abstract thinking; and (3) developing algorithmic thinking. Awareness of such potentials could, we hypothesized, assist teachers when helping students to mathematize their work in type 1 situations.

The type 2 situation, is when the programming part concerns something that is already mathematical, as in using programming to build a mathematical tool, solve a mathematical problem, or to explore mathematical phenomena. In type 2 situations, the mathematics is already relatively fixed, but an important responsibility of the teacher, particularly when working with pupils who are programming novices, is to make sure that the pupils are properly introduced to elements of

programming that can be useful in approaching the mathematical problem at hand (Guin & Trouche, 2002).

In order to investigate the teachers' ideas about the relation between mathematics and programming empirically, we have chosen to focus on how the teachers conceptualize this relation. We use the notion of *conceptions* to signify what the teachers think are important aspects of the relation between the two areas of knowledge. Our construct of conception is built upon the same constructivist post Piagetian approaches as our mathematics education approaches (Papert, 1980; Vergnaud, 1998), and as a consequence, active articulation and representation of the relation between the mathematics and programming plays a critical role in shaping individual conceptions. We explore the conceptions through questions focusing on importance of the relation, preparedness of the teachers to teach programming and the qualities of the relations between the two topics, based in the three intersection points from Misfeldt and Ejsing-Dunn (2015).

Methods and instruments

To understand how the change in curriculum and the work in the PD modules are experienced by Swedish mathematics teachers, we designed a survey addressing various aspects of these issues.

Participants

The participants were teachers from school years 1–12 in municipal schools in Stockholm. Some months before the study, the participants attended seminars organized by the Education Administration that aimed to facilitate the introduction of programming into school mathematics. Prior to these seminars, the participants – as well as the vast majority of Swedish mathematics teachers – had no formal education in and very little experience in programming. When attending the seminars, teachers submitted their email addresses, and these addresses were subsequently used to contact them about the survey. Answering the survey was optional, and the teachers were guaranteed anonymity. After the responses were gathered, the teachers who responded received the opportunity to participate in the present study. They were informed that their answers and personal data would be stored according to the current GDPR regulations. Currently, 133 teachers have chosen to participate in the study, 77% (102 teachers) from primary school and 23% (31 teachers) from upper secondary school – however, not all teachers answered every question of the survey.

The survey

The survey was developed by the authors of this paper; the included statements are based on the revision of the Swedish curricula with regard to programming in mathematics, on feedback from teachers at seminars about introducing programming, and on authors' experience of designing PD programs for mathematics teachers. The statements deal with 17 topics, representing the categories: a) teachers' prior experiences of teaching mathematics and programming; b) teachers' conceptions of how programming should be implemented in mathematics; c) teachers' conceptions of how programming could develop pupils' understanding of mathematical concepts and procedures, and pupils' problem-solving competency. In order to achieve an appropriate level of reliability and validity of the responses (expected to be above 100) – in concordance with studies about survey scales in social sciences, that point out that the “optimum number of alternatives is between four

and seven” (Lozano, Garcia-Cueto, & Muniz, 2008) – we decided to use a four-alternative Likert scale. By using an even scale, i.e., a scale without a neutral middle category – and by taking into consideration that the participants had little or no previous experience of programming – we aimed to discern participants’ responses in more distinct ways. Thus, participants were asked to answer to every statement on a scale of 1 (meaning “not at all”) to 4 (meaning “to a great extent”).

The survey underwent a substantial a priori testing with a group of teachers with similar levels of experience in programming in mathematics as the participants, thereby confirming that included statements were compatible with the aims of this study. In this paper, we are focusing teachers’ answers to 12 statements – displayed at the next section – related to mathematical thinking and mathematics as a topic and a set of learning objectives on one side, and programming activities and objectives on the other. The first eight statements focus on teachers and pupils’ mathematical knowledge and potential related to programming, and on their understanding of mathematical concepts, procedures and algorithms in the context of programming. The last four statements deal with teachers’ enthusiasm and preparations related to programming, their views on programming and mathematics as different subjects and on learning programming by tinkering.

Results

We performed a simple descriptive analysis in this paper, thus, the paper does not present or confirm any hypotheses. Rather, we generated an overview of the replies and present our questions and their relationship to the framework.

In the survey, we gathered data about a number of things as described above. We asked the eight questions shown in Table 1, and the distributions of the answers were more or less the same.

Question	Not at all	2	3	To a great extent
I benefit from my mathematical knowledge when I am programming.	8	32	59	32
My pupils benefit from their mathematical knowledge when they are programming.	7	36	57	28
I can do more things related to mathematics when using programming.	12	34	60	22
My pupils can do more things related to mathematics when using programming.	11	39	62	15
I can obtain a better understanding of mathematical concepts by using programming.	20	43	48	14
My pupils can obtain a better understanding of mathematical concepts by using programming.	19	33	57	16
I can obtain a better understanding of mathematical procedures and algorithms by using programming.	15	33	54	27
My pupils can obtain a better understanding of mathematical procedures and algorithms by using programming.	9	26	64	29

Table 1: The distribution of the number of answers to respective questions about the relationship between programming and mathematics.

As seen in Table 1, the most typical answer was category 3. The answers to every question have more or less the same distribution; almost half of the teachers answered 3 and less than one fifth of them answered 4 (“to a great extent”). The rest of the teachers, less than one third of them, were divided between 1 (“not at all”) and 2 (that might be interpreted as “to a small extent”).

Do you feel enthusiastic about teaching programming in mathematics?	23	29	55	23
Do you feel well prepared to teach programming in mathematics?	40	42	43	6
Programming and mathematics are two different disciplines that should not be taught within the same subject.	52	38	24	18
It is important that students learn to modify and adapt given programs according to certain criteria (tinkering).	12	29	64	20

Table 2: The distribution of the number of answers associated to respective statements about teachers’ motivation for and self-esteem regarding teaching programming in their mathematics classes.

According to Table 2, the answers associated to the teachers’ levels of preparation to teach programming in mathematics respectively to their opinion about the relationship between programming and mathematics as disciplines, are distributed towards less affirmative categories. All together, we take the results shown in Table 1 and Table 2 as signs of two issues that both need further statistical inquiry in order to be considered stable results: (1) Swedish mathematics teachers do see a clear relationship between mathematics and programming – however, this does not mean, that the teachers view these topics as coinciding; (2) despite admitting the benefits of programming, Swedish mathematics teachers are not well prepared for teaching programming in mathematics. Rather, the teachers express that they and their students can use their mathematical competencies while programming and feel that it is a good idea to do this. Yet, simultaneously, they do not currently feel well prepared to take on the task of teaching programming. In the following section, we will discuss these results.

Discussion: approaches to including programming in compulsory schools

Many countries, municipalities, and schools are currently struggling with how to introduce programming as a body of knowledge in the school system. Mathematics tends to play an important role in a number of these attempts. There are many ways in which this can be done in terms of curriculum structure. Programming can be included in mathematics and science curricula, as in the case we have explored here. Of course, this can also be done in different ways, and different teachers will have different competencies in this regard. Another approach is to develop programming as a topic in its own right. However, such a topic can have different “flavors” and foci and different relationships to the more traditional school topics. The Swedish case is an example of a country addressing this problem by imbedding programming into mathematics (and science), and the data from our case suggest that there are a number of synergies and potentials with such an approach. In general, the teachers who answered our survey do see a relationship between programming and mathematics, and they do want to build on that relationship in their teaching. This tells us that the route of integrating programming into mathematics seems feasible in Sweden. However, we should be aware of the fact that both the sample size and current sampling strategy challenge the generalizability of the results. Accordingly, these results say nothing about whether

combining mathematics and programming is the best way to address the integration of programming in Swedish schools or even if this integration is a good idea in the first place. Yet, the relationship between the topics and the motivation for taking on the task seems to be there, even though the capacity for teaching programming is not yet in place. We are not free from the problem of training teachers to take on this specific task.

The introduction of programming in the mathematics curriculum poses an interesting implementation problem. What are the critical choices and concerns that we need to consider in this respect? In this paper, we have addressed mathematics teachers' conception of the relationship between mathematics and programming, but this is not the only relevant concern. Stakeholders such as end users (pupils and teachers), implementation plans, the potential for diffusion, etc., are important concerns. We also believe that the discussion of whether to teach programming in relation to other topics or as a topic in its own right could benefit from a broader "implementation framework," such as the one discussed by Century and Cassata (2016). To mention just one concern, it is critical to have sound implementation of programming in relation to mathematics education, and that could benefit from being viewed through the lens of implementation research; we can look at teacher's resistance to programming as part of mathematics. This resistance is rare but might exist, as seen in Table 2. If programming is included as a part of mathematics at all levels, no mathematics teachers can avoid teaching it. Accordingly, programming – that is, not a priori natural tool for mathematics education – might also be viewed in the light of instrumental distance and double professional geneses from the part of the teachers (Haskejian, 2014). In that sense, this structure is more fragile for the minority with negative views, whereas the development of an entirely new topic might make it easier for teachers to choose whether they want to engage in the teaching of programming.

Conclusion

In this paper, we have presented an initial descriptive analysis of Swedish mathematics teachers' experience regarding the relationship between mathematics and programming. The data collection is still ongoing, and the sample size is expected to increase. Furthermore, we are not yet in a situation where we can conduct a strong statistical analysis of the data, so the stability and generalizability of the results are currently limited. However, the results that we do have point in the direction of a meaningful relationship between mathematics and programming that can be used to support the teaching of programming within the subject. Yet, they also suggest that this will not be easy and that Swedish teachers – despite a positive attitude towards working with programming in mathematics – do not feel that they are prepared to take on this task. This result indicates that it might be a good idea to build the capacity for teaching programming from within the topic of mathematics. However, the capacity problem seems to persist in the sense that it is indicated that teachers need to be prepared and trained to teach programming. Furthermore, it might be the case that some teachers do not at all see the relationship between mathematics and programming, nor the relevance of teaching programming in their mathematics classes, and such teachers might also experience the task as very challenging. However, we assume that further data collection and statistical analysis will allow us to better understand the detailed clustering of teachers' attitudes on the subject of programming.

References

- Boesen, J., Helenius, O., & Johansson, B. (2015). National-scale professional development in Sweden: theory, policy, practice. *ZDM Mathematics Education*, 47(1), 129–141.
- Century, J., & Cassata, A. (2016). Implementation research: Finding common ground on what, how, why, where, and who. *Review of Research in Education*, 40(1), 169–215.
- Dubinsky, E., & Harel, G. (1992). *The Concept of function: aspects of epistemology and pedagogy*. Washington, DC: Mathematical Association of America.
- Guin, D., & Trouche, L. (2002). Mastering by the teacher of the instrumental genesis in CAS environments: necessity of instrumental orchestrations. *Zentralblatt für Didaktik der Mathematik*, 34(5), 204–211.
- Haspekian, M. (2014). Teachers' instrumental geneses when integrating spreadsheet software. In A. Clark-Wilson, O. Robutti, & N. Sinclair (Eds.), *The Mathematics Teacher in the Digital Era* (pp. 241–275). Dordrecht: Springer Science and Business Media.
- Jones, S. P., Bell, T., Cutts, Q., Iyer, S., Schulte, C., Vahrenhold, J., & Han, B. (2011). *Computing at school. International comparisons*. Retrieved from <https://www.computingschool.org.uk/data/uploads/internationalcomparisons-v5.pdf>
- Lindvall, J., Helenius, O., & Wiberg, M. (2018). Critical features of professional development programs: Comparing content focus and impact of two large-scale programs. *Teaching and Teacher Education*, 70, 121–131.
- Lozano, L. M., Garcia-Cueto, E., & Muniz, J. (2008). Effect of the number of response categories on the reliability and validity of rating scales. *Methodology: European Journal of Research Methods for the Behavioral and Social Sciences*, 4(2), 73–79.
- Misfeldt, M., & Ejsing-Duun, S. (2015). Learning Mathematics through Programming: An Instrumental Approach to Potentials and Pitfalls. In K. Krainer & N. Vondrová (Eds.), *Proceedings of the Ninth Congress of the European Society for Research in Mathematics Education* (pp. 2524–2530). Prague, Czech Republic: Charles University in Prague.
- Papert, S. (1980). *Mindstorms: children, computers, and powerful ideas*. New York: Basic Books.
- Vahrenhold, J., Nardelli, E., Pereira, C., Berry, G., Caspersen, M. E., Gal-Ezer, J., Kölling, M., A. McGettrick, A., & Westermeier, M. (2017). *Informatics Education in Europe: Are We All in the Same Boat?* New York: Association for Computing Machinery.
- Vergnaud, G. (1998). A comprehensive theory of representation for mathematics education. *The Journal of Mathematical Behavior*, 17(2), 167–181.
- Wilson, C., Sudol, L. A., Stephenson, C., & Stehlik, M. (2010). *Running on empty: The failure to teach K-12 computer science in the digital age*. New York: Association for Computing Machinery.
- Wing, J. M. (2006). Computational thinking. *Communications of the ACM*, 49(3), 33–35.

Designing an problem for learning mathematics with programming

Morten Munthe

Norwegian University of Life Sciences, Faculty of Science and Technology, Norway;

morten.munthe@nmbu.no

Keywords: Programming, design-based research, problem solving

Programming has a long history within mathematics education. From the introduction of programming languages such as LOGOS, Basic and Pascal in the 1970s, to the more recent use of computer algebra systems (CAS). More recently, programming has received an increased focus from both the academic community and society. The combination of mathematical knowledge and the knowledge of programming is considered a valuable skill set in the future work marked (Gravemeijer, Stephan, Julie, Lin, & Ohtani, 2017). In response to this, programming is to be included in the mathematics classroom in Norway from autumn 2020.

This poster presents a part of a larger project involving students electing science mathematics in upper secondary school (16-18 y.o.). In this project, the students receive extra lessons at the beginning of the school year, where they learn a set of basic programming commands (such as print, input, mathematical operations, *if*-statements, *for*-loops, and *while*-loops). They are then given mathematical problems, which facilitates for deep learning through discussions, problem solving and programming. This project follows the students for two consecutive years, and periodically presents them with problems from different areas of mathematics. The project investigates how the use of programming can facilitate for the learning of mathematics in the classroom and this poster illustrates the creation of problems that facilitates for learning mathematics with programming.

The project is design-based. Design-based research (DBR) has many focal areas, and this poster presents parts of DBR where the focus is the creation and development of mathematical problems through iterations. The problems are vital as they create ways to learn and discuss mathematics not easily achieved or not possible without programming.

The design process combines Rabardels instrumental approach (Rabardel, 1995) with Vygotsky's activity theory (Vygotsky, 1980). The instrumental approach is used to create problems that facilitate for the development of utilization schemes, and activity theory is used to create problems that facilitate for students discussions. Discussions are vital for learning mathematics. In activity theory, the mediating artefact that helps the students learn mathematics is here the programming language. The learning is mediated through social interactions between groups of students and between students and their teacher. In instrumental approach the instrument is defined as a two-part entity consisting of both the artefact and the utilization schemes (Rabardel & Samurçay, 2001). The utilization schemes will start as basic usage schemes, where the students will learn a set of commands and their affordances. As their abilities and network of commands increases, they will develop instrumented action schemes. The action schemes will enable the students to create programs to solve mathematical problems (Drijvers & Trouche, 2008).

To illustrate the iteration process, the poster will show the overarching structure of the project, give an example of a mathematical problem, and present responses from students through logs and

interviews. The structure will show how problems develop over time, and the responses will show how student input affects the development of problems. To embody a problem, an example from the mathematical area of quadratic equations is used. Articles targeting quadratic equations suggest that students struggle with them (Zakaria, 2010). This includes solving quadratic equations instrumentally, validating solutions, and understanding the relationship between different forms of visualisation such as function, graph, and zero-points.

The mathematical problem of quadratic equations

The students were asked to create a program that would solve any quadratic equation. The problem was set up as a building block scheme, where they started solving quadratic equations with one or two solutions. Afterwards they were asked to solve a quadratic equation with no solution, and then problem solve how they could circumvent the error they received. As the problem progressed, they were given further questions and/or hints of what to discover. This included intersection with the axes, an expression for the derivative, factorising the equation, and so on. The students were given freedom to program what information the user would receive when they input a quadratic equation.

A couple of weeks after the quadratic equation problem, ten of the students were interviewed. Amongst their responses, they compared programming to the ready-to-use CAS in programs such as GeoGebra and reported that with CAS they merely typed in equations and pressed solve, but in programming they had to understand the process deeper to create the code that solved the equation.

The mathematical problems given to the students' have changed considerably from the initial iteration to the present iteration. The initial design of the problem focused on using programming to solve a general quadratic equation. As the work progressed, the design changed to increasingly include problems and formulations that forced the students to discuss and critically review their program to progress. The problems have now a design that helps the students should they feel frustrated about the programming. The problems have also focused on using programming as a tool to facilitate mathematical discussions and the creation of mathematical ideas. The next iteration will run in autumn 2018, and the poster will include the examples and results from this study as well.

Drijvers, P., & Trouche, L. (2008). From artifacts to instruments, A theoretical framework behind the orchestra metaphor. *Research on technology and the teaching and learning of mathematics: Synthesis and Perspectives* (Vol. 2). Dordrecht, the Netherlands: Kluwer Academic Publishers.

Gravemeijer, K., Stephan, M., Julie, C., Lin, F.-L., & Ohtani, M. (2017). What Mathematics Education May Prepare Students for the Society of the Future? *International Journal of Science and Mathematics Education*, 15(1), 105–123.

Rabardel, P. (1995). *Les hommes et les technologies; approche cognitive des instruments contemporains* [People and technology - a cognitive approach to contemporary instruments]. Paris: Armand Colin.

Rabardel, P., & Samurçay, R. (2001). *From artifact to instrument-mediated learning*. Paper presented at the Symposium on New challenges to research on Learning.

Vygotsky, L. S. (1980). *Mind in society: The development of higher psychological processes*. Cambridge, MA: Harvard university press.

Zakaria, E. (2010). Analysis of Students' Error in Learning of Quadratic Equations. *International Education Studies*, 3(3), 105–110.

Developing MAP for integrating mathematical applets in teaching sequence

Gal Nakash-Stern¹ and Anat Cohen²

¹Tel-Aviv University, Faculty of Education, Tel-Aviv, Israel; galnakash@mail.tau.ac.il

²Tel-Aviv University, Faculty of Education, Tel-Aviv, Israel; Anatco@tauex.tau.ac.il

In this paper, we present the way in which the math teacher proceeds to select an applet, and especially its main considerations when preparing for the lesson or preparing the study unit. In addition, this study examines what the teacher's meta-data should be in order to make a knowledgeable select of applets and integrate them into the teaching sequence. This study aims to help the teachers cope with the heavy load of the Open Educational Resources (OER) and help them in their day-to-day management of the study units. Therefore, qualitative research was carried out to examine the teachers' choices and considerations regarding their goals and sequence of teaching. The present study offers a way to deal with this difficulty by means of a Map that will link the teacher's pedagogical-content considerations. This map may be used by the teacher as a tool for intelligent choice of applets.

Keywords: Mathematical applets, Map, Meta-data, teaching sequence.

Introduction

A well-informed integration of technology in teaching and learning at school positively affects students regarding cognitive features and effective ones (emotional and motivational), as well as features connected with the teachers' choices in the classroom and outside of it. Using technological tools for the purpose of teaching is very common nowadays (Stehr, He, & Nguyen, 2018). These tools are often used for the sake of innovation, and for introducing a fresh aspect to increase students' motivation (Horzum, 2015; Smith, Shin, & Kim, 2017). This occasionally leads to the development of new technological tools that are not always best fitted to the students, and do not attach importance to mathematical content. Thus, if mathematical content is not taken into account, the choice of using certain technology for the purposes of teaching and studying does not grant any educational benefits, and may indeed miss the actual goal (Dębowska et al., 2013).

The recent development of various educational resources containing digital learning materials for the use of teachers is especially relevant to this study (Cohen, Kalimi, & Nachmias, 2013). These educational resources - most of which are free for use (such as the Israeli Ministry of Education's "Educational Catalogue") - offer various activities and material and in varying formats, from short texts, videos, and applets up to full lesson plans. Hence, teachers are given a chance to make use of existing learning materials in order to optimize and improve their work. Among these educational resources there is specifically a major supply of game-based applets, interactive web utilities (Pejuan, Bohigas, & Jaén, 2016), aimed at various subjects in Mathematics and for a broad age-range. It is a well-known fact that using these applets has a positive impact on students (Hershkowitz, Tabach, & Dreyfus, 2017), and that using the applets through a guided model can provide better outcomes in the acquisition of language and of mathematical terminology (Dijanić & Trupčević, 2017).

Despite the potential for teaching and learning encompassed within existing learning materials, and their many benefits, studies suggest that their usage, as well as their combinations to match the specific user's needs, are relatively low (Hilton, Lutz, & Wiley, 2012; Pirkkalainen, Jokinen, Pawlowski, & Richter, 2014; Bernstein, 2015). One argument is that many educators are not aware of these growing educational resources, or that they are not entirely convinced of their effectiveness (Cannell, Macintyre, & Hewitt, 2015). Furthermore, there is a concern that the abundance of displayed information might lead to confusion, discrepancies and wasting time when searching for information - due to the lack of a single unified system which would license and catalogue learning material (Nash, 2005). It could also lead to difficulties in evaluating the quality and reliability of information and its management (Clements, Pawlowski, & Manouselis, 2015; Gurung, 2017).

There are two significant challenges facing those teachers who are interested in using mathematical applets and making informed usage of them. The first is related to the stage of searching and selecting the materials that will best suit the goals of their specific teaching subject; and the second is regards to the optimum usage of those materials within the teaching process in class during a lesson, or during a few consecutive lessons.

Main research goals and questions

Three main goals for this research (1) Understanding what data is needed for teachers to integrate applets within their teaching sequence; (2) Identifying specific features within applets that will enable an informed integration within the teaching sequence; (3) Creating a Map based on meta-data fields that teachers can choose an appropriate applet and integrate it within the classroom's teaching sequence. In order to achieve these goals two questions were asked: (1) What are the main considerations that teachers operate in order to integrate applets into teaching sequence? (2) What is the meta-data that can help teachers to make decisions about using those applets? Meta-data in educational aspects (pedagogic - content) and, Meta-data in technological aspects.

Methodology

The research was conducted in three main stages. The first stage included a review of various meta-data models connected to the world of studies and education. A theoretical framework was built based on these models (e.g Dublin Core and LOM) including the meta-data of existing mathematical applets. The meta-data was divided into educational dimensions and technical-technological dimensions. The educational dimension contains the teachers' pedagogical requirements and contents, and the technological dimension describes the applets (Figure 1).

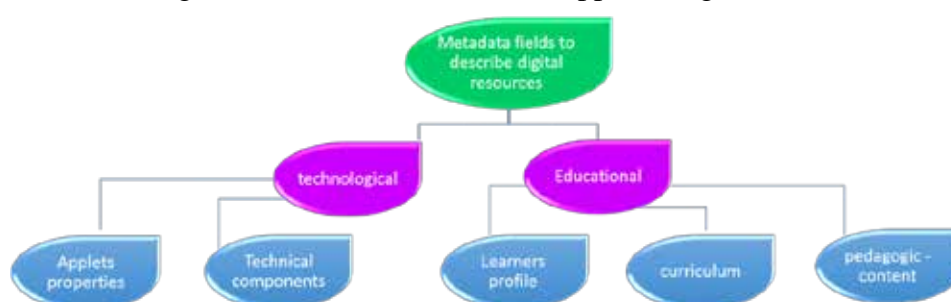


Figure 1: The theoretical framework

The meta-data fields which describe the Mathematical applet in each dimension are grouped into different categories of metadata. The branching of these metadata categories shows a comprehensive view of all the characteristics that can be considered when examining applets.

The second stage included semi-structured interviews with 12 mathematics teachers who use applets in elementary schools. The interviews aimed to establish the theoretical framework, and to examine the teachers' perception of integrating applets within their teaching sequence in accordance with their teaching goals. The interviews were divided into four stages in accordance with the stages the teacher faced when implementing the applets: applet searching, locating, using, and feedback. The interviews were conducted as one-off sessions with each teacher. This qualitative stage draws its data from the natural system, in which the researcher and the interviewees are on the same communication level, and the research output is created from opportunities in their interaction.

The third stage dealt with analyzing the findings, and developing a tool in the form of a Map for applets integration. This stage of analysis and tool-building placed emphasis on the teachers' answers concerning their ways of choosing applets and integrating them into their math class teaching sequence. This research was based on Grounded Theory, in which data collection was carried out before the study is fully understood (Shkedi, 2003).

Preliminary findings

The findings' analysis was divided into two levels: addressing the teachers' considerations regarding the integration of applets within their teaching sequence, and addressing the meta-data they would find useful for their decision making process. Based on these, a comprehensive Map was constructed.

Teachers' considerations

A number of considerations arose regarding the teachers' select of an applet and planning of their teaching sequence - mainly pedagogical and technological considerations. From the teachers' point of view, the main considerations were pedagogical considerations which included mainly the teaching goals, the pedagogy, the mathematical content, the location and time frame. Moreover, it was found to be important to consider their teaching experience and professional knowledge, their teaching style and even their personality. The technological considerations include mainly authorizations, certification (Figure 2).

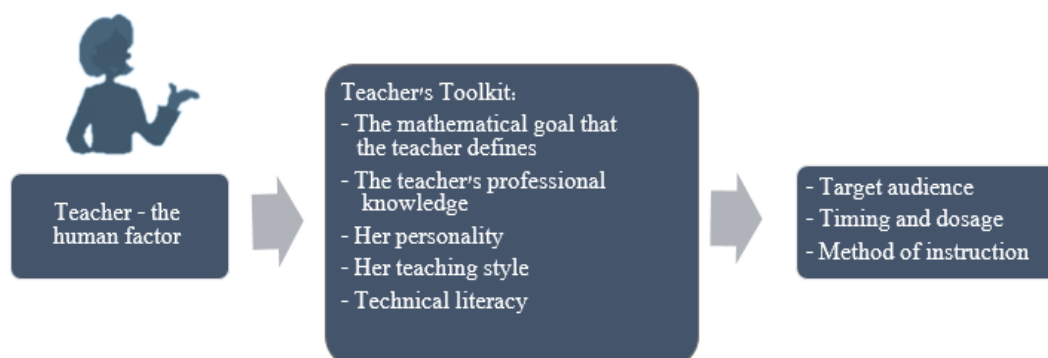


Figure 2: The teacher's considerations for integrating applets

Meta-data

Beyond the considerations that the teachers must use when choosing an applet, there is also the matter of the specific data that is required from the applet or database they are examining. The teachers defined the meta-data from pedagogical aspects as well as technological ones. Pedagogical aspects included mainly the teaching sequence in relation to the objective of use, the way of studying, acquired skills, students' profiles in relation to difficulty levels, timeline, mediation levels, the student experience evoked by motivational factors and configuration. In accordance with the findings' analysis, a set of Metadata fields was created for the purpose of assisting the teachers in an optimal search for the applet most suitable for their teaching sequence. Figure 3. presents the main meta-data fields that can assist the teachers in their decision-making process while constructing their teaching sequence with the use of applets (Figure 3).



Figure 3: Pedagogical and technological metadata fields

A map for applets integration in teaching sequence

The pedagogical and technological considerations as well as the set of metadata are presented by process map. This map shows the teacher's way of thinking in making the choice in four stages: the search stage, the detection stage, the use stage, and the feedback stage. At each stage the teachers referred to a number of different categories. In the search phase, the teachers referred mainly to the availability of information, pedagogical considerations and a structural model. At the point of identification, the teachers referred mainly to the data they had in the applet and to the superlative information that still did not exist, when they referred mainly to the information they knew and their

experience. At the point of use, the teachers referred to their meta-goals, motivational factors, and time and place of use of the applet. In the fourth and final stage, the teachers referred to the effectiveness of feedback, the type of feedback required, feedback interactivity, and feedback as a learning tool.

According to the map (Figure 4), the teacher can filter out the considerations that lead her to decide whether to select an applet. The integration applet Map is presented in four main steps: filters, properties, receipt of products and choice of characteristics and in the end decision-making, from the search stage to reaching the desired applet. The filter stage includes all the pre-requisite knowledge the teacher needs when choosing an applet that includes her professional knowledge, her personality, her mathematical goal, and more. At this stage, the teacher also defines her target audience, the method of instruction and the timing of her teaching sequence. The properties stage includes the different characteristics of the applet and its target audience. The third stage, which is defined as the receipt of the products and the examination of characteristics, is from a stage in which all the knowledge that the teacher has is integrated into this stage and it examines the continuation of the process in order to select the applet. In the fourth and final stage, the teachers arrive at a crossroads where they have to make a choice: Should they choose the current applet, or should they go back to the second and third stages, and re-examine other applets.

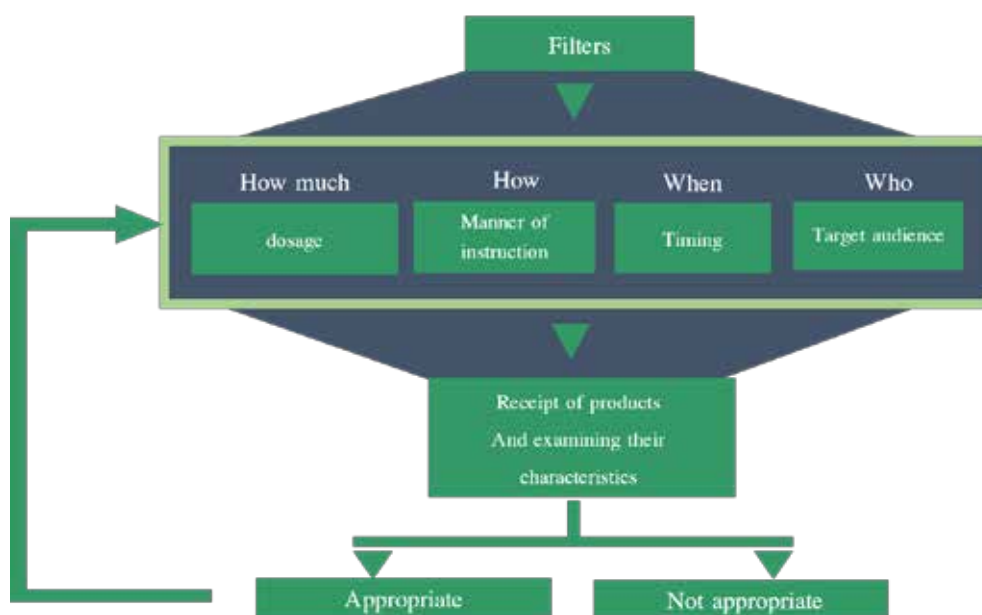


Figure 4: A map for applets integration in teaching sequence

In conclusion, this research looked at the considerations and the metadata which would influence teachers when choosing applets and integrating them into the teaching sequence. The interviews indicated great significance attached to the teacher's personality, needs and authority. Another issue that emerged through the interviews was the students' needs - the teacher's understanding of what the student needs to get; how the students will connect to the applet; and how we get the students to understand mathematics by using the right applet. Another issue which is just as important as the teacher and student's needs, is the teachers' learning process during their search for the desired applet. During the interviews, the teachers explained how they approached searching and choosing the applet,

as well as how they integrated it within their teaching sequence, and these led to conclusions regarding their method of learning.

Discussion and conclusions

In this research, the pedagogical consideration was the main one for choosing applets. According to the pedagogical consideration, teachers choose the applet most suited to their teaching sequence. Since the mathematical content is highly significant in building up the students' mathematical knowledge (Kimeswenger, 2017), the teachers will first search for an applet appropriate for that content. Most of the teachers interviewed stated that without that element of information they would not be able to begin the search, hence - this is a primary filter when choosing a database or applet. Similarly, Namukasa, Gadanidis, Sarina, Scucuglia, and Aryee in their research (2016) found that among the most important considerations were the pedagogy and content that the teachers wanted to teach in their mathematics lessons. They also stated that mathematical terms or "mathematical thinking" would be the most critical when choosing a digital object. This issue was addressed as well by Kotsopoulos et al. (2017), who explained the importance of the students' computational mathematical thinking, which should take precedence.

The study found that technical components such as installation instructions and necessary hardware and software programs were not essential elements when choosing an applet. Most teachers, when asked about the technical aspect of choosing an applet, answered that they do not attribute much importance to those aspects when choosing to use an applet. The teachers stated that the only factor impacting on their choice would be the hardware or program's digital license - as defined by Green (2017) during his OER license research, where he examined how they influence studying. The teachers stated they are already used to the "wonders of technology" and that they know how to handle anything that comes their way. Much to our surprise, the technical aspect that we had emphasized at the beginning of the research did not end up being a hindrance or even a consideration when choosing an applet. This surprised us a great deal, since some populations find study-suitability very difficult during times of technological advancements (Göthe, Oberauer, & Kliegl, 2007).

During this research, we mapped out the considerations and information the teachers would need when choosing an applet or mathematical resources. Then, similar to Kimeswenger (2017) we recognized the need for developing a tool, which will help teachers to navigate in the heavy load of resources and to assess learning materials. Thus, we built a Map for integrating applets in teaching sequence. The Map consists of the knowledge the teachers will need for choosing the applet and for integrating it into the teaching sequence. We believe that the Map we have created may assist in developing a technological tool with which teachers may integrate all the elements necessary for their teaching. Beyond the teacher's familiarization with the educational resources and applets, it is necessary to develop a tool in the form of Google, consisting of mathematical educational resources and applets, with the added option of feeding it criteria that would make it possible to obtain the desired product, and which could assist the teachers' choice of an applet, and shorten search duration.

Since this research did not deal with the construction of lesson units by teachers, it is vital for future research to deal with that subject in greater depth and regarding the following influencing factors: How long it takes the teachers to learn the usage of applets; how long it takes to build a lesson plan -

whilst relating to pedagogical components as well as to the teacher's teaching goals; the chronology of lesson building; and how the applets assist the teachers.

In an age of rapid and frequent changes, we must pay attention to the fact that teachers are required to implement new technologies on a daily basis as part of their lesson structure. Hence, the main importance of this research is in assisting teachers integrate mathematical applets within their teaching sequence in the classroom. Teachers nowadays are laden with a huge amount of applets and resources (Peralta, Alarcon, Pichara, Cano & Bozo, 2017) which is why we developed the presented Map. Teachers are expected to have an extremely high level of literacy due to current usage of many technological tools. Therefore, it is important for future research to address the way in which the teachers learn how to use technological tools, and to actually implement them in the classroom.

Acknowledgment

This study is founded by the Education Ministry's chief scientist.

References

- Bernstein, S. (2015). OER and the value of openness: Implications for the knowledge economy. *Globalisation, Societies and Education*, 13(4), 471–486.
- Cannell, P., Macintyre, R., & Hewitt, L. (2015). Widening access and OER: Developing new practice. *Widening Participation and Lifelong Learning*, 17(1), 64–72.
- Clements, K., Pawlowski, J., & Manouselis, N. (2015). Open educational resources repositories literature review—Towards a comprehensive quality approaches framework. *Computers in Human Behavior*, 51, 1098–1106.
- Cohen, A., Kalimi, S., & Nachmias, R. (2013). The use of digital repositories for enhancing teacher pedagogical performance. *Interdisciplinary Journal of E-Learning and Learning Objects*, 9, 201–218.
- Dębowska, E., Girwidz, R., Greczyło, T., Kohnle, A., Mason, B., Mathelitsch, L., Silva, J. (2013). Report and recommendations on multimedia materials for teaching and learning electricity and magnetism. *European Journal of Physics*, 34(3), L47.
- Dijanić, Ž., & Trupčević, G. (2017). The impact of using GeoGebra interactive applets on conceptual and procedural knowledge. In *The Sixth International Scientific Colloquium Mathematics and Children* (Mathematics education as a science and a profession). Retrieved from https://bib.irb.hr/datoteka/878910.Dijanic_Trupcevic_Impact_GeoGebra_knowledge_finish.pdf.
- Göthe, K., Oberauer, K., & Kliegl, R. (2007). Age differences in dual-task performance after practice. *Psychology and Aging*, 22(3), 596–606.
- Green, C. (2017). Open licensing and open education licensing policy. *Open: The Philosophy and Practices that are Revolutionizing Education and Science*, 29–41.
- Gurung, R A R. 2017. Are OE Resources High Quality?. In: Jhangiani, R S and Biswas Diener, R. (eds.) *Open: The Philosophy and Practices that are Revolutionizing Education and Science*, 79–86. London: Ubiquity Press. doi: <https://doi.org/10.5334/bbc.f>. License: CC-BY 4.0

- Hershkowitz, R., Tabach, M., & Dreyfus, T. (2017). Creative reasoning and shifts of knowledge in the mathematics classroom. *ZDM Mathematics Education*, 49(1), 25–36
- Hilton III, J. L., Lutz, N., & Wiley, D. (2012). Examining the reuse of open textbooks. *The International Review of Research in Open and Distributed Learning*, 13(2), 45–58.
- Horzum, M. B. (2015). Interaction, structure, social presence, and satisfaction in online learning. *Eurasia Journal of Mathematics, Science & Technology Education*, 11(3), 505–512.
- Kimeswenger, B. (2017). Identifying and assessing quality criteria for dynamic mathematics materials on platforms. *Proceedings of the Tenth Congress of the European Society for Research in Mathematics Education (CERME10)*. Dublin, Ireland. Retrieved from https://keynote.conference-services.net/resources/444/5118/pdf/CERME10_0407.pdf
- Kotsopoulos, D., Floyd, L., Khan, S., Namukasa, I. K., Somanath, S., Weber, J., & Yiu, C. (2017). A pedagogical framework for computational thinking. *Digital Experiences in Mathematics Education*, 3(2), 154–171.
- Namukasa, I., Gadanidis, G., Sarina, V., Scucuglia, S., & Aryee, K. (2016). Selection of apps for teaching difficult mathematics topics: An instrument to evaluate touch-screen tablet and smartphone mathematics apps. *International perspectives on teaching and learning mathematics with virtual manipulatives* (pp. 275–300) Springer.
- Nash, S. S. (2005). Learning objects, learning object repositories, and learning theory: Preliminary best practices for online courses. *Interdisciplinary Journal of Knowledge and Learning Objects*, 1(2), 217–228.
- Pejuan, A., Bohigas, X., & Jaén, X. (2016). An evaluation tool for physics applets. *Journal of Technology and Science Education*, 6(1), 36–51. doi:<http://dx.doi.org/10.3926/jotse.172>
- Peralta, M., Alarcon, R., Pichara, K. E., Mery, T., Cano, F., & Bozo, J. (2017). Understanding learning resources metadata for primary and secondary education. *IEEE Transactions on Learning Technologies*
- Pirkkalainen, H., Jokinen, J. P., Pawlowski, J. M., & Richter, T. (2014). Removing the barriers to adoption of social OER environments. Paper presented at the *International Conference on Computer Supported Education*, 19–34.
- Smith, M. S., & Stein, M. K. (2011). *5 practices for orchestrating productive mathematics discussions*. Reston, VA: National Council of Teachers of Mathematics
- Shkedi, A. (2003). *Words of meaning: Qualitative research-theory and practice*. Tel-Aviv: Tel-Aviv University Ramot. (Hebrew).
- Stehr, E. M., He, J., & Nguyen, H. (2018). Selecting, Sequencing, and Connecting: Using Technology to Support Area Measurement through Tasks, Strategies, and Discussion. In *Proceedings of the Interdisciplinary STEM Teaching and Learning Conference* (Vol. 2, No. 1, pp. 13–26).

The impact of technology on the teachers' use of different representations

Helena Rocha

UIED, DM, FCT, Universidade NOVA de Lisboa, Portugal; hcr@fct.unl.pt

The potential of using different representations is widely recognized, but not much is known about how teachers use them nor about the impact of the technology on such use. The goal of this study is to characterize the teachers' representational fluency when teaching functions at high school level, discussing, at the same time, the impact in the use of representations resulting from the use of technology. Adopting a qualitative approach, I analyze one teacher's practice. The results suggest that algebraic and graphical representations are seen as more important, that tabular representation is assumed as irrelevant and that the access to technology impacts the representations used and how they are used.

Keywords: Technology, different representations, functions.

Introduction

Work with different representations is recognized by several authors as an important experience to promote the development of links and strengthen the understanding of mathematical concepts (Dreher, Kuntze, & Lerman, 2016). And the technology is pointed as having the potential to easily allow the students to alternate among representations (Cavanagh & Mitchelmore, 2003). Although the potential of using different representations is widely recognized, only a few authors paid attention to how they are used (Dreher et al., 2016; Molenje & Doerr, 2006). And even those who do it, do not focus on the impact of the technology on the teachers' choices in what concerns the use of the different representations. This is the new aspect addressed in this article. The goal is to characterize the teachers' representational fluency when teaching functions at high school level in a context where technology is available, discussing, at the same time, the impact in the use of representations resulting from the availability of technology. With this focus, I specifically intend to answer the following research questions: How does the teacher balance the use of the different representations of functions? How does the teacher articulate the multiple ways of representing a function within and among representations? What is the impact of technology on the teachers' balance and articulation of the different representations?

Representational fluency

Zbiek, Heid, Blume and Dick (2007) characterize the representational fluency as the ability to move from one representation to another, transferring the knowledge from one representation to another and combining it with the new knowledge available on the new representation. And this includes the transition between representations of different kinds but also transitions between different representations of the same type of representation, as emphasized by Moore et al. (2013) and Even (1998). This means that it is important to consider a transition, for instance, from an algebraic representation of a function to a graphical representation, but that it is also important to consider a transition from a graphical representation of a function to another graphical representation of that

same function (for example, when we are using technology and we need to look for a suitable viewing window for the graph).

Kendal and Stacey (2001) use the expression *privileging* (used originally by Wertsch in 1990) to refer to the teachers' specific way of teaching. And the authors think of it as a reflection of the teachers' beliefs and professional knowledge that characterizes their practice. *Privileging* includes the teachers' options about what they teach and how they teach it. In what is relevant to this study, *privileging* includes the teachers' decisions about what representations are (intentionally or unintentionally) used and about how they are used. And how the teachers privilege a specific approach and devalue others can tell us much about their professional knowledge (Dreher et al., 2016; Rocha, 2016). When studying the teacher's representational fluency it is important to know if some representations are preferred over others. I use the word *balance* to refer to how the teachers privilege specifically the use of some representations over others.

Although several authors recognized the relevance of using different representations based on the contribution it can bring to the development of mathematical understanding (Duval, 2006; Zbiek et al., 2007), the way how the teachers balance the representations has not received much attention. Molenje and Doerr (2006) conducted one of the few studies with this focus. Their conclusions suggest that the teachers express some concern about how they balance the different representations. Nevertheless, the use of algebraic and graphical representations is dominant in relation to the numerical representation. And this study also achieved another interesting conclusion: when the teachers actually use the different representations, it is possible to identify a pattern in the way how they do it. According to the authors, some teachers tend to start by an algebraic representation, move to a graphical representation and then to a numeric representation. Other teachers tend to move from the algebraic representation to a numerical representation and only then to a graphical representation. In a previous study conducted by myself on the teachers' use of different representations (Rocha, 2016), I found more diversity on the articulation of representations than the one found by Molenje and Doerr (2006), but I also found some preference for the use of some specific sequences of representations. These options will promote a limited use of representations by the students (because they tend to reproduce their teachers), with consequences for the students' learning and for their flexibility with different representations and with functions in general (Rocha, 2016). As Dreher et al. (2016) emphasize, the use of different representations is not enough to promote learning, it is essential to pay attention to how they are being used. And these findings suggest that besides studying how the teachers balance the different representations, it is also important to understand how the teachers articulate them. I use the word *articulate* to refer to how the teachers privilege a specific pattern when going from one representation to another. The way how the teacher balances and articulates the different representations is assumed as central on the characterization of the teacher's representational fluency. As so, these are the concepts used to analyze the teacher's representational fluency.

Methodology and study context

Given the nature of the problem under study and in line with the ideas advocated by Yin (2003), the study adopts a qualitative and interpretative methodological approach, undertaking one teacher case

study (in the part of the study presented here). Data were collected by semi-structured interviews, class observation, and documental data gathering. The teacher's lessons with one of her classes were followed while she taught functions. It was performed an interview after each lesson, with the purpose of knowing the analysis that the teacher did of the events. A test, with questions about changing between representations, was applied to the students by the researcher at the end of the study. The results of this test and some selected answers given by the students were used on a final interview to the teacher as a starting point to discuss her use of representations in her lessons. It was only at this point that the teacher became aware of the specific focus of the study on the use of representations. During the study, 12 lessons of 90 minutes at 10th grade (age 16) were observed. All interviews and observed lessons were audio-recorded and later transcribed. Data analysis was mainly descriptive and interpretative in nature, and guided by the goals of the study. The tasks proposed by the teacher were assumed as the unit of analysis. For each task the representations adopted by the teacher and the articulation between them were identified. Each type of articulation identified was then analyzed with the intention of characterizing it and understand the balance ascribed by the teacher to each representation. The representations taken into account were the ones usually available on the technologies and used on the study of functions: algebraic, graphical, numerical and tabular. Due to the goals of the study, when analyzing a task what was taken into account was the teacher's point of view, ie, the representations she chooses to use or suggests to the students.

The teacher participating in the study has a professional experience of about 20 years and a positive attitude towards the use of technology to teach mathematics. She likes to use computers on her practice, but when teaching functions she prefers to use graphing calculators and avoid the trouble of moving to a different classroom. As so, the graphing calculator was the only technology she used during this study, and this is why this is the only technology mentioned in this article. All the 25 students in this class had their own graphing calculator, which they could use at all times.

Results and discussion

An analysis of the tasks proposed by the teacher allowed the identification of nine different types of articulation between representations. Table 1 presents the sequences of representations used, a brief description of the strategy used to solve the task and an example of a possible task (please take into account that the examples presented were simplified due to space constrains). The sequence algebraic ® graphical ® numerical was used often on tasks with a real context and asking something about it (for instance, corresponding to the zeros or maximum of the function, or to the values for which the function is increasing or assumes positive values). It was also used on strictly mathematical questions, namely to solve inequalities. The sequence algebraic ® graphical was used when the goal was the graph of the function. And when the standard window did not offer a good viewing of the graph, the sequence became algebraic ® graphical ® graphical, including a change among graphical representations, ie, using different representations of the same type of representation. The sequence algebraic « graphical was used on exploratory tasks where the teacher intended the students to relate these two representations, expanding their mathematical knowledge, or to use previous knowledge to guide their successive attempts to solve the task. All these four sequences required the use of technology. And in all the other five sequences the

technology was not used. However, some of these sequences were not as used as others. That is the case of the sequence graphical \otimes algebraic that was only used once, and of the sequence graphical \otimes numerical that was only used on an introductory lesson to the theme. Besides that, it is possible to notice that certain sequences were never used and that the tabular representation was never used as well.

Representation	Teacher's approach	Example of task
algebraic \otimes graphical	Insert the function on the calculator and press graph	Draw the graph of $f(x) = -x^2 + 3x + 5$
algebraic \otimes graphical \otimes graphical	Insert the function on the calculator and press graph Use zoom / change the window	Draw the graph of $f(x) = -x^2 + 100$
algebraic \otimes graphical \otimes numerical	Insert the function on the calculator and press graph. Use menu <i>calc</i> In some cases (see 2 nd example) it is possible an approach without using the calculator	Knowing that the height of a remote controlled airplane is given by $f(x) = -x^2 + 4x$ find the maximum height reached by the airplane. Solve the inequality: $x^2 + 4x + 3 > 0$
graphical \otimes algebraic	Use paper and pencil and visually get information from the graph (calculator used at most to check)	Look at the graph of the function and find its algebraic expression
algebraic \ll graphical	Insert one (or more) function on the calculator, see the graph, change the function and move back and forward between the representations trying to come to a conclusion	Study the family of functions $y = ax^2, a \in \mathbb{R} \setminus \{0\}$ Slalom: Find a polynomial function to represent the course of a skier when he goes through both doors without touching the flags at (1, 4), (2, 4), (5, 4), (6, 4)
algebraic \otimes numerical	Use paper and pencil	Find the zeros of $f(x) = 2x^2 - 8x + 6$ Solve the inequality: $2x^2 + 12x + 10 < 0$
algebraic \otimes algebraic	Use paper and pencil	Write the polynomial function $f(x) = x^3 - x$ as a product of factors
numerical \otimes algebraic	Use paper and pencil	Write the expression of the 2 nd degree polynomial function with a zero for $x=1$ and $x=-2$ and going through the point (0, 4)
graphical \otimes numerical	Direct reading of the graph (use paper and pencil)	What is the maximum value reached by the function on the graph?

Table 1: Sequence of representations used by the teacher

The teacher recognizes the importance of using different representations to promote a deeper understanding of the concepts and emphasizes in particular the contributions of graphic representation to the understanding of algebraic representation:

T: I think that using graphs and algebraic expressions is very important. Some students have some difficulty in working analytically. They get lost and at a certain point they no longer understand what they are doing. For instance, they don't know why they equal the expression to zero when they are looking for the zeros of the function... and why they can't just replace the x by 0. Having the graph helps to understand... we want the value of x when y is 0. (...) I think the graphical representation is easier for them and if you work with it and with the algebraic representation you are helping them.

And she assumes that the technology allows the students to quickly access a wide variety of graphs and that it turns the work around functions much easier. It becomes possible to link different aspects about functions in a way that was not possible before:

T: Technology changes everything! The technology allows us to move instantly from the algebraic expression to the graph. And that turns possible to develop deeper relations among these representations. We can see on the graph the impact of changing a parameter on the function. This is not possible without technology.

The results achieved by the students on the test on representations suggest that they are effectively familiar with the relationship between algebraic and graphical representations. Nevertheless, the results also show that the students have difficulties in getting information from a table. 48% of the students failed to identify, based on a table including the relevant information of a function f , an interval for x where the values of f were increasing; but 80% managed to answer the same question based on a graph. 88% of the students were unable to find the expression of a function using the information on a table of values; but all recognized the quadratic function when the information was provided by a graph and 92% were able to find the algebraic expression. When confronted with these results, the teacher recognizes she does not use the tabular representation, assuming that the students' lack of familiarity with the representation might be the source for the difficulties of some students. But somehow she seems surprised and expresses her belief about the similarity between the numerical and tabular representation. A similarity that is actually recognized by several authors, such as Goos and Benninson (2008). In the teacher's own words:

T: I have to admit that nowadays I don't use tables so much. When I was a student we didn't have technology and we use a table to register some values of the function and then mark them on a graph or whatever... With technology we don't need that and... I know the calculator provides a table but we can get everything from the graph using the menu *calc*, so there is no need... for the table. It's the same. But maybe not for them. I think they get confused and didn't know in what column they should read the values. Maybe I should use the table. I don't know... I thought it was the same.

About privileging paper and pencil or technology when moving from one representation to another, the teacher says that she tries to balance the two options:

T: I try to do everything with and without technology because our syllabus requires that. (...) There are some exercises that they don't know how to do without the technology. For instance, find the maximum of a function. And there are also others that they cannot do on the calculator. For instance, factor a polynomial function... But we solve inequalities with and without technology. I think we achieve a deeper understanding when we can do something in two different ways.

Nevertheless, some sequences are always done using (or not) technology (see Figure 1). In some cases there is no surprise on that. For instance, the change from one graphical representation to another is usually due to an unsuitable choice of the viewing window. So it is to expect that it happens always when the technology is being used. But there is no reason to never use the technology when moving from a graphical representation to an algebraic one (and this is the option of this teacher). This suggests that the teacher is not fully aware of her options in what concerns the use of the different representations.

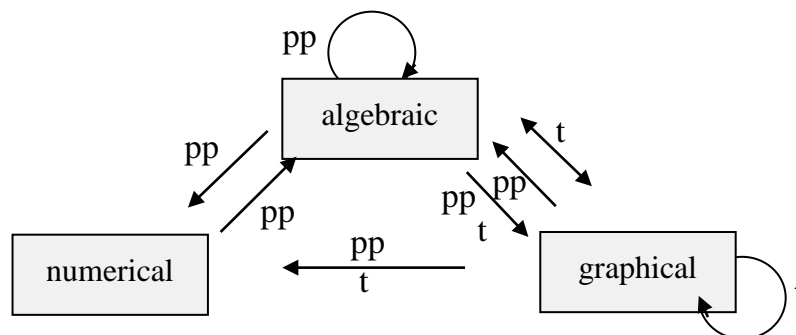


Figure 1: Representations used by the teacher and their sequence of use
(pp - paper and pencil, t - technology)

Conclusion

Algebraic and graphical representations seem to be assumed as more important than other representations. A conclusion in line with the results achieved by Molenje and Doerr (2006), who also concluded that these representations are used more often than others, meaning that representations are not equally balanced by the teacher. This can be related to the characteristics of the representations. As stated by Friedlander and Tabach (2001), algebraic representation is concise, comprehensive and effective, being also the most valued representation in Mathematics. But students tend to find it difficult (Quesada & Dunlap, 2008). The graphical representation provides a visual representation and an intuitive approach to the concepts, turning learning more intuitive (Friedlander & Tabach, 2001). It is thus understandable that these two representations are the most used. After all, the graphical representation helps the students understand the most valued representation: the algebraic one. And this is the central point. The representations beyond the algebraic one are mainly used to promote understanding over the most important representation and not so much to promote a global understanding of functions, as advocated by Dreher et al. (2016) and several other authors. The numerical representation, whose relevance is assumed to be minor due to its focus in particular cases (Friedlander & Tabach, 2001), is also used, although not so often. However, that is not the case of the tabular representation that is never used. The reason for the lack

of use of this representation has to do with the fact that numerical and tabular representations provide similar information and, as a consequence, tend to be assumed as identical, a result also identified by Rocha (2016).

Although the teacher enrolled in this study articulates the different representations in a flexible way, it is possible to identify a preference for certain sequences and to the use (or not) of technology in each one. It is also possible to notice that the algebraic and the graphical representation are the ones who are articulated in a more diversified way, a circumstance that is certainly related to the fact that these two representations are the ones used more often. These are also the two representations that seem to suffer a deeper impact from the use of technology. The ease of access increases the moments where the graphical representation is used and consequently impacts the balance and the articulation the teacher does of the representations. Simultaneously, the ease of access to numeric values straight from the graphic (when technology is being used), relegates the tabular representation for a situation where its value is no longer recognized. The technology changes the teacher's use of the tabular representation. At the same time, it prevents the teacher from realizing, that from a mathematical point of view, there is a difference between this representation and the numerical one. A difference that somehow is emphasized (or even created) by the technology where is often possible to get a numerical representation based on some automatic process (eg., using technology someone asking for a zero can get an answer even if he has no idea about what that is).

The presence of technology impacts the way how the teacher articulates and balances representations, turning the work around some representations more usual than around others and allowing some different sequences on the use of representations, this implies that technology modifies the teacher's representational fluency. And this fluency is known to be closely related to the teachers' professional knowledge (Dreher et al., 2016; Rocha, 2013). As so, an analysis of the teachers' representational fluency could give important information about their knowledge. And it would be interesting to analyze if different types of representational fluency are related to different levels of teachers' knowledge and, of course, practices.

Acknowledgment

This work is supported by national funds through FCT - Foundation for Science and Technology, I. P., in the context of the projects PTDC/CED-EDG/32422/2017 and PTDC/MHC-FIL/2583/2014.

References

- Cavanagh, M., & Mitchelmore, M. (2003). Graphics calculators in the learning of mathematics: teacher understandings and classroom practices. *Mathematics Teacher Education and Development*, 5, 3–18.
- Duval, R. (2006). A cognitive analysis of problems of comprehension in a learning of mathematics. *Educational Studies in Mathematics*, 61, 103–131.
- Dreher, A., Kuntze, S., & Lerman, S. (2016). Why use multiple representations in the Mathematics classroom? Views of English and German preservice teachers. *International Journal of Science and Mathematics Education*, 14(2), S363–S382.

- Even, R. (1998). Factors involved in linking representations of functions. *Journal of Mathematical Behaviour*, 17(1), 105–121.
- Friedlander, A., & Tabach, M. (2001). Promoting multiple representations in algebra. In A. Cuoco & F. Curcio (Eds.), *The roles of representation in school mathematics* (pp. 173–185). Reston: NCTM.
- Goos, M. & Benninson, A. (2008). Surveying the technology landscape: teachers' use of technology in secondary mathematics classrooms. *Mathematics Education Research Journal*, 20(3), 102–130.
- Kendal, M., & Stacey, K. (2001). Influences on and factors changing technology privileging. In M. van den Heuvel-Panhuizen (Ed.), *Proc. of the 25th PME* (Vol. 4, pp. 217–224). Utrecht, Netherlands: PME.
- Molenje, L., & Doerr, H. (2006). High school mathematics teachers' use of multiple representations when teaching functions in graphing calculator environments. In S. Alatorre, J. Cortina, M. Sáiz & A. Méndez (Eds.), *Proc. of the 28th NA-PME* (Vol. 2, pp. 884–887). Mérida, México: PME.
- Moore, T., Miller, R., Lesh, R., Stohlmann, M., & Kim, Y. (2013). Modeling in engineering: the role of representational fluency in students' conceptual understanding. *Journal of Engineering Education*, 102(1), 141–178.
- Quesada, A., & Dunlap, L. (2008). The preparation of secondary pre- and inservice mathematics teachers on the integration of technology in topics foundational to calculus. In W-C. Yang, M. Majewski, T. Alwis & K. Khairine (Eds.), *Proc. of 13th Asian Technology Conference in Mathematics*. Bangkok: ATCM.
- Rocha, H. (2013). Knowledge for Teaching Mathematics with Technology – a new framework of teacher knowledge. In A. Lindmeier & A. Heinze (Eds.), *Proc. of the 37th PME* (Vol. 4, pp. 105–112). Kiel, Germany: PME.
- Rocha, H. (2016). Teacher's representational fluency in a context of technology use. *Teaching Mathematics and its Applications*, 35(2), 53–64.
- Roorda, G., Vos, P., Drijvers, P., & Goedhart, M. (2016). Solving rate of change tasks with a graphing calculator: a case study on instrumental genesis. *Digital Experiences in Mathematics Education*, 2, 228–252.
- Wertsch, J. (1990). *The voice of rationality in a sociocultural approach to mind*. Cambridge: Cambridge University Press.
- Yin, R. (2003). *Case study research – design and methods*. Thousand Oaks: Sage Publications.
- Zbiek, R., Heid, M., Blume, G., & Dick, T. (2007). Research on technology in mathematics education. In F. Lester Jr. (Ed.), *Second Handbook of Research on Mathematics Teaching and Learning* (pp. 1169–1207). Charlotte: NCTM.

An overview of gamification and gamified educational platforms for mathematics teaching

Cecilia Russo¹ and Zsolt Lavicza²

¹Johannes Kepler University, Linz, Austria; ceciliarusso@msn.com

²Johannes Kepler University, Linz, Austria; lavicza@gmail.com

Keywords: Gamification, education, motivation, platform.

Introduction

Gamification is widely present in our daily lives and it is becoming increasingly important in 21st century education to enhance students' motivation for learning. Students live in highly technological environment and recently efforts are made to adapt for this in education. Therefore, in this research we consider technology to assist in gamifying learning and to create a gamification editor or platform that offers teachers opportunities to develop or customize their own gamified environment based on their needs. We believe it is important, because currently gamification appears in various educational technology platforms, but designed by their developers and these environments do not always cater for the specific needs of teachers, students or courses. Such gamified environments will be also valuable for mathematics teachers as they can integrate gamification elements with other mathematics related technologies and resources.

What is gamification?

Gamification is defined as “the use of game design elements in non-game contexts” (Deterding, Dixon, Khaled, & Nacke, 2011, p.10). It is present in our daily lives, for instance, we receive points for different activities or rewards in order to increase our motivation. These gamification tools proved to be successful in business, marketing, personal development and there are already some attends to use gamification in education.

Gamification elements

Werbach and Hunter (2012) classify the elements in three categories: dynamics, mechanics and components. Dynamics are no visible game elements, but they impact in the player such as emotions and progression. Mechanics are processes that drive the player through the game, these can be challenges, feedback, or rewards. Finally, dynamics and mechanics happen in the game through components and they are the most visible elements in the game, for instance, achievements, badges, levels, points and leaderboards. Game elements can be integrated since one or more work in order to achieve the others.

Although gamified environments had been created as an integrated system, the selection of each elements is very important in order to motivate and engage all player types. In general, players can be interested in different elements of a game. According to Bartel (1996) it is possible to identify four general kinds of players according to their preferences of the game, achiever, explorer, socializer and killer.

Gamification and motivation

According to some motivational approaches such as the self-determination theory (SDT) (Ryan & Deci, 2000) or Flow theory (Csikszentmihalyi, 2014) a person will experience motivation if the environment satisfies three external needs: competence, relatedness, and autonomy and if the person finds challenges, clear goals, immediate feedback, and balance between skills and challenges in the task. To design a gamified environment to raise the students' motivation, we need to add game elements and to choose activities that drive students through the autonomy, competence and relatedness feelings at the same time they experience flow.

Currently, there are some educative platforms with gamification features, which can be used by both teachers and students. Some of them let teachers to create materials or environments with some gamification features, or others offer their materials for a gamified environment. However, these platforms are quite limited and a more general editor to create gamification environment would be desired.

Proposal

The digital poster will introduce a description of the most used gamification elements as well as the connection between them in order to achieve students' motivation. As a part of this research, several educational platforms with gamification features have been reviewed, which will be presented in the poster through a brief description and a summary of their features. In addition, some recommendations will be offered to help developing a new kind of gamification editor platform; especially focusing on how mathematics teachers can utilize such platforms and how they can combine mathematical software and mathematics resources with gamification elements.

References

- Bartle, R. (1996). Hearts, clubs, diamonds, spades: Players who suit MUDs. *Journal of MUD Research*, 6(1), 19. Retrieved from https://www.researchgate.net/profile/Richard_Bartle/publication/247190693_Hearts_clubs_diamonds_spades_Players_who_suit_MUDs/links/540058700cf2194bc29ac4f2.pdf
- Csikszentmihalyi, M. (2014). *Applications of Flow in Human Development and Education: the collected works of Mihaly Csikszentmihalyi*, Dordrecht, Netherlands: Springer.
- Deterding, S., Dixon, D., Khaled, R., & Nacke, L. (2011). From game design elements to gamefulness: defining "gamification". In *Proceedings of the 15th International Academic MindTrek Conference on Envisioning Future Media Environments - MindTrek '11*, 9–15. <https://doi.org/10.1145/2181037.2181040>
- Werbach, K., & Hunter, D. (2012). *How game thinking can revolutionize your business. Gamification of Learning*, Philadelphia: Wharton Digital Press
- Ryan, R. M., & Deci, E. L. (2000). Intrinsic and Extrinsic Motivations: Classic Definitions and New Directions. *Contemporary Educational Psychology*, 25(1), 54–67. <https://doi.org/10.1006/ceps.1999.1020>

Professional development through a web-based portal: The progress of mathematics teachers teaching algebra based on hypothetical learning trajectories

Dilek Tamışlı¹, Nilüfer Köse¹ and Melih Turgut²

¹Anadolu University, Eskisehir, Turkey

²Eskisehir Osmangazi University, Eskisehir, Turkey; mturgut@ogu.edu.tr

The aim of this paper is to present preliminary findings of a large-scale project for designing a web-based portal to contribute to the professional development of mathematics teachers for teaching algebra in lower secondary education. Eleven teachers volunteered to participate in this research that aimed to design hypothetical learning trajectories (HLTs) for sixth-grade algebra context over a three-week period. The teachers designed their own HLTs through a web portal by receiving feedback from mathematics teacher educators online. Their processes of designing and applying lesson plans during the first and third week were analysed according to the components of HLT and the theoretical perspective of the quartet of subject matter knowledge. Data analysis revealed that the teachers managed to define more coherent learning goals and hypothesis for their students' learning as well as making connections between the concepts.

Keywords: Mathematics teacher, Professional development, Hypothetical learning trajectories.

Introduction

In Turkey, as in many countries, studies on the mathematics teacher knowledge received particular attention from researchers (Gökkurt & Soylu, 2016; Türnüklü, Akkaş & Gündoğdu Alaylı, 2015). Research on in-service teachers commonly indicates that a number of issues exist regarding teachers' subject matter knowledge of mathematics. Researchers have addressed major problems in the Turkish context: (i) a lack of certain professional development programs and their sustainability; and (ii) a gap between research and practice, which, in particular, means a lack of communication between mathematics teacher educators and in-service mathematics teachers (Yıldırım, 2013). The latter is of crucial importance since professional development activities are generally organised independently by each public school whereby teachers prepare termly plans without any collaboration with mathematics teacher educators. This research study elaborates the design and use of a web-based portal to contribute to the professional development of mathematics teachers, in which they design their own teaching-learning algebra activities within a perspective of hypothetical learning trajectories (HLT) (Simon, 1995) through close interaction with mathematics teacher educators.

We focus on the algebra context of Turkish (lower) secondary school curriculum and design a large-scale research project adopting a number of theoretical and conceptual elements, such as *mathematics teaching cycle* and HLT (Simon, 1995) and the mathematics *subject matter knowledge quartet*, as described by Rowland, Huckstep and Thwaites (2005).

Theoretical Framework and Description of the Project

The notion of a *learning trajectory* corresponds to possible (anticipated) learning paths that students could follow in a proposed content designed under certain objectives. Since learning, in itself, is a complex process and depends on phenomenological experiences, Simon (1995) adds the word *hypothetical* to learning trajectory to emphasise a teacher's prediction about students learning and elaborates the notion of HLT under three components; 'the learning goal that defines the direction, the learning activities, and the hypothetical learning process' (p. 136). In fact, Simon (1995) considers the HLTs as a part of mathematics teaching cycle, which includes certain key components such as a teacher's knowledge and an assessment of student knowledge (Figure 1).

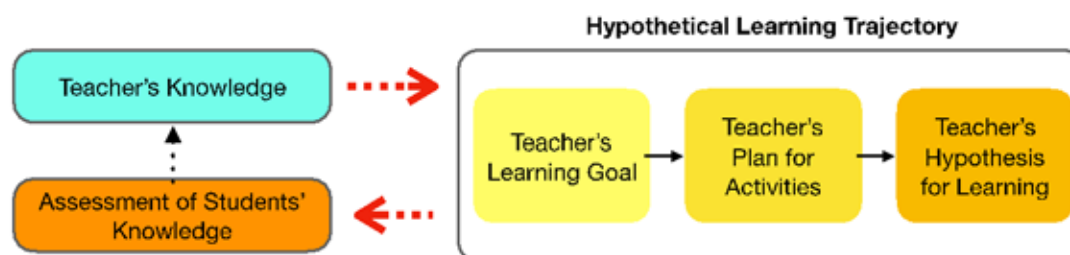


Figure 1: Mathematics Teaching Cycle (adapted from Simon, 1995, p. 136)

In Figure 1, particular emphasis is given to the teacher's knowledge as a starting point. Therefore, in this research, we consider and refer to a quartet of subject matter knowledge of mathematics (Rowland et al., 2005) that has four dimensions; *foundation*, *transformation*, *connection*, and *contingency*. The first component, foundation refers to a repertoire of the teacher's academic knowledge for teaching-learning mathematics including his/her beliefs regarding why mathematics is important and why it should be taught. Here, transformation refers to the transformation of theoretical knowledge into practice by designing and planning pedagogical tasks in terms of choosing appropriate examples and activities for the construction of mathematical meanings. The notion of connection refers to the coherence of designed parts of a lesson or series of lessons through deliberately chosen activities and domain-specific tasks. Such pedagogical task sequences enable students to make a connection between different concepts as well as to the interplay between different representations. The final component contingency refers to 'classroom events that are almost impossible to plan for' (Rowland et al., 2005, p. 263).

Related literature confirms that Simon's (1995) mathematics teaching cycle within HLTs could be a heuristic tool for teachers' professional development (e.g. Wilson, Mojika, & Confrey, 2013). Consequently, we exploit mathematics teaching cycles as twofold: as a perspective for designing interfaces of the web portal (which will be explained in the next subsection); and as an analysis tool to explore teachers' progress as a part of their professional development. In order to elaborate development of teachers' knowledge in depth, we also refer to the subject matter knowledge quartet as an additional analysis tool while looking deep into the teachers' lesson plans.

The Project and Research Question

Since the Internet is now widely used in different platforms as well as in educational contexts, we designed a sustainable and specific web portal to ensure mathematics teachers' professional

development regarding algebra content of the (lower) secondary school mathematics curriculum. We specifically focused on algebra content as the researchers in the project team have background knowledge in epistemological issues and misconceptions regarding learning algebra. In order to create such a portal, at first, a domain <http://megedep.anadolu.edu.tr> was taken, where ‘megedep’ referred to a shortcut of the project’s title in Turkish. Figure 2 displays the (homepage) interface of the website.



Figure 2: Megedep’s (Web portal) interface

The interface includes some practical information in addition to theoretical foundations that are necessary for participating teachers in the project. More precisely, the interface includes a video describing the aim of the project, a manual for using the website, an introductory description for constructivism and the notion of HLT, as well as exemplary lesson designs under the notion of HLT. After registering to the website, the teachers could connect to a user interface including the components of the mathematics teaching cycle, which is sketched in Figure 3a.



(a)

(b)

Figure 3: a. The user interface (translated), b. The user interface to enter components of HLT

When a teacher selects ‘Process’, Figure 3b is shown, where the teacher enters the class level, the topic and the related learning objectives determined by the Turkish Ministry of National Education (MoNE, 2018) of Turkey. In the portal, we followed Khan (2005) for designing an e-learning platform where there exists an effective *feedback* system. When teachers enter the learning goal, possible activities and their hypotheses for students learning, the mathematics (teacher) educators

(MTEs) (in this paper, the authors) of the project receive alerts by email. Through entering their own interface, MTEs review the teachers' input and give feedback to the teachers to improve the anticipated teaching and learning processes. Thereafter, the teachers make revisions, and if they complete necessary improvements, then they could proceed to design a more fine-grain teaching plan. After that, the MTEs again review their plans and provide feedback. The progress continues in a cycle like this. However, it ends when the teachers record their own teaching episode and upload videos to the web portal after having written their responses to some reflective questions (described in the methods section) regarding the process. Thereafter, the MTEs watch the teaching episodes and review the teachers' responses to reflective questions by taking notes and then communicate their ideas to the teachers through the portal for the teachers to prepare and develop the next episodes.

In this paper we provide a brief analysis of the teachers' initial lesson designs and the final (third) lesson designs created within the web portal to explore their professional development progress. We address the research question: How does mathematics teachers' professional development progress when they use megedep portal to design HLTs and lesson plans for teaching algebra?

Methods

Theoretical insights of the mathematics teaching cycle (Simon, 1995) and quartet of subject matter knowledge (Rowland et al., 2005) refer to a qualitative paradigm. In this paper, in order to explore progress of teachers' professional development in depth, we consider the same perspective and adopt a case study design (Bogdan & Biklen, 1998). Eleven (all six grade teachers) secondary school mathematics teachers (T1–T11) with different teaching experiences (ranging 1–15 years) volunteered to participate in the project. All of the participants work in the same city located in central Turkey and have experience of the objectives (algebra) of the national curriculum, having all graduated from faculties of education from different universities. In addition, while T1, T5, T6, T8 and T10 have only a bachelor degree, T7 is studying for a master's degree and also T2, T3, T4 and T11 are studying for doctorates. One participant, T9, already holds a master's degree. All of the participants learnt of the notion of HLT for the first time as they become involved in the project. During the first project meeting (lasting around three hours), all of the participants were introduced to the philosophy behind constructivism, the use of the megedep web portal, and the notion HLT with a number of exemplary cases.

The Data and Analysis

The data comes from two sources: the first is based on the MTEs' evaluations of the teachers' designs of HLTs. In other words, the teachers designed their initial HLTs and MTEs wrote feedback to improve each part. After the teachers' improvements on the HLTs, the designs were reviewed once more. The first part of the data comes from the MTE final reviews of the HLTs. The second part of the data comes from the teachers' responses to reflective questions that were proposed after they completed teaching episodes. Three reflective questions were asked before the teachers applied their HLTs whereas four questions being proposed after they applied their lesson plans.

Table 1 shows the reflective questions that were proposed to the teachers through the megedep interface.

Before application of the lesson plans	After application of the lesson plans
<p><i>-What were the key elements in your lesson plan?</i></p> <p><i>-How and why did you determine the activities in your plan?</i></p> <p><i>-How did you determine your hypotheses for students learning?</i></p>	<p><i>-Which learning goals were obtained and which were not? Explain in detail.</i></p> <p><i>-Which parts of your plan worked well, or which did not? Explain in detail.</i></p> <p><i>-Which hypotheses of student learning appeared in the classroom? Did all? Were there any contingency cases? If so, what did you do?</i></p> <p><i>-In the teaching process, which concepts were conceptualised and which were not? Explain in detail.</i></p>

Table 1: Reflective questions proposed to the teachers through the megedep interface

The teachers prepared three teaching episodes corresponding to three weeks. In other words, they prepared an HLT for each week considering the objectives of the curriculum. MTEs evaluated the first and third week's HLTs, in order to explore the teachers' progression. Similarly, the MTEs also collected all of the responses given to the reflective questions. A thematic analysis (Miles & Huberman, 1994) was employed to elaborate emerging main themes within a perspective of components of HLT and the quartet of subject matter knowledge.

Findings

Since our focus is on designing HLTs and lesson plans as components of professional development, we will present our findings in two subsections; an analysis of the teachers' designs of HLTs and an analysis of the teachers' designs and applications of lesson plans.

Analysis of the Teachers' Design of HLTs

The analysis of the teachers' first HLT designs revealed: four themes appeared for determining learning goals; three themes for determining activities; and four themes for determining the hypotheses for students learning. Table 2 describes these themes and their respective frequencies.

Determining Learning Goals	Determining Activities	Determining Hypotheses
<p><i>-Defining learning goals coherent with curriculum objectives (T1)</i></p> <p><i>-Not sequencing learning goals (T2, T3, T4, T5, T6, T7, T8)</i></p> <p><i>-Referring to objectives as learning goals (T9, T10, T11)</i></p> <p><i>-Defining learning goals, not in relation to objectives (T8, T7, T6, T2)</i></p>	<p><i>-Determination of coherent activities (T7, T8, T6, T11, T9, T3, T2)</i></p> <p><i>-Activities not based on the curriculum objectives (T8, T6, T7, T10)</i></p> <p><i>-Writing only the title of activities (not based on any objective) (T5, T1, T4)</i></p>	<p><i>-Writing hypotheses based on activities (T2, T3, T11)</i></p> <p><i>-Formulating a partial hypothesis not focusing on entire student learning (T4, T9, T1, T5, T10, T8)</i></p> <p><i>-Hypotheses not based on the activities (T7)</i></p> <p><i>-Not a clear formulation (T6)</i></p>

Table 2: Themes regarding the teachers' design of the first HLT

Table 1 reveals that only one teacher defined learning goals according to the objectives of the curriculum, whereas seven teachers could not define sequencing learning goals, i.e. they were not able to express learning goals in order. Three teachers directly referred to the curriculum objectives

as learning goals, while four of them defined the learning goals independent of the curriculum objectives. With respect to a determination of the activities, seven teachers managed to define coherent activities, i.e. activities that are coherent with curriculum objectives and also with the learning goals that they defined. Four teachers expressed activities not based on the objectives and three teachers only wrote the title of activities without giving any details. Three teachers expressed their hypotheses that are coherent with the learning objectives and activities that had been written before. However, it should be noted that these three teachers thought that students would follow the same learning trajectory. Six teachers formulated their hypotheses partially, without focusing on the students' entire learning of the proposed concepts, while one teacher proposed a hypothesis independent of the activities and learning goals. Moreover, one teacher expressed his possible teaching steps, including no trace of the hypotheses of students learning.

After all the teachers had used the megedep portal for three weeks, we analysed their resulting HLTs. Tables 3 shows that there were two emerging themes for determination of the learning goals; one theme for the determination of the activities and two themes for the determination of the hypotheses.

Determination of Learning Goals	Determining Activities	Determining Hypotheses
<p><i>-Defining learning goals based on the curriculum objectives (T6, T1, T3, T4, T7, T11, T5, T2)</i></p> <p><i>-Defining learning goals part by part, not based on all curriculum objectives (T10, T8, T9)</i></p>	<p><i>- Determination of coherent activities (T6, T1, T3, T10, T4, T7, T11, T5, T2, T8, T9)</i></p>	<p><i>- Writing hypotheses based on activities (T3, T11, T5, T2)</i></p> <p><i>- Formulating a partial hypothesis not focusing on entire student learning (T6, T1, T10, T4, T7, T8, T9)</i></p>

Table 3: Themes regarding the teachers' design of the third HLT

Eight teachers managed to define learning goals based on the curriculum objectives. However, there were still three teachers who defined learning goals part-by-part, not based on the curriculum objectives. All of the teachers were able to define activities coherent with the learning goals and curriculum objectives and also explained them in detail. With respect to a determination of the hypothesis, four teachers expressed the hypotheses of students' learning that were coherent with the learning goals and activities, while seven teachers formulated hypotheses part-by-part, not focusing on the conceptual learning.

Analysis of the Teachers' Designs and Applications of the Lesson Plans

The teachers' responses to the reflective questions posed after the first and the third weeks' lesson plans were analysed according to the quartet of subject matter knowledge. When the authors compared the personal analyses on the reflective questions, it was agreed to consider the same themes for the first and the third week's results. As a result, four themes emerged for the foundation component, three themes emerged for transformation component, five themes emerged for connection component, and three themes emerged for the contingency component. Table 4 summarises the emerging themes with the arrows indicating some themes that have specific meanings. For instance, $a \rightarrow b$ means that a is the number of teachers in the first week, while b is the number of teachers in the third week.

Foundation	Transformation	Connection	Contingency
<i>-Recognition of students' misconceptions (7→11)</i> <i>-Proposing affective questions (3→5)</i> <i>-Focusing on computational applications (7→2)</i> <i>-Referring to multiple ways assessing student knowledge (3→8)</i>	<i>-Using multiple representations (11→11)</i> <i>-Selecting and/or preparing carefully-designed problems (2→9)</i> <i>-Explaining mathematical concepts in several ways (3→11)</i>	<i>-The interplay between mathematical concepts and notions (3→11)</i> <i>-The interplay between mathematical problem-solving techniques (4→11)</i>	<i>-Thinking all the goals were achieved by students: no contingency action (2→0)</i> <i>-Explaining which parts of the plans worked and why (6→11)</i> <i>-Explaining how and why certain activities did not work (2→11)</i>

Table 4: Overview of the teachers' design and application of the lesson plans

Table 4 indicates that there is an increase in the number of the teachers, who recognised students' misconceptions, proposed effective questions and referred to multiple ways of assessing student knowledge by the end of the third week's application. In parallel with this finding, the teachers' focus on computational applications decreased. No change occurred in the use of multiple representations while selecting and/or preparing carefully-designed tasks, and the teachers' emphasis on explaining mathematical concepts increased. Similarly, at the end of the third week, the teachers' interplay between mathematical concepts and interplay between mathematical problem-solving techniques increased. With regard to the contingency component, after the first week's application, two of the teachers believed that all of the goals had been achieved by the students. However, at the end of the third week, there is an indication that most of the teachers' beliefs were changed. Moreover, at the end of the third week, the teachers managed to explain how and why certain parts of the plans and proposed activities did not work.

Conclusions and Further Steps

In this paper, we present preliminary findings of an on-going large-scale project aiming to contribute to the professional development of mathematics teachers through a web-based portal. The findings of the study suggested that at the end of three weeks' usage of the megedep portal, the participant teachers managed to define more coherent learning goals, classroom activities and hypotheses for students learning regarding (lower) secondary school algebra. Most progress is observed in the teachers' interplay between the mathematical concepts by referring to different mathematical problem-solving techniques. These conclusions were possible for the teachers' own readings of the existing literature on learning algebra and the MTEs feedback that was given at each step for designing HLTs through the megedep portal. However, expressing hypotheses for students learning as well as determining learning goals based on curriculum objectives are not trivial tasks for the teachers. We aim to acknowledge this fact by showing or preparing more examples from the literature (e.g. Simon, 1995; Simon & Tzur, 2004) in order to provide teachers with a detailed understanding to write hypotheses for their own classroom context. In summary, the main contribution of this paper is to show how a web-based portal could mediate the professional development of mathematics teachers, where the key component in such progress is peers' review

and feedback in lower algebra context provided by the megedep portal. The use of acknowledged digital technologies here constructs a link between a *collaborative design* for teaching-learning algebra and *classroom practice*, which can be considered as novel progress for their professional development. The main ease here is the collaboration, which is independent of time and place.

The next steps of the project can be summarised by conducting the same process with seventh grade teachers, but over seven weeks and this time focusing on the students learning and the use of pre-test and post-test tasks. The results of these steps will be the focus of future research papers.

Acknowledgement

This research is supported by the Scientific and Technological Research Council of Turkey (TÜBİTAK) under SOBAG 1001 programme. We would like to thank TWG15 reviewers for their careful reading of the paper and substantial suggestions that improved the paper.

References

- Bogdan, R.C., & Biklen, S.K. (1998). *Qualitative Research for Education: An Introduction to Theory and Methods* (3rd ed.). MA: Ally and Bacon.
- Gökkurt, B., & Soylu, Y. (2016). Examination of middle school mathematics teachers' pedagogical content knowledge: The sample of cone. *Elementary Education Online*, 15(3), 946–973.
- Khan, B. (2005). *Managing e-Learning: Design, Delivery, Implementation and Evaluation*. Hershey, PA: IGI Global.
- Miles, M., & Huberman, M. (1994). *Qualitative Data Analysis: An Expanded Sourcebook*. Thousand Oaks, CA: Sage Publications.
- Ministry of National Education (MoNE) (2018). *İlkokul ve Ortaokul Matematik Öğretim Programı [Mathematics Curricula for 1-8 Grades]*. Ankara: Talim Terbiye Kurulu Başkanlığı.
- Rowland, T, Huckstep, P., & Thwaites, A. (2005). Elementary teachers' mathematics subject knowledge: The knowledge quartet and the case of Naomi. *Journal of Mathematics Teacher Education*, 8(3), 255–281.
- Simon, M.A. (1995). Reconstructing mathematics pedagogy from a constructivist perspective. *Journal for Research in Mathematics Education*, 26(2), 114–145.
- Simon, M.A., & Tzur, R. (2004). Explicating the role of mathematical tasks in conceptual learning: An elaboration of the hypothetical learning trajectory. *Mathematical Thinking and Learning*, 6(2), 91–104.
- Türnüklü, E., Akkaş, E.N., & Gündoğdu Alaylı, F. (2015). Mathematics teachers' perceptions of quadrilaterals and understanding the inclusion relations. In B. Ubuz, Ç. Haser & M.A. Mariotti (Eds.), *Proceedings of the Eighth Congress of the European Society for Research in Mathematics Education* (pp. 705–714). Ankara, Turkey: Middle East Technical University and ERME.
- Wilson, P. H., Mojica, G. F., & Confrey, J. (2013). Learning trajectories in teacher education: Supporting teachers' understandings of students' mathematical thinking. *Journal of Mathematical Behavior*, 32, 103–121.
- Yıldırım, A. (2013). Teacher education research in Turkey: Trends, issues and priority areas. *Education and Science*, 38(169), 175–191.

Self-efficacy – the final obstacle on our way to teaching mathematics with technology?

Daniel Thurm¹ and Bärbel Barzel²

¹University Duisburg-Essen, Germany; daniel.thurm@uni-due.de

²University Duisburg-Essen, Germany; baerbel.barzel@uni-due.de

Despite the potential of digital technology to enhance the learning of mathematics the use of graphing tools with or without computer algebra systems (CAS) remains low. For this reason, there is a need to identify and understand factors that lead to greater technology uptake. In this quantitative study with 198 upper secondary in-service teachers from Germany the relation between self-efficacy beliefs and frequency of technology use in the mathematics classroom is examined. Results show that higher self-efficacy beliefs are strongly associated with a more frequent use of technology. Based on the results, recommendations for teacher education are given.

Keywords: Self-efficacy, technology, teacher-education, graphing calculators, professional development.

Introduction

Research in the last decades has shown that digital technology like function plotters or computer algebra systems can facilitate the learning of mathematics in many different ways (Drijvers et al., 2016). For this reason, there is an ubiquitous call for the integration of these technologies into mathematics teaching. However current use of technology in the mathematics classroom still remains low:

“Nowadays there exist countless ideas, classroom suggestions, lesson plans and research reports for the use of new technologies in mathematics classrooms. But the situation concerning the real use of DT [digital technology] in mathematics classrooms has not succeeded in the way many had expected in the last decades.” (Weigand, 2014, p. 5; see also Heid, Thomas, & Zbiek, 2013, p. 599)

This indicates that the implementation of technology into the mathematics classroom is not a straightforward task and draws attention to the need to understand the factors influencing technology uptake. This is particularly important for the design of professional development (PD) programs which aim at supporting teachers’ when integrating digital technology. Research shows that beliefs and knowledge as well as external factors like school culture and resources play an important role (Heid, Thomas, & Zbiek, 2013, p. 630). However, less attention has been given to self-efficacy beliefs which capture a persons’ perceived ability to organize and execute courses of action (Bandura, 1997, p. 3). Therefore, this paper explores to what extend self-efficacy beliefs in the domain of teaching mathematics with technology influence the uptake of technology.

Theoretical background

Digital technology in the mathematics classroom comprises a plethora of different technologies. These range from general technology that can be used across different subjects (e.g. word

processing software like MS-Word) to subject-specific technology like digital learning environments, function plotters, geometry packages and computer algebra systems (CAS) that are specifically used in mathematics education. In this paper, unless stated otherwise, the term “technology” is used to refer to these specific tools, that are also known under the term “Mathematics Analysis Software” (MAS; Pierce & Ball, 2009). In the last 30 years, a great number of research projects has shown that MAS can support student learning in many different ways. For example, these tools can facilitate constructivist teaching approaches like discovery learning by giving pupils the opportunity to explore mathematical links on their own. In addition, digital tools can enhance conceptual understanding of mathematics by providing easy access to multiple and linked representations (Drijvers et al., 2016). For this reason, the use of technology in the mathematics classrooms is advocated for by researchers as well as teachers.

Despite this call for a deep integration of technology into mathematics teaching there is a “widely perceived quantitative gap and qualitative gap between the reality of teachers’ use of ICT and the potential for ICT suggested by research and policy“ (Bretscher, 2014, p. 43). Reasons for this are multifaceted and many different factors have been proposed in the last decade which can affect the uptake of technology. These factors include external factors like time constraints and resources (Thomas & Palmer, 2014, p. 72; Heid, Thomas, & Zbiek, 2013, p. 630). However, research indicates that the most important factor is the teacher who is ultimately responsible for how and when technology is used: “Clearly, schools can go only so far to encourage ICT use; actual take-up depends largely on teachers’ personal feelings, skills and attitudes to IT in general” (Mumtaz, 2000, p. 337). Therefore, internal factors like teacher knowledge and teacher beliefs have become the focus of attention. For example, the concept of TPACK (Mishra & Koehler, 2006) acknowledges, that a special type of knowledge is needed by teachers to teach mathematics with technology. Also, pedagogical beliefs, for example about constructivist or traditional philosophies of teaching mathematics, and beliefs referring to the teaching and learning mathematics with technology have been studied, showing that these beliefs can play an important role.

However, it seems that research has given little attention to teacher self-efficacy-beliefs when teaching mathematics with technology. Self-efficacy beliefs are defined as “a judgement of one’s ability to organize and execute the courses of action required to produce given attainments“ (Bandura, 1997, p. 3). This means, self-efficacy beliefs don’t capture the actual ability of a person but rather describe how someone perceives it. Research about the integration of general technology like word processing or presentation software across different subjects has found that self-efficacy beliefs play a crucial role for the uptake of these technologies (Ertmer & Ottenbreit-Leftwich, 2010; Wang, Ertmer, & Newby, 2004). As Ertmer & Ottenbreit-Leftwich note: “Although knowledge of technology is necessary, it is not enough if teachers do not also feel confident¹ using that knowledge to facilitate student learning” (Ertmer & Ottenbreit-Leftwich, 2010, p. 261). Therefore, it is

¹ The term “confidence” is often used interchangeably with the terms “self-efficacy” or “self-efficacy beliefs”. However Bandura notes that „Confidence is a catchword in sports rather than a construct embedded in a theoretical system“ (Bandura, 1997, p. 382). Therefore, we will use the term “self-efficacy beliefs” throughout this paper.

particular surprising that self-efficacy beliefs have not been studied in much detail in the context of teaching with MAS. Apart from the works of Cavanagh & Mitchelmore (2003, p. 16), Doerr & Zangor (2000, p.159) and Hong & Thomas (2006) where the role of self-efficacy beliefs becomes apparent subliminally at some points, we could only identify the work of Thomas & Palmer (2014) explicitly taking self-efficacy beliefs into account. They show that 42% of the surveyed teachers do mention lack of self-efficacy as an obstacle preventing teachers to use calculators more in their teaching. In addition, teachers with higher self-efficacy beliefs showed a more positive attitude to technology and to the use of technology in the learning of mathematics. Hence, they include confidence as a key factor in their model for technology integration. In summary, there seems to be some indication that teacher self-efficacy beliefs play an important role for the integration of technology into the mathematics classroom, but empirical evidence that teachers' self-efficacy beliefs about teaching with MAS is indeed linked to the classroom usage of technology is lacking.

Research question & methodology

The study aims to explore the link between self-efficacy and use of MAS. To achieve this goal, it is necessary to measure teachers' self-efficacy beliefs as well as teachers' technology use. Since the frequency of technology use can be more validly be self-reported by teachers compared to the quality of their teaching (Mayer, 1999) we focus on self-reported frequency of technology use and addresses the following questions: Do teachers with higher self-efficacy beliefs use MAS more often than teachers with lower self-efficacy beliefs? Which areas of technology use show particular strong links to self-efficacy beliefs?

To capture the frequency of technology use we used a likert-scale questionnaire (Thurm, 2018) assessing the use of technology in the following areas: (f1) use of technology for discovery learning, (f2) use of technology for linking multiple representations, (f3) use of technology when practicing, (f4) use of technology to support individual learning. In addition, a category capturing how often the use of technology was subject to critical reflection was included. Items in this category asked for example how often limitations of technology were discussed or how often there was a critical reflection about when to use pen & paper skills and when to use technology to solve a given task.

To measure teachers' self-efficacy beliefs, we developed a questionnaire that assessed self-efficacy in two domains (see below). For each of these domains a set of items was generated and refined until validity of the items was agreed on by teachers and experts. Response category was chosen according to Banduras "Guide for constructing self-efficacy scales" (Bandura, 1997) which recommends that teachers rate the strength of their belief in their ability on a scale from 0-100. In the following we give a brief description of each domain:

(s1) Self-efficacy related to task design & task selection when teaching with technology (4 Items)

The design of tasks is one of the most important factors when teaching with technology: „The inclusion of technology requires an understanding of the kinds of tasks that may utilize the resources provided by the technology to support students' high-level thinking“ (Sherman, 2014, p. 225; see also Drijvers, 2015). If teachers don't feel able to select and design appropriate tasks they are most likely to use their old tasks that are usually not tuned to the use of technology. Two sample

items of the scale were: I can design task for the use with MAS. I can distinguish between good and bad tasks for the use with MAS.

(s2) Self- efficacy related to lesson design & lesson implementation (4 Items)

These tasks however will not unfold their potential on their own. They need to be embedded in carefully designed lessons. Hence teachers must feel able to design and carry out appropriate lessons:

“[...] the teacher has to orchestrate learning, for example by synthesizing the results of technology-rich activities, highlighting fruitful tool techniques, and relating the experiences within the technological environment to paper-and-pencil skills or to other mathematic activities.” (Drijvers, 2015, p.148)

Two sample items of the scale were: I can design and implement lessons that support discovery learning using MAS. I am able to design lessons that make versatile use of MAS.

Both scales were administered in 2014 to 198 upper secondary school teachers within a larger research study (Thurm, Klinger, & Barzel, 2015) in North Rhine-Westphalia, Germany. In this state the use of MAS is compulsory in the final examination in upper secondary since the schoolyear 2014/2015. The average age of the teachers was 43 years, which is comparable to the average age of 45 years for all teachers in North Rhine-Westphalia. Teaching experience with mathematics was distributed as follows: 0-5 years (27%), 6-11 years (19%), 12-17 (16 %), 18-23 (11%), more than 23 years (25%). Due to the fact that MAS had been made compulsory only shortly before the study took place, there was a large number of teachers without any previous experience in teaching with MAS. In total, 52% had no previous experience teaching mathematics with technology and only 12% had more than 5 years' experience in teaching mathematics with technology.

Results

In a first step we used a confirmatory factor analysis to scrutinize the quality of the questionnaires on an empirical base. The goodness of fit was judged using the chi-square-fit index, the root mean square error of approximation (RMSEA), the standardized root mean square residual (SRMR) and the comparative fit index (CFI). The result for the self-efficacy questionnaire showed a good model fit with $RMSEA = 0.041$ $SRMR = 0.022$, $CFI = 0.994$, and $\chi^2 / df = 1.327$. The scales (s1) and (s2) also showed a good reliability with Cronbach' s alpha equal to 0.92 and 0.9 respectively. The goodness of fit and the reliability of the questionnaire assessing frequency of technology use were also high (see Thurm, 2018).

In first step we checked to what extend experience in teaching mathematics and teaching with MAS correlated with self-efficacy and frequency of technology use. As can be seen (Table 1) there is a small correlation between self-efficacy and the number of years teachers previously used technology in their classroom. Subsequently, we calculated the correlation between all scales on a latent level (Table 1). It is obvious that there are significant correlations between all subscales indicating that higher self-efficacy beliefs correspond to more frequent use of technology. Self-efficacy in the area of task design (s1) is most strongly linked to discovery learning (f1) and practice (f3), self-efficacy in the area of lesson design and implementation (s2) is most strongly

linked to discovery learning (f1) and individual learning (f4). In addition, it is remarkably that the scale (s2) consistently shows higher association with frequency of technology use than the scale (s1). Lowest correlation between self-efficacy and frequency of technology use is observed for the areas of multiple representation (f2) and reflection (f5).

		Self-efficacy			
Frequency of use		(s1) Designing tasks	(s2) Designing & implementing lessons	TE mathematics (years)	TE technology (years)
	(f1) Discovery learning	0.427***	0.564***	-0.03	0.14
	(f2) Multiple representations	0.230*	0.317**	0.06	0.07
	(f3) Practice	0.435***	0.445***	0.13	0.13
	(f4) Individual learning	0.391***	0.516***	-0.06	0.11
	(f5) Reflection	0.289**	0.293**	-0.15	0.03
	TE mathematics (years)	-0.08	-0.12	1	0.13
	TE technology (years)	0.27**	0.33**	0.13	1

Table 1: Result of the correlation analysis (* $p < 0.1$, ** $p < 0.01$, * $p < 0.001$, TE=Teaching experience)**

Discussion

The study aimed to provide empirical evidence for the link between self-efficacy and using MAS. The results clearly indicate a strong relationship showing that higher self-efficacy beliefs are associated with more frequent use of technology. In addition, self-efficacy correlates only to a limited extent with teaching experience with technology, which indicates that teachers need additional support for developing their self-efficacy beliefs. In total, the results support the model of Thomas & Palmer (2014) who include self-efficacy as a key variable in their model of technology integration. Furthermore, the importance of self-efficacy becomes even more pronounced when noticing that the size of the correlation between self-efficacy and frequency of technology use is higher compared to the correlation of technology-related beliefs and frequency of technology use found in Thurm (2018). This indicates that self-efficacy beliefs might be even more influential for technology uptake than beliefs about the value of technology in the learning of mathematics.

But why do self-efficacy beliefs seem to play such an important role? One explanation might be, that teaching with technology poses a plethora of new challenges because it requires many changes in the teaching routines and attitudes. For example, traditional task that requires routine pen & paper skills easily become obsolete in the presence of a CAS. In addition, teaching with MAS can lead to more individualized learning, with greater uncertainty for the teacher who cannot longer simply follow a strict teaching plan. For example, Dunham & Dick (1994, p. 443) stress, that teachers teaching with technology need to be much more used to deal with unplanned situations,

show more flexibility and may experience a perceived loss of control. Especially for teachers that are used to a traditional style of teaching this can pose a major challenge:

“[...] the use of technology often means more individualized, student-centered classrooms in which teachers are no longer the sole source and authority of knowledge. This could be very disturbing to many teachers who are used to lecturing and other teacher-centered approaches because it require them to abandon their routines and learn new ways of teaching.“ (Zhao & Cziko, 2001, S.18)

From the results several recommendations for teacher education and professional development can be inferred. Firstly, programs must place a stronger focus on developing teacher's self-efficacy beliefs. Currently, knowledge, pedagogical beliefs and beliefs regarding the teaching of learning with technology seem to be the focus of most technology related professional development programs (e.g. Chamblee et al. 2008). Even though these factors might also increase self-efficacy, the most effective way of increasing self-efficacy is to enable successful mastery experiences for teachers. For example, Tschannen-Moran & McMaster (2009) compared different approaches for fostering self-efficacy beliefs in PD-programs and concluded that authentic mastery experience embedded in the teachers regular teaching context was the most powerful way to foster self-efficacy beliefs. In particular, they stress the role of individual support for teachers: “Without coaching to assist teachers in the implementation of the new skill, a significant proportion of teachers were left feeling more inadequate than they had before“ (Tschannen-Moran & McMaster, 2009, p. 241). However, programs that individually assist teachers to put theory into practice in this way appear to be quite rare in the context of teaching with technology (Gugeon et al., 2009, p.343). This might be due to the fact that individual coaching is quite resource intensive and hard to scale up.

For this reason, it might be fruitful to develop strategies for increasing self-efficacy even when individual coaching is not possible due to a lack of resources. For example, teachers might prepare a class for their fellow PD-participants and carry out part of the class during the PD-meetings. With this respect, approaches like micro-teaching or approximations-of practice (Grossmann, Hammermess & McDonald, 2009) could be a fruitful approach. Another way to increase self-efficacy could be the use of vicarious experiences which refers to hearing about or observing other teacher's successful technology integration (Wang, Ertmer & Newby, 2004).

Finally, the results from this study also give some indication about content selection for PD-programs. The result that self-efficacy beliefs are stronger correlated with frequency of technology use for supporting discovery learning than with frequency of technology use to support multiple representation might reflect that discovery learning requires much stronger self-efficacy beliefs due to its complexity. In contrast, the use of multiple representations is perceived as less complex and less challenging. PD-programs could therefore choose the support of multiple representations as starting point for novice teachers and advance to discovery learning in later stages.

In summary, this study shows that teachers' self-efficacy beliefs are an important factor when teaching mathematics with technology. PD-programs must provide means to strengthen teacher's self-efficacy beliefs if we want to take teachers needs seriously and change the degree of technology integration. Otherwise the outcome of PD-programs might be limited to knowledgeable

teachers that are convinced about the benefits of technology, but lack the self-efficacy to put their knowledge and beliefs into practice. We should not miss the final step that might be self-efficacy beliefs.

References

- Bandura, A. (1997). *Self-Efficacy. The exercise of control*. New York: Prentice-Hall.
- Bretscher, N. (2014). Exploring the quantitative and qualitative gap between expectation and implementation: A survey of english mathematics teachers' uses of ICT. In A. Clark-Wilson, O. Robutti, & N. Sinclair (Eds.), *The mathematics teacher in the digital era: An international perspective on technology focused professional development* (Vol. 2, pp. 43–70). Dordrecht: Springer.
- Cavanagh, M. & Mitchelmore, M. (2003). Graphics calculators in the learning of mathematics: Teacher understandings and classroom practices. *Mathematics Teacher Education and Development*, 5, 3–18.
- Doerr, H. M., & Zangor, R. (2000). Creating meaning for and with the graphing calculator. *Educational Studies in Mathematics*, 41(2), 143–163.
- Drijvers, P. (2015). Digital technology in mathematics education: Why it works (or doesn't). In S. J. Cho (Ed.), *Selected regular lectures from the 12th international congress on mathematical education* (pp. 135–151). New York: Springer.
- Drijvers, P., Ball, L., Barzel, B., Heid, M.K., Cao, Y. & Maschietto, M. (2016). *Uses of technology in lower secondary mathematics education: A concise topical survey*. London: Springer Open.
- Dunham, P. H., & Dick, T. P. (1994). Research on graphing calculators. *The Mathematics Teacher*, 87(6), 440–445.
- Ertmer, P. A., & Ottenbreit-Leftwich, A. T. (2010). Teacher technology change: How knowledge, confidence, beliefs, and culture intersect. *Journal of research on Technology in Education*, 42(3), 255–284.
- Grugeon, B., Lagrange, J. B., Jarvis, D., Alagic, M., Das, M., & Hunscheidt, D. (2009). Teacher education courses in mathematics and technology: Analyzing views and options. In C. Hoyles & J-B. Lagrange (Eds.), *Mathematics education and technology-rethinking the terrain* (pp. 329–345). Boston: Springer.
- Grossman, P., Hammerness, K., & McDonald, M. (2009). Redefining teaching, re-imagining teacher education. *Teachers and Teaching: theory and practice*, 15(2), 273–289.
- Heid, M. K., Thomas, M. O. J., & Zbiek, R. M. (2013). How might computer algebra systems change the role of algebra in the school curriculum? In A. J. Bishop, M. A. Clements, C. Keitel, J. Kilpatrick, & F. K. S. Leung (Eds.), *Third international handbook of mathematics education* (pp. 597–642). Dordrecht: Springer.
- Hong, Y. Y., & Thomas, M. O. J. (2006). Factors influencing teacher integration of graphic calculators in teaching. In S-C. Chu, S-H. Hou & W-C. Yang (Eds.), *Proceedings of the 11th*

- Asian Technology Conference in Mathematics* (pp.234–243). Hong Kong: Asian Technology Conference in Mathematics.
- Mayer, D. P. (1999). Measuring instructional practice: Can policymakers trust survey data? *Educational Evaluation and Policy Analysis*, 21(1), 29–45.
- Mishra, P., & Koehler, M. (2006). TPACK: A framework for teacher knowledge. *Teachers College Record*, 108(6), 1017–1054.
- Mumtaz, S. (2000). Factors affecting teachers' use of information and communications technology: a review of the literature. *Journal of information technology for teacher education*, 9(3), 319–342.
- Pierce, R., & Ball, L. (2009). Perceptions that may affect teachers' intention to use technology in secondary mathematics classes. *Educational Studies in Mathematics*, 71(3), 299–317.
- Sherman, M. (2014). The role of technology in supporting students' mathematical thinking: Extending the metaphors of amplifier and reorganizer. *Contemporary Issues in Technology and Teacher Education*, 14(3), 220–46.
- Thomas, M. O., & Palmer, J. M. (2014). Teaching with digital technology: Obstacles and opportunities. In A. Clark-Wilson, O. Robutti & N. Sinclair (Eds.), *The mathematics teacher in the digital era* (pp. 71–89). Springer, Dordrecht.
- Thurm, D., Klinger, M., & Barzel, B. (2015). How to professionalize teachers to use technology in a meaningful way—Design research of a CPD program. In S. Carreira & N. Amado (Eds.), *Proceedings of the 12th International Conference on Technology in Mathematics Teaching* (pp. 335–343). Faro: University of Algarve.
- Thurm, D. (2018). Teacher Beliefs and Practice When Teaching with Technology: A Latent Profile Analysis. In L. Ball, P. Drijvers, S. Ladel, H-S. Siller, M. Tabach & C. Vale (Eds.), *Uses of Technology in Primary and Secondary Mathematics Education* (pp. 409–419). Cham: Springer.
- Tschannen-Moran, M., & McMaster, P. (2009). Sources of self-efficacy: Four professional development formats and their relationship to self-efficacy and implementation of a new teaching strategy. *The Elementary School Journal*, 110(2), 228–245.
- Wang, L., Ertmer, P. A., & Newby, T. J. (2004). Increasing preservice teachers' self-efficacy beliefs for technology integration. *Journal of Research on Technology in Education*, 36(3), 231–250.
- Weigand, H. G. (2014). Looking back and ahead—didactical implications for the use of digital technologies in the next decade. *Teaching Mathematics and Its Applications: International Journal of the IMA*, 33(1), 3–15.
- Zhao, Y., & Cziko, G. A. (2001). Teacher adoption of technology: A perceptual control theory perspective. *Journal of technology and teacher education*, 9(1), 5–30.

How to distinguish simulations? Development of a classification scheme for digital simulations for teaching and learning mathematics

Jan Franz Wörler¹

¹Julius-Maximilians-University, Wuerzburg, Germany; woerler@mathematik.uni-wuerzburg.de

Computer simulations are used to teach and learn mathematics, and didactic research also uses the term. However, there are sometimes very different meanings of the term ‘simulation’. As a possible result didactic research on the use of simulations can only be compared to a limited extent. The present article therefore clarifies the concept of simulation. Based on this, a scheme for the classification of digital simulations, independent of the concrete content, is designed, which allows to distinguish simulations a priori and objectively according to theoretically derived didactic criteria and thus to order the wide field of “simulations”. Finally, it is briefly outlined how the scheme can help teachers to select suitable simulation implementations for teaching and learning purposes.

Keywords: Simulation, mathematical models, educational experiments, representations

Introduction

There is a multitude of computer programs, apps and files for learning and teaching mathematics, which are called “simulations” by their authors. These are, for example, Excel data sheets for the replication of cube throwing (Böer, 2012) or algorithms in computer algebra systems for calculating hiking trails within the framework of mathematical modelling (Bracke, Götze, & Siller, 2015). In the online portal GeoGebra Materials (www.geogebra.org/materials), on which authors can publish GeoGebra files, over 1000 hits are listed under the search term *simulation* for the year 2017. It can be assumed that at least some of these documents were designed for teaching-learning contexts and are actually used for learning mathematics. MathEduc (www.zentralblatt-math.org/matheduc/), a database for publications with a mathematics didactic background, currently lists over 2000 publications that contain the term *simulation*.

These are just a few examples of “simulations”. However, their consideration already suggests the interpretation that research, theory and practice for learning and teaching mathematics are currently concerned with simulations: simulations are used to teach mathematical content or procedures at present. The above examples also show how differently the term simulation is used: the examples refer to a broad variety of mathematical contents, use different representations, are based on different types of mathematical models, allow partly very extensive manipulations and partly none, are used to pursue different objectives or to fulfill different functions. This leads us to the thesis that the term *simulation* is used in connection with the teaching of mathematics, but that its meaning remains in general individual and vague.

If, however, didactic research aims to collect empirical research data on the use of computer simulations for teaching and learning mathematics and if these data and results are to be comparable, then a common conceptual basis for simulations is indispensable.

This article presents ideas for the design of such a basis by theoretically deriving a multidimensional classification scheme for digital simulations. For this purpose, essential characteristics of simulations

are first deduced, which then depending on their traits are combined into a system to distinguish between simulations. The article therefore investigates the following research questions:

(Q1) Which central characteristics and features do digital simulations for learning mathematics have? Which traits of these characteristics can be derived?

(Q2) How can these characteristics and traits be used to assign computer simulations a priori and objectively into classes and to distinguish them from each other?

Methodological approach

In order to clarify research question Q1, a hermeneutical approach is pursued: it derives essential characteristics of simulations from existing theories (e.g. systems theory) and application sciences by means of a literature research and thus searches for the theoretical meaning of the term *simulation*. The focus will be on those aspects that are important from a didactic point of view. The approach is alternately confronted with a comparison with such properties of programs, apps and files which exist in reality (on the Internet, in textbooks, as learning apps or the like) and which are called "simulations" by their authors. They show concrete characteristics of the properties. In this way, the question is examined in the alternation of deduction from theory and induction from teaching-learning practice and thus does not lose its relation to the practice of teaching mathematics.

Theoretical foundations

When it comes to simulations, a distinction was usually made between physical simulation with concrete models and simulation with abstract or mathematical models (Krüger, 1974). In the latter case, simulation is a calculation carried out on a computer, which Krüger (1974, p. 27) calls "calculation experiment" and which Hockney and Eastwood (1988, p. xix) call "computer experiment". On the one hand, this distinction is very rough. On the other hand, the two categories become blurred as soon as physical experiments are virtually mapped on the computer, as explained in detail in Wörler (2018). Therefore, they are not useful for classification.

For this reason, we assume a more general approach: we interpret simulation—in close agreement with Krüger (1974), Kobayashi (1981) and Greefrath and Weigand (2012)—as the conduct of experiments with models of systems. It is therefore necessary to clarify the terms *experiment* and *model* in order to understand the concept of simulation.

Models

According to Henn (2011, p. 419), "models are simplifying presentations, which consider only certain, somehow objectifiable parts of reality". This characterization corresponds well with the examples of simulations mentioned above, because they refer to a real situation or a real object, which is reproduced virtually on the computer. In addition, simulations are also conceivable that take up intra-mathematical phenomena: experimental work with geometric figures or with integral and derivative can serve as examples for simulations that have no explicit reference to reality.

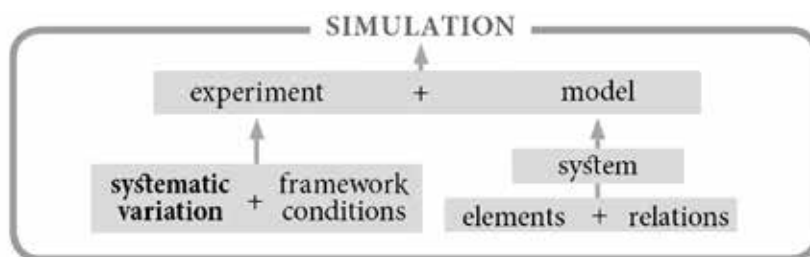


Figure 1: Components of a simulation

Therefore, the term *model* has to be understood more broadly with regard to simulations. For example, Velten (2009, p. 3) states: models are “simplified descriptions of a system”. A system in turn “is an object or a collection of objects whose properties we want to study” (Velten, 2009, p. 8). It consists, according to Bossel (1992), of individual elements connected by relations. A model therefore contains a mapping of the relevant elements and relations of the system. This is illustrated in Figure 1.

Experiments and variations

Experiments are particularly widespread in the social and natural sciences, where they are a central method of gaining scientific knowledge. They can be used to create or to test hypotheses and usually they use the observation of the effects of targeted manipulations of a system. For physics education, for example, Kircher, Girwidz and Häußler (2009, p. 244) describe how to proceed in experiments: “Under fixed and controllable framework conditions, observations and measurements are carried out on physical processes and objects; variables are systematically changed and data are collected”. Accordingly, the systematic variation of independent variables within defined framework conditions is the central component of conducting experiments—and thus also of simulations.

The important role of systematic variation in the learning and teaching of mathematics has already been emphasized: Schoenfeld (1985) sees variation as a heuristic principle in problem solving. Schupp (2002) adds that variation as a student activity can help to convey an authentic picture of mathematics and enable a deeper understanding.

Philipp (2013) interprets intra-mathematical experimentation—in the sense of hypothesis formation and hypothesis testing—as explorative problem solving. She considers this type of problem solving to be a process characteristic of mathematics, but also sees it as a fundamental competence with four partial competences: generating examples, structuring, formulating hypotheses, checking hypotheses.

These activities are addressed in the same way when experimenting with models of objects or systems in simulations. To vary allows the creation of different *system states* (called “data” by Kircher et. al., 2009, p. 244, and called “examples” by Philipp, 2013, p. 156) that can be analysed to learn something about the given system or to understand it. This applies to students as well as to scientists, which is why experimentation is also a central activity inquiry-based approaches (e.g. Artigue & Blomhøj, 2013). Therefore, in the following we will distinguish simulations according to what types of variation they allow.

Types of variation

According to the above considerations, models can be traced back to their elements and relations. Furthermore, experiments are characterized by variation within controlled framework conditions.

Under these assumptions, six different types of variations in simulations can be derived theoretically (Wörler, 2018). Only the following three should be mentioned here, because the other three have mainly theoretical-epistemological value: these types are the possibility of variation of ...

- 1) the number of model elements,
- 2) the properties of the model elements,
- 3) the relations between model elements,

They are hereinafter referred to as *Possibilities of Interaction* between the experimenter (e.g. the learner) and the underlying (mathematical) simulation model. Their existence can be checked objectively and a priori for each concrete implementation of a simulation. In this way, simulations can be distinguished according to the type and the number of implemented Possibilities of Interaction. We use this approach to clarify the research question Q2 below.

Specifics of digital simulations

With regard to the research question Q1 we conclude: Experiments involve the activity of varying. They also require the observation of the effects of the manipulation on the modelled system and its behavior. If experiments are transferred to the computer as digital experiments, these two aspects have to be translated, too.

This means that at least some of the Possibilities of Interaction (see above) have to be technically implemented and offered to the experimenter. Some control elements like checkboxes, sliders, input fields or selection menus must be available in every digital simulation to set and change parameters; Moreno and Mayer (2007) call this type of interaction “manipulating” (p. 311). They distinguish manipulating from “controlling” (p. 311), which includes control elements for the speed or sequence of content (such as pause/play key) but does not influence properties of the modelled system. It occurs especially with moving images or animations. It is, however, consequent also to consider controlling in the classification scheme for simulations: On the one hand, both types of interaction occur in simulations side by side, although only manipulating allows experiments. On the other hand, the connection to preliminary work on the potential of moving images for learning mathematics (Kautschitsch, 1985; Samson, & Schäfer, 2012) succeeds.

Digital experimentation also requires the possibility to observe and evaluate the modelled system and its states. Therefore, a computer output device is indispensable. This can be a conventional PC or smartphone screen. Alternatives could also be virtual reality glasses or simply a PC printer. On such output devices the result of a digital simulation (as final state after a manipulation) or the respective simulation model itself (with intermediate states during manipulation) has to be represented, for example as table, graph or diagram, but also as dynamic visualization of processes or experimental environments. Each digital simulation is therefore necessarily connected with an external representation of these model states.

Based on Bruner's modes of representation (enactive, iconic, symbolic) from 1964, Ladel (2009) proposes a scheme for the analysis of mathematical learning software on the basis of the forms of external representation used. She derives eight computer-based forms of external representation and

specifically distinguishes between static and dynamic representations. Ladel (2009) also shows that how computer programs can be classified with regard to these forms.

Result: classification scheme

In order to answer the research question Q2, the above explanations were combined into a two-dimensional classification scheme: The first dimension is formed by the *Level of Manipulation* (LoM). This number indicates how many Possibilities of Interaction are implemented in a concrete digital simulation, i.e. whether and to what extent a concrete digital simulation allows variations by the experimenter.

For clarification, imagine a dice throwing simulation with two sliders: One controls the number of the dice, one the number of the throws. There are then two ways to interact with the underlying simulation model, which gives the simulation a LoM of 2 (labeled as: LoM 2).

In the broadest sense, the LoM indicates the degrees of freedom that the implementation gives the experimenter for interaction with the underlying simulation model (in the sense of *manipulating*, according to Moreno & Mayer, 2007). In this way, different implementations of a simulation can be analyzed with regard to their LoM and arranged on an ordinal scale.

If we accept LoM 0 (zero) on this scale, animations (generally: moving images) can also be located in the range between LoM 0 (no *controlling* or *manipulation* implemented) and LoM 1 (*manipulation* implemented). We thus take into account the type of interaction in the model that Moreno and Mayer (2007) call “controlling” (p. 311). The distinction between animation and simulation, which is not clear to outsiders in many cases, is transferred into the concrete specification of LoMs: If any controlling option is implemented, the LoM is increased by 0.5.

The second dimension of the classification scheme presented here can be defined according to the scheme of Ladel (2009): The eight types of external representations she proposes can be aggregated into the disjoint categories *isolated static representation* (ISR), *isolated dynamic rep.* (IDR), *multiple static rep.* (MSR) and *multiple dynamic rep.* (MDR). Every concrete implementation of a simulation can be analyzed in terms of how the changes in the model states triggered by the variation are represented on the output device.

		Level of Manipulation							
		0	1	2	3	4	5	LoM	
external representation	isolated	ISR							
		IDR							
	multiple	MSR							
		MDR							

Figure 2: Two-dimensional classification scheme for digital simulations

The result is a $5 \times n$ -classification scheme with the dimensions *external representation* (with the four traits ISR, IDR, MSR, MDR) and *plurality of variations* (indicated in LoM), see Figure 2.

Each digital simulation can be assigned to the scheme: Let's assume that the dice throwing simulation from above represents only the final results of the experiment as bar chart. That would be an isolated static representation (ISR). The simulation would therefore be classified in the cell $ISR \times LoM 2$ of

the schema. If, in contrast, the dice throws are represented sequentially so that the result of the experiment is assembled step by step and the bars in the chart “grow”, the representation is dynamic (IDR), so that the classification $\text{IDR} \times \text{LoM } 2$ results. And if, in addition, a further controller is integrated which allows the speed of the process to be regulated, the LoM would be increased by 0.5 (classification: $\text{IDR} \times \text{LoM } 2.5$); in this case, the position between two cells indicates that a dynamic sequence can be controlled that does not affect the final result.

Discussion and outlook

The classification scheme currently presented indicates the possibilities of experimentation in the form of LoM. With this construct, simulations can be ordered locally, i.e. two implementations of the same phenomenon or mathematical model can be compared with regard to their cognitive requirements: The higher the LoM is, the higher the cognitive requirements are.

Limitations of the scheme

Global ordering is currently not possible with the scheme, however, as the following example shows: A simulation is given in which one unbound variable b can be manipulated (LoM 1) and which displays the function graph (IDR). While the effect of the manipulation is easy to interpret for the graph of the function $f(x) = x + b$, it is much more difficult for $f(x) = x^2 + b \cdot x$ or even $f(x) = x^b + 2$.

Thus, the scheme currently lacks an analysis of the complexity or difficulty of the content, which is reflected in the complexity of the underlying mathematical model. It should take into account the prior knowledge of the experimenter (or learner). Therefore, it is planned to extend the scheme by a didactic analysis of the concrete simulation that examines the mathematical requirements for each possibility of interaction. In this way, the model could also enable global ordering of simulations.

Learning and teaching mathematics

Since extra-mathematical references are often taken up in simulations in order to learn mathematics, content references to related sciences are indispensable in mathematical simulations. Therefore, the scheme is not limited to learning and teaching mathematics. It can be useful whenever mathematical representations are used to experiment with models as a learner activity. That is the case, for example, in teaching and learning of modelling or problem solving in mathematics, but also in biology, physics or technology. This makes the classification scheme useful for Science, Technology, Engineering and Mathematics (STEM) education, too. Here, mathematical competences (e.g. Process Standard “Representation”, National Council of Teachers of Mathematics, 2000, pp. 67–71) are also addressed via subject-specific content (physics, biology and so on).

Implications

A first explorative application of the category system to randomly selected “simulations” from GeoGebra Materials provides that in most cases the user can vary one to four aspects of the application (LoM 1–4; hardly $\text{LoM} > 5$). Often dynamic representations occur and also different forms of representation are combined to multiple dynamic representations (MDR).

One of the aims of the research work on the scheme is also to use the scheme to assess whether a concrete simulation is good or less suitable for a (concrete) learner. According to this, there should

be good and less suitable classes in the scheme, depending on the individual prerequisites and goals. First cautious pointers to such classes are: for a pure visualization of dynamic processes, an implementation with $0 < \text{LoM} < 1$ is sufficient; this includes video clips as well as animations. If simulations are to be used for explorative work in the context of teaching and learning, they have to allow some variations. Thus, only implementations with $\text{LoM} \geq 1$ are suitable. With them, the modeled system can be understood by linking variation and effect, which can serve in problem solving, mathematical modelling or generating and testing hypotheses. It can be assumed that simulations with a high LoM generate a high cognitive load (according to Chandler & Sweller, 1991) for the experimenters (i.e. learners). The performance of the users would thus determine how high the LoM should be at most when selecting a simulation. The respective external representations offered in a simulation, although they bring benefits for the learning process, can also create further obstacles in the learning process (e.g. Ainsworth, Bibby, & Wood, 1998; Ainsworth, 2006; Duval, 2006). Building on this, at least one implication is conceivable: in order to keep the simulations understandable, rather small LoMs should be used for MDR, whereas higher LoMs would be suitable for ISR and IDR (as indicated in Figure 2). By means of such considerations, the presented scheme can help teachers to find suitable simulations for a certain group of learners.

A detailed analysis of the classification scheme as well as the empirical and theoretical validation of the conclusions is still pending.

References

- Ainsworth, S. (2006). DeFT: A conceptual framework for considering learning with multiple representations. *Learning and Instruction*, 16(3), 183–198.
- Ainsworth, S.E., Bibby, P.A., & Wood, D.J. (1998). Analysing the Costs and Benefit of Multi-Representational Learning environments. In M.W. van Someren, P. Reimann, H. P.A. Boshuizen, & T. de Jong (Eds.), *Learning with multiple representations* (pp. 120–134). Amsterdam, NL: Pergamon.
- Artigue, M., & Blomhøj, M. (2013). Conceptualizing inquiry-based education in mathematics. *ZDM Mathematics Education*, 45(6), 797–810.
- Böer, H. (2012). Erst per Hand, dann am Rechner. Simulationen stochastischer Prozesse mit Excel. *mathematik lehren*, 174, 7–10.
- Bossel, Hartmut (1992). *Simulation dynamischer Systeme: Grundwissen, Methoden, Programme*. Braunschweig: Vieweg.
- Bracke, M., Götze, T., & Siller, H.-S. (2015). Mit Hilfe der Mathematik zum Gipfel: Bergsteigen als Thema der mathematischen Modellierung. *Der Mathematikunterricht*, 61(5), 7–12.
- Bruner, J. S. (1964). The course of cognitive growth. *American Psychologist*, 19(1), 1–15.
- Chandler, P., & Sweller, J. (1991). Cognitive Load Theory and the Format of Instruction. *Cognition and Instruction*, 8(4), 293–332.
- Duval, R. (2006). A cognitive analysis of problems of comprehension in a learning of mathematics. *Educational Studies in Mathematics*, 61, 103–131.

- Greefrath, G., & Weigand, H.-G. (2012). Simulieren: Mit Modellen experimentieren. *mathematik lehren*, 174, 2–6.
- Henn, H.-W. (2011). Why Cats Happen to Fall from the Sky or on Good and Bad Models. In G. Kaiser, W. Blum, R. Borromeo Ferri, & G. Stillman (Eds.), *International Perspectives on the Teaching and Learning of Mathematical Modelling, Trends in Teaching and Learning of Mathematical Modelling* (pp. 417–426). Dordrecht, Heidelberg, London, New York: Springer.
- Hockney, R.W., & Eastwood, J.W. (1988). *Computer simulation using particles*. Bristol: Hilger.
- Kautschitsch, H. (1985). Der Videofilm: Geeignetes Mittel zur Visualisierung und Entwicklung mathematischer Begriffe und Modelle. In H. Kautschitsch (Ed.), *Anschauung und mathematische Modelle* (pp. 59–98). Wien: Hölder-Pichler-Tempsky.
- Kircher, E., Girwidz, R., & Häußler, P. (Eds.). (2009). *Physikdidaktik: Theorie und Praxis*. Berlin, Heidelberg: Springer.
- Kobayashi, H. (1981). *Modeling and analysis: An introduction to system performance evaluation methodology*. Reading, MA: Addison-Wesley.
- Krüger, S. (1974). *Simulation: Grundlagen, Techniken, Anwendungen*. Berlin, N. Y.: De Gruyter.
- Ladel, S. (2009). *Multiple externe Repräsentationen (MERs) und deren Verknüpfung durch Computereinsatz: Zur Bedeutung für das Mathematiklernen im Anfangsunterricht*. Hamburg: Kovač.
- National Council of Teachers of Mathematics. (2000). *Principles and standards for school mathematics*. Reston, VA: National Council of Teachers of Mathematics.
- Samson, D., & Schäfer, M. (2012). Video clips and cell phones: VITALmaths in the palm of your hand. In S. Nieuwoudt, D. Laubscher, & H. Dreyer (Eds.), *Mathematics as an Educational Task: Proceedings of the 18th National Congress of the Association for Mathematics Education of South Africa (AMESA)*, Vol. 2 (pp. 29–32). Potchefstroom, RSA: AMESA.
- Moreno, R. & Mayer, R. (2007). Interactive Multimodal Learning Environments Special Issue on Interactive Learning Environments. *Educational Psychology Review*, 19, 309–326.
- Philipp, K. (2013). *Experimentelles Denken: Theoretische und empirische Konkretisierung einer mathematischen Kompetenz*. Heidelberg: Springer Spektrum.
- Schoenfeld, A. H. (1985). *Mathematical Problem Solving*. Orlando: Academic Press.
- Schupp, H. (2002). *Thema mit Variationen: Aufgabenvariation im Mathematikunterricht*. Hildesheim, Berlin: Franzbecker.
- Velten, K. (2009). *Mathematical modeling and simulation: Introduction for scientists and engineers*. Weinheim: WILEY-VCH.
- Wörler, J. F. (2018). Computersimulationen zum Lernen von Mathematik. In G. Greefrath & H.-S. Siller (Eds.), *Digitale Werkzeuge, Simulationen und mathematisches Modellieren* (pp. 23–48). Wiesbaden: Springer Spektrum.

Mathematical practices of teachers in technology-enhanced classrooms: A case of teaching slope concept

Seçil Yemen Karpuzcu¹ and Mine Işıksal Bostan²

¹Middle East Technical University, Faculty of Education, Ankara, Turkey; secilyemen@gmail.com

²Middle East Technical University, Faculty of Education, Ankara, Turkey; misiksal@metu.edu.tr

While it is obvious that teachers need to have mathematical knowledge under different domains, few studies put forward teaching practices associating them with teacher moves in the background of the mathematical knowledge used in teaching in a technology enhanced classroom environment. Moreover, characterizing those practices can show a practical understanding of the knowledge for its usefulness in teaching in which tools and dynamic technologies are deemed necessary. In this study, we examined the characteristics of teachers' mathematical practices in a classroom teaching where the students engaged in a sequence of GeoGebra-integrated tasks designed to support students' conceptualizations of slope of an object. The results suggest teacher moves for the GeoGebra-integrated tasks for conceptualization and suggestions for teaching practices from pedagogical perspectives.

Keywords: Middle school mathematics teachers, GeoGebra, mathematical practices, slope.

Introduction

We all accepted that there are prominent frameworks on mathematics teaching. However, while these frameworks provide tremendous contributions, how teachers' knowledge is used and developed in classroom teaching practice for specific learning areas need to progress when it comes to combining theory and practice (Doerr, 2004; Wasserman, 2015). Specifically, investigating teachers' mathematical practices in slope teaching in school algebra requires having a distinctive spectacle. Although slope is one of the big ideas in curricula, we do not know teachers' mathematical practices in slope teaching during the implementation of an instructional sequence (Cheng, Star, & Chapin, 2013). In this regard, research on knowledge of algebra teaching (McCrary, Floden, Ferrini-Mundy, Reckase, & Senk, 2012) can enlighten this process which includes mathematical practices in connection with the content knowledge. Therefore, the mathematical practices dimension can be used and developed for investigating particular mathematical practices of teachers as their didactical performance.

Dynamic mathematics software (e.g. GeoGebra) is seen as the indispensable part of mathematics teaching technology in 21st century. However, although there are research studies that integrate curricula including new approaches and technology into algebra teaching in the classroom (Bozkurt & Ruthven, 2017; Drijvers, Doorman, Boon, Reed, & Gravemeijer, 2010), studying the practice of slope teaching within the technological environments need further elaborations to reveal mathematical practices of teachers. Thus, interpreting mathematical practices of teachers in slope teaching from the perspective of algebra teaching can provide in depth insight about the mathematical practices in the work of mathematics teaching in technology enhanced classroom environment.

Framework of the Study

The mathematical practices are moves or actions which are seen as the ways for using content knowledge in teaching (McCrorry et al., 2012; Wasserman, 2015). That is, they involve teacher's actions with specific goals and perspectives on particular mathematical ideas that are centralized through the interactions with students in classroom teaching. In terms of algebra strand, McCrorry et al. (2012) characterize Knowledge of Algebra Teaching (KAT) framework that is developed for assessing teachers' mathematical knowledge on algebra teaching. In the framework, considering three domains of knowledge (i.e. knowledge of school algebra, knowledge of advanced mathematics, and mathematics-for-teaching knowledge), teachers' mathematical work as mathematical practices is emphasized under three categories: bridging, trimming, and decompressing. By means of bridging, McCrorry et al. (2012) emphasize ways of making connections across topics, concepts, representations, and domains. In the framework, trimming practices are described as ways of removing complexity of mathematical ideas while holding mathematical integrity (McCrorry et al., 2012). Introducing slope in linear functions graphs in consideration with the future mathematics (instantaneous rate of change in calculus and analysis) can be given as an example for trimming practice (McCrorry et al., 2012). However, making an unfortunate explanation of "multiplying makes bigger" in teaching multiplication of whole number is an example of 'over' trimming when considered the multiplication of fractions and rational numbers (McCrorry et al., 2012; Wasserman, 2015). At last, decompressing is described as making explicit complexity of mathematical ideas in ways that make them comprehensible for students (McCrorry et al., 2012). McCrorry et al. (2012) gave examples of unpacking the algorithm for solving equations and meaning of identities.

In this current study, the KAT framework was used for the analysis of teachers' mathematical practices in classroom teaching. In this regard, bridging refers to teachers' mathematical practices of connecting topics, concepts, representations, domains, and activities in teaching slope of an object (i.e. the slope concept in physical situations) in a technology enhanced classroom environment in which GeoGebra materials and concrete objects were used. Beyond, we characterized the mathematical work of bridging with an agglutination of using tools and technology by putting terms of concrete object and GeoGebra material. In detail, this category involves mathematical situations (e.g. position of a ladder as a physical situation), mathematical concepts (e.g. horizontal length, line segment, ratio, etc.), concrete objects as mathematical objects, and GeoGebra material for representing a mathematical idea. Since teachers can use various kinds of tools and technologies in classroom teaching, we cannot ignore the use of concrete objects and dynamic technology in such kind of mathematical work. Similar characterization of the mathematical work is also considered both for the practices of trimming and decompressing. Trimming refers to teachers' mathematical practices of removing the complexity of slope of an object while holding the mathematical integrity (e.g. by omitting/adding details, modifying level of rigor) in both eighth-grade mathematics curriculum and advanced mathematics in the technology enhanced classroom environment. In other words, we looked for the ways of mathematical work that teachers considered the complexity of slope in the context of physical situation, while maintaining the integrity of slope concept anticipating further slope conceptualizations. Therefore,

this kind of practice corresponds to trimming up or down of the mathematical idea for the essential content anticipating further mathematical ideas related with slope. Moreover, decompressing refers to unpacking the complexity of slope of an object in ways that make them comprehensible to eight-grade students in the technology enhanced classroom environment (e.g. looking for the ways of mathematical work that teachers unpack the computational algorithm of slope as the rate of change of vertical distance relative to horizontal distance of that object/feature).

This paper introduces teachers' actions in their mathematical work in specific to using GeoGebra materials and concrete objects while enacting an instructional sequence in the technology enhanced classroom environment that was designed for eighth graders based on the national curriculum. In this regard, characterizing such actions in teaching with the teacher's rationales for them and interrelations among them is the focus of this study. Therefore, the aim of this paper was to answer the following research questions: What are the characteristics of the teachers' mathematical practices while teaching the slope concept in technology enhanced classroom environment? How do those practices emerge and interrelated with each other in the moment of teaching?

Method

This study was a part of a long term study and used design research method to understand teachers' knowledge base and expertise within the complexity of classroom teaching (Zawojewski, Chamberlin, Hjalmarson, & Lewis, 2008). In the light of Lesh and Kelly's (2000) multi-tier design experiment method, this study involved four tiers. While the tier of students developed mathematical ideas and computational algorithm on slope, the tier of teachers developed and implemented activity sheets involving GeoGebra-integrated tasks through an instructional sequence while examining students' mathematical understanding with the support of the first author. In addition, the tier of facilitator (the first author) developed sessions for teachers and the tier of researchers (two authors and a doctoral student) produced interpretations of teachers' and students' experiences. The whole process of this study involved a prototype study with a teacher and a main study with another teacher after the preliminary research was done and tentative design principles for sessions with teachers and products for data collection were determined. In this paper, we presented findings of the tier of the teacher from the main study which involved the topics of teaching slope, linear equations and their graphs.

Context and Participants

The sequence of activities involving GeoGebra integrated tasks formed the basis for a two-week course for students in two eighth grade classes. The teacher had eight years of experience of teaching middle school students. There were 20 students in 8A class (12 girls, 8 boys) and 23 students in 8B class (12 girls, 11 boys). Throughout their work on the tasks, the teacher set the class seating plan considering group work (heterogeneous, 6-7 students) in collaboration. The teacher allowed the students to study and discuss within the group and between the groups. The groups completed the tasks using laptop computers for the groups, and the teacher's computer with a Bluetooth mouse in addition to the related activity materials. The teacher engaged in whole-class discussions that involved the students discussing their slope computation algorithm and how that slope changes when the attributes of the objects changed.

In this regard, the students were asked (1) to notice and describe slope as a measurement of steepness of a physical object, (2) to describe slope of an object being independent of the length of an object, (3) Relate vertical and horizontal distances to the slope of an object, (4) to structure the computation of slope of a given physical object, and (5) evaluate the effects of horizontal and vertical distances on the computation of the slope of a physical object as a ratio given in GeoGebra materials integrated activities. The teacher also wanted to have students use concrete objects for experiencing the slope of an object practically. In the beginning of the course, the students were given concrete objects (i.e. fixed length battens), tape measures, and Positions of Battens (PoB) activity sheet. In the activity, the students were expected to measure the horizontal/vertical lengths of the objects, to describe the slope as a measurement of steepness and being independent of the length of the object, and to collect data for relating the horizontal and vertical lengths to the slope of the object. The GeoGebra material of the activity was used to have students relate the horizontal/vertical lengths to the slope of the object in the dynamic environment. Then, the students were given Fire Truck (FT) activity sheet and the GeoGebra material. In this activity, the students were expected to compute the slope of a fire truck ladder in different positions with a constant horizontal length and to evaluate the change of the slope as the vertical length changed using GeoGebra. At last, the students were given Tent (Tt) activity sheet and the GeoGebra material. The students were expected to compute the slope of a tent rope in different positions with a constant vertical length and to evaluate the change of the slope as the horizontal length changed using GeoGebra (See materials on <https://ggbm.at/sbffsxt>). The lesson was structured as PoB for the first hour and FT and Tt for the second hour.

Data Sources and Analysis

The data sources of this study included videotapes of all classroom sessions, written field notes and memos, students' activity sheets, students' computers screen records. Following the classroom teaching, there was an analyzing instruction session involving audio recorded semi-structured interview. In this process, the teacher reflected, commented, and made decisions on her practices and students' learning in the lesson and reflected on the further changes for the lessons in the instructional sequence, while watching the episodes of video recording of the classes. In this paper, the data constituted 180 minutes lessons for two classes (90+90) and 90 minutes analyzing instruction session. The data was collaboratively analyzed considering the iterative approach of design research and the comparative analysis method of grounded theory (Glaser & Strauss, 2006). In the analysis, primarily, the researchers met to develop and evaluate the instructional sequence, the progress of the students in classes, and the observations/comments about students' thinking about slope of an object and their use of GeoGebra materials and other representations. The researchers wrote the analytic memos documenting their emergent understandings of the teacher's mathematical practices and observations about students' learning. Secondly, the researchers started with the microanalysis of the transcripts of the videotapes through line-by-line analysis. While doing systematic coding in the analysis, the teachers' acts, events and activities were conceptualized and classified when the actions of the teacher occurred in a pattern during the classroom teaching. Moreover, theoretical comparisons were made to identify the derived properties and dimensions of the concepts from the incidents in the literature. Additional evidences were used

from the interviews with the teacher to confirm and disconfirm the actions and the teacher's reasoning about those actions. In this paper, we present two results of the analysis of the teacher's mathematical practices that involves interrelations among each other: trimming slope computation and its relation to a bridging practice and decompressing components of slope and its relation to trimming slope computation.

Findings

Trimming slope computation and its relation to a bridging practice

In the PoB activity, as a trimming practice, the teacher trimmed the computation of slope of the batten using the GeoGebra material by showing/checking change in the slope. In detail, this practice involved actions of showing and checking the correctness of the computations of slopes of the battens through the use of slope checkbox (that opens dynamic slope computation text) with slider (that changes horizontal length of the batten), and horizontal and vertical lengths checkboxes (that shows their images and values). As evidence, for example, after the groups of students made measurements on their battens and the teacher showed/checked the horizontal and vertical lengths of their battens using GeoGebra material, in the conversation with students the teacher said:

Yes. You take the vertical length of the batten as 57 cm (*The teacher checks the value of the vertical length on the computation after moved slider to make students' vertical length of the batten*). Let's look. Is the value of your slope like this? (*The teacher shows the value of the slope on the slope computation text in the GeoGebra graphics view*).

That is, the teacher moved the slider to create the students' battens and then showed and checked those values on the GeoGebra material. Thus, she both constrained the slope computation as ratio of vertical length to horizontal length and provided various slope computations with different values.

In addition, that trimming practice took place in the background of bridging practice of connecting mathematical situation/concept and GeoGebra material. That is, as a bridging practice, the teacher used the slider tool in connection with the line segment (i.e. the batten) in the GeoGebra graphics view while posing the questions about the position of batten. Therefore, when relating such trimming and bridging practices, the teacher put forward her intention of using the line segment to create a model of a batten at the beginning of the students' learning process and then a model for reasoning about the slope as steepness at the end of their learning experience.

Decompressing components of slope and its relation to trimming slope computation

In all activities, as a decompressing practice, the teacher interpreted the components of the slope of an object using GeoGebra materials in the following of the practice of trimming computation of slope using GeoGebra materials. In detail, in the PoB activity, the teacher interpreted the factors of slope (i.e. attributes that affect/do not affect the slope of the line segment representing the object of batten) using the GeoGebra material (i.e. using the slider tool and the graphics view) and interpreted logic in computation of slope using GeoGebra material after she trimmed the slope computation. That is, after the teacher showed/checked horizontal and vertical lengths of the batten (i.e. line segment object in the GeoGebra graphics view) using the slider of the horizontal length and checkboxes of the lengths and showed/checked the slope of the batten using the slope checkbox

(that opens dynamic slope computation text) with the slider and the checkboxes of the lengths, the teacher and students discussed on how the slope changes in accordance with the changes of the horizontal and vertical lengths while representing slopes of various positions of the batten with their horizontal and vertical lengths values. In the continuum of the discussion, she also used ‘trace’ tool on the line segment (i.e. batten) that shows the trace of the line segment as the slider of horizontal length moves from 1 to 60 with the dynamic slope computation. As evidence, the following conversation occurred:

- Teacher: Ok then, I want you to see how the slope value changes when I change the [position of] batten. Even I clicked trace on command in GeoGebra. Look at both the batten [line segment] and the slope. The value of the computation of the slope! What happens to the slope? *(The teacher moves the slider to the lower part, which increases the horizontal length of the batten, and eventually that moves the batten)*
- Student: Decrease!
- Teacher: It decreases, doesn't it? Look it is 1.17 and then 1.12. What happens gradually?
- Students: Lessens. Becomes smaller.
- Teacher: The slope decreases more and more. What happens when it moves to the other part? *(The teacher moves the slider.)*
- Students: Increases!
- ... *(The students discuss it in their groups)*
- Student Our batten has the longest vertical length and the least horizontal length with the biggest slope.

As seen from the conversation, the teacher paid attention to the complexity of change of the slope that depends on the change in the horizontal length and the vertical length. Therefore, as evidence of decompressing, she unpacked the idea of slope in the physical situations context that involves proportional approaches.

As another example of interpreting logic in computation of slope using GeoGebra material, in the FT activity, the teacher had students interpreted the change in computation of the slopes of fire truck ladder (that stops away 5-unit constant distance from a burning building) using vertical length slider tool after clicked the slope checkbox (that shows dynamic slope computation text) in GeoGebra graphics view and interpreted the change of slopes of the ladder when the horizontal length of the ladder was constant using the slider tool. For instance, while students using the GeoGebra material of the activity in a similar conversation given in below, she said “*We have two variables. One is the vertical and the other is the horizontal length (The teacher shows them on the GeoGebra graphics view). In this question, which one is constant?*” After the students explicitly mentioned the horizontal length was constant in that situation. The teacher added, “... *Thus, we can see how the vertical [length] affects the slope. Could we see clearly the effect of one variable on the slope when the other one is constant?*”. Therefore, the teacher again paid attention to the complexity of change of slope that depends on the vertical length when the horizontal length is constant. In this regard, she unpacked the idea of the slope that involves direct relationship with the vertical length when the horizontal length does not change in a physical situation. Similar

decompressing practice emerged in the Tt activity that the teacher unpacked the idea of slope involving indirect relationship with the horizontal length when the vertical length is constant.

Discussion and Conclusions

This study began with the development of an instructional sequence involving GeoGebra integrated tasks and activity sheets to develop students' conceptualizations of the slope and interpret the slope computation in physical situations. The design of that sequence provided opportunities for students to experience slope with concrete objects and GeoGebra materials, to decide the factors that have an effect and do not effect on the slope of an object, to give meanings to various representations from concrete objects to dynamic visuals and mathematical notations, and to reason about the slope concept.

In accordance with the findings about teachers' mathematical practices, when teachers are engaged in such GeoGebra integrated activities after students experience the slope with the concrete objects, they need to have understanding of what is the meaning of the mathematical idea of the slope as a concept of steepness and as a process of measurement and computation in physical situations, and how this meaning of slope is in connection with measurement, ratio, rate, and division. Therefore, during the decompressing practices in those activities, teachers are likely to enhance students' proportional reasoning underlying the slope computation for an object (i.e. the slope and the vertical length directly proportional when the horizontal length is constant, slope and horizontal length indirectly proportional when the vertical length is constant). Current studies also emphasized this understanding of slope as steepness through its relationship with proportional reasoning (Cheng et al., 2013; Lobato & Thanheiser, 2002). In this regard, such kind of mathematical practices require teachers to have the understanding of the relationship between the concrete and visual (i.e. as having knowledge of the goals and subgoals of steps in using intertwined multiple representations for the computation and the environment in which the computation is used) and the way of giving the aforementioned relationship considering the students' experiences and reasoning. In addition, teachers need to have a mathematical understanding of how to give visual representations in a connected way not also for translating the selected concrete examples but also for generating all possible situations with the concrete object using the dynamic properties of the software (i.e. the constitution of relationship between deep knowledge of computational skill and knowledge of the dynamic representations of mathematical ideas) since this understanding is likely to enhance the background of removing the complexity of slope computation (i.e. trimming). In this regard, while using dynamic software to represent such situations, teachers' knowledge of content and technology come to the forefront. Therefore, while the KAT framework (McCrary et al., 2012) and other studies (Wasserman, 2015) did not mentioned a knowledge dimension related with the technology, it is considered that teachers knowledge of teaching mathematics with technology should be considered as a source for fostering the bridging and trimming practices in classroom teaching. In sum, interrelations among those practices are likely to vary depending on the mathematical idea, teachers' understanding of this mathematical content and their knowledge of students' understanding in this content. As Clark-Wilson (2013) suggested, this paper elaborated the situated nature of use of mathematical knowledge in technology-enhanced classrooms. In this regard, that elaboration illustrate content-specific mathematical practices in teaching with technology that could

be involved in various kinds of activity formats as Bozkurt and Ruthven (2017) exemplified and explored through Drijvers et al.'s (2010) orchestrations. In further research, such kind of mathematical practices could be investigated in teachers' various ways of orchestrations for elaborating their mathematical work as didactical performance.

References

- Bozkurt, G., & Ruthven, K. (2017). Expert and novice teachers classroom practices in a technological environment. In K. Krainer & N. Vondrová (Eds.) (2015). *Proceedings of the Ninth Congress of the European Society for Research in Mathematics Education (CERME9, 4-8 February 2015)* (pp. 2319–2325). Prague, Czech Republic: Charles University in Prague, Faculty of Education and ERME.
- Cheng, D., Star, J. R., & Chapin, S. (2013). Middle school students' steepness and proportional reasoning. *New Waves-Educational Research & Development*, 16(1), 22–45.
- Clark-Wilson, A. (2013). How teachers learn to use complex new technologies in secondary mathematics classrooms - the notion of the hiccup. In B. Ubuz, Ç. Haser, M. A. Mariotti. *Proceedings of the Eight Congress of the European Society for Research in Mathematics Education (CERME 8, February 6-10, 2013)* (pp. 2544–2553). Ankara, Turkey: Middle East Technical University and ERME.
- Doerr, H. M. (2004). Teachers' knowledge and the teaching of algebra. In K. Stacey, H. Chick, & M. Kendal (Eds.), *The Future of the Teaching and Learning of Algebra: The 12th ICMI Study* (pp. 265–290). Dordrecht: Springer Netherlands.
- Glaser, B. G., & Strauss, A. L. (2006). *The discovery of grounded theory: Strategies for qualitative research*. New Brunswick: Transaction Publishers. (Original work published in 1967).
- Drijvers, P., Doorman, M., Boon, P., Reed, H., & Gravemeijer, K. (2010). The teacher and the tool: instrumental orchestrations in the technology-rich mathematics classroom. *Educational Studies in Mathematics*, 75(2), 213–234.
- Lesh, R. A., & Kelly, A. E. (2000). Multitiered teaching experiments. In A. E. Kelly, R. A. Lesh, & J. Y. Baek (Eds.), *Handbook of research design in mathematics and science education* (pp. 197–230). Mahwah, N.J: Lawrence Erlbaum Associates.
- McCrary, R., Floden, R., Ferrini-Mundy, J., Reckase, M. D., & Senk, S. L. (2012). Knowledge of algebra for teaching: A framework of knowledge and practices. *Journal for Research in Mathematics Education*, 43(5), 584–615.
- Wasserman, N. H. (2015). Unpacking teachers' moves in the classroom: navigating micro-and macro-levels of mathematical complexity. *Educational Studies in Mathematics*, 90(1), 75–93.
- Zawojewski, J., Chamberlin, M., Hjalmanson, M. A., & Lewis, C. (2008). Developing design studies in mathematics education professional development: Studying teachers' interpretive systems. In A.E. Kelly, R. Lesh, & J. Baek (Eds.), *Handbook of design research methods in education: Innovations in science, technology, engineering, and mathematics learning and teaching*. (pp. 216–245). New York: Routledge.

TWG16: Learning Mathematics with Technology and Other Resources

Introduction to the papers of TWG16: Learning Mathematics with Technology and Other Resources

Hans-Georg Weigand¹, Nathalie Sinclair², Ana Donevska-Todorova³, Eleonora Faggiano⁴, Eirini Geraniou⁵, Osama Swidan⁶

¹ Universität Würzburg, Germany; weigand@mathematik.uni-wuerzburg.de

² Simon Fraser University, Canada, nathsinc@sfu.ca

³ Humboldt-Universität Berlin (Germany), Mazedonia, anadonev@gmail.com

⁴ Università di Bari Aldo Moro, Italy; eleonora.faggiano@uniba.it

⁵ University College London Institute of Education, UK; e.geraniou@ucl.ac.uk

⁶ Ben Gurion University of the Negev, Israel; osamasw@gmail.com

Keywords: Digital Resources, Mathematical Learning, Educational Technologies

Scope and focus of the Working Group

The scope of this working group is to address opportunities and possibilities, as well as challenges and limitations, of information and communication technology (ICT) and other resources for student learning (see Trgalová, Clark-Wilson & Weigand 2017). ICTs include software programs, various kinds of hand-held devices, online and classroom activities, and sensors. In addition, ICTs are considered in relation to more traditional non-digital resources such as textbooks, worksheets and various types of tools and physical manipulatives. We want to establish an overview of the current state of the art research in technology use in mathematics education, including practice-oriented experiences, research-based evidence, and theoretically enriched perspectives, as seen from an international perspective and with a focus on student learning. We also aim to suggest important trends for technology-rich mathematics education in the future, including a research agenda. Even though TWG 15 is closely related to this theme, it focuses more specifically on the role and practices of the teacher.

In TWG 16, we had 28 presented papers and 14 posters. To promote more indepth discussions, we split up for some sessions into TWG16a and TWG16b.

Relevant topics

In TWG 16, we might roughly classify the presented topics as follows:

- **Content-related topics:** rational numbers, variables, stochastics, multiplicative reasoning, equation transformation, functions;
- **Assessment:** assessment with Dynamic Software Systems (DGS), digital tests (possibilities and limitations), self-assessment, feedback, especially also with ITS;
- **Modelling:** understanding the process of modelling, giving special examples like the “Math City Trail – a mathematical journey through a city”, long-term effects of modelling;
- **Specific tools:** APPs, dynamic geometry, graphic calculators, virtual and augmented reality;
- **Activity structures:** gamification, online courses, flipped classroom, collaborative work.
- **Theoretical perspectives:** activity theory, embodied cognition (esp. gestures).

Some Comments on the result of the TWG 16

Assessment

Assessment is an important part of the teaching and learning of mathematics. On the one side, it is associated with the evaluation of student knowledge and learning at the end of a course or teaching unit (summative assessment). On the other side, assessment should provide constant feedback to students during the learning process (formative assessment). Digital technology can be used in or can enhance both summative and formative assessment in many different ways. Three examples from this TWG: *Irene van Stiphout & Madelon Groenheiden* reflect on the construction of a digital diagnostic test for middle school in the Netherlands. They focused on the constant struggle between testing higher order skills, concrete description of curriculum goals on the one hand, and the limited possibilities of the digital test environment on the other hand. *Yael Luz* describes a pilot experiment in adaptive assessment. A system that automatically analyzes answers and generates immediate feedback is developed. Finally, *Sietske Tacoma, Bastiaan Heeren, Johan Jeuring and Paul Drijvers* investigate how providing automated feedback in an Intelligent Tutoring System can help students in an introductory university statistics course. Over all, assessment will remain a very relevant topic in the years to come.

The big variety of digital tools

It is very difficult to give an overview of present forms of digital technologies. On the one hand, there are still the classical software programmes used like computer algebra systems, dynamic geometry software, and spreadsheets. *Markku Hannula & Mika Toivanen* use Geogebra for problem solving activities and give a critical view to the use of computers, *Edith Lindenbauer* shows how Geogebra can be used to develop functional thinking. *Myrto Karavakou & Chronis Kynigos* create connections among different aspects of trigonometric functions in a programming environment. Some new features have been added to this traditional software, especially 3-D-geometry. On the other hand, mobile technology like tablets and smartphones with a big variety of apps are becoming more and more embedded in students' lives, which leads us to consider their wider use as an educational resource. For example, *Chorney, Gunes & Sinclair* presented the multi-touch App *TouchTimes*, which is designed to support multiplicative thinking. At TWG 16, there was also a first glance of the use of virtual and augmented reality for the learning and teaching process. This will be a very relevant topic for the future, too.

Elementary School

Learning how to use digital technologies starts in Kindergarten and Elementary School. Therefore, it is very important to discuss and evaluate chances and possibilities, but also restrictions and difficulties of the use of software in Elementary School as done within the TWG 16. For example, *Ana Donevska-Todorova & Katja Eilerts* develop criteria for reviewing the quality, potentials and limitations of tablet apps for elementary geometry. *Eitan Ben-Haim, Anat Cohen & Michal Tabach* discuss the suitability of the character of the graphic design on the students' achievements while engaging with mathematical applets. *Melanie Platz* creates a learning environment applying digital learning tools to support argumentation skills in primary school. *Axel Schulz & Daniel Walter* create the tablet-app 'Stellenwerte üben' (Practicing place value)¹

¹ The German version of the tablet-app is provided on Google Play. An English version is in progress.

for practicing the place value concept. They show that previous experience with concrete physical material overlaps and influences the intended use of the implemented virtual features. Finally, an exploratory study by *Sean Chorney, Canan Gunes & Nathalie Sinclair* with *TouchTimes* focuses on how students interact with a new model of multiplication inspired by Davydov's unitising approach, and, in particular, how they develop particular two-handed gesturing practices that involve coordinating two quantities—multiplier and multiplicand—in an embodied way. They argue that this approach provides an alternative to the model of repeated addition, which is frequently over-used in students' initial encounters with multiplication.

Online courses

Nowadays, there is a variety of online courses. They are used mainly at the university level as a substitute for face-to-face lectures. There are “blended learning” approaches in which the online course is used as an additional resource to face-to-face courses, or as an optional resource for special topics, which are not in the mainstream of traditionally taught topics, or as remedial courses (especially for first-year students) that cover basic school mathematics topics. Online courses pose many didactically interesting questions, e.g. how to present the topics, the effect of online in comparison to face-to-face courses, and the behaviour of the students while working online. *Eirini Geraniou & Cosette Crisan* created an asynchronous course on the use of digital technologies in mathematics education where students are not interacting with the lecturer or their peers in real time. They evaluated how the tutors' design considerations and their online pedagogic strategies have influenced students' learning experiences and their engagement with its resources, such as content, peers and tutors. The results show on the one hand students liked the flexible mode of study, but on the other hand, they show the effect of the missing conversations among the students and the necessity of an orchestration of the timing of online contributions.

Games and gamification

Gamification is a topic of much discussion in relation to learning, teaching and motivation. Gamification means the transfer of game principles, game design and game strategies to external fields, like the learning and teaching of mathematics. *Carlotta Soldano & Cristina Sabena* developed game-based activities within a dynamic geometry environment—e.g. one player drags a vertex of a dynamic geometric configuration and the other player must respond in a way that maintains or breaks a constraint—for primary school to foster the development of students' mathematical understanding and their argumentation competencies. *Georgios Thoma* examines problem-solving techniques in the context video games and illustrates the game's potentiality as a problem-solving environment.

The growing variety of theories

The vast and diverse amount of theories related to technology implementation in mathematics education, as already reported in previous CERME research (e.g. Donevska-Todorova & Trgalová, 2017) brings the challenge of their applicability and relatedness with appropriate research methods. There are some well-known theories from other scientific disciplines as the theory of instrumental genesis, the theory of semiotic mediation and activity theory. There is also a growing interest in theories of embodied cognition, particularly in relation to the use of technologies

that offer new ways for students and teachers to express themselves mathematics, through gestures and other body movements, as in the work by Chorney, Gunes and Sinclair. Given the plenary lecture by Paul Drijvers, who also promoted the incorporation of theories of embodiment into existing theories (such as instrumental genesis), and the growing number of non-dualistic theories of learning (of body and mind), we anticipate that this will become an area of fertile growth and change in the upcoming years.

Some thoughts about upcoming topics

A guideline of TWG 16 is to envisage upcoming trends and topics in relation to digital technologies. Online-courses, assessment and gamification are present topics which should be of great interest to mathematics educators and educational researchers in the coming years. There are other topics, which are also represented in the papers of TWG 15. One is space geometry. *Xavier Nicolas & Jana Trgalova* created a virtual environment dedicated to spatial geometry to support the development of vision in space. Another topic is the use of digital technologies in out-door mathematics. *Joerg Zender & Matthias Ludwig* created the mobile app MathCityMap, which poses questions and provides help for questions posed while students do a math trail in the city. *Osama Swidan & Eleonora Faggiano* see modelling under a semiotic lens. While modelling activities are introduced by dynamic digital artefacts, they want to understand the ways students' transit between the simulation of real phenomenon and the mathematical representation. Interesting and challenging is for sure the relation of school mathematics and social media, or digital culture and school culture. *Giulia Bini & Ornella Robutti* use “Internet Memes” combined with augmented reality (AR) technology, to “cultivate classroom discourse and maximize linguistic and cognitive meta-awareness in high school students” (Abstract of the paper). *Florian Schacht & Osama Swidan* address pre-calculus concepts using augmented reality-technology. They use technology design-principles to create an AR-environment, to address technological constraints experienced in experimental situations and discuss alternative ways. And finally, flipped classroom situations (see the paper of *Stefanie Schallert & Robert Weinhandl*) have to be investigated in more detail concerning the learning outcome.

Finally, as technology moves from being an epiphenomenal part of our lives, and of classroom practice, we anticipate that in future CERMEs, many of the content-specific contributions will migrate to other TWGs, as might contributions focused on themes such as assessment. This may be a healthy shift in mathematics education research.

References

- Donevska-Todorova, A. & Trgalová, J. (2017). Learning mathematics with technology. A review of recent CERME research. In Dooley, T. & Gueudet, G. (Eds.). *Proceedings of the Tenth Congress of the European Society for Research in Mathematics Education (CERME10, February 1 – 5, 2017)*. Dublin, Ireland: DCU Institute of Education and ERME.
- Trgalová, J., Clark-Wilson, A., Weigand, H.-G. (2017). Technology and Resources in Mathematics Education. In: Dreyfus, T.; Artigue, M.; Potari, D.; Prediger, S.; Ruthven, K. (Eds.). *Developing Research in Mathematics Education. Twenty Years of Communication, Cooperation and Collaboration in Europe*. Berlin & Heidelberg: Springer. 142–161.

Desirable difficulties while learning mathematics: Interleaved practice based on e-learning

Maria Afrooz and Rita Borromeo Ferri

University of Kassel, Faculty of mathematics education, Germany;

mafrooz@mathematik.uni-kassel.de

Keywords: Desirable difficulties, interleaved learning, blocked learning, e-learning, geometry.

Focus and rationale of the poster

The focus of the poster is the presentation of the project about interleaved practice based on e-learning with the focus on geometry. The poster is intended to provide an overview of the theoretical constructs, the indication of the content, the study design and possible implications.

Indication of the theoretical framework of the study reported

The theoretical framework of the study refers to the theory of desirable difficulties, which is a new approach from empirical research of learning according to the idea: “To make things hard, but in a good way” (Bjork & Bjork, 2011, p. 55). The learning is made difficult in the short term, but in the long term the learning development improves. Research shows (Rohrer, Dedrick & Stershic, 2014; Bjork, 1994) that desirable difficulties lead to a more sustainable learning success.

The poster focusses on the “interleaved learning“, which represents a desirable difficulty. Interleaved practice is defined as an alternating and arrangement of several different learning contents, e.g., A, B, C (Lipowsky et al., 2015, see Figure 1).



Figure 1: Interleaved Practice with the learning contents A, B, C

The positive effect of interleaved practice is explained by the cognitive theories of learning psychology, because the sustainable learning results from a higher cognitive demand and a better memory performance (Bjork & Bjork, 2011; Sweller, Ayres & Kalyuga, 2011).

In contrast to the interleaving is the “blocked learning”, which represents one kind of the traditional learning in mathematics lessons. Blocked learning, in turn, facilitates learning by teaching one learning content at a time before moving on to another, e.g., A, B, C (see Figure 2).



Figure 2: Blocked Practice with the learning contents A, B, C

The possible consequence of blocked practice is that the learners can not remember the first topics after the learning the last learning contents (Bjork & Bjork, 2011).

Indication of and justification for the content

The described project aims at investigating, whether the learning achievements of interleaved learning students differ from blocked learning students by the use of e-learning. Digital media are an important part of today's society and also used in school education for information, communication and networking processes. In the change of society, traditionally structured teaching must also be adapted (Bönsch, 2015). Using e-learning enables an innovative and current method for school education and promotes self-regulated learning (Blaschitz, Brandhofer, Nosko & Schwed, 2012).

Implications for existing research in the area

Possible practical implications for the existing research in e-learning seems to be the development of an e-tutorial for educational settings at school.

One goal of the empirical research in didactics of mathematics should be the promotion of sustainable learning in mathematics school lessons. If interleaved learning proves to be a successful new teaching concept in geometry, the few studies on interleaved practice based on e-learning (e.g., Ziegler & Stern, 2014) have to be expanded in various learning contents of mathematics to explore the effects of interleaved practice further.

References

- Blaschitz, E., Brandhofer, G., Nosko, C. & Schwed, G. (Eds.) (2012). *Zukunft des Lernens. Wie digitale Medien Schule, Aus- und Weiterbildung verändern*. Glücksstadt, Germany: Werner Hülsbusch Verlag.
- Bjork, R. A. (1994). Memory and metamemory considerations in the training of human beings. In Metcalfe, J. & Shimamura, A. P. (Eds), *Metacognition: Knowing about knowing*. Cambridge, England: The MIT Press, 185–205.
- Bjork, E. L. & Bjork, R. A. (2011). Making things hard on yourself, but in a good way: Creating desirable difficulties to enhance learning. In Gernsbacher, M. A., Pew, R. W., Hough, L. M., & Pomerantz, J. R. (Eds.), *Psychology and the real world: Essays illustrating fundamental contributions to society*. New York, NY, US: Worth Publishers, 56–64.
- Bönsch, M. (2015). *Die neuen Sekundarschulen und ihre Pädagogik. Grundstrukturen und Gestaltungsideen*. Weinheim and Basel, Germany: Beltz Juventa.
- Lipowsky, F., Richter, T., Borromeo Ferri, R., Ebersbach, M. & Hänze, M. (2015). Wünschenswerte Erschwernisse beim Lernen. *Schulpädagogik heute*, 11(6), 1–10.
- Rohrer, D., Dedrick, R. F. & Stershic, S. (2014). Interleaved practice improves mathematics learning. *Journal of Educational Psychology*, 107(3), 900–908.
- Sweller, J., Ayres, P. & Kalyuga, S. (2011). *Cognitive load theory*. Explorations in the Learning Sciences, Instructional Systems and Performance Technologies. doi: 10.1007/978-1-4419-8126-4
- Ziegler, E. & Stern, E. (2014). Delayed benefits of learning elementary algebraic transformations through contrasted comparisons. *Learning and Instruction*, 33, 131–146.

Types of graphic interface design and their role in learning via mathematical applets at the elementary school

Eitan Ben-Haim, Anat Cohen and Michal Tabach

Tel Aviv University, Israel; bh.eitan@gmail.com, anatco@post.tau.ac.il, tabachm@post.tau.ac.il

The research goal was to test the suitability of the character of the graphic design on the student's achievements while engaging with mathematical applets for elementary grades. This quantitative research compares two pairs of mathematical applets, which differ only by the type of graphic design; in the extent of detail and the amount of distraction, while the mathematical problems are identical. The first applet has animated graphics based on designs by Matific, a repository of mathematical applets. The second applet was designed specifically for this research in a schematic and visually simple version of the same activities. Students in the schematic graphics group made fewer mistakes and needed less time to complete the activity than students in the animated graphics group. In addition, students with lower mathematics ability succeeded better in the schematic group. No differences between the two groups were observed regarding the level of students' enjoyment.

Keywords: Educational design, graphic design, schematic graphics, cognitive load, mathematical applets.

Introduction

Gamification is an effective learning strategy in mathematics education at the elementary level. Moreover, a clever integration of educational computer games during the learning process contributes to the student's learning, and provides positive experiences (Wouters & Van Oostendorp, 2013). During integration of mathematical computer games both cognitive processes and motivational implications on the learning are taken into account.

The cognitive load theory and the dual-coding theory (Kalyuga, Chandler, & Sweller, 2000) depicts the learning process as two independent learning channels, a visual and a textual channel. The decoding of each channel is processed separately in our minds, and only then can be processed together to create a unified meaning alongside prior knowledge. The decoding and processing procedures strain the working memory, which has a limited load capability (Cook, 2006). The split between the two channels can ease the learning process if the two channels are supplementary. However, an ineffective split may cause additional load on the working memory and therefore decrease learning efficiency. Learners who face difficulty with the learning material, and those who have less prior knowledge, are more likely to be "sensitive" to the dual channel split. Prior studies have shown that such learners are less capable of utilizing visual content that accompanies textual content (Tsai et al., 2016; Mason, Tornatora, & Pluchino, 2013).

Aside from the cognitive aspect, another perspective on the effectiveness of learning by computer games, is through the motivational influence it may have on the learner. Enjoying the learning activity may lead the learner to identify with the learning goals and values (de Lope et al., 2017; Chang, Evans, Kim, Norton, & Samur, 2015; Sedighian & Sedighian, 1996). Graphic design which is

consistent with the learner's interests can help the learner relate to the game. Relatedness, as used by Ryan & Deci (2000), is crucial for achieving intrinsic motivation.

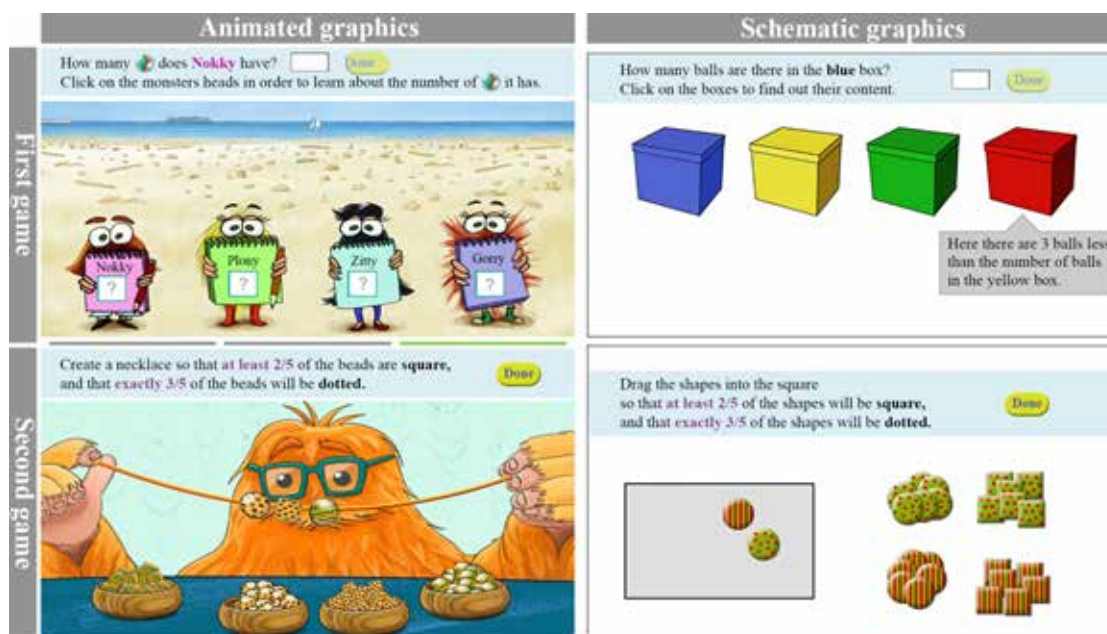
Many studies compare computer games to traditional teaching and identify three advantages of digital technologies: increase entertainment, enhancing motivation of the students, and augmenting their ability to feel involved and active in a learning environment that is individually fitted to their needs (Wouters & Van Oostendorp, 2013; Giannakos, 2013; Chang et al., 2015; de Lope et al., 2017). However, there is a lack of research comparing learning from different computer games. A gap exists between developers, who are not familiar with the design domain, and designers who are not proficient in the educational and pedagogic area of expertise. This gap causes the challenge of creating digital educational materials consistent with theoretical knowledge in the field (de Lope et al., 2017). Learning applets can be compared with many different parameters. This research focuses on one issue: how to design the interface. Specifically, should one use schematic or animated graphics. This research provides a partial and specific response to the lack of empirical work in this area.

The study

The present research stems from a broader study which examines possibilities of better utilizing web-based games in the mathematics classroom, given the practical need for a framework for teachers' choice of mathematical applets, and their integration within the sequence of lessons. Informed by the cognitive load theory and the dual-coding theory, the goal of the presented research is to test the suitability of the character of the graphic design on the student's achievements, in mathematical applets for elementary grades. Three research questions have been studied: (a) How does the learning process differ in learning from animated graphics versus schematic graphics? (b) In what ways are these differences affected by students' proficiency in mathematics? (c) What are the differences in students' enjoyment between graphic designs? Due to space limitation, in this paper we present only the findings relating to the working time and the level of accuracy of the answers (for more details See Ben-Haim, 2018).

Methodology

This research defined two types of graphics: "animated graphics" and "schematic graphics", which differ in the extent of detail and the amount of distraction (Figure 1). This quantitative research compares two mathematical applets. The two applets differ only by the type of graphic design, while the mathematical problems are identical. The first applet has animated graphics based on designs by Matific, a collection of educational math applets which is in use by many schools in Israel. The second applet was designed specifically for this research in a schematic and visually simple version of the same activities.



**Figure 1: Screenshots of two applets from the two types of graphics
(translated into English - originally in Hebrew)**

287 fifth and sixth grade students (50.9% males, 49.1% females) from three elementary state schools in the center of Israel participated in the activity to collect data for this research. All the children were randomly divided into two equal groups: animated graphics group vs. schematic graphics group. The schematic group employed simple and abstract graphics, based on geometric shapes and solid colors (with no shading or hues). In contrast, the animated group employed more complex and colorful graphics, including simple animation. In the animated graphics there is the appearance of depth and space. The elements are figurative and include expressive characters creating an accompanying narrative.

This research monitored students' activity during their play, which enabled the identification of different levels of success between the two groups, differences in working times, and comparison of the students' reports of their degree of enjoyment from the activity. We examined the differences in the learning processes in the two groups. In addition, the students from both groups were divided into two levels based on their proficiency in mathematics. The differences between the groups in performance throughout the activity were compared using statistical tests (t-tests, ANOVA and chi-square) to identify statistically significant differences. Privacy of the children was protected in this research. The schools' names were replaced by numbers, and students' names were not mentioned.

Findings

Differences in the learning process between the two groups

The research results show evidence that students in the schematic graphics group made fewer mistakes than students in the animated graphics group. Figure 2 shows the percentage of students who answered correctly on the first, second or third attempt (light blue and light orange refer to the percentage of students that answered correctly on the first attempt). As can be seen, for all three questions included in the applet, the schematic group (blue) answered with fewer attempts (meaning

fewer mistakes) than the animated group (orange). The differences between the groups are greater in the first and third questions, which were more difficult than the second. Further results show that the schematic group needed less time to complete the activity. Notably, these differences between the groups were observed on the first game of the applet, but not the second.

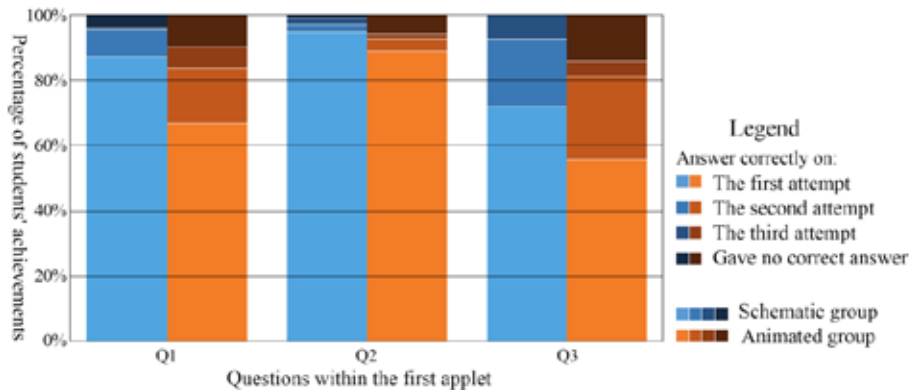


Figure 2: Percentage of students according to success in answering during the applet

Differences between the two groups and the students' proficiency in mathematics

The difference between the two graphic groups is even greater among the students with weaker math achievements (Figure 3). Students with lower mathematic ability succeeded better in the schematic than in the animated graphic group.

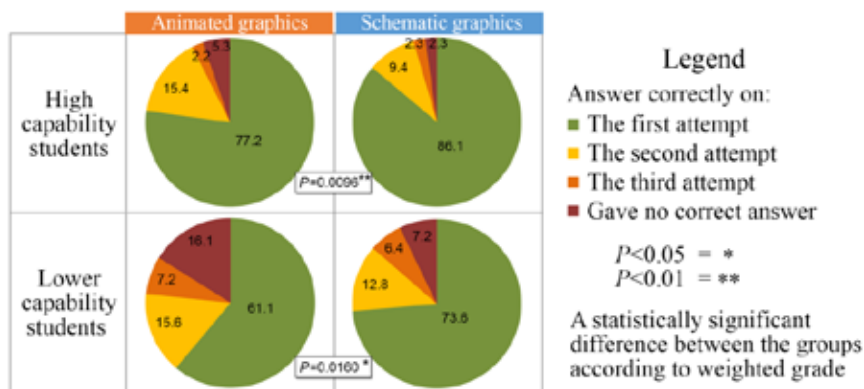


Figure 3: Percentage of attempts to answer during the first applet, comparison of groups and of students' proficiency

Further results arise from two measures by which the students are classified as having low- or high-scores in mathematics: according to the student's school's performance, or according to the student's answer to a final question which was identical in the two groups. Some differences were found, though not always consistently, in distinguishing between low- and high-performing students. In some cases, the animated group was more challenging to low-performing students than to high-performing students. Also, low-performing students in the animated group, required significantly more time than other students.

Differences in students' enjoyment between graphic designs

Contrary to expectations, no differences were observed regarding the level of enjoyment that students reported at the end of the activity with the applet. Students from both graphic groups, and from both

performance levels reported similarly on how much they liked the applets. These findings show no advantage for the animated graphics design with regards to satisfaction.

Discussion

The findings of this research show differences between the two graphic groups. Students in the schematic graphics group made fewer mistakes and needed less time to complete the activity than students in the animated graphic group. In addition, students with lower mathematic ability succeeded better in the schematic group. These findings consistent with the literature on cognitive load theory and on the dual-coding theory (Kalyuga, Chandler & Sweller, 2000). In some cases, the animated group was more challenging to low-performing students than to high-performing students. Also, low-performing students in the animated group, required significantly more time than other students. These results are consistent with professional literature claiming that low-performing students and students with lower prior knowledge, encounter difficulties integrating visual and verbal inputs (Cook, 2006; Mason, Tornatora, & Pluchino, 2013). This means that graphic design of mathematical applets must be adapted to the mathematical knowledge of the learners. Students may find the activity harder when the graphic design is complex, if the activity generates significant cognitive load on the working memory. These findings lead to the conclusion that complex graphics may cause inhibitive cognitive load depending on the learning situation and on the student's performance. Notably, no differences between the two groups were observed regarding the level of students' enjoyment.

The advantage of gamification in the learning process is in its ability to hide the real necessity to learn mathematics (that is remote to the child), and present a goal that the learner can understand and relate to, which also leads the learner to achieve the real goal of learning mathematics (Sedighian & Sedighian, 1996). Gamification may lead to learning via inner motivation, out of interest and curiosity with a clear goal in mind. The design of learning materials should speak in a familiar tone and be relevant to the learner's world (Hui, 2009).

The common misconception regarding digital learning is to think of technology as if it were "chocolate covered broccoli" (Bruckman, 1999, p.75). The advantage of digital gamification is not simply as a means of up grading conventional learning through external motivation (Habgood & Ainsworth, 2011). In order to truly leverage digital integration, the applet must be embedded in the learning process, and must stimulate an active intellectual activity (Sedig, 2008). The visual graphics of mathematical applets must act as the starting point for understanding the problem in a given exercise, leading the learner to insight and solutions (Van Garderen & Montague, 2003). To do this, the graphics must integrate between the game-play of the applet, its plot and the learning content (Wouters & Van Oostendorp, 2013).

The philosopher Marshall McLuhan saw the medium as the source of change in society and coined the phrase "the medium is the message" (McLuhan & Fiore, 1967). In his view, it is not the content transmitted through the medium, rather than the medium itself that comprises the meaning, it is the medium itself that significantly influences the society. In our opinion, this insight echoes in the context of integrating applet-games into the classroom. Applets excite the learner simply by the use of the screen, rather than by the displayed content. It is our belief that as educators, we must not "take

a step back" when the computer enters the classroom. Rather, we must insist on taking an active role directing and navigating the digitally enhanced learning process.

This research was performed with the attempt to maintain objectivity as much as possible, in the collection and analysis of the data. However, there are some limitations in this research. From practical considerations, the studied population was limited, and comparison between the groups was based on only two applets among a large pool of applets. Hence the studied population is not representative of Israeli students, and the activities are not representative of general mathematical learning games, nor of Matific applets in particular. It should be noted that, from among the three schools, only students from school 1 were not familiar with Matific before data was collected. While this research advances the understanding of development and design of digital learning interfaces in math education, further research is needed to extend these preliminary insights, to enhance the benefits of digital learning, and to sharpen teachers' guidelines for implementation.

Conclusion

The results of this research assist us in formulating indicators for teachers, that will enable them to address both personal/experiential aspects of the learner, as well as cognitive aspects. In light of this research, three guidelines have been deduced which could assist developers, designers and teachers to reach a more effective integration of mathematical applets in the elementary school environment: (1) Different graphic designs are suitable for different audiences and for different learning situations. Complex and animated design can cause difficulties if the learning situation is challenging; (2) A schematic graphic design, with few unnecessary details, is more appropriate for applets that tend to have a high cognitive load on the learner; (3) The design must consist of a narrative that connects between the interests of the learner and the content of the learning material. Figure 4 presents the conceptual chart flow that enables practical application of the research findings.

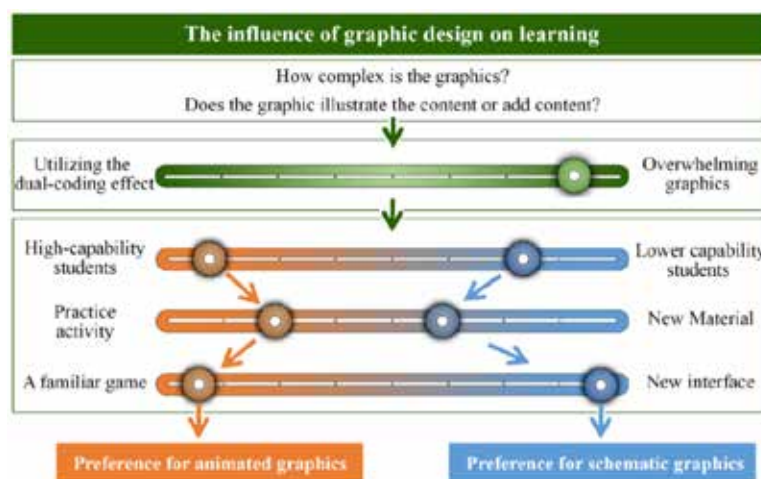


Figure 4: A conceptual chart for selecting graphics according to the characteristics of the students

As shown in figure 4, the teacher must first identify the characteristics of the existing graphics in the applet in question. Two parameters need to be taken into account: (1) complexity of the graphics, and (2) to what extent the graphics serve a pedagogical role. Graphic complexity is rich in detail, contains animations, describes facial expressions and may contain a third dimension, similar to the animated

group in this study. In contrast, schematic graphics portray minimal detail often represented abstractly. The role of graphics covers a spectrum from pedagogical to motivational. Pedagogical graphics are integrated with the learning content and complete that content by visualizing it. Motivational graphics merely motivate and do not clarify the learning material.

In the second step, the teacher may examine the applets suitability to the target audience. Figure 4 depicts the questions that can be asked in the process and portrays two possible scenarios, each leading to a different outcome with respect to a different type of graphic design. Applets identified as having "overwhelming" graphics should lead to closer attention to the following indicator in overall decision making. The three scroll bars at the bottom of figure 4 express different aspects for the given audience. The right-hand side (blue) indicates difficulties that the learners encounter. The left-hand side (orange) indicates less challenging learning situations. The two scenarios depict clear-cut cases, where the three markers clearly lead to one side or the other. To conclude, schematic graphics is preferable when encountering challenging learning situations.

The research conclusions can assist developers and designers of instructional materials in decision making regarding graphics in relation to learning content. Applets built on a linear continuous sequence of activity can design a gradual increase of the graphic load, so that the learner in the early stages of the applet will gradually adapt to the new interface. As the learner progresses throughout the activities, the graphics may unfold into a more complex environment, without having a negative effect on the learner due to the familiarity with the interface. Another rule of thumb regards applets addressing the learning stages of instruction in which the graphics may maintain simplicity and a schematic abstract approach, as opposed to the stages of practice, assessment, evaluation, or recall in which the graphics may consist of a more complex design. This implies that the design team and the pedagogic team must work together in planning educational applets.

While the animated group presents a more attractive design than the schematic group, the former does not incorporate the learning content within the visual design. This is a common major disadvantage among applets. Developers and designers must manage the split between the applet plot and the learning material in order to truly utilize the advantages of digital gamification. This study provides rules of thumb on considerations regarding future development and design of mathematical applets.

Acknowledgment

This study was funded by the chief scientist of the Israel Education Ministry.

References

- Ben-Haim, E. (2018). Types of graphic design and their role in learning-games interface in mathematics education at the elementary age: schematic graphics vs. animated graphics. *MA thesis*, Tel-Aviv University [Hebrew].
- Bruckman, A. (1999, March). *Can educational be fun?* Paper presented at the Game Developers Conference '99, San Jose, CA.
- Chang, M., Evans, M. A., Kim, S., Norton, A., & Samur, Y. (2015). Differential effects of learning games on mathematics proficiency. *Educational Media International*, 52(1), 47-57. DOI: 10.1080/09523987.2015.1005427

- Cook, M. P. (2006). Visual representations in science education: The influence of prior knowledge and cognitive load theory on instructional design principles. *Science Education*, *90*(6), 1073-1091. DOI: 10.1002/sce.20164
- de Lope, R. P., Arcos, J. R. L., Medina-Medina, N., Paderewski, P., & Gutiérrez-Vela, F. L. (2017). Design methodology for educational games based on graphical notations: Designing Urano. *Entertainment Computing*, *18*, 1-14. DOI: 10.1016/j.entcom.2016.08.005
- Giannakos, M. N. (2013). Enjoy and learn with educational games: Examining factors affecting learning performance. *Computers & Education*, *68*, 429-439. DOI: 10.1016/j.compedu.2013.06.005
- Habgood, M. J., & Ainsworth, S. E. (2011). Motivating children to learn effectively: Exploring the value of intrinsic integration in educational games. *The Journal of the Learning Sciences*, *20*(2), 169-206. DOI: 10.1080/10508406.2010.508029
- Hui, C. S. (2009). Learning mathematics through computer games. Proceedings from ATCM 2007: *The 14th Annual Asian Technology Conference in Mathematics*. Beijing, China.
- Kalyuga, S., Chandler, P., & Sweller, J. (2000). Incorporating learner experience into the design of multimedia instruction. *Journal of Educational Psychology*, *92*(1), 126-136. DOI: 10.1037/0022-0663.92.1.126
- Mason, L., Tornatora, M. C., & Pluchino, P. (2013). Do fourth graders integrate text and picture in processing and learning from an illustrated science text? Evidence from eye-movement patterns. *Computers & Education*, *60*(1), 95-109. DOI: 10.1016/j.compedu.2012.07.011
- Ryan, R. M., & Deci, E. L. (2000). Intrinsic and extrinsic motivations: Classic definitions and new directions. *Contemporary educational psychology*, *25*(1), 54-67. DOI: 10.1006/ceps.1999.1020
- Sedig, K. (2008). From play to thoughtful learning: A design strategy to engage children with mathematical representations. *Journal of Computers in Mathematics and Science Teaching*, *27*(1), 65-101.
- Sedighian, K., & Sedighian, A. S. (1996). Can educational computer games help educators learn about the psychology of learning mathematics in children. In E. Jakubowski, D. Watkins & H. Biske (Eds.). *Proceedings of the 18th Annual Meeting of the North America Chapter of the International Group for the Psychology of Mathematics Education* (pp. 573-578). Columbus, OH: ERIC Clearinghouse for Science, Mathematics, and Environmental Education.
- Tsai, M. J., Huang, L. J., Hou, H. T., Hsu, C. Y., & Chiou, G. L. (2016). Visual behavior, flow and achievement in game-based learning. *Computers & Education*, *98*, 115-129. DOI: 10.1016/j.compedu.2016.03.011
- Van Garderen, D., & Montague, M. (2003). Visual-spatial representation, mathematical problem solving, and students of varying abilities. *Learning Disabilities Research & Practice*, *18*(4), 246-254. DOI: 10.1111/1540-5826.00079
- Wouters, P., & Van Oostendorp, H. (2013). A meta-analytic review of the role of instructional support in game-based learning. *Computers & Education*, *60*(1), 412-425. DOI: 10.1016/j.compedu.2012.07.018

Meanings in Mathematics: using Internet Memes and Augmented Reality to promote mathematical discourse

Giulia Bini, Ornella Robutti

Università degli Studi di Torino, Italy, gbini@unito.it, ornella.robutti@unito.it

Levering on the influence and use of social media in students' perception of learning mathematics, this project has a twofold purpose: the research aim is to contribute in breaking away from the idea that digital culture can be considered as opposed to school culture, investigating the epistemic and didactical affordances of mathematical Internet memes, combined with Augmented Reality technology. The coupled educational aim is to cultivate classroom discourse and maximize linguistic and cognitive meta-awareness in high school students. The project is a work in progress of which this paper presents the theoretical background used to frame the study, the results of a first exploratory teaching experiment - conducted with a group of 24 students attending the 12th grade of Liceo Scientifico in Milan - and the methodology and the next steps of the study.

Keywords: digital culture, meme, augmented reality, boundary object, discourse

INTRODUCTION

Internet memes have become a viral form of Web 2.0 communication, with an ever-increasing number of occurrences on social platforms as Instagram (from 37 million in March 2018 to 76 million in March 2019). Nevertheless, Knobel & Lankshear claim that “understanding successful online memes can contribute much to identifying the limitations of narrow conceptions of literacies and new technologies in classrooms” (2007, p.221) still remains almost unanswered. In fact, up to today, the possible didactic relevance of Internet memes is nearly unexplored by academic research and their meaning and use in mathematics education is an unmapped territory. Even if popular culture is playing an increasingly important role in the lives and learning opportunities of young people, Peter Applebaum’s regret that “little work, if any, has been done by math educators to probe the efficacy of mass culture criticism for education in math” (1995, p. 24) strikes for its up-to-dateness.

Levering on the influence and use of social media in students' perception of learning mathematics, this project has a twofold purpose: the research aim is to contribute in breaking away from the idea that digital culture can be considered as opposed to school culture, investigating the epistemic and didactical affordances of mathematical Internet memes, combined with Augmented Reality technology. The coupled educational aim is to cultivate classroom discourse and maximize linguistic and cognitive meta-awareness in high school students. The project is a work in progress of which this paper presents the theoretical background used to frame the study and the results of a first exploratory teaching experiment - conducted with a group of 24 students attending the 12th grade of Liceo Scientifico in Milan - together with the methodology and the next steps of the study.

FROM MEMES TO INTERNET MEMES

In 1976, well before the digital era, evolutionary biologist Richard Dawkins coined the term *meme* as “a unit of cultural transmission”, examples of which are “tunes, ideas, catch-phrases, clothes fashions, ways of making pots or of building arches” that “propagate themselves in the meme pool by leaping

from brain to brain via a process which, in the broad sense, can be called imitation.” (Dawkins, 1976, p.249). Web culture (https://en.wikipedia.org/wiki/Internet_meme) gives credit to Mike Godwin for revamping the concept of memes in 1993, identifying Internet memes as a subset of memes and describing them as an activity, concept, or piece of media that spreads through social channels, evolving in the hands of the digital users and reaching a large audience.

Internet memes can be in the form of viral images, videos or files: in this work, we will focus on those made of “verbal and pictorial parts, which unfold their meaning through collective semiosis” (Osterroth, 2018, p.6); as they integrate different modes of communication, we think they can fall into the category of multimodal artefacts. They usually have a humorous or satirical intent and are widely shared by young people through social platforms (Facebook or Instagram), since they connect the participatory potential of the Internet with the quest for user-generated content that - through shares and likes - provides a form of social validation.

They are deeply rooted in visual media culture and catch users’ attention with their puzzling vibe that calls for the active contribution of the viewer to unlock the meaning and thus adds a gratifying flavour. Internet memes are created by users according to collectively established and shared rules that govern the so-called *memesphere*: these rules dictate the conventional meaning of the pictorial parts and the position, font, syntax and narrative structure of the text, they “cannot be enforced by a specific person, but the community sanctions wrong uses by downvoting, not liking or simply not spreading the misused meme” (Osterroth, 2018, p.7). These same rules shape meme generators websites as <https://imgflip.com/mememplates> or <https://makeameme.org/>: there are several accepted structures, two of the most common being those in Figure 1.



Figure 1: Two prototypical meme structures

Pictorial parts, usually identified with names, might have local or global recognisability: in Figure 2, a blank template of the *Success Kid* meme - globally used to boast of something good - is shown, followed by a general example of the meme propagation by imitation and an example of its psycho-pedagogical adaptation, to end with its mathematical variation.



Figure 2: Template and propagation of the *Success Kid* meme (source Google search, Sept 18)

The last example is representative of a rare situation in which mathematics *spontaneously* leaves the school context and is used to identify the belonging to a group and to set the author's position in the group. This kind of memes, in fact, are usually shared within specialized Internet groups, where products are scrutinized by skilled peers and acceptance grants the author the cited social validation.

MATHEMATICAL INTERNET MEMES AS KNOWLEDGE CARRIERS

To focus more on the concept of mathematical Internet memes and illustrate their epistemic potentiality, we shall analyse two examples of the *Drowning kid in the pool* meme (Figure 3), used to describe a situation where something is typically forgotten. On the left a correct version posted in May 2018 within a [Reddit thread](#), where was identified as “the quintessential math joke”, on the right its wrong variation, posted in another [Reddit thread](#) in June 2018.

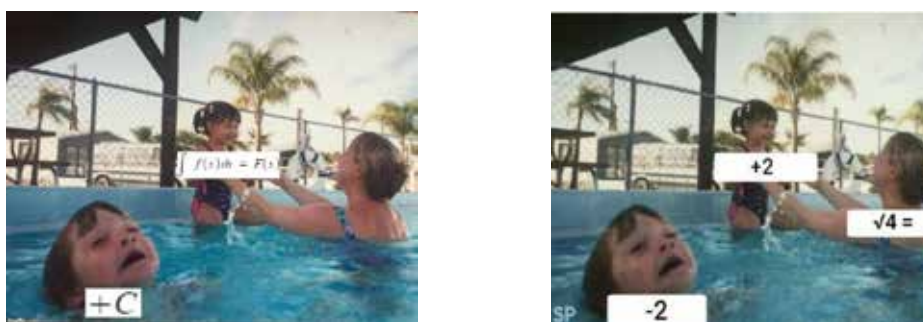


Figure 3: *Drowning kid in the pool* correct (left) and wrong (right) memes

Taking a look at the exchange triggered by the wrong one (some excerpts are listed below), we see how memes can act as knowledge carriers and starters of meaningful mathematical discussions:

- bike0121 This is not really correct. The function \sqrt{x} is always greater or equal to zero. The inverse of x^2 is indeed $\pm\sqrt{x}$, but $\sqrt{4}$ is always $+2$, not -2 .
- Dat_J3w Yea it's positive by convention; the square root of four is still plus/minus two
- functor7 Absolutely not. $\sqrt{4}$ is 100% only the value 2. The solutions to the equation $x^2=4$ are ± 2 . \sqrt{x} is a function, which means it only has one value. \sqrt{x} is a number, not a collection of numbers.

Dozens of Reddit and Facebook mathematically-themed groups (some with evocative names like “Complex Analysis Memes For Holomorphic Teens” and “The Name Of This Group Is Left As An Exercise For Its Members”) with thousands of users showing off their mathematical knowledge, discussing, posting and sharing mathematical Internet memes on a daily basis, suggest that the meaning of a meme can be looked for in a “sphere of practice (SP), [...] defined as the ‘community’ adhering to a common set of rules, within which mathematical meanings are constructed” and could be a suitable setting to address the issue of “communicating, transforming and negotiating the social meaning of school mathematics” (Kilpatrick et al., 2005, p.10).

PARTIAL AND FULL MEANINGS OF A MEME

As a first step of the study on mathematical memes, we tried to figure out how memes act as carriers of meanings and we identified a *triple-s construct* of the three partial meanings that contribute in building up the full meaning of a mathematical Internet meme.

- The first meaning of a meme lies in its being a meme, namely to have a specific and shared structure and graphics (font, colour and text position). It can be considered at a *structural* level (Figure 1).
- The second meaning of a meme is conveyed by the shared conventions connected to viral images, compositional setups and accepted syntaxes. It is at a *social* level (Figure 2, first image).
- The third meaning of a meme is borne by images, symbols or text referring to a specific topic (mathematical, but also political, physical or other). This is at a *specialised* level (Figure 2, last image, textual part).

The first two meanings ground in the popular culture rules that govern the *memesphere*, acting as Kilpatrick's sphere of practice, while the third calls some mathematical skills into action. The interplay of all three *partial meanings* unlocks what we call the *full meaning* of the meme, that triggers the surprise/membership effect. There are people who can only access the first meaning, merely recognising the artefact as a meme (and not a cartoon, for example). Others will stop at the second level, identifying the viral elements only. On the other hand, those who understand the specialized mathematical signs in the meme, but are not aware of the other meanings, will equally miss the full meaning. But those who succeed in appreciating all three meanings will crack the full meaning of the meme: they will laugh and feel part of a community. In fact, "meaning mobilizes feeling, and emotions only translate if we process images and captions in the same way" (Benoit, 2018, p.41).

To sum up, we think that it would be fruitful to investigate whether mathematical Internet memes can contribute to the construction of mathematical meanings and explore the possible epistemic affordances implied by their multiple referents (one of many being their visual component that can cater to different intelligences and learning styles). To pursue this research path we imagined that, having mathematics spontaneously already crossed the boundary between formal and informal learning, it could be worth exploring how to facilitate the crossing in the opposite direction and test mathematical Internet memes in a standard school context.

THEORETICAL FRAMEWORK

It is beyond the scope of this study to evaluate why Internet memes in general, and mathematical Internet memes in particular, have this success in the social arena, although that "aha" moment we all experience when we finally grasp the joke resonates with what Mason (2014, p.1) describes as a "disturbance, experienced as surprise, as puzzlement or perplexity" that somehow "provoke[s] learners into taking initiative" and "call[s] upon learners to make use of their undoubted powers of making sense." Zooming in, we will focus our attention on the learning dynamics connected to the use of mathematical memes within the classroom: in this optics we will try to read our data through the lenses of the Boundary Objects framework as introduced by Star & Griesemer (1989) and further developed by Akkerman & Bakker (2011) and of Anna Sfard's (2001, 2008) theory about discourse and communicational approach to cognition in a Vygotskian sociocultural perspective.

According to Star & Griesemer, (1989, p.393) "boundary objects are objects which are both plastic enough to adapt to local needs and the constraints of the several parties employing them, yet robust enough to maintain a common identity across sites. [...] They have different meanings in different social worlds, but their structure is common enough to more than one world to make them

recognizable, a means of translation.” Our point is that mathematical Internet memes can be looked at as boundary objects between social media and mathematics, two separate worlds with separate rules and languages, whose “intersections of cultural practices open up third spaces that allow negotiation of meaning and hybridity—that is, the production of new cultural forms of dialogue” (Akkerman & Bakker, 2011, p.135), and therefore they can be fruitfully trialled in boundary-crossing activities. In a complementary way we argue that memes, together with the inner discourse brought into being to make sense of them and the collective discussion they trigger in the class group, are aligned with Sfard’s statement that “the term discourse will be used to denote any specific instance of communicating, whether diachronic or synchronic, whether with others or with oneself, whether predominantly verbal or with the help of any other symbolic system [...] learning mathematics may now be defined as an initiation to mathematical discourse, that is, initiation to a special form of communication known as mathematical.” (Sfard, 2001, p.28).

The research questions we are searching answers to are the ones below, they are big and complex ones and we are aware that this study just put a small dent into them, but we think they deserve to be stated because they outline the bigger picture we strongly believe is worth looking for:

RQ1: What are the epistemic affordances, if any, of mathematical Internet memes?

RQ2: Does creating and/or interacting with these memes implies/determines learning?

RQ3: Which characterizations identify a boundary object in this context? Which interactions among the communities of students, teachers and researchers are triggered by these boundary objects?

RQ4: Can memes, students’ explanations vehiculated through the narrative virtual content and classroom discussion be identified as parts of a mathematical discourse?

METHODOLOGY: THE BUILDING OF THE TEACHING EXPERIMENT

The beginning of this project dates back to a few years ago when one high school student (of the first author) provokingly said that he had finally grasped a math concept only when coming across a mathematical Internet meme on the same subject in a social platform. Moving forward from this first naïve appearance of memes in the school environment and trying to figure out how to build a significant task to test our assumptions in an almost unexplored territory is, of course, a challenge that can be tackled only by small steps. We started observing students’ reaction to mathematical Internet memes found in the web (examples in Figure 4) and used by the teacher to catch and hold attention, to stress specific aspects of already taught topics and to trigger classroom discussion.

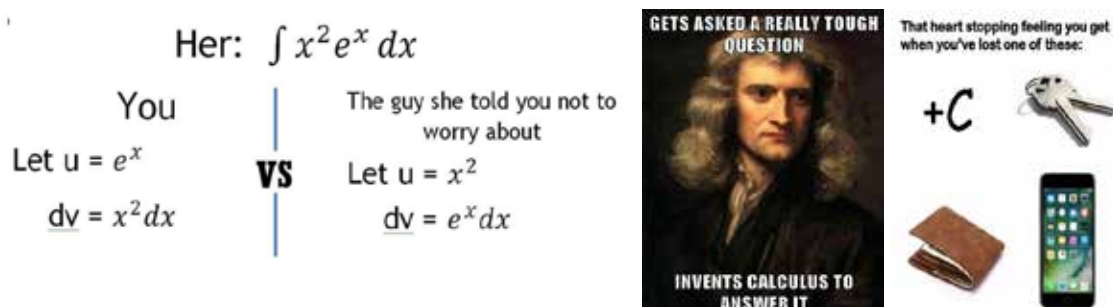


Figure 4: Examples of web-found mathematical Internet memes

The quality of the mathematical discourse enthused by these mathematical Internet memes convinced us that interacting with them calls mathematical competencies into play but, to dig deeper into the

epistemic of memes, we realised that students had to create the memes themselves and shoot videos to keep track of the explanations of the mathematical meanings.

This is when Augmented Reality (AR) comes into action: vision-based AR technology refers to the triggering of a superimposed computer-generated layer (usually a video) when pointing a smartphone or other GPS-enabled device to a precise spot; it allows the connection of the meme to the corresponding explanatory video, that can be then viewed scanning the meme into the phone. Hopefully, the bonded couple meme+video will thus give origin to a multimodal and multimedia learning object, providing opportunities for the single student to maximize his linguistic and cognitive meta-awareness and systematize knowledge, for the class group to connect and revise knowledge and for the teacher to assess students' comprehension of previously studied concepts, to single out possible misunderstandings and misconceptions and give a formative assessment. Last but not least, it could cross the threshold of the school environment, be shared on the web and become part of the global network heritage as a viral meme.

Having students create memes and videos themselves matches different goals: it allows taking advantage of the aforesaid participatory thrust of the digital world, it leverages on the notion of identity as “a perfect candidate for the role of “the missing link” in the researchers' story of the complex dialectic between learning and its sociocultural context” (Sfard and Prusak, 2005, p.I-43) and finally it will hopefully facilitate the emergence of the students' linguistic and cognitive meta-awareness, which are the declared educational aims. This last expectation grounds in the concepts of “active response” and “meaningfulness” advocated by Burbules in his description of the virtual, that “should not be understood as a simulated reality exposed to us, which we passively observe, but a context where our own active response and involvement are part of what gives the experience its veracity and meaningfulness” (2006, p.38).

A FIRST TEACHING EXPERIMENT

At the end of May 2018, a first exploratory teaching experiment was conducted with a group of 12th-grade students, aiming at testing the potential educational effectiveness of memes. The assigned task, to be done individually at home, was to create a meme on one of the year's math course topics (optionally using one of the said meme generator websites) and shoot a video with the smartphone explaining the mathematical concept recalled by the meme. Students then were asked to bond meme and video through [HP reveal](#) (a free augmented reality web app) and post the meme in the collective space, using the free web app [Padlet](#), set up for the occasion to mimic the social media environment, allowing the sought-after tribal reward reactions.

Connecting students' memes to our *triple-s* analysis, we can see that all productions comply with the structural meaning and that they all call for the viewer's engagement mobilizing an emotional reaction due to a misalignment between different parts of text or between text and image. Looking at the social meaning, that seems the element that crosses the boundary “maintaining the common identity” (Star & Griesemer, 1989, p.393), we have identified three main categories (examples in Figure 5).

Finally, examining the memes' specialized meaning, further clarified in the coupled videos, we completed the possible analysis in Table 1 (videos – in Italian - can be seen downloading the HP

Reveal app to a smartphone, following *lifeonmath* and then scanning the images in Figure 5 – due to monitor light reflections, it works better with printed images).



Figure 5: Example 1 (left), Example 2 (centre), Example 3 (right)

CATEGORIES	SOCIAL LEVEL	SPECIALIZED LEVEL
Figure 5 Example 1	meme caption starting with a “ <i>when you/they</i> ” statement	mathematical terms in the meme caption.
Figure 5 Example 2	meme describing the effect of an action or operation	image connected to the mathematical action, mathematical symbols used to label elements in the image
Figure 5 Example 3	meme creating a pun based on a bivalency of meanings	meme caption with terms that have a mathematical and a common use meaning

Table 1: Analysis of the produced memes and videos

Considering these data, a first observation is that technology seems to intervene with different roles: it acts both as an instrument for students to create the learning objects and as an environment with rules that informs designers and users. From the educational point of view, their creations seem to confirm that students knowingly selected a topic in which they felt comfortable (cognitive meta-awareness) and made an effort to explain it clearly using appropriate lexis (linguistic awareness). Looking this preliminary analysis through the lenses of our framework theories, we ventured that the boundary object could be looked for in the social level that “maintain[s] a common identity across sites” (Star & Griesemer, cited), while the couple meme+video appears effective in triggering a special form of mathematical communication in which meta-cognition and language accuracy play a relevant role. This is, of course, a first rough attempt that has to be refined, breaking it down and trying to identify the steps of the boundary crossing (identification, coordination, reflection and transformation) and the commognitive constructs (word use, visual mediators, narratives, and routines), once the observation of the cognitive processes will be implemented.

NEXT MOVES

Although the results of this first exploratory teaching experiment seem encouraging, there are still many shadows hanging over this project, one among others being its replicability. In order to dispel at least this first doubt, in the upcoming months, we are planning to set up a focus group observing 2/3 students, coming from a different school environment, during the process of creating memes and videos on a fixed topic. In the light of the data collected, we will hopefully structure a larger study in

a class group, giving space also to class discussions, teacher's feedbacks and possible students' revisions of the products, together with the assessment of the learning after a few months.

As we recalled in the opening paragraph, this work is still in progress, with no assessed conclusions and many unanswered questions, but we strongly believe it is worth to keep venturing in this almost unmapped territory because this is something more than a traditional technological learning experience, as memes produced by students can leave the school environment and spread virally in the web. It is a unique situation in which the virtual world comes into contact with the school world, expectantly enabling us to learn something new about the impact of the digital revolution and new communication technologies on epistemological pathways and learning practices.

References

- Akkerman, S. F., & Bakker, A. (2011). Boundary crossing and boundary objects in *Review of Educational Research*, 81, 132-169.
- Appelbaum, P. M. (1995). *Popular culture, educational discourse, and mathematics*. Albany: State University of New York Press.
- Benoit, G., (2018). *Mathematics in Popular Culture: An Analysis of Mathematical Internet Memes*, Doctor of Education dissertation, Columbia University.
- Burbules, N.C. (2006). Rethinking the virtual. In J. Weiss et al. (Eds.), *The International handbook of virtual learning environments* (pp. 37–58). Dordrecht: Springer Netherlands.
- Dawkins, R. (1976). *The selfish gene* (40th-anniversary edition), Oxford University Press, UK.
- Kilpatrick, J., Hoyles, C. and Skovsmose, O.: (2005). Meanings of 'Meaning of Mathematics', in J. Kilpatrick et al. (eds.), *Meaning in Mathematics Education*, Springer, New York, NY, 9-16.
- Knobel, M., & Lankshear, C. (2007). Online memes, affinities, and cultural production. In M. Knobel & C. Lankshear (Eds.), *A new literacies sampler* (pp. 199-228). New York, Peter Lang.
- Osterroth, A. (2018). *Semiotics of Internet Memes*. 10.13140/RG.2.2.12320.89605.
- Mason, J. (2004). *A phenomenal approach to mathematics*. WG 16, ICME, Copenhagen.
- Sfard, A. (2001). There is more to discourse than meets the ears: Looking at thinking as communicating to learn more about mathematical learning in *Educational Studies in Mathematics* Volume 46, Issue 1-3, pp 13–57.
- Sfard, A. (2008) *Thinking as Communicating: Human Development, the Growth of Discourses, and Mathematizing*, Cambridge University Press.
- Sfard, A., & Prusak, A. (2005). *Identity that makes a difference: Substantial learning as closing the gap between actual and designated identities*. Proceedings: 29th Conference IGPME, 37-52.
- Star, S. L., & Griesemer, J. (1989). Institutional ecology, 'translations' and boundary objects: Amateurs and professionals in Berkeley's museum of vertebrate zoology, 1907–1939 in *Social Studies of Science*, 19, 387–420.

Students' Process and Strategies as They Program for Mathematical Investigations and Applications

Chantal Buteau¹, Eric Muller¹, Kirstin Dreise¹, Joyce Mgombelo¹, and Ana Isabel Sacristán²

¹Brock University, Department of Mathematics, St.Catharines, Canada; cbuteau@brocku.ca;

²Cinvestav, Mexico; asacrist@cinvestav.mx

This paper focuses on the process of university mathematics students engaging in a sequence of programming-based mathematical project tasks as part of a course. Data of this naturalistic research was collected mainly through four student projects and semi-structured individual interviews. The analysis led to narratives of students' development process (instrumental genesis) in which enacted strategies (instrumented actions) are highlighted. In this paper we discuss a participant's development process. Results suggest that the student, after 1 course, has appropriated programming as instrument for creating a tool for pragmatic purposes; however, not yet as instrument for mathematics investigations and applications, i.e., as an object-to-think-with (Papert, 1980).

Keywords: Programming, Instrumental Genesis, Strategies, University Mathematics Education.

Introduction

There is a resurgence of interest in integrating computer programming—more broadly, computational thinking (CT)—in education (e.g. in UK; Benton et al., 2017). This interest reflects how scientific fields, including mathematics, have developed computational counterparts (Weintrop et al., 2016), as well as the rise and need for proficiency in computational practices as 21st century skills. We see a crucial need to understand how students can be empowered to participate in such computational thinking, now an integral part of the mathematics and broader community.

In our work, we want to better understand how students come to appropriate programming as an instrument for mathematics investigations and applications “as mathematicians do”. This appropriation involves students developing fluency (e.g. enacting strategies to progress forward) as they are (in the process of) engaging in this kind of mathematical work. This includes, not only becoming skilled at programming, but also designing and interpreting the mathematical work facilitated, or made possible, by programming. In this proposal, we discuss the case of a student's fluency development, analysed from the first-year data that was collected as part of a five-year study that examines how postsecondary mathematics students learn to use programming as a CT instrument for mathematics. It is a naturalistic (i.e., not design-based) research that takes place in a sequence of three project-based mathematics courses (called ‘MICA’) implemented in the mathematics department at Brock University (Canada) since 2001, where undergraduate mathematics majors and future mathematics teachers learn to design, program (e.g. in VB.net), and use interactive computer environments to investigate mathematics conjectures, concepts, theorems, or real-world applications (Buteau, Muller, & Ralph, 2015; Muller, Buteau, Ralph, & Mgombelo, 2009).

Conceptual Framework

Our work is framed by various interrelated concepts reflected in the literature on CT, CT in mathematics, and in mathematics education (Buteau, Muller, Mgombelo, & Sacristán, 2018). Wing (2014) defines CT as “the thought processes involved in formulating a problem and expressing its

solution(s) in such a way that a computer—human or machine—can effectively carry out” (p. 5), while Hoyles and Noss (2015) consider CT as abstraction, algorithmic thinking, decomposition, and pattern recognition. CT is an underlying process to computer programming described e.g. by Weintrop et al. (2016) as understanding, modifying, and writing codes (e.g., in *Python* or *C++*). Brennan and Resnick (2012) identify key dimensions for developing CT, namely *computational concepts* (e.g. iteration), *computational practices* (e.g. debugging projects or remixing others’ work), and *computational perspectives* (e.g. a designer’s evolving views about what could be programmed).

CT has changed the nature of contemporary research in mathematics; for example, we now see computer-based proofs and new domains of research related to mathematics and computation such as bioinformatics. The European Mathematical Society (2011) recognizes this emerging way of engaging in mathematical research: “Together with theory and experimentation, a third pillar of scientific inquiry of complex systems has emerged in the form of a combination of modelling, simulation, optimization and visualization” (p. 2).

Based on their literature review and interviews with experts who use CT, Weintrop et al. (2016) outline what they believe to be the integral CT practices for mathematics and science, in particular encompassing this third pillar (Broley, Buteau, & Muller, 2017), across four main categories throughout which programming is an underlying practice: *data practices*, *modelling and simulation practices*, *systems thinking practices*, and *computational problem-solving practices*. E.g., the latter practice involves interpreting and preparing problems for mathematical modeling, assessing different approaches, developing modular solutions, and creating computational abstractions.

In the field of mathematics education, CT is not new; indeed, it has a 45-year legacy that started with the LOGO programming language (Papert, 1980) and extended into the theory of constructionism. Studies of constructionism in undergraduate-level mathematics education show how programming supports students’ understanding of mathematical concepts and contributes to the development of critical thinking skills (e.g., Wilensky, 1995). As for students’ processes when engaging in using programming for mathematical investigations and applications, we proposed a model based on insightful reflections on MICA student experiences (Buteau & Muller, 2010) which was later refined through a literature review (Marshall & Buteau, 2014); see Figure 1.

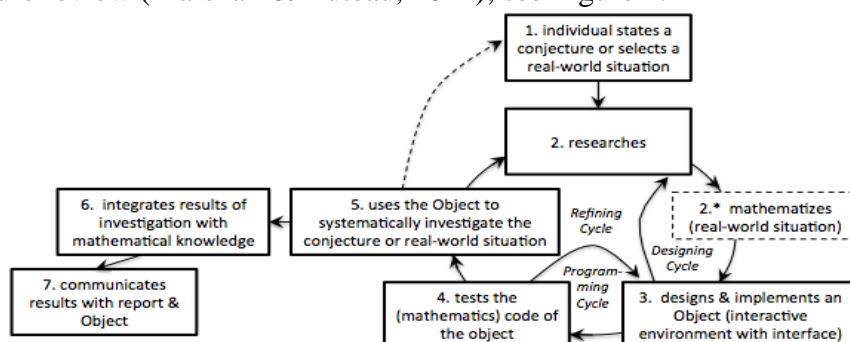


Figure 1. Development process model of a student engaging in programming for a mathematical investigation or application (Marshall & Buteau, 2014)

We use Lave and Wenger’s (1991) concept of “legitimate peripheral participation,” which describes how learners enter into a community of practice and gradually take up its practices, to understand how undergraduate students learn mathematics through CT activities. Based on this idea, mathematics is not knowledge to be acquired but rather is a process of participation through which the student

gradually gains membership to a community (of mathematicians). We thus focus on how students create and use computer tools to engage in opportunities to participate peripherally in practices considered to be integral to the mathematical community as outlined by Weintrop et al. (2016), i.e., in the four CT practice categories. Thus, our work is focussed on how students (newcomers) engage in computational thinking for mathematics as mathematicians (elders) do. In fact, the proposed development process of a student engaging in programming for mathematical work as summarized in Figure 1 (removed of its numbering) seems to align with the process by which pure mathematicians use programming in their research work (Broley, Caron & St-Aubin, 2018).

In this proposal, we focus on this process and the strategies that students enact when engaging in CT-based mathematics work. In the instrumental approach framework (Rabardel, 1995/2002), the process is related to a student's *instrumental genesis* (Artigue, 2002): the process by which the student transforms an artifact into an instrument through schemes of usage and action. The instrumental genesis is a twofold process: instrumentalization –directed towards the artefact–, and instrumentation –directed towards the user–concerning “the development and appropriation of schemes of instrumented action which progressively take shape as techniques that permit an effective response to given tasks” (Artigue, 2002, p. 250). These schemes of instrumented action consist of technical and conceptual components. According to Drijvers, Godino, Font, and Trouche (2013), techniques may be considered “as the observable part of the students’ work on solving a given type of tasks (i.e., a set of organized gestures)” (p.27), e.g., strategies used by a student at a certain step/cycle (see Figure 1) when engaging in a given programming-based mathematical task; and the schemes “as the cognitive foundations of these techniques that are not directly observable, but can be inferred from the regularities and patterns in students’ activities”(p. 27). As Bozkurt et al. (2018) summarize:

An artefact is initially not meaningful to the user until he or she develops associated schemes of instrumented action to use the artefact for achieving a task, and effectively turning the artefact into a useful mathematical instrument. (p.44)

E.g., turning (VB.net) programming into an instrument for mathematics investigation or application as mathematicians do, which we call ‘a CT-instrument for mathematics’. In this proposal we discuss first results commencing to address our research question: *How do post-secondary students come to appropriate programming as a CT-instrument for mathematics?*

Methodology

Our research uses iterative design methods whereby some parts (participant recruitment and data collection) were designed in a way that would be least intrusive to (or constrained by) the natural learning environment. The study follows students’ development over the course of (and beyond) their MICA I-II-III courses as they engage in 14 *exploratory object* (EO) mathematics project tasks, each resulting in an interactive environment and a report of mathematical findings (Muller et al., 2009). This paper focusses on a first analysis of data collected from the first year of our research. It thus draws from MICA I students where six (among 46) participants were recruited (voluntarily). In the MICA I course, there are 4 EO project tasks (which count for 71 % of students’ final grades): 3 assigned individual ones, and a fourth one where students select the topic and can work in pairs or individually. Two-hour weekly labs progressively integrate through guided exercises the learning of computational concepts (variables, loops, etc.) in a mathematical context, whereas two-weekly hour

lectures introduce the math background needed for engaging in the EO tasks (Buteau et al., 2015).

Data from the participants included each participant's 4 project assignments (EO and report) and individual semi-structured interviews after completion of each of these EO tasks. The design of the interview guiding questions was informed largely by the students' development process model (Figure 1). In addition, data collected included weekly post-laboratory session online reflections (answering guiding questions) and an initial baseline online questionnaire before the beginning of MICA I course. Lab session and EO assignment guidelines were also collected and were complemented by an informal understanding of the MICA I course from the research team members' experiences in different capacity (researcher, instructor, course approver, former student).

All of the collected student data were analysed through thematic analysis techniques. Codes were developed based on categories informed by the conceptual framework (and associated literature). Each participant's interview and lab reflection data was coded individually by two coders, followed by a thematic analysis done jointly by the two coders. Themes were consolidated among the six participants' analyses, and led to sixteen themes regrouped in five main meta-themes, one of which concerned strategies. Narratives were composed, following the model steps from Figure 1, of each participant's process of engaging in their four EO projects, highlighting their enacted strategies, and overall summary. We now present preliminary findings by illustrating one of the six participants' development process with a focus on her use and development of instrumented techniques, i.e., *enacted strategies* (in italic, below), as a way to gain insights into her instrumental genesis towards appropriating VB.net programming into a CT instrument for mathematics.

Findings: the case of Hannah

Hannah (pseudonym) is a mathematics and computer science co-major, and thus had programming experience (in Java) prior to her MICA I course. In her first assigned EO project –exploring a conjecture of their choice about prime numbers or hailstone sequences–, Hannah struggled with the initial step of conjecturing (steps 1-2 in Figure 1); once she was passed this, she incrementally designed and programmed (steps 2-3) with ease her interactive environment (EO). When the time came to interpret the mathematics output of her program (steps 5-7), Hannah struggled and provided only data examples without mathematical explanation. In the EO 2 project on a RSA encryption application, Hannah reported feeling more satisfied and confident, finding it overall easier, in particular since she could start right away with designing and programming (i.e., step 1 was provided by the assignment guidelines). However again, her focus on the mathematics (step 5-7) seems to have been limited. We elaborate next on Hannah's engagement in her third EO task.

Hannah's development process and enacted strategies in her third assigned EO project task

Students are then asked to design, program, and use an interactive environment to explore, graphically and numerically, the behavior of a dynamical system based on a two-parameter cubic (Buteau et al., 2015). It follows an introduction of discrete dynamical systems in lectures, guided computer lab activities to program an EO to explore the logistic function system (quadratic, 1 parameter), including an instructor guided exploration of the system as the parameter is changed. At this time, students have been introduced to all basic computational concepts for mathematical work: variables, interface design, loops, conditionals, events, sequencing, and graphing. This assignment has a significant component on mathematical investigation. For Hannah, it is a critical learning opportunity since she

struggled with the mathematical components of the previous two EO projects.

Similarly to EO 2, the assignment guidelines provided the focus of the EO project (step 1 in Figure 1). Hannah voices that she did not research the related mathematics (step 2) when beginning the assignment because the lectures and labs were sufficient; however, in reflection, she believes she would have needed more time spent on the math concept to grasp it. In fact, Hannah missed some lectures due to illness and felt unable to catch up with the mathematical concepts. As in the past assignments, Hannah understands the programming concepts and is able to start designing and programming her project (step 3) in lab time by *remixing from the two previous labs* on the logistic function dynamical system. She used the *computational practice of incremental steps* with testing to complete the programming (programming cycle) – see Figure 2 for a screenshot of her EO:

Hannah: the first step was setting up everything. ... we have to setup the graph... regardless of ... 'a' and 'b'... we're converting it to pixels instead of x and y's... So, we had to make sure that was working first before you could plug in anything.

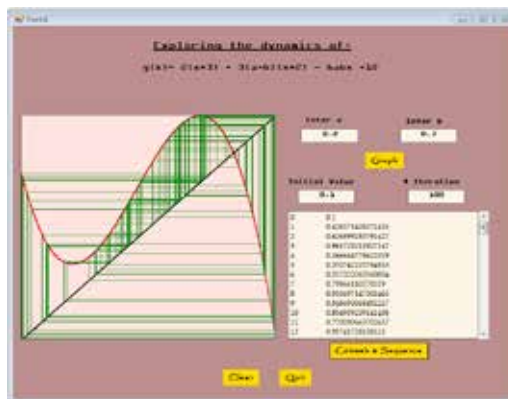


Figure 2. Screenshot of Hannah's third EO project about the 2-parameter cubic dynamical system

Hannah *tested the mathematics* output of her program *against other students' work and known examples from class* (step 4); e.g., Hannah says:

Hannah: I used the, um, same values that, um, [the instructor] put in the labs. And, um, I checked, I compared the sequence and saw the math was working and then the graph and how it looks.

However, she had difficulty in investigating the given math topic or understand its meaning (steps 5 & 6), although she did *investigate* the cubic function *by systematically varying its parameters*:

Hannah: I left 'b' fixed at zero and I increased 'a' a little bit and little bit and I see how it affected the curve....So, yeah, I played around with [a and b] until, um, until I got the fixed points.

but struggled with understanding the cobweb:

Hannah: one of the challenges was, um, the, um, trying to figure out if it actually does converge. Because, um, the way we visualize it is, um, for each of the points. So, if you have 10 points, uh, 10 sequence numbers that you have, you draw lines between them. But, because we don't have like, sort of like, the starting point of the line and the ending point, you don't know if it is going that direction, which direction are going.

In the final part of the assignment, the report, Hannah's lack of understanding becomes clearer. Although her program works, her report does not reflect understanding; in particular, she *uses the*

program to generate an example, rather than elaborating calculations and drawing it by hand as asked (similar to how she completed her EO 2). Her report is lacking in explanations or conclusions to communicate her mathematical knowledge (step 7) and the discussion portion of the report is missing. This EO project could have been a great positive learning experience for Hannah to use programming for mathematics (learning) as this assignment was heavier on the mathematics investigation than previous ones. However, Hannah missed the opportunity partly due to external factors (illness).

Hannah's overall trend over the 4 EOs

Throughout the course, Hannah's focus seems to remain on programming rather than moving on to programming for mathematics, as revealed through her general approach to the 4 EO assignments. Hannah finds difficulty in identifying on her own, a mathematics topic relevant to a programming-based approach (step 1). She prefers to be given a conjecture (as in EO 2) and avoids creating her own when possible (as in EO 4). Once the mathematics problem or conjecture is sorted out, Hannah becomes much more comfortable. Most of the time, she researches thoroughly and uses resources to be well prepared for a solution before starting to program. She wants to understand the mathematics *a priori* and then program it, rather than using programming to understand (her general approach to 'interpreting and preparing problems for mathematical modeling' practice). This method causes difficulty in EO3 as programming for investigation is an intended way for students to understand.

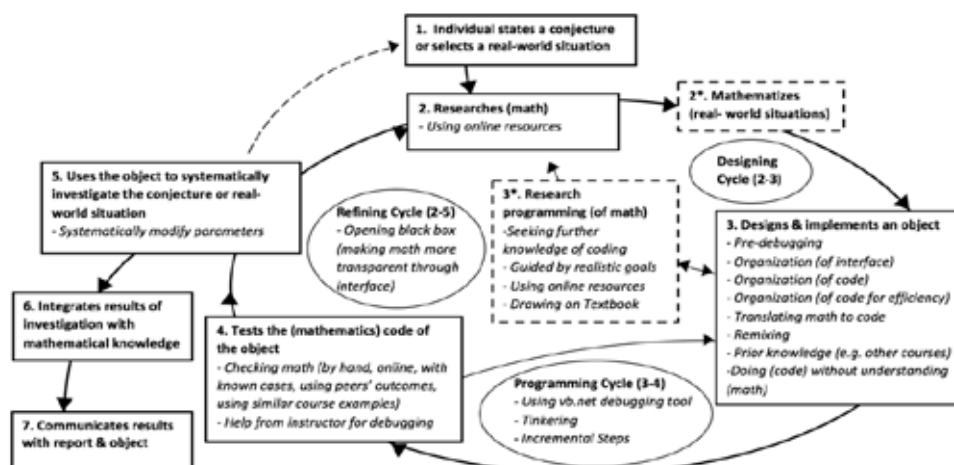


Figure 3. Hannah's summarized enacted strategies during the development of her 4 EO projects

Hannah uses her previous programming experience to help her complete the design and programming (step 3) with ease and little help from others: she *works incrementally* and *uses functions and modules to structure her program* (her approach to 'developing modular solutions' practice). Hannah developed multiple methods of *checking her mathematical work* including *using online resources*, *calculating by hand*, and *comparing known examples*. Because of her heavy preparation (in step 2) and strong programming skills (in step 3) there are not often many bugs to solve (step 4). When attempting to use the program to investigate the math problem (step 5) beyond the creation of the project, Hannah seems to lack confidence. She often isn't sure how or what to conclude from the program output. She doesn't seem to know how to use the program for investigation and wants to understand first, then "explore" later to confirm what she knows rather than to discover new ideas. Her limited investigations make it hard to integrate the results with her math knowledge (step 6). She finds some results noteworthy, but not necessarily what is intended as part of the investigation and

her insights, rather than mathematical, are more often related to programming. Lastly, when communicating her results in her written report (step 7), her descriptions are often short and not thorough in explanations. She provides examples that are either too simple to demonstrate knowledge or uses her program to generate an answer without further explanation of the process. Figure 3 summarizes Hannah's enacted strategies over the course of her 4 EO tasks.

Overall, Hannah seems to treat the course as a programming class for designing mathematics calculators rather than a mathematics class using programming as a tool for understanding and investigation, i.e. as an "object-to-think-with" (Papert, 1980). This perspective seems to limit her ability to dive in and explore new mathematical concepts deeply. In the final interview, Hannah said she intends and is looking forward to take the MICA II course. It will be interesting to see how (and if) she adapts her approach, enacting new strategies, in this more mathematically demanding course.

Conclusion

We have described Hannah's development process (including her strategies) as she engages with designing, programming, and using mathematics EOs. We observed that Hannah seems to appropriate programming as instrument for creating a tool for pragmatic purposes –i.e. as a calculator– however, not yet as instrument for mathematics investigations and applications –i.e., as an object-to-think-with (Papert, 1980). The findings provide insights on Hannah's development of fluency and instrumental genesis –i.e. how far she has come, through MICA I course, to appropriate (VB.net) programming as a CT instrument for mathematics investigations and applications. The transition from an instructionist to a constructionist approach to learning mathematics seems to have remained a challenge for Hannah, even with her previous programming background. In the near future and with the current trend, it is expected that students will arrive in mathematics department with programming skills. The case of Hannah can thus be considered as of a typical 'student' of the near future, and as such, provides insights of how these typical students' instrumental genesis may develop.

The first year student data analysis led to refine further the development process model (see step 2 and step 3* in Figure 3) to better capture the different strategies enacted by students. By highlighting how Hannah's strategies are enacted in the development process model, our study provides a beginning of how we can explore the role of strategies, as techniques, in students' instrumental genesis, leading next to study the related instrumented action schemes. The next steps, in our 5-year research, are also to bring together all of the thematic analysis findings and the development narratives for a deeper insight into students', including Hannah's, instrumental genesis, and to continue follow our participants into their upper-year MICA courses. It will also include the examination of instructors' adoption of learning environment (i.e., instrumental orchestration).

Acknowledgement

This work is funded by SSHRC (#435-2017-0367) and received ethics clearance (REB #17-088).

References

- Artigue, M. (2002). Learning mathematics in a CAS environment: The genesis of a reflection about instrumentation and the dialectics between technical and conceptual work. *International Journal of Computers for Mathematical Learning*, 7(3), 245–274.
- Benton, L., Hoyles, C., Kalas, I., & Noss, R. (2017). Bridging primary programming and

- mathematics: Some findings of design research in England. *DEME*, 3(2), 115–138.
- Bozkurt, G., Uygan, C., & Melih T. (2018). Instrumental genesis of a preservice mathematics teacher: instrumented actions for perpendicular line construction in a dynamic geometry environment. *Proceedings of the 5th ERME Topic Conference MEDA 2018*
- Brennan, K., & Resnick, M. (2012). New frameworks for studying and assessing the development of computational thinking. *Proceedings of the American Educational Research Association (AERA) annual conference* (1–25), Vancouver, Canada.
- Broley, L., Buteau, C., & Muller, E. (2017, February). (Legitimate peripheral) computational thinking in mathematics. *Proceedings of the CERME* (pp. 2515-23), Dublin, Ireland.
- Broley, L., Caron, F., & Saint-Aubin, Y. (2018). Levels of Programming in Mathematical Research and University Mathematics Education. *International Journal of Research in Undergraduate Mathematics Education*, 4(1), 38–55.
- Buteau, C. & E. Muller (2010): *Student Development Process of Designing and Implementing Exploratory and Learning Objects*. In *Proceedings of the Sixth CERME*, 1111–1120.
- Buteau, C., Muller, E., Mgombelo, J., & Sacristán, A. (2018). Computational thinking in university mathematics education: A theoretical framework. *Proceedings of RUME*, San Diego, CA.
- Buteau, C., Muller, E., & Ralph, B. (2015). Integration of programming in the undergraduate math program at Brock University. In *Proceedings of Math+Coding Symposium*, London, ON.
- Drijvers, P., Godino, J. D., Font, V., & Trouche, L. (2013). One episode, two lenses. *Educational Studies in Mathematics*, 82(1), 23–49.
- European Mathematical Society. (2011). *Position paper on the European Commission's contributions to European research*. Retrieved from http://ec.europa.eu/research/horizon2020/pdf/contributions/post/european_organisations/european_mathematical_society.pdf
- Hoyles, C., & Noss, R. (2015). *Revisiting programming to enhance mathematics learning*. Paper presented at the Math + Coding Symposium, Western University.
- Lave, J., & Wenger, E. (1991). *Situated learning: Legitimate peripheral participation*. New York, NY: Cambridge University Press.
- Marshall, N. & C. Buteau (2014). Learning by designing and experimenting with interactive, dynamic mathematics exploratory objects. *Int'l J. for Technology in Mathematics Education*, 21 (2), 49-64.
- Muller, E., Buteau, C., Ralph, B., & Mgombelo, J. (2009). Learning mathematics through the design and implementation of exploratory and learning objects. *International Journal for Technology in Mathematics Education*, 63(2), 63–73.
- Rabardel, P. (1995/2002). *Les hommes et les technologies; approche cognitives des instruments contemporains*. Paris, France: Armand Colin.
- Papert, S. (1980). *Mindstorms: Children, computers, and powerful ideas*. New York: Basic Books.
- Weintrop, D., Beheshti, E., Horn, M., Orton, K., Jona, K., Trouille, L., & Wilensky, U. (2016). Defining computational thinking for mathematics and science classrooms. *Journal for Science Education and Technology*, 25, 127–147.
- Wilensky, U. (1995). Paradox, programming and learning probability. *Journal of Mathematical Behavior*, 14(2), 231–280.
- Wing, J. M. (2014, January 10). Computational thinking benefits society. *Social Issues in Computing* [Web blog post]. Retrieved from <http://socialissues.cs.toronto.edu/index.html%3Fp=279.html>.

Big events in Mathematics using math trails

Amélia Caldeira¹, Ana Moura² and Christian Mercat³

¹School of Engineering, Polytechnic of Porto, LEMA, SYSTEC, Portugal; acd@isep.ipp.pt

² School of Engineering, Polytechnic of Porto, LEMA, CMUP, Portugal; aim@isep.ipp.pt

³Université de Lyon, Claude Bernard, S2HEP EA4148, France; christian.mercat@univ-lyon1.fr

Keywords: Mathematics, outdoor learning, math trail, student motivation, big events

The intention of this poster is to present several big events held in Portugal, in the cities of Porto and Matosinhos, and in France, in the city of Lyon. We consider mathematics learning outside of the school building and we use day-to-day materials (monuments, buildings, traffic, gardens, etc.) as support materials. It is important to bring learning to life and learning outside the classroom (DfES, 2006). One way of experiencing outdoor mathematics is to walk a math trail. We used the Shoaf, Pollak, & Schneider (2004, pp. 4) statement to guide our work and to advise our implementation of math trails. The math trails can be created using the traditional way – paper sheets with tasks on them. But, nowadays, they can be created using smartphones, combining the concept of math trails with advanced technology in a modern learning environment. The MathCityMap-application (MCM-app - www.mathcitymap.eu) provides a new approach to an already well-known idea - experience mathematics in outdoor activities and using smartphones (Jesberg & Ludwig, 2012; Cahyono, Ludwig & Marée, 2015; Cahyono & Ludwig, 2016; Zender & Ludwig, 2016). Through the MCM_app, students went on an outdoor walk along a route and solved mathematic problems that were contextualized with the surrounding environment. The students passed through special places in these cities, where mathematic can be experienced in everyday situations. For example: buildings for logic problems, statues for numbers and counting, lakes and fountains for geometry, a swing to calculate angles measures, lake bridge to calculate areas, garden benches to apply combinatorial calculus, functions to model the proportions of colors along a corridor, or using the GPS tasks to pinpoint the foci of a very large ellipse. A task which was really appreciated was an introduction to the Dewey classification system with decimal numbers, because a new theme can always emerge, since there are always a decimal between two different decimals, there is always room for improvement in this system. And the task was to find the decimal number associated with a given book from the library. Finding the number of pages of mangas in there was as well a hit but the GPS tasks where one had to finish a square or place oneself at the middle between two inaccessible points were unexpected by the students. We have streamlined math trails held around Porto, Matosinhos (Portugal) and Lyon (France), based on the MCM_app: “Matemática vai à Baixa” – Mathematics goes to downtown (competition), June 8, 2016, Porto. Participants - exactly 297 students (age range 9 to 18 years) and 40 teachers; “Matemática vai ao Jardim” – Mathematics goes to the Garden (competition), March 23, 2018, Matosinhos. Participants - exactly 170 students (age range 9 to 18

years) and 23 teachers; Math.en.Jeans Congress, March 22nd-24th, 2018, Lyon, France. Participants - around 700 (students - age range 9 to 25 years, teachers and researchers); the national gathering of the Collège commission, June 21st-23rd, 2018, Lyon, France. Participants – exactly 130 (lower secondary teachers in France). It is very gratifying to note that in all events, teachers and students participated in mass. Stands out the great enthusiasm from the students and mathematic teachers, they participate in general with energy and are willing to repeat the experience. All students and teachers can take advantage of a new context to transmit knowledge, contributing to greater motivation for learning mathematics. Students were amazed to participate in the math trails, but to cross a math trail using mobile devices and GPS functions to find the tasks location were fantastic. These activities generally increased the students' engagement to learn mathematics. The teachers were interested not only to play but as well to understand the different types of questions that could be addressed. These actions were fairly disseminated by the media. Usually mathematics appears in the news surrounded by a negative scenario, but with our events, mathematics came to the house of families in a positive, constructive and dynamic way. In the poster, we would present examples of tasks of the routes from the math trails, highlighted the details to consider them like starting points to promote the modelling process in the learning. To evaluate the degree of satisfaction of teachers and students were conducted surveys in different events, which show the high degree of satisfaction and evaluate the impact on learning (see, for example, Caldeira, Faria, Figueiredo & Viamonte, 2016).

Acknowledgment

We acknowledge the support of the Erasmus+ program funds through the project MoMaTrE grants 2017-1-DE01-KA203-003577.

References

- Cahyono, A. N., Ludwig, M., & Marée, S. (2015). Designing mathematical outdoor tasks for the implementation of The MCM-Project in Indonesia. *Proc. ICMI-EARCOME 7 (pp. 151-158)*. Quezon City, Philippines: EARCOME.
- Cahyono, Adi Nur & Ludwig, Matthias. (2016). MathCityMap: Exploring Mathematics around the city. Proceedings of the 13th International Congress on Mathematical Education 12. Hamburg.
- Department for Education and Skills (DfES). (2006). *Learning Outside the Classroom MANIFESTO*, DfES. Publications, Nottingham, United Kingdom.
- Jesberg, J., & Ludwig, M. (2012). MathCityMap - Make mathematical experiences in out-of-school activities using mobile technology. Proceedings of the International Conference on Mathematics Education 12. Seoul.
- Shoaf, M., Pollak, H. & Schneider, J. (2004). Math Trails. Lexington: COMAP.
- Zender, J. & Ludwig, M. (2016). MathCityMap (MCM): from paper to smartphone – a new approach of an old concept. 13th International Congress on Mathematical Education Hamburg.
- Caldeira, A., Faria, A., Figueiredo, I., Viamonte, A., (2016). Outdoor Math Lessons – Experiences in education from everyday realities. 10th International Technology, Education and Development Conference (INTED 2016). Valencia (Spain).

Multiplicative reasoning through two-handed gestures

Sean Chorney, Canan Gunes and Nathalie Sinclair

Simon Fraser University, Canada; sean_chorney@sfu.ca; cgunes@sfu.ca; nathsinc@sfu.ca

This exploratory study focuses on two-handed gestures when using an innovative iPad application called TouchTimes. We suggest that the use of the two hands is relevant to multiplicative reasoning as it provides a way of expressing multiplication as a coordination of two quantities, rather than simply as repeated addition. We report on the use of TouchTimes by two third-grade girls; we first exemplify the designed two-handed gestures the girls used and then identify some emergent gestures that we see as being relevant to multiplicative thinking, particularly in terms of the relation between the multiplicand and the multiplier in a multiplication expression.

Keywords: Two-handed gestures, multiplicative thinking, touchscreen technology.

Introduction

In this paper we report on an exploratory study involving a pair of grade three students working on an iPad application called *TouchTimes* (TT, Jackiw & Sinclair, 2018) that was designed to offer an accessible model of multiplication that does not rely on repeated addition. TT uses the multi-touch affordance of the iPad to express the relationship between multiplicand, multiplier and product through the use of specifically designed two-handed gestures. It is an extension of *TouchCounts*, also designed by Jackiw and Sinclair (2014), which enables gesture-based actions for counting, adding and subtracting and has been shown to improve subitizing, the ability to differentiate between cardinality and ordinality (Sinclair & Pimm, 2015) as well as basic number sense (Sedaghatjou & Campbell, 2017; Sinclair, Chorney & Gillings, 2016). TT builds on this *TouchCounts* research by extending the gesture-based arithmetic. In this research study, we are interested in the way two handed gestures can support young students' multiplicative thinking.

Research on learning multiplication

Multiplication is difficult for many students, yet very important for subsequent higher-grade topics such as proportion and algebra (Siegler et al., 2012). One of the difficulties with multiplication results from students' excessive exposure to multiplication as repeated addition (Askew, 2018). It is important to develop students' understanding of multiplication in terms of relations, particularly the relationship between the multiplicand and the multiplier. Designed to develop the bi-directional functionality of multiplicand and multiplier, TT allows for both the multiplicand and the multiplier to be changed either during and after a multiplication computation. We hypothesise that this offers not only an empirical environment for experimentation, but also the possibility of noticing the relationship the multiplicand and the multiplier have on the product.

In the work of Clark and Kamii (1996), multiplication has two levels of abstraction. The shift from the many-to-one and an inclusion relation between multiplicand and multiplier. Multiplication is relational and functional in that both multiplier and multiplicands are abstractions that affect each other. For example, in the case of 3×4 , if 3 is the multiplicand and 4 the multiplier, 3 to 1 is the abstraction of three becoming one (the unit) and the 'inclusion relation involves a transfer of units in

that the multiplicand “3” counts the number of items while the multiplier “4” counts the number of triples of these’ (Boulet, 1998, p. 14). In *TT* the physical use of two hands is meant to enact this dual abstraction. We are thus interested in studying the extent to which students’ gestural interactions with *TT* supports their multiplicative thinking.

Brief description of *TouchTimes*

The initial screen of *TT* starts blank, except for a vertical line (Figure 1a). A user can create two kinds of mathematical objects: pips and pods. The first finger(s) down on the screen produces pips, which are coloured discs that appear under each finger. For example, if the user places three fingers on the left side (LS) of the screen, three differently coloured pips appear (Figure 1b). If the user then places four fingers on the right side (RS) while holding the three pips, four ‘pods’ of three pips appear (Figure 1c). Each pod is a bounded object containing a smaller version of the number, colour and configuration of the LS pips. If a finger is lifted on the LS, then there will be two pips there and each of the four pods will contain two pips. More pips can also be created by placing more fingers on the LS; this will affect the RS pods accordingly). If all the pip-making fingers are lifted, the pods disappear too (multiplication by 0), and the screen goes blank. Additional pods can be created on the RS; once created they remain on the screen even when fingers are lifted (this enables multiplication of numbers bigger than $n \times m$, where $n + m = 11$, which is the maximum number of simultaneous touches allowed). The situation can be completely reversed: if the first touch is on the RS, then pips are produced there and touches on the LS produce pods.



Figure 1: (a) Initial screen of *TT*; (b) Creating 3 pips; (c) Creating 4 pods

As soon as there are both pips and pods on the screen, a multiplication expression appears on the top of the screen. For the above situation, the mathematical expression is $3 \times 4 = 12$ (Figure 1c). Once created, pods can be dragged anywhere on the screen and can also be trashed. Pips can also be moved, as long as the fingers are not lifted. In the reversed situation, the multiplication expression is $12 = 4 \times 3$. The two hands have different functions, and in this way, multiplication is experienced relationally, rather than in terms of repeated addition.

Theoretical framing

Research into iPads is still relatively new and there have been various frameworks proposed to study how the iPad interrelates with mathematical thinking. Embodied theories have been common since the iPad offers unique kinaesthetic experiences with number, particularly in terms of the gestures required to create and manipulate mathematical objects. Bairral and Arzarello (2015) use the idea of embodiment to suggest that the action of the body in any type of activity acts as a grounding for cognition. However, we align with researchers based in a nondualist paradigm (challenging the

separation of mind and body), and see embodied action not as a reflection of thought, nor as a grounding of thought, but rather as an aspect of mathematical thinking (de Freitas & Sinclair, 2014).

We employ an embodied framework that sees both the tool (the iPad and application) and the children as a cohesive unit, as an assemblage (de Freitas & Sinclair, 2014). By seeing *TT* not as a separate entity from the students but as ‘entwined’ (Nemirovsky et al. 2013; Arzarello et al., 2002) we can theorize a formation of bodily-based mathematical activity. This form of embodiment shifts from the tool-student duality, suggesting instead that the mathematical thinking *is* action-with-tools.

Given the design of *TT*, we are particularly interested in how gestures are indicative of students’ mathematical thinking. We follow Sinclair and Pimm (2014) in seeing gesture on the iPad as epistemic *and* communicative. Bairral and Arzarello (2015) claim that there are “six basic finger actions for input on a touchscreen: tap, double tap, long tap (hold), drag, flick, and multi-touch (rotate)” (p. 2). For *TT*, we suggest that the last type of gesture, multi-touch, can be expanded and elaborated, particularly in relation to the use of two-handed gestures, on which little research has been conducted in mathematics education. An exception is Duijzer et al. (2017), who study the coordination of action and perception in terms of proportional reasoning in an environment where children move their two hands in the same direction, but at different rates. Bairral and Arzarello (2015) address two kinds of two-handed gestures: (1) when one hand is holding and the other is dragging; (2) when both hands are doing the same gesture (as in when two fingers are dragging away or towards each other to expand or reduce an image). In *TT* each hand performs different movements and different functionalities. One hand acts as the multiplier; the other as the multiplicand. Our research questions therefore are: What are the different types of two-handed gestures used by novice, young learners? How do the two coordinating hands express multiplicative thinking?

Methods

In this study, we examined two students’ first contact with *TT*. We worked with two grade three students in an elementary school in a downtown part of British Columbia. We will call them Jessica and Ava in this paper. This pair of students was chosen by the classroom teacher who thought that they would work well together and to provide Jessica, who often ignores instructions, with a different kind of mathematical experience. We video recorded their interaction with the application. The session lasted for 27 minutes. For the initial seven minutes, the students interacted with the tablet without being given a specific task by the interviewer (third author). After the seventh minute, the interviewer occasionally proposed a mathematical task. We transcribed the video, paying attention to when the girls made two-handed gestures, as well as to their awareness of multiplication. For example, if the girls moved their fingers in such a way that the multiplicand reduced by one, we identified their awareness of changes based on what they said. We distinguished situations in which each girl used a hand, which we call a two-person bi-handed gesture, from situations in which one girl used two hands, which we call a solo bi-handed gesture. We see the former as being highly relevant to exploring the social aspect of joint coordination (see Sebanz & Knoblich, 2009).

Analysis

We present our analysis in two parts. First, we use an *a priori* analysis of the “designed” gestures, that is, the gestures that *TT* was designed to allow, and describe which ones were observed in the

video. We then present two of the “emergent” gestures found, that is, gestures that were not explicitly designed, but that were identified as being relative to the girls’ thinking about multiplication.

A priori analysis of designed gestures

Each gesture identified in Table 1 is done with a single hand. The two-handed gesture comes into existence when any two of these gestures (including identical gestures) are done on different sides of the screen and with different hands (though it is technically possible to use one hand to touch both sides of the screen). The number of two-handed gestures then grows to include all the combinations of any two of the gestures in Table 1.

Single tap (T): Tapping the screen with one or many fingers.
Hold (H): Pressing a screen object continuously without lifting the finger/s.
Drag (D): Moving an object with finger/s on the screen continuously without lifting
Hold and tap (H&T): While some fingers are holding, other finger/s are tapping
Hold and drag (H&D): While some fingers are holding, other finger/s are dragging
Hold and lift (H&L): While some fingers are holding, other finger/s are lifting

Table 1: Designed gestures in *TT*

In Figure 2, we depict three of the more frequent gestures: T, T; T, H; H&T, H. Below, we provide a brief description of each as it occurred in the video.



Figure 2: (a) T, T; (b) H, T; (c) H&L, H

From the students’ perspective, in Figure 2a the middle finger of the first hand taps the RS of the screen and the index finger of the second hand taps the LS of the screen. This two-handed gesture was mostly observed at the beginning of the video as the girls were first exploring *TT*. They stopped using this gesture after a while, either because they realized that this did not create more than one object at a time, or that a holding gesture was necessary to create a pod. In Figure 2b, the first hand holds five fingers on the LS all-at-once, the second hand taps the index finger on the RS. This gesture produces one pod, which is a unit of five pips. In Figure 2c, there are three fingers of one hand on the LS, while lifting the pinky and thumb, while the index finger of the second hand was held on the RS. This gesture was very common and changed the number of pips within each of the pods.

A posteriori analysis of the emergent gestures

We will present two episodes, each of which involved the use of an emergent gesture, which we will refer to as a *three-handed gesture* and a *dancing gesture*, respectively.

At the beginning of the first episode chosen, Jessica holds five fingers of her right hand on the RS and Ava holds two pods on the LS (H, H). There were 15 pods on the screen showing $75 = 15 \times 5$. Jessica then used her left hand to make another pip, thereby making six pips in total (Figure 3a), changing the equation to $15 \times 6 = 90$, and changing all the pods to include six pips.

Jessica: What the
 Ava Woow (*drags index finger, producing 7 pips, as in Figure 3b*)
 Jessica di di di di didi di di di di oh wait I can change the shape

When she put her sixth finger down, Jessica brought her second hand into play so that the girls were making a *three-handed gesture* of hold pips, drag pip and hold pods (Figure 3a). When she said “What the” she seemed to be surprised at the effect of the sixth pip, which changed the configuration of each of the 15 pods, as well as the multiplication statement. Ava then let go of the pods she was holding with her left hand and used her index finger on the RS to create another pip, which she dragged on the screen, saying “woow”. There were now seven pips in each pod and a new equation $105 = 15 \times 7$. This new three-handed gesture now included a hold, a drag and a drag (Figure 3b). As Jessica dragged her sixth finger, the shape of each pod changed to mimic the configuration of her six fingers, which she seemed to realise when she says “I can change the shape”.



Figure 3: (a) Adding a 6th pip; (b) Adding a 7th pip

In this episode the girls make two different three-handed gestures. In the first instance, Ava had been busy making pods and it was only when Jessica brought her third hand into play that she seemed to notice that the additional pip created an important change on the screen, prompting her to say “What the”. Then when Ava sees what Jessica is doing, she changes from a holding pods gesture to a dragging pips gesture. In the first three-handed gesture, Ava does not need to be holding the pods, so the gesture might feel extraneous to the activity. However, it is perhaps because of the fact that she is holding pods that she noticed the interesting effect produced by Jessica’s added pip (the pods would have changed size and configuration right under her fingertips, so to speak). In the second case, Ava and Jessica are both doing drag-pip gestures, and so replicating the same gesture that could have been done by just one hand. However, it is in wanting to mimic Jessica that Ava starts dragging a pip, and so we see how the third hand enables both girls to do the same thing at the same time, together producing a change in the shape of the pods that is more than what each of them could have produced on their own.

In the second episode, Ava was holding five fingers on the left screen (which she held for the complete episode; see Figures 4a, 4b) and Jessica had just finished creating pods and dragging them around the screen. There were 31 pods on the screen and the multiplication sentence at this point was $5 \times 31 =$

155. Jessica touched one finger on the LS under Ava's hand (H, T) and then lifted it up again (H, L). Once more she tapped in the same spot, down and up. The multiplication sentence changed from $5 \times 31 = 105$ to $6 \times 31 = 186$, back and forth. She repeated this a third time and said, "They're dancing again" and both girls giggled. She continued to tap this way for a total of eight repetitions. Jessica, still maintaining one finger on the screen, then adds a second finger, causing each pod to increase to seven pips (Figure 4b). She then began to touch up and down repeatedly with two fingers; the multiplication sentence changing from $5 \times 31 = 105$ to $7 \times 31 = 217$, back and forth (Figure 4a, 4b). This time, however, Jessica added a secondary rhythm. She sang 'di di didi di di' while tapping; on each 'di' she tapped once' on the 'didi' she tapped quickly, and in between phrases, she did not tap. She continued to tap with two fingers like this through four phases of 'di di didi di di'.



Figure 4: (a) Jessica about to tap; (b) Jessica tapping two

We see this 'dancing gesture' as an emergent one that actually combines a repetitive set of (H, T) gestures. It becomes a single gesture for the girls that enables them to make the pods "dance". Aside from the evident visual appeal of this dancing gesture, it also embodies the girls' functional awareness of the relation between the pips and the pods, showing as it does how the number of pips affects the shape and colour of each of the pods. With it, the girls can change the multiplicand very quickly, seeing the effect on both the visual dynamics of the screen, as well as on the multiplication sentence.

Discussion

Our first research question asked, what were the different types of two-handed gestures used by novice, young learners? In our *a priori* table we identified the designed, that is, the basic gestures supported in *TT*, which were the gestures that we expected the children to make. The most frequently-used gesture was the (H, T) in which one girl would hold pips (usually Ava), and the other would create pods one finger at a time. The girls rather quickly began to use hold gestures when they realised that lifting their fingers off the pips would clear the screen. They can often be seen holding both pips and pods, especially at the beginning. Dragging was used both to move pips on the screen, as discussed in the first episode above, and also to drag pods to the trash. The use of the gestures in Table 1 provided a starting point for their developing fluency with the tool.

We also identified emergent gestures that seemed to play more important roles in the girls' understanding of how the pips and pods related to each other. In the first episode, we describe two different three-handed gestures made by the girls that helped both to draw their attention to the relation between the number and position of pips on the screen, and to the shape of the pods. The second three-handed gesture seemed to also have an important social component in allowing both girls to do the same gesture at the same time. As with these *three-handed gestures*, the emergent *dancing gesture* combined two or more of the gestures from Table 1. The dancing gesture can thus

be seen as a bundling of several, sequentially produced (H&T, H) and (H&L, H) gestures. Over the course of the experiment, this gesture occurred multiple times with different numbers of pips and pods. The girls' continued return to this gesture, as well as the identification of its presence by such utterances as, 'they're dancing again', highlight their awareness of the multiplicative relation between multiplicand and multiplier.

Our second research question asked: How do the two coordinating hands express multiplicative thinking? It was in the use of the two emergent gestures that the girls seemed to express and notice the relation between pips and pods. In making the number of pips change, the girls noticed that the number of pips determined the shape and size of the pod, thus observing the effect of the size of the unit on the pods. The fact that the relation between the pips and the pods took some time to notice and control suggests that this is not a simple relation to understand, both in terms of physically coordinating two hands (or more) across two people, and in terms of tracking the bi-directional relation between multiplicand and multiplier. This embodied approach to multiplication seemed to initiate gestures through which the girls could explore/express this multiplicative relation.

Conclusion

In this exploratory study, which looks at how gestures were used in the *TT* app, we identified 6x6 different "designed" gestures and exemplified three of the most commonly-used ones. We then described two additional emergent gestures that were used several times by the girls and seemed important to their growing fluency with the app and their awareness of the multiplicative relation between the pips and pods (multiplicand and multiplier). We propose that the gesture-based multiplicative actions of the girls offered them novel ways to explore and express multiplicative relationships. In the repeated addition approach, the relation privileges a focus on the multiplier (3+3+3+3+...). In *TT*, however, both operands can be manipulated with immediate feedback, both in terms of the visual presentation of the pods, and symbolically through the equation. If repeated addition tends to be algorithmic, linear, sequential and unidirectional, *TT* seems to offer a more interactive, bi-directional and simultaneous instantiation of multiplication.

This research provides insight into the link between action and mathematical reasoning, and has implications for supporting students' multiplicative thinking. In future work, a closer examination of how learners coordinate the gestural expression with symbolic expressions (the equations shown on the screen) should be examined more closely. Also, the collaborative interactions of learners working together, as expressed through the three-handed gestures described here, deserves further attention.

References

- Alibali, M., & Nathan, M. (2012). Embodiment in mathematics teaching and learning: Evidence from learners' and teachers' gestures. *The Journal of the Learning Sciences*, 21(2), 247-286.
- Arzarello, F., Bairral, M., Dané, C., & Iijima Yasuyuki. (2013). Ways of manipulation touchscreen in one geometrical dynamic software. *International Conference on Technology in Mathematics Teaching (ICTMT11)*, pp. 59-61. Bari, Italy.
- Arzarello, F., Olivero, F., and Robutti, O. (2002). A cognitive analysis of dragging practises in Cabri environments. *ZDM* 34(3), 66-72.

- Askew, M. (2018). Multiplicative reasoning: Teaching primary pupils in ways that focus on functional relationships. *The Curriculum Journal*, 29(3), 406–423.
- Bairral, M., & Arzarello, F. (2015). The use of hands and manipulation touchscreen in high school geometry classes. In *CERME 9-Ninth Congress of the European Society for Research in Mathematics Education* (pp. 2460-2466).
- Boulet, G. (1998). On the essence of multiplication. *For the Learning of Mathematics*, 18(3), 12-19.
- Clark, F. B. & Kamii, C. (1996). Identification of multiplicative thinking in children in grades 1-5, *Journal for Research in Mathematics Education*, 27(1), 41-51.
- de Freitas, E. & Sinclair, N. (2014). *Mathematics and the body: Material entanglements in the classroom*. New York, NY: Cambridge University Press.
- Duijzer, C. A. C. G., Shayan, S., Bakker, A., Van der Schaaf, M. F., & Abrahamson, D. (2017). Touchscreen tablets: Coordinating action and perception for mathematical cognition. *Frontiers in Psychology*, 8(144). doi:10.3389/fpsyg.2017.00144
- Jackiw, N., & Sinclair, N. (2018). *TouchTimes* (iPad App). Burnaby, BC: Tangible Mathematics Group.
- Jackiw, N., & Sinclair, N. (2014). *TouchCounts* (iPad App). Burnaby, BC: Tangible Mathematics Group. [<https://itunes.apple.com/ca/app/touchcounts/id897302197?mt=8>]
- Nemirovsky, R., Rasmussen, C., Sweeney, G., & Wawro, M. (2012). When the Classroom Floor Becomes the Complex Plane: Addition and Multiplication as Ways of Bodily Navigation. *Journal of the Learning Sciences*, 21(2), 287-323.
- Sebanz, N., & Knoblich, G. (2009). Prediction in joint action: what, when, and where. *Topics in Cognitive Science*, 1(2), 353-367.
- Sedaghatjou, M. & Campbell, S. (2017). Exploring cardinality in the era of touchscreen-based technology. *International Journal of Mathematical Education in Science and Technology* 48(8), 1225–1239.
- Sinclair, N., Chorney, S. & Gillings, S. (2016). Rhythm in number: Exploring the affective, social and mathematical dimensions of using *TouchCounts*. *Mathematics Education Research Journal*, 28(1), 31-51.
- Sinclair, N., & Pimm, D. (2015). Whatever be their number: Counting on the visible, the audible and the tangible. In M. Meletiou-Mavrotheris, K. Mavrou & E. Paparistodemou (Eds), *Integrating touch-enabled and mobile devices into contemporary mathematics education* (pp. 50–80). Hershey, PA: IBI Global.
- Sinclair, N., & Pimm, D. (2014). Number's subtle touch: expanding finger gnosis in the era of multi-touch technologies. In P. Liljedahl, C. Nicol, S. Oesterle & D. Allan (Eds), *Proceedings of the 38th Conference of the International Group for the Psychology of Mathematics Education and the 36th Conference of the North American Chapter of the Psychology of Mathematics Education* (Vol. 5, p. 209-216). Vancouver, Canada: PME.

Physical and virtual classroom in the learning of mathematics: analysis of two episodes

Agnese Del Zozzo^{1,2} and George Santi^{1,2}

¹ Free University of Bolzano, Italy; adelzozzo@unibz.it, gesanti@unibz.it

² NRD, Department of Mathematics, University of Bologna, Italy;

Keywords: Virtual classrooms, didactical contract, Chevallard's triangle.

Purpose of the study.

The aim of this study is to investigate how a virtual classroom can foster the physical classroom activities in order to create a new learning environment that enhances peer education. The introduction of a virtual space, in addition to the physical one, offers new forms of social interaction that could allow students to overcome their difficulties. This space is available beyond the school time shared in the physical classroom and gives students the opportunity to design it according to their needs, cognitive styles and social practices. Analyzing two episodes, we propose a tentative framework to design an effective implementation of a virtual classroom in the physical classroom.

Introduction.

In a secondary school of Bologna (Italy) where several teachers of different subjects used the G Suite for Education, some mathematics teachers started using [Google Classroom](#) (GC). The following two episodes involved two classes with different mathematics teachers. All the students were acquainted with the basic functions of GC. The first episode happened in a 10th grade class where the teacher proposed GC as a daily tool used by the students to share their questions and doubts with the teacher and the rest of the class. This episode regards the spontaneous behavior of a student who supports her classmates in the solution of an exercise. She shared on the [GC Stream](#) a photo of her notebook (with the solution in pen and some additional comments in pencil) supported by the comment “*I was able to get the right answer. If you want, you can have a look. I added in pencil the passages that I skipped so that you can better understand them*”. This spontaneous behavior of the student inspired a further study for a deeper analysis of the potentiality of virtual classrooms in addition to the physical one.

The second episode regards an experiment carried out with a mathematics teacher available to introduce, for our research, GC in a 12th grade class for a limited period. The teacher proposed GC as a social environment where the students could share their ideas and support each other to overcome their difficulties. An item of a multiple-choice test carried out in the physical classroom highlighted students' difficulties in dealing with the domain of logarithmic functions. The teacher decided to trigger the students' social interaction in the GC to find the correct answer. Therefore, the teacher assigned the same multiple-choice exercise asking the students to answer and compare the results on the Stream. Students posted in the GC Stream only the letter (A, B, C or D) of their answer without discussing the inconsistencies of their results. The students, in the next lesson, admitted that they actually had a debate but on their WhatsApp group avoiding the use of the GC. After this episode, the teacher decided to use GC only to assign homework and to communicate with the students.

Theoretical framework, research questions and methodology.

This study suggests that the introduction of a virtual classroom requires a didactical design that takes into account the relation between the vertices of Chevallard's Triangle (Chevallard & Joshua, 1982): teacher, pupil, and knowledge. From the two episodes, it emerges that the characteristics of the side pupil-teacher determines the students' interaction with the virtual classroom. In the first episode, the students did not perceive any imposition on the part of the teacher. They felt free to use the virtual space spontaneously. Instead, in the second episode the teacher explicitly invited the students to work on a specific task. We believe that an appropriate theoretical framework for an effective introduction of a virtual classroom is Brousseau's (1997) Theory of Didactical Situations. In fact, the first episode can be interpreted as a non-didactical situation where there is not a specific teaching design. Although the students used the GC as a peer education environment, there was no evolution after the episode we described. The second episode can be interpreted as a didactical situation that constrained the students in the clauses and effects of the didactical contract (D'Amore, Fandiño Pinilla, Marazzani, & Sarrazy, 2018). The teacher had an explicit objective that she declared to her students and the potential of the virtual classroom seemed to be absorbed by the dynamics of Brousseau's Didactical Contract. The students, in the GC Stream, strictly attended the teacher's requests. The inconsistencies of the students' answers emerged on the GC Stream and triggered the expected social interaction but the discussion among students took place on the WhatsApp students' group. This kind of virtual group cannot be considered a true virtual classroom because it discards the teacher from Chevallard's triangle. The introduction of a virtual environment requires the presence of all the actors of Chevallard's triangle. The teaching design should realize an a-didactical situation that fosters personal implication on the part of the students and the breach of the didactical contract. Within this framework, the research questions that inform further studies are: how can we design an a-didactical situation in an enlarged learning environment that includes a virtual classroom entangled with the physical one? How do we manage this new variable, the virtual classroom, when designing an a-didactical situation? Within an effective interaction between the physical classroom and the virtual classroom, what artifacts and Semiotic Means of Objectification could emerge (Radford, 2008)?

References

- Brousseau, G. (1997). *The theory of didactical situations in mathematics*. Dordrecht: Kluwer Academic Publisher.
- Chevallard, Y. & Joshua, M.A. (1982). Un exemple d'analyse de la transposition didactique: la notion de distance. *Recherches en didactique des mathématiques*, 3(1), 159-239.
- D'Amore, B., Fandiño Pinilla, M. I., Marazzani, I., & Sarrazy, B. (2018). *El contracto didáctico en educación matemática*. Bogotá: Editorial Magisterio.
- Radford, L. (2008). The ethics of being and knowing: Towards a cultural theory of learning. In L. Radford, G. Schubring & F. Seeger (Eds.), *Semiotics in mathematics education: epistemology, history, classroom, and culture* (pp. 215–234). Rotterdam: Sense Publishers.

Design of a multi-dimensional instrument for reviewing the quality of apps for elementary geometry

Ana Donevska-Todorova¹ and Katja Eilerts²

¹Humboldt-Universität zu Berlin, Germany; ana.todorova@hu-berlin.de

²Humboldt-Universität zu Berlin, Germany; eilertsk@hu-berlin.de

Keywords: mathematics education, geometry, quality, technology, design.

Current state of research and theoretical framework

In contrary to the high speed of technological expansion, the research on didactical quality of technology-supported materials for school mathematics seems to have been less rapid in the last two decades. The current approaches for its evaluation are various but not extensive enough which grounds an intensive ongoing debate in the TWG 16 of the upcoming ERME congress. On the one hand, a conventional approach is the usage of criteria catalogues or checklist. On the other hand, researchers argue against their usage due to different reasons, e.g., their inconsideration of socio-constructivist view of learning (Squires & Preece, 1999) or their tangible usage which is exposed to many factors that cannot be controlled (Krawehl, 2010), e.g., the dynamic feature of the online market changing on a daily basis. Moreover, the usefulness and effectiveness of technological tools may depend on the settings, context and instructional goals, what make it difficult to follow a straight-on checking list for their quality estimation. An undertaken analysis of geometry apps regarding pedagogical, mathematical and cognitive fidelity has shown that the majority of them had limited potential to support students in developing geometrical conceptual understanding (Larkin, 2016). It has emphasized the importance of further reviews and this is relevant not only in Australian context but in other contexts such as the German one. Another study has shown that the majority of existing apps are created for pre- and elementary schoolchildren but are not aligned to the content standards of the targeted audience (Powell, 2014). Therefore, this study focuses on a comprehensive approach for identifying essential potentials and limitations of apps along with analogue media that considers multimedia learning (Mayer, Borges, & Simske, 2018) in addition to educational standards and curricula for mathematics (e.g. in Berlin-Brandenburg schools) referring to content-related- and process-oriented competences as coherent, rather than distant proficiencies.

Research question and methodology

How can the quality of technology-enhanced resources for supporting the development of students' competences regarding "Space and shape" be analysed through a comprehensive approach, is the question to be tackled in the study.

The poster shows a multi-dimensional evaluation instrument (EI) that is a specific part of a comprehensive multidisciplinary and dynamic evaluation model, developed through a research-based design involving qualitative approaches. The EI includes mathematics, didactics and media facets in an appropriate incorporation. A systematical peers- and experts review about its objectiveness, validation, and importance of its criteria items has taken place. Collected feedback was used for adaptation and re-design of the EI, and pilot trials as different phases of the design cycle.

Results and their implications in practice and research

The review criteria in the created EI are grounded on a national framework about excellence of learning environments. Hence, the development of the EI resulted with review criteria structured in six dimensions: (1) mathematical and didactical significance, (2) articulation, communication and social organization, (3) differentiation, (4) logistic and technical support, (5) assessment and (6) networking of resources similarly as the key characteristics of learning environments (Wollring, 2009) and recommendations about implementation of digital media by Krauthausen (2012).

The outcomes of the design-research process would be implemented in a teachers' professional development program about elementary geometry. The aim of the designed instrument is to offer teachers a possibility to systemize the overwhelming amount of apps and actively engage themselves in reviewing processes and sharing best-practice instances, which would enable them to think about the benefits and limitations of a meaningful usage of technology in their classrooms.

Other beneficiaries may also be designers who could consider potentials of technology in future re-designs and novel designs. Finally, the study may contribute in further research in mathematics- and media education towards development of a sustainable evaluation model that may have a potential for both national and international scaling up.

Formal presentation of the research work on the poster

Besides information about the theoretical framing, the poster (A0 size) illustrates the research design in a form of a diagram. Exemplary excerpts of the created on-line EI are presented as tables. Previews of selected apps for elementary geometry available in the German language also appear on the poster.

References

- Krauthausen, G. (2012). *Digitale Medien im Mathematikunterricht der Grundschule*. Springer-Verlag.
- Krawehl, F. (2010). Entwicklung eines Evaluationsinstruments zur fachdidaktischen Bewertung von Unterrichtssoftware für das Grundschulalter. Universitätsbibliothek Dortmund.
- Larkin K. (2016) Geometry and iPads in Primary Schools: Does Their Usefulness Extend Beyond Tracing an Oblong?. In: Moyer-Packenham P. (eds) *International Perspectives on Teaching and Learning Mathematics with Virtual Manipulatives. Mathematics Education in the Digital Era*, vol 7. Springer, Cham.
- Mayer, J., Borges, P. V., & Simske, S. J. (2018). Introduction. In *Fundamentals and Applications of Hardcopy Communication* (pp. 1-5). Springer, Cham.
- Powell, S. (2014). Choosing iPad apps with a purpose: Aligning skills and standards. *Teaching Exceptional Children*, 47(1), 20-26.
- Squires, D. & Preece, J. (1999). Predicting quality in educational software. *Interacting with computers*, 11(5), 467-483.
- Wollring, B. (2009). Zur Kennzeichnung von Lernumgebungen für den Mathematikunterricht in der Grundschule. In: Peter-Koop, A.; Lilitakis, G.; Spindeler, B. (Eds.). *Lernumgebungen – Ein Weg zum kompetenzorientierten Mathematik in der Grundschule*. Offenburg: Mildenerger Verlag, pp. 9–23.

Student engagement in mobile learning activities: breakdowns and breakthroughs

Khristin Fabian

Perth College, University of Highlands and Islands, Perth, United Kingdom;

Khristin.fabian.perth@uhi.ac.uk

Abstract *The ubiquity of mobile devices together with the potential to bridge classroom learning to real-world has added a new angle to contextualising mathematics learning. The goal of this research was to evaluate student engagement in a series of mobile learning activities. The study uses critical incident analysis to evaluate the breakdowns and breakthroughs of mobile learning. Twenty-four Primary 7 students participated in the study. The mobile learning activities were found to have facilitated visualisation, encouraged reflection and promoted active learning. However, some issues regarding mobile use affected student engagement with the activity. The challenges identified highlighted the role teachers play in designing and carrying out novel technology use.*

Keywords: *Mobile learning, Mathematics education, Technology enhanced learning, Student engagement, Issues of mobile learning*

Introduction

The challenge to connect mathematics learning to real-world is not new, but the mobility and connectivity afforded by mobile technologies has renewed interest on this challenge. Potential benefits of using mobile technologies include facilitating learning across context and personalised learning (Cochrane, 2010). Previous mobile learning studies have shown various approaches to bridge the gap between school mathematics and the real-world. For example, Spikol and Eliasson (2010) utilised the built-in sensors of mobile devices to facilitate distance measurement while Crompton (2015) used the mobile camera and an interactive geometry application to facilitate investigation of angle properties. These examples illustrate how mobile technologies seem to be a good fit for contextualising school mathematics.

Sawaya and Putnam (2015) proposed an integrated framework to help teachers design mobile learning activities for maths. The framework consisted of three issues to consider when designing learning tasks: (a) learning goals, (b) activity types and lastly (c) affordances of the technology in reference to what mobile devices offer to support mathematics learning. These technology affordances are not unique to mobile devices but it is the combination of these affordances in a single device that highlights the potential of mobile technologies in supporting various learning activities. A representation of the framework is shown in Figure 1.

Systematic reviews of mobile learning in mathematics have shown an increasing interest in the use of tablet devices in schools (Crompton & Burke, 2016; Fabian, Topping, & Barron, 2016). These studies reported that the majority of mobile learning studies found positive results, typically in the form of evaluation surveys or through an experimental pre-test post-test evaluation of student achievement. A meta-analysis of studies that looked into student achievement have found that using mobile devices for mathematics had a medium effect (Fabian et al., 2016). However, while these results evidence the learning that occurred, these numbers do not communicate the sort of engagement that happens in the classroom.

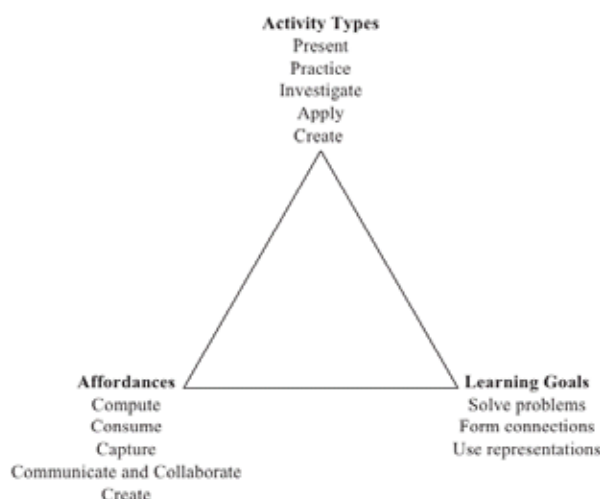


Figure 1: Framework for the design of mlearning activities for mathematics (Sawaya & Putnam, 2015)

Other positive outcomes reported in systematic reviews refer to positive student attitudes towards the use of mobile devices in maths, typically measured using a Likert-type survey (*ie* Did you find the activity fun?). Studies that focus on how the mobile technologies have engaged students are few and mostly short-term evaluations (Baya'a & Daher, 2010; Shih, Kuo & Liu, 2012). In response to this gap, the current study focuses on the evaluation of student engagement in mobile learning activities, drawing a focus on the breakdowns and breakthroughs of using mobile devices for learning mathematics.

The field of mobile learning is relatively new and its potentials and issues related to school use are still being mapped out. Sharples (2009) argued that “there is a need to understand what distinguishes mobile learning from classroom learning or learning with desktop computers (p.18).” Some examples of the distinctive aspects of mobile learning include mobility, portability and its capacity to support both formal and informal learning environments. Adopting new technologies in the classroom provides an array of possibilities but the practice of introducing new technology in the classroom is not without challenge. It was the goal of this study to identify issues in using mobile technologies for maths learning as well as identify advantages afforded by mobile technology use.

Methodology

Twenty-four Primary 7 students participated in mobile-supported constructivist learning activities that covered topics on geometry and information handling. Participation was voluntary. The teacher participant for this study is a female teacher with five years of teaching experience. The student participants (12 boys, 12girls), aged between 10-11 years old were the Primary 7 students assigned to the teacher participant of this study.

The programme consisted of eight mobile learning sessions conducted over a period of 3 months. The activities included topics on geometry and information handling and were all conducted in paired or group settings. Table 1 provides an indication of the mobile learning activities carried out. The activities were recorded and later analysed using critical incident analysis to identify the breakdowns and breakthroughs of the learning activities. Breakthroughs refer to the “observable critical incidents which appear to be initiating productive new forms of learning or important conceptual change” and breakdowns are “observable critical incidents where a learner is struggling with the technology, is

asking for help, or appears to be labouring under a clear misunderstanding (Vavoula & Sharples, 2009, p. 56).”

Table 1: Activities carried out

Session	Mobile Learning Activity	Activity Type
Session 1 - Symmetry (Phase 1)	Students took pictures of symmetrical objects and annotated it with its line of symmetry. Using an application, they also created symmetrical pictures of non-symmetrical objects in their environment.	Practicing math skills; Investigating; Creating content
Session 2 - Area and Perimeter (Phase 1)	Students investigated area and perimeter of surrounding environment using an application. They also investigated properties of area and perimeter of objects using a manipulative.	Practicing math skills; Investigating; Applying mathematical problems
Session 3 - Information Handling (Phase 1)	Students administered surveys on the mobile device. After which they interpreted the data collected and shared these findings with the class.	Investigating; Applying mathematical problems; Creating content
Session 4 - Angles (Phase 1)	Tasks were encoded in QR codes. Students took pictures of objects that corresponds to certain types of angles. They annotated the pictures to show the angle and its' estimated angle measurement.	Practicing math skills; Investigating; Applying mathematical problems; Creating content
Session 5 - Angles (Phase 2)	Using a scavenger hunt theme, students took picture of objects which were man-made and natural angles.	Practicing math skills; Investigating; Applying mathematical problems; Creating content
Session 6 - Symmetry (Phase 2)	Following a scavenger hunt theme, students looked for specific symmetrical objects from their environment.	Practicing math skills; Investigating; Creating content
Session 7 - Area and Perimeter (Phase 2)	Students took pictures of objects and annotated them with their area and perimeter. They then tagged the actual object with this information to create augmented realities.	Practicing math skills; Investigating; Applying mathematical problems
Session 8 - Information Handling (Phase 2)	Students used the phone sensors to gather data from their environment. Data were encoded and analysed collectively.	Investigating; Applying mathematical problems Creating content

Results

Using critical incident analysis, a total of eight breakthroughs (23 occurrences) and 21 different breakdowns (53 occurrences) were identified. Admittedly, there were fewer breakthroughs identified because the focus of the incident analysis was to identify issues within this pilot study. In addition, the wearable camera was worn by the researcher who was also providing the technical support and as such, capturing more of the technical issues that happened as opposed to capturing how the rest of the class was engaging with the activities.

Breakdowns of mobile learning

The breakdowns were categorised into three headings: technical, social and activity design issues. Technical issues refer to problems with the use of the tablet like application stability, responsiveness and network connectivity. Activity design issues refer to problems caused by the learning activity (for example, students not being clear about what to do next or students not having a good grasp of the topic covered). Social issues relate to problems that are related to the social layer of the activity (like collaboration and participation in the activity). There were 10 distinct technical issues, nine activity design issues and two social issues identified. For a list of the breakdowns identified, refer to Table 2.

Table 2: List of breakdowns

Breakdowns	No. of Occurrences	Category
Tablets were not charged	3	Technical
It was not possible to check on students' work remotely	1	Technical
Stability of the applications being used	5	Technical
Access to applications	3	Technical
Difficulty in handling the tablets with the cases	1	Technical
Network connectivity issues	3	Technical
Visibility of the screen in outdoor conditions	2	Technical
The measurement given by the tablet was not accurate	2	Technical
There was no way to verify the app measurement	1	Technical
In a collaborative worksheet, it was not possible to track student input	1	Technical
Too many handouts confuse the students	1	Activity design
Students were not clear about what to do	7	Activity design
Students were not clear about the meaning of some words used and the symbols used in the application	2	Activity design
Some students did not have a good grasp of the topic.	5	Activity design
Students were not sure how to use the application	3	Activity design
Students used the tablets for non-activity related tasks	1	Activity design
Weather conditions were not suitable for the activity	3	Activity design
Students did not finish on time	2	Activity design
Students get tired of repetitively switching between applications	1	Activity design
Students did not participate in the activity.	3	Social
Students did not collaborate.	3	Social

There were far more technical issues identified in the first activity than in the succeeding activities which shows that although students were already familiar with the use of the tablets, the transition to using these devices for learning activities still required some training. It is also possible that fewer issues were identified in the succeeding sessions because students have learned to troubleshoot the issues themselves, as was seen in some footages where more tech-savvy students helped other students encountering technical problems. This observation was also noted by the teacher in the interview---that students were initially worried about all the technical glitches but have adapted over time.

The most common technical issue is the stability of applications being used and this problem has impacted students work. When the tablets or the application malfunctions, students work were not always recovered and would require students to re-do the work. As one student phrased it:

“If it doesn't work then all that you've done is gone unlike when you're working with paper. If you've got sheets there will always be spares but with tablets, you don't... so you do it again, then you get bored of it.”

This issue is problematic particularly for activities that require data gathering as the instability of the tablet could make students lose a significant amount of work. For activities that are chunked into several steps, while this is still an issue, its effect is not as much as that only require going back a few steps.

The most common activity design issue is that students were not clear what to do next (n=7). There were several instances where the students started working on the tablet but end up not being clear about the task and this required an intervention from the teacher to get the class's attention and pause for a while so that the teacher could walk them through the task that they needed to do. This problem typically occurred when students used several applications in one session. For example, in session 1, there were two activities and two different applications used. Students were given an orientation on what they needed to do at the start of the session. They went on to do the first task with one application but got confused with what they had to do next because it required a different application.

Another common issue refers to students' grasp of the topic (n=5). In some instances, students appeared to lack the foundation to be able to work on the activity. For example, in the symmetry activity, although the concepts were covered before the activity, some students were not clear what symmetry was. Although this is a breakdown, because the teacher could observe what the students were doing, this breakdown was resolved by a brief explanation from the teacher, clarifying what is symmetrical and what isn't.

In the outdoor setup, the weather was a contributing factor in the implementation of the activity (n=3). For example, during the area and perimeter session outdoors (Session 7), the weather condition started satisfactory but towards the middle of the lesson, it started to drizzle and thus affected the screen sensitivity of the tablet. This illustrated the need for contingency plans should the weather not be permitting.

There were two issues in the social layer: students not participating in the activity and students not collaborating. Both categories related to student disengagement. In the first issue, students were not participating because of difficulties they encountered in the activity. For example, one student did not complete the activity because the technical difficulty she encountered required that she had to do the activity again. In the second issue, there were cases where students were observed not to be collaborating probably because they were not the ones operating the tablet. Both categories can be argued to be a result of failings of the technology and a shortcoming in the design of the activity.

Breakthroughs of mobile learning

Several breakthroughs were also observed throughout the mobile learning activities. One of the observed advantages of using mobile technologies is that they facilitate contextual learning. For example, in Session 3, the students designed a survey using an application which they later administered in class. Afterwards, they analysed the results using the generated bar graphs from the survey. The process of data collection can be said to add depth to the usual textbook exercise of analysing presented bar graphs. In this exercise, they were not just presented with the data but as they administered the survey, they were also seeing how the survey was being populated.

Another advantage is that it facilitates visualisation of abstract math concepts, thus facilitating the link between abstract math concepts and its concrete representation in the environment. For example, in the angles learning activity, students adjusted the object in their environment to fit the properties that they needed.

The activities were set up as paired or group activities and this allowed students the chance to work collaboratively using the tablets. Collaboration is not limited to the learning activity but also evident in students working together to overcome a technical difficulty. Some students have acted as technical helpers and helped other groups without being asked to do so.

Another advantage of these activities is their capacities to promote active learning environments. The activities provided in the session are all hands-on activities which have been mostly received positively, technical breakdowns aside. The breakthroughs discussed in this section match the potential benefits of mobile learning. The mobile learning activities facilitated active networked learning, but also facilitated visualisation of math concepts as students matched the abstract math concepts with their concrete representations.

Discussion

A critical incident analysis identified technical, social and activity design issues in the mobile learning activities. The technical difficulties of the mobile learning sessions included issues with the battery, stability of the application, accuracy of the measures given by application, and network connectivity. The activity design issues included problems with the content and student background knowledge. The social issues included problems with collaboration and students' adaptability. These problems are not new and has been covered by previous math and mobile learning literature (Kalloo & Mohan, 2011; Wijers, Jonker, & Drijvers, 2010).

The effects of the technical problems in the activity varied. When only a portion of the activity was lost due to the unresponsiveness of the application, students quickly recovered from the problem. When it happened towards the end, with the majority of work being lost, this left some students frustrated. Students tolerated the technical issues up to a point. Students who had encountered several technical issues had mixed views about the use of mobile technologies and these views consequently affected their behavioural engagement. Some students persisted while there were those who became disengaged from the activity. This links back to the technology acceptance model that suggests that there should be a balance of usability and utility (Davis, 1989).

The non-technical issues related to the activity were more difficult to troubleshoot because these were mostly issues related to students' skills and the design of the activities. For example, when students did not have a good grasp of the topic, this meant that the teacher had to quickly go over the maths lesson with the whole class. In this case, it occupied some of the time for the activity. The other option was for the teacher to support the struggling student, and in that case, the teacher became temporarily unavailable to support the rest of the class. Both situations called for a re-think of the design of the learning activity.

The problem was partly caused by bringing in the technology without fully considering the learners and partly by not having fully considered the different scenarios that could go wrong in the classroom. The lesson plans were linear, restrictive and time-bound and did not allow much flexibility in terms of carrying out the lesson. Other mobile learning studies, particularly those carried out outside the

classroom environment identified the need for careful planning of scenarios and flow of activities (Spikol & Eliasson, 2010). This then leads to the concept of classroom orchestration, “the methods and strategies empowered by a technology equipped classroom that an educator may adopt carefully to engage students in activities conducive to learning” (Chan, 2013, p. 515). This highlights the important role of the teacher, their flexibility and adaptability to carry out novel use of technology.

One of the advantages of using mobile devices is the range of activities they are able to support in a single device. While the activities could have been delivered in the same way without a mobile device, the mobile device in these instances allowed students to create artefacts which they shared with the rest of the class at the end of the activity. The artefacts also served as records of how abstract maths was situated in the environment. In addition, the mobile devices facilitated the activities as students moved in and out of the different learning spaces, from gathering artefacts “in the wild” and creating new content as they annotated the artefacts they had gathered, to sharing these new artefacts with other members of the class.

These observed breakthroughs tally with the students’ perceived advantages of mobile learning for math: facilitate visualisation of abstract math concepts as well as engagement in fun and active learning activities that use technology. There was also the benefit of allowing personalisation, ownership of learning and improved student engagement, as the teacher suggested. These tangible benefits map well into Cochrane’s (2010) potential benefits of mobile learning: facilitating learning across contexts, facilitating contextual learning, and providing personalisation in both personal and collaborative environments.

The mobility offered by the technology facilitated learning as students moved in and out of different learning spaces, investigating math properties within their environment. The process of finding concrete representations of abstract math within the environment facilitated a personal learning environment as the students worked on their own devices.

Conclusion

This study evaluated the breakdowns and breakthroughs of using mobile devices for learning mathematics in learning activities that transitioned between the indoor and outdoor environment. It has identified technical, activity design and social issues involved in implementing tablet use in a primary school setting. Some of the issues identified could have been avoided through a more careful orchestration of the learning activity. This points back to the important role that teachers play in designing and carrying out novel technology use. In the activities carried out, there was a shift in the teacher’s role and responsibility, from the person guiding and stimulating discussion to that of a “curator—a collector, organiser and guarantor of educational opportunities (Crompton & Traxler, 2015, p. 230)”. As such, it would be worthwhile addressing how teachers are being trained to target issues surrounding orchestration in addition to training on the use of new technologies..

References

- Baya’a, N., & Daher, W. (2010). Middle School Students’ Learning of Mathematics Using Mobile Phones : Conditions and Consequences. *Journal of Interactive Learning Research*, 21(2), 165–185.
- Chan, T.-W. (2013). Sharing sentiment and wearing a pair of “field spectacles” to view classroom orchestration. *Computers & Education*, 69, 514–516.

<https://doi.org/10.1016/j.compedu.2013.04.011>

- Cochrane, T. (2010). Exploring mobile learning success factors. *Research in Learning Technology*, 18(2), 133–148. <https://doi.org/10.3402/rlt.v18i2.10758>
- Crompton, H. (2015). Understanding Angle and Angle Measure: A Design-based Research Study Using Context Aware Ubiquitous Computing. *International Journal of Technology in Mathematics Education*, 22(1), 19–30.
- Crompton, H., & Burke, D. (2016). *Research trends in the use of mobile learning in mathematics. Blended Learning: Concepts, Methodologies, Tools, and Applications* (Vol. 4). <https://doi.org/10.4018/978-1-5225-0783-3.ch101>
- Crompton, H., & Traxler, J. (2015). *Mobile Learning and Mathematics*. New York: Routledge.
- Davis, F. D. (1989). Perceived Usefulness, Perceived Ease of Use, and User Acceptance of. *MIS Quarterly*, 13(3), 319–340.
- Fabian, K., Topping, K. J., & Barron, I. G. (2016). Mobile technology and mathematics: effects on students' attitudes, engagement, and achievement. *Journal of Computers in Education*, 3(1), 77–104. <https://doi.org/10.1007/s40692-015-0048-8>
- Kaloo, V., & Mohan, P. (2011). A Mobile Learning Study in High School Mathematics: Challenges, Lessons Learned and Recommendations. In *2011 IEEE 11th International Conference on Advanced Learning Technologies* (pp. 45–47). IEEE. <https://doi.org/10.1109/ICALT.2011.21>
- Sawaya, S., & Putnam, R. T. (2015). Using mobile devices to connect mathematics to out-of-school contexts. In *Mobile Learning and Mathematics* (pp. 9–19).
- Sharples, M. (2009). Methods for evaluating mobile learning. In *Researching Mobile Learning: Frameworks, Tools and Research Design* (pp. 17–39). Retrieved from <http://www.peterlang.com/index.cfm?event=cmp.ccc.seitenstruktur.detailseiten&seitentyp=produkt&pk=50553&concordeid=11832>
- Shih, S. C., Kuo, B. C., & Liu, Y. L. (2012). Adaptively ubiquitous learning in campus math path. *Educational Technology and Society*, 15(2), 298–308.
- Spikol, D., & Eliasson, J. (2010). Lessons from Designing Geometry Learning Activities that Combine Mobile and 3D Tools. In *2010 6th IEEE International Conference on Wireless, Mobile, and Ubiquitous Technologies in Education* (pp. 137–141). IEEE. <https://doi.org/10.1109/WMUTE.2010.44>
- Vavoula, G., & Sharples, M. (2009). Meeting the challenges in evaluating mobile learning: A 3-level evaluation framework. *International Journal of Mobile and Blended Learning*, 1(2), 54–75. <https://doi.org/10.4018/jmbl.2009040104>
- Wijers, M., Jonker, V., & Drijvers, P. (2010). MobileMath: exploring mathematics outside the classroom. *ZDM, the International Journal on Mathematics Education*, 42(7), 789–799.

A picture is worth a thousand words: visualizing collaboration through gaze synchrony graphs

Enrique Garcia Moreno-Esteva, Jessica F. A. Salminen-Saari, Miika Toivanen & Markku S. Hannula

University of Helsinki, Faculty of Educational Sciences, Finland;
enrique.garciamoreno-esteva@helsinki.fi

Keywords: Math problem-solving in class, collaboration, mobile gaze-tracking, gaze synchrony, analytic methods

Introduction and research questions

In our case study, in which we attempt to understand the reasons why collaborative behavior arises, we turned to eye tracking during a live lesson involving a mathematics problem solving session in a classroom, and measured shared attention via gaze synchrony. Gaze synchrony is a measure of how much the locus of gaze of the different participants in the study overlaps. Together with a qualitative analysis of the episode, we tried to determine what produces gaze synchrony and why. Our data collection took place in a classroom and not in a lab, making our results ecologically valid. Our resulting picture, an annotated graph, is worth a thousand words when supplemented with specific knowledge about the key events it identifies. With the graph we are able to locate moments when (gaze) focused communication and interaction takes place, and identify what brings about that communication and interaction.

Background

Collaboration is a process whereby two or more people work together towards achieving a particular goal. Intellectual work has become increasingly collaborative. There is remarkable consensus among educational policy makers, that the future labor market needs primarily non-routine analytic and non-routine interpersonal skills, including problem solving, interpersonal communication, and self-management (OECD, 2013). Although the nature and learning of such 21st century skills (see Binkley et al. 2010) has been studied both in psychological and educational research there are some areas that have received little attention, if any. In our study we address the question of what brings about collaborative behavior during non-routine mathematics problem solving in class.

Methodology

In order to study patterns of collaboration during mathematics problem solving sessions in the classroom, student teachers at the University of Helsinki were asked to solve a non-routine problem during a lesson while wearing mobile eye-tracking devices. The problem consists of finding the optimal way to connect four cities located at the vertices of a square with cable, using the shortest amount of it (the optimal solution is given in Figure 1b). Several kinds of data were collected in addition to the eye-tracking data, such as notebook scribble, screen content when laptops or tablets were used, video, voice, and a stimulated recall interview with the subject wearing the eye-tracking devices during which they could see the eye-tracking recording as a form of stimulus. The students work first alone, then in pairs, and then in groups of four. The role of the teacher is to encourage

students to find the best solution possible without providing information about it. Four students were wearing the gaze tracking glasses. The gaze tracking data was processed to measure gaze synchrony and produce the graph in Figure 1a. The red line represents a statistically generated mean of the measure of gaze synchrony. The blue line represents the amount of overlap as given by the gaze tracking data relative to this statistically derived mean, in standard deviation units. The green lines are three standard deviations away from the red mean curve.

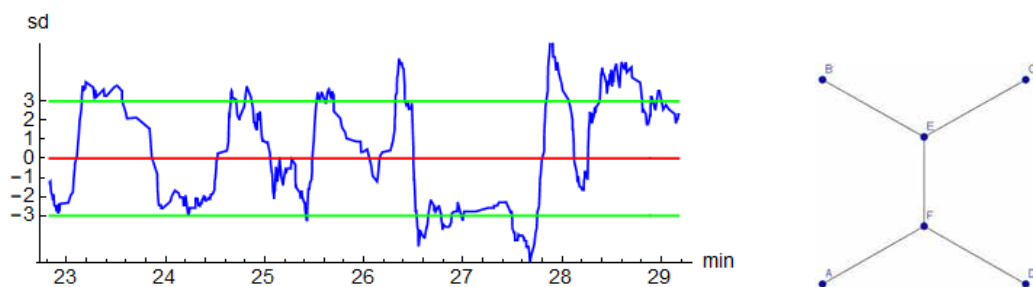


Figure 1: (a) 3-way gaze synchrony graph (b) the optimal solution to the problem

Results and discussion

The graph above and the careful analysis of other audio and video data allow us to construct a storyline that describes the problem-solving episode and which highlights collaborative behavior. Gaze synchrony occurs at the peaks. Leading to these moments is the need of one or more of the students to verify their belief that they have identified a plausible solution (something we call goal proximity). When this belief wanes, students return to work on their own in hope of finding a better solution and gaze synchrony is lost, as indicated by the troughs in the figure. For example, in the picture, towards the right, there is a long trough followed by a high plateau. During the trough, the students are working alone, but then, one of the students thinks he has found the best solution and asks everyone to look at the board to verify this, and the verification process ensues. The graph helped us identify this pattern of collaboration in which discovery and verification alternate, with discovery taking place while students work on their own, and verification signaled by increased gaze synchrony, occurring while the group works together and the visual attention of the group members is more focused on the same targets. We believe that with this tool we might be able to identify, with more data, other collaboration patterns occurring in problem solving sessions in the mathematics classroom and provide teachers with valuable insight informing her interventions.

References

- Binkley, M., Erstad, O., Herman, J., Raizen, S., Ripley, M., Miller-Ricci, M. & Rumble, M. (2012). Defining twenty-first century skills. In P. Griffin, B. McGaw & E. Care (Eds.) *Assessment and teaching of 21st century skills* (pp. 17–66). Dordrecht: Springer.
- OECD. (2013). *OECD Skills Outlook 2013: First Results from the Survey of Adult Skills*. OECD Publishing.

University students' engagement with an asynchronous online course on digital technologies for mathematical learning

Eirini Geraniou¹ and Cosette Crisan²

¹UCL Institute of Education, University College London, UK; e.geraniou@ucl.ac.uk

²UCL Institute of Education, University College London UK; c.crisan@ucl.ac.uk

Promoting students' active and meaningful engagement in online learning environments, and especially in asynchronous courses where students are not interacting with the lecturer or their peers in real time, can be challenging. This paper presents the initial results from an exploratory study on how the tutors' design considerations of a ten-week online asynchronous master's course, together with their online pedagogic strategies have impacted on students' learning experiences and their engagement with its resources, such as content, peers and tutors. The data we focus on consists of students' online contributions and one-to-one interviews. Our research aims to gain an insight into students' views on how their engagement impacted on their online learning for this course, leading thus to identifying opportunities and barriers to take into account when designing for active learning in an online course.

Keywords: Online learning, asynchronous communication, student engagement, digital technologies, mathematical learning.

Introduction

Active learning has a reputation of being effective in supporting students' retention of knowledge, addressing potential misconceptions, promoting engagement and encouraging positive attitudes towards learning (Michael, 2006). Considering these arguments, educators should be encouraging active learning in every mode of study, such as face-to-face traditional teaching, online synchronous, asynchronous or blended learning. Even though active learning strategies, such as Think-Pair-Share, Role Playing, Group Discussion, etc., are widely used and have been shown to be successful in face-to-face, as well as virtual yet synchronous teaching situations, achieving active learning in an online asynchronous learning environment presents a number of 'new' (as is not widely researched and addressed) challenges (Riggs & Linder, 2016). For example, some authors (e.g. Picciano, 2002) claim that online discussions and learning could distance students from convergent thinking, instructor directed inquiry and scientific thinking compared to face-to-face discussion. Others (e.g. Jiang & Ting, 2000; Dixon, 2010) found that students' online learning very much depends on the quantity and quality of their peers' postings in online discussions, which is certainly an unpredictable factor. Haythornthwaite (2002) and Rovai (2002) found that the greater variability in the online social interactions between students in terms of regular presence, participation, etc. and their sense of belonging in a community and trusting their peers in their mutual learning journey can take longer than face-to-face learning in a classroom environment. And just as importantly, practical issues such as easy access to the online platform and the course resources and student support when technical difficulties arise, need to be offered (e.g. Hewitt, 2003).

There are great benefits of learning in an asynchronous environment. Students have more time to reflect on the resources, the tasks, their tutors' and peers' contributions, but they also have more time to invest in offering more thoughtful and insightful contributions (Collison et al., 2000), than perhaps in a face-to-face interaction. Riggs and Linder (2016) found that more students choose online asynchronous courses due to the flexible mode of study, i.e. managing their time to work on the given tasks as and when their own schedules permit, but also spending as much time as they want per task. For more introvert students and those who are not given the opportunity to share their thoughts in face-to-face learning environments due to time constraints in sessions, the authors concluded that online asynchronous courses can give them more time to compose their thoughts and contribute.

To address the above-mentioned challenges, educators have striven to design asynchronous online courses that promote active learning and meaningful engagement from students and offer support by adapting their own pedagogical strategies accordingly (Riggs & Linder, 2016) and developing new such pedagogical strategies. Considering our own experiences as tutors in teaching such a course for the past four years, we recognized our role shifting from that of a subject matter expert, a course developer and a tutor to that of: (i) a technology trainee, to ensure we were familiar ourselves with various digital tools, (ii) a trainer, to support our students in their interactions with these digital tools and (iii) a facilitator or moderator, to manage our students' online contributions and interactions with their peers in online discussion forums. In particular, our role in promoting students' active and meaningful engagement in online discussion forums has been one of our greatest challenges. To identify strategies that support and maintain such engagement throughout the duration of the course, while at the same time evaluating and revisiting the design of our course, we carried out an exploratory study.

In this paper, we present our online asynchronous master's course on digital technologies for mathematical learning, followed by a description of the methodology of our exploratory study that investigated the extent to which and how the asynchronous online experiences impacted on our taught postgraduate students' learning in this course. The initial analysis from this exploratory study data follows. Some conclusions are then drawn, while the key findings of our study are put forward as key recommendations for nurturing active learning opportunities in any online asynchronous course.

Our online asynchronous course

In 2014, we designed a brand new course *Digital Technologies for mathematical learning*, the first and only online course of the University College London (UCL)'s MA in Mathematics Education master programme, which uses the UCL Moodle platform for its delivery. There are two e-learning aspects of this course: (1) its online delivery and (2) the focus on digital technologies of the course itself, consisting of (i) familiarisation of the students with a wide range of digital tools and resources (graph plotters, dynamic geometry environments, statistical software, fully interactive online packages) and (ii) critical reflection on the implications of using such tools in the learning and teaching of mathematics mainly at secondary school level (11-18 years old students).

The main aim of this 10-week course is to encourage students to reflect critically on the potential and limitations of digital technologies for the learning and teaching of mathematics by providing opportunities for students to apply knowledge of relevant research and theory in practice. Besides

getting familiarised with digital tools and reflecting upon their use as ‘learners’ and ‘users’ themselves, students are also encouraged to design activities to use with at least three different digital tools and then evaluate them by trialling them with learners. In this process they carry out mini-research studies and reflect upon the use of digital technologies for mathematical learning. The course is delivered in 10 weeks and each week the tutors upload on the UCL Moodle platform: (1) the learning objectives and a description of the week’s content, (2) the key readings: one essential and two indicative ones and (3) the offline and online weekly tasks, which are tightly structured towards the course aims and the learning objectives. Instead of direct teaching, learning is designed to take place as the result of doing short, manageable offline and online tasks. The *offline tasks* include (1) familiarising with a piece of software and going through scaffolded activities using specific software, and (2) designing and trialling mathematics activities involving the specific software that bridge learners’ interactions with digital media and the mathematical concepts. The *online tasks* include: (1) engaging with the ideas in the key readings and writing a response about the points they agreed or disagreed with or by contributing to online discussion forums with written observations on views and perspectives of fellow students; (2) reflecting on the application of the ideas encountered in the key readings in specific learning contexts such as the offline tasks they designed and trialled. Every week, the students are required to carry out the reading and the weekly tasks, then post their reflections online, and respond to their peers’ posts. There are three themes covered in our course: (a) Visualising, (b) Generalising and Expressing and (c) Modelling. In these three themes, the students interact with many digital tools (DT), such as Excel, GeoGebra, Autograph, the eXpresser microworld, Logo, Scratch and a variety of modelling applications and online digital platforms. Research (e.g., Dixson, 2010) indicated that it can be helpful for instructors of online asynchronous courses to create an architecture for their own engagement, too. As tutors, we made sure that we had social presence demonstrated on a weekly basis through: uploading materials, posting messages, guiding student learning, providing feedback according to set times, sending reminders, contributing to some online discussions.

Methodology

For the four years we have run this course, we have conducted end of theme, as well as end of course evaluations and while the vast majority of our students showed ‘online’ presence by posting their work and occasionally posting questions to tutors regarding practical issues about the work, we have recognised that they were not engaging in online collaborations with their peers as much as we wanted them to, for a full learning experience. In our efforts to encourage our students’ active and meaningful engagement in online collaborations, informed by findings of research (e.g. Dixson, 2010), we trialled some actions, which included: tasks that formed the basis of an online group discussion; collaborative tasks with tutor-nominated groups; pick-a-paper tasks, i.e. ‘choose one paper and its commentary from a member of your small group and post your comparative remarks and reflections’. While these strategies worked in terms of increasing the likely hood of students contributing online, we also became interested in why some students were more engaged than others, why they displayed a higher degree of learner autonomy, evidenced in their inquiring further, seeking assistance and generating new threads of discussion, than others. As such, we became interested in enquiring into *our students’*

perceptions of the extent and the way their asynchronous experiences contributed to their active and meaningful engagement on this course.

To address this research question, we decided to carry out an exploratory study focusing on data collected from our latest cohort of students. This data comprises 20-min interviews with a sample of 10 of the 17 students enrolled on this course and their online contributions throughout the delivery of the course (January-March 2018). Of the 10 students who volunteered for the interviews, three were English native speakers, while seven were international students, for whom English was an additional language. The interview questions focused on students' mode of study and students' experiences of online asynchronous learning, in particular their experiences of participating in online discussion forums. Our intention is to use the outcomes of this exploratory study to inform our thinking and identify issues to research further, but also rethink our practices in terms of communicating with our students and providing effective instructional strategies for improved student communication and collaboration. This will lead to the re-design of our course in its next presentation, focusing on encouraging active learning and engagement with the online course resources.

The interview data was analysed in conjunction with the students' online contributions and written assignments, following the grounded theory approach (Strauss and Corbin, 1990) and using NVIVO to organize, manage and analyse this data. Our students' social processes regarding their mode of study and online contributions were analysed by going through the interview transcripts and coding their comments using labels (i.e. short phrases or sentences) that described what they said. This process was repeated a number of times until there were no more issues identified in the data, no improvements to the current codes were needed and no more codes were produced. At the end of this iterative process, these labels had become analytical representations of the data and turned to the identified categories we share later in the Results section. By doing a constant comparative analysis of the emerging categories, we were able to identify two emerging themes and finalised the categories. Next, we present the emerged themes and categories in the way we linked and integrated them aiming at capturing all the variations in our data and allowing a theory to emerge, that of students' motivation and challenges they faced regarding online contributions in an online asynchronous course.

Results

The two main emerging themes grounded in students' responses are: **Motivation to contribute in online asynchronous learning** encouraged and sustained through *Learning from others; Peer Assistance; Peer students' online study patterns; Interest in and enjoyment of topics*, and **Challenges to contribute in online asynchronous learning** such as *Non-participation; Visibility of learning; Style and Etiquette of communication; Feeling at ease with your peers*. For each of these two emergent themes, students had commented upon the tutors' influence in their learning.

Motivation to contribute in online asynchronous learning: *Learning from others* Those students who engaged with the online activity felt that they benefitted as a result. One international student, Jennie, who enrolled on this course following her undergraduate studies, admitted feeling comfortable to participate in the online discussion forum as she learned a lot from reading the contributions of what she thought of as 'her more experienced and older than her' peers. She admitted looking specifically for their contributions and trusting their views.

Yvette felt that reading research papers, reading other students' work and having to give feedback and comment on others' contributions helped her with her own learning: gaining a deeper insight into the key readings, thus learning about how to engage with research and how to use it to reflect on mathematical learning when digital technologies were used. Similarly, John reckoned he learned from his peers: "I felt like you were in a classroom with other students in a way. Obviously with it being asynchronous it's a lot slower than that, but you kind of need it to be asynchronous so you can actually go and read what people have written. And then it was easy to find again what you've written and how other people have responded", while Jack said that seeing other students' contributions triggered him to respond, hence explicitly engaging with the knowledge base of this course.

Mary and Anne mentioned the opportunities to learn from others, which were facilitated by the tutors' collated feedback on all students' contributions per theme; they would revisit this feedback often, which helped them be more aware of the expectations of this course and improve their future work.

Motivation to contribute in online asynchronous learning: *Peer assistance* All 10 students commented on how useful the UCL Moodle Discussion Forum was for sharing ideas, for reading other students' contributions and reflecting upon their own thinking and understanding of the course material, tasks and resources. "Sometimes if I had no idea how to start my work and I saw how my classmates did it, then I had some directions" (Janet). Having an online record of the peers' contributions enabled the students to revisit aspects of the course at any point throughout the course. One student, Frances, extended this argument by comparing the online contributions to those of a face-to-face learning environment, where "you can only hear a few people's ideas" and mentioned how useful it was to have the time to read and reflect upon them before responding and/or asking questions, which wouldn't have been the case in a time constrained face-to-face interaction: "You have all these online resources to access and explore, and you can ask directly the creators".

Even though there was some peer support offered in Discussion Forums, many students told us that they needed "immediate feedback". For example, Mary argued for the importance of having a tutor 'close by' when learning about and interacting with a new DT. She felt that she needed to ask questions that needed immediate answers in order for her to make progress. Similarly, Patricia and Helen argued about their preference for face-to-face sessions when familiarizing themselves with a new DT, as in that scenario the help was immediate and support was always there (we offered two optional face-to-face sessions as part of this course).

Motivation to contribute in online asynchronous learning: *Peer students' online study patterns* The variance in the students' online presence depended on many factors, such as their interest in the topic, their other commitments (work, studying, deadlines to assignments, etc.), but also their preferred style of studying. All the 10 students agreed they liked the flexible mode of study this course offered, as most of them found it very convenient to choose their own time to study.

Six of the 10 students (Janet, Anne, Patricia, Jack, Frances, Mary) admitted that time management was a challenge in this course. In some cases, it was as result of their own struggle at times to self-manage their work and not because of the structure of the course. But in other cases, it was due to 'wait-time' for others to contribute online to Discussion Forums. Anne agreed that timing is very important even if the course is asynchronous and flexible in that sense. She would never read any

postings that were uploaded too late in the week, as she would have already finished her work by then. Similarly, Patricia argued: “I can’t be bothered to respond to that now, because I’m on to the next one. It’s not fresh in my mind anymore”. Frances, too mentioned how important it was for peers to post on time otherwise “You are delaying your partner’s work too”.

Motivation to contribute in online asynchronous learning: *Interest in and enjoyment of topics & tasks* Looking at the patterns of *all* students’ online participation on a weekly basis throughout the course, we noticed that there were weeks when their online presence was much higher than in others. The 10 students we interviewed argued that this was due to their own interests in certain *topics* covered during certain weeks. For example, Janet said that being interested in a topic encouraged her to work on the task earlier in the week than when she didn’t like the topic or she was not very familiar with it, e.g. programming, and she would engage with others’ online contributions too.

All 10 students valued the *task* which required them to design and trial an activity with learners, then reflect on the mathematical learning. John and Jack argued how great it was to reflect on pedagogical issues regarding students’ learning mathematics with DT. They all commented about learning not only new DT, but also learning how to utilize them in the classroom and use them effectively with learners. Jennie felt that this course was indeed a great preparation for her future career as a mathematics teacher. She felt she got more time to think about the relationship between the DT and mathematics and how it could be used in her own way in mathematics classrooms.

Challenges to contribute in online asynchronous learning: *Peer students’ non-participation* Lack of sustained participation from students seemed to be a key factor for disengagement from online discussion forums. As the course progressed, Jack noticed that not many of his peers participated nor did they respond to his comments. He felt de-motivated and as a result lost his keenness for ongoing online participation. Similarly, due to the lack of peer participation, Anne found it difficult to contribute online, as there were no contributions from others that she could comment on. Even if there were contributions, if too few, there were only so many opportunities to comment on them.

Challenges to contribute in online asynchronous learning: *Visibility of learning* Amongst the reasons mentioned by our students as holding them from contributing online included being afraid of showing their insecurity and lack of confidence in their own expertise with DT or subject matter of the course. Mary confessed: “I know they won’t say are you stupid, how can’t you not know this? But I still feel people get the impression that you don’t know anything and they would hesitate comparing or checking your contributions”.

Visibility of online contributions was even more of a challenge for the non-native English students, who were also worried about the clarity of expressing their thinking in written format. Six out of seven of our international students admitted that they were reluctant to submit comments online. Mary admitted that she would probably hesitate to make a contribution in a face-to-face session for that same reason, but online her contributions remain visible to others for the duration of the course. This was also a concern for Vicky, who commented that she preferred the online mode of communication to the verbal one as it gave her time to think through what she wanted to say, with the advantage that she would ‘correct her English and grammar before posting anything’.

Challenges to contribute in online asynchronous learning: *Style and Etiquette of communication*

Helen mentioned the challenge of communicating in the Discussion Forums; when asking a question, she would need to spend time thinking and articulating the question accurately and in a concise format, whereas a face-to-face scenario is more like having a chat and the question might be formed by itself. The formality of the Moodle discussion forum was mentioned by Anne too. She was put off by the formality of such communications and the fact that tutors would see such contributions and that their posts would also be assessed. Her perception of the role of online contributions led to her being reluctant to upload anything that she hadn't thought through very carefully. Being a native English speaker did not make it easy to adhere to the more formal style of communication; Patricia too admitted feeling occasionally reluctant to post any comments as she had to make them formal.

However, all 10 students admitted that this formality required in all of their online contributions did lead to clarity and coherency of arguments that they were trying to put forward. Having tried to set up a group chat on Facebook Messenger (the seven international students) Jennie found the communications were very informal, with far too many details which she didn't need to read, and with ideas that lacked clarity, although she, like all the others liked the instant feedback.

Challenges to contribute in online asynchronous learning: *Feeling at ease with your peers*

Another reason for being disengaged from the Moodle Discussion Forum was the lack of familiarity with their peers, having not met them in person before the start of the course, which led to a lack of a sense of being part of a community. For example, for Helen it was difficult to post on the forum discussion and comment on work from students she never met face-to-face. Anne thought that her peers who she was not acquainted to were too 'polite' in their comments to her work, so as not to hurt her feelings. This familiarity and friendship with the people on Messenger allowed them to share comments freely, not thinking that they would be upset or offended. Another disadvantage of posting feedback to a peer in a forum is that the way the feedback is articulated might be considered bad criticism and upset their peer, whereas in a face-to-face situation, they could see that the feedback is expressed in a positive manner and their peers can recognize that a student is trying to help and give constructive feedback. For example, in Messenger you can put a smiley face too, and so no matter how the feedback was articulated (as a criticism, for example) the receiver would not see this as a negative comment.

Some conclusions and our key findings

Some of our findings are similar to the ones by authors we referred to earlier in the introduction. All students were very appreciative of the flexible mode of study of our online asynchronous course and the time given to reflect upon peers' contributions, which are similar results to Riggs and Linder's (2016) work. Our students' learning did depend on the quantity and quality of peers' postings (Dixson, 2010) and the tutors' feedback and their trust in their peers (Haythornthwaite, 2002).

However, our study brought to the fore two important aspects not mentioned in the literature we reviewed. We learned from our data analysis that online communication was perceived by our students as a double-edge sword; on one 'edge' they all liked the flexible mode of study, managing their own time, taking time to think through their responses or others' contributions, but the formality of their contributions deterred them from engaging in conversations with peers more fully. We also

learned that we needed to orchestrate better the timing of online contributions in an asynchronous course: while having the flexibility to contribute at their own convenient times, deadlines are even more important to be set and met, in order to ensure an active and meaningful engagement and exchange of views. We thus conclude this paper by putting forward these two key findings as recommendations to designers and tutors of online asynchronous courses, with the aim of nurturing active learning opportunities.

Acknowledgment

This work was supported by UCL Grand Challenge of Transformative Technology, which funded our project: *Supporting active and meaningful engagement in an asynchronous online course*.

References

- Collison, G., Elbaum, B., Haavind, S., & Tinker, R. (2000). *Facilitating online learning: Effective strategies for moderators*. Madison, WI: Atwood Publishing.
- Dixon, M. D. (2010). Creating Effective Student Engagement in Online Courses: What Do Students Find Engaging? *Journal of Scholarship of Teaching and Learning*, 10 (2), 1-13. Indiana University.
- Haythornthwaite, C. (2002). *Building social networks via computer networks: creating and sustaining distributed learning communities*. In K.A. Renninger & W. Shumar (Eds.), *Building Virtual Communities: Learning and Change in Cyberspace.*, (159–190). Cambridge: Cambridge University Press.
- Hewitt, J. (2003). How habitual online practices affect the development of asynchronous discussion threads. *Journal of Educational Computing Research*, 28 (1), 31–45.
- Jiang, M. & Ting, E. (2000). A study of factors influencing students' perceived learning in a web-based course environment. *International Journal of Educational Telecommunications*, 6 (4), 317–338.
- Michael, J. (2006). Where's the evidence that active learning works? *Advances in Physiology Education*, 30 (4), 159–167.
- Picciano, A. G. (2002). Beyond student perceptions: Issues of interaction, presence and performance in an online course. *Journal of Asynchronous Learning Networks*, 6 (1), 21–40.
- Riggs, S. A. & Linder, K. E. (2016). Actively Engaging Students in Asynchronous Online Classes. *IDEA Paper No.64*.
- Rovai, A. P. (2002). A preliminary look at structural differences in sense of classroom community between higher education traditional and ALN courses. *Journal of Asynchronous Learning Networks* 6 (1), 41–56.
- Strauss, A. L. & Corbin, J. A. (1990). *Basics of qualitative research; grounded theory procedures and techniques*. Newbury Park, CA: Sage.

Dynamic vs. static! Different visualisations to conceptualize parameters of quadratic functions

Lisa Göbel and Bärbel Barzel

University of Duisburg-Essen, Germany; lisa.goebel@uni-due.de; baerbel.barzel@uni-due.de

Keywords: Visualisations, parameter, technology.

Background

The technology has gotten faster over the last years; students became more proficient in the use of smartphones etc. But is the power of speed with a quick visualisation when dragging a slider bar or grabbing a graph really beneficial while learning and understanding the concept of parameters? The study presented here uses a guided discovery approach (adapted from Mosston, 1972) to investigate different visualisations to conceptualize parameters of quadratic functions as it is the first non-linear function taught and can serve as a prototype for the conceptualization of parameters of higher polynomial functions. To specify the intended learning process in the study, the core elements for a conceptual understanding are presented: For this study in the frame of quadratic functions the two mathematical objects variables and functions and their “Grundvorstellungen” (as defined in vom Hofe & Blum, 2016) are important for the conceptualization. For functions it is important to develop the ideas of a function as mapping, covariation and object (vom Hofe & Blum, 2016). All these three aspects are crucial, when learning how a graph is changing when one of the parameter changes. Parameters can be classified as a specific type of variables. While many authors distinguish the Grundvorstellungen of variables as unknown, generalized number and changing variable (e.g. Malle, 1993), Drijvers (2003) applies these specifications on parameters. The role of parameter is not fixed to one aspect, but can be placeholder, unknown, changing quantity or generalizer. All roles are crucial to understanding the concept and the conceptualization can be supported through technology. Another important aspect to understand the concept of a function is to be aware and to be able to change between different representations of functions (algebraic-symbolical, numeric-tabular, graphic-visual, situative-linguistical, e.g. Duval, 2006). Duval (2006) describes it as the critical threshold for learning. This can be supported by technological tools (Drijvers et al., 2016). It is still an open question whether the conceptualization differs when different visualisations are used when learning. These points lead to our research questions: How can technology-assisted guided discovery support the conceptualization of parameters in the field of quadratic functions?

Methodology

In a control-group design intervention study with one control- and three experimental groups a total of 14 Year 9 classes worked on a series of tasks designed using a guided discovery approach, which was implemented through hints on the tasksheet how to investigate the influence (for information on the tasks see Göbel, Barzel, & Ball, 2017). The different control- and experimental groups differed only in the kind of visualisation used. The control group had no technological visualisation while the three experimental groups used different types of digital environments (standard function plotter tool, pre-programmed file with the possibility to drag the graph, pre-programmed file with sliders for the parameters) to investigate the influence of parameters in the vertex form of quadratic functions

$f(x) = a \cdot (x - b)^2 + c$. Students designed a summary sheet of their findings during the intervention, which was collected. For an overview on the intervention and the differences between the four groups see Göbel et al. (2017). A paper-pencil test was given to all students to collect baseline data for the comparison between classes. As well as the summary sheets collected a focus group in 13 classes was filmed. The summary sheets were analysed using a coding manual developed by qualitative content analysis. The videos transcripts were analysed with regards to the role of parameters, as well as using technology to explore and validate students' own hypotheses.

Results

Overall it can be said that the dynamic visualisations seem to support the students learning better than the static visualisations. Dynamic groups design significantly more overall appropriate summary sheets. Students in the dynamic visualisations groups, so students using sliders (SL) or drag mode (DM), found out more details about the influence of the parameters than students in the control group or students using a standard function plotter (FP). While in the control group 70,4% of students identified the influence of parameter c adequately (FP 46,3%, DM 76,5%, SL 73,8%), this number drops to 52,1% while identifying the influence of parameter b (FP 40,3%, DM 68,2%, SL 72,3%). Analysis of the summary sheets show that students in the dynamic groups seem to view parameter more as a changing quantity compared to students in the static groups who view parameter as placeholder. The video analysis shows that students use the technology to explore on their own, explain something to each other or to check their hypotheses even though they worked on their own in a guided discovery. Technology-assisted guided discovery can support the learning, but the pre-structuring and dynamic manipulation of the visualisation is crucial for benefiting the learning.

References

- Drijvers, P. (2003). *Learning algebra in a computer algebra environment: design research on the understanding of the concept of parameter*. Utrecht: CD- Press, Center for Science and Mathematics Education.
- Drijvers, P., Ball, L., Barzel, B., Heid, M.K., Cao, Y. & Maschietto, M. (2016). *Uses of technology in lower secondary mathematics education: A concise topical survey*. London: Springer Open.
- Duval, R. (2006) A Cognitive Analysis of Problems of Comprehension in a Learning of Mathematics. *Educational Studies in Mathematics*, 61(1), 103-131.
- Göbel, L., Barzel, B. & Ball, L. (2017). "Power of Speed" or "Discovery by Slowness": Technology-assisted Guided Discovery to Investigate the Role of Parameters in Quadratic Functions. In G. Aldon, & J. Trgalova (Eds.) *Proceedings of the 13th International Conference on Technology in Mathematics Teaching* (pp. 113-123). France.
- Malle, G. (1993). *Didaktische Probleme der elementaren Algebra*. Braunschweig, Wiesbaden: Vieweg.
- Mosston, M. (1972). *Teaching: From Command to Discovery*. Belmont, California: Wadsworth.
- Vom Hofe, R. & Blum, W. (2016). "Grundvorstellungen" as a Category of Subject-Matter Didactics. *Journal für Mathematikdidaktik* 37(S1), 225-254.

The effect of digital tools on visual attention during problem solving: Variance of gaze fixations when working with GeoGebra or on paper

Markku S. Hannula^{1,2} and Miika Toivanen¹

¹University of Helsinki, Finland; markku.hannula@helsinki.fi, miika.toivanen@helsinki.fi

²Volda University College, Norway

Research on reading indicates that visual attention is different when using digital media or print. This study aims to explore whether the choice between paper and GeoGebra influences visual attention during collaborative geometry problem solving. We measured eight students' fixation durations during different lesson phases: teacher instruction, individual work, pair work, group work, students presenting on the board, and whole class discussion. During all phases except teacher instruction we observed a difference in the fixation distributions as indicated by Kolmogorov-Smirnov tests. The use of GeoGebra is related to a slight shift from median length fixations to short fixations, suggesting lower cognitive load when students work with computers.

Keywords: Attention, computers, cooperative learning, eye movements.

Introduction

Paper and pen is a different medium than computer and screen and dynamic geometry environment (DGE) is very different from paper when solving a geometry problem. It is well documented that technology in general (Chauhan, 2017) and DGE in specific (Chan & Leung, 2014) have positive effects on mathematics achievement. There is much research on the specific affordances of DGE in learning and problem solving. For example, Christou, Mousoulides, Pittalis, and Pitta-Pantazi (2005) argue that DGE as a mediation tool encourages students to use modeling, conjecturing, experimenting, and generalizing in problem solving. Healy & Hoyles (2002) claim that DGE can scaffold the solution process and help students move from argumentation to logical deduction, while for less successful students the DGE may prevent them from expressing their mathematical ideas.

One way to examine how the learners' experiences are different in DGE and paper is eye-tracking. Human gaze consists of approximately three to four fixations (maintaining of the visual gaze on a single location) in a second (Rayner, 1998). Hartmann and Fischer (2016) compare eye-tracking information to mind-reading: the target of a fixation usually tells what we think about and the fixation duration corresponds with processing time. Fixation duration is an established indicator for perceptual or cognitive processing difficulty, also in the context of mathematics (Rayner, 1998). Glöckner and Herbold (2011) summarize research evidence to suggest that gazes related to more automatic processes would have shorter fixations (below 250 ms) and more elaborated information processing generally requires long fixations of more than 500 milliseconds.

Visual attention has been studied mostly in the context of reading and research on mathematics is much less frequent (Hartmann & Fischer, 2016; Rayner, 1998). In a systematic review on reading on paper and digitally, Singer and Alexander (2017) found out that reading comprehension is influenced by the text presentation. However, in the context of mathematics, we did not find any comparative eye-tracking studies between digital and non-digital learning environments.

Existing eye-tracking research on mathematics shows that the method is relevant. Andra, Lindstrom, Arzarello, Holmqvist, Robutti, & Sabena, (2015) investigated how students read mathematical texts. In their study, fixation durations were typically in the range from 190 to 250 milliseconds. Fixations were longer for formulas than for graphs or text, but graphs attracted more fixations, leading to longer time spent looking at the graphs. In Lin and Lin (2014) study students were solving problems on tablets, and they suggest fixation counts, time on target, and run counts as relevant measures, because these differentiate successful from unsuccessful solvers and correlate with perceived difficulty.

We find the dominant methodologies for eye-tracking problematic. So far, most studies have been conducted in laboratory situations. We believe that problem solving needs to be studied in ecologically more valid contexts. We are interested in problem solving in contexts, where multiple modalities are present (Arzarello, Paola, Robutti & Sabena 2009) and multiple goals need to be addressed (Hannula, 2006). Most importantly, we are interested in problem solving in collaborative situations. Our earlier studies show that mobile eye tracking provides interesting data on attentional behavior in real classroom situations (e.g. Garcia Moreno-Esteva & Hannula, 2015; Haataja, Garcia Moreno-Esteva, Toivanen, & Hannula, 2018).

While we have not found studies examining the visual attention in digital and non-digital mathematics learning environments, it seems likely that a digital tool would have an effect on visual attention even in the context involving collaboration. We formulate our research question as follows: Does the choice of learning environment (paper vs. GeoGebra) have an overall effect on student attentional processes as indicated by fixation durations when students are solving a geometry problem.

Method

Participants

We examined fixation durations for one teacher and her eight students. The teacher taught the same problem solving session twice in two different Finnish grade nine classrooms. The first lesson was recorded in May 2017 and then the students solved the task using paper and pencil. We call this Paper lesson, even if at the end of the lesson the students continued examining the same problem using computers. The second lesson was recorded in May 2018 and then the students solved the task using GeoGebra software. This lesson we call the GeoGebra lesson, even if the students used also pen and paper to some extent. The ethics review has approved our research procedures.

The mathematics teacher Joanne was an experienced teacher. The students were four girls (using paper) and three girls and one boy (using GeoGebra). The students were selected among volunteers. Data from the first lesson has previously been analyzed from the perspective of student and teacher eye-contact (Haataja, Garcia Moreno-Esteva, Toivanen, & Hannula, 2018; Haataja, Salonen, Laine, Toivanen, & Hannula, forthcoming). The focus in this paper is to examine whether use of computers has an influence on students' fixation durations as an indication of an effect on their visual attention.

In both of the lessons, the teacher first introduced the lesson structure and when students got their respective tools (i.e. paper and rulers or laptop and GeoGebra) ready, the teacher posed the geometry problem to the class. Students first worked individually, then with a pair, then four together, and finally the students' solutions were collected on the board and discussed. During the first lesson, the

teacher also posed an extension problem and during both lessons they continued to examine the problem with a GeoGebra application after discussion. However, that end part of both lessons is beyond the current paper's analysis. The relevant lesson phases are summarized in Table 1.

Lesson phase	Paper and pen (s)	GeoGebra (s)
Teacher gives instructions regarding the lesson structure (1)	44	38
Students fetch papers and rulers	139	
Teacher gives instructions for GeoGebra		92
Teacher poses the problem (1)	273	111
Individual work (2)	373	387
Teacher gives instructions for pair work (1)	45	22
Pair work (3)	205	513
Teacher gives instructions for group work (1)	30	40
Group work (four) (4)	1210	570
Teacher poses task extension	362	
Students come to the board (5)	190	130
Whole class discussion (6)	106	244

Table 1: Lesson phases and their durations. The numbered phases were analyzed in this study

The teacher was instructed to provide encouragement and to ask questions that require students to explicate their thinking but to not provide hints for how to solve the problem. When students were working individually, in pairs, or in groups of four, the teacher's activity consisted of roaming in the classroom and stopping for scaffolding one group at a time.

For the analysis, we included only those lesson phases that took place during both lessons. Moreover, we grouped together four separate instances when the teacher was giving instructions to the class or posing the problem. This way, we have identified six lesson phases that captured altogether 41 minutes and 16 seconds of the paper lesson and 34 minutes and 15 seconds of the GeoGebra lesson. Our analysis will focus on these parts of the lesson.

Apparatus

We recorded the actions and conversations of the problem-solving session using audio recording and three stationary video cameras in the classroom. In this paper, we analyze data from five gaze-tracking glasses that recorded eye movements of the teacher and the target students. The gaze-tracking device consisted of two eye cameras, a scene camera, and simple electronics attached to 3D-printed frames (Figure 1). The devices and software were self made (see, Toivanen, Lukander, & Puolamäki, 2017). The camera frame rate depended on lighting conditions, and maximum rate in optimal conditions was 30 frames/second. Data was recorded on laptop computers that were carried in backpacks allowing subjects to move freely in the classroom.



Figure 1: The gaze-tracking equipment.

Procedure

The recorded data was first analyzed to identify all fixations for all subjects. The fixation durations were estimated from the eye image difference between consecutive cropped eye image frames and setting a threshold for the average pixel-wise difference. This results in more accurate measure, compared to using gaze coordinates which might fluctuate due to algorithmic miscomputations. The information of fixation onsets and durations was then combined with information about timing of lesson phases from a video following teacher actions in the class. After this preliminary organization of data in Excel, the data was imported to SPSS 24 for statistical analyses.

First we analyzed the descriptive statistics of fixation durations. As the distributions were non-normal, we used non-parametric tests in our consequent analyses. When comparing fixation durations of two samples, we decided to use the Kolmogorov-Smirnov *Z*-test rather than Mann-Whitney's *U*-test, because it has more power to detect changes in the shape of the distributions. We analyzed the variation of gaze durations across the different lesson phases separately for students and the teacher for both the paper lesson and the GeoGebra lesson.

We predicted that the gaze behavior might be different across different lesson phases and, therefore, we analyzed the data separately for different lesson phases. Our expectation was that the fixation durations would on average be similar across those lesson phases where the use of tool would not be central (i.e. teacher instruction, students to the board, and discussion) while the possible effect of computer as a tool could be seen during individual work, pair work, and group work.

To check for sufficient similarity of visual behavior of compared individuals in the two conditions, we made pairwise Kolmogorov-Smirnov *Z*-tests for fixation distributions between individuals. For this analysis we selected the lesson phases where we expected the effect of computers to be minimal, i.e. teacher instruction, students to the board, and discussion. We used the information of pairwise differences to identify individuals whose fixation distribution was not comparable with other subjects' distribution. We then removed from future analysis those students whose fixation distribution deviated from other students the most. Finally, we made a comparison between student and teacher fixation distributions for the two lessons (paper and GeoGebra) for the different lesson phases using Kolmogorov-Smirnov *Z*-test.

Results

The total number of fixations during the analyzed lesson phases for all participants was 41,119. The shortest possible fixation to observe was 80 ms (two frames). The observed fixation durations varied from 80 ms to 15066 ms ($Mdn = 234$ ms, $M = 430$ ms, $SD = 654.00$). The durations were non-normally distributed, with skewness of 6.52 ($SE = 0.012$) and kurtosis of 69.62 ($SE = 0.024$).

We then analyzed the similarity of fixation durations for both sessions for the teacher and all students for the lesson phases that were less tool dependent (i.e. teacher instructions, students at the board, and discussion). The Kolmogorov-Smirnov Z-tests showed that the teacher fixations over both sessions were similar across the two sessions and different from all but one students' fixations. All but one compared student pairs had statistically significant differences for at least one of the lesson phases. However, it was possible to identify two students, who stood out more strongly from the group as having a different distribution of fixation durations. We removed these students from the analysis. After this removal, we had three female students from the paper lesson and two female and one male students from the computer lesson.

We then made Kolmogorov-Smirnov tests for each lesson phase to compare fixation durations between the two conditions (working with paper or working with GeoGebra) (Table 2). The results show that during pair work and group work the distributions differ statistically very significantly. The medians indicate that students using GeoGebra had shorter fixations during pair work than students using pen and paper, while the difference was small and opposite during group work. Differences for the other lesson phases were statistically significant ($p < .01$) for pair work and group work.

Lesson phase	Tool	<i>n</i>	<i>Mdn (ms)</i>	<i>Z</i>	<i>p</i>
Teacher instruction	Paper	933	269	.75	.627
	GeoGebra	1826	269		
Individual work	Paper	1775	269	1.38	.045
	GeoGebra	1918	267		
Pair work	Paper	2692	264	3.10	.000
	GeoGebra	1151	204		
Group work	Paper	2880	240	2.17	.000
	GeoGebra	5611	250		
Students at the board	Paper	786	233	1.57	.015
	GeoGebra	923	240		
Discussion	Paper	1177	268	1.59	.013
	GeoGebra	464	233		

Table 2: Kolmogorov-Smirnov Z-test results for tool effect on fixation durations.

To further explore the difference between paper and GeoGebra for visual attention, we looked at the distributions of different fixation lengths. We used the whole session for these students to identify the cut points for deciles. These cut points were then used to divide the distribution of fixation durations for the two lesson phases for paper and GeoGebra condition. We see that the GeoGebra condition had more deviation from the expected distribution of ten percent in each category. For pair work (Figure 2), the students using GeoGebra had more fixations in the time range 100 ms to 200 ms and fewer fixations of longer duration in comparison to paper condition. For group work (Figure 3), students using GeoGebra had fewer gazes in the time range 200 ms to 300 ms and more very long fixations. While the two distributions in the GeoGebra condition are somewhat different, there seems to be a trend for somewhat more short fixations at the cost of average duration fixations.

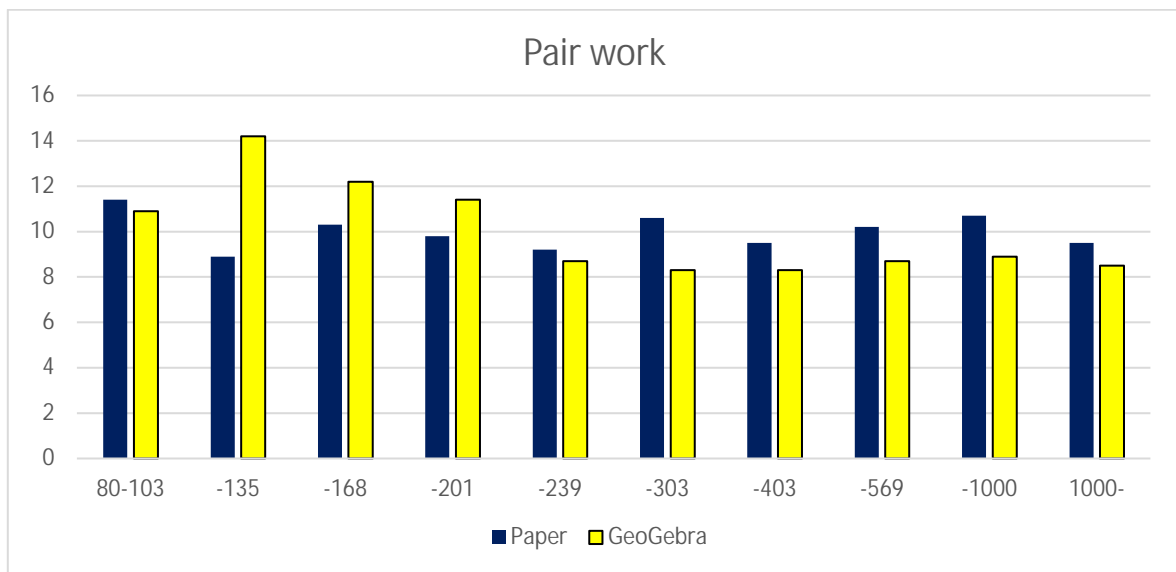


Figure 2: The distribution of fixation durations (ms) for the selected students for pair work

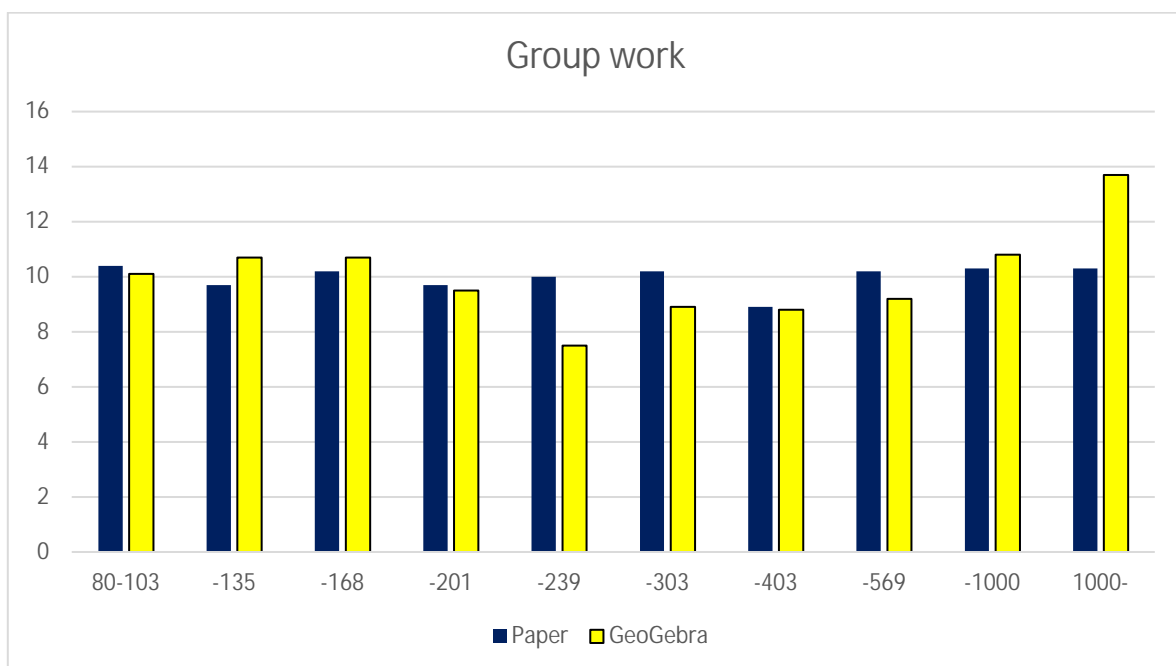


Figure 3: The distribution of fixation durations (ms) for the selected students for group work

Discussion

The results show an effect in student fixation durations for the choice between computer and paper as a media to solve a geometry problem. Use of GeoGebra is related with slight shift in fixation durations towards short fixations during collaborative phases of the problem solving. During this phase, students are comparing their individual solutions and discussing for alternative options. With respect to visual attention, this phase should include attention to other students and their drawings.

Shorter fixations usually indicate lower cognitive load. In this context, it might mean that students who worked interactively with GeoGebra, executed more often simple search tasks, such as searching for cursor on screen, which have a low cognitive demand. Alternatively, it might be related to easier extraction of information from neat GeoGebra drawings in comparison to peers' hand written solutions. Thirdly, the computer screen has a lot of visual attracters (e.g. menus) that may lead to short fixations on distracting elements. We provide one more possible explanation. In our earlier studies we have noticed that during interpersonal interaction in class, short fixations at the other person's face are frequent. It may be that the students working with GeoGebra have more short fixations on peers' faces, either because they have longer discussions or as it is more difficult to share screens than notebooks, they have less time for looking at solutions. These possible explanations can't be answered before we have analyzed student behavior during these events and annotated the targets of the fixations.

These results need to be taken with caution. There is significant variation in fixation durations between individuals and even within an individual across time. Although we tried to control for this variation and removed students with obviously deviating fixation duration distributions, the remaining students are by no means identical in their gaze behavior. Future studies should address larger variation of individual and situational differences. A larger sample of students would allow us to identify clusters of students whose visual attention follows a similar pattern and then compare these groups with different attentional profiles across digital and non-digital contexts. There is also need to examine qualitatively the nature of visual attention where a difference has been found. For example, what are the targets of longest fixations when solving the problem with GeoGebra and not? We also need additional data with different types of tasks. Perhaps some of the differences identified here are specific to the task used? Overall, this is just a beginning of a long journey.

Acknowledgment

This research was funded by the Academy of Finland grant no. 297856 (MathTrack -project).

References

- Andrá, C., Lindström, P., Arzarello, F., Holmqvist, K., Robutti, O., & Sabena, C. (2015). Reading mathematics representations: An eye-tracking study. *International Journal of Science and Mathematics Education*, 13(2), 237-259.
- Arzarello, F., Paola, D. Robutti, O., & Sabena, C. (2009). Gestures as semiotic resources in the mathematics classroom. *Educational Studies in Mathematics*, 70(2), 97–109.

- Chan, K. K., & Leung, S. W. (2014). Dynamic geometry software improves mathematical achievement: Systematic review and meta-analysis. *Journal of Educational Computing Research*, 51(3), 311-325.
- Chauhan, S. (2017). A meta-analysis of the impact of technology on learning effectiveness of elementary students. *Computers & Education*, 105, 14-30.
- Christou, C., Mousoulides, N., Pittalis, M., & Pitta-Pantazi, D. (2005). Problem solving and problem posing in a dynamic geometry environment. *The Mathematics Enthusiast*, 2(2), 125-143.
- Haataja, E., Garcia Moreno-Esteva, E., Toivanen, M., & Hannula, M. S. (2018). Teacher's gaze behavior when scaffolding peer interaction and mathematical thinking during collaborative problem-solving activity. In E. Bergqvist, M. Österholm, C. Granberg, & L. Sumpter (Eds.), *Proceedings of the 42nd Conference of the International Group for the Psychology of Mathematics Education* (Vol. 2, pp. 475-482). Umeå, Sweden: PME.
- Haataja, E., Salonen, V., Laine, A., Toivanen, M., & Hannula, M. S. (Forthcoming). Teacher-student eye contacts during whole-class instructions and small-group scaffolding: A case study with multiple mobile gaze trackers. To appear in the proceedings of CERME 11.
- Hannula, M. S. 2006. Motivation in mathematics: Goals reflected in emotions. *Educational Studies in Mathematics* 63(2), 165–178
- Hartmann, M. & Fischer, M. H. Exploring the numerical mind by eye-tracking: A special issue. (2016) *Psychological Research* 80(3), 325–333. <https://doi.org/10.1007/s00426-016-0759-0>
- Healy, L., & Hoyles, C. (2002). Software tools for geometrical problem solving: Potentials and pitfalls. *International Journal of Computers for Mathematical Learning*, 6(3), 235-256.
- Garcia Moreno-Esteva, E. & Hannula, M. S. (2015). Using gaze tracking technology to study student visual attention during teacher's presentation on board. In K. Krainer, & N. Vondrová, (Eds.). *Proceedings of the Ninth Congress of the European Society for Research in Mathematics Education (CERME 9, February 4 – 8, 2015)*, (pp. 1393-1399). Prague, Czech Republic: Charles University in Prague, Faculty of Education and ERME
- Glöckner, A., & Herbold, A. K. (2011). An eye-tracking study on information processing in risky decisions: Evidence for compensatory strategies based on automatic processes. *Journal of Behavioral Decision Making*, 24(1), 71-98.
- Lin, J. J. H., & Lin, S. S. J. (2014). Tracking eye movements when solving geometry problems with handwriting devices. *Journal of Eye Movement Research*, 7(1), 1-15.
- Rayner, K. (1998). Eye movements in reading and information processing: 20 years of research. *Psychological Bulletin*, 124(3), 372.
- Singer, L. M., & Alexander, P. A. (2017). Reading on paper and digitally: What the past decades of empirical research reveal. *Review of Educational Research*, 87(6), 1007–1041.
- Toivanen, M., Lukander, K., & Puolamäki, K. (2017). Probabilistic approach to robust wearable gaze tracking. *Journal of Eye Movement Research*, 10(4). DOI: 10.16910/jemr.10.4.2

An Exploration of the effect of Bray's Activity Design Heuristics on Students' Learning of Transformation Geometry

Aoife Harrison, [Aibhín Bray](mailto:aharrison@mountanville.ie) and Brendan Tangney

Trinity College Dublin, The University of Dublin, Ireland; aharrison@mountanville.ie,
brayai@tcd.ie, tangney@tcd.ie

Keywords: transformation geometry, contextual mathematics, technology-mediated, active learning.

Introduction

The Irish Mathematics Curriculum, Project Maths, which was introduced into all post-primary schools on a phased basis from 2010, aligns with the core principles that underpin the Programme for International Student Assessment (PISA) mathematical framework (Merriman, Shiel, Perkins, & Cosgrove, 2014). However, there is evidence to suggest that teachers have been slow to move to the more constructivist teaching and assessment style required by the new curriculum (Jeffes et al., 2013; Merriman et al., 2014). In particular, in comparison to other participating countries, students in Ireland performed relatively poorly on the transformation geometry items in the PISA tests in 2003 and 2012.

One approach that has been proposed to address this issue is the use of Bray's Heuristics (Bray, 2016); a set of guidelines for designing technology-mediated, cross-curricular, collaborative and contextual mathematics learning activities. The theoretical framework that underpins Bray's Design Heuristics combines Realistic Mathematics Education (RME) and a particular constructivist model of 21st Century teaching and learning – Bridge21 (www.bridge21.ie). Participation in activities of this kind have been shown to have a positive effect on students' conceptual understanding and engagement with mathematics (Bray, 2016; Tangney, Boran, Knox, & Bray, 2018). The research presented in this paper extends previous work by focusing on student attainment in exam-type questions, asking: How might participation in a transformational geometry activity created using Bray's Design Heuristics, help participants to achieve higher levels of attainment in the topic?

The Activity

Following a number of classroom-based, technology-mediated, exploratory activities designed to provide students with a foundation in basic transformational geometry concepts, participants were presented with a laminated orienteering map of the school campus overlaid with a square grid. An orienteering circuit with 5 bases, each labelled as a set of coordinates from A to E, was set up on the school grounds, with QR codes fixed at each base. Scanning each QR code generated the geometrical transformation required to locate the next base.

The class group was divided into five teams of 4/5 students. Each team was given a card with the coordinates of their team's starting point (e.g. A (-3,5)). Teams were timed from the moment they began to discuss the location of their starting base on the map. The teams dispersed in different directions to locate their first QR code. In order to scan the codes and receive the geometrical transformation, students used a built-in feature of the Snapchat app, which they had on their mobile phones. The geometrical calculations, needed to navigate to the next location, involved Axial

Symmetry, Central Symmetry and Translations and were carried out by the students using white board markers on the laminated maps of their school grounds.

Methodology

The results presented in this paper focus on the quantitative aspect of the overarching exploratory study, exploring changes in attainment in written exams pre- and post-intervention. Participants in this research were 63 students, aged 14-15. The treatment group consisted of one class ($n = 22$) of students and the control group was made up of two classes ($n = 41$) graded at the same level of mathematical ability. The first author was mathematics teacher to the students in the treatment group, and the control group classes were taught by two other mathematics teachers within the school. The transformation geometry module was presented as outlined above to the treatment group while the control group were taught in a traditional, classroom-based fashion. The module took place in 10 x 40-minute single class periods over two weeks, within the normal school timetable. In an attempt to ascertain the impact of the learning experience on the students' ability to apply their knowledge of transformation geometry, the treatment and control cohorts sat the same written exam at the end of the module. This exam consisted of five exam questions, focused on transformation geometry, drawn from past papers of the state examination that Irish students sit at the end of grade 10.

Results

Average scores of the treatment group were 3% lower than the control groups in a pre-intervention, mid-year exam whereas in the post-intervention exam their results were 9% higher than those of the control group (Treatment: $M = 71\%$, $SD = 18$; Control: $M = 62\%$, $SD = 15$). Results of a one-tailed independent samples t -test indicated a statistically significant difference in performance between the participants in the treatment group and the control group ($t(61) = 2.021$, $p = .029$, one-tailed).

Conclusion

This paper provides a small sample of the results of a more significant exploratory study into the possible effects of participation in collaborative, technology-mediated, active learning experiences. The quantitative results described here are limited but have furthered the development of the hypothesis that this approach to activity design has the potential to positively impact on student learning in mathematics in general, and in transformation geometry in particular.

References

- Bray, A. (2016). *Collaborative, Contextual, and Technology-Mediated Mathematics Learning Activities: Design Heuristics and Effects on Student Engagement*. (PhD), Trinity College Dublin, the University of Dublin, Dublin.
- Jeffes, J., Jones, E., Wilson, M., Lamont, E., Straw, S., Wheeler, R., & Dawson, A. (2013). *Research into the impact of Project Maths on student achievement, learning and motivation: final report*. Retrieved from Slough:
- Merriman, B., Shiel, G., Perkins, R., & Cosgrove, J. (2014). *Project Maths and PISA: Comparing the coverage of PISA mathematics items by the Project Maths and pre-Project Maths curricula*.
- Tangney, B., Boran, I., Knox, T., & Bray, A. (2018). Constructionist STEM Activities Using the Bridge21 Model. *Constructionism 2018 - Constructionism, Computational Thinking and Educational Innovation: conference proceedings*, 438-448.

Didactical resource purposes as an aspect of students' decision making regarding resources used to learn mathematics

Eivind Hillesund¹

University of Agder, Norway; eivind.hillesund@uia.no

Keywords: Resources, documentational approach to didactics, university mathematics.

Link to poster: <https://drive.google.com/open?id=1T4MJccfGPJBrQASWcav8BXB7KryYBqdQ>

Introduction

In my ongoing PhD project, I investigate first year engineering students' use of resources to learn mathematics. The project focuses on resource use from a student-centered perspective. Rather than focusing on any particular resources, I look at the use of resources as whole. In my data collection, I aimed to uncover all the resources the students used to learn mathematics, some of their strategies for how to use them, how the strategies evolved over time and what factors influenced which resources they used and how at any given time. I later added students' decision making to my focus based on its prevalence in the collected data. For the poster, I restrict myself one of the themes I uncovered in my thematic analysis of interview data, which I have named didactical resource purposes (DRPs).

Based on a literature review of leading journals in mathematics education, going back to 2010, there are very few studies about resources at university level, with a broad focus and a student-centered perspective. The few that exist (i.e. Gueudet & Pepin, 2016), still cover different aspects of the resource use than I do. Hence, my data is more relevant to didactical resource purposes.

Theoretical framework

I use the documentational approach to didactics (DAD) by Gueudet and Trouche (2009) as my theoretical framework. It is focused on how teachers use resources, both for teaching and professional development. Trouche and Pepin (2014) argue that the documentational approach may also be used to look at students' learning and suggest university mathematics as a good place to experiment with the approach. I hope my research can help expand upon the documentational approach to include perspectives on how students use resources to learn mathematics. I use an inductive approach with a deductive component. After identifying themes, I consider whether it can be related to an aspect of the documentational approach. I derived the term 'didactical resource purpose', from DAD's view that a resource has a material component, a mathematical component and a didactical component. The didactical component of a resource is tied to the organization of activity. DRPs can be considered phases of learning that structure students' use of resources.

Methodology

The study involves nine students from introductory mathematics courses for engineers at three different universities in Norway (here called Alpha, Beta and Charlie). The universities were chosen on the basis of courses that I considered having a different focus (Alpha on material resources, Beta on digital resources and Charlie on social resources). Beyond that, I used convenience sampling. All volunteers from each course were accepted (4 from Alpha, 2 from Beta and 3 from Charlie). They

were interviewed three times, near the beginning middle and end of the semester. The interviews were semi-structured, starting with open questions (i.e. “can you say a bit about how you use resources to learn mathematics”) and moving on to more specific questions (i.e. how many do you usually study with when you study with fellow students). I analyzed the interviews using a thematic analysis approach (Braun & Clarke, 2006), including open coding; test of intercoder reliability; creating themes; reviewing themes; and then naming and defining them. While codes were numerous and often quite specific, themes were fewer and more general. When identifying themes, I took care to count the number of statements from each student that related to the theme and keep track of the extent to which these statements were in response to open or narrow questions. I also compiled a list of related quotes. Both numbers and quotes related to each DRP feature in the poster.

Results

The didactical resource purposes I identified in my analysis can be considered phases of the students’ learning process. Each DRP related to statements from at least seven out of the nine students:

- Introduction. Some resources were commonly used for students’ first encounter with mathematical topics, including lectures, textbook and lecture videos.
- Practice. After introduction, students work mathematically, mostly using resources emphasized in the courses. The textbooks and learning platforms were used to find exercises and calculator, pencil and paper and fellow students were employed to solve them. At University Beta, the program MyMathLabs was used to find and solve exercises.
- Evaluation. Students often checked whether their answers were correct or their work processes were constructive. Resources included answers in the textbook, Wolfram Alpha, GeoGebra, and discussion with fellow students, the lecturer or a parent.
- Explanation. After introduction, during practice or after evaluation, students would look for elaborations on the topic at hand to solidify their understanding or ‘fill gaps’. This process involved a more active search for information than introduction did. Resources for this included textbook, fellow students, student assistants, lecturer, parent, Google, lecture videos, YouTube, Khan Academy, course pages and worked examples in MyMathLabs.

Literature

Braun, V., & Clarke, V. (2006). Using thematic analysis in psychology. *Qualitative research in psychology*, 3(2), 77–101.

Gueudet, G., & Pepin, B. (2016). Students’ work in mathematics and resources mediation at entry to university. In E. Nardi, C. Winsløw, & T. Hausberger (Eds.), *PROCEEDINGS of INDRUM 2016 First conference of the International Network for Didactic Research in University Mathematics* (pp. 444–453). Montpellier, France: Université de Montpellier.

Gueudet, G., & Trouche, L. (2009). Towards new documentation systems for mathematics teachers?. *Educational Studies in Mathematics*, 71(3), 199–218.

Trouche, L., & Pepin, B. (2014). From instrumental to documentational approach: towards a holistic perspective of teachers’ resource systems in higher education. *Research in Mathematics Education*, 16(2), 156–160.

Guidelines for design of didactic sequences utilizing dynamic geometry affordances related to mathematical reasoning competency

Ingi Heinesen Højsted

Aarhus University, Danish School of Education, Denmark; ingi@edu.au.dk

Keywords: Dynamic geometry environments, reasoning competency, research-based guidelines.

Identifying guidelines for fruitful teaching with technology in mathematics education is an important research objective. However, technology, such as dynamic geometry environments (DGE), can be used for different purposes. Therefore, to make sense of guidelines for teaching with DGE, it is necessary to clarify the mathematical aim of the teaching. To this end, the notion of mathematical competencies (Niss & Jensen, 2011), which includes the reasoning competency (RC), can be used. Research on DGE affordances has found potentials regarding development of students' mathematical reasoning (e.g. Leung, 2015), which is promising, because students' inadequate abilities in reasoning is well documented (e.g. Hoyles & Healy, 2007). However, students' accessibility to DGE, does not guarantee greater learning outcome. The manner in which the DGE is used is essential (Jones, 2005). Therefore, to support the utilization of the potentials of DGE regarding RC, it is important to investigate: which research-based guidelines may be formulated for using DGE to support students' development of RC?

An extensive review was conducted using the hermeneutic circle approach (Boell & Cecez-Kecmanovic, 2014), to map out potentials of DGE described in the literature. Initial searches were made with search words such as "dynamic geometry", "geometry software", "geometry technology", "interactive geometry" and "proof", "reasoning", "conjecture" in MathEduc and ERIC databases, as well as reading CERME technology TWG proceedings. After reading literature acquired from the primary search, interesting references were followed and if suitable, added to review. In addition, after reading and gaining some insight into the area of interest, adjusted search words were used in new searches. 136 publications were included. The definition of the RC played a decisive role in the review process. It influenced the choice of search words and was the optic used to decide which DGE potentials described in the literature were deemed relevant for this study.

In synthesizing the review findings, three categories of guidelines were identified: students' cognition, task design and teaching practices. The guidelines emerge from the utilization of four types of DGE affordances: feedback, dragging, measuring and trace. Theoretical constructs from two predominant theoretical frameworks, the instrumental approach (Artigue, 2002) and the Theory of Semiotic Mediation (Bartolini-Bussi & Mariotti, 2008), were found to be suitable in the design of guidelines. Specifically, the notion of semiotic potential is useful in the consideration of what dimensions guidelines might entail. Furthermore, a description can be made of the instrumented techniques to be appropriated along with the utilization schemes needed. The role of the teacher can be described in supporting the mediated signs of the students towards mathematical meanings in order to support their development of RC. The guidelines are considered a priori in an ongoing project, in which the next step is to implement them in practice and refine them through a design-based research approach. To illustrate, table 1 below shows a segment from the a priori guidelines.

Instrumented techniques	Utilization schemes	Tasks	Teacher's role	Reasoning competency
Constructing direct invariants, which induce indirect invariants because of Euclidean theory.	Understanding the difference between direct and indirect invariants, and the connection between them.	Construction tasks with direct invariants, where dragging free points in the construction unveils (surprising) indirect invariants.	Instruction, discussion and feedback: focus on mathematical meanings - Address that direct invariants can induce indirect invariants because of Euclidian geometry governing the environment.	Prerequisite for working on conjecturing tasks. Some initial conjecturing tasks.

Table 1: Example from a priori guidelines

References

- Artigue, M. (2002). Learning mathematics in a CAS environment: The genesis of a reflection about instrumentation and the dialectics between technical and conceptual work. *International Journal of Computers for Mathematical Learning*, 7(3), 245–274.
- Bartolini Bussi, M. G., & Mariotti, M. A. (2008). Semiotic mediation in the mathematics classroom: Artifacts and signs after a Vygotskian perspective. In L. English, M. Bartolini Bussi, G. Jones, R. Lesh, & D. Tirosh (Eds.), *Handbook of international research in mathematics education, second revised edition* (pp. 746–805). Mahwah: Lawrence Erlbaum.
- Boell, S. K. & Cecez-Kecmanovic, D. (2014) A hermeneutic approach for conducting literature reviews and literature searches. *Communications of the Association for Information Systems*. Vol. 34, Article 12. Available at: <http://aisel.aisnet.org/cais/vol34/iss1/12>
- Hoyles, C. & Healy, L. (2007). Curriculum change and geometrical reasoning. In P. Boero (Ed.) *Theorems in school: From history, epistemology and cognition to classroom practice* (pp. 81–115). Rotterdam: Sense Publishers.
- Jones, K. (2005) Research on the use of dynamic geometry software: Implications for the classroom. In: J. Edwards & D. Wright (Eds.), *Integrating ICT into the Mathematics Classroom* (pp. 27–29). Derby: Association of Teachers of Mathematics.
- Leung A. (2015). Discernment and reasoning in dynamic geometry environments. In Cho S. (Ed.) *Selected regular lectures from the 12th international congress on mathematical education* (pp. 451-469). Cham: Springer.
- Niss, M. & Højgaard, T. (Eds.). (2011). *Competencies and mathematical learning - Ideas and inspiration for the development of mathematics teaching and learning in Denmark*. English edition, October 2011 Roskilde University. Roskilde. Retrieved March 13th, 2018 from https://pure.au.dk/ws/files/41669781/THJ11_MN_KOM_in_english.pdf

Issues in modelling terms involving subtraction in a manipulative environment for linear equations—and a possible solution

Thomas Janßen, David Reid & Angelika Bikner-Ahsbahs

University of Bremen, Germany; janssent@uni-bremen.de

In this paper, we present and utilize theories about interface design and didactical models to evaluate how existing manipulatives models for linear equations represent terms involving subtraction. We then outline a redesign of subtraction zones for algebra tiles that can be implemented on a screen. The presented work is intended to serve as an example case for theory-guided design of digital or digitally enhanced didactical models, anticipating the all-important learning activities with the resulting models.

Keywords: Equations (mathematics), educational technology, instructional systems, instructional design, design requirements.

Introduction: Manipulatives environments for linear equations

To help students understand equations and how to solve them, different tangible models are in use. Each consists of material objects or manipulatives (standing for numbers and variables) and an environment that specifies the relationship between the variables and numbers represented by the manipulatives placed in the environment. Probably the best-known model is the balance scale, where known and unknown weights on both sides of a scale are supposed to be kept in balance. Another model uses two sets of objects, some hidden in containers. The two sets are stated to have equal numbers of objects and the equation is framed as a puzzle, to find the number of hidden objects. Affolter et al. (2003) have used matches in matchboxes, Radford and Grenier (1996, p. 184) cards in envelopes. In this model the equality, which had a physical parallel in the balance model, is an abstract social convention. A further abstraction is made when *algebra tiles* (or blocks) are used. Known quantities are represented by squares (or cubes) and unknowns by oblong rectangles (cuboids). They are placed on a mat divided into two sides and students are informed that the amount represented by the tiles on the left side is the same as that on the right side. This model was developed because it is applicable to manipulating quadratic expressions, but has since also been used for linear equations.

We are involved in a research project with the goal of developing an “intelligent” system of algebra tiles with the ability to give feedback to its users (Reinschlüssel et al., 2018). The algebra tiles model was chosen because it can be used as the concepts of algebra are developed further; avoiding the need to introduce a new model for manipulating quadratic expressions, etc. Furthermore, the model allows the representation of terms involving subtraction (such as “ $x - 3$ ”) differently from additive terms involving negative values (“ $x + (-3)$ ”). In the design process, however, shortcomings in the representation of subtraction in the algebra tiles environment became apparent, offering a chance to reconsider its design. The considerations guiding this redesign, specifically describing how a concrete model can sensibly represent equations involving subtraction, are the focus of this theoretical paper.

Theories on (educational) interface design as well as experiences from early design cycles are used to answer the following research questions:

- What are the specific disadvantages of the ways different models represent subtraction?
- How can subtraction be represented in a way that preserves advantages of existing designs but avoids the identified problems?

Line of argumentation

This paper aims to advance the understanding of the design of technology for teaching and learning mathematics. For a theoretically informed discussion of the two questions, approaches from human-computer interaction studies and mathematics education are introduced and set into relation with each other. The subsequent section probes existing models' representation of subtraction. We argue that there are advantages in representing subtraction as in the algebra tiles model but that there are certain specific shortcomings. We show how these shortcomings can be addressed in a screen-based redesign of the algebra tiles model. The discussion will be used to highlight the relevance of the presented work for the design of digital or digitally enhanced didactical models and to point out possibilities how activities can be designed around the layout that we claim solves the identified problems.

State of the art and existing theoretical approaches

There has been little rigorous research regarding the representation of subtraction in manipulative models for equations (see Vlassis, 2002). Thus, it is all the more advisable to take notice of the rich theory around (educational) interface design in general.

Goguen (1999) builds his theory for user interface design on the claim that “user interfaces are representations, that their quality is determined by what they preserve, and that this can be an effective basis for design” (p. 243). To investigate the quality of user interfaces, Goguen defines and investigates *mappings* between *sign systems*, indicating the possibility for mathematics educators to do so for the representation of a given mathematical sign system (such as linear equations) through a certain manipulative environment (such as algebra tiles).

The focus on mappings has been elaborated with regard to teaching models in mathematics education by English and Halford (1995), who name four principles of learning by analogy that can help to analyze (and to design) didactical models (pp. 100–102):

- Learners need to be able to understand the structural properties of the model.
- The mapping between model and concept to be learnt shall be unambiguous to the learners.
- The attributes of objects of the model that are relevant to the concept to be learnt form a cohesive conceptual structure—other attributes shall be designed to not disturb this structure.
- A model shall be applicable to a range of instances.

Taking up the language of mappings, Vlassis (2002), with regard to the balance scale model, goes so far as to claim that “the isomorphism between the object itself and the mathematical notions implied allows students to form a mental image of the operations that they have to apply” (p. 355). However, investigating and optimizing the characteristics of a model will not suffice, and claims that ascribe the success of material models to their alleged relationship to the mathematics to be learnt may be premature. English and Halford (1995) are very clear that a model “will fail miserably if the accompanying explanation is unclear” (p. 99). Gravemeijer (2011) criticizes denoting models as transparent on the grounds that it may suggest transparency to be a feature of the model, not taking

into account that instruction may nevertheless fail to offer students a help in seeing mathematical meaning beyond the mathematics they have already learnt. Meira (1998) argues that transparency should not be seen as an inherent feature of objects used in a model but as a *process* “mediated by unfolding activities and users’ participation in ongoing sociocultural practices” (p. 121). A model that properly illustrates the mathematics to be taught is nothing but a necessary first step.

These considerations let us return to Goguen’s work. With its reliance on semiotics it avoids the epistemological problem of what form of existence is ascribed a) to the representation and b) to the mathematics to be represented. Regarding the former, he writes: “what ‘really exists’ (in the sense of physics) are the photons coming off the screen; the structure that we see is our own construction” (Goguen, 1999, p. 271). Therefore, the models created “are definitely not adequate in certain respects, some known and some unknown” (p. 271). What is then needed in order to learn with such necessarily imperfect models is illuminated by a range of approaches in mathematics education that take learning processes with technology to be thought of—and therefore designed—as processes of semiotic mediation (Mariotti, 2002; cf. Meira, 2008; Duval, 2017).

In the subsequent discussion of existing models, we will follow Goguen’s view on interface design, focusing on the mappings between the interface and the mathematics to be represented, which both are taken as sign systems. This view makes our approach compatible with semiotic theories of learning that may later be helpful regarding learning processes around the designed model. Where appropriate, we enrich this approach by referring to the principles devised by English and Halford.

Discussion of existing manipulatives models representing subtraction

We are particularly interested here in the mapping between negative integers and the operation of subtraction in algebra, and negative tiles and various representations of subtraction in the algebra tile model. In algebra, numbers are distinct from operations, it is possible to subtract from an unknown quantity, it is possible to subtract negative integers, and it is possible to divide a term involving subtraction (i.e., $3x - 9$). Here we discuss ways in which these aspects of the sign system of algebra map onto aspects of the sign system of algebra tiles.

Representing subtraction only by action

The basic implementations of the balance scale and container models do not allow for terms involving subtraction as part of an equation. The only way students experience subtraction with these models is as an action carried out on one representation to produce an equivalent representation. One cannot represent $x - 3 = 6$, but one can represent $x + 3 = 6$, and then subtract three on both sides (i.e., $x + 3 - 3 = 6 - 3$). The subtraction on each side would not be represented by material objects, but by actions of taking away. Only the result of the subtraction, i.e. $x = 3$, is materially represented. Thus, the distinction between an operation (represented as an action) and a number (represented by objects) is preserved, but at the cost of not being able to represent subtraction from an unknown quantity. When progressing to equations that cannot be represented in this way, students are expected to accept that the rules that applied to positive numbers and variables connected by addition and multiplication similarly apply to terms including negative numbers and fractions, subtraction and division. Some students, however, may find this difficult. Vlassis (2002) found that students instructed with the balance scale model had problems as soon as subtraction and negative integers were present in

symbolic equations to be solved. She reasoned that “the negatives place the equation [...] on an abstract level. It is no longer possible to refer back to a concrete model or to arithmetic“ (p. 350).

Representing subtraction with objects that stand for negative integers

An alternative is to introduce objects that stand for negative integers and to define subtraction of positive integers as addition of negative integers. In some virtual implementations, the balance model is amended with “negative weights”, e.g. represented by helium balloons. Unbound by problems of physics, the algebra tiles model allows the introduction of opposite tiles for both the unit tiles and the variable tiles. However, what is then represented are *negative numbers* and *variables with an opposite sign*. All terms in the equations are still *added*. Subtraction from an unknown quantity like $x - 3 = 6$ can be represented (e.g., Balka & Boswell, 2006) but the distinction between operations and numbers is blurred. However, subtraction of negative integers is not possible in such a model, except by accepting a priori that this would mean addition. Hence it is clear that these models, as sign systems, do not involve elements that directly represent terms involving subtraction in linear equations.

Representing subtraction with a fixed subtraction zone above or below an addition zone

Many algebra tiles models introduce a “subtraction zone” to allow terms involving a subtraction (such as “ $x - 3$ ”) to be distinguished from additive terms involving negative values (“ $x + (-3)$ ”). Tiles representing subtracted terms are placed in the subtraction zone. In all models that we are aware of, the subtraction zone is placed below or above the addition zone (see examples in Fig. 1).

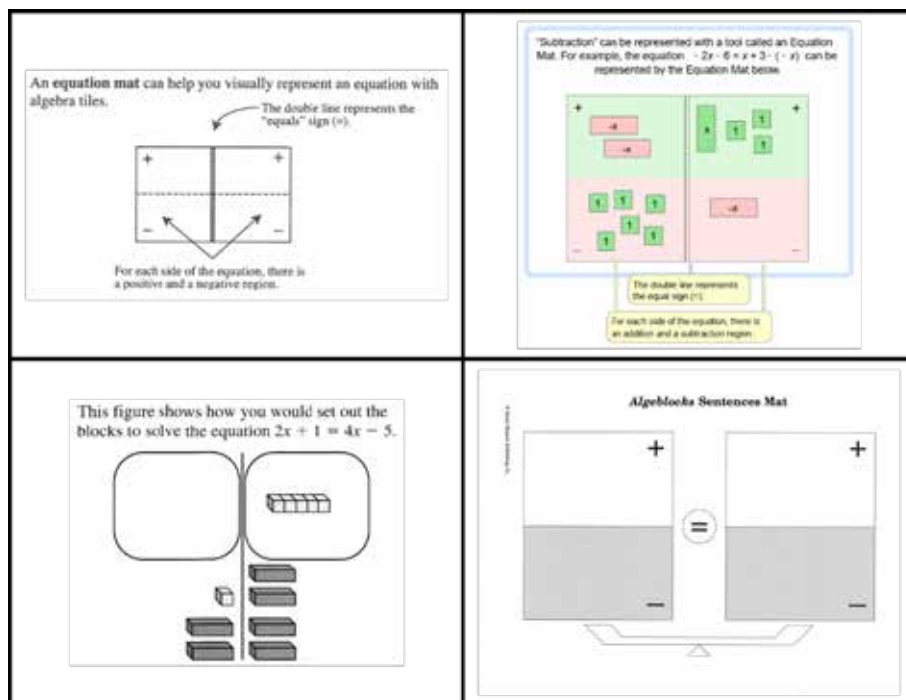


Figure 1: Layout of subtraction zones in different algebra tiles environments, clockwise from top left (disregard the texts): textbook *Algebra Connections* (Dietiker & Baldinger, 2006, p. 69), implemented in an applet under <https://technology.cpm.org/general/tiles/>; applet developed at the Freudenthal Institute (<https://app.dwo.nl/dwo/apps/player.html#202852>, step 8); Algeblocks® mat with an iconic scale; textbook *Algebra* by Wah & Picciotto (1994, p. 212) with so-called minus areas above.

The use of subtraction zones has the potential to provoke fruitful thoughts and discussions. For example, they can help illuminate the relationship between subtraction and negative integers: by placing representations of $a - b$ on both sides (i.e., a tiles in the addition zone and b tiles the subtraction zone), students can add b negative tiles to both zones on one side to make sense of the identity $a - b = a + (-b)$. The spatial juxtaposition of a zone for addition and one for subtraction highlights the basic concept of subtraction as comparison and may already be familiar to students from arithmetic (e.g., English & Halford, 1995, p. 157–159). According to Stacey, Helme, Archer, and Condon (2001), such familiarity with an idea from earlier studies can promote engagement with a model. However, there are still some shortcomings that shall be discussed in the following paragraphs.

First, subtracting a term that itself involves subtraction (e.g. $3 - (4 - x)$) and therefore discussing the rules of dealing with bracketed terms is not possible.

Second, the traditional design of the subtraction zone may lead to misunderstandings about division as an equivalent transformation. Dividing the expression on each side by the same number can be represented with algebra tiles in the last step by evenly assigning the number of unit tiles to the remaining unknown tiles (see Fig. 2). This suggests that as long as some tiles are in the subtraction zones, division is not possible. Unlike in the algebra sign system, it is not possible to divide a term like $2x - 6$ involving subtraction. As Goguen points out, not all aspects of the original sign system can and should always be represented in the sign system of the model. However, the limitation that an equation like $2x - 6 = 0$ can only be divided by 2 after it has been transformed into $2x = 6$ seems arbitrary—and can be avoided, as we will show later.

The remaining blocks (those that cannot be matched with blocks on the other side) can then be rearranged to make it easy to see the solution to the equation.

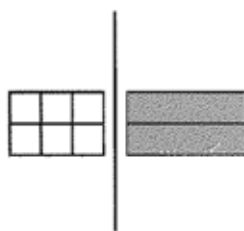


Figure 2: The equivalent transformation of division as even assignment of unit tiles to unknown tiles (Wah & Piciotto, 1994, p. 212).

Third, the primary distinction between left and right can become submerged. The designs of the environments shown in Figure 1 all visually distinguish between the vertical boundary (between the left and right side of the equation) and the horizontal boundary (between the addition zone and the subtraction zone on each side). However, an analysis of how well the first principle of English and Halford—clarity of the model—is met, shows some differences: In two of the models the vertical boundary is more marked (top left: double solid line vs. single dashed line, bottom right: gap vs. no gap, balance scale as framing image), corresponding to the primacy of separation of the sides of the

equation: However we parse the expressions on each side, it is their relation to each other as a whole that is most important (see Fig. 3). The bottom left model in Figure 1 highlights this by having only one real boundary that suggests two sides; the boundary of the subtraction zones seem to lie within their respective side. Only in the top right model some observers may find the continuously colored fields to suggest a stronger connection between the zones on both sides than within each side.

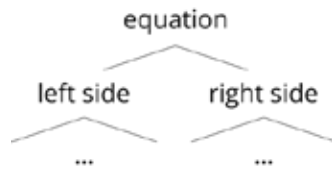


Figure 3: Structure tree for linear equations highlighting that any operation on each side of the equation should be less prominent than the distinction between the two sides

Addressing the shortcomings of existing models

In the design of Wah and Piciotto (1994, see Fig. 1, bottom left), the subtraction zone can be interpreted as lying within the addition zone on each side. When the environment is shown on a screen, one can start with the addition zone only and allow students to draw the subtraction zone whenever they need it, and to change its size and position as circumstances require. Furthermore, nested subtraction zones are possible, representing nested expressions (see Fig. 4, left). This can be helpful in modelling realistic situations without referring to learnt rules for subtracting negative integers at the outset. So for example, an equation like $3x - (3 - x) = 3$ can be modelled without using negative integers, which is desirable if the equation models a situation where all quantities are positive. The subtracted terms are eliminated by adding their equivalents to both sides, reinforcing the concept that subtraction and addition are inverse operations.

The possibility of drawing the subtraction zone anywhere also solves the problem of division. It is now possible by drawing the subtraction zone(s) in a way that allows setting up groups horizontally across addition and subtraction zones (see Fig. 4, right).

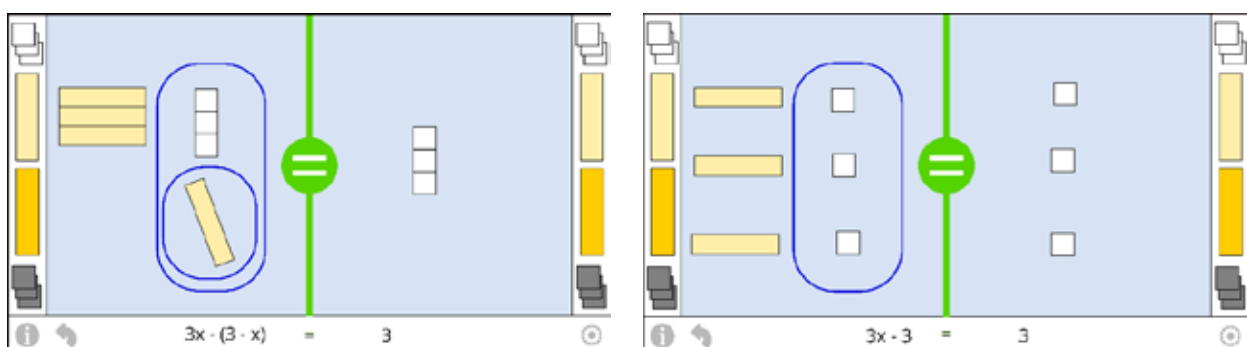


Figure 4: A flexible subtraction zone allows representing nested expressions (see left) and to arrange tiles so that the result of a division becomes perceptible ($x - 1 = 1$ is equivalent to $3x - 3 = 3$, see right).

Discussion and outlook

Quite regularly, instructional designs have such a long use history that it is hard to find their origins, let alone the thinking behind them. Their popularity and success may well be a result of the intuition of experienced teachers. However, as this paper shows, even models used in textbooks may have

significant shortcomings. The redesign of familiar models for new technologies offers a chance to reconsider their foundations: Are the models the best way to represent the mathematics we want students to become aware of? This paper presents a set of theoretical ideas that have helped us to identify problems with how subtraction is modelled in different manipulative environments. Moreover, we do not only highlight shortcomings; the theories presented here positively offer a methodology to think of better designs. This theoretical analysis complements the experience and intuition that have guided the development of models hitherto. We understand mathematical knowledge to be learnt, and models to be designed, as sign systems that need to be linked by a mapping with certain qualities that preserve important aspects of the mathematics. Considering these qualities gives us a way to argue why a certain design should be preferred over a traditional approach.

A well-designed model is nothing but a necessary first step. As noted above, no model is transparent; like any sign system it must be interpreted. Moreover, as Goguen notes, the mapping from one sign system to another cannot be one-to-one, something must be lost. Both the learning *of* the model and learning *from* the model must be facilitated. We diagram this situation in Fig. 5.

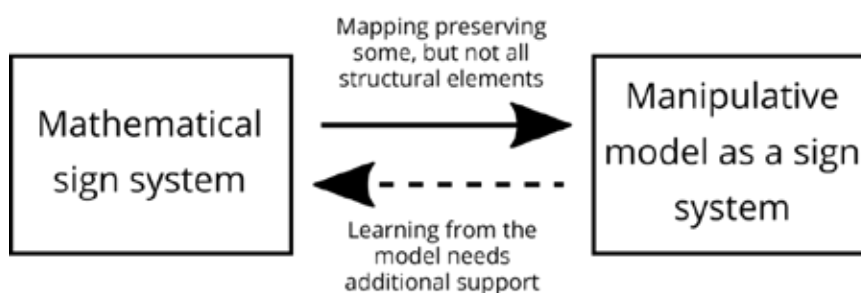


Figure 5: The mathematical sign system (here: linear equations) is mapped to the model sign system (here: the algebra tiles model) in an incomplete manner, necessitating additional support.

To support learning with a model sensible instructional approaches need also to be designed. The focus of this paper does not allow us to go beyond some suggestions: The algebra tiles model can and should first be used without negative tiles or subtraction zones to introduce the initial equivalent transformations (subtracting and dividing). In this way, confusion about the meaning of subtraction zones is avoided as long as they are not needed (see third principle of learning by analogy quoted above). The need to represent equations including terms involving subtraction may then come from a problem situation that is modelled, in which something must be taken away from an unknown quantity. Representing the not-yet-possible subtraction as a set of tiles in a subtraction zone can make a link between the well-established concept of subtraction as taking away and the concept of subtraction as comparison. As can be seen from these suggestions for teaching practice, the application of theories in this paper has the potential to be followed upon by research that explores “how technology mediates knowledge and the consequences of mediation on the knowledge itself” (Trgalová, Clark-Wilson, & Weigand, 2018, p. 152).

Acknowledgment

The research reported on in this paper is part of the ongoing project “Multimodal Algebra lernen” (MAL), which is funded by the German Federal Ministry for Education and Research in the grant program “Erfahrbares Lernen” (experienceable learning) (grant number: 16SV7550K).

References

- Affolter, W., Beerli, G., Hurschler, H., Jaggi, B., Jundt, W., Krummenacher, R., . . . Wieland, G. (2003). *mathbu.ch 8. Mathematik im 8. Schuljahr für die Sekundarstufe I [Mathematics in grade 8 for secondary level I]*. Bern, Switzerland: Schulverlag blmv.
- Balka, D. S. & Boswell, L. (2006). *Working with algebra tiles: Grades 6–12*. Rowley, MA: Didax.
- Dietiker, L. & Baldinger, E. (2006). *Algebra connections*. Version 3.1. Sacramento, CA: CPM.
- Duval, R. (2017). *Teaching Mathematics with Semiotic Representations*. New York, NY: Springer.
- English, L. D. & Halford, G. S. (1995). *Mathematics education: Models and processes*. Mahwah, NJ: Lawrence Erlbaum Associates.
- Goguen, J. (1999). An introduction to algebraic semiotics, with application to user interface design. In G. Goos, J. Hartmanis, J. van Leeuwen, & C. L. Nehaniv (Eds.), *Lecture Notes in Computer Science. Computation for Metaphors, Analogy, and Agents* (pp. 242–291). Berlin, Germany: Springer.
- Gravemeijer, K. (2011). Learning mathematics: The problem of learning abstract knowledge. In J. M. Spector, M. D. Merrill, J. van Merriënboer, & M. P. Driscoll (Eds.), *Handbook of research on educational communications and technology* (3rd ed., pp. 545–549). New York, NY: Routledge.
- Mariotti, A. M. (2002). The influence of technological advances on students' mathematics learning. In L. D. English (Ed.), *Handbook of international research in mathematics education* (pp. 695–723). Mahwah, NJ: Lawrence Erlbaum Associates.
- Meira, L. (1998). Making sense of instructional devices: The emergence of transparency in mathematical activity. *Journal for Research in Mathematics Education*, 29(2), 121–142.
- Radford, L. & Grenier, M. (1996). On dialectical relationships between signs and algebraic ideas. In L. Puig & A. Gutiérrez (Eds.), *Proceedings of the 20th conference of the International Group for the Psychology of Mathematics Education* (Vol. 4, pp. 179–186).
- Reinschlüssel, A., Alexandrovsky, D., Döring, T., Kraft, A., Braukmüller, M., Janßen, T., ... Malaka, R. (2018). Multimodal algebra learning: From math manipulatives to tangible user interfaces. *i-com. Journal of Interactive Media* 17(3), 201–209.
- Stacey, K., Helme, S., Archer, S., & Condon, C. (2001). The effect of epistemic fidelity and accessibility on teaching with physical materials: A comparison of two models for teaching decimal numeration. *Educational Studies in Mathematics*, 47,(2) 199–221.
- Trgalová, J., Clark-Wilson, A., & Weigand, H.-G. (2018). Technology and resources in mathematics education. In T. Dreyfus, M. Artigue, D. Potari, S. Prediger, & K. Ruthven (Eds.), *Developing research in mathematics education: Twenty years of communication, cooperation, and collaboration in Europe* (pp. 142–161). Abingdon, UK: Routledge.
- Vlassis, J. (2002). The balance model: Hindrance or support for the solving of linear equations with one unknown. *Educational Studies in Mathematics*, 49(3), 341–359.
- Wah, A. & Picciotto, H. (1994). *Algebra: Themes, tools, concepts*. Mountain View, CA: Creative Publications.

Exploring with digital media to understand trigonometric functions through periodicity

Myrto Karavakou, Chronis Kynigos

Educational Technology Lab, P.P.P. Dep. School of Philosophy

National and Kapodistrian University of Athens myrtokrvk@math.uoa.gr; kynigos@ppp.uoa.gr;

Trigonometry consists of a multifaceted mathematical field whose fundamental concepts, sine and cosine, have many different representations, some of them approached throughout secondary education. Unfortunately, many of its aspects are taught individually, leading students to make isolated, unconnected meanings on them. This empirical study discusses an alternative view towards trigonometry, in an attempt to create connections among the different aspects, under the scope of one meaningful context; that of periodicity. The use of digital media enables the application of this unconventional proposal, through a set of specially designed activities. In this paper we present a brief description of the main study-in-progress, as well as the results gained by its first implementation to 9th- Grade students, in terms of their meaning making on trigonometric concepts.

Keywords: learning trigonometry, periodicity, digital tools, meaning making

Periodicity for meaning making in Trigonometry

Research on teaching and learning trigonometry has been given surprisingly little attention in relation to, say, algebra or calculus. Studies regarding this field show that students develop weak and narrow understandings on the fundamental concepts of sine and cosine. They also develop a fragmented, disconnected view of the various related representations, such as the triangle model, the unit circle model and Cartesian graphs (Weber, 2008; Gür, 2009; Moore, 2010; Demir & Heck, 2013). The problem is not unrelated to epistemological debate on the nature and functionality of trigonometry in mathematics. Newson and Randolph (1946) argue that the problem has its origins in the predominant definition of sine and cosine in terms of angles, something which they perceived as related to a narrow application of trigonometry. They compare this to the attempt to define arithmetic as the “science of money”, as it is based on one of its limited applications. They instead proposed defining trigonometry as the mathematical science concerned with the trigonometric functions, whose arguments may denote time, or any other magnitude, or just a real number without any connotation. Hirsch, Winhold and Nichols (1991) characterize traditional trigonometry instruction as “memorization of isolated facts and procedures” that is unable to support a robust understanding of the subject. They also suggest a shift in emphasis towards trigonometric functions themselves and their applications at modeling periodic phenomena. Weber (2008) stresses two additional important obstacles that students deal with when learning trigonometric functions: they are initially familiar to sine and cosine as algorithms of ratios within the right-triangle context rather than as procedures regarding any given angle. The right-triangle model consists of a restriction on perceiving any other representation of trigonometric functions, as no links are ever made to this initial approach. Further, trigonometric functions are typically among the first functions that students cannot evaluate directly by performing arithmetic operations; that makes them even more complicated in order to be deeply understood. The literature focus is thus two-fold. Firstly, on posing

the problems that reside in learning trigonometry as currently portrayed from an epistemology perspective mainly emphasizing the right-triangle sine and cosine constructs (Blackett & Tall, 1991; Breidenbach et al., 1992). Secondly on fostering one representation of trigonometric functions as more important over another, while proposing a certain type of exercises (Kendal and Stacey, 1997; Weber, 2008). A fresh alternative look towards this field is presented by Demir and Heck (2013) and focuses on promoting integrated understanding of trigonometric functions by connecting their three representations within a dynamic geometry environment. In this paper we address trigonometry as a field for generating meanings around periodic covariation placing it at the centre of pedagogical focus, in line with with Demir and Heck' s idea and Newson and Randolph's epistemological arguments. We follow on from prior research on the use of digital resources for students to develop understandings of periodicity through trigonometric functions (Gavrilis and Kynigos, 2006), but expand the idea of periodicity beyond the right-triangle context.

Design considerations

In our Lab, we have a history of employing two constructs which for us have been fundamental to the generation of new ideas to exploit various affordances of expressive digital media for mathematical meaning making (Kynigos, 2015). The first is that of 'restructuring' coined by Willensky and Papert in 2010, where the designer questions the existing structure and emphasis of a mathematics curriculum allowing for a fresh look for meaning making opportunities in new structures and perspectives of mathematical ideas, given the new expressivity affordances of digital media. The second is that of 'conceptual field' (Vergnaud, 2009), where these new structures are perceived as an integral part of re-configuring sets of closely related concepts, using a diverse but connected set of meaningful representations for these and creating a set of problem situations where these play a central role for their resolution. So, for us, periodicity was a central characteristic of a special kind of mathematical function such as sine-cosine and tangent connected to diverse representations and part of physical phenomena such as tide. Adopting this perspective, we perceived the design of the tasks we prepared for students under the scope of the conceptual field of periodicity. Into this field, notions of trigonometry, geometry, algebra and physics are linked together so as to strengthen their embedded meanings. Trigonometric functions can be approached through different situations within the meaningful context of periodic phenomena, where students have the opportunity to derive their properties and their actual value. Our assumption is that in that way, we enhance the meaning-making process on these concepts and their various representations within meaningful situations (Noss and Hoyles, 1996) and provide flexible connections between them, as they all share the feature of periodic nature. We saw our perspective and design principle as uniquely enabled by special digital simulations and microworlds which we developed for students to use as media for expressing mathematical ideas. Firstly, we used an available Dynamic Geometry System, Geogebra, to create a simulation of the periodic phenomenon of tide connected to the representation of both the graph of the trigonometric functions and the one of the unit circle that model the phenomenon. Then, we developed a programmable microworld with the MaLT2 tool, which integrates programming and dynamic manipulation of variable values (Kynigos and Zantzos, 2017), to provide opportunities for students to make connections between periodicity and trigonometry of angles through a code-editing task. Our aim was to shed light on what meanings of

the trigonometric field can be produced by students, who engage with the designed tasks around periodicity.

Research setting and tasks

The tasks designed for this study reflected the ideas described above. They were separated into two phases, each of which corresponded to different but complementary intentions by the designers. The first phase was related to the phenomenon of tide (in a non-realistic yet close to students' perception way) simulated in the dynamic environment of Geogebra in order to be modeled in any way possible by students. The second one was dealing with the periodic change of the vertical lines of a right triangle in the programmable media of MalT2, requiring correlation of periodic functions with the trigonometric ones and leading to formalization.

Modeling Periodic Phenomenon

We designed a model in Geogebra that visualizes the periodic rise and fall of sea levels according to the sinusoidal function $f(t)=\sin t$, where the variable t stands for the time passing in hours (Figure 1a). This phenomenon was simulated so that the sea would cover and uncover periodically the surface of an island. It could be observed by moving the cursor of the variable t till it reached the value of 30 hours and then it would start over. The initial task students would be challenged with was to make a schedule for future most suitable time for visits to the island; ones that would last the longest in order to collect its valuable shells. The final task was the construction of a math formula that would receive a value of any future time and export the exact height of the sea levels. The available digital tools were split into two representations which were given to students during the first phase along with a worksheet directing the above exploration process. The first one involved the "trace-leaving" point $M(t,y)$ available for dragging into a Cartesian system (Figure 1b). By following the height that corresponded to every time value, starting from 0 and moving forwards, the trace would form the sinusoidal graph. The second representation was that of the unit circle. Adopting the "wrapping function" model (Podbelsek, 1972), we made a cursor that enables the wrapping around the unit circle of a segment whose starting point is the $(1,0)$ and has the length of the exact same value as the time paused (Figure 1c). When the segment was fully wrapped, the stopping point's coordinates revealed the sine and cosine of that value as well as a corresponding arc/angle. The tasks required the specification of the relationship between time and the height of sea levels in order to find a convenient way to predict the island's uncovered surface at any future time. The particularity of this phase is the fact that the words sine or trigonometry were not mentioned anywhere so as for students to proceed to formalization.

Formalization of the Trigonometric Functions

The second phase interfered in order to "fill" the gaps that the first phase left uncovered; those are the formalization that the functions responsible for the periodic change are the trigonometric ones and their possible reference to angles or any other magnitude. For this matter, we designed an artefact in the programmable environment of MalT2. The code that produced the turtle's trace for this artefact was hidden from the students, whose task was to discover it and reproduce it. The only accessible source was the product of the code: the artefact that represented a right triangle (Figure 2) and the periodic changes of its shape while manipulating the value of its unique variable through

the uni-dimensional variation tool. An additional output that students had access to was the values of the length of every triangle's side. The relations that needed to be "unmasked" were the sinusoidal and cosinusoidal covariation between the visible variable t -that corresponded to a triangle's angle- and a triangle's vertical side.

Findings

The study described above was an educational intervention designed according to the methodology of "design experiments" (Collins et al., 2004). The focus was both on the meaning-making process by students and their interaction with the digital tools. Three small groups of 9th Grade students from a public Experimental School in Athens participated in a first implementation of this study. It took place in the pc-lab of the school during after-class mathematics courses for totally six teaching hours within two weeks.

Phase 1

All three groups engaged with the tasks described above generated rich meanings on the embedded concepts. We analyze below some representative dialogues that help us perceive aspects of this meaning making process.

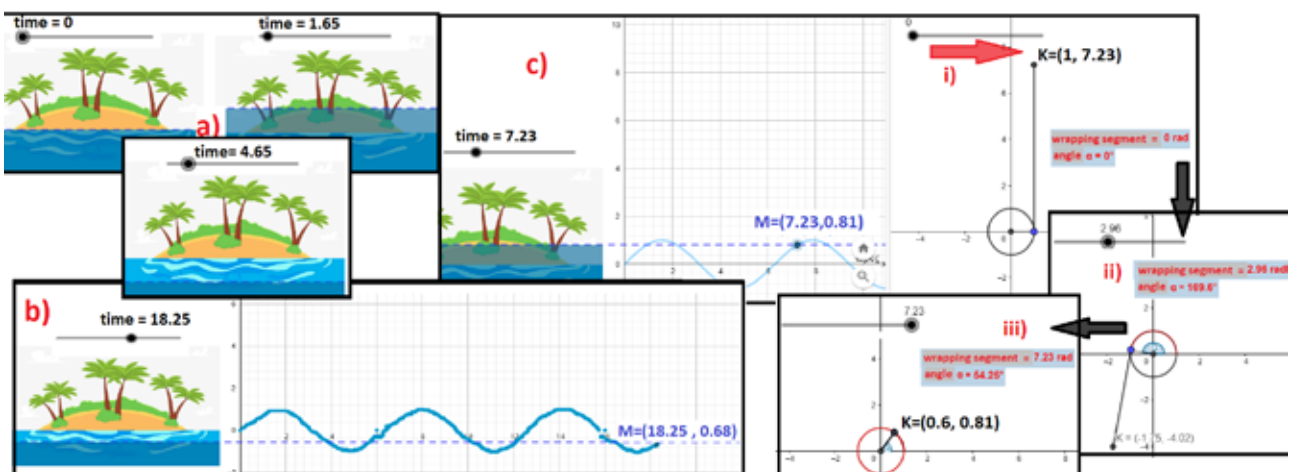


Figure 1: The phenomenon of tide and its two representations at Geogebra

At first, students studied the phenomenon of tide and the way it was affecting the represented island. While studying the simulation and the questions of the worksheet, they all followed a similar thinking flow, presented in this discussion:

Student 1: Well, we could say that the sea levels are going up and down in a steady rhythm. There is a highest and a lowest point the levels reach within a standard period of time; almost 6 hours? In order to predict it, we need to know the relation between time and height, but we don't know the function formula.

Student 2: The best time for visiting the island is when the height is at level 0 and goes downwards. This level is reached many times, maybe even infinite ones. But I can't say their exact value after the 30th hour. But I am sure there is a way to find out because there is a standard pattern. It's like a circle repeated endlessly.

In our understanding, these lines indicate a first approach of the trigonometric functions based on their periodic nature. Dragging the point M helped them express the relation between time and height until the 30th hour. That way they constructed the sinusoidal graph, which inspired them with ideas for predicting accurately the future evolving of the phenomenon:

- S1: The most suitable moments for visiting are at 3.14, 9.42 and 15.7 hours.
- S2: These numbers are odd multiples of 3.14. Therefore we can determine the most suitable for a visit future moments by computing as many multiples as we can. But I can't think of a way to determine the exact height level at any future time.

The graph provided them with the conception that the phenomenon follows a specific pattern defined by its period. What concerned them is the fact that they were unable to find a way to predict the exact correspondence between sea levels and any future time. This enlightenment came during their interaction with the second representation; that of the unit circle. By wrapping the segment - that equals with the time value- around the circle, students realized that the stopping point reveals the height of the sea levels by its ordinate. This procedure improved the way they perceived the periodic nature and led them to discover a convenient way for predicting the phenomenon at future time. They counted the times the segment was wrapped to a full circle and determined the height according to the wrapping of the remaining segment. A possible interpretation of this achievement is the fact that the circle model reminded them of a familiar concept; that of division.

- S4: We must find how many times this whole segment will be wrapping a whole circle. Let's divide it with 6.28.¹ The remainder gives the length of the segment that will determine the height.
- S5: Yeah, all we have to do is wrap the remainder value segment and see the ordinate of K where it stops. The remainder is always lower than 6.28. We can use that as a formula to predict the exact height of sea levels at any future time.

This realization came when they were asked to predict the height of the sea levels at the 300th hour since the beginning of the observation. That led them to the modeling of the phenomenon and the conquest of the wider challenge of the study. A strong link was thus established between the trigonometric function and the notions of periodicity and predictability. However the study is incomplete; no student made the connection between the trigonometric representations and trigonometry itself. As a result, the meanings they produced were rich in trigonometric features but, not surprisingly, they did not correspond to formal trigonometric labels.

Phase 2

As mentioned above, this phase aimed to establish links between periodic covariation and formalized trigonometry. Students started their exploration by manipulating the cursor and observing the changes happening to the triangle. The following parts of their conversation represent their initial thoughts and their completion:

¹ They had already pointed out that an exact circle is fully wrapped when $t=6.28$; thus its perimeter equals to 6.28.

S1: The things here that remain stable are a right angle and the length of the hypotenuse, which is always 100, no matter what value the (variable) t takes.

S2: Yes, except from 0. Oh, and 90. And 180, too. Bet it's 0 at every multiple of 90.

Students S1 and S2 were seeking for regularities in order to find the “unaffected” from the cursor’s movement magnitudes and start the code writing from these constants. Then, while trying to figure out the nature of the observing variation and decode it, many trigonometrically interesting things emerged:

S3: It’s weird because while one vertical side grows, the other one shortens. I think they grow with a steady rhythm. (...) It repeats itself after a period of time. Just like the sea levels did.

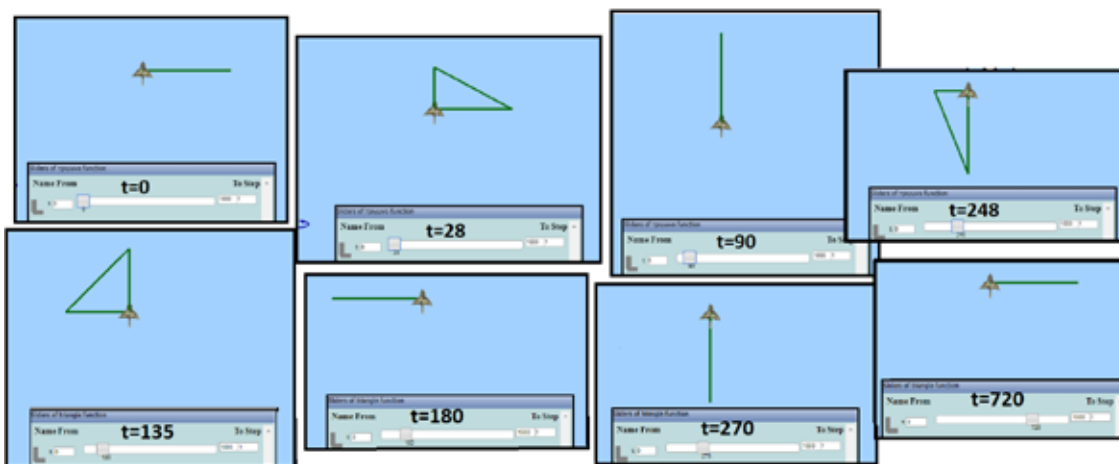


Figure 2: Manipulating the value of the variable t causes changes to the artefact

S1: In order to make a right triangle that remains right, we know that this angle is 90 degrees, so the other two must sum up to 180. Now, can we find the vertical sides based on these constant elements?

S2: Guys! What if we use the variable t as angle and not as length? That way we can find that side by the relation “sine t equals the ratio of the opposite side to the hypotenuse”. That way we find the opposite side!

S1: YEAH! Genius! We can do the same thing with the last side, but using cosine instead.

```

TO triangle :t
  fd 100*sin(:t) rt 90+:t fd 100 rt 180-:t
  fd 100*cos(:t) rt 90
END

triangle 30 |

```

Figure 3: The code producing the artefact made by the students

These students followed the right conceptual path in order to conceive the idea that led them to the interpretation of the artefact. Being familiar with the right triangle model, they easily discovered the

trigonometric relation by thinking of the variable t as an angle. Based on that realization, they managed to correspond each unknown element of the triangle to a functional relation with the known ones. Thus, considering sine and cosine as functions, they got to the discovery of the right code. (Figure 3)

Student S3 made a crucial comment on the completion of the meaning-making process; he realized the resemblance to the phenomenon of tide examined at the previous phase. After the discovery of the functional code, he completed his thought with an even more remarkable comment:

S3: Therefore sine and cosine are responsible for the growing and shortening of the segments. It depends on the angle; when an angle grows the one side, it shortens the other one with the same period. I think it's the first time I realize that.

He expressed the connection between trigonometry and periodicity, building a strong conceptual link between them. We found it quite interesting that he intuitively he connected variability in sine and cosine with segment length rather than angle. This signified the mental abstraction that trigonometric functions can be used in order to express periodic change of the value of a segment. As a result, the completion of this phase came along with the awareness that the value of trigonometric functions goes far beyond the right triangle model.

Conclusion

The students seemed to find periodicity as a familiar concept and to be able to think about functional relations and trigonometric functions to gradually see the mathematical underpinning of periodicity. The tasks allowed them to observe and to express trigonometric functions as elements representing periodicity. They first produced meanings on various trigonometric notions and afterwards they established links between them. They approached sine and cosine as functions and not as just numbers and they listed many of their properties based on their periodic nature. They finally realized that trigonometry is strongly connected with periodicity and thus it can be exploited for modeling periodic phenomena which are of great scientific importance. The role of the digital media was integral during the students' meaning making progress. They managed to interpret periodicity using trigonometric terms, thanks to their exploration with these digital tools. They provided an alternative dynamic and constructionist way to visualize, model and manipulate dynamically periodic situations. It is very difficult to represent periodicity in an alternative way open to exploration. So, this study indicates that it might be interesting to further research the potential of using digital representations of trigonometry so that some constituent elements can be understood through the fertile conceptual field of periodicity rather than the curriculum based focus on angles within a triangle. Maybe this could provide a solution to the constant problem of connectivity among trigonometric concepts and representations and, as a consequence, a promising proposal for learning trigonometry.

References

Blackett, N., & Tall, D. O. (1991). Gender and the versatile learning of trigonometry using computer software. In Furinghetti F. (Ed.) *Proceedings of the 15th Conference of the*

- International Group for the Psychology of Mathematics Education*, Vol. 1, 144–151. Assisi: PME.
- Breidenbach, D., Dubinsky, E., Hawks, J., & Nichols, D. (1992). Development of the process conception of function. *Educational Studies in Mathematics*, 23, 247–285.
- Collins, A., Joseph, D., & Bielaczyc, K. (2004). Design research: Theoretical and methodological issues. *The Journal of the learning sciences*, 13(1), 15–42.
- Demir, Ö., & Heck, A. (2013). A new learning trajectory for trigonometric functions. In Faggiano E. & Montone A. (Eds.), *Proceedings of the 11th international conference on technology in mathematics teaching*, 119–124. University of Bari, Bari.
- Dickson, M. M. (2000). *U.S. Patent No. 6,132,217*. Washington, DC: U.S. Patent and Trademark Office.
- Gur, H. (2009). Trigonometry Learning. *New Horizons in Education*, 57(1), 67–80.
- Hirsch, C. R., Weinhold, M., & Nichols, C. (1991). Trigonometry today. *Mathematics Teacher*, 84(2), 98–106.
- Kendal, M., & Stacey, K. (1997). Teaching trigonometry. *Vinculum*, 34(1), 4–8.
- Kynigos C., & Zantzou I. (2017). Constructing the shortest path on a cylindrical surface. In T. Dooley, & G. Gueudet (Eds.), *Proceedings of the Tenth Congress of the European Society for Research in Mathematics Education (CERME10, February 1-5, 2017)*, 2579–2586. Dublin, Ireland: DCU Institute of Education and ERME.
- Kynigos, C., & S. Gavriliš (2006). Constructing a sinusoidal periodic covariation. In J. Novotná, H. Moraová, M. Krátka, M. Stehliková (Eds.), *Proceedings of the 30th Conference of the International Group for the Psychology of Education*, 4, 9–16. Charles University, Faculty of Education, Prague.
- Kynigos, C. (2015) Constructionism: Theory of Learning or Theory of Design? In Sung Je Cho (Ed.), *Selected Regular Lectures from the 12th International Congress on Mathematical Education*, 417–438. Springer International Publishing Cham Heidelberg New York Dordrecht London, Switzerland 2015. DOI 10.1007/978-3-319-17187-6
- Moore, K. C. (2010). *The role of quantitative reasoning in precalculus students learning central concepts of trigonometry*. Arizona State University.
- Newson, C. V., & Randolph, J. F. (1946). Trigonometry without angles. *The Mathematics Teacher*, 39(2), 66–68.
- Noss, R., & Hoyles, C. (1996). *Windows on mathematical meanings: Learning cultures and computers* (Vol. 17). Kluwer Academic Publishers.
- Podbelsek, A. R. (1972). *A Study of Various Deductive Models for Developing and Teaching Plane Trigonometry Including an Investigation of the General Nature of Trigonometry* (Doctoral dissertation, University of Illinois at Urbana-Champaign).
- Vergnaud, G. (2009). The theory of conceptual fields. *Human development*, 52(2), 83–94.
- Weber, K., Knott, L., & Evitts, T. (2008). Teaching trigonometric functions: Lessons learned from research. *Mathematics teacher*, 102(2), 144–150.

Moving fingers and the density of rational numbers: An inclusive materialist approach to digital technology in the classroom

Doyen Kim¹ and Oh Nam Kwon¹

¹Seoul National University, Department of Mathematics Education, Seoul, South Korea;
dk0209mathed@snu.ac.kr, onkwon@snu.ac.kr

This study aims to examine the relationship between the body and the meaning-making process in mathematics classroom with digital technologies. We investigate a mathematical activity in which students explore the meaning of the concept 'density' of rational numbers with a multi-touch dynamic digital apparatus. A case of elementary school students is studied from the inclusive materialist perspective through microethnographic analysis. The result indicates that students' finger movements toward the digital apparatus played a critical role in developing the meaning of density throughout the activity.

Keywords: Touchpad, GeoGebra, Density, Body, Inclusive materialism.

Introduction

Contemporary digital technologies have become more 'body-friendly' (Sinclair, 2014) with the widespread adoption of haptic input devices. In a haptic technological environment - such as that with touchpad or touchscreen - users interact with technologies through more direct body movements compared to the keyboard-and-mouse environment, and hence a more powerful status is granted to the user's body. This change in the interaction asks the studies concerning the technologies in mathematics classrooms to include our body as one of the central interests (Ferrara, Faggiano, & Montone, 2017).

On this basis, this paper aims to examine the dynamic relationship between the body and the meaning-making process in mathematics classroom with digital technologies. We study a small group of grade 5 students exploring the meaning of density of rational numbers using multi-touch dynamic digital apparatus. We take the inclusive materialist perspective (de Freitas & Sinclair, 2014) to focus on the body movement in mathematical activity with digital technologies. Through a microethnographic analysis, we pay attention to the bodily movement toward the given technology and the development of meaning during the activity.

Our specific research question in this paper is as follows: *In a multi-touch dynamic digital technology environment, how does the meaning of the density of rational numbers evolve in relation to the students' body movements toward the technology?*

Theoretical framework: Inclusive materialism

Existing theoretical approaches

When theorizing the relation between the meaning-making process and technological environment in the mathematics classroom, two theoretical perspectives have been dominant in recent studies, namely the instrumental approach and the semiotic perspective (Drijvers, Kieran, & Mariotti, 2010). These two perspectives together seize the material, social and psychological nature of mathematical

activity with tools. Nevertheless, they do not leave much theoretical room to embrace the role which the body plays. The inclusive materialism, based on the new materialist ontology in which the physical and the mathematical reside on the same ontological realm, reexamine the role the material elements - including the body - play in mathematical activity. In recent years, the studies concerning the multi-touch digital technologies started to adopt this approach to investigate the relationship between the hand movement on touchscreen and mathematical thinking (e.g., de Freitas & Sinclair, 2017).

Inclusive materialism

Breaking with anthropo-centric views, the inclusive materialism argues that all human and non-human elements partake varying degrees of agency and power during a mathematical activity. Therefore, de Freitas and Sinclair (2014) redefine body so that the theory fuses the physical and psycho-social dimensions of the bodily interaction in mathematical activity. They expand the concept of the body and propose the body be "an assemblage of human and non-human components, always in the process of becoming " (p. 25). Here, the boundaries are flexible and porous, and agencies are distributed across the environment of the mathematical activity. By proposing such a comprehensive definition of the body, they suggest that we pay delicate attention to the matters and their material configuration - the physical bodies, utterance, artifacts, signs, representations, and their dynamic relationship - in mathematical activity.

What does the material configuration have to do with the meaning of a mathematical concept? The inclusive materialism takes an ontological turn by which mathematical meanings are not abstract or disembodied, but rather material and concrete. That is, the meaning of a concept is ontologically entangled with specific physical arrangements. In a mathematical activity constructing a circle with a compass, for instance, it is not the case that the compass is a disposable medium for some transcendental, determinate and a priori meaning of the concept 'circle'; instead the meaning of a circle is performed through the process where the circle and the compass are assembled. In other words, meanings emerge through mathematical activity and entail all the material specificity implicated in the activity.

In terms of research, the practical goal of the inclusive materialism lies in capturing the emergent and creative aspect of the meaning-making process. Drawing on the insights from the history of mathematical inventions, de Freitas and Sinclair (2014) deem *mobility* to be critical for such inventiveness. Moving mathematical objects or attending to how they are determined in terms of movement—rather than logically—configure the material elements in new ways. In short, movement actualizes the potential mobility of mathematical objects, creates a new material assemblage, and hence a new meaning as well. In that respect, the design of a mathematical activity should encourage learners to attend to the mobility of material elements and hence new senses that were previously imperceptible, instead of passively following the procedures which already seem possible or logical.

Figure 1: The initial setup of the activity



Research context and method

Participants and the activity

Participants involve a group of grade 5 students (age 10-11) in elementary schools at Seoul, South Korea. Through preliminary oral interview of a class (N=20), we selected four students in each school who had exhibited mid-level achievements in mathematics from the previous semester and, at the same time, displayed low-level understandings of the density in their responses to a questionnaire based on Vamvakoussi and Vosniadou (2007). This paper reports an episode of students A, B, C, D from one of the schools.

The activity is a game called 'point-and-name.' It was a part of a teaching experiment that the authors designed for students to explore the number line for the density of rational numbers using GeoGebra and spanned three lessons. In the beginning, on the screen was a horizontal line with three points on it, each named 0, 0.5, 1 respectively. On the background lied grid lines: In between two adjacent thick grid lines, four equidistant thin lines were placed and divided the space into five parts [Figure 1]. Students sat facing each other and were given touchpad keyboards that were connected simultaneously to a single GeoGebra environment on a shared monitor screen. Split into two teams (AB vs. CD) and taking turns, each team was asked to place a point anywhere on the line in between the two Xs on left and right; name it with a rational number in reference to the previously placed points and their names. To achieve the goal, students could move the points on the line horizontally, and zoom in and out. Once students zoom in, the gaps between the grid lines widen, and new grid lines appear filling the gap. The game ends when a team fails to place a point or give an appropriate name to their points. One of the researchers took the teacher's role only offering technical help.

Data collection and analysis

All three lessons were video recorded and transcribed. We conduct a microethnographic analysis (Streeck & Mehus, 2005) which is effective for the in-depth examination of the interplay among speech, gesture and artifacts in a mathematical activity (e.g., Nemirovsky, Kelton, & Rhodehamel, 2013).

Thereby, we pay particular attention to the following elements to understand the interaction between the learners' physical body and the digital apparatus: (a)the hand motion on touchpads, (b)the cursor movement on the screen, (c)the movement of screen itself (e.g. zooming in/out, panning), (d)the speech of students, (e)the hand gesture in the air. We must watch the hand motions on the touchpad since they are the primary means of manipulating the apparatus for students. The cursor and screen movements are also important for they embody the learner's attention and its shift. Furthermore, in a multi-touch digital technology environment, the gestures in the air are specifically important not only because they communicate meanings coupled with the speech but also they are part of a gestural continuum together with the gestures toward the haptic input device, preserving senses from one to the other (de Freitas & Sinclair, 2017).

On the cognitive side, Vamvakoussi and Vosniadou (2007) had identified various aspects of understanding of the density of rational numbers. Their result suggests that a critical cognitive action in developing the meaning of density is to find a smaller unit than the least common unit of numbers

in an interval in order to conceive a number with the smaller unit which would locate in somewhere 'in-between' the existing numbers (e.g., $\frac{3}{4}$ in the interval $(\frac{1}{2}, 1)$). Understanding that this action could be implemented in any interval of two rational numbers is considered as indicating a sophisticated development of the meaning of density.

Result and discussion

Our major findings are drawn from three notable sequences of the episode. As students carried out the activity through these sequences, the meaning of density had become more and more sophisticated. Each sequence is thematized by a significant development of the meaning of density that had come to the surface. We present each sequence through transcription or a brief depiction that highlights key events, then follow up by discussion.

Sequence 1: “You must follow the rules.”

Shortly after the beginning, students started to establish collectively a set of implicit rules of engagement (*First-rules*) and eventually all began to abide by them to play the game: **First-rule 1.** *A new point must be 0.5-away from an existing point and named accordingly; **First-rule 2.** *A new point must be placed on a thick grid line.* The highlight of the first sequence is presented below.*

- 1 C: (C drags his index finger to the left and then gently taps.) [C’s cursor moves to the left side of '0', and a point appears on the left side of the line.] [Figure 2 (a)]
- 2 D: Why are you putting it there?
- 3 C: You don’t like it?
- 4 D: No. You can’t just do this in whatever way you want.
- 5 C: Then, how?
- 6 D: You must follow the rules. See, it goes from 0 to 0.5, then to 1. What do you think will come next?
- 7 C: 1.5, it is. Let me throw this away. (C right-clicks with his middle finger) [C opens the menu on the point and deletes it.]
- 8 D: (D spread her index and middle fingers away on the touchpad, then double-taps the pad, and drags with her index finger to the right.) [The screen zooms in. The point appears on the line and is dragged right to the place where a thick grid line adjacent to '1' meets the line.] [Figure 2 (b)]
- 9 C: Now you name the point.
- 10 D: (D tabs and then types ‘1.5’) [The name ‘1.5’ appears above the point.] [Figure 2 (c)]

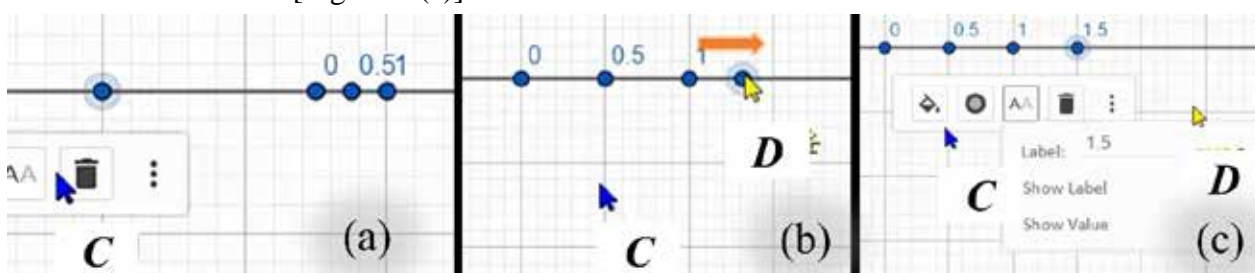


Figure 2: The establishment of First-rules

After Team CD pointed '1.5', A began to led Team AB' turn. A zoomed in, and '0.5' and '1.5' got off the thick grid line because of that. A started counting the number of thick grid lines - including newly appeared ones - between '1' and '1.5' with his cursor. After expressing confusion about how far they should zoom in, A zoomed out, coming back to the scale at which they were. Then A placed '2' on a thick grid line as far away as the distance between '1' and '1.5'. From then on, every new point ended up on a thick grid line, 0.5-away from the point either at far-right or far-left, subsequently producing '2.5', '3', '3.5' and so on [Figure 3].

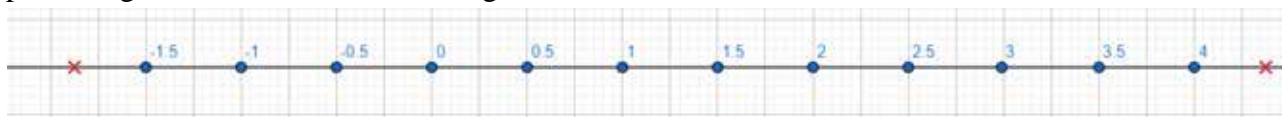


Figure 3: The screen capture at the end of Sequence 1

Although the students did not articulate the rules explicitly, we could infer the First-rules from their discourse and actions in this sequence. Line 6 and Line 10 are good examples where they defined the way the game should be played and complied. These rules suggest that 0.5, the least common unit of numbers given in the initial setup, remained indivisible to students and they did not conceive any smaller unit by which they could play the game. The multiples of 0.5 (e.g., 0, 0.5, 1.5) are treated as if they were successive.

We must note that these rules are neither given by the teacher nor randomly established by the students. Rather, they resulted from the structure consisted of the salient perceptual features of the initial technological terrain: the three points on the line with names '0', '0.5', '1'; evenly distanced from each other; all aligned with the thick grid lines [Figure 1]. This regulation was not included in the instructions from the teacher. Students could have laid their point anywhere in between the Xs and claim its legitimacy by naming it with a proper rational-number. Instead, their attention was captivated by the given structure and, as a result, their subsequent practice began to adapt to it. Although Team AB had zoomed in and thus had a better chance to place their point in between the existing points, they were only *looking closely* at the line to measure the distance between 1 and 1.5. Instead, having their attention fixed only at the thick grid lines, they failed to obtain the measure they wanted since 1.5 was not on one of the thick grid lines. Eventually, they zoomed out so that they could place '2' one thick-grid-line away to the right.

Sequence 2: “We can’t go beyond X.”

In the following sequence, to resolve the problem on hand, students devised new rules (*Second-rules*): **Second-rule 1.** A new point must be 0.1-away from an existing point and named accordingly; **Second-rule 2.** A new point must be placed on a grid line, either thick or thin. The highlights of this sequence are described below.

Once Team CD placed '4', the last point in Figure 3, students encountered an issue: There is no available place for new points. According to the First-rules, they were only supposed to point on the thick grid lines between the two Xs. Zooming in at the interval (3.5, 4), frustrated, A commented, "We can't go beyond X." Instead of giving up, however, Team AB then decided to seek a new place for '0.1'. B zoomed in and started counting thick grid lines between '0' and '0.5', of which she counted eight [Figure 4 (a)].

However, students therein encountered the second issue: No thick grid line corresponded to the proper location of '0.1'. While B was having a hard time finding a thick grid line corresponding to '0.1', A started to notice the use of thin grid lines and suggested B to make use of them. Not long after, B agreed on A. There, they began to count, finding out the interval (0, 0.5) comprised 20 thin grid lines and thus 0.1 corresponded to four of them. At last, a new point appeared near 0 and got dragged slowly to the fourth thin grid line and so did the name '0.1', shortly [Figure 4 (b)]. From then on, students unanimously followed Team AB's method with little verbal exchange, counting four thin grid lines to the right and pointed '0.2', then '0.3' [Figure 4 (c)]. The activity had to stop there since the lesson time was over.

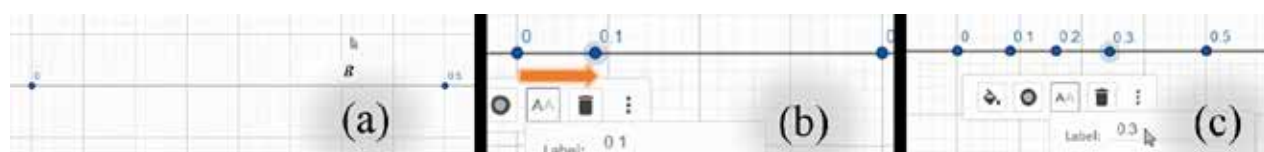


Figure 4: The establishment of Second-rules

After Team AB had devised a solution to place '0.1' in violation of the First-rules, Team CD simply followed their solution for '0.2' with no dispute at all, and Team AB repeated the action for '0.3' in the same way. Even though we were not able to observe further after '0.3', it is reasonable to assume they would have continued to play in the same manner judging based on their previous performance.

This new set of rules suggests the students became able to conceive a smaller unit (e.g., 0.1). Moreover, it shows that they could come up with the numbers which can be placed in between two once-seemingly-successive numbers. At this point, 0.5 was not the indivisible least common unit, and the multiples of 0.5 were not successive for students any longer.

Throughout this sequence, the body movements were at the center. Especially, the act of zooming in and out, rendered by spreading and pinching fingers on the touchpad, eventually evoked the change in students' perceptual habit and made them recognize the potential of thin grid lines – which was imperceptible earlier.

Another noteworthy thing is that the same perceptual change did not occur in the first sequence even though they zoomed in/out in precisely the same manner. The fundamental difference here lies in the degree of X's agency-in-play in the two situations. Once the students reached the barricades, unlike the first sequence, X became a major player in this student-technology-concept assemblage, which dismissed the students' propensity to go further outward according to the First-rules. Instead, it turned their attention to the intervals in between the points. It was not until the formation of this particular configuration that spreading fingers catalyzed such a dramatic shift in practice. Only then, students were *stretching* the number line and space rather than merely *looking closely* at them.

Sequence 3: "We keep stretching."

After the activity was over, the teacher conducted an ill-structured group interview with students on-site. Through students' discourse and gestures, it became apparent that the meaning of density had evolved further, and it was indeed inseparable from the technological environment of the activity.

- 11 T: Let's say we already have placed like, so many points and, say, y'all are really smart people. Then, can we place another point at this time?

- 12 All: Yes.
- 13 B: By stretching more and more (*palm facing forward and all fingers open, B spreads her thumb and index and close them in repeatedly*) [Figure 5 (a)].
- 14 T: Then, until when?
- 15 A, B: Forever.
- 16 B: We do **zero point zero, zero, zero, zero, zero, zero, zero, one [0.0000001]**
- 17 A: **Zero point zero, zero, zero, zero, zero, zero, ... zero, one [0.00000001]**¹ (...)
- 18 C: The further you stretch (*palm facing downward and only index and middle finger open, C spreads them away and close in quickly and repeatedly*) [Figure 5 (b)], the more lines you will have (*palm facing forward, C repeats to spread and squeeze all of his fingers swiftly*) [Figure 5 (c)].
- 19 T: Then, let's say, I would place my points at all the empty place on the line there, and now we don't see any empty place. Can we still lay another point?
- 20 A: We can.
- 21 B: Yes. We keep stretching (*palm facing downward, B spreads her index and middle finger away and bring them in repeatedly*) [Figure 5 (d)].



Figure 5: The students' hand gestures in the air

The students realized that no matter how many points are on the line and how dense they appear to be, they could always find a place for another point in between them. B was enumerating zeros in 0.0000001 out loud (Line 16) to imply that the game could go on by finding a number with a sufficiently small unit in response to the teacher's question (Line 11). Moreover, while enumerating zeros out loud simultaneously with B, A noticed that he could find an even tinier unit if he continued to add zeros before finishing with one. This made A take a brief halt when B finished and then quickly added one more zero and one (Line 17). Also, Line 13, 18 and 21 indicate that students became able to conceive a room to put such numbers by virtually stretching the line and space.

As we have observed from the episode, the body movement is a crucial factor in the invention of new meanings. Students' hand gestures on and off the touchpads demonstrate the catalyzing role of the mobility in the meaning-making process or, in other words, becoming the assemblage of fingers-touchpads-number line-space-'density'. No one possessed the emerged meaning from the beginning. No one was able to produce it by only repeating what seemed possible. The meaning did not exist until the finger movements actualized the latent material configurations and allowed the new senses

¹ This bolded and underlined part in the transcript indicates the moment when speeches of A and B were overlapping. Note that B deliberately continued to add a zero even after A stopped.

in unanticipated ways. It is this emergent nature what makes the meaning genuinely new and inventive.

Concluding remarks

We have scrutinized a case of mathematical activity to examine the relationship between the body movement and the meaning development in a multi-touch digital technology environment. Through the inclusive materialist lens, we could observe how the finger movements toward the digital apparatus played a crucial role in developing the meaning of the density of rational numbers. As Sinclair and de Freitas (2014) note, movements of the hand bring about new material reconfigurations and hence new hand gestures, which participate in the process of communication as well as the invention of meaning. We hope this study will contribute both to the embodied cognition theory and the studies on the integration of digital technologies in mathematics education by encouraging to incorporate the body and the material as central foci of investigation.

References

- de Freitas, E., & Sinclair, N. (2014). *Mathematics and the body: Material entanglements in the classroom*. New York, USA: Cambridge University Press.
- de Freitas, E., & Sinclair, N. (2017). Mathematical gestures: Multitouch technology and the indexical trace. In T. Dooley & G. Gueudet (Eds.), *Proceedings of the Tenth Congress of the European Society for Research in Mathematics Education* (pp. 2531–2538). Dublin, Ireland: DCU Institute of Education and ERME.
- Drijvers, P., Kieran, C., & Mariotti, M.-A. (2010). Integrating technology into mathematics education: Theoretical perspectives. In C. Hoyles & J.-B. Lagrange (Eds.), *Mathematics education and technology: Rethinking the terrain* (pp. 89–132). New York, USA: Springer.
- Ferrara, F., Faggiano, E., & Montone, A. (2017). Introduction: Innovative spaces for mathematics education with technology. In E. Faggiano, F. Ferrara, & A. Montone (Eds.), *Innovation and technology enhancing mathematics education: Perspectives in the digital era* (pp. 1–5). Cham, Switzerland: Springer International Publishing.
- Nemirovsky, R., Kelton, M. L., & Rhodehamel, B. (2013). Playing mathematical instruments: Emerging perceptuomotor integration with an interactive mathematics exhibit. *Journal for Research in Mathematics Education*, 44(2), 372–415.
- Sinclair, N. (2014). Generations of research on new technologies in mathematics education. *Teaching Mathematics and Its Applications*, 33(3), 166–178.
- Sinclair, N., & de Freitas, E. (2014). The haptic nature of gesture: Rethinking gesture with new multitouch digital technologies. *Gesture*, 14(3), 351–374. <https://doi.org/10.1075/gest.14.3.04sin>
- Streeck, J., & Mehus, S. (2005). Microethnography: The study of practices. In K. L. Fitch & R. E. Sanders (Eds.), *Handbook of language and social interaction* (pp. 381–404). Mahwah, USA: Lawrence Erlbaum Associates.
- Vamvakoussi, X., & Vosniadou, S. (2007). How many numbers are there in a rational numbers interval? Constraints, synthetic models and the effect of the number line. In S. Vosniadou, A. Baltas, & X. Vamvakoussi (Eds.), *Reframing the conceptual change approach in learning and instruction* (pp. 265–282). Amsterdam, The Netherlands: Elsevier.

Investigating students' use of dynamic materials addressing conceptions related to functional thinking

Edith Lindenbauer

University College of Education Upper Austria, Linz, Austria; edith.lindenbauer@ph-ooe.at

This paper reports on a qualitative case study about the use of dynamic worksheets addressing typical difficulties and misconceptions concerning functional thinking. The dynamic worksheets designed in this project visualize the transfer between iconic situational and graphical representations and were utilized during an intervention with students in a 7th grade Austrian middle school class. In addition to observational data, diagnostic tests and interviews regarding students' conceptions in the field of functional thinking were conducted. The case study particularly pays attention to the intuitive conceptions of students, the influence of the dynamic worksheets on these conceptions, and whether or not these materials are able to support students in developing appropriate mathematical conceptions. In this paper, an overview of the study and the part of the results related to students' use of dynamic worksheets are presented.

Keywords: Functional thinking, technology, representational transfer, lower secondary school.

Introduction

Functional thinking is an important concept in mathematics education and various students' problems and (mis-)conceptions have been widely researched in this context. The development of technology and technology-based resources now offers new opportunities with regard to multiple, dynamically linked representations. The question arose, whether such materials are able to support students in an early stage of learning functions as well as whether and in what ways they may influence students' conceptions. Based on these considerations, I developed several dynamic worksheets that visualize the representational transfer between iconic situational and graphical representations and integrated them into a qualitative case study to investigate this question.

Theoretical background

Literature review reveals various problems and misconceptions in the field of functional thinking; for example, illusion of linearity (De Bock, Van Dooren, Janssens, & Verschaffel, 2002), problems related to representations of functions such as graph-as-picture errors and slope-height confusions (e.g., Clement, 1989), and difficulties related to aspects of functional thinking whereby particularly the dynamic co-variational aspect is difficult for students to comprehend (Goldenberg, Lewis, & O'Keefe, 1992). These problems can cause misinterpretations of functions and particularly of function graphs. In this study, I follow Vollrath's (1989) description of functional thinking mainly including relational and co-variational aspects, because it best fits for the purpose of my study.

Dynamic Mathematics Software (DMS) allows to examine multiple, dynamically linked representations because changing one representation immediately affects the other(s). Therefore, it may support students' development of functional thinking because it is suitable to emphasize relational as well as co-variational functional aspects, the latter providing a dynamic perspective on functional dependencies (Falcade, Laborde, & Mariotti, 2007). So far, quantitative studies in the field

of technology reveal at best moderate effects on students' achievement, but research related to dynamic representations appears to be more promising (Drijvers et al., 2016; Hoyles, Noss, Vahey, & Roschelle, 2013).

At present, Cartesian coordinates seem to be dominant for representing function graphs in mathematics learning and teaching. Another way to represent functional dependencies is based on a software called DynaGraph providing two parallel lines instead of perpendicular axes (Goldenberg et al., 1992). According to Goldenberg et al. (1992), dynagraphs are powerful tools to examine characteristic properties of functions, to analyze functions qualitatively and therefore to support the understanding of functions. For instance, it is not possible to perceive graphical representations as static “images”, which could lead to graph-as-picture misinterpretations. Dynagraphs are able to complement static representations by adding dynamic perspectives, thus enriching the conceptual development of students. However, we need to examine in more detail the influence of dynamic materials (utilizing Cartesian as well as parallel coordinates) on students' conceptions.

Several researchers (e.g., Vosniadou & Vamvakoussi, 2006) suggest introducing mathematical concepts at an earlier stage in mathematics education in order to help students building a diverse concept image and to avoid that intuitive conceptions develop to misconceptions. This led to my research interest in students in an early phase of learning functions. In Austria, this group is represented by students in grade 7 and in the beginning grade 8 (age 12 to 13), because they have already learned how to interpret Cartesian coordinates. Therefore, they are able to study graphical representations, but they are not accustomed to the concept of the function and have only little experience with different functional relationships.

Dynamic materials

For creating dynamic worksheets, I decided to use the DMS GeoGebra, because it provides the possibility of dynamically linked, multiple representations, it is widely used in Austrian schools, and it is an open-source and free software. Moreover, I focused on the representational transfer between iconic situational and graphical representation due to the age and prior knowledge of the participating students, and additionally because it is particularly problematic (Bossé, Adu-Gyamfi, & Cheetham, 2011). An English version of the worksheets can be retrieved here: <https://ggbm.at/ftqpETqJ>.

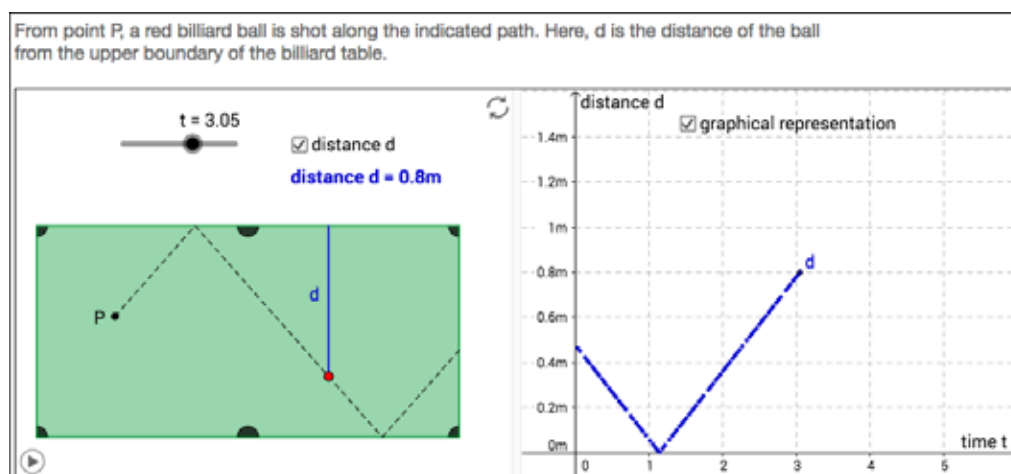


Figure 1: Dynamic worksheet “Billiard”, <https://ggbm.at/Dyf9Pwxj>

Figure 1 is based on a task by Schlöglhofer (2000) and illustrates a typical example of the dynamic materials designed for this project. Each dynamic worksheet concentrates on problems concerning functional thinking described in literature and consists of an interactive GeoGebra applet, which presents an iconic situational model and a graphical representation of a specific example (Cartesian coordinates or dynagraphs). Dynamically linked and interactive representations should address aspects of functional thinking.

Research design

The literature review drew my attention to several research questions (Lindenbauer & Lavicza, 2017). In this paper, I discuss a part of the results related to the following aspect: What kinds of influences of dynamic materials exist on lower secondary students' conceptions concerning functional thinking?

Two 7th grade classes of a middle school in Austria including 28 students with a broad range of different achievement levels participated in the study. I chose a qualitative inductive approach, more exactly Eisenhardt's (1989) approach that integrates features of Grounded Theory in a case study design in which the students represent different cases. Several types of data were collected in this study by diagnostic tests, diagnostic interviews, students' worksheets on paper, and observations during the intervention. These methods were arranged to a research design including five data collection stages: (1) diagnostic test 1, (2) diagnostic interviews, (3) intervention, (4) diagnostic test 2, and (5) diagnostic interviews (Lindenbauer & Lavicza, 2017). During the three-lesson-intervention, students worked in pairs with the designed dynamic worksheets without teacher guidance, because first I wanted to examine the influence of these interactive materials. Ten students were audio- and videotaped when working and the screens of their laptops were recorded, and I supervised these students in my role as researcher. The other students were working in another school's computer lab supervised by their mathematics teachers. Both teachers were instructed before the intervention process in order to guarantee that the participants were not influenced in their learning processes by the teachers' help.

Results concerning dynamic materials

For analyzing data, I followed coding procedures related to Grounded Theory (initial, focused, and theoretical coding). Various categories emerged from the common analysis of data from the second diagnostic tests and interviews as well as observation data. For this paper, I chose to outline results concerning students' use of dynamic materials and representations. Further results will be presented in upcoming papers.

As can be seen in Figure 2, when students worked with dynamic materials, they observed what happened within the dynamically linked representations, either more actively when *manipulating* dynamic representations (e.g., by moving sliders) or more passively by *observing* an animation. The variety and number of codes assigned to data imply an influence of students' *achievement level* on how different students utilized dynamic worksheets; in essence, higher achieving learners appear to use dynamic materials in more diverse ways. For instance, only Harald¹ and Wolfgang, the highest

¹ All student names are pseudonyms to preserve anonymity.

achieving students who I grouped together during the intervention, utilized the trace mode to mark extrema of the functional dependency within a dynagraph representation (“Billiard dynagraph”, see <https://ggbm.at/hSP3H9wv>) and to compare with other function values. Lower achieving students Konstantin and Mario, however, mainly worked with the same dynamic worksheet passively by watching the animation. Possibly, such students’ behavior could be related to the use of visual representations in problem-solving processes. Stylianou and Silver (2004) compared experts and novices and found out that the former utilize visual representations in more diverse ways.

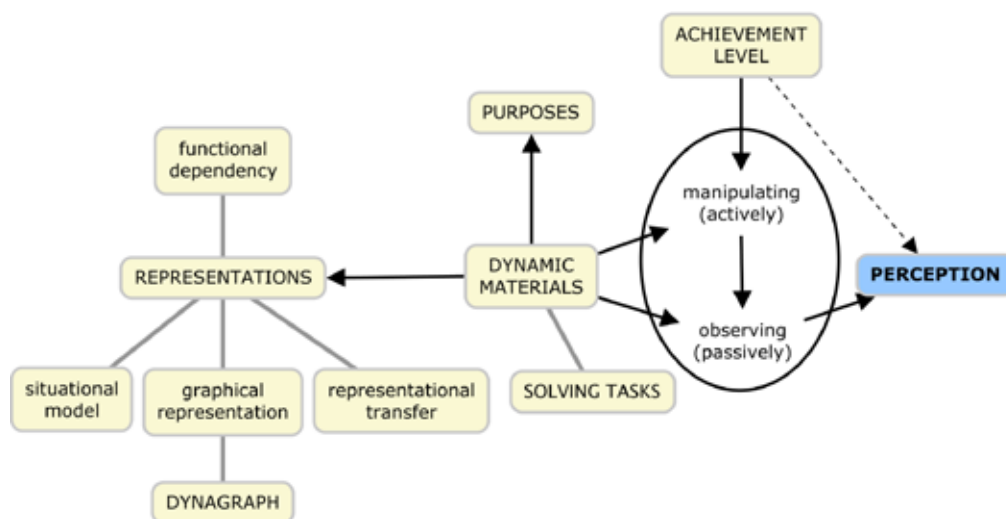


Figure 2: Dynamic materials and related issues

The way of utilizing dynamic worksheets influenced what students observed and consequently what they perceived. *Perception*, which in this context means that students consciously observe a feature and further consider or interpret it, evolved as main category when analyzing data related to the research question (see Figure 2). In brief, data analysis indicates an intention-reality discrepancy between the mathematical content the dynamic materials are intended to visualize and what students really perceive, especially when students focus on visual features of dynamic worksheets (Lindenbauer, 2018). Due to space limitations this issue will not be outlined further in this paper.

As the dynamic materials designed for this project address the transfer between iconic situational and graphical *representations* and visualize functional dependencies, these topics also emerged during the data analysis (see Figure 2). They mainly contain several students’ activities such as manipulating and observing dynamic representations, describing variables or functional dependencies, relating variables and representations, and interpreting graphical representations. Results suggest that for solving tasks, students tend to rely on the more familiar representation – the situational model – if possible. Particularly higher achieving students utilized representations more flexibly while lower achieving learners seemed to focus on one representation. Research results about connections between a flexible use of representations and students’ achievement levels and experience support these observations (Acevedo Nistal, Van Dooren, & Verschaffel, 2014; Stylianou & Silver, 2004).

Potentials and difficulties of working with dynagraphs

During the intervention, students discussed two dynamic worksheets that first utilized Cartesian coordinates and within a second version dynagraph representations instead (“Billiard dynagraph”, see

<https://ggbm.at/hSP3H9wv>, and “Triangle dynagraph”, see Figure 3). At this time, they were not used to dynagraphs, and included paper worksheets only provided a brief explanation.

Intervention data reveals that *dynagraphs* are intuitive for students to work with when solving tasks addressing relational as well as co-variational aspects of presented functional dependencies (e.g., to describe co-variational behavior of functional dependencies, to read off function values) and, thus, provide easy access to graphical representations. For example, during an interview Hannah applied the dynagraph representation within worksheet “Triangle dynagraph” (see Figure 3) correctly for answering questions addressing relational aspects (e.g., minimum of the function) while she had difficulties in answering similar questions by interpreting Cartesian coordinates (Lindenbauer, 2018).

Furthermore, dynagraph representations appear to emphasize co-variational aspects of the presented functional dependency probably because the function value y “moves” along the upper axis when the x value changes. Participants repeatedly described the dependency of function values from arguments in terms of speed and similarly observed the speed of the points representing x and y values relative to each other. Additionally, data implies that this representation also stresses rates of change, which can be experienced directly from changing speed of these moving points. One example provided by Pia, a student between average and low achieving level with lack of understanding of Cartesian coordinates, who rather described the functional dependency in dynamic worksheet “Billiard dynagraph” focusing on co-variational aspects than she did when interpreting Cartesian coordinates. However, students’ focus on speed could also lead to a confusion of variables, especially the x variable with time. In sum, dynagraph representations actually appear to provide a more dynamic perspective on functional dependencies than Cartesian coordinates and enable a more profound examination of the co-variational aspect of functional dependences as already outlined by Goldenberg et al. (1992). In addition, dynagraphs emphasize specific properties of functions including inflection or fixed points. Several students implicitly recognized such points without being asked. When asked to describe how the function value changes when x is increased within dynamic worksheet “Triangle dynagraph” (see Figure 3), Franziska, for instance, implicitly observed the inflection point of the presented functional dependency. She replied:

- 56 Franziska: Here it [area] is increasing faster (she moves the x value from $x = 0$ to $x = 1$) . . . and then slower again.
- 57 Interviewer: Do you have any idea from where it slows down?
- 58 Franziska: So, from here on (She moves dashed line to vertex C).

As the dialogue reveals, Franziska identified the inflection point from which on the change of rate decreases. Apparently, the “speed” of the point representing the function value relatively to those

The dashed line can be moved left and right. F indicates the area of the blue shaded figure. The graphical representation uses two parallel coordinate axes - a so called dynagraph representation - in the lower graphics window.

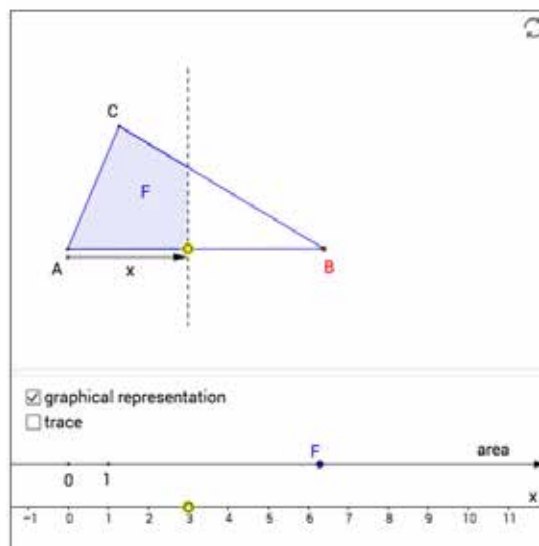


Figure 3: Dynamic worksheet “Triangle dynagraph”, <https://ggbm.at/wrVPlwHE>

representing the argument x can be easily perceived. For these reasons, characteristic features of dynagraphs could be utilized in mathematics teaching to support students in accessing graphical representations, possibly in scaffolding the representational transfer to Cartesian coordinates.

Although students had no difficulties in recognizing dynamic properties of dynagraphs, they did not always interpret them correctly. Konstantin, a lower achieving student, recognized the inflection point as position where the increase of speed changes similar to Franziska (see previous paragraph). However, he related this change of speed to the decreasing non-colored area within the triangle (see Figure 3) when dragging the dashed line from vertex C to the right. In addition, students tried to interpret visual features, such as the denseness of points created by trace mode on the y -axis, similar as they did when working with Cartesian coordinates.

A further student problem, which I call a “projecting error”, appeared when reading off function values. Following solution from Tina when working with dynamic worksheet “Billiard dynagraph” exemplifies this error. Tina described when trying to answer the question about the distance of the ball at $t = 1$ second:

Tina: At one second it [the distance] is about 0.2.



Figure 4: Screenshot of students’ work with dynamic worksheet “Billiard dynagraph”

Figure 4 illustrates that Tina correctly adjusted the value for time on the lower axis to $t = 1$. However, she did not identify the correct function value of about less than 0.1 m (possibly due to the distracting influence of the trace). Instead, as the yellow shaded cursor indicates, she replied the function value exactly above $t = 1$, which would actually be about 0.2 meters.

Dynamic materials

Data related to dynamic worksheets was additionally analyzed separately from other intervention data to provide further insight. On the one hand, in essence the structure of categories manipulating, observing, and interpreting perceived features also evolved from this data analysis and thus triangulates the results. On the other hand, data revealed further typical students’ activities when solving tasks and purposes of dynamic worksheets (see Figure 2). As these results are not specific for this research project but typical activities when working with computer-based materials or technology in general (e.g., Artigue, 2002), I will not provide further details.

Potentials and problems of dynamic materials

This issue summarizes further potentials and problems of working with these dynamic materials. First, they can be supportive within the first steps students have to conduct when translating from iconic situational to graphical representations, namely for understanding and visualizing a situation as well as for identifying and describing the dependent variable. Second, results related to another research question in this project revealed a comprehension gap as obstacle for students to overcome during this transfer. Data analyses indicate that if students are basically not able to understand and

interpret graphical representations in Cartesian coordinates, without teacher guidance students could rather not manage to overcome this comprehension gap by working with the dynamic worksheets alone. Apparently, they would profit from teachers' assistance to help them reflect and reconsider their perceptions and interpretations.

Third, for students who are basically able to make representational transfers, dynamic materials seem to be helpful, because they appear to induce adaptations of students' conceptions. When first confronted with the dynamic worksheet "Triangle" (for situational model see Figure 3), Wolfgang and his colleague represented the functional dependency by a piece-wise linear function (see Figure 5). After the second test, in which both students solved a corresponding task correctly, Wolfgang resumed:

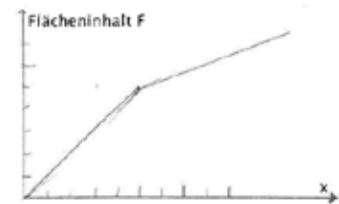


Figure 5: Students' solution

76 Wolfgang: . . . because at first, I thought that it [the area] regularly becomes larger, but then I found out that it grows increasingly.

Apparently, this dynamic worksheet supported Wolfgang in adjusting his conception from regular to irregular increase of the function value and, consequently, from a linear to a curved graph.

Conclusions

The data analyses reveal *perception* as main category of working with dynamic worksheets. In particular, students appear to focus on visual or structural features of iconic situational and graphical representation. Perception seems to depend, among others, on students' achievement levels and their prior knowledge. Therefore, the problem remains how to draw students' attention to those features that are relevant for mathematical learning.

Dynagraphs provide an intuitive access to graphical representations and seem to be easy for students to interpret. Minor difficulties have to be considered when introducing dynagraphs in school, mainly concerning reading off function values. Finally, these results could be influenced by the order of dynamic worksheets utilized during the intervention. Possibly letting students first work with dynagraph representation and then with Cartesian coordinates would provide further insight.

Depending on students' prior conceptions and their understanding of Cartesian coordinates, the dynamic materials utilized in this project have an adaptational influence on students' conceptions. In other words, they appear to support students in improving descriptions of functional dependencies (e.g., leading to qualitative correct ideas about changing slopes of function graphs). However, these materials could also generate new misconceptions, especially when only superficially perceived. Lower achieving students in particular would profit from teachers' assistance to reflect their perceptions and interpretations.

Additional questions arose from this project, for example, how to improve these materials and how to utilize them in regular teaching to support students. Design experiments and instrumental approach respectively could be suitable frameworks to investigate these questions further in other studies.

References

Acevedo Nistal, A., Van Dooren, W., & Verschaffel, L. (2014). Improving students' representational flexibility in linear-function problems: an intervention. *Educational Psychology*, 34(6), 763–786.

- Artigue, M. (2002). Learning mathematics in a CAS environment: The genesis of a reflection about instrumentation and the dialectics between technical and conceptual work. *Journal of Computers for Mathematical Learning*, 7(3), 245–274.
- Bossé, M. J., Adu-Gyamfi, K., & Cheetham, M. R. (2011). Assessing the difficulty of mathematical translations: Synthesizing the literature and novel findings. *International Electronic Journal of Mathematics Education*, 6(3), 113–133.
- Clement, J. (1989). The concept of variation and misconceptions in Cartesian graphing. *Focus on Learning Problems in Mathematics*, 11(1–2), 77–87.
- De Bock, D., Van Dooren, W., Janssens, D., & Verschaffel, L. (2002). Improper use of linear reasoning: An in-depth study of the nature and the irresistibility of secondary school students' errors. *Educational Studies in Mathematics*, 50(3), 311–334.
- Drijvers, P., Ball, L., Barzel, B., Heid, M. K., Cao, Y., & Maschietto, M. (2016). *Uses of technology in lower secondary mathematics education*. Cham, Switzerland: Springer International Publishing.
- Eisenhardt, K. M. (1989). Building theories from case study research. *Academy of Management Review*, 14(4), 532–550.
- Falcade, R., Laborde, C., & Mariotti, M. A. (2007). Approaching functions: Cabri tools as instruments of semiotic mediation. *Educational Studies in Mathematics*, 66(3), 317–333.
- Goldenberg, P., Lewis, P., & O'Keefe, J. (1992). Dynamic representation and the development of a process understanding of function. In G. Harel & E. Dubinsky (Eds.), *The concept of function: Aspects of epistemology and pedagogy* (pp. 235–260). Washington DC: MAA.
- Hoyles, C., Noss, R., Vahey, P., & Roschelle, J. (2013). Cornerstone Mathematics: Designing digital technology for teacher adaptation and scaling. *ZDM Mathematics Education*, 45, 1057–1070.
- Lindenbauer, E., & Lavicza, Z. (2017). Using dynamic worksheets to support functional thinking in lower secondary school. In T. Dooley & G. Gueudet (Eds.), *Proceedings of the 10th Congress of the European Society for Research in Mathematics Education* (pp. 2587–2594). Dublin, Ireland: DCU Institute of Education and ERME.
- Lindenbauer, E. (2018). *Students' conceptions and effects of dynamic materials regarding functional thinking* (Doctoral dissertation). Johannes-Kepler-Universität, Linz.
- Schlöglhofer, F. (2000). Vom Foto-Graph zum Funktions-Graph. *Mathematik lehren*, 103, 16–17.
- Stylianou, D., & Silver, E. (2004). The role of visual representations in advanced mathematical problem solving: An examination of expert-novice similarities and differences. *Mathematical Thinking and Learning*, 6(4), 353–387.
- Vollrath, H.-J. (1989). Funktionales Denken. *Journal für Mathematik-Didaktik*, 10(1), 3–37.
- Vosniadou, S., & Vamvakoussi, X. (2006). Examining mathematics learning from a conceptual change point of view. In L. Verschaffel, F. Dochy, M. Boekaerts, & S. Vosniadou (Eds.), *Instructional Psychology: Past, Present, and Future Trends* (pp. 55–70). Amsterdam, Netherlands: Elsevier.

A virtual environment dedicated to spatial geometry to help students to see better in space

Xavier Nicolas and Jana Trgalova

University of Lyon, Claude Bernard University Lyon 1, S2HEP (EA4148), France;

xavier.nicolas@uca.fr; jana.trgalova@univ-lyon1.fr

We report about an experiment carried out in a school context of teaching spatial geometry with a dynamic geometry environment, based on gesture-based interface for use with immersive, room-scale virtual reality. The work reported in this paper is the first iteration of a research cycle involving teachers, researchers and developers to help high school students better “see” in space and propose principles for the design and use of such environments in a school context. Our study focuses on the impact of “dimensional construction” techniques on the way students perceive a geometric figure represented in a cavalier perspective. Our first results show a significant improvement of students’ performance, demonstrating the appropriation and transfer of these dimensional construction techniques to 2D supports as well as the transition from an iconic to a non-iconic vision of figures, which is an essential condition for geometric activity.

Keywords: Mathematics, learning, geometry, visualization, technology

Introduction

Teaching geometry in space is considered difficult because it is necessary to “see in space,” objects or situations most often represented by drawings in cavalier perspective. In geometry, dynamic geometry environments (DGE) have revolutionized not only the way geometric objects are created and manipulated, but also allowed new didactic situations and modified our very relationship to geometric objects (Laborde, 2003). However, DGE are constrained by a 2D representation mode (screen), which poses perception and usability problems (Dimmel & Bock, 2017). In the domain of technology in education, unlike the professional world, virtual reality (VR) has made a timid entry. A DGE in VR could be relevant to better see in space or at least avoid the problem, but what will happen once the HMD (Head Mounted Display) is removed and the students are back on their tables? An interesting aspect of virtual worlds that can be exploited is their modes of interaction and assistance that are impossible in the physical world as a way of approaching learning differently (Burkhardt, Lourdeaux, & Mellet-d’Huart, 2006). VR can reveal and make tangible concepts or information normally outside the field of human perception (Winn, 2003). This leads us to question whether concrete and intelligible manipulation of geometric objects performed by students in a VR environment can change the way they later see them in cavalier perspective drawings? In this paper, we present a research aiming to evaluate the potential of VR environment in geometry in space, but also to set some benchmarks for academic learning.

Theoretical framework

Seeing in space in geometry

In the context of geometry, the act of seeing involves complex perceptive and cognitive processes. For Duval (2005), a major cognitive problem is how to move from discriminative recognition of

shapes to the identification of objects to be seen. This transition can take two paths: an iconic and a non-iconic path. The iconic path is based on the similarity of the shapes with the object and is not specific to geometry. Seeing in space in an iconic way can also be considered from the perspective of spatial skills as "the ability to generate, preserve, recover and transform well-structured visual images" (Lohman, 1996, p. 98). The non-iconic way relies on considering a representation of figural units linked by relations as a whole. Most of spatial geometry tasks imply this flexibility of vision. The dimensional deconstruction (Duval, 2005), i.e., considering the figural units of smaller dimensions in a geometric object, is the central point for the geometric processing of representations. Following Duval, we start from the premise that getting students to mobilize dimensional deconstruction on a 3D object represented in 2D can help them better "see in space".

According to Chaachoua (1997), to be efficient in geometry, the representations must fulfill three functions: illustration, supporting assumptions and allowing the heuristic change of point of view like the dimensional deconstruction. In spatial geometry, the drawings in cavalier perspective are the most commonly used representations. Mithalal (2014) notes that drawings in perspective struggle to fulfill these functions, and that dynamic geometry environments (DGE) allow them to be partially restored.

In order to tackle our initial question, we need to identify different ways of seeing in space students mobilize in a geometric activity. This involves modelling the ability to "see in space" in an ecological approach, which leads us to choose the anthropological theory of didactics.

The anthropological theory of didactics

The anthropological theory of didactics (ATD, Chevallard, 2012) provides an epistemological framework aiming at the understanding of the ecology of mathematical knowledge. In ATD, any human activity is modelled through the notion of *praxeology* represented by so called "4T-models (T, τ , θ , Θ)". A *type of task* (T) and the relevant *techniques* (τ) for solving tasks t of the type T constitute a practical block or *praxis* (know-how). The technologico-theoretical block or *logos* (know why) covers a *technology* (θ) explaining and justifying the technique and a *theory* (Θ) justifying the underlying technology. In the case where the type of tasks T relates to the field of mathematics, we use the term of *mathematical organization* (MO) rather than praxeology. For Duval, "the way of seeing a figure depends on the activity in which it is mobilized" (Duval, 2005, p. 8). From the ATD perspective, we consider the different ways of seeing as intrinsic *elementary praxis* (EP) because, on the one hand, they only exist through their mobilization within techniques of prescriptible types of tasks and, on the other hand, they are present at a level of granularity that the didactics of mathematics can no longer exceed. We propose the following elementary praxis to describe the possible transitions from a figure to a geometric object. EP1 and EP2 follow the iconic way (Chaachoua, 1997), EP3 the non-iconic way (Duval, 2005).

- EP1: Associate the recognized shapes with the appearance of a physical object seen from a certain point of view (identification by natural observation and resemblance).
- EP2: Associate the recognized shapes with a prototypical image of the object available in a mental catalogue (identification by prototypical shapes).

- EP3: Identify figural units and their relationships (identification by processes supported by dimensional deconstruction).

The relationship to knowledge

In ATD, the notion of *relationship to knowledge* (Chevallard, 1992) leads to considering the didactics from the anthropological perspective. An individual's relationship to particular (piece of) knowledge may be different from the relationship that the educational institution has with that knowledge. In the case of the ability to see in space, the student develops his/her personal relationship within and outside the school walls. The analysis of student productions, and in particular of their mistakes with regard to the different EPs mobilized in the techniques used to solve a geometric task, can provide us with information on the student's personal relationship with the notion of seeing in space. At the secondary level, in geometry, as well as more broadly in mathematics, the curriculum clearly aims to develop a deductive approach. From the point of view of the institutional relationship to "seeing in space", EP1 and EP2 are non-compliant and error-prone relationships. It is the EP3 that is targeted by the teaching of geometry in space.

The concept of ostensive/non-ostensive

The implementation of a technique involves manipulation of *ostensives*, i.e., tangible and manipulable objects, regulated by *non-ostensives*, i.e., theoretical objects as concepts, notions, ideas (Bosch & Chevallard, 1999). Ostensives can belong to different registers: graphic, gestural, discursive and scriptural. The performance of an ostensive can be evaluated according to two criteria: its *instrumental valence*, which is its ability to act, to work and its *semiotic valence*, which is its ability to see, to appreciate in a sensitive way the work done or to plan the work to be done.

According to Chevallard (1994, p 8), "one of the factors of progress in mathematics is the creation of ostensives that are effective from both an instrumental and a semiotic point of view." (our translation).

We have seen in the introduction that drawings in perspective are ostensives whose instrumental and semiotic valences are not sufficient to develop a non-iconic way of seeing in space.

Analysis of *Handwaver*, a DGE in virtual reality

The *Handwaver* application is developed by a research team at the University of Maine to exploit the modes of representation and interaction available in virtual environments to create experiences where learners use pseudo natural gestures to observe, create and manipulate mathematical objects (Dimmel & Bock, 2017). In *Handwaver*, the "stretch" and the "extrude" operators allow to generate geometric objects of n dimensions from an object of $n-1$ dimension (Figure 1).



Figure 1. Different cases of the “stretch” operator: a point is stretched into a line segment, the segment is stretched into a polygon, and the polygon is stretched into a prism (Dimmel & Bock, 2017)

As we focus on 3D objects, we consider the generation of a polyhedron from a polygon as a type of task T, made up of several punctual mathematical organizations (PMO), i.e., relating to a single subtask of T. We describe these praxeologies and the involved ostensives in Table 1.

Type of task T	Construct a polyhedron from a polygon	
Punctual Mathematic Organization	Dimensional construction of prisms PMOdim_prism	Dimensional construction of pyramids PMOdim_pyramid
Subtype of task T	Construct a prism from a polygon	Construct a pyramid from a polygon
Technique	Make a translation of a polygon and join corresponding vertices of the two polygons by segments generating faces of the prism	Extract an apex from the polygon, pull it out of the plane and join it with all vertices of the polygon generating faces of the pyramid
Technology	Definition of a prism: a polyhedron with two polygonal faces lying in parallel planes and with the other faces parallelograms	Definition of a pyramid: a polyhedron with a polygonal base and three or more triangular faces that meet at a point, called apex
Theory	Euclidean geometry	Euclidean geometry
Ostensives	The stretch operator	The extrude operator
Graphical register	Virtual model of the prism reacting in real time to the manipulation of polygonal bases	Virtual model of the pyramid reacting in real time to the manipulation of the apex and the polygonal base
Gestural register	Grasp and stretch (with hands apart) the polygon	Touch the polygon with the extrude tool and move away the apex created (with hands apart)
Discursive register (later introduced by the teachers of our experiment)	“I stretch the polygon”	“I pinch the polygon”

Table 1: Two examples of Punctual Mathematical Organizations related to the type of task T

The a priori analysis of the stretch and extrude ostensives leads us to make the following observations:

- From the point of view of their instrumental valence, the mobilization of pseudo natural gestures makes the techniques easy to apply and retain.
- From the point of view of their semiotic valence, the environment provides immediate feedback on the manipulation of objects in the form of visualization of the polyhedron being generated. This enables the student to control the process of generating polyhedrons, and thus makes the techniques, and more generally the continuity of the process leading from the polygon to the polyhedron, readable and intelligible.

With regard to these two considerations, we hypothesize that these techniques have a strong reversibility potential, i.e., they allow a dimensional deconstruction of the polyhedrons enabling to identify the starting polygon. This leads us to reformulate our initial questioning:

To what extent the use of Handwaver to solve tasks involving dimensional construction techniques help students to move from an iconic (EP1 & EP2) to a non-iconic (EP3) way of seeing drawings in a cavalier perspective?

Methodology

Our methodology relies on a teaching experiment involving two grade 6 classes and their mathematics teachers. Our aim was to design and test activities with *HandWaver* involving the above mentioned techniques. The methodology comprises several phases outlined below.

Phase 1: Identification of errors related with seeing in space

We interviewed six secondary school mathematics teachers through two focus groups in two schools to determine types of tasks where seeing in space is problematic for students. We present here two errors that are widespread according to the teachers at the beginning of secondary school and that persist throughout compulsory schooling:

- Error 1 (E1): The student does not consider cubes or rectangular cuboids as prisms.
- Error 2 (E2): The student does not identify properly the base of a prism or a pyramid in a non-prototypical position.

From the point of view of our theoretical framework, E1 and E2 are characteristic of a relationship of knowledge that does not conform to the one expected by the institution. EP1 leads for example to difficulties with perceiving geometric properties shared by different solids as this requires identifying components or figurative units and their relationships, which EP1 does not allow. EP2 comes from observation of real objects and leads for example to always identify the base of a solid as a face on which the solid sits on. E1 and E2 errors prove the non-mobilization of EP3.

Phase 2: Diagnostic assessment

To investigate these statements, we analyzed the outcomes of a diagnostic assessment administered to 40 grade 6 students (11-12 years old, two classes) who have not had yet teaching of geometry in space. The test consisted of two exercises: classify given solids by family and identify a base for each of the given solids. The solids are represented by drawings in cavalier perspective. E1 and E2 errors were present in all students, confirming the statements collected from the focus group teachers. We note that only EP1 and EP2 are present in students' personal praxeology for these types of tasks. We assume that we can evaluate changes in ways of seeing in space with respect to the presence of these errors in students' productions. We can therefore test the following hypothesis:

The dimensional construction technique makes it possible to develop the EP3 praxis in the students' personal praxeology.

Phase 3: Design and implementation of tasks in Handwaver environment

With the two teachers, we have designed a scenario to allow students to implement the dimensional construction PMOdim_prism and PMOdim_pyramid (Table 1). The scenario outlined below was implemented by each of the two teachers in their 6th grade class of 20 students who passed the diagnostic assessment and whose results are reported above. It should be noted that this was the first session where the notions of prisms and pyramids were introduced at this level of class.



Figure 2. The classroom setting and the generation of a prism using the stretch operator

The implementation went through the following phases in the classroom setting shown in Figure 2 (left):

- Introduction of the activity and demonstration of the environment by the teacher
- Generation of solids in the environment by students with the stretch or the extrude operator - one student manipulated at a time, the others observed the screen (Figure 2, right)
- Classification, by each student, of the solids generated on the basis of the techniques used by the group (mental re-mobilization and reversibility of techniques)
- Discussion, argumentation, validation of the students' classifications (development of a discourse on techniques) - whole class
- Institutionalization by the teacher of prisms and pyramids in relation to the techniques used
- Mental reinvestment of the techniques considering a disc (to generate either a cylinder or a cone) - whole-class discussion

Phase 4: Post-test

A post-test was administered to the students 10 days after the session. As the students were on a school trip during these 10 days, they did not have any mathematics lessons during this period.

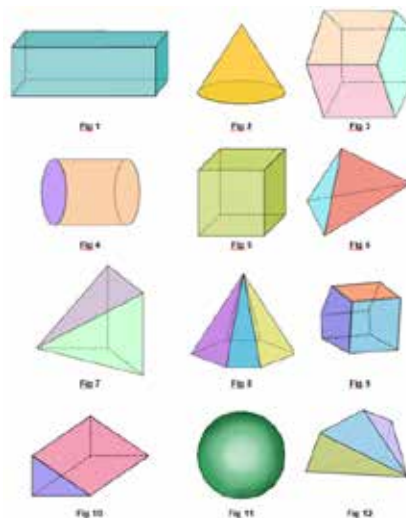


Figure 3. The set of solids from the post-test

The post-test includes the following two exercises:

- Classify the solids in the families of prisms, pyramids, or other.

- Color a base of the solid on each figure (if possible).

In terms of MO, the type of task underpinning the first exercise is “Identify prisms and pyramids in a set of solids in cavalier perspective“(T1) and the type of task underpinning the second one is “Identify the base of solids in cavalier perspective” (T2). The test includes 12 solids represented in cavalier perspective whose visible faces are colored to avoid perceptual aberrations. Among the solids are 5 prisms including a cube and a rectangular cuboid, 4 pyramids, 1 cone, 1 cylinder of revolution, and 1 sphere (Figure 3). A particular attention was paid to draw some of the solids in a non-prototypical position.

Findings and discussion

In the analysis of the post-test results, we focus on those that are relevant to the types of tasks T1 and T2. We obtain the following success rates:

- 79% of students correctly solved T1 (68% for prism and 93% for pyramids).
- 75% of students correctly solved T2

If we consider only the object in the post test who can generate the errors E1 and E2:

- Error 1 (E1) 70% of students correctly solved T1 (Fig:1, 2)
- Error 2 (E2): 59% of student correctly solved T2 (Fig: 3, 4, 7, 9, 10, 12).

Even if we have not submitted a real pre-test, only a diagnostic assessment, the very significant decrease in the presence of E1 and E2 in student production seems indicate the non-mobilization of EP1 or EP2. The new technique used by student is more relevant, that could indicate the mobilization of EP3 and could be link to the PMOs used in the VR environment. This seems to confirm our hypothesis and the a priori analysis of stretch and extrude ostensives in terms of their instrumental and semiotic valence. However the solids generation by extrusion is not new, it is often used in an imaginative way by teachers or in CAD software used by students in technology teaching. Yet mistakes persists. The novelty in VR lies in the use of a behavioral interface that affects the graphical and gestural registers of the ostensive. We must consider how cognition operates within constraints imposed by our physiology. First about the graphical register, artificial environments can use computer technology to create metaphorical representations in order to bring to students concepts and principles that normally lie outside the reach of direct experience. (Winn, 2003). Secondly about the gestural register, in the embodied cognition approach, the mathematical concept of dimensional construction that we mobilized in our experiment, could be considered as a conceptual metaphor (Nunez, 2009), grounded in bodily-based mechanisms : the stretch gesture like stretching gum from a ball to a thread (from a 0D to 1D object), or pulling a blind down (from a 1D to 2D object). So we can suppose in our case that students can easily accept that stretching a polygon makes a 3D object so they can mobilize spontaneously this technique later.

Conclusion

The VR activity implemented seems to have helped students develop a heuristic understanding of drawings in cavalier perspective, based on the identification of figurative units of smaller dimensions, and thus helping to better see in space. In a VR environment we call presence the belief that you are “in” the artificial environment, not in the laboratory or classroom interacting with a

computer. The coupling effect leads to a permeability at the cognitive level between the real world and the artificial world. An environment considered as real by users but where we program the interactions and rules, open a field of great opportunities for learning.

References

- Bosch, M., & Chevallard, Y. (1999). La sensibilité de l'activité mathématique aux ostensifs. *Recherches en Didactique des Mathématiques*, 19(1), 77-124.
- Burkhardt, J.-M., Lourdeaux, D., & Mellet-d'Huart, D. (2006). La réalité virtuelle pour l'apprentissage humain. In P. Fuchs, G. Moreau, B. Arnaldi & P. Guitton (Eds.), *Le Traité de la Réalité Virtuelle* (Vol. 4, pp 43-102). Paris : Presses de l'Ecole des Mines.
- Chaachoua, H. (2010). *La praxéologie comme modèle didactique pour la problématique EIAH. Etude de cas: la modélisation des connaissances des élèves*. Note de synthèse pour une HDR, Université Joseph Fourier, Grenoble.
- Chaachoua, H. (1997). *Fonctions du dessin dans l'enseignement de la géométrie dans l'espace. Etude d'un cas : la vie des problèmes de construction et rapports des enseignants à ces problèmes*. Thèse de doctorat, Université Joseph Fourier, Grenoble.
- Chevallard, Y. (1992). Concepts fondamentaux de la didactique : perspectives apportées par une approche anthropologique. *Recherches en Didactique des Mathématiques*, 12(1), 77-111.
- Dimmel, J., & Bock, C. (2017). Handwaver : a gesture-based virtual mathematical making environment. In G. Aldon & J. Trgalovň (Eds.), *Proceedings of the 13th International Conference on Technology in Mathematics Teaching*. (pp. 323-330). Lyon, France.
- Duval, R. (2005). Les conditions cognitives de l'apprentissage de la géométrie: développement de la visualisation, différenciation des raisonnements et coordination de leurs fonctionnements. *IREM de Strasbourg*, 10, 5-53.
- Laborde, C. (2003). Technology used as a tool for mediating knowledge in the teaching of mathematics: the case of Cabri-geometry. In W.C. Yang, S. C. Chu, T. de Alwis, & M. G. Lee (Eds.), *Proceedings of the 8th Asian Technology Conference in Mathematics* (Vol. 1, pp. 23-38). Taiwan.
- Lohman, D. F. (1996). Spatial ability and g. In I. Dennis & P. Tapsfield (Eds.), *Human abilities: Their nature and measurement* (pp. 97-116). Hillsdale, NJ, US: Lawrence Erlbaum Associates, Inc.
- Mithalal, J. (2010). 3D geometry and learning of mathematical reasoning. In V. Durrand-Guerrier et al. (Eds.), *Proceedings of the 6th Conference of the European Society for Research in Mathematics Education* (pp. 796-805), Lyon, France.
- Núñez, R. (2009). Mathematical Idea Analysis: What Embodied Cognitive Science Can Say about the Human Nature of Mathematics. *Colección Digital Eudoxus*, (8).
- Winn, W. (2003). Beyond Constructivism: A Return to Science-Based Research and Practice in Educational Technology. *Educational Technology*, 43(6), 5-14.

Students' perceptions in a situation regarding eigenvalues and eigenvectors

José Orozco-Santiago¹, Carlos-Armando Cuevas¹ and Luc Trouche²

¹Center for Research and Advanced Studies of the National Polytechnic Institute (Cinvestav-IPN), Mexico; jorozco@cinvestav.mx, ccuevas@cinvestav.mx

²Institut français de l'Éducation, ENS de Lyon-, France; luc.trouche@ens-lyon.fr

In this study we investigate conceptualization processes among university students in solving a problem involving concepts of eigenvalues and eigenvectors in a linear algebra course for engineering. In the pilot phase of the study, we examined a case study of two first-year linear algebra students and analyzed the data through the theory of instrumental genesis in a dynamic geometry paper-and-pencil environment.

Keywords: Linear algebra, Eigenvalue, Eigenvector, Scheme, Instrumental genesis.

Introduction

Linear algebra is one of the first abstract mathematics courses engineering students take in their early years in college. According to Robert and Robinet (1989), when first encountering linear algebra, students express concern about the use of formalism, the overwhelming number of new definitions and the lack of connection between this new field and their existing knowledge of mathematics. Dorier and Sierpinska (2001) distinguish two inseparable sources of difficulty for students in learning processes: the nature of linear algebra itself (conceptual difficulties) and the kind of thinking necessary for the understanding of linear algebra (cognitive difficulties).

After the Linear Algebra Curriculum Study Group (LACSG) recommended the use of technology in early linear algebra courses (Carlson, Johnson, Lay, & Porter, 1993), some teachers began to incorporate Computer Algebra Systems (CAS) into their classrooms. At the same time, several researchers studied the reflexive use of technological tools in classroom teaching/learning processes (involving both the tool and the mathematical content), which gave rise to the *instrumental approach to didactics* as a central theoretical framework (Artigue, 2002; Guin, Ruthven, & Trouche, 2005; Trgalová, Clark-Wilson, & Weigand, 2018).

Eigenvalues and eigenvectors are important concepts in the study of linear algebra (Gol Tabaghi, 2014; Meel & Hern, 2005), and they require an understanding of other concepts such as vector spaces, linear transformation, bases and dimension, among others. In this paper, we present the preliminary results of our doctoral research, whose objective is to orchestrate a teaching situation appropriate for introducing the concepts of eigenvalues and eigenvectors in a traditional course on linear algebra. For this part of our research, we pose the following question: what utilization schemes does the student experience / develop when faced with a geometry task involving the concepts of eigenvalues and eigenvectors?

Theoretical framework

The French mathematics education community (Artigue, 2002; Guin et al., 2005) has extended the instrumental approach (Rabardel, 2002) to the learning of mathematics through the reflexive use of technological tools. Rabardel thus defines an instrument as a “mixed entity made up of an artifact

and a scheme” (p. 37), retaining Vergnaud’s notion of scheme, as “the invariant organization of behavior for a certain class of situations” (Vergnaud, 1998, p. 167). To understand the function and dynamic of a scheme, we must take into account its components. These include one or several goals, each with its sub-goals and anticipations; rules to generate action, information seeking and control; its operational invariants (concepts-in-action and theorems-in-action); and the possibilities of inferences within the situation. Artifacts are associated with two kinds of utilization schemes: usage schemes and instrument-mediated action schemes. Two different users can approach the same artifact differently, develop different utilization schemes, and create two different activities and instruments (Alqahtani & Powell, 2017, p. 14). For a subject, the artifact becomes an instrument through a process, called *instrumental genesis*, “involving the construction of personal schemes or, more generally, the appropriation of social pre-existing schemes” (Artigue, 2002, p. 250). According to Trouche (2004), instrumental genesis is a complex process that requires time, and is related to artifact’s characteristics and the subject’s activity. In instrumental genesis, two processes coexist: instrumentalization and instrumentation. “*The instrumentation process is the tracer of the artifact on the subject’s activity, while the instrumentalization process is the tracer of the subjects’ activity on the artifact*” (Trouche, 2014, p. 311). In a technological environment, interactions between student and artifact must be organized with specific didactic intentions. The crucial role of teachers in this process was soon recognized. To characterize the teacher’s role in guiding students’ mastery of tools and their learning processes, Trouche (2004) introduced the notion of *instrumental orchestration*. An instrumental orchestration consists of two main elements: didactical configuration and exploitation modes.

Methodology

In this paper we present the results of a single task, part of a larger study whose objective is to design an orchestration of a situation to introduce the concepts of eigenvalues and eigenvectors in a first course on linear algebra for engineering students. The task was designed by the teacher, in conjunction with the researcher. The study was carried out in the spring of 2018 and included a case study. The research involved eight volunteer students averaging nineteen years old, all enrolled in a "Fondamentaux des Mathématiques II" class at a public university in France. The session lasted 120 minutes. The students had experience in matrix calculation, vector spaces, and linear transformations, but they had not yet addressed eigenvalues and eigenvectors. They also mentioned having some previous experience with the Dynamic Geometry Environment (DGE), in this case GeoGebra. The students were told that we would be studying the way they solved the problem, or the techniques used, and that they would not be graded. Each student was given the paper assignment and each group (of 2 or 3) was provided with a laptop with GeoGebra and Internet access. The data was collected from observation and field notes by a researcher external to the experiment, and lasted about 120 minutes. For our analysis, we selected two students: Cécile and Henry.

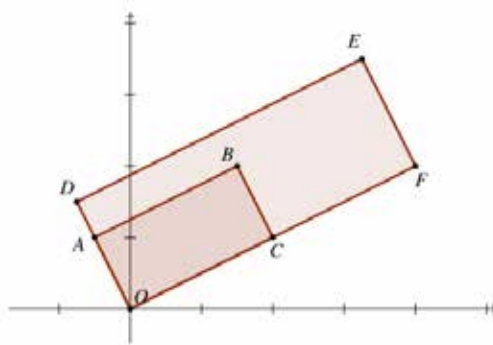
Mathematical context and task design.

An eigenvector of an $n \times n$ matrix A is a nonzero vector \vec{x} such that $A\vec{x} = \lambda\vec{x}$ for some scalar λ . A scalar λ is called an eigenvalue of A if there is a nontrivial solution \vec{x} of $A\vec{x} = \lambda\vec{x}$; such an \vec{x} is called an eigenvector corresponding to λ (Lay, Lay, & McDonald, 2016). Here we consider $n = 2$,

by the availability of a DGE (GeoGebra), considering the potentiality of the *dragging* tool “wandering dragging” (Arzarello, Olivero, Paola, & Robutti, 2002).

The task (see figure 1) was not designed to evaluate the student’s progress in the course. Rather, it was restricted to having the students to work on \mathbb{R}^2 in order to study their conceptualization of eigenvalues (real) and eigenvectors of 2x2 matrices, specifically in solving the first two points in a single class period of 30-50 minutes.

Given the following two rectangles.



1. Find a process to build a linear application f that sends the rectangle OABC to the rectangle ODEF.
2. Apply this process when the points have the following canonical coordinates: $A\left(-\frac{1}{2}, 1\right)$; $B\left(\frac{3}{2}, 2\right)$; $C(2,1)$; $D\left(-\frac{3}{4}, \frac{3}{2}\right)$; $E\left(\frac{13}{4}, \frac{7}{2}\right)$; $F(4,2)$
And build the matrix M of f in this basis
3. In GeoGebra, we code a matrix with the braces $M = \{\{a, b\}, \{c, d\}\}$. We can create a $u = \text{Vector}((1,1))$ then move its end and apply the matrix M by $\text{Vector}(M * u)$. Model the previous situation and check the values.
4. Can we find a vector $v \in \mathbb{R}^2$ such that $f(v) = \lambda v$ for a certain real $\lambda \in \mathbb{R}$? What are the possible values of λ ? What are the possible vectors for a given λ ?
5. Let $v_1 = \overrightarrow{OC}$ and $v_2 = \overrightarrow{OA}$. Give the matrix of the linear application f in this database.

Figure 1. The task discussed in this document

The students are invited to develop intuitive notions of eigenvalues and eigenvectors associated with the matrix M , in the environment of GeoGebra, by means of a draggable vector \vec{v} and its vector image $M\vec{v}$, as the vector \vec{v} is dragged around the screen, the vector $M\vec{v}$ moves accordingly. To find an eigenvalue of the matrix M geometrically, the student will have to drag a position where \vec{v} and $M\vec{v}$ are collinear, in order to explore the relationship involved in the equation $A\vec{x} = \lambda\vec{x}$, and to recognize that there is an infinite number of eigenvectors associated with each eigenvalue.

Instrumental orchestration of the class

The main objective of the orchestration is to introduce and use the concepts of values and eigenvectors in a first course on linear algebra. The secondary objective is to analyze a geometric problem in a paper-pencil environment and in a DGE to explore the problem and validate the solutions proposed by the students. It is defined by a didactical configuration (students organized in heterogeneous working groups, with access to GeoGebra) and exploitation modes (each group

analyzes the problem and proposes solutions using a combination of paper-and-pencil work and GeoGebra; the group is free to ask questions of the teacher and each participant's role is identified).

Data Analysis

The students followed the steps given in the task. Question # 1 can be identified as the phase of data selection, solution strategies and operation to be performed to solve the task:

- A transformation (matrix) that stretches the rectangle horizontally and another transformation (matrix) that stretches it vertically, then a composition of transformations;
- Display a matrix M of 2×2 that $M\overrightarrow{OC} = \overrightarrow{OF}$ and $M\overrightarrow{OA} = \overrightarrow{OD}$ (matrix-vector);
- Display a matrix M of 2×2 that $M\overrightarrow{OC} = 2\overrightarrow{OC}$ and $M\overrightarrow{OA} = \frac{3}{2}\overrightarrow{OA}$ (matrix-vector-scale),
- Discover the matrix M by trial and error with the help of GeoGebra (trial-and-error).

First Case: Cécile.

The components of Cécile's "matrix-vector" scheme were:

Goal: find a linear transformation, such that $T(OABC)=ODEF$	Sub goals: -Identify the possible relations of parallelism and collinearity -Recognize the proportionality constant k ($k \in \mathbb{R}$), such that $\overrightarrow{OF} = k_1\overrightarrow{OC}$ and $\overrightarrow{OD} = k_2\overrightarrow{OA}$ -Check that the result fulfills the conditions of the problem.
Anticipations	Know that you have more than one way to solve the problem--either DGE or paper-and-pencil.
Rules of action	-If I find a matrix that when multiplied by \overrightarrow{OC} , gives \overrightarrow{OF} , then that same matrix must when multiplied by \overrightarrow{OA} , give \overrightarrow{OD} . -If I find a matrix and enter it into GeoGebra, I can test the solution.
Operational invariants	<i>Concepts-in-action</i> - Two vectors are collinear if they can be placed one on top of the other or they are on the same straight line <i>Theorems-in-action</i> - TA1 If when moving the vector \vec{u} both clockwise and counterclockwise, the opening (angle) between the vector \vec{u} and the vector \vec{v} decreases so that the vector \vec{u} superimposes the vector \vec{v} , then the matrix M has an eigenvector - TA2 If the opening (angle) between the vector \vec{u} and the vector \vec{v} does not decrease when the vector \vec{u} moves both clockwise and counterclockwise, then the matrix M does not have an eigenvector.
Possibilities of inference	-If I find a matrix M that when multiplied by \overrightarrow{OA} gives \overrightarrow{OD} , there is a $3/2$ relation.

Table 1: Elements of Cécile's utilization scheme

Cécile began by using the paper-and-pencil technique. From the rectangle $OABC$, she identified \overrightarrow{OA} and \overrightarrow{OC} as the vectors: \overrightarrow{OA} and \overrightarrow{OC} . In the rectangle $ODEF$, she also identified \overrightarrow{OD} y \overrightarrow{OF} as the vectors: \overrightarrow{OD} y \overrightarrow{OF} . She defined a 2×2 matrix which multiplied by the vector \overrightarrow{OA} must give the vector \overrightarrow{OD} , and which multiplied by \overrightarrow{OC} must give the vector \overrightarrow{OF} (see figure 2). From the two systems of linear equations obtained, Cécile grouped the equations with the same unknowns into two 2×2 systems and, after solving the two systems, built the matrix $M = \begin{bmatrix} -19/10 & 39/5 \\ 1/5 & 8/5 \end{bmatrix}$.

$$M = \begin{bmatrix} a & b \\ c & d \end{bmatrix}$$

$$M * OC = OF \rightarrow \begin{bmatrix} a & b \\ c & d \end{bmatrix} \begin{bmatrix} 2 \\ 1 \end{bmatrix} = \begin{bmatrix} 4 \\ 2 \end{bmatrix} \rightarrow \begin{cases} 2a + b = 4 \\ 2c + d = 2 \end{cases}$$

$$M * OA = OD \rightarrow \begin{bmatrix} a & b \\ c & d \end{bmatrix} \begin{bmatrix} -1/2 \\ 1 \end{bmatrix} = \begin{bmatrix} -3/4 \\ 3/2 \end{bmatrix} \rightarrow \begin{cases} -\frac{1}{2}a + b = -\frac{3}{4} \\ -\frac{1}{2}c + d = \frac{3}{2} \end{cases}$$

Figure 2. Cécile's working to find the matrix M

Cécile said she had rarely used GeoGebra in her previous courses, so she requested support from a partner to be able to input the matrix. Afterwards, she input the operations $M * C$, $M * B$ and $M * A$, creating points G, H and I (names automatically assigned by GeoGebra). When entering the operations, she observed that the points obtained did not coincide with the points D, E and F. In fact, she observed that two of the three points did not coincide. She first checked her notes to see if she had made some arithmetic error but was still unable identify the problem, so she turned to the teacher for support. The teacher reviewed Cécile's worksheet and pointed out an arithmetic-algebraic error. Cécile then corrected the solutions to the equation system, obtaining the matrix $M = \begin{bmatrix} 19/10 & 1/5 \\ 1/5 & 8/5 \end{bmatrix}$. Cécile entered this matrix in GeoGebra and performed the operations $D' = M * A$; $E' = M * B$ and $F' = M * C$. This time the points coincided, so the matrix M obtained was considered acceptable.

Proceeding on to question 3, Cécile focused her attention on the edges of the rectangles, mentioning that "while I drag the vector \vec{u} towards the base of the rectangle, the vector \vec{u} follows the vector \vec{v} and reaches it at the base" and "while I drag the vector \vec{u} towards the height of the rectangle, the vector \vec{v} pursues the vector \vec{u} and reaches it exactly at the top." She continued, "when the vector \vec{u} is exactly the same as the base OC, the vector \vec{v} is twice \vec{u} , i.e. if $\vec{u} = (2,1)$ then $\vec{v} = (4,2)$, but when \vec{u} is approximately the base OC, there is a difference of hundredths, between \vec{v} and twice \vec{u} , i.e. if $\vec{u} = (1.13, 0.57)$ then $\vec{v} = (2.27, 1.13)$ (indicated in the Algebraic View). Cécile is able to observe that $\vec{v} = 2\vec{u}$ when $\vec{u} = (2,1)$, and that only then is $\vec{v} = 2\vec{u}$; with other values, she notes, \vec{u} fails to reach twice \vec{u} , due to decimals. Cécile fails to calculate the other eigenvalue and fails to intuit the concepts of eigenvalue and eigenvector.

At this point, we observe that in Cécile's instrumentation process, the tool guides her attention and the instrumentalization process is recognized by the "wandering dragging" functionality. Gol Tabaghi called this dragging modality "*intentional dragging*--which involves dragging a point with the intention of producing a certain configuration" (p. 234).

Second Case: Henry.

The components of Henry's scheme are:

Goal: find a linear transformation, such that $T(A)=D$, $T(B)=E$, $T(C)=F$.	Sub goals: -Identify the possible relations of parallelism and collinearity -Verify that the result fulfills the conditions of the problem.
Anticipations	Know that you have more than one way to solve the problem--either DGE or paper-and-pencil.

Rules of action	- If you succeed in matching point E' with point E, you will have found the matrix M.
Operational invariants	<p><i>Concepts-in-action</i></p> <p>- Two vectors are collinear if they can be placed one on top of the other or they are on the same straight line</p> <p><i>Theorems-in-action</i></p> <p>- If the vectors \vec{v} and $M\vec{v}$ are linearly independent, then the matrix M does not have an eigenvector</p> <p>- If the vectors \vec{v} and $M\vec{v}$ are linearly dependent, then the matrix M has an eigenvector.</p>
Possibilities of inference	- If the vectors \vec{v} and $M\vec{v}$ are dependent, then $\lambda = \ M\vec{v}\ /\ \vec{v}\ $.

Table 2: Elements of Henry's utilization scheme

Henry used a trial-and-error scheme with DGE. Since Henry had experience with GeoGebra, he created four sliders-- x_1 , x_2 , x_3 and x_4 --and then, with the sliders, he created a 2×2 matrix M : $M = \{\{x_1, x_2\}, \{x_3, x_4\}\}$. The interval that he defined for the four sliders was -5 to 5, increments of 0.1; finally he introduced the three points E', D' and F' (see figure 3).

Henry commented that if he could match point E' with point E, the other points (D' and F') would be superimposed as well. On his first attempt, Henry managed to match point E' with point E (see figure 3), but contrary to what he thought, the other two points (D' and F') did not overlap. Subsequently, through trial and error, by moving the sliders, he managed to obtain the matrix M. Henry mentions that the elements of the matrix are decimals, which could cause the points to "overlap, but they are not equal." At this point we believe that Henry saw points E and E' overlapping, and noted that their values were the same in Algebraic View (3.25, 3.25), but the E and E' do not overlap exactly, i.e., they show a slight offset. Henry then turned to the GeoGebra *Relation*¹ tool to verify that they were in fact the same. He did not use paper-and-pencil.

To resolve question 3, since Henry had already entered the matrix M in GeoGebra, he entered only the vector $u = \text{Vector}((1,1))$ and $v = \text{Vector}(M * u)$. Then he began to drag \vec{u} clockwise. Henry used the "Algebraic View" in GeoGebra to observe the numerical values and relied on the Relation tool to explore the relationships between \vec{u} and \vec{v} . As the vector \vec{u} was brought closer to the \overline{OC} segment, he used the Zoom tool to make sure that they were able to overlap, and continued until the two vectors \vec{u} and \vec{v} lay one on top of the other. Henry said: "of course, \overline{OC} and \overline{OF} are collinear," and to avoid further approximation he modified the vector $u = (2,1)$. "When \vec{u} is (2,1)," Henry continued, "the vector \vec{v} is twice \vec{u} ." He then wrote $M\vec{u} = 2\vec{u}$, stating that 2 is λ . With this same analysis he once again modified the value of $u = (-0.5,1)$ and said: "uff, they're decimals, I think the value is...I'd better check it..." Henry then used the *Distance or Length* tool to calculate the norm of \vec{u} and \vec{v} . And after calculating the rules he said that in fact $\lambda = 1.5$.

¹ This command shows, in a message box, the relationship between two objects. It allows you to verify whether two lines are perpendicular/parallel, two (or more) objects are equal, or three points are collinear, among others. (https://wiki.geogebra.org/en/Relation_Command)

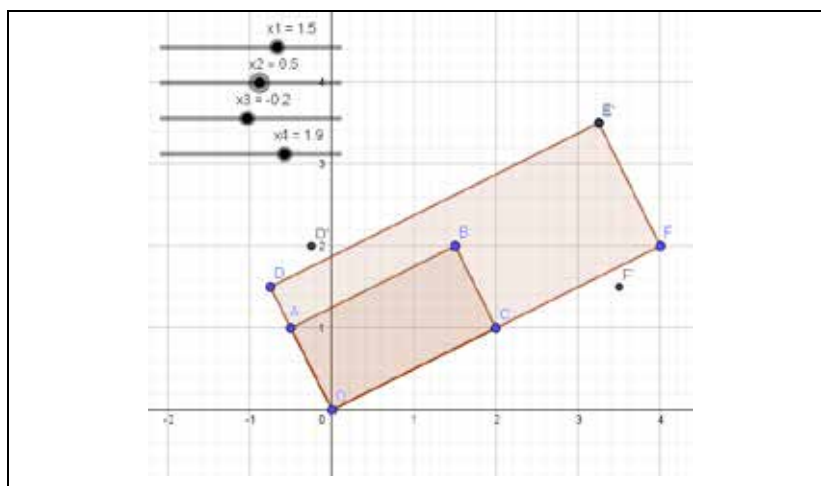


Figure 3. Henry's technique for finding the matrix M

Once finished, Henry began working with the "matrix-vector-scalar" scheme using paper-and-pencil. In obtaining the linear equation systems, Henry represented the systems as lines in the plane and obtained the values through their intersections, concluding satisfactorily with the matrix M. We conclude that Henry displays a good level of instrumentation and instrumentalization of the DGE.

Preliminary conclusion

Using the above tasks, we were able to observe the schemes that students develop, and the difficulties they may encounter, when using the concepts of eigenvalue and eigenvector before formally addressing them in class and when the problems arise outside the context in which they have been taught (given a matrix, obtain its eigenvalues and eigenvectors). The conceptualization of eigenvalues and eigenvectors is a long and continuous process, in which the teacher plays an important role by carefully choosing situations that allow the mathematical knowledge to be meaningful. We believe that the success of Henry's scheme was possible because the elements of the matrix M are exact, and they lay within the interval that he had defined from the beginning (-5 to 5). When dragging \vec{u} and observing the change in \vec{v} , the participants were prompted to look for relationships between these two objects and relate them to the matrix obtained. The use of GeoGebra helped Henry with his conceptual difficulties, while Cécile showed a better conceptual knowledge, relying on geometrical thinking. In this experience we were unable to determine whether the students recognized the existence of an infinity of eigenvectors associated with each eigenvalue. Our future research will study two questions: What orchestrations can help the teacher foster the students' development of conceptual knowledge? And, how can students be helped to recognize how many different eigenvectors are associated with a given eigenvalue?

Acknowledgment

We are grateful to Prof. Christian Mercat and the students of the University Claude Bernard Lyon 1, for allowing us to conduct this research.

References.

Alqahtani, M. M., & Powell, A. B. (2017). Teachers' Instrumental Genesis and Their Geometrical Understanding in a Dynamic Geometry Environment. *Digital Experiences in Mathematics Education*, 3(1), 9–38. <https://doi.org/10.1007/s40751-016-0025-5>

- Artigue, M. (2002). Learning Mathematics in a CAS Environment: The Genesis of a Reflection about Instrumentation and the Dialectics between Technical and Conceptual Work. *International Journal of Computers for Mathematical Learning*, 7(3), 245–274.
- Arzarello, F., Olivero, F., Paola, D., & Robutti, O. (2002). A cognitive analysis of dragging practises in Cabri environments. *Zentralblatt Für Didaktik Der Mathematik*, 34(3), 66-72.
- Carlson, D., Johnson, C. R., Lay, D. C., & Porter, A. D. (1993). The Linear Algebra Curriculum Study Group Recommendations for the First Course in Linear Algebra. *The College Mathematics Journal*, 24(1), 41-46. <https://doi.org/10.2307/2686430>
- Dorier, J.-L., & Sierpinska, A. (2001). Research into the Teaching and Learning of Linear Algebra. En D. Holton, M. Artigue, U. Kirchgräber, J. Hillel, M. Niss, & A. Schoenfeld (Eds.), *The Teaching and Learning of Mathematics at University Level* (Vol. 7, pp. 255–273). Dordrecht: Kluwer Academic Publishers. https://doi.org/10.1007/0-306-47231-7_24
- Gol Tabaghi, S. (2014). How Dragging Changes Students' Awareness: Developing Meanings for Eigenvector and Eigenvalue. *Canadian Journal of Science, Mathematics and Technology Education*, 14(3), 223-237. <https://doi.org/10.1080/14926156.2014.935528>
- Guin, D., Ruthven, K., & Trouche, L. (Eds.). (2005). *The Didactical Challenge of Symbolic Calculators* (Vol. 36). New York: Springer-Verlag. <https://doi.org/10.1007/b101602>
- Lay, D. C., Lay, S. R., & McDonald, J. (2016). *Linear algebra and its applications* (Fifth edition). Boston: Pearson.
- Meel, D. E., & Hern, T. A. (2005). Tool Building: Web-based Linear Algebra Modules. *Journal of Online Mathematics and Its Applications*, 5. Retrieved at <https://www.maa.org/node/115792>
- Rabardel, P. (2002). *People and technology: a cognitive approach to contemporary instruments (translated by Heidi Wood)*. Paris 8 University. Retrieved at <https://hal.archives-ouvertes.fr/hal-01020705>
- Robert, A., & Robinet, J. (1989). Quelques resultats sur l'apprentissage de l'algebre lineaire en premiere année de DEUG. *Cahier de didactique des mathématiques*, 53.
- Trgalová, J., Clark-Wilson, A., & Weigand, H.-G. (2018). Technology and resources in mathematics education. En T. Dreyfus, M. Artigue, D. Potari, & S. Prediger (Eds.), *Developing research in mathematics education: twenty years of communication, cooperation, and collaboration in Europe* (pp. 142–161). Oxon: Routledge.
- Trouche, L. (2004). Managing the Complexity of Human/Machine Interactions in Computerized Learning Environments: Guiding Students' Command Process through Instrumental Orchestrations. *International Journal of Computers for Mathematical Learning*, 9(3), 281-307.
- Trouche, L. (2014). Instrumentation in Mathematics Education. In S. Lerman (Ed.), *Encyclopedia of Mathematics Education* (pp. 307–313). Dordrecht: Springer Netherlands.
- Vergnaud, G. (1998). A comprehensive theory of representation for mathematics education. *The Journal of Mathematical Behavior*, 17(2), 167–181.

Why digital tools may (not) help by learning about graphs in dynamics events?

Sonia Palha

Amsterdam University of Applied Sciences, Centre for Applied Research on Education (CARE),
Amsterdam, The Netherlands; s.abrantes.garcez.palha@hva.nl

Understanding graphs representing dynamic events is a challenge for many students at all levels. And technological tools can provide support in overcoming some of these difficulties. In our research we developed a digital tool that enables students to create, modify and improve graphs from dynamic events using interactive animations and intrinsic feedback. In order to get insight about why the tool helped (or not), the students we conducted a qualitative study in which we interviewed nine students who used the tool. The results offer insight in students' learning and thinking about dynamic graphs and how digital feedback can afford that. These results are useful for researchers, developers and teachers.

Keywords: visualization, intrinsic feedback, graphs, interactive tool, learning with technology.

Introduction

Dynamic graphs remain an essential subject at all levels of High School in mathematics, but it remains a challenging topic for students and even for teachers (Carlson, Larsen, & Lesh, 2003; Moore & Carlson, 2012). Reasons behind students' difficulties frequently involves problems in visualizing change and variation, limited understanding of functions and co-variational reasoning. Moreover the construction of a global graph from a realistic situation and stretch is similar to mathematical problems solving and requires mathematical thinking (Moore & Carlson, 2012; Thompson, 2011). Digital tools can support students to deal with these difficulties in several ways. Dynamic software as Geogebra and applets can support students in visualizing relations through enabling them to draw, move and modify graphs within different representations. And interactive applications that connects animations and graphs can be used to explore relationships between phenomena, and it's graphical representation. The learning potential of dynamic tools can be highly improved by including possibilities for students interaction with the tool like students' own productions and incorporated feedback-features (Laurillard, 2013). However, this also put more demands on the tools' design especially when they build upon students free-hand productions. More knowledge and research on students learning with this type of tools are needed to inform tool-developers and teachers.

Interactive Virtual Math (IVM) is an example of such a tool. It generates and builds upon students free-hand graphs, and it has incorporated feedback. The tool was developed through developmental research (Palha & Koopman, 2016) with the aim to improve students' learning about graphs by dynamic events. The tool creates opportunities for students to experience the thinking and reasoning that is needed to generate, revise and modulate a graph from themselves. When entering the tool they get tasks that encourages them to imagine two variables changing simultaneously. The tool requests the students to produce the graphical representation and the verbal explanation for this relation, which requires students to represent their concept image graphically and verbally. With the

help of the incorporated feedback, the student is challenged to think, reason and act upon his own construction. This is an innovative pedagogical feature of the tool that requires deep knowledge to be developed properly. The tool also includes the use of Virtual Reality (sound, movement, interaction), which is however very limited, but it is expected to improve the experience of the graphic situation.

Previous research (Palha, 2017) about IVM shows that students (age 13-17) find the tool useful because it assists them to improve graphs and/or to gain a more thorough understanding of the subject. The study was a teaching experiment involving three classes at secondary and one class at tertiary education in The Netherlands that used IVM during one lesson (45-50 minutes). Seventy-nine students reported through questionnaires about their experience with the tool and what supported them the most. However, this data didn't provide us much in depth knowledge about the way students improved their graphs and why. During the experiment we also interviewed nine students, and we collected their backlog files in the tool. This data has been analyzed recently, and it provides us with new insights on learning with the tool.

In this paper we report the results of these qualitative analyses. We use the framework for covariational reasoning of Carlson, Oehrtman, & Engelke (2010) and the notion of intrinsic feedback (Laurillard, 2013) to interpret and evaluate the way students utilized the tool. The guiding research question is: how does the tool enable students to improve their graphical representation and/or understanding about dynamic events?

Theoretical background

Learning about dynamic graphs

An example of a dynamic event is the following situation: imagine a bottle filling with water. Sketch a graph of the water's height in the bottle (Carlson et al., 2010). To solve the bottle-task, the students will need considering how the dependent variable (height) changes while imagining changes in the independent variable (volume). The coordination of such changes requires the ability to represent and discern relevant features in the shape of the graph. These mental actions are in the core of covariational reasoning and are clearly defined in the framework of Carlson et al., (2010). The authors define covariational reasoning as entailing five mental actions: (M1) coordinating the value of one quantity with changes in the other; (M2) coordinating the direction of the change; (M3) coordinating the amount of change of one quantity while imagining successive changes in the other quantity; (M4) coordinating the average rate of change of the function with uniform increments of change in the input variable; (M5) coordinating the instantaneous rate of change of the function with continuous changes in the independent variable for the entire domain of the function.

Several researches (Thompson, 2011; Saldanha & Thompson, 1998; Castillo-Garsow, Johnson, & Moore, 2013) reported students' difficulties in engaging with the mental activities M4-M5. These students also have difficulty explaining why a curve is smooth and what is conveyed by an inflection point on a graph. According to Carlson et al., (2010). Students should have opportunities to experience the covariational nature of functions by dynamic events. Thompson (2011) too states it is critical that students first engage in the mental activity to visualize a situation and construct relevant quantitative relationships prior to determining formulas or graphs. Ellis (2007) suggests

that learners should be helped to focus on quantities and generalizations about relationships, connections between situations and dynamic phenomena.

Intrinsic feedback

Technological tools can be designed to help to create a learning environment that fits the characteristics mentioned in the previous section. The learning environment that we have in mind involves learning from experience and by reflection on ones' own productions. These are underlying ideas in theories that account learning as an active and social process. With the use of specific type of tasks, students can translate their concepts into practice. They can compare and evaluate how well they achieve some learning goal. And employ this to improve their initial concept and practice and develop knowledge (Laurillard, 2013).

Digital tools with capability to provide intrinsic feedback can assist students with learning because they: (i) enable the students to modulate their concept image and generate actions that brings them nearby a goal and; (ii) use the feedback of the tool to modulate their practice and revise their actions. According to the framework of Laurillard learning occurs when students engage in a successive cycle involving these actions. Actions and feedback drive the internal modulate-generate cycle that links the students' conception to their repertoire of actions as practice. Through reflective observation students can modulate the abstract concept in the light of concrete experience and generate new actions as active experimentation (p.168).

The prototypical tool IVM aims at creating a practice environment for the learning about graphs by dynamic events, in which student engage in the internal successive cycles described above. Moreover, the tool incorporates features designed to engage students in modulate-generate-revise actions that foster the development of covariational reasoning Carlson et al. (2010). With the tool there is a sequence of trials, mostly with a cyclic character that need to occur and be repeated to assure learning (see table 1 with the description of the tool).

Self-construction -task

Task	the tool sets a task to construct a graph from a non-trivial dynamic event
Learner	the learner draws a graph by the dynamic event and explains his/her thoughts

Compare -task

Task	The tool displays a second task with a dynamic event that corresponds to the more common mistake made by learners with regard to this type of task
Learner	The learner uses the comparison to draw (if needed) an improved graph and/or adapt the explanation
Task	The tool offers a menu in which students can choose between seeing help or to submit their graph

Help 3D-animation (optional)

Learner	The learner chooses help 3D-animation
Task	The tool displays an animated version of the dynamical event in which the same amount of water is added each time student presses a button
Learner	The learner notices that the height of the water increases in the jar and that, for the same amount of added water, the incremented heights are different and depending on the form of the jar; the learner reflects on these relations and becomes aware that the increment of the height is smaller when the jar is broader -in the middle and larger in the extremities. The learner uses the visualization to draw (if needed) an improved graph and/or adapts the explanation

Help interactive animation (optional)

Learner	The learner choose help interactive animation
Task	The tool displays an animation of the dynamical event and an empty cartesian graph in which the learner can move given dots to the estimated height every time the same amount of water is added; both actions, adding the water by pressing a button and moving the dot are performed by the learner.
Learner	The learner moves vertically the first dot to the position he/she thinks that the height of the water will reach and then press the button. The water fills in the jar at a certain height. The learner compares the estimated and the reached height and uses the comparison to move the dot to a more precise location.
<i>Feedback at the end- reward feature</i>	
Learner	The learner submits his/her solution
Task	The tool displays the figure of the jar corresponding to the learner drawings
Learner	The learner compares the form of the jar with the initial form and reflects on the differences and similarities and on the relation between the graph and the shape of the jar. The learner can go again through the tool and use the visualization to draw an improved graph and/or adapt the explanation

Table 1: description of the tool Interactive Virtual Math (IVM)

Method

We interviewed nine students from 10th and 11th grade who utilized the tool in the classroom: two boys (Niels and Abel) and two girls (Miriam and Jenny) from school A, 11th grade, 16-17 years-old; two girls (Olivia and Anne) from school B, 10th grade, 15-16 years-old and two boys (Gerry and Arion) and one girl (Manon) from school C, 10th grade 16 years old. In schools A and B students utilized a computer and construct the graph with the mouse. In the school C school students used a Iphone and draw with the finger. The interviews were semi-structured and focus on the way students used the tool and the reasons to modify or not the original graph. The interviews were performed by the author of this paper or by the teacher. They took about 5-10 minutes per student and were recorded in audio. Additional data included the results of a survey conducted during the lesson and the students productions registered in the tool self (backlog of the tool). The data analysis was qualitative and based on the covariational framework van Carlson et al. (2010) and the notion van learning cycles from Laurillard (2013).

Findings

Students transformed an incorrect graph into a correct graph with the tool (n=5)

To draw a correct graph students need to coordinate the average rate of change of the height as function of the volume and imagining it changing instantaneously with continuous changes in the independent variable (levels MA4 and M5 of the covariation framework). Analysis of the backlog of the tool showed that five from the nine students generated a correct graph, but only after a second or third trial. In their first trial these students sometimes draw straight lines instead of curves or draw a concave up-down graph instead of a concave down-up or an inaccurate global shape. This suggests that the students could reason at the levels MA2 or MA3 of the covariation framework at the start of the assignment. In the interview students were asked to explain how they transformed their graph and why they transformed it. Table 2 provides an overview of the way students engaged in the learning cycle and generated, modulated and revised their initial graph with the tool.

Students	How and why the graph was transformed and which tool-features enabled this
Jenny	Jenny <i>modulated her concept image</i> and <i>generated a better-shape graph</i> after two trials. The student used the feedback from the reward-feature to <i>revise</i> and <i>modulate the steepness</i> of the curves.
Niek	Niek <i>modulated his concept image</i> in two trials. The student used the feedback from the reward-feature to <i>revise</i> and <i>modulate</i> a concave up followed by a concave down graph into a correct graph.
Abel	Abel <i>modulated</i> his concept in two trials. The student used the feedback from the reward-feature to transform part of the graph (an increasing straight line) into a concave down curve.
Gerry	Gerry <i>modulated</i> his concept in three trials. The student used feedback from the reward-feature and help 3D-animation to <i>revise</i> and <i>modulate</i> three increasing straight lines into a concave down followed by a concave up curve and to improve the shape of the graph.
Manon	Self-construction of the graphs (with no formula) enabled Manon to reflect before drawing the graph and therefore <i>modulate her concept image</i> ; feedback from the reward-feature enabled her to <i>generate and revise</i> actions as she improved her graph. Both help-features were consulted but not used.

Table 2: the tool enables students to produce a correct graph with the tool (n=5)

All five students realized that their graph was not correct because of the feedback from the reward-feature. One student, Niels explained:

"when I saw the feedback at the end (...) you can work towards a nice graph and you know how it really should look like, because you know that at a certain point will be slower than elsewhere (...) " when your vase is inside you know that then you have to go to the other side (...) so first slowly and then faster instead of first faster and then slower "

Manon found the tool very instructive especially because the self-construction- task that challenged her to generate an action from her practice repertoire and reflect on it:

"I was already ready to put something in the Graphic Calculator or to do something like that. But this was not possible in this case and I really had to think: ok, what is happening here? what happens in the middle? what happens there ... and that I found very instructive"

Also Gerry, mentioned the self-construction task as a useful feature to visualize the graph.

"You start without having an idea of what looks like; you try to imagine yourself and then when you see the film you realize that it is very different from what you had thought up"

Gerry felt also helped by help 3D-animation and he explained why:

"you saw in the animation (3D) the round shape of the bowl and you saw better how the water was distributed. In the beginning that a lot more space had been taken and in the middle there is much wider and because of that the graphs were very different "

Further, all the students with exception of Abel considered that because of the tool they understand the subject better; Abel considered that he already understood the subject.

Students realized they had an incorrect graph and did not succeed in transforming their graph into a correct one with the tool (n=3)

Three of the nine students (Olivia, Anne and Arion) have done two, sometimes three trials with the tool but were unsuccessful to generate a correct graph. Analysis of the backlog of the tool showed

that the students initially generated a graph with one or more straight lines, which corresponds to M2 in the covariational framework. Interviews with the students provided us with more insight about how students revised and modulated their graphs (Table 2).

Students	How the graph was transformed and which tool-features enabled this
Olivia	The first trial is an increasing straight line, the second trial is a concave down line and third trial is a concave up. The comparison-task and the feedback from the reward-feature enabled student to <i>modulate</i> her concept in the sense that the lines should not be straight. Olivia <i>generates</i> and <i>revise</i> actions when she produces new graphs with curves. She <i>revised</i> and <i>modulate</i> her graph but <i>she could not generate</i> a correct graph
Anne	In the first and second trial the graph is an increasing straight line and the slope of the second trial is smaller. The feedback from the reward-feature and help-3D animation enabled Anne to (<i>partially</i>) <i>modulate</i> her concept as she realized that the lines should not be straight. She <i>revised</i> and <i>modulate</i> her graph but <i>she could not generate</i> a correct graph.
Arion	In the first and second trials the graph has three increasing straight lines. The feedback from the reward-feature enabled student to <i>modulate</i> his concept: that the graph should not have straight lines. However, for technical reasons the student could not work with the tool and use the feedback to improve his graph.

Table 3: the tool enables students to realize their mistake but not to improve it (n=3)

Olivia considered that the tool helped her to improve the graph and she explained why:

“it really helped that in the end I converted my drawing into that shape, as a sphere because I saw a bit connection” (...) “If there is no straight line then there must be a concave up line or a concave down line – I will try both.

Olivia didn’t used the help-features because she doesn’t think that it would be useful to achieve her goal of drawing a correct graph. The visualization of the context is not the problem according to the student but the fact that she can’t draw the graphical representation:

“I went very often trying the tool because I was curious (...) with the movies I do not know much what I had to show”

The other two students did not consider that the tool helped them to improve the graph. Anne because the straight line remained a straight line and Arion because the tool didn’t work well and he could not keep trying (there were in some smartphone technical problems). For these students the intrinsic feedback provided by the tool enabled them to engage in the modulate-generate cycle and modulate their initial concept image towards a more sophisticated one (although not yet correct).

Students realized they had an incorrect graph but did not do nothing about it (n=1)

Miriam was the only student who produces an incorrect graph and did not invest effort to improve it with the tool. In her initial trial she constructs an incorrect graph with three straight increasing lines, which corresponds to the mental action M3 in the framework covariational reasoning. She didn’t consult the help-features. In a second trial Miriam worked with a peer-student who produced a similar graph to her but with curves instead of straight lines. Noticing the difference enabled the student to *revise* and *modulate her concept image*. Additionally, her graph was discussed by the teacher in the classroom. This student only engaged in the learning cycle when the intrinsic feedback of the tool was combined with extrinsic feedback of a peer student and from the teacher.

Conclusions and discussion

Learning dynamic graphs at secondary school represent a challenge for many students. In this study we investigate how and why the IVM-tool enabled students to improve (or not) their graphical representation of a dynamic event. We have seen that all nine students failed to produce a correct graph in a first trial with the tool. Five of these students could improve their initial graph and produced a correct graph in their subsequent trial. The features of the tool that supported them the most were to see the bottle-form correspondent to their graph at the end (reward-feature) and the opportunity to self-construct the graph, because it challenged them to think and try to imagine how the graph it would be. One student referred also to the animation 3D, which have encouraged him to imagine better “how the water was distributed” in the bottle and with relation to the graph. Three other students have tried improving their initial graph with the tool and although they could not produce a correct graph the tool seemed to have helped them to improve their thinking, as they became aware that the graph should not be linear or contain linear parts. They conclude this because of the reward-feature and in combination with other features (comparison-task or with the animation help-3D). One student only improved her graph when this was combined with extrinsic feedback from peer-student and the teacher.

Reflecting upon these results, we realize that even though the tool showed potential to engage students in thinking about mathematical graphs this was insufficient for all the students to generate an appropriate representation. These students realized with the help of the tool what they have done wrong and the feedback maintained them on the task. But the students did not successfully use these and other features of the tool to move forwards. Why did the tool not help the students? Analysis with the covariational framework suggests the three students possessed a limited understanding of covariational reasoning. What can seem to be a reason for students' difficulty in imagining the change of the height varying as function of the volume and (Thompson, 2011; Carlson et al., 2010). The tool contains two animations that were explicitly designed for students to engage in covariational thinking: the animation 3D and the interactive animation. But as our results showed none of the students consulted it or they only did it superficially. We cannot therefore comprehend how these features could have supported the students. Another feature of the tool that we had expected to help the students was the reward-feature and, in a certain way it did. The feedback assisted students to realize they were not constructing the correct graph but did not provide other directions or explanations that help them forwards. This is an aspect that requires further thought and investigation. In addition, expanding the tool with more tasks and different contexts is needed in order to offer students enough opportunities for exploring and practice covariational thinking and reasoning.

This study extends previous research about learning dynamic graphs and covariational reasoning. It adds knowledge about students thinking in contexts of change and their difficulties in constructing graphs from themselves. The results provide directions to improve the instructional environment of IVM that can be useful for teachers and researchers interested in using the tool. Further research is needed to gain more insight in the help-features and to improve the intrinsic feedback. We also need to investigate the learning with the tool in larger settings: with more students, teachers and

whole classrooms. The prototypical version of the tool presented at CERME 11 is available at <https://app.dwo.nl/dwo/apps/player.html#570660>.

References

- Carlson, M., Larsen, S., & Lesh, R. (2003). *Integrating a models and modeling perspective with existing research and practice. Beyond constructivism: Models and modeling perspectives on mathematics problem solving, learning, and teaching*, 465-478. Routledge.
- Carlson, M., Oehrtman, M., & Engelke, N. (2010). The precalculus concept assessment: A tool for assessing reasoning abilities and understandings. *Cognition and Instruction*, 28(2), 113-145.
- Castillo-Garsow, C., Johnson, H. L., & Moore, K. C. (2013). Chunky and smooth images of change. *For the Learning of Mathematics*, 33(3), 31-37.
- Ellis, A. B. (2007). The influence of reasoning with emergent quantities on students' generalizations. *Cognition and Instruction*, 25(4), 439-478.
- Laurillard, D. (2013). *Teaching as a design science: Building pedagogical patterns for learning and technology*. Routledge.
- Palha, S. (2017). Students learning with Interactive Virtual Math: an exploratory study in the classroom. *Ensino e Tecnologia em Revista 1 (1)*, p.80-102. ISSN: 2594-3901.
- Palha, S., & Koopman, S. (2016). Interactive Virtual Math: a tool to support self-construction graphs by dynamical relations. *Proceedings of CERME10* will be available at HAL archives website: <https://hal.archives-ouvertes.fr/>
- Moore, K. C., & Carlson, M. P. (2012). Students' images of problem contexts when solving applied problems. *The Journal of Mathematical Behavior*, 31(1), 48-59.
- Saldanha, L., & Thompson, P. W. (1998). *Re-thinking co-variation from a quantitative perspective: Simultaneous continuous variation*. In S. B. Berensah & W. N. Coulombe (Eds.), *Proceedings of PME- North America*. Raleigh, NC: North Carolina State University.
- Thompson, P. W. (2011). Quantitative reasoning and mathematical modeling. In L. L. Hatfield, S. Chamberlain & S. Belbase (Eds.), *New perspectives and directions for collaborative research in mathematics education*. (Vol. 1, pp. 33-57). Laramie, WY: University of Wyoming

Learning environments applying digital learning tools to support argumentation skills in primary school: first insights into the project

Melanie Platz

University of Siegen, Department of Mathematics, Mathematics Education, Germany;

platz@mathematik.uni-siegen.de

Based on a cooperative project between the Europe University Flensburg, the University of Koblenz-Landau and the University of Siegen (Germany) on the development of an open source electronic mathematical proof system (cf e-proof.weebly.com), a new project has evolved with a focus on primary education. The aim of this project is to support argumentation skills through the iconic and enactive visualization of reasoning processes. The focus is on supporting classical teaching and learning processes in primary education with digital learning environments. Grounded in the philosophy of pragmatism, Design Science research is performed for creating learning environments applying digital learning tools to support argumentation skills in primary school as artifacts. In this paper the first developed learning environment is presented and insights into the results of an empirical pilot study investigating the learning environment are given.

Keywords: Educational media, primary schools, argumentation.

Introduction

The demand of the Standing Conference of the Ministers of Education and Cultural Affairs of the Länder in the Federal Republic of Germany (KMK) is supposed to be addressed in this research project, that in dealing with the digitization of education the “primacy of the pedagogical” (KMK, 2016, p. 51) has to be followed and must be incorporated into educational concepts in which learning is in the foreground (KMK, 2016). Consequently, the potential of digital media for teaching can only unfold, if it is used in a meaningful and an educational reflected way. In this sense, a project on the development of learning environments applying digital learning tools to support argumentation skills in primary school is performed. The scope of this project is to identify opportunities and possibilities, as well as challenges and limitations of learning environments including digital media to support argumentation skills through the iconic and enactive visualization of reasoning processes and their influence on student learning. “In mathematics education, the teaching of reasoning skills plays a major role. These skills form the basis for proofs of mathematical statements and contexts dealt with in higher school-grades in different contexts. It is especially logical reasoning that supports the formation of understanding.” (Platz et al., 2017, p. 2). Wuttke (2005) performed a study, comparing different forms of educational communication in relation to their influence on the generation of knowledge and understanding among the pupils. This study has shown that it is in particular the argumentation in that a variety of connection possibilities to the students’ prior knowledge is provided through the exchange of different and well-founded perspectives, which therefore contributes particularly to understanding (cf. Budke & Meyer, 2015). In the present paper, a first draft version of a learning environment including an applet to be run on a hand-held device with internet-connection and touch-screen, e.g. a tablet PC, is presented. Design Science is performed for learning environment creation. The TPACK-Framework (cf. Koehler & Mishra, 2009) is applied to analyze the developed

learning environment and first insights into the results of an empirical pilot study investigating the learning environment are given.

Objectives

The aim of the overall project is to create learning environments to support argumentation skills through the iconic and enactive visualization of reasoning processes. A central media aspect is to make the handling with teaching and learning material computer-detectable and thus, to infer optimized learning environments. The focus is on supporting classical teaching and learning processes in primary education with both digital and non-digital learning environments.

The objectives of this paper are to

1. employ the TPACK-Framework (cf Koehler & Mishra, 2009) to analyze the developed first draft of a learning environment applying digital learning tools to support argumentation skills in primary school.
2. give an insight into the results of an empirical pilot study investigating the first draft learning environment.

Research Method

In order to optimize the learning environment, Design Science is applied. Design Science is grounded in the philosophy of pragmatism and creates artifacts which is something created by humans usually for a practical purpose. The learning environment applying digital learning tools to support argumentation skills in primary school is a method (artifact) (cf. March & Smith, 1995) to support pupils in gaining argumentation skills. Within the meaning of the Design Science Research Methodology Process according to Peffers et al. (2006), a problem was identified and an objective for a proposed solution was formulated (see sections “Introduction” and “Objectives”) for the first run of the process. Furthermore, an initial prototype was generated (see section “The developed Prototype and the TPACK-Framework”). For demonstration, the prototype (learning environment applying digital learning tools to support argumentation skills in primary school) was tested in an empirical pilot study (see section “The Empirical Pilot Study”) and first evaluation results are presented. The results are communicated among others through this paper. Through the first iteration of the process the prototype will be optimized.

The developed Prototype and the TPACK-Framework

Koehler and Mishra (2009) describe the TPACK (Technology, Pedagogy, And Content Knowledge) framework as a complex interaction between three sets of knowledge: content, pedagogy, and technology. The interaction of these sets of knowledge, both theoretically and in practice, generates the kind of flexible knowledge needed to successfully integrate technology into the classroom (Koehler & Mishra, 2009). In contrast to the original purpose the TPACK framework was designed for, i.e. to be used as an analytical framework for a teacher’s different types of knowledge, it is used in a broader way as a framework that refers to knowledge in general. Taking a closer look at the developed first draft of a learning environment applying digital learning tools to support argumentation skills in primary school, an interaction of technology, pedagogy and content knowledge becomes visible. In the following sections, the learning environment is analyzed

concerning the Pedagogical Content Knowledge (PCK), the Technological Content Knowledge (TCK) and the Technological Pedagogical Knowledge (TPK).

Pedagogical Content Knowledge (PCK): Mathematical Proofs in Primary School

The main task the pupils are concerned with in the empirical pilot study is the following¹:

Task: *If you add two odd numbers together, you always get an even number.
Is that correct? Give reasons!*²

With respect to the argumentation chain developed by Bezold (2009) by formulating the task in this way, the pupils have to question the special attributes and find reasons or respectively reasoning ideas to solve the task. Krummheuer and Fetzner (2005) hold the opinion that proofing in the strictly deductive sense is not yet possible in primary school, but substantial mathematical argumentation (cf Toulmin, 1958, p. 116) can be implemented. Due to Kothe (1979), primary school children have fun on problem solving with appropriate instructions. Here, proof need is: “I want to show the teacher or classmates that my approach is right” (Kothe, 1979, p. 276). The awakening of a need for proof in primary education requires long-term didactic planning to seek opportunities for local sensitization to mathematical thinking, (Kothe, 1979). Semadeni (1984), describes an action proof as “a simplified version of a recommended way in which children can convince themselves of the validity of a statement; in practice, an action proof will require some preliminary or additional exploration”, (Semadeni, 1984, p. 32). In this study, the preformal proof according to Blum and Kirsch (1991) is focused with the aim to find a way to include proofs in primary education: In accordance with the concept of action proofs (cf Semadeni, 1984), a preformal proof can be defined as a chain of formally represented conclusions which refer to valid, not formally represented conclusions which refer to valid, non-formal premises. In contrast to the definition of an action proof, inductive arguments (“etc.”) and indirect arguments (“imagine that ...” or “what would happen if ...”) should not be excluded in this context. The conclusions must be capable of being generalized directly from the concrete case. If formalized, they have to correspond to correct formal-mathematical arguments. To accept a preformal proof it is, however, not necessary for such a formalization to be actually effected or even recognizable. Occasionally, the consensus within the mathematical scientific community is quite sufficient. Preformal proofs have to be valid, rigorous proofs, (Blum & Kirsch, 1991). The concept of a preformal proof is comparable to the concept of the operative or “intuitional” (or “inhaltlich-anschaulich”) proof (“see-proof”), (cf. a.o. Wittmann, 2014, p. 226). To describe the differences and relationships between proof and argument, Pedemonte (2007) refers to Peirce and Polya:

¹The worksheet can be found at the following link: http://www.melanie-platz.com/ES_1/Task_even-and-odd.pdf. In contrast to e.g. Wittmann & Müller (2013a), the formulation of the task is meant to be more open to enable more variety in the solution methods, as the structure of double rows is not unconditionally necessary, when operating with pairs of tiles.

²An example on how a preformal proof for the **Task** above could look like is made available at the following link: http://www.melanie-platz.com/ES_1/Preformal-Proof_even-and-odd.png

the logical connection between statements in an argumentation differs from the logical connection in a proof. Each step of a proof can be described as a deductive step. But argumentation structure is unlikely to be a deductive structure; it can be composed of steps of different nature, such as abductive steps or inductive steps. (Pedemonte, 2007, p. 29)

Pedemonte (2007) derives, that a structural change is required for the construction of a deductive proof, that is from abductive or inductive steps to deductive steps. To enable a support of argumentation skills, the pupils worked together in groups of two, to foster communication between the pupils. Communication is important to gain argumentation competences, as one aspect pupils should learn is to respond appropriately to reasoning in interaction with others (Budke & Meyer, 2015).

Technological Content Knowledge (TCK): reversible tiles as representation

The reversible tile applet is a prototype of a freely available JavaScript-applet developed by the author of this paper, which allows the virtual laying of (reversible) tiles. The applet is available at <http://www.melanie-platz.com/WPA/>. Tiles are a fundamental means of representation in primary education (cf. Wittmann, 2014). Based on the categorization of Krauthausen (2018), the tiles are used in the function of working material and illustrations as argumentation and proving tool. Wittmann (2014), states that this material is from its origin not didactic, but of epistemological nature. The preformal proof stimulated by the *Task* mentioned above is not grafted from the outside, but deeply connected with the nature of numbers. Around 600 BC, Pythagoras and his students discovered and proved universal number-theoretic patterns when laying stones (Wittmann, 2014; Wittmann & Müller, 2013b). “It can be said without exaggeration that stones (tiles) form the cradle of number theory” (Wittmann & Müller, 2013b, p. 142).

Technological Pedagogical Knowledge (TPK): The reversible tile applet

The developed applet is especially suitable for digital devices with touchscreen display (e.g. tablet PCs), which allow a control through touch gestures with the fingers. The tiles in the app are created similar to the analogue tiles. Because of the two-dimensionality of the screen, the tiles are also two-dimensional and cannot be lifted up, as it is the case with the analogue tiles. In the case of the present study, the tool is used in the sense of activist learning as an illustrative tool and to be given to the learners as tool of their own mathematical activity (cf. Krauthausen, 2018). In order to ensure a certain openness of the use of the applet, no structuring aids are given. The applet can thus be used in the function as a medium of argumentation and proof. Referring to the SAMR-Model (Puentedura, 2010), the first step of enhancement can be covered with the developed applet in the learning environment, which is substitution of the analogue material. The second step of enhancement, augmentation (technology acts as a direct tool substitute, with functional improvement), can be rudimentary covered. One advantage of the reversible tile app is that the organizational handling is more suitable for everyday use (to be quickly provided or put away in an orderly manner) than with analogue tiles, as single tiles cannot disappear within the app.

The Empirical Pilot Study

In the framework of a school visit in May 2018 at the Maths Lab “MatheWerkstatt” at the University of Siegen (Germany), a fourth-grade school class of a local regular school containing 23 pupils took part in the empirical pilot study. The school class was separated into groups of six or respectively five pupils who worked at different learning stations during their two hours stay at the university. For the learning station three tablets were made available where pupils worked in groups of two using one tablet per group and discussing their ideas and results. In each of the four cases, one group of two pupils of the three groups of pupils was videographed and the tablet screen was screencasted, both with audio recording. This possibility of the screencast is an advantage of the technology use, because the touch-gestures performed by the pupils coming with their oral argumentation can be captured. Each group worked for 20 minutes at the learning station. The recorded material was transcribed and sections were extracted, where information on the argumentation process and on the User Experience (UX) could be discerned. From these sections, video vignettes were extracted and the argumentation process was represented in a model as it is described below (see Figure 1).

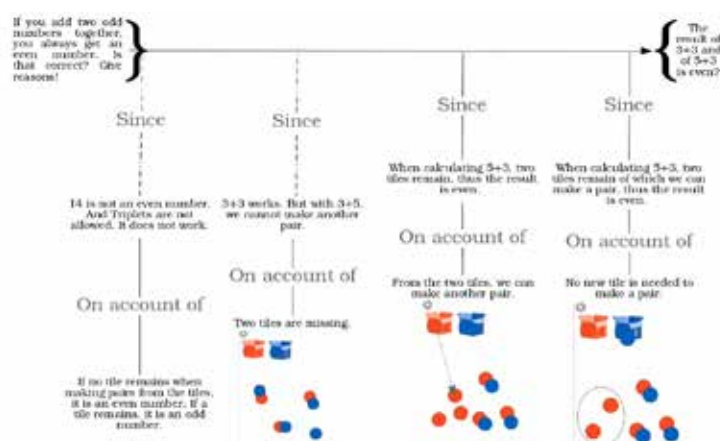


Figure 1: Exemplary representation of an argumentation process in the pilot study; the diagram can be read like a timeline from left to right; the dashed lines mark refutation trials of the assertion; screenshots with markings visualize the action of the pupils while speaking

To investigate and understand preformal proof and argumentation processes, a diagrammatic representation is developed and evaluated. This is in line with van Gelder (2005) who represents the opinion, that a diagrammatic representation of complex argumentation was developed, because

everyone knows that complex structure is generally more easily understood and conveyed in visual or diagrammatic form [...]. Interested in argument but dissatisfied with the tools offered by the logical tradition, Toulmin developed a simple diagrammatic template intended to help clarify the nature of everyday reasoning. (van Gelder, 2005, p. 4)

Nevertheless, Toulmin himself applied his layout to mathematics: as an example, Theaetetus’s proof that there are exactly five platonic solids is visualized in Toulmin et al. (1979). Aberdein (2005) concerns with the application of Toulmin’s layout to multi-step proofs. Pedemonte (2007) uses Toulmin’s model as a methodological tool to compare proof and argument. “This model can be used to detect and analyse the structure of an argumentation supporting a conjecture (abduction, induction,

etc.) and the structure of its proof” (Pedemonte, 2007, p. 23). Reid et al. (2011) investigate the potentials of the refutation of arguments visualized in an adapted model of Toulmin’s layout. The ideas of Reid et al. (2011) are similar to the representation of arguments of Miller (1986). Miller (1986) works with structure trees in order to analytically grasp argumentation processes. A combination of these models is applied to represent the argumentation processes in the pilot study, see Figure 1. Furthermore, in orientation to a framework developed by Barendregt and Bekker (2003), the User Experience of the children while working within the learning environment, was investigated.

Results

With regard to the User Experience, the applet itself seems to be intuitive and the pupils did not have problems in using the applet. No introduction on how to control the applet was needed. One pupil of the test group did not like to work with tiles, as this was found “childish being already in grade four”. The argument of the pupil was, that they had already learned to calculate until one million and tiles were only needed to calculate in grade one. From the conversation with the pupils, it seems likely, that the task was not really understood, i.e. no real need for proof (Kothe, 1979) was awakened. In the example visualized in Figure 1, it seems like the pupils did not understand the reason for making pairs of the tiles. This can be inferred from the interpretation of the pupils’ actions visualized in the screenshot of the third backing, when the pupils added new red tiles to build pairs instead of making pairs of the red tiles representing the number 5 which they already got out. As the need for proof did not seem to be awakened, it is not possible to reconstruct a structural change for the construction of a deductive proof (Pedemonte, 2007) from the conversation of the pupils.

Discussion

The prototype (learning environment applying digital learning tools to support argumentation skills in primary school) was analyzed via the TPACK-Framework and tested in an empirical pilot study and needs to be optimized through the first iteration of the Design Science Process. Due to Kothe (1979), the awakening of a need for proof in primary education requires long-term didactic planning to seek opportunities for local sensitization to mathematical thinking. This is supposed to be reached with an optimized prototype of the learning environment. One important issue for an optimization is to give the pupils more time and instruction, to initiate an understanding of why a proof is needed. Due to Kothe (1979), primary school children have fun problem solving with appropriate instructions. Here, proof need is: “I want to show the teacher or classmates that my approach is right”, (Kothe, 1979, p. 276). To support this creation of proof need, a new prototype should incorporate the theory of discovery learning (cf. Winter, 1989). Discovery learning is based on the idea that knowledge acquisition and progress and the ability to work in problem solving skills happens “by own active action and recourse to the already existing cognitive structure, but usually stimulated and thus made possible by external impulses” (Winter, 1989, p. 3). Furthermore, a central media aspect shall be to make the handling with teaching and learning material computer-detectable and thus, to derive optimized learning environments. One research field is the investigation of “gestures” made by the pupils on a touch screen with relation to semiotics (cf. Peirce, 1931-1935). Huth (2013) states that gestures in particular, can at least temporarily take over the function of possibly unavailable or not possible inscriptions. Such “gestures” can be made detectable with the help of digital media, and automated evaluation and help selection are supposed to be provided. With implementation of these

functionalities, the first step of transformation according to the SAMR-Model (Puentedura, 2010) can be reached, which is modification, i.e. the technology allows for significant task redesign and enables other possibilities to handle heterogeneity in a school class.

Acknowledgments

I especially thank the working group of primary school education of the Institute of Mathematics and Computer Science Education, Goethe University Frankfurt, around Prof. Dr. Rose Vogel for the very enriching meetings and discussions. Furthermore, I thank Dr. Eva Hoffart (Institute of Mathematics Education, University of Siegen) for the opportunity to perform the empirical pilot study in the framework of the “MatheWerkstatt-Seminar” and Kathrin Holten for her very helpful comments.

References

- Aberdein, A. (2005). The uses of argument in mathematics. *Argumentation*, 19(3), 287–301.
- Barendregt, W. & Bekker, M. (2003). *Guidelines for user testing with children*. Eindhoven, The Netherlands; Tech. Rep.
- Bezold, A. (2009). *Förderung von Argumentationskompetenzen durch selbstdifferenzierende Lernangebote*. Hamburg: Verlag Dr. Kovac.
- Blum, W. & Kirsch, A. (1991). Preformal proving: Examples and reflections. *Educational Studies in Mathematics*, 22(2), 183–203.
- Budke, A. & Meyer, M. (2015). Fachlich argumentieren lernen – Die Bedeutung der Argumentation in den unterschiedlichen Schulfächern. *LehrerInnenBildung Gestalten*. Münster: Waxmann Verlag GmbH.
- Huth, M. (2013). Mathematische Gestik und Lautsprache von Lernenden. *Beiträge zum Mathematikunterricht*, 492-495.
- Kothe, S. (1979). Gibt es Entwicklungsmöglichkeiten für ein Beweisbedürfnis in den ersten Schuljahren? *Beweisen im Mathematikunterricht: Vorträge des 2. Internationalen Symposiums für “Didaktik der Mathematik” von 26.9. bis 29.9. 1978 in Klagenfurt*, 275–282. Wien: Verlag Hölder-Pichler-Tempsky.
- Krauthausen, G. (2018). *Einführung in die Mathematikdidaktik-Grundschule*. New York: Springer Spektrum.
- Krummheuer, G. & Fetzer, M. (2005). *Der Alltag im Mathematikunterricht: Beobachten-Verstehen-Gestalten*. München: Elsevier.
- Kultusministerkonferenz (KMK) (2016). *Strategie der Kultusministerkonferenz „Bildung in der digitalen Welt“ (Beschluss der Kultusministerkonferenz vom 08.12.2016)* [Electronic Resource]. https://www.kmk.org/fileadmin/Dateien/pdf/PresseUndAktuelles/2016/Bildung_digitale_Welt_Webversion.pdf
- March, S. T. & Smith, G. F. (1995). Design and natural science research on information technology. *Decision support systems*, 15(4), 251–266.

- Miller, M. (1986). *Kollektive Lernprozesse: Studien zur Grundlegung einer soziologischen Lerntheorie*. Frankfurt am Main: Suhrkamp.
- Pedemonte, B. (2007). How can the relationship between argumentation and proof be analysed? *Educational studies in mathematics*, 66(1), 23-41.
- Peirce, C. S. (1931-1935). *Collected papers of Charles Sanders Peirce. Volumes I-VI*, (ed. by C. Hartshorne & P. Weiss). Cambridge, MA: Harvard University Press.
- Peffers, K., Tuunanen, T., Gengler, C. E., Rossi, M., Hui, W., Virtanen, V. & Bragge, J. (2006). The Design Science Research Process: A Model for Producing and Presenting Information Systems Research. In S. Chatterjee & A. Hevner (Eds.) *Proceedings of the First International Conference on Design Science Research in Information Systems and Technology (DESRIST 2006)*, 83-106, California: sn.
- Platz, M., Krieger, M., Niehaus, E., & Winter, K. (2017). Electronic proofs in mathematics education - a South African teacher professional development (TPD) course informing the conceptualisation of an e-proof system authoring support workshop. In P. Cunningham & M. Cunningham (Eds.) *IST-Africa 2017 Conference Proceedings*, 1-9. IEEE, Ireland: IIMC International Information Management Corporation.
- Puentedura, R. (2010). *SAMR and TPCCK: Intro to advanced practice* [Electronic Resource]. http://hippasus.com/resources/sweden2010/SAMR_TPCCK_IntroToAdvancedPractice.pdf retrieved: 30.08.2018.
- Reid, D., Knipping, C., & Crosby, M. (2011). Refutations and the logic of practice. *PNA*, 6(1):1-10. Spain: Didáctica de la Matemática: Pensamiento Numérico.
- Semadeni, Z. (1984). Action proofs in primary mathematics teaching and in teacher training. *For the learning of mathematics*, 4(1), 32-34.
- Toulmin, S., Rieke, R., & Janik, A. (1979). *Argumentation in science. An Introduction to Reasoning*. New York: Macmillan Publishing Company.
- Toulmin, S. E. (1958). *The Uses of Argument*. Cambridge: Cambridge University Press (2003).
- Winter, H. (1989). *Entdeckendes Lernen im Mathematikunterricht*. Braunschweig/Wiesbaden: Vieweg 1991 (1989).
- Wittmann, E. C. & Müller, G. N. (2013a). *Das Zahlenbuch 4/ Begleitband*. Stuttgart: Ernst Klett Verlag GmbH.
- Wittmann, E. C. & Müller, G. N. (2013b). *Das Zahlenbuch/Materialband mit Kopiervorlagen und CD-ROM 4. Schuljahr: Allgemeine Ausgabe ab 2017*. Stuttgart: Ernst Klett Verlag GmbH.
- Wittmann, E. (2014). Operative Beweise in der Schul- und Elementarmathematik. *Mathematica didactica*, 37, 213-232. Hildesheim: Verlag Franzbecker.
- Wuttke, E. (2005). *Unterrichtskommunikation und Wissenserwerb: zum Einfluss von Kommunikation auf den Prozess der Wissensgenerierung*. Frankfurt: Lang.

Digital media support functional thinking: How a digital self-assessment tool can help learners to grasp the concept of function

Hana Ruchniewicz and Bärbel Barzel

University of Duisburg-Essen, Germany; hana.ruchniewicz@uni-due.de, baerbel.barzel@uni-due.de

Developing functional thinking is a central objective in mathematics education. Students especially need to internalize three aspects of functions: mapping, covariation, and object besides learning to translate flexibly between various representations. However, many learners struggle to recognize and interpret functional relationships. To help these students, a formative self-assessment approach with digital media offers new possibilities. Technology can support understanding not only due to the use of multiple, dynamic, interactive, or linked representations, but offer a constraint-support structure to guide students' actions. We present two case studies in form of task-based interviews from the third cycle of a design-based research study that aims at the development and evaluation of the “self-assessment for functional thinking electronic” (SAFE) tool. The cases show how certain technological features of the SAFE tool support learners' self-assessment and functional thinking.

Keywords: Digital media, technology, functions, formative self-assessment, metacognition.

Why support functional thinking?

Many real-world phenomena, such as measuring the temperature at a weather station over a period of time, can be comprehended functionally. Because of this variety of applications and its importance to grasp further mathematical concepts, the discussion of functional relationships is central in many mathematics curricula. For example, it is one of five key content domains in lower as well as upper secondary mathematics education in Germany. Although the function concept is fundamental in the learning of mathematics, many students have difficulties in its comprehension. Thus, they need support to acquire ‘functional thinking’. For this reason, we use a formative student self-assessment approach as it has proven to enhance student learning (Stacey & Wiliam, 2013).

Theoretical Background

Formative self-assessment and metacognitive activities

According to Wiliam and Thompson (2008), formative assessment (FA) can be conceptualized in five key strategies. These regard mainly the teacher to be responsible for FA. Especially in computer-based assessment, features such as automatic feedback, a limitation of students' responses by e.g. multiple choice formats, or a focus on measuring achievements (Stacey & Wiliam, 2013), leave little room for students to recognize, reflect upon and react to their work. This is why, the FA framework by Wiliam and Thompson was refined in the EU-project FaSMEd to allow formative self-assessment to be understood as a process performed, observed and reflected on by students. It is conceptualized in these five key strategies (KS): 1) understanding learning intentions and criteria for success, 2) eliciting evidence of understanding, 3) providing self-feedback, 4) activating peers as instructional resources for one's learning, and 5) regulating one's learning process. However, strategy four is only relevant when observing formative self-assessment in classroom situations (Ruchniewicz, 2017). For

all these strategies, but especially for the fifth, learners need to use metacognitive activities. They describe the procedural component of one's metacognition. This means all actions of regulation of one's cognitive activities in learning processes. They include: 1) *planning* problem-solving steps with appropriate mathematical tools, 2) *monitoring* in form of controlling tool-use and comparing what is achieved to set goals, and 3) *reflection* on given problems or understanding of mathematical concepts (Cohors-Fresenborg, Kramer, Pundsack, Sjuts, & Sommer, 2010). To enable students to self-assess their functional thinking abilities, this mathematical content needs careful consideration.

Functional thinking

Functional thinking is a didactical concept, that describes all mental images learners need to build and use when dealing with functions, their representations, and their applications in modelling and problem solving to gain a comprehensive understanding of the function concept. "Functional thinking is a way of thinking, that is typical for working with functions" (translated from Vollrath, 1989, p. 6). Three aspects, noticed in German didactics today as Grundvorstellungen (GVs), characterize this "typical" and allow for various views on functions (Vollrath, 1989): 1) *Mapping*: a function assigns exactly one value of a dependent quantity to the value of an independent one. As such a unique mapping, it is viewed in a local and static way. 2) *Covariation*: in a dynamic view, a function describes how two quantities change in relation to one another. While the independent quantity runs through a set of values from a domain, it causes the values of the dependent quantity to change accordingly. 3) *Object*: a function viewed globally is a mathematical object, that has its own specific properties (e.g. characteristic graph, symmetry) and can be operated upon.

Although the three GVs of functions apply for all forms of semiotic representation, they can appear variously according to a function's visualization. Usually, students interact with functions represented verbally, numerically, symbolically, or graphically. The mapping aspect, for instance, is highlighted when calculating a y-value by inserting the x-value into an equation. By contrast, the covariation aspect is of interest when looking at the change of a graph's values for an interval of x-values. Each representation emphasizes different properties of the function (Duval, 2006). Thus, it is central for functional thinking that students learn to work with and translate between various representations. This leads them to a comprehensive understanding of the function concept (Duval, 2006).

Due to the concept's complexity, such a comprehension and, thus, the acquiring of functional thinking is challenging. Numerous misconceptions are described in regards to learners struggling to conceptualize functions. For example, Clement (1985) states that many students falsely treat graphs as literal pictures of the underlying situations (graph-as-a-picture mistake). Others overgeneralize function types or properties, such as using linear functions in inappropriate situations (illusion of linearity). Further, students might swap the x- and y-coordinates or disregard the uniqueness of a function (e.g. Hadjidemetriou & Williams, 2002; Leinhardt, Zaslavsky, & Stein, 1990). To react to such misconceptions and support students' self-assessment, digital media offer new opportunities.

Digital media

Digital media have the potential to enhance formative self-assessment by altering the assessment process due to changes in, e.g. the nature of tasks, types of feedback, or even assessed skills. What is more, they present new chances for learning by e.g. providing dynamic or interactive representations

of mathematical objects (Drijvers et al., 2016). Various studies examine if the use of technology improves achievements. In an ICME survey concerning lower secondary learners, Drijvers et al. (2016, p. 5) summarize: “[t]he overall image is that the use of technology in mathematics education can have a significant positive effect, but with small effect size.” The authors conclude that existing studies give hints for whether achievements can improve, but do not explain why (Drijvers et al., 2016). To answer why digital media can support functional thinking, it is necessary to consider their potential and appraise it against possible risks. Following, we list some of the most important arguments for teaching, learning and assessing functional thinking with digital media:

1) *Fast availability of representations*: Quickly available visualizations of functions leave time for examining functional relationships, generating examples, or checking one’s hypotheses. Yet, the large amount of representations and speed of their availability might lead to a complexity that hinders students to reflect on their actions (Barzel, Hußmann, & Leuders, 2005). Cavanagh and Mitchelmore (2000, p. 118), for instance, identified the tendency “to accept whatever was displayed in the initial window without question” as one of three typical mistakes of 10th and 11th graders asked to interpret linear and quadratic graphs on graphic calculator screens. Students did not reflect upon the visual image on screen or relate it to an inserted algebraic equation (Cavanagh & Mitchelmore, 2000).

2) *Multiple representations*: The aspect of fast availability plays a key role when it comes to screening various representations of the same function at once. Each one stresses different aspects of a function (Duval, 2006). Simultaneous visualizations can support the construction of mappings between those aspects and the translation between representations, which helps learners to solve problems quicker and conceptualize functions (van Someren, Boshuizen, de Jong, & Reinmann, 1998).

3) *Dynamic representations*: In static media, variations of a mathematical object need to be observed, interpreted, and projected upon its representation by the user. Dynamic representations let students experience these changes directly (Kaput, 1992). Especially the covariation GV of functional thinking can, thus, be supported by digital media as the investigation of changes in function values is easier.

4) *Interactivity and linked representations*: Digital media permit „not simply to display representations but especially to allow for actions on those representations“ (Ferrara, Pratt, & Robutti, 2006, p. 242). Moreover, it is possible to link representations so that the variation of one is automatically reflected in another. Such links enable learners to investigate functional relationships as they provide immediate feedback and encourage them to change between representations. Although interactive and linked representations offer great potential to support functional thinking, the technological speed entails the risk of students being overwhelmed by quick changes in visualizations and driven to act upon them without reflection (Zbiek, Heid, Blume, & Dick, 2007).

5) *Effecting student actions*: Student actions are effected by a digital tool’s design. If learners are asked to draw a function graph, the technology might supply them with a suitable coordinate system. Kaput (1992, p. 526) refers to a tool’s “constraint-support structure” stating that “whether a feature is regarded as one or the other does not depend inherently on the material itself, but on the relation between the user’s intentions and those of the designer of the material and the contexts for its use.”

In our study, these arguments for using digital media to support functional thinking guide the design of a digital self-assessment tool and offer hypotheses for the analysis of students’ learning processes.

Methodology

We use design-based research that aims at developing and evaluating the SAFE tool (Ruchniewicz, 2017; Ruchniewicz & Barzel, in print). Several versions of the tool are designed, investigated, and re-designed. This cyclic process is guided by the following research question: *How do certain technological features of the SAFE tool support students' self-assessment and functional thinking?*

Design of the SAFE tool

The SAFE tool's aim is for students to be self-assessors and, thus, no direct feedback is generated. For all tasks, users compare their answer to a sample solution and evaluate on their own whether it is correct or which steps to take next in their learning. The design means to create a balance of providing enough information and autonomy for learners. Therefore, the SAFE tool intends to assess and repeat basic competencies after they have been taught. The learning conjecture is the ability to sketch graphs based on given situations as this reflects a key aspect of functional thinking. The SAFE tool runs as an iPad application and consists of five parts: *Test*, *Check*, *Info*, *Practice*, and *Expand*. These are joined in a hyperlink structure and labelled with various symbols for easy user orientation (fig. 1).



Figure 1: Hyperlink structure of the SAFE tool

Students start by solving the *Test* task, which presents the story of a bike ride and asks them to draw a time-speed graph. They can label the axes using drop-down menus and sketch the graph directly on the screen using their fingers. Afterwards, they move to the task's sample solution. It consists of a simulation of the situation that is linked to one possible solution graph. The simulation can be started and stopped by the user and a qualitative speedometer can be viewed as well (fig. 3a). The learner moves to the *Check*, that provides five statements regarding important aspects about the graph in question alongside common mistakes that could arise. For each statement, the student decides whether it is true or false for his/her own solution. For this diagnostic step, the *Check* includes a pictorial visualization of the situation together with a static representation of the sample graph and the learner's own solution in the same coordinate system (fig. 3b). If an error is identified, the student can choose to read an *Info*, which entails a general explanation to repeat basic ideas about the function concept and specifies them in the time-speed context of the *Test* task, or work on a specified *Practice* task. If the initial graph is correct or a student checks all statements, he/she is presented with two more *Practice* tasks as well as an *Expand* task with a more complex context.

Data collection and analysis

We use case studies in form of task-based interviews with individual students. The interviews are videotaped, transcribed, and analyzed qualitatively. Three subject groups are included: grade 7–9 students (aged 12–15) as they are novices regarding the function concept; grade 10 students (aged 15–16) as they have to repeat curricula contents of years 5–10 for a state-wide assessment; and 2nd semester university students in their bachelor in mathematics education (aged 19–22) as they are experienced, but often need to repeat basic competencies in the transition from school to university.

This paper presents two cases from the third design cycle, which give a first glance of the latest SAFE tool's potential as data collection is not completed. So far 3 interviews with year 9 and 5 with university students are recorded. One university student solves the *Test* and self-assessment without difficulties. One younger student shows poor knowledge of the content and does not recognize graphs as representations of functions. She is unable to identify her mistake on her own. Six learners show similar self-assessment processes. As the diagnostic step of assessing their solution to the *Test* occurs when viewing either the *Test solution* or *Check*, two of the (university) students were chosen as cases to represent both of these ways of self-assessment. As our focus is assessment, the learner's work with other tool parts (*Info*, *Practice*, *Expand*) is not included, as it portrays their next steps of learning.

For data analysis, we use qualitative content analysis with deductive categories. Additional inductive categories will be developed once data collection is completed (Mayring, 2000). In relation to our theoretical basis, three main categories with different subcategories were identified to guide analysis:

Student self-assessment	Functional thinking	Technological features (TF)
Key strategies (KS)	GVs	Linked simulation & graph (TF1)
Metacognitive activities (MA)	Change of representations (CR)	Multiple representations (TF2)
	Misconceptions (M)	Constraint-support structure (TF3)

Table1: Categories guiding the case studies' qualitative content analysis

Results

The *Test* task, that students use for the diagnostic step of their self-assessment, asks them to draw a time-speed graph for this situation: "Niklas gets on his bike and starts a ride from his home. Then he rides along the street with constant speed before it carves up a hill. On top of the hill, he pauses for a few minutes to enjoy the view. After that he rides down and stops at the bottom of the hill." Paul and Ayse solve the task and describe their reasoning in the interviews (fig. 2). Thus, they elicit evidence of their own understanding (KS2). Afterwards, they both move to the sample solution (fig. 3a).

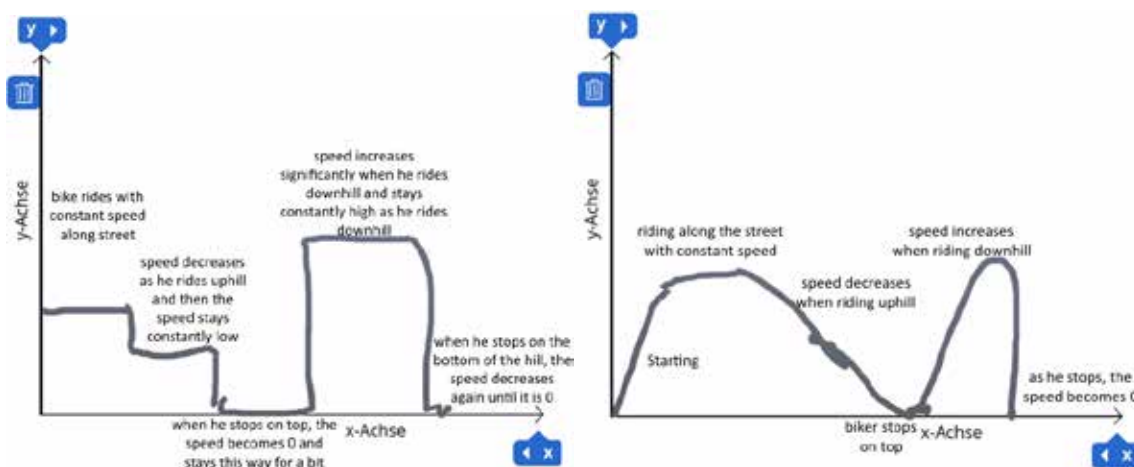


Figure 2: a) Paul's and b) Ayse's *Test* solution and reasoning

Paul starts the simulation, stops it when the bike starts to ride uphill and says: "The first thing I saw was that it is assumed that not - (points at the origin in the sample graph) so that he does not start

directly with constant speed (points along the first increasing graph segment) but that starting from home is also its own time period. That means that you also have to consider that he has to start first and that he is not at any speed at first.” Thus, the linked simulation encourages him to reflect his own solution. He identifies a mistake in his answer by realizing that he previously did not model the first part of the situation, namely starting the bike ride from home. Afterwards, he resumes the simulation and stops it again when the bike stops on top of the hill: “Okay, and then he becomes again, when he rides up the hill, that he does not reach the speed with which he rides uphill at once, but that the speed decreases in shifts.” Here, Paul reflects part of his answer (riding uphill) by comparing it to the sample graph. He recognizes that the speed and, thus, the graph cannot decrease suddenly, but that it slows down with time. Even if Paul does not realize that his graph disregards the uniqueness of the underlying functional relationship (vertical lines in his solution, fig. 2a), the simulation does inspire him to observe the covariation of the quantities time and speed more closely.

Ayse watches the entire simulation at once and directly moves on to the *Check*. Her screen shows the checklist and a multiple visualization of the bike’s path together with her own and the sample solution’s graph in one coordinate system (fig. 3b). Ayse reads checkpoint 2: “I realized correctly when the graph is increasing, decreasing, or remaining constant.” Relating to this, she assesses her solution: “Basically yes, but the duration! So with the variable with the time, so I should have much longer (points to the part of her graph that models the bike stopping on top of the hill) along zero – should have gone along the x-axis when he stops for a few minutes.” Thus, she denies the statement of the checkpoint for her answer and crosses it off (fig. 3b). The checkpoint together with the multiple representation of the functional relationship prompt Ayse to reflect on her solution and discover an error regarding her graph’s slope: while she depicted the bike stopping on top of the hill only as one point of her graph reaching the x-axis, the tool reveals that it should be a constant graph segment with the value of zero. Her reflection shows that Ayse did regard the variation and value of the dependent quantity (speed) while drawing her graph, but she missed to consider the change of the independent quantity (time) as well. The SAFE tool helps her to focus more on the covariation of both quantities.

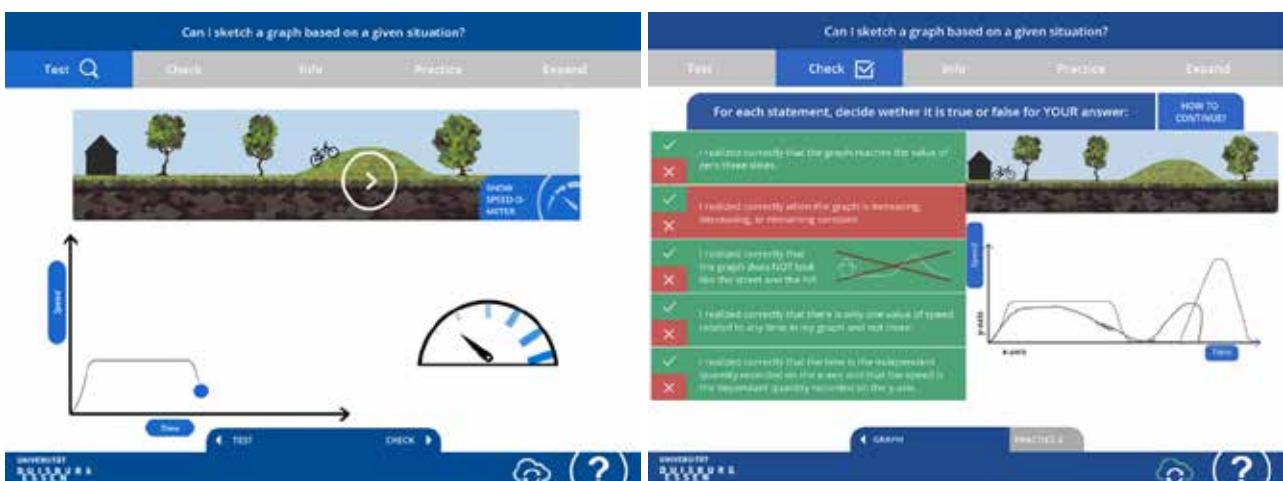


Figure 3: a) Linked simulation and graph as the *Test*'s sample solution, b) Ayse's *Check* screen

Conclusion

The two cases of Paul and Ayse show that the SAFE tool can support students' self-assessment and functional thinking. This becomes apparent when considering how the analysis' categories of self-assessment, functional thinking, and technological features interact with each other in the interviews.

Paul's case reveals that an interactive representation of a simulation linked to a graph (TF1) stimulates him to use the metacognitive activity of reflection (MA3). Further, he starts and stops the simulation several times in order to evaluate different aspects of the graph, which shows that his reflection is supported by this tool functionality (TF3). He evaluates his own graph by comparing it to the sample solution and identifies his own mistakes while regulating this process (KS5). Paul realizes that he missed to model part of the situation (start of bike ride) and translate it into its graphical representation (CR). For another part of the situation (riding uphill), he focusses on the covariation of both quantities. While he initially assumes a more prototypical graph with many constant segments (fig. 2a, M), he addresses a non-linear decrease of the graph's slope to model the bike slowing down when looking at the simulation (GV2). In his reflection, he shows an understanding of criteria for success, namely translating all parts of the situation and correctly sketching the graph's slope (KS1). Additionally, he describes how to change his initial work to correct it, thus, giving himself feedback (KS3).

Likewise, Ayse's case shows that the SAFE tool encourages a reflection of her solution (MA3) and points her attention towards the covariation of both variables (GV2). Her reflection is initiated by the *Check*'s multiple representation of the situation together with her and a sample graph (TF2) as well as a provided checkpoint (TF3). Ayse grasps that change in both variables needs consideration when sketching graphs (KS1). Finally, she formulates a self-feedback (KS3) and regulates her assessment process by reflecting her work, identifying a mistake and crossing off the checkpoint (KS5).

Both students use four key strategies of formative self-assessment and the metacognitive activity of reflection when working on technological features, such as multiple, interactive, and linked visualizations. This enhances their functional thinking by shifting the learners' focus towards the Grundvorstellung of covariation, paying attention to the graph's slope, and translating the entire situation into a graphical representation of the underlying functional relationship. Future investigations of students' work with the SAFE tool will reveal whether these findings can be generalized to inform the design of other digital media to support learners' conceptions of functions.

References

- Barzel, B., Hußmann, S., & Leuders, T. (Eds.). (2005). *Computer, Internet & Co. im Mathematikunterricht* [Computer, internet & more in the mathematics classroom]. Berlin: Cornelsen Scriptor.
- Cavanagh, M., & Mitchelmore, M. (2000). Graphics calculators in mathematics learning: studies of student and teacher understanding. In M. Thomas (Ed.), *Proceedings of the International Conference on Technology in Mathematics Education* (pp. 112–119). Auckland: The University of Auckland and Auckland University of Technology.

- Clement, J. (1985). Misconceptions in graphing. In L. Streetland (Ed.), *Proceedings of the 9th Conference of the International Group for the Psychology of Mathematics Education* (Vol.1, pp. 369–375). Utrecht: PME.
- Cohors-Fresenborg, E., Kramer, S., Pundsack, F., Sjuts, J., & Sommer, N. (2010). The role of metacognitive monitoring in explaining differences in mathematics achievement. *ZDM Mathematics Education*, 42(2), 231–244.
- Drijvers, P., Ball, L., Barzel, B., Heid, M.K., Cao, Y., & Maschietto, M. (2016). *Uses of technology in lower secondary mathematics education: A concise topical survey*. London: Springer Open.
- Duval, R. (2006). A cognitive analysis of problems of comprehension in a learning of mathematics. *Educational Studies in Mathematics*, 61(1), 103–131.
- Ferrara, F., Pratt, D., & Robutti, O. (2006). The role and uses of technologies for the teaching of algebra and calculus. In A. Gutiérrez, P. Boero (Ed.), *Handbook of Research on the Psychology of Mathematics Education: Past, Present and Future* (pp. 237–273), Rotterdam: Sense.
- Hadjidemetriou, C., & Williams, J. (2002). Children's graphical conceptions. *Research in Mathematics Education*, 4(1), 69–87.
- Kaput, J. J. (1992). Technology and Mathematics Education. In D. A. Grouws (Ed.), *Handbook of Research on Mathematics Teaching and Learning* (pp. 515–556). New York, NY: Macmillan.
- Leinhardt, G., Zaslavsky, O., & Stein, M. K. (1990). Functions, graphs, and graphing: Tasks, learning, and teaching. *Review of Educational Research*, 60(1), 1–64.
- Mayring, P. (2000). Qualitative Content Analysis. *Forum: Qualitative Social Research*, 1(2), 1–10. <http://dx.doi.org/10.17169/fqs-1.2.1089>.
- Ruchniewicz, H. (2017). Can I sketch a graph based on a given situation? - Developing a digital tool for formative self-assessment. In G. Aldon, & J. Trgalova (Eds.), *Proceedings of the 13th International Conference on Technology in Mathematics Teaching* (pp. 75–85). Frankreich. <hal-01632970>
- Ruchniewicz, H., & Barzel, B. (2019, in print). Technology supporting student self-assessment in the field of functions – A design-based research study. In G. Aldon, & J. Trgalova (Eds.), *Digital technology to teach, learn and assess mathematics: Featuring extended selected papers from ICTMT 13*. Springer.
- Stacey, K., & Wiliam, D. (2013). Technology and Assessment in Mathematics. In M. A. K. Clements, A. J. Bishop, C. Keitel, J. Klipatrck, & F. K. S. Leung (Eds.), *Third International Handbook of Mathematics Education* (pp. 721–752). New York: Springer.
- Vollrath, H.-J. (1989). Funktionales Denken [Functional thinking]. *Journal für Mathematik-Didaktik*, 10(1), 3–37.
- van Someren, M. W., Boshuizen, H. P. A., de Jong, T., & Reimann, P. (1998). Introduction. In M. W. van Someren, P. Reimann, H. P. A. Boshuizen & T. de Jong (Eds.), *Learning with Multiple Representations* (pp. 1–5). Amsterdam: Pergamon.

William, D., & Thompson, M. (2008). Integrating assessment with learning: what will it take to make it work? In C. A. Dwyer (Ed.), *The Future of Assessment: Shaping Teaching and Learning* (pp. 53–82). Mahwah, NJ: Erlbaum.

Zbiek, R. M., Heid, M. K., Blume, G. W., & Dick, T. P. (2007). Research on technology in mathematics education: A perspective of constructs. In F. K. Lester (Ed.), *Second handbook of research on mathematics teaching and learning* (pp. 1169–1207). Charlotte, NC: Information Age.

Exploring pre-calculus with augmented reality. A design-based-research approach

Florian Schacht¹ and Osama Swidan²

¹University of Duisburg-Essen, Faculty of Mathematics, Germany, florian.schacht@uni-due.de

²Ben-Gurion University of the Negev, Be'er Sheva, Israel, osamas@bgu.ac.il

This paper reports on the development of a learning design addressing pre-calculus concepts using augmented reality-technology. In a first step, both task- and technology design-principles are derived from the research literature and both elements – tasks and technology – will be described and discussed. Within a first design-research cycle, the paper reports on experimental difficulties with the technology used for the first version of the AR-tool and the needs for the development of a second version. By doing so, the paper addresses technological constraints experienced in experimental situations and discusses alternative ways.

Keywords: augmented reality technology, pre-calculus concepts, design research

Introduction

This paper describes a first cycle within a design-based-research project, which aims at a better understanding of pre-calculus concepts by using augmented reality tools. Specifically, we emphasize the capability of AR to merge dynamic features of a real phenomenon (e.g. a moving object along inclined plane) with those of its mathematical representations, which can be displayed graphically and numerically (e.g. plotting points of graph, ordered pairs in a table of values), as well as the learners' own perspectives with respect to the phenomenon. Within the DBR approach (Gravemeijer, 1994; Prediger et al., 2015) we distinguish between two different layers of design-principles, namely the task and the technology design principles. Hence, this paper aims to discuss the design principles of the tasks and the technological tools of such an environment.

Exploring pre-calculus concepts

One of the main goals of teaching pre-calculus concepts is to initiate experiences with functional relations. In calculus, students use quantifiable methods to explore certain characteristics of functions. It is essential to allow pre-calculus explorations though, in which such characteristics are not yet experienced as being standardized, formalized and quantified. That means that students need activities, in which they explore pre-calculus concepts in qualitative learning settings. A detailed exactification by introducing the concepts of rate of change, accumulation or derivative is part of a later stage within the learning process.

One way to design such learning activities is the use of real experiments. Inquiry-based enactment of scientific exploration shows how students can be engaged in learning activities, in which they conduct real experiments and - by doing so - develop the mathematical concepts. One key feature of inquiry-based learning approaches is the shift from deductive ways of teaching to more inquiry-based approaches in order to increase the students' interest in mathematics (Rocard et al., 2007, p. 2; Artigue & Blomhøj, 2013). Within such inquiry-based situations students formulate conjectures based on experimental experiences and ask for reasons and try to prove them (Lakatos (1976) speaks of the quasi-empirical nature of mathematics). Furthermore, the role of physical action and of bodily

experiences is highly important for the genesis of mathematical concepts (e.g., Edwards et al., 2009; Radford, 2014; Roth, 2009). For the context of functional reasoning Duval (2006) points out that different representation modes (like graph, table, symbolic expression) are necessary in order to grasp mathematical concepts in general and especially the concept of function.

On the basis of this very dense discussion we formulate the following content-specific design-principles:

- P1: Enable students to conduct their own experiences.
- P2: Use different representations to foster the mathematization.
- P3: Ensure enough room to verbalize the individual conjectures and to interact with other students in order to prove them.

The role of augmented reality

In a mathematical representation of real phenomena, the correspondence between the original phenomenon and the mathematical representation is usually not acquired directly as an effect of a natural similarity (as in analogies and often in diagrams). For example, considering the function that models the fall of a ball, the graph that represents the relation between time and space does not provide a direct, sensory similarity between the actual position of the ball and the shape of the graph; rather, the analogy is between the numerical expression of the respective phenomenon and its graphic representation, which is spatial.

Within the design-research project described in this paper, we use an augmented reality technology to experience and explore the pre-calculus concepts described above. AR technology uses a wide spectrum of techniques for projecting computer-generated materials, such as text, images, and video, onto users' ordinary unaided perceptions of the real world (Kaufmann et al., 2005). Johnson et al. (2011) observe that AR can be especially used in order to support inquiry-based learning. Despite some educational suggestions, Wu et al. (2013) point out that the use of AR in educational settings still remains in its infancy. AR is commonly used by science educators to help students visualize scientific processes, such as chemical reactions, which cannot be observed easily in the real world (e.g. Wu et al., 2013). Importantly, Cheng and Tsai (2013) conclude that while research on the use of AR in educational settings has examined issues such as development, usability, and initial implementation (Blake et al., 2009; Sayed et al. 2011), students' inquiry skills and the learning processes within AR environments have largely been ignored in the scientific literature.

For mathematics education, Sommerauer and Müller (2014) found that most studies on mathematics education using AR examined the effect of this technology on learning spatial abilities (e.g., Kaufmann et al., 2005); this finding is not surprising, as 3D is one of the key affordances of AR. For example, Kaufmann and Schmalstieg (2003) developed a learning environment that allows students to act on and interact with geometrical objects in space. Similarly, Oronzco and colleagues (Oronzco et al., 2006) developed an AR-rich learning environment to assist students in visualizing multivariable function curves and reported that it helped develop spatial reasoning and visualizability of 3D mathematical objects.

Within the research project, we will examine the way how a learning environment based on AR, given its ability to combine real-world experiments, real-time data regarding these experiences, and

symbolic systems that model them, may help to create the conditions whereby inquiry-based learning will be set into motion in a natural and productive way. This paper reports on the first design-cycle in developing an AR-tool and a learning environment. On the basis of the discussion of the technological aspects of using augmented reality and with reference to the design-principles P1-P3 we formulate the following technology-specific design principles:

- P1*: The digital tool is used within a real experiment conducted by the students.
- P2*: The digital tool augments the students experiments with different representations.
- P3*: The provided data allows students to formulate conjectures and make qualitative experiences with pre-calculus concepts.

The Method of Variation inquiry

This study is guided by the method of the Varied Inquiry (MVI) approach, which is a combination of two theoretical perspectives: the logic of inquiry (Hintikka, 1999) and the variation theory (Marton et al., 2004).

The main idea behind the logic of inquiry involves seeking rational knowledge by questioning (Hintikka, 1999). Hintikka (1999) conceived the process of seeking new knowledge as an interrogative process between two players. The first player (the inquirer) has the role of asking questions, and the second player has the role of answering and is called the verifier (or oracle). The former is the seeker of knowledge who tries to prove a conclusion to be reached from prior experiences or even from theoretical premises. The latter is considered the source of knowledge.

In order to design educational situations that may promote inquiry processes, Arzarello (2016) refers to the variation theory. The variation theory (Marton et al., 2004) defines learning as a change in the way something is discerned, i.e., seen, experienced or understood. According to this theory, meaning emerges as the learner focuses his awareness on the object of learning. In this case, some aspects of the object appear at the forefront of his attention. Yet, not all aspects are discerned at the same time or in the same way. In order to understand an object of learning in a certain way, various specific critical aspects must be discerned by the learner. To facilitate the discerned object of learning, Marton et al. (2004) proposed four interrelated functions (or patterns) of variation to be taken into account when designing educational tasks: (a) contrast: "...in order to experience something, a person must experience something else to compare it with"; (b) generalization: "...in order to fully understand what 'three' is, we must also experience varying appearances of 'three'..."; (c) separation: "In order to experience a certain aspect of something, and in order to separate this aspect from other aspects, it must vary while other aspects remain invariant"; and (d) fusion: "If there are several critical aspects that the learner has to take into consideration at the same time, they must all be experienced simultaneously" (Marton et al. 2004, p. 16).

In the MVI approach, Arzarello (2016) proposes that drawing students' attention to critical aspects, asking to vary them, and observing their effects on the phenomena may foster students' inquiry processes. The main idea of the MVI is creating challenging situations by varying some aspects of the phenomena (real-world or mathematical) while keeping the others invariant. Exploring various aspects of the same phenomena may lead the students to grasp the intended object of learning.

Design and Tasks

This paper reports on a first design-cycle of a learning environment and a digital tool using augmented reality in order to develop a learning design for pre-calculus concepts. Such iterative design-cycles are essential within design-based-research approaches (van den Akker et al., 2006; Gravemeijer, 1994; Gravemeijer & Cobb, 2006; Prediger et al., 2015). Within this research paradigm, research and development are strongly connected (Bakker, 2018). A mathematical design consists of learning activities embedded in certain tasks. Hence, the role of the design-principles concerning the tasks is crucial and they should contain “several representations, several kinds of sensory engagement, and several question types” (Watson et al., 2013, p. 10).

Galileo Experiment	
<p>Task 1</p> <p>Release the cube from the upper side of the inclined plane. Observe the movement of the cube and answer the following questions. What drew your attention when you observe the cube? Write as many observations as you can. Make a conjecture, which one of the observations will change if the plane inclination changes! Make a conjecture what will change if the time is reduced and give reasons?</p>	<p>Task 2</p> <p>Your task is to explore how the change of the plane's inclination may affect the movement of the cube.</p> <p>A. How will the change of the inclination affect the movement of the cube?</p> <p>B. Change the plane inclination in order to verify or refute the conjectures you raised in (A). Do your conjectures change? If yes, why? If not, prove your conjecture.</p> <p>C. Can you find an equation that describes the movement of the cube movement? Why or why not? Justify your answer.</p>
<p>Task 3</p> <p>Your task is to vary the plane inclination in order to explore the motion of the cube. You are requested to explain and justify your answers using the graphic and numeric representations.</p> <p>A. Explain the shape of the curve when the plane inclination changes?</p> <p>B. How do the differences between the y-values of the points on the graphs change when varying the plane inclination?</p> <p>C. Compute the differences of the distance differences. What can you observe? Why? Is your conjecture always true? Can you prove it?</p>	

Figure 1: Learning environment to explore the Galileo experiment with Augmented Reality

Based on the formulation of the design-principles above we have developed both elements (task and tool) in a first version. The design principles of the tasks were motivated by the MVI approach. Each task contains a real-world phenomenon and mathematical representations of the dynamic aspects of the phenomenon. The main idea of the design is to create different situations by varying some aspects of the phenomenon while keeping the others invariant (see table 1). For example, the first task may request students to explore the mathematical model of a ball rolling on inclined plane (as in the well-

known Galileo experiment). In this situation, the time elapsed and the spaces traversed of the ball vary, and the inclination plane angle is invariant. Hence, the crucial aspect of this task is the time-distance relationship. The second task requests students to explore the same situation as in task 1, but this time the angle of the plane is varied, and the students explore how this new situation affects the mathematical model. In this case, the students explore quadratic functions based on their graphs and numeric values. Exploring various aspects of the same phenomenon may lead the students to grasp the intended object of learning, namely, quadratic function and its properties.

Task	Mathematics	Crucial aspects
1	Non-propositional relationship	Time-distance relationship
2	Quadratic functions based on their graphs	Parabola, time-distance relationship
3	Quadratic function based on the second differences	Second differences of the space traversed, parabola, time-distance relationship

Table 1: Mathematical ideas, the crucial aspects of the phenomenon

First design-cycle: prototype and discussion

This section describes the development of two different prototypes. Based on experiments with the first version of the developed AR-tool we identified various disadvantages of the technology in use. The discussion below highlights some of the features of both versions and discusses the reasons for the technological changes within the developmental process.

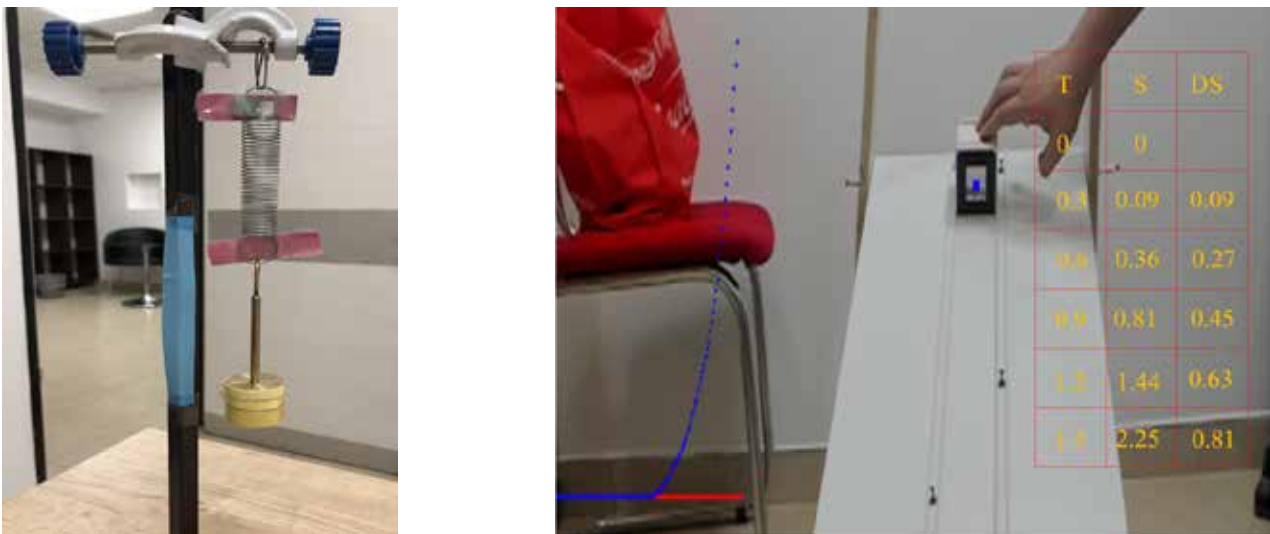


Figure 2: (left side figure, version 1) coded color method for recognizing dynamic object; (right side figure, version 2) Cube movement augmented with graph and table of values

First Prototype: We used MATLAB software in our first attempt to design the AR prototype. MATLAB has the ability to identify the dynamicity of an object and to present it graphically or numerically. To activate this option, the use of a video camera with high resolution is required and the dynamic objects should be color coded. In this way, the specific color given to the dynamic objects is traced and the dynamicity of the physical object is recognized. For example, a mass hanging on a spring was wrapped by yellow coloured paper as well as the beginning and the end of the spring are

coded by another colour (figure 2, left side). In this case, a camera followed the coded-colour papers. To recognize the coded colour paper, the users must calibrate and define the color to be traced in each new experiment. For recognizing the color properly—as a result to collect the data of the dynamic object correctly—a uniform distribution of light in the room is required. In fact, small changes in the light conditions changed the results significantly so that the values and graphs in the different augmented representations showed different results depending on the light conditions of the specific point of view.

Second Prototype: The several constrains that are required for the AR prototype to function properly, which are very difficult to ensure, obliged us to look for a new tool to design the AR prototype. We especially looked for tools that are insensitive to light and friendly for users. Therefore, in the second round of the designing, we decided not to use MATLAB in favour of using ARtoolKit library. ARtoolKit is an open-source computer tracking library for creating augmented reality applications that overlay virtual imagery on the real world. The developer's mission was to write an AR code to detect a moving cubic over an inclined plane. The cubic detection is done by using fiducial values or markers. The ARtoolKit provides several methods for tracking and detecting objects in the real world. The most primitive one is the marker-based tracking and detection. We used a specific marker from the markers-collection called "Hiro". The marker is treated as a pre-defined input. The program extracts features from the input marker. Additionally, the program detects these features of the marker in each frame. The markers are attached to the cube in our experiment (figure 2, right side version), so that it allows the detection of the cube movement in real-time (presenting the distance vs. time function) while using a camera. The data is then displayed on the eyeglasses (see figure 2, right side). The type of eyeglass used is HTC VIVE Pro (<https://www.vive.com/eu/product/vive-pro/>). The data of the dynamic object is displayed graphically and numerically. Hence, one sees the real experiment augmented with the data. The data itself is displayed in different representations. Within the evolving graph, one can see a distance-time function graph. The graph itself can be displayed a set of discrete points, or as a continuous function graph. The table shows three columns: time, distance and the difference between two consecutive distances. Both the graph and the table of values are displayed, so that the students can relate and reflect on the relation of the different representation modes.

Conclusion and Outlook

Based on both task- and technological design-principles we discussed a first cycle of the development of a learning design addressing pre-calculus concepts using AR technology. We have reported on the features of an AR-tool with disadvantages in the experimental situations and a second version, which is much more stable in the experimental situations. The outcome of the described iteration is an AR prototype that can be used in order to explore a dynamic real-life situation with mathematical concepts in the field of pre-calculus. The user wears eyeglasses and the data is displayed in different representation modes simultaneously.

The next step will be to conduct empirical experiments with students in order to study their conceptual developments when using the technology and to empirically evaluate the chosen design-principles.

Acknowledgment

This study was supported by the Israel Science Foundation (Grants No. 1089/18).

References

- Artigue, M., & Blomhøj, M. (2013). Conceptualizing inquiry-based education in mathematics. *ZDM*, 45(6), 797–810.
- Arzarello, F. (2016). *How to promote mathematical thinking in the classroom. Lecture delivered at the 3rd Italian Summer School in Math Education*, UMI-CIIM, Bardonecchia.
- Bakker, A. (2018). *Design Research in Education, A Practical Guide for Early Career Researchers*. London, UK: Routledge.
- Blake, M. B., & Butcher-Green, J. D. (2009). Agent-customized training for human learning performance enhancement. *Computers & Education*, 53(3), 966–976.
- Cheng, K.-H., & Tsai, C.-C. (2013). Affordances of Augmented Reality in Science Learning: Suggestions for Future Research. *Journal of Science Education and Technology*, 22(4), 449–462.
- Duval, R. (2006). A cognitive analysis of problems of comprehension in a learning of mathematics. *Educational Studies in Mathematics*, 61(1), 103–131.
- Edwards, L., Radford, L., & Arzarello, F. (2009). Gestures and multimodality in the construction of mathematical meaning. *Educational Studies in Mathematics Education*, 70(2), 175-189.
- Gravemeijer, K. (1994). Educational Development and Developmental Research in Mathematics Education. *Journal for Research in Mathematics Education*, 25(5), 443-471.
- Gravemeijer, K. & Cobb, P. (2006). Design research from a learning design perspective. In: Van den Akker, J., Gravemeijer, K, McKenney, S. & Nieveen, N. (Eds). (2006). *Educational design research*. London: Routledge, 17-51
- Hintikka, J. (1999). The Role of Logic in Argumentation. In *Inquiry as Inquiry: A Logic of Scientific Discovery* (Vol. 5, pp. 25-46). Dordrecht: Springer Netherlands
- Johnson, L., Levine, A., Smith, R., & Stone, S. (2011). *The 2011 horizon report*. Austin, Texas: The New Media Consortium.
- Kaufmann, H., Steinbugl, K., Dunser, A., & Gluck, J. (2005). General training of spatial abilities by geometry education in augmented reality. *Cyberpsychology & Behavior*, 8(4), 330-341.
- Lakatos, I. (1976). *Proofs and Refutations*. Cambridge: Cambridge University Press.
- Marton, F., Runesson, U., & Tsui, A. (2004). *The space of learning*. Mahwah, NJ: Lawrence Erlbaum.
- Orozco, C, Esteban, P, & Trefftz, H. (2006). “Collaborative and Distributed Augmented Reality in Teaching Multi-Variate Calculus.” Paper presented at the *IASTED International Conference on Web based Education (WBE 2006)*. Puerto Vallarta, Mexico.

- Prediger, S., Gravemeijer, K., & Confrey, J. (2015). Design research with a focus on learning processes – an overview on achievements and challenges. *ZDM Mathematics Education*, 47(6), 877–891.
- Prediger, S., & Wessel, L. (2013). Fostering German language learners' constructions of meanings for fractions: Design and effects of a language- and mathematics-integrated intervention. *Mathematics Education Research Journal*, 25(3), 435–456.
- Prediger, S., Clarkson, P., & Bose, A. (2016). Purposefully relating multilingual registers: building theory and teaching strategies for bilingual learners based on an integration of three traditions. In R. Barwell, P. Clarkson, A. Halai, M. Kazima, J. Moschkovich, N. Planas, M. Setati-Phakeng, P. Valero, & M. Villavicencio Ubillús (Eds.), *Mathematics education and language diversity. New ICMI Study Series* (pp. 193-215). Cham, Switzerland: Springer International Publishing.
- Radford, L. (2014). Towards an embodied, cultural, and material conception of mathematics cognition. *ZDM*, 46(3), 349–361.
- Roth, W.-M. (2009). *Mathematical representation at the interface of body and culture*. Charlotte, NC: Information Age.
- Rocard, M., Csermely, P., Jorde, D., Lenzen, D., Walberg-Henriksson, H., & Hemmo, V. (2007). Science education NOW: a renewed pedagogy for the future of Europe. Downloaded at: https://ec.europa.eu/research/science-society/document_library/pdf_06/report-rocard-on-science-education_en.pdf.
- Sayed, N. A. M. El, Zayed, H. H., & Sharawy, M. I. (2011). ARSC: Augmented reality student card. *Computers & Education*, 56(4), 1045–1061.
- Sommerauer, P., & Müller, O. (2014). Augmented reality in informal learning environments: A field experiment in a mathematics exhibition. *Computers and Education*, 79, 59–68.
- van den Akker, J., Gravemeijer, K., McKenney, S. & Nieveen, N. (2006). *Educational design research*. London: Routledge.
- Watson, Anne; Ohtani, Minoru; Ainley, Janet; Bolite Frant, Janete; Doorman, Michiel; Kieran, Carolyn; Leung, Allen; Margolinas, Claire; Sullivan, Peter; Thompson, Denisse; Yang, Yudong (2013). Introduction. In Margolinas, Claire, Watson, Anne; Ohtani, Minoru; Ainley, Janet; Bolite Frant, Janete; Doorman, Michiel; Kieran, Carolyn; Leung, Allen; Sullivan, Peter; Thompson, Denisse; Yang, Yudong (Eds.): *ICMI Study 22 on Task Design - Proceedings of Study Conference*. 9-16. Springer: UK, Oxford.
- Wu, H.-K., Lee, S. W.-Y., Chang, H.-Y., & Liang, J.-C. (2013). Current status, opportunities and challenges of augmented reality in education. *Computers & Education*, 62, 41–49.

Exploring critical aspects of students' mathematics learning in technology-enhanced and student-led flipped learning environments

Stefanie Schallert¹ and Robert Weinhandl²

¹Johannes Kepler University Linz, Austria; stefanieschallert@gmail.com

²Johannes Kepler University Linz, Austria; robert.weinhandl@bildung.gv.at

Although teaching according to a flipped classroom approach is being increasingly used in schools, it is still the case that this type of education is often teacher-driven, and that teachers play a dominant role in terms of determining learning objectives and materials. Recently, the definition of flipped classrooms is being changed, accordingly the approach is becoming more student-driven and teachers mostly start to play supportive roles. Thus, this new approach is currently referred to as the flipped learning approach. The aim of our research is to identify central elements for students when learning mathematics in flipped learning environments. Therefore, teaching scenarios were developed, applied at a higher secondary level and written feedback from pupils were obtained. The grounded theory based analysis of feedback suggests that it is crucial for students to work together, jointly generate knowledge, become active in determining learning paths and selecting materials.

Keywords: Flipped classroom, Flipped learning, Mathematics education, Student centred learning.

Introduction

Flipped Classroom Approaches (FCA) have been gaining popularity in education and in most cases, digital technologies are used to facilitate creating a flipped environment. Digital technologies include mathematics specific software products such as GeoGebra as well as communication and collaboration platforms such as Moodle or Mahara. In general, modern technologies have been becoming increasingly important in mathematics education. Nevertheless, using technologies should always improve students' learning process, and not simply appease them (Klein, 2002). Even though many scientists and practitioners describe education according to an FCA as progressive, there is already a development of this approach – the flipped learning approach (FLA). However, the terms Flipped Classroom and Flipped Learning are used synonymously in some scientific articles (e.g. González-Gómez et al., 2016; J. Lee, Lim, & Kim, 2017). But the approaches differ regarding their definitions and characteristics. The fact that the two approaches are still used synonymously may indicate that education according to an FLA has not been fully integrated into research and teaching. This can also be observed in the STEM education field, since recent publications use the approaches interchangeably and without differentiation (e.g. Gnaur & Hüttel, 2014; Ponikwer & Patel, 2018).

The first section will discuss the differences between an FCA and an FLA. Here, a special focus is placed on students learning mathematics and how these approaches are linked to social constructivism. Then, we will focus on our actual research question: Which components of an FLA are crucial for both students' well-being in such environments and students' motivation to participate in mathematics education? In order to achieve the research aim, data were collected and evaluated according to a grounded theory approach and action research. Finally, the thesis will discuss the results of the research and, from this, draw conclusions.

Theoretical Background

This section defines the singularities and differences between FCA and FLA. Additionally, relations of these approaches to mathematics education and to the theory of social constructivism are described.

Defining flipped classroom approaches

Even though FCA has been dealt with often at an academic level in recent years this form of education can be found in many classrooms, there is still no uniform definition of this educational approach (Enfield, 2016; Wasserman et al., 2015). But most FCA descriptions have common elements. The fact that direct instructions and passive learning activities take place outside classrooms characterizes many definitions of an FCA. The classroom time is then used for student-centred and active learning activities. This means that in pre-class phases of an FCA, mainly simple learning objectives are pursued and in in-class phases learners and a teacher try to achieve higher learning objectives (Wasserman et al., 2015).

In mathematics education it is quite common utilizing videos in pre-class phases and lessons are used for active, group-based or problem-solving activities. Recently, more and more research projects (e.g. Esperanza, Fabian & Toto, 2016) demonstrate that flipped classroom education can improve students' achievement in learning mathematics.

Defining flipped learning approaches

Many assume that *flipped classroom* and *flipped learning* are similar terms used to describe more or less the same approach. To counter misconceptions, the Flipped Learning Network (FLN) (2014) composed a formal definition of the term “flipped learning”, as follows: “Flipped Learning is a pedagogical approach in which direct instruction moves from the group learning space to the individual learning space, and the resulting group space is transformed into a dynamic, interactive learning environment where the educator guides students as they apply concepts and engage creatively in the subject matter” (FLN, 2014). According to the FLN, an FCA does not necessarily lead to flipped learning. However, FLA can be considered as a development of FCA.

Implementing FLA into mathematics education should lead to flexible learning environments in which students could achieve higher cognitive goals, for instance by tackling real-world problems. Moreover, for the construction of different mathematical meanings, learners can be given the opportunity to make their own experiences and feel the need for an introduction of concepts or terms.

Although many studies have already explored implementing an FCA in mathematics teaching, there is a lack of research investigating flipped learning in mathematics education. In a few mathematics education research studies some elements of an FLA can be found (e.g. Weidlich & Spannagel, 2014). However, these learning environments are often not described according to an FLA.

Social constructivism's influence on flipped learning environments

Social constructivism (SC) (Vygotsky, 1978) is a student-centred learning theory that emphasises importance of the social environments in which learners generate their knowledge themselves. According to SC, students are becoming more active to determine their learn path and teachers' role change from knowledge providers to supporters of the learning environments. FLA has already

incorporated SC in its initial development as in flipped learning environments learning is self-directed and seen as an active process. Moreover, students are also encouraged to learn through social interactions within their groups (Green, 2015).

Research design

This section outlines the participants, the mathematical content and the procedures of our flipped learning experiments.

Framework of our flipped learning educational experiment

The educational experiment was conducted with four classes (students aged from 14 to 16 years) at two different schools in Vienna – an urban college of business administration and a humanistic high school with a focus on classical languages. All four classes were already taught in a traditional flipped classroom setting. The educational experiment lasted between 6 to 7 teaching units and more than 110 students took part in it in total. The centre of education was formed by square functions and their applications. Since students from different types of schools were involved, the experiment was carried out according to the respective curricula of the 9th and 10th grade.

Proceedings of our flipped learning educational experiment

At the beginning of the learning sequences, all students were informed about the tasks to be performed, the goals to be achieved and the deadline. In the college of business administration, students had to solve different tasks, which were made available via an online learning platform. There were also short interactive videos with integrated questions provided to check students' comprehension. Therefore, watching a video became an active process. In the high school, students had to research Leonardo bridges, build such a bridge themselves, and finally mathematically examine this self-built bridge. Students were able to use tablets (college of business administration), their own notebooks (high school) and other learning materials according to their preferences.

In all settings it was essential that learners were given tasks and objectives. However, the availability of time and technological tools enabled the students to self-determine the learning path. This availability should make it easier for learners to individualise learning processes themselves. The provision of modern technologies, as well as databases and communities on these technologies, should enable students to tackle higher mathematics.

Since experimental conditions in education in general, and in a flipped setting in particular, are difficult to produce (Reinmann, 2005) and our research interest focuses on exploring crucial aspects for students when learning mathematics in flipped learning scenarios, we decided on qualitative oriented research methods. Thus, approaches and methods of action research and grounded theory were used to collect and evaluate data.

Research aim and research methods

Exploring which components are significant for students when learning mathematics according to an FLA is the aim of our research. In order to develop these new hypotheses and theories concerning FLA mathematics education, our research is designed according to qualitative research approaches.

The education sequences described above were planned and carried out by us, the authors. We had to assume both the role of a teacher and the role of a researcher. This should help to ensure that both practical and academic knowledge could be gained through the research process. For the action research McKernan's iterative model (McKernan, 1991) was chosen. This model is based on Lewin's four original action research phases: plan, act, observe and reflect (Lewin, 1946).

Additionally, a grounded theory approach (GTA) was applied to develop an FLA mathematics education theory. This theory is based on teaching records and on student feedback forms. Both data collection and evaluation follow GTA principles according to Strauss and Corbin (1990, 1997). Since both perspectives of researchers and the educational environment are of central importance, many elements of a constructive GTA according to Charmaz (2006) can also be found in the present research design. After the last lesson of this sequence, learners were asked to provide open written feedback on the FLA mathematics education experiment. The learners were asked to evaluate the positive and negative experiences and aspects. The feedback guidance was formulated openly and broadly, as on the one hand new hypotheses and theories were to be developed based on feedback forms. On the other hand, precise guiding questions were omitted in order to reduce the risk of students answering as they think teachers would like them to. We were able to achieve a complete survey of all students, which provided 110 feedback forms. First, feedback forms were fully transcribed and openly coded. This led to 30 codes. The comparison of the codes and corresponding transcript passages led to four new codes with an added level of abstraction. The new codes were then mutually examined, axially coded and a synthesis of findings was produced. This led to two central concepts described below according to our research interests.

Results

In the following paragraphs, the two central concepts mentioned above are explained in more detail. The inserted quotations of the learners were translated by us, the authors.

Working together and in groups

The feedback from students shows that they found it positive when learning products were created together and when different tasks could be solved as a group. Learners also appreciated that mathematical knowledge was created collaboratively and that they could support each other in this creative process. Here, certain students also took on the role of coaches, which reduced the time taken to receive help, and was emphasized positively by the learners.

Student: I found it a very good and useful opportunity to teach and support other students. It was all positive. When there was a question, immediate help was given.

Student: It was good to work on topics together and to discuss and debate these topics together.

It was also noted that working with friends was always fun and enjoyable. Moreover, this had a positive effect on the motivation of the learners and led to the mathematics class turning into a more positive place compared to teacher-centred lessons.

Student: By creating the mind map [on the blackboard, concerning a catenary] together, the lesson became funnier and the math was treated in more detail.

In this context, it was important for the students to be involved in the formation process of the groups and to be able to decide which students would form a group. Furthermore, the learners emphasized that it is just as important to be able to work individually (temporarily) in such a setting.

Student: I liked it because we could also work alone.

Active and self-directed learning process

Feedback from learners demonstrates that it was positively received that students themselves could choose the approach and how to tackle a problem. They highlighted that it was exciting to be able to work out a problem and that the answer is not immediately given.

Student: I think it was a good exercise, because you learn to work independently and try to find a solution on your own.

Furthermore, data from the feedback forms show that students liked the speed and intensity of learning as well as the focus of the learning process being chosen by the students themselves. This also means that the learners liked that some of the places of learning could be chosen by them and that the lessons could therefore be better adapted to their needs.

Student: [...] that we actually built the bridge was great and that we had lessons in roof rooms was also great.

Student: [...] I liked it [flipped learning], because everyone could work at their own pace.

In their feedback on the teaching sequence the learners commented that it was perceived as helpful that they themselves could switch between the real world with real problems and mathematical concepts. In line with student feedback, this made it possible to improve the idea of mathematical concepts and to make the significance of mathematics easier to grasp.

Student: It wasn't just numbers, we built the bridge ourselves and the real meaning behind the calculations was better understood this way.

Discussion and further considerations

This section will discuss the findings and contributions and attempt to establish a connection to current literature as well as to school practice. According to sub-codes, further considerations are made in the conclusion, not only regarding isolated and/or non-cumulative feedbacks from learners, but also missing feedback on certain topics.

Working and learning in groups

Since an FLA is characterised by students working in groups and thus exploring the subject matter, it is not surprising that this classroom mode was preferred by students. But it is still rare that mathematics lessons are taught in groups. This applies both to academic discourse and to everyday school practice. Only a few authors (e.g. Bell & Pape, 2012 or Lee & Johnston-Wilder, 2013) have dealt with group work in mathematics lessons. Future research on mathematics education, especially on linking mathematics education and an FLA, should also look at how group work can be integrated into this synthesis and which framework is important here. In this context, on the one hand, it would be important to investigate how mathematics can be learned in a flipped scenario, and, on the other

hand, how learning outcomes achieved in FLA mathematics education can be both secured by students and assessed by teachers. This is because it could be shown that learning actions which are not graded are considered meaningless by pupils and their parents (Häcker, 2011).

Nevertheless, some feedback from learners and literature (e.g. Harkness & Stallworth, 2013) demonstrates that there are students who (also) prefer to work on their own. When group work is integrated into flipped mathematics, it is of paramount importance that these learners are not forgotten. Hence, it would be necessary to expand the students' learning space and options.

Active and self-directed learning process

The feedback data show that students perceived it positively that active learning was possible and that a learning path could be co-determined by them. Already Leonard et al. (2014) demonstrated in this context that different learners have different interests. If the interests of pupils are at the centre of the learning process, it increases the probability can be increased that active and sustainable learning takes place and that the pupils strive to plan their own learning path. For the purpose of creating a learning environment in which the interests of the students dominate and are therefore often self-directed, some basic conditions must be provided. One possibility is that the teacher offers a wide range of tasks from which students themselves can choose. Another possibility would be for tasks to be designed in such a way that they can be modified by learners. The fact that these tasks are present in a self-directed learning process is therefore important, since only then can one count on the fact that learners seriously attempt to solve a problem. This puzzling is necessary to achieve sustainable learning and consequently a better understanding of mathematics among students.

In contrast, the feedback data also revealed that there are students who struggle with taking control of their learning process. With regard to this, the learners mentioned that they missed structure in the teaching units and that a lack of structure hindered their learning process. As a result, a balance between freely selectable tasks as well as a given structure will have to be struck so that the majority of students can benefit from a pupil-active and self-directed learning environment.

Further considerations and conspicuous features

Although modern technologies were of central importance in our teaching experiments and learners made intensive use of them, working with technologies was rarely addressed in the feedback forms. On the one hand, this could be a consequence of the fact that it is not new for students that technologies are used in the learning process. On the other hand, it is very probable that modern technologies are an integral part of the everyday lives of young people in the 21st century and it is therefore not worth mentioning to learners that these technologies are also used in school contexts.

With relations to the desire for a possibility of individual work, some students also addressed discipline and collegiality in the teaching experiment. For this purpose, future research should identify relationships between freedom and discipline that is conducive to the well-being of most learners.

For some students, time management in the teaching experiment was as challenging as its structure. It can be concluded that some students have a high need for such meta-competencies. Future research will also need to examine how learners can be supported in a flipped learning setting so that these skills can be acquired.

Conclusions and further research

The research data indicate that for students it is more important how mathematics is learned according to an FLA than which tools are used and how complex the learning content is in such a setting. From this we conclude that it might be most critical for students to be able to determine their learning paths as well as goals, and to set their own priorities in education. It was surprising to us that neither technology-enhanced learning environments nor tackled content, which was sometimes challenging for students, were stressed. This is particularly true of the content, because certain mathematical concepts are not covered in the curriculum until later (limiting value and complex numbers) or are not included in the secondary curriculum (catenary and hyperbolic cosine).

For learning mathematics according to an FLA, our research has drawn that the amount of direct instruction could be reduced in the individual learning space. Instructions could either be offered just in time, or students could acquire new learning content in a constructivist way. Here, it could be significant, both in an individual and in a group learning space, that a teacher is available to pupils as a guide if pupils learn mathematics in a self-determined way according to an FLA.

Since the research corpus for learning mathematics following an FLA is still weak and undifferentiated from an FCA, this paper could help to initiate further research in this direction. Here, it would be important that characteristics of an FLA (FLN, 2014) are taken into account and that further mathematics education FLA research is clearly distinguished from respective FCA research.

References

- Bell, C. V., & Pape, S. J. (2012). Scaffolding students' opportunities to learn mathematics through social interactions. *Mathematics Education Research Journal*, 24(4), 423–445.
- Charmaz, K. (2006). *Constructing Grounded Theory: A Practical Guide through Qualitative Analysis* (1 edition). London ; Thousand Oaks, Calif: SAGE Publications Ltd.
- Enfield, J. (2016). The Value of Using an E-Text in a Flipped Course. *TechTrends*, 60(5), 449–455.
- Esperanza, P., Fabian K. & Toto C. (2016). Flipped Classroom Model: Effects on Performance, Attitudes and Perceptions in High School Algebra. In K. Verbert (Ed.), *Adaptive and Adaptable Learning* (pp. 85-97). Lyon, France: Springer.
- Flipped Learning Network (FLN). (2014). The Four Pillars of F-L-I-P. Retrieved from <https://flippedlearning.org/definition-of-flipped-learning/>
- Gnaur, D., & Hüttel, H. (2014). How a Flipped Learning Environment Affects Learning in a Course on Theoretical Computer Science. In E. Popescu, R. W. H. Lau, K. Pata, H. Leung, & M. Laanpere (Eds.), *Advances in Web-Based Learning – ICWL 2014* (pp. 219–228). Springer International Publishing.
- González-Gómez, D., Jeong, J. S., Airado Rodríguez, D., & Cañada-Cañada, F. (2016). Performance and Perception in the Flipped Learning Model: An Initial Approach to Evaluate the Effectiveness of a New Teaching Methodology in a General Science Classroom. *Journal of Science Education and Technology*, 25(3), 450–459.

- Green, T. (2015). Flipped Classrooms: An Agenda for Innovative Marketing Education in the Digital Era. *Marketing Education Review*, 25(3), 179–191.
- Häcker, T. (2011). Portfolioarbeit - Ein Konzept zur Wiedergewinnung der Leistungsbeurteilung für die pädagogische Aufgabe der Schule. In *Sacher, W., Winter, F. (Hrsg.): Diagnose und Beurteilung von Schülerleistungen - Grundlagen und Reformansätze*. Baltmannsweiler.
- Harkness, S. S., & Stallworth, J. (2013). Photovoice: understanding high school females' conceptions of mathematics and learning mathematics. *Educational Studies in Mathematics*, 84(3), 329–347.
- Klein, M. (2002). Teaching mathematics in/for new times: A poststructuralist analysis of the productive quality of the pedagogic process. *Educational Studies in Mathematics*, 50(1), 63–78.
- Lee, C., & Johnston-Wilder, S. (2013). Learning mathematics—letting the pupils have their say. *Educational Studies in Mathematics*, 83(2), 163–180.
- Lee, J., Lim, C., & Kim, H. (2017). Development of an instructional design model for flipped learning in higher education. *Educational Technology Research and Development*, 65(2), 427–453.
- Leonard, J., Moore, C. M., & Brooks, W. (2014). Multicultural Children's Literature as a Context for Teaching Mathematics for Cultural Relevance in Urban Schools. *The Urban Review*, 46(3), 325–348.
- Lewin, K. (1946). Action research and minority problems. In G. W. Lewin, (Eds.), *Resolving social conflicts: Selected papers on group dynamics*. New York: Harper & Row (1948).
- McKernan, J. (1991). *Curriculum action research. A Handbook of methods and resources for the reflective practitioner*. London, UK: Kogan Page.
- Ponikwer, F., & Patel, B. A. (2018). Implementation and evaluation of flipped learning for delivery of analytical chemistry topics. *Analytical and Bioanalytical Chemistry*, 410(9), 2263–2269.
- Reinmann, G. (2005). Innovation ohne Forschung? Ein Plädoyer für den Design-Based Research-Ansatz in der Lehr-Lernforschung. *Unterrichtswissenschaft*, 33(1), 52–69.
- Strauss, A., & Corbin, J. M. (1990). *Basics of qualitative research: Grounded theory procedures and techniques*. Sage Publications, Inc.
- Strauss, A., & Corbin, J. M. (1997). *Grounded theory in practice*. Sage.
- Vygotsky, L. S., & Cole, M. (1978). *Mind in Society*. Cambridge: Harvard University Press.
- Wasserman, N. H., Quint, C., Norris, S. A., & Carr, T. (2015). Exploring Flipped Classroom Instruction in Calculus III. *International Journal of Science and Mathematics Education*, 1–24.
- Weidlich, J., & Spannagel, C. (2014). Die Vorbereitungsphase im Flipped Classroom. Vorlesungsvideos versus Aufgaben - Sowiport. In Rummler, Klaus (Hrsg.), *Lernräume gestalten - Bildungskontexte vielfältig denken*. (pp. 237-248). Münster u.a.

‘Practicing place value’: How children interpret and use virtual representations and features

Axel Schulz¹ and Daniel Walter²

¹University of Bielefeld, Germany; axel.schulz@uni-bielefeld.de

²University of Münster, Germany; daniel.walter@uni-muenster.de

The tablet-app ‘Stellenwerte üben’ (Practicing place value)¹ was developed to provide a software for practicing place value concept. There are two goals associated with this project: 1) Developing the app and 2) Investigating how children interpret the given non-symbolic representations and how they use the implemented features. This article presents the underlying theoretical background, a short description of selected features, and a sketch of initial empirical findings on the interpretation and use by primary school children in their second and third school years. First findings suggest that previous experience with concrete physical material overlaps and influences the intended use of the implemented virtual features.

Keywords: Place value, digital media, representational change, primary mathematics education

Place value understanding

The development of the understanding of place value and therefore of the composition of multi-digit numbers is one of the most important goals in mathematics education in primary school (Wittmann, 1994). In addition to that, lack of understanding of the concept of place value is a main indicator for learning difficulties in arithmetic (Scherer et al., 2016, p. 636). Understanding of place value can be assumed when someone 1) knows that the place value system is based on continually grouping by tens (powers of ten), 2) knows about the meaning of place value: The quantity of the value is determined by its position represented by the digits – the values of the positions increase in powers of ten from right to left, 3) knows about the meaning of face value: The digits have to be multiplied by the power of ten assigned to its position, 4) knows that the quantity of the whole numeral is the sum of the values represented by the individual digits and 5) knows the rules and structure of number word formation corresponding to the written number (e. g. Fuson et al., 1997).

In the literature, we can find numerous appropriate activities to foster the development of students’ place value understanding and to strengthen it in practice phases. Some of these activities are the following: Bundle and unbundle unstructured sets of objects according to the power ten (van de Walle, 2004; Hiebert & Wearne, 1992), arrange the bundles according to the place value to introduce and practice the place value system and name the bundles to compile and practice the rules of number word formation (van de Walle, 2004; Gaidoschik, 2003). In addition to these activities there are several manipulatives and representations that seem to be appropriate to work with: Unstructured objects such as linking cubes and tiles, pre-structured objects, for example base-ten blocks (Dienes-Blocks), ‘place value mats’ for sorting or trading base-ten material (e. g. van de Walle 2004, pp. 165–

¹ The German version of the tablet-app is provided on Google Play. An English version is in progress.

169, Gerster & Walter, 1973) and place value charts with tiles or digits for a standardized and conventional representation.

(Virtual) representations and their potentials

Theoretical analyses and empirical findings suggest that there are several features of *virtual representations* that have the potential to support mathematical learning processes. Some examples for these features are the following: Multitouch-Technology (e.g. Sinclair & Heyd-Metzuyanin, 2014), support in structuring an unsorted set of objects (Walter, 2018), reducing an extraneous cognitive load by the means of computational offloading (Rogers, 2012) and informative feedback (e.g. Harrass, 2007). For the present study, we focus on the following two features (see below): *Fitting between virtual representations and mathematical ideas* (e.g. Peltenburg, van den Heuvel-Panhuizen & Doig, 2009) and *synchronously linked representations* (e.g. Ainsworth, 2006). However, it must be pointed out that the existence of the features mentioned above does not automatically lead to an intended use (e. g. Walter, 2018).

Fitting between representations and mathematical ideas

Mathematical objects can not be empirically observed (like for example astronomical or biological objects) and therefore mathematical knowledge can not be developed through this observation. “The only way to have access to [...] [mathematical objects] and deal with them is using signs and [...] representations” (Duval, 2006, p. 107). These representations can be symbolic (e.g. written or spoken numbers “30”, “three tens”) or non-symbolic such as iconic or concrete representations (e.g. three ten-rods of the base-ten blocks; thirty apples in a picture), or something in between (e.g. three tiles in the tens place in a place value chart). In addition to that, these representations can be ‘material/external’ or ‘mental’ – for example three dots in a place value chart or *thinking* of three dots in a place value chart (Duval, 2006, p. 105). In this context, there are (among other things) two aspects that have to be taken into account: 1) The intended way from external representations to mathematical ideas ‘is not straight, easy or clear’ (Söbbeke, 2015, p. 1499) and these representations are not self-explanatory (Dreher & Kuntze, 2015, p. 91). 2) Mathematical ideas are abstract concepts and the representations must not be confused with the mathematical idea or object (Duval, 2006, p. 107).

Nevertheless, the structure of a given non-symbolic representation (no matter if these are concrete, virtual or mental) should ‘fit’ with the structure of a given mathematical idea (e.g. Sarama & Clements, 2016). On the one hand this fitting should be provided by an ‘intended structure’ built in by the manufacturer (Söbbeke, 2005, p. 135; Sarama & Clements, 2016, p. 82), on the other hand this fitting is the result of an epistemological process (Steinbring, 2015, p. 288). These aspects and conditions are taken into account through developing the tablet-app and analyzing its interpretation and use (see section “Design research and study design” below).

Synchronously linked representations

“Comprehension in mathematics assumes the coordination of at least two registers of [...] representations” (Duval, 2006, p. 115). On the one hand this coordination is a learning goal in mathematics education. On the other hand, it is a challenge because representations can be misinterpreted and the representations of different registers do not have to be congruent and,

therefore, a translation between registers is not simple, obvious or self-evident (Duval, 2006, pp. 115–120). An appropriate method to foster the ability to coordinate and translate between different registers and to realize what is mathematically relevant is to analyze *representation variations in at least two registers* (Duval, 2006, p. 125). In contrast to non-virtual representations, virtual representations can automatically be linked so that changes to one representative have a direct effect on another representation. This feature has the potential to support children in overcoming difficulties in switching between different representations (e.g. Ainsworth, 1999; Goodwin & Highfield, 2013).

Design research and study design

There are two goals associated with the presented project: 1) Developing the app considering the described theoretical background and 2) Investigating how children interpret the given non-symbolic representations and how they use the implemented features. To give an insight into the process of this design research project, we give a short description of the implemented features, a short description of the study design and in the next section a sketch of initial empirical findings on the interpretation and use by primary school children.

Implemented features

There are numerous apps focusing on place value (e. g. Burris, 2013; Ladel & Kortenkamp, 2016; Utah State University, n. d.). Though, none of these focus on the practicing phase of the learning, which provide self-generating tasks and informative feedback after entering a result. In addition to that, the implemented features of the app ‘Stellenwerte üben’ as described below can also be found in these apps. However, there is no app that combines all of these features.

Bundle and unbundle: The module ‘Bundle’ requests the bundling of *exactly* ten objects (ten ones or ten tens) to create a bundle of the next higher value (ten ones \rightarrow one ten; ten tens \rightarrow one hundred). To this end, one has to ‘activate’ exactly ten objects (e.g. by using the lasso-function) and to push the bundle-button. Then the ten objects assemble automatically into the next higher bundle and this slides to the respective column of the place value sorting map (see Fig. 1). An essential aspect of this assembling is the transparent value preserving: Even after bundling ten objects, these objects are still apparent (a ten is made of ten ones, a hundred is made of ten tens). In reverse, unbundling is possible, for example, by sliding one hundred in the tens (or ones) column. After doing this the hundreds automatically split into ten tens (or hundred ones). This feature is implemented in all modules with virtual representation of the base-ten material. Sarama and Clements point out that these virtual bundling activities are “more in line with the *mental actions* that we want students to learn” (Sarama & Clements, 2016, p. 85, emphasis in original) than activities with concrete-physical base-ten blocks.

Sorting bundles: The module ‘Sort’ requests the sorting of an unorganized set of ones, tens and hundreds in the place value sorting map. By sliding the objects in the respective columns, the students practice the assignment of a given bundle to the appropriate place value column. In this context, the

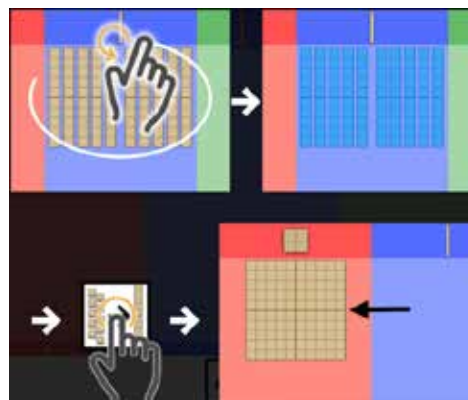


Figure 1: Bundling ten ten-rods

sorting is aligned to the visible quantity of a given bundle. This visual assignment is supposed to strengthen the integration of the ‘quantity’ value aspect and the ‘column’ value aspect of place value understanding (Sayers & Barber, 2014, pp. 24–25).

It has to be taken into account, that these practicing activities (virtual bundling and sorting) *do not only by themselves lead* to a sustainable place value understanding, but there have to be several prior activities and accompanying instruction (e. g. van de Walle, 2004). In addition to this, it has to be taken into account that the described activities are based on representations that are visually clearly distinguishable by their quantity. These activities can be interpreted as didactic stages on the way to an abstract understanding of place value. A rigid adherence to these stages and an unreflected use of this representation could lead to common errors (as described by Ladel & Kortenkamp, 2016, p. 297).

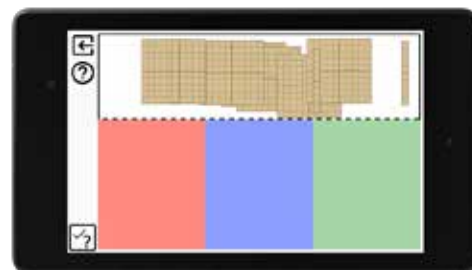


Figure 2: Sorting objects

The research interests arising from these considerations are the following:

- Research question 1 (RQ1): In which ways do students interpret and use the intended fitting between representations and mathematical ideas?
- Research question 2 (RQ2): How do students interpret the non-symbolic representation particularly with regard to the hundred-squares, ten-rods and unit-squares in the place value sorting mat?

Synchronized linked representations: Changes in the iconic register (e.g. unbundle a ten rod) lead to changes in the nonverbal-symbolic register at the bottom of the surface ($0+10+2$ changes into $0+0+12$, see Fig. 3).



Figure 3: Synchronously linked representations in ‘Stellenwerte üben’

- This leads to research question 3 (RQ3): Do children notice the synchronously linked representations and in what ways do they use this feature?

Study design

One focus of our research is to analyze students’ *methods of usage and interpretation* while working with the tablet-app ‘Stellenwerte üben’ (see the research questions developed above). To this aim individual clinical interviews with $n=29$ German second and third graders have been conducted. All children knew the physical base-ten material from classroom. Main tasks have been, among other

things: 1) the creation of non-symbolic representations: “Please show me the number two-hundred-fourty-five using the tablet-app.” (RQ1), 2) the explanation of a created non-symbolic representation: “How do you know this is the number you are looking for?” (RQ1 and 3), 3) an interpretation of 2 ten-rods in the tens place: “Another child has told me this is a representation of twenty tens. What do you think?” (RQ2), and 4) taking away two tens from two bundled hundred-squares “Can you please remove two tens.” (RQ1). All interviews have been transcribed (obtaining both speech and actions) and analyzed using a qualitative content analysis (Mayring, 2015).

Initial empirical findings

It was examined whether and how children *make use* of digital media’s features implemented in the developed tablet-app. Furthermore, we wanted to evaluate how children *interpret* the given non-symbolic representation. These findings might lead to implications for further development, research and for lessons using the described app.

Using the fitting between representations and mathematical ideas

As expected, we found different types of usage. On the one hand, there are children who use the implemented features (here bundling and unbundling by sliding and lassoing) independently and are aware of what they are doing (for an example see the following transcript).

Interviewer: What would you have to do to remove twenty?

Student: I know, I know. Like this. (*Unbundles a hundreds-square by sliding it to the tens-column. Swipes away two ten-rods.*)

Interviewer: Ok, and what is your result?

Student: Hundred-and-eighty.

On the other hand, there are children who imitate the action with concrete base-ten blocks (namely trading). These children erase a given hundred-square, create ten ten-rods instead and take away two of these ten-rods. This finding suggests that previous experience with concrete physical material overlaps and influences the intended use of the implemented feature. This assumed interdependence between virtual and concrete actions is worth a closer look in further investigation.

Interpretation of the non-symbolic representation

The non-symbolic representation of the tablet-app was developed to integrate both the quantity value aspect and the column value aspect of place value understanding (Sayers & Barber, 2014, pp. 24–25). To examine children’s interpretation of this representation (two ten-rods in the tens-column) we asked explicitly for this interpretation (“Another child told us... What do you think?”, see above). By doing this we found two different types of explanation: 1) Children who are aware of the fact that there are exactly two tens. Some of these children referred explicitly to the intended integration of quantity value and column value. 2) Children who mix up the naming of the given representation (“There are twenty tens”). Through further analyses and interviews we want to find out if these answers have their roots in an inaccurate use of mathematical vocabulary or if they are indicators for a conceptual misinterpretation of the intended structure.

Using the synchronously linked representations

As expected, our findings indicate that not all children consider the linked representations *independently* in their methods of use. Most children only focus on and refer to the non-symbolic representation. There are at least two possible explanations for this finding: 1) in the surface's graphical proportioning there is much more room for the non-symbolic representation than for the symbolic representation and 2) the main tasks requested actions with the non-symbolic representation. Nonetheless, it can be stated that there are both low- and high-achieving students who do independently use the linked representations, and all students use this feature when asked for an explanation. In these cases, the linked representations are used to support children's argumentation and as self-monitoring.

Interviewer: Please show me the number two-hundred-fourty-five.

Student: (*Creates two hundreds in the hundreds-column, four tens in the tens-column, five ones in the ones-column.*)

Interviewer: Ok, and how did you know, how many hundreds, how many tens and how many ones you needed?

Student: One square is hundred ones (*points at the hundred-square*) and there are two, thus, two-hundred. You can read this here, too (*points at the symbolic representation*).

Conclusion

The described study investigates children's *usage* and individual *interpretation* concerning a virtual practicing material. The tablet-app was developed to foster and strengthen children's place value understanding and it provides several features which are supposed to support mathematical learning processes. The implemented features are based on mathematical didactic theories and findings. In the following, we summarize the main results and draw some conclusions for teaching and further research.

The described findings validate the previous assumptions (Walter, 2018) that the existence of the described mathematical didactic features of virtual representations does not automatically lead to an intended use. Especially instead of using the synchronously linked representations children mainly focused on the non-symbolic representation, which is quite explainable. Nevertheless, we found that some children (both low- and high-achieving) used the linked representations *independently* and others used them for argumentation when asked for an explanation. This knowledge gives teachers the opportunity to discuss the connection between the different representations in the context of 'math conferences' with all students. In these settings students may become aware of the possibility to change between and use different representations, which they do not yet do independently. Another feature which was not used as intended by some children is the fitting between the virtual actions and the intended mental actions (Sarama & Clements, 2016, p. 85). Some students traded a hundred for ten tens and vice versa, instead of bundling or unbundling. These different types of usage (trading vs bundling and unbundling) could be used for constructive discussions in class: Do these different actions lead to the same results? What aspects of these actions are the same, what are different? This

discussion about actions, representations and the underlying mathematical ideas might lead to a better understanding of some basic aspects of the place value concept.

As mentioned above, some of the reported findings lead to further research interests like the investigation of an interdependence between using concrete and virtual representations. Also of interest is the question if the different interpretations of the non-symbolic representation ground merely on inaccurate use of mathematical vocabulary or if they are indicators for a conceptual misinterpretation of the intended structure. Since the tablet-app was developed for practice, further investigations also might focus more on autonomous usage (without an interviewer) and ways of practicing.

References

- Ainsworth, S. (1999). The functions of multiple representations. *Computer & Education*, 33, 131–152.
- Burris, J. T. (2013). Virtual place value. *Teaching Children Mathematics*, 20(4), 228–236.
- Dreher, A. & Kuntze, S. (2015). Teachers' professional knowledge and noticing: The case of multiple representations in the mathematics classroom. *Educational Studies in Mathematics*, 88(1), 89–114.
- Duval, R. (2006). A cognitive analysis of problems of comprehension in a learning of mathematics. *Educational Studies in Mathematics*, 61(1), 103–131.
- Fuson, K., Wearne, D., Hiebert, J. C., Murray, H. G., Olivier, A. I., Carpenter, T. P., Fennema, E., & Human, P. G. (1997). Children's conceptual structures for multidigit numbers and methods of multidigit addition and subtraction. *Journal for Research in Mathematics Education*, 28(2), 130–162.
- Gaidoschik, M. (2003). Zehner und Einer: Die ersten Schritte. Anregungen für die Erarbeitung von Stellenwertverständnis im Zahlenraum bis 99. In F. Lenart, N. Holzer, & H. Schaupp (Eds.), *Rechenschwäche, Rechenstörung, Dyskalkulie* (pp. 182–189). Graz, Austria: Leykam.
- Gerster, H.-D., & Walter, R. (1973). Mehr System im Mehrsystem-Rechnen. Freiburg im Breisgau, Germany: Herder.
- Goodwin, K., & Highfield, K. (2013). A Framework for Examining Technologies and Early Mathematics Learning. In L. D. English & J. T. Mulligan (Eds.), *Reconceptualizing Early Mathematics Learning* (pp. 205–226). Dordrecht, Netherlands: Springer.
- Harrass, N. (2007). *Computereinsatz im Arithmetikunterricht der Grundschule – Theoretische Grundlegung und empirische Forschung zum Üben mit Lernsoftware*. Hildesheim, Germany: Franzbecker.
- Hiebert, J., & Wearne, D. (1992). Links between teaching and learning place value with understanding in first grade. *Journal for Research in Mathematics Education*, 23(2), 98–122.
- Mayring, P. (2015). *Qualitative Inhaltsanalyse. Grundlagen und Techniken*, Twelfth edition. Weinheim, Germany and Basel, Switzerland: Beltz.

- Ladel, S., & Kortenkamp, U. (2016). Development of a Flexible Understanding of Place Value. In T. Meaney, O. Helenius, M.L. Johansson, T. Lange & A. Wernberg (Eds.), *Mathematics Education in the Early Years* (pp. 289–309). Cham, Switzerland: Springer.
- Peltenburg, M., van den Heuvel-Panhuizen, M., & Doig, B. (2009). Mathematical power of special educational needs pupils: An ICT-based dynamic assessment format to reveal weak pupils' learning potential. *British Journal of Educational Technology*, 40(2), 273–284.
- Rogers, Y. (2012). *HCI Theory: Classical, Modern, and Contemporary*. San Rafael, Calif., USA: Morgan & Claypool.
- Sarama, J., & Clements, D. H. (2016). Physical and Virtual Manipulatives: What is "Concrete"? In P. S. Moyer-Packenham (Ed.), *International Perspectives on Teaching and Learning with Virtual Manipulatives* (pp. 71–94). Cham, Switzerland: Springer.
- Sayers, J. & Barber, P. (2014). It is quite confusing isn't it? In U. Kortenkamp, B. Brandt, Ch. Benz, G. Krummheuer, S. Ladel, R. Vogel (Eds.), *Early Mathematics Learning. Selected Papers of the POEM 2012 Conference* (pp. 21–36). New York, USA: Springer.
- Scherer, P., Beswick, K., DeBlois, L., Healy, L., & Moser Opitz, E. (2016). Assistance of students with mathematical learning difficulties: how can research support practice? *ZDM – Mathematics Education*, 48(5), 633–649.
- Sinclair, N., & Heyd-Metzuyanim, E. (2014). Developing number sense with TouchCounts. In S. Ladel & C. Schreiber (Eds.), *Von Audiopodcast bis Zahlensinn* (pp. 125–150). Münster, Germany: WTM-Verlag.
- Söbbeke, E. (2015). Language use, mathematical visualizations, and children with language impairments. In K Krainer & N. Vondrova (Eds.), *CERME9 – Proceedings of the Ninth Congress of the European Society for Research in Mathematics Education*, (pp.1497–1502), Prague, Czech Republic: Charles University and ERME.
- Steinbring, H. (2015). Mathematical interaction shaped by communication, epistemological constraints and enactivism. *ZDM – Mathematics Education*, 47(2), 281–293.
- Utah State University (n.d.). National Library of Virtual Manipulatives. Retrieved from http://nlvm.usu.edu/en/nav/category_g_1_t_1.html.
- van de Walle, J. A. (2004). *Elementary and middle school mathematics: teaching developmentally*. Boston, USA: Pearson Educations.
- Walter, D. (2018). How Children Using Counting Strategies Represent Quantities on the Virtual and Physical 'Twenty Frame'. In L. Ball, P. Drijvers, S. Ladel, H.-S. Siller, M. Tabach & C. Vale (Eds.), *Uses of Technology in Primary and Secondary Mathematics Education: Tools, Topics and Trends* (pp. 119–143). Cham, Switzerland: Springer.
- Wittmann, E. Ch. (1994). Teaching aids in primary mathematics: Less is more. In L. Bazzini, & H.-G. Steiner (Eds.), *Proceedings of the Second Italian-German Bilateral Symposium on the Didactics of Mathematics* (Vol. 39, pp. 101–111). Bielefeld, Germany: IDM.

Exploring non-prototypical configurations of equivalent areas through inquiring-game activities within DGE

Carlotta Soldano¹ and Cristina Sabena²

¹University of Torino, Italy; carlotta.soldano@unito.it

²University of Torino, Italy; cristina.sabena@unito.it

Inquiring-game activities are inspired to Hintikka's semantical games and are designed within a Dynamic Geometric Environment (DGE). In this report, we focus on inquiring-game activities on the equivalence of quadrilaterals areas, which were proposed to primary school students in Italy. The goal of these activities is to exploit the dynamicity of semantical games and of DGEs to foster students' geometrical thinking. Through a design-based approach and a case-study, we highlight how the double dynamicity of the didactical design allows the students to i) explore non-prototypical configurations and ii) reinvest their geometrical knowledge to make sense of the observed relationships between the figural and the numerical register.

Keywords: Non-prototypical figures, inquiring-games, area equivalence, primary school, DGEs.

Introduction and theoretical framework

In primary school the concept of area and its measurement are among the main goals of learning in all countries. Area measurement is usually the first case in which students encounter numerical computation in geometry (Smith & Barrett, 2017): first by counting units, and then by multiplicative computations. Comparing areas of different regions can be perceptively difficult when the shapes are different or they are not prototypical. Usually, students learn to establish the equivalence of figures both by using measurements and by decomposing them into congruent polygons, by cutting and pasting figures, folding papers, and drawing in paper and pencil environment. In this context, algebraic formulas are also introduced. However, research and international tests show that formulas often remain obscure or even 'black boxes' to many students (*ibid.*). Furthermore, students show difficulties in distinguishing between area and perimeter (D'Amore & Fandiño Pinilla, 2006).

In our study, we explore how inquiring-game activities within Dynamic Geometric Environments (DGEs) may foster students' geometrical reasoning, in particular on area and area equivalence. The study is part of a larger research project in which theorems of elementary geometry are transposed into inquiring-game activities inspired to semantical games (Soldano & Arzarello, 2018). These games are connected with a new form of logic, called 'logic of inquiry', developed by the Finnish logician J. Hintikka (Hintikka, 1999). In this logic, Hintikka made use of games of verification/falsification, known as *semantical games* (Hintikka, 1998), through which he reversed the recursive definition of truth given by Tarski.

For reason of space, we will refer only to the semantical games associated to statements expressed in the form $\forall x \exists y S(x, y)$, since we took inspiration from them to design our games. To this end, we can imagine a situation in which a verifier (V) has the goal of showing the truth of the statement while a falsifier (F) has the opposite goal of showing that it is false. F controls variable x and V controls variable y . F starts the game by choosing a value x_0 for the variable x and then the turn moves to V,

who should find a value y_0 for y such that $S(x_0, y_0)$ is true. In this game, F tries to create difficulties to V by choosing non-typical cases (such as extreme cases). According to Hintikka, the choice of the y_0 by V is a reliable test of truth if the x_0 chosen by F forces V to play in the worst-case scenarios. This game between V and F hence creates a dynamic interplay between them, paralleled by a dynamism at the cognitive level. Such dynamism is assumed to trigger students' inquiring process and foster their understanding of the mathematical situation.

Within DGEs, variables x and y are thought as base-points of geometric constructions. Since dragging preserves the critical attributes of robust constructions (Healy, 2000), by moving the base-points new configurations of the same robust shape can be explored. As it is well known from the literature, students tend to identify shapes with the prototypical examples representing the category (Rosch, 1973), e.g they easily recognize figures when one of their sides is horizontal. Goldenberg and Mason (2008) underline the importance for students of dealing with many and different examples, since they are “a major means for ‘making contact’ with abstract ideas and a major means of mathematical communication” (p.184) and “the variation in examples can help learners distinguish essential from incidental features” (*ibid.*). Variation can also produce the enlargement of students' *personal example space* (Watson & Mason, 2005), namely the “set of mathematical objects and construction techniques that a learner has access to as examples of a concept while working on a given task” (Sinclair, Watson, Zazkis & Mason, 2011, p.1). DGEs may facilitate students' accessibility to non-prototypical examples, thanks to the dynamic exploration of the figures. Non-examples serve to clarify “the boundaries or necessary condition of a concept” and can play the role of counterexample if they are used to “show that a conjecture is false” (Watson & Mason, 2005, p. 65). If a geometric property is not robustly constructed, namely the construction does not retain the critical attributes of the properties, DGE offers the possibility to produce both *examples and non-examples of the considered property*.

Generally, DGEs provide tools for computing an approximate value of the area of the constructed figures. If this value is made visible in the environment, dragging the base-points of a figure produces a double change: one within the figural register of representation and the other within the numerical one. Duval (2006) highlights two different operations with registers of representation, which he calls *treatment* and *conversion*. Both are fundamental for the understanding of mathematical concepts: treatments deal with transformations within the same register of representation, while conversions consider more than one register and the relationships between them. Revisiting Duval theory within DGEs, dragging of a robust figure can be interpreted as a treatment made within the figural register, while the coexistence of figural and numerical registers of representation may engage students to inquire their links by making conversions.

Methodology

Following a design-based perspective (DBRC, 2003), we carried out a teaching-experiment in two Italian 5th grade classrooms with the collaboration of their school teachers and of a master's degree student. We designed a sequence of five DGE inquiring-game activities centered on area equivalence and on the area/perimeter relationship of quadrilaterals. In each activity, pairs of students are invited to play a game in DGE, and to answer to specific questions that guide the inquiry of the geometric

concepts. After all students write their answers to the questions, a classroom discussion is developed under the teacher's guidance. Usually, two hours are dedicated for each inquiring-game activity (including discussion), for an amount of 10 hours.

In this contribution we present a case study from the first activity, focusing on the area equivalence between rectangles and parallelograms. The inquiring game and the worksheets for students are presented below. In previous lessons, students have explored the area and perimeter of quadrilaterals using paper models (cutting and pasting) and in paper&pencil environment. The collected data consist of the audio and screen capture of one pair of students (that we will call Rose and Lily) during the DGE inquiring-game activity, the completed worksheets from all the pairs of students and the video-recording of the classroom discussion. The collected data are analysed according to a semiotic multimodal approach to mathematics (Arzarello, Paola, Robutti & Sabena, 2009), which focuses on students' speech, gestures, drawings and actions within the DGE. Through the produced signs it is possible to grasp how students discover and make sense of the geometric property on which the game is based. More precisely our interest is to explore the potentials and limits of the didactic design based on the double dynamicity provided by the game and by the DGE affordances, with respect to students' geometrical reasoning in non-prototypical configurations.

The inquiring-game activity on parallelogram-rectangle area equivalence

The activity focuses on the relationship between the area of a rectangle and a parallelogram that share one side (named AB): the corresponding game starts from the configuration shown in Figure 1.

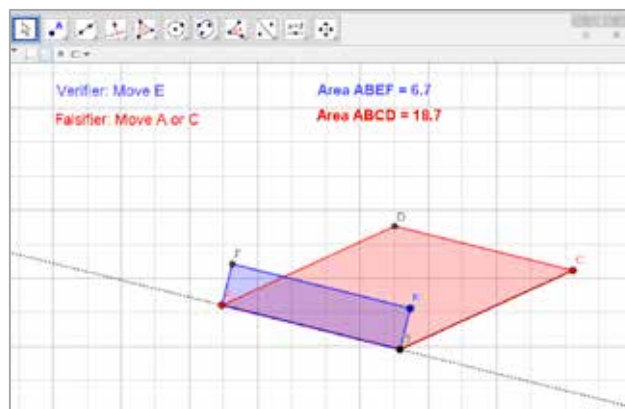


Figure 1: The initial configuration of the parallelogram-rectangle game

Both the parallelogram and the rectangle figures are robust constructions; by moving the free point A, it is possible to change the length of AB and rotate it around the fixed-point B (see Fig. 2a). This move changes also the values of the area of the figures, which are displayed on the screen. By moving point C, it is possible to drag the parallelogram and vary its area while the side AB remains fixed (see Fig. 2b). By dragging point E it is possible to vary the length of EB and the area of the rectangle ABEF. Since the figures share the same side AB, if the heights relative to AB are of the same measure the two figures are equivalent. A key-feature of the design is that this property is not constructed in a robust way, so to allow students to produce examples and non-examples of the property, through the verifier and falsifier's moves. The dotted straight line (the extension of the side AB) is inserted to

help students to visualize the correct position of the height relative to AB of the parallelogram. All draggable points can be moved in either half-plane identified by the line.

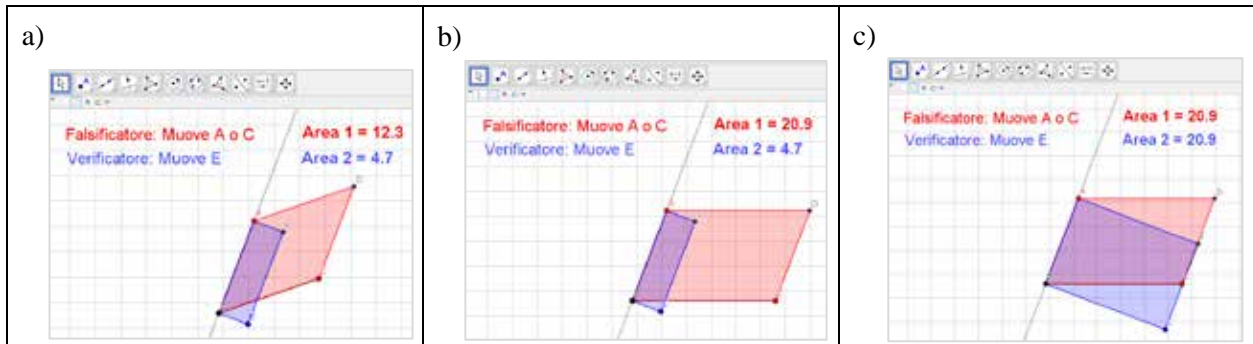


Figure 2: The effects of dragging point A, C and E

The following table contains the English translation of the rules of the game:

<p>Within your pair, choose a verifier and a falsifier.</p> <ul style="list-style-type: none"> - The falsifier can move point A or C, - The verifier moves point E. <p>Each match is made of two moves and the first one is always made by the falsifier.</p> <p>GOALS:</p> <p>The goal of the verifier is to make Area EBEF equal to Area ABCD, while the goal of the falsifier is to prevent the verifier from reaching the goal.</p> <p>The player who reaches her/his goal at the end of the verifier's move wins the match.</p>

Table 1: Rules of the parallelogram-rectangle game

According to the rules of the game, the verifier and the falsifier play a semantical game on the following statement: 'For all positions of point A and C there exists a position of point E such that Area ABEF is equal to Area ABCD'. The verifier can always win, by transforming any non-example of equivalent figure (i.e. rectangle non-equivalent to parallelogram, as in Figure 1) into an example of equivalent one (as shown in Figure 3). In agreement with the teacher we decided to round the area measure to the first decimal place.

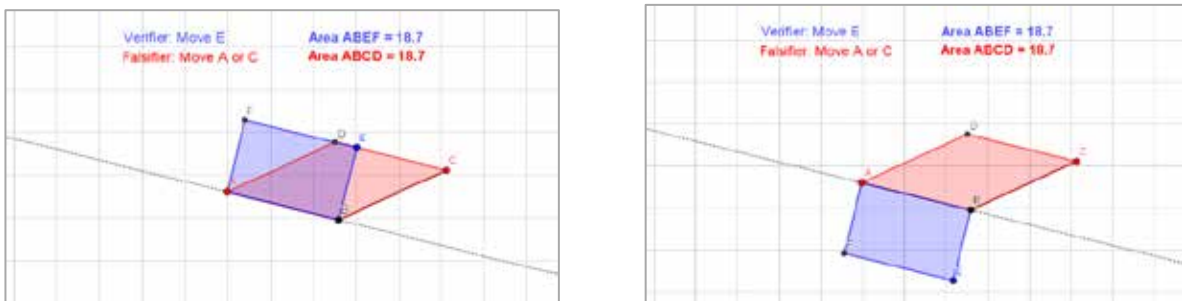


Figure 3: Examples of game configurations showing equivalent areas

The players' moves produce a *double simultaneous treatment*: one in the figural register, since each figure is transformed into another one of the same category, and one in the numerical register since also area values change. The following inquiring questions are proposed to students:

Answer these questions trying to use geometrical language:

1. Consider the case in which the verifier is winning. Write here your observations.
2. Explain why each time the verifier reaches the goal area ABEF is equal to area ABCD.
3. While playing, have you ever found a situation in which the two areas are zero? If not, play a new match to get it and describe what happened to the figures. If you like, make a drawing.

Table 2: Questions proposed to students

The guiding questions are meant to shift students' attention from the game to the geometric properties on which the game is based. Through the first one we collect students' observations, without giving them any hint. The second question focuses on area equivalence, that is the geometric property on which the game is based. It is meant to know whether students are able to convert the results observed in the figural and in the numerical registers using the known geometric properties. More precisely, students can provide two mathematically correct explanations: the first relies on the geometric interpretation of the area formula, the second one is made by showing that the two figures are made by the same congruent polygons (decomposition). Primary students are not expected to completely justify the congruence of the figures in a rigorous way, but chunks of arguments are expected to emerge. Finally, the last question requires students to produce a degenerate configuration and is meant both to investigate their conceptions of these cases, and to foster geometrical reasoning in non-prototypical configurations.

Data analysis

We report about Rose and Lily's inquiry in the game and in answering the worksheet questions. According to the teacher, they are medium-level students; Rose is reflective and her mathematical knowledge is a little bit higher than Lily, who is less reflective and is smarter in more practical activities. They play the game for about 40 minutes and then they turn to answer the worksheet questions. During the game it happens that Lily wins all the matches both when she plays the verifier's role and when she plays the falsifier's. While playing as falsifier, Lily produces non-prototypical configurations (very big and stretched or very small, see as examples matches 3 and 4 reported in Fig. 4) in which it is very difficult for the verifier reaching the goal (sometimes it is impossible for approximation reasons).

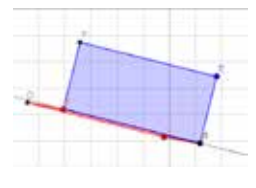
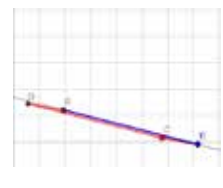
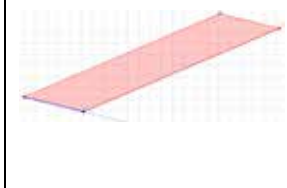
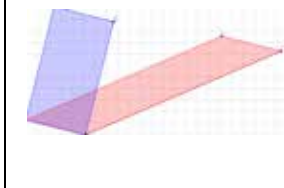
3 rd match		4 th match	
			
Area ABCD = 0,5 Area ABEF = 14,1	Area ABCD = 0,5 Area ABEF = 0,1	Area ABCD = 62,4 Area ABEF = 0,1	Area ABCD = 62,4 Area ABEF = 54,4

Figure 4: Falsifier 'winning' configuration (3rd and 4th matches in Rose and Lily's game)

While playing the verifier's role, Rose notices that her defeats depend on technical aspects of the DGE, namely on the fact that after zooming out many times area measures are expressed by quite big number, even if the figures look as big as usual (see Fig. 4). In this condition, a little dragging produces a huge variation in the numerical values and it is very difficult for the verifier to win. Students' first observations relate to tool affordances rather than geometric properties. They do not even call the figures with their names until the researcher (who is videotaping them, first author) asks them to do it. In doing so, Rose immediately answers correctly, but Lily needs to drag the configuration and to produce prototypical examples of rectangle and parallelogram. From this moment on, Lily and Rose focus on geometrical features. We report an excerpt in which students are discussing the configuration contained in Fig. 5a:

1. Lily: This (*pointing to the parallelogram in Fig. 5a*) is bigger than this (*pointing to the rectangle in Fig. 5a*) but they have the same area
2. Rose: You mean that it has a bigger shape?
3. Lily: Yes, but they have the same area, they are equivalent with different measures.
4. Rose: With different sizes. And why do you believe it happens?
5. Lily: I have no idea... Or maybe here it's called area, but it means the perimeter... no it's impossible...
6. Rose: But Lily, if you look at this side here, the one overlapped (*pointing to AB*), it is equal to this side here (*pointing to CD*), but this is slopped. This one (*pointing to EF*) is equal to this one (*AB*) and this one (*CD*). Do you think that this height (*with her finger on the screen, she is tracing the height relative to AB of the parallelogram, from C to the dotted line*) is equal to this one (*pointing to AF*)?

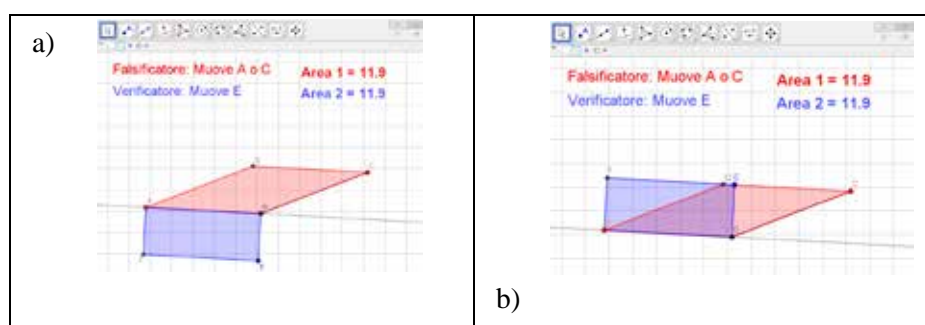


Figure 5: Configurations discussed by Lily and Rose

Lily and Rose highlight a perceptual problem that creates a contradiction: the parallelogram looks bigger than the rectangle and this perceptual observation collides with the fact that they have equivalent areas (lines 1-3). Namely, Lily and Rose observe a contradiction between the figural and the numerical registers (Duval, 2006) due to a visualization problem. In order to solve the contradiction, Rose relies on the algebraic formulas of the areas, which she interprets geometrically on the figures (see her words and gestures in line 6, Fig. 5).

Being the figures in opposite half-planes, it is difficult to visually compare their heights relative to AB (see Rose's last question, line 6). Hence, the researcher suggests considering configurations in

which both figures are in the same half-plane. Following the researcher's suggestion, the students make a treatment in the figural register and discuss the configuration shown in Fig. 5b:

7. Rose: What does it happen? This one (*pointing to the rectangle*), the rectangle...
8. Lily: Is the half of the other [the parallelogram]
9. Rose: How is it possible? If we put this triangle (*pointing to BCE*) here (*pointing to ADF*), we make the whole rectangle. Instead here we have only a piece of parallelogram (*moving her finger on BE*). This triangle which lies outside (*pointing to ADF*) is this triangle (*pointing to BCE*)! Do you understand, Lily?

When looking at Fig. 5b, Rose does not continue in discussing the heights relative to AB, rather she observes that areas are equivalent since they may be obtained by the same congruent polygons (line 9). The imagined treatment in the figural register, based on decomposing and rearranging the figures, allows Rose solving the previous contradiction between the numerical and the figural register. In this way, she avoids referring to the parallelogram height relative to AB, which is not drawn and is not perceptually easy to seize (because the figure is slanted) nor to compare with the rectangle height. Having shown the equivalence of the figures, Rose moves back to the previous height observation and concludes that “if the area is the same then heights should be equal”.

Conclusion

As highlighted in the analysis, it took time for the videotaped students to start a geometric discussion of the game and the researcher had to prompt it through some questions. Anyway, the provided chunk of argumentations revealed that the design worked well: the students made sense of the equivalence between parallelogram and rectangle with arguments that exploited both the areas' formulas and the decomposition of the figures into congruent polygons.

While playing, students produced non-prototypical examples of parallelograms and rectangles. The non-prototypicalities can be related to different aspects: the figures orientation (the produced configurations do not have the base in a horizontal position); the figures size (the explored area values are very big or very small non-integers); the figures proportions (the produced configurations are stretched and the ratio between their sides is unusual). Moreover, a second order of non-prototypicalities should be considered. It refers to configurations of parallelogram-rectangle equivalence in which the figures belong to opposite half-plane (with respect to line AB) or in which the height of the parallelogram referred to side AB lies on the extension of AB. In these cases, it is more difficult or even impossible for students to imagine the decomposition and rearrangement of the showed figures into each other.

Some non-prototypicalities were not considered in the design and they actually did not help students in linking the game situation and the mathematical property at stake. Rose and Lily do not perceive that the parallelogram is equivalent to the rectangle in a case of second order non-prototypicality: the parallelogram, which was not overlapped by the rectangle, looks bigger than the rectangle (lines 1-3). On a design-based perspective, this result will be considered in the second cycle of experimentation.

The exploration of non-prototypical configurations is the effect of the *double dynamicity* characterizing the inquiring-game activity, namely the one provided by the verifier/falsifier game and the one given by the DGE affordances. Implications of this double dynamicity seem promising with respect of developing students' critical thinking and argumentation competences.

Acknowledgment

We wish to thank the teacher Ezio Scali and the master's student Michelina Pitrelli for their fruitful collaboration in the teaching-experiment.

References

- Arzarello, F., Paola, D., Robutti, O., & Sabena, C. (2009). Gestures as semiotic resources in mathematics classroom. *Educational Studies in Mathematics*, 70(2), 97-109.
- D'Amore, B., & Fandiño Pinilla, M.I. (2006). Relationships between area and perimeter: beliefs of teachers and students. *Mediterranean journal for research in mathematics education*, 5(2), 1-29.
- DBRC - The Design Based Research Collective (2003). Design-Based Research: An Emerging Paradigm for Educational Inquiry. *Educational Researcher*, 32(1), 5-8.
- Duval, R. (2006). A cognitive analysis of problems of comprehension in a learning of mathematics. *Educational studies in mathematics*, 61(1-2), 103-131.
- Goldenberg, P., & Mason, J. (2008). Shedding light on and with example spaces. *Educational Studies in Mathematics*, 69(2), 183-194.
- Healy, L. (2000). Identifying and explaining geometrical relationship: interactions with robust and soft Cabri constructions. In T. Nakahara & M. Koyama (Eds.), *Proceedings of PME XXIV*, (Vol.1, pp. 103-117) Hiroshima, JP: Hiroshima University.
- Hintikka, J. (1998). *The principles of Mathematics revisited*. Cambridge: Cambridge Univ. Press.
- Hintikka, J. (1999). *Inquiry as Inquiry: A logic of Scientific Discovery*. Springer, Dordrecht.
- Rosch, E. (1973). On the internal structure of perceptual and semantic categories. In T.E. Moore (Ed.), *Cognitive development and the acquisition of language*. New York, NY: Academic Press.
- Sinclair, N., Watson, A., Zazkis, R., & Mason, J. (2011). The structuring of personal example spaces. *The Journal of Mathematical Behavior*, 30(4), 291–303.
- Smith, J.P. & Barrett, J.E. (2017). Learning and Teaching Measurement: Coordinating Quantity and Number. In J. Cai (Ed.) *Compendium for Research in Mathematics Education*. Reston, VA: National Council of Teachers of Mathematics.
- Soldano, C., & Arzarello, F. (2018). Approaching elementary geometry through the logic of inquiry within technological environments. In: N. Calder, K. Larkin & N. Sinclair (Eds.), *Using Mobile Technology in the Teaching and Learning of Mathematics - Mathematics Education in the Digital Era* (vol 12, pp.247-261). Springer, Cham.
- Watson, A., & Mason, J. (2005). *Mathematics as a constructive activity: Learners generating examples*. Mahwah, NJ: Lawrence Erlbaum Associates, Inc.

The graphing calculator as an instrument of semiotic mediation in the construction of the function concept

Manuela Subtil¹ and António Domingos²

¹Agrupamento de Escolas Fragata do Tejo, Escola Básica 2º, 3º ciclos Fragata do Tejo, UIED¹, Moita, Portugal; mm.pedro@campus.fct.unl.pt

² Universidade Nova de Lisboa, Faculdade de Ciências e Tecnologia, UIED, DCSA, Monte da Caparica, Portugal; amdd@fct.unl.pt

Keywords: Artefact, graphical calculator, semiotic mediation, utilization schemes.

Introduction

According to some authors, the graphing calculator facilitates the students' ability to reflect and generalize, when involved in performing exploratory tasks, leading them to the construction of mathematical knowledge (Doorman, Drijvers, Dekker, Heuvel-Panhuizen, Lange e Wijers, 2007). We present the resolution of the task: "My hand", with the graphing calculator, whose purpose was to consolidate the concept of function and to understand when a cartesian graph corresponds to the representation of a function. On the other hand, looking at the artifact, the graphing calculator, as a instrument of semiotic mediation, we intend to analyze how the transition from personal meanings to mathematical meanings (Mariotti, 2018) was developed, in the resolution of the task.

Theoretical Framework

The use of an artifact in solving a mathematical task can provide the emergence of pre-existing student knowledge, which relates to the mathematical knowledge essential to the teaching-learning activity. The teacher can intentionally exploit the semiotic potential of an artifact that translates into the facility that the artifact possesses in associating mathematical meanings evoked by its use, culturally determined, with personal meanings that each subject develops in its use (instrumented activity) in the completion of specific tasks. In this way, the process of semiotic mediation is developed around the notion of the semiotic potential of an artifact and a didactic cycle (Mariotti, 2012, 2018).

Methodology

This study is framed in a broader qualitative research, following an interpretative approach. The experiment was conducted in the school year of 2016/17, in a class of the 7th grade, with 29 students. In this poster we present the performance of two students, Berta and Maria. The techniques used to collect the data were based on students' written reports, direct observation of the researcher, images of the graphic representations of the graphing calculator screens and logbook (Creswell, 2012).

¹ This work is supported by national funds through FCT - Foundation for Science and Technology in the context of the project UID/CED/02861/2016

The task presented to the students: "My hand"

The task consisted in drawing the outline of a hand using paper and pencil, in a cartesian referential and placing points at choice. The first point had to be equal to the last point, for the line to be closed. Subsequently, each student represented in the graphing calculator, the polygonal line that had as vertices the coordinates of the chosen points. The students had to justify whether the visualized representation was a function and to conclude under what conditions a cartesian graph represents a function. Previously, the students had learned the concept of function and the representation of a function through diagram of arrows and tables. The students individually performed the task with the artifact, the graphing calculator. Afterwards, the individual productions were analyzed, and the collective discussion, managed by the teacher, was developed, promoting the evolution of students' personal meanings towards mathematical meanings (Mariotti, 2018).

Analysis of Results

The graphing calculator, allowed them to visualize another form of representing a function, its graphical representation. The semiotic potential of the graphing calculator, inherent in the visualization capacity and dragging technique (Mariotti, 2012), as well as the collective discussion, fostered the emergence of personal meanings related to mathematical meanings. The student Maria showed evidence that she had mobilized mathematical knowledge learned previously. The personal meanings that arose were related to mathematical meanings learned earlier.

The student Berta showed a certain difficulty in distinguishing the difference between object and image, as well as formally constructing the concept of function. However, these aspects "seem to us" to have been filled with the collective discussion and the insistent orchestration of the teacher. In the poster, the results will be presented in detail.

Conclusion

When learning takes place in the social environment of the classroom, in which individual productions are promoted, resulting from the accomplishment of tasks, using the graphic calculator and later collective discussion, orchestrated by the teacher, it can generate a greater ease in the transition from personal meanings to mathematical meanings.

References

- Creswell, J. W. (2012). *Educational Research, Planning, Conducting, and Evaluating Quantitative and Qualitative Research*. (4 th ed.). Boston: Pearson.
- Doorman, M., Drijvers, P., Dekker, T., Heuvel-Panhuizen, M., Lange, J., & Wijers, M. (2007). Problem solving as a challenge for mathematics education in the Netherlands. *ZDM The International Journal on Mathematics Education*, 39, 405-418.
- Mariotti, M. A. (2012). Proof and proving in the classroom: Dynamic Geometry Systems as tools of semiotic mediation. *Research in Mathematics Education*, 14(2), 163-185.
- Mariotti, M. A. (2018). From using artefacts to mathematical meanings: the teacher's role in the semiotic mediation process. Paper presented at *Atas XXIX Seminário de Investigação em Educação Matemática*. Lisboa: Associação de Professores de Matemática.

Drawing topology using *Ariadne*

Moritz L. Sümmerrmann¹

¹University of Cologne, Germany; moritz.suemmermann@uni-koeln.de

Keywords: Topology, Learning environment, Mathematics education, Computer software.

Research overview

The focus of this work is to build a learning environment, making it possible to learn about paths and homotopies without the use of formalism. Here, learning environment means a microworld given through a software in the sense of Papert (Papert, 1987). To help achieve this goal I have developed *Ariadne*, a software tool for the visualization of and interaction with paths. These paths can be constructed on a wide variety of surfaces, from the plane to manifolds of arbitrary genus, and punctured versions thereof. A more detailed account of *Ariadne*'s capabilities is given in (Sümmerrmann, 2019).

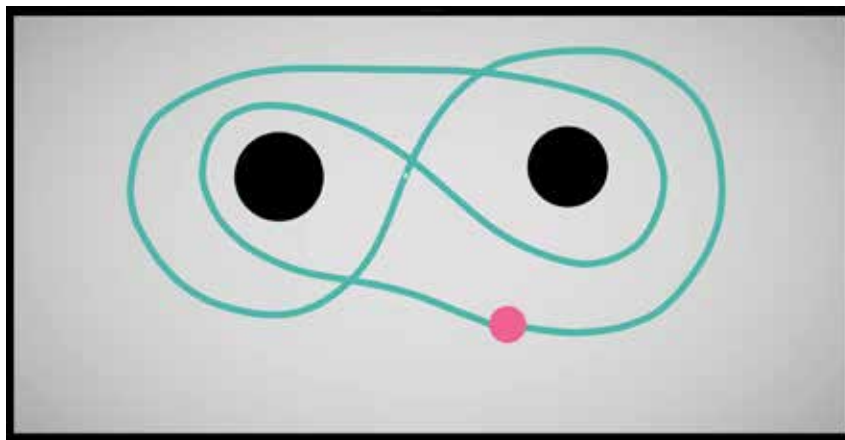


Figure 1: The Pochhammer Contour, a non-nullhomotopic green path starting and ending at the magenta dot with winding number zero around both black punctures, constructed in *Ariadne*.

Topology in general is not present in the school curriculum, which limits the extent of research in the field of topology education. It is, however, a very important part of modern mathematics, so there have been some attempts to visualize topology, either without (Strohecker, 1996; Sugarman, 2014) or with software (Culler, Dunfield, Goerner, & Weeks, n.d.; Scharein, 1998). There has been no attempt to implement interactive continuous deformations as represented by homotopies, which is the focus of *Ariadne*. It also follows a different approach didactically, as its purpose is not only to visualize concepts already known to the user, but to teach the user these concepts by letting him interact with the visualization. The theoretical framework behind the design of *Ariadne* is based on the design principles of Devlin, 2013 and the Artefact Centric Activity Theory from (Ladel & Kortenkamp, 2013).

Ariadne is split into a two- and a three-dimensional mode. Both are usable on any touchscreen device, such as tablet-PCs or smartphones. In 2D, the user can construct points, paths and homotopies of paths on the plane with an arbitrary number of punctures, as well as compute the winding number around these punctures. This allows the user to tackle questions on the existence and equivalence of paths, and thus the treatment of the fundamental group. The same can be done for closed orientable surfaces of genus g in three-dimensional mode.

For the 3D-mode, a mixed reality environment is implemented. This mode facilitates the interaction with two-dimensional surfaces in three-dimensional space, such as the sphere or the torus, and thus alleviates handling issues inherent to the two-dimensional touchscreen. The three-dimensional mode also allows the construction of paths on the universal cover of the chosen surface, which is for

most surfaces the hyperbolic plane. *Ariadne* is being evaluated through individual interviews with students from all age groups, in which they are being posed questions to assess their understanding of the used concepts. Further research directions are a didactical analysis of the topological notions involved in *Ariadne* to ensure that the answer quality is representative for the understanding of the content, planned to be implemented as a qualitative empirical study with mathematicians. The questions can then be refined based on this analysis.

Poster contents

The poster contains a short summary of the mathematical objects involved using some formulas and pictures, so it is clear what mathematics are conveyed with *Ariadne*. This is by no means exhaustive, but intends to sensitize the audience to the subtleties of the concepts involved. In the center of the poster is a tablet-PC, which the conference participants can use to test *Ariadne* for themselves. Another part of the poster is a list of sample questions which can be answered with the help of *Ariadne*, as a demonstration of *Ariadne*'s capabilities. The last part is a short overview on the technicalities of the program for those interested in the mechanisms of action behind *Ariadne*.

References

- Culler, M., Dunfield, N. M., Goerner, M. & Weeks, J. R. (n.d.). SnapPy, a computer program for studying the geometry and topology of 3-manifolds. Available at <http://snappy.computop.org> (15.8.2018) .
- Devlin, K. (2013). The Music of Math Games. *American Scientist*, 101(2), 87-91.
- Ladel, S. & Kortenkamp, U. (2013). An activity-theoretic approach to multi-touch tools in early maths learning. *The International Journal for Technology in Mathematics Education*, 20 (1), 3– 8.
- Papert, S. (1987). Learning Environments and Tutoring Systems. In R. W. Lawler & M. Yazdani (Eds.), *Artificial Intelligence and Education*, (Vol. 1, pp. 79 – 94). Ablex Publishing Corp.
- Scharein, R. G. (1998). *Interactive Topological Drawing*. Unpublished doctoral dissertation, Department of Computer Science, The University of British Columbia.
- Strohecker, C. (1996). Design of an Environment for Learning about Topology and Learning about Learning. In *Proceedings of the Second International Conference on the Learning Sciences*, Association for the Advancement of Computing in Education.
- Sugarman, C. (2014). *Using Topology to Explore Mathematics Education Reform*. Unpublished master's thesis, Harvey Mudd College.
- Sümmerrmann, M. L. (2019). Ariadne – A Digital Topology Learning Environment. *The International Journal for Technology in Mathematics Education*, 26(1), 21–26.

Semiotic analysis of modelling activities in a rich-digital environment

Osama Swidan¹ and Eleonora Faggiano²

¹Ben-Gurion University of the Negev, Be'er-Sheva, Israel; osamas@bgu.ac.il

²University of Bari Aldo Moro, Italy; eleonora.faggiano@uniba.it

In this paper, we report on a research study that aims to understand the ways students transit between the simulation of real phenomenon and the mathematical representation, as the modelling activities are introduced by dynamic digital artefacts. The study took place in a high school in Turin, in which 9th grade students were introduced to the quadratic function through a task to be accomplished with the use of a dynamic digital simulation of a rolling ball on an inclined plane - the Galileo experiment. The semiotic mediation approach guided this study to carefully analyze the modelling activity, enhanced by the use of the digital artefact, in terms of meanings that evolve. Our results identify the signs which refer to the simulation of the real phenomenon and those which refer to the mathematical representation and bring to the fore the evolution from the artefact signs to the mathematical signs.

Keywords: Modelling activity, digital artefacts, semiotic mediation, signs, quadratic function.

Introduction

Mathematical modelling (the process of translating between the real world and mathematics in both directions) is one of the topics in mathematics education that has been discussed and propagated most intensely during the last few decades (Kaiser, 2014). Mathematical modelling is now a compulsory part of the mathematics curriculum in many countries worldwide and one of the main skills within international educational standards. Over the last two decades, a considerable variety of models (Borromeo Ferri, 2006) that explain the interplay between the real phenomena and the mathematical representations have emerged and processed (e.g. Blomhøj & Jensen, 2003; Blum & Leiß, 2007; Voskoglou, 2007). Despite the differences between the variety of models, the transition from the real phenomenon to the mathematical world is considered to be a common point among them. For example, to model this transition, Blum and Leiß (2007) distinguished between the mathematical world and the rest of the world. The transition from the real model to the mathematical model happens through a mathematising process, while the transition from the mathematical world to the real results happens through an interpreting process (Figure 1, taken from Blum & Leiß, 2007). These two processes are complex and require careful analysis in order to avoid useless oversimplification (Blum, 2011). This complexity is also valid when the real phenomenon is simulated by digital artefacts which connect the real phenomenon with mathematical representation. Digital artefacts are widely used to design and develop modelling activities, especially, to simulate complex real phenomena. Digital artefacts, indeed, allow linking multiple representations simultaneously. With their use, data concerning the real phenomena can be precisely displayed and mathematically interpreted. In the context of using digital artefacts, modelling activities are designed by using several kind of signs that are embedded in the artefact. Some of these signs are iconic (they have a great similarity with the real object), others are symbolic (they have a meaning in a specific culture). Bridging the gap between the iconic and symbolic signs is a serious challenge and should be taken into account (Arzarello & Sabena, 2011). Therefore, in addition to the traditional complexities of the transition between the real phenomenon and the mathematical one, the affordances and constraints of the digital artefacts, and

the design principles of the tasks, should be taken into account when analyzing the learning processes of modelling activities (Naftaliev, 2017).

Herein, we assume that the construction of mathematical meanings throughout a modelling activity can be achieved through the mediation of dynamic digital artefacts. Moreover, we believe that the semiotic mediation approach could provide a suitable framework to carefully analyze the transition between the real world and the mathematical representations, identifying the evolution of personal meanings, emerging through the modelling activity, towards mathematical meanings, which are the objectives of the teaching intervention. In this paper, we will report on a research study that aims to understand the ways students transit between the simulation of real phenomenon and the mathematical representation, as the modelling activity is introduced by a dynamic digital artefact. We exemplify our approach by analyzing a teaching experiment concerning the quadratic function. For this purpose, we describe a designed and implemented modelling activity, which is based on the simulation of a rolling ball over an inclined plane – Galileo experiment – through the use of a dynamic digital artefact. We have chosen the Galileo experiment because the mathematical model of the spaces traversed by the ball is quadratic. We have chosen to simulate the real phenomenon using a dynamic digital artefact because it has the potentiality to precisely display the mathematical representation of the model and the real phenomenon using multiple-linked representations. The teaching experiment has been analyzed with the aim of revealing how the use of the digital artefact contributes to the construction of mathematical meanings, and to show how the semiotic mediation approach may help us to shed some light on the students' twofold transition between the real world and the mathematical world.

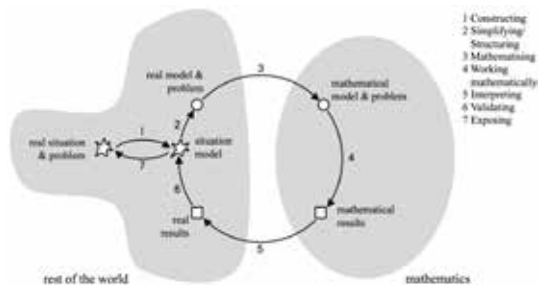


Figure 1: The Blum's modelling model (Blum & Leiß, 2007)

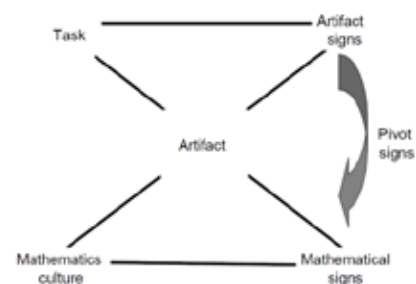


Figure 2: The semiotic mediation approach

Theoretical Framework - Semiotic Mediation Approach

In the context of using artefacts, Bartolini Bussi and Mariotti (2008) have modelled learning process by taking advantage of the potential of artefacts. The model aims to describe how meanings related to the use of a certain artefact can evolve into meanings recognizable as mathematical. The semiotic mediation approach assumes that social interaction and semiotic processes play a key role in learning, particularly in situation in which learners are encouraged to use the artefact in order to solve a given task. This approach considers learning to be an alignment between the personal meanings arising from the use of a certain artefact for the accomplishment of a task and the mathematical meanings that are deployed in the artefact. The relationship that the artefact has with the personal meanings emerging from its use and the mathematical meanings that might be evoked by such use is described

as a double semiotic relationship and defines the *semiotic potential of the artefact*. On one hand, we concentrate on the use of the artefact to accomplish a task, recognizing the construction of knowledge within the solution of the task. On the other hand, we analyze the use of the artefact, distinguishing between the construction of the personal meanings arising in individuals from their use of the artefact in accomplishing the task (top part of Figure 2) and the mathematical meanings; meanings that an expert recognizes as mathematical (bottom part of Figure 2) when observing the students' use of the artefact in order to complete the task (left triangle in Figure 2). Personal meanings emerging from the activities carried out with an artefact may evolve into mathematical meanings, objectives of the teaching intervention. This evolution can occur in the peer interaction during the accomplishment of the task and in the collective discussions conducted by the teacher. In this long and complex construction process of shared mathematical meanings, it is possible to identify evolution paths (called *semiotic chains*) which are described by the appearance and enchainment of different types of signs: artefact signs, mathematical signs and pivot signs. The *artefact signs* refer to the artefact and its use, are produced through the social use of the artefact (upper right vertex in Figure 2) and may evolve into signs (called mathematical sign) that refer to the mathematics context. The *mathematical signs* are related to the mathematical meanings shared in the institution to which the classroom belongs (right side of Figure 2). Through a complex process of evolution of the artefact sign into a mathematical sign, other types of signs, which Bartolini Bussi and Mariotti called *pivot signs*, play a crucial role. The authors suggest that the characteristic of these signs is their shared polysemy: the pivot signs with their hybrid nature, both referring to the use of the artefact and to the mathematical domain, are characterized by their function in the evolution process, fostering the move from artefact to mathematical signs with their intrinsic ambiguity. An a-priori analysis of the semiotic potential of the artefact with respect to the given task has a double role: it can help the teacher in her important role to foster the evolution of signs during the class discussion; it can also be the basis on which researchers can identify students' construction of meanings through the evolution of signs.

Method

Setting and procedure of the teaching experiment

The study took place in a high school in Turin (Italy), in which a senior teacher introduces the Galileo experiment with her eighteen 9th grade students. A short introduction to the activity and its design principles were previously given to the teacher. The teacher was followed by the researchers as she taught one lesson of 1.5 hour. In order to introduce the students to the chosen topic, a short video clip ([Inclined plane experiment](#)) concerning the Galileo experiment about a ball rolling on an inclined plane is provided, and students were asked, before the lesson, to watch the video at their home, to observe and make conjectures concerning what they have observed. The students were initially required to work in small (triads or four students) groups, sharing a worksheet containing the task and a computer for the simulation of the Galileo experiment. The teacher walked around and interacted with the students, when she believed it was needed. As soon as the students accomplished the task in the small groups, the teacher conducted a general discussion with the whole class.

Task given to the students and a-priori analysis of the semiotic potential

The design principles of the tasks are motivated by mathematical modelling approach and by the choice to exploit the potential of digital artefacts. The task presents a simulation of the real world phenomenon and, through the use of a dynamic digital artefact, offers mathematical representations

of the dynamic aspects of the phenomenon to be analyzed. The main idea of the design is to create different situations by varying some aspects of the phenomenon while keeping the others invariant. Figure 3 shows the written modelling task given to the students. It blends the simulation of the rolling ball on the inclined plane with the numerical representation. At the beginning of the lesson the task was given to the students requesting them to explore the mathematical model through the dynamic digital artefact (Figure 3). In the default situation of the simulation, the inclination plane angle is invariant, while the spaces traversed by the ball, when the “Start” button is clicked, vary as the time elapsed. Then, according to the task, students are asked to conjecture and then verify how the plane inclination affects the ball movement and the mathematical model. This can be done, in particular, focusing on the differences of the distance and looking for the equation that describes the movement. These insights may lead the students to grasp the intended object of learning, namely, the quadratic function and its properties.

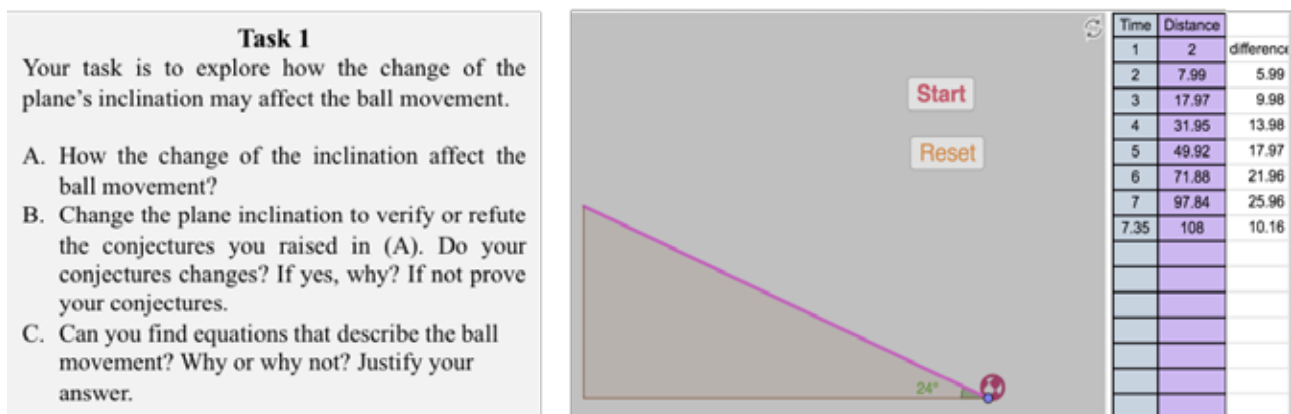


Figure 3: The Galileo experiment task

An a-priory analysis of the semiotic potential of the artefact with respect to the given task (Tab. 1) is fundamental in order to identify the appearance and evolution of signs during the teaching-learning activity, as it describes what is expected to emerge in the classroom.

Table 1: The semiotic potential of the artefact with respect to the task

Mathematical meanings	Semiotic potential
<ul style="list-style-type: none"> - The table represents a correlation between two sets of values (time vs distance). - The third column represents the differences between the distances. - The differences between two consecutive differences in the third column are constant. - The model of spaces traversed by the ball is a quadratic function of the form $s(t) = at^2$. 	<ul style="list-style-type: none"> - When clicking on the start button, the ball rolls down on the plane and the table is filled: this may evoke the idea that there is a correlation between the time and the spaces traversed by the ball and that there is also a constant correlation between two consecutive differences in the third column. - When changing the angle, the values in the second column (except for the last), the last value in the first column, and the values in the third column change as well, but the differences between two consecutive values always remain constant: this may evoke the idea that the inclination affects the ball's movement and that the model of the spaces traversed by the ball is a quadratic function.

Data collection and method of analysis

To collect the data, the learning experiment was entirely video recorded. The students and their actions on the computers were captured. The collective discussion conducted by the teacher, after the students completed the task, was video recorded as well. Segments of the recorded clips of the students' transition between the real-world phenomena and the mathematical representation were identified and analyzed at a macro level according to the Blum's model. Thereafter, to have an in-depth insight into the learning processes, a micro level analysis was done using the semiotic mediation approach. At this level, the artefact signs and pivot signs used in the transition processes were identified and their evolution toward mathematical meanings were also considered and analyzed. In particular, the analysis was developed with the aim to identify semiotic chains in order to reveal the unfolding of the semiotic potential of the artefact throughout the modelling activity and the collective discussion.

Results and discussion

Herein we present results coming from the students' interactions in one of the small working groups and from the subsequent whole class discussion conducted by the teacher.

As students were asked to see the Galileo experiment clip at home, when the first lesson starts they already have their own personal conjectures on the phenomenon. According to the task, they are asked to explore if and how the change of the plane inclination may affect the ball movement, to share their hypotheses and verify them. According to the observations done at home, they agree on the hypothesis that the more the plane is inclined the faster the ball moves. In order to verify their conjecture, they use the provided digital artefact and take notes of the values of the spaces traversed as the time elapses. That was obtained when they started the simulation with the given (24°) inclination plane angle. They realize that the difference between two consecutive numbers in the third column is always 4. Then, they change the angle to 40° and realize that the numbers in the third column are the differences between the corresponding two consecutive numbers in the second column. They take note of the values and change the angle to 45° . At this point, they are watching the first value in the second column and, while the others are comparing it with the one obtained before, one of the students, A., observes that:

00.26.27 A.: Yes, true, look, I told you that in one second it [the ball] always makes more distance.

But it seems that this observation is not useful for them to look for the relation among the variables - time and distance - so A. focuses on the last row and then a pressure of speeches and gestures follows:

00.26.51 A.: Here [*pointing to the last number in the first column*], if you see, instead of being 5.8, it's 5.5... changes... it is faster.

00.27.07 B.: Yes, true, because...

00.27.08 C.: The more it is inclined [*she moves her hands in the collective space in front of the screen: the left hand, raised with the palm facing up, would represent the final point they are focusing on and the right hand, waved up and down, would represent the increasing of the plane inclination*], the faster it [the ball]

is... than this here [*pointing on the screen and on the paper on which they have copied the data before*].

- 00.27.12 B.: The distances increase but this last datum [*pointing on the last difference on screen*] is not useful for us because it [the ball] arrives down before... let's try 50°.

Finally, when the angle is 50°, as the last number they find in the first column is smaller, they are convinced they have verified their hypothesis and then start writing their shared conclusion: “increasing the plane inclination and keeping the same time, distances increase and the ball moves faster if the plane is more inclined; the example shows that to reach the same final distance, 108, if the plane inclination is 40° it takes 5.8 seconds, if the plane inclination is 45° it takes 5.5 seconds”. In the students’ interaction described above it is clear how they are trying to interpret the artefact signs, obtained when accomplishing the task with the digital artefact, in order to give meanings to them in terms of the situation under study. In the following part of the lesson they attempt to find the way to mathematically express the relationship which describes the ball movement. They recognize that the graph of the distances, as times elapsed, cannot be modelled by a straight line. The work at this point is stopped by the teacher who decides to start the whole class discussion.

At a macro level, it is worth noting how in this initial phase of the activity students’ discourses move from the real world to the mathematical world. As a matter of fact, the teacher then needs only four minutes to summarize the situation. And when she asks if there is something that changes when passing from the video clip to the digital artefact the students immediately, and with judgment, answer negatively. The students’ answer reveals that the students consider the artefact as a mean for verifying the conjecture raised when they watched the clip. At this point, it is not clear what is the added value of the digital artefact in constructing meanings. However, the micro level analysis, as we will present below, highlights the specific contribution of the artefact in the process of the construction of meanings.

A micro level semiotic analysis, indeed, reveals how through the use of the digital artefact during the transition phase of the modelling activity, the signs emerge and evolve. The word “faster” referring to the ball when the inclination is increased, for instance, is a pivot sign which evokes, on the one hand the increasing of the numbers in the second column, on the other hand the decreasing of the last number in the first column, which represents the time needed to traverse the distance until the arrival, “to reach the same final distance”.

Hereinafter, the teacher (T.) conducts the class discussion with the aim of focusing on identifying the variables to be used to describe the situation:

- 01.00.20 A.: If when you incline the plan you increase the time... you take less time... the ball takes less time to traverse that distance...
- 01.00.34 T.: the ball takes less time to traverse that distance...
- 01.00.36 A.: the same distance, but as the plane is more inclined, the ball is faster.
- 01.00.42 T.: ok, so, to the same distance... [*she use her hands making an iconic gesture to represent a given quantity for the distance*].
- 01.00.48 A.: but time is smaller.

- 01.00.49 T.: Time is smaller [*she moves on her right as to represent a shifting on something else, namely what changes in the time*] And the same time?
- 01.00.52 A.: the distance... the distance is bigger.
- 01.00.58 T.: the distance is bigger...
- 01.02.20 T.: How can we read the table?
- 01.02.25 D.: when the time is 1 the space is 2.13, when the time is 2 the space is 8.51 and so in a given time the ball traverses a given space.
- 01.02.58 T.: and this space always increases more... as it happens in the video... and so how can I write a relation between this space and the time? Is it a line?
- 01.03.25 E.: No. Because otherwise it would have had all the same differences.
- 01.03.26 T.: and here?
- 01.03.27 E.: And here the differences are not the same.

From the modelling point of view, it is evident here that A. is trying to figure out what he has observed varying the inclination of the plane using the digital artefact in terms of movement of the ball. He is in the transition phase from the mathematical world to the real world. However, A. and his classmates still need to understand how to mathematically express the movement of the ball. The request to interpret the table, and to express the relationship between the time and the distances, allows them to focus on the third column, namely on the differences between the distances.

A semiotic analysis of the episode reveals some more details of the learning processes. Worthy of note is, for instance the semiotic chain in Figure 4 (identified in the transcript above) which highlights the unfolding of the semiotic potential of the digital artefact, through the emergence and enchainment of signs, and will bring to the quadratic function.

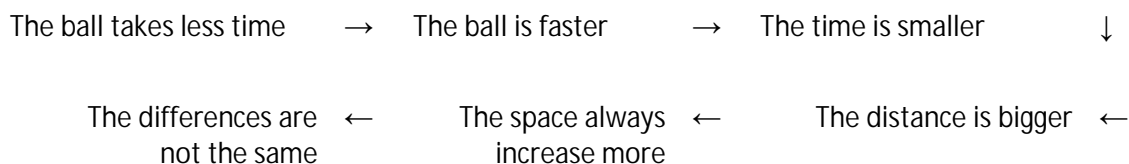


Figure 4: An identified semiotic chain

While students face the real world situation accomplishing the task through the mediation of the digital artefact, indeed, the signs they use are evolving. The focus on the difference of the distances would allow them later on to conjecture that the spaces traversed are proportional to the squares of the times according to a factor which depends on the inclination of the plane.

Final remarks

Literature about modelling mainly focuses on the transition between the real world and the mathematical world. However, in our view, the way students move throughout the transition is not sufficiently addressed. This study attempts to deeply focus on the transition processes between the real and the mathematical worlds. Although these transitions are crucial in order to understand the overall modelling process, we believe that they are challenging and need a detailed analysis. Our

results suggest that a macro level analysis, based on the Blum's model, is not sufficient to reveal the contribution of technology in modelling activities. However, a semiotic micro level analysis can bring to the fore the role of the digital artefact in the complex students' transition processes. The semiotic mediation approach, indeed, helped us to highlight the complexity of the evolution from the artefact signs to the mathematical signs. In this evolution process the students used a variety of signs, some of them refer to the real phenomena while the others refer to the mathematical representation. Through this process the students also produce pivot signs which have a polysemy of meanings, namely they may refer both to the real situation and at the same time to the mathematical representation. Revealing the evolution of signs has not only a theoretical importance but also a practical one: the semiotic chain which bridges the gap between the real situation and the mathematical representation, indeed, can help teachers in their mediating process of the students' learning. This happened, for instance, in the episode we analyzed when the teacher fostered A.'s thought and signs to emerge and to be shared. In this way she guided the class to move from considering the final "real" effect - the ball is faster - to focusing on the distances (traversed) and the "mathematical" information given by their differences.

Acknowledgment

This study was partly supported by the Israel Science Foundation (Grants No. 1089/18).

References

- Arzarello, F., & Sabena, C. (2011). Semiotic and theoretic control in argumentation and proof activities. *Educational Studies in Mathematics*, 77(2-3), 189-206.
- Blomhøj, M., & Jensen, T. H. (2003). Developing mathematical modeling competence: Conceptual clarification and educational planning. *Teaching Mathematics and Its Applications*, 22, 123–139.
- Blum, W., & Leiß, D. (2007). How do students and teachers deal with modeling problems? In C. Haines, P. Galbraith, W. Blum, & S. Khan (Eds.), *Mathematical Modeling (ICTMA12): Education, Engineering and Economics* (pp. 222–231). Chichester: Horwood Publishing.
- Blum, W. (2011). Can modelling be taught and learnt? Some answers from empirical research. In G. Kaiser, W. Blum, R.B. Ferri, & G. Stillman (Eds.), *Trends in teaching and learning of mathematical modelling* (pp. 15-30). Springer, Dordrecht.
- Bartolini Bussi, M. G., & Mariotti, M. A. (2008). Semiotic mediation in the mathematics classroom: Artifacts and signs after a Vygotskian perspective. In L. English (Ed.), *Handbook of international research in mathematics education* (pp. 746-783). USA: Routledge, New York.
- Kaiser, G. (2014). Mathematical modelling and applications in education. In S. Lerman (Ed.), *Encyclopedia of mathematics education* (pp. 396-404). Netherland: Springer, Dordrecht.
- Naftaliev, E. (2017). Interactive Diagrams Used for Collaborative Learning Concerning Mathematical Models of Motion. In G.A. Stillman, W. Blum, & G. Kaiser (Eds.), *Mathematical Modelling and Applications* (pp. 553-563). Netherland: Springer, Cham.
- Voskoglou, M. (2007). A stochastic model for the modeling process. In C. Haines, P. Galbraith, W. Blum, & S. Khan (Eds.), *Mathematical Modeling (ICTMA12): Education, Engineering and Economics* (pp. 149–157). Chichester: Horwood Publishing.

Automated feedback on the structure of hypothesis tests

Sietske Tacoma¹, Bastiaan Heeren^{1,2}, Johan Jeuring^{1,2} and Paul Drijvers¹

¹Utrecht University, Faculty of Science, Utrecht, The Netherlands; s.g.tacoma@uu.nl,
bastiaan.heeren@ou.nl, j.t.jeuring@uu.nl, p.drijvers@uu.nl

²Open University of the Netherlands, Heerlen, The Netherlands

Understanding the structure of the hypothesis testing procedure is challenging for many first-year university students. In this paper we investigate how providing automated feedback in an Intelligent Tutoring System can help students in an introductory university statistics course. Students in an experimental group (N=154) received elaborate feedback on errors in the structure of hypothesis tests in six homework tasks, while students in a control group (N=145) received verification feedback only. Effects of feedback type on student behavior were measured by comparing the number of tasks tried, the number of tasks solved and the number of errors in the structure of hypothesis tests between groups. Results show that the elaborate feedback did stimulate students to solve more tasks and make fewer errors than verification feedback only. This suggests that the elaborate feedback contributes to students' understanding of the structure of the hypothesis testing procedure.

Keywords: Intelligent tutoring systems, domain reasoner, hypothesis testing, statistics education.

Introduction

Hypothesis testing is widely used in scientific research and is therefore covered in most introductory statistics courses in higher education (Carver et al., 2016). This topic is challenging for many students, due to the large number of complex concepts involved (Castro Sotos, Vanhoof, Van den Noortgate, & Onghena, 2007). Students struggle to understand the logic of hypothesis testing and the role and interdependence of the concepts in the testing procedure (Vallecillos, 1999). Appropriate feedback might support students in comprehending this structure and understanding the line of argumentation in hypothesis tests (Garfield et al., 2008). Since group sizes in introductory statistics courses are often large, automated feedback in an online system seems a promising direction.

Carrying out a hypothesis test requires several steps, which have to be performed in a particular order. To address the structure of hypothesis tests, feedback should address all aspects of a solution: not only the content of individual steps, but also the relations between steps. An Intelligent Tutoring System (ITS) can provide such sophisticated feedback on the level of steps and can provide detailed diagnostics of student errors (Nwana, 1990). Such feedback on the step level is generally more effective than feedback on the level of complete solutions (VanLehn, 2011).

Although ITSs vary considerably in design, they generally contain the following four components: an expert knowledge module, a student model module, a tutoring module, and a user interface module (Nwana, 1990). Of these four, the expert knowledge module is the most domain-dependent. It contains information about exercises that students can solve in the ITS and about domain knowledge required to solve these exercises (Heeren & Jeuring, 2014), and is therefore also referred to as *domain reasoner*. Two important paradigms for constructing domain reasoners are model-tracing, in which the ITS checks that a student follows the rules of a model solution, and constraint-based modeling, in

which the ITS checks whether a student violates constraints. There exist ITSs that support hypothesis testing based on either of these approaches (Kodaganallur, Weitz, & Rosenthal, 2005). We combined the two paradigms in a single ITS supporting hypothesis tests, and in this paper we evaluate the feedback by this ITS. The research question guiding this evaluation is: does the feedback provided by the ITS contribute to student proficiency in producing well-structured hypothesis tests? Before describing the design of the ITS and the study design, we briefly discuss the two paradigms; for a more extensive overview, see the work of Kodaganallur and colleagues (2005).

Model-tracing

The model-tracing paradigm concentrates on the solution process. The domain reasoner contains a set of expert rules: rules that an expert would apply to construct solutions to exercises in the domain. It can also contain buggy rules: incorrect rules that arise from incorrect domain knowledge. Finally, the domain reasoner contains a model tracer that can identify which expert and buggy rules a student has applied to arrive at a (partial) solution. After this identification, several actions can take place. If a buggy rule is recognized, a diagnosis of the student's error can be given. Otherwise, a hint for a next step can be provided, or just feedback that the current solution path is correct.

Constraint-based modeling

Constraint-based modeling concentrates on partial solutions, rather than on the solution process. The underlying idea is that incorrect knowledge emerges as inconsistencies in students' partial solutions (Mitrovic, Mayo, Suraweera, & Martin, 2001). Domain knowledge is represented as a set of constraints, consisting of a relevance condition and a satisfaction condition. For instance, in the domain of hypothesis testing a relevance condition might be that the partial solution contains an alternative hypothesis and a rejection region, and the corresponding satisfaction condition that the position of the rejection region (left side, right side or two sides) matches with the sign of the alternative hypothesis. Errors in student solutions emerge as violated constraints, that is, as constraints for which the relevance condition is satisfied, but the satisfaction condition is not. If a student's solution does not violate any constraint, it is diagnosed as a correct (partial) solution.

Methods

Design of the domain reasoner

The technical design of the domain reasoner evaluated in this study is based on the Ideas framework (Heeren & Jeuring, 2014), which uses a model-tracing approach to calculate feedback. However, for the domain of hypothesis testing the constraint-based modeling approach was also considered useful, because of its capability to identify inconsistencies in solution structures. Addressing these inconsistencies might contribute to student understanding of the relations between steps, and hence of the structure of hypothesis tests. Therefore, the domain reasoner designed in this study combines elements of the two paradigms. It contains 36 expert rules, 16 buggy rules, and 49 constraints. Every time a student adds a step to a hypothesis testing procedure, for example defines an alternative hypothesis or calculates the value of the test statistic, the domain reasoner checks the student's solution so far. First, all constraints are checked, and if one is violated, the domain reasoner determines whether a buggy rule was applied. If so, a specific feedback message corresponding to

this buggy rule is displayed to the student, and otherwise a general message for the violated constraint is reported. For example, a student solution that does not contain an alternative hypothesis, but does contain a rejection region, violates the constraint with relevance condition “the solution contains a rejection region” and satisfaction condition “the solution contains an alternative hypothesis”. The corresponding feedback message addresses the role of the hypotheses: “To which hypotheses does this rejection region correspond? First state hypotheses”.

If no constraints are violated, the domain reasoner tries to identify the rule the student applied to arrive at the current partial solution. A feedback message corresponding to the identified rule is shown to the student, for example: “Your rejection region is correct”. If no rule is identified, the student’s partial solution is marked correct (“This is a correct step”), since no constraints are violated. Besides checking partial solutions, the domain reasoner can also provide hints on what next step to take.

The design of expert rules, buggy rules and constraints was informed by discussions with three teachers of introductory statistics courses in various disciplines about the structure of hypothesis tests and common errors by students. Furthermore, textbooks were consulted. Based on this input, we decided to support two methods for structuring hypothesis tests: the conclusion about the hypotheses can be drawn based on comparison of the test statistic with a critical value, or based on comparison of a p-value with a significance level. In each method, a complete solution should contain four essential steps: (1) state hypotheses, (2) calculate a test statistic, (3) either find a critical value or find a p-value, and (4) draw a conclusion about the hypotheses. Although crucial for the logic of hypothesis testing, stating a significance level was not regarded as an essential step, since it was always specified in the task description. Besides these four essential steps, students could include several other steps in their hypothesis tests, such as a summary of sample statistics and an explicit specification of whether the test was left sided, right sided or two sided.

Participants and study design

The domain reasoner was used in a compulsory Methods and Statistics course for first-year psychology students at Utrecht University. In five weeks of this ten-week course, students received online homework sets consisting of 7 to 13 tasks that were selected by the teachers of the course. These homework sets were designed in the Freudenthal Institute’s Digital Mathematics Environment (DME; see (Drijvers, Boon, Doorman, Bokhove, & Tacoma, 2013), which supports various interaction types, such as formula input and multiple choice tasks. To enable intelligent feedback on hypothesis tests, a connection was set up between the DME and the domain reasoner.

The third, fourth and fifth homework set concerned hypothesis testing. Each of these three homework sets contained two tasks that specifically challenged the students’ proficiency in carrying out hypothesis tests, by asking the students to select steps from a drop-down menu and to complete these steps. An example is shown in Figure 1: after selecting a step from the drop-down menu called “Action”, it appears as next step in the step construction area. Next, the student can complete the step by filling in the answer boxes and use the check button to check the hypothesis test procedure so far. After finishing the construction of the hypothesis test, the student should state the overall conclusion in the final conclusion area, below the drop-down menu with steps.

To evaluate the effects of the domain reasoner feedback, students in the course were randomly divided into an experimental and a control group. This allowed for a comparison of student work between both groups, and differences in student behavior and learning effects could be ascribed to the only difference between both groups, the domain reasoner feedback (Cohen, Manion, & Morrison, 2011). From the 310 students in the experimental group 226 students worked on the hypothesis testing tasks, of which 154 gave consent for the use of their work in this study. From the 309 students in the control group 216 students worked on the tasks, of which 145 gave consent. The participants were on average 19.3 years old ($SD = 1.7$ years) and 77% were female. To reduce the Hawthorne effect, i.e. the effect that students might behave differently because they were part of an experiment (Cohen et al., 2011), students were not told about the different conditions and whether they were in the experimental or in the control condition.

Exercise 7
MTS1 HS 9 and 11

How would you react if the grade you received for an exam is much lower than you had expected? Research suggests that most students think they can handle such situations better than their peers, but some students think their coping is worse than that of their peers.

In this study, participants were asked to read a scenario of a negative event and indicate how this event would influence their well-being (-5: worsen much, +5: improve much). Next, they were asked to imagine this same event from the perspective of a peer. The difference between both judgments was noted.

Suppose that for the sample of $n = 25$ students the mean difference score was $M_D = 1.28$ points (own judgment minus judgment peer) with standard deviation $SD = 1.50$.

Round off answers to two decimals, if necessary.

Formulas

a Based on these data, can you conclude that there is a significant difference between the own judgments and judgments of peers? Use a test with $\alpha = .05$.

- Step: State null hypothesis and alternative hypothesis
 $H_0: \mu_D = 0$
 $H_1: \mu_D \neq 0$ Check
- Step: Determine whether the test is left sided, right sided or two sided
The test is Check
- Step: Find critical value
 $t_{crit} = 2.064$ Check
- Step: Determine rejection region
 $t < t_{crit}$ Check

Action: ? ↩

✗ Does the sign you use in the rejection region match with the direction of the alternative hypothesis?

Conclusion: There significant difference between the judgments of ones own reaction and the reaction of a peer.

01
02
03
04
05
06
07
08
09
10
11
12
13
14
15
16

Partial scores

Figure 1: Digital Mathematics Environment displaying one of the hypothesis testing tasks (translated)

The homework sets were equal in both groups, except for the six tasks in which students constructed complete hypothesis tests by selecting and filling in steps. Students in the experimental group received feedback from the domain reasoner, whereas students in the control group only received verification feedback. Hence students in the experimental group received elaborate feedback on errors in the structure of their hypothesis tests, while students in the control group only received feedback on the correctness of their current step, irrespective of previous steps. As a consequence, for solving a task completely, students in the experimental group needed to include all four essential steps, since otherwise one or more constraints would be violated. For students in the control group, tasks were already marked as solved once they contained a correct conclusion about the null hypothesis. A final difference between the two groups was the hint functionality of the domain reasoner, but in this study we did not take the students' use of hints into account.

Data and data analysis

Data for this study consisted of the students' work on the six hypothesis testing tasks in the DME, that is, all their attempts at constructing steps and drawing final conclusions in these tasks. After exporting log files with the students' attempts from the DME, work from students who did not give consent was deleted and all other attempts were anonymized.

Two measures served as indicators for feedback effectiveness: skipping vs. trying behavior and solving vs. failing behavior (Narciss et al., 2014). Skipping vs. trying concerned the number of students who skipped constructing steps and only filled in a final conclusion versus the number of students who tried constructing steps. This can be regarded as a measure of feedback effectiveness, since students who filled in a final answer without constructing steps apparently did not perceive the feedback on the steps as helpful. Solving vs. failing concerned the number of students who produced complete hypothesis tests versus the number of students who failed to produce complete tests. Since feedback was more elaborate in the experimental group than in the control group, we expected the proportion of solving students to be higher in the experimental group.

To find the number of students who tried constructing steps, for each task the number of students who made at least one step using the drop-down menu was counted. The total number of trying students over all tasks was calculated as the sum of these counts. Next, the total number of all trying and skipping students was found by summing the number of students who used the final answer boxes over all tasks. For both groups the proportion of trying students was found by dividing the number of trying students by the number of trying and skipping students. For solving vs. failing, we considered a task solved if a student had correctly included all four essential steps in the solution. The number of solving students was calculated over all tasks, and divided by the total number of trying students, to find the proportion of solving students. Chi-squared tests were used to evaluate whether the two proportions (trying as proportion of all students and solving as proportion of trying students) were significantly larger in the experimental group than in the control group.

The second part of data analysis concerned errors in the structure of hypothesis tests. Structure errors could be missing information, such as stating a rejection region before stating hypotheses, or inconsistent information, such as a rejection region that did not match with the alternative hypothesis. For the first few tasks, we expected an equal number of structure errors in both groups, since students had not received feedback on their errors yet. In later tasks we expected fewer structure errors in the experimental group than in the control group, and we especially expected that fewer students would make the same structure error in multiple tasks in the experimental group. For each task, the proportion of students who made at least one structure error was calculated and the proportions were compared using Chi-squared tests. Next, for each structure error that the domain reasoner could diagnose, the number of students who made it in only one task and the number of students who made it in multiple tasks were counted and these counts were summed. Again, a Chi-squared test was used to compare the proportions between groups.

Results

Table 1 contains the proportion of students who tried using the stepwise structure in the experimental and the control group, and the proportion of students who completely solved the tasks, as proportion

of all students who tried the task. As can be seen in the table, students in both groups tried to construct steps almost 80% of the times, and there is no significant difference between these proportions in both groups: $\chi^2(1, N = 1558) = 0.09, p = .759$. This implies that the domain reasoner feedback did not impact the students' decision to try or skip using the stepwise structure to solve tasks.

	Experimental group	Control group	χ^2	<i>df</i>	<i>p</i> -value	Effect size
Total number of final solutions in six tasks	802	756				
Proportion of students who tried (vs. skipped)	0.77	0.78	0.09	1	.759	
Proportion of students who solved (vs. failed)	0.52	0.40	19.18	1	< .001	0.13

Table 1: Proportions of students who tried vs. skipped, and who solved vs. failed, in experimental and control group, over all six tasks

The proportion of students who included all essential steps in their solutions does differ significantly between the groups: in the experimental group, this proportion was 0.52 and in the control group it was 0.40 ($\chi^2(1, N = 1208) = 19.18, p < .001$). The effect is regarded small ($\phi = 0.13$). This result suggests that the feedback from the domain reasoner did support students in producing more complete hypothesis tests. Although positive, this result is not very surprising, since the domain reasoner feedback explicitly notified students of missing steps. To find out how much the domain reasoner really contributed to the students' proficiency in producing well-structured hypothesis tests, we also considered the errors students made in the structure of their hypothesis tests.

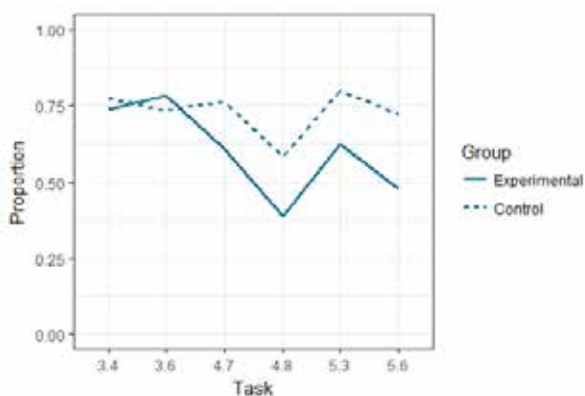


Figure 2: Proportion of students with errors in solution structure in both groups

Task	<i>N</i>	χ^2	<i>df</i>	<i>p</i> -value	ϕ
3.4	297	0.345	1	.557	-
3.6	216	0.501	1	.479	-
4.7	207	5.086	1	.024	0.16
4.8	194	6.665	1	.010	0.19
5.3	158	4.936	1	.026	0.18
5.6	136	7.663	1	.006	0.24

Table 2: Errors in solution structure in both groups for each of the six tasks

Figure 2 shows the proportion of students with errors in their solution structure for both groups, compared to the number of students who attempted the tasks. The total number of students who attempted each task is given in Table 2. The graph in Figure 2 shows that for the first two tasks, 3.4 and 3.6, the proportion of students who made structure errors were quite similar in both groups, and above 0.70. This similarity between groups was to be expected, since students just started working with the feedback. For the latter tasks, however, the proportion of students who made structure errors decreased strongly in the experimental group, and remained higher in the control group. Table 2 displays the results of a series of Chi-squared tests which confirmed this finding: in the first two tasks,

the number of students who made structure errors did not differ significantly between groups, whereas in the latter four tasks, in the experimental group significantly fewer students made errors in solution structure than in the control group. This suggests that the feedback contributed to the students' proficiency in producing hypothesis tests without making structure errors. Considering the numbers of students who made the various structure errors just once and the number of students who repeated the same structure error in multiple tasks corroborates this finding: a Chi-squared test on these numbers yielded $\chi^2(1, N = 1053) = 38.29, p < .001, \phi = 0.19$, indicating that students in the experimental group repeated the same structure error in multiple tasks significantly less often than students in the control group. This confirms that the domain reasoner feedback was effective in reducing students' mistakes with respect to the structure of hypothesis tests.

Conclusion and discussion

In this paper we have evaluated the influence of feedback from an Intelligent Tutoring System that supports hypothesis testing on student behavior in six hypothesis testing tasks. Our aim was to evaluate whether this feedback contributes to student proficiency in producing well-structured hypothesis tests.

Students who received domain reasoner feedback did not use the stepwise structure for producing hypothesis tests in more tasks than students who received verification feedback alone, but they did produce more solutions that included all four essential steps in hypothesis testing. Hence, as a consequence of the domain reasoner feedback, students in the experimental group had more opportunities for valuable practice on these essential steps (Narciss et al., 2014). Students in the control group tended to use the steps more as "isolated checkers", rather than as building blocks for producing complete hypothesis tests. By only selecting the steps they wanted to check and omitting the other steps from their solutions, these students missed out on opportunities to practice with the line of argumentation that is important for understanding hypothesis testing (Garfield et al., 2008).

Not only did the domain reasoner feedback encourage students to produce more complete hypothesis tests, it also supported students in doing this more independently. In the first two tasks the number of errors in solution structure was similar between groups, and hence students in both groups relied equally on the feedback to help them correct their errors. In the final four tasks, however, students who received domain reasoner feedback made significantly fewer structure errors than students in the control group. This indicates that domain reasoner feedback did more effectively support students in resolving their misunderstandings than verification feedback alone, which is in line with earlier findings that elaborate feedback is more effective than verification feedback (van der Kleij, Feskens, & Eggen, 2015).

In this paper, we just examined direct effects of the domain reasoner feedback on student behavior; we have only considered tasks in which domain reasoner feedback was provided and no subsequent work. Future work will focus on longer term learning effects of the domain reasoner feedback; do we see the same effects for other hypothesis testing tasks in which students do not receive feedback on their solution structure? Results from the study discussed in this paper are promising; students demonstrate proficiency in structuring their hypothesis tests and hence seem to have gained understanding of the roles of the different steps in this complex procedure.

Acknowledgments

We thank teachers Jeltje Wassenberg-Severijnen and Corine Geurts and software developers Noeri Huisman, Martijn Fleuren, Peter Boon and Wim van Velthoven for the valuable collaboration.

References

- Carver, R., Everson, M., Gabrosek, J., Horton, N., Lock, R., Mocko, M., . . . Wood, B. (2016). Guidelines for Assessment and Instruction in Statistics Education College Report 2016. *American Statistical Association*. <http://www.amstat.org/education/gaise>
- Castro Sotos, A. E., Vanhoof, S., Van den Noortgate, W., & Onghena, P. (2007). Students' misconceptions of statistical inference: A review of the empirical evidence from research on statistics education. *Educational Research Review*, 2(2), 98–113. <https://doi.org/10.1016/j.edurev.2007.04.001>
- Cohen, L., Manion, L., & Morrison, K. (2011). *Research methods in education* (7th ed.). New York: Routledge.
- Drijvers, P., Boon, P., Doorman, M., Bokhove, C., & Tacoma, S. (2013). Digital design: RME principles for designing online tasks. In C. Margolinas (Ed.), *Proceedings of ICMI Study 22 Task Design in Mathematics Education* (pp. 55–62). Clermont-Ferrand, France: ICMI.
- Garfield, J. B., Ben-Zvi, D., Chance, B., Medina, E., Roseth, C., & Zieffler, A. (2008). Learning to reason about statistical inference. *Developing students' statistical reasoning* (pp. 261–288) Springer, Dordrecht.
- Heeren, B., & Jeuring, J. (2014). Feedback services for stepwise exercises. *Science of Computer Programming*, 88, 110–129. <https://doi.org/10.1016/j.scico.2014.02.021>
- Kodaganallur, V., Weitz, R. R., & Rosenthal, D. (2005). A comparison of model-tracing and constraint-based intelligent tutoring paradigms. *International Journal of Artificial Intelligence in Education*, 15(2), 117–144.
- Mitrovic, A., Mayo, M., Suraweera, P., & Martin, B. (2001). Constraint-based tutors: A success story. In L. Monostori, J. Vancza, M. Ali (Eds.), *Engineering of Intelligent Systems. IEA/AIE 2001* (pp. 931–940). Springer, Berlin, Heidelberg.
- Narciss, S., Sosnovsky, S., Schnaubert, L., Andrès, E., Eichelmann, A., Gogvadze, G., & Melis, E. (2014). Exploring feedback and student characteristics relevant for personalizing feedback strategies. *Computers & Education*, 71, 56–76. <https://doi.org/10.1016/j.compedu.2013.09.011>
- Nwana, H. S. (1990). Intelligent tutoring systems: An overview. *Artificial Intelligence Review*, 4(4), 251–277.
- Vallecillos, A. (1999). Some empirical evidence on learning difficulties about testing hypotheses. *Bulletin of the International Statistical Institute: Proceedings of the Fifty-Second Session of the International Statistical Institute*, 58, 201–204.
- Van der Kleij, F., Feskens, R., & Eggen, T. (2015). Effects of feedback in a computer-based learning environment on students' learning outcomes. A meta-analysis. *Review of Educational Research*, 85(4), 475–511. <https://doi.org/10.3102/0034654314564881>
- VanLehn, K. (2011). The relative effectiveness of human tutoring, intelligent tutoring systems, and other tutoring systems. *Educational Psychologist*, 46(4), 197–221. <https://doi.org/10.1080/00461520.2011.611369>

Problem-solving techniques in the context of an educational video game: the Mudwall puzzle in Zoombinis

Georgios Thoma¹ and Irene Biza²

¹Ormiston Victory Academy, Norwich, United Kingdom; g13thoma@gmail.com

²School of Education and Lifelong Learning, University of East Anglia, Norwich, United Kingdom; i.biza@uea.ac.uk

This paper aims to highlight the problem-solving nature of video games by examining problem-solving techniques in the context of the educational game Zoombinis. Using screen-capturing software, the gameplay of an 8-year-old participant was recorded and analysed in relation to his strategies towards solving the implicit Mudwall problem in the game, from a global-local perspective. Findings indicate the development of techniques — ‘stepping-stone’ and ‘probable-exclusion’— that through Polya’s problem-solving steps, the game’s design and participant’s experimentation, can be used to solve the Mudwall puzzle, illustrating such game’s potentiality as a problem-solving environment.

Keywords: Problem-solving, video games, techniques, global-local problem.

Introduction

Compared to other media, video games offer interactivity to the player. As this unique attribute is constantly explored and worked upon by game designers, educational researchers examine the role video games can play to learning. Playing video games, for example, can create highly motivational and engaging environments for players (Van Eck, 2015). Devlin (2011) and Monaghan (2016) view video games as ideal means of presenting and learning mathematics, which, through their design, can potentially represent mathematics by overcoming the symbolisms used in paper. Literature has focused on ways video games could influence mathematical learning, either be played during students’ spare time (Lowrie, 2005) or be included in traditional classrooms (Moore-Russo et al., 2015) or other classroom settings (Calder & Campbell, 2016). However, even when researchers are optimistic about the future, they are still reserved on what has been realized so far by video games (Ke, 2008). Video games have been studied in many mathematics education research studies mainly as motivational and engaging educational environments (Kebritchi et al., 2010; Chang et al., 2015). Nevertheless, few studies focus on how mathematical content is presented in these games. The study (Thoma, 2017), part of which is presented in this paper, examined the educational game Zoombinis as a mathematical problem-solving environment for young children. Zoombinis has been viewed as engaging, challenging and motivational by previous studies (Yelland, 2002; Moss, 2004). The aim of this study was to examine how the problems are presented in Zoombinis, how young players interact with the game, and how they form techniques to deal with said problems. In this paper, we focus on the techniques developed by one participant in a specific puzzle of the game, called Mudball Wall (Mudwall thereafter). After presenting the theoretical framework of the study, a description of the game—and then the Mudwall puzzle—will be offered showcasing the key features that make it a problem-solving environment. Next, the analysis is presented using excerpts of the participant’s playthrough highlighting his techniques, followed by a discussion with concluding remarks.

Theoretical framework

Downs and Mamona-Downs (2007) propose two perspectives on mathematical problem: the *local* and *global*. The authors argue that every problem's structure implies a global system of principles and assumptions that are related to this and other similar problems. However, the structure of a certain problem remains highly local and specific. Problem-solving approaches and arguments can develop at a local level, that in turn might be generalised from a global perspective, namely a meta-level of similar problems. According to Downs & Mamona-Downs (2007) the "switch" (p.2271) between the two perspectives might happen in two ways: by viewing problem-solving as an amalgamation of both global and local perspectives, or by examining strategies emerging from a local perspective, that become important in the global. One construction that could emerge through the interrelationship of the local-global could be a *technique*. In this paper, the term technique is used based on the definition offered in Mamona-Downs and Downs (2004):

A technique, as does a method, conveys a mathematical argument that can be extended over a variety of tasks. Our convention is that a technique splits the argument into pre-determined stages, each of which addresses a specifically formulated aim. For a method such explicit structuring is not stressed. (p. 236)

While techniques can be linked with a specific mathematical theory, some techniques can be formed as "products of problem-solving activities" and "successfully completed solutions" (p. 237). After formed, techniques can be used as problem-solving tools. This way one technique could deal with many problems, as well as objects, that share similar attributes, very often without the problem-solver being aware of this technique. Additionally, Mamona-Downs and Downs (2004) view each solution as a construction, which can guide a problem-solver towards understanding the technique as a response to past problem-solving experiences. Finally, techniques could be viewed as existing between heuristics and algorithms (Mamona-Downs & Papadopoulos, 2017).

Video games as problem solving environments

Video games generally have an overarching theme, story or goal that create a setting for the player-problem solver. This is what we consider as the global perspective of the problem (*global problem* thereafter). The global problem is not always explicit, but rather it is experienced through solving problems from a local perspective that players face at each puzzle (*local problem* thereafter). Most of these local problems in games hint or build towards a solution of a global problem, either explicitly, shared with the players, or hidden from them until they make the connection themselves. We see video game problem-solving endeavour, having similarities to Polya's basic steps of problem solving (1973, pp. xvi-xvii): trying to understand the problem; making connections between available data to devise a plan; carrying out said plan; and reflecting on actions. Since video games are interactive media and usually offer real-time feedback the player may be guided by the game's design towards the steps mentioned. Additionally, variations of the same problem can guide the development of certain techniques. However, for the above to happen a player must have experience and a clear understanding of the games rules. Thus, the understanding for this paper is that techniques can be formed only once an initial exploration phase has past, when the player has some awareness of the actions they are allowed to perform and has formed an idea or expectations on what results said

actions might yield. Therefore, experimentation is important in these early stages and is usually the first step of a developing technique. In its mathematical essence regardless the problem, experimentation has the following elements:

“Locate the variables, the key-elements of the problem. Keep all except one constant, and start experimenting with this one to understand its role towards the solution of/solving the problem. Afterwards, keep this one constant and experiment using another one. Do the same for each element of the problem until you can understand the role each one plays towards solving the problem.” (translated from Greek, Mamona-Downs and Papadopoulos, 2017, p. 81)

Based on the above, a game can be defined as a collection of global problems, that through experimentation and consecutive playthroughs of local problems, can lead players into reflecting on their actions, and developing techniques that lead them to a solution.

The participant and data collected

The participants of the study were four children aged 6 to 8 years old. A requirement for the study was participants had never played the game before. This way, the exploration and the formation of problem-solving techniques could be captured from their first stage of development. Data were collected by the first author through video captured from participants' gameplay, recording their on-screen actions, exclamations, inquiries, ideas as well as conversations between them and the researcher who is the first author of the paper. To enrich audio data, participants were advised to express their thoughts and actions verbally as has been done in similar studies (Ke, 2008). Additionally, suggestive and encouraging prompts were used by the researcher in an effort to produce more data, while creating a comfortable and game-friendly environment for the participants. The 8-year-old participant presented in this paper, with pseudonym Damian, played the game in four hourly sessions, in different days in a week.

For each participant, the screen recordings were categorized to short segments of playthroughs, namely successful or unsuccessful attempts of the same game puzzle. Then, the data were analysed according to participants' actions to go through the puzzle (experimentation); approaches to understand what works or not (local problem); being able to see the underpinning rules (global problem); being able to transfer what they have learned in one playthrough to the next one (shift from the local to the global); development of techniques. The total amount of time allocated in each stage and the gameplay session were also taken into account.

Zoombinis¹: the game and the global-local problems

Zoombinis are creatures that try to find a new home. Guided by the player in groups of 16, they visit and must go through a total of 12 puzzles before reaching their goal. Each Zoombini has four attributes: hair, eyes, nose and feet, and these are often the variables used in each game puzzles (three Zoombinis can be seen in Figure 2). Each puzzle has a penalty system that stops Zoombinis from progressing, thus forcing the player to backtrack, collect any Zoombinis left behind, and try the puzzle again. This way, players are encouraged to work towards more efficient and effective solutions,

¹ <https://external-wiki.terc.edu/display/ZOOM/The+Game>

improving them through continuous playthroughs of local problems. Based on the above, we define local problems of a puzzle the individual attempts of this puzzle. The puzzle has an underpinning rule that is controlled by variables that are not known to the player, which we call global problem. However, in each of player's attempts the values of these variables change randomly as we explain in the context of Mudwall in the next section. That means the player begins a new attempt with new values of the variables, which justify a new local problem. However, the global problem remains the same and the solver has to unpack it, often working unknowingly towards its solution. While a local problem might be solved by chance, this solution will not work the next time the player visits the puzzle, due to the randomization mentioned before. In order to be effective problem solvers, players need to find techniques for the global problem that corresponds to this puzzle that will allow them to solve every local problem they will encounter at this puzzle. Considering the specific penalty of each puzzle, the global problem is the search for an optimal solution with minimum and ideally zero Zoombinis left behind after the problem is solved.

The Mudwall puzzle

In the Mudwall puzzle, the Zoombinis are faced with a tiled wall that obstruct their journey. The player tries to get the Zoombinis to go over the wall using a mudball launcher machine. This machine fires mudballs onto the 5×5 tiled wall and the player needs to hit the marked tiles that have dots in them (a double-dotted marked tile can be seen in Figure 2). The number of dots on each marked tile corresponds to how many Zoombinis will go over the wall successfully. The machine has buttons of five colours (blue, red, yellow, purple and green) and five shapes (square, triangle, star, circle and rhombus). In each playthrough the 5×5 matrix (named A for the purposes of this paper) is a permutation of five shapes on one axis, and a permutation of five colours on the other axis, which is not known to the player. Each cell of this matrix corresponds to a unique combination of shape and colour. Additionally, there is a hidden permutation of the two axes as well, as the colours or the shapes can either be on the horizontal axis or the vertical one. These random permutations allow for: $5! \times 5! \times 2! = 28800$ possible different 5×5 matrices. Furthermore, on each such matrix, marked tiles are distributed randomly. The number of marked tiles can be from one to eight, based on the number of Zoombinis the participant has at the beginning of this puzzle. We consider the local problem of the Mudwall as: "Are you able to find the coordinates (i.e. shape and colour combination) of all the marked tiles, on this specific wall?". The player does not have an unlimited amount of mud due to the penalty system of the game. Essentially, the player's aim is to use the least possible amount of mudballs to the player to locate the coordinates of the marked tiles. We consider the underpinning global problem: "Can you find the coordinates of the marked tiles, in each possible wall (out of the 28800 that might appear), by firing the least amount of mudballs every time?". In the following section, we describe Damian's playthroughs of the Mudwall puzzle and illustrate the development of his problem-solving techniques.

Analysis of Damian's Mudwall puzzle playthroughs

Damian visited the Mudwall puzzle six times, spending 2 to 4 minutes in each playthrough, for a total of 15 minutes. It is important to highlight that due to the linear progression of the game described above, Damian was engaged with other puzzles in Zoombinis between playthroughs of the Mudwall.

Thus, a considerable amount of time has passed between each of the events described below, ranging from ten-minute gaps up to days. In his playthroughs he was mostly quiet and engaged, and only spoke about any of his strategies when he was sure of their results. In the following pages, matrices (Figures 1 and 3) created by the first author as part of the analysis demonstrate Damian's sequence of actions. Additionally, a screenshot (Figure 2) of the overall playthrough is offered where a step-by-step summary is not necessary.

At his first encounter with the Mudwall puzzle Damian is mostly exploring and experimenting, trying to understand how to interact with the puzzle. He located and used the available buttons of shapes and colours but he was not able to identify the goal of the problem and subsequently solve it. This experimentation phase was expected, as the *Zoombinis* video game constantly enforces an exploratory attitude through gameplay and narration, where players have to identify the variables, the goal and finally the solution of the problems they come across. Before ending his first playthrough, without having successfully launched any of the *Zoombinis* over the wall, he noticed that he run out of mud, which marks his first realisation of the penalty system of this puzzle.

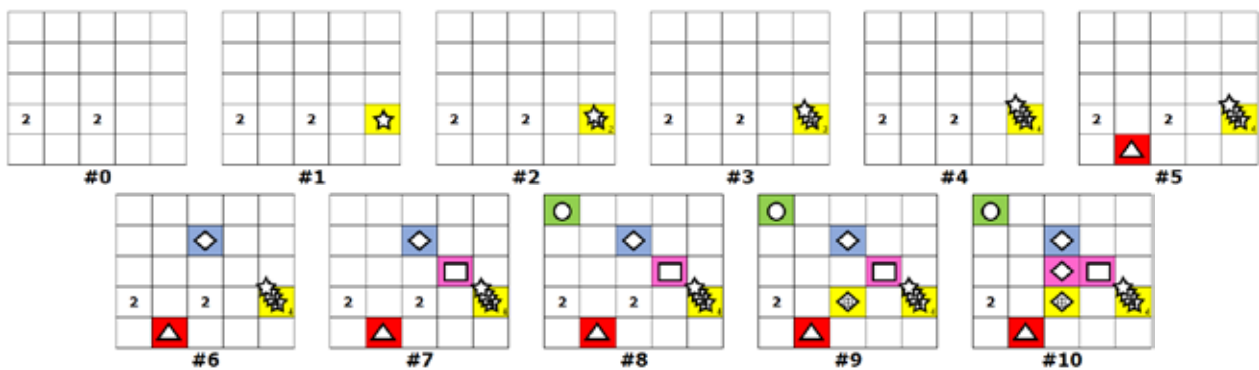


Figure 1: Damian's second playthrough, where he hit his first marked tile #9, the yellow-rhombus marked with a '+' sign in its center

On his second playthrough, Damian shot four times consecutively the same yellow-star mudball (Figure 1, #1 to #4). During his shots, his cursor movements indicated how he was trying to hit adjacent tiles to yellow-star, by point-and-clicking on the tiles themselves, then firing the mudball. After his fourth shot, he stops trying to direct his mudballs this way, and explores different combinations of shape and colour. In his last two shots (Figure 1, #10) a pattern can be seen, the process of keeping one variable unchanged. This will be explored by Damian on his next playthrough. Finally, he managed to hit one marked tile $A_{4,3}$ (Figure 1, #9). After conversing with the researcher, he became aware that this is his aim on the Mudwall puzzle, to aim for the marked tiles.

In the third playthrough (Figure 2), Damian focused on keeping the colour constant and changing the shape. Once the column with the yellow shapes was completed, he tried to complete the blue column until his mud finished. During this playthrough, Damian identified the relationship of colour and shape to columns and rows of the tiled wall.



Figure 2: Damian's third playthrough, one Zoombini has made it over the wall successfully

In his fourth playthrough (Figure 3) Damian found the coordinates of all the marked tiles, getting all his Zoombinis over the wall. This is his first totally successful playthrough, and from this point onwards he was able to develop techniques which he then uses on his last recorded playthroughs. We present this playthrough in detail, aiming to illustrate the techniques Damian developed. His first shot (#1) is a yellow-circle and the second (#2) a red-square (Figure 3). He changed both variables keeping neither colour nor shape constant. The current information does not allow him to relate the shapes and colours to the rows and columns of the matrix. With his third shot (#3) of a red-triangle, Damian keeps one variable constant (colour) and changes the second (shape). This creates a connection between the two mudballs: both share one variable, in this case the red colour (Figure 3, #2 and #3). These two mudballs now reveal that the matrix has colours in the columns and therefore shapes in the rows as illustrated below (Figure 3, #3-known data). We can see the approach of keeping one variable unchanged as systematic experimentation, which we name the *stepping-stone technique*.

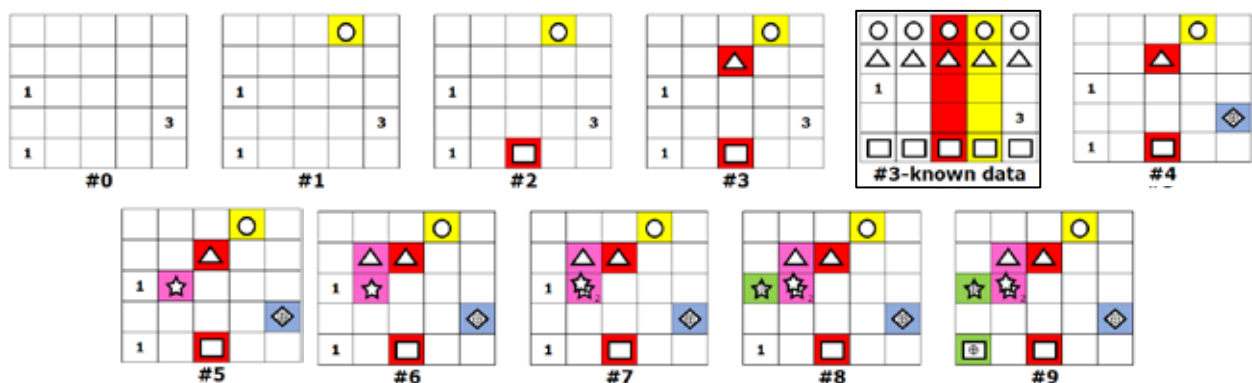


Figure 3: Damian's fourth playthrough and his first fully successful one

Our interpretation is that Damian used the stepping-stone technique with the aim of landing on a marked tile. However, as the colours are in the columns he did not manage to land on the marked tile $A_{5,1}$ and lands instead on tile $A_{2,3}$. By observing that the colours are arrayed on the columns, he can deduce that shapes are on rows. With the new information gained, Damian now focuses to hit either the tile $A_{3,1}$ or $A_{4,5}$ which are marked. He knows that the first row will be circles, the second triangles and the fifth squares. Thus, he eliminates all shapes except rhombus and star, as well as the colours red and yellow, as they belong on the third and fourth column respectively (Figure 3, #3-known data). Finally, he chooses the colour blue, and the shape of a rhombus, both choices for which he has no information yet. His fourth mudball is blue-rhombus that lands on $A_{4,5}$ with success. We see this

elimination of available options as another type of systematic experimentation, which we call *probable-exclusion technique*.

For his fifth (#5) mudball, Damian uses again the probable-exclusion technique and fires a pink-star (Figure 3). This time his shot lands on $A_{3,2}$. He finally finds both tiles $A_{3,1}$ and $A_{5,1}$ using both the probable-exclusion and stepping-stone techniques.

On his fifth and sixth playthroughs Damian employs the strategies shown in his fourth playthrough. He begins by keeping one of the two variables constant in his first two mudballs. From that point he uses interchangeably the stepping-stone and the probable-exclusion techniques, aiming for marked tiles whenever he gains some new information. Both his last playthroughs were successful as he managed to get all his Zoombinis through with mud to spare.

Discussion and conclusion

The aim of this paper was to examine the development of problem solving techniques in the context of the educational video game Zoombinis. We analysed Damian's experimentation approaches in relation to solving the local and global problem of the Mudwall puzzle, a problem he had no experience with. During his first local problem, he explored Mudwall by locating the variables, both colour and shape; as well as the penalty system of the mud decreasing after each shot. In his second local problem, he explored the machine's controls showing awareness of its function and managed to hit a marked tile thus experiencing a successful result, indicating his global problem goal. On his third local problem, he worked with only two colours, minimizing the variety of his choices, but establishing the connection between colour-shape to row-column. Finally, in his fourth playthrough he used the two techniques of stepping-stone and probable-exclusion, that combined lead him to his first successful solution in terms of the game. It is at this stage that Damian can be considered as having simultaneously solved the global problem of finding all the marked tiles without his mud running out. Thus, we identified strategies that go beyond random trial and improvement.

However, not every participant of the original study was as successful as Damian with the Mudwall puzzle. For the limited time of less than five hours of gameplay, all participants showed examples of experimentation, formed techniques and adapted them, some successfully reaching a global solution in the various in-game problems. It was also interesting how similar patterns emerged from the different participants' data, leading to the suggestion that due to carefully crafted game's design, players can be smoothly guided to a specific form of problem solving approaches.

This paper examined the video game Zoombinis as an environment used to learn problem-solving techniques. In their study Mamona-Downs and Downs (2004) highlight some issues regarding teaching techniques, such as students not wanting to use a technique after they had been taught it, and the difficulty to identify the underlying technique through the mathematical tasks which were provided for that reason. In my view, in the context of the video game, the first issue potentially could be resolved as students are the ones discovering and adapting the technique themselves. Problem-solvers implicitly guided by a global problem, they have the agency to interact and experiment in a story-driven and challenging environment and thus find the need for a more efficient solution. Along the way, techniques and other constructions formed from this process, would be something players developed on their own and something that is efficient at providing a solution.

References

- Calder, N., & Campbell, A. (2016). Using Mathematical Apps with Reluctant Learners. *Digital Experiences in Mathematics Education*, 2(1), 50-69.
- Chang, M., Evans, M.A., Kim, S., Norton, A., Deater-Deckard, K. & Samur, Y. (2016). The Effects of an Educational Video Game on Mathematical Engagement. *Education and Information Technologies*, 21(5), 1283-1297.
- Devlin, K. (2011). *Mathematics education for a new era: Video games as a medium for learning*. AK Peters/CRC Press.
- Downs, M., & Mamona-Downs, J. (2007). Local and Global Perspectives in Problem Solving. In D. Pitta-Pantazi & G. Philippou (Eds.), *Proceedings of The Fifth Congress of the European Society for Research in Mathematics Education* (pp. 2270-2279). Larnaca, Cyprus.
- Ke, F. (2008). A case study of computer gaming for math: Engaged learning from gameplay?. *Computers & Education*, 51(4), 1609-1620.
- Kebritchi, M., Hirumi, A., & Bai, H. (2010). The effects of modern mathematics computer games on mathematics achievement and class motivation. *Computers & education*, 55(2), 427-443.
- Lowrie, T. (2005). Problem solving in technology rich contexts: Mathematics sense making in out-of-school environments. *The Journal of Mathematical Behavior*, 24(3), 275-286.
- Mamona-Downs, J., & Downs, M. (2004). Realization of techniques in problem solving: the construction of bijections for enumeration tasks. *Educational Studies in Mathematics*, 56(2), 235-253.
- Mamona-Downs, J., & Papadopoulos, I. (2017). *Επίλυση προβλήματος στα μαθηματικά [Problem solving in mathematics]*. Πανεπιστημικές εκδόσεις Κρήτης, Ηράκλειο.
- Monaghan, J. (2016). Games: Artefacts in Gameplay. In J. Monaghan, L. Trouche & J. M. Borwein (Eds.), *Tools and Mathematics* (pp.417-431). Springer International Publishing.
- Moore-Russo, D., Diletti, J., Strzelec, J., Reeb, C., Schillace, J., Martin, A., ... & Scanlon, S. (2015). A study of how angry birds has been used in mathematics education. *Digital Experiences in Mathematics Education*, 1(2-3), 107-132.
- Moss, T.P. (2004). *Playful thoughts: A study of the effects of "Logical Journey of the Zoombinis" on elementary students' mathematical attitudes and reasoning skills*. Ph.D. thesis, Teachers College, Columbia University. Retrieved September 17, 2018 from <https://www.learntechlib.org/p/120752/>.
- Polya, G. (1973). *How to solve It (2nd)*. New Jersey: Princeton University.
- Thoma, G. (2017). *A case study of young students' formation of problem solving methods and development of techniques in the context of Zoombinis, an educational video game* (Unpublished Master's dissertation). UEA, UK.
- Van Eck, R. N. (2015). SAPS and digital games: Improving mathematics transfer and attitudes in schools. In T. Lowrie & R. Jorgensen (Zevenbergen) (Eds.), *Digital Games and Mathematics Learning* (pp. 141–173). Springer Netherlands.
- Yelland, N. J. (2002). Playing with ideas and games in early mathematics. *Contemporary issues in early childhood*, 3(2), 197-215.

Repeated sampling in a digital environment: A remix of data and chance

Marianne van Dijke-Droogers¹, Paul Drijvers² and Arthur Bakker³

Utrecht University, The Netherlands

¹m.j.s.vandijke-droogers@uu.nl; ²p.drijvers@uu.nl; ³a.bakker4@uu.nl;

Drawing statistical inferences (SI) is essential in a society where data are of increasing importance. Understanding the relation between data and chance, necessary to understand statistical inference, is however challenging for students. Technological innovations – such as the Sampler in TinkerPlots (TP) – enable students to investigate this relationship by modeling a population and simulating repeated samples. Along this line, the research reported here presents the results of a pilot with fourteen 9th-grade students, inexperienced with sampling, in a Learning Lab. The pilot focuses on how students use TP as a digital environment for exploring data and chance – i.e. what strengths and constraints they encounter – and how they subsequently use this information for SI. The results suggest that the participating students encountered difficulties in modeling the population, however, they were able to simulate, explore and reason inferentially through repeated sampling in TP.

Keywords: TinkerPlots, repeated sampling, (informal) statistical inference, modeling, statistics education

Drawing statistical inferences (SI) is essential in a society where data play an increasingly important role. However, the handling of variation and uncertainty involved in drawing inferences based on sample data, is challenging for students (Castro Sotos, Vanhoof, Van den Noortgate, & Onghena, 2007; Konold & Pollatsek, 2002). New technological innovations – such as the Sampler-option in TinkerPlots – enable students to model and investigate the interaction between data and chance in order to gain insight into variation and uncertainty (Biehler, Frischemeier, & Podworny, 2017; Pfannkuch, Ben-Zvi, & Budgett, 2018). Following this approach, Van Dijke-Droogers, Drijvers, and Bakker (2018) suggested an approach of repeated sampling with a black box filled with colored balls to introduce students, inexperienced with sampling, to the key statistical concepts of sample, frequency distribution from repeated samples and the simulated sampling distribution. This approach with a black box seemed promising to invite students to investigate the intertwined relationship between data and chance. As a follow-up to this study, the research reported here investigates *how* activities in the digital environment of TinkerPlots can strengthen the statistical insights of students, i.e. the interrelation between data and chance.

Theoretical background

Statistical inference

Statistical inference includes making statements about an unknown population based on observed sample results. In contrast to descriptive statistics, which concerns describing the data under

investigation, inferential reasoning includes the handling of sampling variation and interpreting the role of chance.

Digital environments for statistical modeling

Recent digital environments that use dynamic visualizations and offer opportunities to create statistical models, enable students to investigate the intertwined relationship between data and chance. Tools such as TinkerPlots that have both data analysis and sampling capabilities, support young students to think about the modeling process. Creating statistical models to simulate data from repeated sampling can be helpful to develop key statistical ideas of distribution and sampling variation (Konold, Harradine, & Kazak, 2007). In an instant of time, a model of the population can be built in a digital environment and then be used to generate a large number of (repeated) sample results. In this way, student can explore sampling variation due to chance, especially when they visualize the results of repeated sampling in a sampling distribution. In this way, students engage in modeling, dealing with variation and thinking about the context (Pfannkuch et al., 2018). The work by Garfield, delMas and Zieffler (2012) shows that students can learn to think and reason statistically – or as the authors call it “really cook” – by using statistical modeling in digital environments.

Repeated sampling in the black box activity

This learning—or cooking—effect is reflected in the work by Van Dijke-Droogers et al. (2018) on repeated sampling from a black box filled with small colored balls (“balletjes” in Dutch). The results of that study suggest that repeated sampling from a black box is a promising approach to introduce students to the concepts of sample, frequency distribution on repeated sampling (resampling) and the simulated sampling distribution, and, therefore, invites reasoning about variation and uncertainty involved in SI. An important characteristic of this 3-step learning approach seems the strong connection between a physical black box experiment in step 1, the visualization of expected sample results from resampling with a black box in a frequency distribution in step 2, and the simulated sampling distribution on resampling in the digital environment of TinkerPlots in step 3. An overview of the learning steps in the black box activity is displayed in Table 1.

-
1. Repeated sampling with the physical black box
 2. Visualization of expected sample results from repeated sampling with the black box in a frequency distribution, by manually drawing a sketch
 3. Simulation of a large number of samples from repeated sampling with the black box and visualization of results in the sampling distribution, by using the Sampler-option in TinkerPlots
 4. Using the digital environment of step 3 in a new context
-



Table 1: Overview of learning steps in the black box activity

Van Dijke-Droogers et al. (2018) focused on step 2 and showed that students could, based on their experience in step 1, imagine and sketch a frequency distribution from repeated samples with most sample results close to the population proportion and in which strong deviations hardly occur. As a next step, the aim of the research presented here, is to gain insight into *how* statistical modeling with

the Sampler-option in TinkerPlots can strengthen the statistical insights of students concerning sampling variation due to chance. Therefore, we added a fourth step to the black box activity to investigate *how* students use TinkerPlots to explore data and chance in new situations and *how* they use this information for SI.

Methods

To investigate how students explore and reason with TinkerPlots, we conducted a pilot study in the Teaching and Learning Lab of Utrecht University.

We have chosen to run the pilot in a lab setting. The advantage of this lab setting, over a classroom environment, was that detailed recordings could be made of the actions and conversations of several teams of students working on the same assignment at the same time. During a five-hour session, seven 9th-grade students worked in teams of 2 or 3, on tasks addressing steps 1 to 4 of the learning trajectory. This pilot was repeated in a similar five-hour session, with seven other students. The teams worked on a laptop, the screen of which was displayed on an interactive whiteboard. Camera recordings of their actions on the screen were made, and student conversations were recorded. Students noted their findings as a team on a student worksheet. We worked with students from pre-university level, the 15% best performing students in our educational system. Figure 1 shows the setup in the Learning Lab.



Figure 1: An impression of the setup in the Learning Lab

During the pilot, students went through learning steps 1–4 of the black box activity. Special focus was on how students applied their digital experiences from step 3 to investigate the role of variability and chance in the new context of step 4. In step 3, students used the sampler option in TinkerPlots to simulate repeated samples from the context of the black box. While doing so, they used an instruction sheet with the necessary technical actions in TinkerPlots. In this step, students investigated possible sample results by modeling a black box filled with 750 yellow and 250 orange balls at different sample sizes and different number of repetitions. During a group session in step 3, students discussed the boundaries of common sample results and decided that the middle 80% of the results can be regarded as “most common sample results”. They indicated the 10% highest sample results as “exceptionally high” and the 10% lowest sample results as “exceptionally low”. It was expected that the students would apply their experiences from step 3 in the new context of step 4, as detailed in Table 2. This table shows an overview of components A to G with statistical insights, TinkerPlots activities in step 3 and expected students’ activities in step 4.

Components of statistical insights	TinkerPlots activity in step 3 with the black box	Expected students' activity in TinkerPlots at step 4
A Sample results vary due to chance	Context: A black box is filled with 750 yellow and 250 orange balls. For each sample, the number of yellow balls is counted. Examine the sample results you can expect.	Context: At the beginning of the school year 210 out of the 300 students on a specific primary school were used to having breakfast daily.. Task 1: To investigate whether this is still the situation at the end of the school year, a sample of 30 students will be taken. Examine which sample results you can expect if the breakfast habits of students are unchanged.
B A model of the population can be entered and examined in a digital environment	Model the population in TinkerPlots by using the Sampler-option. The model can be entered as a pie chart, bar graph, histogram, dot plot or curve.	Students enter a model of the population in the same way as described in the cell on the left (TP activity B)
C Sample size effects sampling variation due to chance	Enter the sample size you want to examine.	Students enter the sample size they want to examine. In this example, the sample size is 30.
D Sample data can be listed in a table A visualization of sample data in a plot provides a clear overview	Simulate one sample, the results are automatically displayed in a table. To make a plot of the sample data, explore the data and choose a visualization that provides a clear overview.	Students simulate one sample of which the data are automatically listed in a table. They use the Plot-options to explore and clearly visualize their data.
E Repeated sampling in a digital environment can produce a large number of sample results. These results can be listed in a table by choosing one specific characteristic.	Use the history button to have repeated samples memorized. To do this, choose a specific characteristic—for example the number of yellow balls—that you want to record from each sample.	Students use the history button to record the number of “students who had breakfast” from each sample.
F A visualization of multiple sample results in a plot can be used to estimate possible sample results	Visualize the sample results in a sampling distribution. Use dividers to examine possible sample results, i.e. most common sample results, exceptionally high or low	Students visualize the sampling distribution and use dividers to examine possible sample results
G A larger sample size reduces the variation in the corresponding estimates of the population and hence, leads to a better outcome.	Estimate most common sample results and extrapolate these to the population. Then, try different sample sizes later for comparison. Draw a conclusion about the effect of larger sample sizes to the estimate of the population	Students estimate most common sample results and exceptionally high or low results to draw their inferences corresponding to the task (other sample sizes were addressed in tasks 2–4)

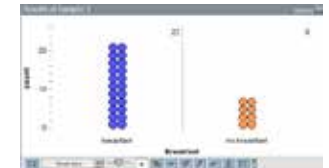


Table 2: An overview of statistical insights, TinkerPlots activities in step 3 and expected students' activities in step 4

Sample size 30	Expected number of students having breakfast daily (interval notation)
Most common sample results	
Exceptionally high results	
Exceptionally low results	

Table 3: Table on student worksheet

Task 2: In the past year a lot of attention has been paid to a 'healthy' breakfast at the school. At which sample result, sample size 30, is it likely that the breakfast habits of students have improved? Support your answer with data.

Task 3: At the end of the school year, a sample of 30 students was not feasible. Therefore, a sample will be taken of only 10 students. With which sample result can you now assume that the breakfast habits of students have probably improved?

Task 4: On closer inspection, the school board decides to postpone the sample to the next school year and to draw a sample of 100 students at that time. For which sample result is it likely that the breakfast habits of students have improved?

Task 5: Compare the sample results and corresponding estimates of the population at different sample sizes. What can you conclude about the population estimates from a larger sample size?

Table 4 Tasks 2-5 on Student Worksheet

For Task 1 in step 4, students could use a table on their worksheet, as displayed in Table 3. Students used TinkerPlots to determine most common sample results. For Tasks 2 to 5, more in-depth questions that mainly focused on the role of sample size were asked within the same context, as shown in Table 4. Students were free to choose their own working method within TinkerPlots.

Results

The analysis of the video-recordings shows that the expected students' activities in components A and C to G did occur. However, the students encountered difficulties with component B. Students started with discussing the breakfast context in component A. Students seemed to be involved in this real-life context as they exchanged and discussed all kinds of possibilities and expectations based on their personal experiences and intuition, for example "Only 70% of these students have breakfast, that's way too low for a healthy school. Here, we have a lot more students who have breakfast." After sharing their thoughts, they started working in TinkerPlots. Here, in component B, making a model of the population in TinkerPlots, the difficulties began as 3 out of 6 teams used the sample information for their model. As such, they modeled the population by entering 21 for breakfast and 9 for no breakfast. When simulating samples from this population they got confused and asked the teacher for help. Referring to the black box activity in step 3, made them aware of the difference between population and sample. Another difficulty with the modeling was that 2 teams used a pie chart with percentages. These students entered 70% for breakfast and 30% for no breakfast. Although they used similar proportion as the given population, working with percentages refers to an endless population

and in this case the population size is given with 300. So, a finite population of 300 is a better model. After struggling at component B, the other components were performed as expected, although students occasionally needed guidance from the teacher, which mainly consisted of linking the new context in step 4 to the known context of the black box activity in step 3.

The activities in TinkerPlots (re)strengthened the statistical insights of students. As a first strength, each new component offered opportunities for students to discuss and reason about their actions in the digital environment and the implication of their actions. For example, at component A, a student stated “Well, they should take a larger sample to get a better picture of the school” and “Probably 21 students of the sample will have breakfast, or at least about 21 students. 22 or 23 is possible too. Even 30 is possible, but I don’t think that will happen”. Statistical concepts such as the effect of sample size and possible sample results that were addressed in steps 1–3 of the black box activity, were again considered and discussed by students in a new context.

As a second strength, students referred to terms from steps 1–3 of the black box activity, as they were using terms like “yellow and orange balls” and “content” of the black box. The lay-out and set-up of the digital environment offered opportunities to easily relate both contexts. The following fragment shows an example of students’ reasoning while modeling the population in task 1 of learning step 4, where terms related to repeated sampling with the black box are underlined:

Student 1: Okay, we have a sample of 30. If nothing has changed, then probably 21 students will have breakfast.

Student 2: I think so...

Student 1: But it could be 22 or 23 students. I think that 27 or more cannot happen. What do you think?

Student 2: Of course, it is possible, but....

Student 1: What should we enter here (*pointing at the empty startup window of the Sampler*)? This is actually the total content, right? So, all students of the school?

Student 2: Why not the 30 students... we are supposed to check on 30 students

Student 1: I think, we should take the 300, because that are all students, like all the balls in the box and the 30 is just a sample, the visible ones... don’t you think?

Student 2: Okay, so then we must enter 210 with breakfast and 90 no breakfast.

A third strength concerned the easy and rich way in which students could explore the data. They could easily create and compare different graphs, like pie charts, dot plots, etc. On the other hand, these explorations took a lot of time and it seemed like students based their decisions, for example about the format of the graph, on personal ideas and less on clarity. Moreover, choosing the right colors and shapes for the balls, was time consuming.

A fourth strength was that every component required action in TinkerPlots. Students could not thoughtlessly enter their values, but they had to be alert and aware of their actions.

In step 4, students were asked to carry out five investigative tasks and to note their answers on student worksheet. An outline of the results on students' worksheet are displayed in Table 5.

Task	Results	Frequency in teams of students	Example of students' reasoning
1.	Correctly filled in Table	6 out of 6	-
2.	Correct conclusion	6 out of 6	More than 25 students is exceptionally high, so probably the breakfast habits of students is improved. 24 students is the boundary of most common sample results. So, with 26 students or more, it can be assumed that the breakfast habits have improved.
3.	Correctly filled in Table	6 out of 6	-
	Correct conclusion	6 out of 6	With a sample result of 9 or 10 students (out of 10) that have a daily breakfast, we can assume that the breakfast habits are improved, because this is an exceptionally high number.
4.	Correctly filled in Table	6 out of 6	-
	Correct conclusion	5 out of 6 (one team empty)	When more than 80 students (out of 100) are having a daily breakfast, this is extremely high, and therefore it is assumable that more students are having a daily breakfast.
5.	Correct conclusion		A larger sample size gives a more precise estimate of the population The larger the sample size, the less variation in the corresponding estimate and the bigger the chance of a good estimate

Table 5: Overview of results on students' worksheet

Conclusion and Discussion

The research reported here focused on how activities in the digital environment of TinkerPlots can strengthen students' statistical insights, i.e. the interrelation between data and chance. The main difficulty of students was creating a correct model of the population and, more particularly, distinguishing sample and population characteristics from a given context. However, entering the characteristics into the tool, TinkerPlots, did not cause any problems. The awareness of the difference between sample and population can be improved by spending more time and instruction to modeling a population in a variety of contexts.

A first strength of the activity in the digital environment of TinkerPlots was that students exchanged and discussed statistical information which may lead to a deeper notion of the concepts addressed. A second strength was that the lay-out in the digital environment could easily be related to the black

box activity (balls, sample size). Students explanations contained black box terms several times. A third strength concerned the convenient and rich way in which students explored the data. However, choosing appropriate representations was also time consuming and mainly based on personal preference over clarity. A fourth strength was that every thinking component required action in TinkerPlots, which increased their awareness of the statistical concepts involved.

Although the results seemed promising, a few critical points must be considered. The fact that the students went through the learning steps quite easily may have been caused by the short time frame in which the activities logically followed each other. Although the students were given quite open tasks in step 4, their approach was strongly influenced by their previous activities in step 1 – 3. In addition, the students occasionally needed help from the teacher, which consisted of linking the new context to the black box activity in step 1 – 3.

The results show that this activity with repeated sampling in the digital environment of TinkerPlots is a promising way of how the interaction between data and chance can be taught in a brief session. Researcher who would like to repeat this activity should consider that this research highlights the results of a small-scale pilot in a laboratory setting with high performing students.

References

- Biehler, R., Frischemeier, & D., Podworny, S. (2017). Editorial: Reasoning about models and modeling in the context of informal statistical inference. *Statistics Education Research Journal*, 16(2), 8–12.
- Castro Sotos, A. E., Vanhoof, S., Noortgate, W. van den, Onghena, P. (2007). Students' misconceptions of statistical inference: A review of the empirical evidence from research on statistics education. *Educational Research Review*, 1(2), 90–112.
- Garfield, J., Ben-Zvi, D., Le, L., & Zieffler, A. (2015). Developing students' reasoning about samples and sampling variability as a path to expert statistical thinking. *Educational Studies in Mathematics*, 88(3), 327–342.
- Konold, C., & Kazak, S. (2008). Reconnecting data and chance. *Technology Innovations in Statistics Education*, 2(1). Article 1. Retrieved from <http://escholarship.org/uc/item/38p7c94r>
- Konold, C., & Pollatsek, A. (2002). Data analysis as the search for signals in noisy processes. *Journal for Research in Mathematics Education*, 33(4), 259–289.
- Pfannkuch, M., Ben-Zvi, D., & Budgett, S. (2018). Innovations in statistical modeling to connect data, chance and context. *ZDM Mathematics Education*, 50 (online).
- Van Dijke-Droogers, M.J.S. van, Drijvers, P.H.M., & Bakker, A. (2018). Repeated Sampling as a step towards Informal Statistical Inference. In M. A. Sorto, A. White, & L. Guyot (Eds.), *Looking back, looking forward. Proceedings of the Tenth International Conference on Teaching Statistics (ICOTS10, July, 2018), Kyoto, Japan*. Voorburg, The Netherlands: International Statistical Institute.

Reflections on item characteristics of non-routine items in diagnostic digital assessment

Irene van Stiphout and Madelon Groenheiden

National Institute for Test Development Cito, The Netherlands; irene.vanstiphout@cito.nl and madelon.groenheiden@cito.nl

This article reflects on the construction of a digital diagnostic test for middle school in the Netherlands. During construction there was a constant struggle between testing higher order skills, concrete description of curriculum goals on the one hand, and the limited possibilities of the digital test environment on the other hand. Four item characteristics emerged that helped constructing non-routine items while managing with this challenge.

Keywords: Diagnostic tests, digital assessment, non-routine items.

Introduction

Task design plays an important role in mathematics education (e.g. Kieran, Doorman & Otani, 2015). In digital assessment, task design is complicated because task design requires time and keeping up with the newest developments (Venturini & Sinclair, 2016) while digital tools are constantly changing and being developed. Although there are strong arguments in favor of digital assessment (Stacey & Wiliam, 2013), significant challenges remain such as scoring higher order thinking skills and partial credit scoring (e.g., Sangwin, Cazes, Lee & Wong, 2010).

This article aims to contribute to the exemplification of how non-routine tasks can be constructed in a digital environment by reflecting on the construction of a national diagnostic test for middle school. Note that being non-routine depends on students' prior knowledge and proficiency. The diagnostic test aims to address key mathematical ideas that are important in the curriculum. The detailed goals and the automatic scoring of the test resulted in struggles between specific curriculum goals, the key mathematical ideas and the (limited) possibilities of a digital environment. During the construction process, four item characteristics emerged to overcome these challenges. The central question that is addressed in this article is how to design non-routine items in a digital test environment. Although the problems we met were neither new nor original, in our view, the context in which they took place was, because the test was meant for all students in Dutch education, had to serve diagnostic purpose and should enable automatic scoring. During the development of the test, the construction process evolved from a fuzzy and rather undirected process to a much more goal oriented and efficient process of creating non-routine items. Our reflection therefore aims to provide insight into how to construct non-routine items in a digital environment.

Dutch educational test

The Diagnostic Educational Test (DET) was an initiative of the Dutch ministry of Education. It was administered at the end of middle school: grade 8 in vocational education and grade 9 in senior general higher education and pre university education. Its aim was to provide insight to students, parents, teachers and schools into how well prepared students are for upper secondary education. The national assessment authority (NAA) formulated several requirements for the DET. The test

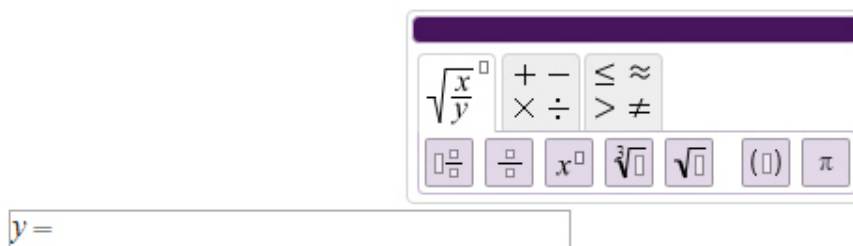


Figure 1: Formula window with editor palette above in the DET

was to be taken on a computer. Technology should enable students to do mathematics interactively. Students were to use a digital test player environment and the scoring was to be automatic. This implies that the DET is an assessment *with* technology as well as *through* technology (Stacey & Wiliam, 2013).

For the construction of the items the digital environment Questify developed by the National Institute for Test Development (Cito) was used. Questify has several item templates such as numerical answers, drag and drop, and multiple choice. During the construction of test items, a template using GeoGebra and the Digital Mathematics Environment (Drijvers, Doorman, Boon, Reed & Gravemeijer, 2010) was added to these standard templates, in order to enable students to draw lines and figures. In school, students use a digital test player, developed by the NAA, that enables students to enter mathematical symbols such as square roots, powers, fractions, and formulas. See Figure 1. Each digital environment puts a demand on students' digital skills. In order to minimize the effects of this demand, we limited the number of buttons in the formula window and in Geogebra to a minimum. The automatic scoring uses an intelligent open source computer algebra system Maxima, that is able to recognize equivalent expressions and can deal with dependency in answers. The digital environment also makes it possible to add adaptivity to the test. In this way, students are presented with items that fit their level of expertise.

The test had to be based on curriculum goals described by the Dutch Institute for Curriculum Development. These goals encompass a domain on reasoning and reflecting as well as the mathematical domains numbers and variables, ratio, measurement and geometry, relations, and information management and statistics. For practical reasons, the examples below are restricted to one domain: geometry. However, our findings hold for the other four domains as well. The diagnostic framework consisted of a matrix combining the mathematical domains with didactic competences: seeing mathematical structure, having a proceptual view, seeing intertwinement. Since this framework was not confirmed by psychometrical analysis, we will not discuss it in depth in this paper.

Within these conditions, Cito developed the DET. Items were constructed by groups of mathematics teachers, the so called construction groups. They based their items on the diagnostic framework, the curriculum goals and the test advise commission. The items were then discussed with Cito test experts and screened by fellow test experts. During the next step, the test experts discussed the items with an expert panel of the national assessment authority. Approved items were then included in a pretest among students (age 14-15 years). The results of items in the pretest were interpreted by the test experts and again discussed with the NAA. This eventually led to a final version of the item.

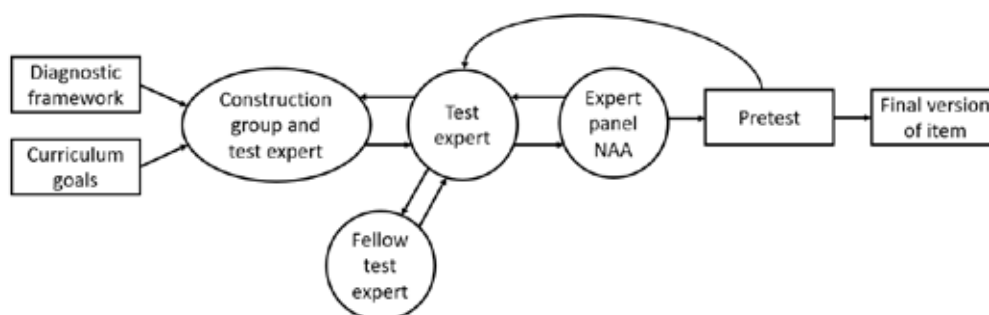


Figure 2: Overview of the construction process of items in DET

Figure 2 provides an overview of this chain. The discussions in the construction groups, among test experts and in the expert panel, combined with psychometrical information on the pretest led, through a repetitive process of continuous reflection, adaptation and revision, to a feasible approach.

During the construction we were confronted with several conflicting interests. Below, we discuss the challenges we felt between higher order goals, the detailed specified curriculum goals, and the limited possibilities of the digital test environment.

Challenges in the construction of non-routine problems

The first challenge was the ambition to focus on key conceptual ideas, while relating each test item to detailed specified curriculum goals. The focus on conceptual ideas was complicated because students had to have an overview of mathematical topics taught in several years in the test without preparing themselves specifically for the test. An additional purpose of the test was to provide insight in how well prepared students were for upper secondary education. These considerations led to the requirement to focus on key mathematical ideas and activities that are important in the ongoing curriculum (CvTE, 2014) without losing the connection to common educational practice. This focus put the construction under pressure: on the one hand, the focus is on key conceptual understandings students should master before going to upper secondary school, while on the other hand, each item in the test had to relate to detailed specified curriculum goals.

Another challenge between conceptual activities such as reasoning, and the limitations of the automatic scoring module to evaluate students' answers became apparent. Mathematics education in The Netherlands is influenced by the theory of Realistic Mathematics Education and Freudenthal's view on mathematics as a 'human activity' (e.g. Freudenthal, 1968, 1973; Gravemeijer, 1994). Recently, the cTWO (Dutch Committee for the future of mathematics education) stressed the importance of so-called 'mathematical thinking activities' such as reasoning, interpreting, organizing, structuring, manipulating (cTWO, 2007). The challenge was to construct items in a digital environment that focuses on conceptual goals and at the same time do justice to the idea of mathematics as a human activity. The prerequisite for automatic scoring is at odds with activities such as proving, reasoning and explaining because automatically evaluating these kinds of answers is technologically complicated (Drijvers, Ball, Barzel, Heid, Cao, & Maschietto, 2016). However, the focus on conceptual goals stresses the importance of including these kinds of activities.

In the following section we will discuss two examples to illustrate the way we managed these challenges. For practical reasons, these examples are restricted to the domain geometry.

Examples of geometry items of DET

One of the curriculum goals is that students are able to calculate the area and circumference of a triangle (SLO, 2012). An item that fits this specific goal on a procedural level of understanding is to calculate the area of a triangle given its base and height. Students have to recall the formula ‘area of a triangle = $\frac{1}{2} \times \text{base} \times \text{height}$ ’ and substitute the base and height to find the answer. However, this kind of question does not meet the idea of key conceptual understanding we were looking for. Students should be able to understand the formula from a conceptual point of view. A way to show this understanding is to draw a rectangle around the triangle. The rectangle clearly shows that the area of the triangle is half the area of the rectangle.

In our view, to understand the formula in terms of variables and the relations between them is of an even higher conceptual level. For example, triangles with the same base and height have the same area. Or triangles that have equal products of base and height, have the same area. In the ongoing curriculum, this is the level that indicates understanding of the formula for the area of a triangle. The item in Figure 3 illustrates this way of thinking. Two triangles are given with an equal base. The heights of the triangles is equal, but not specified. The question is to compare the areas of both triangles and to conclude whether the area of triangle I is greater than, equal to or smaller than the area of triangle II, or that the information is not sufficient to compare both areas. To answer this question, students should understand that the areas of both triangles are equal given equal base and equal, but unknown, height.

In our view, this item addresses both aspects of the first challenge: a detailed specified curriculum goal (compute the area of a triangle) and a key mathematical concept (reason about the formula). With respect to the second struggle between reasoning and the digital possibilities, we had to compromise. Clearly, the multiple-choice template leaves no room for creativity or for multiple correct answers. There is room, however, for multiple strategies because students can for example estimate the height and calculate the area in the way they are used to.

The screenshot shows a digital assessment interface. At the top, it says 'Import User' and 'Vraag 1 van 1'. Below that, there is a diagram of a large triangle with a vertical line from the top vertex to the base, dividing it into two smaller triangles, labeled I and II. The base of triangle I is marked as 4, and the base of triangle II is also marked as 4. To the right of the diagram, the text reads: 'Compare the area of triangle I with the area of triangle II. Which statement is true?' followed by four radio button options:

- The area of triangle I is greater than the area of triangle II.
- The area of triangle I is equal to the area of triangle II.
- The area of triangle I is smaller than the area of triangle II.
- You do not have enough information to know which area is greater.

 The interface also includes navigation icons like a search icon, a question mark, and a calculator icon.

Figure 3: Multiple-choice item from the DET in the domain of geometry for vocational education students grade 9

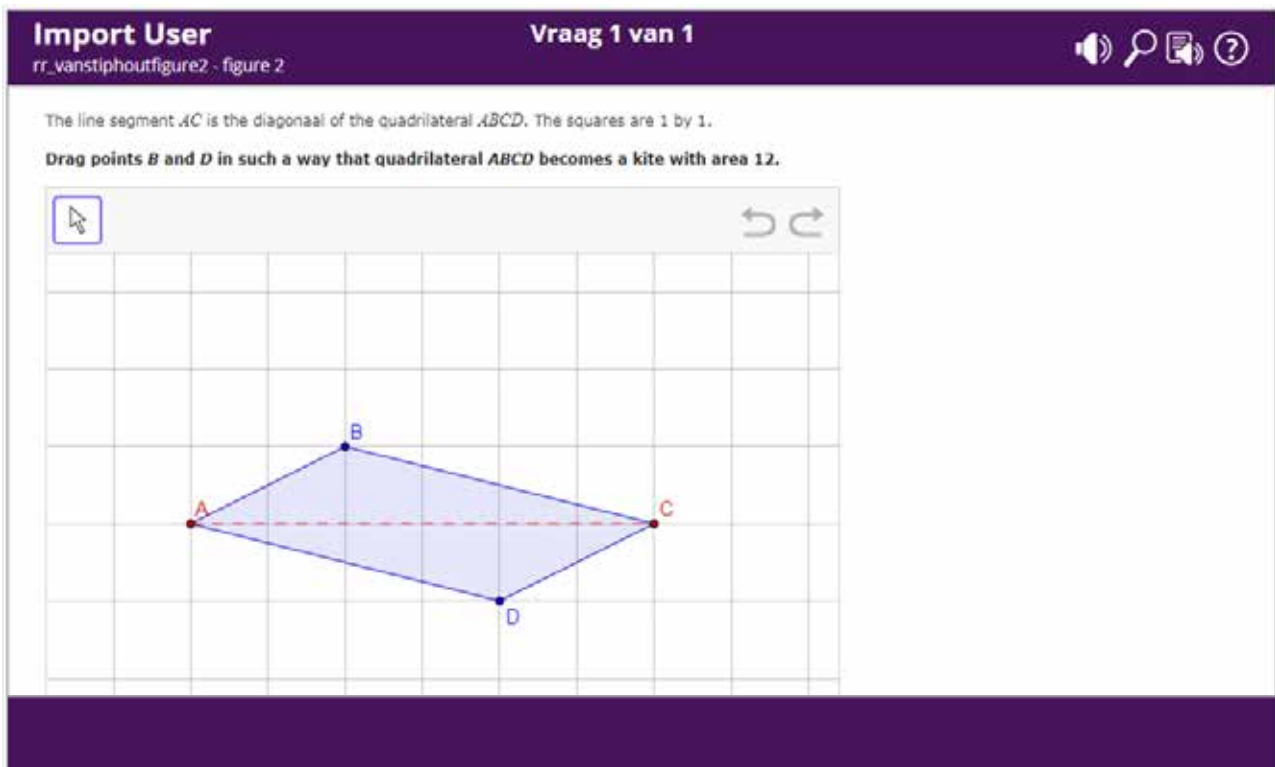


Figure 4: GeoGebra item from the DET in the domain of geometry for vocational education students grade 9

The second example is also about calculating area. Figure 4 shows an item for senior general education and pre-university students in grade 9. A curriculum goal for these students is to be able to calculate the perimeter and the area of triangles, squares, rectangles and circles, and from simple figures that are built of these figures (SLO, 2012). The item in Figure 4 asks students to construct a kite with given area. In the GeoGebra figure in the test player environment, the points A and C are fixed, so students are not able to drag these points. Neither can the dashed line segment AC be moved. The points B and D can be grabbed and moved along the grid. The line segments AB , BC , CD and AD move along while dragging points B and D . The purpose is to move points B and D in such a way that the quadrangle becomes a kite with area 12. In the automatic scoring module, a Boolean variable was defined for the position of points B and D . This Boolean combined three conditions for the position of B and D . First, the distance between those points has to be 4. Second, BD has to be perpendicular to AC because in a kite the diagonals are perpendicular. Third, the middle of BD has to be on the horizontal line through A and C , or B and D lie on the perpendicular bisector of AC . The latter two cases are due to whether AC or BD is the axis of symmetry. The only button students have at their disposal is the button with the arrow in the upper left corner. As a consequence, the only thing students can do is grab point B or D and drag it.

The struggle between the detailed goal and key mathematical understanding in this item is addressed by leaving room for different approaches and different correct answers. Students do not have to start from scratch and do not have to create anything new. Instead, they start with a given situation that has to be changed. In this way, they adjust the situation within the scope of the GeoGebra environment. Usually, in routine textbook items, the figure is given and the question is to

calculate the area. In this item, one diagonal is given and the question is to construct a quadrilateral with given properties. Because of the many different correct answers, students have to show a certain amount of boldness in making choices and to consider which characteristics contribute in which way to the area.

In our view, with respect to the struggle between reasoning and the digital opportunities, the item in Figure 4 is a fine example of finding a balance between the use of digital opportunities and the ability to construct and to create.

Item characteristics

The examples above illustrate how the DET managed the challenges we mentioned. We want to emphasize that good functioning items have to meet other requirements as well as managing the challenges. The diagnostic character of the test should provide insight in where the learner is right now (Black & Wiliam, 2009) and perhaps give suggestions on how to improve. From a psychometrical point of view, features of items such as validity, reliability, duration, etc. are of importance. Constructing a high quality test requires both psychometrical and didactical expertise. In this article we will not elaborate on diagnostic or psychometrical properties, but focus on the content in relation to the digital test environment. During the five-year period of item construction (2012-2017) the following four item characteristics emerged as helpful in constructing non-routine problems.

Key mathematical concept

The detailed specified curriculum goals can be interpreted in a conceptual way. The curriculum of grade 7 to grade 9 contains many procedures students have to learn. Examples are expanding brackets, solving linear and quadratic equations. To come to grips on key mathematical concepts, we used Sfard's (1991) notion of operational and structural conceptions and shifted the focus from procedures to the math behind these procedures. In the first example the focus shifts from calculating the area of a triangle with given base and height to reasoning about the formula of the area of a triangle.

Creativity

The next step was to look for activities in the digital environment that match the key mathematical concept. The limited item templates and the limited possibilities of the automatic scoring module asked for creativity in the construction. We wanted students to construct, to invent, to draw, to create, instead of just following a standard procedure so that we could do justice to the idea of mathematics as a human activity (cTWO, 2007).

In the beginning, we only had regular item templates such as short answer, multiple choice and drag and drop. One strategy we used to create non-routine problems was for example instead of asking to calculate, ask *how* to calculate by showing different calculations. Another strategy was to present different steps in order to work out a solution to a problem and ask students to put these steps in the right order. We admit that the multiple-choice item in the first example above leaves no room for creativity. However, in the second example of the kite with area 12, students have to create their own kite and have to show a certain amount of boldness to use the construction space.

Multiple strategies

In the ongoing curriculum, the ability to solve problems is valued higher than solving problems in specific ways. Therefore, we wanted items that allow for multiple strategies. In the first example students can reason or pick a number for the height to calculate the area, depending on their level of expertise. In the second example, students can make it easier or harder depending on where they drag and drop the points. The freedom to choose their own strategy matches the ideas of the aforementioned characteristics.

Multiple correct answers

In our view, the best items were items that allowed for multiple (or even infinite) correct answers, because obviously, calculating is not the most important part of these items. The first example above is multiple choice, so it has only one correct answer. In the second example however, many different answers yield a kite with area 12. To have this characteristic, items should challenge students to make a choice. Clearly, the possibility to regard different answers as correct puts heavy demands on the digital environment.

Summarizing, based on these item characteristics, we developed the following approach to efficiently construct non-routine items. Start with a detailed specified curriculum goal (e.g. ‘the student can calculate the area of a triangle’). Unravel this specific goal into the key underlying mathematical concept (e.g. understand the formula $\frac{1}{2} \times \text{base} \times \text{height}$ in terms of variables and the relations between them). Determine activities in the digital environment that address this key mathematical concept (e.g. arranging, categorizing, dragging and dropping, etc.). Quite often, it turned out that items constructed this way allowed for multiple strategies and multiple correct answers.

Concluding remarks

Digital assessment has many opportunities. For example, Drijvers et al. (2016) argue that the benefit of digital testing is that it can challenge teaching practices that mainly focus on procedures and promote incorporating mathematical understanding. The diagnostic test developed by Cito in The Netherlands focused on non-routine tasks that appealed to key mathematical concepts. Based on our experiences in the DET with the construction of non-routine items, we extracted four item characteristics that helped us to come to grips on challenges with the limited possibilities of the digital environment the goals of the test. These four characteristics are: focus on key mathematical concepts, ask for creativity, allow for multiple strategies, and allow for multiple correct answers.

Although the examples in this article are only from the domain of geometry, our experience is that these item characteristics worked in the domains of numbers and variables, ratio, relations and information management and statistics as well. Furthermore, the characteristics are applicable not only for middle school. We believe that anyone who wants to construct non routine items in a digital test will face the challenge with the technological limitations and as a consequence might benefit from the heuristics described above.

Design principles often are tailored to specific topics or to specific activities (e.g. Kieran et al., 2015). Our characteristics cover five domains and all kind of activities and emanate from practical

experience on national level. This generalization over topics and activities is valuable, but asks for more theoretical underpinning. The problems we described illustrate that digital diagnostic assessment is still in an early stage. Fortunately, technological resources for mathematics education and assessment are growing rapidly, so hopefully these problems will be resolved in the near future.

Acknowledgment

We would like to thank our colleagues Paul Drijvers, Wilma Vrijs and Ger Limpens from Cito, who provided valuable comments on earlier drafts of this paper.

References

- Black, P., & Wiliam, D. (2009). Developing the theory of formative assessment. *Educational Assessment, Evaluation and Accountability*, 21(1), 5–31. doi: 10.1007/s11092-008-9068-5
- College voor Toetsen en Examens (CvTE). (2014). *Publieksversie toetswijzer diagnostische tussentijdse toets voor Nederlands, Engels en wiskunde*. Utrecht: CvTE.
- Commissie Toekomst Wiskundeonderwijs. (2007). *Rijk aan betekenis. Visie op vernieuwd wiskundeonderwijs*. Utrecht: cTWO.
- Drijvers, P., Doorman, M., Boon, P., Reed, H., & Gravemeijer, K. (2010). The teacher and the tool: Instrumental orchestrations in the technology-rich mathematics classroom. *Educational Studies in Mathematics*, 75(2), 213–234. doi: 10.1007/s10649-010-9254-5
- Drijvers, P., Ball, L., Barzel, B., Heid, M. K., Cao, Y., & Maschietto, M. (2016). *Uses of technology in lower secondary mathematics education; A concise topical survey*. New York: Springer.
- Freudenthal, H. (1968). Why to teach mathematics so as to be useful. *Educational Studies in Mathematics*, 1, 3–8. doi: 10.1007/BF00426224
- Freudenthal, H. (1973). *Mathematics as an Educational Task*. Dordrecht: Reidel.
- Gravemeijer, K. (1994). *Developing Realistic Mathematics Education*. PhD-thesis, Utrecht: CD-β press.
- Kieran, C., Doorman, M. and Ohtani, M. (2015). Frameworks and principles for task design. In A. Watson & M.Ohtani (Eds.) *Task design in mathematics education*. pp. 19-81. NY: Springer.
- Sangwin, C., Cazes, C., Lee, A., & Wong, K.L. (2010). Micro-level Automatic Assessment Supported by Digital Technologies. In C. Hoyles & J.-B. Lagrange (Eds.), *Mathematics education and technology – Rethinking the terrain. The 17th ICMI study*. (Vol. 13, New ICMI Study Series, pp. 227-250). NY: Springer. doi: 10.1007/978-1-4419-0146-0_10
- Sfard, A. (1991). On the dual nature of mathematical conceptions: Reflections on processes and objects as different sides of the same coin. *Educational studies in mathematics*, 22(1), 1-36.
- SLO. (2012). *Advies tussendoelen kernvakken onderbouw vo*. Enschede: SLO.
- Stacey, K., & Wiliam, D. (2013). Technology and assessment in mathematics. In M. A. Clements, A. Bishop, C. Keitel, J. Kilpatrick, & F. Leung (Eds.), *Third international handbook of mathematics education*, pp. 721–751. New York: Springer.
- Venturini, M., & Sinclair, N. (2016). Designing assessment tasks in a dynamic geometry environment. In A. Leung & A. Baccaglioni-Frank (Eds.), *Digital technologies in designing mathematics education tasks* (pp. 77–98). New York: Springer.

Role of tablets in teaching and learning mathematics

Fabrice Vandebrouck¹ and Barbara Jaworski²

¹Université Paris Diderot, LDAR, Paris, France; vandebro@univ-paris-diderot.fr

²Loughborough University, Loughborough, UK; B.Jaworski@lboro.ac.uk

Keywords: Mathematics learning and teaching, secondary level, tablets, activity, actions, goals.

Introduction to the research question

The poster focuses on teaching and learning mathematics in three secondary classrooms in Paris, through the use of digital technology in the form of tablets. We are interested in the interactivity of teacher and students and the roles played by the tablets in engaging students with the mathematics in focus. We see tablets as tools used to satisfy the goals of both the students and the teacher in relation to their actions in the classroom. Here we use the language of Activity Theory which we take as a theoretical basis for our analysis of classroom activity. Indeed, taking the tablets as a focus, understanding their role in the teaching and learning of mathematics cannot be investigated without consideration of all the Activity in which they are used. Our broad research question about the use and role of the tablets for this study can be reformulated as follows: in what ways are the tablets engaged in the Activity (or Activity systems) which take place in the mathematics classroom?

Methodology

We observed three lessons in which tablets are involved. We adopted a methodology which fits with Activity Theory as well as some French developments in the field of didactics of mathematics (Vandebrouck, 2018). For instance we include an *a priori mathematical analysis* in which we outline the mathematical knowledge or concepts to be addressed by students, the way these concepts are addressed by curriculum, epistemology, mathematics, and the difficult ideas which are evident to us from our didactical experience (the mathematical *relief* of the concepts according to Robert cited in Vandebrouck, 2018). We use didactical tools to analyze students' tasks (Horoks and Robert, 2007) as a way to understand both some of the teachers' motives (in relation with teaching mathematics) and the student's actions (in relation with these tasks). Videos showing classroom actions and interactions provide some evidence of the students' and teachers' actions and what students achieved in relation to the goals to be reached.

Following Engestrom et al. (1999), the units of analysis are then the Activity Systems that are collective, tools (or artefact) mediated and object oriented: actions are understandable when interpreted against the background of entire activity systems. Analysing teachers and (some) students' actions/interactions, we identify Activity Systems in the classroom (in reference to different teachers' motivations or students' motive/goals). Analysing the Activity Systems permits us to understand the effective use of *tablet-based tasks* by students and the role of these tasks as teacher' tools to which the outcome of the activity is a response. We highlight the way these systems evolve during the teaching process with tensions and perturbations (Abboud, Clark-Wilson, Jones, Rogalski, 2018). In particular we highlight those systems where the tablet plays a role, in order to address ways in which the tablets contribute to the teaching and to the students' mathematical learning.

Results: tablets between the individual and the collective dimension of activity

In the first lesson, the tablets are tools to support a task with GeoGebra. They permit organization of the session in a traditional classroom (rather than in a computer laboratory) and are expected to favour communication between students in small groups. However, each student has his or her own tablet and the mathematical task is given in the tablet environment. So there is not really a need for communication between students. Moreover, the configuration of the classroom (small groups of four students) does not permit a whole class discussion and an organization of the Activity System in order to overcome this absence of communication between students. It seems that the tablets act as barriers for the collective dimension of activity which was one motive of the activity. In the second lesson, the situation is quite similar. However, the discussions occur among pair of students since there is only one tablet for each pair. Nevertheless, a tension appears between the pairs of students who succeed in the given task and the pairs of students who do not. So, the teacher organizes a new activity system with a reduced objective and a reorganisation of tools. The new motive is the success and understanding of all students in the task. The teacher gives his own tablet to a pair of students. This tablet is projected onto the board so that all the students can watch and follow the steps of the construction under the teachers' whole class instruction/discussion. The collective discussion is possible because of the classical organization of the classroom (not in small groups).

In the third lesson, students are supposed to investigate their previous knowledge in a relatively autonomous way in small groups as in the first lesson. The tablets are tools to provide several exercises (using Wi-Fi) and the tasks are solved on paper with pencils. Then students work together. The tablets are also present to provide a new kind of task for students: making collective videos for explaining their procedures and results on some exercises. This is also a way for the teacher to draw attention to some tensions between students. Indeed, tablets and videos allow the teacher to project solutions of some tasks onto the board and they foster class discussions. As in the second lesson, the tablet is then a fundamental tool in the teacher's activity system, compensating for the original organization with small groups and individual aspects of the session.

From our analyses of data from the three classrooms we see ways in which the tablets take a central role in the Activity Systems involved. These will be shown briefly within the poster.

References

- Abboud, M., Clark-Wilson, A., Jones, K., & Rogalski, J. (2018). Analyzing teachers' classroom experiences of teaching with dynamic geometry environments: comparing and contrasting two approaches. *Annales de didactique et de sciences cognitives, Special Issue*, 93-118.
- Engeström, Y., Miettinen, R., & Punamäki, R. L. (Eds). (1999). *Perspective on activity theory*, Cambridge, UK: Cambridge University Press.
- Horoks, J. & Robert, A. (2007). Tasks Designed to Highlight Task-Activity Relationships. *Journal of Mathematics Teacher Education*, 10(4-6), 279-287
- Vandebrouck, F. (2018). Activity Theory in French Didactic Research. In: Kaiser G., Forgasz H., Graven M., Kuzniak A., Simmt E., Xu B. (Eds), *Invited Lectures from the 13th International Congress on Mathematical Education*. (pp 679-698) ICME-13 Monographs. Springer, Cham

The long-term effects of MathCityMap on the performance of German 15 year old students concerning cylindric tasks

Joerg Zender and Matthias Ludwig

Goethe University Frankfurt am Main, Faculty of Mathematics and Computer Science, Germany;
ludwig@math.uni-frankfurt.de, zender@math.uni-frankfurt.de

At the Goethe University Frankfurt am Main a study amongst 9th graders was conducted. It was about the effects of a mobile app supported mathematics trail on the performance concerning tasks on cylinders. It was supported by the MathCityMap app. In the first test after the treatment, the treatment group performed significantly better than the control group. After half a year, the same test was written as a follow-up. Now the treatment group has nearly the same results than the first time, but the control group performed significantly worse. This leads to the assumption, that the treatment may have an influence on the long-term memory. This is supported by theories such as outdoor education, integrated thematic instruction, enactive learning or self-determination.

Keywords: Mathematics activity, handheld devices, mathematics trail, outdoor education.

Introduction

A mathematics trail (or maths trail) is a walk at which mathematical problems can be discovered and/or solved along the way (Shoaf, Pollak, & Schneider, 2004). To find these problems, a maths trail guide is needed, whether as a person or a printed/electronic version. Mathematics trails have been around at least since the early eighties (Lumb, 1980). The first publications mentioned the importance to make the mathematics in the environment visible for children (Blair, Dimbleby, Loughran, Taylor, & Vallance, 1983). Therefore, mathematics trails have been introduced internationally on the IMU conference on the popularisation of Mathematics (Blane, 1989). Although maths trails have been in use for quite some time now, surprisingly few studies have been conducted about them. So far, there has been no systematic approach to research the learning outcome and the long-term effects of mathematics trails in school.

Another way to use maths trails in school can be found by Toliver (1993), who let the pupils find mathematical tasks in the surrounding of the school. The focus is not to solve problems but to find some and therefore discover the mathematics around us. It took quite some time, since Traylor (2005) asked if maths trails have the potential to not only make mathematics visible but also improve the learning outcome of the pupils. She left this question without an answer but could show that a general treatment in problem posing does not increase the problem-solving skills of pupils.

Various authors have been stating the positive motivational aspects of maths trails (Shoaf et al., 2004), and newer quantitative studies have revealed this positive effect (Cahyono & Ludwig, 2017). Since we know about the influence of motivation towards performance in mathematics (Chiu & Xihua, 2008), there seems to be a clue, that running a maths trail is not only affecting the motivation but could also help to increase the performance of the pupils. On the one hand, Ryan and Deci (2000) have written on the three needs of motivation: autonomy, competence, and relatedness.

Sending pupils in small autonomous groups on a maths trail can support these needs. For sure the autonomy is given, but also the relatedness if the pupils work together.

On the other hand, maths trails are strongly supported by learning theories of Bruner (1971). Bruner stated that it is important for learning that it is represented on three levels, the symbolic, the iconic and the enactive level. Going on a maths trail directs to the enactive level, while the school lessons normally address strongly the symbolic level and illustrations on the blackboard and in textbooks supports the iconic level. If pupils go out and measure, they can see the real objects and discuss to choose the right model for the task. In addition to the iconic and symbolic level they have experienced in the classroom, they can get their hands-on mathematics in an enactive way. Running a maths trail is one way to enrich the school lesson by an enactive element. This idea of learning with all senses is also supported by the integrated thematic instruction model (Kovalik & Olsen, 1994). Kovalik and Olsen stated that learning with all senses, making real experiences instead of just reading of them, will be remembered longer by the children than any other form of lesson.

Furthermore, we know that outdoor education can have positive effects if it is carefully planned and conducted as well as being integrated into the school curriculum (Dillon et al., 2006). This should not be underestimated and taken care of when setting up a mathematics trail. And finally, yet importantly, walking a maths trail is a moderate physical activity, which we have clue for its positive effect on mental performance (Westman, Olsson, Gärling, & Friman, 2017).

MathCityMap

In addition to these approaches, the MathCityMap project was established at the Goethe University of Frankfurt (Jesberg & Ludwig, 2012). It provides users with a web portal as a GUI for a database of maths trail tasks and routes as well as with an application for smartphones (iOS and Android) to compile this data into a mobile trail guide (see figure 1). The app gives feedback on solutions (wrong/right) and the users can take hints from the app. Following the ideas of Aebli (1983) it is important to give direct feedback, so no wrong solution is without comment.

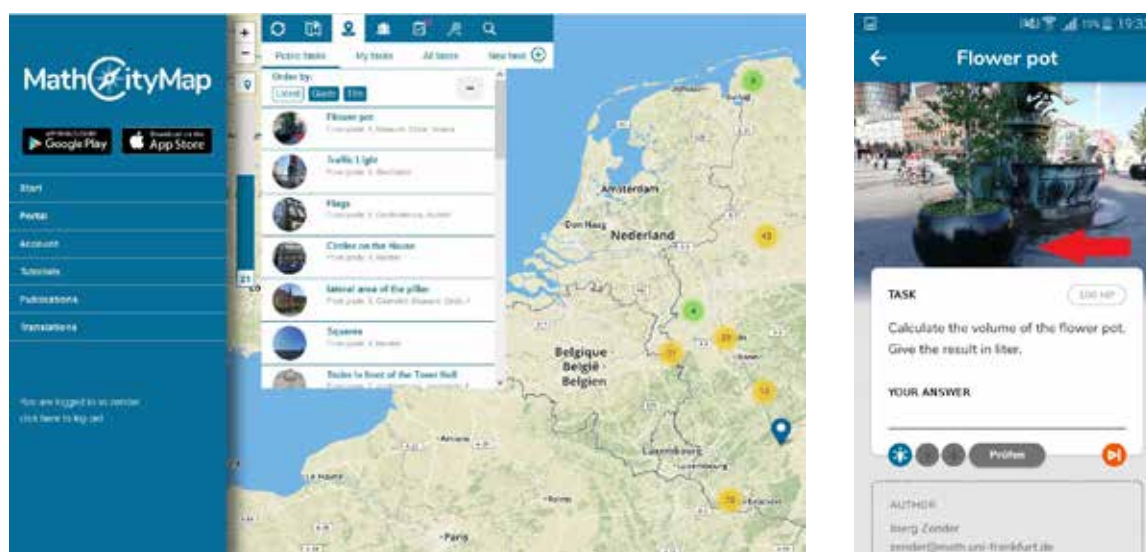


Figure 1: MathCityMap webportal (left) and smartphone application (right)

Research question

With all these clues, the question remains, what effects can we expect for pupils going on a math trail? Especially what effect does it have on the long-term memory? To answer these questions, we have conducted a study in 2017 in Frankfurt.

Method

In 2017, we collected 23 classes in the area of Frankfurt am Main and surrounding with a total of 629 pupils from 9th grade to conduct a study concerning the effects of mobile-supported mathematics trails with the MathCityMap app. All these classes wrote an entrance exam based on the German VERA8 test to measure the general mathematical performance of the pupils. Since some pupils missed the day of the exam, only 578 have participated. After this was done, the classes were separated in treatment and control group, to control the variable of mathematical performance. Also, from every participating school, at least one class was picked for control and one for treatment group, to control the variable of being on a certain school. Other variables that could influence the results, like the quality of the teacher, have been randomized by the number of pupils participating. A total of 323 pupils have taken part in the treatment. Both groups wrote another exam to compare their performance, only 529 participated in that exam. In the end, there were 273 pupils of the treatment and 182 of the control group we have full data from. For the follow-up test half a year after the treatment, we have full data for only 42 pupils from the treatment and 37 from the control group.

The treatment itself contained walking two maths trails for 90 minutes each in a group of three. The trails include ten tasks from which five (every second) was a task related to the topic of cylinders. After an analysis for German textbooks for ninth graders (see figure 2), we found only four different type of textbook word problems for cylinders of a certain amount (see table 1). Asking for

- the volume (V),
- the surface (S),
- the lateral surface (L) or
- the height (h), if volume and diameter or radius (r) is given.



16. The Ashtray on the right side is made of Brass (measurements are in mm). 1 cm³ of Brass weights 8,6g. What is the weight of the Ashtray?
17. An advertising pillar (see left side) has a diameter of 1,30 m. It is 3,20 m high. The base of 50 cm should not be covered. 1 m² advertising aerea costs 99 Euro, including taxes.

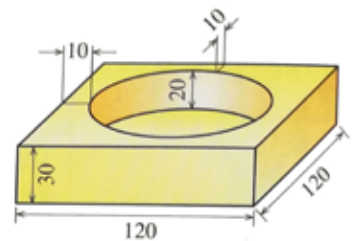


Figure 2: Part of a German textbook page with tasks on cylinders

Table 1: Analysis of German textbooks

Given	Asked	Book 1	Book 2	Book 3	Book 4	Book 5	Book 6	Total	In %
r, h	V	13	7	9	2	15	11	57	50,9
r, h	S	1	3	3	2	5		14	12,5
r, h	L	5	3	2	2	4	1	17	15,2
V, r	h	6		3		5	3	17	15,2
V, h	r	2	1	1				4	3,6
S, r	h					2		2	1,8
S, h	r							0	0,0
L, r	h							0	0,0
L, h	r	1						1	0,9
L, S	r							0	0,0
L, S	h							0	0,0
L, S	V							0	0,0
Total		28	14	18	6	31	15	112	100

For all these four kinds of tasks, an outdoor task has been created in both trails (see figure 3). In case of the advertising pillar (see figure 2), a real advertising pillar was used. Being outdoors, we tried to create authentic tasks in the sense of Vos (2011). The pupils used the MathCityMap app on smartphones provides by the Goethe University. On these phones, all progress has been logged, so that we have full data of the tasks solved by the pupils, the results they have given, the feedback they received, the time they needed and so on.

1. Task: Memorial of Alzheimer



What is the weight of the plate? 1m^3 steel weights 7900kg. Give the solution in kg.

Solution:



Figure 3: Sample tasks from the study about the weight of a cylindric plate

Results

For the first test after the treatment, the treatment group has performed significantly better than the control group (t-test, $p < 0.01$), but the effect size was small ($d = 0.398$). Divided into grammar school and secondary school, the effect was limited to the grammar schools (Zender & Ludwig, 2018). By dividing the grammar school pupils ($N = 256$) into three performance groups of the same size due to the results of the entrance exam, it was revealed that the low performer and the middle group had both shown significant differences between the treatment and the control group ($p < 0.01$ for both) with middle effects (low performer: $d = 0.631$, middle performer: $d = 0.699$). Only for the high performer, no effect could be found.

The Follow-Up test also shows some interesting results. Unfortunately, only two schools with two classes each have participated ($N = 79$). Both are secondary schools. Compared to the first test, the treatment group scored nearly with the same mean and there is no significant difference between the first test and follow up. On the other hand, the control group has had a significant difference, they got worse in the follow up (see table 2).

Table 2: Differences between the first test and the follow up test

Group	<i>N</i>	<i>M</i>	<i>SD</i>	<i>P</i>	<i>D</i>
Control	37	-1.838	1.860	0.000	-1.150
Treatment	42	0.071	1.538	0.384	0.034

Can the effect of the single maths trail tasks be estimated? The pupils have used smartphones from the Goethe University and their efforts have been logged on these phones. Therefore, we know precisely which tasks the pupils have solved, so that we can observe the learning outcome of different groups on specific tasks. One example is the type of task where the volume and the radius or diameter is given, and the height is asked. This was a task in the test after the treatment. We have the control group ($N = 196$) with no specific treatment and treatment group can be divided into three groups. Those who have not solved a corresponding maths trail task ($N = 118$), those who have solved one corresponding task ($N = 122$) and finally those who have solved both corresponding tasks ($N = 73$). The difference between having at least one task solved to none task solved is significant (X^2 , $p < 0.01$) with a small effect ($V = 0.19$), see table 3.

Table 3: Effects on solving maths trail tasks to solving textbook task

	<i>Control</i>	<i>Related tasks in the Treatment</i>		
		<i>None solved</i>	<i>One solved</i>	<i>Both solved</i>
Textbook solved	10%	7%	23%	33%
Textbook not solved	90%	93%	77%	67%

About the benefit of using mobile technology to support the math trail, we also have data. As mentioned, the smartphones logged the progress of the pupils. From the existing log data, we know that 78% of the groups, who tried to solve a task, were successful. Only 37% of them were successful in the first try. This leads to the assumption that in a setting without technology, 63% of the groups would have written down wrong answers and would have been aware of their fault only later in the classroom.

Discussion

In his study in Indonesia, Cahyono (2017) could show the significant but small effect on the mathematical performance of pupils when taken part in a maths trail. These findings are similar to the one we have in Germany, also a significant and mostly small effect on the short run. What is new is the follow-up test, which gives us the hint that the results of the test are stable for the treatment group and getting significantly worse for the control group. Although the sample size is small, and we must be careful with clues, the results are supported by the theories of Bruner (1971) and Kovalik and Olsen (1994) according to the importance of enactive learning. It is also interesting that the treatment group we have tested in the follow-up did not perform significantly better in the first test, but their adopted knowledge seems to be more stable than that of the control group.

One possible assumption is that the mobile supported maths trails (which can be created and conducted with MathCityMap) have the potential to influence the mathematical performance of pupils not only for the moment of the treatment but also for the long-term memory. The technology is in two ways important for the maths trail activity. First, the teacher can use the technology to create a trail, monitor the pupils while being outside and collect their results. So, the teacher can open up the classroom to go outside but is still in control of the learning environment without being physically present around the pupils.

On the other hand, we have also benefits for the pupils. As mentioned above, they get direct feedback on their solutions. For sure, they validate their results amongst each other in the group of three, but the app allows getting a validation from the teacher, while the pupils are still at the object of the task. The feedback in combination of the available hints makes it possible that they can revise their solution, get new measurements, find another model and so on. With the support of the log data of the smartphones, it could be shown, that only about 37% of the pupils are able to solve a task properly on the first try. 63% of the pupils would have noticed their fault later in the classroom. Too late to revise the task and perhaps not being interested to solve it anymore. By the high number of right solutions after feedback, we can estimate the motivational potential the app has for the pupils. The use of technology is the main reason the pupils finish the task properly. The app is the main reason that a successful maths trail could be set up by the teacher without accompanying the pupils. This leads to the possibility to be on the maths trail as an autonomous group of three for the pupils. From Deci and Ryan (2000) we know about the importance of autonomy for intrinsic motivation, and Hattie (2014) could show the positive effects of working in small groups. These positive effects are results of the maths trail, but the technology allows the teacher to set up such a powerful learning environment.

Further research is needed to give better clue if this assumption holds true. Moreover, if it does hold true, we have to research deeper on the reasons for success. This is very important, not only to give the advice that maths trails are good for schools but also to point out what it is to take care about when running a trail at school to make it a success. What we do know so far is that going out on a maths trail should be done more frequently. A single event is not half as strong as two related events (Zender & Ludwig, 2018).

What we also now have a clue about is that the maths trail tasks have an influence on the learning outcome. It is not “just” movement and fresh air since we can see that the performance of the control group and the group without solving corresponding tasks are very similar. Because the treatment group had some of their lessons replaced by the maths trail activity, it could explain, why they are a bit worse, if they have not solved a corresponding task. There is maybe a lack of practice, and this is something a teacher should care about when designing a maths trail activity. On the other hand, we can see the significant increase of success on the test task when solving one or even both corresponding tasks of the maths trail. So, we know now that there is an effect, but little do we know about criteria of good tasks. What makes a maths trail task successful? Also, on this interesting topic, further research is needed.

At last, we have clues about the benefits of using technology, the direct feedback for example. We can conclude from the data that most of the pupils would have written down wrong answers without the technology. But we have no control group walking a maths trail only pen and paper to determine the effect size on the learning outcome. Again, further is research is needed. We are just at the beginning to understand maths trails and technology.

References

- Aebli, H. (1983). *Zwölf Grundformen des Lehrens: eine allgemeine Didaktik auf psychologischer Grundlage*. Klett-Cotta.
- Blair, H., Dimpleby, B., Loughran, B., Taylor, I., & Vallance, J. (1983). From St Philip's to St Martin's: A Birmingham Maths Trail. *Mathematics in School*, 12(4), 14-15.
- Bruner, J. S., Olver, R. R. & Greenfield, P. M. (1971). *Studien zur kognitiven Entwicklung*. Stuttgart: Klett.
- Cahyono, A. N. (2017). *Learning mathematics in a mobile app-supported math trail environment* (Doctoral dissertation, Johann Wolfgang Goethe-Universität in Frankfurt am Main).
- Cahyono, A. N. & Ludwig, M. (2017). Examining motivation in mobile app-supported math trail environments. In T. Dooley & G. Gueudet (Eds.), *Proceedings of the tenth congress of the european society for research in mathematics education* (CERME10, February 1-5, 2017) (pp. 2523–2530). Dublin: DCU Institute of Education and ERME.
- Chiu, M. M. & Xihua, Z. (2008). Family and motivation effects on mathematics achievement: Analyses of students in 41 countries. *Learning and Instruction*, 18 (4), 321–336.
- Deci, E. L. & Ryan, R. M. (2000). Intrinsic and extrinsic motivations: Classic definitions and new directions. *Contemporary educational psychology*, 25 (1), 54–67.

- Dillon, J., Rickinson, M., Teamey, K., Morris, M., Choi, M. Y., Sanders, D. & Benefield, P. (2006). The value of outdoor learning: evidence from research in the UK and elsewhere. *School science review*, 87 (320), 107–111.
- Hattie, J. (2014). *Lernen sichtbar machen für Lehrpersonen*. Baltmannsweiler: Schneider Verlag Hohengehren GmbH.
- Jesberg, J. & Ludwig, M. (2012). Mathcitymap - make mathematical experiences in out-of-school activities using mobile technology. Talk on the 12th International Conference on Mathematics Education. Seoul.
- Kovalik, S. & Olsen, K. (1994). *ITI: The model. integrated thematic instruction*. third edition. Covington Square, 17051 S.E. 272nd Street, Suite 18, Kent, WA 98042: Books for Educators.
- Lumb, D. (1980). Mathematics trails in newcastle. *Mathematics in School*, 9(2), 5–5.
- Blane, D. (1989). Mathematics trails. ICMI Papers on The Popularization of Mathematics. Leeds, UK.
- Ryan, R. M. & Deci, E. L. (2000). Intrinsic and extrinsic motivations: Classic definitions and new directions. *Contemporary educational psychology*, 25(1), 54–67.
- Shoaf, M.-M., Pollak, H. O. & Schneider, J. (2004). *Math Trails*. COMAP, Incorporated.
- Toliver, K. (1993). The key toliver mathematics program. *The Journal of Negro Education*, 62(1), 35–46.
- Traylor, K. C. (2005). Effect of problem posing on eighth grade students' mathematical problem solving skills. *Instructional Technology Monographs*, 2 (2), Retrieved from <http://itm.coe.uga.edu/archives/fall2005/ktraylor.htm>.
- Vos, P. (2011). What is 'authentic' in the teaching and learning of mathematical modelling? In G. Kaiser, W. Blum, R. Borromeo Ferri, & G. Stillman (Eds.), *Trends in teaching and learning of mathematical modelling* (pp. 713–722). New York: Springer.
- Westman, J., Olsson, L. E., Gärling, T. & Friman, M. (2017). Children's travel to school: satisfaction, current mood, and cognitive performance. *Transportation*, 44 (6), 1365–1382.
- Zender, J. & Ludwig, M. (2018). Einsatz von MathCityMap in der Sekundarstufe I - Eine Studie über den Leistungswachs bei Schülern aus Klasse 9. In: *Beiträge zum Mathematikunterricht*. Paderborn, Germany (in Press).

Exploring the role of context in students' meaning making for algebraic generalization

Angela Zoupa and Giorgos Psycharis

National and Kapodistrian University of Athens, Greece

mekkapsaki@hotmail.com, gpsych@math.uoa.gr

In this paper we present results of a study aiming to investigate 7th grade students' construction of meanings for algebraic generalization. The students worked in groups using a specially designed microworld to explore tasks aiming to link figural patterns to realistic situations. Our focus is on the role of specific contextual elements (i.e. realistic task, digital tools, means of symbolization) on students' meaning making. The combined use of Abstraction in Context and microgenetic analysis indicates the critical role of the available software structures in mediating students' generalizations from the real context of the task to the algebraic context of school mathematics.

Keywords: Generalization, Algebraic thinking, Objectification, Microgenetic analysis.

Introduction

In this study we investigate 7th grade students' construction of meanings for algebraic generalization. The students collaborated in groups of three using the exploratory microworld eXpresser (Noss et al., 2009) to create figural patterns by expressing their structure through repeated building blocks of square tiles and developing the rules underpinning the calculation of the number of tiles in the patterns. The microworld allows students to use (iconic) variables to reproduce their constructions for different number of repetitions, to express generalization and to check their correctness through appropriate feedback. In this paper, we focus on the role of specific elements of context (i.e. realistic task context, digital tools, various means of symbolization inside and outside the digital environment) on students' meaning making for algebraic generalization.

Theoretical framework

A way to introduce students to algebra is to be aware of a pattern or regularity and then try to express it through a relationship (Mason, Graham, & Johnston-Wilder, 2005). There is something inherently arithmetic in algebra and something inherently algebraic in arithmetic, and pattern activity brings these two aspects together (Radford, 2014). Algebraic thinking is characterized by its analytical nature and it is related to the semiotic system used by students to work with symbolic expressions and relations including not necessarily alphanumeric symbolism but also non-symbolic and embodied forms of expression (ibid). Radford (2010) developed the theory of objectification with which he describes the semiotic transition of students from the distinction of a similarity in its expression as a generalization in more mathematical ways through the use of signs (gestures, words, symbols). In order to investigate the process of generalization by students as an algebraic activity, Radford (2014) suggested three features of algebraic thinking: (1) indeterminacy: the existence of unknown quantities (e.g., variables, parameters), (2) denotation: the need to name and symbolize these indeterminate quantities in different ways (not only with algebraic symbolism, but also with alphanumeric signs, natural language, gestures, or a mixture of these); (3) analyticity: the manipulation of indeterminate

quantities (through operations such as addition, multiplication) as if they were known. According to the theory of objectification, knowledge moves through specific problem-solving/posing activities from an abstract indeterminate form of possibilities (what students can potentially do and think and in what ways) to a concretized form of reasoning and action (“bringing-forth” something to the realm of attention and understanding). Recognizing the centrality of the abstract-concrete duality in the process of objectification, in this study we consider objectification as an abstraction process taking also into account the link between knowledge construction and context (Cole, 1996). Context includes dynamic factors such as student interactions with peers, teachers, tools, realistic scenarios and algebraic expressions, that may affect an abstraction process (e.g., for algebraic generalization). The role of context is crucial to learning processes and the complexity of learning processes is due, at least in part, to the context’s influences on the student’s constructions of knowledge (Dreyfus, 2010).

We combine Abstraction in Context (AiC) (Hershkowitz, Schwarz, & Dreyfus, 2001) and microgenetic analysis (Siegler, 2006) in order to address the role of specific contextual elements on the development of students’ algebraic thinking. AiC offers a way to describe at the micro-level how meanings are constructed by shedding light on their connections to the existing mathematical knowledge through three epistemic actions: recognizing (R), building-with (B) and constructing (C). Recognizing an already known mathematical concept, process or idea occurs when a student recognizes it as inherent in a given mathematical situation. Building-with involves combining existing knowledge elements (i.e. recognized constructs) to achieve a goal, such as solving a problem or justifying a solution. Constructing is carried out by assembling or integrating previous knowledge elements by vertical mathematization to produce a new structure. The microgenetic analysis, originated in the Vygotskian psychology, provides tools and techniques to analyze discourse data and take a deeper look at the genesis of knowledge construction and the role of contextual factors including the social interactions and the use of tools in the learning environment. In this study, we investigate 7th grade students’ objectification of algebraic generalization. AiC offers a framework to describe and analyze objectification as an abstraction process while microgenetic analysis allows us to take a deeper look at how the realistic task context, the available tools and the various means of symbolization inside and outside the digital environment influence students’ construction of meanings. We aim to contribute in the research literature that explores the role of contextual factors in the development of students’ algebraic thinking by taking a deeper look at the genesis of knowledge construction at the micro-level.

The microworld

EXpresser is a mathematical microworld designed to support 11-14 year-old students in their reasoning and problem-solving of generalization tasks (Noss et al., 2009). It supports students to perceive structure and find ways to express structural relationships, to identify variants and invariants in patterns and to recognize and articulate generalizations. In Figure 1 there is a model of a snake where the body combined by red tiles while the head and tail by blue. Students are asked to construct a model that works for any number of red tiles according to how old is the snake and find a rule for the total number of tiles that compose snake in any month of its life. EXpresser consists of two main areas: (a) My Model (a work area, Figure 1 on the right of the screen); and (b) Computer's Model

(Figure 1 on the left). In My Model, students can use building blocks of square tiles to make patterns that can be combined to models.

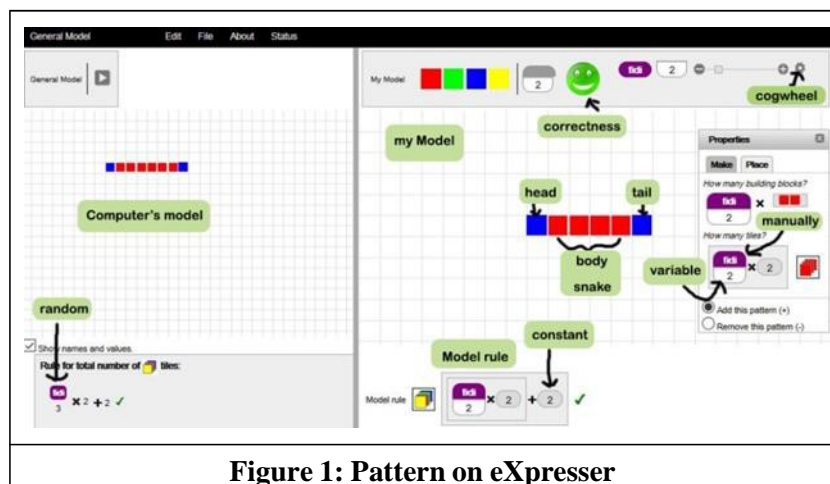


Figure 1: Pattern on eXpresser

eXpresser allows students to work with (icon) variables so as to reproduce dynamically (i.e. to ‘animate’) their patterns for different numbers of repetitions, to express generality through semi-algebraic relations and to test the validity of these relations for random values of repetition through appropriate feedback. By default, all numbers in eXpresser are constants and it is possible to

change its value by “unlocking” them to become variables that can be handled by a slider (Figure 1). From the "cogwheel" icon (next to the slider) students can configure the variable's "domain" and specify its interval of values and the step of the variation (Figure 2). Students can convert a constant number to a variable in My Model while in Computer's Model the variables take random values.



Figure 2: Properties of slider

Students can construct a model rule for the total number of tiles and only if it is correct pattern will be coloured (Figure 1). Otherwise, as an indication of error, the pattern appears colorless. Finally, when students find the

general rule in Model Rule the face icon on the central toolbox becomes green and smiling (Figure 1). As variables take random values, they provide a rationale for generality (Mavrikis et al., 2013). Thus, the environment incorporates an ‘algebra’ and a language aiming to make generalization more concrete for the students by facilitating expression of structure.

Methodology

Our research approach is informed by the influential idea of “design” in learning (Cobb et al., 2003) aiming to explore the role of alternative representations and means of expression on students’ meaning making for algebraic generalization. The study took place in a lower secondary experimental school in Athens with one class of 7th grade (13-year-old) with 18 students and one experimenting teacher. The students worked in groups of three for 12 teaching hours (6 two-hour sessions, one session per week) over two months. In the end of the implementation, 1-hour interviews with each group of students were conducted intended to capture details about students’ thinking and approaches over the whole implementation. At the beginning of the study we knew that students had not worked with patterns before (patterns are not included in the Greek mathematics curriculum) and they had minimum use of algebraic symbols. Thus, we expected to see if and how their interaction with the available tools and resources would influence the meanings that they would create for algebraic generalization.

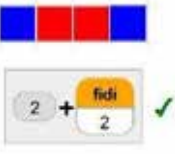
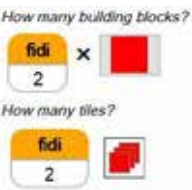
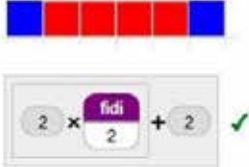
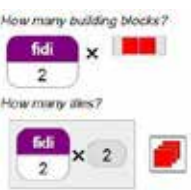
Task design aimed to link patterns to problems associated with realistic workplace contexts, thus the need for algebraic generalization was expected to arise as part of problem solving. The activity sequence was divided in three phases and for each one of them we designed a series of tasks. In the first phase students assumed the role of a herpetologist by studying the development of snakes through a simple linear pattern (*Snakes*). The second phase referred to the organization of a wedding party by professionals (*Table Arranging*). Initially students investigated the problem for 38 guests with concrete manipulatives and, next, a demanding version of the problem (132 guests) leading to a more complex linear pattern of unified tables was explored through eXpresser. In the third phase, students acted as pool designers to explore high complexity second degree patterns (*Pool designer*). In this paper, we analyze data from the first phase. *Snakes* engaged students in exploring the growth rate of a snake (i.e. grows by 2 cm every month, lives 25 years, its length reaches 6 meters) in order to identify the appropriate size of its cage. Assuming that one square tile in eXpresser corresponds to 1 cm, students were asked to construct a simple linear pattern that would grow by 2 squares tiles each time and thus would depict the snake in any month of its life. The questions involved in the worksheet were: “1. How many squares will the pattern have when the snake is 5 months old? (Respectively for 10, 25,100). 2. Describe with words how the pattern works. 3. Describe with an algebraic formula how many red square tiles appear for each month”. Our general goal was to engage students in investigating the relationship between the age of the snake and the total square tiles of the pattern.

The collected data consists of video and audio recordings (four groups). The data were fully transcribed for the analysis. The unit of analysis was the thematic episode defined as an extract of actions and interactions around students’ conceptualization and expression of generalizations. The analysis was carried out in two levels. First, the episodes were analyzed through AiC to highlight the evolution of students’ epistemic actions while constructing generalizations. Next, the same episodes were analyzed through microgenetic analysis (Siegler, 2006) that involved: (a) coding of students’ and teacher’s utterances in relation to contextual elements (i.e. task, tools, symbolization) that appeared to be crucial in students’ conceptualization and expression of generalizations, namely context snake, context snake in eXpresser, context algebra in eXpresser and context algebra; (b) categorizing the utterances in clusters of meanings emerging through constant comparison. In this paper we analyze an episode from the interview of one group of three students (Group 1).

Results

In this episode, students had already constructed the snake pattern in eXpresser and they had responded to question 1 through a numerical generalization. As they wrote on the worksheet: “each month the snake grows 2 cm, so for 5 months the number of square tiles would be 2×5 , for 10 months 2×10 , for 25 months 2×25 , and for 100 months 2×100 ”. They explained that for providing the answer for 5 months they counted one by one the red square tiles on the screen, they did not do the same for the rest of the numbers. In question 2 the students answered that “the pattern is increased by 2” and in question 3 they provided the algebraic formula: “ $x+2$ ”. This answer, that appears to be wrong (the correct one is $2x+2$), challenged the researcher to engage students in a discussion in order to justify their choice of symbols in relation to their designed pattern (Figure 3, 4). We note that the designed pattern appeared to work correctly in eXpresser. The students had unlocked a number called “fidi” (snake in Greek) to become a variable and used the corresponding slider to choose values for the

variable (in Figure 3 the value ‘2’ is chosen). The students recognized that the pattern consisted of 2 constant blue square tiles (for the snake’s head and tail) and one building block of 2 red square tiles that had to be repeated for designing the body. In order to create the variable the students pulled a red square tile to My Model and unlocked it (Figure 4). Then, they opened the cogwheel in the corresponding slider (Figure 2) and set the domain of the variable, by changing the minimum value from 1 to 2, the maximum from 1 to 300 and the increment from 1 to 2. As they explained, they put 2 to the minimum because the snake at birth is 2cm, they put 300 to maximum because it grows for 25 years until reaching 6 meters and they put 2 in the increment because it increases 2cm each month.

			
<p>Figure 3: Pattern Group 1</p>	<p>Figure 4: Pattern properties Group 1</p>	<p>Figure 5: Pattern Group 2</p>	<p>Figure 6: Pattern properties Group 2</p>

For correct coloring the red squares, the students used the variable to complete the Model Rule (Figure 3) by adding to “fidi” the constant number 2 representing the constant (blue) squares tiles. This way the values of the variable in the slider represent the length of the snake in cm. These values actually result by a ‘hidden’ multiplication of the number of months by 2. For instance, value 6 in the slider means 6cm length indicating that 3 months are multiplied by 2. By exploiting the structures provided by the software, the students achieved to construct a pattern working correctly and thus they concluded that the required symbolic generalization was “ $x+2$ ”. However, this formula cannot be used for calculating the total length of the snake in relation to its month of life. We note that students had already answered questions 1 and 2 by multiplying specific number of months by 2. In the following excerpt, the researcher discusses with group 1 students about their pattern and formula. She attempts to understand their formula and brings to the fore the fact that although the pattern works in eXpresser the formula cannot be used for answering the questions.

- 11 Researcher: What does $x+2$ means to you?
- 12 Student 2: We put x for the body and 2 for the head and tail. So 2 would be constant independently of the length of the snake. **(Recognizing)**
- 13 Researcher: So x refers to red squares and 2 to the blue ones.
- 14 Student 1: Yes for the tail and the head. **(Recognizing)**
- 15 Researcher: Can this formula help us answer the question 1? What about the 5 months?
- 16 Student 1: 5 times 2.
- 17 Researcher: But here you write plus 2.
- 18 Student 2: [*She seems to be confused*] Is it the squares? ... 7 [*adding 2 to 5*] times 2 gives 14? ... **(Recognizing)**
- Student 1: Our x here [*showing the icon of “fidi”*] will not help us because it shows how many red tiles appear in the pattern. If we don’t know the number of red tiles we can’t find it very easily [*refers to number of months*]. **(Recognizing)**
- 19 Researcher: So what does your x show?

- 20 Student 1: Our x is for the red tiles. It basically expresses what is already on the screen.
- 21 Researcher: What do you mean exactly? Can you change something to help us more?
- 22 Student 2: For the months...?
- Student 1: Probably... Yes, 2 times the months. Actually x should have to express the number of months. **(Building-with)**
- 23 Researcher: In your pattern x doesn't refer to months. It refers only to even numbers, 2 months, 4, or 6. For 5 months, what would you do?
- 24 Student 1: Our x refers to the whole body of snake...it refers to something different...

In the above dialogue the students recognized that the variation of months is embedded implicitly in their formula in eXpresser without being symbolized in some way. In the next part of the episode, the researcher aims to challenge students' views on symbolization by presenting them a pattern created by another group (Group 2) in a different way (Figure 6). In particular, group 2 constructed a pattern based on the formula ' $2x+2$ ' where x takes all natural numbers as values in the slider. The researcher invites the students to reflect on the two formulas.

- 25 Researcher: In your pattern, x does not refer to months. In order to find out how old the snake is you told me that you have to multiply the variable by 2... Here is a pattern of another group. [*The Researcher shows the pattern of Figure 5*]
- 26 Student 1: Yes actually it [*the slider*] gives values expressing months ... These students (Group 2) multiplied by 2 (Figure 5) so as to refer to the whole month otherwise this [*she showing the iconic variable in properties, Figure 5*] would refer only to a half month. Therefore "fidi" [*iconic variable*] refers to the half body of snake, so they multiplied by 2 in order to find the whole. **(Recognizing, Building-with)**
- 27 Researcher: So when the slider shows 2, we see how long the snake would be in 2 months. Which is the formula of this pattern. (Group 2)?
- 28 Student 2: [*calculates total number of tiles for value 2 in the slider*] 2 times 2 add 2, its 6. **(Building-with)**
- 29 Researcher: Can you express it by symbols?
- 30 Student 1: 2 times x add 2, because x here refers to something different from our x . Here it refers to months. **(Construction)**

The above episode represents an instance of objectification since the students appeared to conceptualize in more sophisticated ways different symbolic forms. In terms of AiC, the episode represents a construction process leading to students' construction of meanings for their own formula as well as the formula ' $2x+2$ '. The main challenge faced by the students was to conceptualize the role of iconic variables and linking them both to the construction of different patterns and to the realistic context of the task. We observe that initially the students recognized that the environment's iconic structures are associated directly by their previous mathematical constructs and they linked the variable x to eXpresser's unlocked variable (line 12). Then they recognized that the x of their formula doesn't work for answering to questions 1 and 2 in the worksheet (line 18) since it refers implicitly to numbers of months (line 22). Thus, they were able to build with it an explanation of their own strategy. In line 26, the students recognized that the value of x in the new pattern represents number of months and the graphical outcome "refers to the half body of snake". Building-with these two

recognizing actions they provided a justification for group's 2 solution: the multiplication with 2 is necessary in order to calculate the total length of the snake (line 26). This is a sophisticated justification since the students conceptualized the variation of months inside the variation of snake's length. Next, the students constructed the new formula initially by the use of specific numbers (line 28) and subsequently with the use of variables (line 30) following an analytic algebraic approach. At the same time they developed a new meaning for the variable by objectifying x as a sign representing number of months.

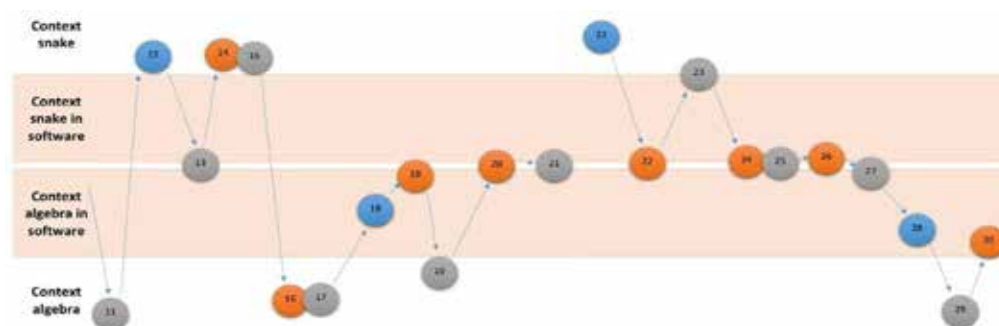


Figure 7: Microgenetic analysis: Gray is for Researcher, Orange for Student 1 and Blue for Student 2

The microgenetic analysis of the above episode shows a rich meaning generation where each symbol is conceptualized in different ways in relation to the different elements of context and utterances cannot be confined to a single context (Figure 7). The analysis revealed four clusters of meanings corresponding to specific contextual elements: real world snake (context snake); snake represented in eXpresser (context snake in software); quasi-algebraic symbolic expression in eXpresser (context algebra in software); algebraic symbolism (context algebra). In the beginning of the episode we see that students refer to symbols in relation to the real context or in relation to school mathematics. In the progression of the episode we note that students' utterances belong to different levels simultaneously. For example, when students use x they refer to snake body while with number 2 on head and queue respectively (line 12). Then the same x in the software is a set of red squares. Indeed, when the researcher asks whether " $x+2$ " can help us to calculate the red squares in relation to the snake's life (line 15), the students realize that the x of their formula doesn't work for answering to questions referring to the snake's length in different months (line 18). Looking at Figure 7, the students' answer is based on the properties of iconic variable in eXpresser as well as on the representation of the snake in the environment for different values in the slider. This way student's utterance is placed at the intersection of two contextual elements: context snake in software and context algebra in software. Finally, while observing the pattern created by another group, the students identify that symbol x refers at the same time to red squares and months of snake's life. This is why the constructed meaning is placed again at the intersection of two contextual elements (Figure 7, line 26). Taking a global view of the microgenetic diagram, we see that students' interaction that leads to the construction of algebraic generalization in the algebraic context (line 30) takes place mainly within the two contextual elements in the middle. This finding highlights the critical role of the software structures in mediating students' generalization from the real context of the task to the algebraic context of school mathematics.

Conclusion

The analysis revealed an objectification process accompanied by meaning generation for algebraic generalization. In terms of AiC, the students conceptualized different symbolic forms of expression related to different patterns. This was carried out through a sequence of epistemic actions including: linking previous mathematical constructs to eXpresser's variable (unlocked numbers); recognizing the role of variable in the constructed patterns; relating variable values to the graphical outcome of patterns; conceptualizing covariation of different variables for the construction of patterns (e.g., months and snake's length); and constructing formulas for patterns not through a trial-and-error arithmetic method but in algebraic analytic way. The microgenetic interpretive analysis allowed us to identify, analyze and discuss the role of the different contextual elements to students' construction of meanings. Four clusters of meanings appeared interrelated to the context of real snake, the representation of snake in eXpresser, the quasi-algebraic context of eXpresser and the context of school algebra. As regards the role of contextual elements in students' construction of algebraic generalizations, the analysis revealed the critical role of software representations/structures in mediating the making of links between realistic tasks and algebra.

References

- Cobb, P., Confrey, J., diSessa, A., Lehrer, R., & Schauble, L. (2003). Design experiments in educational research. *Educational Researcher*, 32, 1: 9–13.
- Cole, M. (1996) *Culture in mind*. Cambridge, MA: Harvard Univ. Press.
- Dreyfus, T. (2010). Interacting parallel constructions of knowledge in a CAS context. *International Journal of Computers for Mathematical Learning*, 15(2), 129–149.
- Hershkowitz, R., Schwarz, B. B., & Dreyfus, T. (2001). Abstraction in context: Epistemic actions. *Journal for Research in Mathematics Education*, 22, 195–222.
- Mason, J., Graham, A., & Johnston-Wilder, S. (2005). *Developing thinking in algebra*. London, UK: Paul Chapman Publishing.
- Mavrikis, M., Gutierrez-Santos, S., Geraniou, E., & Noss, R. (2013). Design requirements, student perception indicators and validation metrics for intelligent exploratory learning environments. *Personal and Ubiquitous Computing*, 17(8), pp. 1605–1620.
- Noss, R., Hoyles, C., Mavrikis, M., Geraniou, E., Gutierrez-Santos, S., & Pearce, D. (2009). Broadening the sense of 'dynamic': a microworld to support students' generalization. *ZDM*, 41(4), 493–503.
- Radford, L. (2010). Layers of generality and types of generalization in pattern activities. *PNA, Pensamiento Numérico Avanzado*, 4(2), 37–62.
- Radford, L. (2014). The progressive development of early embodied algebraic thinking. *Mathematics Education Research Journal*, 26(2), 257–277.
- Siegler, R. S. (2006). Microgenetic analyses of learning. In W. Damon, R. M. Lerner, D. Kuhn, & R. S. Siegler (Eds.), *Handbook of child psychology: Volume 2: Cognition, perception, and language* (6th ed., pp. 464-510). Hoboken, NJ: Wiley.

TWG17: Theoretical Perspectives and Approaches in Mathematics Education Research

Introduction to the Thematic Working Group 17 on Theoretical Perspectives and Approaches in Mathematics Education Research of CERME11

Angelika Bikner-Ahsbals¹, Arthur Bakker², Heather Lynn Johnson³, Man Ching Esther Chan⁴

¹University of Bremen, Faculty of Mathematics, Bremen, Germany; bikner@math.uni-bremen.de

²Utrecht University, Freudenthal Institute, Utrecht, the Netherlands; A.Bakker4@uu.nl

³University of Colorado Denver, School of Education and Human Development, Colorado, USA; heather.johnson@ucdenver.edu

⁴The University of Melbourne, Melbourne Graduate School of Education, Australia; mc.chan@unimelb.edu.au

Keywords: Networking of theories, methodology, embodied design, teaching and learning path, epistemology, design genre, generativity, generalizability, generality.

1 Theory as a fundamental part of mathematical education research

The discussion about what a theory is, why theory is needed, and how theory is used is a necessary and ongoing debate in the community of mathematics education as a scientific discipline. Although there is no clear agreement in the field (Assude, Boero, Herbst, Lerman, & Radford, 2008; Niss, 2018), we can gather some of the essential elements of theories from this debate. Theories can be taken as tools or objects (Assude et al., 2008); as lenses to “see,” “observe,” and “understand” phenomena of teaching and learning mathematics. Researchers can draw on theory to improve coherence and consistency of scientific argumentation, but researchers also need to guard against becoming blind to aspects that a theory does not capture. While theories provide a language, a more or less structured and coherent system of concepts, theorizing is a way of sense making (Mason & Waywood, 1996). Background theories encompass a philosophical stance to “understand what are taken to be the things that can be questioned and what counts as an answer to that questioning” (Mason & Waywood, 1996, p. 1056), while foreground theories are about particular research objects addressing a foreground aim such as “what does and can happen within and without educational institutions?” (p. 1056). Some of these foreground theories may developed into an epistemological tool for investigating a specific phenomenon, for example, the epistemic action model of Abstraction in Context (Tabach, Rasmussen, Dreyfus, & Hershkowitz, 2017). Theories are integral to the research process because “[t]heory is the essential product of the research activities, and theorizing, therefore, its essential goal” (Bishop, 1992, p. 711).

2 An overview about the previous work of the CERME theory groups

Kidron, Bosch, Monaghan and Palmér (2018) have offered a comprehensive overview about the theory working groups of CERME over the years, and we would like to highlight some aspects of the groups in view of the Theoretical Perspectives Thematic Working Group (TWG) of CERME11. We aim to provide insights as to why continuing work on theory is necessary for an ongoing establishing and re-establishing of mathematics education as a scientific discipline. The founding of this

working group can be taken as a reaction to the increasing diversity of theoretical approaches towards the end of the millennium which provided varied perspectives, such as cognitive, sociological, institutional, or activity theory-based views, to name a few. This diversity of theoretical approaches raised the question of how coherence can be maintained in the field since in these approaches, similar words may be used for different things or different words for similar phenomena, thus causing problems when communicating research results (Bikner-Ahsbabs, 2009). From the discussion on the diversity of theories at CERME4, the notion of networking of theories emerged (Artigue, Bartolini Bussi, Dreyfus, Gray, & Prediger, 2006). This notion takes the diversity of theories as a rich feature of the field, thus, respects the identity of different theory cultures, and does not aim at achieving a unifying theoretical understanding in the field (Bikner-Ahsbabs, 2009). Important steps to understand how the networking of theories can maintain coherence in the field of mathematics education research include the use of networking strategies in research involving multiple theories (Prediger, Bikner-Ahsbabs, & Arzarello, 2008) and the development of networking methodologies for the investigation of theory use in research. When networking theories, the aim is not to create a uniform theory, but rather to embrace complexities and re-new our theoretical understanding arising from examining networking practices.

Differences in background theoretical views also create differences in the notion of what theories are. For this reason, the networking of theories faces difficulties not only through incommensurable and incompatible assumptions of theories but also because the notions of theory used by researchers may not be the same (cf., Niss, 2018). In many sessions over the years, participants generally agreed upon using the concept of theory developed by Radford (2008; 2012), whereby a theory $[(P,M,Q)R]$ is a way of producing understanding based on a set of relatively stable principles (P), methodologies (M) related to the principles, paradigmatic questions (Q), and its use in research produces results (R) that contributes to its further developing. Monaghan (2011) proposed to consider “theoretical genesis” as similar to “instrumental genesis”: A theory is an artifact addressing and developing a specific research practice, which in turn may allow researchers to use the theory more creatively in a new way. Thus, theories or theoretical approaches frame research practices as well as develop further through the act of research.

3 Main issues raised at the Thematic Working Group 17 at CERME11

The thematic working group on Theoretical Perspectives and Approaches in Mathematics Education Research of CERME11 has taken up the tradition of addressing multi-theoretic approaches but put more emphasis on the interplay between theory and methodology, and how this interplay may advance research practice. Key issues addressed included epistemological and philosophical considerations, ontology of concepts, and contributions on design research involving new directions such as embodied design and the use of technology. To advance our knowledge on the triad of theory-methodology-research, one specific objective was to identify argumentative grammars for design research, and (re-)new theory strands such as embodiment.

Nineteen papers and two posters were presented at the conference as part of the TWG. In the proceedings, these contributions are grouped according to five topics. In what follows, we present vari-

ous interconnections between theory and methodology in a diagram and describe – based on the diagram – key points raised by the papers to emphasize their contributions to the aims of the TWG.

4 Essential contributions to the interplay of theory and methodology

Building from Radford's (2008) theory triplets (P, M, Q), we propose a graphic organizer (Fig. 1) illustrating the interplay among researchers' work with theories, their elaboration of methodology, and enactment of research.

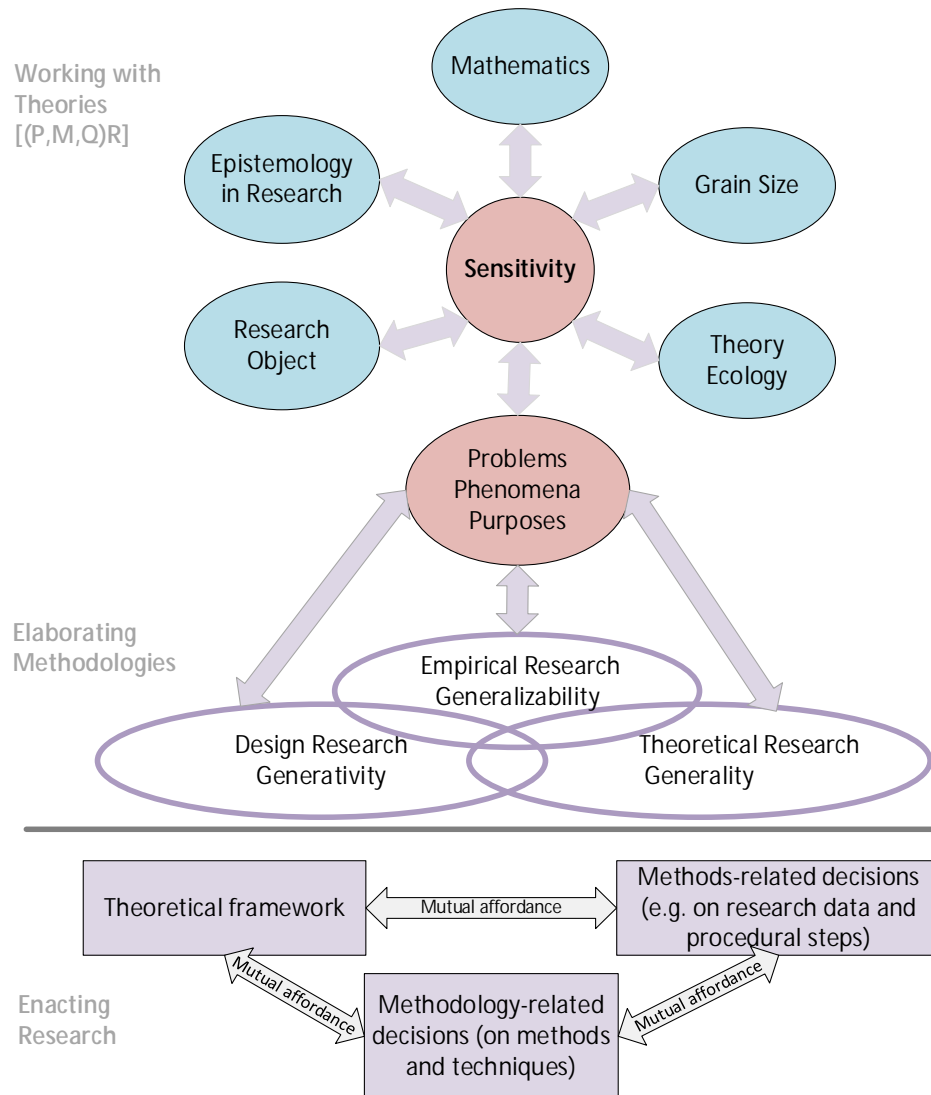


Figure 1: A graphic organizer outlining the interplay among researchers' theoretical working, elaborating methodology, and enactment of research.

We place Working with Theories in the top layer, because researchers' methodology-related decisions are driven by their tacit or explicit sensitivities to theoretical assumptions. When working with theories, researchers are expected to make explicit their sensitivities to research epistemologies, grain sizes of theories, kinds of mathematical knowledge, objects of research, ecologies of theories, and research problems, phenomena, or purposes. While we show each of these elements as discrete ovals in the graphic organizer, we view these sensitivities to be overlapping. For example, research-

ers may choose to network theories of different *grain sizes* to investigate *phenomena* of students' ways of coming to know mathematics as *research objects*. Yet, networking of theories is not an aim in itself but was developed to solve problems. Further, decisions in networking are never neutral, because scholars developed theories with particular perspectives, for example, based on specific research results and within particular ecological paradigms. Researchers' methodological decisions relate to their research problem, phenomenon, and purpose. We view this relationship as reflexive—researchers' theorizing informs their research problems, which in turn inform their methodologies, and their methodologies in turn inform their research problems.

There are three overarching kinds of research which inform researchers' methodological decisions: design research, empirical research, and theoretical research. For these three kinds of research we distinguish three quality criteria: generativity, generalizability, and generality. To illustrate what we mean by generativity, generalizability, and generality, we draw on research presented in the Theoretical Perspectives TWG of CERME11. The design research carried out by two different groups—Bakker, Shvarts, and Abrahamson, as well as Alberto, Bakker, Walker-van Aalst, Boon, and Drijvers—resulted in new tasks *generating* a design genre. The theoretical research conducted by de Freitas, Ferrara, and Ferrari addressed affectivity as a *general* concept of the body's responsivity, illustrating it through an empirical example. Liljekvist, van Bommel, Randahl, and Olin-Scheilier addressed a particular research problem, engaging in empirical research to develop *generalizable* knowledge. The base layer of the diagram focuses on the enactment of research. Researchers' theoretical frameworks *afford* and *constrain* their methodology-driven and methods-driven decisions, when collecting and analyzing research data, and vice versa.

4.1 Reciprocity of theory and methodology: mutual affordances

The first topic, reciprocity of theory and methodology for research and design, sets the scene: The topic emphasizes the epistemological nature of research, highlights and describes the reciprocity of theory and methodology in research, and how such reciprocity may impact on design and research.

Kidron compared the procedures of a priori analyses and their epistemological roles in the application of two theories, suggesting that differences in the a priori analyses reflected different analytical focus priorities based on the theories and, hence, illustrated the reciprocity of theory and methodology. Chan and Clarke conceptualized and explained this reciprocity between theory and methodology in terms of mutual *affordance*, where affordance refers to “the investigative options made possible (and also constrained) by the choice of theory or methodology”. In the case of design research, Hanke and Bikner-Ahsbabs encapsulated the mutual affordances between theory and methodology into a design principle “boundary crossing by design(ing),” linking the theoretical construct of boundary crossing with a course design for pre-service mathematics teacher training.

4.2 Philosophical considerations: interplay of epistemology and ontology

The second topic addresses philosophical, epistemological, and ontological considerations. The papers provide examples of the interplay of theory and methodology and this interplay's epistemological and ontological implications on the level of *generality*. The papers address analytical ways of arguing, thus generality, but also illustrating the generality by concrete examples.

Lensing argued that concepts and discourse form an ontological source of building mathematical objects. Radford illustrated the epistemological power of joint labor on tasks and material as ontological source in the classroom. Kuzniak and Vivier transformed the notion of the work mathematicians do as the epistemological source of concepts to the mathematical work in the classrooms. They conceptualized this work as the dialectic between the cognitive and the epistemological levels when learners build mathematical objects or concepts. Zarianakos developed a phenomenological research methodology to understand epistemic processes and highlighted the usefulness of a phenomenological attitude to investigating such processes. Finally, Flores advocated for the legitimization of a visuality's perspective for mathematical visualization. Using art laboratories as a case example, her poster challenged mathematics education researchers to rethink what mathematics and mathematics education are.

4.3 Embodied design: generativity and theory-methodology-design bundle as key ideas

The third topic focuses on embodied design with coordination as a key aspect, yet the nature of coordination presented in the papers varies. The papers reported on theoretical coordination, coordination of scientific criteria of design research, epistemological coordination, and coordination of individual affect and individual movement by a trans-individual activity and of disciplines.

Alberto et al. coordinated embodied design and instrumental genesis into the concept of embodied instrumentation; in this kind of networking, the researchers regarded the body as part of an instrumental genesis with an artifact. Their example illustrated a specific design genre where the movements of both hands must be coordinated to explore a problem of the sine graph. Referring to the same design genre, Bakker, Shvarts and Abrahamson made a plea for attending to generativity in addition to generalizability in education research. Such double attention generates the need for scientific coordination of generalizability and generativity—two criteria resonating with the two parts of design research, the design(ing) and the theorizing based empirical data. Based on a cultural-historical approach, Shvarts' poster abstract added an example of embodied action-based design. She showed that in her research, three kinds of couplings could be epistemologically coordinated through the whole bundle theory-methodology-design: theory-methodology, theory-design and method-design, where the theory-methodology-design bundle serves as the comprehensive lens for the *perception-action system distributed* between the tutor and student during the teaching-learning process.

The fourth contribution on embodiment by de Freitas, Ferrara and Ferrari provided a theoretical idea which was based on affectivity as the responsive nature of the human body. This kind of affectivity was substantiated by examining the coordination of students' movements while they collectively performed a task involving body movements to produce and express a circle.

4.4 Research on teaching and learning paths: the need to go beyond existing solutions

The fourth topic continues discussions about design research, addressing the need to go beyond a single theoretical framework or existing frameworks. Johnson, McClintock, and Gardner coordinated Variation Theory as a pedagogical theory of learning with the theory of Quantitative Reasoning, as a subject-specific theory for design. This kind of networking was possible because the research linked two different but compatible theory grain sizes. Tasks, shaping a design genre already, were

reconsidered for the new design step of transfer. This step required an additional theoretical model that was *sensitive* to transfer, thus allowing the *generativity* of the design genre be expanded. Similarly, Fonger, Ellis, and Dogan coordinated radical constructivist theory with Harel's Duality, Necessity, Repeated Reasoning principle for instructional design of a learning trajectory for quadratic growth. While exploring the design of the trajectory, the authors identified *shifts of understanding* among mathematics students, which demanded the inclusion of an instructional theory into the theorized trajectory, thus expanding the concept of the learning trajectory towards a teaching and learning trajectory.

While the first two contributions within the fourth topic addressed designing and investigating the (designed) learning path empirically, Gosztonyi's contribution turned this focus around. She described reverse engineering as a reverse design process of already designed series of mathematical problems: The aim is to reconstruct the rationale behind these series so that teachers can design new series of (selected) problems. Gosztonyi's research is an example of coordination between historical and empirical research methods.

Finally, Bampatsikou et al. took a unique approach to analyze students' learning paths applying Peirce's complete classification of sign relations. According to Bampatsikou et al., the take-up of these classes of signs may "mark those characteristics of the tasks that turn students' conceptualizations to higher level signs" in their semiosis, thus, resonating with the results of Fonger et al.

4.5 Theorizing the new: advancing research in terms of theory and methodology

The final topic aimed at showing how new requirements in educations (e.g., new mathematical problems, programming, social media), coming from outside or inside a theory culture, have become driving forces for new ways of theorizing and, hence, advancing research.

Connecting mathematics and programming, Lagrange and Laval explained how a framework of connected working spaces may account for students' work across domains; hence, contributing to the generativity of designs for cross-domain research. Liljekvist et al. illustrated how they combined theoretical frameworks for investigating professional development through the social media as a new way of interacting. Lagrange and Laval as well as Liljekvist et al. provided new dimensions to the work of research, suggesting new complexities that may emerge.

Makar and Fielding-Well observed that socio-mathematical norms have not been investigated in recent developments of inquiry-based learning even though such norms can strongly impact on teaching. Similarly, Itsios and Barzel observed that the fundamental concept of *Grundvorstellungen* has not yet been applied to students' difficulties in understanding exponential expressions. The two papers provide examples of ways to strengthen theoretical approaches that had emerged in different ecologies by expanding their scope and carefully consider the ontological status of the concepts involved. The lack of a theory's applicability can also lead to a theoretical expansion. Exactly this was presented by Otaki, Asami-Johansson and Bahn showing an extension of the Anthropological Theory of the Didactics to embrace and investigate the para-didactic system of the Japanese lesson study.

5 Lessons learned and moving forward

As in previous ERME conferences, this group agreed upon the dynamic, evolving nature of theories in research. From this perspective, scholars should neither demand that theories be used with absolute rigor nor allow arbitrarily applications of theory. To form coherent research frameworks, scholars engage in reconsidering, reinterpreting and reusing theories to investigate new phenomena, solve new problems and serve new purposes. Thus, theories develop and evolve through research. Working on coherence and consistency is an ongoing research task, particularly necessary for the Networking of Theories, in which reconsidering the compatibility of the theories or theoretical approaches is an additional epistemological necessity. Achieving generativity, generalizability, and generality affords the potential of the research results to be useful for answering new questions.

Bridging theory and methods to advance research is methodological work. To do so in a coherent and consistent manner, researchers need sensitivity, which is both, brought in by scholars in the field and required from the field. Our graphic organizer (Fig. 1) shows the different sensitivities that were considered during our group's discussions. The presentations on embodied design challenged the group to discuss what counts as mathematics (4.3). Theory ecology was an implicit topic in several contributions (4.5, 4.2). In the presentations focused on philosophical contributions, the group more explicitly addressed sensitivities to the ontology of concepts (4.2). In the presentations on teaching and learning paths, the group examined links between the grain size of the research focus and what researchers took up as research objects, whether the focus was on a micro-step while solving a task, a whole learning path, series of problems or on transfer of knowledge (4.4).

The different sensitivities intertwine, following the epistemology of research in mathematics education—what counts as new knowledge, how that knowledge is achieved and substantiated in the field. New knowledge was gained in terms of *epistemological criteria* (affordance, generativity, generalizability, generality, phenomenological methodology), *extending the scope of theoretical constructs* (Grundvorstellungen, socio-mathematical norms, para-didactic system, and interdisciplinary research), the nature of design research (on transfer, on teaching learning trajectories, on embodied design), *strengthening theoretical constructions analytically* (mathematical work, Theory of Objectification, formation of objects), or in terms of *advancing the networking of theories* strand by adding networking cases.

With our graphic organizer (Fig. 1), we offer a space for the interplay among researchers' theoretical working, elaborating of methodology, and enactment of research. Notably, we are not trying to find a homogenous, one size fits all epistemological path. Rather, we are working to navigate in the field in order to advance our research in different directions, for example, in the directions of methodology, methods, theory, scope, design, epistemology and ontology. Looking ahead, as topics on epistemology and ontology were addressed and the problem of discerning different argumentation grammars is not yet solved, both should be included in future calls of the TWG on Theoretical Perspectives and Approaches in Mathematics Education Research of ERME.

6 References

Artigue, M., Bartolini Bussi, M., Dreyfus, T., Gray, E., & Prediger, S. (2006). Different theoretical perspectives and approaches in research in mathematics education: Report from Working Group

11. In M. Bosch (Ed.), *Proceedings of CERME4* (pp. 1239–1243). Saint Feliu de Guíxols, Spain: FUNDEMI IQS – Universitat Ramon Llull.
- Assude, T., Boero, P., Herbst, P., Lerman, S., & Radford, L. (2008). *The notions and roles of theory in mathematics education research*. Paper presented by the survey team at ICME 11, Mexico. https://www.mathunion.org/fileadmin/ICMI/files/About_ICMI/Publications_about_ICMI/ICME_11/Assude.pdf (14.04.2019)
- Bikner-Ahsbabs, A. (2009). Networking of theories—why and how? Special plenary lecture. In V. Durand-Guerrier, S. Soury-Lavergne, & S. Lecluse (Eds.), *Proceedings of CERME6*. <http://www.inrp.fr/publications/edition-electronique/cerme6/plenary-01-bikner.pdf> (26.08.2010)
- Bishop, A. J. (1992). International perspectives on research in mathematics education. In D. A. Grouws (Ed.), *Handbook of research on mathematics teaching and learning* (pp. 710–723). New York, Oxford: Macmillon Publishing Company.
- Kidron, I., Bosch, M., Monaghan, J., & Palmér, H. (2018). Theoretical perspectives and approaches in mathematics education research. In T. Dreyfus, M. Artigue, D. Potari, S. Prediger, & K. Ruthven (Eds.), *Developing research in mathematics education: Twenty years of communication, cooperation and collaboration in Europe* (pp. 254–268). Oxon: Routledge.
- Mason, J. & Waywood, A. (1996). The role of theory in mathematics education and research. In A. J. Bishop, M.A.K. Clements, C. Keitel-Kreidt, J. Kilpatrick, & C. Laborde (Eds.), *International handbook of mathematics education* (pp. 1055–1089). Dordrecht, the Netherlands: Kluwer.
- Monaghan, J. (2011). Theoretical genesis of an informal meta-theory to develop a way of talking about mathematics and science education and to connect European and North American literature. In M. Pytlak, T. Rowland, & E. Swoboda (Eds.), *Proceedings of CERME7* (pp. 2493–2502). Rzeszów, Poland: University of Rzeszów.
- Niss, M. (2018). The very multifaceted nature of mathematics education. In E. Bergqvist, M. Österholm, C. Granberg, & L. Sumpter (Eds.), *Proceedings of the 42nd Conference of the International Group for the Psychology of Mathematics Education* (Vol. 5, pp. 30–50). Umeå: PME.
- Prediger, S., Bikner-Ahsbabs, A., & Arzarello, F. (2008). Networking strategies and methods for connecting theoretical approaches: First steps towards a conceptual framework. *ZDM-International Journal on Mathematics Education*, 40(2), 165–178.
- Radford, L. (2008). Connecting theories in mathematics education: Challenges and possibilities. *ZDM - The International Journal on Mathematics Education*, 40(2), 317–327.
- Radford, L. (2012). *On the growth and transformation on mathematics education*, Paper presented at the International Colloquium. The Didactics of Mathematics: Approaches and Issues. A Homage to Michèle Artigue. <http://www.luisradford.ca/pub/Connecting%20theories%20-%20Paris%20Oral%20Presentation%20rev2014.pdf> (14.06.2015)
- Tabach, M., Rasmussen, C., Dreyfus, T., & Hershkowitz, R. (2018). Abstraction in Context and documenting collective activity. In T. Dooley, & G. Gueudet (Eds.), *Proceedings of CERME10* (pp. 2683–2690). Dublin, Ireland: DCU Institute of Education and ERME.

Table of Contents: Thematic Working Group 17

Introduction to the Thematic Working Group 17 on Theoretical Perspectives and Approaches in Mathematics Education Research of CERME11

Angelika Bikner-Ahsbabs, Arthur Bakker, Heather Lynn Johnson, Man Ching Esther Chan

Reciprocity of theory and methodology: mutual affordances

Comparing a priori analyses

Ivy Kidron

Rethinking the connection between theory and methodology: a question of mutual affordances

Man Ching Esther Chan, David Clarke

Boundary crossing by design(ing): a design principle for linking mathematics and mathematics education in preservice teacher training

Erik Hanke, Angelika Bikner-Ahsbabs

Philosophical considerations: interplay of epistemology and ontology

How concepts turn into objects: an investigation of the process of objectification in early numerical discourse

Felix Lensing

On the epistemology of the Theory of Objectification

Luis Radford

An epistemological and philosophical perspective on the question of mathematical work in the Mathematical Working Space theory

Alain Kuzniak, Laurent Vivier

A phenomenological methodology based on Husserl's work in the service of mathematics education research

Andonis Zagorianakos

Creating art laboratory settings and experiencing mathematical thinking: towards a philosophical dimension in mathematics education research.

Cláudia Regina Flores

Embodied design: generativity and theory-methodology-design bundle as key ideas

Networking theories in design research: an embodied instrumentation case study in trigonometry

Rosa Alberto, Arthur Bakker, Oia Walker-van Aalst, Peter Boon, Paul Drijvers

Generativity in design research: the case of developing a genre of action-based mathematics learning activities

Arthur Bakker, Anna Shvarts, Dor Abrahamson

Theory, methodology and design as an insightful bundle: a case of dual eye-tracking student-tutor collaboration on an embodied mathematical task

Anna Shvarts

Assembling mathematical concepts through trans-individual coordinated movements: the role of affect and sympathy

Elizabeth de Freitas, Francesca Ferrara, Giulia Ferrari

Research on teaching and learning paths: the need to go beyond existing solutions

Locally integrating theories to investigate students' transfer of mathematical reasoning

Heather Lynn Johnson, Evan McClintock, Amber Gardner

Epistemological and methodological foundations of creating a learning trajectory of children's mathematics

Nicole L. Fonger, Amy Ellis, Muhammed F. Dogan

Conceiving teaching trajectories in the form of series of problems: a step for the theoretical reconstruction of the Hungarian Guided Discovery approach

Katalin Gosztonyi

Students' learning paths about ratio and proportion in geometry: an analysis using Peirce's theory of signs

Georgia Bampatsikou, Triandafillos A. Triandafillidis, Stefanos Asimopoulos, Kostas Hatzikiriakou

Theorizing the new: advancing research in terms of theory and methodology

Connected Working Spaces: the case of computer programming in mathematics education

Jean-baptiste Lagrange, Dominique Laval

Multi-theoretical approach when researching mathematics teachers' professional development in self-organized online groups

Yvonne Liljekvist, Jorryt van Bommel, Ann-Christin Randahl, Christina Olin-Scheller

Extending Yackel and Cobb's socio-mathematical norms to ill-structured problems in an inquiry-based classroom

Katie Makar, Jill Fielding-Wells

Understanding powers – individual concepts and common misconceptions

Christos Itsios, Bärbel Barzel

Questioning the paradidactic ecology: internationally shared constraints on lesson study?

Koji Otaki, Yukiko Asami-Johansson, Jacob Bahn

Comparing a priori analyses

Ivy Kidron

Jerusalem College of Technology, Israel; ivy@jct.ac.il

The present research study is a theoretical reflection on the notion of a priori analysis in two different theories: the Theory of Didactical Situations (TDS) and the theory of Abstraction in Context (AiC). For both theories the epistemological perspective is of importance. The a priori analyses offered by the two theories are different. This difference reflects the different priorities of focus of analysis of both theories. The study demonstrates that, in their effort of networking theories, researchers of both theories will benefit of comparing their a priori analyses.

Keywords: A priori analysis, a posteriori analysis, Abstraction in Context (AiC), networking theories, Theory of Didactical Situations (TDS).

Introduction

The most recent Working Group on theory discussed the importance of developing networking with regard to the design dimension. As we will see in the following, the notion of a priori analysis is closely related to the phase of design. The present paper offers a theoretical reflection on the notion of a priori analysis in two different theories. It investigates the differences in the a priori analyses of the two theories and the influence of the different a priori analyses on the networking of theories. Dealing with a priori analyses, the focus of the paper is on methodology.

The theories discussed in this paper are the Theory of Didactical Situations (TDS) and the theory of Abstraction in Context (AiC). There are two main reasons for the choice of these theories. The first one is that this paper is based on my networking experience with these theories (Kidron, Lenfant, Bikner-Ahsbabs, Artigue, & Dreyfus, 2008; Kidron, Artigue, Bosch, Dreyfus, & Haspekian, 2014). The second reason is that the a priori analyses take into account the mathematical epistemology of the given domain and for both theories the epistemological perspective is of importance. The two theories consider the epistemological dimension in different ways. TDS combines epistemological, cognitive, and didactical perspectives. TDS focuses on the epistemological potential of didactical situations. AiC analysis is essentially cognitive and focuses on the students' reasoning; mathematical meaning resides in the verticality of the knowledge constructing process and the added depth of the resulting constructs. An epistemological stance is underlying this idea of vertical reorganization (this term will be explained in more details in a next section). For both theories the epistemological dimension has an important role. In the literature, the important role of epistemology is discussed in details in Artigue (1990, 1995). Kidron (2016) analyses the connection between epistemology and networking of theories.

In the next two sections, I will present shortly each theory and deal with the question what is an a priori analysis for each theory. Then, I will deal with the differences of the a priori analyses and demonstrate that, in their effort of networking theories, researchers of both theories benefit of comparing their a priori analyses.

TDS a priori analysis

A short introduction to TDS is offered by Artigue, Haspekian and Corblin-Lenfant (2014). This well-established theory belongs to the French school. It began to develop in the 1960s in France, initiated by Guy Brousseau (1997). Artigue et al. (2014, p. 48) wrote;

... we focus on three characteristics that create the specific lens through which TDS considers the teaching and learning of mathematics: the systemic nature of teaching and learning; the epistemology of mathematical knowledge; and the vision of learning as a combination of adaptation and acculturation. These characteristics determine the questions that TDS raises and tries to answer, as well as the methodologies it privileges.

The first characteristic, the systemic perspective of TDS is expressed by the central object of the theory, the idea of situation, which is itself a system. A special attention is given to the second characteristic, the epistemology of mathematical knowledge, while discussing TDS a priori analyses. The third characteristic relates to the cognitive dimension.

The theory is structured around the notions of a-didactical situation (in a-didactical situation there is no didactical intentions and the teacher refrains from interfering) and didactical situations, and includes concepts relevant for teaching and learning in mathematics classrooms. The social dimension also has an important role in TDS. In essence, the central object of the theory, the situation, incorporates the idea of social interaction.

The systemic view led to the concept of *didactical engineering* (Artigue, 1989, 2013) which is explained in Artigue et al. (2014, p. 50):

It is a methodology which is structured around a phase of preliminary analysis combining epistemological, cognitive, and didactical perspectives, and aiming at the understanding of the conditions and constraints to which the didactical system considered is submitted, a phase of design and a priori analysis of situations reflecting its optimization ambition; and, after the implementation, a phase of a posteriori analysis and validation.

The notion of “milieu” is an important construct in TDS. The a-didactic milieu was initially defined by Brousseau as the system with which the student interacts in the a-didactic game. In the design of learning situations, there is a special attention to the constituents of the milieu organized for the learner.

In her chapter “Perspectives on design research: the case of didactical engineering”, Artigue (2015) presents the evolution of Didactical Engineering (DE) in the last three decades and explains its links with TDS. She also presents its characteristics as a research methodology. In this chapter we read that design has always played a fundamental role in the French school. We also read how design is connected to the a priori analysis.

In Artigue et al. (2014, pp. 54–60), we have a detailed example that explains the components of the TDS a priori analysis and the requests of the a priori analysis for developing the systemic analysis typical for TDS. For example, the need for information of the mathematical knowledge of the

students, of the particular situation at stake, of the teacher's expectations regarding this situation. The methodology for analysis is described in the following sentence:

We developed thus our analysis using the usual techniques of TDS, that is to say, preparing an a priori analysis focusing on the determination of the cognitive potential of an a-didactic interaction with the milieu, for a *generic* and *epistemic* student, that is, a student accepting the a-didactical game and able to invest in it the mathematical and instrumental knowledge supposed by the teacher. (Artigue et al., 2014, p. 63)

In TDS a priori analysis, the researchers make assumptions about the supposed mathematical knowledge of the students which is necessary for a productive interaction with the "milieu". The a priori analysis must then play its role of reference as well as its role of revealing the didactic phenomena. Then the a posteriori analysis is compared to the a priori analysis and sometimes the hypotheses which were done in the a priori analysis are not in accord with the a posteriori analysis of the collected data. This comparison of the a priori analysis and the a posteriori analysis is important for the TDS researchers in order to deeply understand the functioning of the "situation".

AiC a priori analysis

Dreyfus & Kidron (2014) offers a short introduction to AiC. The theory is explained in more details in (Schwarz et al., 2009). AiC has been developed over the past 18 years with the purpose of providing a theoretical and methodological approach for researching, at the micro-level, learning processes in which learners construct deep structural mathematical knowledge. Methodologically (and this is the focus of the present study), the AiC researchers are offered tools that allow them to observe and analyze students' thinking processes. A detailed treatment of the methodology is offered by Dreyfus, Hershkowitz and Schwarz (2015). AiC view of abstraction is grounded in the works of Davydov (1990) and Freudenthal (1991). In the introduction part, I wrote that AiC focuses on the students' reasoning and that mathematical meaning resides in the verticality of the knowledge constructing process and the added depth of the resulting constructs. Freudenthal ideas led his collaborators to the idea of "vertical mathematization". This idea is explained by Dreyfus et al. (2015, p. 186–187):

Vertical mathematization points to a process that typically consists of the reorganization of previous mathematical constructs within mathematics and by mathematical means by which students construct a new abstract construct. As researchers in mathematics education, we preferred the expression "vertical reorganization" to the expression "Vertical mathematization" to discern between what is intended by the teacher - the mathematization, and what often happens - a reorganization....In vertical reorganization, previous constructs serve as building blocks in the process of constructing.

Thus, AiC defines abstraction as a process of vertically reorganizing some of the learner's previous mathematical constructs within mathematics and by mathematical means in order to lead to a new construct (for the learner). For the convenience of the readers I will report some more details about AiC written in Kidron (2016, p. 154). The process of abstraction has three stages: the need for a new construct, the emergence of the new construct and the consolidation of this new construct. The second stage, the emergence of the new construct. is analyzed by means of three observable epistemic actions: **Recognizing**, **Building-With** and **Constructing**. Recognizing takes place when the learner

recognizes that a specific knowledge construct is relevant to the problem she or he is dealing with. Building-with is an action comprising the combination of recognized knowledge elements, in order to achieve a localized goal, such as the actualization of a strategy, or a justification, or the solution of a problem. Constructing consists of integrating previous constructs by vertical mathematization to produce a new construct.

In view of AiC essential cognitive perspective, the focus is on the students' processes of construction of knowledge. In the AiC approach, contextual aspects are considered to be integral factors of the learning process. Context is regarded in a wide sense, comprising historical, physical and social context. Historical context includes students' prior learning history, physical context includes artefacts such as computers and software, and social context refers to interaction with peers, teachers and others.

The importance of design is considerable in AiC. This is in accord with the epistemological stance which is underlying the idea of vertical reorganization. The design is accompanied by its epistemological aspects. As a part of the AiC methodology, an effort is made to foresee students' expected processes of construction of knowledge and an a priori analysis of the activities is carried out.

The AiC a priori analysis consists first on assumptions about the previous mathematical knowledge of the students, in particular, previous constructs which have been constructed in the past and that may be helpful in the present task. Then, the AiC a priori analysis consists of intended constructs that are required in the given task. For each intended construct, the AiC researchers give an operational definition. The operational definition will help the researchers in their decision if the student did express the intended construct. It will offer a criterium for evidence if the intended construct has been constructed. Different researchers in the team conduct separately their a priori analyses. Then the a priori analyses are compared and discussed until there is agreement between the researchers.

Comparing the a priori analysis and the a posteriori analysis, the AiC researchers note that sometimes the students achieve new constructs which were not expected in the AiC a priori analyses. This fact is an important and interesting stage in the research. Sometimes, students only achieve constructs that partially match a corresponding intended construct in the a priori analysis (Ron, Dreyfus, & Hershkowitz, 2010)

The AiC a priori analysis is not only a list of intended constructs. It is more a structure of intended constructs with some interactions between the different constructs. Some constructs are contained in others. Some intended constructs might be a prerequisite for others. Sometimes, possible paths of thinking are taken into account. This is relevant, for example, for a priori analyses of justification tasks. Justification is a specific case of construction of knowledge. Each itinerary of thinking towards the justification might be in itself a kind of construction of knowledge and different itineraries of thinking, each with a structure of intended constructs will appear in the a priori analysis.

Comparing the a priori analyses and the benefit for networking

For both theories, TDS and AiC, the epistemological perspective is of importance but their a priori analyses have a different focus. In AiC the focus of the a priori analysis is on the learner's construction

of knowledge. The a priori analysis reveals hypotheses about constructs that might be observed during the construction process. For AiC, processes of abstraction are inseparable from the context in which they occur. The notion of context is very wide in AiC. The context has many components. For example, the task, the computer, the teacher, the social interaction between students are considered as part of the context. The AiC a priori analysis with its focus on the learner's processes of construction of knowledge cannot take explicitly into account all the contextual factors. In a later phase, the researchers will analyze the influence of the context on the construction processes that were observed in the analysis of data. For example, Kidron & Dreyfus (2010) analyzed the influence of the computer on the construction processes observed in the analysis of data. They describe how instrumentation led to cognitive constructions and how the roles of the learner and the CAS intertwine. But there is an essential difference if you analyze your data taking into account in advance the contextual factors or if you first analyze the data and the processes of construction of knowledge and only then you analyze the influence of the contextual factors on the construction processes.

For TDS, the situation is different. The focus is on didactical systems. TDS observes the entire situation and not only the student and the mathematical activity. For example, TDS is interested in relations between systems and the teacher is an element of the system. As a consequence, TDS considers already in the a priori analysis the role of the teacher and how he/she may extend the results of the a-didactical situation. As a consequence of the different foci between TDS and AiC, context is not theorized and treated in the same way in the different theories. This fact has an important consequence on the differences of the a priori analyses.

AiC a posteriori analysis might be influenced by the fact that some contextual factors are not taken explicitly into account in the a priori analysis. As a consequence, some excerpts which might add direct knowledge in the analysis of the cognitive processes might be missed if one focuses first on the cognitive processes and only then analyzes the influence of other parts of the context.

Kidron et al. (2014) refer to a networking case that links three theories. The issue of context is compared and contrasted in the three theories. The analyses from the different perspectives refer to a set of data from a video recording that show a session from the group-work of two students, during a teaching experiment on the exponential function in secondary school.

In Kidron et al. (2014, p. 175), the authors noted that

An interesting, and also revealing, point is the fact that, in the analysis, AiC researchers focus on the autonomous work of the students, while TDS researchers pay more attention to the episode where the students interact with the teacher...

The a posteriori analyses of the two theories are influenced by the differences in the a priori analyses and their different priorities in their focus of analysis. Different units of analysis are taken into account and as a consequence of the focus of analysis, as demonstrated in the a priori analysis, each theory shapes the kind of data that is appropriate to this focus. As pointed by Radford (2008):

... it is through a methodological design that data is first produced; then the methodology helps the researcher to “select” some data among the data that was produced but also helps the researcher to “forget” or to leave some other data unattended. (p. 321)

As a consequence, the different a posteriori analyses conducted within the two theories complement each other. Each analysis highlights a specific view which reflects the focus of research of the given theory. AiC analysis, with its specific tools, offers a fine grained analysis of the students constructing processes. TDS, with its different focus, analyses the entire situation and, in particular, the interaction between the teacher and students. For example, in Kidron et al. (2014, p. 172) we read how TDS analyses the role of the teacher:

TDS complements the AiC analysis in analyzing how the teacher extends the outcomes of the a-didactical interaction. The TDS analysis seems to start where the AiC analysis stops.

The different a priori analyses result from the different priorities of the theories with regard to the focus of analysis. Investigating these differences in the a priori analyses might lead to a better understanding of the different a posteriori analyses and to the insights offered by one theory to the other one in the networking process.

Concluding remarks

Reflecting on the role of a priori analysis in both theories, TDS and AiC, we realize its importance and why it is necessary towards a better understanding of the a posteriori analysis of the collected data. For both theories, the a priori analysis plays a role of reference while comparing the a priori and a posteriori analyses. For TDS, it plays the role of revealing the didactic phenomena and helps to deeply understand the functioning of the “situation”. For AiC, it offers a structure of intended constructs that are required in a given task as well as possible paths of thinking. We also realize the importance that each theory keeps the specific characteristics of its a priori analysis. I wrote in a previous section that there is an essential difference if you analyze your data taking into account in advance the contextual factors or if you first analyze the data and the processes of construction of knowledge, and only then you analyze the influence of the contextual factors on the construction processes. This essential difference is tightly connected to the specific characteristics of the different a priori analyses for AiC and TDS. In Kidron et al. (2008, p. 262), we read that:

In networking, we want to retain the specificity of each theoretical framework with its basic assumptions, and at the same time profit from combining the different theoretical lenses. What we aim at is to develop meta-theoretical tools able to support the communication between different theoretical languages, which enable researchers to benefit from their complementarities.

Comparing a priori analyses might enable to support the communication between theories:

Realizing some common points in the a priori analyses enables the beginning of a dialogue between the theories. In the case of networking between TDS and AiC, for example, the common points in the epistemological dimension help towards the beginning of the dialogue (as demonstrated in Kidron, Artigue, Bosch, Dreyfus, & Haspekian, 2014). This idea could be used for other theories and other cases of networking: Some other common points in the a priori analyses, for example on the social dimension, might help towards the beginning of the dialogue.

Realizing the differences in the a priori analyses, we better understand the choices of data (as well as the “data which was left unattended”) that researchers of each theory select for their a posteriori analyses. Sometimes, the data which was left unattended by one theory might add direct knowledge

in the analysis of this theory and, as a consequence, some cognitive processes, for example, might be missed. The complementary insights which are missing might be offered by means of networking theories. This situation might happen in different cases of networking theories.

This paper offers a reflection on a priori analyses, epistemology and networking. It contributes to the TWG discussion on the reciprocity of theory and methodology for research and design. The notion of a priori analysis is closely related to the phase of design. It allows making epistemological assumptions explicit. The TWG discussions addressed importance to the notions of mathematical epistemology and design. The common points in the epistemological dimension which enable the beginning of the networking between AiC and TDS contributed to these discussions.

Acknowledgment

This research was supported by the Israel Science Foundation (grant number 1815/16).

References

- Artigue, M. (1989). Ingénierie didactique. *Recherches en Didactique des Mathématiques*, 9(3), 281–308.
- Artigue, M. (1990). Épistémologie et didactique. *Recherches en Didactique des Mathématiques*, 10(23), 241–286.
- Artigue, M. (1995). The role of epistemology in the analysis of teaching/learning relationships in mathematics education. In Y. M. Pothier (Ed.), *Proceedings of the 1995 annual meeting of the Canadian Mathematics Education Study Group* (pp. 7–21). Ontario: University of Western Ontario.
- Artigue, M. (2013). Didactic engineering in mathematics education. In S. Lerman (Ed.), *Encyclopedia of mathematics education*, Berlin/Heidelberg: Springer.
- Artigue, M. (2015). Perspectives on design research: The case of Didactical Engineering. In A. Bikner-Ahsbabs, C. Knipping & N. Presmeg (Eds.), *Approaches to qualitative research in mathematics education* (pp. 467–496). Dordrecht, the Netherlands: Springer.
- Artigue, M., Haspekian, M., & Corblin-Lenfant, A. (2014). Introduction to the Theory of Didactical Situations. In A. Bikner-Ahsbabs & S. Prediger (Eds.), *Networking of theories in mathematics education* (pp. 47–65). Dordrecht, the Netherlands: Springer.
- Brousseau, G. (1997). *Theory of didactical situations in mathematics: Didactique des Mathématiques, 1970–1990* (N. Balacheff, M. Cooper, R. Sutherland, & V. Warfield, Ed. & Trans.). Dordrecht: Kluwer.
- Davydov, V. V. (1990). *Types of generalisation in instruction: Logical and psychological problems in the structuring of school curricula* (Soviet studies in mathematics education, Vol. 2, J. Kilpatrick, Ed., J. Teller, Trans.). Reston: National Council of Teachers of Mathematics. (Original work published 1972.)
- Dreyfus, T., Hershkowitz, R., & Schwarz, B.B. (2015). The nested epistemic actions model for Abstraction in Context: Theory as methodological tool and methodological tool as theory. In A.

- Bikner-Ahsbabs, C. Knipping & N. Presmeg (Eds.), *Approaches to qualitative research in mathematics education* (pp. 185–217). Dordrecht, the Netherlands: Springer.
- Dreyfus, T., & Kidron, I. (2014). An introduction to abstraction in context. In A. Bikner-Ahsbabs & S. Prediger (Eds.), *Networking of theories in mathematics education*. (pp. 85–96). Dordrecht, the Netherlands: Springer.
- Freudenthal, H. (1991). *Revisiting mathematics education: China lectures*. Dordrecht: Kluwer.
- Kidron, I. (2016). Epistemology and networking theories. *Educational Studies in Mathematics* 91(2), 149–163.
- Kidron, I., Lenfant, A., Bikner-Ahsbabs, A., Artigue, M. & Dreyfus, T. (2008). Toward networking three theoretical approaches: the case of social interactions. *Zentralblatt für Didaktik der Mathematik*, The International Journal on Mathematics Education, 40(2), 247–264.
- Kidron, I., & Dreyfus, T. (2010). Interacting parallel constructions of knowledge in a CAS Context. *International Journal of Computers for Mathematical Learning* 15(2), 129–149.
- Kidron, I., Artigue, M., Bosch, M., Dreyfus, T., & Haspekian, M. (2014). Context, milieu and media-milieu dialectic— a case study on networking. In A. Bikner-Ahsbabs & S. Prediger (Eds.), *Networking of theories in mathematics education* (pp. 153–177). Dordrecht, the Netherlands: Springer.
- Radford, L. (2008a). Connecting theories in mathematics education: Challenges and possibilities. *Zentralblatt für Didaktik der Mathematik—The International Journal on Mathematics Education*, 40(2), 317–327.
- Ron, G., Dreyfus, T., & Hershkowitz, R. (2010). Partially correct constructs illuminate students' inconsistent answers. *Educational Studies in Mathematics*, 75(1), 65–87.
- Schwarz, B.B., Dreyfus, T., & Hershkowitz, R. (2009). The nested epistemic actions model for abstraction in context. In B.B. Schwarz, T. Dreyfus & R. Hershkowitz (Eds.), *Transformation of knowledge through classroom interaction* (pp. 11–41). London: Routledge.

Rethinking the connection between theory and methodology: a question of mutual affordances

Man Ching Esther Chan¹ and David Clarke²

The University of Melbourne, Melbourne Graduate School of Education, Australia;

¹ mc.chan@unimelb.edu.au

² d.clarke@unimelb.edu.au

Theory and methodology are key considerations in research design. Different ways of conceptualising their connection can characterise differences in research practice. This paper examines connections between theory and methodology and the concomitant implications for ontology and epistemology associated with conducting research in a laboratory classroom applying a multi-theoretic research design. Using the Social Unit of Learning project as a case example, we argue that the relationship between theory and methodology is not one of “prescription” in either direction, but rather of mutual “affordance,” both regarding the analyses afforded by the complex data set and the extent to which each theory affords analytical consideration of specific constructs of relevance to the setting and the interactions recorded there. These constructs shape the way in which the multimodal material is reconstructed as data amenable to particular forms of analysis.

Keywords: Classroom research, research design, research methodology, social interaction.

Connection between theory and methodology

Pick up any textbooks on educational research, and you will usually find the words *theory* and *methodology*. The fundamental issues of whether theory or methodology should take priority in the process of research design, or how theory and methodology should be connected in the research process, can polarise researchers, with the views on the issues being used to characterise different research paradigms or approaches (see Guba & Lincoln, 1989; Strauss & Corbin, 1990). In this paper, we address connections between theory and methodology and the concomitant implications for ontology and epistemology associated with conducting research in a laboratory classroom when employing a multi-theoretic research design. We argue that in our research design, and in educational research in general, the relationship between theory and methodology need not be one of “prescription” in either direction, but rather of mutual “affordance,”¹ both regarding the theoretical analyses afforded by the complex data set (i.e., generated by the methodology) and the extent to which each theory affords consideration of specific constructs of relevance to the setting and the interactions recorded there (via the methodology). We first consider a few different possible relationships between theory and methodology.

¹ The word *affordance* was coined by Gibson (1986) in ecological psychology to describe the possibilities that the environment *offers* to an animal as the animal inhabits and interacts with the environment. We use the term to refer to the investigative options made possible (and also constrained) by the choice of theory or methodology.

Theory can be thought of as “a coherent system of logically consistent and interconnected ideas used to condense and organise knowledge” (Neuman, 2014, p. 9), while *methodology* can be seen as “concerned with the logic of scientific inquiry” and in particular, consideration of “the potentialities and limitations of particular techniques or procedures” (Grix, 2002, p. 179). Blumer (1954), for example, believed that some social theories exist independent of research methodology, and one does not prescribe the other. Another way to think about the connection between theory and methodology in the research process is as a sequence of critical decisions beginning with the choice of research methods (i.e., research techniques or procedures), which is framed or shaped by the methodology, which, in turn, is governed by the theoretical perspective, which reflects epistemological assumptions (i.e., a theory of knowledge) (see Crotty, 1998).

Crotty (1998) used the connection between objectivism (epistemology), positivism (theoretical perspective), survey research (methodology), and statistical analysis (methods) as an example of such a connective chain of research process. Crotty’s conceptualisation of the research process is shared by Grix (2002), who argued that “it is our ontological and epistemological positions that shape the very questions we may ask in the first place, how we pose them and how we set about answering them” (p. 179). In particular, Grix asserts that “we should guard against ‘method-led’ research, that is, allowing ourselves to be led by a particular research method rather than ‘question-led’ research, whereby research questions point to the most appropriate research method” (p. 179). Grix therefore suggests that theoretical considerations should lead or govern methodology and, thereby, methods in the research process.

Also emphasising the importance of theory in the research process, Neuman (2014) presented alternative sets of research procedure for quantitative and qualitative research processes. In his schematic depiction, the qualitative research process starts with acknowledging the social self and ends with informing others, with each step guided or informed by theory (see Figure 1).

The quantitative research process according to Neuman (2014) takes on the same structure as Figure 1, beginning with topic selection (Step 1) and ends with reporting (Step 7), with each step guided, shaped or informed by theory. Different from Grix (2002) who believed that “methods themselves should be seen as free from ontological and epistemological assumptions” (p. 179), Neuman’s depiction of the research process is less linear than Crotty’s, and has theory identified as influencing every step in what is conceived to be a cyclic research process. However, as can be seen in Figure 1, the relationship between theory and the individual research steps represented by Neuman is unidirectional where theory “radiates” outwards to influence each research step. None of the research steps appears to influence theory.

In conducting the Social Unit of Learning project, we found the connection between theory and methodology differs from the research process characterised by Crotty (1998) or Neuman (2014). The combined use of the laboratory classroom and the employment of a multi-theoretic research design (Clarke et al., 2012) in the Social Unit of Learning project offer a unique opportunity to reflect on the connections between theory and methodology and the concomitant implications for ontology and epistemology in the study. Further description of the project is provided below.

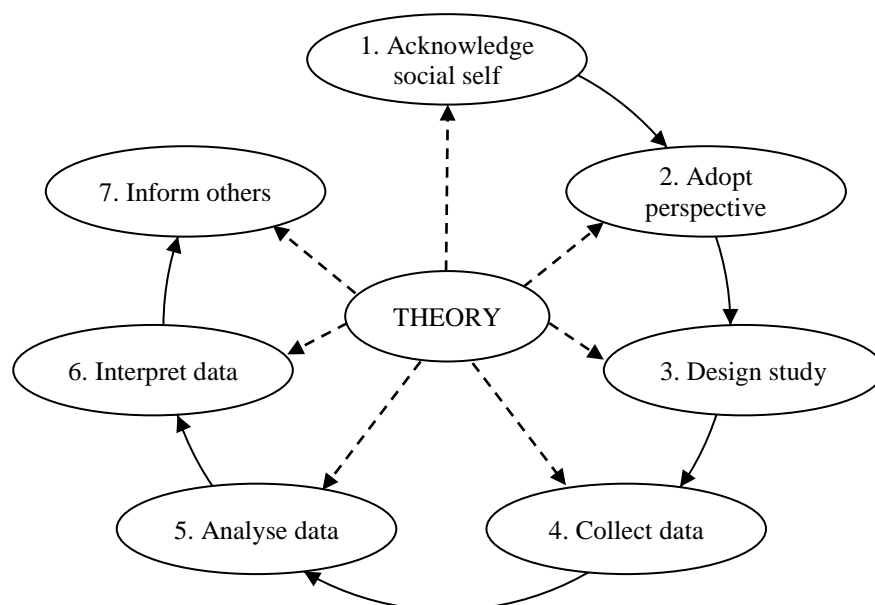


Figure 2: Steps in the qualitative research process depicted by Neuman (2014, p. 21)

The Social Unit of Learning project

The University of Melbourne has set up a laboratory classroom, the Science of Learning Research Classroom (SLRC), to study classroom teaching and learning. The facility has the capability to capture classroom social interactions with a rich amount of detail using advanced video technology. With 10 built-in video cameras and up to 32 audio inputs, the comprehensive and detailed recording of every participant in the classroom offers the possibility for systematic examination of the link between the processes and products of learning activities within the classroom setting. The facility has made possible research designs that combine a good approximation to natural social settings with the retention of some degree of researcher control over the research setting, task characteristics, and possible forms of social interaction afforded or encouraged. Such designs allow conclusions to be drawn with greater confidence about connections between interactive patterns of social negotiation and associated knowledge products (learning).

Using the SLRC, the Social Unit of Learning Project aimed to investigate the social aspects of learning and, particularly, those for which “the social” represents a fundamental and useful level of explanation, modelling and instructional intervention (Chan & Clarke, 2017). The project design can be seen as more akin to design experiments (Cobb, Confrey, diSessa, Lehrer, & Schauble, 2003) which involve “both ‘engineering’ particular forms of learning and systematically studying those forms of learning within the context defined by the means of supporting them” (p. 9). The project was designed to specifically serve the purpose of theory generation and testing through the application of a multi-theoretic research design (Clarke et al., 2012), taking advantage of the rich data that can be generated by the laboratory classroom facility.

The multi-theoretic research design adopted by the project involved the construction of a complex data set composed of video records and other supplementary data. The design allows an analytical team to juxtapose different interpretive accounts arising from different theoretically-grounded analyses in order to compare and contrast the capacity of different theories to characterise different aspects of the research setting. The theory generated from the research is intended to be a direct

reflection of an attempt to provide explanatory accounts in relation to a specific data set, so in its first instantiation would be most similar to what might be called a “local theory”. However, an accumulation of several such analyses of different situations might reveal similarities in the emergent local theories that suggested sufficient generalisability and commonality for more general theory, which would be less specifically tied to the data of any particular project.

Data generation

Intact Year 7 classes from a secondary school in metropolitan Melbourne were recruited with their usual teacher in order to exploit established student-student and teacher-student interactive norms. By *intact*, we are referring to the existing social relationships between students, and between the teacher and students, which are left intact and not interrupted by a selective process introduced by the researcher. Eleven classes of Year 7 students (12 to 13 years old; 264 students in total) participated in the project. The students in each of the classes completed problem solving tasks individually, in pairs, and in small groups (four to six students) within a 60-minute session in the laboratory classroom. The problem solving tasks used in the project were drawn from previous research (e.g., Sullivan & Clarke, 1991) and were purposefully chosen to make the thinking and/or social processes of the problem solving activity more visible. The tasks have the characteristics of allowing students to express their thinking through multiple modes (e.g., verbal, graphical, textual, etc.) and approach the task using different strategies or prioritise different forms of knowledge or experience. For example, two classes of students were given the following three tasks:

Task 1 (individual task) provided students with a graph with no labels with the following instructions: “What might this be a graph of? Label your graph appropriately. What information is contained in your graph? Write a paragraph to describe your graph”.

Task 2 (pair task) was specified as follows: “The average age of five people living in a house is 25. One of the five people is a Year 7 student. What are the ages of the other four people and how are the five people in the house related? Write a paragraph explaining your answer.”

Task 3 (small group task) stated that “Fred’s apartment has five rooms. The total area is 60 m². Draw a plan of Fred’s apartment. Label each room, and show the dimensions (length and width) of all rooms”.

The resulting data collected in the project included: all written material produced by the students; instructional material used by the teacher; video footage of all of the students during the session; video footage of the teacher tracked throughout the session; transcripts of teacher and student speech; and pre- and post-session teacher interviews.

Investigating the social aspects of learning

A multi-theoretic research design (Clarke et al., 2012) was employed to examine the complex data set from the project from multiple perspectives by multiple researchers, as well as interrogate the different theoretical perspectives through answering research questions such as the following:

1. What commonalities and differences in process and product are evident during problem solving activities undertaken by learners as members of different social units (individual, pairs, small groups, and whole class groupings)?

2. Which existing theories best accommodate (that is, provide a coherent and plausible explanation for) the documented similarities and differences in process and product and in what ways do the accounts generated by parallel analyses predicated on different theories lead to differences in instructional advocacy?

An international multi-disciplinary research team (combining education, cognitive and emotive psychology, learning analytics, and neuroscience perspectives) was recruited to develop analytical frames for coding the data.

Ontological and epistemological positioning

A major consideration regarding the validity of research findings and research evidence in educational research is the issue of *ontology*, which is “an area of philosophy that deals with the nature of being, or what exists” (Neuman, 2014, p. 94). The issue is distinguished from *epistemology*, which is “concerned with the theory of knowledge, especially in regard to its methods, validation and ‘the possible ways of gaining knowledge of social reality, whatever it is understood to be’ (Blaikie, 2000, p. 8)” (Grix, 2002, p. 177). In the Social Unit of Learning project, we recognise the active role that the researchers play in constructing the research setting to make the social aspects of learning visible as well as in data selection and interpretation (Chan & Clarke, 2019). Ontological considerations place limits on the authority of any claims the research team might make regarding the generalisable characteristics of classroom learning. Any such claims must acknowledge the researchers’ role in shaping the research setting to optimally simulate the common features of institutionalised classroom settings. Of course, it is the researchers’ intention that such generalisability of findings be afforded by the optimised setting. We consider regularities in the multiple student interactions (e.g., across many pairs of students or across different social units) to suggest generalisable characteristics of the social aspects of learning.

With regard to the epistemological position of this project, we construct knowledge by considering both the regularities and differences in the interpretive accounts generated by the research team (cf. complementary accounts, Clarke, Emanuelsson, Jablonka, & Mok, 2006), and reconstructing these regularities as propositions. In this project, knowledge about classroom learning is generated inductively through the aggregation of these propositions to create new theory.

Mutual affordances of theory and methodology

Different from the research process depicted by Crotty (1998) and Neuman (2014), the relationship between theory and methodology we are positing for the Social Unit of Learning project resembles a symbiotic one. In as much as the chosen theory highlights particular constructs, analytical consideration of these constructs is afforded by the data set generated through the research design (methodology) which has anticipated the need for such data (see Figure 2).

We characterise this symbiotic relationship as one of mutual and reciprocal affordance, since the chosen theory frames and affords the consideration of the constructs (such as engagement) that are the focus of the research and these in turn place anticipatory constraints on the forms of data required from the methodology. This mutual affordance can be illustrated by the consideration of questions such as:

- What (theoretically-grounded) analyses are afforded by the data produced by the researcher's methodology?
- What constructs are foregrounded or prioritised by the chosen theory?
- How do we connect the constructs to the data?

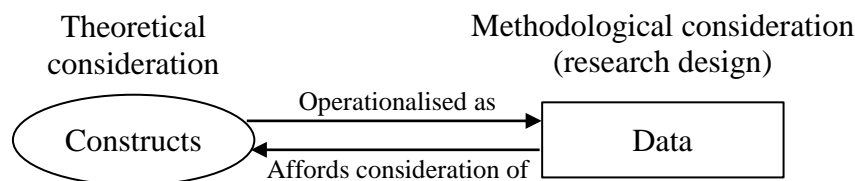


Figure 2: Mutual affordances of theory and methodology as illustrated by the reciprocal relationship between constructs and data in the Social Unit of Learning project

The investigation of the social aspects of learning does not necessarily prescribe a particular methodology. However, when the research is conceptualised through a particular theory with its sets of interrelated constructs, researchers need to draw selectively from existing research traditions and established methodologies with their tenets for appropriate and rigorous investigative methods.

To provide further examples, multimodal learning analytics (Ochoa, 2017) was used in the project to extract features in the video and audio data to characterise behavioural student engagement. Learning analytics is “the measurement, collection, analysis and reporting of data about learners and their contexts, for purposes of understanding and optimising learning and the environments in which it occurs” (Conole, Gašević, Long, & Siemens, 2011, p. 3). While learning analytics generally involves analysing log-file data captured by online systems (e.g., Learning Management System), multimodal learning analytics also includes the coding of more natural activities such as gestures, gaze, speech, or writing (Ochoa, 2017). Applying advanced techniques, Ochoa and his research team were able to automate the coding of student gaze direction, student posture, teacher position, student talk, and teacher talk to create indicators of student engagement, student attention, and teacher attention during various task conditions (individual, pair, and small group) (Chan, Ochoa, & Clarke, in press).

Another analytical thread applied in the project was interactivity analysis. The analysis of student interactivity was drawn from the theory of Commognition developed by Sfard (2015). Commognition theory resolves the thinking-communication divide by equating communication with thinking. The theory is particularly powerful for conceptualising how learning occurs and has led to the development of particular analytical tools for investigating learning, specifically in the classroom context. Interactivity analysis involves fine-grained analysis of student utterances to identify patterns of interaction between the students, such as instances where one person consistently ignores or responds (reacts) to the other person's utterances or frequently initiates new topics (Sfard & Kieran, 2001). The interactive patterns can be seen as indicators of student engagement (both social and cognitive) in terms of the level of interpersonal correspondence between two people in their dialogue.

The investigation of a superordinate construct such as “engagement” can stimulate the use of a set of related mediating constructs (e.g., shared attention, participation, etc.) in psychology (Shernoff, 2013) in the case of the multimodal learning analytics work, while also stimulating the use of

another set of constructs (e.g., communication, discursive interactions, etc.) within a specific sociocognitive theory (Sfard & Kieran, 2001) in the interactivity analysis. These constructs shape the way in which the multimodal material is reconstructed as data amenable to particular forms of analysis. The specific analyses carried out were afforded by the complex data set available to the project, subject to the theory affording the consideration of specific constructs of relevance to the setting and the interactions recorded.

Implications

The recognition of the reciprocity between theory and methodology has significant implications for the detailed design of any research project, since it cannot be assumed that by making the decision on one (theory or methodology or methods), the consequent decisions are thereby prescribed. The relationship must be seen as progressing in both directions taking us not only from theory to methodology and then to methods but also from methods back through methodology to theory. A researcher engaged in planning the minutiae of any one of these critical decision points is reminded in our paper to take into account those decisions in both directions throughout the research process because of the mutually affording nature of all connections.

Conclusion

It is the combination of unusually rich data that can be generated by the laboratory classroom facility and a multi-theoretic research design that has highlighted for us the necessity of considering the affordances offered by each of the selected theories, the chosen methodology, the resultant data set, and the dynamic mutuality of these affordances. As argued in this paper, the research process is not simply algorithmic with each step prescribing the form to be taken in any subsequent step. The reflective researcher must instead engage in a continually recursive reflection in the nature of the connection between any key decision and those adjacent to it in their research process in either direction.

Acknowledgment

This research is supported under Australian Research Council's Discovery Projects funding scheme (Project number DP170102541).

References

- Blaikie, N. (2000). *Designing social research: The logic of anticipation*. Malden, MA: Polity Press.
- Blumer, H. (1954). What is wrong with social theory? *American Sociological Review*, 19(1), 3–10.
- Chan, M. C. E., & Clarke, D. J. (2017). Learning research in a laboratory classroom: Complementarity and commensurability in juxtaposing multiple interpretive accounts. In T. Dooley & G. Gueudet (Eds.), *Proceedings of CERME 10* (pp. 2713–2720). Dublin, Ireland: DCU Institute of Education and ERME.
- Chan, M. C. E., & Clarke, D. J. (2019). Video-based research in a laboratory classroom. In L. Xu, G. Aranda, W. Widjaja & D. Clarke (Eds.), *Video-based research in education: Cross-disciplinary perspectives* (pp. 107–123). New York: Routledge.

- Chan, M. C. E., Ochoa, X., & Clarke, D. J. (in press). Multimodal learning analytics in a laboratory classroom. In M. Virvou, E. Alepis, G. A. Tsihrintzis & L. C. Jain (Eds.), *Advances in learning analytics*. Cham, Switzerland: Springer.
- Clarke, D. J., Emanuelsson, J., Jablonka, E., & Mok, I. A. C. (Eds.). (2006). *Making connections: Comparing mathematics classrooms around the world*. Rotterdam, the Netherlands: Sense.
- Clarke, D. J., Xu, L. H., Arnold, J., Seah, L. H., Hart, C., Tytler, R., & Prain, V. (2012). Multi-theoretic approaches to understanding the science classroom. In C. Bruguière, A. Tiberghien & P. Clément (Eds.), *E-Book proceedings of the ESERA 2011 biennial conference: Part 3* (pp. 26–40). Lyon, France: European Science Education Research Association.
- Cobb, P., Confrey, J., diSessa, A., Lehrer, R., & Schauble, L. (2003). Design experiments in educational research. *Educational Researcher*, 32(1), 9–13.
- Conole, G. i., Gašević, D., Long, P., & Siemens, G. (2011). *Proceedings of the 1st International Conference on Learning Analytics and Knowledge*. Banff, Alberta, Canada: The Association for Computing Machinery. Retrieved from <https://dl.acm.org/citation.cfm?id=2090116>
- Crotty, M. (1998). *The foundations of social research: Meaning and perspective in the research process*. St Leonards, NSW, Australia: Allen and Unwin.
- Gibson, J. J. (1986). *The ecological approach to visual perception*. New York: Psychology Press.
- Grix, J. (2002). Introducing students to the generic terminology of social research. *Politics*, 22(3), 175–186.
- Guba, E. G., & Lincoln, Y. S. (1989). *Fourth generation evaluation*. Newbury Park, CA: Sage.
- Neuman, W. L. (2014). *Social research methods: Qualitative and quantitative approaches* (7th ed.). Essex, England: Pearson Education Limited.
- Ochoa, X. (2017). Multimodal learning analytics. In C. Lang, G. Siemens, A. F. Wise & D. Gašević (Eds.), *The handbook of learning analytics* (pp. 129–141). Alberta, Canada: Society for Learning Analytics Research (SoLAR).
- Sfard, A. (2015). Learning, commognition and mathematics. In D. Scott & E. Hargreaves (Eds.), *The SAGE handbook of learning* (pp. 129–138). London: Sage.
- Sfard, A., & Kieran, C. (2001). Cognition as communication: Rethinking learning-by-talking through multi-faceted analysis of students' mathematical interactions. *Mind, Culture, and Activity*, 8(1), 42–76. doi:10.1207/s15327884mca0801_04
- Sheroff, D. J. (2013). *Optimal learning environments to promote student engagement*. New York: Springer.
- Strauss, A. L., & Corbin, J. M. (1990). *Basics of qualitative research: Grounded theory procedures and techniques*. Newbury Park, CA: Sage.
- Sullivan, P., & Clarke, D. J. (1991). Catering to all abilities through “good” questions. *The Arithmetic Teacher*, 39(2), 14–18. doi:10.2307/41194944

Boundary crossing by design(ing): a design principle for linking mathematics and mathematics education in preservice teacher training

Erik Hanke¹ and Angelika Bikner-Ahsbabs²

¹University of Bremen, Germany; erik.hanke@uni-bremen.de

²University of Bremen, Germany; bikner@math.uni-bremen.de

Preservice teachers experience a fragmentation in their study program between two academic areas, university mathematics and mathematics education. To reduce this problem, we conduct a design study linking mathematics and mathematics education on two levels: First, the “dovetailing” of mathematics (here the course on complex analysis) and mathematics education, and second, students’ “interlinking” of content and pedagogical content knowledge in the development of learning materials for talented pupils. This paper contributes to the topic on theory and methodology by introducing the design principle “boundary crossing by design(ing)” in “nested design cycles”.

Keywords: Boundary crossing, boundary object, complex analysis, reflection, teacher education.

Introduction

Many preservice teachers in mathematics experience two types of discontinuities in mathematics teacher training. First, in their views, much of the mathematics they learned in school does not seem very helpful for the rigorous proof-oriented style in university mathematics courses. Second, preservice teachers may not see how the mathematics in their university courses is related to their practice as a teacher (Hefendehl-Hebeker, 2013; Prediger, 2013). Several attempts to minimize the perceived gap between university and school mathematics have been developed, for example with special exercises, or through capstone courses (e.g., Bauer & Partheil, 2009; Winsløw & Grønbaek, 2014). Furthermore, empirical studies show that the combination of mathematical knowledge and pedagogical content knowledge for teaching and learning mathematics (i.e. in the sense or similar to that of Ball, Thames, and Phelps (2008)) is important for evaluating situations in the classroom (e.g., Blömeke et al., 2014). Mehlmann and Bikner-Ahsbabs (2018) give an overview of recent trends in German mathematics preservice teacher education around the “double discontinuity” and the general criticism of preservice teachers towards their study programs which they experience as fragmented. Because there is barely any explicit research on how preservice teachers may link the scientific disciplines of mathematics and mathematics education¹ concerned with school mathematics, we ask how this fragmentation between the mathematical discipline at university and mathematics education in preservice teacher training can be overcome at least partially by making changes in the curriculum, and how preservice teachers establish interlinkages of the two areas. At the University of Bremen, we conduct the design study “Spotlight-Y” on these issues. Two out of three design cycles have been completed so far, and as a theoretical result from our first design cycles, we will establish the design

¹ We understand mathematics education as the scientific discipline about the teaching and learning of mathematics. In German preservice teacher training, mathematics education is mainly concerned with school mathematics.

principle *boundary crossing by design(ing)* in a *nested design cycle* to initiate the overcoming of the fragmentation in preservice teacher training. We will show how this design principle is interwoven with the methodology and theory of our study. At the end, examples of empirical findings round off the paper.

Linking mathematics and mathematics education in a two-fold way

Linking mathematics and mathematics education can be viewed as a two-fold phenomenon in higher education: On the institutional level it is a matter of curriculum and we call the linkage of the domains on this level *dovetailing* (German: *Verzahnen*). On the students' level we call the linkage of the domains in students' thinking and acting *interlinking* (German: *Vernetzen*). This distinction corresponds to a distinction between “curriculum to be taught” and “learned curriculum”. Our design study is devoted to an empirically grounded description of these two notions and their connections. Thus, with this terminology our general research questions in the project can be rephrased as: How can dovetailing be realized to initiate interlinking? Which circumstances foster or hinder students' interlinking and which interlinking strategies can be identified? To interlink the two scientific areas, our students have to cross the boundaries between them.

Theoretical background: Boundary crossing

The idea of boundary crossing has origins and applications in the fields of general education and social theory (Akkerman & Bakker, 2011). Boundaries can be described as “sociocultural differences that give rise to discontinuities in interaction and action” (Akkerman & Bakker, 2011, p. 139) and boundary crossing as the “efforts by individuals or groups at boundaries to establish or restore continuity in action or interaction across practices” (Bakker & Akkerman, 2014, p. 225). Means to achieve this are boundary objects which “are artifacts that articulate meaning and address multiple perspectives” (Akkerman & Bakker, 2011, p. 140), e.g., a concrete task or solution. Aside from this initial understanding of a boundary object, it can also be conceptualized as a “shared problem space” (Akkerman & Bakker, 2011, p. 147) where motives of different domains act together and “materiality derives from action, not from [...] ‘thing’-ness” (Star, 2010, p. 603).

It is the interpretation of the members of the communities that give objects their meaning as boundary objects in social contexts (Star, 2010). Consequently, even if teachers or researchers intend to implement objects as boundary objects in their teaching or research, it may not be the case that the people who work with the objects understand them as such. However, because the aim is “to integrate different types of knowledge typically developed in different practices” (Bakker & Akkerman, 2014, pp. 224–225), boundary objects “may provide learning opportunities” (Akkerman & Bakker, 2011, p. 141), and students working with boundary objects may carry out interlinking actions or even practices, probably implicitly. Interesting for our purpose are three out of four mechanisms for the process of boundary crossing identified by Akkerman and Bakker (2011) when considering learning in terms of boundary crossing in the broadest sense. *Identification* is about finding out particularities of the social practices and seeing the relevance of different practices which meet at a certain border. *Coordination* means to mediate between social worlds. *Reflection* differs from identification in the sense that particularities of one community's practice are made explicit for another community (*perspective making*) or are regarded from the viewpoint of the other community (*perspective taking*).

In Spotlight-Y the notion of reflection is much broader than the boundary crossing mechanism of reflection (see section “*Boundary crossing by design(ing) through a nested design approach*”), but perspective making and taking can be part of it.

Methodology

Curricular linkage: Dovetailing in the lecture on complex analysis

The project “Spotlight-Y” consists of three cycles of developing the course on complex analysis with the aim to overcome fragmentation (see Hanke & Schäfer 2018a, 2018b; Mehlmann & Bikner-Ahsbals, 2018, for details). Each cycle takes a year with a lecture in complex analysis being split into a branch for future teachers and future mathematicians after around nine weeks of the lecture. While the future mathematicians continue with more advanced complex analysis, the preservice teachers prepare learning materials (exercise sheets and means to explore and visualize with GeoGebra) for talented secondary school pupils about a mathematical topic they identified in the lecture (e.g., power series expansion, spherical geometry, or differentiation as dilation-rotation) and implement this on a day for experimental mathematics for classes of school students visiting university (XMaSII). In parallel with the complex analysis lecture, the preservice teachers participated in a seminar in mathematics education which also covered the design of tasks. Our assumption is that through boundary crossing in preparing and implementing of this practical teaching, the preservice teachers will overcome fragmentation by showing interlinkage between the knowledge from both areas. So far, 35 students participated in the teacher branch in complex analysis during the last two years.

Approach for designing the lecture

To develop the teaching of complex analysis as described above we conduct a design study (Gravemeijer & Cobb, 2006). It aims at achieving a design as well as local theoretical knowledge about how the design works, clarifying circumstances under which the fragmentation in teacher training can be alleviated, and helping to identify obstructions. Each design cycle consists of four elements (Prediger et al., 2012; see Figure 1, left): First, a learning object or phenomenon has to be restructured. This leads to the development of a (local) design² based on a specific aim. Then, the design is executed in a design experiment. Insights from these steps are used to theorize the phenomenon, and these insights allow for a better description of the learning object or phenomenon, changes in the curricular implementation, design of the lecture, and execution. The cycle can then start over again. The core idea of our methodological frame is the nature of the design experiment. It contains an embedded cycle of the same structure that initiates “boundary crossing” in students’ work (Figure 1, right).

Boundary crossing by design(ing) through nested design cycles

In our design study, two cycles are nested (Figure 1). The outer cycle (grey, left) is the methodical frame for research and teaching: The learning object for us as researchers is dovetailing and

² The word *local* is used here to distinguish the overall design in the design study “Spotlight-Y” from the designs developed in it: In the outer research cycle it is the course design of complex analysis including teaching strategies, and in the inner cycle it stands for the designs the students develop for their learning arrangement (see Figure 2).

interlinking university mathematics and mathematics education in preservice teacher education. The general design of the lecture was described in the section “Curricular linkage: Dovetailing in the lecture on complex analysis” and the design experiment is the course work in the branch for preservice teachers in the lecture on complex analysis. The inner circle (red, right) frames the development and implementation of the learning materials by our students. Here, the learning objects (for students and pupils) are the mathematical phenomena the students choose from the lecture.

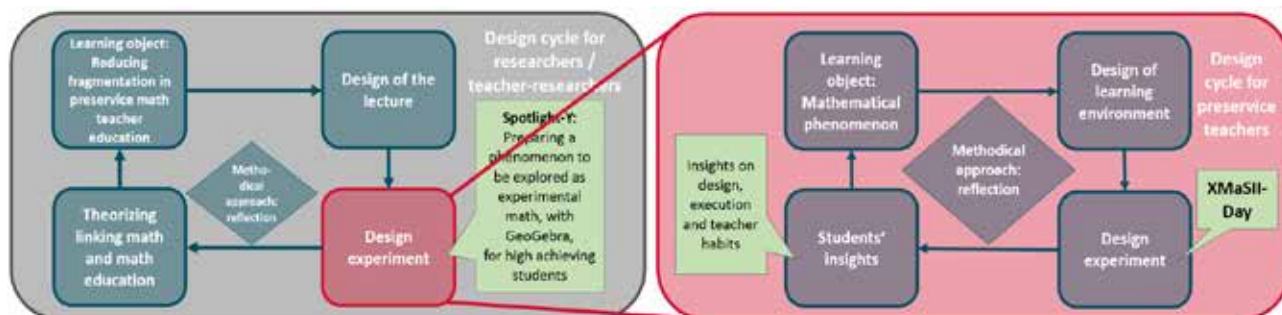


Figure 1: Nested design cycles in Spotlight-Y

The process is accompanied with three types of written reflective activities. We understand *reflection* as anticipatory as well as retrospective (re-)consideration of own work, including experiences of various kinds, thoughts about personal relationships to the two disciplines (mathematics and mathematics education), the own role as a future teacher, and possibilities for the improvement of local designs of learning arrangements. In a *preflection*, the preservice teachers describe the mathematical phenomenon and anticipate difficulties at the beginning of their planning, in *ad-hoc-notes*, they reflect on observations right after the execution of XMaSII, and in a final *portfolio*³ they reflect on the full process and their professional development, each with guiding stimuli (Hanke & Schäfer, 2018a, 2018b). This is in accordance with the notion of reflection-on-action as proposed by Schön (1983) and reflection-pre-action by Bikner-Ahsbahs (2017).

Instances of interlinking mathematics and mathematics education can be identified in students' reflections from which we extract interlinking strategies (see results section). Such a strategy may be a certain local mechanism a student implemented, or a personal insight. Since the reflections are written after a teaching episode with classes of school students (the design experiment), we might also reconstruct interlinking strategies which have not appeared in action, but which have been thought about by the students. The reflections have two functions: First, they serve to reconstruct and typify the interlinkages between university mathematics and mathematics education, and second, students experience reflection as a means to learn from own practical experience (planning, executing, assessing) and be aware of interlinking activities (Mehlmann & Bikner-Ahsbahs, 2018).

In the inner cycle, in the branch for the preservice teachers, the boundary of the scientific lecture and mathematics education is crossed by referring to each other. The *initial boundary object* is the student task to create the XMaSII-day learning arrangement. This task can be interpreted from the

³ A portfolio is a collection of all written work, this includes the exercise sheets, written planning and description as well as answers to final reflective questions (see Hanke & Schäfer, 2018a, 2018b, for details).

mathematical as well as the mathematics education side. The specificities of the implementations and reflections indicate how the students interlink both areas. The work of the students leads to a design process which initiates boundary crossing. All data, in the form of exercise sheets, computer arrangements and different kinds of written reflections shape a *dynamic boundary object* which is assembled by the students' work at the boundary of mathematics and mathematics education and which, at the same time, is subject to change. We call this design principle (van den Akker, 1999) *boundary crossing by design(ing)*. “By design” refers to the curricular implementation, and “by designing” refers to the processes the students engage in. The boundary crossing or interlinking mechanisms we observe stand for the interlinking practices of students and can be further used for the next cycle of the branch for preservice teachers in the lecture on complex analysis. In that sense, the design principle *boundary crossing by design(ing)* serves as our epistemic means to describe to which results acting at the boundary of mathematics and mathematics education may lead. In other words, *dovetailing* is the attempt to initiate boundary crossing and the students' boundary crossing may lead to thinking and acting between mathematics and mathematics education, i.e. *interlinking*. Thus, boundary crossing is regarded as a mediator between dovetailing and interlinking.

The novelty of *boundary crossing by design(ing)* is not the fact that mathematics and mathematics education are asked to be combined—this is expected practice of any (future) teacher. It is that the linkage we try to establish is between the two scientific domains, mathematics at university and mathematics education for preservice students' teaching (cf. Introduction).

Exemplary results of the first two cycles

Having developed the methodology and the design principle, we conjecture that implementing the design principle into the third cycle will initiate students' interlinking between complex analysis and mathematics education, and we ask whether we will find the same or new interlinking strategies of the students. But how do these interlinkings show up and what conditions foster or hinder them? Until now, this is answered by analyzing the data of the first two cycles, and here, we give some examples.

Results indicate that interlinking is an additional demand (concerning mathematical expertise and/or time) which is often not accomplished by our preservice teachers, and happens in microscopic ways. Besides others, the students were asked to *describe which elements of the course on complex analysis changed their views on the scientific discipline of mathematics and mathematics as a school subject*. This question aimed at a retrospection on the course as a whole. One of the students wrote (we note that the learning arrangement of this student did not deal with extension of number sets but with differentiation):

The extension of number sets with the set of complex numbers is very demanding at first. Pupils who encounter negative numbers for the first time might feel similarly. The experiences I made in this course can help me to empathize with pupils and understand why the extension of numbers with the set of irrational numbers can be difficult for them and why they may not consider the number π as a number.

In addition, the experience of the lacking imagination of the graphical representation of complex functions can help to understand the difficulties pupils have with the visualization of graphs of functions. (translated from German)

This description expresses the sensitization for pupils' difficulties by analogy. The example in the quote shows an experience-based perspective on problems with extensions of number sets and diagrams which can be regarded as a coordination mechanism with the potential for a transformation mechanism (see: Akkerman & Bakker, 2011). For example, a transformation could occur if the student presented a suggestion for how to deal with these issues in class. We may conclude that in this case the student's own experience with subject matter sensitizes for learning processes of pupils. What is not important is that the content in the student's learning process is beyond school but that what is learnt, in each case, is new for the respective learner (student and pupil).

To the stimulus "*What did you learn personally? Do you feel assured in your role as a teacher? How and why (not)?*" another student expressed (his learning arrangement was about power series),

So I find the problem to prepare a very complex and alien (German: fremd) topic for pupils very interesting and instructive because I, myself, had to cope with this topic intensively once again.

Unfortunately, I had to realize that exactly in this transformation very much time and work had to be invested which lacked for example for the precise planning and execution. At any time, the subject specific understanding (German: das fachliche Verständnis) was the most important aspect of the planning. (translated from German)

This utterance shows that the creation of a learning arrangement about a demanding mathematical topic requires resources in order to engage deeply with the subject matter. Here, the need for these resources sidelined the planning actions for the actual planning and implementation.

Discussion and reflection

Reflecting on the two design cycles at the university level we went through, the steps of how the design principle developed becomes clear. Due to the fragmentation in preservice teacher education, our first design principle was to *link university mathematics and mathematics education through providing practical experience for our students in one mathematics lecture*. The method seemed clear; the students identify a mathematical phenomenon from the lecture, plan and implement learning materials for talented pupils, and thus, overcome fragmentation. But this did not happen with most of the students. Therefore, after the completion of the first design cycle, we clarified the relationship between this method and our research design. That is, our students were actually performing a design cycle similar to ours on the research level. Thus we obtained a more precise methodology, the *nested design approach*. Since we were not able to rely on previous research, we had to bridge the distinction between *dovetailing* and *interlinking* theoretically. The theory of *boundary crossing* serves this purpose. The concise link between theory and methodology was achieved after the second cycle and on this basis we obtained the current design principle. *Boundary crossing by design(ing)* condenses the theoretical approach of boundary crossing and links it to the task of creating and implementing learning materials while taking into account two scientific domains. This design principle addresses two different kinds of design: *design research* at the university level for course development in which the students *design learning arrangements*. These threads together can lead to insights into the reduction of the fragmentation in teacher training we strive for. Ultimately, our project exemplifies that a suitable design principle does not necessarily stand at the beginning of a design study but can be achieved through development and confluence of methodology and theory.

Our students valued the practical experience in the project. Even when they did not manage to produce explicit interlinkages of the two domains, in some cases of interlinking the two domains we observed a kind of coordinating, a mechanism of boundary crossing. Hence, we should ask what kind of conditions hindered the preservice teachers to experience interlinking mathematics and mathematics education (of school mathematics). We next aim at developing a scaffolding procedure. For example, cognitive overload might be avoided by a concrete example of how a phenomenon of complex analysis could be transposed into a learning arrangement for talented pupils or by a more detailed structure for the task to create a learning arrangement that assists preservice teachers in their boundary crossing.

Last, we highlight an important epistemic obstruction resulting from our methodological approach. The contents and depths in the students' reflections limit the depths of our insights. Also, reflections mainly on a descriptive level are at most an indicator for students' weak interlinking. This means we also have to reconsider the stimuli which we ask our students to consider.

Acknowledgment

This project is part of the “Qualitätsoffensive Lehrerbildung”, a joint initiative of the Federal Government and the *Länder* which aims to improve the quality of teacher training. The programme is funded by the Federal Ministry of Education and Research (no. 01JA1612). The authors are responsible for the content of this publication.

References

- Akkerman, S. F., & Bakker, A. (2011). Boundary crossing and boundary objects. *Review of Educational Research*, 81(2), 132–169.
- Bakker, A., & Akkerman, S. F. (2014). A boundary-crossing approach to support students' integration of statistical and work-related knowledge. *Educational Studies in Mathematics*, 86, 223–237.
- Ball, D., Thames, M. H., & Phelps, G. (2008). Content knowledge for teaching. What makes it special? *Journal of Teacher Education*, 59(5), 389–407.
- Bauer, T., & Partheil, U. (2009). Schnittstellenmodule in der Lehramtsausbildung im Fach Mathematik. *Mathematische Semesterberichte*, 56(1), 85–103.
- Bikner-Ahsbals, A. (2017). Design Research—ein Ansatz zum Forschenden Lernen. In S. Doff & R. Komoss (Eds.), *Making change happen. Wandel im Fachunterricht analysieren und gestalten* (pp. 87–110). Wiesbaden, Germany: Springer VS.
- Blömeke, S., König, J., Busse, A., Suhl, U., Benthien, J., Döhrmann, M., & Kaiser, G. (2014). Von der Lehrerbildung in den Beruf – Fachbezogenes Wissen als Voraussetzung für Wahrnehmung, Interpretation und Handeln im Unterricht. *Zeitschrift für Erziehungswissenschaft*, 17(3), 509–542.
- Gravemeijer, K., & Cobb, P. (2006). Design research from a learning design perspective. In J. van den Akker, K. Gravemeijer, S. McKenney, & N. Nieveen (Eds.), *Educational design research* (pp. 17–51). London: Routledge.

- Hanke, E., & Schäfer, I. (2018a). Learning complex analysis in different branches – Project Spotlight-Y for future teachers. In V. Durand-Guerrier, R. Hochmuth, S. Goodchild, & N.M. Hogstad (Eds.), *Proceedings of the Second Conference of the International Network for Didactic Research in University Mathematics (INDRUM2018, 5-7 April 2018)* (pp. 54–63). Kristiansand, Norway: University of Agder and INDRUM.
- Hanke, E., & Schäfer, I. (2018b). Modellprojekt 2: Spotlight-Y (Mathematik). In Universität Bremen (Ed.), *Resonanz. Magazin für Studium und Lehre an der Universität Bremen. Sonderheft 2018: Schnittstellen gestalten. Das Zukunftskonzept für die Lehrerbildung an der Universität Bremen. Professionalisierung zum Reflective Practitioner* (pp. 70–74). Bremen, Germany: Universität.
- Hefendehl-Hebeker, L. (2013). Doppelte Diskontinuität oder die Chance der Brückenschläge. In Chr. Ableitinger, J. Kramer, & S. Prediger (Eds.), *Zur doppelten Diskontinuität in der Gymnasiallehrerbildung. Ansätze zu Verknüpfungen der fachinhaltlichen Ausbildung mit schulischen Vorerfahrungen und Erfordernissen* (pp. 151–168). Wiesbaden, Germany: Springer.
- Mehlmann, N., & Bikner-Ahsbahr, A. (2018). Spotlights Lehre – Ein Ansatz zur Vernetzung von Fachwissenschaft und Fachdidaktik an der Universität Bremen. In I. Glowinski, A. Borowski, J. Gillen, S. Schanze, & J. von Meien (Eds.), *Kohärenz in der universitären Lehrerbildung. Vernetzung von Fachwissenschaft, Fachdidaktik und Bildungswissenschaften* (pp. 77–102). Potsdam, Germany: Universitätsverlag Potsdam.
- Prediger, S. (2013). Unterrichtsmomente als explizite Lernanlässe in fachinhaltlichen Veranstaltungen. In Chr. Ableitinger, J. Kramer, & S. Prediger (Eds.), *Zur doppelten Diskontinuität in der Gymnasiallehrerbildung. Ansätze zu Verknüpfungen der fachinhaltlichen Ausbildung mit schulischen Vorerfahrungen und Erfordernissen* (pp. 151–168). Wiesbaden, Germany: Springer.
- Prediger, S., Link, M., Hinz, R., Hußmann, S., Ralle, B., & Thiele, J. (2012). Lehr-Lernprozesse initiieren und erforschen–Fachdidaktische Entwicklungsforschung im Dortmunder Modell. *MNU*, 65(8), 452–457.
- Schön, D. (1983). *The reflective practitioner. How professionals think in action*. New York: Basic Books.
- Star, S. L. (2010). This is not a boundary object: Reflections on the origin of a concept. *Science, Technology, & Human Values*, 35(5), 610–617.
- van den Akker, J. (1999). Principles and methods of development research. In J. van den Akker, R. Branch, K. Gustafson, N. Nieveen, & T. Plomp (Eds.), *Design approaches and tools in education and training* (pp. 1–14). Dordrecht, the Netherlands: Kluwer Academic Publishers.
- Winsløw, C., & Grønbaek, N. (2014). The ecological Klein’s double discontinuity revisited: contemporary challenges for universities preparing teachers to teach calculus. *Recherches En Didactique Des Mathématiques*, 34(1), 59–86.

How concepts turn into objects: an investigation of the process of objectification in early numerical discourse

Felix Lensing

Freie Universität Berlin, Germany; lensinfo@zedat.fu-berlin.de

Mathematical discourse begins where the concrete ends. Despite the intangibility of mathematical objects, we still speak about them in a way that is quite similar to the way in which we speak about material objects. We speak of numbers, classes, and functions as if we were talking about self-sustained entities. But with what right? On the example of the use of number-words in early numerical discourse, I shed some light on the mechanisms by means of which mathematical objects obtain their peculiar ontological status. It turns out that any mathematical object refers back to a concept from which it originates. To better understand the process of objectification, I am thus asking: how do concepts turn into objects? By juxtaposing Piaget's notion of reflecting abstraction with Peirce's notion of hypostatic abstraction, I then propose an explanatory model of the transition from concepts to objects.

Keywords: Objectification, reflecting abstraction, Piaget, hypostatic abstraction, Peirce

I. Introduction

- 1 MH: How many is two and one more?
- 2 Patrick: Four.
- 3 MH: Well, how many is two *lollipops* and one more?
- 4 Patrick: Three.
- 5 MH: How many is two *elephants* and one more?
- 6 Patrick: Three.
- 7 MH: How many is two *giraffes* and one more?
- 8 Patrick: Three.
- 9 MH: So how many is *two* and one more?
- 10 Patrick: Six.¹

Although Patrick (4 years and 1 months) seems to have no problem in recognizing the number-words in the posed questions, he is for some reason unable to cope with them in the first and last question. How can it be that he does not see the pattern common to both questions? What seems unfamiliar to him are not the number-words themselves, but it is the way in which these words are used. In general, we can distinguish between two different uses of number-words (cf. Dummet, 2002, pp. 99–100): Number-words can either occur as adjectives, as in ascriptions of number such as ‘There are *two* giraffes’, or as nouns, as in most arithmetic propositions such as ‘*Three* is a prime number’. In their adjectival use, number-words function as predicates. They cannot stand for themselves, but they characterize something else. In that use, a number-word specifies how many there are of a certain kind and thus it must occur as the number of something, or more precisely as the number of a concept (‘three *lollipops*’, ‘three *giraffes*’, ‘three *elephants*’). In contrast, number-words that occur as nouns stand for something that can be investigated in its own right. In this substantival use, numbers are regarded as

¹ ‘MH’ stands for Martin Hughes. The transcript is taken from Hughes (1986, pp. 47–48).

self-sustained entities without any intrinsic reference to the concepts which they are possibly ascribed to. Armed with this distinction, we are now able to formulate Patrick's difficulties in a more concise way: While Patrick seems to be familiar with the adjectival use of number-words (see lines 3–9), the substantival one appears foreign to him (see lines 1–2 and 9–10). Consequently, he does not see addition as an operation between numbers as abstract objects, but only as an operation performed on two concepts. To him, adding up means to join two collections of objects. Taking this into consideration, it becomes understandable why he shows difficulties grasping the first question. From an adjectival standpoint, it is of no importance which kinds of objects are conjoined (lollipops, giraffes, elephants, etc.) as long as there are some. An addition cannot be performed *in vacuo*. The question 'How many is two and one more?' is thus incomplete for Patrick, he feels that there is something missing, namely a pair of concepts with which the operation is executed. These observations gain in importance as soon as it is added that they are by no means a personal exception but rather are typical of many preschool children aged 3 to 4 years (cf. Hughes, 1986, p. 46; Sfard, 2010, p. 47). It is the result of an intricate process of successive steps of objectification that numerals and number-words can be treated as referring to the self-sustained entities we call numbers (cf. Sfard, 2010, p. 136). Within this process, the adjectival use of number-words precedes the substantival use, or bluntly put: *numbers are first concepts, and only become objects in a second step.*

This developmental sequence, however, is not restricted to the genesis of numbers. Rather, it repeats itself at all levels of mathematical sophistication. For example, Bakker (2007) observed in a teaching experiment on the concept of distribution in an 8th grade in the Netherlands that the students' discourse about the concept of spread took a similar turn:

[M]any used the noun 'spread,' [...], whereas students earlier used only predicates such as 'spread out.' [...] Statistically, however, it makes a difference whether we say, 'the dots are spread out' or 'the spread is large.' In the latter case, spread is an object-like entity that can have particular aggregate characteristics that can be measured (for instance by the range or the standard deviation) (Bakker, 2007, p. 24)

Or, to provide a historical example: It took several centuries to move from the study of specific examples of functions to the study of functions as such, that is, to the investigation of functions as objects for which certain general characteristics such as continuity or differentiability can be formulated (cf. Kleiner, 1989; Sfard, 1991, pp. 14–16). The departure point of this article is the conviction that what we have observed in the case of number can be generalized: *At any level of mathematical sophistication, mathematical objects are products, i.e., they are produced in processes of objectification, and at any level of mathematical sophistication, the mathematical objects in question refer to concepts from which they originate.*

In this paper, I take early numerical discourse as an example to investigate the transition from concepts to objects as a key element of the *process of objectification* (in the sense of: Sfard, 2010). I attempt to provide a model of the mechanisms which underlie this last step in process of objectification. The rationale of the paper is thus a theoretical one and it is precisely here where the novelty of this contribution lies: There are plenty of works in mathematics education (cf. Bakker, 2007; Sfard, 1991) in which it is described *that* this transition happens, but I do not know a single one that provides an explanatory model of *how* it could actually work. In order to provide such a model, I pursue the following plan: At first, I clarify the use of the words

‘object’ and ‘concept’ in order to formulate the theoretical reference-problem as clearly as possible (II.); in the next two sections, I then successively explore the adjectival (III.) and the substantival use of number-words in more detail (IV.); this leads to an explanatory model of the transition from concepts to objects which is developed in the fifth section by juxtaposing Piaget's notion of reflecting abstraction with Peirce's notion of hypostatic abstraction (V.).

II. On the distinction between concept and object

When speaking about material objects, we either use terms that tell us which individual is being talked about, or we use terms that characterize something as an instance of a certain kind. ‘Socrates’, ‘Berlin’, and ‘Donau’ are examples for the former kind of terms, while ‘human being’, ‘city’, and ‘river’ are examples for the latter. To adopt a usual phraseology, we will call these two kinds of terms *singular* and *general* terms. A singular term “purports to name one and only one object” (Quine, 1966, p. 205), while a general term does not name the individual object to which it refers at all but, instead, is said to be true of each of many objects of a certain kind (ibid.). The general term ‘human being’, for example, is true of the object *Socrates*, but it is not true of the object *Berlin*. Singular and general terms thus differ in their *way of reference*: While a singular term refers to one object and one object only, a general term divides its reference. It can always be applied to a multiplicity of objects. What a general term names is thus not any particular object, but at best its own rule of application, i.e., the operation used to decide whether or not the term is true of an object. We want to call these operations concepts: *A concept is any operation that is associated with a general term and that allows to decide whether or not the term is true of a particular object.*

Therefore, concepts are not to be found in the realm of being but belong to the realm of doing. We operate *upon* objects (as they are singled out for our investigation), while we operate *through* concepts (as it is the conceptual operation by means of which the general term is applied to a particular entity). In contrast to everyday language, objects to which mathematical terms refer are never components of our stream of direct experience. Mathematical discourse begins where the concrete ends. We cannot point at or see mathematical objects such as numbers, classes, or functions. Despite their intangibility, however, we still adopt a jargon that is quite similar to the way in which we speak about material objects. On the one hand, there are singular terms such as ‘ $1 + 4$ ’, ‘ $\sqrt{2}$ ’, or ‘ π ’, which purport to name one and only one object, on the other hand, there are general terms such as ‘prime number’, ‘continuous’, or ‘equilateral’, which characterize the objects in question as instances or non-instances of a certain concept. In mathematical discourse, the distinction between singular and general terms thus remains intact (see already Peano, 1891/1973, p. 156). The difference between mathematical terms and everyday terms is not the way of reference, *but the kinds of objects referred to.*² In the case of everyday language, the terms are mostly concrete in the sense that the objects referred to can be investigated as parts of our sensory material, while, in the case of mathematical discourse, they are not components of our direct experience and are thus abstract. Besides the division into the singular and the general, there is thus another division that must be taken into consideration, the one into the *concrete* and the *abstract*. On the expression layer, we then distinguish between

² For a more detailed discussion of what it is that makes a concept a mathematical concept, see also: De Freitas, Sinclair & Coles (2017).

singular and general *terms* on the one hand, and between concrete and abstract terms on the other hand, while, on the content layer, all singular terms name *objects* and all general terms stand for *concepts*.

Note that the two divisions cross each other: There are concrete and abstract singular terms such as ‘Socrates’ and ‘ π ’, and concrete and abstract general terms such as ‘human being’ and ‘prime number’ (cf. Quine, 1966, p. 204). An investigation of the relations between these different kinds of terms unveils that we can find correspondences. The abstract singular term ‘redness’ corresponds to the general term ‘red thing’; ‘sweetness’ is the abstract singular term to the general term ‘sweet’, and the general term ‘round’ can be matched to the abstract singular term ‘roundness’. This series of correspondences is a systematic feature of our language (cf. Quine, 1966, pp. 204–205): For every general term, be it concrete or abstract, we can come up with a corresponding abstract singular term which names the (abstract) attribute that is ‘shared’ by all the objects which fall under the concept in question (or, respectively of which the associated general term is true). The term ‘roundness’, for example, names the attribute that all round things have in common. It names the particular form or gestalt that we recognize in our sensory experience from case to case when encountering a round thing. That also leads us to a hypothesis as to why general terms precede their corresponding abstract singular terms in cognitive development: *If the corresponding abstract singular term is what all of the objects that fall under a particular concept have in common, it is hardly possible to recognize this common attribute if the concept in question has not yet been learned.*

III. Numbers as concepts

Equipped with this terminology, it is worth returning to the introductory example, which made obvious that number-words can either function as general or singular terms, meaning they can stand for concepts or objects. Let us take a closer look at the adjectival use of number-words first since it precedes the substantival use in the developmental sequence. As a reminder, our introductory thesis was: *numbers are first concepts, and only become objects in a second step.* Since we have clarified at this point what is meant when speaking of a concept, we can now ask for the operation or rule of application which is associated with a number-word when it functions as a general term. However, before we can do that, there is one more thing that needs to be clarified in advance: *the relation of number-words to the sensuous world.* It is important not to conceive number-words, not even in their adjectival use, as referring to certain complexes of our direct stream of experience. One and the same sensory impression can always give rise to a majority of equitable ascriptions of number:

While looking at one the same external phenomenon, I can say with equal truth both ‘It is a group of trees’ and ‘It is five trees’, or both ‘Here are four companies’ and ‘Here are 500 men’. Now what changes here from one judgement to the other is neither any individual object, nor the whole, the agglomeration of them, but rather my terminology. But that is itself only a sign that one concept has been substituted for another. This suggests [...] that the content of a statement of number is an assertion about a concept (Frege, 1970, §46)

Whether a certain sensory impression gives rise to one application of a number-word or another, hence solely depends on the way in which we *conceptually* organize or structure this experience. If a number-word is used as a general term, what falls under the associated concept

are again also concepts. What the number-word ‘four’ stands for is then a *second order concept* (cf. Frege, 1970, §53), a concept that comprises all of those concepts with exactly four objects. Such a concept does not collect the counted objects or certain aggregates of them, but only the concepts structuring that material. In their adjectival use, number-words are, therefore, abstract general terms. Since a general term cannot stand on its own but is always predicated of something else, in this case of other concepts, it becomes clear why Patrick cannot make sense of the questions without any reference to other concepts. His behavior indicates that he treats the number-words as standing for second order concepts. In this use, there must be some concepts upon which the addition is executed. Now we can come back to the question of what the operation or rule of application might look like that is associated with the term ‘four’.

In the case of the number-word ‘four’, this operation might be depicted as following: We coordinate one after the other all the objects that fall under the concept in question with all terms of the number-word sequence starting from ‘one’ until we come by the word ‘four’. If the counting procedure stops at ‘four’, that is, if all objects were counted up to this point, we say that the given concept falls under the concept *four* (or, respectively that the term ‘four’ is true of the particular concept). If the procedure already stops before or if we exceed ‘four’ without having finished the counting procedure, we will say that the given concept does not fall under the concept *four* (or, respectively that the term ‘four’ is *not* true of the particular concept). Here it is important to emphasize that there is no need at all to suppose an entity such as an attribute that is common to all the concepts comprising exactly four objects. Without a doubt, we can learn and apply the operation described above without supposing the number-words to refer to a separate abstract object of any kind. This observation holds true quite generally: the “use of the general term does not of itself commit us to the admission of a corresponding abstract entity into our ontology” (Quine, 1950, p. 630). Therefore, we should consider the final step of objectification, leading to the treatment of numbers-words as singular terms, as an additional step that requires the use of number-words as general terms already learned. So, how, we must ask, do numbers become objects?

IV. Numbers as objects

Let us assume we have a box in front of us which contains eleven marbles and we are supposed to determine how many marbles there are in the box. Wanting to communicate our counting result, we have at least two options: (1) ‘There are eleven marbles in the box’; (2) ‘The number of marbles in the box is eleven’. These two options correspond to our two forms of number-word use: in (1) ‘eleven’ functions as general term that is predicated of the concept *marbles in the box*, while in (2) ‘eleven’ can be said to stand for the same abstract entity as ‘the number of marbles in the box’, indicating that it functions as an abstract singular term. We argued above that, for a given general term, the corresponding abstract singular term can name the attribute that is shared by all the things which fall under the concept in question. However, for number-words functioning as general terms the situation is somewhat different. It appears to be quite difficult to come up with a feature or attribute that all of the concepts have in common to which a number word such as ‘eleven’ can be successfully applied. What is the distance in meters between the penalty spot and the goal? How many corner points does the maple leaf on the Canadian flag have? How many criminals are there in Danny Ocean’s gang? How many academy awards did the film Titanic win? And, last but not least, what do these

things have to do with our marbles? At the level of content, all these different manifestations of the number eleven obviously have nothing in common. So, what exactly is it that repeats itself from one manifestation to the other?

No matter if we count our marbles, the vertices of the maple leaf of the Canadian flag, or the meters from the penalty spot to the goal, in each of the cases we perform a counting procedure. The sameness does not lie at the level of the concepts upon which the counting procedure is executed, but it lies at the level of the procedure itself, that is, at the level of our operations with these concepts. What repeats itself from one counting act to the other is the fact that all of them end up with the number-word ‘eleven’. But this is itself only a sign that one and the same concept is applied: the second order concept associated with the number-word ‘eleven’. To go one step further in the process of objectification, a child capable of the adjectival use must thus recognize all the successive counting acts ending up with the same number-word as applications of the same concept. This requires a minimal reflexive loop: In order to sense this kind of ‘operational’ sameness, the child must make her own operations the object of her own operations. She must relate several successive applications of a number-word to each other and analyze them into sameness and difference of the counting results. However, in order to be able to identify several counting acts that end up with the same number word, a series of *factual* (the acts might be executed on very different concepts), *temporal* (the acts are most likely executed one after the other) and *social* (the acts might be executed by different people) *differences* between the individual acts must be left out simultaneously.³

V. Piaget versus Peirce: What is abstraction?

What we are facing here is a two-sided process in which something is *retained* and at the same time something else is *left out*. Traditionally, this two-sided process is referred to as *abstraction* (cf. Locke, 1836, book 2, chapter 11, §9). In any process of abstraction there is a certain kind of material or substance upon which the abstraction is carried out. We cannot simply abstract something but rather we always abstract *from* something. Now, what is unusual in our case is this very substance of abstraction. The substance upon which the abstraction is carried out does not consist of objects of a certain kind but of our own operations. To take account of this reflexivity, Piaget has introduced the notion of *reflecting abstraction* (cf. Piaget, 2014, pp. 317–323; Glasersfeld, 2003, pp. 103–105). In contrast to what Piaget calls *empirical abstraction*, a reflecting abstraction is an operation that runs on operations:

[W]hen we are acting upon an object, we can also take into account the action itself, or operation if you will, since the transformation can be carried out mentally. In this hypothesis the abstraction is drawn not from the object that is acted upon, but from the action itself (Piaget, 1971, p. 16)

We can now see that the process of relating several counting acts and analyzing them into the sameness and difference of the counting results can be reconstructed as a reflecting abstraction. It runs upon several applications of the second-order concept associated with the number-word

³ This distinction between three *meaning dimensions* – a factual, a temporal, and a social –, in which we can seek for commonalities and differences, stems from the German sociologist Niklas Luhmann (cf. Luhmann, 1995, pp. 59–102).

‘eleven’. The child must retain what all of the counting acts have in common while simultaneously leaving out all the features in which these successive acts differ from each other. But what is the outcome of this process? Have we already arrived at the substantial use of number-words? To cut it short: yes and no.

In general, we can say that the ‘minimal’ attribute shared by all things that fall under a certain concept is this purely formal feature, the fact that the things fall under that very concept. What all concepts that fall under the second order concept *eleven* have in common, is that they bear the same relation to this concept. They fall under it because in each case the counting procedure ends with the word ‘eleven’. And to identify this formal sameness, we must perform a reflecting abstraction. In this way, the notion of reflecting abstraction allows extending the notion of a common property or a shared attribute far beyond the immediate, sensuous world. At best, we might then say that in the process of reflecting abstraction the successive mental or communicative acts are ‘condensed’ into an object-like entity, an attribute, which is the common feature of all these different acts. But, in the end, that is mere speculation. How, one might ask, is this mysterious object-like entity anchored if we obviously cannot perceive it?

In order to provide an answer to this question, we have to move away from the content layer, the series of operations on operations, onto the expression layer, the layer of the use of signs to fix these volatile operations (cf. Sfard, 1991, p. 21). It is precisely here where the notion of reflecting abstraction comes into trouble. It can explain how we get to sense the operational sameness described above, however, what it cannot explain is how this sameness is objectified. We therefore want to complement Piaget’s account on abstraction with Peirce’s considerations on the very same topic. Peirce has introduced the notion of *hypostatic abstraction* to describe the exact process we are interested in, the transition from a general term to an abstract singular term or in Peirce’s own words:

That wonderful operation of hypostatic abstraction by which we seem to create *entia rationis* that are, nevertheless, sometimes real, furnish us the means of turning predicates from being signs that we think or think *through*, into being subjects thought of. We thus think of the thought-sign itself, making it the object of another thought-sign. (CP 4.549)

It is noticeable that Peirce gives a beautiful account on the reflexive loop we have already described above: Whenever we apply a general term or a predicate we think *through* the sign or the concept associated with it in precisely that sense that we always predicate it of something else, while in any attempt to transform it into an object, we must reflect on this very use and make it the subject of another thought. That is to say, we must think *of* the sign *through* which we have thought before. So far nothing new, but in the second part of the quotation Peirce goes beyond what we have already described before. We “think”, Peirce writes, “of the thought-sign itself, making it the object of another thought-sign” (ibid.). As noticed before, what stays the same from application to application of number words in their adjectival use is nothing but the purely formal feature that the number-words are true of all the concepts to which they are successfully applied. We can now add that, what the corresponding abstract singular term names, is ultimately nothing other than the sign thought through before. Number-words functioning as singular terms name the sign, i.e., the *relation* between the general term and the particular counting procedure associated with it. This way, the conceptual operation becomes crystallized or frozen. When a number-word is used as a singular term, the operation must not

be performed anymore but is rather only implied or pointed at. We say that we ‘know’ what the numeral ‘1,098,7877’ stands for because it “points to the last element in a familiar counting procedure” (Glaserfeld, 1995, p. 100), a procedure that no longer needs to be executed.

Concluding, I want to generalize this thesis. We do not need to posit some sort of ontological realm to answer the question of how we can speak about numbers, classes, and functions as self-sustained entities. What a singular term in mathematical discourse stands for is ultimately no more than another sign, it is the relation between the general term (from which the singular term in question originates) and the associated conceptual operation.

References

- Bakker, A. (2007). Diagrammatic reasoning and hypostatic abstraction in statistics education. *Semiotica*, 2007(164), 9–29.
- Dummett, M. (2002). *Frege: Philosophy of mathematics*. London: Duckworth.
- De Freitas, E., Sinclair, N., & Coles, A. (Eds.). (2017). *What is a mathematical concept?*. Cambridge University Press.
- Frege, G. (1970). *The foundations of arithmetic: A logico-mathematical enquiry into the concept of number*. New York: Harper & Brothers.
- Glaserfeld, E. v. (2003). *Radical constructivism*. London: Routledge.
- Hughes, M. (1986). *Children and number: Difficulties in learning number*. Padstow: Blackwell.
- Kleiner, I. (1989). Evolution of the function concept: A brief survey. *The College Mathematics Journal*, 20(4), 282–300.
- Locke, J. (1836). *An essay concerning human understanding*. London: T. Tegg and Son.
- Luhmann, N. (1995). *Social systems*. Stanford: Stanford University Press.
- Peano, G. (1973). The principles of mathematics, Society and Technology. In G. Peano & H. C. Kennedy (Eds.), *Selected works of Giuseppe Peano* (pp. 153–161). Toronto: University of Toronto Press.
- Peirce, Charles S. (1931–1966). *The collected papers of Charles S. Peirce*, 8 vols., C. Hartshorne, P. Weiss, and A. W. Burks (eds.). Cambridge: Harvard University Press.
- Piaget, J. (1971). *Genetic epistemology*. New York: W.W. Norton & Company Inc.
- Piaget, J. (2014). *Studies in reflecting abstraction*. New York: Psychology Press.
- Quine, W. V. (1950). Identity, ostension, and hypostasis. *The Journal of Philosophy*, 47(22), 621–633.
- Quine, W. V. (1966). *Methods of logic*. Cambridge: Harvard University Press.
- Sfard, A. (1991). On the dual nature of mathematical conceptions: Reflections on processes and objects as different sides of the same coin. *Educational Studies in Mathematics*, 22(1), 1–36.
- Sfard, A. (2010). *Thinking as communicating: Human development, the growth of discourses, and mathematizing*. Cambridge: Cambridge University Press.

On the epistemology of the Theory of Objectification

Luis Radford

Laurentian University, Faculty of Education, Ontario, Canada; lrادford@laurentian.ca

In this paper I discuss some concepts that are part of the epistemology dimension of the Theory of Objectification—a Vygotskian theory of teaching and learning whose philosophical background comes from dialectical materialism. The epistemological concepts are presented in the first part of the paper. In the second part, they are illustrated through a classroom example.

Keywords: Knowledge, knowing, processes of objectification, learning, concept.

Introduction

This article seeks to contribute to the research field of theoretical perspectives in mathematics education. Its goal is to offer a short account of the manner in which a central, yet controversial, concept in mathematics education—the concept of learning—is conceived of in the Theory of Objectification (TO). To do so, this article describes the epistemological dimension of the TO as a dynamic whole system driven by dialectical relationships between knowledge, knowing, and learning. Drawing on a previous paper (Radford, 2013), I revisit a classroom example to illustrate the ideas presented in the article and to add a new epistemological element—the concept of *concept*. The example also provides insights about the interplay between the theoretical principles of a theory and its methodology and shows how the TO addresses a specific sensitivity of mathematical epistemology: one in which mathematical knowledge is considered as a cultural-historical entity in motion, an entity that is incessantly renewed and expanded and continuously brought to life by sensuous, practical, and material human activity.

Knowledge

In the Theory of Objectification, knowledge is understood as a *general entity* that, ontologically speaking, is already in the culture when we are born. Knowledge includes historical archetypes and culturally constituted processes of thinking, reflection, and action. Let us imagine a rural community that, in the course of time, has produced ways of thinking, reflecting, and doing things—for example, how to sow the earth, how to think about space, quantity, time, etc. These ways of thinking, reflecting upon, and doing things are general archetypes that constitute the knowledge of the culture. Let us now imagine a baby born at this moment in that culture. For this baby, those ways of thinking about the world, space, quantity, time, etc., appear as *possibilities*—possibilities of action and reflection. Another culture (e.g., a culture based on capitalist ways of commercial production in a contemporary European or North American country) will offer individuals born at this moment other possibilities; that is to say, other knowledge. These possibilities are *potential* actions/reflections, or *capacities* to do something. It is in this sense that knowledge can be considered as *potentiality*.

According to Aristotle, potentiality (δύναμις) is synonymous with power or disposition. Living beings and mechanisms have potentiality. A musical instrument, for example, has the ability to produce sounds. A fish has the ability to move in the water. *Actuality* (ἐνέργεια, *energía*), by

contrast, is the concrete happening of that which, before being put in motion, before being actualized, was potentiality. Potentiality is something undefined, without form, like a sound *before it is produced* or like the capacity of the fish *before it travels* in the water; something purely potential that, through *movement*, becomes materialized or actualized (*act*-ualized: transformed by an *act*-ion). However, the potentiality that living beings and mechanisms enjoy can be natural or acquired. The fish is biologically equipped to move in the water. Other potentialities or capacities are acquired, as Aristotle indicated (1998) in *Metaphysics* (1048a). This is the case of knowledge. Knowledge is this: *generative capacity, potentiality*. Algebraic knowledge, for example, is potentiality embedded in the culture: capacities that are offered to individuals in order to think, reflect, pose, and solve problems in a *specific way*.

Knowledge as the generative capacity of action and thinking changes from one culture to another and from one historical period to another. It would be a mistake, though, to think that the idea of knowledge I am outlining here stands in a Platonic line. The fact that when each one of us was born and was confronted with a series of scientific, ethical, aesthetic, legal and other forms of knowledge/thinking already established historically and culturally, does not mean that those forms of knowledge are Platonic forms, universal and timeless, independent of human labour. On the contrary, knowledge in each culture is produced by concrete people through their own labour—through their own actions, their own reflections, their joys, their suffering, and their hopes. To be more precise, I suggest that *knowledge is a system of embodied, sensible and material processes of action and reflection, constituted historically and culturally*. The adjectives *embodied, sensible, and material* mentioned in the previous definition signify that the processes of action and thinking are not mental cogitations occurring inside the head, but actions of real individuals who work and live in a social and cultural world. These actions are carried out through the body, the human senses, and through the use of physical objects and cultural artefacts.

Knowing

Knowledge is *related* to each one of its concrete instances or actualizations, but is, at the same time, *different* from each one of them. In its materialization or actualization, each of these concrete actualizations keeps in a sublated manner the generality of the ideal form that engenders it, but it *does not* coincide with the ideal form. In the TO, the actualization of knowledge has a specific name: *knowing*. Knowing is the concrete conceptual content through which knowledge is embodied and materialized or actualized. Although knowledge and knowing belong to two different ontological spheres—the former is *general*, the latter *singular*—they are interrelated in a dialectical manner and are part of a *dynamic whole system*. Knowing as the *actualization* of knowledge evokes indeed this *temporal* dimension of a whole in continuous movement. And what produces the movement is *activity*: knowledge and knowing are related through activity. Indeed, knowing can appear only through activity. This activity actualizes knowledge, brings it to life—like the activity of playing a violin brings musical notes to life, or the classroom activity of solving an algebraic equation brings algebraic knowledge to life. We can now state in a more precise way the relationship between knowledge and knowing: knowing is a sensible developed form of knowledge—much like the bud's example that Hegel offers in his *Phenomenology of the Spirit*: the blossom originates from the bud; it is the materialization or actualization of the bud, yet it does not

coincide with the bud. The blossom is a sensible developed form of the bud: although different, “their fluid nature makes [the bud and the blossom] moments of an organic unity . . . in which each is as necessary as the other; and this mutual necessity alone constitutes the life of the whole” (Hegel, 1977 p. 2). The *dialectical moment* is precisely the moment in which one becomes the other, the moment in which algebraic knowledge as *general* becomes transformed into something sensible, *singular*—that is, an object of consciousness. “It is of the highest importance,” Hegel notes, “to interpret the dialectical [moment] properly, and to [re]cognise it. It is in general the principle of all motion, of all life” (Hegel, 1991, p. 128). Up to here I have dwelled on concepts that have to do with aspects of the general theoretical stance of the TO. Now we enter into the educational-epistemological realm and deal with the concept of learning.

Learning

In student-centred pedagogies the student is considered to *construct* his/her *own* knowledge. No one can construct it for him/her. To *construct* a concept is equated to *learning* such a concept. In this conception, knowledge (K) appears as an *extension* of the subject (S). Since knowledge is not something different from the subject, but the subject’s *own* construction; in other words, since there is an identity between the thinking self and the products of its cogitations (Ilyenkov, 1977), this conception can be summarized through the equation: $S = K$. The intention behind the TO is to move beyond this individualistic stance.

To theorize learning, sociocultural theories have resorted to a series of concepts, such as enculturation (mainly formulated in anthropological research) and internalization (borrowed from Vygotsky’s work). I have argued elsewhere (Radford, 2018) that both concepts are insufficient to come up with an operational definition of learning from an educational perspective. To put it in a nutshell, the concept of enculturation adopts as its explanatory principle the idea of social practice, but leaves it uncritically analyzed. In enculturation approaches a social practice often amounts to what people *do*. Furthermore, in enculturation approaches the agentic dimension of individuals remains usually at the periphery. In Rogoff’s (1990) account, the individuals are certainly considered as active participants. But learning is conceptualized as *apprenticeship*; that is, something occurring through “the guidance and challenge of other people” (Rogoff, 1990, p. 19). In the end, learning is a process whose goal is to *adapt* oneself to existing social practices. Education is reduced to reproduction. There is little room to investigate education as transformation of people and the world. Likewise, there is little room to investigate the individuals as agentic entities, such as the manners in which the individuals come to position themselves and be positioned in social practices. There is little room to investigate the tensions that arise from the normative dimension of cultures (what Bakhtin, 1981, called a centripetal force) and the agentic movements of the individuals (the centrifugal force in Bakhtin’s terminology). A similar critique may hold for Vygotsky’s concept of internalization; that is, the “*transition of a [psychological] function from outside inward*” (Vygotsky, 1998, p. 170; emphasis in the original). It might be worth noticing that the content of Vygotsky’s concept of internalization (Вращивание – vraschivanie) is not learning, but the higher psychological functions (such as memory and perception). The problem that internalization seeks to explain is not how the child learns but how the higher psychological

functions arise from social relations, and how these functions evolve. How, then, is learning theorized in the TO? In the rest of this article I sketch the answer to this question.

Processes of objectification

As suggested earlier, in the TO, knowledge is considered as a culturally and historically constituted system of thinking and action. When each one of us was born, these systems (always in motion, always changing) were already there, existing in our culture in the form of knowing how to plant corn seeds, knowing how to calculate mortgages, etc. In other words, at birth, to each one of us, knowledge appeared as a cultural-historical generative, *latent capacity*. Our *encounter* with culturally and historically constituted systems of thought (e.g., mathematical, scientific, aesthetic, legal, etc.) is what in the TO is called *objectification*.

To understand the meaning of this encounter, let us bear in mind that the noun “objectification” tries to convey the idea that, before our encounter with knowledge, knowledge presents to us as something *different* from us: something that in its *alterity*, its own presence *objects* us; that is, resists or opposes us. The equation is: $S \neq K$. Before our encounter with knowledge, knowledge is the sign of a *difference*. *Object-ification* is the attempt to erase that difference. But because knowledge is an ideal (general) form always changing (constantly being recreated, refined, and expanded), the difference that the encounter tries to erase is not something that can happen totally. There is always a residue, a surplus that remains beyond our always local, situated, and concrete encounters with knowledge. As a result, objectification is always partial, a Sisyphean attempt at embracing knowledge—at becoming conscious or aware of it. “Object” in objectification does not refer to the verb “to objectify,” but to the verb “to object” (as when something, a desk, a chair, *objects* us). This is why, in the TO, in providing accounts of learning, instead of saying that students objectified knowledge, we talk about students engaged in *processes of objectification*. More precisely, *processes of objectification are those social, collective processes of becoming progressively conscious of a culturally and historically constituted system of thought and action*—a system that we gradually and partially notice and at the same time endow with meaning. Processes of objectification are those processes of attempting to notice something culturally significant, something that is revealed to the consciousness not passively but by means of the corporeal, sensible, affective, emotional, artefactual, semiotic, and creative activity of the individuals. In this context, learning is defined as the outcome of processes of objectification. And since systems of thought (mathematical, etc.) are always revealed partially, these processes are always endless—and hence, so is learning.

Processes of subjectification

Learning includes emotions and affect, not as merely concomitant phenomena of learning, but as *constitutive* parts of it. The educational implication is that instead of being a purely mental endeavour, learning mathematics involves emotions and affect in manners that touch and shape us profoundly. This is why classrooms do not produce knowledge only; they produce *subjectivities* (i.e., unique human beings) as well. In the TO, the investigation of the production of subjectivities in the classroom is carried out through the construct of *processes of subjectification*: the processes where, co-producing themselves against the backdrop of culture and history, teachers *and* students

come into presence. To come into presence refers to the idea of the student as someone who, through classroom activity, comes to *occupy a space* in the social world and to *be a perspective* in it. To come into presence is a *dialectical* movement between culture and the individual. The dialectical nature of this movement brings us to conceive of the individuals as entities in flux—entities who are continuously co-producing themselves and find in their culture the raw material of their own existence. Both the individual and culture are coterminous entities in perpetual change, one continuously becoming the other and the other the one. In this dialectical movement, students as well as teachers are considered as subjectivities in the making, openness towards the world. Teachers and students are conceptualized as unfinished and continuously evolving projects of life, in search of themselves, engaged together in the same endeavour where they suffer, struggle, and find enjoyment and fulfillment together.

Joint labour

In the TO, what makes learning possible is human *activity*. Processes of objectification and subjectification are embedded in activity. Now, the activity where learning occurs can be alienating. This is what happens in the classroom activity of both the traditional teaching and its pedagogy of knowledge transmission and the constructivist student-centred pedagogy of knowledge construction. In the first case, the students do not have room to *express* themselves. As a result, the activity *alienates* them from their own product—the knowledge that was produced in the classroom. In the second case, the student is involved in doing things and expresses herself. However, that expression remains confined to the subjective sphere of the self. Since knowledge is understood as that which is produced by the action of the student, the student is not in conversation with the world. There is a mere monological conversation of the subject with the subject itself. The student is alienated from the historical-cultural world and is confined to live in a “taken-as-shared” universe. The TO resorts to a different, non-alienating concept of learning activity. First, the teacher does not appear as a possessor of knowledge who is delivering or transmitting knowledge to the students or as someone scaffolding strategies to the students. Nor do the students appear as passive subjects receiving knowledge or as the authors of their own knowledge. Second, teaching and learning are not considered as two separate activities, one carried out by the teacher (the teacher’s activity) and the other carried out by the student (the student’s activity). In the TO, teaching and learning are conceptualized as a single and *same* activity: the same teachers-and-students’ activity. This concept of activity does not reduce activity to a series of actions that individuals perform, perhaps in coordination with each other, in the attainment of their respective goals. This line of thinking reduces activity to a functional and *technical* conception. In the TO, following Marx and Leont’ev, activity is a *form of life*, a kind of *energy* formed by the individuals in their pursuit of something common, an energy that is sensible and sensual, material and ideational, discursive and gestural. To avoid confusion with other meanings, in the Theory of Objectification, activity in the latter sense is termed *joint labour*. Joint labour is the chief ontological category of the TO and its unit of analysis. Sensuous, material joint labour is considered the ultimate field of aesthetic experience, subjectivity, and cognition. It asserts the fundamental ontological and epistemological role of matter, body, movement, action, rhythm, passion, and sensation in what it is to be human.

An example

I would like to refer to an example that comes from a Grade 4 class (9-10-year-old students) where the students were dealing with a sequence generalization problem based on the following story: “For his birthday, Marc receives a piggy bank with one dollar. He saves two dollars each week. At the end of the first week he has three dollars, at the end of the second week he has five dollars, and so on.” The teacher provided the students with bingo chips of two colours (blue and red) and numbered plastic goblets intended to represent Week 1, Week 2, etc., and invited the students to work in small groups to model the saving process until Week 5. Then, drawing on the model, the teacher invited the students to find the amount of money saved at the end of Weeks 10, 15, and 25. After some discussion, the students came up with an arithmetic strategy, the “doubling strategy”: they found the number of bingo chips in Week 5, doubled this amount and removed one bingo chip. The teacher came to see the students’ work and engaged in the conversation:

- 1 Teacher: (*Trying to make noticeable to the students the co-variational structure*) What do you remark about Week 5 (*She shows the goblet corresponding to Week 5*) and (*Pointing to the red bingo chips*) the number of bingo chips? (*Making the same actions*) The fourth week and the number of bingo chips?
- 2 Albert: (*Hesitantly and at the same time interested*) It’s always twice . . .
- 3 Teacher: (*Repeating*) It’s always twice.

This teaching-learning activity was the first one of a sequence of activities dealing with algebra. Algebraic knowledge already exists in the students’ culture. It is part of the school curriculum. However, until that morning, for the students, algebraic knowledge existed as a pure generative capacity of actions and thinking. Learning requires making algebraic knowledge something noticeable, an object of consciousness. The classroom activity was organized by the teacher so that, working collaboratively with the students, algebraic knowledge could be materialized or instantiated and so progressively it could manifest itself through one of its developed forms—i.e., as knowing. The three lines of the excerpt above show this progressive transformation of knowledge into knowing. Indeed, the mathematical variables started being noticed. They started becoming objects of consciousness. However, their co-variational algebraic nature remained unnoticed. Joint labour reaches here a tension that derives from the contradictory ways in which the terms of the sequence have been so far perceived (an arithmetical one, based on doubling, and an algebraic one, based on a co-variational approach to the problem). This contradiction is not a flaw of a didactical design: it is the very motor that keeps the activity unfolding. To encounter algebraic thinking as featured in the teacher’s didactical project, the teacher and the students have to keep working together to try to make the algebraic approach *appear* in the classroom and become an object of the students’ consciousness. Its appearance is a bit like the appearance of Beethoven’s 7th symphony: for it to become an object of consciousness it has to aurally appear through the activity of the orchestra. Since mathematics is simultaneously visual, tactile, aural, material, artefactual, gestural, and kinesthetic, it can only come into life here through the sensuous and artefactual joint labour of the teachers and the students.

After some discussion and failed attempts at making noticeable the algebraic structure of the bingo chips’ visual arrangement (see Figure 1, Pic 1), the teacher came back to an analysis of Week 5:

- 4 Teacher: (*Taking with her hand again the goblet of Week 5; see Pic 1*) What did you do here?
- 5 Albert: (*Takes a long breath while the teacher holds the goblet of Week 5; see Pic 2*) OK.
- 6 Teacher: (*Still holding the goblet, speaks softly*) 5 . . .
- 7 Albert: (*In sync with the teacher's gesture that points next to the red chips; see Pic 3*) Times 2 . . .
- 8 Krysta: (*Who has followed the discussion*) Times 2 equal . . .
- 9 Teacher: (*Pointing at the blue bingo chip; see Pic 4*) Plus 1.
- 10 Albert: (*Almost at the same time*) Plus 1.
- 11 Teacher: (*Now pointing to an empty space where Week 10 would be*) 10?
- 12 Albert: (*The teacher points silently at the place where the red bingo chips should be; see Pic 5*) Times 2.
- 13 Krysta: (*At the same time*) Times 2.
- 14 Teacher: (*Points silently at the place where the blue bingo chip should be; see Pic 6*)
- 15 Krysta: Plus 1.
- 16 Albert: (*Looking at the teacher*) Minus 1?, times 2, minus 1?, plus 1?

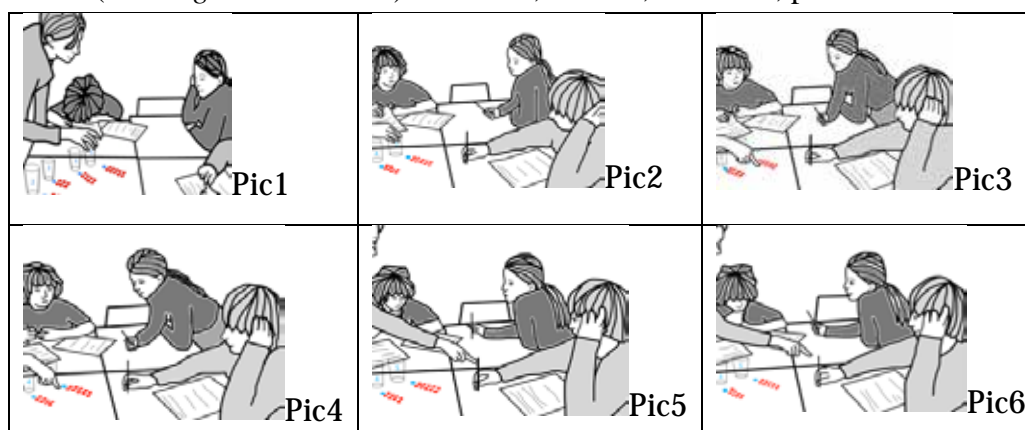


Figure 1: Joint labour and the appearance of an algebraic approach to solve the problem

The example illustrates three things. First, what joint labour *is*: a spatial-temporal *dynamic system* that is created by the students and the teacher. It is made up of the *energy* that the teacher and the students spend in trying to solve the problem and whose fabric includes language, gestures, perception, body position, and artefacts. It is a fluid carrier of half-expressed and half-understood intentions and motives. Second, the example shows some of the intricacies of the transformation of knowledge into knowing. Knowing is this specific manner in which algebraic knowledge is being *instantiated* from a particular problem and through joint labour (distinguishing the variables and their relational-functional nature, expressing it through language, gestures, etc.). Third, the example let us have a glimpse of how learning occurs. Indeed, the example shows how, wrapped in this energy of which joint labour is made up, the teacher moves her hand silently to indicate with an indexical gesture the imaginary position of the blue chip (see Pic 6). She is very tense, as the outcome of the joint labour is still uncertain. She awaits Albert's answer with a tension that is reflected in her body and language intonation. Her question is an *invitation* to Albert to come to position himself in a mathematical practice. The question is *already* a positioning. But still Albert

has to accept. He could have just given up. But he does not. Albert, who is also very tense, accepts the teacher's question/invitation and says "Minus 1? Times 2 Minus 1? More 1?" The answer attests to the fact that Albert is positioning himself and being positioned in a social practice where things are thought of in a certain manner. But the answer attests also to the fact that the co-variational algebraic manner by which to see the variables is progressively becoming intelligible to Albert's consciousness. More generally, in the joint labour we see the unfolding of a social process that is at the same time a process of subjectification and objectification. Albert is living an encounter with key aspects of algebraic knowledge. The difference between S and K in the equation $S \neq K$ is being reduced. Since knowledge is a *general*, the difference will never vanish. Even though, there is still room for Albert to perceive better the nuances of the algebraic variables and how they relate to each other. It did not take long. During the general discussion, which started right after the end of the previous excerpt, the teacher invited Albert to explain how to find out the number of bingo chips in Week 4. He said: "4 times 2 . . . plus 1, 4 times 2 plus 1 equals . . . 9."

Concept

As knowledge is put into motion through joint labour, it becomes materialized into something sensible; that is, knowing. In the course of its materialization, knowledge is *refracted* in the students' consciousness. This refraction is always different: it changes from student to student. A concept is precisely the subjective refraction of knowledge in consciousness through the mediation of knowing. A concept enables us to *do* things and to *think* about them in certain ways. While knowledge and knowing are historical-cultural entities, a concept is of a subjective order: the subjective and partial version of cultural knowledge. In the example discussed above, algebraic knowledge is refracted in Albert's consciousness—as the *concept* of algebraic generalization of (linear) sequences. Although still fragile, this concept, originated in activity, becomes an "organ" of Albert's body. It is something that allows and empowers him to perceive sequences and to think of them in a new way. No less important, the concept connects Albert with culture and history and transforms him at the same time into a cultural-historical subject.

References

- Aristotle. (1998). *Metaphysics* (H. Lawson-Tancred, Trans.). London: Penguin Books.
- Bakhtin, M. M. (1981). *The dialogical imagination*. Austin: University of Texas Press.
- Hegel, G. W. F. (1977). *Hegel's phenomenology of spirit*. Oxford: Oxford University Press.
- Hegel, G. (1991). *The encyclopaedia logic*. (T. F. Geraets et al., Trans.). Indianapolis: Hackett.
- Ilyenkov, E. V. (1977). *Dialectical logic*. Moscow: Progress Publishers.
- Radford, L. (2013). Three key concepts of the Theory of Objectification: Knowledge, knowing, and learning. *Journal of Research in Mathematics Education*, 2(1), 7–44.
- Radford, L. (2018). Desafíos encontrados en la elaboración de la TO. *PNA*, 12(2), 61–80.
- Rogoff, B. (1990). *Apprenticeship in thinking*. Oxford: Oxford University Press.
- Vygotsky, L. S. (1998). *Collected works (Vol. 5)*. New York: Plenum Press.

An epistemological and philosophical perspective on the question of mathematical work in the Mathematical Working Space theory

Alain Kuzniak¹ and Laurent Vivier²

¹Université Paris-Diderot, LDAR (EA4434), France; alain.kuzniak@univ-paris-diderot.fr

²Université Paris-Diderot, LDAR (EA4434), France; laurent.vivier@univ-paris-diderot.fr

The theory of Mathematical Working Spaces (ThMWS) is a young theory that appeared in the field of didactics of mathematics a decade ago with the objective of describing and constructing the mathematical work of students in a school context. To this end, the theoretical framework aims to link and closely combine epistemological and cognitive approaches. In this article, we deepen the very notion of mathematical work by focusing first on an epistemological approach that specifies the nature of work in mathematics and then on a philosophical approach that connects work and communication in a dialectical relation. These two approaches highlight the more or less implicit ideological assumptions that guide our research in didactics.

Keywords: Mathematical work, work and communication, semiotics genesis, paradigms.

Introduction

Developed for more than a decade as a methodological and theoretical tool, the Mathematical Working Space model has recently been presented as a theory by eminent researchers in the field of mathematics education. In particular, Radford (2017) uses the theory of MWS together with Brousseau's Theory of Didactic Situations (1997) to exemplify theories in mathematics education which reflect on mathematical knowledge and know-how that the much of the mainstream research in the domain seems to neglect:

However, I think that focusing on knowledge is what educational approaches such as the French didactic theories excel at – for example, the theory of didactic situations or its young sibling theory “the mathematical working space”. (Radford, 2017, p. 503)

This focus on content is essential in the theory of MWS and is reflected in the central place given to “mathematical work”. Moreover, one of the specificities of the theory is that it was conceived to interact with a diversity of constructs and perspectives in the field. This plasticity poses the challenging question of the real nature of its relationships with other theoretical approaches, which may be grounded on very different epistemological and methodological principles. The epistemological stances from a given theoretical model shape the nature of the objects and problems being studied, but according to our view they also influence the capacity of integration of, and exchanges with, other theoretical frameworks. This capacity refers to Kidron's *epistemological sensitivity* (2016), which is likely to foster the possible networking between different approaches.

In this contribution we would like to focus on this epistemological question which relates to a point highlighted in the call for contributions for this topics group, namely the epistemological dimension of theories for example in terms of *argumentative grammars or background philosophy*. This contribution complements the one presented at CERME10 (Kuzniak & Nechache, 2017) where we showed the interactions between methodological development and the evolution of the MWS

theory. To characterize its *epistemological sensitivity*, we propose to question the epistemological and ideological assumptions underlying our theoretical approach and stemming from the fact that we are interested in the nature of "mathematical work". We will also highlight the specificity of the theory and its originality in the field of didactics of mathematics.

The French environment of didactics of mathematics

We think it is useful to start by presenting the particular French context in which the ThMWS is embedded and developed. Despite some theological quarrels linked to the personality of the various researchers involved in its growth, it must be recognized, that the didactics of mathematics in France is based on a community of theoretical and methodological principles that contribute to establishing a real cultural homogeneity. In a fairly simple way, we can say that the didactics of mathematics in France is supported on three essential pillars associated to symbolic figureheads enjoying strong international recognition (at least at symbolic level through the award of scientific prizes and medals).

- The Theory of Didactic Situations, the foundations of which were laid by Brousseau (1997), where it is essential to link theoretical and empirical research in close connection with the classroom. Its aim is to develop an experimental didactics that goes beyond the classical didactics as described in Comenius' *Magna Didactica*, which Brousseau regularly cites in his presentations and where all guidelines and ideas have been given a priori and are not validated by field studies.
- The Anthropological Theory of Didactics, initiated by Chevallard (1992), is based on an anthropological and holistic vision of learning and teaching acts. This holistic framework, based on the study of praxeologies, aims at a theoretical autonomy of didactics which is independent of other scientific fields such as mathematics, sociology or psychology.
- The Theory of Conceptual Fields developed by Vergnaud (1991) is less well known but brings a psychological and cognitive dimension, based on Piaget's learning theory, to these two theories strongly influenced by mathematical epistemology.

As underlined above, these theories benefit from a kind of international visibility and recognition with the award of the Klein Medal to Brousseau, the Freudenthal Medal to Chevallard and the fact that Vergnaud was one of the founders of PME. The following theoretical contributions are less widely known but very present and influent in the French context:

- Duval's contribution (2006) on semiotics with the development of semiotics registers. In this approach, signs and semiosis are essential because they mediate mathematical objects that are only accessible through their different semiotic representations.
- The ergonomic approach combines Piaget's and Vygotsky's contributions and led to "French Activity Theory" as it is presented in a recent special issue of *Annales de Didactique* (2018). It is also based on a reflection on instruments and tasks and includes the developmental dimension of activity.

It is within this context that the theory of MWS (Kuzniak, Tanguay, & Elia 2016, Gómez-Chacón, Kuzniak, & Vivier 2016) has been developed by seeking to link and preserve very closely the

epistemological and cognitive viewpoints. The epistemological point of view is very focused on mathematical content with a reflection on its organization. While the cognitive viewpoint follows Duval's approach in geometry and focuses on the visible and tangible aspects of the subject's activity. The interaction of the two perspectives was achieved by placing mathematical work at the centre of the reflection. The specific study of the mathematical work is based on three dimensions and geneses: semiotic, instrumental and discursive.

A short presentation of the theoretical framework: The model with its diagrams

The purpose of the theory of Mathematical Working Space is to provide a tool for the specific study of the mathematical work in which students and teachers are effectively engaged during mathematics sessions. The abstract space thus conceived refers to a structure organised in a way that allows the mathematical activity of individuals who are facing mathematical problems.

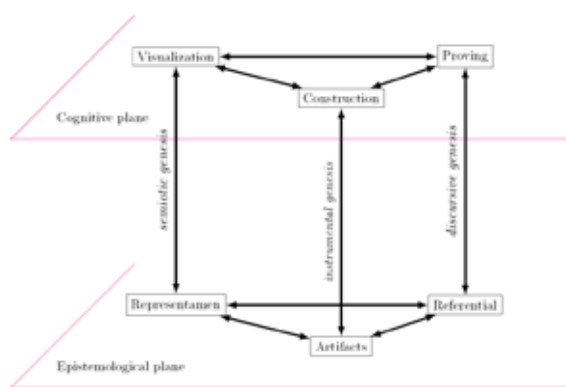


Figure 1: The MWS diagram

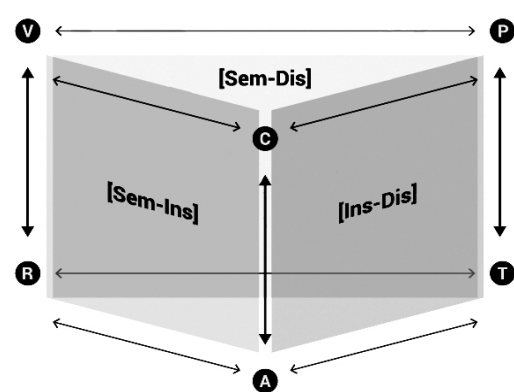


Figure 2: The three vertical planes in the MWS

To grasp the specific activity of students solving problems in mathematics, the two epistemological and cognitive facets of mathematics are present and articulated in the model into two planes: one of an epistemological nature in close relation to the mathematical content in the field being studied; the other of a cognitive nature, related to the visible action of the individual solving problems (Figure 1). Three components in interaction are characterised for the purpose of describing the work in its epistemological dimension, organised according to purely mathematical criteria: a set of concrete and tangible objects (representamen); a set of artefacts such as drawing instruments or software; a theoretical system of reference based on definitions, properties and theorems. The second level of the MWS model is centred on the subject, considered as a cognitive subject. Three cognitive components are introduced as follows: visualisation related to deciphering and interpreting signs; construction depending on the used artefacts and the associated techniques; proving conveyed through actions producing validations, and based on the theoretical frame of reference. Therefore, analysing mathematical work through the lens of MWSs allows tracking down the process of bridging the epistemological plane and the cognitive plane, in accordance with three different dimensions: An instrumental dimension (Ins) related to the experimental and empirical part of work, a discursive dimension (Dis) related to the strategic and theoretical part, and finally a semiotic dimension (Sem) that expresses the importance of signs as an intuitive source and support

for mathematical work. The shaping of work involves different but intertwined genetic developments, each identified as a genesis linked to a specific dimension of the model: semiotic, instrumental and discursive geneses.

In order to understand this complex process, the interactions that are specific to the execution of given mathematical tasks will be associated to the three vertical planes, naturally occurring in the MWS diagram: the [Sem-Dis] plane, conjoining the semiotic genesis and the discursive genesis of proof, the [Ins-Dis] plane, conjoining the instrumental genesis and the discursive genesis of proof, the [Sem-Ins] plane, conjoining the semiotic genesis and the instrumental genesis (Figure 2).

The exact definition and precise description of the nature and dynamics between these planes during the solving of a series of mathematical problems remains a central concern for a deeper understanding of mathematical work. To achieve this description, studies performed within the framework of MWS theory closely examine the design and implementation of classroom teaching situations according to a specific methodology supported on MWS diagrams (Kuzniak & Nechache, 2017).

The necessary clarification of what is “le travail mathématique” in schooling

In the following, our study focuses on the real scope and meaning of “le travail mathématique”, in particular we wish examine the theoretical construction developed in the context of the didactics of mathematics and see its solidity when the same notion is considered from other perspectives, epistemological and philosophical, that a priori do not belong to the world of education. First, we kept the expression “travail mathématique” in French, because one of the first difficulties we encounter in this study is the translation into English of the term "le travail mathématique". We have opted for "mathematical work" which is not its exact equivalent as we will see later. This difficulty in translating the meaning of the term "mathematical work" is found again in the choice of translating, after long discussions, "Espace de Travail Mathématique" into “Mathematical Working Space” to insist on "working" more than on "the workplace".

To achieve this study, we begin by following the easiest and least controversial path, that of epistemology, which makes it possible to question the term "mathematical work" by emphasizing the "mathematical" aspect in order to identify precisely the meaning of mathematics when it is considered through the idea of work. A second, steeper and more controversial path, because it may be political, will make us question ourselves on “work”, the first term of the pair, from a philosophical point of view.

An epistemological perspective on mathematical work: Thurston and Granger

Mathematical work as a recursive and progressive process

The notion of “mathematical work” must be taken as a syntactic whole which combines closely work and mathematics. In order to define the idea of work within our framework, we use the dual approach of Habermas (1969), which stresses both instrumental action and rational choice as constitutive of work.

By « work » or purposive-rational action I understand either instrumental action or rational choice or their conjunction. Instrumental action is governed by technical rules based on

empirical knowledge (...). The conduct of rational choice is governed by strategies based on analytic knowledge. (...) Purposive-rational action realizes defined goals under given conditions. (Habermas, 1969, p. 92-93).

But what exactly is this specific action that allows mathematical work to be identified? According to Thurston (1994), the difficulty in defining mathematics stems from the essentially recursive nature of the mathematical activity. So, he characterizes mathematics as the field that contains as a central core the study of numbers and space geometry, and then he defines this field in extension as what is being produced by the work of mathematicians, “those humans who advance human understanding of mathematics” (Thurston, 1994, p. 162). In this view, mathematics ‘scientificity’ comes from the critical and repeated revision of the research and results generated by mathematics and by those who produce it along processes always open to reassessment and questioning.

These processes are necessarily in the long run, and we may thus evaluate that having access to full mathematical work is not possible without being engaged in such a progressive and recursive process. This idea of mathematical work in constant evolution and construction, even in the school context, is a central point of our vision on mathematics learning and teaching.

The mathematical work and its style

Defining mathematics from the point of view of mathematicians' activity implies to look at the results of this work in order to better understand the nature and contents of mathematics. To achieve this, it will be necessary to study the resulting work, fruit of the work elaborated by mathematicians. This work is a formalisation of abstract concepts that requires a codification of the discourse. Granger (1963) calls style the particular way of presenting rational knowledge by submitting it to codified norms that give objects a specific meaning. These standards help to set the direction of work on problem solving. They make it possible to exclude certain practices by limiting the possibilities of interpretation and therefore exploration of the reader or student. In that sense, the notion relates to the idea of paradigm introduced by Kuhn (1966). For us, a paradigm will stand for a combination of beliefs, convictions, techniques, methods and values that are shared by a scientific group. Gaining access to a mathematical paradigm will involve meeting the mathematicians' work and going through the solutions and solving processes of distinctive problems that qualify as exemplars according to Kuhn. In studies conducted within the framework of the theory of MWS, the exact definition of paradigms is important because it allows revealing and understanding the expectations of teachers and educational institutions and also to explore the real distance between this expected work and the work actually carried out by the students.

A philosophical and critical perspective on mathematical work: Work and communication

In this section, we examine the second part of the formulation "mathematical work", and deal with the question of work. To move forward in this direction, we will rely mainly on the philosopher Fuchs (2016) who published a critical and social essay on work and communication in the age of the digital economy. As we will see his approach joins and sharpens our own conceptions and research on mathematical work developed now in a rich technological and digital environment which has deeply changed the traditional way of working in mathematics especially at school.

On the difficulty to translate the word “travail” in “le travail mathématique”

Fuchs revisits the question of terminology and sense of the word “travail” in different languages by pointing out the distinction between *work* and *labour*. He stresses on the fact that whereas the etymological root of terms such as *work* or *werk* (German) is creating, acting, doing, the etymological root of words such as *labour* and *Arbeit* (German) is toil, slavery and hardship (Fuchs, 2016, p. 17). This etymological distinction is also found in French—on the one hand *ouvrier* (work) and on the other hand *travailler* (labour). But at the same time the origin of the word “travail” in French is controversial and does not refer to the same roots. The word “travail” seems to have a broader meaning than work and the word “*labour*” (labour) is rarely used in French. Thus, for example, the equivalent of Labour Day is la “*fête du travail*”.

In the context of our study, we will consider three large dimensions of work close to the French idea of “travail”: work as a long-term process with a certain permanence; the result of work which can be named a work; the goals and stakes of work which will be precisely here of mathematical nature.

On the relationship between work and communication

As we have seen above, the communication of the work of proof is part of the mathematical work, it makes visible the rationality of the arguments presented. But what is the exact nature of this relationship? Fuchs studies four modes of relationship between work and communication. The first two assume a pre-eminence of one over the other, the third proposes their independence and finally the last one proposes a dialectical link between the two. For Fuchs, Habermas, whom we mentioned above, is the main defender of the dualist position. Habermas’ theory of communicative action makes a sharp distinction between on the one hand purposive (instrumental, strategic) action (including work) that is orientated on success and on the other hand communicative action that is orientated on reaching understanding. According to Fuchs, Habermas' vision is a little naive insofar as it assumes that communication is always part of a positive and rational dynamic.

In addition to this dualist vision of the relationship between communication and work, Fuchs emphasizes authors who favour a dialectical approach to work and communication. Curiously and unexpectedly by us, he underlines the singular contribution of Lev Vygotsky and his Activity Theory and stresses on the fact that Lev Vygotsky (1896–1934) was a Marxist psychologist from Belarus who developed a theory of activity, whose basic point is that human cognition and language are grounded in human activity. As we have pointed out above, this theory is particularly important and natural in France where Vygotsky is considered for his research in psychology which is used in combination with Piaget's studies. Moreover, the reference to Marx is common among the main French philosophers (from Althusser to Comte-Sponville via Badiou) and is not considered as sulphurous and diabolical as it is the case in some national traditions with an anti-communist or liberal influence. Perhaps, this specific relationship between Activity Theory and Marxism helps to understand the different ways this theory is received depending on countries because of the close relation existing between Marxism and communism.

To come back to the scientific content of Vygotsky's writings, it should be retained that Vygotsky (1978) argues that. ‘The sign acts as an instrument of psychological activity in a manner analogous to the role of a tool in labor’ (Vygotsky 1978, 82). Tools as means of work and signs as means of

communication have for Vygotsky in common that they are both forms of mediated activity. The difference is for him that the tool is externally oriented on changing nature and the sign is internally oriented: The sign is a means of internal activity aimed at mastering oneself.

Again close to our approach which insists on semiotic aspects, Fuchs also points out a much less well-known Italian author, Rossi-Landi, who favours the semiotic approach as a support for this dialectic between work and communication and introduces semiotic production processes:

Rossi-Landi's semiotic theory (...) helps to clarify the dialectic of work and communication: language-use and communication are work that produce words, sentences, interconnected sentences, arguments, speeches, essays, lectures, books, codes, artworks, literature, science, groups, civilisation and the linguistic world as totality (Fuchs, p. 191).

Thus, this reflection on the dialectics of work and communication is in line with our way of considering mathematical work as the result of different processes: a semiotic process that relates to the treatment of signs; an instrumental process that promotes the link with material or digital tools; finally, a discursive process that relates to rational proof. The singular importance we attach to the discourses of proof reveals more particularly the very nature of the work associated with mathematics where proof, particularly in its demonstration form, is crucial in the realization and coherence of mathematical work.

Conclusion

The Theory of Mathematical Working Spaces aims to describe the forms of mathematical work carried out by students in the school environment. As its name suggests, it places mathematical work at the centre of reflection on teaching and learning. In this context, the primary purpose of educational institutions and teachers is to develop an environment that enables students to solve mathematical problems in an appropriate way. The organization of MWSs into two levels, epistemological and cognitive, allows the description of the work of students confronted with a set of tasks with a mathematical purpose.

In our framework, mathematical work results from the interactions between signs, tools and properties through the interweaving of the three semiotic, instrumental and discursive geneses. We were also able to verify that our vision of mathematical work based on circulation in the MWS diagram (Figures 1 and 2) has many justifications in the field of didactics of mathematics. The reflexive detour that we have made by relying on contemporary epistemological and philosophical approaches, has also shown us that our issue has encountered some strong questions in these fields such as the relationship between forms of work and communication. Our way of seeing resonates with certain current problems of critical philosophy confronted with the evolution of the world of work in an increasingly technological environment and subject to new rules of production and alienation.

Even if the confrontation of our theory with this political and social approach does not radically transform our way of thinking, it does contribute to better positioning our research in a broader current of thought and above all it helps to reveal the ideology that often underlies some work carried out in our research field in an unconscious or implicit way. In particular, it can explain some

misunderstandings or difficulties in receiving our research: one of the most visible being the understanding and use of the term “mathematical work” which seems doubly provocative in today's world of mathematics education. The use of this term implies for the subject acting to go beyond the only laborious and technical part of work and thus that work focused on mathematics contributes to the intellectual emancipation of students and professors that is still in the making-phase.

References

- Brousseau, G. (1997). *Theory of didactical situations in mathematics*. New York: Springer.
- Chevallard, Y. (1992). Concepts fondamentaux de la didactique: perspectives apportées par une approche anthropologique. *Recherches en didactique des mathématiques*, 12(1), 73–112.
- Duval, R. (2006). A Cognitive Analysis of Problems of Comprehension in a Learning of Mathematics. *Educational Studies in Mathematics*, 61(1–2), 103–131.
- Fuchs, C. (2016). *Critical theory of communication: New Readings of Lukács, Adorno, Marcuse, Honneth and Habermas in the Age of the Internet*. London: University Press of Westminster.
- Gómez-Chacón, I., Kuzniak, A., & Vivier, L. (2016). El rol del profesor desde la perspectiva de los Espacios de Trabajo Matemático. *Boletim de Educação Matemática – BOLEMA*, 30(54), 1–22.
- Granger, G.G. (1963). *Philosophie du style*. Paris: Armand Colin.
- Habermas, J. (1970). *Technology and Science as Ideology*. Boston: Beacon Press.
- Kidron, I. (2016). Epistemology and networking theories. *Educational Studies in Mathematics*, 91(2), 149–163.
- Kuhn, T. S. (1966). *The structure of scientific revolutions* (2nd ed.). Chicago: University of Chicago Press.
- Kuzniak, A., Tanguay, D., & Elia, I. (2016). Mathematical Working Spaces in schooling: an introduction. *ZDM-Mathematics education*, 48(6), 721–737.
- Kuzniak, A. & Nechache, A. (2017). On dialectic and dynamic links between the Mathematical Working Space model and practice in the teaching and learning of mathematics. In Dooley, T. & Gueudet, G. (Eds.). *Proceedings of CERME10*. Dublin, Ireland.
- Radford, L. (2017). On inferentialism. *Mathematics Education Research Journal*, 29(4), 493–508
- Thurston, W. (1994). On proof and progress in mathematics. *Bulletin of the American Mathematical Society*, 30(2), 161–177.
- Vergnaud, G. (1990). La theorie des champs conceptuels. *Recherches en didactique des mathématiques*, 10(2), 133–170.
- Vygotsky, L. S. (1978). *Mind in society: The development of higher psychological processes*. Cambridge, MA: Harvard University Press.

A phenomenological methodology based on Husserl's work in the service of mathematics education research

Andonis Zagorianakos

Mathematics Department of the University of Athens; matheart7@math.uoa.gr

The paper introduces a phenomenological methodology based on Husserl's work and on Merleau-Ponty's radical extension of Husserl's work. The phenomenological reduction and bracketing (epochè) are introduced as the critical methodological instruments in exploring the emergence of mathematical understanding, by casting phenomenological light on the learner's intentional cognitive constitutions, from the passive to the active stage of her or his lived experience. An empirical example is used in order to showcase the impact of the researcher's methodological shifting, from the natural to the phenomenological attitude (the reduction and the epochè), and the methods and techniques that are used, in allowing the methodology to produce results. A summarising diagram and some notes for the usefulness of the methodology application for mathematics education research are included.

Keywords: Phenomenological methodology, Husserl, intentionality, reduction, bracketing, epochè, phenomenological attitude.

Introduction

The aim of this paper is to introduce a phenomenological methodology as a valuable frame for mathematics education research (MER). Examples of my use of this methodology have been published in *Educational Studies in Mathematics* (2015) and other international journals, as well as presented at CERME9, PME (2014, 2015) and BSRLM (2012, 2013) conferences. Critical distinctions emerge, between my use of phenomenology and that of other phenomenological or phenomenologically informed researchers in MER (e.g., Radford, Roth, Nemirovsky). The distinctions are concerned with the principal use of Husserl's work in my research—which is either taken for granted, critically disputed or scarce in the influential work of these scholars. Most importantly, the central difference in my work is the thematisation and application of Husserlian *methodological* concepts, such as the phenomenological reduction and the epochè. These concepts are used precisely for the purpose introduced by Husserl (i.e., phenomenology as methodology), and they are missing in the aforementioned researchers' phenomenological contributions. In my work, these concepts have been used in order to put in motion Husserl's mature work on the life-world (Lebenswelt) and the living present of learners. My conviction is that the same methodology could be applied to research with teachers, mathematical classrooms, curricula etc., each time providing critical distinctions. In this sense, the application of the phenomenological methodology presented here and as applied to learners suggests the viability of its application to other phenomena in mathematics education research.

The key concept of intentionality as a starting point for the application of the methodology

This paper follows Husserl's (1970, p. 168) conceptualisation of the central role of intentionality for the study of mathematical cognitive situations. The **intentional aspect** of conscious acts is concerned

with the fact that every conscious act is *about* something; I fear *something*, I hope *something*, I judge *something* (as true or false), I love *someone*, I hate *something*, and so on. Also, everything perceived is always perceived in a certain manner, with fear, hope, in shaping a judgement, with love, hate, etc. In the same respect the key feature of conscious acts, and in particular the cognitively motivated acts, are *about* something, present or absent, real or supposed as real, valid or not, but in any case, present for these acts. Husserl (1983) adopted Brentano's conception of intentionality as being the main feature of conscious acts and extended it critically. Mature Husserl (e.g. 1970, p. 168) thematised further the "uncover[ing] and the "clarification of what is accomplished" in the "intentional origins" region of lived experience. What does this mean in terms of the mathematics education research perspective? It means that by focusing on the region of intentional origins we could uncover and clarify what is accomplished in them, since, as he explains "every sort of intentional unity becomes a '*transcendental clue*' to guide constitutional 'analyses'...[which are] *uncoverings of intentional implications*" (Husserl, 1969, p. 245, italics in the original), particularly related to an operative, embodied sense on which abstract knowledge is grounded.

In order to explore the intentional aspect of the mathematical cognitive experience, the phenomenological reduction and the epochè (see the following sections) must be applied, as the two basic methodological instruments. The aim of the methodology is to open up the "currently constituted intentional unity" (1969, p. 245) of the learners' understandings, and thus to understand better how they *arrive* at their understandings, in their engagement with mathematical tasks and questions.

Epochè (bracketing) and phenomenological reduction—A first introduction

The methodology is supported by a phenomenological perspective that presents an intentional view of the cognitive life-world. This perspective approaches the mathematical lived experience as being intentionally supported; the researcher tries to study it without pre-conceptions on what it ought to be, but merely focuses on the intentionally emerging appearances, as they appear *for* the learner. The suspension of preconceptions is one of two basic methodological instruments. This suspension amounts to a two-fold task:

- To spot and put aside actions that are not relevant to the student's experience;
- To suspend the researcher's own intentions, and prevent him or her from interfering with the intentions running through the phenomenon of cognition under study.

In this sense all objectivity is *suspended*, as was introduced by Husserl (1983, p. 60), who used the term *epochè* for this process. Husserl employed *epochè* in order to combine it methodologically with his *phenomenological reduction*. This is the second basic methodological instrument. It is tantamount to the "leading back" from the natural targets of our concern, to "what seems to be a more restricted viewpoint, one that simply targets the intentionalities themselves" (ibid.).

So a combination of *epochè* (suspension or bracketing), and *phenomenological reduction*, shapes the core of the methodology. What are revealed through this combination are not the objects as such, but *as they are intended* (imaginatively, through remembering, judging, etc.), focusing on the manners or modalities in which such objects are 'given'. In other words, we look *at* what people normally look *through* (ibid.).

The application of the phenomenological methodological lens in a designed experiment

Here I present an experiment that is phenomenologically analysed, and organised in accordance with phenomenological investigations. It was an experiment in which the teacher allowed all possible interactions between the students, usually working in groups, but he did not provide any guidance to his students, concerning the open tasks that he introduced. I present the case of Mary (pseudonym), one of 13 students, i.e. prospective teachers of mathematics for secondary education, in a course entitled *The nature of mathematics* (NoM). As the teacher's part in the collective or individual thought processes of the students' treatments of the tasks was bracketed (epochè, in Husserl's terms) the thinking strategies themselves came to the fore; the research field was enriched by the various approaches to the tasks, by different or by the same students. *Reflective* and *pre-reflective intentional layers* were thus traced as such (see the following section), as they were grounding the students' constitution of the mathematical objects.

As soon as the intentional layers¹ of the students' engagement in the task are exclusively targeted the researcher enters the *phenomenological attitude*, which guides her or him to further analytical reflections, followed by new findings (cf. the *unit of phenomenological knowledge production* component of the diagram in Figure1). With the use of the *phenomenological reduction* and the *bracketing*—considered as a single methodological instrument by the mature Husserl—we are entering the study of the *natural attitude*, which is “our straightforward involvement with things and the world” (Audi, 1999, p. 405), by describing it with the *phenomenological attitude*. The *phenomenological attitude* is “the reflective point of view from which we carry out philosophical analysis of the intentions exercised in the natural attitude and the objective correlates of these intentions”. Further, “the process by which we move to the phenomenological attitude is called the phenomenological reduction, a ‘leading back’ from natural beliefs to the reflective consideration of intentions and their objects” (ibid.).

The application of the phenomenological methodology in this case had the effect that, what were before *brilliant ideas* that suddenly possessed the students, or *desperate efforts* to ‘survive’ by acquiring some sense of the task, now became telling appearances of the operative affordances that each student brought and was able to release actively, either in the team in which the student was working, or individually, during and/or after the sessions.

The transformation of the working field of research was the result of (a) the focusing on the intentional acts that brought the learners' objects to the surface, in a regressive analysis that starts from the ‘final’ objects and goes back to their genetic appearances, and (b) the neutralising/bracketing (epochè) of factors that played no part in the perception of the objects that were chosen to be activated by the students. From this analysis it occurred that it is the double application of the phenomenological reduction (a) and the epochè (b) that allows the transformation of the cognitive event into a *phenomenon*—in the Husserlian sense that this methodology suggests.

¹ The intentional layers are the layers of intentions of the learner, as he or she is devising an object for a mathematical enquiry.

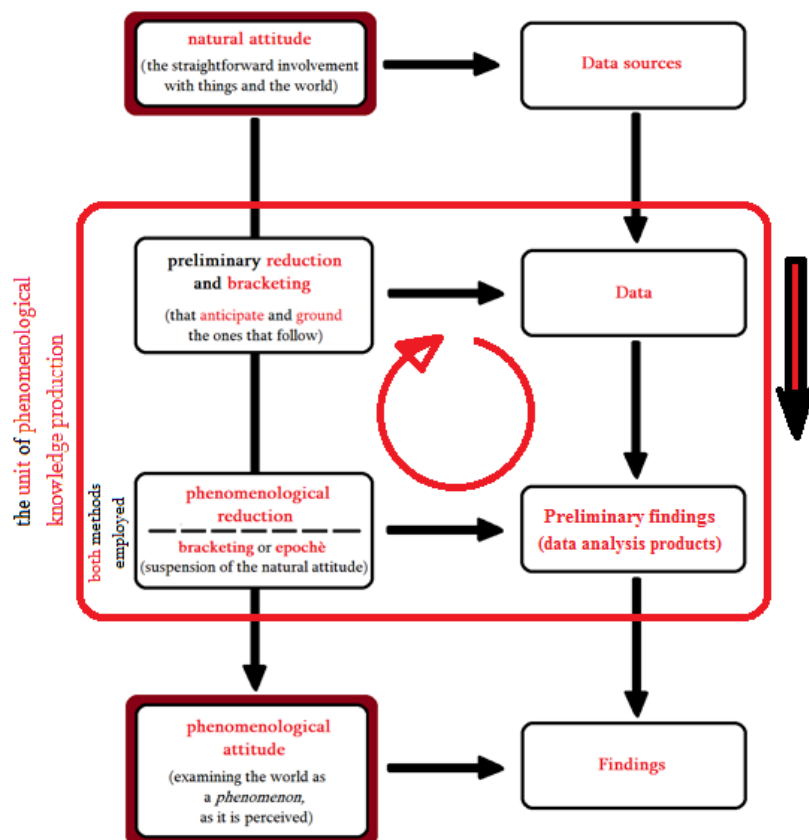


Figure 1: Methodology diagram

Methodological affordances and results

The transformation of the data sources' natural appearances into a phenomenon affords us, as researchers, with the following: (a) the ability to discern *structures* that the students' strategies follow, which could be helpful in teaching design (Zagorianakos, 2016; Zagorianakos & Shvarts, 2015); (b) better understanding of the students' learning horizons, which may also entail further phenomenological analysis, e.g., of a student's change of attitude (Zagorianakos, in press).

Description of the illustrative example—The use of the methodology

The bird's-eye view empirical intuition, as triggering a series of abstract intuitions.

Mary (pseudonym) was a prospective teacher of mathematics in English secondary education. During the NoM course (see previous section) a task was introduced that was required to be solved in teams of three or four students by involving bodily experience. One of each team actualised a fixed point, 10 meters or steps away from a wall, while the rest of her or his team were trying to embody the track of the sought line, in which each point was supposed to have the same distance from the fixed point and from the wall. The room where the task took place had very wide walls, enough for the four teams of three or four students to explore the task. What will be sampled here from that study is how the methodology allowed the phenomenological detection of the crucial influence of the embodied intuitive stock of Mary. The *embodied* grounding of Mary's mathematical achievements was revealed methodologically by the reduction to (focusing on) her intentional cognitive treatment of the mathematical task, and by bracketing (neutralising) what did not affect Mary's experience.

By tracking how Mary *intentionally* handled her drawing of the wall and the Cartesian plane, I noticed how she transformed her drawing into a different view of the classroom, where she was confusedly trying to embody the solution of the task. Mary's view was an intuition,² drawing back to the Scholastics' perception of a 'new vision', which allowed her a breakthrough that followed her up to the end of her treatment of the task. It was in an **actively embodied** rather than in a metaphorical sense that Mary used her perception of a "bird's-eye view". It was this initial embodied intuition that was operating, as a sensory-motor environment to all her understandings, up to the end (see following paragraphs). This phenomenon was lit by *full bracketing of non-significant issues to her constitutive moments*, of the objects that helped her unlock the task. By mentioning non-significant components, I mean all the actions that did not interfere with the student's (constitutive) building process, such as the teacher's non-guidance protocol. Therefore, bracketing is not arbitrary, and it could be responsible for further analyses, as soon as the reduction's furthest application is done (Zagorianakos, in press). Mary's example is not fully analysed here: it has been drawn to showcase the applicability of the methodology, realised by the methods and the techniques, which are introduced in the following section.

Methods and Techniques of the methodology—The student's progress with the task

The methods included participant observation, gathering of documents that included the learners' reflections on their learning processes, and interviews (email or in person). The methods concerned semi-structured live interviews, where the technique was to trigger the flowing of the students' reflections on the actions that brought objects to the surface. Another interview technique was to drive the discussion without force towards the intentional acts that led the learners to their constitutive moments of objects. How did they feel about them? What was special, for them, about these objects? The methods were used so that the intentions that led to the mathematical objects would be revealed; and the techniques were aiming at keeping the researcher in low profile, while bringing the student's narrative vividly to the foreground. Due to such methods and techniques I took advantage of the teacher's self-bracketing in order to study how the students' mathematical experiences were structured.

Let's see how the student's development with the task happened:

After the investigation in the classroom, when the student was in utter confusion about what the sought line was supposed to look like, Mary went home. There she drew on grid paper the wall as a straight line, and a Cartesian plane with the y-axis perpendicular to the 'wall', and the two axes intersecting ten grids away from the line (wall). The student's first intuition appeared, as she grasped her drawing on the grid paper as a *bird's-eye-view* over her very recent, embodied but unsuccessful classroom activity.

Not metaphorically, but in a very actual sense the student realised due to her *bird's-eye-view* perception of her diagram how wrong her perception of the task had been in the classroom: she

² From late Latin *intuitio(n)-*, from Latin *intuit-*, *intueri* 'contemplate', from *in-* 'upon' + *tueri* 'to look'. [Concise Oxford English Dictionary (Eleventh Edition)]. Intuitive in the sense of a special, immediate regard on what is given, as intended.

actually observed that the sought line could not be a straight line parallel to the wall (as she had initially supposed), at half way distance from the fixed point and the wall, while being constantly equidistant from the wall and the fixed point. It is evident that her bird's-eye-view perception had equipped her with a movable vision over the classroom, through the diagram, and a trace of this was that her perceptions were time-related: the straight line was equidistant from the wall and the fixed point at some point, but not in the following of the process of a “movable point”, in which the student started perceiving the curve. So then she started with three points and she started looking for more points belonging to the sought line, by using a ruler parallel to the line (wall) and between that line and the x-axis, thinking of the sought line as being continuous and therefore aiming at finding the points where her ruler intersected with the sought curve. While being in this *operational mode* Mary employed the Pythagorean Theorem (PT) as an *objectification instrument*, to track points belonging to the sought curve and thus unlock its shape. The student's intentional roots were traced; they revealed that the student's recollection of the Pythagorean theorem was in the service of her *intention* to find more points belonging to the curve, while *operatively* using her bird's-eye-view perception of her diagram. This insight adds an *operatively intentional layer*, a clearly embodied layer right at the appearance of the PT as a points' determining instrument.

After finding five points symmetrically located around the y-axis (two of them by using the PT) she had the intuition that the line must have a “bell-shape”, from where she thought of the x-square functions. The student's idea of x-square functions was the second intuitive step, described by Husserl as an abstract *intuitive step*, based on the empirical (“bell-shape”) intuition.

Her exploration culminated in a critical abstract intuition which, through the “synthesis of coincidence” (Husserl, 1973, p. 74) brought to the surface the general rule, the general formula for all curves, with any given distance from a ‘wall’. And even then, the *embodied* sense of her understanding of the algebraic solution remained vivid in her recollection: She perceived the curve as an empirically driven “moveable point”, since “you could stand on anywhere on the line $y = \frac{a}{2} - \frac{x^2}{2a}$ and you would be equidistant from the wall and a fixed point” (interview extract).

The view that the phenomenological methodological components offered to the study

So, the *phenomenological reduction* and *bracketing* (*epochè*), as distinguished from methodic doubt, and being a suspension compatible with certainty, led me to the *phenomenological attitude*. This attitude is equivalent to focusing exclusively on the intentions and their correlated objects in the natural attitude, without “*excluding* of a living conviction, which remains alive” (Husserl, 1983, p. 60). Bracketing enhances focusing and focusing is indicating what needs to be bracketed or seriously studied, phenomenologically or otherwise.

The study of the student's intentional apparatus became my Ariadne's thread in unlocking Mary's lived experience. I finally managed to understand how she imaginatively (with imaginative intention) flew on the wings of her *bird's-eye view* intuition, over the diagram that she drew at home, on grid paper—i.e., using the mathematical diagram as a re-presentation of the classroom where the embodied treatment of the task took place—and finally, how she developed her *bird's-eye view* intuition in order to accomplish all her subsequent intuitions.

The cultural artefacts (grid paper, Cartesian plane etc.) were imperative for Mary's accomplishments, but it was through (and due to) the researcher's phenomenological reduction and bracketing that the focusing on the intentional apparatus of the learner's lived experience finally disclosed the following aspects: (a) *how* the first, empirical bird's-eye view intuition (not 'just' as a metaphor but as an actual, embodied perception) was essential in unlocking the task (Zagorianakos & Shvarts, 2015, pp. 152–154); and (b) *how* her embodied and mental intentionalities were intertwining as she moved further, in activating a general formula for all parabolas (ibid.). The shifting from the natural to the phenomenological attitude (the reduction and the epochè) is a critically innovative *methodological* move, which can unlock the lived experience of the learner by transforming it into a *phenomenon*, in its original (Husserlian) sense, for the researcher. So the methodology is concerned with the study of *focusing* on the learner's object constitution—objects that become mathematical objects as they fulfill the demands of a mathematical task or a question brought in a mathematical context. The focusing is on the objects as they appear *for the learner* and therefore, *as they are intended by the learner*. This focusing allows for the tracing of the *intentional paths* that bring the learner into *contact* with a particular *object*, due to the learner's *pairing* of the object with a certain strategy, while solving a problem:

Through 'something reminds me of something' a *pairing* of two given things in consciousness first arises. Through reflection we see that association is not a blind mechanism, because I can recreate and understand through which connecting point(s) a pairing originally arose in consciousness. (Held, 2003, p. 43)

As an example of the analytical potential that the methodology has made accessible, Mary's intuition on the shape of the curve—as being an x-squared curve, after her empirical intuition of the shape of the 5 points as a bell shape—is phenomenologically perceived as an association generated by a pairing. The empirical image of the bell was paired with the x-squared curves' graph, due to the student's intention to explore a possibility for embodying mathematically the empirical image. This intentional trail from operative (embodied) to active mathematical knowledge production (culminating in Mary's formulas) is a viewpoint on Mary's mathematical lived experience that was developed due to the methodology of intentional focusing (reduction), and teacher bracketing (epochè), in this phenomenological experiment. Practicing this methodology may make the researcher realise the radical view the methodology may offer in the study of cognitive events, particularly when enriched by a phenomenological theoretical viewpoint.

The methods encompass *regressive* and *repetitive reflections* on the data, without taking anything for granted, as far as the appearances of the objects *for the learners* are concerned. The key is to focus exclusively on the acts, and on the intentions that are expressed through them, as they are directed towards objects, as they surface and as they are intended by the learners. Then the focus moves on to objects that triggered the acts and on the acts that brought the latter objects to conscious exploration, within the learner's lived experience. In this sense, this methodology, by using the phenomenological attitude has the effect of a phenomenological mill unit. This is what the *unit of phenomenological knowledge production* element of the methodology diagram (Figure 1) depicts, as the vertical arrow is moving: The vertical arrow in the diagram is making one full route from the top to the bottom of the rectangle, synchronously to the inner round circle arrow completing one round. Then the whole

process is repeated in a more informed manner, phenomenologically, thus producing sounder and more evident ‘images’ (adumbrations), and according findings of the phenomenon under examination. A top-bottom vertical arrow on the left side of the methodology diagram (Figure 1), which is moving through the *unit of phenomenological knowledge production* rectangle, is concerned with the researcher’s own shifting of attitude, from the natural to the phenomenological one. The cognitive phenomenon, as it is unfolding for the researcher, is an orchestration of expressions in the conscious reflective and in the subconscious pre-reflective areas of knowledge production. The methodology shows the switching from a natural attitude to the phenomenological attitude. This is done by specifically thematising the intentional layers that are concealed (taken for granted) in the ‘natural’ reading of the phenomenon (which is the study field), and can take place by applying the epochè, the neutralising of natural intentions that must occur when we contemplate the intentions that we are studying. The researcher’s own change of attitude and the transformative effects on her/his previous (‘natural’) viewpoint are thus enabled to be at the centre of analytical attention.

References

- Audi, R. (1999). *The Cambridge dictionary of philosophy*. Cambridge: Cambridge University Press.
- Husserl, E. (1969). *Formal and transcendental logic*. The Hague: Martinus Nijhoff Publishers.
- Husserl, E. (1970). *The crisis of European sciences and transcendental phenomenology: An introduction to phenomenological philosophy*. Evanston: Northwestern University Press.
- Husserl, E. (1973). *Experience and judgment*. (J. Churchill & K. Amerikas, Trans.). London: Routledge & Kegan Paul.
- Husserl, E. (1983). *Ideas pertaining to a pure phenomenology and to a phenomenological philosophy: First Book, "General introduction to a pure phenomenology"*. The Hague: Martinus Nijhoff Publishers.
- Held, C. (2003). Husserl’s phenomenology of the life-world. In D. Welton (Ed.), *The new Husserl: A critical reader*. Bloomington, IN: Indiana University Press.
- Zagorianakos, A. (2015). *The study of intuition as an objectifying act from a Husserlian perspective, in the cases of three prospective teachers of mathematics*. Doctoral dissertation, Manchester Metropolitan University.
- Zagorianakos, A. (2016). The study of the intuition of essence of a prospective teacher of mathematics from a phenomenological perspective. *Mediterranean Journal for Research in Mathematics Education*. 15, 69–94.
- Zagorianakos, A. (2019, in press). A phenomenological approach to mathematical lived experience: Towards a radical change of attitude to student’s (mis)conceptions. In Shvarts A. (Ed.), *Proceedings of the PME and Yandex Russian conference: Technology and Psychology for Mathematics Education*. Moscow, Russia: HSE Publishing House.
- Zagorianakos, A. & Shvarts, A. (2015). The role of intuition in the process of objectification of mathematical phenomena from a Husserlian perspective: A case study. *Educational Studies in Mathematics*, 88(1), 137–157.

Creating art laboratory settings and experiencing mathematical thinking: towards a philosophical dimension in mathematics education research

Cláudia Regina Flores

Federal University of Santa Catarina, Faculty of Education, Florianópolis, Brazil;

claudia.flores@ufsc.br

Keywords: Historical critical attitude, philosophical perspective, visuality.

This Poster reports on an empirical study that aimed to legitimize the *visuality's perspective for mathematical visualization* (Flores, 2012), as a frame for research on visualization in mathematics education. The study was initially presented at ICME 12, 2012. As I have argued, discourse analyses and social practices of learning should be first linked in order to establish such perspective. Then, by means of a historical-critical attitude in the work of philosophy and critical educational research, art laboratory settings have been created and developed with elementary school children, in order to critically analyze both mathematical visuality practices and also mathematics research under a philosophical perspective. For the former, I have been investigating how arts have regulated ways of looking and thinking within a regime of mathematical thinking. From this, I found ways to carry out abstraction, special distribution, among others, as an exercise of thought. My works invites mathematics education researchers to open spaces of reflection on research of visualization in mathematics education, particularly in relation to the mathematical thinking, but also suggests that bodily experience of mathematics may be fundamental for learning

A laboratory can be conceptualized: “as an experimental system that should allow for (new) things to happen, to appear as such, [...], emphasizing the practice of making as trying to call into presence” (Masschelein, 2012, p. 367). “It is about registering, seeing, illuminating, bringing into play, penetrating, inviting, inspiring, experimenting; it is about exposing oneself and trying the words and verbs again.” (Masschelein, 2012, p. 368). This means that educational research is not necessarily about revealing something or offering knowledge, but foremost “an exercise of thought.”

In addition, the basis of this theoretical perspective is aligned with Foucault's idea that “we must try to proceed with the analysis of ourselves as beings who are historically determined”, opening up a realm of historical inquiry and putting itself to the test of reality.

The critical ontology of ourselves [...] has to be conceived as an attitude, an ethos, a philosophical life in which the critique of what we are is at one and the same time the historical analysis of the limits that are imposed on us and an experiment with the possibility of going beyond them. (Foucault, 1984, p. 47).

Experiencing mathematics with Cubist art

In the case of organizing, developing and analyzing workshops, laboratory means being involved in a protocol that offers a certain chance for something to appear and communicate. This can force researchers to think not only about the practice of producing and analyzing data, but also about

practices of receiving (of looking/listening), which means being attentive and allowing us to re-invent practices of doing research. As an example, let me consider one work carried out by our Research Group in Contemporary Studies and Mathematics Education - GECEM, Federal University of Santa Catarina.

Francisco (2017), inspired by Cubist art, has carried out a workshop with children of the fifth year of Elementary School, at Colégio de Aplicação, at the Federal University of Santa Catarina, Brazil. The workshop was formed by both the photographs of the children and the cubist painting of portraits. The experience itself was constituted by putting clippings of photographs that were taken from each of the children inside yellow and blue boxes. Each one received their own little box containing pieces of their photos. The pieces were cut by the researchers in various shapes, which could be regular but also irregular. The children were challenged: How might the children reconstruct their self-portraits when the images were not complete images of themselves nor plain geometric figures? Their solution was to make a portrait similar to cubist portraits. By doing that, children experienced an inventive process of assembling, disassembling and reconstructing their own image. Thus, such performances, which expand mathematics education's habitual use of doing research, contribute not only for a contingency of knowledge, but also for an exercise of thought, which means an exercise of transformation.

Final words

Art laboratories are a place for exposing and registering, while gathering students, teachers and researchers around the questions of our present time (how mathematical thinking organizes the way we represent and look at the world). The role of philosophy, then, is to make us think about what we see, to expose our thinking to what is happening, i.e. what mathematics is, what mathematics education is. The contribution of this research is to rethink the role of mathematical thinking not only in the creation of arts but also in our relationship with them, and consequently, to transform it.

Acknowledgment

We are gratefully acknowledge the Brazilian agencies CNPq and Capes for the financial support.

References

- Francisco, B. M. (2017). *Um Oficinar-de Experiências que Pensa com Crianças: matemáticas-cubistas, formas brincantes e ex-posições*. (Master in Science and Technology Education Dissertation). Federal University of Santa Catarina, Florianópolis, Brazil.
- Flores, C. R. (2012). Visuality and mathematical visualization: seeking new frontiers. In Cho, Sung Je (Ed.) *Proceedings of 12th International Congress on Mathematical Education* (pp. 7059- 7065). Seoul, Korea.
- Foucault, M. (1984). What is enlightenment? In P. Rabinow (Ed.), *The Foucault reader* (pp. 32- 50). New York: Pantheon.
- Masschelein, J. (2012). Inciting an attentive experimental ethos and creating a laboratory setting. Philosophy of education and the transformation of educational institution. *Zeitschrift Pädagogik*, 58(3), 354- 370.

Networking theories in design research: an embodied instrumentation case study in trigonometry

Rosa Alberto¹, Arthur Bakker¹, Oia Walker-van Aalst², Peter Boon¹ and Paul Drijvers¹

¹ Utrecht University, Freudenthal Institute, the Netherlands; r.a.alberto@uu.nl; a.bakker4@uu.nl; p.boon@uu.nl; p.drijvers@uu.nl

² University of California, Berkeley, the United States; oia.walker.van.aalst@berkeley.edu

There is increasing attention for the embodied and extended nature of mathematical cognition but the bodies of literature on embodied and on extended cognition have developed mostly separately. We propose a new step in the tradition of networking theories: design research from two theoretical perspectives to promote integration. Embodied design and instrumental genesis inspired us to elicit embodied instrumentation: learning via techno-physical interaction with digital artifacts. A case study illustrates a design and subsequent problem solving by a student (aged 16), who uses her body and the designed artifact to solve trigonometric equations. We reflect on the benefits of not only analyzing but also designing from different theories to network these theories.

Keywords Mathematics curriculum, schemata (cognition), sensory experience, learning theory, networking theories

Introduction

With the recently foregrounded E-perspectives (embodied, extended, embedded, enactive, enculturated, etc.) on cognition, there is increasing attention for the embodied and extended nature of mathematical learning. So far, however, embodied and extended cognition have their own bodies of literature in mathematics education, for example embodied design (Abrahamson, 2014) and the instrumentation approach to tool use (Artigue, 2002). Both theoretical frameworks shift from a traditional view on cognition to allowing other players, such as tools and physical interaction to be part of, or at least heavily shape, emerging mathematical cognition. Consequently, educational designers carefully design learning experiences with (digital) materials to stimulate schemes that are relevant for the targeted mathematical knowledge: being either sensorimotor dynamics or instrumented techniques (Drijvers, 2019).

In this paper, we propose that using both theoretical lenses can enhance mathematical learning and its study. However, as observed by Bikner-Ahsbabs and Prediger (2014), the synthesis and integration of theories is rare and challenging. Until now the networking of theories in mathematics education has primarily involved two groups analyzing the same dataset collected by one of the research groups using their “home” theory. To promote integration, which we consider fruitful in the case of embodied and extended cognition, we take a possible new step in the tradition of networking theories: conducting design research in which the design is informed by two different theories. To explore the value of integrative design research, we elicited, by means of a newly designed digital tool, a phenomenon for which it made sense to analyze it by the integration of embodied design and the instrumentation approach to tool use: *embodied instrumentation* as learning via techno-physical interaction with digital tools (cf. Drijvers, 2019). Joining forces within

design research seems promising, because it requires cycles of joint theorization, designing, implementation, and analysis (Bakker, 2018).

We aim here to explore how design research can facilitate integration of theoretical views that hold promise to be combined, in our case embodied and extended cognition. To guide this exploration, we circle around the question, *What could embodied instrumentation look like?* We applied this question to the domain of trigonometry. A major Achilles heel for students seen throughout mathematics education is that graphic, algebraic, or numerical representations are treated as isolated conceptions instead of as different symbol systems that jointly make up the conception of functions (Drijvers & Gravemeijer, 2005).

In this paper we elaborate the idea of embodied instrumentation, then describe a digital tool based on embodied instrumentation for trigonometry, and provide an empirical illustration of how a case-study student was using her body (sensorimotor) and the tool's elements (techniques) to solve trigonometric equations in the form of $\sin(\theta) = c$. Through this, we hope to shed light on the added value of integrating embodied and extended views for mathematical learning and integrative design research in general.

Embodied instrumentation: techno-physical mathematical learning

Under the foregrounded E-perspectives, cognition does not just reside inside the learner, but distributes across their interactions in the physical and social (cultural and linguistic) world (Smith & Gasser, 2005). These embodied and extended views on cognition shift away from the traditional idea of internal representation and computation that is fed by external environmental sense-information, though the latter is not seen as part of cognition (Wilson & Golonka, 2013). Cognition emerges from embodied multimodal experiences; when people act and perceive in the world, their sensorimotor schemas self-organize, which leads to increased functional acting in and understanding of their environment (Smith & Gasser, 2005). Put more radically, the range and kind of embodied experiences determine the emerging cognition.

Much of multimodal interaction is mediated through tools, extending the scope and kind of actions people can carry out. A useful lens on the interaction of user and digital tools is the instrumentation approach (e.g., Artigue, 2002). The instrumentation approach considers the careful designing of educational tools to enhance mathematical learning. Under this flag, the bare tool is considered an *artifact*. Central in learning is the process of *instrumental genesis*: The user applies and thereby develops *instrumentation schemes* appropriating the use of the artifact to solve a specific class of tasks (Artigue, 2002; Drijvers & Gravemeijer, 2005; V erillon & Rabardel, 1995). What students actually do (using instrumented techniques) depends on the opportunities and constraints of the artifact and their knowledge. At the same time, the doing itself contributes to their understanding. Artigue (2002) highlights this pragmatic and epistemic value of instrumentation schemes which co-emerge dependently. However, in most applications of instrumentation approach in mathematics education the embodied nature of these instrumentation schemes is rarely studied. The body seemed to have disappeared from sight when the tools became more complex and calculations more hidden from the user. Yet going back to original sources of the ideas (V erillon & Rabardel, 1995), there is ample potential to revive the attention for the embodied origin of instrumental genesis.

A neighboring framework to fill this gap is embodied design for mathematics. With the increased availability of technologies, embodied learning for mathematics now includes multimodal learning experiences with various sensors and motion trackers. An emerging embodied design genre in mathematics education is the Mathematics Imagery Trainer (MIT) (Abrahamson, 2014). Within this pedagogical framework, mathematical cognition is promoted through relevant embodied experiences. As such, mathematical cognition is re-defined as grounded in sensorimotor schemes for material interaction. In the activities students learn about co-variation (proportions, functions) by discovering their own bimanual motion patterns (Abrahamson & Bakker, 2016). For example, in the original task, designed to foster reasoning about proportional equivalence such as $1:2 = 2:4$ (the MIT-P for proportion), students project two cursors on a screen by manipulating two Wii remotes. When the ratio is set to say 1:2, the screen turns green only when the right hand remote is twice as high as the left hand remote; otherwise it is red. Multimodal learning analytics, including hand- and eye-tracking methods, revealed that while students develop effective ways of moving in or enacting proportional equivalence, their gaze converged to specific locations (where no object is visually present per se). These are shown to have value both pragmatically (improved coordination) and epistemologically (understanding). These gaze points are attentional anchors (AAs), a phenomenon known to occur in a variety of physical activities (juggling, swimming), and other MIT versions designed to promote the learning of multiplicative reasoning (Duijzer, Shayan, Bakker, Van der Schaaf, & Abrahamson, 2017) and parabola functions (Shvarts & Abrahamson, 2019).

Designing an embodied instrumentation tool for trigonometry

We set ourselves the goal to design activities based on embodied instrumentation via techno-physical interaction, which promote learning, understanding and solving of trigonometric equations in the form of $\sin(\theta) = c$. The first and second authors have a background in embodiment theory and the last author in instrumentation approach. Each initially designed a task to meet the learning goal from their theoretical perspectives, which were then discussed. The differences between the two initial artifacts were mainly on a practical level: the embodied design perspective being more informal in the domain of geometry and the instrumentation approach being more algebraic and formal, including a constant and symbolic language. A key realization was that this could be used to integrate the artifacts in a progressively formalizing sequence. These activities were developed in the Digital Mathematics Environment, piloted with four students, and adjusted where needed. We report here on the designs of the second design cycle.

Figures 1 and 2 show elaborations on the tasks, the digital tools and the intended learning schemes. In the initial tool, users drag two points; their left hand moves along a unit circle and their right along a sine graph as illustrated in Figure 1a. The rotation (angles in radians) along the arc of the unit circle and the x -axis of the sine graph were both marked in blue to make salient the equivalence of the angle in both representations. Users are instructed to move two points so that a frame turns green. Consistent green is only achieved when the angles (or the length of the blue marking) are equivalent in the unit circle and the sine graph (as in Figure 1a), otherwise the frame is red (as shown in Figure 1b). The intended relevant sensorimotor solution to this problem was to keep the hands at the same height, representing a grounded scheme of the sine of an angle, and equivalence across the unit circle and the sine graph.

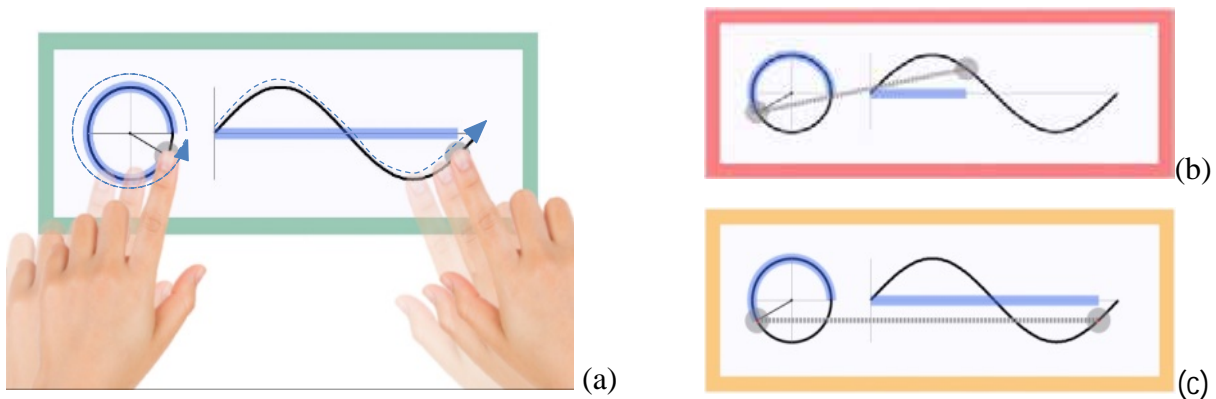


Figure 1: Example of the artifact when (a) enacting equivalence of angle and sine (green color feedback), (b) incorrectly enacting equivalence (red color feedback) with a (slanted) segment, and (c) enacting equivalence of sine for complementary angles (orange color feedback) with the segment

Solving the task is done first without, and then with, a segment connecting the points on the unit circle and sine graph (two examples shown in Figures 1b and c). The idea is that the segment would work as a shortcut for action and perception coordination, as a conspicuous measure of horizontality. This highlights the height of both points, enabling more successful and continuous interaction. Visually, the segment intersects both graphs when orange is achieved, and as such it might prime the relevance of intersections in equation solving (Figure 1c).

The second task involves solving trigonometric equations of the form $\sin(\theta) = c$, solving for both the angle (in radians) and the sine value. Values of the angle θ are shown in both the unit circle and the sine graph. An additional element has been added, a constant that users can move up and down with a touchpoint (Figure 2a). The idea is that the values and constant would invoke a quantification process, and would link the positions of the points to elements and values in the equation. Solving the equation of $\sin(\theta) = 0.86$ would involve moving the constant up to the y -value of 0.86 (the vertical distance), and then moving the point on either the unit circle or sine graph to intersect this and read the value of the angle rotation (solution is shown in Figure 2b). The constant-line would further make salient that there are multiple solutions for the same sine value.

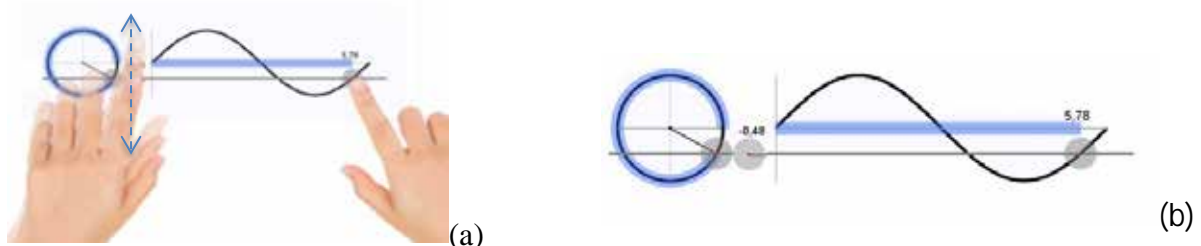


Figure 2: Example of the artifact with constant and values with (a) moving the constant up and down to manipulate the sine value (emphasis added) and (b) the solution to $\sin(\theta) = -0.48$

A case study

As part of the design research cycle, we asked a case-study student, Spring (pseudonym), to interact with the artifact and solve the two tasks in a clinical interview. Spring (aged 16 years and left

handed) had just completed grade 11 at a US high school. She encountered trigonometry in a Pre-Calculus course (Grade 11) and prior to that in an Algebra 2 with Trigonometry course (Grade 10). Spring is a top student with a grade point average of 4.2 (US system). We conducted a short pre-interview to assess her prior knowledge. In some instances the option of sketching and (unrecognized) writing was made available. Spring remembered the main terms from trigonometry (arc length, sine, cosine, radian) fairly well, and remembered several formulas. She was able to identify the sine of an angle in a triangle, and relate certain angles in degrees to radians. We repeated the four pre-interview questions after the session and recorded a debrief session with the student and researchers. During the entire clinical interview we used audio, video and eye-tracking (Tobii X2-60) to monitor closely how Spring was using her body (actions, perceptions, and verbalizations). We present here the findings on how she came to use the newly developed tool in the context of new discoveries and relationships in a clinical interview with two interviewers (second and third author).

Finding and keeping green

Spring easily found places that were green. However, maintaining the green while moving was a more difficult task, and Spring looked back and forth between her two fingers (horizontal gaze direction) while trying to achieve this. Her initial description of her strategy was to keep the speed of both fingers the same. She explains:

Spring: If I move my hands at the same speed I will go the same distance, for each ... So I get the same distance in the same time. So, I get to the same points at the same time, with both my hands.

Interviewer: You mean distance on the graph or the blue line?

Spring: Distance on the graph. So, I am following the black, and the gray.

This initial strategy is commonly seen when students begin to interact with MIT artifacts: Keeping the hands at the same speed and looking between them (in a horizontal direction) resonates with familiar intrinsic dynamical tendencies (Duijzer et al., 2017). In doing so in this trigonometric context, the student reasoned that the arc length in the unit circle corresponded with the curve length instead of x value (angle in radians) in the sine graph.

Using the segment

When the segment (Figures 1b–c) was added (after 22 minutes), Spring almost immediately shifted her strategy, and verbalized that she had to keep the segment horizontal. While keeping the segment level, she gazed at the middle of the segment, most likely attending to the vertical displacement.

Spring: When the helper line [segment] is horizontal you know you are at the correct ... y value. You are at the correct units for both of them...because...it's the same thing graphed over, in different formats.

Spring: This is definitely easier, its ...it feels more like I am using it as a singular thing rather than a...you know like...two dots, and trying to keep them alike. [...] So, like it feels more, like the two graphs feel more connected, so it's a more

obvious... like it's easier for me to focus on how to keep them green, how to keep them both showing the same thing.

Adding the segment changed the interaction both pragmatically and epistemically. Prime indicators of effective scheme development here seemed to be: (1) a convergence of gaze to the middle of the segment, (2) more successful enactments, (3) reasoning about the vertical distance (sine) of both points, and (4) a sense of coherence between the two representations. These results coincide with previous research in which attentional anchors emerge as a means to improve coordination and understanding (Abrahamson, 2014; Abrahamson & Bakker, 2016; Duijzer et al., 2017).

Using the constant and values to solve trigonometric equations

In the second task, the constant was added with the values for θ and sine (after 30 minutes; Figure 2). Although we did not anticipate this, the position Spring gazed at in the middle of the segment coincided with the positioning of the touchpoint that would move the constant in a vertical direction. Spring was quick to use this constant as intended and elaborated on her previous explanations:

Spring: So, it's, mmm, it's measuring the same sine value in both the first and second quadrant I think. So this keeps it level, so there is, we can't switch it, it's always going to be attached to the graph. [...] So, the yellow is that it's the same sine value, but not the same distance, or radians, or... So, it's dealing with the different quadrants, or something?

Spring used a well-organized sensorimotor instrumentation scheme to solve each of the equations. For example, she solved $\sin(\theta) = 0.86$ by moving the constant up 0.86, and then moving the point on the unit circle so that it intersects with the constant. She spontaneously showed two solutions, by moving the point first to the intersection with the same angle rotation, and then to the complementary angle. For the second type of equations, she used a similar scheme, but the action sequence was reversed. For example, $\sin(2) = a$ was solved by moving the point on the unit circle to 2, followed by moving the constant to a height that intersected the point to find its sine value. To solve the equation $\sin(2.5\pi) = a$, students are required to rotate beyond one rotation of 2π . As the tool is limited to one rotation, this equation is solved without the tool providing the correct angle markings and values. Spring solved this successfully by moving the point on the unit circle over a full round, while saying, $\frac{1}{2}\pi$, π , 2π and then kept moving to "add another half." This might show how the epistemic value of the instrumented sensorimotor schemes can assist to overcome practical constraints of the tool.

Conclusion and Discussion

In this paper, we aimed to contribute to the tradition of networking theories by exploring a possible new approach: design research from two theoretical perspectives to promote integration between these perspectives. Embodied design and instrumentation approach inspired us to elicit embodied instrumentation or learning via techno-physical interaction with digital artifacts. This approach assumes that bodily and instrumental experiences of mathematics are fundamental for learning. Design research requires cycles of joint theorization, designing, implementation, and analysis

(Bakker, 2018), and as a methodological approach provided a structured way to integrate embodied and extended perspectives on each of these components in the research cycle. As such, the frameworks inspired both the design and the analysis.

Bringing back the embodied nature of instrumentation schemes through embodied instrumentation, can, we believe, enhance both students' mathematical learning and our ability to study it. Insights from both embodied design and the instrumentation approach facilitated careful alignment of embodied and instrumental experiences to promote trigonometric problem solving. Multimodal learning analytics allowed us to assess how a student was using her body and the digital tool to solve trigonometric equations, and provided empirical insight into the phenomenon of embodied instrumentation in trigonometry. Spring's repeated and flexible use of a well-organized sensorimotor instrumentation scheme might be indicative of embodied instrumental genesis, though ideally one would like to study longer-term processes to make such claims.

The difficulty of linking symbols to previous and current actions and perceptions requires a more in-depth analysis of our tasks and digital tool. For some of our previous pilot students the gap between enacting and solving trigonometric equations was too large, and they were unable to link the symbols of the equation to their sensorimotor experiences. Coinciding with previous research we found converging gaze patterns that served as an attentional anchor (Abrahamson, 2014; Abrahamson & Bakker, 2016; Duijzer et al., 2017) by improving both coordination and understanding in trigonometry as well as creating a sense of coherence between the two representations. Adding epistemic value from physical interaction (making movements relevant) into current digital tools in mathematics may increase the educational potential of these tools.

Integration is a step in the networking of theories that is driven by the question of what each approach can learn from each other. Theory cultures and their boundaries are dynamically (re)produced and developed by their members' ways of understandings and acting based on a set of principles, related methodologies and paradigmatic questions. The activity of networking theories is a way of renewing theory cultures, and could be sparked by solving a problem that all members share (Bikner-Ahsbals et al., 2010). Integrative design research can provide a structure to elicit a phenomenon that is interesting for different parties to be involved in. Its cycles of joint design, implementation, and analysis seem to provide a structure for sensible theoretical integration by making explicit the theoretical influence on design choices, measurement tools, and interpretations.

Acknowledgment

The research reported here was funded by the Netherlands Organisation of Scientific Research under grant number 652.001.004.

References

Abrahamson, D. (2014). Building educational activities for understanding: An elaboration on the embodied-design framework and its epistemic grounds. *International Journal of Child-Computer Interaction*, 2(1), 1–16. <https://doi.org/10.1016/j.ijcci.2014.07.002>

- Abrahamson, D., & Bakker, A. (2016). Making sense of movement in embodied design for mathematics learning. *Cognitive Research: Principles and Implications*, 1(1), article 33. <https://doi.org/10.1186/s41235-016-0034-3>
- Artigue, M. (2002). Learning mathematics in a CAS environment: the genesis of a reflection about instrumentation and the dialectics between technical and conceptual work. *International Journal of Computers for Mathematical Learning*, 7(3), 245–274.
- Bakker, A. (2018). *Design research in education: A practical guide for early career researchers*. London: Routledge.
- Bikner-Ahsbabs, A., Dreyfus, T., Kidron, I., Arzarello, F., Radford, L., Artigue, M., & Sabena, C. (2010). Networking of theories in mathematics education. In M. M. F. Pinto & T. F. Kawasaki (Eds.), *Proceedings of the 34th Conference of the International Group for the Psychology of Mathematics Education* (Vol. 1, pp. 145–175). Belo Horizonte, Brazil: PME.
- Bikner-Ahsbabs, A., & Prediger, S. (2014). *Networking of theories as a research practice in mathematics education*. Dordrecht, the Netherlands: Springer.
- Drijvers, P. (2019, in press). Embodied instrumentation: combining different views on using digital technology in mathematics education. In U. T. Jankvist, M. van den Heuvel-Panhuizen, & M. Veldhuis (Eds.), *Proceedings of the Eleventh Congress of the European Society for Research in Mathematics Education*. Utrecht, the Netherlands: Freudenthal Group & Freudenthal Institute, Utrecht University and ERME.
- Drijvers, P., & Gravemeijer, K. (2005). Computer algebra as an instrument: Examples of algebraic schemes. In D. Guin, K. Ruthven, & L. Trouche (Eds.), *The Didactical Challenge of Symbolic Calculators* (Vol. 36, pp. 163–196). Boston, MA: Springer. <https://doi.org/10.1007/0-387-23435-7>
- Duijzer, C. A. C. G., Shayan, S., Bakker, A., Van der Schaaf, M. F., & Abrahamson, D. (2017). Touchscreen tablets: Coordinating action and perception for mathematical cognition. *Frontiers in Psychology*, 8, 1–19. <https://doi.org/10.3389/fpsyg.2017.00144>
- Shvarts, A., & Abrahamson, D. (2019). Dual-eye-tracking Vygotsky: A microgenetic account of a teaching/learning collaboration in an embodied-interaction technological tutorial for mathematics. *Leaing, Culture and Social Interaction*, 22, 100316. <https://doi.org/10.1016/j.lcsi.2019.05.003>
- Smith, L., & Gasser, M. (2005). The Development of Embodied Cognition: Six Lessons from Babies. *Artificial Life*, 11(1–2), 13–29.
- Vérillon, P., & Rabardel, P. (1995). Cognition and artifacts: A contribution to the study of thought in relation to instrumented activity. *European Journal of Psychology of Education*, 10(1), 77–101.
- Wilson, A. D., & Golonka, S. (2013). Embodied Cognition is Not What you Think it is. *Frontiers in Psychology*, 4, 1–13. <https://doi.org/10.3389/fpsyg.2013.00058>

Generativity in design research: the case of developing a genre of action-based mathematics learning activities

Arthur Bakker¹, Anna Shvarts¹ and Dor Abrahamson²

¹Utrecht University, the Netherlands; a.bakker4@uu.nl, a.y.shvarts@uu.nl

²University of California, Berkeley, USA; dor@berkeley.edu

Educational research is often of limited use to designers, as it typically offers descriptions of or explanations for how education was or currently is. In this paper we argue that generalizability is not enough; what deserves more attention is generativity. Designers and educators need actionable knowledge on how education could be. To substantiate the criterion of generativity, we here develop the construct of a design genre—a theory-driven class of designs targeting a particular form of learning. As an example we discuss the evolution of an action-based genre of embodied design through iterative theory-design clarifications. Initially instantiated in the form of activities for promoting the understanding of proportional reasoning, the genre has been elaborated through the process of applying it to additional notions such as parabolas and trigonometry. We argue that this genre was generative for design, theory development, and methodological innovation.

Keywords: Mathematics curriculum, generalization, sensory experience, instructional design, learning theory.

Generativity

Educational research mostly investigates practice “as it was” or “as it is.” Generating new desirable types of education—“as it could be”—has largely been left to practitioners and designers. With its focus on generalizability, educational theories typically provide little help to designers or educators in making design decisions, for example on how to use new tools, develop a new teaching approach, or achieve new learning goals (Klaassen & Kortland, 2013). It has been argued that educational research is a linking science (Dewey, 1900) or a design science (Glaser, 1976), more similar to engineering, medicine, and management than to physics, biology, or psychology. What linking or design sciences are looking for is “actionable knowledge” (Argyris, 1996). Design research originates in the wish to produce such actionable, advisory knowledge (Bakker, 2018).

Discussing the role of theory in design research, diSessa and Cobb (2004) distinguished several kinds of theory such as grand theories, orienting frameworks, frameworks for action, and domain-specific theories. The authors observe that the more general such theories are, the less informative these typically are to the designer or educator. In their view, “theory must do real design work in generating, selecting, and validating design alternatives at the level at which they are consequential for learning” (p. 77). An example of what they consider good innovation is the general construct of socio mathematical norms, yet they admit this notion is not very prescriptive for design.

In line with the aforementioned need to produce actionable knowledge, we propose that educational researchers should not just care about generalizability (deriving general ideas from empirical specificities) but also about *generativity* (deriving ideas for specific design solutions from general principles). The aim of this paper is to argue that so-called *design genres* (Abrahamson, 2014), as

theory-driven types of designs targeting a particular form of learning, offer useful knowledge to educational researchers, design researchers, and designers alike. We also submit that design genres may fulfill the criteria of generalizability and generativity in the sense if they are research-based and productive in generating new actionable knowledge, but also provide concrete advice on how to design tasks in this particular genre (cf. Watson & Othani, 2015). Thus they would fulfill the role theories should play in design research according to diSessa and Cobb (2004).

To illustrate the notion of generativity, we explore how the formulation of such a genre facilitated the process of creating similar designs outside of the source laboratory. We reflect on the evolution of an *action-based genre of embodied design* (see Figures 1 and 2). This design genre originated in Abrahamson's Embodied Design Research Laboratory (Berkeley), and was extended by Shvarts in Moscow and Bakker, Alberto, and colleagues in Utrecht to other mathematical domains. In terms of design, we reflect on a set of general and generative principles that slowly developed through iterative cycles of collaborative design research.

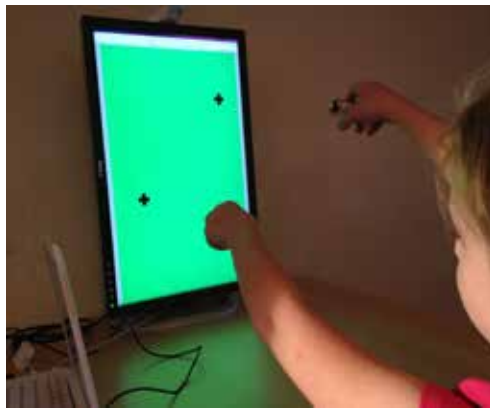


Figure 1: Solving a movement riddle in the Mathematics Imagery Trainer, a child learns to move physically in a new way that is then articulated formally as governed by a proportional function

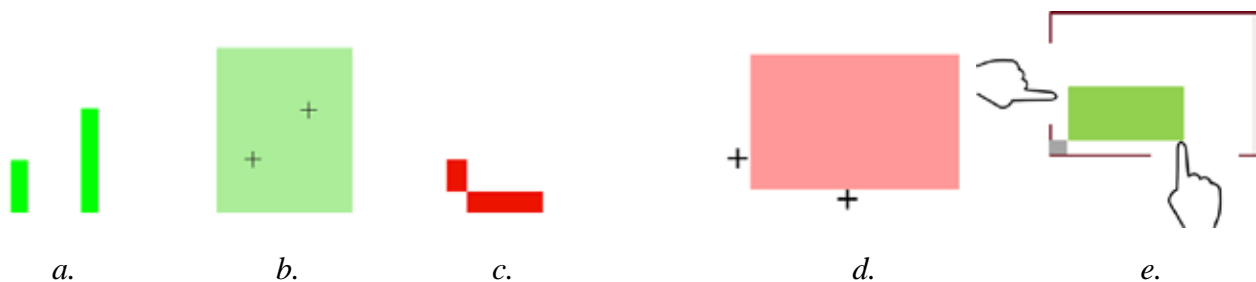


Figure 2: Five versions of the MIT-proportion applications: (a) parallel bars; (b) parallel with full screen feedback; (c) orthogonal bars; (d) orthogonal with full screen feedback; (e) rectangle feedback

A prototypical action-based design for proportion

Our design research is inspired by a range of philosophical positions and cognitive-science research arguing for the embodied origin and nature of cognition (Dreyfus & Dreyfus, 1999)—none of which yielded specific ideas for design. Accordingly, we sought to develop and evaluate action-based learning activities that could potentially support students' sensorimotor grounding of mathematical content. As part of our research program, we deliberately focus on mathematical domains beyond

simple arithmetic to explore whether theories of embodiment hold promise for more advanced topics too.

Figure 2 presents a set of schematic screen images featuring computer-based materials we have been exploring (there are also versions with lines or grids, and with numbers). These activities build on, yet extend, earlier research by Abrahamson and colleagues on the Mathematics Imagery Trainer for Proportion (MIT-proportion). Clinical research on the MIT-proportion has demonstrated the emergence of students' sensorimotor schemes, as they attempt to satisfy the task specifications: First, manipulate two virtual objects on the screen so that the bars (2a) or entire screen (2b) becomes green; and then move both objects simultaneously keeping the green feedback. Unknown to the students, the favorable feedback of green appears only if the objects they manipulate make for a particular proportion between key magnitudes relative to a spatial frame of reference, for example a 1:2 ratio between the heights of the two bars in Figure 2a or between the y- and x-axis, linear extensions in Figure 2c.

We found patterns in students' solution process on these tasks that could be summarized well in Piagetian terms of reflective abstraction (Abrahamson, Shayan, Bakker, & Van der Schaaf, 2016). Eye-tracking technology allowed us to study the emergence of sensorimotor action schemes in more detail than hitherto possible. For example, the gaze data showed that students focus their attention at particular locations on the screen so as to coordinate their bimanual movement. We came to understand these sensory behaviors as evidence that students were developing *attentional anchors*, spontaneous perceptual constructions that facilitate the enactment of challenging movements by focalizing the coordination of motor actions. That is, we were witnessing the emergence of new goal-oriented sensorimotor schemes. For example, Figure 3a shows a typical scan path when students keep the bars green (see Duijzer, Shayan, Bakker, Van der Schaaf, & Abrahamson, 2017, for an automated analysis of patterns in how students looked in particular areas of interest). Students look halfway up along the tall bar before they express the insight that it is twice as tall as the shorter bar. Arriving at this insight took between 10 seconds and 9 minutes.



Figure 3: (a) typical scan path when trying to keep the bars green while moving them up. (b–e) attentional anchors when keeping green in the orthogonal task with full screen color feedback

Expanding a genre of action-based embodied designs

Intending to expand this genre of educational designs, we varied on the initial interactive activity along several dimensions, such as mathematical domain, the form of interactive feedback, or characteristics of input movements (bimanual/unimanual, in the air in front of the screen / on a touchscreen or a tablet / via touchpad). These new designs were somewhat intuitive, unstructured, or loosely meditated. While we were aiming to keep the core of the design, stating just what that core

might be was still work in progress. We found ourselves in a situation not unlike a child participating in a cognitive developmental psychology experiment investigating the emergence of categorical reasoning (Vygotsky, 1962): Tasked to select from a pool of colored geometrical shapes a set of some yet-to-be-defined class, the child groups a red and a yellow triangle, since they both are triangles, but then adds a yellow circle, since it too is yellow, and then, perhaps, a trapezoid, since it is similar in another way. In this process of iteratively varying on different aspects of the design, we came to recognize a need to articulate the limits of variation that would keep intact some constant qualities of this genre's essential features, whatever these would turn out to be.

Orthogonal design for proportional reasoning

Urged by a request from a high school mathematics teacher, Lee, Hung, Negrete and Abrahamson (2013) envisioned a first variant on the original MIT-proportion activity, in which the hands would move not in parallel but orthogonally. This variant, which expands the original activity from 1D to 2D, was implemented at Utrecht University (Figures 2c–e; 3b). The new task demanded of students to solve the challenging movement problem of coordinating simultaneous motor action along orthogonal axes. Figures 3b–e include a student's eye fixations (the orange blobs overlain on screenshots from the video-recording). The student told us he is imagining a diagonal line connecting his left- and right-hand index fingertips and that he is moving *this diagonal line* sideways to the right, keeping constant the line's angular orientation to the base line. As such, the diagonal line constituted an attentional anchor for this student and others who arrived at similar solutions. We speculate that this sensorimotor scheme—a bimanual coordination oriented on a perceptual construction—could serve as the foundation for further developing various mathematical concepts, such as function, covariation, or slope. This task elicited rich geometrical language as students explained their strategy, including reference to angles, lines, rectangles, triangles et cetera.

Conic sections

It has been shown that visualization of the parabola as a vase-like curve on a surface may lead to a wrong conceptualization (Aspinwall, Shaw, & Presmeg, 1996). As an alternative Shvarts designed opportunities for individual students to experience a parabola as a locus of equidistant points (MIT-parabola, see Figure 4a–b). The solution is to move Vertex C on the screen such that it is equidistant from a straight horizontal line (Vertex B directly below Vertex C, running along the parabola's directrix) and a separate point (Vertex A, fixed on the parabola's focus). Consistent with the embodied-design principle that semiotic symbols should be absent in the initial activity (Abrahamson, 2014), only a triangle is featured on the screen during the first stage of the task (the dashed lines in Figure 4 are for illustration only and are never shown to the students). Once students had accomplished the embodied task and were ready to mathematize their solution in the form of the canonical parabola formula, the axes were introduced. Dual eye-tracking of this activity (i.e., of both the tutor and the student) revealed the traces of attentional anchors along the triangle's median. These traces appeared in the eye movements both of the students and the tutors (Shvarts & Abrahamson, 2018).

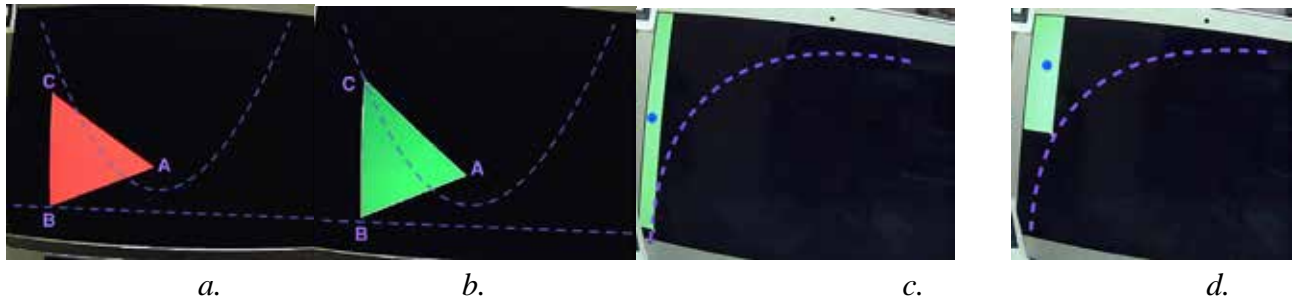


Figure 4: (a, b) MIT-parabola; and (c–d) MIT-area. The dashed lines were not shown to the students. Yet another task (MIT-area, see Figures 4c–d) implies another conic section, the hyperbole: The top left vertex of a rectangle on the screen was fixed, while a participant was moving the opposite vertex to change the size and form of the rectangle. The rectangle turned green if it had a particular area. The eye-movement data (blue) demonstrate a simple attentional anchor of fixating in the center of the rectangle (Figures 4c-d) while grasping the area by extrafoveal vision.

Trigonometry

Alberto, Bakker, Van Aalst, Boon and Drijvers (submitted) designed a new task in the same genre, now for trigonometry (MIT-trig). The student slides the left-hand fingertip on the perimeter of a unit circle and the right-hand fingertip on a sine graph (Figure 5). Whenever the radian value on the circle corresponds to the x -value in the sine graph, the frame around these two objects becomes green. The student needs to keep the frame green while moving both hands. Analysis of a case-study participant indicates that she used an attentional anchor on a segment connecting the two fingers, which seemed to help her keep the two fingers at the same height. Mathematized, this came to mean that the left- and right- fingertip positions are equally “high” or “low” on the grid, thus sharing the same y -value, $\sin(x)$. This awareness appeared to support her bimanual coordination process of keeping green while moving.

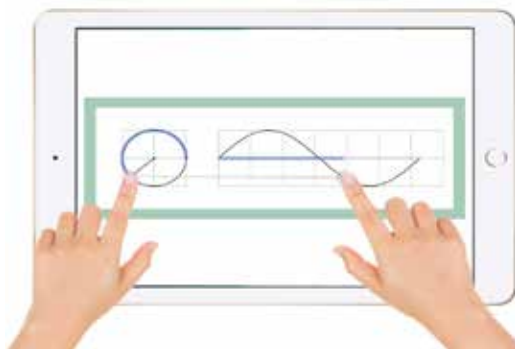


Figure 5: The frame is green if the radian (unit circle, left) and x -value (sine graph, right) correspond. **A reflection on theoretically driven and empirically grounded principles**

We have referred to the set of embodied tasks discussed above as exemplars of a design genre, an action-based genre of embodied design (Abrahamson, 2014). In so doing, we conceptualize a design

genre as capturing both the “why” and “how” of generating learning activities in the form of a set of principles that instantiate the theoretical presumptions concerning the process of learning (the “why”) and that guide a designer through the design process (the “how”). The embodied design framework builds on enactivist and dynamic systems theory to stipulate the creation of a goal-oriented task that calls for a sensorimotor investigation of the problem field. The design *core objective* is that students’ new knowledge will emerge in a form of sensorimotor coordination constituted as a solution for a motor problem (Bernstein, 1967), when they encounter unexpected constraints in the course of attempting to accomplish the activity task. The student’s solution to the enactment problem is a new sensorimotor coordination applied to a spontaneous construction of an attentional anchor in the perceptual field; this new perceptuomotor scheme constitutes an embodied form of mathematical knowledge underlying the task design. The motor coordination undergoes automation that frees space for mathematical reflection and cultural referencing.

As design genres evolve, theoretically driven design objectives settle as definitive and essential principles guide the process of designing new activities. At the same time, the introduction of new activities as plausible exemplars of the genre may challenge both conscious and unconscious assumptions, causing a team to rethink the principles that had been taken as definitive and essential. Wherever a resolution cannot be reached, new research questions may emerge. For example, the design dimension of *feedback*, which had not been on the fore of our agenda, drew our interest only once we realized the variable effect of feedback on attention: An abrupt change of color or contour within the visual field may attract overt attention and thus disrupt the vulnerable construction of new eye-movement patterns governing manual control. The solution in MIT-trig was to introduce a rectangular frame around the central interactive arena (Figure 5). This rectangle creates a uniform stimulus amenable to peripheral vision, thus enabling the student to retain foveal vision on the virtual manipulatives. That said, we recognize that there is much more for us and our colleagues to learn and experiment so as to optimize for design decisions along the dimension of feedback.

Another design dimension in need of further research is that of *uni-* vs. *bimanuality*. Is bimanuality an essential attribute of the genre? Our current designs entail both bi- and unimanual tasks. A simplistic assumption would be that two hands are necessary to provoke the need for new coordination. Moreover, much of mathematics is relational in nature. However it could be that coordinations are formed between manual and visual tracking of object on the screen. We are currently devising a study to investigate this problem. Thus the theory–design dialectics determining the research team’s iterative efforts contributes to the theoretical rather than empirical generalization of the activities into a design genre (Davydov, 1990).

Conclusions

In this paper we proposed that design genres do not only allow for generalizability but also generativity. We have argued that the emerging design genre illustrated here was generative: It helped in making concrete design decisions and thus in speeding up the design process outside of the source laboratory. Note that this was also possible due to our attempts to generalize while designing: By framing any design decision as a case of a more general theoretical idea (cf. Abrahamson, 2018), we were able to identify features of the design that were important in achieving particular goals (e.g.,

development of sensorimotor action schemes that were relevant grounding for mathematical reasoning). Based on these features, new designs were developed for promoting reasoning about other mathematical topics.

As a bonus we can also highlight the notion of *generativity* in a more research-oriented sense: The innovative designs led to phenomena of learning that could hitherto not be studied, and thus led to many new research questions. Given the multimodal nature of students' observed sensorimotor behaviors, we were urged to draw on multidisciplinary bodies of literature, including sports and kinesiology, such as the construct of an attentional anchor developed by Hutto and Sánchez-García (2015). Throughout, we have debated what counts as mathematical activity. If students coordinate two hands in a way that we consider mathematically relevant, in what sense does this capacity constitute a precursor to conceptual understanding? Would the sensorimotor experience enable them to evoke the meaning of particular mathematical signs and reason through relevant problems? What design features help to promote reflection and argumentation? Is there any evidence that students re-use the sensorimotor schemes that have proved useful in earlier tasks?

The design-research approach to develop theory by design has generated methodological contributions, too, for example dual eye-tracking, by which we can now investigate student–student or student–tutor joint attention. Such research settings, where people collaboratively develop new sensorimotor action schemes, open up new areas of multidisciplinary research that accounts for intersubjective multimodal coordination processes (Shvarts & Abrahamson, 2018). Contemporary educational theory appears to lack powerful conceptual and methodological frameworks for studying these processes. It is hence also at this level of motivating and developing new research programs that, we believe, design genres can be generative.

Aforementioned types of generativity may also impact educational practice. We speculate that the learning of many mathematical topics across the curriculum (function, covariation, etc.) can be supported by activities in the same design genre. When students recognize a new task as related to a previous task, the instrumentation phase could be more efficient. Finally, we expect that evidence of design genre's generativity for design, theory, and methods will make design research more appealing to researchers, educators, and policymakers.

Acknowledgment

We thank Rosa Alberto for interesting conversations about the prospects of interspersing mainstream mathematical curriculum with embodied action-based learning activities.

References

- Abrahamson, D. (2014). Building educational activities for understanding: An elaboration on the embodied-design framework and its epistemic grounds. *International Journal of Child-Computer Interaction*, 2(1), 1–16. doi:10.1016/j.ijcci.2014.07.002
- Abrahamson, D. (2018). Teaching design research as a case of cultivating a community of professional practice. In A. Bakker (Ed.), *Design research in education: A practical guide for early career researchers* (pp. 153–171). London, UK: Routledge.

- Abrahamson, D., Shayan, S., Bakker, A. & Van der Schaaf, M. F. (2016). Eye-tracking Piaget: Capturing the emergence of attentional anchors in the coordination of proportional motor action. *Human Development*, 58(4–5), 218–224.
- Alberto, R. A., Bakker, A., Van Aalst, O., Boon, P., & Drijvers, P. (submitted to CERME11, 2019). Embodied Instrumentation: An eye-tracking case study in trigonometry.
- Argyris, C. (1996). Actionable knowledge: Design causality in the service of consequential theory. *The Journal of Applied Behavioral Science*, 32(4), 390–406.
- Aspinwall, L., Shaw, K. L., & Presmeg, N. C. (1996). Uncontrollable mental imagery: Graphical connections between a function and its derivative. *Educational Studies in Mathematics*, 33(3), 301–317.
- Bakker, A. (2018). *Design research in education: A practical guide for early career researchers*. London, UK: Routledge.
- Bernstein, A. N. (1967). *The co-ordination and regulation of movements*. Oxford, UK: Pergamon.
- Davydov, V. V. (1990). *Types of generalization in instruction: Logical and psychological problems in the structuring of school curricula*. (J. Teller, Ed.). Reston, VA: National Council of Teachers of Mathematics.
- diSessa, A. A., & Cobb, P. (2004). Ontological innovation and the role of theory in design experiments. *The Journal of the Learning Sciences*, 13(1), 77–103.
- Dreyfus, H. L., & Dreyfus, S. E. (1999). The challenge of Merleau-Ponty's phenomenology of embodiment for cognitive science. In G. Weiss & H. F. Haber (Eds.), *Perspectives on embodiment: The intersections of nature and culture* (pp. 103–120). New York: Routledge.
- Duijzer, C. A., Shayan, S., Bakker, A., Van der Schaaf, M., & Abrahamson, D. (2017). Touchscreen tablets: Coordinating action and perception for mathematical cognition. *Frontiers in Psychology*, 8(144).
- Hutto, D. D., & Sánchez-García, R. (2015). Choking RECTified: Embodied expertise beyond Dreyfus. *Phenomenology and the Cognitive Sciences*, 14(2), 309–331.
- Klaassen, K., & Kortland, K. (2013). *The role and nature of theory in design research*. Paper presented at ESERA, Cyprus, September 2–7.
- Lee, R. G., Hung, M., Negrete, A. G., & Abrahamson, D. (2013). *Rationale for a ratio-based conceptualization of slope: Results from a design-oriented embodied-cognition domain analysis*. Paper presented at AERA, San Francisco, CA, April 27–May 1.
- Shvarts, A., & Abrahamson, D. (2018). *Towards a complex systems model of enculturation: A dual eye-tracking study*. Paper presented at the annual conference of the American Educational Research Association (Special Interest Group: Learning Sciences). New York, NY, April 13–17.
- Vygotsky, L. S. (1962). *Thought and language*. Cambridge, MA: MIT Press.
- Watson, A., & Ohtani, M. (Eds.) (2015). *Task design in mathematics education*. New York: Springer.

Theory, methodology and design as an insightful bundle: a case of dual eye-tracking student-tutor collaboration on an embodied mathematical task

Anna Shvarts

Utrecht University, the Netherland; a.y.shvarts@uu.nl

Keywords: Eye movements, research methodology, epistemology.

While the importance of reflection on methodological dimension for the networking theories was already stated (e.g. Bikner-Ahsbals & Prediger 2014), here we claim that educational design is another essential dimension in distinguishing a phenomenon that might be unattainable as far as it has not been lit by a particular theory-methodology-design bundle. In this poster, we explore a bundle of a culture-historical approach, dual eye-tracking (DUET) method, and action-based interactive design; we argue that these three aspects being taken together form a lens that manifests in the teaching/learning process a *perception-action system* that is *distributed* between the tutor and student. The argument is based on multimodal data from student-tutor collaboration on interactive activity, where a student was required to discover a parabola in an embodied way as a set of points equidistant from the focus and directrix (Shvarts & Abrahamson, 2018).

Theory-methodology coupling. A culture-historical approach provides us both with the theory and methodology for investigating the psyche's development, and yet they are interconnected. Vygotsky proposes an "experimental-genetic method" that aims to restore the development process and to expose the higher psychic functions in the form of moving, "flowing flood" (Vygotsky, 1978). This method involves the active participation of a researcher in interaction with a pupil that, unlikely to natural science, do not distort the data, but on the contrary allow the genesis of mathematical functions to emerge. A theoretical presumption here is the social nature of psychological functions that emerge in intersubjective interactions. In our study, an experimenter interacts with the student as a tutor, and later interaction is reproduced between the just-instructed participant and a new pupil. DUET appears to be a perfect way to investigate this collaboration: while often eye-movements are interpreted with the presumption of the *eye-mind hypothesis*, the data from DUET might be perceived as evidence of a psychic function as distributed between a student and a tutor. Then *joint attention* is not a result of initiation or response by single participants, but a functional end that emerges from "the multiple pathways" (Yu & Smith, 2016, p. 18) within their system.

Theory-design coupling. Traditionally from Vygotsky's point of view, communication between a student and a teacher is considered as mediated by some cultural artifacts, signs. However, Roth argues that in his late writing Vygotsky departs from the mediation as a primary mechanism that serves communication (Roth, 2018). This embodied character of collaboration is particularly accessible in an activity which is deliberately designed so that introduction of mathematical notations is postponed to the moment when a student has experienced mathematical concepts in an embodied way (Abrahamson, Shayan, Bakker, & van der Schaaf, 2015). The involvement of a student and a tutor in a motor problem that required formation of a new sensory-motor coordination allowed us to trace this function as socially distributed.

Method-design coupling. As eye-tracking let us observe oculomotor spatially articulated activity, we shall involve the participants in the design that benefits from an eye-tracking observation. The embodied action-based design is particularly suitable as it provides an opportunity for the learner to elaborate mathematical knowledge at first in the form of sensory-motor coordination. It is through eye-tracking we may gather empirical evidence of *attentional anchors* — the perceptual aspects of sensory-motor coordination that serves the efficiency of movement (Abrahamson et al., 2015).

Theory-methodology-design bundle. A combination of all three couplings let some phenomena surface; we present the one phenomenon that seems to be of great importance for educational science. While the students' eye-movements manifested emerging *attentional anchors*, the same was found in the tutors' oculomotor behavior, whether they were a researcher or an instructed participant. Thus, we obtained evidence of embodied coupling between the student and tutor: The tutor's perception is *as if* it regulates the student's action. While de facto it is the student who conducts the movements, the tutor enacts these movements in their imagination thus anticipating student's progress in learning and sensing her *micro-zone of proximal development*. This coordination between student's action and tutor's perception allows us introducing *intersubjectively distributed perception-action system* that evolves in the teaching/learning process.

Shall this be a local phenomenon of particular activity under the particular lens? We argue that this theory-methodology-design bundle does not limit generalization of the findings: The phenomenon of an intersubjectively distributed perception-action system is made spatially articulated due to the design settings, visible through dual eye-tracking methodology and understood under the light of Vygotsky's theory of irreducibly collaborative teaching/learning. Finally, it becomes influential far beyond particular experimental settings just like the phenomenon of diffraction of light and its dual wave-particle nature goes far beyond the settings in which it was spotted.

Abrahamson, D., Shayan, S., Bakker, A., & van der Schaaf, M. (2015). Eye-Tracking Piaget: Capturing the Emergence of Attentional Anchors in the Coordination of Proportional Motor Action. *Human Development*, 58(4–5), 218–244.

Bikner-Ahsbals, A., & Prediger, S. (2014). Networking as research practices: Methodological lessons learnt from the case studies. In *Networking of theories as a research practice in mathematics education* (pp. 235–247). Cham, Switzerland: Springer International Publishing.

Roth, W.-M. (2018). Birth of Signs: A (Spinozist-Marxian) Materialist Approach. In N. Presmeg, L. Radford, W.-M. Roth, & G. Kadunz (Eds.), *Signs of signification: Semiotics in mathematics education research* (pp. 37–53). Cham, Switzerland: Springer International Publishing.

Shvarts, A., & Abrahamson, D. (2019). Dual-eye-tracking Vygotsky: A microgenetic account of a teaching/learning collaboration in an embodied-interaction technological tutorial for mathematics. *Learning, Culture and Social Interaction*, 22, doi.org/10.1016/j.lcsi.2019.05.003

Vygotsky, L. S. (1978). *Mind in society: the development of higher psychological processes*. Oxford, England: Harvard University Press.

Yu, C., & Smith, L. B. (2016). Multiple sensory-motor pathways lead to coordinated visual attention. *Cognitive Science*, 41, 1–27.

Assembling mathematical concepts through trans-individual coordinated movements: the role of affect and sympathy

Elizabeth de Freitas¹, Francesca Ferrara² and Giulia Ferrari²

¹ Manchester Metropolitan University, UK; l.de-freitas@mmu.ac.uk

² Università di Torino, Italy; francesca.ferrara@unito.it, giulia.ferrari@unito.it

This paper explores new developments in affect theory for studying the circulation of affect across mathematics classrooms. We use Maxine Sheets-Johnstone's term "affectivity" to characterize the responsive nature of bodies and the potential scaling-up through sympathy and coordinated movement. We examine cooperative classroom tasks that entail sympathetic coordinated movements, including diverse kinds of often imperceptible body movement (gesture, face, eye, foot, etc.). We discuss how mathematical concepts are assembled through the affective bonds that form when students participate in these tasks. Our methodology is notable for how it bridges three scales: (1) the micro-phenomenological scale of the pre-individual affect, (2) the individual scale of human movement, and (3) the transindividual scale of collective endeavour (the making of a concept).

Keywords: Affect, sympathy, collaborative tasks, movement, materiality.

Introduction

Research into the various ways that the human body factors in mathematics education has recently expanded, as new theoretical developments and innovative experimental methods have introduced significant insights about the material dimensions of teaching and learning. Some have criticized this work for how it downplays the role of the environment more broadly, while others have expressed concerns that, even as it attends more carefully to the role of the body in teaching and learning, it seems to support a mind/body split, with continued emphasis on individual cognition rather than collective and distributed learning experiences. These concerns are linked to the methodological use of design experiments that are all too often narrowly focused on individual experience. This narrow focus on the individual is particularly pronounced when we turn to research on the role of affect in mathematics education, which has typically focused on the relationship between beliefs, attitudes and emotions within individual bodies (McLeod & Adams, 1989; Zan et al., 2006).

The socio-cultural turn tried to correct this narrow focus and looked to emotions as socially organised phenomena that are constituted in discourse and shaped by relations of power, but this approach tends to lose sight of the specific practices entailed in mathematical behaviour. Moreover, most socio-cultural studies of the emotional dimension of mathematics continue to assign particular emotions to particular students, who show frustration or anxiety or joy, as they encounter the socio-cultural rituals of school mathematics (Radford, 2015). Such an approach remains focused on the individual, rather than the affective ecology, and tends to black-box the mathematics. More recent attempts to move from beliefs to "affective systems" show promise in their attempt to study *ensembles* of emotions, feelings, attitudes, beliefs, and conceptions (Philippou & Christou, 2002),

and in their recognition that affect is dynamic and variable in intensity (Pepin & Roesken-Winter, 2015). And yet we find the research therein continues to methodologically emphasize expressions of belief and value, through reliance on conventional research methods, such as interviews and self-reporting, without actually operationalizing key ideas from systems theory (Varela & Depraz, 2005) and without tapping the extensive work outside of psychology on affective networks (Massumi, 2015). Moreover, attending to the dynamics of emotional or motivational states in a classroom or other learning community are still rare (Hannula, 2012).

In this paper we pursue a theory of affect that better helps us follow the *movement* of affect across learning events with multiple and diverse participants, in such a way that the mathematics itself is imbricated within the process. This involves delving deeper into the affective nature of mathematical practices which are lived in and through material practices. For that purpose, we turn to recent work on affect in the humanities. Since the 2000s, scholars across the humanities have pursued what is known as the *affective turn* (Clough & Haley, 2007; Gregg & Seigworth, 2010). Shifting away from psychological approaches that focus on affect as individual judgements of value (like, dislike, happy, unhappy), this new approach aims to study the *collectively dispersed nature of affect across a material ecology* (Gregg & Seigworth, 2010). In particular, we follow Massumi (2015) and Sheets-Johnstone (2009, 2011) in studying affect and emotion less as that which is produced and possessed by a psychological subject, and more as an impersonal intensive flow across relational and provisional learning assemblages. We use the term ‘learning assemblage’ to designate the way learning is achieved through affective resonances and the assembling of diverse agencies. The challenge is then to develop research methods that lend themselves to the study of complex ecologies of material-mathematical practices.

Our approach is significant for how it moves away from the individualistic theories of cognitive psychology towards a renewed interest in (1) the somatic and embodied expressions of affect, as bodily organic forces rather than ideational enactments of interior states and (2) the transindividual collective nature of circulating affect. The flow of affect contracts and expands across an event, recruiting our bodies and participation to varying degrees, where affect is itself a kind of pre-conscious micro-movement. The notion of “degree” is crucial here, as it underscores how affect can be contracted in one body and not another with varying intensity. This approach studies classrooms as dynamic affective ecologies and tracks the way that learning rests fundamentally on somatic and unconscious ways of moving together. Concepts emerge and settle in such an environment as a function of sympathy (de Freitas, 2018). We believe that sympathy is the seed of learning because it affords opportunities for collaborative inventive practices. We emphasize this point, because it helps open up discussion of how achievements in classrooms are truly collective insofar as they are *done through us (and not by us)*. This directs attention to the collective nature of learning.

In this paper we discuss briefly a teaching experiment to show how mathematical concepts can be coordinated through affect and sympathetic relations. In particular, we focus on the coordinated movements of two girls in a grade nine classroom, Barbara and Lucrezia, while they are working on a specific task. We track the way that the task brought forth opportunities for these two girls to develop new forms of relationality in their shared achievement, and that their coordinated

movements are directly linked to the complex set of differentials and gradients that comprise the circle concept under study. The methodology involved a teaching experiment that *primed the classroom* so that the circle concept could only be achieved through a coordination of different kinds of movement. In other words, the mathematical task demanded a sympathetic coordination between students. Our initial video analysis focused on the verbal and the gestural. A second analysis focused on micro-movements (head orientation, facial expression, rhythm and speed of coordination) which involved new coding methods that were then combined with field notes from classroom observation. Although not adequate space here to present our methods in detail, we discuss briefly how the data can be analysed in terms of affective ecologies (for more see de Freitas, Ferrara, & Ferrari, 2018).

Theoretical framework for multi-scale analysis






The words emotion and affect are commonly used together, not always with too much care for their different meanings. Here, we draw on the work of Maxine Sheets-Johnstone (2009, 2011), to help distinguish these terms, and to build a theory of affectivity that lends itself to an analysis of pre-individual and trans-individual activity. Sheets-Johnstone is at pains to show how emotions are not only “coping mechanisms” that evaluate or appraise or cope with the sudden break-down of rational discernment. She describes *affectivity* as the fundamental “responsivity” of life, drawing on a long line of phenomenology. Affectivity characterizes the way bodily activity is implicated in collective feelings (common sensibility) but also in pre-conscious sensibility. Affectivity thus characterizes the responsive pre-conscious nature of bodies, how they turn away or lean in, and at the same time how they join with other bodies in coordinated movements. For Sheets-Johnstone, there is a congruency between affect and bodily motion, precisely because affect is lived through bodily movement. In other words, the dynamics of feelings (of comfort, agony, excitement, ...) coincide with micro-facial expression, minute changes in bodily posture, foot-tapping rhythms, changes in heart rate, etc. She posits that “the affective and the kinetic are clearly dynamically congruent; emotion and movement coincide” (Sheets-Johnstone, 2009, p. 377). For Sheets-Johnstone, emotions are not enacted, but *emerge in movement*. She critiques the term ‘enaction’ because it continues to posit an interior state that is then enacted.

And yet we note that delight, grief, remorse, etc, all move different bodies in different ways, and that one needs to reckon with that essential heterogeneity in the emotional landscape. We therefore need to extend her work to better address this heterogeneity in experience. Our theoretical approach aims to attend to the important *tensions* and indeed corporeal *incongruencies* sustained in collective endeavours. We turn to the concept of *sympathy* to better understand how distinctive and disparate movements inform the affective dimensions of learning. The word sympathy comes from ancient Greek (*sumpátheia*) and refers to the state of *feeling together*, derived from a composite of *fellow* and *feeling* (Schliesser, 2015). Sympathy is a complex concept with a complex history. Over the centuries, the notion of sympathy has been used to describe all sorts of activity—everything from contagious yawn catching to cosmological harmony (Brouwer, 2015). In the 19th century, work in physiology defined sympathy as the “action of sensation, the coordination of organs in the body, and the ‘social principle’ that allows ‘fellow-feeling’ to emerge in a society.” (Forget, 2003, pp.

291–292). Sympathy involves an association achieved through imagination and reason (body-mind), as well as an ethical or perhaps normative action to modify one’s own actions so as to *feel with* the other. Importantly, there is no uni-directional sympathy—there is always at least two different agencies engaged. Sympathy is a kind of *agreement* between bodies, when they are mutually affected by each other and sustain a tension. We caution that such agreement is not erasure of otherness, as is often the case with appeals to empathy (Schliesser, 2015). Sympathy is “something to be reckoned with, a bodily struggle”; not a matter of identification or ‘putting oneself in the other’s shoes’ but a matter of modulating related movements—a process of *becoming other that does not erase the other* (Deleuze & Parnet, 2007, p. 53). A sympathetic coordination is not a bland alignment, nor an identification amongst parts, nor the creation of a unified homogeneous assemblage, but rather describes the assembling of heterogeneous agencies and powers. For the purposes of this paper, we suggest that sympathy involves (1) a *contagion* of feeling, (2) a *common sense* or shared sensibility, and (3) a *compassion* for the other. Below we discuss how affectivity and sympathy can help us theorize the ways that mathematical concepts are lived through embodied encounters. Our theoretical approach is meant to bring many scales together – the pre-individual affect, the individual body, the transindividual collaboration of the two girls, and finally the fanning out of affect across the whole class.

Participants and video data

The teaching experiment involved WiiGraph technology, an interactive software application that uses Wii remotes’ multiple features to detect and graphically display the location of two users (a, b) as they move along life-size number lines (Nemirovsky, Bryant, & Meloney, 2012). The experiment took place in a secondary school in Northern Italy, as part of a wider study carried out during regular mathematics lessons. The study involved a class of 30 grade 9 students (aged 15-16) in activities aimed at introducing the concept of function through a graphical approach using digital technology. In this excerpt, the students (Lucrezia and Barbara) move the Wii remotes in order to create a circle graph on a screen. WiiGraph assembles the girls’ collective movement as the partial derivatives of the circle. In other words, as they move their bodies, the graph captures their instantaneous speeds db/dt and da/dt . The girls’ speeds must be different but coordinated for the combined effect to compose a circle. The two Wii remotes must be moved with a rhythmic pattern, and indeed at related rates of changing speed, in order to achieve the effect. The movement is thus directly linked to the mathematical relationships. We focus here on how affect circulates across minute movements as the two girls coordinate their activity to explore the circle concept. There is ample evidence of disagreement (shrugging shoulders and shaking heads) as they discuss their strategy, and indeed these tensions are the important friction that sustains a sympathetic coordination. We see that the learning assemblage evolves through these tensions, when sympathy becomes a bodily struggle. A relationship of response-ability emerges through sympathetic coordinated movement. In the transcript below, R is the researcher (second author), while L and B indicate the two girls.

<p>L: More or less like this</p> <p>B: We get a thing of this kind, maybe (<i>B tilts her head, raises her eyebrow as she raises her hand, twists her torso and smiles</i>) (1)</p> <p><i>L and B both look at the screen</i></p> <p>L: For me, no... (<i>L giggles</i>)</p> <p>B: Let's try</p> <p>L: ... cuz, when you were here, I was here (<i>by crossing arms, points to the two extremes</i>) (2) (<i>L emphasizes their difference, then slouches and shrugs a little</i>)</p>	 <table border="1" data-bbox="1086 546 1390 607"> <tr> <td data-bbox="1086 546 1238 607">1</td> <td data-bbox="1238 546 1390 607">2</td> </tr> </table>	1	2		
1	2				
<p>B: Hm hm, a little more. You've to be here, like this, pock (<i>B questions L's account, and further models for L, now using her two separate hands to mimic both her and L's movements. "Pock" marks the point when the second hand reaches the maximum distance</i>) (3-4)</p> <p>L: But if you go fast (<i>L raises pitch, as though sceptical, but with humour. Then shakes her head, and offers mocking smile</i>)</p> <p>B: Well, fast, it's up to us (<i>B shrugs a little, slows slightly, but continues to move both hands to-fro</i>) (5-6)</p>	 <table border="1" data-bbox="1086 936 1390 996"> <tr> <td data-bbox="1086 936 1238 996">3</td> <td data-bbox="1238 936 1390 996">4</td> </tr> </table>  <table border="1" data-bbox="1086 1193 1390 1256"> <tr> <td data-bbox="1086 1193 1238 1256">5</td> <td data-bbox="1238 1193 1390 1256">6</td> </tr> </table>	3	4	5	6
3	4				
5	6				
<p>R: Can you tell me (<i>the two girls both turn towards R</i>), excuse me, please, tell us what you've decided to do, what you're deciding to do</p>					
<p>B: We're thinking that, because she's in front of me, we stand like this, kind of, if I start here, she starts (<i>B points with the other hand to a middle position. She uses confident voice and L nods approvingly</i>) (7, 8), I start here, she starts like this, when I will arrive here, she will follow me (<i>performs again a back and forth movement with L</i>) (9), a little, she will be there when I will be here (10)</p> <p>L: While she goes backward (<i>L interjects, and nods, looking at R</i>)</p>	 <table border="1" data-bbox="1086 1554 1390 1615"> <tr> <td data-bbox="1086 1554 1238 1615">7</td> <td data-bbox="1238 1554 1390 1615">8</td> </tr> </table>  <table border="1" data-bbox="1086 1812 1390 1872"> <tr> <td data-bbox="1086 1812 1238 1872">9</td> <td data-bbox="1238 1812 1390 1872">10</td> </tr> </table>	7	8	9	10
7	8				
9	10				
<p>R: Will the speed at which you move matter?</p> <p>L: Yes, yes (<i>L confidently nods repeatedly</i>)</p>					

B:	We have to move at the same distance, at the same speed, and at a constant speed
	<i>L begins nodding in agreement, but interjects as though to correct B</i>
L:	With the same rhythm, but she starts before, and I follow her (<i>L reaches her hand out and flaps the air between the two girls as she speaks</i>)
B:	We decide the speed, but we have to move at the same speed and at a constant speed between us (<i>B is incorrect in this claim</i>). <i>L begins by nodding, then shakes her head a little, indicating some mixture of dis/agreement, but says nothing</i>

Table 1: B and L's discussion about how to make a circle

Data analysis and discussion

In the beginning of the project, Barbara was reluctant to take part in group work: she expressed herself in long meandering statements that often confused her class mates. In the process of the teaching experiment, we noticed a serious change in Barbara's position and relationality within the class, although some students continued to dismiss her contributions. Lucrezia, in contrast, was initially silent and timid in class. She also experienced a change in her way of engaging in collective discussions, becoming more willing to intervene and express her opinion, as the experiment unfolded. The two girls came forward to join the collaborative effort of creating a circle, despite their very different ways of being in the class. We can see the way that the productive intensity of the task comes from the various contrasts or tensions that are entailed—there are two girls, each with their own life history; two orthogonal directions to be performed; two very different movements to produce the one graph. Sympathy is the coming together of these contrasts, not so one obliterates the other, but instead as an onto-creative act in which new joint learning comes forth.

The graph of the circle (eventually achieved) is a truly collaborative effect, *a doing done through the individuals (rather than by the individuals)*. The circle is made through Lucrezia and Barbara, an achievement that emerges between the cooperating agencies. This is a task that demands all three components of a sympathetic relation: (1) there is a circulation of feeling as minute facial expressions and changes in bodily posture occur, the two girls leaning in and out, attending to the micro-scale corporeal signals that circulate beneath consciousness; (2) there is a common sense or shared sensibility in the shared obligation to follow each other and work with a shared objective (the circle concept); (3) there is the compassion for the other, and the care of ensuring that others are coming along, moderating the tensions that sustain any learning assemblage. Barbara and Lucrezia are both individually eager to achieve the circle, but all too aware that this achievement depends entirely on coordinating with the independent movements of the other.

The two girls are together determined to make a circle, and there is a shared intensity while the power to lead shifts back and forth. And yet such moving-together and power-switching is successful precisely because the two girls are coordinating at the pre-individual scale of micro gestures and *petites perceptions*. The task itself has created an opportunity for shared affect and transindividual sympathy. The flow of affect recruits other student bodies by varying degrees, when the class “oohs” and “aahs” and someone says “beautiful” as the periodic functions are shown

alongside the circles. We hear the affective tone of these responses, and can track the rippling effect across the class, as the emotion fans out. Other student bodies shift in their seats, lean in and squint, as evidence of a sympathetic investment in the collective endeavour. As Massumi (2015) claims, sympathy “can reverberate across a relational field, faster than the field of conscious calculation.” (p. 84). For him, this is how the micro ethnographic scale reverberates out to other scales: “it is a defining characteristic of complex environments that the extremes of scale are sensitive to each other, attuned to each other’s modulations. This is what makes them oscillatory. They can perturb each other” (p. 10). Affectivity can “channel” through the individual body, reverberating out to the larger scales. *The pre-individual scale of affect can be studied for how it fuels an enveloping social-emotional space in the classroom.*

Conclusion

We stress here that the dynamic movement buried in the mathematical concept is significant. This teaching experiment helps the students grasp the many different ways in which related movements are at work in the apparently fixed and familiar figure of the circle, deepening their understanding of the geometric concept. Thus, the task itself reveals how the affective bonds of coordinated movement are inherent to the circle concept. The task itself demands that the students form assemblages in ways that are productive of collaboratively and responsibly learning together. In this case, the bodily agreement or coordination produces rich mathematical thinking—an assembling of gradients and directions that speaks directly to the circle concept and the associated periodic functions. As the students act, they also perceive these graphs on the screen. This expanded sensitivity points to the complex entanglement of affect and concept, demonstrating how innovative technologies add to our understanding of fundamental aspects of mathematics learning. The amorphous concept of circle is implicated in mathematical activity in different ways, distinctively inflected by the flow of affect between Barbara and Lucrezia. Similarly, other mathematical concepts, if considered as dynamic and variable, are embodied in different material practices (de Freitas & Ferrara, 2015; de Freitas & Sinclair, 2017). Rather than reduce all experiences of mathematics to the same emotional note, our approach attends to the nuanced or tonal differences between one experience and another. Our aim is to attend to the specific and dynamic configuration of affect that *is* mathematics in all its multiplicity.

References

- Brouwer, R. (2015). Stoic sympathy. In E. Schliesser (Ed.), *Sympathy: A history* (pp. 15–35). Oxford, UK: Oxford University Press.
- Clough, P.T., & Haley, J. (Eds.) (2007). *The affective turn: Theorizing the social*. Durham, NC: Duke University Press.
- de Freitas, E. (2018). Love of learning: Amorous and fatal. In R. Braidotti & S. Bignalle (Eds.), *Posthuman ecologies: Complexity and process after Deleuze*. London: Rowman & Littlefield.
- de Freitas, E., Ferrara, F., & Ferrari, G. (2018). The coordinated movements of collaborative mathematical tasks: The role of affect in transindividual sympathy. *ZDM: International Journal of Mathematics Education*, 51(2), 305–318.

- de Freitas, E., & Ferrara, F. (2015). Movement, memory and mathematics: Henri Bergson and the ontology of learning. *Studies in Philosophy and Education*, 34(6), 565–585.
- de Freitas, E., & Sinclair, N. (2017). Concepts as generative devices. In E. de Freitas, N. Sinclair & A. Coles (Eds.), *What is a mathematical concept?* (pp. 76–89). New York, NY: Cambridge University Press.
- Deleuze, G., & Parnet, C. (2007). *Dialogues II*. New York, NY: Columbia University Press.
- Forget, E. (2003). Evocations of sympathy: Sympathetic imagery in Eighteenth-century social theory and philosophy. *History of Political Economy*, 35(1), 282–308.
- Gregg, M., & Seigworth, G. J. (Eds.) (2010). *The affect theory reader*. Durham, NC: Duke University Press.
- Hannula, M. S. (2012). Exploring new dimensions of mathematics-related affect: Embodied and social theories. *Research in Mathematics Education*, 14(2), 137–161.
- Massumi, B. (2015). *The power at the end of the economy*. Durham, NC: Duke University Press.
- McLeod, D. B., & Adams, V. (Eds.) (1989). *Affect and mathematical problem solving: A new perspective*. New York, NY: Springer.
- Nemirovsky, R., Bryant, C., & Meloney, M. (2012). *WiiGraph user guide*. Center for research in mathematics and science education. San Diego, CA: San Diego State University.
- Pepin, B., & Roesken-Winter, B. (Eds.) (2015). *From beliefs to dynamic affect systems in mathematics education: Exploring a mosaic of relationships and interactions*. Cham, Switzerland, CH: Springer.
- Philippou, G., & Christou, C. (2002). A study of the mathematics teaching efficacy beliefs of primary teachers. In G.C. Leder, E. Pehkonen & G. Toerner (Eds.) *Beliefs: A hidden variable in mathematics education?* (pp. 211–232). Dordrecht, Netherlands: Kluwer.
- Radford, L. (2015). Of love, frustration, and mathematics: A cultural-historical approach to emotions in mathematics teaching and learning. In B. Pepin & B. Rösken-Winter (Eds.), *From beliefs and affect to dynamic systems: Exploring a mosaic of relationships and interactions* (pp. 25–49). Cham, CH: Springer.
- Schliesser, E. (2015). Introduction: On sympathy. In E. Schliesser (Ed.), *Sympathy: A history* (pp. 3–14). Oxford, UK: Oxford University Press.
- Sheets-Johnstone, M. (2009). Animation: The fundamental, essential, and properly descriptive concept. *Continental Philosophy Review*, 42(3), 375–400.
- Sheets-Johnstone, M. (2011). *The primacy of movement*. (2nd Ed.). Amsterdam: Benjamins.
- Varela, F. J., & Depraz, N. (2005). At the source of time: Valence and the constitutional dynamics of affect. *Journal of Consciousness Studies*, 12(8), 61–81.
- Zan, R., Brown, L., Evans, J., & Hannula, M. S. (2006). Affect in mathematics education: An introduction. *Educational Studies in Mathematics*, 63(2), 113–121.

Locally integrating theories to investigate students' transfer of mathematical reasoning

Heather Lynn Johnson¹, Evan McClintock², and Amber Gardner³

School of Education and Human Development, University of Colorado Denver, USA;

¹heather.johnson@ucdenver.edu

²evan.mcclintock@ucdenver.edu

³amber.gardner@ucdenver.edu

To theorize the study of students' transfer of mathematical reasoning, we integrate Lobato's theory of actor-oriented transfer, Thompson's theory of quantitative reasoning, and Marton's variation theory. Linking theory and method, we argue for an expansion of design possibilities for researchers' investigations of students' transfer of reasoning. To bolster our argument, we provide empirical data of a secondary student's transfer of a particular form of reasoning—covariational reasoning. Our research has implications for researchers' development of new theoretical and methodological approaches to investigate complex phenomena, such as students' mathematical reasoning.

Keywords: Transfer of learning, reasoning, learning theories, instructional design,

Investigating students' transfer of mathematical reasoning is a complex, multifaceted endeavor. We identify three key elements of this endeavor. The first two elements focus on students' perspectives: students' engagement in mathematical reasoning and students' transfer of their mathematical reasoning. The third element focuses on researchers' design of mathematical task sequences to engender students' mathematical reasoning. We view these elements to be interconnected, and in our theorizing of these elements, we work to address this interconnectedness.

Networking theories can take a variety of forms, depending on the degree of connections between and among theories, as well as researchers' goals with connecting theories (Bikner-Ahsbabs & Prediger, 2010). We are working to locally integrate theories (Bikner-Ahsbabs & Prediger, 2010), in which we extend beyond combining or coordinating theories to explain empirical phenomena, to building new theories. Specifically, we integrate Lobato's (2003) theory of actor-oriented transfer, Thompson's (2011) theory of quantitative reasoning, and Marton's (2015) variation theory to theorize our study of students' transfer of a particular form of reasoning—covariational reasoning.

We aim to extend possibilities for researchers to investigate students' transfer. We argue that researchers can investigate students' transfer of mathematical reasoning by research designs other than pre- and post-tasks. To provide backing for our argument, we share empirical data of a secondary student's transfer of a particular form of reasoning—covariational reasoning (Thompson & Carlson, 2017). We address implications for researchers' development of new theoretical and methodological approaches to investigate complex phenomena, such as students' mathematical reasoning.

Integrating theories to investigate students' transfer of covariational reasoning

Task designers, teachers, and researchers share a goal of promoting students' mathematical reasoning. While mathematical reasoning comprises students' mental activity, in our view, it is impossible to

separate students' mental activity from their embodied experiences (English, 2013). Interacting with mathematical tasks can provide students opportunities to engage in mathematical reasoning. By mathematical task, we mean something more than a problem statement. From our perspective, tasks encompass the intentions of a task designer, the implementation of a task by a teacher/researcher, students' interaction with the task, and physical materials associated with the task (Johnson, Coles, & Clarke, 2017). Ideally, when students develop a form of mathematical reasoning, they could engage in that form of reasoning on subsequent tasks and in different situations.

We aim to infer students' reasoning based on their observable behavior. In our view, students are experts in their own mathematical reasoning, and our role is to elicit and explain that reasoning. Our stance on students' reasoning influences our assumptions about the viability of their reasoning. First, we do not assume that students working on a task will share our goals for the task (e.g., Johnson, Coles, & Clarke, 2017). Second, we acknowledge that students may engage in mathematical reasoning that is different from the reasoning we intend. Third, we assume students' different forms of reasoning to be viable and productive. Hence, we do not seek to "fix" students' reasoning. Rather, we seek to understand and engender students' mathematical reasoning, in its myriad forms.

Employing a transfer lens, researchers can investigate how students might engage in different forms of mathematical reasoning across a range of tasks and situations. Yet, researchers' perspectives on transfer impact what researchers may construe as evidence of students' transfer of reasoning (Lobato, 2003; 2014; Marton, 2006). To address the problem of investigating transfer of students' reasoning, we employ an actor-oriented transfer perspective (Lobato, 2003; 2014), because it affords researchers the opportunity to gather evidence of transfer of reasoning beyond forms of reasoning that a researcher may intend.

From an actor-oriented transfer perspective, transfer is generalization, rather than application (Lobato, 2003; 2014). Meaning, students who generalize some form of reasoning from one task to another would engage in transfer, even if they do not apply a particular solution method. Hence, an actor-oriented transfer perspective broadens the scope of what is possible for students to transfer. Furthermore, a researcher's theoretical perspective on transfer impacts methods used to gather evidence of students' transfer. Researchers employing an actor-oriented transfer perspective examine students' constructions of similarities across tasks, rather than students' task performance (Lobato, 2003; 2014). Because students' mathematical reasoning is not the same as task performance, an actor-oriented transfer perspective is a productive theoretical lens to use to investigate students' reasoning.

We focus on students' engagement in and transfer of a particular form of reasoning—covariational reasoning—which is critical for students' development of a conception of function (Thompson and Carlson, 2017). We draw on Thompson's theory of quantitative reasoning (Thompson, 2011; Thompson & Carlson, 2017) to explain our perspective on covariational reasoning. When students engage in covariational reasoning, they form and interpret relationships between attributes they conceive of as capable of varying and possible to measure. For example, consider a situation involving a toy car moving around a track. A student engaging in covariational reasoning could form and interpret relationships between different attributes, such as the toy car's distance traveled around the track and its distance from some stationary object. Because an actor-oriented transfer perspective

focuses on students' generalization rather than performance, it is a useful theoretical lens to explain invariance in students' engagement in quantitative (and covariational) reasoning across tasks and situations (Thompson, 2011).

Researchers employing a variation theory perspective (Kullberg, Kempe, & Marton, 2017; Marton, 2006; 2015) consider critical aspects of objects of learning (intended objects of learning), problematize ways in which to provide students opportunities to experience those critical aspects (enacted objects of learning), and acknowledge the viability of learning that students actually demonstrate (lived objects of learning). Although we focus on a particular form of reasoning—covariational reasoning—we acknowledge that students may engage in or transfer forms of reasoning other than what we intend. From a variation theory perspective, students discern the similar (and generalize) because they discern difference, and consequently, designers should design opportunities for students to experience difference. Simply put, variation (in terms of difference) is a necessary condition for students to experience discernment.

Networking theories is useful for addressing complexities inherent in investigations of students' mathematical reasoning. For example, our investigation of students' transfer of covariational reasoning is intertwined with students' creation and interpretation of dynamic graphs in a Cartesian coordinate system. Drawing on Variation Theory, we considered critical aspects to include the types of attributes that students would encounter (e.g., length measures), the motion of objects in physical space (e.g., up/down, left/right, curving paths), and the representation of those attributes in a Cartesian coordinate system. Accordingly, we varied those critical aspects to provide opportunities for students to engage in covariational reasoning.

Networking (coordinating) Thompson's theory of quantitative reasoning and Marton's variation theory of learning, Johnson, McClintock, Hornbein, Gardner, and Grieser (2017) explained how researchers could design learning experiences to engender students' discernment of critical aspects of covariation. We extend this research in two ways. First, we connect the investigation of students' transfer of reasoning, employing an actor-oriented transfer perspective on transfer. Second, we build from coordinating theories to locally integrating theories, to contribute to theory development.

Extending design possibilities for actor-oriented transfer

Lobato (2014) identified four criteria on which researchers should base claims of actor-oriented transfer. We summarize these claims, centering students' mathematical reasoning, which is our focus. First, students should demonstrate a change in reasoning on transfer tasks, from a pre-interview to a post-interview. Second, students should demonstrate the new reasoning during interview tasks occurring between the pre- and post-interviews. Third, researchers should provide evidence that students' reasoning during the interview tasks influenced their reasoning on the post-interview tasks. Fourth, researchers should provide evidence that changes in students' reasoning in a post-interview occurred as a result of their work on the interview tasks, and was not just a spontaneous occurrence.

We posit an extension of design possibilities for researchers employing an actor-oriented transfer perspective. From our perspective, inherent in Lobato's (2014) design criteria is an assumption that researchers design transfer tasks that are separate from interview tasks. We argue that by leveraging Variation Theory in task design, researchers can investigate students' transfer by analyzing students'

reasoning on subsequent tasks across a set of interviews. In making this argument, we follow Cobb's (2007) recommendation for theory expansion rather than replacement. In particular, we aim to expand design possibilities, rather than to replace one design type with another design type.

An empirical example: A task sequence and a student's work

To illustrate how we locally integrated theories, we provide an example from the work of a 9th grade student, Aisha, during three individual, task-based interviews, conducted by Johnson. Task sequences in each interview had a different background (first a Ferris Wheel, second a Cannon Man, and finally a Toy Car), given by a computer animation. Aisha worked on a tablet (an iPad), with pencil and paper available. In each task sequence, Aisha sketched and/or interpreted different Cartesian graphs to represent a relationship between attributes in a situation given in an animation.

The Cannon Man and Toy Car task sequences were more involved than the Ferris Wheel task sequence. For the Ferris Wheel, Aisha needed to sketch only one graph. For the Cannon Man and Toy Car, Aisha explored change in individual attributes, manipulating dynamic segments located on the horizontal and vertical axes. Next, Aisha sketched a graph representing a relationship between both attributes. Then, Aisha repeated the process for a second graph with attributes represented on different axes. After sketching each graph, Aisha viewed a computer-generated graph. Transcripts that follow are from each interview. Figure 1 shows graphs that Aisha drew in each interview. The Cannon Man and Toy Car graphs shown in Figure 1 (middle, right) are the second Cartesian graph that Aisha drew during each interview.

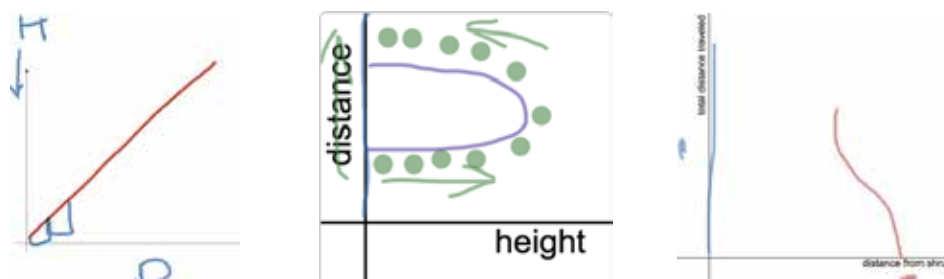


Figure 1: Aisha's Ferris Wheel, Cannon Man, and Toy Car graphs, respectively

Ferris Wheel

Johnson asked Aisha to sketch a graph relating a Ferris wheel cart's height from the ground and total distance traveled, around one revolution of the Ferris wheel. While sketching the graph shown in Figure 1, left, Aisha explained why she drew the graph the way that she did.

Aisha: I feel like the height would be more like the line (sketches a line, Figure 1, left). Distance would be more like the rise and run of the situation (sketches small segments, Figure 1, left). Cause you're using the rise and run to find the line, and you need to use the distance to find the height.

Cannon Man

Johnson asked Aisha to sketch a graph relating a Cannon Man's height from the ground and total distance traveled, with the height on the horizontal axis and the distance on the vertical axis. After

Aisha sketched the graph shown in Figure 1, middle, Johnson asked her to explain how her graph showed Cannon Man's height and distance.

Johnson: Can you show me how you see the height increasing and decreasing in this purple graph? (Points to the curved graph Aisha drew, Figure 1, middle)

Aisha: It's (the height's) increasing here, since it's (the graph's) backwards in my opinion (Sketches green dots, beginning on bottom left near the vertical axis, then moving outward, Figure 1, middle). Decreasing here. (Continues to sketch green dots, until getting close to the vertical axis, adding arrows after sketching dots, Figure 1, middle)

Johnson: How is the distance changing?

Aisha: (Turns iPad so that vertical axis is horizontal. Draws arrow parallel to vertical axis, Figure 1, middle.) That way. Continues to get bigger.

Toy Car

Prior to sketching the graph shown in Figure 1, right, Aisha stated, without prompting from Johnson, that distance traveled was the "same as the Cannon Man." Johnson asked Aisha to clarify.

Johnson: So, you said the total distance traveled is like the Cannon Man. Why is that like the Cannon Man again? Cause Cannon Man goes up and down, and this one moves around. How are those things the same?

Aisha: Just because Cannon Man is coming back down, doesn't mean his distance is going down. His distance is still rising.

To explore change in each of the individual attributes, Aisha manipulated dynamic segments located on the horizontal and vertical axes. For the total distance, Aisha began at the origin, continually moving the segment up, along the vertical axis. She explained: "I moved it up. It continuously went up, because the distance doesn't decrease. The total distance traveled doesn't decrease." For the distance from the shrub, Aisha began to the right of the origin, initially moving the segment to the left, and then to the right. She explained: "I moved it (the segment) to the left, because it (the Toy Car) was getting closer to the shrub. Then, when it (the Toy Car) started to turn, I started to moved it (the segment) back up to the right, because it (the Toy Car) was getting closer to the shrub." Next, Aisha sketched the graph shown in Figure 1, right. After viewing the computer-generated graph, Aisha explained what she thought the curved graph represented. Aisha stated: "This (moving her finger from left to right along the horizontal axis) is tracking the distance from the shrub, and this (moving her finger along the curved graph, beginning near the horizontal axis) is also tracking the distance."

Employing individual theories as analytic lenses

We explain how we draw on individual theories to analyze Aisha's transfer of covariational reasoning. While we present the accounts separately, we conceive of these accounts as something more than complementary. In our view, each theoretical lens is like one of the intertwined strands of a braid or cord.

Thompson's theory of quantitative reasoning

In our task design, we made strategic choices about the kinds of attributes that students would represent in graphs. In particular, we selected length attributes (e.g., height, distance) because we anticipated it would be less difficult for students to conceive of measuring length attributes than for other kinds of attributes, such as area or volume. During clinical interviews, Johnson asked students to represent ways in which individual attributes were varying (e.g., increasing and/or decreasing), and to explain how graphs they sketched represented different attributes.

For the Cannon Man and Toy Car, Aisha provided evidence of engaging in an early form of covariational reasoning. In contrast, for the Ferris wheel, Aisha attempted to show how one might obtain one value given another value. For the Cannon Man and Toy Car, Aisha conceived of both attributes as possible to measure and capable of varying. Her graphs (Figure 1, middle, right) represented both attributes, one varying in a single direction (increasing), and another varying in different directions (increasing and decreasing).

Marton's Variation Theory

For the Cannon Man and Toy Car task sequences, we incorporated patterns of variation and invariance to provide opportunities for Aisha to discern critical aspects of covariation (intended object of learning). First, Aisha could vary each attribute individually, then both attributes together. Second, Aisha repeated the process for a new Cartesian graph with the same attributes represented on different axes. We designed each of the first two elements against a background of invariance (e.g., the Cannon Man). Next, we repeated the first two elements against a new background (e.g., the Toy Car). When creating a new background, we varied different elements while keeping other elements the same. In particular, we varied the motion of the object (e.g., the Toy Car moved in a curved line; Cannon Man moved up and down), while keeping the kinds of attributes (length measures) invariant.

When Aisha interacted with the Cannon Man task sequence, she discerned differences between the motion of the Cannon Man (up/down) and the total distance traveled (enacted object of learning). After interacting with both the Cannon Man and Toy Car task sequences, Aisha discerned that the differences in the motion of the Cannon Man and the Toy Car did not impact the total distance traveled, which still increased in both situations (lived object of learning). We argue that the opportunity to experience difference in the motion of objects for the Cannon Man and Toy Car contributed, in part, to Aisha's transfer of covariational reasoning.

Lobato's theory of actor-oriented transfer

We adapted Lobato's (2014) criteria to align with Aisha's work during the task sequence we reported. We analyzed for evidence of the following: (1) Aisha's change in reasoning from the first interview (Ferris Wheel) to the third interview (Toy Car); (2) Aisha's engagement in covariational reasoning during the second interview; (3) Influence of Aisha's reasoning during the second interview on her reasoning during the third interview; and (4) Attribution of Aisha's changed reasoning to the interview tasks, rather than to a spontaneous occurrence.

For the Ferris Wheel, Aisha provided evidence that she was doing something other than engaging in covariational reasoning (1). We interpret that Aisha was conceiving of how she might use a formula

or rule to determine one amount (height), given another amount (distance). For the Cannon Man, Aisha demonstrated evidence of engaging in covariational reasoning (2). Rather than attempting to show how one might obtain one value given another value, she conceived of both attributes as possible to measure and capable of varying. Aisha's explanations provide evidence of how she construed similarities in an attribute (total distance), common to the Toy Car and the Cannon Man (3). We interpret Aisha's reasoning for the Toy Car to be influenced by her reasoning for the Cannon Man (4). First, Aisha identified a common attribute across both the Toy Car and the Cannon Man (total distance). Second, Aisha related the toy car's total distance traveled and its distance from the shrub. Third, Aisha's substantial change from the Ferris Wheel to the Toy Car strongly suggests that her reasoning for the Cannon Man influenced her reasoning for the Toy Car.

Locally integrating theories to theorize the “tension of intentions” in task design

In integrating these theories, we aim to theorize the “tension of intentions” when researching task design to account for the student perspective. We aim to position students' perspectives as being just as viable as the perspectives of designers, teachers, and researchers. Accordingly, we aim not to place one theory as hierarchically superior to another, but rather to weave together the theories into a new form. In so doing, we bring together different assumptions: Students' reasoning depends on their conceptions of attributes as being possible to measure and capable of varying (Thompson's theory of quantitative reasoning), students discern difference, rather than sameness (Marton's Variation Theory); and transfer depends on the student perspective (Lobato's theory of actor-oriented transfer).

To claim that we can integrate theories, we need to address their epistemological roots (Bikner-Ahsbabs & Prediger, 2010). Lobato's and Thompson's theories have roots in students' conceptions, which makes integrating those theories more straightforward. In contrast, Marton's theory has roots in students' experience. We argue that both students' conceptions and experiences are central to their learning opportunities. For example, in our research, students' experiences with Cartesian graphs and students' conceptions of attributes were both central to their covariational reasoning. Through centering the student perspective, we integrate these different theories.

Conclusion: Rethinking design possibilities for transfer studies

We view a reflexive relationship between theoretical perspectives and research methods. Employing alternative transfer perspectives, such as an actor-oriented transfer perspective, can result in innovations in methods to investigate transfer. A variation theory lens afforded us novel opportunities to design for and investigate students' transfer of covariational reasoning. Rather than designing a set of pre- and post-tasks, that in our view were structurally similar, we designed task sequences that incorporated difference within and across backgrounds of invariance. Analyzing across students' work on the task sequences, we gathered evidence of students' transfer of reasoning from an actor-oriented transfer perspective. Overall, we acknowledge that the perspectives of designers, teachers, and researchers can impact students' opportunities to engage in mathematical reasoning. In our theorizing, we aim to address this tension of intention, by centering the student perspective.

Acknowledgment. The development of the digital task sequences was supported by a US National Science Foundation Grant (DUE-1709903). Opinions, findings, and conclusions are the authors.

References

- Bikner-Ahsbabs, A., & Prediger, S. (2010). Networking of Theories—An Approach for Exploiting the Diversity of Theoretical Approaches. In B. Sriraman & L. English (Eds.), *Theories of Mathematics Education: Seeking New Frontiers* (pp. 483–506). Berlin, Heidelberg: Springer.
- Cobb, P. (2007). Putting philosophy to work: Coping with multiple theoretical perspectives. In F. K. Lester (Ed.), *Second handbook of research on mathematics teaching and learning* (pp. 3–38). Charlotte, NC: Information Age.
- English, L. D. (2013). Analogies, metaphors, and images: Vehicles for mathematical reasoning. In English, L. D. (Ed.), *Mathematical Reasoning: Analogies, metaphors, and images*. (pp. 11–26). New York: Routledge.
- Johnson, H. L., Coles, A., & Clarke, D. (2017). Mathematical tasks and the student: Navigating “tensions of intentions” between designers, teachers, and students. *ZDM—The International Journal on Mathematics Education*, 49(6), 813–822.
- Johnson, H. L., McClintock, E., Hornbein, P., Gardner, A. N., & Grieser, D. (2017). When a critical aspect is a conception: Using multiple theories to design dynamic computer environments and tasks to promote secondary students’ discernment of covariation. In Dooley, T., & Gueudet, G. (Eds.), *Proceedings of the Tenth Congress of the European Society for Research in Mathematics Education* (CERME10, pp. 2738–2745). Dublin, Ireland: DCU Institute of Education and ERME.
- Kullberg, A., Kempe, U. R., & Marton, F. (2017). What is made possible to learn when using the variation theory of learning in teaching mathematics? *ZDM—The International Journal on Mathematics Education*, 49(4), 559–569.
- Lobato, J. (2003). How design experiments can inform a rethinking of transfer and vice versa. *Educational Researcher*, 32(1), 17–20.
- Lobato, J. (2014). Research methods for alternative approaches to transfer. Implications for design experiments. In Kelly, A. E., Lesh, R. A., & Baek, J. Y. (Eds.), *Handbook of design research methods in education: Innovations in science, technology, engineering, and mathematics learning and teaching*. (pp. 167–194). Routledge.
- Marton, F. (2015). Necessary conditions of learning. New York: Routledge.
- Marton, F. (2006). Sameness and Difference in Transfer. *Journal of the Learning Sciences*, 15(4), 499–535.
- Thompson, P. W. (2011). Quantitative reasoning and mathematical modeling. In S. A. Chamberlain & L. L. Hatfield (Eds.), *New perspectives and directions for collaborative research in mathematics education: Papers from a planning conference for wisdom* (Vol. 1, pp. 33–56). Laramie, WY: University of Wyoming College of Education.
- Thompson, P. W., & Carlson, M. P. (2017). Variation, covariation and functions: Foundational ways of mathematical thinking. In J. Cai (Ed.), *Compendium for research in mathematics education* (pp. 421–456). Reston, VA: National Council of Teachers of Mathematics.

Epistemological and methodological foundations of creating a learning trajectory of children's mathematics

Nicole L. Fonger¹, Amy Ellis² and Muhammed F. Dogan³

¹Syracuse University, USA; nfonger@syr.edu

²University of Georgia, USA; amyellis@uga.edu

³Adiyaman University, Turkey; mfatihdogan@adiyaman.edu.tr

This paper argues for creating learning trajectories of children's mathematics by integrating evidence of shifts in the mathematics of students, theory of goal-directed instructional design, and evidence of instructional supports. We networked two theories in support of this stance: a radical constructivist theory of learning, and Duality, Necessity, Repeated Reasoning (DNR)-based instruction. We exemplify how our networking of theories guided methodological choices by drawing on a program of research aimed at understanding and supporting students' ways of understanding quadratic growth as a representation of a constantly changing rate of change. We close by discussing challenges for creating and sharing learning trajectories.

Keywords: Learning trajectory, constructivism, cognition, learning theories, epistemology.

Learning trajectories in mathematics education

Attention to learning trajectories and progressions remains a prominent strand of research in mathematics education (e.g., Clements & Sarama, 2004). The influence of this domain of research is evident in the development of mathematics standards (e.g., National Governor's Association Center for Best Practices, 2010; UK Department of Education, 2009), funding priorities, topics conferences (e.g., the Third International Realistic Mathematics Education Conference), and special reports (e.g., Daro, Mosher, & Corcoran, 2011). Given the relatively wide-spread promulgation of trajectories and progressions in our discourse in research and practice, there is a need to articulate theoretical and methodological foundations of learning and teaching (Simon, 2013). This paper argues for the importance of creating learning trajectories as research-based models of teaching and learning that take seriously a commitment to understanding and supporting students' mathematics.

The notion of a learning trajectory has different meanings among mathematics education researchers. Simon's (1995) original discussion offered a description of a *hypothetical learning trajectory (HLT)* consisting of "the learning goal, the learning activities, and the thinking and learning in which students might engage" (p. 133). An HLT constitutes a starting point for task design, and is then modified into a learning trajectory based on empirical data, often in the form of a teaching experiment. Clements and Sarama (2004) described a learning trajectory as an elaboration of children's thinking and learning in a specific mathematical domain, connected to a conjectured route through a set of tasks. These definitions emphasize the construct as a tool for *hypothesizing* what students might understand about a particular mathematical topic and how that understanding may change over time in interaction with carefully designed tasks and teaching actions.

Building on this body of work, we argue that the main purpose of a learning trajectory is to effectively convey the relationships between teaching, task-design, and shifts in student

conceptions. We advocate for a stance that articulates an integrated system of ways of bringing about conceptual change in the mathematics of students in relation to theory-driven instructional support. Thus, in order to create learning trajectories, we need mutually informing theories of learning and teaching. This paper elaborates two such theories, the radical constructivist theory of learning and Duality, Necessity, and Repeated Reasoning-based instruction, and identifies how these two related theories influence our methodological approach to building learning trajectories. We provide an example situated in a rate of change approach to quadratic function.

Theoretical and epistemological framing

A theory of learning mathematics

In discussing the theory that guides our approach to crafting learning trajectories, we address three major issues: (a) distinguishing students' mathematics from the mathematics of students, (b) leveraging the epistemic student, and (c) leveraging a model of learning. Theory of instructional design is treated in the next section.

Learning trajectories articulate students' evolving conceptions within a particular instructional context. In order to do this, we distinguish from our own mathematics as researchers and teachers, our students' mathematics, and the models we create of our students' mathematics. The need to distinguish our own mathematics from students' mathematics is borne out of our epistemological stance. We consider mathematical knowledge to develop as part of a process in which children gradually construct and then experience a reality as external to themselves (von Glasersfeld, 1995; Piaget, 2001). From this perspective, knowledge is considered viable if it stands up to experience, enables one to make predictions, and allows for the enactment of desired objectives.

The term *students' mathematics* refers to the models students construct to organize, comprehend, and control their experiences – i.e., students' knowledge. The *mathematics of students* is the set of models we construct of our students' knowledge (Steffe & Olive, 2010). Often there is little distinction between these two notions in curricula or in standards documents. We believe, however, that the mathematical knowledge we attribute to students in the creation of a learning trajectory must be viewed as different from our own knowledge. Our goal is to determine how to engender and explain students' productive thinking. By distinguishing our mathematics from the students' mathematics, we recognize that students bring significant knowledge to bear when engaging in school mathematics, and we position students as logical, coherent thinkers and doers of mathematics. The job of establishing a learning trajectory then becomes one of explaining students' thinking in a way that portrays it as coherent and internally consistent (Steffe, 2004).

Individual students differ in their personal backgrounds, knowledge, and dispositions. A learning trajectory should depict not one particular student or group of students, but rather the *epistemic student*. An epistemic student is an organization of schemes that researchers build to explain students' characteristic mathematical activity and how that activity changes in the context of teaching (Steffe & Norton, 2014). Researchers construct epistemic students through teaching interactions with specific students, but epistemic students are not specific to those particular interactions. Instead we conceive them to be useful models of students' schemes that one can leverage to describe, explain, and predict the mathematical actions of similar students who may be

operating at the same level.

Formulating an explanation of changes in students' concepts and operations is not merely an empirical matter. We also bring to bear a set of conceptual tools in order to interpret students' activity and problem solving. These tools have their origins in the radical constructivist (RC) model of knowing (von Glasersfeld, 1995; Piaget, 2001). For the purposes of learning trajectory construction, we rely particularly on the constructs of mental operation, scheme, assimilation and accommodation, and abstraction. A *mental operation* is an internalized, reversible mental action that is an element of a larger structure, such as a scheme, constituted by the coordination of operations. A *scheme* is an organization of actions or operations which enables anticipation of results without having to engage in mental activity. As an example, Piaget (2001) described the mental operation of combining objects (such as addition). Several successive additions are the equivalent of a single addition (so one can compose additions), and they can be inverted into the operation of taking away, or subtraction.

Treating new material as something already known is an act of *assimilation*. When assimilating, one encounters an experience and incorporates it into a scheme. When the enactment of a scheme results in an unexpected outcome, a learner may experience perturbation or disequilibrium. One response can be a change in the learner's recognition, in effect spurring a reorganization of one's scheme. This reorganization is *accommodation*, which many consider to be the source of conceptual change.

DNR-based instructional design

The theory of DNR-based instruction (*Duality, Necessity, and Repeated Reasoning*; Harel, 2008a; 2008b) informs our instructional design principles. Drawing on the RC theory of knowing, Harel (2008b) noted that "any observations humans claim to have made is due to what their mental structure attributes to their environment" (p. 894). He emphasized that researchers' observations are merely models of students' conceptions; using our language, these are models of the mathematics of students (Harel, 2013). Drawing on the mechanisms of assimilation and accommodation, Harel (2013) characterized knowing as a developmental process that proceeds through a back-and-forth between the two in order to reach equilibrium.

The duality principle addresses two forms of knowledge, *Ways of Understanding* (WoU) and *Ways of Thinking* (WoT). WoU can be thought of as subject matter, consisting of students' definitions, theorems, proofs, problems, and their solutions (Harel, 2008a). WoT are students' conceptual tools, such as deductive reasoning, heuristics, and beliefs about mathematics (Harel, 2013). The Duality Principle states that students develop WoT through the production of WoU, and, conversely, the WoU they produce are afforded and constrained by their WoT (Harel, 2008a). We contend that the mathematical content of a learning trajectory must be formulated in terms of both WoU and WoT.

The *necessity principle* states that in order for students to learn the mathematics we intend to teach them, they must have an intellectual need for it (Harel, 2008b). We can engender intellectual need through problematic situations that necessitate the creation of new knowledge in order to be resolved. Finally, the repeated reasoning principle addresses the need for teachers to ensure that their students internalize, retain, and organize knowledge (Harel, 2008a). Repeated reasoning should not be confused with drill and practice of routine problems. Rather, it is an instructional

principle that advocates providing students with sequences of problems that require thinking through puzzling situations and solutions; the problems must respond to students' intellectual need.

Methodological approach and rationale

Our methodological approach to establishing learning trajectories is a direct consequence of our theoretical and epistemological framing. We elaborate how our networked theories (RC, DNR-based instruction) informed our methodologies. We describe three aspects: (a) leveraging theory to create an HLT, (b) ongoing refinement of an HLT into an LT through enacting a teaching experiment, and (c) finalization of an LT through retrospective analysis.

Creation of an HLT

We enact a form of design-based research to simultaneously engender and study innovative forms of learning (Cobb & Gravemeijer, 2008). The planning phase involves creating an HLT (Simon, 1995) informed by the networking of the RC theory of learning and the theory of DNR-based instruction. Our HLT was a tentative progression of student concepts and associated tasks that we hypothesized would necessitate a WoU that quadratic functions represent a constantly-changing rate of change between two covarying quantities. Simultaneously, our aim was to support a WoT that functions can be representations of covariation and can be explored and understood through a covariational lens (Thompson & Carlson, 2017). Consequently, we devised a dynamic representation of proportionally-growing rectangles in which students could investigate situations that, to us, entailed the three continuously covarying quantities, height, length, and area (Figure 1).

The relationship between height, h , and area, A , can be expressed as $A = ah^2$ where a is the ratio of length to height. We wanted the students to develop the following specific WoUs: (a) the rate of change of a rectangle's area grows at a constantly-changing rate for each same-unit increase in height (or length); (b) the rate of the rate of change of the rectangle's area is constant for same-unit height (or length) increases; (c) given a height h , the rectangle's area could be determined by ah^2 ; and (d) the rate of the rate of change of area is dependent on the change in height. In order to engender these WoUs, we devised tasks in which students had to predict the nature of growth, determine areas for specific height values and vice versa, and decide whether given tables of values represented rectangles that grew in proportion to one another or not. See Ellis (2011) for an elaboration of the mathematics.

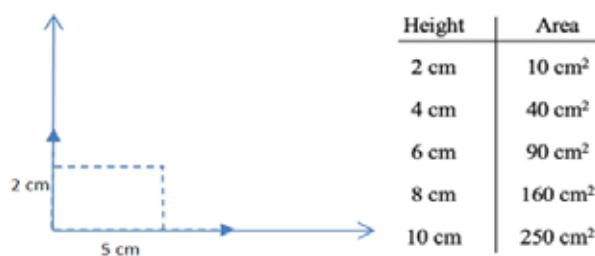


Figure 1: A growing rectangle and associated table of height-area values

Teaching experiment: Ongoing refinement of an HLT into a tentative LT

Drawing from the theories we networked, we engaged in an in-depth, 15-day teaching experiment following the method of Steffe and Thompson (2000). We taught 15 lessons to a group of 6 middle-

grades students (ages 13- 14) who were enrolled in pre-algebra (3 students), algebra (2 students), and geometry (1 student). The second author was the teacher-researcher (TR). One purpose of a teaching experiment is to gain direct experience with students' mathematical reasoning, which affords the creation and testing of hypotheses about the mathematics of students in real time. This means that our mathematical tasks were not wholly predetermined, but instead were created and revised on a daily basis in response to hypothesized models of students' mathematics. Because our problem context relied on area models, it was important to first identify the students' existing schemes and operations for area. After conducting pre-interviews and developing an initial model of the mathematics of students, we created new tasks to necessitate more robust constructions of area as not dependent on whole-unit iterations. During and between each session, we engaged in an iterative cycle of (a) teaching actions, (b) assessment and model building of students' thinking, and (c) task revision and creation on an ongoing basis. In this manner, during each session, we continually revised our HLT into a tentative, empirically based LT.

Retrospective analyses: Finalizing an LT

In addition to our ongoing analysis, we relied on retrospective analysis to inform the development of a learning trajectory as a model of the mathematics of students (Steffe & Thompson, 2000). One purpose of retrospective analysis is to build a model of the epistemic student and to characterize students' changing WoU and WoT throughout the course of the teaching experiment. A secondary purpose, for us, was to contextualize and explain changes in students' schemes and operations with respect to the tasks and teaching actions they encountered. We aimed to elaborate features of tasks, teacher moves, questioning, and socio-mathematical norms that supported the students' scheme accommodation. Our inclusion of instructional supports into a learning trajectory relied both on our analyses of empirical data and on our understandings of the local instructional theories grounding our design and enactment of the teaching experiment. Figure 2 identifies the goals, tools and constructs we leveraged in order to create a learning trajectory. Notice how the primary and secondary aims are linked to a coordination of RC and DNR-based instructional design theories.

Analytic Aim	Goals, Tools and Constructs
Primary Aim: Identify the mathematics of students	<i>Identify</i> WoU and WoT: Describe (a) students' mathematical definitions, theorems, and concepts; (b) heuristics, reasoning, strategies, and beliefs about mathematics
	<i>Characterize</i> WoU and WoT: Identify operations and schemes
	<i>Exemplify</i> WoU and WoT: Provide data evidence of specific WoU and WoT
Secondary Aim: Contextualize and explain changes in the mathematics of students	Identify <i>shifts</i> in WoU and WoT: Articulate instances of scheme accommodation and abstraction
	Identify <i>task features</i> fostering shifts: Identify the WoU necessitated by each task; clarify relationships between tasks elements and students' existing WoU
	Identify <i>instructional supports</i> fostering shifts: Determine teacher moves promoting accommodation and abstraction; characterize student engagement and discourse; identify socio-mathematical norms

Figure 2: Analytic aims, goals, tools, and constructs for creating a learning trajectory

An excerpt of a learning trajectory for quadratic function

In our previous work, we identified WoT and WoU in students' learning of quadratic function from a rates of change perspective (Fonger, Dogan, & Ellis, 2017). Below, we provide an example of a

link between goal-directed instructional supports and a shift in student thinking (i.e., an excerpt of a LT). We focus on one shift from a student's WoU that (a) the rate of the rate of change of the rectangle's area is constant with Δx implicit, to (b) the rate of the rate of change of area is dependent on Δx , which is explicit. In the excerpt, the students had already created well-ordered tables for the growing rectangles (Figure 3). They had also attended to the constantly changing rate of change of area as determined by finding area increases for same-unit increases in, but there was a lack of coordination of change in area with change in height. Prompted to explain the growth in area of a 2 cm by 3 cm rectangle (Task A), one student said, "It goes 4.5 and then 7.5 and then 10.5 and then...just keeps going." In this manner, the students attended to the area's growth, but did not coordinate it with growth in height or length. In response, the TR prompted the students to draw diagrams of the growing area, predicting that the act of drawing would necessitate a coordination of height and area. The students' drawing activity did necessitate a coordination, but many students kept the change in height implicit, as evidenced by their language "every time." For instance, Jim drew a picture of a growing 2 cm by 3 cm rectangle and explained the rate of change of area as "how many new squares it's gaining *every time* it grows."

In an attempt to further encourage an explicit coordination of the rate of area with a quantified change in height, the TR asked the students to create a table for a 2 cm x 5 cm growing rectangle (Task B), anticipating that the students would make tables with different height increments. This did occur: For instance, Jim created a table in which Δx was 1 cm, and Daeshim created a table with Δx as 2 cm (Figure 3). The different tables resulted in a conflict about whether the constantly-changing rate of change of area should be 5 cm² or 20 cm² until one student, Jim, realized that the rate depended on Δx : "I'm going up by 1's and they're going up by evens." After a class discussion in which the students agreed that the rate could legitimately be either 5 cm² or 20 cm², depending on Δx , Jim exclaimed, "Your rate of growth can change no matter what!" In subsequent days the TR encouraged the students to think about other proportionally-growing rectangles, and, ultimately, to draw diagrams relating changes in area to the rectangles' dimensions. These diagrams further emphasized explicit attention to all three quantities, height, length, and area, and enabled the students to explicitly link the change in area to the change in height. For instance, Daeshim determined that the rate of the rate of change of area would be twice the area of the original rectangle; Jim found that it would be equivalent to twice the length for any 1 cm by L cm rectangle.

H	L	A
1	2.5	2.5
2	5	10
3	7.5	22.5
4	10	40

H	L	A
2	5	10
4	10	40
6	15	90
8	20	160
10	25	250
12	30	360
14	35	490
16	40	640
18	45	810
20	50	1000

Figure 3: Jim and Daeshim's well-ordered tables for a 2x5 growing rectangle

We propose that a learning trajectory should include not only an articulation of particular WoUs and the shifts between them, but also a hypothesized connection between these shifts and specific instructional supports. Although space constraints limit an in-depth discussion of all of the

instructional supports in play, we see that the instructional move to prompt diagram drawing necessitated a functional accommodation: students began to attend to and then coordinate increases in height and length, not just area. In addition, the open structure of the task to determine rates of change of area for a 2 cm by 5 cm rectangle further encouraged explicit attention to Δx .

Discussion

In the domain of research on learning trajectories, attention to a theory of instructional design is lacking. Moreover, methodological approaches to creating learning trajectories as a retrospective practice are scant in the literature. In this research we networked RC and DNR-based theories to inform our methods of task development, pedagogical actions, and retrospective analyses. This approach and the resulting product (i.e., an empirical LT for quadratic growth) are novel and not elaborated in the literature thus far.

This paper contributes to an understanding of how a networking of theoretical assumptions can guide methodological choices in establishing learning trajectories. Specifically, we argue for learning trajectories research to be guided by theoretical lenses on the mathematics of students as well as on a theory of instructional design. In this domain of research, there is a need for researchers to move beyond a focus on creating hypothetical learning trajectories, attending to their methods of creating learning trajectories.

This paper makes explicit the theoretical perspectives undergirding our approach to learning trajectories research. One challenge we see is leveraging learning trajectories as a way to not only frame a study (e.g., in creating hypothetical learning trajectories), but to also retrospectively create and share learning trajectories in ways that are consistent with the theories undergirding their creation. This research illustrates one approach for addressing the challenge of creating learning trajectories as empirically based models of an interweaving of shifts in students' mathematical understandings and goal-directed, theoretically grounded instructional practices.

References

- Cobb, P., & Gravemeijer, K. (2008). Experimenting to support and understand learning processes. In A. E. Kelly, R. Lesh, & J. Y. Baek (Eds.), *Handbook of design research methods in education: Innovations in science, technology, engineering, and mathematics learning and teaching* (pp. 68–95). New York: Routledge.
- Clements, D. H., & Sarama, J. (2004). Learning trajectories in mathematics education. *Mathematical Thinking and Learning*, 6(2), 81–89. doi:10.1207/s15327833mtl0602_1
- Daro, P., Mosher, F. A., & Corcoran, T. B. (2011). *Learning trajectories in mathematics: A foundation for standards, curriculum, assessment, and instruction* (Research Report #RR-68). Philadelphia: Consortium for Policy Research in Education. Retrieved from www.cpre.org/sites/default/files/researchreport/1220_learningtrajectoriesinmathcciireport.pdf
- Ellis, A. B. (2011). Generalizing-promoting actions: How classroom collaborations can support students' mathematical generalizations. *Journal for Research in Mathematics Education*, 42(4), 308–345.

- Fonger, N. L., Dogan, M. F., & Ellis, A. (2017). Students' clusters of concepts of quadratic functions. In B. Kaur, W. K. Ho, T. L. Toh, & B. H. Choy (Eds.), *Proceedings of the 41st Conference of the International Group for the Psychology of Mathematics Education* (Vol. 2, pp. 329–336). Singapore: PME.
- Harel, G. (2008a). DNR perspective on mathematics curriculum and instruction, Part I: focus on proving. *Zentralblatt fuer Didaktik der Mathematik*, 40(3), 487–500. doi:10.1007/s11858-008-0104-1
- Harel, G. (2008b). A DNR perspective on mathematics curriculum and instruction. Part II: with reference to teacher's knowledge base. *Zentralblatt für Didaktik der Mathematik*, 40(5), 893–907. doi: 10.1007/s11858-008-0146-4.
- Harel, G. (2013). Intellectual need. In K. R. Leatham (Ed.) *Vital directions for mathematics education research* (pp. 119–151). New York: Springer.
- National Governors Association Center for Best Practices & Council of Chief State School Officers. (2010). *Common core state standards for mathematics*. Washington, DC: Authors.
- Piaget, J. (2001). *Studies in reflecting abstraction*. Sussex, UK: Psychology Press.
- Simon, M. A. (1995). Reconstructing mathematics pedagogy from a constructivist perspective. *Journal for Research in Mathematics Education*, 26(2), 114–145. doi:10.2307/749205
- Simon, M. A. (2013). The need for theories of conceptual learning and teaching of mathematics. In K. R. Leatham (Ed.) *Vital Directions for Mathematics Education Research*, pp. 95–118. New York: Springer
- Steffe, L. P. (2004). On the construction of learning trajectories of children: The case of commensurate fractions. *Mathematical Thinking and Learning*, 6(2), 129–162.
- Steffe, L. P., & Olive, J. (2010). *Children's fractional knowledge*. New York: Springer.
- Steffe, L. P., & Thompson, P. W. (2000). Teaching experiment methodology: Underlying principles and essential elements. In A. E. Kelly & R. A. Lesh (Eds.), *Handbook of research design in mathematics and science education* (pp. 267–307). Mahwah: Lawrence Erlbaum.
- Steffe, L.P., & Norton, A. (2014). Perspectives on epistemic algebraic students. In L. Steffe, K. Moore, & L. Hatfield (Eds.), *Epistemic algebraic students: Emerging models of students' algebraic knowing. Wisdom^e Monograph, Vol. 4* (pp. 303–316). Laramie, WY: U. of Wyoming.
- Thompson, P. W., & Carlson, M. P. (2017). Variation, covariation, and functions: Foundational ways of thinking mathematically. In J. Cai (Ed.), *Compendium for research in mathematics education* (pp. 421–456). Reston, VA: National Council of Teachers of Mathematics.
- UK Department for Education. (2009). *The national strategies: The framework for secondary mathematics*. London, UK: Crown.
- von Glasersfeld, E. (1995). *Radical constructivism: A way of knowing and learning*. London, UK: Falmer.

Conceiving teaching trajectories in the form of series of problems: a step for the theoretical reconstruction of the Hungarian Guided Discovery approach

Katalin Gosztonyi

Eötvös Loránd University of Budapest, Hungary; kgosztonyi@caesar.elte.hu

In this article I introduce the term “series of problems” to give an account on a phenomenon existing in Hungarian mathematics education, the conception of long teaching trajectories based on problems. I will present a long research process aiming to reveal a “theory in act” hidden behind this phenomenon, and discuss the methodological tools developed in order to access to these hidden theoretical bases. The first part of the paper presents the historical-epistemological-didactical analysis of the origins of the Hungarian approach in question; the second part discusses the analysis of teachers’ work, and introduces the idea of reverse engineering aiming to reveal the implicit principles to the teachers’ design practice.

Keywords: Series of problems, Guided Discovery approach, Reverse engineering, Teaching trajectories, Hungarian mathematics education

Introduction

In Hungary, there exists a tradition of mathematics education through problem solving and mathematical inquiry called “*felfedezettő matematikaoktatás*” that I translate as “Guided Discovery” (GD) approach. This approach was originally developed and practiced for the education of gifted students, but the reform movement of T. Varga, realized in the 1960s and ‘70s, transformed it into a basis of general mathematics education and a guiding principle of the official curriculum for primary and lower secondary school (Halmos & Varga, 1978). The approach is still recognized by Hungarian specialists of mathematics education as relevant and coherent with modern educational trends. At the same time, it is practiced in ordinary classes only by a narrow circle of teachers, and its dissemination poses problems. Furthermore, the approach exists only “in act;” its theoretical description has never been developed. Although Varga actively participated in the international discourse on mathematics education in the ‘60s and ‘70s, and developed his conception at the same time as Brousseau or Freudenthal¹, his publications were mostly focused on experimentation and curriculum development, and less on the theoretical description of the underlying conception.

This article treats a step of a longer research project aiming to reconstitute the underlying theory of Varga’s approach. I consider this reconstruction necessary for several reasons. On the one hand, it is an inevitable first step for its large-scale implementation, for the development of more adapted resources and teacher education programs. On the other hand, it is necessary to introduce Varga’s work to the current international discussion on Inquiry Based Mathematics Education: to enrich

¹ Varga and Freudenthal met quite late when both of their conceptions were already well developed, but they mutually recognized each other’s work and perceived conceptual proximities (Varga, 1975).

both the international discourse by the specificities of Varga's approach and the Hungarian mathematics education by the dialogue with other approaches.

In this paper, I focus on one important aspect of the Hungarian approach: the long and complex teaching trajectories shaped by series of problems. The concept of Series of Problems appears to be crucial in this approach, both for curriculum and resource-developers and for teachers (Gosztonyi, 2015a). However, a theoretical understanding of this phenomenon is missing. Originally, the term "series of problems" was introduced in the frame of an interdisciplinary history of science project as a more or less undetermined methodological tool to analyze the structure of historical texts (Bernard, 2015). In this specific Hungarian context, by "series of problems" (SoP) I mean a list of problems with a conscious ordering which is relevant for an (or several) educational purpose(s). In what follows I will discuss the relevance of this notion for the Hungarian context, the difficulties to develop theoretical frames and methodological tools for the analysis of SoP, and the research process of this development.

In the first part of the article, I briefly summarize how a combined, historical-epistemological-didactical analysis of Varga's reform contributed to reveal the main principles of the GD approach. In the second part, I present an ongoing analysis of nowadays teachers' work, developed in the frame of a larger research project focused on Varga's legacy (MTA-ELTE project)². I suggest to describe the methodology of this analysis as *reverse engineering*³: a progressive elucidation of the hidden principles of this "theory in act", starting from teacher's actual designs.

Back to history

The first step for the reconstruction of the GD approach was to go back to its origins, in the frame of a comparative study between Varga's reform and the contemporary French "Mathématiques modernes" reform, carrying out their combined, historical, epistemological and didactical analysis, based on written sources (Gosztonyi, 2015b). The analysis of the historical context of the reforms pointed out, among other things, the crucial role of mathematicians in defining the epistemological foundations of mathematics and its teaching: a "bourbakist" epistemology in the French case, and a "heuristic" one in the Hungarian case. The didactical analysis of different sources (curricula, textbooks, teachers' handbooks) showed the epistemology be one of the main driving forces for realizing the reforms.

One of the theoretical frameworks used for the didactical analysis was Brousseau's *Theory of Didactical Situations* (1998). This theory proved to be powerful to reveal important characteristics of each reform – but also insufficient to explain some specificities of Varga's one. One of the most important aspects is the long teaching trajectories shaped by SoP.

Brousseau developed his theory from the 1970s, in the French context of the debates following the "Mathématiques modernes." Thus, the emergence of the theory goes back to the historical context I

² MTA-ELTE Complex Mathematics Education Research Group, working in the frame of the Content Pedagogy Research Program of the Hungarian Academy of Sciences (ID number: 471028).

³ I am grateful to Arthur Bakker for suggesting this term during the conference. See also (Calderon, 2010).

studied. The comparison of an early experimentation of Brousseau with Varga's works contributed to understand their conceptual differences.

Characteristics of the Hungarian Guided Discovery approach and the importance of SoP

The analyses described above helped to identify some main characteristics of the GD approach. In the background of Varga's reform project, a quite coherent "heuristic" epistemology of mathematics and of mathematics education can be outlined in the 20th century's Hungarian mathematical culture (Gosztonyi, 2016), represented by mathematicians living in Hungary as well as by Pólya and Lakatos. These thinkers considered mathematics to be a continuously progressing and changing human creation, and as a social, dialogic activity. The development of mathematics appeared as a collective process based on a diversity of experience, driven by problems, attempts of solutions, and new questions emerging from these attempts. They posited that mathematical knowledge only could be attained through the experience of mathematical creation, and thus students should be guided through similar discovery processes.

The idea of organizing problems into ordered series appears often in the writings of these authors. For example, R. Péter's book popularizing mathematics, *Playing with infinity* (Peter, 1961) is written as an interesting inquiry story where one question invites the other. Pólya's work, especially later books like *Induction and analogy* (1954), also present inquiry processes shaped by series of problems, and analyses their structure.

This epistemology deeply influenced Varga's "Complex Mathematics Education Reform" conception (Gosztonyi, 2015b). The coherence of his curriculum is assured by a parallel treatment of different mathematical themes. Elements of mathematical knowledge are introduced through long, progressive processes (taking often several years), based on numerous small, concrete problem situations. Problems crossing different themes contribute to the variety of experiences. In the treatment of these problem situations, collective discussions led by the teacher play a crucial role. The use of various manipulative tools and representations, playfulness, students' autonomy and creativity are also in the focus of the reform project.

In the teacher's handbooks related to Varga's reform, researchers can find numerous commentaries on the importance of organizing problems into series. Primary school teachers' handbooks describe a number of activities with ideas for their repetitions, variations, and ordering. However, the principles of the organization are dispersed in the books and rarely generalized. The handbooks insist on the importance of teachers' autonomous work on conceiving of long teaching processes on their own. In middle-school textbooks, new knowledge is often introduced by fictive dialogues of students around short series of problems.

Analysis of published examples

Although SoP play a central role in Varga's conception, they are seldom theorized. Problem collections used to be presented without commentaries about tasks' connections and their possible roles in a teaching process. Furthermore, mostly fragments of SoP are published; long-term series are rarely presented. Some specific historical documents, however, present more detailed examples and furnish enough commentary to understand the logic and the purpose of their construction.

One example is the above mentioned book of R. Péter, describing in one of the chapters a classroom situation driven by a dialectic of problems, attempts of solutions and new problems motivated by these attempts. The text is written in a literary style; thus, its structuration by problems is not obvious at the first glance, but the rich meta-discourse makes possible to identify the problems and to understand the rationale behind the structuring of the text (Gosztonyi, 2015a).

In the documentation of Varga's reform, one of the most transparent examples is the introduction of combinatorics in primary school. Here, a double structuration of the series can be identified. On one hand, a sub-series is related to a given material, varying several variables and progressively introducing restrictions (e.g., building colored towers, building colored towers with a given height, finding all towers with a given height, varying the number of colors and levels, using a color only once, using the same color several times but not for neighbor levels, and so on). On the other hand, same or similar tasks are repeated with different materials (e.g., building towers with Cuisenaire rods, coloring flags or drawing houses, creating words with given letters, writing melodies with musical notes, and so on). The ordering is not strict here, but a progression in the abstraction should be respected by teachers. The observation of the analogies between these tasks serves as a basis for generalization and abstraction.

The comparison of this example with Brousseau's above mentioned teaching progression revealed important differences between the two authors' conceptions, and contributed to understanding the role of SoP in the Hungarian case. For Brousseau, the progression is based on one "fundamental problem situation," and a decontextualization (through phases of institutionalization) is necessary for the passage to other situations. For Varga, the progression is based on a diversity of problems and their convenient ordering to favor progressive generalization through the recognition of links between the problems. (Gosztonyi, 2017).

In summary, the analysis of written documents representing the heritage of the Hungarian GD approach, confirms the importance of SoP in the planning of teaching by GD, identifies some key principles concerning the role and the structuration of SoP, and highlights tools to analyze and represent SoP (e.g., by graph representations or the structuration by main and sub-series).

Analysis of teachers' work designing Series of Problems

Subsequent research steps involve analyzing the GD approach of expert teachers, drawing on the key principles and analytic tools described above. Several of these teachers reacted vividly when I proposed the term "Series of Problems" to them. It resonated with the kind of planning they considered crucial. However, they rarely make these practices explicit.

The documents created by these expert teachers typically contained a list of problems, with or without solutions. But the documents are only a skeleton of their planned teaching process. Essential elements remain implicit: the main teaching goals, the organization of classroom work, the planned discussions, and choices and adaptations they consider to make 'on the spot', depending on the students' reactions (e.g., change of order, omission of some problems or introduction of new ones). Furthermore, these projects are conceived as long-term developments, even for several years, and only parts of them appear in written documents. Expert teachers confirm having a complex

network of problems in mind that they can mobilize in order to create problem series and to adapt them to their aims and to the students' needs or interest—during preparation or in the classroom.

Gaining access to these complex implicit networks is necessary but quite challenging. Its reconstruction is an iterative process, combining two approaches: (1) an a priori analysis on the principles revealed by the analysis of historical documents, and (2) a study of the expert teachers' documentational processes (in the sense of Gueudet & Trouche, 2010).

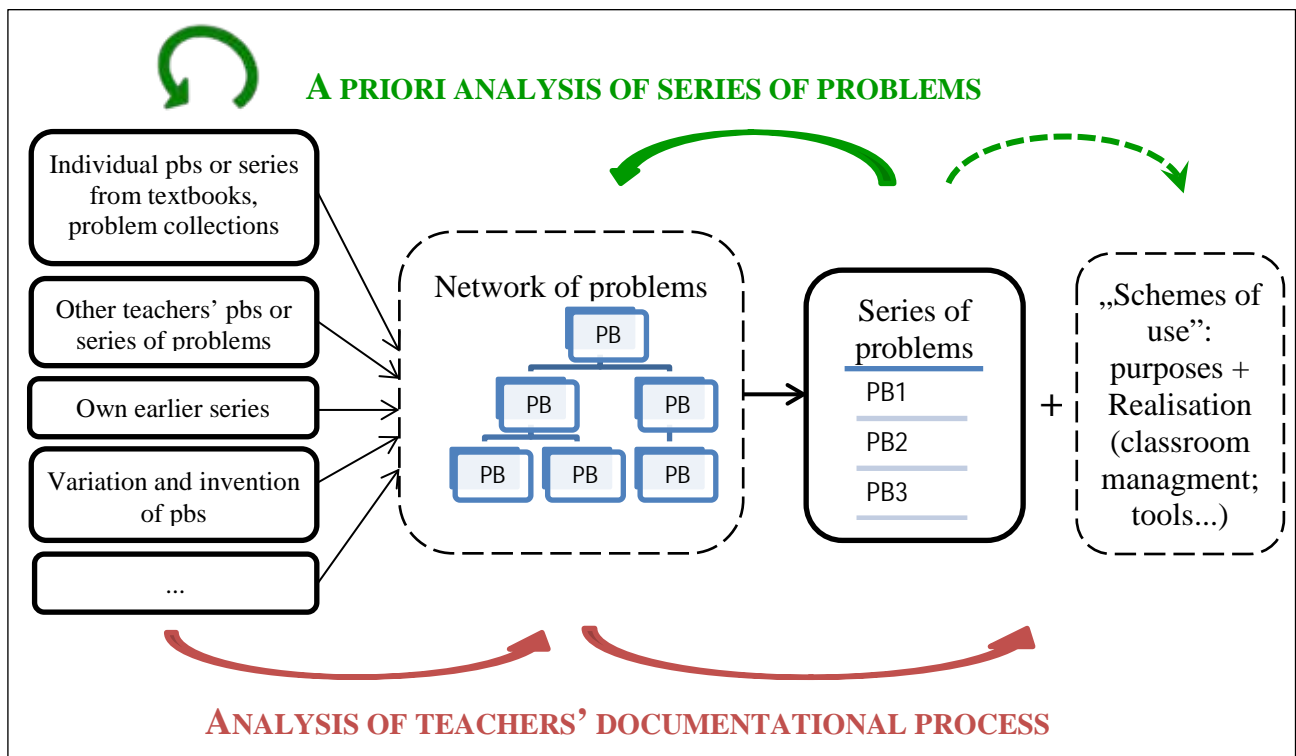


Figure 1: Analysis of Series of Problems

(the visible elements are marked with bold, the hidden ones with broken outline)

For the MTA-ELTE project, a mixed group of researchers, teacher trainers and expert teachers of the GD approach was created in order to fulfill a double aim: analyzing the expert teachers' practices (with a special focus on SoP), and fostering dissemination of the approach by developing resources and teacher education programs. However, complex negotiations were necessary to meet the interest and expectations of each participant. While I felt necessary to focus first on the analysis of teachers' practices, this was not motivating and relevant enough for the participating teachers. Thus, we decided to develop a collection of commented examples of SoP. The purpose of this collection under preparation was not to offer ready-made resources for teaching, but generic examples, which introduce the reader into the practice of using and preparing SoP. In addition, preparing commented examples also served the project's research aim: for teachers to explicate their teaching purposes and principles of structuration of SoP. I call this procedure *reverse engineering*. Starting from teachers' existing designs of SoP, researchers reconstruct tacit principles driving teachers' choices during the design of these trajectories.

In the first step, teachers were asked to provide examples from their own practice of what they consider SoP. The received examples were of quite different nature: SoP of short and long-term sequences; SoP to introduce new mathematical notions, SoP to explore heuristic strategies, and SoP to serve diagnostic purposes. Confronting the new and previously analyzed examples led to discussion on various questions: classification of purposes, different structuration principles, and forms of representation. These discussions evoked new examples. For example, most SoP consisted of short sequences at the beginning, because this was easier to document for teachers; but during the discussions, they all agreed about the importance of long-term planning, leading to the description of long trajectories built by SoP.

In the next step, teachers were asked to write commentaries to their SoP, addressing colleagues unfamiliar with the GD approach, focusing on the didactical aims of their trajectories and on explaining the SoP-structure. The group is currently comparing these first writings in order to define the main elements to be included in each commentary.

In the further phases of the project, the MTA-ELTE project team will conduct experiments; giving commented examples to non-expert teachers, and asking them to use the examples as inspiration to develop their own teaching trajectories, and offer them consultation with expert teachers of the group. This part of the project will give evidence of how well the created resources may mediate the GD-approach and provoke further exploring of the expert teachers' practices.

Eszter's case

Eszter is an expert teacher of our group, a high school teacher for 20 years. As a long-term example, she proposed an example taken from geometry⁴, built around the concepts of incidence and distance in the Euclidean plane/space, equidistant sets (loci) of points, and especially a “core” problem: finding the equidistant points from three different lines in the plane. This series covers a very long period: It starts at the first year of high school, and some parts of it concern the last year's curriculum. Although some notable theorems of higher level mathematics appear in the series (in a problematized form), the aim of the SoP, according to Eszter, is not to learn these theorems, but to familiarize students with the above mentioned concepts, related mathematical techniques and problem solving skills through the exploration of interesting geometrical questions.

The first version consisted of a “core” series of four problems with increasing complexity about the loci of points (red dots in Figure 2). In this “core sub-series”, the order of the problems is strict. This order is intended to make the latter, more difficult problems progressively available for students. Several other sub-series are conceived, based on this core, exploring different mathematical themes (blue dots), including space

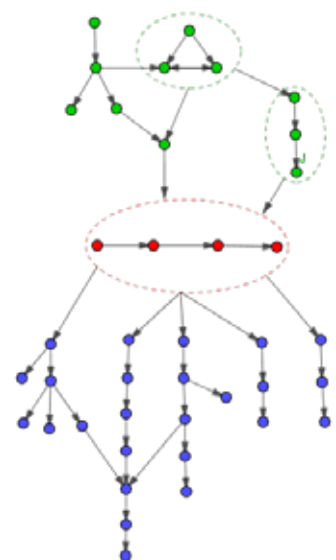


Figure 2: Eszter's graph

(Simplified version)

⁴ The complete collection of problems can be found here:

https://drive.google.com/open?id=1Nhe5DbX3Wgs29l75GhTlrGN8_5rs1-yI

analogies, angles and similarities, and the boundaries of geometry and combinatorics. Eszter immediately proposed a graph to represent the structure of the SoP. Her arrows showed complex mathematical or didactical interdependences between the problems, but also illustrated the flexibility of the structure which is not visible in the simple numerated list of problems. Some problems or sub-series are sequential, while for other problems, the order can be freely chosen. The representation of this structure helps the reader to understand which problems could be deleted without impacting a longer trajectory, or where new problems could be inserted.

After a first discussion, we agreed that it would be useful to complete this SoP with a preparatory part which treated the lower secondary school level prerequisites. Thus, Eszter added a new part to her graph (green dots in Figure 2). As she explained, the problems of this part serve for diagnostic purposes in her high school work. They also fill possible gaps in students' knowledge. The problems presented illustrate different types of tasks which have to be explored in order to prepare students for the "core." More tasks can be inserted, depending on the students' needs. In order to make this "typology" more accessible, Eszter added a coding system to the graph (e.g. D stands for distance, L for loci of points, S for space analogies). Some subgroups of problems are related to some of these codes, but many problems have multiple codes. The network of problems is less hierarchic here than in other parts leaving more flexibility to the teacher. However, the discussion also revealed some further hidden interdependences of the ordering. This suggests that Eszter's didactical choices are even more complex than what was in her current version of the graph. Another iterative process of discussions and the preparation of representations is necessary to reveal implicit choices.⁵

The discussions with Eszter led to a progressive exploration of her design and its guiding choices, while the graph representation plays the role of a mediator. Her case also shows individual specificities beyond the common principles shared with the colleagues (e.g. Eszter accords even more importance to the flexibility in her SoP than most of her colleagues).

Conclusion

This paper presented a research process aiming to make explicit a "theory in act" existing in the Hungarian context of mathematics education and to develop theoretical bases and methodological tools to analyze the work of the teachers who follow this approach. The first phase of this process consisted in the analysis of the historical sources of the approach with complex research tools from history, epistemology and didactics, while the current second phase is focused on teachers work. The process is essentially iterative; the analysis of the epistemological background offered some first steps to reveal main principles of the hidden theory. The use of existing didactical theories in the analysis of Varga's reform documents helped not only to reveal its characteristics but also to point out the limits of the use of those theories, specificities of the GD approach which needs new theoretical development to be analyzed. These studies helped to choose the aspects to focus on while analyzing teachers' work—the structuration of teaching trajectories by SoP being one of them. The principles revealed by these analyses and the tools developed by case studies of

⁵ A more detailed version of the graph was presented in form of a poster at CERME 11.

representative written examples contribute to interpret the teachers' designs but also to provoke teachers to make their guiding principles explicit. Collective discussion and interpretation of the teachers' designs led to further elucidation of the fundamental principles of the approach and to the development of tools to investigate their design process. The term "reverse engineering" is used to describe the iterative process of exploring teachers' designs and describing their guiding design principles. Through reverse engineering, "theories in act" about SoP will be gained, so they may contribute to the discourse on Inquiry Based Mathematics Education (Artigue & Blomhøj, 2013).

References

- Artigue, M., & Blomhøj, M. (2013). Conceptualizing inquiry-based education in mathematics. *ZDM*, 45(6), 797–810. <https://doi.org/10.1007/s11858-013-0506-6>
- Bernard, A. (Ed.). (2015). *Les séries de problèmes, un genre au carrefour des cultures*. SHS Web of Conferences 22. EDP Sciences. Retrieved from <https://www.shs-conferences.org/articles/shsconf/abs/2015/09/contents/contents.html>
- Brousseau, G. (1998). *La théorie des situations didactiques*. Grenoble: La Pensée Sauvage.
- Calderon, M. L. (2010). Application of reverse engineering activities in the teaching of engineering design. *Proceedings of the International Design Conference–Design 2010* (pp. 1249–1258).
- Gosztonyi, K. (2015a). Séries de problèmes dans une tradition d'enseignement des mathématiques en Hongrie au 20^e siècle. In A. Bernard (Ed.), *Les séries de problèmes, un genre au carrefour des cultures*, 13. EDP Sciences. <https://doi.org/10.1051/shsconf/20152200013>
- Gosztonyi, K. (2015b). *Traditions et réformes de l'enseignement des mathématiques à l'époque des « mathématiques modernes »: le cas de la Hongrie et de la France*. (PhD). University of Szeged; Université Paris-Diderot-Paris 7, Szeged; Paris.
- Gosztonyi, K. (2016). Mathematical Culture and Mathematics Education in Hungary in the XXst century. In B. Larvor (Ed.), *Mathematical Cultures. The London Meetings 2012-2014* (pp. 71–89). Basel: Springer.
- Gosztonyi, K. (2017). *Understanding didactical conceptions through their history: a comparison of Brousseau's and Varga's experimentations*. Presented at the CERME10, Dublin. Retrieved from https://keynote.conference-services.net/resources/444/5118/pdf/CERME10_0594.pdf
- Gueudet, G., & Trouche, L. (Eds.). (2010). *Ressources vives. Le travail documentaire des professeurs en mathématiques*. Rennes, France: Presses Universitaires de Rennes.
- Halmos, M., & Varga, T. (1978). Change in mathematics education since the late 1950's—ideas and realisation. Hungary. *Educational Studies in Mathematics*, 9(2), 225–244.
- Peter, R. (1961). *Playing with Infinity* (Z. P. Dienes, Trans.). New York: Dover Publications.
- Polya, G. (1954). *Induction and analogy in mathematics*. Princeton: Princeton University Press.
- Varga, T. (1975). *Komplex matematikatanítás. Kandidátusi alkotás ismertetése* (Thesis). MTA, Budapest.

Students' learning paths about ratio and proportion in geometry: an analysis using Peirce's theory of signs

Georgia Bampatsikou¹, Triandafillos A. Triandafillidis², Stefanos Asimopoulos³
and Kostas Hatzikiriakou⁴

^{1,2,3,4} University of Thessaly, Greece; mpampats@uth.gr, ttriant@uth.gr, asimstef@uth.gr,
kxatzkyr@uth.gr

In this paper we use Peirce's theory of signs to analyze the conceptions of four twelve-year-old students on ratio and proportion while solving geometric problems of the stretchers/shrinkers type. The students participated in a series of interdisciplinary activities based on the principle of the camera obscura. We will present the learning paths of these students as chains of signification described in terms of Peircean semiosis. We will emphasize the challenges that they encountered during the reconstruction of their initial ideas and we will classify their conceptualizations in terms of Peirce's classification of Signs.

Keywords: Peirce, Semiotics, Classes of Signs, Ratio and Proportion, Elementary School.

Introduction

In the 1990s semiotics has started to gain momentum as an analytical tool among researchers in the field of mathematics education (Presmeg, Radford, Roth & Kadunz, 2018; Sáenz-Ludlow & Kadunz, 2016). By and large semiotics is the study of how signs come to signify, a theory of “signification” (Presmeg, Radford, Roth, & Kadunz, 2016, p. 1). Mathematics, as a highly symbolic practice, calls for a study of the nature of sign systems in order to understand the processes of its teaching and learning (Sáenz-Ludlow, 2006). In the same decade, mathematics education research was marked by the development of theoretical constructs that acknowledged the social origins of knowledge and consciousness. In these paradigms, knowledge and consciousness are seen as products of communication embedded in experiences that take place in historically-, culturally- and geographically-inscribed contexts (Lerman, 2000). Knowledge and experience, then, are co-constructed, as the one partakes in shaping the other. As this process is replete with signs, semiotics may elucidate the production of mathematical meaning by learners, as well the shaping of contexts that support learners' conduct with mathematical content and practices.

In our paper, we will use Peircean semiotic theory to analyze instances of the development of four twelve-year-old students' ideas concerning ratio and proportion, as they participated in a series of interdisciplinary tasks based on the principle of camera obscura. Charles Sanders Peirce (1839–1914) was an American philosopher, logician, mathematician, scientist, and semiotician. Contrary to other semioticians' claim for an essentialist dyadic structure between a ‘signifier’ and a ‘signified’, Peirce suggested that a Sign signifies only when it is interpreted in one's mind. He argued for a triadic structure for the process of semiosis among the *Sign* or *Representamen* (signifier), the *Object* (signified), and the *Interpretant*. The Interpretant, the most innovative and distinctive feature in Peirce's account on semiosis, refers to the interpretation and nature of the Sign and Object relation. The Interpretant, as we will have the chance to see later on, has the potential to generate a new Sign, thus moving the signification process towards a higher level of interpretation and generalization (Sáenz-Ludlow & Kadunz, 2016).

By analyzing students' participation in these activities, we will explore how their learning paths constitute chains of signification described in terms of Peircean semiosis (Sáenz-Ludlow, 2003), as Signs transform to more mature thoughts that become a kind of new knowledge. We suggest that Peirce's ten classes of Signs may constitute an analytical 'tool' that can be used by researchers and teachers alike for deconstructing and classifying students' conceptualizations, not only in ratio and proportion tasks, but in other instructional situations as well. We present this analytical tool in the section that follows, along with an outline of Peirce's semiotics emphasizing the process of semiosis.

Theoretical considerations

Even though he provided various definitions, Peirce defined "a Sign as anything which is so determined by something else, called its Object, and so determines an effect upon a person, which effect I call its Interpretant, that the latter is thereby mediately determined by the former" (Peirce, 1998, pp. 478). The Interpretant, coming as the most groundbreaking and distinguishing characteristic of Peirce's account on semiosis, refers to the understanding that we have of the Representamen and Object relation. According to Peirce signification is not a dyadic relation, as a Sign signifies only when it is interpreted in one's mind. The Interpretant does not refer to the user but to the interpretation, the meaning that is generated for a user (Atkin, 2013).

The importance of Interpretant is clearly visible in the process of *semiosis*, in which Signs transform to other thoughts that are more mature and become a kind of knowledge. When the relation of an Object₍₁₎, a Representamen₍₁₎ and an Interpretant₍₁₎ is established, the Interpretant₍₁₎ is potentially converted to a Representamen₍₂₎ for a new Object₍₂₎ and determines a new and more advanced Interpretant₍₂₎, and so on. The conceptual process of *semiosis* is theoretically unlimited, as the chain of meaning-making continues to new Signs interpreting a prior Sign or set of Signs (Figure 1).

However, in practice this process becomes limited by force of habit (Parker, 1998).

Peirce suggested that each of the three interrelated components of a Sign, namely Representamen, Object, and Interpretant, can be separated into a trichotomy. Representamens signify their Objects not through all their features, but in virtue of qualities, existential facts, or conventions and laws. In the first trichotomy, Signs then can be classified as *Qualisigns*, *Sinsigns*, and *Legisigns* respectively. The Representamen is the form in which the Sign appears, the spoken or written form of a word for instance, whereas the Sign is the whole meaningful ensemble. Peirce also believed that the nature of the Object constrains the nature of the Sign in terms of what is required for a successful signification. He thought about three categories of Objects, then, which were qualitative, existential or physical, and conventional or law-like in nature, constituting the second trichotomy. Thus, when a Sign reflects qualitative features of an Object, then the Sign is an *Icon*. When there is physical connection to its Object, then the sign is called an *Index*, and when there is a rule or law between it and its Object, then the sign is called a *Symbol*. The icon is an intuitively familiar trichotomy, as portraits, paintings, or diagrams fall under the *Icons* category. *Indices* may include fingers pointing to something or somewhere and proper names, while *Symbols* comprise broad speech acts like

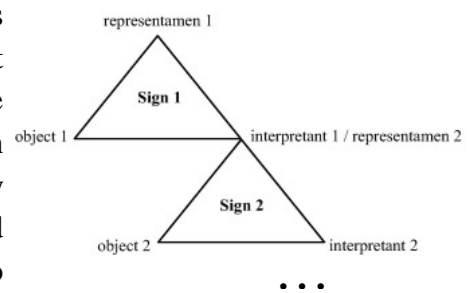


Figure 1: The infinite process of semiosis

assertion and judgment. Last, but not least, Peirce thought that Signs could be classified in terms of their relation with their Interpretant. In this third trichotomy, he suggested three categories by identifying qualities, existential facts, or conventional features as the basis for classifying the Sign in terms of its Interpretant. If the Sign determines an Interpretant by focusing our understanding of the Sign upon the qualitative features it employs in signifying its Object, then the Sign is classified as a *Rheme*. If a Sign determines an Interpretant by focusing our understanding of the sign upon the existential features that it employs in signifying an Object, then the Sign is a *Dicent*. Finally, if a Sign determines an Interpretant by focusing our understanding on some conventional or law-like features employed in signifying the Object, then the Sign is a *Delome*, or as Peirce frequently—but confusingly—called it, an *Argument* (Atkin, 2013; Colapietro, 1989; Freedman, 1996).

These three previous trichotomies produce combinations that are called ‘classes’. In order to categorize a Sign in these classes, we have to ask three questions: 1) What is the relation of the Sign with itself? (1st trichotomy), 2) What is the relation between the Sign and its Object? (2nd trichotomy), and 3) What is the relation between the Sign and its Object for its Interpretant? (3rd trichotomy). The kind of relation that answers the first question qualifies the second, which in turn qualifies the third. Once though we characterize a Representamen as, for example, a Qualisign, which is at the first level of the first trichotomy, the relation of the Sign to its Object and its Interpretant in the second and third trichotomy has to be at the first level as well, as the Sign cannot be related to an Object and an Interpretant from a higher level. According to these restrictions, then, the classes of Signs are ten (see Table 1). Even though the classes are hierarchically related, every link in the chain of signification does not necessarily constitute a more mature conceptual construct than those in the preceding links of the chain. Thus, in the highest level of Representamen, the Interpretant may be a Rheme (classes V, VI and VIII). Signs of this kind appear often in the mathematics classroom, as students may be familiar with representations of mathematical ideas but their interpretations about them may still be vague or confined to these representations. The chain of signification as outlined in the beginning of this section, along with Pierce’s taxonomy of Signs, may allow us to analyze the continuum of students’ conceptualization (i.e. learning path) of ‘complex’ concepts like ratio and proportion (Sáenz-Ludlow, 2003).

Table 1: Peirce’s classes of Signs

	S = R, O, I
I	Qualisign, Icon, Rheme
II	Sinsign, Icon, Rheme
III	Sinsign, Index, Rheme
IV	Sinsign, Index, Dicent
V	Legisign, Icon, Rheme
VI	Legisign, Index, Rheme
VII	Legisign, Index, Dicent
VIII	Legisign, Symbol, Rheme
IX	Legisign, Symbol, Dicent
X	Legisign, Symbol, Delome

An experimentation on ratio and proportion

We implemented the analytical tool that we outlined in the previous section in a data set produced from a research study that aimed to highlight students' ideas about ratio and proportion in geometry. Students’ ideas about these concepts were produced through their participation in a series of tasks that were part of an interdisciplinary experimentation. In particular, we wanted to address the two following questions: a) what are the conceptualizations of twelve-year-old students about ratio and proportion related to geometrical shapes; and b) how these conceptualizations could be modified through their participation in a series of interdisciplinary tasks. According to Lamon (1993), the

stretchers/shrinkers type of ratio and proportion problems, which have reference to geometry, pose difficulty for students in terms of recognizing their multiplicative structure. The students' strategies for solving ratio and proportion problems in a geometric context are the *nonconstructive strategies* of 'avoiding', 'visual or additive', and 'pattern-building'; the 'preproportional', 'qualitative proportional, and 'quantitative proportional' types of reasoning, which are considered as *constructive strategies*. The common ineffective strategy that students use in order to solve similar problems is the 'visual or additive strategy', which stresses the aforementioned students' difficulty with the multiplicative structure (Lamon, 1993).

Students worked in pairs for a total of seven 90-minute sessions over a period of 3 weeks. In this paper we will discuss the learning paths of four out of the eight students who participated in the study, those of George, Helen, Bill, and Peter. The tasks that comprised our research were based on an experimental construct that followed the principle of the rectilinear propagation of light in the *camera obscura*. We used this device in order to depict proportional geometrical shapes. In most tasks students had to investigate the similarity of rectangles formed by tiny led light sources placed on their vertices and their image on a screen placed behind the pinhole on a plane parallel to that of the rectangle. The use of this model gave us the opportunity to negotiate in a non-typical way the concepts of multiplicative relationships, internal and external ratios and also connect fractions with ratio and proportion. According to the Science and Mathematics programs of study, the students were familiar with the concepts at hand. Research data was comprised of the teacher-researcher's fieldnotes (first author), the fieldnotes of a 'non-participant' observer, the transcripts of the recordings in each pair, as well as the students written work.

In the tasks of the initial diagnostic assessment, which was silent and individual, we asked students to draw the parents of a little boy fish, whose body and tail were isosceles right-angled triangles of different size (students were familiar with this fish as it is the main character in a widely-read series of children's books in Greek). The only direction we gave to the students was that the parents needed to be similar to the boy but larger. In the second session of the experimentation we asked students to find the relation between two rectangles that were similar. Students were only aware that one of the rectangles was bigger in size than the other. In the third session, in one of the tasks, we gave students a number of rectangles of various sizes and we asked them to find which of these were similar. In the fourth session of the experimentation, we gave students a rectangle (7×3 cm) and we asked them to draw a similar one knowing only the length of one of its sides (11.2 cm). In a summative assessment during the final session, which was silent and individual as the initial diagnostic assessment, we asked students to investigate regular hexagons in terms of their similarity.

Students' chains of signification

In the task of the diagnostic assessment, the four students spontaneously measured the length of the sides of the triangles that comprised the little boy fish. They concluded that the triangles were isosceles, making no reference though to the measure of the angles in the two triangles. While drawing the parents, five of the students followed an additive strategy, without paying attention to the proportion between the size of the triangles of the body and tail of the boy fish and those of his parents. Helen and Bill tried to ensure that the triangles were isosceles to begin with, and that the measure of the interior angles matched roughly the ones in the boy's body and tail. So they drew the

two equal sides of the body and the tail of the parents by increasing their length by the same amount. For example, in drawing the father, one student increased the two sides from 5 to 8cm for the body and from 2.5 to 4.7cm for the tail. While drawing the third side of the triangles, though, the students realized that they could not enlarge this third side in same the manner that they had enlarged the other two. So, they increased the length of the third side as much as was needed in order to complete the triangles in their drawing. George designed one parent by doubling the sides of both triangles, thus paying attention to the interior angle in their drawings, but used an additive strategy for the other parent since they thought that they could multiply with a whole number (*Qualisign, Icon, Rheme*; in this case, the Sign constructed by the student is interpreted by the student as being of the same nature and quality with the given fish boy with O1: the multiplicative structure in the stretchers/shrinkers problems, R1: the students' drawings, and I1a: the use of multiplication and addition interchangeably and that ratio needs to be a whole number). Peter used multiplication for both parents, choosing the numbers 3 and 2 as operators for the father and the mother respectively (*Sinsign, Icon, Rheme*; the Sign is interpreted by the student as possibly standing for its Object with O1: the multiplicative structure in the stretchers/shrinkers problems, R1: the drawings and I1b: that multiplication as probably related to ratio and proportion).

In the second session, the four students spontaneously measured the lengths of their sides and Helen and Bill suggested that they should “find the difference between their lengths” (*Qualisign, Icon, Rheme*; the Sign is interpreted by the student as being of the same nature and quality with the given Representamen, with O2: the multiplicative structure of stretchers/shrinkers problems, R2: oral sentence, I2a: the relation between the two similar rectangles can be expressed by subtraction of their lengths). George, who had used a multiplicative strategy in drawing one parent and an additive in the other in the diagnostic assessment, disagreed by saying that “we need to divide to find out how many they are” (*Sinsign, Index, Rheme*; the Sign is interpreted by the student as possibly standing for another event-index, with O2: the multiplicative structure of stretchers/shrinkers problems, R2: oral sentence, I2b: division is related to ratio and proportion). At this point, Peter, who had used a multiplicative strategy in drawing both parents, disagreed, by saying “since we say twice or three times, we have multiplication” (*Legisign, Icon, Rheme*; is a type/law, a ‘regularity of the indefinite future’ that is interpreted by the student as possibly standing for its Object, with O2: the multiplicative structure of stretchers/shrinkers problems, R2: oral sentence, I2c: multiplication is related to ratio and proportion). Taking advantage of these statements, the researcher suggested that they should try both ideas, subtraction and division. In their first attempt, having completed the subtractions, they did not reach to a conclusion concerning the relation between the two rectangles. In their second attempt, instead of multiplication, which is directly related to the multiplicative strategy, the students decided to use division by dividing the larger by the smaller number. Having observed that the two quotients were equal when rounded to one decimal point, the four students concluded that we could ascertain whether two rectangles are similar by using division.

In the third session, the four students measured the sides of the rectangles and circled the similar ones on their sheet showing preproportional reasoning. Only George chose to express the relation between the similar rectangles by making a clear reference to the operator that constituted them as similar, showing qualitative proportional reasoning (*Legisign, Index, Rheme*; is a type interpreted by the student as possibly standing for its Object - another event, with O3: the multiplicative

structure of stretchers/shrinkers problems, R3: written expression, I3: division is related to ratio and proportion and the concept of unit plays a role to the result).

At the first part of the fourth session, the four students used the internal ratio (length 1 \div length 2 = breath 1 \div breadth 2) in their calculations, and after they had drawn the desired rectangle they used the external ratio (length 1 \div breadth 1 = length 2 \div breadth 2) simply to check their answer without realizing that both ratios could be used interchangeably in order to express the desired relation between the rectangles (*Legisign, Icon, Rheme*; is a type/law, a ‘regularity of the indefinite future’ interpreted by the student as possibly standing for its Object, with O4: the internal and external ratio of similar shapes, R4: arithmetic operations, I4: the relation of similarity can be found with operations between lengths and widths, widths and lengths, and widths-widths and lengths-lengths and also ratios are pure numbers, without measurement). In the second part of this session, in an attempt to enhance the qualitative proportional reasoning through the use of mathematical terminology in the ‘stretchers/shrinkers’ tasks, we asked the students to express division in an alternative way. So expressions of the kind “seven divided by two” transformed to “seven over two,” especially from George and Peter, implicating thus a fractional terminology in the discussion (*Legisign, Symbol, Rheme*; is a type interpreted by the student as possibly standing for its Object-law, with O5: fractions are directly related to ratios, R5: oral sentences, I5: division can be alternatively expressed with a fraction and their terminology). All of the students though tended to always select the largest number as the numerator, as it was more convenient in the subsequent calculations. So we gave them a similar rectangle on the screen that was reduced in size and asked them to express the reduction with a fraction. All of them claimed that the answer for the reduction was “3.5 over 1.5, because in this way we begin from what it was (i.e. the length of the rectangle formed by the led light sources) and then we have the ‘reduced’ one” (i.e. the length of the rectangle on the screen).” The researcher then made a reference to maps their relation to the size of the actual land that they represent, and the four students immediately recognized that the ratio in the legend can be as small as 1 over 50000 (*Legisign, Symbol, Delome/Argument*; is a type interpreted by the student as semiotically standing for its Object-law, with O6: the role of numerators and denominators in ratios, R6: oral sentences, I6: flashback to maps and the various ratios in order to express the reduction may follow the same principles as in this situation). After this discussion, Bill, George, Helen, and Peter concluded that “the numerator expresses the representation on the map and the denominator the physical representation,” and therefore the fraction that expresses the relation between the rectangles can be larger or smaller than 1 when it represents a stretch or a shrink (*Legisign, Symbol, Rheme*; is a type interpreted by the student as possibly standing for its Object-law, with O7: the role of numerators and denominators in fractions, R7: oral sentences, I7: there is a fixed way to express the enlargement or zooming out and numerators and denominators determine the result).

In the tasks of the summative assessment, Bill, George, Helen, and Peter were able to transfer successfully the understanding that they had built in relation to similar rectangles in the sessions of the experimentation (*Legisign, Symbol, Dicient*; is a type interpreted by the student as physically standing for its Object-law, with O8: the multiplicative structure of stretchers/shrinkers problems and the role of numerators and denominators in ratios, R8: written sentences and written expressions, I8: the appropriate way to express ratios for enlargement or reduction, without measurements).

As we can see, the four students started the sessions (diagnostic assessment) with vague ideas about ratio and proportion in geometrical shapes. Only Peter used multiplicative strategy in all tasks while the other students used the additive strategy. In the instructional sessions that followed, it became evident that students produced arguments in order to support their statements. As a result of this effort some of the students constructed conceptualizations that fall in the upper levels in Peirce's list of Sign classes. In the summative session they managed to transfer their knowledge to a new context. The development of the four twelve-year-old students' conceptualizations concerning ratio and proportion while working on tasks that required the stretching and shrinking of rectangles and regular hexagons, were the Signs that the students constructed. Following Peirce's classification of Signs and the strategies students used while working on these tasks, the criteria used to classify the students' Signs can be summarized as below (Table 2):

Table 2: Signs constructed by the students

Sessions of Experimentation	Students' Signs according to ten classes of Peirce	
1 st : diagnostic assessment with individual tasks	Qualisign, Icon, Rheme (I) Sinsign, Icon, Rheme (II)	Bill, George, Helen Peter
2 nd : conservation of properties in stretcher/shrinker problems	Qualisign, Icon, Rheme (I) Sinsign, Index, Rheme, (III) Legisign, Icon, Rheme (V)	Bill, Helen George Peter
3 rd : stress of the multiplicative strategy	Legisign, Icon, Rheme (V) Legisign, Index, Rheme (VI)	Bill, George, Helen Peter
4 th : enhancement of multiplicative strategy by similar rectangles and ratios of lengths and widths	Legisign, Symbol, Rheme (VIII)	Bill, George, Helen, Peter in plenary session
division related to fraction, terminology, role of numerator and denominator, legend of maps	Legisign, Symbol, Delome (X) Legisign, Symbol, Rheme (VIII)	George, Peter Bill, George, Helen, Peter in plenary session
5 th : summative assessment with individual tasks	Legisign, Symbol, Dicent (IX)	Bill, George, Helen, Peter

Closing Remarks

The learning process is affected by many factors, such as students' ideas, the interaction between them, the context, the tasks, the representations involved, etc. This means that the learning process is neither rectilinear nor individual; it is 'fluid' and infinite, and includes a number of conceptualizations. Following Peirce's suggestions on how to make our ideas clear, the meaning of a concept or a sign consists in the habit to which it gives rise in the interpreter, be it either a habit of action or a habit of thought. This habit guides future actions, and is forever on trial in the light of upcoming experiences (Triandafillidis, 2002). We see students' chains of signification side by side to their activity sequences while they engage with tasks in an elaborated Hypothetical (Teaching) Learning Trajectory that a teacher/researcher has designed. By using Peirce's classes of Signs then, we expand the work of other researchers who have used Peirce's theory of Signs to analyze the learning process based on the triadic nature of a Sign's three components. Our work may also assist a teacher/researcher to concretize students' produced Signs, the ideas that are involved, to what extent students become familiar with the concepts, and also mark those characteristics of the tasks that turn students' conceptualizations to higher level Signs, i.e. habits of action or thought that

would endure future trials. In other words, it may help a teacher/researcher to apprehend turning points in students' activity sequences and the distance of a student's Sign from the mathematical goal(s) that she has set, as well as to take appropriate instructional actions in order to support the construction of Signs that are more mature and more relevant to the mathematical ideas at hand.

References

- Atkin, A. (2013). Peirce's theory of Signs. In E. N. Zalta (Ed.), *The Stanford encyclopedia of philosophy* (Summer 2013 Edition). Retrieved from <https://plato.stanford.edu/archives/sum2013/entries/peirce-semiotics/>
- Colapietro, V. M. (1989). *Peirce's approach to the self: A semiotic perspective on human Subjectivity*. Albany: State University of New York Press.
- Freadman, A. (1996). Peirce's second classification of signs. In V. M. Colapietro & T. M. Olszewsky (Eds.), *Peirce's doctrine of Signs: Theory, applications, and connections* (pp. 143-159). Berlin: Mouton de Gruyter.
- Lamon, S. J. (1993). Ratio and proportion: Connecting content and children's thinking. *Journal for Research in Mathematics Education*, 24, 41-61.
- Lerman, S. (2000). The social turn in mathematics education research. In J. Boaler (Ed.), *Multiple perspectives on mathematics teaching and learning* (pp. 19-44). Westport, CT: Ablex Publishing.
- Parker, K. (1998). *The continuity of Peirce's thought*. Nashville: Vanderbilt University Press.
- The Peirce Edition Project. (Eds.). (1998). *The essential Peirce* (Vol. 2). Bloomington I.N.: Indiana University Press.
- Presmeg, N., Radford, L., Roth, WM., & Kadunz, G. (2016). Introduction: What is semiotics and why is it important for mathematics education?. In: *Semiotics in Mathematics Education*. ICME-13 Topical Surveys. Cham: Springer.
- Presmeg, N., Radford, L., Roth, WM., & Kadunz, G. (2018). Introduction: *Signs of signification: Semiotics in mathematics education research*. ICME-13 Monographs. Cham: Springer.
- Sáenz-Ludlow, A. (2003). A collective chain of signification in conceptualizing fractions. *Journal of Mathematical Behavior*, 22, 181-211.
- Sáenz-Ludlow, A. (2006). Learning Mathematics: Increasing the Value of Initial Mathematical Wealth. *Revista Latinoamericana de Investigación en Matemática Educativa, RELIME* [Special Issue], 225-245.
- Sáenz-Ludlow, A., & Kadunz, G. (2016). Constructing knowledge seen as a semiotic activity. In A. Sáenz-Ludlow & G. Kadunz (Eds.), *Semiotics as a tool for learning mathematics: How to describe the construction, visualisation, and communication of mathematical concepts* (pp. 1-21). The Netherlands: Sense Publishers.
- Triandafillidis, T. A. (2002). "On "How to make our ideas clear": A pragmatist critique of explication in the mathematics classroom', *For the Learning of Mathematics*, 22(3), 2-9.

Connected Working Spaces: the case of computer programming in mathematics education

Jean-baptiste Lagrange¹ and Dominique Laval²

¹LDAR, Université Paris Diderot, France; jb.lagrange@casyopee.eu

²LDAR, Université Paris Diderot, France; dominique.laval@gmail.com

In current approaches of mathematics education at the upper secondary level, activities proposed to students involve several domains in interaction. After studying activities about modelling or functions, we question here the development in many mathematical curricula around the world of activities involving computer programming, sometimes labelled “coding” or “algorithmics”. The motivation of this paper is that a suitable theoretical framework is required to make sense of students’ work in activities involving various domains, taking into account the semiotic dimension as well as the use of instruments, and the contents and reasoning specific to each domain.

Keywords: Connected Working Spaces, computer programming, modelling, functions, mathematics and other domains.

Introduction

We are concerned with teaching/learning situations associating mathematical domains and other domains, and problems arising in these situations. Here are three examples. First, with regard to co-variation and functions, many researchers stress the need to offer students domains of sensual experience of co-variation for instance by way of dynamic geometry before or in parallel with formal approaches of functions. Modelling is another activity associating domains of everyday experience or scientific or professional domains in order that students make sense of mathematical notions and processes. Finally, there is now a big emphasis in many curricula on the introduction of programming (or algorithmics, or coding) into mathematical activities. Our concern, looking at real classroom situations or even experimental situations, is the lack of connection between the experience in the other domains and the mathematical formalism, techniques, etc. There is also a lack of connection between the processes of solving and reasoning in other domains on one side and in mathematics on the other side. In this paper, we consider especially the case of computer programming in mathematics education. Few research studies have been done in this area (Lagrange, 2014) and then this paper is based upon a recent doctoral research study carried out by the second author (Laval, 2018). We have two aims: to discuss how current theoretical frameworks analyze various aspects of activities involving mathematics and other domains, and to propose a framework, taking into account comprehensively these aspects.

Theoretical developments and question

Classically, activities involving mathematics and other domains are analysed by considering that entities involved in the task appear under different semiotic representations, each pertaining to a field. This is the “multi-representation” view. Among the many theoretical approaches of multi-representations, we start from Duval’s (2006) consideration of the plurality of representations for a given object. For Duval there is no other ways of gaining access to the mathematical objects but to

produce some semiotic representations and he stresses that representations are organized in semiotic systems. In a semiotic system, some representations are called “registers” and there is a need for a specific focus on processes of work inside and between the registers. In this multi-representational approach, activities for students in different fields are considered helpful because of the opportunities they offer for working on different semiotic representations and coordinating these. In spite of the usefulness of frameworks like Duval’s, the “multi-representation” view is for us too reductively semiotic and cannot alone really make sense of activities involving several fields in interaction, and of their potentialities. In some curricula, much emphasis has been put on the work on representations and students can be fluent in the processes of conversion and treatments, but this does not necessarily imply a deep understanding of notions at stake. For instance, even when students are proficient in dealing with the four classical representations of functions (verbal, symbolic, graphic, and tabular), fundamental aspects of functions (correspondence, co-variation, mapping, etc.) and their coordination remain problematic.

Another framework for making sense of activities of coordinating different domains (especially mathematical domains) is by Douady (1986). For Douady, a setting is constituted of objects from a branch of mathematics, of relationship between these objects, their various expressions and the mental images associated with these objects. When students solve a problem, they can consider this problem in different settings. Switching from one setting to another is important in order that students progress and that their conceptions evolve. According to authors like Perrin-Glorian (2004), it is sometimes difficult to distinguish the representational and the settings approaches, especially when a phase of work can be thought of both as a switch between settings and as a conversion of representations. Actually, rather than contradicting, the two approaches complement: beyond its mathematical contents, each setting offers specific semiotic systems, and coordinating the settings also implies coordinating the semiotic systems.

Another concern is how instruments are taken into account in the students’ mathematical activity. Twenty years ago, sophisticated calculators became available for students’ work and a framework was developed: the instrumental approach of the use of digital technologies to teach and learn mathematics. This approach has been inspired by research work in cognitive ergonomics but researchers like Lagrange (1999) insisted on the intertwined development of knowledge related to the instrument and of knowledge about mathematics in an instrumental genesis. This is important because otherwise an instrumental approach would be only a psychological framework with little insight for mathematics education. Authors like Bartolini Bussi & Mariotti (2008) also noted that the use of instruments and the associated reflection involve a lot of signs that, for a student, may have not immediately a mathematical meaning, and they propose the idea of “semiotic mediation” to refer to the classroom activity necessary in order to ensure the productivity of the work with instruments at a semiotic level.

Each framework, multi-representation, coordination of mathematical settings and instrumental approach, puts a focus on a specific dimension: the semiotic processes or on the contents and reasoning, or on the use of instruments (Figure 1). We present the framework of connected working spaces, taking into account comprehensively these three dimensions in order to address work in mathematical domains as well as in non-mathematical domains where mathematical notions can

take sense. This framework was proposed by Minh & Lagrange (2016) and by Lagrange (2018) for activities related respectively to functions and to modelling and we question here its utility for addressing the new challenge brought about by activities involving computer programming in mathematics education.

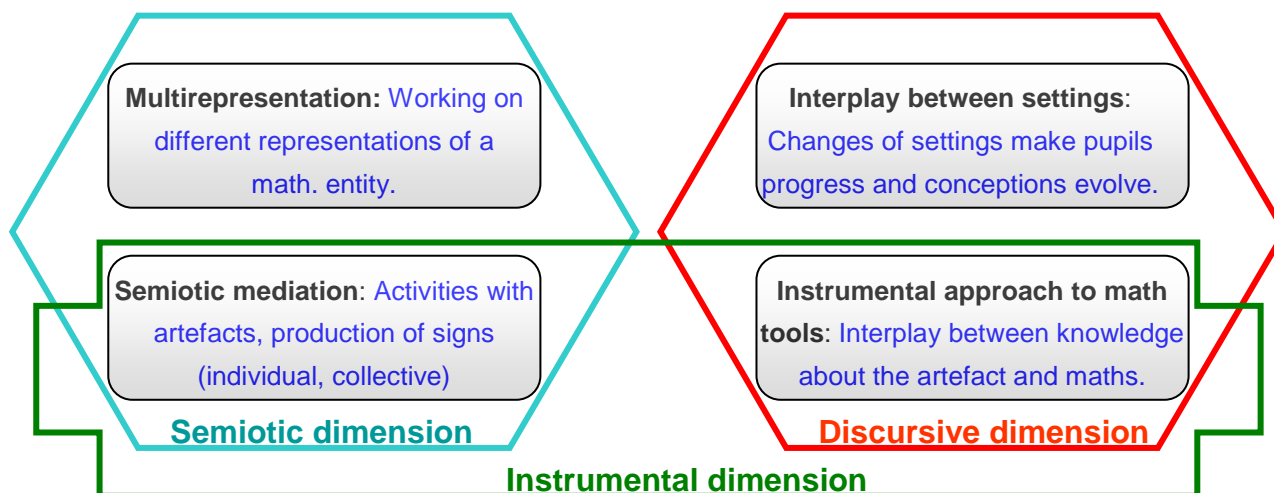


Figure 1: Four frameworks, three dimensions.

Connected Working Spaces

The framework of the Mathematical Working Spaces (MWS) allows characterizing the way the concepts make sense in a given work context. According to Kuzniak & Richard (2013) a MWS is an abstract space organized to ensure the mathematical work in an educational setting. Work in a MWS is organized around three dimensions:

- Semiotic: use of symbols, graphics, concrete objects understood as signs.
- Instrumental: construction using artefacts (geometric figure, graphs, program...)
- Discursive: justification and proof using a theoretical frame of reference.

Activities considered in this paper involve several domains, and for each of these domains, a working space. The framework of “Connected Working Spaces” has been introduced in order to give account of how connections between Working Spaces bring meaning to the concepts involved. This extended MWS framework takes into account the semiotic and instrumental dimensions as well as the contents and mode of reasoning, in different domains of activity and their interaction in a mathematical activity. Then it is not contradictory with the theoretical developments outlined above (Figure 1), but it rather aims to organize them in a comprehensive structure. What we expect from this framework is to help building and analysing situations on a given topic involving a mathematical and another domain, identifying the three dimensions in the corresponding Working Spaces, contrasting these and looking for possibilities of connection.

Connecting Algorithmic and Mathematical Working Spaces: The Intermediate Value Theorem (IVT)

Activities involving computer programming in mathematics education connect two distinct Working Spaces: an Algorithmic Working Space (AWS) and a Mathematical Working Space

(MWS). In the continuation of this paper we will focus on a particular topic that can be considered both from a computer science and a mathematical point of view: the solution of an equation $f(x)=0$ for a given function f defined on a closed interval $[a ; b]$. We will consider this topic relatively to how it can be a subject for secondary students' work, that is to say how it implies connecting the two Working Spaces. From a computer programming point of view, specific algorithms allow approaching solutions as close as possible. We consider algorithms able to find, for an arbitrary precision e , an interval $[u ; v]$ with the property $P(e)$: $|u - v| < e$ and $f(u) \times f(v) \leq 0$. The simplest algorithm scans iteratively the sub intervals of length e , until finding a suitable one (Figure 2, left). A more efficient algorithm is based on dichotomy (Figure 2, right). In the corresponding AWS, the semiotic dimension is characterized by specific marker of iterative (While...) and alternative (If...) treatments and by variables, whose value, as a difference with mathematical variables, change along the treatment by way of the specific operation of assignment (sign \leftarrow in Figure 1). Mathematical expressions are also involved. The associated semiotic system can be at stake for students not fluent in algebra, especially the notation $f(\dots)$. There is a strong instrumental dimension, since algorithms are intended to be executed by an automatic device and it is expected that execution will help students to make sense of the formalism. The discursive dimension is characterized by questions like the termination of an algorithm (does it terminate in a finite number of steps?), its effectivity (does it return an appropriate solution?) and its efficiency (how many steps are necessary for a given set of data?).

A scan algorithm	A dichotomy algorithm
$u \leftarrow a$	$u \leftarrow a$ Else
$v \leftarrow a + e$	$v \leftarrow b$ $v \leftarrow m$
While $f(u) \times f(v) > 0$	While $v - u > e$ Endif
$u \leftarrow u + e$	$m \leftarrow \frac{u+v}{2}$ End While
$v \leftarrow \min(b, v + e)$	If $f(u) \times f(m) > 0$ then Return $[u; v]$
End While	$u \leftarrow m$
Return $[u; v]$	

Figure 2: Algorithms approximating a solution of an equation $f(x)=0$.

From a mathematical point of view, the Intermediate Value Theorem (IVT) guarantees the existence of a solution on the interval $[a ; b]$ under the sufficient conditions: f is continuous and $f(a) \times f(b) < 0$. The corresponding MWS has a strong discursive dimension: it includes properties of functions like continuity and monotonicity; it is focused on a mathematical solution, rather than on a process of approximation. A classical proof is based on two adjacent sequences. In addition to the usual mathematical formalism, the semiotic dimension is then characterized by the formalism of infinite sequences, different from the iterative variables of the algorithms, although both are defined by way of the dichotomy method. Students are introduced progressively into these notions and formalism from 10th to 12th grade. The instruments here are paper and pencil calculations, and graphical display of functions. Figure 3 summarizes the dimensions in the two Working Spaces.

Organizing the Working Spaces: A classroom experiment

The outcome of the above analysis is that the algorithms and the theorem have different targets: while the IVT is about solutions, the algorithms aims at obtaining an interval with the property $P(e)$.

Mathematical Working Space	Algorithmic Working Space
<ul style="list-style-type: none"> • Discursive dimension: <ul style="list-style-type: none"> – Focus on a mathematical solution, – Properties of functions. • Semiotic dimension: <ul style="list-style-type: none"> – Usual mathematical formalism, – Formalism of infinite sequence. – Graphs (iconic). • Instrumental dimension: <ul style="list-style-type: none"> – Paper and pencil calculations, Graphs. 	<ul style="list-style-type: none"> • Discursive dimension: <ul style="list-style-type: none"> – Focus on process of approximation: termination, effectivity, efficiency. • Semiotic dimension: <ul style="list-style-type: none"> – Specific markers of treatments. – Variables. – Mathematical expressions. • Instrumental dimension: <ul style="list-style-type: none"> – Execution by automatic device.

Figure 3: The Working Spaces

However, there are clear links. First, the IVT ensures that, with the sufficient condition of continuity, an interval with the property $P(e)$ actually contains one or more solutions, and the corollary that, with the additional sufficient condition of monotonicity, it contains the unique solution. Second, the algorithms, especially the dichotomy algorithm provides a mode of generation of sequences that play a crucial role in a proof of the IVT. From these links, different organisations of the MWS and the AWS can be envisioned. In a first organization, after being taught about the IVT, students can work on the algorithms with a function verifying the sufficient conditions in order to get an approximation of the solution. We name this organisation “application”: computer programming is considered as an application of “pure” mathematics. This is the most common scheme that we found when looking at textbooks in France. As for us, we envision other organisations making the Working Spaces interact more closely. It is because, as we wrote above, knowledge is at stake in both Working Spaces, and interaction can help understanding. Working on an algorithm, and after proving that the returned interval has the property $P(e)$, students can experiment on diverse functions, in order to infer sufficient conditions for the IVT. They can then work on a proof by conceiving recurrent sequences from the iterative variables in the algorithm.

Classroom situations

We designed classroom situations in order to test the hypothesis that, transitioning from “application” to other organisations, students make connections between Working Spaces in the various dimensions. The situations were implemented in three French classes at 10th, 11th and 12th grade in order to get evidence about the work of students with different mathematical attainments. Each class had around 30 students and had nothing particular with regard to the work expected. The duration of each situation was between one-half and one hour. The students had worked before on the dichotomy method for discrete numbers (Laval, 2016) and this work was mainly in the AWS. Otherwise they had no previous experience in the domain, except that, for the 12th graders, the IVT had been introduced and not proved. A first situation was “application”: a continuous monotonic function was given and the dichotomy method was exposed by way of a flow chart. The students had to give some evidence of the existence of a unique solution, and to implement the method for this function in a textual programming environment allowing execution. The situation was intended to make students work in the AWS and MWS and coordinate these especially in the semiotic and discursive dimensions. Then, in a second situation, with the same function and the same programming environment, students had to complete a scan algorithm where the condition of continuation (following While) was missing. While this situation clearly involves the AWS in the

three dimensions, the MWS is in the background, both with regard to the formalism and to the properties of the function.

We analyse here particularly two subsequent situations. A situation was intended to make students aware of sufficient conditions for the IVT, by encountering functions for which the dichotomy algorithm does not return a suitable interval. They were requested to implement and execute a dichotomy algorithm for “hidden” functions, i.e., functions that students could use in the algorithm and display graphs, but whose formula was not given. Students had to answer the question “does the interval returned by the algorithm actually contain the unique solution?” See an example in Figure 4. The task is reflective, both in the AWS and the MWS: evaluating the effectivity of the algorithm at a mathematical level. The students were expected to be influenced toward an affirmative answer by the “application” situation where mathematical effectivity was not discussed. Students at 12th grade knew the IVT, but were expected not to focus on sufficient conditions, because all examples treated before were continuous monotonic functions. However, the students were expected to double check by graphing the functions, or computing values. This connection between the AWS and the MWS involves the instrumental and the discursive dimensions.

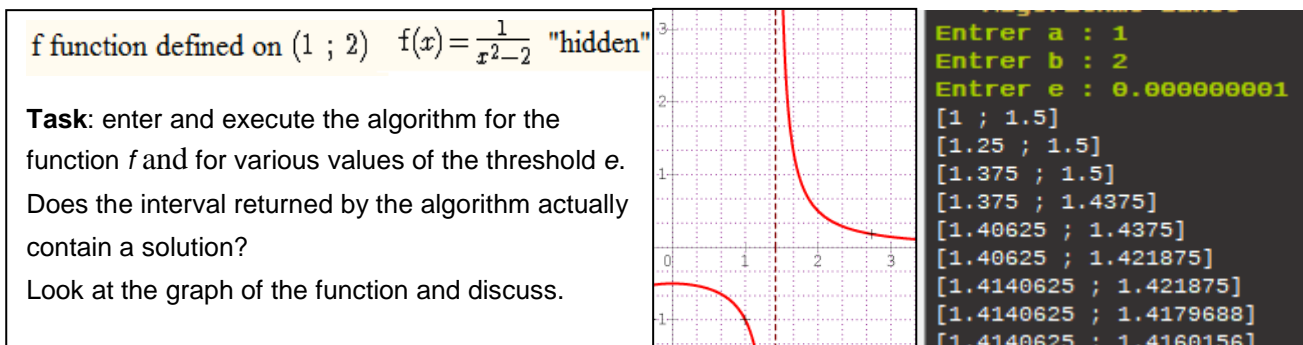


Figure 4: A situation to make students aware of sufficient conditions for the existence of a solution.

The last situation was implemented only for 12th grade students. Students were invited to build a proof of the IVT, using adjacent sequences and the dichotomy method. The semiotic dimensions of the MWS and the AWS are at stake in this task, with a process of conversion, from the iteration on variables in the AWS, to sequences in the MWS. In the discursive dimensions the convergence of the sequences had to be inferred from the fact that $P(e)$ holds for arbitrary e . However, the convergence does not prove that the limit is a solution, and students were expected to use explicitly a theorem on continuous functions and sequences, and another about the compatibility of limit and order. This work is specific to the MWS and had been prepared by the focus on sufficient conditions in the third situation.

Observation and evaluation

In the situation with the “hidden” functions (Figure 4), the students considered that the very small interval returned by the algorithm was an evidence of the existence of a single solution. Most students reconsidered this finding after graphing and recognizing the unusual shape of the graph. They calculated the values of the function at the boundaries of the intervals returned by the algorithm for decreasing values of the threshold e and found values of the function decreasing at the left boundary and increasing at the right boundary. They deduced that these intervals approach a

pole rather than a solution. The outcome of this third situation is that, except for a few 10th graders, the students made a clear distinction between the effectivity of the algorithm in the AWS and its effectivity to approach a solution in the MWS. 11th and 12th graders had a notion of sequences and convergence that helped them to consider more closely the phenomenon.

As mentioned before, the situation on the proof of the IVT was implemented only at 12th grade. At the beginning, the students were confused, not connecting sequences and the IVT, which they thought related to functions. Then some of them proposed to look at the values of the boundaries of the intervals along the execution of the dichotomy algorithm for a particular function. This is a typical answer:

The sequences (u_n) and (v_n) are adjacent because (u_n) is increasing, (v_n) is decreasing and $(v_n - u_n)$ becomes closer to zero when n becomes bigger and bigger. Then these two sequences converge towards a common limit c . Because f is continuous, $f(u_n)$ and $f(v_n)$ converge towards $f(c)$ which is zero. The theorem is proved by way of the computer for a particular function.

This “proof” is a mix of observation (behaviour of the sequences, value of $f(c)$) and deduction (convergence of the sequences) and, for the students it is valid only for one function. Within the duration of this situation students could not go much beyond. Only one observed that a proof of the behaviour of the sequences could be made by induction. For us, the students adequately took advantage of the work in the AWS but in some way stayed halfway between the AWS that produces evidence on an example, and the MWS in which a formal proof for a generic function was expected. Students had no difficulty to operate the semiotic conversion from computer variables to sequences. In contrast, their answer witnesses a notion of proof still confusing instrumental evidence and mathematical reasoning.

Instrumental		Semiotic
AWS (execution) ↔ MWS (graph)		AWS (iterative variables) ↔ MWS (recurrent sequences)
Discursive		Instrumental-Discursive
AWS (effectivity) ↔ MWS (existence)		AWS (observation of variables' behavior) ↔ MWS (partial proof of IVT)

Figure 5: Connections by students in the situation of Figure 4 (left) and in the proof of the IVT (right).

Conclusion

This paper investigates the usefulness of the Connected Working Spaces framework for addressing activities for students involving distinctive domains and especially computer programming and mathematics. We used this framework for designing a classroom experiment to test a hypothesis: for a particular topic involving computer programming and mathematics, it is possible to characterize an AWS and a MWS, and to create situations in order that students make fruitful connections between these Working Spaces in the three dimensions, semiotic, instrumental and discursive. We observed a variety of connections validating this hypothesis (Figure 5). In the situation of Figure 4, students operated the delicate coordination of the discursive dimensions in the AWS and the MWS by combining work in the instrumental dimensions. In the proof of the IVT, the students took advantage of the work in the instrumental and discursive dimensions of the AWS for their discursive work in the MWS, although they were only partially successful. Previous studies

about functions and modelling already gave insight into a potential of the Connected Working Spaces framework and this paper extends the analysis to computer programming and mathematics education. It also witnesses of a framework that do not contradict with other approaches like multi-representation, settings and instruments but rather connects these in a comprehensive analysis of students' work.

References

- Bartolini Bussi, M.G., & Mariotti, M.A. (2008). Semiotic mediation in the mathematics classroom: Artefacts and signs after a Vygotskian perspective. In L. English, M. Bartolini, G. Jones, R. Lesh, B. Sriraman, & D. Tirosh (Eds.) *Handbook of international research in mathematics education* (2nd edition) (pp. 746–783). New York: Routledge Taylor & Francis Group.
- Douady, R. (1986). Jeux de cadres et dialectique outil–objet. *Recherches en didactique des Mathématiques*, 7(2), 5–31.
- Duval, R. (2006). Quelle sémiotique pour l'analyse de l'activité et des productions mathématiques? *Relime*, 9(4), 45–81.
- Kuzniak, A., & Richard, R. P. (2014). Spaces for mathematical work: Viewpoints and perspectives. *Relime*, 17(4.1), 17–26.
- Lagrange, J. B. (2018). Connected Working Spaces: Designing and evaluating modelling based teaching situations. In E. Bergqvist, M. Österholm, C. Granberg, & L. Sumpter (Eds.) *Proceedings of the 42nd Conference of the International Group for the Psychology of Mathematics Education* (Vol. 3, pp. 291–298). Umeå, Sweden: PME.
- Lagrange, J. B. (2014). Algorithmics. In S. Lerman (Ed.), *Encyclopedia of Mathematics Education*. Dordrecht: Springer Science+Business Media Dordrecht.
- Lagrange, J. B. (1999). Complex calculators in the classroom: Theoretical and practical reflections on teaching pre–calculus. *International Journal of Computers for Mathematical Learning*, 4(1), 51–81.
- Minh, T.K., & Lagrange, J. B. (2016). Connected Functional Working Spaces: A framework for the teaching and learning of functions at upper secondary level. *ZDM Mathematics Education*, 48(6), 793–807.
- Laval, D. (2017). L'algorithme de dichotomie « discret » : une stratégie « rapide » et « gagnante ». In I. Gómez–Chacón, A. Kuzniak, K. Nikolantonakis, P.R. Richard, & L. Vivier (Eds.) *Mathematical Working Space: Proceedings Fifth ETM Symposium* (pp. 267–279). Florina, Greece: University of Western Macedonia.
- Laval, D. (2018). *L'algorithmique au lycée entre développement de savoirs spécifiques et usage dans différents domaines mathématiques*. Thèse de Doctorat. Paris : Université Paris–Diderot.
- Perrin–Glorian, M. J. (2004). Éclairages et questions pour la didactique des mathématiques: Cadres et registres en jeu dans la résolution de problèmes. *Annales de Didactique et de Sciences Cognitives*, 9, 67–84.

Multi-theoretical approach when researching mathematics teachers' professional development in self-organized online groups

Yvonne Liljekvist¹, Jorryt van Bommel¹, Ann-Christin Randahl¹ and Cristina Olin-Scheller²

¹Karlstad University, Department of Mathematics and Computer Science, Karlstad, Sweden; yvonne.liljekvist@kau.se; jorryt.vanbommel@kau.se; ann.christin.randahl@kau.se

²Karlstad University, Department of Education, Karlstad, Sweden; christina.olin-scheller@kau.se

Abstract: Teachers worldwide are using social media as a professional development resource. In studying social media as 'a place' for teachers' professional development, we investigated large Facebook groups with themes connected to teaching and learning in compulsory schools. The interaction in these groups was analysed within the framework of systemic functional grammar. In order to reveal knowledge known and shared by teachers as a community, we have also used Shulman's (1987) framework. Most posts received responses and this response is in line with the expected response pattern. The speech functions 'Questions' and 'Offers' were most common. Further, most posts addressed subject specific knowledge. The multi-theoretical approach used when researching mathematics teachers' professional development in self-organized online groups showed that these large Facebook groups facilitated professional learning.

Keywords: Functional grammar, mathematics teachers, PCK, professional development, social media.

Introduction

Studies have shown that Swedish mathematics teachers, to a large extent, participate in self-organized online groups both while working as well as during their free time (e.g., van Bommel & Liljekvist, 2015; van Bommel & Liljekvist, 2016). Moreover, participation in online communities is a global phenomenon: teachers worldwide are using social media as a professional development resource (e.g., Bissessar, 2014; Patahuddin & Logan, 2015; Tour, 2017). Hence, in studying social media as 'a place' for teachers' professional development, we investigated large Facebook groups with themes connected to teaching and learning in compulsory schools. It is well known that the subject being taught is in the centre of teachers' work (e.g., Kansanen & Meri, 1999; Shulman, 1987). Subject-specific Facebook groups (e.g., mathematics education) in an online teacher community may therefore imply a higher potential for professional development, and the subject-specific theme (e.g., mathematics for primary school) of some of the teacher self-organized online groups make these groups particularly interesting to study.

If we want to understand the conditions for informal professional learning in online communities better, we have to acknowledge the change of the setting and develop theories that take such change into account (Liljekvist, 2017; Liljekvist, van Bommel, & Olin-Scheller, 2018). Our study investigate these online communities at three levels: descriptive level (van Bommel & Liljekvist, 2016), interaction level (Randahl, Olin-Scheller, van Bommel, & Liljekvist, 2017), and the motivational level. These three levels give us an opportunity to answer the questions: how and what do teachers

discuss in the groups. However, this paper goes beyond such a question and addresses the theoretical frameworks we used to capture a variety of aspects of this practice, in order to identify signs of a professional approach (Talbert, 2010) in these communities. Further, the paper addresses the need to go beyond a specific theory when researching this phenomenon and a brief description is given of how the analytical framework was adapted to the context and empirical findings.

According to Little (2002), locating professional development in teachers' communities of practice directs attention to three considerations: (I) the representations of practice (e.g., how school practices become known and shared); (II) the practice orientation (e.g., whether or not the teacher community improves teaching, and how this interaction advances or impedes teacher learning); (III) the interaction norms (e.g., how participation and interaction are organized, and how this organization supports teacher learning and practice reform).

Hence, to understand how these practices become known and shared, the interaction in these groups was analysed within the framework of systemic functional grammar (Halliday & Matthiessen, 2013). Due to Facebook's construction with posts and comments, language (in a broad sense) is used to initiate exchanges in all conversations, for giving and demanding information, goods, and services. In addition, when analysing the practices represented and to reveal knowledge known and shared by teachers as a community (Little, 2002), we have used Shulman's (1987) framework. These two frameworks allowed us to categorize teachers' professional communities both in a general way and in relation to subject-specific education. Combining the two frameworks gives us more than two single descriptions: it provides us with a possibility to deepen the analysis of our data and reveals other aspects of mathematics teaching.

Analytical framework

Speech functions as enacting interpersonal relations

People use language to interact with others or to express their view about the world and how they interpret it. Within the framework of Systemic Functional Linguistics (SFL), this is described as the meta functions of the language (Halliday & Matthiessen, 2013). Halliday and Matthiessen distinguish between three meta functions of language, that is, its ideational, interpersonal, and textual functions. The ideational function is a matter of expressing how one sees the world and how one interprets this experience. The interpersonal function concerns how the text creates a relationship between speaker and listener. Finally, the textual function concerns aspects that make language relevant, which is sometimes looked upon as a "help-function" to organize and mediate.

Dealing with relation-making processes in online groups, we concentrate on the interpersonal function. In a conversation, the speaker not only plays an initiating role in exchanging information, but also requires something of the listener. "Typically, therefore", Halliday & Matthiessen (2013, p. 135) conclude, "an 'act' of speaking is something that might more appropriately be called an **interact**: it is an exchange, in which giving implies receiving and demanding implies giving a response" (bold in original). In the semantic system of speech function, anyone can initiate either a giving or a demanding exchange in the conversation. That is, we can give or ask for information and we can offer someone something or ask someone to do something. These four primary speech functions: statement, question, offer, and command (see, e.g., Halliday & Matthiessen, 2013) were mapped on the posts in

a group. It is therefore possible to analyse what the teacher wanted to accomplish when posting in the group by asking what speech function was used.

Further, the response given can be analysed as either *expected* or *discretionary* responses (Holmberg & Karlsson, 2006). For instance, the desired response to a question is an answer and the discretionary response is to neglect to answer. Hence, it is possible to uncover interactional patterns in online groups. For example, when making a statement, a member of a group can acknowledge as well as contradict a particular matter, indicating that statements may initiate discussions. Another example: if posts mainly evoke the desired responses, this could indicate a community of trust. Finally, when posting a question, a teacher expects someone in the group to have the answer as well as being willing to give it. In this way, questions can reveal the knowledge base of the group.

Disclosing the shared professional knowledge

In the knowledge base framework, Shulman (1987) outlines seven categories that he suggests constitute the teacher's understanding needed to promote comprehensive student learning. His framework incorporates teacher awareness of various educational aspects, such as content, pedagogy, and organization: content knowledge (CK); general pedagogical knowledge (PK); curriculum knowledge (CuK); pedagogical content knowledge (PCK); knowledge of learners (KoL); knowledge of educational context (KEC); and, knowledge of educational ends (KEE).

Together these categories serve as a way to visualize the shared professional knowledge in these Facebook groups, organized by and for teachers. However, we learnt from our empirical material that three of the categories (i.e., CK; PCK; and KoL) were difficult to differentiate from each other (van Bommel & Liljekvist, 2016; Randahl et al., 2017). These categories appeared simultaneously in many posts, hence, we decided to use an overarching category (PCK+) in further analysis, as we did not need a finer-grained analysis in this part of the study. By doing so, we adopt the framework to the Scandinavian/German educational tradition where the relation between the teaching, studying and learning activities in the classroom “the didactic relation” (e.g., Kansanen & Meri, 1999) is considered the professional knowledge base.

Method

The data were collected from large Facebook groups. The groups are formed and maintained by teachers, that is, self-organized and not initiated by schools, the Ministry of Education, researchers, etc. It is plausible that every member in the group has a connection to the education field, since the administrator of the group checks a member's affiliation to a school when entering the group. Through membership, one can post and comment. At the time of data collection, the groups were open for the general public to read. In this paper, we include the results from the analysis of three strategically selected Swedish Facebook groups with a theme connected to mathematics education, each with, at time of data collection, between 2000 and 15 000 members. The groups are labelled MA1–3.

By scrutinizing the activity pattern in the groups, a stratified random sample of posts could be conducted based on time of the school year (for a detailed description see van Bommel, Liljekvist, & Olin-Scheller [2018]). This method makes it possible to draw conclusions of the interaction on the

groups as a whole. Eighty-four to ninety-eight initial posts were collected per group with a total of 1762 responses to these initial posts. The average amount of responses per initial post differed from 3.1 in MA3 to 10.1 in MA2. The interaction sometimes contained images (77 in total), documents (13 instances) or links to other sites (229 instances).

The posts were categorized using the analytical framework developed from speech functions (Halliday & Matthiessen, 2013) and the knowledge-base framework (Shulman, 1987). Coding reproducibility was ensured via a multi-step process, where both inter and intra coder reliability was examined. All four authors were involved in the coding process, and all data was coded by at least two persons. Furthermore, the responses on the posts were analysed to confirm the coding of speech functions, as the response validates the speech function (e.g., Holmberg, 2011). Finally, the internal consistency of the categories was controlled for by scrutinizing all posts in each category, to ensure that all posts coded in each category were consistently coded. The procedure described, in which we recorded every step in the sampling, coding, and categorization, made it possible to backtrack, retrace, and correct errors made in the coding process.

Data

Below, four examples from our data are given (translated into English for this paper), including one or two of the responses to give some insight in the direction of the conversation. The examples will be referred to in the section results and the categorizations for each framework are stated in brackets, along with the number of responses.

Example 1: (Question, PCK+, 23 responses, 2 likes)

Initial post: Hi, I would need some tips for a thematic theme on length. The students are in grade 2 and have not previously reviewed cm, dm, m or how to measure. Anyone who has some good / cool lesson tip / tasks I could use. Thanks in advance!

Response: Estimate how long things are, then measure...


Response: We take one-meter-ropes and dm-ropes out to the forest and try to find objects of such length.



Example 2: (Question, CK, 13 responses, 4 likes)

Initial post: We discussed the definition of a circle in our team – What would you say, does a circle have one side or no side at all?

Response: No sides, closed curve

Example 3: (Offer, PCK+, 6 responses, 163 likes)

Initial post: We measure outdoors! An elephant of 3.5m, a whale of 15m and a crocodile of 6m
 [Several images of outdoor work included]

Response:   Fun! What a cute crocodile!

Example 4: (Statement, PCK+, 0 responses, 7 likes)

Initial post: Problem solving increases student performance in mathematics. [link to blog]

Results

Interactional patterns exposed by speech functions

Each post was analysed with a focus on the interpersonal function, which concerns the relationship-making process (Table 1). The four speech functions, that is, statement, question, offer, and command, convey what the teacher wants to accomplish when posting in the group. The speech functions ‘Questions’ and ‘Offers’ dominated as shown in Table 1.

Table 1: The distribution of speech functions in each group

	Statement	Question	Offer	Command	Total
MA1 ($n=90$)	5	48	34	3	90
MA2 ($n=84$)	9	44	25	6	84
MA3 ($n=84$)	8	12	56	8	84
Total ($N=258$)	22	104	115	17	258

To examine the interactional patterns and exchanges of the teachers posting in these groups, the responses to each post were analysed. The results show that 85.3% of all posts get responses. Most responses (80 %) are in line with the expected response pattern, that is, what the teachers wanted to accomplish when posting in the groups. In the examples above, we see that the questions received numerous responses (Example 1 and 2) whereas the statement (Example 4) did not receive any responses at all.

Knowledge addressed

To indicate the practice known and shared (Little, 2002), Shulman’s (1987) framework was used for the analysis. Using Shulman’s categories, the content of the initial posts could be analysed giving a descriptive overview of the content addressed by the teachers in these communities. These descriptive results were then combined with the previously described results regarding the interaction patterns in each group. As Questions and Offers dominated, we focus on these two speech functions (Table 2).

The analysis showed that most *Questions* deal with PCK+, that is, issues regarding subject-specific teaching and learning. Example 1 illustrates such posts. This overall pattern is similar in all groups (see Table 2). However, few questions were raised in MA3 so the pattern is not as distinct as in the other groups.

Further, the results regarding the *Offers* in the posts show that, similar to the category *Questions*, mainly subject specific knowledge (PCK+) were shared (Table 2) as illustrated by Example 3. In MA3, a few more posts offered content knowledge (CK), similar to Example 2. MA3 also distinguished itself from the other groups in the number of posts unrelated to Shulman’s framework (38.2%). Many of these posts contained mathematical jokes or humorous video clips related to mathematics.

Summary

The interaction that is the foundation of the Facebook groups is centered on asking for and sharing subject-specific knowledge (PCK+). Most posts received responses, and the responses were of the expected kind. The online groups were therefore mainly used as forums for making subject-specific education known and shared, but, broadly speaking, not as forums for discussion. Having used a stratified random sample, conclusions can be drawn regarding typical interaction patterns in large self-organized groups.

Table 2: Knowledge addressed in Questions and Offers

Knowledge base	Questions				Offers			
	MA1	MA2	MA3	Total	MA1	MA2	MA3	Total
PCK+	33	23	6	62	22	12	16	50
CK	2	6	4	12	0	2	11	13
PK	2	8	0	10	4	2	2	8
KEC	4	5	2	11	1	0	1	2
KEE	3	2	3	8	3	3	4	10
Total	44	44	15	103	30	19	34	83
Unrelated	7	5	0		3	5	21	

Discussion

In this paper, we have shown how two different frameworks enlighten different aspects of our data. When combining these frameworks, a new dimension of the data becomes discernible in terms of the way in which the mathematics teachers use self-organized online groups to advance their professional collaboration and professional development. More specifically, we were able to analyse what teachers wanted to accomplish when engaging in such groups. Further, we could see which parts of the teaching practice became visible. This is an important result, as it is an empirical question of whether the characteristics of groups of teachers working together are those of a community where professional development may occur. Since teachers' professional community is extended to social media (Liljekvist et al., 2018; Macià & García, 2016; Tour, 2017), we aimed at empirically investigating teachers' interaction in self-organized groups, addressing subject-specific knowledge, in order to understand how the groups are used as resources for professional development. The multi-theoretical approach used shows that these large Facebook groups display the characteristics of groups of teachers that merits professional development.

The teachers' online interaction is oriented towards practice to enhance students' learning; therefore, as Little (2002) illustrates in her studies of within-school teacher communities, the issues raised are closely tied to the teachers' everyday professional lives. The subject-specific themes of the groups seem to structure the interaction towards the PCK+, which could be described as the centre of teachers' knowledge base, or more specifically, the "didactic relation" between the teaching-

studying-learning activities (Kansanen & Meri, 1999). The teaching practice that becomes known and shared (Little, 2002) in the three Facebook groups is characterized by a focus on pedagogical content knowledge, learners, and the material and methods used in the classroom. In forthcoming studies, it is now possible to go further and inquire into posts and comments to reveal the individual themes within the PCK+ category, for instance, what kind of subject is at play, and if and how teachers learn in these communities.

The representations of practice in the groups display the same pattern in what teachers want to accomplish when posting; they request knowledge from and offer knowledge to colleagues, and illustrate and share practices. This is in line with our understanding regarding professional learning communities in schools (cf. Little, 2002). By combining systemic functional grammar and the knowledge-base framework, we can go beyond the context of social media interaction and explain how teachers use the resources in self-organized groups to develop their collective knowledge on pedagogical and subject-specific issues related to their everyday practice. Furthermore, these three Facebook groups are used in only a limited way as an arena for debating and discussing school policy matters. This is indicated by the small proportion of statements (22 of the 258 relevant posts), by the fact that most statements get responses that merely confirm the content in question, and by the educational aspects focused on in the posts. Here, a focus on educational context and educational ends would have indicated an interest in such matters. Discussions around such issues might occur in other Facebook groups with such themes. We want to conclude that the willingness to respond and to share knowledge and teaching methods in the self-organized groups facilitates rather than impedes professional development.

Acknowledgment

This work was supported by the Swedish Research Council under Grant number 2015-01979, and by the research group ROSE (Research on Subject-specific Education). Magnus Kallin supported in the data collection and Jari Appelgren in the data analysis.

References

- Bissessar, C. S. (2014). Facebook as an informal teacher professional development tool. *Australian Journal of Teacher Education*, 39(2), 121–135. doi:10.14221/ajte.2014v39n2.9
- Halliday, M. A. K., & Matthiessen, C. (2013). *Introduction to functional grammar* (4th ed.). Abingdon, UK: Routledge.
- Holmberg, P. (2011). Texters interpersonella grammatik [Interpersonal grammar in texts]. In P. Holmberg, A. Karlsson, & A. Nord (Eds.), *Funktionell textanalys [Functional text analysis]* (pp. 97–113). Stockholm, Sweden: Norstedt.
- Holmberg, P., & Karlsson, A. (2006). *Grammatik med betydelse: en introduktion till funktionell Grammatik* [Grammar with meaning: An introduction to functional grammar]. Uppsala, Sweden: Hallgren & Fallgren.
- Kansanen, P. & Meri, M. (1999). The didactic relation in the teaching-studying-learning process. In B. Hudson, F. Buchberger, P. Kansanen, & H. Seel (Eds.), *Didaktik/Fachdidaktik as Science(-s) of the Teaching Profession?* (pp. 107–116). Umeå, Sweden: TNTEE Publications.

- Liljekvist, Y. (2017). Mathematics teachers' re-sourcing and use of social media: can the 'prosumer' concept convey what's going on?. In T. Dooley, & G. Gueudet (Eds.), *Proceedings of the Tenth Congress of the European Society for Research in Mathematics Education* (pp. 2271). Dublin, Ireland: Institute of Education, Dublin City University and ERME.
- Liljekvist, Y., van Bommel, J., & Olin-Scheller, C. (2018). Professional Learning Communities in a Web 2.0 World: Rethinking the conditions for professional development. In I. H. Amzat & N. P. Valdez (Eds.), *Teacher empowerment toward professional development and practices: Perspectives across borders* (pp. 269–280). Singapore: Springer Singapore.
- Little, J. W. (2002). Locating learning in teachers' communities of practice: Opening up problems of analysis in records of everyday work. *Teaching and Teacher Education*, 18(8), 917–946. doi:10.1016/s0742-051x(02)00052-5
- Patahuddin, S. M., & Logan, T. (2015). Facebook as a learning space: An analysis from a community of practice perspective. In M. Marsham, V. Geiger, & A. Bennison (Eds.), *Mathematics education in the margins: Proceedings of the 38th annual conference of the Mathematics Research Group of Australasia* (pp. 485–492). Sunshine Coast, Australia: MERGA.
- Randahl, A.-C., Olin-Scheller, C., van Bommel, J., & Liljekvist, Y. (2017). Svensklärare på sociala medier: En ämnesdidaktisk analys av tre svensklärargrupper på Facebook [Swedish teachers in social media: A subject didactical analysis of three Facebook groups for the teaching of Swedish]. In B. Ljung-Egeland, C. Olin-Scheller, M. Tanner, & M. Tengberg, *Textkulturer [Text Cultures]* (pp. 259–276). Karlstad: Karlstad University Press.
- Shulman, L. S. (1987). Knowledge and teaching: Foundations of the new reform. *Harvard Educational Review*, 57(1), 1–21. doi:10.17763/haer.57.1.j463w79r56455411
- Talbert, J. E. (2010). Professional learning communities at the crossroads: How systems hinder or engender change. In A. Hargreaves, A. Lieberman, M. Fullan, & D. Hopkins (Eds.), *Second international handbook of educational change* (pp. 555–571). Dordrecht, the Netherlands: Springer.
- Tour, E. (2017). Teachers' self-initiated professional learning through Personal Learning Networks. *Technology, Pedagogy and Education*, 26(2), 179–192.
- van Bommel, J., Liljekvist, Y. (2015). Facebook and mathematics teachers' professional development: Informing our community. In K. Krainer, & N. Vondrová (Eds.), *Proceedings of the Ninth Congress of the European Society for Research in Mathematics Education* (pp. 2930–2936). Published online: <https://hal.archives-ouvertes.fr/hal-01289653>
- van Bommel, J., & Liljekvist, Y. (2016). Teachers' informal professional development on social media and social network sites: when and what do they discuss? ERME-topic conference: Mathematics teaching, resources and teacher professional development, Humboldt-Universität, Berlin, Germany, 5–7 October 2016. Published online: <https://hal.archives-ouvertes.fr/ETC3>

Extending Yackel and Cobb's sociomathematical norms to ill-structured problems in an inquiry-based classroom

Katie Makar¹ and Jill Fielding-Wells²

¹The University of Queensland, Australia; k.makar@uq.edu.au

²Australian Catholic University, Australia; jill.wells@acu.edu.au

The aim of this paper is to extend and adapt Yackel and Cobb's (JRME, 1996) identification of sociomathematical norms in mathematical inquiry to problems that are ill-structured. The background theory influenced the design and local theory development of the research. This paper uses excerpts from an upper primary classroom to address the ill-structured mathematical inquiry question, Which bubble gum is the best? Two norms are illustrated: (1) mathematising the ambiguity in an inquiry question, and (2) using the inquiry question to check progress towards a solution. Children demonstrated productive social norms and emergence of the sociomathematical inquiry norm of mathematising, but using the inquiry question was less prevalent. In both cases, children found it challenging to productively coordinate their everyday (relevant) and mathematical knowledge.

Keywords: Sociomathematical norms; mathematical inquiry; mathematising; knowledge building

Problem statement and literature

Yackel and Cobb (1996; Yackel, Cobb, & Wood, 1991) explicate social and sociomathematical norms as central to learning mathematics in a classroom that practices inquiry. Social norms consist of expectations within the learning community, such as actively listening to peers and explaining and justifying one's solution (Makar, Bakker, & Ben-Zvi, 2015). Sociomathematical norms are distinct from social norms to highlight an epistemic focus unique to mathematical activity (Kazemi & Stipek, 2001). Sociomathematical norms overlap with but do not coincide with Brousseau's didactic contract (Laborde & Perrin-Glorian, 2005). For example, social and sociomathematical norms tend to place more emphasis on the social environment than a didactic contract (Allan, 2017).

Yackel and Cobb (1996) illustrated sociomathematical norms through examples in a second-grade classroom in which a teacher and his students discussed possible solutions and solution methods of mathematical problems. Yackel and Cobb emphasised an inquiry approach (distinct from a traditional approach), which allowed and encouraged students to contribute their ideas to create a collective learning environment. In their paper, Yackel and Cobb point out a taken-as-shared perspective of mathematical difference (including novelty and efficiency) and what constituted an acceptable mathematical explanation (justification, argument). The examples in their paper were closed-ended and well-structured in that the questions were clearly stated and had a single correct answer.

Although much of school mathematics is focused on closed-ended problems, there is a further set of problems utilised in inquiry-based learning. These are open-ended in nature and/or contain ambiguities in the problem statement or method of solution (ill-structured). In ill-structured problems, the problem statement, purpose, or method of solution contains ambiguities that must be (re)negotiated (Reitman, 1965). Well-structured problems contain complete information, limit the

solution process to a set of known and organised principles and procedures, and knowable solutions, whereas ill-structured problems often require integration of knowledge (integrated, domain-specific and contextual), may require information beyond the problem, have multiple or no solutions or solution pathways, hold uncertainty around success criteria (determining if the problem has been solved), and require personal judgement and interpersonal negotiations (Jonassen, 2010). The importance of ill-structured problems has been highlighted in the literature as indicative of problems encountered outside of school, in everyday life and the professions (Jonassen, 2010; Yeo, 2017). For example, the question “How long does it take to get to the airport?” can be solved mathematically (as well as by experience or authority), but the answer may be dependent on the purpose (flying out or picking someone up, weighing the implications of being early or late, level of precision needed) and context (traffic, method of transport). In many applied problems, the initial question requires the solver to reformulate it into one that can be solved using a mathematical investigation (e.g., by clarifying ambiguities, being explicit about measures and assumptions, etc.). Research on ill-structured problems can be complex and highly context contingent. Tasks and solution pathways are less explicit, problem contexts and purposes often contain uncertainties or emergent constraints that may require responsive action, and success criteria can be implicit, subjective or absent.

This paper explores how Yackel and Cobb’s (1996) sociomathematical norms could be extended to the solution of ill-structured problems in which the ambiguities of the problem are negotiated and the solution depends on an argument based on mathematical evidence (Makar et al., 2015). The research question under investigation is, *What sociomathematical norms were evident in an inquiry-based classroom addressing an ill-structured mathematical problem?* To address our research question, the paper analysed a lesson to identify sociomathematical norms specifically related to mathematical inquiry of an ill-structured problem driven by the inquiry question, *Which bubble gum is the best?*

The authors’ interests are to develop research with close proximity to classroom practice in order to better understand and facilitate teaching and learning at the level of the classroom (Cobb & Yackel, 1996). We see theory as contributing to coherence across the diversity of mathematics education research by developing common languages and lenses to better share, build on, critique, improve and adapt research findings to practice. In this light, the contribution of this paper to TWG17 is three-fold: (1) re-emphasise the utility of Yackel and Cobb’s (1996) foundational theory on sociomathematical norms by re-working and extending the theory to broader and more contemporary notions of mathematical inquiry, thus facilitating its application to practice; (2) re-imagine sociomathematical norms to theoretically unite the diversity of research on mathematical inquiry; that is, the paper invites mathematics education researchers to build on Yackel and Cobb’s work to elaborate the practical and theoretical application of sociomathematical norms across a diverse set of contexts for learning mathematics; and (3) acknowledge and value the influence of researchers’ background theory on epistemological and methodological decisions and insights from research. Elaborating and unifying the concepts and language of sociomathematical norms can provide more coherent body of research in mathematics education to improve its application to classroom practice. Better alignment and explicit discussion of researchers’ epistemological lenses in relation to methodological decisions is essential to interpret, adapt and translate research findings across contexts.

Methodological approach

The study took knowledge building (Scardamalia & Bereiter, 2006) as its background theory, valuing how knowledge develops collectively through active discourse, the goal is idea improvement rather than “truth”, and understanding is emergent. The methodological focus therefore did not isolate actions of the teacher or individual students, but analysed collective activities in context.

Setting and data

The data come from a multi-age classroom (children aged 10-12 years) of about 25 students in a low socioeconomic community in semi-rural Australia. We drew on video data from a class that conducted a mathematical inquiry around the question, *Which bubble gum is the best?* Students identified valued and measurable characteristics of bubble gum, developed appropriate measures, collected data on 3-4 brands of bubble gum and used their data to determine the best bubble gum.

Classroom videos were retrospectively analysed using an approach adapted from Powell, Francisco and Maher (2003). To respond to the research question, sections of video logs from the lessons were highlighted that provided insights into sociomathematical norms specifically related to ill-structured problems. Videos of these sections were reviewed again to be more selective in relation to the purpose. For example, highlighting was removed if episodes illustrated only social norms. Remaining highlighted episodes were transcribed and annotated to elaborate potential sociomathematical norms. From these episodes, a storyline was constructed to make sense of annotations by seeking connections between the inquiry problem, interpretations of students and teacher’s actions, mathematical ideas that emerged and potential evidence of sociomathematical norms. This was a non-linear process supported by the background theory that often required returning to observe video, refine or rework interpretations, or enlarge or reduce contexts around episodes. Narrative was drafted to draw out local theory and further reflect on insights unique to each episode. In the process of writing, the selection of excerpts was narrowed to maximise insights and coherence in relation to the research question.

Classroom context

The teacher was experienced in teaching mathematics through inquiry after participating in research and professional development on mathematical inquiry by the first author for a number of years. The students were accustomed to working collaboratively, which was evident from the ease with which they worked with peers (freely generating and critiquing ideas, seeking approval from group before recording on a common page, keeping one another on task). Their collaborative social norms could be considered routine (Yackel et al., 1991), however their experience in solving ill-structured problems was limited. Therefore, the teacher was more explicit in co-constructing expectations with the class about acceptable activity when working in mathematical inquiry.

As argued in Yackel and Cobb (1996), an expectation within mathematical inquiry is for students to work towards autonomy. The teacher demonstrated this expectation in whole class discussions to have students generate ideas, with her explicitly privileging those that she wanted students to adopt as valued. Students worked collaboratively to devise and carry out a solution as the teacher rotated between groups to check and support their progress. She also paused the class regularly when she saw common issues to discuss as a whole class.

Illustrating norms of mathematical inquiry with ill-structured problems

We identified two sociomathematical inquiry norms in the lesson that specifically aimed to build student autonomy in solving ill-structured problems in mathematical inquiry. First, we illustrate the norm of mathematising the ambiguity in the inquiry question (*Which bubble gum is the best?*) so it could be investigated mathematically. Mathematising involves “translating a realistic problem into the symbolic mathematical world, and vice versa” (Jupri & Drijvers, 2015, p. 2483). Second, we illustrate the norm of using the inquiry question to drive and self-check progress. This second norm is different than mathematising. The use of the inquiry question during the solution process required students to shuttle back and forth between the real and the mathematical worlds, re-checking if their mathematical processes and evidence were still progressing the real world problem.

Mathematising

The teacher first oriented students towards mathematising the inquiry question. Her actions indicated that she was co-constructing the norm of mathematising as an expected activity in solving ill-structured inquiry problems, making explicit their obligations towards working autonomously. After introducing the inquiry question, the teacher led a whole class discussion to generate ideas to compare the brands of bubble gum. Students’ early suggestions were general, so the teacher pressed students to extend their ideas as a step towards productively mathematising by considering possible measures.

Oliver: Um, you could chew the bubble gum and then see which one is the best.

Teacher: So what would I be measuring, Oliver? [Oliver: Um, the taste, the texture.] Ok, so hang on a minute, there’s some good ideas! So I could measure the taste, texture. What do you mean by texture, Oliver?

Oliver: Uh, how it feels.

Teacher: Yes, ok. ... What else would I be measuring for bubble gum to be the best? Imagine you are a supermarket and you decide I can only stock one bubble gum. Which one will I stock? How will I know it’s the best?

The teacher set a possible purpose for students to come up with relevant criteria that could be investigated mathematically. Not all ideas were relevant, which may be an artefact that school mathematics often does not often trigger sense-making (Schoenfeld, 1991). For example, students suggested examining which gum was healthiest, comparing smell, packaging, size, market, weight, dimensions (length, width, height), ingredients. The teacher recorded their ideas, emphasising ideas that were relevant and measurable in her intonation (“Yeah! The smell!”) and queried, but did not discount others (“Market? What do you mean by market?”). Yackel and Cobb (1996) point to this as a way that teachers signify productive ideas without explicitly labelling ideas as “good” or “bad”.

After recording students’ ideas, the teacher supported them to mathematise the problem by coming up with ways of measuring valued qualities. Students had no experience with non-conventional measures, so their suggestions (size, graphs, columns, packets) reflected familiar mathematics or personal knowledge, but not coordination of relevant and mathematical. The teacher was patient and continued to ask for ways they might compare taste (relevance) until she found an idea that she could build on to mathematise comparison of taste.

Adele: Vote out of 10?

Teacher: Ah, so you'd do a survey? Oh, thank you! And you said a vote out of 10, so in actual fact that's giving them a rating. ... If I want to measure taste, I can't measure it with a ruler. ... (Draws a number line labeled 0 to 5) Where you would place the bubble gum if this [one] is the best and this [other one] is the worst? What number would you give it (the best one)?

Oliver: I would give it a 4 ½.

Teacher: 4 ½? So how would you show that on there, Oliver (points to the number line)? (Oliver gets up and points to the space between 4 and 5.)

The teacher used the opportunity to explicitly teach students about rating scales as a tool to mathematise the problem. She left the students' ideas on the board (both productive and less so) and reiterated the task to start them off in their collaborative groups. Allowing students to wrestle initially demonstrated that the teacher expected them to generate and develop ideas to mathematise the problem. She didn't leave them unsupported, however, and used skilled questioning to press their ideas to be relevant and produce mathematical evidence. A group wanting to weigh the bubble gum were asked, "Does it have to be the heaviest to be the best bubble gum? ... Which of those [ideas] is the most important, do you think?". She left them to decide whether to include weight. In other groups, she probed how they would record their measures and responded "Ooo! High five!" when a student suggested a table. She further probed, "Talk about what that table is going to look like, Jack. What it's going to have in it?" The guidance was moderated according to the progress of the group, but the expectation to work autonomously was consistent. For groups who struggled, the teacher spent more time pressing their thinking to deepen or refocus their ideas to make progress, then moved on.

Teacher: What are we measuring?

Charlotte: Taste.

Teacher: Rightio, what else?

Students: The smell. The width

Amelia: If you can smell it, you can see how strong it is.

Teacher: Ok, so you're going to smell how strong it is. ... How would you show me you are measuring smell? So how will I know out of your 4 pieces of bubble gum, which one smells the best? ...

Amelia: Well, we'll smell it first and then we'll write it down. [Teacher: What will you write down?] How, what we think, what, how strong it is in our opinion. ...

William: We'll put 1, 2, 3, 4, 5 on it.

Teacher: ... Draw it for me, William. ... What does 1, 2, 3, 4, 5 stand for?

In this example, the teacher pressed students to be specific so that they could operationalise their ideas through mathematising the problem. Later, the teacher was giving instructions to a teacher aide and was overheard by a student.

Teacher: [Are] they up to tasting?

Teacher Aide: Yeah. ... They've done a scale for smell. ...

Teacher: [Ask] what else can they do with it? They can blow bubbles and stuff like that and try and see if they can measure and how they would go about doing that as well.

Noah: You know you just gave us the answers! We can blow bubbles!

Noah's comment indicated that the teacher violated a classroom norm, that in mathematising the problem, students should generate their own criteria and measures for what makes bubble gum "best". Because norms are not visible, they are often only detected when a member of the community breaks the norm (Yackel & Cobb, 1996). Noah's comment assisted us to identify mathematising as an emergent norm of mathematical inquiry with ill-structured problems.

Focus on the inquiry question

Students' ideas were often too vague or not relevant to the question. Therefore, another norm the teacher worked to instil was the value of the inquiry question to help students locate relevant measures and keep them on track towards a solution. In the example below, she noted that students were falling into patterns of mathematical activity that neglected sense-making. She modelled using the inquiry question as a way for them to self-check sense-making as they worked.

Teacher: Ok, just stop for a moment. Eyes up here. ... (Talks about one group drawing a graph.) But if you are drawing a graph, you really need to think, "Well, what am I showing on the graph?" ... You have to come back to the question *Which bubble gum is the best?* With all of your results, at the end of the day, you have to come back to that question. ... You have to be able to tell me which one is the best and justify why our bubble gum is the best. ... By *saying* it's the best is not proving anything. Your results have to prove it. ... Jack's group is looking at a table of results and they're doing some graphing, other people are looking at scale ratings, fantastic idea! ... If you need scales, how many will you need? How many lines will you draw? How many tables will I need? You need to look at what you are measuring, how I will record that information?

The teacher maintained an expectation of autonomy in using the inquiry question to check progress. She often stopped at groups, checked one element and moved on, indicating an expectation that students work autonomously. One group was weighing bubble gum when the teacher arrived.

Teacher: Ok, so if you are going to tell me that that bubble gum is the heaviest, does that mean it's the best?

Sam: No, I think that Hubba Bubba (brand of bubble gum), because it—

Teacher: So what is the point of telling me that that bubble gum is the heaviest if it doesn't tell me which one is the best? Because my question is *Which bubble gum is the best?*

Sam: Well, it's more popular—

Teacher: ... I'm understanding what you're saying, but I'm just concerned that the testing you're doing is not going to show me anything. At the end of the day, your testing has to show me which bubble gum is the best.

Delia: Hubba Bubba because it's got the strongest smell, it's more popular and more people would buy it.

Teacher: So was there any point in weighing it? ... Do we need to know which one is heavier when we want to know which one is the best?

The teacher continued to press students on connecting their activity to sense-making (Kazemi & Stipek, 2001) through the inquiry question. Sam and Delia's additional contributions (Hubba Bubba is more popular) connected their everyday knowledge to the inquiry question, but not to evidence the group had collected (weight). Using the inquiry question to guide their investigation was more abstract than mathematising in that students needed to step back and reflect on a larger purpose of the activity. We did not see evidence of students self-monitoring their progress with the inquiry question in this lesson and suspect it would take much more time to develop into a norm than mathematising.

Discussion

In this paper, we addressed the research question, *What sociomathematical norms were evident in an inquiry-based classroom addressing an ill-structured mathematical problem?* We considered mathematical inquiry in solving ill-structured problems using mathematical evidence (Makar et al., 2015). Two sociomathematical inquiry norms were illustrated during a lesson in which students addressed the mathematical inquiry question, *Which bubble gum is the best?*

- Ill-structured inquiry questions need to be mathematised through relevant and mathematical measures in order to be solved.
- The inquiry question is used to guide and check progress and mathematical evidence towards a solution.

These two were considered sociomathematical inquiry norms because they are central to mathematical inquiry in that (1) the question contains ambiguities that require negotiation in order to mathematise it into an operational investigation, and (2) a mathematical inquiry is driven by an inquiry question and its solution and evidence must respond to the inquiry question. Acknowledging these as useful norms to develop in an inquiry classroom can assist teachers in initiating, maintaining and extending student autonomy when addressing ill-structured inquiry problems in mathematics.

Theory adds coherence to a field by developing common language and lenses through which to gain insights and improve practice while acknowledging that researchers' background theory affects what is researched and how. Yackel and Cobb's (1996) research on sociomathematical norms has had a significant effect in progressing the mathematical reform agenda. Their work identified sociomathematical norms to ensure that teaching both improved social practices and focused on mathematics (Kazemi & Stipek, 2001). Given the nature of distinctive types of mathematical tasks (Yeo, 2017) and efforts to extend students' mathematical experiences to more open-ended problems, it would be useful for the field to extend the types of sociomathematical norms that would be useful in different forms of mathematical activity. We hope this paper makes some progress on this mission.

Acknowledgment

The authors acknowledge funding from the Australian Research Council (LP0990184; DP170101993) and thank the teacher and students for their contributions.

References

- Allan, D. E. (2017). *Student actions as a window into goals and motives in the secondary mathematics classroom*. Unpublished doctoral dissertation, Faculty of Education, Simon Fraser University.
- Cobb, P., & Yackel, E. (1996). Constructivist, emergent, and sociocultural perspectives in the context of developmental research. *Educational Psychologist, 31*(3–4), 175–190.
- Jonassen, D. H. (2010). *Learning to solve problems: A handbook for designing problem-solving learning environments*. New York: Routledge.
- Jupri, A., & Drijvers, P. H. M. (2016). Student difficulties in mathematizing word problems in algebra. *Eurasia Journal of Mathematics, Science and Technology Education, 12*(9), 2481–2502.
- Kazemi, E., & Stipek, D. (2001). Promoting conceptual thinking in four upper-elementary mathematics classrooms. *The Elementary School Journal, 102*(1), 59–80.
- Laborde, C., & Perrin-Glorian, M.-J. (2005). Teaching situations as object of research: Empirical studies within theoretical perspectives. *Educational Studies in Mathematics, 59*, 1–12.
- Makar, K., Bakker, A., & Ben-Zvi, D. (2015). Scaffolding norms of argumentation-based inquiry in a primary mathematics classroom. *ZDM, 47*(7), 1107–1120.
- Powell, A. B., Francisco, J. M., & Maher, C. A. (2003). An analytical model for studying the development of learners' mathematical ideas and reasoning using videotape data, *The Journal of Mathematical Behavior, 35*, 405–435.
- Reitman, W. (1965). *Cognition and thought: An information processing approach*. New York: Wiley.
- Scardamalia, M., & Bereiter, C. (2006). Knowledge building: Theory, pedagogy, and technology. In K. Sawyer (Ed.), *Cambridge handbook of the learning sciences* (pp. 97–118). New York: Cambridge University Press.
- Schoenfeld, A. H. (1991). On mathematics as sense-making: an informal attack on the unfortunate divorce of formal and informal mathematics. In J. F. Voss, D. N. Perkins, and J. W. Segal (Eds.), *Informal reasoning and education* (pp. 311–343). Hillsdale, NJ: Lawrence Erlbaum.
- Yackel, E., & Cobb, P. (1996). Sociomathematical norms, argumentation, and autonomy in mathematics. *Journal for Research in Mathematics Education, 27*(4), 458–477.
- Yackel, E., Cobb, P., & Wood, T. (1991). Small-group interactions as a source of learning opportunities in second-grade mathematics. *Journal for Research in Mathematics Education, 22*(5), 390–408.
- Yeo, J. B. (2017). Development of a framework to characterise the openness of mathematical tasks. *International Journal of Science and Mathematics Education, 15*(1), 175–191.

Understanding powers–individual concepts and common misconceptions

Christos Itsios¹ and Bärbel Barzel²

¹University of Duisburg-Essen, Germany; christos.itsios@uni-due.de

²University of Duisburg-Essen, Germany; baerbel.barzel@uni-due.de

The topic of powers and exponents is generally considered one major obstacle for learners in schools and universities. Our main goal is to answer the question: How can we bridge the gap between individual conceptions in students' minds and the relevant mental models (Grundvorstellungen) to conceptualize powers? With reference to this learning object, two tasks from our test instrument and initial results are presented, which are part of our diagnostic tool to enable the uncovering of students' individual images and misconceptions in the area of powers, by means of comparing the prescriptive with the descriptive level of relevant mental models.

Keywords: Grundvorstellung, conceptual change, understanding, mental models, powers.

Introduction

Even though the subject of power expressions and its modern exponential notation has been dealt with for a long time (Euler, 1770), it seems that students of all ages still face difficulties when confronted with them, as well as with exponentiation in general. That has been documented over the years, mainly in school settings (e.g. Confrey & Smith, 1994; Pitta-Pantazi et al., 2007; Avcu, 2010). The key issue seems to be the lack of understanding of basic rules and algorithms used to manipulate powers. To guard against such occurrences, there is a need for a *conceptual change* in students' minds (vom Hofe & Blum, 2016, p. 237), in order to gain a deeper understanding on the conceptual level. Hahn and Prediger (2008) have proposed that opportunities for conceptual change should even precede the introduction of rules on the procedural level, or as Sfard (1995) puts it: "Operational thinking must be replaced by structural"¹. This proposition considers the distinction of knowledge into *conceptual* and *procedural* knowledge (Hiebert & Lefevre, 1986). Taking the above into consideration, we pose a twofold question: Which mental models (*Grundvorstellungen*, vom Hofe & Blum, 2016) should students form for a confident and flexible manipulation of power expressions, and which individual models do they have? To answer this, we first concern ourselves with the identification of adequate mental models through a subject matter analysis and an expert survey. On the basis thereof, we carry out a design research study, where we go from a first pilot study to developing test items, over to a number of three cycles, to aid us in achieving a final version of our diagnosis instrument. Our goal is to find out what students' individual mental models are and whether they are consistent with the desirable normative models. In the present article, after setting the theoretical background, we will provide some insights into our methodology and evaluate the potential explanatory power on a small item sample of the test instrument.

¹ An extended discussion of this can be found in Long (2005, pp. 62f).

Theoretical Background

In this section we will present the theoretical approaches used in the study to operationalize understanding. First, an outline of the construct of mental models or *Grundvorstellungen* (vom Hofe & Blum, 2016) together with related terminology used in international literature will be given. Furthermore, the various transformations between representations will be displayed, since they play an essential role for successfully dealing with mathematical concepts. This sets the basis for the generation of the items used in the test instrument.

The concept of Grundvorstellungen (GVs)

Particularly when modeling with the help of mathematics, one needs to activate the suitable GV(s) to translate between the “real word” and the “world of mathematics”, which in turn—when successfully performed—means, that the topic has been understood (Bossé, Adu-Gyamfi, & Cheetham, 2011, p. 117). The concept of *Grundvorstellungen*, or *mental models*, has a long tradition in German subject-matter didactics. It is used to describe the connection between mathematics and reality on a conceptual level (vom Hofe & Blum, 2016). Three aspects of GVs can be distinguished. The *normative aspect* constitutes the basic idea of the concept; it is to be understood prescriptively as the desired status to be reached when understanding a concept. The *descriptive aspect* characterizes the individual perceptions and notions of learners; it is, therefore, a representation of the students’ conceptualization. Finally, the *constructive aspect* compares the normative and the descriptive aspect to provide some insight concerning students’ difficulties of understanding, as well as offer solutions for overcoming misconceptions (Hefendehl-Hebeker et al., 2019).

Considering that the concept has also been referred to as a theory, our view is the one offered by Radford, who mentions: “... Mogens Niss (1999) contends that a theory in math education has two goals. First, it entails a descriptive purpose, aimed at increasing understanding of the phenomena studied. Second, it has a normative purpose, aimed at developing instructional design.” (Radford, 2012, p. 4). Moreover, Hefendehl-Hebeker et al. (2019) add: “... the approach of the GV concept combines normative and descriptive methods with a constructive aim. In this sense, analyses of students’ work based on the GV concept typically do not remain at the descriptive level but lead to indications of a constructive ‘repairing’ of the analyzed problems.” (p. 35).

To differentiate and clarify the concept from internationally used terms we should mention the theoretical proximity of GVs to *concept image* and *concept definition* (Tall & Vinner, 1981). Although both approaches refer to understanding of mathematics using Piaget’s cognitive psychology (vom Hofe 1998) and constructivism (Hahn & Prediger 2008) as background theories, GVs are mostly understood in their normative level, as a didactic category for teachers to make explicit which mental models are appropriate for understanding the specific mathematical concept or operation. To differ clearly between the normative mental models according to the mathematical concept and the descriptive mental models in students’ minds, some authors replace the descriptive aspect with the term *individual mental models* (e.g. Prediger 2008). Vom Hofe (1998) uses the term *basic model* as a prescriptive notion and *individual image* as a descriptive notion, explaining his integrative view as a “holistic view of mathematical thinking and doing,” offering “methodical and

theoretical possibilities for combining normative didactic conceptions with descriptive and interpretive working methods” (p. 326).

Furthermore, Soto-Andrade and Reyes-Santander (2011) compare Grundvorstellungen with Lakoff & Nunez’s (2000) *conceptual metaphors*. The similarity of both is constituted by a similar mechanism of transmission: Real experience is the source domain allowing for concept formation, the goal is to provide abstract concepts with meaning. However, they differ in the aspect of their implementation in practice and in that through GVs, preexisting mathematical concepts are represented, rather than constructed. In this paper we will use the terms *normative* and *descriptive aspect* of GVs to mean *mental models* for the former and *individual models* for the latter, as used in Prediger (2008), according to Fischbein’s definition of a mental model as a “meaningful interpretation of a phenomenon or a concept” (Fischbein, 1989, p. 12). Following the conceptual change theory, we will refer to the descriptive aspect in a competence-oriented meaning, rather than adhere to a deficit-oriented analysis. The formation of GVs is the key element of concept formation, thus, also entails conceptual change (Kleine, Jordan, & Harvey, 2005).

Grundvorstellungen of Powers

From the normative point of view, there are four aspects that can be extracted and considered as mental models for powers with natural numbers as both the base and the exponent. Following a literature review², a subject matter analysis and an expert survey our preliminary results were presented in a first draft (Itsios & Barzel, 2018). After further expert talks, the identified mental models were redrafted and rephrased. These are:

- (GV1) *Repeated Multiplication (RM)*: this mental model can appear in two different ways—a more dynamic one (RM-d), describing a temporal-successive process where new objects emerge, e.g. the repeated doubling of a number of bacteria per hour, and a more static one (RM-s), focusing on the end result of a repeated action, as a whole or an object, describing the end result of a repeated action, e.g. a binary tree.
- (GV2) *Combinatory Conception (CC)*: this refers to the number of possible permutations with repetition (number of n-tuples), e.g. there are 10^5 possible combinations for a lock with five cylinders, each using a digit from 0 to 9.
- (GV3) *Stretching by the same factor (SF)*: this represents a magnification without the emergence of new objects, e.g. 5^2 can mean zooming into an image twice with a five-fold magnification.

Transformations among Different Representations

When learning a mathematical concept, students should engage in three actions as proposed by Lesh, Post and Behr (1987): *recognition* of the concept in multiple representations, flexible *manipulation* within these representations and *translation* between different representations. A

² Although we do not adopt the theoretical framework of combining embodied mathematics with conceptual metaphors, we acknowledge the work done in Mowat (2010), as this offers a database of mathematics teachers’ concept images on exponentiation.

stable use of multiple representational systems can be a guarantee for an easier development of concepts in mathematics and demonstrating mathematical understanding can mean being competent in the manipulation of these systems. These systems can vary from equations, graphs and tables to diagrams, charts or even verbal and written forms (Goldin, 2002, p. 197; Pape & Tchoshanov, 2001, p. 120). There is even a stipulation in the specific content of powers, that conceptual connections between representations is a prerequisite for deeper understanding of concepts (Nataraj & Thomas, 2012, p. 557). These transformations among representations set the basis for the design of our test instrument, which will be introduced in the next section.

Design and Methodology

A first draft of the test instrument was designed using 20 items in total, including three open-ended questions and 17 calculation tasks. For the construction of the items, the aforementioned GVs, as well as most appropriate transformations among representations were taken into consideration, to make the test as comprehensive as possible. This was then tested with a sample of 117 subjects (87 civil and mechanical engineering and 30 university mathematics students) and after a first assessment all responses were categorized according to the frequency of their occurrence. Then, together with the right answer, the three most frequent wrong answers were used as possible choices for each item. The final version comprises the initial three open-ended questions, one calculation task and 16 single-choice items. Following a baseline diagnosis, a total of 176 Grade 10 students from two different schools³ were tested in the main study, with the purpose of determining individual conceptions as well as to detect which GVs can be activated. For the purposes of this article we will present two items regarding the transformations from symbolic to graphical, as well as from symbolic to verbal.

Item Sample

Figure 1 shows two of the three open-ended questions (items A2 and A3), in which the diagnostic potential of individual mental models becomes evident. With them, we can explore the ideas that are prevalent in learners' minds about their conceptual understanding of power expressions and their connection to everyday life situations.

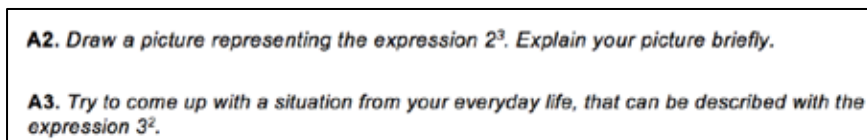


Figure 1: Test items A2 and A3

Item A2 requires the translation from symbolic to graphical and we expect that mainly Grundvorstellung RM-s will be activated. By requiring a brief explanation, we add a second transformation that students must perform, namely graphical to verbal. Since practically none of the test subjects' answers includes an explanation, we will consider item A2 to address only the transformation symbolic to graphical. Item A3 requires the translation from symbolic to verbal and

³ One comprehensive school (Gesamtschule) and one secondary school (Realschule).

the Grundvorstellungen RM-d, CC and SF are expected to be activated. In case RM-s is activated, the translation should still be considered to be under symbolic to verbal, not symbolic to graphical, since the task requires a verbalization of the situation, regardless of the fact that the given situation could describe a spatial arrangement.

Some results

Our assumption concerning the results is the following: if an appropriate GV is activated, then there will be a plausible answer given. We make no claims to the opposite, namely, if no reasonable answer is given, as to whether the corresponding GV is present in the student's mind or not. We analyzed the data by categorizing each response to a corresponding pattern, within a small expert group to ensure interrater agreement. In Table 1, the results to item A2 are presented together with the respective response frequencies and in each case an example is given, followed by the relevant GV that most likely could be supported due to the proximity to an individual model. Only a total of 51 Grade 10 students answered this question, including isolated cases with answers that are not hereby listed, because we could not diagnose the structure of those responses. In these drawings we often encountered indications of repeated multiplication (RM), with correct answers as well as misconceptions. 16 answers corresponded to a more static view (RM-s, 1st row), where 2^3 is misunderstood as multiplication, presented in a spatial-simultaneous arrangement. We also saw substantial dynamic versions, for example a sequence (2nd row), which we see either as figured numbers or just as cardinality of the relevant numbers. We also attributed RM-d, when the variables were given as symbols, where we can say that the calculation is perceived correctly, but without any hints as to whether the meaning can be properly elaborated (3rd row).

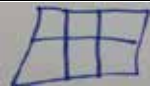


Response pattern	N	Example	GV
Type of calculation misconception (multiplication)	16		RM-s
Cardinal numbers as symbolic sequence	7		RM-d
Repeated multiplication with symbolic variables	7		RM-d

Table 1: Results and response frequencies to test item A2

What can be extracted from these results is that learners have not yet adequately shown that they can activate and use the necessary GVs to deal with the given task. However, their individual models, albeit not wrong, remain confined within the world of mathematics and symbols, rather than extending to real-life applications. Table 2 shows the answers given to test item A3, with a total of 46 Grade 10 students answering this question. Some isolated cases have not been listed under the response patterns, showing—again—no structure or diagnostic value. The last column shows, as previously in Table 1, the GV that in our opinion has to be activated, in order for the initial presented idea to make sense in the context of the given power expression.

Here we encountered cases where 3^2 is misunderstood as multiplication, presented in a temporal-successive way (1st row). The most common given response that can be considered feasible is shown in the 2nd row, where the power expression is viewed as a 3-by-3 spatial-simultaneous arrangement. Very few students (3) tried to present a situation, such that the Combinatory Conception could be identified, but failed to present it accurately (3rd row).

Response pattern	N	Example	GV
Type of calculation misconception (multiplication)	17	I am ill. I have to take pills. Two in the morning, two at noon and two in the evening.	<i>RM-d</i>
Area	7	I want to find out the area of a square-shaped room to lay a new carpet. Each side of the room has a length of 3m. I calculate $3^2 = 9$, then I know that I need a 9m^2 carpet.	<i>RM-s</i>
Combinatorics	3	I own 3 dresses, 3 handbags and 3 pairs of shoes that I can combine.	<i>CC</i>

Table 2: Results and response frequencies to test item A3

Looking at the first row of Table 2, we can identify a misconception that could be used as an opportunity for supporting learning. Further support, e.g. interviews, could be structured in a way that students are asked to compare the result of 3^2 with their own result (six), leading to a cognitive dissonance. This, in turn, could be the starting point of a conceptual change within their individual images to fit into the normatively set mental models.

Discussion

In all presented cases, we can observe that multiplicative thinking is predominant, with more than 50% of given answers showing that the two variables in question are combined in a multiplicative fashion, mostly assuming commutativity⁴. That can be seen in the first example of Table 2, where the numbers 2 and 3 of the expression are combined in a way that results in a multiplication context. After categorizing the response patterns for items A2 and A3 we identify the main problem to be a fixation on previous arithmetic operations of a lower level (multiplication). This problem encompasses depicting a number raised to the third power (see Table 1, first example given) as an array or a two-dimensional area, rather than a three-dimensional object, for example a cube.

Looking at the results of items A2 and A3 we can assume, that the main problem overall is a misconception of the mathematical object of exponents and powers. Confusing multiplication with exponentiation seems to be a principal reason for the demonstrated findings. A possible explanation for these findings is the lack of context variety offered to students when introducing the concept,

⁴ Responses to item A3 included both cases, where 2 and 3 were the multiplier and the multiplicand, respectively, and vice versa.

leading to a false notion of what exponentiation is and when it can be applied, even if plain calculation tasks can be performed faultlessly.

Regarding this TWG, our contribution is twofold. First, by expanding the range of Grundvorstellungen to include the normative GVs for powers, as mentioned above. Second, with our example we have shown how the concept of GVs can help to bridge the gap between individual models in students' minds and the relevant mental models which are necessary for the specific conceptualization. The method of connecting and comparing preexisting ideas and misconceptions with the normative level of GVs shows promising prospects to adequately describe our results, potentially leading to an accurate diagnosis and treatment of these misconceptions.

References

- Avcu, R. (2010). Eight graders' capabilities in exponents: making mental comparisons. *Practice and Theory in System of Education*, 5(1), 39–48.
- Bossé, M. J., Adu-Gyamfi, K., & Cheetham, M. R. (2011). Assessing the difficulty of mathematical translations: Synthesizing the literature and novel findings. *International Electronic Journal of Mathematics Education*, 6(3), 113–133.
- Confrey, J., & Smith, E. (1994). Exponential functions, rates of change, and the multiplicative unit. *Learning Mathematics* (pp. 31–60). Springer, Dordrecht.
- Euler, L. (1770). *Vollständige Anleitung zur Algebra*. St. Petersburg. Retrieved May 18, 2018, from http://www.deutschestextarchiv.de/euler_algebra02_1770.
- Fischbein, E. (1989). Tacit models and mathematical reasoning. *For the learning of mathematics*, 9(2), 9–14.
- Goldin, G. A. (2002). Representation in mathematical learning and problem solving. In L. D. English (Ed.), *Handbook of international research in mathematics education* (pp. 196–218). Mahwah: Erlbaum.
- Hahn, S., & Prediger, S. (2008). Bestand und Änderung—Ein Beitrag zur Didaktischen Rekonstruktion der Analysis. *Journal für Mathematik-Didaktik*, 29(3–4), 163–198.
- Hefendehl-Hebeker, L., vom Hofe, R., Büchter, A., Humenberger, H., Schulz, A., & Wartha, S. (2019). Subject-Matter Didactics. In H. N. Jahnke & L. Hefendehl-Hebeker (Eds.), *Traditions in German-Speaking Mathematics Education Research* (pp. 25–59). Springer, Cham.
- Hiebert, J., & Lefevre, P. (1986). Conceptual and procedural knowledge in mathematics: An introductory analysis. *Conceptual and Procedural Knowledge: The Case of Mathematics 2*, 1–27.
- Itsios, C. & Barzel, B. (2018). Potenzen und Potenzrechnung—eine Herausforderung. In Fachgruppe Didaktik der Mathematik der Universität Paderborn (Ed.), *Beiträge zum Mathematikunterricht 2018* (Vol. 2, pp. 867–870). Münster: WTM-Verlag.

- Kleine, M., Jordan, A. & Harvey, E. (2005). With a focus on 'Grundvorstellungen'. Part 1: theoretical integration into current concepts. *Zentralblatt für Didaktik der Mathematik*, 37(3), 226–233.
- Lakoff, G., & Núñez, R. E. (2000). Where mathematics comes from: How the embodied mind brings mathematics into being. *AMC*, 10(12), 720–733.
- Lesh, R., Post, T. R., & Behr, M. (1987). Representations and translations among representations in mathematics learning and problem solving. In C. Janvier (Ed.), *Problems of representations in the teaching and learning of mathematics* (pp. 33–40). Hillsdale, NJ: Lawrence Erlbaum.
- Long, C. (2005). Maths concepts in teaching: Procedural and conceptual knowledge. *Pythagoras*, 2005(62), 59–65.
- Nataraj, M. S., & Thomas, M. O. (2012). Student understanding of large numbers and powers: The effect of incorporating historical ideas. In J. Dindyal, L. P. Cheng, & S. F. Ng (Eds.), *Mathematics education: Expanding horizons. Proceedings of the 35th annual conference of the Mathematics Education Research Group of Australasia* (pp. 556–563). Singapore: MERGA.
- Niss, M. (1999). Aspects of the nature and state of research in mathematics education. *Educational studies in mathematics*, 40(1), 1–24.
- Pape, S. J., & Tchoshanov, M. A. (2001). The role of representation(s) in developing mathematical understanding. *Theory into practice*, 40(2), 118–127.
- Pitta-Pantazi, D., Christou, C., & Zachariades, T. (2007). Secondary school students' levels of understanding in computing exponents. *The Journal of Mathematical Behavior*, 26(4), 301–311.
- Prediger, S. (2008). The relevance of didactic categories for analysing obstacles in conceptual change: Revisiting the case of multiplication of fractions. *Learning and instruction*, 18(1), 3–17.
- Radford, L. (2012). *On the growth and transformation of mathematics education theories*. Paper presented at the International Colloquium: The Didactics of Mathematics: Approaches and Issues. A homage to Michèle Artigue. Retrieved June 18, 2018 from <http://www.luisradford.ca/pub>.
- Sfard, A. (1995). The development of algebra: Confronting historical and psychological perspectives. *The Journal of Mathematical Behavior*, 14(1), 15–39.
- Soto-Andrade, J., & Reyes-Santander, P. (2011). Conceptual metaphors and “grundvorstellungen”: a case of convergence? In M. Pytlak, T. Rowland, & E. Swoboda (Eds.), *Proceedings of CERME7* (pp. 1625-1632). Rzeszów, Poland: University of Rzeszów.
- Tall, D. & Vinner, S. (1981). Concept image and concept definition in mathematics with particular reference to limits and continuity. *Educational Studies in Mathematics*, 12(2), 151–169.
- Vom Hofe, R., & Blum, W. (2016). “Grundvorstellungen” as a Category of Subject-Matter Didactics. *Journal für Mathematik-Didaktik*, 37(1), 225–254.

Questioning the paradidactic ecology: internationally shared constraints on lesson study?

Koji Otaki¹, Yukiko Asami-Johansson^{2, 3} and Jacob Bahn³

¹Hokkaido University of Education, Japan; otaki.koji@k.hokkyodai.ac.jp

²University of Gävle, Sweden; yuoasn@hig.se

³University of Copenhagen, Denmark; jacob.bahn@ind.ku.dk

This paper aims to propose a methodological tool for comprehensively studying variables on teachers' design and analysis of their own lessons. Our theoretical base is the anthropological theory of the didactic, especially the notion of para-didactic system and the scale of levels of didactic co-determinacy. Fusing these constructs, we create a new ecological scale of factors on teachers' didactic activities outside didactic situations, which makes us more sensitive to the ecology and economy of teachers' working. The functionality of the model is put to the test by an ecological analysis of data from an international lesson study situation where an archetypal phenomenon appears—teachers' excessive concern with either microscopic mathematical topics or general teaching methods. Our analysis of conditions on this phenomenon with the new tool identifies two constraints on lesson study in relation to teachers' professional terminology and authority.

Keywords: ATD, ecological analysis, noosphere, profession, para-didactic system

Introduction

The Japanese *lesson study* as an approach for improving the quality of lessons has attracted great interest as a promising opportunity for developing of the scholarship for the teaching. There are many challenges for transplanting lesson study worldwide outside Japan. Winsløw, Bahn & Rasmussen (2018) categorised two different directions of the research about lesson study: *descriptive* and *intervention*. The descriptive research investigates lesson study itself as a research object and the intervention research use it as a method for the professional development. Our approach in this paper is located in the descriptive direction. Lesson study is a complex and contingent entity, since it is originated from teachers' spontaneous effort, which deeply affected by the Japanese society and its schooling culture. Consequently, the development of theoretical and methodological tools for describing lesson study has been challenged within the research community. Our aim in this paper is to provide an additional contribution to this endeavour.

In this study, we try to expand the analytic range of lesson study research within the ATD, i.e. the *anthropological theory of the didactic* (cf. Chevallard, 2019), which was created and developed by Yves Chevallard and his colleagues over the last 40 years (if we count from the birthyear of the *didactic transposition theory*, which is the origin of ATD). ATD is well established in both French and Spanish speaking communities and is still actively developing around the world. A feature of ATD is the *ecological* way of problematising didactic reality, that is, the habit of questioning *conditions* and *constraints* of all kinds and origins. This reality is related to any *didactic fact* of all types regarding the diffusion of knowledge, e.g., explaining a proof of the Pythagorean theorem in a classroom, writing a mathematics textbook for elementary school students, and so on and so forth.

The ecological questioning in didactics is crucial for both the understanding of the didactic world and the intervening to it. It is because any specific teaching activity is definitely determined not only by student, teacher, and content at stake, but also by institutional, cultural, and historical variables. However, in our view, the ecological approach has not fully percolated through a relatively new research field of ATD: the *paradidactic field*. The adjective *paradidactic* was introduced into didactics by Winsløw (2011)—with a special focus on lesson study—for studying teachers’ didactic activities outside didactic situations: the planning and reflecting upon their lessons. In the *paradidactic field*, the *ecological analysis* is usually conducted by the notion of *paradidactic infrastructure* (ibid.), which is an application of the notion of *didactic infrastructure*. Within ATD, the noun *infrastructure* means the fundamental construction to make a certain human activity function—their nature, size, and materiality do not matter—e.g., the infrastructure of camping activity consists of a tent, cooking equipment, firewood, a camping car, a camping site, etc. Regarding teachers’ activities, lesson study is based on a *paradidactic infrastructure*, that is, a structured set of basic conditions for *paradidactic activities*, e.g., the *open lesson*—which is an opportunity for many teachers to observe a same lesson and discuss it—conditioned by a time table, an equipment of the school where the event is held, a theme of the conference, organisers and advisers in the discussion, the lesson itself, and so on (cf. Miyakawa & Winsløw, 2013). Indeed, the notion of *paradidactic infrastructure* allows us to study the ecology of *paradidactic activities*. However, this notion does not amply enlarge and indicate our scope of ecological analysis in the *paradidactic field*. In other words, following kinds of methodological questions cannot be answered clearly: what kinds of conditions have to be investigated in the analysis for understanding and explaining *paradidactic phenomena*? To what extent do we need to look for *paradidactic conditions*? Which conditions are uncontrollable for teachers? Which connections are there between different *paradidactic conditions*? In this paper, we will propose a new methodological tool for the ecological approach, adapting a well-known hierarchical model of types of conditions—the *scale of levels of didactic co-determinacy*—to the *paradidactic field*.

A methodological tool for questioning the ecology of the paradidactic

In this section, we would develop a methodological tool for analysing the ecology of lesson study. However, at first, let us tell beforehand for readability that our analysis consists of two phases. The first one is the *economic* (or classically didactic) phase which means the analysis of the dynamics of target systems, e.g., a lesson. In the *economic phase*, we will clarify some properties of teachers’ foci or interests in the lesson study, by using the original scale of levels of *didactic co-determinacy* (Fig. 1). Next, at the second phase—called the *ecological*—we will identify some constraints on the lesson study, by using our new model—the scale of levels of *paradidactic determinacy* (Fig. 2).

The scale of levels of didactic co-determinacy: an *economic* tool for paradidactic research

One of the main purposes of didactics is to investigate the ecology of *didactic systems*. Any didactic system is made of a group of students, one or more teachers, and a *didactic stake*, i.e., something to be learnt by the students. In didactic systems of mathematics, student’s mathematical activities are affected by the teacher’s didactic activities, and vice versa. Such dynamics of didactic systems are called the didactic co-determination, which works under conditions of different kinds and origins.

The *scale of levels of didactic co-determinacy* is a model of hierarchy of genres of such conditions on the functioning of the didactic system (Fig. 1). The level of *didactic system* is divided into five sub-levels depending on degrees of taxonomical generality of didactic stakes—*discipline*, *domain*, *sector*, *theme*, and *subject*. The level of *pedagogy* includes every condition about teaching methods, ideas, and approaches which are independent of the nature of each disciplinary field. Subsequently, a didactic system with a pedagogy functions within a *school* system, which in turn depends on a set of characteristics of a given *society*, *civilisation*, and ultimately *humankind*.

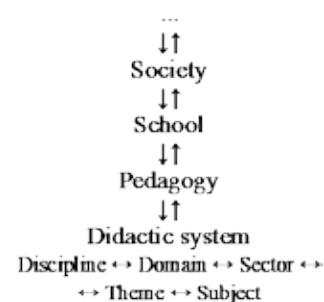


Figure 1:
Didactic ecological scale

In any didactic system, the role of teachers is to make students study a certain didactic stake. This is a fundamental type of works of the teacher. However, there exists another important sort of activities of teachers outside didactic systems. It is to design, observe, and reflect upon didactic systems themselves. The role of such kinds is played in “institutional systems about didactic systems” which is called *paradidactic systems*. In the studying of such systems, we can use the didactic scale (Fig. 1) in the economic way—e.g., the assorting of teachers’ foci—rather than the ecological way. In other words, it cannot work well as a tool for investigating conditions on paradidactic systems. Then, we need some new model for the paradidactic ecological analysis.

The scale of levels of paradidactic determinacy: an *ecological* tool for paradidactic research

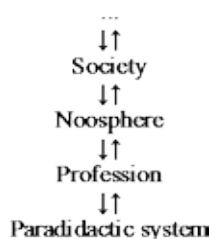


Figure 2: Paradidactic ecological scale

Let us describe here any paradidactic system by a nested system—an institutional system containing *its participants* and *a didactic system as its object of study* which we call a *paradidactic stake*. Then, similar to the case of didactic systems, we can think of a determinative mechanism inherent in paradidactic systems. Since the didactic system and the paradidactic system live in different types of institutional environments, let us propose a new hierarchical model of levels of conditions and constraints for studying the ecology of paradidactic systems (Fig. 2).

The paradidactic determination acts on different groups of conditions starting from the first level of *paradidactic system*. Principal conditions at this level mean properties of each item of the paradidactic system. In addition, as portions of conditions at the paradidactic system level, let us indicate the set of local clauses of paradidactic systems as what we name the *paradidactic contract*—*implicit* rules, e.g., avoiding negative comments about students’ abilities or attributing every failure in the lesson to the teacher’s didactic acts—applying the notion of *didactic contract* in the theory of didactic situations led by Guy Brousseau. The second level is the *paradidactic profession*—about the notion of *profession*, see also Chevallard (1992a)—professions more or less *acting* paradidactic activities. In this paper, we would focus on the profession of *teacher*, but there exist other kinds of professions which could be involved in different paradidactic systems: governmental official, teacher educator, mathematician, and so on. The third level is the *didactic noosphere*. Roughly speaking, the noosphere is the institution related to designing and evaluating school systems in some way (cf. Chevallard, 1992a, b). Noospheres are usually fuzzy and

heterogeneous institutions which consist of *professionals* within professions of different kinds. Simply illustrating, a meeting responsible for developing a national mathematics curriculum could be an epitome or miniature of the noosphere. In any noosphere, an institutional worldview consisting of visions of different types—e.g., transformative, pedagogical, ethical—implicitly integrates professionals of different kinds—politician, teacher, mathematician, and so on—into a noosphere. Higher levels than the *society* are similar to the original didactic scale.

An economic analysis: The case study of an international lesson study

Context of the open lesson

The demonstration lesson and the post lesson reflection—of which the open lesson consists—under investigation in this article was part of a one-day conference at an ordinary public school, situated to the North of Copenhagen, Denmark. The content of the conference included two open lessons and a number of 30 minutes workshops on the function and usage of specific teaching materials. Conducting open lessons is not an ordinary practice in Denmark, but in the image of Japanese lesson study conferences (*jogyō kenkyū kai*), teachers and school leaders from several primary and secondary schools in and outside the municipality, municipality officials, teacher educators, researchers etc. observed and discussed the teaching of ordinary classes. While the classes were ordinary, the situation was extraordinary for the participants, though the class being taught in the open lesson under scrutiny here had tried a similar situation once before: one year earlier, Hiroshi Tanaka of the Attached School of the University of Tsukuba taught that same class in the first open lesson. A large number of the participating observers had joined the (single) open lesson of the first Danish *jogyō kenkyū kai*. The open lesson includes three different languages (Japanese, Danish and English) with several types of translations. During the demonstration lesson, the Japanese teacher used mainly Japanese and the third author mediated between the teacher and the Danish students. The post lesson reflection session was conducted in both English and Japanese, where the second and third authors interpreted every Japanese comment and question into English and vice versa.

The paradidactic bipolarisation in the post lesson discussion

The teachers at the Attached School of the University of Tsukuba play a leading role in the community of Japanese mathematics teachers at elementary level by publishing a number of educational books and performing lectures about teaching practice. Seiyama, who designed and implemented the demonstration lesson, is an experienced mathematics teacher in elementary school and has demonstrated several lessons in foreign countries. The participants were given his lesson plan beforehand. In this Seiyama describes the goal and the intended lesson process. The demonstration lesson is about considering how the total number of a fold lines on a paper changes when one repeats folding it in half. This was followed by a post lesson reflection session, where teachers from different schools in the region participated. Also, teacher educators from different universities in Copenhagen, as well as, a professor of the University of Copenhagen who specialises in didactics of mathematics were invited to give the participants some feedback regarding the observed lesson. The number of participants was approximately 180.

The discussion was organised in three phases: the Japanese teachers', the first group's and the second group's. The division of the Danish participants depended on their experience of post lesson

reflection: the first group consisted of the teachers and researchers who had experienced some post lesson reflections before, and the members of the second group did not have such experiences at all. Below, we describe a representative phenomenon, from the paradidactic situations described above, that we call the *paradidactic bipolarisation*, i.e., the shortage of *didactic* viewpoints in teachers' interests. This phenomenon is observed as the *thematic confinement* (cf. Barbé, Bosch, Espinoza, & Gascón, 2005) and the *pedagogical generalism* (cf. Florensa, Bosch, Cuadros, & Gascón, 2018)—it has two opposite *poles*. Teachers could usually focus on the level of specific topics (at the pole of thematic confinement) or the level of generic educational matters (at the pole of pedagogical generalism) *without* questioning interlevel intermediates between the both levels, e.g., the entire design of a course in a school discipline (for example, a geometry course in secondary school mathematics). Let us illustrate each of the two poles with data from the international open lesson.

Thematic confinement: teachers' exclusive concern on specific matters in the demonstration lesson

Generally speaking, teachers' discussion of the teaching tends to focus on the piece of knowledge taught in the lesson itself under the predetermined body of knowledge-to-be-taught. As a result, teachers usually talk about not the domain of the subject matter, but its topic, e.g., not treating Euclidian geometry but considering the Pythagorean theorem. Let us note that the analysis has the neutral nature, that is to say, we are not evaluating in any way. As we discuss in the next section, this focus of the teachers is systemically produced. The discussion of the first group including several Japanese teachers was not an exception (Hereafter, "DP" and "JP" means a Danish participant and Japanese participant respectively; these comments are not from a dialogue.):

DP 1: (...) regarding the girl who answered 5. She could reason $1 + 2 + 2$ using preceding numbers. It could express the richness of the task? What is your idea of (helping the students) finding out the next number by adding some of the preceding numbers of the folds (when you constructed this task)?

JP 1: Seiyama should have let the pupils observe the figure more consciously. If I were him, I would use the paper more effectively when I let the pupils guess the answer. There were so many different conjectures by 3 folds, so, before I let them to fold paper I would let them look at the paper (individually) and let them guess again. Therefore, if they guess the number of lines at the same time they fold the paper, they could have understood the relation between the rule of the increasing of the lines and the figure much better. Thus, he should have used the figure more not only they control the answer but even when they guessed.

From the scale of levels of didactic co-determinacy, these comments are exclusively related to the levels of theme and subject—a specific issue of school (early) algebra. The absence of the concerns on broader organisations of mathematics—discipline, domain and sector—indicates that it is difficult for teachers to deal with lessons beyond the thematic level: the thematic confinement.

Pedagogical generalism: teachers' exclusive concern on generic matters in the demonstration lesson

Indeed, didactic facts beyond the thematic level usually disappear from teachers' eyes, but it does not mean that teachers always ignore all other levels higher than the theme. Factors at the pedagogical

level—out of the levels within a certain discipline—may become visible for teachers as is the case of the thematic confinement. In our case, such tendency is distinct in the second group:

- DP 4: How do you instruct the students who think fast and find the answer quickly? How do you give them more difficult task so that they do not get bored? I think this is the weakness of this kind of lesson that very talented students get bored if they found the pattern very fast.
- DP 6: There are other students who do not see the pattern. (...) If you implement this kind of teaching method, can you see even those weak students can find those patterns easily? Can you actually train their ability to see the pattern?

The issue they are problematizing exclusively concerns about generic teaching methods, which are not related to any specific contents: the pedagogical generalism.

An ecological analysis: constraints on post lesson discussion in lesson study

In the previous section, we have analysed data coming from the participants' comments in a paradidactic system regarding a didactic system. This analysis conducted by the *original* didactic scale (Fig. 1) has been a clarification of a law regulating teachers' activities—the paradidactic bipolarisation—at the paradidactic system level within the *new* paradidactic scale (Fig. 2). In this section, we will discuss some constraints, which bring about the law, using our new model.

The lack of didactic notions: a constraint at the levels of society and noosphere

The history of didactics is relatively young. The motion initiated by some pioneers, e.g., Guy Brousseau, emphasized the existence of *didactic* phenomena, which are irreducible to as cognitive, semiotic, pedagogical and so forth (Bosch & Gascón, 2006). Since then, didacticians have been producing a number of theoretical constructs, *didactic contract*, *praxeology*, etc. However, these notions have not permeated into the community of teachers. Florensa et al. (2018) reported the result from interviews of university teachers, where they were asked about questions or difficulties in the beginning of their educational courses for preparing teaching at universities. The study showed that the participants' concerns are fulfilled with general issues and detached from the target content, i.e. the didactic stake: the pole of pedagogical generalism. Through reflecting upon the teachers' responses, the authors indicate the problem of the *lack of didactic notions* within the university teacher education, which could be identified as a condition at the society and noosphere levels. Commonly, the teachers do not have words to talk about how to connect between the target content and the way of teaching it. Thus, even if they can think about the didactic stake, their foci are limited at very specific ecological levels: the pole of thematic confinement. As a consequence, it becomes difficult for them to recognise and overcome the paradidactic bipolarisation phenomenon.

Generally, one cannot inquire the target content fully without using didactic notions. It is because “knowledge” tends to be regarded as an unchanging reality. This commonsensical belief is based on a prospering epistemology which is possibly set at the civilisation and society levels: the *epistemological absolutism*. This absolutism often gives a privileged authority to scholarly knowledge, regarding knowledge at school as some deficient form of it. In other words, absolutists consider that scholarly knowledge has universality. They cannot accept the principle of *institutional*

relativity of knowledge—as the historian emphasizes the importance of the historical analysis from *not* current perspective but from the analysed period's, the ATD-didactician insists that *school mathematics* exists in its own right. Then, knowledge-to-be-taught easily becomes unquestionable for teachers (see also Chevillard, 2007). Consequently, the pedagogical generalism as one pole of the paradidactic bipolarisation—focusing on wide-ranging teaching methods and purposes—flourishes in many paradidactic systems including the one in our case. At the same time, controllable conditions among the didactic levels from the discipline to the subject are limited for teachers, i.e. the thematic confinement as the other pole of the paradidactic bipolarisation. In both cases, there exists passivity towards bodies or organisations of knowledge.

The teachers' developmental byplay: A constraint at the levels of noosphere and profession

So far, we have used the word *teacher* with twofold meaning, that is, as a professional institution—i.e. profession—in our societies, and as a general position of players in all kinds of didactic systems. However, let us focus here on the teacher as a profession by the notion of *schoolteacher*. The relatively restricted nature of the profession of schoolteacher is a frequently observed social fact, which is a main topic of ATD. For example, the schoolteacher has often been regarded as an occupation with limited autonomy in decision-making on its working process, compared with e.g., doctor and lawyer. This *semiprofessional* feature is typically visible in the work arranging knowledge-to-be-taught at school. In many countries, the national curriculum is more or less made by some kind of governmental paradidactic system. In the case of modern Japan, the committee organised by the ministry of education decides school disciplines, their domains and their sectors. In short, the type of tasks of curriculum development is generally not a main role of schoolteachers but of governmental curriculum-makers.

The supporting role of the schoolteacher in the process of development of curriculum—we call it the *schoolteachers' developmental byplay*, at the noosphere and profession levels—affects the different poles of the paradidactic bipolarisation phenomenon. Schoolteachers cannot freely decide sectors, domains, and disciplines, because the arrangement of knowledge-to-be-taught at these three levels is not their prerogative. This distribution of responsibility between schoolteachers and curriculum developers could percolate spontaneously through to most schoolteachers as a natural part of their professional common sense. For example, in the Japanese case, this tendency clearly appears as a paradidactic methodology of lesson study, which could be a condition at the profession and paradidactic system levels. Lesson study is usually conducted around a subject and a theme, applying some general pedagogy, e.g., competency-based education. As a consequence, the schoolteachers' developmental byplay tends to produce an implicit rule “the schoolteacher should focus on the thematic level when they talk about the target knowledge—not about the general matter”. It is a clause in the paradidactic contract at the profession and paradidactic system levels.

Final remarks

We think that our new scale has dual value in didactic research. As the first, it allows us to study the ecology of the paradidactic. The second and rather indirect function is to invoke sensitivity to the boundary between the purely didactic and the para-didactic realities, since such a demarcation is difficult to recognise for most educators and researchers. In further research, we need to examine the

functionality of our tool by explaining more various cases of lesson study, since our data was one specific and rather unique case. We consider that such examination of the tool should not limit its scope within lesson study. In addition, there are possibilities of application to teacher education research, research of curriculum and/or textbook development, and meta-research of didactics. It is because such domains have objects of study with the nested structure similar to the teachers' paradidactic system. We believe that the scale can cast new light on the various objects of didactics.

Acknowledgments

The authors would like to thank Carl Winsløw and Klaus Rasmussen for useful comments. This work is supported by JSPS KAKENHI (JP16K17433).

References

- Barbé, J., Bosch, M., Espinoza, L., & Gascón, J. (2005). Didactic restrictions on the teacher's practice: The case of limits of functions in Spanish high schools. *Educational Studies in Mathematics*, 59(1–3), 235–268.
- Bosch, M. & Gascón, J. (2006). Twenty-five years of the didactic transposition. *ICMI Bulletin*, 58, 51–64.
- Chevallard, Y. (1992a). Fundamental concepts in didactics: Perspectives provided by an anthropological approach. In R. Douady & A. Mercier (Eds), *Recherches en Didactique des Mathématiques, Selected Papers* (pp. 131–167). La Pensée Sauvage.
- Chevallard, Y. (1992b). A theoretical approach to curricula. *Journal für Mathematikdidaktik*, 13(2/3), 215–230.
- Chevallard, Y. (2007). Readjusting didactics to a changing epistemology. *European Educational Research Journal*, 6(2), 131–134.
- Chevallard, Y. (2019). Introducing the anthropological theory of the didactic: An attempt at a principled approach. *Hiroshima Journal of Mathematics Education*, 12, 71–114.
- Florensa, I., Bosch, M., Cuadros, J., & Gascón, J. (2018). Helping lecturers address and formulate teaching challenges: An exploratory study. In V. Durand-Guerrier et al. (Eds.), *Proceedings of the INDRUM 2018* (pp. 373–382). Kristiansand, Norway: University of Agder and INDRUM.
- Miyakawa, T., & Winsløw, C. (2013). Developing mathematics teacher knowledge: The paradidactic infrastructure of “open lesson” in Japan. *Journal of Mathematics Teacher Education*, 16(3), 185–209.
- Winsløw, C. (2011). A comparative perspective on teacher collaboration: The cases of lesson study in Japan and of multidisciplinary teaching in Denmark. In G. Gueudet, B. Pepin, & L. Trouche (Eds.), *From text to 'lived' resources: Mathematics curriculum materials and teacher development* (pp. 291–304). Springer.
- Winsløw, C., Bahn, J., & Rasmussen, K. (2018). Theorizing lesson study: Two related frameworks and Two Danish Case Studies. In M. Quaresma et al. (Eds.) *Mathematics lesson study around the world: Theoretical and methodological issues* (pp. 123–142). Springer.

TWG18: Mathematics teacher education and professional development

International perspectives on mathematics teacher professional development

Stefan Zehetmeier (Austria), João Pedro da Ponte (Portugal), Laurinda Brown (United Kingdom), Àngela Buforn (Spain), Janne Fauskanger (Norway), Marita Friesen (Germany), Maria Mellone (Italy), Libuse Samkova (Czech Republic)

Rationale

The study of mathematics teacher education and professional development has been a central focus of research over recent decades. Also, during previous ERME conferences, various research activities regarding this topic have been presented and discussed. Within CERME 11 TWG 18, we focus on mathematics teacher education (pre-service and in-service), professional development and teachers' professional growth, teachers' professional development practices, models and programmes of professional development (contents, methods and impacts) and the professional development of teacher educators and academic researchers. TWG 18 offers a communicative, collegial and critical forum for the discussion of these and other related issues, which allows diverse perspectives and theoretical approaches and which contributes to the development of our knowledge and understanding as researchers, educators and practitioners.

Participants

53 papers were originally submitted to TWG18 and underwent a peer review process. All papers were revised by authors, according to reviewers' remarks. 43 papers were accepted as paper presentations, 10 were re-submitted for a poster presentation. Two of the accepted papers were withdrawn and one was re-assigned from another TWG. Finally, 42 papers were to be presented during the TWG sessions.

This led to the decision (according to ERME rules) to split the TWG into two sub-groups: TWG18a (with a particular focus on teachers and teacher educators) and TWG18b (with a particular focus on professional development settings).

10 posters were originally submitted and underwent a peer review process in TWG18: all authors revised their posters, according to the reviewers' remarks and all posters were accepted. Together with the re-submitted posters (see above), and 7 withdrawals, finally, 13 posters were presented during the conference poster session.

Organisation

TWG sessions 18a and 18b comprised both plenary and sub-group working phases. During the plenary phases, two (or three) papers were presented for a maximum of five minutes each, in which the authors provided their paper's central message(s) and challenging questions for discussion. These plenaries were followed by parallel sub-groups, which were each managed by one of the presenting authors. Participants were free to choose and join one sub-group, where they discussed the paper for 30-40 minutes. Afterwards, the TWG's participants met in plenary to listen to and to discuss reports of each sub-groups' central topics and to summarise emerging issues. In addition, in 18b, the five-minute presentation of papers was followed by a brief commentary to the set of papers by one of the TWG leaders.

Topics

The presentations in TWG18a and TWG18b were categorised into 13 main topics:

- Beliefs
- Educators
- Knowledge
- Noticing
- Particular Mathematics Topics
- Tools
- Curriculum Innovation and Professional Practices in Professional Development
- Evaluation of Professional Development Programs
- Collaboration and Communities in Teacher Professional Development
- Lesson Study
- Use of Video for Professional Development
- Use of ICT for Professional Development
- Initial Teacher Education

Open questions and emerging issues

This section provides several key questions and issues, which emerged during the sessions of TWG18a and TWG18b:

Beliefs

Open questions: What gets pre-service teachers into teacher education? How do we change pre-service teachers who do not want to be changed? How to support pre-service teachers to be exploratory in their teaching? What motivates mathematicians to be involved in projects with mathematics teacher educators?

Emerging issues: The potential of investigating the effect of ‘Missions’ on pre-service teachers’ thinking (e.g., getting into the habit of looking at their own experiences to make sense of the theoretical input of the course) and practices (in school placement or in their practice after graduation).

Educators

Open questions: How do educators’ theoretical perspectives change over time? Parallels between mathematics teacher educators and mathematics teachers – what makes teachers confident teaching mathematics and what makes students in classrooms confident doing mathematics?

Emerging issues: Questioning our own assumptions of what we take for granted about how mathematics could be taught and shifting those assumptions by working across boundaries of contexts and countries.

Knowledge

Open questions: What is our knowledge of the rationale that pre-service teachers have for what they do? How do we support pre-service teachers in developing through video analysis experiences?

Emerging issues: We need to have a national comparison of teachers' knowledge. Validity of simulations for measuring teaching practice.

Noticing

Open questions: How to change beliefs so that students' errors can be analysed more productively? Changing beliefs from when pre-service teachers were students themselves? Do different types of critical events influence the way the pre-service teacher interprets?

Emerging issues: Different uses of critical events and reflections across the different countries. Safe place inside the university where pre-service teachers can make errors and reflect on them.

Particular Mathematical Topics

Open questions: What about combining things that are shared between different subjects such as problem solving, e.g., mathematics and science modelling? Is it important that pre-service teachers struggle in terms of mathematical content and also struggle in the classroom?

Emerging issues: Differences in our countries producing generalist teachers (5 taught subjects) or specialist teachers (2 taught subjects).

Tools

Open questions: Action research: takes too much time for pre-service teachers to do? In different situations, do the pre-service teachers move between different roles, such as teacher and researcher?

Emerging issues: The school community as a community of practice that pre-service teachers have to enter. Action research – different experiences across countries – pre-service and in-service teachers have different experiences. Being systematic from the very beginning, thinking about quality.

Curriculum Innovation and Professional Practices in Professional Development

Open questions: How to use curriculum innovation and aim of improving student achievement for professional development? In large-scale professional development programmes, how can results similar to those that arise in small-scale programmes be achieved?

Emerging issues: Potential and limitations of practice-based professional development programs.

Evaluation of Professional Development Programs

Open questions: How to research and how to measure the impact of professional development?

Emerging issues: Relating teachers' learning to quality of instruction and students' achievement.

Collaboration and Communities in Teacher Professional Development

Open questions: What settings are successful in combining collective and collegial work with space for individual growth?

Emerging issues: The crucial role of the teacher educator/mediator/facilitator and how he/she may be trained.

Lesson Study

Open questions: Teachers' dispositions regarding personal investment in professional development are a crucial factor for the success of lesson study. What steps may be taken to improve them?

Emerging issues: Need to have a theoretical orientation regarding pre-service and in-service teachers' learning. The crucial role of the Lesson Study (LS) facilitator and how he/she may be trained. LS is complex, in particular if it is not part of the culture. There is a need for future research on how to build collaborative trust among participants.

Use of Video for Professional Development

Open questions: In observing videos, how to identify a "productive" discussion and how to measure the extent of the "productivity"?

Emerging issues: The key role of theories regarding teacher learning and of practical questions regarding working contexts in research in the use of videos in professional development.

Use of ICT for Professional Development

Open questions: How can ICT elements be used to enhance and inform teacher education and professional development? How can the implementation of ICT elements be facilitated?

Emerging issues: Role of specific facilitation and monitoring, importance of collaboration with colleagues and need for quality control / standards.

Initial Teacher Education

Open questions: What are appropriate learning and identity development aims for pre-service teachers (both primary and secondary) in different national contexts?

Emerging issues: Combining attention to didactical, cognitive, affective and social issues in Initial Teacher Education.

Summary

There is a common agreement in TWG18 on the principles leading to more effective professional development of teachers that emerged across the 13 topics: bringing new elements to the teachers' work while keeping connected to the teachers' reality; clarifying these new elements in relation to existing frameworks and practices; combining collective and collegial work with space for individual growth; and supporting teachers in introducing new elements in their practice and reflecting on their consequences and possible constraints.

Working with example sets: A productive focus in Lesson Study

Jill Adler¹ and Jehad Alshwaikh²

¹University of the Witwatersrand (Wits), School of Education, South Africa; jill.adler@wits.ac.za

²Jehad Alshwaikh, Faculty of Education, Birzeit University, Palestine; Wits jalshwaikh@gmail.com

The Wits Maths Connect Secondary Project, a research linked professional development project, included Lesson Study with teachers in school clusters. Planning and reflection is carried out using a Mathematics Teaching Framework, a key aspect of which is exemplification. We illustrate that and how working on example sets in a lesson has been productive in our (LS) work. Through this we build a case for a focus on exemplification when studying and working on mathematics teaching, and for support at a more general level for theoretically informed Lesson Study.

Keywords: Lesson study, mathematics, secondary, exemplification, South Africa

Introduction

The Wits Maths Connect Secondary Project (WMCS) is a research linked professional development (PD) project that has included Lesson Study (LS). Based on a view of professional learning as a collaborative practice, and thus with some similarities to the Japanese model, the LS model developed in the WMCS project has two distinct features. It is framed by a theoretically driven and empirically elaborated framework for mathematics teaching that includes an emphasis on exemplification; it has been shaped by conditions of learning and teaching in the WMCS project schools, and thus by constraints typical of low-income schooling contexts (Adler, 2017).

Lesson study has become widely used in PD globally and differently interpreted across contexts (e.g. Quaresma et al., 2018). Adaptations of Japanese LS have taken root in the US, the UK, and Australia (Wood, 2018; Huang et al., 2017), and spread across countries in Asia and Africa. Fujii (2014) reported on a project where LS was promoted in countries such as Malawi and Uganda and argued that cultural practices in Japanese schools were not ‘transferred’ together with doing LS. In South Africa, while there is recognition of the benefits of LS, Jita et al. (2008) state many challenges, in particular time for running the training and enacting the process and more critically the role of knowledgeable others which was undermined through a cascade model of expanding the reach of LS. The difference with practices in Japan is apparent, particularly in relation to LS in Japan being an in-school practice, where experienced and knowledgeable others are part of the systemic culture.

It is precisely these conditions that inspired the WMCS to (re)design lesson study in ways that both supported the goals of the wider project (see below), and the conditions of teachers’ work in South Africa. Hence the key design features of the WMCS model mentioned earlier – it takes constraints on time into account, and it focuses on current teaching practices like exemplification.

Exemplification and variation

There is an extensive literature on the significance of exemplification in mathematics teaching (e.g. Antonini et al. 2011; Watson & Mason 2006). Bills & Watson (2008) and Sinclair et al. (2011) argued the need not only for deliberate and careful selection and sequencing of examples, but that teaching needs to bring learners’ attention to connections between selected examples, and to the underlying

patterns of variance amidst invariance that enable generalisation and/or appreciation of structure. This linked work on examples and variation in and for mathematics teaching has inspired and influenced our attention to exemplification in our research and PD work.

Zaslavsky's research has focused on teachers' awareness of their example use in their teaching and students' use of examples in their thinking (Ellis et al., 2017). Teachers' were not necessarily aware of how they were using examples. Teachers' thus can be supported in this work. For Kullberg et al. (2017), the application of variation theory in teaching enables critical features of the object of learning to come into focus. They argued further that multiple examples are not simply cumulative. Their ordering, simultaneous presentation, and the teacher drawing attention to similarities and differences are critical. We agree and have thus worked with teachers on their use of examples. In order to bring the object of learning into focus and enable learners to generalise through the use of examples, we have highlighted two necessary aspects for a sequence of examples, and the accumulating example set in a lesson. There needs to be *similarity* from one example to the next - where a feature is kept *invariant* while other features vary. In addition, there need to be *contrasting* examples that can draw attention to difference between key features. With a focus on variance amidst invariance, and contrast, it is possible to build generality and create possibilities for appreciating the critical features and structure of particular mathematical objects.

Of course, examples are always embedded in a task. While examples are selected as particular instances of the general case, tasks are designed to bring particular capabilities to the fore (Marton & Tsui 2004). In our LS work, constructing an example set across a lesson includes attention to tasks, and as we will show this was the collective work of the LS group – teachers and researchers.

The WMCS, framework of mathematics teaching and model of Lesson Study

WMCS has aimed at improving mathematics teaching in disadvantaged schools in one province in South Africa. With a sociocultural orientation to learning as mediated, and to mathematics as a network of scientific, connected and hierarchic concepts (Vygotsky, 1978), we zoomed in on exemplification and explanatory talk in the lesson, viewing these as key mediational means in instruction. We developed an analytic framework, detailed in Adler & Ronda (2015), for describing and interpreting shifts in mathematics made available in teaching. It focuses on four key elements of a mathematics lesson: First is the *object of learning*, the 'what' of learning or lesson goal, and what students are expected to know and be able to do at the end of a lesson. This leads to *exemplification* - to the sequence of examples, with their associated tasks and representations, that can be used to bring the object of learning into focus with learners. As reflected in our discussion on exemplification, attention is on how to work with variance amidst invariance, to build generality and illuminate structure. We also focus on *Explanatory communication*, and *Learner participation* but these are not in focus in this paper.

Between 2013 and 2016 we explored a model of LS in the project. We worked in a school after school hours in small collaborating groups of teachers from clusters of schools. We used the framework above as structuring device to guide lesson planning and reflection, adapting it into a teaching framework referred to in the project as a Mathematical Teaching Framework – MTF, and illustrated in Figure 1 below. The MTF includes all the components of the analytic framework mentioned above

and is intended to assist teachers in planning and then as an observation/reflection tool on the ‘quality’ of mathematics offered in their teaching in LS. In this paper we focus on exemplification in the MTF framework in our LS work.

Lesson goal		
Exemplification Examples, tasks and representations	Learner Participation Doing maths and talking maths	Explanatory communication Word use and justifications
Coherence and connections to the lesson goal		

Figure 1 WMCS Mathematics Teaching Framework

Our Lesson Study model

While our cycle follows mainstream practice of LS, differences, particularly in relation to time and place, are a function of resource constraints. Our LS cycle takes place one afternoon a week after school hours for three consecutive weeks, and involves teachers from a cluster of neighbouring schools. In week 1, the LS group plan a one hour lesson on a topic agreed by the teachers. In week 2, one teacher teaches the lesson to a class of learners who agree to remain after school for the lesson. After the learners leave, the LS group spends the following hour reflecting on the enacted lesson and planning the second lesson which is taught in the third week, to a different class, but the same grade. *A Lesson Study cycle thus involves six hours* of face to face collaboration, an evolving lesson plan, and reflection on both taught lessons. In our model, a LS cycle takes place over a relatively short time, outside of normal class teaching.

The study: data and method

While we carried out LS in three clusters of schools, in 2016 we undertook a systematic study of our most participative and sustained LS cluster. A specific question in the study was on the evolution of the example set and in particular:

- What changes occur in the example set across the lesson plans over a cycle?
- How do these changes evolve?

We focus on one LS cycle where four teachers (Thembi, Lerato, Thabi and Sipho) from three different schools in the cluster, and four researchers (Frank, Linda, Jehad and Jill) from the project met in May to plan the first teaching. The teachers chose to work on “simplifying algebraic expressions with brackets in different positions” in Grade 10 because of persistent errors they observed with their learners’ manipulation of algebraic expressions when these included brackets in various positions. In order to systematically research our co-learning, we collected all relevant information: written lesson plans; audio and/or video-recordings of all LS sessions. We draw particularly from the lesson plans, post lesson reflective discussions and teacher reflections to engage with our research questions.

Our analysis proceeded with a description of the exemplification in the first lesson plan in terms of the MTF framework, and so our interpretation of variance amidst invariance, and similarity and

contrast in the accumulating example set. We identified examples that were removed/added, where this occurred, and how this linked with changing representations and tasks in Plans 2 and 3. Our analysis of the reflective discussions after each lesson included the identification of “example change moments” – moments in the reflective discussion where there was specific attention to exemplification, *and* the discussion led to some change. We described by whom and how the discussion was initiated, and how it evolved.

The lesson plans and evolving example sets

In Table 1 below, we present the example sets for the Introductory and Activity 3 in each lesson plan produced: the initial plan (P1), the revised plan (P2), and then a re-revised plan (P3). The substantial changes are highlighted, and we now use these to illustrate the collective work of the LS group.

P1	P2	P3
<p><u>Introduction:</u> Calculate the following:</p> <p>a) $4 + 3(4 + 5) =$ b) $(4 + 3)4 + 5 =$ c) $(4 + 3)(4 + 5) =$</p>	<p><u>Introduction:</u> simplify the following expressions:</p> <p>a) $4 + 3(4 + 5) =$ b) $(4 + 3)4 + 5 =$ c) $(4 + 3)(4 + 5) =$</p>	<p><u>Introduction:</u> simplify the following expressions:</p> <p>a) $4 + 3(4 + 5) =$ b) $(4 + 3)4 + 5 =$ c) $(4 + 3)(4 + 5) =$ d) $(4 + 3) - (4 + 5) =$ Insert brackets in the left side to result in the given sum e) $4 - 3 + 5 = -4$ f) $4 + 3 - 5 = -35$</p>
<p><u>Activity 3: Simplify</u></p> <p>a) $(x - 3x) + 5 =$ b) $(x - 3)x + 5 =$ c) $x(-3x + 5) =$ d) $x - (3x + 5) =$</p>	<p><u>Activity 3: insert bracket(s) in the expressions on the left side so that the two sides are equal</u></p> <p>a) $x - 3x + 5 = -3x^2 + 5x$ b) $x - 3x + 5 = -2x - 5$ c) $x - 3x + 5 = x^2 - 3x + 5$</p>	<p><u>Activity 3: insert bracket(s) in the expressions on the left side so that the two sides are equal</u></p> <p>1. $x - 3x + 5 = -3x^2 + 5x$ 2. $x - 3x + 5 = -2x - 5$ 3. $x - 3x + 5 = x^2 - 3x + 5$</p>

Table 1 Examples in the introductory activity and activity 3 across the three plans

With respect to the examples, the LS group agreed to introduce the lesson with numerical expressions. This representation of expressions with brackets would have meaning for learners and provide a semantic basis for moving on to algebraic expressions, and so more abstract symbolic forms. The numbers 4, 3, 4 and 5 and the + operation in each expression were invariant. Only the position of the brackets changed from one example to the next. The task was to calculate the value of these expressions. Communication with learners was to focus on ‘what was the same and what was different’ across the examples, thus bringing into focus the impact of the changing position of the brackets. The examples of algebraic expressions that followed in Activity 1 and 2 were similarly structured with x , 3, x and 5 and the + operation invariant while the position of the brackets changed with each subsequent example. Activity 3 included the operation of subtraction/negative terms and if time there was a 4th activity prepared. The accumulating example set reflects the group’s interpretation of variation for this lesson where similarity first within each activity example set and then across these could build generality in relation to the application of the distributive law and the more visible form of the changing position of brackets the expression. Contrast was introduced in

Activity 2 where two binomials were now added, and thus potentially bringing attention to the operation between brackets.

The changes made to the examples in P2 and P3

Changes from P1 to P2 can be seen in Activity 3. There are now equations, with the expressions on the left retaining the same numbers and variables as in P1. Brackets now need to be inserted to produce an identity. The task for learners thus changed. Further changes appear from P2 to P3. There are additional examples of numerical expressions in the Introduction. It appears that the change in Activity 3 in P2 led to a change in the Introduction in P3. Across the three plans the accumulating example sets expanded. This was accompanied by a movement between the numerical and algebraic representations of expressions and changes in task demand. How then, did these changes in exemplification come about? What reflective processes provoked and produced these?

How did the change in plans evolve?

We identified key ‘example change moments’ in the reflective discussion where there was specific attention to exemplification, *and* the ensuing discussion led to a change in the lesson plan. The vignette below, from the reflection after Lesson 1, takes us into the discussion, allowing us to see when the selected change moment occurred, who initiated it, how it was taken up by others and then evolved into a change in the example set.

Vignette - when the exemplification is “not enough”

Thembi taught Lesson 1, and closely followed the joint plan (P1). The hour long reflective discussion began, as was the practice in the WMCS LS, with the teacher herself reflecting on the lesson. After twenty minutes of general reflection, Frank asked the group to reflect on the example sets. It was at this point that Thembi voiced a key concern with her learners’ responses to Activity 3.

Thembi: Remember ... activity three ... they all answered “yes it will make a difference” ... already they picked up from activity one and two that ... if the bracket is put in a different place it changes the solution. ... But for me ... that was not enough ...

It was not immediately apparent to others what Thembi meant by “not enough”. Some thought she felt that Activity 3 was “too easy”. Following further discussion on how to ‘change’ activity 3, Linda made a suggestion that caught Thembi’s attention (“that’s brilliant”), and resulted in a change to the example set:

Linda: I had another suggestion ... what if you ... gave them the answer and then said: where must I put the brackets to get this answer?

Thembi: ...where you give them x minus three x plus five but then give them the solution and ask them where should we put the brackets? That will be, yes I think that’s brilliant.

Attention moved to collectively generating the example set that appears in Activity 3, P2 above. Staying with the expressions in b, c, and d in P1, the task now was to “insert brackets on the left expression “so that the two sides are equal”. Thabi expressed concern that this would be too much of a “jump” for learners. All agreed that as he was to teach the next lesson, he could give more time to the activity, and then perhaps not complete all of the other activities in the lesson.

This vignette evidences that the moment of explicit attention to examples was initiated by Frank (WMCS), and thus by the project interest supporting teachers to use the MTF to frame and steer reflection. Significantly, it was Thembi (teacher) who responded to this initiative with a teaching/learning concern in her enactment that unsettled her. In this way, Activity 3 came into focus. It took some time for the group to understand Thembi's concern and to offer productive suggestions. Finally, the suggestion from Linda (WMCS) satisfied Thembi, and despite Thabi's concerns, it was accepted, and the example set changed. Interestingly, there were difficulties in Lesson 2, and reflection that again co-produced the changes to the introductory activity highlighted in Table 1. We do not include more detail here due to space limitations. Briefly, discussion focused on how to scaffold the more demanding task, resulting in the suggestion that numerical examples be done first¹.

Discussion

The vignette shows how changes were initiated through “example change moments”. Here, as in other instances, the initiation was by a project member/researcher, reflecting the structuring of the reflection by the elements of the MTF framework, in particular by attention to exemplification. However, it was the teachers' engagement with these initiations that directed the discussion in relation to their learners and their teaching/learning concerns. It was possible to trace the substance of these discussions, as we elaborate below. Together this leads us to posit two main themes that emerge from vignette and that illustrate exemplification as an explicit focus in our LS and as powerful for teachers.

Theme 1: Changes are a collective accomplishment

The vignette above illustrates how the initiation and evolution of change to the example set across the lesson, and particularly in the Introduction and Activity 3, was a *collective accomplishment* of both the teachers and the WMCS teacher educators/researchers. While a researcher initiated an explicit focus on the example set, the change was evidently a function of the driving concern of the teacher and the suggestions and additional instructional resources offered by teachers and particularly researchers together. Our evidence here reinforces the emphasis on the role of “knowledgeable others” in other models of LS (cf Takahashi & McDougal, 2014). We suggest that this role is crucial and has significant implications for any attempt to “cascade” the implementation of LS in contexts where experience with professional collaboration on the one hand, and focused lesson engagement on the other, are new. Cascading down, inevitably dilutes such roles. The important implication for the practice of LS in ‘less resourced’ contexts is that the human resources of knowledgeable others should not be side-stepped nor undervalued. This is a learned role. It is not a role that officials in a system can necessarily carry out without being inducted into LS activity over time (cf. Jita et al., 2008).

Theme 2: Changes are a function of the MTF framework and so theoretically informed

The vignette also shows how discussion was shaped by attention being drawn to the MTF framework, and particularly the example set. The example set was initially informed and shaped by principles of

¹ A detailed and in-depth report on this research can be found in “A case of Lesson Study in South Africa”, Adler & Alshwaikh (in press).

variation, as were the changes. The additional examples in the example set kept the numbers and/or terms in all the examples invariant while the signs were changed, or the task was shifted from expansion to insertion of brackets. Here we see the deep inter-relation between theory and practice constituted in LS reflection. It was the teachers' practice-based concerns that influenced the ultimate joint decisions. As in Kullberg's (2017) learning study, the role of variation was a theoretical resource in the LS work.

Concluding remarks

In this paper we have illustrated part of a LS cycle on “simplifying algebraic expressions with brackets in different positions” with Grade 10 learners in the context of a professional development project in South Africa. Structured by a framework developed in the project to support lesson planning and reflection, we described a key change moment in the reflection following the first enactment of the plan where Thembi expressed her concern with the example set in Activity 3; and how this shaped the subsequent lesson plan, its enactment and the reflection following. Through this we have made a case for explicit focus on exemplification and example sets in LS. Examples are critical for mathematics teaching and learning. Deliberate attention to how they are selected and sequenced and embedded in appropriate tasks is important in professional activity like LS. We zoomed in on one LS cycle with one LS cluster, indeed our most sustained and participative cluster. This was to illustrate the possible, which of course then could have broader purchase.

A related concern here could be that our focus on example sets and what they offer for teacher learning might be relevant to SA but not extend to lessons that are more problem based. We suggest (following Wood (2018)) that different solutions or strategies to a set of problems are themselves examples. How and what is variant and invariant in these would shape what is possible to learn. Attention in LS reflection to the different examples of possible solutions would hold similar possibilities and particularly if framed by principles of variation.

Furthermore, changes to the example set, and so exemplification – the additions, deletions, changing representations, and changing task demands – evolved as a function of the collective enterprise of the LS group - teachers and teachers educators or knowledgeable others. The implications for this in LS across contexts are serious. There are cost implications if knowledgeable others are to be included in any expanded form. Without this, however, LS will not function optimally, whatever the context.

Finally, we have pointed to the impact and the value of structured and theoretically informed observation and reflection. Planning, teaching and reflection were structured and shaped by the WMCS theoretical approach, the MTF tool used with teachers in our LS. Our work thus adds impetus to arguments for theoretically informed LS, and can hopefully stimulate further research along these lines.

Acknowledgment

This work is based on the research supported by the South African Research Chairs Initiative of the Department of Science and Technology and National Research Foundation (Grant No. 71218). Any opinion, finding and conclusion or recommendation expressed in this material is that of the author(s) and the NRF does not accept any liability in this regard.

References

- Adler, J. (2017). *Mathematics Discourse in Instruction (MDI): A discursive resource as boundary object across practices*. Paper presented at the 13th International Congress on Mathematical Education, ICME-13, Hamburg.
- Adler, J., & Alshwaikh, J. (in press). A Case of Lesson Study in South Africa. In R. Huang, A. Takahashi, & J. da Ponte (Eds.), *Theory and practices of lesson study in mathematics: An international perspective*. Dordrecht: Springer.
- Adler, J., & Ronda, E. (2015). A Framework for Describing Mathematics Discourse in Instruction and Interpreting Differences in Teaching. *African Journal of Research in Mathematics, Science and Technology Education*, 19(3), 237-254.
- Antonini, S., Presmeg, N., Mariotti, M. A., & Zaslavsky, O. (2011). On examples in mathematical thinking and learning. *ZDM*, 43(2), 191-194.
- Bills, L. & Watson, A. (2008) Editorial introduction. *Educational Studies in Mathematics*, 69(2), 77-79.
- Ellis, A. B., Ozgur, Z., Vinsonhaler, R., Dogan, M. F., Carolan, T., Lockwood, E., Lynch, A., Sabouri, P., Knuth, E. & Zaslavsky, O. (in press). Student thinking with examples: The criteria-affordances-purposes-strategies framework. *Journal of Mathematical Behavior*.
- Fujii, T. (2014). Implementing Japanese Lesson Study in foreign countries: Misconceptions revealed. *Mathematics Teacher Education and Development*, 16(1), 65-83.
- Goldenberg, P., & Mason, J. (2008). Spreading light on and with example spaces. *Educational Studies in Mathematics*, 69(2), 183-194.
- Huang, R., Fang, Y., & Chen, X. (2017). Chinese lesson study: a deliberate practice, a research methodology, and an improvement science. *International Journal for Lesson and Learning Studies*, 6(4), 270-282.
- Jita L.C., Maree J.G., & Ndjalane T.C. (2008). Lesson Study (Jyugyo Kenkyu) from Japan to South Africa: A Science and Mathematics Intervention Program for Secondary School Teachers. In Atweh B. et al. (Eds.) *Internationalisation and Globalisation in Mathematics and Science Education* (pp. 465-486). Dordrecht: Springer
- Kullberg, A., Runesson, K. & Marton, F. (2017). What is made possible to learn when using the variation theory of learning in teaching mathematics? *ZDM Mathematics Education*, 49, 559-569.
- Marton, F., & Tsui, A. B. M. (Eds.). (2004). *Classroom discourse and the space of learning*. London: Lawrence Erlbaum.
- Quaresma, M., Winsløw, C., Clivaz, S., da Ponte, J.P., Ni Shúilleabháin, A., & Takahashi, A. (2018) (Eds.) *Mathematics Lesson Study Around the World: Theoretical and Methodological Issues*. ICMI-13 Monographs. Springer. Dordrecht.
- Sinclair, N., Watson, A., Zazkis, R., & Mason, J. (2011). The structuring of personal example spaces. *The Journal of Mathematical Behavior*, 30(4), 291-303.
- Vygotsky, L. S. (1978). *Mind in society: The development of higher psychological processes*. Cambridge, MA: Harvard University Press.
- Takahashi, A., & McDougal, T. (2016). Collaborative lesson research: maximizing the impact of lesson study. *ZDM*, 48(4), 513-526.
- Watson, A., & Mason, J. (2006). Seeing an Exercise as a Single Mathematical Object: Using Variation to Structure Sense-Making. *Mathematical Thinking and Learning*, 8(2), 91-111.
- Wood, K. (2018). The many faces of lesson study and learning study. *International Journal for Lesson and Learning Studies*, 7(1), 2-7.

Reflections upon a research project seen as a means for teachers' professional development¹

Mette Andresen

Department of Mathematics, University of Bergen, Norway; mette.andresen@uib.no

Keywords: Secondary school teachers, teacher empowerment, educational development.

Focus of the study presented in this poster

The term 'research-and-development projects' reflects multiple goals of a certain type of design research project in mathematics, which includes teaching experiments like by Cobb (1999). Such goals are: i) Students' learning, and change of their beliefs ii) Change of norms, roles and relations between students and the teacher iii) Teachers' professional development iv) Researchers' experiences from actual classrooms v) Theoretical knowledge about i), ii) and iii). This study aims to contribute with theoretical knowledge about teachers' professional development.

Theoretical foundation for the study

Main heuristics are from a) an interpretative framework for analyzing individual and collective activity in classrooms (Yackel & Rasmussen 2002), and b) A research based theoretical foundation for the study of educational development projects (Sowder 2007). The study reflected upon a research-and-development project involving eight upper secondary mathematics teachers who designed and completed teaching experiments in their own classrooms, focusing on students' strategies for inquiry and problem solving and based on discussions of problem-solving behavior by Schoenfeld (2011), and Pólya (1985). The participants shared a wish to find ways to support and stimulate students' creativity and students' ability to think mathematically in an intellectually independent way. The study's reflections were centered on the question: *How can teachers' ideas and visions about a change towards more inquiry and intellectual independence in problem solving be realized by the means of a research project?*

The research project

The hypothesis underlying the research project's setup was a need for coherence between the norms and values realized by the teacher and those requested of the students. Therefore, the teachers had to develop and share their ideas about, and materials for, the teaching experiment with the peer group, based on their own experiences and visions, supported by the project activities and taking an inquiry approach. The research project is described in Andresen (2015).

Data

Data for this study was in the form of: i) Notes and video recordings of students' work and classroom activities in all eight classes ii) Notes and materials from meetings in the project group iii) Two group interviews with all the teachers in October 2013 and in May 2014.

¹ This poster is a short version of the author's paper: *A research project seen as a means for teachers' professional development* which was accepted but never presented at CERME 9, TWG18.

Results

The research project has served as a means for the teachers to get experiences with teaching according to their own, shared, desire with respect to students' inquiry and intellectual independence in problem solving. All the teachers were engaged with the project and all of them wanted to continue the project. They had tried out experiments that could realize their ideas and visions. All the teachers had a high degree of ownership of the teaching experiments. Nevertheless, elements of disappointment were revealed in the teachers' reports. Some teachers reported a lack of clear results of the experiments, which was explained mainly with reference to i) the period of time spent on the experiments, ii) the students' differing expectations and iii) students' earlier experiences with mathematics. The teachers expressed a common wish to continue the experiments.

Conclusion

This study has shown that a research project can be suitable to frame teachers' development by enactment of their visions and beliefs about mathematics teaching. There is no guarantee, though, that the desired goals and learning outcomes for the students will be reached. One possibility for improvement would be a prolongation in time of the project. As the main conclusion, this study points to stressing the importance of the teachers' visions about desirable teaching. This is in accordance with the study's theoretical foundation, and even goes further: It is well known (Sowder 2007) that a research-and-development project can succeed only if the teachers' beliefs are in line with its overall goals. Partly based on this study, a framework was outlined by Andresen (2018) for analysis of the role of the teachers' visions about desirable teaching for successful professional development, and for analysis of the impact of taking the visions into account already in the initial design phase. A large potential for professional development may, seemingly, be realized in projects which include the teachers' visions about desirable teaching in their starting point.

References

- Andresen, M. (2018). In the case of jeopardizing the learning outcomes: Could we have known better? In *Proceedings of Madif 11*.
- Andresen, M. (2015). Students' creativity in problem solving. *Acta Mathematica Nitriensia*, 01(01), 1–10.
- Cobb, P. (1999). Conducting teaching experiments in collaboration with teachers. In A. E. Kelly & R. Lesh (Eds.), *Handbook of research design in mathematics and science education* (pp. 307–333). Mahwah, NJ: Lawrence Erlbaum.
- Pólya, G. (1985). *How to solve it: New aspects of mathematical method*. Princeton, NJ: Princeton University Press.
- Schoenfeld, A. (2011). *How we think: A theory of goal-oriented decision making and its educational applications*. New York, NY: Routledge.
- Sowder, J.T. (2007). The mathematical education and development of teachers. In F. K. Lester (Ed.), *Second handbook of research on mathematics teaching and learning* (pp. 157–223). Reston, VA: NCTM.
- Yackel, E., & Rasmussen, C. (2002). Beliefs and norms in the mathematics classroom. In G.C. Leder, E. Pehkonen, & G. Törner (Eds.), *Beliefs: A hidden variable in mathematics education?* (pp. 313–330). Dordrecht: Kluwer.

Portfolios as a way of documenting and reflecting learning processes in a mathematics teachers' professional development program

Jennifer Bertram¹

¹Ruhr University Bochum, Faculty of Mathematics, Germany; jennifer.bertram@rub.de

Keywords: Portfolio, learning processes, self-regulated learning, professional development, mathematics teacher.

Theoretical framework

Inclusion is one of the current challenges in the education system. Because of its complexity, inclusion in secondary education increases the need for subject-specific teaching development and corresponding measures for teacher professionalization, e.g. in form of teacher professional development (PD) programs. The knowledge about individual learning processes of teachers participating in a PD program is fundamental to organize a professional learning development systematically and effectively (Prediger, Leuders, & Rösken-Winter, 2017). Therefore, we are interested in what and how teachers learn when participating in a PD program on inclusive mathematics classes.

How to make teachers' learning processes visible within a PD program?

In general, only a few studies focused on the processes of teachers' learning (Goldsmith, Doerr, & Lewis, 2014). First of all, the question "How to make learning processes visible?" aroused our interest. Schunk (2012) specifies different methods of investigating learning, for example with the help of a self-report. Portfolios can be used as one method of documenting and structuring self-reports. Learners can use portfolios to observe, document and reflect their learning progresses as well as to plan further learning steps (Gläser-Zikuda, Fendler, Noack, & Ziegelbauer, 2011).

In this study we based our considerations on the extended process-model of self-regulation (Schmitz & Schmidt, 2007). This model uses the basic assumption that self-regulation "refers to self-generated thoughts, feelings and actions that are planned and cyclically adapted to personal goals" (Zimmerman, 2000, p. 16 as cited in Schmitz & Schmidt, 2007, p. 11). One important element of this idea is the pursuit of goals during three learning phases: pre-actional, actional and post-actional (see Figure 1).

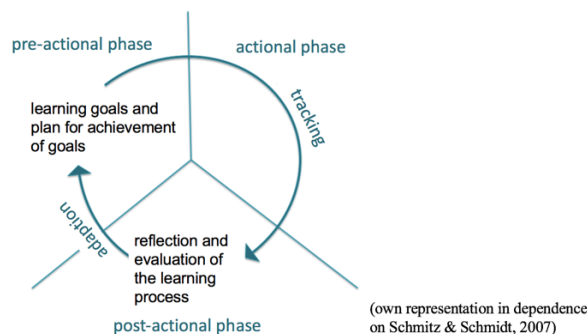


Figure 1: Extended process model of self-regulated learning

During the pre-actional phase the learner compares his situation with the desired goal and defines steps for achieving the goal (Gläser-Zikuda et al., 2011; Schmitz & Schmidt, 2007). In the actional

phase the learner tracks his goals and in the post-actional phase he reflects his learning process and evaluates it by comparing the actualized status with his expectations at the beginning (ibid.).

Method

In order to uncover teachers' learning processes within a PD program, we understand self-regulated learning as a tool for developing reflection tasks as a basis for the work with portfolios. The creation of the reflection tasks is based on the PD program content and refer to the cyclic interplay of pre-actional and post-actional phase as explained above. At the moment we can rely our research on three portfolios, which were filled out at distance of six to eight weeks each. In the first portfolio (PF1), teachers wrote down a personal learning goal, which they want to achieve through the whole PD program, and formulated planning steps for achieving it (pre-actional). Within the second portfolio (PF2) they wrote down, which steps they made and how they evaluate their learning process (post-actional). In this context the teachers also looked back to what experiences they made in their inclusive mathematics classes (post-actional). Afterwards, they planned further steps for getting closer to their desired goal (pre-actional). In portfolio three (PF3) the teachers were asked to formulate their personal learning goal again, with or without a modification based on their previous experiences (post-actional). Finally, they planned again how to pursuit their learning goal (pre-actional).

Results

With the help of case examples, typical teachers' answers are going to be introduced aiming at the discussion of further development and reflection of our portfolios as a research method. For example one teacher formulates the personal learning goal that she wants to prepare lessons at different levels of learning. She plans to reach her goal within the topic of percentage calculation (PF1, pre-actional). Later on she writes that she had used different methods with her pupils and she describes her learning process as being in flow (PF2, post-actional). She still wants to prepare a lesson in cooperation with a colleague (PF2, pre-actional). At last, she describes which aspects of lesson preparation she wants to improve (PF3, post-actional) and in which aspects she wants to work on collaboratively (PF3, pre-actional). All in all, we would like to discuss our portfolios, based on the self-regulated learning model, used as a possibility for making teachers' learning processes within a PD program visible.

References

- Gläser-Zikuda, M., Fendler, J., Noack, J., & Ziegelbauer, S. (2011). Fostering self-regulated learning with portfolios in schools and higher education. *Orbis Scholae*, 5(2), 67-78.
- Goldsmith, L. T., Doerr, H. M., & Lewis, C. C. (2014). Mathematics teachers' learning: A conceptual framework and synthesis of research. *Journal of Mathematics Teacher Education*, 17(1), 5-36.
- Prediger, S., Leuders, T., & Rösken-Winter, B. (2017). Drei-Tetraeder-Modell der gegenstandsbezogenen Professionalisierungsforschung: Fachspezifische Verknüpfung von Design und Forschung. *Jahrbuch für allgemeine Didaktik*, 2017, 159-177.
- Schmitz, B., & Schmidt, M. (2007). Einführung in die Selbstregulation. In M. Landmann & B. Schmitz (Eds.), *Selbstregulation erfolgreich fördern: Praxisnahe Trainingsprogramme für effektives Lernen* (pp. 312-326). Stuttgart: Kohlhammer.
- Schunk, D. H. (2012). *Learning theories: An educational perspective* (6th ed.). Boston, MA: Pearson.

The story of Maia: I will try to survive!

Annette Hessen Bjerke

OsloMet – Oslo Metropolitan University, Oslo; annette.hessen@oslomet.no

Two major concerns in mathematics teacher education research are the role of subject matter knowledge and the development of self-efficacy in teaching mathematics (SETM) in pre-service teachers (PSTs). These two bodies of research are normally not brought together, but I do so by investigating PSTs' SETM using an instrument developed with Skemp's two ways of understanding mathematics as the point of departure, and by exploring the sources of SETM through longitudinally conducted semi-structured interviews over a period of nearly two years. A focus on how one PST, Maia, drew on different sources of SETM, contributing to a new understanding of the agency of those PSTs that are recognised as "weak" because "they don't know any maths".

Keywords: Pre-service teachers, mathematics teacher education, self-efficacy, subject matter knowledge

Introduction

There is an ever-growing body of research investigating what teachers need to know in order to teach (Adler & Sfard, 2016). Unlike most research on subject matter knowledge (SMK) in the context of teaching mathematics, rather than investigating *what* knowledge is needed, this paper gives one particular pre-service teacher (PST) a voice in the matter, allowing an exploration of how *she* perceives the role of, and the need for, SMK as she develops her ideas about the teacher she not only *wants* to be, but *can* be. The importance of such a perspective is supported by Kagan (1992), who noted that PSTs' perceptions lie at the heart of teaching, and Pajares' (1992) comparison of 16 studies, concluding that PSTs' perceptions play a pivotal role in the way they acquire knowledge during pedagogical training.

One way of studying PSTs' perceptions of their own SMK and its role in teaching, is by paying attention to their self-efficacy in teaching mathematics (SETM). Teacher efficacy is considered one of the key motivation beliefs influencing teachers' professional behaviours and pupil learning (Klassen, Tze, Betts, & Gordon, 2011). Because of the situatedness of teacher efficacy, there is a need for more attention to domain-specific explorations (Klassen et al., 2011). Mathematics is an especially interesting context, since PSTs often express doubt about their own self-efficacy in mathematics (Gresham, 2007). Moreover, research indicating that teacher efficacy develops mainly during teacher education (Hoy & Spero, 2005) underlines the importance of investigating how and to what extent SETM develops in PSTs. In this paper, this is done in two ways, by a quantification of SETM through instrumentation, and through interviews focusing on one PST's perception of her own SMK and the need for such.

Theory

Bandura's social-cognitive construct of self-efficacy is concerned with judgements of personal capability (Bandura, 1997). Self-efficacy is defined as a person's judgement of his or her abilities to execute successfully a course of action (Bandura, 1997), a future-oriented belief about the level of competence one expects to show in a specific situation. It has two

components: a personal belief about one's own ability to cope with a task, a personal self-efficacy, and judgments about the outcomes that are likely to flow from such performances, an outcome expectancy (Bandura, 2006, p. 309). In this paper, teacher efficacy is understood as a measure of "the extent to which teachers believe their efforts will have a positive effect on student achievement" (Ross, 1994, p. 4), the 'personal self-efficacy' component of Bandura's theory. Moreover, SETM is understood to be the component of teacher efficacy corresponding to Bandura's concept of personal self-efficacy, seen in the subject-specific situation of teaching mathematics.

Bandura (1997) describes four sources of information that may contribute to the formation of efficacy beliefs: *mastery experiences*, *vicarious experiences*, *verbal persuasion*, and *physiological responses*. *Mastery experiences* are constituted by previous perceived success in performing a particular task, such as actual classroom teaching, and are seen by Bandura as the most powerful source of efficacy information (Bandura, 1997). Because teaching lacks absolute measures of adequacy, teachers can appraise their capabilities in relation to the performance of others (Bandura, 1997). *Vicarious experiences* are situations in which one watches another person successfully perform or the behaviour one is contemplating (Bandura, 1997). *Verbal persuasion* involves verbal input from others with the intention of enhancing a person's belief that they have the capability to perform a given task at a certain level. It "is likely to be effective when it is received from a highly competent individual who is perceived as an expert in the field" (Palmer, 2011, p. 580), such as a PST's mentor in school placement. Verbal persuasion alone may be limited in its power to create an enduring increase in teacher efficacy, but may work together with other sources to provide teachers with encouragement to strengthen their teaching skills (Tschannen-Moran & McMaster, 2009). Bandura (1997) viewed verbal persuasion as a comparatively weak source. *Physiological responses* can be a source of efficacy information, providing indirect information about capability to deal with challenging situations (Palmer, 2011). Bandura (1997) viewed this source as the least effective source as they were not reliably diagnostic of one's capability.

Following his review of teacher efficacy research, Wyatt (2014) argued that poor conceptualisations of the role of knowledge have obscured understandings of how teachers' self-efficacy beliefs develop. Moreover, Morris, Usher, and Chen (2017), add that it is clear that teachers' knowledge, and their beliefs about that knowledge, can play an important role in their development of self-efficacy. There is a need to better understand the role of knowledge in the development of teacher efficacy (Klassen et al., 2011). I follow Bandura (1997) and Wyatt (2014), who noted that knowledge is not a source of self-efficacy in itself.

In discussing SMK, Shulman (1986) emphasises that a teacher should not only understand *that* something is so, but also understand *why* it is so. This distinction is related to Skemp's (1976) *instrumental understanding* - 'rules without reasoning', and *relational understanding*, requiring "knowing both what to do and why" (Skemp, 1976, p. 20). Even though Skemp (1976) underlines that to have strong knowledge of mathematics does not guarantee 'success' as a mathematics teacher, he adds that teachers who do not possess such knowledge are likely to be limited in their ability to help students develop relational understanding, which is the goal in mathematics teaching, and therefore in mathematics teacher education, where theoretical

perspectives are often related to reform teaching (Grossman et al., 2009) focusing on relational understanding.

In my work, the emphasis is on how PSTs perceive the role of SMK, how they perceive the need for such knowledge and how such knowledge (or lack of it) influences them and colours their interpretation of their experiences as they progress through teacher education. SMK is central both in the instrument used on cohort-level (reported in Bjerke and Eriksen (2016)), and in the way in which the sources that PSTs draw upon in order to develop SETM are closely related to their perceptions of their own SMK and its role in teaching.

Methodology

This paper reports on data collected for a larger research project within a generalist primary teacher education programme for grades 1 – 7 (ages 6 – 13). Data were collected from a cohort of 191 PSTs admitted to a University College (UC) in Norway. At this UC, PSTs must take a minimum of 30 ECTS in mathematics, where the compulsory course spans the first two of a four-year programme, with 3 – 5 weeks school placement in each semester.

The instrument

SETM was investigated on cohort level through instrumentation. The instrument consists of 20 items, given to the cohort of PSTs at the beginning (pre-test) and the end (post-test) of their compulsory mathematics methods course (at the end of their second year). Each item asks of the respondent how confident they are helping a child to solve a mathematics task, 10 strictly algorithmic tasks focusing on rules and procedures in mathematics as in knowing *that* (i.e. “Calculate $-17 + 5$ ”), and 10 focusing on reasoning as in knowing *why* (i.e. “Explain why division doesn’t always make a number smaller”). In this way, the instrument asks of the respondents to consider their own SMK (see Bjerke and Eriksen (2016) for a description of the instrument’s content and validation).

Through Rasch analysis, items and persons are measured on the same interval scale, in logits, that allows us to avoid using non-equal interval values in parametric analyses that assume linearity (Boone & Scantlebury, 2006). The higher the person estimate, the more self-efficacious a person feels (Boone & Scantlebury, 2006). Selected findings from Rasch analysis of the data from the instrument implementation in Bjerke and Eriksen (2016) and Bjerke (2017a) are reported in this paper in order to place Maia amongst her peers.

Semi-structured interviews

The sources of SETM were identified through analysis of interviews with 10 PSTs in the current cohort. The semi-structured interviews were conducted over a period of nearly two academic years. Interviews 1, 3 and 5 are conducted before three consecutive periods of school placement, while interviews 2, 4 and 6 are conducted after the same periods of placement, resulting in six individual interviews with 10 PSTs who volunteered to participate (by indicating this on their instrument response). The overall aim was for PSTs to tell their story, from their very first thoughts as novices, through two years of experience of repeated placements and the role of the UC in their preparation for teaching mathematics, up to the point where they had considerable

placement experience and were ready to look ahead and reflect on the mathematics teacher they can be. The semi-structured interviews were informed by their answers on the instrument.

To analyse the data, references to the role of SMK in UC and school placement contexts were identified, noting connections to experiences of success and failure as applied to accounts of being and becoming a mathematics teacher. In analysing accounts of success and failure, particular attention was given to Bandura's (1997) four sources of self-efficacy. A later, more contextually bounded, holistic case study approach, enabled me to note common trends across the group. More importantly for this paper, it enabled me to identify and explore one PST, Maia, who acted as a foil to the presentation of the data from the other nine participants (Bjerke, 2017a), and was for that reason selected as a case study. This paper gives Maia's story.

Findings

As expected, there is a spread in novice PSTs' SETM (Bjerke & Eriksen, 2016), with Maia among those with lowest SETM within her cohort (with a measure of $-.69$ logits in a cohort with mean 0.55 and $SD = 1.16$ (Bjerke & Eriksen, 2016)). On cohort level, PSTs report being more confident helping a child to solve mathematics tasks focusing on rules and procedures in mathematics than tasks focusing on reasoning. Maia is representative of this trend, and a closer look reveals that Maia is 'Not confident' or 'Somewhat confident' on 15 of the 20 tasks in the instrument. She reports being 'Very confident' on one rules-task; she is very confident that she can help a child "Calculate $342 - 238$ ". This stands in stark contrast to the thematically related reasoning-task, "Explain why, when subtracting, you can sometimes borrow from the place to the left", where she reports being 'Not confident' (Bjerke, 2017a). Holding Maia's responses to these two tasks up against each other highlights the impression the analysis gives of Maia: she is more confident when mathematics is limited to calculations following algorithmic procedures without questioning *why* these procedures work.

It is not first and foremost her placement amongst her peers that makes Maia an interesting case, but rather how she, during interviews, elaborates and explains her low SETM. A dominant theme in Maia's story is her own experience of mathematics, which she says she was 'OK at' in upper secondary school, where indeed she gained above average marks. In the first interview, Maia states that she likes mathematics when she is able to do it, but when she does not 'get it', she does not like it. This and related statements highlight the role of emotion in her novice story, looking back as well as looking forward: she does not know if she likes the thought of becoming a mathematics teacher, and she has few ideas and thoughts on what to expect from teacher education; she simply hopes that it 'fits' her way of doing mathematics. As it turned out, it did not 'fit' and Maia found it challenging at UC, because of the focus on a relational understanding.

Following her first school placement in her first semester, whereas other PSTs began to see the possibility that UC could support them in developing the kind of knowledge they need for teaching, Maia was hazy about what she might learn from the UC way of doing mathematics. Consistent with her response on the instrument, she expressed awareness of, and concern about, her inability to explain mathematics, but she did not see UC as a potential source of support. Instead, she relied heavily on her mastery experiences in placement learning:

Learning by doing ... it's totally different in school placement, it can't be compared to what is presented to us at UC (interview 2)

An issue of 'fit' between her way of learning mathematics (instrumental focus) and the teaching at UC (relational focus) persisted in her second semester, in interview 3. In the period immediately before the third interview, UC teaching had focused on 'The Family of Quadrilaterals'. The PSTs had investigated how the different classes of quadrilaterals connect to each other, and the fact that, for instance, a square meets all the requirements of a rectangle, and hence can be described as a rectangle. Maia expressed confusion about this inclusive definition, and was critical of the UC mathematics curriculum:

I'm getting more and more confused ... It's a bit uncomfortable to know that I have to teach things I didn't learn myself when I went to school ... It's hard to learn something that doesn't make sense. I don't want to talk about a square as a rectangle (interview 3)

While at the novice stage other PSTs took a generally positive emotional stance focusing on building their sense of development as mathematics teachers on the recognition that a different and more relational kind of SMK, focusing on knowing *why*, might be required and possible (Bjerke, 2017a), Maia's account of the teacher she would like to be reflected her new negativity about mathematics. The sense of building relational understanding based on underlying principles was strikingly absent in Maia's sources of SETM. This appeared to contribute to her insecurity in general: She simply hoped to be able to make her pupils understand that

...it [mathematics] might be alright, there are worse subjects (interview 3)

After the second school placement, in interview 4, Maia's story was noticeably more positive: her narrative was far more grounded in her mastery experience in school placement, with major emphasis on the benefits in terms of *feeling* like a teacher:

I've learned so much that it's hard to put it into words. It's another world ... I felt we [the PSTs in her group] were one of the teachers (interview 4)

She described how she felt at home in school placement. She relied on verbal persuasion in the form of praise in order to gain a sense of SETM. Success in placement was crucial:

It was nice to get feedback after lessons, because [the mentor] pointed out positive things ... I need to show that I'm meant to be here ... (interview 4)

In her third semester, in the run-up to her third placement, she still doubted her ability to be a mathematics teacher:

A part of me wants to be [a mathematics teacher] ... but I don't know if I'm capable of teaching this subject ... I struggle so much myself (interview 5)

After the third placement, in interview 6, she felt more confident due to guidance from her mentor as a source of vicarious experience:

My mentor taught me how to show to children how to calculate and why [the mentor] did it this way (interview 6)

She gave several examples of what she meant by this: "when to say 'digit', when to say 'number', when to say 'decimal' rather than 'decimal number'". Instead of dealing with these

issues in the UC-context, she relied on copying her mentor, trying to remember ‘when to say what’, as a vicarious source of self-efficacy. In this way, Maia’s account of how she learned to be a mathematics teacher remained heavily dependent on her learning in school placement, copying her mentor, building on vicarious experiences against a background of insecurity in her mathematics knowledge:

That’s where I learn everything; that’s where I learn to become a teacher (interview 6)

However, the decontextualized nature of this source of self-efficacy and the role of SMK in it, meant that Maia had to employ a particular strategy in order to manage her mathematics teaching, involving preparing which calculations to do on the blackboard, doing them herself before the lesson and thinking through how to explain every step in a way that pupils would understand. She worried about the demands of this strategy:

I’m afraid it will be too tough, that I’ll fall badly behind and almost drown (...) I’ll try to survive the last years in teacher education and get through it (interview 6)

While both pre- and post-test analysis on cohort-level places Maia amongst those with lowest SETM, it is important to notice that, despite the negative outlook of her developmental story, Maia is closer to the mean by the end of her 2nd year than she was as a novice (Bjerke, 2017a), revealing that her SETM has developed more during these two years compared to the average PST. During the mathematics method course, spanning the two first years of teacher education, Maia’s responses on the pre- and post-test show that she has gained confidence in all items in the instrument that are comparable (five are not comparable due to how they are interpreted differently by the students as novices and as 2nd year PSTs (Bjerke, 2017b)). She is no longer ‘Not confident’ on any tasks, and on all comparable tasks, she has ticked one confidence-level higher on the post-test compared to what she did on the pre-test. From this we can read that the difference in confidence-level between rules- and reasoning-items is still an issue towards the end of the course.

Discussion and concluding remarks

The analysis reveals that SMK is indeed an issue in Maia’s developmental story: she finds mathematics challenging at UC, much due to the focus on relational understanding. She looks upon teacher education as something to be ‘survived’. While her perception of her own SMK and the role of such is indeed an issue, her reflection of this situation, and how she dealt with it, is equally important. She expresses awareness of, and concern about, her inability to explain mathematics, but she does not see UC as a potential source of support. The role of SMK in sources of SETM in the sense of understanding connections and underlying principles is strikingly absent, and it appears to contribute to her insecurity in general. But still, we see that her strategy of over-preparing in exhaustive and rigid details in order to manage her mathematics teaching. Drawing on her placement as a strong source of mastery has resulted in positive development in her SETM.

In line with Bandura’s (1997) understanding that mastery experience generally has the strongest effect, Maia’s story of her development as a mathematics teacher is dominated by a strong emphasis on mastery. She deals with the demands of teaching by focusing her learning in school placement, drawing on vicarious experiences when trying to copy her mentor. A longitudinal

reading of her interviews reveals a repeated negativity in her story after periods of lectures at UC (in interviews 1, 3 and 5), and a positivity after each period of school placement (in interviews 2, 4 and 6). In the interviews where she talks about UC-teaching, there are not many signs of sources of SETM. She focuses on experiences of failure and what she finds hard, and the fact that UC teaching in mathematics does not seem to “fit” her way of doing mathematics. Meanwhile, in the interviews taking place after periods of school placements, she points to both mastery experience, verbal persuasion and vicarious experiences as sources of her SETM. She notices the role of her own SMK in these sources, tending to avoid the difficulties arising due to the UC’s focus on relational understanding and instead focusing on praise from her mentor, strategies of copying her mentor, and over-preparation with an overall instrumental focus. She appears to find a strong source of SETM in her placement relaying heavily on praise, which in turn might prevent her from further development, given that verbal persuasion is found to be a comparatively weak source (Bandura, 1997) and on its own may be limited in its power to create an enduring increase in teacher efficacy (Tschannen-Moran & McMaster, 2009).

Bringing together research on SMK and on teacher efficacy enabled me to explain in more detail the complex role of SMK in Maia’s story. Bandura (1997) argues that self-efficacy is central to the exercise of human agency. My investigation of this construct, in PSTs from novice to more experienced, offers a new way of recognising the agency of “weak” PSTs. The story of Maia is an example of someone with low SETM, who seems unwilling to reflect on the role of SMK, and unwilling to engage in the ‘new dimension’ of mathematics - the focus on relational understanding and the ability to *explain* mathematics - and who sees teacher education as something to survive; she is easy to describe as a “lost cause”.

Based on my own experience as a teacher educator, I suspect that there are many PSTs like Maia in different teacher education programmes, struggling with the focus. Maia wants mathematics to be like it was in upper secondary school, which she saw as a set of rules to learn and use, requiring a purely instrumental understanding. Teacher education demands that she engage in knowing *why*, being able to explain *why* it makes sense to use rules, not only *how* to use them. My findings suggest that such “hopeless cases” are not solely “those who cannot do any maths”, but rather, might be someone who has a hesitation to engage with SMK in a new way.

Applying these insights, building on the recognition of Maia’s positivity after each school placement where she finds strong sources of SETM, I suggest there is a need to bring in new pedagogies of practice in teacher education that focuses on mastery of reform teaching where relational understanding is considered a key to success. Building on Grossman et al.’s (2009) suggestions, teacher education should seek to offer PSTs opportunities to experience alternative ways of teaching through *representations of practice* (e.g. by participating in reform teaching led by the course instructor), *decompositions of practice* (e.g. by using videos and analysing those based on theoretical frameworks such as Skemp (1976) on relational understanding), or through opportunities where PSTs are enacting teaching practices, rather than contemplating them as in *approximations of practice* (lesson planning, rehearsals, co-teaching with experienced teachers where SMK is focused).

References

- Adler, J., & Sfard, A. (Eds.) (2016). *Research for educational change: Transforming researchers' insights into improvement in mathematics teaching and learning*. New York, NY: Routledge.
- Bandura, A. (1997). *Self-efficacy: The exercise of control*. New York, NY: Freeman.
- Bandura, A. (2006). Guide for constructing self-efficacy scales. In F. Pajares, & T. Urdan (Eds.), *Self-efficacy beliefs of adolescents* (Vol. 5). Greenwich, CT: Information Age.
- Bjerke, A.H. (2017a). *The growth of self-efficacy in teaching mathematics in pre-service teachers: Developing educational purpose*. (Ph.D.), Oslo and Akershus University College of Applied Science, Oslo and Akershus University College of Applied Science.
- Bjerke, A.H. (2017b). The growth of self-efficacy in teaching mathematics in pre-service teachers: Developing educational purpose. *NOMAD*, 22(3), 71–84.
- Bjerke, A.H., & Eriksen, E. (2016). Measuring pre-service teachers' self-efficacy in tutoring children in primary mathematics: An instrument. *Research in Mathematics Education*, 18(1), 61–79.
- Boone, W.J., & Scantlebury, K. (2006). The role of Rasch analysis when conducting science education research utilizing multiple-choice tests. *Science Education*, 90(2), 253–269.
- Gresham, G. (2007). A study of mathematics anxiety in pre-service teachers. *Early Childhood Education Journal*, 35(2), 181–188.
- Grossman, P., Compton, C., Igra, D., Ronfeldt, M., Shahan, E., & Williamson, P. (2009). Teaching practice: A cross-professional perspective. *Teachers College Record*, 111(9), 2055–2100.
- Hoy, A.W., & Spero, R.B. (2005). Changes in teacher efficacy during the early years of teaching: A comparison of four measures. *Teaching and Teacher Education*, 21(4), 343–356.
- Kagan, D.M. (1992). Implication of research on teacher belief. *Educational Psychologist*, 27(1), 65–90.
- Klassen, R.M., Tze, V.M.C., Betts, S.M., & Gordon, K.A. (2011). Teacher efficacy research 1998–2009: Signs of progress or unfulfilled promise? *Educational Psychology Review*, 23(1), 21–43.
- Morris, D.B., Usher, E.L., & Chen, J.A. (2017). Reconceptualizing the sources of teaching self-efficacy: A critical review of emerging literature. *Educational Psychology Review*, 29(4), 795–833.
- Pajares, M.F. (1992). Teachers' beliefs and educational research: Cleaning up a messy construct. *Review of Educational Research*, 62(3), 307–332.
- Palmer, D. (2011). Sources of efficacy information in an inservice program for elementary teachers. *Science Education*, 95(4), 577–600.
- Ross, J.A. (1994). *Beliefs that make a difference: The origins and impacts of teacher efficacy*. Paper presented at the The Annual Meeting of The Canadian Association for Curriculum Studies, Calgary, Canada. Retrieved from <https://eric.ed.gov/?id=ED379216>
- Shulman, L.S. (1986). Those who understand: Knowledge growth in teaching. *Educational Researcher*, 15(2), 4–14.
- Skemp, R.R. (1976). Relational understanding and instrumental understanding. *Mathematics Teaching*, 77, 20–26.
- Tschannen-Moran, M., & McMaster, P. (2009). Sources of self-efficacy: Four professional development formats and their relationship to self-efficacy and implementation of a new teaching strategy. *The Elementary School Journal*, 110(2), 228–245.
- Wyatt, M. (2014). Towards a re-conceptualization of teachers' self-efficacy beliefs: Tackling enduring problems with the quantitative research and moving on. *International Journal of Research & Method in Education*, 37(2), 166–189.

Connecting mathematical knowledge with engagement in mathematics teaching practices

Timothy Boerst¹ and Meghan Shaughnessy²

¹University of Michigan, USA; tboerst@umich.edu

²University of Michigan, USA; mshaugh@umich.edu

Research suggests that mathematical knowledge is likely to influence how mathematics is taught. In turn, how mathematics is taught impacts students' opportunities to learn mathematics. We report on a study examining the connection between preservice teachers' mathematical knowledge and the nature of their eliciting and interpreting of student thinking. Our findings suggest that preservice teachers elicit and interpret student thinking with more emphasis on student understanding in situations in which they have strong mathematical knowledge of an algorithm used by the student compared to situations in which they have weaker mathematical knowledge about the algorithm used.

Keywords: Teacher education-preservice, instructional activities and practices.

Mathematical knowledge, dispositions, and pedagogical skill

Mathematical knowledge and pedagogical skill are crucial to effective teaching. Studies show teachers with substantial mathematical knowledge (Hill, Rowan, & Ball, 2005) and command of core teaching practices like formative assessment (Black, & Wiliam, 1998) have a greater impact on student learning of content. In the United States (US), mathematical knowledge and pedagogical skill are assets delineated in standards used to appraise both accomplished teachers (NBPTS, 2012) and beginning teachers (CCSSO, 2013). That mathematical knowledge and pedagogical skill are important in mathematics teaching is seldom questioned, but this does not mean that the field has determined the nature of the relationship between them. Mathematics teaching is a complex professional activity involving teachers in interaction with students, content, and context (Cohen, Raudenbush, & Ball, 2003). It is easy to imagine a multitude of ways in which mathematical knowledge and pedagogical skill are mutually influencing, if not mutually defining. For example, mathematical knowledge impacts the content and characteristics of questions that teachers ask during a lesson. Oriented in the other direction, pedagogical skill impacts the extent to which a teacher has access to student thinking that can be a substantial driver of a teachers' own mathematical development. This paper focuses on understanding the interrelations between mathematical knowledge and pedagogical skill empirically with respect to preservice teachers who are enrolled in a teacher preparation program.

Prior studies on teacher effectiveness connect teachers' mathematical knowledge with the achievement of their students. Often these studies examine the number and type of professional development experiences (Blank, & Atlas, 2009) or teachers' performance on mathematics content tests. When mathematics content tests are used, they tend to focus on general mathematical knowledge or mathematical knowledge identified as central to mathematics teaching (Hill, Rowan, & Ball, 2005). Such studies provide a connection between the mathematics that teachers know and the achievement of their students. What these studies do not explain is the way in which teaching is shaped by mathematical knowledge in ways that generate enhanced achievement for students. In a comparative study of Chinese and US mathematics teachers, Ma (1999) advanced the notion that the

way that teachers hold mathematical knowledge (e.g. the depth of understanding of foundational ideas interwoven with knowledge of how those ideas are shown across the breadth of mathematical topics) supports their engagement in teaching. Some examples of engagement in teaching are the questions teachers are able to ask students, the examples they create, and their analyses of student work. Among other mathematical foci, Ma explored differences in teachers' understanding of subtraction algorithms. Her findings illustrate the potential impact of the teachers' understanding and the ways in which different types of understanding might provide the basis for teaching that would support students' learning about subtraction. Needed are studies that can show connections between teachers' knowledge and the ways in which they engage in teaching practices. This would especially support teacher preparation, where resources are most plentiful, to scaffold improvement.

Since mathematical knowledge is likely to impact/influence mathematics teaching, it is important to understand how those resources impact teaching. To enhance the utility of what is learned, it will be important to focus studies on practices of teaching that are routine and crucial to students' learning of mathematics. Two such practices are eliciting student thinking and interpreting student thinking. Teachers use these practices to encourage students to share their thinking about specific academic content in order to evaluate student understanding, guide instructional decisions, and surface ideas that will benefit other students (TeachingWorks, 2016). Research on learning supports the use of teaching practices that enable teachers to know about and build on students' ideas. It also shows that teachers who know about their students' thinking and use that knowledge to influence their instruction have a significantly greater impact on student achievement (Black, & Wiliam, 1998). Hence, understanding the connection between mathematical knowledge and preservice teachers' engagement in the teaching practices of eliciting and interpreting student thinking is likely to be use to the wider field.

In this context, this paper reports on research driven by a desire to better understand the ways in which mathematical knowledge influences preservice teachers' engagement in eliciting and interpreting student thinking. We studied these teaching practices of preservice teachers within a mathematical content strand that dominates the primary grades – number and operation – zooming in on the operation of subtraction. Within subtraction, we focus on the use and understanding of different algorithms to solve problems, an area in which preservice teachers experience difficulty connecting their knowledge of traditional algorithms to alternative approaches (Son, 2016). Our research was guided by the question: What is the relationship between preservice teachers' mathematical knowledge of particular mathematical algorithms and the ways in which they approach eliciting and interpreting student thinking about those algorithms?

Using simulations to learn about preservice teachers' engagement in eliciting and interpreting student thinking

A practical problem that arises is how to study the ways in which preservice teachers' mathematical knowledge of particular mathematical algorithms impact their eliciting and interpreting of student thinking. We chose to design and use simulations in which preservice teachers engage in eliciting and interpreting a student's thinking about the use of a particular subtraction algorithm. Simulations are approximations of teaching that place authentic, practice-based demands on a participant while purposefully suspending or standardizing some elements of a teaching situation (Shaughnessy &

Boerst, 2018). For each simulation, we developed a piece of student work and then designed an elaborate protocol detailing how a student would: complete the process shown in the work; reason about the process used; talk and act when questioned about the process. Those taking on the role of the student (teacher educators) were trained so that they could use information from the protocol as the basis for engaging in the situation and so that they could respond in ways that aligned with the profile of student thinking and acting.

Our decision to use simulations was driven by four factors. First, simulations of practice have proven to be usable in many professions to gauge clinical knowledge and skills (e.g. Boulet et al., 2009). Second, simulations provide reliable access to teaching situations that other methods, such as interviewing real children or interviewing in school contexts, could not. Third, simulations allow for the standardization of the assessment context (Shaughnessy, Boerst, & Farmer, 2018). Fourth, our goal required a design that would purposefully put preservice teachers in situations where their mathematical knowledge was low. The use of simulations allowed us to accomplish this while preserving our own ethical commitments to educating children and consistently positioning preservice teachers to work productively with children.

Methods

We collected information about the mathematical knowledge of preservice teachers and used that information to assign them to three teaching simulations that each strategically positioned preservice teachers to elicit a student's thinking about a particular algorithm that had been used to compute an answer to a subtraction problem. Specifically, the simulations were designed to present opportunities to elicit a student's thinking about algorithms about which the preservice teachers had different degrees (known to the researchers) of mathematical knowledge. Twenty-four elementary preservice teachers from one teacher preparation program participated. Because our goal was not to bound our analysis to any point in time during a teacher education program, we purposefully recruited preservice teachers who were at different points in the program. Specifically, two were at the beginning of the teacher education program, eight were at the midpoint of the teacher education program, and 14 were at the end of the program. Next, we describe the pre-assessment, the assignment of preservice teachers to specific simulations, and the administration of the teaching simulations.

Pre-assessment of mathematical knowledge

We designed an assessment of mathematical knowledge inclusive of four subtraction algorithms that could be encountered in a subsequent teaching simulation. These algorithms, shown in Figure 1, include: A) the US traditional algorithm for subtraction; B) adding up subtraction; C) subtracting from the base; and D) expand and trade subtraction. Largely, these algorithms represent processes that are either directly taught through common US mathematics curriculum materials or are likely to surface in some form during mathematics work in US classrooms. One was deliberately picked to represent an algorithm that would likely be unknown to preservice teachers.

Figure 1. Pre-assessment subtraction algorithm examples

Preservice teachers were shown two examples of students' use of each of the subtraction algorithms, resulting in eight total examples to analyze. Half of the examples showed how the algorithms could result in correct answers and the other half of the examples showed how the algorithms could result in incorrect answers. This was done because of the potential for inaccuracy to influence preservice teachers' understanding of the different algorithms. For each example, preservice teachers were asked to determine accuracy of the answer, describe the steps that the student likely used to arrive at the answer, provide an explanation about the mathematical validity of the student's method, and apply the student's approach to another problem. The intent was to capture information that would allow us to categorize each preservice teacher's mathematical knowledge of each algorithm as "strong", "moderate", or "weak" relative to the mathematical knowledge shown across the algorithms. For each preservice teacher, the subtraction algorithm about which they demonstrated the most understanding was designated as "strong" and the subtraction algorithm about which they demonstrated the least understanding was designated as "weak. Those algorithms that were neither strong nor weak were designated as "moderate."

Assignment of preservice teachers to particular simulations

We used information from these pre-assessments to assign preservice teachers to three simulations. One simulation involved a "student" using an algorithm for which the preservice teacher was characterized as having strong mathematical knowledge (relative to the other algorithms). Another simulation involved a "student" using an algorithm for which the preservice teacher was characterized as having weak mathematical knowledge (relative to the other algorithms). An additional simulation involved a "student" using an algorithm for which the preservice teacher was characterized as having moderate mathematical knowledge (relative to the other algorithms).

Administration of the teaching simulations

All simulations were facilitated through the same sequence of stages. First, the preservice teacher prepared for an interaction with one simulated student (i.e., a teacher educator taking on the role of the student) by reviewing a specific piece of student work and considering what would be relevant to ask the student. For each simulation, they had 10 minutes for this preparation work. Second, the preservice teacher elicited and probed the simulated student's thinking to understand the steps she took, why she performed particular steps, and her understanding of the key mathematical ideas involved. Preservice teachers had five minutes to interact with the student. All preservice teachers finished their interactions within this time frame. All simulations were video recorded to support

scoring and research purposes. Third, following the simulation, the preservice teacher responded to questions about their interpretation of the student's process and understanding and their prediction about the student's performance on a similar problem. Interviewers followed up on the preservice teachers' responses as needed.

Methods of analysis

We analyzed the simulation performances in which the preservice teachers elicited student thinking and the follow up interview in which the preservice teachers interpreted student thinking. Because the simulations made use of highly specified protocols for the student's processes, understandings, and ways of being, we were able to use checklists to track on the absence or presence of particular moves (Shaughnessy, & Boerst, 2018). Our checklists for the eliciting portion of the teaching simulations are based on an articulation of "high-quality" eliciting of student thinking. For example, high-quality eliciting student of thinking includes: eliciting the process/steps involved in using the algorithm and probing understanding of the algorithm and ideas underlying the algorithm. The checklist includes specific things that the preservice teacher might do in the context of each teaching simulation (e.g., probes why borrowing works) and specific responses that the student provides based on their preparation and training (e.g., "When you borrow, you're not changing the problem. You're just moving the same amount to a different place) when prompted by the preservice teacher. The practice of interpreting student thinking includes describing the components of the algorithm used by the student, making claims about the student's understanding of the algorithm, and substantiating claims by drawing on evidence from a larger body of data gathered from the eliciting. The checklist includes specific things that the preservice teacher might do in the context of each teaching simulation (e.g., describes the student's understanding of why borrowing works). For interpreting, we also cross-check any evidence that a preservice teacher cited with the information gathered during the interaction with the student to ensure that they had the evidence that they cited. For each situation, we further specified crucial "core" components of the process and understandings that were at the heart of the student's algorithm, ones that would be particularly important to attend to in the interpretation.

Each performance was appraised by two members of the research team. Disagreements were resolved through review of the data and remediating differences of interpretation by developing and refining a codebook.

Findings: Connecting the preservice teachers' eliciting with their mathematical knowledge and disposition

As noted previously, we analyzed the quality of each preservice teacher's eliciting performance in a context in which the preservice had "*strong mathematical knowledge*" of the subtraction algorithm versus their performance in which they had "*weak mathematical knowledge*" of the subtraction algorithm. We next turn to findings related to their eliciting and interpreting of student thinking.

Eliciting practice

For each teacher, we compared their eliciting performances in the strong mathematical knowledge simulation context (SM) and the weak mathematical knowledge simulation contexts (WM). There were no differences across the two conditions with respect to the preservice teachers' eliciting of the student's procedural steps to solve the problem. However, preservice teachers probed for the students' understanding of the process more frequently in the SM simulation ($M = .792$, $SD = .2518$) than in

the WM simulation ($M = .313$, $SD = .3848$), $t(23) = 5.468$, $p < .001$. In other words, when preservice teachers had stronger understanding of mathematics of the student's algorithm (relative to the second algorithm), they more frequently elicited the student's understanding about core ideas.

Interpreting practice

For each preservice teacher, we compared their interpreting performances in the SM simulation context and the LM simulation context. Preservice teachers did not differ in their skills in interpreting the procedural steps of the algorithm used by the student in the two contexts. Almost all of the preservice teachers named all of the student's steps in both contexts. However, the quality of their interpretation of the student's understanding of the process that was used was significantly higher in the SM simulation ($M = .500$, $SD = .3612$) than in the WM simulation ($M = .188$, $SD = .3234$), $t(23) = 3.498$, $p < .002$. In other words, preservice teachers were better at interpreting the students' understanding in situations in which they had strong mathematical knowledge of the algorithm compared to a situation in which their mathematical knowledge was comparatively weaker.

Implications and next steps

Preservice teachers demonstrated different eliciting and interpreting skills across two situations – one in which they had relatively high mathematical knowledge of a particular subtraction algorithm being used by a “student” and one in which they had relatively weak mathematical knowledge of a different subtraction algorithm. Preservice teachers focused their eliciting and interpreting practices more on student understanding when they had relatively strong mathematical knowledge. In some ways this finding is not surprising. Strong mathematical knowledge of an algorithm may enable preservice teachers to know what to ask about in terms of understanding. Further, in interpreting student thinking, mathematical knowledge of an algorithm may impact preservice teachers' abilities to identify the mathematical understanding that are worth naming. To be clear, in our work with preservice teachers we have seen cases where preservice teachers with strong mathematical knowledge of a situation did not elicit much thinking from the student, but instead made assumptions about the process and the students' understanding based on a combination of the student's written work and their own understanding of the algorithm. A contribution of the study was gain a better sense of the degree to which such engagement was common (or not) in our context. While this study does not provide insight into the reason(s) behind the differences in the practices, this outcome is useful because it shows concretely that differences in practice predicted by researchers like Ma (1999) who had theorized that greater mathematical knowledge would enable engagement in teaching practices that support student understanding of mathematics.

Some elements of the preservice teachers' eliciting and interpreting were not significantly different across the two situations. Notably, there were not marked differences in the extent to which preservice teachers elicited procedural aspects of the student's algorithm. Likewise, there were not marked differences in preservice teachers' interpretations of procedural aspects across the different algorithms. When coupled with the previous analysis, this indicates a nuanced relationship between knowledge and teaching practice. The degree to which mathematical knowledge impacts the focus of teaching practices with respect to some facets of mathematics (understanding) more than others (procedural) is interesting. It is plausible that differences were not seen due to the fact that eliciting information about steps in a mathematical process, like an algorithm, may be more straight forward than eliciting information about understanding and thereby are not as heavily impacted by the degree

of mathematical knowledge one has about an algorithm. The similarity of eliciting and interpreting with respect to the steps in an algorithm is notable for the questions it suggests. What enables preservice teachers to elicit and interpret student thinking about the procedural aspects of an algorithm irrespective of the depth of their mathematical knowledge about the algorithm? What compels preservice teachers to elicit student thinking about the procedural aspect of an algorithm and to attend enough to the procedural aspects to be able later to produce accurate evidence-based interpretations?

A clear limitation of the study findings presented here is consideration of other factors that might be contributing to the differences in eliciting and interpreting practices. For instance, a teacher's mathematical dispositions may shape teaching practices in ways that impact students' opportunities to learn mathematics (Thompson, 1992; Philipp, 2007). As an example, in our own work with preservice teachers, we frequently hear differing, and often strongly expressed, dispositions toward particular computational algorithms. These dispositions influence and give structure to how teachers perceive students' engagement in mathematics. Studies have illustrated ways in which dispositions can impact the classroom practices of teachers (e.g., Fennema et al., 1996). Some of the connections between teaching practice and content knowledge that we have shared in this paper could be explained by the influence of mathematical disposition. For instance, it is just as plausible that a positive mathematical disposition may result in preservice teachers believing that it is worth asking questions about understanding because they personally know that the algorithm can be understood as it is that strong mathematical knowledge is the resource driving that approach to the practice. Given the potential for mathematical knowledge and mathematical dispositions to be mutually influencing (e.g. the more robust the mathematical knowledge of the teacher about an algorithm the more favorable the disposition to engage in and with the algorithm), in current work, we are teasing apart their influences with respect to engagement in teaching practices.

Acknowledgments

The research reported here was supported by the National Science Foundation under Award No. 1535389. Any opinions, findings, and recommendations expressed are those of the authors and do not reflect the views of the National Science Foundation. The authors acknowledge the contributions of Merrie Blunk, Rosalie DeFino, Susanna Owens Farmer, Erin Pfaff, and Xueying Ji Prawat to the design of the simulations, data collection, and data analysis.

References

- Black, P., & Wiliam, D. (1998). Assessment and classroom learning. *Assessment in Education: Principles, Policy, and Practice*, 5(1), 7–74.
- Blank, R., & Atlas, N. (2009). *The effects of teacher professional development on gains in student achievement*. Washington, D.C.: Council of Chief State School Officers.
- Boulet, J., Smee, S., Dillon, G., & Gimpel, J. (2009). The use of standardized patient assessments for certification and licensure decisions. *Simulations in Healthcare Spring*, 4(1), 35–42.
- Cohen, D. K., Raudenbush, S., & Ball, D. L. (2003). Resources, instruction, and research. *Educational Evaluation and Policy Analysis*, 25(2), 119–142.
- Council of Chief State School Officers. (2013). *Interstate Teacher Assessment and Support Consortium InTASC Model Core Teaching Standards and Learning Progressions for Teachers 1.0: A Resource for Ongoing Teacher Development*. Washington, DC: Author.

- Council of Chief State School Officers. (2010). *Common Core State Standards*. Washington D.C: National Governors Association Center for Best Practices.
- Fennema, E., Carpenter, T., Franke, M., Levi, L., Jacobs, V., & Empson, S. (1996). A longitudinal study of learning to use children's thinking in mathematics instruction. *Journal for Research in Mathematics Education*, 27(4), 403–434.
- Hill, H. C., Rowan, B., & Ball, D. L. (2005). Effects of teachers' mathematical knowledge for teaching on student achievement. *American Educational Research Journal*, 42(2), 371–406.
- Learning Mathematics for Teaching. (2008). *LMT measures of Mathematical Knowledge for Teaching: Elementary Number Concepts and Operations*, 2008. Ann Arbor, MI: Authors.
- Ma, L. (1999). *Knowing and teaching elementary mathematics: Teachers' understanding of fundamental mathematics in China and the United States*. Mahwah, N.J.: Erlbaum.
- National Board for Professional Teaching Standards. (2012). *Early childhood/generalist standards, 3rd Edition*. Washington, D.C.: NBPTS.
- Philipp, R. (2007) Mathematics teachers' beliefs and affect, In F. Lester (Ed.), *Second handbook of research on mathematics teaching and learning* (pp. 257–315). Charlotte, N.C.: Information Age.
- Shaughnessy, M., & Boerst, T. (2018). Designing simulations to learn about preservice teachers' capabilities with eliciting and interpreting student thinking. In G. J. Stylianides & K. Hino (Eds.), *Research advances in the mathematical education of pre-service elementary teachers – An international perspective* (pp. 125–140). New York: Springer.
- Shaughnessy, M., Boerst, T., & Farmer, S. O. (2018). Complementary assessments of preservice teachers' skill with eliciting student thinking. *Journal of Mathematics Teacher Education*. <https://doi.org/10.1007/s10857-018-9402-x>
- Son, J. (2016). Moving beyond a traditional algorithm in whole number subtraction: Preservice teachers' responses to a student's invented strategy. *Educational Studies in Mathematics*, 93, 105–129.
- TeachingWorks. (2016). High leverage teaching practices. Retrieved November 1, 2016, from <http://www.teachingworks.org/work-of-teaching/high-leverage-practices>.
- Thompson, A. (1992). Teachers' beliefs and conceptions: A synthesis of research. In D. Grouws (Ed.), *Handbook of research on mathematics teaching and learning* (pp. 127–146). New York: Macmillan.

High school teacher training challenges in the Italian interdisciplinary project *Liceo Matematico*

Laura Branchetti¹, Roberto Capone², Francesco Saverio Tortoriello²

¹University of Parma, Department of Mathematical, Physical and Computer Science, Italy;
laura.branchetti@unipr.it

²University of Salerno, Department of Mathematics, Italy, rcapone@unisa.it, fstortoriello@unisa.it

Keywords: *Teacher education, Teacher professional development, Teaching methods, Interdisciplinarity, Mathematics Teacher's Specialized Knowledge*

The project *Liceo Matematico* and the issue of teacher training

In this work, we deal with a challenging research question: what teacher training activities are effective to train mathematics high school teachers to teach properly interdisciplinary modules involving Mathematics? The context of the research is an Italian national project for high schools, named *Liceo Matematico* (Capone *et al.*, 2016), that aims at turning Mathematics, hard subject to learn, into a tool to connect disciplines and deal with current social challenges. To make this possible, it is necessary first to deepen into the epistemology of disciplines and to look for fruitful connections between them, then to design suitable modules for high school students. Operationally, the project consists in additional activities for high school students (40 hours per year), carried out by voluntary mathematics high school teachers, trained by university teachers. University teachers identify topics, epistemological issues and interdisciplinary connections (Frodeman, Thompson Klein and Mitcham, 2010) relevant in order to pursue the general goal of the project, and then propose possible classroom activities. Each module is proposed in 2 steps: in the first the contents are presented with a frontal lesson, while in the second step the didactical activities are before proposed to the teachers and then discussed with them in terms of potential students' difficulties and connections with the curriculum. After the course, the high school teachers have to choose some modules and adapt them for their students, consistently with the school institutional constraints and goals. We focus our attention on the teachers' choices and adaptations of the modules proposed in the training course.

Research framework: Mathematics Teachers Specialized Knowledge

To describe the aspects of teachers' knowledge considered in the training course, we chose to use the Mathematics Teacher's Specialized Knowledge (MTSK) model elaborated by Carrillo-Yañez, Climent, Montes, Contreras, Flores-Medrano, Escudero-Ávila, Vasco, Rojas, Flores, Aguilar-González, Ribeiro and Muñoz-Catalán (2018). Such model is focused on "the specialized components of mathematics teachers' knowledge, that is, their knowledge of mathematics as the object of teaching and learning" (*ibid.* 2018, p. 14). It includes three sub-domains of Mathematical Knowledge: mathematics content itself (*Knowledge of Topics, KoT*); the interlinking systems which bind the subject (*Knowledge of the Structure of Mathematics, KSM*); how one proceeds in mathematics (*Knowledge of Practices in Mathematics, KPM*). For what concern the pedagogical content knowledge (PCK), two sub-domains concerned teaching and learning (Ball *et al.*, 2008), *Knowledge of Mathematics Teaching (KMT)* and *Knowledge of Features of Learning Mathematics (KFLM)*, while the last sub-domain of PCK is *Knowledge of Mathematics Learning Standards (KMLS)*.

Methodology of the research

We carried out a preliminary study after the first year of teacher training to investigate whether and how the course had provided teachers with the suitable knowledge that could allow them to adapt the trainers' proposals without transforming them so much to lose their most important aspects. We analyzed the modules proposed by university teachers using the model MTSK and then we used the same model to analyze the teachers' choices and adapted modules. Finally, we analyzed the teachers' adaptations in terms of differences and similarities with the original proposals, identifying the sub-domains of MSKT that were more considered by the teachers to adapt the modules.

Data analyses

For the first year the modules proposed by university teachers were: theorems with Origami; programming languages; congruence and divisibility; the language of Physics; From frescoes to videogames. The modules addressed merely the following domains: KoT (5/5), KSM and KPM (3/5); the only modules including interdisciplinary aspects explicitly were Languages of Physics and Art & Science. Looking at patterns in teachers' choices and adaptations, it emerged that the interdisciplinary modules were the less considered and, in these cases, the teachers felt the necessity to modify them a lot, separating and juxtaposing Mathematics and the other disciplines, using merely the epistemological perspective of Mathematics and using the other disciplines just to engage students and act on motivation, without really integrating the two as it was proposed in the modules.

Discussion and conclusions

One of the main aspects of the *Liceo Matematico* project is interdisciplinarity. This preliminary analysis showed that the interdisciplinary activities were the most problematic to adapt for the teachers and the less chosen, so we realized that another kind of specialized knowledge is necessary for the teachers to carry out meaningful interdisciplinary activities, that we name *Mathematics Interdisciplinary Knowledge (MIK)*, i.e. the awareness of the different epistemological status of the disciplines, fruitful connections and critical issues emerging when mathematics is integrated with other disciplines, both sciences and humanities. Without a specific meta-reflection on these aspects the teachers fail in identifying the crucial points of interdisciplinary activities. In the second year we are interacting with the teachers addressing explicitly this point and looking for activities in the course that potentiate the MIK domain. As a general aim, we will try to characterize explicitly this domain providing examples and clarifying its specificity, according to our a priori analysis and results.

References

- Capone, R., Dello Iacono, U., Tortoriello, F.S., & Vincenzi, G. (2016). Math high school: A teaching proposal. *Proceeding of History and Pedagogy of Mathematics*, Montpellier, France.
- Carrillo-Yañez, J., Climent, N., Montes, M., Contreras, L. C., Flores-Medrano, E., Escudero-Ávila, D., Vasco, D., Rojas, N., Flores, P., ... & Muñoz-Catalán, M. C. (2018): The mathematics teacher's specialised knowledge (MTSK) model. *Research in Mathematics Education*.
- Frodeman R., Thompson Klein, J., & Mitcham, C. (Eds.) (2010). *The Oxford handbook of interdisciplinarity*. Oxford: Oxford University Press.

Researching as a mathematics teacher educator: analysing mathematics teachers' detailed descriptions of first lessons

Laurinda Brown

University of Bristol, School of Education, Bristol, UK; Laurinda.Brown@bristol.ac.uk

As a mathematics teacher educator, researching classroom environments and practices has supported me in linking theory and practice so that awarenesses developed support the prospective teachers with whom I work. The research has built a belief that there is not one way to teach mathematics. How do experienced mathematics teachers create the environment in which they teach? What do they consistently do from their first lessons with a group? This paper reports on interviews with effective teachers of mathematics in the UK where they stay with the detail of what happened in recent first lessons with a group new to them to illuminate their decision-making processes as they establish the culture of their classrooms. Energetic statements arising out of the detail, such as “I like to give things a story” can be used to support novice prospective teachers, like with Alf Coles, to find the teacher they can be when faced with not knowing what to do when teaching their first lessons.

Keywords: Mathematics teacher educator research, classroom environment, interviewing.

Background

Over my career as a mathematics teacher educator (MTE), I have interviewed many experienced teachers of mathematics. As I accepted the post of lecturer in mathematics education, in 1990, I left the classroom and my then role as a curriculum developer. I became fascinated by the mathematics teaching of others that seemed so different from my own. This paper explores stories from experienced mathematics teachers related to the detail, elicited using an interview, of their first lessons with a new group of students, investigating the questions: How do experienced mathematics teachers create the environment in which they teach? and What do they consistently do from their first lessons with a group? The first set of interviews explored the first lessons of experienced teachers because my prospective teachers did not have access to these and did not know what to do in their own first lessons. They may have had ideals of what they wanted to be as a teacher, with a view of what a classroom in which learning mathematics takes place might be like, but they did not have the experience to have honed the skills that would allow this vision to exist.

I have continued to interview practising teachers as part of my research to extend my awarenesses of possible practices, rather than come to some fixed view of what mathematics teaching looks like. Over time, my interviewing practices have changed and these interviewing practices have also influenced my practice as an MTE. In what follows, I will first discuss my interviewing practices and how these link to my practices as an MTE and will then move on to discuss cases of interviews.

On interviewing

The original “first lesson” interviews were designed using Bruner’s (1990) ideas of a “culturally sensitive psychology”:

[which] is and must be based not only upon what people actually do but what they say they do [...] how curious that there are so few studies that [ask]: how does what one does reveal what one thinks and believes. (pp. 16–17)

I will be reporting on what the teachers actually do and what they each say they do in their mathematics teaching to illuminate their decision making in the next section. It was the access to the decision making that was supportive of the developing prospective teachers because I had a range of anecdotes available in group and individual discussions in those early days. However, as my interviewing skills developed, especially through Claire Petitmengin's writing and protocol, the process of interviewing became part of the structures of the course.

First lesson interviews

First lessons with a new group of students were important to teachers in establishing their ways of working, but were often times where observers of the lessons were not so welcome. This included having a video-recorder in the classroom because it might cause a distraction in an important lesson or sequence of lessons. As a new mathematics teacher educator, I was fascinated by observing different mathematics teachers and their students interacting. The nearest I could come to observing first lessons was to interview teachers as soon after the lesson as possible.

At the time, I designed an interview protocol where each teacher interviewed was invited to tell me in detail about a first lesson or sequence of lessons with a group of students who had not been taught by them before. I wanted to focus on what happened in some detail as the teacher established their ways of working with the class. In looking at the transcripts again, I was struck by how similar my current interviewing protocol is and was moved to listen again to the tape-recordings (having found a player!) listening this time for when each teacher's voice was more energetic. This energetic voice was heard at times when they were talking *about* the detail, seeming to discover meaning in what they had been doing. The first-lesson interviews were an important critical incident in my own development as a mathematics teacher educator. I started to listen for energetic comments from my prospective teachers, as evidence of their learning, articulations of what previously had been implicit.

Claire Petitmengin's interview protocol

The protocol for interviewing I currently use is adapted from the work of Petitmengin (2006) and has strong similarities with those early interviews. Petitmengin designed the protocol for her doctoral study, related to supporting epileptics to identify internal changes prior to having a fit. The design of the study linked the third-person neuroscience that had shown the changes in mappings of the brain, with a phenomenological first-person protocol redesigned as a second-person interview. The behaviours for the interviewer were the focus of Petitmengin's protocol and are as follows:

Stabilising attention. A regular reformulation by the interviewer of what the subject has said, asking for a recheck of accuracy (often in response to a digression or judgement). Asking a question that brings the attention back to the experience, such as, "How did you do that?"

Turning attention from "what" to "how" (never "why").

Moving from a general representation to a singular experience, a re-enactment, reliving the past as if it were present. Talking out of their experience, not from their beliefs or judgements of what

happened, often involves a move to the present tense. Staying with the detail is important, a maximal exhaustivity of description that allows access to the implicit. (adapted from pp. 239–240)

One of the changes in my own behaviour as an interviewer over the years has been to let go of “why” questions, whilst still supporting interviewees “talking out of their experience, not from their beliefs or judgements” (Petitmengin) to focus on “what people actually do [and] say they do” (Bruner). The changes in my behaviour as interviewer also led to changes in my behaviour as MTE. There was a realisation that the actions in the protocol were useful for supporting any learning, which could be described as “access to the implicit”. So, using these strategies could support the prospective teachers in supporting the learning of the students in their classrooms, getting them to talk through what they were doing when stuck on a problem say, and asking for evidence or examples when faced with an assertion. I developed an activity under the label of “diagnostic questioning” for prospective teachers to listen in pairs to each other solve a mathematical problem whilst the “interviewer” used strategies to draw out the other rather than get involved in the mathematics themselves. Over time, Alf Coles and I, who were colleagues teaching the prospective teachers together, extended the protocol for what we call narrative interviewing to a fourth point:

Getting to new category labels. After dwelling in the detail, telling stories and exploring without judgement or digressions, invite statements of what is being worked on. In this way, new category labels might be identified [...] that will link to learning new actions. (adapted from Brown & Coles, 2018, p. 178)

The prospective teachers need to act in the classroom even when they have no experience to draw on. In a small group, led by one of the MTEs acting as facilitator, the prospective teachers are asked to think of a story when they were feeling uncomfortable in their recent classroom experience. One person tells their story, without judgements or digressions, minimally and this is followed by others in the group telling stories that seem similar to them in some way (see The Mathematical Association, 1991, working group chaired by Barbara Jaworski). At some point, a discussion about what is similar about the stories happens and these statements might be different for different students. This discussion might give a range of “new category labels”, for example, “How do I know what they know?”; “How do I know that they know?” that can be worked on by those prospective students who find them meaningful by trying out a range of actions in their classrooms that can be used flexibly to support the classroom environment. In this way, developing my skills as an interviewer impinged directly on my practice as an MTE.

Cases from the original first-lesson interviews

The teachers (10 in all from which I will illustrate two) were chosen by the three local advisory mathematics teachers who had observed them in their classrooms as being particularly effective (deliberately not defined because I wanted a range). The teachers were encouraged to stay with the detail of their first lesson with a new group of students and, in so doing, they also commented *about* the detail, without being prompted to by me. This might mean comments about their images of teaching and learning mathematics or about what mathematics was to them. These comments were said energetically, often quickly and explosively. In Petitmengin’s terms, I would now read these

comments as giving “access to the implicit”. In listening back to the original tape-recordings, for analysis, I paid attention to these energetic comments.

Case 1: “I like to give things a story”

One teacher in his first lesson with a new group described using the following problem:

I had a dream last night and, in that dream, this is what I heard. You must build a tower and from the top of the tower, sort of like a plus sign from the side, it should look like two staircases meeting. We haven't decided yet how big the tower should be but when we decide, you must be able to build it and organise the building of it.

After telling the problem, the following exchange occurred where there was a shift in the teacher's comments to be *about* what he had described, giving access to his thinking and beliefs:

Teacher: I like to give things a story because I like to give the children a natural language as a parallel to the mathematical language.

Laurinda: So, a story for you would apply basic language, not mathematical language. Any other things that you would say in the story?

Teacher: I think it allows enabling people to enter the world of maths you are talking about then if you have got a story if it's amusing or catchy in any way they might get interested in the first place, but it does provide short simple language with which they can converse with one another. So, it allows for group work which is something else I think.

In this extract, my contribution is stabilising attention, repeating back what I have heard said and returning the focus to the story, to the detail of what happened. This comment is followed by the teacher saying more *about* the thinking behind his decisions, giving insight into his vision of how the lesson will develop, what will be done over a sequence of lessons before returning to the detail of what happened:

By the end of two days' work we were going to have posters of this and I wanted the posters to be different and I wanted people to have things to look at which would be new for them and interesting, and I wanted different people to have different problems that they would be solving [...] just to show that a huge range of possibilities can come out of story anyway. There is not one right answer, there are lots of answers [...] I then asked them in groups again, individually, to write down the task and everything and the story and then in groups giving them five minutes to do that, in their groups to decide what kind of questions or concerns or worries the architect has.

Thoughts on Case 1

The word “story” is part of a rich set of interconnected images for this teacher. There are reasons such as using natural language alongside the mathematical language and also criteria for choosing a story, given that the children will do different things so that the children can see a “huge range of possibilities” emerging. Story is also linked to metacomments, where the students are asked to review each other's design and come up with questions for the architect. The element of role play makes the learning student-centred, in that they have to make decisions. The teacher sets up the environment of

the classroom and comments on the students' actions, whilst the students themselves are given the responsibility of doing the mathematics. Mathematics teaching and learning being about story is closely linked to this teachers' and their students' behaviours.

Case 2: “Mathematics is a study of pattern”

The teacher begins the mathematical part of his first lesson with:

So, on the board I write mathematics is a study of pattern. Basically, in a sentence I would say it is and then I draw little arrows and say there are two basic big areas of maths, one is numbers and the other is shape. I give them all this philosophical stuff. Today we are going to do an activity that is going to combine between these two things.

Quite soon after the description of what happened above, the teacher energetically, talking about what he does, revealing his passion, says:

What I find with children is they all think that maths is just numbers [...] I always try to emphasise how the two areas really do link because I think apart from anything else, anybody using the creative side of their brain, geometry can help a lot in understanding power in the numbers [...] bad experience with number work seems to block their whole mathematical enjoyment and I try to emphasise that maths is lots of things and not just knowing your times tables.

The teacher is clear what he wants students to be doing sitting them in groups to work together:

Well I'm looking for the children to be confident enough to be able to take an original idea and then move it on themselves into different areas.

Thoughts on Case 2

The teacher in Case 2 sees mathematics as pattern, linking to a passion for overcoming students' previous bad experience with number. All his interactions with students supported this. The problem, given to students first, is one that he has used before, many times and has confidence in. Initially, the teacher reports that, when asked what mathematics is at the start of the lesson, no-one responds, whereas, twenty minutes in to exploring a problem, that links number and shape, students are describing patterns and asking questions. The teacher is able to comment, about their work, to students that they are doing mathematics.

What follows is a report of using the interview protocol over four years, with the same teacher, Alf Coles, initially new to the profession, showing how the interviews change over time.

Alf Coles's first-lesson interviews

I first started working with Alf Coles in 1995. In the early days of working with him, he was a new teacher and I interviewed him at the beginning of his second year of teaching. I will use the first-lesson interview of 1995 to give some background to where the fourth protocol item developed and discuss differences with the interviews with experienced teachers.

Getting to new category labels

When I first met Alf, he was in his first year of teaching and did not have the experience to link his teaching practice with his beliefs. The protocol of asking for details of his first lessons gave us an

opportunity to see what underpinned his practice. There seemed, however, to be no energetic comments *about* his teaching occurring within the interview linked to what he does as a teacher. The following interchange from 1995 shows how Alf is finding some actions that support his ideal image of teaching mathematics as opposed to actually being able to achieve that ideal in his practice:

AC: With my year 9 class who I had in year 8 one of the things that I said to them at the beginning is that one of my aims this year is to try to make you independent thinkers, although who knows what independent means. That felt quite nice because I could come back to that.

LB: That was in a first lesson?

AC: Yes. That gave some power to when they said, “Can you tell us how to do this?” that I could say, “I’m wanting you to do this independently.”

Compared to how the teachers in the original first-lesson interviews talk about their teaching, in the 1995 interview, when reliving the first lessons with a new year 7 (11–12 years old) group, there were no comments from Alf about the details of his teaching and no energetic comments. It was in our conversation after the interview, when I reported back to him about this, that the comment above about the year 9 (13–14 years old) group emerged. This was an energised statement and evidence, to me, that he had begun his journey to be able to act in a way consonant with his beliefs. The interview was at the start of our work together and also developed into a conversation about what we might work on and what it was I was interested in. Some of my comments were linked to what he was saying. My comment, out of my experience of other first lesson interviews, was a response to Alf talking about his vision of teaching mathematics:

AC: A sense of what it’s like to create a space for students to work on their own images. A sense of how that could be maintained. Picking up from what students have said at the beginning of class [...] by some people giving their method or explaining what they’re doing it’s not that you’re taking away the journey from the others it’s helping them along.

LB: [A] description of you at the moment is that you have no metacommenting. Some teachers when they are teaching are metacommenting. Some people think of this as patter - [...] “remember to reflect on what you’re doing as well as do it.” [...] I don’t think I’ve spotted any. [I]t’s not good or bad. I think what happens to [experienced] teachers is that they become very clear about what they’re trying to do, so all those metacommments become completely standardised and in a sense they become close to their behaviours - it’s a sort of autopilot. Right down to a [child] comes up and says, “I’ve got a problem with this” gets a reply, “OK, you tell me.” It’s a metacomment because it’s saying, “I’m not going to engage with this until you tell me.”

As we continued to work together, each year I did another first-lesson interview at the start of a new academic year until, by 1999, a pattern had become established and the interviews were similar, with similar comments about what was happening. At this point, we wrote up our research in a book

(Brown & Coles, 2008). The 1999 interview illustrates the way in which the interview shows what Alf did and what he said he did. Alf states, near the start of the lesson,

AC: And I said welcome to mathematics at secondary school. [A]s well as all the skills and techniques like adding or multiplying or taking away that they will have learnt and they will continue to learn it's also about learning to become a mathematician [...] and learning to think mathematically [...] [I]f you're thinking mathematically then it's about noticing things about what's around you and it's about writing things down about what you notice [...] a question about something [...] maybe they've seen a pattern and a question that mathematicians often ask is "Why?" Make a prediction maybe based on that pattern. Say why they think that pattern will continue.

This purpose of the year "about learning to become a mathematician", was linked to behaviours for the students like asking questions and making predictions. There were also metacomments about the students' ways of working that Alf made, such as, "That's a really nice example of how working together mathematically as a group that in talking about how you're doing something you can recognise where you've gone wrong." These comments are not pre-planned. In the complex decision-making, moment-by-moment in his classroom, Alf's comments about what his teaching is about are underpinned by metacomments close to his and his students' behaviours in doing mathematics.

In working with Alf for the last twenty years, we have come to see staying with the detail, dwelling in it, as a mechanism for finding the images of teaching, new category labels, that can be linked closely to actions as teaching strategies emerge that support students. This is particularly important for working with prospective teachers of mathematics, who are in the position that Alf was in in 1995. Ideals, such as independence or autonomy, of what they want to be as a teacher, are not linked with a view of what a classroom in which learning mathematics like that might take place, nor to teaching strategies. They simply do not have the experience to have honed the skills that would allow this vision to exist.

Novice and expert teachers can learn in the same way, staying with the detail of what happens and dwelling in it, what Varela (1999) calls "deliberate analysis",

Indeed, even the beginner can use this sort of deliberate analysis to acquire sufficient intelligent awareness to [...] become an expert. (p. 32)

For an expert teacher, this could be creating a new label linked to a behaviour to solve an issue arising in their classroom. Intelligent awareness "allows experts to unpick, if necessary, the reasons an action was taken, and hence open themselves up to alternative possibilities in the future" (Brown & Coles, 2011, p. 862). This again, for us, is Petitmengin's "access to the implicit", bringing to conscious attention the behaviours that support the ideal images of teaching to be put into practice.

The first-lesson interviews with experienced teachers were not designed to change what the teachers were doing. These teachers were experienced and effective according to local mathematics advisory teachers. I was interested in how they did what they did.

Conclusions

So, how do experienced mathematics teachers create the environment in which they teach? From their first lessons, they are able to comment to students about their behaviours, for example, “you're doing mathematics” (Case 2) and give them activities related to their beliefs about what mathematics is, such as the story problem (Case 1). In cases 1 and 2, the teachers use problems they have confidence in to achieve their clear images of what their classrooms can look like with their students, “describing patterns and asking questions” (Case 2) or “different people having different problems they would be solving” (Case 1). What do they consistently do from their first lessons with a group? What does seem to be the case is that for all these teachers their beliefs are closely linked to their and their students' actions in their mathematics classrooms. Their different beliefs lead to different actions but, through the teachers metacommenting about actions they see as fitting their image of their mathematics classroom, the students know how to do mathematics in this teacher's classroom. Even though the practices vary with the images of mathematics and mathematics teaching and learning of the students, what seems important is the students knowing what to do. Prospective teachers, similarly to Alf Coles, can use this same process of staying with the detail to raise new possibilities for action. Paying attention to the variety of practices that could lead to effective mathematics teaching and learning supported my own development as an MTE, in that I came to see my role as not replicating my own classroom practices. As an MTE I gained conviction in there not being one way to teach or learn mathematics.

References

- Brown, L., & Coles, A. (2008). *Hearing silence: Steps to teaching mathematics*. Cambridge, UK: Black Apollo Press.
- Brown, L., & Coles, A. (2011). Developing expertise: How enactivism re-frames mathematics teacher development. *ZDM Mathematics Education*, 43(6–7), 861–873.
- Brown, L., & Coles, A. (2018). Reciprocal interviewing. In C. Comanducci & A. Wilkinson (Eds.), *Matters of telling: the impulse of the story* (pp. 177–184). Leiden, The Netherlands: Brill Rodopi.
- Bruner, J. (1986). *Actual minds, possible worlds*. Cambridge, MA: Harvard.
- Bruner, J. (1990). *Acts of meaning*. London, UK: Harvard University Press.
- The Mathematical Association (1991). *Develop your teaching: A professional development pack for mathematics – and other – teachers*. Oxford, UK: Stanley Thornes.
- Petitmengin, C. (2006). Describing one's subjective experience in the second person: An interview method for the science of consciousness. *Phenomenology and the Cognitive Sciences*, 5, 229–269.
- Varela, F. (1999). *Ethical know-how: Action, wisdom, and cognition*. Stanford, CA: Stanford University Press.
- Varela, F., Thompson, E., & Rosch, E. (1993). *The embodied mind: Cognitive science and human experience*. Cambridge, MA: The MIT Press.

Using mixed-assessments to evaluate opportunities to learn in mathematics teacher education

Nils Buchholtz¹, Katrin Vorhölter², Anna Orschulik² and Nadine Krosanke²

¹University of Oslo, Norway; N.F.Buchholtz@ils.uio.no

²University of Hamburg, Germany; Katrin.Vorhoelster@uni-hamburg.de, Anna.Orschulik@uni-hamburg.de, Nadine.Krosanke@uni-hamburg.de

Keywords: Summative assessment, formative assessment, e-portfolio, opportunities to learn, mixed methods.

Focus and rationale

Many teacher education programs require practical activities, like internships in schools or teaching experiments. Our task as teacher educators is to evaluate these activities and to assess performance-related achievements, either for certification reasons or for program development. However, the assessment of the development of teaching competence of pre-service teachers in practical teaching activities is methodically challenging. In our study, we wanted to overcome current challenges with this issue by using an innovative methodological approach. In our evaluation study on mathematics pre-service teachers' opportunities to learn (Buchholtz et al., 2018), a mixed-assessment was applied, consisting of a summative assessment (SA) of pre-service teachers' perceived study content and a formative assessment (FA) on situation-specific learning opportunities during internships in schools.

Theoretical background

In their review of research on the assessment of competencies in higher education, Blömeke, Gustafsson, and Shavelson (2015) model competence as a continuum that comprises dispositions, situation-specific skills, and performance. They also point to the challenges of an appropriate assessment: Pure cognitive-analytical approaches (like knowledge tests) lack sufficient validity because relevant parts, like the situational or contextual facets, can be underrepresented, and pure performance-based assessments might neglect the contribution of dispositional resources. Assuming that "the whole is greater than its parts" (p. 9), Kaiser et al. (2017) recommend working with a broader range of combined and situated assessment formats that are able to cover processes mediating the transformation of dispositions into performance. Other authors such as Carr and Claxton (2002) also understand learning as a situated activity; these authors point to the situatedness of what they call learning dispositions. Accordingly, they favour formative assessment (FA) approaches such as interviews and self-reports like those that appear in portfolios when it comes to the assessment of performance-related competence. However, unlike in summative assessment (SA) forms, FA forms presuppose that we have to give up the idea of comparing the achievements of pre-service teachers in a standardised way.

Methodology and corresponding research design

Against this background, two basic ideas of the mixed methods methodology can be transferred to the level of assessment (Kelle & Buchholtz, 2015). Using a *combination* of SA and FA can extend the scope of the assessment, i.e., both widen and deepen the assessment by gathering as much

information as possible on multiple components of the assessed phenomenon or different, but closely related phenomena. The basic idea of an *integration* of SA and FA is to assess one phenomenon with different assessment forms, for example by using SA in a formative way for giving feedback, or integrating FA as a part of an overall SA (Buchholtz, Krosanke, Orschulik et al., 2018).

Respectively, in our study, a panel-survey measuring the professional knowledge and learning opportunities of 187 pre-service teachers was *combined* with the analysis of 30 individual e-portfolios from internships in order to holistically address both dispositional and situation-specific aspects of learning opportunities to develop teaching competence. In particular, the FA during the internship was composed of 18 predetermined tasks affording situation-specific skills. The pre-service teachers had to address the tasks during their observations of other teachers or their own teaching in school, and to work on them as a written contribution to their personal e-portfolio. In favour of an increased interpretability of assessment results, a mutual complementation of the collective findings from the panel study with the findings from individual FA was sought (e.g. when identifying evidence for learning opportunities in FA). This approach might also partly overcome the challenge posed by the inability to standardize FA in teacher education.

Results

With SA data, we were able to determine comparatively that the analysed pre-service teachers had significantly higher perceptions of the number of learning opportunities regarding heterogeneity and research in mathematics education. Additionally, we used the data from the FA to identify pre-service teachers' situation-specific skills and to link the individual learning opportunities of the pre-service teachers with specific situational aspects of the school internships. With this combination, we were able to make detailed statements about the types of learning opportunities the pre-service teachers had, for example when dealing with errors in the classroom or differentiating instruction.

References

- Blömeke, S., Gustafsson, J. E., & Shavelson, R. (2015). Beyond dichotomies: Competence viewed as a continuum. *Zeitschrift für Psychologie*, *223*(1), 3–13.
- Buchholtz, N., Krosanke, N., Orschulik, A., & Vorhölter, K. (2018). Combining and integrating formative and summative assessment in mathematics teacher education. *ZDM Mathematics Education*, *50*(4), 715-728. <https://link.springer.com/article/10.1007/s11858-018-0948-y>
- Carr, M., & Claxton, G. (2002). Tracking the development of learning dispositions. *Assessment in Education: Principles, Policy and Practice*, *9*(1), 9–37.
- Kaiser, G., Blömeke, S., König, J., Busse, A., Döhrmann, M., & Hoth, J. (2017). Professional competencies of (prospective) mathematics teachers: Cognitive versus situated approaches. *Educational Studies in Mathematics*, *94*(2), 161–182.
- Kelle, U., & Buchholtz, N. (2015). The combination of qualitative and quantitative research methods in mathematics education: A “mixed methods” study on the development of the professional knowledge of teachers. In A. Bikner-Ahsbals, C. Knipping, & N. Presmeg (Eds.), *Approaches to qualitative research in mathematics education. Examples of methodology and methods* (pp. 321–361). Dordrecht: Springer.

Mathematical knowledge for teaching of a prospective teacher having a progressive incorporation perspective (PIP)

Esra Bukova Güzel¹, Gülseren Karagöz Akar², Aytuğ Özaltun Çelik³, Semiha Kula Ünver⁴ Nurdan Turan⁵

¹Dokuz Eylül University, Faculty of Education, Turkey; esra.bukova@gmail.com

²Boğaziçi University, Faculty of Education, Turkey; gulserenkaragoz@yahoo.com

³Pamukkale University, Faculty of Education, Turkey; aytug.deu@gmail.com

⁴Dokuz Eylül University, Faculty of Education, Turkey; semiha.kula@deu.edu.tr

⁵Boğaziçi University, Faculty of Education, Turkey; nurdanturan.94@gmail.com

This study examined mathematical knowledge for teaching of a prospective teacher having a PIP, Alin, and it revealed the relationship between PIP and mathematical knowledge for teaching. The case study design was used and the participant was selected by criterion sampling. Data were gathered from Alin's lesson plans, transcripts of her practicum-teachings, interviews done before and after her teachings, and self-reflections on her teaching. Results showed that Alin having a PIP demonstrated all the codes in the Knowledge Quartet. Results also showed that knowing the perspective a prospective teacher has allows to draw on the basis of her mathematical knowledge for teaching. This indicates that the perspective a prospective teacher has might induce her mathematical knowledge for teaching. We suggest ways to promote the development of a PIP on the part of prospective teachers during methods courses.

Keywords: Progressive incorporation perspective, Knowledge quartet, Prospective teachers.

Introduction

The perspectives prospective mathematics teachers have on mathematics, mathematics learning and mathematics teaching have affordances and limitations on their teaching (Jin & Tzur, 2011). Mathematics teacher education is not an easy task because of the traditional views prospective mathematics teachers hold (Ball & Cohen, 1999; Lloyd & Wilson, 1998). Therefore, researchers suggested that to develop mathematical knowledge for teaching on the part of prospective teachers, their learning to teach should be highlighted instead of giving them certain skills during methods and practice-teaching courses (Ebby, 2000; Hiebert, Glad, & Morris, 2003; Shulman, 1986; Simon, 1995).

Based on a series of research with in-service teachers, some researchers have come to the conclusion that (prospective) mathematics teachers might have a continuum between traditional perspective, perception-based perspective (PBP) and conception-based perspective (CBP) on mathematics, mathematics learning and mathematics teaching (Simon, Tzur, Heinz, & Kinzel, 2000; Heinz, Kinzel, Simon, & Tzur, 2000; Tzur, Simon, Heinz, & Kinzel, 2001). Jin and Tzur (2011), in their work with a group of mathematics teachers in China, have placed an intermediate category in this continuum between the perception-based perspective and the conception-based perspective: the Progressive Incorporation Perspective (PIP) (see Table 1).

Perspectives	View of knowing	View of learning	View of teaching
Traditional Perspective (TP)	Independent of the knower, out there	Learning is passive reception	Transmission, lecturing instructor
Perception-Based Perspective (PB)	Independent of the knower, out there	Learning is discovery via active perception	Teachers as explainer (points out)
PIP (PIP)	Dialectically independent and dependent on the knower	Learning is active (mentally); focus on the known required as start, new is incorporated in to known	Teacher as guide and engineer of learning conducive conditions
Conception-based Perspective (CBP)	Dynamic; depends on the knower's assimilatory schemes	Active construction of the new as transformation in the known (via reflection)	Engaging students in problem solving; Orienting reflection; facilitator

Table 1: Placing PIP within teacher perspectives (Jin & Tzur, 2011, p. 20)

They used the term “perspectives” to refer to both the knowledge and beliefs teachers might hold regarding the nature of mathematics, mathematics learning and mathematics teaching and also the practices they might engage in based on such acknowledgment. Tzur and his colleagues proposed that teachers holding CBP would act accordingly with the views of radical constructivist epistemology. They proposed that PIP would be a more realistic target for the teacher education since “a PIP-rooted teacher’s practice can engender students’ learning processes envisioned by CBP without requiring the teacher’s explicit awareness of such view...”. They argued that providing ways for prospective teachers to develop a PIP during methods and practice teaching courses will contribute greatly to the field of mathematics education. In this respect, in the larger study, during the methods and the practice-teaching courses, our purpose was to examine prospective secondary mathematics teachers’ development of PIP to teach mathematics effectively. In this paper, we report on the “mathematical knowledge for teaching (MKT)” of a prospective mathematics teacher who has been educated through these courses and has a PIP. Therefore, for this part of the study, investigating prospective teachers’ MKT once they have a PIP, we prepared a chart showing the list of characteristics a teacher would show in practice before, during and after the teaching. Also, when investigating MKT, we used the Knowledge Quartet (KQ) framework (see Table 2) (Rowland, Huckstep, & Thwaites, 2005).

Dimension	Contributory Codes
Foundation	(a) theoretical underpinning of pedagogy, (b) awareness of purpose, (c) identifying pupil errors, (d) overt display of subject knowledge, (e) use of mathematical terminology, (f) adherence to textbook, (g) concentration on procedures
Transformation	(a) teacher demonstration, (b) use of instructional materials (c) choice of representations, (d) choice of examples
Connection	(a) making connections between procedures, (b) making connections between concepts, (c) anticipation of complexity, (d) decisions about sequencing, (e) recognition of conceptual appropriateness
Contingency	(a) responding to students' ideas, (b) deviation from lesson agenda, (c) teacher insight, (d) responding to the (un)availability of tools and resources

Table 2: The Knowledge Quartet: dimensions and contributory codes (Thwaites, Jared & Rowland, 2010, p. 86)

The reasons we chose to use KQ in juxtaposition with the teacher perspectives framework was the following: First, we hypothesized that the framework corresponds to the three dimensions, nature of mathematics, mathematics learning and mathematics teaching, expressed in the perspectives. This is because as well the theoretical knowledge and beliefs related to mathematics and mathematics

education are handled in KQ, the theoretical knowledge possessed by teachers is transformed into teaching through connections and the existence of contingency moments revealing students' thoughts, mistakes and difficulties. Thus, student knowledge is also an important component of MKT. Secondly, we hypothesized that prospective teachers holding different perspectives regarding the nature of mathematics, mathematics learning and mathematics teaching might depict different MKT (Karagoz Akar, 2016). By the same token, even if prospective teachers depict the same MKT they might do so with having different reasons. For instance, prospective teachers with a PBP might not be able to anticipate students' difficulties and respond to their ideas in spite of the fact that they might specifically know the 'why' behind the concepts since they are not able to think from their students' point of view (e.g., Tzur et al., 2001). On the other hand, prospective teachers with a PIP might anticipate students' difficulty and deviate from the agenda because they purposefully take every opportunity to expose and discuss students' mistakes (Jin & Tzur, 2011). In this regard, scrutinizing the coherency between teacher perspectives and the domains in the Knowledge Quartet might help to uncover the reasoning behind (prospective) teachers' MKT. In other words, we conjectured that once prospective teachers had the PIP perspective, their MKT would reveal itself during their teaching. We chose the Knowledge Quartet framework for evaluating MKT of prospective teachers since it allows to depict the MKT of teachers' during their teaching qualitatively. Therefore with this study, we planned to make three main contributions to the field. First, how the practices of a prospective mathematics teacher with PIP before, during, and after teaching will be examined. Secondly, how such practices comprehensively revealing the relation between the characteristics of the PIP and the codes of KQ through empirical data, including before-during-after teachings and interviews, will be depicted. Third, and most importantly, how this correspondence presents evidences that a prospective teacher with a PIP is able to perform effective mathematics teaching will be explored. Diagnosing the reasons might provide teacher educators with particular steps to follow towards establishing more sophisticated perspectives and a full grasp of mathematical knowledge for teaching on part of prospective teachers. It is in this respect that the purpose of this study was to examine the MKT of a prospective mathematics teacher (Alin) who has a PIP and to reveal the relation between PIP and MKT. In light of our goal, the research questions were: "What are the indicators that Alin has the PIP?"; "How is Alin's MKT while examining the codes of KQ?"; "How is Alin's perspective reflected in MKT?"

Methodology

Participants

In the larger study, the participants were seven prospective secondary mathematics teachers who were in their fifth year of study at one of the universities, in which the medium of language is English, in Turkey. For the report in this paper, we chose one prospective teacher, Alin, having the highest GPA (Grand Point Average) (3,44). Based on the first week of the classes during the methods course, we observed her as a verbal individual. Also, she volunteered to participate in the continuing set of interviews and the teaching sessions till the end of the study. We used the data from her because the data were representative providing context that allowed us to examine the relationship between PIP and MKT.

Data Collection

For this study, Alin's practice teachings were videotaped and transcribed. Also, we conducted interviews with Alin to talk about her lesson plans prior to the teachings, observed her teachings and conducted interviews upon completion of the teachings within the same week. In this regard, we used a modification of account of practice methodology (Simon & Tzur, 1999). Therefore, we conducted an interview prior to and after the practice teachings and we also observed the lessons. In addition, Alin wrote self-reflection papers after watching her videotaped lessons based on reflection tasks (Öner & Adadan, 2011). For instance, in the interviews, we asked the rationale behind Alin's choice of the learning goal(s), the tasks and how she thought that the tasks she has chosen would allow students to learn meaningfully. We also asked what evidences of learning and difficulties of students she observed during teaching. In this paper, we report on one of Alin's practice teaching. She taught an 80 minute lesson to the 10th grade students in a private high school.

Data Analysis

First, each researcher analyzed Alin's perspective on mathematics, mathematics learning, and mathematics teaching and then analyzed her MKT through the Knowledge Quartet framework. We used coded analysis (Clement, 2000) for both frameworks. We analyzed the data to support theoretical hypotheses generated by the two frameworks and provided empirical data to show the coherence between these two frameworks that might yield to hypothesis generation, in the following way: First, each researcher read the lesson plans and transcripts from the practice teachings line by line, looking for Alin's explanations regarding her perspective. Using the characteristics of teacher perspectives taking into consideration of previous research, we looked for her existing meanings. Once we spotted a line of explanation regarding her meanings in any of the data sources, we also checked her reflection papers that could possibly provide further evidence of such meaning. Based on the conjectures, we continued to examine the rest of the data. Then, we came together to have a consensus on the data set and our analyses and went back to the whole data set to challenge our conjectures. After determining Alin's teaching perspective on mathematics, mathematics learning and mathematics teaching, secondly, using the codes from the Knowledge Quartet (see Table 2), we examined both this same data set and read further each of the data sources line by line to determine Alin's MKT. Then we came together to have a consensus on the whole data set to challenge our conjectures. Finally, we wrote the narrative regarding the relationship between Alin's perspective and her MKT.

Results

In this section, we share data showing Alin's perspective on mathematics, mathematics learning, and mathematics teaching and her MKT in relation to her perspective. Alin modified a task for her students to make sense of the function $f(x) = ax^2 + bx + c$ and the meaning of the coefficients a , b , and c on the graph of the function. During the pre-teaching interview, Alin stated that students could construct mathematical meanings by performing the mental operations required for the concept. Moreover, she said that her lesson plan would promote such learning.

Researcher: What do you want the students to learn as a concept?

- Alin: ... we need to observe the change of “ a ” one by one, and keep “ b ” and “ c ” constant so that we can only be aware of the change in “ a ” ... Let me say the amount of change in y in terms of x , rather than amount of increase, because “ a ” can be negative too. It is necessary for students to observe how the amount of change in y is changing. When “ a ” changed and x changed as one unit, they can compare the amount of change corresponding to y , so that they can have an idea about the shape of the graph, I mean the arms (referring to the parts of the parabola)... Actually, what I am learning is to compare the amount of change in y with respect to change in x as one unit for different “ a ” values.
- Researcher: Why do you think this [lesson] plan will promote your students’ learning?
- Alin: ...I’m starting with the amount of change in $y = x^2$; therefore, students need to recognize the arms of the graph gets open and there is a decrease, I mean, there is a change in slope... Starting always with $y = x^2$, how this change is formed and how this change affects the graph, so thinking this point... I mean, my activity provides quantitative operations by playing with something existing in their mind that they know.
- Researcher: You said playing with something they know, what do they know? Like could you explain one more time what is quantitative operations?
- Alin: They know what $y = x^2$ is, what its roots are, how the change occurs in $y = x^2$, I mean, how the slope is changing and how it looks in the graph. However, they don’t have any idea about what happens to the graph when “ a ” changes, because they don’t observe $ax^2 + bx + c$ for changing “ a ” values. Therefore, the quantitative operations formed in their mind when they changed “ a ”, I mean the thing they know in their mind, is like how the slope in $y = x^2$ is, how the amount of increase is, and drawing the graph.

Alin expressed that students need to compare the amount of change and examine how the change in the dependent variable occurs when the independent variable changes one unit, in order to construct the meaning of the coefficient “ a ” for a quadratic function. For Alin, students might create an idea about the graph and its structure by only performing these mental operations—comparing the amount of change. This suggests that for Alin mathematics is constructed depending on the learner's mind. Also, Alin planned her lesson hypothetically depending on her students’ mental operations and actions. We propose that this could be considered as an additional characteristic for the PIP. When we consider the MKT, data showed that Alin had awareness of the purpose for her teaching, and concentrated on the ways to reach that purpose. She effectively analyzed which mental operations students need to perform to make sense of the meaning of “ a ”. Her analyses revealed that she has a strong subject knowledge and theoretical background about coefficient “ a ” for quadratic functions. Moreover, her expressions about mathematical structure of the concept and her use of mathematical terminology supported that she has a strong subject knowledge. Also, she anticipated the complexity of the concept: She planned her lesson in such a way that by keeping “ b ” and “ c ” constant, students’ examining the change of “ a ” would be more efficient. Moreover, she gave priority to students’ mental processes and planned her lesson depending on students’ ideas rather than adhering the textbook or planning randomly. Her consideration of graphical demonstrations while students were examining the coefficient “ a ” showed that Alin has knowledge about different representations and she could integrate these representations into her lesson with relations to each other, too. Alin also stated that she planned to focus on students’ mental processes throughout the teaching so that students could

create concepts and structures of quadratic functions relating with their prior knowledge. She leaned on her choice of examples to this.

Researcher: You said you are starting with $y = x^2$. Why do you start with this?

Alin: Because $y = x^2$ is easy for students to understand and play on it, I mean they can use it to examine others... They know it very well, also they won't work away to find roots, but they will examine the change in "a" directly.

Data indicated that Alin chose $y = x^2$ as an example because students already knew this function. This suggested that she wanted to re-activated their prior knowledge: Alin believed that students learn new mathematical concepts by forming relationships between the new and old knowledge in the process. While planning her lesson, Alin's consideration of possible students thoughts' on examining the amount of change in the $y = x^2$ revealed that Alin took teaching process into consideration before she executed teaching. All these approaches Alin has taken in the process of before teaching displayed the first three dimensions of the knowledge quartet. In addition, data showed that Alin is aware that there might be unexpected events in the class:

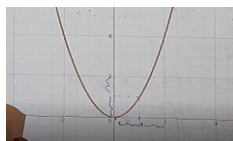
Researcher: ... What is the purpose of your questions? I mean why did you plan to ask these questions?

Alin: I will ask (questions) so that they can make relations. Some students could go faster but some could not. I can change my questions in a way to make them more understandable by the students. I can ask questions to fix their misunderstandings. I mean I will react regarding to students' thinking.

She explained that she prepared questions in her lesson plan to enable students to form connections and she is willing to make differences in classroom context depending on students' approaches because students could make connections in different ways. She also thinks that her plan could undergo some changes depending on the teaching process. Therefore, it can be interpreted that the contingency dimension is present in Alin's actions even prior to teaching.

This was also evident in her teaching: During teaching, she realized that students faced some difficulties. So, she deviated from her plan by presenting an example that was not in her lesson plan.

Alin: ...how does y values change when $y = x^2$ as x increases one by one, so when you consider the change of x... When you consider the change of it from 0 to 1, how does my y values change? From 1 to 2, how does y values change? (Waiting for several seconds)...



Okay, let's consider linear functions; like $y = 2x$. (Drawing on the board) In the linear function like this, when x goes through 1 to 2. When x is 1; y is 2. and x is 2 which value of y do you get?

When the students faced some difficulties to make sense of the change in y corresponding the one unit change in x, Alin tried to overcome such difficulty by providing an example not given in her lesson plan. She gave a linear function example of $y = 2x$ and wanted students to examine the amount of change in y given x. This approach revealed the codes of responding to students' ideas, deviation from agenda, and teacher insight during instruction presented in the contingency unit of the Knowledge Quartet. With this example and her questioning, Alin further allowed the students to overcome the difficulty and examine the amounts of change in the quadratic function. This showed that Alin provided opportunities for her students to reflect on their prior knowledge and connect it to

the new knowledge. Alin's approach also showed that she possessed the PIP's characteristic features: mathematics is both independent and dependent of the learner. That is, for her both linear and quadratic functions had qualities –the amount of change in the dependent variable given the change in the independent variable—out of the learner. Yet, the learners needed to make sense of such relationship on their own. She further explained her reasons about her choice of this example during the interview after teaching:

Alin: ...I did not give $y = x$ as an example because it goes as one to one, so I gave $2x$ as an example.... We talked on the board to look at x^2 . When we look at it, after the things between x values, when we draw the y values with arrows, students said that y values are increasing... In terms of their answers; whether they learned by heart or understood the rate of change. (I asked) Are you sure? Why? Re-express what your friend said... I was like pushing them like that...

Alin explained that she chose the example, $y = 2x$ rather than $y = x$ since the function $y = 2x$ could have triggered them to focus on the amount of change. Her insight during her instruction was strong enough that she realized her students' difficulties. She aimed at triggering their mental processes to form the concept by using the common features of linear and quadratic functions.

Discussion and Implementation

This study investigated mathematical knowledge for teaching of a prospective teacher having a PIP and revealed the relationship between PIP and mathematical knowledge for teaching. Results showed that the teaching of a prospective teacher having a PIP was effective because she planned her lesson with a view on mathematics as depending on learners' minds and revised her hypothetical plan for her teaching by considering both the learners' actions and reasoning. We might link the revisions of a hypothetical plan with contingency situations presented in the KQ, too. For instance, Alin considered her students' thoughts and deviated from her plan when she determined that her students had some difficulties during teaching. This is important because hypothetically determining the teaching process envisioning students' reasoning prior to the teaching is suggested to be an important part of MKT (Silverman & Thompson, 2008). This is also important in terms of noticing skills prospective teachers need to acquire (Jacobs, Lamb, & Philipp, 2010). Results of the study also suggest that if prospective teachers are trained to have a PIP, the strong MKT arises by itself. Particularly, the effects of Alin's perspective are seen precisely in the deep examination of data done with respect to the KQ framework before, during and after teaching. For example, Alin was aware of her students' having a different mathematics than hers. That is, she did not adhere to the textbooks, rather she focused on her students' mental actions and prior knowledge while she was deciding and arranging the lesson activities. Also, she always took into consideration her students' prior knowledge, even during teaching, and reactivated their prior knowledge to connect it to the newly established knowledge. So these were related with the connection, transformation and foundation dimensions in the KQ as well as her perspective on teaching. Based on these results, we suggest examining which codes of the KQ are activated before, during and after teaching and examining MKT of prospective teachers having different perspectives. Finally, we suggest to promote the development of a PIP on the part of prospective teachers during methods courses.

Acknowledgement

This paper is supported by Boğaziçi University Research Project, Grant Number: 11220.

References

- Ball, D. L., & Cohen, D. C. (1999). Developing practice, developing practitioners: Toward a practice-based theory of professional education. In L. Darling-Hammond & G. Sykes (Eds.), *Teaching as the learning profession: Handbook of policy and practice* (pp. 3–32). San Francisco: Jossey-Bass.
- Clement, J. (2000). Analysis of clinical interviews: Foundations and model viability. In A. E. Kelly & R. A. Lesh (Eds.), *Handbook of research design in mathematics and science education* (pp. 547–589). Mahwah, NJ: Lawrence Erlbaum Associates, Publishers.
- Ebby, C.B. (2000). Learning to teach mathematics differently: The interaction between coursework and fieldwork for pre-service teachers. *J Math Teacher Educ*, 3, 69–97.
- Heinz, K., Kinzel, M., Simon, M. A., & Tzur, R. (2000). Moving students through steps of mathematical knowing: An account of the practice of an elementary mathematics teacher in transition. *The Journal of Mathematical Behavior*, 19(1), 83–107.
- Hiebert, J., Morris, A. K., & Glass, B. (2003). Learning to learn to teach: An “Experiment” model for teaching and teacher preparation in mathematics. *J Math Teacher Educ*, 6, 201–222.
- Jacobs, V. R., Lamb, L. L., & Philipp, R. A. (2010). Professional noticing of children's mathematical thinking. *Journal for Research in Mathematics Education*, 41(2), 169–202.
- Jin, X., & Tzur, R. (2011). *Progressive incorporation of new into known: A perspective on and practice of mathematics learning and teaching in china*. Paper presented at Fifteenth Annual Conference of the Association of Mathematics Teacher Educators (AMTE), Irvine, CA.
- Karagöz Akar, G. (2016). Prospective secondary mathematics teachers’ perspectives and mathematical knowledge for teaching. *Eurasia Journal of Mathematics, Science and Technology Education*, 12(1), 3–24.
- Lloyd, G., & Wilson, M. (1998). Supporting innovation: The impact of a teacher's conceptions of functions on his implementation of a reform curriculum. *Journal for Research in Mathematics Education*, 29(3), 248–274.
- Oner, D., & Adadan, E. (2011). Use of web-based portfolios as tools for reflection in preservice teacher education. *Journal of Teacher Education*, 62(5), 477–492.
- Rowland, T., Huckstep, P., & Thwaites, A. (2005). Elementary teachers’ mathematics subject knowledge: The knowledge quartet and the case of Naomi. *J Math Teacher Educ*, 8(3), 255–281.
- Shulman, L. S. (1986). Those who understand: Knowledge growth in teaching. *Educational Researcher*, 15(2), 4–14.
- Silverman, J. & Thompson, P.W. (2008). Toward a framework for the development of Mathematical knowledge for teaching. *J Math Teacher Educ*, 11, 499–511.
- Simon, M. A. (1995). Reconstructing mathematical pedagogy from a constructivist perspective. *Journal for Research in Mathematics Education*, 26(2), 114–145.
- Simon, M. A., Tzur, R., Heinz, K., & Kinzel, M. (2000). Characterizing a perspective underlying the practice of mathematics teachers in transition. *Journal for Research in Mathematics Education*, 31(5), 579–601.
- Simon, M.A. & Tzur, R. (1999). Explicating the teachers’ perspectives from the researchers’ perspectives: Generating accounts of mathematics teachers’ practices. *Journal for Research in Mathematics Education*, 30(3), 252–264.
- Thwaites, A., Jared, L., & Rowland, T. (2010). Analysing secondary mathematics teaching with the knowledge quartet, *Informal Proceedings of the British Society for Research into Learning Mathematics*, (pp. 85–90). Newcastle: UK.
- Tzur, R., Simon, M. A., Heinz, K., & Kinzel, M. (2001). An account of a teacher's perspective on learning and teaching mathematics: Implications for teacher development. *J Math Teacher Educ*, 4(3), 227–254.

Teachers' Collaboration in a Mathematics Lesson Study

João Pedro da Ponte¹ and Marisa Quaresma²

¹Instituto de Educação, Universidade de Lisboa, Portugal; jpponte@ie.ulisboa.pt

²Instituto de Educação, Universidade de Lisboa, Portugal; mq@campus.ul.pt

We aim to understand how primary teachers who participated in a lesson study developed their collaboration relationships. The research is qualitative and interpretive with a case study design. The results show that the involvement in moments of planning and analysis of the students' work, where teachers reflected on practice and for practice helped them to develop collaborative relationships, moving from storytelling and scanning to joint work. The teachers were encouraged to express their voices regarding their participation in the lesson study and this led to an increasing involvement in the group, favoring the development of their reflection and knowledge of mathematics teaching.

Keywords: Lesson study, collaboration, reflection, professional development

Introduction

Lesson study is a professional development process widely practiced in many countries around the world. Teachers work in a collaborative way on a curriculum topic or issue related to students' learning, study curriculum documents and teaching materials, and plan and teach a research lesson which is then object of reflection (Fujii, 2016; Lewis, 2016; Takahashi & McDougal, 2018). During the lesson, taught by one of the teachers, the participants observe the events and afterwards analyze students' learning, emerging difficulties, and possible alternatives to consider. In lesson study, the discussions held by the group elicit, challenge and question the conceptions and practices of teachers (Cajkler, Wood, Norton, Pedder & Xu, 2014; Fujii, 2016). This collaboration provides teachers opportunities to run risks in their practice and to try new ideas in a structured and supported way, with focus on students' learning (Fujii, 2016).

Collaboration is central in discussions about teachers' professional development. According to Fullan and Hargreaves (1992), for change to occur in the classroom, teachers must be encouraged to collaborate with their colleagues in a learning community. Ponte (2012) suggests that teachers learn through their activity and the reflection that they make on that activity and such learning depends both on their personal commitment and collective support. However, a recent survey on collaboration made for ICME 13 (Robutti et al., 2016), showed that very little is known about the dynamics that take place in collaborative processes. Therefore, the aim of this paper is to understand how collaborative relationships among teachers may develop in a lesson study.

Collaboration

In collaboration, teachers work together aiming to achieve a common goal, negotiating working processes and making decisions together (Boavida & Ponte, 2002; Menezes & Ponte, 2009; Robutti et al., 2016). Research on teachers' professional development has pointed out the benefits of joining teachers and researchers in collaborative processes (Boavida & Ponte, 2002; Hollingsworth &

Clarke, 2017). The role of participants may be distinct, as the important point is that they work in horizontal relationships so that there is mutual support to achieve the common goals of the group (Boavida & Ponte, 2002). When involved in collaborative processes focused on their own practices, teachers work with more experienced colleagues and with researchers, they may develop new knowledge, which is in their zone of proximal development (Blanton, Westbrook & Carter, 2005).

Little (1990) distinguishes four kind of professional relationships among teachers, with different nature and potential: (i) storytelling and scanning for ideas; (ii) aid and assistance; (iii) sharing; and (iv) joint work. Storytelling and scanning for ideas corresponds to interactions among teachers that are occasional and stand on opportunity, where teachers seek to obtain specific ideas, solutions, or confirmations in brief exchanges of experiences in informal settings. In aid and assistance, teachers expect to get support from their colleagues in solving problematic situations. This relation is unidirectional and unequal and keeps the individual teacher as the sole decision maker. Sharing takes place by the exchange of resources, methods, ideas and opinions, and necessarily involves some level of exposition of the teacher regarding his/her colleagues. Finally, joint work occurs “among teachers that rest on shared responsibility for the work of teaching (interdependence), collective conceptions of autonomy, support for teachers’ initiatives and leadership with regard to professional practice, and group affiliation grounded in professional work” (Little, 1990, p. 519). This form of collaboration requires much responsibility, commitment, and time from the participants but has stronger potential for solving problems and developing knowledge in a group that seeks to improve teaching practice. The work developed in the lesson study is intended to be collaborative and, in this way, in this research we analyze the interaction of the group according to the four kinds of relationships stated by Little (1990).

Methodology

This research is qualitative and interpretative (Erickson, 1986), based on a group of teachers who participated in a lesson study in 2013-14, in a school in Lisbon. This lesson study originated in a request from the school principal to support a project to improve students’ results in mathematics. Seven teachers were appointed by the principal but, after five sessions, only three (Irina, Manuela, Antónia, fictitious names) remained in the group. Several teachers gave up indicating little interest in the activity or other personal reasons. The three participating teachers had between 10 and 15 years of experience and all had initial teacher education as primary teachers. However, Irina had a specialization in teaching Mathematics and Science and Manuela in teaching Portuguese and French. Our team included the two authors, another researcher and an assistant for data collection. We directed all sessions, leading the planing and assuming the role of experts in the post-lesson reflection. We sought, essentially, to center the work of the group in the exploratory approach (Ponte & Quaresma, 2016), with special attention to the tasks to propose to students, students’ reasoning, and classroom communication processes.

The lesson study had twelve sessions. Session 1 included the introduction of participants, the establishment of the general work program and the definition of the topic to address. Sessions 2 to 4 were dedicated to study the topic and the exploratory approach and sessions 5 and 6 to the planning of the research lesson. Session 8 was the research lesson and session 9 the post-lesson reflection. In sessions 10, 11 and 12, which we called “follow-up”, the teachers planned, carried out and reflected on

two lessons that they made, as a way to deepen the work undertaken before. After the post-lesson reflection, we made an individual semi-structured interview to each teacher and in the last session we made a focus group interview, asking the teachers to reflect on the lesson study and the work developed, on the various aspects of the exploratory approach and on the work of students. Two main adaptations from the usual Japanese model were made in this process: (i) setting up a collaborative environment, including teachers and researchers, from the beginning to the end of the lesson study; and (ii) follow-up sessions, that allowed teachers plan new lessons together, addressing new topics, putting into practice what they learnt in previous sessions, and reflecting on the results. Data were gathered by participant observation through the undertaking of a research journal (elaborated by a researcher and completed by the others), audio recording of working sessions (designated as Sx), with transcriptions, and video recording of the research lesson, and individual interviews to participant teachers (E). Data were analyzed in an inductive way, taking into account the four teachers' forms of interaction indicated by Little (1990): (i) storytelling and scanning for ideas; (ii) aid and assistance; (iii) sharing; and (iv) joint work.

First part of the lesson study

Study of the topic and of the exploratory approach

In session 1, taking into account students' difficulties, it was decided that the topic to study would be addition and subtraction of fractions by juxtaposing of line segments. Sessions 2 to 5 addressed mathematical and didactical issues relevant to teaching and learning this topic. Therefore, in session 2, the group solved tasks and identified students' difficulties. In session 3, there was a discussion about students' current knowledge and a diagnostic worksheet for the teachers to carry out in their classes was elaborated. In session 4, the responses of the students were analyzed, taking into account the nature of tasks, seeking to identify generalizations and justifications and surprising features in students' responses. In session 5, possible generalizations in addition and subtraction of rational numbers were identified. The main ideas related to the exploratory approach were discussed in depth: using challenging tasks, supporting students' reasoning, figuring out strategies to solve problems and making generalization and justifications, and promoting students' communication of their ideas with particular attention to whole class discussions. During these sessions, Irina had a very active participation working jointly with the researchers but Manuela and Antónia participated very little, interacting in aid and assistance way with the group. One perturbing factor of the group dynamic in this phase of the work was the reluctance of all teachers to assume the role of teaching the research lesson. This situation was finally overcome in session 5, when it was decided that Irina would take that role. She made the initial draft of the lesson plan that was discussed in session 6.

Post-lesson reflection and interviews

The post lesson reflection was carried out in session 9 as a reflection on practice. The group agreed that Irina prepared well the research lesson and its enactment corresponded very well to the planning. Some video excerpts from the lesson, representing students' strategies and difficulties, were analyzed. We made several challenges to the teachers, but only Irina sought to respond to them. When questioned, Antónia and Manuela, only described the events to support the judgments made by other participants. In a quite reserved stance, they narrated observations that they made during the lesson and supported the group in forming a general idea about the lesson participating in

an aid and assistance way and storytelling and scanning for ideas. In contrast, Irina shared with the group her ideas and opinions (joint work). However, during this analysis of students' difficulties, she seemed to feel unease, assuming that her work was being criticized.

After this post-lesson reflection we made individual interviews to the teachers. Surprisingly, these interviews turned out to be quite deep reflections about the work previously carried out in the lesson study. Irina made a deep reflection of the activity carried out in the former sessions, including the research lesson. Manuela and Antónia, indicated the reasons why they were not much involved in the sessions: Manuela felt difficulty in understanding much of the mathematical discussions that went on and felt insecure in participating and Antónia found the analysis of students' strategies and difficulties too detailed. The expression of feelings and difficulties by the teachers, in a relationship of great confidence with the researchers, created a completely new working environment.

Follow up

Planning

In session 10, we asked teachers to plan a lesson that they would be teaching, taking into account the work carried out before. Manuela suggested that they could plan a lesson together and that she and Antónia could teach it, instead of Irina that had made much work previously.

And why we do not the following: we give Irina a break, we plan [together with Marisa], I and Antónia [make the tasks in our classes] and present them [in the next session]? And you [Irina] may use them later in your class. (S10).

In this way, Manuela recognized that she and Antónia were not much active in their participation in the previous phase of the lesson study. Now, she was willing to assume an active role. This shows that she felt more confident with what she learnt in the previous sessions. It was then decided that both teachers would use the tasks in their classes and Irina would support them in reflecting about the results to present and discuss in the next session. In this way, the three teachers prepared a lesson about the relationship between fractions and decimals in a setting of shared responsibility of planning a lesson in joint work.

However, Antónia and Manuela began their planning quite insecure. They opened the textbook and began to scan different pages. It was noticeable that they were uncomfortable with the perspective of picking tasks from the textbook, perhaps as they thought that we would not find that much appropriate. Taking into account the struggle of the teachers, Marisa suggested that, instead of selecting a task, they could adapt it. Manuela agreed: "I think so, increasing the difficulty, isn't it? Because that one is very basic. But I think yes, mixing up tenths, hundredths and thousandths, with different denominators" (S10). At that point, Antónia and Irina also began giving suggestions and registering more ideas to elaborate the task:

Antónia: Or A, B and C, in order to have two equivalent and one different.

Irina: Ah, yes.

Antónia: For example, to have two equivalent fractions. They understand that . . . Are equivalent fractions, albeit having different denominators.

- Manuela: Why we do not give a hypothesis here... That is, why do not give equivalent fractions?
- Marisa: Ah, one of these being as a fraction. Yes, instead of all being as decimals . . .
- Manuela: For example, here are four as decimals, isn't? And one in words. Why we do not take out that is in decimal and put it in fraction?
- Irina: Exact.
- Marisa: May be.
- Irina: And then, during the discussion, we can ask them to write this also as a fraction. (S10)

So, in joint work, the teachers constructed the first question of the task (Figure 1):

-
1. In the squared paper, paint 0.4 in green; $40/100$ in blue and “four hundredths” in yellow.

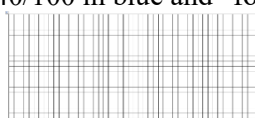


Figure 1: Task elaborated by the teachers in session 10

Irina went on providing suggestions, Manuela was much more participative and engaged than usual, and Antónia, albeit less participative than the colleagues, was also involved, contrarily to what happened in former sessions. This session witnessed two important aspects. The first is the change in attitude of Manuela and Antónia that began to assume strong participation in the common activity. This change seemed to result from the confidence that was established in the group after the interviews. The second aspect is the difficulty of the teachers in assuming an authorship role and a critical stance regarding tasks. This difficulty, however, was overcome with our suggestion of adapting tasks. It seems that the work carried out in the lesson study brought the teachers towards a point in which they were ready to assume this way of working, only with minimal support of a more experienced partner.

Reflection

In session 11, the three teachers reflected on their classroom experience in carrying out the task prepared in session 10. Antónia reported that her students had many difficulties in solving the first question:

Mine, I only had one that was able to make everything right. A group. Then, I had three more that could make one part right and another wrong, they made well the four tenths, but then the forty hundredths, which corresponded to the same thing, they did not. And that is it. I think that they had here several squared that confused them. (S11)

Antónia tried to understand the difficulty of the students and suggested that they could get confused by having squared paper to represent the numbers indicated. She suggested that may have led the students to “not understand what the unit was” (S11). She showed surprise and frustration with the difficulties of her students: “they already know this well . . . They know how to transform decimals in fractions and fractions in decimals” (S11). The other teachers tried to find an explanation for the difficulty of her colleague: “I think that the fact that this looks visually different, it is only enough

that one is as a decimal and the other as a fraction, this is enough to prevent them of seeing something that is equivalent” (S11). Seeking to find reasons for the students’ difficulties, still in a superficial way, Antónia referred that they forgot what they knew, whereas Manuela focused in the differences between fraction and decimal representations.

In the sequence, Manuela also presented her analysis of the work of her class. All students had the question on the painting of 0.4 correct but failed the next questions. In response, Antónia pointed out some similarity in the results of the two classes: “Here, there is something more or less similar. My [students] that got some [questions] right, the green [0,4], which was first. After that...” (S11)

Irina also tried to find a reason for the difficulties of the students, referring that “from the moment in which we begun to work with decimals, fractions become in trouble” (S11). She considered that the work with decimals led the students to forget about fractions. Up to this point, the teachers were still scratching the superficial features of the issue.

Taking into account that most students failed in representing the hundredth part of the unit, Manuela suggested that this mistake was related to visualizing the hundredth part of the picture that they were shown, in contrast with the visualization of tenths: “Here they visualize very well the tenth parts” (S11). Irina agreed, saying: “the hundredth is not easy for them to see. It is not intuitive” (S11). That is, Manuela began to base her analysis of the strategies of the students noting an important constrain related to the material that they received, which is a quite interesting reflection.

As the difficulty of the students was identified, Irina reflected on her own practice, notably on the work that she usually does concerning the representation of decimals:

When we speak of the tenth, usually we use a bar divided in ten. Then, suddenly, we start speaking of the hundredth, and the unit instead of being the bar with ten, becomes a square with one hundredth. And, suddenly, we begin to speak of the thousandth, and we get this. Therefore, the unit that is always one, change its form. And that messes up the students in an extraordinary way. (S11)

Irina identified a problem of her practice as she considers that the way she presents the submultiples of the unit to the students does not facilitate their understanding of the unit and of that relationship with the submultiples. All participants agreed with Irina, that decided to take the discussion one step further, challenging the group to think in a solution for the problem: “But, and now? This is a reflection. What do we do?” (S11). She went on, pointing that the representation requires that students really understand the decimal number system and what the unit is.

In the sequence of the discussion, Antónia suggested to her colleagues that they could do the same way she did in the discussion of the task, cutting the rectangle in 10, 100, and 1000 parts and Irina agreed. In addition, Manuela referred the need of the students to have flexibility to interpret other representations. Irina concurred but underlined the importance of changing their practice making an initial work consistent with the rectangle representation, as a basis to later understand more simplified representations of the unit. This discussion was mediated by Marisa, who raised questions. But the teachers themselves developed a deep reflection about her own teaching practice, questioned the solutions and difficulties of the students and tried to find explanations for what happened, analyzing with much detail the origin of the difficulties. The teachers did not limit themselves to trying to

understand the problem, they sought to overcome it in a reflection for practice. Irina continued to show a strong inclination to carry out the reflection further, proposing well-grounded solutions, and Manuela and Antónia had a strong participation, with a great engagement in analyzing students' learning in relation to their practice. The change in attitude of Antónia and Manuela led the group to a joint work mode, in which all participants were involved in a common activity.

Discussion

During the lesson study, we challenged the teachers in different ways. Irina, who taught the research lesson and was very confident in mathematics teaching, was always much involved in all activities. From very early, she worked jointly with us in constructing an exploratory task for the research lesson, in order to favor students' learning and understanding. The post-lesson reflection was carried out in a frame of joint work between Irina and the researchers. However, Manuela and Antónia were little involved in the activities remaining in the mode of storytelling and scanning for ideas.

In the follow-up sessions, all teachers were called to plan, teach and reflect about two lessons. Manuela and Antónia become very active and participating. They were going now to teach their classes with their own students and no observers. However, the main reason for this active participation was the reflection that they made in the interviews, in which they assumed a very personal voice regarding their development trajectories. This key importance of teachers' voice in collaborative processes is also underlined in Robutti et al. (2016). With the support from Irina, they felt confident to adapt tasks from the textbook and make them more challenging for their students. In the lesson study, they appeared to have developed new knowledge, which was in their zone of proximal development (Blanton, Westbrook & Carter, 2005). Therefore, from this point on, all group (teachers and researchers) began to work jointly, sharing a common responsibility for the work.

Conclusion

This lesson study, favored the development of joint work among the participants and that led them to get involved in reflecting about their own practice and the way students learn. Such reflections are important levers for professional development. During the follow-up, the work carried out favored the creation of an environment of integration of knowledge (Lewis, 2016), in which teachers constructed actively their knowledge by designing tasks and collecting data from their students, establishing connections among different data sources. This has largely resulted from the possibility that the teachers had to express their voice and individuality and the challenges and responsibilities that they progressively assumed, namely the responsibility for the decisions of the group, for the materials produced, in particular for the selection and elaboration of challenging tasks and the preparation of the lesson plans that all teach. With this, they identified problems in their practice and created solutions with strong rationales. This evolution only occurred when the teachers felt confident to question their conceptions and practices and to try out new ideas (Cajkler et al., 2016; Fujii, 2016; Ponte, 2012). The follow-up sessions were much important to bring together the members of the group. The fact that all teachers taught and reflected on two lessons at this phase led them to get more involved and with more responsibility in the development of the work, suggesting the value of all participants teach a lesson and share that experience with the group. Other modifications in the format of a lesson study, such as teaching and reflecting on a pilot lesson during the planning, may contribute to similar results.

This and other adaptations are to be experimented in order to take the most out of this professional development process, taking into account the local culture of the participating teachers.

Acknowledgment

This study is supported by FCT – Fundação para a Ciência e Tecnologia through Project PEST (PEst-OE/CED/UI4107/2014) and also through a grant to Marisa Quaresma (SFRH/BD/97702/2013).

References

- Blanton, M.L., Westbrook, S., & Carter, G. (2005). Using Valsiner's zone theory to interpret teaching practices in mathematics and science classrooms. *Journal of Mathematics Teacher Education*, 8(1), 5-33.
- Boavida, A. M., & Ponte, J. P. (2002). Investigação colaborativa: Potencialidades e problemas. In GTI (Ed.), *Reflectir e investigar sobre a prática profissional* (pp. 43-55). Lisboa: APM.
- Cajkler, W., Wood, P., Norton, J., Pedder, D., & Xu, H. (2015). Teacher perspectives about lesson study in secondary school departments: A collaborative vehicle for professional learning and practice development. *Research Papers in Education*, 30(2), 192-213.
- Erickson, F. (1986). Qualitative methods in research on teaching. In M. C. Wittrock (Ed.), *Handbook of Research on Teaching* (pp. 119-161). New York: Macmillan.
- Fujii, T. (2016). Designing and adapting tasks in lesson planning: a critical process of Lesson Study. *ZDM Mathematics Education*, 48, 411–423.
- Fullan, M., & Hargreaves, A. (1992). Teacher development and educational change. In M. Fullan & A. Hargreaves (Eds.), *Teacher development and educational change* (pp. 1-9). London: Falmer.
- Hollingsworth, H., & Clarke, D. (2017). Video as a tool for focusing teacher self-reflection: Supporting and provoking teacher learning. *Journal of Mathematics Teacher Education*, 20(5), 457-475.
- Lewis, C. (2016). How does lesson study improve mathematics instruction? *ZDM Mathematics Education*, 48, 571–580.
- Little, J. W. (1990). The persistence of privacy: Autonomy and initiative in teachers' professional relations. *Teachers College Record*, 92(4), 509-536.
- Menezes, J. L., & Ponte, J. P. (2009). Investigação colaborativa de professores e ensino da Matemática. Caminhos para o desenvolvimento profissional. *Jornal Internacional de Estudos em Educação Matemática*, 1(1).
- Ponte, J. P. (2012). Estudiando el conocimiento y el desarrollo profesional del profesorado de matemáticas. In N. Planas (Ed.), *Teoría, crítica y práctica de la educación matemática* (pp. 83-98). Barcelona: Graó.
- Ponte, J. P., & Quaresma, M. (2016). Teachers' professional practice conducting mathematical discussions. *Educational Studies in Mathematics*, 93(1), 51-66.
- Robutti, O., Cusi, A., Clark-Wilson, A., Jaworski, B., Chapman, O., Esteley, C., Goos, M., Isoda, I., & Joubert, M. (2016). ICME international survey on teachers working and learning through collaboration. *ZDM Mathematics Education*, 48(5), 651-690.
- Takahashi, A., & McDougal, T. (2018). Collaborative lesson research (CLR). In M. Quaresma, C. Winslow, S. Clivaz, J. P. Ponte, N. Shuilleabhain & A. Takahashi (Eds.), *Lesson study around the world: Theoretical and methodological issues* (pp. 143-152). New York, NY: Springer.

How to visualize classroom norms through social interaction

A pilot study of two frameworks

Jonas Dahl¹, Christina Svensson² and Richard Wester³

¹Malmö University, Sweden; jonas.dahl@mau.se

²Malmö University, Sweden; christina.svensson@malmo.se

³Lunds kommun, Sweden; rickard.wester@lund.se

Keywords: Classroom norms, interaction, mathematics education, professional development.

In this pilot study we investigate if and how two different frameworks can be used to visualize classroom norms through classroom social interaction.

Background

Between 2013-2016 the Swedish National Agency for Education launched a curriculum-based professional development project, the so-called Mathematics Boost (Swedish: Matematiklyftet) (Skolverket, 2016). The aim was to develop and improve mathematical classroom teaching with a focus on four different didactical dimensions: formative assessment, teachers' knowledge about competencies, social interaction and socio-mathematical norms (Skolverket, 2016).

Parts of the Mathematics Boost and the national evaluation afterwards is based on Cobb and Yackel's framework of classroom norms (Skolverket, 2016). Cobb and Yackel divide classroom norms into social norms (SN), socio-mathematical norms (SMN) and mathematical praxis (MP). According to Cobb and Yackel (1996), these classroom norms are reflexively connected. Our approach in this project is that for classroom norms to change or develop all three aspects above needs to be challenged, in this case, through the Mathematics Boost.

The national evaluation of the Mathematics Boost (Skolverket, 2016) showed development in some aspects of social interaction. A reasonable interpretation, based both on the national evaluation and on the writings of Cobb and Yackel, is that the SN hence is challenged and developed. According to the evaluation, it is impossible to state anything about SMN in regard to change or development but it is also stated the SMN will probably change over time (Skolverket, 2016).

Following the idea that classroom norms are reflexive and needs to be challenged simultaneously as mentioned above, another explanation for the lack of development could be that the SMN has not been challenged enough through the Mathematics Boost. As a complement to the national evaluation in 2016 we therefore pose the question for a coming study: Which classroom norms were challenged through the Mathematics Boost? But first we need to investigate how to visualize classroom norms through classroom social interaction.

Pilot study

In order to do this, we put two different frameworks into a test, one developed by Kilhamn and Skodras (2018) and one suggested by the Swedish Institute for Educational Research (Fredriksson, Envall, Bergman, Fundell, Norén & Samuelsson 2017), originally a framework by Hufferd-Ackles,

Fuson and Sherin (2004). Both frameworks are hence in a Swedish context and they both focus on social interaction but in different ways. The former framework is created in order to analyze the analyze level of teacher questions with a focus on responses from students (Kilhamn & Skodras, 2018). The latter is focused on how discourse is moved from a teacher centered to a student centered discourse when it comes to who poses questions, the type of questions/answers, sources of mathematical ideas and responsibility for learning (Hufferd-Ackles, Fuson & Sherin, 2004). Neither of the frameworks are created for the purpose that we have in our project but we have connected different parts of the frameworks to SN and SMN respectively. Hence, in this poster presentation, we put these frameworks into a test in order to investigate if and how these connections is possible to make in order to help us visualize classroom norms through classroom social interaction.

Method and initial results

Out of a total of 60 video-recorded classroom situations during the Mathematics Boost we have, in this pilot study, analyzed six classroom situations via transcriptions of what the teacher and students express. Our initial results using the two different frameworks show that they can help us visualize the level of social interaction. Our initial results also indicate that we can connect these different levels to SN and SMN. The first framework shows the potential for if and when SMN are challenged through social interaction. The second framework show if and when teachers and students are on the same level of social interaction, that is, if and when they agree on SN.

The poster

On the poster we present the frameworks and how we connect SN and SMN to these. We also present our initial results that indicate that despite the potential relatively high level of social interaction, that is SN, the social learning stays on a low level. That is we show that the SMN are not challenged enough. In the long run this means, due to the reflexivity in the model, that there are limited chances for MP to develop.

References

- Cobb, P., & Yackel, E. (1996). Constructivist, emergent, and sociocultural perspectives in the context of developmental research. *Educational psychologist*, 31(3-4), 175–190.
- Fredriksson, K., Envall, I., Bergman, E., Fundell, S., Norén, E., & Samuelsson, J. (2017). *Klassrumdialog i matematikundervisningen: matematiska samtal i helklass i grundskolan*. Skolforskningsinstitutet.
- Hufferd-Ackles, K., Fuson, K. C., & Sherin, M. G. (2004). Describing Levels and Components of a Math-Talk Learning Community. *Journal for Research in Mathematics Education*, 35(2), 81–116.
- Kilhamn, C., & Skodras, C. (2018). Questioning questions - revisiting teacher questioning practices. Proceedings from Madif 11. Retrieved 11/16 2018 from http://ncm.gu.se/media/madif/madif11/madif11_024_kilhamn.pdf
- Skolverket. (2016). Utvärdering av Matematiklyftets resultat. Retrieved 01/19 2017 from <http://www.skolverket.se/publikationer?id=3706>

Understanding student teachers' professional development by looking beyond mathematics teacher education

Andreas Ebbelind

Linnaeus University, Department of Mathematics, Sweden; andreas.ebbelind@lnu.se

The empirical material in this paper is from a multiple case study exploring the role, if any, that social practices related to teacher education and beyond teacher education play in primary student teachers' tales of themselves as teachers-to-be. The case of Lisa is used as an example to illustrate how different past and present social practices influence how she talks about competitive teaching during different phases of her teacher education. Of particular influence is her past school-related experiences as they in turn influence how she interprets other social practices. Thus, the case of Lisa illustrates the importance of widening our research interest beyond teacher education if we want to understand the process of becoming mathematics teachers.

Keywords: Professional development, teacher education, social practices.

Introduction

Student teachers' professional development is by many researchers considered as a rather complex process (Skott, Mosvold & Sakonidis, 2018). One concern is how student teachers' school-related experiences influence how they perceive teacher education and how they view their future profession. According to Forgasz and Leder (2008) prior experience impact student teachers becoming as teachers more than undergoing teacher education. To this, Scott (2005) concludes that student teachers are less sceptical to advise from others, "outside" teacher education, than from teacher educators in mathematics. Student teachers use educated teachers at the internship or from other settings or family and friends instead of teacher educators to conclude their vision of future teaching. For example, internship, which is often part of teacher education, is said to frame how student teachers perceive the content in mathematics education courses. Thus, the teaching of the internship supervisor during internship becomes important in student teachers' professional development (Mosvold & Bjuland, 2016).

To widen the perspective of the "outside" this paper reports parts of a multiple case study with the aim of contributing with insights about how experience from teacher education and other past and present social practices play for generalist student teachers' tales of themselves as primary mathematics teachers-to-be. This is in line with Morgan (2012) and Skott (2018) that mentions that we need to look outside the immediate social practice [teacher education in this case] if we want to view what the [student] teachers bring into the situation. To be interested in any data "that point to any practice [...] that appear to orient the [student] teachers' action or meaning making as they relate to the profession (Skott, 2018, p. 615)".

Thus, this paper aims to illustrate how different past and present social practices play for a primary generalist student teacher, tales as primary mathematics teacher-to-be. The empirical material used relate to how a student teacher, whom I will refer to as Lisa, talks about competitive teaching during different phases of her teacher education.

The process of becoming a mathematics teacher

To enter teacher education and become a teacher is in this paper regarded as an emerging learning process. To follow the process of developing into a teacher is partly to follow how student teachers negotiate and re-negotiate their mathematical and pedagogical knowledge. In this process Hodges and Hodge (2017) recognise student teachers bringing together different perspectives on teaching and learning mathematics, often conflicting while creating their idea of teaching mathematics. While bringing different perspectives together student teachers can, for example, position themselves in relation to future pupils, relate their participation to different educational models, expand educational models through new experience and develop a critical positioning to either the teaching at internship or the pedagogy taught and used at teacher education (Bjuland, Cestari, & Borgersen, 2012).

Jong (2016), as an example, illustrate that teacher education in different ways impact student teachers' professional development. However, attention is on to the characteristics of their participation that draw on ideas from past teaching experience and their cultural, socioeconomically and linguistically background. Jong concludes that becoming a teacher starts the day when children enter school for the first time and meet different educational models. These models influence the idea of teaching that student teachers have. The main result in Jong's study is that any social practices related to teaching and learning mathematics might be critical in professional development, this because social practices, past and present, are used to negotiate and re-negotiate the meaning of teaching mathematics.

The conceptual framework Patterns of Participation

The overall study and this paper start with an interest in professional development, a construct that elaborates within the conceptual framework of Patterns of Participation (PoP). Professional development can be viewed as "a process of flexibility, autonomy, and adaptation to the teaching context" (Hošpesová, Carrillo & Santos, 2018, p. 181). Learning and thus becoming a teacher is therefore considered from a situated perspective. Thus a perspective, that considers learning as participation in social practices take social, cultural and historical systems as well as prior experiences and present participation into consideration when studying professional development. A social practice as a collective way of being with a common endeavour where entities interact and reconcile/mould together.

PoP "seeks to understand how a [student] teacher's interpretations of and contributions to immediate social interaction relate dynamically to her prior engagement in a range of other social practices" (Skott, 2013, p. 549). Skott makes an important move, according to Lerman (2013), when focusing on the emergence of the situation, the process. "This dynamic process is studied through eliciting the teacher's interpretation of what she does in classrooms and how that relates to her prior engagement in other social practices (p. 625)". The intention with PoP is to disentangle shifts of participation in different social practices, and by doing so shed light on the role of the student teacher in the practices that emerge.

Through the conceptual framework Patterns of Participation, Skott tries to accomplish three things. First, he tries to reduce the emphasis on objectification in research about student teachers and teachers. Secondly, he tries to re-centre the student teacher and teacher in research. Finally, he tries to re-conceptualise what is known as beliefs, knowledge, and identity in participatory terms. In this

quest Skott (2018) point out that the conceptual framework PoP focuses on the pre-reified processes that precede, give rise to, what others term beliefs, knowledge, and identity.

Patterns of Participation draw on two main theoretical sources, symbolic interactionism and social practice theory. Symbolic interactionism views humans as actors and reactors in situations, and position meaning as something that one engages in when experiencing things in the situation, on the spot. Humans respond to the situation by interacting with others and with the self, and by taking [interpreting] the role of others (Skott, 2018). Social practice theory views social practices as ordered across time and space. They are linked historically to other social practices (Wenger, 1998). Social practices are stratified. Most important is that social practice theory stress that it is through the engagement with different or using different social practices within communication that individuals understand the world around them when they, for example, emerge into the teaching profession.

By considering that social practices are ordered, stratified, in time and space allow researching complex patterns in multiple social practices. To make visible and describe this plurality of relations lies in the core of PoP but also to make visible how these pluralities of relations change over time.

The overall study

The overall study adopts a multi-sited ethnographic approach. Two primary student teachers were followed for two and a half years as cases during their teacher education with a focus on their education in mathematics. Often student teachers at primary school level are generalists with no specialisation or interest to the teaching of mathematics. However, that was not the case in this study. The student teachers in this study related strongly to the teaching of mathematics in the interview before entering teacher education and they were selected as critical cases (Flyvbjerg 2006) based on their commitment, their mathematical knowledge and interest. The choice of critical cases was based on the indicated research gap related to the lack of research related to primary student teachers that are interested in mathematics, mathematics teaching, mathematics learning and regard themselves as knowledgeable/proficient in mathematics.

In Sweden, the combined course in mathematics and mathematics education for primary school student teachers is a 30 ECTS point course in the four-year teacher education programme (240 ECTS). ECTS means European Credit Transfer System, where one year of studies is 60 ECTS (40 weeks). Student teachers have four internship periods, five weeks each, during their teacher education. Teacher education in Sweden does not have any pre-requisite of university studies before entering the education.

In this paper, only one of the student teachers is used as an example, Lisa. Lisa, who is in her early 20s, started teacher education directly after high school. Lisa's positive experiences of participating in a competitive mathematics classroom are expressed as her primary reason for entering teacher education. Lisa perceived herself as "good" at mathematics and had the highest possible grade in upper secondary school. It is also worth noticing and most important concerning this paper that Lisa described herself as extremely competitive both as a private person and as an athlete, playing soccer at a high national level.

The role of social practices in different phases

The empirical material in this paper is interview transcripts, five in total, and field-notes from observations made during the internship and the mathematics education course. During the mathematics education course, I attended 31 lectures, seminars, examinations or study-group sessions. Based on the multi-sited ethnographic approach, considering social practices as ordered in time and space and considering the “outside”, persons related to Lisa were also interviewed, in this paper the internship supervisor whom I will refer to as Mr Higgins.

Lisa’s professional development is described, in this paper, in three different main phases related to how she re-negotiates the use of competitions in teaching mathematics. Each phase will start with excerpts in time spread over the actual phase. Then there will be a summary accentuating the role of social practices within the phase. This section set out to offer the reader a “virtual reality” to explore (Flyvbjerg, 2006), to provide the reader with situated aspects (Bjurland et al., 2012).

Phase one – The internship experience strengthens her experience of learning mathematics

In phase one, Lisa re-engages in her prior school-related experience, the social practice of her upper secondary mathematics classroom. This experience is later in this phase re-negotiated with the social practice where her internship supervisor Mr Higgins is a part.

In the first interview, conducted before entering teacher education, Lisa talks a lot about how she, from an early age, developed a passion for mathematics as a subject. She credits this passion to the fact that she found mathematics easy and she recalls positive memories with the subject itself. During primary school, Lisa perceives herself as extremely good in mathematics. "Secondary school was okay, it became harder, but it was not hard [...] I chose a direction with as much mathematics as possible, so I thought it was fun." Lisa especially remembers two teachers. "Both were extremely interested... they taught playfully..." Lisa describes these teachers as knowledgeable and dedicated to their commitment as teachers. She also describes how they frequently used "competitive teaching" which increased Lisa's motivation: "this to get it a little more challenging and you got interested."

The first internship is conducted approximately eight months after Lisa enters teacher education. Lisa’s supervisor Mr Higgins "admits" in an interview two months before that he uses competitions when teaching mathematics, all the time. However, he emphasises that the main idea is for students to compete with themselves, but that there might be some competition among the pupils as well. One example is how the class "do multiplication every third week [...] we do it both on Mondays and on Fridays... on time... it might seem a little stressful and inconvenient, but they like it very much."

At the internship, Lisa is stunned after her initial participation in Higgins classroom.

I think he explains in a way that is very close to pupils thoughts... it is very close to pupils, and it is... it is at their level of understanding ... and it is very playful all the time [...] they [pupils] are involved in everything he does... then they have tests in mathematics where the competitive instinct comes into play... when he says something it becomes fascinating...

Lisa accentuates her admiration for the teaching that she participates in and relate the teaching to the use of competitions, "he has it all the time." Lisa concludes that "I am very impressed with him as a teacher and would I... I would be like him."

Two relevant social practices are visible in Lisa's tales. Lisa re-engages in the past social practice, upper secondary mathematics classroom, as a hugely successful pupil. The success was related to the competitive structure which increased her motivation. The common endeavour of participating in competitive teaching practices that she shared with some others is central in her positive experience of mathematics education. It is also central to her view of teaching. Lisa do not question her first internship. Her prior participation in the upper secondary mathematics classroom is instead reinforced as valid in the present school-related social practice.

These two social practices are closely related, there are many similarities. Lisa brings two different social practices together, her past and present participation moulds together while re-negotiating the role of competitions. By participating in a present educational model, the role of competitions is actualised from past participation to present experience.

Phase two – Questioning competitive teaching when teaching

The second phase links to the 30 ECTS course in mathematics education and the common endeavours of the teacher educators. This paper stresses two different ways of participating, ways of being, within the mathematics education course. There are also other social practices of importance, for example, the study group containing three other student teachers.

During the mathematics education course, it became apparent, to Lisa, that most students did not enjoy mathematics at school and competitive teaching is filled with anxiety. She immediately starts to question her experience in mathematics classrooms and begins to align with the teaching in mathematics education. To understand this shift in her participation, the re-negotiation of her past participation, we need to enter lecture halls and seminar sessions that the mathematics education course provided during the first week.

Several different teacher educators indicate that the student teachers' bad experience of mathematics teaching might relate to competitive teaching. During the first week, it becomes clear to Lisa that her positive experience of competitive teaching is uncommon and she starts to question her past participation in mathematics classrooms. "Everyone is more or less competitive, and it is a huge strong feeling in all of us... or in me... it is [...] it suits them who are good and not those who have difficulties ... so I do not know how much one will use it ... you will have to think about the pros and cons... and then usually... well, the disadvantages take over ..." There are positive things with competitive teaching "everyone concentrates more and makes every effort to get ahead [of others] or to win... there will be more ... a bit more fight and quality ... sort of ..." However, the negative side takes over "it ruins the confidence and quality deteriorates because it usually goes on time and that it should go as quickly as possible ... instead of as good as possible. I think it is important that they compete against themselves, but I think it is difficult for students to grasp that ..."

However, when engaging in informal discussions in other social practices, she talks differently. For example, in her study-group, she several times during this course highlight that "competitions are excellent" and "to get ahead in the textbook is a great feeling."

During the course in mathematics education, Lisa starts to contrast her prior experience with the mathematics education course developing a critical stance against the kind of teaching that is promoted by the teachers. "You do not agree with everything they say."

At the beginning of the mathematics course, Lisa makes a shift concerning competitive teaching. By participating in the social practice set up by mathematics education, she tries to balance her past participation while re-negotiating the role of competitive teaching. The manifestation of the conflict, Lisa participates in, can be viewed between the prior experience of competitive teaching and the present experience of mathematics teacher education. Also relevant is the experience of the "other", those with negative experience from the past. The point is that Lisa re-engages and engage in two distinctly different themes that relate to different social practices, that do not relate to each other, trying to balance the role of competitive teaching during the mathematics education course. The teacher education course in mathematics education has a significant role in the shift describes, how Lisa use past and present experience. While trying to bring these different perspectives together, Lisa starts to develop a critical positioning to the promoted teaching presented at the mathematics education course.

Phase three – Competitions is positive for all learners

The last phase starts before the end of the mathematics education course. She engages in an imagined, present or future, social practice and relates that social practice against the content promoted at the teacher education course.

Even though Lisa think that this has been the best course, so far in her teacher education experience, she does not align with the general promoted teaching of the teacher educators. Lisa concludes that she is still positive to competitions even though it is described as an insufficient teaching strategy by the teacher educators. She admits that she may "sound mean" but "everyone is competitive more or less... everyone wants to win, and no one likes to lose".

I do believe that competitions engage pupils... then one might not do it so outspoken that the one who wins gets a candy box ... but competitions are there... not that anyone gets knocked down because they never win... however, still there... something that engages them and makes them want to make an effort... and that...well... in that way, I do even believe that one can involve them who have it easy and those who find mathematics hard ... that they can applaud and encourage each other in this way... but then I do not know if competitions are the perfect teaching way, but I do think that it can be of importance to put it into teaching... and mathematics feels like a subject where it can be easily done.

Lisa also conducts her second internship with Mr Higgins as a supervisor. He still works in the same way, and Lisa is very comfortable in that classroom. She highlights that Higgins still uses competitions as a teaching strategy and in the final interview, two years and five months after the first one Lisa concludes that "Higgins is an excellent role-model at the moment... he is in my thoughts a splendid teacher... he is like the teachers I liked when I was young".

There is an apparent shift in Lisa's PoP. She is no longer obliged to participate in the collective way of being and share the common endeavour set by the teacher educators. She need not consider the

role of the mathematics education course and the way of participating in this social practice. While bringing different perspectives together Lisa positions herself concerning future pupils, expand her educational model related to competitive teaching and develop a critical positioning to the teaching promoted by teacher education.

Discussion

This paper aimed to illustrate how different past and present social practices play for Lisa's, a generalist student teacher, tales of herself as primary mathematics teacher-to-be. In the result section, it has been illustrated what experiences from teacher education and other relevant social practices that are visible. PoP has offered a way to follow the re-negotiation of the meaning of teaching mathematics, how Lisa is using different social practices within communication to understand the world around her when emerging into the teaching profession.

Lisa's pathway through teacher education is viewed as "a process of flexibility, autonomy, and adaptation to the teaching context" (Hošpesová, Carrillo & Santos, 2018, p. 181). In her professional development, she has for example negotiated and re-negotiated her experience of competitions, upper secondary, internship, teacher education, and study-group work. She has first of all re-engaged positively in prior experience and in teachers teaching rather than teacher educators promoted teaching. The teaching of the teacher educators has been used as a discursive counterpart. Most important has been her own experience of being a pupil at school and how she re-negotiated that experience with Mr Higgins teaching practice. It can also be interpreted that her background as an athlete has contributed to her professional development.

Lisa draws on competitive classroom when entering teacher education and she still draws on competitive classrooms at the end of this study. In this sense, there is no shift in her participation. However, the third phase is no regression to the first phase, as Lisa brings in different perspectives and social practices in the different phases. Lisa uses other information in her argumentation and justification during different parts of her teacher education. Also notable is that teacher education promotes another teaching than the one Lisa draw on, and this evolves into the fact that Lisa questions some of her assumptions during her education. In this way, the mathematics education course has played a role, but in the end, not the role the teacher education community expects or wants.

The different phases in this paper are critical because we can interpret how social practices play a role in her tales of herself as teacher-to-be. We can interpret how past and present social practices influence how Lisa talks about competitive teaching during different parts in her teacher education. The point is, by looking closer to the process one can understand how and what students change or not. Many things happen during an education, both inside and "outside". While most others, for example, Hodges and Hodge (2017) focuses on social practices related to teacher education I suggest that there are other social practices of importance when student teachers become educated teachers. There is a need to be interested in any social practice when trying to understand student teachers as teachers-to-be.

References

- Bjuland, R., Cestari, M., & Borgersen, H. (2012). Professional mathematics teacher identity: Analysis of reflective narratives from discourses and activities. *Journal of Mathematics Teacher Education*, 15, 405-424.
- Flyvbjerg, B. (2006). Five misunderstandings about case study research. *Qualitative Inquiry*, 12, 219-245.
- Forgasz, H., & Leder, G. (2008). Beliefs about mathematics and mathematics teaching. In P. Sullivan & T. Wood (Eds.), *The International Handbook of Mathematics Teacher Education* (Vol. 1, pp. 173-192). Netherlands: Sense Publishers.
- Hodges, T., & Hodge, L. (2017). Unpacking personal identities for teaching mathematics within the context of prospective teacher education. *Journal of Mathematics Teacher Education*, 20, 101-118.
- Hošpesová, A., Carrillo, J., & Santos, L. (2018). Mathematics teacher education and professional development. In T. Dreyfus, M. Artigue, D. Potari, S. Prediger & K. Ruthven. (Eds.), *Developing Research in Mathematics Education*. (pp. 181-195) London: Routledge.
- Jong, C. (2016). Linking reform-oriented experience to teacher identity: The case of an elementary mathematics teacher. *The Journal of Educational Research*, 109, 296-310.
- Lerman, S. (2013). Theories in practice: Mathematics teaching and mathematics teacher education. *ZDM - The International Journal on Mathematics Education*, 45, 623-631.
- Morgan, C. (2012). Studying discourse implies studying equity. In B. Herbel-Eisenmann, J. Choppin, D. Wagner, & D. Pimm (Eds.), *Equity in Discourse for Mathematics Education* (Vol. 55, pp. 181-192): Springer Netherlands.
- Mosvold, R., & Bjuland, R. (2016). Positioning in identifying narratives of/about pre-service mathematics teachers in field practice. *Teaching and Teacher Education*, 58, 90-98.
- Scott, A. (2005). Pre-service teachers' experiences and the influences on their intentions for teaching primary school mathematics. *Mathematics Education Research Journal*, 17(3), 62-90.
- Skott, J. (2013). Understanding the role of the teacher in emerging classroom practices: Searching for patterns of participation. *ZDM - The International Journal on Mathematics Education*, 45, 547-559.
- Skott J. (2018) Re-centring the individual in participatory accounts of professional identity. In: G. Kaiser, H. Forgasz, M. Graven, A. Kuzniak, E. Simmt, & B. Xu. (Eds.), *Invited Lectures from the 13th International Congress on Mathematical Education. ICME-13 Monographs*. Springer, Cham
- Skott, J., Mosvold, R., & Sakonidis, C. (2018). Classroom practice and teachers' knowledge, beliefs and identity. In T. Dreyfus, M. Artigue, D. Potari, S. Prediger & K. Ruthven. (Eds.), *Developing Research in Mathematics Education*. (pp. 162–180) London: Routledge.

Retrospective reflections on ‘Missions’ as pedagogies of practice

Elisabeta Eriksen, Annette Hessen Bjerke, [Camilla Rodal](mailto:camilla.rodal@oslomet.no) and Ida Heiberg Solem

OsloMet – Oslo Metropolitan University, Oslo; elisabeta.eriksen@oslomet.no;
annette.hessen@oslomet.no; camilla.rodal@oslomet.no; ida.solem@oslomet.no

Many preservice teachers (PSTs) experience a tension between theoretical input from university and from school placement. What to do about this theory-practice divide is an ongoing debate. In this paper, when investigating the potential of a type of assignment, ‘Missions’, to reduce this divide in mathematics teacher education, we give PSTs a voice in the matter. Their statements connect specific features of the assignments to theory on mathematics pedagogy and to professional practice. Two factors emerge as central to ‘Missions’ bridging theory and practice: PSTs’ lack of familiarity with mathematical investigations and the synergies between several pedagogies of practice – both prior to and during the work on the assignments.

Keywords: Pedagogies of practice, missions, maths preservice teachers, theory-practice divide.

Introduction and background

Preservice teachers (PSTs) often experience a disconnect and tension between theoretical input from university and practice in school placement (Nolan, 2012). When in conflict, PSTs reject theoretical perspectives from university, which highlights that, in their eyes, practice is a highly valued component of teacher education, more important than the university input for their future as mathematics teachers (Solomon, Eriksen, Smestad, Rodal, & Bjerke, 2017).

Nolan (2012) notes that, in mathematics, tension between practice in schools and university’s theorisation of that practice mirrors the conflict between inquiry-based focus at university and instrumentalism in schools, where the PSTs’ habitus plays a pivotal role. Habitus is strongly rooted in experiences from early schooling, and is, for that reason, hard to change (Nolan, 2012). PSTs’ ideas of what mathematics teaching is and ought to be, is influenced by memories from their own years as students (Arvola, 2005). For alternative views to stand a chance, it is important to offer PSTs opportunities to reflect critically over their own experience as students, at the same time as they are offered support in experimenting with less familiar approaches to teaching mathematics (Leavy, & Hourigan, 2016).

As a response to this disconnect between theory and practice, in Norway, the practice component of teacher education is expanded. Researchers within the field are sceptical of such quantitative solutions for qualitative problems (McDonald et al., 2014): it is hard to see that such an expansion on its own can bridge the theory-practice divide, but what the alternative is, is an ongoing debate.

In this paper, we explore the potential of ‘Missions’, a type of assignment developed at our university, to be part of such a solution in mathematics teacher education. We do this through a two-pronged approach: first we analyse the text of the Missions in order to identify how they address theory and practice, and second, giving PSTs a voice in the matter, we investigate how they experience these assignments as part of their teacher education programme, which includes 100 days of school placement.

In the Missions, working in groups of 3 – 5 PSTs, the idea is for the PSTs either to observe and interpret students' strategies and methods within a topic, or plan and conduct an activity with students and holding a specific focus (mathematical or methodological). The chosen activity shall provide opportunities for investigative work (Skovsmose, 1999). In preparation, the PSTs must think through what kind of suggestions, solutions and prior conceptions the students might bring up - and how to meet their contributions. During implementation, the focus shall be on student thinking, communication of ideas, and how the PSTs manage to challenge the students and provide support. After implementation, the process shall result in a written report where, on the basis of theory, PSTs shall analyse and discuss their observations and the work produced by the students. Critical reflection on the process and their own role as mathematics teachers is a crucial part of the report.

Theory

As teacher education is ultimately preparing PSTs for their professional practice, in recent years educational researchers have become increasingly preoccupied with how this is reflected in the design of the programmes. In mathematics teacher education, the inclusion of actual records of teaching, such as samples of student work and transcripts of classroom episodes, have become widespread, as they are seen as “extremely powerful sites for learning” (Boaler, & Humphreys, 2005, p. 4).

One particularly useful tool for analysing the design of teacher education programmes, in this respect, comes from Grossman et al. (2009), who have developed a framework for pedagogies of practice, pedagogies used in the education of professionals in order to connect to their future practice. They have identified three types of pedagogies: *representations*, *decompositions* and *approximations of practice*.

Representations of practice are activities that illustrate facets of practice that allow novices to develop images of professional practice and ways of participating in it, such as portrayals of decontextualized classroom dilemmas that teachers pursue in their ongoing work. *Decompositions of practice* are activities in which teaching is parsed into components that are named and explicated, such as when analysing videos of lessons by using a certain framework. Finally, *approximations of practice* are activities in which PSTs engage in experiences akin to real practice that reproduce some of the complexity of teaching.

In mathematics teacher education, theoretical perspectives are often related to reform teaching. The relative difficulty of reform teaching can cause the teacher to fall back on more traditional, teacher-centred approaches. One way of addressing this during university courses, is through opportunities to experience alternative ways of teaching through *representations of practice* (e.g., by participating in student-centred teaching led by the course instructor), *decomposition of practices* (e.g., by using videos and analysing those based on specific theoretical frameworks), or *approximations of practice* (lesson planning, rehearsals, co-teaching with experienced teachers). In *approximations of practice*, the PSTs are enacting teaching practices, rather than contemplating them (Grossman et al., 2009).

The idea behind the Missions is closely connected to an understanding of teacher competence as something dynamic and action-oriented that needs to be developed in close interaction with the field of practice (Kværne, & Solem, 2012). If the goal is to educate mathematics teachers with such competence, we need to understand what this requires of the components we choose to incorporate

in programme designs, such as the Missions. Schoenfeld and Kilpatrick (2008) have developed a theoretical framework for *proficiency* in teaching mathematics that considers both knowledge of theoretical perspectives and competence in enacting teaching practices. The seven categories are: *knowing school mathematics in depth and breadth; knowing students as thinkers; knowing students as learners; crafting and managing learning environments; developing classroom norms and supporting classroom discourse as part of “teaching for understanding”; building relationships that support learning; and reflecting on one’s practice*. The names of the categories are relatively self-explanatory and, for lack of space, we refer the reader to the original source for details.

Methods

This paper reports on a study with a generalist primary teacher education programme for grades 1 – 7 (ages 6 – 13) at a University in Norway. The participants are in their third year of a four-year programme, undertaking a specialization mathematics course that builds on the compulsory 30 ECTS in mathematics methods from the first two years. During each academic year, PSTs spend 30 days in school placement, leaving them with a minimum of 60 days in schools before their first Mission. All PSTs undertaking the course were invited to participate in the study, and ten volunteered.

The ten PSTs were interviewed in pairs. The questions raised in the semi-structured interviews focused on their ideas on two Missions’ purpose and function, PSTs’ perception of the use of theory, and their experiences with these two Missions. Considering their development as future mathematics teachers, we encouraged the pairs to discuss the role played by the Missions and by teaching mathematics in school placement.

The analysis of the two Missions is organised through a comparative perspective. Our analysis of the text of the two Missions is conducted in order to identify references to theory (operationalised through the syllabus of the course) and teaching practice (operationalised through tasks of teaching). Once these two Missions are identified as pedagogies of practice, we proceed to characterize them by means of the framework of Grossman et al. (2009), including an overview of constraints that are a means of reducing complexity.

In order to capture PSTs’ experiences with these two Missions as pedagogies of practice, for our analysis of the interview data, we developed coding categories close to Schoenfeld and Kilpatrick’s (2008) theoretical framework. This framework was chosen because it considers both theory and practice, and the seven aforementioned categories were operationalised in a way that enables PSTs’ statements to be immediately linked to one of the categories, or associated to a category due to the literature in the course syllabus. The authors conducted the coding individually, and coding categories were discussed until agreement was reached.

Findings

To identify the two Missions’ traits as pedagogies of practice, we begin with an analysis of the text of the assignments, before proceeding with an analysis on how PSTs perceive these two Missions and the university instructors’ intentions in employing pedagogies of practice that both resemble normal teaching practice and reduce complexity.

The two Missions

Both Missions are reform-oriented, mathematical investigations (Skovsmose, 1999) as presented in the course syllabus – and requiring PSTs in groups to bring to the classroom activities where the students are challenged to explore, explain and justify mathematical ideas. In both cases a written report was required, a *decomposition of practice* addressing the planning stage, the implementation and the reflection following the lesson. Table 1 displays a comparison of the two Missions.

	Mission 1	Mission 2
Lesson type	Investigation	Investigation
Topic and activity	Algebra - The Border Problem (Boaler & Humphreys, 2005)	Not set
Grade, class size, timeframe	Not set	Not set
Methodical considerations	Follow closely the model in Boaler & Humphreys (2005) or make different choices as long as the investigative nature is preserved	Lead the lesson so that the investigative nature of the task is preserved
Collect documentation	Proof of the students' inquiry processes. Focus: The emergence of important algebraic ideas, students' use of representations as theorised in Boaler & Humphreys (2005)	Proof of the lesson being a true investigation as defined in Skovsmose (1999). Focus: The nature of teacher-student and student-student communication as theorised in the course literature (i.e., Solem and Ulleberg (2013))

Table 1: Comparison between the two Missions

In both cases, work on the Missions was preceded by teaching sessions at the university. In addition to introducing theoretical input, these sessions included a sequence of a *representation of practice* and a *decomposition of practice* directly relevant for each of the two Missions. Specifically, the course instructor opened each session by conducting an investigation with the PSTs (“The Border Problem” prior to Mission 1, and a selection of different investigative activities prior to Mission 2), collecting artefacts – *representations of practice*. Next, the course instructor introduced a theoretical perspective and then presented the PSTs with opportunities to participate in a *decomposition of practice*, using theoretical perspectives in analysing artefacts from their own work, as well as from examples of implementations in primary and middle school classrooms. For Mission 1 an additional opportunity for the PSTs to engage with *representations* and *decompositions of practice* was provided. Boaler and Humphreys (2005) is compulsory reading and includes a video recording of a classroom implementation of The Border Problem, as well as an in-depth discussion of that session. In Mission 2, the PSTs were free to choose the activity; although they could choose one where *representations*

and *decompositions of practice* were available (e.g., the activities used by the course instructor), overall, support is reduced compared to Mission 1, and so the complexity is higher.

We argue that the two Missions ensure that the PSTs engage in *approximations of practice*. The assignments, as set by the course instructors, require planning and enacting a lesson, and are therefore proximal to the practice of teaching. At the same time, the complexity of the teaching situation is reduced by narrowing the scope to the specific traits of investigations, to the concept of variable introduced by translating between representations and to communication in the mathematics classroom, respectively. Additionally, complexity is reduced as the PSTs are only required to select some pivotal moments for discussion, and may simply ignore others. Rather than being evaluated based on how ‘successful’ the lesson has been in terms of learning goals for the students, the written report – a *decomposition of practice* – will be evaluated based on the manner in which PSTs connect observations from the classroom with the theoretical input from their course, as well as their reflections on the implementation. This gives room to experiment in a safe environment - reflections on ‘failures’ such as reducing a student’s opportunity for productive struggle, or on misinterpreting a student idea are welcome in the report, and will be regarded by the instructor as a positive learning experience for the PSTs. Finally, as the PSTs are required to work in groups, this provides them with a type of support unusual for the practice of teachers - at least in Norway.

PSTs’ reflections on the two Missions

The rationale of using pedagogies of practice is that they are simultaneously proximal to actual practice, and have reduced complexity. In the eyes of the PSTs, the main reason why the course instructor has chosen to give these two Missions is because enactment makes theory meaningful: “...a very good opportunity to understand what is expected of us as teachers, the contrast [between theory and practice] is not so great when I can try out what I’d learn about” (PST1).

Specifically, the contrast between the analytical stance of a *decomposition of practice* in isolation and the combination of *approximation* and *decomposition of practice* emerges as the PSTs reflect on how the two Missions supported their understanding of the concept of mathematical investigations:

One could for sure just say: “Be careful, don’t deprive [the pupils] of this opportunity [to figure things out themselves]”, but this was something else entirely. It gave me a completely different awareness, by allowing me to experience it (PST2)

In both statements, the presence of the course instructor is noticeable - “what is expected”, “one could [...] say”, indicating they perceive the two Missions to be part of teacher education, pedagogies of practice rather than pure professional practice.

In other statements, however, the perspective of professional practice emerges, with its demand on the PSTs’ knowledge of the depth and the breath of mathematics: “you go deeper [in the mathematical ideas], and learn more about *why* it is like it is” (PST5).

Making sense of mathematics is an experience included even in *representations of practice*, such as the investigations led by the course instructor during the session at the university; however, planning for an actual lesson (i.e., an *approximation of practice*) is significantly different, forcing PSTs to consider not only themselves, but also the students:

It takes a lot - preparing for all possible answers that might come, and all possible questions. You end up pondering imaginable scenarios and preparing how you could explain it from there (PST8)

The theme of *knowing students as thinkers*, their possible ways of approaching the tasks, and their possible questions, as well as the theme of *knowing students as learners*, what might be a helpful way of meeting their contributions, recur again and again as central to the assignment:

Normally, if the students had given the wrong answer you would just think “OK, that’s wrong”. But as it is [in Missions], you have to think what might be the thought behind the answer (PST5)

PST7 relates her first-hand experience with the difference between *knowing students as learners*, and actually successfully *crafting and managing a learning environment* that aligns with that knowledge:

You had gone through [The Border Problem] quite thoroughly, you knew there were six ways [of thinking] and possible misconceptions and so on, you had seen quite a lot of examples [...] so you got started on Mission 1 from a position of strength. [...] But] how we prepared [for the lesson in Mission 1] and how we put it across to the students did not help them as we thought it would. When we left the classroom we were thinking “Damn, we should have done a lot better!” We knew what to do – we had been through it all [at uni] – but we haven’t dug deep enough (PST7)

As investigative work is at the heart of these assignments, the learning environment was often discussed in terms of characteristics of this approach:

I still remember the maths classes where you practiced algorithms and if you asked why it worked, the teacher said “It’s just the way it is”. I can see it’s tempting to say that... The Missions give us a chance - no, force us - outside the “It’s just how it is”- box, since they are made so that the tasks don’t work unless you actually understand. It’s probably [their] the most valuable quality (PST4)

The comparative freedom in Mission 2, got mixed receptions:

On the first assignment, you got very clear constraints on what to do. On the second one, my group chose to do several tasks, and then we didn’t get the depth we needed, we sailed more on the surface of what an investigation should be (PST4)

My group designed the activity [for Mission 2], and we found it gave us more ownership of the lesson. It was ours, and it was easier to learn from it. [Working with a given task in] Mission 1 was necessary to show us how to [investigate] (PST3)

Regardless of the risk of failure, the PSTs regard the two Missions as opportunities to think deeply about what happens in the interaction with the students:

When you plan a lesson, teach it and then write about it, you become more aware of how you react to what the students say - it’s not just that you ask them something, they say something in return and you don’t think too much about the answer. You actually reflect on the conversation! (PST10)

The *classroom discourse in mathematics* appears often in PSTs’ reflection. This could be in part due to the explicit focus on communication in Mission 2 (Table 1), that retrospectively spills over in what they remember from Mission 1, but could also be in part a direct consequence of having communicated with children, and being required to document it. *Establishing classroom norms* are

mentioned in connection with these assignments as well: “The assignments contributed [towards the awareness that] it’s not just what you teach, but how you teach it, too!” (PST1). However, this code appears less frequently, perhaps given that PSTs spent a short time with students during Missions.

In comparing the *approximations of practice* in Missions 1 and 2 with those of mentored teaching in school placement, some PSTs expressed the value they placed on school placement because it offered something unique: the teacher mentors’ insight in building relationships that support learning - “[the mentors] know the children, and know how they need to be taught” (PST9). One mentor made a lasting impression on PST1 because of her awareness of mathematics teaching as more than a collection of isolated moments: “My mentor wanted us to reflect on our role, what makes us teachers ... She wanted us to take a long term perspective, more than just the weeks we were there, or the year” (PST1). Except for this relational aspect, and the opportunity to develop norms over time, the value of teaching in school placement did not connect to mathematics specifically:

[In school placement] we were two in charge of a class - lots of teaching! There wasn’t much time for either seeking advice or getting feedback (...) So [teaching in school placement] is something else [than the Missions] entirely but now I feel much better prepared for lesson planning - at least in maths, after having done the Missions. You start thinking in another way than before (PST2)

Time creates a constraint on reflection in school placement. By contrast, as we have seen, PSTs valued the opportunities that Missions 1 and 2 give them to *reflect on their own practice* by requiring them to plan as a group, and to hand in *decompositions of practice*:

You get an opportunity to think things through - what shall we do? And why should we do that? And what do we want to achieve in the end? (PST2)

We could just as well had had three Missions and no school placement, if you are thinking in terms of mathematics. School placement is good practice, but you don’t get much of the subject-specific reflection, more about the organisational aspects...The subject specific ends up neglected (PST3)

Discussion and concluding remarks

PSTs see the two Missions as *approximations* and *decompositions of practice* - close to teaching practice, enacting and analysing a practice of reduced complexity. As indicated in the introduction, the divide between theory and practice is an issue of great concern for researchers and teacher educators (Nolan, 2012); bringing theory into practice has proven difficult (Solomon *et al.*, 2017).

In this study, we explored the potential of the two Missions to bring together theoretical perspectives with teaching practice. The framework used for the analysis (Schoenfeld, & Kilpatrick, 2008), with its double orientation towards theory and practice, allowed us to examine the two Missions’ contribution to these two elements of mathematics teacher education in the PSTs’ retrospective reflections. PSTs consider the two Missions as contributing to both dimensions, and, furthermore, they complement the contribution of teaching in school placement. Both the two Missions and school placement are *approximations of practice*. While the two Missions provide the mathematics-specific focus lacking from the school placement, the long-term aspects, such as building relationships with the students, are mostly lacking from the two Missions, – although they provide at least an opportunity to appreciate that certain classroom norms are worth attempting to establish.

The PSTs' reflections highlight the synergies between several pedagogies of practice. The interaction with real children (*approximation of practice*) and a focus that - by their own account - forces PSTs outside their comfort zone mathematically, as well as in terms of teaching methods. PSTs value the requirement of group work, and of submitting a *decomposition of practice*, a written report including a reflection drawing on theory. The progression from Missions 1 to 2 gives an opportunity to develop further. Everyone appreciated the role of Mission 1: it allowed PSTs to enact an investigative lesson by 'imitating' Humphreys' video (Boaler, & Humphreys, 2005). The two Missions form a 'chain' of *approximations of practice* with an increasing degree of complexity from periods of mentored school placement, via a Mission 1, to a more open Mission 2. While some PSTs willingly took off the training wheels in Mission 2 and experimented with self-chosen activities, others stuck with the familiar examples from the class at the university (*representations of practice*). Habitus is strongly rooted and hard to change (Nolan, 2012), and these approaches to teaching mathematics are unfamiliar to many PSTs. However, if new approaches should stand a chance, these opportunities to try out less familiar investigative activities are of great importance (Leavy, & Hourigan, 2016).

References

- Arvold, B. (2005). *Goals embedded in tradition: Springboards for mathematics teacher education*. Paper presented at the 15th ICMI Study on the professional education and development of teachers of mathematics, Brazil.
- Boaler, J., & Humphreys, C. (2005). *Connecting mathematical ideas: Middle school video cases to support teaching and learning*: Portsmouth, NH, Heinemann.
- Grossman, P., Compton, C., Igra, D., Ronfeldt, M., Shahan, E., & Williamson, P. (2009). Teaching practice: A cross-professional perspective. *Teachers College Record*, 111(9), 2055–2100.
- Kværne, L., & Solem, I. (2012). *Hva ser lærerstudenter av elevers læring i matemaikk? En drøfting av studenters utvikling av læringsavdekkingskompetanse med hovedvekt på matematikk som aktivitet*. Paper presented at the Fou i Praksis, rapport fra konferansen om praksisrettet FOU i lærerutdanningen, Trondheim.
- Leavy, A. M., & Hourigan, M. (2016). Using lesson study to support knowledge development in initial teacher education: Insights from early number classrooms. *Teaching and teacher education*, 57, 161–175.
- McDonald, M., Kazemi, E., Kelley-Petersen, M., Mikolasy, K., Thompson, J., Valencia, S. W., & Windschitl, M. (2014). Practice makes practice: Learning to teach in teacher education. *Peabody Journal of Education*, 89(4), 500–515.
- Nolan, K. (2012). Dispositions in the field: Viewing mathematics teacher education through the lens of Bourdieu's Social Field Theory. *Educational Studies in Mathematics*, 80 (1-2), 201–216.
- Schoenfeld, A. H., & Kilpatrick, J. (2008). Toward a theory of proficiency in teaching mathematics. *International handbook of mathematics teacher education*, 2, 321–354.
- Skovsmose, O. (1999). Undersøgelseslandskaber. In O. Skovsmose & M. Blomhøj (Eds.), *Kan Det Virkelig Passe? : LR Uddannelse*.
- Solem, I. H., & Ulleberg, I. (2013). Hva spør lærere om? En modell for å undersøke spørsmål som stilles i klassesamtalen i matematikk. In H. Christensen & I. Ulleberg (Eds.), *Klasseledelse, fag og danning* (pp. 139–155): Gyldendal Akademisk.
- Solomon, Y., Eriksen, E., Smestad, B., Rodal, C., & Bjerke, A. H. (2017). Prospective teachers navigating intersecting communities of practice: early school placement. *Journal of Mathematics Teacher Education*, 20(2), 141–158.

Learning to represent students' mathematical ideas through teacher time-outs in rehearsals

Janne Fauskanger¹ and Kjersti Wæge²

¹University of Stavanger, Faculty of Arts and Education, Department of Education and Sports Science, Stavanger, Norway; janne.fauskanger@uis.no

²Norwegian University of Science and Technology, Norwegian Centre for Mathematics Education, Trondheim, Norway; kjersti.wage@ntnu.no

Abstract

This study examines rehearsals embedded in cycles of enactment and investigation, and more specifically, the discussions the participants engage in when instruction is paused – Teacher Time-Outs (TTOs). The paper studies the ambitious teaching practices that are revealed in the discussions, as well as the aspects of these practices that the participants have the opportunity to learn. Approximately 60% of the rehearsal time was spent on teaching and 40% on TTOs. The use of representations was a key aspect in 28% of these discussions. It is particularly interesting that the discussions in the rehearsals make it possible for the participants to learn how to represent students' mathematical ideas in writing on the board while at the same time paying close attention to connections between student talk and mathematical correctness. Implications from these findings are also discussed.

Keywords: Mathematics teaching, rehearsals, teacher time-outs, professional development

Introduction

The aim of professional development (research) is to support in-service teachers (ISTs) in developing ambitious teaching practices (e.g. Lampert, Beasley, Ghouseini, Kazemi, & Franke, 2010; McDonald, Kazemi, & Kavanagh, 2013). Ambitious teaching entails mathematical meaning making, identity building and creating equitable access to learning experiences for all students. It requires that teachers know their students as learners and engage deeply with their thinking. Ambitious teaching practices enhance student learning of complex ideas and performances (Lampert et al., 2013, Ghouseini et al., 2015). Examples of ambitious practices are aiming toward goals, eliciting and responding to students' mathematical ideas and using representations (Lampert et al., 2010) (see more examples in Table 1).

Recently, teacher education and professional development (PD) have had more focus on teaching practices and pedagogies of enactment (cf. Grossman et al., 2009; Lambert et al., 2013; Gibbons, Kazemi, & Lewis, 2017). The focus of this paper is on *rehearsals*. These researchers emerging research indicates that the use of rehearsals contributes positively to the development of ISTs' ambitious teaching practices (Gibbons, Kazemi, Hintz, & Hartmann, 2017; Kazemi, Ghouseini, Cunard, & Turrou, 2016; Lampert et al., 2013; Valenta & Wæge, 2017), as well as to the development of mathematical knowledge for teaching (Ghouseini, 2017). Previous research highlights the need for more research on rehearsals (Kazemi et al., 2016; Lampert et al., 2013).

We report on findings from the PD project *Mastering ambitious mathematics teaching* (MAM). In the MAM project, ISTs are invited to collaborate in learning cycles of enactment and investigation where the overarching aim is to learn to enact the practices that constitute ambitious mathematics teaching. Rehearsals are an important element of these cycles, and we especially examine the use of teacher time-outs (TTOs) during them. The ISTs work on instructional activities (IAs) in the rehearsals. IAs are developed to highlight and support ISTs' learning of specific ambitious teaching practices and to focus on specific mathematical ideas. The IAs in the MAM project include choral counting, quick images, number strings, problem solving and games (cf. Lampert et al., 2010). The ISTs learn to teach IAs through cycles of enactment and investigation.

Lampert et al. (2013) explore what teacher educators and novice teachers do together during rehearsals so they can “learn to enact the principles, practices, and knowledge entailed in ambitious teaching” (Lampert et al., 2013, p. 226). They suggest that rehearsals provide room for novice teachers to open up their instructional decisions to one another. Kazemi et al. (2016, p. 16) suggest that rehearsals, as nested in learning cycles, provide repeated opportunities for novice teachers “to investigate, reflect on, and enact teaching through coached feedback”. Furthermore, rehearsals bring the student teachers “into interaction with one another around instructional decision making that is responsive to students' contributions”, enabling them to “come in close contact with how their colleagues make sense of and take up the practices that are being learned” (Kazemi et al., 2016, p. 28). In the context of PD, Valenta and Wæge (2017) found that the interactions between the ISTs and the teacher educator during rehearsals were mainly discussions on using mathematical representations, using a mathematical goal, paying attention to student thinking and eliciting and responding to students' mathematical ideas – all important principles and practices of ambitious mathematics teaching. They suggest that rehearsals offer ISTs “the environment and opportunity to work simultaneously on a variety of aspects of practice” (Valenta & Wæge, 2017, p. 3387).

The organisational TTO procedure has been highlighted as a promising way for ISTs to learn together in and through practice (Gibbons, Kazemi, Hintz et al., 2017). The participants can pause the instruction to think out loud together and share decision-making with one another before continuing with the enactment. For example, Fauskanger and Bjuland's (in press) analyses suggest that TTOs enable ISTs to develop a better understanding of how to elicit students' mathematical ideas by, for example, practising questions to ask. Research indicates that TTOs provide opportunities for ISTs to make changes and to shift the focus in the interactions “from one of judgment and evaluation to one of collective consideration and opportunistic experimentation in the midst of teaching mathematics” (Gibbons, Kazemi, Hintz et al., 2017, p. 29). Gibbons, Kazemi, Hintz et al. (2017, p. 48) hypothesize that TTOs support the ISTs' “ability to be adept at moment-to-moment decision-making to engage students in rich discussions” and “to cultivate learning environments where everyone [is] positioned as capable of doing substantive mathematics” at the same time as ISTs become good at “at drawing on students' multiple knowledge bases.” These researchers point out, for instance, that future research should attempt to understand more about how TTOs might support ISTs in developing their instructional practices. In this paper, we address the following research questions: (a) Which (if any) of the practices entailed in ambitious mathematics teaching are the focus of attention in the TTOs taken during rehearsals? and (b) Bearing the TTOs in mind, which aspects of the practice of using

representations do the ISTs have opportunities to learn to enact? The second research question is the main focus of this paper.

Methodology

Design, data material and participants

The ISTs learn to teach instructional activities (IAs) through cycles of enactment and investigation. Each cycle involves the following six steps:

1. The ISTs read an article and watch a video of a teacher's enactment of a particular IA.
2. The supervisor leads a discussion/analysis of the article and the observed video.
3. Groups of ISTs prepare to teach the IA to a group of students, guided by the supervisor.
4. One IST (the rehearsing IST) enacts the IA in a rehearsal, where the supervisor and the other ISTs act as students. During this rehearsal, all participants can ask for TTOs.
5. The IST enacts the activity with a group of students. All participants can ask for TTOs.
6. Each group of ISTs analyse the enactment, guided by the supervisor. This is followed by a guided analysis of the enactment with all the ISTs.

Thirty ISTs from 10 elementary schools participated in the project. The ISTs were divided into four groups. One group consisted of those teachers who did not want to take part in the research, whereas two out of the three remaining groups (groups 2 and 3) were randomly chosen to be part of the research reported on in this paper. The ISTs' teaching experience varies from one to 30 years. The ISTs participated in 12 sessions, which included nine cycles of enactment and investigation, over the course of two years. All the sessions were videotaped where one researcher observed each group and took notes. The data material from groups 2 and 3 consists of video recordings of the rehearsals (step 4 above) from the nine cycles of enactment, resulting in 18 recorded rehearsals.

Analytical approach

A sociocultural view of ISTs' learning frames this research as the ISTs work together and learn ambitious teaching practices in a community of practice. We analysed the video recordings of the rehearsals, looking specifically for opportunities for ISTs' learning. First, all the TTOs in the rehearsals were identified according to the following definition of a TTO: The instances where the rehearsal is explicitly paused (often with a TTO hand signal) so the participants can better understand and/or act in relation to their colleagues' thinking, pedagogical choices and/or mathematical content (cf. Gibbons, Kazemi, Hintz et al., 2017). Second, we undertook a conventional content analysis (Hsieh & Shannon, 2005) of each of the TTO episodes, i.e. we used an inductive coding process with the aim of identifying aspects of ambitious teaching practices in the TTOs and which of these the ISTs have opportunities to discuss.

Findings

In a previous study, we found that approximately 60% of the rehearsal time was spent on ISTs teaching the IAs and 40% on TTOs, showing the back-and-forth pattern between facilitating deliberate practice and posing questions (Wæge & Fauskanger, submitted). Moreover, we identified 175 TTOs and found five common dimensions of ambitious teaching practice that were addressed during them (Wæge & Fauskanger, submitted). An overview of these practices is given in Table 1.

Note that many of the TTOs involved simultaneous work on multiple aspects of practice, thus many of the TTOs involved more than one category.

Ambitious teaching practice	Example	Number of TTOs
Setting up a task, i.e. the TTOs consisted of questions and discussions on the practice of launching a problem.	The rehearsing IST has just posed a problem when one of the observing ISTs asks for a TTO: “There’s something I’m wondering about. Justification. Should she [the rehearsing IST] say something about that [invite the students to justify while presenting the task]?” (session eight, problem solving, group 3)	42
Using a goal to work towards, i.e. discussions on the practice of directing students’ attention on a learning goal for the lesson.	The rehearsing IST has just written the student solution “three times ten minus one” on the board: $3 \times 10 - 1$. The supervisor intervenes by saying: “Now, the question about [the use of] parentheses becomes interesting [referring to the expression $3 \times 10 - 1$].” (session three, quick image, group 2)	35
Supporting mathematical discussions, e.g. using talk moves (cf. Kazemi & Hintz, 2014).	The rehearsing IST gives the ISTs (acting as students) some time to think about the problem 400 - 379, and then asks them to share their solutions when one of the observing ISTs asks: “Should we ask them [the students] to turn to each other and talk or should we let them think individually first?” (session six, strings, group 2)	23
Using representations, i.e. representing students’ mathematical ideas in writing (on the board), making connections between student talk and representations, and making connections between different kinds of representations (Lambert et al., 2010, Lambert et al., 2013).	The rehearsing IST, representing a student strategy on the board, pauses and asks: “Do I write in between (points on the number line)?” (session five, strings, group 3)	49
Organising the board, i.e. organisation on the smartboard and utilising space.	The rehearsing IST is representing a student solution on the open number line when the supervisor intervenes by saying: “I’m thinking of another thing right now and that is where to put the number line and the tasks.” (session six, strings, group 2)	27

Table 1: An overview of the content of the 175 analysed TTOs (Wæge & Fauskanger, submitted)

With Wæge and Fauskanger’s (in review) study as our point of departure, in this paper we focus on one dimension, namely the “use of representations”. Table 1 shows that this dimension is an important feature in many of the TTOs (shaded in Table 1).

Use of representations

Using representations (Lambert et al., 2010) is one of the key practices in ambitious teaching. Representing students’ mathematical ideas in writing on the board, making connections between student talk and written representations, and making connections between different kinds of representations, such as the open number line, arrays and tables are important features in 28% of the TTOs. In many of these TTOs the participants discussed how to write student ideas or strategies on the board so they could represent the students’ thinking and at the same time keep mathematical

correctness in focus. For instance, they discussed the use of parentheses when representing students' ideas, the use of arrows instead of the equal sign and the degree to which they should focus on the convention related to the order of factors (in Norway, i.e. 3×4 normally represents three groups of four). The importance of recording exactly what the students said was emphasised in several of these TTOs, however, this sometimes led to mathematical incorrectness and thus TTOs were requested.

To illustrate the TTOs in which the participants discussed how to represent the students' ideas or written representations, we provide an example from a rehearsal of a game where number sentences¹ presented by the students were written on the board. In this game, the students worked on finding number sentences using given numbers. Just prior to the coded exchange, the rehearsing teacher represented what one student said by writing the following two number sentences (all supposed to equal the given number 8): $5 + 3 = 8$ and $9 - 5 = 4 \times 3 = 12 : 6 = 2 \times 4 = 8$. We join the rehearsal as one of the observing teachers intervenes:

- 1 OT1²: Then the question is/ (interrupted by OT2)
 2 OT2: Then the question about [correct] notation is relevant.
 3 S: Yes, and it can't be [written] like that (pointing to $9 - 5 = 4 \times 3 = 12 : 6 = 2 \times 4 = 8$)
 4 RT: Ok, it can't be written like this? (...) ³ (session nine, game, group 3)

The use of the equal sign in the number sentence is not mathematically correct, and the observing ISTs suggested taking a closer look at the use of notation in the number sentences (Lines 1, 2). The supervisor supported their suggestions, pointing out that they needed to find another way to write the number sentences (Line 3). The use of arrows was introduced in the MAM project, but these ISTs do not appear to be used to writing an arrow instead of the equal sign when recording students' thinking. As the discussion continued, some of the ISTs suggested that the number sentence could be written the way it was because that was the way the student presented it. However, at the end of this TTO the participants concluded that they would replace the equal sign with arrows so the number sentences would be mathematically correct: $9 - 5 \rightarrow 4 \times 3 \rightarrow 12 : 6 \rightarrow 2 \times 4 = 8$.

A second representative example is taken from another group rehearsing the same IA, but now all the number sentences were to equal 6. The following was written on the board: $5 + 1$, $8 - 5 + 2 + 1$, $10 - 8 + 2 + 5 + 1$ when one of the observing ISTs asked for a TTO (referring to $10 - 8 + 2 + 5 + 1$):

- 1 OT1: Should we ask them [the students] what they are thinking as they do this?
 2 RT: Yes.
 3 OT1: Ask them to explain their thinking. (session nine, game, group 2)

In what followed, the participants discussed what to do when they wrote exactly what the students were saying and it turned out to be mathematically incorrect. After arguing back and forth whether to write exactly what the students were saying or to represent their ideas in a mathematically correct way, they agreed to use "circles" (e.g. $10 - \textcircled{8} + 2 + 5 + 1$). The rehearsal continued, but similar

¹ In their planning, the ISTs used the term equations. When analysing the rehearsals, however, we find that sometimes the "equations" are written as equality strings or false equations (e.g. $9 - 5 = 4 \times 3 = 12 : 6 = 2 \times 4 = 8$) or without an equal sign (e.g. $9 - 5$). For this reason we use the term "number sentence" (cf. Ghouseini, 2017).

² In the transcripts, OT represents one of the observing ISTs, RT is the rehearsing teacher and S is the supervisor.

³ (...) indicates that the TTO continues.

examples were presented by ISTs acting as students (e.g. $20 - 8 = 12 + 3 = 15$) when the supervisor requested a TTO to ask the ISTs what they would do if these examples were presented by students in the enactment phase. In the ensuing discussion, some of the ISTs pointed out the importance of writing exactly what the students were saying, whereas others pointed to the importance of writing what was mathematically correct. This group did not reach a conclusion on this matter before continuing the rehearsal.

The next example, taken from a rehearsal of a string, shows a discussion on how to represent students' ideas in writing. The first problem in the string was to focus on a run where four students were going to run equally long where the total distance was one hundred metres. One of the observing ISTs (acting as student) said that he knew that "they have to run 25 metres each" because "four times 25 equals one hundred". When representing this on an open number line on the board, the rehearsing IST started by dividing a line segment into two and then by dividing each of these parts into two again thus representing $(100 : 2) : 2$ instead of 4×25 . The supervisor asked for a TTO:

- 1 Supervisor: What is interesting here is that you have thought, you have explained that you were thinking four times 25 (referring to the observing IST who presented this idea). You just knew that, right. But, when you (referring to the rehearsing IST) were making the number line now, what did she do, do you recognise that [what she did represent] (looking at all the observing ISTs)?
- 2 OT1: She divided into two and then divided into two again.
- 3 S: Yes, you halved and then halved again.
- 4 RT: Ok.
- 5 S: It's important that we are aware of this [that this represents $(100 : 2) : 2$ and not 4×25]. (...) (session six, strings, group 2)

The supervisor wanted the rehearsing IST to represent exactly what the student was saying (4×25 , Lines 1, 5) and she invited the observing ISTs to recognise this (Line 1). One of the observing ISTs recognised that the rehearsing IST had represented $(100 : 2) : 2$ instead of 4×25 (Line 2). As the discussion continued, the rehearsing IST asked if she should present the strategy $(100 : 2) : 2$. This was followed by a short discussion on the pros and cons relating to ISTs presenting their own ideas. The supervisor advised the rehearsing IST to represent 4×25 on the number line as "25 and 25 and 25 and 25" (showing the four "jumps" by pointing to the number line). They agreed that the rehearsing IST in the enactment should illustrate 4×25 as four jumps of the length 25 and in addition writing 25 above each arch as illustrated in Figure 1.

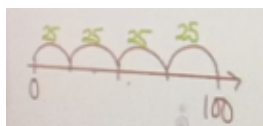


Figure 1: 4×25 represented on a number line

These three examples illustrate that the TTOs in the rehearsals could support the ISTs' learning of the practice of representing students' ideas or strategies and their paying close attention to connections between student talk and written representations. The ISTs could also learn more about

the balance between representing students' mathematical ideas or strategies as presented by the students and representing these ideas or strategies in a way that is mathematically correct.

Concluding discussion

In this study we have identified and analysed ambitious teaching practices that are revealed in TTOs in rehearsals, exploring which practices the ISTs have opportunities to learn to enact during the TTOs. The findings show that ISTs have opportunities to work on and learn to enact the practices of setting up a task, using goals to work towards, supporting mathematical discussions, organising the board and using representations. Opportunities for learning these practices have also been found in previous studies (cf. Kazemi et al., 2016; Lampert et al., 2013; Valenta & Wæge, 2017), which have also found opportunities in TTOs in the enactment phase of cycles of enactment and investigation (cf. Fauskanger, 2019; Gibbons, Kazemi, Hintz et al., 2017). In this paper, we have focused on the practice of using representations. The findings show that TTOs especially have the potential to create opportunities for ISTs to learn how to present students' mathematical ideas in writing and also show the importance of representing student ideas as accurately as possible while also focusing on the mathematical correctness of the representation. Balancing the dilemma between student talk and mathematical correctness has not previously been found in research on TTOs in rehearsals and is thus a unique finding from this study. Our findings also indicate that the ISTs might need more mathematical knowledge for teaching (MKT) and that the TTOs can be a point of departure for strengthening ISTs' MKT (cf. Ghouseini, 2017).

Previous research on TTOs in enactment (Gibbons, Kazemi, Hintz et al., 2017), as well as in rehearsals (Lampert et al., 2013), challenges future research to elaborate on how TTOs as a procedure in PD can be sustained and developed. By using the data material from the MAM project, it is possible to study the development of TTOs in each group for a two-year period. Further analyses of the data material will also make it possible to learn more about whether and how the supervisors develop their TTO expertise (cf. Gibbons, Kazemi, Hintz et al., 2017). Similar projects in new contexts are also welcome in order to study the potential of using TTOs in new contexts. In the Norwegian context the new guidelines for initial teacher education highlight ambitious teaching practices (cf. Mosvold, Fauskanger, & Wæge, 2018) and the number of days in field practice in schools has been extended. Based on the promising opportunities for ISTs to learn ambitious teaching practices through TTOs in the enactment of teaching (Fauskanger, 2019), studying TTOs in student teachers' field practice will be an important context for future TTO research.

Acknowledgment

We would like to thank to all the participants in the MAM project.

References

- Fauskanger, J. (2019). Ambisiøse undervisningspraksiser i Teacher Time Out. [Ambitious teaching practices in Teacher Time Outs]. *Nordic Studies in Mathematics Education*, 24(1), 75–94.
- Fauskanger, J., & Bjuland, R. (in press). Learning to elicit and respond to students' mathematical ideas through teacher time-outs. *Mathematics Teacher Education and Development Journal*.

- Gibbons, L. K., Kazemi, E., Hintz, A., Hartmann, E. (2017). Teacher Time Out: Educators learning together in and through practice. *NCSM Journal of Mathematics Education Leadership*, 18(2), 28–46.
- Gibbons, L., Kazemi, E., & Lewis, B. (2017). Developing collective capacity to improve mathematics instruction: Coaching as a lever for school-wide improvement. *Journal of Mathematical Behavior*, 46, 231–250.
- Ghousseini, H. (2017). Rehearsals of teaching and opportunities to learn mathematical knowledge for teaching. *Cognition and Instruction*, 35(3), 188–211.
- Grossman, P., Compton, C., Igra, D., Ronfeldt, M., Shahan, E., & Williamson, P. (2009). Teaching practice: A cross-professional perspective. *Teachers College Record*, 111(9), 2055–2100.
- Hsieh, H.-F., & Shannon, S.E. (2005). Three approaches to qualitative content analysis. *Qualitative Health Research*, 15 (9), 1277–1288.
- Kazemi, E., Ghousseini, H., Cunard, A., & Turrou, A.C. (2016). Getting inside rehearsals: Insights from teacher educators to support work on complex practice. *Journal of Teacher Education*, 67(1), 18–31.
- Lampert, M., Beasley, H., Ghousseini, H., Kazemi, E., & Franke, M. (2010). Using designed instructional activities to enable novices to manage ambitious mathematics teaching. In M.K. Stein & L. Kucan (Eds.), *Instructional explanations in the disciplines* (pp. 129–141). New York, NY: Springer.
- Lampert, M., Franke, M.L., Kazemi, E., Ghousseini, H., Turrou, A.C., Beasley, H., . . . Crowe, K. (2013). Keeping it complex: Using rehearsals to support novice teacher learning of ambitious teaching. *Journal of Teacher Education*, 64(3), 226–243.
- McDonald, M., Kazemi, E., & Kavanagh, S.S. (2013). Core practices and pedagogies of teacher education: A call for a common language and collective activity. *Journal of Teacher Education*, 64(5), 378–386.
- Mosvold, R., Fauskanger, J., & Wæge, K. (2018). Fra undervisningskunnskap i matematikk til kjernepraksiser – endringer i grunnskolelærerutdanningens matematikkfag. [From mathematical knowledge for teaching to core practices – changes in mathematics in initial teacher education]. *Uniped. Tidsskrift for universitets- og høyskolepedagogikk*, 41(4), 401–411.
- Valenta, A. & Wæge, K. (2017). Rehearsals in work with in-service mathematics teachers. In T. Dooley & G. Gueudet (Eds.), *Proceedings of the Tenth Congress of the European Society for Research in Mathematics Education (CERME10, February 1-5, 2017)* (pp. 3881–3888). Dublin, Ireland: DCU Institute of Education and ERME.
- Wæge, K. & Fauskanger, J. (in review). Learning to teach through teacher time-out when rehearsing mathematics teaching. *Journal of Mathematics Teacher Education*.

How does the professional vocabulary change when pre-service teachers learn to analyse classroom situations?

Marita Friesen¹, Carmel Mesiti² and Sebastian Kuntze¹

¹Ludwigsburg University of Education, Germany; friesen@ph-ludwigsburg.de; kuntze@ph-ludwigsburg.de

²University of Melbourne, Australia; cmesiti@unimelb.edu.au

We conducted a university course with pre-service teachers specifically focused on learning to analyse the use of multiple representations in classroom situations. We were particularly interested in the professional vocabulary pre-service teachers used when they analysed these classroom situations. Before and after the course, we collected 136 written analyses from 17 pre-service teachers who were asked to evaluate the use of multiple representations in four classroom situations. Our findings indicate that the pre-service teachers' professional vocabulary improved with respect to breadth and specificity. They also used more terms related to essential aspects of theory on multiple representations. As teachers' increased and appropriate use of professional vocabulary appears to play a role with regard to their competence in analysing classroom situations, further research into this topic is encouraged and might give insight into corresponding competence development.

Keywords: Teacher education, analysing classroom situations, professional vocabulary.

Introduction

Being able to analyse classroom situations, that is to identify and interpret events which are relevant for students' learning, is an important prerequisite for providing students with adequate learning opportunities and learning support (e.g., Sherin, Jacobs & Philipps, 2011). Since the use of multiple representations and the ability to flexibly change between them plays an essential role for the learning of mathematics (Duval, 2006; Acevedo Nistal et al., 2009), teachers' ability to *analyse classroom situations regarding the use of representations* can be described as an important aspect of mathematics teachers' professional competence (Friesen & Kuntze, 2016; Friesen, 2017). The question of how such a competence can be developed and how competence development in that field can be assessed and described consequently merits special attention in mathematics teacher education.

The study presented in this paper connects our prior research of pre-service teachers' growth in analysing classroom videos (Friesen, Dreher & Kuntze, 2015) with teachers' use of professional vocabulary when analysing classroom situations regarding the use of representations (Friesen, Mesiti & Kuntze, 2018). Since the International Classroom Lexicon Project (e.g., Mesiti & Clarke, 2017) has drawn attention to the professional vocabulary teachers use when describing classroom phenomena, it has been assumed that what teachers identify and interpret when observing classroom situations might not only be channelled by their knowledge but also by *what they can name*. Taking also into consideration that learning the language of a discipline can be regarded as part of learning the discipline itself (e.g., Schleppegrell, 2007), we assumed that documenting pre-service teachers' use of professional vocabulary might provide insight into their development when they learn to

analyse classroom situations. In this next phase of our research, we turn our attention to change in pre-service teachers' professional language when they learn to analyse classroom situations regarding the use of multiple representations.

Below we outline our study's theoretical background, starting with multiple representations and their role for the teaching and learning of mathematics. After presenting the state of research into teachers' competence of analysing and teachers' use of professional vocabulary, we follow with a description of the university course from which we obtained our data.

The use of multiple representations in the mathematics classroom

The use of multiple representations plays a crucial role for the teaching and learning of mathematics. As mathematical objects are abstract in nature, they can only be accessed by using representations such as: formulae, graphs, diagrams, tables, written and spoken language (e.g., Goldin & Shteingold, 2001). Bruner (1966) coined three stages of representation in which any idea or body of knowledge can be presented to a learner: by action (*enactive* representation), by images or graphics (*iconic* representation) or by symbolic propositions (*symbolic* representation). According to Duval (2006), representations of mathematical objects can be organised in a more fine-grained manner in so-called representation *registers*. Each register (e.g., oral or written language, symbols, shapes, drawings, sketches, diagrams, graphs, etc.) contains some information about the mathematical object it stands for or emphasises certain aspects of the mathematical object. Since many tasks involve several representation registers and some registers are more efficient for solving problems than others, the use of *multiple registers* of representations can be regarded as indispensable for the teaching and learning of mathematics. Teachers and students generate and use multiple representation registers for introducing new topics, for explaining, for solving problems and for sharing ideas in the classroom (Duval, 2006; Acevedo Nistal et al., 2009).

Numerous studies show, however, that using multiple representations of a mathematical object and changing between them involves high cognitive demands for the learners (Ainsworth, 2006; Duval, 2006): The changes between multiple representation registers, so-called *conversions*, require the learners of mathematics to identify and coordinate the relevant constituents from different representation registers. It can consequently lead to serious problems in understanding when students fail to see that different registers (e.g., verbal explanation, written symbols and drawing) represent the same mathematical object (Duval, 2006).

For this reason, mathematics teachers have to be able to *analyse classroom situations* regarding the use of multiple representations in order to support their students in connecting different representation registers when conversions occur (Friesen & Kuntze, 2016). We define such competence of analysing as a teacher's ability "to link relevant observations in a classroom situation to corresponding criterion knowledge so that unconnected changes of representations can be identified and interpreted with respect to their role as potential learning obstacle" (Friesen, 2017, p. 39). Being able to analyse classroom situations as described above can be regarded as highly relevant for students' learning with multiple representations and thus for the instructional quality in the mathematics classroom.

The role of professional vocabulary for analysing classroom situations

Representations of practice in the form of video clips, narratives, student-teacher dialogues or cartoons play an important role when pre-service and in-service teachers learn to analyse classroom situations (e.g., Sherin, Jacobs & Philipps, 2011). Breaking down practice into its constituent parts requires, however, a *specific language* for describing and naming these parts (Grossman et al., 2009). It is also assumed that learning the language of a discipline is a part of learning the discipline itself (Schleppegrell, 2007). There is hence a consensus that having a specific language for describing teaching practice is essential in pre-service teacher education as well as for the discussion of in-service teachers' practice and its development within the teaching community (Grossman et al., 2009). At the same time, the teaching community has been characterised as suffering from a lack of professional language (Grossmann et al., 2009) whereas different communities, speaking different languages, have been found to employ different naming systems (e.g., Mesiti, Clarke, Dobie, White & Sherin, 2017).

In this context, the International Classroom Lexicon Project (e.g., Mesiti et al., 2017) seeks to document the *professional vocabulary*, or lexicon, mathematics teachers use *when describing classroom phenomena*. Research teams in ten countries (Australia, Chile, China, the Czech Republic, Finland, France, Germany, Japan, Korea and the USA) are currently identifying and comparing the lexicon of their middle school teachers (e.g., Mesiti & Clarke, 2017). Mesiti et al. (2017) argue that teachers' interactions with classroom settings are mediated by their capacity *to name* what they see and experience. The concept of teacher noticing (e.g., Sherin, Jacobs & Philipps, 2011) plays an important role in this context; it is assumed that what teachers identify and interpret in a classroom situation is not only constrained by their knowledge and experience but also by *what they can name* (Mesiti et al., 2017). We therefore concluded, that the professional vocabulary teachers use also provides potential for research into teachers' competence of analysing the use of representations. In a corresponding study, we took an initial step and documented the professional vocabulary used by in-service teachers in their written analysis of classroom situations regarding the use of representations (Friesen, Mesiti & Kuntze, 2018). The results encouraged us to use a similar method for the documentation of pre-service teachers' professional vocabulary before and after a university course with the objective to gain insight into the participants' development when they learn to analyse classroom situations. In the following paragraphs we will describe the university course, our research questions and our method for documenting the pre-service teachers' professional vocabulary.

Learning to analyse: a university course

The objective of this single semester course is to develop pre-service teachers' competence when analysing the use of multiple representations. It is offered on a regular basis at Ludwigsburg University of Education (e.g., Friesen, Dreher & Kuntze, 2015). At the beginning of the course, key elements of theory related to the use of multiple representations in the mathematics classroom are introduced. Accordingly, criteria are developed which are used during the course for the analysis of videotaped classroom situations and textbook learning material. The core of the course work is the collaborative and criteria-based analysis and reflection of how multiple representations are used and dealt with in learning material and classroom situations. Emphasis is put on the pre-service teachers'

ability to distinguish different registers of representation and to identify unconnected conversions and interpret them with respect to their role as potential learning obstacles. In this context, the participants become acquainted with specific terms from theory on using multiple representations in the mathematics classroom, such as *register*, *conversion*, *change of representations*, *connection of representation registers*, etc. (cf. Duval, 2006). The course sessions also provide the opportunity to further develop and improve learning material and classroom situations according to the theory-based criteria. The pre-service teachers are, for example, encouraged to create alternatives for the teachers' reactions in videotaped classroom situations with the aim to support students in using multiple representations and making connections between different representation registers.

Research interest and research questions

What teachers see in classroom situations might be channeled by *what they can name* and it might consequently be assumed that teachers' professional vocabulary plays a role with respect to their degree of competence and sophistication in analyzing classroom situations. We are consequently interested in how professional vocabulary develops and how the professional vocabulary used by pre-service teachers changes during a single semester university course. Building on our prior research (Friesen, Mesiti & Kuntze, 2018), we are particularly interested in identifying changes in the professional vocabulary of pre-service teachers after having learned to analyse classroom situations regarding the use of multiple representations. This leads to the following research questions:

- What professional vocabulary do the pre-service teachers use for analysing classroom situations before and after a course focusing on the use of representations?
- In what way does the professional vocabulary change?

Sample, methods and data analysis

The data analysed in this study was collected from 17 mathematics pre-service teachers who studied the university course described above. All but one of the pre-service teachers were female, between 21 and 27 years old ($M_{age}=23.2$; $SD_{age}=1.5$) and in their sixth or seventh semester.

In order to address the research questions, we asked the pre-service teachers at the beginning and end of the university course to evaluate other teachers' teaching in four different classroom situations (learning of fractions, grade six). The classroom situations were presented in a paper-and-pencil test in the two formats text (student-teacher-dialogues complemented with pictures of the teacher-generated and student-generated representations) and comic (cf. Friesen, 2017). Each classroom situation was followed by an open-ended question: *How appropriate is the teacher's response in helping the students to solve the task? Please evaluate the use of representations and give reasons for your answer.* The narratives of the four classroom situations were designed in a similar way: A group of students struggle with solving a task, they show the teacher their workings with a certain representation register (e.g., calculation, written symbols) and ask the teacher for help. Initially, the teacher tries to support the students with a verbal explanation. As they still do not understand, the teacher changes the representation register (e.g., by making a sketch or drawing). However, the teacher does little to connect the student-generated and the teacher-generated representations and there is no support for the students to see that the different representations belong to the same

mathematical object. Based on the theory of learning with multiple representations as outlined above, such unconnected conversions are very likely to cause further problems in the students' understanding. The teacher's response can therefore be evaluated as not appropriate for helping the students in all of the four classroom situations.

As the 17 pre-service teachers were asked to analyse four classroom situations before and after the university course, 136 written answers could be examined for this study. In order to extract the professional vocabulary from the pre-service teachers' answers, we adopted a method previously developed with similar research involving in-service teachers (Friesen, Mesiti & Kuntze, 2018). We were interested in identifying change with respect to the professional vocabulary in use by pre-service teachers before and after the course, hence, the answers from the pre-test and the post-test were analysed separately. As a first step, lexical items (nouns, verbs, adjectives, adverbs carrying the meaning of the sentence) were extracted from the pre-service teachers' written answers. As classroom phenomena were also described using terms which were non-lexicalised (i.e. not expressed as a single word), we included such terms in a second step of analysis. In the next step, we grouped the extracted terms in lexical categories which we had derived in our prior study (Friesen, Mesiti & Kuntze, 2018): (1) terms related to general pedagogical practices which are not specific to the mathematics classroom, (2) terms related to mathematical content and to practice specific to the mathematics classroom and (3) terms related to representations and their use in the mathematics classroom including stages of representations, representation registers, changes of representations and the connection of registers. Figure 1 shows these steps of analysis for a pre-service teacher's answers from the pre-test and the post-test (same classroom situation).


<p>Ich finde die Erklärung am Zahlenstrahl nicht wirklich geeignet, da es auch eine formale Erklärung ist.</p> <p>Die erste Erklärung ($\frac{2}{3}$ geht öfter in 6 als 1) finde ich verständlicher. Das könnte ikonisch dargestellt werden, um eine anschauliche Erklärung zu geben.</p> 	<p>I think that the explanation with the number line is not really appropriate because it is also a formal explanation. I find the first explanation ($2/3$ go more often in 6 than in 1) is easier to understand. This could be represented iconically in order to give an illustrative explanation.</p> <p>(pre-test, written analysis for classroom situation 1)</p>
<p>Es ist gut, dass die Lehrperson andere Darstellungen verwendet und es nicht nur anhand der Rechnung zu erklären versucht.</p> <p>Ich finde es nicht gut, dass die Lehrperson zwei verschiedene Darstellungen nutzt (verbal wie oft passt $\frac{2}{3}$ in 6, am Zahlenstrahl Rechenoperationen).</p> <p>Sie verknüpft diese Darstellungen nicht miteinander. Es wäre besser, nur eine zu wählen und diese genauer zu erklären (z.B. $\frac{2}{3}$ in 6 bildlich darstellen).</p>	<p>It is good that the teacher uses other representations instead of trying to explain only the calculation. I think it is not good that the teacher uses two different representations (verbal: how often $2/3$ go in 6, on the number line: arithmetic operations). She doesn't connect these representations to each other. It would be better to choose just one representation and explain this one in more detail (e.g., represent $2/3$ in 6 iconically).</p> <p>(post-test, written analysis for classroom situation 1)</p>

Figure 1: Sample answers from pre-test and post-test; extracted terms are shaded

Results

The analysis of the pre-service teachers' written responses for professional vocabulary resulted in the extraction of 422 terms (pre-test) and 359 terms (post-test). Figure 2 indicates that the share of terms related to representations and their use in the mathematics classroom has increased from pre-test to post-test (from 38% to 52%).

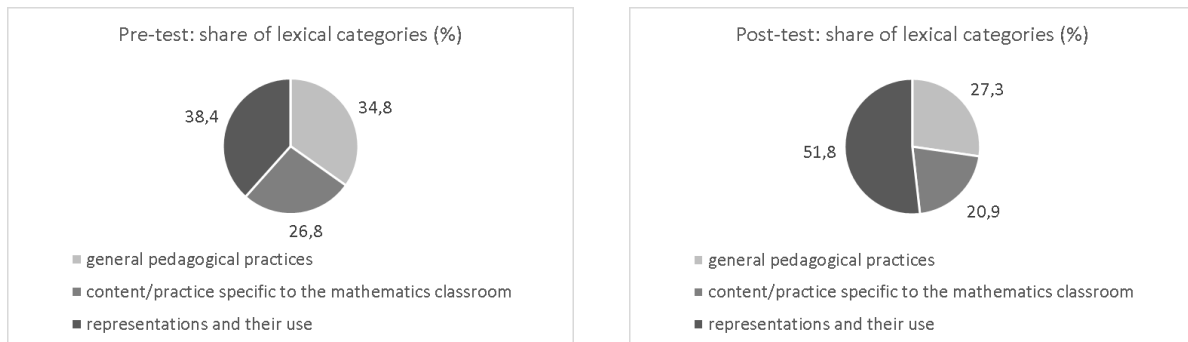


Figure 2: Extracted terms organised in lexical categories, pre-test and post-test

A closer examination of the terms that were most frequently used to describe phenomena of the presented classroom situations reveals that there was little change between pre-test and post-test concerning the lexical categories (1) general pedagogical practices and (2) mathematical content/practices. The terms that were most frequently used to describe general pedagogical practices were *(to) explain/explanation* and *(to) understand/understanding* both in the pre-test and the post-test. The terms that were most frequently used to describe content and practices specific to the mathematics classroom were *fraction*, *(to) divide*, *(to) multiply* and *result* both in the pre-test and the post-test. This is very similar to the terms most frequently used by in-service teachers when analysing the same classroom situations (see Friesen, Mesiti & Kuntze, 2018 for a list of terms). The change in the pre-service teachers' professional vocabulary from pre-test to post-test became visible in the lexical category grouping terms related to representations and their use in the mathematics classroom. First, we compared the shares of subcategories, as can be seen in Figure 3. About half of the terms related to representations were used to describe different representation registers. The share of terms used to describe stages of representations decreased from pre-test to post-test, whereas, in the post-test, more terms were used to describe classroom phenomena related to changes of representations and the connection of registers; both essential aspects for learning with representations.

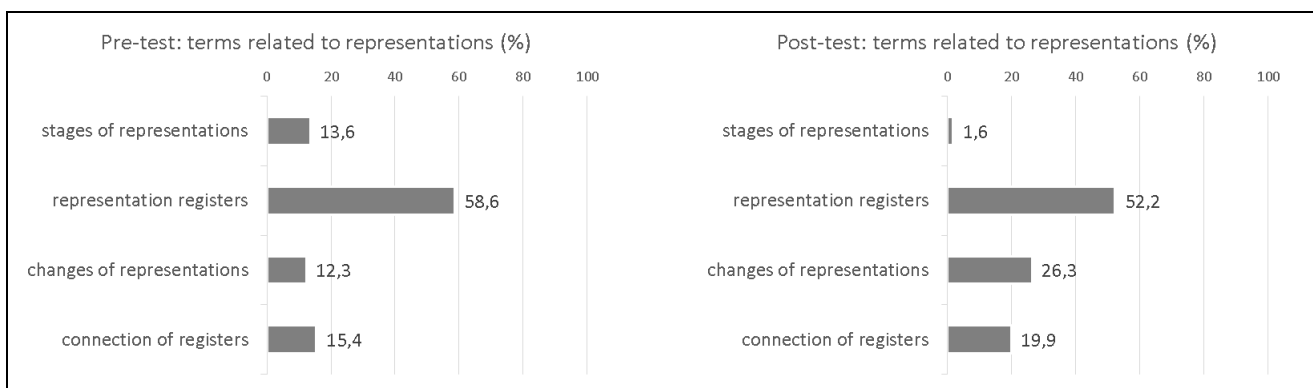


Figure 3: Terms related to representations, change in subcategories between pre-test and post-test

The terms changed, however, not only regarding their number but also regarding quality. In the case of terms used for describing registers of representations, we found for the pre-test that besides the specific terms *number line*, *diagram*, *drawing* and *pizza*, the general term *representation* was used 45 times to describe very different kinds of registers in the four classroom situations. In the post-test, the pre-service teachers used the general term *representation* only 15 times. Instead, terms with *register* appeared 15 times to describe the same phenomena (e.g., *diagram register*, *drawing register*, *verbal register* etc.) or the pre-service teachers extended the word *representation* by adding a more specific description, e.g., *representation with pizzas*, *iconic representation*, *verbal representation*, etc. In the case of terms for describing changes of representations, the pre-service teachers used terms such as *choose* or *use another representation* in the pre-test. The most frequent terms for describing changes of representation were constructions with *illustrate*, such as *illustrate the problem with pizza slices* (2 and 8 times, respectively). In the post-test, more specific terms such as *change of representations* and *conversion* could be found in the answers (6 and 12 times, respectively).

Discussion

Whereas the language used by students and teachers in the mathematics classroom plays an essential role in mathematics teacher education and corresponding research, the professional language teachers use for analysing classroom situations and describing classroom phenomena has so far garnered less attention. The argument that teachers are not likely to identify and interpret classroom phenomena that they cannot name underlines, however, the importance of supporting the development of a professional lexicon as part of teacher education programmes. The aim of this study was to document pre-service teachers' professional lexicon with a focus on representations and to examine if pre-service teachers' use of professional vocabulary changes when they learn to analyse classroom situations in a university course. Although this study is limited to a small sample and to analysing the use of representations, its findings encourage further research into this topic and further development of the applied methods. The documentation of the pre-service teachers' professional vocabulary before and after the course revealed a change concerning several aspects: First, the pre-service teachers' lexicon concerning multiple representations and their use appears to have grown and has become more specific at the same time; additionally, the professional vocabulary used in the post-test is, for example, characterised by a wider range of terms for aspects that play a central role for learning with multiple representations (changes of representations, connection of registers) and also indicates a greater level of specificity regarding terms related to registers of representation. It might be concluded that having a name for certain registers can help to identify them whereas identifying different registers of representation can be seen as necessary prerequisite to identify conversions and to interpret them as potential learning obstacles. The relation between teachers' professional vocabulary and their corresponding competence of analysing should consequently be investigated in more depth. A next step is to bring together the documentation of teachers' professional vocabulary and their competence scores when analysing classroom situations regarding specific criteria.

Acknowledgement

This study is part of the project EKoL and supported by Ludwigsburg University of Education and the Ministry of Science, Research and the Arts in Baden-Wuerttemberg.

References

- Acevedo Nistal, A., van Dooren, W., Clareboot, G., Elen, J., & Verschaffel, L. (2009). Conceptualising, investigating and stimulating representational flexibility in mathematical problem solving and learning: a critical review. *ZDM Mathematics Education*, *41*(5), 627–636.
- Ainsworth, S. (2006). A conceptual framework for considering learning with multiple representations. *Learning and Instruction*, *16*, 183–198.
- Bruner, J. S. (1966) *Toward a theory of instruction*. Cambridge, MA: Harvard University Press.
- Duval, R. (2006). A cognitive analysis of problems of comprehension in a learning of mathematics. *Educational Studies in Mathematics*, *61*, 103–131.
- Friesen, M. (2017). *Teachers' competence of analysing the use of multiple representations in the mathematics classroom and its assessment in a vignette-based test*. Doctoral dissertation. <https://phbl-opus.phlb.de/frontdoor/index/index/docId/545>
- Friesen, M., Dreher, A. & Kuntze, S. (2015). Pre-Service Teachers' Growth in Analysing Classroom Videos. In K. Krainer & N. Vondrová (Eds.), *Proceedings of CERME 9*, (pp. 2783–2789). Prague, Czech Republic: Charles University in Prague, Faculty of Education and ERME.
- Friesen, M. & Kuntze, S. (2016). Teacher students analyse texts, comics and video-based classroom vignettes regarding the use of representations – Does format matter? In C. Csíkos, A. Rausch, & J. Sztányi (Eds.), *Proceedings of PME 40*, (Vol. 2, pp. 259–266). Szeged, Hungary: PME.
- Friesen, M., Mesiti, C. & Kuntze, S. (2018). What vocabulary do teachers use when analysing the use of representations in classroom situations? In E. Bergqvist, M. Österholm, C. Granberg, & L. Sumpter (Eds.). *Proceedings of PME 42* (Vol. 2, pp. 435–442). Umeå, Sweden: PME.
- Goldin, G., & Shteingold, N. (2001). Systems of representation and the development of mathematical concepts. In A. A. Cuoco & F. R. Curcio (Eds.), *The role of representation in school mathematics* (pp. 1–23). Boston, Virginia: NCTM.
- Grossman, P., Compton, C., Igra, D., Ronfeldt, M., Shahan, E., & Williamson, P.W. (2009). Teaching practice: A cross-professional perspective. *Teachers College Record*, *111*(9), 2055–2100.
- Mesiti, C., & Clarke, D.J. (2017). Structure in the professional vocabulary of middle school mathematics teachers in Australia. In A. Downton, S. Livy, & J. Hall (Eds.). *Proceedings of MERGA 40*, (pp. 373–380). Adelaide, MERGA.
- Mesiti, C., Clarke, D.J., Dobie, T., White, S., & Sherin, M. (2017). “What do you see that you can name?” Documenting the language teachers use to describe the phenomena in middle school mathematics classroom in Australia and the USA. In B. Kaur, W.K. Ho, T.L. Toh, & B.H. Choy (Eds.) *Proceedings of PME 41*, (Vol. 3, pp. 241–248). Singapore: PME.
- Schleppegrell, M.J. (2007). The Linguistic Challenges of Mathematics Teaching and Learning: A Research Review. *Reading & Writing Quarterly*, *23*(2). 139–159.
- Sherin, M.G., Jacobs, V.R. & Philipp, R.A. (2011). *Mathematics Teacher Noticing: Seeing Through Teachers' Eyes*. New York, NY: Routledge.

Prospective mathematics teachers' interpretative knowledge: focus on the provided feedback

Jeannette Galleguillos¹ and Miguel Ribeiro²

¹Universidad de Valparaíso, Chile; jeannette.galleguillos@uv.cl

²State University of Campinas – UNICAMP, Brazil; cmribas78@gmail.com

In this work, we focus on the meaning prospective mathematics teachers assign to a set of students' productions and the feedback provided to these students. Based on these findings, we discuss prospective teachers' interpretative knowledge required for providing a fruitful feedback to students, having their reasoning as the starting point. Data collection (written responses) for this investigation took place at a workshop involving 19 prospective teachers from a Chilean university. Thematic analysis of their responses revealed two distinct types of feedback, namely that grounded in the nature and focus of the interpretation provided, and that focusing on the content of prospective teachers' knowledge.

Keywords: Mathematics teachers' interpretative knowledge, error analyses, teachers' feedback.

Introduction

Teachers' knowledge is one of the core factors considered when developing highly demanding mathematical practices (Ball, Thames, & Phelps, 2008). Thus, in that sense, it is essential to focus on the content of such knowledge and, in particular, on the dimensions that would allow teachers to develop such mathematical practices, having the students' own reasoning and understanding as a starting point for the mathematical discussions, as well as for determining the feedback to be provided to these students. By better understanding the provided feedback, the aim is to enrich (prospective) teachers' knowledge and experience related to teaching practice. The knowledge grounding such type of practice is perceived as specialised.

In order to deepen and broaden our understanding on the content of teachers' interpretative knowledge and promote its development, we have been developing tasks for teacher education with a specific focus of developing teachers' knowledge (e.g., Jakobsen, Ribeiro, & Mellone, 2014; Policastro, Mellone, Ribeiro, & Fiorentini 2018, submitted). We have been using tasks that probe into teachers' interpretative knowledge in different teacher education contexts (initial, continuous, and complementary) as a prompt to orchestrate mathematical discussions (Bussi, 1996). The aim is to develop the solvers' awareness (Mason, 2001) and specialised knowledge—in this case, the Mathematics Teachers' Specialized Knowledge (Carrillo et al., 2018). Such specialised knowledge would permit teachers to give meaning to non-standard student reasoning (Mellone, Jakobsen, & Ribeiro, 2015), as well as to better understand the causes of students' errors (Tulis, 2013), thus treating them as real learning opportunities in Borasi's (1994) sense.

In the scope of a broader project, the aim of the present study is discussing secondary prospective teachers' Interpretative Knowledge (IK) based on the feedback they provide to students when analysing and commenting on productions students provided to a specific mathematical problem.

Theoretical Framework

Shulman (1986) emphasised the need for integration of pedagogical and disciplinary knowledge in teacher education. Other researchers contributed to the mathematics teacher development, proposing

to move away from a segregated and advanced training in “pure” mathematics to focus on the development of specialised knowledge that allows the teacher to teach mathematics. Amongst several teachers’ knowledge conceptualisations that have emerged, in the scope of the work we have been developing, we assume the specialised nature and content of teachers’ knowledge in the sense of the Mathematics Teachers Specialized Knowledge (MTSK) conceptualisation (Carrillo et al., 2018). Teachers’ specialised knowledge grounds teachers’ interpretations of the students’ comments and productions (e.g., Di Martino, Mellone, Minichini, & Ribeiro, 2016).

Interpretative Knowledge is perceived as the knowledge that allows teachers to give sense to pupils’ answers, in particular to those that contain errors, or to “non-standard” solutions, i.e., adequate answers that differ from those teachers would give or expect (Jakobsen et al., 2014). It sustains the teachers’ ability to support the development of pupils’ mathematical knowledge, starting from their own reasoning, even if students’ ideas are incomplete and/or non-standard. Moreover, IK is associated with the notion of discipline of observation and, in particular, with the idea of teachers working “on becoming more sensitive to notice opportunities in the moment, to be methodical without being mechanical” (Mason, 2001, p. 61). Such knowledge thus allows teachers to consider errors and non-standard reasoning as learning opportunities (Borasi, 1994; Mellone et al., 2015).

One way to enrich prospective teachers’ interpretive knowledge is to offer opportunities to face student productions and to provide and discuss feedback, as part of their teaching practice. The term feedback is defined as “information provided by an agent (e.g., teacher, peer, book, parent, self, experience) regarding aspects of one’s performance or understanding” (Hattie & Timperly, 2007, p. 81). The feedback can be constructive, i.e., one that includes hints, corrections, examples or explanations. Kulhavy and Stock (1989) termed this type of feedback as elaborative and defined it as any method that goes beyond indicating only the answer is correct or incorrect. Still, there is no consensus that providing elaborative feedback benefits learning more than simply indicating whether the answer is correct (Shute, 2008). Some authors even argue that complex and detailed information can counteract the effectiveness of feedback. Santos and Pinto (2010) studied the evolution of written feedback provided by a middle school mathematics teacher, reporting that her feedback evolved, developing plasticity, adjusting to the specific students or to the tasks, creating reflection moments by delivering elaborate clues, and encouraging the correction of the situation.

In the present study, we examined prospective mathematics teachers’ interpretative knowledge by analysing the feedback they provided to students. The quality of the feedback has been the greatest influence on student performance (Black & Wiliam, 1998), thus opportunities for interpreting students’ productions are perceived as chances for improving feedback and students’ learning.

Methods


In the present study, we focus on the answers given by 19 prospective mathematics teachers (PTs), who worked in small groups on interpreting students’ productions related to a math problem adopted from Cañadas, Castro, and Castro (2008). Most participating PTs were in the seventh semester of a 10-semester course and had already completed courses in mathematics, pedagogy, and mathematics education, and had some school practice experience.

The tasks were conceptualised following a particular design (e.g., Ribeiro, 2016; Ribeiro, Mellone, & Jakobsen, 2013), whereby the first part focused on accessing and developing PTs’ MTSK, while


the Interpretative Knowledge – Interpretative Task – and the provided feedback was examined in the second part. Here, we focus on this last part of the task, as the goal is to examine PTs’ IK when interpreting students’ productions and the feedback provided. In the first step of the task implementation, PTs were required to solve a problem that would later be explored with their students (Figure 1).

Complementarily, PTs were asked to refer to and reflect upon their own difficulties when solving the problem. In the next phase of the task, PTs were provided with three student productions, and were required to give meaning to each one of these productions, as well as provide what they consider to be a fruitful feedback to each student. The productions included in the task either contained errors, were incomplete, or involved a non-standard approach to problem-solving. Here, we discuss some productions included in the task, as shown in Figure 2(a)–2(c).

Imagine you have white and grey square tiles of the same size. We make a row with the white tiles and then surround the white tiles with grey tiles, as the drawing shows:

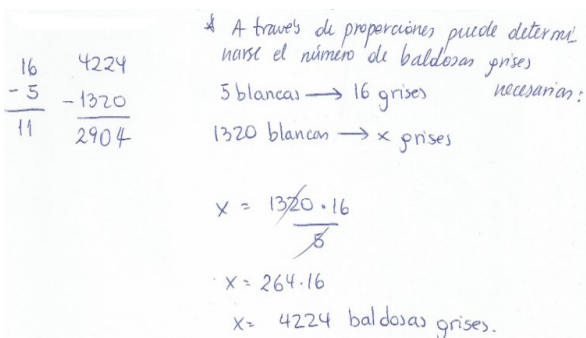


- How many grey tiles would you need if you had 1320 white tiles and wanted to surround them in the way you did in the drawing?



- How many grey tiles are necessary for any number of white tiles?

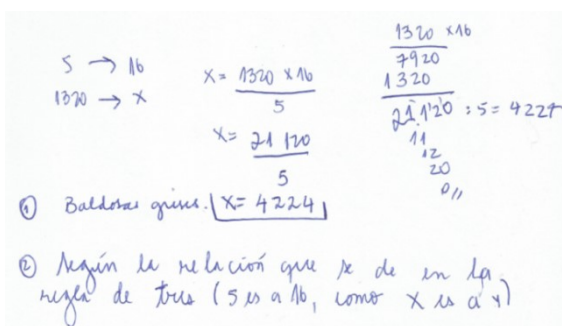
Figure 1: Tiles problem (Cañadas et al., 2008)



Through the proportions, you can determine the number of grey tiles needed:

5 white → 16 grey
 1320 white → x grey
 $x = \frac{1320 \cdot 16}{5}$; $x = 264 \cdot 16$, $x = 4224$ grey tiles.

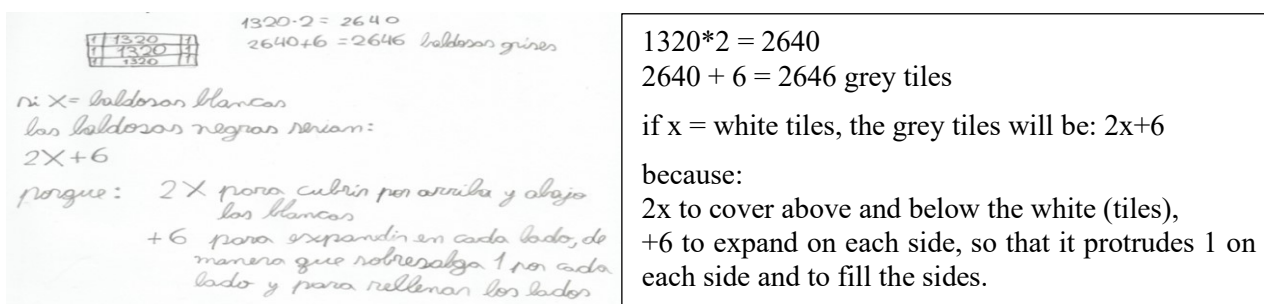
Figure 2(a): Camilo’s productions



5 → 16 $x = \frac{1320 \cdot 16}{5}$
 1320 → x $x = \frac{21120}{5}$

(1) Grey tiles $x = 4224$
 (2) According to the relationship that occurs in the rule of three (5 is to 16, as x is to y).

Figure 2(b): Aracelli’s productions



$1320 \cdot 2 = 2640$
 $2640 + 6 = 2646$ baldosas grises
 si $x =$ baldosas blancas
 las baldosas negras serian:
 $2x + 6$
 porque: $2x$ para cubrir por arriba y abajo
 las blancas
 $+6$ para expandir en cada lado, de
 manera que sobresalga 1 en cada
 lado y para rellenar los lados

$1320 \cdot 2 = 2640$
 $2640 + 6 = 2646$ grey tiles
 if $x =$ white tiles, the grey tiles will be: $2x + 6$
 because:
 $2x$ to cover above and below the white (tiles),
 $+6$ to expand on each side, so that it protrudes 1 on
 each side and to fill the sides.

Figure 2(c): Javiera's productions

The data utilised in the analyses included PTs' productions when solving the Interpretative Task, focusing on PTs' perception of the problem difficulty and the feedback given to three students based on the solutions offered. The written feedback that the prospective teachers provided to the students' answer was analysed categorizing the emergent feedback.

Analyses and discussions

Data was analysed in two phases. As noted earlier, all participating PTs were first asked to solve the problem in small groups and discuss any difficulties they encountered. In the next phase, feedback the PTs provided to Camilo and Aracelli based on their productions was discussed (these students utilised a similar strategy for solving the problem).

Difficulties in solving the problem

Eight of the nine groups of PTs solved the problem correctly, while the remaining group adopted the "rule of three" which yielded incorrect answer (Figure 3). When this group examined the solutions provided by other PTs, they were able to identify their mistake (pertaining to task interpretation) and subsequently provided a correct answer.

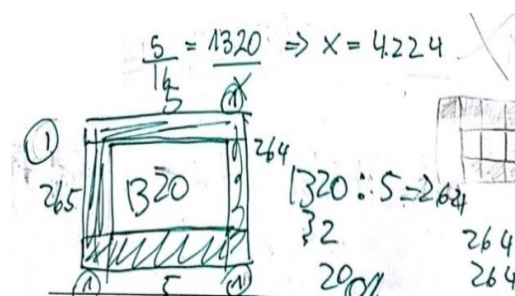


Figure 3: Mistake in understanding the problem

Concerning the PTs' difficulties, four out of nine groups stated that they had difficulty understanding how to represent the figure when the number of tiles increased (e.g., "We doubt how the white tiles were placed."; "Yes, because we did not know in what way the tiles would be grouped."). These results confirm that PTs had difficulties in understanding the statement of the problem, even though the manner in which the tiles should be grouped was explained explicitly in the problem statement "we make a row of white tiles" (see Figure 1).

Categorising the feedback

Most of the PT groups pointed out that both Camilo and Aracelli (Figure 2(a) and (b)) solved the problem by incorrectly applying the "rule of three" without giving further explanation of how they should have proceeded, while some groups provided indication on the way the problem should be addressed. When analysing the feedback provided to these two students based on their productions, four categories emerged in relation to Camilo's and Aracelli's solutions:

- (i) Feedback on how to solve the problem: Guide on how the students should proceed to solve the problem, particularly stating that they should think inductively.

- (ii) Confusing feedback: When the feedback seems to be correct, but it can be confusing for the student.
- (iii) Counterexample as feedback: An example is used to refute the error exposed.
- (iv) Superficial feedback: The content of such feedback was insufficient (too broad or inconsistent) to allow the solver to understand its meaning.

(i) Feedback on how to solve the problem

Two PT groups focused their feedback on explaining to the student how he/she should proceed in order to solve the problem. They specifically indicated that the problem should be approached inductively, suggesting that the student should think what happens if there is one white tile before considering, what happens if there are two, three white tiles and so on. How many grey tiles would there be in each case? Then, they prompted the student to think about what happens in general terms. We observed that these PTs could correctly interpret the students' mistakes, and thus indicate the correct approach to solving the problem.

(ii) Confusing feedback

One of the groups focused on explaining why the number of grey tiles is not proportional to that of the white tiles. They stated that “proportional thinking should not be used, since the number of grey tiles does not increase by the same amount as white tiles; thus, they are not proportional” (see Figure 4).

d) Realizar por proporción la actividad es decir cada 5 baldosas blancas hay 16 grises

$$\frac{5}{16} = \frac{1320}{x}$$

$$x = 4224$$

la manera de abordar el problema es errónea ya que no se usa el pensamiento proporcional ya que la cantidad de baldosas grises no aumenta en la misma cantidad que las baldosas blancas por lo tanto no son proporcionales.

Entonces si podemos afirmar que las baldosas que están arriba y abajo de las baldosas blancas están en proporción 1:2 si contar los bordes.

deja preguntas ¿ que pasa con los bordes la cantidad de baldosas en los bordes, cuando aumentan o disminuyen las baldosas blancas?

Para llevar a que el alumno haga la conexión entre la cantidad de baldosas superior e inferior más la baldosa de los bordes, de esta manera o para que generalice para cualquier número de baldosas blancas.

Perform the activity by proportion, that is, for every group of 5 white tiles, there are 16 grey tiles.

$$\frac{5}{16} = \frac{1320}{x}, x = 4.229.$$

The way to approach the problem is erroneous, since proportional thinking should not be used, because the number of grey tiles does not increase by the same amount as the white tiles. Therefore, they are not proportional. So, yes, we can say that the tiles that are above and below the white tiles are in a 1:2 ratio, not counting the edges.

Then ask what happens with the number of tiles at the edges when the white tiles increases or decreases? Lead the student to make the connection between the number of upper and lower tiles plus the tiles at the edges before prompting him/her to generalise for any number of white tiles.

Figure 4: Confusing feedback

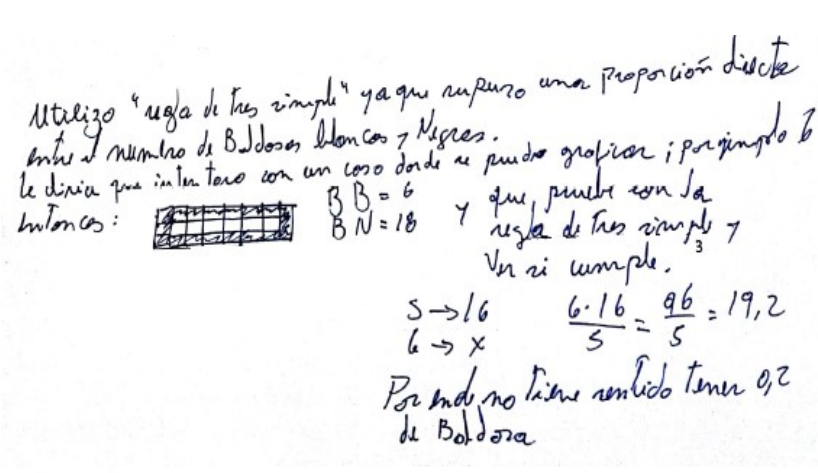
We posit that the last expression can lead the student to incorrectly conclude that, if the number of grey tiles increases/decreases by the same amount as that of the white tiles, those variables are proportional. Instead, feedback should focus on the fact that the number of tiles does not increase/decrease “by the same proportion.”


Second, they stated, “we can affirm that the tiles that are above and below the white tiles are in proportion 1:2, without counting the edges.” Thus, they explained when the figure would be proportional. Although this reasoning is true, it could be confusing to the student, because the problem is not one of proportionality. As a result, this was termed as *confusing feedback*. In sum, although the PTs in this group could interpret the students’ mistakes, when providing an elaborated feedback, they opted for a rather complex solution, which can confuse the students.

(iii) Counterexample as feedback

Two groups used a counterexample to respond to the student (Figure 5). In this excerpt, a group provided feedback suggesting that the student should draw a figure for the case of 6 white tiles with their 18 grey tiles (if proportional), while also applying the “rule of three” that would yield 19.2 grey tiles. The group interpreted this as a contradiction, along with the impossibility of having 0.2 tiles. However, it would have been more informative to argue that there is no multiplicative relation between white and grey tiles.

This group used a *counterexample* in their feedback to confirm that the number of grey tiles is not proportional to that of the white tiles. The use of a counterexample requires that the teachers have a comprehension of the mathematics knowledge involved in the problem (KoT), as this would allow them to provide an explanation for student’s errors. From the MTSK perspective, teachers are required to have the mathematics knowledge of the theme that allows approaching the problem in the correct way, but also ability to explain why other ways do not work. Explaining why something is incorrect requires interpreting the students’ reasoning and building feedback on these mistakes.



Utilizo “regla de tres simple” ya que supuse una proporción directa entre el número de baldosas blancas y negras.
le decía que intentara con un caso donde se pueda graficar; por ejemplo 6
entonces:  $BB = 6$ $BN = 18$ y que prueba con la regla de tres simple y
Ver si cumple.
 $5 \rightarrow 16$ $\frac{6 \cdot 16}{5} = \frac{96}{5} = 19,2$
 $6 \rightarrow x$
Por ende no tiene sentido tener 0,2 de baldosa

(S)he used “simple rule of three” because (s)he assumed a direct proportion between the number of white and grey tiles. I would tell him/her to try a case where you can draw a diagram. For example, we can assume that there are 6 white tiles. So, $BB = 6$, $BN = 18$ and try the simple rule of three to see if it works.
 $5 \rightarrow 16$ $\frac{6 \cdot 16}{5} = \frac{96}{5} = 19.2$.
 $6 \rightarrow x$
Clearly, it does not make sense to have 0.2 tiles.

Figure 5: Counterexample as feedback

(iv) Superficial feedback

Some of the feedback on Camilo’s and Aracelli’s productions was *superficial*, that is, too vague for a clear understanding by the student. For example, PTs stated: “I would ask what is proportion, so

that [students] can argue if it can actually be used in the exercise,” or “I would ask if the rule of three is used for all cases. . . . Analyse if there is a proportion to apply the rule of three.” The nature of such feedback would neither allow students to understand their mistakes nor to envisage how to proceed in order to solve the problem correctly.

Some final comments

Some prospective mathematics teachers experienced difficulties in understanding and interpreting the posed problem, which is in the space of problems (and content) they will need to work on with their students in the near future. This finding highlights the need for enhanced preparation that would ensure that prospective mathematics teachers can solve the problem independently in order to, at least, be able to perceive a correct typical answer (Ribeiro et al., 2013).

Data analysis further revealed two dimensions of feedback study participants provided to students: the nature and focus of the interpretation provided, and the content of prospective teachers' knowledge. In the feedback on *how to solve the problem*, the groups focused on explaining how students should proceed in order to obtain the correct solution, disregarding explaining why the original answer was incorrect. Feedback that was classified as *confusing feedback* and *counterexample as feedback* focused on explaining why there is a mistake. Such feedback is particularly linked with the elements of PTs' space of solutions, usually referred to as having a single approach to guide to students (Jakobsen et al., 2014). Further, when the PTs attempted to provide elaborate feedback, they supported their explanations with erroneous arguments, or worded it in a way that can be confusing for the students. These feedback categories reveal some critical points that need to be addressed in teacher education in order to enrich and expand the *superficial* or *confusing feedback*, empowering a meaningful interpretation that should have students' reasoning, knowledge, and understanding as a starting point for the mathematical discussions to be developed.

Acknowledgements: This research is partially supported by the grant 2016/22557-5, São Paulo Research Foundation (FAPESP) and is a part of the activities comprising the project CONICYT PCI/Atracción de capital humano avanzado del extranjero, n° 80170101 (Chile).

References

- Ball, D., Thames, M. H., & Phelps, G. (2008). Content knowledge for teaching: What makes it special? *Journal of Teacher Education*, 59, 389–407.
- Black, P., & Wiliam, D. (1998). Assessment and classroom learning. *Assessment in Education: Principles, Policy & Practice*, 5(1), 7–74. doi:10.1080/0969595980050102
- Borasi, R. (1994). Capitalizing on errors as “springboards for inquiry”: A teaching experiment. *Journal for Research in Mathematics Education*, 25(2), 166–208.
- Bussi, M. G. B. (1996). Mathematical discussion and perspective drawing in primary school. *Educational Studies in Mathematics*, 31(1–2), 11–41.
- Cañadas, M. C., Castro, E., & Castro, E. (2008). Patrones, generalización y estrategias inductivas de estudiantes de 3° y 4° de Educación Secundaria Obligatoria en el problema de las baldosas. *PNA*, 2(3), 137–151.
- Carrillo, J., Climent, N., Montes, M., Contreras, L., Flores-Medrano, E., Escudero-Ávila, D., & Muñoz-Catalán, M. (2018). The mathematics teacher's specialised knowledge (MTSK)

model. *Research in Mathematics Education*, 20(3), 236–253. doi:10.1080/14794802.2018.1479981

- Di Martino, P., Mellone, M., Minichini, C., & Ribeiro, M. (2016). Prospective teachers' interpretative knowledge: Giving sense to subtraction algorithms. In S. Zehetmeier, M. Ribeiro, B. Roesken-Winter, & B. Potari (Eds.), *Proceedings ERME topic conference mathematics teaching, resources and teacher professional development* (pp. 66–75). Hall: ERME.
- Hattie, J., & Timperley, H. (2007). The power of feedback. *Review of Educational Research*, 77(1), 81–112. doi:10.3102/003465430298487
- Jakobsen, A., Ribeiro, C. M., & Mellone, M. (2014). Norwegian prospective teachers' MKT when interpreting pupils' productions on a fraction task. *NOMAD*, 19(3–4), 135–150.
- Kulhavy, R. W., & Stock, W. A. (1989). Feedback in written instruction: The place of response certitude. *Educational Psychology Review*, 1(4), 279–308. doi:10.1007/BF01320096
- Mason, J. (2001). *Researching your own practice*. London, UK: Routledge Falmer.
- Mellone, M., Jakobsen, A., & Ribeiro, C., M. (2015). Mathematics educator transformation(s) by reflecting on students' non-standard reasoning. In K. Krainer & N. Vondrova (Eds.), *Proceedings CERME 9* (pp. 2874–2880). Prague, Czech Republic: ERME.
- Policastro, M., Mellone, M., Ribeiro, M., & Fiorentini, D. (2018). Designing tasks for teacher education: from a research methodology to teachers' knowledge development. Manuscript submitted for publication.
- Ribeiro, M. (2016). Tareas para alumnos y tareas para la formación: discutiendo el conocimiento especializado del profesor y del formador de profesores de matemáticas. In S. Estrella, M. Goizueta, C. Guerrero, A. Mena, J. Mena, E. Montoya, A. Morales, M. Parraguez, E. Ramos, P. Vásquez, & D. Zakaryan (Eds.), *XX Actas de las Jornadas Nacionales de Educación Matemática* (pp. 31–39). Valparaíso, Chile: SOCHIEM, PUCV.
- Ribeiro, C., Mellone, M. & Jakobsen, A. (2013). Prospective teachers' knowledge in/for giving sense to students' productions. In A. Lindmeier & A. Heinze (Eds.), *Proc. 37th Conference of the International Group for the Psychology of Mathematics Education* (Vol. 4, pp. 89–96). Kiel, Germany: PME.
- Santos, L., & Pinto, J. (2010). The evolution of feedback practice of a mathematics teacher. In M. F. Pinto & T. F. Kawasaki (Eds.), *34th Conference of the International Group for the Psychology of Mathematics Education* (Vol. 4, pp. 145–152). Belo Horizonte, Brazil: PME.
- Shulman, L. S. (1986). Those who understand: Knowledge growth in teaching. *Educational Researcher*, 15(4), 4–14.
- Shute, V. J. (2008). Focus on formative feedback. *Review of Educational Research*, 78(1), 153–189. doi:10.3102/0034654307313795
- Tulis, M. (2013). Error management behaviour in classrooms: Teachers' responses to student mistakes. *Teaching and Teacher Education*, 33, 56–68.

Using participant generated influence maps to gain insights into the influences on early career primary teachers' teaching of mathematics

Alison Godfrey

University of Leicester, United Kingdom; ag384@le.ac.uk

Set within a study looking to understand influences on early career primary teachers' teaching of mathematics through analysis of the personal perspectives of eight participants, this paper discusses the use of a 'visual data' approach. Participants were asked at the end of the two-year research period to create maps showing the relative and overlapping influences on their development over the previous two years as teachers of mathematics, describing their thinking to the interviewer as they did so. Deeper and broader responses have resulted, giving richer data than using verbal data alone, whilst this approach has proved to be a very interesting and motivating experience for the participants. New insights have emerged as to how early career teachers see the influences on their development as teachers of mathematics.

Keywords: Teacher characteristics, professional development, elementary school mathematics, research tools.

Introduction

This paper outlines how a participant generated visual technique contributed to a study that seeks to gain insights into the influences on early career primary teachers' teaching of mathematics.

Whilst there is a minimum required mathematical qualification for all those entering the teaching profession in England, early career teachers have varied mathematical backgrounds, attitudes and beliefs about the subject. They enter a complex and changeable educational landscape where schools have considerable freedom in the organisation of their mathematics teaching and offer varied opportunities for professional development (Advisory Committee on Mathematics Education, 2013). The study followed eight primary school teachers through their first two years of teaching and sought to answer the research question: How do factors related to the teacher themselves and factors related to the school context combine to influence the development of early career primary teachers' teaching of mathematics? The participants entered the teaching profession with a range of mathematical backgrounds and all studied for their teaching qualification at the University of Leicester.

The aim of the tool outlined in this paper was to support participants to articulate their views on the influences on them as early career teachers of mathematics, and the connections between these influences. Participant-generated visual data had been successfully used in previous interviews and similarly this new tool was developed to achieve greater depth and breadth in interview responses than from purely verbal techniques, enabling participants to have more control over their responses whilst providing some structure. In addition, the tool was designed to be interesting and motivating, both as an ethical end in itself and to encourage participants to give the fullest responses possible.

Theoretical background – influences on teacher development

The literature identifies a number of potential influences on teachers as they develop their teaching of mathematics, relating both to the teachers themselves and their school context. These include a

teacher's beliefs, their background, including the interrelated aspects of subject knowledge, attitudes to mathematics and emotions, and their proactivity in response to reflection on their practice within their school community.

A teacher's beliefs about what makes a good mathematician can influence their practice (Ernest, 1989). Ernest considers, for example, that those who believe mathematics to be about accumulating skills and rules see themselves as "instructors, aiming to develop skills mastery in their pupils, while those who see mathematics as a unified body of knowledge to be understood, see themselves as "explainers", aiming to develop conceptual understanding of this knowledge in their pupils. Recent discussions in the UK about a mastery approach in the teaching of mathematics are in line with the relational understanding described by Skemp (1976) and have focused on securing "a deep, long-term, secure and adaptable understanding of the subject" (NCETM, 2015), but it cannot be assumed that all teachers seek to teach for this type of understanding.

Building on Shulman's seminal papers (1986, 1987), researchers have acknowledged that a teacher's subject knowledge in various forms influences their practice. Askew et al. (1997) found that the connectedness of teachers' subject knowledge "in terms of the depth and multi-faceted nature" of the meanings and uses of concepts in mathematics (p. 69) is particularly influential. Ball, Thames, & Phelps (2008), for example, emphasise the importance of Specialised Content Knowledge (SCK), knowledge that is specific to teachers of mathematics, enabling them to explain procedures, analyse errors and consider appropriate examples. Additional background elements that teachers bring to their classroom practice are their own emotional disposition towards mathematics and perceived competence in the subject (Di Martino & Zan, 2010).

A teacher's practice can change over time, influenced by their personal reflection on practice and proactivity to make changes within the context of their teaching community (Turner, 2008). Although the influence of their school context is likely to have a significant impact on an individual teachers' professional development opportunities, the community within the school might have a range of different foci and agendas (Levine, 2010) and the current provision for Continuing Professional Development (CPD) for teachers in England is fragmented and inconsistent between schools (ACME, 2013).

My study seeks to extend the existing literature, particularly exploring the relative importance and interconnected nature of these factors through highlighting teachers' own perspectives.

Visual Data

There is agreement in the literature that participant-generated visual data, i.e., that "generated through the data collection process" (Wall, Higgins, Hall, & Woolner, 2013, p. 3), can provide additional and complementary data to verbally answered interview questions (e.g., Prosser, 2007; O'Kane, 2000). It can add breadth and depth, facilitate deeper thinking and assist participants to reveal additional information, views and emotions that may not have been revealed through verbal questioning alone. It is also empowering, giving participants a greater voice in the research process and allowing them more control over the content of the discussions (O'Kane, 2000), and it can be motivating and fun for the participants (Wall et al., 2013).

A range of tool designs have been used in educational research to support visual data collection. *Q-sorting* involves the sorting of statements into a defined template alongside or in addition to a verbal interview. Data can be analysed quantitatively and thus statistical comparisons can be made between participants, offering an in-depth and systematic approach to analysing subjectivity (Thomas & Watson, 2002). *Diamond ranking*, similarly, is a technique that can be used within interviews to explore the participant's perceptions or ideas, as they rank images or statements within a nine-section diamond-shaped structure (Wall et al., 2013). Usually, the activity of ranking these is accompanied by the participant talking through their rationale for how they placed the items within the diamond structure and the sorting exercise acts as a stimulus for discussion.

Although the literature reviewed suggests visual techniques can be valuable to the researcher, the quality of data is dependent on the quality of the facilitation and how the data relates to other data being collected (Wall et al., 2013). A full rationale is therefore needed for the use of my approach and how verbal questioning was used alongside the visual strategy.

Methodology

An initial interview at the end of their one year postgraduate teaching course focused on each of the eight participants' relationship with, and attitude to, mathematics and their progress in teaching the subject as a student teacher. Twice yearly interviews over the following two years, including discussion of documentation related to their progress as early career teachers, provided evidence on their ongoing development as teachers of mathematics. Interview questions were designed to probe the participants' beliefs, attitudes and subject knowledge for teaching mathematics, what they perceived to be the characteristics of effective teachers of mathematics and their perspectives on their development as teachers of the subject. Within each interview they also talked about two particular lessons: their chosen *best* and *most challenging* lessons since the previous interview. Participant-generated visual data was a particular feature of the interviews, which combined verbal questioning with a range of visual tools, including participants graphing their relationship with mathematics (Godfrey, 2017), visually organising statements about subject knowledge and discussing points about secure learning in mathematics from concept cartoons (Samková & Hošpesová, 2015). Through these means evidence was collected of factors influencing their development as teachers of mathematics.

For the final interviews of the project, I developed a new visual tool to assist participants in talking in greater depth and breadth about the influences on them as a teacher of mathematics and in particular to discuss the relative importance of these factors and the way the factors combined. Given the longitudinal nature of the study, a secondary purpose was to ensure that the interview was interesting and motivational since visual techniques could provide variety and interest (Wall et al., 2013).

Rather than using an open question such as, "What has influenced you as a teacher of mathematics?", I decided to provide some prompts to ensure that participants discussed the likely influences the literature suggested would have an impact on their trajectory as teachers of mathematics, even if only to discount these, thus ensuring breadth in responses. Four prompts were provided: "My own background as a learner of mathematics and my feelings about the subject" (labelled *background* on the photographs below and aimed at participants considering their own subject knowledge, attitude to mathematics and emotions); "My beliefs about what makes a good mathematician" (labelled

beliefs); “My school context and changes within the school context – i.e. the influences that I have had from being here in this particular school” (labelled *school*); “My own self-imposed changes/actions through my proactivity and reflection on practice” (labelled *reflection*).

In order to ensure that the participants considered the relative influence of these labels, and where they overlapped, circles of translucent plastic in different sizes and colours were provided. Each participant was asked to match the largest influence to the largest circle, the second largest influence to the second largest circle, and so on. They were then asked to arrange the circles to match the impact of these influences and the relationship between them, overlapping them if appropriate, and to verbalise their thinking as they did so (see Figure 1). Thus, an interactive approach was used, with some structure given for their thinking, but without the constraints of diamond ranking or q-sorting. Participants were free to create and adapt their mapping to fit their way of thinking.

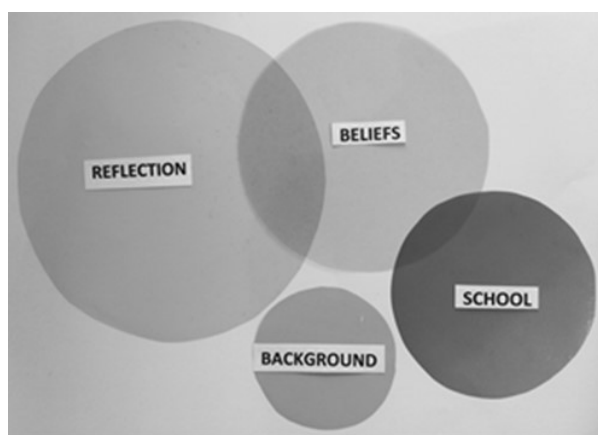


Figure 1: Rama's influence map

Various follow-up questions were planned that could be used to further probe about the impact of these influences, for example: “How do you think having a strong maths background has impacted on your teaching of the subject? Has your attitude to teaching mathematics changed? What are your beliefs about what makes a good mathematician? Have you felt well supported by your school in these first two years of teaching? How do you feel about changes imposed by your school? What motivates you to develop your own practice?”

The design of the tool facilitated detailed narratives from individuals, gave them some control over the content of the discussion and allowed comparison between participants.

Findings

In considering the relative influences of the factors and how these overlapped, participants reflected on how, why and to what extent these influences were connected, thus giving a depth of response that might not have been communicated purely verbally. Rama, for example, explained:

The most important [...] is my proactivity and reflection on my practice. [...] I always like to reflect on my lessons and try to make it better. I always try and think, was it right for my children, was it not, let's change it a little bit. [...] This [reflection] goes with this [beliefs] because I have really strong thoughts of what makes a good mathematician and how it should be taught in a lesson and what I want to get out of the children [...] that's helped me to reflect, if that makes sense.

Participants varied the extent to which they overlapped circles to show the significance of connections. This can be seen on Rama’s map (figure 1) where there is a larger overlap between reflection and beliefs than between school and beliefs. This second overlap was created as she discussed working alongside a colleague with similar beliefs: “We actually want the same thing – we’ve both thought let’s change it and not try to use the workbooks”.

The structure of the influences map seemed to be effective in supporting participants’ articulation of ideas, which they might not otherwise have discussed, thus giving additional breadth to the data collection. The use of the cards meant that participants had to mention aspects that for them had little or no influence – data which would probably not have been obtained from a straight verbal question.

Gina commented:

My own self-imposed changes are probably the least because there’s been so many other things that have to be put in place that I’ve had to just go by the wayside with those.

Without prompting, Gina may not have mentioned this; her comments support the overwhelming influence of her school context (figure 2).

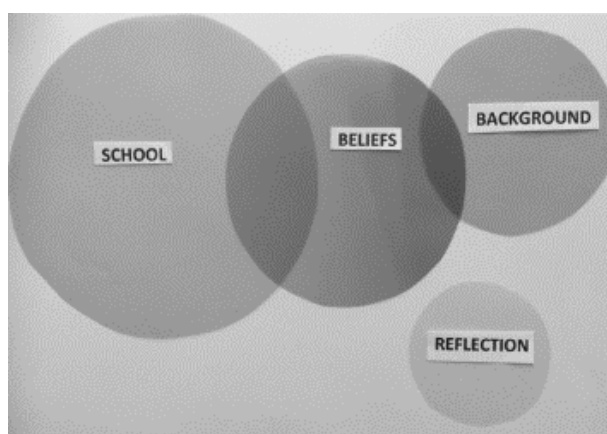


Figure 2: Gina’s influence map

For some participants, the influence map prompted their thinking beyond the structure I had proposed. Penny, for example, used the four cards as a starting point to consider additional elements in her personal situation. She was keen to stress that the impact of her school context was very small, other than being sent on courses, one specific course in particular. She described the impact that this one hour mathematics course had on her practice due to gaining both new ideas, which she implemented from the following day, and renewed enthusiasm for implementing changes in her teaching of mathematics: “The course was brilliant – just gave you that impetus to carry on, gave you ideas to do, spot on”. We improvised to create a further map label for *courses* and also for *research*, referring to my project, which she considered of particular significance because it caused her to reflect, look back at her practice and consider changes she could make. Summing up how my previous interview had caused her to reflect and change her practice, she said, “I relooked at everything after your last visit.”

Penny's final map is shown in figure 3. Again, the overlapping here is interesting, with other influences strongly linking with the learning she gained from the course and a strong connection shown between the influence of being involved in my research and her reflection.

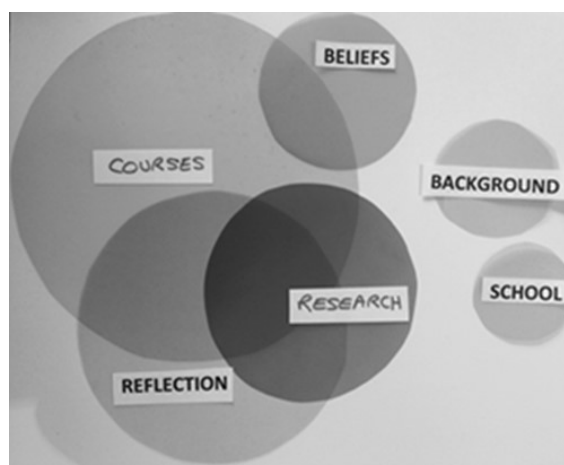


Figure 3: Penny's influence map

The control that Penny and others took over the use of the map to express their opinions demonstrates that a benefit of using the tool was the ready engagement of participants who had already been interviewed several times. This aspect was further evidenced by specific comments made by Rahim, who clearly found the process stimulating:

That was a really good opportunity for me to reflect on what different things have influenced me and how I feel like I've progressed based on different elements, so that was a really helpful exercise.

As illustrated above, the analysis of the data from the influences tool is enhanced with the addition of the verbal data given alongside the visual. From this starting point, further analysis is being undertaken to explore other evidence of these influences from earlier interviews. Interview data has been summarized using a mind mapping technique to facilitate this process. Individual narratives are being developed and some comparisons made between cases, including those with different qualifications and interest in mathematics.

A brief example of how the visual and verbal data from the creation of the maps is being integrated with other data comes from one element of Gina, Penny and Rama's maps (Figure 4). These maps show a very contrasting picture of what they feel has influenced their development as teachers of primary mathematics, but for all the influence of their background as a learner of mathematics and their feelings about the subject ('BACKGROUND') was considered a relatively small influence. Gina, who has the weakest mathematical background of the three, overlapped the circles relating to her beliefs and background, giving the following commentary as she created her map:

I think my own background always sticks in my mind because I know there were things that I feel like I didn't learn well enough that really impacted me later on, so I'm very hyper aware that when children don't get something that we can't just leave them there.

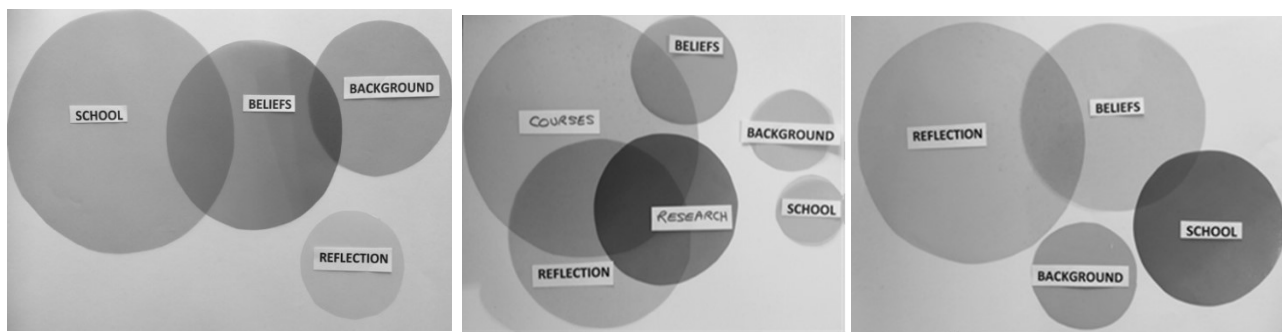


Figure 4: Contrasting influence maps: Gina, Penny and Rama

Penny has her own mathematical background, which, in her case, includes a Master's degree in mathematics, as a separate and smaller influence than the other influences on her because, although she “loves maths”, her teaching of the subject would “just happen regardless”. Rama similarly stated that although her mathematical background was important, she “had grown as a person” since her days as a learner of mathematics. However, other evidence from across their series of interviews highlighted that both were keen to pass on their love of mathematics to children and that their strong subject knowledge was a foundation on which they proactively sought to develop their practice.

Conclusion

Initial analysis across all the participants in the study indicates the different perceptions early career primary teachers hold of the influences on them as teachers of mathematics. Supported by the use of the influence-mapping tool, participants were explicit about the relative impact of each of the suggested influences on their development and how these influences were inter-connected. The map supported depth and breadth of responses, whilst giving the participants some control over the content of their discussions and the motivational aspect of the tool was appreciated by the participants.

Whilst not directly comparable because of participants' different interpretations of the headings used, useful insights can be drawn from the range of influence maps. The influences of the school context and self-imposed changes through proactivity and reflection on practice were strong influences for most of the eight participants. Only two placed the four influences in the same order. Even then, their maps visually contrast with differences in the way the circles were overlapped, and this is reflected in contrasting verbal narratives. Further analysis of the broad data set is being undertaken to explore how factors related to the teacher themselves and factors related to the school context combine to influence the development of early career primary teachers' teaching of mathematics.

References

- Advisory Committee on Mathematics Education. (2013). *Empowering teachers: Success for learners*. London: ACME. Retrieved from <http://www.acme-uk.org/media/14054/acmepdreport2013.pdf>
- Askew, M., Brown, M., Rhodes, V., Johnson, D., & Wiliam, D. (1997). *Effective teachers of numeracy: Report of a study carried out for the Teacher Training Agency 1995-96, by the School of Education, King's College London*. London: King's College London.
- Ball, D., Thames, M., & Phelps, G. (2008). Content knowledge for teaching what makes it special? *Journal of Teacher Education*, 59(5), 389-407. doi:10.1177/0022487108324554

- Di Martino, P., & Zan, R. (2010). 'Me and maths': Towards a definition of attitude grounded on students' narratives. *Journal of Mathematics Teacher Education*, 13(1), 27-48. doi:10.1007/s10857-009-9134-z
- Ernest, P. (1989). *Mathematics teaching*. New York, NY: Falmer.
- Godfrey, A. (2017). Factors influencing the developing effectiveness of early career teachers' mathematics teaching – initial findings. *Proceedings of the Tenth Congress of the European Society for Research in Mathematics Education* (pp. 2868-2875). Dublin, Ireland: DCU Institute of Education and ERME.
- Levine, T. (2010). Tools for the study and design of collaborative teacher learning: The affordances of different conceptions of teacher community and activity theory. *Teacher Education Quarterly*, 37(1), 109-130. Retrieved from <http://www.jstor.org/stable/23479301>
- National Centre for Excellence in the Teaching of Mathematics (2018). *Mastery explained*. Retrieved from <https://www.ncetm.org.uk/resources/49450>
- O'Kane, C. (2000). In P. Christensen, & A. James (Eds.), *Research with children: Perspectives and practices* (1st ed.). London: Routledge.
- Prosser, J. (2007). Visual methods and the visual culture of schools. *Visual Studies*, 22(1), 13-30. doi: 10.1080/14725860601167143
- Samková, L. & Hošpesová, H. (2015). Using concept cartoons to investigate future teachers' knowledge. *Proceedings of the 9th Congress of the European Society for Research in Mathematics Education* (pp. 3241-3247). Prague, Czech Republic: Charles University in Prague, Faculty of Education and ERME.
- Shulman, L. (1986). Those who understand: Knowledge growth in teaching. *Educational Researcher*, 15(2), 4-14. Retrieved from <http://journals.sagepub.com/home/edr>
- Shulman, L. (1987). Knowledge and teaching: Foundations of the new reform. *Harvard Educational Review*, 57(1), 1-22. Retrieved from <http://hepg.org/her-home/home>
- Skemp, R. (1976). Relational understanding and instrumental understanding. *Mathematics Teaching*, 77, 20-26.
- Thomas, D., & Watson, R. (2002). Q-sorting and MIS research: A primer. *Communications of the Association for Information Systems*, 8, 141-156.
- Turner, F. (2008). Growth in teacher knowledge; individual reflection and community participation. *Proceedings of the British Society for Research into Learning Mathematics*, 28(2), 109-114. Southampton, England: University of Southampton.
- Wall, K., Higgins, S., Hall, E., & Woolner, P. (2013). 'That's not quite the way we see it': The epistemological challenge of visual data. *International Journal of Research & Method in Education*, 36(1), 3-22. doi:10.1080/1743727X.2012.730278

A zone theory analysis of identity formation in mathematics teacher educators

Merrilyn Goos¹ and Anne Bennison²

¹University of Limerick, Ireland; merrilyn.goos@ul.ie

²University of the Sunshine Coast, Australia; abenniso@usc.edu.au

Researchers in mathematics teacher education are beginning to investigate the nature and development of mathematics teacher educator (MTE) expertise. Consistent with our sociocultural perspective on learning, we conceptualise mathematics teacher educator learning as participation in social practices that develop professional identities. In this study we used Valsiner's zone theory to investigate identity formation in a pair of mathematics teacher educators – one a mathematician and the other a mathematics educator – who collaborated to develop new approaches to teacher education that integrate content and pedagogy. Analysis of interviews with the MTEs traced their identity trajectories from past to present to possible futures, highlighting their capacity for individual agency in changing their environment or seeking out professional learning opportunities.

Keywords: Mathematics teacher educators, identity, Valsiner's zone theory.

Introduction

Researchers in the field of mathematics teacher education are becoming interested in how mathematics teacher educators (MTEs) themselves learn and develop (e.g., Beswick, Chapman, Goos, & Zaslasky, 2015; Chapman, 2008). The nature of MTE expertise has most often been conceptualised in terms of content and pedagogical knowledge and their interaction (e.g., Chick & Beswick, 2018; Zazkis & Zazkis, 2011), while the process of MTE development has been explained through reflective self-studies tracing growth through practice (e.g., Tzur, 2001). Our research takes a different approach, drawing on sociocultural theories of mathematics teacher development (Lerman, 2001) to propose that MTE learning is better understood in the context of social and cultural experiences that develop their professional *identities*. We view identity as a performative process of *becoming* that addresses social interactions and institutional contexts, while acknowledging that an individual's knowledge, beliefs, and attitudes can influence their identity enactment. Our study contributes to the field by extending our previous investigations of mathematics teacher identity (Bennison, 2015; Goos, 2013) to examine identity formation in mathematics teacher educators – both mathematicians and mathematics educators who teach in initial teacher education programs.

In Australia, as in many other countries, secondary initial teacher education programs are structured so that future teachers of mathematics learn the content they will teach by taking courses taught by mathematicians in the university's mathematics department, and then quite separately they learn how to teach this content by taking content-specific pedagogy courses within the university's education department. Such arrangements offer few opportunities to interweave content and pedagogy in order to develop mathematical knowledge for teaching (see Cooper & Zaslavsky, 2017, for an example of co-teaching). Integration of content and pedagogy was the aim of the study we report on here – the *Inspiring Mathematics and Science in Teacher Education* (IMSITE) project – which deliberately

fostered collaboration between mathematicians and mathematics educators in teacher education programs. The research question that gives focus to this paper is: How does interdisciplinary collaboration between mathematicians and mathematics educators shape their identities as MTEs?

Theoretical framework

Our previous research on mathematics teacher identity adapted Valsiner's (1997) zone theory of child development to study interactions between teachers and their professional environments. In this paper we elaborate on Goos's (2014) mathematics teacher zone theory framework and draw on other research on MTE development to consider influences on MTEs as learners.

Valsiner (1997) extended Vygotsky's concept of the zone of proximal development (ZPD) to incorporate the social setting and the goals and actions of human participants. Valsiner redefined the ZPD as a set of emerging possibilities for development that arise when individuals negotiate their relationships with the learning environment and the people in this environment. Thus for MTEs, the ZPD represents possibilities for development of new kinds of knowledge, beliefs, and practices related to preparing future teachers (Chick & Beswick, 2018; Cooper & Zaslavsky, 2017).

Valsiner (1997) introduced two additional zones to explain human development. The first is the zone of free movement (ZFM), representing environmental constraints that may either hinder or enable access to particular areas or resources or ways of acting with resources. For MTEs, constraints might include their perceptions of the knowledge and motivation of teacher education students; the structure of teacher education programs (e.g., extent of connection between courses on mathematics, general pedagogy, mathematics teaching methods); and university organisational structures and cultures that influence timetabling, allocation of resources, and norms of what counts as "good teaching". The second new zone is the zone of promoted action (ZPA), representing the means by which an individual's actions are promoted. For MTEs, the ZPA could represent teacher education approaches promoted via reflection on their practice, their research with teachers, participation in formal professional development or informal interaction with colleagues (Chapman, 2008; Tzur, 2001).

The ZFM and ZPA are dynamic and inter-related and form a ZFM/ZPA complex that directs development along a set of possible pathways. However, individuals still have a degree of agency in changing the environment and their relationships with people in order to achieve their emerging goals. Thus identity is shaped, but not fully determined, by participation in social practices. The possibility of exercising agency within a structured social system is key to understanding identity in terms of developmental trajectories that link past, present, and future (Wenger, 1998).

Research design and methods

The IMSITE project was undertaken over three years in six Australian universities and involved a team of 23 university academics who were either education specialists (mathematics and science educators) or discipline specialists (mathematicians and scientists). Its purpose was to improve the quality of teacher education by encouraging collaboration between Faculties and Schools of science, mathematics and education on course design and delivery. Within each university, these interdisciplinary teams developed and implemented approaches targeting recruitment and retention strategies that promote teaching careers to undergraduate mathematics and science students,

innovative curriculum arrangements that combine content and pedagogy, and continuing professional learning that builds long-term relationships with teacher education graduates.

This paper is concerned with the collaboration between a mathematician (Leonard) and a mathematics educator (Joanne) at one of the participating universities. We selected this pair as the focus for the paper because a zone theory analysis of their interdisciplinary collaboration reveals interesting insights into the productive tensions that shape MTE identities.

Leonard and Joanne were interviewed together by the first author at the end of the first year of the IMSITE project, and separately by the second author midway through the project's third year. They were asked to describe their prior history of collaboration, the extent of collaboration between mathematicians and mathematics educators in their university, barriers to and enablers of such collaborations, and activities that they considered to be successful in bringing together mathematicians and mathematics educators. Interviews lasted for 20 to 40 minutes and were transcribed in full.

To analyse the interview transcripts we used the approach developed in our previous research with teachers to trace identity trajectories from past to present to possible future (Goos, 2013), which allowed us to capture the temporal character of identity as a process of becoming (Wenger, 1998). We began by annotating interview transcripts to identify responses that provided information about the MTEs' past, present, and future ZPDs, ZFM, and ZPA, which we interpreted in terms of the theoretical framework outlined above. We then constructed a table for each interview with columns for the ZPD, ZFM, and ZPA and rows for past, present, and future influences. The annotated interview excerpts linking the MTEs' responses to both zonal and temporal dimensions were then electronically copied and pasted into relevant table cells, and a single summary table was produced. We inspected the table horizontally, across columns, to identify alignments and misalignments between the zones within a given time period. We inspected the table vertically, across rows, to identify events that triggered a change in alignment between ZPD and ZFM/ZPA from past to present or that could anticipate a change from present to future. This analysis aims to reveal productive tensions arising from a misalignment within the zone system that led MTEs to change their environment or seek new learning opportunities. The findings are discussed in the next section and summarized in Table 1. Interview excerpts are labelled with the relevant analytical category (ZPD, ZFM, ZPA) to illustrate the relationship between data and theory.

Findings

The analysis begins in the temporal dimension of the *past*, and looks across the zonal dimensions of the ZPD, ZFM, and ZPA. Because the two academics had not yet begun to collaborate their identity trajectories are analysed separately here. Leonard was an applied mathematician working in the School of Mathematics and Statistics. He held a PhD in physics and also a Diploma in Education (an initial teacher education qualification for secondary school teachers) that he completed several years ago to better understand how teachers were prepared. Joanne was an experienced teacher of secondary school mathematics with a PhD in mathematics education, who worked in the School of Education in a different Faculty from Leonard. Leonard taught large undergraduate mathematics classes with students from different degree programs, while Joanne taught mathematics pedagogy subjects to

future secondary school teachers: thus both MTEs had well-developed mathematics content knowledge and pedagogical knowledge appropriate to their teaching assignments. Before the IMSITE project started they had met each other in various professional contexts. For example, Joanne had been President of the national mathematics teacher association and Leonard was involved in a mathematical enrichment program for secondary school students. Their *past ZPDs*, before joining the IMSITE project, therefore offered possibilities for development of shared knowledge and collaborative teacher education practices.

However, both MTEs reported barriers to collaboration in the form of institutional structures and cultures that defined their zones of free movement. The structure of the initial teacher education programs at this university created disciplinary “silos” that separated content from pedagogy: there was no coordination between the School of Education and the School of Mathematics and Statistics when it came to preparing future teachers. Leonard also claimed that the mathematics department was not interested in educational research.

Leonard: Educational research is always viewed as a kind of second tier research activity compared to discipline research, and compared to, say, industrial linkage research. (Interview 2; ZFM)

At the same time, Joanne found it difficult to raise the visibility of mathematics education in the university, and even within her own School and Faculty.

With respect to the zones of promoted action experienced in the past, Leonard reported having been positively influenced by two mathematician colleagues whose research had been in mathematics pedagogy. Because pedagogical research was not considered a mainstream activity in his discipline, “meeting the right human beings at the right points in time” (Interview 2; ZPA) was important for his development. He was encouraged by these colleagues to attend mathematics education conferences, where he was able to spend more time with Joanne, a regular participant. For Joanne, conferences, research with teachers and reflection on her own teacher education practice were key elements of her ZPA as a MTE.

Summarising *past* zone configurations: Leonard’s and Joanne’s MTE identities developed along mostly separate trajectories. Leonard’s past ZFM did not allow or value his development as a MTE because of established cultural norms in his department. However, he did not see this as a serious barrier.

Leonard: Given that I actually love the educational side of things, it wasn’t a problem for me. (Interview 2; ZPD)

Leonard’s past zone configuration was characterised by productive tension between his desired direction for development (part of his ZPD) and the university’s ZFM/ZPA complex, which did not seem to allow, and did not promote, a trajectory towards pedagogical research. He had attempted to resolve this tension by seeking out an external ZPA in the form of mathematics education conferences. No such tensions were evident within Joanne’s past zone configuration.

We move now to the temporal dimension of the *present*, encompassing the IMSITE project and the collaboration between Joanne and Leonard. Thus the unit of analysis is now the pair of academics.

At the time the IMSITE project began, Leonard said that his position as a relatively senior academic made it possible for him to pursue educational research collaborations that might pose a career risk for younger mathematics academics. Yet he admitted not fully understanding the disciplinary norms of educational research.

Leonard: I don't really know how it works inside an education department – each kind of discipline is like a different country with its own rules and social norms. (Interview 2; ZFM)

	ZPD	ZFM	ZPA
Past	<p>Joanne:</p> <ul style="list-style-type: none"> <input type="checkbox"/> Experienced secondary school mathematics teacher <input type="checkbox"/> PhD in mathematics education <p>Leonard:</p> <ul style="list-style-type: none"> <input type="checkbox"/> Applied mathematician with secondary mathematics teaching qualifications <input type="checkbox"/> Interested in teacher education <p style="text-align: center;">Leonard</p> <p style="text-align: center;">TENSION: Interest in education discouraged by institutional structures and cultures.</p>	<ul style="list-style-type: none"> <input type="checkbox"/> Teacher education programs separate content (taught in School of Mathematics and Statistics) from pedagogy (taught in School of Education) <input type="checkbox"/> School of Mathematics and Statistics indifferent to educational research <input type="checkbox"/> School/Faculty of Education indifferent to mathematics education 	<p>Joanne:</p> <ul style="list-style-type: none"> <input type="checkbox"/> Research with teachers <input type="checkbox"/> Reflection on MTE practice <input type="checkbox"/> Conferences <p>Leonard:</p> <ul style="list-style-type: none"> <input type="checkbox"/> University mathematicians who conducted pedagogical research <p style="text-align: center;">Leonard seeks external ZPA:</p> <ul style="list-style-type: none"> <input type="checkbox"/> Attended mathematics education research conferences
Present (IMSITE project)	<ul style="list-style-type: none"> <input type="checkbox"/> Both academics have credibility in mathematics and education communities <p style="text-align: center;">TENSION: Interest in collaboration discouraged by institutional structures and cultures.</p>	<ul style="list-style-type: none"> <input type="checkbox"/> Perceptions of students (risk of attrition) <p style="text-align: center;">Change the ZFM:</p> <ul style="list-style-type: none"> <input type="checkbox"/> Social networking <input type="checkbox"/> Tutorial timetabling <input type="checkbox"/> Alumni conference 	<p>IMSITE project:</p> <ul style="list-style-type: none"> <input type="checkbox"/> Promotes interdisciplinary collaboration <input type="checkbox"/> Provides funding, time, resources
Future	<p>TENSION: Maintaining MTE identity trajectory after project funding ends</p>		

Table 1: Zone theory analysis of Leonard's and Joanne's MTE identity trajectory

Joanne described a parallel experience where she worked hard to establish her academic credibility with the mathematicians she encountered in her role as President of the national mathematics teacher association. Thus at the start of the IMSITE project Leonard and Joanne were developing the kinds

of knowledge, beliefs, and goals that would be encouraged by the project – that is, their emerging *present ZPDs* were conducive to interdisciplinary collaboration.

Nevertheless, neither Leonard nor Joanne believed that institutional factors involving, for example, teacher education program structures, academic workloads and budgets, could be overcome, even though IMSITE participants in other universities had managed to do so.

Joanne: I dismissed that idea fairly early on, even though I heard them [other IMSITE participants] talking about it. I couldn't see how it would work in my context. (Interview 2; ZFM)

Despite these difficulties, another element of Leonard's and Joanne's zone of free movement, related to their joint perception of the students they taught, gave rise to a further productive tension between their interest in collaborating and the barriers that stood in their way. Leonard taught mathematics courses and Joanne mathematics pedagogy courses in a 5-year Bachelor of Science/Bachelor of Education degree. In this program students took mathematics content subjects in the first two years, and did not experience mathematics pedagogy subjects until the third year, by which time many had dropped out of the program. This was a common program structure in Australian universities, with mathematics and mathematics education academics based in different Schools and teaching into the program but seldom interacting with, or even knowing, each other. Joanne recounted a crucial development that occurred when the IMSITE project brought her into closer contact with Leonard and they realised they were teaching the same students.

Joanne: I said to you, you know what? You teach the students maths and I teach them education. We should at least be sharing what we know about the students; starting to compare, contrast, talk about issues, like retention. We started talking about the fact that we would lose some of them. (Interview 1; ZFM)

Accepting what they could not alter about their institutional context (ZFM), Leonard and Joanne set about making small changes to build a sense of community and collective identity as future mathematics teachers amongst their students. To do so they developed three initiatives. The first involved social networking events that brought together beginning students who were studying mathematics, but not yet any education subjects, in the first year of their degree, and later years students who were studying mathematics pedagogy and had been on school placements. Leonard led the second initiative, which rearranged tutorials in his large first year mathematics subject so that they were timetabled and streamed to allocate all future teachers to the same tutorial class, thus helping them to identify with peers who were aspiring to a teaching career. The final initiative, organised by Joanne, was an annual mathematics education alumni conference that connected her current students with recent graduates, experienced secondary school mathematics teachers, mathematicians, and mathematics educators.

Each of these initiatives required some modification of the institutional ZFM (e.g., altering the tutorial timetable and allocation of tutors and rooms; finding times and university venues for social networking events) to bring the institutional environment into alignment with the MTEs' trajectory of identity development. The initiatives were made possible by the IMSITE project, which offered a ZPA that promoted collaboration and provided the necessary resources (e.g., funding for a project

officer). The project supported the growing academic credibility of mathematicians who were developing a non-traditional identity in educational research.

Leonard: The impact of the project is measured in a more tangible way than just counting up the number of publications and citations. So I'm very happy that I'm part of a project that's got visible positive tangible impacts. (Interview 2; ZPD)

Summarising *present* zone configurations: the IMSITE project appears to have created a modified ZFM/ZPA complex for Leonard and Joanne that offered possibilities for these MTEs to develop new knowledge and practices for teacher education, thereby expanding their ZPDs. To the extent to which this occurred, we could say that the project developed their identities as MTEs, which now seem to be on interconnected trajectories.

Anticipating the *future* zone configurations of these MTEs raises the question of sustainability once IMSITE project funding ended. While both Leonard and Joanne were comfortable with being recognised as “champions” of a collaborative approach between their disciplines, they wished to share their experience with other mathematics educators and mathematicians, both within and outside their own university, so that their ideas could be taken up and adapted to different contexts. There was a sense, then, that their future identity trajectories would be oriented towards seeking further opportunities for collaboration.

Discussion

In this paper we have begun to explore how interdisciplinary collaboration between mathematicians and mathematics educators can shape their identities as MTEs. Using the theoretical lens provided by Valsiner's (1997) zone theory, we have shown how individuals can exercise agency by changing their professional environment or at least their interpretation of the constraints it imposes (zone of free movement), as well as seeking out opportunities for professional learning outside their immediate environment (zone of promoted action). In addition, incorporating the idea of *productive tensions* into zone theory creates a theory of goal-directed change that can be used to understand MTEs' identity development. For example, Leonard's and Joanne's new goal of cohort building in the teacher education program motivated them to work around institutional constraints to connect mathematics content with mathematics pedagogy. We would also highlight that individuals can experience multiple and fluid identities because of their membership of different communities: Leonard and Joanne saw themselves as mathematics teacher educators who were crossing boundaries between their respective disciplines. The ways in which MTEs negotiate multiple identities, and the extent to which they can inspire others to cross disciplinary boundaries while preparing future teachers, deserves further investigation to enhance our understanding of their professional learning and development. Boundary crossing and identity formation of MTEs also needs to be studied in other cultural contexts that present different, or fewer, challenges to interdisciplinary collaboration.

Acknowledgment

This project was funded by the Australian Government Office for Learning and Teaching (grant #MS13-3174). Following the cessation of the OLT in June 2016 the Australian Government Department of Education and Training continued to support the Enhancing the Training of

Mathematics and Science Teachers program and projects. The views expressed in this article do not necessarily reflect the views of the Australian Government Office for Learning and Teaching or Department of Education and Training.

References

- Bennison, A. (2015). Supporting teachers to embed numeracy across the curriculum: A sociocultural approach. *ZDM Mathematics Education*, 47(4), 561–573.
- Beswick, K., Chapman, O., Goos, M., & Zaslavsky, O. (2015). Mathematics teacher educators' knowledge for teaching. In S. J. Cho (Ed.), *The proceedings of the 12th International Congress on Mathematical Education: Intellectual and attitudinal challenges* (pp. 629–632). Cham, Switzerland: SpringerOpen.
- Chapman, O. (2008). Mathematics teacher educators' learning from research on their instructional practices. In B. Jaworski & T. Wood (Eds.), *International handbook of mathematics teacher education* (Vol. 4) (pp. 110–129). Rotterdam, The Netherlands: Sense.
- Chick, H., & Beswick, K. (2018). Teaching teachers to teach Boris: A framework for mathematics teacher educator pedagogical content knowledge. *Journal of Mathematics Teacher Education*, 21(5), 475–499.
- Cooper, J., & Zaslavsky, O. (2017). A mathematics educator and a mathematician co-teaching mathematics – affordances for teacher education. In T. Dooley, & G. Gueudet (Eds.), *Proceedings of the Tenth Congress of the European Society for Research in Mathematics Education (CERME10, February 1-5, 2017)* (pp. 2025–2032). Dublin, Ireland: DCU Institute of Education and ERME.
- Goos, M. (2013). Sociocultural perspectives in research on and with teachers: A zone theory approach. *ZDM Mathematics Education*, 45(4), 521–533.
- Goos, M. (2014). Creating opportunities to learn in mathematics education: A sociocultural perspective. *Mathematics Education Research Journal*, 26(3), 439–457.
- Lerman, S. (2001). A review of research perspectives on mathematics teacher education. In F-L. Lin, & T. Cooney (Eds.), *Making sense of mathematics teacher education* (pp. 33–52). Dordrecht, The Netherlands: Kluwer.
- Tzur, R. (2001). Becoming a mathematics teacher educator: Conceptualizing the terrain through self-reflective analysis. *Journal of Mathematics Teacher Education*, 4(4), 259–283.
- Valsiner, J. (1997). *Culture and the development of children's action: A theory of human development*. (2nd ed.) New York, NY: John Wiley & Sons.
- Wenger, E. (1998). *Communities of practice: Learning, meaning and identity*. Cambridge: Cambridge University Press.
- Zazkis, R., & Zazkis, D. (2011). The significance of mathematical knowledge in teaching elementary methods courses: Perspectives of mathematics teacher educators. *Educational Studies in Mathematics*, 76(3), 247–263.

Analyzing attitude towards learning and teaching mathematics in members of professional learning communities: A case study

Birgit Griese

Paderborn University, Germany; birgit.griese@math.upb.de

This paper presents a first step in a larger study in the context of professional learning communities following a five-day professional development course in stochastics at upper secondary level. Its focus is the analysis of one teacher's attitude towards learning and teaching mathematics in connection with his first teaching sequence on inference statistics after taking part in a professional learning community. The aim is to explore his views in reference to learning as transmission of knowledge actuated by the instructor or as a constructive activity by the learner. This is realized on the basis of the account the teacher gives on his teaching, on his observations in class, and on his reasons for the decisions involved. Additionally, a Q-sorting with statements for transmissive and constructivist views on learning was employed. Together, our investigations of the data reveal a nuanced picture of the teacher's attitudes and notions, of the diverse learning support he offered, and of perspectives of his further professional development.

Keywords: Teacher professional development, professional learning community, constructivism.

Introduction

In the course of their active careers, teachers need to regularly adapt their work due to shifts such as changes in curriculum guidelines, an altered structure of their classes, or technological development. In Germany, various innovations constitute challenges, e.g. competence-orientation, digitalization, and inclusive settings. The increased emphasis on statistics and probability theory is particularly relevant for teachers at upper secondary level. It has created a high demand for mathematics teacher professional development (PD), and a majority of teachers report that they would like to have more PD than they receive (OECD, 2009, Figure 3.5). However, after decades of neglecting stochastics, “the more challenging a reform is to teachers’ existing beliefs and practices, [...] the more it may need [...] ongoing professional development to achieve depth” (Coburn, 2003, p. 9). Theoretically corroborated PD courses, designed e.g. by researchers and teacher educators in the German Center for Mathematics Teacher Education (*Deutsches Zentrum für Lehrerbildung Mathematik, DZLM*) aim to fulfil the demand for sustainable PD that impacts not only at the surface but effects a real change towards learning based on understanding. Professional learning communities (PLCs) which allow teachers to reflect and discuss their teaching stand the chance to contribute substantially to this goal. Nevertheless, mid- or long-term professional growth fostered by the activities connected with a PD course remains under-researched.

In order to describe individual PD appropriately, it is advisable to first classify the underlying attitudes towards the learning and teaching of mathematics (as in Grigutsch, Raatz, & Törner, 1998) because “the affective cannot be separated from the cognitive” (Brown & Coles, 2011, p. 864): “A teacher’s belief about how students engage in mathematical activity and learn are critical factors in the ability and tendency to design and carry out inquiry-based instruction” (Lloyd, 2002, p. 150). To

be particular, mathematics educators and academic researchers tend to take the view that mathematical knowledge needs to be (re)constructed by the learner in order to be understood properly, and teachers often feel constrained by the necessity to also adequately prepare their students for tests and examinations presumed to stress routines and algorithms – even if the majority of teachers report constructivist views on learning (OECD, 2009, Figure 4.2). Thus, there is the possibility, if and when these two positions clash, that the potential benefit of a PD course suffers. Thus it is a meaningful first step in the evaluation of the impact of a PD course and the PLCs that emerged in its wake to a) investigate the attitude towards the learning and teaching of mathematics held by the participants of the course. Later steps include exploring b) what the participating teachers relate and reflect about their lessons, c) what tasks and tests they use, d) the correlations between their attitudes, their reflections, and their tasks, and finally e) theorizing about possible reasons for the connections.

Theoretical background

There are numerous epistemological theories on the evolvement of mathematical knowledge (e.g. APOS by Dubinsky, cf. Arnon, Cottrill, Dubinsky, Oktac, Roas Fuentes, Trigueros, & Weller, 2014; *Abstraction in Context*, cf. Dreyfus, 2012; or the theory on advanced mathematical thinking found in Tall, 1997), and many share the basic belief that learners need to actively (re)construct mathematical knowledge in order to comprehend it. The corresponding view on how mathematics should be taught is described as *relativistic*, meaning an instructional style “based on [...] student understanding” (Wilson & Cooney, 2002, p. 132). These attitudes can be summarized under the label *constructivism*, viewing mathematics as a process, seeing learning as an independent and discursive activity pursued by the learner, and trusting in students’ eagerness and ability to learn.

However, particularly concerning beliefs on how mathematics should be taught, another, *transmissive* (or *dualistic*, according to Wilson and Cooney, 2002), view gains importance: of mathematics as a toolbox containing recipes and algorithms that solve tasks, of definite solutions, of learning by following examples and instructions.

There is consensus that epistemological beliefs on how mathematical knowledge is constructed and beliefs on how mathematics should be taught are not perfectly congruent: Studies (Chan & Elliot, 2004) found correlations, though mostly both traits are found in individuals. Moreover, it remains an open question if transmissive and constructionist views are the extremes of one dimension or two separate dimensions (Voss, Kleickmann, Kunter, & Hachfeldt, 2011). It is to be expected that an individual teacher may exhibit attitudes for both transmissive and constructivist positions, e.g. that he or she may seem convinced that acquiring knowledge is an active process demanding discussion and exchange of ideas, but at the same time prefer teaching methods that rely on guided step-by-step instructions or an instructor demonstrating the only correct way to solve a task very early on. This ostensible contradiction may allow deeper understanding of teacher practices in combination with their convictions and therefore an important gain of insight for research in mathematics teacher PD.

What is more, studies have identified mathematics as the subject that is most often taught in a pre-structured way (OECD, 2009, Figure 4.5), so this may be particularly true for the subject we are interested in. Previous research has shown that, not only for mathematics, “short-term professional development initiatives often remain at the surface and do not effect the desired change” (Roesken,

Pepin, & Toerner, 2011), which is ascribed to the fact that the underlying beliefs are not easily changed and the beliefs on how mathematical knowledge is built sustainably influence the way teachers teach mathematics. PLCs present a chance to address these beliefs and allow access to participant teachers' views and maybe even classrooms.

The relevance of teachers' transmissive or constructionist views towards teaching and learning is most often seen in connection with students' progression and performance in tests. This is not our main focus here; we intend to understand teachers' attitudes towards learning and teaching first, with a later perspective on exploring their individual PD. Our research questions for this paper are:

(RQ1) What attitude towards learning and teaching mathematics does a teacher show in connection with having taught stochastics after partaking in professional development on this topic?

(RQ2) In how far can this attitude be categorized as transmissive or as constructivist?

Circumstances of the study

The data collected for this study must be seen in connection with an approved five-day PD course on stochastics at upper secondary level conceptualized by DZLM mathematics educators and researchers (Oesterhaus & Biehler, 2014). The course stretched out over several months and covered a broad range of stochastic content, strictly following the principle of promoting understanding. Some participants of this course came forward to partake in subsequent work in a professional learning community (PLC) with other teachers from their respective schools. For this, selected contents of the PD course were presented, discussed, and adapted. This allowed a unique insight into teaching practice in connection with a radically constructivist PD approach. Changes in the curriculum had involved teaching in-depth stochastics, which traditionally is often avoided. Consequently, the PD course was well-frequented, and participants were motivated.

Methodology

Interviews with individual teachers were conducted after he or she had taught a sequence on stochastics, usually covering probability, tree diagrams, conditional probability, binomial distributions, and in advanced courses also hypothesis testing. The interviews were conceptualized to serve the overall research purposes and thus followed a guideline touching on the teaching sequence (underpinned by the course register, worksheets etc.) with specifics about didactic decisions, students' reactions, PLC meetings and the individual's benefit for professional growth connected to them, and cooperation among teachers. For the research focus presented here, interviewees' utterances were examined for passages revealing indications for the respective teacher's attitude towards learning and teaching, and wherever possible, these passages were categorized as referring to a transmissive or a constructivist view. In the examples given below, Vic¹ recounts a classroom situation typical of a constructivist teaching attitude, and Joe reports that his students opposed his approach to establish understanding and demanded a more transmissive method.

¹ All names given are aliases. Teachers' statements were translated from German by the author.

Vic: I ventured to say, frequently: I’m lost here, I have to think about this again. Or: You are right, as far as I can see at the moment. And the next time, I could say: I thought about this, and it occurred to me that ... (Vic_1, 01:05:25)

Joe: Subsequently, they [the students] reproached me: Why did we start with a task that is not one-to-one relevant for the exams? (Joe_1, 00:02:55)

In this case study, we concentrate on Vic, who is an experienced teacher with hardly any history of teaching stochastics himself, but who addressed teaching this content in an advanced course.

			address tasks that can be solved in different ways			
		discuss their ideas with others	(re-)invent mathematical contents	apply established rules, formulae, procedure		
	follow the well-structured explanations of the teacher	address imperfect ideas in class	allow individual strategies, even if wrong	secure insights individually	work in a self-regulated way	
quote exact definitions and mathematical terms	learn many rules and terms by heart	develop routines by drill and repeated practice	to use technical terms correctly	understand the meaning behind mathematical ideas	master mathematical procedures accurately	think strictly logically and precisely
1	2	3	4	5	6	7

Figure 1: Q-method score sheet by Vic, statements (abbreviated here) placed in given fields, from “1: less important” to “7: superimportant”

The Q-method (Fluckinger & Brodke, 2013) is a popular tool for assessing personality. Subjects (in our case, teachers participating in a PLC at their school, after one of them had attended the five-day PD course) are asked *not to rate* statements (like in Likert-scale surveys) but to rank them by placing them on a score sheet of a given shape (see Figure 1, where statements are condensed to keywords). This way, the common case is avoided that the vast majority of statements are rated as equally “very important”. In a Q-survey the number of fields on the “important” right side of the score sheet is limited. The Q-sorting can take place with statements printed on cards to be physically placed on the score sheet, or with digital alternatives (e.g. FlashQ by Christian Hackert, <http://www.hackert.biz/flashq>) that can be sent via e-mail; we use both.

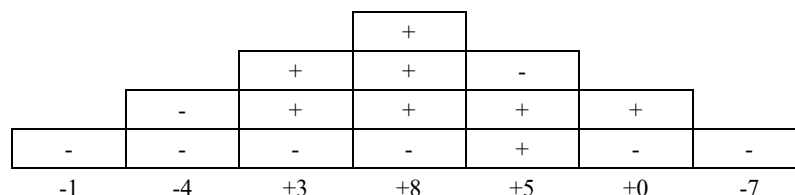


Figure 2: Calculation of Q-index $-1-4+3+8+5+0-7=+4$, transmissive statements with negative, constructivist statements with positive algebraic sign, absolute values by position

The 16 statements used for our investigation of attitude towards the learning of mathematics, the so-called Q-sample, are taken from Jaschke (2017). Eight statements each represent the transmissive or

the constructivist view. For example, *Learners are to develop routines by drill and repeated practice* (bottom statement in column 3 in Figure 1) stands for a transmissive perception of learning, and *Learners are to work on mathematical problems in an autonomous and self-regulated way* (top statement in column 6 in Figure 1) describes a constructivist notion. The completed score sheet allows the calculation of an index: Transmissive statements are equipped with a negative algebraic sign to their respective position; constructivist statements retain their respective position with a positive algebraic sign; the index is calculated by adding up all values (Figure 2 shows an example). In our survey, this results in index values between -20 (clearly transmissive) and +20 (clearly constructivist).

Results

Vic's utterances in the interview reveal his differentiated perspective on the learning and teaching of mathematics, containing elements both of transmissive and of constructivist attitude.

Interview utterances categorized as transmissive

Vic reports that at the beginning of the teaching unit, he opted for a guided approach (“I set that [the null hypothesis in the introductory example], [...] and then I defined the errors of the first and second kind”, Vic_1, 00:19:58) with clear-cut step-by-step tasks for the students (“Then I kept to the worksheets from [name of publisher]: [...] very well preprocessed, for filling in, for working with”, Vic_1, 00:21:33). He continues to secure the essence of the lessons and calculations by scanning and printing important summaries from his preferred publisher's material in color on his home printer (Vic_1, 00:21:55), thus choosing scripted synopses over students' individual résumés.

Interview utterances categorized as constructivist

On the other hand, Vic sees the narrow solutions provided for the marking of central exams critically (Vic_1, 00:31:59). He relates that his students “had to try out [their approaches at calculating the probability of an error]” (Vic_1, 00:20:36), which is typical of a constructivist view. He very much appreciates the fact that his students liked to take part in discussions, and acknowledges that both himself and the students profited from these interactions (Vic_1, 00:58:25). Vic appreciates the creative strategies some of his students use (e.g. when attempting to solve a third degree polynomial equation by trying systematically, Vic_1, 00:35:56), although he is aware that in exams, such strategies can result in an inconvenient loss of credits (Vic_1, 00:36:31). His concerns about his students' performance also become clear when he talks about the case of a student who did not abide to “what is to be done at school, [he] always reinvented the wheel” (Vic_1, 00:38:48) and thus was graded lower than his presumed potential – until in the final exams, when he came out with full credits. This experience boils down to the fact that a constructivist approach to learning bears the danger of demerits. Still, Vic likes to offer a choice (Vic_1, 00:28:04) of different topics or complexities. He also appreciates it when understanding is promoted (like in double tree diagrams, where a higher base rate results in a higher number of false-positive diagnoses, Vic_1, 00:25:59, 00:26:14, or in a responsive spreadsheet that enables the observation that with a higher sample size, the standard deviation of a random variable decreases, but the mean stays the same, Vic_1, 00:53:37).

Interview utterances referring to affective aspects

Vic also keeps an eye on students' motivation (“And they found that interesting, I think”, when referring to the latter of the above examples, Vic_1, 00:53:55), particularly as he has learned that

many students in this course possess a pronounced dislike against probability and stochastics (“the term *stochastics* brought horror to some students’ – about a third of the course – faces at first”, Vic_1, 00:56:12). He does not lose hope of imparting some of the fascination he feels to his students and underpins this with anecdotic evidence of a student who was rather successful, in spite of her initial strict dislike (Vic_1, 00:57:25). He is particularly aware of offering alternative procedures to weaker students (e.g. using absolute numbers when calculating conditional probabilities, Vic_1, 00:26:35) and values their potential (“when I was able to reconstruct it, I gave full credits”, Vic_1, 00:26:51). Vic mentions more than one incident of perceiving distinct learning difficulties, e.g. when he recounts that some students were at a loss when having to transfer routines to new contexts (Vic_1, 00:33:33).

Vic’s vision of ideal teaching

As a prospect, when considering how to teach the content next time, Vic’s ideal of constructivist instruction based on solid content knowledge becomes clear; he phrases his goals as “feeling more at home” (Vic_1, 00:47:00) in inference statistics, as “enhancing my collection of tasks” (Vic_1, 00:47:59). His vision of the teaching he would like to conduct in the future encompasses extended phases of reflection (Vic_1, 00:50:00), which he substantiates with the observation that what students find out themselves stays in their minds, even if it is wrong (Vic_1, 00:50:00), thus displaying his awareness of the pitfalls of self-guided learning and his own responsibility for his students’ learning goals and their examination performance.

The Q-sorting

Vic’s Q-sorting produces the Q-index +4, a moderately constructivist view. We found that particularly his positioning of the transmissive statements are worthwhile interpreting. One of the transmissive statements considered most important reveals Vic’s concern with his students’ learning outcome: *Learners are to master mathematical terms and procedures reliably and accurately* (column 6). The other one describes what you could call a general goal for mathematics lessons: *Learners are to think strictly logically and precisely* (column 7). The transmissive statements rated least important by Vic also tell a story (see columns 1 and 2 in Figure 1): They refer to rote-learning without considering if the content is understood. The overall picture presented by this Q-sorting can be summarized as rejecting mindless routines, emphasizing autonomous exploring, but simultaneously keeping an eye on learning goals.

Discussion

Vic’s data indicates his constructivist belief of sustainable learning as an active process that needs time to explore, to discuss, and to reflect in order to be effective, based on his personal experience. Nevertheless, his responsibility to promote all students’ learning success makes him avoid very open approaches to new content that might throw some students off track, and he makes sure that learning outcomes are clearly communicated and accessible for everyone. This illustrates one of Clarke’s (1994) important principles of PD, that “changes in teachers’ beliefs about teaching and learning are derived largely from classroom practice” (p. 38). Vic’s teaching decisions are also influenced by the specific students in his course. There are some students keen to debate and discuss, some rattled by the prospect of having to come to grips with the unpopular content, and others with limited mathematical abilities. As a consequence, Vic does not follow only one approach in his teaching, but

switches between more guided and more open activities. The reasons he gives do not stem from general scientific results but from current observations of this specific group of learners and previous experiences that form his treasure trove and enable him to draw on his collection of reactions, explanations, examples, and tasks that can support a variety of learners to overcome their unique learning obstacles. His aim of augmenting this trove with more tasks in order to further improve his teaching metaphorically sums up this perspective. Vic's attitude towards the learning and teaching of mathematics cannot be seen as one place on a line with the poles *transmissive* and *constructivist view*, although the Q-index +4 gives an orientation and acts as a first classification. Vic's reports on his teaching as flexible with respect to individual learners and variable teaching aims (such as introducing a topic, or corroborating a procedure in preparation of a centralized exam). When analyzing his teaching decisions in more detail, e.g. his choice of task or method later in our ensuing studies, we need to consider these variables, too.

Further research perspectives

As indicated above, this paper presents a first step in a larger study aimed at investigating the impact of a PD course and its subsequent PLCs on the professional growth of the members of these PLCs. The next steps could be as follows:

- Broaden the investigation of attitude towards the learning and teaching of mathematics to more members of the PLCs.
- Analyze PLC members' reflections in interviews in terms of evidence for professional growth.
- Explore PLC members' tasks and tests used when teaching selected content.
- Look for correlations between teachers' attitudes, evidence for professional growth, and their tasks and test, and search for qualitative and theoretical corroboration that (some of) these correlations are causal.

In discussions at CERME, other lines of research were suggested for consideration, such as taking a closer look at the interactions among the PLC, or concentrating on affective aspects, e.g. specificities of the content, or teachers' expectations of what they should be able to achieve.

Altogether, these lines of research raise the hope of generating interesting results.

References

- Arnon, I., Cottrill, J., Dubinsky, E., Oktac, A., Roas Fuentes, S., Trigueros, M., & Weller, K. (2014). *APOS Theory: A framework for research and curriculum development in mathematics education*. New York, Heidelberg, Dordrecht, London: Springer.
- Brown, L., & Coles, A. (2011). Developing expertise: How enactivism re-frames mathematics teacher development. *ZDM*, 43(6-7), 861–873.
- Chan, K.-W., & Elliot, R. G. (2004). Relational analysis of personal epistemology and conceptions about teaching and learning. *Teaching and Teacher Education*, 20(8), 817–831.
- Clarke, D. (1994). Ten key principles from research for the professional development of mathematics teachers. In D. B. Aichele & A. F. Coxfors (Eds.), *Professional development of teachers of*

- mathematics: Yearbook of the National Council of Teachers of Mathematics* (pp. 37–48). Reston, VA: NCTM.
- Coburn, C. E. (2003). Rethinking scale: Moving beyond numbers to deep and lasting change. *Educational Researcher*, 32(6), 3–12.
- Dreyfus, T. (2012). *Constructing abstract mathematical knowledge in context*. Retrieved from http://www.icme12.org/upload/submission/1953_F.pdf, last accessed 07/02/2016.
- Fluckinger, C. D., & Brodke, M. R. H. (2013). Positive reactions to a Q sort for personality assessment. *The International Journal of Q Methodology*, 36(4), 335–341.
- Grigutsch, S., Raatz, U., & Törner, G. (1998). Einstellungen gegenüber Mathematik bei Mathematiklehrern. *Journal für Mathematik-Didaktik*, 19(1), 3–45.
- Jaschke, T. (2017). Mathematikunterrichtsbezogene Überzeugungen mithilfe der Q-Methode erfassen. *Zeitschrift für Weiterbildungsforschung*, 40(3), 261–274.
- Lloyd, G. (2002). Mathematics teachers' beliefs and experiences with innovative curriculum materials. In G. C. Leder, E. Pehkonen, & G. Törner (Eds.), *Beliefs: A hidden variable in mathematics education?* (pp. 149–159). Dordrecht, Boston, MA: Kluwer.
- OECD (2009). *Creating effective teaching and learning environments: First results from TALIS*. Retrieved from www.oecd.org/edu/school/43023606.pdf, last accessed 15/09/2018.
- Oesterhaus, J., & Biehler, R. (2014). Designing and implementing an alternative teaching concept within a continuous professional development course for German secondary teachers. In K. Makar, B. de Sousa, & R. Gould (Eds.), *Sustainability in statistics education. Proceedings of the Ninth International Conference on Teaching Statistics, ICOTS9, Flagstaff, Arizona*. Voorburg, Netherlands: International Statistical Institute. Retrieved from www.iase-web.org/Conference_Proceedings.php?p=ICOTS_9_2014, last accessed 25/03/2017.
- Roesken, B., Pepin, B., & Toerner, G. (2011). Beliefs and beyond: Affect and the teaching and learning of mathematics. *ZDM*, 43(4), 451–455.
- Tall, D. O. (1997). *Advanced mathematical thinking*. London: Kluwer.
- Timperley, H., Wilson, A., Barrar, H., & Fung, I. (2007). *Teacher professional learning and development: Best evidence synthesis iteration*. Wellington, N.Z.: Ministry of Education.
- Voss, T., Kleickmann, T., Kunter, M., & Hachfeld, A. (2011). Überzeugungen von Mathematiklehrkräften. In M. Kunter, J. Baumert, & W. Blum (Eds.), *Professionelle Kompetenz von Lehrkräften. Ergebnisse des Forschungsprogramms COACTIV* (pp. 235–257). Münster, München u.a., Germany: Waxmann.
- Wilson, M., & Cooney, T. (2002). Mathematics teacher change and development. In G. C. Leder, E. Pehkonen, & G. Törner (Eds.), *Beliefs. A hidden variable in mathematics education?* (pp. 127–147). Dordrecht, Boston: Kluwer.

Math MOOC UniTo & MathCityMap - Exploring the potentials of a review system in a MOOC environment

Iwan Gurjanow¹, Eugenia Taranto^{2,3}, Matthias Ludwig¹, Virginia Alberti³, Roberta Ferro⁴

¹University of Frankfurt; gurjanow@math.uni-frankfurt.de; ludwig@math.uni-frankfurt.de

²University of Catania; ³University of Turin; eugenia.taranto@unito.it; alberti.virginia@gmail.com

⁴L.S. “De Amicis”, Cuneo, Italy; bettaferro@libero.it

During CERME10 in Dublin, a collaboration between the University of Turin and the University of Frankfurt has been initiated. The outcome was a module of a Massive Open Online Course (MOOC) for in-service teachers to improve mathematics teaching by creating outdoor math trail tasks for their students with the help of MathCityMap (MCM). MCM is a digital tool to create, manage and run math trails with mobile devices. Teachers had to create math trail tasks that were in line with previously defined task design guidelines to complete the MOOC module. An expert review system was used to improve and ensure material quality. The involvement of the teachers, the efforts of the reviewers and, in general, this collaboration have given satisfactory results that will be presented in this paper.

Keywords: MOOC, MathCityMap, teacher education, expert review system, material quality.

Introduction

Since October 2015, the Department of Mathematics “G. Peano” at University of Turin, Italy, has been engaged in an innovative initiative: the *Math MOOC UniTo* project (cf. Taranto et al., 2017). The project provides MOOCs (Massive Open Online Courses) for Italian in-service mathematics teacher education, with the use of the platform DI.FI.MA. (<http://difima.i-learn.unito.it>), a Moodle platform, managed by the mentioned department, where more than 2,500 Italian teachers of all school types are enrolled. The aims of these online courses are to cover the main topics in the official Italian programs for secondary school (Arithmetic and Algebra, Geometry, Relations and Functions, Uncertainty and Data) from a mathematical, didactical, and methodological point of view, and to give teachers an opportunity for professional development at the national level. So far, three MOOCs have been delivered: *MOOC Geometria* (based on geometry contents, from October 2015 to January 2016); *MOOC Numeri* (based on arithmetic and algebra contents, from November 2016 to February 2017) and *MOOC Relazioni e Funzioni* (based on relations and functions contents, from January 2018 to April 2018). In the following, we concentrate on the last one, which we will indicate as *MOOC Rel&Fun* in the following.

During CERME10 in Dublin, some team members of the MOOC Rel&Fun became acquainted with the *MathCityMap* project (MCM). This project has been developed by the Goethe University of Frankfurt, Germany, and enables teachers to implement smartphone supported mathematical trails in mathematics classes. One key feature is the MCM web portal. It allows teachers to easily create tasks in their local surroundings and therefore fits well into a MOOC for teacher education, since the MOOC-teachers learn necessary skills online and can directly apply them by creating tasks in their environment. A collaboration between these two projects was established with the intention to

provide an innovative approach to teach the mathematical contents of relations and functions in the real world with the support of technology on the one hand. On the other hand, the MCM project (including the math trail idea) is an expanding project and it was worth introducing and disseminating it in Italy. This paper aims to report outcomes and examples of mathematical tasks created by MOOC-teachers according to MCM task design guidelines, as well as to explore potentials of an expert review system as one way to ensure task quality in a MOOC environment.

Theoretical framework

Mathematics trails

Blane and Clarke (1984) were among the first ones to present the mathematics trail idea to a broader scientific audience. According to Shoaf, Pollak and Schneider (2004, p. 11), math trails are accompanied by a trail guide booklet showing mathematically interesting places and tasks, usually including a map, for the user to follow. A meta-analysis on outdoor learning indicates that students do not only remember fieldwork and outdoor visits for many years, but also the experience of outdoor learning is considered “more effective for developing cognitive skills than classroom-based learning” (Dillon et al., 2006, p. 107). Students need to understand the problem, find an appropriate mathematical model, collect data, work mathematically and validate and discuss their answer. These activities come close to the modelling cycle as described by Blum and Leiß (2005) and help to promote modelling.

The mathematical contents depend on the tasks that a math trail offers. Problems in the field of geometry and measurement are obvious, since many geometrical forms shape our environment. Nevertheless, it is possible to find many tasks in the other content fields of mathematics. In contrast to original trails, math trails at school are not voluntary; they are mostly prepared by teachers for their students with a focus on a certain topic and are subject to organizational obstacles. Since the available time is usually set by lessons of a certain period (e.g., 45 or 90 minutes) and the learning group consists of about 20 to 30 individuals, it is necessary for the teacher to structure the math trail activity well to be a success. There are many aspects a trailblazer has to consider while creating a math trail. For this reason, task design guidelines, which are presented in a following paragraph, have been formulated to help authors generate material with high quality.

The MathCityMap project

The MathCityMap project combines the idea of math trails with the possibilities of web technologies and mobile devices (cf. Gurjanow, Ludwig & Zender, 2017). With the help of the MCM web portal (<https://mathcitymap.eu>), teachers can digitally create and manage tasks and trails. Furthermore, the web portal offers task templates, many public tasks, and the possibility to automatically generate a PDF math trail guide. The purpose of the MCM web portal is to make the challenge of creating a math trail more convenient. It is available in eleven languages (Italian included, thanks to the collaboration born with Math MOOC UniTo). The MCM application for smartphones is a digital math trail booklet that uses GPS to display the tasks position on map and presents the task to the users. Additionally, users benefit from a stepped aid system, in case they get stuck and an automatic feedback system that evaluates entered answers. The app is meant for persons (e.g., students) who would like to walk a math trail.

MCM content quality assurance

“Carefully designed classroom tasks can be a powerful tool for enhancing the quality of math and science teaching, influencing the classroom culture and fostering students’ learning” (Maaß et al., 2014, p. 8). This is also the case for math trail tasks, since they constitute the core of the math trail activity. Web communities (e.g., Wikipedia or GeoGebraTube) that allow users to create content in general face the issue of maintaining quality standards. Peer or expert reviews are a common way to ensure quality in academic papers and material produced by different authors (Price & Flach, 2017). MathCityMap implements an expert review system to maintain a high quality of published tasks and trails. Experts are selected for each participating country. They are often experienced teachers or academics from the field of mathematics education who are well informed about specific circumstances of mathematics teaching in their respective country. The experts may decide if the task or trail meets the quality criteria and accept the publication or, if revision is needed, they decline the publication with a message, indicating necessary changes (cf. Jablonski, Ludwig & Zender, 2018). Published content can be viewed and accessed by all visitors or app users.

Task design guidelines have been formulated to help new authors and to ensure a good user experience. These guidelines are the basis of the MCM review system. The first set of aspects is derived from popular published math trails like “A mathematics trail around the city of Melbourne” (Blane & Clarke, 1984), “Maths Trailing in Dorset” (Ashworth, Cobden & Johns, 1991, p. 7) and from a more general description on how to create math trails by Shoaf et al. (2004, p. 10) and the British Association of Teachers of Mathematics (1991). The first collection of task design guidelines that come from the intersection of all of these sources, deals with the challenge of creating outdoor tasks.

1. Uniqueness. Every task should provide a picture that helps to precisely identify the situation, the object of the task and what the task is mainly about.
2. Attendance. To solve a task, the user should have to be present, therefore the task data can only be obtained locally. This also means that a picture and description of a task should never be enough to expose the solution.
3. Activity. The one who solves the task must be active in some way (e.g., measure, count or sketch).
4. Multiple solutions. The task should be solvable in various ways.
5. Reference to reality. “Problems that arise naturally from the situation are best” (Shoaf et al., 2004). The task should not appear too artificially.
6. Tools. The tools that are required to solve the task should be noted on the trail guide. In general, you should not expect people to bring extraordinary tools.

The second set of aspects deals with challenges of mathematics trails as a teaching method. After preparing the math trail the teacher steps back in a passive role, while students actively discover the trail in small groups. To support the groups in case they cannot find an approach to solve the problem, the MCM app provides a stepped hint system.

7. Stepped hints. Every task should provide at least two hints.

8. Sample solution. Authors should provide an elaborated sample solution including measured data.

Research Question

In the MOOC Rel&Fun, as regard the use of MCM, MOOC-teachers were invited to generate math trail tasks connected to the topic of relations and functions. In order to improve material quality, Maaß et al. (2014) recommend that teachers should experience and reflect new tasks themselves prior to develop own material. However, for their nature, the math trails are bound to particular surroundings. It leads to the fact that MOOC-teachers were not able to experience MCM math trail tasks before designing their one, since the existing Italian tasks were - at that time - few and only located in Turin (where the MOOC team worked). Nevertheless, it was a main concern of the module to produce tasks that are in line with the task guidelines. This leads us to our research question: *What are advantages and disadvantages of an expert review system to ensure material quality?*

Methodology

MOOC Rel&Fun, like those who preceded it, is open, free, and available online for teachers on the DI.FI.MA platform. It consists of modules with a duration ranging from one to two weeks. Each module requires the performance of a task. Once the task is executed, the platform releases a badge¹. The users have time to perform the task from the beginning of the module in which it is inserted, until the closing date of the MOOC. The MCM module started in the fourth week of the MOOC Rel&Fun and lasted 2 weeks (since MOOC Rel&Fun lasted 11 week in total, the MOOC-teachers had 7 weeks to be able to accomplish the task provided by the module). As already mentioned above, the aim of the module was to learn how to use a new technology (MCM web portal and app) to create a math trail task on the subject of relations and functions. In the following, we explain in detail the integration of MCM into the MOOC Rel&Fun. In particular, we refer to *German team* meaning the MCM members, while with *Italian team* we mean the MOOC Rel&Fun members.

The MCM module begins by sharing the theoretical and technical aspects of MCM with the participants. The German team made a video in which they illustrated the spirit of the MCM project to the MOOC-teachers. The voice output was in English. The Italian team added Italian subtitles. Subsequently, it was necessary to make the MOOC-teachers autonomous to work with MCM, namely, allow them (i) creating new tasks; (ii) compiling a new trail; (iii) using the MCM app to walk a trail. Therefore, for each of these points a video tutorial was necessary. Both the teams agreed that for these videos the voice should be in Italian. So, the German team prepared English transcriptions and the Italian team added the voice to the mute tutorial videos made by the German team. Having clarified the technical details, it was time to show some examples to the MOOC-teachers. In the web portal, there were already some tasks, but they were mostly in German or English. A few months before the start of the MOOC, in October 2017, the German team visited Turin to explore the city with the Italian team. They together created and implemented some Italian tasks in the web portal.

¹ Digital badges are a validated indicator of accomplishment, skill, quality or interest that can be earned in various learning environments (Carey, 2012). In the case of our MOOC, they are created by a course administrator and then they can be issued automatically by the platform each time the user accomplish the tasks required within the module.

Subsequently, the Italian team prepared some Sways², where the methodological and mathematical details of each task were explained. In addition, a card with the criteria for designing a good task (task design guidelines), formulated by the German team, has been loaded onto the platform available to the participants. In this way, the teachers had high quality examples to take inspiration from and all the information needed to perform the module task. This one consisted of (i) creating a math trail task on the web portal on the topic of relations and functions; (ii) requesting publication of the task through the review process; (iii) sharing the link of their public task on a specific repository created in the MOOC module. Only three members of the Italian team were responsible for reviewing the MOOC-teachers' math trail tasks. They could directly approve the task for publication if it complied with the task design guidelines. Otherwise, they declined the publication by sending an e-mail to the MOOC-teacher through the MCM review system explaining the reasons for the refusal. The data on the review effort was gathered from the MCM review database. It stores each review that was performed by each Italian reviewer and links it to a particular task. The module ends with a questionnaire that intends to investigate the MOOC-teachers' satisfaction level on MCM and their intention to use it again with their students.

Data analysis

There were 358 enrolled teachers in MOOC Rel&Fun. As far as the MCM module is concerned, 287 tasks were created by the MOOC-teachers. 257 of them were added to the review system. Among these, at the closing of the MOOC, 231 tasks (90%) were considered to meet the task design guidelines and therefore got published. The Italian team performed 396 review processes (multiple reviews until publication of a task are possible) to ensure content quality. The MCM review database shows that among the 257 tasks that were submitted to get published, 119 (46%) tasks matched the MCM task design guidelines on their first review, 138 (54%) tasks did not. The MOOC-teachers revised 112 out of the 138 (81%) declined tasks according to reviewers' feedback and were later on published. In reality, the situation has been a little more complex. The tasks that were directly accepted were not always in line with the design criteria, so there were less than 119 tasks that matched task design guidelines on the first review. The Italian team has indeed noticed this: when they immediately declined the tasks, the MOOC-teachers not always revised and submitted their tasks again for review. Instead, when reviewers sent feedback with a request of revision without declining the task³, the MOOC-teachers made the changes and the reviewers could approve their task like if these revised tasks were their first submission. However, unfortunately, we are not able to exactly quantify this data.

In the following, we indicate the common errors identified by the Italian team for declining the MOOC-teachers' tasks.

<i>Most common errors</i>	<i>Less frequent errors</i>
---------------------------	-----------------------------

² Sway (<https://sway.office.com/>): Microsoft tool that allows users to combine text and media to sustain the showing of online content.

³ Sending personal emails, like the MOOC team used to do for other commitments in the MOOC (i.e. soliciting the MOOC-teachers to get the badge of the modules, ...).

Instruction of the task unclear or ambiguous, namely in the same task there was more than one question	picture related to the task unclear and not always shared according to the indications
No indication of the unit of measure in the task instruction	incorrect geolocation ⁴
Solution provided without the data collected or without the calculations made ⁵	inserting the entire solution in the hints
If the solution was expressed by a range of possible values, this range was not always indicated in a plausible manner	inserting more than one hints in the space that is generally dedicated to a single hint
Solution difficult to read because the text editor was not used ⁶	create the task inside the school premises ⁷

Table 1: MOOC-teachers' common errors designing a math trail task with MCM

We now show an example of activity that has been published. The task in Figure 1 was created by a teacher from Lecco (a city in Northern Italy) for students of grade 11.



Figure 1: Pendulum equation as a function of time

- $s(t) = 0,94 \cdot \sin(360^\circ t / 2,33)$
 $s(t) = 1,88 \cdot \sin(360^\circ t / 2,33)$
 $s(t) = 0,94 \cdot \cos(360^\circ t / 2,33)$
 $s(t) = 1,88 \cdot \cos(360^\circ t / 2,33)$

Figure 2: Solution as a multiple choice

This is her delivery: “Starting from a position that forms an angle of about 44 degrees with the vertical, determine the equation that describes the displacement by the swing, as a function of time, while it oscillates. The units of measurement to be used are the meters and the seconds”. The teacher chose to represent the solution as a multiple choice (Figure 2) and inserted three hints: (i) a YouTube video (<https://goo.gl/dqJuMH>); (ii) an image (Figure 3); (iii) a sentence: “Calculate the amplitude of the movement (maximum displacement) and the time of complete oscillation”. She indicates that the tools needed to solve this task are the folding ruler and the calculator. She also clearly describes the procedure she followed for the resolution.

“I moved the swing to form an angle of about 44 degrees with the vertical (Figure 4). I measured the length of the wire and I got 1.36 m. Taking advantage of the stopwatch of the phone I measured

⁴ someone had put the Mole, a typical monument of Turin, in Switzerland

⁵ someone was looking for the monuments data on the internet, so he did not actually go there in person to find the data

⁶ i.e. m2 instead of m² to indicate the square meters

⁷ if on the one hand this was done for security reasons related to the responsibilities that teachers have on their students when they propose activities outside of the school; on the other hand, in this way, the possibility of making the task accessible and usable by anyone is lost.

the time it took the swing to make one full oscillation. I repeated the same operation three times and I calculated the average time. So, I got that to make a complete oscillation it takes 2.33 sec. I calculated the maximum displacement $A = 1.36 \cdot \sin(44^\circ) = 0.94$. Finally, I wrote the pendulum equation as a function of time: $s(t) = 0.94 \cdot \cos(360^\circ \cdot t / 2.33)$ with t in seconds”.

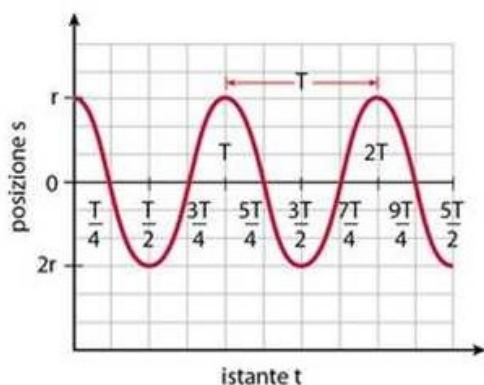


Figure 3: Second hint



Figure 4: Explanation of the solution

Discussion and Conclusion

The collaboration between Math MOOC UniTo and MathCityMap was a success. MOOC-teachers were very engaged and created almost 300 math trail tasks all over Italy. 142 MOOC-teachers completed the questionnaire inserted in the MCM module and the 76% of them were satisfied with the module contents and would recommend MCM to colleagues. Although the MCM module provided tutorial videos, as well as best practice examples and explicitly formulated task design guidelines, not all and not immediately were able to meet the task of the module. The review phase was indeed challenging and demanding. In fact, if we consider the data of the MCM review database, only 46% of the created tasks met the task design criteria. The expert review system helped to improve a total of (at least) 112 tasks (44 %). At the end of the module, 90% of the tasks were considered good quality and allowed their respective authors to obtain the desired module badge. The quota of revised tasks (112 out of 138, 81%) is remarkably high and shows that teachers accepted and appreciated the expert feedback. In general, teacher education that aims to improve mathematics classes through high quality material, especially those that want their participants to create own material adapted for their students, need to take care of material quality (Maaß et al., 2014). In the case of a MOOC for teacher education, the expert review system turned out to be a suitable method to achieve this goal. In total 396 review processes were necessary to implement the review system during the MOOC MCM module. On the one hand, we recognize that a disadvantage of the review system is that of having to manually write reviews. This implies that reviewers must be highly motivated to accomplish this task and to assure high-quality materials. On the other hand, the possibility of giving highly adapted feedback that considers not only the mathematics but also the cultural background and the educational landscape of mathematics classes in Italy, could be identified as a major advantage of the review system. However, the success of the review system relies on the willingness of the participating teachers to accept the review and to revise the task. Since we did not explicitly examine factors that lead to a revision of a task, the willingness can be traced back to a mixture of a high-quality feedback

combined with the desire to obtain the module badge and the satisfaction with the module contents. Finally, we can certainly state that the engagement of MOOC-teachers in creating the math trail tasks and the efforts made by the reviewers have constituted a heritage, not only for the MOOC community but also for all MCM users.

Acknowledgment

The research has been partially supported by the Università degli Studi di Catania, “Piano della Ricerca 2016/2018 Linea di intervento 2 - Modelli Matematici nell’Insegnamento-Apprendimento della Matematica”.

References

- Ashworth, F., Cobden, D., & Johns, J. (1991). Maths trailing in Dorset. *Mathematics in School*, 20(1), 2–7. Retrieved from <http://www.jstor.org/stable/30214743>.
- Blane, D.C. & Clark, D. (1984). *A mathematics trail around the city of Melbourne*. Monash Mathematics Education Centre: Monash University.
- Blum, W., & Leiss, D. (2005). „Filling up“ – the problem of independence-preserving teacher interventions in lessons with demanding modelling tasks. In M. Bosch (Ed.), *Proceedings of the 4th Congress of the European Society for Research in Mathematics Education*. FUNDEMI IQS.
- British Association of Teachers of Mathematics (1991). *The what, why, how and when of mathematics trails*. Derby, ATM. Retrieved from https://www.atm.org.uk/write/mediauploads/resources/maths_trails_pdf.pdf.
- Carey, K. (2012). A future full of badges. *The chronicle of higher education*. Retrieved from <https://www.chronicle.com/article/A-Future-Full-of-Badges/131455/>
- Dillon, J., Rickinson, M., Teamey, K., Morris, M., Choi, M. Y., Sanders, D. & Benefield, P. (2006). The value of outdoor learning: evidence from research in the UK and elsewhere. *School science review*, 87(320), 107.
- Gurjanow, I., Ludwig, M. & Zender, J. (2017). What influences in-service and student teachers’ use of MathCityMap? In T. Dooley & G. Gueudet (Eds.), *Proceedings of the Tenth Congress of the European Society for Research in Mathematics Education (CERME10)* (pp. 2366–2374). Dublin, Ireland.
- Jablonski, S., Ludwig, M. & Zender, J. (2018). *Teachers as partners in task design. A dialog-based review system to ensure a certain quality of tasks in the MathCityMap web community*. Accepted to be presented at ERME Topic Conference – Mathematics Education in the Digital Age (MEDA), Copenhagen, Denmark.
- Maaß, K., Wernisch, D., Schäfer, E. & Reitz-Koncebowski, K. (Eds.). (2014). *Conference Proceedings in Mathematics Education – Educating the educators: International approaches to scaling-up professional development in mathematics and science education*. Essen, Germany.
- Price, S. & Flach, P. A. (2017). Computational support for academic peer review: a perspective from artificial intelligence. In M. Vardi (Ed.), *Communications of the ACM (60)* (pp. 70–79). ACM New York, NY, USA.
- Shoaf, M., Pollak, H. & Schneider, J. (2004). *Math Trails*. Lexington: COMAP.
- Taranto, E., Arzarello, F., Robutti, O., Alberti, V., Labasin, S. & Gaido, S. (2017). Analyzing MOOCs in terms of their potential for teacher collaboration: the Italian experience. In T. Dooley & G. Gueudet (Eds.), *Proceedings of the Tenth Congress of European Society for Research in Mathematics Education (CERME10)* (pp. 2478–2485). Dublin, Ireland.

Cross-linking maths: Using keynotes to structure a curriculum for future teachers

Tanja Hamann¹ and Barbara Schmidt-Thieme²

¹²University of Hildesheim, Institut für Mathematik und Angewandte Informatik, Germany;
bst@imai.uni-hildesheim.de

Keywords: Teacher education curriculum, history of mathematics, language.

Initial conditions and requirements

Subject-specific content knowledge is an essential component of professional teacher knowledge (for the concept of professional knowledge see for example Schwarz, 2013). It forms a basis for the ability to judge a specific topic's significance for an entire subject and thus forms an important requisite for didactical reflections (Dreher et al., 2018). Considering this, mathematics teachers' content knowledge must comprise not only advanced insight into specific topics but also a netlike overview of mathematics as one, consisting of notions and relations between them as well as methods and basic principles. A survey in a second-year lecture on arithmetic showed that the students were not able to connect what they heard about equivalence relations, functions or groups to corresponding contents they had learned in previous lectures (e. g. congruence and the group of congruence mappings in geometry, isomorphisms and linear functions in linear algebra).

To achieve that students are able to see these parallels, a university curriculum for future teachers demands cross-links between the single courses. Basic notions (such as sets, functions, algorithms, relations...) that are found in diverse mathematical subdomains seem suitable for serving as cross-links between scientific lectures, both, in a horizontal and a vertical way. This would transfer Bruner's (1969) concept of fundamental ideas and a spiral curriculum onto teacher education, also suggested in Dreher et al. (2018, pp. 330 f.).

Basic ideas and fundamental notions can be found when one looks into the history of a subject as they should appear throughout time (Schweiger, 1982), though maybe in different disguises. Apart from that aspect, including the history of mathematics into teacher education has been suggested long-since, presumably bearing a whole lot of further benefits (Schubring, 2000; Katz, 2000; Jankvist et al., 2016), for example experiencing mathematics as a process conducted by human beings rather than as a mere product and thus influencing future teachers' beliefs. In addition, through history of mathematics one learns about the synthesis of notions and terms. This is of special importance for future teachers as it surely facilitates due decompression of scientific content into school content, which requires thorough analysis. (Dreher et al., 2018, 331)

Generation, clarification and precision of mathematical concepts and notions require the use of language (e.g. Morgan et al., 2014). Without language, definitions and propositions could not be worded and not be taught either, so language forms another essential part of content as well as pedagogic content knowledge. Due to increasing heterogeneity in pupils' language abilities, it is necessary that future teachers learn to illustrate subject matters on differing language levels and that they become able to vary by those levels.

The Hildesheim concept of “Learning along Keynotes” (LaK)

We suggest that integrating the three keynotes – basic notions, history and language of mathematics – into a teachers’ curriculum and thus cross-linking the courses supports the construction of a professional teacher content knowledge as required. Therefore, the keynotes should become a constitutional part of all scientific lectures throughout studies. Our poster presents a concept of how the three keynotes might constitute a scaffolding for a spiral curriculum, where historical and language elements serve as enrichment as well as embedding of basic contentual and methodical concepts. We also present an exemplary concretization for the basic notion “algorithm”.

LaK started 2018 in a first-year (linear algebra) and a second-year (arithmetic) lecture at the university of Hildesheim. Historical and linguistic tasks that are mostly integrated into exercises associated to the lectures comprise transferring formulas into common language or working on original historical texts.

To emphasize the netlike structure students are encouraged to design concept maps for a selection of basic notions (see poster for complete list) and augment them in the course of their studies, starting from first year and going on through all lectures. The next step will be to design appropriate tasks for all scientific lectures as well as a research frame for evaluating the concept in the form of a long term study.

References

- Bruner, J. S. (1969). *The process of education*. Cambridge, MA: Harvard University Press.
- Dreher, A., Lindmeier, A., Heinze, A., & Niemand, C. (2018). What kind of content knowledge do secondary mathematics teachers need? A conceptualization taking into account academic and school mathematics. *JMD*, 39, 319-341.
- Jankvist, U. T., Mosvold, R., & Clark, K. (2016). *Mathematical knowledge for teaching teachers: The case of history in mathematics education*. Paper presented at History and Pedagogy of Mathematics 2016, Montpellier, France.
- Katz, V. J. (2000). *Using history to teach mathematics: An international perspective*. Washington, DC: Mathematical Association of America.
- Morgan, C., Craig, T., Schuette, M., & Wagner, D. (2014). Language and communication in mathematics education: an overview of research in the field. *ZDM*, 46, 843-853.
- Schubring, G. (2000). History of mathematics for trainee teachers. In Fauvel, J., & van Maanen, J. (Eds.), *History in mathematics education: The ICMI Study* (91-142). Dordrecht, The Netherlands: Springer Science+Business Media.
- Schwarz, B. (2013). *Professionelle Kompetenz von Mathematiklehramts-studierenden: Eine Analyse der strukturellen Zusammenhänge*. Wiesbaden, Germany: Springer Spektrum.
- Schweiger, F. (1982). “Fundamentale Ideen“ der Analysis und handlungsorientierter Unterricht. *Beiträge zum Mathematikunterricht 1982* (103-111).

Teacher education: Developing the individual within the collaborative

Fiona Haniak-Cockerham

Manchester Metropolitan University, England; f.cockerham@mmu.ac.uk

This study explored student teachers' ability to develop their own teaching identity whilst teaching collaboratively as a trio in a "University School Model" of initial teacher education. The paper considers this from a psychoanalytical viewpoint in which the student teachers' emotions and desires are explored in relation to how they experience their work with their peers. The main focus is on how they negotiated the tensions around differing individual pedagogies within the group whilst maintaining the delicate balance between compliance and integrity. The paper concludes that it was through the process of navigating these tensions that they challenged their own pedagogy and in the course of working collaboratively, modified their developing teacher identity.

Keywords: Collaboration, identity, emotion, psychoanalysis.

Introduction

Although 'a considerable amount of current research on teaching and teacher education focuses on teacher collaboration' (Meirink et al., 2007, p.145), previous research tends to focus on qualified teachers supporting each other, or qualified teachers' collaboration with student teachers. Taking a different approach, this paper is concerned with student teachers collaborating with their peers. The paper describes the thinking behind the "University School Model" (USM) and the way in which the author worked with student teachers over the course of a year. Employing Britzman (1998, 2003, 2010) and Bibby's (2011) psychoanalytical approaches to teacher education, it acknowledges there are emotional tensions in developing a teacher identity but that learning to teach is a social process requiring negotiation. Although there is a resistance to changing their perception of teaching, the USM incurs differing pedagogies and argues that this is central in supporting student teachers' development and their autonomy. It considers the university tutor's role and implications for initial teacher education (ITE).

Literature review: Collaborative teaching and multiple placements

A significant amount of research has focused on the role of collaborative practice (Cajkler et al., 2014; Eraut, 2007; Meirink et al., 2007) and the effect this has in supporting the developing professional. Cajkler et al. (2014, p.521) found that planning lessons collaboratively led teachers to be 'more courageous and give greater responsibility to students to manage their own learning'. Their study also suggests that collaboration led to a greater willingness for pedagogical risk-taking and 'opportunities for participants to develop individual expertise leading to greater confidence to make changes... and address learning challenges with creative and engaging approaches' (Cajkler et al., 2014, p.526). They conclude that working collaboratively allows for a deeper study of pedagogy.

Teachers in their developing years take on a challenging role within the first weeks on teaching placement, and can struggle to survive in extremely crowded and demanding environments (Eraut, 2007). Their survival depends on being able to reduce their cognitive load by prioritisation and routinisation, and therefore they may not focus on the pedagogical issues within their teaching (Eraut,

2007). However, collaborative teaching contexts enable sharing of responsibilities within the classroom and therefore more space for reflection, allowing for routinisation to be less of a necessity in the first few weeks, but developed reflectively with evaluation over time.

Collaborative practice in a 'traditional' model of teacher education takes the form of the student teacher working as an 'apprentice' with the class teacher or a subject mentor. Student teachers in this situation may feel obliged to incorporate advice and ideas from 'expert' teachers and mentors in their school placements into their own teaching, therefore becoming merely compliant with the ideas that have been shared rather than being co-constructors of them. A related issue is that established teachers may find it difficult to articulate their practice to student teachers on placement, since what started as explicit routines in their early experiences have become tacit routines over time (Eraut, 2007). In contrast, teaching with student teacher peers means that routines which are not yet instinctive can therefore be evaluated and re-assessed together, becoming established in unison. This shift from working alongside more experienced teachers towards working and collaborating with peers is the context for this research.

The University School Model of teacher education

During my necessarily infrequent visits to observe student teachers during their school placements as part of traditional ITE programmes, I was often dismayed to see students who had previously been creative and innovative in their teaching revert to procedural didactic methods. One reason for this commonly observed gap between the theory learnt at the university and the practice seen in school (Allen, 2009) is that the student teacher in placement is isolated from the support and advice of the university tutor. Too often, the once inventive and imaginative practice enthused over at the university is sacrificed to ensure compliance with the reductionist process-driven teaching dominant in many school placements (Cockerham & Timlin 2014).

To address this issue, Manchester Metropolitan University developed a collaborative teacher education programme, namely the 'University School Model' (USM) in 2010. The USM involves placing six student teachers in a school, where they teach collaboratively in two groups of three, as well as individually. The unique attribute of this model is that the university tutor works in the placement school alongside teachers and student teachers, visiting weekly for a whole day. This provides an opportunity to observe and work regularly with student teachers, supporting the integration of practice based on theory and promoting teacher autonomy and professionalism in a more cohesive manner.

Collaborative teaching during these placements is paramount in developing innovative lessons as well as encouraging student teachers to become more reflective practitioners. "Learning about teaching is a collaborative activity" (Northfield and Gunstone, 1997, p.49) and the USM works on the assumption that it is most productive when conducted in groups where ideas and experiences can be discussed. Although working in a group with differing pedagogies and priorities can lead to tensions and emotions that student teachers find hard to navigate, differences of opinion are crucial in fostering discussion and debate about their perceptions of what makes a "good" mathematics teacher, enabling them to identify and articulate their beliefs about teaching (Meirink et al., 2007). The research

questions which frame this paper are: What opportunities for student teacher's development arise from the USM of collaborative teaching? What emotional support and tensions are evident whilst working collaboratively in the USM?

Theoretical framework

The field of psychoanalysis has many influential perspectives, however this paper focuses on the approaches of Britzman (1998, 2003, 2010) and Bibby (2011) due to their specific insights into mathematics education. Britzman (2010) asserts that psychoanalysis is the best way to turn education 'inside out' in order to start to understand something of its emotional situation and its inhibitions, symptoms and anxieties. She claims that it is 'one of the few practices and theories in the human professions that begins with and is affected by the relation between our object world and our sense of relationships with self, others and knowledge' (Britzman, 2010, p.86). Student teachers are placed in a situation of negotiating the balance of being a student themselves whilst trying to teach others, and what characterises the relationship between student teachers and their 'others' is the dependency and desire to be seen as already knowledgeable without having to learn (Britzman, 2003). Britzman (2003) also discusses the overfamiliarity of the teacher profession as a significant contribution affecting those learning to teach: student teachers draw on their subjective experiences of teaching from their previous experience of education, as a pupil. We all know what a teacher is and does from our years of observation in our own school system growing up, leading to the scenario that 'many students leave compulsory education believing that "anyone can teach"' (Britzman, 2003, p.27). For Anna Freud (cited in Britzman, 2010) this denial of needing to learn how to teach is the ego's defence against its own vulnerable certainty. Consequently, teachers rarely disclose 'the more private aspects of pedagogy: coping with competing definitions of success and failure, and one's own sense of vulnerability and credibility' (Britzman, 2003, p.28). Britzman (1998) argues that learning to teach demands a change in the learner, in that they must reconsider their previous speculations. Education depends on persuading the student teacher to transcend conflict in order to learn, and psychoanalysis insists that the conflict is purely internal. Therefore, the problem of learning to be a teacher becomes 'how the social and the individual can come to tolerate ethically the demands of the self and the demands of the social' (Britzman, 1998, p.8)

However, the beliefs we have about teaching are formed not only from our conscious perceptions of good teaching, but also our unconscious self. Earlier experiences we have relating to vulnerability, that of being educated, create resonances in the unconscious, and these unconscious phantasies are projected onto our current situations, that of being a teacher, affecting our beliefs and values and structuring our actions (Bibby, 2011). Thus, unconscious processes profoundly influence and are intertwined with more conscious processes (Britzman, 1998). The unconscious part affects the way we view the self, the self we project to others and the decisions we make.

The sense we make of ourselves, our identity, our ego, is made up of a layering of identifications that we have either found or been presented with 'out there' (Bibby, 2011), and is therefore dependent on other people's responses to us. This is in contrast to the popular image student teachers bring to their teaching practice, that of 'teaching as an individual activity, privatised by the walls between classrooms' (Britzman, 2003, p.63). In order for the student teachers to reflectively question their

teaching identity, it is crucial that they experience images provided by others; this system of judgements frames how we come to be seen and known in terms of being located in the others' field (Bibby, 2011). You can only know yourself through interactions with others, learning to teach therefore is a social process of negotiation (Britzman 2003). Lacan (cited in Bibby 2011:34) states that there is a gap between the 'me' the trainee teacher is experiencing themselves, including what they see mirrored by other people, and the 'me' they would like to experience; desire is the urge to close the gap between these two versions of 'me'. This can be the cause of significant anxiety for the student teachers. There exists a tension between anxiety and desire, there cannot be one without the other and there can be no learning without them (Britzman, 1998), therefore this is an emotional conflict that they must negotiate in order to learn how to teach.

Methodology

This research was carried out at Manchester Metropolitan University (MMU) with twelve student teachers on a Post Graduate Certificate of Education course (PGCE). The participants were members of my personal tutor group, who were placed in two 'University Schools', chosen on the basis of their previous experience of working as a placement school and their established expert practice. All twelve students agreed to take part in the study, and were assured of their anonymity and given the option to withdraw at any time. I discussed the ethical implications of the situation at length with them, and assured them that it would not affect the support or grading that they received throughout the year. In the USM, students teach two out of their three classes in the first placement as a trio and only one out of the three classes in the second placement. Other lessons are taught individually. Every week the university tutor visits for a full day throughout both placements, working alongside the students to help with planning, observe lessons, give feedback and advice, and provide pastoral support throughout the year.

There are four key sources of data in this research. I used a reflective journal to capture an autobiographical perspective on my practice, as the visiting university tutor. The student teachers reflect weekly on their progress on their placements as part of the PGCE course, and these were used to provide insights into their developing teacher identity. I held four focus groups during the placements to discuss various issues, including on one occasion my delivery of a lesson which had been planned by six of the student teachers, and observed by the students and the class teacher. At the end of the lesson the students gave me feedback, along with the class teacher. The lesson was also video recorded, and played to the focus group. At the end of the PGCE course, once the students' grades and final forms were completed, they participated in individual semi-structured interviews, focusing on their experiences of working in the USM, their ability to work collaboratively and the tensions surrounding this, and reflecting on the teacher they became as a result of their experiences. Both focus groups and interviews were audio recorded. This paper focuses on the interviews, analysed with a particular emphasis on considering the emotional aspect of teaching collaboratively and the effect this had on their developing identities as teachers. The data was operationalised by the theoretical framework and a thematic analysis was conducted. Two of the themes are discussed in this paper with respect to the research questions.

Findings

Teaching collaboratively

One of the main issues facing the student teachers in the USM is the idea of teaching collaboratively. They come to the course thinking that they simply require some practice in the classroom and that will be sufficient in making them a ‘good teacher’. The idea of having to work alongside other student teachers who may not be as strong as them, may not agree with them, may hold them back in their teaching or may be seen as needing support, was difficult:

Edward: When we all found about the trios, we were all definitely concerned.

Sarah: When we heard about it initially we were a bit like, oh, I don’t want to do that. I want to go in by myself.

Jennifer: I was a bit apprehensive about the trio at first, cos I just thought I don’t want to do it, I don’t want to be held back or whatever by someone else.

A common perception was that ‘learning’ from a peer is not effective for teacher education; they wanted to be in the classroom alone. There was an intrinsic denial that being influenced by their peers would support their own development as a teacher; they felt that learning can only take place from an experienced ‘teacher’. The prevalent idea was that education is the knowledge given by the expert and received by the novice.

Carol: I thought “well, you are just a trainee like me”. I found it easier to draw on people who had more experience than my own, than the people that I was working with.

The university tutor has a delicate role to play in this situation. The dichotomy of being influential in the student teachers’ developing pedagogies, whilst also have a role in ensuring the collaborative nature of the placement is effective:

Carol: I think, especially because when you are working in a three, the people are very different, they come from very different walks of life with very different ideas and opinions. And to have that visit every week [from the university tutor] it lubricates the situation and helps everyone to have a common idea and stops one personality maybe dominating others.

In spite of their misgivings and the tensions of the situation, the students reported that the support they receive from collaborating with peers in their lessons and in planning, means that they can try innovative teaching strategies with reduced fear of failure:

Sarah: But I think you have the opportunity to try different things...[you can] try it. Because there are three of you it can’t go drastically wrong.

Developing the individual within the collaborative

There is a subtle balance to strike when teaching as a trio, between gaining credibility and recognition for your individuality in the classroom and successfully working together and collaborating with your peers. The need to ensure that you are being assessed individually is often a contentious issue:

Carol: because people come into this and they are like this is *my* training I think that is the heart of it. This is *my* training and I need to push myself forward even though we are collaborating. Unless people are willing to give that idea up...you end up getting caught up in a situation where you're like oh alright this is all about *me* too.

Whilst teaching collaboratively there are multiple 'others' constructing the student teacher's view of themselves. The students needed to orchestrate the experience of working with their peers and negotiate how their potentially conflicting pedagogical beliefs would inform their teaching. They also needed to work with the class teachers and subject mentor in whose classroom they were a guest, and therefore expectations to comply. In addition, they needed to work with the university tutor who comes with their own views about effective teaching, and also to manage their own internal beliefs based on their prior experience of education of the teacher they want to be. The latter is the most difficult to modify, since how students see themselves in the role of the teacher is the "phantasy" that has led them to undertake this journey. There is a strong desire to become this teacher and therefore the inclination to teach as they were taught is hard to challenge, but is a crucial element in learning to teach. The importance of these personal histories is the independence of individual journeys: the experience that one person had of education, and which has shaped their desire to be a teacher, is different to anyone else's experience:

Justin: I kinda remember things, of ways I was taught ...and I think if that's the way that I learnt it and I thought it was good then, maybe students now will think it's a good way to learn as well.

Edward: Yeah, because obviously I had my feelings of what I wanted to be as a teacher. Shafia obviously had her idea, which was definitely a lot closer to Claire's [the class teachers] than mine.

The notion of "teaching practice" is thus about the individual finding a path between these fluctuating versions of themselves. In Edward's case, his strong sense of the teacher he wanted to be was brought into question by the class teacher and his collaborative partner. Edward was adamant that he was not willing to change his teaching style. However, by the end of the placement he reflected back to say:

Edward: I think it has changed me slightly on where I was going to be, or where I thought I would be, but I think that was more for the better.

Emotional support and tensions

Inevitably, the student teachers are all vying for their persona and their pedagogy to be dominant. When working as a group, if lesson planning and making decisions regarding how to teach a topic lead to differing views, this tension brings with it a strong emotional element. There is a sense of anxiety amongst the student teachers about which methods to teach, how to deal with behaviour, and how to manage the learning. The desire to teach the best lesson possible and be a successful teacher leads to further anxiety. This emotional tension can be difficult to navigate if the lesson is not being planned and delivered in a manner which reflects the teacher they are striving to become. However, the presence of anxiety and therefore desire is needed in order to progress; to close the gap between the image they see of themselves and the image which is projected to others.

However, there is also an opportunity for a student's ego to protect itself from the judgement of others by not contributing ideas and hiding behind the work of others. If the lesson does not go as well as planned there is an opportunity to remove yourself from the emotional disturbance of the feedback because you can convince yourself that this was not your lesson:

Edward: Because I don't like conflict too much so I just like "ok we will do it that way". I think that's probably bad in terms of teaching...going into a lesson and not being fully committed to the lesson...because it's not the way I wanted to do it.

The student teachers' anxiety at the start of the placement about not wanting to collaborate and the desire to teach on their own was alleviated in all of the participants in this research; this was mainly explained in terms of the emotional support they gave each other. This outweighed the emotional conflicts of teaching as a trio, with the anxieties and tensions this incurred:

Jennifer: If you go into it big headed, that you're the best teacher ever and you don't need it [the support from your peers] you'll fail because you need the people around you, you need that safety blanket.

Edward: It's nice having people around you that are in the same boat...obviously, you have two other people who are kind of your back bone in that sense and are supporting you

Overall the concern about them developing into the teacher they envisioned at the start of their placement was diminished throughout the year and the USM facilitated their ability to explore their autonomy and their agency in developing their teacher identity.

Jess: I think it has been easy to develop, there has been lots of support. This model has been really good for that. And I've not been one for asking for help but the help was always there.

Alison: You are obviously not always going to get on with your trio, it is inevitable that you are going to have differences, but you'll become the teacher you want to be in the end anyway.

Conclusion

The 'University School Model' of ITE aims to foster collaborative learning which supports student teachers in developing as teachers informed by the university and protected to some degree from mere compliance with placement school practices. What this research has found is at first there is a resistance to working collaboratively in a classroom, due to a host of emotional reasons: their ego, their preconceived perceptions of their teacher identity, fear of being held back. However, throughout the placement, students' ideals about teaching are challenged through working with peers, and although they may resist the change, the situation allows them to develop their pedagogy in a 'safe' environment. Collaboration with their peers allows them to shift their version of themselves, and experience differing pedagogies without the possibility of failure resting solely on their shoulders. The pressure of compliance from their supporting teachers and the university tutor are still perceptible, but the collaborative nature supports them in the negotiation and articulation of their

teacher identity. It allows creative and innovative lessons to be explored due to the support of the other student teachers in the room, with a shared responsibility, yet with an emphasis on their personal development. The students' final overall conclusion was that they all individually achieved their desire of becoming the teacher they wanted to be, despite their original notions of this being challenged. This research highlights the nature and role of emotion in the development of student teachers' teacher identities. It is interesting to consider how 'the teacher they wanted to be' at the start of the PGCE evolves as a result of experiences in the USM and the effect the individual personalities in their trios had on their development. It also highlights the role of the university tutor as a facilitator in this development. These are areas to be explored further.

References

- Allen, J. M. (2009). Valuing practice over theory: How beginning teachers re-orient their practice in the transition from the university to the workplace. *Teaching and Teacher Education*, 25, 647-654
- Bibby, T. (2011). *Education: An 'impossible profession'? Psychoanalytic explorations of learning and classrooms*. London: Routledge. doi:10.4324/9780203844458
- Britzman, D. P., & ProQuest (Firm). (1998). *Lost subjects, contested objects: Towards a psychoanalytic inquiry of learning*. Albany, NY: State University of New York Press.
- Britzman, D. P. (2003). *Practice makes practice: A critical study of learning to teach* (Rev. ed.). Albany, NY: State University of New York Press.
- Britzman, D. P. (2010). *The very thought of education: Psychoanalysis and the impossible professions*. Albany, NY: State University of New York Press.
- Cajkler, W., Wood, P., Norton, J., Pedder, D., & Xu, H. (2015). Teacher perspectives about lesson study in secondary school departments: A collaborative vehicle for professional learning and practice development. *Research Papers in Education*, 30(2), 192-213.
- Cockerham, F. and Timlin, R. (2014) 'University schools: A collaborative approach to ITT in secondary mathematics', in the *8th British Congress of Mathematics Education* (pp. 67–74). Nottingham.
- Eraut, M. (2007). Learning from other people in the workplace. *Oxford Review of Education*, 33(4), 403-422. Doi:10.1080/03054980701425706
- Meirink, J. A., Meijer, P. C., & Verloop, N. (2007). A closer look at teachers' individual learning in collaborative settings. *Teachers and Teaching*, 13(2), 145-164. Doi:10.1080/13540600601152496
- Northfield, J., & Gunstone, R. (1997) Teacher education as a process of developing teacher knowledge. In J. Loughran & T. Russell (Eds.) *Purpose, passion and pedagogy in teacher education* (pp. 48-56). London: Falmer.

Teacher Professional Development and Collegial Learning: A literature review through the lens of Activity System

Frida Harvey and Anna Teledahl

Örebro University, Sweden; frida.harvey@oru.se; anna.teledahl@oru.se

This study maps key features of effective Teacher Professional Development (TPD) and the framework of Communities of Inquiry (CoI), in an effort to gain an understanding of how these features contribute to teachers' collegial learning. Activity system, as described by Engeström (1987)/(1999), is used as a theoretical lens which allows for the visualization of TPD as a complex system. The result indicates that, apart from differences in the level of detail in the description of various features, there are differences in the demands the two models place on teachers. Establishing norms that promote collegial learning, in which critical inquiry is expected, emerged as a critical issue. This highlights the importance of viewing any variant of TPD as a process, in which the functions of features shift. Awareness of this process may prove important in designing and implementing future TPD initiatives.

Keywords: Activity Systems, Collegial learning, Communities of Inquiry, Teacher Professional Development

Introduction

In recent years, there have been calls for raised achievement in mathematics in a number of European countries, of which Sweden is one. In an effort to respond to these calls, the Swedish National Agency for Education (SNAE) launched several teacher professional development (TPD) initiatives, which build on the idea of collegial learning. SNAE describes collegial learning as activities in which teachers collectively and systematically analyse their teaching, in an effort to develop their practice and improve student achievement. Several studies have identified a shift in TPD where a traditional culture of viewing TPD as single occasions of "new knowledge being handed to teachers", is replaced by a new culture (e.g. Villegas-Reimers, 2003). Evaluations of the largest of these Swedish initiatives, Matematiklyftet [the Mathematics Lift], show that teachers, who have participated, have developed their ability to plan, carry out, and reflect on their teaching. What is left to investigate is in what way the various features of the initiative have contributed to this development (Österholm, Bergqvist, Liljekvist, & van Bommel, 2016). The question of what it is that makes TPD, and in particular, the kind of TPD which is based on ideas of collegial learning, effective, acts as a starting point for our study. We aim to explore this question through an inquiry into previous research on what makes TPD, in general, effective, but also by turning to a specific theory for collegial learning, Communities of Inquiry (CoI). In order to tackle the complexity of TPD as an endeavour we have turned to Cultural-Historical Activity Theory (CHAT). By using Engeström's model of activity systems (1999) we believe we can create a model of TPD and collegial learning that accounts for multiple dimensions, thus offering an opportunity to understand possible tensions between the two models of which the latter is part of the former.

Purpose and guiding research questions

By viewing TPD as an activity system, and categorize findings from previous research as parts of this system, we believe we can gain a comprehensive understanding of different aspects of collegial professional development. We hope that such insights will contain a problematization of prerequisites for TPD, which may prove helpful in future TPD initiatives. First, we investigate the question: *What characterizes effective professional development of teachers?* When we have mapped aspects of TPD, we look for differences between these and the corresponding aspects of the particular form of TPD known as *Communities of Inquiry*. The latter is expressed in the question: *What are the possible similarities and differences between general models for effective teacher professional development and Communities of Inquiry?*

Theory

Cultural-Historical Activity Theory (CHAT) is a theory that offers both an analytical and conceptual framework to understand human practices. The theory takes a social perspective on human actions and learning, meaning that human activities are understood in relation to their history, culture and context (Engeström, 1987). Within CHAT, Engeström (1987) has developed a model for analysis, which he calls activity system. An activity system is “the smallest and most simple unit that still preserves the essential unity and integral quality behind any human action” (p. 81). Activity systems have been used increasingly as a research framework in educational research in recent years (Gedera & Williams, 2016).

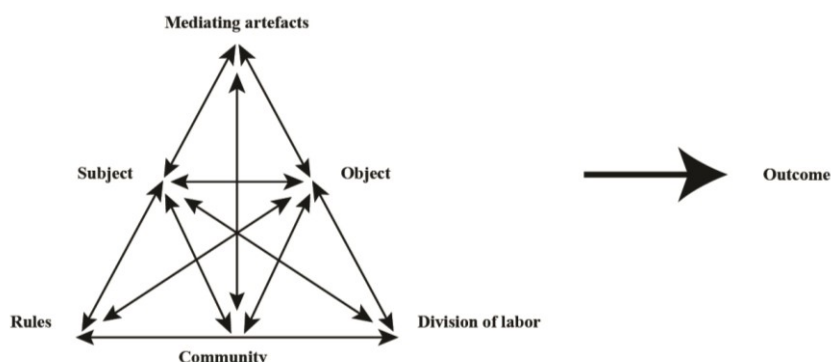


Figure 1: Activity system, as illustrated by Engeström (1999)

The activity system consists of six nodes as shown above. The *object* is the underlying “true” motive for the activity. *Subject(s)* are the participants who share the object of activity, for example teachers in a TPD-community. *Mediating artefacts* are the tools, with which the object is achieved. A tool can be a material object but also a procedure. *Rules* describe the rules and norms, both explicit and implicit, which are shared by the participants in the activity. *Community* refers to the context to which the subjects belong. This context may also include others, for example those who, in different ways, contribute to a shared object. *Division of labour* describes both the expressed roles of the subjects and the implicit hierarchical structures. To every activity system there is also an *outcome*, which can be defined as the change and/or result of an activity. A central aspect of CHAT is the analysis of tension within and between the nodes of the activity system. It is imperative to development and learning, to identify such tensions. (Definitions are a synthesis of Engeström, 1987; Engeström, 1999).

Engeström (1987) stresses that an activity system can have any size, it may consist of one single person or an entire society. All those who share the object of an activity are part of the activity system. In educational research, the activity system has been commonly used as an analytical tool to interpret data, foremost for its usefulness in making the context of educational processes visible (e.g. Jaworski, 2009; Walshaw & Anthony, 2008). In this article, TPD is seen as one activity system.

Method

In our aim to investigate what research says about effective collegial TPD, we turned to literature in two different ways. 1) In order to identify key features TPD in general, we turned to studies, which implemented a meta-analysis of previous research. Meta-studies offer opportunities, not only for quick and easy access to numerous studies in a specific field, but also to take advantage of a synthesis aimed at highlighting, comparing or critiquing, the most prominent aspects of a particular phenomenon. It is, however, important to consider that meta-studies often lack the nuances and depth, which systematic reviews of existing literature, provide. To partly counter such drawbacks we chose meta-studies conducted by researchers, which we through extensive reading, perceived as prominent researchers in the field of TPD: Borko (2004), Desimone (2009) and Darling-Hammond, Hylar, and Gardner (2017). 2) The concept of TPD encompasses a number of different models for professional development. Collegial learning is a specific model for professional learning that has gained popularity in recent years. In Sweden, the model is the preferred model in national development initiatives. In order to compare the key features of TPD with research on collegial learning as a specific model for TPD, we chose to focus on the framework of Communities of Inquiry (CoI), as described by Garrison (2016), since this can be understood as a particular framework for collegial learning. To further anchor, the general framework of Garrison, in the context of mathematics education we also chose to include Jaworski's article on CoI in mathematics teaching development (Jaworski, 2008). Teacher learning and professional development are complex endeavours, which are difficult to grasp. In order to deal with this complexity we turned to Engeström's description of an activity system, consisting of six nodes. Viewing TPD as an activity system, allowed for the mapping of, not only the various concepts involved, but also the relations between these concepts. The activity triangle thus offered a visual, as well as analytical tool, with which we could manage the inherent complexity.

Viewing collegial TPD as one single activity system, which then constituted our unit of analysis, allowed us to explore the literature through the questions; what does research say about *the object, the subjects, the division of labor, the mediating artefacts*, etc. Salient features were noted in table 1. After having created an image of collegial TPD as a complete activity system, we explored each node looking for similarities, differences and possible gaps in our collective knowledge. Our aim is to provide insights into PD that will prove helpful in future initiatives.

Key features of an activity system for effective teacher professional development

In this section, key features of effective TPD as well as aspects of CoI are organized in relation to the nodes of the activity system. Similarities and differences found in each node are compiled in Table 1, and further presented in more detail under each of the headlines.

Node	Effective TPD	Communities of Inquiry
<i>Subject</i>	Teachers, facilitator	Teachers, facilitator
<i>Object and outcome</i>	Teacher learning, changes in practice	Better understanding of what is being questioned, developed thinking/reflection, inquiry is a way of being, connecting ideas/experiences and applying new ideas in practice. All the above lead to changes in practice
<i>Mediating artefacts</i>	Long term activities built on active learning, content focus related to subject matter knowledge, task with relevance for classroom practice	Questioning of practice or problems in practice as a starting point for critical discussions, sharing, comparing and developing experiences and ideas through critical discussions, exploratory working methods, inquiry as a tool, inquiry cycle
<i>Rules</i>	Collective support, trust, challenging/critical discussions, active learning	Critical review of experiences, ideas and results of teaching, exchange of experiences is not enough, inquiry as a way of being, open communication
<i>Community</i>	Teachers' beliefs and prior knowledge, school reforms	Social context; for example, educational content and communication medium
<i>Division of labor</i>	Facilitator foster norms of critical discussions, teachers act as active learners	Facilitator designs and organizes the meetings (structure and content), proposes tasks, keeps discussions focused, problematizes discussions, gives feedback and guides the teachers, teachers are inquirers who explore and analyse their teaching practice

Table 1: Similarities and differences between effective TPD and CoI

Subject

In all the three meta-studies, TPD initiatives are described as including more than one participant. This can be seen as a reflection of a focus on collective participation. Borko (2004) mentions teachers and facilitators as subjects, while Desimone (2009) and Darling-Hammond et al. (2017) mention only teachers as subjects in TPD. The teachers, together with a facilitator, are all participants in the framework of CoI (Garrison, 2016). Facilitators seem to have a more pronounced and central role in CoI than in research on effective TPD.

Object and outcome

Borko (2004) has investigated the impact of TPD on teacher learning whereas Desimone (2009) makes it clear that TPD should increase teacher learning *and* change practice to be seen as effective. It may be seen as unproblematic to view teacher learning as the object of the TPD activity system. Desimone's reference to a *change in practice*, however, highlights an uncertainty regarding what teacher learning entails. When it comes to CoI, Garrison (2016) argues that learning is manifested in teachers' different ways of thinking, reflecting and acting, which is the result of activities where the focus is on connecting different experiences and ideas, rather than just sharing them. Jaworski (2008) pinpoints this difference by arguing that the teachers, not only change their thinking regarding certain phenomena, but that they develop inquiry as a way of being, they are "taking the role of an inquirer; becoming a person who questions, explores, investigates and researches within everyday, normal practice" (Jaworski, 2008, p. 312). This indicates that the process of inquiry instead of being a means, turns into the object. Teachers who collectively act as inquirers, into their own teaching, have opportunities to tackle didactical and pedagogical challenges in a systematic and effective way.

Mediating artefacts

The mediating artefacts described in research of effective TPD can be categorized into three overall categories; 1) long term activities built on active learning (Darling-Hammond et al., 2017; Desimone, 2009), 2) content focus related to subject matter knowledge (Borko, 2004; Desimone, 2009) and 3) tasks with relevance for classroom practice (Darling-Hammond et al., 2017). The content focus limits the scope of the TPD, and acts as a guard against diversions and irrelevant questions, and it can therefore be seen as a mediating artefact. Darling-Hammond et al. (2017) argue for the importance of feedback and opportunities for reflection, while Borko (2004) is more explicit regarding the implementations when she proposes that classroom-material such as video recordings, student work and lesson plans, could be the starting point of professional development for teachers. In CoI there are more specific examples of mediating artefacts. For example Jaworski (2008) proposes that the long term activity should be designed as inquiry cycles where teachers plan lessons, act & observe, reflect & analyse and finally get or give feedback on the lessons. This cyclic process, where the questioning of practice is a starting point, can carry on for longer or shorter periods. Such a model offers a concrete tool to use in the TPD. In relation to the second category, Garrison (2016) proposes that the content should be focused on sharing, comparing and developing experiences and new ideas through critical discussions. To the third category, Garrison adds that the tasks should be exploratory in character. Jaworski uses the expression "inquiry as a tool" (p. 310) with which she argues that teachers need to use, for example, questions and exploratory methods to practice and develop inquiry as a way of being. What Jaworski (2008) and Garrison (2016) propose can be understood as a refinement of the more general categories found in research of effective TPD.

Rules

Norms concerning collegiality seem to be important in effective TPD (Borko, 2004; Darling-Hammond et al., 2017). Borko (2004) stresses the importance of trust, which enables challenging discussions on teaching, and she argues that this is one of the most important

features of TPD. Desimone (2009) and Darling-Hammond et al. (2017), stress that teachers are expected to be active learners. In CoI, the importance of a critical review of experiences, ideas and results of the teaching, is stressed. This is something that goes beyond the mere exchange of experiences (Garrison, 2016; Jaworski, 2008). Garrison (2016) argues that norms of inquiry require open and risk free communication, where all participants can share ideas and experiences, without the risk of being ridiculed or attacked. Before such norms, of active learning, critical reviews and inquiry, are established however, they can be considered artefacts mediating learning, rather than part of a set of ingrained expectations. The rules and norms are quite similar between effective TPD and CoI. There is, however, in the case of TPD as well as CoI, a lack of description of how, and by whom, these rules and norms should be implemented and established.

Community

The participants in a TPD are also participants in other contexts where teacher learning and improvement of practice is the motive. Consequently, for TPD to be effective it must be in consonance with teachers' contexts, for example prior beliefs and knowledge (Desimone, 2009). Desimone also mentions the importance of coherence between the content of TPD and for example school reforms. In the same vein Garrison (2016) argues that individuals are inseparable from their context. Examples of elements of the social context, mentioned by Garrison, are educational content and communication medium. Aspects concerning community seem quite peripheral in research of both effective TPD and CoI, which indicates that the concept may not be well defined.

Division of labor

Desimone (2009) and Darling-Hammond (2017), which only mention teachers as subjects, argue that teachers need to be active learners, which could be understood as taking on a role. Borko (2004) describes the role of the facilitator, whose most important task is to foster trust and norms, which enable discussions. All three studies describe several key features such as time, active learning, norms of collegiality etc., but it is not clear, who is responsible for their implementation, or for upholding them, once they are established. According to CoI, the facilitator has a leading role. Garrison (2016) argues that the facilitator's task is to design and organize the activities, as well as to keep the conversations focused and exploratory in order to create rich and meaningful discussions. This could entail posing challenging questions, giving feedback or guiding teachers. The teachers are described as inquirers who participate actively in discussions, as well as explore and analyse their teaching practice. Garrison stresses that the teachers should be increasingly independent in the learning process. Although division of labor is described in more detail in CoI, concerning the role of the facilitator, little is said about how the facilitators should work to achieve this trusting, but also challenging, work environment. This points to an area where more research is needed.

Discussion

By using Engeström's (1987) activity system, we have tried to visually represent what research says about effective TPD and CoI.

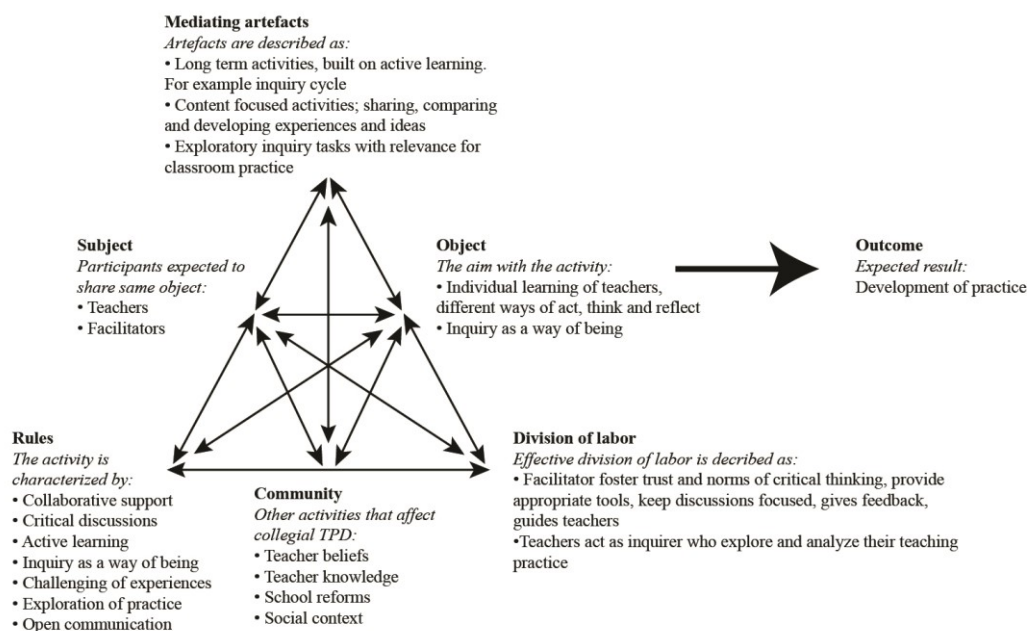


Figure 2: Activity system for effective collegial teacher professional development

Aspects of effective TPD and CoI, which have proved complex, are mainly those that can be sorted under the nodes: object, rules and, mediating artefacts. Some key features were sorted under more than one node in our categorization. Inquiry is positioned under each of these three nodes. This demonstrates the complexity of teacher learning, but also the flexibility of this framework. As the activity evolves the content of the nodes shifts, and creates a dynamic system. The activity system as an analytical framework thus has potential to identify different phases of the learning process. The inquiry process is an example of a process, which initially can be seen as a tool to foster changes in the way teachers approach a certain issue. When the tool however has become a part of teachers' natural approach, its function shifts and it can be seen as part of the rules and norms that govern the teachers' interaction. Jaworski (2008) argues that inquiry may be seen as a way of being and therefore can be seen as the object of TPD. CHAT as an analytic lens allowed us to view inquiry as a process, which can be found under the three nodes, object, rules or mediating artefacts, depending on what stage of a TPD initiative we are analysing. Theoretically, there is a considerable difference between viewing a process as a means or as a goal, which could generate what Engeström (1987) calls tensions in the activity. Empirically, however, it is natural that you can adopt a process by using it, by living through its different steps.

If the process of inquiry is viewed as a mediating artefact, something that can be used to achieve the goal of learning, then this is the aspect in which we find the greatest difference in detail, between previous research on TPD in general, and CoI. Inquiry, exploration and challenging of experiences are examples of concepts from CoI that refines some of the key features of effective TPD. Jaworski (2008) and Garrison (2016) stress that simply talking or sharing experiences, is not enough for a collegial activity to result in learning. Collective, critical and systematic reviews and analysis of experiences and practice are crucial to building new collective knowledge and collegial learning. We believe this constitutes a tension, between a new collegial culture and a previous, more individually oriented culture. A culture, which no longer equates,

passively acknowledging other's accounts of their teaching, with learning that informs and changes one's own practice, requires engagement from the teacher community. It places demands on the analytical and social skills of the participating teachers, on the pedagogical skills of the facilitator, and on the organization, that supports collegial work. In order for the teacher community to meet such demands, teachers as well as school administration need an awareness of the prerequisites for collegial learning that are highlighted in this article. In order for collegial learning to be successful, several important norms, such as trust and risk-free, open communication, must be implemented. Collectively asking questions about, investigate, or critically review, one's own practice requires a social environment, in which trust is considerable. Few examples are given on how the teachers and/or a facilitator should foster such norms. This is characteristic for many of the key features presented in figure 2. Research offers pointers on *what* and *who*, but very little is said about *how* the processes can be achieved. The processes leading to collegial learning is an area in need of more research.

References

- Borko, H. (2004). Professional development and teacher learning: Mapping the terrain. *Educational Researcher*, 33(8), 3-15.
- Darling-Hammond, L., Hyler, M., & Gardner, M. (2017). *Effective teacher professional development*. Palo Alto CA: Learning Policy Institute.
- Desimone, L. (2009). Improving impact studies of teachers' professional development: Toward better conceptualization and measures. *Educational Researcher*, 38(3), 181-199.
- Engeström, Y. (1987). *Learning by Expanding*. Helsingfors: Orienta Konsultot Oy.
- Engeström, Y. (1999). Activity theory and individual and social transformation. In Y. Engeström, R. Miettinen, & R.-L. Punamäki (Eds.), *Perspectives on activity theory*. Cambridge: Cambridge University Press.
- Garrison, D. R. (2016). *Thinking collaboratively: Learning in a community of inquiry*. New York, NY: Routledge.
- Gedera, D., & Williams, J. (2016). Preface. In D. Gedera & J. Williams (Eds.), *Activity theory in education. research and practice*. Rotterdam: Sense Publisher.
- Jaworski, B. (2008). Building and sustaining inquiry communities in mathematics teaching development: Teachers and didacticians in collaboration. In K. Krainer & T. Wood (Eds.), *The international handbook of mathematics teacher education (vol. 3): Participants in mathematics education: Individuals, teams, communities and networks*. Rotterdam: Sense.
- Jaworski, B. (2009). *The practice of (university) mathematics teaching: Mediatonal inquiry in a community of practice or an activity system*. Paper presented at the CERME 6, Lyon France.
- Walshaw, M., & Anthony, G. (2008). The teacher's role in classroom discourse: A review of recent research into mathematics classrooms. *Review of Educational Research*, 78(3), 516-551. doi:10.3102/0034654308320292
- Villegas-Reimers, E. (2003). *Teacher professional development: An international review of the literature*. Paris: UNESCO: International Institute for Educational Planning.
- Österholm, M., Bergqvist, T., Liljekvist, Y., & van Bommel, J. (2016). *Utvärdering av Matematiklyftets resultat. Slutrapport*. Umeå: Umeå Universitet.

Between natural language and mathematical symbols (<, >, =): the comprehension of pre-service and preschool teachers' perspective of “Numbers” and “Quantity”

Dina Hassidov¹ and Bat-Sheva Ilany²

¹Talpiot College of Education, Israel; hasidov@netvision.net.il

²Hemdat Hadarom College, Israel; bat77i@gmail.com

This paper deals with a study that relates to the understanding of the concepts that constitute part of symbolic thinking. The goal of the study was to understand how pre-service teachers (PST) and preschool teachers (PT) understand and use the mathematical symbols <, >, and = when comparing numbers, figures and shapes of different sizes and thicknesses. Using both quantitative and qualitative methods, we examined a study population of 71 PST attending a course for teaching mathematics to pre-schoolers and 149 PT. Our results show that the majority of participants did not answer the questions correctly, with a significant difference between how the two groups validated their answers, indicating that the participants do not correctly understand that mathematical symbols should only be used in the mathematical context.

Keywords: Preschool teachers, pre-service teachers, mathematics education, early childhood, mathematical symbol.

Introduction and theoretical framework

Mathematical language in Early Childhood is a language of symbols, concepts, definitions, and theorems. It does not develop naturally like a child's natural language, but needs to be taught (Ilany, & Margolin, 2010). In essence, children are engaged in mathematics in daily life from birth, and today's global trend is to introduce “formal” mathematics at a young age. Preschool math practice aims to develop mathematical awareness and cultivate mathematical thinking from an early age, thus shaping the child's future mathematical thinking, general thinking, and cognitive abilities. Studies have shown that the volume and quality of preschool math practice predict a child's success in math in elementary school (Clements, & Sarama, 2006, 2015).

The first skills include being able to use the concepts of “bigger”, “smaller,” and “equal to” to recognize differences between objects. Some PT introduce the mathematical symbols =, <, and > already in preschool and, unfortunately, ask the children to use these mathematical relational symbols to compare non-mathematical objects. This leads children to believe that these symbols are not restricted to mathematical values and, moreover, even when comparing numbers, to use them incorrectly. For example, a child in grade one may write “6 < 4” because the four looks bigger and thicker than the six, indicating that he is looking at the numbers as graphical entities and not mathematical ones. Such instances have led to the study of how PST and PT themselves use these mathematical symbols (Hassidov, & Ilany, 2017). Different quantities are compared through relations of order using various strategies based on the properties of these relations. According to Cantor's (1971) sorting principles, the set of real numbers has an intrinsic linear order. In other words, between any two quantities, one and only one of three following options holds true: (i) the two values are equal to each other; (ii) the first is greater than the second; (iii) the first is smaller than the second. If we

plot real numbers on a number line, two numbers, a and b , are equal only if the points that represent them coincide. If b is greater than a , the point representing b will be to the right of a . Here, we can also say that a is less than b . It is useful to present the ways that a relationship between two quantities can be described by using three pairs of relations, where each proposition of the pair is the negation of the other: $a = b$ $a \neq b$; $a > b$ $a \leq b$; $a < b$ $a \geq b$. Recall that the strategies used to compare two quantities are based on the general properties of comparison relations. The relation of equality is an equivalence and maintains the three properties of any equivalence relation: reflexivity, $a = a$ (each value is equal to itself); symmetry, $a = b \Leftrightarrow b = a$; and transitivity, $a = b \& b = c \Rightarrow a = c$ (two values equal to a third are also equal to each other).

Symbolic reasoning means the ability to grasp the meaning of a symbol representing an object or idea, without having an expression in the symbol itself (Bialystok, 1992). It is an evolving ability and one of the developing expressions of thought (Thomas, Jolley, Robinson, & Champion, 1999). Its development is characterized by changes that occur in the form of the mental representation of an object. Young children believe that the symbolic representation reflects the nature of the object it represents (Bialystok, 1992). For example, children may write the names of large objects using large letters (Thomas et al., 1999). Nemirovsky and Monk (2000) noted that young children do not distinguish between the symbol and the object that the symbol represents. The early development of symbolic reasoning in children should allow them to properly use mathematical symbols later in formal math. Teaching mathematics to pre-schoolers today requires professional knowledge on the part of the PT (Charalambous, Panaoura, & Philippou, 2009). Unfortunately, studies conducted in recent years indicate that PT assigned with teaching preschool mathematics do not have adequate knowledge. This may stem from negative personal experiences or a lack of appropriate training in college (Hassidov, & Ilany, 2014, 2015). They often use the knowledge and experience they bring from daily life, meaning that they might not always give the correct mathematical importance to the symbol. If PT incorrectly understand the use of mathematical symbols, it is reasonable to assume that they will subsequently pass this misinformation on to the children, leading to incorrect use in the future. It is thus crucial to teach the proper mathematical use of symbols from the preschool level (Hassidov, & Ilany, 2017). PT often use the knowledge and experience they bring from daily life, meaning that they might not always give the correct mathematical importance to the symbol. If the teachers incorrectly understand the use of the symbol, they will subsequently pass this on to the children, leading to their incorrect use in the future. Although young children can identify symbols and write them, this does not necessarily reflect an understanding of the symbol's mathematical meaning or their relationship to numbers. The concept of equality is an especially difficult concept to comprehend for children, since this term can be used both relationally and mathematically. Using the “=” symbol incorrectly with children makes it even harder for them to properly understand its concept.

Many studies have examined how children of various ages comprehend the “equal” sign. They show that children aged 5–12 tend to perceive the equal sign as an operational symbol and not as a sign of comparison. PST translate the symbols as a command to perform a mathematical operation. It is important to grasp that the meaning of a symbol cannot be changed by non-mathematical factors (such as a change in size or other physical factor). In a study dealing with the knowledge of PST and PT regarding their understanding of the significance and use of mathematical symbols between numbers, Hassidov and Ilany (2017) found that PST and PT do not fully understand that mathematical

symbols should relate only to the mathematical nature of the object. If one number was written in a larger, smaller, or thicker format than another, they often regarded the physical qualities and not the mathematical (i.e., the values of the numbers). Furthermore, even when they used the symbol correctly, the reasoning behind its use was often flawed.

Research Questions

This study examines how PST and veteran PT understand the concepts of $>$, $<$, and $=$. Its objectives were twofold:

- 1) How do PST and PT comprehend and use the relational symbols ($>$, $<$, and $=$) in perspective of "Numbers" and "Quantity"?
- 2) Is there any difference between how the two groups comprehend and use these symbols?

Method

The study population comprised 71 second- or third-year PST participating in a year-long course dedicated to the teaching and learning of mathematics in early childhood and 149 veteran PT. Data were collected via semi-structured interviews and a 25-item questionnaire designed by the authors. Of the 25 questions in the questionnaire, eight (questions 1, 2, 3, 17 and 7, 9, 10, 16) addressed the use of mathematical symbols between shapes and numbers that had some graphical difference (size, thickness, placement) (Table 1). Respondents were asked to either place a relational symbol between two figures or indicate "X" if they believed there was no appropriate answer, and then justify their answers. Analysis was both qualitative and quantitative.

Questionnaires were filled out by the PST before any formal study of the subject. The researchers interviewed a random sampling of 30 PST. This was followed by a class discussion on the use and meaning of mathematical symbols, and the subject's place in the preschool curriculum. Questionnaires were filled out by the PT and then individual interviews were conducted to ascertain the PT reasoning for their answers. Relevant background information was collected (e.g., professional experience).

Results

Overall, not one of the participants gave the correct answer and justification for questions 1, 2, 3, and 17. Even the very few who gave the correct answer ("X") gave flawed justifications, the correct one being that these symbols cannot be used for graphical objects and only for numerical entities. A significant difference was found between the two groups: a large number of PT did not supply any justification for their reasoning (58.4% for question 1, and 57.7%, 60.4%, and 66.4% for questions 2, 3, and 17, respectively) compared to the number of PST who did not (19.8%, 14.1%, 16.9%, 28.2%, respectively).

Questions for example: 2; 17 (Quantitative) asked which mathematical symbol, if any, should be placed between the shapes of different sizes and thickness.

Question 2: contained three smileys. The results were similar to question 1: most did not answer "X," and those who did, justified it incorrectly. Similarly, there was a significant difference ($p < 0.001$) between the groups (see Table 2). The vast majority of both PST and PT answered "=", indicating that they focused on the number of smileys (numerical properties). However, one preschool teacher said:

“There are the same number of smileys, but the area is different.” That is, her answer was based on quantity, but her justification also considered the shape. Another wrote “I counted the smileys.” One wrote: “Based on my experience, I would teach that the second is larger. But there can be different levels,” indicating that she feels that different criteria can be used under different circumstances. One PST teacher wrote: “I looked at the number of smileys. There is no importance to the length of the rectangle, only the number.” One PST teacher indicated “=” but wrote “The same quantity in each rectangle, although the left rectangle has a greater area.” Those who indicated “<” justified their answer by indicating either the size or thickness of the rectangles. One preschool teacher answered, “They look to me to be the same, except that one rectangle is longer.” A PST teacher who marked “<” wrote “the rectangle on the right is thicker and coloured.” Again, although 4% of the PT gave the correct answer (“X”) their justifications were incorrect. For example: “They cannot be compared because the shapes are not the same.”


















Question	Possible Answers												
	<		>		=		X						
	PT	PST	PT	PST	PT	PST	PT	PST					
1				98	100	0	0	0	0	2	0		
2				5	0	16	6	74	94	4	0		
3				95.4	96	1.3	1	1.3	3	3	0		
17		+				1.3	0	2.7	4	92	90	4	6
7	$\frac{1}{2}$		$\frac{1}{4}$	14.1	0	*80.5	*97.2	0.7	0	4.7	2.8		
9	5		5	0	0	26.2	14.1	*70.5	*77.5	3.3	8.4		
10	6		4	17.4	2.8	*77.9	*91.6	0	0	4.7	5.6		
16	2×3		6	1.3	0	6	0	*86	*98.6	6.7	1.4		

Table 1: Quantitative (questions 1, 2, 3, and 17) and Numerical (questions 7, 9, 10, and 16) - Analysis of the responses of PST and PT (all values represent percentages, *correct answer)

Differences between correct answers: Question 7 $p^*=0.001$, distribution $p=0.006$;
Question 10 $p^*=0.01$, distribution $p=0.01$; Question 16 $p^*=0.003$, distribution $p=0.032$.

Justification for question 1		Graphic properties*	Numerical properties*	Both size and quantity*	No answer*	Number who gave correct justification	
PST N=71	N	1	56	0	14	0	
	%	1.4	78.8	0	19.8	0	
PT N=149	N	6	53	3	87	0	
	%	4	35.6	2	58.4	0	
Justification for question 2							
PST N=71	N	2	52	7	10	0	
	%	2.8	73.2	9.9	14.1	0	
PT N=149	N	18	41	4	86	0	
	%	12.1	27.5	2.7	57.7	0	
Justification for question 3							
PST N=71	N	1	57	1	12	0	
	%	1.4	80.3	1.4	16.9	0	
PT N=149	N	3	54	2	90	0	
	%	2.1	36.2	1.3	60.4	0	
Justification for question 17						Another answer X	
PST N=71	N	10	36	4	20	1	0
	%	14.1	50.7	5.6	28.2	1.4	0
PT N=149	N	4	44	1	99	1	0
	%	2.7	29.5	0.7	66.4	0.7	0

Table 2: Quantitative analysis (value and percent) of the justifications given by PST and PT to questions: 1; 2; 3; 17 * p<0.001

Question 17: Each side had two triangles, one being “upside down.” On the left, they were in a single row with a plus sign (“+”) between them. On the right, they were one on top of the other. Once again, the vast majority (94% of PST and 96% of PT) answered incorrectly and there was a significant difference ($p<0.001$) between the justifications they gave (Table 2). One preschool teacher who indicated “>” said: “There are two triangles and the addition operation, so that side is larger than the right side.” One who indicated “=” wrote, “We haven’t learned this yet.” Another gave an answer that seemed confused, “They are equal from two standpoints. One is that on each side one triangle goes up, and one goes down. So, they make the shape of an equilateral diamond.” A teacher who indicated “=” said, “The placement of the triangles is not important. What is important is their quantity.” One PST who answered “X” justified it with “There is no answer because I didn’t know which symbol to use. There are two triangles on each side, but they are not arranged the same.” Some PT answered “X” because they did not know which of the others to use.

Questions for example: 9; 10; 16 (Numerical) asked which mathematical symbol, if any, should be placed between numbers of different sizes and thickness.

	PST	N=71	PT	N=149
Justification for question 7: $\frac{1}{2} \square \frac{1}{4}$	%	N	%	N
Correctly answered	PST	68	PT	120
None given.	19.7	14	49.7	74
The sequence of numbers.	18.3	13	2.7	4
A quarter plus a quarter equals half.	11.3	8	2.0	3
Because half is greater than a quarter.	32.4	23	12.8	19
Based on number of items.	14.1	10	13.4	20
Incorrectly answered	PST	3	PT	29
None given.	0	0	14.1	21
The $\frac{1}{4}$ is larger according to the picture but $\frac{1}{2}$ is larger according to quantity.	4.2	3	0	0
Based on graphic property.	0	0	0.7	1
We never learned fractions.	0	0	4.7	7
Justification for question 9: $5 \square 5$	%	N	%	N
Correctly answered	PST	55	PT	105
None given.	16.9	12	36.2	54
The sequence of numbers.	45.1	32	16.1	24
Incorrect reason (based on graphic property).	2.8	2	13.4	20
Based on number of items.	12.7	9	4.7	7
Incorrectly answered	PST	16	PT	44
None given	2.8	2	16.8	25
Both have the same value but differ in size and thickness.	8.5	6	1.3	2
The left number is larger than that the right one.	11.3	8	11.4	17
Justification for question 10: $6 \square 4$	%	N	%	N
Correctly answered	PST	65	PT	116
None given.	19.7	14	47	70
The sequence of numbers.	63.4	45	24.8	37
Incorrect justification.	0	0	0.7	1
Based on number of items.	8.5	6	5.4	8
Incorrectly answered	PST	6	PT	33
None given	0	0	14.1	21
There is no answer because 4 is graphically larger but 6 is numerically larger.	5.6	4	0.7	1
The 4 is larger because of the size.	2.8	2	7.4	11
Justification for question 16: $2 \times 3 \square 6$	%	N	%	N
Correctly answered	PST	70	PT	128
None given.	22.5	16	55.7	83
The sequence of numbers.	53.5	38	28.9	43
Based on quantity.	22.5	16	1.3	2
Incorrectly answered	PST	1	PT	21
None given	0	0	8.1	12
We didn't learn this subject	1.4	1	2	3
Because of the size of the numeral.	0	0	4	6

Table 3: Numerical - analysis (value and percent) of the justifications given by PST and PT to questions: 7; 9; 10 and 16

Question 9: Table 1 shows that 77.5% of the PST and 70.5% of the teachers answered correctly, but as can be seen in Table 3, only 45.1% of the PST and 16.1% of the teachers who answered correctly

gave the correct explanation. Of those who gave an incorrect explanation, 2.8% of the PST and 13.4% of the teachers gave the reason to be the graphic form of the numbers, and 12.7% of PST and 4.7% of the teachers referred to the quantity of items (one numeral) on each side. One reason given by a teacher indicated her deliberation between the graphic or numerical quality of the numbers: “It depends on how one looks at the question: according to shape, one is larger than the other; according to numerical value, they are equal.” Of those who answered incorrectly, 8.5% of the PST and 1.3% of the teachers argued that no symbol could be put between the digits because there can be multiple answers based on how one looked at the question (“Both numbers have the same value but not the same size and thickness”). 11.3% of the PST and 11.4% of the PT argued the number on the left is larger. One PST wrote: “Looking at the numbers, they are equal in terms of quantity or value, but the type is bigger and it’s confusing.”

Question 10: Table 1 shows that 91.6% of the PT answered correctly compared with 77.9% of PT (Table 3). This question deals with getting to know the first ten numbers. From table 1 it could be seen that there is a significant difference in the scattering distribution between kindergarten PST to PT ($\chi^2_{(2)} = [9.271, p=0.01]$). It can also be seen that 91.6% of the PT answered correctly, compared to 77.9% of the kindergarten PT ($\chi^2_{(1)} = [6.19, p=0.01]$). In Table 3 we see that 63.4% of the PST and 24.8% of the PT correctly explained that it was due to the sequence of numbers. Some participants (8.5% of PST, 5.4% of PT) incorrectly based their answer on the number of items on each side and not their numerical value. Of the incorrect answers, 17.4% of the PT, but only 2.8% of the PST answered that “four” was larger than “six” based on the numbers’ graphic properties.

Question 16: Table 1 shows that 98.6% of the PST answered correctly compared with 86% of PT ($p<0.01$). Of the 21 (14.1%) of PT who answered incorrectly, 10 answered “X,” claiming that a number of answers were possible, and 9 (6%) claimed that 3×2 was greater than 6 due to the graphic properties of the numerals (Tables 1 and 3).

Additional findings. Interviews and discussions with the PST and PT revealed that most of them thought it was possible to use more than one mathematical symbol, between numbers, as an answer.

Discussion and conclusions

This study found that most of the participants failed to answer the questions correctly. The justifications given to the questions show a significant difference between the PST and PT with respect to how many justified their answers, yet it is clear that all participants did not appreciate the significance of the mathematical symbols and how to use them, specifically, that mathematical symbols should be used only for mathematical symbols. This was clear since even when the answer given was correct (“X”), the justification was generally incorrect (Hassidov & Ilany, 2017; Ilany & Hassidov, 2018). The results of this study show that PT feel that mathematical symbols may be used in different ways, depending on context: sometimes with respect to the quantity and sometimes to the shape or size of graphical images and they did not restrict them only to their mathematical significance. The conclusion is that the participants do not properly understand the significance of the symbols =, <, and > nor how to use them. This will, in all probability, mean that they will not teach the concepts properly to preschoolers. Indeed, studies have shown that PT believe the signs can be used in many ways. Using the same words in everyday life and in mathematics leads to misconceptions regarding the meaning of the mathematical signs. PT thus do not see any problem if

a child writes “ $5 > 5$,” and have stated that they teach the child to use the symbol “ $>$ ” between two objects, as “in this case the size is important; in another case the length may be important. It depends on the context.” PT may even believe it is correct to use two different signs at the same time; however, they must understand the cognitive conflict that this gives children and must understand that it is never possible to use two different signs between two numbers at the same time. PT must be made aware that the signs “ $<$, $>$, and $=$ ” must be used only in the mathematical sense. PT who incorrectly see quantity as a graphical concept and do not see the mathematical significance will, most likely, pass on this misconception to the children. This might lead the children to think that the size of the number or graphical object is what determines the relationship and which symbol to use.

References

- Bialystok, E. (1992). Symbolic representation of letters and numbers. *Cognitive Development*, 7, 301–316.
- Charalambous, C. Y., Panaoura, A., & Philippou, G. (2009). Using the history of mathematics to induce changes in pre-service teachers’ beliefs and attitudes: Insights from evaluating a teacher education program. *Educational Studies in Mathematics*, 71, 161–180.
- Clements, D. H., & Sarama, J. (2006). Young children’s mathematical mind. *Scholastic Parent & Child*, 30–37.
- Clements, D. H., & Sarama, J. (2015). Developing young children's mathematical thinking and understanding. In S. Robson, & S. Flannery (Eds.), *The Routledge international handbook of young children’s thinking and understanding* (pp. 331–344). New York: Routledge.
- Dauben, J. (1971). The trigonometric background to Georg Cantor's theory of sets. *Archive for History of Exact Sciences*, 7, 181–216.
- Hassidov, D., & Ilany, B. (2014). A unique program (“Senso-Math”) for teaching mathematics in preschool: Evaluating facilitator training. *Creative Education (CE)*, 5(11), 976–988.
- Hassidov, D., & Ilany, B. (2015). The “Senso-Math” Preschool Program: Successful cooperation between mathematics facilitators and preschool teachers. *Proceedings of the 39th Conference of the International Group for the Psychology of Mathematics* (Vol. 3, pp. 41–48). Hobart, Australia: PME.
- Hassidov, D., & Ilany B. (2017). Between Natural Language and Mathematical Symbols ($<$, $>$, $=$): The Comprehension of Pre-Service and Preschool Teachers-Perspective of Numbers. *Creative Education*, 8, 1903–1911. <https://doi.org/10.4236/ce.2017.812130>
- Ilany, B., & Margolin, B. (2010). Language and mathematics: Bridging between natural language and mathematical language in solving problems in mathematics. *Creative Education (CE)*, 1(3), 138–148.
- Nemirovsky, R., & Monk, S. (2000). “If you look at it the other way...” An exploration into the nature of symbolizing”. In P. Cobb, E. Yackel, & K. McClain (Eds.), *Symbolizing and Communicating in Mathematics Classrooms: Perspectives on Discourse, Tools, and Instructional Design* (pp. 233–257). Hillsdale, NJ: Lawrence Erlbaum.
- Thomas, G. V., Jolley, R. P., Robinson, E. J., & Champion, H. (1999). Realist errors in children’s responses to pictures and words as representations. *Journal of Experimental Child Psychology*, 74, 1–20.

Similarities and differences in problem solving: case of “exhibition grounds”

Radka Havlíčková, [David Janda](#), Derek Pilous and Veronika Tůmová

Charles University, Faculty of Education, Prague, Czech Republic; derek.pilous@seznam.cz

Keywords: Problem solving, Number paths.

Introduction

Problem solving strategies play one of the major roles in mathematics education research in the last decades (Schoenfeld, 1992). Its importance naturally arose from teaching practice in which teachers work with solving strategies intuitively, on the basis of their own experience, without any particular theoretical framework. One of the authors made an interesting observation in his teaching: there are problems with no simple algorithmic solution and more than one solution in which both mathematically less experienced solvers and more experienced solvers find the first solution in comparable time, but the more experienced solvers are more successful and faster when finding all the solutions of the problem. Therefore, measuring of reaction time when solving such problems might capture the difference between the above groups of respondents. If it is the case, this connection could be used as a further source of information about particular heuristic strategies with implications for teaching practice and teacher preparation.

Theoretical background

Since Polya (1957) introduced the modern conception of heuristics in mathematics education, a lot of research effort has been put into the exploration and description of possible connections between the level of mathematical knowledge and the ability to solve non-procedural problems. Problem solving process, and especially differences between more and less experienced solvers, have been examined by many authors. Lester (1994) summarized main findings in this domain when characterizing a good problem solver by five basic characteristics. We follow these findings when formulating our research questions:

1. What relationship is there between the time of finding the first solution and the time of finding all the solutions for different groups of solvers?
2. What relationship is there between parameters of the solutions such as the number of solutions, their order and multiplicity of submission, and the solver's knowledge?

Methodology

The learning environment called *exhibition grounds* is in accordance with our motivation as it provides problems to solve with several solving strategies and more than one solution. The task is to go through all the rooms of the exhibition center. A solver records his/her way by filling numbers into the squares (see Figure 1). Each room can be passed only once. Some rooms are filled by numbers from the start which means that these rooms must be visited in a prescribed order. The start and end rooms must be on the border of the grid and one can go only left, right, up or down from one room to another. It is forbidden to jump rooms, go diagonally, go through the same room twice or leave empty rooms behind. The solution is correct when each square is numbered with different numbers from 1

to $m \times n$ for an exhibition ground with m rows and n columns. The exhibition ground used in the study and all correct solutions are shown in Figure 1.

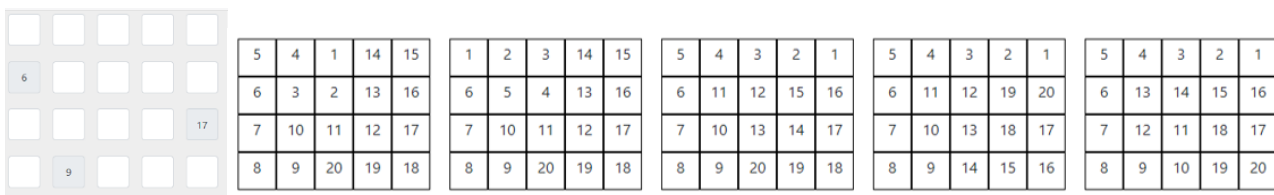


Figure 1: Exhibition ground used in the study with all the correct solutions

The research sample consists of two groups of respondents, 49 students of general high school of age 16–17 and 28 future mathematics teachers in 1st–3rd year of their study. The sample is an opportunity one as our study was exploratory. The exhibition ground from Figure 1 was used in the study. There was no time constraint and students received no information that their reaction time is measured due to our previous findings that this kind of information can significantly influence a solver's behavior (Pilous & Janda 2017). In total, 77 respondents submitted 305 correct solutions.

Results and conclusions

Each respondent found at least one solution, only 15 respondents in total found all five solutions, 12 from the high school and 3 from the university. Due to the small number of solvers who found all the solutions, direct comparison as described in RQ 1 (first solution vs. all solutions) is not significant here. However, several relationships between the time of finding the first solution and the time of finding all the solutions for both groups of solvers was found. The university respondents found the first solution as well as all solutions approximately twice as fast in average as the high school respondents, but they spent less time overall on the task and found less unique solutions in average. Both groups shared a dominant order of submitted solutions, especially for the first two. We also observed similarity between series of average solving times of both groups. The significance and interpretation of this observations will be subject of a forthcoming study.

References

- Lester, F. K. (1994). Musings about mathematical problem-solving research: 1970-1994. *Journal for research in mathematics education*, 25(6), 660–675.
- Pilous, D., & Janda, D. (2017). Reaction time of simple categorization of subclasses of functions. In *Proc. Aplimat 2017: 16th Conference on Applied Mathematics, Bratislava: STU* (pp. 1189–1196).
- Polya, G. (1957). *How to Solve it: A New Aspect of Mathematical Method. 2nd Ed.* Doubleday.
- Schoenfeld, A. H. (1992). Learning to think mathematically: Problem solving, metacognition, and sense-making in mathematics. In D. Grouws (Ed.), *Handbook for Research on Mathematics Teaching and Learning* (pp. 334–370). New York: MacMillan.

Formulating our formulations: the emergence of conviction as becoming mathematics teacher educators

Tracy Helliwell and Julian Brown

University of Bristol, UK; tracy.helliwell@bristol.ac.uk and julian.brown@bristol.ac.uk

This paper is an expression of how the authors are collectively becoming mathematics teacher educators, as they write and speak into one another's lives through the process of co/autoethnography. Extracts are presented from extended conversations between the authors, illustrating their process of formulating through reflecting on, and consciously appreciating, their unformulated actions as mathematics teacher educators. In their expression of the process of becoming, the authors begin to formulate the notion of conviction. From their enactivist perspective, they see their convictions emerging through the process of becoming mathematics teacher educators and their process of becoming mathematics teacher educators as the emergence of their convictions.

Keywords: Becoming, mathematics teacher educators, co/autoethnography, conviction.

The development of the mathematics teacher educator

There is a separation articulated in literature within the domain of mathematics teacher education, between what is termed as a 'mathematics teacher educator' and what is termed a 'didactician'. Even (2014) characterises didacticians as a subset of mathematics teacher educators, specifically, didacticians are mathematics teacher educators who "work in the field of teaching development with practicing [sic] teachers, including university faculty as well as practice-based mathematics educators" (p. 329). The particular feature here of the didactician is the focus on the development of *practising* teachers. Didacticians are not necessarily based at a university and include, for example, professional development providers and teacher-leaders. For us, we use mathematics teacher educator (MTE) in reference to ourselves. This is not to say that we do not work with practising teachers, but it is important to note that we are both based in a university where we work primarily with prospective teachers of mathematics on a one-year course, where prospective teachers work towards a Postgraduate Certificate in Education (PGCE), that includes qualified teacher status. We each have over ten years of experience teaching mathematics in secondary classrooms having both completed our PGCEs at the same university in which we now work, on the same course that we now teach. Tracy completed her PGCE in 2003 and has worked as an MTE for two and a half years. Julian completed his PGCE in 2006 and has worked as an MTE for one year.

As a community of teacher educators who value teaching practices that incorporate teachers researching their own teaching, there is a discernible argument that, as teacher educators, we too should participate in such inquiry into our own teaching and development. The development of mathematics teacher educators (MTEs) is a growing area of research within mathematics education. One useful distinction that has been made within this research domain is between what is termed "the *education* of mathematics teacher educators" and "the mathematics teacher educator *as learner*" (Krainer, Chapman, & Zaslavsky, 2014, p. 431). Research on the education of MTEs reports on studies of the preparation and professional development of MTEs through formal courses and programs designed specifically to prepare educators to educate teachers. Research on the MTE as

learner, however, places its emphasis on the “teacher educators’ autonomous efforts to learn, in particular, through reflection and research on their practice” (p. 432). MTEs are in a powerful position to research their own lived experience as insiders, rather than outsiders looking in, both as practitioners and researchers, researching their own practice. However, it is still being acknowledged (see e.g., Lin & Rowland, 2014) that only a few *full* studies exist where the prime focus is on the learning of the MTE (see e.g., Nicol, 1997; Tzur, 2001), rather than the learning of the MTE being reported on as a derivative of the research conducted by those MTEs.

One such full study on the learning of the MTE from Tzur (2001) is one in which he tells the story of his own development as a mathematics teacher educator through self-reflective analysis. This work from Tzur demonstrates how powerful self-reflection can be and how it can form the basis of rich data about what it might mean to learn as an MTE. Another significant piece of research is found in Nicol’s (1997) thesis; *Learning to teach prospective teachers to teach mathematics*, which is a study that investigates the problems, tensions, and dilemmas that she experienced as a beginner teacher educator learning to teach prospective elementary teachers. Her study reports her efforts in designing and investigating a pedagogy of mathematics teacher education, which makes attempts to place inquiry at the focus of teaching and learning.

What and how mathematics teacher educators learn

In 2008, a series of International handbooks of mathematics teacher education were published, in four volumes (with new editions currently underway). Volume 4: *The mathematics teacher educator as a developing professional* (Jaworski & Wood, (Eds.), 2008), described as focusing on the knowledge and roles of teacher educators working with teachers in teacher education processes and practices, is divided into three sections: Challenges to and theory in mathematics teacher education; Reflection on developing as a mathematics teacher educator; and Working with prospective and practising teachers; what we learn; what we come to know. A distinction being made here, which is also made by Lin and Rowland (2014) in their critical overview of research on teacher knowledge and professional development from a decade of PME (Psychology of Mathematics Education) conference proceedings, is between *what* and *how* mathematics teacher educators learn. For Lin and Rowland, studies on *what* MTEs learn are “classified as aiming to reveal or characterise mathematics educator’s learning outcomes”, whereas studies of *how* MTEs learn aim to “explore or comment on mathematics educators’ learning processes” (p. 509). According to Lin and Rowland, MTE learning had not been frequently reported on and studies that investigate how-oriented-questions were the least frequent of all (they identified three research reports over the decade of proceedings). This paper is one response to the gap in the *how* of MTE learning, but in reporting our research, we also accept the inevitability of the *what*; in reporting any research, including research into process, there is an immediate objectification.

Becoming mathematics teacher educators

In his 1962 essay, Rogers offers a vision of an individual who is in the process of becoming a fully functioning person. The individual that Rogers describes is becoming “all of one piece”, where the “distinctions between ‘role self’ and ‘real self’, between defensive façade and real feelings, between

conscious and unconscious, are all growing less” (p. 29). Here, we begin to comprehend the process of becoming as a unification of ourselves at the surface level with ourselves at the level of depth.

If we consider becoming from the perspective of learning, Hager and Hodkinson (2009) adopt a metaphor of learning *as* becoming in that “people become through learning and learn through becoming whether they wish to do so or not, and whether they are aware of the process or not” (p. 633). This view of learning as an inevitable process, rather than as a fixed state of having become (as with, for example, an acquisition model of learning (see Sfard, 1998)), signifies a change in the learner themselves as well as a change in the activity the learner is engaging with.

From an enactivist perspective, we see knowing as doing through being in and bringing forth a world in which we participate. The process of coming to know is thus a process of *becoming* through which both knower and known are transformed. Within enactivism, knowing is embodied, yet extends from the body of the individual in that the individual is not seen as distinct from the world but embedded in “a series of increasingly complex systems” (Sumara & Davis, 1997, p. 416) such as classrooms or universities. Unlike constructivism, where the focus is on cognitive knowing, enactivism considers alternative ways of knowing, including non-cognitive ways. In terms of epistemology, a useful categorisation of types of human action is made by Davis (1996, p. 193) that is, the “formulated” (cognitive) and the “unformulated” (non-cognitive) and with enactivism, the emphasis is on the unformulated. Davis goes on to propose that “formulations continually emerge from our unformulated actions” (pp. 193–194) and it is through this constant emergence that we develop our habits as MTEs, our “know-how” (Varela, 1999, p. 19). In contrast to know-how, we “know-what” through a process involving “reflection and conscious appreciation” (Varela, 1999, p. 19) and therefore becoming MTEs can be viewed as a process of continual emergence of our formulations (know-what) through jointly reflecting on, and consciously appreciating, our unformulated actions (know-how), and so it goes on.

Becoming mathematics teacher educators *through* co/autoethnography

Julian: I think when we spoke before, you made use of that [word] when you talked about what happened in a maths class, in your classroom.

Tracy: But I used that without really thinking about what it meant. I mean, I don’t think I’ve ever thought about what it meant quite like I am now.

Our conversations are not bounded by a working day and move beyond strict boundaries of a workplace agenda to touch on concerns of our wider lives. We seek to make explicit use of extended conversations with one another to support our becoming through continual emergence of our formulations. Having captured two such extended conversations, we draw on co/autoethnographic (Coia & Taylor, 2005) methods, moving us beyond our accounts of our unformulated actions, as we write and speak into one another’s lives. As enactivists, we reject the strict separation of self/other that appears in existing co/autoethnographic literature (e.g. Coia & Taylor, 2005) and instead look to the co-emergence of shared meaning through being connected (Begg, 2001) in becoming MTEs together. For us, the process of co/autoethnography does not *enable* our becoming, rather our combining in the process is itself the becoming. In what follows, we present three extracts from two of our extended conversations, illustrating our process of formulating through reflecting on and

consciously appreciating our unformulated actions as MTEs. We see these extracts as expressions of our becoming.

Extract 1: Modelling being in a classroom

- Tracy: I just didn't feel like I could do it. I didn't feel like I could just go and tell this 25-year-old man to stop rocking on his chair, whereas if he was a 16-year-old boy, I wouldn't have any issue doing it.
- Julian: So, you saw this as an issue with teaching adults?
- Tracy: I didn't know what else it could be, I mean, they're adults and they're children, that's the difference right, but it's not that, it just didn't make sense at the time.
- Julian: And now?
- Tracy: And now I'd quite happily tell someone not to rock on their chair in the PGCE group, and I think the difference is how I see myself, in that role, not as authoritarian or something, but that I'm modelling being in a classroom, and suddenly then it's okay. So, I'm doing it for a different reason. I'm not trying to teach him not to hurt himself. I mean he might do, he might well hurt himself, but, it's then not about me and my issue that they're adults. That's not the issue anymore. The issue is that I want that room to feel like I want their classrooms to feel; safe and respectful.
- Julian: Modelling being in a classroom feels like another one of those tenets.
- Tracy: Yes, it is! and suddenly, I've got this conviction and now I *can* go and tell people to stop rocking back on their chairs.

Extract 2: Your relationship is with the mentor

- Julian: I've felt really positive about the opportunities that have come up to work on mathematics with the school-based mentors when I've gone into schools for joint lesson observations.
- Tracy: During the lessons?
- Julian: Yes, but also afterwards. There have been one or two cases that I guess have stayed with me, of the three of us talking after the lesson and carrying on working on the mathematics, like moving from area of compound shapes to think about conversion between units of measurement in area, and then in volume. The sharing of different images to illustrate those felt really powerful between the three of us.
- Tracy: Say more...
- Julian: So, part of it was me exploring the wisdom of the course that in the debrief conversations we as university tutors are really working with the mentors. I suppose at this point, it has been partly me trying to inhabit the convictions that were spoken in the context of the course. But now I can see that it also really connects with something that emerged for me strongly when I moved from the PGCE course to

start in my first school, which was about working on mathematics together as teachers.

Tracy: So, you were carrying this on from your role as a teacher, with other teachers?

Julian: Well, yes. But really, that move to my first teaching job was a sense of loss, of no longer having those spaces to work together on the mathematics. And it's something I've tried to grow again ever since. So, working with the mentor feels like modelling as well as working on the mathematics, creating a space together to unpack what's going on. It has developed another layer of significance for me. I feel a conviction about the value of creating those spaces with the mentor, who might then expand the spaces throughout their work with our prospective teacher.

Extract 3: Working at the meta level

Tracy: We talked before about an algebra session where I used a visualisation. I hadn't spent long enough working through what I was going to say in setting up the visualisation, so it wasn't a surprise that there were a few different versions of what people were seeing.

Julian: What people were seeing as the image?

Tracy: Yes, their mental images. Having said that, if I had somehow set it up so perfectly that everybody saw the same thing, then we wouldn't have spent that period of time testing out one another's images, I had to work quite hard to make sure that happened and that was a good discipline for them to experience I think.

Julian: I think you said that you'd commented along those lines during the session, something about it being important to spend time making sure everybody was seeing the same thing.

Tracy: Yes, that's working at the meta level right? I think I might have said something similar doing this in a mathematics classroom though so that's not something new.

Julian: So, what is new, what is different now?

Tracy: Someone from the group asked a question while I was setting up the visualisation and I refused to answer it, I think maybe I gestured something to communicate that when it happened, and then much later on, I returned to it and addressed my not answering someone's question explicitly. Then I think I said something like, "something you need in the classroom, if you're going to do visualisation, is to establish the rules, and I don't think I established the rules clearly". I don't think I would have said that in my classroom at school. Again, that is about being meta, being explicit about my decision making.

Julian: For me there is also something there about when to step in and step out of the mathematics.

Tracy: Yes, a splitting of my attention in that moment, I knew it had to be dealt with, but not at that time, it got logged as something that had to be returned to. It's not that they must do visualisation, but that if they choose to, there are some rules, rules that I had conviction about as a teacher. I guess my conviction now, as a mathematics teacher educator, comes from these experiences in the classroom.

Our emerging formulations: formulating the formulating

The extracts above serve to express snapshots of our process of becoming MTEs, each one offering a sense of us formulating our unformulated actions as MTEs. This next section serves to express our emerging formulations from having brought these extracts together, formulations that have arisen for us through a process of reflecting on and consciously appreciating within and across these three snapshots. The title of this section is our attempt at emphasising the continual emergence of new formulations, through formulating (expressed in this section) the formulating (expressed in our extracts). One way of us consciously appreciating the formulating expressed within these three extracts is by looking for patterns both within each extract and across all three extracts.

Each extract is richly veined with marks of the formulations articulated about the university course with which we work. The tenets we hear in these extracts, "I'm modelling being in a classroom"; "as university tutors we are really working with the mentors"; "that's working at the meta level right?", were previously heard in conversations with Laurinda Brown, who was PGCE tutor to each of us, and Alf Coles, who has worked on the course with Laurinda and whom we joined as PGCE tutors. We have articulated to one another the "trying on" of these tenets at the level of unformulated actions. Through the process of becoming MTEs we have begun to make sense of these tenets in ways that we find meaningful. Acting on these tenets and developing a sense of owning them can also be seen as formulating our formulating.

There is a sameness which has become apparent to us as we search for patterns across the extracts, that reflects something of the structure of each one in relation to how we view the process of becoming as the continual co-emergence of our formulations from our unformulated actions. In extract 1, an unformulated action for Tracy was *not* moving to stop one of the PGCE students rocking on his chair. In extract 2, an unformulated action for Julian was his carrying on working on the mathematics. In extract 3, an unformulated action for Tracy was refusing to answer a question. From these unformulated actions, we try out different formulations on one another as they co-emerge. From the extracts we see these formulations are then followed by a sequence of further re-formulations, marked by, for example, "but it's not that"; "yes, but also"; "well, yes. But really"; "having said that".

An element of what guided our choice of extracts to present is the emerging theme of conviction. So strong has this theme become for us in our conversations, we are no longer able to separate what appears from these extracts to be changing or emerging convictions from how we are becoming MTEs. What follows is a further formulating, the focus this time on becoming MTEs *as* the emergence of convictions.

Becoming mathematics teacher educators *as* the emergence of convictions

In the extracts above, we draw repeatedly on language of conviction as we work on our formulations. In formulating conviction, we look first to Descartes (1991), who adopted conviction to describe a state of belief “when there remains some reason which might lead us to doubt” (p. 147), and knowledge as “conviction based on a reason so strong that it can never be shaken by any stronger reason” (p. 147). If conviction is to be characterised as belief, strongly held, then it carries with it some particular quality that sets it apart from other states of believing.

For us, however, the sense-making process that informs statements, which might be labelled as beliefs, is inherently a product of the emergent interactions of the (changing and changed) individual with the (changing and changed) world, for which we adopt the enactivist term “structural coupling” (Reid et al. 2000; Maturana, 2002, p. 15). We are interested in how our own sense of conviction emerges and becomes something that can be articulated as we are becoming MTEs. We see changes in conviction as a manifestation of changes in our structural coupling, strengthened (or weakened) through the process of formulating our unformulated actions. Gallagher and Zahavi (2008) identify conviction as fundamentally intertwined with changes in ourselves,

I remain the same as long as I adhere to my convictions; when they change, *I* change. Ideals and convictions are identity-defining; acting against one’s ideals or convictions can mean the disintegration (in the sense of a dis-integrity) of one’s wholeness as a person. (p. 206)

Thus, as our convictions change (or emerge) then we change, through a process of becoming. It is our convictions that define us as MTEs (our “identity”) and to act against our convictions, for example, if Tracy were to *not* model a classroom with the PGCE group or if Julian were to *not* model being a mentor, would “mean the disintegration (in the sense of dis-integrity)” of ourselves as MTEs.

We recognise in ourselves the sense of integrity that comes from being able to identify the alignment of our actions and our convictions. Within the Cartesian epistemology mentioned above, conviction might be seen as a deficient form of knowing, a position held when there is still doubt. The identity-defining property of conviction, however, makes conviction, for us, more than a label. From our enactivist perspective, we see the emergence of our convictions as coming to know. We view our convictions emerging through the process of becoming MTEs, and our process of becoming MTEs as the emergence of our convictions.

It was our intent to present in this paper the process of our becoming, the process of our formulating. We acknowledge that in the creation of this paper there exists a paradox. The value for us continues to be in the formulating (the *how*) but we accept that what gets presented here is inevitably a formulation (the *what*) at a point in time.

References

- Begg, A. (2001). Ethnomathematics: Why, and what else? *ZDM Mathematics Education*, 33(3), 71–74.
- Coia, L., & Taylor, M. (2005). From the inside out and the outside in. In C. Kosnik, C. Beck, A.R. Freese & A.P. Samaras (Eds.), *Making a difference in teacher education through self-study* (pp. 19–33). Dordrecht: Springer.

- Davis, B. (1996). *Teaching mathematics toward a sound alternative*. New York, NY: Garland.
- Sumara, D., & Davis, B. (1997). Enactivist theory and community learning: Toward a complexified understanding of action research. *Educational Action Research*, 5(3), 403–422.
- Descartes, R. (1991). *The philosophical writings of Descartes Volume III*, (trans.) J. Cottingham, R. Stoothoff, D. Murdoch, & A. Kenny. Cambridge: Cambridge University Press.
- Even, R. (2014). Challenges associated with the professional development of didacticians. *ZDM Mathematics Education*, 46(2), 329–333.
- Gallagher, S., & Zahavi, D. (2008). *The phenomenological mind: An introduction to philosophy of mind and cognitive science*. Oxford: Routledge.
- Hager, P., & Hodkinson, P. (2009). Moving beyond the metaphor of transfer of learning. *British Educational Research Journal*, 35(4), 619–638.
- Jaworski, B., & Wood, T. (Eds.), (2008). *The international handbook of mathematics teacher education Vol. 4: The mathematics teacher educator as a developing professional*. Rotterdam: Sense.
- Krainer, K., Chapman, O., & Zaslavsky, O. (2014). Mathematics teacher educator as learner. In S. Lerman (Ed.) *Encyclopedia of mathematics education* (pp. 431–434). Dordrecht: Springer.
- Lin, F., & Rowland, T. (2014). Pre-service and in-service mathematics teachers' knowledge and professional development. In A. Gutiérrez, G.C. Leder, & P. Boero (Eds.) *The second handbook of research on the psychology of mathematics education: The journey continues* (pp. 483–520). Rotterdam: Sense.
- Maturana, H. (2002). Autopoiesis, structural coupling and cognition: A history of these and other notions in the biology of cognition. *Cybernetics & Human Knowing*, 9(3–4), 5–34.
- Nicol, C. (1997). *Learning to teach prospective teachers to teach mathematics* (Doctoral dissertation, University of British Columbia, Canada). Retrieved from <https://open.library.ubc.ca/cIRcle/collections/ubctheses/831/items/1.0054692>
- Reid, D.A., Dowden, B., Jeans, S., and d'Entremont, J. (2000). *The psychology of students' reasoning in school mathematics*. Wolfville, NS, Canada: Acadia University.
- Rogers, C.R. (1962). Toward becoming a fully functioning person. In A.W. Combs. (chairman), *Perceiving, behaving, becoming: A new focus for education, Yearbook 1962* (pp. 21–33). Washington, DC: Association for supervision and curriculum development.
- Sfard, A. (1998). On two metaphors for learning and the dangers of choosing just one. *Educational Researcher*, 27(2), 4–13.
- Tzur, R. (2001). Becoming a mathematics teacher-educator: Conceptualising the terrain through self-reflective analysis. *Journal of Mathematics Teacher Education*, 4(4), 259–283.
- Varela, F. (1999). *Ethical know-how: Action, wisdom and cognition*. Stanford, CA: Stanford University Press.

Tasks Designed for Training Secondary Mathematics Teachers Using Technology

Alexánder Hernández, Josefa Perdomo-Díaz and Matías Camacho-Machín

Universidad de La Laguna, España;
alexander.hernandez@ull.edu.es; jperdomd@ull.edu.es; mcamacho@ull.edu.es

The central purpose of this research is to design a series of prompts that arise based on classroom events that emerge when using technology to solve problems. We analyze several teaching situations that occur when solving problems using GeoGebra and study a case involving two mathematics majors who are taking a course called “Mathematics for Teaching”. These prompts offer a resource for training future secondary school mathematics teachers, through the development of their Mathematical Understanding for Secondary Teaching [MUST] (Heid, Wilson, & Blume, 2015).

Keywords: Problem solving, Teacher education, Technology, GeoGebra.

Introduction

When training mathematics teachers, it is agreed that the knowledge of the discipline that teachers require is substantially different from that needed by other professionals who also use mathematics (Ball, Thames, & Phelps, 2008). This knowledge includes knowing *what* and *how*, which Kilpatrick, et al. (2015) incorporate to expand the construct *Mathematical Knowledge for Teaching* into *Mathematical Understanding for Teaching* (p. 13). This mathematical knowledge and its use in the classroom are described in detail within the MUST framework (Heid, Wilson, & Blume, 2015) and will be used in this research. One of our reasons for using this framework is that it relies on analyzing the experiences of secondary school mathematics teachers. These experiences generate prompts based on a series of events that arise during the teaching and learning process, and that are used to build resources for training teachers.

The experiences that arise in teaching and learning contexts where technology is involved exhibit specific characteristics that have to be identified and analyzed. What specific events appear when using technology? Are there differences from those that arise when using paper and pencil? Can prompts be developed based on these technological events?

The goal of our research is to identify those events that take place during a problem-solving scenario that relies on technology, and to generate prompts based on these events. We believe that these prompts would be much more difficult to generate in a problem-solving context that relies solely on the use of pencil and paper. To this end, we analyze the case of two students solving a problem using Dynamic Geometry Systems (DGS).

Conceptual framework

When selecting a framework for our research, it is important to consider the nature of teachers' knowledge. In this regard, Heid, Wilson, & Blume (2015) note that

Any such Framework needs to capture the dynamic nature of teachers' use of mathematics in their teaching rather than simply to list knowledge, skills, and proficiencies for teaching mathematics. (p. 41)

This is why we opted to select the MUST reference framework to define the prompts that arise when using technology while solving problems. As defined by Kilpatrick, et al. (2015), a prompt is:

an episode that has occurred in the context of teaching mathematics (usually in a mathematics classroom) and raises issues that illuminate the mathematics understanding that would be beneficial for secondary teachers. (p. 3)

The mathematics understanding referred to in the above paragraph may be viewed from three perspectives, *Mathematical Proficiency*, *Mathematical Activity* and *Mathematical Context of Teaching*, each with different strands (see chapter 2 from Heid, et al., 2015, for more details). *Mathematical Proficiency* refers to the mathematical knowledge and skills that a teacher needs in order to teach the subject in secondary education, which includes not only the mathematics associated with this educational level, but also that in previous and subsequent levels. When we speak of *Mathematical Activity*, we refer to the set of specific mathematical actions that a teacher has to do as part of the profession, such as linking concepts, justifying arguments and generalizing mathematical facts. Lastly, *Mathematical Context of Teaching* includes aspects of mathematical understanding that come into play exclusively in the teaching profession, such as, for example, understanding how students think mathematically, recognizing the mathematical nature of their questions and mistakes or recognizing when a mathematical argument or solution provided by a student is incomplete or satisfies the conditions of a problem.

To define these prompts, we first identify events that occur in various problem-solving episodes. Santos-Trigo and Camacho-Machín (2013), taking into account Polya's work, analyze different paths taken by a solver when faced with the task of solving a problem using technology. Based on this analysis, they identify five episodes: *Comprehension Episode*, *Problem Exploration Episode*, *The Searching for Multiple Approaches Episode*, *Extension Episode* and *The Integration Episode* (for more details, see Santos-Trigo & Camacho-Machín, 2013).

In this paper, the analysis will focus on the first three episodes: *Comprehension Episode*, *Problem Exploration Episode* and *The Searching for Multiple Approaches Episode*. These episodes are detailed later in this paper.

In the context of DGS, the *Searching for Multiple Approaches Episode* is particularly relevant, as this episode requires, not following the same steps, but rather attempting to use different concepts in each path in order to enhance the problem-solving process and the learning of mathematics.

Methodology

Participants

Data were collected from a Problem-Solving Workshop implemented during nine two-hour sessions of the course *Mathematics for Teaching*, where students solve the tasks in pairs, using GeoGebra. The workshop was taught in the computer laboratory to seventh-semester mathematics majors who, in a short time (two years), will be qualified to be secondary school teachers. There were eighteen

students enrolled in this course which main goal was to introduce university mathematics students to the knowledge for teaching secondary school mathematics.

Task

In the workshop, the students solved a total of four problems that had previously been analyzed by the research team. In this paper, we analyze only one of the problems we call *Equal chords*.

Equal chords: There are two circles with centers at A and C. Two lines are drawn from each center that are tangent to the other circle. The points where these tangents intersect with the circles define two chords, IJ and KL (see Figure 1). Prove that the lengths of these two chords are the same, $IJ=KL$.

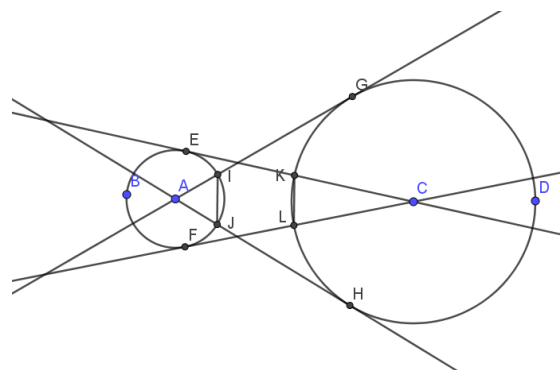


Figure 1: The equal chords task

The main characteristic of this task is that the statement includes a figure that the students must construct in order to solve the problem. The construction of the figure gives the problem a series of affordances that are important to mathematical understanding for secondary teaching. Santos-Trigo (2019) notes that

With the use of GeoGebra, these questions become relevant not only to identify and explore needed to draw the figure, but also provide an opportunity for learners to connect the problem goal with a series of mathematical ideas and resources to solve and extend the initial statement. (p. 73)

Data

Three types of data were gathered for the analysis: the GeoGebra files, the handwritten notes and the recordings of the student pair work sessions, which were made using the OBS Studio software.

In this research report we use a case study methodology to present an analysis of the work done by a pair of students, Evan and Sophie, while solving the problem *Equal chords*. Both the students and the activity were chosen due to the quality and variety of their discussions.

Data Analysis and Results

Comprehension Episode

The students began by reproducing the figure shown in the problem statement. Both agreed in the way in which the circumferences, the intersection points and the chords were drawn, but they disagreed when representing the tangent lines, which entailed a combination of mathematical and technical aspects involving the use of the DGS.

The GeoGebra graph shown the two circles

Sophie: What are you doing?

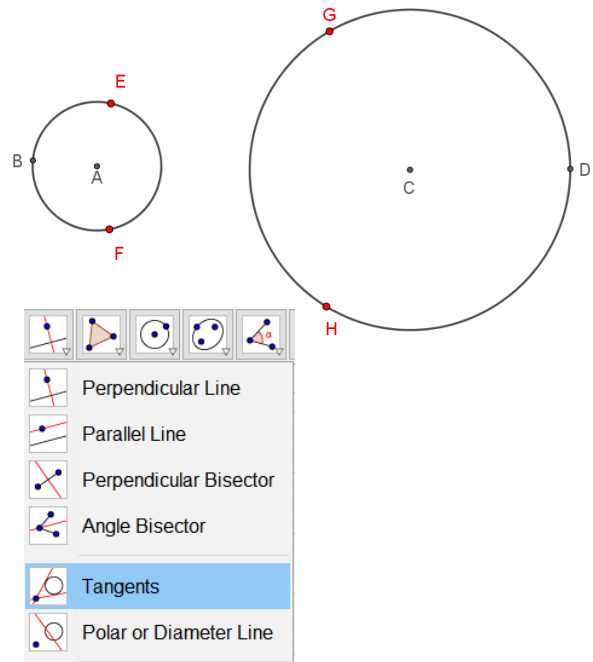
Evan: Are the points...? [referring to the tangent points]

Sophie: Yes?

Evan: Yes, E,F,G,H [draws them on the circle] and now from here.

Sophie: Wouldn't that be later? With the construction of the intersection point between the tangent and the ...

Evan: No, leave from there. We have to calculate now. Click on that [indicating to Sophie the perpendicular line tool to expand the menu], tangents and points



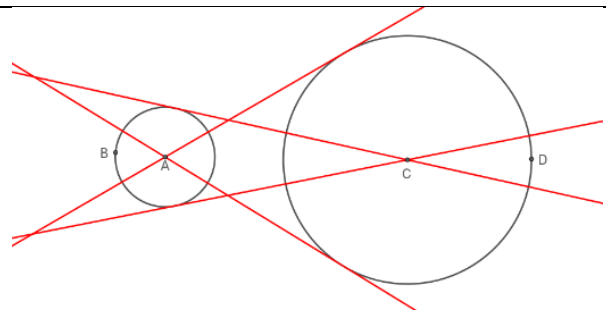
With the “Tangents” tool selected, they click on one of the centers and the points drawn on the circumference. Nothing happens.

Sophie: Yes, right

They repeat the process several times. At one point, they click on the circumference and the tangents appear.

Evan: What did you do?

Sophie: I clicked on the circumference, not on the points [referring to the points they had drawn earlier]



It is important to realize that the concept of a straight tangent to a circle from an outside point involves three objects: the outside point, the circle and the straight tangent. These objects are related with one another and with other objects, like the tangent point and the radius (which is perpendicular to the tangent). The “Tangent” tool is a programmed function whose inputs are a point and a conic section or curve. This means that when the students try to represent the straight tangent by selecting two points, GeoGebra helps them realize that the tangent point cannot be placed by “eyeballing” it, as one would do with pencil and paper; rather, a relationship must be established between the outside point

and the circle. Moreover, this way of building tangent lines is robust, as it allows preserving the tangency when any of the objects is dragged. This first event yields the following:

Prompt 1
Two students want to represent the tangent lines to a circle from an outside point. To do so, they represent a point that is on the circumference and then use the “Tangents” tool by selecting that point and the outside point. The software does not generate the tangent line. In fact, the software does not show anything. Why is this? What important properties relate the radii of the circumference and the straight lines tangent to it?

Table 1: Prompt that arose during the Comprehension Episode

Problem exploration episode

The students finished building the figure and verified that the chords indeed have the same length. Then, by dragging the centers of the circles or the points that define their radii, they verified that the property holds in a variety of individual cases. They considered how to demonstrate their equality. During this episode, the students did several online searches and measured angles, segments and the arcs of the circumferences. (Figure 2)

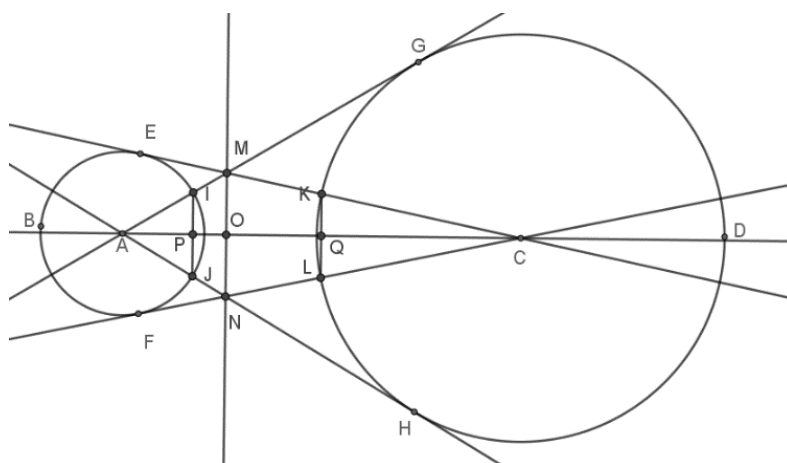


Figure 2: Construction with auxiliary objects

They drew other lines, like AC, which passes through both centers, and another connecting the points where the tangents intersect, M and N, looking for relationships that would let them show the equality of the chords. They considered different possibilities: (i) The lengths of the minor arcs IJ and KL are the same; (ii) the line perpendicular to chord KL that passes through C also passes through A; (iii) the trigonometric ratios of angles MOA and MOC are related by the common side MO of the right angles MOA and MOC; (iv) triangles API and MOA are similar and equal to KQC and MOC. This episode yielded conversations like the following:

Evan: *Now we have to see what the relationship is between the two circles and the tangent lines.*

Sophie: *The length of the arc is not the same, is it?*

Evan: *Well...*

Sophie: No, because the line is the same but this one has more of an arc and this one less [pointing first to chord IK and then KL], so that has nothing to do with it, you see?

Evan: But their lengths are the same [moves his hand in an effort to explain]. Do you have a string?

The discussion was mathematical in nature. Can two arcs be traced on the same segment that have the same length? The students' intuitions differed, with Sophie thinking that different arcs have different lengths, and Evan thinking the opposite, stating that if the two ends of a piece of string are fixed, they can be arranged to create different curves. They tried to settle their differences by calculating the lengths of the arcs using GeoGebra. This yields the second prompt.

Prompt 2
Using GeoGebra, a student traces out different arcs of a circle atop the same segment and measures their length, concluding that they are all the same. How might this relationship be justified?

Table 2: Prompt that arose during the Problem Exploration Episode

Searching for Multiple Approaches Episode

At the end of the first session, a group discussion was held in which the various properties observed by all the pairings were presented, some of which had not been previously identified by Evan and Sophie, such as, for example: (i) line AC bisects angles GAH and ECF formed by the tangent lines (Figure 2); (ii) the radii of the circles at the tangent points are perpendicular to the tangent lines. The students considered proving that the chords are equal by approaching the problem in three different ways: (i) by writing the general equations for the tangent lines and attempting to find the equations for the circles to solve the systems; (ii) by using the fact that line AC bisects the angles that form the straight lines and studying the trigonometric ratios of the right angles API, MOA, KQC and MOC; (iii) by finding similarity relationships between triangles API and AGC, along with triangles KQC and EAC. Being unsuccessful with the first two approaches, they focused on the third.

Sophie: Why did you draw that? [referring to triangle AGC]

Evan: Because this new triangle is similar to these two [referring to triangles API and MOA]

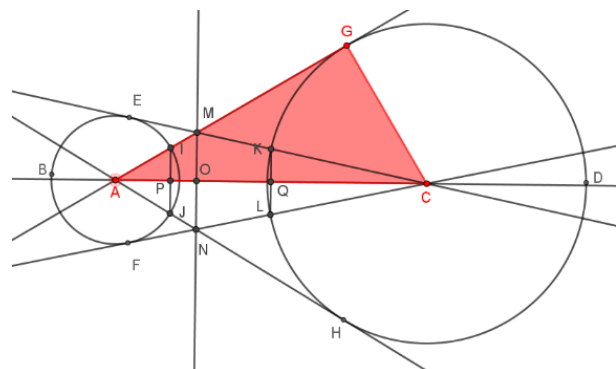
Sophie: The big one?

Evan: Yes

Sophie: ...but, why is it similar?

Evan: Because the angles are the same

Sophie: I know that, but are you sure that this one here... If the big one were similar, shouldn't



*this be a right angle?
[referring to angle ACG]*

*Evan: No, similar doesn't mean they
are superimposed, it means
they are equal to one another*

This event, arising from two similar triangles not in the Thales position, yields the following:

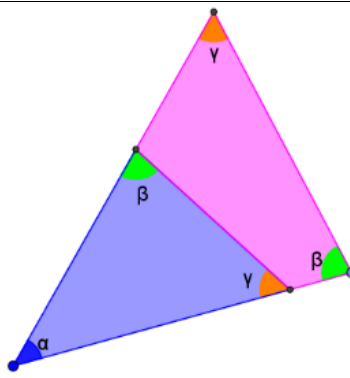
<p>Prompt 3</p>	
-----------------	--

Table 3: Prompt that arose during the Searching for Multiple Approaches Episode

Conclusions

By using technology, students can devote time to look for mathematical properties, discuss them and explore different approaches to verify them. We have seen how these types of discussions give rise to interesting events for developing prompts that would not easily arise in a context with no technology. The questions that students ask themselves by making use of technology would not arise if using paper and pencil. For example, Evan and Sophie, when representing the tangent lines from an outside point, consider the objects that define them and how they can be drawn so as to preserve their property of being tangent to the circle.

In this research report we identify three events that resulted in three prompts of a different nature, depending on how the episodes in which technology is used to solve problems are framed: *Comprehension Episode*, *Problem Exploration Episode*, *The Searching for Multiple Approaches Episode* (Santos-Trigo & Camacho-Machín, 2013). We also saw that when technology is used to solve problems, situations arise that cast doubt and arouse interest in the participants, the prospective mathematics teachers. We have also shown that by analyzing these moments, the opportunity is created to propose activities to train mathematics teachers. The mathematical endeavor that is revealed when the time comes to solve mathematics problems that are properly selected, when technology is present, has been shown to be an important element for improving the mathematical understanding of properties and results that have often been forgotten. We believe that this type of activity must be part of the initial training of mathematics teachers.

These prompts serve as resources for promoting the development of Mathematical Understanding for Secondary Teaching, offering opportunities to reflect on the mathematics related to them. What are the underlying mathematical concepts? What mathematical structures are involved?

Heid et al. (2015) argue that in the context of training future teachers, developing situations provides an opportunity to think about the content of secondary education curricula, to develop activities that are based on events related to the use of GeoGebra, activities that generate opportunities to think concurrently about the contents of the curriculum and the mathematical ideas that can be explored with DGS, and to connect them both.

Acknowledgement

This research has been supported by the project of the National Plan of the Spanish Ministry of Education and Science with reference EDU2017-84276-R.

References

- Ball, D. L., Thames, M. H., & Phelps, G. (2008). Content Knowledge for Teaching. What Make It Special? *Journal of Teacher Education*, 59(5), 389–407.
- Heid, M., Wilson, P. S., & Blume, G. W. (Eds.). (2015). *Mathematical Understanding for Secondary Teaching: A Framework and Classroom-Based Situations*. United States of America: NCTM and IAP.
- Kilpatrick, J., Blume, G., Heid, M. K., Wilson, J., Wilson, P., & Zbiek, R. M. (2015). Mathematical Understanding for Secondary Teaching: A Framework. In M. K. Heid, P. Wilson, & G. W. Blume (Eds.), *Mathematical Understanding for Secondary Teaching: A Framework and Classroom-Based Situations* (pp. 9–30). Charlotte: Information Age Publishing Inc. and NCTM.
- Santos-Trigo, M. (2019). Mathematical problem solving and the use of digital technologies. In P. Liljedahl, & M. Santos-Trigo (Eds.), *Problem solving in mathematics education. Current themes, Trends and Research* (pp. 63–89). Berlin: Springer.
- Santos-Trigo, M., & Camacho-Machín, M. (2013). Framing the use of computational technology in problem solving approaches. *The Mathematical Enthusiast*, 10(1&2), 279–302.

Opportunities for Adopting a Discourse of Explorations in a Professional Development Setting

Einat Heyd-Metzuyanim¹ and Talli Nachlieli²

¹Technion – Israel Institute of Technology, Haifa, Israel; einat.metz@gmail.com

²Levinsky College of Education, Israel; tallin@levinsky.ac.il

We examine the productiveness of discussions in a professional development (PD) towards explorative mathematics instruction (EMI). The artifacts used in the PD session under examination were a video-clip of a classroom discussion, together with the Quadrants coding scheme, a scheme originally developed for research purposes. We define productive discussions by relying on the linguistic tool of lexical chains that point to lexical cohesion. The analysis shows that the use of the coding scheme as an artifact, together with a video clip, offered increased opportunities for surfacing misalignments between the teachers' framing of learning and instruction and the PD leader's framing of it. These misaligned frames, which draw on the Acquisition Pedagogical Discourse, vs. Explorations Pedagogical Discourse, are usually difficult to surface.

Keywords: explorative mathematics instruction, productive pedagogical discussions, professional development, lexical cohesion

Introduction and theoretical background

For the past three decades, calls for more reform, student-centered, instruction, are voiced in mathematics education (Gregg, 1995). We adopt the Commognitive framework, and define such instruction as explorative mathematics instruction (EMI), teaching that provides students opportunities for explorative participation (Heyd-Metzuyanim, Tabach, & Nachlieli, 2016). Efforts to help teachers adopt explorative teaching practices are widespread, mainly through professional development (PD) (Sztajn, Borko, & Smith, 2017), yet the processes of learning these practices have not yet been sufficiently explicated and theorized.

Whereas teachers who teach in a teacher-centered approach rely on an *Acquisition Discourse*, those who promote student-centered instruction rely on an *Explorations Discourse*. Our use of Discourse (with a capital D) here comes to signify the historical, social and institutionalized nature of these pedagogical Discourses, which are not just a matter of how teachers and teacher-educators talk, they exist in documents, regulations and curricula. One of the best examples of the Explorations Discourse can be found in "reform" documents such as the NCTM (2000). The Acquisition Discourse does not have such institutional documents as exemplary instantiations, yet it is the common Discourse that is often seen in classrooms worldwide (Nachlieli & Tabach, 2018). In documents, it can often be found as the anti-thesis of actions valued by the Explorations Discourse (for example, by stating that teachers should *not* be using their time in the classroom for 'drill and practice' or that students' ideas are those that need to be heard, *not* teachers') (Heyd-Metzuyanim & Shabtay, 2019). Pedagogical discourse (with a small d) – that discourse which includes teachers' talk (inter or intra-personal) about *how, what and whom* to teach, draws upon the pedagogical Discourses, often in a multi-voiced combination of Explorations and Acquisition Discourses. There is never a teacher (or teacher

educator) that talks "purely" in one of these Discourses, but PD leaders or teacher educators that try to move teachers towards more explorative instruction often draw more on the Explorations Discourse, whereas teachers who are initial participants in such PDs often draw more on the Acquisition Discourse.

Acquisition Discourse rests on the assumptions that learning mathematics entails acquiring a certain set of facts and skills, where the role of the teacher is to "dispense" this knowledge, and the role of the student is to "acquire" it. Accordingly, teachers relying on an Acquisition Discourse value the demonstration (by the teacher) and the execution (by the student) of precise procedures. Different realizations of mathematical objects (Sfard, 2008), as well as different procedures for solving similar problems are less valued since they are not necessarily efficient and since they can be a source of "confusion" for the students. In contrast, Exploration Discourse frames learning as a form of participation in a community, where mathematical objects are explored and narratives about them are authored by students, facilitated by the more experienced participant, namely the teacher. Teachers relying on the Explorations Discourse value the presentation of different realizations of mathematical objects, and the authoring of narratives by students, even if those are not yet articulated precisely according to the rules of the mathematical community (Heyd-Metzuyanim & Shabtay, 2019).

Previous studies have shown that shifting from Acquisition towards Explorations pedagogical Discourse is a difficult and complex process (Heyd-Metzuyanim, Smith, Bill, & Resnick, 2018b). It has also been shown that this process involves *misaligned frames* (Heyd-Metzuyanim, Munter, & Greeno, 2018a). Frames are those parts of the pedagogical discourse that relate to interpretations. They are usually tacit, and take form in what people notice, accentuate and foreground. In relations to these frames of classroom instruction, Heyd-Metzuyanim et al. (2018a) differentiated between the *subjectifying* aspects of frames, namely, those interpretations relating to *who* speaks in the classroom, and the *mathematizing* aspects of frames: what mathematical objects and routines are talked about. In their study of a US teacher participating in a PD intended to promote EMI, Heyd-Metzuyanim et al. (2018a) noticed that the teacher was well aligned with her PD coach in relation to the subjectifying aspects of framing the envisioned lesson that they were planning together: they both valued students' discussion, group work and agency. Yet with relation to the mathematizing aspects of the frame, they differed. While the PD coach aimed to expose students to different realizations of the mathematical object at the focus of the lesson, the teacher was focused only on the execution of specific procedures. This misalignment went unnoticed during the coaching session, yet led to the failure of the lesson planned together by the two parties. This case highlighted the need to study what factors can contribute to more productive discussions in a PD setting, which can surface misalignments and provide opportunities for teachers to engage with more implicit aspects of the Exploration pedagogical discourse.

Productive discussions in PD settings have been the focus of increasing numbers of studies (e.g. Borko, Jacobs, Eiteljorg, & Pittman, 2008). Many have pointed to the usefulness of video to increase the productiveness of teachers' conversations as well as the utility of observation-assisting artifacts such as protocols and scoring rubrics to fix teachers' attention on important aspects of instruction (Borko et al., 2008; Schoenfeld, 2017). Yet studies examining the usefulness of video and observational artifacts rarely explicate what "productive discussions" actually means. In our specific

context of promoting EMI, our assumption is that teachers in the PD setting start out by mostly drawing on Acquisition Discourse whereas the PD leader draws mostly on the Explorations Discourse. This may lead to tacit differing interpretations (frames) that go unnoticed since the participants (teacher and leader) assume they are talking about the same thing while in fact they are framing teaching-learning interactions differently, in accordance with the differing Discourses on which these frames draw. Thus, a productive discussion, in the context of these sessions, would be *a discussion that surfaces misalignment between Acquisition frames of teachers vs. Exploration frames of the PD leader.*

We turn to the notions of *lexical cohesion* (Halliday & Hasan, 1976) and *lexical chains* (Morris and Hirst, 1991) to conceptualize productiveness of discussion for our purpose. Cohesion is a semantic term that refers to the meanings that exist within the text (Halliday & Hasan, 1976). Cohesion occurs where the interpretation of some element in the text is dependent on that of another. As argued by Morris and Hirst (1991), lexical chains help determine coherence and discourse structure, and hence the larger meaning of the text. We adopt the idea here to study the cohesion of the text that was produced by the teachers and instructors during the discussions in the PD and thus to learn about the productivity of the pedagogical discourse by visually showing the topics discussed and followed and the specific words chosen by different participants. Our research goal is thus to characterize productive discourse processes that promote pedagogical discourse of explorations by examining discourse cohesion and its relation to the surfacing of misaligned frames.

Method

The study took place in the context of the TEAMS PD program (Teaching Exploratively for All Mathematics Students), a program that included 16 4-hours sessions over two years (2016-2017). The PD introduces teachers to the 5 Practices for Orchestrating Mathematics Discussions (Smith & Stein, 2011) as well as to Accountable Talk™ tools (Heyd-Metzuyanim et al., 2018b). Teachers participating in this program were relatively experienced (ranging from 15-31 years of teaching). 14 of the teachers taught in middle-school and 2 taught in elementary school. 9 teachers continued from the 1st to the 2nd year. At the end of the first year, we analyzed the first year data using the Quadrants coding scheme (QCS) (Stein et al., 2017). The analyzed data included 3-4 video-recorded lessons of each of the participating teachers. Our analysis revealed that teachers were adopting explorative instructional practices to varying extents. In particular, our findings showed that teachers had trouble to maintain Explicit Attention to Concepts (EAC) whenever they raised Students Opportunities to Struggle (SOS). Through the process of analyzing teachers' videos according to the QCS, we came to the realization that such a process may be beneficial for the teachers as well. Therefore, we chose to open the second year of the PD with introducing the QCS and the findings of our analysis.

For the current study, we watched and partially transcribed all 16 PD sessions. Partial transcriptions were intended to capture the activities of the session, as well as important conversations and themes. Based on these partial transcriptions, we focused on the first session of the 2nd year since it was a pivotal session in several aspects. First, it was where we made our first use of the QCS (Stein et al., 2017) together with video, in attempt to assist teachers to better grasp our vision of EMI. We thus chose to present two rubrics (EAC and SOS) to the teachers, together with a de-identified video of

one lesson which we thought was particularly rich in opportunities for EMI. The rubrics each include 4 or 5 levels with 1 being lowest. Presentation of the full rubrics is beyond the scope of this report but the relevant parts for the reported discussion will be detailed in the findings section. Viewing this session at the end of the year, after all sessions were observed and partially transcribed, revealed that this indeed was a session where intense pedagogical reasoning occurred, yet only in specific episodes. To better understand these occurrences and the discursive processes underlying them, we fully transcribed the session, after which we chose two clips from the discussion. These clips were similar in that they both referred to the QCS (in particular, to the EAC rubric) as well as included some “example” of instruction to talk about, yet different in that one of them was before the video was shown and the other after it. This offered us an opportunity to examine more closely the role of the video, together with the QCS, in the rising level of productiveness of the talk.

Findings

The session that we chose to focus on began with Talli (2nd author and leader of the PD) presenting to the teachers the results of the 1st year video analysis, in order to launch the main focus of the 2nd year PD plan: to work with teachers on how to preserve conceptual depth while letting students author mathematical narratives and struggle with problems on their own. Talli then presented the teachers two rubrics from the QCS: the EAC and SOS rubrics. Teachers were asked to read the rubrics in groups, discuss them, and were then called for a whole-group discussion. She opened by stating that there are no simple criteria for determining if the EAC level is 4, 3, 2 or 1 and that there could be “significant arguments” around them, but that those arguments are important because “they help us notice nuances”.

The discussion started in rather unproductive ways. One teacher, Rony, was asked, based on her former experience with coding videos according to the Quadrants scheme, to give an example of a “level 4” of EAC. She tried doing so, yet other teachers related more to the specificities of her example and her choice of concept words, than to levels of the EAC rubric. The lexical chain analysis performed on this episode revealed that the EAC lexical chain died off right after Rony's description of her envisioned lesson and was not picked up by other teachers. Talli cut off this discussion quite promptly, as she was sensing the teachers were not relating to the subject that she considered to be the goal of the discussion. Einat (1st author) tried giving examples of lessons that were coded as '4' vs. lessons that were coded as '3', yet these were not very productive in eliciting lexical chains focused on elements from the EAC rubric either.

Following that, Talli announced that they will be seeing a 16-minute video-clip of an 8th grade classroom discussion around a ratio problem. She first gave out the task so that teachers got an opportunity to solve and discuss it shortly before viewing the video. The task read as follows:

Dafna prepared a necklace of blue and red beads. Two fifths of Dafna's necklace were blue and the rest were red. Draw four different possible necklaces.

Following the viewing of the clip, Talli opened the discussion:

2.1 Talli Let's start with the attention to concepts

- 2.2 Valerie I did not see here much attention to concepts, by the way... attention to concepts... there wasn't much. I hardly wrote any concepts here (on her "scoring" worksheet).
- 2.3 Talli Which concepts?
- 2.4 Lena But attention to concepts needs to be at the beginning of the lesson? Already? They just started...
- 2.5 Veronica But we didn't watch the end of the lesson, when **the teacher** summarizes all the things that appear on the board. ...She called to the board all sorts of student groups so that they show what they-... And **she** wanted actually, on the board, to show all sorts of ways, all sorts of different answers, so that other kids from the different groups see what others were thinking. I think that what we are not seeing is the end (made by) **the teacher**, that should be at the end of the lesson, after all the answers are shown on the board.

We see the discourse in this excerpt as productive, since all speakers repeatedly relate to the same lexical chain, that of EAC (underlined). We also see all teachers relating repeatedly to the video-clip (in wavy underline), referring to actions observed in it. This shows us the productiveness of the video as a tool for supporting the cohesion of the talk, as well as for focusing the teachers on EAC. The lexical chain of EAC remained active for 17 turns. Within it, some teachers objected to Valerie's assertion that there was not much attention to concepts. For example:

- 3.1 Yafit I think that actually there is attention to concepts because, as someone says the answer, she repeats things, and then she asks them "do you agree? Disagree?" It's a type of, it's also a type of explication of a concept. Or clarification. Attention to concept does not have to be writing the concept on the board. Also, along the way they said, someone there said the word ratio, (quoting the **teacher**) "oh, you talked about ratio, what did you mean?" And then he, like, so I think it's also a type of attention to concepts.

As the discussion continued, some ideas for concepts that would have justified a higher scoring of the EAC rubric started being voiced by the teachers. These included "ratio", "expansion", "part whole relationship" and "correspondence". Talli revoiced and summarized these ideas, and then she tried eliciting other ideas. She asked

- 3.2 Talli What else do you have to say about the... what we saw here? What other concepts she-, what did the teacher do with these concepts?

Talli's intention here was to stir the conversation to several mathematical ideas that she thought were prominent in the clip, yet none of the teachers seemed to notice them. In particular, she was frustrated by the teachers' lack of appreciation of the students' ideas, and most importantly one idea which related to the routine of dividing the blue beads to two, finding out the basic unit, then multiplying it by 3. The teachers only noticed the routine (employed by the first two students in the clip) of expansion: multiplying both sides of the ratio by a constant number. Despite her questions, the teachers only repeated the concept names (expansion, part-whole) raised before. As Talli was ready to give up and stir the conversation to the issue of scoring the clip, Valerie said:

- 3.3 Valerie The fifth, also
- 3.4 Talli The fifth, what?
- 3.5 Valerie I don't know, the fifth disturbs me here
- 3.6 Talli In what way does it disturb you?
- 3.7 Valerie Because a fifth of what? Of the blues? The reds? Which fifth (is it) here?

- 3.8 Naomi The fifth of the group (Yafit: The fifth as a part, a part)
- 3.9 Valerie But it's a split group. The group is split. Which fifths are (they) talking (about)? The 1 out of 5 blues? Of the reds?

Now, a lively discussion revolved with multiple lexical chain entries, focused on the "fifth". Veronica stated it was "once two fifth, once three fifths", adding that "it's dividing by two or dividing by three. It depends what they want the fifth (for)".

One teacher, Lena, got confused by all this discussion of finding "fifths". She said

- 4.1 Lena But **we** already know how many reds and how many blue there are.

For Talli, this was a good opportunity to highlight one of the student routines she saw as most significant in the video clip:

- 4.2 Talli No, but, **one student** came and said another idea. **She** said, listen, "you want to create more necklaces? If you tell me how many blue (beads) there are, **I** will already tell you how many reds there are ... **I** will take the blues, **I'll** divide them by two because ... all the blues are two fifth, **I** will find this one part. The other part **I** will multiply by three, to find the red (ones)". That's the fifth. That's the idea of the fifth

- 4.3 Lena Oh, OK. So **that's** a different division.

Lena's short exclamation is an important indicator of the productiveness of this exchange, where the lexical chain around the "fifth" was prominent, along with the lexical chain reporting on students' speech in the video. Although there are good reasons to believe most of the teachers did not see the importance of the students' routines of division in search of a "unit", Lena's exclamations showed it most clearly. Her first request for clarification [4.1] made use of the "how many" quantification word. It is therefore highly probable that she was only seeing the routine of multiplying the two sides of the ratio (as this routine relates to natural numbers, 2 and 3, multiplied by a coefficient of expansion). In addition, her use of "we" in 4.1 for objecting on what "we already know", indicates she was not making any differentiation between her own mathematical reasoning and the students' mathematical reasoning. In contrast, when she used the word "division" after Talli's explanation [4.3], Lena was probably already seeing the routine of dividing into fifth and using the fifth as a unit (since only with relation to this routine, the word "division" makes sense). Also, Lena's use of "that" indicates that she was now differentiating between her own mathematical reasoning and that of the revoiced student. This change may have resulted from Talli's repeated reference to the voice of the student (seen in the I pronouns of the video actions lexical chain).

Misalignment of frames

The productiveness of talk, which rose considerably once the video and coding scheme were introduced to the discussion, made certain misalignments between Talli and the teachers more apparent. Interestingly, Talli was able to pick up in real time only on the mathematical aspects. The subjectifying aspects remained hidden until the analysis was performed.

The misalignment of the mathematical aspects of frames was most noticeable in the discussion of the "fifth" and in what the teachers saw as important mathematical narratives versus what Talli saw as important. Talli interpreted the video clip as containing rich stems for discussion of the ratio object, including visual realizations of 2 different "necklaces", the fractions $2/5$ and $3/5$, the signifiers 2:3

and some verbal statements describing routines for calculating the ratio. She therefore thought the clip should be scored as a 3, where, according to the EAC rubric

One or more concepts are discussed and/or defined in some detail. This entails **explicit** noting of the concept in a whole-class setting. Explanation and/or elaboration of critical features of the concept may be incomplete, and connections to the larger web of mathematical ideas ... are notably present, but weak (EAC rubric level 3, the Quadrants coding scheme).

In contrast, the teachers hardly saw any "concepts" in the clip. It seems that for them, "concepts" meant keywords on the board, together with explicit explanations *made by the teacher*. They were not searching for stems of different realizations of the ratio object. Talli therefore insisted on eliciting more ideas about "concepts", until finally the "fifth" was raised by Veronica [3.3].

The misalignment of frames in the subjectifying aspect was more nuanced. It appears only when one looks closely at the pronouns relating to the performer of actions (**bolded**) in the lexical chains referring to the video (wavy-underlined). While Talli talked about routines that surfaced in the discussion, focusing mainly on those narratives authored by the students, the teachers almost solely focused on the teacher. Veronica [2.5] as well as Yafit [3.1], even while "defending" the lesson as containing more attention to concepts than Valerie claimed, still based their justifications on the actions of the teacher ("**She** wanted to show", "**she** repeats (what the students has said)", "**she** asked"). This focus on the teachers' actions, both for evaluating what *did* happen and what *did not* happen in the lesson in terms of EAC, was prevalent in most of the teachers' talk.

Discussion and Conclusions

This paper's goal was to characterize productive discussions in PD settings that promote EMI, by surfacing misalignments between frames of the PD leader, who was drawing on the Explorations Discourse and frames of the teachers, who were relying on the Acquisition Discourse. Our analysis of the PD pedagogical discussions included identifying lexical chains, both those relating to the rubric of EAC and those relating to the video-clip. This analysis showed that by using a video-clip of a classroom discussion and the Quadrants rubrics, misalignment between the teachers and the PD leader surfaced, and could therefore be referred to and further discussed. The misalignment in mathematizing aspects of the explorative frame, which are often difficult to notice (Heyd-Metzuyanim et al., 2018a), surfaced in this discussion well. However, subjectifying aspects of misalignment that related to whose contribution is valued (students or teacher), remained hidden during the discussion, perhaps because they were not attended to in advance by the PD leader. Our findings strengthen earlier studies regarding the usefulness of using video together with rubric scores in a PD setting (e.g. Schoenfeld, 2017). The contribution of this study is also methodological, in introducing and exemplifying the use of linguistic tools to analyze the productiveness of PD discussions.

Acknowledgments

This study and the TEAMS project are supported by the Trump foundation, grant no. 220.

References

- Borko, H., Jacobs, J., Eiteljorg, E., & Pittman, M. E. (2008). Video as a tool for fostering productive discussions in mathematics professional development. *Teaching and Teacher Education*, 24(2), 417–436.
- Gregg, J. (1995). The tensions and contradictions of the school mathematics tradition. *Journal for Research in Mathematics Education*, 26, 442–466.
- Halliday, M. A., & Hasan, R. (1976). *Cohesion in English*. Longman: London.
- Heyd-Metzuyanim, E., Tabach, M., & Nachlieli, T. (2016). Opportunities for learning given to prospective mathematics teachers: between ritual and explorative instruction. *Journal of Mathematics Teacher Education*, 19(6), 547-574.
- Heyd-Metzuyanim, E., Munter, C., & Greeno, J. G. (2018a). Conflicting frames: a case of misalignment between professional development efforts and a teacher’s practice in a high school mathematics classroom. *Educational Studies in Mathematics*, 97(1), 21-37.
- Heyd-Metzuyanim, E., Smith, M., Bill, V., & Resnick, L. B. (2018b). From ritual to explorative participation in discourse-rich instructional practices: a case study of teacher learning through professional development. *Educational Studies in Mathematics*, 1–17. <https://doi.org/10.1007/s10649-018-9849-9>
- Heyd-Metzuyanim, E., & Shabtay, G. (2019). Narratives of ‘good’ instruction: teachers’ identities as drawing on exploration vs. acquisition pedagogical discourses. *ZDM - Mathematics Education*. <https://doi.org/10.1007/s11858-018-01019-3>
- Morris, J., & Hirst, G. (1991). Lexical cohesion computed by thesaural relations as an indicator of the structure of text. *Computational linguistics*, 17(1), 21-48.
- Nachlieli, T., & Tabach, M. (2018). Ritual-enabling opportunities-to-learn in mathematics classrooms. *Educational Studies in Mathematics*. <https://doi.org/https://doi.org/10.1007/s10649-018-9848-x>
- National Council of Teachers of Mathematics. (2000). *Principles and Standards for School Mathematics*. Reston, VA.
- Schoenfeld, A. H. (2017). Uses of video in understanding and improving mathematical thinking and teaching. *Journal of Mathematics Teacher Education*, 20(5), 415–432.
- Sfard, A. (2008). *Thinking as communicating*. New York: Cambridge University Press.
- Smith, M. S., & Stein, M. K. (2011). *5 Practices for Orchestrating Productive Mathematics Discussions*. Reston: VA: National Council of Teachers of Mathematic.
- Stein, M. K., Correnti, R., Moore, D., Russell, J. L., & Kelly, K. (2017). Using Theory and Measurement to Sharpen Conceptualizations of Mathematics Teaching in the Common Core Era. *AERA Open*, 3(1), 233285841668056.
- Sztajn, P., Borko, H., & Smith, T. M. (2017). Research in Mathematics Professional Development. In *Compendium for Research in Mathematics Education* (pp. 793–823). Reston: VA: National Council of Teachers of Mathematic.

On the efficiency of a professional development program for mathematics teachers in upper-secondary schools in Iceland

Freyja Hreinsdóttir

School of Education, University of Iceland, Iceland; frejyah@hi.is

Keywords: Out-of-field teachers, upper secondary school, ICT, professional development

Introduction

The poster is about an ongoing study on the efficiency of a two year long in-service program for 25 mathematics teachers at the University of Iceland.

In 2014 a report was published by the ministry of Education in Iceland on the teaching of mathematics in upper secondary school in Iceland (Jónsdóttir et al. 2014). The report states that among other issues there are relatively many out of field teachers teaching mathematics, there is very little use of tasks that promote creative reasoning and use of ICT in the teaching of mathematics in upper secondary school is not very common. There is a shortage of educated mathematics teachers in the country and the Icelandic mathematics curriculum is rather vague on the use of ICT in mathematics so teachers in general do not feel required to use it. Many of the teachers interviewed expressed the need for more professional development which they felt was inadequate in Iceland.

After the report was published the University of Iceland started a two year long in-service program in the fall of 2015 for 25 mathematics teachers at the University of Iceland. The number of upper-secondary mathematics teachers in Iceland is about 150 so this was about one sixth of the total number of teachers. The aim of the program was to educate out-of-field teachers on various aspects of mathematics and mathematics education as well as to increase their use of ICT in the teaching of mathematics. The first course in the program was an intensive ICT course covering GeoGebra, LaTeX, software for screencasts etc. The teachers were taught basic use of the software and given assignments to do in their own teaching. This was followed by courses in combinatorics, statistics, mathematics education, calculus, number theory, geometry and mathematical modelling.

Surveys

During the 2 years the participants filled in 3 surveys where they were asked about: their expectations, organization of the program, usefulness of individual courses, the program as a whole and if and how it had affected their teaching and more.

Use of ICT

At the end of the first course (September 2015) the teachers filled out a survey (partially based on Goos & Bennison, 2008) on their knowledge and views on several types of software as well as the likelihood of using them in their future teaching. Their view was generally positive, they had learned a lot, they viewed ICT as something that could be used to help students understand mathematics and had plans to use ICT in their teaching. At the end of the program (June 2017) the actual use of ICT had been a little less than they had planned.

Expectations and reasons for participating in the program

The main reason the participants stated was that they wanted to learn more mathematics and they were interested in the content of the program in general. They expressed (in answers to open questions) that they wanted to be better at teaching and believed that learning more mathematics would make them more secure in their teaching. The next most popular reason was learning to use ICT. The possibility to meet other teachers and collaborate with them was not rated very highly as a reason to join but turned out to be a valuable experience.

Program as a whole

When asked to evaluate the program as a whole (in June 2017) the answers were generally positive but some disappointment was expressed such as “there should have been more practical didactics teaching us how to teach certain material”.

Long term usefulness of the program

Teachers decide in general to participate in a PD program because they have some expectations about a positive outcome. Sometimes these expectations are unrealistic and sometimes there is a clash between these expectations and the plans of the PD organizers and teachers (see e.g. Nipper et. al. 2011 and Liljedahl 2014). It is important that PD organizers are aware of this and try to address this in their work. In the organization of the PD program mentioned above the ambition was to improve mathematics teaching in upper secondary schools in Iceland so it is therefore of great interest to examine further the long-term usefulness of the program. In an ongoing investigation selected participant are being interviewed about their overall view about the program, how they handled the differences between expectations and reality and if and how the program has resulted in changes in their teaching. It is also of interest to see what obstacles they have come across when they wanted to make a change in their teaching.

References

- Goos, M., & Bennison, A. (2008). Surveying the technology landscape: Teachers' use of technology in secondary mathematics classrooms. *Mathematics Education Research Journal*, 20(3), 102-130.
- Jónsdóttir, A., Briem, E., Hreinsdóttir, F., Þórarinnsson, F., Magnússon, J., & Möller, R. (2014). *Úttekt á stærðfræðikennslu í framhaldsskólum*. Retrieved from <https://www.menntamalaraduneyti.is/media/frettir2014/Uttekt-a-staerdfraedikennslu-i-framhaldsskolum-2014.pdf>
- Liljedahl, P. (2014). Approaching professional learning: What teachers want. *The Mathematics Enthusiast*, 11(1), 109-122.
- Nipper, K., Ricks, T., Kilpatrick, J., Mayhew, L., Thomas, S., Kwon, N. Y., Klerlein, J.T. & Hembree, D. (2011). Teacher tensions: Expectations in a professional development institute. *Journal of Mathematics Teacher Education*, 14(5), 375-392.

Algebraic solutions of German out-of-field elementary school teachers

Lara Huethorst

TU Dortmund University, Germany; lara.huethorst@math.tu-dortmund.de

In Germany out-of-field elementary school teachers are a frequent phenomenon but not regarded as unproblematic. In order to foster the pupils' algebraic thinking, teachers themselves need to be aware of the structures. Additionally, tasks which foster process-related competences too can only be set when the teacher knows which discoveries can be made by using a specific task. In this article theoretical background is given to process-related competences, teacher training and out-of-field teaching at German primary schools. A teacher training course is presented and first insights into the algebraic solutions of the participating teachers are given.

Keywords: Professional development, teacher training, out-of-field teaching, algebraic thinking.

Introduction

In Germany, out-of-field teaching, which is to be understood as trained primary school teachers who have been trained in different subjects than mathematics, exists fairly frequently in primary schools due to terms and structures of the first and second phases of teacher education. As a result, a national study points out that nearly one third of all interviewed primary school teachers, according to their own statements, teach mathematics outside their area of expertise (Richter, Kuhl, Reimers, & Pant, 2012). Hence, teacher training courses are needed to support teachers in teaching their daily mathematics courses. Therefore, this paper presents a teacher training course for out-of-field primary school teachers with the focus on usage of task formats to foster process-related competences.

Firstly, process-related competences are described and why out-of-field teaching cannot be regarded as problem-free. In a second step, the design of the study is described. Thirdly, the teacher training design is presented to lead to the fourth part of giving insights into how out-of-field mathematics teachers themselves solve arithmetic tasks.

Theoretical background

There are several widespread theoretical topics relevant to fully acknowledge the key findings of the study which are briefly described in what follows below.

Process-related competences

In the German framework, agreements for elementary schools, math competences are divided into two different but intertwining kinds. On the one hand, there are content-focused competences, including numbers and operations; space and shape; data; frequency and probability; and sizes and measuring. On the other hand, there are so called process-related competences. They include problem-solving, arguing, communicating, presenting and modelling (KMK, 2004). By now, the latter are found in almost every curriculum in all German federal states. They are considered to be indispensable for a successful usage, acquisition and implementation of mathematics (KMK, 2005). The following example explains that in more depth:

Number-chains follow the rules of the Fibonacci sequences. The two first numbers are start numbers,

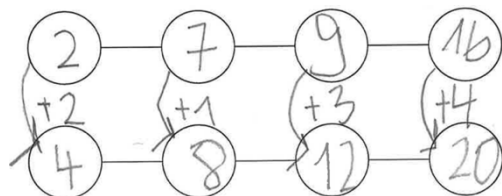


Figure 1: Number-chains

which can be chosen freely from all natural numbers including 0 (they can also be identical or different). This task is one of those which “have the potential to address algebraic thinking” (Steinweg, Akinwunmi, & Lenz, 2018, p. 283). Not only (early) algebra can be fostered with number-chains but process-related processes as well.

The children need to get adequate assignments and support. An assignment which fosters the competence of arguing is, for example, one which asks the students to (1) guess what happens when the first start number is increased by one, (2) calculate four examples and test their guess, (3) derive a rule from that and (4) give justification for the rule. It is important to describe and generalize the finding so that the children acquire knowledge about connections and relationships between numbers.

Eichholz (2018) showed in her study on out-of-field teachers in German elementary school that some of the participating teachers show little knowledge about these process-related competences. This indicates that there is a necessity to have a closer look at how teachers can be supported in learning and teaching general mathematics competences.

Out-of-field teaching in German primary schools

Due to the federal education system in Germany, study regulations vary widely in the 16 federal states. Although non-obligatory framework agreements state that studies at university to become a teacher comprise content knowledge and pedagogical content knowledge in both German and mathematics and an additional third subject (KMK, 2013), this is not the case in all states. For an overview on whether the education in the first and second phase of teacher education brings forth more generalists or specialist see Porsch, 2017. The principle of class teacher (Porsch, 2016) is dominant in German elementary school so that out-of-field teaching occurs frequently. However, there are enormous variations in percentages of teachers who teach mathematics without being fully educated from about 1.5% to almost 45 % in the different federal states (Richter *et al.*, 2012).

Nevertheless, it is widely known that the competences of a teacher have considerable impact on the competences of their pupils. COACTIV, a German wide additional study to PISA, for example, showed that both content knowledge and pedagogical content knowledge of a teacher have an impact on students’ performances (Baumert & Kunter, 2011). There is not only a high correlation between content knowledge and pedagogical content knowledge, content knowledge also proved to be mandatory for pedagogical content knowledge (Krauss *et al.* 2008). Moreover, “[m]ore traditional beliefs were associated with more traditional practices” (Stipek, Givvin, Salmon, & Mac Gyvers, 2001, p. 221), such as emphasis on performance or speed, which contradicts the contemporary views on how a good mathematics class should look like. As Porsch (2015) pointed out, out-of-field teachers agree less often with constructivist views and therefore, according to self-disclosure, realize them less often.

These results imply that there is a need to focus research on out-of-field teaching in German primary schools and its consequences. However, there are quite contradictory results in German research. While a nationwide investigation showed that elementary school students have poorer scores when

being taught by an out-of-field teacher, which is especially true for the weakest 5% (Richter et al., 2012), reanalysis of the same data indicates opposing results. Ziegler and Richter (2017) state that other reasons are responsible for the comparably weak performances of these pupils. The fact that children with weaker cognitive skills and migrant background experience more out-of-field teaching could be an explanation for the first result. Nevertheless, it needs to be investigated why there are such differences in out-of-field teaching concerning that group of elementary school pupils.

(Pre-)Algebra in German primary schools

“Generalizations are the life-blood of mathematics” (Mason, Burton, & Stacey, 2010, p. 8). However, “German primary curricula and standards mention studies on algebra in a very limited way, if at all” (Steinweg, Akinwunmi, & Lenz, 2018, p. 284). Nonetheless, problems like little conceptual knowledge of variables are as present in Germany as they are in other countries (ibid.). This does not mean that there are no opportunities in German elementary school to foster algebraic thinking – but it stays implicit: “The objective is to encourage teachers to integrate algebraic thinking into their classroom. Moreover, the aim is to enable teachers to become aware of their already addressing algebraic thinking” (ibid., p. 286). The presented part of the study focuses on the algebraic thinking of teachers based on the assumption that teachers cannot set adequate tasks to foster algebraic thinking if they have not completely understood the mathematical structures themselves. This knowledge provides them with the opportunity to concentrate the pupils’ focus on interesting patterns and structures.

Teacher training

“Professional teachers require professional development” (Wilson, & Berne, 1999, p. 173). That there is a need for teacher training is commonly known, so various research results can be used to develop and legitimate the presented teacher training course. There are five core features which can be identified in most research literature: (1) duration, (2) content-focus, (3) active learning, (4) collective participation and (5) coherence (i.e., Desimone, 2009; Garet, Porter, Desimone, Biram, & Yoon, 2001). Derived from these core features of teacher training, the German National Center for Mathematics Teacher Training (Deutsches Zentrum für Lehrerbildung Mathematik, DZLM) has developed six design principles: participant orientation, competence orientation, diversity of teaching and learning, case study, stimulating cooperation and stimulating reflection (Barzel, & Selter, 2015). The following project is affiliated to the DZLM, however, elaborating on the six DZLM design principles is not possible in the scope of this paper (see Barzel, & Selter, 2015).

Design of the study

“Practice, at least in education, requires a cyclic alteration of research and development” (Freudenthal, 1991, p. 159). That is why this study was performed cyclically and was constantly revised. Prediger’s working group has developed a Design Research Cycle that is specifically adapted “for teachers with a focus on content-specific professionalization processes” (Prediger, Schnell, & Rösike, 2016, p. 97). The cycle is divided into four working areas which are “(a) specifying and structuring PD goals and contents in hypothetical intended professionalization trajectories, (b) developing the specific PD design, (c) conducting and analyzing design experiments in PD settings,

and (d) developing contributions to local theories on professionalization processes” (ibid., p. 98). The examined course was performed three times, with results from the first two courses being presented.

To gain insights into the level of knowledge and the beliefs of the participating teachers – about 25 in the first two circles – before and after the course, several research tools were used. At the beginning of the first lesson and in the last there were two different questionnaires. The first examines beliefs of how mathematics is learned, how it must be taught, the teachers’ self-concept regarding the process-related competences and other related features. These items are all from tested questionnaires which fulfil common quality criteria. The second questionnaire, which was designed by the author, is about how the participants themselves solve two different elementary school tasks. An operative change must be described in a first step. In a second step, the changes must be explained at elementary school level and, thirdly, the participants are asked to give an algebraic explanation. Each participant generates his or her personal code, so that the questionnaires stay anonymous but can be matched. Data evaluation is made mainly qualitatively by comparing pre- and posttest results and (possible) changes in beliefs. However, categories have been created, to allow statements about trends. Additionally, semi-standardized interviews with volunteers were conducted. The focus is on the questionnaire about the elementary school tasks to gain answers to the research question: How far do the algebraic solutions of out-of-field teachers primary school teachers, who participate in a training course with a focus on tasks (formats) to foster the process-related competences, change?

Design of the teacher training course

Based on the core features of teacher training and the DZLM design principles, the constructed course is presented briefly, before one exemplary period is described in more detail.

There are five appointments which last three hours. For each meeting one typical elementary school task format is combined with one process-related competence (except modelling), so that the participants gain knowledge in two different ways. On the one hand they are supposed to completely understand the task on a deeper mathematical level. On the other hand, they should be able to use their (newly gained) knowledge to set assignments which foster the process-related competences as well as the content-related ones (with help from Primakom, a platform for out-of-field teachers on which they can undertake training – regardless of point or period of time or place).

	Topic of the appointment	Primakom pages
1	Fostering process-related competences – documentation with the example of discovery calculation packs	<ul style="list-style-type: none"> • Mathematics – more than calculation
2	Recognizing and explaining patterns and structures, operative changes with the example of Fibonacci sequences	<ul style="list-style-type: none"> • Fibonacci sequence • Arguing
3	Discovering and communicative math classes – math conferences with the example of number pyramids	<ul style="list-style-type: none"> • Number pyramids • Communicating
4	Combinatorics – problem solving strategies of pupils with the example of “building colorful towers”	<ul style="list-style-type: none"> • Building colorful towers • Problem solving

5	Good geometric tasks – building up concepts of symmetry and space with the example of fold-and-cut tasks	<ul style="list-style-type: none"> • Fold-and-cut-tasks • Presenting
---	--	--

Table 1: Topics of the Appointment

Between two appointments there are always approximately four school weeks, distance phase, so that the participating teachers have the opportunity to try out what they have acquired in the presence phase beforehand. Reflecting on one's own lessons can be enabled only when following this concept of *duration*, which is essential, according to Hippel (2001), when wanting to take the step from professional knowledge to professional action. In order to provide support during the distance phases, each topic is supplemented with one or two pages of an internet site (<https://primakom.dzlm.de>). The *content focus* is realized through the concentration on task formats and process-related competences. This covers the point of *coherence*, since these tasks can be found in almost every elementary school mathematics textbook allocated to different grades and are adaptable for all grades so that every participating teacher can use what is learned during the presence phases in their own class in the distance phases. To satisfy *active learning*, the participating teachers solve assignments with the focus on algebraic structures of the task. Additionally, they are asked to illustrate their findings using elementary school appropriate material, for example sachets, and variables.

First results

In the questionnaire about the teachers' solutions of elementary school tasks, in this example number-

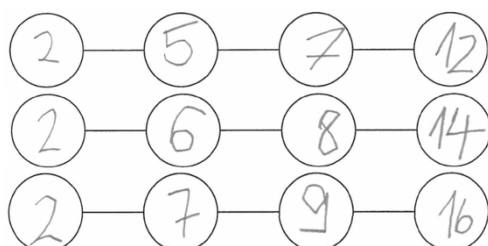


Figure 2: Operative changes in number-chains

chains, the teachers are asked to describe operative changes in number-chains, to give an explanation where these changes derive from what they could use in their elementary school classes and to give an algebraic explanation. It becomes clear that the participating teachers differ widely in their explaining and algebraic competences at the beginning of the course. Two examples, in each case of the same participants, of the pre- and post-tests for the following tasks are presented in what follows below: "Give an algebraic explanation (with variables) for the changes of the last number. Also give a reason for your algebraic explanation". As shown in table 1, number-chains have been discussed during the course.

In contrast, the other task in the questionnaire has not been talked about during the course. The first example of the pre-test illustrates that some conventions are known, for example, that variables are represented by small letters and often start with a. The explanation is, "When I add to a two numbers $b + c$, I get the final number d . If I increase both numbers by 1, the final number increases by two". But the formation rules do

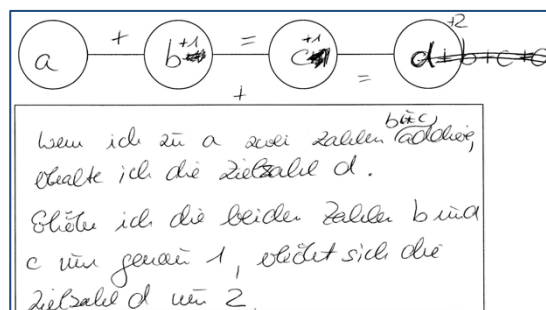


Figure 3: Pretest teacher A

not become clearer by the variables because they do not show the connections between the two starting numbers and the final number. That is why it cannot be counted as an explanation for the increase of the final number. But it has been recognized that the second starting number has increased by one, the third number as well and the final number by two. Nonetheless, the causal relation to the

formation rules is not established. In the post-test, it can be seen that some other mathematical conventions have not been noted, such as that the notation of two variables without an operation sign stands for multiplication instead of addition. In the teacher's explanation, however, it becomes clear that she knows it is addition: "In the addition of two variables b is taken twice, so that the result is increased by two times b ". This could be

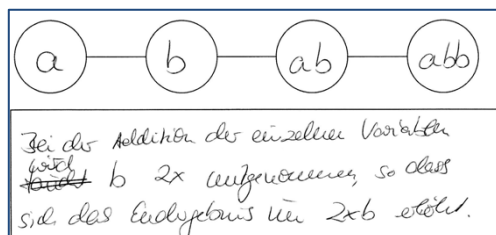


Figure 4: Post-test teacher A

because, during the course, the elementary-school-appropriate representation to support the pupils' generalizing competences are little sachets and no operation sign is needed in this case.

Teacher B tries to illustrate the formation rules similar to teacher A. She describes: "The first number-chain consists of (in the little chart) a: starting number, b: 2nd number, c: 3rd number, d: final number. The other numbers need to change". This, again, is no illustration of the formation rules of the number-chains. But the changes are marked by the numbers in the circles, although this is not highlighting why these changes occur. In contrast to the pre-test, the post-test

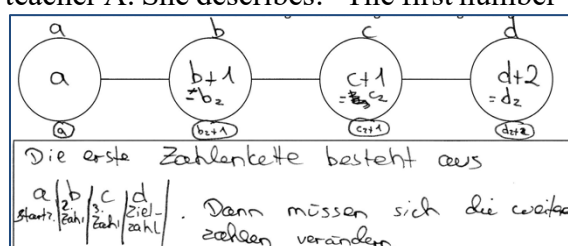


Figure 5: Pre-test teacher B

shows a different result for teacher B as well. She highlights the $2b$ by circling and underlining and explains "When b is increased by one, the final number is increased by two because b is two times in the final number". The formation rule gets evident through the used variables, but she does not use numbers to illustrate the changes. Nonetheless, she explains that because of two b in the final number, by whichever number b is increased, it is doubled in the final number. This is, in contrast to the pre-test, a very good algebraic explanation.

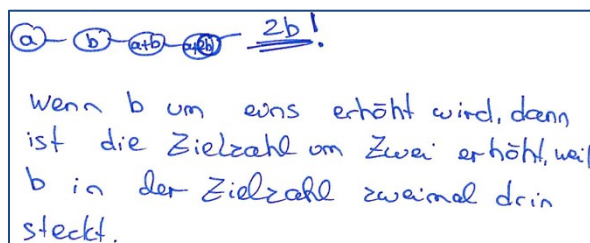


Figure 6: Post-test teacher B

Both examples show that there is a growth in algebraic competences for these two teachers. While in the beginning the formation rules cannot be expressed algebraically, the post-test shows that they can illustrate the changes and the reason for this case after the course. Their explanations change from being descriptive to being explanatory. This tendency emerges in a first analysis for the elementary school appropriate explanation as well as for the algebraic explanation. Before the course, the changes were described, but the answers of the participating teachers were not fully coherent and explanatory. This is only true for some teachers. A few participants were able to express the reasons for the operative changes in the pre-test as well. However, there is a very rare, in this case only one, questionnaire which is categorized as being fully explanatory in both questions (elementary school

appropriate and algebraic). Whether the teachers were not able to see where the changes derive from or whether they could not express it properly, either with words or variables, cannot be answered.

Conclusion and outlook

This shows that there is a need for teacher training courses that foster the teachers' algebraic competences. They are often able to name the changes and to describe them, but they are not able so explain why these changes occur and where these changes derive from. In order to foster students' algebraic thinking and use the (full) potential of a task to foster content-focused and process-related competences at the same time, teachers need to be aware of the mathematical patterns and structures of such a task. Teachers need to be able to decide whether a student's explanation is sufficient; teachers themselves need to know what is important to explain and not only to describe a process. In a next step, the other task of the questionnaire, which has not been discussed during the course, will be analyzed further. This may give insights into how far the participating teachers are able to transfer what is learned to other tasks. The solutions for both task formats will be categorized so that more than trends can be named. Additionally, the interviews will be considered to underline detailed analysis of some participants. Further investigations on design principles for teacher training courses and possibilities to support teachers need to be done.

References

- Barzel, B., & Selter, Ch. (2015). Die DZLM-Gestaltungsprinzipien für Fortbildungen. *Journal für Mathematik-Didaktik*, 36(2), 259–284.
- Baumert, J., & Kunter, M. (2011). Das mathematikspezifische Wissen von Lehrkräften, kognitive Aktivierung im Unterricht und Lernfortschritte von Schülerinnen und Schülern. In, M. Kunter, J. Baumert, W. Blum, U. Klusmann, S. Krauss, & N. Neubrand (Ed.), *Professionelle Kompetenz von Lehrkräften. Ergebnisse des Forschungsprogramms COACTIV* (pp. 29–54). Münster: Waxmann.
- Desimone, L. M. (2009). Improving impact studies of teachers' professional development: Towards better conceptualizations and measures. *Educational Researcher* 38(3), 181–199.
- Eichholz, L. (2018). *Mathematik fachfremd unterrichten. Ein Fortbildungskurs für Lehrpersonen in der Primarstufe*. Wiesbaden: Springer Spektrum.
- Freudenthal, H. (1991). *Revisiting mathematics education. China Lectures*. Dordrecht: Kluwer.
- Garet, M. S., Porter, A. C., Desimone, L., Birman, B. F., & Yoon, K. S. (2001). What makes professional development effective? Results from a national sample of teachers. *American Educational Research Journal*, 38(4), 915–945.
- Hippel, von A. (2011). Fortbildung in pädagogischen Berufen – zentrale Themen, Gemeinsamkeiten und Unterschiede in der Fortbildung in Elementarbereich, Schule und Weiterbildung. *Pädagogische Professionalität*, 57. Beiheft, 248–267.
- KMK (2004). *Bildungsstandards im Fach Mathematik für den Primarbereich. Beschluss vom 15.10.2004*. München, Neuwied: Wolters-Kluwer, Luchterhand Verlag.

- KMK (2005). *Bildungsstandards im Fach Mathematik für den Primarbereich (Jahrgangsstufe 4)*. Beschluss vom 15.10.2004. München: Wolters Kluwer.
- KMK (2013). *Rahmenvereinbarung über die Ausbildung und Prüfung für ein Lehramt der Grundschule bzw. Primarstufe (Lehramtstyp 1)*. Beschluss der Kultusministerkonferenz vom 28.02.1997 i. d. F. vom 10.10.2013. Berlin: KMK.
- Krauss, S., Neubrand, M., Blum, W., Baumert, J., Brunner, M., Kunter, M., & Jordan, A. (2008). Die Untersuchung des professionellen Wissens deutscher Mathematik-Lehrerinnen und -Lehrer im Rahmen der COACTIV-Studie. *Journal für Mathematik-Didaktik*, 29 (2), 223–258.
- Mason, J., Burton, L., & Stacey, K. (2010). *Thinking mathematically*. Harlow: Pearson Education.
- Porsch, R. (2015). Unterscheiden sich Mathematiklehrkräfte an der Grundschule mit und ohne Fach-Lehrerbefähigung hinsichtlich ihrer berufsbezogenen Überzeugungen? Ergebnisse aus TIMSS 2007. *Mathematica Didactica*, 38, 5–36.
- Porsch, R. (2016). Fachfremd unterrichten in Deutschland. Definition – Verbreitung – Auswirkungen. *Die Deutsche Schule*, 108(1), 9–32.
- Porsch, R. (2017). Spezialisten oder Generalisten? Eine Betrachtung der Fachausbildung von Grundschullehrerinnen und -lehrern in Deutschland. In M. Radhoff, & S. Wieckert (Ed.), *Die Grundschule im Wandel der Zeit* (pp. 151–162). Hamburg: Dr. Kovač.
- Prediger, S., Schnell, S., & Rösike, K.-A. (2016). Design research with a focus on content-specific professionalization processes: The case of noticing students' potentials. In S. Zehetmeier, B. Rösken-Winter, D. Potari, & M. Ribeiro (Ed.), *Proceedings of the third ERME topic conference on mathematics teaching, resources and teacher professional development* (pp. 96–105). Berlin: Humboldt-Universität zu Berlin / HAL.
- Richter, D., Kuhl, P., Reimers, H., & Pant, H. A., (2012). Aspekte der Aus- und Fortbildung von Lehrkräften in der Primarstufe. In P. Stanat, H. A. Pant, K. Böhme, & D. Richter (Ed.), *Kompetenzen von Schülerinnen und Schülern am Ende der vierten Jahrgangsstufe in den Fächern Deutsch und Mathematik. Ergebnisse des IQB-Ländervergleichs 2011* (pp. 237–259). Münster: Waxmann.
- Steinweg, A. S., Akinwunmi, K., & Lenz, D. (2018). Making implicit algebraic thinking explicit: Exploiting national characteristics of German approaches. In C. Kieran (Ed.), *Teaching and learning algebraic thinking with 5- to 12-year-olds: The global evolution of an emerging field of research and practice* (pp. 283–307). Cham/Heidelberg: Springer International Publishing.
- Stipek, D. J., Givvin, K. B., Slamon, J. M., & MacGyvers, V. L. (2001). Teachers' beliefs and practices related to mathematics instruction. *Teaching and Teacher Education*, 17, 213–226.
- Wilson, S. M., & Berne, J. (1999). Teacher learning and the acquisition of professional knowledge: an examination of research on contemporary professional development. *Review of Research in Education*, 24(1), 173–209.

Ziegler, C., & Richter, D. (2017). Der Einfluss fachfremden Unterrichts auf die Schülerleistung: Können Unterschiede in der Klassenzusammensetzung zur Erklärung beitragen? *Unterrichtswissenschaft*, 45, 136–155.

Mathematics teacher educators' critical collegueship

Suela Kacerja¹ and Rune Herheim¹

¹Western Norway University of Applied Sciences, Norway; skac@hvl.no; rher@hvl.no

In this paper, we apply the ideas of Lord (1994) about critical collegueship to understand how mathematics teacher educators (MTEs) can work together to become more critical in their teaching practices. There is relatively little research on MTEs' learning and development from a critical perspective. Our study examines a group of MTEs working together to develop novel teaching and do research about initiating critical discussions. During two meetings, the MTEs discussed their different perspectives after using indices such as the Body Mass Index (BMI) in teaching. Identified examples of Lord's elements were a willingness to seek and try out promising ideas, and being open to share perspectives and ask for arguments. Such collaboration supports reflections for developing teaching and research.

Keywords: Critical collegueship, mathematics teacher educators, reflections.

Introduction and previous research

There are several studies concerning mathematics teachers' knowledge for teaching (e.g. Ball, Thames, & Phelps, 2008; Rowland, Hucksteps, & Thwait, 2005), as well as mathematics education courses designed for mathematics teachers' professional development. Zaslavsky and Leikin (2004) pointed to the lack of research on becoming a MTE and lack of formal training programs. "Mostly, teacher-educators are 'self-made'" (Zaslavsky, 2008, p. 94). Some studies about MTEs focus on the mathematical knowledge for teaching mathematics teachers (Zopf, 2010), and MTEs' practices in providing professional development (Kuzle & Biehler, 2015). In a historical overview, Jaworski (2008), in line with Zaslavsky & Leikin (2004), found that a very small number of studies reflect on the MTE's learning "from engaging in teacher education, through reflecting on their own practice, or through research into the programs they design and lead" (p. 3). Our study is a contribution to narrow this gap by focusing on how MTEs can collaborate to become more critical about their teaching practices.

According to Zaslavsky and Leikin's (2004) model of MTEs' professional development, MTEs learn through learning (facilitated by an experienced MTE) and through teaching (to mathematics teachers), while collaborating with other colleagues of similar or differing expertise. The need for MTEs to reflect, individually and collectively, on different aspects of their own practice and development is pinpointed as important for their learning (e.g. Tzur, 2001; Jaworski, 2008; Zaslavsky & Leikin, 2004; Garcia, Sanchez, & Escudero, 2007). Individual reflections upon the different stages of becoming an MTE include reflections on learning mathematics, learning to teach it, learning to educate mathematics teachers, and learning to mentor educators (Tzur, 2001). In collective reflections between colleagues when preparing and teaching different courses, practices such as sharing experiences, reading and conducting research, and continuous efforts to improve courses (Roth McDuffie, Drake, & Herbel-Eisenmann, 2008), as well as MTEs adopting theoretical perspectives to examine their teaching practices (Garcia et al., 2007), can influence MTEs' development.

Zaslavsky (2008) argued that one of the identified practices, from which MTEs can learn, is the choice and design of tasks and resources by which students can learn specific content or ways of teaching. In our research group, we collaborate on identifying and implementing new teaching ideas that can promote critical mathematical discussions (in line with Skovsmose, 1994) amongst pre-service and in-service teachers. We collectively reflect upon the implementation of these ideas in our own teaching. One idea we aim to investigate in our project is the use of indices as mathematical models for in-service teachers to experience initiating and developing critical discussions about the role of mathematics in society. Indices, such as the BMI, have proved to be fruitful entry points to such discussions (see Kacerja et al., 2017). Reflecting collectively as MTEs upon our own practice can help us learn more about being teacher educators (Roth McDuffie et al., 2008; Zaslavsky & Leikin, 2004).

In the data presented in this paper, we reflect as a group upon our experiences with critical discussions after two colleagues had tried out a task about the BMI with in-service teachers. We investigate how we communicate in the group and how we invite and present ideas and perspectives from a critical collegueship perspective (Lord, 1994). Critical collegueship is a particular type of collegiality and is elaborated on in the next section. The question we pose in this paper is: *What aspects of critical collegueship can mathematics teacher educators' collaboration bring about?* By focusing on the critical collegueship aspects by Lord (1994), we explore how such a collaboration can support our work as MTEs.

Critical collegueship among mathematics teacher educators

Lord (1994) emphasised professional development of teachers and discussed critical collegueship as one kind of collegueship to support teachers' reflections. Colleagues sharing interests and experiences, being open and respectful, willing to try out new ideas and to be critical, are crucial conditions for such a collegueship. The main difference between critical collegueship and other kinds of collective reflections is the support of a "critical stance toward teaching" (p. 192). The critical stance in our study means we do not only share our ideas with colleagues, but we also ask for, and articulate, the assumptions behind these ideas.

Lord (1994, pp. 192–193) identified six characteristics of critical collegueship:

1. Creating and sustaining productive disequilibrium through self-reflection, collegial dialogue, and on-going critique;
2. Embracing fundamental intellectual virtues (e.g. openness to new ideas, willingness to reject weak practices or flimsy reasoning, accepting responsibility for acquiring and using relevant information, willingness to seek out the best ideas, greater reliance on organized and deliberate investigations, assuming collective responsibility for creating a professional record of teachers' research and experimentation);
3. Increasing the capacity for empathetic understanding;
4. Developing and honing the skills and attributes associated with negotiation, improved communication, and the resolution of competing interests;
5. Increasing teachers' comfort with high levels of ambiguity and uncertainty;
- and 6. Achieving collective generativity.

The characteristics for which a collegueship can be considered critical, according to Lord, have to do with a sense of responsibility for seeking improvement and accepting that the best solution is not yet achieved. It requires participants to be comfortable with uncertainty and to make efforts to develop

and accept new ideas by self-reflection and on-going critique. Differences are seen as driving forces that can facilitate a productive disequilibrium. Our joint interest as MTEs is to learn more about ways of fostering critical discussions in teacher education about the role of mathematics in society. The ideas within critical collegueship support such group reflections. This is the reason why critical collegueship is chosen as a framework for analysing the discussions.

While Lord (1994) defined critical collegueship for groups of teachers reflecting together, Males, Otten, and Herbel-Eisenmann (2010) used Lord's framework to study the collegiality of a group of mathematics teachers and researchers. They identified challenging interactions in which participants asked questions to push for in-depth reflections, and located elements of Lord's intellectual virtues in those interactions. In our paper, we apply critical collegueship within a group of MTEs. We extend critical collegueship as one way of thinking about professional development of MTEs, by reflecting upon our own discussions. In line with Males et al., we focus on the discussions when different perspectives about practice come into play. It is in these situations that it becomes more likely for MTEs to argue for their ideas and invite the colleagues to share their perspectives.

The study, participants, and data analysis

The study focuses on a group of seven teacher educators, including the two authors, collaborating on developing teaching and research. In this paper, we use data from two meetings in which teaching about indices and critical discussions was focused upon. All seven of us took part in the first meeting shortly after TE1¹ and MTE2 had collaborated on a 3-hour workshop on indices for in-service teachers. This was part of a course in Numeracy across the curriculum. The in-service teachers discussed the BMI task for 60 minutes in two groups of six persons. They examined the BMI's mathematical components and formula, its use in society, and the appropriateness of using indices in school teaching. In the next semester, we had a second meeting and continued to discuss ideas for developing our teaching about indices as part of our project. In addition, we discussed a research paper we had written about stimulating critical discussions in mathematics where data from in-service teachers' discussions were analysed (see Kacerja et al., 2017).

The two meetings were audiotaped and transcribed. In line with Lord (1994), we, the authors, investigate discussions when different perspectives in teaching and research come into the fore as driving forces. An example of this is when one MTE argued that we should teach a kind of scheme for dissecting indices, while one of the others thought it was important for in-service teachers to be free to investigate. The first author identified such interactions from both meetings, and both authors examined them from a critical collegueship perspective. We also looked for the use of words such as "yes", "maybe", "but" etc., in order to identify the different characteristics of the critical collegueship. The examples presented in the following are representative for the situations where different perspectives occurred.

¹ TE1 is a teacher educator within social science, while the six others are within mathematics education, thus MTE.

Different perspectives

As previously argued, we identified discussions showing different perspectives on two related topics – the ways to teach critical skills, and the mathematical level in the discussions. We now analyse aspects of critical collegueship in the chosen utterances.

Different perspectives on how to teach critical skills

The first meeting begins with TE1 describing the teaching and his experiences from the workshop. The goal of the lesson was to create an awareness about the importance of being critical to the use and misuse of numbers in society. While TE1 and MTE2 agree upon the goal, differences came to the fore about how to achieve that goal. TE1 then said, “It was actually too little time and too much material” in the teaching session before the group discussions, and continued by saying:

TE1: I wish I had more time, and maybe do something more, dissect an index to really give them a useful example, a template in principle, a recipe, how one can approach an index. How one can take the pieces apart and see what those mean, what the different numbers mean, the different variables in an index.

TE1 explains what he would do differently next time to improve his teaching. He is critical to his planning of “too much material” and shows by this self-reflection a characteristic of critical collegueship. For him, a way to achieve the goal could be to show the teachers an example of how one could criticise an index, by dissecting it and working with its different components to get a sense of the numbers. The use of “maybe” indicates an openness in his reflection. This is strengthened by the wording “I wish”, a choice of words that makes it possible to characterize the whole utterance as a “what if ...?” approach, a focus towards what can be possible to do. A few utterances later, MTE2 presents a different opinion:

MTE2: Yes, and as you said TE1, one can look at this from two sides; how much material should they be presented with beforehand for a discussion like this, and how much should they not [be presented with] ...

MTE2 starts with a “yes” and acknowledges TE1’s point of view. However, she also wants to bring into attention another point of view. There is a dilemma about how much guidance the in-service teachers should get before they start exploring the problem themselves. MTE2 does not comment upon the goal of the lesson, she is only trying to look at an alternative way for achieving it – she creates some disequilibrium. From Lord’s (1994) perspective, disequilibrium provides participants with opportunities to reflect upon other’s ideas and bring their own arguments into the discussion.

MTE2 elaborates afterwards on her argument with a “because” and exemplifies with an episode from the in-service teachers’ group discussions in which one teacher was fascinated about how much she had learned. For MTE2, this is an argument that supports the idea of giving teachers the opportunity to explore the use of mathematics, without necessarily having ready-made schemas, as TE1 suggested. MTE2 argues that the dialogue the in-service teachers had is important for learning to explore, while a recipe “can limit the dialogue and they [the in-service teachers] can become preoccupied with doing it the same way [as the MTE]”. The argument concerns potential negative effects from presenting a recipe; it could hinder the teachers’ explorations and make them adhere too

strictly to the TE's schema. MTE2 provides arguments to support her idea of giving the teachers some space to explore the problem themselves, emphasizing dialogue, wondering and exploration. She presents ideas and counter-arguments, thinks aloud and refers to examples. MTE2 sets some standards for the level of reasoning required for the group discussions to be fruitful, in line with Lord's (1994) emphasis on negotiation and improved communication.

In all of the utterances presented above, as in other cases of disequilibrium in our data, the participants start their utterance by acknowledging the colleague's point of view using phrases like "yes", and "agree", and then introduce an alternative view starting by "because" and supported by examples. Acknowledging colleagues' ideas and arguments relates to Lord's focus on "the capacity for empathetic understanding" (1994, p. 192). By using phrases such as "maybe" and "you can look at it from two sides", TE1 and MTE2 apply some fundamental intellectual virtues in their discussions by opening up for other opinions. They acknowledge the others' views and seek the best ideas by looking at the topic from different points of view. TE1 and MTE2 use classroom examples to support their arguments by using relevant information. This is typical for the participants in both meetings, and in line with previous research (Males et al., 2010). The MTEs explore together how to initiate critical discussions in their teaching without having the answers available. They are, as Lord (1994) put it, coping with uncertainties and ambiguities that TE1 and MTE2 reflect upon.

Different perspectives on the mathematical level in the discussions

Exploring the mathematics of the BMI, and the in-service teachers' mathematical competence to do that, also generated different perspectives. In the first meeting, MTE4 stated that the teachers did not explore in depth the mathematics behind the chosen index. Similarly, TE1 pointed to the lack of mathematical competence as a barrier that hindered the teachers in doing so. He supported his argument by referring to what the teachers expressed during the discussions. This fits with his earlier reflections about how he would organize the teaching differently next time to help teachers overcome this barrier, showing again signs of self-reflection for improving his teaching.

Another disequilibrium occurs in the second meeting, when discussing an article in which we all looked at the competence showed by in-service teachers when working with the BMI task. Similarly to TE1 and MTE4, MTE5 thinks there were "relatively little mathematical discussions". MTE6 asks MTE5 what mathematical discussions are in her opinion. MTE5 answers that she is thinking about discussing mathematical concepts. MTE6 then adds, "Yes ... but there is also a broader understanding of mathematics, of mathematical discussions, to discuss mathematics in use and its role in society". As MTE2 also did earlier, MTE6 accepts MTE5's perspective about what she regards as mathematical discussions with a "yes", but he also introduces his perspective by saying "but there is also". MTE6 presents his view by arguing, in line with a critical mathematics education approach (Skovsmose, 1994), that mathematical competence includes being able to use mathematics and evaluate its use in different contexts. Mathematics goes beyond discussing mathematical concepts; it also involves a broader perspective of its use in society. This is reflected in the goal of the lesson formulated by TE1. MTE6 supports his argument by focusing on competences the teachers showed in their discussions from this extended perspective on mathematics by saying: "They showed many good reflections connected to challenges about indices, and about indices in a school context."

It is possible to identify several fundamental intellectual virtues in this discussion. The MTEs are invited to share ideas and arguments, problems are investigated from different viewpoints, and viewpoints are elaborated upon with several arguments before deciding the next step. In the two meetings, the MTEs clarify their expectations about in-service teachers showing mathematical competence, but also the competence to evaluate and criticize how mathematics is used in society. They search for better ideas to improve the teaching about critical discussions, as Lord (1994) emphasized, as they continue to reflect about the tasks. At the end of the second meeting, when MTE4 wonders if she should ask more targeted mathematics questions in the next teaching session in order to guide the teachers to thoroughly explore mathematics, MTE2 argues:

MTE2: One thing is to go more in depth into the mathematics [of the index], if they are able to do that. But we would also like them to stay there and understand that there is something here that could be necessary for them to understand. They see its meaning ...

MTE2 acknowledges again the other colleagues' idea of more in-depth exploring of the mathematics. She then continues in line with her earlier ideas about giving the teachers the time and possibility to discover things by themselves, to get the feeling that they need to learn something. She connects this to the meaning the teachers themselves would give to an index, and to the mathematics of the index.

So far, the MTEs have shared their ideas, been open-minded for other arguments and ways of doing, argued for their views, and presented alternative points of view. One could then ask what effect this exchange of ideas has on the MTEs and their collaboration. By the end of the meeting, MTE2 continues with a proposal for further developing the task about critical mathematics and BMI:

MTE2: As you [MTE4] mentioned with proportionality ... Is it possible to design a teaching session where one first goes through the main mathematical ideas of the index? But not specify the index. Then talk [teach] about inverse proportionality without saying that it is the BMI we are talking about ...

MTE2 starts with taking into account MTE4's earlier idea of proportionality. By raising a question, "is it possible to design ...?", MTE2 tries to negotiate with MTE4 and the others to find a teaching approach that takes into consideration many of the colleagues' comments. She proposes one way to organize the session by starting with some teaching about the mathematical concepts of BMI, such as inverse proportionality, but without giving any scheme for how to do it. By so doing, the in-service teachers would be given some mathematical foundation when exploring the mathematics of the formula, as MTE5, TE1, and MTE4 called for. At the same time, MTE2 takes care of her own idea of giving the teachers the freedom to explore by adding "then they [the in-service teachers] could get the BMI formula and see if they connect it [to inverse proportionality]. We haven't tried that". MTE5 agrees with MTE2 by saying "I thought the same ... teaching about proportionality independently of the index". MTE6 also supports MTE2's idea by saying, "start the teaching with some mathematics". Everyone agrees that it is a good idea to try out MTE2's proposal. The negotiation highlights the importance of giving the in-service teachers more support to develop and show mathematical competence, while at the same time giving them freedom to show their competence on reflecting upon the mathematics' use in society. The MTEs have together come to an idea while trying to avoid

the pitfalls expressed earlier by the colleagues, a kind of “collective generativity” (Lord, 1994). The best agreed upon solution in this round of discussions is to teach some mathematics and see if this will help the teachers in their discussion of the index.

Conclusions

In this paper, we have focused on identifying aspects of critical collegueship in mathematics teacher educators’ collaboration on developing teaching about critical discussions. We singled out utterances when colleagues had different perspectives because it is when we disagree that we ask each other for more arguments. This is a vital element of the critical collegueship perspective as it creates conditions for the participants to dig into the assumptions behind their ideas, and thus adopt a critical stance in terms of Lord’s framework. We, MTEs, are also in a position to reflect better upon our own views when challenged to argue and exemplify the teaching, and modify it for better results. In this aspect, our results fit with findings from Males et al. (2010).

During the collaboration to develop our teaching, there were particularly two aspects that generated different perspectives. One aspect is about the way of organizing such teaching and the amount of guidance to give teachers, and the other concerns expectations about the level of mathematics in the teachers’ discussions. We, MTEs, discuss different perspectives and consider them, showing several elements of Lord’s framework, especially fundamental intellectual virtues such as openness to new ideas, respect, and seeking better solutions. We support our points of view with arguments from classroom examples, as MTE2 and TE1 did, and from theoretical ideas influenced by critical mathematics education (see Skovsmose, 1994), as MTE2 and MTE6 did. Examining our practice with theoretical lenses, as with the critical perspective lenses, is a way for us to develop as MTEs (Garcia et al., 2007).

At the end, the agreed solution covers some of the challenges discussed in the two meetings. The engagement brings about some collective generativity. The solution indicates that we, MTEs, value the development of teachers’ mathematical competency, but also the importance of the freedom to develop their critical competence by not giving them too much guidance. In this way, we move forward in developing our understanding of what critical mathematical discussions are and how to support them in our teaching. As Roth McDuffie et al. (2008) pointed out, sharing experiences, looking for improvement in our practice, and doing research together, facilitate such development. It can be concluded that we, MTEs, enrich our own views by listening to our colleagues’ arguments and by trying to make sense of their reasoning, when we collectively reflect upon and analyse our work.

Given the very few possibilities for MTEs to develop their knowledge and skills, and given that collaboration of MTEs about teaching and research is a common practice, it is important to study what and how such collaborations can support the MTEs’ work, as we have done in our study. Lord (1994) discussed critical collegueship as a way to support teachers’ reflections. In this study, the concepts in Lord’s elements of critical collegueship helped us identify and discuss the potential such collaboration has in supporting MTEs’ reflections.

References

Ball, D. L., Thames, M. H., & Phelps, G. (2008). Content knowledge for teaching: What makes it so special? *Journal of Teacher Education*, 59, 389–407.

- Garcia, M., Sanchez, V., & Escudero, I. (2007). Learning through reflection in mathematics teacher education. *Educational studies in mathematics*, 64(1), 1–17.
- Jaworski, B. (2008). Mathematics teacher educator learning and development: an introduction. In B. Jaworski & T. Woods (Eds.), *The international handbook of mathematics teacher education. The mathematics teacher educator as a developing professional*, vol. 4 (pp. 1–16). Rotterdam, The Netherlands: Sense publishers.
- Kacerja, S., Rangnes, T., Herheim, R., Pohl, M., Lilland, I. E., & Hansen, R. (2017). Stimulating critical mathematical discussions in teacher education: use of indices such as the BMI as entry points. *Nordic Studies in Mathematics Education*, 22(4), 101–116.
- Kuzle, A., & Biehler, R. (2015). A protocol for analysing mathematics teacher educators' practices. In K. Krainer & N. Vondrová (Eds.), *Proceedings of the Ninth Congress of the European Society for Research in Mathematics Education* (pp. 2847–2853). Prague, Czech Republic: Charles University in Prague, Faculty of Education and ERME.
- Lord, B. (1994). Teachers' professional development: Critical collegueship and the role of professional communities. In N. Cobb (Ed.), *The future of education: Perspectives on national standards in education* (pp. 175–204). New York: College Entrance Examination Board.
- Males, L. M., Otten, S., & Herbel-Eisenmann, B. (2010). Challenges of critical collegueship: examining and reflecting on mathematics teacher study groups' interactions. *Journal of Mathematics Teacher Education*, 13, 459–471.
- Roth McDuffie, A., Drake, C., & Herbel-Eisenmann, B. (2008). The elementary mathematics methods course. Three professors' experiences, foci and challenges. In B. Jaworski & T. Woods (Eds.), *The international handbook of mathematics teacher education. The mathematics teacher educator as a developing professional*, vol. 4 (pp. 247–264). Rotterdam, The Netherlands: Sense publishers.
- Rowland, T., Huckstep, P., & Thwaites, A. (2005). Elementary teachers' mathematics subject knowledge: the knowledge quartet and the case of Naomi. *Journal of mathematics teacher education* 8, 225–281.
- Skovsmose, O. (1994). *Towards a philosophy of mathematics education*. Dordrecht: Kluwer.
- Tzur, R. (2001). Becoming a mathematics teacher-educator: conceptualizing the terrain through self-reflective analysis. *Journal of Mathematics Teacher Education*, 4, 259–283.
- Zaslavsky, O. (2008). Meeting the challenges of mathematics teacher education through design and use of tasks that facilitate teacher learning. In B. Jaworski & T. Woods (Eds.), *The international handbook of mathematics teacher education. The mathematics teacher educator as a developing professional*, vol. 4 (pp. 93–114). Rotterdam, The Netherlands: Sense publishers.
- Zaslavsky, O., & Leikin, R. (2004). Professional development of mathematics teacher educators: growth through practice. *Journal of Mathematics Teacher Education*, 7, 5–32.
- Zopf, D. A. (2010). *Mathematical knowledge for teaching teachers: the mathematical work of and knowledge entailed by teacher education* (Doctoral dissertation). Retrieved from <https://deepblue.lib.umich.edu/handle/2027.42/77702>

Prospective Secondary Mathematics Teachers' Development of Core-Practices During Methods Courses: Affordances of Quantitative Reasoning

Gulseren Karagöz Akar¹

Esra Bukova Güzel²

Serkan Özel³

¹Boğaziçi University, Faculty of Education, Turkey; gulserenkaragoz@yahoo.com

²Dokuz Eylül University, Faculty of Education, Turkey; esra.bukova@gmail.com

³Boğaziçi University, Faculty of Education, Turkey; ozels@boun.edu.tr

To investigate the development of the progressive incorporation perspective for effective mathematics teaching, a multi-case study with seven out of twenty-six prospective secondary mathematics teachers was conducted for fourteen weeks during a methods course. The course was built on four-core ideas: quantitative reasoning, task-analysis, conceptual analysis and interviewing. In this paper, we report on the change in prospective teachers' conceptions of mathematics and mathematics learning upon completion of working on quantitative reasoning. Results showed that quantitative reasoning might bring about change on prospective teachers' awareness on practices such as attending to students' thinking and distinguishing their mathematics from their students' mathematics. Results suggest the inclusion of quantitative reasoning in methods courses in mathematics teacher education.

Keywords: quantitative reasoning, teacher education, prospective teachers

Introduction

Education of prospective teachers is an ongoing challenge (Chapman, 2016; Grossman & McDonald, 2008). Although there has been considering effort on the change of prospective teachers' practices in methods courses, there is still need for focusing on significant change in prospective teachers' thinking about mathematics teaching and learning (Chapman, 2016). In fact, researchers argued that the possible reasons for the difficulty of change might be due to the lack of pedagogical principles prospective teachers need to hold (Jin & Tzur, 2011; Simon, 2006b). Such principles involve developing i) a view of mathematical understanding consistent with the problem-solving view, ii) a view of mathematics learning (Simon, 2006b) and (iii) the teachers' distinction between their mathematics and their students' mathematics (Silverman & Thompson, 2008; Simon, 2006b). Silverman and Thompson (2008) also suggested that prospective teachers need to have an image of (e.g., hypothesize) how their students might come to think of mathematical understandings they envision. In this paper, we embrace these as core practices.

Previous research depicted evidence of these proposed difficulties. Particularly, Yeh and Santagata (2015) study showed that prospective teachers regarded students' procedural fluency as evidence of conceptual understanding. Results also showed that prospective teachers detected student actions as evidence of student learning rather than attending to their thinking. Similarly, Simpson and Haltiwanger (2016) study showed that prospective secondary mathematics teachers had difficulty in interpreting student mathematical thinking in written work. They suggested studying the ways to develop prospective teachers' abilities to make sense of students' thinking. It is in this respect that, in this study we investigated the possible affordances quantitative reasoning (Thompson, 1994) might

provide prospective teachers in terms of the pedagogical principles they need to hold regarding the nature of mathematics, mathematics learning and mathematics teaching. We investigated the following research question: What changes in the prospective teachers' awareness on the practices of effective mathematics teaching might develop focusing on quantitative reasoning during methods courses? Results showed a change in prospective teachers' views on the nature of mathematics. They were also able to characterize procedures and concepts in relation to quantitative reasoning. In addition, they realized the need to distinguish their thinking from students' thinking as well as developing a sense of what mathematics learning means. With this report, we propose that in methods courses prospective mathematics teachers need be given opportunities to engage in tasks focusing their attention on quantitative reasoning. We make suggestions on how to include such tasks pointing to our experience as teacher educators. In the next section we provide our reasons as to why we considered quantitative reasoning as part of the methods course we developed. We explain our reasons with connections to the teacher perspectives framework (Jin & Tzur, 2011) based on which the larger study was conducted.

Theoretical Framework

In the larger study of which this study was part, our purpose was to examine the prospective secondary mathematics teachers' development of the progressive incorporation perspective to teach mathematics effectively during methods course. Jin and Tzur(2011) postulated the teacher perspectives framework following on the work of (Heinz, Kinzel, Simon, & Tzur, 2000; Simon, Tzur, Heinz & Kinzel, 2000; Tzur, Simon, Heinz, & Kinzel, 2001). They used the term "perspectives" to refer to both the knowledge and beliefs teachers might hold regarding the nature of mathematics, mathematics learning and mathematics teaching and also the practices they might engage in based on such acknowledgment. Tzur and his colleagues proposed that teachers holding CBP (conception based perspective) would act accordingly with the views of radical constructivist epistemology. Therefore, they suggested that PIP would be a more realistic target for the teacher education since "a PIP-rooted teacher's practice can engender students' learning processes envisioned by CBP without requiring the teacher's explicit awareness of such view..."

Therefore, for the first part of the methods course, we used quantitative reasoning framework (Thompson, 1994). Thompson (1994) defined quantitative reasoning as an individual's analysis of a situation into a quantitative structure. So, quantities live in an individual's conception of situations such that in order for an individual to comprehend a quantity, the individual must have a mental image of an object and attributes of this object that can be measured (Thompson, 1994). For instance, a rectangular shape could be thought as an object with the attribute, area, that could be measured. Then, a fraction could be thought as a quantity as the measure of a particular size of the total area of the rectangular shape. For the construction of quantities, Thompson differentiated numerical operations from quantitative operations. Quantitative operations are the non-numerical operations an individual mentally act. For instance, equi-partitioning the total area of a rectangle in purpose of determining a particular size would be an example of quantitative operations. Numerical operations are the result of the evaluation of quantitative operations. So, an individual imagining the fraction such as $\frac{1}{2}$ as a quantity, can engage in equi-partitioning of the shaded area of a rectangular shape showing $\frac{1}{2}$ into more equal pieces (e.g., equi-partitioning into five more equal pieces). This numerically results in the

fraction 5/10. Thompson stated that over emphasis on the numerical operations prevent students to learn mathematics meaningfully. Therefore, he proposed that prospective teachers need to pay attention to the mental processes (i.e., quantitative operations) required of an individual for the development of mathematical understandings (Silverman & Thompson, 2008). They stated,

“the prospective teacher must put herself in the place of *a student* and attempt to examine the operations that a student would need and the constraints the student would have to operate under in order to (logically) behave as the prospective teacher wishes a student to do.” (p. 19).

So, we hypothesized that if we engage prospective teachers’ in tasks focusing their attention on the distinctions between quantitative and numerical operations, their awareness on the students’ mathematical reasoning might develop. This also might have allowed them to pay attention to the nature of mathematics. That is, in this framework mathematics is built through an individuals’ mental actions and the results of these actions. This view of mathematics aligns with the problem-solving view in which “...mathematics is built from human activity: counting, folding, comparing, etc.” (Confrey, 1990, p. 109). A teacher with progressive incorporation perspective or conception based perspective is also expected to hold this view of mathematics (Jin & Tzur, 2011)

Method

Participants

Seven prospective secondary mathematics teachers participated in the study. They were at their fifth-year of study at one of the universities, in which the medium of language is English, in Turkey. We chose these prospective teachers for the following reasons: First, their GPA’s (Grand Point Average) ranged between 3,44 and 2,76 out of 4,00. This provided a spectrum of GPA’s of all prospective teachers taking the methods course; two in the top, three in middle and two in the lower range. Second, based on the first week of the classes and the written-pre assessment we gathered prior to teaching sessions, we observed them as verbal individuals. That is, they were talkative, and, volunteered to participate in the continuing five-set of interviews till the end of the study.

Data Collection

Data were collected for a total of five weeks during the methods course the first author taught. The methods course was four hours per week. For this multi-case study (Yin, 1984), we conducted classroom teaching experiments for the teaching sessions(Cobb, 2000) (see Figure 1).

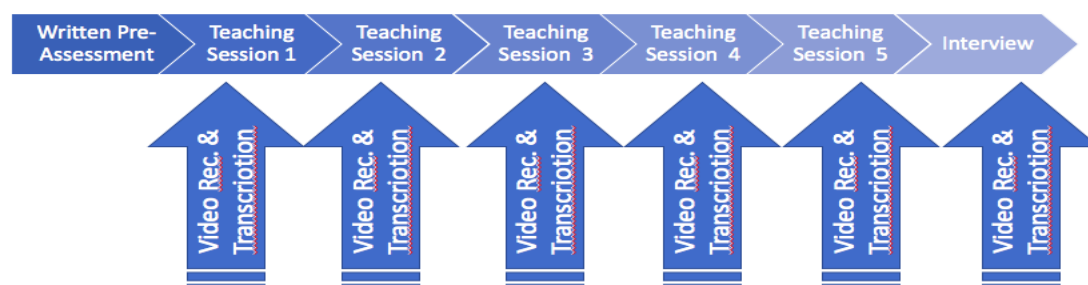


Figure 1: The data collection period during the methods course

In this method, the teaching sessions are planned in advance. However, for each teaching session, we revised the (sub) learning goals depending on our hypotheses about prospective teachers’

development. Prior to the teaching sessions, we gave a written pre-assessment to prospective teachers to collect their thoughts on mathematics learning and teaching. Then, each of the teaching sessions was videotaped and transcribed afterwards. Prospective teachers also kept weekly journals concerning both in-class and out-of-class discussions, due online of the night after each class. The classes were Tuesdays and Thursdays, so that we could watch the videotapes and read the journals in between the teaching sessions. In the journals, we purposefully asked prospective teachers to reflect back and forth on the relationships among the constructs discussed. In this way, each teaching session was revised and re-planned based on the ongoing assessment. Then, we conducted an interview upon completion of working on quantitative reasoning. Data sources included prospective teachers' written responses to pre- assessment and the journals; transcripts of the videotapes of i) whole-class discussions and iii) the interviews. These data seemed central to understanding the shifts in the practices contributing to advances on the part of prospective teachers.

The Procedure

The first set of classes in the methods course included mostly concrete examples to focus on the nature of mathematics. First, we included tasks in terms of the distinction between prospective teachers' thinking on quotitive and partitive division types based on measuring and equal sharing (quantitative operations). For this, we asked prospective teachers to come up with a word-problem for which the solution was given as $10/5=2$. Then, we asked them to sort different division problems they came up with into two categories by paying attention to the similarities and differences. They worked in groups to sort the word-problems. Following they shared their ideas during the class discussion. With this task, we wanted to direct their attention to both their classmates' and their own mental actions (i.e., measuring and equal sharing) and the numerical operations, such as division, they used. Then, we asked them to think about the two examples in chapter 1 from Van de Walle (2007). In these examples, Marlena and Darrell, two students' work on division problems are shared. We wanted to observe and assess if they could focus on these students' mental actions—measuring and equal sharing. After that, we had a classroom discussion on chapter 1 from Van de Walle (2007). The next week, we asked prospective teachers to work in groups to come up with a way to teach improper fractions to 5th grade students. For this, we also asked them to explain their thinking for instance what $11/6$ means to their group members. We wanted to take their attention to again to their classmates' mental operations as well as theirs. Following, we provided them with the first author's articulation of the understanding of improper fractions (Tzur, 1999) from the point of view of quantitative operations. Also, for the out-of-class activity, prospective teachers considered the first author's articulation of between-state ratio (Karagoz Akar, 2007) based on a task from a reform curriculum (Everyday Mathematics) and had a discussion on it during the next class hours. Then, in the third week, we taught the geometric meaning of differentiation using a task we modified from the national reform-based curriculum. Following week, we used a task sequence to teach the algebraic and geometric meaning of the binomial form of complex numbers (Saraç & Karagoz Akar, 2017). We also had a discussion on Thompson(1994). For the out-of-class activity, for both of the teaching sessions on differentiation and complex numbers, prospective teachers were asked to articulate on reasoning processes they have engaged in.

Analysis

We analyzed the data using the constant comparative method (Strauss ve Corbin, 1990). In this method, the researcher constantly reads and analyzes data both during and at the end of the data collection. Also, s/he reads the data and compares and contrast his/her hypotheses (conjectures) both within all data from one participant and among participants. Therefore, we read the transcripts of the teaching sessions, the journal entries and the transcripts of the interviews line by line. Our goal was to determine what core-practices these seven prospective teachers' recognized and developed during these five weeks. Reading the transcripts of the teaching sessions and the journal entries from the first week together with the written-pre assessment, and the transcripts of the data from the interviews at the end of the five weeks, we all coded the data individually. Then, comparing the list of codes on the data from each participant, we came up with a set of codes representing the whole data. Following, we came together to discuss and have a consensus on the codes. We then finalized the list of the codes depicting prospective teachers' awareness of the core-practices. In the following section, for illustrative purposes, with reference to the data from one prospective teacher, Mina, in the middle range of seven prospective teachers, we share the results. Focusing on data just from one prospective teacher, we hope to maximise the possibility of the reader's achieving some familiarity with the context for the analysis.

Results

Beginning of the study

As stated earlier, in the second week of the study, we had asked prospective teachers to discuss in groups how to teach improper fractions to 5th grade students. Then, all the groups choosing a representative shared their ideas in the class discussion. Mina spoke on behalf of his group members and other prospective teachers agreed upon the idea: They first started with proper fractions and used it to work towards improper fractions.

Mina: First, we thought that they (referring to students) need to know proper fractions. Like, they need to know that they are between 0 and 1. Like this could be shown by shading some part of shape, like rectangle. Like for instance dividing the shape into 6 pieces and shading 5 pieces and counting 5 pieces. But then this should be shown on the number line dividing the interval between 0 and 1. Then, in the same way we can divide the interval between 1 and 2 into six pieces. Now, we divided the interval between 0 and 1 into six pieces and divided the interval between 1 and 2, then when we count like 1,2,3,4,5 until 11, the number $11/6$ will be in between 1 and 2. Then what $11/6$ means because because we divided each piece into 6, they will know that the denominator is 6 and since we counted until 11, they will know that that point will correspond to $11/6$. Like they will see that $11/6$ is there.

S1: Super idea

S2: I think it is very meaningful showing it with the number line.

As the excerpt showed, prospective teachers viewed mathematics as obviously apperant to their students as it seemed to them. Such knowledge existed in the drawings they shared with their students. That is, their view of mathematics corresponded to a Platonist view of knowledge. They also agreed on using the number line to depict the connections to their students supposedly acquired previous knowledge such as proper fractions. This suggested that they considered that their students would think the same way as they think.

End of the five weeks period

Data from the interviews at the end of the five weeks period showed a change in prospective teachers' awareness on the nature of mathematics and their students' thinking.

Questions asked during the interview	Mina's answers	The codes depicting data from the interviews on seven prospective teachers
Why do you think that we have focused on the quantitative reasoning framework?	Like I thought while working on them like mathematics includes two processes like it has procedures and the meanings behind those procedures... For instance $\frac{1}{2}$ like was thinking numerically earlier. For instance when I say $\frac{1}{2}$ is equivalent to $\frac{5}{10}$, like I say now that multiplying with 5 has a meaning when I divide the shape into two equal pieces and then shade one part. That multiplying with 5 means for me now dividing the shape, $\frac{1}{2}$, into 5 more equal pieces. Like those numbers have meaning....So like we work on quantitative and numerical operations so that like we will know the reasons behind like formulas...	Mathematics is made up of both numerical and quantitative operations—a human activity Awareness of the need for key mathematical ideas
Remember we asked you to articulate on your engagement in the tasks focusing on differentiation and complex numbers. How do you think that this experience might benefit you a prospective teacher?	Like yes as I said earlier like we should know the mental processes of our students like how they think... I saw my process now I can focus on theirs... Like to imagine how they might think so that they could learn like construct them connecting them...	Awareness of the need to focus on students' thinking Awareness of their students thinking differently from theirs
How do connections in conceptual understanding occur?	Eeee like linking them ...like it is like to me mathematical understanding, what is the reason behind this. Like I said earlier not numerical, quantitative...	Awareness of the nature of mathematics learning with understanding

Table 1: Codes depicting prospective teachers' awareness of the core practices.

As the codes depicted, there was a change in prospective teachers' awareness of the views on the nature of mathematics. Data showed that, for instance, Mina regarded mathematics knowledge as human activity, aligned with the problem solving view. Also, he was aware of the need to understand mathematics meaningfully so that he could anticipate his students' thinking to help them construct

those ideas on their own. In addition, he was aware that his thinking would be by nature different from his students' thinking.

Discussion

In this study, we investigated the change in prospective teachers' awareness on the practices involved in effective mathematics teaching once they engaged in tasks focusing on quantitative reasoning during methods courses. Results showed that their views on the nature of mathematics has changed. Contrary to the data from the beginning, after engaging in tasks requiring them to analyze both their and their classmates' thinking in terms of quantitative and numerical operations for almost one and a half-month period, they started viewing mathematics as a human activity. Regarding the teacher perspectives framework (Jin and Tzur, 2011), this change is the first stage for the development of progressive incorporation perspective. Though, research on beliefs suggest that establishing change is not easy (e.g., Wilson and Cooney, 2002). Still, we argue that asking prospective teachers to reflect on and write about specifically their own thinking might have brought about the change in their views on the nature of mathematics. So, we propose to the field such task as a core practice for teacher educators to use in methods courses. Yet, with caution, we argue that there is need to examine the effect of engagement in tasks focusing on quantitative reasoning on both prospective and inservice teachers' beliefs on mathematics. Results also showed that prospective teachers' awareness on the need for focusing on their students' thinking developed. In addition, they recognized that their thinking processes would by nature differ from their students' thinking processes. Previous research emphasized the need to study the ways to develop prospective teachers' abilities to make sense of their students' thinking since they had difficulty in interpreting thinking (Simpson & Haltiwanger, 2016). In addition, research has shown that prospective teachers confused students' procedural fluency with conceptual understanding (Yeh & Santagata, 2015). To the contrary, results of this study indicated prospective teachers' awareness of the nature of concepts and procedures. Therefore, we suggest focusing on quantitative reasoning during methods courses as a possible way to provide prospective teachers for paying attention to their students' thinking differentiating their procedural fluency from their concepts. We also recommend the use of tasks focusing on quantitative reasoning in professional development workshops for inservice mathematics teachers. As a final note, considering the core-practices as conglomerate components of effective mathematics teaching, we suggest that the effect of quantitative reasoning on both prospective and inservice teachers' mathematical knowledge for teaching might be investigated.

References

- Karagoz Akar, G. (2007). *Conceptions of Between Ratios and Within Ratios*. Unpublished dissertation, The Pennsylvania State University, College of Education, State College, PA, USA.
- Saraç, M., & Karagoz Akar, G. (2017). A Prospective Secondary Mathematics Teacher's Development of the Meaning of Complex Numbers Through Quantitative Reasoning. In Galindo, E., & Newton, J., (Eds.). (2017). *Proceedings of the 39th annual meeting of the North American Chapter of the International Group for the Psychology of Mathematics Education*. Indianapolis, IN: Hoosier Association of Mathematics Teacher Educator, 267-271.
- Chapman, O. (2016). Approaches and challenges in supporting mathematics teachers' change,

Journal of Mathematics Teacher Education, 19, 1-5.

- Cobb, P. (2000). Conducting Teaching Experiments in Collaboration with Teachers. In Anthony, E., Kelly, E., & Lesh, R. (Eds.), *Research Design in Mathematics and Science Education* (pp. 307-335). NJ: Lawrence Erlbaum Associates.
- Heinz, K., Kinzel, M., Simon, A.M. & Tzur, R. (2000). Moving students through steps of mathematical knowing: An account of the practice of an elementary mathematics teacher in transition. *Journal of Mathematical Behaviour*, 19, 83-107.
- Jin, X. & Tzur, R. (2011). *Progressive Incorporation of New into Known: A Perspective on and Practice of Mathematics Learning and Teaching in China*. Paper presented at Fifteenth Annual Conference of the Association of Mathematics Teacher Educators (AMTE), Irvine, CA
- Silverman, J. & Thompson, P.W. (2008). Toward a framework for the development of Mathematical knowledge for teaching. *Journal of Mathematics Teacher Education*, 11, 499-511.
- Simpson, A. & Haltiwanger, L. (2016). "This is the first time I've done this": Exploring secondary prospective mathematics teachers' noticing of students' mathematical thinking. *Journal of Mathematics Teacher Education*, 20, 335-355.
- Simon, M. A. (2006b). *Pedagogical concepts as goals for teacher education: Towards an agenda for research in teacher development*. Paper presented at the Twenty Eighth Annual Meeting of the North American Chapter of the International Group for the Psychology of Mathematics Education, Mexico: Universidad Pedagógica Nacional
- Simon, M.A., Tzur, R., Heinz, K. & Kinzel, M. (2000). Characterizing a Perspective Underlying the Practice of Mathematics Teachers in Transition. *Journal for Research in Mathematics Education*, 31(5), 579-601.
- Strauss, A., & Corbin, J. (1990). *Basics of qualitative research: Grounded theory procedures and techniques*. Newbury Park, CA: Sage.
- Thompson, P. (1994). The Development of the Concept of Speed and its Relationship to Concepts or Rate. In Harel, G. & Confrey, J. (Eds.), *The Development of Multiplicative Reasoning in the Learning of Mathematics* (pp. 179-234). New York, Albany: New York Press
- Tzur, R., Simon, M.A., Heinz, K., & Kinzel, M. (2001). An account of a teacher's perspective on learning and teaching mathematics: Implications for teacher development. *Journal of Mathematics Teacher Education*, 4, 227-254.
- Van de Walle, J.A. (2007). *Developing understanding in mathematics. Elementary and Middle School Mathematics: Teaching Developmentally*. (pp. 22-36). Pearson.
- Wilson, M., & Cooney, T. (2002). Mathematics teacher change and development. In Leder, G. C., Pehkonen, E. & Torner, G. (Eds.), *Beliefs: A Hidden Variable in Mathematics Education?* Dordrecht: Kluwer Academic.
- Yeh, K. & Santagata, R. (2015). Preservice teachers' learning to generate evidence-based hypotheses about the impact of mathematics teaching on learning. *Journal of Teacher Education*, 66(1), 21-34.
- Yin, R.K. (1984). Analyzing case study evidence. *Case Study Research: Design and Methods*. In Bickman, L., & Rog, D. (Eds.). (pp. 99-121). California: Sage Publication.

Acknowledgement: This paper is supported by Boğaziçi University Research Project, Grant Number: 11220.

From judgmental evaluations to productive conversations: Mathematics teachers' shifts in communication within a video club

Ronnie Karsenty¹, Yochai Peretz² and Einat Heyd-Metzuyanim²

¹Weizmann Institute of Science, Dept. of science Teaching, Israel; ronnie.karsenty@weizmann.ac.il

²Technion - Israel Institute of Technology, Faculty of Education in Science and Technology

The study reported here explored how secondary mathematics teachers, participating in a school-based video club, communicated with each other and with the facilitator along the different sessions of the club. Specifically, their evaluative comments were analyzed, with respect to the non-judgmental norms that this club aimed to nurture. Three types of evaluative comments were identified, reflecting varying degrees of teachers' capability to interpret and discuss observed teaching moves while attributing possible rationalizations to the filmed teacher's decisions. It was found that the amount of highly judgmental comments decreased as the club proceeded, allowing for a more productive communication.

Keywords: Video club, school-based professional development, peer-discussions.

Introduction

Video club is a form of professional development that has become known since the early 1990's (Sherin, 2004; Sherin & van Es, 2009). In a video club, a group of teachers meet on a regular basis, usually under the guidance of a facilitator, to watch and discuss classroom video selected according to a certain aim. Different video clubs vary in their goals, agendas and the frameworks employed to direct teachers' conversations. For example, a video club can be established around the aim of enhancing teachers' proficiency to notice and analyze students' mathematical thinking (Sherin, Jacobs, & Philipp, 2011; van Es & Sherin, 2008). Another case is a club focusing on a certain teaching proficiency, such as running class discussions (Coles, 2010). Video clubs can be school-based, or alternatively region or university-based, but in general groups are meant to be small enough (usually 5-15 participants) to allow for genuine peer-conversations and sharing of ideas and insights.

One of the core issues associated with conducting video clubs is establishing norms of discussion. Apart from the basic intent to ensure a climate of trust, where teachers feel safe to raise ideas, norms also "orient individuals to one another, as well as to how information is communicated, what constitutes an idea worthy of investigation, and how to make sense of one's practice" (van Es, 2009, p. 104). Different video clubs may embrace different norms, according to their focus, goals and agenda. However, there is an apparent consensus in the literature that teachers' comments slipping into evaluations, judgments or negative reactions, lead to discussions with little value (Coles, 2010; Jaworski, 1990; van Es & Sherin, 2008).

In this paper we report on a study conducted within one video club, in which we explored the types of evaluative comments made by teachers and followed their frequency along a sequence of sessions. In the following, we describe the context of this club and the emergent research question, present a brief account of the data collection and analysis means, and demonstrate central findings.

Context, rationale and research question

The video club studied was conducted as part of a professional development project named VIDEO-LM (Viewing, Investigating and Discussing Environments of Learning Mathematics), developed at the Weizmann Institute of Science in Israel. The project is aimed at promoting secondary mathematics teachers' reflective skills, as well as their mathematical knowledge for teaching. A large collection of videotaped lessons serve as learning objects and sources for discussions with groups of teachers within video clubs. The videos are taken, in a sense, as “vicarious experiences” which allow for indirect exploration of one's own perceptions on the practice of mathematics teaching, through the observation of unknown peers in action (Arcavi & Schoenfeld, 2008; Karsenty, 2018). Peer-conversations are guided by the use of an analytic framework, comprised of six viewing lenses through which the lesson may be discussed: (1) mathematical and meta-mathematical ideas around the lesson's topic; (2) explicit and implicit goals that may be ascribed to the teacher; (3) the tasks selected by the teacher and their enactment in class; (4) the nature of the teacher-student interactions; (5) teacher dilemmas and decision-making processes; and (6) beliefs about mathematics, its learning and its teaching as inferable from the teacher's actions (for further details on the framework and its utilization, see Karsenty & Arcavi, 2017; Karsenty 2018).

VIDEO-LM clubs maintain an agenda based on the working assumption that the filmed teacher is acting in the best interest of his/her students. Thus, observers are required to "step into the shoes" of the filmed teacher in an attempt to understand his/her goals, decisions and beliefs. This 'exercise' of attributing reason to another teacher's moves is meant to encourage reflective thinking about the span of possible actions and decisions available within teaching situations. VIDEO-LM facilitators attempt to establish nonjudgmental norms of discussion, through the redirection of highly evaluative comments into “issues to think about”; instead of judgmental comments about the filmed teacher's decisions, participants are asked to consider alternative paths and their ensuing tradeoffs.

To date, more than 70 VIDEO-LM clubs were conducted across Israel. The specific club at the focus of this study was a school-based club, held during 2017 in an urban high school in the center of Israel. The school's population is characterized by a high proportion of low achievers, and most students study mathematics towards the basic level of Matriculation¹. The mathematics department includes 7 teachers, 5 of them with a teaching experience of over 30 years, and 2 with under 10 years of experience. Only 2 teachers in this team teach the higher Matriculation mathematics tracks exclusively, whereas the other 5 teach mainly in the basic track. The facilitator of this VIDEO-LM club (the second author of this paper) is a member of this department. Although being the youngest teacher in the team, he is the only one who has taken a VIDEO-LM facilitator course and had become a qualified facilitator, and his colleagues all agreed to participate in the club under his lead.

Setting

The club met 8 times during the year (about once a month), with each session lasting around 2 hours. In a preliminary discussion with the head of department, it was decided that the club will focus on

¹ In Israel, the mathematics Matriculation exam is obligatory for receiving a Matriculation certificate, and can be taken in one of three levels: basic, intermediate or high.

videotaped lessons filmed in low-track Matriculation classrooms, due to the characteristics of the school mentioned above. In the first 6 sessions, the facilitator (henceforth: YP) selected videos of teachers unknown to the team, from the VIDEO-LM collection. In the 7th session, YP showed a video of his own teaching, and in the last session the group watched a lesson taught by one of the other teachers, who volunteered to be videotaped for this purpose.

Rationale and research question

This video club enabled investigation of a situation that is less explored in the literature on video clubs for mathematics teachers; unlike most cases, where the facilitator is external to the group, here the facilitator was a fellow-teacher from the same team. This situation potentially allows for intimacy among participants, who are familiar and comfortable with one another, with no outsiders present. This was an interesting opportunity for us to study what teachers talk about, and how they communicate. The emerging research question was thus the following: What characterizes the peer-conversation taking place in a school-based VIDEO-LM club, facilitated by a member of the group?

Data collection and analysis

Data was collected mainly through video recordings of 7 out of the 8 sessions (one session was audiotaped). The recordings were supplemented by a researcher journal where YP documented his insights. The content analysis performed on the collected data included the following steps:

1. Performing a coarse transcription of all the recorded data from sessions, and identifying recurring themes/issues of interest.
2. Selecting sessions for in-depth analysis. Of the six sessions in which videos of unknown teachers were discussed, we decided to select the first two and the last two (# 1,2,5,6) to enable a perspective on shifts over time. In addition, the two sessions in which videos of team members were discussed (# 7,8), were also selected for analysis. These six sessions were then fully transcribed.
3. Segmenting transcripts into units of analysis. The basic unit was defined to be an idea unit, i.e., a transcript section in which one idea appears, whether in a single turn or along a number of turns.
4. Classifying each idea unit into one of the themes detected in step 1, using the Atlas.ti software.
5. Identifying categories within each theme (e.g., within the theme of evaluative comments, levels of evaluations were identified).
6. Systematically categorizing all turns of talk according to the identified categories. This classification was validated by two researchers.

Findings

One of the interesting themes identified in step 1 of the analysis, was teachers' evaluative comments. About 18% of the idea units were classified within this theme. As described earlier, VIDEO-LM clubs attempt to establish nonjudgmental norms of discussion. Thus, it was interesting for us to categorize types of evaluative comments and examine whether there were any shifts in the teachers' adherence to the expected norms. In this report, we focus solely on this issue.

We identified three categories of evaluative comments. These categories are stated and illustrated below. Due to space limitations we limit the illustrations to examples from 2 sessions.

Category (a): Decisive negative judgment towards teaching moves observed in the video.

This category was characterized by keywords such as ‘you cannot do this’; ‘unacceptable’; ‘it’s disturbing’; ‘I would never do that’; ‘it hurts to see this’, etc.

Example (a)1.

In Session 1, teachers watched a lesson on the topic of exponential growth and decay, given in a low-track 11th grade. When asked to relate to the teacher’s decisions that they have noticed, the following conversation evolved between the facilitator and one of the teachers:

- 94 Sapir: Another decision of the teacher that’s disturbing, to me personally it’s extremely disturbing, the children are passive, there’s no textbook to read from, he writes the question and answer on the board for them... which is pretty organized, okay, but [...] I wouldn’t have written the question, only the answer. But the children see the question in front of their eyes in the textbook. That is, to me it was very disturbing that the children sit like that [crosses her arms] like...
- 95 YP: So let’s ask the same question again. The teacher arrived in class, apparently in the beginning of the year, and said “you have no textbook” [...] He arrives and decides to write the exercises on the board, one by one. We’ll see it also later, each exercise he writes on the board, the question and sub questions...
- 96 Sapir: What’s the advantage in this? I don’t...
- 97 YP: I’m asking you.
- 98 Sapir: I don’t see an advantage.

In this communication, Sapir not only harshly criticizes the teacher’s decision not to use a textbook, but also rejects any attempt to find a possible reason for it. Her use of words such as "extremely disturbing", "very disturbing" and her refusal to respond to YP's requests to take the teacher's viewpoint, are all signals of a high level of negative judgmental talk.

Example (a)2.

In Session 2, teachers watched a lesson in analytic geometry in a low-track 12th grade, introducing the concept of a canonical circle. At a certain stage the teacher, together with the students, arrived at the equation $x^2+y^2=13^2$, by applying the Pythagorean theorem to a triangle drawn in the first quadrant (with one side on the x-axis, another side parallel to the y-axis, the point (x,y) as the edge of the hypotenuse, and $R=13$). Then, he asked what if $y=0$, wrote on the board $x^2=13^2$ and under this, following a student’s answer, wrote $x=13$. He then showed the point (13,0) on the graph. Following the video, Olga criticized the fact that the teacher did not state the negative solution, -13:

- 507 Olga: You can’t write that and not say a word.
- 508 Iris: You can.
- 509 Olga: You can’t.
- 510 Iris: You can.
- 511 Olga: No.
- 512 Iris: In a weak class you can.
- 513 Olga: No.

This communication between Olga and Iris is an example of an unproductive argument. It starts with a back and forth "you can, you can't" exchanges, devoid of any justifications. Then, after three such exchanges, Iris brings in a justification based on the circumstances of this being 'a weak class', to which Olga simply answers 'no', without relating to the content of Iris' claim. Later in the session, when the facilitator brings forward the issue of the teacher's beliefs, Olga returns to her objection:

- 601 YP: What, in your view, are the teacher's beliefs about the students' role in the lesson, about the teacher's role in the lesson?
- 602 Olga: Okay, I relate this to what we talked about, let's say... If I would have heard such a thing like $x^2=13^2$ and the answer... I would have said to the students, [I would have] stopped and said to the students, do you agree with what I wrote? I give them the floor and I want to hear their response.
- 603 YP: Okay, and what did he [the teacher] do?
- 604 Olga: He didn't do such a thing, at all.
- 605 YP: So what is his belief, derived from that?
- 606 Olga: So maybe like Iris says, that he didn't want to cut the flow and he continues, but I think **it's unacceptable**.
- [...]
- 631 YP: Did you perceive any belief that he might have regarding low achievers? Let go of yourself for a moment, detach yourself. [...] did you see anything that you can say "I think that his credo about low achievers is XYZ", did you see something like that?
- 632 Olga: There are several things here that, let's say, bother me
- 633 YP: Not what bothers you...
- 634 Olga: No, when I begin, let's say, with these students, I would start differently.

In the above episode, we see Olga solely focusing on what she sees as undesirable teaching moves [602, 632, 634], despite the recurring request of the facilitator's to "detach herself" and to state the teachers' beliefs [605, 631, 633]. Although, in line 606 she feebly cites Iris's reasoning in response to this request, she immediately goes on to state that it is "unacceptable".

Category (b): Disagreement with moves observed in the video, and proposing an improvement.

This type of disagreement often came in the form of suggestions, sometimes as if the filmed teacher was present in the room, and avoided decisive negative judgments. Keywords are 'you need to'; 'you should'; 'it's worthwhile'; 'I'm used to'; "I'm not sure about this", etc.

Example (b)1.

In session 1, Uri relates to the teacher's choice to introduce exponential growth and decay as a case, or continuation, of geometric series:

- 142 Uri: [the teacher says that] exponential growth and decay is like a geometric series and that's it. It's a little different, **you need to explain**, from daily life. I even would have given an example of materials that decay, even just an example of a person loosing 3 percent of his weight, like, what is decay?

Example (b)2.

In the video screened in session 2, the students phrase a definition of a circle which is incorrect: “a circle is a central point with all points at the same distance from it”. The teacher writes it on the board, and gradually refines it by erasing and replacing several words, until the written definition is “a circle is all the points that are at the same distance from a certain point”. Olga comments:

- 380 Olga: Also it's worthwhile to explain what was not good.
 381 YP: Ah, you think this is something that's missing?
 382 Olga: I think it's missing.
 383 YP: But could it be that it would harm the students had he explained what was not good?
 384 Olga: I think it's important to explain, to make an emphasis on it.

Clearly, Olga's words “it's important to explain”, as well as Uri's words “you need to explain”, signify a more tolerant and less negative critique than the ones raised by Sapir and Olga, as demonstrated above. Such moderate disagreements are more likely to open up inquiries shared by the group, rather than a direct clash as seen earlier in Example (a)2.

Category (c): Inspecting possible reasons for observed teaching moves, even if the speaker disagrees with them or testifies that s/he would not have performed such moves in his/her class.

This category is less characterized by specific keywords, and more by whole sentences that convey a complex view on the subject at hand, as demonstrated in the next example.

Example (c):

This example goes back to the issue of writing “ $x^2=13^2$; $x=13$ ”. In contrast to Olga, Iris expresses a much more elaborated stance towards the choice not to write $x=-13$ on the board:

- 490 Iris: Perhaps it's a flaw... I would not leave on the board $x^2=13^2$ and then $x=13$, I would not leave this on the board.
 491 YP: Yes, I saw that it bothered you in the middle [of watching the video].
 492 Iris: Yes, you saw that I flinched. So I would have written $x_2=-13$, I would show that these are exactly these symmetrical points that we talked about, but I think he gained more than he lost by not paying attention to it, I think it's...
 493 YP: It bothered you, but...
 494 Iris: It's to his credit that he didn't correct this.
 495 YP: Why do you think, why didn't he correct it? Obviously he knows that it's plus-minus.
 496 Iris: [...] he didn't want to linger, he wanted to continue in the same line... I think it's nice, I'm not sure I could have done this.

Category C, as exemplified in Iris' stance, demonstrates the ability to view a certain practice from the perspective of another person.

In addition to these three categories of evaluative comments, we identified a fourth category associated with evaluation, which we termed “adhering to non-evaluative norms”. This category included all turns in which an explanation to the observed teaching actions was offered, without personal reservations, or turns in which the speaker objected to judgmental comments of peers.

The frequency of all four categories across the six analyzed sessions appear in Table 1.

Category	Session 1	Session 2	Session 5	Session 6	Session 7	Session 8
(a) Decisive negative judgment	26.67%	21.74%	20.75%	67.74%	0.00%	0.00%
(b) Disagreement, proposing improvement	34.67%	33.70%	0.00%	22.58%	20.00%	47.06%
(c) Justifying a different perspective	8.00%	32.61%	18.87%	9.68%	50.00%	17.65%
(d) adhering to non-evaluative norms	30.67%	11.96%	60.38%	0.00%	30.00%	35.29%

Table 1: Frequency of turns classified to categories a-d, out of all turns classified as evaluative

As can be seen, the amount of decisive negative judgmental comments decreased over the sessions, with the exception of session 6. We note that YP was displeased with his facilitation of session 6, and that this session merits a closer analysis, not carried out yet, in order to better understand its occurrences. We also note that the lack of judgmental comments in the last two sessions may be partly attributed to the fact that the videos were of lessons taught by team members, present in the discussions. We conjecture that gradual adaptation to the VIDEO-LM norms, combined with sensitivity to colleagues, has brought up this absence of decisive negative judgments.

Regarding the other types of evaluative comments, that are more productive in nature, no patterns were discerned in the analyzed data.

Theme	Session 1	Session 2	Session 5	Session 6	Session 7	Session 8
Evaluation	31.58%	17.78%	10.53%	16.67%	9.09%	8.33%

Table 2: Frequency of idea units classified to the theme of evaluation, out of all classified idea units

Inspecting the frequency of idea units classified to the theme of evaluation (see Table 2), clearly shows that teachers allocated less and less of their attention to the act of evaluation (again, with the exception of session 6), hence more attention was given to other foci of discussion (e.g., pedagogy oriented towards low achievers). We see this shift as a positive one; if the video is used more as an artifact around which to raise issues of practice, and less as a source for criticism, it is more likely that reflective thinking will take place.

Discussion and Conclusions

Our goal in this study was to examine the characteristics of peer-conversations taking place in a school-based VIDEO-LM club, facilitated by a fellow teacher who was an integral part of the group. We focused on one of the most important norms of VIDEO-LM sessions: avoiding judgmental talk. We constructed a categorization system that helps to distinguish between different types of evaluative comments. This is, to the best of our knowledge, a novel endeavor. The types of evaluative comments found in our analysis differ in their degree of potential productiveness: while type A is clearly unproductive (and this coheres with conclusions of previous studies), in type B teachers are able to move slightly beyond criticism and offer suggestions for improvements of teaching moves. However,

they still can only see the situation from their own perspective, thus their “span of possibilities”, or teaching repertoire, does not seem to expand. In type C evaluations, teachers move beyond their own perspective and provide a rationale for a teaching decision that they themselves would probably not have taken. This is a form that seems to be at least partially productive as it offers revisiting one’s habitual practices. Finally, type D comments can be seen as productive as they may result in reflecting upon and perhaps modifying one’s own practice.

Our findings show a decrease in evaluative discourse over the course of the year, at least in type A comments. This is an encouraging finding, as it points to shifting towards more productive forms of discussions. For facilitators, the awareness of the process by which such a decrease can occur is of practical importance. For researchers, this methodology can provide a fruitful path towards a better understanding of how and under which circumstances evaluative talk can be decreased.

References

- Arcavi, A., & Schoenfeld A. H. (2008). Using the unfamiliar to problematize the familiar: The case of mathematics teacher in-service education. *Canadian Journal of Science, Mathematics, and Technology Education*, 8(3), 280–295.
- Coles, A. (2010). Using video for professional development: A case study of effective practice in one secondary mathematics department in the UK. In M. Joubert (Ed.), *Proceedings of the British Society for Research into Learning Mathematics*, 30(2).
- Jaworski, B. (1990) Video as a tool for teachers’ professional development. *British Journal of In-Service Education*, 16(1), 60-65.
- Karsenty, R. (2018). Professional development of mathematics teachers: Through the lens of the camera. In G. Kaiser, H. Forgasz, M. Graven, A. Kuzniak, E. Simmt, & B. Xu (Eds.), *Invited Lectures from the 13th International Congress on Mathematical Education* (pp. 269-288). Hamburg: Springer.
- Karsenty, R. & Arcavi, A. (2017). Mathematics, lenses and videotapes: A framework and a language for developing reflective practices of teaching. *Journal of Mathematics Teacher Education*, 20(5), 433-455.
- Sherin, M. G. (2004). New perspectives on the role of video in teacher education. *Advances in Research on Teaching*, 10, 1-27.
- Sherin, M. G., Jacobs, V. R., & Philipp, R. A. (Eds.). (2011). *Mathematics Teacher Noticing: Seeing Through Teachers’ Eyes*. New York: Routledge.
- Sherin, M. G., & van Es, E. A. (2009). Effects of video participation on teachers' professional vision. *Journal of Teacher Education*, 60(1), 20-37.
- van Es, E. A. (2009). Participants' roles in the context of a video club. *Journal of the Learning Sciences*, 18(1), 100-137
- van Es, E., & Sherin, M. G. (2008). Mathematics teachers’ “learning to notice” in the context of a video club. *Teaching and Teacher Education*, 24, 244-276.

Construction of teachers' roles in collegial discussions

Odd Tore Kaufmann¹ and Andreas Ryve²

¹Østfold University College, Faculty of Education, Halden, Norway; odd.t.kaufmann@hiof.no

²Østfold University College, Faculty of Education, Halden, Norway & Mälardalen University College, Västerås, Sweden; Andreas.ryve@mdh.se

This paper investigates how teachers portray their teaching role in a professional-development community. By analyzing data from five groups, the goal of the study is to understand how teachers navigate between several discourses advocating different classroom practices and how the role is portrayed within these practices. In the majority of interactions, teachers position themselves within a traditional teacher discourse, an official Swedish discourse, or a reform-oriented discourse. The analysis provides examples of different teacher roles both within and between groups. Teachers who advocate a reform-oriented teacher role indicate that, in this type of role, they face challenges, and they stress that they need more specialized content knowledge.

Keywords: teacher role, pedagogical reform, traditional pedagogy, professional development.

Introduction

In initiatives to reform teaching and learning of mathematics, professional development of teachers is typically an essential part. A central component in such professional-development programs is often teachers' collegial discussions (Cobb & Jackson, 2012). Within professional-development programs, collegial discussions may be seen as a means to facilitate teacher development, which, in turn, is conceptualized as a means to improve and change classroom practices (Desimone, 2009). The opportunities created in collegial discussions for teacher development, however, are related to the characteristics of these discussions. In this paper, we examine one characteristic of collegial discussions: how the role of teachers is discussed and constructed. In particular, we are interested in understanding how teachers navigate between several discourses of advocated classroom practices and how the teacher role is portrayed within these practices. For this purpose, we conjecture that Sweden provides a productive case study. The argument for such a conjecture is that in the early years of the OECD, Sweden was one of the leading countries in educational policy. But with medium results on PISA tests and a shift toward students' learning outcomes, the mode of governance changed. Sweden has now become a country that needs advice in order to raise its educational performance (Pettersson, Prøitz & Forsberg, 2017). In the last decades, education systems have been radically and extensively transformed (Pettersson et al., 2017) and conflicting discourses about mathematics teaching and classroom practices are currently being exchanged in Sweden (Ryve, Hemmi, & Kornhall, 2016). In the traditional discourse, the instructive role of teachers is emphasized, whereas another official discourse emphasizes the role of the teacher as a motivator who should not disturb the students' development. Finally, a reform-oriented discourse stresses that teaching should be student centered and teacher led (see Ryve et al., 2016; Hemmi & Ryve, 2015). In this context, we pose the following research question:

How do teachers navigate in collegial discussions between discourses that advocate different classroom practices and the role of teachers within these practices?

We examine this question by analyzing five groups of mathematics teachers engaged in collegial discussions as part of a national large-scale professional-development program in Sweden.

Perspectives on the role of teachers

There seems to be a consensus within mathematics education research on how students learn mathematics, as exemplified in the publication by the National Council of Teachers of Mathematics (2000). This document contains recommendations for teachers whereby students should develop procedural knowledge and conceptual understanding, be able to reason mathematically, and be able to communicate mathematical ideas. To achieve such aims, teachers have to work differently than the “traditional” way of teaching. In traditional classrooms, students work with procedural tasks and have few opportunities to reason and draw the connection between key mathematical concepts. To achieve high-quality teaching, new forms of teaching are required, which are based on the thinking of students (Franke, Kazemi, & Battey, 2007).

Teacher role

Two decades ago, Fennema et al. (1996) asserted that the role of a teacher had evolved from demonstrating procedures to helping students build their mathematical thinking. They described two types of teachers: reform-oriented and traditional. Reform-oriented teachers think that students learn best by doing and learning mathematics on their own and that the teacher’s responsibility is to facilitate learning, and traditional teachers think that the teacher’s responsibility is to direct and control all classroom activities and that the students are responsible for absorbing and processing the given information. Even today, scholars and researchers use these labels to describe the role of the teacher (Louie, 2016). Although this is not a definite observation, in reform-oriented classrooms, teachers are responsible for facilitating discussions of the students’ approaches to mathematical tasks so that all students are actively involved in the discussion. The teacher role includes carefully inserting questions and explanations to ensure that the mathematical strategies and ideas of the students are clear to all learners (Franke et al., 2007).

The role of the teacher is important to describe a productive mathematical classroom and effective mathematics teaching. White (2003) emphasized the importance of the teacher role to include and influence the mathematical thinking of all their students. The teacher must value student ideas, explore student answers, incorporate students’ background knowledge, and encourage student-to-student communication. These two first themes are quite similar to Fraivillig, Murphy, and Fuson (1999) who describe successful teaching as eliciting student solution methods, supporting the students’ conceptual understanding, and extending the students’ thinking. Hahn & Eichler (2017) investigated the impact of a professional-development course on teacher’s beliefs toward teaching and learning mathematics. Three teachers were interviewed after the course; their responses with reference to teaching and learning of mathematics changed from a transmission-oriented view to a more constructivist-oriented view. Cai, Wang, Wang, and Garber (2009) summarized studies

from more than ten countries on what teachers emphasized as the characteristics of effective teaching and identified the following common themes for strong mathematical knowledge: All teachers highlighted that an effective teacher should have a strong background in mathematics. They should have a personality that conveys enthusiasm about teaching and students. Teachers should stimulate students' thinking and be good listeners to interact with their students more effectively. Lastly, the ability to manage a classroom was an important characteristic of an effective teacher.

As previously mentioned, a shift has occurred from teacher-centered teaching to student-centered teaching. Teachers who value student-centered teaching often use various strategies and tools to engage students in learning and tend to believe that students construct their own knowledge through active investigation and meaningful exploration (Kutaka et al., 2018). According to the standards of the National Council of Teachers of Mathematics (2000), which influence the Swedish national curricula, the student's role in the classroom is to engage in solving challenging, nonroutine tasks. Students should explain and justify their reasoning, make connections between solutions and key mathematical ideas, and share mathematical authority with the teacher in assessing what is a mathematically acceptable solution and on what grounds. To build on these standards, teachers should develop and build on the students' thinking in the classroom.

Method

Context

Between 2013 and 2016, the Swedish National Agency for Education launched a 649 million kr (approximately 65 million euro) curriculum-based professional-development (PD) project. Called "Boost for Mathematics" (Skolverket, 2018), this project aims to improve the teaching of mathematics. The most central components are 24 modules, eight per grade level (1–3, 4–6, and 7–9), developed to support teachers working in teams to plan, establish, and reflect on pedagogical practices in the mathematics classroom. The curriculum is distributed digitally from a website (<http://www.skolverket.se/kompetens-och-fortbildning/larare/matematiklyftet>) and includes articles, instructions, images, and video films. Each module is designed to support groups of teachers (during one semester) in engaging in eight iterations containing individual preparation, collective planning with colleagues, individual classroom teaching, and collective reflections on classroom instruction. In the PD program, teachers complete two modules, taking one module per semester. The PD sessions are held at each school with the support of a trained coach. This study is part of a larger study that was carried out in a Swedish municipality, wherein all public elementary schools ($n \approx 40$) participated in the PD program. This paper focuses on five randomly selected schools. The number of participants in these groups, including the coach, ranged from 6 to 12 persons for a total of 39 teachers. The data were collected by videotaping two meetings of each group, where the first meeting was based on collective planning with colleagues and the second meeting was based on collective reflections on classroom instruction. This study analyzes a total of 10 sessions, which were held quite early in the second module during the spring semester, ranging from 33 to 90 min (two sessions for five groups), with the average being 63 min.

Analysis

To understand how teachers navigate between different discourses when they engage in collegial discussions, we have chosen, as described in the context, to look deeper into collective planning and reflections on classroom instruction of five groups of teachers. The groups had been working together with “The Boost for Mathematics” for about six months and had established norms of participation that could affect teacher participation.

As part of data reduction, we began by identifying and transcribing all discussion episodes that related to the teacher role. In part of the analysis, we defined an episode of pedagogical reasoning as a coding unit:

Units of teacher-to-teacher talk allow teachers to exhibit their understanding of an issue in their practice. Specifically, episodes of pedagogical reasoning are moments within teachers’ interactions in which they describe issues in, or raise questions about, teaching practices that are accompanied by some elaboration of reasons, explanations, or justifications (Horn, 2007, p. 46).

Episodes of pedagogical reasoning in which teachers explicitly discuss their roles were analyzed. On the basis of the literature on the teacher roles and the Swedish context, we portray three different teacher roles that may appear in the discussion among the teachers in this project.

The traditional role: teachers emphasize themselves as instructors who offer clear explanations and present the content clearly. There is, therefore, no need for much knowledge about the students’ mathematical thinking. Furthermore, the teacher stresses classroom management.

The reform-oriented role: teachers emphasize the anticipation of and building on the students’ knowledge. Furthermore, the teachers design, initiate, and follow-up learning opportunities. Moreover, they challenge the students to think and interact. The teachers summarize and show connections, as well as discuss different solutions, mathematical ideas, and misconceptions with their students.

The official Swedish teacher role: teachers emphasize the motivation of students to make connections among different subjects. The teacher’s role is to be a coach and help make learning fun. Mathematical knowledge on the part of the teacher is not necessary, but social skills are essential. The teacher should be reactive, rather than proactive, to the student’s needs. This role could be compared to “discovery-learning” which, as proposed by Alfieri, Brooks, Aldrich, and Tenenbaum (2011), emphasizes students’ motivation, discovery of facts and relationships by students themselves, and that the teacher must provide guidance only on the students’ request.

Results

The general overview of the episodes of pedagogical reasoning shows that all the three discourses were present in the teachers’ collegial discussions. We identified 13 episodes in which the teachers emphasized the traditional role, 16 episodes that represented the official role and 14 episodes that represented a reform-oriented role. Even though the total number of these three discourses were

quite similar, we found differences among the groups. In one group, we identified seven episodes representing the traditional role and one episode representing each of the other two groups. In another group, there were five episodes representing a reform-oriented role and two episodes representing the official role. Depending on different situations, teachers also navigate between roles. For instance, the teachers' role is portrayed differently when they discuss the introduction of a lesson, often portrayed as a traditional teacher role to introduce and show students procedures. In the middle of the lessons, students mainly worked in pairs, and a more apparent official teacher role appeared to motivate the students such that all students took part in the discussion. The episodes also revealed differences in how the teachers regarded their own roles. For example, when the teachers discussed the reform-oriented role, they expressed, to a great extent, the challenges of such a role. In the remainder of this chapter, we present some examples of episodes representing the different roles. In addition, the episodes illustrate the affordances and constraints related by the teachers to the different roles. All transcribed materials were translated from Swedish and all the names are pseudonyms.

This excerpt illustrates a traditional teacher role. In this group, each teacher presented and discussed their reflections on their own classroom instruction. In this episode, one of the teachers, Louise, emphasized her own role as an instructor who offered explanations of the content. She talked more about what she did as a teacher (I wrote, I took) than about the students' roles.

Louise: First, we had that thought-board (Swedish: Tanketavla) in common and I wrote this on the board because when I had done this and copied up I wrote everyday language and mathematical language so they could see which one. Then I gave them a very easy task, I took seven plus ten, and started in the middle. I had not even thought that we could start other places. Then we made it in common and I used an example, and I noticed that there were some who wrote exactly the same words that I had written. They wrote it and drew exactly the same.

Further on in the same discussion, there are several instances of these types of descriptions of the teacher's role, such as "First, I explained what is a thought-board and made a presentation in PowerPoint. After that, I tried to explain what everyday language is and what mathematical language is as well." The teachers speak of the role of the teacher as that of a transmitter of knowledge who explains to students what to do and models the tasks for the students. The students are, in a way, invisible in these discussions because, when the teachers talked about the lessons, they base the discussion on the task, as opposed to how the students worked with these tasks.

In the next excerpt, Mike reflects on his last lesson. His plan was to spend time discussing the tasks. Realizing that this plan would not work, he let his students finish their work. He assumed the role of a motivator who guided and supported his students but would not disturb them when they were working. His role was more that of a coach.

Mike: They worked with a problem attached to which I thought would be the fraction and percentage we have worked with from 32 rich mathematical problems. This

related to going to the theatre with different prices. What amazed me was that it was so astoundingly slow at the beginning when the students were going to work with the problem. I do not know if it was, I am not sure, because of the interruption or if their brains had an overturn or whatever it was. Because I feel that I did not intend to spend so much time, because I thought that these two first tasks they will blow away so I really could spend time on showing and discussing in whole class and so on. No, this turned out to be a lot of pilotage and support and everything we talked about earlier.

In episodes identified as the official role, the teachers are in the background motivating their students, and encounter a rather passive teacher role. They often reflect on their lessons regardless of whether their students had a fun time. Furthermore, in such episodes the teacher does not intend to discuss the mathematical content with their students other than to prepare the students for the mathematical content. In the next example, Amy describes the teacher role as one of asking questions to move the students forward. She supports the students' thinking by letting them present their thoughts. Amy wants to build upon their thinking using examples from them that are different but correct. In addition, she wants to challenge their thinking. She describes her role as proactive rather than reactive. We can find several representatives of a reform-oriented teacher role in how Amy reflects on her own role as a teacher.

Amy: When you (teacher) ask better questions, or better questions, but questions that make their reasoning go forward. But at this point I am in the start phase. It is great and I have written them on a piece of paper so that I can have a little note to watch and remember and get going. Ehh. Yes and then even more, I do it today, but even more show in different ways to think that the children can come up and show themselves, or like today, when we should make the diagnosis, and introduced to the children that we used different examples that they could see that aha, I thought in this way, and even that might be right and so.

Several episodes in which the teachers related to the reform-oriented role reveal the challenges of such a role. Sarah expresses her limitation about the mathematical concept of "relationship." She finds it difficult to understand. She notices that, in her student-centered teaching, she has problems with teacher-led questions to guide the students further because of her weak understanding of the concept of "relationship." Even if she supports the reform-oriented teacher perspective, she faces difficulties in implementing it:

Sarah: I am very inexperienced in talking about relationships to lead him in a good way. I have another group that is also on their way but they write in a different way. Here, I feel that I need to develop because they have written what they see as a pattern, and already at an early stage, they say we have seen the pattern. I feel when I explain this, my question is— what is a relationship, what is it?

Discussion and conclusion

The preceding excerpts are presented to show how teachers navigate between several discourses of advocated classroom practices and how the teacher role is portrayed within these practices. We found three different teacher roles: a traditional-oriented teacher, a reform-oriented teacher, and an official discourse-oriented teacher. The portraying of the teacher role varies both within a group of teachers and between groups. Within a reform-oriented perspective, the findings reveal a particular discourse describing how teachers portray their role. Teachers find this type of role quite hard to fill in their classroom. They especially emphasize the challenge of acquiring the requisite specialized content knowledge (Ball, Thames, & Phelps, 2008). In a way, teachers have remained in the previously dominant discourse in Sweden of encouraging and discussing mathematics, and they do not highlight other parts of the reform discourse that relate to the role of the teacher in setting goals, challenging, conducting discussions, etc. The findings also show that teachers who portray their role as official often blame students when they reflect about their own role in the classroom and their lessons. A reform-oriented teacher with a student-centered and teacher-led lesson does not blame student difficulties on inherent traits. This can be helpful in understanding how teachers use students' ideas as a support in teaching (Jackson, Gibbons, & Sharpe, 2017).

How teachers talk about their own role can be helpful in understanding their potential for learning in collaborative meetings to improve and change classroom practices (Desimone, 2009). The findings reveal conflicting discourses about the teacher role and classroom practices (Ryve et al., 2016). Such conflicting discourses may affect the potential for teacher learning as they are not made explicit and resolved.

This paper has focused on how teachers portray the teacher role. Further developments and studies will compare this evolution between different groups of teachers and explore the connections between the teacher and student roles.

References

- Alfieri, L., Brooks, P.J., Aldrich, N.J., & Tenenbaum, H.R. (2011). Does discovery-based instruction enhance learning? *Journal of Educational Psychology*, *103*(1), 1–18.
- Ball, D.L., Thames, M.H., & Phelps, G. (2008). Content Knowledge for Teaching: What Makes It Special? *Journal of Teacher Education*, *59*(5), 389–407.
- Cai, J., Wang, T., Wang, N., & Garber, T. (2009). Studying effective teaching from Teachers' perspectives: The journey has just begun. In J. Cai, G. Kaiser, G. Perry, & N.Y. Wong (Eds), *Effective mathematics Teaching from teacher' perspectives: National and cross-national studies* (pp. 303–317). Rotterdam: Sense Publisher.
- Cobb, P., & Jackson, K. (2012). Analyzing Educational Policies: A Learning Design Perspective, *Journal of the Learning Sciences*, *21*(4), 487–521.
- Desimone, L.M. (2009). Improving impact studies of teachers' professional development. Toward better conceptualizations and measures. *Educational Researcher*, *38*(3), 181–199.

- Fennema, E., Carpenter, T.P., Franke, M.L., Levi, L., Jacobs, V., & Empson, S.B. (1996). A longitudinal study of learning to use children's thinking in mathematics instruction. *Journal for research in Mathematics Education*, 27(4), 403–434.
- Fraivillig, J.L., Murphy, L.A., & Fuson, K.C. (1999). Advancing children's mathematical thinking in everyday mathematics classroom. *Journal for Research in Mathematics Education*, 30(2), 148–170.
- Franke, M.L., Kazemi, E., & Battey, D. (2007). Mathematics teaching and classroom practice. In F. K. Lester Jr, (Ed.), *Second Handbook of Research on Mathematics Teaching and Learning* (pp. 225–256). Charlotte, NC: Information Age Publishers.
- Hahn, T. & Eichler, A. (2017). Changes in beliefs of teachers on a PD course after reflecting on students' learning results. In T. Dooley, & G. Gueudet (Eds.). *Proceedings of the Tenth Congress of the European Society for Research in Mathematics Education (CERME 10)* (pp. 2884–2892).
- Hemmi, K., & Ryve, A. (2015). Effective Mathematics Teaching in Finnish and Swedish Teacher Education Discourses. *Journal of Mathematics Teacher Education*, 18(6), 501–521.
- Horn, I.S. (2007). Fast Kids, Slow Kids, Lazy Kids: Framing the Mismatch Problem in Mathematics Teachers' Conversations. *Journal of the Learning Sciences*, 16(1), 37–79.
- Jackson, K., Gibbons, L., & Sharpe, C.J. (2017). Teachers' views of students' mathematical capabilities: Challenges and possibilities for ambitious reform. *Teachers College Record*, 119(7), 1–43.
- Kutaka, T.S., Ren, L., Smith, W.M., Beattie, H.L., Edwards, C.P., Green, J.L., ... & Lewis, W.J. (2018). Examining change in K-3 teachers' mathematical knowledge, attitudes, and beliefs: the case of Primarily Math. *Journal of mathematics teacher education*, 21(2), 147–177.
- Louie, N.L. (2016). Tensions in equity- and reform-oriented learning in teachers' collaborative conversations. *Teaching and Teacher Education*, 53(1), 10–19.
- National Council of Teachers of Mathematics. (2000). *Principles and standards for school mathematics*. Reston, VA: National Council of Teachers of Mathematics.
- Pettersson, D., Prøitz, T.P., & Forsberg, E. (2017). From role models to nations in need for advice: Norway and Sweden under the OECD's magnifying glass. *Journal of Education Policy*, 32(6), 721–744.
- Ryve, A., Hemmi, K., & Kornhall, P. (2016). *Skola på vetenskaplig grund [School on a scientific basis]*. Stockholm: Natur & Kultur.
- Skolverket (2018). *Matematiklyftet [Boost for Mathematics]*. Retrieved from <https://larportalen.skolverket.se/#/moduler/1-matematik/alla/alla>
- White, D.Y. (2003). Promoting productive mathematical classroom discourse with diverse students. *Mathematical Behavior*, 22(1), 37–53.

From instrumental to relational – Malawi mathematics teacher educators’ research lessons

Mercy Kazima¹, Janne Fauskanger² and Arne Jakobsen³

¹Department of Curriculum and Teaching Studies, University of Malawi, Zomba, Malawi;
mkazima@cc.ac.mw

²University of Stavanger, Faculty of Arts and Education, Department of Education and Sports Science, Stavanger, Norway; janne.fauskanger@uis.no

³University of Stavanger, Faculty of Arts and Education, Department of Education and Sports Science, Stavanger, Norway; arne.jakobsen@uis.no

This paper discusses the type of research lesson planned by mathematics teacher educators participating in a lesson study cycle. An earlier study found that mathematics teacher educators’ research questions were not clearly formulated and as a reason, their initial lesson plans for research lessons did not make student teachers’ learning visible. This follow up study analysed the lesson plans further before and after comments from knowledgeable others and looked into the type of lesson planned to be conducted, with the hypothesis that the type of lesson would determine the type of student teacher learning made visible. Data in form of lesson plans were collected from five teacher education colleges. Theory driven content analyses was used and Skemp’s (1976) categories of instrumental and relational teaching were the point of departure. The findings include that the initial lesson plans were mostly presenting instrumental type of lessons, but after comments from the knowledgeable others, the revised lesson plans were presenting a more relational type of lessons with student teachers’ learning more visible.

Keywords: Malawi, mathematics teacher education, lesson study, type of research lesson.

Introduction and background

Lesson study is a new concept in Malawi teacher education and it is also relatively new in Malawi education as a whole. Lesson study was introduced to mathematics teacher educators in all public primary teacher education colleges as a form professional development and as part of a five year project which aims at improving the quality of mathematics teacher education in Malawi (Kazima & Jakobsen, 2018). The project is wide and professional development of mathematics teacher educators is one out of five components. In the project, we decided on using lesson study as a model for professional development because lesson study offers the opportunity for the teacher educators to work together and to study and learn from their own teaching. Since it was the first experience of lesson study in Malawi teacher education, we developed a research project, alongside the professional development, to study the teacher educators’ understanding of lesson study. The research was informed by previous studies of lesson study outside Japan as discussed below. The findings from our first study (Fauskanger, Jakobsen & Kazima, 2018) prompted us to do this follow up study where we ask the following research question: Which type of research lesson do Malawi teacher educators plan in their first experience with lesson study? Details are discussed in the following sections. First,

we situate our study by discussing relevant previous research on the use of lesson study in new contexts outside Japan.

Lesson study originated from Japan where it has been practiced for more than a hundred years. It is so much part of the teaching profession that it is like air to teachers in Japan (Fujii, 2014). Studying own teaching and learning from students' learning is key to lesson study in Japan, thus having a clear research question and carefully planning a research lesson that reveals students' learning are important aspects of Japanese lesson study (Takahashi, 2013). Due to its success in Japan, lesson study has been introduced to many other contexts outside Japan and many report on benefits that are experienced by teachers or student teachers that participated in the lesson studies (da Ponte, 2017). However, many also report on challenges that participants experience when implementing lesson study for the first time. There are at least four related challenges that inexperienced participants face. First, they do not always see the importance of a research question as a starting point for planning their research lessons (Bjuland & Mosvold, 2015; Fujii, 2016). Second, they often overlook the importance of predicting students' responses (Lewis, Perry, & Murata, 2006). Third, they do not emphasise on planning focused observation of students' learning (Bjuland & Mosvold, 2015, Fujii, 2016). Fourth, they do not plan for teaching activities in order to make students' learning visible (Bjuland & Mosvold, 2015).

Lesson study in Africa has been reported used in a few countries including Malawi, Uganda and Zambia (Fujii, 2016, Ono & Ferreira, 2009). In these three countries, the reported lesson study was initiated by some Japan related initiatives supported by the Japan International Consultative Agency as part of aid towards the education sector. Fujii (2014) studied the lesson study in Malawi and Uganda schools and revealed a number of misconceptions among the teachers implementing the lesson study. Some of the misconceptions were that the teachers did not distinguish lesson study from workshop. The after teaching discussion often focused on the teacher and how the teacher can improve and not necessarily on students' learning. He also found that re-teaching of the research lesson was taken as necessary regardless of the outcomes of the first teaching. These misconceptions illustrate further the challenges of introducing lesson study to new context outside Japan.

In more recent years, there has been growing use of lesson study in teacher education. Larssen et al. (2018) report from a review of lesson study in teacher education where they found that there were variations in the way lesson study was adapted to new contexts, for instance, how observations were conducted. This emphasizes the challenges of lesson study when introduced to inexperienced participants in new contexts.

Methodology

Data were collected within the professional development that was designed for the Malawi mathematics teacher educators by the wider project. For the purpose of this paper, the lesson plans analysed are produced by all mathematics teacher educators at five teacher education colleges. Two teacher education colleges participated in the first year, and three participated in the second year. The professional development started with a three day workshop that introduced the teacher educators to lesson study. The teacher educators were also introduced to concept study of multiplication and fractions, the two concepts which the teacher educators suggested they find most difficult to teach

and would like to research on. During the three days, the teacher educators also worked in groups and started designing their research lesson. The three authors of this paper facilitated the workshop and acted as knowledgeable others in discussing the planned lesson study. After the workshop teacher educators from each teacher college continued working together drafting their initial lesson plan, before it was sent to the knowledgeable others for comments. The knowledgeable others provided comments and encouraged the teacher educators to revise and improve their lesson plans. The process from the introductory workshop to final lesson plan took at least about four months (May-September). In this study, we collected all initial draft lesson plans and final lesson plans after revisions.

The lesson plans were analysed using theory driven content analysis (Hsieh & Shannon, 2005). The first study drew from literature and focused on three aspects of research question, prediction and observation (Fauskanger, Jakobsen & Kazima, 2018). In this follow up study, we draw on Skemp (1976) and use the two categories of teaching mathematics (i) instrumental and (ii) relational as the point of departure. Skemp (1976) divided teachers' mathematical understanding into two divergent categories: (i) Instrumental understanding—a lower version of understanding—for example rote memorization of algorithms and (ii) Relational understanding, which encompasses a deep, conceptual understanding. When relating his framework to teaching, Skemp (1976) suggests that a teacher who teaches from an instrumental paradigm cannot produce students who learn mathematics relationally. More recent studies confirm that conceptual and connected mathematical knowledge is a premise for conceptual teaching (Tchoshanov, 2011). This highlights the importance of studying whether Malawi teacher educators' research lessons tend to be of 'the type' instrumental or 'the type' relational.

Results and discussion of findings

Teacher College A

The research lesson plan from Teacher College A focused on multiplication of two-digit numbers using different strategies. In their initial lesson plan draft, the teacher educators planned that student teachers would be asked to use as many strategies for multiplying two-digit numbers as possible, and then later share their strategies with the rest of the class. Then student teachers would work in groups to critique the different strategies that were presented. The research lesson was planned to be an instrumental understanding type of lesson (Skemp, 1976) because the emphasis was on the strategies or algorithms and on how to perform the algorithms. There was no explicit emphasis on understanding why the strategies would work, thus the research lesson focused on what to do and not the reasoning behind the strategies. In Skemp's (1976) words, the lesson seemed to be about 'rules without reason'. However, there were opportunities for relational understanding (Skemp, 1976) where the lesson plan suggested that student teachers should present their work on the chalkboard. The interaction that could go on between the student teachers presenting their work and the rest of the class could include explaining how as well as why their strategies work. Another opportunity was where the student teachers were going to be asked to critique the different strategies presented for multiplying two-digit numbers. This could include discussions of the mathematical reasoning behind each strategy. The lesson plan was silent on this and therefore in the enactment of the plan the teacher educators could easily miss the opportunity.

Comments from the knowledgeable others were explicit in pointing out that explanations of reasons why the strategies work should be included in the plan. For example they commented:

(...) one important point is not only to ask them [student teachers] to demonstrate how to solve [the tasks] using their own strategy, but to explain WHY their strategy/algorithm work – this is important. For example, many of the algorithms use the [distributive] property that $67 \times 28 = (60 + 7) \times (20 + 8)$ and then different ways of multiplying the parenthesis is behind the algorithm. (...) So we propose to ask them [student teachers] to demonstrate and explain why the algorithm work.

After revision, Teacher College A's lesson plan included suggestions from the knowledgeable others in that it was explicit that student teachers will be required to give reasons for why their strategies would work. As an example, the teacher educators added to the goals of the lesson the statement: "student [teachers] will explain why different strategies work." The lesson structure also changed from focusing on student teachers practicing different strategies of multiplying two-digit numbers to student teachers' understanding of, and reasoning behind, the different strategies of multiplying two-digit numbers. The teacher educators wrote in the revised plan that they "want students to understand and appreciate that there are a variety of strategies when multiplying numbers and reasons why these algorithms work." In relation to evaluation, the teacher educators wrote "[a]re student [teacher]s able to justify their strategies" as one of their criteria for evaluating their research lesson. This indicates that the revised lesson plan was not only focusing on the 'what' to do when multiplying two-digit numbers, but also on the 'why', thus a movement towards a relational understanding (Skemp, 1976) type of lesson.

Teacher College B

The first research lesson plan from Teacher College B, started with a demonstration by the teacher educator on how to represent multiplication of mixed numbers using paper as a resource. This was followed by the teacher educator asking the student teachers to work in groups and come up with other resources they can use for modelling the same multiplication and finally for the groups to demonstrate their representations to the rest of class. The lesson had the potential to be relational if the groups' demonstrations and discussions of their representations included justifying why their representations would work. However, the lesson plan did not indicate that such discussions would take place. Without the justification and mathematical explanations of why the representations work, then the lesson would be only for instrumental understanding with student teachers copying what the teacher educator did without much understanding. Comments on this first draft of the lesson plan from the knowledgeable others were explicit in suggesting that the teacher educator should not demonstrate and let student teachers copy their procedure, but rather should ask student teachers to do the task as a problem solving activity. The knowledgeable others wrote:

... before demonstrating, you are recommended to invite the students to solve the problem. Only if you invite them to find solutions by themselves, you will be able to learn about their strategies. It would also be interesting if you started the lesson with a more open problem for the students to solve. Problem solving makes it easier for you to observe students' strategies and their learning.

This change in focus has the opportunity to make the research lesson become a relational understanding type of lesson (Skemp, 1976). The knowledgeable others also commented that the

lesson should not only focus on modelling and how to do the different representations using various resources but should also emphasise why each of the representations works. The teacher educators at College B revised their research lesson plan and implemented the suggestions from the knowledgeable others. The revised lesson plan started with the teacher educators presenting a mixed number multiplication problem and asking the student teachers to work in groups and to investigate possible resources they can use to model the mixed number multiplication. This change from demonstrating for the student teachers to asking them to investigate in a problem solving manner, made the lesson shift from the instrumental lesson it was at first to a relational type of lesson. The rest of lesson plan, however, was still not explicit on soliciting justifications and mathematical explanations for the resources and modelling presented by the student teachers. Thus, the research lesson could still miss opportunities for more relational understanding by student teachers.

Teacher College C

The initial draft lesson plan from Teacher College C was for a research lesson that started by asking student teachers to model addition of two fractions with the same denominator. According to the lesson plan, this was something that the student teachers had done in the previous lessons. The lesson proceeded to group activity of modelling of addition of fractions with different denominators with step by step instructions from the teacher educator. The lesson was an instrumental understanding (Skemp, 1976) type of lesson because the student teachers could have easily completed all the tasks by following the instructions without understating the mathematical reasoning behind the procedures. Comments from the knowledgeable others suggested changes that could lead to a more relational type of lesson, but were not explicit on this. For example, where teacher educators wrote that they intended to invite the student teachers “to model addition of $2\frac{3}{5} + 1\frac{1}{2}$ using papers ... [using] the following procedure – model whole’s i.e. 2 and 1 by ensuring that the size [of the whole] is the same.” The knowledgeable others commented that: “you can let the student teachers reflect on this and not tell them immediately that the size (area) has to be the same - so this can also be a point of observation. Do the student teachers understand that the size has to be the same?”

Although not explicit, the knowledgeable others suggested that student teachers should not be told immediately what to do but should be left to first think for themselves and find their own strategies of solving the problems presented. This was important because it could shift the instrumental lesson to a relational lesson, and it could also offer opportunities for teacher educator to observe student teachers’ learning.

The revised research lesson plan by Teacher College C took the advice of the knowledgeable others. The revised lesson plan was a relational type of lesson because the teacher educator posed the questions to the student teachers and allowed them to find solutions without giving the step by step instructions. The lesson plan also included prompts for asking the student teachers to explain their solutions. For example, the teacher educators wrote that they would ask the student teachers to “explain their solution strategies to the class” and to “facilitate student [teacher]s’ discussion on their solutions in order to understand ideas behind the solutions.” These changes have the potential to bring out student teachers’ reasoning and justifications for their solutions into the lesson, and might result in a relational understanding type of lesson (Skemp, 1976).

Teacher College D

Teacher College D's research lesson plan was on division of fractions. Their initial lesson plan started with a demonstration by the teacher educator modelling division of two fractions using the number line. This was followed by an activity for student teachers to do in groups. The activity was another example of division of two fractions and student teachers were to model using number line in the same way as demonstrated by the teacher educator. Finally, there were more exercises for the student teachers to practice. The student teachers could do these activities by copying the teacher educator's example without much understanding. This was a typical instrumental type of lesson where the teacher educator demonstrates an example and the student teachers observe and later imitate and copy the process on other examples. Comments from the knowledgeable others suggested that the teacher educators should not demonstrate how to model the division of fractions on the number line, instead should just pose the question to the student teachers and let them think and come up with their own ways of modelling the division; "This might be a nice way to start the lesson ... if you start with a more open approach, it is easier to observe students' thinking". The teacher educators were also challenged to think more carefully about the pairs of fractions they use as examples or tasks in the division of fractions lesson because some pairs of division are easier to model than others. For example the knowledgeable others wrote: "This [referring to $1\frac{1}{5} \div 1\frac{1}{6}$] is really difficult to model. Why have you chosen these fractions for the students to model on the number line? You are recommended to think carefully about which fractions to use and in what order".

In reaction to these comments, the teacher educators revised the research lesson plan to a more relational type of lesson. The revised lesson plan started with easier fractions to model and posed the question to student teachers to work in groups and find ways of modelling the division of given fractions. The group activity was followed by individual work where student teachers were asked to model more division of fractions tasks. This lesson had the opportunity to be a relational type of lesson because the student teachers would not be told what to do and copy, instead they would be invited to think, discuss and to find ways of solving the problems. However, the lesson plan did not emphasise on student teachers justifying their solutions or explaining their reasons, therefore these could be missed and that would make the lesson less relational than it could be.

Teacher College E

The research lesson by Teacher College E was on modelling multiplication of mixed numbers. The initial draft lesson plan was the only one of the five initial lesson plans that presented a relational understanding type of lesson. The lesson plan started by posing a problem; to model of $3 \times \frac{1}{2}$, for student teachers to do without giving them steps of procedure to follow. The lesson plan also included asking questions that would seek student teachers' understanding of mathematical reasoning behind the tasks. For example, they wrote: "Ask student [teacher]s to explain the meaning of $3 \times \frac{1}{2}$ " and "Encourage student [teacher]s to demonstrate and explain their solutions." The whole research lesson was structured in four parts as follows: (i) introduction, (ii) posing the problem, (iii) individual problem solving and (iv) discussing student teachers' solutions. This might result in relational understanding lesson because students would be made to 'problem solve' and discuss their solutions, thus they would understand the strategies as well as the mathematical reasoning behind the strategies.

Comments from the knowledgeable others further encouraged the relational understanding type of lesson although not explicitly. For example in response to the lesson plan's point of evaluation that stated "Do students understand the meaning of $3 \times \frac{1}{2}$ ", the knowledgeable others wrote: "How will the observers observe if the students understand? Through listening to discussions? Through analysing their written work?" This was suggesting that the teacher educators should be more specific in the activities that would display student teachers' relational understanding. However, there was no revised lesson plan from Teacher College E.

Summary and conclusion

Table 1 summarises the type of lessons from the five teacher education colleges.

Initial draft plan	Final plan
4 (out of 5) research lesson plans mostly instrumental types of lessons and following the common general format: <ul style="list-style-type: none"> - Teacher educator demonstrating example - Similar activity for student teachers - Class discussion - Conclusion 	All 4 lesson plans more relational types of lessons more focused on student teachers and their learning. General format changed towards: <ul style="list-style-type: none"> - Teacher educator posing problem - Student teachers use their own methods to solve problems - Teacher educator observing student teachers - Student teachers discussing their solutions to problems
One lesson plan of relational type of lesson: <ul style="list-style-type: none"> - Problem solving approach 	Lesson plan not revised

Table 1: Summary of type of lessons by the 5 teacher colleges

Looking at all five teacher colleges, our analysis indicates that four of the five colleges initially had instrumental type of research lesson in their plans for the research lesson while only one college had a research lesson plan indicating a relational type of lesson. After comments and encouragement from the knowledgeable others to think about student teachers' learning and about how to make this learning visible in the research lesson, all the four lesson plans improved and became more relational type of lessons. This suggests that focusing on how to make student teachers' learning visible when planning research lessons can shift a lesson plan from an instrumental type to more relational type of research lesson. A relational type of lesson, which allows problem solving by the student teachers, enables student teachers' learning to be visible and therefore more appropriate for observation of student teachers' learning in lesson study. To plan such a lesson is however, challenging (Bjuland & Mosvold, 2015). The finding that the type of research lesson improved to make student teachers' learning visible suggests that lesson study has the potential to be a useful model for teacher educators' professional development in Malawi. . The study informs further work and other researchers in the field of lesson study the important role of knowledgeable others (Takahashi, 2013) for newcomers to lesson study and one important implication for future research would be to learn more about this role.

Acknowledgment

The study was kindly funded by the Norwegian Programme for Capacity Building in Higher Education and Research for Development (NORHED).

References

- Bjuland, R., & Mosvold, R. (2015). Lesson study in teacher education: Learning from a challenging case. *Teaching and Teacher Education*, 52, 83–90.
- da Ponte, J. P. (2017). Lesson studies in initial mathematics teacher education. *International Journal for Lesson and Learning Studies*, 6(2), 169–181.
- Fauskanger, J., Jakobsen, A., & Kazima, M. (2018). Malawi mathematics teacher educators' understanding of Lesson Study. Manuscript submitted for publication
- Fujii, T. (2014). Implementing Japanese lesson study in foreign countries: Misconceptions revealed. *Mathematics Teacher Education and Development*, 16(1), 2–18.
- Fujii, T. (2016). Designing and adapting tasks in lesson planning: A critical process of lesson study, *ZDM – The International Journal on Mathematics Education*, 48(4), 411–423.
- Hsieh, H. F., & Shannon, S. E. (2005). Three approaches to qualitative content analysis. *Qualitative Health Research*, 15(9), 1277–1288.
- Kazima, M., & Jakobsen, A. (2018). Improving quality and capacity of mathematics teacher education in Malawi project: collaboration between University of Malawi and University of Stavanger. Manuscript submitted for publication
- Larsen, D. L. S., Cajkler, W., Mosvold, R., Bjuland, R., Helgevold, N., Fauskanger, J., . . . Norton, J. (2018). A literature review of lesson study in initial teacher education. Perspectives about learning and observation. *International Journal for Lesson and Learning Studies*, 7(1), 8–22.
- Lewis, C. C., Perry, R., & Murata, A. (2006). How should research contribute to instructional improvement? The case of lesson study. *Educational Researcher*, 35(3), 3–14.
- Ono, Y., & Ferreira, J. (2009). A case study of continuing teacher professional development through lesson study in South Africa. *South African Journal of Education*, 30(1), 59–74.
- Skemp, R. (1976). Relational understanding and instrumental understanding. *Mathematics Teaching*, 77, 20–26.
- Takahashi, A. (2013). The role of the knowledgeable other in Lesson Study: examining the final comments of experienced Lesson Study practitioners. *Mathematics Teacher Education and Development*, 16. Retrieved 4 April 2018 from <https://www.merga.net.au/ojs/index.php/mted/article/view/204/192>.
- Tchoshanov, M. A. (2011). Relationship between teacher knowledge of concepts and connections, teaching practice, and student achievement in middle grades mathematics. *Educational Studies in Mathematics*, 76(2), 141–164.

How can we help teachers using guided discovery method, who have not used it before

Eszter Kovács-Kószó¹, Katalin Gosztonyi² and József Kosztolányi¹

¹University of Szeged, Bolyai Institute, Szeged, Hungary; k.k.eszter8@gmail.com,
kosztola@math.u-szeged.hu

²Eötvös Loránd University, Hungary; kgosztony@caesar.elte.hu

Keywords: Guided discovery, group working, series of problems.

Introduction

In Hungary, there is a tradition of mathematics education focusing on problems and on mathematical discovery that we call Guided Discovery approach. This method was elaborated in the 20st century, first of all for the education of gifted students. Later the reform movement led by Tamás Varga in the 1960s and 70s developed a coherent general educational program for primary and lower secondary schools based on this approach (Pálfalvy, 2000). Although Hungarian specialists of mathematics education consider the approach actual and relevant until today, only a narrow circle of teachers follow it, and its large-scale dissemination remains problematic.

In my PhD research project, launched in September 2018, I would like to contribute to the elaboration of a more successful dissemination processes. In my analyses, I want to focus on one significant aspect of teaching by Guided Discovery: on the interactions between teacher and pupils, and amongst students. I plan to realize experimentations with teachers are willing to this approach and who want to discover it to improve their teaching practice. My purpose is to give an aid to teachers which could improve the number of “rich interactions” in their classroom.

Experiments

I plan to follow two directions. The first one is based on my previous project held during my master studies, when I have tried to develop teaching projects based on group work. The second direction will be realized in collaboration with the members of the MTA-ELTE Complex Mathematics Education Research Group. A subgroup of this research project focuses on one of the specificities of Varga’s Guided Discovery approach: the planning of teaching trajectories in form of series of problems (Gosztonyi 2018). They examine the work with series of problems of expert teachers following the guided discovery approach, and they elaborate a commented collection of examples of series of problems to initiate other teachers into the approach.

In my experimentations first, I will analyze some lessons focusing on the interactions in both cases. Then I will try to help to the teacher to use one of the methods mentioned above and check the following lessons in the view of how the selected method could improve the quality of the teaching. Especially I want to answer the following question: Does the number of ‘rich interactions’ rise as an influence of the new way of teaching? If the answer will be ‘yes, it does’, I believe the quality of the teaching will rise also.

The project above has five parts. The first and most important element is the definition of ‘rich interactions’. If the number of ‘rich interactions’ and its ratio with all interaction is rising, it shows at least three things: students become more active and thinking more intensively about the mathematical content, realize more effectively what they have not understand yet and become braver about asking from the teacher or from another student.

Secondly, I will try to help the teacher to familiarize with the ‘new’ method. This will be different in the two threads of the project. In the first one, the teacher will get a complete plan for a period of teaching which will take about five to ten lessons. During this time group learning will dominate on the lessons which is unusual in Hungarian practice so the teacher will get a short, practical summary about how he or she should organize and control work.

In the second project the teacher will get a commented series of problems issued from the above-mentioned collection of the MTA-ELTE project. It is not necessarily connected with the following topic of the lesson, it is just an example. Then he or she will get time to measure it. The purpose is to help the teacher be able to create his or her own series of problems for his or her own class for the next period. During this he or she will have the opportunity to consult with one of the expert teachers mentioned above.

The third part will be the classroom realization. I will film the lessons and let the teacher work alone with the class.

After this, in the fourth part I will take an interview with the educator about how useful or efficient the experiment was in his or her opinion and I would be also interested in what he or she sees the most critical points of the lessons.

The last part will be the analysis of the data collected. The whole experiment will be repeated for three times in case of both versions. We hope this experiment will help us to support enthusiastic teachers to improve their method.

The poster

The presented poster is available through the following link:

<https://drive.google.com/file/d/10ZRMvctth-snOqwTvG7e8dGqsyWOnhOqK/view?usp=sharing>

Acknowledgment

Eszter Kovács-Kószó is grateful for the scholarships of New National Excellence Program of the Ministry of Human Capacities of Hungary (ÚNKP-18-3-II-SZTE-13).

References

- Gosztonyi, K., Vancsó, Ö., Pintér, K., Kosztolányi, J., & Varga, E. (to be published). Varga’s “Complex Mathematics Education” *Reform: at the crossroad of the New Math and Hungarian Mathematical Traditions*. Accepted to the ICMI Study 24: Curricular Reforms conference.
- Gosztonyi, K. (2018). *Teachers documentary work with series of problems*. In V. Gitirana, T. Miyakawa, M. Rafalska, S. Soury-Lavergne, & L. Trouche (Eds.), *Proceedings of the Re(s)ources 2018 international conference* (pp. 195–198). ENS de Lyon.

Diagnostic competence of future primary school teachers hypothesizing about causes of students' errors

Macarena Larrain

Universität Hamburg, Germany; mlarrainj@uandes.cl

Understanding students' thinking and learning processes is one of the main challenges teachers are faced to during teaching. This occurs in a process that includes perceiving relevant information, interpreting it and finally making pedagogical decisions. In particular, mathematical errors constitute a rich source of information about students' reasoning. In this paper, the diagnostic competence of future primary teachers in error situations is analyzed, focusing specifically in the process of interpreting the perceived information by hypothesizing about causes of students' errors. Results suggest that this competence can be fostered in teacher education and show that not only mathematical content knowledge but also practical experiences and beliefs are relevant for its development.

Keywords: Diagnostic competence, future primary teachers, errors analysis, mathematics teachers' competence.

Introduction

Effective teaching of mathematics in primary classrooms under a student-centered paradigm entails several challenges for teachers. In order to design and carry out effective teaching sequences that provide adequate opportunities for each student to learn, teachers need to enact several professional competencies that have been described and researched in the field (Shulman, 1986; Ball, Thames, & Phelps, 2008; Kaiser, Blömeke, König, Busse, Döhrmann, & Hoth, 2017). In particular, teachers' diagnostic competence has been regarded as a crucial component as students' thinking and understanding should be taken as the starting point for building further mathematical knowledge. Thus, teachers need to be able to understand students' thinking and adapt teaching strategies accordingly to promote learning.

Mathematical errors are unavoidable in the learning process and their educational potential has been widely acknowledged (Keith, & Frese, 2008) as they constitute an opportunity for teachers to look into students' mathematical thinking. Therefore, future teachers ought to learn about errors, their relevance and their underlying reasons, and start developing their diagnostic competence during teacher education programs.

This article focuses on future primary school teachers' diagnostic competence in error situations, particularly on the features related to their ability to hypothesize about causes of students' errors. On the one hand, aspects that may have an influence on future primary teachers' level of this competence are explored. On the other hand, the influence of an intervention in the frame of an university course on the development of this competence is investigated.

Theoretical Background

Teachers' professional competences

According to Weinert (2001), competences are composed by cognitive facets and affect-motivational facets. In teacher education, the cognitive facets can be associated with Shulman's (1986) categorization of teaching knowledge into subject-matter knowledge, in this context Mathematics Content Knowledge (MCK), General Pedagogical Knowledge (GPK) and Pedagogical Content Knowledge (MPCK). The affect-motivational facets usually include teachers' professional motivation and beliefs. Relevant studies such as the Teacher Education and Development Study in Mathematics (TEDS-M) and Cognitive Activation in the Classroom (COACTIV) have included these facets in their conceptualizations of professional competence (Döhrmann, Kaiser, & Blömeke, 2014; Baumert, & Kunter, 2011). Both specific cognitive abilities and affect motivation components are considered the main aspects of teacher professional competence.

Blömeke, Gustafsson and Shavelson (2015) suggest a situated model to assess teachers' professional competences that includes not only these cognitive and affect-motivational facets as disposition traits but also situation-specific skills, such as perception, interpretation and decision-making. These skills are key in the competence continuum that puts disposition traits in action in a particular classroom situation and therefore gives place to teachers' observable performance. In this model, the focus is neither on particular knowledge nor on the performance itself, but on the steps of the process in which resources activated and mediated by perception, interpretation and decision-making skills lead to performance as observable behavior in real-life situations.

Diagnostic competence in error situations

Teachers' diagnostic competence is a relevant component in promoting learning mathematics in a learner-centered paradigm. Student-centered teaching requires teachers who are able to, during class, identify and comprehend each student's current level of understanding, make ongoing analyses of students' learning and make instructional decisions oriented towards building further skills and knowledge. In heterogeneous classrooms, teachers are faced to the challenge of identifying and understanding a wide variety of students' mathematical thinking that children may also communicate unclearly or incompletely (Radatz, 1979; Barmby, Harries, Higgins, & Suggate, 2007). In other words, teachers need to continuously 'diagnose students' achievements and learning processes during class' (Hoth, 2017, p. 2901).

In accordance with situated approaches, Prediger (2010) suggests that diagnostic competence has both a cognitive and an affective component. The cognitive element comprises the theoretical knowledge about mathematics concepts and mathematics learning required to analyze and understand students' thinking. The affective component includes teachers' beliefs, interest and curiosity about students' thinking, and an interpretative attitude that allows them to understand the underlying reasoning of students' thinking. Additionally, situation-specific skills, namely perception, interpretation and decision making skills, also affected by the cognitive and affective disposition traits, influence teachers' observable behavior. This suggests that diagnostic competence is a complex construct that cannot be assigned to a single component of Shulman's (1986) categorization

of teachers professional knowledge, but implies an integrated and situated understanding of teachers' competence.

This study focuses on diagnostic competence in particular class situations, where students' mathematical errors arise. It uses the definition of diagnostic competence in error situations by Heinrichs and Kaiser (2018) as

the competence that is necessary to come to implicit judgements based on formative assessment in teaching situations by using informal or semi-formal methods. The goal of this process is to adapt behavior in the teaching situation by reacting to the student's error in order to help the student to overcome his/her misconception. (p. 81)

The relevance of mathematical errors found in students' work or during teacher-student or student-student interaction in class relies on their potential as a source of information for teachers about students' erroneous conceptualizations or misconceptions (McGuire, 2013). Thorough comprehension of a student's understanding or misunderstanding and of where their knowledge and skills need further support is necessary for discerning what pedagogical resources should be provided to support students learning (Brodie, 2014; Radatz, 1979).

Students' errors that are not amenable to carelessness or a simple slip, are usually persistent and systematic and can be explained as the outcome of cognitive structures erroneously built, frequently connected to previous (correct) knowledge and experiences or by the overgeneralization of concepts or principles from other domains. Because there is an underlying reasoning explaining the erroneous ideas, they make sense for the student (Brodie, 2014). The eradication of this type of errors is difficult because involves complex cognitive restructuring. This represents a challenge for teachers, who need to design pedagogical strategies that support students in recognizing that their thinking is not correct and in reorganizing their knowledge. This also explains the relevance of teachers' diagnostic competence, as students' errors need to be considered and addressed during teaching (Smith, diSessa, & Roschelle, 1993; Brodie, 2014) not only because teachers need to understand student thinking in order to design and deliver appropriate learning experiences, but also because doing so is more effective than avoiding or ignoring them in the classroom (Keith, & Frese, 2008).

Considering different models describing teachers' diagnostic competence and error analysis knowledge, Heinrichs and Kaiser (2018) developed a model for future teachers' diagnostic competence in error situations, which is also used in this study. It consists of three phases. First, teachers attend to students' work and perceive the error, which is essential for the error to be dealt with. In the second phase, teachers interpret the error and hypothesize possible causes for that error in that specific situation. Finally, considering this hypothesis and aspects of students' knowledge that need further improvement, teachers design a strategy to deal with the error so misunderstandings can be overcome.

The study presented in this article focuses primarily on the second phase of this model and therefore, the following hypotheses are stated:

1. It is possible to foster the development of future primary teachers' competence to hypothesize about the causes of students' mathematical errors within a university course.

2. Future primary teachers' competence to hypothesize about the causes of students' mathematical errors is related to other features of their background, knowledge and beliefs.

Methodological Approach

The aim of the main study in which this article is based is to investigate how future primary teachers' diagnostic competence in error situations can be assessed and fostered within a university course. Therefore, a university course and an online pre- and post-test assessment were designed. Future teachers in their third or fourth year of studies from 11 Chilean universities participated in the course and 131 answered both pre- and post-test questionnaires.

The course's goal was to foster the development of future primary teachers' diagnostic competence as used in error situations and it was designed on the basis of the model by Heinrichs and Kaiser (2018) described above. It consisted of four sessions in which prospective teachers made individual analyses and engaged in group discussions about primary students' mathematical errors.

During the sessions, videos and samples of students' written work were used to present the error situations, as has been argued for in similar studies (Hofmann & Roth, 2017). The usefulness of students' written work and videos of students working in class has been argued for as they constitute a good opportunity to generate discussions and analyses of students' thinking (Arcavi, 2016).

A set of questionnaires was applied to measure the impact of the course. In the first part, future teachers provided background information. In the second part, in order to collect data about their beliefs about the nature of mathematics and about mathematics teaching and learning, questionnaires from the Teaching Education and Development Study in Mathematics (TEDS-M) (Tatto, Schwille, Senk, Ingvarson, Peck, & Rowley, 2008) were used. Additionally, future teachers answered a multiple-choice Mathematical Knowledge for Teaching questionnaire from the MKT framework (Hill, Ball & Schilling, 2008) adapted and validated for Chile in the Refip project (Martínez, Martínez, Ramírez, & Varas, 2014).

Finally, in order to measure future teachers' diagnostic competence in error situations, a computer-based assessment was developed covering all three phases of the model by Heinrichs and Kaiser (2018) described above. Four different errors related to numeracy and arithmetic in primary school were chosen and assigned randomly, so that each participant worked through two errors before the course and other two errors after it. Students' errors were presented using video-vignettes together with information about the context, the students and the learning goals for the lesson. Future teachers were allowed to watch and pause the video multiple times but it was not possible to go back to the video once they started answering the items.

In particular, to assess the competence to hypothesize about possible causes of students' errors, which is the focus of this article, future teachers were asked to answer a set of close items based on the videos. In order to find the real cause for an error, teachers need to first think on a wide variety of reasons that may be leading to the error and then be able to discriminate between those that are possible in that particular situation and those that are not because of certain aspects of the circumstances. To evaluate this, future teachers were presented with eight statements with causes of the error in question and they had to decide, for each statement, whether it was a possible cause or

not. The plausibility of each of the causes was rated using experts' diagnoses. Mathematics teachers and academics working in the field of didactics of mathematics participated as experts. These dichotomous items were evaluated using methods of Item Response Theory (IRT). In particular, a one-parameter Rasch model (Wu & Adams, 2007) was used to determine the difficulties of the test items and the estimates for the latent abilities of every participant. The scaling showed an adequate fit (EAP Reliability = 0.65).

Results

Future teachers' competence to hypothesize about the causes of students' errors showed a mean of 50 with a standard deviation of 10 in the pre-test. This competence was significantly improved at the second testing-time, when future teachers exhibited a mean of 52.6 (SD =10). A paired samples t-test was conducted and a significant difference between these means was found ($t(130) = -2,649$, $p = .009$), with a small effect size (Cohen's $d = .231$).

In order to test the second hypothesis, future teachers' competence to conjecture about the causes of error situations was related to their beliefs, knowledge and background prior to starting the course. In the beliefs questionnaires, they agreed with statements viewing mathematics as an inquiry process and the learning of mathematics as an active one. In other words, they revealed a tendency towards constructivist beliefs about the nature of mathematics and about the learning of mathematics. These constructivist beliefs showed a significant correlation of a medium-size effect with their competence to hypothesize about causes of students' errors ($r = .378$, $p = .000$ and $r = .384$, $p = .000$, respectively).

It was also of interest to test the association between professional knowledge and the hypothesizing about errors' causes competence. Analyses indicated that better results in the Mathematical Knowledge for Teaching test are significantly correlated to a higher competence level for hypothesizing causes for students' errors ($r = .307$, $p = .000$). Similarly, a significant correlation was found between this competence and the number of mathematics or mathematics education courses that future teachers have finished within their university programs ($r = .144$, p (one-tailed) $= .050$).

Additionally, the link between future teachers' practical experiences and their competence to hypothesize about the causes of students' errors was explored. A significant, albeit small, correlation was found with the number of school practices future teachers have done within their university program ($r = .164$, p (one-tailed) $= .031$). Relatedly, the differences in the means on the competence level of future teachers who have no teaching experience in primary classrooms and those who taught primary students sometimes or frequently proved to be significant with a medium effect size ($t(124) = -3,023$, p (one-tailed) $= .001$, $d = .543$). Moreover, when focusing on their experience teaching specifically mathematics in primary classrooms, a similar difference is showed between the groups with and without such experiences ($t(129) = -2,297$, p (one-tailed) $= .011$, $d = .404$). Yet another kind of teaching experience was explored, namely private tutoring, as it is assumed to intensively expose future teachers to interpreting students' thinking and analyzing students' errors. Although no significant differences in the competence to hypothesize about the causes of students' errors of future teachers with and without tutoring experience for children of any age group was found ($t(129) = -1,367$, p (one-tailed) $= .087$), a significant difference was revealed in favor of future teachers who

have tutoring experience particularly with primary students ($t(129) = -1.630$, p (one-tailed) = .052, $d = .284$).

Other aspects of future teachers' revealed no link with their competence to hypothesize about the causes of students' errors. For instance, no significant difference was found between participants enrolled in different types of teacher education programs ($F(3,127) = 1.637$, $p = .184$). Also, the semester of studies they were attending did not correlate significantly with this competence ($r = .121$, p (one-tailed) = .084).

Finally, multiple regression analyses were conducted including all variables with significant effects on the competence of hypothesizing about the causes of students' errors. The model that better predicts this competence ($F(2,128) = 15.641$, $p = .000$) includes only both beliefs variables, i.e. beliefs about the nature of mathematics as an inquiry process ($\beta = .202$, $p = .045$) and about the learning of mathematics as an active process ($\beta = .291$, $p = .004$). Together, both beliefs scales explain a 19,6% ($R^2 = .196$) of the variance in the competence of hypothesizing about the causes of students' errors.

Summary and Discussion

Teaching mathematics for understanding in heterogeneous classrooms requires teachers being able to provide individualized and differentiated learning opportunities to build further knowledge and skills. In order to do this, teachers need to understand individual student's thinking. Students' mathematical errors have been recognized as a rich source of information about their reasoning and, therefore, teachers' diagnostic competence in error situations has been regarded as pivotal for effective teaching.

When faced to an error situation, teachers are expected to work through a three-step model that includes perceiving the mathematical error, developing hypotheses about causes for that error in that particular situation and making a decision about how the error should be dealt with (Heinrichs, & Kaiser, 2018). This article focused particularly on the second phase of this model, i.e. on future primary teachers competence to hypothesize about the causes of students' errors. Factors influencing the level of this competence in future primary teachers, considering various aspects of their background, including specialized knowledge for mathematics teaching, beliefs and experiences were studied. Moreover, the possibility of fostering the development of this competence with an intervention within a university course was investigated.

The findings of the study reveal that constructivist beliefs about the nature of mathematics and about teaching and learning mathematics are related to higher levels of the hypothesizing competence. This means that, within this sample of future primary teachers, those who view mathematics as an inquiry process in which trying and discovering take place, and the teaching and learning of mathematics as an active and student-centered process, tend to have a higher ability to discriminate between plausible and not plausible causes for students' errors. These findings are in line to what has been found by Heinrichs (2015) in her study with prospective secondary teachers.

In addition, specialized knowledge for teaching primary mathematics was also found to be related to higher levels of the competence of hypothesizing about students' errors. Both a higher number of finished mathematics or mathematics education university courses and better achievements in the Mathematical Knowledge for Teaching questionnaire were related to higher competence levels on

hypothesizing causes for errors. This supports the view that dispositions traits such as knowledge and beliefs are relevant for professional competence.

Besides professional knowledge and constructivist beliefs, practical knowledge was also found to correlate with future primary teachers' competence of hypothesizing. It can be argued that targeted experiences displayed higher effects than general experiences. For instance, the number of school practices future teachers have participated in, revealed a significant but small effect correlation whereas teaching in primary classrooms exhibited a medium-size effect. Similarly, no significant difference was found between the groups with and without private tutoring experiences to children of any age but such a difference was found between groups with and without private tutoring experience particularly to primary-school students. This suggests that practical experiences make a significant difference when they are targeted to the same age group they will be teaching.

Concerning the impact of the university course, findings show that future primary teachers' competence of hypothesizing about students' errors can, in fact, be fostered within teacher education. However, as the intervention was quite time-limited and rather short its effects on the participating future teachers was apparently restricted. Taking these results together, an encouraging challenge is posed to teacher educators, as complex opportunities to learn need to be provided, in which practical experiences, beliefs and specialized knowledge are considered and interrelated.

References

- Arcavi, A. (2016). Promoviendo conversaciones entre docentes acerca de clases filmadas de Matemáticas. *Cuadernos de Investigación y Formación en Educación Matemática*, 11(15), 385–396.
- Ball, D. L., Thames, M. H., & Phelps, G. (2008). Content knowledge for teaching: What makes it special? *Journal of Teacher Education*, 59(5), 389–407.
- Barmby, P., Harries, T., Higgins, S., & Suggate, J. (2007). How can we assess mathematical understanding? In J. Woo, H. Lew, K. Park, & D. Seo (Eds.), *Proceedings of the 31st Conference of the International Group for the Psychology of Mathematical Education, Vol. 2* (pp. 41–48). Seoul: PME.
- Baumert, J., & Kunter, M. (2013). The COACTIV model of teachers' professional competence. In M. Kunter, J. Baumert, W. Blum, U. Klusmann, S. Krauss, & M. Neubrand (Eds.), *Cognitive activation in the mathematics classroom and professional competence of teachers*. Boston, MA: Springer.
- Blömeke, S., Gustafsson, J.-E., & Shavelson, R. J. (2015). Beyond dichotomies: Competence viewed as a continuum. *Zeitschrift für Psychologie*, 223(1), 3–13.
- Brodie, K. (2014). Learning about learner errors in professional learning communities. *Educational Studies in Mathematics*, 85(2), 221–239.
- Cooper, S. (2009). Preservice teachers' analysis of children's work to make instructional decisions. *School Science and Mathematics*, 109(6), 355–362.

- Döhrmann, M., Kaiser, G., & Blömeke, S. (2014). The conceptualisation of mathematics competencies in the international teacher education study TEDS-M. In S. Blömeke, F. J. Hsieh, G. Kaiser, & W. H. Schmidt (Eds.), *International perspectives on teacher knowledge, beliefs and opportunities to learn* (pp. 431–456). Dordrecht, Netherlands: Springer.
- Heinrichs, H. (2015). *Diagnostische Kompetenz von Mathematik-Lehramtsstudierenden: Messung und Förderung*. Wiesbaden, Germany: Springer.
- Heinrichs, H., & Kaiser, G. (2018). Diagnostic competence for dealing with students' errors: Fostering diagnostic competence in error situations. In T. Leuders, K. Philipp, & J. Leuders (Eds.), *Diagnostic competence of mathematics teachers* (pp. 79–94). Cham, Switzerland: Springer.
- Hofmann, R., & Roth, J. (2017). Assessment of students' thinking when working with graphs of functions – Promoting pre-service teachers' diagnostic competence. In T. Dooley, & G. Gueudet (Eds.), *Proceedings of the Tenth Congress of the European Society for Research in Mathematics Education (CERME10)* (pp. 3524–3531). Dublin, Ireland: DCU Institute of Education and ERME.
- Hoth, J. (2017). Situation-specific diagnostic competence of mathematics teachers – a qualitative supplementary study of the TEDS-follow-up project. In T. Dooley, & G. Gueudet (Eds.), *Proceedings of the Tenth Congress of the European Society for Research in Mathematics Education (CERME10)* (pp. 2900–2907). Dublin, Ireland: DCU Institute of Education and ERME.
- Jacobs, V. R., & Philipp, R. A. (2004). Mathematical thinking: Helping prospective and practicing teachers focus. *Teaching Children Mathematics*, 11(4), 194–201.
- Kaiser, G., Blömeke, S., König, J., Busse, A., Döhrmann, M., & Hoth, J. (2017). Professional competencies of (prospective) mathematics teachers—cognitive versus situated approaches. *Educational Studies in Mathematics*, 94(2), 161–182.
- Keith, N., & Frese, M. (2008). Effectiveness of error management training: a meta-analysis. *Journal of Applied Psychology*, 93(1), 59–69.
- Mc Guire, P. (2013). Using online error analysis items to support preservice teachers' pedagogical content knowledge in mathematics. *Contemporary Issues in Technology and Teacher Education*, 13(3), 207–218.
- Prediger, S. (2010). How to develop mathematics-for-teaching and for understanding: the case of meanings of the equal sign. *Journal of Mathematics Teacher Education*, 13(1), 73–93.
- Radatz, H. (1979). Error analysis in mathematics education. *Journal for Research in Mathematics Education*, 10(3), 163–172.
- Smith III, J. P., diSessa, A. A., & Roschelle, J. (1993). Misconceptions reconceived: A constructivist analysis of knowledge in transition. *The Journal of the Learning Sciences*, 3(2), 115–163.
- Shulman, L. S. (1986). Those who understand: Knowledge growth in teaching. *Educational Researcher*, 15(2), 4–14.

- Weinert, F. E. (2001). Concept of competence: a conceptual clarification. In D. Rychen, & L. Salganik (Eds.), *Defining and selecting key competencies* (pp. 45–65). Seattle, WA: Hogrefe and Huber.
- Wu, M., & Adams, R. (2007). *Applying the Rasch model to psycho- social measurement. A practical approach*. Melbourne: Educational Measurement Solutions.

Thinking about Mathematics classroom culture through spontaneous videos

Cristina Loureiro¹, Cristina Morais² and Helena Gil Guerreiro³

¹ESE do Instituto Politécnico de Lisboa, CIED, Portugal; cristina@eselx.ipl.pt

²Externato da Luz; Instituto de Educação, Universidade de Lisboa Portugal;
cristina.morais@campus.ul.pt

³Agrupamento de Escolas Braamcamp Freire, Instituto de Educação, Universidade de Lisboa, Portugal; hg@campus.ul.pt

This paper focuses on the use of video to think about Mathematics classroom culture. The study follows a design-based research focused on professional development. We discuss here this use in a first design cycle with three design principles that sought to create conditions for teachers to (i) share authentic situations in their classroom, (ii) collaboratively discuss classroom episodes with other teachers and (iii) acquire progressive confidence and predisposition for their learning. Data was collected through training team diaries, teachers' reports and their individual and anonymous assessment questionnaires. We present opportunities and constraints that allow us to face the organization of a second design cycle, maintaining the use of video as an accessing medium to real classroom situations of teachers in a training situation.

Keywords: Mathematics, video, classroom, teacher development.

Introduction

This work is integrated in a teachers' training project, named SAM Culture Project¹, that seeks to articulate the study of classroom culture in Mathematics with the professional development of teachers, in a perspective of interdependence between theory and practice.

We stand out three key aspects of this project: a) classroom culture considered as the system of relations and knowledge built in each learning community through the actions of both teacher and students (Goos, Galbraith, & Renshaw, 1999); b) learning from experience faced as a parallel between student learning and teacher development (Mason, 2010), facing the practice of teaching as a field of learning for the teacher himself (Doerr & Lerman, 2010; Leikin & Zazkis, 2010; Mason,

¹ The SAM Culture Project team consists of 2 mathematical educators and 9 teachers, all of them project trainers of the project and facilitators of the professional development sessions.

2010), and c) looking for ways to bring to training sessions teachers' classroom episodes using video as a means to access the classroom (van Es & Sherin, 2006; Cyrille & Sébastien, 2015).

Research conducted over the past decade suggests that video can be a powerful tool for facilitating teacher learning, allowing access to real classrooms situations and capturing teaching in all of its complexity while, at the same time, affording space and time for reflection (Tekkumru-Kisa & Stein, 2017). In the particular case of using videos made by teachers themselves, its role is recognized in the development of evaluation processes carried out in collaborative working modalities, highlighting the discussions about the videos of the participants' classes (Borko, Jacobs, Eiteljorg, & Pittman, 2008) and choosing the objectives of video viewing based on the learning goals (Cyrille & Sébastien, 2015). Videos produced by teachers own will, intended to be shared with peers and focusing a particular moment of the lesson, selected by the teacher himself, which we define as spontaneous videos can be the touchstone to discuss Mathematics classroom culture. Thus, this paper aims to discuss the role, contributions and limitations, of using video to reflect on Mathematics classroom culture, in a context of teacher training.

Theoretical considerations

To think classroom culture in Mathematics in terms of classroom norms and practices led us to reflect on the social space of learning. This reflection focuses on various axes that characterize this culture, namely, the rules that establish it, the roles assumed by the various actors, the resources and mathematical tasks used, as well as the evaluation that regulates learning. Classroom culture constitutes a dynamic system, in permanent construction, which is why we intend to analyze these axes in interrelation (Cobb & Yackel, 1996). Some aspects of the complex relationship between these axes can be captured using mobile devices, which, for their simplicity, enable to save at any time a significant classroom episode to promote reflection on practice.

The use of authentic classroom videos in professional development sessions has been widely scrutinized and analyzed by international research (Cyrille & Sébastien, 2015; Tekkumru-Kisa & Stein, 2017). The videos need to be carefully selected, associated with reflection instruments, and used in ways to help teachers to notice and reason about important aspects of instruction and learning that occur in the video (Tekkumru-Kisa & Stein, 2017).

There are several reasons to use classroom videos of teachers participating in a professional development program (Borko, 2011; Borko et al., 2017). Teachers find videos from their own classrooms and the classrooms of colleagues to be more motivating and better support their learning than videos from classrooms of teachers they do not know. Using video from teachers' own

classrooms reduces the possibility of teachers dismissing what they see because “those kids are not the same as ours”. Using videos from classrooms where the teachers know each other requires a moderate amount of trust to view the student clips and a high degree of trust to watch the teacher clips. “To share their videos, teachers must feel that they are part of a safe and supportive professional community” (Borko et al., 2017, p. 5). This must be accounted for in the design of professional development sessions.

Combining the use of video from experienced teachers with the use of videos from the classrooms of teachers participating in a professional development program has been followed in many professional development programs. Roth et al (2017) followed this orientation in a long training program where professional development leaders model how to productively analyze these videos and they coach teachers in their analytical efforts at the same time they access to expertise models.

In addition to the cognitive aspects, research has also sought to know the motivational and emotional aspects present in the analysis of teachers’ classrooms videos in collaborative work environments (Kleinknecht & Schneider, 2013). These authors highlight the complexity of the network of cognitive, motivational and emotional dimensions involved in the analysis of videos of authentic situations, linking this analysis to the ways in which occurs and the role of professional development leaders. They demonstrate “the benefits of comparing teachers’ analysis of their own and others’ videos” and point out that “the individual analysis of one’s own and others’ videos results in differential effects on cognition, motivation, and emotion may not always be intuitive or easily observable in individual and group settings” (Kleinknecht & Schneider, 2013, p. 22).

One of the key aspects is leaders’ catalyst role to help teachers to notice and reason about important aspects of instruction and learning that occur in the videos (van Es & Sherin, 2006; 2017). Leaders use their experience to plan and facilitate productive discussions around carefully selected video clips to support teachers’ learning (Borko et al., 2017). One idea is to build tools to scaffold and streamline different video situations, supporting visualization and reflection in an interconnected way. The aspects to be observed, as well as the issues to be reflected during a small group discussion episode, are not the same as in a collective discussion episode. Different class moments require reflection scripts with specific characteristics. According to Borko, Koellner, Jacobs, and Seago (2011), a careful and intentional planning for video viewing and discussion can help ensure a critical, evidence-based, and meaningful analysis, performed with a proper language.

Jacobs, Seago and Koellner (2017) use a strategy for using the videos where teachers work on and discuss the same problem they will see later students working on during the video clip, in a way that teachers might make predictions about how students will solve the problem or what mistakes they

might make.

In summary, we can affirm that the potential of this learning resource for teacher learning is significant, but its use is complex, involving diverse risks and requiring multiple care.

Methodology

This study follows a design-based research focused on professional development (Cobb, Confrey, diSessa, Lehrer, & Schauble, 2003; Cobb, Jackson, & Dunlap, 2016).

The option for this modality is justified by the interdependence between theory and practice that characterizes this professional development project. It allows to articulate two dimensions in which researchers and teachers collaborate: reflecting on the Mathematics classroom culture, through the analysis of their learning environment, and seeking to promote changes in the teaching practices.

The intervention includes a training workshop, entitled "Classroom Culture - Contributions for the learning of mathematics" with 26 hours. The first cycle was comprised with three editions of this workshop. We intend to construct and improve frameworks, theoretical based, to promote joint reflection on classroom culture and the consequent improvement of practices through the implementation of future cycles of intervention. The workshops involved 45 teachers from elementary school (grade 1 to 6), in Lisbon. Teachers enrolled voluntarily without knowing that the use of video would be privileged. The trainers of these workshops were researchers from the SAM Culture project.

Data were collected using the training team diaries (TD), trainers' reports (TR), and individual and anonymous assessment questionnaires, which were given to teachers at the end of each workshop (AQ).

Considering the potential of using video to reflect on Mathematics classroom culture, the training team organized an initial task involving a video and its discussion. It was a video of a moment from a collective discussion during a math task, recorded by an ordinary teacher, without previous preparation or editing. The training task intended to focus on aspects related to the axis of social and sociomathematical norms and to promote confidence on sharing spontaneous videos produced by teachers themselves to discuss classroom episodes. Throughout the three training workshops, the same anchor video and discussion script were used. It was intended that this video, used as an anchor video (Borko et al., 2008), would be an example, not a model to be followed, to motivate the production of spontaneous videos and their sharing in the context of the teacher training.

Thus, the access to the teachers' classrooms was planned through the use of spontaneous videos. This use had underlying design principles that sought to create conditions for teachers to (i) share

authentic situations in their classroom, (ii) collaboratively discuss classroom events with other teachers and (iii) acquire progressive confidence and predisposition for their learning.

The preliminary analysis allowed the training team to make changes between workshops. At the end of the process, the retrospective analysis was carried out to revisit the data in order to identify opportunities and constraints of using videos to think about the culture of the classroom in Mathematics.

The use of video in a first design cycle

In the first workshop, the use of the anchor video associated with the training task allowed, according to the trainer, to think about social and socio mathematical norms, emphasizing that "clearly it was something that they never had thought" [TD]. The awareness of aspects related to norms seems to have happened through the visualization of the video, as referred by a teacher "I became aware that sometimes we are not careful with this [norms] and other times we already do it and we do not know it" [TD]. However, the anchor video did not trigger the production of videos by teachers, as the trainer says "I realized that videos will not appear, despite my attempt to motivate" [TD]. The first video only appeared at the session before the last workshop session "breaking the ice" [TD] and leading to the production and sharing of two videos in the following session.

The reflection on the intention of sharing videos produced by teachers led to the re-thinking of the structure of the following workshops. In addition to performing the task that involved the use of anchor video, these workshops contemplated the creation of a moment of video sharing at the beginning of each session. This decision made teachers feel involved, from the first sessions, in the production and sharing of videos, as the trainers describe "teachers are truly committed to (...) collecting data from their experiences" [TD].

Having created the necessary confidence in teachers to share their classroom moments, the production and sharing of videos in all sessions became routine, as one of the trainers says, stating that "the initial fear was dissipating as the first trainees ventured, creating themselves at ease "[TR]. The difficulty in involving the trainees in the discussion of the videos triggered in the training team the need to create instruments to focus their analysis. One of these tools was an observation guide for shared videos structured according to the different stages of the development of a task in the classroom. Subsequently, another structured script was created in order to focus attention on the axes of the classroom culture (Figure 1).

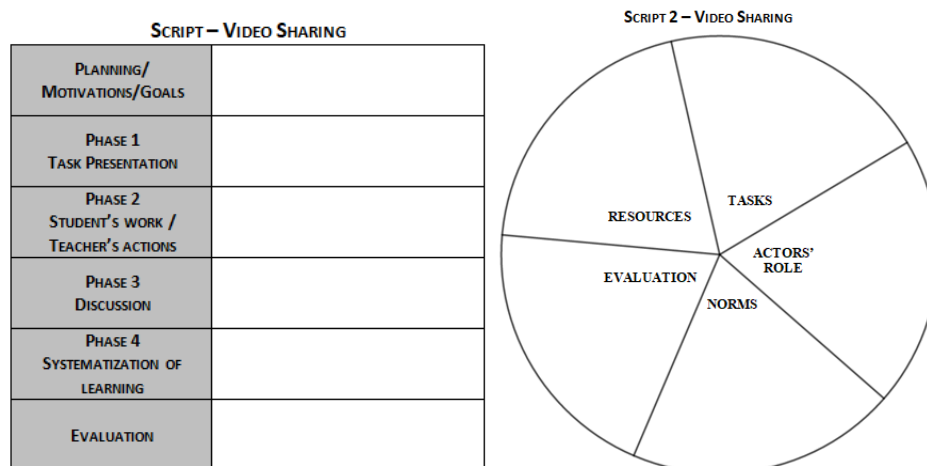


Figure 1: Scripts to support video sharing

Regarding the data from the evaluation questionnaires of the three editions of the training workshop, all the teachers who answered (29 out of 45 participants) considered that the use of videos is appropriate to discuss aspects of classroom culture in Mathematics. In addition, all teachers also considered that the use of video is a way to bring the classroom itself to the discussion with a view to its improvement.

Although with little expression, constraints are identified with difficulties of producing videos during the class as "to record at the same time that I was exploring the task with the students" [AQ], referred by one of the teachers. Issues of student anonymity, such as "not being able to use student images", [AQ] are also cause for concern. However they do not constitute an obstacle to the production of spontaneous videos.

Opportunities offered by that use of videos are recognized by most teachers, particularly at the "Actor Roles" axis. Some teachers point out that video allows the "reflection and discussion of the role of the teacher as a mediator in learning" [AQ], contributing to "modify their methods of action [by observing their attitudes]" [AQ]. Regarding the role of students, teachers report that "the use of video made it possible to observe the reactions, behaviours, difficulties or facilities in explaining reasoning and how we can 'influence / direct' learning [AQ]. In addition, it is viewed as an important tool for "sharing student mathematical resolutions" [AQ]. The use of video is thus understood as an opportunity to revisit the classroom by "observing more than once" [AQ] moments of solving a task, allowing one to look at and discuss with others, in a "joint analysis of what happened in the classroom context "[AQ].

Final remarks

Considering the use of videos to reflect on Mathematics classroom culture, teachers valued the use of spontaneous videos to discuss and reflect about teachers and students' role during whole class mathematical discussions. They recognized that the constraints associated with its production, namely the authorization to capture images and the dual role of teacher and video maker, do not constitute an obstacle to the production of spontaneous videos. From the motivational point of view, teachers were predisposed to the production and sharing of video episodes of their classrooms.

We highlight this way of producing videos, focused on the motivational and emotional dimensions (Kleinkrecht & Schneider, 2013), as a way to bring the classroom to the training process as was valued by teachers. Intentionally, the videos were analysed in a less directive way to promote the gain of confidence. However, this aspect reinforces the concern to create instruments to focus the visualization and discussion of the videos (Tekkumru-Kisa & Stein, 2017) in the axes of the Mathematics classroom culture.

The three editions of this workshop allowed us to identify the need to increase the design principles enunciated for the use of spontaneous videos. Thus, we add a new principle to create conditions for teachers to develop productive discussions supported by instruments of reflection constructed with them on a theoretical basis. From a perspective of continuity, the refined design principles will guide the next cycle of intervention.

In summary, the balance between promoting the emergence of spontaneous videos and their critical reflection, supported by guiding instruments, is an important aspect of teachers' professional development in order to think about Mathematics classroom culture. The search for this balance reflects the complexity of the relationships between the cognitive, motivational and emotional dimensions in the use of videos (Kleinkrecht & Schneider, 2013) for teachers' learning.

References

- Borko, H., Carlson, J., Mangram, C., Anderson, R., Fong, A., Million, S., Mozenter, S., & Villa, A. M. (2017). The role of video-based discussion in model for preparing professional development leaders. *International Journal of STEM Education*, 4(29), 2–18.
- Borko, H., Jacobs, J., Eiteljorg, E., & Pittman, M. (2008). Video as tool for fostering productive discussions in mathematics Professional development. *Teacher and Teacher Education*, 24, 417–436.
- Borko, H., Koellner, K., Jacobs, J., & Seago, N. (2011). Using video representations of teaching in practice-based professional development programs. *ZDM Mathematics Education*, 43, 175–187, doi: 10.1007/s11858-010-0302-5.

- Cobb, P., Confrey, J., DiSessa, A., Lehrer, R., & Schauble, L. (2003). Design experiments in educational research. *Educational Researcher*, 32(1), 9–13.
- Cobb, P., Jackson, K., & Dunlap, C. (2016). Design research: An analysis and critique. In L. D. English & D. Kirshner (Eds.), *Handbook of international research in mathematics education* (3rd edition, pp. 481–503). New York, NY: Routledge.
- Cyrille, G. & Sébastien, C. (2015). Video viewing in teacher education and professional development: A literature review. *Educational Research Review*, 16, 41–67.
- Doerr, H. M., & Lerman, S. (2010). Teachers learning from their teaching: The case of communicative practices. R. Leikin & R. Zazkis (Eds.), *Learning through teaching mathematics* (pp. 247–262). Springer. doi: 10.1007/978-90-481-3990-3_13
- Goos, M., Galbraith, P., & Renshaw, P. (1999). Establishing a Community of Practice. In L. Burton (Ed.), *Learning mathematics. From hierarchies to networks* (pp. 36–61). London: Falmer Press.
- Jacobs, J., Seago, N. & Koellner, K. (2017). Preparing facilitators to use and adapt mathematics professional development materials productively. *International Journal of STEM Education*, 4(30), 1–14. doi: 10.1186/s40594-017-0089-9
- Kleinknecht, M. & Schneider, J. (2013). What do teachers think and feel when analyzing videos of themselves and other teachers teaching? *Teaching and Teacher Education*, 33, 13–23.
- Leikin, R., & Zazkis, R. (2010). Teachers’ opportunities to learn mathematics through teaching. R. Leikin & R. Zazkis (Eds.), *Learning through teaching mathematics* (pp. 3–21). Springer. doi: 10.1007/978-90-481-3990-3_1
- Mason, J. (2010). Attention and intention in learning about teaching through teaching. R. Leikin & R. Zazkis (Eds.), *Learning through teaching mathematics* (pp. 23–47). Springer. doi: 10.1007/978-90-481-3990-3_2
- Roth, K., Bintz, J., Wickler, N., Hvidsten, C., Taylor, J., Beardsley, P. Caine, A., & Wilson, C. (2017). Design principles for effective video-based professional development. *International Journal of STEM Education*, 4(31), 1–15. doi: 10.1186/s40594-017-0091-2
- Tekkumru-Kisa, M. & Stein, M. K. (2017). A framework for planning and facilitating video-based professional development. *International Journal of STEM Education*, 4(28), 2–18. doi: 10.1186/s40594-017-0086-z
- van Es, E. & Sherin, M. (2006). How different video club designs support teachers in “learning to notice”. *Journal of Computing in Teacher Education*, 22(4), 125–135.
- van Es, E. & Sherin, M. (2017). Bringing facilitation into view. *International Journal of STEM Education*, 4(32), 2–14. doi: 10.1186/s40594-017-0088-x
- Yackel, E. & Cobb, P. (1996). Sociomathematical norms, argumentation, and autonomy in mathematics. *Journal for Research in Mathematics Education*, 27(4), 458–477.

Preservice teachers' learning about critical mathematics education

Camilla Meidell¹, Diana Paola Piedra Moreno² and Georgia Kasari³

Western Norway University of Applied Sciences, Norway

[1came@hvl.no](mailto:came@hvl.no) [2dppm@hvl.no](mailto:dppm@hvl.no) [3geka@hvl.no](mailto:geka@hvl.no)

Keywords: Argumentation for critical mathematics education, modelling, preservice teachers.

Introduction

We describe three PhD proposals that support the project Learning about Teaching Argumentation for Critical Mathematics Education (LATACME). The studies intend to explore how preservice teachers (PTs) include argumentation processes during their teaching practice in grades 1-7 within multilingual classrooms (MC). Argumentation for critical mathematics education (CME) in this case, is understood as a social production with multiple representations, such as oral and written expressions, gestures, and diagrams. In this production, contrasting, evaluating, and confronting the use of mathematical tools to understand social issues are essential for critical argumentation to take place.

Intervention for multimodal argumentation with PTs in multilingual classrooms

The first study focuses on how multimodal argumentation processes are supported in multilingual mathematics classrooms. Multimodal argumentation in this case is seen in a translanguaging perspective (García, 2009) and, thus, will be investigated as a pedagogical context within which PTs can give equal opportunities for all students to participate in multimodal argumentation. For this reason, groups of PTs will be involved in interventions during the implementation of teacher education courses with a focus on modelling and Information and Communication Technology (ICT). The goal of the interventions is to consolidate with PTs and students an inclusive approach in language diverse classrooms that enables multimodality and CME. Thus, this study is connected to the following ones, through the multimodal and critical aspects of teaching and learning argumentation in both primary and teacher education level. After the data collection, a multimodal analysis of video-recorded classroom observations with the PTs will further look at how school students deploy and expand aspects of their communicative repertoires when they engage in critical argumentation processes. Finally, the study seeks to provide insights on how classroom members' diverse social, cultural and linguistic resources in the Norwegian school context empower them during the co-construction of meanings in multilingual-multimodal interactions.

A case study of PTs' use of mathematical modelling to support students learning

The second project aims to explore how PTs support students to develop argumentation skills in mathematics and critical competence through mathematical modelling. The focus on how to expand students' argumentation skills connects to the previous project, but this one is centered on the context of modelling. This is explored by looking at how PTs argue for their didactical choices in the process of defining criteria for creating and implementing a mathematical modelling activity with the goal of promoting students' argumentation skills and critical competence in mathematics, as well as looking at how PTs support these goals in the classroom. The data will be gathered by following the process of one or two groups of PTs in relation to their work with a mandatory assignment in one of their

teacher education courses. The data will be analyzed with the use of the PTs' own definition on what they view as important aspects to include in modelling activities. Further, the ways by which PTs strengthen students' argumentation skills in mathematics will be analyzed by using Conner, Singletary, Smith, Wagner and Francisco's (2014) framework for teachers support of students' argumentation skills. This study expects to develop both theoretical and practical knowledge in relation to PTs knowledge and argumentation in relation to how to expand students' argumentation skills and critical competence in mathematics.

Possibilities for teacher education in CME

The third project will identify elements that can be done in teacher education to let PTs explore activities of argumentation as open dialogues to do critical mathematics in multilingual school communities. The possibilities for teacher education in CME will be built in negotiation with different educational stakeholders (one PT, their colleagues, teacher educators, and school supervisors) in an effort of expanding the classroom practice towards a socio-political network of practices in mathematics education (Valero & Skovsmose, 2012). While some elements will be identified from a literature review in three teacher education dimensions for CME: modelling; ICT; and MC (which connects to both previous projects), others will arise from the educational stakeholders' considerations, the results of class observations, and collaborative problem-solving interviews with all the stakeholders. The data will be collected systematically when all stakeholders work together, which happens before, during, and after the PTs' practicum. This research will contribute to deep theoretical and practical knowledge by understanding the perceptions of diverse educational stakeholders about what "critical" argumentation in mathematics education can be as intended to students and teachers' practices. It will also analyze how PTs use argumentation as a characteristic of being critical teachers (Sánchez, et al., 2012) in the sense that it permeates not only their attitudes and reflections about the students work but also their own teaching practice. Finally, it will support ideas of teacher education in CME by developing connections between theory and practice.

Final note

The poster was presented at the Eleventh Congress of the European Society for Research in Mathematics Education in Utrecht, the Netherlands. The digital version of the poster can be found at: https://www.researchgate.net/figure/Poster_fig1_329338224.

References

- Conner, A. M., Singletary, L. M., Smith, R. C., Wagner, P. A., & Francisco, R. T. (2014) Teachers' support for collective argumentation: A framework for examining how teachers support students' engagement in mathematical activities. *Educational Studies in Mathematics*, 86(3), 401-429.
- García, O. (2009). *Bilingual education in the 21st century: A global perspective*. Malden: Wiley/Blackwell.
- Sánchez, B., Torres, J., Fonseca, J., Rodríguez, J., Piedra, P., & Hernández, E. (2012). Necesidades de formación en investigación y características del profesor investigador. *Memorias del III Congreso Internacional en Educación y Formación Docente* (pp. 2161-2174). Bogotá: Ascofede.
- Valero, P., & Skovsmose, O. (2012). *Educación matemática crítica: Una visión sociopolítica del aprendizaje y la enseñanza de las matemáticas*. Bogota: Ediciones Uniandes.

Retrospective competence assessment in a PD course on teaching statistics with digital tools in upper secondary schools

Ralf Nieszporek and Rolf Biehler

Paderborn University, Germany;

Ralf.Nieszporek@math.upb.de; Biehler@math.upb.de

Recent changes in German national standards and curricula have made statistics including digital tools an inherent part of the final examination at upper secondary schools. In previous years, many teachers focused only on mandatory content like algebra or analysis and almost completely avoided optional stochastic content. Thus they are now facing the challenge to create and implement lessons for a topic in which they are inexperienced and feel insecure. The professional development course presented in this study has the aim to increase teachers' knowledge and competence in statistics, including the use of digital tools like graphic calculators and GeoGebra. A newly developed questionnaire was used to assess teachers' development during the course and led to preliminary findings concerning the knowledge and competence for advanced topics of inference statistics and the expertise of using digital tools in this field.

Keywords: Professional Development, retrospective competence self-assessment, probability and statistics, digital tools.

Design of the professional development course

There is a high demand for professional development courses on teaching statistics and the use of digital tools (like GeoGebra and graphic calculators) in Germany. Due to a recent change in the national standards (KMK, 2012), a new state curriculum was implemented in the German federal state of North Rhine-Westphalia (NRW) which made statistics including digital tools mandatory for the final exams (*Abitur*) in upper secondary schools. This obligation forced teachers to negotiate new and difficult challenges in their teaching practice. Many of them had not come into contact with statistics during their university education and they managed to also completely avoid this topic in their previous teaching practice. Therefore, content knowledge for teaching statistics or using digital tools in class is often missing (Batanero, Burrill & Reading, 2011). Teachers consequently feel insecure when teaching this topic. To meet the steadily increasing need for support, a professional development (PD) course was developed at Paderborn University. A team consisting of experienced facilitators, teacher educators, and practitioners revised an already existing course concept (Biehler, 2016) in the sense of *Design Research* (McKenney & Reeves, 2012). The improvements for the course were based on two foundations: on the one hand research on teacher education and proven ideas for designing teaching lessons (Biehler & Prömmel, 2010; Prömmel, 2013), and on the other hand concepts for PD course construction and research like the design principles of the German Center for Mathematics Teacher Education (DZLM) (Barzel & Biehler 2017) or the three-tetrahedron model for content-related PD research (Prediger, Leuders & Rösken-Winter, submitted, 2018).

The new state curriculum of NRW demands a wide variety of statistical topics to be covered in school lessons. It was possible to concentrate the essence of the curriculum in five PD attendance days (see Table 1 for the content of each day) distributed over half a year with opportunities for teachers to try

out the newly learned concepts in their lessons. In addition to that, the PD course also offers self-learning material so that teachers can deepen their knowledge on various topics like simulations with graphic calculators (GC), combinatorics, or the normal distribution.

Day	Topic	Content (examples)
1	Getting started in statistics and probability at upper secondary level, using GCs and simulation – in heterogeneous classrooms	Far-reaching and apposite examples for the law of large numbers and the $\frac{1}{\sqrt{n}}$ -law, introduction to digital tools (GeoGebra, GC) and simulations
2	Conditional probability, statistics independence, and expectation as basic concepts in stochastic modeling	Natural (absolute) frequencies in tree diagrams, complementing contingency tables with double tree diagrams
3	Modeling with probability distributions, particularly with the binomial distribution: suggestions for teaching in a content-related and process-oriented way	The binomial distribution dynamically visualized with digital tools, interconnecting insights from previous day by using the same examples, strengthen modelling critique
4/5	Teaching inference statistics (hypothesis testing) with the goal of understanding, with authentic examples for the binomial distribution	Hypothesis testing via p-values to predefined significance level, errors of the first and second kind, power function, choice of the null hypothesis

Table 1: Topics covered in the five-day PD course

The aim of our study is to implement and analyze a PD course with an emphasis on increasing participants' knowledge and competence in teaching statistics with digital tools. This excerpt of our larger study focuses day five which covers the field of teaching more advanced topics of inference statistics testing like:

- Interpretation of hypothesis testing results (with focus on didactics and language)
- Type I and type II errors
- Choice of null hypothesis
- Operation characteristics and power function

More information on the PD design, PD aims and the course content can be found in Biehler, Griese & Nieszporek (to be submitted).

Theoretical framework

The TPACK framework created by Mishra and Koehler (2006) expands the mathematical knowledge for teaching framework (MKT) by Hill, Ball, and Schilling (2008). In addition to *content knowledge* (CK) and *pedagogical knowledge* (PK), Mishra and Koehler enriched the model with elements of *technology knowledge* (TK). However, those knowledge facets and their intersections like *pedagogical content knowledge* (PCK) or *technology pedagogical content knowledge* (TPACK) are not sufficient as the only input for a PD course. It is essential for teachers and for their daily practice to acquire additional skills beside pure knowledge on the topic, as they are confronted with different classes or situations and have to constantly undergo planning activities. Planning activities can be performed with fictional classes where problems and difficulties have to be anticipated and adequate reactions must be found. Therefore, they can be implemented in PD courses rather easily to strengthen

the skills of the participants. In contrast to knowledge dimensions these skills were grouped as competences in regard to Weinert (2001). Table 2 illustrates some of the knowledge and competence dimension addressed in our PD course.

Knowledge	Content	I have content knowledge relating to the topic.
	Background of the content	I know the didactical and curricular background and the learning goals of the topic
	Ideas for implementation	I know ideas for the implementation of the topic in lessons.
	Approaches for digital tools	I know approaches for using digital tools / GCs in the context of the topic.
Competences	Handling misconceptions	I am capable of recognizing and reacting appropriately towards misunderstandings (...).
	Planning	I can create a lesson plan incorporating the goals of the topic.
	Teaching the content	I can teach the topic in a goal-oriented way.
	Integrating digital tools	I am capable of implementing the approaches for the use of digital tools / GCs (...) in school lessons in a didactically advantageous way.

Table 2: Knowledge and competences addressed in the PD course, via statements to be rated

Teachers' heterogeneous knowledge and teaching experiences

For a long time, statistics and especially inference statistics have not been compulsory for upper secondary level, and were often neglected in university courses for teachers. This resulted in deficits regarding statistics knowledge of current in-service teachers, and some teachers might have mixed or mistaken content and horizon knowledge in some fields (Wassong & Biehler, 2010; Ball, Thames & Phelps, 2008). They are hardly able to simplify the content matter for class, which should also be taught in a PD course on statistics (Godino, Batanero & Font, 2007).

In addition to this deficiency, knowledge and competences towards digital tools are also demanded by new curriculum in NRW. GCs (or computer algebra systems, CAS) have also become mandatory in the final examination. Therefore, it is necessary to have at least a basic knowledge in programming, simulating or visualizing and interpreting distributions to fulfil the new demands. Due to the mismatch of teacher training and curriculum, this lack of experience must be addressed by a PD course, too.

Research questions

We will address the following research questions:

1. *General assessment of course success from participants' perspective.* To what extent (from before until after the PD course) do participants report to have acquired knowledge and competence in reference to conducting lessons in advanced topics of inference statistics testing?
2. *Suitability of PD course in respect to the heterogeneity of teachers' previous experiences.* What differences concerning the self-reported development of knowledge and competence facets (from before until after the PD course) can be observed in different groups of teachers with comparable previous experience in teaching statistics and/or using graphic calculators?

Results for PD day 4 including a detailed description of the underlying theory, competence models and methodology can be found in Nieszporek, Griese & Biehler (to be submitted). The procedures used in this article form the foundation for this paper and the analysis of the course success. Due to space limitations it is only possible to give a brief overview of the results for PD day 5 in this article.

The ReCoS questionnaire

With reconsideration of the course concept and the corresponding theoretical background, the ReCoS questionnaire (see Figure 1) was developed to fulfill our needs. ReCoS is an abbreviation for **retrospective competence self-reports** which describes the questionnaire quite well. It combines the knowledge and competence dimensions presented earlier (Table 2) with the specific content facets of each day. The PD course participants rate their before and after level of the facets subsequent to each PD day. The self-reports were made via German school grades (1=excellent, 2=good, 3=satisfactory, 4=pass, 5=poor, 6=fail).

Item No.:	I		II		III		IV		V		VI		VII		VIII	
	Before the PD	After the PD	Before the PD	After the PD	Before the PD	After the PD	Before the PD	After the PD	Before the PD	After the PD	Before the PD	After the PD	Before the PD	After the PD	Before the PD	After the PD
Interpretation of hypothesis testing results																
Type I and type II errors																

Figure 1: ReCoS questionnaire matrix, see Table 2 for the content of the columns

Pre/post or knowledge test designs were not feasible measurement tools for our project. Reasons range from organizational difficulties (lack of time for a detailed knowledge test due to a tight PD course schedule) to ethical concerns or motivation on behalf of the teachers. There are also good reasons for a retrospective test instrument like ReCoS. On the one hand different effects like *response shift* or *practice effects* were prevented. On the other hand, there was no *sensitization* towards a specific aspect or topic of the PD (Willson & Putman 1982).

Data collection and sample size

The ReCoS questionnaire matrix was adjusted to the topic of each PD day and distributed at the end of the respective day. A different questionnaire measuring individual experience levels via a six-point Likert scale (from *inexperienced* and *highly experienced*) was filled in by the participants at the beginning of the whole course. Individual anonymous codes were used to match the two questionnaires. 32 out of a total of 60 participants filled in both questionnaire types completely and thus only their data was used for further analysis.

Either SPSS 25 or R were used for statistical analysis like test for normal distribution (Kolmogorov-Smirnov), significance of competence increase (Wilcoxon signed-rank test) or building of scales of items and participants' groups.

Results

The general success of the PD course is illustrated in Figure 2. The ReCoS matrix shows the mean increase for each item. First of all, every change between the before and after competence self-assessment is positive. The changes were significant ($p < 0.001$, Wilcoxon signed-rank test) and were around 1 which is equal to an increase of one school grade.

Item No.:	I	II	III	IV	V	VI	VII	VIII
	I have content knowledge relating to the topic XXX.	I know the didactical and curricular backgrounds and the learning goals of the topic XXX.	I know ideas for the implementation of the topic XXX in lessons.	I know approaches for using digital tools/GC in the context of the topic XXX.	I am capable of recognizing and reacting appropriately towards misunderstandings and pupils' faulty reasoning regarding topic XXX.	I can create a lesson plan which incorporates the goals of the topic XXX.	I can teach the topic XXX in a goal-oriented way.	I am capable of implementing the approaches for the use of digital tools/GC in context of the topic XXX in school lessons in a didactically advantageous way.
Differences between before and after score means								
Interpretation of hypothesis testing results	1.09	0.70	1.28	1.16	1.00	1.06	1.00	1.16
Type I and type II errors	1.09	0.80	1.25	1.32	0.97	1.09	1.06	1.22
Choice of null hypothesis	0.97	0.73	1.25	1.13	0.97	1.16	1.09	1.16
Operation characteristics and power function	1.61	1.18	1.64	1.52	1.22	1.48	1.30	1.41

Figure 2: Mean differences between the before and after scores of each item, a difference of one positive point describes an increase by one school grade, sample sizes between 29 and 32

Overall, the differences for each item do not vary much. Item II (*I know the didactical and curricular backgrounds and the learning goals of the topic*) is an exception. For almost every content facet the self-assessment increases less than 1 grade, which stands in contrast to the confidence in creating lesson plans (item VI) or teaching the topic (item VII). This might be a hint that teachers have insecure knowledge of the curriculum (a discussion of the curriculum was not part of the PD) or have difficulties understanding this specific item. Nevertheless, some scales within the questionnaire can be identified.

Content-specific facet	Knowledge	Competences	Technology
	α	α	α
Before scores			
Interpretation of hypothesis testing results	0.910	0.982	0.897
Type I and type II errors	0.924	0.948	0.909
Choice of null hypothesis	0.933	0.979	0.927
Operation characteristics and power function	0.942	0.969	0.910
After scores			
Interpretation of hypothesis testing results	0.913	0.965	0.848
Type I and type II errors	0.906	0.947	0.930
Choice of null hypothesis	0.901	0.968	0.951
Operation characteristics and power function	0.925	0.965	0.898

Table 3: Cronbach's α for the different scales, separately for the before and after items, sample sizes between 29 and 32

The theoretical framework of the course suggests a separation of the items into two scales *knowledge* (Item I – III) and *competences* (Item V – VII) for each content facet. Item IV and VIII form a separate

scale called *Technology*, because technology plays a big role in the PD course and the abilities for using digital tools in school differ from the content components combined within *knowledge* and *competence*. The theoretical considerations are supported by empirical results. As is presented in Table 3, the identified scales within ReCoS show good to excellent Cronbach's α . In the following passages we will focus on the content facet *type I and type II errors*.

Table 4 shows the heterogeneity of experience among the teachers. The expertise reported in the field of teaching statistics and using the GC is not very high overall. It is striking that the participants were more unexperienced in handling digital tools ($n=21$), even when tools like GeoGebra or GC are commonly used for topics like algebra or analysis. This lack of experience for statistics appears to be a singularity.

Experience in teaching statistics	Experience in using GCs in statistics		
	Low	Medium	High
Low	n = 15 (L)	–	–
Medium	n = 5 (V)	n = 9 (M)	–
High	n = 1	n = 1	n = 1

Table 4: Distribution of participants in terms of self-reported experience in the use of GCs in statistics and in teaching inference statistics

For obvious reasons, we will disregard the groups consisting of only one person here, and instead focus on the participants who had low experience in teaching statistics and using GCs (*group L*), those who had varied experienced in both fields (*group V*) and those who reported medium experience (*group M*). This selection reduced the sample size to 29 for further analysis.

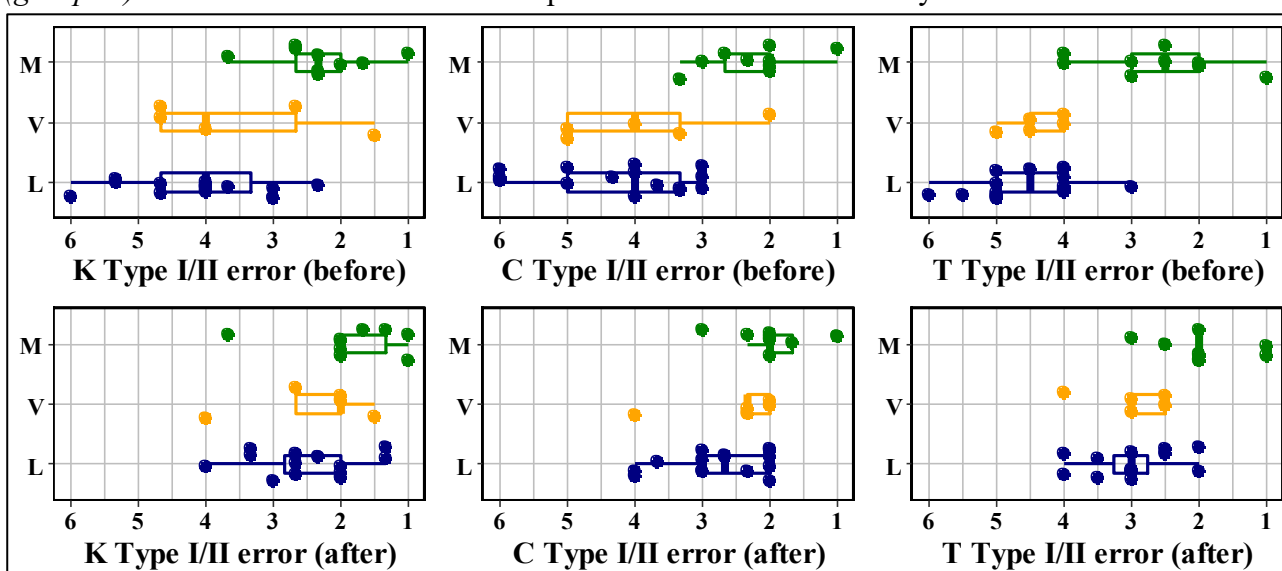


Figure 3: Jitterplots and boxplots of the three scale pairs *knowledge* (K), *competences* (C) and *technology* (T) for the content *type I and type II errors* (Type I/II error), group L: blue ($n=15$), group V: orange ($n=5$), group M: green ($n=9$), scale range from 6=fail to 1=excellent, made with R

The increase of the mean differences (Figure 2) can be rediscovered in the boxplots in Figure 3. This figure visualizes the development of the three groups (L, V and M) for the content facet *type I and type II errors*. The before scores of each group fit their previous experience on teaching statistics.

This means that the lowest experienced group (L) has the lowest before scores compared to the other two more experienced groups. Only group V, who also rated their experience in using digital tools low, shows equally low before scores in the technology scale. The after scores illustrate the huge increase of *knowledge*, *competence* and capability for *technology* reported earlier for the mean (Table 2). Even the most experienced group M rated themselves higher in all three scales after the PD course.

It is striking that there is a larger spread in the before scores of each group, which is remarkably reduced in the after scores of all three scales. Especially the participants of groups V and M rate their skills uniformly high. Only the lowest experienced group L shows a reduced but still high spread in the *knowledge* scale. There might be a ceiling effect at grade 2 (good) because only very few participants rated their skills higher with grade 1 (excellent). The rating system based on school grades might be the reason for that.

Discussion and remarks

Overall, the PD course increased the knowledge and competences of the participants by a significantly high amount (Figure 2) and was a success. But at the same time there are some hints as to where the PD course can be improved in a future design research cycle. We expected that the participants would rate their *knowledge* higher than their *competence* level after the PD course, because they supposedly would need to test the new material and ideas for teaching in their classes. There is a small difference between the score levels, but the *competence* after scores were almost as high as the corresponding *knowledge* scores. The different opportunities in the PD course to test and discuss the new input (for more details see Biehler et al., 2018) seem sufficient to encourage the participants to cover *type I and II errors* appropriately in class. Participants also feel more capable of using digital tools not only for calculating purposes but also for its didactical opportunities in the learning process.

The distribution of the before scores of each group (Figure 3) supports our division of the participants via their pre experience level. For example, the group of varied experience (V) shows medium high pre scores in *knowledge* and *competences* but has low scores in *technology*. The three different groups vary significantly from each other in the pre scores. This difference is still apparent in the after scores but relatively smaller since the after scores of groups L and V are almost on the same high level as group M. Also, the heterogeneity within each group is reduced on all scales.

It is important to have in mind that ReCoS only provides self-reported data and also that the sample size of 29 is not a large one. Therefore, we plan to contrast our results with data from other PD days and to use data from different other sources (questionnaires, audio transcript) to validate our findings. The comparison of the results from day 4 and 5 seems to be satisfying.

Acknowledgment

We would like to thank the Deutsche Telekom Stiftung who funds the DZLM and also the regional government of Arnsberg for cooperation and the opportunity to implement the course concept just as Birgit Griese for the help in the development process of the methodology and evaluation of day 4.

References

Ball, D. L., Thames, M. H., & Phelps, G. (2008). Content knowledge for teaching: What makes it special? *Journal of Teacher Education*, 59(5), 389–407.

- Biehler, R. (2016). *Professional Development for teaching probability and inference statistics with digital tools at upper secondary level*. Paper presented at the International Congress on Mathematics Education, Hamburg. http://iase-web.org/documents/papers/icme13/ICME13_I1_Biehler.pdf last accessed 07/08/2018.
- Barzel, B., & Biehler, R. (2017). Design principles and domains of knowledge for the professionalization of teachers and facilitators - Two examples from the DZLM for upper secondary teachers. In S. Zehetmeier, B. Rösken-Winter, D. Potari, & M. Ribeiro (Eds.), *Proceedings of the Third ERME Topic Conference on Mathematics Teaching, Resources and Teacher Professional Development (ETC3, October 5 to 7, 2016)* (pp. 16–34). Berlin: Humboldt-Universität zu Berlin. Retrieved from <https://hal.archives-ouvertes.fr/ETC3>, last accessed 03/12/2018.
- Biehler, R., Griese, B., & Nieszporek, R. (submitted). Traditions and innovations for inference statistics at upper secondary level in Germany: An approach via a nationwide center for teacher training and professional development. *Journal for Mathematics Teacher Education*.
- Biehler, R., & Prömmel, A. (2010). Developing students' computer-supported simulation and modelling competencies by means of carefully designed working environments. In C. Reading (Ed.), *Data and context in statistics education: Towards an evidence-based society. Proceedings of the Eighth International Conference on Teaching Statistics (ICOTS8, July 11-16, 2010)*, Ljubljana, Slovenia. Voorburg, The Netherlands: International Statistical Institute.
- Godino, J. D., Batanero, C., & Font, V. (2007). The onto-semiotic approach to research in mathematics education. *ZDM*, 39(1), 127–135.
- KMK. (2012). *Bildungsstandards im Fach Mathematik für die Allgemeine Hochschulreife (Beschluss der Kultusministerkonferenz vom 18.10.2012)*. Retrieved from http://www.kmk.org/fileadmin/veroeffentlichungen_beschluesse/2012/2012_10_18-Bildungsstandards-Mathe-Abi.pdf, last accessed 07/08/2018.
- McKenney, S. E., & Reeves, T. C. (2012). *Conducting Educational Design Research*. London, New York: Routledge.
- Mishra, P., & Koehler, M. J. (2006). Technological pedagogical content knowledge: A framework for teacher knowledge. *Teachers College Record*, 108(6), 1017–1054.
- Nieszporek, R., Griese, B., & Biehler, R. (submitted). Development of competence patterns in PD courses for inference statistics at upper secondary level. *Journal for Mathematics Teacher Education*.
- Nimon, K., Zigarmi, D., & Allen, J. (2011). Measures of program effectiveness based on retrospective pretest data: Are all created equal? *American Journal of Evaluation*, 32(1), 8–28.
- Prediger, S., Leuders, T., & Rösken-Winter, B. (to be submitted, 2018). Which research can support PD facilitators? Strategies for content-related PD research in the Three-Tetrahedron Model. *Journal for Mathematics Teacher Education*.
- Prömmel, A. (2013). *Das GESIM-Konzept - Rekonstruktion von Schülerwissen beim Einstieg in die Stochastik mit Simulationen*. Wiesbaden: Springer Spektrum.
- Wassong, T., & Biehler, R. (2010). A model for teacher knowledge as a basis for online courses for professional development of statistics teachers. In C. Reading (Ed.), *Data and context in statistics education: Towards an evidence-based society. Proceedings of the Eighth International Conference on Teaching Statistics, ICOTS8*. Ljubljana, Slovenia; Voorburg, Netherlands: International Statistical Institute.
- Weinert, F. E. (2001). Concept of competence: A conceptual clarification. In D. S. Rychen & L. H. Salganik (Eds.), *Defining and selecting key competencies* (pp. 45–66). Göttingen: Hogrefe.
- Willson, V. L., & Putnam, R. R. (1982). A meta-analysis of pretest sensitization effects in experimental design. *American Educational Research Journal*, 19(2), 249–258.

Learning through/about Culturally Relevant Pedagogy in Mathematics Teacher Education

Kathleen Nolan¹ and Lindsay Keazer²

¹University of Regina, Regina, SK, Canada; kathy.nolan@uregina.ca

² Central Connecticut State University, CN, Unites States; keazer@ccsu.edu

Keywords: Culturally relevant pedagogy, mathematics teacher education, teacher learning

Introduction

This presentation is grounded in self-study research by two mathematics teacher educators' (MTEs) as we taught courses in culturally relevant pedagogy (CRP) in mathematics and engaged in research conversations to discuss our learnings from students and from each other. The research is situated in the nexus between prospective and practicing teachers' (PTs) expectations for classroom 'tips & techniques' and MTEs' desires to disrupt dominant discourses in mathematics. We collected data from PTs through their projects and reflections on course content during offerings of CRP courses in our two institutions. We analyzed that data through a themes-based approach focused on MTE learning which was fostered by tensions and dilemmas stemming from students' responses to the disruption of dominant discourses. In this presentation, we describe our research contexts and the learning stimulated from listening to our PTs' thinking.

Research overview

Dominant discourses of mathematics have been well-established through a history of being "culturally defined as objective, value-free, logical, consistent and powerful knowledge-based discipline" (Burton, 1994, p. 207). Efforts to disrupt these dominant technical-rational traditions in mathematics classrooms are evident in research on power, privilege and oppression. For instance, Willey and Drake (2013) indicate that subtle signs of power and privilege are manifested in, for example, "neglecting students' cultural and intuitive mathematics knowledge" (p. 62). They urge us, as MTEs, "to sharpen our sociopolitical lenses in order to notice and disrupt manifestations of privilege and oppression in mathematics education" (p. 68).

We draw on the work of Ladson-Billings (1995), who defines culturally relevant pedagogy as "a pedagogy of opposition... not unlike critical pedagogy but specifically committed to collective, not merely individual, empowerment" (p. 160). In mathematics education, Aguirre & Zavala (2013) state that culturally responsive mathematics teaching "involves a set of specific pedagogical knowledge, dispositions, and practices that privilege mathematical thinking, cultural and linguistic funds of knowledge, and issues of power and social justice in mathematics education" (p. 167).

In general, MTE research on their instruction has focused on what PTs learn from their instructional approaches, rather than on their own learning as they conduct research (Chapman, 2008). Chapman (2008) offers that MTEs should study their teaching by reflecting on the thinking of their students/PTs, examining the conflicts between intent, thinking, and behaviors, and using them to inform MTE instructional approaches. In line with Chapman's advice, this research taught us to listen to our students and their thinking about CRP in mathematics classrooms; to understand and work

through students' questioning and resistance that emerges when dominant discourses of mathematics are disrupted in teacher education courses. Our research situates our learning and development as we struggle, in designing and teaching CRP courses, with questions of who and what is considered 'relevant,' and as we analyze how students respond to CRP in mathematics.

Discussion and results

Three themes emerged from our data that capture our learning as MTEs. The first is our need to clarify our own ideas about CRP. We found ourselves repeatedly questioning how to define and teach CRP, underscoring our belief that “[c]ultural responsiveness is not a practice; it's what informs our practice so we can make better teaching choices for eliciting, engaging, motivating, supporting, and expanding the intellectual capacity of ALL our students” (Hammond, 2015, p. vii).

A second learning theme is the need to negotiate understandings of CRP with PTs. We take seriously the warning of Aronson and Laughter (2016) to not turn CRP into “a buzzword or checklist of steps” (p. 198), that CRP must “be embraced more fully as a guiding ethos for every aspect of the classroom” (p. 198). As MTEs, we learned to be careful that we do not teach CRP courses which will merely make the dominant (technical-rational) mathematics more accessible, but that our courses are disruptive enough to make mathematics different in an enduring manner.

Finally, a third learning theme is the value of learning from others - from tensions created in our work with PTs, but also from each other, as MTE colleagues. This additional layer of collaboration fosters our growth and development as MTEs. Without the opportunity to discuss the tensions and dilemmas emerging in our practices, we would have remained isolated in our own individual contexts, struggling on our own with similar tensions and questions about CRP in mathematics.

References

- Aguirre, J., & Zavala, M. (2013). Making culturally responsive mathematics teaching explicit: A lesson analysis tool. *Pedagogies: An International Journal*, 8(2), 163-190.
- Aronson, B., & Laughter, J. (2016). The theory and practice of culturally relevant education: A synthesis of research across content areas. *Review of Educational Research*, 86(1), 163-206.
- Burton, L. (1994) Clashing epistemologies of mathematics education: Can we see the ‘wood’ for the ‘trees’? *Curriculum Studies*, 2(2), 203-219.
- Chapman, O. (2008). Mathematics teacher educators learning from research on their instructional practices. In B. Jaworski & T. Wood (Eds.), *International handbook of mathematics teacher education* (vol. 4) (pp. 115-135). Rotterdam: Sense.
- Hammond, Z. (2015). Culturally responsive teaching & the brain: Promoting authentic engagement and rigor among culturally and linguistically diverse students. Thousand Oaks, CA: Sage.
- Ladson-Billings, G. (1995). Toward a theory of culturally relevant pedagogy. *American Educational Research Journal*, 32, 465–491.
- Wiley, C., & Drake, C. (2013). Advocating for equitable mathematics education: Supporting novice teachers in navigating the sociopolitical context of schools. *Journal of Urban Mathematics Education*, 6(1), 58–70.

Using teachers' research to elicit professional development among pre- and in-service mathematics teachers: a qualitative meta-analysis of mathematics education in graduate programs

Tikva Ovadiya

Oranim Academic College of Education, Tivon; Jerusalem Academic College of Education, Israel;
tikvao@actcom.net.il

This study used qualitative meta-analysis to analyze the professional development of 38 pre-service student-teachers who conducted a qualitative study in mathematics education as part of their learning requirements. The analysis of the teacher-researchers' (TRs) studies used qualitative meta-analysis and focused on learning through activity (LTA) (Simon, 2018). Analysis was based on a meta-model that was constructed to characterize the development of the TRs according to the following parameters: skill of mathematics instruction, pedagogical perceptions, pedagogical knowledge, and problem-solving methods. In this paper, I present and discuss the meta-model study of only the last parameter (problem solving).

Keywords: Professional development, teacher researchers, qualitative meta-analysis, learning through activity (LTA), problem solving.

Introduction

Professional development programs for pre- or in-service mathematics teachers or teacher educators generally include practice in conducting research, based on the perception that the short- and long-term goals of post-secondary and graduate teacher-education programs are to develop expert teachers, and that conducting original research is one way of obtaining expertise. Most teachers in college or university programs claim that they have developed professionally, and this study examines various aspects of their professional development as a result of research that they carried out in their practical teaching environments.

Aspects examined included the structure of their research tools, task design, data analysis, interpretation of results and data, and so forth. A meta-model was developed to incorporate all these elements and more. The model describes the main categories found in the studies: problem solving, theory, beliefs and attitude, assessment, and environment and setting. In addition, the model describes the catalysts for the TRs' professional development for each category examined, describes the study tracks, and illustrates whether the TRs followed a partial or complete pathway to their goal. The elements highlighted in the model are the LTA components identified as part of the TRs' research process.

Theoretical background

The teacher as researcher

Requiring pre- or in-service teachers to engage in research as part of their practical instruction moves their education away from the educator-centered model (where the educator “communicates” information toward the student) towards a more student-centered approach, thus shifting pre-service teachers from receivers of pedagogical knowledge from “higher” authorities (i.e., the educator) into creators of such knowledge (Cochran-Smith & Lytle, 2009). Allowing pre-service teachers to conduct their own original research offers not only an instructional tool for teacher educators to engage in student-centered, problem-posing pedagogy (Souto-Manning, 2012), but also offers a tool for the pre- and in-service teachers themselves to investigate any worries or problems of practice they may have in their classrooms and schools in the future (Baumann & Duffy, 2001). Knowing how to conduct proper research will become a tool that extends beyond the teacher-education classroom, allowing in-service teachers to continue their professional development after completing their formal coursework and providing them opportunities to improve teaching and learning (Lysaker & Thompson, 2013), explore questions of influence and social justice (Fecho & Allen, 2011), change their understanding of their own students’ understanding of the various concepts (Parkison, 2009), improve their skill in intervention (Christenson et al., 2002), improve and change their beliefs, and take action appropriate to their findings. Snow-Geron (2005) found that teacher-researchers (TRs) changed not only their classroom practices, but also their attitude towards teaching. Even small-scale research projects allow TRs to improve their understanding of the research process (Gray, 2013), their selected topic(s) of study (Goodnough, 2010), and even about themselves (Reis-Jorge, 2007).

Previous studies have found that conducting research leads teachers to professionally develop their teaching skills and to better understand their beliefs and attitudes toward themselves as teachers and toward their students/pupils as learners. In this study, I focus on teachers in the field of mathematics education. The goal was not only to examine the extent of professional development that the research project effected, but also to focus on the catalysts for development that emerged in the TRs’ research process.

Learning through activity: theoretical framework

As the facilitator of the in-service teachers’ research projects, I utilized the learning through activity (LTA) theory as a strategy to investigate my students’ professional development. The LTA theory aims to integrate conceptual learning and instructional design. With respect to mathematics, LTA research is based on the questions: How do humans learn mathematical concepts? and How can instruction be designed to enlist these learning processes? Guided by these questions, LTA researchers have examined the design of mathematical concept study units and have developed a theory that simultaneously guides the work and derives from it (Simon, Kara, Placa, & Avitzur, 2018).

As defined by some of the studies on LTA, a “mathematical concept” is a researcher’s assumption used to characterize student knowledge. It does not represent what a student might actually say about her understanding but rather provides focus with respect to the learners’ *actions* and allows the researcher to recognize specific, higher-level actions that result when lower-level (current) actions are coordinated with the actions of the learning activity. This coordination of actions, along with

explanations to understand the concepts involved and reflective abstraction, becomes the source of a newer, more advanced concept (Simon et al., 2018). Based on this definition, theory designers also have defined specific “instructional” actions and procedures that promote conceptual learning. These may include hypothetical learning trajectory (HLT), guided reinvention, specific design steps, and use of computer applications, all of which can lead to a coherent process of building mathematical concepts.

Method

Research goals

The research goals were two-fold: 1) identify and characterize dimensions and aspects related to the professional development of teachers in the role of researcher in mathematics education, and 2) identify the catalysts that lead to this professional development.

To this purpose, the research questions were as follows:

1. What characterizes the professional development of TRs in the wake of the process of research on mathematics education?
2. Under what aspects does professional development takes place? What are the catalysts for professional development?

I narrowed focus onto two specific themes: “perceptions of concepts” and “conducting instruction.”

Population

No direct population. The qualitative analysis was conducted by examining the research study projects carried out by undergraduate students. (These projects were presented as their theses). Fifty-six student studies were initially examined, but only 38 that met the three criteria – the research involved mathematics education, the findings were qualitative, and the TR’s or mentor’s journal were available – were chosen for the meta-analysis (8 teacher educators, 18 elementary school teachers, 12 high school teachers).

Meta-analysis

Meta-analysis studies act as a guide for prospective research by qualitatively analyzing studies in a specific field to comparatively identify similarities and differences between them (Çalık & Sözbilir, 2014). This present meta-analytical study is aimed at systematically analyzing in-service teacher research on a variety of subjects in mathematics education so as to identify any professional development that occurred thereby and to determine any deficiencies and gaps therein.

Data analysis

The research process involved hermeneutic and dialectic aspects: hermeneutic to do justice to the original primary findings and dialectic to compare and contrast them with each other.

The first stage consisted of an initial reading of all the papers to familiarize myself with the subjects, methods, data analyses, findings, and results of each study. Next, at the second stage I formulated sub-questions that I attempted to answer during rereading. They were: What characterizes the topics that teachers choose to study? What do teachers ask in studies about student learning? What do teacher educators ask about their associate teachers? What do teachers ask about themselves? What

characterizes the process by which teachers build the research structure? What do teachers learn from the definition of intervention principles? How do teachers analyze data as researchers? Where and for what reason do teachers note in their work or journals the difference between being teachers and being researchers? Do teachers eventually indicate changes in their perceptions or beliefs?

In the third stage, I constructed a number of meta-models based on the answers to the above questions. These included meta-models pertaining to research subjects and populations, classification of research questions and research methods, application of theories, and the TR's skills and perception of mathematics instruction.

In the fourth stage, the meta-model was expanded based on LTA theory so as to recognize which TR actions complied with the theoretical predictions. The categories that evolved were "problem solving," "theory," "beliefs & attitudes," "assessment," and "surroundings". At this stage, I built the framework of the expanded model. I chose random events from the studies and examined them based on the categories in the extended model and, as a result, was able to refine the model.

Triangulation

I supplemented the qualitative meta-analysis with three types of data: the final versions of the papers the TRs submitted, the journals they submitted to me, and the notes that I, as facilitator, wrote throughout the procedure.

Findings

The meta-models constructed revealed five main categories that fell under "mathematics instruction, skills perceptions, and knowledge" and that involved project mechanisms unique to teachers' work in the research milieu. I then narrowed it down to the "sub-meta-model" of "problem solving" (see Figure 1 as part of an entire model) to provide a detailed analysis of the professional development of the TRs as it occurred during the research process.

Meta-model research: mathematics instruction, skills perception, and knowledge

As mentioned above, all the studies chosen for analysis included some form of "conceptual learning" and "instruction" and could be described through meta-model analysis. All the categories and subcategories in the meta-model can be divided into actions, thoughts, perceptions, or catalysts, and the four categories that pertain to the LTA instructional design framework. In constructing the meta-model, I analyzed events and attempted to identify these four components (shaded elements, Figure 1). Thus, it was possible to identify in which cases the process of teaching and intervention promoted perception of mathematical concepts and those that did not.

Professional development in problem solving

In the meta-model, "problem-solving" includes any new action, skill, or perception of problem-solving instruction that occurred during the TRs' research. The TRs did not use standard problems from textbooks or online per se, but selected exercises or problems suitable for the topic at hand. In addition, where changes in perception were observed, they redesigned tasks and imagined the solution their population might hypothetically give. Their design of their study tools evolved and changed if they recognized that their hypothetical path did not suit their population, as for example, they had

fifth-grade material but were teaching a third-grade class (for which no appropriate problem sets were available).

Identification of catalysts

Using LTA theory helped me define and recognize the intervention processes constructed by the TRs. If I recognized them as one (or more) of the four components of instruction that promote development of a mathematical concept, I examined the events to pinpoint the elements (i.e., catalysts) that led to this development. Catalysts included the following: assessing and analyzing solutions according to personal or theoretical interpretation, research questions that focus on identifying the development of concepts or actions, research questions that focus on changing the learning environment, and teaching and intervention.

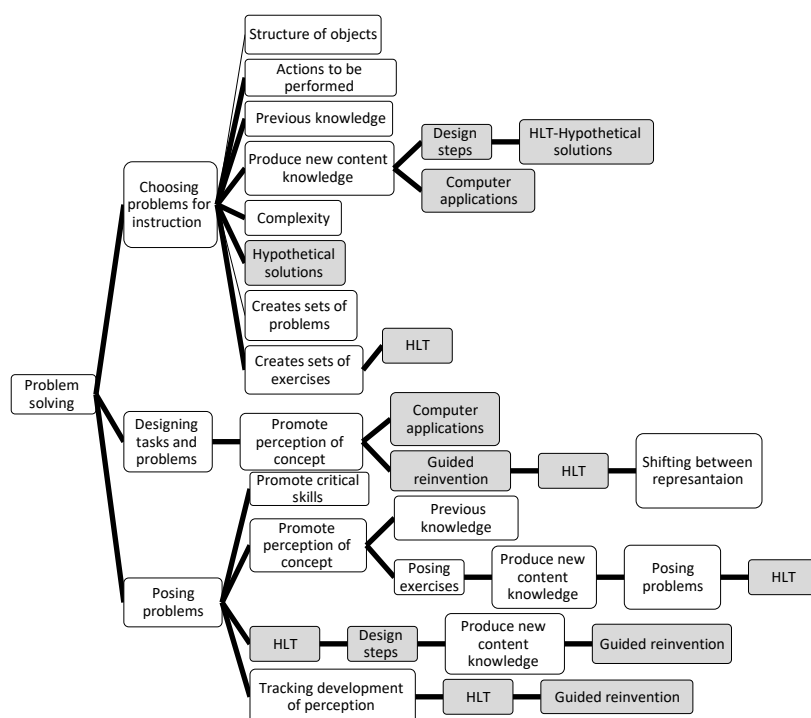


Figure 1: The “problem solving” component of the meta-model research

Below are three cases that illustrate the professional development of the TR with a focus on the catalysts.

Example 1: Designing tasks and problems to promote graphic representation

Rachel, a 12th-grade teacher, wanted to help her students solve calculus problems through graphic drawings. She found a problem online and adapted it to the non-computer environment. After analyzing the students’ solutions, she realized that her students did not yet have sufficient knowledge to solve the problem. She then chose problems from the textbook, redesigning them to encourage a graphic representation of the solution. However, she discovered that most students solved the problem algebraically; only a few applied graphic representations. She therefore proceeded to design two tasks: drawing the derivative of a given logarithmic function, and graphing the original function of a derivative presented as a denominator. She specifically chose functions where the students would have to consider many aspects of the “derivative” concept. At this point, she wrote some hypothetical (correct and incorrect) solutions, and made a hypothetical list of aspects of perception related to the

understanding of the original function and its derivative. In her journal, Rachel reflected how preparing the list of hypothetical solutions in advance helped her understand how her students might perceive the two concepts. From this stage on, Rachel worked as follows: 1) She chose a set of problems which, combined, developed understanding of the mathematical concept in the context of graphic representation and offered a multiplicity of examples and graphical solutions to problem. 2) She redesigned textbook problems to fit her research goal (fostering understanding of graphic representations of functions and shifting from one graphic representation to another). At each stage, she prepared a list of hypothetical solutions and implemented “guided reinvention”. She also posed questions to enhance her understanding of the solution process based on her analysis of each lesson.

Rachel is an example of a formative teacher who posed problems in accordance with the goal: developing a perception of graphs in calculus. LTA follow-up (HLT, guided reinvention, design steps, and computer application) enabled analysis of the stages of development and their identification. The catalyst was her investigation of the students’ solutions whereby she concluded that the original problem did not invite a graphic solution, leading her to design her own problems that focused on her research goal. By posing problems, she learned new mathematics content knowledge.

Example 2: Designing tasks and problems to promote transfer of learning

Betty, a grade-2 teacher, wanted to promote her pupils’ perception of the multiplication operation by solving problems involving tessellations. Her research goal was to promote transfer of learning from tessellation problems to multiplication problems and vice versa. Her research paper and journal indicated that she focused on the problem-solving aspect as follows: First, she found problems in the textbooks and redesigned them into a set appropriate for second graders. After analyzing her pupils’ solutions, she concluded that they understood the three basic properties of tessellation. Next, she posed tessellation problems using the categories she had created and introduced multiplication questions. At each stage, Betty wrote hypothetical solutions in advance and then analyzed the actual results to ascertain how her pupils perceived multiplication and tessellation. Also, at each stage, she focused on the dual purpose of posing problems whose solution reflects a perception of multiplication expressed through tessellations, and vice versa, which was supposed to reinforce each.

Betty’s professional development in problem solving was two-fold: 1) while posing the problems she refreshed the multiplication concept by creating different tessellations not necessarily with geometrical polygons; and 2) she considered the generic process of designing and posing problems: setting a learning goal, formulating steps to achieve it via specific concepts, posing appropriate problems, writing hypothetical solutions, analyzing the problem, and posing new problems accordingly. The catalyst was her unique study linking these two concepts and the fact that she had to design assessment rubrics to identify the development of the concepts.

Example 3: Designing tasks and problems to identify teachers’ perception of division by fractions

Sofie is a teacher facilitator. Her research focused on teachers’ perception of division by fraction, a concept that is sometimes confusing even to in-service teachers. She had previously experimented with the concept of the addition and subtraction of fractions, but she strongly suspected that teachers had difficulty posing problems that clearly taught the nature of division by fraction. She composed a

set of division exercises illustrating different aspects of division by fractions. Her plan was to interview teachers and ask them to pose a word problem for each exercise. She believed that how the problems were formulated would reveal the teachers' perceptions. Sofie first formulated and solved a set of hypothetical problems herself to determine if her chosen exercises were suitable and if they encompassed all aspects of division by fraction. Sofie's professional development was expressed in two ways: 1) Based on theories she had learned and papers she read, she composed and recomposed the set of exercises five times until she deemed them satisfactory. (She thus showed that she had learned to compose exercises as a series so as to develop various aspects of fractional division.) 2) Sofie learned how to convert the exercise into "realistic problems" so that the concepts of dividing by fractions were reflected in the formulation of the problem. Thus, her own concept of division by fractions developed and deepened. In addition, her research led her to construct a path for teaching the subject so that her students would develop a broad, coherent perception of the action. Sofie's catalyst was her exceptional interview structure that obliged her to overhaul exercises to solve the appropriate problem. An additional catalyst was reading studies and theories regarding the understanding of division by fractions. She tried to examine the perception of teachers against the perception of students.

Discussion and implications

In this brief article, I have presented a general model of the main and sub-categories that indicate the professional development of in-service teachers who conducted research. I then elaborated on the "problem-solving" category. This present article augments previous papers that discuss similar aspects (Baumann & Duffy, 2001; Cochran-Smith & Lytle, 2009; Goodnough, 2011; Fecho & Allen, 2011; Friedrich & McKinney, 2010; Labaree, 2003; Lysaker & Thompson, 2013; Moran, 2007; Souto-Manning, 2012; Vetter, 2012).

Three major findings emerge from the analysis of these studies in which TRs were required to deal, on their own and perhaps for the first time, with formative assessment at every stage of their research, using intermittent results to (re)build and improve their research tools and intervention actions. First, it is clear that such assignments support the coherent perception of mathematical concepts and processes and support the TRs' own skills in constructing a lesson to promote the development of their own coherent perceptions. This finding is consistent with the LTA theory (Simon et al, 2018). Second, it supports the general model of the skills and actions of the TR, which illustrates the catalysts in the sub-categories. (For example, what and when do teachers learn from theory?) Identifying catalysts and understanding their role in each category may help facilitators design studies with a higher potential for enabling the professional development of the TRs. Third, enhancement of the TRs' mathematical content was a central goal (and outcome) of this study. At the outset of their projects, the TRs considered themselves quite knowledgeable about the subject that they had decided to study, but, while building their research tools, they realized that there was a need for them to deepen their content knowledge.

Because this study was conducted using qualitative meta-analysis research, it presents a summary of findings from all the TR studies. This method is effective because it generates a comprehensive result that includes many aspects of the phenomenon (McShane, & Böckenholt, 2017). Thus, the "problem-solving" meta-model can be used to create a pathway that describes each of the studies individually.

If a particular path lacks some necessary component(s), e.g., “step design” or HLT, this indicates that the TR progressed less than one who did employ all the components.

Finally, the complete model can assist the facilitator in guiding TRs in designing research structure, making sure that they include activities with the potential to develop and promote mathematical “knowledge.” A paper regarding the use of the complete model is currently in preparation.

References

- Baumann, J. F., & Duffy, A. M. (2001). Teacher-researcher methodology: Themes, variations, and possibilities. *The Reading Teacher*, 54(6), 608e615.
- Çalık, M., & Sözbilir, M. (2014). Parameters of content analysis. *Egitim ve Bilim*, 39(174).
- Christenson, M., Slutsky, R., Bendau, S., Covert, J., Dyer, J., Risko, G., et al. (2002). The rocky road of teachers becoming action researchers. *Teaching and Teacher Education*, 18(3), 259-272.
- Cochran-Smith, M., & Lytle, S. L. (2009). *Inquiry as stance: Practitioner research for the next generation*. New York, NY: Teachers College Press.
- Fecho, B., & Allen, J. (2011). Teacher inquiry into literacy, social justice, and power. In D. Lapp, & D. Fisher (Eds.), *Handbook of research on teaching the English language arts* (3rd ed., pp. 232e246). New York, NY: Routledge.
- Goodnough, K. (2010). The role of action research in transforming teacher identity: Modes of belonging and ecological perspectives. *Educational Action Research*, 18(2), 167-182.
- Gray, C. (2013). Bridging the teacher/researcher divide: Master’s-level work in initial teacher education. *European Journal of Teacher Education*, 36(1), 24-38.
- Lysaker, J., & Thompson, B. (2013). Teacher research as a practical tool for learning to teach. *Language Arts*, 90(3), 181-190.
- McShane, B. B., & Böckenholt, U. (2017). Single-paper meta-analysis: Benefits for study summary, theory testing, and replicability. *Journal of Consumer Research*, 43(6), 1048-1063.
- Parkison, P. T. (2009). Field-based preservice teacher research: Facilitating reflective professional practice. *Teaching and Teacher Education*, 25(6), 798-804.
- Reis-Jorge, J. (2007). Teachers' conceptions of teacher-research and self-perceptions as enquiring practitioners. A longitudinal case study. *Teaching and Teacher Education*, 23(4), 402-417, 7.
- Simon, M. A., Kara, M., Placa, N., & Avitzur, A. (2018). Towards an integrated theory of mathematics conceptual learning and instructional design: The Learning Through Activity theoretical framework. *Journal of Mathematical Behavior*. IN PRESS.
- Snow-Gerono, J. L. (2005). Naming inquiry: PDS teachers' perceptions of teacher research and living an inquiry stance toward teaching. *Teacher Education Quarterly*, 32(4), 79-95.
- Souto-Manning, M. (2012). Teacher as researcher: Teacher action research in teacher education. *Childhood Education*, 88(1), 54-56.
- Vetter, A. (2012). Teachers as architects of transformation: The change process of an elementary-school teacher in a practitioner research group. *Teacher Education Quarterly*, 39(1), 27-49.

A quasi-experimental impact study of a professional development course for secondary mathematics teachers in South Africa

Craig Pournara and Patrick Barmby

Wits School of Education, University of Witwatersrand, South Africa;

craig.pournara@wits.ac.za; patrick@nomoremarking.com

We report on the impact of a mathematics professional development course on teachers' mathematical knowledge for teaching and their learners' attainment. Teachers' scores on a mathematics test improved significantly. Using a quasi-experimental design we examined the learning gains of Grade 9 learners (N=991) from nine secondary schools taught by teachers who had attended the course. We compared these results with those of learners (N=988) in the same schools taught by teachers who had not participated in the course. The intervention group learners made larger gains but these were not statistically significant. The teachers who had done the course had far fewer years of teaching mathematics at senior secondary level than their colleagues. This highlights the importance of a matched comparison teacher sample in impact studies.

Key words: Learning gains, mathematics teacher knowledge, impact of professional development.

Introduction

There are attempts across the world to improve teachers' mathematical knowledge in order to raise learner attainment. In South Africa, despite a wide variety of programmes costing many millions of Rand, there is little evidence that these interventions have had much impact on learners' performance in mathematics. The impact problem is frequently attributed to teachers' poor mathematical knowledge (Carnoy *et al.*, 2011; Taylor & Taylor, 2013).

In 2010 the Wits Maths Connect Secondary project (WMCS) set out to develop models of professional development for secondary mathematics teachers that would improve learner attainment in Mathematics. In 2012 the Transition Maths 1 (TM1) course was offered for the first time to a small group of teachers in one district in the broader Johannesburg area. In 2013 the Learning Gains I impact study showed that learners taught by teachers who had attended the course out-performed learners in the same schools taught by teachers who had not attended the course. The results were treated as "evidence of promise" since the sample was small, the gains were small and the variation within the treatment and comparison groups was large (Pournara, Hodgen, Adler, & Pillay, 2015). The notion of *learning gains* was employed as a measure of learner attainment where the gain is the change in test-score from pre- to post-test over one academic year. It is a useful notion in the context of impact studies because it enables us, to some extent, to attribute learning gains to the teaching received from a particular teacher in a given year. We are well aware of a range of interventions that are taking place in secondary schools and so we make all claims with caution, knowing that no individual intervention at the level of the teacher can account entirely for improvements in learner attainment.

The TM1 course has been revised and refined annually since 2014, and has now been offered to four more cohorts of teachers across the Gauteng province of South Africa, totaling approximately 150 teachers. A follow-on impact study, Learning Gains II, commenced in 2016 to extend the Learning Gains I study with a more robust instrument and a larger sample of teachers, learners and schools.

The key question the study seeks to answer is, “What is the effect of teachers’ participation in the TM1 course on their learners’ attainment in Mathematics?”

We begin with a brief review of the literature on teacher knowledge, mathematics professional development and the impact of these on learner attainment. Thereafter we provide a description of the TM1 course, giving the reader some insight into the mathematics and teaching components of the course by means of specific examples of tasks.

Teacher knowledge and learner attainment

Shulman’s (1986, 1987) distinctions between subject matter knowledge (SMK) and pedagogical content knowledge (PCK) have provided much impetus for a great deal of research on teacher knowledge. While it is widely agreed that the knowledge teachers need for teaching mathematics is more than sound content knowledge of mathematics itself, the elaboration of the detail takes different forms. Some refer to the additional knowledge as PCK (e.g., Krauss, Baumert, & Blum, 2008) while others (e.g., Ball, Thames, & Phelps, 2008) distinguish sub-categories of SMK as common, specialised and horizon content knowledge, and further sub-categories of PCK such as knowledge of content and students, curriculum and teaching. While we find the SMK-PCK distinction useful, the boundaries between them are too blurred to be useful as analytical constructs. We therefore choose to speak of “mathematics-for-teaching” (MfT) (Adler, 2005; Adler & Davis, 2006) as an amalgam of mathematical and teaching knowledge. MfT includes both subject content knowledge and mathematics-specific pedagogical knowledge.

Elsewhere (Pournara *et al.*, 2015) we have argued that in contexts where teachers’ mathematical knowledge bases are poor, proxy measures such as state certification, number of post-school maths/maths education courses taken and years of teaching experience may be relevant predictors of learner attainment in secondary mathematics. However, these proxy measures alone are insufficient as measures of teachers’ mathematical knowledge.

Attempts to measure teachers’ mathematical knowledge have taken various forms across the world. In some instances, teachers have been given the same/similar test items to the learners they teach. Harbison and Hanushek (1992) and Mullens, Murnane, and Willett (1996) found that primary teachers’ scores on such tests were good predictors of learner performance. In South Africa, Taylor and Taylor (2013) reported the poor performance of Grade 6 teachers and learners on items in the SACMEQ III study, thus implying a link between (poor) teacher knowledge and (poor) learner performance. More sophisticated measures have been developed in Germany and the United States (Baumert *et al.*, 2010; Hill, Ball, & Schilling, 2008; Krauss *et al.*, 2008). These studies have both found associations between teacher knowledge and learner attainment.

While teacher knowledge is key in all contexts, it is particularly crucial in contexts of poverty and low achievement. Nye, Konstantopoulos, and Hedges (2004) and Krauss *et al.* (2008) have shown that variances in learning gains attributable to teaching are higher in low socio-economic status (SES) schooling contexts.

Professional development and learner attainment

The impact of professional development is a concern across the world. Based on a literature survey in English publications, Adler, Ball, Krainer, Lin, and Novotna (2005) reported a predominance of small-scale qualitative studies. The review of studies of professional development relating to school mathematics by Gersten, Taylor, Keys, Rolfhus, and Newman-Gonchar (2014) showed that very few

of the initiatives which met acceptable standards of rigour also led to positive effects on learner attainment. Sample-McMeeking, Orsi, and Cobb (2012) reported the effects of a middle school intervention in the US where teachers took university summer courses in mathematics lasting two to three weeks. They reported an effect size of 0.20 (Hedge's g) on learner attainment for teachers who had attended two courses but there was no discernible effect size for those who had attended only one course. Further work is clearly required to carry out rigorous studies on the impact of teacher professional development on learner attainment in mathematics, and this study makes a contribution in this regard.

The Transition Maths 1 course

The TM1 course is underpinned by the assumption that focusing on teachers' MfT will lead to better teaching which will in turn translate into improved learner attainment. It is targeted at teachers currently teaching in Grades 8 and 9 (first two years of secondary school in South Africa), and aims to address the transition from mathematics in the Senior Phase (Grades 7–9) to mathematics in the Further Education and Training (FET) phase (Grades 10–12). Teachers are typically nominated by their school or district to attend the course. They are then required to write a selection test before being accepted. The course was offered free of charge to teachers. While it is an officially recognized Short Course of the University, it does not carry accreditation towards a qualification but does carry Continuing Professional Development (CPD) points.

The course consists of eight two-day contact sessions over a ten-month period and focuses on mathematics content (75%) and aspects of mathematics teaching (25%) – a similar ratio to the course described in Sample-McMeeking *et al.* (2012) mentioned above. The mathematical content of the course includes algebra, number, functions, Euclidean geometry and trigonometry. Teachers submit seven assignments and write two tests which include mathematics content and tasks related to teaching.

We approach the learning of MfT through *revisiting* known mathematics (Pournara, 2013) and learning new mathematics. When working with familiar mathematics, a revisiting approach frequently draws on extreme cases and problematizes taken-for-granted aspects to deepen teachers' knowledge rather than merely redoing known mathematics to improve procedural fluency (Kilpatrick, Swafford, & Findell, 2001). For example, in working with linear functions we provide teachers with five representations (verbal, table, function machine, equation and graph) of the same function, say $y = 2x + 1$. We then invite them to consider questions about each representation, including some that are likely to be new and unusual, for example: “Where is *double* in the graph?”; “Where is *double* in the table?”; and “When the input is -1 , the output is also -1 . Is there another output-value that is the same as the input-value?”

We extend teachers' knowledge beyond the mathematics they currently teach so that they can teach Grade 10 (and possibly beyond) in the future. We therefore deal with Grade 11 curriculum content in algebra, functions and trigonometry, paying attention to common procedures in the senior secondary years such as completing the square, which we approach algebraically and geometrically. We reinforce connections between representations and between procedures by asking teachers to solve quadratic equations using three methods (factorizing, quadratic formula and completing the square) for typical examples such as $3x^2 - 5x - 2 = 0$ and unusual cases such as $k^2 = 5$.

The focus on mathematics teaching is built around the notion of teachers' *mathematical discourse in instruction* (Adler & Venkat, 2014) which is operationalised through what is known as the

Mathematics Teaching Framework (MTF). Here we focus on key elements common to all teaching practices: identifying and articulating a lesson goal; designing and selecting example sets; selecting representations; selecting and designing tasks; producing explanations and justifications; and, building opportunities for meaningful learner participation in lessons. Each of these aspects is sufficiently close to teachers' current practice and hence possible to implement and then to work on so as to become more skillful at each one. We illustrate the teaching focus through an example from a session on explanations where we deal with the pervasive error of conjoining in algebraic simplification. Teachers are asked to produce an explanation that will convince Grade 8 learners that $4p + 5 \neq 9p$. This typically leads to a range of responses from teachers such as those illustrated in figure 1.

- 1) *Numerical approach using a single case*: The letter stands for an unknown number. So, let's try $p = 2$. If $p = 2$, then what is $5p + 4$? Is it the same as $9p$?
- 2) *Appealing to everyday life using letter as object*: We can think of $5p$ as 5 pencils, but 4 is just a number. When we add, we won't get 9 pencils.
- 3) *Appealing to everyday life using letter as specific unknown*: We can think of p as a box with a number of sweets, but we don't know how many sweets are in the box. Is $5 \square + 4$ the same as $9\square$? i.e., Is 5 boxes of sweets plus 4 more sweets the same as 9 boxes of sweets?
- 4) *Comparing different algebraic expressions using principles of variation*: Let's compare different algebraic expressions. What is the same/different about the following expressions: a) $5p + 4p$ b) $5p + 4m$ c) $5p + 4$

Figure 1: Four possible responses to explain $4p + 5 \neq 9p$

We then ask teachers to study these responses and to evaluate each explanation in the light of its mathematical correctness, its generalizability and the extent to which it is appropriate for Grade 8 learners. While we have not yet researched teachers' responses to this kind of task, anecdotally we have noticed that they are not aware of the limitations of the *letter as object* (Küchemann, 1981) explanation. We therefore highlight the important yet subtle distinctions between explanations (2) and (3), showing why (3) is more productive for making sense of algebraic symbols later in algebra. We recognize that explanation (4) shows evidence of teachers' take-up of ideas of variation (Marton & Tsui, 2004; Watson & Mason, 2006), which we explicitly teach in the teaching sessions.

Research design and methods

We adopted a quasi-experimental design to assess the effect of the TM1 intervention on the participating teachers and on the attainment of their learners. We describe the sample of teachers taking part in the TM1 course in 2016 and the methods used to analyse their gains in MfT during the course. We then examine a sample of Grade 9 learners during the 2017 school year to assess the impact of the TM1 course in the first year after teachers' participation in the TM1 course.

Forty teachers completed the TM1 course in 2016. The gains in their MfT were assessed by means of tests, administered at the start and the end of the course. The test at the end of the course was more cognitively demanding than the test at the start and covered more topics. Both tests were developed by the project team.

Eleven teachers, in 9 schools, were invited to participate in the study because they were teaching Grade 9 Mathematics in 2017 and 15 of their colleagues, also teaching Grade 9 Mathematics, agreed to be part of the comparison group. In terms of analysis, a repeated measures t-test analysis was used to compare the mean test scores at the start and the end of the course. This was carried out only for the 11 teachers in the study.

At the same time, we tracked 991 Grade 9 learners taught by TM1 teachers over the 2017 school year. We refer to these as the TM1 learners. We also tracked 988 Grade 9 learners from the same schools but taught by teachers who had never participated in the TM1 course. These learners are referred to as the comparison group. A test was administered to both groups in February and September 2017.

The learner test, designed by the project team, tested key aspects of number, algebra and functions. Most items were typical curriculum items at Grade 8 and 9 levels. The test was designed to contain a spread of items across difficulty levels. It was piloted in 2016 with Grade 9 and 10 learners in schools similar to those participating in the study. A Rasch analysis showed that the test was fit for the purpose of testing learning gains at Grade 9 level although there were a few too many items that were difficult for many learners.

Each test response was marked as *correct*, *wrong* or *missing* with only 1 mark being allocated for a correct response. Therefore a learner's test mark simply indicated how many items s/he had answered correctly. There was no consideration of partially correct responses.

A repeated measures ANOVA analysis was carried out to see whether the interaction between pre/post gains in the learner assessment and the learners' group (control vs TM1 group) was statistically significant.

Results

We first present the quantitative results and analysis from the TM1 tests for teachers, and then the results of the learner test.

Looking firstly at the TM1 maths tests, the mean test scores for the teachers before and after the TM1 course were compared. The mean pre-course test mark was 57.3% and the mean final test mark was 72.1%. A repeated sample t-test analysis showed that this increase was statistically significant at the 5% level ($t = 3.67$, $df = 10$, $p < 0.05$). We therefore concluded that the course had a significant impact on the teachers' MfT. Given that the final test was more cognitively demanding and covered more topics, the statistics may under-report the impact of the course on teachers' MfT.

The results of the Grade 9 Learning Gains test scores were as follows: for the TM1 group the mean score increased from 13.2% to 19.5% from pre- to post-test. By contrast the comparison group's mean scores increased from 13.9% to 19.7%. The TM1 learners made greater gains, closing the gap between the two groups. However, using a repeated measures ANOVA analysis, the interaction between pre/post-test and learner group was not found to be significant (Wilks' Lambda = 1, $F(1, 1975) = 0.91$, $p = 0.34$). We therefore concluded that there was no statistically significant difference in the gains in the learner test scores pre to post between the comparison group and the TM1 group.

The teachers' levels of teaching experience provide a possible explanation for the apparent lack of impact of the intervention. We compared the TM1 teachers and the comparison group teachers on their number of years of teaching Mathematics (in general) and on their number of years teaching Mathematics in each of Grades 8 to 12 (Table 1). We report on all 11 TM1 teachers but only on 12 comparison teachers because the biographical data for the remaining 3 teachers was incomplete.

	N	Years of Maths Teaching	Grade 8	Grade 9	Grade 10	Grade 11	Grade 12
TM1 teachers	11	14.6	7.0	9.6	3.6	1.9	1.1
Comparison teachers	12	13.3	4.5	5.8	4.1	4.3	4.0

Table 1: Teachers' average years of experience of Mathematics teaching per grade

The data shows that both groups had, on average, been teaching mathematics for a similar number of years although within each group there was a wide range of years of experience. While on average the TM1 group had more experience teaching at Grade 8 and 9 levels, the comparison group had considerably more experience teaching in Grades 11 and 12. This suggests that participation in the TM1 course does not make up for years of teaching experience at senior secondary level, particularly beyond Grade 10. However, based on the learner results, it could be argued that participation in TM1 enabled the teachers to do “as good a job” in teaching Grade 9 Mathematics as their colleagues who have more experience in teaching higher grades.

Given that the teachers in the comparison group are the “more senior” teachers with respect to mathematics, it is not surprising that the TM1 learners did not significantly outperform the comparison learners. If it can be assumed that teachers teaching higher grades have stronger mathematical knowledge for teaching, then the overall findings of this study fit with the underlying assumptions behind TM1 – that paying attention to teachers' mathematical knowledge for teaching is a necessary condition for improving teaching.

Discussion and implications

As noted above, proxy measures of teachers' knowledge may have some predictive power in contexts where teachers' mathematical knowledge is generally poor. Based on the data presented, the proxy measure “number of years of mathematics teaching” needs to take into account the levels at which teachers are teaching within the secondary school. Secondly, as Clarke (1994) has argued, the impact of professional development programmes on teachers' practice is delayed. Therefore, attempts to measure the impact of teachers' participation in TM1 on their learners should not be undertaken in the first year after completing the course.

Impact studies, irrespective of whether or not they report statistically significant results, do not provide insights into the mechanisms which enable or constrain the desired change. Based on the data reported here, little can be said about why the gains were small for both the TM1 learners and the comparison group. Further research is necessary to unearth possible reasons for the continued low performance of learners in Grade 9 Mathematics. A related qualitative study is underway to investigate the nature of learners' errors and the extent to which these errors may change between pre- and post-test. Such changes in the nature of learners' errors cannot be picked up by a coding system that does not make allowance for partially correct responses. This points to the need for mixed methods impact studies where quantitative impact analyses are complemented by qualitative studies such as those that attend to learner error.

In terms of research design, particularly in the context of secondary mathematics in South Africa, the above finding on teacher background and learner attainment shows the importance of matched sampling in the teacher group. This will likely expand the size, cost and complexity of the study since it is seldom possible to find comparison teachers, within the same schools, who have similar years of experience in Grades 8 and 9 but have not participated in TM1. Inevitably this means the inclusion

of new comparison schools, which potentially strengthens the findings of the study. However, experience has shown that schools such as those participating in this study are not in a position to confirm which teachers are teaching in each grade until early-to-mid February by which stage data collection for a study such as this has already commenced. Consequently the matching of teachers is likely only possible after the pre-test learner data has been collected. This leaves some of the matching of teachers up to chance as the researchers have little control over these matters.

Acknowledgements

This work is based on research of the Wits Maths Connect Secondary Project at the University of the Witwatersrand, supported by the FirstRand Foundation Mathematics Education Chairs Initiative and the Department of Science and Technology, and administered by the National Research Foundation. Any opinions, findings and conclusions or recommendations expressed in this material are those of the authors and do not necessarily reflect the views of the institutions named above.

References

- Adler, J. (2005). Mathematics for teaching: What is it and why is it important that we talk about it? *Pythagoras* 62, 2–11.
- Adler, J., Ball, D., Krainer, K., Lin, F. L., & Novotna, J. (2005). Reflections on an emerging field: Researching mathematics teacher education. *Educational Studies in Mathematics* 60(2), 359–381.
- Adler, J., & Davis, Z. (2006). Opening another black box: Researching mathematics for teaching in mathematics teacher education. *Journal for Research in Mathematics Education* 37(4), 270–296.
- Adler, J., & Venkat, H. (2014). Teachers' mathematical discourse in instruction: Focus on examples and explanations. In H. Venkat, M. Rollnick, J. Loughran & M. Askew (Eds.), *Exploring mathematics and science teachers' knowledge: Windows into teacher thinking* (pp. 132–146). Abingdon, Oxon, UK: Routledge.
- Ball, D., Thames, M., & Phelps, G. (2008). Content knowledge for teaching: What makes it special? *Journal of Teacher Education* 59(5), 389–407.
- Baumert, J., Kunter, M., Blum, W., Brunner, M., Voss, T., Jordan, A., . . . Tsai, Y.-M. (2010). Teachers' mathematical knowledge, cognitive activation in the classroom, and student progress. *American Educational Research Journal* 47(1), 133–180.
- Carnoy, M., Chisholm, L., Addy, N., Arends, F., Baloyi, H., Irving, M., . . . Sorto, A. (2011). The process of learning in South Africa: The quality of mathematics teaching in North West Province *Technical report*. Pretoria: HSRC/Stanford University.
- Clarke, D. M. (1994). Ten key principles from research for the professional development of mathematics teachers. In D. B. Aichele & A. F. Coxford (Eds.), *Professional development for teachers of mathematics: The 1994 Yearbook of the National Council of Teachers of Mathematics* (pp. 37–48). Reston, VA: NCTM.
- Gersten, R., Taylor, M. J., Keys, T. D., Rolhus, E., & Newman-Gonchar, R. (2014). *Summary of research on the effectiveness of math professional development approaches*. Washington, DC: U.S. Department of Education, Institute of Education Sciences, National Center for Education Evaluation and Regional Assistance, Regional Educational Laboratory Southeast.
- Harbison, R. W., & Hanushek, E. A. (1992). *Educational performance of the poor: Lessons from rural northeast Brazil*. Oxford, UK: Oxford University Press.
- Hill, H., Ball, D., & Schilling, S. (2008). Unpacking pedagogical content knowledge: Conceptualizing and measuring teachers' topic-specific knowledge of students. *Journal for Research in Mathematics Education* 39(4), 372–400.
- Kilpatrick, J., Swafford, J., & Findell, B. (2001). *Adding it up: Helping children learn mathematics*. Washington: National Academy Press.

- Krauss, S., Baumert, J., & Blum, W. (2008). Secondary mathematics teachers' pedagogical content knowledge and content knowledge: Validation of the COACTIV constructs. *ZDM Mathematics Education*, 40, 873–892.
- Küchemann, D. (1981). Algebra. In K. Hart (Ed.), *Children's understanding of mathematics: 11–16* (pp. 102–119). London, UK: John Murray.
- Marton, F., & Tsui, A. B. M. (2004). *Classroom discourse and the space of learning*. New Jersey, NJ: Lawrence Erlbaum Associates.
- Mullens, J., Murnane, R., & Willett, J. (1996). The contributions of training and subject matter knowledge to teaching effectiveness: A multilevel analysis of longitudinal evidence from Belize. *Comparative Education Review* 40(2), 139–157.
- Nye, B., Konstantopoulos, S., & Hedges, L. (2004). How large are teacher effects? *Educational Evaluation and Policy Analysis* 26(3), 237–257.
- Pournara, C. (2013). *Mathematics-for-teaching in pre-service mathematics teacher education: The case of financial mathematics*. Unpublished PhD thesis, University of Witwatersrand, Johannesburg.
- Pournara, C., Hodgen, J., Adler, J., & Pillay, V. (2015). Can improving teachers' knowledge of mathematics lead to gains in learners' attainment in mathematics? *South African Journal of Education* 35(3), 1–10.
- Sample-McMeeking, L. B., Orsi, R., & Cobb, R. B. (2012). Effects of a teacher professional development program on the mathematics achievement of middle school students. *Journal for Research in Mathematics Education* 43, 159–181.
- Shulman, L. (1986). Those who understand: Knowledge growth in teaching. *Educational Researcher* 15(2), 4–14.
- Shulman, L. (1987). Knowledge and teaching: Foundations of the new reform. *Harvard Educational Review* 57(1), 1–22.
- Taylor, N., & Taylor, S. (2013). Teacher knowledge and professional habitus. In N. Taylor, S. van der Berg, & T. Mabogoane (Eds.), *What makes schools effective? Report of the National Schools Effectiveness Study* (pp. 202–232). Cape Town, South Africa: Pearson.
- Watson, A., & Mason, J. (2006). Seeing an exercise as a single mathematical object: Using variation to structure sense-making. *Mathematical Thinking and Learning* 8(2), 91–111.

Orchestrating collective mathematical discussions: practices and challenges

Ana Maria Roque Boavida¹, Ana Paula Silvestre² and Cátia Prata³

¹Escola Superior de Educação, IPS de Setúbal, Portugal; ana.boavida@ese.ips.pt

²Escola Superior de Educação, IPS de Setúbal, Portugal; ana_paula_silvestre10@hotmail.com

³Escola Superior de Educação, IPS de Setúbal, Portugal; catiaprata@hotmail.com

Keywords: Mathematics teaching practices, problem solving, collective discussions, challenges.

Theoretical framework

Currently, there is a wide agreement concerning the idea that students' understanding of mathematics, their ability and confidence to use it to solve problems, and the development of a fruitful disposition toward mathematics, are shaped by the teaching they encounter in the classroom (NCTM, 2000; Smith, & Stein, 2011). Besides, researchers agree that “within mathematics classrooms, the nature and character of the discourse that students and teachers engage in has a profound impact on students’ opportunities to learn mathematics, and it shapes their identities as mathematical knowers and doers” (Cirillo et al., 2014, p. 141).

If we intend to support and foster students’ “mathematical proficiency” (Kilpatrick, Swafford, & Findell, 2001, p. 5), it is essential that the mathematical discourse that occurs in the classroom takes as a starting point the students' exploration of cognitively challenging tasks; it is also crucial that they actively engage in whole-class discussions of the strategies they used to solve these tasks. In fact, research has shown that whole-class discussions with these characteristics and in which the teacher, relying on what the students say and do, moves them towards a more powerful, efficient, and accurate mathematical thinking, are a resourceful context for learning mathematical ideas and processes (Lampert, 2001).

Even though these collective discussions rooted in students’ thinking and work and about relevant mathematical tasks can provide important opportunities to learn mathematics, to orchestrate “a productive mathematical discussion (...) turns out to be an extremely demanding and intricate task. The role of discussion coordinator is particularly difficult” (Sfard, 2003, p. 375). Even experienced teachers face difficulties and challenges that would not exist if the control of the classroom discourse was mainly in their hands. These challenges, well documented in the literature (for example, Boavida, 2005; Lampert, 2001; Smith, & Stein, 2011), increase when the teachers who try to conceive and implement mathematical teaching practices which emphasise productive whole-class discussions based on problem solving, are prospective teachers.

The research: aim and results

This presentation relies on two studies developed by two prospective elementary mathematics teachers (Prata, 2017; Silvestre, 2017). Both of the studies aims to understand how they could develop teaching practices focused on the orchestration of mathematical collective discussions and to analyse the challenges that these practices pose to a future teacher. From a methodological point of view, the

studies fit into an interpretative paradigm. During the last year of their teaching training programme, the two prospective teachers conceived and carried out, in primary schools and over about five weeks, pedagogical interventions in which several problems related to selected mathematical concepts were proposed. Over this period they acted both as researchers and teachers. The empirical data were collected mainly by participant observation and documental analysis.

The results of the studies illustrate that the five-practices model proposed by Smith and Stein (2011) has helped the prospective teachers to manage better the orchestration of collective discussions around problem solving strategies generated by the students. Besides, they highlight the importance of selecting challenging tasks that foster the emergence of several solution strategies and which context is close to the students' experience. The main challenges experienced by the prospective teachers are related to help the students to understand that errors are valuable "ways of thinking" preventing, at the same time, that those who have failed feel themselves in a vulnerable position; to support their reasoning without telling "what to do" to get the right answer; to change the pattern of interaction from "funneling" to "focusing"; and to honor students thinking while assuring that the mathematical ideas that are in the heart of the teaching agenda remain prominent.

References

- Boavida, A. (2005). *A argumentação em Matemática: Investigando o trabalho de duas professoras em contexto de colaboração*. Lisboa: APM.
- Cirillo, M., Steele, M., Otten, S., Herbel-Eisenmann, B., McAneny, K., & Riser, J. (2014). Teacher Discourse Moves: Supporting Productive and Powerful Discourse. In K. Karp (Ed.), *Annual Perspectives in Mathematics Education 2014: Using Research to Improve Instruction* (pp. 141–149). Reston, VA: NCTM.
- Kilpatrick, J., Swafford, J., & Findell, B. (Eds.). (2001). *Adding It Up: Helping Children Learning Mathematics*. Washington: National Academy Press.
- Lampert, M. (2001). *Teaching problems and the problems of teaching*. New Haven, CT: Yale University Press.
- NCTM (2000). *Principles and standards for school mathematics*. Reston, VA: NCTM.
- Prata, C. (2017). *As discussões coletivas no 2.º ano de escolaridade enquanto via para ensinar a subtrair: um estudo sobre as práticas de uma futura professora*. <https://comum.rcaap.pt/handle/10400.26/17575>
- Sfard, A. (2003). Balancing the unbalanceable: The NCTM Standards in light of theories of learning mathematics. In J. Kilpatrick, W. G. Martin, & D. Schifter (Eds.), *A research companion to Principles and Standards for School Mathematics* (pp. 353–392). Reston, VA: NCTM.
- Silvestre, A. P. (2017). *Preparação e orquestração de discussões coletivas em Matemática: Desafios experienciados por uma jovem professora no 5.º ano de escolaridade*. <https://comum.rcaap.pt/handle/10400.26/17723>
- Smith, M., & Stein, M. (2011). *5 practices for orchestrating productive mathematics discussions*. Reston, VA: NCTM.

Pre-service mathematics teachers interpret observed teachers' responses to students' statements

Sigal Rotem, Michal Ayalon and Shula Weissman

University of Haifa, Israel; sigal.h.rotem@gmail.com

In this paper, we will present and exemplify a three-level category scheme used for categorizing the depth of interpretations pre-service mathematics teachers offer for teachers' responses to students' mathematical thinking in observed critical events. The category scheme is a result of top-down literature analysis and bottom-up analysis of 38 critical event reports submitted during one academic year within a clinical preparation context. This category scheme may help teacher educators to gain a better understanding of PTs' interpretations of teachers' responses, and therefore to plan field-based training programs that help PTs to broaden their theory-practice connection.

Keywords: pre-service mathematics teachers, critical events, noticing, reflection.

Introduction

Reflection has had a growing role in teacher education over the past four decades (e.g., Zeichner, 1981) and is considered to lie at the heart of teachers' professional practice (Clarke, 2000). Teacher educators argued for the integration of reflection with field-based preparation, in order to help pre-service mathematics teachers (PTs) learn how actions connect to particular purposes in context and to support PTs' ability to link theory with practice (e.g., Ball & Forazani, 2009; Zeichner, 1981). In this research we follow Karsenty and Arcavi's (2017) definition of reflection, which is "analytical and careful observation of 'what was done' in order to attempt to understand intentions, plans, actions and utterances" (p. 435). A common use of reflection in teacher education (in-service and pre-service) is asking teachers to analyze classroom situations (e.g., van Es et al., 2017). However, research indicates that when PTs are merely asked to reflect on situations that they observed, their reflection may focus on aspects of teaching that are irrelevant to building further mathematical instruction (e.g., Santagta & Guirno, 2011). This suggests that a structured framework for reflection is needed. Recent research indicates that *professional noticing framework* is an appropriate framework for structured reflection (Jacobs et al., 2010). In this research we built on Jacobs et al. framing of professional noticing framework, which requires PTs to: (1) identify a critical event (2) interpret the mathematical thinking of the student/s in the critical event, and (3) offer an alternative response as if they were the teacher responding to the critical event. This framework is used here to analyze authentic mathematics classroom situations that PTs observed in their clinical preparation program. We refer to these situations as *critical events*. In this study we built on Stockero and Van Zoest (2013) and Goodell (2006) definitions and define critical events as moments in the classroom that if pursued by the teacher may enhance students' mathematical learning, and therefore provide the teacher with an opportunity to reflect and thus to learn about teaching.

In most studies PTs are asked to focus on the student's mathematical thinking as it is expressed in student-teacher interactions (e.g., Jacobs et al., 2010; Simpson & Haltiwanger, 2017). This study takes a slightly different approach, and seeks to focus not only on the student but on the teacher as well. The premise is that an analysis of teacher responses is an inseparable part of the critical event

analysis and that focusing on the relationships between the student's statements and the teacher's responses in the given event will contribute to reflection. In addition, research shows that PTs struggle when it comes to offering an alternative response as if they were the teacher in critical event (e.g., Jacobs et al., 2010). Although not in the scope of this paper, we began looking for ways to support PTs to base their alternatives for teaching on the students' mathematical thinking as expressed in the event. A possible approach for achieving this aim is to direct the PTs to focus their attention to the teacher's response. The current paper takes a first step in building a characterization for the PTs' interpretations for the teachers' statements in the observed events.

This paper presents an analysis of PTs' written interpretations for a teachers' responses in critical events which were submitted during a clinical training program. We analyzed 38 reports submitted by the PTs. The reports contain PTs' analysis of the critical event according to the three elements of the professional noticing framework (Jacob et al., 2010) plus analysis of an observed teacher's response to the student. Our analysis of the reports was conducted bottom-up together with adaptations of some existing frameworks to construct a three-level rubric to assess the depth of PTs' interpretations of a teachers' response in observed critical events. This rubric may help teacher educators to gain a better understanding of their PTs' interpretations of an observed teacher's response, and therefore, may help to plan field-based training programs for teachers.

Literature review

In correspondence with the importance specified above of offering interpretation to the teachers' responses in critical events, we built mainly on three bodies of research: (a) reflection, which we ask PTs to perform in the context of their clinical training; (b) critical events as a construct for reflection; and (c) teachers' professional noticing which is the basis of our structured reflection framework.

Reflection, as in analytical articulation of instructions and teaching actions in order to understand consideration that led those actions (Karsenty & Arcavi, 2017) is, according to Clarke (2000), "not just an option pursued by good teachers; rather, to teach is to reflect." (p. 201). Karsenty and Arcavi (2017) offered a bottom-up characterization for different aspects that in-service teachers attended while reflecting on observed mathematics lessons. Potari and Jaworski (2002) looked at teachers' reflection using the teaching triad framework, which perceives teaching practice as an integration of management of the lesson, being sensitive – cognitively and affectively – to the students and managing the mathematical challenge of the lesson. Teachers' reflection has been found to be a productive tool to link practice with mathematics teaching theories (e.g., Jacobs et al., 2010). Additionally, recent research suggests that teachers' involvement in deep reflection and analysis of teaching strategies and intentions may hold opportunities to learn from such examination new ways of instruction, insights and horizons (Karsenty & Arcavi, 2017). In this research we ask PTs to reflect on critical events they observed during their clinical training classroom observations. The theoretical base for critical events is cases which are descriptions of events that represent a broad pedagogical phenomenon or a dilemma with theoretical aspects (Shulamn, 1986) and which exhibit unexpected moments that are valuable in regard to students' learning (e.g., Stockero & Van Zoest, 2013). In the research literature critical events also appear as ordinary teaching-learning situations that make teachers question their practice and, through reflection, provide a gateway for the teacher to improve

his/her teaching (Goodell, 2006). As our use here of critical events is meant to promote PTs' learning about teaching mathematics, we define critical event as moments in the classroom that if pursued by the teacher may enhance students' mathematical learning, and therefore provide the teacher with an opportunity to reflect and thus to learn about teaching.

But just asking PTs to reflect on observed critical events is not enough; there is a need to teach PTs how to reflect on teaching in disciplined and structured ways (e.g., Santagta & Gurino, 2011). Therefore, the third body of research that informed this study is the teachers' professional noticing framework (Jacob et al., 2010) which is defined as: (1) attending to student thinking within student-teacher interactions; (2) interpreting student understanding based on these interactions; and (3) offering a response based on this analysis. For example, deciding when to ask students for more clarification or to follow up on a student's statements requires the teacher first to attend to the student's statement, then to interpret its mathematical meaning and then to formulate an immediate response. Therefore, these skills are considered core elements of teaching practice that should be practiced in teacher training programs (Ball & Forzani, 2009). Research focusing on cultivating these skills among PTs indicates that PTs struggle when asked to offer alternative responses for the teaching reflected in a critical event (e.g., Jacobs et al., 2010). For example, Rotem and Ayalon (2018) found that even when PTs offered a rich interpretation for the students' statements in the critical event, interpretations for the teacher's response and the suggested teaching alternatives were general in their nature and detached from the interpretation they offered for the students' statements. To date, most researchers have focused on assessing the interpretation teachers ascribe to students' statements in the event (e.g., Simpson & Haltiwanger, 2017). Interpretations for the teachers' statements were seldom in the focus of research. An exception for this is van Es et al.'s (2017) study, which investigated the development of PTs' noticing of ambitious mathematics pedagogy in the context of a video-based course designed to foster PTs' skills of interpreting classroom interactions. They used the term 'making thinking visible' to capture the extent to which the PTs attended to the teacher's role in making student thinking visible. Van Es et al. (2017) identified three levels of skill: (a) not paying much attention to the teacher's strategies making student thinking visible, but rather to management and arrangement of the students and class; (b) identifying the teaching strategies and judging their effectiveness; and (c) inferring the ways the teacher made student thinking visible, and how they influenced on student thinking and learning. For the study presented in this paper, we built on van Es et al.'s three levels of skill to develop a three-level category scheme for categorizing the depth of interpretations PTs offer for teachers' responses to students' mathematical thinking in observed critical events. Consequently, our research question is: *What are the main characteristics for the levels of interpretations PTs offer to a teacher's response in a critical event, which they identified?*

Research context: ACLIM-5 clinical training program

The study took place in the context of ACLIM-5 (a Hebrew acronym meaning "clinical training for unique 5-unit (high track) mathematics teaching"). ACLIM-5 is a large university's three-year training program designed to support the development of high track mathematics pre-service teachers. Due to the limited space of this paper we will not elaborate regarding the program. We will note, however, that this study focused on the first year of the program, in which PTs study for their teaching

certificate. PTs participated in a course on critical events in which they were required to submit a critical event reports based on lesson observations. The reports consisted of four main parts: (a) prompts for describing the critical event that was identified during classroom observation, the mathematical context, and the student-teacher interaction. (b) prompts for interpreting the students' statements. (c) prompts for interpreting the teacher's response, E.g. "offer interpretations for the teacher's actions. What was going through his mind? What was it based on?" and (d) a request for alternative ways of responding, other than the teacher's response. Sections (a), (b) and (d) of the report resonance Jacobs et al. (2010) framing of professional noticing. Here, PTs' answers for (c), served as the data source for this study.

Data collection

The data for this paper was taken from the critical event reports submitted in the first year of the first ACLIM- 5 course. In the course participated one male and 12 female. Five studied toward a dual degree in Mathematics and Education, and eight graduated with a B.Sc. from the university's department of Mathematics. The data consist of 38 critical events reports describing real-life classroom events from PTs' observations, submitted during the academic year.

Data analysis

Data analysis was conducted in three phases. First, we used bottom-up characterization for PTs' answers within (c) section. Then we searched for compatibilities between the bottom-up characterization and research literature that was mentioned above (e.g., Potari & Jaworski, 2002; van Es et al., 2017). Finally, we built the coding scheme, using both the bottom-up and literature-based characterization.

Findings

Our analysis of 38 critical reports resulted in a three-level scheme for categorizing the depth of interpretations that were assigned by PTs to the teacher's response in critical events. Van Es et al. (2017) three-level framework for analyzing PTs' attention to the teacher's making student thinking visible, served us as a base ground for developing the scheme, while using a bottom-up approach to allow other characteristics for each level of interpretation to emerge. Eventually, we have received a refined coding scheme for level of interpretation, as presented in Table 1.

Table 1: Coding scheme for level of interpretation

Levels of interpretation of teacher's response	Characteristics of level of interpretation
Descriptive/affective	Participant describes the teacher's response in general terms while attending to affective aspects of the students or to the management and arrangement of the students and class;
Semi interpretation	Participant points out the teaching strategies that the teacher used when responding to the students' statements; and/or judges the effectiveness of the strategies.
Full interpretation	Participant details the teaching strategies that the teacher used when responding to the students' statements and proposes considerations that may have led to the teacher's response and judges the effectiveness of the strategies.

Low level of interpretation to teacher's response- descriptive/affective interpretation

The results of the bottom-up analysis indicated that when asked to interpret teachers' statements, PTs tended to describe teachers' statements while attending to the management and arrangement of the students and class without offering an explanation for the considerations behind the teacher's statements. This echoes van Es et al. (2017) low level of interpretation - attending mainly to management and arrangement of students and class. Some PTs interpreted the teacher's actions or statements as aiming to motivate the students by addressing their affective needs. For example, in a critical event which was described by Faith and in which the teacher asked a student to share with the class an original way of drawing the graph of $f(x) = \sin(2x - \frac{\pi}{3})$ within the segment $[0, \pi]$ without analyzing the function, but through transforming the basic *sin* function, Faith interpreted the teacher's response as:

- 1 He [the teacher] gave the student a positive feeling
- 2 and she [the student] felt that she had deep and beautiful thinking [...]
- 3 and this provided an opportunity for other students to think differently.

Faith started by attending to the teacher's intentions (line 1) and then she offered her interpretation of the student's feeling as result of the teacher's response (line 2). Together, lines 1-2 could imply that Faith sees the teacher's response as an expression of his attention to the student's affective aspects. Line 3 could imply either that Faith considered the teacher's response to be a way to motivate other students in the class or a way of promoting students' awareness to the different ways to solve the problem. However, Faith's interpretation is very general in the sense that it can be assigned to various lessons (not just mathematics) and it is disconnected from the specific critical event that was observed. Her general interpretation can be characterized by attending to teacher's affective sensitivity to students (Potari and Jaworski, 2002)

Medium level of interpretation to teacher's response- Semi interpretation

The bottom-up analysis indicated that at this level PTs tended to point out at the teacher's teaching strategy and sometime judged its effectiveness but still without regarding considerations behind the teacher's statements. This echoes van Es et al. (2017) medium level of interpretation - "identifies teaching strategies and choices the teacher makes in the lesson to make thinking visible; and/or judges the effectiveness of strategies."

Vanessa observed and reported on the same critical event as Faith. Vanessa's interpretation was as follows:

- 1 The teacher enjoyed the student's response,
- 2 and shared it with the rest of the students
- 3 to see whether she was correct or not, and asked them to apply it.
- 4 When he shares the response with the class, and discusses it
- 5 it means she is going in the right direction [...]
- 6 It encourages the student to think more deeply while answering other questions.
- 7 The teacher wants to encourage students to think analogously while analyzing functions
- 8 and not just to rely on rules, so he shares the student's response with the class to discuss.

Here, in lines 2-4 Vanessa point out the teacher's strategy in the critical event - the teacher made the student's solution a focus for a whole classroom discussion. From line 3 it may follow that Vanessa sees the teacher's strategy as aiming to evaluate the student statement "to see whether she was correct or not". The effectiveness that Vanessa sees in this strategy may be seen as: (I) a way to acknowledge the student's solution (line 5); (II) a way to encourage the student to "think deeper" when approaching other questions (line 6); and (III) a way to motivate the class to adopt a different kind of approach to function analysis, one that is based on function transformation (line 7-8).

High level of interpretation to teacher's response- Full interpretation

The characteristics of this category - *Participant details the teaching strategies that the teacher used when responding to the students' statements and proposes considerations that may have led to the teacher's response; and judges the effectiveness of the strategies* - are similar to those of the medium level of interpretation, with two modifications. First - the participant details the teaching strategies - and second - they propose considerations that may have led to the teacher's response. This characterization is meant to keep the overall language of the levels of interpretation while also echoing our purpose in interpreting teachers' responses, which is to attempt to understand the intentions, actions, statements and considerations that led to the response. This level differs from van Es et al. (2017) high level of interpretation as in this category the emphasis is on the consideration that PTs ascribe the teacher's response. An example of high-level interpretation of a teacher's response can be found in Adel's critical event interpretation. In the critical event two students, one after the other, asked the teacher whether E is the orthocenter of the triangle (the mathematical task that was at the center of the critical event is presented in figure 1).

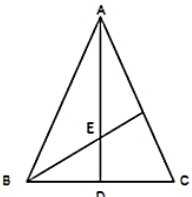
<p>In the isosceles triangle ABC ($AB=AC$), E is the bisectors intersection point. When the line AE is extended, it intersects the base of the triangle at point D (see the figure). Given that: $\sphericalangle ABC = \alpha$, $AE=m$. (a) using m and α express the length segment ED. (b) using m and α express the radius of the circumscribed circle to triangle ABC.</p>	
--	---

Figure 1: The mathematical task that was presented in Adel's critical event.

The teacher answered the first student privately and then, when the second student asked the same question, he facilitated a discussion with the whole class. Adel's interpretation of the teacher's response was as follows:

- 1 When the first student gave a wrong answer,
- 2 the teacher explained to him privately why what he said was wrong.
- 3 The teacher explained to the student that E is not the orthocenter of the triangle,
- 4 but rather the bisectors meeting point.
- 5 After a second student gave the same answer,
- 6 the teacher thought that there was something wrong with his [the teacher's] explanation,
- 7 and perhaps the rest of the students had also misunderstood.
- 8 So, the [teacher] asked the class: was what the student just said correct? [...]
- 9 The discussion was an effective way to understand the mistake
- 10 and for the teacher to understand why they [the students] think their answer is correct.

In the beginning of her interpretation Adel repeats the course of events (line 1-5). Then Adel offers her idea regarding what led to the teacher's response: because more than one student had this confusion the teacher might have thought that his instruction was not clear enough (line 6-7). In line 8 Adel goes back to the critical event and articulates the teacher's strategy: making the students' statements public within a whole class discussion. Adel reflects about the effectiveness of the response. She sees this strategy as a way that might help the teacher to understand his students' thinking (line 10).

Applying this three-level analytic framework to the 38 critical event reports, we found that 58% of PTs' critical event interpretations for teachers' responses were low-level, 26% of PTs' critical events interpretations were of medium level and 16% were high-level. These findings raised several thoughts regarding ACLIM-5 clinical training programs as well as theoretical insights which are elaborated in the next section.

Discussion

Our bottom-up analysis of critical event reports together with inspiration drawn from van Es et al. (2017) rubric allowed us to categorize coding scheme for depth of levels of interpretation to an observed teacher in a critical event, which does not appear in the literature so far. The first level has a descriptive/affective nature, the second level indicates that the PT tries to interpret the teacher by pointing out the teaching strategy the teacher used and its effectiveness. In the third level, the PT offer considerations that may have led to the teacher's response in the critical event.

From a practical standpoint this scheme will guide our further research regarding the ACLIM-5 clinical preparation program, to investigate whether there is a change in the level of interpretation as PTs become in-service teachers. Furthermore, to investigate whether there is a connection between in-depth interpretation of a teacher's response in a critical event and offering a teaching alternative to that is based on the students' mathematical thinking as it is interpreted by the PT in the critical event. From a theoretical standpoint, a connection between in- depth interpretation for a teacher response in a critical event and suggested teaching alternatives, could serve as a basis for further conceptualization of the professional noticing framework by adding a subprocess - interpreting the teacher response in the student-teacher interaction - in the gap between student interpretation and suggested alternative (e.g., Jacobs et al., 2010).

Acknowledgment

The project is generously supported by Trump (Israel) Foundation (Grant # 213) and the University of Haifa. We thank Prof. Roza Leikin for her help in monitoring the project.

References

- Ball, D. L., Thames, M. H., & Phelps, G. (2008). Content knowledge for teaching: What makes it special?. *Journal of teacher education*, 59(5), 389-407.
- Clarke, D. (2000). Time to reflect. *Journal of Mathematics Teacher Education*, 3, 201–203.
- Goodell, J. E. (2006). Using critical incident reflections: A self-study as a mathematics teacher educator. *Journal of Mathematics Teacher Education*, 9(3), 248-221.
- Jacobs, V. R., Lamb, L. L., & Philipp, R. A. (2010). Professional noticing of children's mathematical thinking. *Journal for research in mathematics education*, 41(2), 169-202.
- Karsenty, R., & Arcavi, A. (2017). Mathematics, lenses and videotapes: a framework and a language for developing reflective practices of teaching. *Journal of Mathematics Teacher Education*, 20(5), 433-455.
- Potari, D., & Jaworski, B. (2002). Tackling complexity in mathematics teaching development: Using the teaching triad as a tool for reflection and analysis. *Journal of Mathematics Teacher Education*, 5(4), 351-380.
- Rotem, S. H., & Ayalon, M. (2018). Using critical events in pre-service training: examining coherence level between interpretations of students' mathematical thinking and interpretations of teacher's response. In E. Bergqvist, M. Österholm, C. Granberg, & L. Sumpter, (Eds.), *Proceedings of the 42th conference of the international group for the psychology of mathematics education* (Vol. 4, pp. 51-58). Umeå, Sweden: PME
- Santagata, R., & Guarino, J. (2011). Using video to teach future teachers to learn from teaching. *ZDM*, 43(1), 133–145.
- Simpson, A., & Haltiwanger, L. (2017). “This is the First Time I’ve Done This”: Exploring secondary prospective mathematics teachers’ noticing of students’ mathematical thinking. *Journal of Mathematics Teacher Education*, 20(4), 335-355.
- Shulman, L. S. (1986). Those who understand: Knowledge growth in teaching. *Educational researcher*, 15(2), 4-14.
- Stockero, S. L., & Van Zoest, L. R. (2013). Characterizing pivotal teaching moments in beginning mathematics teachers’ practice. *Journal of Mathematics Teacher Education*, 16(2), 125-147.
- Van Es, E. A., Cashen, M., Barnhart, T., & Auger, A. (2017). Learning to Notice Mathematics Instruction: Using Video to Develop Preservice Teachers' Vision of Ambitious Pedagogy. *Cognition and Instruction*, 35(3), 1-23.
- Zeichner, K. M. (1981). Reflective teaching and field-based experience in teacher education. *Interchange*, 12(4), 1-22.

Using Concept Cartoons in future primary school teacher training: the case of problem posing and open approach

Libuše Samková¹

¹University of South Bohemia in České Budějovice, Czech Republic; lsamkova@pf.jcu.cz

The contribution focuses on an educational tool called Concept Cartoons from the perspective of problem posing activities of future primary school teachers within the framework of the open approach to mathematics. It introduces Concept Cartoons, the open approach to mathematics, and a small qualitative empirical study conducted with future primary school teachers. The aim of the presented study is to observe how open might be problems posed by future primary school teachers in the Concept Cartoon form. The results of the study confirm that Concept Cartoons can be successfully employed in problem posing activities and that they have a potential from the perspective of the open approach to mathematics.

Keywords: Concept Cartoons; elementary school teachers; mathematics education; open approach to mathematics; preservice teacher education.

Introduction

The study presented here reports about an educational tool called Concept Cartoons, and about the way how the tool can be employed in future primary school teacher training. In particular, it will focus on the possibility to use Concept Cartoons during problem posing activities and observe the posed Concept Cartoons from the perspective of the open approach to mathematics. The study follows up the contributions of me and my colleagues from previous CERME and ERME conferences, as it discusses mathematics problems of a given structure and their employment in future teacher training (Tichá & Hošpesová, 2015), problem posing of future teachers (Tichá & Hošpesová, 2010), and future teachers facing or composing potential pupils' misconceptions in the Concept Cartoon form (Samková & Hošpesová, 2015; Samková, 2017; Hošpesová & Tichá, 2017). The issues of teachers posing problems and teachers facing potential pupils' misconceptions are the topics that have been broadly discussed at CERME and ERME conferences in TWGs related to teacher professional development, e.g. by Malaspina, Mallart and Font (2015), Milinković (2017), Kuntze and Friesen (2017). The topic of Concept Cartoons is close to the concept of polyvalent math tasks presented at CERME by Hellmig (2010).

In the following text, I will introduce the idea of Concept Cartoons and my experience with them, and the open approach to mathematics. Then I will describe an empirical qualitative study addressing the following research question: “*How open are problems posed by future primary school teachers in the Concept Cartoon form?*”

Theoretical background

Concept Cartoons

An educational tool called Concept Cartoons appeared in Great Britain more than 20 years ago (Keogh & Naylor, 1993), in order to support discussion and involvement of primary school pupils during science lessons. Later the tool also expanded to other school subjects and school levels.

Concept Cartoon is a picture showing a situation familiar to pupils from school or everyday reality, and several children discussing the situation in a bubble-dialog. Each bubble presents an alternative viewpoint on the pictured situation. The alternatives might be correct as well as incorrect; the correctness also might be unclear or conditioned by circumstances not mentioned in the picture. Sometimes the picture includes a blank bubble with just a question mark, to indicate that there might be other alternatives not presented in the picture yet. For a sample see Fig. 1.

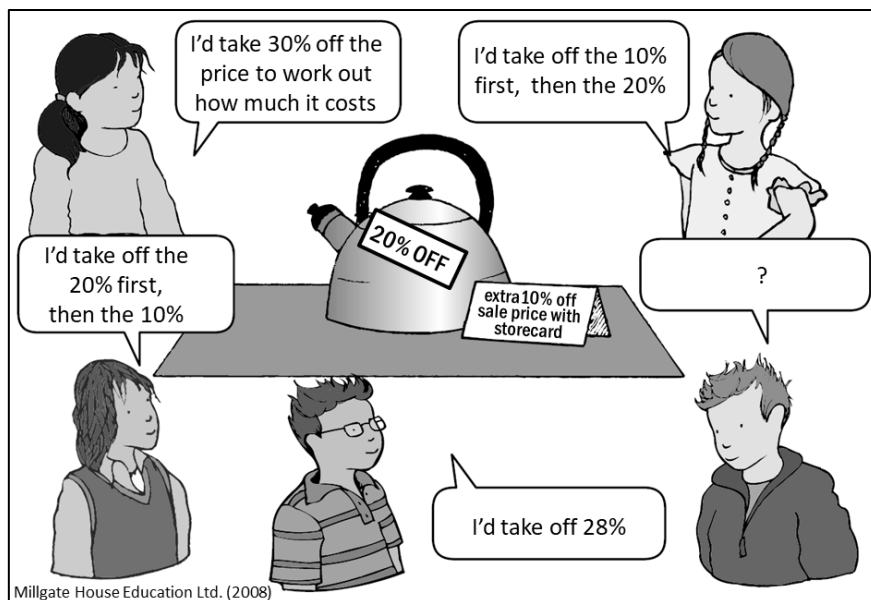


Figure 1: An original Concept Cartoon with three correct bubbles, one incorrect bubble, and a blank bubble; taken from (Dabell, Keogh, & Naylor, 2008: 4.11)

When working with Concept Cartoons in the classroom, pupils are asked to decide which children in the picture are right and which are wrong, and justify the decision. In that setting, it turned up that the lack of agreement amongst the pictured children encourages the pupils to join the discourse and defend their opinions (Naylor, Keogh, & Downing, 2007).

Besides the original classroom use, we started to consider each Concept Cartoon as an educational model of a contingent situation (Samková & Hošpesová, 2015), and more widely as a representation of practice oriented on diagnostic purposes (Samková, 2018b). In that sense, Concept Cartoons do not cover all aspects of school practice but might be regarded as a result of a decomposition of practice according to Grossman et al. (2009). Following this line, I created my own set of Concept Cartoons and accompanied them by a list of indicative questions focusing more deeply on conceptions and misconceptions probably hidden behind individual bubbles (Samková, 2018b). We included these Concept Cartoons as a diagnostic tool in future primary school teacher training, and conducted several studies: on aspects of pedagogical content knowledge (Samková & Hošpesová, 2015; Samková, 2018b), reasoning on selected topics (Samková & Tichá, 2017), or comparison between information on mathematics content knowledge that can be obtained through Concept Cartoons and through word problems in standard written tests (Samková, 2018a). In this paper, I will focus on Concept Cartoons within the framework of open approach to mathematics.

Open approach to mathematics

Open approach to mathematics is a method of mathematics teaching that employs problems called open. These problems have multiple levels of grasping (i.e. their starting situation is open), multiple correct ways of solving (i.e. their process is open), multiple correct answers (i.e. their end products are open) and/or multiple ways to transform the problem into a new one (i.e. ways to develop are open) (Nohda, 2000; Pehkonen, 1997). Such problems allow us to perceive mathematics in all its diversity. For samples see Table 1. Also Concept Cartoons themselves may be considered as open problems, since they present various alternatives (of grasping, solving, solutions) in their bubbles.

There are 4 beds of seedlings in a forest nursery, each of them having 5 rows with 240 seedlings. How many seedlings are there?	starting situation is open (it is not clear whether 240 is the amount for each of the rows, or altogether for all 5 rows); process is open (for the first case above: we may count the number of rows in all beds and multiply it by 240, or count the number of seedlings in one bed and multiply it by 4);
90-minute tickets in Prague cost 32 crowns; 24-hour tickets cost 110 crowns. How much will Ivan pay for the tickets on a weekend trip?	starting situation is open (we do not know how much or how often will Ivan travel around the city, how long the trip will last: less than 24 hours? more than 48 hours? how much more? ...); end products are open (there are 13 different solutions, from minimal pay of 0 crowns, to maximal pay of 330 crowns).

Table 1: Samples of open problems (left), with their open-approach characteristics (right)

Open problems that have multiple solutions of different levels of difficulty while every pupil is probably able to find a solution appropriate with his/her actual knowledge are called polyvalent (Hellmig, 2010). The Concept Cartoon from Fig. 1 might be considered as polyvalent, since it has three different correct bubbles, and each of the them requires a different level of knowledge to justify its correctness: the easiest is the bottom left bubble where the discounts are in the same order as in reality in the shop; the top right bubble deserves an additional knowledge that changing order of discounts does not change the final price; the bottom middle bubble is the most difficult, it is the only one with some other calculations behind. The incorrect bubble (top left) deserves another type of knowledge – that a combination of discounts cannot be solved by their addition.

Design of the study

Participants

Participants of the research were 29 future primary school teachers – full time students of the 5-year teacher training program at our university. They had already finished all mathematics content courses of the program, and in the time of the study they were attending the course on didactics of mathematics. During the mathematics content courses the participants had several times worked with Concept Cartoons, discussing them in the classroom or responding in written form to various sets of questions related to them, i.e. they got familiar with the format of Concept Cartoons.

Course of the study

In the data collection stage, the participants were asked to create their own Concept Cartoon that could be assigned to primary school pupils during a mathematics lesson. They worked on the task individually, in the form of a compulsory written homework where they introduced the Concept Cartoon, and gave a short explanation of the task and the bubbles.

During data analysis I searched for answers to the research question “How open are problems posed by future primary school teachers in the Concept Cartoon form?”. I processed collected data qualitatively, using open coding and constant comparison (Miles & Huberman, 1994). During open coding I focused on the composition of the Concept Cartoon, on its mathematical correctness, and on displays of openness in relation to Nohda’s definition of open problems (2000). For better arrangement, some of the codes were denoted by plus or minus sign to distinguish between positive and negative aspects (correct or incorrect format, open or non-open parameters of the task, etc).

The following code categories appeared as relevant for my study:

- A. the format of the Concept Cartoon (this category included codes *proper format, improper format, no bubbles, no alternatives, each bubble solves a slightly different task, independent bubbles, conditional bubbles*, etc.);
- B. grasping of the task in the picture and its levels (codes *unique, multiple, unclear, too open to be comprehensible, various parameters, diverse interpretations of the assignment*, etc.);
- C. ways of solving the task in the picture (codes *unique, multiple, diverse procedures offered in bubbles*, etc.);
- D. number of solutions and their interpretations (codes *unique solution, multiple solutions, unique interpretation, multiple interpretations of unique solution*, etc.);
- E. difficulty and smartness of the posing process (codes *detailed preparation needed, smart pre-calculations made*, etc.).

Subsequently, I analysed the codes and categories in order to divide the participants into groups according to the level of openness provided in their Concept Cartoons. Since each Concept Cartoon that is properly formatted might be considered as an open task, the participants who were not able to pose their Concept Cartoon in a proper format were assigned to the lowest level group named LL. The other participants were assigned to groups named L#, where # stands for a number from 1 to 4 denoting in how many code categories of B to E did the individual participant cause positive codes.

Findings

Improper vs proper format of the Concept Cartoon (category A)

Three of the participants composed their Concept Cartoon in an improper format; they form the LL group. These participants offered either a picture without bubbles or a picture with bubbles that discussed diverse situations not much related to the picture.

Thirteen of the participants composed the Concept Cartoon in a proper format but with no other openness: they prepared a task with a unique solution, grasped it unambiguously, and did not considered multiple correct ways of solving (see Fig. 2a). These participants form the L0 group.

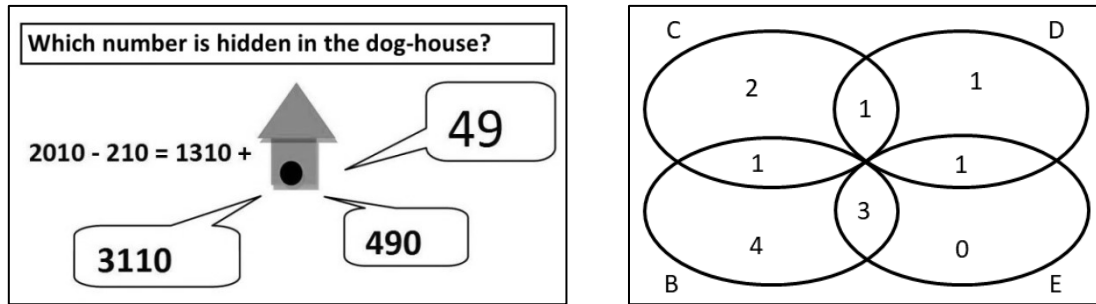


Figure 2: The Concept Cartoon posed by Beata, translated from Czech (left); numbers of participants displaying particular open aspects in their Concept Cartoon (right)

Openness of the Concept Cartoon with proper format (categories B to E)

The other participants composed a properly formatted Concept Cartoon that can be considered as open: seven of them caused positive codes in one of the categories B to E (they form the L1 group), six of them caused positive codes in two of the categories B to E (they form the L2 group). The distribution of the participants among the code categories with positive codes is shown in Fig. 2b, a detailed description of particular open aspects is given in the following text.

Multiple levels of grasping the task in the picture (category B)

Eight of the participants presented in their bubbles various ways how the pictured task might be grasped. For instance, Francis prepared a task about clocks (Fig. 3), and contrasted various possible ways of grasping the term "most hours". Her Concept Cartoon provokes many questions: "What does it mean most hours?", "Shall we take the biggest number in the notation, or the latest hour?", "Is 10 in the morning the same as 10 in the evening?". Annie prepared a task about 30 candies in a bag, and contrasted relative and absolute meanings of numbers (see Fig. 10 in Samková & Tichá, 2017). Morris prepared a practically based task about part-time job offers, and contrasted three different ways to make money (weekly wage, monthly wage, and daily task wage; see Fig. 8 in Samková & Tichá, 2016).

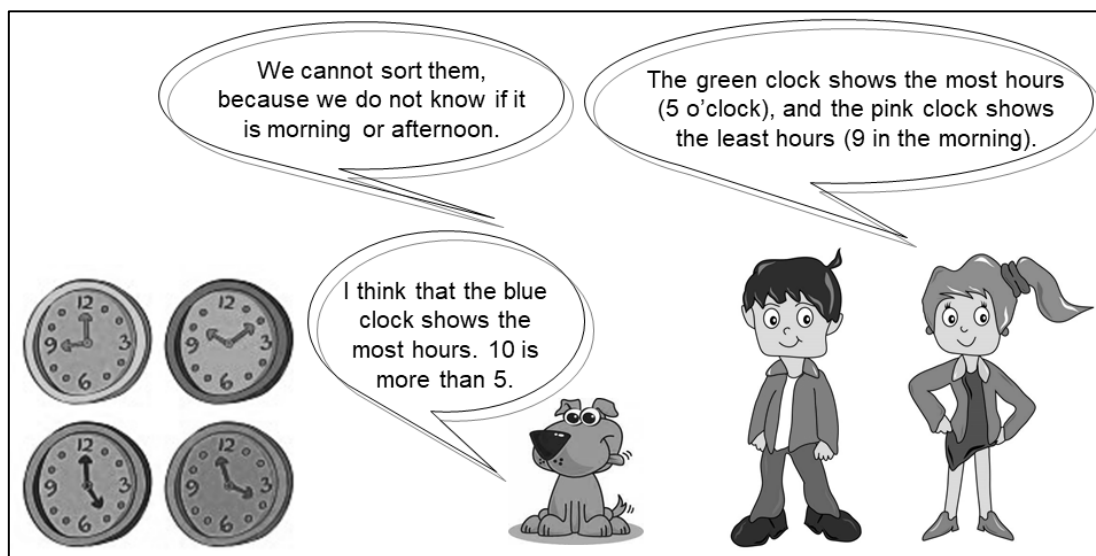


Figure 3: The Concept Cartoon posed by Francis, translated from Czech

Multiple correct ways of solving the task (category C)

Four of the participants posed tasks that allow multiple correct ways of solving; e.g. Viola offered in her bubbles two diverse ways of solving a task about Easter eggs (see Fig. 4).

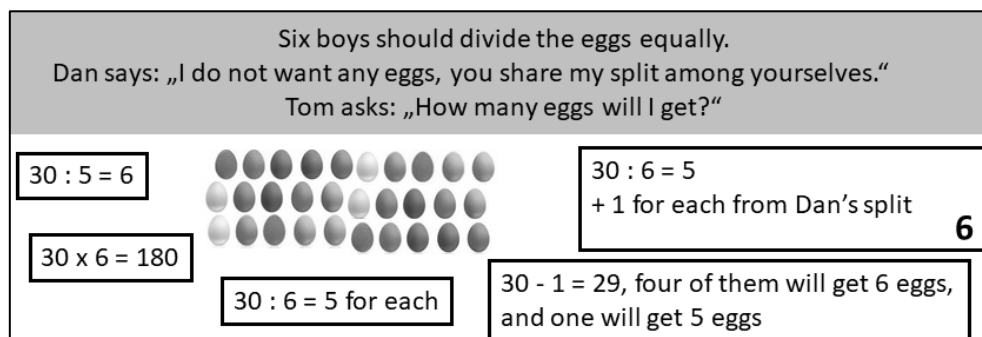


Figure 4: The Concept Cartoon posed by Viola, translated from Czech, graphically adjusted

Multiple correct answers to the task (category D)

Only two of the participants posed tasks with multiple solutions. Tammy prepared a wordless Concept Cartoon based on a geometric task with two different solutions (see Fig. 7 in Samková & Tichá, 2016), Diana prepared a task with eight different solutions (see Fig. 6 in Samková & Tichá, 2016). In each of these Concept Cartoons, the particular solutions of the task are of the same difficulty, based on a common idea, i.e. these Concept Cartoons cannot be considered as polyvalent.

One of the participants (Helen) posed a task with a unique solution but interpreted the solution in multiple ways. In her bubbles she described various properties of the solution.

Difficulty and smartness of the posing process (category E)

Four of the participants presented Concept Cartoons that required detailed preparation of the content of bubbles and smart pre-calculations; all of them belong to L2 group. For instance, Morris in his Concept Cartoon about part-time jobs prepared five bubbles based on diverse wage conceptions but the diverse calculations hidden behind particular bubbles lead to numbers that are almost the same. Since the aim of his task is to compare the jobs and find the most suitable one, such an arrangement makes the task open for wide discussions. Ruth in her task about who is the fastest runner assigned that Rex ran 10 rounds in 3 min 20 sec, Punt'a ran 7 rounds in 2 min 27 sec, and Max ran 5 rounds in 1 min 50 sec. One of the misconceptions in her Concept Cartoon originated in an erroneous conversion of the times into decimal notation (e.g. 3 min 20 sec converted to 3.20 min). She prepared the numbers in the assignment so smartly that with that erroneous conversion the order of the runners differs from the order in the correct solution.

Conclusions

The presented study hopefully enriched the puzzle on “*How can we meaningfully employ Concept Cartoons in future teacher education*” by another piece of knowledge, by studying the tool during problem posing activities within the framework of the open approach to mathematics and by looking for answers to the research question “*How open are problems posed by future primary school teachers in the Concept Cartoon form?*”.

The results confirmed that Concept Cartoons can be successfully employed during problem posing activities, and that they have a potential also from the perspective of the open approach to mathematics. Although for the participated future primary school teachers it was the very first opportunity to create their own Concept Cartoons, almost all of them were able to compose a properly formatted Concept Cartoon, and almost half of them were able to compose a Concept Cartoon that positively displayed openness in one or two of the following aspects: multiple levels of grasping the pictured task, multiple correct ways of solving the task, multiple number of solutions and their interpretations. Some of the participants also proved their ability to thoroughly think about the task they pose, and presented Concept Cartoons that required detailed preparation and smart pre-calculations.

The described results of problem posing activities of future primary school teachers also illustrate how Concept Cartoons may help to elaborate a wide range of pedagogical content knowledge: authors of the Concept Cartoons had to pose an appropriate mathematical problem, present at least one of its correct solutions and several possible pupil misconceptions, and combine them into one complex bubble-dialog task.

Such results are in accordance with the recent research showing the importance of implementation of mathematical problem posing activities into future teacher education (Singer, Ellerton, & Cai, 2015).

References

- Dabell, J., Keogh, B., & Naylor, S. (2008). *Concept Cartoons in Mathematics Education (CD-ROM)*. Sandbach, Great Britain: Millgate House Education.
- Grossman, P., Compton, C., Igra, D., Ronfeldt, M., Shahan, E., & Williamson, P. (2009). Teaching practice: A cross-professional perspective. *Teachers College Record*, 111(9), 2055–2100.
- Hellmig, L. (2010). Effective 'blended' professional development for teachers of mathematics: design and evaluation of the „UPOLA“-program. In V. Durand-Guerrier, S. Soury-Lavergne, & F. Arzarello (Eds.) *Proceedings of CERME 6* (1694–1703). Lyon, France: INRP.
- Hošpesová, A., & Tichá, M. (2017). Concept Cartoons created by prospective primary school teachers. In S. Zehetmeier, B. Rösken-Winter, D. Potari, & M. Ribeiro (Eds.) *Proceedings of ETC 3* (319–320). Berlin, Germany: Humboldt-Universität zu Berlin.
- Keogh, B., & Naylor, S. (1993). Learning in science: Another way in. *Primary Science Review*, 26, 22–23.
- Kuntze, S., & Friesen, M. (2017). Assessing pre-service teachers' competence of analyzing learning support situations through a multi-format test instrument comprising of video, comic, and text vignettes. In S. Zehetmeier, B. Rösken-Winter, D. Potari, & M. Ribeiro (Eds.) *Proceedings of ETC 3* (36–45). Berlin, Germany: Humboldt-Universität zu Berlin.
- Malaspina, U., Mallart, A., & Font, V. (2015). Development of teachers' mathematical and didactic competencies by means of problem posing. In K. Krainer & N. Vondrová (Eds.) *Proceedings of CERME 9* (2861–2866). Prague, Czech Republic: Charles University, Faculty of Education.

- Miles, M. B., & Huberman, A. M. (1994). *Qualitative data analysis: A sourcebook of new methods*. London, Great Britain: SAGE.
- Milinković, J. (2017). Faults in preservice teachers problem posing: What do they tell us? In S. Zehetmeier, B. Rösken-Winter, D. Potari, & M. Ribeiro (Eds.) *Proceedings of ETC 3* (238–247). Berlin, Germany: Humboldt-Universität zu Berlin.
- Naylor, S., Keogh, B., & Downing, B. (2007). Argumentation and primary science. *Research in Science Education*, 37, 17–39.
- Nohda, N. (2000). Teaching by open-approach method in Japanese mathematics classroom. In T. Nakahara & M. Koyama (Eds.) *Proceedings of PME 24 (Vol. 1)* (39–53). Hiroshima, Japan: Hiroshima University.
- Pehkonen, E. (Ed.) (1997). *Use of open-ended problems in mathematics classroom*. Helsinki, Finland: University of Helsinki.
- Samková, L. (2017). Using Concept Cartoons to investigate future teachers' knowledge: New findings and results. In S. Zehetmeier, B. Rösken-Winter, D. Potari, & M. Ribeiro (Eds.) *Proceedings of ETC 3* (207–216). Berlin, Germany: Humboldt-Universität zu Berlin.
- Samková, L. (2018a). Assessing future teachers' knowledge on fractions: Written tests vs Concept Cartoons. *ERIES Journal*, 11(3), 45-52.
- Samková, L. (2018b). Concept Cartoons as a representation of practice. In O. Buchbinder & S. Kuntze (Eds.) *Mathematics Teachers Engaging with Representations of Practice. ICME-13 Monographs*. Cham, Switzerland: Springer International Publishing AG.
- Samková, L., & Hošpesová, A. (2015). Using Concept Cartoons to investigate future teachers' knowledge. In K. Krainer & N. Vondrová (Eds.) *Proceedings of CERME 9* (3241–3247). Prague, Czech Republic: Charles University, Faculty of Education.
- Samková, L., & Tichá, M. (2016). On the way to develop open approach to mathematics in future primary school teachers. *ERIES Journal*, 9(2), 37–44.
- Samková, L., & Tichá, M. (2017). On the way to observe how future primary school teachers reason about fractions. *ERIES Journal*, 10(4), 93–100.
- Singer, F. M, Ellerton, N. F., & Cai, J. (Eds.) (2015). *Mathematical problem posing: From research to effective practice*. New York, NY: Springer.
- Tichá, M., & Hošpesová, A. (2010). Problem posing and development of pedagogical content knowledge in pre-service teacher training. In V. Durand-Guerrier, S. Soury-Lavergne, & F. Arzarello (Eds.) *Proceedings of CERME 6* (1941–1950). Lyon, France: INRP.
- Tichá, M., & Hošpesová, A. (2015). Word problems of a given structure in the perspective of teacher training. In K. Krainer & N. Vondrová (Eds.) *Proceedings of CERME 9* (2916–2922). Prague, Czech Republic: Charles University, Faculty of Education.

Generation and generation tasks in mathematics didactics

Marianne Schäfer¹ and Rita Borromeo Ferri²

¹University of Kassel, Germany; mschaefer@mathematik.uni-kassel.de

²University of Kassel, Germany; borromeo@mathematik.uni-kassel.de

As part of the PRONET project of the University of Kassel¹, the further development of teacher training through the "implementation of a coherent professionalisation concept" is being investigated. The aim of the subproject is to combine mathematical-didactic knowledge with pedagogically relevant and cognitive-psychologically anchored concepts, including the "desirable difficulties". The generation effect is one of the four best-known "desirable difficulties" and aims to ensure that knowledge is not merely predetermined but is generated to a certain extent from one's own knowledge. In order to achieve this, we have developed for the first time generation tasks on mathematical-didactic topics of a basic lecture for mathematics teachers at their study beginning. The generation tasks and first results are part of this paper and are complemented by the basic theory of "desirable complications".

Generation effect, mathematics didactics, desirable difficulties, mathematical-didactic knowledge, teacher education

Theoretical Background

The focus of this contribution lies on the generation and is reflected approach by the university students. For this reason Generation and generation tasks in mathematics didactics training of future teachers are illustrated more detailed.

Desirable difficulties of learning

One possible encouragement of sustainable knowledge building is the concept of 'desirable difficulties' (Bjork, 1994, 2011; Lipowsky et al., 2015). The term "desirable difficulties" is a cognitive psychological concept and a didactic procedure that makes learning more difficult in the short term, but sustainable with the goal to a better retention of the learning content (ibid.). Desirable difficulties include such popular techniques as the testing effect, the distributed learning, the generating effect, and the interleaving practice (Bjork & Bjork, 2011).

Generation effect

The generating effect appears, when the information is generated from own knowledge (e.g. Salmecka & Graf, 1978). The focus of our research is on the generation effect. This effect has been recognized, reproduced and characterized as extremely stable within controlled learning environments and with simple learning content (e.g. word pairs) (Slamecka & Graf, 1978; Bertsch

¹ The project is financed as part of the PRONET project from the "Quality Initiative for Teacher Education" programme of the Federal Ministry of Education and Research in Germany.

et al., 2007). Chen et al. (2015) have shown that the generation effect is more distinctive if very less is dictated by the task itself or by solution examples and teacher interference. They also found that this increase and stabilisation of the generation effect depends on the type of task. While learners benefited more from the generation in simple tasks, the learning outcomes in complex tasks through guided learning were higher (ibid.). In the field of mathematics, the generation effect is only within the framework of multiplication tasks (cf. McNamara & Healy, 2000) but is not researched with reference to mathematical-didactic knowledge. It becomes clear from the previous studies that generation tasks can extend beyond word pair formation, but that the complexity should not be increased immeasurably, otherwise there is a danger that there will be no more lasting learning effect.

Generation and generation tasks in mathematics didactics training of future teachers

Generation in mathematical didactics means therefore to stimulate the cognitive thought processes of the students and to have new information generated from themselves by means of suitable generation tasks. The self-dependent generation of knowledge takes place within the framework of mathematics didactic generation, for example by linking to previous experiences, for example by generating examples. Another possibility is the creation of individual memory aids in which students use their personal thinking structure to memorize new knowledge. In particular, it should be noted that the generation tasks developed include the basic, recurring contents of mathematics didactics on the one hand and are not too complex in terms of the task and the focus of content on the other. In addition, it must be taken into account that the prospective teachers can build on their own knowledge, although the "new knowledge" cannot be presented to them in advance, otherwise there is no generation effect. Therefore, the above-mentioned lecture contents were chosen which are simple enough to dispense with illustrated examples and complex enough to serve as a basis for further study and structural (mathematical-didactic) expertise (Borromeo Ferri & Schäfer, 2017).

Research questions

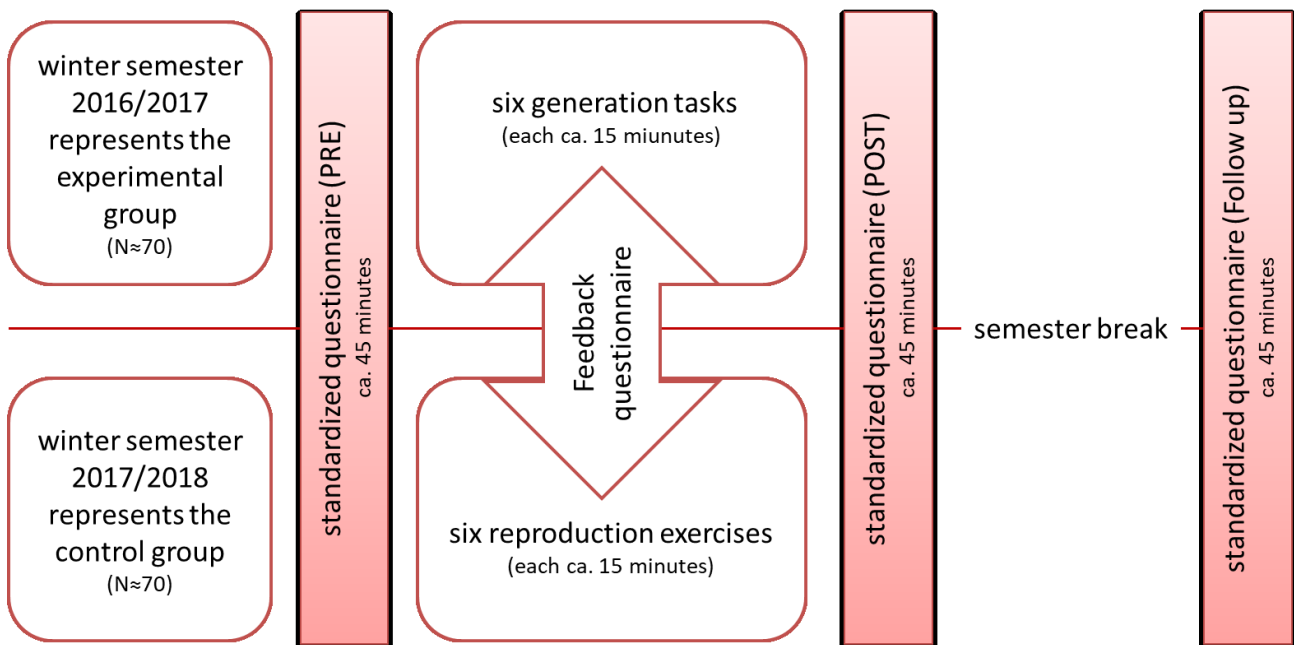
On the basis of the theoretical background to the generation effect, it was shown that the specific generation can be regarded as a research gap in mathematics didactics. It is to be examined whether and how the generation effect is shown by the use of generation tasks with a mathematical-didactic focus and how effectively the knowledge thus acquired is consolidated among the students. An all-encompassing answer to this main question is not yet possible at this point in time, as the statistical data could not yet be fully evaluated. Therefore, in this paper we limit ourselves to demonstrating what marked generation tasks and highlight the following two research questions:

1. Are there any differences between the generation and reproduction cohort regarding the perception of the learning process?
2. Are there any differences between the generation and reproduction cohort regarding the perception of the tasks?

Methodology

The study is conceived as a prospective and hypothesis-generating comparison of two cohorts attending the mathematics didactic basic lecture at the University of Kassel, Germany. The cohort of the winter semester 2016/2017 represents the experimental group and works on the generation tasks. The control group is represented by the cohort of the winter semester 2017/2018 and works on the reproduction tasks. The teacher training students attend the lecture for the first time and are on average in the 1st to 3rd semester. The semester differences are due to the fact that the lecture is attended by various teacher training courses (secondary school, grammar school and vocational school). In order to ensure the comparability of the two cohorts, both the lecture contents and their sequence are held identically by the same professor in both years. Likewise, all questionnaires, feedback forms, the subject areas of the tasks used and the survey times are identical. The study design is graphically illustrated below (Fig. 1).

Figure 1: study design



Due to the fact that this paper has put the emphasis on generation tasks, an insight into what generation tasks are will now be given. The aim of these tasks, as explained above, is to move students of teaching professions to generate their own knowledge out of themselves in a mathematics didactic basic lecture. What does it mean to generate knowledge and how should this be done? Producing knowledge out of them means nothing other than that the teacher training students open up new fields of mathematics didactics for them with little input. For example, the general mathematical competences will be addressed within the framework of the lecture. This is followed by a generation task, which calls for a memory aid to be considered in order to memorize these six competencies. The desirable difficulty for the teacher training students now consists in using a useful memory aid for them without knowing the deeper theoretical contents of the competences. The theoretical contents of the mathematical competences are discussed after the

generation task. In this approach, the main difference to reproduction tasks also becomes clear, since these are always carried out after a theoretical input and usually allow this to be summarised. An exemplary comparison of generation and reproduction tasks in the field of general mathematical competences is given in Table 1. A total of six grading tasks have been developed and applied for use in the mathematics didactic basic lecture. These deal with basic mathematical-didactic content on the topics (1) mathematical educational standards, (2) general mathematical competences, (3) mathematical competence: mathematical modelling and the modelling cycle, (4) mathematical competences: solving problems mathematically, (5) mathematical thinking styles and (6) psychology of mathematics.

Table 1: Example Generation and Reproduction Task²

generation task
<p>The general mathematical competences of the lower secondary level are:</p> <ul style="list-style-type: none"> • argue mathematically • solve problems mathematically • mathematical modelling • use mathematical representations • to deal with mathematics symbolically/formally/technically • communicate mathematically <p>Create a personal memory aid to memorize general mathematical skills.</p> <p>Explain (briefly) your procedure and briefly justify your choice of memory aid.</p>
reproduction task
<p>Julia, Stefan, Sarah, Carsten and Nadine take the school bus to school every morning. Since they get on at the first stop, they always manage to sit in the five seats of the last row. One day Julia remarks: "The school year takes about 210 days. Is it possible that we five always sit in the last row in different ways?"</p> <p>What is the guiding idea behind the task? Which mathematical competence(s) are relevant to answer the question?</p>

In order to answer the research questions underlying this paper, we have developed, used and evaluated a feedback questionnaire that students of teaching professions can use with regard to their perception of the learning process and their perception of the tasks questioned. The perception of

² Translation of the German original by the authors.

the learning process questions whether there has been in-depth information processing or whether students have perceived it as in-depth information. This scale comprises four items, an item example is here: "I have succeeded in developing my own thoughts and ideas on this subject". The perception of the tasks questions to what extent the students come to the conclusion that the respective task was meaningful, helpful, stimulating or similar. This scale comprises five items, an item example for this is "The task used in the pre-presentation illustrates the benefit of the learning content". The two perceptions were recorded using a 6-stage, end-point-based scale. The scale ranges from the negative endpoint "Does not apply at all", which is rated one in the evaluation, to the positive endpoint "Fully applies", which is rated six. In order to analyse the differences, a grouping variable was first created that distinguishes between the cohorts and their tasks in generation tasks and non-generation tasks (reproduction tasks). Subsequently, a scale was introduced for each perception and each task, so that in the end 12 scales were created. Six scales for the perception of the learning process and six scales for the perception of the tasks. These 12 scales were checked for their one-dimensionality by means of a main component analysis (PCA), which turned out to be given for all of them. The scales for the perception of learning process show a reliability of $0.85 \leq \alpha \leq 0.90$. The scales for the perception of the tasks show a reliability of $0.76 \leq \alpha \leq 0.87$. All items can be described as selective in their respective scales. Due to the sample size of $N = 117$ student teachers, the verification of the normal distribution has been recorded. For this reason, a T-test for independent samples is performed to investigate the differences and Cohan's δ is calculated manually to determine the effect strength³.

Results

1. Are there any differences between the generation and reproduction cohort regarding the perception of the learning process?

When the mean values and the standard deviation are considered for the first time, the first differences can be seen purely descriptively on all task scales with the exception of the scale for the fourth task. These descriptive mean differences are checked by means of a T-test for independent samples. It turned out that two of the six task scales for the perception of the learning are a significant difference in the mean value in favor of the cohort that worked with the generation tasks. This significant mean difference is reflected in the tasks three and five. Task three is the generation task that deals with the mathematical competence of mathematical modeling and the modeling cycle. This is a medium effect ($\delta = 0.63$). Task five contains the three levels of representation according to Bruner (enactive, iconic, symbolic) (Brunner et al., 1971). This is an almost medium effect ($\delta = 0.48$).

Table 2 below gives an overview of all mean values, standard deviations, sample distribution, significance level and effect strength for the respective task scales one to six.

³ Cohan's d is calculated using the online calculation tool: <https://www.psychometrica.de/effektstaerke.html> and to the rehearsal again with <http://www.soerenwallrodt.de/index.php>.

Table 2: table of results for the perception of the learning process

task number	perception of the learning			level of significance	Effect strength Cohan's δ	
		<i>N</i>	<i>MW</i>	<i>SD</i>		
1	GA	73	4,03	0,86	p=0.204	
	NGA	35	4,25	0,81		
2	GA	65	4,19	0,86	p=0.720	
	NGA	35	4,25	0,72		
3	GA	73	4,63	0,68	p=0.003	0.63
	NGA	35	4,16	0,90		
4	GA	65	4,06	1,05	p=0.961	
	NGA	35	4,07	0,82		
5	GA	65	4,40	0,75	p=0.023	0.48
	NGA	35	3,99	0,98		
6	GA	66	4,10	0,76	p=0.086	
	NGA	35	3,81	0,82		

GA = generation tasks and NGA = non-generation tasks

2. Are there any differences between the generation and reproduction cohort regarding the perception of the tasks?

The second question dealt with the question of whether differences in the perception of the tasks of the two cohorts were recognizable. Here, too, the first mean value differences could be seen purely descriptively on all six scales. A T-test for independent groups was also performed to test the significance of the differences. It was found that the performance of the cohorts in two tasks differed significantly. These significant differences were seen in the scales for tasks three and four. Task four dealt thematically with the graduated aid according to Zech (1996). It is striking that the significant effect was only in the case of task three in favor of the cohort that worked with the generation tasks. This is a medium effect ($\delta = 0.52$). In the case of task four, the effect in favor of the not yet generation group is significantly positive, although this is only weak ($\delta = 0.38$).

Table 3 below gives an overview of all mean values, standard deviations, sample distribution, significance level and effect strength for the respective task scales one to six.

Table 3: table of results for the perception of the tasks

task number	perception of the tasks				level of significance	Effect strength Cohan's δ
		<i>N</i>	<i>MW</i>	<i>SD</i>		
1	GA	73	3,92	1,08	p=0.078	
	NGA	35	4,29	0,77		
2	GA	65	3,91	1,10	p=0.071	
	NGA	35	4,31	0,94		
3	GA	73	4,67	0,80	p=0.014	0.52
	NGA	35	4,25	0,92		
4	GA	65	3,89	1,21	p=0.045	0.38
	NGA	35	4,30	0,82		
5	GA	65	4,43	0,99	p=0.106	
	NGA	35	4,11	0,76		
6	GA	66	3,86	1,06	p=0.103	
	NGA	35	3,52	0,86		

GA = generation tasks and NGA = non-generation tasks

Conclusion

The differences determined in the course of the T-test provide initial indications of a possible effect of the generation tasks, as these are assessed by the students as being much more meaningful. They acknowledge the in-depth information processing and the value of the transfer and assess it positively. As part of a further study, we also analyse the extent to which students have gone through a "generational process". In order to be able to work this out, the generation tasks and interviews are evaluated with regard to the solution process and reflection. The first interview and task analyses showed that the experimental cohorts were able to reproduce the contents of the generation tasks better than the control cohorts were able to reproduce the contents of the reproduction tasks. Furthermore, an initial analysis has shown that no appreciable proportion of self-reflection is discernible in the context of reproductive tasks. In contrast, there are different approaches to reflection in the solutions of the generational tasks. On the one hand, individual solution steps are reflected and corrected if necessary. On the other hand, the individual participants reflect the entire solution process. In particular, the reflexion-in-the-action (Korthagen et al., 2002) is very pronounced in the generation tasks. One possible reason may be that the generation tasks address deeper cognitive structures, similar to problem-solving tasks, and thus their contents are anchored more sustainably in the memory. So far, however, the results are purely indicative, as only a few interviews and task solutions of the teacher training students have been evaluated so far. For this reason, it is necessary to deepen the analyses in the upcoming research process. For this purpose it is planned to develop a detailed coding manual for the analysis of the generation tasks and interviews on the one hand and to evaluate the questionnaire and the knowledge tests on the other hand. Further evaluations then compare the cohorts and include other factors such as choice of

subjects, motivation (MOLAMA), learning strategies, mathematical thinking, study satisfaction or mathematical convictions.

References

- Bertsch, S., Pesta, B. J., Wiscott, R., & A., M. M. (2007). The generation effect: A meta-analytic review. *Memory & Cognition* (35), pp. 201-210.
- Bjork, E. L., & Bjork, R. A. (2011). Making things harder on yourself, but in a good way: Creating desirable difficulties to enhance learning. In M. A. Gernsbacher, R. W. Pew, L. M. Hough, & J. R. Pomerantz, *Psychology and the real world: Essays illustrating fundamental contributions to society* (pp. 56-64). New York: Worth Publishers.
- Bjork, R. A. (1994). Memory and metamemory considerations in the training of human beings. In J. Metcalfe, & A. Shimamura, *Metakognition: Knowing about Knowing*. (pp. 189-192). Cambridge: MA:MIT Press.
- Borromeo Ferri, R., & Schäfer, M. (2017). Aufbau von nachhaltig gelerntem mathematikdidaktischen Professionswissen im Studium durch die Integration von Generierungsaufgaben. In U. Kortenkamp, & A. Kuzle, *Beiträge zum Mathematikunterricht 2017* (pp. 825-828). Münster: WTM.
- Bruner, J. S., Oliver, R. S., & Greenfield, P. M. (1971). Studien zur kognitiven Entwicklung. Stuttgart: Kohlhammer.
- Chen, O., Kalyuga, S., & Sweller, J. (2015). The Worked Example Effect, the Generation Effect, and Element Interactivity. *Journal of Educational Psychology*, Vol. 107, No. 3, pp. 689-704.
- Korthagen, F., Kessels, J., Koster, B., Lagewerf, B., & Wubbles, T. (2002). Schulentwicklung und Lehrerbildung. Reflexion der Lehrtätigkeit. *Übersetzt von Wolfgang Meyer*. Hamburg: EB-Verlag.
- Lipowsky, F., Richter, T., Borromeo Ferr, R., Ebersbach, M., & Hänze, M. (2015). *Schulpädagogik Heute*. Retrieved November 25, 2015, from Wünschenswerte Erschwernisse beim Lernen: www.schulpaedagogik-heute.de/conimg/Archiv/SH_11/06_01.pdf
- McNamara, D. S., & Healy, A. F. (2000). A Procedural Explanation of the Generation Effect for Simple and Difficult Multiplication Problems and Answers. *Journal of Memory and Language* (43), pp. 652-679.
- Salmecka, N. J. (1978). „The Generation Effect: Delineation of a Phenomenon.“. *Journal of Experimental Psychology: Human, Learning and Memory*, Vol. 4, No. 6, pp. 592-604.
- Zech, F. (1996). Grundkurs Mathematikdidaktik. Weinheim: Beltz Verlag.

Interweaving Mathematical-News-Snapshots as a facilitator for the development of Mathematical Knowledge for Teaching

Ruti Segal^{1,2}, Atara Shriki^{1,2}, Nitsa Movshovitz-Hadar² and Boaz Silverman²

¹Oranim Academic College of Education; rutisegal@gmail.com, atarashriki@gmail.com

²Technion, Israel Institute of Technology; nitsa@ed.technion.ac.il, boazs02@gmail.com

The study described in this paper accompanies a three-year R&D project that is currently in its final year. Participants are 25 high school mathematics teachers, of whom 14 have started their 2nd year and 11 are currently in their 3rd year of integrating Mathematical-News-Snapshots in their classes. This study examines the effect of integrating these snapshots in the ordinary high school curriculum on the development of several components of Mathematical Knowledge for Teaching. The findings indicate that teachers perceive the integration of Snapshots of contemporary mathematics as contributing to the development of their Specialized Content Knowledge, Knowledge of Content and Students, and Horizon Content Knowledge.

Keywords: Specialized Content Knowledge, Knowledge of Content and Students, Horizon Content Knowledge, Mathematical News Snapshots (MNSs).

Theoretical background

Knowledge of mathematics teachers

Over the past few decades, the mathematics education research community has become interested in characterizing the required knowledge for mathematics teaching. Shulman (1986) recognized that the required teacher's knowledge is unique and suggested two main types of knowledge teachers required, not necessarily in mathematics: Subject Matter Knowledge (SMK) – a deep understanding of the subject matter, and Pedagogical Content Knowledge (PCK) – a repertoire of representations, analogies, models, explanations, and demonstrations.

Relying on Shulman's work, Ball & Bass (2003) attempted to distill the knowledge required from mathematics teachers. They defined the term "Mathematical Knowledge for Teaching" (MKT) as knowledge that crosses areas and levels of school mathematics, knowledge that supports connected ideas of the mathematics teacher, and emphasizes the ability to plan, evaluate, integrate and manage appropriate mathematical content for teaching. Following this work, Ball, Thames & Phelps (2008), presented six different components of mathematical knowledge for teaching. Three of them are particularly relevant to this study:

- Specialized Content Knowledge (SCK). This component includes the mathematical knowledge and skills unique to teaching that is not typically needed for purposes other than teaching, such as searching for student errors, intelligent integration of examples during instruction;
- Knowledge of Content and Students (KCS). This component combines knowing about students and knowing about mathematics, namely, knowing how students think, what may confuse them, what kind of mathematical task may be easy or difficult for them, and more. This kind of knowledge requires an interaction between specific mathematical understanding and familiarity with students and their mathematical thinking;

- Horizon Content Knowledge (HCK). “Horizon knowledge is an awareness of how mathematical topics are related over the span of mathematics included in the curriculum” (ibid p. 403).

Ball & Bass (2009) suggested a more detailed definition of HCK:

“knowledge as an awareness – more as an experienced and appreciative tourist than as a tour guide – of the large mathematical landscape in which the present experience and instruction is situated. It engages those aspects of the mathematics that, while perhaps not contained in the curriculum, are nonetheless useful to pupils’ present learning, that illuminate and confer a comprehensible sense of the larger significance of what may be only partially revealed in the mathematics of the moment.” (Ibid ,2009, p. 5).

They present four components of HCK: A sense of the mathematical environment surrounding the current “location” in instruction; major disciplinary ideas and structures; key mathematical practices; core mathematical values and sensibilities.

There is a strong connection between MKT components and mathematical quality of instruction (Hill et al., 2008; Ma, 1999). Teachers with a strong MKT can present their students with rich mathematical links, representations and examples beyond what is given in most textbooks. These teachers are familiar with the curriculum and with ways to relate students to various subjects. In contrast, teachers with a poor MKT have a limited arsenal of examples to cater to diverse student needs.

The Mathematical News Snapshots project

Mathematics is a dynamic field that is developing constantly. The current number of publications in the mathematical reviews database is presently over three million, and over 80,000 additional reviewed papers are added to the database each year (American Mathematical Society, 2018). However, school mathematics curricula generally do not reflect this dynamic nature nor the constant struggle of mathematicians to discover new results. As a result, high school graduates often graduate while erroneously perceiving mathematics as a field in which all questions and answers are known in advance, and there is little space for further research (Amit & Movshovitz-Hadar, 2011). In some countries, this situation has led to a decline in enrollment to mathematically intensive academic studies, and even developed into an economic, social, and national concern (Noyes & Adkins, 2017).

The Mathematical News Snapshots (MNSs) project, in which the current study is situated, was set up to provide a better perspective of the nature of contemporary mathematics by introducing high-school students to current frontiers in the rapidly growing area of mathematics (Movshovitz-Hadar, 2008). The chosen method was to prepare high school teachers to interweave snapshots of mathematical news in their teaching on a regular basis. Each MNS is developed in the form of a PowerPoint presentation, with three main characteristics (Amit & Movshovitz-Hadar, 2011): (i) A new mathematical result published in the professional literature in the past few decades; (ii) Exposition of about 25 minutes focusing on the new result, elaborating on its history, the main underlying ideas, and the people involved in the field; and (iii) Taking into account students’ limited background, preferably linking it to some topics in the mandatory curriculum, without harming the progress in their teaching.

The current study focuses on one question – *how do high-school mathematics teachers perceive the contribution of integrating MNSs (in their mathematics lessons) to the development of their*

Mathematical Knowledge for Teaching? This study is part of a larger research program that examines the experiences of teachers as well as of students participating in the MNS project.

Method

Setting: Mathematics teachers participating in the MNS project attend a dedicated three-year professional development program. This program involves both face-to-face meetings and online meetings in which teachers are getting acquainted with seven MNSs each school year (Grades 10-12) and hold discussions about the mathematical, historical, and innovative contents of the MNSs. Following the implementation of each MNS in their classes, teachers are required to document their experiences (e.g., their own reflections and their students' responses) into an online database via a dedicated proprietary software called "Ramzor" (lit. Traffic Light). These reports often entail information regarding students' comments and classroom atmosphere, as well as suggested accompanying activities, recommended videos, and questions regarding possible mistakes in the presentation. The project staff provides ongoing one-on-one support for each participating teacher. To date, we have completed two and a half (out of three) years of our longitudinal study.

Sample: The participants are 25 high school mathematics teachers who volunteered to participate in the MNS project: 14 teachers have integrated MNSs for one year ("beginning teachers" – Group A), and 11 teachers have integrated MNSs for two consecutive years with the same students ("continuing teachers" – Group B). (They are continuing this year, but the data is restricted to the 2nd year).

Research instruments: Three data collection instruments are used in this study: Teacher questionnaires, teacher interviews, and field notes.

Teacher questionnaires. At the beginning of the first year (prior to the students' first introduction to the MNSs) and at the end of each school year, each participating teacher is asked to complete a questionnaire. The questions involve three types of items: 5-level Likert-type scale items, multiple-choice items, and open-ended items. The intention was to trace the development of teachers' MKT following the integration of MNSs in their lessons. The questionnaires were constructed with, and validated by, a team of mathematics education experts.

Participants' interviews. We conducted an informal semi-structured interview with each teacher at the end of each school year, in the form of a friendly conversation conducted online via video chat. The interviews dealt with the considerations that guided the teacher in integrating the MNSs.

Field notes – Analysis included all (and only) comments made by teachers on the proprietary software and during conversations with the project staff.

Data analysis: We utilized a qualitative research paradigm, implementing a process of open and axial coding, to identify the main categories and sub-categories (Corbin & Strauss, 2008). At the first stage, the teachers' responses to the questionnaires were analysed, to generate preliminary categories. In the second stage, the data analysed from the observations and interviews in order to identify and map the initial categories. We identified a correlation between the reports received from the final evaluation questionnaire and the knowledge obtained from the interviews that supports the findings (Miles & Huberman, 1994). In the third phase of the analysis, while reviewing the findings of the first and second stages, we focused on the data related to the development of key components of MKT.

Findings

The integration of the MNSs introduced teachers to diverse and innovative mathematics contents, in a systematic and structured manner. The teachers' experience in integrating the MNSs led to the development of various teachers' knowledge components, as they perceived it. Some of which are presented below.

Teachers' perceptions about Integrating MNSs as a lever for the development of their mathematical knowledge

In each end-of-year questionnaire the teachers were asked to relate to the contribution of the integration of the MNSs to their mathematical knowledge, both in the context of school curriculum and beyond the curriculum. Table 1 presents the distribution of teachers' degree of agreement with the statement: To what extent did the integration of MNSs in your mathematics lessons contribute to the expansion of your mathematical knowledge?

Teachers		Degree of Agreement				
		Very Large	Large	Medium	Little	Not at all
Group A (N=14)	Curricular context	14.29	14.29	7.14	57.14	7.14
	Extracurricular	28.57	28.57	28.57	7.14	7.14
Group B (N=11)	Curricular context	9.09	0	36.36	45.46	9.09
	Extracurricular	18.18	27.27	36.37	18.18	

Table 1: Teachers' grading of their mathematical knowledge development, according to groups and type of knowledge (in percentage)

Here are a few quotes (translated from Hebrew to English) from group A teachers' testimonials about the expansion of their mathematical knowledge: "*The MNSs helped me understand, and present in class the distinction between proofs and refutation*"; "*I realized that there are proofs of impossibilities, such as the impossibility to trisect an angle*"; "*I learned about the existence of notions such as Mersenne number*". As can be seen from Table 1, both groups perceived the contribution of integrating the MNSs to their mathematical knowledge beyond the curriculum was greater than its contribution to knowledge related to the curriculum itself. Group A teachers maintained that: "*I was exposed to mathematics theorems such as Fermat's last theorem and Kepler's theorem*"; "*I became familiar with interesting mathematical subjects that I did not know, like the connection between guarding an art gallery and mathematics*". Similar to Group A, Group B teachers reported that: "*My mathematical knowledge was expanded, through integrating MNSs for example I learned from the MNS about Efron cubes that the transitive rule does not always holds*"; "*Through integrating MNSs, I learned with my students a lot about contemporary mathematics*"; "*There are many mathematical contents I was not familiar with. For example, the frequency of the digit 1 as a leading digit*". The findings from the interviews with the teachers reinforced the findings from the questionnaires. They indicated that all the interviewed teachers (Seven out of seven) perceived an expansion and deepening

of their mathematical knowledge. *"It was new to me that nowadays mathematicians employ technology not only for proving theorems but also for validating proofs"*. In addition, the teachers were exposed to the protracted work of proving mathematical theorem: *"I did not know that to prove the Fermat Last Theorem it took 300 years"*; *"I am happy to learn new things in mathematics, as the MNSs power point presentation there are many references, to mathematical background materials and applets"*.

Teachers' perceptions about integrating MNSs as an attribute for their recognition of the importance of exposing students to contemporary mathematical subjects beyond the curriculum

Table 2 presents the distribution of teachers' degree of agreement with the statements: To what extent integrating the MNSs contribute to your recognition of the importance of exposing students to contemporary mathematical subjects beyond curriculum?

Teachers	Degree of Agreement				
	Very Large	Large	Medium	Little	Not at all
Group A (N=14)	21.43	50	21.43	7.14	
Group B (N=11)	18.18	63.64	18.18		

Table 2: Teachers' grading of their recognition about the importance of exposing students to contemporary mathematical subjects beyond curriculum (in percentage)

The teachers in Group A reported that their recognition about the importance of exposing the students to the content of the MNSs motivated them to join the project to start with, and to carry on their participation in it. In addition, teachers in Group A, reported about their desire to change the students' image about mathematics as a dynamic, and constantly evolving field: *"The exposure of the students is very significant to their image of mathematics"*; *"It's important for me that my students really recognized that mathematics is an ever-growing field"*. The teachers in Group B added: *"It is important that students recognize the world of mathematics beyond matriculation exam"*. The teachers' awareness of the importance of exposing students to MNSs also related to an opportunity to deal with the fears of students from math: *"One of my goals in integrating MNSs in my class is to try to remove fear of mathematics and try to develop a love for mathematics"*. In addition, integrating MNSs helped teachers emphasize the use and the connection of mathematics to daily life: *"It was very important to me at every MNSs presentation to note the fact that mathematics connects to science, which has many uses and is constantly evolving"*. The teachers' interviews strengthened the findings from the questionnaire. Five out of seven interviewed teachers reported that they chose to participate in the project to expose themselves and their students to mathematics as a field of constant development: *"Mathematics is perceived by students, as frozen and unchanging"*. Integrating MNSs enabled teachers to present mathematics in an orderly, interesting and exciting way: *"the integration of MNSs gave me an opportunity as a teacher to present a story after story of things that can ignite students' imagination"*. With integrating the MNSs *"I can open to my students horizons for what is*

happening in mathematics. I did not have the ability to connect things together without participating in this project"

Teachers' perceptions about integrating MNSs as a way to deepen teachers' knowledge about the relationships between mathematics, and its applications to science and society.

Table 3 shows the distribution of teachers' degree of agreement with the statement: To what extent integrating the MNSs contribute to your knowledge about the relationships between mathematics and its applications to science and society?

Teachers	Degree of Agreement (in percentage)				
	Very Large	Large	Medium	Little	Not at all
Group A (N=14)	14.29	35.71	42.86	7.14	0
Group B (N=11)	18.18	36.37	27.27	18.18	0

Table 3: Teachers' grading of their recognition of the relationships between mathematics and its applications to science and society

The teachers in Group A, reported on important knowledge from integrating MNSs in their lessons, which links mathematics to its uses: "*It is Important as a teacher to have the knowledge beyond the curriculum that connect mathematics to other fields such as: agriculture, the connection to taxes, music, world maps*". Group B teachers also reported a rich expanse of examples illustrating the relationship between mathematics and science through integrating MNSs: "*I was amazed to discover the connection between origami folds and the development of science and medicine*". All the interviewed teachers reported about the contribution of the MNSs to their knowledge of the relationship between mathematics, sciences and society. The integration of the MNSs has given teachers the exposure, and understanding, the relationship between mathematics and scientific phenomena around them: "*for example, soap bubbles were very interesting. Why the bubble is round, and it has to do with both science and mathematics, I knew that the Hungarian cube knew has math around it, but now I did deepen my knowledge about it. The MNSs enriched my knowledge, opened my horizons, and the integration of the MNSs in students instruction forced me to understand it more deeply*". In addition, all the interviewed teachers reported the contribution of integrating MNSs, to their knowledge about the relationship between mathematics and computer science. An example of teachers report: "*The fact that the computer becomes a significant player in the stages of proof is very impressive, such as the color of the map*". The teachers reported a deepening of the relationship between mathematics and phenomena occurring in nature: "*For example, in the Fibonacci series, I was very excited by the physical explanation of the series' shows in the flowering mechanism. MNSs help me to understand why, and the explanation took me a few steps forward*".

Discussion

The present study focused on high-school mathematics teacher's perceptions of the contribution of integrating MNSs to various component of their MKT during the first two years. The findings as appeared above in Tables 1, 2, 3 indicate that teachers perceive the interweaving of MNSs in their mathematics lessons, as a catalyzer for the development of at least three components of their MKT.

This goes hand in hand with the claim by Shulman (1986) and Ball et al (2008) that this is the unique mathematical knowledge required for teaching mathematics.

Teachers also expressed their perceptions that by integrating MNSs in their mathematics lessons, they developed their SCK as well as their KCS. By intelligent integration of MNSs during instruction teachers perceived that they deepened their knowledge about the connection between mathematics and other field, about different ways for proof theorems, hence they have expanded their SCK. By introducing various ways in which students' curiosity can be stimulated, and identified topics in which students were interested in the curriculum and beyond, teachers have expanded their KCS.

Another component that the findings illuminate is the HCK as defined by Ball et al. (2008). The findings indicate that teacher's perceptions the significant contribution of integrating MNSs on their MKT component, related to HCK (Ball et al. 2008). By exposed to the MNSs, they strength and deepen their awareness of the dynamic, lively and ongoing mathematics development. The teachers found out about the connections between the development of mathematics and the development of science and society. According to HCK, defined by Ball & Bass (2009), by integrating MNSs in their mathematics lessons, the teachers reflected in the various HCK components: They developed a sense of the mathematical environment surrounding the current "location" in instruction, by identified links between topics taught in the mathematical curriculum to topics outside the curriculum. They were exposed to major disciplinary ideas and structures such as various possibilities of mathematical theorem, to the logical structure of mathematical content. Finally, the teachers stated they appreciated being exposed to core mathematical values such as, collaborative work and persistence, as expressed in the MNSs, with the description of mathematicians work with their colleagues in other fields.

In conclusion, this study will continue in examining more components as the third year of this study unfolds.

Acknowledgment

This research was supported by the Israeli Ministry of Science and Technology.

References

- American Mathematical Society (2018). MathSciNet by the Numbers. <https://mathscinet.ams.org/mathscinet/help/about.html>. Retrieved Aug. 31, 2018.
- Amit, B., Movshovitz-Hadar, N. (2011). Design and high-school implementation of Mathematical-News-Snapshots - An action research into 'Today's News is Tomorrow's History'. In B. E., Krongellner, M. C. Tzanakis (eds.). *History and epistemology in mathematics education: Proceedings of the 6th European Summer University*, (pp. 171–184), Verlag Holzhausen GmbH/Holzhausen Publishing Ltd. Austria.
- Ball, D. L., & Bass, H. (2003). Toward a practice-based theory of mathematical knowledge for teaching. In: B. Davis & E. Simmt (Eds), *Proceedings of the 2002 annual meeting of the Canadian Mathematics Education Study Group*, pp. 3–14. Edmonton, AB: CMESG/GCEDM
- Ball, D. L. & Bass, H. (2009) With an eye on the mathematical horizon: knowing mathematics for teaching to learners' mathematical futures. *Paper presented at the 43rd Jahrestagung der*

Gesellschaft für Didaktik der Mathematik, Oldenburg, Germany. Retrieved 15 May 2011 from www.mathematik.uni-dortmund.de/ieem/BzMU/BzMU2009/BzMU2009-Inhalt-fuer-Homepage.htm.

- Ball, D. L., Thames, M. H. & Phelps, G. (2008) Content knowledge for teaching: what makes it special? *Journal of Teacher Education* 59(5), 389–407.
- Corbin, A., & Strauss, J. (2008). *Basics of qualitative research: Techniques and procedures for developing grounded theory*, 3rd edition. SAGE Publications.
- Hill, H.C., Blunk, M.L., Charalambous, C. Y., Lewis, J.M., Phelps, G.C., Sleep, L. & Ball, D.L. (2008). Mathematical knowledge for teaching and the mathematical quality of instruction: An exploratory study. *Cognition and Instruction*, 26, 430–511.
- Ma, L. (1999). *Knowing and teaching elementary mathematics: Teacher's understanding of fundamental mathematics in China and the United States*. Mahwah, NJ: Lawrence Erlbaum Associates.
- Miles, M.B., & Huberman, A.M. (1994). *Qualitative data analysis: A sourcebook of new methods*. (2nd ed.) Beverly Hills, CA: Sage.
- Movshovitz-Hadar, N. (2008). Today's news are tomorrow's history - Interweaving mathematical news in teaching high-school math. In E. Barbin, E. Stehlikova, & N. C. Tzanakis (eds.) *History and epistemology in mathematics education: Proceedings of the fifth European Summer University* (pp. 535–546), Vydavatelsky Press, Prague.
- Shulman, L. S. (1986). Those who understand: Knowledge growth in teaching. *Educational Researcher*, 5(2), 4–14.

Examining pedagogical and classroom discourse through the lens of figured worlds: The case of an elementary school teacher

Galit Shabtay¹ and Esther Levenson²

Kibbutzim College of Education, Israel; galit.shabtay@smkb.ac.il

²Kibbutzim College of Education and Tel Aviv University, Israel; levenso@tauex.tau.ac.il

The problem solving approach to teaching and learning mathematics has for some time been the focus of professional development (PD) programs. This paper discusses a case study of an elementary school teacher who participated in such a program. We apply the lens of figured worlds when analyzing her pedagogical and classroom discourses to reveal which aspects of explorative figured worlds penetrate her discourse. Findings indicated that the teacher adopted some aspects of explorative figured worlds but resisted others. The lens of figured worlds can help us, as teacher educators, to plan continued PD.

Keywords: Figured worlds, explorative instruction, professional development.

Introduction

Although there is a consensus among researchers and teacher educators regarding the benefits of what may be called explorative instruction (i.e., inquiry-based, student-centered, and cognitively demanding instruction) (Schoenfeld, 2014), studies have shown that teacher-centered, ritual instruction is still very prominent in many classes (e.g., Resnick, 2015). Resistance to explorative instruction may even be found amongst teachers who have taken part in professional development specifically promoting this type of instruction (Heyd-Metzuyanim, Munter, & Greeno, 2018). One way to explain this phenomena is by viewing it through the lens of ‘figured worlds’ (Holland, Lachicotte, Skinner, & Cain, 1998). Figured worlds are based on one’s interpretation of situations and may be revealed through discourse.

This paper presents a case study of one teacher, Yifat (a pseudonym), and analyzes her pedagogical and classroom discourses after participating in a professional development (PD) program centered on problem solving and explorative instruction. Through the lens of figured worlds, we analyze her discourses and examine which aspects of explorative instruction she adopted and which were missing.

Theoretical background

This section begins by offering some background on the notion of figured worlds and how it relates to mathematics education. It continues by describing the problem solving approach to teaching mathematics. Finally, as this paper analyzes the teacher’s pedagogical and classroom discourses, the section ends by presenting how discourse is understood in the commognitive approach.

A figured world is defined by Holland and her colleagues (Holland, et al., 1998) as “a socially and culturally constructed realm of interpretation in which particular characters and actors are recognized, significance is assigned to certain acts, and particular outcomes are valued over others” (p. 52). People ‘figure’ out who they are through the activities of their world, in relation to the social types that populate these figured worlds, and in social relationships with the people who perform in these

worlds. In addition, artefacts and signs are attributed meaning that might differ from how those outside of the figured world interpret them. To sum up, the people within the figured world take on roles that come along with responsibilities, and in addition, certain actions, outcomes, and objects are valued more than others.

Relating figured worlds to mathematics education, Boaler and Greeno (2000) pointed out that the difference between ritual and explorative instruction may not just be a matter of certain teaching techniques or forms of classroom organization, but a matter of widely different figured worlds. They defined the problem-solving, group-work mathematics instruction found in some secondary schools as a “connected knowledge” figured world. In contrast, the more common teacher-centered instruction was conceptualized as a figured world based on “received knowledge”. Ma and Singer-Gabella (2011) showed that it was difficult for prospective teachers to move from the “traditional” figured world (in which they supposedly studied at school) to the “reform” figured world of mathematics instruction, supported and enacted in their training program.

Over the years, evidence has shown that the “connected knowledge” figured world is fruitful for mathematics learning (Schoenfeld, 2014). In particular, Hiebert and Grouws (2007) highlighted two significant aspects of such teaching: Explicit Attention to Concepts (EAC), and Students’ Opportunity to Struggle (SOS). These two aspects are part of the problem-solving approach to teaching mathematics (Hino, 2015). This approach emphasizes meticulous planning of detailed mathematics lessons that include implementing rich problems in such a way that students are active participants who explore mathematics. The teacher’s role is to create learning opportunities that support students’ conceptual understanding through problem solving, as well as supporting student agency and authority (Schoenfeld, 2014). Relating to all of the above, Shabtay and Hed-Metzuyanin (2018) described the figured world of exploration as one where students are free to struggle, mathematics is at the center, and the teacher and students share responsibility for the learning process.

Learning, including learning mathematics, may be seen as the process of becoming a full participant in a certain discourse (Sfard, 2008). Such participation may be characterized as lying on an axis between ritual and explorative participation (Viirman, 2015). In Sfard’s commognitive framework (Sfard, 2008), a basic assumption is that doing mathematics means engaging in mathematical discourse. Discourses, according to Sfard, are different types of communication “set apart by their objects, the kinds of mediators used, and the rules followed by participants, and thus defining different communities of communicating actors” (p.93). While these discourses are not stable or distinct, but rather overlapping and constantly developing, it still makes sense, within a given context, to see them as “distinct enough to justify talking about discourses [. . .] as reasonably well-delineated wholes” (p. 91). Regarding the classroom as a community, Tabach & Nachlieli, (2016) defined a pedagogue, as a person who assumes the role of the leading participant in the discourse. Thus, pedagogical discourse is a discourse about teaching and learning (Shabtay & Heyd-Metzuyanin, 2017). Similar to any other discourse, it is made up of certain key words, narratives, and meta-rules that dictate what to teach students, how to teach them, and who can learn (or not learn). This view is based on Sfard’s (2008) view of mathematizing as participating in a discourse about mathematical objects. The pedagogical (the how and for whom) is closely intertwined with the what (Shabtay & Heyd-Metzuyanin, 2017).

Through the lens of figured worlds, this study examines which explorative narratives may be found in a teacher's classroom discourse and in her pedagogical discourse, after participating in a PD program focused on the problem solving approach to teaching mathematics.

Methodology

Yifat is an elementary school teacher with a B.Ed. degree and a specialization in mathematics. At the time of the study, Yifat had 11 years of experience teaching mathematics to fourth and fifth graders (10-11 years old), and was the mathematics coordinator in her school. This case was chosen because it illustrates the gap between a teacher's classroom and pedagogical discourses. In addition, Yifat consented to be part of the study, and agreed that her lesson and interview be recorded.

Yifat participated in a PD program for mathematics teachers centered on designing and implementing lesson plans according to the problem-solving approach (Hino, 2015). During the program, teachers engaged in cognitively demanding tasks, viewed videoed lessons demonstrating the problem solving approach, discussed the pedagogical gains and mathematical ideas that emerged from those lessons, and designed lesson plans modeled on the problem-solving approach. The PD program took place over a period of eight months, and included 10 sessions. In addition, each teacher met with the PD educator three times on an individual basis, receiving personalized instruction and advice for planning and implementing mathematics lessons using the problem-solving approach in their specific classes.

Relevant to the present study, the seventh meeting of the program dealt with the construction of prime and composite numbers. During that meeting, teachers, including Yifat, engaged with a cognitively demanding task that involved representing different prime number with different signs, and composite numbers with an appropriate combination of prime number signs. For example, a card representing the number 2 had a circle on it, the card for 3 had a triangle, and the card for six had both a circle and a triangle (see Figure 1 for the symbols which represented the numbers from one to ten). During the session, teachers also viewed a Japanese lesson, demonstrating how this activity may be implemented as part of a problem-solving teaching approach to learning these new concepts. At the end of this session, Yifat invited the teacher educator to come to her fourth grade class and observe her teaching this exact lesson. Yifat expressed her belief that she "finally understood the problem-solving approach," and that she felt students would enjoy the lesson and experience meaningful learning.

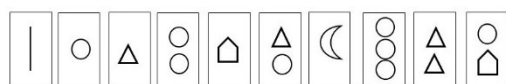


Figure 1: Cards with symbols representing the numbers from 1-10

Data collection and analysis

Yifat was interviewed both before and after the observed lesson. The first interview dealt mainly with the goals of the lesson, the main mathematical ideas, and the planned pedagogical processes. The post-teaching interview revolved around achievement of goals, class-driven processes, and the mathematical ideas that emerged from students and the teacher during the discussions. Each interview was audio-taped and transcribed. The lesson was video-taped and transcribed.

Relating back to the theory of figured worlds described previously, a qualitative analysis was carried out on all transcriptions searching for four dimensions of figured worlds: characters, valued actions, outcomes, and artifacts. The characters, in this case the teacher and students, play roles that involve responsibilities. Thus, when analyzing characters, we analyze the roles Yifat plays and those she refers to during her interviews. Noting the value that Yifat places (or does not place) on these four dimensions, we describe Yifat's figured world and compare it to an explorative figured world.

Findings

In the transcripts below actions are underscored with one line, outcomes with a double line, and roles and responsibility are indicated with a broken line. Artifacts are in bold.

The first interview took place in the teacher's classroom, during the recess prior to the mathematics lesson. Yifat was anxious, and yet proud, to show the teacher educator what she had prepared.

Interviewer What's new?

Yifat Hi. (Yifat is preoccupied with **a bag of flashcards**).

Interviewer Do you need help?

Yifat Look. I made these **symbols**. **These (she places the flashcards on the table)**.

Interviewer Okay.

Yifat You'll see. I will arrange it for them after they sort them like this. (She arranges the cards as in Figure 1. She has more cards that have not been arranged yet.) Then we will discuss the topic. That's okay, isn't it?

Interviewer What are you going to try to achieve today? How would you describe your objective?

Yifat Uh ...That they know what a prime number is, and what a composite number is.

Interviewer Hmm...and how did you plan the lesson?

Yifat You'll see. I planned it just like the teacher in the clip. Don't worry (she is busy with the flashcards, putting them back into the bags)...I need the sticky stuff so that I can stick them on the board (gets up to get the glue).

From the lines above, we see Yifat's preoccupation with the flashcards, signifying their value in her eyes. Yifat also states her intent to emulate the teacher in the film. Emulation is an action that might indicate her tendency towards being a ritualistic learner, i.e., she watched a documented lesson during a professional development meeting, and would like to replicate the lesson. Thus far, it seems that Yifat has chosen an appropriate problem, and has brought along appropriate props (cards) that will help her achieve the goal of students "knowing" (Yifat's term) what prime and composite numbers are. Note that she does not relate to explorations and discussions as objectives, or valued outcomes.

The observed lesson was 47 minutes long. The teacher began by randomly sticking the cards on the board and telling the children to decide how the cards could be sorted. Yifat proceeded to spend 30 minutes listening to various suggestions of how to sort the cards, calling on different students to

demonstrate their method on the board. Finally, she arranged the cards on the board in ascending numerical order as represented by the symbols, in accordance with her lesson plan (see Figure 1).

For the next 12 minutes, she again led a whole-class discussion, this time relating to the arrangement of the cards on the board. Yifat tried to steer the discussion towards explaining the arrangement of the cards, as depicted below.

- Yifat Let's make things clear. You (meaning the class) said skip by twos, and Noa just said even numbers (referring to the cards with circles on them). Let's check everything. Imagine that I have more and more cards. And there's always a shape. There's a circle, and another shape, and a circle and something else, and a circle and something else. (Pause) And what's here?
- Student A (something unintelligible)
- Yifat Here is another circle. And something. I am skipping on purpose. What do you say? Yoav, do you agree with what she said?
- Yoav Yes.
- Yifat Daniel, do you agree?
- Daniel Yes.
- Yifat So wait a second. Let's make some sense out of this so we can understand what's going on. Michal said (referring to the circles) that 2 and 2 and 2 and other items were added. And Roni says ... (referring to the triangles) it skips by 3.

In the above segment of classroom discourse, Yifat takes the lead, saying “Let’s make things clear.” Although she takes the lead in the discourse, her use of the word “let’s” hints at her inclusion of the students in the process of making sense of the symbols. She also turns to different students and asks them if they agree, sharing with them the responsibility for learning. Yet, Yifat’s questions are closed yes or no questions. She does not ask those students to expound on their thoughts. Finally, her valued outcome is that we will “understand what’s going on.” During the last five minutes of the lesson, Yifat wrote down the numbers from 1-10 under each of the symbols and introduced the notions of prime and composite numbers. It was only during those five minutes, that mathematics was at the center of the discourse.

In the interview following the lesson, Yifat talked about the differences between this particular lesson and her regular lessons:

“Look, this was a really different type of lesson. They haven't learned composite or prime numbers at all. So, it's the first level of acquisition. And also, it's...the first time that I...gave a lesson like this, when the whole lesson is...um...only the one problem. It's different from what we usually do. They always have a lot of practice, exercises... Here (pointing to the **cards**) ... they are just symbols that you have to categorize...and understand.”

The actions mentioned by Yifat are student actions. In the past, they practiced; in the present, they categorized. Most interesting are the outcomes she values. The outcome of her lesson plan is the

“different” type of lesson she perceives as having enacted. The outcome for her students is that they will “acquire” the first level of understanding. The terminology Yifat uses gives us a mixed message regarding her figured world. On the one hand, she consciously attempts to break with her former lesson style. She chooses to implement a cognitively demanding task. Yet, she resorts back to words such as “acquisition,” and “giving a lesson,” that remind us of a traditional figured world.

Asked if she has achieved her goals for this lesson, the following exchange ensues:

- Interviewer Okay. So, in your opinion...did you achieve your goal?
- Yifat Of course. Look, it's only the beginning, and [so] I had to explain...so...yes.
- Interviewer Um...what was your objective?
- Yifat That they would know what a prime number is and what a composite number is. That they would know how to differentiate between the two.
- Interviewer Okay. How do you know that they have, in fact, made that distinction?
- Yifat Because, look. I told them. They also said that there are **cards with one symbol and there are cards with a number of symbols.** ...I'm sure that most of them understood. And whoever didn't, I will sit with them in a small group and explain it again. You know, it's only the beginning. Look. They can't arrive at it by themselves. My job is...I have to explain it to them and that's how they'll know. They would never get to it by themselves.
- Interviewer Why?
- Yifat Because it's too complex. Later, when things are clarified, I'll be able to let them come up with symbols for 13 or 17, and construct 12 or 18.

The actions Yifat values for herself (e.g., explaining, telling), go hand-in-hand with how she describes her “job”, or role, as an “explainer”. Although during the classroom discourse Yifat did ask students to share their ways of sorting the symbols, during the interview she ascribes a passive role for her students, claiming unequivocally that they would not be able to arrive at the mathematical conclusions on their own. This interview offers evidence that Yifat’s figured world is mostly traditional.

Referring to the main characteristics of the problem-solving approach, Table 1 summarizes the similarities and differences between Yifat’s figured world and the explorative figured world. Yifat does choose to present a cognitively demanding in her class. She perceives this lesson as being quite different from those she usually teaches. Additionally, Yifat led a discussion concerning the task she presented to her pupils. These are all part of the explorative figured world. However, Yifat did not offer enough of an opportunity for her students to struggle with the problem. Recall that after she randomly stuck the symbols on the board, she immediately began to call on students to share their ways of sorting, without giving them time to think about it. When she finally arranged the cards in order, she still had difficulty shedding her central role as the teacher who explains, and where the students are attentive. These are elements of a more traditional figured world. In other words, Yifat is struggling between two worlds.

	Explorative figured world	Yifat's figured world
Teachers select cognitively demanding tasks	+	+
Students present their own ideas	+	+
Collaborative group discussions	+	+/-
Shared mathematical authority	+	+/-
Students are offered opportunities to struggle	+	-
Explicit attention to concepts	+	-

Table 1: A comparison between Yifa's figured world and an explorative figured world

Discussion

The aim of this study was to investigate what explorative narratives enter into a teacher's classroom and pedagogical discourses after attending PD focusing on a problem-solving approach to teaching. From the first, we get mixed messages. Yifat is very enthusiastic about the task, yet is preoccupied with the artifacts (the cards). Though not entirely insignificant, the cards are actually mere props, to be used in the ultimate aim of having students engage with the concept of prime and composite numbers. Yet, during the lesson, more time is spent discussing the artifacts than on the mathematical concepts they were supposed to elicit; not enough time is allowed for exploring the possible significance of the symbols and how they might be related to mathematics (Hiebert & Grouws, 2007). This is also reminiscent of Henningsen and Stein (1997), who argued that a teacher must not only select and appropriately set up worthwhile mathematical tasks, but must proactively and consistently support students' cognitive activity. In addition, although her classroom discourse shows her attempts at sharing authority, her second interview contradicts this view. These findings are in line with Sfard's approach (2008), that discourses are not stable, but rather overlapping and constantly developing.

While acknowledging that discourses may be overlapping, as teacher educators, we attempt to move teachers toward a more explorative discourse. Sfard (2016) suggested that for teachers to be explorative in their teaching, they must have experienced explorative mathematics learning for themselves. Yifat had limited experience with this type of learning, most of which stemmed from the PD program. Indeed, Yifat explicitly states that her aim is to imitate the teacher in the filmed lesson. She does not say that her aim is to offer the students the same type of experience she has recently had in the program. From paying attention to her discourse, we might infer that additional time must be given for teachers to experience for themselves explorative learning.

By focusing on characters, actions, outcomes, and artifacts, we can see what parts of a figured world a teacher adopts, and which seem to be restricted. As teacher educators, we can utilize this lens to listen to teachers' discourses and identify aspects that perhaps need more attention. Yifat is ready to adopt appropriate tasks, and willing to listen to her students. At this point, we would say that more attention could be paid to authority, while at the same time placing the mathematics at the center. Insight into a teacher's figured world, can help teacher educators plan appropriate professional development.

References

- Boaler, J., & Greeno, J. (2000). Identity, agency, and knowing in mathematics worlds. In J. Boaler (Ed.), *Multiple perspectives on mathematics education* (pp. 171-200). Westport, CT: Ablex.
- Henningsen, M., & Stein, M.K. (1997). Mathematical tasks and student cognition: Classroom-based factors that support and inhibit high-level mathematical thinking and reasoning. *Journal for Research in Mathematics Education*, 28(5), 524-549.
- Heyd-Metzuyanim, E., Munter, C., & Greeno, J.G. (2018). Conflicting frames: a case of misalignment between professional development efforts and a teacher's practice in a high school mathematics classroom. *Educational Studies in Mathematics*, 97(1) 21-37.
- Hiebert, J.C., & Grouws, D. (2007). The effects of classroom mathematics teaching on students' learning. In F.K. Lester (Ed.), *Second handbook of research on mathematics teaching and learning* (Vol. 1, pp. 371–404). Charlotte, NC: NCTM.
- Hino, K. (2015). Comparing multiple solutions in the structured problem solving: Deconstructing Japanese lessons from learner's perspective. *Educational Studies in Mathematics*, 90(2), 121-141.
- Holland, D., Lachicotte, W., Skinner, D., & Cain, C. (1998). *Identity and agency in cultural worlds*. Cambridge, MA: Harvard University Press.
- Ma, J.Y., & Singer-Gabella, M. (2011). Learning to teach in the figured world of reform mathematics: Negotiating new models of identity. *Journal of Teacher Education*, 62(1), 8-22.
- Resnick, L.B. (2015). Talking to learn: The promise and challenge of dialogic teaching. In L.B. Resnick, C. Asterhan, & S. Clark (Eds.), *Socializing intelligence through academic talk and dialogue* (pp. 441–450). Washington DC: American Educational Research Association.
- Schoenfeld, A.E. (2014). What makes for powerful classrooms, and how can we support teachers in creating them? A story of research and practice productively intertwined. *Educational Researcher*, 43(8), 404–412.
- Sfard, A. (2016). Ritual for ritual, exploration for exploration: Or, what learners are offered is what you get from them in return. In J. Adler, & A. Sfard (Eds.), *Research for Educational Change* (pp. 41–63). Elsevier.
- Shabtay, G., & Heyd-Metzuyanim, E. (2018). Examining teachers' discourse on students' struggle through figured worlds. In E. Bergqvist, M. Österholm, C. Granberg, & L. Sumpter, (Eds.), *Proceedings of the 42nd Conference of the International Group for the Psychology of Mathematics Education* (Vol. 4, pp. 155-162). Umeå, Sweden: PME.
- Shabtay, G., & Heyd-Metzuyanim, E. (2017). Teachers' discourse on students' conceptual understanding and struggle. In B. Kaur, W.K. Ho, T.L. Toh, & B.H. Choy (Eds.), *Proceedings of the 41st Conference of the International Group for the Psychology of Mathematics Education*, (Vol. 4, pp. 177-184). Singapore: PME.
- Tabach, M., & Nachlieli, T. (2016). Communicational perspectives on learning and teaching mathematics: Prologue. *Educational Studies in Mathematics*, 91(3), 299-306.

Impacts of a mathematical mistake on preservice teachers' eliciting of student thinking

Meghan Shaughnessy,¹ Rosalie DeFino,² Erin Pfaff,³ Merrie Blunk⁴ and Timothy Boerst⁵

¹University of Michigan, USA; mshaugh@umich.edu

²University of Michigan, USA; rdefino@umich.edu

³University of Michigan, USA; erpfafe@umich.edu

⁴University of Michigan, USA; mblunk@umich.edu

⁵University of Michigan, USA; tboerst@umich.edu

We report on a study of preservice teachers' eliciting performances in a scenario in which a student has made a mistake and, if sufficiently probed, is able to recognize the mistake and revise their work. Our findings reveal the skills and capabilities of one group of preservice teachers at the start of a teacher education program.

Keywords: Teacher education-preservice.

Student responses in teaching

Mr. Chinn, an experienced sixth grade teacher, is circulating in his sixth-grade mathematics class as students work independently on a set of problems involving operations with fractions, including mixed numbers. He pauses by Chloe and notices that she has arrived at an answer for a subtraction problem with “mixed numbers” that looks wrong. By mixed numbers, we mean numbers that combine integers and proper fractions. Chloe’s work, shown in Figure 1, has resulted in an incorrect answer.

$$\begin{array}{r} 2 \\ \cancel{3} \frac{2}{5} \\ - 1 \frac{3}{5} \\ \hline 1 \frac{9}{5} \end{array}$$

Figure 1: Student work, the student makes a mistake

Mr. Chinn decides that he does not want to assume what Chloe was doing and so he asks her some questions about her work: “Chloe, what did you notice when you started to work on this problem?” Chloe responds, “I was trying to take three-fifths away from two-fifths but I didn’t have enough so I needed to borrow.” Mr. Chinn nods and follows up, “Where did you borrow from?” Cloe responds, “I borrowed from the 3 and then the two-fifths become twelve-fifths.” Mr. Chinn wonders whether Chloe is overgeneralizing “borrowing” from work with subtracting multi-digit numbers or if she has made a bookkeeping error. He asks some more questions and presses Chloe to explain the value of the “little one” in fraction notation and Chloe pauses, and then says softly, “I think I made a mistake.” Mr. Chinn asks her what she thinks is a mistake and to articulate why she thought she did it. Through this interaction, he learns that Chloe believes she was just “working too quickly” and that she forgot that she was borrowing “five-fifths.” Then, Mr. Chinn asks Chloe to solve the problem again. When

Chloe changes the “two-fifths” to “seven-fifths,” Mr. Chinn asks Chloe how she knew to write seven-fifths and why the mixed number can be re-written as “three and seven-fifths.”

In this episode, Mr. Chinn encounters a regular problem of practice in mathematics teaching. A student is doing something when solving a mathematics problem that misaligns with the lesson’s mathematics goal of accurately computing the difference. The processes of teaching and learning often involve such mismatches between goals and the current status of students’ performances. For example, students might use an approach that is not familiar to a teacher. Or a student may make what Bass (personal communication) terms a “bookkeeping” error. Radatz (1980) refers to such an error as a mistake, an isolated and unrepresentative mis-executions of an algorithm (a careless move) as opposed a systematic and persistent mis-execution that reflect a conceptual or procedural misunderstanding. Chloe’s response reflects a book-keeping error. Another possibility is that student’s work might reflect a misunderstanding that results in an incorrect answer. Of course, other sorts of mismatches happen in teaching that are crucial, such as when teachers favors/expects a particular approach or route of reasoning and a student treads an alternative path. In a broader sense these mismatches illustrate a broader categorization of students’ actions/productions that are “*not what the teacher is looking for.*” This is not about anticipation as teachers may very well anticipate that students might produce some of these responses. This is more about the need for teachers to have generative responses when there is a mismatch between what the teacher prefers/hopes to see and the variability in what students produce in the course of learning mathematics.

Interactions around student responses that are not what the teacher is looking for can be powerful sites of learning for both teachers and students (Borasi, 1994; Hiebert et al., 1997). When the answer is incorrect, the joint sense-making required to interpret student thinking goes beyond the identification and correction of mistakes/errors into the conceptual analysis of why the mistake/error was made (Borasi, 1994; Kazemi, & Stipek, 2001). The information that teachers can uncover by eliciting students’ thinking can then guide their pedagogical response. This is not to say that all student responses that are different from the responses that teachers are looking for have the same potential for being a site for learning. For example, one could argue that a bookkeeping error has less potential to support learning for the teacher and the student compared to an instance in which a student’s work reflects a misunderstanding that results in an incorrect answer. While the importance of interacting with students around incorrect answers is well-documented, research suggests that practicing teachers vary greatly in their attention to and treatment of errors and mistakes in classroom discussion (Bray, 2011; Santagata, 2005; Silver, Ghouseini, Gosen, Charalambous, & Strawhun, 2005). Less is known about the ways in which preservice teachers (PSTs) elicit student thinking when they see answers that are not the answers that they want students to produce. This matters for several reasons. For one, when students do something that the teacher is not looking for, this indicates a place where the teacher could learn something about the student and/or about mathematics. Both of which merit being able to leverage the opportunity. For another, when students make what seem to be mistakes, asking questions may reveals understandings that are not evident from their written work.

In this study, we examine PSTs’ skills around asking questions to learn about student thinking (eliciting student thinking) when a student has an incorrect answer. We explored a case in which the student makes a bookkeeping error, a mistake, in their arithmetic process and will recognize the

mistake if asked specific questions about their reasoning. The context is challenging for many PSTs. It has significant implications for students because teachers' understanding the basis of student's mistakes is necessary for responsive instruction. In other words, teachers need to know the degree to which a mistake reflects underlying understandings in order to ascertain how to move a student's understanding forward. Specifically, we sought to analyze the extent to which PSTs' (a) elicited the full process used; (b) elicited the student's understanding of the process, and (c) elicited the student's mistake, including the reason for the mistake and their revised process. We illustrate how knowledge of this kind of skill can be gathered through the use of a simulation in which a PST interacts with a teacher educator who is taking on the role of a student, what such findings reveal about PSTs in one teacher education program, and the implications of these findings.

Focusing on PSTs' skills at the beginning of teacher preparation

There has been increasing focus on preparing PSTs for the work of teaching by focusing on specific instructional practices (e.g., Ball, & Forzani, 2009; Ball, Sleep, Boerst, & Bass, 2009; McDonald, Kazemi, & Kavanagh, 2013). In "practice-based teacher education," learning goals for PSTs are tied to developing skills in carrying out specific teaching tasks. To help PSTs develop skill, it would be useful to know what they bring with them to teacher education, so as to be able to design the program in ways that capitalizes to their prior ways of acting and interacting. Prior research provides knowledge of some of the orientations and assumptions that PSTs bring to teacher preparation and their knowledge of subject-matter content. Research on particular teaching practices often focuses on the utility of the approach, composite parts of the teaching practice, and/or challenges in learning to enact particular teaching practices. Such knowledge is useful for the design of teacher education; however, it is insufficient. Needed is knowledge of the skill with which PSTs can enact particular teaching practices upon entry to a teacher education program.

We build on a prior study which examined the skills with eliciting student thinking at the start of a teacher education program (Shaughnessy, & Boerst, 2018a). PSTs elicited the thinking of a student who arrived at a correct answer to a multi-digit addition problem using a method that was likely to be unfamiliar to PSTs. That study revealed skills with eliciting student thinking that could be built on (e.g., eliciting the student's process), needed to be learned (e.g., eliciting the student's understanding), and needed to be unlearned (e.g., directing the student to use a different process). However, the case of eliciting when a student has made a mistake is different. We wondered whether PSTs would learn that the student had made a mistake and what understandings underlie the mistake.

The practice of eliciting student thinking

In teaching, "teachers pose questions or tasks that provoke or allow students to share their thinking about specific academic content in order to evaluate student understanding, guide instructional decisions, and surface ideas that will benefit other students" (TeachingWorks, 2011). Eliciting student thinking makes the nature of students' current knowledge available to the teacher. Such information is essential for engaging students' preconceptions and building on their existing knowledge (Bransford, Brown, & Cocking, 2000). In actual practice, eliciting student thinking is often done in conjunction with interpreting student thinking and responding to student thinking in ways that support students in building on their current understandings (Jacobs, Lamb, & Philipp, 2010).

Because of the crucial nature of the practice and the need to teach PSTs to do this work, it is necessary to specify the work involved in eliciting student thinking. We conceive of the work of eliciting student thinking in the context of a mathematics problem as asking questions to bring out the student's process and the student's understanding of key ideas underlying the process (Shaughnessy, & Boerst, 2018b). Students are at the center of this work. It is their thinking which is sought and intended to be understood, and the work is situated in mathematical context that focus dialog, shape interaction, and influence follow-up questions. Throughout this paper, we use "skill with eliciting student thinking" to refer to the degree to which PSTs are able to engage in this work.

Studying skill with eliciting student thinking

Since 2011, we have used teaching simulations to study PSTs' skill with eliciting student thinking. A simulation serves as an "approximation of practice" (Grossman, Hammerness, & McDonald, 2009). Simulations have been used in many professional fields such as medicine and more recently in the preparation of teachers (Self, 2016). In these simulations, a PST interacts with a "standardized student" (a teacher educator taking on the role of a student using a well-defined set of rules for responding) around a specific piece of written work. This form of assessment has advantages over field-based interviews to assess skill with eliciting student thinking (Shaughnessy, Boerst, & Farmer, 2018). Field-based interviews leave the particular student thinking being elicited to chance and can be highly variable. The teaching simulation uses highly specified protocols that enable us to control key aspects of the student's process, understanding, and demeanor. This leads to comparable eliciting contexts for all of our PSTs and facilitates fair and more nuanced assessment of PSTs' eliciting skill.

We design teaching simulations to have a consistent three-part format (Shaughnessy, & Boerst, 2018b). First, PSTs are provided with student work on a problem and given 10 minutes to prepare for an interaction. Second, PSTs have five minutes to interact with the standardized student, eliciting the student's thinking to understand the steps they took, why they performed particular steps, and their understanding of the key mathematical ideas involved. Third, PSTs are interviewed about their interpretations of the student's thinking. In total, the assessment takes approximately 25 minutes.

We designed this simulation to be one in which the student uses non-standard process (meaning a process other than the standard US algorithm) for solving multi-digit subtraction problems and makes a mistake. The process we selected is sometimes referred to as "Expand and Trade" (see the student work in Figure 2). The process involves writing the value of the minuend and subtrahend in expanded form and making any necessary trades. When used correctly, the user would then subtract the numbers place-by-place in expanded form. This student correctly applies the expanding and trading process, but mistakenly adds values by place instead of subtracting. This student has conceptual understanding of expanded form, the meanings of addition and subtraction, and when, how, and why to make trades. In this instance, however, the student loses sight of the fact that they are solving a subtraction problem due to the addition symbols in the expanded form. This is a bookkeeping error. During the interaction, the student will change their mind when pressed to: make and evaluate an estimate for the original problem, represent their process with a picture, talk about the meaning of the operation, explain why trades were made, solve another multi-digit subtraction problem, or re-solve the original problem. The student is trained to only reveal the mistake if pressed by the PST on one of these specific points.

$$\begin{array}{r}
 583 \rightarrow 500 + 80 + 3 \\
 - 295 \quad 200 + 90 + 5 \\
 \hline
 600 + 260 + 18 = 878
 \end{array}$$

Figure 2: Student work, the student makes a mistake

Methods

Thirty PSTs enrolled in a university-based teacher education program in the United States participated during the first week of the teacher education program. The simulations were video-recorded. In this paper, we focus our analysis on: (a) eliciting the student's original process, (b) eliciting the student's understanding of the process, (c) eliciting the student's mistake, including the reason for the mistake and the revised process and solution. For each of these components, we identified specific "moves" and tracked their presence or absence in each performance. We used the software package Studicode© to parse the video into talk turns. Then, we identified "instances," which contain a question posed by a PST and the student's response to that question. Two independent coders applied all of the relevant codes to each instance. Disagreements were resolved through discussion and by referencing a code book.

Findings

Eliciting the student's original process

The student's process had five steps: expanding both the minuend and subtrahend, comparing the numbers in each place, trading, adding (rather than subtracting) numbers by place, and adding the partial sums to arrive at the answer. The highest rates of eliciting occurred around the expansion (70%), the comparison of the numbers in each place (90%), and the trading steps (80%). In fact, 65% of PSTs elicited all three of these steps and 90% of the PSTs elicited two or more. However, only 53% of the PSTs elicited that the student added numbers by place in the expanded form after trading. This was surprising given that it was the point where the mistake occurred. The smallest percentage of eliciting occurred around the adding of the partial sums (10%). This was not surprising given that (a) it occurred after the point where the student made the mistake and may have not been relevant if the PST had asked questions that resulted in the student revealing that they had made a mistake, and (b) it could be easily inferred from the written work. Given that these PSTs elicited some, but not all, of the student's steps, we concluded that they brought skills relevant to eliciting a student's process that may be leveraged and built upon in the teacher education program; however, there was also a need for these PSTs to work on identifying and actively asking about steps that are particularly important to understand in the context of the problem.

Eliciting the student's understanding of the original process

We coded whether PSTs elicited the student's understanding of six mathematical ideas underlying the process. The highest percentages of eliciting of understanding occurred around the operation in the problem (27%), why the student expanded (37%), and why the student traded (27%). The lowest percentages occurred around the equivalence of expanded form and the "original" number (7%), the

reasonableness of the answer (7%) and what trading means (0%). This suggests that limited eliciting of understanding of mathematical ideas occurred. However, when we looked across the set of ideas, we found that 67% of PSTs elicited the student's understanding of one or more idea. Thus, we concluded that this 67% of PSTs brought skills relevant to eliciting the student's understanding in this scenario, but note that their eliciting does not show discernment of which understandings are more important to focus on and/or more relevant to subsequent instruction.

Eliciting the student's mistake, including the reason for the mistake and the revised process

We coded the extent to which the PSTs elicited the student's mistake, including their understanding of why they made the mistake. We found three foci in PSTs' performances: eliciting the student's realization that a mistake had been made (47% of PSTs), pointing out the mistake and getting the student to admit a mistake without first eliciting the mistake from the student (20% of PSTs), and only asking questions that were not focused on the mistake (33% of PSTs). In other words, 67% of the PSTs uncovered the mistake either by eliciting it or asking the student to confirm that they made a mistake; 33% percent did not learn about the mistake through questioning.

We now turn to the 47% of the PSTs who elicited the student's realization that a mistake had been made. These 14 PSTs elicited the mistake in different ways. The most common way, used by 11 PSTs, was to ask about the operation involved in the problem and to press on how the operation in the problem (subtraction) differed from the operation that the student had used (addition). Another two PSTs posed another problem for the student to solve or asked the student to redo the original problem. The student profile specifies that the student should correctly apply the Expand and Trade method if prompted to solve another problem. A third approach to eliciting the mistake was to ask about why the student had made the trades. One PST leveraged this to ask why the student had added.

We next turn briefly to the 20% of the PSTs uncovered the student's mistake by pointing it out themselves and getting the student to admit the mistake. Often, PSTs made statements about what it appeared the student had done based on the written work. For example, one PST stated her impression that that expansion and trades were executed correctly and that the student had added instead of subtracting. This exchange took place after the PST had elicited the steps of the student's original process through the trading step. In the exchange, the idea that the student mistakenly added instead of subtracted is introduced by the PST, not elicited from the student. The student merely confirms what the PST has stated. We see this approach to uncovering the mistake as qualitatively distinct from eliciting the mistake through asking questions.

To explore what PSTs did after learning the student had made a mistake, we considered the 20 cases in which PSTs uncovered the student's mistake either by eliciting the student's realization that a mistake had been made or pointing out the mistake. Twelve of the 20 PSTs did not ask any further questions about the mistake. These PSTs need to learn to ask additional questions once a student recognizes a mistake. Of the 8 PSTs who followed up about the mistake, 5 made statements based on their own inferences about how and/or why the student made the mistake and got the student to agree. The remaining 3 PSTs asked questions to learn about how and/or why the mistake was made. These findings suggest that these 8 PSTs bring skills relevant for eliciting a student's mistake, but may need to learn reasons and strategies for eliciting how and why a mistake was made.

Discussion

Understanding the skills with teaching practices that PSTs bring to teacher education is key to designing experiences that are responsive to the needs of PSTs (Shaughnessy, & Boerst, 2018a). This study examined the ways in which PSTs at the beginning of a teacher preparation program elicited the thinking of a student who made a mistake when solving a subtraction problem. Learning about the reason for a mistake is important for teachers to accurately assess and respond to student thinking. For example, a student who has made a mistake due to misunderstanding about ideas underlying the process would need different instruction than a student who has made a bookkeeping error when carrying out a well-understood process. However, at the start of their teacher education program, these PSTs focused more on eliciting the revised method and/or solution than asking about why the mistake was made. We hypothesize that there might be multiple reasons that this pattern occurred. Some PSTs might refrain from directly asking the student why they made the mistake because they are fearful of embarrassing the student by asking them to talk about it. For other PSTs, limitations in their content knowledge for teaching might impede being able to identify important mathematical ideas related to the process. Still other PSTs might not have been able to formulate a question that could be used to elicit evidence of the student's understanding.

The data suggest several directions for continuing research. First, these PSTs were in their first week of a teacher education program. In what ways do their skills with eliciting student thinking develop over time? Second, what course activities might effectively cultivate an inclination to elicit how and why students make mistakes? Third, the assessment itself involved a mistake where the student was using a “non-standard” approach to solve the problem. Anecdotally, we have reason to think that some PSTs were discounting the student's reasoning because they believed that the student should be using a different method to solve the subtraction problem. A future study could compare skills in eliciting around a mistake with a “standard” and an “alternative” algorithm.

Acknowledgment

The research reported here was supported by the National Science Foundation under Award No. 1535389. Any opinions, findings, and recommendations expressed are those of the authors and do not reflect the views of the National Science Foundation.

References

- Ball, D. L., & Forzani, F. M. (2009). The work of teaching and the challenge for teacher education. *Journal of Teacher Education*, 60(5), 497–511.
- Ball, D. L., Sleep, L., Boerst, T., & Bass, H. (2009). Combining the development of practice and the practice of development in teacher education. *Elementary School Journal*, 109(5), 458–474.
- Borasi, R. (1994). Capitalizing on errors as “springboards for inquiry”: A teaching experiment. *Journal for Research in Mathematics Education*, 25(2), 166–208.
- Bransford, J. D., Brown, A., & Cocking, R. R. (Eds.). (2000). *How people learn: Brain, mind, experience, and school*. Washington, DC: National Academy Press.

- Bray, W. S. (2011). A collective case study of the influence of teachers' beliefs and the knowledge on error-handling practice during class discussion of mathematics. *Journal for Research in Mathematics Education*, 42(1), 2–38.
- Grossman, P., Hammerness, K., & McDonald, M. (2009). Redefining teaching, reimagining teacher education. *Teachers and Teaching*, 15(2), 273–289.
- Hiebert, J., Carpenter, T. A., Fennema, E., Fuson, K. A., Wearne, D., Murray, H., Olivier, A., & Human, P. (1997). *Making sense: Teaching and learning mathematics with understanding*. Portsmouth, NH: Heinemann.
- Jacobs, V. R., Lamb, L. L., & Philipp, R. A. (2010). Professional noticing of children's mathematical thinking. *Journal for Research in Mathematics Education*, 41(2), 169–202.
- Kazemi, E., & Stipek, D. (2001). Promoting conceptual thinking in four upper-elementary mathematics classrooms. *The Elementary School Journal*, 102(1), 59–80.
- McDonald, M., Kazemi, E., & Kavanagh, S. S. (2013). Core practices and pedagogies of teacher education: A call for a common language and collective activity. *Journal of Teacher Education*, 64(5), 378–386.
- Radatz, H. (1980). Students' errors in the mathematical learning process: A survey. *For the Learning of Mathematics*, 1(1), 16–20.
- Santagata, R. (2005). Practices and beliefs in mistake-handling activities: A video study of Italian and U.S. mathematics lessons. *Teaching and Teacher Education*, 21(5), 491–508.
- Self, E. (2016). *Designing and using clinical simulations to prepare teachers for culturally responsive teaching*. Unpublished doctoral dissertation. Vanderbilt University: Nashville, TN.
- Silver, E. A., Ghouseini, H., Gosen, D., Charalambous, C., & Strawhun, B. T. F. (2005). Moving from rhetoric to praxis: Issues faced by teachers in having students consider multiple solutions for problems in the mathematics classroom. *Journal of Mathematical Behavior*, 24(3–4), 287–301.
- Shaughnessy, M., & Boerst, T. (2018a). Appraising the skills that preservice teachers bring to teacher education: Skill with the practice of eliciting a student's thinking. *Journal of Teacher Education*, 69(1), 40–55.
- Shaughnessy, M., & Boerst, T. (2018b). Designing simulations to learn about preservice teachers' capabilities with eliciting and interpreting student thinking. In G. J. Stylianides & K. Hino (Eds.), *Research advances in the mathematical education of pre-service elementary teachers: An international perspective* (pp. 125–140). Springer.
- Shaughnessy, M., Boerst, T., & Farmer, S. O. (2018). Complementary assessments of preservice teachers' skill with eliciting student thinking. *Journal of Mathematics Teacher Education*. <https://doi.org/10.1007/s10857-018-9402-x>.
- TeachingWorks. (2011). High leverage teaching practices. Retrieved February 25, 2018, from <http://www.teachingworks.org/work-of-teaching/high-leverage-practices>.

Beliefs and expectations at the beginning of the bachelor teacher training program in mathematics

Evelyn Süss-Stepancik¹ and Stefan Götz²

¹University College of Teacher Education, Lower Austria, Austria; evelyn.stepancik@ph-noe.ac.at

²University of Vienna, Austria; stefan.goetz@univie.ac.at

Keywords: Beliefs, expectation, student teachers, mathematical training, factor analysis.

Introduction

Since 2016/17, a new bachelor teacher training program has been implemented in a cluster of four tertiary education institutions in the North East of Austria to provide a common secondary level teacher training program. The education of future maths teachers in mathematics as a science is separated from the program for other maths students. The first compulsory lecture for future maths teachers is an introduction to university mathematics. It offers mathematical terminology, parts of the mathematical toolbox and methods of proving. Thus the students' beliefs, which are already developed due to their school experience, are faced with mathematics at university level.

Contextualising our study in the field of belief research

In the field of mathematical belief research, the pivotal work of Grigutsch, Raatz, and Törner (1998) is well known. It deals with maths teachers' beliefs and shows that the beliefs of mathematics teachers represent four main dimensions: scheme, formalism, process and application. Rach, Heinze, and Ufer (2014) also follow that conception, but they focus on specific expectations of students in terms of relevant learning opportunities. They found that students' expectations are mostly realistic and have a small influence on the students' success. In our approach, we incorporate both the beliefs and expectations of future math teachers. We define the following research questions:

1. Which beliefs and expectations do student teachers hold at the beginning of their maths study?
2. Which significant changes can be observed between the beginning and the end of the first term?

The inquiry instrument and a description of the setting

We developed a questionnaire similar to Grigutsch et al. (1998) and "Mathematics teaching in the 21st Century (MT21)" (Schmidt, 2006, Part C). It is divided into two parts: the first 41 statements deal with the personal view of mathematics; the second part consists of 19 statements to investigate subjective expectations. In both sections, different four-point Likert scales are used to measure the level of agreement with the given statements. The first one spans from *strongly agree* (1) to *strongly disagree* (4), the second one from *fully* (1) to *not at all* (4). An example of the first part is: *If one doesn't know the correct procedure to solve mathematical tasks, then one is lost.* And from the second part: *My mathematical education qualifies me to learn prospective and unknown content of the subject curricula on my own.* We surveyed students before and after attending their first mathematical course in 2017/18 (winter term) using the same questionnaire. 374 students participated in the pretest, 186 in the posttest. The paired sample has a size of 150 participants.

Evaluation process

An exploratory *factor analysis* was carried out to get an insight into the beliefs of the young student teachers. The data from the paired sample were tested by the *Wilcoxon test* for significant differences (caused by the attended lecture) between the data of the pretest and posttest. Finally, *frequency distributions* were generated for each factor regarding the pre- and the posttest in order to explain the detected differences. Data analyses were conducted using SPSS.

Results

From three relevant factors, two should be mentioned here. The first one contains 16 items (Cronbach alpha 0.869, explained variance 11.990 %). This factor contains items like: *My mathematical education empowers me to follow mathematical in-service trainings*. It can be interpreted as, “Autonomy concerning the subject teaching design”. This shows that future maths teachers have specific expectations concerning their mathematical training at the beginning of their study. It seems that the conviction of becoming experts in mathematics made a considerable shift ($p = 0.027$): from *fully expect* (69.51 % to 55.67 %) to *expect partially* (29.27 % to 41.24 %). Although the relative frequency of *hardly expect* is small, it increases by a factor of more than 2.5.

The other factor refers to mathematics without practical utility (two items, Cronbach alpha 0.817, explained variance 3.697 %). One statement with negative loading is given for illustration of this belief: *Many aspects of mathematics have practical relevance*.

Discussion

Regarding the first factor, the results indicate that the first maths lecture, “Introduction to mathematics”, cannot fully answer the students’ expectations. The originally strongly anticipated expectations of getting more mathematical autonomy had decreased. In the light of Shulman’s (1987) conceptualisation of content knowledge, the described changes are hardly conducive.

References

- Grigutsch, S., Raatz, U., & Törner, G. (1998). Einstellungen gegenüber Mathematik bei Mathematiklehrern. [Attitudes of mathematics teachers towards mathematics.] *Journal for Didactics of Mathematics*, 19(1), 3–45.
- Rach, S., Heinze, A., & Ufer, S. (2014). Welche mathematischen Anforderungen erwarten Studierende im ersten Semester des Mathematikstudiums? [Which mathematical demands do students expect in the first semester of their study?] *Journal for Didactics of Mathematics*, 35(2), 205–228. doi: <https://doi-org.uaccess.univie.ac.at/10.1007/s13138-014-0064-7>
- Schmidt, W. (2006). *Mathematics teaching in the 21st century*. Ann Arbor, MI: Inter-university Consortium for Political and Social Research [distributor]. Retrieved from <https://doi.org/10.3886/ICPSR34430.v1>
- Shulman, L. (1987). Knowledge and teaching: Foundations of the new reform. *Harvard Educational Review*, 57(1), 1–23.
- URL for the digital poster: www.lernzukunft.at/beliefs_expectations_math_cermell1.pdf

Preservice teachers' geometrical discourses when leading classroom discussions about defining and classifying quadrilaterals

Gry Anette Tuset

Western Norway University of Applied Sciences, Norway; gry.tuset@hvl.no

In this paper I use Sfard's commognitive framework to investigate four geometrical discourses, as they appeared when preservice teachers (PSTs) were leading classroom discussions about defining and classifying quadrilaterals in authentic lower secondary school classrooms. Their tryouts are part of a broader learning teaching project in a practice-based teacher education course in Norway. The focus is on mathematical problems PSTs address in learning-teaching situations, with students and geometrical discourses, in their efforts to promote hierarchical relations between quadrilaterals using pre-constructed dynamic figures in Geogebra. The analysis shows that PSTs create opportunities to talk about hierarchical relations. However, they struggle to move between static and dynamic ways of talking about geometrical objects when needed and it seems challenging to build appropriately on students' prototypical and partitional contributions.

Keywords: Commognitive framework, Defining and classifying quadrilaterals, Preservice teachers

Introduction

The most challenging work preservice teachers (PSTs) face in enacting current reforms is to orchestrate classroom discussions that use students' responses in such ways that they advance the mathematical learning of the whole class (Lampert, Beasley, Ghouseini, Kazemi, & Franke, 2010). The PST is expected to execute skilled ways to support and challenge students when they are presenting their ideas, and build upon them by contrasting, comparing and connecting their ideas to accepted disciplinary ideas (Stein, Engle, Smith, & Hughes, 2008). For students, age 13-15, it could mean helping them move from using visual recognition or informal properties check when identifying and comparing geometrical shapes, to using definitions and state logical arguments to justify claims about these shapes (Sfard, 2008; Moss & Sinclair, 2012).

Defining and classifying quadrilaterals contribute to the development of geometrical thinking and mathematical argumentation and proof (Fujita & Jones, 2007). Research reports, however, that PSTs and students find it difficult to understand and accept hierarchical relations of geometrical shapes (e.g., Fujita & Jones, 2007; Millsaps, 2013). A significant reason is their reliance on prototypical images. Hershkowitz (1990) describes prototype examples as the subset of examples that have all the necessary properties and, in addition, other specific (none-necessary) properties that have strong visual characteristics. Prototype images often lead to what de Villiers (1994) calls partitional definitions, which exclude, for instance, rectangles from being parallelograms. In mathematics, hierarchical definitions, which includes rectangles as parallelograms, are preferred because they are more economical and useful. Consequently, defining and classifying quadrilaterals are highly interrelated activities (de Villiers, 1994).

Leading classrooms discussions is a complex and situated activity (Stein et al., 2008). One way of looking at this complexity is to see teaching as an activity of problem solving and problem posing (Lampert et al., 2010). These problems arise in establishing and maintaining relationships between the teacher, students and the mathematics because of the constraints and possibilities the

participants generate during instruction (Lampert et al., 2010). For instance, the way the teacher creates and exploits opportunities for mathematics learning can constrain or promote the kind of mathematics students can engage in (Sfard, 2017). Similarly, students and the mathematics can both constrain and open up what the teacher can do to teach. To solve these problems of practice, the teacher needs to deal with a wide range of issues across social, temporal, and intellectual domains. This paper focus on mathematical problems PSTs address in situations, with students and mathematics, in their efforts to promote hierarchical relations between quadrilaterals using shape makers (i.e. pre-constructed dynamic figures in Geogebra). For this purpose, I use Sfard's (2008) commognitive approach to examine the geometrical discourses that developed in four whole-classroom discussions led by PSTs in authentic classrooms. The framework enables me to make claims about PSTs' geometrical discourses in terms of how they communicate when teaching (Sfard, 2017). In the following, I will first briefly outline key concepts from the commognitive framework related to characteristics of geometrical discourses. Then I will introduce the context of the study and illustrate identified mathematical problems with excerpts from the discussions.

Theoretical background

The movement towards a geometrical discourse that includes hierarchical definitions are, by Sfard (2008, p. 256) called meta-level development, because the rules that governs the participation change and words are used differently than colloquial discourses. Taking a participationist view, these changes must be mediated by an experienced participant in the desired discourse (Sfard, 2008, p. 254). I therefore argue, as Sfard (2017, p. 55), that being able to capture mathematical problems PSTs address in their attempts it is necessary to go into the finest details of the geometrical discourse offered. From a commognitive perspective (Sfard, 2008, p. 93), this means the use of *words* (e.g., parallelograms) and *visual mediators* (e.g., shape makers created for the sake of communication) to surface how geometrical objects are perceived and the construction and substantiation of *geometrical narratives* (stories about geometrical objects) to characterize the *routines* (e.g., how to identify shapes) employed in the classroom.

Sfard (2008, p. 228) describes orders of geometrical discourses, where each subsequent discourse is a meta-discourse of the former and geometrical objects typically arise as a result of *saming* lower order objects. Drawing on Sfard's work, Sinclair and Moss (2012, p. 31) present three orders of geometrical discourses relevant for school. In first and second discourse, identification routines rely on a continuous transformation of a figure into a prototype and some informal properties check of necessary and specific properties. The words are mainly used as proper names of concrete objects or as family names of exclusive classes of concrete objects. In the third geometrical discourse, transformability is no longer the official identification routine. Here, recognition needs to be followed by a discursively mediated procedure, such as, checking if the conditions described in a definition holds or not. The set of properties listed in a definition are seen as necessary and sufficient conditions for determining membership in a category. This means that the new routine opens up for the possibility to call a figure by several names (Sinclair & Moss, 2012).

Studies (e.g., Millsaps, 2013; Sinclair & Moss, 2012) report that dynamic environments are helpful to move towards more sophisticated geometrical discourses. It is especially the actual witness of

continuous transformations of shapes when dragging a figure that is promising because students flex their prototypical range of shapes they are ready to call the *same* (Sinclair & Moss, 2012). However, according to Sinclair and Yurita (2008), the transitions between dynamic and static media are challenging, because the transitions influence the talk about geometrical objects. For instance, in dynamic geometry, identification routines become time-dependent and human-based operations that invite students to act on the figure. In addition, Millsaps (2013) found that PSTs struggle to move between the two discourses when they explore shape makers that embody hierarchical definitions.

Methods

The PSTs in this study are undertaking a one-year mathematics course as part of a four-year Norwegian teacher education program for lower secondary school teachers. They were provided opportunities to move back and forth between campus and practicum to collaboratively prepare for, enact and reflect on their teaching. In their preparation, the PSTs investigated seven shape makers. See Figure 1. Each maker generates a category of shapes with all necessary properties of specific quadrilaterals. The PST rehearsed discussions about these makers where they all acted, in turns, as teachers and students. Afterwards, four practicum groups planned a lesson using Stein et al.'s (2008) framework to prepare for classroom discussions in authentic classrooms. One PST taught the lesson. Others video recorded the activity.

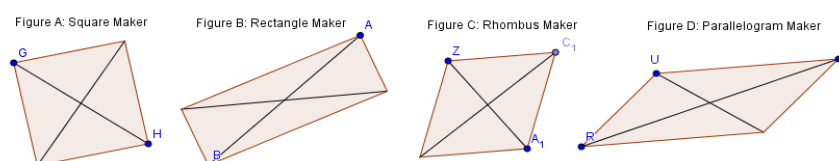


Figure 1: Four of the seven Shape Makers of specific quadrilaterals

The videos and transcripts of the enactments and the rehearsals are data in this paper, as well as PSTs' portfolios about the tryouts. The focus is the geometrical discourses that surfaced in four classroom discussions with students. In addition, the rehearsals and the portfolios provide a window to PSTs' geometrical discourses before and after the enactments in the classroom.

The transcriptions of the classroom discussions were first organized into mathematical episodes that encompass the whole discussion around a claim about the shape makers. 55 episodes were identified and categorized in three groups; 1) 17 episodes about necessary and specific properties; 2) 18 episodes about the naming process; 3) 10 episodes addressed hierarchical relations. Since classification is closely related to definitions (de Villiers, 1994), I analyzed all episodes focusing on the use of words and routines related to orders of geometrical discourses (Sinclair & Moss, 2012). I looked especially for instances in the talk that seemed to constrain or promote the geometrical discourse in order to capture mathematical problems the PSTs address in these complex settings.

Findings and analysis

The analysis shows that the four PSTs, called by pseudonyms Andy, Fay, Joy and Lisa, manage to create opportunities to talk about hierarchical relations in their discussions. However, PSTs struggle to address the problems that arise in the learning-teaching situations.

The problem of moving between dynamic and static ways of talking about geometrical objects

This problem arises in almost all of the hierarchical episodes, which resonates with what Sinclair and Yurita (2008) and Millsaps (2013) report in their studies. For instance, in Lisa's, Joy's and Fay's first hierarchical episode they ask students if the diagonal angles are perpendicular in Figure B (the rectangle maker). The students answer "no." In contrast to squares, perpendicular diagonals is a specific property in rectangles. The PSTs exploit the opportunity offered and similar problems arise. However, they address them differently as illustrated by excerpts from Joy's and Lisa's discussion.

In Joy's discussion, another student disagrees and says; "yes, you can make the diagonals perpendicular. If you make it into a square. Just take it in"[19]. The student uses the terms "make it" and "take it in" to describe the dynamic movement involved in dragging the rectangle maker until it looks like a square. Joy acknowledges the suggestion and demonstrates the transformation-based routine on the smartboard.

Joy: Then it is not a rectangle anymore, it is a square. But a square is also the same as a rectangle. (3s) It can be a rectangle, but a rectangle cannot be a square. (2s). [20]

Joy reinforces the dynamic, exclusive way of talking about a rectangle becoming another shape, a square, in the first sentence (Millsaps, 2013). Then she contradicts this statement using an inclusive way of talking. Finally, she concludes with a dynamic and incorrect way of talking about the asymmetric relation between a square and rectangle. In the rehearsals, Joy's group addressed the same problem using the words "can be" and "cannot be" to express these asymmetric relations as well. In contrast, they used "can be" appropriately ("A rectangle can be a square, but a square cannot be a rectangle"). This shows that Joy struggles to articulate hierarchical relations when she moves between dynamic and static ways of talking about figures. Joy does not address these contradictory statements and she avoids hierarchical episodes in the rest of the discussion.

Lisa was in the same rehearsal group as Joy. In her discussion with students, she manages to use the term "can be" appropriately when she explains why diagonals "can be" made perpendicular in Figure B. She states the following inclusive narrative: "This is because a rectangle also can be a square"[43]. However, Lisa does not address the opposite asymmetric relationship, as Joy did. Nor does she verify the claim by using the hierarchical definitions she introduced to the students in the beginning of the lesson. In the other hierarchical episodes, Lisa repeats the same narrative, replacing "rectangle" with "rhombus" and "parallelogram." To conclude, the way the PSTs' address the problem of moving between dynamic and static ways of talking about geometrical objects seems to constrain the kind of mathematics students can engage in during the discussions.

The problem of building on students' prototypical and partitional contributions

In Fay's and Andy's discussions, another problem surfaced. Namely, the problem of building on students' prototypical and partitional contributions. I use excerpts from Fay's talk about parallelograms (Figure D) to illustrate how students' contributions and the mathematical discourse seem to constrain and open up what PSTs can choose of possible solutions during the discussion.

Diagonals “can be” perpendicular: Fay’s first hierarchical episode surfaced in the discussion about perpendicular diagonals being a specific property in rectangles. Fay drags the rectangle maker to show that it is possible to make the diagonals perpendicular. When Fay asks if it can be named anything else than rectangles [50], a student suggests that it can “if we take it in”[51]. Fay reinforces the dynamic, exclusive way of talking about shapes when she uses the terms “become” and “could it” in her following questions; “what had it become then?”[52] and “could it be a square?”[54]. A student confirms and Fay concludes by saying “But, then the sides are of equal length, right?”[58].

Diagonals “are not” of equal length: After the discussion about squares and rectangles, Fay asks a student about the diagonals in Figure D (the parallelogram maker). “Are they not of equal length?”[61], a student replies. Fay asks if “they look equal?”[62]. The student revises his answer (“no, no, just kidding”[63]). Fay replies “OK” and concludes with a prototypical claim that diagonals “are not equal”[64]. Equal and perpendicular diagonals are specific properties to parallelograms and necessary properties to rectangles and rhombs, respectively. There are therefore many possible solutions and Fay has to make a decision which one to pursue. In this situation, Fay does not use dragging to explore these “can be” possibilities as she did in the discussion about rectangles “becoming” a square. She chooses to follow the path of “not equal diagonals.”

Figure D is a parallelogram because it is “slanted:” Fay reinforces the idea that Figure D is different from Figure A and B because the lengths of the diagonals are not equal (“OK, but we have just had two shapes where they (*diagonals*) were equal, so this must be something else then?”[66]). A student suggests that it is a parallelogram [69]. Fay prompts for an explanation why.

- 77 Student: No, eh well. It is slanted.
- 78 Fay: It is slanted. (2s) What do you think? Do you think it has something to do with the angles maybe? (*Points at figure D shown on the smartboard*)
- 79 Student: Yes
- 80 Fay: Yes. In a parallelogram. Will this be 90 degrees? (*Points at an angle*)
- 81 Student: Heh?
- 82 Fay: Will this be 90 degrees? (*Points at another angle*)
- 83 Student: No
- 84 Fay: No. Will this be? (*Discovers that she can use her finger to drag the figure*)
- 85 Student: You can pull it together.
- 86 Fay: Yes. If I do this? (*She drags and figure D looks like a slanted rhombus.*)
- 87 Student: No

In this situation, the student contributes with a prototypical and partitional claim about parallelograms (Hershkowitz, 1990). Fay repeats the student’s narrative and draws attention towards the angles in the vertices [78]. The phrasing of the questions has changed from the dynamic “could this be” to a static “will this be” 90 degrees. However, the student’s suggestion in [85] provides Fay with an opportunity to search for counter examples where the angles “can be” 90 degrees and therefore flex the student’s prototypical claim (Sinclair & Moss, 2012). She follows the student’s suggestion but drags the figure so that the diagonals become perpendicular, not the

vertices [86]. The potential opportunity provided by the student therefore becomes a confirming example, which is not sufficient to substantiate that the vertices “will not be” 90 degrees nor to convince the student that not all parallelograms are slanted. Fay does not address this problem in the discussion, but uses the dragging experience to verify that figure D cannot be a square, at least [93].

In parallelograms, the diagonals are not equal, the vertices are not 90 degrees, and the diagonals are not perpendicular: Fay drags the parallelogram maker back to a prototypical parallelogram.

- 95 Fay: Okay, we say that the diagonals are not of equal length, and the vertices are not 90 degrees. Are these 90 degrees? The angles inside here? (*Points at the diagonal angles*).
- 96 Student: No
- 97 Fay: Not 90 degrees? Yes, maybe this is a recipe for a parallelogram?(2s) Maybe.
- 98 Student: Maybe
- 99 Fay: Yes, because this is the only one we have seen until now that have different lengths on the diagonals. (*Points to the diagonals*)

During the discussion, Fay has shifted from talking about necessary properties used as conditions for determining membership in a category of specific quadrilaterals, such as squares and rectangles, to talking about conditions that exclude membership in a category of parallelograms. Fays advocates a “recipe”[97] where excluding conditions, such as “diagonals are not equal” and “vertices are not 90 degrees,” are sufficient conditions for naming a figure a parallelogram, because parallelograms “is the only one” they have seen that have different length of diagonals [99]. Furthermore, she claims that diagonal angles are not 90 degrees in parallelograms, despite the fact that she recently presented a counter example (the slanted rhombus). Thus, the dynamic perspective is absent when Fay talks about the properties of parallelograms, which I believe happened when she decided to follow the path of “not equal diagonals”[64] instead of the dynamic “can be” talk she promoted earlier. The other critical learning-teaching situation was when Fay decided to build on the prototypical claim about parallelograms being slanted [77]. I have tried to show how these decisions changed the inclusive talk that started in the first hierarchical episode where rectangles could become squares, and ended as a static and exclusive talk where rectangles and squares are excluded as parallelograms. These problems, I believe, affected the conflicting geometrical discourses that surfaced in the final hierarchical episode in Fay’s discussion.

Parallelograms cannot be a rectangle, but a rectangle is a parallelogram: In her final hierarchical episode, Fay recalls a peer PST’s teaching some weeks ago to sum up and end the discussion.

- 109 Fay: He talked about a rectangle that could be a parallelogram and the opposite. (.) Or, can parallelograms be a rectangle? (7s) Can it? (2s) Can this be a rectangle? (3s) (*Points at the parallelogram maker*) If I say to make this a rectangle, it must be 90 degrees at the angles here. (*Points at the vertices*) Can it?
- 110 Students: No
- 111 Fay: No, but can this (*Points at the rectangle maker*) be a parallelogram?
- 112 Student: Yes
- 113 Fay: Yes. Why?

- 114 Students: Because the opposite sides are parallel.
- 115 Fay: Yes, they are parallel and they are parallel. Right, this and this. (*Points to the pair sides in the rectangle*) They just go upwards and will never intersect each other. Yes. (2s) Figure B, it is in fact a parallelogram as well, but it can also be a rectangle.

In this episode, Fay asks students to compare rectangles and parallelograms. First, she asks if parallelograms can be a rectangle [109]. She waits for 7 seconds and there is no response. Fay simplifies the question by drawing attention to the vertices in the slanted parallelogram in Figure D and recalling that in rectangles they must be 90 degrees [109]. Several students reply no, which is correct according to visual recognition and the offered partitional definition that excludes rectangles from being parallelograms. Then Fay prompts for the opposite relation between rectangles and parallelograms asking if a rectangle “can be” a parallelogram [111]. The student claims yes, and she uses the lengths of the opposite sides as a necessary and sufficient property to determine membership in parallelograms [114]. The student uses the definition of parallelograms that most students in lower secondary school know. Fay acknowledges the contribution and she demonstrates what sides are parallel [115]. Fay ends up with two conflicting narratives, which are both endorsed using “accepted” definitions of parallelograms by the class community. The first uses the vertices not being 90 degrees to exclude rectangles from being parallelograms [109]. The second uses the opposite parallel sides to include rectangles as parallelograms [115]. Both suggestions are based on student’s contributions and Fay’s attempt to build on them. Fay does not identify the problem, which resonates with Millsaps’ (2013, p. 38) study that reports on PSTs being capable of holding two conflicting claims about hierarchical relations when they are moving between dynamic and static geometry.

Concluding remarks

Several studies have used interviews or questionnaires to examine PSTs’ hierarchical reasoning and they report that PSTs struggle even though they have taken geometry courses as part of their teacher education program (e.g., Fujiti & Jones, 2007; Millsaps, 2013). It is therefore no surprise that PSTs in this study meet similar challenges when they are trying to lead classroom discussions about defining and classifying quadrilaterals in authentic classrooms with students. However, what challenges and how they tackle them in this setting has not been sufficiently investigated.

The analysis show that the PSTs are in their early process of individualizing hierarchical relations between quadrilaterals. They manage to create opportunities for students to engage in hierarchical relations. However, none of the PSTs use hierarchical definitions in their reasoning about the shapes. This resonates with Fujita and Jones (2007) reporting that PSTs prefer to rely on specific examples when identifying shapes, even though they know definitions. When PSTs need to step in and out of dynamic and static discourses, they struggle to connect and articulate hierarchical relations as illustrated in Lisa’s and Joy’s discussions. Millsaps (2013, p. 38) reports on similar challenges where experiences with shape makers actually can reinforce some aspects of existing partitional definitions. She therefore highlights discussions about the use of classification narratives to support the transformation from partitional to hierarchical definitions (Millsaps, 2013, p. 40). Trying to interpret and build on incomplete contributions from students is challenging for PSTs

(Lampert et al., 2010). I believe Fay's discussion illustrates how difficult it is for PSTs to balance between honoring students' participation and promoting mathematical discourse in classrooms. Especially when the discussion requires a sensitivity to step in and out of geometrical discourses when needed and provide opportunities for students to engage meta-level development (Sfard, 2008).

References

- de Villiers, M. (1994). The role and function of hierarchical classification of quadrilaterals. *For the Learning of Mathematics*, 14(1), 11–18.
- Fujita, T. & Jones, K. (2007). Learners' understanding of the definitions and hierarchical classification of quadrilaterals: Towards a theoretical framing. *Research in Mathematics Education*, 9(1), 3–20.
- Hershkowitz, R. (1990). Psychological aspects of learning geometry. In P. Nesher, & J. Kilpatrick (Eds.), *Mathematics and Cognition* (pp. 70–95). Cambridge, UK: Cambridge University Press.
- Lampert, M., Beasley, H., Ghouseini, H., Kazemi, E., & Franke, M. (2010). Using designed instructional activities to enable novices to manage ambitious mathematics teaching. In M. K. Stein & L. Kucan (Eds.), *Instructional explanations in the disciplines* (pp. 129–141). New York, NY: Springer.
- Sfard, A. (2008). *Thinking as communicating: Human development, the growth of discourses, and mathematizing*. New York, NY: Cambridge University Press.
- Millsaps, G. (2013). Challenging preservice elementary teachers' Image of Rectangles. *Mathematics Teacher Educator*, 2(1), 27–41.
- Sfard, A. (2017). Ritual for ritual, exploration for exploration: Or, what learners are offered is what you get from them in return. In J. Adler & A. Sfard (Eds.), *Research for educational change: Transforming researchers' insights into improvement in mathematics teaching and learning* (pp. 41–63). New York, NY: Routledge.
- Sinclair, N., & Yurita, V. (2008). To be or to become: How dynamic geometry changes discourse. *Research in Mathematics Education*, 10(2), 135–150.
- Sinclair, N., & Moss, J. (2012). The more it changes, the more it becomes the same: The development of the routine of shape identification in dynamic geometry environment. *International Journal of Educational Research*, 51–52, 28–44.
- Stein, M. K., Engle, R. A., Smith, M. S., & Hughes, E. K. (2008). Orchestrating productive mathematical discussions: Five practices for helping teachers move beyond show and tell. *Mathematical Thinking and Learning*, 10(4), 313–340.

Developing professional development programmes with gamification for mathematics teachers in Uruguay

Fabián Vitabar, Zsolt Lavicza and Markus Hohenwarter

Johannes Kepler University, Linz, Austria;

fvitabar@gmail.com; zsolt.lavicza@jku.at; markus.hohenwarter@jku.at

Uruguay is a country with an extensive government policy providing all teachers and students laptops and connectivity. In order to carry out new professional development programmes for teachers of mathematics to use digital technologies in classrooms, we developed a qualitative study, collected data, and analysed teachers' concerns and needs for classroom-based technology use, identifying a set of guidelines to assist teachers. The programme was designed to offer teachers key experiences that can help them to achieve their didactical goals. As traditional courses and assessment did not address the detected needs, game components were incorporated into the teacher training programme. Gamification contributed to the solution of several problems such as formal assessment, certification, passing grades, adaptive content and self-evaluation. This paper reports and links two studies about identifying teachers' needs and the impact of a gamified professional development programme developed in Uruguay.

Keywords: Teacher education, professional development, gamification, technology uses in education.

Introduction

Uruguayan schools were transformed in the past decade, because of the utilisation of digital technologies for educational purposes. *Plan Ceibal*, a government policy that has provided a laptop to each student and teacher in public schools for more than a decade now, as well as connectivity all over the country, significantly changed classrooms in Uruguay (Plan Ceibal, 2017).

The new presence of digital technologies was challenging for teachers, who had to face these changes on their own, or supported by special, but often ineffective, professional development programmes. Such transition for teachers was not easy, especially because of some characteristics of Uruguayan teachers of mathematics: most of them have multiple jobs (60% teach in at least two schools), there is an important deficiency in their training (only 1 out of 3 of those who are teaching mathematics at middle schools finished their basic teacher's training) and they do not have enough time for attending professional development activities (paid hours are only for teaching) (INEEd, 2017; González, González, & Macari, 2013).

Consequently, professional development was required by teachers and strongly encouraged by authorities and supervisors. Nevertheless, as Assude, Buteau, and Forgasz (2010) state and our research confirmed, these activities did not significantly impact teachers' everyday lessons. The problems of identifying professional development programmes' long-term impact and promoting their sustainability have been analysed in several contexts (Loucks-Horsley, Stiles, & Hewson, 1996; Zehetmeier & Krainer, 2011; Zehetmeier, 2017).

Teachers and their supervisors agree about the minimal impact of existent professional development programmes on technology transition. Thus, we carried out a first qualitative study to identify the key

aspects that should be addressed in these programmes to assist mathematics teachers to utilise didactical advantages of digital technologies on a regular basis.

This paper summarizes results of the first phase of this study and reports on subsequent research: after designing and implementing a professional development programme according to the key aspects we found, we analysed its impact based on teachers' perceptions. The unexpected appearance of gamification elements when designing the programme resulted in an interesting and challenging contribution.

How to assist teachers of mathematics to improve their technology-based lessons?

The first part of this study suggested two key aspects of professional development, as follows.

Research design and methods

The major research question of this phase was: What key aspects should be addressed in a professional development programme for mathematics teachers in Uruguay to assist them to utilise didactical advantages of digital technologies on a regular basis?

Experts who were interviewed suggested that this question had been discussed by national supervisors and trainers, but they provided unclear answers. We wanted to investigate teachers' concerns and difficulties, but letting other relevant key elements emerge as well. Thus, we decided to design a qualitative study based on a Grounded Theory approach (Glaser, & Strauss, 2009). Experts, teachers and their supervisors participated in (13) semi-structured interviews. Participants were asked about their and trainees' concerns; the obstacles teachers encounter while trying to use technologies in their classrooms; and also about their personal experiences of learning/teaching with technologies.

Data were processed using TAMS Analyzer (Weinstein, 2015), identifying emerging concepts through coding and recoding the interview transcriptions. This process let us also detect topics participants addressed spontaneously, which were not directly asked by the researchers. We can assume that if certain subjects show up regularly, even with no explicit questions, they might be closely related with our study aims (Cohen, Manion, & Morrison, 2015).

In order to offer more comprehensive answers to the research question, scientific literature was reviewed and integrated (e.g., Assude, Buteau, & Forgasz, 2010; Fullan, 2016; Loucks-Horsley, Stiles, & Hewson, 1996; Zehetmeier & Krainer, 2011).

Findings, first set: Obstacles and concerns

Interviewees were asked about the obstacles teachers encounter while they try to use digital technologies in their teaching. We detected four main obstacles: (a) a lack of *resources*: teachers say that devices do not work as expected, there are technical issues, connectivity fails, and it is not true that every student has a functioning computer because they are often broken; (b) a lack of *time*: teachers point out that it is very difficult to plan different lessons, as they do not have enough time to do so; (c) a lack of *feedback*: teachers say that they need to be encouraged by principals and supervisors to change their ways of teaching, otherwise they feel that they might not be working as they should; and (d) a lack of *confidence*: teachers are taken out of their comfort zones, so they might need assistance and encouragement to believe in their own teaching skills in technology-assisted environments.

We also investigated teachers' interests and concerns regarding training topics. The data showed that teachers' concerns evolve gradually. Inexperienced and untrained teachers usually belong to the first step, and experienced trainers are placed in the top one (Figure 1). Each teacher recognizes other steps; nevertheless, they point out that the most concerning one is their own. Those who are at the top of the stairs declare that they have been in the previous stages before, but thanks to experience and training their concerns evolved. Steps are represented in Figure 1 and explained below.



Figure 1: Teachers' concerns

Usage: teachers think that they need to be skillful at using software to be able to use it in their classrooms.

Potential: teachers understand that knowing what is possible to do with computers is more important than knowing how to do it.

Pedagogy: teachers are concerned with how technologies could help students to understand mathematical concepts.

Adoption: using technologies in classrooms on a regular basis is even more important, because otherwise learning is not as meaningful as it could be.

Benefit: teachers are focused on students and their learning outcomes, and they think that if everything else does not help you achieving the main goal then that is not important.

Teachers usually recognize the steps that they already went through, but they do not clearly visualize themselves in the higher stages. According to supervisors and experts, teachers should be assisted to be raised to higher steps as quickly as possible, because that means important improvement in their skills.

These findings are also consistent with previous research in the same topic (Biehler & Nieszporek, 2017; Liu & Huang, 2005; Loucks & Hall, 1979).

Findings, second set: Collaboration and leadership

One of the unexpected results of this phase was the importance of collaboration among teachers. Even when teachers were not asked about it, they expressed that being part of a team and being able to discuss pedagogies was a condition to improve their skills and learn how to use technologies in their lessons. Every interview suggests that it is not possible to evolve without teamwork.

Schools' leadership style also arose unexpectedly as a key aspect. Flexible rules, less bureaucracy and principals' good will are necessary conditions for teachers to improve their technology-assisted teaching skills.

Findings, third set: Innovation and motivation

In addition to the findings from the gathered data, we should also pay attention to the scientific literature on pedagogical innovations. Teachers adopting technologies on a regular basis arose as an important educational change in several aspects (Berman, 1981; Fullan, 2016). In order to assist teachers in this process, the complexity of every innovation should be carefully monitored.

Using multiple resources to keep and raise teachers' motivation at a high level is also essential, because the Uruguayan educational system does not offer them significant rewards for attending professional development programmes.

Preliminary conclusion: A set of guidelines, a set of experiences

We can summarise the previous findings in the following set of guidelines, which describe the key aspects of a professional development programme that should facilitate teachers' development with technology:

(1) Assist teachers to face the typical obstacles by teaching them particular solution strategies; (2) offer them various topics during courses according to each step of concerns (Figure 1) and try to guide them to be raised to the subsequent step, this should be done individually considering teachers' specific needs; (3) encourage them to collaborate, we discovered that it is a crucial aspect for their development; (4) guarantee schools' support to teachers (principal and supervisors should agree with the courses, computers must be available, etc.); (5) remember that the patterns of every innovation apply; and (6) keep motivation level as high as possible through various strategies (discussed in previous papers in detail).

It is important to point out that, according to interviewees, teachers' learning is associated with certain vital experiences in their teaching careers, but maybe not to traditional courses. If a traditional course makes a change in participants, it means the course promotes these key experiences (i.e., it includes collaborative planning, observing lessons, being observed, discussing pedagogies and results, etc.). As Loucks-Horsley, Stiles, & Hewson (1996) state, it is necessary to provide teachers with opportunities to develop knowledge and skills, but it seems that courses with a traditional format are not sufficient.

A pilot programme from a new perspective

The first part of this study highlighted that professional development activities for Uruguayan mathematics teachers do not fully satisfy their needs; thus, they are not completely sufficient for their development. Experts, teachers and their supervisors expressed that courses are interesting and you can learn because of them, but they only slightly affect their pedagogies.

Through the comparison of courses and guidelines, we can detect that numerous training conditions were satisfied, such as supporting innovations' characteristics and helping teachers to tackle common obstacles. Missing points are detected: course syllabi are rigid and therefore they do not care about individual concerns, and the formal structure of a course does not guarantee the crucial experiences like collaboration, team planning, lesson observation and discussions, etc. Even when collaboration was encouraged in best-rated courses, assessment was based on traditional methods, such as tests, examinations, writing or presenting. As Zehetmeier & Krainer (2011) recommend, "Considering and facilitating these fostering factors (and at the same time avoiding the hindering factors) when

designing and implementing professional development projects is one important step on the journey to sustainable in-service teacher professional development”.

One of the main challenges for professional development programmes seems to be reassuring teachers that they will experience what is needed for them to learn, and also taking those experiences as valuable components of the certification process. We designed a pilot professional development programme, which implemented every guideline and we tried it in different courses. We outline here the main characteristics of that programme.

In order to increase teachers’ motivation and help them to overcome the common obstacles, agreements with schools and training institutes were signed. Schools would guarantee adequate conditions for teachers (fully working devices, availability of computer laboratory, flexibility with teacher to observe colleagues’ lessons) and the training institute would issue certificates.

The basic structure was a traditional online course (because teachers do not have time for face-to-face workshops), four months long. 16 participants began the course and 4 of them finished, which is a more than acceptable ratio for an online free course. Through detecting teachers’ interests (by questionnaires and analysis of forum posts), the moderator assigned special materials and tasks to each participant, addressing personal concerns and expectations.

Assessment was designed to oblige teachers to go through the key experiences, so it was mandatory to work together, observing lessons, welcoming someone else into his/her classroom, giving feedback, etc. A multi-dimensional credits system was designed to establish the passing point, thus key experiences were not avoidable. From the very beginning, teachers knew how many credits of each kind they needed to be able to pass the course. Nevertheless, there was also a minimum total amount of credits they had to collect; getting the minimum of each type would not be enough, they had to go deeper and obtain more credits in any aspect they preferred.

This assessment and certification system led us to a complex set of rubrics; it was accurate and let us achieve our goals, but it could be confusing for teachers, hindering motivation and transparency. This led to the emergence of gamification components in the study.

We represented the credits with colourful stars (one colour for each dimension), so the goal was to collect as many stars as possible. We designed a personal dashboard (Figure 2) for each participant, in which you could see how many stars you have, which colours are missing and how to obtain them.

In this case, game elements are not changing the essence of the design, but they only make it nicer. As Stott & Neustaedter (2013) explain, most of what gamification, in the sense of Deterding *et al.* (2011), implies is already recognized and utilized in school, although under different designations.

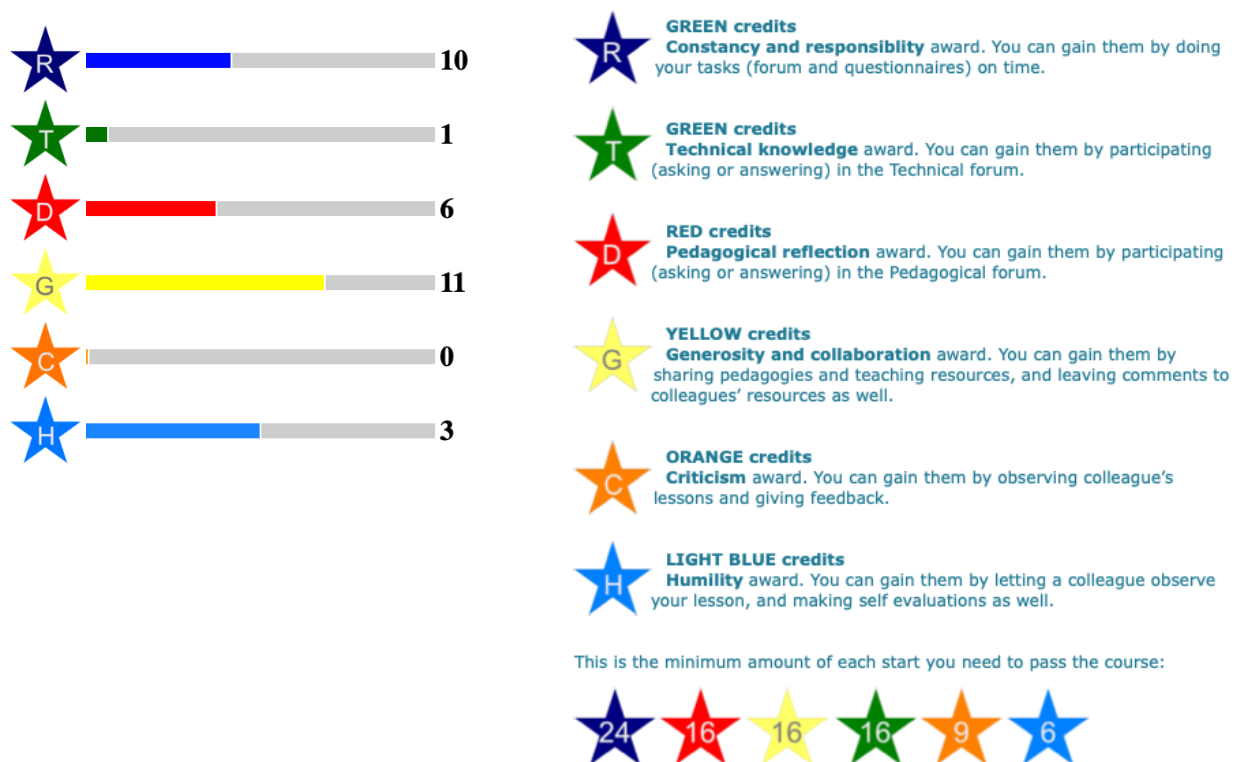


Figure 2: Personal dashboard and definition of credits

Research design and methods

The second part of this study intends to answer the following questions: To what extent can this course design address teachers' needs and expectations? What is the contribution of game elements in this professional development programme?

A case study was designed to understand participants' evolution during the course (Yin, 2003; Cohen, Manion, & Morrison, 2015).

An online platform (learning management system) was used, and forum posts and interactions were analysed. Questionnaires (to identify main participants' concerns regularly and detect evolution), several interviews and lesson observation were carried out before, after and during the course. All data was transcribed and processed with qualitative data analysis software (Weinstein; 2015). Most of these data were used during the course to adapt contents to participants' concerns.

Preliminary findings

The analysis showed that teachers were pleased with the flexibility of the programme; they enjoyed that content was adapted to their concerns and they actually tried out in their classrooms what they learnt. All teachers expressed that this experience changed the way they think about teaching; suggesting that an important modification in their perceptions happened, that can be associated to a progress in the concerns model. They found the opportunity in this programme to develop their skills and knowledge (Loucks & Hall, 1979). They also expressed that assessment was a bit overwhelming at the beginning, but afterwards the funny stars and the dashboard made it easier, motivating them and eventually they were not worried about certification. Game elements helped them in terms of self-assessment and motivation.

Discussion

We began thinking about the contribution of gamification in teacher training as a necessity to motivate teachers and change the environment of the teacher-training course. Understanding gamification as the utilisation of game components in non-game contexts (Deterding et al., 2011), using game elements like collection of stars and personal dashboards helped us to deal with the complexity of the course's design. We cannot assume that the presence of gamification elements is the reason for the course to be successful (Dicheva et al., 2015), we need further measurement of changes (Stott, & Neustaedter, 2013). There are also drawbacks in the integration of gamification in education (Hanus & Fox, 2015), but based on our experiences and this study there are good prospects for further developments.

This study confirmed that it is possible to design a professional development programme for teachers, which has serious assessment and certification, but is based in key personal experiences, adapted to different concerns and expectations (Loucks & Hall, 1979). Traditional methodologies should be modified to achieve this goal, but it can be done as demonstrated above.

Gamification arose as an unexpected ally, simplifying assessment, enhancing motivation and offering new opportunities for adaptive content. Thus, we believe that teacher training courses with gamification elements should be designed and further researched.

References

- Assude, T., Buteau, C., & Forgasz, H. (2010). Factors influencing implementation of technology-rich mathematics curriculum and practices. In C. Hoyles, & J.-B. Lagrange (Eds.), *Mathematics education and technology - rethinking the terrain* (pp. 405–419). Springer.
- Berman, P. (1981). Educational change: An implementation paradigm. In R. Lehming, & M. Kane (Eds.), *Improving schools. Using what we know* (pp. 253–286). Beverly Hills: Sage.
- Biehler, R., & Nieszporek, R. (2017). Upper secondary teachers' stages of concern related to curricular innovations before and after a professional development course on teaching probability and statistics including the use of digital tools. In T. Dooley, & G. Gueudet (Eds.), *Proceedings of the Tenth Congress of the European Society for Research in Mathematics Education (CERME10, 1–5 February 2017)* (pp. 2804–2811). Dublin, Ireland: DCU Institute of Education and ERME.
- Cohen, L., Manion, L., & Morrison, K. (2015). *Research methods in education (7th ed.)*. New Delhi: Routledge.
- Deterding, S., Dixon, D., Khaled, R., & Nacke, L. (2011). From game design elements to gamefulness. *Proceedings of the 15th International Academic MindTrek Conference on Envisioning Future Media Environments - MindTrek '11*, 9.
- Dicheva, D., Dichev, C., Agre, G., & Angelova, G. (2015). Gamification in education: A systematic mapping study. *Educational Technology & Society* 18(3), 75–88.
- Fullan, M. (2016). *The NEW meaning of educational change*. New York, NY: Teachers College Press.

- Glaser, B. G., & Strauss, A. L. (2009). *The discovery of Grounded Theory: Strategies for qualitative research*. New York, NY: Aldine Transaction.
- González, F., González, M., & Macari, A. (2013). *Evolución de las profesiones docentes en Uruguay. Desafíos para la próxima década*. Montevideo. Retrieved from <https://www.ineed.edu.uy/images/pdf/evolucion-profesiones-docentes.pdf>.
- Hanus, M. D., & Fox, J. (2015). Assessing the effects of gamification in the classroom: A longitudinal study on intrinsic motivation, social comparison, satisfaction, effort, and academic performance. *Computers and Education* 80, 152–161.
- INEEd. (2017). *Informe sobre el estado de la educación en Uruguay 2015-2016*. Montevideo: INEEEd.
- Liu, Y., & Huang, C. (2005). Concerns of teachers about technology integration in the USA. *European Journal of Teacher Education* 28(1), 35–47.
- Loucks, S., & Hall, G. (1979). Implementing innovations in schools: a concerns-based approach. In *Annual Meeting of the American Educational Research Association* (San Francisco, April 8–12, 1979). San Francisco.
- Loucks-Horsley, S., Stiles, K., & Hewson, P. (1996). Principles of effective professional development for mathematics and science education: A synthesis of standards. *National Institute for Science Education Brief* 1(1), 1–6.
- Plan Ceibal. (2017). *Plan Ceibal: 10 años. Hicimos historia haciendo futuro*. Montevideo. Retrieved from <https://www.ceibal.edu.uy/storage/app/media/documentos/ceibal-10-2.pdf>.
- Stott, A., & Neustaedter, C. (2013). *Analysis of gamification in education*. Surrey, 1–8. Retrieved from <http://carmster.com/clab/uploads/Main/Stott-Gamification.pdf>.
- Weinstein, M. (2015). *TAMS Analyzer*. Retrieved from <http://tamsys.sourceforge.net>.
- Yin, R. K. (2003). *Case study research: Design and methods (3rd ed.)*. Thousand Oaks: Sage Publications.
- Zehetmeier, S., & Krainer, K. (2011). Ways of promoting the sustainability of mathematics teachers' professional development. *ZDM* 43(6–7), 875–887.
- Zehetmeier, S. (2017). Researching the sustainable impact of professional development programmes. In T. Dooley & G. Gueudet (Eds.), *Proceedings of the Tenth Congress of the European Society for Research in Mathematics Education (CERME10, 1–5 February 2017)* (pp. 3019–3025). Dublin, Ireland: DCU Institute of Education and ERME.

Action research as a potent methodology for improving teaching and learning in mathematics

Eda Vula

University of Prishtina, Faculty of Education, Kosovo; eda.vula@uni-pr.edu

This paper represents an effort of the author to better understand teachers' perceptions of their experiences during their engagement in the action research process. In completing their action research projects, teachers not only learned how to conduct research themselves but, also, they shared some of their experiences. The course structure has had the effect of encouraging teachers to try new methods in their teaching, to use new resources and to improve the communication outside class in order to improve their teaching and their students' performance in mathematics. Further, it was discussed about the possibility of involving teachers, both, pre-service and in-service, in the action research studies and the possibility of support for them from the university and the government as an initiative for the successful implementation of education reforms.

Keywords: Action research, teachers, perceptions, improvement, teaching.

Introduction

During the last two decades, the system of education in Kosovo underwent several reforms in order to respond to social, cultural and political developments in the country and broader societal aspirations for integration in European and global processes. Along with ongoing reforms, special attention was paid to the development of education programs for quality teacher training in line with common European principles for teacher competencies and qualifications. Unfortunately, the results from the Programme for International Student Assessment (PISA), conducted in 2015 and in which Kosovo participated for the first time, were quite discouraging. (OECD, 2016). Until recently, the teachers' qualification programs for subject teaching, as well for mathematics were mainly based on subject knowledge, being developed in the academic unit of the University of Pristina. Because the relationship between "academic" and "professional" courses was mostly "bloodless" and teacher training in Kosovo was mainly academic and heavily subject-based (Vula, Saqipi, Karaj, & Mita, 2012, p. 38), the Ministry of Education and Technology in Kosovo made the decision in 2012 to reform the study programs for subject teachers' qualification according to the consecutive model. Thus, all teachers should complete 3 years of academic studies for the respective subject in the relevant academic programs at Bachelor level and 2 years at Masters level at the Faculty of Education, where they have specific training in subject pedagogy and practice teaching. These programs have started to be implemented for the first time in the 2016/2017 academic year. Students enrolled in these programs are those who have no experience in teaching (prospective teachers), but also those who are already mathematics teachers in grades 6-12 and want to advance their qualification at Masters level. Last academic year, the action research course was offered as an elective course, and all of the enrolled students were already teachers. As a course instructor (author), my objective was not only to review the action research projects conducted by teachers but also to better understand the teachers' perceptions in terms of their benefits, experiences as a researcher and their students' benefits during the action research process.

Literature review

Action research is a method used for improving educational practice (Koshy, 2010). Considered as a powerful tool for change and improvement at the local level (Cohen, Manion, & Morrison, 2007), it is any systematic intentional inquiry conducted by teacher-researchers to improve their practice and students' outcomes (Mills, 2013; Cochran-Smith & Lytle, 1993). It is a study process of a real situation in a classroom which assists in teacher education through linking theory and practice (Stenhouse, 1975). According to Elliott (1991), the theoretical understanding of education, knowledge, learning, and teaching are derived from curriculum practices and teachers. Thus, two of the most essential purposes for doing action research are the improvement of the quality of activities or teaching practice and the development and testing of the practical theories that guide one's own practice (Feldman, Altrichter, Posch & Somekh, 2018). According to Koshy (2010), action research is "a constructive inquiry in which the researcher constructs his/her knowledge on specific issues through planning, action, evaluation, refining and learning from experience" (p. 9). It is one of the most essential motives for teachers to improve the quality of their actions and a potent methodology for educational reform (Somekh & Zeichner, 2009). Action research is intended to support teachers with the challenges and problems of practice and carrying through innovations. Somekh and Zeichner (2009) focused on the remodelling of action research theories and practices in response to local cultures. They presented five variations of action research: in times of political upheaval and transition; as a state-sponsored means of reforming schooling; co-option of action research by Western governments and school systems to control teachers; as a university-led reform movement; and as locally-sponsored systemic reform sustained over time. According to Somekh and Zeichner's analyses, a common feature in these variations of action research is the importance each demonstrates of working towards a resolution of the impetus for action with the reflective process of inquiry and knowledge generation, to generate new practices (2009). Improving teaching practice and generating new ones is very important for teachers' everyday work, but action research has impact also on increasing teachers' self-confidence for their role as researchers and fostering collaboration amongst peers in their school environment (Vula & Saqipi, 2015). Action research should be part of both preservice and in-service teachers' professional development programs. Examining the curriculum of action research for teachers' education requires a critical appraisal of the ways in which preservice teachers think critically and creatively about their practical experience to know and understand research and teaching, as well as how they craft their own pedagogies (Capobianco & Ní Ríordáin, 2015). On the other hand, action research curriculums used by in-service teachers are focused on the teachers' own situations, training to validate their own teaching practice. Krainer & Zehetmeier (2013) present an example of a national initiative for fostering mathematics and science education. They have introduced the "lessons learned" from a project that promoted teachers' investigation into their own work. In that project, teachers were key stakeholders in innovation and research. The authors provide exemplary research results for the teachers' critical stance towards innovation and inquiry as an important basis for disseminating inquiry-based learning. The individual and the social dimensions, as well as actions and reflections, should be part of the professional development programs (Zehetmeier, Andreitz, Erlacher, & Rauch, 2015). In addition to the individual engagement of the teacher researchers, it has been shown that teachers are successful and can achieve tremendous results when they co-operate with their colleagues and are supported by the university teachers (Altrichter, Posch & Somekh, 1993). Other researchers have shown that teachers' perceptions on action research

are related with an opportunity for them to deepen their knowledge of the content they provide, to strengthen the pedagogical aspect of the classroom, increase sensitivity to the affective concerns of students and place themselves as creators of knowledge and researchers (Sardo-Brown, 1995; Goodnough, 2011; Vula & Saqipi, 2015). Bonner (2006), in her study of professional development of two teachers, has shown that throughout action research projects, both teachers acquired “richer knowledge” of how to teach mathematics, and “new ways of thinking” about learning about their students, and about themselves (p. 40).

This study aimed to reveal the perceptions of mathematics teachers on the impact of the action research projects on their teaching and students’ learning, as well as the benefits of the process itself.

Method

Eleven teachers attended the action research course offered in the spring semester of the 2017/18 academic year. The course was offered to the master degree program for mathematics teaching at the Faculty of Education, University of Prishtina. The course participants (teachers) attended 15 weeks of action research course instructions, applications, and action research methodology. During the course, the teachers were expected to think about a problem or issue they encounter in their classrooms. As part of the course assignment, each teacher was asked to conduct his/her own action research project based on his/her individual classroom students’ needs. First, the teachers worked on their research problem, purpose, methodology and literature review. Then, during class discussions, the instructor and the teachers were “critical friends” in regards to the teacher project ideas, the development and implementation of the systematic plan, serving as a validation group for action research projects. They established trusting relationships, which became the grounds for giving and receiving feedback on the validity of the evidence (McNiff & Whitehead, 2009). Later, the teachers conducted their research in their classrooms, where they collected the data, analyzed and further discussed their findings as a final report paper, part of their assignments.

After completing the course, a questionnaire with three open-ended questions was sent to them via email. The questions were related to teachers and students benefits on conducting the action research project, as well as their experiences as a researcher-practitioner. In this paper, only four teachers who responded fully to the open-ended questions have been reviewed and discussed. The participants are mathematics teachers with diverse teaching experiences: Egzon has three years of teaching experience in a non-public middle school; Isuf has ten years of teaching experience in a rural middle school; Qendresa and Besmir have five years of teaching experience in a secondary school.

As a lecturer for the action research course, I played the role of a facilitator helping the teachers carry out their own action research. The teachers’ action research reports, my notes during class lectures, discussions, and the written responses to the open-ended questions used to conduct the research are presented in this paper. A qualitative content analysis research methodology (Cohen, Manion and Morrison, 2007) was used to identify major themes related to the three questions on the impact of the action research process: What are you and your students’ benefits of doing an action research study? What are some of your key experiences as a researcher? What advice would you give to colleagues about action research study?

Findings

All teachers inquired into different aspects of their teaching by defining research questions of relevance to their everyday situations, by collecting data, interpreting, drawing conclusions and writing down their findings in the research reports. The summaries of the action research projects, which are described below, are taken from the four teachers' reports.

The descriptions of teachers' action research reports

In his action research project, Egzon explains the reason why he was concerned with students' poor engagement in doing their homework in mathematics. As a mathematics teacher in a middle school, he had reviewed numerous sources about the importance and effect of performing homework, but he was more concerned about managing this process. In other words, he wanted to see if using the online platform would efficiently link the relationship between performing homework and observing or controlling their performance by students. Thus, in order to conduct his project on the online platform he involved the parents, strengthening the communication between parents, students and himself. Since the school where Egzon works is non-public and learning is conducted in English, he has been able to use the internet and other resources needed for the project. The engagement of Egzon in an action research project influenced not only an increase in the level of performance of the homework and the improvement of communication between parent, student and teacher but also the enhancement of quality in understanding the mathematics concepts and time management efficiency in carrying out the homework.

Isufi is another middle school mathematics teacher who works in a rural school. His concern was related to students' difficulties understanding fractions. Even though fractions are taught in primary education, according to the curriculum, in the sixth-grade students expand their understanding of fractions and continue learning fraction operations. As a mathematics teacher, Isufi was concerned with his student's preconceptions of fractions. Most students were confused about the concept of fractions, so he decided to explore more on teaching methods that could facilitate students' learning. He decided to use not only physical manipulatives but also virtual manipulatives. Similar to many schools in Kosovo, the school where Isufi works deals with a lack of labs and not all teachers know English. However, he planned to use ten computers that the school had so that each student would have the opportunity to use them. Isuf expressed that using new methods in the class was a challenge for him, especially when resources are not in the native language. But it is worth trying when such an action raises the students' interest and improves their learning.

Isufi had hypothesised that teaching his students how to use manipulatives, both physical and virtual, would improve their understanding of the fractions concept. Thus, after he collected data from several action research projects, he found that nearly all of his students improved their knowledge of fractions.

How to motivate and encourage students to learn mathematics? was one of the questions that Qëndresa, a mathematics teacher in the secondary school, often asks herself. She was concerned that her students spent most of their time using smart phones on social networks, so she thought of exploring if their phones could be of use to learn mathematics. Thus, she decided to engage students with IXL's interactive mathematics platform and to systematically evaluate if the students can improve their results in solving quadratic inequalities. She engaged her 32 students to use the

interactive platform for the period of a month. The students were enthusiastic and curious to use the platform, she observed. Although it was challenging, Qëndresa noted a change in students' behaviors. After completing her research, Qëndresa concluded that:

Practising online tasks specifically of the IXL Math platform, makes all students active, more responsible problem solvers and more focused on tasks to cover the gaps and understand concepts by having fun and testing themselves.

Another action research study has been done by Besmir in secondary school. Unlike the previous action research studies, he put his effort into attempts to arrive at conceptual understandings of probability, which be considered problematic when students are asked to connect with everyday problems. Previously, Besmir reviewed the different studies in the field of probability teaching and was inspired by the findings of Zhonghe Wu's study *Using the MSA model to assess Chinese sixth graders' mathematics proficiency*. He adapted the MSA Model for his teaching of probability. His action research was based on quantitative data. He used a quasi-experimental design in order to assess the impact of the MSA model. For the intervention, he has developed learning plans based on the MSA model. This model shows the conceptual understanding, presenting a strategy that demonstrates the procedural steps for problem-solving and application or creating a similar word problem in a realistic situation. For implementing his study, he has separated all students into two groups, experimental and control group. In the experimental group, the teaching was based on the MSA model, whereas in the control group it was with traditional methods. A t-test analysis of scores from pre- and post-tests indicated that the experimental group performed significantly better than the control group.

The teacher's perceptions on the action research process

All of the teachers have shown that the benefits of an action research study were numerous. Some benefits mentioned by the teachers were related to the innovations in their teaching and their commitment to using various resources to improve the performance of their students. Below, are some of the thoughts shared by the participants:

The action research conducted in my classroom was a new experience for me, it was quite challenging. First, I had to analyze many research studies that have treated the same problem. I had to examine not only the theory that we have learned in other courses but also the different practices of teachers which helped me to improve the pedagogical aspect of my teaching and also to strengthen the academic components. (Besmir)

Teachers had observed that the carrying out of their action research projects in their classes increased the engagement of the students as well. The use of class activities that were not used earlier in the classrooms was one of the factors that stimulated students to be more active in mathematics class.

Self-confidence, passion for math, dealing with success and failure, accepting similarities and differences in problem-solving methods, giving and receiving help in group work were some of their characteristics that I didn't notice before. (Qëndresa)

My experience with action research had two effects. First, it has changed my habits and the second, I have changed my expectations for my students. I see action research as a stimulus

not only for changing my teaching but also as a stimulus for students' engagement in the learning process. (Egzon)

Action research is a methodology that also helps us as teachers to turn the attention to ourselves, to understand our teaching methods, to find out what would be the best way to present different mathematical concepts to students, to measure our knowledge and supplement them if needed. (Besmir)

As a result of doing action research, teachers also shared some key experiences. The problems that arise in classrooms are often overlooked. For them, action research has increased their responsibility to deal more in detail with students' needs. Through action research, the teachers gained a lot of information during their literature reviews. The literature review has helped them find models and examples, which were later used in their teaching, practicing the new pedagogical methods. However, because there is limited research in mathematics education in the Albanian language, for some of them using the resources in English was a bit challenging. Thus, an important impact of the action research studies was not only to supplement gaps in the teachers' pedagogical knowledge and subject knowledge but, also to practice and improve their English.

Action research can be considered as a tool to make changes in our classrooms. Each step we make towards a change by adapting to today's time and student preferences can be successful. Therefore, I recommend all math teachers to consider action research as the method that gives them the answer every time they have a dilemma to reach out to their goals. (Isuf)

In addition to the benefits, the teachers have also presented some of the difficulties during the action research process. Difficulties in access to relevant documents, the understanding of the English language during the literature review, the data analysis and the limited time to complete the research by the end of the semester.

As I found it harder during the research process, I had a look at the literature. Lack of access to academic sites, or the cost of access to documents or relevant literature has been the most difficult part of the research. (Egzon)

However, due to the many benefits, they proposed that action research studies be a compulsory course for all preservice teachers, as well as a professional development program for all in-service teachers.

Discussion and conclusion

This paper aimed to explore how teachers formulate their own research problems and conduct their action research projects. Also, this paper examined the teacher's perceptions of their experience when they carry out action research as novice researchers. From the action research reports and the teacher's perceptions, it has been shown that there were different topics to which teachers oriented their research, but all of them were concerned about the effectiveness of their 'new teaching activities' and their impact on students' outcomes. The teachers' reports on the impact of their action research show that these are consistent with other studies on how action research contributes positively to their development and professional autonomy by improving their teaching and increasing the students learning (Cohran-Smith & Lytle, 1993; Krainer & Zehetmeier, 2013).

The cases presented by teachers in this paper confirmed the finding from Capobianco and Ní Ríordáin (2015) that although their efficacy as mathematics teachers is sometimes difficult, through action

research, difficulties can be recognized, accepted, and addressed in a positive and productive manner. The case of Egzon indicates that action research helped him to look for new ways of collaboration with parents and students in order to improve students' engagement in doing homework. Isuf and Qëndresa indicate that action research encourages teachers to use technology in their class even when it is challenging for them. On the other hand, the case of Besmir shows that action research encourages him to analyze different sources, to examine the literature related to his field of interest and stimulates him to experience new methods in his classrooms that for others have been successful.

Teachers' experience with action research has shown that they are able to do research in their classrooms successfully and that they can achieve remarkable results when the opportunities are given, especially if they are supported by the university teachers. Action research provides more opportunities for them to be responsible for improving their basic content knowledge, as well as for gaining knowledge and skills in research methods and applications (Altrichter et al., 1993; Loucks-Horsley et al., 2012). Thus, including action research in the study programs for teacher training for both preservice and in-service teachers will help them to create trust as an important conducive factor for generating new ways for learning (Krainer & Zehetmeier, 2013).

Action research in Kosovo can be approached as a potent methodology for educational reform. Action research engages teachers to investigate and teach through analyzing deeply the content and pedagogical issues needed for their teaching. Furthermore, action research challenges teachers to carry out changes, which are necessary for the implementation of mathematics curricula for pre-university education and to align them with international standards. Thus, universities need to consider including action research as a core unit in all teacher preparation degree programs (Hine, 2013) and stimulate collaboration with their students, in-service teachers, and schools, in order to conduct action research studies in mathematics classes as well as in all other subjects.

We started as a small-scale effort involving a few teachers to conduct research in their classrooms aiming to grow into an important part of school-based professional development. The effort for a university-led reform movement (Somekh & Zeichner, 2009), supported by the government as a national initiative, could be a possibility for fostering mathematics education. Ultimately, as cited by Krainer and Zehetmeier (2013), teachers should be key stakeholders in innovation and research, as well as in all educational reforms. This paper suggests that such an effort to prepare teachers to take the role of teacher-researchers is one of the possibilities to answer their concerns about teaching and learning in mathematics.

References

- Altrichter, H., Posch, P., & Somekh, B. (1993). *Teachers investigate their work. An introduction to the methods of action research*. London, UK: Routledge.
- Bonner, P. (2006). Transformation of teacher attitude and approach to math instruction through collaborative action research. *Teacher Education Quarterly*, 33(3), 27-44.
- Capobianco, B.M., & Ní Ríordáin, M. (2015). Navigating layers of teacher uncertainty among preservice science and mathematics teachers engaged in action research. *Educational Action Research*, 23(4), 581–598.

- Cochran-Smith, M., & Lytle, S. L. (1993). *Inside/outside: Teacher research and knowledge*. New York, NY: Teachers College Press.
- Cohen, L., Manion, L., & Morrison, K. (2007). *Research methods in education (6th ed.)*. New York, NY: Routledge.
- Elliott, J. (1991). *Action research for educational change*. Buckingham, UK: Open University Press.
- Feldman, A., Altrichter, H., Posch, P., & Somekh, B. (2018). *Teachers investigate their work. An introduction to action research (3rd ed.)*. New York, NY: Routledge.
- Hine, G.S.C. (2013). The importance of action research in teacher education programs. *Issues in Educational Research*, 23(2), 151-163.
- Goodnough, K. (2011). *Taking action in science classrooms through collaborative action research. A guide for educators*. Rotterdam, The Netherlands: Sense.
- Koshy, V. (2010). *Action research for improving educational practice. A step-by-step guide (2nd ed.)*. London, UK: Sage.
- Krainer, K., & Zehetmeier, S. (2013). Inquiry-based learning for students, teachers, researchers, and representatives of educational administration and policy: Reflections on a nation-wide initiative fostering educational innovations. *ZDM Mathematics Education*, 5, 875–886.
- McNiff, J., & Whitehead, J. (2009). *Doing and writing action research*. London, UK: Sage.
- Mills, G.E. (2013). *Action research: A guide for teacher researchers (5th ed.)*. London, UK: Pearson.
- OECD (2016). *PISA 2015 Results (1): Excellence and equity in education*. Paris: OECD.
- Sardo-Brown, D. (1995). The action research endeavors of six classroom teachers and their perceptions of action research. *Education*, 116(2), 196–200.
- Somekh, B., & Zeichner, K. (2009). Action research for educational reform: Remodeling action research theories and practices in local contexts. *Educational Action Research*, 17(1), 5–21.
- Stenhouse, L. (1975). *An introduction to curriculum research and development*. London, UK: Heinemann.
- Vula, E., & Saqipi, B. (2015). Developing action research for developing teachers in Kosovo. *Turkish Online Journal of Qualitative Inquiry*, 6(4), 1–21.
- Vula, E., Saqipi, B., Karaj, T., & Mita, N. (2012). Moving towards practice-oriented and research-based teacher education: Challenges of Kosovo and Albania. *Excellence in Higher Education*, 3, 37–45.
- Zehetmeier, S., Andritz, I., Erlacher, W., & Rauch, F. (2015). Researching the impact of teacher professional development programmes based on action research, constructivism, and systems theory. *Educational Action Research*, 23(2), 162–177.

TWG19: Mathematics Teaching and Teacher Practice(s)

Introduction to the papers of TWG19: Mathematics Teaching and Teacher Practice(s)

Charalampos Sakonidis¹, Reidar Mosvold², Ove Gunnar Drageset³, Siún Nic Mhuiri⁴, Rukiye Didem Taylan⁵

¹Democritus University of Thrace, Greece; xsakonid@eled.duth.gr

²University of Stavanger, Norway; reidar.mosvold@uis.no

³University of Tromsø, Norway; ove.drageset@uit.no

⁴Dublin City University, Ireland; siun.nicmhuiri@dcu.ie

⁵MEF University, Turkey; tayland@mef.edu.tr

Since its birth in the aftermath of CERME10, discussions in TWG19 concentrated on identifying its research territory and on creating opportunities for collaboration among the participants beyond the conference sessions. These discussions led to shifting the focus of the group on mathematics teaching and teacher practice (s) and to an initiative of working on shared data that fueled fruitful explorations related to conceptualizations and theorization of mathematics teaching. The participants' contributions and the work carried out during CERME11 sessions challenged further the core ideas of how mathematics teaching can be defined and studied while an emerging distinction between teaching as an activity and teaching as work stimulated further the group's discussions.

Introduction

Thematic Working Group 19 (TWG19) emerged as a result of the splitting of a TWG called “From a study of teaching practices to issues in teacher education” into three sub-groups after CERME8. One of the new groups targeted teacher education and professional development (TWG18), another focused on teacher knowledge, beliefs and identity (TWG20), and TWG19 targeted “Mathematics teacher and classroom practices”. Since its conception, TWG19 has been in a process of developing its identity. In discussions, core concepts have been taken for granted, without explicit or shared definitions. This became apparent at CERME10, where participants called for a development of common grounds — or at least for efforts to increase awareness about differences in conceptualizations, theories and methods, and of the implications of these differences. After CERME10, two changes have been made to move forward TWG19's work: 1) the name of the working group has been adjusted, and 2) an initiative of offering sets of shared data for analysis and use in the working group has been initiated.

This introductory paper discusses the ongoing development of TWG19's identity and where the continued development appears to be heading. Due to a large number of submitted papers, the group split into two (TWG19a and TWG19b) for CERME11, but we tried to maintain a sense of community by having three common sessions, and by discussing the same overarching questions in split sessions. In the final session, team leaders shared reports to the whole group and facilitated a concerted discussion around these questions. This joint introduction to TWG19a and TWG19b testifies to these

efforts. There are three main sections in this introduction. The first section discusses emerging issues and critical considerations as reflected in the section name. The second section reports from the joint activity around the initiative of analyzing and using shared data, and the third section discusses patterns and trends in the individual papers that were presented. The introductory paper concludes with a discussion of the collective efforts made to deal with the emerging issues and some reflections on the way ahead.

Emerging issues to pursue: some critical considerations

After CERME10, the name of TWG19 changed from “Mathematics teacher and classroom practices” to “Mathematics teaching and teacher practice(s)”. The change of wording is intentional and deserves elaboration. First, the change from teacher to teaching signals that the group targets teaching rather than teachers and their characteristics; teacher knowledge, beliefs and identity are the focus of TWG20. This shift reflects a development that Skott, Mosvold and Sakonidis (2018) described and reflected upon in their recollection of research on classroom practice, knowledge, beliefs and identity over ten biannual CERME conferences and corresponds with a general shift of focus in research on teaching. Although the shift from teachers to teaching has emerged over several decades, conceptualizations of teaching appear to be underdeveloped in our field. While discussing the problem of theorizing teaching, Jaworski (2006, p. 188) suggests that “the big theories do not seem to offer clear insights to teaching and ways in which teaching addresses the promotion of mathematics learning”. Furthermore, Jaworski suggests that one of the problems lies in how learning and teaching are connected with practice, and this relates to a second change in the name of TWG19.

The shift from classroom practices to teacher practice(s) signals that the primary focus of the research in TWG19 is on practices of teachers and teaching rather than on any practices in classrooms. Use of the term practice has changed over the years. Jaworski (2006) discussed “teaching as learning in practice”, whereas Schön and DeSanctis (2011) consider teaching to be a reflective practice. The former suggests conceiving teaching as a social practice in which teachers are practitioners, whereas the latter offers a view of how teachers “act in the classroom as informed, concerned professionals and about how they continue to learn” (Lerman, 1998, p. 33). The discussions by these authors imply some of the different meanings that might be attached to the term practice. Lampert (2010) distinguishes between four different meanings of the word practice, and three of those are relevant for TWG19. First, practice might refer to what teachers do in contrast to theory. Second, the word is used to describe a collection of practices, some of which might be more core or high-leverage than others. A third use is to consider teaching as a professional practice, like the practice of law or medicine. The word practice in the new name of TWG19 might encompass all three meanings.

The first joint session of TWG19a and TWG19b at CERME11 was devoted to discussing some of these foundational issues, and attempts were made to contribute to the discussion of the underdeveloped conceptualizations and theorization of mathematics teaching. To introduce the discussion, two of the presented papers drew on different theoretical foundations. In the first presentation, Watson drew on developments in cognitive psychology, neuroscience and ontology to provide a theoretical account of teacher decision making and how this influences practice. He argued that the momentary decisions influence the character of the lesson and proceeds to focusing on

algorithmic reasoning, a conscious process making use of heuristics and pre-established routines and processes to reduce the demand on working memory. In mathematics teaching, in-the-moment decisions have to be immediate and thus well-practiced. The algorithmic mind quickly accesses routines and procedures that are learnt through participation and provide well-rehearsed and culturally-embedded approaches to respond to situations in the classroom. Watson concluded that it is important to further study teachers' decision making, to better understand the affective dimensions, the culturally embedded routines and strategies acquired through participation in the professional community. In the second paper, Sakonidis argued that mathematics teaching tends to be seen today as a professional practice shaped by the expectations and norms of the learning settings where it is exercised. Sociocultural theories provide useful lenses for the relevant research and three of them appear to readily lend themselves to this direction: the theory of learning participating in a community of practice, Cultural-historical activity theory, and Skott's (2013) patterns of participation theory. Sakonidis concluded by highlighting the need for dynamic perspectives to disentangle and understand the ever-evolving outcome of individual and communal acts of meaning-making (by both teachers and students) characterizing the practice of mathematics teaching.

Following the presentation of these two papers, Hoover and Mosvold presented their reflections on the developments in the field of research on mathematics teaching. They started by reflecting on the different meanings of teaching, and how the field has proposed dichotomies like pedagogic versus didactic, art versus science, ambitious versus conventional, and profession versus occupation. Based on these initial reflections, they proposed a distinction between teaching as *activity* and teaching as *work*. The first interprets teaching as activities done by teachers, whereas the second considers teaching to be work to be done. Each of these understandings has different implications for studying teaching. Studies of teaching as activity tend to seek empirical descriptions of what teachers are doing, and they study methods of expert teachers in order to improve teaching. On the other hand, studies of teaching as work tend to investigate the demands of instruction by applying conceptual analysis, and they conceptualize professional practice for teacher education as a means to improve teaching. This distinction was taken up by participants in the group and stimulated productive discussions.

In search of answers to the emerging issues in a joint research activity

As another effort to move the group forward, TWG19 decided to prepare sets of shared data for CERME11. These shared data sets were made available for analysis and use in participants' papers, and they were also available for use in presentations and as a common reference point for discussions in the group. Four sets of data were prepared and uploaded to a secure server that all participants in TWG19 were given access to. Three of the data sets contained videos of mathematics teaching, whereas one data set contained transcripts only. Each data set was accompanied by a document that laid out policies for sharing and reuse, and a document with information about the person or institution that shared the data as well as with permissions and limitations for usage.

Videos are extensively used in research on teaching. In a presentation to the group about sharing data, Mosvold, Hoover and Suzuka suggested that study of a complex phenomenon like teaching requires good data, and that video data provides access to nuances in communication and interaction. Videos also provide more detail about context. While adding value, video data also introduce some

challenges — including practical as well as ethical concerns. Sharing and reusing video data provide benefits like better utilization of data, access to high-quality data, saved costs, as well as increased quality and scope of analysis. However, successful sharing and reuse of video data demand careful considerations around issues of usability and reuse of data. Many find the challenges entailed in sharing and reusing data so severe that they are reluctant to get involved. Engaging in this initiative has provided us with useful experiences that we hope might help us as a field move forward towards overcoming the anticipated difficulties.

Having multiple eyes look at the same data opens up for richer and more nuanced interpretations. For instance, five papers analyzed a Norwegian video where a teacher facilitates a group of students' presentations of their solutions to a problem of figuring out when the king of Norway was born, given that he celebrated his 80th birthday on that particular day. Some participants focused on how the teacher was moderating the dialogue, how he elicited students' mathematical thinking (Drageset), and how he positioned students as mathematical authorities whose thinking were put on public display and collectively analyzed (Bass & Mosvold). Others emphasized how the teacher's use of revoicing might interrupt and even prevent further development of the discourse (Kleve, Solem, & Aanestad), and Nic Mhuiri followed up by observing that student interactions were always funneled through the teacher and never developed into discussions in whole class. Whereas most papers applied particular frameworks or theories in their analysis of this video, Hoover and Goffney used conceptual analysis to identify aspects of mathematics teaching that might disrupt patterns of inequity.

Another frequently analyzed video displays Deborah Ball teaching fractions on the number line. From his analysis of turns in the conversation, Drageset noticed how the teacher often requested students to ask questions instead of entering a traditional pattern of initiation-response-evaluation. He also discussed how the teacher moderated the discourse while simultaneously guiding students' participation and attending to norms. Mosvold and Bjuland also mentioned attending to norms of participation in their use of the data set to unpack the role of positioning in the work of teaching mathematics. A couple of papers also observed how assigning students with agency and authority becomes visible in this instance of mathematics teaching (Bass & Mosvold; Nic Mhuiri). Again, the nuances provided by the sum of the analyses exceeds the contributions of each individual paper.

Engaging in analysis of shared data prompts some new questions: Why do we see different things when analyzing the same data? Can we reach agreement of some kind in our analyses? Is agreement even a goal? After all, our efforts to analyze and discuss these shared data sets did not lead to a shared understanding of mathematics teaching, but they stimulated productive discussions about different conceptualizations of teaching.

In search of answers to the emerging issues in individual participants' research

The papers reporting on studies of mathematics teaching and teacher practices that did not use the shared data sets can be placed in three groups: 1) teachers' practices, actions and resources before or during daily instruction; 2) teachers' implementation of teaching practices and actions developed in the context or in the aftermath of a particular purposeful professional development (PD) activity; 3) developing tools or practices of monitoring classroom instructional activity. Emerging issues from these groups of papers are discussed below.

Papers reporting on issues related to daily teaching practices, actions and resources apply established theoretical or conceptual frameworks to examine their functionality and effectiveness. For instance, Pericleous used cultural-historical activity theory to investigate how the activity of proving was constituted in a primary classroom. She analyzed tensions that arose for the teacher and identified points of contradiction between the classroom micro-system and elements of the macro-system, such as curriculum context. In a series of focus group interviews, Grundén used critical discourse analysis to interrogate teachers' planning practice(s) in mathematics. The results described how teachers construct their own discourse of mathematics teaching in resistance to the official discourse of the National Agency of Education. Grundén contended that critical discourse analysis is useful for attending to the complexity of mathematics teaching. Rudsberg, Sundhäll and Nilsson inquired into teachers' monitoring of students' meaning making. To this purpose, they adopted a framework of epistemological move analysis and a pragmatic perspective on learning to analyze lesson transcripts. The results suggested that epistemological move analysis might enhance our understanding of the relationship between students' meaning-making and the related actions of teachers.

Stouraitis and Potari studied a prospective secondary school teacher's first field experiences. Using activity theory, the authors focused on emerging contradictions considering prospective teachers' planning and enactment of a lesson plan, as well as what led to such contradictions and how contradictions could potentially influence prospective teacher learning. Calor et al. examined teachers' use of a model based on small-group work, drawing on socio-cultural notions such as collaborative learning and scaffolding as well as on cognitive ideas like Janvier's approach to representation systems. The analysis of a pre- and post-test on mathematical level raising shows that more mathematical level raising occurred in the small-group than in the control condition. Olsson and Teledahl described an investigation into how principles of feedback might be used by a mathematics teacher to encourage students' creative reasoning. Their analysis illustrates the challenges that this presents for teachers and highlights associated issues such as the existing classroom norms for interaction, as well as teachers' beliefs about the object of teaching.

Andrews explored what happens mathematically when teachers and learners engage in between-desk-teaching across different mathematics topics. From a multiple case study, he focused on the case of one teacher who used between-desk-teaching practice with a strategic purpose that could potentially support student understanding. Taylan and Esmer used the instructional actions framework to examine a novice teacher's instructional actions in response to unexpected classroom moments. Analyzing lesson planning meetings and observations as well as teacher interviews, they found out that responses to unexpected moments include both supporting and extending actions. Kayali and Biza studied a teacher's use of the available resources in relation to their teaching aim. Based on the 'Knowledge Quartet' (Rowland, 2010), their analysis highlights different aspects of a teacher's classroom work and leads to suggesting replacing code 'instructional materials' to 'resources' and expanding the Knowledge Quartet by adding a code named 'connection among resources'.

The submissions related to teachers' implementation of instructional practices and tools developed in professional development contexts aim at providing rich mathematical classroom activity for all students. In particular, Büscher focused on teachers' designed tasks during a professional development course to reconstruct their categories of differentiation for percentage problems. The

results show that teachers tended to differentiate in ways that exclude low-achieving students from conceptually rich learning opportunities due to their partitioning of their envisioned ideal-typical solution paths. Psycharis, Potari, Triantafillou and Zachariades investigated how secondary school teachers attempted to balance mathematical challenge and differentiation in whole class settings in the context of a professional development program which aimed to support teachers in engaging all learners while teaching challenging tasks.

Klothou, Sakonidis and Arsenidou used a multiple case study approach to investigate the use of learning trajectories in teaching fractions by three primary teachers participating in a PD project. The analysis shows that all teachers tended to view learning trajectories primarily as a way of organizing mathematical content more than as an elaboration of the possible development of student thinking. The study by Medová, Bulková, and Čeretková was conducted in the context of a professional development program focusing on inquiry-based learning in upper secondary mathematics. Results indicate that students' independent learning was observable more often in the inquiry-based lessons than in regular lessons, whereas teachers played a more dominant role in the regular lessons. Maugesten explored Norwegian lower primary teachers' views about good mathematics teaching by using a focus group interview with teachers after a two-year school-based professional development. The results reveal that teachers focused on communication in classroom and use of representations, student thinking in and about the subject of mathematics, and resources, textbooks, and tasks that are related to everyday mathematics.

Finally, the papers related to developing tools or practices of monitoring classroom instructional activity concentrated on cognitive as well as social determinants of this activity. Thus, Nowińska reported on the development of a rating system for analyzing metacognitive activities: Metacognitive-discourse instructional quality. This is illustrated with examples of how one can identify different parts of metacognition related to planning, monitoring, and reflection. She emphasized that such a rating system needs to identify patterns that are stable across lessons and practice. Arnesen and Grimeland also presented an investigation of teachers' planning. They asked teachers to identify the mathematical ideas they would focus on and use Bloom's Taxonomy to classify the learning goals teachers had identified for lessons. Findings indicate that higher-order cognitive process categories were poorly represented in the learning goals and teachers' descriptions of mathematical ideas were vague or absent.

The study by Mellroth and Boesen provides a proposal for teachers to help them notice mathematically highly able students by illuminating aspects of students' problem-solving processes. The paper of Ableitinger, Anger and Dorner is unique in its efforts to attend to student voice. Student feedback was collected in post-lesson interviews and quantitative and qualitative methods were used to compare students' and researchers' choice of significant events in mathematics lessons. The analysis indicates differences between students' and researchers' choices of significant events. Even when both groups identified the same event as significant, different reasons were given for this choice.

Summarizing, all papers presented above highlight challenges of accessing interesting data in consistent ways within or across instructional settings. The adopted theoretical frameworks view teachers as professionals coordinating the instructional activity aiming at rich learning environments

and maximum participation. These frameworks offer analytical tools and sometimes provide — combined or coordinated — new theoretical lenses allowing useful insights into various aspects of mathematics teaching and teacher practice(s). The accompanying methodologies are mostly qualitative. Although these methodologies vary, they tend to concentrate on examining instructional routines, actions, tools and practice(s) by analyzing teachers' designs, classroom implementations or classroom excerpts and so on.

Towards a collective effort to deal with the emerging issues

Discussions in TWG19 at CERME11 often revolved around the core questions of what we mean by teaching and how we study it, and the distinction between teaching as activity and teaching as work was discussed frequently. The majority of participants in TWG19 tend to consider teaching as what teachers do, but there is considerable variation in this view of teaching as activity and how it is studied. Some consider teaching as what teachers do, but they also include teachers' thinking and emotions (e.g., Watson). Others focus more squarely on teacher actions and study patterns of such actions (e.g., Sakonidis). Yet others emphasize that teaching is a communicational activity (e.g., Nachlieli et al.). Among the papers viewing teaching as activity, many were concerned with the connection between teaching and learning (e.g., Ayan; Grundén, Serrazina et al.). Some consider the teacher as an agent who shapes new classroom practices (Nic Mhuiri). Others consider the teacher as a facilitator or an orchestrator (Baldry), who provides students with opportunities to explore (e.g., Pericleous). Yet others consider the teacher as a transmitter of knowledge (Ableitinger et al.). Teachers' use of feedback is supposed to influence student learning, and Olsson and Teledahl investigated development of productive feedback practices.

Other papers lean towards a conceptualization of teaching as work to be done. A couple of papers are explicitly directed towards such a conceptualization of mathematics teaching (e.g., Hoover & Goffney; Mosvold & Bjuland), whereas others point in this direction implicitly. For instance, Nachlieli et al. studied tasks that teachers are faced with, and Santos et al. investigated demands of teaching mathematics. It is also worth noticing that some papers appear to study what teachers do, but they still make claims about the work to be done (e.g., Baldry).

Having the distinction between teaching as activity or work out there seemed to fuel the discussions. People started engaging with questions about the purpose of distinguishing between teaching as activity and teaching as work, and how the conceptualization of one might be independent of the other. The discussion of papers often targeted foundational questions about implications of our views on teaching, of applying different theoretical frameworks to analyze teaching, and about how different methods and types of data might or might not inform us about teaching and the demands of teaching. The effort of introducing and using shared data was another initiative that seemed to stimulate productive discussions in the group. Some reflected on how seeing different things in the same data must prompt careful reflection about use of different theoretical frameworks, whereas others suggested that seeing different things might be fruitful and provide a broader and more complete image of teaching.

Conclusion

TWG19 is still developing its identity, but the group is taking some important steps forward. The name change stimulated some important foundational discussions about conceptualizations of teaching and methods of studying teaching. The distinction between teaching as activity and teaching as work was useful, but further conceptual work is needed. The participants' contributions, despite the polyphony identified in their attempts to conceptualize mathematics teaching as well as in the theoretical lenses and the methodologies employed to study its classroom manifestations, somehow highlight the issues to consider and the questions to pursue in the way ahead.

The initiative of sharing data was also interesting, and several participants were interested in contributing to and using such data sets in upcoming conferences. Sharing and reusing data provide opportunities for richer analysis, but it also appears to be a productive space for developing shared understandings and possibly also better consensus about the object of study. However, further efforts are needed to investigate what kinds of (video) data are most suitable for joint analysis of mathematics teaching, how to organize an even more productive space for such joint analysis, and how such analysis might be scaled up. It is also imperative to investigate ways of organizing analysis of shared data in order for it to be more than an interesting exercise in data analysis.

References

- Jaworski, B. (2006). Theory and practice in mathematics teaching development: critical inquiry as a mode of learning in teaching. *Journal of Mathematics Teacher Education*, 9, 187–211.
- Lampert, M. (2010). Learning teaching in, from, and for practice: What do we mean? *Journal of Teacher Education*, 61(1-2), 21–34.
- Lerman, S. (1998). The intension/intention of teaching mathematics. In C. Kaner (Ed.), *Proceedings of MERGA* (Vol. 1, pp. 29-44). Griffith University: MERGA Inc.
- Rowland, T. (2010). Foundation knowledge for teaching: Contrasting elementary and secondary mathematics. In V. Durand-Guerrier, S. Soury-Lavergne, & F. Arzarello (Eds.), *Proceedings of the VI Congress of the European Society for Research in Mathematics Education (CERME 6)* (pp. 1841–1850). Lyon: Institut National de Recherche Pédagogique.
- Schön, D. & DeSanctis, V. (2011). The Reflective Practitioner: How Professionals Think in Action. *The Journal of Continuing Higher Education*, 34(3), 29–30.
- Skott, J. (2013). Understanding the role of the teacher in emerging classroom practices: searching for patterns of participation. *ZDM - the International Journal on Mathematics Education*, 45(4), 547–559.
- Skott, J., Mosvold, R., & Sakonidis, C. (2018). Classroom practice and teachers' knowledge, beliefs, and identity. In T. Dreyfus, M. Artigue, D. Potari, S. Prediger & K. Ruthven (Eds.), *Developing research in mathematics education: Twenty years of communication, cooperation and collaboration in Europe* (pp. 162–180). Oxon, UK: Routledge.

Comparison of students' and researchers' choice of significant events of math lessons

Christoph Ableitinger¹, Astrid Anger² and Christian Dorner³

¹University of Vienna, Austria; christoph.ableitinger@univie.ac.at

²University of Vienna, Austria; astrid.anger@univie.ac.at

³University of Graz, Austria; christian.dorner@uni-graz.at

Considering the learners' perspectives on classroom teaching is central in our project 'AmadEUs', in which we work together with 79 students of four school classes in Austria and 23 pre-service teachers. In a first stage, we interviewed these students about significant events in math lessons they had just attended. In this paper, we analysed what kinds of events our students have mentioned and chosen and compared them with our (researchers') choice of significant events. While different groups of students tended to choose similar events, we observed differences between students' and researchers' choices of significant events. In a qualitative analysis, we tried to identify the characters of most commonly selected events by students in contrast to the teachers' and the researchers' selections.

Keywords: student voice, teaching practices, significant events, learners' perspective, secondary school mathematics

Introduction

Mathematics education is a complex network with several players involved, such as students, teachers, researchers and teacher educators, who prioritize different aspects of quality and therefore attach importance to different events during math lessons. Hence, one can understand and optimize teaching practice only through research that takes into account various perspectives, and particularly those of the learners as an essential part (see Clarke, Keitel, & Shimizu, 2006). Through giving students the opportunity to articulate their opinions, thoughts and feelings, valuable insights into their attitudes towards mathematics can be gained. Hence, listening to their voices has the potential to influence educators and policy makers (Mok, Kaur, Zhu, & Yau, 2013). This so-called Student Voice approach and some related studies will be further discussed in the theoretical framework.

One aim of our study is to explore which events of math lessons students consider as significant. The results do not only inform us about what kinds of events students consider as important for their learning, we might also get a clue about which events actually stay in their mind and in which events they might pay more attention to. This knowledge has the potential to influence and improve teaching practices (Huang & Barlow, 2013; Lee & Johnston-Wilder, 2013).

By comparing the choice of students to our own (researchers') choice of significant events (by that we mean short sequences of approximately 2-5 minutes) of the math lessons, we want to detect blind spots of typical researcher's views on mathematics education on the one hand. Through contrasting the two perspectives, we expect to maintain student-specific choices of concrete situations in the learning process, which can help teachers in their prospective lesson planning (McIntyre, Pedder, & Rudduck, 2005). On the other hand, it is also interesting to discover events that are significant to

researchers but not to students (and vice versa). For this, our study may give hints, where and in which way crucial points of lessons need to be made explicit to students, in case they do not attach importance to these points sufficiently by themselves.

Theoretical framework

Our study takes the perspectives of students into account. Such “Student voice” approaches have been of growing interest in the past two decades. Early work that has been conducted on the voice of students (e.g. McCallum, Hargreaves, & Gipps, 2000; Pollard & Triggs, 2000; Fielding, 2001) revealed the potential of listening to students in order to understand teaching and learning and making it more effective. In the course of this development, Robinson and Taylor (2007) aimed at theorizing student voice, carving out core values of student voice work. Flutter and Rudduck (2004) analysed different student voice initiatives and derived potential benefits to students, teachers and schools, including the potential to improve learning (as the participation of students might have a positive impact on their meta-cognitive development) as well as teaching (as teachers and researchers are provided with valuable insights).

As Allen (2003) pointed out, it took some time until students have been consulted to articulate their views about mathematics teaching and learning, but meanwhile several studies have been conducted in this field (e.g. Taylor, Hawera, & Young-Loveridge, 2005; Sullivan, Tobias, & McDonough, 2006; Lee & Johnston-Wilder, 2013; McDonough & Sullivan, 2014). While some studies concentrate on what students attach importance to in math lessons in general (e.g. Wilkie & Sullivan, 2018), only few studies deal with significant events of certain experienced math lessons. Of interest is the Learner’s Perspective Study (LPS), which has been designed to analyse and compare practices of mathematics classrooms around the world (Clarke, Keitel, & Shimizu, 2006). Within LPS, Huang and Barlow (2013) compared important events selected by students and teachers. They examined 15 videotaped consecutive mathematics lessons of one teacher, the corresponding lesson plans, teacher interviews and 30 student interviews. During the teacher interview, he described his intentions in the lesson, the important events from his point of view as well as his actions, thoughts and feelings during the important events. The two researchers analysed the data set in order to verify whether the important events identified by students coincided with the teachers’ intended important events within the lessons.

Using a slightly different research design than LPS, we seek answers to the following research questions:

What kinds of events of math lessons are significant for students and/or researchers?

By what criteria do students and researchers select these events and in what way do these criteria differ from each other?

Method

Teaching units: Four school classes (79 students) who visited our University were taught by pre-service teachers in the following topics: Percentage calculation (6th grade), introduction to probability theory (10th grade), combinatorics (11th grade), application of the differential calculus (11th grade). Each class was divided into two groups. These 8 lesson sequences have been videotaped.

Identifying significant events of the math lessons: Right after each lesson, interviews were conducted and recorded among all students (groups of 2-4) to ascertain events that seemed significant to them (we used the German word “wichtig”). We do not predetermine the term “wichtig” as a survey construct, because we do not aspire to infer causal relationships to other constructs. In fact, we seek to learn more about what is important to students when reflecting on their attended math lessons. We thus chose the word “wichtig” out of a group of words with a similar meaning (such as “wesentlich”, “markant” or “maßgeblich”, which all translate to significant or important, respectively) for its easy comprehensibility and its openness for all kinds of aspects that could be meaningful to the students. “Wichtig” expresses that some aspect is of essential relevance (Duden, 2016).

We decided to use semi-structured interviews (Galletta, 2013) to reveal significant events from the students’ point of view. Our interview protocol consists of three segments: For the opening segment, we formulated two open-ended questions that stimulate students to talk about the math lesson they just experienced. The middle segment consists of more specific and structured questions directly related to our research that should jog the students’ memories as well as help them to reflect on different aspects of the lesson. These questions cover the scope of our intended meaning of important/significant events. In the concluding segment, students have to come to an agreement about the five most important/significant events.

In addition, we (as researchers) watched the complete video material (because we did not attend the lessons) and took notes of significant events. At the end of this process, each of us had to choose the five most significant events from his/her own point of view.

In order to conduct an analysis, assistants fragmented each lesson sequence into short scenes due to certain criteria (e.g. change of teaching method, change of subject, presenting or discussing a new example, etc.). Altogether, this procedure led to 221 scenes (for all lesson sequences). After our own selection of events (the researchers’ choice) had been completed, we evaluated the audio material of the student interviews in order to mark their significant events. Each scene was then labelled according to the number of selected events that coincide with that scene (at least partially). For example, the scene label *2R1S* means that two (out of three) researchers and one of the three groups of students selected significant events that occurred during this scene (see Figure 1 for a short extract of one lesson sequence). At this stage, we were able to analyse the data quantitatively and qualitatively respectively.

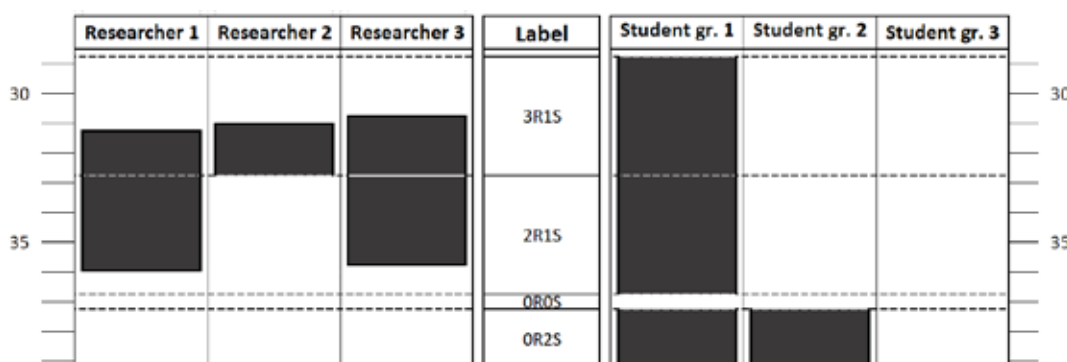


Figure 1: Scene labels according to selected significant events

Results

Differences in significance between students and researchers

In order to measure the disparity between researchers' and students' selection, we determined the difference of the number of researchers' and students' marks for each scene. While the difference is at most 1 in 75% of all scenes ($n=221$), we observed 15 scenes (7%) which have been found significant by either all researchers and no group of students, or vice versa. These scenes are of great interest. 85 scenes (38%) are marked solely by either students or researchers. We must mention that 42 of these 85 scenes are labelled as significant by only one group of students or one researcher, respectively.

In more detail, 23% of all scenes are significant for at least one group of students, but not for any researcher. The majority of these scenes belong to student-centred learning phases. Furthermore, students but not researchers highlighted many events assigned to group work phases and games (due to their active participation) as well as summaries. Students have predominantly chosen events in which they had fun, events that suited them as well as events in which they could easily follow, irrespective of the professional or didactical quality.

On the other hand, 15% of all scenes are significant for at least one researcher, but not for any group of students. Such scenes often contain mathematical errors of the teachers or didactical mistakes (e.g. confusing explanations, explanations that might lead to misconceptions, etc.) and have been commonly chosen by us due to the revealed lack of (pedagogical) content knowledge of the acting teacher. A small part deals with interesting procedures of the teachers that have been either considered as appropriate or inappropriate by us.

Qualitative analysis of a particular scene

For the following scene (which all researchers and students marked as significant), we go more in-depth into the corresponding justifications stated by students and researchers.

Combinatorics (11th grade), minute 63–68

Description of the scene: The teachers use this scene to sum up the content of the lesson. The graphic shown in Figure 2 is drawn on the blackboard to help students identify combinatorial problems as either a variation, permutation or combination and to repeat the associated formulas which have been taught in this lesson. During that scene, one teacher confuses variation with combination and gets corrected by his colleague.

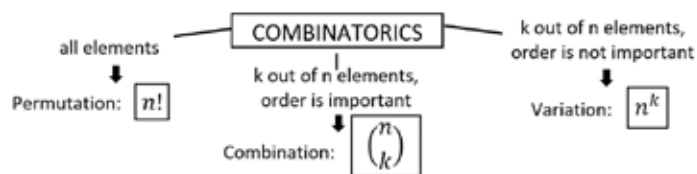


Figure 2: Decision tree

Perspective of students: All groups of students appreciated the summary as a ‘helpful overview’ and identified that scene as a key point. They described the provided graphic as ‘very good’, ‘well-structured’ and ‘easy to follow’. It also helped them to solve problems they had to work on after that scene. Furthermore, they liked that the teachers helped and corrected each other and got the feeling that errors are permitted.

Perspective of researchers: We observed several inaccuracies and errors. The teachers define the permutation solely by choosing all elements of a certain set. They do not mention whether order matters or repetition is allowed and even indicate once that the order does *not* matter:

Teacher: If I cannot deduce from the task that the order matters or that a subset is chosen, then it is always a permutation.

In their graphic, combination and variation only differ in the matter of the order. It is neither mentioned that combinations are without repetition nor that repetitions are allowed in variations. By saying, “We choose k out of n elements”, the teacher indicates that k cannot be greater than n in variations. A correct and thoroughly overview must include those two aspects (order and repetition) for each counting problem.

Further, the scene indicates a highly syntactical approach:

Teacher: No selection occurs; I just take all elements. I’ve only got an ‘ n ’.

Student: I see. This is a permutation.

Teacher: Yes, this is a permutation, because we do not have a ‘ k ’ [...] because I simply need one number.

Without being able to verify the criteria of a permutation, students give the correct answer, knowing that the formula of permutations (out of the three presented formulas $n!$, n choose k and n^k) is the only one that consists of one parameter.

Comparison and discussion: While all groups of students looked upon that scene favourably, we chose that scene due to the syntactical approach and inaccuracies/errors showing a lack of (pedagogical) content knowledge. As students do not know any other counting problem apart from those three presented in that lesson, the given overview is sufficient to distinguish between them, although misconceptions might result (e.g. that k cannot be larger than n in a variation). As the whole topic is new to them, they trust in the expertise of the teachers and are not able to identify errors. Thus, they focus on the use of the summary (e.g. repeating the formulas), whereas we focus on the content quality. We agree that a summary of counting problems is a good idea, but the poor implementation has been decisive for our selection.

Discussion and conclusions

The results have demonstrated that the difference of the number of researchers’ and students’ marks for each scene is at most 1 in 75% of the cases, however, the reasons for choosing certain scenes are quite different, as we have shown in the above mentioned example.

While we focused on events that deploy the didactic strategies of the teachers or revealed existing or missing (pedagogical) content knowledge, the students concentrated on student-centred learning phases, summaries, quizzes and games. This emphasis on student-centred learning phases is in line with the findings of Huang and Barlow (2013) and Mok et al. (2013). Their interviewed students attached importance to seatwork and group work. Wilkie and Sullivan (2018) illustrated that students wish among others more such phases in their math lessons. In the present study, students described teacher-centred phases as ‘conventional instruction’, which could be a reason for choosing student-centred events. Being active is more meaningful and therefore more memorable to them. The findings of Lee and Johnston-Wilder (2013) confirm the importance of quizzes and games for students. In their study, students explicitly demand more interactivity, games and creative tasks. The significance of such events might issue from feelings of success (discover connections, find solutions to certain problems and so on) or emotional involvement. According to Huang and Barlow (2013) and Mok et al. (2013), students valued review and feedback parts as important. Those findings are also in line with our study: Students have chosen summaries as significant and valuable events (as has been shown in the qualitative analysis). However, our data reveals that the researchers did not mention summaries unless they included mistakes or highlights.

Contrary to our expectations and to the results of Mok et al. (2013), students barely talked about teacher explanations. This even holds true for some appalling explanations by the teachers that were not even mentioned by the students during the interviews, although some questions focused on teacher explanations. We conclude that the students did either not remember those scenes or did not attach any importance to them. In a certain way, their focus on methodical aspects of math lessons is understandable, due to students’ less developed meta-cognitive skills and the fact that highlights during classes are kept in mind more strongly. These findings are in line with the study of Waldis, Grob, Pauli and Reusser (2010), who compared student ratings with class observer ratings of math classes and found differences between these two groups when rating cognitively activating instructions and the structure of math classes.

In cases where students and researchers selected the same events, different reasons were decisive. This is similar to the result of Huang and Barlow (2013), who obtained differences in students’ and teachers’ interpretations in such match cases. We presented an example, where students described the visualisation and the associated explanation as well-structured while we as researchers valued it as confusing and identified several content-related mistakes. This may be due to a certain inability of students to detect mistakes or to think about alternative approaches to particular concepts (Lee & Johnston-Wilder, 2013) while still being involved in the learning processes and not being able to oversee the topic as a whole. Some statements expressed by students during the interviews hypothesise that they tend to evaluate the quality of explanations according to how easily they are able to solve corresponding tasks. This implies that their self-assessment relating to their mathematical understanding depends on (amongst other aspects) the tasks they need to solve.

For mathematics teaching practice, we can deduce that students obviously and understandably depend on the teachers’ knowledge and the way content is dealt with in class. We have seen that they did not mention several inconsistencies or misleading actions of the teachers, which were obvious to us as researchers and teacher trainers, respectively. Hence, teachers cannot fully rely on students’ feedback

concerning content-related or didactical inappropriateness, they should – beside asking students for regular feedback – see to get feedback from experienced mathematics teachers or teacher educators (e.g. through job shadowing) in order to gradually improve their teaching practice.

It is essential for the learning process that students are aware of essential content points of the lesson (e.g. phases where concept formation and the development of basic mathematical ideas are in the centre of interest), but our study reveals that they hardly mentioned them nor valued many of them as important. According to Huang and Barlow (2013), the agreement on the importance of such events between students and teachers is necessary for effective learning. We deduce from our results that teachers have to emphasise these essential content points on a meta-level to be sure that the students value these events appropriately. Teacher training has to do its duty at this point by calling the teachers' attention to this problem.

What we can learn from the students' choices of events and the associated justifications is that teachers indeed should make an effort to include more student-centred and methodically varied learning phases into their math lessons (as they do have the potential to motivate students and to enhance their activity as well as their attention). However, it is crucial that there has to be a strong focus on the quality of the content promoted in these phases. As we have seen in our data, games and quizzes are popular among students, but it is difficult to get any content-related feedback to these events from them on the spot, even in cases where we have chosen the same scene out of misleading or confusing aspects. Hence, entertaining elements have the potential to inspire students and to stay in mind. However, they must not cover the content and the learning goals of the lesson.

Teachers can gain useful insights into their students' learning by knowing what classroom events they perceive as important, as they are then able to adjust their teaching practice in order to catch their attention and draw it to essential content points. In addition, a lot can be learned from students' justifications of their selected events as this has the potential to reveal – through further analysis – certain predispositions students have towards math lessons in general.

Acknowledgement

AmadEUs is a project carried out as part of the funding programme Sparkling Science which is supported by the Austrian Federal Ministry of Education, Science and Research.

References

- Allen, B. (2003). Pupils' perspectives on learning mathematics. In B. Allen, & S. Johnston-Wilder (Eds.), *Mathematics education: Exploring the culture of learning* (pp. 233–241). London: Routledge.
- Clarke, D., Keitel, C., & Shimizu, Y. (2006). The Learner's Perspective Study. In D. Clarke, C. Keitel, & Y. Shimizu (Eds.), *Mathematics Classrooms in Twelve Countries: The Insider's Perspective* (pp. 1–14). Rotterdam: Sense Publishers.
- Fielding, M. (2001). Students as Radical Agents of Change. *Journal of Educational Change*, 2(2), 123–141.
- Flutter, J., & Rudduck, J. (2004). *Consulting Pupils: What's in it for schools?* London/New York: Routledge.

- Galletta, A. (2013). *Mastering the Semi-Structured Interview and Beyond: From Research Design to Analysis and Publication*. New York: NYU Press.
- Huang, R., & Barlow, A. T. (2013). Matches or Discrepancies: Student Perceptions and Teacher Intentions in Chinese Mathematics Classrooms. In B. Kaur, G. Anthony, M. Ohtani, & D. Clarke (Eds.), *Student Voice in Mathematics Classrooms around the World* (pp. 161–188). Rotterdam: Sense Publishers.
- Huang, R., & Li, Y. (2012). What Matters Most: A Comparison of Expert and Novice Teachers' Noticing of Mathematics Classroom Events. *School Science and Mathematics, 112*(7), 420–432.
- Lee, C., & Johnston-Wilder, S. (2013). Learning mathematics – letting the pupils have their say. *Educational Studies in Mathematics, 83*(2), 163–180.
- McCallum, B., Hargreaves, E., & Gipps, C. (2000). Learning: The pupil's voice. *Cambridge Journal of Education, 30*(2), 275–289.
- McDonough, A., & Sullivan, P. (2014). Seeking insights into young children's beliefs about mathematics and learning. *Educational Studies in Mathematics, 87*(3), 279–296.
- McIntyre, D., Pedder, D., & Rudduck, J. (2005). Pupil voice: Comfortable and uncomfortable learnings for teachers. *Research Papers in Education, 20*(2), 149–168.
- Mok, I. A. C., Kaur, B., Zhu, Y., & Yau, K. W. (2013). What really matters to Students? A Comparison between Hong Kong and Singapore Mathematics Lessons. In B. Kaur, G. Anthony, M. Ohtani, & D. Clarke (Eds.), *Student Voice in Mathematics Classrooms around the World* (pp. 189–208). Rotterdam: Sense Publishers.
- Pollard, A., & Triggs, P. (2000). *What pupils say: changing policy and practice in primary education*. London: Routledge.
- Robinson, C., & Taylor, C. (2007). Theorizing student voice: values and perspectives. *Improving schools, 10*(1), 5–17.
- Sherin, M. G., & van Es, E. A. (2005). Using video to support teachers' ability to notice classroom interactions. *Journal of Technology and Teacher Education, 13*(3), 475–491.
- Taylor, M., Hawera, N., & Young-Loveridge, J. (2005). Children's views of their teacher's role in helping them learn mathematics. In P. Clarkson, A. Downton, D. Gronn, M. Horne, A. McDonough, R. Pierce, & A. Roche (Eds.), *Building connections: Research, theory and practice*. Proceedings of the 28th annual conference of the Mathematics Education Research Group of Australasia (pp. 728–734). Melbourne: MERGA.
- Waldis, M., Grob, U., Pauli, C., & Reusser, K. (2010). Der schweizerische Mathematikunterricht aus der Sicht von Schülerinnen und Schülern und in der Perspektive hochinferenter Beobachterurteile (Swiss math classes from students' perspectives and in the perspectives of highly inferential observer estimations). In K. Reusser, C. Pauli & M. Waldis (Eds.), *Unterrichtsgestaltung und Unterrichtsqualität. Ergebnisse einer internationalen und schweizerischen Videostudie zum Mathematikunterricht* (pp. 171–208). Münster: Waxmann Verlag GmbH.
- Wichtig (2018). In Duden. Retrieved from <https://www.duden.de/rechtschreibung/wichtig>
- Wilkie, K., & Sullivan, P. (2018). Exploring intrinsic and extrinsic motivational aspects of middle school students' aspirations for their mathematics learning. *Educational Studies in Mathematics, 97*(3), 235–254.

Between-desk-teaching as a deliberate act of making content available: The case of Bernie teaching ratio

Nick Andrews

University of Oxford, UK; nicholas.andrews@education.ox.ac.uk

Between-desks-teaching is recognised as a feature of mathematics classrooms across the world. Previous studies have sought to describe the range of purposes of this lesson event within a lesson and have been concerned with the orchestration of the classroom. Yet there has been little attention given to the role of between-desks-teaching beyond a single lesson, such as its contribution to how mathematical content is made available to learners over time. The current study explores what is happening mathematically when teachers and learners engage in between-desks-teaching across a topic. There is a particular focus on one case in which this lesson event features extensively. This case reveals how between-desks-teaching can have a strategic purpose and has potential to be used deliberately when teaching a topic.

Keywords: Mathematics instruction, Instructional design, Student centred learning, Research methodology, Teacher education.

Introduction

In this paper I focus on between-desk-teaching and how it can be distinctive in terms of its purpose when teaching a topic over a series of lessons. To do so, I draw on data from a wider exploratory study of four cases of classroom practice over a series of lessons. I then focus on one particular case in order to understand better the distinctive contribution of between-desks-teaching to how subject matter is transformed and connected over time in this context. This study therefore, in common with previous CERME papers (Skott, Mosvold, & Sakonidis, 2018), brings to the surface a specific act within mathematics teaching and discusses how it provides opportunities for learning.

Between-desk-teaching has been identified as a feature or “lesson event” of mathematics classrooms across the world (O’Keefe, Xu, & Clarke, 2006, p.73). It is a distinct event from ‘classwork’, which might include teacher exposition and whole-class discussion, but is a sub-set of ‘seatwork’, which is when “students work individually or in small groups on assigned tasks” and “talk is mostly private — teacher-student or student-student” (Stigler & Hiebert, 1999, p.67). It is this mostly private teacher-student talk, while students work on assigned tasks, which defines between-desk-teaching, although O’Keefe et al. (2006) also point to instances where this talk becomes more public. Inoue, Asada, Maeda, and Nakamura (2019) describe how between-desk-teaching offers learners individual support when problem solving, while Jakonen (2018) states that teacher actions during this lesson event are ‘occasioned’ in that they are sensitive to the learner’s present situation. Yet between-desk-teaching is often ‘repetitive’ in that the teacher addresses the same issue both with multiple learners and also potentially multiple times with the same learner (Jakonen, 2018).

O’Keefe et al. (2006) discuss both the monitoring and guiding functions of between-desk-teaching. Providing feedback, including references to learning goals (Svanes & Klette, 2018), or observing learners working serve a monitoring function. The guiding function can be associated with either

‘extending’ or ‘enabling’ teacher prompts (Roche & Clarke, 2015). Extending prompts are typically discussed in the literature with reference to challenge and questioning (e.g. Svanes & Klette, 2018), while enabling prompts may involve telling, modelling or offering hints (Svanes & Klette, 2018), or referring to prior learning or suggesting alternative approaches (Inoue et al., 2019).

While between-desk-teaching can be analysed as a distinct lesson event, or as an event within a lesson (Inoue et al., 2019), O’Keefe et al.’s (2006) study emphasises that in order to understand its purpose consideration needs to be given to the events that surround it and whether these events are classwork or seatwork. In terms of how content is made available to learners, between-desk-teaching can be seen as a bridge between independent-of-the-teacher seatwork and classwork, or vice versa. When the flow is from seatwork to classwork, the purpose of between-desk-teaching is more likely to be ‘monitoring student activity’ (O’Keefe et al., 2006) in order to inform the precise nature and focus of the classwork to follow, whereas when the flow is from classwork to seatwork the purpose is more likely to be ‘guiding student activity’ and making connections between the assigned task and the whole-class teaching that preceded it (Inoue et al., 2019). This emphasises how these lesson events mutually influence each other, but that there is a pedagogical choice regarding their sequencing.

The previous studies of between-desks-teaching discussed above focus particularly on the nature of teacher-learner participation during this lesson event rather than how the subject matter is being transformed and connected through these interactions. My own work however has focused on how subject matter is made available to learners over the course of teaching a topic (Andrews, 2017), through the actions of the teacher. I use the term ‘manifestation’ of a mathematical concept to refer to the form of content I observe the teacher offering learners at any moment in time, and a manifestation may be categorised as visual, technical, functional, or a combination of these. Visual manifestations often include diagrams or forms of imagery, technical manifestations often relate to methods or symbolic manipulation, and functional manifestations include worded problems and applications of methods.

In order to connect the sequencing of manifestations with opportunities for learning, I draw on a theory of growth in mathematical understanding (Pirie & Kieren, 1989; Pirie & Kieren, 1994). This constructivist theory proposes a progression of levels, each of which represents a reorganisation of knowledge structures, from ‘primitive knowing’, through ‘image having’ and ‘formalising’, to ‘structuring’ and beyond (Pirie & Kieren, 1989). I associate visual, technical and functional manifestations with opportunities to focus learners’ attention on image having, formalising and structuring respectively. I associate visual-functional, visual-technical and functional-technical manifestations with opportunities to shift the focus of learners’ attention, captured by Pirie & Kieren’s (1989) terms ‘image forming’, ‘property noticing’ and ‘observing’ respectively.

In a recent paper I highlight mathematical differences between what is addressed during classwork and seatwork in each of the four cases studied (Andrews, 2018). One pattern in practice revealed in this paper is a flow from classwork to seatwork within lessons and also across lesson series, with greater foregrounding of visual manifestations during classwork and functional manifestations during seatwork. This analysis suggests a degree of alignment in these cases between how content is made available to learners over time and the underlying progression proposed in Pirie & Kieren’s theory.

The current study builds on this recent paper and explores ways in which between-desk-teaching might support this progression.

From the range of purposes of between-desk-teaching identified above, I focus particularly in this paper on the guiding function and references back to prior learning (Inoue et al., 2019). Pirie and Kieren describe growth as “levelled but non-linear” (Pirie & Kieren, 1994, p.166) and use the term ‘folding back’ to describe returning to a previous level “in order to extend one’s current, inadequate understanding” (Pirie & Kieren, 1994, p.173). I associate teacher references during between-desk-teaching to prior learning with offering explicit opportunities for learners to ‘fold back’ to a previous level of understanding in order to come to understand the assigned task at hand. In such a situation the between-desk-teaching will not, in terms of manifestation, align to the assigned task but rather more closely to what has been offered previously (for example through classwork). The current study explores therefore whether during seatwork between-desk-teaching aligns with the assigned task, or is more associated with opportunities for folding back. Addressing this question over a series of lessons on a given topic rather than an individual lesson affords exploring patterns in practice, which in turn reveals if between-desk-teaching is being deployed as a strategic act for transforming and connecting the subject matter of a topic.

Methodology

A summary of the approach taken to address the current research question will be offered here. A methodological paper detailing the range of approaches taken in the wider study is being worked on separately, and this will in due course provide fuller details and justifications of methods employed. The approach is an analysis of the text of what the teacher is seen to offer learners over the course of a series of lessons on a single mathematical topic. By text here I mean the literal text of teacher-talk during lessons, whether that be public or privately to individual learners, and also the tasks, video clips, simulations, physical resources and other teaching media that the teacher makes available.

A quantitative approach is taken in order to detect differences in manifestation over periods of time through applying what I call a *tri-polar analysis*. The relative stressing of the three elements of the triad {visual, functional, technical} in the ratio $v : f : t$ and satisfying the condition that $v + f + t = 1$ can be succinctly represented by the Barycentric co-ordinate (v, f, t) .

How the teacher makes content available to learners is conceptualised as having two elements: teacher-talk and given-tasks. Teacher-talk may be public (for example, during periods of classwork) or private (during seatwork). Given-tasks are only present during seatwork and are the prompts that initiate subsequent activity in a lesson rather than that activity itself. The combination of teacher-talk and given-task during an individual between-desk-teaching event may serve to alter what is offered to learners when compared to what would have been available through the given-task alone. Therefore the effect of between-desk-teaching is revealed in any differences between what is offered during seatwork through considering both teacher-talk and given-task in unison to what would have been offered over the same time period through the given-task alone.

For the current study, the text of each lesson series is parsed into 30-second intervals, each of which is then qualitatively coded for manifestation. Each manifestation category is associated with a Barycentric co-ordinate. The quantitative code for teacher-talk for the interval is the mean of the

Barycentric co-ordinates of all of the manifestation categories present in the teacher-talk in that interval (or $(0, 0, 0)$ if there is no teacher-talk), and the quantitative code for given-task for the interval is determined similarly. The overall quantitative code for the interval (referred to as the interval centre) is either the co-ordinate for teacher-talk if there is no given task, the co-ordinate for given-task if there is no teacher-talk, or the mean of the teacher-talk and given-task co-ordinates. Each 30-second interval is also coded as either seatwork or classwork. The seatwork centre for the lesson series is then the mean of the Barycentric co-ordinates of all the intervals coded as seatwork, and the classwork centre is similarly defined. The given-task centre is the mean of the quantitative codes for given-task of all the intervals coded as seatwork. A statistical analysis of the visual co-ordinates for each interval using the Wilcoxon rank-sum test (Wilcoxon, 1945) allows the stressing of visual manifestation between classwork and seatwork, and between seatwork and given-task to be compared quantitatively (reported here using an effect size), and a similar analysis is conducted on the functional and then the technical co-ordinates. The extent of differences is represented by the effect size, and an effect size greater than .3 is treated as a material difference. By this I mean that the difference is large enough to infer systematic differences in how content is made available associated with strategic differences in teacher action.

The current paper initially reports on four lesson series taught in local secondary schools in England with students aged between 13 and 16. One of the teachers, Ashley taught a series of five lessons on geometrical constructions. Bernie was at the same school as Ashley and taught a series of four lessons on ratio with one class and three lessons on linear equations with another. Courtney was at a different school and taught a series of four lessons on linear equations. In each case, the teacher determined the topic and the teaching approach. The four cases are used to address the question of whether there are mathematical differences in what the teacher makes available through between-desk-teaching when compared to the underlying given-task alone. A closer analysis is then conducted of Bernie teaching ratio in order to understand better between-desk-teaching in this case.

Cross-case findings

Table 1 sets out the seatwork and given-task centres for the four lesson series studied. For each case the statistical significance of any differences between seatwork and given-task are given. The number (n) of 30-second intervals given over to seatwork is also given in each case.

The seatwork and given-task centres are descriptive statistics, and so comparisons between them only indicate where there are differences. It is the statistical analysis that quantifies these differences. The Barycentric co-ordinates highlight differences in each case between the seatwork and given-task centres, which indicate that during between-desk-teaching teacher-talk did not always align mathematically with the given-task. Instead this form of teacher-learner participation changed the mathematical nature of the activity. The greatest misalignment between seatwork and given-task was in the case of Bernie teaching ratio, and as this is an extreme case it has been selected for further analysis below. As this difference was material, the inference is that between-desk-teaching was being deployed as a strategic act for transforming and connecting the subject matter of a topic in this case.

Table 1: The seatwork and given-task centres of the four lesson series

Case		Seatwork	Given-task
Ashley teaching geometric constructions	<i>n</i>	410	
	Centre	(0.24, 0.27, 0.49)	(0.24, 0.32, 0.44)
	Difference	**	
Bernie teaching ratio	<i>n</i>	301	
	Centre	(0.06, 0.29, 0.65)	(0.00, 0.39, 0.61)
	Difference	MAT	
Bernie teaching linear equations	<i>n</i>	208	
	Centre	(0.20, 0.02, 0.78)	(0.18, 0.02, 0.80)
	Difference	NS	
Courtney teaching linear equations	<i>N</i>	270	
	Centre	(0.17, 0.09, 0.74)	(0.15, 0.12, 0.73)
	Difference	NS	

*N.B. Difference indicators show whether differences between the centres were material (MAT), statistically significant at the 1% level (**), or not statistically significant at the 1% level (NS)*

The particular case of Bernie teaching ratio

The lesson series was concerned with translating part-to-part relationships into part-to-whole relationships, such as dividing quantities in a given ratio. Inspection of the statistical analysis of differences between the classwork, seatwork and given-task centres (see table 2) indicate that the visual and technical components of manifestation were stressed more during classwork. This underlying pattern in practice is triangulated by the narrative account of the lessons that follows.

Table 2: The classwork, seatwork and given-task centres for Bernie's lesson series on ratio

Case		Classwork	Seatwork	Given-task
Bernie teaching ratio	<i>n</i>	82	301	301
	Centre	(0.14, 0.11, 0.75)	(0.06, 0.29, 0.65)	(0.00, 0.39, 0.61)
	Difference		MAT	MAT

*N.B. Difference indicators show whether differences between the centres were material (MAT), statistically significant at the 1% level (**), or not statistically significant at the 1% level (NS)*

In the classwork event of Lesson 1 Bernie displayed the problem “share £20 in the ratio 2 to 3” on the interactive whiteboard and learners were tasked with solving it individually. The problem was presented along with twenty circles representing the twenty £1 coins that were to be shared between the two people. After allowing a brief period for individual consideration, Bernie led a whole-class sharing of ways to solve this problem. As part of this, Bernie demonstrated how the 20 coins might be shared in the ratio two to three by counting them out two, then three, then two, then three, and so on. This classwork phase of the lesson was categorised as featuring visual and technical manifestations as Bernie offered a visual representation of an enactive method of sharing the money

in the given ratio. Building on Lesson 1, Bernie provided an opportunity for the whole class to recap methods for sharing quantities in a given ratio at the start of Lesson 2. The first example offered was: “share £140 in the ratio 3 to 4.” Three methods were suggested by learners, the third of which was a simple integer ‘scaling up’ method: $4 : 3 \equiv 40 : 30 \equiv 80 : 60$ and $80+60=140$. The limitations of this method were revealed by the second example: “share £45 in the ratio 2 : 3 : 7.” Following this, Bernie endorsed a single method, the first step of which was dividing the quantity by the total of the parts. Thus there was an emphasis placed on formal methods in this introductory classwork phase to the lesson, with technical manifestation foregrounded.

Technical and particularly functional manifestations were emphasised in the given-tasks assigned to learners during seatwork. For example, in Lesson 1 learners were provided with the opportunity to practise sharing quantities of money in given ratios, for example: “divide £20 in the ratio 4 : 1”, and “divide £10 in the ratio 3 : 2.” The given-task here was categorised as technical. In each of the following lessons students were set problems that required sharing in a given ratio, but increasingly these became worded, contextual problems. Thus functional manifestation was more emphasised over time.

The effect of between-desk-teaching was that overall seatwork was materially different to the assigned given-task, with visual manifestation emphasised more and functional less. This can be largely attributed to Bernie drawing on the image of ‘moneybags’ when between-desk-teaching in order to represent a unitary share, such as in Lesson 1:

In effect you've got 3 bags of money and 2 bags of money, which altogether is 5 bags of money. If you share your £10 equally into those 5 bags you'll have £2 in each bag won't you? That person gets 3 bags [and] that person gets 2 bags, yes? (Bernie, Ratio Lesson 1)

Between-desk-teaching in Lesson 2 also referenced moneybags and included four separate conversations with different students over a period of 10 minutes in which Bernie offered essentially the same explanation of the solution to the same problem. It is interesting to note that while Bernie used a particular visual method for dividing in a given ratio during classwork in Lesson 1, the visual method offered when between-desk-teaching was equivalent but not identical. Lesson 3 continued to include between-desk-teaching in which Bernie made reference to moneybags, but not Lesson 4. This suggests a progression from Lesson 3 to Lesson 4, as in Lesson 4 there was less recourse to the imagery of moneybags in Bernie’s between-desk-teaching.

My reading of the between-desk-teaching actions across Lessons 2 and 3 was as a return to more familiar-to-the-learner manifestations of ratio, which I associated with offering learners explicit opportunity to ‘fold back’ (Pirie and Kieren, 1989) to a secure level of understanding. In Lessons 2 and 3, this secure level of understanding was inferred to be a visual method for sharing quantities in a given ratio. Whereas in Lesson 4 Bernie was heard to return to more technical manifestations of ratio when between-desk-teaching, which I associated with offering learners explicit opportunity to fold back from an inadequate contextual understanding to a more secure understanding of a method for sharing in a given ratio.

Discussion

There are indications in this lesson series that between-desk-teaching was a lesson event foregrounded by Bernie in the context of teaching ratio to this class. Firstly, in total 52% of lesson time across the series was given over to between-desk-teaching compared to 27% to independent-of-the-teacher seatwork and 21% to classwork. Secondly, I have offered examples of Bernie repeating the same explanation on multiple occasions through between-desk-teaching when an alternative choice could have been to explain once to the whole class. This was an instance of the repetition effect noted by Jakonen (2018).

Furthermore I infer from the statistical analysis that between-desk-teaching was being deployed strategically as a way of making content available to learners. Non-linear opportunities were offered for growth in understanding (Pirie & Kieren, 1994) that were sensitive to the needs of individual learners (Jakonen, 2018). Teacher explanation at the start of the lesson series emphasised visual methods for solving ratio problems, while technical and increasingly functional components of manifestation were emphasised in the given-task that were subsequently assigned. While the methods of problem solving offered through between-desks-teaching in Lessons 2 and 3 were not identical to the methods seen at the start of Lesson 1, there was a clear intention to offer visual representations of problems in order to facilitate their solution, and for these to remain available throughout the lesson series. By Lesson 4 it can be inferred that visual representations were no longer needed, but symbolic representations of contextual problems were being offered through between-desks-teaching by this stage. In summary, whether through conscious deliberation or out of habit Bernie's actions aligned in this context with choosing to use between-desks-teaching in order to offer learners explicit opportunities to fold back to a secure level of understanding from earlier in the lesson series.

Conclusion

Previous studies have considered between-desks-teaching as an isolated event or as an event within a lesson (e.g. Inoue et al., 2019), but the current study has taken the lesson series as the unit of analysis. There is stronger evidence of Bernie's between-desks-teaching being a deliberate act because this phenomenon was explored across a series of lessons. A further affordance of this research design is that through the analysis of teacher-talk and given-task it supports making sense of the contribution of between-desk-teaching to the way content is made available to learners over time. The lesson series is a unit of time over which teachers typically plan, and while the role of between-desks-teaching at this grain size may not be an issue they (and researchers) currently attend to, it could be. The two case studies involving Bernie reported in this paper offer an ideal example of when it might be appropriate for a teacher's attention to be drawn to this. In the case of Bernie teaching ratio, as we have seen, between-desk-teaching was used extensively and strategically. Yet in the case of teaching linear equations it was not used in this strategic way at all. Such contrasts in the practice provide in my experience powerful prompts for teacher reflection.

References

- Andrews, N. (2017). Differences in the forms of content teachers are seen to offer over time: Identifying opportunities for teacher growth. In T. Dooley & G. Gueudet (Eds.), *Proceedings of*

the Tenth Congress of the European Society for Research in Mathematics Education (CERME10, February 1–5, 2017) (pp. 3232–3239). Dublin, Ireland: DCU Institute of Education & ERME.

- Andrews, N. (2018). Are there mathematical differences in what is addressed through different modes of interaction in classrooms? In F. Curtis (Ed.), *Proceedings of the British Society for Research into Learning Mathematics*, 38(2), June 2018.
- Inoue, N., Asada, T., Maeda, N., & Nakamura, S. (2019). Deconstructing teacher expertise for inquiry-based teaching: Looking into consensus building pedagogy in Japanese classrooms. *Teaching and Teacher Education*, 77, 366–377.
- Jakonen, T. (2018). Professional embodiment: Walking, re-engagement of desk interactions, and provision of instruction during classroom rounds. *Applied Linguistics*. Available from: <https://ezproxy-prd.bodleian.ox.ac.uk:5876/applij/advance-article/doi/10.1093/applin/amy034/5123669>
- O’Keefe, C., Xu, L., & Clarke, D. (2006). Kikan-shido: Between desks instruction. In D. Clarke, J. Emanuelsson, E. Jablonka, & I. Mok (Eds.), *Making connections: Comparing mathematics classrooms around the World* (pp. 73–106). Rotterdam, Netherlands: Sense Publishers.
- Pirie, S., & Kieren, T. (1989). A recursive theory of mathematical understanding. *For the Learning of Mathematics*, 9(3), 7–11.
- Pirie, S., & Kieren, T. (1994). Growth in mathematical understanding: How can we characterise it and how can we represent it? *Educational Studies in Mathematics*, 26(2), 165–190.
- Roche, A., & Clarke, D. (2015). Describing the nature and effect of teacher interactions with students during seat work on challenging tasks. In M. Marshman, V. Geiger, & A. Bennison (Eds.), *Mathematics education in the margins (Proceedings of the 38th annual conference of the Mathematics Education Research Group of Australasia)* (pp. 532–539). Sunshine Coast: MERGA.
- Skott, J., Mosvold, R., & Sakonidis, C. (2018). Classroom practice and teachers’ knowledge, beliefs and identity. In T. Dreyfus, M. Artigue, D. Potari, S. Prediger, & K. Ruthven (Eds.), *Developing research in mathematics education: Twenty years of communication, cooperation and collaboration in Europe* (pp. 162–180). Abingdon, UK: Routledge.
- Stigler, J., & Hiebert, J. (1999). *The teaching gap: Best ideas from the world’s teachers for improving education in the classroom*. New York, NY: Free Press.
- Svanes, I. K., & Klette, K. (2018). Teachers’ instructional practices during pupils’ individual seatwork in Norwegian Language arts. *Education Inquiry*, 9(3), 247–266.
- Wilcoxon, F. (1945). Individual comparisons by ranking methods. *Biometrics Bulletin*, 1(6), 80–83.

Teachers' learning goals for a mathematics lesson

Kristin Krogh Arnesen and Yvonne Grimeland

Norwegian University of Science and Technology, Norway; kristin.arnesen@ntnu.no

Due to current policy, including a curriculum that is managed by objectives, it is common that Norwegian mathematics teachers specify a learning goal for each lesson they teach. This study aims to identify characteristics of such goals. To this end, we analysed 50 learning goals with the revised Bloom's Taxonomy. A main finding is that there is an emphasis on students' understanding; however, the cognitive process categories Analyse, Evaluate, and Create were poorly represented in our data. Moreover, we asked the teachers to identify mathematical ideas (related to the learning goal) they would focus on in the lesson. In our data, the stated mathematical ideas were vague, and many teachers did not state any mathematical ideas at all. We discuss possible reasons for this.

Keywords: Learning goals, identifying mathematical ideas, revised Bloom's Taxonomy

Introduction

To plan lessons with the intended learning outcome (in this paper called a “(learning) goal”) as the point of departure is an old tradition. Tyler's influential model for planning (Tyler, 1949) is described by John (2006) as linear, meaning that you start with identifying a goal for the lesson, and then choose activities, assessment, and other elements that fit the goal. More dynamic models (see e.g. John (2006)) also include specifying goals. In one framework for learning how to teach (Hiebert, Morris, Berk, & Jansen, 2007), specifying the learning goals for an instructional episode is listed as the first item of the framework. Moreover, learning goals are closely linked with theory on assessment for learning, where one principle is that students should understand the learning intentions, including an understanding of what would count as success criteria (Hodgen & Wiliam, 2006). Thus, goals are typically not only a part of a teacher's planning process, but also present in the classroom. For instance, it is common in Norwegian schools that pupils get a goal for the week/day/lesson in every subject (Vikan & Buland, 2014). Another influence on the use of learning goals in Norway is that the education system is managed by objectives. The practice of using learning goals in teaching is probably similar to what is found in other countries where the education system is managed by objectives, e.g. Denmark (see Hansen, 2016). In Denmark, a study has shown that visible learning goals implicitly lead to a focus on skills and performance instead of mathematical competence (Hansen, 2016). A Norwegian Master's thesis investigating the mathematical competences present in five 8th grade teachers' learning goals (as they appeared in teaching) found that most of the goals had a short-time horizon and mostly focused on procedures, rather than on understanding (Selling, 2017).

In mathematics teaching, deciding upon a goal is closely connected with identifying a particular mathematical topic to discuss (Superfine, 2008). This identifying process can be linked with Askew's term “precision” (Askew, 2008). Being precise, including about the mathematical knowledge at stake, is one of the key elements in his framework for mathematics subject knowledge for teaching. It is suggested in a study by Sullivan, Clarke, Clarke, Farrell, and Gerrard (2012) that teachers tend to concentrate on activities and general aspects of pedagogy rather than on content objectives when planning mathematics lessons. In the study, Australian teachers were asked “what is the most

important idea that you will focus on for [the next mathematical topic you plan to teach]?”. Only half of the teachers in the study could describe the important ideas with a level of precision “likely to assist them in their planning” (Sullivan et al., 2012, p.478). In the conclusion to the study, the authors write that “it seems that teachers may need support in articulating the ‘important ideas’ on which they will focus and the sequencing and interrelationship of these ideas” (Sullivan et al., 2012, p. 478). Our study is based on the assumption that identifying mathematical ideas, or relationships between them, is intrinsic to producing adequate learning goals. It is therefore of interest to gain more knowledge about teachers’ identification of ideas underpinning the goals. To this end, our research questions are:

What characterises teachers’ mathematical learning goals for mathematics lessons?

What characterises teachers’ identified mathematical ideas behind the learning goals?

With the above stated assumption in mind, there is a hypothetical outcome where the two research questions gain similar results (a mathematical learning goal may be referring to a mathematical idea). However, for the first question, we aimed to analyse the learning goals given explicitly to students, and there could be pedagogical reasons not to give the mathematical idea to students in advance. Thus, the second research question will give more insight into the teachers’ practices regarding learning goals. In order to answer the research questions, we designed a questionnaire, which was answered anonymously by 51 teachers from primary and lower secondary school. In the subsequent analysis, we used two frameworks: The revised Bloom’s Taxonomy (Krathwohl & Anderson, 2001) and a framework from the already mentioned paper by Sullivan et al. (2012).

As the study is set in Norway, we provide the reader with some contextual background. In Norway, the non-linear “didactic relation model” for lesson planning (Bjørndal & Lieberg, 1978) has become part of the Norwegian “pedagogical canon”, as it is used in a number of textbooks in teacher education (Engelsen, 2006). In this model, six (originally five) elements are shown as mutually interplaying, with “goal” being one of them (Bjørndal & Lieberg, 1978). However, although goals are not the typical starting point for lesson planning in Norway, they are an important part of teachers’ practices. More precisely, “[g]oals are visible in a variety of ways; in the weekly plans, when teachers write goals on the blackboard and when they discuss goals orally in class” (Vikan & Buland, 2014, p. 17). The current curriculum, implemented in 2006 (Ministry of Education and Research, 2016), is written in terms of goals. For all school subjects, there is a subject curriculum, which consists of a list (ordered by year) of so-called *competence aims*, and the students are assessed by whether they have achieved these competence aims.¹ As an example, the curriculum for mathematics lists that after year 4 (aged 9–10), a student should be able to “make estimates of and find numbers by means of counting in one’s head, using counting aids and written notes, making estimates by calculating with simple numbers, and assessing answers” (Ministry of Education and Research, 2010). The competence aims are further decomposed, ultimately by the teacher(s) when planning a lesson.

¹ Regulations of the Education Act, 2006, §3-3. Available at <https://lovdata.no/dokument/SF/forskrift/2006-06-23-724?q=forskrift%20til%20opplæringslova>

Theoretical frameworks

One of the most well-known models for analysing goals is Bloom's Taxonomy (Bloom et al., 1956). We build our analysis of the learning goals on the revised Bloom's Taxonomy (Anderson & Krathwohl, 2001), in which the original taxonomy has become a two-dimensional model, with one dimension focusing on the cognitive aspect of the goal, the other on the knowledge at stake. Unlike the original taxonomy, the revised version does not stress a rigid hierarchical structure – that is, a goal in a given category in either dimension is not necessarily “better” or “more demanding” than a goal in the previous category in that dimension. On the other hand, the revised taxonomy is meant as a tool to, among other things, “help educators consider the panorama of possibilities in education” (Anderson & Krathwohl, 2001, p. 35). As such, it is most common among educators, but it is also used in research (see e.g. Hansen, Herheim, & Lilland, 2017). We chose the revised Bloom's Taxonomy because it would give an overview of the learning goals, suggesting some characteristic features and some features that do not appear among the goals.

We explain here how we have interpreted the categories of the revised Bloom's Taxonomy. The four categories of the knowledge dimension are interpreted as follows: *Factual knowledge* means terminology and conventions. *Conceptual knowledge* consists of mathematical concepts, ideas, and models. *Procedural knowledge* includes everything related to *doing something* (Anderson & Krathwohl, 2001): computing, algorithms, strategies. *Metacognitive knowledge* is knowledge about cognition, including meta-knowledge of strategies. Moreover, the six categories of the cognitive process dimension are interpreted as follows: *Remember* is about memorising things (like definitions, terminology, or the steps of an algorithm). The *Understand* category is for goals including verbs like “learn”, “know”, “explain” and others listed by Anderson and Krathwohl (2001) (in our data, it is hard to identify the category in other ways). The *Apply* category is for doing something of a non-algorithmic nature. Note that this differs slightly from Anderson and Krathwohl's description, as we would classify performing a given algorithm to a standard problem as *Remember procedural knowledge* rather than *Apply procedural knowledge*. *Analysing* means breaking something down to look at relationships, while *Evaluate* is to test or detect something based on given criteria. Finally, *Create* means to produce something new, like a hypothesis or an argument.

To analyse the teachers' stated mathematical ideas, we use a framework introduced by Sullivan et al. (2012). The framework consists of five categories, which we have interpreted as follows: For *A mathematical idea within the topic*, the mathematical idea/relationship is clearly specified. For the second category, *An element of a hypothetical learning trajectory*, the mathematical idea/relationship is underlying the response, but not explicitly stated – instead, the focus is on the students' discoveries or activities. The third category, *A sub-topic of the larger mathematical topic*, is characterised by keyword-style answers. The two final categories have self-explanatory titles: *A statement which could apply to most other topics and not specifically an important idea tied to the particular topic* and *A statement which describes aspects of pedagogy and does not particularly address content*. We did not intend to connect the two frameworks. Instead, it was our aim to treat the two research questions separately, and then use the second to shed light on the first, as the goals are our main topic of interest.

Method

The research questions require data in the form of teachers' mathematical learning goals, together with information on what the teachers regard as the mathematical idea underpinning the learning goals. To obtain this, we designed an anonymous questionnaire for teachers, introduced by the request "base your answers on the next mathematics lesson you give". The questionnaire and the quoted responses are translated from Norwegian by the authors. The questions relevant for the research questions treated in this paper are Q2: "What is the content-related learning goal of the lesson?"; Q4: "Is there a particular mathematical relationship or idea within the learning goal you want to especially focus on in the lesson? If yes, what?"; Q6: "Do you as the teacher have any other content-related or pedagogical goals for the lesson, that are not made known to the students? If yes, what?" Additionally, we asked about the overall topic of the lesson, the age of the students, and whether the goal would be made explicitly known to the class.

We piloted a first version of the questionnaire among a group of in-service teachers taking a course given by the first author. In the discussion with the pilot respondents, we were made aware that the terms "mathematical relationship/idea" could be hard to distinguish from "content-related goal". As suggested by the pilot respondents, we changed the order of some questions, intending to make this distinction clearer. Yet, we chose to keep the terms used, as this would be in line with the terms used in the theoretical frameworks of the study. Nevertheless, this suggested confusion could indicate that the validity of the study is not optimal, as we will comment further upon in the discussion.

In-service teachers supervising school placement of student teachers were chosen as the cohort because we had easy access to them via the university's digital learning management system (LMS). In general, supervisors have not taken more mathematics courses than other teachers have. The respondents are called "teachers" throughout this paper. We posted information of the study in the digital LMS, and additionally issued individual messages to all teachers, with a link to the digital questionnaire. Later we sent two reminders to all the teachers. In this period, we obtained 29 digital answers. To get more data, the second author visited a meeting for supervisors hosted by the university the following term, distributing paper copies of the questionnaire (as well as link to the digital version). At the meeting, 22 completed questionnaire sheets were handed in. Thus, the data in this study consists of 51 questionnaire answers (29 digital and 22 on paper). It makes sense to assume that most teachers answering in the first round had access to their actual planning notes, while most teachers answering in the second round did not. Yet, we have treated the answers from both rounds as one data set, because the teachers at the meeting had the option of answering digitally later, which they chose not to do (so we can assume they considered that they remembered the details sufficiently). Some teachers might have answered the questionnaire twice (once in each round); this has not been taken into consideration during analysis, as we cannot identify them in the data material. The teachers work in primary or lower secondary school, and the majority (37 teachers) teach grades 4-7. One teacher in the cohort did not state a goal when answering Q2; thus, 50 goals were analysed.

After collecting all the data, the first author coded the replies to Q2 and Q4 with the revised Bloom's Taxonomy and Sullivan's framework for mathematical ideas, respectively. Then the coding was discussed with the second author. We used the revised Bloom's Taxonomy as follows: First, we coded

by the knowledge dimension, subsequently by the cognitive process dimension. Not all goals were easy to reliably classify by the framework. For instance, it is sometimes unclear whether a goal belongs to the *Remember* or the *Understand* category, in particular for goals in the *Procedural* knowledge category. In these situations, we used the replies to additional questions (in particular Q4) to look for indicators on how to classify the goal. We also intended to use Sullivan's framework to analyse goals given as replies to Q6, but here the replies were (with very few exceptions) either blank, or belonging to the last of the five categories (general aspects of pedagogy). Thus, we concluded that this question did not shed light on the research question, and we include no analysis of the replies.

Because of the methodological weaknesses in the study, we need to be careful when addressing the data. Nevertheless, we can view the results as preliminary results, initiating discussions and indicating directions of future research.

Results

The complete results of the analysis are presented in Table 1 (Q2) and Table 2 (Q4). From the analysis of Q2 (the goals), the most prominent findings are *a focus on understanding* and *a lack of higher-level goals*. Regarding Q4 (the mathematical ideas), the analysis reveals a *vague/missing description of mathematical ideas*. All teachers except two state that they would present the goals to their students before the class.

The knowledge dimension	The cognitive process dimension					
	1. Remember	2. Understand	3. Apply	4. Analyse	5. Evaluate	6. Create
A. Factual knowledge	2					
B. Conceptual knowledge	1	10	2			
C. Procedural knowledge	6	13	6			
D. Metacognitive knowledge		4				
Other	6					

Table 1: Revised Bloom's Taxonomy table. Number of goals in each intersected category

A focus on understanding

Of the 50 goals that were analysed, 27 goals – more than half of the goals – were found to belong to the *Understand* category. Examples include “understand fractions as a part of a set” (*Understanding conceptual knowledge*; the knowledge at stake can be identified as the set model for fractions) and “The students should learn addition with regrouping” (*Understanding procedural knowledge*; the respondent states in reply to Q6 that no algorithm will be given, but that the work builds a fundament for a later understanding of the standard algorithm). In contrast, there are few goals identified in the *Remember* category.

A lack of higher-level goals

By “higher-level”, we mean the three upper categories in the cognitive dimension; *Analyse*, *Evaluate* and *Create*. No goals were found to fit within these categories. The “highest” category we found

examples of in our analysis were C3, *Applying conceptual knowledge*. In this category, any method mentioned for the given procedure is subject to the students' exploration, or there is no method given at all. One example, with a given method, is "that the students should get experience with using strategy with 'friendly numbers' in computing". With a particular idea highlighted in the reply to Q4, this goal could belong to category C4, but no such idea is stated.

Category	Number of replies
1. A mathematical idea within the topic	8
2. An element of a hypothetical learning trajectory	8
3. A sub-topic of the larger mathematical topic	7
4. A statement which could apply to most other topics and not specifically an important idea tied to the particular topic	12
5. A statement which describes aspects of pedagogy and does not particularly address content	3
Missing	11
Uncategorised	1

Table 2: Sullivan et al.'s framework. Number of replies in each category

Vague/missing description of mathematical ideas

As Table 2 shows, only 16 of the 50 analysed replies fall into the two top categories in Sullivan et al.'s framework. Eleven of the teachers do not state a mathematical idea at all. Examples of category 1 and 2 include "the relationship between division and multiplication" and "understanding that decimal numbers consist of parts that are less than one whole" (category 1); "strategy thinking – how to find fourths and eights – focus on halving" and "converting to correct unit of measurement before computing" (category 2). Examples from category 3 are "friendly numbers" and "the decimal number system". In category 4, we find "focus on exactness and using a sketch figure", in category 5 "more than one way leading to the target". The uncategorised reply is "show a way to do it ['it' is division by one digit numbers]", where we do not know whether the "show" regards the teacher or the students.

Discussion

We can assume from the preliminary findings that many teachers intend to teach for understanding, judging by their use of verbs like "understand", "learn", "see" and so on (the verbs attributed to the *Understand* category in Bloom's Taxonomy). This is in contrast to Selling's findings, where the goals were dominated by a focus on procedures and not understanding (Selling, 2017). One reason for this difference can be that we have analysed learning goals from the teachers' lesson planning, while Selling analysed goals that appeared – explicitly or implicitly – during lessons. Nevertheless, the teachers' focus on students' understanding is an uplifting finding. As terms like "understand" and "learn" are ambiguously used in pedagogics and mathematics education research, more information is needed in order to get a more detailed picture of the teachers' use of such words. Yet, it is tempting – from the researchers' point of view – to connect the idea of "understanding" to a focus on the

mathematical ideas underpinning what is to be understood. Here, we note an intriguing discrepancy between the emphasis on understanding in the learning goals and the vague/missing description of mathematical ideas.

When discussing the teachers' seemingly disappointing reports on mathematical ideas, it is necessary to return to the methodological problem we encountered when wording Q4 in the questionnaire. Because we wanted to elicit information about the teachers' view on mathematical ideas, we ended up using a term – mathematical idea – that seemed unfamiliar and confusing to the pilot respondents. As mathematicians, we may have assumed that the meaning of the term is evident. However, a brief search in literature reveals that very few papers using the term (or similar terms, like “big idea”) actually define it. An exception is the in the German-speaking tradition, where mathematics educators use “fundamental ideas” to guide their mathematics teaching (see Vohns, 2016), but this is – from our experience – not familiar to the Norwegian mathematics education community. Interestingly, we find traces of a similar problem in Sullivan et al.'s paper (2012). In their study, they asked the teachers “what is the most important idea that you will focus on for that topic”, assuming that the teachers would interpret “idea” as “mathematical idea”. When the responses showed that this was not always the case, the authors conclude that “[t]he fact that the important idea in the teaching of a forthcoming mathematical topic in the mind of a teacher might not be mathematical is revealing in itself” (Sullivan et al., 2012, p. 468).

Following this discussion, we infer that we cannot conclude whether we have found a problem with the teachers' level of precision (cf. Askew, 2008), with the teachers' own mathematical competence, or with the use of a term that is understood differently by the researchers and by the teachers. To ensure the validity of further studies, such terms should be avoided. Other approaches (like interviews) can help to distinguish the teachers' mathematical focus when writing learning goals.

When it comes to the third finding, the lack of higher-level goals, there is also a potential explanation due to the same issue. The teachers' replies to Q2 were partly analysed based on their reply to Q4. Thus, it is possible that some goals were misjudged due to our use of the term “mathematical idea”. At the same time, many goals were easy to analyse without the need to consider Q4. Based on this, the preliminary findings indicate the same trend that has been found in Denmark, i.e. that the focus on visible learning goals can lead to more focus on skills and less on competences (Hansen, 2016).

References

- Anderson, L., & Krathwohl, D. (2001). *A Taxonomy for learning, teaching, and assessing: A revision of Bloom's Taxonomy of educational objectives* (Complete ed.). New York, NY: Longman.
- Askew, M. (2008). Mathematical discipline knowledge requirements for prospective primary teachers, and the structure and teaching approaches of programs designed to develop that knowledge. In P. Sullivan, & T. Wood (Eds.), *The International Handbook of Mathematics Teacher Education* (Vol. 1, pp. 13–36). Rotterdam, Netherlands: Sense Publishers.
- Bjørndal, B., & Lieberg, S. (1978). *Nye veier i didaktikken? En innføring i didaktiske emner og begreper* (Pedagogisk perspektiv). Oslo, Norway: Aschehoug.

- Bloom, B. S. (Ed.), Engelhart, M. D., Furst, E. J., Hill, W. H., & Krathwohl, D. R. (1956). *Taxonomy of educational objectives: The classification of educational goals. Handbook 1: Cognitive domain*. New York, USA: David McKay.
- Engelsen, B. (2006). *Kan læring planlegges? Arbeid med læreplaner – hva, hvordan, hvorfor* (5. ed.). Oslo, Norway: Gyldendal akademisk.
- Hansen, R. (2016). På vej mod en målbevidst, målstyret kompetenceorienteret matematikundervisning. *Studier i læreruddannelse og -profession*, 1(1), 28–54.
- Hansen, R., Herheim, R., & Lilland, I.E. (2017). Teachers' mathematical discussions of the body mass index. In Norén, E., Palmér, H., & Cooke, A. (Eds.), *The Eighth Nordic Conference on Mathematics Education, NORMA 17*. Stockholm, Sweden: SMDF.
- Hiebert, J., Morris, A.K., Berk, D., & Jansen, A. (2007). Preparing Teachers to Learn from Teaching. *Journal of Teacher Education*, 58(1), 47–61.
- Hodgen, J., & Wiliam, D. (2006). *Mathematics inside the black box: Assessment for learning in the mathematics classroom* (Black box assessment for learning series). London, UK: GL Assessment.
- John, P.D. (2006). Lesson planning and the student teacher: re-thinking the dominant model. *Journal of Curriculum Studies*. 38(4). 483–498.
- Ministry of Education and Research (2010). *Curriculum for the Common Core Subject of Mathematics*. <https://www.udir.no/kl06/MAT1-04?lplang=http://data.udir.no/kl06/eng>
- Ministry of Education and Research (2016, 22 April). *Læreplanverket for Kunnskapsløftet*. <https://www.udir.no/laring-og-trivsel/lareplanverket/hvordan-er-lareplanene-bygd-opp/>
- Selling, A. J. V. (2017). *Målsättningar i matematik – en studie av fem högstadielärares målsättningar i matematikundervisning* (Master's thesis, University of Oslo). Retrieved from <https://www.duo.uio.no/handle/10852/57888>
- Sullivan, P., Clarke, D., Clarke, D., Farrell, L., & Gerrard, J. (2012). Processes and priorities in planning mathematics teaching. *Mathematics Education Research Journal*, 25(4), 457–480.
- Superfine, A. C. (2008). Planning for Mathematics Instruction: A Model of Experienced Teachers' Planning Processes in the Context of a Reform Mathematics Curriculum. *Mathematics Educator*, 18(2), 11–22.
- Tyler, R. (1949). *Basic principles of curriculum and instruction*. Chicago, IL: University of Chicago Press.
- Vikan, L., & Buland, T. (eds.) (2014). *Vurdering i skolen. Utvikling av kompetanse og fellesskap. Sluttrapport fra prosjektet Forskning på individuell vurdering i skolen (FIVIS)*. Trondheim, Norway: NTNU, Program for lærerutdanning og SINTEF Teknologi og samfunn.
- Vohns, A. (2016). Fundamental Ideas as a Guiding Category in Mathematics Education—Early Understandings, Developments in German-Speaking Countries and Relations to Subject Matter Didactics. *Journal für Mathematik-Didaktik*, 37(1), 193–223.

A math teacher's participation in a classroom design research: teaching of ratio and proportion

Rukiye Ayan¹ Mine Isiksal-Bostan¹ and Michelle Stephan²

¹Middle East Technical University, Faculty of Education, Ankara, Turkey; rayan@metu.edu.tr;
misiksal@metu.edu.tr

²University of North Carolina Charlotte, Cato College of Education USA; mstephal@uncc.edu

The purpose of this study is to explore how a mathematics teacher contributed to a classroom design research and how this contribution promoted student learning and the establishment of students' mathematical practices of linking composite units and iterating linked composites, which is the basis for proportional reasoning. In this classroom design research study, a classroom learning trajectory and related instructional sequence were formulated based on the theory of Realistic Mathematics Education and implemented by the teacher. Findings showed that the teacher contributed to the design research in each phase, and her contributions promoted students' mathematical practices regarding linking composite units and iterating composite units.

Keywords: Realistic mathematics education, proportional reasoning, classroom design research.

Introduction

Proportional reasoning lies at the heart of many mathematical structures, especially those included in the primary and middle school mathematics curricula (Lesh, Post, & Behr, 1988). However, several studies reported students' difficulties and misconceptions in proportional reasoning. These difficulties are said to have stemmed from the fact that proportional reasoning instruction is superficial and limited since it is conventionally referred to as solving missing-value problems with procedural algorithms, such as cross multiplication (Lesh et al., 1988). Thus, it is clear that there is a need for improved instruction for proportional reasoning.

Simon (1995) was a pioneer in proposing the development and use of Hypothetical Learning Trajectories (HLT) for improving instruction in such a way that lessons are designed in line with related research findings on student thinking and learning. Stephan (2015) introduced the construct of a classroom learning trajectory, which is referred to as anticipated classroom mathematical practices that might evolve over the course of an instructional sequence. Using Stephan's approach, we conducted a classroom design research project, in which we formulated a classroom learning trajectory and related instructional sequence for ratio and proportion for seventh grade based on the theory of Realistic Mathematics Education (RME) since working in realistic contexts can be an instructional aid for meaningful learning and reinventing mathematical ideas (Gravemeijer, 1994). While the larger study concentrates on these issues, we particularly focus on the teacher's role in classroom design research for the big ideas of linking composite units and iterating linked composites in this paper. The research questions addressed are:

1. How does a seventh-grade math teacher participate in the preparation/design phase of a classroom design research study? How does this contribution promote the emerging and establishment of mathematical practices regarding linking composite units and iterating linked composites?

2. How does a seventh-grade math teacher support the emerging and establishment of mathematical practices regarding linking composite units and iterating linked composites through the implementation of the instructional sequence?

Methods

Design research studies have gained importance in the last two decades and have been conducted for various goals in educational research area from designing and examining innovations, such as activities, institutions, interventions, or curricula (Design-Based Research Collective, 2003). This study is a classroom design research in which an instructional sequence is formulated, tested, and revised by a research team including teachers and university members (Stephan, 2015). A classroom design research cycle entails three phases as design, implementation, and analysis (Stephan, 2015).

This classroom design research study was conducted in a seventh-grade classroom in a public school located in a rural area in the capital city of Turkey. Hence, most of the students had low socioeconomic statuses. The students had been instructed on calculating the ratio of two quantities and finding different values of the quantities that are directly proportional in sixth grade. They had not been instructed on ratio and proportion in seventh grade prior to the study. The teacher was female with 10 years of experience in teaching in seventh grade. She was selected since she adopted student-centered teaching practices and was willing to cooperate with the researchers in every part of the study. Even though she had not been trained specifically before the study, she was informed about the purposes of the study and the literature on proportional reasoning, RME, and HLT.

Instructional Sequence

The approach that undergirds the design of the proportional reasoning instructional sequence is RME. The roots of RME are based on the idea of mathematics as a human activity. Freudenthal (1968) stated that people need to see mathematics not “as a closed system, but rather as an activity, the process of mathematizing reality and if possible even that of mathematizing mathematics” (p. 7). Within the context of RME studies, students are guided to reinvent mathematical ideas through organizing realistic contexts that are didactically rich (Gravemeijer, 1994). In addition, students are encouraged to create and reason with models and mental imagery associated with the physical tools, inscriptions, and tasks they employ.

In the instructional sequence, which was developed for the students in the USA, the instruction begins with a story about a bad dream in which aliens were chasing the teacher and a bar of food was enough to satisfy three aliens. In this way, students were encouraged to link together one food bar with three aliens and knew that if this relationship was broken, there would be an alien attack. As students solve problems, they are encouraged to organize their pictures or numbers, and eventually a ratio table is introduced as an efficient way to keep track of how the two quantities may scale up or down. For the purposes of this paper, we will not describe the remainder of the instructional sequence because we focus our analysis only on the first part, *linking composite units and iterating linked composites*. For more information of the sequence and the materials themselves, see <https://cstem.uncc.edu/sites/cstem.uncc.edu/files/media/Ratio%20T%20Manual.pdf>

A small part of the HLT that is related to this study can be seen in Table 1 below. The Big Idea column describes the learning goal for that portion of the instruction, and the Tools/Imagery column outlines the specific inscriptions and/or notations that are intended to support the corresponding learning goal. The third column, Possible Topics of Discourse, is meant to guide teachers in the types of questions or mathematical conversations that are important for that section of the sequence. The HLT for the entire proportional reasoning sequence can be reached via the same link.

Big idea	Tools/Imagery	Possible Topics of Discourse
Linking composite units	Connecting pictures of aliens to food bars	If the rule is 1 food bar feeds 3 aliens, the rule can't be broken if we add more food bars
Iterating linked composites	Informal symbolizing (e.g., tables, two columns of numbers, pictures of aliens and food bars)	How students keep track of two quantities while making them bigger

Table 1: A small part of the HLT related to linking and iterating

Data collection

Cobb, Confrey, Lehrer, and Schauble (2003) stress that the units of analysis in a design research are the key elements of a learning environment and these are:

the tasks or problems that students are asked to solve, the kinds of discourses that are encouraged, the norms of participation that are established, the tools and related means provided, and the practical means by which classroom teachers can orchestrate relations among these elements. (p. 9)

Therefore, in this study, it is crucial to analyze the teacher's contribution to each phase of the study and how her contribution had an impact on the emerging and establishment of students' mathematical practices of linking and iterating. The related data were collected through the videotapes of class sessions, audiotapes of teacher interviews and research team meetings, and analysis of student work.

Data analysis

The teacher's contribution to the design research was documented by an analysis of the written transcripts of her interviews and of the design team meetings. These qualitative data were analyzed by an interpretative framework and a related analytic approach that focuses on the "meanings made both by the social actors and by the researcher" (Miles & Huberman, 1994, p. 8). Students' mathematical practices were analyzed using Stephan and Rasmussen's (2002) adaptation of the Toulmin's (1969) argumentation model. After classroom argumentation process was coded as claim, data, or warrant, the ideas that emerged were noted. The criteria by Stephan and Rasmussen were used in order to see what mathematical ideas became taken-as-shared (or established) by the classroom community. For the last part of the analysis, these taken-as-shared ideas were organized around common mathematical activities, which were later named as classroom mathematical practices. Seven mathematical practices were obtained in the larger study; however, we focus only on the first mathematical practice in this study.

Findings

Findings are presented by describing the teacher's contribution to each phase of the study with specific examples. In addition, the first classroom mathematical practice regarding linking composite units and iterating linked composites is explained with details in order to reveal how the teacher's contribution to the design phase was realized in the classroom and had an impact on the establishment of students' mathematical practice of linking composite units and iterating composite units.

Teacher's contribution in the preparation/design phase

The initial phase of the classroom design research is mostly about reviewing literature, finding a realistic and engaging context, and hypothesizing a classroom learning trajectory. Literature review was conducted by the design team on teaching and learning of ratio, proportion, and related concepts and instructional activities and tools. In addition, the teacher was interviewed regarding her experiences on the learning and teaching of related topics and curriculum. Even though an already developed and tested trajectory was available, a number of adaptations and modifications were needed for Turkish students. For instance, the context was changed from alien-food bars to fish-food bars in order to make it more experientially real for Turkish students. Moreover, pictures were added to some of the questions, and quantities in some of the problems were changed in order to improve the sequence and the HLT. While deciding on these changes, the design team was engaged in anticipatory thought experiments in which they tried to imagine possible classroom mathematical discourse, which were helpful in shaping the design and coming up with conjectures about the teaching and learning of the topic. Even though the teacher had an active role in all of this process, we represent below a number of substantial teacher suggestions in order to reveal the unique value of her contribution to this phase. To begin with, the teacher suggested that pictures of food bars and/or fish were included for some problems in order to visually support students' processes of linking units and iterating composite units. In addition, she suggested that some values in the questions should be altered in a way that it was possible to make connections between questions. For instance, the question "how many fish can be fed with 5 food bars?" was followed by "how many fish can be fed with 9 food bars?" and "how many fish can be fed with 10 food bars?" in order to support the use of build-up strategies.

Teacher's contribution to the implementation phase

The teacher launched the trajectory with the adapted version of the bad dream story in which her fish were making noise and attacking her since they were hungry. The teacher, then, asked students if they had pets and how they fed their pets. Students suggested that pets had to be fed with a certain amount of food each day: if they were underfed they would be hungry and if they were overfed they would get sick or even die from overfeeding. This was an on-action (unplanned) instructional move that laid the ground for students to make sense of why the rule could not be broken.

In the first problem in the sequence, seven fish and four food bars were given, and the rule was one food bar for three fish. The question asked whether or not there were enough food bars for those fish. The sequence started with simple whole number ratio situation with pictures of both food bars and fish in order to help students link the composites concretely. Even though those questions were easy for the students, starting with those questions made it possible for the teacher to capitalize on taking

three fish as a unit and linking this unit with one food bar. This was also helpful for students to group the three fish and link them with a food bar with arrows as given in Figure 1 below.

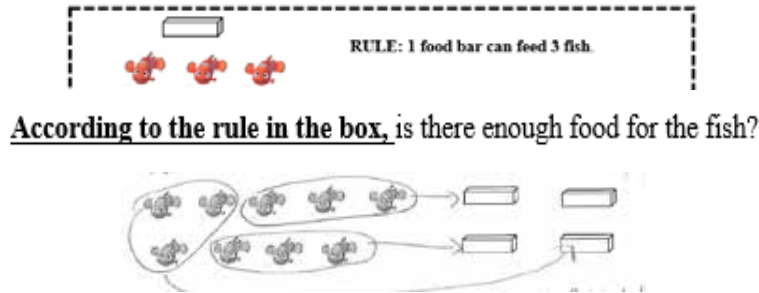


Figure 1: Linking units by with arrows

In the later problems, pictures of either food bars or fish were provided as suggested by the teacher. Whereas some students drew the pictures as in Figure 2a, some of them just wrote the corresponding number of fish numerically as in Figure 2b. Therefore, it was inferred that the teacher’s suggestion was helpful for students to make pictorial, numerical, and mental linking and iteration.



Figure 2a: Linking units by grouping

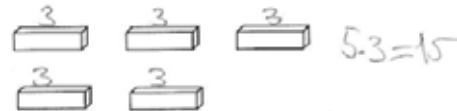


Figure 2b: Linking units with numerical values

After a few problems through which this link was established, scaling up problems were posed (e.g. How many fish can be fed with 5 food bars? with 10 food bars?). Pictures were not included in the problems in order to help students create mental images of composite units and the link. In their solutions, a number of students drew pictures of food bars and/or fish, and some used numerical build up strategies as illustrated in the figures 3a, 3b, and 3c below. This gave us evidence that the students reasoned with models and mental imagery, and associated those with the physical situation.

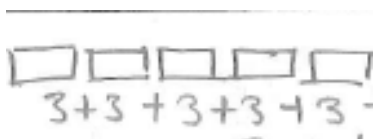


Figure 3a: Drawing pictures and linking with numbers

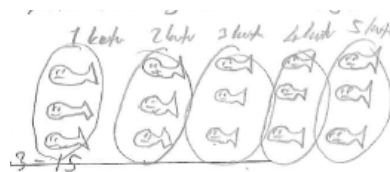


Figure 3b: Drawing pictures and linking with numbers

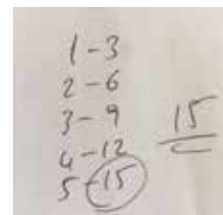


Figure 3c: Numerical build-up

After finding the answer for the number of fish that can be fed with nine food bars as 27, a student answered the following question that asked the number of food bars for feeding 10 fish immediately as 30 by building up on nine and 27. He explained his reasoning as “We found that nine food bars could feed 27 fish in the previous question. So, I added three to 27 and found that 10 food bars can feed 30 fish since the number of fish goes up by three...since one food bar can feed three fish.” Therefore, the teacher’s suggestion regarding changing numerical values helped students make connections and improve their understanding of the link between the number of food bars and fish.

Later on, after all the students explained their answers with pictorial and numerical strategies, the teacher took the opportunity to introduce a long ratio table in order to keep track of students' iterations, organize information, and make calculations more easily. By using long ratio tables, students were able to make such interpretations as "When the number of food bars goes up (or down) by one, the number of fish goes up (or down) by three". In the following instances, students started to use abbreviated build-up strategies where they did not add values one by one; instead, they made interpretations of the type "when the number of food bars is doubled (or tripled, quadrupled etc.) the number of fish is also doubled (tripled, quadrupled etc.)" as in Figure 4 below.

13. Yukarıdaki kurala göre yem ve balık arasındaki ilişkiyi gösteren tabloyu doldurunuz.

Yem (Kutu)	1	2	3	4	5	6	7	8	9	10	11	12	13	14	15
Balık	3	6	9	12	15	18	21	24	27	30	33	36	39	42	45

Figure 4: Representation with abbreviated build up strategies

After the one-to-three relationship was established among the classroom community, the instructional sequence was continued with different rules (e.g. 2-4, 2-3). When the rule was two food bars for four fish, a couple students used the given rule, whereas most of the students discovered that they could change the rule to one food bar for two fish. Below is a conversation in which students discussed about changing the rule when the question asked the number of food bars needed for feeding 12 fish:

Student 1: Six food bars are needed for 12 fish [claim] because I divided 12 by two. [data]

Teacher: Why did you divide 12 by two? [challenge]

Student 1: Because four fish can be fed with two food bars. [warrant]

Student 2: Then you have to divide by four, right? [challenge]

Teacher: Why do you think you have to divide by four? [challenge]

Student 2: (Draws 12 circles to represent 12 fish and groups each four fish by a bigger circle) I grouped [the fish] by fours and obtained three groups [of four fish]. I know that I need two food bars for each group. So, I multiplied three by two [data] and obtained six. [claim]

Student 3: We changed the rule. If two food bars feed four fish, then one food bar feeds two fish. [warrant] So we divided each value by two. [data]

Teacher: What does everyone think about this?

Student 4: It is easily seen with the pictures (Linking one food bar with two fish as in Figure 5). It is easily seen that one food bar feeds two fish. It is easier to use this rule. We can group fish by twos after we change the rule. [warrant]

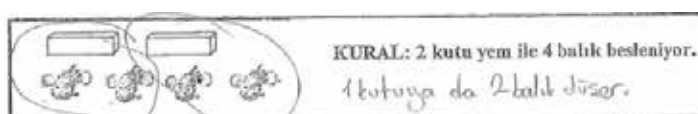


Figure 5: Changing the rule while preserving the link between the number of food bars and fish

As deduced from the figure and the dialogue, students changed the rule while preserving the link and the invariant relationship between the number of food bars and fish, which was an evidence of the strength of the link between food bars and fish. On the other hand, even though she did not use the term, Student 4 also referred to the concept of unit rate and how using unit rate makes calculations easier. Therefore, it could be deduced that including the pictures of fish and food bars as suggested by the teacher helped students to make sense of the ideas of equivalent ratios and unit rate.

Following the above activities, problems with a non-integer ratio (i.e. two food bars for three fish) were included in order to strengthen students' linking and iterating processes. At some point in the instruction, the teacher needed to communicate with the first researcher (participant observer in the classroom). While the students were filling in the table using the rule two food bars for three fish, a student asked if she had to fill in the table by building up by ones or by twos and threes. The teacher communicated with the researcher, and they decided that the tables had to be filled by building up by twos and threes. The teacher asked the student which way made more sense for her. The student replied that filling in the tables by twos and threes was meaningful since there would be decimal values while building up by ones and decimal values for the number of fish would not make sense.

Teacher's contribution to the analysis/revision phase

Design research includes ongoing and retrospective analysis. As part of the ongoing analysis process, the teacher participated in the daily/weekly design team meetings that focused on how students were engaged with the tasks and the required revisions, which helped the teacher see whether or not the intended learning goals and practices emerged. The retrospective part of the analysis was conducted by the university members since they were trained in this area.

Discussion and Conclusion

The power of design research is that it blends theory, research, and practice. It is reported that teachers can benefit from classroom design research in such a way that they would be up-to-date research-wise and experienced in developing/adapting tasks that would help students learn meaningfully (Stephan, 2015). The findings of our study have further shown that the teacher could contribute to classroom design research aiming at developing an instructional sequence and classroom learning trajectory for linking composites and iterating linked composites.

The teacher contributed to the study and the establishment of students' mathematical practices regarding linking units and iterating composite units by implementing the activities and the HLT in the pre-planned ways. The findings obtained by Toulmin analysis related to students' participation behaviors of claiming and providing data/warrants for their claims and the documentation of mathematical practices showed that she contributed to the establishment of the mathematical practice of linking units and iterating linked composites. What is more, the teacher made a few on-action instructional decisions and communicated with the researcher in the implementation phase. Apart from implementing the instruction, the teacher contributed to the design research in the design/development phase by making suggestions on the necessary adaptations to the tasks and the HLT. However, it might not be obvious how substantially the teacher contributed to the design phase in this study. It should be noted that the analysis included the teacher's contribution only in the first part of the HLT and the instructional sequence, which were the anchor that laid the ground for the

rest of the activities. Since it was the anchor activity it was well developed, and the teacher did not need to make big modifications. It is anticipated that the teacher's contribution to the design phase would be more substantial in the rest of the activities. Still, we claim that teachers can be valuable sources in designing instruction since teaching plans should be informed by students' mathematics (Steffe, 1991) and teachers are supposed to know their students. Lastly, the teacher contributed to the analysis phase by participating in the daily/weekly design team meetings that focused on enhancing student learning and required revisions. Engaging teachers more in classroom design research that focuses on a variety of mathematical topics could give more information about the contributions of the teachers to each phase of the studies.

Acknowledgment

This research is part of the research project 217K430, funded by the Scientific and Technological Research Council of Turkey.

References

- Cobb, P., Confrey, J., Lehrer, R., & Schauble, L. (2003). Design experiments in educational research. *Educational Researcher*, 32(1), 9–13.
- Design-Based Research Collective. (2003). Design-based research: An emerging paradigm for educational inquiry. *Educational Researcher*, 32(1), 5–8.
- Freudenthal, H. (1968). Why to teach mathematics so as to be useful. *Educational Studies in Mathematics*, 1(1), 3–8.
- Gravemeijer, K. (1994). *Developing realistic mathematics education*. Utrecht, The Netherlands: CD-Press.
- Lesh, R., Post, T., & Behr, M. (1988). Proportional reasoning. In J. Hiebert & M. Behr (Eds.), *Number concepts and operations in the middle grades* (pp. 93–118). Reston, VA: Lawrence Erlbaum & National Council of Teachers of Mathematics.
- Miles, M. B., & Huberman, A. M. (1994). *An expanded sourcebook: Qualitative data analysis*. Thousand Oaks, CA: Sage Publications.
- Simon, M. A. (1995). Reconstructing mathematics pedagogy from a constructivist perspective. *Journal for Research in Mathematics Education*, 26(2), 114–145.
- Steffe, L. (1991). The constructivist teaching experiment: Illustrations and implications. In E. von Glasersfeld (Ed.), *Radical constructivism in mathematics education*, (pp. 177–194). Dordrecht, The Netherlands: Kluwer.
- Stephan, M. L. (2015). Conducting classroom design research with teachers. *ZDM*, 47, 905–917.
- Stephan, M., & Rasmussen, C. (2002). Classroom mathematical practices in differential equations. *The Journal of Mathematical Behavior*, 21(4), 459–490.
- Toulmin, S. (1969). *The uses of argument*. Cambridge, England: Cambridge University Press.

A comparison of the treatment of mathematical errors arising from teacher-initiated and student-initiated interactions

Fay Baldry

University of Leicester, UK; fb128@le.ac.uk

This paper explores teachers' treatment of errors as they occur both within and outside of Initiate-Response-Evaluate (e.g., Cazden, 1988) interactions. Data are drawn from a classroom-based video study in England, involving three participating secondary mathematics teachers and six classes. This paper focusses on one of those teachers, whose lessons contained the widest range of treatment of errors. This included facilitating extended peer-to-peer turn-taking and bald negative evaluation of student contributions; the later appeared to be atypical, both in relation to the other teachers in this study and the wider literature. Analysis showed, for this teacher, indirect evaluation of errors was associated with teacher-initiated interactions, whereas bald negative evaluation was associated with student-led exchanges. Here, consideration is given to the interactional patterns related to the treatment of errors, and the potential impact on learning opportunities for students.

Keywords: Classroom norms, errors, mathematics education, misconceptions.

Introduction

Patterns of classroom talk vary, but Lefstein and Snell (2011), amongst other, report that in Anglo-American schools whole-class talk is typically controlled by the teacher. Moreover, a large proportion of interactions are in Initiate-Response-Evaluate (IRE) format, that is to say these are initiated by the teacher asking a question, which is followed by a student response and concluded with another teacher-turn, in which the mathematical validity of the student contribution is evaluated (Cazden, 1988). The role and treatment of mathematical errors has been reported in previous studies (e.g., Steuer, Rosentritt-Brunn, & Dresel, 2013), but the ubiquitous nature of IRE interactional patterns means that many of these discussions draw on evidence from this type of turn-taking exchange. Other types of interaction patterns, such as talk initiated or led by students, are less common in many classrooms (Edwards-Groves, Anstey, & Bull, 2014), but a move away from univocal teacher talk has been associated with enhancing learning opportunities (Alexander, 2004; Edwards-Groves et al., 2014). This paper focusses on one secondary school teacher in England and the shifts in turn-taking patterns that are seen when he teaches two classes. In particular, this study analyses the treatment of errors as they arise in IRE exchanges and student-initiated turns, with the aim to explore the leverage of errors to develop productive talk in different types of interaction.

Theoretical Framework

The use of 'error' varies between studies; some use the term to indicate anything treated as such by the teacher (e.g., Ingram, Pitt, & Baldry, 2015), whereas others use 'error' when they identify an issue with a mathematical contribution (e.g., Heemsoth & Heinze, 2016), although it is supposed there is considerable overlap between these two conditions. Whilst research has highlighted the role errors can play in providing learning opportunities (Bray, 2011), there is evidence a productive use of errors is not a routine part of many teachers' pedagogical practice (Ding, Li, Piccolo, & Kulm,

2007). The potential conflict between errors being seen as learning opportunities and the notion that errors should be avoided has been discussed. For instance, Swan (2001) argues some teachers avoid errors because they believe students might be confused by the discussion and erroneously remember the error rather than the correct solution. The notion that errors are embarrassing has been used to justify the avoidance of errors and to explain why both teacher and students take mitigating actions when they do occur (Pekrun, 2009). However, work by Steuer et al. (2013) has shown that the classroom climate and students own goal orientations have a significant effect on the affective reaction of students to errors.

Questions permeate most aspects of whole-class talk and hence are often the precursor to mathematical errors. In many classrooms, IRE sequences dominate whole-class interactions, being described as the ‘default’ setting for many teachers (Resnick, Michaels, & O’Connor, 2010). Whilst questions can play a variety of roles, from developing student understanding through to a tool for drawing attention to mathematically important features (Mason, 2000), within IRE interactional sequences the questions asked are often more limited in scope (Edwards-Groves et al., 2014). Teachers frequently ask questions that have a single expected response, with a shared understanding that the teacher knows the answer and that they will evaluate the accuracy of the student’s response in the third turn. Within this type of turn-taking, correct solutions are usually acknowledged immediately by the teacher, whereas errors are rarely directly acknowledged as such (Ingram et al., 2015). When errors do occur in student responses, the negative evaluation in the third turn is often communicated indirectly, through teachers’ pedagogical actions, such as redirecting the question to another student, asking follow-up questions or other actions to draw attention to the nature of the problem. Indeed, the pedagogical moves taken to avoiding direct evaluation are often directed towards allowing students to undertake additional mathematical work in subsequent turns, including self or peer correction of the error (Ingram et al., 2015). However, whilst there are examples of learning opportunities being created after an error has been identified in an IRE sequence, there is also evidence that teachers tend to reduce the mathematical load in subsequent turns and may ‘funnel’ students towards particular solutions (Jones & Tanner, 2002), thereby limiting the learning opportunities made available. From a conversation analysis perspective, the avoidance of direct negative evaluation would imply that errors are embarrassing and should be avoided (Seedhouse, 1997), but Steuer et al. (2013) argue that the lesson context is more complex, with students’ engagement shaped by their reading of the error climate of the classroom.

This study seeks to contribute to the understanding of the treatment of errors through the exploration of their occurrence in different patterns of whole-class interactions.

Methodology

This paper draws on data from a classroom-based video study in England. As part of a qualitative case study in the interpretative tradition, eighteen secondary mathematics lessons have been observed and recorded by this author. Three teachers participated and for each teacher two classes with different attainment profiles were observed. Lessons were recorded with two static video cameras and lesson artifacts, such as students’ work, were collected. Semi-structured interviews were conducted with the teachers before and after each lesson and lesson planning documents were

obtained. Audio data from each lesson was transcribed and collated with copies of mathematics written or projected in the shared space of the class whiteboards. The initial coding of the transcripts classified activities as either mathematically relevant or not, with episodes in the former category being subject to further scrutiny. As part of the wider study, the Orchestration of Mathematics Framework (OMF) has been developed to capture teachers' pedagogical moves and the potential impact this has on the mathematics made available to learners (Baldry, 2017). The further analysis of the mathematically relevant episodes involved an iterative process of coding interactions against this conceptual framework and cross-referencing with other data sources, such as teacher interviews and student work.

A key element of the analysis was the nature of interaction patterns in class-level talk, including the treatment of errors, although it is acknowledged that the interpretation of interactions is predicated on understanding the classroom culture (Larsson, 2015). The notion of classroom norms (Cobb, Stephan, McClain, & Gravemeijer, 2001) has been drawn on to establish whether interactions are typical or atypical, and thereby allow inferences beyond the particular occurrence, but this is limited to what is discernible at a whole-class level. This paper focusses on one teacher, Sam, and four lessons from two classes, selected when the analysis highlighted distinct patterns of interaction in relation to errors. These have been chosen because they do appear to be atypical, both in relation to the other two teachers in the study and the wider literature. Here, 'errors' are taken to be students' contributions that include a mathematically incorrect statement, but these occurrences were also all treated as errors by Sam. The practices of one teacher cannot be generalized to others, and indeed it could be argued that the analysis of a limited number of lessons in a study of this size may not provide a sufficiently representative picture to allow comparisons (Staub, 2007). However, I believe that a consideration of these more atypical behaviours has the potential to contribute to our wider understanding of the relationships between interactional patterns of whole-class talk, the treatment of errors and the learning opportunities for students.

Findings

Across all lessons, whole class-level talk represented about one third of the lesson time, and IRE interactional patterns accounted for at least two thirds of this talk. Most questions asked by Sam had a limited range of appropriate mathematical responses and about 20 percent were 'simple', that is to say students should have been able recall the answer immediately and without effort. About 75 percent of IRE exchanges were positively evaluated, a rate that was relatively stable across the lessons. The majority of the remaining exchanges were coded as containing negatively evaluations, although there were a few ambiguous cases. The interactional patterns in IRE exchanges across both classes were very similar. For example, when discussing the rules of indices, the following IRE interactions occurred, but similar exchanges were regular occurrences in all lessons:

- 30 Sam: What does two to the power four mean
 31 Student 1: Sixteen
 32 Sam: What does it mean
 33 Student 1: Oh it means two times two times two times two
 34 Sam: Excellent (.) good

- ⋮
- 53 Sam: So two the power five times two to the power four (.) what's that
- 54 Student 2: Two to the power nine
- 55 Sam: Two to the power nine (.) OK (.) what is (.) three to the power four times two to the power three (...)
- 56 Student 3: Is it six to the power seven
- 57 Sam: (..) what we can't do (.) really easily (..) we just can't add those powers this time (..) Tom

Extract 1: Positive and negative evaluation in IRE sequences

Most questions asked by Sam had a limited range of appropriate mathematical responses (e.g., line 53) and when the questions were more ambiguous his reaction in the third turn indicated a particular response was sought (e.g., line 32 and 34). Acceptable answers were indicated in two main ways. First, they were often explicitly acknowledged, with expressions such as “yep”, or by the inclusion of a positive indication of quality, such as “excellent” (e.g., line 34). Second, Sam regularly repeated a student's response (e.g. line 55), and the analysis indicated there was a taken-as-shared understanding that this also indicated an acceptable response. Negative evaluations occurred when students' responses contained mathematical errors (e.g., line 56), and when there was no error *per se* but the response was deficient in some way (e.g., line 31). For example, in line 33, the student recognises where his response does not meet Sam's requirements and self-corrects. In line 56, a student offers a mathematically incorrect response; Sam paused before offering some indication as to location of the error and then nominated another student who had their hand up to answer.

One notable shift away from IRE sequences was when there were sequential student turns. Whilst Sam sometimes nominated students to answer questions, it was also common practice for students self-nominate by calling out. In both classes, there were instances where different solutions were given before Sam responded. There did, however, appear to be differences in how the interactions were controlled by Sam when both errors and a correct solution were present. In particular, in the higher attaining class there were eight occasions where there were extended peer-to-peer exchanges. For example, when Sam asked for the value of a in $k^7 \div k^7 = a$ the following occurred:

- 244 Students: k
- 245 Student 1: Yes its k isn't it
- 246 Student 2: One
- 247 Student 3: 'Cause seven divided by seven is one
- 248 Student 4: Seven minus seven is zero
- 249 Student 3: No isn't it zero
- 250 Student 5: k divided by k is k
- 251 Student 2: One
- 252 Student 6: I think it's zero
- 253 Student 2: No it isn't its one guys ok its one
- 254 Sam: Er vote then (.) vote for zero

Extract 2: Class A multiple student contributions

There were no discernable responses from Sam after a number of students had offered “ k ” (lines 244 & 245) or the correct reply of “one” (line 246). The students continued to self-nominate by calling out, although the students were not necessarily responding to the immediately preceding turn (e.g., line 249). After Sam called for a vote for zero or one, started in line 254, he reverted to IRE sequences, where he focused the interactions on the mathematically correct answer by asking about situations related to a/a , where a was a range of natural numbers; some of these questions would have been simple for students to answer, such as “four divided by four”.

In the lower attaining class, there were twelve occasions when two or three students self-nominated and called out answers that included an error before Sam replied. For example:

- 308 Sam: What is eight to the power one
 309 Student 1: One
 310 Student 2: Eight
 311 Sam: Eight (.) well done folks

Extract 3: Class B multiple student contributions

In these cases, all the students appeared to be responding to Sam’s original question. In the nine occasions where responses include both an error and a correct response (e.g., lines 309 & 310), Sam positively evaluated the correct response and offered no discernable reaction to the error. The remaining three occurrences only contained errors and were followed up by further IRE exchanges.

The other notable variation was the explicit negative evaluation of errors. In whole-class discussions, there were twelve occurrences of Sam using a bald “no” in class B, the lower attaining class, with one in the higher attaining class. In all but one case an element of correction was included in the turn containing negative evaluation and the student did not take the subsequent turn. Three quarters of occurrences arose outside of IRE interactions, including the one case from class A when students were offering prepared explanations. Towards the end of the discussion about $2^2 \times 3^4$ the following exchange occurred in class B:

- 168 Sam: If I tried to do (..) two squared plus three to the power of four that’ll (.) sorry times three to the power four (.) is two times two times (.) three times three times three times three (..) I can physically work it out (.) I can work out what the number is but I can’t simplify it like we do in these ones (..) because they’re different numbers
 [writing: $2^2 + 3^4 = 2 \times 2 \times 3 \times 3 \times 3 \times 3$, pointing at common bases in earlier examples]
 169 Student: Sir can’t you do five to the something like three add two equals five and you do five to the power whatever
 170 Sam: No because look we can’t do to the power five or the power six because we’ve got these threes and these twos and they’re different numbers and you can’t combine them (..)

Extract 4: Bald negative evaluation

In line 168, Sam concluded his turn with a statement rather than a clearly defined question, so the comment made in line 169 was coded as student-initiated. Sam took the following turn (line 170);

he immediately gave a bald “no” and proceeded to offer an explanation that appeared to be directed at correcting the student’s comment. The student did not take the subsequent turn.

Discussion

In common with many other studies (e.g., Resnick et al., 2010), the IRE sequence was the dominant form of whole-class interaction for both classes. Moreover, within these IRE exchanges, Sam’s treatment of errors typically conformed to the well-reported approach of indirect negative evaluation in the third turn (e.g., Ingram et al., 2013). These structures allowed Sam to shape the focus of the interactions and provided opportunities for students to undertake further mathematical work to correct errors. The focus on the correct solution and the use of simpler questions after errors could be seen as reducing or removing the mathematical learning opportunities; alternatively, considered as a whole, they could be seen as serving to highlight the underlying mathematical structure. In these situations, the responsibility to correct errors lies at least partially with the students, but the arbiter of mathematical correctness resides with Sam.

When other types of whole-class talk were considered, different interactional patterns emerged, including differences between classes. In both classes there were instances where contradictory solutions were called out by students in response to a question from Sam. In class A, a regular occurrence was for peer-to-peer exchanges to continue beyond multiple replies to Sam’s original question and extended sequences of peer-to-peer turns were formed. The established norm was that if Sam did not respond verbally when the evaluative third turn would have otherwise occurred, then peer-to-peer turns were allowed. Whilst some later students turns appeared to be responding to Sam’s original question, and many were simply making statements of their own position, students also offered justifications or engaged with other students’ comments. For example, in Extract 2, line 247, the third student added a justification for “one”, even though in this case the reasoning was faulty. Sam eventually took a turn and control of the interactions (e.g. extract 2, line 254); these peer-to-peer exchanges were all followed by IRE sequences, which focused the interactions on the correct solution; errors made in the peer-to-peer exchanges were rarely mentioned or interrogated. For instance, after the vote that followed extract 2, Sam constructed an IRE sequence around a/a , where a was a range of natural numbers, but the potential origins of zero were not discussed, such as attending to the exponents of $k^7 \div k^7 = k^a$ or thinking $k^a = 0$. In these student-led exchanges, students had the opportunity to consider alternative solutions and some took the opportunity to articulate their reasoning, argue for their position or to challenge others; a shift in accountability, albeit briefly. However, the resolution of the debate was conducted through the more typical IRE exchanges with the final arbitration residing with Sam.

When class B is considered, there did appear to be similar potential starting points that had led to the peer-to-peer turns in class A. For example, extract 3 was one of nine occasions where both incorrect and correct responses were offered in response to Sam’s question, but none of these extended to further peer-to-peer turn taking. Instead, Sam took control of the exchanges at an earlier stage and drew immediate attention to the correct answer through positive evaluation.

The explicit negative evaluations of students’ contributions were predominantly associated with class B and student-initiated comments. As in extract 4, they occurred during whole-class talk when

the students self-nominated to take the next turn and without a direct question being asked by Sam. In a previous study, Ingram et al. (2015) found explicit negative evaluations by the teacher, and the associated corrections, occurred when there was an issue with communication of ideas rather than with the substance of the answer, although these appeared to relate to IRE sequences. In contrast, in this study explicit negative evaluation were associated with key conceptual issues, and occurred outside of IRE exchanges. For instance, in extract 4, the bald “no” followed on from a student misapplying a rule of indices by attempting to combine powers with different bases. The corrections associated with the “no” allowed Sam to redirect the focus of the interactions back to his chosen approach within one turn, but removed the opportunity for students to correct their own or their peer’s error. One possible explanation for the correlation between bald negative evaluations and student-initiated comments is that these, by their nature, have not been planned for in the same manner as responses to questions within IRE sequences. As such, they were not an integral part of Sam’s pedagogical goals; the bald evaluations and corrections allowed a swifter realignment with those goals. From a conversation analysis perspective, a bald evaluation would carry the message that making an error is not embarrassing. However, the benefit of this potential acceptance of errors would have to be considered alongside the management of the pedagogical trajectory away from student-initiated comments, which could be read by students as devaluing their contributions.

Conclusion

This paper seeks to complement existing research on the treatment of errors, in particular in relation to errors that occur outside of IRE sequences associated with more student-led talk. Here, within the extended peer-to-peer exchanges, students had the opportunity to consider and challenge alternative solutions. However, for this teacher at least, the resolution of those questions relied on the more common IRE exchanges, thereby revalidating the teacher as the arbiter of correctness. The potential tensions between the interactional message that errors are to be avoided and the positive role they can take in learning have been discussed in previous studies. Here, Sam’s use of bald negative evaluations has raised an alternative question; the possibility of a positive interactional message that errors are a natural part of talk, set against the potential loss of learning opportunities and diminishment of the value of student contributions. It is hoped that by raising awareness of these interactional structures, teachers could make informed choices about the different routes available to their treatment of errors and the potential impact on student learning.

References

- Alexander, R. (2004). *Towards dialogic teaching : rethinking classroom talk* (2nd ed.). Thirsk, UK: Dialogos.
- Baldry, F. (2017). Analysing a teacher’s orchestration of mathematics in a ‘typical’ classroom. In T. Dooley & G. Gueudet (Eds.), *Proceedings of the tenth congress of the European Society for Research in Mathematics Education* (pp. 3041–3048). Dublin, Ireland: DCU Institute of Education and ERME.
- Bray, W. S. (2011). A collective case study of the influence of teachers' beliefs and knowledge on error-handling practices during class discussion of mathematics. *Journal for Research in Mathematics Education*, 42(1), 2–38.

- Cazden, C. B. (1988). *Classroom discourse: The language of teaching and learning*. London: Heinemann.
- Cobb, P., Stephan, M., McClain, K., & Gravemeijer, K. (2001). Participating in Classroom Mathematical Practices. *Journal of the Learning Sciences*, 10(1-2), 113–163.
- Ding, M., Li, X., Piccolo, D., & Kulm, G. (2007). Teacher interventions in cooperative-learning mathematics classes. *The Journal of Educational Research*, 100(3), 162–175.
- Edwards-Groves, C., Anstey, M., & Bull, G. (2014). *Classroom talk: Understanding dialogue, pedagogy and practice*: PETAA Newtown.
- Heemsoth, T., & Heinze, A. (2016). Secondary school students learning from reflections on the rationale behind self-made errors: A field experiment. *The Journal of Experimental Education*, 84(1), 98–118.
- Ingram, J., Pitt, A., & Baldry, F. (2015). Handling errors as they arise in whole-class interactions. *Research in Mathematics Education*, 17(3), 183–197.
- Jones, S., & Tanner, H. (2002). Teachers' Interpretations of Effective Whole-class Interactive Teaching in Secondary Mathematics Classrooms. *Educational Studies*, 28(3), 265–274.
- Larsson, M. (2015). *Exploring a framework for classroom culture: a case study of the interaction patterns in mathematical whole-class discussions*. Paper presented at the Tenth Congress of the European Society for Research in Mathematics Education (CERME9), Prague, Czech Republic.
- Lefstein, A., & Snell, J. (2011). Classroom discourse: The promise and complexity of dialogic practice. *Applied linguistics and primary school teaching*, 165–185.
- Mason, J. (2000). Asking mathematical questions mathematically. *International Journal of Mathematical Education in Science and Technology*, 31(1), 97–111.
- Pekrun, R. (2009). Emotions at school. In K. R. Wentzel & A. Wigfield (Eds.), *Handbook of motivation at school* (pp. 575–604). New York: Routledge.
- Resnick, L. B., Michaels, S., & O'Connor, C. (2010). How (well structured) talk builds the mind. In D. D. Preiss & R. J. Sternberg (Eds.), *Innovations in educational psychology: Perspectives on learning, teaching and human development* (pp. 163–194). New York: Springer.
- Seedhouse, P. (1997). The case of the missing “no”: The relationship between pedagogy and interaction. *Language learning*, 47(3), 547–583.
- Staub, F. C. (2007). Mathematics classroom cultures: Methodological and theoretical issues. *International Journal of Educational Research*, 46(5), 319–326.
- Steuer, G., Rosentritt-Brunn, G., & Dresel, M. (2013). Dealing with errors in mathematics classrooms: Structure and relevance of perceived error climate. *Contemporary Educational Psychology*, 38(3), 196–210.
- Swan, M. (2001). Dealing with misconceptions in mathematics. In P. Gates (Ed.), *Issues in mathematics teaching* (pp. 147–165). London: Routledge.

Teacher responses to public apparent student error: A critical confluence of mathematics and equitable teaching practice

Hyman Bass¹ and Reidar Mosvold²

¹University of Michigan, School of Education, Ann Arbor, Michigan, USA; hybass@umich.edu

²University of Stavanger, Faculty of Arts and Education, Stavanger, Norway;
reidar.mosvold@uis.no

This paper uses analysis of shared video data to discuss teacher responses to public student apparent error. Drawing upon conceptions of student thinking and theories of agency, authority, and mathematical identities, we argue that certain ways of responding to public student apparent error have the potential to elevate student thinking and empower students with mathematical agency, authority, and standing. We also suggest that such teaching practices may be a high-leverage site to develop equitable mathematics teaching.

Keywords: Mathematical knowledge for teaching, teaching practices, positioning, agency, authority.

Introduction

Maria's 7th grade class is beginning to learn arithmetic with integers. She is called to the board to show her solution to the subtraction problem, $38 - 52$. Maria writes and says the following:

3 8 "8 take away 2 is 6"
 $\underline{-52}$ "3 take away 5 is -2"
 -2 6

Is Maria right? What is there to understand here about place value, with negative numbers? How might the teacher respond to Maria? And what effect will this have on her?

These questions, about this and about countless other similar scenarios, are the object of our study. We are concerned here with the interactions of the mathematics, the student's thinking and standing, and the impact of the teacher response on all three. We are not proposing that there is a "right" teacher response, but we do argue that the response is consequential for the individual student's learning and standing, as well as for that of the collective. Moreover, much knowledge and insight goes into understanding the range of possible responses and their consequences. In particular, what mathematical knowledge for teaching, what knowledge of student thinking, and what cultural and psychological sensitivities might be involved? So, our research question is:

What kinds of teacher responses to public student apparent error can help cultivate students' mathematical agency, authority, and standing?

Student mathematical productions are rarely flawless. Overt error may distract teacher attention from otherwise robust reasoning. A student's lack of technical vocabulary may cloud insightful conceptual expression. Such apparent flaws happen with all students, but they are understandably common among students who are educationally disadvantaged, because of race, ethnicity, poverty, language, etc. For this reason, we feel that our research question matters for equitable instruction.

The title refers to a core task of teaching. Three terms there – “public,” “apparent error,” and “equitable” – deserve comment. “Public” indicates that this is about collective learning and norm setting, more than bilateral teacher-student transactions. The student work and teacher response communicate to the whole class, not just to Maria. “Apparent error” draws attention to the teacher’s perception without evaluating the student’s thinking. Rougée (2017) has studied teacher responses to “apparent student error,” but her study explored the teacher stress and anxiety this can precipitate. As indicated above, we believe that our focus is a high leverage site for “equitable teaching practices.” The latter are often described in terms of inclusive classroom culture and participation structures. Our interest focuses further on how equitable practices intersect with content.

Our method is to first examine records of practice (video and other artifacts), to generate hypotheses about teacher responses to public student apparent error that can either cultivate or degrade students’ mathematical agency, authority, and standing. Robust conclusions of this kind will ultimately require more longitudinal data.

We will here explore the above task of teaching in two cases, one involving 4th graders identifying fractions on the number line, the other showing another group of 4th graders figuring out a difficult subtraction problem before having learned a general subtraction algorithm. These examples will help to open the analytical space behind our question.

Conceptual frameworks

Teacher responses to public student apparent error, the focal phenomenon of our study, is a site of confluence of three research traditions – 1) mathematical knowledge for teaching, 2) student mathematical thinking, and 3) agency, authority, and identity – each with its own theoretical frame and perspective. It is our task to coordinate, if not integrate, these traditions for our work. To understand the “work of teaching” we use the “Instructional Triangle” (I Δ) of Cohen, Raudenbush, and Ball (2003), as later elaborated by Ball (2018).

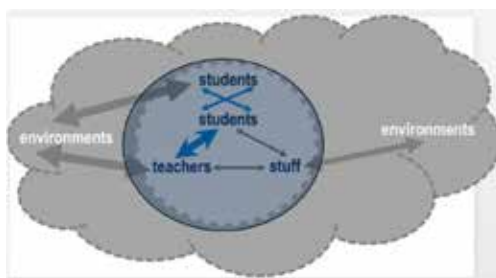


Figure 1. Revised instructional triangle (Ball, 2018)

The “stuff” in our case is “mathematics.” The inner circle represents instruction, where mathematical knowledge for teaching primarily resides. Student mathematical thinking spills into the environment. Agency, authority, and standing constitute an arena in which the instruction may attempt to disrupt inequitable environmental influences. Much mathematics education research is situated at a vertex, or along an edge of the I Δ . Our question spreads across the entire diagram.

Mathematical knowledge for teaching

For decades, a core problem in research on mathematics teaching has been what knowledge is needed to teach well. Researchers have approached this problem in different ways. Some have produced lists of what teachers should know. Others have investigated what knowledge teachers have, and yet others have studied knowledge teachers use. Ball (2017) suggested flipping the question by focusing instead on what mathematics the work of teaching entails (see also Ball et al., 2008). This shift was not new. Already two decades ago, it was elaborated in several publications (e.g., Ball, 1999; Ball & Bass, 2000; Ball, Lubienski, & Mewborn, 2001). The present paper follows this line of research and targets the challenges that are embedded in a particular mathematical task of teaching. Eliciting, interpreting, and responding productively to student thinking, all entail deep and flexible mathematical knowledge.

(Interpreting and responding to) student thinking

As we indicated above, mathematical thinking, by experts as well as students, is rarely flawless. It is typically a mix of ideas, some intuitive or sketchy, some more formalized, some of it sound, some of it not yet fully formed, some of it incorrect. Simply calling this complex package “error” is to ignore the substantial mathematical value there to be discerned. The phrase “apparent error” is our way of keeping open this broader range of possibilities.

When a child publicly presents a problem solution, or a mathematical explanation or comment, what tasks of teaching does this present? One is to *understand* the child’s thinking. This may draw on several knowledge resources: Of the mathematical terrain and the diverse ways it can be represented; of typical student (mis)conceptions and representations of the ideas; and of the child’s identity and background, and the culturally diverse forms of children’s communication (language, gesture, etc.). Once the child’s thinking is understood, what can the teacher do to help make this understanding shared by the other children? And if the teacher does not at first understand, what can she do to probe the child’s thinking to gain such understanding? The above are all challenging tasks of teaching.

Once the teacher possesses an adequate understanding of the child’s thinking, what is the next move? In some common practice, the teacher will first notice (perhaps even before fully understanding the child’s thinking) the mathematical flaws, and either announce them, or simply pass on, without comment, to another student in search of a more “acceptable” response. This can be characterized as a *deficit teacher response*. The opposite kind of response, sometimes called assigning competence (e.g., Cohen & Lotan, 1995), or *asset oriented response*, is to offer some detailed public appreciation of the positive mathematical qualities of the child’s thinking, without prematurely announcing that the mathematical work is done. Sometimes the teacher might even invite other students to comment on “what was good” about the child’s contribution. Again, enactment of this kind of move calls upon a fine-tuned understanding of the mathematics as well as of the student thinking.

Agency, authority, identity

Teaching is relational work, challenging in its complexity. We highlight three aspects of this complexity: agency, authority and identity.

Agency is the capacity, freedom and autonomy of an actor to act in a given environment. The environment of concern here is the mathematics classroom. Agency may either be encouraged and

supported, or constrained and suppressed, for example through the influence of such factors as race, social class, religion, gender, ethnicity, perceived ability, customs, etc.

Authority is characterized by Benne (1970, p. 393) as a social relationship between the bearer (of the authority, a person or group), the subject(s) (of the authority), and the field (context). The bearer receives willing obedience from the subjects while helping provide for their need of advice, leadership, guidance, or direction in the field. This is an example of “reasoned power,” but distinct from more general forms of power, which may be based on domination and coercion. Benne distinguishes three kinds of authority: Expert (as in the doctor-patient relation); Rule-based (as in say the playing of baseball); and “Anthropogological” authority (partly exemplified by the doctor-medical student relationship, an apprenticeship into practice). In rule-based authority, the rules that govern behavior represent an implicit consensual authority of the community of players, who are thus individually subjects, and collectively bearers.

Authority in a mathematics classroom has at least two aspects. One, common to all classrooms, is about behavioral norms, based on socio-cultural norms. Another, more pertinent here, is about *disciplinary authority*, about how to certify the authenticity of a piece of mathematical knowledge. Education reforms over the past half-century have moved in the direction of giving students more disciplinary agency and authority. How can that be interpreted in the above framework? For Benne, the ‘bearer’ of authority is a human agent, a person or group of persons; so how can we speak of “the authority of the discipline?” Amit and Fried (2005) suggest that mathematics, with its “fixed set of rules,” supports a kind of rule-based authority. We think instead of the discipline as a growing (inanimate) body of knowledge and methods, but that it is the cumulative product of (centuries of) human effort. How do new concepts or methods gain entry into (the current form of) this corpus? There are disciplinary norms for such membership, but human judgment (peer review) is needed to decide if these norms have been adequately met. Thus, in our view, disciplinary authority is mediated through those (human) agents empowered to certify proposed disciplinary claims.

So conceived, it now makes sense to speak of the distribution of disciplinary agency and authority in a mathematics classroom. In the traditional transmission model of instruction, the teacher alone bears expert authority to which the student subjects are expected to conform. In contrast, distributing agency among students means that they can participate in the construction of new knowledge and methods, finding new solution strategies, noticing patterns, speculating, conjecturing, proposing evidence. Distributing authority means that students themselves will judge the adequacy of claims of their peers, and find ways of resolving disagreement. This is somewhat captured in the third mathematical practice standard of the Common Core (2010): Construct viable arguments (agency) and critique the reasoning of others (authority).

This broad distribution of mathematical agency and authority among students, as co-producers (with the teacher) of knowledge, resembles what Benne (1970) calls anthropogological authority.

(Mathematical) identity refers to how students consider themselves as mathematical doers, thinkers, and learners. Aguirre, Mayfield-Ingram, and Martin (2013) define mathematical identity as “the dispositions and deeply held beliefs that students develop about their ability to participate and perform effectively in mathematical contexts and to use mathematics in powerful ways across the contexts of

their lives” (p. 14). Positive mathematical identity involves willingness to take risks to engage in discourse and to see one’s self as capable and worthy of being heard (Berry, 2018). This is related to *productive disposition*, the habitual inclination to see mathematics as sensible, useful, and worthwhile, coupled with a belief in diligence and one’s own efficacy (NRC, 2001). A premise of our work is that positive mathematical identity can be cultivated and supported by equitable teaching.

Case 1: Fractions on the number line

This diverse class of 9 to 10-year old children has learned how to name what fraction of (the area of) a rectangle is shaded. The method is to first assure that the (*whole*) rectangle is divided into a number (d) of *equal* size parts, to then count the number (n) of those equal parts that are shaded, and finally to name the fraction as n/d . The lesson segment in the video shows the start of their learning how fractions correspond to points on the number line. This is based on linear measure, in contrast with the area measure of shaded rectangles; on the number line one is counting lengths of intervals, and the unit of measure (the *whole*) is taken to be the interval from 0 to 1. We see the students presented with the following task (Figure 2).

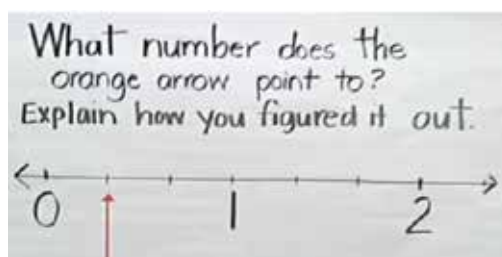


Figure 2. Naming fractions on the number line.

The correct answer is $1/3$, but the student notebooks show a variety of answers. The teacher asks who would like to come up and show their work; she calls on Aniyah. The teacher reminds the class that they should “listen closely and see what you think about her reasoning and her answer.” Aniyah puts “ $1/7$ ” next to the orange arrow (an “evident error”), at which point Toni asks, in surprise, “Did she say one-seventh?!” Aniyah responds, “Yeah, because there are seven equal parts, . . .” as she counts, with her spread thumb and index finger, the seven *intervals* (not hash marks) visible on the displayed (portion of the) number line. Here we see the “public student apparent error” to which the teacher responds, not to Aniyah, but to the class: “Before you agree or disagree, I want you to ask questions if there’s something you don’t understand about what she did.” Toni asks, “Why did you pick one-seventh?!” The teacher, affirming “That’s a very good question,” also says, “Let’s listen to her answer.” Aniyah says, “. . . because there’s seven equal parts.” Lakeya asks, “If you start at the zero, how did you get one-seventh?” She may have been thinking about counting hashmarks instead of intervals. Dante then struggles to formulate a more speculative, but difficult to understand question, perhaps to the effect that, “If you moved the orange arrow to where the one is, would you still know it was one-seventh to put it where the orange line is now?”

Several things are noteworthy about the teacher response to Aniyah’s “apparent error.” Though Aniyah’s “one-seventh” is wrong, it is so far not challenged or corrected either by the teacher or the students, though, at the teacher’s invitation, the children pose questions to understand *Aniyah’s thinking*, which is made central to the instruction. The mathematical issue is resolved by the end of

the lesson (beyond the video segment), but we here see the teacher publicly sheltering *Aniyah's standing*, as author of well articulated mathematical reasoning, which is flawed only in not using the standard unit (interval) as the whole. Further the teacher confers on Aniyah's peers the authority to question, and eventually evaluate, Aniyah's solution, free of teacher judgment. In these ways, the students are given/assigned remarkable collective agency and authority to develop the mathematics.

Case 2: Subtracting before you know how

In this case, the teacher presents a group of five 4th graders with the following problem: “The king celebrates his 80th birthday today” (this was in 2017). “In what year was he born?” This amounts to calculating $2017 - 80$. The teacher has not yet taught these students how to subtract large numbers by using a standard algorithm, though some may know this already. The students show four different approaches. One starts by taking away 17 from 80 to get 63, and then subtracts 63 from 2000 by using a standard algorithm. Another student uses the standard algorithm directly to subtract 80 from 2017. In both these cases, the teacher explains their thinking to the other students, and provides a lot of praise. Two other students come up with more unexpected approaches to solving the problem. Below, we take a closer look at one of these student's method.

When Brian (pseudonym) is called to the board to present his solution, the teacher comments that he noticed how Brian finished the problem quickly. He continues, “So I'm very excited to hear what you were thinking!” Brian explains that he just got rid of the 17, so that you only have 2000. He writes down $2000 - 80$. Brian then states, “So, then we have 1920, which is pretty easy!” When Brian has written down this partial answer, the teacher interrupts, “So, now I would just like to repeat what you did. I just want to repeat what you did, so that I understand your thinking.” The teacher asks Brian to move a little bit to the side, before he continues, “I understood from what you were saying, Brian, what you did that I understood, was that, to begin with, you didn't want to deal with the 17. You just jumped back to (points to 2000), and thought: What if we are in 2000 now? And then, when we go 80 years back, we get to 1920. And, now I'm eager to know, what did you do next?” Brian jumps up to continue his explanation, “And then I just added 17, which is pretty easy, simply 20 plus 17.” The teacher proclaims that this is “simply fantastic,” before Brian moves on to write down the answer on the board. When Brian has finished explaining, the teacher asks, “Did anyone understand this clever way?” Anna responds that she understood it, and that she thought it looked like a good way of thinking about the problem. The teacher then continues to rephrase what Brian did when he decided to “jump back 17” and start on 2000, and how “he already then knew that he had jumped back 17 years too long (...) So, when he got to 1920, he had to jump 17 years forward again, to correct it.”

One of the students early displayed an incorrect answer and seemed otherwise distracted at times. He was the only student not called to present his work. His was the only appearance of apparent error. For each of the others, at issue was the uncertainty of their solution strategies, for which they were each praised in varying degrees.

Concluding discussion

The choices made by the teachers in these two cases differ in several respects. We will here highlight and discuss two particular differences in the teachers' responses. The first relates to how the teachers assign competence to students. In case 1, we notice only one instance of explicit teacher affirmation

or praise, whereas the teacher in the second case offers a lot of praise to the students. We argue that both teacher responses can be described as asset oriented, and we posit that assigning competence does not have to include direct praise or public teacher statements. The teacher in case 1 assigned competence to Aniyah by inviting her to be the teacher. She positioned Aniyah as a recognized contributor, with standing, in the mathematical discussion, and she conferred on Aniyah's peers the authority to analyze and critique Aniyah's work. In the case 2, the teacher assigned competence to Brian by re-voicing his thinking and praising his contribution. This leads to the second highlighted difference, relating to the distribution of mathematical agency and authority, which we next discuss.

The work of mathematics teaching demands a mathematical knowledge that exceeds ability to solve a problem by using the standard algorithm. The teacher in case 2 chose not to confine attention to the two solutions using variants of the standard algorithm, thus disrupting the rule-based authority that is common in many mathematics classrooms. Instead the teacher highlights an unexpected student solution strategy, which he has to interpret and evaluate on the fly and assure that all of the students understand. By bringing Brian to the board, and expressing excitement and eagerness to understand Brian's thinking, the teacher publicly affirms Brian's agency and standing. It is interesting to notice how the teacher, in the middle of Brian's explanation, decides to interrupt to repeat what Brian did and make sure he understands Brian's thinking. It is likely that the teacher in fact understood well what Brian had done, but, by saying "so that I understand your thinking," the teacher was nominally putting himself on the same level as the other students, thus modeling the kind of inquiry needed to understand another student's thinking. In case 1 above, the teacher assigns this work to the students, whereas the teacher in case 2 does not do so. He himself is modeling, by example, how such inquiry is done. This effort is further reinforced when, after Brian has finished his explanation, the teacher again decides to re-voice Brian's explanation, to emphasize the crux of his thinking. Throughout this episode, the teacher demonstrates, and so models, attentive listening, and a pressing need to understand Brian's mathematical thinking. Brian is positioned as a mathematical authority, but one whose thinking needs to be publicly analyzed and sanctioned by the teacher, so that Brian's knowledge is not only validated and praised, but becomes collective, thus hoping to support all of the students' understanding. In case 1, Aniyah also gains mathematical authority, but only after public resolution of the integrity of her thinking by her peers, who are assigned this responsibility.

We have presented two examples of teacher responses to "public student apparent errors." We described, in each case, teacher moves that might have potential to cultivate the mathematical agency and authority of the students. In both cases, student agency is well supported, but in case 2, more of the mathematical authority appears to still reside with the teacher

Acknowledgment

Our thinking about these ideas owes much to discussions with Deborah Ball and Mark Hoover.

References

Aguirre, J., Mayfield-Ingram, K., & Martin, D. (2013). *The impact of identity in K-8 mathematics: Rethinking equity-based practices*. Reston, VA: The National Council of Teachers of Mathematics.

- Amit, M., & Fried, M. N. (2005). Authority and authority relations in mathematics education: A view from an 8th grade classroom. *Educational Studies in Mathematics*, 58(2), 145–168.
- Ball, D. L. (1999). Crossing boundaries to examine the mathematics entailed in elementary teaching. *Contemporary Mathematics*, 243, 15–36.
- Ball, D. L. (2017). Uncovering the special mathematical work of teaching. In G. Kaiser (Ed.), *Proceedings of the 13th International Congress on Mathematical Education, ICME-13* (pp. 11–34). Springer.
- Ball, D. L. (2018). Just dreams and imperatives: The power of teaching in the struggle for public education. Presidential Address at 2018 American Educational Research Association Annual Meeting, New York, NY, April 15, 2018. Retrieved from https://youtu.be/JGzQ7O_SIYY?t=35m26s and https://deborahloewenbergball.com/s/041518_AERA-presidential-address.pdf
- Ball, D. L., & Bass, H. (2000). Interweaving content and pedagogy in teaching and learning to teach: Knowing and using mathematics. In J. Boaler (Ed.), *Multiple perspectives on the teaching and learning of mathematics* (pp. 83–104). Westport, CT: Ablex.
- Ball, D. L., & Forzani, F. M. (2011, Summer). Building a common core for learning to teach, and connecting professional learning to practice. *American Educator*, 35(2), 17–21, 38–39.
- Ball, D. L., Lubienski, S., & Mewborn, D. (2001). Research on teaching mathematics: The unsolved problem of teachers' mathematics knowledge. In V. Richardson (Ed.), *Handbook of research on teaching*, 4th edition (pp. 433–456). New York, NY: Macmillan.
- Ball, D. L., Thames, M. H., & Phelps, G. (2008). Content knowledge for teaching: What makes it special? *Journal of Teacher Education*, 59(5), 389–407.
- Benne, K. D. (1970). Authority in education. *Harvard Educational Review*, 40(3), 385–410.
- Berry, R. Q. (2018). Positioning students as mathematically competent [Blog post]. Retrieved from https://www.nctm.org/News-and-Calendar/Messages-from-the-President/Archive/Robert-Q_-Berry-III/Positioning-Students-as-Mathematically-Competent/
- Cohen, E. G., & Lotan, R. A. (1995). Producing equal-status interaction in the heterogeneous classroom. *American Educational Research Journal*, 32, 99–120.
- Cohen, D. K., Raudenbush, S. W., & Ball, D. L. (2003). Resources, instruction, and research. *Educational Evaluation and Policy Analysis*, 25(2), 119–142.
- Common Core State Standards Initiative. (2010). Common Core State Standards for mathematics. Retrieved from <http://www.corestandards.org>
- National Research Council (NRC) (2001). *Adding it up: Helping children learn mathematics*. Washington, DC: The National Academy Press.
- Rougée, A. O. T. (2017). How do mathematics teachers manage students' responses in-the-moment? Unpublished doctoral dissertation. University of Michigan, Ann Arbor, Michigan.

Conceptual learning opportunities in teachers' differentiated task designs for inclusive mathematics education

Christian Büscher

TU Dortmund University, Germany; christian.buescher@math.tu-dortmund.de

Inclusive mathematics education creates new challenges to teachers, requiring additional knowledge and possibly changed classroom practices. One teaching job gaining importance is differentiating through task design, as teachers need to provide conceptually rich learning opportunities even to students with mathematical learning disabilities. However, more insight is needed into how teachers engage in this job. This study analyses teachers' designed tasks during a professional development course to reconstruct their categories of differentiation for percentage problems. The observed teachers tend to differentiate in a way that excludes low-achieving students from conceptually rich learning opportunities on percentages. This can be explained by the differentiation strategy of splitting and partitioning teachers' envisioned ideal-typical solution paths to percentage problems.

Keywords: Teacher practices, inclusive education, percentages, differentiation, professional development.

Introduction

In recent years, a shift can be observed in research on teacher expertise from a focus on general dispositions or concrete performance towards a focus on situation-specific skills (Blömeke, Gustafsson, & Shavelson, 2015). This places an emphasis on the wide array of necessary tasks or jobs demanded of teachers in their classroom work, from small jobs such as choosing and illustrating examples (e.g. Fauskanger & Mosvold, 2017) to large jobs such as adapting textbooks for their own course (e.g. Priolet & Mounier, 2017).

Such a focus calls for careful attention given to the concrete situations of teachers' classroom work, as every situation imposes different situational demands. Recently, a new class of situations is gaining increased attention in mathematics education research: the situations of inclusive mathematics education. In Germany and probably many other countries, large parts of mathematics teachers feel unprepared for dealing with these new situational demands. Research is needed into how teachers can face these situational demands of their teaching jobs in order to develop professional development (PD) courses to support teachers of inclusive mathematics classrooms.

This paper investigates the ways teachers engage with one central job of inclusive mathematics classrooms, namely the job of differentiating through task design in the context of percentage problems. First, this paper introduces a theoretical framing of the construct of teaching jobs, as well as a short overview on situational demands in inclusive mathematics education. The empirical part then illustrates how teachers use ideal-typical solution paths for differentiating through task design, involuntarily limiting conceptual learning opportunities for already low-achieving students.

Teaching jobs as a focus for research

For conceptualizing teachers' competences and practices, there exist a variety of conceptualizations and specification for these skills, such as 'core tasks and problems of teaching' (Bass & Ball, 2004)

or ‘core practices’ (Forzani, 2014). Empirical research shows how each of these skills, such as choosing and illustrating examples, poses a complex interplay of situational demands to teachers (Fauskanger & Mosvold, 2017). What teachers need to know in order to master these tasks, however, so far remains underspecified.

Already over 25 years ago, Bromme (1992) identified this as a task for empirical research. Instead of providing a list of knowledge or dispositions, Bromme (1992) places specific situational demands (tasks of teaching) into the heart of teacher expertise. Each situational demand requires specific knowledge attained by teachers. This knowledge takes the form of *categories* – personal units of meaning that can structure cognition – that “enable experts to discern a specific order within problematic situations or to construct it (e.g. by arranging instruction)” (ibid., p. 151, translated). Examples for categories for the situational demand of inclusive mathematics education might include ‘learning for all’ or knowledge of specific learning disabilities. It follows that PD programs need to support teachers in coping with their situational demands in teaching by supporting their development of categories.

This study follows the approach outlined by Prediger (in press) to conceptualize teachers’ situational demands as teaching *jobs* (in line with Bass & Ball, 2004) that are organized through teachers’ personal *categories* in order to draw attention to teacher practices instead of knowledge. The empirical task remains to identify the jobs required of teachers by inclusive education and to empirically reconstruct their categories activated for mastering these jobs.

Conceptual learning in inclusive mathematics education

Since the ratification of the UN Convention on the Rights of Persons with Disabilities in 2008 (UN, 2006), inclusive education has seen an increased interest in educational systems across many countries and in mathematics education research. In Germany, ratification of the convention has resulted in a shift from an educational system in which students diagnosed with various disabilities were segregated from ‘regular’ students towards an inclusive system in which (most) students visit the same schools, with or without disabilities. This posed increased challenges to the majority of teachers who had little to none previous experiences with students with disabilities, creating a great demand for professional development (PD) of teachers for inclusive education.

Concerning mathematics education, the largest new group of students for teachers is the risk group of under-achieving students in mathematics, here referred to as students with MLD (mathematical learning disabilities/difficulties, for an overview on terminology see Scherer et al., 2016). MLD is a construct without a clear consensual definition, hindering making distinctions between biological, cognitive, and non-cognitive contributing factors (Lewis & Fisher, 2016). However, research in mathematics education indicates that students with MLD do not fundamentally differ in their learning from students without MLD: under constructivist perspectives on learning, both groups require conceptually rich learning situations in which they can draw on their own experiences in order to develop mathematical concepts (Scherer et al., 2016).

The teaching job of differentiating through task design

The increased heterogeneity of inclusive classrooms faces teachers with increased demands of differentiated instruction (Tomlinson & Moon, 2013). This heterogeneity can refer to a variety of aspects, including their learning resources (working memory, interest, language proficiency) and mathematical knowledge (informal experiences, conceptions, formal knowledge). Every learner needs instruction that recognizes his or her individual needs. Thus, one teaching job that is of increased importance for inclusive education is the job of *differentiating through task design*.

Differentiated task design can take several forms (see Tomlinson & Moon, 2013). This paper focuses on two forms in particular (for the third form of open-ended differentiation see Buró & Prediger, 2019): students with MLD might need conceptually rich tasks for content different from other students (i.e. differentiated in content). They also need tasks that pose demands that they are able to fulfill (i.e. differentiated in access). In turn, such differentiating tasks might also pose dangers, as they might alienate students with MLD by providing learning content different from that of the ‘regular’ students.

These categories for task design thus provide a first list of possible categories for teachers to draw upon in their job of differentiating through task design. However, reconstructing such categories remains an empirical task (Bromme, 1992), as teachers’ personal categories might be richer than the mentioned ones. More insights are needed into how teachers enact this job of differentiating through task design, and how they ensure the conceptually rich learning opportunities required especially by students with MLD. This job here is treated as requiring topic-specific investigation, as differentiating in content requires topic-specific content knowledge. Because a majority of studies about MLD focus on elementary arithmetic (see Lewis & Fisher, 2016), this study instead opts to focus on a topic from secondary school, namely percentages. Thus, two research questions emerge for this paper:

(RQ1) What categories do teachers draw on when engaging in the job of differentiating through task design for percentage tasks?

(RQ2) How do these categories influence the learning opportunities for students with MLD in differentiated percentage tasks?

Methodology

Research was carried out during a PD course on inclusive education for the content of percentages, situated in the methodological approach of Design Research for teachers with a focus on content-specific professionalization processes (Prediger et al., 2016). Data were collected in this PD course, which is briefly introduced in this section.

Design of a PD course for inclusive mathematics education for percentages

The PD course aimed at in-service mathematics and special education teachers consisted of three distinct phases. In the first phase, the 25 participants received information on didactic concepts and models as well as on concepts and models of special education. Each of the participants had some own experiences with teaching inclusive classrooms and students with MLD, but most mathematics teachers lacked formal education about special needs, and most special education teachers lacked formal education about mathematics education. This phase consisted of three sessions (15 hours total)

with the research team and participants. Topics included use of representations, fostering understanding for all, language-responsive teaching, working memory and learning, and automatization of routines. During this phase, the teachers were encouraged to discuss these concepts and to relate them to their own experiences. The second and third phases consisted of practice and reflection phases and are not part of this study.

Course-integrated instruments for eliciting teachers' categories

Investigation into teachers' categories was carried out through *course-integrated instruments*. These were instruments designed to collect written products by the teachers. However, they were not collected in a classical pre-post design, but rather were employed at various points throughout the PD sessions. These instruments served a dual role: on the one hand, they provided the data needed for research, so that they were used as *instruments* for professional development. On the other hand, they activated the participants' prior experiences and, after having been filled out, provided the basis for discussions, so that they could be used as *means* for professional development.

These instruments were designed to actualize the situational demands teachers face in inclusive classrooms in small situations, i.e. to elicit teaching jobs. Figure 1 shows the course-integrated instrument used to elicit the job of differentiating through task design for percentages.

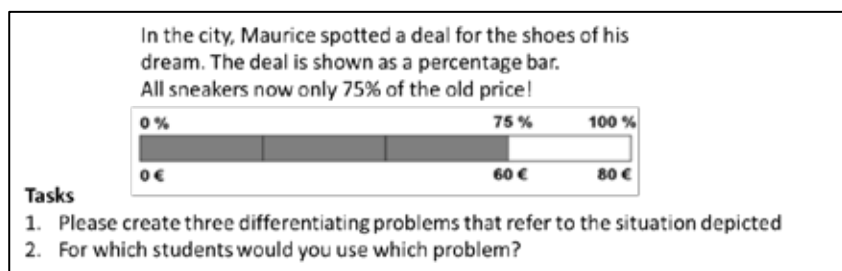


Figure 1: The course-integrated instrument (translated from German)

This instrument was given in the third session of the first phase of the PD course. It uses parts of a task on percentages already known to the teachers from the PD course. They also already were familiar with the basic ideas of the percentage bar, which was new to most of the teachers prior to the PD course (see Buró & Prediger, 2019).

Data collection and data analysis

The instrument was given to the teachers who had 15 minutes to create the differentiated tasks. This short time-frame was chosen to cut down the time for possible group work, so that results would reflect the personal categories more closely. Afterwards, a discussion took place and the written products were collected and digitized. Of the 17 products filled out by teachers, 1 was dropped for being too short for analysis. Data analysis then consisted in reconstructing three types of categories of differentiation: the types of differentiating tasks created by teachers, the perceived groups of students for which teachers create differentiation, and the mathematical learning opportunities provided to these groups through differentiation. The types of tasks were deductively reconstructed as belonging either to tasks differentiated in content or in access. For the perceived groups and mathematical learning opportunities, categories were generated inductively by comparing and contrasting all teacher products. Categories were then refined and condensed, and then used in a

deductive analysis in order to enable a comparison of the different written teacher products. As the categories thus also are an empirical result, they will be illustrated below.

Teachers' categories for differentiating through task design

Two teachers' products are printed in Figure 2. They can illustrate some common elements of the teachers' differentiations through task design which were reconstructed in the analysis. The first teacher, 'Anna' (left side), differentiates between four different levels (L-M-S-gS, interpreted as the initials of the German words for easy-medium-hard-very hard). This structuring is reconstructed as a differentiation into levels of 'low-middle-high' by combining the levels of 'S' and 'gS'. Her tasks, however, do not differ in complexity, but in content. Students who are assigned to the low level ('L') are tasked with simply reading the given values and with calculating a difference without any reference to percentages. Such instances are coded as *description* (reading, simple description of the involved numbers without explanation) and *subtraction*. Students in the middle level ('M') are assigned with a task that superficially does relate to percentages, but ultimately results again in a simple calculation of a difference. This again is a task of *subtraction*. Students in the high level ('S', 'gS') are tasked with filling out the missing steps in the percentage bar. This is a type of task that was discussed during the PD course as a task that can elicit *proportional* reasoning, often signified by 'simultaneously counting up' percentages and percent values until reaching the desired values. Finally, they are also tasked with a different *percentage* problem.

<p>L - Read off, what is the old price? Answer: _____ the new price? Answer: _____</p> <p>L - How many € did Maurice pay less? Answer: _____</p> <p>M - By how many percent did the old price drop? Answer: _____</p> <p>S - Write fitting numbers on the indentations on the percentage bar!!</p> <p>gS - How many € does Maurice have to pay, if the sneakers are priced at only 50% of the old price?</p>	<p>a) Read off the old price and the new price from the percentage bar</p> <p>b) Calculate how many € Maurice did save. Specify how many percent of the old price Maurice did save.</p> <p>*c) Maurice has 70 € saved up. He sees sneakers with an old price of 90 €. Can he afford the shoes?</p> <p>**d) How high would the old price have to be, so that he could he afford the shoes?</p> <p>For all: Mark the upper and lower parts of the percentage bar with labelled arrows.</p> <p>2. For which students would you use which problem?</p> <p>a), b) for all students</p> <p>*c) for the fast, high-performance students</p> <p>**d) for the really clever ones!</p>
--	--

Figure 2: Two teacher differentiations through task design (translated from German)

The second teacher, 'Beatrice', chooses other categories for her differentiation. Whereas Anna does not make explicit if students are open to change levels as they see fit, Beatrice creates tasks in a progression in which students are expected to follow as far as they are able to, reconstructed as 'for all-middle-high'. She begins with a 'for all' category, which includes the task of *proportional* reasoning (counting up through labelled arrows) that Anna assigned to a much higher level. Her other two tasks a) and b) consist of *description* and *subtraction*. Students in the middle level are then given a different *percentages* problem, as are students in the high level (although a different, probably harder problem).

Comparing these two teachers reveals some interesting differences. In the differentiation of Anna, students with MLD would probably be assigned to the low level, and thus would receive learning opportunities for describing and subtraction, but not for percentages. Even if they would reach the next level, they still would be given learning opportunities for subtraction only. Such learning opportunities are also provided through the differentiation employed by Beatrice. However, through the category ‘for all’ she also includes a learning opportunity for proportional reasoning that students with MLD have access to – an important conceptual foundation for the learning content of percentages, which they could then utilize should they be able to reach the next level. This trend of lacking learning opportunity for percentages can also be observed throughout the differentiations of all teachers. Table 1 gives an overview on the learning content that teachers assign to their levels of differentiation.

	For all	Low	Middle	High
Description	6	10	3	1
Subtraction	1	3	3	1
Proportional	1	2	4	1
Explaining	0	1	4	6
Percentages	0	0	4	5

Table 1: Number of occurring learning contents for levels of differentiation (n=16)

The learning opportunities for students with MLD are reflected through the combination of the levels *for all* and *low* (the two grey columns). The learning contents that are conceptually relevant for percentages are represented through the categories *proportional*, *explaining*, i.e. the task of explaining the algorithm or procedure to find a percentage value, and *percentages* (the three grey rows). This shows a lack of conceptual learning opportunities for students with MLD (the dark grey intersection). Students with MLD are most commonly given tasks involving the rather passive description of the given situation or reading of values (16 occurrences). Of the remaining 8 occurrences, half consist of tasks involving simple subtraction. Only in 4 occurrences, these students have access to learning opportunities that involve conceptual understanding of percentages (proportional reasoning as foundation for percentages and explaining strategies for calculating percentage values).

The categories of Ideal-typical solution paths, partitioning, and conceptual foundations

For the aim of teacher PD, this result of missing conceptual learning opportunities requires further explanation, i.e. an identification of the categories underlying the job of differentiating through task design. Anna’s tasks can serve as an example representative of most of the teachers’ products. Her differentiation follows an observable structure: in order to fully understand the situation, students first need to read the relevant information (low level), then acknowledge and quantify the changing values (middle level), and finally use concepts of proportion and percentage to interpret the situation (high level). Breaking down this *ideal-typical solution path* results to her in five small subtasks. Her strategy now is to *partition* this ideal-typical solution path and to assign different tasks to different students. Unfortunately, this results in conceptually poor learning opportunities for students on the

lower levels, as the conceptual heart of the percentage problem is placed at the end of the ideal-typical solution path, and thus only accessible for students assigned to the high level.

Beatrice follows a similar overall structure, but with different emphasis. Her ideal-typical solution path places proportional reasoning as the first part of the solution. This is an important *conceptual foundation* of percentage problems. Because her solution path is not neatly partitioned, but includes a level for all students, students with MLD also gain access to conceptual learning opportunities in this way.

Conclusions

Like all students, students with MLD require conceptually rich learning opportunities to develop understanding of key mathematical concepts such as percentages. For teachers new to this group of students, this increases the complexity of the teaching job of differentiating through task design. This study shows the ways teachers can enact this job, and how this can influence the learning opportunities students have access to. The empirical analysis shows how partitioning ideal-typical solution paths can result in students with MLD being denied access to conceptual learning opportunities on percentages, instead providing access to subtraction. A more useful approach is to provide access to conceptual foundations by including tasks that focus on proportional reasoning, to be approached by all students. Teachers that used this approach drew on their context knowledge of percentages to present students with MLD with valuable conceptual learning opportunities. However, such an approach was chosen by only a very small fraction of teachers.

This study has followed the approach outlined by Bass & Ball (2004) to focus on teachers' tasks, namely the job of differentiating through task design. However, this study also illustrates that insights are needed into *how* teachers fulfill these tasks. The approach of identifying teachers' categories outlined by Bromme (1992) proved useful as a framework for describing how teachers fulfill their jobs. The approach allowed this study to focus on the situational demands of one very specific job. In classroom practice, however, teachers have to face several such jobs simultaneously. More insights are needed into how this added complexity can be mastered.

So far, the categories of ideal-typical solution paths, partitioning, and conceptual foundations have been reconstructed from one course-integrated instrument during one PD course session. More insights are still needed to empirically ground and to refine these categories. Also, the missing conceptual learning opportunities need to be interpreted carefully: it might justifiably be the case that giving students with MLD access to learning subtraction is a necessary and reasonable decision, e.g. for students that still struggle with subtraction.

Acknowledgement. The presented study has been conducted within the project Matilda which is financially supported by the German Ministry of Education and Research (BMBF-research grant no. 01NV1704 to S. Prediger and J. Kuhl) in the framework of DZLM, the German Center for Mathematics teacher education (which is financially supported by the German Telekom-Foundation).

References

Bass, H., & Ball, D. L. (2004). Anna practice-based theory on mathematical knowledge for teaching: the case of mathematical reasoning. In J. Wang (Ed.), *Trends and challenges in mathematics education* (pp. 295–313). Shanghai: East China Normal University Press.

- Blömeke, S., Gustafsson, J.-E., & Shavelson, R. J. (2015). Beyond Dichotomies. *Zeitschrift für Psychologie*, 223(1), 3–13. <https://doi.org/10.1027/2151-2604/a000194>
- Bromme, R. (1992). *Der Lehrer als Experte: Zur Psychologie des professionellen Wissens*. Münster: Waxmann.
- Buró, S., & Prediger, S. (2019). Low entrance or reaching the goals? Mathematics teachers' categories for differentiating with open-ended tasks in inclusive classrooms. *Paper presented at CERME 11, Utrecht*
- Fauskanger, J., & Mosvold, R. (2017). Core practices and mathematical tasks of teaching in teacher education: What can be learned from a challenging case? In T. Dooley, & G. Gueudet (Eds.), *Proceedings of the Tenth Congress of the European Society for Research in Mathematics Education* (pp. 2844–3851). Dublin: DCU Institute of Education / ERME.
- Forzani, F. M. (2014). Understanding “Core Practices” and “Practice-Based” Teacher Education. *Journal of Teacher Education*, 65(4), 357–368. <https://doi.org/10.1177/0022487114533800>
- Lewis, K. E., & Fisher, M. B. (2016). Taking Stock of 40 Years of Research on Mathematical Learning Disability: Methodological Issues and Future Directions. *Journal for Research in Mathematics Education*, 47(4), 338. <https://doi.org/10.5951/jresematheduc.47.4.0338>
- Tomlinson, C. A., & Moon, T. R. (2013). Differentiation and Classroom Assessment. In J. H. McMillan (Ed.), *SAGE handbook of research on classroom assessment* (pp. 415–430). Los Angeles: SAGE.
- Prediger, S. (in press). Promoting and investigating Teachers' Pathways towards Expertise for Language-Responsive Mathematics Teaching. To appear in *Mathematics Education Research Journal*. doi.org/10.1007/s13394-019-00258-1
- Prediger, S., Schnell, S., & Rösike, K.-A. (2016). Design Research with a focus on content-specific professionalization processes: The case of noticing students' potentials. In S. Zehetmeier, B. Rösken-Winter, D. Potari, & M. Ribeiro (Eds.), *Proceedings of the Third ERME Topic Conference on Mathematics Teaching, Resources and Teacher Professional Development* (pp. 96–105). Berlin: Humboldt-Universität zu Berlin / HAL.
- Priolel, M., & Mounier, E. (2017). Mathematics textbooks and teaching activity. In T. Dooley & G. Gueudet (Eds.), *Proceedings of the Tenth Congress of the European Society for Research in Mathematics Education* (pp. 3137–3142). Dublin: DCU Institute of Education & ERME.
- Scherer, P., Beswick, K., DeBlois, L., Healy, L., & Moser Opitz, E. (2016). Assistance of students with mathematical learning difficulties: How can research support practice? *ZDM*, 48(5), 633–649. <https://doi.org/10.1007/s11858-016-0800-1>
- UN General Assembly (2006). *Convention on the Rights of Persons with Disabilities*. New York: United Nations.

Effects of a Scaffolding Model for small groups in mathematics

Sharon Calor¹, Rijkje Dekker¹, Jannet van Drie¹, Bonne Zijlstra¹ and Monique Volman¹

¹University of Amsterdam, Research Institute of Child Development and Education, Faculty of Social and Behavioral Sciences, Amsterdam, The Netherlands; S.M.Calor@uva.nl, R.Dekker@uva.nl, J.P.vanDrie@uva.nl, B.J.H.Zijlstra@uva.nl, M.L.L.Volman@uva.nl

We investigated whether teachers' use of the Small-Group Scaffolding model (SGS model), when supporting heterogeneous student-groups in a collaborative setting in math lessons, raised students' mathematical level more than teacher support without use of the model. Participants were eight teachers and 266 students of two schools working collaboratively in 73 small heterogeneous student-groups on the topic of Early Algebra. The five teachers in the experimental condition were taught to scaffold the groups in their classes according to the SGS model (give support adapted to student-groups' needs). The three teachers in the control condition were not given prior instruction of how to support the students. Analysis of a pre- and post-test on mathematical level raising showed that more mathematical level raising occurred in the Scaffolding condition than in the control condition. We concluded that using the SGS model can lead to more mathematical level raising.

Keywords: scaffolding, mathematics, collaborative learning, mathematical level raising, teacher-student interaction.

Background

According to Freudenthal (1991) and Van Hiele (1986), the learning of mathematics occurs in discrete steps, implying the existence of levels of mathematical thinking. Van Hiele (1986) described four levels: 1) Visual level: the forms of mathematical objects are the object of study, 2) Descriptive level: the properties of mathematical objects are the object of study, 3) Theoretical level: relations between the properties of mathematical objects are the object of study, and 4) Formal logical level: relations between theorems are the object of study. Freudenthal (1991) built upon this theory and stated that the levels are more relative than discrete, meaning that level raising occurs every time a mathematical activity (performed at a lower level) consciously becomes the object of reflection (at a higher level). Freudenthal (1971) defines a mathematical activity as an activity of organizing subject matter, which can be matter from reality or mathematical matter, according to mathematical patterns or new ideas. For example, at a lower level, patterns of the number of tables and chairs in a table setting can be studied. At a higher level, these patterns themselves become the object of reflection when one tries to create a formula with which the number of chairs in a particular table setting can be calculated when the number of corresponding tables is given.

According to Freudenthal (1978), when students collaborate in a heterogeneous small group (a small group of students of mixed ability) on one task, there will often be at least one student who experiences an "Aha moment" (jumping to a higher level) when understanding the subject matter. A typical higher-level activity will follow for that student, such as reflecting on how he/she mastered the subject matter and explaining to other students in the group what he/she just learned. In other words, discussions between students in a heterogeneous group while performing mathematical activities (mathematical discussions) enhance mathematical level raising.

A reoccurring problem with attaining mathematical level raising when learning Early Algebra in secondary education is that students find it difficult to make a shift from studying patterns at a lower level to understanding formulae at a higher level (Kieran, 1992; Sfard & Linchevski, 1994; Van Stiphout, Drijvers, & Gravemeijer, 2011). Janvier (1987) addressed this problem by defining Algebra representations, situation, graph, table and formulae as four ways to describe the relation between two variables in a formula. He calls the ability to switch between the representations a translation skill. According to Janvier (1987), translation skills are best learned when they are taught in a pair-wise manner. For example, the translation skill modeling is learned best when students first learn how to construct a situation from a formula, followed by learning how to construct a formula given a situation, or vice versa. In this study, all translation skills involving the representation formulae are considered to contribute to mathematical level raising. These translation skills are: Parameter recognition (formulae to situation), Computing (formulae to table), Sketching (formulae to graph), Modeling (situation to formulae), Fitting (table to formulae) and Curve fitting (graph to formulae).

Collaborative learning is considered an important means to improve students' learning of mathematics (Webb, 1982). Several studies have shown that mathematical discussions in small heterogeneous student-groups contribute significantly to mathematical reasoning and level raising (Freudenthal, 1991; Dekker & Elshout Mohr, 1998, 2004). Dekker and Elshout Mohr, (1998) developed a 'Process model' (PM), which promotes and operationalizes mathematical discussions. This model distinguishes three types of learning activities: key activities, which help mathematical level raising; regulating activities, which regulate key activities and mental activities that occur in students' minds. They found that stimulating mathematical discussions by the teacher resulted in more mathematical level raising compared to providing content support (Dekker & Elshout Mohr, 2004). However, teachers find it difficult to support mathematical discussions in small-group learning (Webb, 2009).

Content support adapted to the level of the student's understanding (contingency) is considered one of the key features of scaffolding (Van de Pol, Volman, & Beishuizen, 2010). The other two key features of scaffolding are diminishing content support over time (phasing out) and returning responsibility for learning processes to the learner. Scaffolding in the context of group work seems to enhance learning outcomes in general (Van de Pol, Volman & Beishuizen, 2010; Webb, 2009). Van de Pol, Volman and Beishuizen (2012) developed a model to describe scaffolding interactions, the Contingent Teaching Model (CTM), in which teacher support is adapted to the level of individual students. It consists of four steps: applying diagnostic strategies, checking the diagnosis, applying intervention strategies, and checking students' learning. In the CTM individual students are scaffolded in a small-group setting.

In the context of collaborative learning teachers often scaffold individual students within small groups. How teachers can scaffold small groups at group level and what the effect is on students' mathematical learning, has not yet been investigated. A combination of stimulating discussions and providing contingent content support adapted to the level of the group might result in more mathematical level raising. To help teachers support small heterogeneous student-groups we integrated the CTM (Van de Pol, et al., 2012) and the PM (Dekker & Elshout Mohr, 2004) into a

scaffolding model for small student groups (Calor, Dekker, Van Drie, & Volman, 2019). We call this model the Small-Group Scaffolding model (SGS model).

In Figure 1 a flowchart representation of the SGS model is shown. The model consists of six teaching steps: evaluating if the question is a question of the whole group, applying diagnostic strategies, checking the diagnosis, giving contingent content support, checking students' learning, and giving process support (stimulating mathematical discussions).

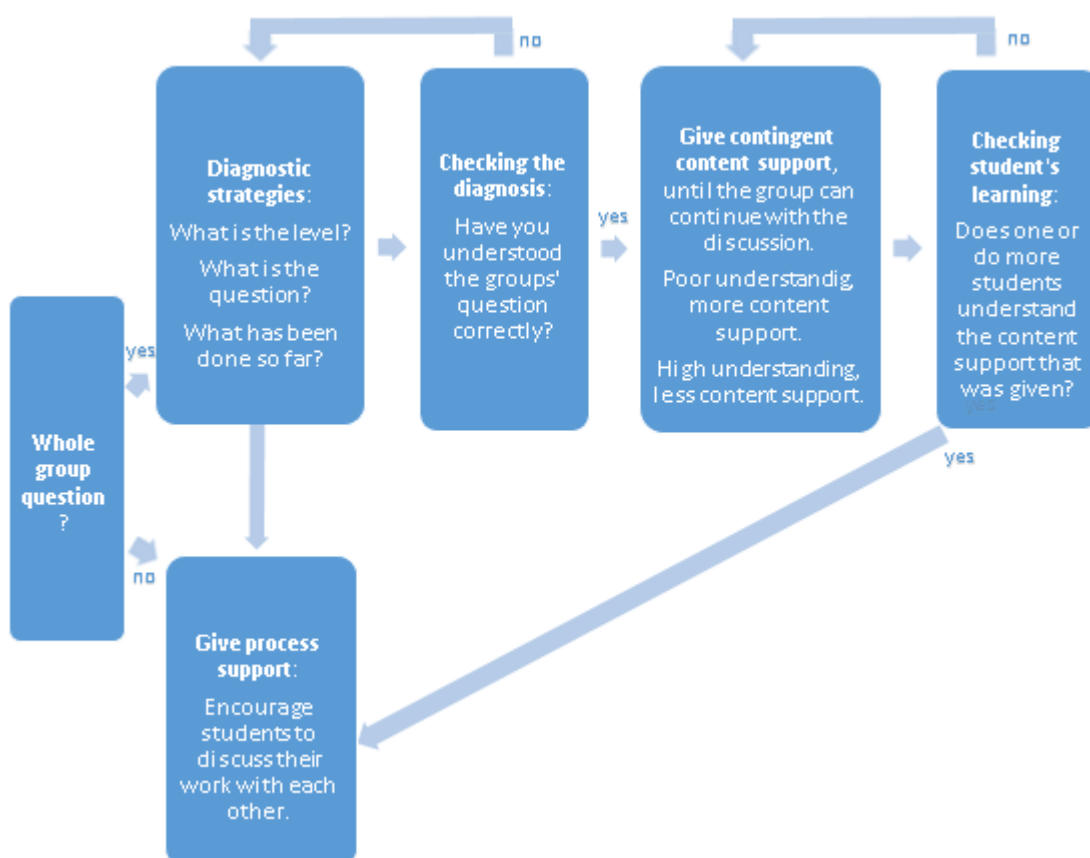


Figure 1: A Flowchart of the Small-Group Scaffolding model (Calor et al., 2019)

Following the Small-Group Scaffolding model, teachers should first determine if the question is a question of an individual in the group or if it is a question of the whole group. In case the question is a question of the whole group, the teachers should diagnose the group's current level of understanding in the second step, by for example asking students what they have done so far and asking the students to show or tell their work to the teacher. It is possible that one or more students come up with an answer to the question during this step. In that case, the teacher should encourage the students to explain the answer to each other. If none of the students come up with an answer during step two, teachers can check if their diagnosis is correct in the third step. In the fourth step, the teachers should give contingent support to the group (increase support when the students show poor understanding and decrease support when students show high understanding) until one or more students understands the question. In step 5, the teacher should check if at least one of the students understood the content support. If this is the case, teachers should stop giving content support (phasing out, the second key feature of scaffolding) and return responsibility for learning back to the group (third key feature of

scaffolding) (Van de Pol et al., 2010). Returning responsibility for learning to the group can be done by encouraging students to explain and show their work to each other and to criticize each other's work, i.e. give process support, in the last step. In case the outcome of the determination of the question in the first step was that the question was not a question from the whole group, but rather a question of one or more individuals in the group, teachers should return responsibility for learning back to the group by giving process support.

In this study, we combined Fruedenthal's, Janvier's, and sociocultural perspectives as theoretical lenses to study mathematical lessons.

Research question

Does the use of the Small-Group Scaffolding model raise seventh grade students' mathematical level in Early Algebra?

Hypothesis

We hypothesize that the mathematical level of students will be raised more in the Scaffolding condition than in the control condition.

Method

In a quasi-experimental design, we compared the mathematical level raising of students who were taught by teachers who were trained to give help to students according to the SGS model with those of students who were taught by teachers who gave help without prior instruction. In both conditions students worked on an Early Algebra unit that was especially designed to invoke mathematical discussions and raise the level of mathematical knowledge (Calor, Dekker, Van Drie, Zijlstra, & Volman, 2018).

Participants were eight teachers (7 males, 1 female) and their 266 seventh grade students of two schools in Amsterdam, the Netherlands (5 teachers and 169 students of two schools in the Scaffolding condition and 3 teachers and 97 students of one school in the control condition). Two of the eight teachers (one in the Scaffolding condition and one in the control condition) worked with an Early Algebra unit in a collaborative setting in a previous study (Calor et al., 2018). Other than that, the teachers had no experience with collaborative learning. Teachers were matched into pairs according to age and teaching experience. Of every pair one teacher was randomly assigned to a condition. Every teacher taught their own seventh grade class. Teachers in the Scaffolding-condition were trained on the job so that they could be engaged in inquiry into the SGS model and reflection on its use and to provide an opportunity for them to make connections between their learning and classroom practice (Borko, Jacobs, & Koellner, 2010). Prior to the lesson series, teachers in the Scaffolding condition were trained in a two-hour training to give help to students according to the SGS model. In addition, before and after every lesson the use of the model was discussed individually with the teachers and questions were answered. The aim of the research was only known to the teachers in the Scaffolding condition. The teachers in the control condition were instructed to let the students work together on the assignments and give their usual support. All students worked in small heterogeneous groups (46 Scaffolding and 27 control condition). Small student-groups consisted of students of mixed ability according to track advice related to the students by their primary school administration.

Ideally groups consisted of four students, but due to class size restrictions 24 groups of three students (13 Scaffolding and 11 control condition) and one group of two students were formed (Scaffolding condition). Students' age varied between 12 and 15 years. Groups in the Scaffolding condition were instructed by the teacher to explain and show/tell their work to each other, ask each other for explanations, and to criticize each other's work. Teachers in both conditions implemented the lessons as intended (teachers in the Scaffolding condition used the SGS model to support students, whereas teachers in the control condition gave support as they normally would). Implementation check was performed by the first author during and after lessons (check with teacher and watch videotape of lessons).

In both conditions, students worked on a lesson series of 12 lessons of 60 minutes on the topic of Early Algebra for five weeks. We replaced five of these lessons, with lessons that explicitly aim to invoke mathematical discussions and raise the level of mathematical knowledge (Calor et al., 2018). During these five lessons, students worked collaboratively on the same assignment. Every lesson started with 10 minutes introduction by the teacher, followed by students working collaboratively for 50 minutes. During the remaining lessons students sat together in the same small heterogeneous groups and worked on regular assignments from the textbook.

Students' mathematical levels in Early Algebra were measured by means of a test. A pre-test was administered in the lesson prior to the intervention, and the same test was administered as a post-test in the lesson after the intervention. The test aims to measure the mathematical levels of students based on the translation skills from Janvier (1987). The highest level implies being able to translate from representation formulae to representations situation, tables and graphs and vice versa. The lowest level implies not being able to translate from and to the representation formulae at all.

The test consists of six questions and 17 sub-questions, of which 10 were used to measure mathematical levels. They consist of questions involving all translation skills of the representation formulae (Janvier, 1987). The other seven questions were discarded (not included in the scores) during determination of level raising. They consist of basic primary school arithmetic questions so that students would be able to answer at least some of the questions when the test was administered as a pre-test. Scores of 0, 1 and 2 were assigned; 0 meaning low mathematical level, 1 meaning medium mathematical level, and 2 meaning high mathematical level. The sub-questions of the test corresponded to the switches between the Janvier representations involving formulae (Janvier, 1987). The first sub-question only involved a less abstract representation of a formula; therefore, the score for this question was limited to 1 (medium mathematical level). The sum of the scores amounts to a maximal number of 19 points in total that students could score for the test. The levels that were assigned to the sub-questions were discussed with a second coder (the second author of this article). Students worked individually on the test for 60 minutes. An example of a basic primary school arithmetic question is: "Out of one package pancake mix you can bake six pancakes. How many pancakes can you bake with 12 packages of pancake mix?" An example of a question that measures mathematical level is: "Shane wants to get in shape, therefore he goes swimming. With the following (word) formula you can calculate Shane's costs. Number of times swimming $\times 3 + 30 =$ costs. (Here, 3 stands for €3, the cost for swimming once at a swimming pool for a member and 30 stands for €30, the cost of a yearly membership to a swimming pool.) Draw a graph for this formula." A score of 2

(high mathematical level) was assigned when the graph was drawn correctly (linear relationship in the graph was depicted correctly); a score of 1 (medium mathematical level) was assigned when small errors occurred in the graph (e.g. graph starts at (0,0) rather than (0,30)); a score of 0 (low mathematical level) was assigned when the graph made no sense (e.g. when only names of axes were written down). Another example of a question that measures mathematical level raising is: “Eric saves money to buy a smartphone. Every month he saves €27,-. He has currently no money in his savings account. Give the formula with which the amount of money on Eric’s savings account can be calculated”. A score of 2 (high mathematical level) was assigned when the formula was correct; a score of 1 (medium mathematical level) was assigned when the formula contained small errors or when the linear relationship was explained in words; a score of 0 (low mathematical level) was assigned when the formula made no sense (e.g. when only 27 was written down).

Interrater reliability for the pre- and post-test between two coders, determined in a prior study, was excellent (ICC 0.95) (Calor et al., 2018).

A multilevel model for repeated observations on fixed occasions with an unrestricted covariance matrix (Snijders & Bosker, 2012) was used to test for differential growth between the Scaffolding condition and the control condition. The fixed occasions are the measurements (pre- and post-test) nested in individual students. The measurements (pre- and post-test) are the first level, the individual students are the second level, the small groups are the third level, and the classes are the fourth level. This multilevel model (Snijder & Bosker, 2012) enables us to test the growth in the Scaffolding condition against the growth in the control condition.

Results

We present the means of the pre- and post-test on mathematical level for the Scaffolding condition and control condition in Table 1.

	Scaffolding condition	Control condition
	M (SD)	M (SD)
Pre-test	2.04 (3.32)	1.43 (2.66)
Post-test	11.93 (5.88)	9.22 (6.44)

Table 1: Means and Standard Deviations Pre- and Post-test on Mathematical Level, Scaffolding condition (N=169) and Control condition (N=97), Maximum Score of 19

Table 1 shows that the students’ mathematical level improved a fair amount in both conditions. For the Scaffolding condition (SC), the mean score increased from 2.04 to 11.93, and for the Control condition (CC), it increased from 1.43 to 9.22.

A multilevel model for repeated observations on fixed occasions with an unrestricted covariance matrix (Snijders & Bosker, 2012) was used to test for differential growth between the SC and the CC.

We report on the model for three levels (with measurements (pre-test post-test) nested in individual students and classes) since there was no significant improvement in model fit for four levels (measurements, individuals, groups, classes).

The expected outcome for the CC was pre-test = 1.40 and post-test = 1.40 + 9.20. For the SC the expected outcome was pre-test = 1.40 + 0.692 and post-test = 1.40 + 0.692 + 9.20 + 2.116. Thus, compared to CC the growth in the SPC is 2.116 larger. This differential growth is significant ($p = 0.003$).

Discussion/conclusion

In this study, we investigated whether the mathematical level of students who were taught by teachers who were trained to give help according to the Small-Group Scaffolding model was raised more than the mathematical level of students in a control condition.

With respect to our hypothesis, multilevel analyses showed that the mathematical level of students in the Scaffolding condition was raised significantly more than the mathematical level of students in the control condition.

This study was conducted at two schools, which limits the generalizability of our findings. In addition, the conditions were observed at different schools. Consequently, results might be affected by qualitative differences between the schools. For example, the average pre-test score for the Scaffolding condition was higher than that of the control condition. This could be indicative of a higher aptitude, which in turn might be favorable for the growth in the Scaffolding condition. However, this is not very likely since there are no large descriptive differences between secondary schools in the Dutch education system (e.g. track advice given in primary schools determines the track students follow in seventh grade).

In a follow-up study, we will report elaborately on the scaffolding behavior of the teachers in both conditions. We will also focus on the quality of mathematical discussions in the groups, since reflection during mathematical discussions may have a positive effect on mathematical level raising (Freudenthal, 1978).

We conclude that the Small-Group Scaffolding model is a useful extension of the Contingent Teaching Model (Van de Pol et al., 2012). In addition, we conclude that using the SGS model for Early Algebra can raise the mathematical level of students (ability to switch back and forth between representation formulae and other algebra representations (Janvier, 1987)). The SGS model can therefore be useful to help teachers support small heterogeneous student-groups.

Future research should focus on the investigation of what kind of help the teachers in the conditions gave to the students and whether or not the quality of the mathematical discussions mediates mathematical level raising. In addition, this study should be replicated on a larger scale to find more robust findings.

References

Calor, S. M., Dekker, R., Van Drie, J. P., Zijlstra, B. J. H., & Volman, M. L. L. (2018). *Let's discuss math: Effects of shift-problem lessons on mathematical discussions and level raising in early algebra*. Manuscript submitted for publication.

- Calor, S.M., Dekker, R., Van Drie, J.P., & Volman, M.L.L. (2019). *Scaffolding small groups at group-level: Improving the scaffolding behavior of mathematics teachers during mathematical discussions*. Manuscript in preparation.
- Dekker, R., & Elshout-Mohr, M. (1998). A process model for interaction and mathematical level raising. *Educational Studies in Mathematics*, 35(3), 303–314.
- Dekker, R., & Elshout-Mohr, M. (2004). Teacher interventions aimed at mathematical level raising during collaborative learning. *Educational Studies in Mathematics*, 56(1), 39–65.
- Freudenthal, H. (1971). Geometry between the devil and the deep sea. *Educational Studies in Mathematics*, 3(3), 413–435.
- Freudenthal, H. (1978). *Weeding and Sowing: Preface to a Science of Mathematics Education*. Dordrecht, the Netherlands: Reidel.
- Freudenthal, H. (1991). *Revisiting Mathematics Education – China Lectures*. Dordrecht, the Netherlands: Kluwer Academic Publisher.
- Janvier, C. (1987). Translation process in mathematics education. In C. Janvier (Ed.), *Problems of representation in mathematics learning and problem solving* (pp. 27–31). Hillsdale, NJ: Lawrence Erlbaum Associates.
- Kieran, C. (1992). The learning and teaching of school algebra. In D. A. Grouws (Ed.), *Handbook of research on mathematics teaching and learning* (pp. 390–419). New York, NY: Macmillan.
- Sfard, A., & Linchevski, L. (1994). The gains and pitfalls of reification – the case of algebra. *Educational Studies in Mathematics*, 26, 191–228.
- Snijders, T. A. B., & Bosker, R. J. (2012). *Multilevel Analysis: An Introduction to Basic and Advanced Multilevel Modeling* (2nd ed.). London, England: Sage Publishers.
- Van de Pol, J., Volman, M., & Beishuizen, J. (2010). Scaffolding in teacher-student interaction: a decade of research. *Educational Psychology Review*, 22(3), 271–297.
- Van de Pol, J., Volman, M., & Beishuizen, J. (2012). Promoting teacher scaffolding in small-group work: A contingency perspective. *Teaching and Teacher Education*, 28(2), 193–205.
- Van Hiele, P. M. (1986). *Structure and insight*. Orlando, FL: Academic Press.
- Van Stiphout, I., Drijvers, P., & Gravemeijer, K. (2011). The development of students' algebraic proficiency. *International Electronic Journal of Mathematics Education*, 8(2), 62–80.
- Webb, N. M. (1982). Student interaction and learning in small groups. *Review of Educational Research*, 52(3), 421–445.
- Webb, N. (2009). The teacher's role in promoting collaborative dialogue in the classroom. *British Journal of Educational Psychology*, 79, 1–28.

How to improve teacher students' awareness of critical aspects in a lesson plan

Jonas Dahl, Anna Wernberg and Cecilia Winström

Malmö University, Faculty of Education, Sweden; Jonas.dahl@mau.se, anna.wernberg@mau.se,
Cecilia.winstrom@mau.se

Keywords: Learning study, mathematical knowledge for teaching, theory of variation, critical aspects.

Introduction

In this poster we will present a learning study conducted by three Swedish teacher educators. The aim of the learning study was to identify critical features concerning the teaching and learning of Mathematical knowledge for teaching (MKT). Two classes of teacher students and 30 lesson plans were analysed using the theory of variation.

Teacher student's theoretical knowledge of learning and teaching mathematics is crucial for their teaching practice. In previous courses we have discerned how teacher students on one hand can describe different strategies for solving a problem and on the other hand describe common misconceptions pupils have in elementary mathematics. Nevertheless, they do not comprehend the relationship between them. To address the problem, we have conducted a learning study focusing on the theoretical framework Mathematical Knowledge for Education (MKT), prepared by Ball, Thames and Phelps (2008), to describe the knowledge required to teach mathematics (Figure 1). The work was also guided by prior research (Bommel, 2012).

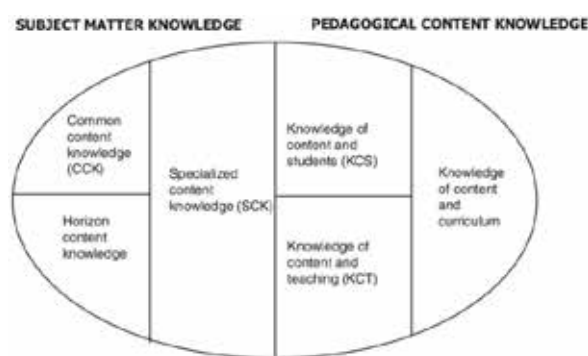


Figure 1: Domains of Mathematical Knowledge for Teaching

Method

Learning study offers a potential platform for teachers to collaboratively explore their own practice in order to generate and share knowledge about teaching and students learning. The first learning study was carried out in Hong Kong in 1999. By now over 300 learning studies have been developed in Hong Kong and it has been developed in other parts of the world, including Sweden. Lo and Marton (2012) stress that,

learning study has been found to improve students learning, reduce the gap between the high and low achievers and contributed to teachers' professional development and the learning of researchers (p. 9).

A learning study is an iterative process where a small group of teachers handle a particular pedagogical content. The students' way of making sense of the pedagogical content, initially and after a lesson is systematically scrutinized and revised once or twice and carried out in a different class. The whole process is well documented. The variation theory (Marton & Lo, 2012) is used as a theoretical tool for planning the lessons as well as analysing the lesson and the teacher students' lesson plans.

Data collection

The data collected consists of lesson plans (written test) and two video recordings of iterative seminars given in the teacher education course. The mathematical topic covered was probability. Prior to, and after each seminar, the teacher students handed in a lesson plan.

Preliminary results

The analysis of the lesson plans revealed how and what the student teachers understood or not and thus what critical features the seminar should focus on. We could see in the lesson plan that the students wrote an aim with the lesson, a didactic plan for the lesson and also how they would evaluate the pupils learning. What was missing was the connection between the three (critical aspect). In the seminar we let student teachers look at a lesson plan conducted by someone else than the students as well as questions about the alignment between aim, lesson and evaluation in order for them to discern the critical aspects. The result showed that the students had not discerned the critical aspects and one reason could be the lack of contrast between different lesson plans since we only addressed one lesson plan in the seminar. For the second seminar we discussed one lesson plan in whole class and addressed questions about what was missing in the lesson plan between the linking in the alignment. In order for the teacher students to discern the critical aspects they got a lesson plan to compare and contrast with the first one discussed. One critical aspect we overlooked was the student's ability to make the lesson plan concrete enough to work in a classroom. A second learning study will be conducted taking into account the need to varyate concrete lesson plans.

References

- Ball, D. L. Thames, M. H., & Phelps, G. (2008). Content knowledge for teaching: What makes it special? *Journal of Teacher Education*, 59(5), 389–407.
- Bommel, J. van (2012). *Improving teaching, improving learning, improving as a teacher: mathematical knowledge for teaching as an object of learning* (Ph. D. thesis). Department of Mathematics, Karlstad University.
- Lo, M. L., & Marton, F. (2012). Towards a science of the art of teaching – Using variation theory as a guiding principle of pedagogical design. *International Journal of Lesson and Learning Studies*, 1(1), 7–22.

How teachers use interactions to craft different types of student participation during whole-class mathematical work

Ove Gunnar Drageset

UiT – The Arctic University of Norway, Norway; ove.drageset@uit.no

This article investigates how different types of teacher interactions craft different types of student participation. The article is based on shared data within Thematic working group 19: Mathematics Teaching and Teacher Practice(s) for CERME 11. Using conversation analysis, each turn was characterized. The findings illustrate the main teacher and student interactions for each classroom, and how some types of teacher interactions typically lead to specific types of student interactions in the following turn. This is a contribution to increase our understanding of how teacher interactions can be used deliberately to activate students' participation in different ways.

Keywords: Interaction, discourse, student participation, moderating, whole-class mathematical work.

Theory

When describing classroom discourse, the IRE pattern (Cazden, 1988; Mehan, 1979) might be the most widely referenced concept. It describes a pattern where the teacher initiates a task or discussion, the student(s) responds, and the teacher evaluates, and is often seen as the default pattern of classroom discourse. According to Franke, Kazemi, and Battey (2007), the IRE pattern describes a procedure-bound pattern with little emphasis on students' thinking and explanations. Often IRE is described as a rather teacher-dominated pattern, where the students only answer when given permission and where the teacher maintains a position of authority given by role rather than by mathematical arguments. However, it is not only who asks the question or who evaluates that decides the quality, but also the quality of the questions and evaluations. Mercer and Littleton (2007) argue that instead of looking at the number of questions (initiatives) a teacher asks, one should look at the function of these questions. It is also necessary to study the function as part of the dialogue, studying how different initiatives nurture specific responses and how these are typically evaluated. This must be done within both IRE patterns and other patterns, leaving the focus on characterizing a discourse as inside or outside IRE behind us and instead look for details that inform about different qualities.

Several authors have described discourse frameworks and concepts that go into more detail. One such example is Fraivillig, Murphy, and Fuson (1999) who, based on a study of one skillful teacher, describe the ACT (Advancing Children's Mathematics) framework, consisting of three components: eliciting children's solution methods, supporting children's conceptual understanding, and extending children's mathematical thinking. These components describe three main ways the teacher acts to advance students' mathematical thinking in detail. Another example is the eight communicative features suggested by Alrø and Skovsmose (2002): getting in contact, locating, identifying, advocating, thinking aloud, reformulating, challenging, and evaluating. These do not separate between teacher and student interactions, but instead describe fundamental types of communication in mathematics independent of who says what. A third example is the redirecting, progressing, and focusing framework (Drageset, 2014) describing thirteen actions teachers use to orchestrate the

classroom discourse. Redirecting actions typically occur when the teacher wants the student(s) to change their approach. This is done either by putting aside the student's suggestion, by advising a new strategy, or by asking a question in such a way that it includes a correction. Progressing actions are about moving the progress forward. This is done by demonstrating the entire solution process, by simplifying through hints and suggestions, by asking closed and often basic questions to move along one step at a time while the teacher controls the process, or by asking open questions and leaving it to the student(s) to choose how to progress. Focusing actions are about stopping the progress to look deeper into some important detail and consist of two main types. One type is to ask students either to elaborate in detail how they solved a problem or thought to arrive at the answer, to justify why their answer or method was mathematically correct, to apply the method to a similar problem, or to assess. The other type is the teacher pointing out important ideas or rules either during the solution process (notice) or after the solution has been found or agreed upon (recap). In a further development of the framework, a third type of focusing actions called moderating is added (Drageset & Allern, 2018). This describes how teachers moderate the discourse in three different ways: choosing whom to speak, requesting student questions, and requesting alternative methods. In general, moderating interactions describe how a teacher can develop and control the discourse while the content of the discourse is the students thinking, questions, and explanations.

In addition to the framework describing different teacher interactions, Drageset (2015) developed five categories of student comment: explanations, initiatives, teacher-led responses, unexplained answers, and partial answers. These add to the categories describing teacher actions, together providing a set of concepts able to describe all mathematically-related comments in these five practices. Together, Alrø and Skovsmose (2002), Drageset (2014), and Fraivillig et al. (1999) illustrate three different approaches to investigate classroom discourse in detail. While Fraivillig et al. (1999) concentrated their effort on describing the main actions performed by the teacher to help students advance their mathematical understanding, Alrø and Skovsmose (2002) described all turns without separating teacher and students, and Drageset (2014, 2015) chose to describe teachers' and students' participation separately before looking at connections. Common to the latter two is the characterization of single comments in order to develop categories.

However, looking at single comments, or turns, yields a very limited scope. According to Sacks, Schegloff, and Jefferson (1974), turns are the most fundamental feature of conversation. Even though people take turns in speaking, sequentially and one at a time, it is not possible to characterize a conversation as a series of individual actions. Instead, conversations are social practices where each turn is thoroughly dependent on previous turns, and individual turns cannot be understood in isolation from each other (Linell, 1998). This means that characterizing different types of single turns are insufficient if one wants to study the discourse. Instead, one needs to study how different types of turns affect one another. It is also important to know that some responses are more relevant or preferred than others (Linell, 1998). Often, a student knows what type of answer is relevant. Such relevance can be related to social norms and socio-mathematical norms (Yackel & Cobb, 1996). Arguably, when a student knows how what is a relevant or preferred answer, then norms are established. And these norms, or relevant answers, do not emerge out of definition or information from a teacher, but gradually through an appropriation process as described by Newman (1990).

Method

This article reports from a study of shared data within Thematic Working Group 19 for the CERME 11 conference. Three short videos from different classrooms and a transcript from a fourth were shared by different participants of the TWG 19. The idea is that participants in TWG 19 can get a greater insight into the analyses and frameworks of each other when they also have access to the data.

Based on the knowledge that each turn in a conversation is thoroughly dependent on previous turns (Linell, 1998), this article aims to investigate this question: How do teachers use of different types of interactions craft different types of student participation during whole-class mathematical work? To achieve this, the transcripts were analyzed turn by turn, categorizing each turn using the redirecting, progressing and focusing framework developed by Drageset (2014, 2015) and Drageset and Allern (2018). Then the most frequent types of teacher interactions were identified to search for patterns on how students responded to these types. And the student interactions describe the ways the students participate during the whole-class mathematical work.

While the data from each classroom is too limited to say much about the classrooms, this type of data is valuable for its variety. This variety illustrates very different ways of crafting student participation, which is also useful for further development of the frameworks and concepts.

Findings

In the following, findings related to each classroom will be described. All concepts in *italic* are concepts from the redirecting, progressing and focusing framework by Drageset (2014, 2015) and Drageset and Allern (2018).

Kleve's classroom

This lesson is studied based on the transcript alone. It comes from a fourth-grade class with 24 students in Norway. The teacher is educated as a pre-school teacher and thus not formally qualified for teaching in school. In this lesson, five students have solved one task each on the blackboard. Then the discourse started, and the teacher talked with each student and the entire class about each task.

For each task, the discourse starts with a task that is solved, but the process and thinking behind the task is not visible. The first question the teacher asked for each task are these:

- Let's see. What is the place value system about, Herman?
- When we are going to find the product of something. What do we have to think about then? Hamid?
- And half of something, Marte, what do we have to think about then?
- Finding x, then we are going to find the missing number. What do we have to do then Oskar?
- Greater than and less than, Tobias. That became [i.e. You got...?]

The first four are similar as they all ask students for an explanation. Herman is asked to explain a concept (place value). Hamid, Marte, and Oskar are all asked to explain a process, either what one needs to think about or what one needs to do. All these questions are about *enlightening details*, to make the thinking behind an answer visible. All these resulted in *student explanations*.

The last question to Tobias is about getting an answer, not requesting an explanation. Instead, this is an *open progress initiative* which resulted in an answer with no explanation (*unexplained answer*).

Further on, the task discourses vary, but also tend to look like this towards the end:

Teacher: And seventy-three and thirty-seven?

Students: Greater than.

Teacher: And twenty-six minus two is?

Students: 12

Teacher: And twelve plus twelve is?

Students: Equal.

All the teacher interactions are questions that have only one correct answer and demands no process to answer (as the answers are already on the blackboard). This means that the teacher interactions are *closed progress details* while the student interactions are *teacher-led responses*. This pattern is found towards the end of four out of five task discourses.

Overall, the discourse pattern seemed to be that the teacher requested details of students thinking first (*enlighten detail*), the student explained, and towards the end the teacher went through all remaining answers using *closed progress details*, receiving *teacher-led responses*.

Sakonidis's classroom

This classroom consists of 22 students at grade five in Greece. The teacher is a mathematician with an interest in advancing children's mathematical thinking. The video shows the teacher at the blackboard with fraction circles, talking with the entire class. This is an excerpt from the discourse:

Student: Eight

Teacher: Eight. How many pieces do I need for a whole pizza here? (Pointing out a circle that is divided into two six pieces, one in light green and the rest in dark green)

Student: Six

Teacher: Six. And here, how many do I need for a whole pizza? (Pointing out a circle that is divided into two four pieces, one in light green and the rest in dark green)

Student: Four

In the above excerpt, both teacher interactions start with a confirmation, then moves on to the next question (next figure). The questions have only one correct answer, and as the figures are drawn on the blackboard it is not difficult to answer (count) correctly. Such questions are *closed progress details* because there is only one correct answer. The student's answers are *teacher-led responses* as the answer are given by the figure.

In this lesson, the dominating type of teacher interactions is *closed progress details*, each followed by a *teacher-led response*. This leads to a typical IRE pattern where the teacher asks all the questions, evaluates all answers, and talk much more than the students.

Hoover's classroom

This video is from a summer mathematics program with approximately 30 fifth graders in the USA. The teacher has more than 30 years of experience and is also a researcher. The video shows a student suggesting a solution on the blackboard and the subsequent dialogue. Quite often the teacher interacted in a particular way, as illustrated by these examples:

- Okay, would some- You'd like to ask another question, Dante?
- Okay, Toni, what's your question for her?
- Okay, any more questions for Aniyah?

These teacher interactions are similar as they are all about getting students to ask Aniyah about her thinking. It was typical for this lesson that the teacher *requested student questions*.

Another type of interaction observed repeatedly looked like this:

- Before you agree or disagree, I want you to ask questions if there's something you don't understand about what she did. No agreeing and disagreeing. Just- All you can do right now is ask Aniyah questions.

Here the teacher tells the student how to participate in the discourse. The teacher is *moderating* the discourse by *guiding participation and norms*.

The pattern of this classroom seems clear. The teacher sets up the situation by letting a student answer and controls the interaction through the use of *guiding participation and norms* and *requesting student questions*. Then the students' participation follows as requested, with one student *asking questions* and the one by the blackboard subsequently *explaining*. It is also interesting to notice that the teacher does not talk every second time and that the student interactions are rarely short and sometimes long.

Drageset's classroom

This classroom shows a lesson with five students in grade four and their teacher in Norway. The lesson is part of a large government project where the effect of more teachers at the first grades will be explored. The teacher has about 20 years of experience. The lesson shows these students solving one task (the King is 80 years in 2017, when was he born?) and sharing their strategies. This teacher uses several types of interactions, such as these:

- But remember, you remember what we've been saying. It's not the answer that's going to impress me. What's going to impress me the most is the way you got the answer.
- A good tip right now is not to trust that one sitting beside you.
- You can only trust yourself here. Think for yourself and trust yourself.

Here the teacher informs the students about how to work, which is *guiding participation and norms*. In addition, the teacher regularly asked such questions as these:

- Are there anyone else that wants to show their way of thinking?
- Now it's your turn to explain if you want.

- But you were also, I noticed, quite quick to finish. (...) It looked like you did it in your head for a bit, then [snaps] wrote your answer down. So, I'm eager to know how you did it.

All these are examples of the teacher *requesting alternative methods*. It was the main feature of this lesson that the students presented a variety of solution methods of finding the King's birth year. Both *guiding participation and norms* and *requesting alternative methods* are examples where the teacher controls the dialogue through *moderating*, while the main content of the discourse is the students' explanations. However, bringing alternative methods forward did not result in a discussion.

Another type of teacher interaction was such as this one:

- I just want to repeat what you did so the others will understand what you meant. If you can move aside for a bit. What I understood is that you didn't bother about the 17 at first. You just went straight back and thought that: "What if we're in the year 2000 now?" If we then move 80 years back, we land in 1920. But now I'm eager to know, what did you do next?

Here the teacher stops the student explanation to tell the other students what is done so far and subsequently asking the student to continue the explanation. Such *pointing out* was frequently used by the teacher, and almost all long teacher interactions were about *pointing out*. While the teacher let the student explain, he used *pointing out* to make the explanation clearer and more complete. In this way, the student explanation was complemented and clarified.

The students participated in three main ways; *offer to answer*, *needing clarification*, and *explaining*. The two first were observed in the first part of the lesson, while the students worked on the task individually. The *student explanations* were observed during the last part of the lesson when they shared strategies on the blackboard. Of these explanations, almost all were *explanations of action*.

This lesson had two clear parts. In the first part, when the students worked individually, the teacher mainly contributed by *guiding participation and norms* while the students *offered to answer* when they were ready and *needed clarification*. In the second part, the teacher *requested (alternative) methods*. As a consequence, the students shared their strategy one at a time (*student explanation*) and the teacher *pointed out* during or after their explanations. The use of *pointing out* did not lead to any student interaction, either the student continued explaining, or the *pointing out* ended the explanation.

Discussion and conclusion

This article has analyzed transcripts and videos from four classrooms to find out how different types of teacher interactions leads to specific types of student interactions. Based on which type of student interaction that follows each type of teacher interaction, there are some clear patterns.

	Most frequent teacher interactions	Most frequent student interactions
Kleve's classroom	<ul style="list-style-type: none"> · Closed progress details · Enlighten detail 	<ul style="list-style-type: none"> · Teacher-led responses · Student explanation
Sakonidis' classroom	<ul style="list-style-type: none"> · Closed progress details 	<ul style="list-style-type: none"> · Teacher-led responses

Hoover's classroom	<ul style="list-style-type: none"> · Moderating <ul style="list-style-type: none"> ○ Guiding participation and norms ○ Requesting student questions 	<ul style="list-style-type: none"> · Student explanation · Student questions
Drageset's classroom	<ul style="list-style-type: none"> · Pointing out · Moderating <ul style="list-style-type: none"> ○ Guiding participation and norms ○ Requesting alternative methods 	<ul style="list-style-type: none"> · Student explanation · Offer to answer · Needing clarification

Table 1: Summary of the most frequently used interactions in each classroom, based on concepts from Drageset (2014), Drageset (2015), and Drageset and Allern (2018)

Perhaps the clearest pattern found is that when a teacher asks for *closed progress details* the student responds with a *teacher-led response*. In these sequences, the teacher asks very easy questions and the students answers shortly. A focus on answer and repetition seems to be a feature of this pattern.

Another pattern is that when the teachers requested the students to *enlighten details* about their thinking or solution process, the student responded with an explanation of the actions or thoughts. This might seem insignificant, but according to Franke et al. (2007), one of the most powerful moves a teacher can take is to make such details about thinking visible for all. Similarly, *requesting alternative methods* resulted in student explanations. This also creates opportunities for discussing different methods or strategies, but this was not observed here.

The teacher interaction of *requesting student questions* was of particular interest. This naturally leads to the students asking questions, but also lead to student explanations in a dialogue between students.

The interaction *pointing out* did not lead to any particular student interactions. Typically, the student either continued the explanation afterward or did not say more when the *pointing out* came as a conclusion. The use of *pointing out* illustrated how this is a tool for clearing up students' explanations.

While both *requesting student questions* and *pointing out* focused on displaying student thinking, it is worth noticing a clear difference. While the teacher in the third classroom (shared by Hoover) was emphasizing that students should ask to find out what the student was thinking, the teacher in the fourth classroom (shared by Drageset) instead pointed out what seemed to be necessary for the other students to understand, and effectively removed the need for student questions.

The interactions that were *guiding participation and norms* seemed to lead to the requested behavior, but this was not possible to see clearly in the turn-by-turn analysis. In general, these interactions are examples of how a teacher can work deliberately to establish norms of how to respond and of what is expected from an answer. This means that *guiding participation and norms* illustrates how these teachers seem to work to establish what Linell (1998) calls preferred responses. When preferred responses are related to the content of mathematics, such as what counts as an explanation, the preferred responses are the same that Yackel and Cobb (1996) calls socio-mathematical norms.

This article has illustrated how the types of teacher interactions rather consistently decide which type of student response comes in the next turn. And responses that are consistent arguably describe how the students participate. Further research is needed in order to understand how teacher turns can be

used deliberately to activate students' participation in different ways, and the sharing of data from different classrooms and cultures is ideal for such a work. The findings also illustrate that the framework used apply cross-nationally and yield coherent characterizations of instructional interactions during whole-class mathematical work.

References

- Alrø, H., & Skovsmose, O. (2002). *Dialogue and learning in mathematics education: Intention, reflection, critique*. Dordrecht: Kluwer Academic Publishers.
- Cazden, C. B. (1988). *Classroom discourse: the language of teaching and learning*. Portsmouth, NH: Heinemann.
- Drageset, O. G. (2014). Redirecting, progressing, and focusing actions—a framework for describing how teachers use students' comments to work with mathematics. *Educational Studies in Mathematics*, 85(2), 281–304. doi:10.1007/s10649-013-9515-1
- Drageset, O. G. (2015). Different types of student comments in the mathematics classroom. *Journal of Mathematical Behavior*, 38, 29–40. doi:10.1016/j.jmathb.2015.01.003
- Drageset, O. G., & Allern, T. H. (2018). Curious classrooms. Changing classroom discourse in mathematics using roles. Submitted for review.
- Fraivillig, J. L., Murphy, L. A., & Fuson, K. C. (1999). Advancing children's mathematical thinking in everyday mathematics classrooms. *Journal for Research in Mathematics Education*, 30(2), 148–170.
- Franke, M. L., Kazemi, E., & Battey, D. (2007). Mathematics teaching and classroom practice. In F. K. Lester (Ed.), *Second handbook of research on mathematics teaching and learning* (pp. 225–256). Charlotte, NC: Information Age Publishing.
- Linell, P. (1998). *Approaching dialogue. Talk, interaction and contexts in dialogical perspectives*. Amsterdam: John Benjamins.
- Mehan, H. (1979). *Learning Lessons: social organization in the classroom*. Cambridge, MA: Harvard University Press.
- Mercer, N., & Littleton, K. (2007). *Dialogue and the development of children's thinking: a sociocultural approach*. London: Routledge.
- Newman, D. (1990). Cognition, computing, and cooperation. In S. P. Robertson, W. Zachary, & J. B. Black (Eds.), *Cognition, computing, and cooperation* (pp. 84–94). Norwood, N.J.: Ablex Publ. Corp.
- Sacks, H., Schegloff, E. A., & Jefferson, G. (1974). A simplest systematics for the organization of turn-taking for conversation. *Language*, 50(4), 696–735.
- Yackel, E., & Cobb, P. (1996). Sociomathematical norms, argumentation, and autonomy in mathematics. *Journal for Research in Mathematics Education*, 27, 458–477.

Beyond the immediate – illuminating the complexity of planning in mathematics teaching

Helena Grundén

Linnaeus University, Sweden; annahelena.grunden@lnu.se

In mathematics education, there is a growing interest in research on social aspects such as how mathematics teaching in classrooms is informed by society. Consequently, new sets of theoretical frameworks and methods have to be taken into account. In a focus group study, Critical Discourse Analysis (CDA) was used as a theoretical framework, which enabled the researcher to see how mathematics teachers resist and construct a discourse of mathematics teaching apart from the official discourse. Also shown in the study is that power relations are circulating and thereby influencing teachers in the process of planning in mathematics. In this paper, results from the study are used to emphasize CDA as useful for mathematics education researchers seeking to grasp the complex, dynamic, and emerging nature of mathematics teaching.

Keywords: Critical Discourse Analysis, mathematics teaching, power.

Introduction

Prior studies within the TWG19 have in different ways underlined “the dynamics of the research activity aiming at ‘unpacking’ teaching practice”, mainly by focusing “the micro-level of classroom practice, on the resources teachers draw on as they engage in it, and their (intentional or unintentional) professional activity” (Sakonidis, Drageset, Mosvold, Skott, & Taylan, 2017, p. 3039). However, mathematics teaching is framed by “contextual, epistemological, and social issues” (Potari, Figueiras, Mosvold, Sakonidis, & Skott, 2015, p. 2972), which means that ‘unpacking’ teaching practice and exploring the complexity of mathematics teaching requires research moving beyond immediate classroom situations.

Teachers’ planning is one aspect of mathematics teaching practice(s) that often is done outside classrooms. One aspect of understanding development of this specific part of teaching practice(s) is to explore influence of various factors such as “how micro-level interactions (classroom and school) are informed by macro-level structures (society, culture and the politics)” (Sakonidis et al., 2017, p. 3033). Theoretical frameworks and methods traditionally used for classroom studies might not be enough to grasp what Sakonidis et al. (2017) refer to as the macro-level structures, i.e., society, culture, and politics. Hence, a framework acknowledging “the significance of the multiple micro- and macro factors that may influence how learning and lives in classrooms unfold” (Skott, Mosvold, & Sakonidis, 2018, p.171) is needed.

An ongoing focus group study focuses on planning in mathematics teaching. The study aims to explore in what ways power is visible in mathematics teachers’ talk about planning and the research questions guiding the study are: “What practices are visible when teachers talk about planning in mathematics?”, and “In what ways do teachers refer to these practices?”. In this paper, theoretical assumptions underlying the design of the study and preliminary results from the study are presented

through an empirical example, discuss Critical Discourse Analysis (CDA) as an option for studies aiming at going beyond the immediate and observable classroom events.

Theoretical framing

In the following section, CDA and relevant theoretical constructs of practice, power, and discourse are presented in relation to previous mathematics education research. CDA is emphasized as a useful approach when wanting to explore relations between educational practices and social contexts (Mullet, 2018). In CDA the research interest is social practices, which include both communicative interaction (between actors) and the structural conditions framing the communication (Chouliaraki & Fairclough, 1999). Hence, a CDA perspective will embrace both structures and actors acknowledging that discourses shape humans as much as humans shape discourses (Fairclough as cited in Lund & Sundberg, 2004, p. 25). There is a dialectic relation between on the one hand to preserve and reproduce structures, and on the other hand, actors transforming and diversifying discourses (Lund & Sundberg, 2004). Adopting this perspective in relation to planning in mathematics would imply seeing the teacher as an actor within the structure of mathematics, the structure of mathematics education, and the structure of school.

Within CDA there is no disjunction between micro-, macro-, and meso level. Instead of analyzing different levels, different aspects of practice are analyzed through phases of text, discursive practice, and social practice. Texts expressed discursively are produced within a social practice (Chouliaraki & Fairclough, 1999). CDA has been used and discussed in mathematics education, mainly with a focus on texts and linguistics (e.g., Le Roux, 2008; Morgan, 2014). However, staying close to the text is not the only possibility. In CDA, focus on three levels is possible: “the communicative interaction itself; the discursive resources used in the interaction and the orders of discourse from which they are drawn; the social structures and socio-cultural practices within which the interaction is situated” (Chouliaraki & Fairclough, 1999 as cited in Morgan, 2014, p.6). In Le Roux (2008) Fairclough’s three-dimensional model is used “as a framework for studying the relationship between the written text of a mathematics problem, the associated discursive practices (the processes of text production, distribution and consumption of the text) and the wider social practice of which the discursive practices form part” (La Roux, 2008, p. 313). The three-dimensional model can also be used to describe a teacher talking about planning. The teacher produces a text (the talk) within a discursive practice (i.e., the college of mathematics teachers in the school) that is embedded within a social practice.

Practices

Within the CDA perspective, as well as in prior mathematics education research, the term ‘practice’ is common. However, there is not a mutual understanding of the term. In mathematics education research, the term has evolved from a cognitive, individual perspective focusing on actions and behaviors and underlying beliefs, intentions and knowledge, to a sociocultural perspective within which ‘practice’ is a social phenomenon and includes teachers’ and students’ recurrent activities and norms (Skott et al., 2018). The meaning of the term ‘practice’ has in some studies also expanded to include parts of teachers work that happens outside the mathematics classroom (Skott et al., 2018). This latter understanding of the term is in line with meaning of practice in the CDA perspective where

‘practice’ grasps both individuals’ actions and the more habitual, common ways of acting (Chouliaraki & Fairclough, 1999). Hence, thinking of planning for mathematics teaching as a practice would enable to see teachers’ actions both as individual and shared by other mathematics teachers. It would also enable to get hold of the relationship between abstract structures and peoples acting, or how social structures govern people’s possibilities to act.

In the CDA perspective, using the term practice implies that there are internal power relations and a struggle between different actors. In the practice of planning, there are actors such as colleagues, students, and school leaders who may not share the same ideas about mathematics teaching. These different ideas lead to tensions and influence teachers’ planning (Grundén, 2019), which can be seen as a struggle between actors. This struggle reproduces and transforms structural conditions. However, the internal power relations of a practice are also influenced by its relation to other practices (Lund & Sundberg, 2004). Teachers’ planning in mathematics teaching is thus framed by structural conditions produced in past and present educational systems but is also framed by structural conditions produced by mathematics community, and mathematics education community. Hence, there is an on-going struggle where structural conditions are negotiated.

Power

In mathematics education research, different notions of power are used (Gutiérrez, 2013; Valero, 2008). In this paper, power is used from a CDA perspective, i.e., always present in and between practices, and seen as situated, relational, and in constant transformation. Transformation occurs when people participate and act in the construction of discourses (Valero, 2004). Hence, power in relation to planning for mathematics teaching is in constant circulation and transformation. Power is not seen as only operating from ‘above,’ from for example government and school leaders. On the contrary, all actors within a practice, such as teachers, students, and parents as well as government and school leaders might have power.

Discourse

Another construct important within the CDA perspective is discourse. The term is used in a variety of ways in mathematics education research and the conceptual clarity in many discourse studies is weak. In a literature review on mathematics education, articles were found to focus on three topics: discourse as social interaction; minds, selves, and sense-making; and cultural and social relations (Ryve, 2011). In this paper, the focus is on social structures and meaning is seen as situated and co-constructed which would place the research within the topic area of cultural and social relations. In Ryve’s categorization, this implies an interest in “macro processes of social and institutional actions” (p. 172). Many studies within this topic area draw on work of Foucault, with the consequence that discourses are analyzed as language games maintained by power relations and little agency is ascribed to individuals (Ryve, 2011). This perspective is often criticized since there are few possibilities to transcend the binding discourse order (Lund & Sundberg, 2004).

On the other hand, within the CDA perspective there is a dialectic relationship between humans and discourses (Lund & Sundberg, 2004) and discourse is seen as “use of language seen as a form of social practice, and discourse analysis is analysis of how texts work within sociocultural practice” (Fairclough, 1995, p.7). Within a discursive practice such as a college of mathematics teachers

planning for teaching, texts are produced, distributed, and consumed in specific ways and in line with the social context in which it is embedded. What is analytically interesting is not to “discover” and construct “new” discourses but how the individual teachers through acting represent, produce, and legitimate discourses on specific grounds. Discourses are studied based on their effects on different levels; situational, institutional, and societal (Lund & Sundberg, 2004, p. 26)

Empirical example – Focus group

Results from a previous study (Grundén, 2017) in which teachers were interviewed with a focus on meaning in relation to planning in mathematics show that teachers refer to aspects beyond the immediate planning in their talk, they refer to practices other than the practice of planning in mathematics. In an ongoing study, focus group interviews are used to explore how these practices are visible and how power operates within and between them. The researcher met with six different groups at four different schools. The number of participants in the groups was between 2 and 5. The interviews lasted between 65 and 90 minutes. After an introduction consisting of a presentation, a reminder of informed consent, and a short presentation of the previous study the researcher started the discussion by placing pieces of paper in the middle of the table. On some of the pieces, there were words written; some of them were empty. The words that were written were six common influencing aspects identified in the previous interview study: Students, School management, National tests, Templates/forms, Parents, and Textbook. Participants were asked to look at the words and think about if any of them had any relation to their process of planning in mathematics. The words were seen as stimuli for the discussion. Participants were also told that they could add aspects they thought were missing and remove aspects that they did not think were related to planning. During the discussion, the role of the researcher was to ask follow up questions and challenging questions and to make room for all participants and invite them in the conversation, and through small words and gestures confirm that she was listening.

Since the aim of the study was about the practice of planning rather than individual teachers' planning the discussions were transcribed without marking different voices. Instead, all statements were seen as examples from the practice of planning in mathematics teaching. For this paper, preliminary results from one of the focus groups are presented. The reason for presenting results from this group was a telling example of when a social practice influenced planning in mathematics teaching. The group consists of four teachers working in school year 1 at the same school, a small school with pre-school class, first class, and second class. The teachers had scheduled time together every week and were used to working together. At the beginning of the discussion, the group wanted to add an aspect, ‘National support for assessment,’ that for them was related to planning. A transcript of the discussion that followed was analyzed as described in the following section.

Acknowledging meaning as situated and power as an issue in social practices (e.g. Valero, 2004) implies that power is present also in the interview situation. In this study, efforts were made to diminish influence of researcher by letting participants choose and talk freely about issues related to planning introduced with no further explanation. However, there is always a possibility that researchers influence arguments in texts produced by participants which have to be taken into considerations when valuing results.

Analysis and results

There is no particular method for analysis in CDA studies. However, there are common features in the analysis made within the perspective where the analysis “oscillates between a focus on structure and a focus on action” (Fairclough, 2001 as cited in Mullet, 2018, p. 118). Mullet (2018) describes a general analytical framework for CDA in which several CDA approaches are condensed into seven stages of analysis. The first three stages are preparatory and include selecting the discourse under investigation, select data sources and prepare them, and examine the background of text and producers of text. The fourth stage when analyzing a text is to identify overarching themes for example by using thematic analysis. (Mullet, 2018). After that analysis of external (stage 5) and internal relations (stage 6) in the text takes place. When analyzing external relations, interdiscursivity, social practices’ influence on arguments in the text as well as the text’s influence on social practices are examined. The analysis of internal relations is focused on “patterns, words, and linguistic devices that represent power relations, social context (e.g., events, actors, or locations), or speakers’ positionalities.” (p. 124). In stage 7 meanings of major themes and internal and external relations identified in stage 4, 5, and 6 are interpreted.

In the following section, results of the external and the internal analysis of the focus group study are presented. The theme of the first example is assessment material on number sense from the National Agency of Education that is mandatory to conduct with all year 1 students. One of the groups wanted to add ‘National assessment support’ to the words in the middle of the table. The following discussion took place¹:

- 1 Teacher: It is extremely time-consuming. It takes too much time from teaching
- 2 Teacher: ...teaching has to come first, before Skolverket’s [National Agency of Education] assessment support ...
- 3 Teacher: We have also said that the assessment support and national tests have never shown us something we didn’t already know.
- 4 Teacher: And the municipality requires documentation from us, and they have chosen another type of documentation than Skolverket wants, which leads to additional workload”.

In this section, we can see that there are social practices influencing arguments in the text (stage 5). Teachers talk about Skolverket [National Agency for Education] (line 2 and 4) and municipality (line 4) which both can be seen as actors within an official practice. Other elements of the official practice are visible when teachers talk about the assessment support (line 1, 2, and 3) and national tests (line 3).

By focusing on patterns, words, and linguistic devices, i.e., the internal relations (step 6) in the text we can see how teachers have to relate to the assessment support when planning. In the first utterance, a teacher implicitly expresses that they have less time for ‘teaching,’ thereby also implicitly saying that doing the assessment tasks with students is not part of ‘teaching.’ By the choices of words

¹ My translation from Swedish

‘extremely’ and ‘too’ the teacher reinforces the impression that the assessment support is something that is not considered valuable. This view is also visible in the second utterance, where the teacher emphasizes that teaching is something else, more valuable than the assessment support. By seeing Skolverket as the owner of the material, the teacher distances herself and gives the impression that the assessment support intrudes teaching.

In the third statement, the participant sees herself as part of a practice by referring to ‘we.’ Within the practice, information obtained by assessment support and national tests is unnecessary because it already has emerged through teaching. In the last statement “the municipality requires” another type of documentation than “Skolverket wants” indicates that the documentation for Skolverket seems more reasonable than the documentation for the municipality. This is strengthened by the claim that the requirements from the municipality lead to “additional workload.”

The counterpart in the above example is Skolverket, which on their webpage describes the assessment support as follows:

In the subject of mathematics there is a national assessment support in number sense for school year 1–3. It is mandatory for head of school² to use assessment support in school year 1. It is Skolverket’s assessment support in number sense, published in 2018, that should be used [...]. The assessment support aims to make it easier for you as a teacher to follow up on students’ knowledge in school year 1–3. With help from assessment support students that already have, or are in the risk of having, difficulties in number sense in mathematics can be early identified. You can also see when a student has come further in her knowledge development and need further stimulation (Skolverket, 2018³).

Here, the words ‘support’ and ‘mandatory’ are of interest. Making support mandatory assumes that users, in this case, the teachers, are in need of support and that they do not seek the support they need. Since the assessment support is “mandatory for the head of school” an alternative interpretation could be that Skolverket by saying that it is mandatory wants to clarify that the head of school has to create conditions for teachers to make the assessments. However, there are wordings such as ‘for you as a teacher’ indicating that teachers are the actual receivers, and teachers are also the ones who conduct the assessments in the material.

Through the analysis of the four utterances and the quotation from Skolverket, it is possible to see that power is circulating around and within the practice of planning. Through the way the teachers speak, it becomes clear that the assessment material is seen as worthless and something that stands in the way for teaching. On the contrary, Skolverket emphasizes the assessment support as helpful in teachers’ possibilities to individualize teaching. The teachers can either choose to resist given instructions and not let their students do the assessments or choose to follow them and thereby renounce what they count as teaching. In this case, the teachers choose to conduct the assessments, which in line with the analysis have the consequence that students have less mathematics teaching.

² In Sweden, ‘head of school’ means the authority responsible for a school or several schools. It can be a municipality, the state, or a private actor.

³ My translation from Swedish

Discussion and conclusion

By analyzing what the teachers said with regard to external relations (Mullet, 2018) Skolverket's influence on arguments in the text was made visible. It was also visible how decisions made by Skolverket influenced decisions that the teachers made regarding their teaching. By focusing on internal relations (Mullet, 2018), the resistance of the teachers was apparent. In their meta-reflection on planning the teachers emphasize explicit power relations and perceive Skolverket and the municipality as disturbing power factors. When expressing dissatisfaction, they resist the official practice and make room for an alternative discourse of mathematics teaching where the actors of the official discourse are not invited. Hence, teachers enter as actors in a discursive struggle for power where they, on the one hand, perceive instructions and requirements from Skolverket and the municipality as “something else” than their own pedagogical discourse and on the other hand realize that they have to follow instructions and requirements given by them.

Relating the power relations and the struggle between actors visible in the above examples to what is happening in the mathematics classroom is two-folded. On the one hand, it contributes to explanations of what is happening in the teaching situation when the students do the assessment tasks, but also bring clarity to aspects of teaching that never are visible in classrooms. Teachers in the example abandon what they consider to be teaching to comply with the directives of Skolverket. Insights like this might be important for example in discussions about implementing research results. Often it seems to be assumed that teachers do not teach desirable ways because they do not know how to do. Consequently, implementing research seems to be about telling teachers how to do. Findings indicate that an awareness that teachers make decisions in a practice influenced by others and sometimes not teach the way they want is crucial in implementation work.

So, is CDA useful in mathematics education research? Results presented above indicate that theoretical constructs from CDA such as practice (e.g., Chouliaraki & Fairclough, 1999) and power (e.g., Valero, 2004) help to make visible what Sakonidis et al. (2017) describe as how classroom and schools are informed by society, culture and politics. Hence, CDA might be a possible answer to the call for a framework that acknowledges “the significance of the multiple micro- and macro factors that may influence how learning and lives in classrooms unfold” (Skott et al., 2018, p.171), and studies using CDA might contribute to research in mathematics teaching with insights beyond the immediate.

References

- Chouliaraki, L. & Fairclough, N. (1999). *Discourse in late modernity: rethinking critical discourse analysis*. Edinburgh, Scotland: Edinburgh Univ. Press.
- Fairclough, N. (1995). *Critical Discourse Analysis*. London, UK: Longman.
- Grundén, H. (2017). Practice of planning in mathematics teaching – meaning and relations. In T. Dooley & G. Gueudet (Eds.), *Proceedings of the Tenth Congress of the European Society for Research in Mathematics Education* (pp. 3065–3072). Dublin, Ireland: DCU Institute of Education & ERME.

- Grundén, H. (2019). Tensions between representations and assumptions in mathematics teaching. In J. Subramanian (Ed.), *Proceedings of the Tenth International Education and Society Conference*. Hyderabad, India: MES10
- Gutiérrez, R. (2013). The socio-political turn in mathematics education. *Journal for Research in Mathematics Education*, 44(1), 37–68.
- Le Roux, K. (2008). A critical discourse analysis of a real-world problem in mathematics: Looking for signs of change. *Language and Education*, 22(5), 307–326.
- Lund, S. & Sundberg, D. (2004). *Pedagogik och diskursanalys*. [Pedagogy and discourse analysis]. Växjö, Sweden: Växjö Universitet.
- Morgan, C. (2014). Understanding practices in mathematics education: Structure and text. *Educational Studies in Mathematics*, 87(2), 129–143.
- Mullet, D. R. (2018). A general Critical Discourse Analysis framework for educational research. *Journal of Advanced Academics*, 29(2), 116–142.
- Potari, D., Figueiras, L., Mosvold, R., Sakonidis, C., & Skott, J. (2015). Introduction to the papers of TWG19: Mathematics teacher and classroom practices. In K. Krainer & N. Vondrová (Eds.), *Proceedings of the Ninth Conference of the European Society for Research in Mathematics Education* (pp. 2968–2973). Prague, Czech Republic: Charles University in Prague, Faculty of Education and ERME.
- Ryve, A. (2011). Discourse research in mathematics education: A critical evaluation of 108 journal articles. *Journal for Research in Mathematics Education*, 42(2), 167–199.
- Sakonidis, C., Drageset, O. G., Mosvold, R., Skott, J., & Taylan, R. D. (2017). Introduction to the papers of TWG19: Mathematics teachers and classroom practices. In T. Dooley & G. Gueudet (Eds.) *Proceedings of the Tenth Congress of the European Society for Research in Mathematics Education* (CERME10, February 1–5, 2017) (pp. 3033–3040). Dublin, Ireland: DCU Institute of Education and ERME.
- Skolverket, (2018, November 24). *Matematik*. Retrieved from https://bp.skolverket.se/web/bs_gr_grgmat01_1-3
- Skott, J., Mosvold, R., & Sakonidis, C. (2018). Classroom practice and teachers' knowledge, beliefs and identity. In T. Dreyfus, M. Artigue, D. Potari, S. Prediger, & K. Ruthven (Eds.), *Developing research in mathematics education. Twenty years of communication, cooperation and collaboration in Europe* (pp. 162–180). Oxon, UK: Routledge.
- Valero, P. (2004). Socio-political perspectives on mathematics education. In P. Valero & R. Zevenbergen (Eds.), *Researching the socio-political dimensions of mathematics education, issues of power in theory and methodology* (pp. 5–24). Boston, MA: Kluwer Academic Publisher.
- Valero, P. (2008). Discourses of power in mathematics education research: Concepts and possibilities for action. *PNA*, 2(2), 43–60.

The work of equitable mathematics teaching: Leading a discussion of student solutions

Mark Hoover¹ and Imani Goffney²

¹University of Michigan, USA; mhoover@umich.edu

²University of Maryland, USA; igoffney@umd.edu

Mathematics teaching produces and reproduces social injustice. It also has the potential to disrupt patterns of inequity and advance just communities of practice. Drawing from literature on equitable mathematics teaching, we analyze the work of leading a discussion of student solutions in ways that nurture healthy identities, relationships and societies. From a conceptual analysis of a Norwegian mathematics lesson, we first identify dynamics of race and gender at play, then identify three key aspects of mathematics teaching that can serve to disrupt these dynamics while creating opportunities for alternative identities, relationships and futures: (i) having regard for property and its use; (ii) taking up student thinking as participatory citizenship; and (iii) orchestrating collective mathematical work. We discuss nuances of this work and implications for research on teaching.

Keywords: Research on teaching, equity, work of teaching, mathematics teaching.

Inequities that play out in classrooms are well documented and a growing body of literature has proposed ways of teaching attentive to social differences (e.g., Ladson-Billings, 2014; NCTM Research Committee, 2018). Nevertheless, conceptualizations of equitable teaching are nascent. We need specifications that can undergird professional practice in a coherent educational system. At the same time, specific dynamics of oppression are intimately contextual. We need to more fully understand the dynamics of marginalization and privilege as they play out in classrooms and the work involved in altering those dynamics. In this study, we analyze a discussion of students' mathematical solutions to conceptualize further the work of equitable mathematics teaching. Video and transcript of this discussion was part of a collection of data shared with TWG19 participants at CERME11. Accordingly, descriptions given in this paper are abbreviated.

Conceptual and contextual background

We view teaching as responsible design and management of instructional interactions. We draw on features visible across developing theories of teaching — the didactical/instructional triangle, emphasis on interaction and joint action, and regard for milieu and broader environments (Brousseau, 1997; Cohen, Raudenbush, & Ball, 2003; Jaworski, 1994; Wickman 2012). We see teaching as professional practice identified through logical analysis in professionally useful domains and decomposable into constituent tasks for the purpose of examining, learning, and reconstituting new knowledge and skill into practice (Ball & Forzani, 2009; Grossman & McDonald, 2008; Hoover, Mosvold, & Fauskanger, 2014).

In this work, we focus on specifying teaching in ways that disrupt patterns of inequity and advance healthy communities of practice. We understand equity to mean being equal, fair, and even-handed, with “reasonableness and moderation in the exercise of one's rights, and the disposition to avoid insisting on them too rigorously” and with “recourse to general principles of justice (the *naturalis*

aequitas of Roman jurists) to correct or supplement the provisions of the law” (Equity, 2018). While recognizing no definitive authority for deciding what is equitable, we understand regard for equity as integral to teaching. In order to decide questions of equity, we draw on our sense of humanity and invite readers to do the same. Further, we want to be explicit that we understand education to be both a matter of development of the child and an invitation to children to reimagine the world. Equitable teaching is more than just not being inequitable. We understand teaching to be about engagement in and creation of a healthy learning community — one that both enriches without oppressing and is open and responsive to individuals, their experiences, and their spirit.

Design of the study

To understand the work of leading of a discussion of students’ mathematical solutions, we analyzed a session from a national study in Norway. Intervention schools were provided an additional mathematics teacher, with the goal of evaluating whether increased teacher-student ratios, with increased small-group instruction, will increase student learning. For the session we analyzed, the additional teacher is experienced and locally recognized as skilled. At this school, rotating groups of 4-6 students leave their regular mathematics class to work in a small group with this teacher. The session is 21.5 minutes, with 5 year-four students, two boys (B1 and B2) and three girls (G1, G2, and G3). It occurred in 2017 on the 80th birthday of the King of Norway. The teacher asked students to determine the year in which the king was born. Sitting around a large table, students work on their own for about 6 minutes, at which time the teacher has students share solutions.

Our analysis is empirical yet focused on concept formation (Gerring, 2001). It is conceptual-analytic research in line with Sleep (2012). Drawing on our experiences, literature, and records of teaching practice (such as video, transcript, lesson plans, student work, and interviews), we generate and test ideas about recurrent tasks of teaching. We build, revise, and discard ideas based on logical coherence with purpose, enactment, and learning of teaching and on coordination of different perspectives, in particular of the discipline of mathematics and of pedagogy (Thames, 2009). In this study of entailments of equitable teaching, we first examined potential patterns of structural oppression and marginalization. Then we analyzed opportunities for disrupting these patterns.

Potential patterns of structural oppression and marginalization

First we examine interactions in the classroom that might be indicative of the reproduction of societal patterns of marginalization and oppression. The teacher begins by encouraging students to cooperate, yet during the first six minutes of the video, G1 and B2 dominate the verbal bandwidth, primarily talking to themselves, or no one in particular, with occasional, mostly ignored responses. As the task is launched, B2 announces that the problem is “child’s play” and that the answer is 1933, which he then amends to 1923. G1 says, “21st of January,” to which G3, the one identified black student, says, “It’s not the 21st of January, he has his birthday on the 21st of February.” G3’s comment is participatory in the sense that she has listened to G1 and is responding substantively to her, yet G1 dismisses her concern, adjusts her thinking, and covers her statement with, “But, I’m writing when he was born, so the 21st of February...January....” Perhaps her response is sincere and responsive, but its forceful expression seems to shut down and end the exchange. Sexism and racism are well-documented societal issues. Might they bear on these classroom interactions?

A similar dynamic plays out again two minutes later when G3 announces, “I know! It’s 1937!” to which G1 puts up a hand to stop her and shouts, “You can’t say it out loud! We’re trying here....” The teacher also counters G3, “But remember, you remember what we’ve been saying. It’s not the answer that’s going to impress me. What’s going to impress me the most is the way you got the answer.” After a brief flurry then of students all wanting to explain and the teacher saying to wait, G3 reflects further, quietly stating, “It has to be 1937. I’m certain.” This time, B2, sitting next to her says, “No, it isn’t.” This sequence is striking in several ways. G1 objects to G3 for announcing her answer, when B2 has announced his several times without objection. Likewise, each of the boys indicated that he has an answer, but the teacher did not counter them. G3, a black girl, is shut down by a white girl, white teacher, and white boy in succession. Given the documented marginalization of people of color internationally, this exchange warrants consideration. Might it be a case of the reproduction of patterns of marginalization and oppression that occur in the larger society? Whether it is or not, noticing it matters for teaching and can inform the development of disruptive practice.

Turning to the teacher’s engagement with student solutions, several other observations can be made. Following the explanation of G1’s approach (reducing 80 by 17, then subtracting 63 from 2000), the teacher praises her ability to figure out the calculation, when “you haven’t really learned this.” He again repeats that he is “extremely impressed” and “should almost write an article” about her solution. Then, following B1’s explanation (removing 17 from 2017, subtracting 80, then adding 17 back in), the teacher characterizes it as a “clever way”. In contrast, following G2’s explanation (conventionally subtracting 80 from 2017), he acknowledges that she did it “elegantly and nice”, but then makes the point that B1’s approach is easier and “really smart”. Given the lavish praise given to G1, the teacher’s qualified praise for G2’s work seems inconsistent, as G2 performed the “difficult calculation” and did so flawlessly. G2 began the session expressively, but with the dominance of the talk of G1 and B2, her voice remains muted for the remainder of the lesson.

The last student to present was G3. She says, “What I did was first: Nineteen... [Writes 1900.] And then I did... Plus... 20 since the King is 80 years old. Then I added 17. [Writes 1937.]” On the board, she now has, “ $1900 + 20 = 1920 + 1937$ ”. The teacher says she started with the year 1900, “But now you’re challenging me, I’m actually not entirely sure how you thought. Why did you start at 1900 and why did you add 20?” The teacher has an exchange with G3 and ends by saying he sees and that it is pretty clever, but a full explanation is not elicited, and the teacher does not offer a recapitulation to the other students as he does with each of the approaches.

These exchanges suggest societal dynamics of power and privilege that might be forming and playing out. Both boys in the class speak with authority and a sense of entitlement, without hesitancy and with an expectation that others care and will listen. One talks extensively, with limited regard for others around him and little apparent understanding of the problem or its solution. The other works independent of the group, quickly generating a correct answer and presenting his solution with conviction and little attention to audience. These ways of being are consistent with what McIntosh (1988) identifies as white male privilege — where privilege is unearned benefits resulting from societal patterns of discrimination and oppression. Dynamics of privilege are central to sexism and racism (Collins, 2018; Keith, 2017; Lipsitz, 1998) and deserve thoughtful consideration in teaching and learning.

Turning to the girls, the first also talks extensively, forcefully inserting herself into exchanges about the problem, in contrast to the second girl, who seems to retreat after a few early comments. These two ways of being in the classroom are suggestive of the overbearing woman and the deferential woman sub-stereotypes respectively (Kite, Deaux, & Haines, 2008). They exist in relation to one another within two core dimensions of gender stereotypes: agentic being more male (active, confident, competent, and independent) and communal being more female (emotional, expressive, understanding, and concerned with the welfare of others) and remain relatively consistent across age and nationality (see Kite, Deaux, and Haines, 2008 for a review). How might these dynamics of privilege and enacted stereotypes be symptomatic of larger societal patterns? How might they be creating such patterns? How do they shape these students' identities and what sort of patterns do they establish for relationships these students have with others in the future?

Also noteworthy are patterns related to racial discrimination. In the wake of the WWII, reference to race became taboo in European politics and academia (Wodak & Reisigl, 1999). Rising immigration, though, has resurfaced its visibility and prompted policies aimed at monitoring racism and advancing integration and cultural diversity. As Maeso and Araújo (2017, p. 29) argue, though, these anxieties and policies “fail to address its [racism's] embeddedness in political culture, and therefore in institutional structures and practices.” Or, as De Genova (2018, p. 1765) contends, the “migrant crisis” is an “unresolved racial crisis that derives fundamentally from the postcolonial condition of ‘Europe’ as a whole.” Norway is implicated in this history. In their analysis of the 2011 attack in Oslo, Mulinari and Neergaard (2012, p. 15) point out that Norway has parliamentary representation for culturally racist parties and that mainstream discourses, policies, and practices make this permissible, again implying that racism is alive and well in Norway and in its institutions.

Might dynamics of sexism and racism be playing out in these classroom interactions? The boys act with entitlement and are treated in kind. The girls navigate in relation to the boys. G3 is negatively critiqued and her approach devalued. It is unclear whether her solution has been understood. It is not sufficiently supported to be useful to others. How is this experience likely to shape her sense of self? What does it suggest about how these children are likely to engage across gender and race in the future? Blacks are often seen as less capable; Black women as invisible. The enactment of privilege, stereotypes, and discrimination is hard to dismiss in this session.

Opportunities for equitable teaching

Next we examine teaching's possibilities for disrupting patterns of inequity and advancing healthy communities of practice. Teaching is a powerful force. It shapes learning and lives. The children's experiences shape their sense of themselves as doers of mathematics, as capable or not. It shapes their sense of their relations to others, with regard to both connection and power. How do they work together? How do they contribute their ideas, take up the ideas of others, and develop new thinking? In many ways, participation in this class is practice for participation in the world. How might teaching shape that practice and the future world? We start by observing that the potential power of teaching in this session is extensive in large part because of the choice of the problem for these students, the orchestration of the session as problem solving, and the focus on explanation. These could be used to create rich opportunities for forming identities, relationships, and ways of working

together in the world. Within teaching, though, are discretionary spaces, often filled with habitual talk and actions, unconsciously accumulated from being in the world as it is (Ball, 2018).

Teaching is a complex space, with much to consider. Our focus on disrupting patterns of inequity and advancing healthy communities led us to identify three key aspects of teaching as it plays out in this session: (i) having regard for property and its use; (ii) taking up student thinking as participatory citizenship; and (iii) orchestrating collective mathematical work. These are related in significant ways, but we distinguish them as offering different lenses on the dynamics of the work of teaching related to this session.

First is an issue of property. Who has say over what? At the start of the session, the teacher tells students to “close the book for now.” G1’s book is open and she is looking between her book and a worksheet. While talking, the teacher nonchalantly reaches down, closes her book, and slides both it and the worksheet away from her and into table space in front of him. Whose property is this? Respect for personal space and personal property are important, as are agency and skills of self-monitoring, transition, and collaboration. What message does this action send? This may seem like a small matter, but it continues throughout the lesson. For instance, to whom does the whiteboard belong? The teacher? Or is it the class’ whiteboard and a resource for collective work? Extending this to intellectual property, who has authority when it comes to student explanations? The teacher maintains extensive control over G1’s explanation. He stands at the whiteboard, creates a representation for her approach, and makes claims about her thinking. It is as if he uses her work as a medium for presenting his own thinking, in a way that might be experienced and seen as co-opting her thinking for his purposes. Who owns ideas and how do we know?

We do not mean to imply that any one of these actions is good or bad. Our point is that issues of property in classrooms are important sites of power and that without thoughtful consideration will likely be places where patterns of marginalization play out. On the flip side, they are sites for disruption. Providing a sense of property in a classroom, where respect for property is accorded, can give students, who may otherwise feel marginalized, a sense of belonging, of being valued, of having a legitimate place at the table of knowledge. While implicit and explicit messages tell girls and children of color they do not belong in mathematics, being a property owner in a mathematics classroom can create a strong counter narrative. Teaching can help this happen. Equitable mathematics teaching reflects on the multiple forms of property that exist in a mathematics classroom, ways property might be distributed, with what effect, and how to ensure respect for it.

This leads us to a second important aspect of teaching: taking up student thinking. Whether student thinking is taken up, and how it is taken up, matter. As already mentioned, the teacher dominates the presentation of G1’s work. It is then striking to watch B1 stride to the whiteboard, take the pen from the teacher’s hand, and explain his approach. With white male privilege, B1 claims the space and his ideas. He begins, “I thought like this. We remove 17 so there’s only 2000 left.” Then, midway in B1’s presentation, the teacher steps in to “repeat” what B1 said for the benefit of others. The teacher says, B1 “didn’t bother about the 17 at first,” but thought, “What if it we’re in the year 2000 now?” This differs from what B1 actually said and is likely confusing for other students. B1 began by “bothering” about the 17. He began by removing 17 to simplify the subtraction, with the

idea of compensating later. This is left implicit in B1's explanation but is consistent with what he said. Greater focus on B1's thinking, perhaps with questions to ask why he removed 17, or at least checking in with him about an interpretation, might push back on the low demand placed on his explanations as a privileged white male. It might also create for other students, more equitable access to his thinking. In contrast, for a marginalized student, focus on their thinking might serve to include them more fully and communicate value for their thinking. Either way, the work of hearing students and interpreting and treating their thinking with integrity is crucial to equitable teaching and opportunities for disrupting patterns of privilege and marginalization. Our point here is that everyone suffers from oppression, in different ways and to different extents. If teaching acquiesces to white male privilege and skips over marginalized students, it may routinely fail to provide learning opportunities — prematurely accepting explanations of white males and dismissing the explanations of others.

For the first three students who explain their approach, the teacher steps in to explain the student's thinking, often couched as necessary for other students' understanding. We suspect that this is a pedagogical impulse that many teachers feel. Teachers often feel responsible for students' understanding and know they are, as the teacher, the one who is supposed to know the content. As they struggle to understand unconventional, emergent thinking, they may feel compelled to explain each student's thinking to the other students. Unfortunately, the demands of knowing intimately what others think are great and such a teaching practice often serves to reenact dynamics of privilege for some and marginalization for others. It runs a risk of causing students to feel unheard, silenced, and invisible. And it can undermine students' opportunities to learn from and with their peers. It is also a missed opportunity in the sense that a focus on student thinking can be used to counter patterns of oppression. Honoring each student's thinking as offered, with support for its expression and its respectful, authentic reception by other students, can nurture the healthy communities of practice that can rebuild our world.

This relates to the third key aspect of teaching implicated: the nature of the collective mathematical work. Collective work is an obvious avenue for addressing identities, relationships, and future worlds. This session again suggests challenges and opportunities. The teacher starts by characterizing the task as challenging and encouraging students to "cooperate". What, though, does it mean to cooperate on this problem? What might students need to be taught about how to cooperate for this work? A minute later, as a way to encourage students to focus on thinking about the problem and not jumping quickly to an answer, the teacher says, "A good tip right now is not to trust that one sitting beside you ... only trust yourself ... think for yourself." At this point, students are working relatively independently, and this comment reinforces independent work.

As the class shifts from problem solving to presenting their approaches, the nature of the collective work changes, as does the work of teaching. To prepare productive citizens, schools need to provide students with skills and experience crucial to public engagement, even in mathematics classes. Students need to learn how to present their mathematical ideas to an audience, be aware of who has and has not had airtime, and respond substantively to other's mathematical ideas. Mathematical work has a specific form and function. Students need to learn what counts as a mathematical explanation and how mathematical claims are decided, but many of its features extend broadly to

public discourse — clear communication, attention to audience, space for others to express themselves, thoughtful listening, respect for differences, and so forth. Equitable mathematics teaching creates opportunities for collective mathematical work and accountable discourse. In addition, it supports students' contributions, making sure students are ready to contribute, instructing them on how to present, teaching others how to listen, and supporting productive response. The teaching in this session creates opportunities for collective work and public discourse, but it provides inadequate student support (e.g., not teaching students how they might cooperate), inserts itself in ways that close off opportunities (e.g., explaining students' thinking for them), and truncates exchanges in ways that undermine authentic public discourse (e.g., providing a teacher summation in lieu of responses from others and collective resolution).

Our analysis of leading a discussion of student solutions in this brief session reveals three key aspects of teaching that can serve to disrupt inequitable dynamics. Each involves nuanced work, operating in big and small ways in classrooms. Together, they provide an image of sensibilities and skills that would serve teachers well. They also suggest the depth that would be required to disrupt patterns of privilege and marginalization and avoid reproducing them.

Acknowledgment

This material is based upon work supported by the National Science Foundation.

References

- Ball, D. L. (2018, April). Just dreams and imperatives: The power of teaching in the struggle for public education. Presidential Address at 2018 American Educational Research Association Annual Meeting, New York, NY.
- Ball, D. L., & Forzani, F. M. (2009). The work of teaching and the challenge for teacher education. *Journal of Teacher Education*, 60(5), 497–511.
- Brousseau, G. (1997). *Theory of didactical situations in mathematics: Didactiques des mathématiques, 1970–1990* (N. Balacheff, M. Cooper, R. Sutherland, & V. Warfield, Trans.). Dordrecht: Kluwer.
- Cohen, D., Raudenbush, S. W., & Ball, D. L. (2003). Resources, instruction, and research. *Educational Evaluation and Policy Analysis*, 25(2), 119–142.
- Collins, C. (2018). What is white privilege, really? Teaching Tolerance Magazine, 60. Retrieved from <https://www.tolerance.org/magazine/fall-2018/what-is-white-privilege-really>
- De Genova, N. (2018). The “migrant crisis” as racial crisis: Do Black Lives Matter in Europe? *Ethnic and Racial Studies*, 41(10), 1765–1782.
- Equity. 2018. In *OxfordDictionaries.com*. Retrieved from <http://www.oed.com/view/Entry/63838?redirectedFrom=equity#eid>
- Gerring, J. (2001). *Social science methodology: A criterial framework*. Cambridge: Cambridge University Press.

- Grossman, P., & McDonald, M. (2008). Back to the future: Directions for research in teaching and teacher education. *American Educational Research Journal*, 45(1), 184–205.
- Haines, E. L., Deaux, K., & Lofaro, N. (2016). The times they are a-changing... or are they not? A comparison of gender stereotypes, 1983–2014. *Psychology of Women Quarterly*, 40(3), 353–363.
- Hoover, M. Mosvold, R., & Fauskanger, J. (2014). Common tasks of teaching as a resource for measuring professional content knowledge internationally. *Nordic Studies in Mathematics Education*, 19(3-4), 7–20.
- Jaworski, B. (1994). *Investigating mathematics teaching: A constructivist enquiry*. London: Falmer Press.
- Keith, T. (2017). *Masculinities in contemporary American culture: An intersectional approach to the complexities and challenges of male identity*. New York, NY: Routledge.
- Kite, M. E., Deaux, K., & Haines, E. L. (2008). Gender stereotypes. In F. L. Denmark & M. A. Paludi (Eds.), *Psychology of women: A handbook of issues and theories* (2nd ed., pp. 205–236). Westport, CT: Greenwood Press.
- Ladson-Billings, G. (2014). Culturally relevant pedagogy 2.0: aka the remix. *Harvard Educational Review*, 84(1), 74–84.
- Lipsitz, G. (1998). *The possessive investment in whiteness: How white people profit from identity politics*. Philadelphia, PA: Temple University Press.
- McIntosh, P. (1988). White privilege and male privilege: A personal account of coming to see correspondence through work in women's studies. In M. Anderson, & P. Hill Collins (Eds.), *Race, class, and gender: An anthology* (pp. 94–105). Belmont, CA: Wadsworth.
- Maeso, S. R., & Araújo, M. (2017). The (im)plausibility of racism in Europe: Policy frameworks on discrimination and integration. *Patterns of Prejudice*, 51(1), 26–50.
- Mulinari, D., & Neergaard, A. (2012). Violence, racism, and the political arena: A Scandinavian dilemma. *NORA-Nordic Journal of Feminist and Gender Research*, 20(1), 12–18.
- NCTM Research Committee. (2018). Asset-Based Approaches to Equitable Mathematics Education Research and Practice. *Journal for Research in Mathematics Education*, 49(4), 373–389.
- Sleep, L. (2012). The work of steering instruction toward the mathematical point: A decomposition of teaching practice. *American Educational Research Journal*, 49(5), 935–970.
- Thames, M. H. (2009). Coordinating mathematical and pedagogical perspectives in practice-based and discipline-grounded approaches to studying mathematical knowledge for teaching (K-8). Unpublished doctoral dissertation, University of Michigan, Ann Arbor.
- Wickman, P. O. (2012). A comparison between practical epistemology analysis and some schools in French didactics. *Éducation et Didactique*, 6(2), 145–159.
- Wodak, R., & Reisigl, M. (1999). Discourse and racism: European perspectives. *Annual Review of Anthropology*, 28(1), 175–199.

Learning from Lessons: A study on structure and construction of mathematics teacher knowledge – First results of case study

Judith Huget and Andrea Peter-Koop

Bielefeld University, Faculty of Mathematics, IDM, Germany; jhuget@math.uni-bielefeld.de

Keywords: Teacher learning, teacher attention, teacher knowledge, mixed methods, international comparison, mathematics lessons.

Introduction

Teachers are not only learning professionally during their university training; their learning continues and shifts to professional development programs and their own classroom practice. Understanding the teacher learning process should therefore help improve teacher knowledge and development at all levels (Chan, Clarke, Clarke, Roche, Cao & Peter-Koop, 2018). “Learning from Lessons”, a project about studying the structure and construction of mathematics teacher knowledge, aims to “understand teacher in situ learning” (ibid, p. 91) by generating and analyzing data on the teacher’s adaptation of a pre-designed lesson, planning a follow-up lesson and comparing the collected data from three different countries. In this poster the theoretical background of the study, the research questions and the extensive international data collection will be presented and first results from the German case studies will be introduced and discussed.

Theoretical background and following research questions

The theoretical background is based on the non-linear “interconnected model of teacher professional growth” initially developed by Clarke and Peter (1993) and elaborated on by Clarke and Hollingsworth (2002). In this model (see Fig. 1), teacher learning is determined throughout the enactment between several domains and reflection as essential mechanisms for occurrence of teacher learning.

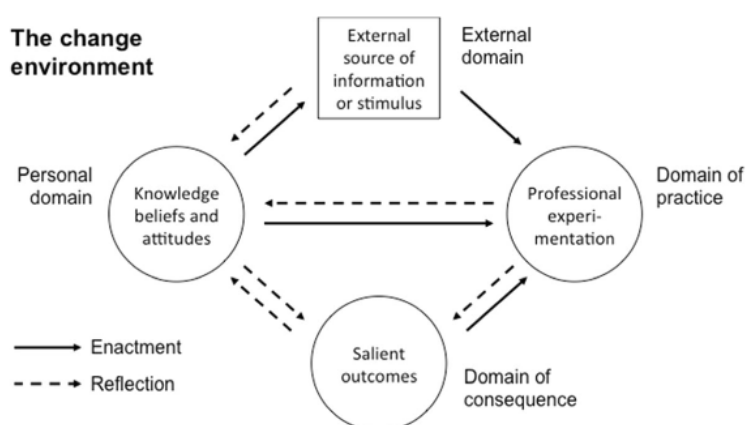


Figure 1: The interconnected model of teacher growth (Chan et al., 2018, 93)

The main research questions of the international collaborative project are:

To what classroom objects, actions and events do teachers attend and with what consequence for their learning?

How is teacher selective attention influenced by

- existing teacher knowledge and beliefs?
- the lesson's content and structure?
- contextual characteristics of school and classroom?

Do teachers in different countries/cultures attend to different classroom events and consequently derive different learning benefits from teaching a lesson?

Data collection and analysis

The international data collection involves both qualitative (video and audio material from lessons and interviews) as well as quantitative data (questionnaires). A codebook that allows for the consistent coding of the qualitative data from all three countries is currently being developed by the international research team. Two sub-studies are being carried out in order to address the research questions guiding the project:

Case studies with Grade 5, 6 and 7 teachers from Australia, China and Germany observing two teachers per Grade level and focusing on the interaction between the teacher and the lesson in sufficient detail seek to reveal the mechanisms connecting teacher attention to teacher learning. observing two teachers per grade level.

Online surveys in all three countries aim at recruiting at least 40 teachers per Grade level in each country seek to collect data about patterns in teacher attention and consequent learning in order to generate and test hypotheses.

Participating teachers in both sub-studies will teach lessons according to their modifications of lessons plans provided for specific topics and develop and teach a follow-up lesson as well as respond to questionnaires about their beliefs, their pedagogical and mathematical content knowledge drawn from the TEDS-M study.

Acknowledgment

This research is supported under Australian Research Council's Discovery Projects funding scheme (Project number DP170102540).

References

- Chan, M. C. E., Clarke, D. J., Clarke, D. M., Roche, A., Cao, Y., & Peter-Koop, A. (2017). Learning from Lessons: Studying the structure and construction of mathematics teacher knowledge in Australia, China and Germany. *Mathematics Education Research Journal*, 30(1), 89–102. doi:10.1007/s13394-017-0214-6
- Clarke, D. J. & Hollingsworth, H. (2002). Elaborating a model of teacher professional growth. *Teaching and Teacher Education*, 18(8), 947–967.
- Clarke, D. J., & Peter, A. (1993). Modelling teacher change. In W. Atweh, C. Kanes, M. Carss, & G. Booker (Eds.), *Contexts in mathematics education* (Proceedings of the 16th conference of the Mathematics Education Research Group of Australasia, pp. 167–175). Brisbane, Australia: MERGA.

‘Balancing’ the ‘live’ use of resources towards the introduction of the Iterative Numerical method

Lina Kayali¹ and Irene Biza¹

¹School of Education and Lifelong Learning, University of East Anglia, United Kingdom;

l.kayali@uea.ac.uk, i.biza@uea.ac.uk

This paper draws on the Knowledge Quartet (Rowland, Huckstep, & Thwaites, 2005) to analyse an introductory to the Iterative Numerical Method Year 13 lesson of a secondary mathematics teacher who uses a range of paper based and electronic resources including Autograph, a mathematics-education software. Data were collected during one lesson observation and a follow up interview with the teacher. Analysis identifies the different aspects of the Knowledge Quartet dimensions: foundation, transformation, connection and contingency, in relation to the introduction to the Iterative method and to the teaching of Year 13 students. Findings demonstrate how the teacher used students’ contributions as resource for his teaching; how he balanced his use of resources; and how he created connections between these resources while he remained attentive to exam requirements.

Keywords: Knowledge Quartet, foundation, transformation, connection, contingency, resource.

Introduction

For some decades, it was thought that access to more teaching resources (e.g. textbooks, mathematics-education software) meant better teaching practice (Cohen, Raudenbush, & Ball, 2003). However, “more resources do not necessarily lead to better practice” (Adler, 2000, p. 206), and priority should be given to how such resources are used (Adler, 2000; Cohen et al., 2003). This is especially important when digital resources are used as these are thought to add to the complexity of teaching (Clark-Wilson & Noss, 2015), also due to the overwhelming number of resources available online nowadays. Teachers interact with these resources, choose from them and manage them; and “these interactions play a central role in the teacher’s professional activity” (Gueudet, Buteau, Mesa, & Misfeldt, 2014, p. 141) and have great impact on students’ learning (Carrillo, 2011). Resources influence and are influenced by teachers’ professional knowledge, and a close look at the interactions between the two help identify opportunities to develop both (Rowland, 2013). The study presented here explores secondary mathematics teachers’ ways of managing and balancing the different resources that influence their work, especially when they use a range of resources including mathematics-education software (Kayali & Biza, 2017). We are interested in how teachers use the available resources in relation to their teaching aims and how they materialise and manage their lessons in the light of the available resources. To reflect on such complex teaching situations, we draw on the *Knowledge Quartet* (Rowland et al., 2005) to analyse lesson observations and post observation interviews. Here, we present analysis of an introductory to the Iterative Numerical Method Year 13 lesson observation and a follow-up interview from one participant. With this analysis, we aim to investigate the resources used by this participant and the characteristics of his work with these resources by using the Knowledge Quartet. In the following two sections we offer an overview of what we consider as resource in this paper, and of the Knowledge Quartet. Then, we present a detailed analysis of selected parts of the lesson and teacher’s reflections. We conclude the paper with a discussion on our findings.

Resources

Resources include artefacts, teaching materials, as well as social and cultural interactions that can be used or affect a teacher's teaching and teaching preparation work (Gueudet & Trouche, 2009). An artefact is an object that is designed and used for a specific purpose (Gueudet & Trouche, 2009). It could be a mathematical technique for solving a specific problem, a mathematics-education software or a tool like a pen. Teaching materials are textbooks, calculators, and any other materials designed for teaching mathematics (Adler, 2000). Social and cultural interactions are the interactions with the environment, students and colleagues, for example a student's feedback on an activity (Gueudet & Trouche, 2009). The term "resource" can also be "the verb re-source, to source again or differently" (Adler, 2000, p. 207). This implies that teachers interact with resources, manage them and reuse them to achieve their teaching aims (Gueudet, 2017). And "the effectiveness of resources for mathematical learning lies in their use, that is, in the classroom teaching and learning context" (Adler, 2000, p. 205). In this paper, we closely examine one teacher's use and interaction with resources, in the wider range defined above, using the Knowledge Quartet lens.

Knowledge Quartet

The Knowledge Quartet (Rowland, Huckstep, & Thwaites, 2005) was developed as a tool for analysing teachers' knowledge and beliefs. It can be used to trigger teachers', teacher educators' and researchers' reflections towards the development of mathematics teaching (Rowland, 2013). It is defined by four dimensions: *foundation*, *transformation*, *connection* and *contingency* (Rowland et al., 2005). The first dimension, foundation, represents teachers' knowledge and beliefs. This includes their knowledge about mathematics as well as about the teaching and learning of mathematics, and their beliefs about mathematics and its teaching and learning (Rowland, 2005). The codes listed under this dimension look at teachers': *adherence to textbook*; *awareness of purpose*; *concentration on procedures*; *identification of errors*; *overt subject knowledge*; *use of theoretical underpinning*; and *use of terminology*. The transformation dimension "concerns the ways that teachers make what they know accessible to learners and focuses in particular on their choice and use of representations and examples" (Thwaites, Jared, & Rowland, 2011, p. 227). Its codes cover aspects such as *choice of examples*; *choice of representation*; *demonstration*; and *use of instructional materials*. The connection dimension looks at teacher's choices in terms of their lesson plans, sequence of activities, and their connections between procedures and concepts where possible. Its codes concern teachers' *anticipation of complexity*; *decisions about sequencing*; *making connections between procedures*; *making connections between concepts*; and *recognition of conceptual appropriateness*. Finally, the contingency dimension examines how teachers respond to "unanticipated and unplanned events" (ibid, p. 227). This involves their *responses to unexpected student contributions*; *deviation from agenda*; *use of opportunities*; and *responses to the (un)availability of tools and resources* (ibid). The four dimensions of the quartet afford a focused look at the details of teachers' work in class which has great impact on students learning and achieving learning outcomes (Carrillo, 2011). In this paper we use these dimensions to investigate the characteristics of one teacher's use of resources.

Methodology

The study is conducted in East Anglia region of the UK and looks at upper secondary mathematics teachers' work when they employ mathematics-education software along with other resources. It provides qualitative findings established on an interpretative research methodology that values the participant's views and reflections and looks for meanings within the participant's environment (Merriam & Tisdell, 2016; Stake, 2010). Here, we discuss one video-recorded lesson observation (50-minute long) and the audio-recorded follow-up interview of one participant, George, with 15 years of teaching experience mostly in upper secondary education. George was teaching a mixed gender group of Year 13 students (17-18 years old), who were preparing for their school leaving examination. The lesson was on *Numerical Methods*. George started the lesson by introducing the chapter "Numerical Methods" from Wiseman and Searle (2005, pp. 118-135) including four methods: Change of Sign method, Iterative method, Mid-ordinate rule, and Simpson's rule by justifying why teaching this chapter is important. Then, he briefly introduced the four methods, and started explaining the Iterative method in detail using Autograph (a dynamic environment with visualising graphs affordances, see <http://www.autograph-maths.com>). George then showed his students some past exam questions about the Iterative method and went over their mark schemes. Finally, he asked his students to solve some textbook questions of his choice in the remaining time of the lesson. Later, George was interviewed (by the first author), and he reflected on his teaching of Iterative method and especially on points the first analysis had identified, such as his choices of resources and actions in the lesson (e.g. his aims, justification of his choices). An analysis of George's actions during the lesson and his responses in the interview was performed using the Knowledge Quartet. In the next section, we offer a detailed account of selected parts of the lesson observation, where his work with resources in the class was more visible through his communication with students, and relevant parts from the interview. These parts regard the introduction to Numerical methods and the demonstration of the Iterative method to the students also with the use of Autograph.

Introducing the Iterative method- A look through the Knowledge Quartet lens

Introducing "Numerical methods"

In his introduction to the chapter of "Numerical Methods" and its four methods: Change of Sign method, Iterative method, Mid-ordinate rule, and Simpson's rule; George justified its importance:

The whole chapter is about things that you can't solve by doing the algebra to them, or just by integrating them, okay. And, it turns out that there are way more functions and things that you can't solve algebraically than there are ones that you can, ok. There are loads of horrible things to integrate that are too difficult to integrate, that it's just easier to do a numerical thing and kind of approximately, a bit like a trapezium rule

George reminded the students that they saw trapezium rule and Simpson's rule in a previous lesson. He explained that Simpson's rule and the mid-ordinate rule were about finding the area and extension of the trapezium rule, while the change of sign method and the Iterative method were about solving equations. Then, he briefly introduced the four methods, and mentioned that he was going to focus on the "Iterative method" and when this lesson's methods are good to use. This introduction reflected George's *awareness of purpose* and how he was addressing *connections* (e.g. numerical methods and

trapezium rule). He tried to *connect concepts/procedures*, for example, to connect Simpson’s rule and integration used in previous lessons to the methods he was planning to teach in this lesson.

Rearranging an equation – Why $x^2 + 4x + 1 = 0$?

After the introduction to the chapter, George started explaining the method, he mentioned that he needed to use an equation that cannot be factorised but can be solved using the quadratic formula. He spontaneously chose the quadratic equation $x^2 + 4x + 1 = 0$, and asked his students to suggest rearrangements of the equation to the form $x = \dots$ (e.g. $x = \frac{-x^2}{4} - \frac{1}{4}$). After that, he asked them to find the equation roots using what they previously learned on how to solve quadratic equations or using calculators. Students used calculators and gave the approximate answers “-0.267” & “-3.732”. George was spontaneous in his *choice of example*. He chose a quadratic equation with the aim that students would be able to solve it with the formula but not with factorisation; which would show them that the Iterative method worked. His choice was based on *awareness of purpose* which is to show the students that the Iterative method gives them a good approximation of the solutions. George also tried to *connect procedures* when he asked his students to create different rearrangements of the equation. Later, after finding the different rearrangements, George again tried to create a *connection* between the equation’s solutions students found on their calculators and the Iterative method would “zoom in on the answers”. He was always *responding to students’ ideas*, commenting on when two rearrangements were the same and just written differently and on when a student completed the square instead of rearranging the equation. George was *demonstrating* about iteration to students while at the same time inviting them to contribute. These contributions were essential parts in the flow of his lesson, for example, when students suggested the rearrangements and calculated the quadratic solutions. We consider these *students’ contributions* as a *resource* (Adler, 2000; Gueudet, 2017) that George triggered and used during the lesson, along with other resources.

The use of Autograph

After working with the students on finding the equation’s different rearrangements and solutions, George’s next step was to use Autograph (*instructional material*) in order to further explain about the Iterative method and show how the different rearrangements would work. He used Autograph to graph the functions $y = x$ and $y =$ the other side of the rearrangement (e.g. for $x = \frac{-x^2}{4} - \frac{1}{4}$ he graphed $y = x$ and $y = \frac{-x^2}{4} - \frac{1}{4}$). The first rearrangement he graphed on Autograph (Figure 1) was $x = \sqrt{-4x - 1}$ and it did not “work” as George said while pointing at the graphs on Autograph:

Now, I can see that the blue one [$x = \sqrt{-4x - 1}$] does not quite, I think it almost touches, but not quite touches the red one [$y = x$], okay. So, they in fact don’t cross. So, for that particular rearrangement sadly it’s not going to work out. So, let’s not do that one, let’s pick a different one. Which one do you want?

We noticed here one *contingency* incident (*use of opportunity*: (un)anticipated outcome on the software) that happened when George entered the equations from one rearrangement on Autograph and noticed that the graphs of these equations did not cross, in this case he commented that some rearrangements did not work and asked the students to pick a different one. Again, a student’s contribution here is a *resource* that George used to demonstrate ideas. In this case, one student picked

$x = \frac{-1}{x+4}$. George graphed $y = x$ and $y = \frac{-1}{x+4}$ on Autograph (Figure 2 left) and commented that the two graphs crossed this time at two points. Having noted that the two points are close to $x = -0.2$ and $x = -3$, George explained that the Iterative method is based on replacing the x in the denominator of this rearrangement by x_n and replacing the isolated x by x_{n+1} . Thus, he suggested the formula $x_{n+1} = \frac{-1}{x_n+4}$ to be used to complete a table with a starting value $x_0 = 1$. This shows how George *used different representations* such as tables and graphs; and tried to create *connections between procedures* and also *between different resources* (student's contribution + Autograph).



Figure 1: $y = x$ and $y = \sqrt{-4x - 1}$ on Autograph

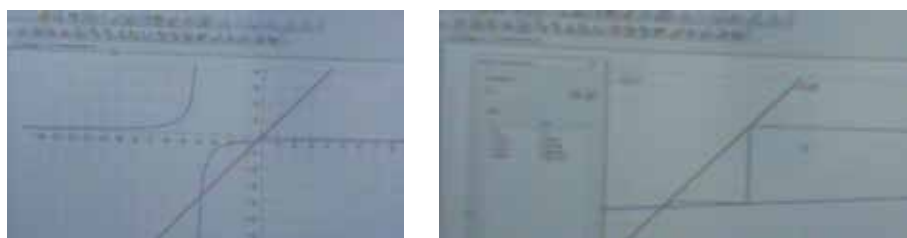


Figure 2: George's work on the rearrangement $y = x$ and $y = \frac{-1}{x+4}$ on Autograph

After showing the Iterative method procedure on the board, George decided to show how the Iterative method works on the graph by using Autograph (Figure 2 right):

Look at this you started with number 1, okay. The number 1 went, which way did it go? It's gone down to the curve, across to the line and that was our 0.2 [sic]. And then, here look at that down to the curve across the line, down to the curve if I zoom in further oh missed it. Down to the curve and across to the line. Zooming in further, look at that! And we could keep on going down to the curve, across to the line zoom in zoom in zoom in there. It is, look at that, and the thing if I zoom out again looks like a staircase kind of. So, this is staircase diagram.

This use of Autograph showed teacher's *knowledge about the software* affordances and its use. It also showed an attempt to *connect different representations* (staircase diagram + formula). George then used $x_{n+1} = \frac{-1}{x_n+4}$ with different starting points for x_n on Autograph. When he used $x_0 = 10$ as a starting point, the software returned "overflow", namely no convergence, and he changed the point to $x_0 = -10$ without commenting on the outcome. He did not *use this opportunity* to explain what that meant during the lesson. One student asked what would happen if $x_n + 4 = 0$ in $x_{n+1} = \frac{-1}{x_n+4}$. At that point George used the graph on Autograph to show that this would not work, as he commented:

You know like when you know your tan graph at 90 degrees, that 90 degrees on a tan graph is effectively saying we've got an infinitely tall triangle which wouldn't be a triangle at all, because it would be at 90 degrees. You're talking two parallel lines that's why tan of 90 doesn't work.

This is a *contingency* moment (*responding to students' ideas*) where George used Autograph as *instructional material* and *connected concepts* students had met previously (dividing by zero, tan of 90 degrees, parallel lines, asymptotes of the graph of the tangent line) to respond to student questions.

How to zoom on to a specific root?

Afterwards, George worked on different formula rearrangements and different starting points to show how some rearrangements “work” (when the two functions cross at two points) and some do not (when the two functions do not cross). He also wanted to show how a rearrangement that “works” can lead to one root or to different roots of the equation, when different starting values (x_0) are used. But, until this point, his work on different rearrangements with different starting points was leading to the same root. This made the students question how they could zoom to a specific root and how they could tell if they were going to zoom in on a certain root in the exam. George said “I don’t know the answer to this” but he promised to comment on this question later during the lesson (not deviating from the *lesson's agenda*). He returned to this point later when he invited students to practice on past-exam questions by saying that exam questions would provide both rearrangement and initial point. His response reflected his attention to *exam requirements* and their importance to his teaching. After that conversation about how to zoom to specific roots, a student suggested the use of calculators to do the Iterative method. The teacher approved the student’s use and method of use of calculators by commenting that it was a “really quick way”. This is an example of him *responding to the availability of resources* (student’s contribution + calculator). The use of calculators facilitated the zooming in on the other root, as this way was quicker students tried different starting points and found out that $x=3$ would lead to the second root (-3.732). George used $x=3$ on Autograph and showed the students how this number worked for the purpose of zooming in on to the other root. This is an example of *connections between resources* (student contribution +calculator +Autograph+ staircase diagram).

George’s reflections

In the interview, George was invited to reflect on three aspects. First, about his spontaneous choice of equation, he said he preferred working “live” in the class over showing the students “a specific and special example”. He added that he was happy to work slowly with different examples to show that not all examples work. George’s spontaneous choice of equation reflected his confidence to *deviate from his agenda* which could create more contingent moments during the lesson. His purpose was to “show” the students that not all rearrangements “work out”. Second, about what the “overflow” means on Autograph, he said it indicated that the Iterative method “instead of converging, it will diverge” at that point. During the lesson, George did not *use the opportunity* to explain the meaning of this outcome to the students. His focus was on getting a number and comparing this number to one of the equation roots students had found. Third, he was asked about the use of calculators. He said:

That’s what they need to do in the exam. So, the Autograph is just to explain, show, demonstrate it in a lesson. When they then move onto the calculators, that’s them saying yeah they are happy with it, they understand it, and this is what they then need to do. This is how they do it in the exam.

George’s comment on the use of calculators reflected again his considerations of *exam requirements* while at the same time his attention to *connections between resources*.

Discussion and conclusion

In this study we are interested in how teachers, in our case George, use the available resources in relation to their teaching aims and how they materialise and manage their lessons in the light of the available resources and we used the Knowledge Quartet lens to analyse teacher actions and justification of these actions. In our analysis, we noticed aspects of George's foundation knowledge including his awareness of purpose, use of terminology, identifying errors, concentration on procedures, his subject knowledge as well as his knowledge about the mathematics-education software (Autograph here) and exam requirements. When a student asked him a question he could not answer, he responded that students were not required to know the answer for the exam, so he could not answer the question because it was "beyond exam requirement". This indicates how important the exam requirements are in his teaching priorities. In his transformation of ideas, he was spontaneous in his choice of "live" examples and representations, and he seemed confident in these spontaneous choices. His use of instructional materials included the use of Autograph, textbook, past-exam papers and calculators. He used the textbook as source of exercises for classroom practice. He also asked for students' contributions and used these contributions as an essential resource in the flow of his teaching also in connection to other resources and instructional materials including Autograph. For him, students' contributions were predictable, as they were within a range of possible answers (like choosing one rearrangement of equation). He made decisions about sequencing the different parts of the lesson and frequently connected concepts and procedures. He was responding to students' ideas and sometimes using these as opportunities to create connections between concepts. In terms of contingency, George was responding to students' ideas and to the availability of tools and resources, and sometimes deviated slightly from his lesson's agenda without losing his overall aim. We distinguish the students' ideas under the contingency dimension from the students' contributions under the transformation dimension, as these are unpredictable students' ideas that George did not directly invite. While students' contributions are a deliberate result of George questioning students and engaging them in his demonstration of mathematical ideas, thus, we see them as a characteristic part of his teaching. As we consider students' contributions as resources used frequently by George, we suggest an extension of the code "*use of instructional materials*" that includes the use of resources. We recommend the code to be rephrased to "*use of resources*" to involve both instructional materials and students' contributions under the transformation dimension. We also saw George connecting between different resources he used (e.g. Autograph, textbook and student contributions). We recommend the code "*connection between resources*" to be added to the connections dimension. These suggestions are established on the episode included in this paper as well as other episodes with George. Overall, our standpoint is that the use of resources is intertwined with teachers' aims and actions (Gueudet & Trouche, 2009). The analysis of George's lessons, as well as of other lessons in this study, indicate that this use is a 'balancing' act on resources that become 'live' in their lessons. These resources go beyond textbooks or other digital (or not) materials and include students' contributions as well, which teachers use, balance and connect in their work.

Acknowledgment

This research is funded by a studentship from the Faculty of Social Sciences, UEA.

References

- Adler, J. (2000). Conceptualising resources as a theme for teacher education. *Journal of Mathematics Teacher Education*, 3(3), 205–224.
- Carrillo, J. (2011). Building mathematical knowledge in teaching by means of theorised tools. In T. Rowland & K. Ruthven (Eds.), *Mathematical knowledge in teaching* (Vol. 50, pp. 273–287). Dordrecht: Springer.
- Clark-Wilson, A., & Noss, R. (2015). Hiccups within technology mediated lessons: A catalyst for mathematics teachers' epistemological development. *Research in Mathematics Education*, 17(2), 92–109.
- Cohen, D. K., Raudenbush, S. W., & Ball, D. L. (2003). Resources, instruction, and research. *Educational Evaluation and Policy Analysis*, 25(2), 119–142.
- Gueudet, G. (2017). University teachers' resources systems and documents. *International Journal of Research in Undergraduate Mathematics Education*, 3(1), 198–224.
- Gueudet, G., Buteau, C., Mesa, V., & Misfeldt, M. (2014). Instrumental and documentational approaches: From technology use to documentation systems in university mathematics education. *Research in Mathematics Education*, 16(2), 139–155.
- Gueudet, G., & Trouche, L. (2009). Towards new documentation systems for mathematics teachers? *Educational Studies in Mathematics*, 71, 199–218.
- Kayali, L., & Biza, I. (2017). "One of the beauties of Autograph is ... that you don't really have to think": Integration of resources in mathematics teaching. In T. Dooley & G. Gueudet (Eds.), *Proceedings of the 10th Conference of European Research in Mathematics Education* (pp. 2406–2413). Dublin: Dublin City University.
- Merriam, S. B., & Tisdell, E. J. (2016). *Qualitative research. a guide to design and implementation* (4 ed.). San Francisco, CA: Jossey-Bass.
- Rowland, T. (2013). The knowledge quartet: The genesis and application of a framework for analysing mathematics teaching and deepening teachers' mathematics knowledge. *Sisyphus: Journal of Education*, 1(3), 15–43.
- Rowland, T., Huckstep, P., & Thwaites, A. (2005). Elementary teachers' mathematics subject knowledge: The knowledge quartet and the case of Naomi. *Journal of Mathematics Teacher Education*, 8(3), 255–281.
- Stake, R. E. (2010). *Qualitative research: Studying how things work*. New York: Guilford Publications, Inc.
- Thwaites, A., Jared, L., & Rowland, T. (2011). Analysing secondary mathematics teaching with the knowledge quartet. *Research in Mathematics Education*, 13(2), 227–228.
- Wiseman, G., & Searle, J. (2005). *Advanced maths for AQA: Core maths C3 and C4*. Oxford: Oxford University Press.

The King's birthday, potentials for developing mathematics teaching

Bodil Kleve¹, Ida Heiberg Solem¹ and Gerd Ånestad¹

¹OsloMet – Oslo Metropolitan University, Norway; bodil.kleve@oslomet.no

In this paper, we have analysed a video in which a small group of students were asked to find out when the Norwegian King was born given his 80 years of age today on his birthday Feb 21st 2017. We have identified potentials for initiating shifts in discourse in which children's ways of solving a problem could become an explicit object of reflection. We suggest that revoicing as a talk move to encourage collective reflection, did not work as suggested in the research literature. Additionally, working on a number line could have been a joint activity of making what was previously done in action, to an object of reflection.

Keywords: Reflective discourse, collective reflection, empty number line, revoicing.

Background and context

The lesson, from which this episode is taken, is part of a Norwegian national project, which investigates if decreased student/teacher ratio is beneficial for students' learning. In the project, one dedicated teacher takes a group of students, typically 4–6 into a separate classroom to teach specific subjects and methods. The teacher is by the researchers in this project, acknowledged as a “skilled teacher” with more than twenty years teaching experience. According to the research team, the episode investigated here, is a typical example of this teacher's teaching practice.

Five year-four children (two boys and three girls) were seated around a table, and the teacher was standing up front by the flip over. The episode lasted for about twenty minutes. The teacher presented a task (problem) that the children were asked to solve:

I am going to give you a task now, []. You will get a sheet on which you may draw. Just close your books for now. The task is to find out when the [Norwegian] King was born. He is 80 years today, so you shall try to find out in what year he was born. [] The year is 2017, and 80 years backwards.

After having presented the problem, the teacher said they were allowed to collaborate. He emphasized that the task “is quite challenging” and that he would give them some time to solve the problem. One of the children, a girl, here called Tove, addressed the teacher and the other children several times throughout the whole episode. As a response to her, the teacher said: “I will give you a tip, not to trust anybody else, but only to think for yourself and trust yourself”.

When having started working on the task, the children both aloud and inaudible, suggested solutions. However, the teacher interfered after about 2 minutes saying: “*remember what we have been saying, it is not the answer that is going to impress me. It is the way you have got the answer, that will impress me the most*”. He thus emphasized the process rather than the product. The children continuously volunteered to come up with an answer. However, the teacher told them to wait yet another minute.

We watched the video clip several times. Focusing on the rehearsal of students' proposed solutions of the problem, we noticed that the teacher frequently revoiced students' explanations and made

claims about their thinking: “So you have been thinking like this,...”, was a repetitive comment from the teacher on students’ proposed solutions.

Against this backdrop, we address the role of classroom discourse in examining potentials for supporting mathematical sense making within a group of children. We draw on the concepts of *reflective discourse* and *collective reflection* (Cobb, Boufi, McClain, & Whitenack, 1997) in searching for potentials for development of possibilities for mathematical learning in this episode (Cobb, Stephan, McClain, & Gravemeijer, 2011).

Theoretical and methodological perspectives

Reflective discourse and collective reflection

Cobb et al. (1997) focused on classroom discourse, which appeared to support the development of students’ conceptual activity. In this work, they considered students’ conceptual activity as a source of mathematical ways of knowing, and meaningful mathematical activity as creation and manipulation of mathematical objects. They introduced the term “reflective discourse which is characterized by repeated shifts such that what the students and teacher do in action subsequently becomes an explicit object of discussion” (Cobb et al., 1997, p.1). They emphasized the teacher’s role, because the teacher is in the position to judge the significance of the children’s mathematical activity, and thus initiate shifts in discourse. One such shift may occur in further probing children for more ways of solving a task. Another shift occurs when the children’s different solutions of a mathematical problem may emerge as an explicit object of discourse. This activity involves comparing different solutions and a discussion of how they may relate to each other together with a corresponding reflection. This reflection does not occur simultaneously for all children since all participate in a common discourse, but it occurs as a collective reflection. Pragmatically, analysis of “reflective discourse” can clarify how teachers may support students’ mathematical development and potentials for such, and the term “collective reflection” refers to the joint activity of establishing what was previously done in action, as an object of reflection. Students’ participation in the discourse “collective reflection” may constitute conditions for possibilities of learning (Cobb et al., 1997; Cobb et al., 2011). The role of students is crucial in these activities. If no child is able to respond to the teacher’s initiation of shift in discourse, no shift will occur. The individual child’s reflective activity may contribute to developing a discourse with potential for mathematical sense making.

Cobb et al. (1997) argue that the teacher must initiate shifts in discourse so what the children have done in action, becomes an explicit object of reflection. In our data, the activity was solving a problem and proposing solutions. Our research problem was to investigate how students’ access to mathematics was supported, and to identify potentials for initiating shifts in discourse where children’s ways of solving the problem could become an explicit object of reflection and a collective reflection could take place.

The issue of revoicing

Chapin, O’Connor, & Anderson (2013) presented four suggestions for using whole-class discussions in problem solving: to understand the problem; to explain one solution method, to extend students’ knowledge and to compare solution methods. We consider the latter crucial with regard to collective reflection in our study. In order to encourage whole-class discussions, Chapin et al. (2013) suggested

talk moves which may help individual students clarify and share their thoughts: wait time; turn and talk; stop and jot; will you share that with the class and revoicing (so you are saying....). They suggested revoicing as a talk move if it seemed as if what the student was trying to say made things more confusing if the student carried on. As a goal for the teacher is to improve all students' mathematical thinking, the teacher cannot give up on an unclear explanation from one student. Revoicing was also suggested if a student says something insightful, which might move the class or group forward. Revoicing what a student is saying, will give that student a chance to clarify and the other students a chance to hear it again, may be in a clearer version. We wanted to further investigate revoicing as a talk move, and we discuss how a group discussion on comparing solution methods could become a discourse of collective reflection.

Kazemi and Hintz (2014) build on the talk moves of Chapin et al. (2013) and emphasise revoicing as “repeat some or all of what the student has said, then ask the student to respond and verify whether or not the revoicing is correct. Revoicing can be used to clarify, amplify, or highlight an idea” (p. 21).

Since the mathematical activity involved multidigit subtraction, using both standard algorithm and mental strategies, we have also drawn on Plunkett (1979) as well as on theories about the use of empty number line (Beishuizen, 2003; Gravemeijer, Bruin-Muurling, Kraemer, & Van Stiphout, 2016).

In addressing our research problem, we posed the following research questions: (i) What potentials for facilitating productive mathematical discussions did we see? (ii) How did revoicing as a talk move influence the group's discourse in supporting students' access to mathematics?

Presentation of the episode and analysis

The purpose of our analysis was to identify potentials for development of reflective discourse and collective reflection. We discuss four students' presentations in light of the frameworks presented above. The teacher frequently revoiced students' explanations and thoughts. In the literature (Chapin et al., 2013; Kazemi & Hintz, 2014), revoicing is suggested as a talk move to encourage whole-class discussions in order to extend students' knowledge and to compare solution methods. We have analysed the part of the episode in which the students presented their solutions.

Tove was the first student (after eagerly volunteering) who was asked by the teacher: “Can you tell us about the way to figure out the answer?”

Tove: I started with seventeen minus eighty. I removed seventeen from eighty so I could figure out what to remove from 2000

Teacher: What answer did you get when you removed 17 from 80?

Tove: I got 63

Teacher: What do you want with 63? What are you going to do with these 63?

Tove: I will remove 63 from 2000 to find the answer.

At this point, the teacher intervened Tove's explanation, while he was drawing on the board:



Figure 1: Teacher's drawing to illustrate Tove's thinking

Teacher: Right. Look at this. Tove, look at this. We are here in 2017, and now we are traveling 80 years back in time. She started by thinking... First, she wanted to go to the year 2000, and then go from 2000 to the year the King was born. Right? Therefore, you started with 80 minus 17, and got 63. She removed 17 from 80. Then you got 63. Then she wanted to find what 2000, from here, and jumping 63 years backwards from year 2000. That is how she thought. You tried to do 2000 minus 63, but this is a really difficult equation. Because... You have not really learned this, with such large numbers. Did you manage to finish it, too?

Alternating between addressing Tove directly and as a third person, the teacher made claims about her thinking in saying “She started by thinking...,” and “That’s how she thought”. He revoiced her explanation, probably in order to clarify for the group. He underpinned and highlighted with an illustration (figure 1). The empty number line which he drew, indicated a linear or sequential way of thinking (Beishuizen, 2003). However, studying the continuation of Tove’s explanation, there was a move away from a linear thinking towards the use of the standard algorithm, as the teacher also did:

Teacher: So you tried to do 2000 minus 63, but this is a really difficult equation

Tove: Yeah. I removed a thousand and exchanged it for 10 hundreds, and then I exchanged a hundred for tens, and a ten for ones. (Removed 3 from 7. 3 from 10. Yeah, 3 from 10. Then I had 7 left, so I removed... Umm... 9... Umm, 6... [] 9 minus 6. Then I had 3. But I still didn’t have any to be removed here, and I didn’t have 10 here, since I removed one. So I have 9 here. Then I removed one thousand, so I have one left.

While sitting, Tove explained orally how she had subtracted 63 from 2000 through the use of standard algorithm for subtraction. She was not only referring to digits, but to “ones”, “tens”, “hundreds” and “thousands”. Again, the teacher intervened:

Teacher: I must say that I am extremely impressed. You managed to figure out by yourself without having learned it before. I still want to show her way first, then you can explain afterwards. I just want to show her way of thought.

At this point, the teacher had left his earlier sequential thinking and use of empty number line. He revoiced what Tove had explained (orally), claimed her thoughts (I just want to show her way of thought) and used the flip over to explain and show the standard algorithm in detail.

The teacher monitored the conversation, and there was no communication between the students. The other four students in the group were not invited to participate. Instead of asking if there were questions or comments to Tove’s explanation, he “wanted to show her way of thought”, without

knowing if there was a need for that. As an alternative initiation of the whole-class discussion, (Kleve & Solem, 2014), the other students could have been invited to ask clarifying questions (Chapin, et al., 2013). Although having emphasized that it was not the answer as such, that was going to impress him, he neither challenged Tove's thinking, nor encouraged students to ask clarifying questions.

After having spent some time on Tove's way of solving the problem, three more students were invited to present their strategies. Lars, Vera and Kari. The teacher had obviously noticed that Lars had written down the right answer without any written calculations very quickly. Inviting Lars to explain he said: "I am eager to know how you have been thinking to get the answer, how did you think?" This initiated a shift discussed by Cobb et al. (1997). Lars responded to the invitation and walked up front.

Lars: I thought like this. We remove 17 so there's only 2000 left (writing 2000 on the flip over).

T: Yeah.

Lars: Then do minus 80 (writing 80 underneath).

T: Ah, you thought like that!

Lars: Afterwards we get 1920. That is simple...

Teacher: Can you write 1920, so we have it written down? I just want to repeat what you did so the others will understand what you meant. If you can move aside for a bit. What I understood is that you did not bother about the 17 at first. You just went straight back, and thought that: "What if we are in the year 2000 now?" If we then move 80 years backwards, we will land on 1920. Now I am eager to know, what did you do next?

Lars: I added 17, which is simple. Just 20 plus 17.

Teacher: Fantastic!

Lars: And that is... Nineteen...

Teacher: 1920 plus 17. Then you got? Nineteen?

Lars: Thirty...Thirty-seven.

Teacher: Did anyone understand this clever way?

As an answer to the teacher's question, a fifth student, said:

Per: Yeah. When he wrote 1920, I thought it looked like... I thought it looked good, in a way. Seemed like a good way to think.

Per's comment indicated an individual reflective activity, which was not followed up.

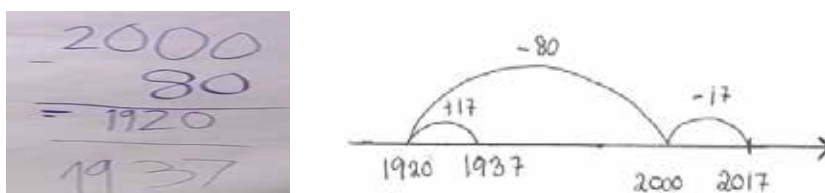


Figure 2: Lars' presentation and our illustration of it with an empty number line

Again, the teacher's use of revoicing and making claims about a student's thinking became evident. In this case, the teacher intervened, saying, "I just want to repeat what you did so the others will understand what you meant". A reason for revoicing might have been that the teacher found Lars' presentation being "clever". According to Chapin et al. (2013), revoicing is recommended when a student says something insightful, because there may be a potential then to move the class forward.

At this point we see another possibility for moving the class forward through a potential shift in discourse. Comparing Tove's and Lars' solutions and making that into an object of reflection could have created conditions for possibilities of learning (Cobb et al., 1997). What were the similarities between the two ways of solving the problem? How did Tove's solution differ from that of Lars'?

Following and contrasting this, Vera now volunteered to present saying: "I actually did not really do it that complicated". Hence, a comparison of methods was initiated by a student, and a potential shift in discourse was identified. Vera went to the board and subtracted 80 from 2017, using the standard algorithm. The teacher praised Vera's method and compared it to that of Lars:

You actually chose to use the algorithm in subtracting from 2017. It demands good knowledge to set that up. You worked it out elegantly and nicely and got the correct answer. However, his [Lars'] way of doing it was a method that is easy to use in mental calculation. [To Lars]: Really smart, that is why you spent so little time.

Here the teacher emphasized why a mental strategy may be smart compared to the use of the standard algorithm (Plunkett, 1979). The teacher elaborated the shift in discourse, initiated by Vera, further. He referred to mental calculation and speed, and a potential occurred to move the class forward. However, a discussion, which could have involved a collective reflection on the differences, did not take place. In figure 2, we have illustrated Lars' mental strategy, his sequential way of thinking, on a number line. Such an illustration could have been useful in comparing the two methods (Beishuizen, 2003; Gravemeijer et al., 2016).

The last student to present was Kari. She was invited to present her solution on the flip over:

Kari: First I did: Nineteen... [Writes 1900]. And then I did... Plus... 20 since the King is 80 years old. Then I added 17. [Writes 1937]

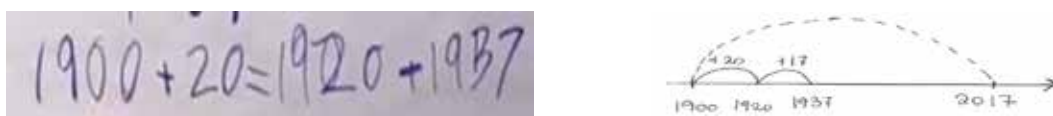


Figure 3: Kari's presentation and our illustration of it with an empty number line

- Teacher: Right. You started with the year 1900. Now you are challenging me, I am actually not entirely sure how you have been thinking. Why did you start at 1900 and why did you add 20?
- Kari: It is since the King became 80 years old,...
- Student: [Whispers] 8 and 2 are “ten-buddies”
- Kari: and 8 and 2 are “ten-buddies” so then I added 20.
- Teacher: Ah, I see, because you knew that there are 80 years between 1920 and 2000?
- Kari: Yeah
- Teacher: I see! So you started here and tried to come up to the year where you had 80 years from there, up to the year in which we are now? I have to say, that is pretty smart.

The teacher seemed to have a different approach to Kari’s presentation than to the others. Kari had used a mental strategy, which for the teacher seemed “difficult to catch” (Plunkett, 1979, p. 3). In response, he asked clarifying questions rather than revoicing Kari’s presentation. Although a student “rescued” Kari in answering why she added 20 (“ten-buddies”), the teacher neither utilized it as a potential to involve the other students in further discussion nor to ask clarifying questions.

Discussion

Potentials for facilitating productive mathematical discussions

In the episode there were shifts in discourse, for example when the teacher was further probing for more ways of solving the task. However, these shifts were not followed up by a collective reflection. Potentials for other shifts in the discourse, which could lead to collective reflection, have been identified. We pointed out a possible shift in discourse in suggesting to compare Tove’s and Lars’ solutions and make that an object of reflection. Per’s comment on Lars’ way of solving the problem indicated an individual reflective activity, which was a potential for collective reflection. In her presentation, Vera initiated a shift in discourse. The teacher followed this up in comparing Vera’s use of the standard algorithm with Lars’ informal strategy, which he valued. Here the students could have been invited to participate in a collective reflection on the methods, which would have created possibilities for learning. With regard to Kari’s use of informal strategies, the teacher was challenged, and did not utilize the other students’ help (“ten-buddies”) for a further discussion.

Tove and Vera used standard algorithm for subtraction while Lars and Kari displayed a sequential way of thinking. Although the teacher started by representing Tove’s explanation with an empty number line, sequential thinking, he left it, preferring Tove’s use of the standard algorithm. He never went back to the number line when Lars and Kari both demonstrated a sequential way of thinking. We have illustrated Lars’ and Kari’s ways of thinking on empty number lines, figure 2 and figure 3.

Mental strategies, as Lars and Kari used, are difficult to explain (Plunkett, 1979). Representations are useful in making mathematics accessible for students, for sharing different strategies and ideas, hence facilitating productive mathematical discussions (Duval, 2006). Working on a number line (see figure 2 and figure 3) could have been a joint activity of making what was previously done in action to an

object of reflection and thus create conditions for possibilities of learning (Cobb et al., 1997). This could serve as a tool for Vera, who found Lars' method complicated, to see connections (similarities and differences) between the different strategies.

“Revoicing” or revoicing: A pitfall or potential for developing productive mathematical discussions?

In the analysis above, we have pointed out instances where the teacher revoiced students' contributions, but in a way that students were not encouraged to respond or contribute and take part in a discussion. Rather, the revoicing discussed in our analysis served as an interruption. When Per commented on Lars' method, he was not encouraged to explain further. Contrary to what is recommended in the research literature, revoicing as a talk move was neither used to clarify or amplify ideas, nor to extend students' knowledge and compare strategies. Our findings suggest that, instead of being a mean for shift into a reflective discourse, “revoicing” became a pitfall for developing a productive mathematical discussion.

References

- Beishuizen, M. (2003). The empty number line as a new model. In I. Thompson (Ed.), *Issues in teaching numeracy in primary school* (pp. 174–187). Buckingham, Philadelphia: Open University Press.
- Chapin, S. H., O'Connor, C., & Anderson, N. C. (2013). *Classroom discussions in math. A Teacher's guide for using talk moves to support the Common Core and more*. Sausalito, CA: Math Solutions.
- Cobb, P., Boufi, A., McClain, K., & Whitenack, J. (1997). Reflective discourse and collective reflection. *Journal for Research in Mathematics Education*, 28(3), 258–278.
- Cobb, P., Stephan, M., McClain, K., & Gravemeijer, K. (2011). Participating in classroom mathematical practices. In E. Yackel, K. Gravemeijer, & A. Sfard (Eds.), *A journey in mathematics education research. Insights of the work of Paul Cobb* (pp. 117–167). London: Springer.
- Duval, R. (2006). A cognitive analysis of problems of comprehension in a learning of mathematics. *Educational Studies in Mathematics*, 61(1), 103–131.
- Gravemeijer, K., Bruin-Muurling, G., Kraemer, J., & Van Stiphout, I. (2016). Shortcomings of mathematics education reform in the Netherlands: A paradigm case? *Mathematical Thinking and Learning*, 18(1), 25–44.
- Kazemi, E., & Hintz, A. (2014). *Intentional Talk, How to structure and lead productive mathematical discussions*. Portland, ME: Stenhouse Publishers.
- Kleve, B., & Solem, I. H. (2014). Aspects of a teacher's mathematical knowledge in his orchestration of a discussion about rational numbers. *Nordic Studies in Mathematics Education*, 19(3&4), 119–134.
- Plunkett, S. (1979). 'Decomposition and all that rot'. *Mathematics in School*, 8(3), 2–7.

Learning trajectories and fractions: primary teachers' meaning attributions

Anna Klothou¹, Charalampos Sakonidis² and Vagia Arsenidou³

^{1,2,3}Democritus University of Thrace, Department of Primary Education, Greece;

¹aklothou@eled.duth.gr; ²xsakonid@eled.duth.gr ³varsenid@eled.duth.gr

A learning trajectory constitutes a hypothesis and a description of students' thinking related to learning a mathematical notion. The study reported here, employing a multiple case study approach, investigates the use of learning trajectories in the teaching of fractions by three 5th grade Greek primary school teachers. Particularly, the research problem pursued concerns the teachers' meaning making and use of the concept of learning trajectories introduced by a recent Mathematics Curriculum reform. The results of analyzing the teachers' answers to two semi-structured interviews and the transcripts of a non-participant observation of their lessons show that learning trajectories were understood as means of planning teaching and used as 'maps' of navigating classroom instruction, predominately successful when students' previous knowledge and thinking, and not just their difficulties, are taken into consideration.

Keywords: Learning trajectories, fractions, mathematics education, teaching mathematics.

Learning trajectories in mathematics education

Learning trajectories consist of three parts: the goal, the developmental path and a sequence of appropriate tasks that correspond to each level of thought and help the child proceed to the next level. There is also a relationship between developmental progress and the activities selected (Clements & Sarama, 2009). The "big ideas" of mathematics, i.e., sets of ideas and skills that are coherent and are central to mathematics, are the objectives (Kuntze et al., 2011). Developmental paths refer to the levels of thinking, each of which is more sophisticated than the previous one and leads to the achievement of the mathematical objective (Clements & Sarama, 2009). Notwithstanding the distinct levels, it is not to be assumed that the track is linear or specified. Various factors, such as differences between formal and informal learning, affect the development of a learning trajectory (IEP, 2014). Finally, the sequence of the tasks is a set of work corresponding to each level of thinking, supporting the learning of mathematical ideas and skills belonging to each stage and including solving, investigating, experimenting and communicating in the context of the student's activity.

Learning trajectories are promising tools that can help in curriculum development, mathematics teaching and assessment. A substantial use of learning trajectories can bring about several reversals in the expected developmental paths of students and in the expected research findings as it opens new routes in learning. Moreover, it seems to give new possibilities both for the design and the implementation of the curriculum as well as for teaching due to the detailed theoretical basis it can offer (Clements & Sarama, 2009). There are two studies worth mentioning that make use of the notion of learning trajectory. The first is part of a wider research program emphasizing the development of formative assessment tools for the trajectory of fractions (Confrey & Maloney, 2010). The results of the study reveal that a coherent trajectory leads to its redesigning,

distinguishing between the levels of thought on the one hand and the parameters of the tasks on the other, clarifying the non-linearity of the procedure. The second study concerns the work of Steffe (2004), who has been extensively involved with students' learning and knowledge of fractional numbers. According to the findings of this study, a trajectory allows teachers to understand how students construct mathematical concepts in order to influence the evolution of notions and processes so that, through productive teaching, productive learning is supported.

The study aims to explore the understanding and the use of the notion of learning trajectories by three primary teachers teaching fractions in the 5th grade, where this mathematical notion holds a central position in the respective curriculum, concluding their 'fractional' thinking at the threshold to secondary education and to being introduced to the set of rational numbers in a mainly formal way.

Fractions in school mathematics: Students' difficulties

Understanding fractions is crucial for pupils' mathematical thinking because of its significance in becoming numerate citizens; also for its relation to learning related fundamental mathematical notions like proportion and percentage or developing powerful mathematical modes of thinking like algebra. In the current discussion in mathematics education the focus is on educating pupils as numerate future citizens, i.e., citizens who can operate successfully in the modern society by understanding and handling quantitative data that they encounter in everyday life. Being competent in dealing with the notion of rational numbers constitutes a basic prerequisite. During schooling, many hours are devoted to teaching fractions, but the difficulties and misconceptions of students identified as early as in the 1970's persist, fueling substantial research activity on children's understanding of fractions and on developing new teaching tools and approaches to the subject matter. The numerous studies on fractions tended to initially focus their interest on the way students learn but also on the difficulties they meet. Subsequently, research interest shifted to teaching fractions with emphasis on the conceptual or the procedural mode of the relevant knowledge pursued and on how students responded to these two modes of knowing and thinking. Finally, attention was drawn to the teachers' role and teaching practices (Van Dooren, Lehtinen & Verschaffel, 2015).

The main students' difficulties identified in the relevant studies arise from the different nature of fractions compared to natural numbers. Rational numbers indicate the relation between two quantities, whereas natural numbers refer to one quantity. Also, rational numbers are dense because of continuity and infiniteness, while natural numbers are distinct. Unlike natural numbers, where each number is represented in a unique way, rational numbers can be denoted by fractions, decimals and percentages or even by a set of equivalent fractions. Furthermore, operations may differ in the two sets of numbers. For example, the result of division and multiplication of fractions is not less or bigger than the original number respectively, when the divisor or the multiplier is less than 1, as happens with natural numbers.

Apart from students' difficulties arising from the close connection of rational numbers and thus of fractions with natural numbers, difficulties with fractions have been found to also be related to the abstract nature of the processes involved in operating with fractions as well as to the erroneous

application of the related rules. Finally, teachers' inadequate knowledge of fractions and poor teaching practices as well as cultural issues have been identified to contribute to students' learning of this important mathematical notion.

The study

The reported study focuses on: (a) teachers' meaning making of the learning trajectories in general; (b) teachers' understanding and use of the notion of learning trajectories in teaching highly demanding mathematical learning contexts: fractions in the 5th grade. The method adopted is a 'multiple case study' of three female teachers working in an experimental primary school in an urban area of northern Greece.

The three teachers have had almost the same years of teaching experience but different scientific and professional profiles. Teacher A is a graduate of both a primary education and a mathematics department, with 17 years of teaching experience; teacher B, a graduate of a primary education department, holds a postgraduate diploma and a PhD and has 14 years of teaching experience. Finally, teacher C is a graduate of a two-year course with 16 years of teaching experience. Teachers A and C participated actively in the piloting of a new mathematics curriculum which promoted active learning and approaches like 'learning trajectories' that support this type of learning, while teacher B did not. The research tools employed were a semi-structured interview (one initial and one at the end of the study) and a series of non-participant observations of their mathematics instruction. The non-participant observation was used to provide information for the final interview and to offer a further source of data thus enhancing the credibility of the study.

The first semi-structured interview, consisting of two parts, served the first research question. The questions in the first part explored teachers' understandings of conceptual aspects of the construction of learning trajectory in mathematics and how its use influences the choice of the mathematical content. The questions in the second part were related to the teaching and learning benefits of exploiting learning trajectories in the mathematics classroom (in the context of the new mathematics curriculum).

For the second research question, a second semi-structured interview was conducted, which also consisted of two parts. The questions in the first part were common to all three teachers: on planning, implementing and reflecting on teaching fractions based on the notion of learning trajectory. In the second part of the interview, based on extracts from each teacher's instruction identified in the observations, the teachers were asked to comment on how they used the learning trajectory approach. For each participating teacher, two double teaching sessions on fractions were observed (non-participant observation). Field notes were kept, with the emphasis being on teachers' communication with students, on tasks used and generally on teachers' actions and discourse. The aim was to identify ways in which the trajectory of fractions was used and adapted to the students' needs. Where necessary, a brief discussion with the teachers was carried out to clarify and explain choices.

A combination of Grounded Theory and Content Analysis techniques was used for analyzing the data. More specifically, a three-stage analysis was followed for the interview data: (a) careful reading of the data and detection of relevant extracts (b) coding of the extracts and grouping them in

sub-groups of similar meaning and (c) repetition of stage (b) within each of the emerging sub-groups for the formation of third level categories. For reliability reasons, the whole process was realized simultaneously by the three researchers. The non-participant observation data collected for the second research question were used for completing and refining categories emerging from the interview data analysis, but also for providing critical teaching incidents used in the final interview for the teachers to comment on.

Results

Due to the limited space, only the results of the 1st and 2nd semi-structured interviews will be presented. As far as the first research question is concerned, the meanings attached to the notion of a Learning Trajectory (LT) developed by the three teachers converge only to some respect to the relevant literature.

In particular, teacher A considers that the trajectories are organized into thematic areas (algebra, geometry, etc.). She recognizes a similarity between LT and mathematics as a discipline. This similarity concerns both the way mathematical knowledge is organized and the historical progress of human thinking in mathematics.

The trajectory matches with mathematics in my view, how they are structured...in this way the approach of knowledge suits with the construction of knowledge and of human's thought because it seems that the notion of number has progressed developmentally in a similar way. And this helps a lot... (teacher A)

Teachers B and C seem to be more influenced by learning theories and interpret the organization of knowledge through LTs in a similar way.

In the trajectory you are interested in student's understanding, you want to activate his thought rather than to help him practice his memory and to simply remember the terms... (teacher B)

Teacher B, recognizing constructivist elements in the idea of LTs, considers them as providing a specifically arranged infrastructure for the construction of the mathematical knowledge, where the pre-existing knowledge serves to shape the new.

In the trajectory, I think that somehow a gradual construction of knowledge must be carried out...that is, starting with the natural numbers, we will go to the fractions... (teacher B)

Teacher C, on the other hand, indicates various and somewhat contradictory views on how knowledge is organized in learning paths through LT notion (e.g., constructivism as well as behaviorism).

We start to break the notion into parts and after each one is completed, we say that we have completed the particular part... (teacher C)

It appears that the three teachers' understandings of LTs are not identical but are overall compatible to the relevant literature with respect to the way in which a LT organizes and represents the progress of knowledge. But what they certainly do not distinguish is that a LT is not a simple organization of cognitive objectives but an empirically formulated proposal on how a student learns a mathematical concept. In addition, organizing knowledge along a LT suggests a learning approach

with specific characteristics derived from the constructivist perspective. These basic characteristics are conceptual understanding (teacher B) and engagement in active learning (teacher C).

Now, I do not know what exactly they learn. But I see that they start to investigate, they ask questions, I like that. In traditional contexts they wouldn't do that because they do not work this way.... But now they pose questions, they ask, "Why do we do that in this way?" (teacher B)

We felt that our experience was positive, and we saw that children responded very well, they liked this approach. Through an informally provided feedback, we see that their high school mathematics teachers are very pleased with these students... (teacher C)

This line of thinking is compatible with the concept of LT, since the first use of the term was made by Simon (1995), who proposed it as a teaching tool for the "constructivist" teacher.

On the other hand, teacher A considers LT to be independent from learning and teaching issues, limiting its use to the level of organizing mathematical content, which can be then framed by a variety of teaching approaches chosen by the teacher. This is a position also adopted by teacher C. However, teacher B argues that LT use in teaching improved her own knowledge of mathematical concepts resulting in her understanding better students' thinking. Finally, all three teachers report that LTs, combined with various teaching practices, contributed both to the learning process (teacher B) and to the learning outcomes (all teachers) in a variety of ways, such as, by facilitating logical connections and strengthening exploratory learning.

But if you can use the model or remember the wall of fractions, you can reach the equivalence much more easily... Or let's say the addition $1/4 + 1/2$, if the student depicts it and puts $1/4$ and $1/2$ close, he ends up much more easily to rules of addition than if you dictate the rule to him. (teacher B)

Teacher A also reports that she has too identified improvement in students' attitudes towards the lesson, but this is not the case for teacher C, who believes that the improvement noticed can be attributed to various factors. This finding is in line with that of Clements and Sarama's (2009) about LTs and the reinforcement of mathematical knowledge.

As far as the second research question is concerned, that is, how teachers claim to use LTs, the analysis of the relevant data reveals that LTs provided a general framework for organizing teaching, within which each teacher worked in her own way. Thus, the intermediate stages of the trajectory of fractions appeared to have provided successive intermediate learning targets for the instruction. Thus, teacher A attempted to incorporate LTs from different areas of the curriculum to simultaneously meet different objectives. This choice is of interest since the relevant research refers to the contribution of interacting LTs to pupils' learning. For achieving these objectives, tasks were organized, which not only corresponded to the objectives but also incorporated socio-cultural features, such as the history of mathematics and issues of everyday life, according to teacher A. Thus, in terms of lesson planning, LTs were used by teachers as a 'curriculum' that organizes the learning objectives. However, it is noteworthy that during the implementation of the lesson plan, LTs tended to be adapted by the teachers accordingly to the students' emerging needs.

All three teachers attempted to obtain relevant information about students through informal assessment processes during the instruction. This was mainly done through students' answers to the tasks, with the emphasis being on the explanations and the justification provided. At the same time, feedback was provided through students' work (teacher A) and by the way the students used the manipulatives and the models of fractions while dealing with the tasks (teachers B and C).

Also, the difference is that with LT I also use manipulatives. I do not just use the textbook or representations only, I use materials that students use, test them, change, see them differently... (teacher C)

Teacher A provided additional comments for each student individually about the progress and the difficulties in relation to the basic learning objectives included in the trajectory of fractions. Thus, she could have a "picture" of the whole class with regard to the points of the trajectory that students found more difficult. In one way or another, therefore, the teachers collected information about their students' learning. Likewise, the three participating teachers interpreted the information collected in their own way and proceeded to make decisions about their instruction. Their interpretations influenced their teaching choices. It seems, however, that LT supported a more focused interpretation taking into account students' past knowledge and thinking in order to guide the learner to the desired objective through a developmental path.

Maybe the knowledge they are building using the trajectories is more solid...When you tell them about the multiplication or the division, if they have learnt only the procedures without understanding them, they cannot go on...but with the trajectories it is so easy for them to perceive $\frac{3}{6}$, $\frac{4}{8}$, $\frac{5}{10}$ and they say "this is a half" without any stress. (teacher C)

The LT of fractions seems to have played an active role in teaching, whereas the developmental path that it offered made it easier for the teachers to link the pupils' previous knowledge to the new one. Thus, there were several occasions where, in order to understand some issues and to deal with the difficulties of fractions, teachers used students' knowledge coming from other trajectories (i.e., natural numbers). This approach is consistent with the literature claiming that teachers should adjust LTs on the basis of children's pre-existing knowledge and preferences. It also presents similarities with the use of learning trajectories by the Dutch TAL project, where the aims of a trajectory were linked to each other in ways that could be achieved through this association (Simon & Tzur, 2004).

When dealing with students' difficulties, however, the choices for the development of the instruction did not always include the active use of the trajectory of fractions. For example, an occasion in which the trajectory did not seem to have played an important role was the extended stay on a target, backing it up with extra tasks and supporting material (often digital).

We had difficulties in finding $\frac{1}{2}$ of $\frac{3}{4}$. We had difficulties in these things, but again, the models and various digital applications in the internet showed the way...How one can use $\frac{1}{2}$ of $\frac{3}{4}$... and we also used manipulatives where the students, in groups, were experimenting...how I can find $\frac{1}{3}$ of $\frac{3}{6}$, let's say. (teacher A)

Another option was to use LT to simplify activities to suit the potential of students. This may indicate a case in which, as the relevant literature suggests, the teacher adapted the trajectory to

students and chose activities appropriate to their level (Clements & Sarama, 2009). Thus, on the one hand, the objectives were not always at the ideal level, but on the other, students were given the opportunity to follow a course compatible with their level and needs.

In addition, teachers tended to allow each student to go at their own pace and go along with their own progress on a “micro-scale”. This personal progress often began from the intuitive and ended up to the formal level or started from a simple and reached to a more complex stage (teacher A). This appears to be very close to the proposal of the new Mathematics Curriculum (2014) according to which the sense of number is cultivated progressively and at successive levels of abstraction and generalization. Furthermore, there were many occasions where different solutions to problems corresponding to different levels of understanding would appear (teacher B) indicating that a LT allows students to expose individual differences in learning (IEP, 2014). It therefore follows that, in general, the notion of LT has been used in the class by teachers in various ways as a general framework and as a useful tool, not just as a list of cognitive objectives and corresponding tasks.

You can go ahead and see that something has not been understood...don't you come back to negotiate it again? You have to. So, you can come back and deal with the notion again (teacher B)

In general, however, LT's incorporation into teaching was proven to be more substantial when using the knowledge held by the students. In other words, a learning trajectory may be more useful and effective in teaching when the teacher takes into account the basic principles of constructivism, such as the developmental progress of learning and the importance of pre-existing knowledge. This goes back to its original purpose, when the term was first mentioned by Simon (1995), considering it as a tool for designing teaching according to constructivist principles.

Discussion and concluding remarks

The participating teachers interpret the concept of LT in ways that present similarities and deviations from the official literature. They tend to recognize that there is a certain sequence in teaching and to identify constructivist elements such as building on pre-existing knowledge and active engagement of the learner in the learning process. However, they view LT as a way of organizing mathematical content rather than as assumptions about the development of students' thinking when learning a mathematical notion, and so it seems that they perceive it yet as another local curriculum. As to the meaning attributions related to the application of LTs, overall, the contribution of LT to teaching is found either in organizing the content or in improving teachers' knowledge of mathematical notions and consequently in improving teaching. Thus, the participating teachers treated LTs just as means of organizing the mathematical content. At the same time, the use of the notion of LT did had a positive effect both on the learning process and the learning outcomes, as it encouraged exploratory learning procedures, exploited learning through connections between the notions and led to a solid and structured formulation of knowledge.

Learning trajectories appear to have provided the teachers with a general framework for organizing their teaching in ways that shared common features but also varied. These ways were not limited just to organizing the content. At the first phase, the use of LTs was related to lesson planning, including the development of individual objectives for a mathematical notion and the corresponding

tasks. However, during the instruction and on several occasions, the teachers modified the originally planned instruction under the light of emerging issues and students' thought. Thus, in order to teach the new mathematical content, the pre-existing knowledge that was part of the trajectory of fractions or of a different trajectory was used. Also, LT was adapted to the capabilities and the level of students' thinking through simplification of objectives and varied problem solving processes. Furthermore, a personal route of the students from the intuitive to the formal and from the simple to the complex was realized, for example, in the comparison of fractions. In contrast to the above, the LT of fractions was not particularly effective in cases where difficulties were simply identified without further interpretation of students' thinking. Teachers tended to stay for a long time in a learning objective without actually taking into account students' background so as to combine it with the trajectory at hand.

References

- Clements, D. H., & Sarama, J. (2009). *Learning and teaching early math: The learning trajectories approach*. New York, NY: Routledge.
- Confrey, J., & Maloney, A. (2010). The construction, refinement, and early validation of the equipartitioning learning trajectory. In K. Gomez, L. Lyons & J. Radinsky (Eds.), *Proceedings of the 9th International Conference of the Learning Sciences* (Vol.1, pp. 968–975). Chicago, IL: International Society of the Learning Sciences.
- Institute of Educational Policy (IEP) (2014). *Mathematics in Primary Education. Curriculum "Tools of Teaching Approaches"*. Athens: IEP/ ESPA 2007-13.
- Kuntze, S., Lerman, S., Murphy, B., Kurz-Milcke, E., Siller, H. S., & Winbourne, P. (2011). Professional knowledge related to big ideas in mathematics – an empirical study with preservice teachers. In M. Pytlak, T. Rowland, & E. Swoboda (Eds.), *Proceedings of the Seventh Congress of the European Society for Research in Mathematics Education* (pp. 2727–2726). Rzeszów, Poland: University of Rzeszów and ERME
- Simon, M. A. (1995). Reconstructing mathematics pedagogy from a constructivist perspective. *Journal for Research in Mathematics Education*, 26(2), 114–145.
- Simon, M. A., & Tzur, R. (2004). Explicating the role of mathematical tasks in conceptual learning: An elaboration of the hypothetical learning trajectory. *Mathematical Thinking and Learning*, 6(2), 91–104.
- Steffe, L. P. (2004). On the construction of learning trajectories of children: The case of commensurate fractions. *Mathematical Thinking and Learning*, 6(2), 129–162.
- Van Dooren, W., Lehtinen, E., & Verschaffel, L. (2015). Unraveling the gap between natural and rational numbers. *Learning and Instruction*, 37, 1–4.

Good mathematics teaching at lower primary school level

Marianne Maugesten

Østfold University College, Norway; marianne.maugesten@hiof.no

This paper explores Norwegian lower primary teachers' views about good mathematics teaching as revealed in a focus group interview at the end of a two-year school-based professional development program. Analyses of the empirical data indicate three main categories of findings: the teachers' facilitation of learning, the students' thinking in and about mathematics and the use of teaching aids in teaching. The results are discussed in relation to other Nordic studies and possible implications are also provided.

Keywords: Mathematics teachers' discussion, lower primary school, good mathematics teaching.

Introduction and theoretical background

This study investigates teacher views about good mathematics teaching. Several studies attempt to identify the components of good mathematics teaching without finding a clear answer (Cai, Kaiser, Perry, & Wong, 2009; Franke, Kazemi, & Battey, 2007; Hiebert & Grouws, 2007; Kilpatrick, Swafford & Findell, 2001). A challenge is that cultural as well as political differences influence mathematics teaching. Views about the role of the teacher, about the subject in school and society, and about learning differ across cultures (Cai et al., 2009). In the Chinese context, for instance, mathematics teaching is teacher-oriented and exam-oriented, and teachers are more focused on the students and their learning than on themselves and their teaching (Li, 2011). In the Nordic context, Fauskanger, Mosvold, Valenta and Bjuland (2018) conducted a study in which upper primary school teachers' views on good mathematics teaching were revealed through group interviews at the start of a major professional development project. The teachers referred to their role as teaching facilitators by having good structure, classroom management, and the possibility to differentiate using different types of assignments, which both motivates the students and invites more and diverse solutions. According to Fauskanger et al. (2018), good teaching was also about motivated, engaged, creative and curious students. In another study, Fauskanger (2016) investigated views on the ingredients of good mathematics teaching among lower and upper primary school mathematics teachers who participated in a professional development program. These teachers felt that student response was the most decisive factor for high quality teaching. They emphasized teacher qualities such as enthusiasm and attitude towards the subject rather than the teachers' own knowledge. Hemmi and Ryve (2015) studied Swedish and Finnish teacher educators' views of good mathematics teaching through focus group interviews and individual interviews. There were many apparent similarities between Sweden and Finland, but the Finnish teacher educators emphasized clear presentation of mathematics for the whole class, routines for mental arithmetic and homework, and clear learning goals for each class, while the Swedish teacher educators referred to the relationship with each individual child, building on the students' capabilities and finding mathematics in everyday situations. In three studies carried out among Finnish student teachers (at lower primary school level), Kaasila and Pehkonen (2009) looked

at students teachers' views of good mathematics teaching. They believed that teachers needed to be goal-oriented, listen to the students' thinking and show flexibility when unexpected episodes arise. The student teachers pointed out that teachers should have knowledge of varied work methods, base their teaching on the students' day-to-day experiences and have a particular focus on problem solving. Continuous assessment and development of socio-mathematical norms were considered important elements of good mathematics teaching.

Teaching mathematics is complex and researchers have attempted to distinguish the different aspects to identify main practices. These are referred to as core practices (McDonald et al., 2013) or high-leverage practices (Forzani, 2014). This study focusses on the Nordic context, therefore core practices are not discussed further.

The study in this paper is based on a group of Norwegian teachers at lower primary school level who, together with a teacher educator in a focus group interview, reflected on their own mathematics teaching at the end of a two-year school-based mathematics professional development program. The content in this development program were decided by the headmaster in cooperation with representatives of the mathematics teachers at the school. Among the themes were numeracy, different approaches to the four arithmetical operations and how to lead productive mathematical discussions. This study does not measure the effect of the program, but it can be assumed that the teachers' descriptions of good mathematics teaching has been influenced by them trying out exercises and activities in their own classes and by improved research-based knowledge of mathematics didactics throughout the two-year period. To my knowledge of research in the field, few studies have examined Norwegian lower primary school teachers' descriptions of good mathematics teaching. On this basis, the study seeks to answer the following research question: What might Norwegian lower primary school teachers' views about good mathematics teaching look like? Teaching refers to the interaction between teachers and students relating to subject matter. Cohen, Raudenbush and Ball (2003) describe this interaction as the instructional triangle.

Methodological approach

The empirical data used in this study is from a focus group interview with seven lower primary school teachers at a school that has completed a two-year professional development program for mathematics teachers. The interview included two teachers from each of the years one to year three and one from year four. Two were men and five were women. Two of these were experienced preschool teachers who have worked at lower primary level for about 15 years. The others were primary and lower secondary teachers with between 15 to 30 ECTS credits in mathematics and between four and 20 years of experience from primary and lower secondary school. The school has three teachers on each of the four years of lower primary school.

The participants were informed of the topic of the focus group interview in advance. They were asked to discuss and reflect on their own mathematics teaching on the basis of their experiences from competence raising and what they had tried out, and their definition of good mathematics teaching. The interview lasted one hour and was recorded and transcribed in full.

Transcripts from the focus group interviews were analyzed using conventional content analysis (Fauskanger & Mosvold, 2015; Hsieh & Shannon, 2005) used in studies that attempt to describe a phenomenon in order to better understand it. The phenomenon described in this study is mathematics teaching. In conventional content analysis, inductive codes are linked to suitable categories, as shown in a table in Figure 1. The interview subjects are referred to as R1 to R7. The transcribed interviews were placed in a table with rows containing individual statements, such as R3 in Figure 1, key words from these, inductive codes and categories. The material was analyzed twice with a two-month interval to prevent categories being overlooked. One of the challenges of conventional content analysis is not obtaining a complete understanding of the context because of categories being left out (Hsieh & Shannon, 2005).

Category	Inductive code	Examples of individual comments
The teachers' facilitation of learning	Communication in the classroom	R3: 'Some years ago, if I spent much too much time on a conservation, it felt like "when are we going to do the maths?"'
	Representation – particularly transitions between representations	R4: 'because we've used manipulatives before too... And the transition from using manipulatives to actually drawing up maths problems [...]'
The students' thinking in and about the subject of mathematics	The students' thinking in the subject of mathematics	R5: 'show them that there is more than one way of working it out, several strategies.'
	The students' thinking about the subject of mathematics	R3: 'The challenge is that there are a few students in the class that you don't manage to engage in the conversation, that only really become involved when they are given the maths problem in the book'.
Subject resources in the facilitation	Textbook	R6: 'And then I suppose it's very safe. You probably very much trust that those who have written the textbooks know what we need to get through and...it's also related to time pressure sometimes, that it's easy.'
	Type of task: open, explorative, tasks related to daily activities	R2: '...to see the maths in everything around us. Grasp the everyday situations.'

Table 1: Codes and categories

Results

The analysis of the empirical data led to three main categories of findings: teachers' facilitation of learning, students' thinking in and about mathematics and use of teaching aids in teaching. These three main categories are sometimes related. For example, the students' thinking in and

about a mathematics exercise might be connected with the teacher's facilitation of learning through communication in the classroom. This is in line with the description of teaching in the instruction triangle as an interaction between subject matter, the students and the teacher (Cohen et al., 2003). Through the focus group interview, the teachers emphasized increased awareness of several areas at the same time as they still had challenges in a number of these areas. When the results are presented, both challenges and increased awareness are shown in each category.

Teachers' facilitation of learning

The teachers seemed to use more whole class conversations and dialogue in mathematics teaching after participating in the professional development. They also said that it was challenging to engage the students in subject-related talks. The teachers viewed the dialogues with the students and between students as an aid to developing the students' thinking: 'Kind of building a bridge between the terminology they have and... sort of new knowledge' (R3). This remark may indicate a view of learning in which the students develop new knowledge from already established terms. The same teacher had started using learning pairs and felt that the students gave each other ideas that were useful to the subsequent conversation with the whole class. The teachers did not feel that the class failed if they spent time on discussion and deviated from the class plan (R1). R6 reported that they often used to think 'Oh no, now I have to get the other part done,' where the other part referred to solving exercises in the textbook. This can mean that the teacher thought more about quality and what led to learning than quantity, as in solving lots of math problems in the mathematics teaching. R3 described the use of dialogues in teaching as a *quantum leap* in relation to before the professional development program. In communication with the students, the teachers expressed that they had become more precise in their use of terms, as described by R1: 'addition and subtraction, and not plus and minus.'

R4 specified what was meant by more dialogue in the following example. Previously, the date and day were written on the board in the morning assembly, while the content was now more mathematical: 'Who's birthday is next? How many days are there until...? How long ago was Christmas?' The teachers developed math problems from the information that emerged, and the students were encouraged to develop their own problems.

Several teachers found dialogues to be challenging for both students and teachers in mathematics classes. Students needed to practice talking and explaining their thoughts. Some students asked (R2): 'Can't we just do a task?' The teachers stated that they needed to learn what questions to ask in order to elicit student thinking. To address some of the challenges described by the teachers in my study, it will be necessary to develop classroom norms and relations that are in line with several of the high-leverage practices (Forzani, 2014).

The teachers in the study taught at lower primary level and found it important to use various representations, such as concrete manipulatives and semi-concrete manipulatives, drawings, verbal representations and written representations in the form of math problems and numbers intended to help more students to understand more. They expressed great awareness of the use of new representations such as sketches of blank number lines: "Blank number line. Open number line. I think it's almost been revolutionary. I use it in nearly every possible context, very positive to use," (R6). The transition from concrete representation to abstract ideas was

challenging for the students, according to several of the teachers. R4 gave an example where she lined the students up at the front of the class to show doubles and halves. For the students to understand what numbers represented half and double, the teachers felt that they had improved their knowledge as to what questions to ask in order for the students to see the connection between the practical and the written parts. The teachers believed that this transition was important (R3). This indicated that they found it important to facilitate students' learning and how their current abilities could be related to what they were going to learn.

The students' thinking in and about the subject of mathematics

This category was also concerned with communication in mathematics teaching. When students explain their thoughts, it takes place in a communication situation. The teachers felt that the students must be given time to think and ask questions and that they, as teachers, should not feel that the students should rather be solving written math problems. By letting the students show their thoughts when solving problems, the teachers could emphasize that mistakes can be positive in that they can help the teachers and students to understand. "And understanding kind of how they think, and going into it and understanding a bit more why things are wrong and why it is hard, I think is very important" (R4). This showed that knowing about common student mistakes and ways of thinking was important for the teacher. According to the teachers, the students also became aware of there being more than one way of reaching the solution. They believed that the students acquired a better understanding by explaining their thoughts since this formed a 'bridge' between the terminology the students already had and new knowledge.

The teachers gave examples of their students' remarks when thinking *about* the subject of mathematics: "Oh yes, now I understand it." This expressed a sense of mastery. However, the teachers also described the challenges relating to students' different understandings of the mathematics subject. As mentioned earlier, it can be a challenge to get the students to talk in mathematics classes precisely because they are of the impression that mathematics means solving lots of math problems. R3 explained it in the following way: "The challenge is that there are a few students in the class that you don't manage to engage in the dialogue, that only really become involved when they are given the math problem in the book." She also believed that this particularly applied to students who were quick at calculations and those who were not particularly motivated in the subject of mathematics. This may indicate a view that mathematics is about quickly solving lots of math problems.

Subject matter/resources

When the teachers described the content of their own teaching, the main topics of discussion were the textbook and different types of tasks (often aside from the book). They expressed an increased awareness in relation to both.

In relation to the types of tasks, R4 explained that she no longer made booklets containing extra tasks, but used open-ended and problem-solving tasks that the students could work on over time. She also stated that, "I hope they have become better at thinking at least, to sort of, solve problems." This may imply that the teachers felt that investigation and problem solving were key elements of students' understanding, and thereby of good mathematics teaching. The

teachers also told that they discussed mathematics teaching with colleagues more than earlier, because the tasks were challenging. At lower primary level, the teachers gave the students notebooks where they could draw and write problems and solutions themselves. An open exercise for year one students was the hundred-day party where the mathematical topics the teachers covered were even numbers, odd numbers, ten friends, bridging through ten, counting, subtraction and addition. The teachers in my study explained that they had become more alert to the mathematics in everything around them, which could be linked to the types of exercises. R2 commented: “Grasp the everyday situations. And get them into what’s related to mathematics in the class.” When the teachers in my study seem to have increased awareness of using mathematics in all subjects, this might relate to the fact that the basic skill of calculation in all subjects had been a theme in the professional development program. R7 summed up what she thought good mathematics teaching was in the following way: “When the students understand when and how they can use their knowledge of mathematics in everyday life.”

When the textbook was raised as a topic, there was some disagreement among the teachers. R7 told that she has become “critical to the textbooks, and I don’t completely trust that the textbooks necessarily meet all the learning goals.” R2 has become more aware of being freer in relation to the textbook, while R6 finds the textbook safe. This shows that teachers can disagree about the textbook’s role in mathematics teaching.

According to the research question, the teachers’ views about good mathematics teaching was described in the three main categories of findings in this section. Some of them were related to results in other Nordic studies, as discussed in the next session, but also to the content of the two-year professional program. This paper does not assess the effect of the program, but the teachers’ views about good mathematics teaching can be influenced by this content and improved research-based knowledge. The teachers emphasized the use of open-ended and problem solving tasks and acceptance of communication and dialogues to facilitate learning.

Discussion

There were both similarities and differences between how good mathematics teaching was described by the teachers in this study as compared with other Nordic studies (Fauskanger, 2016; Fauskanger et al., 2018; Hemmi & Ryve, 2015; Kaasila & Pehkonen, 2009) that have examined good mathematics teaching.

The Norwegian teachers’ descriptions of dialogs in lower primary school teaching were similar to those of other studies. Fauskanger et al. (2018) pointed out that facilitating conversation and discussion in mathematics teaching was a key aspect of students’ learning at the same time as such conversation could inform the teacher about the students’ thinking. International research highlights classroom discussion in mathematics teaching (e.g., Franke et al., 2007).

Based on the empirical data, students’ thinking appeared to influence the planning of mathematics teaching for the participating teachers. Similar to the Finnish study the findings of this study documented that the teacher needs to listen to the students in order to understand their way of thinking (Kaasila & Pehkonen, 2009). The student teachers in Hemmi and Ryve’s (2015)

study believed that Swedish teachers build on an extreme expression of constructivism and were therefore more student-focused, while the Finnish referred to whole class discussion.

Selecting open tasks and investigative activities that are motivating and give the students opportunities to show several solutions was emphasized by both Fauskanger et al. (2018) and Hemmi and Ryve (2015). Connecting mathematics with everyday life seemed to be important both in the Swedish and Finnish education studies (Hemmi & Ryve, 2015; Kaasila & Pehkonen, 2009) which are in line with the findings of my study.

In this concluding discussion, I will highlight one characteristic of good teaching that the teachers focused on and one characteristic that previous research has highlighted, but that was not mentioned in my focus group interview.

During the focus group interview, the teachers believed that using several different representations and working on the transition between these both contributed to good teaching and entailed a challenge. Using different representations has not been included in the characteristics of good mathematics teaching in other Nordic studies. This could of course mean that the use of representations and the transition between representations were included in some of the other categories in these studies. However, it may also be explained by the fact that the teachers in my study were teachers at lower primary school level and here, the need to use different representations was greater, and the transition from concrete to abstract thinking was more difficult than for older students. Work on expressing math problems or amounts in numbers after using manipulatives were considered particularly difficult for this age group.

A characteristic of good mathematics teaching mentioned in both Fauskanger et al. (2018) and Kaasila and Pehkonen's (2009) studies, is the structure of classes, with clear learning goals and classroom management. This was not mentioned, nor asked about, in the lower primary school teachers' focus group interview. This does not mean that it is not important to the lower primary school teachers in this study; it is perhaps more important here than in other years. However, the teachers might see classroom management and clear learning goals as such obvious factors that they did not mention them explicitly when they described mathematics teaching.

At the end of the professional development program the teachers felt that they had not only become more aware of dialogues with the students, but they also had more conversations and reflections among themselves. They feel that such discussion and reflection provide support and inspiration for their teaching. Knowledge sharing among the teachers may therefore contribute to long-term competence raising and deserve further research. Effect studies of professional development also need to be researched further.

References

- Cai, J., Kaiser, G., Perry, B., & Wong, N. (Eds.). (2009). *Effective mathematics teaching from teachers' perspectives: National and cross-national studies*. Rotterdam: Sense Publishers.
- Cohen, D. K., Raudenbush, S. W., & Ball, D. L. (2003). Resources, instruction, and research. *Educational Evaluation and Policy Analysis*, 25(2), 119–142. doi:10.3102/01623737025002119

- Fauskanger, J. (2016). Matematikklæreres oppfatninger om ingrediensene i god matematikkundervisning. *Acta Didactica Norge*, 10(3), 1–18.
- Fauskanger, J., & Mosvold, R. (2015). En metodisk studie av innholdsanalyse - med analyser av matematikklæreres undervisningskunnskap som eksempel. *Nordic Studies in Mathematics Education*, 20(2), 79–96.
- Fauskanger, J., Mosvold, R., Valenta, A., & Bjuland, R. (2018). Good mathematics teaching as constructed in Norwegian teachers' discourses. In E. Norèn, H. Palmèr, & A. Cooke (Eds.), *NORMA 17 – Nordic Research in Mathematics Education* (Vol. Skrifter från SMDF, nr 12 Göteborg: Svensk förening för matematikdidaktisk forskning, pp. 239–249). Göteborg.
- Forzani, F. M. (2014). Understanding “core practices” and “practice-based” teacher education: Learning from the past. *Journal of Teacher Education*, 65(4), 357–368. doi:10.1177/0022487114533800
- Franke, M. L., Kazemi, E., & Battey, D. (2007). Mathematics teaching and classroom practice. In F. K. Lester, Jr. (Ed.), *Second Handbook of Research on Mathematics Teaching and Learning* (Vol. 1, pp. 225–256). Charlotte, NC: Information Age Publishing.
- Hemmi, K., & Ryve, A. (2015). Effective mathematics teaching in Finnish and Swedish teacher education discourses. *Journal of Mathematics Teacher Education*, 18(6), 501–521. doi:10.1007/s10857-014-9293-4
- Hiebert, J. S., & Grouws, D. A. (2007). The Effects of Classroom Mathematics Teaching on Students' Learning. In F. K. J. Lester, Jr. (Ed.), *Second handbook of research on mathematics teaching and learning* (Vol. 1, pp. 371–404). Charlotte, NC: Information Age Publishing.
- Hsieh, H. F., & Shannon, S. E. (2005). Three Approaches to Qualitative Content Analysis. *Qualitative health research*, 15(9), 1277–1288.
- Kaasila, R., & Pehkonen, E. (2009). Effective mathematics teaching in Finland through the eyes of elementary student teachers. In J. Cai, G. Kaiser, B. Perry, & N. Wong (Eds.), *Effective mathematics teaching from teachers' perspectives: National and Cross-National Studies* (pp. 203–216). Rotterdam: Sense Publishers.
- Kilpatrick, J., Swafford, J., Findell, B. (2001). *Adding it up: helping children learn mathematics*. Washington, DC: National Academy Press.
- Li, Y. (2011). Elementary teachers' thinking about a good mathematics lesson. *International Journal of Science and Mathematics Education*, 9(4), 949–973. doi:10.1007/s10763-010-9263-y
- McDonald, M., Kazemi, E., & Kavanagh, S. S. (2013). Core practices and pedagogies of teacher education: A call for a common language and collective activity. *Journal of Teacher Education*, 64(5), 378–386. doi:10.1177/0022487113493807

Analysis of differences between teachers' activity during their regular and constructivist lessons

Janka Medová, Kristína Bulková and Soňa Čeretková

Constantine the Philosopher University in Nitra, Faculty of Natural Sciences, Department of Mathematics, Nitra, Slovakia; jmedova@ukf.sk, kristina.bulkova@ukf.sk, sceretkova@ukf.sk

Different aspects involved in the constructivist teaching mode were assessed in the eight observed mathematics lessons conducted by four upper-secondary in-service teachers. Four among these lessons were identified as 'regular' by the teachers themselves, the other four lessons followed the same constructivist lesson plan designed by the respected educational expert. The main differences were found in the way how the students were working and achieved their independent learning capabilities. The lessons following the constructivist lesson plan were clustered together by the means of hierarchical cluster analysis. The regular lessons were more influenced by the teachers' personalities than the constructivist lessons.

Keywords: Teacher behaviour, teaching styles, professional development.

Introduction

The traditional transmissive “chalk-and-talk” methods have already been criticized continually, while concurrently the student-centred pedagogies have frequently and gradually been approved for several decades (Steffe & Kieren, 1994). Teachers face a lot of issues and challenges when implementing awaited constructivist approaches (Appleton & Asoko, 1996). Teachers lacking any experience in the constructivist classroom often struggle with the setting up such a learning environment that is demanded for the constructivist perspective (Windschitl, 2002).

According to Schoenfeld (2010) the teachers' decisions during the lesson are influenced by their resources (i.e., knowledge, material just being available), goals (e.g., such aims which they are trying to achieve) and orientations (e.g., their beliefs, values, biases). Teachers' professional knowledge can be seen as an outcome of their overall different experiences they have been involved in, including both formal and initial training, as well as professional development and informal forms of learning through their own practice or media. The overall teachers' knowledge has been constructed and developed gradually. Such process has been always influenced by their prior beliefs, pre-knowledge or originating knowledge and experiences of the knowers (Smith, 1993). As such, different people experiencing the same intervention will achieve and develop their own and usually quite different constructions of that experience (Lachance & Confrey, 2003).

Theoretical framework

Beerenwinkel and von Arx (2017) describe the constructivist-oriented teacher as a person who activates the overall students' pre-knowledge and provides them with some suitable issues and problems, often related to their everyday context. During the problem-solving activity of students, the teacher creates a space for independent learning, encourages rethinking and seeks to demonstrate certain scientific approach to generating such knowledge.

According to Widodo & Duit (2004), there are four categories comprising the significant indicators for the constructivist teaching: (a) construction of knowledge (CK); (b) personal relevance (PR); (c) social interaction (SI), and (d) independent learning (IL). Beerenwinkel and von Arx (2017) defined evident facets for each of the listed indicators that are suitable for quantification. Construction of knowledge can be assessed according to status in the learning process, activation of pre-knowledge, providing problems, evolutionary development of knowledge, revolutionary development of knowledge, thinking aloud and demonstration of the scientific approach to knowledge generation. Personal relevance is based on exploring the interest, accounting for needs, everyday-life context and transfer to other subjects. Social interaction can be quantified according to extent of student-student interaction, student-teacher interaction with the whole classroom and student-teacher interaction while individual work or group work. Independent learning is manifested in space for independent learning, encouraging the rethinking, fostering the metacognition, benefit from independent learning and metacognitive abilities.

In our study we focused on the differences between the regular lessons of Slovak mathematics teachers and the lessons conducted by the same teachers based on the lesson-plan prepared by the relevant expert in constructivist teaching and learning. We stated the following research questions: (i) In what facets of constructivist teaching does the regular lesson differ from the lesson based on the lesson-plan prepared by the relevant expert? (ii) What are the relations between the episodes from regular and constructivist lessons of investigated teachers? (iii) What are the (implicative) relations between the facets of constructivist teaching observable in the lessons of investigated teachers?

Materials and methods

Within the project PRIMAS supported by the European Union FP7 the course aimed at the professional development (CPD) of mathematics teachers was implemented at the authors' university. The CPD focused on the implementation of inquiry-based learning and thus also constructivist teaching in upper-secondary schools. Several authors (e.g. Jaworski, 2006) see inquiry as fitting with the constructivist view of knowledge and learning.

The structure of the course followed the spiral model of teachers' professional development, consisting of the following three repeating steps: Reflection - Analysis - Implementation. The course was aimed at the transformative learning of the participating teachers as mentioned by Thompson and Zeuli (1999). Firstly, the teachers reflect on the lesson they labelled as 'regular'. Later in the course, the teachers went through this cycle for three more times. They did specific changes in their practice, videotaped their lesson, reflected on it and came with specific conclusions that might influence their further practice. The first change was in the way of questioning. The second lesson should follow expert-prepared lesson plan. Detailed lesson plans including typical student questions and suggested answers were chosen with the aim to offer teachers tools that they were not familiar with prior to the study. Any and every positive experience in implementing constructivist approach is very good motivation for their further practice. The third lesson was planned by teachers themselves according their experience from previous cycles.

In order to answer the research questions we analysed eight videotaped lessons taught by the four participants of CPD that implemented the same lesson plan named *Counting trees* (Mathematics Assessment Resource Service, 2015). Two lessons for each participating teacher were analysed. The first of the lessons were recorded after the first 90-minute session of the CPD. The teachers were required to record their regular mathematics lesson following the national curricula. The second analysed lesson was the one following the *Counting trees* lesson plan. The teachers did not get any special support to this particular resource. On the other hand, the constructivist lesson was carried out after completing the 52 out of the 60 group contact lessons of the CPD. The subsequent sessions reflecting on the lessons were conducted in researcher-teacher pairs.

The lessons were divided into smaller episodes according to the activity during the lesson (i.e., teacher lecturing, group-work, etc.). The time for each episode was recorded. Each episode was labelled by pseudonym of the given teacher, number of lesson (1 - regular, 2 - constructivist) and phase of lesson. The defined facets were assessed for each episode. The levels were defined from 0 (the facet was not manifested in the observed lesson) to 3 (the facet regularly occurs in the observed lesson). The facets describing the personal relevance got almost for each observation the zero value, so we decided to omit this indicator from the further analysis.

The weighted arithmetic mean for each facet was calculated and the mean value of the lessons was compared by the means of paired *t*-test (De Winter, 2013) performed in R environment (RCoreTeam, 2018). The hierarchical cluster analysis was performed using the Euclidean distances and UPGMA clustering method. The cophenetic correlation coefficient was used to determine the most accurate clustering method. The statistical implicative analysis (SIA) (Gras et al., 1996) using package *rchic* (Coutrier, Pazmiño Maji, Conde González, & García-Peñalvo, 2015) was applied to explore the implicative relations between the facets of constructivist teaching.

Results

Four of the observed facets significantly differed between the regular and constructivist lesson. The means, *t* statistics and *p* values are summarized in Table 1. The evolutionary development of knowledge (CK4) and teachers' thinking aloud (CK6) were more prevalent in the course of the regular lessons. Surprisingly, the revolutionary development of knowledge (CK5), typical for the constructivist classroom was not significantly higher in the lesson based on the constructivist lesson plan.

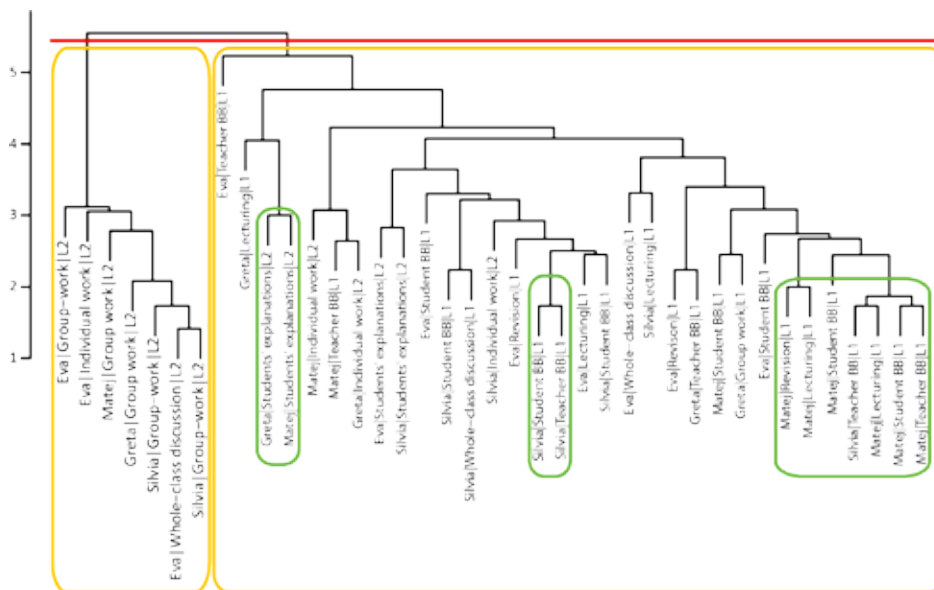
The student-student interactions occurred more often in the constructivist lessons as there was actually a large space devoted to the group-work during the lesson. The level of student-teacher interactions did not differ significantly, neither for the individual, nor for the group communication. Fostering metacognition features (IL3) and benefits from the independent learning (IL4) were the two characteristics of individual learning that did differ significantly between the two lesson types.

Facet	Description of facet	Lesson 1	Lesson 2	<i>t</i>	<i>p</i>
-------	----------------------	----------	----------	----------	----------

		<i>M</i>	<i>SD</i>	<i>M</i>	<i>SD</i>		
CK1	Status in the learning process	0.82	0.47	0.03	0.01	2.00	0.092
CK2	Activation of pre-knowledge	0.99	0.55	0.36	0.68	0.43	0.354
CK3	Providing problems	0.40	0.03	0.18	0.17	0.30	0.395
CK4	Evolutionary development of knowledge	0.75	0.27	0.06	0.07	2.95	0.049
CK5	Revolutionary development of knowledge	0.36	0.07	0.36	0.22	-0.01	0.496
CK6	Thinking aloud	2.15	0.87	1.19	0.56	4.12	0.027
CK7	Demonstration of the scientific approach to knowledge generation	0.25	0.14	0.00	0.00	1.50	0.137
SI1	Student-student interaction	0.18	0.02	2.05	0.19	-6.17	0.013
SI2	Student-teacher interaction (classroom)	1.67	0.23	0.85	0.42	1.98	0.093
SI3	Student-teacher interaction (individual work or group work)	0.84	0.82	1.62	0.07	-2.22	0.079
IL1	Space for independent learning	0.51	0.25	2.03	0.07	1.53	0.133
IL2	Encourage rethinking	0.64	0.14	0.68	0.58	0.20	0.432
IL3	Foster metacognition	0.38	0.02	1.62	0.01	-11.34	0.004
IL4	Benefit from independent learning	0.22	0.04	1.39	0.27	-2.85	0.052
IL5	Metacognitive abilities	0.62	0.15	1.00	0.28	-0.49	0.337

M = mean, *SD* = standard deviation, Lesson 1= the regular lesson, Lesson 2 = the *Counting trees* lesson

Table 1: Mean values of the levels for the facets describing indicators of constructivist teaching



Name of the teacher|Episode of the lesson|Number of lesson; BB means solving a task on the blackboard; L1 regular lesson, L2 *Counting tree* lesson.

Figure 1: Dendrogram grouping the episodes from the observed lessons

The observed variables from our analysis of the observed lessons were grouped into two clusters (Figure 1). The first one contained the variables representing episodes of constructivist lessons: the students work in groups (Eva, Greta, Matej, Silvia|Group-work|L2) with students' individual work (Eva|Individual work|L2) and whole-class discussion (Eva|Whole-class discussion|L2). The second cluster comprised of several smaller subclusters grouped by the same type of an episode of lesson and by the style of teaching conducted by the observed

teacher. For example, one subcluster contained almost all episodes of the observed lesson Matej1 (see Fig. 2 in green square). Some of teachers connected discussion in groups with the work on the project. In the first cluster, also one variable for individual work (Eva|Individual work|L2) is grouped. We assume that the teacher encouraged students also during their individual work.

The fifteen facets of constructivist teaching were grouped into the three clusters (Figure 2). In the first cluster, only two didactical variables were grouped: CK6 (thinking aloud), and SI2 (student-teacher interaction in the classroom). The second cluster contained the following five grouped variables: SI1 (student-student interaction), IL3 (fostering metacognition), IL4 (benefit from the independent learning), IL1 (space for the independent learning), and SI3 (student-teacher interaction during the individual or group work). The third cluster comprised of the following three didactical variables: CK1 (status in the learning process), CK4 (evolutionary development of knowledge), CK3 (providing problems), CK7 (demonstration of the scientific approach to knowledge generation).

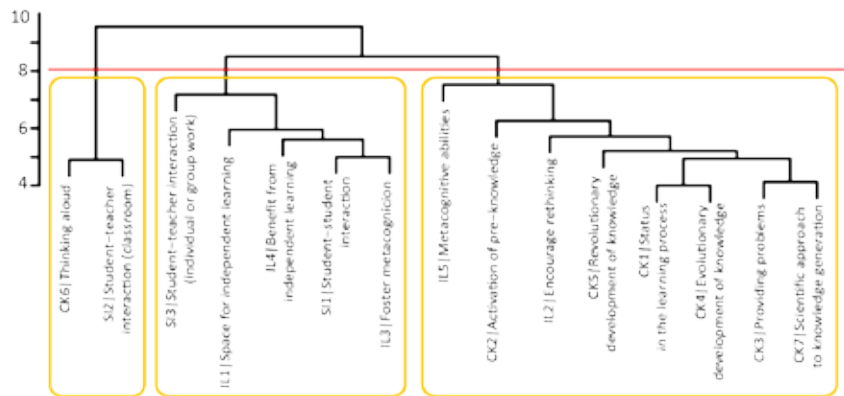


Figure 2: Dendrogram of different facets of constructivist teaching

The statistical implicative analysis produced the three R-rules (Figure 3). The first connected subgraph $IL2 \rightarrow CK6 \leftarrow SI2 \leftarrow CK2$ represents the aspects influencing the teachers’ thinking aloud.

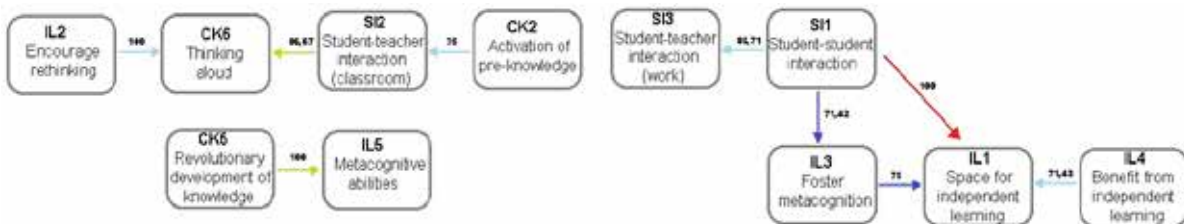


Figure 3: R-rules of the different facets concerning to constructivist teaching

Based on the results of the *t*-test we can conclude that since the lessons varied in their structure, the actual and real difference was mainly in the way how the students had been working. The teachers did not engage in “think aloud” too much and more time was devoted to the individual work of students. Student-student communications were observed more frequently which implied greater benefits for students as a result of independent thinking during constructivist lessons.

The variables grouped in the first cluster imply that the discussion in classroom about the given problem or topic is encouraged by teacher's thoughts aimed at revising or expanding a knowledge structure or framework. Students had real opportunities to reflect on their observations (or perceptions) related to the discussed issue (e.g., creating a definition, possible strategies, or solutions). Teachers' thinking aloud about the topic influenced the intensity of the interaction in the classroom between the teacher and students.

The variables in the cluster 2 represent the aspects of group-work in the classroom. The teacher supporting interactions between the students in groups, helps students share their opinions about the given topic and strategies in the solving process. The independent work gives some space to the students for managing time, tools, and strategies to achieve their assignment. Especially as far as the group work, the mutual discussion can bring several diverse ideas as far as the methods, form of collaboration, or managing of timing, and developing their soft or mathematical skills. The teacher enters into a conversation or group work only as a facilitator.

Based on the cluster 3, any knowledge, that is new for the students, can be easier integrated by linking it or by the reinterpretation and reinforcing of an existing previous knowledge. The scientific approach in the learning process may keep and support the quality of any new information for its integration into the knowledge structure. The grouped variable CK5 (revolutionary development of knowledge) confirms the teacher's role as a facilitator in the learning process, where the teacher gives comments, stimulating cognitive conflicts. In this sense, the variables IL2 (encourage rethinking), CK2 (activation of pre-knowledge) and IL5 (metacognitive abilities) represent such a new knowledge, that is activated through the discussion process, where the students can explain their arguments and thinking and the teacher encourages them to do so.

Results of the SIA indicate that the pre-knowledge covering a topic is activated in the discussion process headed by the teacher. Such discussion factually does represent an interaction between the teacher and the students in the classroom. Encouragement of rethinking is clearly an influential aspect to thinking aloud. The second rule (SI1→IL3)→IL1 contains the strongest implication: SI1→IL1, meaning, the mutual interaction between the students is conditionally a factor for their independent learning. Especially, while they are involved in group work in the classroom, students have a space to discuss their opinions independently from the teachers' leading. The teacher is only a guide who can help with some ideas in small groups (SI1→SI3). We concluded that for the independent work it is necessary to create a space for discussions between the students focused on developing the relevant questions, ideas or solutions. Discussion is interrupted by the teacher only with some comments enhancing the discourse. Finally, the rule CK5→IL5 represents how cognitive conflicts offered by the teacher can help the students to explicate their thinking, learning or problem solving.

Discussion

The study builds on the characteristics of constructivist teaching described by Widodo and Duit (2004) and further elaborated by Beerenwinkel and von Arx (2017) for science education. The framework was implemented and used as a base for our quantitative analysis of eight mathematics lessons. Four lessons were usual for the teachers, and four were based on

constructivist lesson plan designed by an expert. Students' activity was changed and the teacher had to adopt the new role of a mentor and facilitator of students' discussion.

Teachers in Slovakia frequently engage in lecturing practices. On the other hand, this style of teaching-lecturing is not seen too frequently in countries such as Iceland or Japan where independent work of students connected with between-desk-teaching is usual. It also differs from the situation in Finland where the whole-class discussion is the usual teaching approach (Gunnarsdóttir & Pálsdóttir, 2015). The second lesson provided students with more opportunities for independent learning. Taylan (2015) recognised independent learning in both, individual and group work if the mathematical discussion was carefully prepared. It was the case also in *Counting trees* lesson plan that suggested teachers' questions to start and support students to discuss. The teachers' thinking aloud apparently decreased in the constructivist lessons. Despite Ayalon and Hershkowitz's (2015) claim that different teachers can see the same task differently, the proposed lesson plan seemed to have similar effects in participating teachers' classes. It may indicate similar experience with setting up the constructivist learning environment. The participating teachers were involved in the CPD aiming at the constructivist teaching style. We can assume teachers' willingness to teach in the constructivist mode as they had chosen this kind of course.

Conclusions

The outcomes and results of the study confirmed actual differences between the usual lesson and a lesson based on constructivist lesson plan. The episodes of the constructivist lessons when students worked independently were clustered together. Clustering the episodes of the regular lessons depended more on teachers' personality than on the phases of the lessons. Teachers during their regular lessons appeared to hold the main authority in the classroom. Based on our observations, teachers' thinking aloud or interaction between the student(s) and the teacher were more prevalent in the regular lessons. On the other hand, when the teacher was following the constructivist lesson plan, a higher level of independent learning was observed. The carefully prepared lesson plan enables the teacher to implement lesson in a constructivist approach. Further research is needed to evaluate impacts of the actual experience with constructivist lessons on teachers' regular practice.

References

- Appleton, K., & Asoko, H. (1996). A case study of a teacher's progress toward using a constructivist view of learning to inform teaching in elementary science. *Science Education*, 80(2), 165–180.
- Ayalon, M., & Hershkowitz, R. (2015). Teachers' attention to tasks' potential for encouraging classroom argumentative activity. In K. Krainer & N. Vondrova (Eds.), *Proceedings of the Ninth Congress of European Society for Research in Mathematics Education* (pp. 2982–2988). Prague, Czech republic: CERME.
- Beerenwinkel, A., & von Arx, M. (2017). Constructivism in practice: An exploratory study of teaching patterns and student motivation in physics classrooms in Finland, Germany and Switzerland. *Research in Science Education*, 47(2), 237–255.
- Coutrier, R., Pazmiño Maji, R. A., Conde González, M. Á., & García-Peñalvo, F. J. (2015). *Statistical implicative analysis for educational data sets: 2 analysis with RCHIC*. Paper

- presented at the XVIII Congreso Internacional EDUTEC "Educación y Tecnología desde una visión Transformadora", Riobamba, Ecuador.
- De Winter, J. C. (2013). Using the student's t-test with extremely small sample sizes. *Practical Assessment, Research & Evaluation*, 18(10), 1–12
- Gras, R., Almouloud, S. A., Bailleul, M., Lahrer, A., Polo, M., Ratsimba-Rajohn, H., & Totohasina, A. (1996). *L'implication statistique: nouvelle méthode exploratoire de données, applications à la didactique*. Grenoble: La Pensée sauvage.
- Gunnarsdóttir, G. H., & Pálsdóttir, G. (2015). Instructional practices in mathematics classrooms. In K. Krainer & N. Vondrova (Eds.), *Proceedings of the Ninth Congress of European Society for Research in Mathematics Education* (pp. 3036–3042). Prague, Czech republic: CERME.
- Jaworski, B. (2006). Theory and practice in mathematics teaching development: Critical inquiry as a mode of learning in teaching. *Journal of Mathematics Teacher Education*, 9(2), 187–211.
- Lachance, A., & Confrey, J. (2003). Interconnecting content and community: A qualitative study of secondary mathematics teachers. *Journal of Mathematics Teacher Education*, 6(2), 107–137.
- RCoreTeam (2018). R: A language and environment for statistical computing. Vienna, Austria: R Foundation for Statistical Computing. Retrieved from <https://www.R-project.org/>
- Schoenfeld, A. H. (2010). *How we think. A theory of goal-oriented decision-making and its educational applications*. Oxford: Routledge.
- Mathematics Assessment Resource Service (2018). Sampling and Estimating: Counting Trees. Retrieved on August 15, 2018, from: <http://map.mathshell.org/lessons.php?unit=7400&collection=8>
- Smith, J. K. (1993). *After the demise of empiricism: The problem of judging social and educational inquiry*. Norwood, NJ: Ablex.
- Steffe, L. P., & Kieren, T. (1994). Radical constructivism and mathematics education. *Journal for Research in Mathematics Education*, 25(6), 711–733.
- Taylan, R. D. (2015). *Characterizing a highly-accomplished teacher's instructional actions in response to students' mathematical thinking*. In K. Krainer & N. Vondrova (Eds.), *Proceedings of the Ninth Congress of European Society for Research in Mathematics Education* (pp. 3136–3143). Prague, Czech republic: CERME.
- Thompson, C. L., & Zeuli, J. S. (1999). The frame and the tapestry: Standards-based reform and professional development. In L. Darling-Hammond & G. Sykes (Eds.), *Teaching as the learning profession: Handbook for policy and practice* (pp. 341–375). San Francisco: Jossey Bass.
- Widodo, A., & Duit, R. (2004). Konstruktivistische sichten vom lehren und lernen und die praxis des physikunterrichts. *Zeitschrift für Didaktik der Naturwissenschaften*; (10), 233–255.
- Windschitl, M. (2002). Framing constructivism in practice as the negotiation of dilemmas: An analysis of the conceptual, pedagogical, cultural, and political challenges facing teachers. *Review of Educational Research*, 72(2), 131–175.

Noticing mathematical potential – A proposal for guiding teachers

Elisabet Mellroth¹ and Jesper Boesen²

¹Karlstad University, Department of Mathematics and Computer Science, Sweden;

elisabet.mellroth@kau.se

²Jönköping University, School of Education and Communication, Department of Education and Psychology, Sweden; jesper.boesen@ju.se

It has been shown to be problematic for teachers to use Krutetskii's definition of mathematical abilities to recognize mathematically highly able pupils (MHAPs). Aiming to concretize what teachers can notice in pupils' problem-solving processes, we connect a 10-year-old boy's problem-solving process to some of the abilities defined by Krutetskii. The results give clear descriptions of what teachers can observe in pupils' mathematical activities to notice their mathematical potential. We concretize, for example, how a pupil's abilities to grasp a problem's formal structure and to generalize can be observed. To be able to notice MHAPs, teachers need research-based support on how and what to observe in their pupils. Our proposed guide needs to be tested and validated to explore if it will help teachers to notice MHAPs and subsequently support their learning.

Keywords: Mathematical ability, highly able pupils, teachers.

Background

Schnell and Prediger (2017) have shown that teachers need the capacity to notice pupils' mathematical potential in order to support all pupils in their development. Mellroth, van Bommel, and Liljekvist (2019) have shown that this is a challenging task for teachers when it concerns highly able pupils. It is therefore important to give teachers research-based guidance on how to discover pupils who need more challenges than others, for example MHAPs. If a teacher does not notice these pupils and provide greater challenges for those who, for example, improve their skills quickly, the pupils "may slip into a stage of boredom" (Liljedahl, 2017, p. 1147).

Krutetskii's (1976) work on the mathematical abilities is, for many, still the seminal work on the nature of mathematical ability. However, using his ideas to notice pupils' mathematical potential poses significant difficulties for many teachers. This is shown by Mellroth, et al. (2019) in a study where teachers working in groups analysed pupils' potential to show, in their problem-solving processes, the abilities defined by Krutetskii. The following transcript of a discussion among three teachers (A, B, and C), shows some of the teachers' frustration:

1 B: So, we are supposed to use those and apply them to a problem we choose.

2 A: The words are pretty difficult.

3 C: This is harder, oh!

Teacher A reads aloud the Swedish translation of one of the abilities from Krutetskii's work.

4 B: Oh my God!

Primary teachers are the ones who first meet children in formal learning situations, and they should therefore be given the best support to notice pupils' mathematical potential. It is also these teachers' responsibility and duty to support and challenge all children. Teachers in primary school do not usually have deep knowledge in mathematics. It is, however, reasonable to argue that all teachers of young children want the best for their pupils and want to give them the challenges necessary for learning. To do this for pupils with high ability in mathematics, teachers need to be able to notice them (Shayshon, Gal, Tesler, & Ko, 2014).

The aim of this paper is to propose a structure to help primary teachers notice their pupils' mathematical potential. More precisely, through richer descriptions and commented examples from a pupil's problem-solving process, we concretize what teachers can notice as characteristic of mathematical high ability. In this paper we will present and describe the development of such an emerging structure, based on the seminal work of Krutetskii (1976). How well the structure works to improve teachers' observational skills remains for further studies to explore.

Krutetskii's way of describing mathematical ability

There are newer frameworks than Krutetskii's (1976) describing mathematical ability, such as those used by Schnell and Prediger (2017). It is, however, easy to ascertain that these frameworks are descendants of Krutetskii's (1976), so we have chosen to use the original framework, since it is unquestionably the most used in the research field of education for MHAPs.

Several researchers suggest that pupils should be active in problem-solving activities that are meaningful for them, in order for their teachers to be able to notice their mathematical potential (Krutetskii, 1976; Schnell & Prediger, 2017; Singer, Pelczer, & Voica, 2015). In particular, so-called rich problems fulfil many criteria known to be important for supporting and stimulating MHAPs by, for example, demanding higher order thinking (Sheffield, 2003). Therefore, when MHAPs work with rich problems, it can be assumed that they are participating in an activity that is meaningful for them.

In his work, Krutetskii (1976) describes mathematical abilities and categorises them into four groups. His four groups divide the components of mathematical ability in the following way (pp. 350-351): 1. Obtaining mathematical information; 2. Processing mathematical information; 3. Retaining mathematical information; and 4. General synthetic component. The first three groups proceed from basic stages in problem solving. The fourth, specified as a mathematical cast of mind, is a more general component that Krutetskii identified during his experiments. To fulfil the aim of this article, we here present and explain some of the mathematical abilities described by Krutetskii. Due to space limitations, we have chosen to focus on the abilities for which we can show clear evidence in one empirical case. This paper focuses on primary teachers. As the third component has been shown to be easier to observe in older students (Szabo & Andrews, 2017), we exclude it from this paper. The fourth component requires observation over a longer period of time (Krutetskii, 1976), so we also exclude also it. We describe here how the abilities chosen are interpreted in this paper.

1. Obtaining mathematical information

"1a. The ability for formalized perception of mathematical material, for grasping the formal structure of a problem" (Krutetskii, 1976, p. 350)

This is the ability to grasp the formal mathematical structure. Children with this ability want to understand the mathematical structure of the problem. They are not only interested in individual variables, but also in the relationships between different variables. Children with this ability have a need or desire to understand the mathematical structure of the problem and to discover relationships available to connect these relationships. Children who lack this ability often work unsystematically. They mainly utilize the mathematical connections they already know, even if the connection to the actual problem may be weak.

2. Processing mathematical information

The second group contains six subdomains, a-f; of these, a, b, d and f are accounted for below.

“2a. The ability for logical thought in the sphere of quantitative and spatial relationships, number and letter symbols; the ability to think in mathematical symbols” (Krutetskii, 1976, p. 350)

This is the ability to think logically and to understand mathematical symbols. Children with this ability think logically—for example, they easily identify a common principle in a series of numbers or pictures (Vilkomir & O’Donoghue, 2009)—and they have no problem understanding and working with mathematical symbols.

“2b. The ability for rapid and broad generalization of mathematical objects, relations, and operations” (Krutetskii, 1976, p 350)

The ability to generalize mathematically materials can be viewed in two ways: 1. The pupil can apply a known general concept to a specific case, that is, based on a known general concept, the pupil can propose a concrete case that applies in the given situation; 2. Based on a concrete case, the pupil can rapidly extrapolate to a general formula. Krutetskii makes a distinction between the pupil using an already-known generalization and deducing a new generalization. When using the term rapid, he is not primarily referring to time, but rather to the number of concrete examples a pupil needs before he or she can deduce or apply a general relationship (Krutetskii, 1976).

“2d. Flexibility of mental process in mathematical activity” (Krutetskii, 1976, p. 350)

This is the ability to have a flexible mind-set. Children with this ability are not limited by only using known methods. They do not necessarily try to apply a known method to the problem. The important thing for these children is the search for solutions, and they easily change strategies.

“2f. The ability for rapid and free reconstruction of the direction of a mental process, switching from a direct to a reverse train of thought (reversibility of the mental process in mathematical reasoning)” (Krutetskii, 1976, p. 350)

This is the ability to recognize and work with reverse problems. Children with this ability easily solve a reverse problem without any special instructions. They quickly identify it as the opposite of what they had just solved, and it is not difficult for them to switch between a direct and a reverse way of thinking. Given the equation $12/3=4$, an example of a reverse problem would be $4 \times 3 = 12$.

Method

For this paper, we use empirical data from a previous study (Mellroth, 2009). Data consists of audio recordings, field notes, and the pupil's written solutions from six 50-minute-long problem-solving sessions. During these meetings, the pupil worked with nine tasks, five of which were rich problems (Sheffield, 2003). Field notes and audio recordings were taken by one of the authors over a period of one semester. The pupil was a 10-year-old boy, "Marcus", in his fourth year at a public primary school. The sessions were carried out during school hours, at the school. Each session comprised either one or two tasks. Sessions were led by one of the authors, and only the pupil and the researcher were present during the sessions. The sessions had the following format: The task was introduced both orally and on paper, and the pupil was instructed to think aloud. In general, no specific feedback was given to the pupil during the sessions, but in some instances feedback of the following nature was given: "This isn't completely correct, can you try to explain it in a different way?" Sometimes encouraging statements, such as "you can continue in this way", were made. The pupil was chosen because his teacher had identified him as potentially highly able in mathematics. In addition, Marcus's problem-solving process clearly fulfils the criteria of MHAPs given by Krutetskii (1976), demonstrated below. Therefore, the case of Marcus is a good example that concretizes how teachers can notice mathematical potential. In advance of his participation, Marcus and his parents were informed about the study, the aim, and the methods, and the pseudonym Marcus was chosen by the boy. The study was performed following ethical recommendations for research.

Here we show results of the analysis for one problem, the flowerbed. Analysis was carried out in the following way: A) a holistic overview of the whole solution process was written down, B) each of Krutetskii's components (1, 2a-f, 3, and 4) was analysed separately, meaning that we sought examples of evidence for that specific component in the whole solution. This was repeated and discussed between the authors until we reached agreement. We first present the task, then Marcus's solution process, and finally how we interpret the abilities to be concretized in Marcus's solution process.

The Flowerbed

Dilan has a flowerbed. He wants to put paving stones around it. The flowerbed has four sides of the same length, each paving stone is the same size as the flowerbed (see left picture in Figure 1).

- 1) How many paving stones does Dilan need to be able to encircle the whole flowerbed?
- 2) Dilan decides that he want to have two flowerbeds next to each other and put paving stones around them in the same way (see right picture on in Figure 1).

How many paving stones are needed if he wants to have the following number of flowerbeds:

- 3) 10?
- 4) 30?
- 5) 90?
- 6) If Dilan has 50 paving stones, how many flowerbeds can they be used to encircle?
- 7) If he has 79 paving stones, how many flowerbeds can they be used to encircle?



Figure 1: The flowerbed with surrounding paving stones

In this problem, hands-on material can be used, but eventually it will become impossible, or very time consuming, to build or draw a solution. To be able to completely solve the problem, the pupil must work in a structured way and find a connection between the number of paving stones and flowerbeds.

Marcus's problem-solving process

Marcus very quickly grasped the structure of the flowerbed. After introduction of the problem, he immediately started to work on the solution; it was a rare quiet moment. However, he seldom did any writing, but he was thinking aloud and was encouraged to do so. His way of approaching the problems was similar in all the problem-solving sessions. The flowerbed consists of subtasks 1–7, and as soon as Marcus had finished one subtask, he was eager to continue with the next.

Holistic description of the solution process

When working with the problem, Marcus quickly gave correct answers on the first three subtasks. After answering the third subtask, he was asked to explain his thinking.

5 Marcus: Well, it is 10 flowerbeds, and 2 on each side, that equals 12, times 2, equals 24. Then there are also 2 on the edges, so 26.

The researcher continued to give Marcus subtasks 4 and 5, and he answered correctly and quickly, without making notes. Thereafter, subtask 6 was given. Marcus thought a little bit more, but less than three minutes. His answer, 24 flowerbeds, was incorrect. The researcher asked him to explain his thinking. At this point, there was an illustrating picture on the table (see left image in Figure 2).



Figure 2: Illustration of the problem, produced during the solution process

6 Marcus: First I took away those 2 [he points to the 2 dark grey side pieces in the middle image of Figure 2], then it is 48, then divide by 2, equals 24. So, 24 flowerbeds.

The correct answer is 22 flowerbeds. The researcher drew the image on the right in Figure 2 to show her thought process.

7 Researcher: It is possible to count backwards to check if the calculation is correct. Let's try.

The researcher explained her thought process to explore if Marcus was able to change his thinking. Marcus was convinced his solution was correct, but he followed willingly and without difficulty.

8 Researcher: I am thinking: Double the number of paving stones going out from the number of flowerbeds, then add 6, since it will always be 6 on the sides. Then we can check. If we have 24 flowerbeds, how many paving stones are needed? First we will have 2 rows of paving stones...

Marcus interrupts the researcher.

9 Marcus: It must be 22 flowerbeds.

The researcher and Marcus together checked the answer, based on his way of thinking, as shown in the middle image in Figure 2. The length of the rows with paving stones equals 22 plus 2, and two of

these is $2 \cdot 24 = 48$. Finally, add the 2 paving stones on the sides to get 50 in total. Correct. The allotted time for the problem-solving session was running out; only 5 minutes remained, and Marcus looked tired, so the researcher suggested ending the session. But Marcus noticed that one more subtask remained, number 7, and he wanted to also do it before he joined his regular class, which was on break. The researcher told him that only 5 minutes remained; Marcus replied,

10 Marcus: I can do it!

11 Marcus: 36 flowerbeds and 1 paving stone is left over.

12 Researcher: How did you get that?

13 Marcus: First I searched for something that was reasonable.

Marcus gave his answer after thinking for 2 minutes. In the discussion, he explained that he tried 31 and 34 flowerbeds and then concluded that it must be 36 flowerbeds and that one paving stone would be left over.

Interpretations of how the abilities are concretized

With the goal of concretizing for teachers how MHAPs may show some of the abilities defined by Krutetskii (1976), we here describe the process and criteria we used to tie Marcus's problem-solving process to specific abilities, as describes in the section about Krutetskii's abilities.

1a. The ability for formalized perception of mathematical ...

Marcus seemed to quickly grasp the problem statement, as is shown by his rapid and correct responses to the first three subtasks, where he did not explain how he came to the correct answer. However, when he explained his thinking—" Well, it is 10 flowerbeds, and 2 on each side, that equals 12, times 2, equals 24. Then there are also 2 on the edges, so 26" — he showed that he had grasped the mathematical structure of the problem.

What further strengthens the conclusion that he has an ability to see the mathematical structure is that he showed no signs of unsystematically searching for solutions, that is, he did not randomly guess.

2a. The ability for logical thought ...

In his solution there is no evidence of the use of mathematical symbols other than numbers and the word addition. What evidence for logical thought can be seen? We claim that his rapid answers in subtasks 1–3, together with the explanation in subtask 3, transcript row 5, shows evidence of logical deduction, as he identified a common principle from the two given figures. In addition, when the problem was turned around in subtask 6, where the number of paving stones is given instead of the number of flowerbeds, he had no difficulty understanding the problem. Furthermore, he also deduced, without hesitation, that there is a paving stone left over in subtask 7 (see transcript row 11).

2b. The ability for rapid and broad generalization ...

Marcus showed proof of this ability when he explained his thinking on subtask 3 (transcript row 5). On his own, he deduced a general way to solve the problem. Thereafter, through his work on subtasks 6 and 7, it can be deduced that he used the general solution proposed by the researcher (transcript row

8), that is, after a single case, he adapted the given generalisation to new cases (transcript rows 9, 11, and 13).

2d. Flexibility of mental process in mathematical activity

When Marcus rapidly adopted the alternative strategy the researcher suggested for arriving at the solution (transcript rows 8 and 9), he showed that he can easily change strategies.

2f. The ability for rapid and free reconstruction ...

Subtask 6 reverses the problem. First Marcus gave the wrong answer. However, when he described his thinking (transcript row 6), it became clear that he did understand the question and that he had a strategy to solve it. Therefore, we claim that he quickly identified the reverse problem.

Discussion and implications

We strongly believe that teachers can notice pupils' mathematical potential when they are supported by clear explanations in conjunction with examples of how MHAPs can show their mathematical abilities. We also argue that this is a matter of schools' responsibilities since MHAPs are present in most classes, pupils from homes with high socio-economic statuses will manage well, but MHAPs can origin from all homes, and hence it's important that the school as organization have knowledge on how to support these pupils. Using previous research as a basis, we have proposed rich descriptions and provided and commented on examples of a MHAP's problem-solving process." We have thereby concretized what teachers can pay attention to in their pupils' problem-solving processes in order to identify those who may be highly able in mathematics.

To continue the work begun in this paper, the next step is to conduct a study to explore if our descriptions—or ones similar to them—give teachers support in noticing MHAPs. We have designed and piloted a workshop with this aim. In it, teachers are asked to evaluate pupils' oral and/or written solutions, to note if they find indicators of a certain ability (based on those proposed by Krutetskii), and if they do find them, to rate how strong the indicators are. In addition, they are asked to grade, on a scale of 0 to 2, how easy it is to detect the ability based on the pupils' solutions. However, to show its value the workshop must be validated with a larger number of teachers.

To be able to notice MHAPs, teachers need support based on research. This support can be orchestrated, for example, through professional development programmes (Shayshon et al., 2014). Observing mathematical abilities by using Krutetskii's (1976) framework is likely not the only way teachers can notice MHAPs. For example, as Singer et al. (2015) wrote, allowing pupils to work with problem modification is also a suitable way to notice MHAPs, who generally work in a structured manner, changing one variable at a time to control how changes may affect the problem. The results reported by Singer et al. (2015) also provide important knowledge for teachers to use in their endeavours to notice MHAPs.

Naturally, the support teachers give to pupils after they have noticed their mathematical potential is important, for example to prevent boredom, which can be a result of too little challenge (Liljedahl, 2017). Of special importance is teachers' ability to notice and support mathematical potential in underprivileged pupils, for example those from disadvantaged socioeconomic backgrounds (Schnell & Prediger, 2017). One way for teachers to support the learning of all pupils, including MHAPs, is

to use rich problems (Nolte & Pamperien, 2017; Sheffield, 2003). Pupils have different learning needs; some require more help to understand a concept or problem, while others need complex tasks to develop their learning (Sheffield, 2003). It is therefore important that research is conducted with the aim of giving teachers support on how to differentiate teaching in the regular classroom. To develop pupils' learning according to their potential is, of course, the main goal of teaching. To do this for MHAPs, however, the first step is to help teachers notice them (Shayshon et al., 2014).

References

- Krutetskii, V. A. (1976). *The psychology of mathematical abilities in schoolchildren*. Chicago, IL: The University of Chicago Press.
- Liljedahl, P. (2017). On the edges of flow: Student engagement in problem solving. In T. Dooley & G. Gueudet (Eds.), *Proceedings of the Tenth Congress of the European Society for Research in Mathematics Education* (pp. 1146–1153). Dublin, Ireland: DCU and ERME.
- Mellroth, E. (2009). Hur man kan identifiera och stimulera barns matematiska förmågor [How to identify and challenge children's mathematical abilities]. (Master's thesis). Retrieved from DiVA <http://www.diva-portal.org/smash/get/diva2:224739/FULLTEXT01.pdf>
- Mellroth, E., van Bommel, J., & Liljekvist, Y. (2019). Elementary teachers on orchestrating teaching for mathematically highly able pupils. *The Mathematics Enthusiast*, 16(1–3), 127–154.
- Nolte, M., & Pamperien, K. (2017). Challenging problems in a regular classroom setting and in a special foster programme. *ZDM*, 49(1), 121–136.
- Schnell, S., & Prediger, S. (2017). Mathematics enrichment for all: Noticing and enhancing mathematical potentials of underprivileged students as an issue of equity. *Eurasia Journal of Mathematics, Science & Technology Education*, 13(1), 143–165.
- Shayshon, B., Gal, H., Tesler, B., & Ko, E. (2014). Teaching mathematically talented students: A cross-cultural study about their teachers' views. *Educational Studies in Mathematics*, 87(3), 409–438.
- Sheffield, L. J. (2003). *Extending the challenge in mathematics: Developing mathematical promise in K-8 students*. Thousand Oaks, CA: Corwin Press.
- Singer, F. M., Pelczer, I., & Voica, C. (2015). Problem posing: Students between driven creativity and mathematical failure. In K. Krainer & N. Vondrová (Eds.), *Proceedings of the Ninth Conference of the European Society for Research in Mathematics Education* (pp. 1073–1079). Prague, Czech Republic: Charles University in Prague, Faculty of Education and ERME.
- Szabo, A., & Andrews, P. (2017). Examining the interaction of mathematical abilities and mathematical memory: A study of problem-solving activity of high-achieving Swedish upper secondary students. *The Mathematics Enthusiast*, 14(1–3), 141–159.
- Vilkomir, T., & O'Donoghue, J. (2009). Using components of mathematical ability for initial development and identification of mathematically promising students. *International Journal of Mathematical Education in Science and Technology*, 40(2), 183–199.

The work of positioning students and content in mathematics teaching

Reidar Mosvold¹ and Raymond Bjuland²

¹University of Stavanger, Faculty of Arts and Education, Stavanger, Norway;

reidar.mosvold@uis.no

²University of Stavanger, Faculty of Arts and Education, Stavanger, Norway;

raymond.bjuland@uis.no

Whereas other studies have applied positioning theory to analyses of teaching and learning mathematics, this paper takes a practice-based approach to unpack what positioning in mathematics teaching might entail. From analysis of a shared video where a teacher leads a mathematical discussion of the naming of a fraction on the number line, we unpack the work of continually balancing attention to the mathematical content with positioning of students in their relation to each other, to the teacher, and to the mathematical content.

Keywords: Mathematics teaching, work of teaching, positioning, intentionality.

Introduction

There is agreement in the field of mathematics education that a special knowledge of mathematics is required to teach well. Numerous studies have investigated the nature and composition of this knowledge, how it can be developed and improved, and whether and how it influences student learning and the quality of teaching (Hoover, Mosvold, Ball, & Lai, 2016). Studies have investigated how much and what mathematical knowledge teachers need to know, what teachers should know, or what knowledge mathematics teachers use in teaching. Ball (2017) suggests that our field should shift attention from the mathematics teachers need to know towards the entailments of the special mathematical work of teaching. She thereby calls for more attention to the knowing and doing that is embedded in teaching. To illustrate what this might look like, she analyzes a record of practice where the teacher (Ball) calls on an African American girl to name a fraction on the number line and then facilitates a mathematical discussion around this. From her analysis, Ball (2017) identifies, names, and unpacks the special mathematical work of teaching. One aspect of this work is attending to positioning of students and their mathematical identities. In the present paper, we analyze the same data to further unpack what positioning might entail in mathematics teaching.

Conceptual background

The idea of positioning is not new. To position someone is to place them in a certain location or disposition, or to make a certain location or disposition available. Positioning can refer to placement of objects, but it can also refer to the relation, rank or standing of one person relative to another (Oxford English Dictionary). The latter is in focus here. Positioning theory has developed from social psychology and linguistics; social psychology contributes with theories of roles and subjectivity, whereas the idea of a discursive production of selves comes from linguistics (Davies & Harré, 1990). Positioning theory has been applied in mathematics education for some years, but the importation of the theory from one field to another is not void of challenges (Herbel-Eisenmann, Wagner, Johnson, Suh, & Figueras, 2015). We will examine some of these challenges in our concluding discussion.

In this paper, we have deliberately decided to start with analysis of practice rather than with theory, because we do not take it for granted that a theory developed to describe interpersonal relations in social psychology is relevant to studies of mathematics teaching. Our practice-based approach targets positioning in teaching, and three important assumptions underlie this approach. First, we consider teaching to be a professional practice. Describing a practice as professional implies some kind of consensus among professionals in terms of specifying the given practice. Currently, no such consensus exists, but we base our work on plausible conceptions of practice that practitioners might realistically agree about (Hoover, Mosvold, & Fauskanger, 2014). To this end, engaging in analysis of shared data of mathematics teaching is particularly promising. Second, we follow Ball (2017) when we describe teaching as “work”. This implies an emphasis on the effortful and dynamic nature of teaching. It also implies a shift in focus from characterizing teaching as actions of teachers to exploring the work that is to be done in teaching, and the entailments of this work. Third, we consider teaching to be instructional interactions between teacher and students around a particular content, within an environment (Cohen, Raudenbush, & Ball, 2003).

Data material and analytic approach

To explore positioning in mathematics teaching, we analyze one of the shared datasets that has been prepared for use in TWG19. This dataset shows a group of students (age 9–11), who have worked individually with a problem of naming fractions on a number line. Ball (2017) explains that the class has just shifted from naming fractions with area models to identifying fractions on the number line. The students have written their answers in their notebooks, and the teacher has been walking around, noticing the students’ range of ideas and explanations.

Based on our conception of teaching, our analysis is grounded in three basic questions: How does the teacher position particular students? How does the teacher position herself? How does the teacher position the mathematical content? When approaching these questions, we carefully consider instances of the teacher’s verbal as well as non-verbal communication that constitute evidence of positioning. We also ask about possible intentions behind making the identified positions available.

Analysis

As a first step in our analysis, we divided the video into thematic sequences. We identified six thematic sequences, and our analysis below is organized around these.

Sequence 1: Positioning Aniyah in the role of teacher

Teacher: (standing near the back of the room) Who would like to try to explain what you think the answer is? And show us your reasoning by coming up to the board? Who’d like to come up to the board and try to tell– And you know, it might not be right. That’s okay because we’re learning something new. I’d like someone to come up and sort of be the teacher and explain how you are thinking about it. Who’d like to try that this morning? (Several children raise their hands to volunteer.) Okay, Aniyah? (Aniyah, a Black girl, gets up from her seat and walks to the whiteboard at the front of the classroom.)

Before selecting Aniyah to come up, the teacher provides some important signals to the class. First, she signals that she is more interested in their explanations and reasoning than in their answer. To emphasize this characterization of the available position, she states that “it might not be right,” and that this is okay. Furthermore, she explains that the reason why it is okay to present an incorrect answer is that they are now in the process of learning something new, and they are therefore not expected to know this already. She thereby indicates that students can successfully participate in the discussion without having the correct answer. Second, she describes the available role as one in which a student is going to “be the teacher.” When a student is invited to take the role of teacher, this implies that the teacher will temporarily step out of this role herself.

Several students volunteer to present on the board, but the teacher decides to call on Aniyah. We assume that this is an intentional act. The teacher might have decided that Aniyah’s solution is mathematically useful for the learning trajectory of the class. Another possibility is that the teacher keeps an eye out for students who rarely present at the board. Another possibility is that the choice is related to Aniyah’s racial identity. Aniyah is one of 22 African American students in class, and the teacher might attempt to disrupt systemic patterns of racism and inequity by calling on her — as indicated by Ball (2017). The first possible reason for calling on Aniyah refers to the mathematical quality of her reasoning, the second refers to her identity and role in the class, whereas the third relates to pressing issues in the environment outside the class. Balancing consideration for all three aspects is a challenge that is embedded in the mathematical work of teaching.

Sequence 2: Positioning students in relation to social norms of presenting mathematical ideas

- Teacher: When someone’s presenting at the board, what should you be doing?
- Students: Looking at them.
- Teacher: Looking at that person—uh-huh.
- Aniyah: (to the teacher) You want me to write it?
- Teacher: (to Aniyah) You’re trying to mark what you think this number is and explain how you figured it out. (to class) Listen closely and see what you think about her reasoning and her answer. (Teacher moves to back of the classroom; Aniyah is in front at the whiteboard. Aniyah writes $1/7$ by the orange line).

In this second sequence, the teacher provides two additional signals about the norms of participation when someone is presenting at the board. The teacher first emphasizes that the students should always look at whoever is presenting. Understanding what others say in a discussion is necessary to productively contribute, and the other students have to pay careful attention to Aniyah’s presentation in order to understand her thinking. Paying attention without looking is hard. The students seem to know how to behave when someone presents, but the teacher’s question emphasizes this norm of participation. After telling Aniyah what to do, the teacher asks the class to listen and see what they think about Aniyah’s reasoning and answer. This explicit emphasis on the norms of participation signals a certain position that the students should take while interacting with each other, but it also signals a positioning of the students in relation to the mathematical content. The students in class are directed to take a position of someone who listens carefully to make sure they understand Aniyah’s

reasoning, and they are asked to critically consider what they think about the reasoning as well as the answer. This position is different from a more traditional pattern in recitation, where the students answer the teacher's question and then receive feedback.

Sequence 3: Positioning Toni by praising her question

- Aniyah: I put one-seventh because there's—
- Toni: Did she say one-seventh? (An African American girl, sitting close to where Aniyah is standing, asks quietly, almost to herself)
- Aniyah: Yeah (Hearing her question, Aniyah turns toward her and nods). Because there's seven equal parts, like one, two, three, four, five, six, and then seven (Demonstrates using her fingers spread to measure the intervals to count the parts on the number line).
- Teacher: (still standing at the back, addresses the class) Before you agree or disagree, I want you to ask questions if there's something you don't understand about what she did. No agreeing and disagreeing. Just—all you can do right now is ask Aniyah questions. Who has a question for her? Okay, Toni, what's your question for her?
- Toni: Why did — (looks across at children opposite her and laughs, twisting her braid on top of her head)
- Teacher: (to Toni) Go ahead, it's your turn.
- Toni: (to Aniyah) Why did you pick one-seventh? (Toni giggles, twisting her braid.)
- Dante: (laughing across the room at Toni) You did not!
- Teacher: Let's listen to her answer now. (to Toni) That was a very good question. (to Aniyah) Can you show us again how you figured that— why you decided one-seventh?
- Aniyah: First, I thought it might be seven because there's seven equal parts.
- Teacher: Did you write one-seventh? I can't see very well from here.
- Aniyah: Uh-huh. Yes.

This is the crux of the episode, and there are at least three decisive moments that require careful balancing of considerations for the interactions between students and with the mathematical content.

First, there is the moment when Toni interrupts with her first question. With a low voice, she asks: "Did she say one-seventh?" The teacher could have decided to tell Toni to be quiet when someone else is presenting. Instead, she decides to wait. By doing that, the teacher gives Aniyah the necessary space to stay in the role of a teacher and respond to Toni's question. We notice how Toni's question triggers Aniyah to continue her reasoning and show how the unit interval must be partitioned in equal parts by using her fingers spread to measure the intervals to count the parts on the number line.

Second, we notice how and when the teacher decides to interact. After Aniyah has given her explanation in response to Toni's first question, the teacher remains in the back of the classroom. This highlights her intention to remain in the role of facilitator, and thereby maintains the positioning

of Aniyah as the teacher. The teacher positions the children to participate in the discussion, establishing an open atmosphere by guiding the children to pose clarifying questions and not agree or disagree in this initial phase of the discussion. She also limits the space of acceptable interactions to maintain the positioning of students in relation to the mathematical content that we described above. After having reminded the children about the social norms and rules, the teacher encourages Toni to pose her question to Aniyah. By allowing Toni to pose her question instead of rebuking her for interrupting Aniyah, the teacher allows Toni to take the role of a productive contributor in the mathematical discussion that is unfolding.

Third, it is interesting to notice how the teacher reacts to Toni's question. She could have commented on Toni's laughter and pointing, and thereby positioned her as disrupting the discussion. Instead, the teacher praises her question. This decision influences the ongoing positioning of Toni. Her question is seen as an important mathematical question, and the teacher's move emphasizes the importance of asking questions in mathematics, which represents an indirect positioning of the mathematics. By repeating and rephrasing it to Aniyah, the teacher also puts Aniyah in a position to further develop her explanation. The teacher's question — "Can you show us again?" — indicates that she wants Aniyah to relate her answer to the figure on the board. Aniyah repeats that there are seven equal parts, illustrating the distance from zero for a given point on the number line.

Sequence 4: Positioning of Lakeya and repositioning of Aniyah

Teacher: (The teacher nods affirmatively, and turns to the class) Okay, any more questions for Aniyah? In a moment, we're going to talk about what you think about her answer, but first, are there any more questions where you're not sure what she said, or you'd like to hear it again or something like that? Lakeya?

Lakeya: (looks back at the teacher at the back of the room) If you start at the—

Teacher: (gestures toward Aniyah) Talk to her, please.

Lakeya: Oh! (turns toward Aniyah) If you start at the zero, how did you get one seventh?

Aniyah: Well, I wasn't sure it was one-seventh, but first, I thought that the seven equal parts.

The teacher then refrains from evaluating Aniyah's explanation and thereby enables Aniyah to stay in the role of teacher. The teacher clarifies that they will soon discuss Aniyah's answer, but encourages more children to participate by posing clarifying questions. This comment indicates that understanding an argument is crucial in mathematics, and it thereby positions the mathematics in the discussion. This gives Lakeya an opportunity to ask a question and contribute to the discussion. We notice how the positioning of Lakeya also constitutes a repositioning of Aniyah. By asking Lakeya to address Aniyah and not herself, the teacher affirms Aniyah's position as teacher in this context. The teacher gives Aniyah the responsibility and agency, and Aniyah gets the opportunity to explain her thinking again.

In this sequence, the teacher could have commented that Toni has just asked a similar question, or that Aniyah has already explained this. Instead, the teacher appears to notice a difference in the questions of Toni and Lakeya. Toni asked why Aniyah picked "one SEVENTH", which indicates an emphasis on the whole. Lakeya asked how she got "ONE seventh", indicating a focus on the parts.

By deciding to let Aniyah respond, the teacher enables Lakeya to remain in the position of a productive contributor to the discussion, and she allows Aniyah to stay in the role as a teacher. Again, we see how the positioning of one student constitutes a repositioning of another, and we see how the teacher is challenged to balance attention to the positioning of students with attention to the content.

Sequence 5: Balancing positioning of Dante and Aniyah

Teacher: Okay, would some— You'd like to ask another question, Dante?

Dante: Yeah.

Teacher: Yes, what?

Dante: So, if it's at the zero, how did you know that if like if I took it and put it at the— Hold on. Which line is— What if it didn't like— What if the orange line wasn't there, and you had to put it where the one is? What if the orange line wasn't there? And how would you still know it was one-seventh to put it where the orange line is now?

Aniyah: (pauses) I don't know.

Teacher: (pauses) Okay. Does everyone understand how Aniyah was thinking?

Students: Yes.

Following Aniyah's response to Lakeya, Dante is given the opportunity to contribute. We observe that Dante relates Aniyah's answer to the orange line in the figure. His three repeated "What if"-statements indicate that Dante not only asks questions, but he also attempts to make sense of Aniyah's answer and extend their mathematical thinking about the mathematical content. Aniyah does not know how to answer Dante's questions. The teacher could have decided to praise Dante's contribution, but this might have been interpreted as a repositioning of Aniyah. When she decides not to comment, she gives both Dante and Aniyah the opportunity to remain in their positions as contributors to the discussion. When the teacher asks if they now understand Aniyah's thinking, this again represents positioning of the mathematics by emphasizing understanding of an argument, and by indicating that mathematics is the collective thinking of people. The supportive response from the class might be interpreted to indicate that Dante has made his classmates aware of the connection between Aniyah's answer one-seventh and the position on the number line. The response from the class might thus serve as an implicit positioning of Dante. The positioning of Dante could also involve a repositioning of Aniyah, indicating that her idea and explanation could be a starting point for a more focused discussion that follows.

Sequence 6: Positioning of Aniyah by allowing her to stay or going out of the role as teacher

Teacher: Yes? Okay. (to Aniyah) You can sit down now. We're going to try to get people to comment. Do you want to take comments up there? Would you like to stand there and take the comments, or do you want to sit down and listen to the discussion? What would you prefer?

Aniyah: Sit down.

Teacher: Sit— You'd like to sit down? Okay.

In this last sequence, the teacher decides to not simply ask Aniyah to sit down. Instead, she gives Aniyah the choice to stay in her role as a teacher and take comments from the board, or to sit down and listen to the discussion. This choice might be seen as an implicit positioning of Aniyah.

Concluding discussion

Earlier in our paper, we mentioned how it might be challenging to import positioning theory for use in mathematics education (Herbel-Eisenmann et al., 2015), and how we deliberately decided to avoid using this theory and take a practice-based approach instead. We will now make two points that elaborate on some of these challenges and point to some potential contributions of our analysis. The first point relates to how positioning in mathematics teaching involves a careful balancing of multiple considerations regarding the interaction between students and teacher around a particular content. The second relates to the challenges of identifying positionings in analysis of teaching.

Whereas studies that use positioning theory in mathematics education tend to investigate how positionings might influence the development of students' mathematical identities (Herbel-Eisenmann et al., 2015), our analysis has identified various challenges that might be involved in the work of positioning students and the mathematical content. Our analysis indicates that positioning is tightly integrated with teaching. Teaching can be seen as interactions between teacher and students around a particular content with an ever-present influence with the environment (Cohen et al., 2003), and positioning in teaching is tightly connected with these instructional interactions. The challenges of positioning in mathematics teaching is thus rarely about singular and easily identifiable positionings. Positioning of one student tends to imply repositioning of another. The teacher is often challenged to make quick decisions that influence positioning of students, while simultaneously balancing this with careful attention to the mathematical content. In positioning the students — both in relation to each other, to the teacher, and to the mathematical content — the teacher has to balance multiple considerations. We suggest that the complexity of this balancing is at the heart of the work of teaching; this balancing defines the work that has to be done by the teacher. When the teacher invited Aniyah to present her thinking at the board, she had to navigate concerns for Aniyah and her developing mathematical identity, the development of other students, and to the class as a whole. At the same time, the teacher had to make decisions about her own position and how to lead the mathematical discussion without removing Aniyah from her position, and without placing any of the students in a negative position. The teacher also had to balance the positioning of the students and herself in relation to the students while paying careful attention to the mathematical content being discussed, and she had to make decisions about how to position the students and herself in relation to the mathematical content. We observe how establishing and maintaining norms of participation played an important role here, and we suggest that establishing and maintaining norms is also a deliberate and challenging work that is tightly related to positioning in teaching.

In their discussion of how positioning theory has been used in mathematics education, Herbel-Eisenmann et al. (2015) also notice how positionings tend to be identified in a singular way. Although the focus of our study was not on identifying positionings, but rather to unpack some of the challenges of positioning in mathematics teaching, our analysis indicates that the identification of positionings in mathematics teaching is complex. As observers, we rarely know for sure how a teacher intended

to position students in a particular moment of interaction, and we rarely know how students experienced being positioned. For instance, Aniyah might have experienced being positioned by the teacher in a way that differs from what the teacher's intentions were, and Dante, Lakeya, and Toni might have yet other interpretations of how Aniyah was positioned. In addition, the students are positioned (or experienced being positioned) in relation to the teacher, to each other, and to the mathematical content.

In her discussion of the special mathematical work of teaching, Ball (2017) identified positioning as an integral part of this work. In the present paper, we have further unpacked entailments of positioning in mathematics teaching, with a particular emphasis on the challenges of balancing positioning of students while at the same time retaining careful attention to the mathematical content. Although we have only analyzed one example of a slice of the mathematical work of teaching, we suggest that this balancing of positioning students in relation to the mathematical content is at the core of mathematics teaching. However, further studies are needed to investigate what this balancing might entail in different parts of the work of teaching, with different content, and at different grade levels. Further efforts are also needed to investigate ways of studying the intentionality and interpretation that is involved in this work.

References

- Ball, D. L. (2000). Bridging practices: Intertwining content and pedagogy in teaching and learning to teach. *Journal of Teacher Education*, 51(3), 241–247.
- Ball, D. L. (2017). Uncovering the special mathematical work of teaching. In G. Kaiser (Ed.), *Proceedings of the 13th International Congress on Mathematical Education* (pp. 11–34). Springer.
- Cohen, D. K., Raudenbush, S. W., & Ball, D. L. (2003). Resources, instruction, and research. *Educational Evaluation and Policy Analysis*, 25(2), 119–142.
- Davies, B., & Harré, R. (1990). Positioning: The discursive positioning of selves. *Journal for the Theory of Social Behaviour*, 20, 43–63.
- Herbel-Eisenmann, B. A., Wagner, D., Johnson, K. R., Suh, H., & Figueras, H. (2015). Positioning in mathematics education: Revelations on an imported theory. *Educational Studies in Mathematics*, 89(2), 185–204.
- Hoover, M., Mosvold, R., Ball, D. L., & Lai, Y. (2016). Making progress on mathematical knowledge for teaching. *The Mathematics Enthusiast*, 13(1–2), 3–34.
- Hoover, M., Mosvold, R., & Fauskanger, J. (2014). Common tasks of teaching as a resource for measuring professional content knowledge internationally. *Nordic Studies in Mathematics Education*, 19(3–4), 7–20.

Evolving discourse of practices for quality teaching in secondary school mathematics

Talli Nachlieli, Yishay Mor, Einat Gil and Yael Kashtan

Levinsky College of Education, Israel;

tallin@levinsky.ac.il, yishay.mor@levinsky.ac.il, einat.gil@levinsky.ac.il, kyael@levinsky.ac.il

This paper presents initial findings from the project PRAQTAL: PRActices for Quality Teaching. Our project focuses on conceptualizing and identifying teaching practices for quality teaching of secondary school mathematics and physics. This work is driven by the understanding that to document, conceptualize, analyze and promote quality teaching, we need to constitute a discourse which articulates the diverse practices of teachers, in their multiple resolutions, and link them to educational theories on one hand and specific instruments on the other. For this purpose, we adopted Commognition as a conceptual framework. Here, we present our working definition of a teaching practice and our criteria for quality teaching practices. We discuss the procedures for identifying and documenting practices and their representation and illustrate our arguments with an example from the project's emerging database.

Keywords: Teaching practices, quality teaching, routines, secondary school mathematics.

Introduction

This paper presents initial findings from project PRAQTAL: PRActices for Quality Teaching. PRAQTAL focuses on conceptualizing and identifying practices for quality teaching of secondary school mathematics and physics. Why focus on teaching practices? Our team arrived at the need to explicate practice from two seemingly distinct paths: the first coming from an attempt to improve a teacher-education program from more “reflective” and “principles” based towards “practice” based. We noticed that the task of shifting the preservice teachers’ traditional-teacher-centered approach towards more reform-student-centered approach (Gregg, 1995) calls for explicit discussion and explication of practices. The second path originated in a series of projects aimed at promoting innovative and effective use of technologies in mathematics education. One of the core observations of these projects was the gap between theories of teaching and learning, and the actions practitioners took in the classroom. Following the traditions of educational design research (Mor & Winters, 2007) and learning design (Mor, Craft & Hernández-Leo, 2013), these projects identified this gap with a need for articulating and sharing design knowledge: the knowledge of solving practical challenges, or affecting change, by translating abstract theory into action, and explaining action by reference to theory. The initial account of practitioner experience was expressed in the form of design narratives. The derived design knowledge was captured in design patterns (Warburton & Mor, 2015): statements of the form “in context X, you are likely to encounter the challenge Y, and can address it using method Z”. The aim of the pedagogical design patterns community is to use this structure to articulate and share valuable elements of educational practice.

Teaching practices

The need to explicate practice, specifically for promoting teaching programs, resulted in the flourishing of many projects that aim at identifying and teaching teaching-practices (Grossman, 2018). Some projects were content specific, some focus on specific grade levels, others are general, but most grew from the needs of training programs for preparing teachers to practice. A prime example is the University of Michigan *Teaching Works* project (<http://www.teachingworks.org/>) that identified a set of high-leverage instructional practices to prepare beginning teachers “who are skillful at connecting with and helping their students develop.” Several additional projects are discussed in Grossman’s book *Teaching core practices in teacher education* (2018). McDonald et al. (2013) identify a major shift in teacher training: from a focus on the knowledge required for teaching to a greater attention to the core practices of teaching. This move towards core practices, argue McDonald et al, reflects an attempt to connect the development of knowledge of teaching with the capacity to enact this knowledge in the classroom. McDonald et al. review the shifts in pedagogical approaches in teacher training over the last half century, corresponding to the change in dominant perspective on teaching and learning. From an “acquisition” model of learning, to “participationist” model of learning. However, Grossman and McDonald (2008) warn us that the field of research on teaching lacks a structured method and vocabulary for describing, analysing, evaluating and improving practices of teaching.

Various definitions are offered for teaching-practices. One such definition is offered by Windschitl (2016), who defines teaching practices as the recurring professional work devoted to planning, enacting and reflecting on instruction. This definition emphasizes the role of teaching practices prior, during and after instruction in class. According to Windschitl, the purpose of teaching practices is to overcome the divide between teacher instruction and student learning. The CPC group (Core Practices Consortium) whose aim is to develop shared understanding and common language regarding what it takes to prepare teachers for practice, to improve learning opportunities available to all students. They have identified characteristics that most sets of core-practices adhere to: (1) high frequency in teaching; (2) practices that teachers can enact in classroom across different curricula or instructional approach; (3) practices that allow teachers to learn more about students and about teaching; (4) practices that preserve the integrity and complexity of teaching; and (5) practices that are research-based and have the potential to improve student achievement (Grossman, Hammerness and McDonald, 2009).

Lampert (2010) addresses the difference between teaching practices and the practice of teaching. The practice of teaching involves adopting the identity of a teacher, doing what teachers do and believing what teachers believe in. This raises the question whether a practice can be learned in isolation or whether it requires participation in collective activity.

For the purpose of our project we need a working definition of teaching-practice and quality teaching-practice. To this end, we adopt the socio-cultural commognitive conceptual framework that conceptualizes mathematics (and any other discipline) as a special type of communication or discourse, including unique ways of saying and doing (Sfard, 2008), and learning mathematics as changes in the learner’s mathematics discourse. Adopting the commognitive conceptual framework,

we identify teaching-practice with a teaching-routine. Let us explain: according to our initial understanding, teaching practice is *a recognizable pattern of actions used by teachers in a given context to achieve specified aims*. This definition includes three constituents: pattern of action, context and aims. By the term “pattern of actions” we refer to actions that are repeated in situations that the performer would consider as similar. The assignment of a practice to a given context is crucial. Practices are inherently situated in material, social and intentional environments, and only make sense within these environments. Finally, practices are not arbitrary, they serve a goal. Identifying practices with routines will address those three requirements. Following Lavie, Steiner and Sfard (2019), we define a teaching-practice similar to their definition of routines: *the task the teacher saw herself performing together with the procedure she executed to perform the task* (p. 161). Such task could be *having to address a student's idea that she had not thought of earlier, or eliciting students' thinking*.

Thus, our goals in project PRAQTAL are to identify typical, interesting or challenging tasks that the teachers set themselves before, during and after a lesson, and possible related teaching-practices. That is, for each task we identify the various procedures that teachers chose to execute to perform the task. The plurality is used here to denote that our point of departure is that for each task, different teachers may consider different procedures to perform.

The advantage of this definition is that a task and therefore also a routine are recursive structures: a task could be parted to sub-tasks and a routine to sub-routines. This recursive structure is apparent in Table 1. This conceptualization of teaching-practices allows us to view teaching from different “zoom-ins” or different granularities: the highest level (left-most column in Table 1) provides us with the rationale for everything that takes place in class. This is apparent with the highest meta-level of “providing students opportunity to become explorative participants in the mathematics discourse”. At the other end, the *procedure* and *empirical example* (two right-most columns of Table 1), provide us detailed steps to follow and perform, with different levels of sub-tasks in between. This relates to one of the issues with which we were concerned early on - the question of the “granularity” of practices: is “pausing for 5 seconds after asking a question” a teaching practice? Is “leading a classroom discussion” one? The first seems too miniscule, the second too expansive. The answer we found is that practices are networked in a fractal manner (as alluded to in the project name): they are spread across a continuous space with granularity on one axis and generality on the other. Complex practices are composed of other smaller-size practices. This granularity is apparent by Table 1. So “pausing for 5 seconds...” could be written in the procedure column of Table 1 as a part of procedure for performing a “larger size” task, such as “eliciting students' thinking”.

Quality teaching and quality teaching-practices

Now we are left with the task of defining what counts as a quality teaching-practice (QTP). Defining mathematics as a specific type of discourse with unique ways of saying and doing, and learning mathematics as becoming more central participants in the mathematics discourse (Sfard, 2008), makes itself evident that QTP will be those that are most likely to prompt and support learners in participating in this discourse. Specifically, in the lessons we observed in our study and in literature, we identified three meta-tasks (or principles) that seem to underlay today's thinking

about mathematics teaching and seem to be shared by all mathematics teachers: (1) Provide students opportunities to become central participants in mathematics discourse; (2) Help students to develop a positive identity as mathematics learners; and (3) Encourage students to participate in equitable, egalitarian mathematical discourse. Therefore, our definition for quality-teaching-practice is *a teaching-practice that a teacher would perform that is aligned with the above three meta-tasks*. By the words “aligned with” we mean that the QTP supports at least two of those tasks, and does not violate any of those tasks.

Sourcing, Documenting and Representing Practices

Having considered the definition of a QTP, we set out to identify and articulate such objects. In this section we explain how we identify teaching-practices. Our identification of a teaching-practice includes identifying typical, challenging or interesting tasks that the teacher saw herself as having to perform, and then identifying various procedures that could be enacted to perform the task. Our two primary sources of data are video recordings of secondary-school mathematics lessons taught by expert-teachers, and literature. Each video-taped lesson is fully transcribed, and subtitles are added to the video. We also have video-taped discussions with the teachers about the lesson before and after the lesson, written documents about the lesson (such as the teacher’s lesson plan) and access to the teacher for any questions that we have during our analysis of the lesson. This is highly required as our analysis, which is based on identifying the tasks that the teacher considered herself facing when choosing to perform certain actions, is interpretative in nature. Having the teachers react to our findings allow us to learn more about teaching practices that often remain implicit.

For each video-taped lesson, we focus on the teaching-actions performed by the teacher and ask: *what is the task that the teacher may achieve by those actions?* We return to the teachers and discuss our suggestions with them. We then ask whether the teaching-practice, that is, the task and the related procedure, supports at least two of the three meta-tasks defined earlier and does not violate any of them. If we find that the teaching-practice is repeated, either in a specific lesson or across different lessons, or if we find similar teaching-actions reported upon in the literature, we designate it as a candidate for quality-teaching-practice. We use Table 1 as our primary working-tool. In Table 1, the leftmost “meta-task” column is fixed, and includes the three meta-tasks described earlier (in Table 1 we only present the first of the three meta-tasks in the sake of brevity). The other columns become more and more fixed as we continue with our analysis. Rubrics in the two right-most columns keep adding as we analyze lessons. We document the performed action(s) found in the analyzed lessons in the “empirical example” column of Table 1 and list the various tasks and sub-tasks that a teacher performing these actions could be facing.

To clarify our methodology, an example from a 90-minute lesson on complex-numbers is demonstrated next. The lesson was taught in an advanced 12th grade mathematics classroom in an Israeli high-school. This lesson was the first on this topic. Before focusing on the specific example, we describe the lesson’s thematic structure: In this lesson the teacher faced the challenge of teaching a new mathematical object, a set of numbers that the students are not yet familiar with – the complex numbers. Her choice was to follow the idea that ontogenetic processes often follow phylogenetic ones, and walk her students through the historical development of those numbers, in

four steps: (1) realize that as long as you only have real numbers, there is a no such thing as square root from negative number, (2) conclude that a 3rd power polynomial has at least one root. (3) introduce the students to the suggestion of Girolamo Cardano which led to mathematics results including square roots of negative numbers, and then Rafael Bombeli's suggestion of determining such entities as mathematics objects – numbers. (4) Show that the new entity “complex number” is a number by showing that it has similar attributes as the corresponding operations on rational and real numbers. Our example focuses solely on this fourth section, during which the following discussion took place [timestamp 57:50]:

- Teacher ... so I see that this addition has different characteristics that are... the existence of a neutral element in addition
- Student but why do we need this?
- Teacher To know the structure. I want to convince you that this structure of the complex-numbers justifies the name “numbers”. Ok, why do I call these numbers? In what sense are those numbers? I want to convince you that this behaves similarly to real numbers regarding operations.

In this short excerpt, we find a student's interesting question “why do we need this?” This question is interesting as it seemed from the video that the student was not having a difficulty with the mathematics procedures that the students and teacher were performing neither was she trying to say that “she is not interested”, or that “she does not want to study”. It seemed that she was trying to make sense of the reasons for which the teacher was showing that the set of complex numbers have different specific characteristics (thus – proving that it is a field). The teacher's answer addresses the three meta-tasks: (1) *Provide students opportunities to become participants in mathematics discourse*: in mathematical discourse, when an object is introduced by expanding a familiar class (category), it is imperative to check its properties against the definition of the class to which it is supposed to belong, or by considering its characteristics (the object of *number* is not well defined in mathematics). More generally, when a new object is introduced or when an object is identified, this identification should adhere to the conditions of a mathematical definition. As was found in various studies, this is not a simple endeavor, and therefore requires explicit teaching:

The discursive activity of defining seems to be pushed aside by our strong tendency to use words in a direct, unmediated manner, without accounting for this use and without monitoring its appropriateness. This inclination for unmediated, spontaneous use of words is the basic characteristic of human communication. In schools, one's spontaneous uses of words are supposed to be translated into scientific. For this modification to happen, the students will have to learn to suspend their spontaneous discursive decisions for the sake of reflective, meta-discursively mediated choices of words. This, as was already observed, is a difficult thing to learn (Nachlieli & Sfard, 2003. pp. 3-355–3-356).

(2) *Enable students to develop a positive identity as mathematics learners*: the teacher's answer explicates her encouragement of students' questions, of seeing the students as capable of participating in a challenging mathematics discussion.

(3) *Encourage students to participate in egalitarian mathematical discourse:* In the classroom, when a teacher introduces an object, students often accept it as belonging to that class/category. It is as if they accept the teacher as the primary authority. In this example the teacher encourages her students to break away from the ritual participation of accepting a “truth” because it was stated by the teacher, and leads them to an empowered, explorative participation, where they identify objects by reference to a definition. This is apparent through the words “I want to convince you” – the teacher stresses that she needs to do the work of convincing the students, that she does not expect them to just accept whatever she tells them. She does not place herself as the primary authority.

The QTP that we elicited from this excerpt, based also on literature (e.g. Sfard & Nachlieli, 2003), includes the following task and practice:

Task. When the teacher faces the task of introducing new objects, or of expanding a familiar class (category), the new object needs to be identified by checking its properties against the definition of the class, or by considering its characteristics.

Procedure.

1. The teacher raises the question, or invites the students to raise the question, or addresses the question if arises: is this object compliant with the definition of the base class?
2. The teacher guides the students in independent verification of the new object against the conditions of the definition.
3. The teacher ascertains that the students continue to work with the object as compliant with the definition.

Meta-task	Task	Sub-task	Procedure	Empirical example
1. The task of providing students opportunity to become explorative participants in the mathematics discourse	1.1 modeling explorative mathematics discourse 1.2 inviting students to participate in explorative math discourse	1.1.1 modeling objectified mathematics discourse	When introducing a new object that belongs to a familiar class, the teacher explicates the need to check whether this object compliant with the definition of the base class, see steps 1-3 in the procedure as described above.	"I want to convince you that this structure of the complex-numbers justifies the name "numbers"." Following, the teacher and students prove that the set of complex numbers are a field.

Table 1: Recursive structure of a teaching-practice

The design of a practice

The mission of the PRAQTAL project is not just to identify and document quality teaching practices, but also to make those available to pre- and in-service teachers. For this purpose, we

develop an accessible presentation of practices which is communicative and appealing to practitioners.

On our website, we present practices as tri-partite structure, described in Diagram 1.

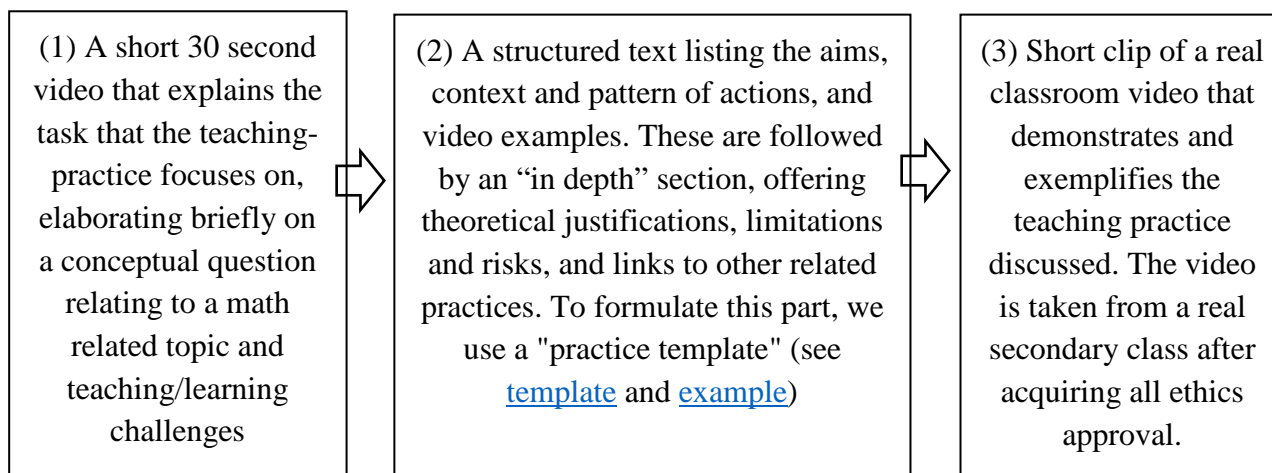


Diagram 1: The tri-partite structure of a teaching practice

Discussion

In this paper we presented the initial work of project PRAQTAL. We began this account with our personal paths into the domain of teaching practices, and noted how these resonated with a general trend in educational research and teacher training. Most of the work in the field focuses on deriving practice recommendations from theoretical frameworks and developing teacher training programs based on these. Our approach was to first move beyond the intuitive treatment of the core concepts, and systematically define the constructs of *teaching-practice* and *quality-teaching-practice*, based on the commognitive conceptual framework. We adopt commognition for three main purposes: (1) for the conceptualization of our basic terms, such as: “practice” and “quality teaching practice”, (2) to develop a methodology for discourse analysis of transcripts of mathematics lessons that helps us identify teaching practices, and (3) findings from commognitive studies serve as main literature from which we identify possible teaching practices that we then look for empirically (an example is teaching practices that promote meta-level learning, a commognitive idea that we continue to develop in the field of teaching practices. This is beyond the scope of this paper). On these foundations, we proceeded to formulate a methodology for sourcing, articulating and communicating practices. Our methodology blends discourse analysis and design based traditions in mathematics education research, and the standard of quality stems from a commognitive framework. We illustrate this methodology through an example. At this stage, we have the building blocks for a combined scientific and pragmatic inquiry into the teaching practices of mathematics. The next steps are to build an extensive language of practices, validated empirically and theoretically, and map the connections between them. In parallel, we will develop our framework for practices-oriented teacher training. True to our constructivism roots, we reject the urge to “deliver knowledge of practices” to teachers and teachers in training, and instead aim to base our offering on co-construction and critical discussion of representations of practices. We invite the community to join us in these endeavours.

Acknowledgement

The PRAQTAL project reported in this study is supported by the Trump foundation, grant number 235. The ideas voiced in the paper are a result of discussions among PRAQTAL team which include the authors and Roni Mualem, Avital Elbaum-Cohen and Sara Haupt, and the advisors: Anna Sfard and Shulamit Kapon.

References

- Gregg, J. (1995). The tensions and contradictions of the school mathematics tradition. *Journal for Research in Mathematics Education*, 26, 442–466.
- Grossman, P. (2018). *Teaching Core Practices in Teacher Education*. Cambridge, MA: Harvard Education Press.
- Grossman, P., Hammerness, K., & McDonald, M. (2009). Redefining teaching, re-imagining teacher education. *Teachers and Teaching: theory and practice*, 15(2), 273–289.
- Lampert, M. (2010). Learning teaching in, from, and for practice: What do we mean? *Journal of Teacher Education*, 61(1-2), 21–34.
- Lavie, I., Steiner, A., & Sfard, A. (2019). Routines we live by: from ritual to exploration. *Educational Studies in Mathematics*, 101, 153–176.
- McDonald, M., Kazemi, E., & Kavanagh, S. S. (2013). Core practices and pedagogies of teacher education a call for a common language and collective activity. *Journal of Teacher Education* 64(5), 378–386.
- Mor, Y., Craft, B., & Hernández-Leo, D. (2013). Editorial: The art and science of learning design. *Research in Learning Technology*, 21, 1–8.
- Mor, Y., & Winters, N. (2007). Design approaches in technology enhanced learning. *Interactive Learning Environments*, 15, 61–75.
- Nachlieli, T., & Sfard, A. (2003). The activity of defining. In N. A. Pateman, B. J. Dougherty & J. Zilliox (Eds.), *Proceedings of the 27th Conference of the International group for the Psychology of Mathematics Education* (Vol. 3, pp. 3-349–3-356). Honolulu, Hawaii.
- Sfard, A. (2008). *Thinking as communicating: Human development, the growth of discourses, and mathematizing*. Cambridge: Cambridge University Press.
- Sfard A., & Lavie, I. (2005). Why cannot children see as the same what grown-ups cannot see as different? Early numerical thinking revisited. *Cognition and Instruction*, 23(2), 237–309.
- Warburton, S., & Mor, Y. (2015). Double Loop Design: Configuring Narratives, Patterns and Scenarios in the Design of Technology Enhanced Learning. In Y. Mor, M. Maina & B. Craft (Eds.), *The Art and Science of Learning Design* (pp. 93–104). Rotterdam: Sense publishers.
- Windschitl, M., & Calabrese Barton, A. (2016). Rigor and equity by design: Locating a set of core teaching practices for the science education community. In D. H. Gitomer & C. H. Bell (Eds.), *Handbook of research on teaching* (pp. 1099–1158). Washington, DC: AERA.

A lens on two classrooms: Implications for research on teaching

Siún Nic Mhuirí

Dublin City University, Ireland; Siun.NicMhuiri@dcu.ie

This paper uses the Teaching for Robust Understanding framework (Schoenfeld, 2013) as an analytic lens on episodes of mathematics teaching from two different countries. This lens highlights differences in teaching approaches across the two settings and draws attention to the need for further interrogation of how culture, curriculum and values inform teaching practices. It also has implications for research practices as it shows that the theoretical frameworks and methodological tools that are used in research are not value free or culturally neutral.

Keywords: Research frameworks, culture, international, mathematics teaching.

Introduction

My motivation in writing this paper is to address some of the questions that were raised in TWG19 at CERME10. I hope to contribute to discussions on methods used to conduct research on mathematics teaching. I have a particular interest in how research frameworks are used by different communities. At CERME10, I presented a view of research frameworks as theoretical frameworks or methodological tools which ‘frame’ or structure a coherent set of understandings about a theme (Nic Mhuirí, 2017). In this paper, I use the Teaching for Robust Understanding (TRU) framework (Schoenfeld, 2013) to analyze segments of mathematics lessons. I raise questions about how culture, curriculum and values inform teaching practices and how research frameworks reflect this (or not). I conclude by considering the implications for research practice more generally.

Theoretical Framework

I situate my work in the sociocultural perspective where learning is conceived as transformation of participation in social practices (e.g., Lerman, 2001). From this perspective, a classroom community can be understood as a community of practice (CoP) (Wenger, 1999). The CoP theory developed from research on apprenticeship contexts. Critics argue that it does not offer a theoretical base for formal teaching where teachers are accountable for learning outcomes (e.g., Goos & Bennison, 2008). Attention to teacher as agent for educational and social change (Cochran-Smith & Lytle, 2009) is necessary to envisage how new practices might come to be established within the community. Notwithstanding student agency and the influence of the wider sociocultural context, the teacher is assumed to have agency, and generally some authority, in choosing actions which shape the practices of classrooms, i.e., “the repeated actions in which students and teachers engage as they learn” (Boaler, 2002, p. 113). However, teaching is more than simply a collection of practices. Following Biesta and Stengel (2016), I recognize teaching as relational, intentional and purposeful. Firstly, teaching implies a relationship between the person teaching and the one being taught. The teacher also has a role to play in ‘relationally bridging’ student and subject (Grootenboer & Zevenbergen, 2008). While learning may occur, in the absence of teaching, teaching is considered to be intentional as teachers deliberately aim to teach their students. Furthermore, education is a “teleological practice where the question of what education is *for* can never be evaded” (Biesta & Stengel, 2016, p. 33, original emphasis).

Biesta and Stengel contrast ‘purpose’ with the more concrete ‘aims’ which a teacher might endeavor to achieve. They describe the purpose of education as concerned with justification for engaging in teaching and consider ‘purpose’ to be normative and indicative of what is ‘educationally desirable’ (2016, p. 31). They identify three important domains of educational purpose: qualification; socialization; and subjectification. Qualification is understood as connected with “the transmission and acquisition of knowledge and skills” and socialization is understood as “the way in which through education we become part of existing cultures and traditions and form our identity” (Biesta & Stengel, 2016, p. 26). Subjectification is “an educational orientation concerned with the ways in which human beings can be subjects in their own right, rather than objects of the actions and activities of others (2016, p. 21). It is difficult to argue with Mosvold and Hoover’s (2017) contention that “while there are other important aims of education, teaching is centrally about supporting the learning of subject matter” (p. 3111). However, Biesta and Stengel maintain that such aims should be articulated in relation to the domains of educational purpose.

The view of education proposed by Biesta and Stengel centralizes teacher agency as it highlights the role of teacher judgment. In every activity, teachers make (tacit) judgments about the balance between the three domains of educational purpose. This has connections with Schoenfeld’s (2015) theory of teachers’ decision-making. He maintains that for a well-practiced activity like teaching, decision making is a function of teachers’ knowledge, resources, goals, beliefs and orientations. His model of in-the-moment decision making offers a fine-grained lens on teacher judgments. By situating such judgments in the broader field of the three domains of educational purpose, Biesta and Stengel’s philosophy facilitates consideration of the bigger picture. It raises questions about how society, culture and curriculum shape teachers’ orientations and how beliefs about educational purpose influence everyday decision-making.

Methodology

The data was collected by international researchers for different purposes. It was shared amongst TWG19 members who had expressed an interest in engaging in the analysis of common data at CERME10. Four pieces of data were shared, three of which contained video clips. I focused only on the video data which consisted of episodes from an American, a Greek, and a Norwegian classroom.

I will use the TRU Framework (Schoenfeld, 2013) for analysis. This framework consists of five dimensions: *the mathematics*; *cognitive demand*; *access to content*; *agency, authority and identity*; *uses of assessment*. *The mathematics* involves the disciplinary concepts and practices made available for learning. *Cognitive demand* aims to capture the extent to which students have opportunities to engage in ‘productive struggle’. *Access to content* addresses the extent to which activity structures support the active engagement of all students. *Agency, authority and identity* refers to the extent to which students have opportunities to instigate and contribute to discussions in ways that contribute to their agency, mathematical authority and to the development of positive identities. *Uses of assessment* relates to how classroom activities elicit student thinking and subsequent interactions respond to those ideas. Schoenfeld (2013) describes his goals in the creation of the framework as being concerned with identifying a relatively small but ‘complete’ number of categories of classroom activities for observation, i.e., no other categories or dimensions are thought

to be necessary for analysis. This claim of ‘completeness’ was the main reason for choosing to use the framework as a methodological tool. The TRU framework can be used for evaluation purposes but I aim only to highlight important issues and to interrogate the process of analysis itself.

The TRU approach to classroom observations separates or parses lesson by the nature of the activity structure that occurs: *Whole class activities* (including *topic launch*, *teacher exposition*, and *whole class discussion*); *small group work*; *student presentations*; and *individual student work*. Each episode should be relatively short but ‘phenomenologically coherent’ (2013, p. 617). The TRU framework contains detailed rubrics for all five dimensions across each of these activity structures. It might be considered that these activity structures are relatively unambiguous and should be easily recognized across international classrooms, e.g., individual work or small group work. However, issues of curriculum and culture should not be ignored (Andrews, 2011). For example, the activity structure ‘*topic launch*’ would seem to have strong connections to the ‘Launch-Explore-Summarize Teaching Model’ used in the US based Connected Mathematics Project Curriculum (<https://connectedmath.msu.edu/>). The extent to which this model of instruction is recommended by, or embedded in, other jurisdictions internationally is questionable. It is also possible that other important activity structures exist locally that are not captured in the TRU framework (c.f., Clarke et al., 2007). Despite these concerns, it was possible to categorize the data using the TRU activity structures so it was decided that it was appropriate to proceed with analysis.

To some extent the data was ‘pre-parsed’ as only selected elements of the lessons were shared. There were a variety of activity structures in evidence across the different classroom. The activities in the Greek classroom were conducted in a whole class setting with some elements of teacher exposition and whole class discussion. The activity structures in the Norwegian classroom involved a whole class topic launch, small group work/individual work and a series of student presentations. The activity in the US classroom centered on a single student presentation. Given the constraints of this paper, I decided to focus on the student presentations across the US and the Norwegian data. An overview of the data is shown in table 1.

US Data	Norwegian Data
Summer program for 5 th graders. Majority low SES participants. Experienced teacher recognized as expert (Professor Deborah Ball, University of Michigan) Video clip (c. 3 minutes) and contextual information.	Small group (5 students) primary teaching. Experienced teacher recognized locally as expert Video clip (c. 21 minutes) with English subtitles and transcription.

Table 1: Overview of data

Overview of video content

In the US video, a student presents a solution to a task concerning what fraction is marked on a number line. She gives the incorrect answer of $1/7$. Her justification is that there are seven equal parts shown on the number line. The teacher invites students to question her reasoning.

In the Norwegian example, the teacher gives the students the task of figuring out what year the King was born. In effect, students have to compute $2017 - 80$. After about 5 minutes, the teacher asks students to present their solution methods. These are summarized below.

- *Presentation 1:* $80 - 17 = 63$, $2000 - 63 = 1937$. The calculations were carried out using the standard algorithm even though the procedure has not yet been taught for higher number ranges. The teacher models the students' thinking on an empty number line and also models the algorithm.
- *Presentation 2:* $2000 - 80 = 1920$; $1920 + 17 = 1937$. The calculations were done mentally but recorded in vertical format at the board.
- *Presentation 3:* $2017 - 80 = 1937$ using standard algorithm.
- *Presentation 4:* $1900 + 20 = 1920$; $1920 + 17 = 1937$. Teacher questioning appears to aim to expose reasoning.
- *Presentation 5:* The first student complains that she did not have a chance to write her method (standard algorithm) on the board. Teacher invites her to do this.

Results

Due to space limitations the full TRU framework rubric for student presentations is not presented here. Instead, under each heading, I give a brief overview of all levels with a full description of the most relevant levels (in italics). I then present an analysis of relevant classroom events.

The Mathematics

Level 1 (answers without reasons) and Level 2 (procedural mathematics with no expectation of reasoning) do not apply in either case. Level 3 is described as follows: The Mathematics presented is relatively clear and correct AND either includes justifications and explanations OR the teacher encourages students to focus on central mathematical ideas and explaining and justifying them.

In the US classroom, explanations were given by the presenter Aniyah but the mathematics was incorrect. The teacher encouraged other students to ask questions but not to evaluate (i.e., agree or disagree with) her solution. Toni questioned why she chose one-seventh. Lakeya questioned her choice of 1 for the numerator. Dante's question is unclear but may also be targeting the numerator. The focus on justification and key mathematical ideas would place this at level 3 of the rubric.

In the Norwegian classroom, the mathematical reasoning was correct and the explanations were generally clear (level 3). Where this was not clear (e.g., presentation 4), the teacher asked clarifying questions. In presentation 5, the student inverted the numbers when writing the standard subtraction algorithm. She appeared to recognize her own error and the teacher said he understood her thinking. He appeared to value reasoning above procedures. All presentations can be described by level 3.

Cognitive Demand

Level 1 (familiar facts and procedures) does not apply to either case. Level 2: Presentation offers possibilities of conceptual richness or problem solving challenge, but teaching interactions tend to 'scaffold away' these possibilities, resulting in a straightforward or familiar focus on facts and procedures. Level 3: The teacher's hints or scaffolds support presenters and/or class in 'productive struggle' in building understanding and engaging in mathematical practices.

In the US classroom, the mathematics was cognitively demanding for the presenter Aniyah and perhaps for others, e.g., Dante. Other students were invited to ask questions and in this way possibly provide support for Aniyah. The extent to which these interactions were ‘productive’ for her and/or other students is not obvious on completion of the clip. Level 3 most closely describes this extract but it was the classroom community, rather than the teacher, that was providing the scaffolding.

The task in the Norwegian classroom was of appropriate challenge. One student solved it quickly but others needed more time and one student did not come to a correct solution. In presentation 1, the student was clear in her ideas but this transitioned quickly to teacher explanation. The second student presented a mental method. Again, the teacher took responsibility for explaining this. No scaffolding occurred in presentation 3. It might be considered that a more challenging example of the standard algorithm had been addressed in presentation 1. This might explain why the teacher did not dwell on this example. The teacher’s questions in presentation 4 appeared to attempt to scaffold the presenter and clarify her ideas. Across all presentations, the focus remained on student thinking rather than procedures. However, the teacher’s actions are closer to level 2 than to level 3. While presenters did not often need the teacher’s support, his input may have the effect of ‘scaffolding away’ the opportunities for students to build their own understanding of each other’s ideas.

Access to Mathematical Content

The descriptions for this dimension refer to teacher-presenter conversations (C) and whole class discussions (W). Level 1 (no support (C) or significant disengagement (W)) and level 2 (ineffective scaffolding (C) or uneven participation without teacher action (W)) do not apply. Level 3: Teacher supports presenters if needed (C) or the presentation evolves into whole class activity in which the teacher actively supports broad participation and/or what appear to be established participation structures result in such participation (W).

The US classroom was very much orientated to the whole class situation (W). Not all students contributed to this discussion but the teacher deliberately orchestrated whole-class consideration of Aniyah’s idea. This is indicative of level 3 of the framework.

In the Norwegian classroom, the interaction was between the teacher and each presenter in turn (C). The teacher asked clarifying questions. Some questions might be considered to be dual-purpose in that the other students might have benefitted from them. However, the discussion never ‘evolves into whole class activity’ (W) and the students were not explicitly asked to comment on each other’s ideas or to make connections across suggestions. It is hard to match this with TRU framework descriptions as for teacher-presenter conversations (C) level 3 still refers to active supporting of presenters (which was only necessary in presentation 4).

Agency, authority and identity

Level 1 (presentation constrained by teacher questions) does not apply. Level 2: Presenters have the opportunity to demonstrate individual proficiency but the discussions do not build on student’s ideas. Level 3: Student presentations result in further discussions of relevant mathematics or students make meaningful reference to other students’ ideas in their presentations. (To qualify as an idea what is referred to must extend beyond the tasks, diagrams etc. that is referred to)

In the US classroom, Aniyah's presentation appeared to launch some classroom discussion of meaningful mathematics. This would place it at level 3 of the framework. It can be argued that students such as Toni take on an evaluative role. She acts as a mathematical authority and demonstrates agency. Such activities are envisaged to contribute to positive mathematical identity. The nature of Aniyah's experience is less clear and at the end she chooses to sit down rather than continue presenting/defending her idea. It is necessary to track participation over a longer period before one can make any claims about identity or agency (Nic Mhuirí, 2014).

The Norwegian classroom can technically be considered at a level 3 but while students are the source of ideas, they are not the source of discussion. Talk is teacher-led at all times. Student contributions are reformulated and explained by the teacher presumably for the purposes of ensuring others understand. Consequently the teacher retains mathematical authority. He also 'rates' the solution strategies of two students. After presentation 3, he first praises the girl who used the standard algorithm. Then he compares it to the previous presentation, saying "But his way to do it, I'd say, uses a method that's easy to calculate in your head. Really smart." By implication, the solution using the standard algorithm in a number range students have not officially been taught yet, is positioned as not as 'smart.' This hierarchical positioning of solutions, and by implication students, does not occur anywhere else but it does speak to issues of identity and authority.

Use of Assessment

Level 1 (reasoning not pursued) and level 2 (specific student ideas not utilized) do not apply. Level 3: In presentation and discussion, the teacher solicits student thinking and responds to student ideas by building on productive beginnings or addressing emerging misunderstandings.

The US classroom episode is aligned with the level 3 description and might be considered formative assessment in action. The teacher is activating the other students to respond to Aniyah's misunderstanding. It would be necessary to see how this plays out to judge whether the strategy is effective for Aniyah and other students.

In the Norwegian classroom, the teacher emphasizes student thinking. In presentation 1, the teacher uses the student's ideas as a launch to model her solution on an empty-number line and to model the standard subtraction algorithm. This episode might be considered to 'build on productive beginnings' (level 3). Levels of understanding were not generally made explicit in the classroom dialogue. The teacher posed a question which explicitly sought to assess students' understanding just once. It is possible that in this small group the teacher could closely observe indications of student (mis)understanding. Late in the episode, (c. 18 minutes) a student explained that he had attempted to solve the task using the standard algorithm but had gotten an incorrect answer. It remains unclear whether he learned how to complete this correctly from the class dialogue.

Discussion

On an evaluative level, the short US video scored higher on the dimensions of the TRU framework than the Norwegian example. The analysis showed differences in the extent to which agency was devolved to students. This devolution was carefully orchestrated by the teacher in the US classroom. Student presentations never evolved into whole-class discussion in the Norwegian

setting. All interactions were funneled through the teacher and it was never explicitly stated that the students should attempt to understand each other's reasoning though this may have been an implicit teacher expectation. Such norms were possibly well established in comparison to the US summer school where the teacher was working to establish norms. Indeed, when the Norwegian students were working on developing solutions, they displayed some annoyance that one of the participants indicated the answer before all had completed working. In one of his only explicit directions, the teacher gave the following instruction: "A good tip right now is not to trust that one sitting beside you [...] you can only trust yourself. Think for yourself and trust yourself." This appears to emphasize individual effort and indicates an expectation that all students should be able to devise a solution independently. Individual thinking, including errors, was valued in the US classroom but the teacher also seemed to be trying to set an expectation that the community should support the individual in making sense of mathematics. It might be argued that particular forms of socialization and subjectification (Biesta & Stengel, 2016) were being actively pursued by the US teacher.

The extent to which certain forms of socialization and subjectification are interwoven into the TRU framework warrants further attention. The framework presents a leveled or hierarchical positioning of various teacher practices that is not value-free. For example, in the Access to Mathematical Content dimension, two different participation structures are recognized: teacher-presenter conversations and whole-class involvement. In the Norwegian classroom, it appears that teacher-presenter conversations occur for the benefit, but without the involvement, of the whole-class. This participation structure is not recognized by the TRU framework but has some similarities to Andrew's (2011) discussion of the 'implicit didactics' of Finnish classrooms where teachers' extended conversations with a competent child in a whole-class setting appeared to be a common feature. These embedded, but unspoken, expectations raise particular challenges for researchers.

Any research lens is informed by the values of the researcher and the research tradition from which the lens is drawn. Often what is valued by a lens remains implicit and unexplored. In this case, the disconnection between the TRU framework and the Norwegian classroom highlights something about the lens itself. This disconnection also raises questions about culture, and whether it is suitable to use a framework developed in one environment to analyze teaching in a different context where conceptions of expert practice may be quite different (Clarke et al., 2007). The aim of this paper however was not to compare teachers (or contexts) but to explore some of the challenges of conducting research in mathematics education. Limitations to this research include the length of the US video and the outsider-status of the researcher in relation to both contexts. The analysis of the Norwegian data was conducted with an English transcript and it is likely that particular nuances of language and meaning have been lost in translation. However, this brief analysis does draw attention to the need for further interrogation of how culture and values inform teaching practices and research frameworks.

References

- Andrews, P. (2011). Finnish mathematics teaching: a case of uniquely implicit didactics. In T. Dooley, D. Corcoran, & M. Ryan (Eds.), *Proceedings of the Fourth Conference on Research in Mathematics Education, Ireland, 2011* (pp. 3–18). Dublin, Ireland: St. Patrick's College.

- Biesta, G. J., & Stengel, B. S. (2016). Thinking philosophically about teaching. In D. Gitomer & C. Bell (Eds.), *Handbook of research on teaching* (5th ed., pp. 7–67). Washington, DC, USA: American Educational Research Association.
- Boaler, J. (2002). The development of disciplinary relationships: Knowledge, practice and identity in mathematics classrooms. *For the learning of mathematics*, 22(1), 42–47.
- Clarke, D., Mesiti, C., O’Keefe, C., Xu, L. H., Jablonka, E., Mok, I. A. C., & Shimizu, Y. (2007). Addressing the challenge of legitimate international comparisons of classroom practice. *International Journal of Educational Research*, 46(5), 280–293.
- Cochran-Smith, M., & Lytle, S. L. (2009). *Inquiry as stance: Practitioner research for the next generation*. Teachers College Press.
- Goos, M. E., & Bennison, A. (2008). Developing a communal identity as beginning teachers of mathematics: Emergence of an online community of practice. *Journal of Mathematics Teacher Education*, 11(1), 41–60.
- Grootenboer, P., & Zevenbergen, R. (2008). Identity as a lens to understand learning mathematics: Developing a model. *Navigating currents and charting directions*, 1, 243–250.
- Lerman, S. (2001). Cultural, discursive psychology: A sociocultural approach to studying the teaching and learning of mathematics. *Educational Studies in Mathematics*, 46(1–3), 87–113.
- Mosvold, R., & Hoover, M. (2017). Mathematical knowledge for teaching and the teaching of mathematics. In T. Dooley & G. Gueudet (Eds.), *Proceedings of the tenth congress of the European Society for Research in Mathematics Education* (pp. 3105–3112). Dublin, Ireland: DCU Institute of Education and ERME.
- Nic Mhúirí, S. (2017). Considering research frameworks as a tool for reflection on practices: Grain-size and levels of change. In T. Dooley & G. Gueudet (Eds.), *Proceedings of the tenth congress of the European Society for Research in Mathematics Education* (pp. 3113–3120). Dublin, Ireland: DCU Institute of Education and ERME.
- Nic Mhúirí, S. (2014). Investigating student participation trajectories in a mathematical discourse community. In P. Liljedahl, C. Nicol, S. Oesterle & D. Allan (Eds.), *Proceedings of the 38th Conference of the International Group for the Psychology of Mathematics Education* (Vol. 4, pp. 297–304). Vancouver, Canada: PME.
- Schoenfeld, A. H. (2013). Classroom observations in theory and practice. *ZDM*, 45(4), 607–621.
- Schoenfeld, A. H. (2015). How we think: A theory of human decision-making, with a focus on teaching. In S. Cho (Ed.), *Proceedings of the 12th International Congress on Mathematical Education* (pp. 229–243). Cham, Switzerland: Springer.
- Wenger, E. (1999). *Communities of practice: Learning, meaning, and identity*. Cambridge, UK: Cambridge University Press.

Assessing how teachers promote students' metacognition when teaching mathematical concepts and methods

Edyta Nowińska

A. Mickiewicz University in Poznan, Poland; nowinska@amu.edu.pl

An important aspect of teaching mathematics is designing learning environments and guiding students' learning activities in such a way that learners can develop or improve their mathematical competencies. Promoting students' metacognition in teaching mathematics is regarded as having an important role in achieving this goal. Unfortunately, rarely anything is known about how metacognition can be effectively fostered in regular mathematics classes. The paper presents an analysis and an assessment of metacognitive activities practiced in a regular mathematics lesson. It also describes the rating system used for this assessment, and exemplifies how this tool can be used to analyze the extent to which teacher's practices are conducive to foster students' metacognition, as well as to describe the need for a further improvement of these activities.

Keywords: Metacognition, instructional quality, classroom discourse.

About the role of metacognition in teaching and learning mathematics

In mathematics education, metacognition is usually understood as knowledge about cognition and regulation of cognition (Veenman, Van Hout-Wolters, & Afflerbach, 2006; Willson and Clarke, 2004). Most definitions of metacognition differentiate between *metacognitive knowledge* (e.g. the person's knowledge about cognitive tasks in mathematics, about strategies to cope with these tasks, and about one's own competencies related to these tasks and strategies), *metacognitive skills* (e.g. the person's procedural knowledge for regulating one's own problem solving and learning activities) *and the execution of such skills in form of metacognitive activities* (for an overview see Veenman et al., 2006). Such differentiation is important for theoretical considerations concerning the meaning of metacognition, whereas in concrete situations it is hardly possible to distinguish between these different components.

Metacognition has been ascribed an essential role in regulating students' cognitive processes in *problem solving*, but also in the *learning of mathematics in general*, in particular when constructing and organizing knowledge (cf. Schraw & Moshman, 1995; Wilson & Clarke, 2004), as well as in a *self-regulated use* of mathematics in different contexts in order to achieve some goals (Boekaerts, 1999). Thus, from a teachers' perspective, promoting students' metacognition can be considered as a *mean* for effective teaching – for engaging students in cognitive processes needed to understand the mathematical concepts and methods to be learned. But it must be also considered as a *goal* of teaching – as an essential aspect of students' mathematical competencies to be improved through teaching.

Much research has been done on modelling, analyzing and promoting metacognition in solving mathematical problems. Many paradigms adopted to this context in the past research were based on the assumption that the way students learn to solve problems is “to first acquire the mathematical knowledge needed, then acquire the problem-solving strategies that will help them to decide which already known procedure to deploy, then acquire the metacognitive strategies that will trigger the

appropriate use of problem-solving strategies (...).” (Lesh & Zwojewski, 2007, p. 793). Such paradigms not only separate problem solving from concept development. They also separate metacognition from teaching mathematical concepts and reduce promotion of metacognition to teaching a list of simple rules (e.g., make a plan, draw a picture, mark important words, control your solution, evaluate the result). I consider this separations as one possible reason for the unimpressive results (ibid.) from this kind of research, because it seems hardly possible to acquire adequate metacognitive knowledge for solving problems without being engaged in metacognitive processes when constructing substantial meta-mathematical knowledge, meaning knowledge about relevant mathematical concepts, methods, and reasoning strategies (cf. Veenman et al., 2006). And therefore I see the need for shifting the focus of research on metacognition from teaching problem solving to regular teaching situations in which the learners have to learn mathematical concepts and methods.

An operationalization of metacognition in teaching and learning mathematics

Since rarely anything is known about how metacognition can be effectively fostered in class when teaching and learning new concepts and methods (cf. Wilson & Clarke, 2004), a deep analysis of metacognitive practices in regular classes can be the first step for research aiming at enhancing students’ metacognition. For this, an operationalization of the construct “metacognition” for the context of teaching and learning mathematics is needed. This has been done by the research group Cognitive Mathematics at the University of Osnabrueck. Its result is a category system¹ decomposing metacognition in *planning*, *monitoring* and *reflection*. Planning means organizing cognitive activities in order to achieve some goals as well as specifying cognitive challenges to be overcome (e.g., planning the use of mathematical methods and concepts to write a proof or planning the use of a particular strategy or representation to solve an equation). Monitoring means controlling cognitive activities and their results (e.g., controlling the validity of logical statements of arguments and the consistency of an argumentation or the validity and adequacy of tools and methods used in mathematical modelling or the correctness of meaning extracted from a mathematical text). Reflection means thinking about different aspects of cognitive activities involved in learning and understanding mathematics (e.g., analyzing relations between concepts, conceptions, misconceptions and external representations of mathematical concepts, analyzing the process of developing new mathematical concepts, analyzing mathematical concepts, methods and strategies with regard to the kind of problems and contexts for/in which they can be applied).

On the role of discourse in promoting metacognition

Promoting metacognition in mathematics class does not mean teaching only one individual student how to organize, control and evaluate her/his cognition when learning and applying mathematical concepts and methods. It rather means organizing the teaching in such a way that as many as possible students are engaged in metacognitive activities. This can be achieved by establishing a *discursive* discussion culture with rules that force the students to control and regulate their own cognition and comprehension when other students or the teacher explain their ideas, solutions, conceptions or difficulties in understanding the discussed mathematical ideas. Such discursive culture implies that

¹ www.mathematik.uni-osnabrueck.de/fileadmin/didaktik/Projekte_KM/Kategoriensystem_EN.pdf

the teacher and the students precisely control what the classmates say, reflect on differences between various conceptions and reasoning strategies mentioned in the class, and use this reflection to regulate their own understanding. However, this can be practiced in an effective and beneficial way, only if the teacher and the students use class discussions to precisely explain their cognition and if they aim for a coherent discussion. Such discursive aspects of class discussion seem to be inevitable for promotion of metacognition in regular mathematics classes.

To analyze such kind of discursive practices in regular mathematics classes, the category system decomposing metacognition in planning, monitoring, and reflection (see footnote 1) also includes two categories for analyzing and coding the precision and coherence of class discussions: *discursivity* and *negative discursivity* (both are not in the focus of this paper; for details see Nowińska, 2016b).

Research question

To deepen our understanding on how metacognition is practiced in regular mathematics lessons, 24 lessons videotaped in six classes have been analyzed and assessed with the rating system described in the next section. One research question in this explorative study was: Which implications can be drawn from these assessments to improve the instructional quality with regard to metacognitive activities? This paper presents some results from this research. It reveals and explores an alarming fact concerning metacognitive practices in a regular mathematical instruction, and explains the need for a further improvement of the metacognitive-discursive quality. In doing so, it contributes to the discussion about how metacognition can be effectively implemented into mathematical instructions.

In the following, to begin with, the tool used for analyzing and assessing metacognitive activities is presented. Afterwards, metacognitive activities in one class are analyzed with this tool in order to make the alarming aspect more “visible”.

The rating system for assessing metacognitive-discursive instructional quality

To assess the extent to which metacognitive activities are used to elaborate mathematical concepts, methods, and students’ cognition related to them, one needs a reliable evaluation method which also takes into consideration the *discursive* aspects of the class discussion. Such a method has been developed at the University of Osnabrueck, and evaluated in cooperation with the German Institute for International Educational Research (DIPF) in Frankfurt. It is based on the application of two tools explained in detail in Nowińska (2016a). The first tool is the afore-mentioned category system for coding metacognitive and discursive activities of teachers and students in their utterances in public class discussions (PCD). The second is a rating system for an evaluation of *metacognitive-discursive* instructional quality (MDQ). This tool was presented at the Third ERME Topic Conference (Nowińska, 2016b), and the evaluation results concerning the reliability of the ratings at CERME10 (Nowińska & Praetorius, 2017). The wording “metacognitive-discursive” has been chosen to stress that metacognitive activities are analyzed together with discursive aspects of class discussion.

The rating system is a set of seven rating scales for assessing different aspects of the instructional quality of these activities. In the two-step rating procedure, the rater first watches the video and reads the transcript; thereby she/he interprets each verbal student’s and teacher’s utterance and codes metacognitive and discursive activities using the category system. In the second step, the rater

assesses the quality of these activities with regard to seven rating dimensions (quality aspects). Thereby she/he uses the video and the transcript with all codes for metacognitive and discursive activities set by her/him in the first step. Each rating dimension is given by an item called guiding question (*GQ*) and by a nominal rating scale consisting of several answering categories². The answering categories describe in detail how the relevant quality aspects are reflected in the class discussion. Different answering categories describe qualitatively different situations. Their order on the rating scale is based on the increasing quality of the class discussion with regard to the particular quality aspects. The rater has to choose the answering category that best describes the situation given in a class. For reasons of space, in the following, only three of seven guiding questions are explained.

The *first GQ* regards the extent to which learners practice metacognition in PCD in an autonomous and elaborated way, and focus it on the mathematical content (e.g. concepts, conceptions, methods) to be learned. There are four answering categories to it. The first category says that metacognitive activities are carried out solely by the teacher, and/or no effort is made to foster students' metacognitive activities in order to elaborate the mathematical content and students' understanding of it. The fourth category says that the learners are autonomous in practicing metacognition and thereby they make efforts to elaborate and understand the mathematical content.

The *second GQ* focuses on justifications combined with metacognitive activities, and on the extent to which they are used to elaborate on the mathematical content and on students' understanding of it. It asks for the extent to which students combine their metacognitive activities with elaborated justifications in an autonomous way, and also for the extent to which such justifications and coherent global argumentations of the whole class seem to be important in the culture established in the class (and consequently fragmentary justifications have to be corrected). There are four answering categories graduated in an analogue way as these to the first *GQ*.

The *third GQ* puts the focus on a hypothesized learning effectiveness of metacognitive and discursive activities of students and the teacher. The rater has to assess the extent to which the metacognition she/he observed in the videotaped PCD contributes to construct or deepen students' meta-mathematical knowledge or to foster their meta-mathematical skills related to the mathematical content of the lesson (tasks, questions, tools, methods, reasoning, concepts, conceptions). The first answering category describes a PCD without any constructive use of metacognitive and discursive activities; the second says that only very few learners make efforts to deepen their meta-mathematical knowledge or to reflect on their meta-mathematical skills, but their metacognitive activities are not elaborated by the classmates or the teacher. The third and last answering category says that metacognitive aspects of the mathematical content are discussed in a constructive and elaborated way.

Analyzing and assessing metacognition in mathematical instruction

The lesson analyzed in this paper was videotaped in one class in grade 7 in a German secondary school (Gymnasium) during the introduction to linear equations. Four lessons in this class were videotaped and analyzed with the rating system, and all of them feature the alarming aspect described

² https://www.mathematik-cms.uni-osnabrueck.de/fileadmin/didaktik/Projekte_KM/GuidingQuestions.pdf

in this paper. The term ‘alarming aspect’ is used here to emphasize some striking characteristic of the instructional quality of metacognitive and discursive activities of the teacher and of the students in lessons planned for an introduction of new mathematical concepts and methods. Due to the small number of lessons, the case of the lesson analyzed in this paper has to be used with caution. But since similar aspects were also observed in other classes, there seems to be a tendency for some similar teaching practices also in the case of other teachers/classes.

The instructional context of the introduction of a new mathematical concept

To motivate the introduction of the term ‘equation’, the teacher uses two mathematical problems. One of them is: “The three major oceans (Pacific, Atlantic, and Indian Ocean) together have a water surface of 320 million square kilometers. The Pacific Ocean is twice as large as the Atlantic, and the Indian Ocean is 10 million square kilometers smaller than the Atlantic Ocean. The surface x (in million square kilometers) of the Atlantic is unknown.” The teacher makes no comments on the concept of equation to be learned in this lesson.

Solving this problem requires the use of metacognitive activities of planning a solution, controlling the solution steps and the result, and reflecting on the text and the solution process. Since solving the problem should motivate the introduction of equation and of a method for solving equations, students’ reflection about the formal representation of an equation and about the regulation of their own cognitive activities needed to write and solve an equation would be required to construct *metacognitive mathematical knowledge* about the new mathematical content.

Most of the learners solved the problem at home. In the class, Sabrina presents her solution (Figure 1):

x: Atlantik	$x + y + z = 320 \text{ Mio. km}^2$	$x = 82,5 \text{ Mio. km}^2$
y: Pazifik	$x + 2x + x - 10 \text{ Mio. km}^2$	$y = 165,0 \text{ Mio. km}^2$
z: Indischer Ozean	$4x - 10 \text{ Mio. km}^2 = 320 \text{ Mio. km}^2$	$z = 72,5 \text{ Mio. km}^2$
	$4x = 330 \text{ Mio. km}^2$	$\frac{320 \text{ Mio. km}^2}{4}$
	$330 : 4 = 82,5 \text{ Mio. km}^2$	

Figure 1: Problem solution

The transition from the equation in line 3 to this in line 4 raises many questions. A few students try to find out why one is allowed to change the equation in line 3 to the equation in line 4 (for reasons of space, the utterances are presented here in a shortened and more precise version):

Johana: I do not understand how you get from line three to line four.

Sabrina: Here, I did not know what to do, and then I asked my mother and she simply said, if you have to subtract something from x or from the variables, then you add that here to the result of it to be able then to continue the calculation.

Jonas: (...) $4 \cdot x - 10$ million that is equal to 320 million. And then four times x without minus 10 million, it is clear that there are then 10 million more, because then you do not make the subtraction. That's why it's 330 million. (...)

Anna: (...) we want to have x on the left side alone. (...) and then you can only get the minus 10 million..., if you want to get rid of it, you just have to put 10 million on both sides. So on the left you have then $4x$ minus 10 million plus 10 million. One

can then... yes you can take this away. Then there is only $4x$, and on the other side 320 million plus 10 million. (...)

An analysis and assessment of metacognitive activities

Johana **reflects** (R6b) on her understanding of the solution, whereas Jonas and Anna **reflect** (R4) why one is allowed to change the equation in line 3 to the equation in line 4. (The meaning of codes R6b and R4 is explained in the category system linked in footnote 1.). Jonas analyzes the effect of the subtraction by 10 million on the value of $4x$ and describes a relation between $4x-10$ and $4x$. He uses this relation to find the value of $4x$ if it is known that $4x-10$ equals 320 million. Anna describes a clear goal of changing the equation (“we want to have x on the left side alone”) and suggests an arithmetic operation to change the term on the left side, but she does not explain why the terms on both sides of the equation have to be changed and can be changed as suggested by her.

The teacher arranges the class discussion in such a way that the students discuss their solutions without his guidance. This situation encourages the learners to take the responsibility for *solving the task* and to regulate their own cognition, thus to practice metacognitive activities such as planning, controlling and reflection. The students make use of this opportunity. They seem to be willing to plan, control and reflect their mathematical activities. In the sense of the *first guiding question*, this scene shows a high quality of metacognitive activities (answering category 4). High quality means that many metacognitive activities can be observed in students’ utterances and that these activities indicate students’ efforts to understand the solution.

The class discussion is led by a small group of students, who practice their metacognitive activities in an elaborated way by giving justifications related to mathematics and to their own understanding. They elaborated on the solution steps presented by Sabrina and on their own understanding of these steps. In the sense of *the second guiding question*, the lesson seems to indicate a high quality of metacognitive activities with justifications (answering category 4 to guiding question 2), meaning that giving elaborate metacognitive comments on the mathematical activities seems to be a desired, well established rule of the classroom culture in the class. But on the other hand, following this rule does not mean that the global class argumentation is coherent and focused on a precise elaboration of students’ understanding of the mathematical content. Consequently, this indicates a low quality of metacognitive activities with justifications (answering category 2 instead of 4 must be chosen).

Can this kind of metacognitive activities support students’ understanding of the new mathematical concept? Can it help to construct or deepen students’ meta-mathematical knowledge or to foster their meta-mathematical skills related to the mathematical content of the lesson? The three solution ideas as described by Sabrina, Jonas and Anna in the transcript differ significantly from each other. Unfortunately, the teacher makes no effort to elaborate on these approaches and to initiate co-constructive processes with regard to the meaning and adequacy of the new formal representation and of transforming it to find a solution. In the whole class discussion there are no activities indicating that the students reflect on each other ideas in order to understand how they differ from their own ideas, and whether all of them are correct and based on a valid mathematical argumentation. *Only very few students* try to explain the meaning of the equation and seem to have an idea of how to justify the transformations of the equation (answer 2 to guiding question 3). But since their ideas are not

elaborated and related to each other, the process of solving the equation is not effectively used to co-construct metacognitive mathematical knowledge about equations, and to make this knowledge well comprehensible for *all* students. Thus, despite lots of students' metacognitive activities, there are no visible effects concerning the construction and acquisition of metacognitive mathematical knowledge or fostering mathematical skills at the level of the whole class discussion. In the sense of the *third guiding question*, the metacognitiv-discursive quality of this lesson must be assessed as low (answering category 1 to guiding question 3), meaning that the extent to which metacognitive activities are used to foster students' understanding is not satisfying.

Discussion

Training programs for fostering students' metacognition in learning mathematics concentrate on problem solving. But it seems hardly possible to acquire adequate metacognitive knowledge for solving problems – or even more general speaking, for a self-regulated use of mathematics in order to achieve a particular goal – without being engaged in metacognitive processes when constructing substantial mathematics-specific knowledge, such as knowledge about relevant concepts, methods, and strategies for thinking and reasoning (cf. Veenman et al., 2006). The lesson described in this paper shows that engaging students (in this particular class) in such metacognitive processes is not in the teacher's focus when solving a mathematical problem designed to introduce a new mathematical concept (equation). The teacher supports students' metacognition in the sense that he encourages them to plan, control and evaluate the solution among themselves. But he neither supports students' reflection on the new mathematical concept used in this process nor tries to explain or relate to each other the different conceptions described by the students to explain one step in solving an equation.

This is an alarming feature of the instructional quality of mathematics lessons. Mathematics teachers are expected to foster students' metacognition in order to deepen their understanding of mathematics and to enhance their skills in regulating their own cognition when using mathematics in different contexts. This alarming feature shows how promotion of metacognition in regular mathematics lessons is reduced to engaging the students in self-regulated processes of solving mathematical problems and tasks without taking care on the discursive quality of their mathematical discussion, and on their efforts in elaborating mathematical concepts and methods.

The rating system used to analyze the lesson can also be used to describe the need for a further improvement of instructional quality with regard to fostering students' metacognition. The high assessments given to the lesson with regard to the first and second guiding questions indicate that the students are able to execute metacognitive activities and willing to justify their answers and conceptions related to solving a linear equation. Unfortunately, the teacher does not use this potential to change the class discussion to a *discourse about the new mathematical concept*. In different words, the teacher does not make any efforts to shift the focus of the discussion from discussing the local steps of solving the given problem to a coherent discussion about the new mathematical representation (a formal representation of an equation) worked out in the process of solving this problem. This is, regrettably, the case in all four lessons videotaped in this class. This observation let us assume that improving the instructional quality with regard to students' metacognition requires changes in the discursive quality of the class discussion.

But this means more than just changing some social rules of discussion or increasing the number of students involved in the discussion. It rather means that the teacher and the students have to precisely control what the classmates say, explain differences between various conceptions and reasoning strategies mentioned in the class, and use this reflection to regulate their own understanding. It seems hardly possible to achieve this change without a close cooperation between teachers and researchers, and without engaging teachers in reflection on their practice.

The one lesson described in this paper does not allow us to generalize our assessment to all lessons of the particular teacher in this particular class. But, since the assessments given to all four lessons videotaped in this class are quite stable between lessons, it can be assumed that the problem described here is a general problem in this class. A transcript from the lesson following this one discussed in this paper is published in Nowińska (2016b). It shows that the students reflect on the sense of applying equivalence transformations to solve linear equations, and on their own difficulties in understanding the solution process. The teacher does not use these metacognitive activities to elaborate on the mathematical content and on students' understanding of it. He even seems to ignore students' reflections and justifications concerning their difficulties in understanding the mathematical content.

References

- Boekaerts, M. (1999). Self-regulated learning: Where we are today. *International Journal of Educational Research*, 31, 445–457.
- Lesh, R., & Zwojewski, J. (2007). Problem solving and modeling. In: F. Lester (Ed.), *Second Handbook of Research on Mathematics Teaching and Learning. A Project of the National Council of Teachers of Mathematics* (763–804). Charlotte, NC: Information Age Publishing.
- Nowińska, E. (2016a). *Leitfragen zur Beurteilung metakognitiv-diskursiver Unterrichtsqualität*. Osnabrück: FMD.
- Nowińska, E. (2016b). The design of a high inference rating system for an evaluation of metacognitive-discursive teaching and learning quality. In S. Zehetmeier et al. (Eds.), *ERME Topic Conference on Mathematics Teaching, Resources and Teacher Professional Development* (46–55). (<https://hal.archives-ouvertes.fr/ETC3/>)
- Nowińska, E., & Praetorius, A.-K. (2017). Evaluation of a rating system for the assessment of metacognitive-discursive instructional quality. In T. Dooley. & G. Gueudet (Eds.), *Proceedings of the Tenth Congress of the European Society for Research in Mathematics Education* (3121–3128). Dublin, Ireland: DCU Institute of Education & ERME. (https://keynote.conference-services.net/resources/444/5118/pdf/CERME10_0379.pdf)
- Schraw, G., & Moshman, D. (1995). Metacognitive theories. *Educational Psychology Review*, 7(4), 351–371.
- Veenman, M., Van Hout-Wolters, B., & Afflerbach, P. (2006). Metacognition and learning. Conceptual and methodological considerations. *Metacognition and Learning*, 1(1), 3–14.
- Wilson, J. & Clarke, D. (2004). Towards the modelling of mathematical metacognition. *Mathematics Education Research Journal*, 16(2), 25–48.

Teachers' probing questions in mathematical classrooms connected to their practice of encouraging students to explain their thinking

Anna Östman

Mälardalen University, School of Education, Culture and Communication, Västerås, Sweden;

anna.ostman@mdh.se

Keywords: probing questions, teachers' practice, talk moves, elementary school.

Introduction

Asking questions is a common used teaching activity in mathematical classrooms and by arguing that there is a relationship between teaching and learning (Smith & Stein, 2011), the conclusion is that questions play an important role in teachers' practice in the mathematical classroom (Boaler & Brodie, 2004). Boaler and Brodie (2004) studied teachers' questions to find the nuances and differences of teachers' questions in mathematical classrooms. They found nine different types of questions (e.g. recall questions, questions supporting students in developing mathematical knowledge, questions which explore meanings and relationships, probing questions to get students to explain their thinking and questions generating discussions). The probing questions are considered critical in encouraging students to explain, clarify and reason. Connected to the probing questions, talk moves are considered useful for teachers in having a fruitful discussion with students (Smith & Stein, 2011; Kazemi & Hintz, 2014). The talk moves that can be seen in mathematical classrooms are for example revoicing, repeating and wait time (Kazemi & Hintz, 2014). Asking questions seems to be a teaching activity that teachers do not plan ahead of the lesson even though teachers make explicit that questions are important in the teaching (Boaler & Brodie, 2004). Asking probing questions also make students aware of their own responses and make students answer in the way they think the teacher expects an answer (Smith & Stein, 2011). Therefore, in this study I have chosen to focus on the specific questions where teachers are probing students to make their thinking explicit, e.g. "How did you think?", "How did you get your answer?"

The aim of the study is to categorize the different types of responses teachers give to students when students have answered teachers' probing questions. The prospective results will be analysed with the attempt to present different types of interaction patterns emerging from data, which are connected to teachers' responses and teachers' talk moves when students have made their thinking available and explicit through oral explanations. The results will be presented both qualitatively and quantitatively.

Theoretical framework and methodology

The data in this study consists of videotaped mathematics lessons from 16 teachers, one lesson from each teacher, with six to nine years old students. In the data analysis, all episodes where teachers ask probing questions (Boaler & Brodie, 2004) were first identified together with the lesson phase in which each probing question appeared. In these episodes teachers' talk moves (Kazemi & Hintz, 2014) were used to find categories of different interaction patterns among teachers' responses. The interaction patterns are grown from the data and the patterns are used to explore the different ways teachers follow up students' answers after the probing question.

Findings

Preliminary findings from the 16 teachers indicate that probing questions are used in all phases of the mathematical lessons and that students' responses to the probing questions vary between different teachers. The probing questions are most common during the lesson phase whole class discussion and student work. In the preliminary results, I have found that teachers use revoicing in 50% of the interactions following probing questions. Revoicing seems to help students extend their thinking and the results show that when a student's first answer is short without an explicit thought and teachers follow up with revoicing, students often express a developed thought (see Example 1). In contrast, when a student first answers with an explicitly developed thought and the teacher uses the talk move revoicing the next answer from the student is often short (see Example 2).

Example 1: Short student answer and teacher revoicing – students express a developed thought

Teacher: Tell me, how do you think?

Student: I counted

Teacher: You counted

Student: I counted; first, I counted those [showing cards with number 6, 1] and then those [showing cards with numbers 3, 4, 2]

Example 2: Developed student answer and teacher revoicing - students stop deepening their answer

Teacher: Please, explain your pattern, how do you think?

Student: The pattern starts over here [pointing to the pearls] and we were thinking small large small large

Teacher: You did think small large small large

Student: Yes

The preliminary results also show that teachers who regularly use the talk move wait time have students answering the probing question with developed thoughts. However, the talk move wait time is not commonly used by the teachers in this study.

References

- Boaler, J., & Brodie, K. (2004). The importance, nature and impact of teacher questions. In D. E. McDougall & J. A. Ross (Eds.), *Proceedings of the twenty-sixth annual meeting of the North American Chapter of the International Group for the Psychology of Mathematics Education* (Vol. 2, pp. 774–782). Toronto: OISE/UT.
- Kazemi, E., & Hintz, A. (2014). *Intentional talk: How to structure and lead productive mathematical discussions*. Portland, ME: Stenhouse Publishers.
- Smith, M., & Stein, M. K. (2011). *Five practices for orchestrating productive mathematical discourse*. Reston, VA: National Council of Teachers of Mathematics.

Linking the micro and macro context: A sociocultural perspective

Maria Pericleous

Cyprus Ministry of Education and Culture, Cyprus; mariapericleous19@gmail.com

In this paper, I present and discuss findings from a research study the aim of which is to investigate the activity of proving as constituted in a Cypriot classroom for 12 year old students. Through Cultural-Historical Activity Theory (CHAT), the influence of research literature, curriculum prescriptions, the students and critically the teacher are documented. The evolution of objects, in particular the aims of the teacher, and other components in the activity systems are traced. Perceiving the mathematics classroom as a nested activity within educational context levels, this paper considers the role of the broader social context in which this classroom is situated.

Keywords: CHAT, contradictions, proving, mathematics

Theoretical framework

It is now acknowledged that proof and proving should become part of students' experiences throughout their schooling (Hanna, 2000; Stylianides, 2007; Yackel & Hanna, 2003). It is also argued that argumentation, explanation and justification provide a foundation for further work on developing deductive reasoning and the transition to a more formal mathematical study in which proof and proving are central (Yackel & Hanna, 2003). But what is meant by proof and proving? Mathematical argumentation is a discursive activity based on reasoning that supports or disproves an assertion and includes the exploration process, the formulation of hypotheses and conjectures, explaining and justifying the steps towards the outcome and the proof of the statement. Thus, proof is at the core of mathematical argumentation, as a justification, an explanation and a valid argument. Research has responded to the need to conceptualize proof and proving in such a way that it can be applied not only to older students but also to those in elementary school (Stylianides, 2007). The challenge remains however to understand how proof and proving is shaped by the practices in the mathematics classroom. This is in accordance with Herbst and Balacheff (2009), who argue that the focus should not only be on proof as the culminating stage of mathematical activity, but also on the proving process and how this is shaped by the classroom environment. Thus, in understanding how proving is constituted in the classroom, a wider network of ideas is required as these ideas no doubt have an impact on how proof in the narrow sense is constituted.

To address this issue, I refer to pre-proving, that aspect of mathematical reasoning that might nurture proving. What are the roots of proving? The purpose of this study is to investigate proof and proving in the naturalistic setting of the classroom and the way the structuring resources of the classroom's setting shape this process. Instances of students proving statements have been identified in this classroom community but instances where the argument was not in the conceptual reach of the classroom have also been identified. However, this study also points to those aspects of reasoning that appear to have the qualities of proving, even though they may not be proving in themselves. That is, analyses of video-recorded whole class discussions show how processes of explaining and exploring are key sub-systems within the central activity of proving as they provide a key pathway, which often includes defining. Thus, pre-proving refers to those elements that direct mathematical

reasoning towards the ultimate goal of formal proving, namely exploring, explaining, justifying and defining. This study considers mathematical explanation an act of communication, the purpose of which is to clarify aspects of one's mathematical thinking that might not be apparent to others (Yackel & Cobb, 1996). Justification is "the discourse of an individual who aims to establish for somebody else the validity of a statement" (Balacheff, 1988, p. 2). There is insufficient scope in this short paper to consider in detail these various levels and so this specific study focuses on the way the activity of the mathematics classroom (micro context) is influenced and dependent upon wider educational context (macro context). This is in accordance with Balacheff (2009) who argues that among the important pieces in trying to understand the nature and role of proof in a mathematics class is describing the general usage of the word proof in these contexts and the demands this usage imposes in the classroom.

CHAT based underpinnings

As this study is exploring the various forces that impact on the activity of proving, Cultural Historical Activity Theory (CHAT) is being employed as a descriptive and analytical tool alongside collaborative task design (a means of gaining access to the teacher's objectives), to capture the interaction of different levels, such as the actions of teachers, students and the wider field as evidenced in curricula and research documentation. The analysis and discussion in this paper draws upon the following CHAT perspectives: (i) the object of the activity and (ii) the notion of contradictions. Initially, the unit of analysis in CHAT is an activity, a "coherent, stable, relatively long-term endeavor directed to an articulated or identifiable goal or object" (Rochelle, 1998, p. 84). Engeström (1987) introduced the activity system, a general model of human activity that embodies the idea that both individual and social levels interlink at the same time. Jaworski and Potari (2009) argue that the activity system is a micro context within broader macro context levels. Thus, the activity of a mathematics classroom is influenced and dependent upon the structure and organization of the school and the Ministry of Education as wider educational contexts. The object of a collective activity is something that is constantly in transition and under construction. It has both a material entity and is socially constructed and its formation and transformation depends on the motivation and actions of the subject indicating that it proves challenging to define it.

Among the basic principles of CHAT is the notion of contradictions. Contradictions are imbalances, ruptures and problems that occur within and between components of the activity system, between different developmental phases of a single activity, or between different activities. These systemic tensions lead to four levels of contradictions (Engeström, 1987). Contradictions are important because they may lead to transformations and expansions of the system and thus become tools for supporting motivation and learning. That is, contradictions do not serve as points of failure or problems that need to be fixed. "Rather than ending points, contradictions are starting places" (Foot, 2014, p.337). This paper focuses on tertiary contradictions that appear between the object and the culturally advanced form of the central activity, a clash between the micro and macro level. Compared with other studies investigating tertiary contradictions, this study takes a rather different approach in discussing the tertiary contradiction that has emerged within this particular activity system. That is, the collaborative task approach assisted in exposing the teacher's object. Even though introducing a new mediational tool resulted in new actions being brought into the activity, this did not affect the object of proving

as a cultural historical activity system. Thus, when elaborating on tertiary contradictions, this discussion focuses on a possible clash between the micro and macro level of this activity system, due to a differentiated object.

Data collection and analysis

This study was conducted in a Year 6 classroom in a public primary school in Cyprus. This mainstream school is considered to be a dynamic school; it actively encourages teachers and students in engaging at a deeper level with the educational experience. Apart from the researcher, the participants were the teacher, a Deputy Principal at the school who endorses the integration of technology in teaching mathematics, and voluntarily agreed to take part in the research, and 22 students (11–12 years old) of mixed abilities. Even though using computers was part of the classroom's routine, the students were not familiar with Dynamic Geometry Environments (DGEs). The data collection process was undertaken in three phases. Phase I aimed at identifying the system level and the teacher level, by employing documentary analysis and semi-structured interview. The system level, which remained the same throughout the study, in the broader sense, refers to the policy statements, curriculum, textbooks, research about proof and proving. The official documentation was analyzed so as to collect information concerning the role of proving in primary education, the objectives for teaching and learning geometry, the geometrical tasks illustrated as important for developing geometric thinking and understanding, the approaches the ICT offers in facilitating the teaching and learning of school geometry. The teacher level refers to the teacher's attitudes and perceptions concerning the role of proof in the curriculum and in the mathematics classroom, compared with what the teacher actually does in the everyday mathematics classroom. The interview with the teacher aimed at exploring the teacher's beliefs and views regarding the nature of mathematics, the nature of teaching mathematics and the nature of learning mathematics. The main research focus of Phase II was to map the current situation of the classroom. The data collection process included video data from the classroom observations and field notes from the informal discussions with the teacher. My involvement in the classroom could be described as moderate participation. In Phase III, the researcher collaborated with the teacher to design DGE-based tasks as a means to gain access to the teacher's objectives. The tasks were the research vehicle, the window for generating data rather than any kind of curriculum intervention. The research instruments were classroom observation, informal discussions with the teacher and the DGE-based tasks. In Phase III, I had an active role in the classroom. My involvement was related with answering questions related with the tools the DGE provided, which the students had to use in order to explore the tasks, and asking probes. Each phase of data collection was distinct as it corresponded to specific purposes. At the same time, themes of interest, emerging from the ongoing analysis of each phase, also informed the design, implementation and analysis of the subsequent phases. The content of the curriculum covered during the classroom observations was the area of triangles, and the circumference and the area of circle.

The overall process of analysis of the collected data was one of progressive focusing. According to Stake (1981, p.1), progressive focusing is “accomplished in multiple stages: first observation of the site, then further inquiry, beginning to focus on relevant issues, and then seeking to explain”. The systematization of the classroom data led to the evolution of two broad activities: (i) the activity of

exploration including the exploration of mathematical situations, exploration for supporting mathematical connections (between the content of mathematics, with which the students are engaged, with parts of mathematics that they would be taught in secondary school or that were taught either recently or in the past, as well as between classes of problems) and exploration of the DGE and (ii) the activity of explanation which focuses on clarifying aspects of one's mathematical thinking to others, and sometimes justifying for them the validity of a statement. These activities were then interpreted through the lens of CHAT, by generating the activity systems of both exploration and explanation. Analysis of the classroom data revealed that the activity of explanation unfolded and expanded around mathematical definitions and defining as activity. What is the connection between definitions and explanation? Definitions are conventions that require no explanation. However, the teacher wanted reference to the attributes that involved properties. That is, the move from a definition involving only perception to a definition that involved properties needed explaining. The situation of the classroom regarding proving activity was further scrutinized by contrasting the outcome of the activity with the social context in which it emerged. Instances of both congruence and diversion existed between the micro and macro level.

What is the object of developing proving in the classroom?

It has been illustrated that pre-proving activity is closely connected with exploration and explanation. Correspondingly, the object of developing proving in the classroom is related with these notions. The object has multiple manifestations for the participants engaged in the activity. Exploration is related with the pre-proving activity when information is revealed through the immediate feedback students get from the manipulation of objects. For instance, on a blank DGE window, the teacher asked the students to find the area of triangles. The students had the opportunity to explore this mathematical situation on a DGE and decide for themselves which tools should be utilized that would assist them in finding the area of the triangles.

Additionally, explanation entails a process where mathematical definitions are being formulated. The students cannot rely only on perception as a definition in this particular classroom is considered more what a concept really is rather than a description of how a concept is used. For instance, the question "What is the altitude in a triangle?" directed the classroom towards formulating the definition of the altitude in a triangle. Explanation also entails a process where the sociomathematical norms are being negotiated. For instance, the first lesson where the students were introduced to the area of mathematics related with circle, was initiated by a question.

Teacher: What is circle?

Student: It is a shape that does not have sides or angles.

Teacher: I draw a circle according to this definition. (*The teacher draws a non-regular shape with curved lines.*)

Student: This is not a circle.

Teacher: We said that in mathematics our definitions must be accurate.

Students are expected to use precise mathematical language when communicating their ideas as well as when writing coherent geometrical explanations, clarifying aspects of their mathematical thinking

to others, as well as justifying for them the validity of a statement. For instance, following the classroom discussion on defining circle, the teacher asked students to determine whether several shapes illustrated on the whiteboard were circles.

Teacher: Is this a circle?

Student: No.

Teacher: I do not accept your answer. Why?

Student: There ... on the right ... the other shapes are not circles because their center does not have the same distance from their circumference.

As proofs begin with an accepted set of definitions and axioms, it can be argued that ultimately all proofs depend on the underlying definitions and the earlier results derived from these definitions. Thus, understanding and explaining these definitions is a prerequisite when approaching a proof. For instance, after the class reached a conclusion regarding the mathematical formula for the circumference of circle and made hypotheses concerning the mathematical formula for the area of circle, the teacher gave each pair a circle divided in either 8 or 10 pizza pieces, commenting that they could use the pizza slices to explore the area of circle.

Student: We finished. Can we tell you? Radius times half the circumference. It's a rectangle thus the length is the radius and the width is half the circumference because it's half.

In addition, making forward connections provides more information and knowledge about the axiomatic system in which the classroom community is working. Forward connections also strengthen the formulated definitions. For instance, after the class explored the number of altitudes in a triangle, the teacher made the following comment:

Teacher: This is what I was trying to achieve. All the altitudes pass ... this is not part of our curriculum but part of the mathematics curriculum of secondary school, but it's good for you to know because it helps you. A triangle has three altitudes. From each vertex I can construct an altitude to the opposite side.

Consideration of the aforementioned manifestations of the object leads to the conclusion that the object of the central system of pre-proving activity is related with exploration that leads to explaining and justifying for a specific part of the mathematics curriculum. Nevertheless, the object is simultaneously hindered due to the dichotomies, tensions and conflicts. At a first glance, this object seems to be clear and distinct. However, this object is multifaceted. The teacher on one hand understands the importance of providing enjoyable exploring opportunities that keep students' motivation and interest to engage with the problem. As a result, the teacher provides opportunities that can be approached by the students in their own way. On the other hand, students, through the exploration of these opportunities are expected to reach those conclusions regarding triangles and circles as pre-determined by the teacher. The two poles of the object lead to a constant struggle in the teacher's everyday practice. The teacher, due to this multifaceted object, is faced with the play paradox (Hoyle & Noss, 1992) as well as the planning paradox (Ainley, Pratt, & Hansen; 2006). As a result, teacher would at times decide to close down an exploration opportunity. For instance, after

exploring the circumference and area of circle, the teacher, asked the students to find a relationship that related the circumference and the area of the circle. Soon after that she asked them to prove mathematically that the ratio area/circumference of a circle is $r/2$. In a similar way, the object of the activity of explaining as part of pre-proving is multifaceted. The object for the teacher is twofold: explaining mathematical procedures and explaining related with 'proving'. On one hand, the teacher's object is related with engaging students in formulating definitions (of concepts and formulas) in the same way that mathematicians do. In order for these definitions to become operable for the students, they need to focus on the properties required. Thus, this process includes a continuous interplay between the concept image and the concept definition, promoting the characteristics of definitions and making the distinction between 'ordinary' and mathematical definitions. Even though the above facilitate the justification of statements, a tension within the object arises. That is, ensuring that the classroom engages in the construction of stipulated definitions and that these definitions are not just descriptive for the students seems to be competing with moving to justification based on these definitions. Furthermore, even though the teacher is embracing this object, she is simultaneously faced with the play and planning paradoxes, influencing the way she intervenes while this process of explaining and justifying develops in the classroom. If the students' argumentation leads to a discussion that diverts from the teacher's object, the teacher may decide not to take advantage the opportunity that arises, for further engaging students in explaining and justifying.

Identifying points of contradiction

Tertiary contradictions appear between the object of activity in a central activity and the 'culturally more advanced' activities. Analysis of the micro activity system as a classroom which is nested within the system level such as the institutional level in which the school is part of, as well as the cultural-historical level which is involved with the available research literature results into identification of a tertiary contradiction due to a differentiated object. The two poles of the object of the central activity of the classroom related with pre-proving activity will unavoidably clash with the object of pre-proving activity as identified in the system level. Initially, a contradiction between the classroom level and the institutional level resides in the fact that there is no clear identification of an object related to proving. That is, analysis of the official documentation indicates a general object of mathematical activity that is not necessarily in accordance with the object of the teacher related to pre-proving activity. To be more precise, the information collected from the official documentation points to low level of expectation with regards to exploration and investigation in problem solving in Year 6. Analysis of the report of the official documentation shows that proof and proving is not being acknowledged as a key criterion, nor mentioned in the mathematics curriculum. Furthermore, explaining and justifying points to an explanation being given by providing the mathematical operations used to find the answer and the justification being provided by using the definition. Adding to the above, there is no formal requirement regarding definitions. Definitions as approached by the official documentation are descriptive and extracted. This is not in accordance with the teacher's practice where definitions play a vital role. One may argue that a consideration of the educational objectives, as pre-determined by the mathematics curriculum, leads to the conclusion that the outcome of the teacher's practice is the one intended by these objectives. However, in order for this to be achieved, the pre-proving activity is narrowed down. Thus, for instance, providing answers based on

definitions and properties of shapes clashes with providing explanations based on the conceptual aspects of the definitions and the shapes. In a similar way, this tertiary contradiction concerns the cultural-historical level as well. Even though at a first glance the teacher's objects seem to be in line with the established research literature related with proving, the dilemmas the teacher needs to confront, as well as the ambiguity of the notion of proving existing at the institutional level, clash with the cultural-historical level.

Discussion and conclusions

A consideration of the above rationally points to the inference that the advanced form of the central activity object is not yet the dominant form of the activity. Thus, it can be argued that a first step towards a unification of these activities should be the resolution of the tension that exists within the macro system. Would providing a mathematics curriculum, which defines its object concerning proving and defining activity by incorporating crucial elements from the research literature, lead to a desired outcome?

The discussion regarding tertiary contradictions reveals the value of this concept in understanding systems of activity. By identifying the manifestation of contradictions through the materialized tensions, a holistic view of the phenomenon under investigation emerges. It is accepted that not all emergent contradictions can be resolved simultaneously. While a resolution exists for some contradictions, others are suppressed. That is, the contradiction on the teacher's object is continually present, surfaces in the teacher's everyday practice in various forms and is foundational to the other levels of contradiction. However, since this contradiction remains, the discussion should be centered on the means that the teacher can turn to for a possible and fruitful resolution of the contradictions that emerge in the other levels. Elaboration of the emergent tertiary contradictions leads to asking whether a possible balance between the macro level would be an aid in the resolution of the tensions manifested as contradictions in the micro level. Due to the way the aforementioned forces impact on the classroom activity, providing a straightforward answer is not an easy task. Undoubtedly, as it has been exemplified, proof and proving might be encouraged in all school levels. This indicates that exemplification of the role of proof, explanation, exploration and definitions might be included in the mathematics curriculum and the relevant curriculum material. Perhaps, a clear connection between the aforementioned would relieve, to an extent, the teacher from paradoxes. That is, knowing that the above aspects of mathematical reasoning might not be necessarily competing with each other and may be the way for a resolution of the play and planning paradoxes, as the purpose and utility underlining the task design would not clash with the object of the central activity system (Ainley et al., 2006).

Adding to the above, the fact that the official documentation is implemented in the classroom by the teacher points once again to the crucial role of the teacher. Specifically, the above findings further highlight the role of the teacher's knowledge about proof in mathematics teaching. Keeping in mind the findings of this study related with definition construction as part of pre-proving activity, it is important to consider essentially that the types, the characteristics and functions of mathematical definitions should be taken into account when understanding and describing the mathematical knowledge for teaching when engaging students in proving activity. Would this element of

knowledge enable mathematics teaching to support desirable student learning outcomes in the domain of proof and in mathematics more broadly?

References

- Ainley, J., Pratt, D., & Hansen, A. (2006). Connecting engagement and focus in pedagogic task design. *British Educational Research Journal*, 32(1), 23–38.
- Balacheff, N. (1988). *A study of pupils' proving processes at the junior high school level*. Unpublished paper presented at the Joint International Conference 66th NCTM and UCSMO Project: Chicago.
- Balacheff, N. (2009). Bridging knowing and proving in mathematics: A didactical perspective. In G. Hanna, H. N. Jahnke & H. Pulte (Eds.), *Explanation and proof in mathematics. Philosophical and educational perspectives* (pp.115–135). New York, NY: Springer.
- Engeström, Y. (1987). *Learning by expanding: an activity-theoretical approach to developmental research*. Helsinki, Finland: Orienta-Konsultit.
- Foot, K. A. (2014). Cultural-Historical Activity Theory: Exploring a theory to inform practice and research. *Journal of Human Behavior in the social Environment*, 24(3), 329–347.
- Hanna, G. (2000). Proof, explanation and exploration: an overview. *Educational Studies in Mathematics*, 44(1-2), 5–23.
- Herbst, P., & Balacheff, N. (2009). Proving and knowing in public: The nature of proof in a classroom. In D. Stylianou, M. Blanton & E. Knuth (Eds.), *Teaching and learning proof across the grades: A K-16 Perspective* (pp. 40–63). New York, NY: Routledge.
- Hoyles, C., & Noss, R. (1992). A pedagogy for mathematical microworlds. *Educational Studies in Mathematics*, 23(1), 31–57.
- Jaworski, B., & Potari, D. (2009). Bridging the macro- and micro-divide: using an activity theory model to capture sociocultural complexity in mathematics teaching and its development. *Educational Studies in Mathematics*, 72(2), 219–236.
- Rochelle, J. (1998). Activity theory: A foundation for designing learning technology? *The Journal of the Learning Sciences*, 7(2), 241–255.
- Stake, R. E. (1981). The art of progressive focusing. In *65th Annual Meeting of the American Educational Research Association* (pp. 1–8). Los Angeles, CA: AERA.
- Stylianides, A. J. (2007). Proof and proving in school mathematics. *Journal for Research in Mathematics Education*, 38(3), 289–321.
- Yackel, E., & Cobb, P. (1996). Sociomathematical norms, argumentation and autonomy in mathematics. *Journal for Research in Mathematics Education*, 27(4), 458–477.
- Yackel, E. & Hanna, G. (2003). Reasoning and proof. In J. Kilpatrick, W. G. Martin & D. Schifter (Eds.), *A research Companion to NCTM's Principles and Standards for School Mathematics*, (pp. 227–236). VA: NCTM.

Teachers' attempts to address both mathematical challenge and differentiation in whole class discussion

Giorgos Psycharis¹, [Despina Potari](mailto:Despina.Potari@math.uoa.gr)¹, Chrissavgi Triantafillou¹ and Theodoros Zachariades¹

¹National and Kapodistrian University of Athens, Greece; gpsych@math.uoa.gr, dpotari@math.uoa.gr, chrtriantaf@math.uoa.gr, tzaharia@math.uoa.gr

In this paper we investigate how a group of six mathematics teachers in Greece deals with the need to balance work on mathematically demanding tasks and differentiation in lesson planning and enactment. Videotaped lessons and pre and post reflection interviews were analysed with a specific focus on whole class discussion. The findings show certain teaching practices that appear to promote both mathematical challenge and differentiation and emerging patterns of actions that make the challenge accessible to students.

Keywords: Mathematically challenging tasks, whole class discussion, differentiation.

Introduction

Research on challenging tasks and differentiation has contributed to deepen our understanding of teaching. The former explored ways to engage students in rich mathematical activity through tasks advancing their thinking and reasoning (Stein, Smith, Henningsen, & Silver, 2000). The latter pertains to research in differentiating teaching so as to engage all the students in mathematically productive learning experiences (Sullivan, Mousley, & Zevenbergen, 2006). Bridging challenging tasks and differentiation constitutes an area that is not explored at the research level. However, it seems to be at the core of everyday teaching since working with rich mathematical tasks requires taking into account explicitly how all students could be engaged with them both at the level of lesson planning and enactment. Whole class discussion can be seen as a terrain providing fertile opportunities to study in what ways teachers might work at the intersection of mathematical challenge and differentiation. During whole class sessions a teacher faces the need to preserve a mathematically productive discussion and at the same time to respond to diverse students' abilities, learning styles and paces (Sullivan, Mousley & Zevenbergen, 2004). The present study aims to address this issue by focusing on mathematics teachers' attempts to work at the intersection of mathematical challenge and differentiation while designing tasks and orchestrating whole class discussions in their classrooms. The research question is: "How do teachers attempt to balance mathematical challenge and differentiation in whole class settings?"

Theoretical framework

Challenging tasks are those that require students to: process multiple pieces of information with an expectation that they make connections between those pieces and see concepts in new ways; explain their strategies and justify their thinking to the teacher and other students; engage with important mathematical ideas; and extend their knowledge and thinking in new ways (Stein et al., 2000). Working with challenging tasks seems to be rather demanding for the teachers at the level of design and enactment. Lesson planning involves design of tasks that support a learning trajectory and extend students' thinking (Sullivan et al., 2006). Handling the enactment of challenging tasks during whole

class sessions requires specific actions by the teacher to support students' mathematical discourse. These involve talk moves such as revoicing, repeating, reasoning and adding on (Chapin, O'Connor, & Anderson, 2009) as well as key practices such as anticipating, monitoring, selecting, sequencing, and making connections between student responses (Stein et al., 2008). Stein et al. (2000) proposed three paths to describe how teachers handle the demands of challenging tasks in their lessons: lowering, maintaining, or increasing the challenge.

Differentiation is a process of aligning learning targets, tasks, activities, resources to individual learners' needs, styles and paces (Beltramo, 2017). In supporting teachers in dealing with differentiation issues at the level of lesson planning existing literature suggests focusing on content, process, and product (Tomlinson, 2014) or providing enabling prompts to support students experiencing difficulty and posing extension tasks for students who finish the tasks quickly (Sullivan et al., 2006). Researchers suggest that the goal of addressing differences between students in lesson enactment can be effectively carried out by building of "a sense of communal experience" (ibid, p. 118) where all students benefit from participation on common discussions.

Whole class discussion constitutes a phase of the lesson enactment where mathematical challenge and differentiation can be at interplay providing opportunities for further study. According to Dooley (2009), whole class discussion is both emergent because the outcome cannot be predicted in advance and collaborative because it is the outcome of the collective activity between the teacher and the students. Focusing on the tensions involved in teachers' attempts to build on students' ideas for mathematically productive class discussion, Sherin (2002) highlights the need to maintain the student-centered process of mathematical discourse and to direct the content of the mathematical outcomes. In the present study our focus is on teachers' actions to balance mathematical challenge and differentiation in this rather complex part of the lesson.

Methodology

EDUCATE is a professional development (PD) European project aiming to support teachers to engage all their students in challenging tasks. To achieve this goal, four partners/university teams from different countries collaborate to develop teacher education activities and materials. The current study took place in the introductory phase of the project where the partners' aim was to explore teachers' needs and challenges in relation to working with challenging mathematical tasks and differentiation without being engaged in any teacher education/PD activity. In this paper, we use the data collected in Greece and it involves the teaching of six practicing secondary school mathematics teachers (Adonis, Eugenia, Markos, Gianna, Kosmas, Takis, all pseudonyms) who participated in the study in a volunteering base. All of them were experienced, qualified teachers but without any PD professional development experience related to address together mathematical challenge and differentiation. Their years of experience ranged from 10–25 years at the time of the study. Three of them worked in experimental schools and the rest of them in typical public schools. Also, three of them were teaching in lower secondary and the rest in upper secondary school classes. One of them had a doctoral degree in mathematics education (Kosmas), three held a master's degree in mathematics education (Adonis, Markos, Gianna) and one held a master's degree in pure mathematics (Takis). All teachers had collaboration with the university team either during their studies or through

their participation in other research projects. Participants were informed about the project rationale/aims and they were asked to design challenging tasks and enact them as part of their everyday teaching with the goal to engage all their students. They were also informed that we were interested in the challenges and difficulties encountered by them when implementing these tasks without further details on how to proceed with this goal.

Data collection included: video-recording of two lessons for each teacher (12 video-recordings in total); pre- and post-lesson reflections/interviews (12 in total); teachers' designs for their lessons (e.g., worksheets, digital resources) and students' work. The recorded lessons lasted one teaching hour (45-50 minutes) and were carried out between December 2017 and January 2018. Under a grounded theory approach (Charmaz, 2006), we analysed lesson planning and enactment with a particular focus on whole class sessions considering the setting up of the task and the discussion of students' solutions. Balance of mathematical challenge and differentiation in teachers' designs was addressed by triangulating the analysis of teachers' lesson plans, teaching materials and pre-lesson reflections focusing on (a) the designed tasks, (b) the used resources and (c) the decisions related to classroom implementation (i.e. group work, role of teacher, classroom norms). In the videotaped lessons, we identified episodes indicating a balance between mathematical challenge and differentiation. Mathematical challenge was originated either by the task itself, a student's query or the teacher's extending prompt or question. Differentiation was expressed by the teacher's attempts to make the challenge accessible to all students. Shifts in the students' engagement with the challenge in the episodes were identified (by us) mainly by interpreting students' progressive participation in the mathematical discourse.

Results

In the first part of this section we analyse teachers' designs. In the second part we present selected episodes from classroom observations indicating a balance between mathematical challenge and differentiation. Our focus is on the teaching actions and their interplay that indicate a process of making the challenge accessible to all students and not on cases where this was not evident.

How mathematical challenge and differentiation were balanced in lesson planning

Each lesson was based on a sequence of tasks and activities to be undertaken by students so as to support each teacher's learning goals. Most tasks (21 out of 25) can be characterized as challenging offering opportunities to students to: model an everyday situation through arithmetic, algebraic and geometrical relations (Markos – 7th grade, Adonis – 7th grade, Gianna – 10th grade, Eugenia – 8th grade); link algebraic and geometrical representations (Kosmas, 10th grade); or conjecture and prove a geometrical property (Kosmas – 10th grade, Takis – 10th grade).

Analysis of teachers' pre-lesson interviews allowed us to identify their goals and actions for proactively planning the level of mathematical challenge and support provided to meet different students' needs. As regards the mathematical challenge, the teachers attempted to integrate it in their didactical designs and make it accessible to all students through the following planning actions: (a) *Designing tasks with multiple solutions and different entry points*. For example, Kosmas asked students to use both algebraic and geometrical ways to solve equations with absolute values. The teacher knew that there were students (e.g., Maria) who could easily handle the geometrical way

while they had difficulties in the algebraic. The teacher considered the use of the geometrical way as challenging as it required a deeper understanding of the meaning of absolute value. Offering different entries for the students was related to the process of exploration often in the context of open and/or modelling problems. For example, Eugenia designed a modelling task on estimating the height of the classroom as an application of the tangent trigonometric notion. (b) *Using different kinds of resources (e.g., manipulatives, digital applets, diagrams, typical and non-typical measuring instruments)* to facilitate the making of connections between different representations. Markos, for instance, used digital tools (*Algebra Arrows* applet) to facilitate students' focus on the structure of arithmetic and algebraic expressions. Eugenia offered a hand-made protractor (a measuring instrument originated in the ancient Greek mathematics) and she commented about the critical role of this tool in mediating the conceptualization of the notion of tangent ratio. (c) *Creating an inclusive and mathematically challenging learning environment* by encouraging students to share their work in groups and in whole class discussions and avoiding evaluative comments. These actions were included in different ways in all teachers' didactical agendas. For example, Eugenia attributed emphasis to the roles and responsibilities she assigned to the students in each mixed ability group according to their mathematical backgrounds and interests.

How mathematical challenge and differentiation were balanced in lesson enactment

The episodes that follow are chosen to indicate illustrative ways by which the teachers stimulated the mathematical challenge and attempted to balance it with differentiation in different phases of the lesson. Episode 1 is selected from the setting up of the task and the challenge is based on the teacher's strategy. Episodes 2 and 3 are taken from the discussion of students' solutions and the starting point was students' difficulties or unexpected responses. In parentheses (italics) we characterize teachers' actions and at the end of each episode we summarize the teachers' actions.

Episode 1: Stimulating the key mathematical idea by exploring the validity of students' responses

This episode took place in one of Kosma's lessons in Geometry (10th grade). The task given to the students was the following: "How many degrees is the sum of the three angles of a triangle? How can we be sure about the answer?" (In the worksheet, there is an oblique triangle drawn and a triangle with an obtuse angle). In this task the challenge concerned the students' engagement in appreciating the need for proof. In the episode, we see how Kosmas promotes the challenge and at the same time the way that he formulates the task to allow the engagement of all students.

The teacher asks the students: "Are we sure that the sum of the angles of a triangle is 180 degrees?" (*stimulating the challenge*). Although most of the students reply that they know it from previous grades, Alexis, one of the students having usually limited participation in the lesson, suggests to prove it by measuring. The teacher asks him "If you measure the angles do you think that you will find 180 degrees?" and he asks all students to draw triangles and measure their angles by the use of a protractor (*valuing students' ideas by addressing them to the whole class; encouraging empirical solutions*). Alexis finds 179 degrees and other students 178, 179, 180, 181. The teacher writes these responses on the board (*recording and discussing all students' answers*) and asks students: "How can we be sure? It seems that we cannot be sure by measuring" (*refuting the empirical solutions*). Through these actions the teacher seems to point out the key mathematical idea to the students by building on Alexis'

suggestion for an empirical measurement. He intentionally accepts Alexis' suggestion and invites all students to perform measurements in different triangles. Next, he records all students' answers on the board as a way to question the validity of the approach. In his pre- and post-lesson reflection the teacher mentioned that he targeted the empirical justification to be discussed: "The discussion was what I wanted as the responses varied. It also went well since most students were involved, also by working in groups felt less exposed to evaluation" (Kosmas' post-lesson reflection). In this episode, the teacher stimulates the mathematical challenge of the task, encourages students to explore an inappropriate idea coming from a student, summarizes their responses, provokes the refutation and reinforces the challenge.

Episode 2: Using digital resources to address mathematical challenge and students' difficulties

This episode took place in one of Markos' lessons (7th grade) about the structure and equivalence of arithmetic and algebraic expressions through their connection to a realistic situation. The task and the corresponding questions revolved around the idea of describing an everyday situation (Maria's account balance after shopping) with different ways through simple arithmetic expressions (initially) and algebraic ones with the use of one and more than one variables (subsequently). The problem situation is described as follows: "Maria has 500€ in her bank account. She bought meat that cost 10€ She also bought fish that cost 20€ She used her debit card and received a message from her bank on her mobile, informing her that her account balance is 470€". The challenging dimensions of the task were related to the use of a realistic situation as a context of reference in conjunction with a multi-representational applet (*Algebra Arrows*) to identify the structure of arithmetic and algebraic expressions. We note that the construction of expressions in the environment is concretized by connecting Input/Output fields (including numbers or variables) to operation fields through the use of arrows. The environment provides the final result of the calculation as well as its structure (that is represented through arrows and symbolically). The students – who were familiar with the use of the applet - were given a worksheet involving the questions and a printed representation of the work area of *Algebra Arrows*. They worked in groups for about 5 minutes on a specific question with paper and pencil on the worksheet. After each group work session, the teacher used the *Algebra Arrows* representations (provided through a projector) to discuss students' solutions/reflections in a whole class discussion.

The episode took place after students describing the account balance and their relation [the expressions were: $500-10-20$ and $500-(10+20)$]. The class discussion concerned the students' solution to the questions: "If it is not known the initial amount of Maria's money in her account, construct through the use of *Algebra Arrows* two different expressions to describe the amount of money left in the account. What is the relation between the two expressions?" During the preceding group work session the teacher knew that the group 1 students (4 girls) had written correctly two expressions using variable for describing the situation – i.e. $x-(10+20)$ and $x-10-20$ – but they faced difficulty to consider them as equal. The teacher invites the students to discuss about the solutions in a whole class session. Before constructing the two expressions with the applet, he asks the students what are these expressions (*stimulating all students to provide the solution*). One student answers: " $x-(10+20)$ and $x-10-20$ ". Then Markos constructs the two expressions with the applet and asks students to provide the answer before this is projected (*using multiple and interconnected digital*

representations to justify an answer). Next, he comes back to the group 1's concern posing the question they discussed during autonomous work to the whole class showing the two fields in the applet: "Girls, I remember that earlier you were concerned if it is the same 'x' that appears here [in the expression $x-(10+20)$] and the 'x' that appears there [in the expression $x-10-20$]. This is a question for the whole class. I ask: Does this 'x' express the same thing?" (*posing an individual student difficulty to the whole class; stimulating all students to reflect on the provided representations*). One student (Nick) replies: "They are the same as they are connected with the same field – entitled Maria's Money: x - in the applet". The teacher indicates that both expressions are built by using the same field symbolized as 'x' (*revoicing the correct answer*): "Look the arrows starting from the cell containing Maria's initial amount of money. We speak about Maria's money in both expressions (*linking the digital representations to the realistic context*). In this episode, the teacher brings an individual student's difficulty in the whole class through the use of digital representations, stimulates all students to reflect on the provided representations, revoices a student's correct answer, strengthens the challenge by providing links to the realistic context.

Episode 3: Building on students' unexpected responses to extend the challenge for all students

This episode took place in one of Adonis' lessons (7th grade) about the exploration of the binary number system in the context of a real problem with three questions. The task context is a flour mill in the 19th century. The owner (the miller) has only one weight of 1kg, one of 2kg, one of 4kg, one of 8kg and one of 16kg. He claims that he can weigh sacks of flour until 31kg using these weights. In the first two questions, the students are asked how the miller weighs (1) a sack of 18kg and (2) sacks of 1, 2, 3, ... 31 kg (table is given to be filled in). The third question is how many kilos were contained in a sack where the miller has written on it the number 1011. Before the episode, the teacher had explained how weigh scales were used in the 19th century. The students completed the first and the second question rather easily. The mathematical demand increased in the third question when the students had to identify how the binary system 'works'. The teacher draws a sack on the blackboard and besides he writes the number 1011 and asks: "What does the number 1011 mean?" (*stimulating the challenge*). Fenia provides the following answer: "The number 1011 means that the miller used 1 weight of 16kg, none of 8kg, 1 of 4 kg and 1 of 2kg". The teacher asks students if they agree with Fenia (*valuing students' ideas by addressing them to the whole class*). Students provide different wrong responses (e.g., "It means 1kg and 11gr", "It means the price, 10Euros and 11cents"). In the realm of the rich discussion where different opinions were expressed, Ian suggests: "Perhaps we have to start from the right. One weight of 1kg, 1 weight of 2kg, none weight of 4kg and 1 weight of 8kg". This idea created uncertainty among the students, and it was also unexpected for the teacher ("I couldn't decide immediately how to handle it. I let the discussion to continue and I think that finally we reached a consensus", Adonis' post-lesson reflection). The teacher writes Fenia's and Ian's responses on the board to make them accessible to all students (*recording students' responses on the board*). Then he invites all students to compare these two solutions focusing on the place value of the digits (*stimulating the key mathematical idea*). He proposes to look at the tables they had filled on the distribution of weights from 1Kg to 31Kg in the previous question and asks students to find the place value of each digit (*linking the key mathematical idea to a previously answered question*). The teacher writes on the board upon each digit the values that the students provide (1, 2, 4, 8 from left to right).

The disagreement is still evident in the discussion and it is made explicit by one student who says: “We do not know if the miller represented the weights by writing the digits from left to right or vice versa”. Most of the students seem to consider it as a dilemma. The teacher invites – for first time - a high achiever (Tom) who raised his hand in all questions. Tom says: “The value of each digit depends on its place and the number system that the miller uses”. The teacher revoices Tom’s opinion emphasizing that the value of each digit depends on its place. There are students still providing wrong answers about the place value of the digits. The teacher writes on the board an integer (i.e. 1357) in the decimal number system and asks the students to find the place value of each digit (*simplifying the initial challenge through a familiar case*). A lot of students provide correct responses, but the teacher brings back the challenge: “Why do I have to accept it? How do we know what is the value of each digit?” (*bringing back the challenge*). The teacher addresses students who are reluctant to respond (*giving voice to silent students*). One of these students says: “We know it as a rule” and another one adds: “We have defined it. We have agreed to use it this way”. The discussion continues this way and more students participate. The teacher continues to bring as examples integers from the decimal number system (*simplifying the initial challenge*) and invites students to compare the two systems (*extending the challenge*). In this episode, the teacher brings a challenging issue by an individual student in the whole class, stimulates all students’ reflection, gives voice to silent students, makes links to familiar representations and extends the challenge by inviting students to make comparisons.

Conclusions

In this study we focused on teachers’ attempts to balance mathematical challenge and differentiation. Mathematical challenge was targeted by all teachers through the design of mathematically demanding tasks and the use of different resources (e.g., realistic contexts, diagrams, concrete materials, digital representations) to engage students in exploring, connecting and reflecting. During lesson enactment the teachers’ approaches to stimulate the challenge involved building on students’ ideas (revoicing, rephrasing, reformulating) as well as scaffolding by simplifying (e.g., bringing a familiar case/situation) and extending in a dynamic way (e.g., comparing different approaches/solutions/representations). Valuing students’ contributions and addressing them to all students appears at the core of teachers’ orchestration of the whole class discussion. The teachers appear to use students’ ideas (e.g., difficulties, indications of high-level reasoning) as a basis for communal reflection through the following actions: making the challenge accessible to students; recording all students’ answers; inviting students to connect different solutions; questioning proposed ideas; and favoring the development of an inclusive learning environment (e.g., encouraging silent students to participate). As regards the existence of some patterns in teachers’ approaches to balance mathematical challenge and differentiation, our analysis reveals a dynamic interplay of actions moving back and forth between providing challenging questions and prompts. Far from being characterized as linear, this process indicates underlying ‘zig-zag’ patterns related to the complexity of teaching practice when the teacher aims to keep the challenge and at the same time to maximize learning opportunities for all students. This is an interesting finding that needs further exploration taking into account that in existing literature teachers’ attempts to enact highly demanding tasks have been characterized with an emphasis on the part of mathematical challenge at a global level (upgrading/downgrading, lowering/maintaining/increasing, Stein et al., 2000). Our analysis indicates

the need to take a more detailed look on teachers' actions and on the spot decisions while working at the intersection of mathematically demanding tasks and differentiation.

Acknowledgement

This study has been conducted in the context of project “Enhancing Differentiated Instruction and Cognitive Activation in Mathematics Lessons by Supporting Teacher Learning (EDUCATE)”, which has been funded with support from the European Commission. This publication reflects the views only of the authors, and the Commission cannot be held responsible for any use which may be made of the information contained therein.

References

- Beltramo, J. (2017). Developing adaptive teaching practices through participation in cogenerative dialogues. *Teaching and Teacher Education*, 63, 326–337.
- Chapin, S. H., O'Connor, C., & Anderson, N. C. (2009). *Classroom discussions: Using math talk to help students learn*. Sausalito, CA: Math Solutions.
- Charmaz, K. (2006). *Constructing grounded theory*. London: Sage.
- Dooley, T. (2009). A teacher's role in whole-class mathematical discussion: Facilitator of performance etiquette? In V. Durand-Guerrier, S. Soury-Lavergne & F. Arzarello (Eds.), *Proceedings of the 6th ERME Congress (CERME)* (pp. 894–903). Lyon, France: INRP.
- Sherin, M. G. (2002). A balancing act: Developing a discourse community in a mathematics classroom. *Journal of Mathematics Teacher Education*, 5, 205–233.
- Stein, M. K., Smith, M. S., Henningsen, M. A., & Silver, E. A. (2000). *Implementing Standards-based mathematics instruction: A casebook for professional development*. New York, NY: Teachers College Press.
- Stein, M. K., Engle, R. A., Smith, M. S., & Hughes, E. K. (2008). Orchestrating productive mathematical discussions: Five practices for helping teachers move beyond show and tell. *Mathematical Thinking and Learning*, 10(4), 313–340.
- Sullivan, P., Mousley, J., & Zevenbergen, R. (2004). Describing elements of mathematics lessons that accommodate diversity in student background. In M. Johnsen Joines & A. Fuglestad (Eds.) *Proceedings of the 28th PME Conference* (Vol. 4, pp. 257–265). Bergen: PME.
- Sullivan, P., Mousley, J., & Zevenbergen, R. (2006). Teacher actions to maximize mathematics learning opportunities in heterogeneous classrooms. *International Journal of Science and Mathematics Education*, 4(1), 117–143.
- Tomlinson, C. A. (2014). *The differentiated classroom: Responding to the needs of all learners* (2nd ed.). Alexandria, VA: ASCD.

Investigating the relation between teachers' actions and students' meaning making of mathematics

Karin Rudsberg¹, Marcus Sundhäll² and Per Nilsson³

¹Örebro University, School of Humanities, Education and Social Sciences, Örebro, Sweden; karin.rudsberg@oru.se

²Örebro University, School of Science and Technology, Örebro, Sweden; marcus.sundhall@oru.se

³Örebro University, School of Science and Technology, Örebro, Sweden; per.nilsson@oru.se

In this paper we present and illustrate a framework for analyzing the relation between teachers' actions and students' meaning making in mathematics. We adopt a pragmatic perspective on learning, and a methodological approach using already analyzed material, to see whether and how the framework of epistemological move analysis can contribute when analyzing the relation between teachers' actions and students' meaning making. The results suggest that epistemological move analysis can be used to identify teachers' purpose in students meaning making in mathematics, by analyzing students' responses. Further, it makes it possible to identify what earlier knowledge students use, and how they use it, to re-actualize mathematical objects, relations and concepts.

Keywords: Mathematics teaching, meaning making, pragmatism, epistemological move analysis.

Introduction

The teacher plays a major role in making classroom talk the arena for learning mathematics and teachers' interactive strategies are central to how students become engaged in math-talks in a classroom practice (Walshaw & Anthony, 2008). To succeed in eliciting and extending students' mathematics, a teacher should encourage the mathematical activities of analyzing, making connections, and generalizing (Fraivillig, Murphy, & Fuson, 1999). It has been proven important that a teacher stimulates students to struggle with important mathematics by challenging them with non-routine tasks and trying to find out more efficient solution methods (Hiebert & Grouws, 2007). However, providing successful math-talks in practice can be challenging. Teachers tend to funneling (Bauersfeld, 1998) students' responses towards the answer they want, blocking them from being fully engaged in math-talk (Brodie, 2011). Also, rather than addressing problems in terms of the underlying concepts, students address problems mainly in terms of what they think that the teacher is expecting (Millar, Leach, & Osborne, 2001).

Talk-based teaching of mathematics is a complex teaching practice, calling for the need of theoretical constructs that take serious the social and interactive nature of teaching and learning (Lerman, 2000). However, concerns have been raised that a focus on social and interactive issues in mathematics teaching may steer away learning from content (Lerman, 2006). For instance, analyses of practices or activity systems common in sociocultural traditions tend to focus on what is done in a general objective (Bakker, Ben-Zvi, & Makar, 2017), which leaves little room for fine-grained analysis of how students make sense of mathematical content.

In the present paper we use a pragmatic perspective on learning (Dewey, 1929/1958) as a starting point, where meaning making is considered to emerge "in the process of doing and undergoing the

consequences of action” (Rudsberg, Öhman & Östman, 2013, p. 600). Based on this perspective the aim of this paper is to present and illustrate a framework that enables detailed investigations of teachers’ role in directing students’ meaning making processes of mathematics in talk-based teaching. The methodological approach in this paper is to use already analyzed material to see whether and how the framework can contribute when analyzing the relation between teachers’ actions and students’ meaning making. We aim to clarify and investigate both social and individual aspects of the meaning making process in mathematics, in a descriptive manner.

Theoretical background

A pragmatic perspective on meaning making: The first question to be addressed is how to understand learning and meaning making in classroom practice. Often the visibility of such processes is seen as a central problem (Östman & Öhman, 2010), for example the problem of not knowing what the students have in mind. The problem of visibility is often connected to a view of learning as something mental, something that takes place in the student’s head hidden from the observer (Rudsberg & Öhman, 2013). However, here we take Dewey’s theory of action (Dewey, 1929/1958)¹ as a starting point in which meaning making and learning are understood in terms of people’s actions; something they do, in relation to the environment and the specific situation at hand. This can be seen as a way to dissolve dualisms, such as, for example, between the concepts of inner mind and reality (Garrison, 2001). Dewey (1929/1958) describes life as a process of constant change that contains an active phase, doing, and a passive phase, undergoing the consequences of action. Accordingly, meanings are seen as the way that humans respond to the environment and they are practical in the sense that “we use them as *means to consequences*” (Garrison, 2001, p. 284). Dewey (1929/1958) states that meaning “is not indeed a psychic existence; it is primarily a property of behaviour” (p. 179). Communication is seen as a coordinating activity in which the participants make something in common (Garrison, 2001). In this way, “meaning making emerges in the process of doing and undergoing the consequences of action” (Rudsberg et al., 2013, p 600) and in this process experiences continually changes. Continuity can be seen as the process where students re-actualise earlier knowledge in order to make meaning in a new situation. In the process of re-actualization earlier knowledge also transforms i.e., earlier knowledge is not perceived as fixed entities. Meaning making can thus be understood as a practical social process (Garrison 1995). Hence, in this pragmatic perspective meaning making and learning is possible to observe *in* students’ coordinating activities. Learning takes place when students develop a new or more developed and specific repertoire of coordinating activities (Semetsky, 2008).

Epistemological move analysis: Epistemological move analysis (EMA) is based on a pragmatic understanding of epistemology, where it is seen as both a part and a result of human practices (Wickman & Östman, 2002). This means that what counts as relevant knowledge is different in different practices and the knowledge that is considered to be true and valid is a discursive construction (*ibid.*). EMA focuses on the relation between the epistemological moves that the teachers make and the students’ meaning making (Lidar, Lundqvist & Östman, 2006). An *epistemological*

¹ For a more thorough elaboration of Dewey’ theory of action and its use, see, for example, Östman and Öhman (2010).

move can be defined as the way a teacher's utterance affects a student's meaning making in an educational situation, that is, the way a teacher's actions facilitate a certain meaning making. In other words, how a teacher's answer to, and/or evaluation of, a student's utterance affects the student's meaning making. EMA has been used in educational practices of, for example, science education (Lidar et al., 2006). From previous research, we can delineate at least five different types of epistemological moves: *confirming*, *re-constructing*, *instructional*, *generative*, *re-orienting* (ibid.)².

As described above EMA enables investigations of the relation between the teacher's actions and students' meaning making in mathematics. In order to investigate students' meaning making EMA includes Practical Epistemology Analysis (PEA) (Lidar, Lundqvist & Östman, 2006). That is, EMA can be seen as a development of PEA with a specific focus on the role of teachers' actions. EMA aims at giving account of both the content and the processes of students' meaning making in relation to the teacher's moves. In the analysis of students' meaning making four central components are used; *encounter*, *gap*, *stand fast* and *relation* (Wickman & Östman, 2002). Teaching takes place in situations where students *encounter* their environment and interact with, for example, other students and the teacher. The interaction is made in relation to the purpose of the activity. That is, the first step of the analysis is to clarify what the student encounter and the purpose of the activity. In education, students sometimes do not immediately know how to proceed, i.e., the students cannot proceed by habit and a *gap* occurs. In teaching situations, a *gap* becomes visible when for example the teacher asks a question or when the students hesitate. In order for the interaction to proceed the *gap* needs to be filled, by, for example, responding to a question. This is done in the process of re-actualization. In the process of re-actualization the students bridges the *gap* by creating *relations* between their earlier knowledge, what *stands fast*, and the problem at hand. That is, the students' earlier knowledge becomes actualized in a new situation. The earlier knowledge becomes visible in the educational practise as the students use knowledge without hesitation and no explanations are needed. The relations created by the students constitute the content of the individual's meaning making.

In our analysis we focus on the relation between the teacher's actions and students' meaning making. The teachers' actions, for example, giving instructions, asking questions or making comments, can be seen as guidelines that direct the students' meaning making in a certain way. These actions made by the teachers indicate both what counts as knowledge and appropriate ways of acquiring this knowledge in the specific educational practice. Here it is important to notice that we categorize teachers' epistemological moves in terms of the function they have for the students' meaning making. On this account, we have analyzed whole events in order to clarify the differences between students' utterances before and after the teacher's actions. An event consists of a sequence consisting of three turns, including (1) a student's actions, (2) teachers' actions that encourage a student's action, and (3) a student's actions after the teacher's actions (Klaar & Öhman, 2014).

² The moves identified in this study will be described in the analysis; for a description of earlier identified epistemological moves see, for example, Lidar et al. (2006) and Rudsberg and Öhman (2010).

Illustration of EMA in mathematics education

To illustrate epistemological move analysis we use two examples from Blanton's and Kaput's paper focusing on classroom practices in algebraic reasoning (Blanton & Kaput, 2005). These examples are rich in mathematical content, given that the characterization is built on features of algebraic reasoning. Blanton and Kaput aim to "understand those types of instructional practice that indicated a generative and self-sustained capacity to build on students' algebraic reasoning" (ibid, p. 416). From this study we have chosen examples from audio-taped classroom talks. To identify the teacher's purpose of these classroom talks, the authors have studied notes by and interviews with the teacher. By using epistemological move analysis we can study the relationship between the purpose that the teacher expresses and the purpose visible in how the student responds to his/her moves. Blanton's and Kaput's paper includes several examples of principles for task-design and indications on what kind of question the teacher should ask to promote algebraic reasoning. However, their intention is "not to address how June's practice affected student achievement; this would require a more detailed look at how her actions played out in the classroom and how students were involved" (ibid, p. 435). In this paper we aim to employ such a detailed look by analyzing how the teacher's epistemological moves direct and support students' meaning making. This way we can clarify students' meaning making concerning both process and knowledge content in the actual situation. Important to notice, however, is that we do not investigate whether or not this change is of long term.

Algebraic treatment of number: In reviewing homework of addition tasks, the teacher shifts focus to properties of even and odd numbers and, during this sequence, there is an *encounter* established between the teacher (June) and two students (Tony and Jenna). In the first part of this encounter a scheme of even and odd numbers is used. The teacher's purpose is that the students should find an algebraic principle of parity in adding odd and even numbers. This aim becomes visible when the teacher uses large numbers to guide Tony to use an algebraic principle instead of computation that specifies even and odd numbers. The transcript (ibid.) used in this illustration is the following: "June challenged a student's use of arithmetic strategy to deduce that $5+7$ was even:

- 1 June: How did you get that?
- 2 Tony: I added 5 and 7 and then I looked over there [pointing to a visible list of even and odd numbers on the wall] and saw that it was even.
- 3 June: What about $45678+85631$? Odd or even?
- 4 Jenna: Odd.
- 5 June: Why?
- 6 Jenna: Because 8 and 1 is even and odd, and even and odd is odd." (p. 422).

Teacher "spontaneously shifted the focus from computing sums to determining if the sum of two numbers would be even or odd. When students responded by first computing the sum to determine if it was even or odd, June began to use numbers that were sufficiently large so that students could not compute. Instead, they were forced to attend to the structure in the inscriptions themselves." (ibid, p. 417). The *gap* in this encounter is between the use of addition in order to determine if the sum is even or odd and the ability to use an algebraic principle in order to determine if the sum will be even or odd. The *gap* becomes visible when the teacher (line 3) uses large numbers.

The students are able to make arguments on the parity of sums of odd and even numbers without using computations. The *stand fast* can be regarded as computation of specific numbers and using the list on the wall to determine odd and even numbers. This is *re-actualized* into the ability to use numbers as placeholders, or variables, for *any* odd or even number. This change is made because of the teacher's epistemological moves in line 3 and 5. Together these moves enabled the student to change the way of determining if a sum of two positive integers will be even or odd. Hence, the student has made new mathematical meaning about the structure of the inscription itself in terms of an algebraic principle of even and odd numbers. This way the teacher's epistemological moves in line 3 and 5 are *generative move* as they have the function of generate students learning of algebraic principles and relations. The teacher's purpose becomes visible in line 5 since the response by the student in line 6 is built on an algebraic principle rather than on computation.

Finding a mathematical formula: In working with the concept of area, the teacher introduced an activity in which students should determine how many two-colored counters were needed to cover a large purple square. In this sequence we can conclude that it is an *encounter* between the teacher and four students (June, Mari, Zolan, Stephanie, Kevin) and also one more student (unidentified in the audio-taped recording), who may or may not be one of the other four students. The teacher's purpose is that the students reach an understanding of how to use length and width to determine the area of rectangular planar objects, i.e., finding a formula for the area. This purpose becomes visible in line 23 as it generates the concepts of length and width in line 24. The transcript (ibid.) used in this illustration is as follows: "June had the following conversation with her students:

- 13 June: Do I know how big the square is?
 14 Mari: No.
 15 June: What do you see [referring to the large square which students had covered with tiles]?
 16 Zolan: Four columns, four rows.
 17 June: [June then covered a desk with the large purple squares like those she had given students.] So, what would the area of the desk be?
 18 Stephanie: Twenty-four big squares.
 19 June: What if we found the area of this table [pointing to a large table in the room]?

One student suggested using a ruler. Kevin proposed to examine how many purple squares are in a row and in a column.

- 20 Zolan: Count how many [purple squares] are in the bottom row.
 21 June: One, two, three, four, ... eighteen. [June counts out the number of purple squares in the bottom row.] And how many 18s do I need?
 22 Kevin: Seven!
 23 June: What's the best way to find area?
 24 Kevin: You measure this way and that way [indicating length and width] and multiply.
 25 June: What do you call "this way" and "that way"?
 26 Student: Length and width!" (p. 428-429).

The purpose in this encounter is located between the use of square tiles for covering rectangular planar objects and finding a formula for area of such objects. In line 13 the teacher asks the students if they know the size of the large purple square after the students have covered it with tiles. However, the teacher's first question (line 13) does not have any function in terms of meaning making, since the student cannot bridge the gap that the question creates. Indeed, the teacher's question (line 13) is an action, but it is not an action that qualifies as an epistemological move. A *gap* between square tiles and the size of a planar object becomes visible when the teacher in line 15 asks the students to look at the square and explain what they see. This is an *instructional move* since the student's answer is describing what he (Zolan) can see and not mentioning anything on area. This means that the gap lingers. In the third question (line 17) the teacher explicitly asks the students to find the area of the desk. This is a *re-orienting move* since the students now are focusing on the total amount of squares rather than numbers of columns and rows. Here it *stands fast* for the student how to cover a square object with square tiles (line 18). This earlier knowledge is re-actualized in order to make new meaning to view area as a grid of square tiles. Hereby the students are able to fill the gap.

When the teacher explicitly asks the students to determine the area of another planar object (line 19), the gap changes. The new *gap* is between using columns and rows and finding the formula for area. Related to the change of gap the student also actualizes other earlier knowledge that becomes visible when the teacher asks the students to determine the area of yet a new object (line 19). Here the knowledge that *stands fast* can be regarded as knowing how to use columns and rows to cover a rectangular planar object. This is re-actualized when the student starts to investigate the grid in a new way by counting the numbers of squares in the bottom row (line 20). In this way the teacher's action functions as a *re-orienting move*.

Finally, the teacher makes two *re-constructing moves* (line 21 and 23). The first becomes visible when the student (line 22) shows awareness of the importance in comparing the total number of square tiles with the numbers of columns and rows. Thereafter the student (line 24) is able to relate number of columns and rows to create a formula for area. Finally, the students are able to fill the gap by finding a formula, in terms of length and width, for determining area of planar objects.

Concluding remarks

The analysis shows how teacher's epistemological moves during math-talk is crucial for students' meaning making processes, both concerning the procedure (how) and the mathematical content (what). For example, in the first illustration the *generative move* deepens the student's mathematical knowledge in terms of an ability to build on algebraic principle rather than computation when determining even and odd numbers. We can conclude that the teacher enables the students to generalize (Fraivillig et al., 1999), which is done by challenging them to find a more general and efficient solution to the problem at hand (Hiebert & Grouws, 2007). By using EMA it was possible to identify how the students' earlier knowledge in this specific situation was *re-actualized* into the ability to use numbers as placeholders for *any* odd or even number. More explicitly, this re-actualization is made because of the teacher's epistemological move (line 3), made visible by the student's answer in line 6, where the latter uses numbers 1 and 8 as placeholders for odd and even numbers. By this re-actualization the student fills the gap that becomes visible by the teacher's

question in line 3. In this way the student has made new meaning about an algebraic principle of odd and even numbers. Here we stress that the contribution in using EMA is to point out what actually takes the meaning making a step forward, rather than analyzing certain approaches in forehand intended to promote specific motives. The strength in EMA is in the situational, rather than long term. However, in combining EMA with well-known strategies promoting algebraic reasoning, such as the framework used by Blanton & Kaput, sustainable learning perspectives may be closely related to situational and contextual perspectives.

This can be compared with our second illustration. In the first part of the transcript the teacher poses different questions with the purpose of enabling for the students to understand a formula for the area of rectangular objects. However, in the first part of the sequence the students answer the teacher's questions without re-actualizing any earlier knowledge about area. Instead they answer the question more in terms of what they think that the teacher are expecting (Millar et al., 2001). Important to notice here is also that the teacher's purpose, to understand how to determine area, isn't visible in the students' actions until later in the sequence (line 19-20). At the end of the sequence (line 24-26), after the re-constructing move, which also clarifies the teacher's purpose, the students re-actualize earlier knowledge that enables them to establish a formula for area. By using EMA we can identify that the teacher's purpose is not initially clear to the students. The students are not able to see how the general properties for area correlate to the teacher's purpose. The students try to answer the question (line 13) but are not able to fill the gap until the teacher changes character of the questions (line 23). This illustration can be seen as an example of funneling (Bauersfeld, 1998), with the consequence of students being partly blocked from being fully engaged in the talk (Brodie, 2011).

To summarize, using EMA, we *can* analyze the relation between teachers' actions and students' meaning making concerning process (how) and content (what) in mathematics. This way, EMA can contribute to the research on social and interactive processes in mathematics (Lerman, 2006). Further, EMA makes it possible to identify the role of teachers' purpose in students' meaning making in mathematics. However, it should be stressed that meaning making is seen as situational. We believe that the concept of re-actualization should get more attention in studying the role of teachers' actions for students' meaning making in mathematics. Re-actualization should not be misinterpreted as transfer or application, but rather as the process describing *what* stands fast in a certain encounter and *how* the students use knowledge that stands fast to create *new* meaning of mathematical objects, principles or concepts. Based on the present analysis, we claim that EMA offers analytical tools to enhance our understanding of the relationship between content and process in student's meaning-making in mathematics and the roles teachers' actions can have in providing directions for meaning-making.

References

- Bakker, A., Ben-Zvi, D., & Makar, K. (2017). An inferentialist perspective on the coordination of actions and reasons involved in making a statistical inference. *Mathematics Education Research Journal*, 29(4), 455–470.
- Bauersfeld, H. (1998). Interaction, construction, and knowledge: Alternative perspectives for mathematics education. In D. Grouws, T. Cooney, & D. Jones (Eds.), *Perspectives on research on effective mathematics teaching* (pp. 27–46). Reston, VA: NCTM.

- Blanton, M., & Kaput, J. (2005). Characterizing classroom practice that promotes algebraic reasoning. *Journal for Research in Mathematics Education*, 36, 412–446.
- Brodie, K. (2011). Working with learners' mathematical thinking: Towards a language of description for changing pedagogy. *Teaching and Teacher Education*, 27(1), 174–186.
- Dewey, J. (1958). *Experience and nature*. NY: Dover publications. (Originally published 1929).
- Garrison, J. (1995). Deweyan pragmatism and the epistemology of contemporary social constructivism. *American Educational Research Journal*, 32(4), 716–740.
- Garrison, J. (2001). An introduction to Dewey's theory of functional "trans-action": An alternative paradigm for activity theory. *Mind, Culture, and Activity*, 8, 275–296.
- Fraivillig, J. L., Murphy, L. A., & Fuson, K. C. (1999). Advancing children's mathematical thinking in everyday mathematics classrooms. *Journal for Res. in Mathematics Education*, 30(2), 148–170.
- Hiebert, J., & Grouws, D. A. (2007). The effects of classroom mathematics teaching on students' learning. In F. K. Lester (Ed.), *Second handbook of research on mathematics teaching and learning* (pp. 371–404). Greenwich, CT: Information Age.
- Klaar, S., & Öhman, J. (2014). Children's meaning making in nature in an outdoor-oriented and democratic Swedish preschool practice. *European Early Childhood Education Research Journal*, 22(2), 229–253.
- Lerman, S. (2000). The social turn in mathematics education research. In J. Boaler (Ed.), *Multiple perspectives on mathematics teaching and learning* (pp. 19–44). London: Ablex.
- Lerman, S. (2006). Cultural psychology, anthropology and sociology: The developing 'strong' social turn. In J. Maasz & W. Schloeglmann (Eds.), *New Mathematics Education Research and Practice* (pp. 171–188). Rotterdam: Sense Publisher.
- Lidar, M., Lundquist, E., & Östman, L. (2006). Teaching and Learning in the Science Classroom. *Science Education*, 90(1), 148–163.
- Millar, R., Leach, J., & Osborne, J. (2001). *Improving Science Education: The Contribution of Research*. Buckingham: Open University Press.
- Östman, L., & Öhman, J. (2010). A transactional approach to learning. Paper presented at the Annual Meeting of the American Educational Research Association, Denver, CO, April 2010.
- Rudsberg, K., Öhman, J., & Östman, L. (2013). Analysing Students' Learning in Classroom Discussions about Socio-scientific Issues. *Science Education* 97(4), 594–620.
- Semetsky, I. (2008). On the creative logic of education, or: re-reading Dewey through the lens of complexity science, *Educational Philosophy and Theory*, 40(1), 83–95.
- Walshaw, M., & Anthony, G. (2008). The teacher's role in classroom discourse: A review of recent research into mathematics classrooms. *Review of Educational Research*, 78(3), 516–551.
- Wickman, P-O. & Östman, L. (2002). Learning as discourse change: a sociocultural mechanism. *Science Education*, 86(5), 601–623.

Mathematics teaching and teachers' practice: tracing shifts in meaning and identifying potential theoretical lenses

Charalampos Sakonidis

Democritus University of Thrace, Greece; xsakonid@eled.duth.gr

The paper reports on meaning shifts of the terms 'teaching' and 'teachers' practice' in mathematics education over time and presents three theoretical frameworks arguing for their advantages in studying mathematics teachers' instructional practice, an especially complex but relatively unexplored sociocultural activity. An exemplification is then offered through the exploitation of one of the theoretical lenses suggested in the case of the mathematics teaching practice of a primary school teacher, Antigoni. The results of the data analysis informed by the lenses employed revealed a dynamic and strongly contextual understanding of the teacher's teaching practice connecting her current with past and present practices of hers, a feature specific to the framework used.

Keywords: Mathematics teaching practice, mathematics teachers' practice, meaning shifts, theoretical lenses.

Introduction

The identification of TWG19's exact research interest has been of concern since its birth in 2016, not only because of the obvious need to avoid overlapping with neighbouring CERME Working Groups but mainly for reasons of conceptual clarity and coherence. This concern is evident in the writings of the members of the leading team in several occasions. Thus, in Sakonidis et al. (2017) we argued that the work reported in the first TWG19 sessions at CERME10, related predominately to teachers operating on critical aspects of mathematics classroom instruction or inquiring into their own teaching suggested a shift of research focus from teachers to teaching. In a memo circulated to potential participants of TWG19 in CERME11, Mosvold, one of the members of its leading team, commenting on the shift of the group's research interest to mathematics teaching and teachers' practice(s), pointed out ambiguities in the use of the terms 'teaching' and 'practice' evident in their weak conceptualizations and the poorly addressed theoretical underpinnings of the latter. The meaning concerns related to the two central constituents of TWG19 focus were again raised in a chapter written for a volume on the twenty years of CERME research (Skott, et al., 2018), suggesting a social approach to attributing meaning to these constructs that will allow making sense of the corresponding practices in relation both to the contingencies emerging as classroom processes unfold and to the social practices of which they are part.

The paper is an attempt to further the above discussion. It first reports on the meaning shifts of the terms 'teaching' and 'practice' in mathematics education over time. It then presents some potentially useful theoretical frameworks for studying mathematics teaching and teachers' practice. An attempt to exemplify such a study is then provided through the analysis of an extract of a mathematics lesson taking place in a Greek primary classroom. The paper concludes with some moving ahead thoughts and considerations.

Mathematics teaching and teachers' practice(s): meaning advancements

Despite the significance of teachers' activity for pupils' learning but also for their own professional learning and development, as it is gradually acknowledged, research on teaching remains underdeveloped. Most of the relevant studies seek to understand or support teachers' actions that highlight mathematical processes and inquiry into what it takes for teachers to engage students in actively learning mathematics. The actual meaning of teachers' activity related to students' learning is left unchallenged.

The term 'teaching' has been used with different meanings in mathematics education, nurtured by different motives and purposes. Often seen as inseparable from learning, teaching tends to be related to teachers' actions, like orchestrating instructional activity, managing tasks and regulating communication within a classroom but also beyond it. Irrespectively of its meaning, teaching signals a highly complex activity that unfolds under conditions of uncertainty (given then unpredictability of human beings). Research such as that of Hattie (2015) documents the complexity of teaching: the challenge of making sense of the interplay between different aspects of it, the difficulty to appreciate institutional realities and the complexity of accountability which systems, parents and the general community demands. Teaching takes place through teacher's perception of, and interaction with its context which shapes his/her moment-by-moment decisions about what is important to teach, how students learn, how to manage student behavior and so on. This complexity of teaching is burdened in the case of mathematics teaching, given its highly valued learning outcomes worldwide and the difficulties teachers and students face in pursuing them due to intervening epistemological, cognitive sociocultural as well political factors.

Research on teaching over the past several decades has evolved from an emphasis on teacher characteristics to a focus on teachers' actions/behavior, to cognitive views of teachers as decision-makers and reflective practitioners (Grossman, Hammerness, & McDonald, 2009a) and more recently to teachers as participants in the practice of teaching (e.g., Lerman, 2013). This later trend enables making sense of teaching as a human activity situated in social settings. Furthermore, drawing on sociocultural theories, allows incorporating both intellectual and technical activities and encompassing both the individual practitioner (the teacher) and the professional communities (teachers, stakeholders of education, educators, and so on) (Chaiklin & Lave, 1996). For Wenger (1998) a practice includes "all the implicit relations, tacit conventions, subtle cues, untold rules of thumb, recognizable intuitions, specific perceptions, well-tuned sensitivities, embodied understandings, underlying assumptions, and shared world views. Most of these may never be articulated, yet they are unmistakable signs of membership in communities of practice" (p. 47).

Practice in complex domains like teaching, and especially mathematics teaching, involves the orchestration of understanding, skill, relationship and identity to carry out particular activities with others in specific settings. When people learn a practice, they enter a historically defined set of activities developed over time by others (Engeström, Miettinen, & Punamäki, 1999). As members of a profession, practitioners have a responsibility to their colleagues (Shulman, 1998), reinforcing the collective meanings of professional practice. They also use aspects of their own personalities, as well as their professional identities, as an intimate part of their practice (Grossman et al., 2009b). Based

on the above considerations, teaching is seen as teachers' multifaceted practice aiming at promoting students' mathematics learning in a variety of settings, shaped by the expectations and norms of these settings, learned from and shared with other practitioners and preserved by the traditions of educational thought and practice within which it has developed and evolved.

Mathematics teaching and teachers' practice: promising theoretical perspectives

The research interest of TWG19 delimited by the meaning attributed to the terms 'teaching' and 'practice' in the previous section is clearly served by the sociocultural tradition of teaching and learning mathematics. The available theoretical frameworks tend to see teaching as learning in practice, thus drawing mainly on the known theories of learning as well as on social theory to formulate their own perspective. Three among these appear to readily lend themselves to TWG19 research focus: Wenger's approach to learning as developing an identity through participation in a community of practice, Cultural-historical activity theory's focus on the learning that emerge in the institutionalized contexts of practical activities culturally and historically mediated within a society and recently Skott's participatory approach concentrating on patterns in individual teachers' participation in different social practices. Below, a brief presentation of each of these frameworks is offered highlighting elements that are related to TWG19's research interest.

Wenger (1998) describes community as "a way of talking about the social configurations in which our enterprises are defined as worth pursuing and our participation is recognizable as competence" (p. 5). These configurations are the basis of practice which is always social, whereas communities and learning are always socio-historically situated in webs of social relations. In a Community of Practice (CoP) members negotiate joint enterprises, ways of engaging with each and repertoires or languages for meaningful interactions and progress towards their goals. Belonging to a CoP, or developing identity within it, involves engagement, imagination and alignment. Thus, for example, in practices of mathematics learning and teaching, participants engage in their practice alongside their peers, use imagination in interpreting their own roles in the practice and align themselves with established norms and values. A teacher learns through a continuous process of 'becoming' in the context of the relationships in her classroom and with her colleagues within the education system and the society of which she is a part, as well as in relation to her own history, which is also socially situated. How these relationships are configured constrains and affords learning for particular teachers and communities of teachers.

Human activity is "a system with its own structure, its own internal transformations, and its own development" (Leont'ev, 1979, p. 46), activated by a motive and comprising goal-directed actions carried out by means of operations. Within an activity system, actions are mediated by tools and signs but also by or through community, rules of activity and division of labor (Engeström 2001). Individual and group actions within the activity system are seen as independent units of analysis that become understandable only when interpreted against the background of entire activity systems. Engeström (2001) considers contradictions and tensions as sources of change and development leading to transformations in activity systems. Individuals begin to question and deviate from the established norms, and the object and the motive of the activity are re-conceptualized to embrace a radically wider horizon of possibilities than in the previous mode of the activity. This, which Engeström calls

‘expansive learning’, gives rise to new knowledge and practices for a newly emerging activity system. Teaching practice is subject to extra-school influences such as policies emanating from school systems, teacher networks, district educational leadership and so on constituting activity systems with varied goals, motives, tools and rules which unavoidably shape teachers’ practice (s).

Skott (2013) developed a ‘patterns-of-participation’ (PoP) framework that aims to identify trends and developments in the recurrent “and possibly routinised ways in which the teacher engages with the students and the contents” (p. 548). He claims that teachers engage in everyday classroom interaction by reinterpreting and transforming past and present practices in the process. Hence, their contribution to the interaction is shaped by their participation in other significant discourses (mathematical, meta-mathematical or related to broader issues of the social situation), depending on the meaning attributed to the interaction itself. Thus, in each classroom interaction “the ‘pieces’ form a fluctuating pattern that indicates the shifting significance of different, prior discourses and practices as well as the dynamic relationships between them” (p. 548). Skott argues that teachers negotiate classroom practices by interpreting possible contributions to the interactions symbolically. To do this, they draw on their own schooling practices, interactions with colleagues, parents or the school management, theoretical discussions in their professional development program and so on.

I believe that the three frameworks presented above offer different but equally challenging perspectives to study mathematics teaching and teachers’ practice. CoP framework allows examining this practice as the enterprise of a particular community (related to school), CHAT within broader sociopolitical systems/environments and PoP as the result of the teacher’s contingent pattern of participation across practices and discourses (even beyond school). In the next session I employ PoP to present the case of Antigoni, the teacher in the uploaded video (for CERME11’s participants to work on) as an illustration of how the above three frameworks can help explore mathematics teachers’ practice exhibited during classroom teaching.

The use of PoP: the case of Antigoni

Antigoni, a primary teacher of 17 years of teaching experience, graduate of a Mathematics as well as of a primary education Department, is very committed to her profession; critically confident with respect to her mathematical but also her pedagogical knowledge and skills as evidenced, for example, in her open class for anyone who wishes to attend her mathematics lessons; and scientifically and professionally active as documented by her Master’s degree in Education, a considerable list of publications and conference contributions, as well as her regular participation in classroom intervention projects and professional development courses related to Mathematics.

Antigoni’s teaching practice has often been studied over the years of our cooperation from within various theoretical perspectives and in the pursue of different research questions. The lesson that the uploaded extract comes from is part of the data being collected in the context of a project focusing on the mathematics teaching practice of five primary teachers, one of them is Antigoni, including interviews, (video and audio) taped meetings before and after planned lessons and field notes. The analysis presented below aims to identify the roles Antigoni enacts in the practice emerging in her mathematics teaching.

Antigoni always liked mathematics as well as teaching. As a university mathematics student, she would choose courses that would offer opportunities “to dive in issues related to educating people in thinking mathematically, a question still haunting me”. And she still talks fondly about a University teacher, “the only one”, who offered optional courses on problem solving where she felt for the first time confident enough “to pose my own questions, to bring in the class my own problems, collaborate with others to solve a problem and feel OK to fail to find the solution to a problem for days!” (Antigoni as a student).

She is very enthusiastic about her being a mathematician and a primary teacher “in a territory where most fellow teachers fear ... or are anxious when teaching mathematics ... often stuck to the textbooks provided by the government and going by the book”. She was also worrying initially about mathematics teaching, but she then thought:

Come on, you love mathematics! (laughs) ... This is your chance to prove that primary mathematics is more important but also harder to learn ... and teach because... a primary teacher lays the foundation of a solid mathematics learning trajectory! (Antigoni as teacher)

Antigoni approached us in the Primary Education Department of the nearby University about twelve years ago asking for help “as I was feeling like trying hard but with no results!” This is where a fruitful collaboration started originally with few visits in her class and gradually incorporated small projects (e.g., putting aside the textbook, introducing investigative tasks for small groups, discussing specific areas of the curriculum, e.g., introducing fractions in the 3rd grade, diverting from the ‘desirable’ sequence of teaching the content of the mathematics curriculum, inviting fellow teachers to work together in her class, explaining to teachers what she was trying to do, and so on).

I still remember how suspiciously Maria looked at me (a very close friend and fellow teacher in the same school) when I asked her to join me in reading the relevant literature, plan and teach together my class the idea of ratio, an idea used to be taught much later that year (laughs)... Also, the parents of ... who were furious for ‘wasting valuable time on ‘experimentations’. I am still anxious when I meet parents for the first time to talk to them... And of course, Headmaster ... who never liked me for ...messing up his school! (Antigoni as a colleague)

Nowadays, Antigoni works with a group of at least half of the teachers of the school, planning and implementing shared teaching sessions, runs almost every year a Students’ Mathematics’ Club, works with us in organizing professional development courses for the teachers of her school with a specific focus every year and this year plans to invite teachers of other schools in a two-days meeting to share with them what they do (Antigoni as a professional).

With respect to teaching mathematics, Antigoni believes that primary mathematics is for all students who should be taught in ways that would “allow them to go deep into the heart of mathematics” through tasks that make sense to them, boost their confidence in “acting mathematically”, support their conceptual understanding and “help them feel safe”. As far herself is concerned, she thinks that her teaching “is OK if you think in constructivist terms but still away from being able to genuinely promote collective learning of mathematics”. In the uploaded extract the mathematical focus is on the concept of fraction and especially on the idea that the whole is made up of the sum of all its fractional units. Antigoni addresses the whole class with the question “how many fractional units

make up the whole” but things get wrong when she asks for the symbolic writing of the idea (Antigoni as a teacher).

- Teacher: How would I write it to make a whole pie out of these (three) pieces?
- Student: (comes to the blackboard) The whole pie?
- Teacher: Yes, the whole pie. Let’s see.
- Student: (writes the fraction three thirds – $3/3$)
- Teacher: Ah!! And how to you make up these three thirds?
- Student: From three pieces.
- Teacher: How do you write that down? Do write ‘equals’, how do you write that down in mathematics?
- Student: (writes the equal sign to the right of $3/3$)
- Teacher: How exactly do you make three thirds for this pizza?
- Student: In ones?
- Teacher: What do you mean? What are the ‘ones’ here?
- Student: One piece
- Teacher: Write down the “one piece”
- Student: One plus one plus one. (writes $3/3=1+1+1=3$)
- Teacher: Do you agree? One plus one plus one is three. Is it the same as what he’s written on the board? Maria?
- Maria: Three out of three pieces.
- Teacher: Can we see that by the way you’ve written it? How can we show that it’s three out of the three pieces? Let’s see.
- Student: (erases $1+1+1=3$)
- Teacher: Let’s help him a little. How do we write each piece of this pizza? Can someone help? Chryssa?
- Chryssa: One third!

The discussion goes on for a little more, the student writes $3=1/3$ but it’s obvious that he doesn’t really follow. Watching the episode afterwards Antigoni expressed her disappointment for the students’ difficulty but argues that the idea is not an easy one and insists on ‘giving space’ to students to communicate their thoughts.

Summarizing, Antigoni’s narrations of herself as a committed and determined professional relate to the challenges offered by both mathematics and teaching in exploring and making sense of the world as well as communicating with others, pursued and enjoyed by her from early on. Collaboration, team work and issues of knowledge accessibility are at the heart of Antigoni’s professionalism, sometimes

constrained by factors external to her teaching practice. She acknowledges in her teaching practice students attempt to communicate their thinking, encourages ‘epistemologically correct mathematics’, thus valuing mathematics as a scientific discipline but prioritizes students’ confidence and inquiring approaches. Finally, her strong ties with mathematics appears to weaken any challenge to her professional self.

Concluding remarks

Despite its importance, it’s only recently that teachers’ instructional activity per se attracted the interest of the research community, being seen until then mostly in relation to students’ learning. Shifting the emphasis from teachers to teaching, which is viewed as a social practice, the relevant research employs predominately sociocultural and especially participatory perspectives to understand the emerging character of this practice “taking into consideration working contexts, meanings and intentions ... the social structure of the context and its many layers – classroom, school, community, professional structure and educational and social system” (Ponte & Chapman, 2006, p. 483). These activities mutually structure and frame each other to constitute the teaching practice (Skott, 2013).

The theoretical frameworks available in the literature for studying the practice of mathematics teaching as presented above recognize the high level of complexity associated with it. Within this complexity lie affordances and constraints, shaped by culture, the environment and people in it. This suggests that no single framework is likely to capture the complexity of the mathematics teaching practice across widely variable contexts. A variety of dynamic perspectives is necessary which will help us disentangle and understand the ever-evolving outcome of individual and communal acts of meaning-making (by both teachers and students) characterizing the practice of mathematics teaching. Antigoni’s narrations revealed the dynamic relationship between present and past teaching and other practices and hence discourses she participated, without allowing though for its development to be traced. A more careful consideration of mathematics teaching as a social practice being informed by teachers’ participation in (not necessarily compatible) discourses beyond classroom setting, predominately but not exclusively related to mathematics, might offer challenging lenses for making better sense of how these discourses are enacted and interact both at the micro and the macro level within the classroom, shaping teachers’ moment-to-moment teaching practice(s).

References

- Chaiklin, S., & Lave, J. (1996). *Understanding practice: Perspectives on activity and context*. Cambridge, UK: Cambridge University Press.
- Cole, M. (1996). *Cultural psychology: A once and future discipline*. Cambridge, MA: Harvard University Press.
- Engeström, Y. (2001). Expansive learning at work: Toward an activity theoretical reconceptualization. *Journal of Education and Work*, 14, 133–156.
- Engeström, Y., Miettinen, R., & Punamäki, R-L. (Eds.). (1999). *Perspectives on activity theory*. Cambridge, UK: Cambridge University Press.
- Hattie, J. (2015). The applicability of visible learning to higher education. *Scholarship of Teaching and Learning in Psychology*, 1(1), 79–91.

- Grossman, P., Hammerness, K., & McDonald, M. (2009a). Redefining teaching, re-imagining teacher education. *Teachers and Teaching*, 15(2), 273–289.
- Grossman, P., Compton, C., Igra, D., Ronfeldt, M., Shahan, E., & Williamson, P.W. (2009b). Teaching Practice: A Cross-Professional Perspective. *Teachers College Record*, 111(9), 2055–2100.
- Leont'ev, A. N. (1979). The problem of activity in psychology. In J.V. Wertsch (Ed.), *The concept of activity in Soviet psychology* (pp. 37–71). New York, NY: M. E. Sharpe.
- Lerman, S. (2013). Theories in practice: mathematics teaching and mathematics teacher education. *ZDM – The International Journal on Mathematics Education*, 45(4), 623–631.
- Ponte, J. P., & Chapman, O. (2006). Mathematics teachers' knowledge and practices. In A. Gutierrez & P. Boero (Eds.), *Handbook of research on the psychology of mathematics education: Past, present and future* (pp. 461–494). Rotterdam: Sense.
- Sakonidis, C., Drageset, O.G., Mosvold, R., Skott, J., & Taylan, R. D. (2017). Introduction to the contributions of TWG19: Mathematics teachers and classroom practices. In T. Dooley, & G. Gueudet (Eds.), *Proceedings of the 10th Congress of the European Society for Research in Mathematics Education* (pp. 2954–2961). Dublin, Ireland: DCU Institute of Education and ERME.
- Shulman, L. S. (1998). Theory, practice, and the education of professionals. *Elementary School Journal*, 98, 511–526.
- Skott, J. (2013). Understanding the role of the teacher in emerging classroom practices: searching for patterns of participation. *ZDM – the International Journal on Mathematics Education*, 45(4), 547–559.
- Skott, J., Mosvold, R., & Sakonidis, C. (2018). Classroom practice and teachers' knowledge, beliefs, and identity. In T. Dreyfus, M. Artigue, D. Potari, S. Prediger & K. Ruthven (Eds.), *Developing research in mathematics education – twenty years of communication, cooperation and collaboration in Europe*, Vol. 1, (pp. 162–180). London and New York: Routledge-New Perspectives on Research in Mathematics Education – ERME series.
- Wenger, E. (1998). *Communities of practice: Learning, meaning and identity*. Cambridge: Cambridge University Press.

Pre-service teachers' experiences in selecting and proposing challenging tasks in secondary classrooms

Leonor Santos¹, Hélia Oliveira¹, João Pedro da Ponte¹, Ana Henriques¹

¹Instituto de Educação, Universidade de Lisboa, Portugal; mlsantos@ie.ulisboa.pt; hmoliveira@ie.ulisboa.pt; jpponte@ie.ulisboa.pt; achenriques@ie.ulisboa.pt

This study aims to know if pre-service secondary school mathematics teachers are able to select, adapt or design appropriate challenging tasks and what are the main challenges that they face when working with challenging tasks in the classroom. The study is qualitative, based on observation and interviews. The participants are two preservice teachers at the 2nd (and final) year of their master of teaching degree. The results show that the preservice teachers, albeit facing several constrains, were able to find and adapt interesting tasks. They also identified several challenges in this activity, in the planning phase, during students' autonomous work and, most especially, during the whole class discussions.

Keywords: Challenging tasks, preservice teachers, planning, students' autonomous work; whole class discussions.

Introduction

What students learn in mathematics mostly depends on the mathematical experiences offered to them in mathematics lessons (NCTM, 2014). Particularly powerful to promote the development of mathematical understanding are challenging tasks that require students to establish connections among different aspects of mathematics, formulate their own solution strategies and explore several pathways to solutions (Sullivan et al., 2015). These kind of intellectual activities requires new pedagogies in teaching mathematics and, consequently, raises new challenges to teachers, namely putting demands on teachers' knowledge (Sullivan & Mornane, 2014), on teachers' understanding of tasks, particularly their potential and demands (Foster & Inglis, 2017), and on teachers' classroom practice (Ponte & Quaresma, 2016). Most studies addressing this issue involve in-service teachers, but we want to understand which main issues arise when pre-service teachers (PTs) are encouraged to propose challenging tasks in the classroom. This was the general issue that prompted us to develop a study with two pre-service secondary school mathematics teachers, aiming to answer the following research questions: (i) What are the nature of the tasks selected, adapted or designed by the PTs? and (ii) What are the main challenges that PTs face when they propose and enact challenging tasks?

Theoretical framework

The centrality of tasks in mathematics classroom instruction has been recognized both by theoretical perspectives and empirical research (Shimizu et al., 2010). Several curricular documents around the world recommend the inclusion of "rich" or challenging tasks in mathematics teaching in order to promote students' high level thinking such as problem solving and reasoning (NCTM, 2014). However, different conceptualizations on the nature of such tasks have been proposed by distinct authors, and using different language, for instance "rich", "authentic" or "complex" tasks (Shimizu et al., 2010). The profusion of terms, and particularly the lack of explicitness concerning their meaning, often does not contribute to develop a clear understanding in the educational settings

about the core characteristics these tasks should have. As Foster and Inglis (2017) found in their study with a large number of mathematics teachers in the UK, teachers express contrasting perspectives about the nature of the tasks, namely having one task classified both as demanding and non-demanding or as engaging and non-engaging by different teachers.

One of the most well-known taxonomy for tasks is the one by Stein and colleagues which includes four levels of cognitive demand to characterize the mathematical tasks: two for lower-level and two for higher-level demands (Stein & Smith, 1998). According to the authors, the tasks that exhibit a lower-level of cognitive demand may be targeted at *memorization* or to use *procedures without connections*, that is without explicit attention to concepts and understanding; those rated as higher-level involve complex thinking and reasoning processes and are denominated as *procedures with connections* and *doing mathematics*. We have adopted the definition of cognitively demanding tasks proposed in this framework. Tasks may assume the form of problems, exploratory or inquiry tasks.

The practice of proposing and enacting challenging tasks that are set and maintain the intended level of cognitive demand has showed problematic for many teachers (Stein & Smith, 1998), and attention has been given to teacher education programs that might support teachers in developing new practices (Ponte et al., 2017). One of the main issues is the need to move to new lesson structure that support a student-centred approach and value classroom discourse, namely through the promotion of whole-class discussion as an effective enactment of challenging tasks in the classroom (Russo & Hopkins, 2017; Sullivan & Mornane, 2014). As the study by Crespo (2003) shows when they are “left to their own devices preservice teachers’ tendencies were to pose unproblematic problems to their pupils” (p. 264). It seems important that PTs are able to articulate their vision about teaching, namely the need to diversify the nature of the tasks that are usually proposed in the classroom, making possible for them to collaborate in the future with other teachers in developing new teaching practices (Towers, 2010) that may include challenging tasks.

Two important aspects of the teaching practice with challenging tasks are the questions the teacher poses to the class and how he/she sequences it (Mata-Pereira & Ponte, 2017) and providing appropriate enabling prompts for those students who experience difficulties in the task, such as, “reducing the number of steps, simplifying the complexity of the numbers or varying the forms of representation” (Sullivan et al., 2015, p. 126). In the case of PTs who lack the experience of teaching, these actions may even more challenging. Teacher education programs need to provide PTs with opportunities to learn within a “practice-based” experience that allows them to develop skills targeting specific practices (Forzani, 2014) such as selecting and supporting the enactment of challenging tasks in the classroom.

Context of the study and methods

This study was carried out with two PTs on the second year of the Master of Teaching degree at Universidade de Lisboa. During their field experience, PTs were invited to select challenging tasks to propose in two lessons that they were about to teach in their school placement, that would be observed by their respective university supervisor (the two first authors). By then, PTs had attended the teacher mentor classes for about one month and had the opportunity to interact with students, but this was the first time they were responsible for teaching a lesson by themselves. The request for teaching with challenging tasks was not a surprise to PTs since, in alignment with current

curriculum orientations for mathematics teaching, this masters' program provides extensive discussion on inquiry-based perspectives on mathematics teaching (Ponte et al., 2017).

Five PTs were attending the course. For this study, we select as cases two PTs that we regard as more contrasting considering the focus of our study: Marta and Magdalena, both fictitious names. Marta is 22 years old and graduated in Applied Mathematics and Computation. She developed her teaching practice in a private school, in an urban area of Lisbon. She taught a 12th grade class (age 17) with 13 students who are interested and motivated for studying, show good achievement in mathematics (only two have medium achievement, all the others have high). They are usually focused on the proposed mathematical work and try to help each other when working in pairs. Magdalena is 24 years old and graduated in Applied Mathematics. She teaches a 10th grade class (age 15) with 17 students in another private school near Lisbon. The students are heterogeneous regarding their school achievement, 35% had a negative grade in Mathematics at the end of the 1st school term and show many difficulties in the topics covered in previous years. Most of them show lack of study habits and are not very participative in class.

Following a qualitative research approach, data collection processes included the observation of two lessons with video recording, pre- and post-lesson reflections audio recorded with PTs, post-lesson written reflections, and their lesson plans. A first reflection (R1) occurs before each observed lesson. Immediately after, and preceding the post-lesson reflection (R2), there was a discussion about the lesson with the supervisor and mentor. Content analysis was used to analyse data, with pre-defined categories for the nature of the tasks (Stein & Smith, 1998). In the case of the challenges faced by the two PTs there were no predefined categories but we had as reference the review of literature presented in the theoretical framework.

The nature of tasks

In both observed lessons, PTs proposed one task to the class. The tasks sought to introduce or create the need for new knowledge, in particular to relate the signal of the second derivative with the direction of the concavity of the graph of a function (Task 1, Marta) or they were problems (Tasks 1a, 1b and 2, Magdalena). Task 2 by Marta was a problem of optimization, which sought to lead students to feel the need to know how to differentiate trigonometric functions. In both tasks, the students in Marta's class used the graphic calculator. All tasks included several questions and can be rated as *High Cognitive Demand* with different level of intellectual challenge (Table 1).

Table 1. Characterization of the tasks concerning the level of intellectual demand

Task 2 - Marta Tasks 1a and 2 - Magdalena	Procedures with connections	Requires "some degree of cognitive effort. Although general procedures may be followed, they cannot be followed mindlessly".
Task 1 - Marta Task 1b -Magdalena	Doing Mathematics	Requires "students to access relevant knowledge and experiences and make appropriate use of them in working through the task" and "considerable cognitive effort".

Magdalena's task 1a and 2 and Marta's task 2 are characterized in the group of *Procedures with connections*, because they demand to apply previous knowledge in new situations (to calculate

measurements from a geometric object; to study a trigonometric function in a way similar to what they had done for other types of functions), requiring a transfer of knowledge. The other tasks present characteristics of *Doing mathematics*, since they require considerable cognitive effort, such as to apply to the second derivative of a function what they had learned about the first derivative (Task 1, Marta) or to establish diverse relationships between geometric objects, demanding a good visualization capacity, in particular, students need to use their knowledge about volumes of solids (cube and pyramid) (Task 1b, Magdalena).

PTs' perspectives about the tasks are similar to our analysis, but they do not use the same terminology since this taxonomy was not explored with them. The aspects they mention are that their students were not used to solving these kinds of tasks, they were called to develop mathematical ideas that had not yet been covered in class, and required processes of reasoning more complex than usual:

The task is challenging for students because it addresses the second derivative and its geometric meaning without first introducing it “theoretically”. (Marta, pre-lesson R1)

They are challenging tasks because they confront the students with unexpected things, that they are not used to, and lead them to think and reflect on how they might get there. I think (...) this helps them to develop their mathematical reasoning. (Magdalena, pre-lesson R1)

For Marta, although the two tasks have in common being challenging, there are differences between them. While she considered task 1 as “a more oriented task” (that students have to answer a sequence of questions), she regards task 2 as “a problem” (Marta, post-lesson R 2). Task 1 is very structured, appealing mainly to calculations. Task 2 leads students to look at the proposed situation in a global way. For Magdalena, the proposed tasks are mainly problems, with the exception of a few questions from one of the tasks (task 1b) proposed in the first lesson which she considered to be exploration or investigation.

Pre-service teachers' challenges when working on challenging tasks

Regarding planning for these lessons, the two PTs did not hesitate to say that *to obtain challenging tasks* was quite a challenge for them: “The biggest challenge before the class was to build from scratch task 1 and to find a second task that would be challenging, suitable and relevant to this class” (Marta, post-lesson reflection 2). They searched in textbooks, but found no task with the sought features, so they also used other resources: Marta looked at materials of the Association of Mathematics Teachers brought especially by the teachers of her school. Magdalena made an extensive search in the internet and in several textbooks. For the second lesson she felt that it was difficult to find a suitable situation. When finally she found a situation that seemed promising to design the task, she still needed some guidance from her supervisor to guarantee it could be solved by different processes.

In their lesson plans, the two PTs expressed the intention to adopt an exploratory approach to teaching either by her own initiative in the case of Magdalena, or by the supervisor's suggestion, in the case of Marta. In both cases, PTs made plans that took into account the different phases of an exploratory teaching approach: introduction of the task, students' autonomous work and discussion with the whole class, accompanied by a synthesis of key ideas.

In all lessons, the introduction of the task was of short duration. Students were informed that they would work autonomously during a determined period of time and then there would be a whole-class discussion. At this stage of the lesson, no questions were raised by the students. It has not been observed, or referred by Marta or Magdalena, any challenge during this phase of the lessons.

During the students' autonomous work, the PTs circulated, accompanying the students' work, namely by answering some clarifying questions. Magdalena assumed that her role in these classes should be to support students through questioning, not telling them exactly what they should do. Nevertheless, she recognizes that this type of intervention sometimes has not the intended effect, in particular with students with greater difficulties. So, one of the challenges in these lessons is to know what *type of intervention* she should develop in line with the diversity of students in the class:

I stand for not giving the answer and instead to guide students. But sometimes I'm afraid to say something that leads them to the answer and that they figure out [the answer]. (...) I think it's important that they think for themselves but when I am in front of students with more difficulties sometimes I don't know at which point should I just guide and guide... To me, that is most difficult. (Magdalena, post-lesson R2)

Associated with this phase of students' autonomous work, these PTs mention the challenge of time management in supporting different groups. Magdalena due the unexpected difficulties that came out in the first task, had to spend too much time with some students in order to understand what they were doing, to identify their errors and to think of questions or prompts that could help. Consequently, she has spent a lot of time with some students, limiting the possibility of supporting other students. Marta also mentions the challenge of "making a good management of the time I am spending with each group" (Marta, post-lesson R2), which she relates with the decision of when to leave the group and let those students work autonomously:

Even if students in the group still remain with some doubts, I can give some guidance but I also need to know when to let them working and struggling by their own and come back to them later on (...) after supporting other groups (...) [But] to me, this decision is not always very easy: to give some guidance and to know when I should leave the group. (Marta, post-lesson R2)

The *time to devote to this stage* of autonomous work on the task and, consequently, the decision of when it is appropriate to close this phase and move to the whole-class discussion it is also an issue identified by these PTs:

[I verified] that the students were not working as I had previously planned, which is not necessarily negative. The time that I had set was showing to be too short. It was a challenge that I had to face: to decide whether I should to move for discussion or not. (Marta, post-lesson R1)

The whole-class discussion presents also some problems to these PTs, such as *to take advantage* from this phase of the lesson, to explore it in a developed way. In the first lesson, Marta solved on the board the first questions of the task with the contributions of the students, and they did not raise any doubts, apart from some calculation problems. In fact, the real discussion began with question 1.5. when Marta questioned: "Who is able to explain to the class what is demanded in 1.5.?" A student began to answer, but Marta said: "Use your own words to explain what is asked here. It is a

question that raised a lot of confusion”. Marta supported the discussion about the calculation of the limits, and simultaneously the graph of the given function and the tangent lines at given points were constructed in Geogebra. After the students’ explanation, Marta also gives her own but there is no effective discussion. The discussion happens, in each moment, essentially between Marta and a certain student; there is no discussion among the students.

In the first moment of the discussion of task 2 (Figure 1), Marta begins by asking a group of students to explain what they did:

S: We tried to define a formula for the wire length.

Marta: Do you begin immediately to think in getting a formula?

S: Initially we tried a little by eye.

Marta: And what was your perception?

S: At the junction of the two triangles, if they joint at a midpoint (Marta, lesson 2)

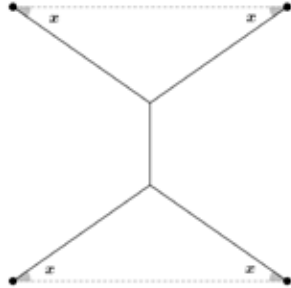
<p>1. Four villages are located on the four corners of a 1 km side square. When making a new cable installation linking the four villages, the company responsible for the project came to the conclusion that the most economical solution is the one of the following figure. It is known that this type of installation is considered for $x \in \left[0, \frac{\pi}{4}\right]$.</p> <p>1.1. “As the angle x increases, the total length of cable required decreases”. Do you agree with this statement? Justify.</p>	
--	--

Figure 1. First question of task 2 in Marta’s lessons

Marta decided not to use the material that she had prepared previously to support the discussion with the whole class and asked the students to go to the board to explain what they have done. She tries that each group presents his strategy, although the decision on *which should be the sequence* of students’ work for presentation to the class was also a challenge for her:

In the second discussion, as there were already so many groups knowing [how to solve the task] (...) knowing where to start [this was an issue]: [should I begin] by those who have not got there or [should I] give opportunity [to the others],.. I think this was also a challenge... (Marta, post-lesson R2)

Magdalena also had the intention to promote whole-class discussion after the students solved the tasks. In the first lesson, in face of students’ struggling where they had many computations to complete, there was no time for the majority of students to solve the second part (Figure 2), which was the one that had more potential for discussion. In the second lesson, the students also took much more time than predicted to solve the task. In the face of lack of time, only one student presented his solving strategy and there was no interaction with other students apart from some questions for some clarification. So, the capacity to have a real *perception of the difficulty that the tasks may present to students* has been for Magdalena a restriction to develop a fruitful whole class discussion.

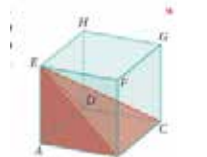
<p>In the figure it is represented the cube [ABCDEFGH] and the pyramid [ABCDE]. It is known that $\overline{EC} = \sqrt{12} \text{ cm}$. Determine the volume of the part of the cube that is not occupied by the pyramid.</p>	
---	---

Figure 2. Task 1b in Magdalena's lessons

Conclusion

In this study, both PTs were able to find and adapt interesting tasks. However, they faced the constraint of finding or designing challenging tasks aligned with the specific mathematical topic they had to teach during their practice. They considered the tasks challenging since they were different from what is usually proposed to these students and appealed to mathematical ideas that students had not yet covered, being a means for new learning or to promote processes of reasoning that are more complex than usual (NCTM, 2014). This indicates that the teacher education environment provided the two PTs with the intellectual resources and dispositions necessary to identify and adapt challenging tasks to propose in their classes, contributing to their development of a shared idea of the nature of these tasks.

For an effective enactment of challenging tasks in the classroom, the two PTs adopted a new lesson structure (Russo & Hopkins, 2017; Sullivan & Mornane, 2014), identifying several challenges in this process. In planning, although always considered in the lesson plan, they see the *anticipation of students' difficulties in solving the task* as underdeveloped due to their lack of experience in teaching as they do not have a deep knowledge of the students (Magdalena). During students' autonomous work, the *time and the support to give to students* were problematic for both PTs, namely in order to maintain the intended level of cognitive demand, as it has been found in other research with in-service teachers (Stein & Smith, 1998). During the whole class discussion, Marta faced challenges such as *selecting and sequencing the presentation of student's strategies*, knowing which ones to use, the most appropriate ways of doing it, namely when most groups had already solved the proposed questions correctly; *involving* all students in the discussion, even those who have more difficulties or are more reserved; *promoting a broad discussion among the students* which requires knowing how to break with the teacher-student-teacher circle; and *going deep in the exploration of what students say*, especially of what is mathematically important, but is difficult to understand for some students (Mata-Pereira & Ponte, 2017). From these results, we may say that the teacher education program supports teachers in developing new practices (Ponte et al., 2017) especially in moments of planning. During the lessons, where it is necessary to take decisions in action, the pre-service teachers faced diverse challenges, most of them similar to those of in-service teachers.

Acknowledgement

This study has been developed under the scope of the Project EDUCATE - Enhancing Differentiated Instruction and Cognitive Activation in Mathematics Lessons by Supporting Teacher Learning, funded by the European Commission. This communication reflects the views only of the authors, and the Commission cannot be held responsible for any use which may be made of the presented information.

References

- Crespo, S. (2003). Learning to pose mathematical problems: exploring changes in preservice teachers' practices. *Educational Studies in Mathematics*, 52, 243–270.
- Forzani, F. M. (2014). Understanding “Core Practices” and “Practice-Based” Teacher Education: Learning From the Past. *Journal of Teacher Education*, 65(4), 357–368.
- Foster, C., & Inglis, M. (2017). Teachers' appraisals of adjectives relating to mathematics tasks. *Educational Studies in Mathematics*, 95(3), 283–301. doi:10.1007/s10649-017-9750-y
- Mata-Pereira, J., & Ponte, J. P. (2017). Enhancing students' mathematical reasoning in the classroom: Teacher actions facilitating generalization and justification. *Educational Studies in Mathematics*, 96(2), 169–186.
- NCTM (2014). *Principles to actions: Ensuring mathematical success for all*. Reston: NCTM.
- Ponte, J. P., & Quresma, M. (2016). Teachers' professional practice conducting mathematical discussions. *Educational Studies in Mathematics*, 93(1), 51–66.
- Ponte, J. P., Santos, L., Oliveira, H., & Henriques, A. (2017). Research on teaching practice in a Portuguese initial secondary mathematics teacher education program. *ZDM Mathematics Education*. 49(2), 291–303. doi 10.1007/s11858-017-0847-7
- Russo, J., & Hopkins, S. (2017). Student reflections on learning with challenging tasks: ‘I think the worksheets were just for practice, and the challenges were for maths’. *Mathematics Education Research Journal*, 29, 283–311. doi 10.1007/s13394-017-0197-3
- Shimizu, Y. (2010). A task-specific analysis of explicit linking in the lesson sequences in three Japanese mathematics classrooms. In Y. Shimizu, B. Kaur, R. Huang, & D. Clarke (Eds.), *Mathematical tasks in classrooms around the world* (pp. 87–102). Rotterdam: Sense Publishers.
- Stein, M. K., & Smith, M. S. (1998). Mathematical tasks as a framework for reflection: From research to practice. *Mathematics Teaching in the Middle School*, 3(4), 268–275
- Sullivan, P., & Mornane, A. (2014). Exploring teachers' use of, and students' reactions to, challenging mathematics tasks. *Mathematics Education Research Journal*, 26(2), 193–213.
- Sullivan, P., Askew, M., Cheeseman, J., Clarke, D., Mornane, A., Roche, A., & Walker, N. (2015). Supporting teachers in structuring mathematics lessons involving challenging tasks. *Journal of Mathematics Teacher Education*, 18, 123–140. doi:10.1007/s10857-014-9279-2
- Towers, J. (2010). Learning to teach mathematics through inquiry: a focus on the relationship between describing and enacting inquiry-oriented teaching. *Journal of Mathematics Teacher Education*, 13(3), 243–263.

Teachers' actions in classroom and the development of quantitative reasoning

Lurdes Serrazina¹, Margarida Rodrigues¹ and Ana Caseiro¹

¹ESELx - Escola Superior de Educação, Instituto Politécnico de Lisboa, Portugal, UIDEF, Instituto de Educação, Universidade de Lisboa, Portugal; lurdess@eselx.ipl.pt; margaridar@eselx.ipl.pt; anac@eselx.ipl.pt

The main goal of this paper is to understand how teachers' actions in classroom influence the way students solve a task involving quantitative additive reasoning. The study used a qualitative methodology and a teaching experiment was carried out. One task was proposed to two different classes (2nd and 3rd graders), of the same public school, with two different teachers. The results show that 2nd grade students solved the task with ease, but 3rd graders had difficulties. Teachers' actions of guiding and challenging and how teachers developed the process of communication in classroom do influence students' performance.

Keywords: Quantitative reasoning, teacher's actions, students and teacher interaction.

Introduction

This paper reports on part of the research carried out by a project focused on flexible calculation and quantitative reasoning developed by teachers of the Higher Education Schools of Lisboa, Setúbal and Portalegre in Portugal. The research question for this paper is: How do the teachers' actions in whole class discussion influence the way students solve a task involving quantitative additive reasoning? We present the whole class discussion of a task involving quantitative difference in a 2nd and a 3rd grade classes and analyse how the teachers' actions of guiding and challenging influence students' quantitative additive reasoning (Thompson, 1993).

Theoretical framework

The communication processes that take place in the classroom, as well as the tasks proposed to students, are essential aspects of teachers' practices (Ponte & Quaresma, 2016; Boaler, 2003). Franke, Kazemi and Battey (2007) stress the importance of processes that support students' language development, like resaying - saying the same idea in a different way, usually closer to formal mathematical language, questioning the meaning and supporting the development of students' mathematical thinking. The questions posed by the teacher are a fundamental aspect of communication, with inquiry questions being particularly important, admitting a range of legitimate responses. Related to discourse, Ruthven, Hofmann, and Mercer (2011) propose a dialogic approach as "one that takes different points of view seriously, encouraging students to talk in an exploratory way that supports development of understanding" (p. 4-81). Thus, the decisions that teachers make are crucial, especially those that are taken during the whole class discussions, a particular form of classroom work used in exploratory teaching (Ponte, 2005). It is important that different points of view be considered and that students be encouraged to explain and justify their reasoning and solutions, thus developing, with the teacher's support, their understanding (Ruthven, Hofmann, & Mercer, 2011). In order to have a fruitful whole class discussion, Stein, Engle, Smith, and Hughes

(2008) stress the importance of teachers anticipating the way students may think, monitor their work, collect the pertinent information, select the issues to deal with during the discussion, think about the sequence for students' interventions, and establish connections among different solutions during the discussion. This preparation is important, but a good discussion may involve many aspects that cannot be foreseen before and teachers need to be prepared to face them (Cengiz, Kline & Grant, 2011; Ponte & Quaresma, 2016). Ponte, Mata-Pereira and Quaresma (2013) present a framework for analysing a discussion where they distinguish four fundamental kinds of actions related to mathematical aspects: (i) Inviting, seeking to initiate a discussion; (ii) Supporting/Guiding to lead students to present information, making questions or observations; (iii) Informing/Suggesting, introducing information, giving suggestions, validating students' responses; and (iv) Challenging to encourage students to produce new representations, interpret a statement, establish connections, or formulate a reasoning or an evaluation.

Quantitative reasoning involves reasoning about relationships between quantities. It “is the analysis of a situation into a quantitative structure — a network of quantities and quantitative relationships” (Thompson, 1993, p. 165). The relationships, in this kind of reasoning, are established between quantities. Numbers and numeric relationships are of secondary importance. Thompson (1993) connects the notion of quantity to the idea of measure, clarifying that quantities when measured have numerical value, but the reasoning does not depend on their measures. For example, we can think about the heights of two persons determining who is taller than the other without having to know the actual values. “Quantities are attributes of objects or phenomena that are measurable” (Smith & Thompson, 2008, p. 101), but “what is important is relationships among quantities” (Thompson, 1993, p. 165). A quantitative operation is the comparison between two quantities to find the excess of one relative to the other and the quantitative difference is the result of the quantitative operation of comparing two quantities additively. According to Thompson (1993), numerical difference, as the result of subtracting, is not synonymous to quantitative difference, which is an item in a relational structure. A quantitative difference is not always evaluated by subtraction and subtraction can be used to compute quantities that are not quantitative differences. For Smith and Thompson (2008), quantitative reasoning implies “to focus on quantities and how they relate in situations” (p. 121). Therefore, teachers' actions should lead to discussions of quantities, not numbers. “The goal is to get students to describe situations as they see them” (p. 122). Teachers “should imagine how their students might describe the situation differently and what conceptual difficulties might be lodged in their descriptions” (Smith & Thompson, 2008, p. 121). In whole class discussion teachers should invite students to share their solutions, guide and support them through questions focused on situations description, and challenge them to explain their reasoning. Thus, the discourse used by teacher is a key aspect accounting for students' understanding of quantitative relationships.

Methodology

This study follows a qualitative approach framed in an interpretative paradigm (Bogdan & Biklen, 1994). It is focused on the educational processes and the meanings of the study participants. The project adopts the modality of teaching experiment conceived with the purpose of developing in students the flexibility of calculation and the quantitative reasoning.

The data were collected from two classes in a public primary school in Lisboa, with 26 students each – a 2nd grade class (7-8 years old) in November 2015 and a 3rd grade class (8-9 years old) in October 2015. The Project team defined a sequence of tasks involving addition and subtraction problems. The task sequence was previously discussed and analysed with the two classroom teachers having been made minor adjustments.

Both teachers are female expert teachers with a large experience of teaching. The two teachers are considered good teachers of mathematics and both try to develop an exploratory teaching in their classes. However, teachers are quite different in what concern their relationship with mathematics. Catarina (2nd grade teacher) likes mathematics and did a specialization in mathematics education. Catia (3rd grade teacher) always had trouble with mathematics that she wanted to overcome, that's why she wanted to participate in this project. The two teachers are friends, work together, and they had been invited, at the beginning of the project, to collaborate with the project team members and both accepted.

The names of students and teachers have been changed to ensure confidentiality. The data collection was done through participant observation, complemented with field notes and videotaping of the classes, including whole class discussion. The students' productions were also collected. In the part of the exploration of the tasks, the videotaping focused on two pairs of students in each class, selected by habitually verbalize their reasoning among themselves.

The task was the sixth of a sequence. In the previous lessons and in the first part of this lesson the students had solved other tasks where they had to make comparisons in gains and losses problems. The task solved by 2nd and 3rd grade students was the same, but the magnitude of numbers was adapted accordingly. Figure 1 shows how the task was presented to the 2nd grade students.

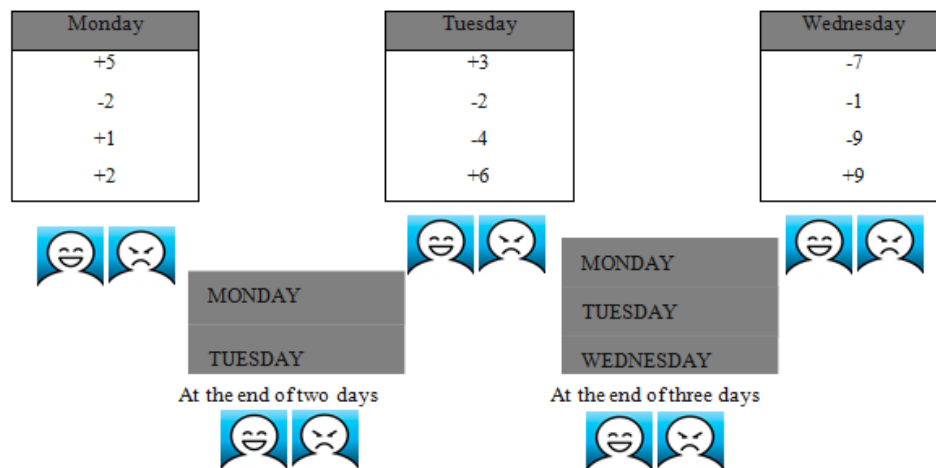


Figure 1: The task solved by 2nd grade students.

For the 3rd graders the numbers were: Monday: +50, -20, +10, +20; Tuesday: +30, -40, +60; Wednesday: -74, -94, +90. The students should select a smiley or a sad face circling it depending on their sense of whether there would be more gains or more losses at the end of the day(s). The students should also find the quantity representing how many marbles they won or lost at the end of the day, that is, the final quantitative difference. They did not work with the notation of negative

numbers before this task. The analysis focuses on whole class discussions and especially on categories of action coming from Ponte et al. (2013) and Smith and Thompson (2008) frameworks: *the inviting action* seeks to get students to share their solutions; *the guiding action* seeks to get students to describe the situation, modelling it and focusing on quantities; *the challenging action* seeks to encourage students to explain the quantitative relationships.

Results

2nd grade: The teacher introduced the task saying to students “This new proposal has only the gains and losses in different games, let's see what happens at the end of each day”. First, students solved the task in pairs, being videotaped the pairs Paulo and João and Luís and Lúcia.

Paulo seemed to deal easily with the quantitative difference whether it was an excess or a deficit. This facility is evident in the way the task was carried out by Paulo and João pair. They did it very quickly, in two minutes, although João followed Paulo's notes (he wrote "+8" after 3 days, and rectified later to "+1", when looking at Paulo's sheet). As the researcher got closer, Paulo explained that he looked at the nulls ("nulls", for example, -2, +2), having calculated only the remaining ones.

Luís and Lúcia approached the task using a different strategy. They gathered the gains, they joined the losses, and only then did the comparison. In the situation related to Wednesday, the students surrounded the sad face, understanding that at the end of the day, the player lost marbles. But they were stuck in the numerical record because it was a loss. With the researcher's guidance, when she came close, they wrote "-17; +9".

In the whole class discussion, the most presented strategy was to add, on the one hand, the gains, and on the other, the losses, and then determine the difference. For example, for Tuesday, the teacher invited the Marta and Mónica pair to go to the blackboard and record their results. They wrote quickly: "+9 - 6 = +3" and drew a 'smile'.

Mónica: We did +9 which is what won +6+3.

Teacher: And the other 6?

Mónica: Out of what he lost: the 4 and the 2.

Teacher: How do you get 3? (addressing the class)

Students: The difference between 9 and 6 is 3 to win.

First, the teacher *guided* students through a question that led students to focus on losses (quantitative difference). Then *challenged* students to explain the results: “How do you get 3?”. Here the students seemed to dominate the situation and the teacher's questioning led students to explaining their quantitative reasoning.

But the teacher *challenged* the class, trying to have another explanation:

Teacher: Is there another explanation?

Paulo: Yes, the +6, -4 and -2 annul themselves. (The teacher records on the blackboard: +6-4-2=0)

Paulo: And only +3 left over.

This idea of 'annulling' was used by other students in the following situations, correctly by many. Paulo had the opportunity to present his explanation when the teacher asked for other explanation.

3rd grade: The teacher introduced the task saying that now they had to look just for gains and losses and should find what happened at the end of each day. Then, students started to explore the task in pairs, and showed difficulties confounding the notion of quantitative difference with the absolute amount of marbles, increasing these difficulties for Wednesday.

At the whole class discussion, the teacher *invited* Vítor to present his solution for Monday:

- Vítor: So, he had 50 on Monday...
- Teacher: Won...
- Vítor: 50, but then he lost 20; then he won 30 and won. He was happy. (...)
- Teacher: Does everyone agree?
- Students: Yes.
- Teacher: How many marbles did he win?
- Students: 60. [And Vítor puts the sign +, +60]

Vítor began by confusing the notion of quantitative difference with the absolute amount of marbles: when he says "he had 50", he seems to assume that the player began the game of marbles with 50 marbles. But, the teacher *guided* him, focusing on quantitative difference when she referred to "won" and after Vítor took a discourse centered on the gains and the losses describing the situation.

Concerning Tuesday, Rui explained his solution on the blackboard.

- Rui: Then, on Tuesday, he won 30 more, he had 60. Then on Tuesday he lost 40. (...)
- Teacher: In general, he won more or lost?
- Rui: He won. (...)
- Teacher: So, overall, how much did he win?
- Rui: I think he got 60. [Rui records $30-40+60=60$ on the blackboard] (...)
- Student A: It's wrong! It's fifty because 30 minus 40...
- Alexandre: From 30, you cannot take out 40.

Again, there is a conceptual confusion between the quantitative difference and the absolute amount of marbles: "he had 60"; "he got 60"; "From 30, you cannot take out 40". The teacher tried to focus on global balance "In general, he won more or lost?" and "So, overall, how much did he win?" [*guiding* action]. Rui, confronted with the reactions of his peers, corrected his solution adding the gains ($30+60=90$) and subtracting the lost marbles ($90-40=50$). At the end, Rui circled the result 50, concluding that the player won 50 marbles on Tuesday.

Then, the teacher *invited* Alexandre to present his solution for Wednesday:

- Alexandre: I saw we had 94.

- Teacher: So, let's start at the beginning ... on Wednesday, in the first game, what happened in the first game, Alexandre?
- Alexandre: He lost 74.
- Teacher: He lost 74, and after, in the second?"
- Alexandre: And after he lost 94.
- Teacher: And after he lost 94 ... and after he won ...
- Alexandre: He won 90.
- Teacher: 90. And then, with the data we have there what did you do? Tell us.

The dialogue began by focusing on the modelling of the situation, with the teacher *guiding* about what was going on the three games on Wednesday. Alexandre continued explaining his solution: " $94+90=184-74=110$ ", justifying the addition of 94 and 90 because "94 is the largest number and 90 was the second largest number". Alexandre tried to have an explanation for the computations, not for the situation. Again, the teacher tried to *guide* him, seeking to focus his reasoning on losses:

- Teacher: But why did you take out 74 now?
- Alexandre: Because I had already spent these numbers; it was just missing 74, I went to take them out.
- Teacher: You were to take out that because it was missing ... but Alexandre, in fact, he lost 74 and lost 94... (...) What does this mean?
- Alexandre: He got less than zero.
- Teacher: I can only loose what I have...

On Wednesday, the balance between gains and losses is negative: after the three games, the player lost 78 marbles. The quantitative difference in this situation requires ignoring the absolute number of marbles and Alexandre was not able to deal with a negative point of departure ("He got less than zero"). Alexandre seems to consider 94 as the initial number. The teacher revealed difficulty *to guide* the student's reasoning referring to the assumed need of knowing the initial number of marbles ("I can only loose what I have..."). In this situation, Jaime offered himself to explain. He added all the numbers (" $74+94+90=258$ ") and went to the blackboard to explain why he added 74 plus 94:

- Jaime: Because 74 and 94 were what you had before.
- Teacher: 74 and 94 were the marbles he had, because he can only loose, we can only loose what we have, isn't it? I cannot loose 74 marbles if I had nothing. (...) My friends, the 74 and 94 what were they?
- Jaime: That's what they had.
- Teacher: They only lost because they had them.

The students confused the quantitative differences with the initial number of marbles. Again, the teacher tried to *guide* students focusing them in the modelling of the situations. However, the teacher could not reorganize her discourse when the situation became more complex. Catia had difficulty to *challenge* students in a way that they could understand the quantitative relationship

without knowing the absolute amounts of marbles. An impasse was created, and, in the meantime, the class had to end, it was time to break.

Discussion

The results show that the two classes reacted differently to the task. 2nd graders seem to do it without any difficulty. In contrast, 3rd graders had difficulties, namely the fact that they did not have the initial number of marbles. These difficulties increased for Wednesday where the losses are greater than the gains, as no student did it correctly. From the beginning of the solution, while the 2nd grade students added the losses and gains, 3rd grade students started to operate with numbers, apparently not thinking about the meaning of their procedures. This was not usual in the class because, as stated earlier, both classes used to do exploratory work in mathematics.

Catia, the 3rd grade teacher, started to guide students focusing on the modelling of the situation, but confronted with the students' answers, her questioning could not overcome the students' conceptual understanding of quantitative relationships. Although she had solved the task before, trying to anticipate students' responses, she was not able to deal with it when the situation became more difficult (on Wednesday). She began guiding the students to the description of the situation, as advocated by Smith and Thompson (2008), but at the end she got lost as her students. She repeated a statement which did not help as it was focused on the absolute numbers involved ("we can only lose what we have") and this did not help students to solve the situation because it probably reinforced the confusion between the relative change of losses (-74-94) and the absolute amount of marbles ("what you had before"). She seems to have not understood students' difficulty and was not able to retelling the situation (Franke et al., 2007). On the contrary, the 2nd grade teacher, Catarina, was always at ease with the situation, challenging her students in different ways, much more focused on the quantities in presence.

Final remarks

As Ruthven et al. (2011) state, the questions posed by teachers are fundamental aspects of classroom communication. Catarina and Catia have a similar inviting action seeking to initiate the discussion and to get students to present and share their solutions. However, they differed regarding ways of communication concerning this specific task, with Catarina's questions being more focused on the quantities and how these are related to the situation (Smith & Thompson, 2008). So, how teachers develop the process of communication in classroom has a crucial role in students overcoming the challenging situation related to quantitative difference. Thus, 2nd grade students were able to focus on quantitative difference, looking at gains and losses, and dealing, naturally and comprehensively with negative number notation. On the contrary, the 3rd grade students were not able to disconnect from arithmetic operations and the need to consider an initial number and they were unable to focus on quantitative reasoning. So, it could be argued that the 2nd grade students were able to conceive a quantitative difference independently of numerical information about quantities (Smith & Thompson, 2008). For us, this situation is intrinsically linked to teachers' actions and more specifically to the ways teachers guided and challenged students through questioning so that they latter could advance in their quantitative reasoning process. This study allows to emphasize the important role of teacher's actions of guiding and challenging in

promoting students' ability to reason with quantitative relationships, even when the initial values are unknown.

Acknowledgment

This paper is part of the Project *Flexibilidade de cálculo e raciocínio quantitativo* funded by Instituto Politécnico de Lisboa.

References

- Boaler, J. (2003). Studying and capturing the complexity of practice: The case of the dance of agency. In N. Pateman, B. J., Dougherty, & J. T. Zilliox (Eds.), *Proc. 27th Conf. of the Int. Group for the Psychology of Mathematics Education* (Vol. 1, pp. 3–16). Honolulu, USA: PME.
- Bogdan, R., & Biklen, S. K. (1994). *Investigação Qualitativa em Educação: Uma introdução à teoria e aos métodos*. Porto: Porto Editora.
- Cengiz, N., Kline, K., & Grant, T. J. (2011). Extending students' mathematical thinking during whole-group discussions. *Journal of Mathematics Teacher Education*, 14, 355–374.
- Franke, M. L., Kazemi, E., & Battey, D. (2007). Understanding teaching and classroom practice in mathematics. In F. K. Lester (Ed.), *Second handbook of mathematics teaching and learning* (pp. 225–256). Greenwich, CT: Information Age Publishing.
- Ponte, J. P. (2005). Gestão curricular em Matemática. In GTI (Ed.), *O professor e o desenvolvimento curricular* (pp. 11–34). Lisboa: APM.
- Ponte, J. P., Mata-Pereira, J., & Quaresma, M. (2013). Ações do professor na condução de discussões matemáticas. *Quadrante*, 22(2), 55–81.
- Ponte, J. P., & Quaresma, M. (2016). Teachers' professional practice conducting mathematical discussions. *Educational Studies in Mathematics*, 93(1), 51–66.
- Ruthven, K., Hofmann, R., & Mercer, N. (2011). A dialogic approach to plenary problem synthesis. In B. Ubuz (Ed.), *Proc. 35th Conf. of the Int. Group for the Psychology of Mathematics Education* (Vol. 4, pp. 81–88). Ankara, Turkey: PME.
- Smith, J. P., & Thompson, P. W. (2008). Quantitative reasoning and the development of algebraic reasoning. In J. J. Kaput, D. W. Carraher & M. L. Blanton (Eds.), *Algebra in the early grades* (pp. 95–131). New York, NY: Lawrence Erlbaum Associates.
- Stein, M. K., Engle, R. A., Smith, M., & Hughes, E. K. (2008). Orchestrating productive mathematical discussions: five practices for helping teachers move beyond show and tell. *Mathematical Thinking and Learning*, 10, 313–348.
- Thompson, P. W. (1993). Quantitative reasoning, complexity, and additive structures. *Educational Studies in Mathematics*, 25(3), 165–208.

Contradictions in prospective mathematics teachers' initial classroom teaching as sources for professional learning

Konstantinos Stouraitis¹ and Despina Potari¹

¹National & Kapodistrian University of Athens, Greece; stouraitisk@gmail.com,
dpotari@math.uoa.gr

In this paper we study the first field experiences of a prospective mathematics teacher in a secondary school. Using Activity Theory we focus on contradictions emerging in the process of designing and enacting lessons, the sources for these contradictions and the potential impact on teacher learning. The two prevailing tensions related to students' engagement in doing mathematics and students' unexpected difficulties can be interpreted as contradictions between the actual and intended status of the object and between the teacher's goals and the mediating tools. Sources for these contradictions seem to be the contradictory teacher's experiences from the teacher education context and typical characteristics of mathematics teaching in Greek secondary schools. We find that the teacher becomes more aware about these contradictions and the different possibilities to deal with them.

Keywords: Activity theory, initial field experience, contradictions, professional learning.

Introduction

The transition from university teacher education to school reality is a complex process that involves challenges and tensions for the prospective teacher. Research has focused on this process, initially considering beliefs and knowledge (e.g. Potari & Georgiadou-Kabouridis, 2009; Skott, 2001; van Zoest & Bohl, 2002) while more recently teacher identity (Losano et al., 2017). Both the early and the more recent studies show that prospective and novice mathematics teachers' tensions are related to the various constraints of the school reality that often contradict to the images of innovative teaching approaches that are promoted in teacher education. In the study of Solomon et al. (2017), these tensions are related to the fact that teacher education programs offer an ideal way of teaching that is far from the school reality where emphasis is often given in achieving good results in mathematics. Bridging the gap between theory and practice in early school placement of prospective and novice teachers is necessary for facilitating smooth transition from university to school.

Losano et al. (2017) also talk about the tensions and contradictions that first year secondary school teachers face in their attempts to adopt innovative teaching approaches in the complex reality of school and mathematics classroom. They claim that this first teaching period offers very rich learning opportunities for the novice teachers as they reflect on their prior experiences and they project to their future career. Their findings indicate that the novice teacher of their study faced contradictions that in some cases were overcome while in others they remained conflicts. In particular, several past and present voices participated in the process of developing this teacher's professional identity. They also show that sometimes novice teachers align to the identities afforded by the existing mathematics teaching at schools while they also introduce transformations in teaching. This parallel way between innovative approaches and school established practices has also been reported in earlier studies

(Potari & Georgiadou-Kabouridis, 2009). Research has also indicated that curriculum resources that align with reform oriented practices and the interaction between the interns and the mentors are crucial factors supporting the intern's teaching development (van Zoest & Bohl, 2002). The study of Nolan (2016) also shows the constraints novice teachers face to use inquiry teaching approaches when the school reality is different from what they wanted to do. Although they recognize the limitations of the existing school and classroom structures, they keep silent and they do not take actions to change it.

All the above studies show that prospective and novice mathematics teachers face tensions while trying to enact innovative teaching approaches in their first teaching. Dealing with these tensions they use teaching approaches that may vary from reform oriented to rather traditional. Looking for interpretation of those contradictory behaviours we begin to recognize the role of context in this complex process. In our paper we attempt to address this complexity by focusing on the tensions that a prospective secondary school teacher faces in her initial classroom teaching and the ways that she deals with these tensions. In particular we address the following questions:

What are the contradictions that a prospective teacher faces in her initial teaching experiences and which are their sources?

How does this prospective teacher deal with these contradictions and what does it imply for her professional learning?

Theoretical background

We adopt Activity theory and in particular the Engeström's (2001) perspective to study the contradictions, their sources and the process of dealing with them. Activity is collective, tool-mediated and it needs a motive and an object while it is realized through the actions – goals and operations – conditions (Leont'ev, 1978). Activity in our case is the teaching of mathematics at the secondary school with students' learning as the central motive. The subject is the prospective teacher Karen who performs actions (both in her planning and classroom enactment) related to specific goals that she makes explicit in the discussion she has with the researchers about her planning. These actions become operationalized through the tools she employs and the conditions under which teaching takes place. The institutional, social and classroom contexts are conditions on which teaching is developed. Tensions and contradictions are the driving forces for the development of the activity and in our case of mathematics teaching. Contradictions are historically accumulated structural tensions within and between activity systems. These tensions lead to changes in the activity, and in particular they emerge when a new element comes. Contradictions may refer to different elements of the activity system such as tools and object or communities and tools (Engeström, 2001). In our case the new element can be the innovative approaches promoted in the teacher education program that the prospective teacher attempts to enact in the rather traditional mathematics teaching history that characterizes mathematics teaching in the Greek secondary schools. Contradictions in the research related to mathematics teaching concern pedagogical, professional or epistemological issues and they emerge in the teachers' decision making process (Potari, 2013; Stouraitis, 2016; Stouraitis et al., 2017). Studying their content and their sources allow us to have access to the practices that Karen participates when she experiences them and tries to handle them.

The process of overcoming contradictions in the AT perspective is linked to the expansive cycle of Cole and Engeström (1993), a developmental process containing internalization and externalization in repeated cycles. In the internalization the subject carries out routinely the activity, while the emerging contradictions promote the subject's self reflection and the search for solutions. This externalization can lead to adoption of a new model for the activity that is also implemented by other subjects. As our study is mainly exploratory and our focus is on one prospective teacher that we interviewed and observed her teaching for a rather short time we cannot talk about a full cycle of expansion. However, initial indications of externalization that can be seen as signs of professional learning can be identified in our case and we recognized them in our analysis through Karen's attempts for innovations, her critical questioning on existing teaching practices and her projections on future changes that she could do into her teaching.

Methodology

The context of the study

In this case study we focus on Karen, a prospective secondary school teacher towards the end of her undergraduate studies. Karen studies mathematics at the university where she also attends mathematics education courses that aim to provide theoretical knowledge but to link it to mathematics teaching and learning at school. At the period that the study began, Karen was doing a course on teaching and learning problem solving and a course related to field experience where she observed lessons at school and she taught herself three lessons. Two of these lessons were in the context of an Erasmus+ project (EDUCATE) focusing on the design and enactment of mathematically challenging tasks that meets all the students' learning needs. Karen taught these two lessons in a state upper secondary school in December 2018 in the class of the first author. From March to May 2018, Karen did her internship in the same school. The first author of this study, the classroom teacher, acted as mentor for Karen while the second author was the teacher educator supporting Karen at the university. Both contexts in teacher education and school placement support reform oriented approaches.

Karen "always wanted to do this job [mathematics teacher]". She valued teaching from her experiences as a student at school, where one of her teachers was "close to us [the students]" and made connections between mathematics and other contexts. Also, Karen has prior teaching experiences as a private tutor preparing students for the class or university entrance examinations where a more procedural approach to mathematics is expected.

Data collection and analysis

Karen conducted two lessons in the context of the university course and EDUCATE, and three more lessons as part of her internship. She attended several lessons by the classroom teacher and her peer Ken. Informal discussions were taking place after each lesson. The data for this study include two videotaped and transcribed lessons, field notes for all five lessons, students' worksheets, audiotaped and transcribed interviews before and after her lessons, online communication (emails), and two interviews in the beginning and the end of the internship. All these data were generated from December 2017 to May 2018. Analysing the data, firstly, we identified Karen's goals and the undertaken actions, the emerging tensions and Karen's attempts to overcome them. As indicators for the emerging tensions we used Karen's sayings about her worries, such as her uncertainty about

students' engagement, or about something that bothered her as for example a student response that did not expect. Tensions were grouped and interpreted as contradictions. For example, one group of tensions was related to time pressures and was interpreted as a contradiction between the tools used by Karen and the rules that regulate the school work.

Results

In the process of planning and enacting teaching, Karen experienced several tensions. These tensions related with Karen's goals to engage all students in doing mathematics, students' difficulties, time pressures, and Karen's sensitivity towards students' emotions. Here, we focus on the first two as prevailing tensions in this period and because these tensions seem to trigger Karen's learning.

Contradiction between the actual and intended status of the object

Classroom management and students' engagement are sources of tensions for Karen during her first teaching experiences. These tensions may be explained by Karen's no prior teaching experience, the big differences between students' achievement in the specific classrooms and her ambitious goal to engage all students in doing mathematics.

These tensions are expressed by Karen's worries if the students "will finally be able to deal with the tasks", if they will recognize the aim of modelling and a purpose of doing mathematics. They are also expressed as Karen's desire to succeed in her choices about classroom management. A challenging decision was to try to engage a group of five students which "do not want to learn mathematics" and "they have not any relation with mathematics, neither knowledge, nor interest".

We can interpret these tensions as manifestations of a contradiction between the actual students' mathematical engagement (the object of the activity) and students' mathematical learning as Karen's intended outcome of the teaching activity.

Karen deals with these tensions mostly through the design of the tasks and the forms of classroom interaction she orchestrates. The tasks were: modelling situations like the renovation of a house as context for forming and solving linear equations and the investigation of a crime as framework to use properties and different representations of exponential and logarithmic functions; logical puzzles; and typical school tasks like solving quadratic equations by using the formula and translating formulas and ordered pairs to graphs and points and vice versa. As sources that inspired the task design about modelling Karen mentions the university courses she attends. For the more typical school tasks she refers to the internet and classroom textbook and to discussions with friends and peers. There were lessons where the autonomous group work of students prevailed, while others were mostly conducted by whole class discussion with short time spaces to work individually or in pairs. She also used specific strategies to promote students' involvement, for example she asked students to write their answers on a piece of paper and show it in the class and she asked them to play a language game, complementing a phrase with letters collected for each equation they solved. As sources inspiring her decisions about classroom management Karen mentions her teachers and especially some strategies and games they used in the classroom, her involvement in collective sports and activities that "helped me [her] to understand the importance of group work". Nevertheless, she says that some mathematical topics must be presented by the teacher, because "it cannot be done differently", implying that she

does not know any other way to carry out teaching topics that include “introduction of something new, or understanding the steps of a proof”. After the second lesson Karen says that a pattern for teaching mathematics should be “teaching [teachers exposition and discussion], applying the procedures individually ... and [later] some problem solving or modelling tasks with students work in groups”.

In her last lesson Karen seems less stressful, although her goal to engage all students is still strong. She identifies and describes her feelings in the classroom talking about “the burden of being on the board”, and saying “there were times I was speaking, noticing students and thinking something else simultaneously. It is another level of multitasking”. In a next interview explains: “Multitasking is what you do all the time in the 45 minutes in the classroom”. She thinks that “your preparation and planning helps you improvising” because “there are too many factors in this time. Students’ responses, questions you don’t expect, your worksheet does not function as you expected, which word to use...” In her last teaching she had “too many thoughts. Thoughts connected with my actions and words ... like cartoons, these moments I thought I had multiple personalities, all talking to me ...” For her future as teacher, Karen thinks that she should be “always trying to find new ways of teaching, to develop, to inquire”.

Karen deals with the contradiction between the actual and the intended status of the object with the tasks she gives to the students and with her choices about the classroom orchestration. She mostly draws on innovative approaches like modelling processes, group work and playing games. Most of them come from Karen’s participation in the teacher education program and reform oriented approaches she experienced as student or as intern teacher attending the teaching of practicing teachers. Nevertheless, there are cases where Karen follows more traditional teaching approaches often met in mathematics classrooms in Greek schools. In this process Karen enhances her reflection becoming more aware about her decisions and actions in teaching and about the importance of lesson planning in the enactment of her goals. We cannot talk about Karen overcoming the contradiction, but she becomes more aware about it and she searches for “effective” ways to deal with this.

Contradiction between the teacher’s goals and the mediating tools

Several tensions that Karen experienced are related with unexpected students’ difficulties. These emerged in the lessons and in some cases they could be explained in terms of Karen’s actions and the tools she used. Here we focus on students’ difficulties in relation to the tools Karen used in her teaching.

These tensions are experienced by Karen as unexpected students’ queries, misunderstandings or difficulties to proceed in the task. For example, in the first lesson, the written description of the task was complicated, requiring more explanations. In the fourth lesson, investigating a crime, students should solve an exponential system to find k and c in the expression $T(t) = T_0 + c \times e^{-kt}$ consuming time and disrupting the focus on modelling process. In a previous lesson, answering why D must not be negative in the expression $(x + \frac{b}{2a})^2 = \frac{D}{4a^2}$ Karen gives a rather procedural explanation that the amount under the square root must not be negative, although her goals are conceptually oriented.

We can interpret these tensions as manifestations of a contradiction between Karen's goals and the tools she used either as tasks or as explanations. While Karen's declared goals focus on conceptual understanding of mathematics, the tools she uses do not support these goals, on the contrary they orient students towards more procedural approaches.

Karen experiences these tensions as students' difficulties, not as contradictions between her goals and the mediating tools. Thus, she responds to them providing additional explanations and support or giving time. For example, she considers finding k and c as time consuming but not as disrupting from her modelling goals. She considers students' difficulties with locating points on a graph rather as a procedural difficulty to find a point than not understanding the translation between graphical and algebraic concepts and relations. Responding to the perceived difficulties Karen tries to reduce time or to give short exercises for students to solve. In the discussions after the lessons Karen explains her responses involving the mathematical content and the ways this content is usually taught. For example, on her explanation that the amount under the square root must not be negative, she says that "this is the proof ... this is the mathematical way to do it" adding that "a part of mathematics must be taught doing mathematics". The teacher educator, the classroom teacher and her peer challenge Karen's interpretations providing more conceptual explanations and approaches. Karen discusses and accepts these possibilities, not without resistance. For example, she says "you may need more time [to find k and c], but this is in fact the mathematical modelling". After enacting the lesson in two different classrooms she thinks that "[to reduce the time] I could give c , so they should only find k ".

Although Karen's initial responses are rather procedurally oriented, in the discussions with the teacher educator, the classroom teacher and her peer, she appears open to other approaches and interpretations. In some cases an ambiguous shift has identified: Karen seems to adopt more conceptual approaches as potential ways to respond to the certain difficulties in the future. For example, ending the discussion about the task requiring the parameters k and c , she says that she could also think to give students k and c , and in another teaching period to come back and say "let's see how this is done in reality" implying how k and c can be calculated in a real situation.

The contradiction between goals and mediating tools seems to emerge as contradiction among the different Karen's experiences and communities she participated. Her conceptually oriented goals are based on her participation in the teacher education program and the context of the internship. In the last interview she says that through these experiences she has changed the way of thinking, especially "to think not only the time [the time planning of the lesson] but also the way a student thinks ... I have developed in setting my goals, considering how students think ...". Procedural approaches may come from her experiences as student and from her involvement in teaching as private tutor. For example, after the second lesson she says about her choice to spend time providing explanations on the blackboard: "there are some mathematical issues that you must teach this way, [students] to understand how we step from one to the other". Although Karen initially does not see any contradiction between her goals and the tools, in the discussions seem to open some possibilities for her awareness and future shifts. This was often expressed as possible change to the task, like the aforementioned change with k and c , or changes to the given answers, like focusing to the square in

the first part of $(x + \frac{b}{2a})^2 = \frac{D}{4a^2}$ to explain the requirement $D \geq 0$. In the last interview, Karen

mentions as negative feature in teaching “the noise ... that is what you do [your actions] to impede your goals”. She says that it almost happened to her in some lessons, but she refers only the excessive use of the context without including procedural oriented tasks or responses blurring her goals about students’ conceptual understanding.

Conclusions

Like the findings of other studies (Potari & Georgiadou-Kabouridis, 2009, Losano et al., 2017) Karen’s first enactments in the school classroom include both innovative and more established practices. This finding cannot be interpreted by the differences between the school context and the teacher education program, since both supported reform oriented approaches. We do not disregard the institutional factors that may imply a more traditional way of enacting the lesson in the school classroom, neither the ideal way to consider teaching in a teacher education program. But the specific context of Karen’s early school placement was focusing on students’ conceptual understanding and involvement in doing mathematics. Karen’s participation in different communities may support an interpretation for her mixed practices. Her experiences from the classroom teaching as a student and later as a private tutor, her participation in communities of university students discussing issues about teaching are also sources for Karen. These communities are also interacting with other communities without an immediate relation to mathematics teaching and learning (athletics, theatre) but seem to have a role in Karen’s way of becoming a teacher. Karen’s approach of the motive of the activity, that is the students’ mathematics learning, is influenced by these past and current activities and communities she participates. Similar findings are also reported for in service teachers (Stouraitis, 2017).

The tensions Karen experiences as worries, pressures and students’ difficulties are manifestations of contradictions fuelled by the aforementioned different approaches to teaching practice. Contradictions between the actual and the intended status of the object and between the teacher’s goals and the mediating tools, are two main groups of the emerged contradictions. The subject (Karen) has a prevailing role in these contradictions through the intended status of the object, the goals and the use of tools. Karen tries to overcome most of the tensions she experiences, although she does not identify all of them as contradictions. In line with other studies, the teacher deals with some of the contradictions aiming their overcoming, while other remain as tensions. But in the process of planning, enacting, reflecting and discussing her lessons and some tensions, Karen becomes more aware about contradictions and the different possibilities to deal with them. In some cases, a shift appears, rather as a potentiality to undertake a different action than a clear change. Additionally, this shift is verbally expressed by Karen when she talks about her development through her first teaching experiences and her learning. We consider these shifts as indications of self reflection and search for solutions, a crucial aspect of the cycle of expansive learning (Cole & Engeström, 1993).

The interaction between the interns and the mentors is recognized as a crucial factor related to teaching development (van Zoest & Bohl, 2002). In our case, discussions before and after the lessons with the teacher educator, the classroom teacher and Karen’s peer appear to be a supportive context for Karen’s reflection. These discussions were inquiry oriented, without a predefined intended outcome and promoted Karen’s reflection and growth of awareness. In this context Karen expressed

the aforementioned shifts. Karen's growing awareness and shifts and mostly the way she considers her future career can be interpreted as indicators for a developing professional identity. And this process seems to be initiated and supported by the collective context.

References

- Cole, M., & Engeström, Y. (1993). A cultural-historical approach to distributed cognition. In G. Salomon (Ed.), *Distributed Cognitions: Psychological and Educational Considerations*, (pp. 1–46). Cambridge: Cambridge University Press.
- Engeström, Y. (2001). Expansive learning at work: Toward an activity theoretical reconceptualization. *Journal of Education and Work*, 14(1), 133–156.
- Leont'ev, A. N. (1978). *Activity, consciousness and personality*. Englewood Cliffs: Prentice Hall.
- Losano, L., Fiorentini, D., & Villarreal, M. (2018). The development of a mathematics teacher's professional identity during her first year teaching. *Journal of Mathematics Teacher Education*, 21(3), 287–315.
- Nolan, K. T. (2016). Schooling novice mathematics teachers on structures and strategies: a Bourdieuan perspective on the role of “others” in classroom practices. *Educational Studies in Mathematics*, 92(3), 315–329.
- Potari, D. (2013). The relationship of theory and practice in mathematics teacher professional development: An activity theory perspective. *ZDM*, 45(4), 507–519.
- Potari, D., & Georgiadou–Kabouridis, B. (2009). A primary teacher's mathematics teaching: the development of beliefs and practice in different “supportive” contexts. *Journal of Mathematics Teacher Education*, 12(1), 7–25.
- Skott, J. (2001). The Emerging practices of a novice teacher: The roles of his school mathematics images. *Journal of mathematics teacher education*, 4(1), 3–28.
- Solomon, Y., Eriksen, E., Smestad, B., Rodal, C., & Bjerke, A. H. (2017). Prospective teachers navigating intersecting communities of practice: early school placement. *Journal of Mathematics Teacher Education*, 20(2), 141–158.
- Stouraitis, K. (2016). Decision making in the context of enacting a new curriculum: An activity-theoretical perspective. In C. Csíkos, A. Rausch, & J. Sztányi (Ed.), *Proceedings of the 40th Conference of the International Group for the Psychology of Mathematics Education* (Vol. IV, pp. 235–242). Szeged, Hungary: PME.
- Stouraitis, K., Potari, D., & Skott, J. (2017). Contradictions, dialectical oppositions and shifts in teaching mathematics. *Educational Studies in Mathematics*, 95(2), 203–217.
- Van Zoest, L. R., & Bohl, J. V. (2002). The role of reform curricular materials in an internship: The case of Alice and Gregory. *Journal of Mathematics Teacher Education*, 5(3), 265–288.

Analyzing a novice teacher's instructional actions in response to unexpected moments in teaching

Rukiye Didem Taylan¹ and Merve Esmer²

¹MEF University, Faculty of Education, Istanbul, Turkey; tayland@mef.edu.tr

²Darüşşafaka Schools, Istanbul, Turkey; merve.esmer@dek.k12.tr

This study investigated instructional actions of a novice teacher in 6th grade mathematics classrooms during unexpected moments of teaching. The teacher was selected as a case due to her commitment to lesson planning and her interest in creating meaningful mathematical discussions. Unexpected moments of teaching are defined as moments when there is an interruption to the lesson planning. These moments are significant as how teachers notice and decide to act in these moments may determine the quality of instruction. The analyses of lesson planning meetings, lesson observations and interviews with the teacher revealed only three cases of unexpected moments as she taught algebra. The results indicated that unexpected moments of teaching in the form of student questions and responses helped the teacher reflect for future lessons. The instructional actions during these moments had the potential to support and extend student thinking.

Keywords: Instructional actions, student thinking, teacher noticing, pivotal moments in teaching.

Introduction

Teaching practices play a significant role in shaping student learning (Franke, Kazemi, & Battey, 2007). Research studies (Franke et al., 2007; Hiebert & Grouws, 2007) underline the importance of teachers choosing and implementing high-cognitive demand tasks and shaping meaningful mathematical discussions. Teachers are expected to support their students in achieving learning goals, pay attention to students' knowledge and motivation, and adjust instruction accordingly (Ball, Lubienski, & Mewborn, 2001; National Research Council [NRC], 2005). This type of student-centered instruction demands that teachers not only teach the curriculum as given but change it by taking into account their students' needs during the moment of instruction.

In general, previous studies (Fenenma & Franke, 1992) and reform documents (National Council of Teachers of Mathematics [NCTM], 2000) indicate the importance of planning in order to create meaningful mathematical discussions in student-centered instruction. When teachers use research-based protocols and consider students' prior knowledge in preparing a lesson plan, they may be able to incorporate student thinking in better ways (Smith, Bill, & Hughes, 2008). Adjusting lesson plans according to student needs and building meaningful discussions are important skills generally attributed to more experienced and highly-accomplished teachers (Taylan, 2015).

Although the relationship between the nature of mathematical discussions and student learning is complex, it is documented that some teacher instructional actions during classroom discussion may have more potential than others to advance or extend student thinking. In a framework developed by Cengiz, Kline and Grant (2011), *inviting students to evaluate a claim and provide reasoning and probing, challenging and providing counter arguments to student claims and pushing for alternative ways* were categorized as instructional actions that extended student thinking during

class discussions. Actions that supported student thinking involved *repeating a student idea*, *suggesting interpretation of student thinking*, *introducing different representations*, *reminding of the learning goal*, and *recording and acknowledging student thinking* (Cengiz et al., 2011). *Complimenting or evaluating student thinking*, *redirecting to peers*, *requesting basic information* and *clarifying questions* were actions that were classified as other actions which did not support or extend student thinking. Managing discussions by considering the influence of different actions as described in research-based frameworks may help teachers in supporting and extending student thinking in more productive ways.

Consideration of potential student responses to tasks helps teachers in responding to their students' needs in-the-moment of teaching during classroom discussions, but it may not be enough to advance students' mathematical thinking. In fact, Rowland, Thwaites and Jared (2015) defined contingency as part of necessary teacher knowledge which helped teachers face unexpected moments when they had to deviate from their plans during teaching. Teachers need to pay attention to both development of mathematical concepts and student ideas that come up spontaneously during discussion (Sherin, 2002). Stockero and Van Zoest (2013) defined pivotal teaching moment (PTM) as moments when teachers notice and act upon those moments and change the flow of the instruction according to students' thinking, i.e., students' unexpected comments and questions, misconceptions, or confusions. During these unexpected circumstances teachers may choose to ignore the PTMs or build upon them to extend the lesson that they planned before. In this study, the focus of inquiry was a novice teacher's instructional actions during unexpected moments of teaching by taking into account her planning and reflections on teaching. Understanding planning and teacher decision-making processes has a potential to contribute to both research in teacher professional development and actions involving student-centered teaching, as little is known about how to act productively in such situations.

Method

This is a case study (Yin, 2003) of a novice mathematics teacher. The authors explore instructional actions of the teacher during unexpected moments of teaching using qualitative methods.

Participants

The participant teacher held a master's degree from a highly selective teaching program in Turkey. She had two years of teaching experience in middle school. The school where she taught was a private school in Istanbul, Turkey and teachers were supported and encouraged to prepare detailed lesson plans collaboratively. The participant teacher's lessons and planning meetings were observed by one of the authors. The participating teacher was selected due to her experience in developing detailed lesson plans both as a teacher candidate and as a teacher.

Research Tools

Research tools included semi-structured interviews with the teacher, observations of mathematics lessons and recordings of lesson planning meetings. Planning meetings were conducted with the participating teacher and other mathematics teachers who taught 6th grade in the same school. During observations of three planning meetings, algebra lessons were planned by a group of

teachers teaching 6th grade in the school. All three meetings were observed and transcribed. Planning meeting transcriptions were useful to understand how teachers planned to create mathematical discussion environment and designed the lessons.

The interviews which took place both before and after observations provided opportunities to understand the teacher's perspective and her decisions about creating mathematical discussion environments in the class and how classroom talk could lead to student understanding. The interviews before classroom observations were about the teacher's thoughts on planning and anticipation of teaching decisions, for instance exploring the questions that the teacher planned to ask. The interviews after classroom observations allowed the authors to ask the teacher to reflect on how the lesson went and discuss her decision-making process as well as student learning. During these interviews, the teacher was asked to reflect on what went well or what she would change for the next lesson based on the experience. The teacher also had a chance to express what caught her attention and whether she made a decision to change the lesson plan due to unexpected moments. The interviews which lasted about half an hour took place both before and right after each lesson observation.

Overall, there were five lesson observations, five interviews before the observations and five interviews after the observations with the teacher. Additionally, there were observations of three lesson planning meetings and one general interview with the teacher in order to gain insights into her beliefs and perspectives as a mathematics teacher which helps us understand her actions in better ways. Beliefs are inherently related to instructional actions. Data collection took place over three weeks when the participating teacher taught algebra in the 6th grade. The second author observed both planning meetings and the mathematics lessons as a participant observer. Five lessons in algebra were observed. Classroom talk during each lesson was recorded and transcribed. Attending planning meetings, observations of the lessons and conducting pre-and post-observation interviews allowed researchers gain insights about the complexities involved in teacher decision making during the unexpected moments in teaching and details of the lesson flow.

Data Analysis

During the data collection and across five lesson observations three unexpected moments of teaching were observed. The unexpected moments were selected because they happened as a result of interaction with students, which were not anticipated in the planning meetings. An example of these moments was unanticipated student difficulty that was not discussed during the planning meetings. These moments were also confirmed with the teacher as unexpected during the interviews which took place after the lessons. To analyze the instructional actions during those unexpected moments, classroom talk during the unexpected moments were transcribed and teacher's actions were classified according to a framework developed by Cengiz et al. (2011).

Results

According to the analyses of lesson planning meetings, classroom observation transcripts and interviews before and after observations, three unexpected teaching moments were revealed. Unexpected answers, comments and questions in relation to teacher and student learning are provided in the next sections.

Several episodes of teacher instructional actions and her reflections in the context of responding to students' unexpected answers, comments and questions were discussed by taking into account of constructs of teacher noticing and pivotal teaching moments. Analysis of transcripts using the instructional actions framework (Cengiz et al., 2011) revealed that teacher instructional actions included supporting and extending actions. More specifically, *recording and acknowledging student thinking* and *inviting students to evaluate a claim, challenging/providing counter arguments to student claims* were observed as the teacher responded to changes in the lesson flow. Considering students' engagement and answers in the discussion, it may be argued that teacher was able to create a rich discussion environment by demonstrating such instructional actions.

Unexpected Moments of Teaching-1

The first unexpected moment was identified in the introductory lesson to the algebra concept. The lesson plan associated with this topic involved "the birthday magic activity" which was a number guessing game. This was the first time the 6th grade students were going to hear about the topic of algebra. Students were expected to engage with this activity, use four operations using their birthdays and come up with a number. At the end of the activity, the teacher planned to guess students' birthdays and explain that the use of algebra was needed in order to perform this magic. The teacher aimed to motivate students for learning algebra.

During the planning meeting, the teachers decided to provide the following instructions for the students about the birthday magic activity:

Start with the birthday month (if your birthday month is October, you will start with 10). Multiply this number by 5. Add 7 to the result. Then multiply this result by 4 and add 13. Multiply the result by 5 and add the birthday date (First lesson plan).

The teacher planned to subtract 205 from the resulting student answer and guess students' birthdays. The teacher anticipated that students would understand the pattern of the birthday magic activity after several examples.

In the following episode, the first unexpected moment occurred when a student used a different strategy than what the teacher thought before lesson. Below is the transcript of student answer and teacher response when a student was trying to guess a peer's birthday:

Student: I found the answer like this. I was born on the 25th of January and the result was 330. When my friend said 328, I went back two days, my friend must be born on the 23rd of January.

Teacher: Well, you found like that, by using a clue. What if the number associated with your friend's birthday was not close to yours? How would you find it then, if you did not have a clue?

Although the teacher acknowledged the student answer in the above episode, she also challenged this answer and pushed the student to find alternative ways so that the answer would not be relevant in only specific circumstances. The instructional actions occurred during this lesson were requesting basic information, clarifying questions, complimenting and evaluating, challenging/providing

counter arguments to student claims, pushing for alternative ways, inviting students to provide reasoning and probing (Cengiz et al., 2011).

In the same introductory lesson, there was another unexpected moment. Before the lesson, the teacher expected the resulting number she would get from students to be 4 digits. However, during the activity, some students provided three digit answers. The teacher had a difficulty in deciding which two digits of student answers were birth month or birth day. Additionally, some students made calculation mistakes in producing their birthday number, which resulted in inaccurate guesses. Here is what teacher said about how the lesson went according to plan:

Teacher: Actually, we did not think of using calculator but if student made calculations incorrectly then the activity does not work. Now, our learning outcome is not addition or subtraction. That's why we (the group of 6th grade teachers) decided to use calculator as a last-minute decision. That's why actually my plan changed. I made a strategy like first subtract 200 and then 5. Later I thought I can also use tablet and it would be faster. During the activity, I was sure about one student's birthday but the answer was wrong. After that I was confused because while we were studying we always went through 4 digits. When students said 3 digits, I couldn't decide what the birthday would be: the first two digits or last two digits. Maybe I should have practiced more on my own (Post-lesson interview after the first lesson).

As observed in the above transcript, the teacher attributed the unexpected moments in teaching to not being well prepared and anticipating different patterns. Although the teacher was going to ask a few students' birthdays in the plan, she asked all students with the unexpected confusion. As a result of this unexpected moment, the teacher reflected for future lessons and thought about how to prepare better and anticipate student answers in more productive ways.

Unexpected Moments of Teaching- 2

During this lesson students practiced operations with algebraic expressions. This unexpected teaching moment occurred when a student asked an unexpected question about writing an algebraic expression. In one of the questions, the students found an answer in the form of: $1+y/7$. After that the following conversation took place between the teacher and a student:

Student: Can we add them $(1+y/7)$?

Teacher: Can we add them? Are those similar terms?

Student: Teacher, but can't we write 1 as whole part?

Teacher: Hmm. Do you mean like this, "1 whole $y/7$ " as in fractions?

Student: Yes.

Teacher: Yes, you can. Like this (Teacher wrote the answer on the board.)

Student: Yes.

Teacher: I'm thinking. You can. Nice. Are there any questions? Are you sure?

In this lesson, the unexpected moment didn't change the flow of the lesson. Teacher clarified the meaning of what the student suggested and acknowledged the student answer. The teacher also recorded the answer on the board and shared it with class. The instructional actions were complimenting, requesting basic information, repeating student idea, claim, question, recording student thinking. In this specific unexpected moment, the teacher challenged the student answer in the beginning (“Are those similar terms?”) but later accepted what the student meant. The student made a connection with the concept of fractions. However, the teacher did not invite other students to evaluate the claim and make the discussion public. During the post lesson interview, the teacher said she was not expecting this connection with prior topics and she was pleasantly surprised. Although the teacher's aim was to create a discussion environment, in this unexpected moment there was a lost opportunity to create a pivotal moment of teaching to make student thinking public, which could help other students make similar connections.

Unexpected Moments of Teaching- 3

The last unexpected moment was identified during the lesson about patterns and algebra. The teacher asked students to give a number pattern. The unexpected teaching moment occurred when a student posed a question that the teacher had not considered prior to the lesson.

Student: Teacher, can we make it like this? (i.e. “a pattern like this?”)

Teacher: Say it.

Student: $1x, 2x, 3y, 1x, 2x, 3y$

Other students are giving similar examples, they discuss constructing different patterns by using numbers instead of x and y 's. In this moment, the whole class was involved.

Teacher: Let's write, $x, 2x, 3y, x, 2x, 3y$. Is this a pattern? (directing this question to the whole class, inviting other students to the discussion)

Students were engaged and providing different answers. Some provided the right answer and some were not sure about the answer.

Teacher: $x, 2x, 3y$ is a pattern. To understand that it is a pattern we want to see that it is repeating. There are variables but are they repeating with a rule, that is the important point.

Later during the interview, the teacher revealed that she did not expect this question. During this moment the teacher had a choice to ignore the student question or just acknowledge it and continue. Instead, she chose to make the discussion public and have other students participate in the discussion. The teacher changed the flow of the lesson for a few minutes based on a student response and spared time for discussion.

Teacher: I like it when students ask something beyond expected, they (students) can be so creative and such responses make classroom discussion become richer (the last interview).

The instructional actions during this unexpected moment were found as requesting basic information, repeating student idea, claim, question, acknowledging student thinking, recording student thinking, reminding of the goal, suggesting an interpretation, inviting students to evaluate a claim, and challenging/providing counter arguments to student claims.

Discussion

Results of data analyses revealed only three unexpected moments of teaching. In general, the planning sessions were very detailed and planning discussions among teachers encouraged them to think of potential student answers, weaknesses and strengths. There were not many unexpected moments for the teacher probably because she participated in collaborative and detailed planning sessions together with experienced teachers. Considering three unexpected moments of teaching, not all were pivotal teaching moments for the classroom, i.e., they did not allow for extended understanding among all students. There may be several reasons as to why this happened. For the first unexpected moment, the teacher had a difficulty because it was the first time she tried to play a guessing game with students but there were some answers that she did not anticipate. For the second unexpected moment, the teacher did not ignore the unexpected student question but did not make the student question public or invite other students to evaluate the claim. In contrast to the first two unexpected moments, during the third unexpected moment the teacher made the unexpected question public in the classroom and initiated classroom discussion.

The beginning teacher in this study considered how she could teach the next lesson in a better way with experience of unexpected moments of teaching. Experiencing unexpected moments appeared to have the potential to help the teacher's professional growth and planning for richer discussions for the next cycle of teaching similar concepts. This phenomenon was also mentioned by Smith et al. (2008). Analysis of instructional actions during unexpected moments revealed that the teacher demonstrated similar actions in different cases. Future research may utilize different frameworks in analyzing teacher actions. The analysis of instructional actions did not seem to predict quality of discussion on its own, which may need to be supported by other frameworks in future studies. This was a case of a novice teacher who was motivated to build instruction by considering student thinking. Analysis of the interviews and observations indicated that the teacher valued different types of student thinking and explored student thinking by asking open-ended questions and initiating classroom discussions. The instructional actions included types of actions that had potential for supporting and extending student thinking (Cengiz et al., 2011; Taylan, 2015). These findings are in contrast with previous research which documented beginning teachers mostly focused on classroom management and on their experience as beginner teachers (Schmidt, Klusmann, Lüdtke, Möller, & Kunter, 2017). The teacher in this study was in a high-achieving school and did not have many classroom management problems, which helped her build meaningful classroom discussion environments. Our study revealed detailed planning and teacher collaboration culture and as well as individual experiences and motivation seemed to help this teacher in creating and managing mathematical discussions.

References

- Ball, D. L., Lubienski, S., & Mewborn, D. (2001). Research on teaching mathematics: The unsolved problem of teachers' mathematical knowledge. In V. Richardson (Ed.), *Handbook of research on teaching* (pp. 433–456). New York, NY: Macmillan.
- Cengiz, N., Kline, K., & Grant, T. J. (2011). Extending students' mathematical thinking during whole-group discussions. *Journal of Mathematics Teacher Education*, *14*(5), 355–374.
- Schmidt, J., Klusmann, U., Lüdtke, O., Möller, J., & Kunter, M. (2017). What makes good and bad days for beginning teachers? A diary study on daily uplifts and hassles. *Contemporary Educational Psychology*, *48*, 85–97
- Fennema, E., & Franke, M. (1992). Teachers' knowledge and its impact. In D. A. Grouws (Ed.), *Handbook of research on mathematics teaching and learning* (pp. 147–164). New York, NY: Macmillan.
- Franke, M. L., Kazemi, E., & Battey, D. (2007). Understanding teaching and classroom practice in mathematics. In F. Lester (Ed.), *Second handbook of mathematics teaching and learning* (pp. 225–256). Greenwich, CT: Information Age.
- Hiebert, J. C., & Grouws, D. A. (2007). The effects of classroom mathematics teaching on students' learning. In F. K. Lester (Ed.), *Second handbook of research on mathematics teaching and learning* (pp. 371–404). New York, NY: Information Age Publishing.
- National Council of Teachers of Mathematics (NCTM), (2000). *Principles and standards for school mathematics*. Reston, VA: Author
- National Research Council (NRC), (2005). *How students learn: History, mathematics, and science in the classroom*. Washington, DC: The National Academies Press.
- Rowland, T., Thwaites, A., & Jared, L. (2015). Triggers of contingency in mathematics teaching, *Research in Mathematics Education*, *17*(2), 74–91.
- Sherin, M. G. (2002). A balancing act: Developing a discourse community in the mathematics classroom. *Journal of Mathematics Teacher Education*, *5*(3), 205–233.
- Smith, M. J., Bill, V., & Hughes, E. K. (2008). Thinking through a lesson: Successfully implementing high-level tasks. *Mathematics Teaching in the Middle School*, *14* (3), 132–138.
- Stockero, S. L., & Van Zoest, L. R. (2013). Characterizing pivotal teaching moments in beginning mathematics teachers' practice. *Journal of Mathematics Teacher Education*, *16* (2), 125–147.
- Taylan, R. D. (2015). Characterizing a highly-accomplished teacher's instructional actions in response to students' mathematical thinking. In K. Krainer & N. Vondrová (Eds.). *Proceedings of the Ninth Congress of the European Society for Research in Mathematics Education* (pp. 3136–3142). Prague, Czech Republic: Charles University and ERME
- Yin, R. K. (2003). *Case study research: Design and methods*. Thousand Oaks, CA: Sage.

Feedback for creative reasoning

Anna Teledahl¹ and Jan Olsson²

¹Örebro University, School of Science and Technology, Örebro, Sweden; anna.teledahl@oru.se

²University of Mälardalen, Department of Education, Culture and Communication, Västerås, Sweden; jan.olsson@mdh.se

This study investigates how principles of feedback to encourage students' creative reasoning can be used by a mathematics teacher. An experienced teacher was introduced to principles, developed in pilot studies, and was instructed to plan a lesson based on four principles for feedback. During the lesson the teacher's interactions with students were recorded and the following analysis focused on the way feedback resonated with the principles. The result indicates that providing feedback which challenges students to reason creatively is difficult and complex. There are pitfalls that originate in established classroom norms for interaction, as well as beliefs about the object of teaching, and it appears that the principles, in order to become a powerful tool, require the teacher and students, to practice using them.

Keywords: Instructional design, teaching methods, feedback.

Introduction

Students, who are encouraged to construct their own solutions and create arguments when solving mathematical tasks, tend to, if they are successful, learn or remember more from such activities than students who are being guided by templates and prepared examples (Jonsson, Norqvist, Liljekvist, & Lithner, 2014). Despite the disadvantages, described in numerous research reports, of teaching mathematics by providing solution methods to tasks, such teaching is still prevalent in many classrooms, in Sweden, as well as around the world (Boesen, Lithner, & Palm, 2010; Hiebert & Grouws, 2007). Teaching where students create and justify their own solutions (i.e., engaging in creative reasoning) requires different teacher-student interactions than traditional teaching. Rather than explaining which method to use as well as how and why it works the teacher must encourage students, not only to construct own solutions, but also to challenge them to justify their choice of method (Hmelo-Silver, Duncan, & Chinn, 2007).

A teacher-student interaction aimed at supporting students' construction of solutions can be compared to feedback aimed at supporting the students' learning processes and thus relies on the active involvement of the student (Hattie & Timperley, 2007; Nicol & Macfarlane-Dick, 2006). Research on formative assessment and feedback often reports general guidelines on how to provide feedback in teaching but few studies present empirical results detailing how feedback can be prepared and designed in classroom situations (Hattie, 2012; Palm, Andersson, Boström, & Vingsle, 2017). Hence there is need for a deeper understanding of how formative assessment/feedback can be implemented at a classroom level (Hirsch & Lindberg, 2015). As a preparation for this study a series of four pilot studies, involving mathematical problem solving, was conducted. The interaction between students and their teacher was studied with the aim of identifying what characterizes the kind of feedback that leads students to reason creatively. The findings can be interpreted as four basic principles: (1) find out how the students are thinking, demand that students are specific, (2)

encourage the students to formulate their thinking without interrupting or interpreting, (3) challenge the students to explain why their solution is working (or not working) – instead of confirming or disconfirming, and (4) encourage the students to find a way to test their solution. The present study investigates how the principles can be used by a teacher who is unfamiliar with them. Our aim is to refine the principles and to form guidelines for formative feedback that teachers can use to foster creative reasoning.

Background

Teaching that encourages students to construct and justify solutions to mathematical tasks entails a focus on reasoning. Furthermore, it is reasonable to assume that teachers' feedback may guide the character of students' reasoning. The following paragraphs will outline distinctions between different types of reasoning and feedback relevant for the didactic design addressed in this paper.

Imitative and creative reasoning

If the teacher explains a definition of a mathematical concept and then demonstrates how to solve tasks associated with this particular concept, it is possible for students to solve similar tasks by remembering the procedure without understanding the definition. Lithner (2008) found that students trying to apply memorized procedures often had difficulties when solving tasks for which there had been no recent teaching. For example, calculating $2^3 + 2^4$ using a memorized process could mean mixing up whether the numbers should be added or multiplied. The reasoning associated with such an approach is defined as imitative (IR) (Lithner, 2008). A variant of IR is AR, algorithmic reasoning which is relevant for this paper. AR entails recalling a memorized, stepwise, procedure or following procedural instructions from a teacher or textbook, that are supposed to solve a task (Lithner, 2008). AR is algorithmic in the sense that it solves the associated task, but it does not require an understanding of the mathematics on which the procedure is based.

An alternative approach to the example above, $2^3 + 2^4$, may be to consider what the mathematical meaning behind the expression is, i.e., 2^3 means $2 + 2 + 2$, and 2^4 means $2 + 2 + 2 + 2$. After realizing this, the next step is to put the two together, $2 + 2 + 2 + 2 + 2 + 2 + 2$, which is 2^7 . If the student can express mathematical arguments for the solution she is engaged in creative mathematical reasoning (CMR). CMR is characterized by the construction or reconstruction of a solution method and the expressing of arguments for the solution method and the solution (Lithner, 2008).

Feedback

It is possible for students to reach correct answers to tasks without understanding the mathematical concepts involved (Brousseau, 1997). If a student should fail in his or her attempts to solve a mathematical task, the most obvious feedback from the teacher may be an explanation regarding how to solve the task, not to explain the mathematics it is based on. Should the student, however, be responsible for the construction of the solution method, she is helped by understanding the mathematics required by the task. In such cases, it is appropriate for the teacher to inquire into the student's thinking. Inquiring into students' thinking can be seen as part of formative feedback at the process level whereas delivering or assessing a right or wrong answer is seen as task level feedback

(Hattie & Timperley, 2007). Research indicates that 90 % of feedback in classrooms is on task-level (Airasian, 1997). Feedback on process-level focuses on the underlying mathematical processes, which can support students' conceptual understanding as well as their autonomy (Kazemi & Stipek, 2001). This type of feedback creates interactions in which students have an opportunity to develop their ability to use mathematical ideas to formulate arguments and justifications for their choices (Michaels, O'Connor, & Resnick, 2008).

Development of principles for feedback aimed at supporting creative reasoning

The principles for feedback were developed iteratively during a year in four pilot studies in collaboration with a teacher (see Olsson & Teledahl, 2018). The starting point for the pilot studies was the design of appropriate tasks for CMR. Then possible solutions to the tasks, together with the potential difficulties that students will encounter, were considered. For each of these solutions and difficulties feedback aimed at supporting CMR was designed. The lessons were recorded and the interactions between the teacher and the students were analyzed with the aim of identifying the characteristics of the feedback that led students to reason creatively. The result of every analysis was used in the planning of the next lesson. After the fourth intervention, principles for feedback supporting CMR were formulated. These principles (see Introduction) were used in the present study to support the design of the intervention (to setup student activities where feedback for CMR is appropriate) and to prepare the teacher to formulate feedback for CMR.

Method

In order to test the previously developed principles for feedback a new study was set up in which a lesson was planned so that students would have the opportunity to engage in CMR. The principles were also used to prepare the teacher and help him support students' CMR through feedback. During the lessons the teacher's interactions with students were recorded. Compared to other possibilities (e.g., interviews) data was considered to be reasonably close to the thinking processes that create feedback and reasoning. Feedback is considered as both a response to students' actions and guiding their continued reasoning. The chain students' action – teacher's feedback – students' continued reasoning was the unit of analysis.

Sample

A teacher and students in 8th grade of a Swedish elementary school volunteered to participate. The teacher is experienced in teaching mathematics through problem solving and the students were used to problem-solving activities. The teacher did not participate in the pilot studies where the principles for feedback were developed. Instead, he was introduced, during a half-day seminar, to the idea of supporting students' CMR through feedback according to the principles. Transcripts from the pilot studies were discussed and tasks suitable for the class participating in this study were considered. The teacher considered the class to be average in terms of achievement, and a mix of students with Swedish as their native or second language. With respect to feedback, in his everyday teaching, the teacher considered it his intention not to guide students to solutions, although he did not have explicit strategies for achieving this. Neither the lesson, nor the feedback, would thus be considered something out of the ordinary and according to the teacher, the interactions were typical for his style of teaching.

Lesson plan

The teacher was instructed to plan a lesson containing problem solving. The role of the teacher was to support students in constructing solutions rather than explaining how to solve the problems. It was assumed that successfully constructing solutions, without knowing a solution method in advance, would require students to engage in CMR. The tasks were designed in line with Lithner's (2017) principles: (1) creative challenge, no solution methods are available from the start and it must be reasonable for the students to construct the solution, (2) fair conceptual challenge to understand mathematical properties (e.g., representations and connections) and (3) justification challenge, is it reasonable for the particular student to justify the construction and implementation of a solution. The tasks were part of the curriculum and involved combinatorics. *Task 1a* asks the students to find all of the different ways to put three blocks of different colors in a row. The students were supplied with concrete materials. In *task 1b* another block, of yet another color, is added. The teacher was also instructed to prepare to give feedback according to the principles.

Procedure

During the lesson, the students worked in pairs. The tasks were presented in written text and the students were asked to present written solutions. The students were encouraged to collaborate and call the teacher if they did not understand the instructions, or if they got stuck. The teacher was wearing a recording device, which recorded his interactions with students. The recordings were transcribed into written text, with a focus on spoken language.

Analysis method

The analysis focused on the chain students' action – teacher's feedback – students' reasoning in connection teacher's feedback, and was performed through the following steps:

(I). Parts of transcripts where the teacher interacts with students, and where it is considered possible to provide feedback according to the principles, were identified. (II). Parts of transcripts, where the teacher's feedback resonates with the principles for feedback, were identified. (III). It was determined whether feedback, according to the principles, supported or did not support students' CMR. (IV). In interactions, where the principles were not implemented consistently or only partly implemented, possible trajectories leading to CMR were considered and the way the principles could have supported CMR was analyzed.

The analysis was a joint effort that involved the teacher.

Results

The lesson was conducted according to plan in the sense that students got engaged in problem solving where they did not have access to a solution method for the tasks. Interactions with the teacher could be observed when a solution to a task was reached or when students asked for help. We will now present two extracts from the transcripts which can be seen as examples of interaction where the teacher can be considered to have possibilities to provide feedback according to the principles.

In the first example, which is representative of a number of interactions during the session, the student had come to a solution to *task 1a*:

1. Teacher: Explain the way you are thinking.... it looks like you have some system.
2. Student: Well.... if you start with a block.... for instance, a green one.... you can always change the order of the other two blocks.... and in this case, there are three blocks.... so, you have plus two combinations.... so, in this case it can be green-white-yellow and green-yellow-white.... so, if we have three blocks it will be three times two.
3. Teacher: OK.... you can go on to the next task

The teacher asks the student to explain her thinking (line 1) which is in line with the first principle. While the student did not know how to solve the task in advance it is reasonable to assume that the answer (line 2) represents, at least partly, CMR (constructing a solution). As a whole only the first principle is used. The student is not articulating arguments explicitly, which could have been encouraged by first inviting her to express her understanding (principle 2) and then challenge her to explain why her method results in correct answer (principle 3). The last utterance in line 2, when the student suggests a way to calculate the numbers of combinations, can be used to challenge her to justify their solution (principle 4). The teacher's comment on line 3 does not correct the student, which gives her an opportunity to find out that although the calculation is correct in connection to *task 1a*, it will not work in *task 1b*. This is an example of when the teacher's decision to refrain from explaining, gives the student an opportunity to discover the error in her conclusion. In the next task (1b) the teacher has the opportunity to challenge the student's reasoning using principles 2-4.

The second excerpt was chosen as an example where principle 3 could have been appropriate. It introduces a similar situation as example 1 and indicates the importance of the formulation of feedback. A pair of students have come to a solution on task 1a and now call for help with task 1b.

1. Teacher: What did you conclude on task 1a?
2. Student: We conclude that for every color.... if it is situated in one place.... there are two combinations for where the others could be situated.... that goes for every color situated in each place.... but if you add one block there will be four blocks and there will be three combinations for each block in each position.
3. Teacher: Are you sure?
4. Student: No.... there will be more then.
5. Teacher: How many positions can this be in?
6. Student: Then it would be.... these ones.... ok.
7. Teacher: If there were three blocks they could be situated in....
8. Student: If they were three they can.... yes.
9. Teacher: This was the prior task [1a].... wasn't it?
10. Student: Then there will be six ways for these.
11. Teacher: Yes.... if the blue one is first.... but you don't have to put the blue one first.
12. Student: No.
13. Teacher: So, how many could it be.... how many ways is it if the yellow is first?

14. Student: If the yellow is first there will be six ways.
 15. Teacher: OK, so how many is it all together?
 16. Student: Twenty four.
 17. Teacher: OK.... could it be more ways.... are there any others that could be first?
 18. Student: No, these are the only ones you can have first.

In the planning for feedback it was considered that the reasoning connected to 1b could be continued from the solution of 1a. Therefore, on line 1 the teacher focuses the feedback to the task 1a. The question posed in line 1 may be associated to principle 1. The student's reasoning on line 2 includes both how the solution is constructed and arguments which are components in CMR. The teacher's question on line 2 could have been in line with principle 3, but the student seems to perceive the question as an indication she is wrong. From here the teacher's feedback instead of following the principles is mainly on task-level, i.e., its purpose is to guide the students to a solution, not to support CMR. The student does not fulfil the CMR from line 2, instead, the reasoning turns into guided AR (imitating the teacher's reasoning).

Summary of results

Mathematical reasoning is considered creative (CMR) if students themselves construct or reconstruct a solution method to a problem and express arguments to support this. The two examples above indicate that students, who are encouraged to explain their thinking, express CMR. Through their explanations it seems clear that they have constructed solutions to problems, for which they did not have access to a solution method in advance. Less clear is the way students formulate arguments for their solution. In neither of the examples are students encouraged to justify or articulate arguments. The principles for feedback in this study were developed to encourage students to construct their own solution methods and formulate mathematical support for their solutions. The results indicate that it may not be an easy task, even for experienced teachers, to implement these principles.

Discussion

Creative reasoning is a powerful tool in the learning of mathematics. In mathematical problem-solving creative reasoning, where conjecturing and justifying are viewed as important parts, leads students to construct their own solutions to mathematical tasks, something that previous studies have found beneficial for their learning (Jonsson et al., 2014; Olsson & Teledahl, 2019). How to design teaching, in particular feedback, which will encourage students to construct solutions and present support for why they are correct, is still something that we know too little about.

Teaching where students are constructing solutions while engaging in CMR does not entail a passive teacher (Hmelo-Silver et al., 2007). The teacher in this study planned the activities with the intention of creating situations where feedback, in line with the principles, would be appropriate. In the first excerpt, the students have managed to solve task 1a and principle 1 is used to challenge the students to articulate their reasoning explicitly. After the students have explained their thinking, the teacher without verifying the students' solution, encouraged them to move on to task 1b. By not confirming or disconfirming the solution to the first part of the task the teacher creates an opportunity for the students to discover that their method for solving in 1a will not work in 1b. He

does not challenge them to explain anything, or ask them why they think it works, but rather leaves them to test their solution in the next stage. He is thus creating an opportunity for the students to continue their CMR, and for himself to challenge the students to formulate arguments for their solution, at a later stage when they, hopefully, have made useful discoveries about their original idea. This situation leads us to realize that the teacher not only has to consider the principles for *how* to challenge students to explain and provide argument but also *when* to do so. In this interaction giving students time and space might lead them to insights that helps them to argue for their final solution. It might be challenging to teachers to be consistent in constantly providing feedback, according to the principles, but also to retain a sensitivity to when it may be a good idea to leave the students alone.

Example 2 shows, what may be an even greater challenge, to avoid explaining how to solve a task when students ask for help. Again, principle 1 seems to work well. Students express their reasoning and leave space for feedback in line with principles 2, 3, and 4. Here, the teacher may have in mind not to explain the way to solve the task, but instead of asking the students to explain he uses questions that, step by step, guides the students towards a solution. On the surface, it might seem like he is sticking to the principles, given that he is using questions instead of statements and hints, but the questions can be seen as a way to implicitly provide the solution. The responsibility for the mathematical reasoning shifts to the teacher and the students miss an opportunity not only to develop their ability to provide mathematical arguments but also to retain their autonomy (Kazemi & Stipek, 2001; Michaels, O'Connor, & Resnick, 2008). It may be tempting for the teacher to explain or to guide the students to a solution, not only because it saves time when the teachers is stressed, but also because it produces a result, a solution. In this way the product, rather than the process, becomes the main object. A solution to a problem, even if it was obtained by imitating the teacher (AR according to Lithner, 2008) is considered more valuable than CMR, which may not even result in a complete solution. To focus feedback on the underlying thinking process that will solve the task is most likely difficult and it places high demands on both teachers and students.

Since the collaborative teacher in the pilot studies was involved in developing the principles for feedback she became gradually aware of how to use them and what they would lead to. In addition, while she was positive to the idea of students learning through CMR, she also practiced using the principles between the four interventions, which were planned in collaboration with the authors. The teacher, who participated in the current study, was also positive to teaching according to the principles. The difference was that he was introduced to the concept through a few hours of instructions. The two examples of interaction, shown above, highlight how important it is to carefully formulate your questions. In every classroom there is an established pattern for teacher-student interaction, and in order for such patterns to develop towards CMR teachers and students need, not only to practice using the guidelines, but also to reflect on their current patterns of interaction.

References

Airasian, P. W. (1997). *Classroom assessment* (3rd ed.). New York, NY: McGraw.

- Boesen, J., Lithner, J., & Palm, T. (2010). The relation between types of assessment tasks and the mathematical reasoning students use. *Educational Studies in Mathematics*, 75(1), 89–105. doi:10.1007/s10649-010-9242-9
- Brousseau, G. (1997). *Theory of didactical situations in mathematics*. Dordrecht, The Netherlands: Kluwer Academic Publishers.
- Hattie, J. (2012). *Visible learning for teachers: Maximizing impact on learning*. Abingdon, England: Routledge.
- Hattie, J., & Timperley, H. (2007). The power of feedback. *Review of Educational Research*, 77(1), 81–112. doi:10.3102/003465430298487
- Hiebert, J., & Grouws, D. A. (2007). The effects of classroom mathematics teaching on students' learning. In F. K. Lester (Ed.), *Second handbook of research on mathematics teaching and learning* (pp. 371–404). Greenwich, CT: Information Age.
- Hirsh, Å., & Lindberg, V. (2015). *Formativ bedömning på 2000-talet – en översikt av svensk och internationell forskning*. Stockholm, Sweden: Fritzes.
- Hmelo-Silver, C., Duncan, R., & Chinn, C. (2007). Scaffolding and achievement in problem-based and inquiry learning: A response to Kirschner, Sweller, and Clark (2006). *Educational Psychologist*, 42(2), 99–107.
- Jonsson, B., Norqvist, M., Liljekvist, Y., & Lithner, J. (2014). Learning mathematics through algorithmic and creative reasoning. *The Journal of Mathematical Behavior*, 36, 20–32.
- Kazemi, E., & Stipek, D. (2001) Promoting Conceptual Thinking in Four Upper-Elementary Mathematics Classrooms. *The Elementary School Journal*, 102(1), 59–80.
- Lithner, J. (2008). A research framework for creative and imitative reasoning. *Educational Studies in Mathematics*, 67(3), 255–276. doi:10.1007/s10649-007-9104-2
- Lithner, J. (2017). Principles for designing mathematical tasks that enhance imitative and creative reasoning. *ZDM*, 49(6), 937–949.
- Michaels, S., O'Connor, C., & Resnick, L. B. (2008). Deliberative discourse idealized and realized: Accountable talk in the classroom and in civic life. *Studies in Philosophy and Education*, 27(4), 283–297. doi:10.1007/s11217-007-9071-1
- Nicol, D. J., & Macfarlane-Dick, D. (2006). Formative assessment and self-regulated learning: a model and seven principles of good feedback practice. *Studies in Higher Education*, 31(2), 199–218. doi:10.1080/03075070600572090
- Olsson, J., & Teledahl, A. (2018). Feedback to encourage creative reasoning. In J. Häggström, Y. Liljekvist, J. Bergman Ärleback, M. Fahlgren & O. Olande (Eds.), *Perspectives on professional development of mathematics teachers* (pp. 151–160). Göteborg, Sweden: SMDF
- Palm, T., Andersson, C., Boström, E., & Vingsle, C. (2017). A review of the impact of formative assessment on student achievement in mathematics. *Nordic Studies in Mathematics Education*, 22(3), 25–50.

Revisiting teacher decision making in the mathematics classroom: a multidisciplinary approach

Steven Watson¹

¹University of Cambridge, Faculty of Education, UK; sw10014@cam.ac.uk

The purpose of this paper is to consider the role of mathematics teachers' thinking and decision making in the classroom. This has been a somewhat neglected area of research since the mid-1980s, but I will argue here that understanding the nature of teachers' thinking and decision making in lessons is important in understanding practice and can inform approaches to initial teacher education and professional development. While mathematics teachers' knowledge and beliefs are important, the decisions they make and the actions they implement in the lesson influence the learning environment, culture and interpretation of tasks and activities. I draw on my own empirical research along with a multidisciplinary account based on developments in cognitive psychology, neuroscience and ontology (e.g., posthumanism) to provide a theoretical account of teacher thinking and decision making and how this influences practice.

Keywords: Teachers' decision making, teaching practices, teaching methods, teachers' knowledge, teachers' beliefs.

There was considerable research into teachers' thinking and decision making during the 1970s and 1980s, but since the mid-1980s this was rather displaced by a surge of interest in teachers' knowledge (Borko, Roberts, & Shavelson, 2008). It is not entirely clear why there was a change in direction, but it is likely that the seminal American Educational Research Association presidential speech by Lee Shulman in 1986 heralded widespread interest in teachers' pedagogic content knowledge (Shulman, 1986). Since then researchers have been more interested in what teachers know in terms of discipline-based pedagogical knowledge than they have been in teachers' thinking. This is not to say, of course, there have been no recent contributions to the field of teacher decision making. Notably, Alan Schoenfeld's book *How We Think* (2011) directly addresses teacher decision making and thinking in the classroom and builds on the earlier research. But there remains further opportunity to revisit and extend the existing research using recent thinking from neuroscience and psychology. My aim here is to argue why, while acknowledging the important contribution of research into teachers' knowledge and beliefs, research into teacher thinking is necessary in order to gain a better understanding of the nature of classroom practice.

The background to this is mine and colleagues' recent research (Watson, Kimber, Major, & Marschall, 2018) into how teachers implement ambitious teaching approaches (Stylianides & Stylianides, 2014) in post-16 (A Level) mathematics classrooms. An intense idiographic inquiry led us to consider how teachers make decisions in the classroom and the nature of the underlying thinking and reasoning processes. We found we could not easily explain, like many researchers before us, why even in the context of supported teaching reforms, a teacher almost naturally tends to a traditional teacher-centred approach in the classroom. And when the teacher is encouraged and supported in implementing ambitious teaching and in giving mathematical authority/authorship (Povey & Burton, 1999) to the students they seem compelled to retain authority/ authorship. This is not by any means a

criticism of teachers, but it is undoubtedly a phenomenon that warrants exploration and a search for further understanding. Our research, building on past research into teacher thinking and recent developments in cognitive psychology, neuroscience and ontological accounts such as posthumanism, suggests that in-the-moment decision making (Schoenfeld, 2011) in the classroom has an important role in this.

It is first necessary to distinguish between teachers' thinking in the lesson as they interact with students and the thinking and decision making that takes place in the planning of and reflecting on lessons. I adopt here the following categorization of teacher thinking developed by Clark and Peterson (1986):

- Teacher planning (preactive and postactive thought);
- Teacher interactive thoughts and decisions;
- Teacher theories and beliefs.

There are qualitative differences between the decisions made in the moment in the lesson and the teacher's thinking about the lesson before and after the lesson. Decisions in the classroom have to be made quickly in a complex and demanding environment. But both interactive, in-the-moment decisions and planning are underscored by a teacher's theories, knowledge and beliefs. The knowledge and perspectives in memory provide the resources that contribute to reasoning processes. The turn to pedagogic content knowledge in the late 1980s tends to privilege the role of teachers' theories and beliefs, I argue here (and following our empirical research) it is the momentary decisions that influence the character of the lesson. That is, in-the-moment decisions can lead to a lesson becoming more traditional and teacher-centred even though the teacher may have the knowledge of and hold beliefs in reform-oriented student-centred approaches (or 'ambitious' teaching)¹.

Traditional teacher-centred teaching typically involves teacher exposition or demonstration followed by student practice on routine graduated exercises and might conclude with a whole-class review. In contrast, student-centred² practice involves students in collaborative dialogic problem-solving, inquiry-based or investigative activities in which they construct meaning and conceptual understanding (or 'relational' rather than 'procedural' understanding, see, Skemp, 1976) where the mathematical authority and authorship (Povey & Burton, 1999) is transferred to students. This has been given a catch-all characterization of 'ambitious' teaching (Stylianides & Stylianides, 2014).

From the perspective of cognitive psychology, human reasoning and decision making are characterized as either unconscious and intuitive Type 1 processes or rational and conscious deliberative Type 2 processes (Evans & Stanovich, 2013). Intuitive unconscious reasoning is rapid

¹ The implicit assumption here is that the traditional teacher-centred teaching is a default and largely prevalent approach to practice – this is certainly underpinned by evidence from the Office for Standards in Education (Ofsted) in England (Ofsted, 2008, 2012). I contend this to be a justifiable claim for high school and secondary mathematics teaching practice in Europe and the US (see, for example, Cuban, 1993; Stigler & Hiebert, 1999).

² The characterisation of traditional teacher-centred practice and student-centred practice draws on Larry Cuban's historical analysis of classrooms in the USA (Cuban, 1993).

and is employed in complex and demanding situations where decisions have to be made quickly (Johnson-Laird, 2006). Conscious reasoning uses working memory to construct mental models and assess possibilities prior to making a decision and taking action. Research into teacher decision making in the 1970s and 1980s acknowledged the distinction between unconscious (Type 1) and conscious (Type 2) reasoning and recognized that classroom demands require intuitive Type 1 decisions (Clark & Peterson, 1986; Shavelson & Stern, 1981). At the same time, Clark and Peterson recognized deliberative aspects of teachers' interactive decision making in the classroom. Shavelson and Stern (1981) suggested teachers draw on existing routines and sub-routines to simplify their interactive decision making.

...teachers' interactive teaching may be characterized as carrying out well-established routines. In carrying out the routine, the teacher monitors the classroom, seeking cues, such as student participation, for determining whether the routine is proceeding as planned. This monitoring is probably automatic as long as the cues are within an acceptable tolerance. However, if the teacher judges the cue to be outside tolerance (e.g., student out-of-seat behavior during discussion), the teacher has to decide if immediate action is called for. If so, the teacher has to decide if a routine is available for handling the problem. The teacher may take action based on a routine developed from previous experiences (Shavelson & Stern, 1981, p. 483).

This implies a heuristic approach to decision making that is not entirely intuitive and involves conscious decisions using rehearsed actions and pedagogic routines. The nature of teacher decision making is somewhere between Type 1 and Type 2 reasoning.

Recent research on human reasoning goes beyond a Type 1 and Type 2 dichotomy and offers an intermediate type of reasoning. Stanovich, West and Toplak (2011) propose an algorithmic system. This is a Type 2 conscious process but makes use of heuristics and preestablished routines and processes to reduce the demand on working memory. Algorithmic reasoning draws on knowledge which is "...tightly compiled due to overlearning and practice" (Stanovich et al., 2011, p. 107) and is based on social and cultural knowledge acquired through participation (Stanovich et al., 2011).

In our research (Watson et al., 2018), most of the decision making in the classroom was based on algorithmic reasoning. For example, during the lesson we observed the teacher deciding to stop the class and explain a specific aspect of the mathematics to the whole class. He explained in a stimulated recall interview later that he made the decision to take this action during the lesson. He said that he felt that there were enough student misunderstandings to warrant some remedial action. This heuristic, he said, was learnt during his initial teacher education programme. He explained how he observed that if a teacher found that there were three or more students with a similar question, then it could be assumed that more students were likely to have the same difficulty, then they would stop the class and offer an explanation to the whole class. Based on his explanation of this vicarious learning process, it appeared likely that this heuristic had been supported with some justification from a mentor or experienced teacher. This is an example of algorithmic reasoning, it is a simplified (and almost intuitive) judgement of the situation and the retrieval of rules, procedures and strategies (Stanovich et al., 2011).

Mathematics teaching and teaching more generally is replete with pedagogical routines and strategies. Indeed, Alexander's (2001) analysis of primary classrooms observed complex hierarchical and temporal systems of routines and rituals. Leinhardt characterizes teachers' knowledge as "...highly proceduralized and automatic and in which a highly efficient collection of heuristics exist for the solution of specific problems in teaching" (Leinhardt, 1988, p. 146).

As a secondary mathematics teacher, my own practice featured automated, proceduralized routines and heuristics. For example, I had a routine for teaching how to solve simultaneous equations. It was highly procedural, I would refer to it as a 'recipe'. And as an experienced mathematics teacher, I did not have to think, in the moment, about the pedagogical process in too much detail. I had learnt it from other teachers and used it on many occasions. If students were having difficulty solving simultaneous equations I could quickly stop the class and invoke this routine. I knew that if students were becoming anxious (and potentially disruptive) I could quickly and authoritatively provide this well-rehearsed explanation and give the students some routine practice questions, and this would provide reassurance and calm the situation.

It is widely acknowledged in the literature that a major preoccupation for all teachers is the management of the classroom and the management of student behaviour (Martin, Sass, & Schmitt, 2012). Shavelson and Stern explain the main aim of the teacher is to "maintain the flow of activity" (Shavelson & Stern, 1981, p. 484) and that decisions are made when there is an indication of a "potential problem or unexpected event" (p. 484). At these points teachers become "aware of reality" and their attention focuses on student behaviour (Shavelson & Stern, 1981). Therefore, what prompts a teacher to make an in-the-moment or interactive decision is strongly influenced by the affective system, that is the senses, the autonomic system and physiology. While Schoenfeld offers a highly rationalistic account of goal-oriented in-the-moment decision making based on his previous research on mathematical problem solving, he acknowledges the importance of affect. He advocates for future research in decision making to work toward a "rapprochement of the physiological and psychological" (Schoenfeld, 2011, p. 195).

Indeed, this rapprochement can be observed in posthuman accounts of practice and potentially provides a compelling interdisciplinary account of thought, experience, affect and behaviour in the context of classroom practice. A posthuman³ critique of teacher thinking represent a departure from the Cartesian mind/body duality (Strom, 2015); posthumanism emphasizes the physical, the material, the experiential and the embodied nature of cognition (Braidotti, 2013). The posthuman classroom is not populated by discrete individuals but is "...an assemblage of multiple human and non-human elements that are all connected and work together to jointly produce teaching and learning activity" (Strom, Mills, Abrams, & Dacey, 2018, p. 144). A feeling or sensitivity to the environment is processed by the amygdala, which is reciprocally connected with the brain cortex and the thalamus. The amygdala is often associated with 'fight or flight' responses. Effectively it helps us decide

³ Posthumanism is not a rejection of humanity but a counter to humanism, as an anthropocentric project and a challenge to Enlightenment rationality that privileges the mind as a conscious and rational system as the primary mechanism for solving individual and collective problems.

whether a response should be intuitive and reactive or conscious and deliberative. Importantly it draws on episodic memories which have affective and emotional signatures to quickly make sense of the situation (Markowitsch & Staniloiu, 2011). In contemporary liberal society human responses are much more nuanced than simply ‘fight or flight’: in any critical situation then the amygdala is involved in the following processes, do we have to react quickly or intuitively with deeply embedded culturally and evolutionarily compiled behaviours? Is there time to invoke socially learned and culturally embedded heuristics, strategies, routines and processes (the algorithmic mind)? Or is there time to reflect and construct and mentally evaluate alternative hypothetical courses of action and use logical processes? (see, for example, Janak & Tye, 2015; Markowitsch & Staniloiu, 2011; Pessoa, 2017; Phelps, 2006).

Much human behaviour is intuitive, we respond to the context with culturally and evolutionarily compiled behaviours, like, for example, the fight or flight response. Algorithmic responses are invoked where simple decisions and well-practised responses are required, and these have been the focus of the research I have referred to in this paper (Watson et al., 2018). Reflective Type 2 thinking might take place in the planning and evaluation of lessons, or in the work of research and scholarship, for example.

While it might be argued that the goal of teachers’ decisions is to optimize student learning (see Schoenfeld, 2011) and this might be possible in the planning and design of lessons, tasks and activities, in interactive decision making, in the classroom, decisions have to be more immediate. The primary aim, in the moment, is to manage the social situation, as Cuban observes:

... teachers have learned to ration their time and energy to cope with conflicting and multiple societal and political demands by using certain teaching practices that have proved over time to be simple, resilient, and efficient solutions in dealing with large numbers in a small space for extended periods of time (Cuban, 2009, pp. 10–11).

The algorithmic mind quickly accesses routines and procedures that are learnt through participation and provide well-rehearsed and culturally-embedded approaches to respond to situations in the classroom. The mainstay of these established cultural scripts (Stigler & Hiebert, 1999) correspond to traditional teacher-centred approaches. Moments of doubt, pressure and uncertainty in a classroom are likely to result in an almost automatic response with teacher-centred routines, as we found in our research (Watson et al., 2018). This shifts the mathematical authority/ authorship back to the teacher. Research into mathematics teachers’ beliefs has shown that there is frequently a misalignment between teachers’ espoused and enacted beliefs (Thompson, 1984; Wilson & Cooney, 2002), teachers may profess beliefs in reform-oriented student-centred ambitious teaching, yet their teaching is largely traditional and teacher-centred. Cuban refers to teacher-centred progressivism (Cuban, 2009), where there are many surface features of reform and student-centred practice but fundamentally the pedagogy is teacher-centred – the mathematical authority/ authorship remains with the teacher. The classic illustration of this is Cohen’s case of Mrs Oublier (Cohen, 1990). The difference between espoused and enacted beliefs, and the manifestation of teacher-centred progressivism can be explained by considering the momentary interactive decisions and algorithmic reasoning that leads

to teachers implementing culturally established and embedded teacher-centred routines and scripts, as Leinhardt (1988) observes:

[The] resistance to change on the part of the teacher should not be perceived as a form of stubborn ignorance or authoritarian rigidity but as a response to consistency of the total situation and a desire to continue to employ expert-like solutions (Leinhardt, 1988, p. 146).

The “expert-like solutions” represent the momentary intuitive judgements that draw on the teacher’s established knowledge – the essence of practical reason in Aristotelian terms⁴.

In this paper, I have considered the nature of teachers’ decision making in the classroom. Drawing on multidisciplinary approach, I have argued how important momentary interactive decisions are in the classroom, how they can shape the character of the lesson and influence the nature of students’ learning experiences. It seems as important as ever to research this decision making further, to better understand the affective dimensions, the culturally embedded routines and strategies that teachers acquire through participation in the professional community (and vicariously as a student, see, Lortie, 2002; Stigler & Hiebert, 1999, for example). An improved understanding of mathematics teachers’ interactive decisions would also inform the design of reform-oriented professional development and initial teacher education.

I suggest the main implication for future research is to give greater attention to teachers’ decision making from a multidisciplinary perspective while using techniques such as stimulated recall. What I have presented here prepares the way for a model of teacher thinking that integrates cognition, affect and the social setting. Further research could develop and test the model.

Acknowledgements

I would like to pay tribute to the late Professor Malcolm Swan, my PhD supervisor, with whom I did not always agree but always respected his profound insight into mathematics education. It was within the Shell Centre milieu that this line of thinking was born. I also thank Dr Matthew Inglis (Mathematics Education Centre, Loughborough University) who introduced me to the ideas of Type 1 and 2 reasoning, the work of Philip Johnson-Laird and Jonathan Evans on human reasoning from a cognitive perspective. Finally, to my colleagues in the Mathematics Education Research Group and the Culture, Politics and Global Justice cluster in the Faculty of Education, University of Cambridge who have provided helpful formative criticism from hugely diverse disciplinary, philosophical and theoretical perspectives.

References

- Alexander, R. J. (2001). *Culture and pedagogy: international comparisons in primary education*. Malden, MA: Blackwell Pub.
- Aristotle. (1998). *The Nicomachean ethics*. (W. D. Ross, Trans.). Oxford: Oxford University Press.

⁴ The Nicomachean Ethics (Aristotle, 1998) alludes to effective practical wisdom in terms of a harmony of conscious reasoning, intuition and affect.

- Borko, H., Roberts, S. A., & Shavelson, R. (2008). Teachers' decision making: from Alan J. Bishop to today. In *Critical Issues in Mathematics Education* (pp. 37–67). Springer, Boston, MA. https://doi.org/10.1007/978-0-387-09673-5_4
- Braidotti, R. (2013). *The posthuman*. Cambridge, UK: Polity Press.
- Clark, C. M., & Peterson, P. L. (1986). Teachers' thought processes. In M. C. Wittrock (Ed.), *Handbook of research on teaching* (3rd ed., pp. 255–296). New York, NY: Macmillan.
- Cohen, D. K. (1990). A revolution in one classroom: the case of Mrs. Oublier. *Educational Evaluation and Policy Analysis*, 12(3), 311–329. <https://doi.org/10.3102/01623737012003311>
- Cuban, L. (1993). *How teachers taught: Constancy and change in American classrooms, 1890–1990* (2nd ed.). New York, NY: Teachers College Press.
- Cuban, L. (2009). *Hugging the middle: How teachers teach in an era of testing and accountability*. New York, NY: Teachers College Press.
- Evans, J. S. B. T., & Stanovich, K. E. (2013). Dual-process theories of higher cognition: advancing the debate. *Perspectives on Psychological Science*, 8(3), 223–241. <https://doi.org/10.1177/1745691612460685>
- Janak, P. H., & Tye, K. M. (2015). From circuits to behaviour in the amygdala. *Nature*, 517(7534), 284–292. <https://doi.org/10.1038/nature14188>
- Johnson-Laird, P. N. (2006). *How we reason*. Oxford, New York: Oxford University Press.
- Leinhardt, G. (1988). Situated knowledge and expertise in teaching. In J. Calderhead (Ed.), *Teachers' professional learning* (pp. 146–168). London: Falmer Press.
- Lortie, D. C. (2002). *Schoolteacher* (2nd ed.). Chicago and London: The University of Chicago Press.
- Markowitsch, H. J., & Staniloiu, A. (2011). Amygdala in action: Relaying biological and social significance to autobiographical memory. *Neuropsychologia*, 49(4), 718–733. <https://doi.org/10.1016/j.neuropsychologia.2010.10.007>
- Martin, N. K., Sass, D. A., & Schmitt, T. A. (2012). Teacher efficacy in student engagement, instructional management, student stressors, and burnout: A theoretical model using in-class variables to predict teachers' intent-to-leave. *Teaching and Teacher Education*, 28(4), 546–559. <https://doi.org/10.1016/j.tate.2011.12.003>
- Ofsted. (2008). *Mathematics: Understanding the score*. London: Office for Standards in Education.
- Ofsted. (2012). *Mathematics: Made to measure*. London: Office for Standards in Education.
- Pessoa, L. (2017). A network model of the emotional brain. *Trends in Cognitive Sciences*, 21(5), 357–371. <https://doi.org/10.1016/j.tics.2017.03.002>
- Phelps, E. A. (2006). Emotion and cognition: insights from studies of the human amygdala. *Annual Review of Psychology*, 57(1), 27–53. <https://doi.org/10.1146/annurev.psych.56.091103.070234>
- Povey, H., & Burton, L. (1999). Learners as authors in the mathematics classroom. In L. Burton (Ed.), *Learning mathematics: from hierarchies to networks* (pp. 232–245). London: Falmer.

- Schoenfeld, A. H. (2011). *How we think: A theory of goal-oriented decision making and its educational applications*. Abingdon, Oxon: Routledge.
- Shavelson, R. J., & Stern, P. (1981). Research on teachers' pedagogical thoughts, judgments, decisions, and behavior. *Review of Educational Research*, 51(4), 455–498. <https://doi.org/10.3102/00346543051004455>
- Shulman, L. S. (1986). Those who understand: Knowledge growth in teaching. *Educational Researcher*, 15, 4–14.
- Skemp, R. (1976). Relational understanding and instrumental understanding. *Mathematics Teaching*, 77, 20–26.
- Stanovich, K. E., West, R. F., & Toplak, M. E. (2011). The complexity of developmental predictions from dual process models. *Developmental Review*, 31(2), 103–118. <https://doi.org/10.1016/j.dr.2011.07.003>
- Stigler, J. W., & Hiebert, J. (1999). *The teaching gap: best ideas from the world's teachers for improving education in the classroom*. New York, NY: Free Press.
- Strom, K. (2015). Teaching as assemblage: negotiating learning and practice in the first year of teaching. *Journal of Teacher Education*, 66(4), 321–333. <https://doi.org/10.1177/0022487115589990>
- Strom, K., Mills, T., Abrams, L., & Dacey, C. (2018). Thinking with posthuman perspectives in self-study research. *Studying Teacher Education*, 14(2), 141–155. <https://doi.org/10.1080/17425964.2018.1462155>
- Stylianides, G. J., & Stylianides, A. J. (2014). The role of instructional engineering in reducing the uncertainties of ambitious teaching. *Cognition and Instruction*, 32(4), 374–415. <https://doi.org/10.1080/07370008.2014.948682>
- Thompson, A. G. (1984). The relationship of teachers' conceptions of mathematics and mathematics teaching to instructional practice. *Educational Studies in Mathematics*, 15(2), 105–127. <https://doi.org/10.1007/BF00305892>
- Watson, S., Kimber, E., Major, L., & Marschall, G. (2018). A phenomenological study of a novice mathematics teacher's instructional decision making. Unpublished working paper, Cambridge. Retrieved from <http://bit.ly/2x1C7yL>
- Wilson, S., & Cooney, T. J. (2002). Mathematics teacher change and development. In G. C. Leder, E. Pehkonen, & G. Törner (Eds.), *Beliefs: A hidden variable in mathematics education?* (pp. 127–148). Dordrecht: Kluwer.

TWG20: Mathematics teacher knowledge, beliefs, and identity

Introduction to the papers of TWG20: mathematics teacher knowledge, beliefs, and identity

Miguel Ribeiro¹, Francesca Martignone², Fatma Aslan-Tutak³, Kirsti Rø⁴, Miguel Montes⁵, Sebastian Kuntze⁶

¹ State University of Campinas (UNICAMP), Brazil; cmribas78@gmail.com

² Università del Piemonte Orientale, Italy; francesca.martignone@uniupo.it

³Bogazici University, Turkey; fatma.tutak@boun.edu.tr

⁴Norwegian University of Science and Technology (NTNU), Norway; kirsti.ro@ntnu.no

⁵University of Huelva, Spain; miguelmontesnavarro@gmail.com

⁶Ludwigsburg University of Education, Germany; kuntze@ph-ludwigsburg.de

Rationale

For TWG 20, 27 papers and 5 posters have been presented. Due to the high number of papers, the TWG20 was divided into two subgroups, A and B. Although the proposals were expected to embrace three intertwined domains, similarly to what occurred previously (CERME10), the focus of the presented papers at CERME11 was mainly on teachers' knowledge. The topic of teachers' beliefs was addressed in several papers, including studies on teachers' conceptions and student teachers' collective orientations, while only one paper focused explicitly on the topic of teachers' identity – also a tendency from previous conferences. Several research by PhD students were discussed.

Main topics

Teacher knowledge

When TWG 20 first started as a new TWG in CERME9 (2011), most of the discussion was evolving around teacher knowledge models, how they emerged, developed and how they explain teacher knowledge and partly around their comparison. In TWG 20 during CERME11, compared to previous conferences, models were given less attention. Looking back and reflecting on discussions during CERME11, the group has moved from discussing on teacher knowledge models to mostly using models for further exploration of teacher knowledge in various contexts and on different topics (Piñero, Castro-Rodríguez, & Castro; Spratte, Euhus, & Kalinowski; Aguilar-González & Rodríguez-Muñiz, in this volume). There has been discussion of how different stakeholders in mathematics education see teacher knowledge. Jacinto and Jakobsen's paper focused on teachers' perception on horizon content knowledge while examining teacher education programs in Malawi. Similarly, Dahlgren, Mosvold, and Hoover studied teacher educators' understanding of mathematical knowledge for teaching. In this paper authors used MKT model (Ball, Thames & Phelps, 2008) primarily to examine teacher educators' views and not their knowledge of teaching mathematics. During the discussions, conceptualizing knowledge from different perspectives gained attention: e.g. Crisan's paper focused on advanced mathematics knowledge of teachers and ways to support teachers in that respect. Similarly, Pehlivan and Aslan-Tutak focused on preservice secondary mathematics teacher knowledge of mathematical representation translations without taking any teacher knowledge model as the theoretical framework but focusing on participants' knowledge of mathematics. When

carrying out research on teacher knowledge, models of the knowledge of mathematics teachers can provide a structure for research. However, as there is a variety of different models, the potential benefits from the structuring role of teacher knowledge models can only be drawn on if the key question is answered why a certain teacher knowledge model is chosen/used and what can be gained from using this specific model. The features of the teacher knowledge models argued respond to specific needs of describing and explain specific phenomena: e.g. integration of beliefs in the models by Carrillo et al. (2018) and Kuntze (2012). The MTSK model (Carrillo et al., 2018) was used in nine papers focusing various perspectives of mathematics teaching such as analysis of development of tasks, university level teaching, secondary school level teaching and policy analysis. Another model, the Knowledge Quartet (KQ, Rowland, Huckstep & Thwaites, 2005), which has been present in several papers in past CERMEs was used by Bretscher (in this volume) to analyse interviews with teachers, and by Karlsson (in this volume) to analyse student teachers' lesson plans.

Teacher noticing

As the notion of teacher noticing has received more and more attention as a potentially meaningful aspect of teacher expertise (Aytekin & Bostan; Zindel, in this volume), it has also played a role in this TWG, in particular as far as its interrelatedness with teacher knowledge, beliefs and identity was concerned (Kilic, Dogan, Arabaci, & Tun, in this volume). The TWG20 group was aware that different definitions and conceptualisations of teacher noticing have been developed and that covering the full range of aspects of noticing would extend beyond the scope of this TWG. During the discussions, the participants acknowledged the need to be precise about the notion of noticing used. There might be intersection domains between aspects of noticing with models of teacher knowledge, for example, the “contingency” domain in the Knowledge Quartet model may be seen as covering some aspects of noticing. Relationships between noticing and teacher knowledge might even imply that noticing gets a “meeting point” for different models of teachers' knowledge. Also Interpretative Knowledge (Ribeiro, Mellone, & Jakobsen, 2016; Policastro, Ribeiro, & Almeida; Di Bernardo, Mellone, Minichini, & Ribeiro, in this volume) could be considered as such a “meeting point” of different teacher knowledge models.

Teacher beliefs and identity

Teachers' knowledge and beliefs are strictly intertwined, as it has been highlighted in a theoretical model used by many researchers who attended CERME11: i.e Mathematics Teachers' Specialized Knowledge (MTSK) model (Carrillo et al., 2018). Among the papers presented in the CERME11 TWG20, several studies make use of the term conception, assumed to include teachers' knowledge as well as their beliefs. Some of the papers presented in TWG20 dealt with teacher beliefs about specific topics: e.g. a study about different countries teacher's beliefs about Inquiry-Based Learning (Huang, Doorman, & van Joolingen, in this volume); two ongoing studies that aim at theorizing models that can be used to analyse and characterize teachers' conceptions of argumentation in mathematics teaching-learning processes and at arguing possible repertory grids to research teachers' conceptions of argumentation (Ayalon & Naama, in this volume; Klöpping & Kuzle, in this volume); a study on teachers' conceptions about learning mathematics through classroom discourse (Kooloos, Oolbakkink-Marchand, Kaenders, & Heckman, in this volume). Other papers showed evidence of

teaches' perspective about how to promote students' creativity (Sánchez, Font, & Breda, in this volume), of teachers' beliefs about the use of experiments in mathematics classroom (Geisler & Beumann, in this volume), and of student teachers' collective orientations on heterogeneity (Tewes, Bitterlich & Jung, in this volume). A transversal-issue discussed was the correlation between beliefs about mathematics and the styles of teaching in different contexts (Safrudiannur & Rott, in this volume). As underlined above, only one paper presented in the CERME11 TWG20 explicitly dealt with teacher identity (Rø, in this volume). Mathematics teacher identity has been explored from a range of theoretical perspectives; however, studies focusing on social practices and structures within which teacher identities develop seem to predominate in the research field (Rø, in this volume). Possible implications of focusing on teachers' identity were discussed in the TWG20, including theoretical considerations made when choosing an identity perspective. Taking an identity perspective on mathematics teacher learning, one can get insight into the participative experiences of (prospective) mathematics teachers, either when entering the profession or when moving across mathematics practices at university and school.

Transversal and new issues emerged

Cultural aspects

During TWG20 discussions the cultural issue emerged in a strong way. Although the cultural and context aspects were always part of research on “teacher knowledge, beliefs and identity”, they often remain overshadowed or were even implicit in the papers. These issues cannot be considered as secondary when investigating on the curricular knowledge needed in different countries, on the teacher education programs, on the methodologies and activities that a teacher designs and develops in his/her classes. Also the use of research products, as well as the impact of the research, is very culturally dependent: e.g., the models used to describe and analyse teacher knowledge and their use in teacher education programs design are under the influence of cultural factors. The work carried out in the TWG20 gave researchers from different countries the opportunity to compare and ask their colleagues for information on different contexts and thus to reflect on how certain approaches and choices are specific to certain realities. It is important to specify that cultural and contextual aspects cannot be reduced to the content of curricula or only to organizational issues (such as the school systems or teacher education programs), but also include the beliefs about mathematics and teaching mathematics, different backgrounds, the roles of teacher educators, teachers and students in teaching-learning processes, the types of research carried out and the models applied to study them. Knowing and trying to understand other cultural contexts can help you better understand your own even though it is always very difficult to be aware and to analyse the features of the culture in which we are embedded. These reflections can be developed in all educational research and, in particular, in the research on “teacher knowledge, beliefs and identity”: in fact, culture shapes teachers, teacher educators, and researcher.

Teacher education programs, teacher educators and tasks in teacher education

In the discussion on teacher knowledge, two transversal elements received attention: tasks, and mathematics teacher educators. The first element was considered as a research goal itself, in research focusing in how tasks aiming to foster knowledge development are built, but also a methodological

tool to gather data about teacher knowledge. The second element regards the crucial role of the mathematics teacher educators (MTE) in the implementation of the tasks and the dynamics of in-service teacher training. The discussion around tasks for developing teachers' professional knowledge focused on three aspects: their design, their use to analyse teachers' knowledge, and their implementation. Concerning design, teachers' knowledge frameworks were used to guide it, using the frameworks' descriptors to structure the elements emphasized. In the papers presented, the design was founded in both MTSK and MKT frameworks, for example focusing on patterns (Aguilar, Ribeiro, & Ponte, in this volume) or on polygons (Montes, Climent, Carrillo, & Contreras, in this volume) or on rational numbers (Policastro, Mellone, Ribeiro, & Fiorentini, in this volume). Tasks were also used as a methodological tool to explore teacher knowledge, in particular, about definition (Codes, Climent, & Oliveros, in this volume), real numbers (Delgado-Rebolledo & Zakaryan, in this volume), and combinatorial (Semanišínová & Hubeňáková, in this volume). The implementation was slightly discussed as a part of the methodological section in the papers addressing tasks, yet receiving much more attention in the group discussion by emphasizing the role of MTE as the main agent in the implementation of the task. In addition to discussion on MTEs during papers which were not focusing on them, there were also papers focusing on MTEs (Mosvold & Hoover, in this volume; Almeida, Ribeiro & Fiorentini, in this volume). The discussion on TWG20 brought attention on them, as a key agent on the development of teacher knowledge. First, the term 'mathematics teacher educators' is not understood with the same meaning in each context, neither the content taught by them. It generated also a deep discussion the possibility to analyse MTEs knowledge with frameworks focusing (primary or secondary school) teacher knowledge. Second, and specially linked to research design, it was discussed how do MTEs impact on research. Finally, and related to the context-dependent meaning of some terms, teacher education programs received attention in the discussion and also in one paper (Estela-Caldatto & Ribeiro, in this volume), agreeing that researchers, MTEs, teachers and stakeholders need to link research on teacher knowledge, beliefs and identity and the design of teacher education programs.

References

- Ball, D., Thames, M. H., & Phelps, G. (2008). Content knowledge for teaching: What makes it special? *Journal of Teacher Education*, 59(5), 389–40.
- Carrillo, J., Climent, N., Montes, M., Contreras, L.C., Flores-Medrano, E., Escudero-Ávila, D., Vasco, D., Rojas, N., Flores, P., Aguilar-González, A., Ribeiro, M., & Muñoz-Catalán, M.C. (2018). The Mathematics Teacher's Specialised Knowledge (MTSK) model. *Research in Mathematics Education*, 20(3), 236-253.
- Kuntze, S. (2012). Pedagogical content beliefs: global, content domain-related and situation-specific components. *Educational Studies in Mathematics*, 79(2), 273–292.
- Ribeiro, C. M., Mellone, M., & Jakobsen, A. (2016). Interpretation students' non-standard reasoning: insights for mathematics teacher education. *For the Learning of Mathematics*, 36(2), 8–13.
- Rowland, T., Huckstep, P., & Thwaites, A. (2005). Elementary teachers' mathematics subject knowledge: The knowledge quartet and the case of Naomi. *Journal for Mathematics Teacher Education*, 8(3), 255–281.

Mathematical and didactical knowledge about patterns and regularities mobilized by teachers in a professional learning task

Marcia Aguiar¹, Alessandro Jacques Ribeiro² and João Pedro da Ponte³

¹Federal University of ABC, Brazil, marcia.aguiar@ufabc.edu.br

²Federal University of ABC, Brazil, alessandro.ribeiro@ufabc.edu.br

³University of Lisbon, Portugal, jpponte@ie.ulisboa.pt

Investigating teachers' knowledge for teaching mathematics has been an important theme in mathematics teacher education. In this paper we aim to analyze which mathematical and didactical knowledge secondary mathematics teachers have about patterns and regularities. For this, we developed a teacher education process with mathematics teachers in Brazil during 15 weeks using professional learning tasks (PLT) specially built for this purpose. The research is qualitative-interpretative and data were collected by audio and video recording, with gathering of written documents. The results show that PLT allowed to recognize what mathematical and didactical knowledge teachers had in the beginning of the teacher education process, and how the PLT enabled the development of new professional teacher knowledge.

Keywords: Professional learning task, mathematical and didactical knowledge, teaching of algebra.

Introduction

To unveil and to understand teachers' mathematical and didactical knowledge (Ponte, 1999) constitutes an important field of research in teacher education and, in particular, when practice is considered as a starting point (Lampert, 2010) for the construction of teacher professional knowledge. This underscores the importance of investigating the role of professional learning tasks (PLT) (Ball & Cohen, 1999; Smith, 2001; Swan, 2007) as a means to foster reflection on teachers' knowledge and to share their classroom experiences.

Regarding the specific field teaching of algebra, researches document the difficulties encountered by teachers in their teaching practice (Doerr, 2004; Ribeiro, 2012). At the same time, researches also highlights the importance of working with patterns and regularities as a promising path for the development of algebraic thinking (Mason, 1996; Twohill, 2015; Vale & Pimentel, 2015).

Thereby, our aim in this paper is to investigate the mathematical and didactical knowledge mobilized by mathematics teachers to solve individually and collectively a professional learning task related to teaching of algebra in basic education about patterns and regularities. To this end, we took a mathematics teachers' education programme as a research setting, aiming to answer the following research question: *In what way does a professional learning task allow (and favour) access to teachers' mathematical and didactical knowledge?*

Professional learning tasks and teachers' knowledge

In our research, teacher professional learning is a process anchored in classroom practice (Ball & Cohen, 1999; Ponte & Chapman, 2008; Smith, 2001) based on collective activity. Researches by Ball and Cohen (1999), and White, Jaworski, Agudelo-Valderrama and Gooya, (2013) emphasize

the creation of opportunities for teachers to learn each other, in order to break with a type of isolation that is very present and usual when one considers the work of the teacher, thus increasing opportunities for them to start learning in a collective way. Thus, teacher professional learning, in this perspective, are mediated by professional learning tasks (PLT), assumed in our research as

tasks that involve teachers in the work of teaching, can be developed in order to find a specific goal for teachers' learning and takes into account the previous knowledge and experience that teachers bring to their teaching (Ball & Cohen, 1999, p. 27).

PLT may support the access the professional knowledge of the teachers about patterns and regularities. In order to consider the different dimensions of professional teacher knowledge, which will be better discussed later, it must be considered in the composition of the PLT the use of records of practice (Ball, Ben-Peretz & Cohen, 2014), such as protocols of student solutions, parts of curriculum proposals and teaching plans, must be taken into account. These resources allow us to bring aspects of classroom practice into the context of teacher education processes as important components of professional learning tasks (Smith, 2001).

In the perspective of teacher professional knowledge, we are interested in Ponte's perspective (1999), which discusses a view of teacher professional knowledge strongly anchored in teaching practice, arguing that teacher knowledge is action-oriented. In his perspective, this knowledge unfolds in four domains: knowledge of teaching contents, knowledge of the curriculum, knowledge of students and knowledge of the teaching process. For the author, this knowledge

is closely related to several aspects of the personal and informal teacher's knowledge of everyday life as the knowledge of the context (the school, the community, the society) and the knowledge that he/she has of himself (Ponte, 1999, p. 3).

Regarding the teachers' mathematical and didactical knowledge about patterns and regularities and their connections with mathematics teaching, we should consider how relevant it is that teachers mobilize knowledge that make possible to understand the students' algebraic thinking and to support the overcoming of difficulties they usually have regarding the generalisation of numerical and geometrical patterns (Orton & Orton, 2005). In order to be able to mobilize mathematical and didactical knowledge on the subject matter, it is necessary to consider, during the teacher education processes, professional learning tasks that contemplate mathematical situations involving different types of patterns in which algebraic expressions that generalise them are asked for (Zazkis & Liljedahl, 2002).

In order to promote discussions and reflections in the teacher education process regarding teachers' mathematical and didactical knowledge, teacher educators should stimulate the development of PLT using some specific practices for this purpose (Stein, Engle, Smith & Hughes, 2008).

Stein *et al.*, (2008) propose five practices developed in classroom, which are called: anticipating, monitoring, selecting, sequencing and connecting. For this purpose, the authors argue that anticipating is the process in which the teacher, before taking the task to his/her classroom, anticipates the possible resolutions of the students and their possible difficulties. In the classroom, monitoring is the process in which the teacher will monitor the discussions that occur in small groups and thus he/she will select the most interesting resolutions to share with the classroom, whether they are unusually resolutions like those that may present errors and difficulties of the

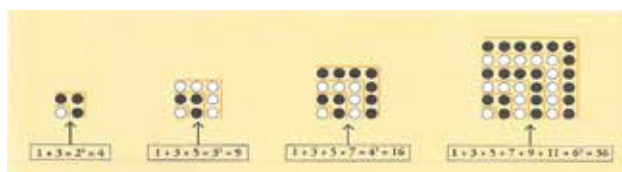
students. When the discussion is open to the whole classroom, the selected groups are presenting their resolutions within a sequencing, drawn up by the teacher. With this, the teacher should connect the student's resolutions with the mathematical knowledge proposed in the task in question. Thus, from these five practices, we conjecture that they can also help to foster discussions and mathematical and didactic reflections when used in teacher education process.

Research methodology

Context of the study. The teacher education process in which the data were collected had the general aim of developing and expanding participant teachers' mathematical and didactical knowledge regarding patterns and regularities in school mathematics. It was carried out during 15 weekly meetings of 4 hours, led by the first and second authors of this article. The meetings combined moments of (i) individual work, (ii) work in small groups, and (iii) plenary collective discussions. The participants were mathematics teachers (pre-service and in-service) and the activities were mostly carried out at the university, with 3 meetings held at basic education schools. The work sessions included moments of theoretical studies (a total of 8 hours) and *hands on* work, which were mediated by professional learning tasks developed by the leaders of the meetings.

Participants and developing of the PLT. The participants of our study were teachers who teach mathematics in Brazilian secondary schools. In relation to the PLT that we explore in this paper (Figure 1 below), for the begging of the teacher education process we counted on the participation of 42 teachers, being 10 pre-service teachers and 32 in-service teachers (7 of these with no classroom experience). Of the 32 in-service teachers, 17 had been graduated for less than 5 years; 7 had between 5 and 10 years of teaching practice; 8 had more than 10 years of teaching practice. For the implementation of PLT, the 42 participants were distributed in 9 groups (3 to 6 participants), organized by the facilitators so that in all groups there were (i) teachers with and without classroom experience, and (ii) pre-service and in-service teachers. Teachers groups were built in this manner in order to promote the exchange of experiences and knowledge among participants. Of the three facilitators present, two were teacher educators and researchers in teacher education.

Observe the following squares and the strategy used to calculate the sum of the first odd numbers, starting from 1.



- Inspired by the idea, calculate the sum of the 9 first odd numbers.
 - Generalise a formula to calculate the sum of the n first odd numbers, starting from 1.
- Based on your classroom experience and considering the mathematical task solved previously, answer the following questions:
- If your students were to resolve this mathematical task, which strategies do you think they could use?
 - Which difficulties do you think your students can have when solving this kind of task?
 - For which secondary school grade do you think this kind of task is appropriate?
 - Have you ever seen tasks of this nature in the curricular materials you use in the classroom? If you have, what type of curricular material is that?
 - Do you usually use this kind of mathematical tasks in your mathematics classes? If you do, in what secondary education grades? If you do not, please justify.

Figure 1: Example of Professional Learning Task¹

Thus, PLT's main goal was to raise teachers' prior knowledge about patterns and regularities. It was planned for and developed in three moments: individual, small group discussion, and plenary collective discussion. These moments were accompanied and encouraged by the facilitators who, to favour the collective discussions, using five practices presented by Stein *et al.*, (2008).

Data sources. Our study follows a qualitative research approach (Bogdan & Biklen, 1994), under the interpretive paradigm (Crotty, 1998), with the data collection taking place through video and audio recordings (both within each group as with the whole group) and through gathering of written documents resulting from the development of the PLT. The analyses considered: (i) teachers' individual notes; (ii) notes written by small groups of teachers; (iii) the audios of small group discussions; and (iv) the video of the collective discussion. The audio and video records were analysed in full, in articulation with the documents produced, and allowed the organisation and analysis of the data in order to identify the mathematical and didactical knowledge about patterns and regularities contemplated in PLT.

Results

Individual work. We begin the analysis considering teachers' individual work. It was observed, in general, that teachers found it difficult to mobilise mathematical knowledge to solve the mathematical situations presented in the PLT, regardless of their school year. The teachers sought to describe the observed mathematical pattern and to present an algebraic expression that represented the generalisation of this pattern. Afterwards, in the part of the PLT that explored the didactical knowledge – in relation to the students and in relation to the teaching processes – the teachers said that (i) they would have difficulties to solve the mathematical task by missing the perception of a pattern in the sequence, therefore having trouble in writing an algebraic generalisation; (ii) regardless of the school year, the students would use strategies for solving mathematical tasks by using counting processes or constructing the other elements of the sequence presented, just as the teachers themselves did, as can be seen in the statement²:

T7: [The students will have] The same difficulties I'm having.

Still with regard to didactical knowledge, the teachers said that, in their classroom, they do not propose mathematical tasks similar to those they were working on because (i) they have a tight schedule; (ii) students have difficulty in solving tasks of this kind; (iii) they do not have the adequate preparation to work with this type of tasks, as stated by teacher T8:

T8: I did not use this type of task because I am not used to let students build their own knowledge. So, my concern in learning how to support them build the formulas, and not going to the classroom with ready-made formulas.

Group work. At a second moment, the teachers began working in small groups, comparing their own responses with those of their peers and, through collective discussions, reflecting on their mathematical and didactical knowledge regarding patterns and regularities. During the discussions

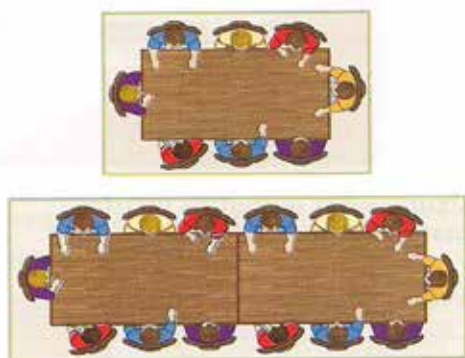
¹ Due to the space constraint, we present the PLT used with the teachers of grades 8-9, since the PLT structure of the other teachers (grades 6-7 and 10-12) was the same, changing only the mathematical situation of part 1 of the PLT.

² We use T for teacher-participant and TE for teacher educator/facilitator.

in small groups, many similarities were observed in the way they had worked individually, but, nevertheless, it is worth mentioning that the groups thought it difficult to find new mathematical strategies for solving tasks, even when working in groups. Only three groups stated that they found different solutions. During the small group discussions, the teachers emphasised that the students would be able to use counting processes or build the other elements of the sequence, but they would still have a hard time finding the pattern in the sequence, and even more in writing the generalisation in algebraic expression. In their discussions, the teachers recognised that, although they had difficulties in carrying out tasks similar to those in the classroom, this approach is very important for students to overcome their difficulties and to build their knowledge through tasks – and not just through “teacher's talk”.

While teachers worked in small groups, the facilitators carried out the practices proposed by Stein *et al.*, (2008) in order to prepare the next stage of the development of the PLT, namely, plenary collective discussions, which included three moments: (a) the first, aimed at sharing the teachers' mathematical knowledge and sharing unusual answers; (b) the second, aimed at sharing teachers' didactical knowledge regarding the students' difficulties; and (c) the third, aimed at sharing whether teachers used mathematical tasks of this kind in their classrooms.

Observe at the pictures and answer:



- a) How many people can settle at the tables, if we arrange 3 tables as shown beside?
 b) Write an expression that gives the number of people accommodated at 13 tables.
 c) Complete the general conclusion: the number of people is _____
 (Attention: Do not forget that the number of people depends on the number of tables).
 d) Write the conclusion in a formula where the letter p represents the number of people, and the letter m , the number of tables.

Figure 2: Example of Professional Learning Task³

First part of the plenary collective discussion. Throughout the first part of the plenary collective discussion, it was perceived that, in fact, the teachers themselves thought it difficult to explain different solutions to the other participants, since they always tried to rely on the mathematical properties of Arithmetic Progressions (AP), exploring little other possible strategies. T1's statement shows us this:

T1: The exercise was exactly the same [as that of the previous group] and then we get pretty much the same idea. I even got into the same situation [as the teacher who spoke before]. I started with an AP, I did the AP formula, I did the computation with the AP and I said: “hold on... The grade 6 student will not think about the AP”, [see Figure 2] and then we begin thinking in other ways (...) and we arrived

³ Due to the space constraint, we present only mathematical situation of the PLT used with the teachers of grades 6-7. The complete PLT structure was the same presented in Figure 1

at $p = 6m + 2$ [p = people and m = tables] and thinking about AP, I got the relation $a_{13} = 8 + (13 - 1) \times 6$ and the result equals 80.

It can be seen in this statement, which was recurrent in the other groups, how teachers were not distant from the concept of arithmetic progression and also of what their students could think and do (although it had been reinforced by the facilitators that at that moment the mathematical knowledge of the teachers themselves was being discussed). In counterpoint to this idea, teacher T4 said:

T4: The answer [of our group] is different from that here [the answer that was already written on board, $S_n = n^2$ regarding to Figure 1] (...) So it would start at zero and go up to n [the teacher then writes down on the board $\sum_{i=0}^n 2n - 1$].

T5: But this [solution] is for the 9th grade?

T4: We did not think about the student, this solution is ours.

It is interesting to note here that this group stated that it worked with the two solutions exposed in the dialogue, one that would possibly be that of the students, and another, that would be theirs. With this, facilitator TE2 asked:

TE2: For you, the meaning of n is the same in the two expressions [$S_n = n^2$ and $\sum_{i=0}^n 2n - 1$]?

T4: Yes! n indicates the natural numbers 0, 1, 2...

Such confusion presented by teachers about the meaning of the variable does not mean necessarily lack of mathematical knowledge, probably a difficulty orally expressing such knowledge.

With this, we perceive that the group of teachers present different representations about the generalization of patterns but they have difficulties in presenting their justifications of these representations.

Second part of the plenary collective discussion. Continuing with the plenary collective discussion, now focusing on the dimensions of teachers' didactical knowledge, teacher T2 pointed out that the students could construct a numerical table with the relation between the number of tables and people (Figure 2) and this would help him to realise the pattern. On the other hand, teachers T9, T10 and T6 had other concerns:

T9: At least in the few years that I have been in the classroom, the biggest problem I encounter is the algebraic part. (...) Teaching them [the students] that they have to solve the exercise in a way and still look at its generic part. I believe it is very difficult for the 6th and 7th graders.

T10: I think like this: If you do not insist... The student has difficulty but if the teacher has already been working this in the classroom, I think the student can get it.

T6: But that is the purpose of the activity, for the teacher to know the students' previous knowledge, so he can get to algebra.

At this point, the facilitator TE1 suggested that teachers were only thinking about the difficulty of the symbolic representation, but if students in any school year could explain the generalisation without the use of symbols and, even so, they already be a way of thinking algebraically.

This led to the establishment of a controversy in the plenary collective discussion, as pointed out by teacher T3:

T3: It may be the way we work with students. We give the contents and then the student finds it easy. We do not make the student an investigative being. We come and give him/her the formula to solve the problem. Wouldn't the lack of learning be one of the great problems in the classroom? The question that we don't go there and make the child investigate, search for things. Shouldn't we invest in this line of child's reasoning?

That thought - expressed by T3 - took the proportion of a challenge to be pursued by the group of teachers and facilitators throughout the teacher education process, that is, that the teachers' work with their students should become a more investigative exploratory approach rather than just follow a traditional approach to teaching.

Discussion and Conclusion

By developing the PLT, it was possible to realize that the teachers showed some difficulties in their mathematical knowledge regarding to the concept of variable what could implicate the recognition of patterns and regularities and the formulation of algebraic expressions to represent complex mathematical sequences (Zazkis & Liljedahl, 2002). In the dimension of didactical knowledge (Ponte, 1999), it can be noted that the teachers, possibly due to the fragility in mathematical knowledge, did not feel safe and comfortable to use tasks with their students such as those proposed in the PLT. From the point of view of teachers' knowledge of students, their solution strategies and difficulties, we noted that, throughout the development of the PLT, the teachers conjectured about students' algebraic thinking and how they could help them to overcome the difficulties they could present regarding the generalisation of numerical and geometrical patterns (Orton & Orton, 2005).

Regarding the structure of PLTs (Ball & Cohen, 1999; Smith, 2001), we conclude that the results show their potential to favour the mobilisation, connection and (re)construction of mathematical and didactical knowledge about patterns and regularities in the teaching of mathematics and, in special, to establish relations with classroom practice. In particular, we highlight as potential of the PLT proposed in this paper, the use of the five practices to prepare and lead (plenary) collective discussions (Stein *et al.*, 2008). This framework enabled the group of teachers and facilitators to share knowledge and experiments that made teachers, for example, (i) wonder both why they do not provide investigative and challenging tasks for students to explore different kinds of numerical and geometric sequences, and (ii) how such work may contribute to the development of algebraic thinking in their students. Therefore, we believe that the use of PLT in teacher education process can help to unveil and understand the teachers' mathematical and didactical knowledge.

References

- Ball, D. L., Ben-Peretz, M., & Cohen, R. B. (2014). Records of practice and the development of collective professional knowledge. *British Journal of Educational Studies*. 62(3), 317-335.
- Ball, D. L., & Cohen, D. K. (1999). Developing practice, developing practitioners: Toward a practice-based theory of professional education. In G. Sykes & L. Darling-Hammond (Eds.), *Teaching as the learning profession: Handbook of policy and practice* (pp. 3-32). San Francisco, CA: Jossey Bass.

- Bogdan, R., & Biklen, S. (1994). *Investigação qualitativa em educação*. Porto: Porto Editora.
- Crotty, M. (1998). *The foundations of social research: Meaning and perspective in the research process*. London: Sage.
- Doerr, H. M. (2004). Teachers' knowledge and teaching of algebra. In K. Stacey, H. Chick, & M. Kendal (Eds.), *The future of the teaching and learning of algebra: The 12th ICMI Study* (pp. 267-289). Boston, MA: Kluwer.
- Lampert, M. (2010). Learning teaching in, from, and for practice: What do we mean? *Journal of Teacher Education*, 61(1-2) 21-34.
- Mason, J. (1996). Expressing generality and roots of algebra. In N. Bednarz, C. Kieran, & L. Lee, L. *Approaches to algebra: Perspectives for research and teaching* (pp. 65-86). Dordrecht: Kluwer.
- Orton, A., & Orton, J. (2005). Pattern and the approach to algebra. In A. Orton (Ed.) *Pattern in the teaching and learning of mathematics*. London: Continuum.
- Ponte, J. P. (1999). Didáticas específicas e construção do conhecimento profissional. In J. Tavares (Ed.), *Investigar e formar em educação: Actas do IV congresso da SPCE* (pp. 59-72), Porto: SPCE.
- Ponte, J. P., & Chapman, O. (2008). Preservice mathematics teachers' knowledge and development. In L. D. English (Ed.), *Handbook of international research in mathematics education* (pp. 225-263). New York, NY: Routledge.
- Ribeiro, A. J. (2012). Equação e conhecimento matemático para o ensino: Relações e potencialidades para a Educação Matemática. *Bolema*, 26(42), 535-557.
- Smith, M. S. (2001). *Practice-based professional development for teachers of mathematics*. Reston, VA: NCTM.
- Stein, M. K., Engle, R. A., Smith, M. S., & Hughes, E. K. (2008) Orchestrating productive mathematical discussions: Five practices for helping teachers move beyond show and tell. *Mathematical Thinking and Learning*, 10, 313–340.
- Swan, M. (2007). The impact of task based professional development on teachers' practices and beliefs: A design research study. *Journal of Mathematics Teacher Education*, 10, 217-237.
- Twohill, A. (2015). Shape patterning tasks: An exploration of how children build upon their observations when asked to construct general terms. *Proceedings of the 10th Congress of the European Society for Research in Mathematics Education (CERME)*, Dublin, Ireland.
- Vale, I., & Pimentel, T. (2015). Padrões visuais, generalização e raciocínio. In S. D. A. Machado, B. L. Bianchini, & C. S. A. Maranhão (Orgs.), *Teoria elementar dos números: Da educação básica à formação dos professores que ensinam matemática* (pp. 167-198). São Paulo: Iglu.
- White, A. L., Jaworski, B., Agudelo-Valderrama, C., & Gooya, Z. (2013). Teachers learning from teachers. In M. A. Clements, A. J. Bishop, C. Keitel, J. Kilpatrick, & F. K. S. Leung (Eds), *Third international handbook of mathematics education* (pp. 393-430). New York, NY: Springer Nature. <http://dx.doi.org/10.1007/978-1-4614-4684-2>.
- Zazkis, R., & Liljedahl, P. (2002). Generalization of patterns: The tension between algebraic thinking and algebraic notation. *Educational Studies in Mathematics*, 49, 379-402.

Mathematics Teachers' Specialized Knowledge Model as a Metacognitive Tool for Initial Teacher Education

Álvaro Aguilar-González¹ and Luis J. Rodríguez-Muñoz²

¹Universidad de Oviedo, Spain; aguilaralvaro@uniovi.es

²Universidad de Oviedo, Spain; luisj@uniovi.es

Mathematics specialized knowledge models for teachers have been used as a conceptual framework for defining how teachers' knowledge is implemented in the classrooms, as well as for guiding the design of initial teacher education (ITE) programs. In this communication, besides the design of the ITE program, we present how the model of Mathematics Teacher's Specialized Knowledge (MTSK) has been used as a metacognitive tool enhancing primary and early-childhood teachers to reflect about their own professional competencies, to self-assess in relation to the different subdomains in the model, and to start acquiring research related skills during a postgraduate ITE program.

Keywords: initial teacher education, MTSK, research skills, specialized knowledge model.

Introduction

Teachers' knowledge models emerged in the 1980s, mainly from the seminal work of Shulman (1986), as a theoretical framework characterizing the knowledge that teachers need to operate in order to carry out their teaching tasks. In addition to non-specialized models such as T-PACK (Mishra & Koehler, 2006), other models of specialized knowledge were developed in the field of mathematics teaching. Thus, the Mathematical Knowledge for Teaching (MKT) model by Ball, Thames and Phelps (2008) stood out. These authors were interested in the study of professional knowledge, basically because specific knowledge, besides mathematical knowledge, was revealed as necessary to teach mathematics. In other words, a teacher has to know different but not less demanding mathematics than other professionals.

At CERME8, the Mathematics Teacher's Specialized Knowledge (MTSK) model was presented by Carrillo, Climent, Contreras, and Muñoz-Catalán (2013) as an evolution of the studies of Shulman (1986) and Ball et al. (2008). MTSK considers the specialized character of the teacher's knowledge in an integral way in every subdomain, whereas MKT included the mathematics teacher's specialized knowledge into a single subdomain.

The context for this experience is strongly dependent on the introduction of European Higher Education Area in Spain, that opened up the possibility that early childhood and primary education graduates could access to postgraduate programs (master degrees, and maybe further doctoral studies). Master level is not a requirement for becoming an in-service teacher in Spain, but in the recent years is becoming more popular among recent graduates (in part, because the master level is a requirement in other UE countries). In Spain there are master degrees oriented to a specific topic (didactics of mathematics, for example) but for early childhood and primary education graduates most of the master programs are devoted to provide them with general innovation and research skills (since early childhood and primary teacher are generalist profiles in Spain, only specialized for certain topics in primary as Physical Education, Foreign Language, Music and others, but not for Mathematics). In

this context, the current research was designed with a twofold objective. Firstly, to find out whether, at master level, training graduate teachers about models of specialized mathematical knowledge improves metacognition about their professional development and identity as mathematics teachers. Secondly, to find out whether this training (together with other topics) promotes basic research skills. Consequently, two research hypotheses were formulated: (H1) Including models of specialized mathematical knowledge in the syllabus of the master program for graduate teachers favors metacognition about their profession, and (H2) Including models of specialized mathematical knowledge in the syllabus of the master program for graduate teachers promotes research skills in educational research.

This communication is structured as follows: first, a theoretical framework is described and metacognition is framed within the context; later, the methodological design is described together with the population and the sample, and the data collection process; finally, results are presented and, subsequently, the discussion together with the conclusions derived from the study.

Theoretical Framework

The MTSK model is fully developed in Carrillo et al. (2018), it is composed of the domains Mathematical Knowledge (MK) and Pedagogical Content Knowledge (PCK), which, in turn, are divided into 3 subdomains each. In addition, the core of the model includes the mastery of teachers' beliefs about mathematics, its teaching and learning, permeating the knowledge and giving meaning to their practice. The MK domain encompasses knowledge of the connections between concepts, structuring ideas, procedure reasoning, proving, and different ways of proceeding in mathematics, also considering the knowledge of mathematical language. Within the MK we find the following subdomains: Knowledge of Themes (KoT); Knowledge of the Structure of Mathematics (KSM); and Knowledge of Mathematical Practice (KPM). On the other side, the PCK refers to teacher's knowledge of mathematical content as an object of teaching and learning. The PCK domain is divided into three subdomains: Knowledge of the Teaching of Mathematics (KMT); Knowledge of the Learning Characteristics of Mathematics (KFLM); and Knowledge of the Mathematics Learning Standards (KMLS).

Additionally, it is convenient to specify the scope of the discussion on metacognition and research skills. The majority of theoretical frameworks used in metacognition focus on two components: those dealing with declarative and procedural knowledge, and those dealing with the regulation of that knowledge when an individual performs a task (Schraw, Crippen, & Hartley, 2006). In our approach, we handle the latter meaning when designing the training activity for the graduate students (Lombaerts, Engels, & Athanasou, 2007). The proposed activity is aligned with what Zimmerman (1990) states as one of the key features which can be seen in most definitions of self-regulated learning, that is, systematic use of metacognitive motivational and/or behavioral strategies. Therefore, we are considering higher evidence of metacognition when the graduate students are not only aware of their own thinking but also use it as an instrument to regulate their own learning experience when doing the task.

On the other hand, according to Spanish Higher Education Qualifications framework, the acquisition of research skills should start in the postgraduate training. In other words, the master degree is

conceived as the prior stage of the research training, which is properly developed during the PhD degree. Then, a master graduate should acquire a minimum level of research skills allowing him/her starting, under supervision, in active research teams. Literature is abundant on so-called research-based learning, especially in the field of STEM (Science, Technology, Engineering and Mathematics) (see a review in Camacho, Valcke, & Chiluita, 2017), but it is scarce about how to develop this competence for educational research, specifically on how to characterize it during ITE postgraduate programs.

To this end, we align ourselves with the theoretical position defined in Moreno Bayardo (2005), who defines training for educational research in terms of the development of research skills. Specifically, for this experience, we are placed in the so-called “Nucleus G: Metacognitive Skills”, where the author argues that “the human being encounters the need to develop (and, in fact, in many cases he achieves it) metacognitive skills before getting involved in deformation processes for research” (Moreno Bayardo, p. 530). It should be pointed out that, although there are works whose explicit objective is fostering metacognition in the professional development of teachers (e.g., Rojas & Deulofeu, 2013), within the Spanish context there is only one former experience (Pascual & Montes, 2017) using a specialized knowledge model to develop metacognition, but it was during the undergraduate ITE and, therefore, activity did not involve research skills, whereas, our research focus on how to help the graduate students to move from a teacher identity to a potential research identity.

Methodology

Population and sample

The population of this study consists of graduates of Early Childhood and Primary Education who are enrolled in a master degree aimed at research and innovation skills. Several masters with these characteristics are taught in the different Spanish universities, but we have only had access to data from the University of Oviedo, in whose Master Degree in Research and Innovation in Early Childhood and Primary Education in the academic year 2017-2018 there were a total of 35 students enrolled. Therefore, it is an intentional non-random sampling, and the sample is formed by 32 individuals who completed the experience and the survey (response rate of 91.42%).

Educational context

The master degree in Research and Innovation in Early Childhood and Primary Education at the University of Oviedo is oriented to graduates in both educational stages for training them as future researchers and professionals in the field of learning and teaching. The subject in for which the intervention was designed is Research and Innovation in Didactics of Mathematics (5% of credits in the program). We remark this is not a specific master program in mathematics education, but generalist, and this fact hardens deepening into mathematics educational issues. One of the five basic competences of this master program aims to acquire sufficient skills to identify trends in innovation and research in the knowledge areas involved, and discussing their compatibility with the explicit beliefs and theories of the teaching staff. Taking the context into account, we proposed the experience described below for promoting the aforementioned competence.

Intervention planning

Previous lectures to the intervention had been developed, during 10 hours, for presenting the meaning of research and innovation in mathematics education, as well as to identify the work that in-service teachers can do within these fields. Among these general ideas, the notion of professional knowledge of the teacher was used, and more specifically, the notion of specialized knowledge in mathematics was implicitly involved to perform different tasks developed by the students. Also, main research lines in mathematics education were described by reading and discussing examples of papers. But, in this communication we focus on the work that was carried out during two work sessions in the classroom in which the activities related to the presentation on the professional knowledge of the teacher and the use of the MTSK model were presented and carried out. In the first session there was a training, led by the professors, on the research problem of models to describe specialized teachers' knowledge. This session explained the different theoretical positions on teacher knowledge, the differences between content knowledge and pedagogical knowledge and their intersections, the genesis of the first models of specialized knowledge and the role of teacher beliefs and conceptions in their interaction with knowledge. In the second session, the MTSK and its subdomains were dealt with in detail. Afterwards, divided into small groups, the students carried out a work based on the transcription of a fragment of real class of Early Childhood Education (4 years old level) where the teacher worked with geometric bodies. The main objective of the activity carried out by the teacher is the recognition of different geometric bodies and the identification of their elements (faces, edges, vertices, etc.). The graduate students had to identify the subdomains and categories of knowledge of the MTSK present in the class transcription. Finally, they had to respond individually to an anonymous questionnaire, which is presented in the following section.

Assessment instruments

In addition to the aforementioned deliverable group task about identification of subdomains of the MTSK model, students had to answer a questionnaire consisting of context questions (age, sex and teaching experience, and whether they had been previously trained or not about the models of knowledge), and of 7 questions for assessing the usefulness of the model or models like it in the professional teaching environment (with Likert scale responses from 1 to 5). Finally, 3 open-ended questions were posed which are based in the nature of subdomains of MTSK. The instrument had been content validated through a pilot carried out in the previous year, which resulted in removing two of the initial open-ended questions (because of redundancy and misinterpretation).

RESULTS

The sample (n=32) was composed by 19 women and 13 men, with average age 26.25 years old (median 24). Only 6 students have had experience as formal teachers (5 at primary and 1 at early childhood level), that is, most of the students were recently graduated teachers without further experience than the internship. Also, 6 stated that they had previously heard about teacher knowledge models. And only 1 of the participants stated that he/she was yet aware of specialized models for mathematics. Table 1 shows the mean, median and standard deviation of all the Likert type questions (1=absolute disagreement to 5= absolute agreement with the statement).

As for the open-ended questions, below we point out some of the most significant or frequent ones. To the question "Would you add anything to the subdomains MK and PCK to better describe the

activity of the mathematics teacher?”, the most frequent answer was like “I do not consider myself sufficiently qualified”. One student considered that “the affective aspects of the teacher-student relationship should be more pointed out”. Another one remarked that “it would incorporate the methodologies in a more explicit way, including the different types that exist”.

Statement	M	Me	DT
1. I believe that it is positive for my training as a teacher to know a model that describes the knowledge of mathematics teachers.	4,03	4	0,73
2. For my daily life as a teacher, I believe that these theoretical models do not improve my training.	2,44	2	1,14
3. The work about knowledge models has allowed me to reflect on professional aspects that I had not thought about.	3,81	4	1,03
4. The knowledge models have helped me to structure ideas which I had thought about my profession, but not in such a formal way.	3,16	3	0,92
5. I find the work on knowledge models interesting, but of little use for my professional future.	2,72	3	1,12
6. I think knowing these models is interesting as a general culture but it will not be something I will apply when I have to program or teach.	2,91	3	1,26
7. I consider that these models help to criticize and reflect on my activity as a teacher.	4,06	4	0,86

Table 1: Mean (M), median (Me) and standard deviation (DT) of all the Likert-type answers.

Second open-ended question was “Has this model allowed you to reflect on any aspect of your professional development that you had not previously thought about? Which one?”. There were some self-critical answers, from the point of view of metacognition, such as: “that I have insufficient mathematical training” or “about my scarce mathematical and didactic training”. Other answers even advanced in metacognition, at a higher cognitive level. Thus, some students stated that the model has helped them to reflect on specific aspects such as “the importance of knowledge of resources, materials and ways of presenting the content” or “the importance of teacher's knowledge, not only of the subject itself, but also of the didactic part”; and, in some cases students established relations between categories: “the relationship between current and previous contents”, “beliefs about mathematics or its teaching/learning and the scope they may have in the teaching process”, “the need to spin each content of the curriculum with other elements whose relationship does not seem so direct” or “the need to be aware of [...] the learning standards used in other countries”.

Finally, in response to the third open-ended question: “Has the use of this model motivated you to reflect on mathematics as a discipline or on your professional development?”, the most frequent responses referred to “considering my professional development in different facets” or equivalent. Answers with a greater level of deepening, were less frequent: “that research is a source of educational improvement”, “to overcome the myth of difficulty or fear of mathematics” or “I would like to see the analysis of the knowledge that is put into practice in classes of different educational levels”. We particularly highlight the following answer: “[this model] reminds me of the concept of metacognition and, in a similar way, I see its usefulness”. Finally, this answer also denotes progress in metacognitive processes: “[the subdomain of] the characteristics of learning mathematics in a specific subject have seemed very interesting to me, and I would have to take it into account when planning my classes”.

DISCUSSION AND CONCLUSIONS

Results of the Likert answers are homogeneous in terms of the analyzed context variables (sex, age, professional experience), hence, statistical analyses have not been included. The values of the Likert scale show that there is a high degree of agreement with the statements expressed in positive. Specifically, the agreement is very high in statements 1 and 7. On the other hand, when the statements are posed negatively the agreement is considerably reduced (numbers 2, 5, and 6). In addition, in statement 3 the degree of agreement is also quite high, although the dispersion is greater due to the existence of more extreme values. Finally, with statement 4 a problem of interpretation arises, since values are grouped symmetrically around 3, which indicates that perhaps the duality of the question should be reformulated (this had not happened in the piloting). From these results, we can conclude that, overall, the activity motivated the reflection of future teachers and they considered it useful for their professional activity, which is something authors did not expect initially, due to the generalist background of the graduate students. In addition, the link between research and daily activity as a teacher in the classroom is recognized, albeit less clearly. The metacognitive facet is also implicitly recognized in the answers (statements 3 and 4).

From the analysis of the open-ended questions, we can deduce that students found more difficult to formalize their opinions, since around half of the answers were very short or blank. Based on evidence from longer answers, regarding MTSK subdomains, for most of the students the training was insufficient to be able to critically judge the model; this evidences that explicit training on models was short. Even though, it seems interesting to us pointing out that two students felt that temporal programming is not sufficiently represented in the model. It is also noteworthy the answer referring to the insufficient representation of the affective relationship between teachers and students. This answer can be interpreted from two of the domains of the MTSK model: firstly, the contribution made by the MTSK model in the didactic domain is to link the content of the subdomains to the relevance of the relationship with the mathematical content, so that the affective relationship to which that response refers would not be included in that domain; on the other hand, it could be aimed at mastering the teacher's beliefs, attitudes and emotions towards mathematics and its teaching/learning as central elements, intimately related to professional identity, where the teaching staff give the students a very specific role when working in mathematics. There is a much greater reflection deepening in the answers to the second open-ended question. For example, self-criticism is expressed regarding the background in mathematics and its didactics. Other answers show a deeper understanding of the model, since they reveal relationships between different components of the subdomains (curricular organization, permeability of teachers' beliefs and conceptions, international learning standards, etc.). Answers to the third open-ended question also go in depth. Especially, those about the use of the model as a metacognitive tool, which seems to be completely aligned with the objectives of this research, or other answers that, without explicitly expressing metacognition, do it implicitly by the establishing relations between teaching practice and the knowledge of teachers' knowledge models.

In summary, we consider that data support the veracity of hypothesis H1, about the improvement of metacognitive processes through this activity. This is consistent with Rojas and Deulofeu (2013), although they did not explicitly use a knowledge model. On the contrary, we do not have sufficient

evidence to maintain hypothesis H2, related to promotion of research competencies. In this case, we understand that graduate students' identity is closer to a teacher identity and far from researcher one, which underlines the role of identity, as an important factor in the teacher's understanding of professional life (Beauchamp, 2009). We also believe that we have had little impact on this facet during the intervention, which resulted in the knowledge model being considered more as a tool for self-assessment or reflection rather than as a field of research.

We believe that, as in Pascual y Montes (2017), it is clear that by encouraging the critical and reflective attitude of students we obtain information that can be used in the design of training, especially in the reorientation of training in research skills. This reflection itself is essential in the professional development of mathematics teachers (Schön, 1983) but, in addition, it also provides us critical information from the user of the ITE program about the validity of the training proposal. In our case, we found that focusing on just one of the nuclei of Moreno Bayardo (2005) has not been enough for training research skills in mathematics education among generalist master students. One limitation of our work comes from the instrument, because Likert scales could miss richer students' thinking about the task, therefore we plan to overcome this in the future by using semi-structured interviews. Obviously, the sample is also limiting but, in this case, we are constrained by the scope of this educational programs and by the possibility of getting access to other universities.

We consider that this work opens a promising path for future research. Thus, we propose to go deeper into this working methodology for promoting metacognition and constructing recently graduate teachers' identity as future educational researchers (Hong, 2010). This approach will allow us to obtain a greater connection among the topics of the training and, thus, achieving a better development of researcher identity, which we think it is our main challenge within this ITE master program. In addition, we will also analyze from the descriptive and reflexive points of view the productions of the students in the task of analyzing a transcription of a real class, that was linked to the one presented here. By making this, we will complete the double perspective that we want to study on metacognition: self-assessment (the one already approached here) and peer-assessment. Finally, we also propose to redesign the activity on the basis of the revised Bloom taxonomy (Anderson & Krathwohl, 2001), so that we can cognitively classify the levels of students' responses.

Acknowledgment: This research has been supported by the Grant TIN2017-87600-P of the Ministry of Science, Innovation and Universities of the Government of Spain.

References

- Anderson, L. W & Krathwohl, D. R. (2001). *A taxonomy for learning, teaching and assessing: A revision of Bloom's Taxonomy of educational objectives*. New York, USA: Longman.
- Ball, D. L., Thames, M. H., & Phelps, G. (2008). Content knowledge for teaching: What makes it special? *Journal of Teacher Education*, 59(5), 389–407.
- Beauchamp, C. (2009). Understanding teacher identity: an overview of issues in the literature and implications for teacher education. *Cambridge Journal of Education*, 39(2), 175-189,
- Camacho, M. H., Valcke, M., & Chiluita, K. (2017). Research based learning in Higher Education: a review of literature. In L. Gómez Chova, A. López Martínez, & I. Candel Torres, *INTED 2017*.

- 11th International Technology, Education and Development Conference. Conference Proceedings* (pp. 4188–4197). Valencia, Spain: IATED.
- Carrillo, J., Climent, N., Contreras L.C., & Muñoz-Catalán, M.C. (2013). Determining specialised knowledge for mathematics teaching. In B. Ubuz, C. Haser, & M.A. Mariotti (Eds.), *Actas del CERME8* (pp. 2985–2994). Antalya, Turkey: ERME.
- Carrillo, J., Climent, N., Montes, M., Contreras, L.C., Flores-Medrano, E., Escudero-Ávila, D., Vasco, D., Rojas, N., Flores, P., Aguilar-González, A., Ribeiro, M., & Muñoz-Catalán, M.C. (2018): The mathematics teacher's specialised knowledge (MTSK) model, *Research in Mathematics Education*, DOI: 10.1080/14794802.2018.1479981
- Hong, J. (2010). Pre-service and beginning teachers' professional identity and its relation to dropping out of the profession. *Teaching and Teacher education*, 26, 1530-1543.
- Lombaerts, K., Engels, N., & Athanasou, J. (2007). Development and validation of the self-regulated learning inventory for teachers. *Perspectives in Education*, 25(4), 29-47.
- Ministerio de Educación (2011). Real Decreto 1027/2011, de 15 de julio, por el que se establece el Marco Español de Cualificaciones para la Educación Superior. *Boletín Oficial del Estado*, 185(3-VIII-2011), 87912–87918.
- Mishra, P. & Koehler, M. J. (2006). Technological Pedagogical Content Knowledge: A framework for teacher knowledge. *Teachers College Record*, 108(6), 1017–1054.
- Moreno Bayardo, M. (2005). Potenciar la educación. Un currículum transversal de formación para la investigación. *Revista Iberoamericana de Calidad, Eficacia y Cambio en Educación*, 3(1), 520–540.
- Pascual, M.I. & Montes, M. (2017). Las preguntas de los maestros egresados como guía de su formación: una aproximación metacognitiva. In J.M. Muñoz-Escolano, A. Arnal-Bailera, P. Beltrán-Pellicer, M.L. Callejo, & J. Carrillo (Eds.), *Investigación en Educación Matemática XXI* (pp. 387–395). Zaragoza, Spain: SEIEM.
- Rojas, F. & Deulofeu, J. (2013). Elementos de impacto de las prácticas instruccionales de los formadores en la formación inicial de profesores de matemáticas. In A. Berciano, G. Gutiérrez, A. Estepa, & N. Climent (Eds.), *Investigación en Educación Matemática XVII* (pp. 475–482). Bilbao, Spain: SEIEM.
- Schön, D. (1983). *The Reflective Practitioner: How professionals think in action*. London, UK: Temple Smith.
- Schraw, G., Crippen, K. J., & Hartley, K. (2006). Promoting self-regulation in science education: Metacognition as part of a broader perspective on learning. *Research in Science Education*, 36, 111–139.
- Shulman, L. (1986). Those who understand: knowledge growth in teaching. *Educational Researcher*, 15(2), 4–14.
- Zimmerman, B.J. (1990). Self-regulated learning and academic achievement. An overview. *Educational Psychologist*, 25, 3-17.

Knowledge of a mathematician to teach divisibility to prospective secondary school teachers

Marieli Vanessa Rediske de Almeida¹, Miguel Ribeiro¹, Dario Fiorentini¹

¹State University of Campinas, Brazil; marieli.almeida@outlook.com; cmribas78@gmail.com; dariof@unicamp.br

Mathematics teachers' knowledge has been studied extensively in the last decades, especially in research building on Lee Shulman's work. However, the same emphasis has not been placed on research on the mathematics teacher educator's (MTE) knowledge. Notwithstanding, the concern to characterize the knowledge of these educators has been emphasized in recent studies of mathematics education and models for knowledge of MTEs have appeared in literature. In this perspective, we present an episode which occurred in a Number Theory undergraduate classroom, where a mathematician, who acts in teacher preparation, demonstrates Euclid's division algorithm theorem. The data, which is part of a case study, is analyzed with the objective of identifying indicators of knowledge of MTEs. Among the results, knowledge of MTEs emerge in relation to knowledge of topics, knowledge of the structure of mathematics and knowledge of practices in mathematics.

Keywords: Mathematics teacher educator, mathematician, number theory, Euclid's division algorithm theorem, Mathematics Teachers' Specialized Knowledge.

Introduction

One of the roles of a Mathematics Teacher Educator (MTE) is to promote Prospective Mathematics Teachers (PMTs) knowledge in order to make them capable of establishing connections between teacher education and their practice. According to Jaworski (2008, pp. 1), MTEs "are professionals who work with practicing teachers and/or prospective teachers to develop and improve the teaching of mathematics". Considering that the knowledge of Mathematics Teachers (MT) is specialized, regarding the perspective of the Mathematics Teachers' Specialized Knowledge - MTSK (Carrillo-Yañez et al., 2018), the work of the MTE is even more important. In this sense, this work intends to contribute to research about the knowledge of the MTE and its role in teacher education, particularly, in a Number Theory course for PMTs.

Even if Number Theory has many connections with school algebra, many MTs understand this topic as being unrelated to their pedagogical practice (Smith, 2002). The theme divisibility, for example, is frequently treated by PMTs as being a trick or a procedure to be memorized, rather than a relation between integer numbers (Zazkis, Sinclair, & Liljedahl, 2003).

The topic divisibility is present from the earliest years of the schooling, including division of natural numbers for example. The integer numbers are gradually introduced in the mathematics school curriculum and some divisibility criteria are presented. In this context, there is a natural underlying question: Why is Euclid's division algorithm valid? This question is answered in a Number Theory course for PMTs, where the Euclid's Division Algorithm Theorem is presented.

In Brazilian universities, mathematicians are mostly responsible for the mathematical preparation of PMTs. These professionals "act as teacher educators de facto, without explicitly identifying

themselves in this role” as claimed by Leikin, Zazkis and Meller (2017, pp. 2). In this scenario, our foci of research is the knowledge these professionals reveal in their teaching. These mathematicians, who are eventually in the role of preparing PMTs, have a solid knowledge in the scientific field of mathematics and aim to develop research in this field and, on the other hand, their pedagogical content knowledge arises from practice (Fiorentini, 2004).

This paper is part of a broader research project which aims to understand and characterize, in the scope of Number Theory, the specialized knowledge of those who act as mathematics teacher educators. In this paper we address the particular research question: *What elements characterize the specialized knowledge of a mathematics teacher educator in relation to Euclid’s division algorithm theorem?*

Literature review

The knowledge of the MTE is different than both the knowledge of the PMT and the knowledge of the MT (Jaworski, 2008; Zopf, 2010; Contreras et al. 2017). Jaworski (2008) called this knowledge Mathematics Teacher Educator Knowledge, which has particular aspects as well as common points with both the knowledge of the PMT and the knowledge of the MT. In the intersection, they need to know: mathematics, the pedagogy related to mathematics, and the curriculum which the mathematics teacher based their work. Furthermore, the MTE also needs to know: both the professional and the research literature linked to the teaching and learning of mathematics, to know teaching and learning theories, and to know research methodologies that investigate teaching and learning on schools/educational systems.

Zopf (2010) observes that the difference between the knowledge of the MTE and the knowledge of the MT lies in the mathematical content. While the teacher teaches mathematics, the MTE teaches the knowledge to teach mathematics. The teaching purposes are also different, since the children learn mathematics for themselves, while the teachers learn mathematics for teaching their students. Therefore, Zopf (2010) proposes the Mathematical Knowledge for Teaching Teachers (MKTT) in order to describe the knowledge of the MTEs, which includes the knowledge necessary for teaching.

Building on Shulman's work, Carrillo-Yañez et al. (2018) divide the knowledge of the mathematics teacher into two domains: Mathematical Knowledge (MK) and Pedagogical Content Knowledge (PCK). Thereafter, Contreras et al. (2017) state that the knowledge mobilized by MTEs and teachers present differences when MK and PCK are considered. The differences in MK are related with the fact that the knowledge of the MTE is larger in terms of reach and depth, that is, the mathematical knowledge of the MTE has a more coherent and solid theoretical structure, besides the MTE has more experience with the validation/construction of the mathematical knowledge. On the other hand, PCK contains knowledge about the characteristics of learning of the PMTs, knowledge about how to teach the content of the teacher education and knowledge of different ways to organize the content of teacher education. In this paper we will focus on the MK of the teacher educator participant.

Teacher educator’s knowledge: theoretical perspective

In Carrillo-Yañez et al. (2018), the authors discuss their Mathematics Teachers' Specialized Knowledge (MTSK) model. In this model, it is considered that the teacher’s knowledge to teach is

specialized and that the MK is subdivided into three subdomains: the Knowledge of Topics (KoT), the Knowledge of the Structure of Mathematics (KSM) and the Knowledge of Practices in Mathematics (KPM). On the other hand, the PCK is also subdivided into three subdomains: the Knowledge of Mathematics Teaching (KMT), the Knowledge of Features of Learning Mathematics (KFLM) and the Knowledge of Mathematics Learning Standards (KMLS). At the center of the model, are the domain of the teachers' beliefs, which are related to all subdomains. In this paper, because we are interested in the knowledge of a mathematician who works in teacher education, we will focus on his Mathematical Knowledge.

KoT includes knowledge of procedures, definitions and properties, representations and models, registers of representations and applications. The KSM subdomain includes knowledge of connections between mathematical items, such as connections based on simplification, connections based on increased complexity, auxiliary connections and transverse connections. In its turn, KPM includes knowledge about demonstrating, justifying, defining, making deductions and inductions, giving examples and understanding the role of counterexamples. In the context of Number Theory, particularly in the scope of the Euclid's division algorithm theorem, the MTE knowledge includes, for example:

KoT – To know definitions and results that compose the proof of the Euclid's division algorithm theorem, such as the definition of absolute value and the well-ordering principle.

KSM – To establish connections between the Euclid's division algorithm theorem and posterior topics in the Number Theory course, such as linear congruence.

KPM – To know different types of proofs, such as the proof by contradiction that justifies the fact that the remainder is less than the divisor, in proof of the Euclid's division algorithm theorem.

Context and methods

Our investigation had a qualitative approach. In particular, we adopted the instrumental case study (Stake, 2006) as the research method, looking for information about the subject's knowledge that can be included in the theory about the MTE knowledge. In order to answer the research question, we discuss a classroom episode of a Number Theory course for secondary PMTs, where the MTE aims to present Euclid's division algorithm theorem as well as its proof. The participant Andre, a pseudonym, has Graduation, Master degree and PhD in Mathematics. Since the Master, his research interests lie in Algebra and Geometry. Andre has been teaching at the mentioned university for five years, where he teaches for students of different undergraduate courses, such as Mathematics, Physics and Chemistry. In the period which his classes were observed, Andre was teaching the Number Theory course to undergraduate students in mathematics for the second time in his academic career.

The case study of Andre is part of a larger research study which aims to understand what are the knowledge of MTEs, in particular the ones that teach Number Theory to prospective secondary school mathematics teachers. The results reported in this paper are exclusively based on this participant.

The aforesaid Number Theory course is a 15 week-long course, which is offered once in each semester as a common discipline for prospective teachers and bachelors of mathematics. Furthermore, the PMTs, are oriented to take these classes in the 6th semester of their undergraduate. The course

includes standard contents of a first course in Number Theory, such as divisibility, prime numbers, linear congruence, Diophantine equations and primitive roots.

The data collection occurred in the period between March and July of 2018, in a Brazilian university, comprising class recordings and field notes from the researcher. The classes of this Number Theory course were observed and recorded. Starting from the transcript of the recording of the subject's classes, we divided each class into episodes and chose the episode in which Andre demonstrates Euclid's Division Algorithm Theorem to present and discuss the knowledge revealed by the MTE in this episode, using the MTSK categories.

Analysis and discussion

The class episode and its discussion

Andre started the topic of divisibility at the end of the previous class, when he presented the definition and some basic properties of divisibility. The episode that we analyze here is part of a class, which the teacher educator started defining prime numbers. Thereafter he proved the existence part of the Fundamental Theorem of Arithmetic¹. In the sequence, he proved that there are infinite prime numbers, and he defined Greatest Common Factor² as well as he proved some properties³. Then, in the episode that follows, the MTE introduces and proves Euclid's Division Algorithm Theorem (EDAT): Considering $a \in \mathbb{Z}$ and $b \in \mathbb{Z}_+$, there are unique integers r and q such that $a = bq + r$, where $0 \leq r < b$.

The episode begins with Andre enunciating the EDAT (Figure 1) and drawing the attention of the students to the connections between this result and linear congruence, which will be introduced later in the course. Andre also notes that the proof of the EDAT must be done in two parts: existence and uniqueness. Considering the limited number of pages allowed in this paper, we approach in our analysis the existence proof only. His proof starts considering the set S of all possible non-negative remainders of the division of a by b (Figure 2). Naturally, the first step is to prove that S is not empty, thereunto Andre discusses with the students to find an integer x such that the expression $a - bx$ is non-negative. The conversation continues for some time and the students do not find this particular x . One of the students apologizes for his incorrect answer and Andre discusses the importance of the students asking questions as well as the need for observing the details of the enunciation of the theorem. Thereafter, Andre provides the sought x (Figure 3). Since S is a non-empty set of non-negative integers, thus S has a minimal element. He denotes this minimum by r and in the sequence he proves that this element satisfies the theorem conditions (Figure 4). The existence of r implies the existence of q .

Andre: Let's see the night star! The Euclid's Division Algorithm Theorem. Then we consider two integers a and b . Actually, I'm going to get b as positive so I do not

¹ Any integer greater than 1 can be written as a finite product of prime numbers.

² The Greatest Common Factor of two integer numbers is the largest positive integer number that divides each one of these integers.

³ Such as "If $d = \gcd(a, b) \Rightarrow \gcd\left(\frac{a}{d}, \frac{b}{d}\right) = 1$ ".

have problems. Then there exist, and are unique, integers q and r such that a is equal to b times q , plus r , with r being positive, but strictly smaller than b . Ok?

EUCLID'S DIVISION ALGORITHM

Let $a, b \in \mathbb{Z}$, with $b > 0$, so EXIST and are UNIQUE $q, r \in \mathbb{Z}$ such that $a = b \cdot q + r$ with $0 \leq r < b$.

Figure 1: Euclid's division algorithm theorem written on the blackboard

The choice $b > 0$ in the enunciation of the EDAT means that Andre is enunciating a particular version of that result. In the general version, the only condition is that b to be a non-zero integer. Probably, Andre regards this option to save time, since the proof considering $b \neq 0$ is divided into more cases. This is an observation that is not mentioned by Andre to the students. He knows how to prove the EDAT (KoT) and he considers $b > 0$ in order to save time in this class.

Andre: So, in a few classes, which I'm not sure exactly when it is going to be, the division algorithm will be a direct consequence of the congruencies when we study the arithmetic modulo n . But in this moment we will prove (the EDAT) with the tools that we have.

In the above transcript, Andre establishes a connection between the EDAT and the linear congruence, which is a later topic in the course (KSM). He also establishes a simplification connection in the moment that he states that the EDAT can be seen as a consequence of the modular arithmetic (KSM), and it seems that he attempts to promote this connection in the students.

Andre: It is saying there [pointing to the content in the Figure 1] that my proof must to be written in two parts. Firstly, I must to prove that they exist (q and r) and then I must to prove that they are unique. In this point, we should have understood that the most difficult part (of the proof) is the existence. Regarding the uniqueness, let us suppose that there exist two and we will see that they are the same. Actually, there is no secret about how to prove the uniqueness, but we will begin by demonstrating the existence. OK.

When he states that the proof should be done in two parts (existence and uniqueness), Andre demonstrates knowledge about proof techniques (KPM), and about how to demonstrate the existence and uniqueness of q and r (KPM).

Andre: First part. I will consider this set (Figure 2). I take all the sets (integers) of the form $a - xb$, where a and b are the numbers that I gave at the beginning, x is an integer and $a - xb$ is non-negative. OK? I am getting this subset of integers.

Proof. Existence

To consider $S = \{a - xb \mid x \in \mathbb{Z} \text{ e } a - xb \geq 0\}$

Figure 2: Set S written on the blackboard

In this part, it is possible to identify a heuristic strategy to this particular topic: the choice of an appropriate set S of natural numbers to approach a property of that set (KPM), namely, the existence of a minimum element in the set.

Andre: I would like to prove that it (S) is not empty. Because it is not just a subset of integers. It is a subset of non-negative integers. This is one of my hypothesis, that these integers are non-negative. We know that a non-empty subset of this $\mathbb{Z}_{\geq 0}$ always admits a minimum. I will play with this. Firstly, I have to prove that it is not empty. To prove that it is not empty, it is enough to show an element in there. Am I right? What element will I get?

To prove that the set S is non-empty, Andre notes that it is a subset of non-negative integers and thus S admits a minimal element (KoT). Then, he remembers the fact of all set composed by non-negative integers has a minimum, that is, he refers to the well-ordering principle, which demonstrates that he knows this result (KoT). When he observes that to demonstrate $S \neq \emptyset$ is necessary just to exhibit one of its elements, Andre gives the way to verify if a set is non-empty (KoT).

Andre: No, that is okay. Do not apologize. Do not apologize, this question allows us (to see) the details, that every detail that is written is important. It is not a and it is not $x = 0$. What is the number that we know that is positive? It is b . So to get around this, I would put the minus in a to obtain a positive sum. The only problem is that I do not know if the a is positive or negative. [...] So I get minus the absolute value of a . So I have no problem. Because I have the absolute value of a , I will get a plus the absolute value of a multiplied by b . The b , yes, it is strictly positive from this one here (initial condition of the theorem). So, this means that there are at least one. Then this value is greater than or equal to zero.

$x = - a $	\Rightarrow	$S \neq \emptyset$	admits minimum
$a + a b \geq 0$			I call it $r \geq 0$

Figure 3: Proof that S is non-empty written on the blackboard

When Andre discusses the importance of the student questions, he exposes his beliefs about the need to perceive and to consider all the conditions of the enunciation theorem. In addition, he demonstrates to understand that this is an aspect to be developed together with his students.

Andre: Then S is not empty. If S non-empty is a subset of it ($\mathbb{Z}_{\geq 0}$), S admits a minimal element. If there is a minimal element, I must to call it of something. I call it by r . Then let us see if this r is exactly what I want. OK! First property. The r which I already know is greater than or equal to zero. Since r is an element of this form, the minimum of this set (refers to the set S), all elements that lie in that set are non-negative, in particular r is also non-negative. [...] What is the set that I considered? I chose exactly all the integers on the type $a - xb$ equal to an integer. This means that I am considering all relations such that a is equal to x times b plus one integer. Then, this set S is chosen exactly to satisfy this relationship here. Am I right? So, I am defining the remainders, I am defining the smallest of the remainders and I want to see that the smallest of the remainders fits here [he refers to $a = bq + r$, in the theorem].

After calling r the minimal element of the set S , Andre tries to demonstrate that this r is in the conditions of the theorem. Thus, after showing that if r is an element of the set S then $r \geq 0$ (KoT), Andre intends to prove the fact that the remainder is less than b , revealing his knowledge of different types of proofs (KPM), such as the proof by contradiction.

I want to prove $r < b$.

By contradiction, I will assume that $r \geq b$. Then, $0 \leq r - b = a - bq - b = a - (q + 1)b$.

I name $q = x$ such that $a - bq = r$

$\Rightarrow r - b \in S$

$r - b < r$.

Figure 4: Proof that r is strictly less than b written on the blackboard

Andre: It means that this integer here is on the type a minus one integer times b . And the integers of the type a minus another integer times b are, from definition, the elements of S . Because also ... they are non-negative. This implies that r minus b is an element in S , because it is an element that is exactly written in the form that the elements of S were defined and it is non-negative. It satisfies both the conditions, then it is an element within S . Being an element of S , and being strictly small than r , there is a contradiction. Why? Because by definition, r is the minimum. So there can not exist another element strictly small than r within the set S . To come in a contradiction means that the hypothesis that I started all this is absurd. Then, it is impossible r to be greater than b , this implies that r must to be strictly small than b . Thereat, we finish the existence proof. Why? Because I prove that there are those integers q and r that satisfy what I want. I wondered two numbers q and r such that a is equal to b times q , plus r .

This kind of proof by contradiction used by Andre (KPM) is recurrent in algebra. When the thesis is contested, a conflict arises in relation to the minimality of an element.

Some final comments

In this paper, we analyzed the mathematical knowledge of a mathematician, who teaches for PMTs. The Mathematics Teachers' Specialized Knowledge applies to the analysis of this MTE's knowledge because Andre is teaching mathematics to PMTs. In order to characterize the knowledge of this MTE from the demonstration of Euclid's division algorithm theorem, we find evidence of knowledge of topics, knowledge of the structure of mathematics and knowledge of practices in mathematics. However, this knowledge of the MTE about Euclid's Division Algorithm Theorem is different from the expected knowledge of PMTs and MTs in the same topic, considering that they will not teach this theorem.

The focus is not to evaluate or to prescribe which should be the knowledge of MTEs. Our interest is to investigate which is the existing knowledge in MTEs who participates in our case study, considering the particular Brazilian teacher education context and the role of mathematicians in this context. In this sense, our findings can aid in the elaboration of a model for the specialized knowledge

of MTE, as proposed by Contreras et al. (2017), and may also contribute to the investigations into the knowledge of the MTEs. Furthermore, we propose to investigate indications of what are the fundamental knowledges of these MTEs.

Acknowledgment

This study was financed in part by the Coordenação de Aperfeiçoamento de Pessoal de Nível Superior - Brasil (CAPES) - Finance Code 001.

References

- Carrillo-Yañez, J., Climent, N., Montes, M., Contreras, L. C., Flores-Medrano, E., Escudero-Ávila, D.; Vasco, D.; Rojas, N.; Flores, P.; Aguilar-González, A.; Ribeiro, M. & Muñoz-Catalán, M. C. (2018). The mathematics teacher's specialized knowledge (MTSK) model. *Research in Mathematics Education*, 20(3), 236-253. doi:10.1080/14794802.2018.1479981
- Contreras, L.C., Montes, M., Muñoz-Catalán, M.C. y Joglar, N. (2017). Fundamentos teóricos para conformar un modelo de conocimiento especializado del formador de profesores de matemáticas. In: J. Carrillo y L.C. Contreras (Eds.), Avances, utilidades y retos del modelo MTSK. *Actas de las III Jornadas del Seminario de Investigación de Didáctica de la Matemática de la Universidad de Huelva* (pp. 11–25). Huelva, Spain: CGSE.
- Fiorentini, D. (2004). A investigação em Educação Matemática sob a perspectiva dos formadores de professores. In C. Alves, C. Morais, C. Martins, M. Pires, & P. Barros (Orgs.), *Actas do XV Seminário de Investigação em Educação Matemática* (pp. 13–35). Lisbon, Portugal: Associação dos Professores de Matemática.
- Jaworski, B. (2008). Development of the mathematics teacher educator and its relation to teaching development. In B. Jaworski & T. Wood (Eds.), *The international handbook of mathematics teacher education* (Vol. 4, pp. 335–361). Rotterdam, The Netherlands: Sense Publishers.
- Leikin, R.; Zazkis, R.; Meller, M. (2017). Research mathematicians as teacher educators: focusing on mathematics for secondary mathematics teachers. *Journal of Mathematics Teacher Education*, 21(5), 451–473.
- Smith, J. C. (2002). Connecting undergraduate number theory to high school algebra: A study of a course for prospective teachers. In *Proceedings of the 2nd International Conference on the Teaching of Mathematics* (pp. 1–8). Crete, Greece: John Wiley & Sons Inc.
- Zazkis, R., Sinclair, N., & Liljedahl, P. (2013). *Lesson play in mathematics education*. New York, NY: Springer. <https://doi.org/10.1007/978-1-4614-3549-5>.
- Zopf, D. (2010). *Mathematical knowledge for teaching teachers: The mathematical work of and knowledge entailed by teacher education*. (Unpublished doctoral dissertation). University of Michigan, Ann Arbor. Retrieved from http://deepblue.lib.umich.edu/bitstream/2027.42/77702/1/dzopf_1.pdf. September 5, 2018.

Emergent model for teachers' conceptions of argumentation for mathematics teaching

Michal Ayalon & Samaher Naama

University of Haifa, Israel

mayalon@edu.haifa.ac.il samaher.yassin@gmail.com

In recent years, there has been a growing appreciation of the importance of incorporating argumentation into the mathematics classroom. Whereas considerable research has been done on argumentation, little has specifically focused on teachers' conceptions. This paper presents an exploratory study as part of ongoing research into teachers' conceptions of argumentation for teaching mathematics. Drawing on the literature on argumentation and empirical data, we propose an emergent model, presented as a 5-by-2 construct featuring five types of conceptions across two dimensions: structural and dialogic. This paper illustrates the emergent model at this initial stage of the research using an individual case study of a teacher. The overall aim of the research is to theorize a model that can be used to analyze and characterize teachers' conceptions of argumentation for teaching mathematics.

Keywords: argumentation; teachers' conceptions; mathematics teaching

Introduction

In recent years, there has been a growing appreciation of the importance of incorporating argumentation into the mathematics classroom. Existing research suggests that participation in argumentation activities that require the student to explore, confront, and evaluate alternative positions, voice support or objections, and justify different ideas and hypotheses, promotes meaningful understanding and deep thinking (Asterhan & Schwarz, 2016). This view is reflected in recent educational reform documents all over the world, and in Israel in particular, that underscore argumentation as one of the important goals for students. However, argumentation in the mathematics classroom is not yet commonplace (e.g., Bieda, 2010). Recently, there has been considerable research dedicated to argumentation; however, little of that work has specifically focused on teachers' conceptions of argumentation (Ayalon & Hershkowitz, 2018; Staples, 2014). Considering the fact that teachers' conceptions impact the way in which this key practice is implemented in the classroom, there is a strong need to learn what characterizes them. This paper addresses this need. It presents an exploratory study as part of ongoing research into teachers' conceptions of argumentation for teaching mathematics. Drawing on the literature on argumentation and empirical data, we propose an emergent model, presented as a 5-by-2 framework comprising five categories of conceptions of argumentation for teaching mathematics across two dimensions: structural and dialogic. This paper illustrates the emergent model at this initial stage of the research.

Theoretical Background

Argumentation

There are diverse definitions of argumentation in the education literature. A commonly accepted definition is that of van Eemeren and Grootendorst (2004) who argue that argumentation is “a verbal, social, and rational activity aimed at convincing a reasonable critic of the acceptability of a standpoint

by putting forward a constellation of propositions justifying or refuting the proposition expressed in the standpoint” (p. 1). According to this definition, argumentation entails generating claims, providing evidence to support the claims, and evaluating the evidence to assess their validity. It posits argumentation in a social context and, if incorporated in classroom discourse, affords a venue for the articulation and critical evaluation of alternative ideas, eventually supporting collaborative knowledge construction (Asterhan & Schwarz, 2016). Argumentation that "balances between critical reasoning and collaborative knowledge construction" (Asterhan & Schwartz, 2016, p. 167) is considered to be productive for learning (Felton, Garcia-Mila, & Gilabert, 2009).

Following these descriptions, the present work considered argumentation as having two important meanings – structural and dialogic (McNeill et al., 2016). The structural meaning of argumentation focuses on the aspect of discourse in which a claim, presented as an idea, conclusion, hypothesis, solution etc., is supported by an appropriate justification which, in our case, represents the types of justifications that are valued within the mathematics community. The dialogic meaning regards argumentation as the interactions between individuals when they attempt to generate and critique each other's ideas. This meaning aligns with the common view of mathematics as a social enterprise whereby mathematicians are part of a community with established norms of argumentation for advancing mathematical knowledge.

Teaching for argumentation

Mathematics teaching that encourages argumentation provides students with opportunities to take an active part in both structural and dialogic meanings – to construct arguments, share, consider others' ideas and critically evaluate their validity (Ball & Bass, 2003). Such teaching requires the teacher to make sense of students' ideas and interactions, identify and evaluate the strengths and weaknesses, promote adherence to standard disciplinary criteria for determining the truth of a claim, encourage students to elaborate their thinking, and lead them to listen to each other, critique and question ideas (Nathan & Knuth, 2003). It entails the teacher's drawing on various resources, such as the mathematics involved, student thinking, socio-cultural background, affect, and curriculum-related aspects (Ayalon & Even, 2016; Ayalon & Hershkowitz, 2018; Staples, 2014). As noted above, argumentation in the mathematics classroom is rare (e.g., Bieda, 2010), which suggests that teaching for argumentation is perhaps challenging. Whereas research on argumentation is rapidly growing, little research specifically focuses on teachers' conceptions in the context of argumentation.

This study draws on existing research to propose a preliminary working definition for mathematics teachers' conceptions of argumentation for mathematics teaching, with the intention of further developing this definition as a research goal. The use of 'conceptions' refers to both knowledge and beliefs, according to Thompson (1992), who described teachers' conceptions of the nature of mathematics as their combined knowledge and beliefs pertaining to the discipline of mathematics. Following this definition, the present study focuses on teachers' conceptions of argumentation in mathematics teaching, under the assumption that in order to develop teachers' instructional practices for argumentation, we need to better understand their conceptions. In particular, we focus on teachers' conceptions as they relate to both the structural and dialogic aspects of argumentation.

Methodology

The data for the overall research were collected through observations of lessons and semi-structured interviews which preceded and followed the lesson observations. For this paper, we focused on data obtained from the first part of the interviews conducted prior to the lesson observations, in which the teachers were asked to express their views on argumentation for teaching mathematics and to provide examples of argumentation, as manifested in their own teaching.

Research participants

Eight middle-school mathematics teachers, each having more than five years of teaching experience, participated in this study. The decision to focus on this particular school population stemmed from the emphasis placed on argumentation in the middle-school curriculum in Israel.

Data collection

The data used for this paper consisted of individual, semi-structured interviews with the teachers. The interview lasted approximately one hour. During the interviews, the teachers were presented with a written quote from the national mathematics curriculum that reflects the importance ascribed to students' involvement in argumentation activity in the mathematics classroom. According to this quote, one main goal of the curriculum is that students will engage in justifying their claims, communicate them to others, and critique their own and their peers' arguments. The teachers were asked: (1) What do you think about this quote? Do you agree or disagree? Why? (2) What strategies, if any, do you use in your classroom to achieve this goal? (3) What have you found supports or hinders you in achieving your goals? The teachers were urged to provide detailed responses as well as instances from their own classroom. The interviews were audio-recorded and subsequently transcribed.

Data analysis

We combined directed content analysis and inductive content analysis (Patton, 2002). Directed content analysis included a classification of teachers' statements about argumentation in mathematics teaching into one of the two aspects of argumentation: structural or dialogic. The structural aspect dimension included discourse pertaining to elements of arguments, such as claims and justifications and what counts as an appropriate justification in class. The dialogic aspect dimension included discourse associated with students' interactions when generating and critiquing arguments. We then used inductive content analysis for devising categories for the two dimensions. During this phase of analysis, we first identified initial categories based on some of the data collected for a particular teacher. We then refined and expanded the initial categories based on more data collected for the same teacher. Finally, the devised categories were refined by the analysis of data collected for all the participating teachers. This process resulted in five categories of teachers' conceptions of argumentation: (1) what is argumentation; (2) teaching strategies for argumentation; (3) mathematical task characteristics; (4) student characteristics; and (5) socio-cultural characteristics. We ultimately received a 5-by-2 framework featuring these five categories for each of the two dimensions: structural and dialogic.

In this paper, we provide examples that illustrate the way in which several of the framework's different components were devised based on the teachers' discourse about argumentation in teaching. The

examples of categories are taken from an interview with one teacher named Adam (pseudonym), as we found his interview rife with illustrations for various categories. Note that each category was identified in other teachers' interviews as well. Naturally, one citation may refer to more than one aspect of argumentation.

Findings

Adam is a middle-school teacher (grades 7-9) with 25 years of experience in teaching mathematics. He serves as the mathematics teaching coordinator and is considered by his colleagues to be a leading teacher in his school. When asked for his opinion of the quote taken from the curriculum with regard to the importance of engaging students in argumentation, he replied:

The things said in the quote are very important in the learning of mathematics. This [argumentation] helps to promote students' understanding of the material; the teacher can understand, identify and emphasize the thought process of each student who raises claims in class and justifies his or her answer [1-1] ... Also, critiquing others' arguments helps students to develop their mathematical thinking [1-2].

This initial response from Adam implies *what argumentation means* to him. His response relates both to the structural aspects of argumentation and to its dialogic aspects. He mentions claims and justifications (structural, 1-1), alongside critical assessment of one another's arguments (dialogic, 1-2). According to Adam, this activity allows the teacher to learn about students' thought processes, and helps to develop students' mathematical understanding. When asked how he uses argumentation in his classes, he replied:

In my classes, I always use argumentation activities. The students raise ideas, explain, and bring justifications [2-1]. Different solutions for the same problem arise, and a fruitful dialogue develops in which the students explain their solutions, try to convince others, and find mistakes in others' solutions, and critique each other [2-2]. The students listen to each other and give criticism politely and respectfully [2-3]. This atmosphere encourages students to participate in math classes, so that the student feels like a central part of the lesson [2-4]. Also, a student who correctly justifies her/his solutions will feel greater self-confidence [2-5].

Adam's answer informs us more of *what argumentation means* to him, both from a structural perspective (2-1) and a dialogic perspective (2-2, 2-3). This answer expands on his previous response by relating, also, to persuading others of the correctness of one's views, and to assessment that is not only critical, but also respectful (2-3). There is mention here of *class norms* of respectful critical dialogue (2-2, 2-3). He also mentions *students' emotional characteristics* – student engagement and the student being in the “center” – that are connected to the student's participation in dialogue (dialogic, 2-4) and to self-confidence stemming from justification of a solution (structural, 2-5). When he was asked to give more details regarding the way in which he encourages argumentation activities in his class, Adam said:

In general, I try to give the students open, multiple-solution tasks [3-1], and give students space to express themselves and to present their solutions and examine them together with the rest of the class, and reach agreements together [3-2]. For instance, tasks involving word problems, or problems that involve finding generalizations – there are students who manage to come up with various hypotheses and solutions, some correct and some not, and there are students who struggle

[with the challenge] [3-3]. What's important is that when we work with these tasks in my class, it always turns into a mathematical discussion [3-4] which the students enjoy [3-5], and in which students listen to each other's solutions and explanations and critique them, try to challenge their arguments and also to defend arguments [3-6]. When I give them problems to solve individually, my sense is that the students feel like it's a competition, who will find a solution first and give a correct justification [3-7] - after all, I don't accept answers without a clear, written explanation and mathematical justification [3-8] - and who will present their solution to the class [3-9] ... I mean "competition" in a positive sense.

In Adam's answer, he notes the *characteristics of mathematical tasks* that encourage argumentation in class. Open, multiple-solution tasks serve Adam's purposes when it comes to the dialogic activity he mentioned earlier [3-1]. Here, Adam also discusses *students' skills* in coming up with hypotheses and various methods of solving (3-3). Two additional characteristics of the dialogic aspect of argumentation, which Adam did not mention earlier, come up in the context of working with these types of tasks: one relates to students working towards consensus (3-2); the other relates to defending one's arguments (3-6). This response also makes note of the *socio-cultural norms* that pertain to argumentation activity, in Adam's mention of mathematical dialogue: "when working with these tasks in my class, it *always* turns into a mathematical discussion" (3-4), and in the expectation in his class for a justification of the claims (structural, 3-9). He also mentions the norm of writing arguments clearly (3-8). Adam previously mentioned students' engagement in argumentation activities; here, he adds a competitive but friendly, good-spirited atmosphere between the students, challenging who will solve the problem first and present the solution, with its justification, to the whole class (3-9). He also mentions enjoyment (3-5).

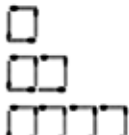
Adam was then asked to give an example of a hypothetical implementation of an argumentation activity in his class. He chose to talk about employing the known "match train" task, which includes an examination of concrete cases involving small numbers (1, 2, and 3 wagons) and then the formation of an algebraic expression. Figure 1 presents part of a script Adam wrote down for an imaginary dialogue in his class focused on finding the number of matches needed for any number of squares.

When discussing his script, Adam emphasized: "I took into account ways in which students' thinking about building generalizations might be incorrect, such as employing empirical methods or using invalid proportional reasoning" [4-1]. He also referred to his approach of "prompting as many arguments as possible" [4-2] as well as "bringing students' ideas to the class for judgment" [4-3], while "emphasizing important ideas given by students, such as the use of counterexample" [4-4]. In addition, Adam said: "I would use various strategies for providing students with scaffolding in generating arguments [4-5]. For example, by using real matches to help students develop a sense of the situation [4-6], suggesting counterexamples to use in refuting students' claims [4-7] ... and using a table of values to support students' efforts to reach a generalization and to identify invalid claims, such as the one suggested by student #3" [4-8].

Adam's concrete example of implementation of a task provides us with more ideas about the way he conceives argumentation: First, in terms of the structural aspect, with claims and justifications requested in class and distinguishing between accepted and unexpected justifications (4-1). Secondly, in terms of the dialogic aspect, his approach here is very similar to the one he raised with regard to argumentation in his earlier responses (4-2, 4-3). In this response, we can also see Adam referring to

student characteristics related to common ways of thinking (4-1), along with a reference to *teaching strategies* associated with promoting argumentation, such as prompting students' dialogue (4-2, 4-3), explicating important mathematical argumentation ideas in class (4-4), and providing students with scaffolding through the use of various examples (4-7), representations (4-8) and tools (4-6).

Let's make "trains" from matches.



S1: I will continue counting.
 S2: It is not an efficient method.
 Teacher: Do you agree? If we would like to build a train with 1,000 wagons, will you count the number of matches?
 Students: no, it is too hard.
 Teacher: So what will we do?
 S3: We will multiply the number of matches by four.
 Teacher: Students, what do you think about it?
 S4: I think it is not okay. If we have for example two squares we will need 7 matches and not 8.
 Teacher: Very good argument. We have here a counterexample for the claim that the number of matches is the number of squares multiplied by four.
 S5: For each additional wagon we need more three matches.
 Teacher: What do you think class?
 Students: yes yes
 Teacher: Let's draw on the board... Follow me and think about the generalization...

Fig. 1 A part of the script Adam wrote for an imaginary dialogue in his class

Overall, the above statements from Adam's interview illustrate the way in which several of the different components of the framework were devised. Figure 2 presents the emergent framework for teachers' conceptions on argumentation for mathematics teaching. Several of the categories were identified in Adam's statements as presented in this paper, and therefore appear in the model, accompanied by their indexes in brackets. Other categories were not illustrated in this paper; however, they will be further elaborated upon in the conference presentation.

Mathematics teachers' conceptions of argumentation	
Structural aspects	Dialogic aspects
<p>What is argumentation?</p> <ul style="list-style-type: none"> • Elements of argumentation: claims and justifications (1-1, 2-1, 4-1) • Types of justifications valued (4-1) 	<ul style="list-style-type: none"> • Students raising different point of view (2-2, 3-2, 4-2) • Students listening critically to each other's arguments (1-2, 2-2, 4-3) • Students defending their ideas (3-6) • Students attempting to convince others of their opinion (2-2) • Students listening to each other respectfully (2-3) • Students working towards consensus (3-2)

Teaching strategies	<ul style="list-style-type: none"> • Encouraging and scaffolding students' justifications (e.g., through questioning, using concrete examples and tools) (4-5, 4-6, 4-7, 4-8) • Encouraging self-evaluation of claims • Providing criteria for justification • Explicating important mathematical argumentation ideas (4-4) • Requiring written justifications (3-8) 	<ul style="list-style-type: none"> • Encouraging students to present different points of view (4-2) • Encouraging students to respond critically to each other's arguments (4-3) • Giving value to students collaborating on, generating and critiquing arguments
Task characteristics	<ul style="list-style-type: none"> • Open tasks that afford various solutions (3-1) • The types of justifications that the task invites 	<ul style="list-style-type: none"> • Open tasks that afford various solutions (3-1)
Student characteristics	<ul style="list-style-type: none"> • Students' ways of mathematical thinking (e.g., tendency to use empirical-based justification) (4-1) • Students' skills of generating arguments, including difficulties (3-3) • Students' self-confidence (2-5) 	<ul style="list-style-type: none"> • Students' skills of presenting arguments to the class • Students' skills of responding to others' ideas • Students' skills of revising their arguments based on the class/group discussion • Students' engagement (2-4) • Students' enjoyment (3-5) • Students' competition: who will present her/his work to class (3-9)
Socio-cultural characteristics	<ul style="list-style-type: none"> • Norm of providing justifications for claims (3-8) • Norm of writing arguments clearly (3-9) 	<ul style="list-style-type: none"> • Norm of collaborating on generating and critiquing arguments (2-2, 3-4) • Norm of respectful dialogue (2-3)

Fig. 2 Emergent model for teachers' conceptions of argumentation in teaching mathematics

Conclusion

This paper presented an exploratory study as part of ongoing research into teachers' conceptions of argumentation in the teaching of mathematics. It proposed an emergent 5-by-2 framework comprising five categories of conceptions of argumentation for teaching mathematics across two dimensions: structural and dialogic. The study opened with a presentation of the theoretical distinctions related to argumentation, focusing on structural and dialogic aspects as the main dimensions of argumentation (McNeill et al., 2016). The empirical investigation of the teachers' discourse on argumentation in their teaching resulted in five categories of teachers' conceptions of argumentation: (1) what is argumentation, (2) teaching strategies for argumentation, (3) mathematical task characteristics, (4) student characteristics, and (5) socio-cultural characteristics. These categories reflect the complex process of establishing argumentation in the mathematics classroom and the roles that teachers need to fill in order to facilitate argumentation (Ayalon & Even, 2016; Ayalon & Hershkowitz, 2018; Mueller, Yankelewitz, & Maher, 2014; Yackel, 2002), and adhere to notions of productive argumentation that promotes learning (Asterhan & Schwarz, 2016).

This is the beginning of learning about mathematics teachers' conceptions of argumentation in the mathematics classroom. We intend to continue our research, basing the work on the categories

developed in this paper. First, the model will be applied to characterize each participating teacher's conceptions. Second, since the research literature shows that teachers' declarative conceptions can be different from those realized in their actual teaching (e.g., Lev-Zamir & Leikin, 2013), we intend to use the model for analyzing the teachers' lessons, and for ascertaining the relationships between teachers' declarative conceptions and their conceptions 'in-action' with special attention devoted to argumentation. The analysis will also search for new categories, in order to refine the model to be used to analyze and characterize teachers' conceptions of argumentation in the teaching of mathematics.

References

- Asterhan, C. S. C., & Schwarz, B. B. (2016). Argumentation for Learning: Well-trodden paths and unexplored territories. *Educational Psychologist*, *51*(2), 164–187.
- Ayalon, M., & Even, R. (2016). Factors shaping students' opportunities to engage in argumentative activity. *International Journal of Science and Mathematics Education*, *14*, 575–601.
- Ayalon, M., & Hershkowitz, R. (2018). Mathematics teachers' attention to potential classroom situations of argumentation. *Journal of Mathematical Behavior*, *49*, 163–173.
- Ball, D. L., & Bass, H. (2003). Making mathematics reasonable in school. In J. Kilpatrick, W. G. Martin, & D. Shifter (Eds.), *A research companion to principles and standards for school mathematics* (pp. 27–44). Reston, VA: National Council of Teachers of Mathematics.
- Bieda, K. N. (2010). Enacting proof-related tasks in middle school mathematics: Challenges and opportunities. *Journal for Research in Mathematics Education*, *41*(4), 351–382.
- Felton, M., Garcia-Mila, M., & Gilabert, S. (2009). Deliberation versus dispute: The impact of argumentative discourse goals on learning and reasoning in the science classroom. *Informal Logic*, *29*, 417–446.
- Grootenboer, P., & Marshman, M. (2016). *Mathematics, affect and learning middle school students' beliefs and attitudes about mathematics education*. Singapore: Springer.
- McNeill, K. L., Katsh-Singer, R., González-Howard, M., & Loper, S. (2016). Factors impacting teachers' argumentation instruction in their science classrooms. *International Journal of Science Education*, *38*(12), 2026–2046.
- Mueller, M., Yankelewitz, D., & Maher, C. (2014). Teachers promoting student mathematical reasoning. *Investigations in Mathematics Learning*, *7*(2), 1–20.
- Nathan, M. & Knuth, E. (2003). A study of whole classroom mathematical discourse and teacher change. *Cognition and instruction*, *21*(2), 175–207.
- Patton, M. Q. (2002). *Qualitative Research and Evaluation Methods*. Thousand Oaks: Sage.
- Staples, M. (2014). Supporting student justification in middle school mathematics classrooms: Teachers' work to create a context for justification. *Annual Meeting of the American Educational Research Association*, Philadelphia, PA. Retrieved from: http://digitalcommons.uconn.edu/merg_docs/4
- Thompson, A. (1992). Teachers' beliefs and conceptions: A synthesis of research. In D. A. Grouws (Org.), *Handbook of Research on Mathematics Teaching and Learning* (pp. 127–146). New York, NY: Macmillan.
- Van Eemeren, F. H., & Grootendorst, R. (2004). *A Systematic Theory of Argumentation*. Cambridge, UK: Cambridge University Press.

A student teacher's responses to contingent moment and task development process

Emine Aytekin¹ and Mine Işıksal Bostan²

¹Düzce University, Faculty of Education, Düzce, Turkey; aytekinem@gmail.com

²Middle East Technical University, Faculty of Education, Ankara, Turkey; misiksal@metu.edu.tr

The study attempted to investigate the ways a prospective teacher, Elif, responded to contingent moments in her teaching practice. In addition, her perceptions regarding changes in the nature of the tasks based on the students' unanticipated thinking after the teaching were examined. Elif attended to a two-hour class of teaching seminar in which categorizations of mathematical tasks were presented. Then, during her enrollment in teaching practicum course, she taught a lesson on algebra by considering the categorization of the tasks. The lesson plan, her video record of teaching, semi-structured pre and post interviews were analyzed based on contingent trigger categories and kinds of teachers' responses to them and tasks during the phase of selecting, enacting and revising were analyzed based on its cognitive demand. Results showed that the contingent moments lead her to reanalyze the content and implementation of the designed tasks for further teaching.

Keywords: Specialized Content Knowledge, Knowledge Quartet, Contingency, Pre-service teachers, Cognitive Demand

Introduction

A mathematical task (i.e. a problem or a set of problems) is “a classroom activity, the purpose of which is to focus students' attention on a particular mathematical idea” (Stein, Grover, & Henningsen, 1996, p. 460). The teacher's pedagogical knowledge in planning lessons has a crucial role in the way mathematical tasks are selected and implemented (Stein, Grover & Henningsen, 1996). Thus, designing tasks based on students' understanding and identifying students' ways of thinking during task implementation as parts of teachers' knowledge are important abilities for effective teaching (Fernande, Llinares and Valls, 2010). Hence, as Chapman (2013) stated, during practice teachings, focus be placed on pedagogical knowledge regarding the nature of task.

In the context of task implementation, eliciting students' ways of thinking has become an important skill for teachers during practice teachings. Rowland and Zazkis (2013) concluded that “a teacher's responses to problematic contingent moments that arise in teaching mathematics are fundamentally dependent on their mathematical knowledge, which prompts and guides pedagogical implementation” (p. 151). It is a fact that due to the nature of the learning environment, which is dynamic and complex, teachers as well as novice teachers encounter many challenges in responding to student needs (Foster, 2014). Hence, teachers should be well prepared for such potential contingent situations and moments for the following teaching practices (Rowland, Thwaites, Jared 2015). Thus, the present study aimed to reveal the novice teacher's knowledge regarding the contingencies so that mathematics teacher educators can have a better understanding of novice teachers' pedagogical knowledge (Liston, 2015). Hence, the study initially attempted to examine how a preservice teacher responded to these contingent moments.

Not only declining or maintaining the cognitive demand level, but also transforming tasks with lower cognitive demands into high-level tasks are closely linked to students' ways of thinking and teachers' decisions at contingent moments. At a more detailed glance, teachers' decisions regarding the nature of a task and sequences of tasks are shaped by students' opinions and their ways of thinking at the moment that is related to active facet of contingent knowledge. Moreover, proactive aspect (Hurst, 2017) of it includes teachers' planning of task design where they seek to address students' misconceptions. Hence, eliciting students' ways of thinking and unexpected responses might ensure effective task implementation and design. In this respect, it is believed that experiencing 'Contingency' instances may provide novice teachers with opportunities to improve their pedagogical knowledge (Rowland, Thwaites & Jared 2015) by transforming tasks into high-level tasks or maintain tasks' cognitive demand. Hence, the second aim of the study was to explicate how these contingent moments guide teachers in thinking about the nature of the tasks implemented. This is important since research needs to identify how the opportunity of contingent moments and knowledge in features of the level of the tasks support teachers' ways of altering tasks in following teaching practices. Thus, the research questions of the present study were stated as follows: (1) How does a novice mathematics teacher respond to contingent moments during her teaching of algebra? (2) How do contingent moments help the preservice teacher to reconsider the nature of the task for further teaching?

Theoretical Framework- Knowledge Quartet Model (KQ)

An empirical framework called as Knowledge Quartet developed by Rowland, Huckstep and Thwaites (2005) has been used to assess and develop both pre-service and in-service mathematics teachers' mathematical knowledge during planning and teaching. It comprises four main units; namely, foundations, transformation, connection and contingency. The last component of the knowledge quartet, *contingency*, is described as 'the "opposite" [their emphasis] of planning – to situations that are not planned and that have the potential to take a teacher outside of their planned route through the lesson' (Rowland and Zazkis, 2013, p. 139). Contingency is concerned with a teacher's ability to make convincing, meaningful responses to unanticipated student answers, questions and statements. "Responding moves", similar to *contingency*, are regarded as key moments in organizing a lesson (Brown & Wragg, 1993). Based on the model, contingent moments are associated with the codes of "responding to students' ideas; deviation from agenda; teacher insight; (un)availability of resources" (Rowland, Turner & Thwaites p. 4). Therefore, in this study, we first identified contingent moments in the video recording of the pre-service teacher's instruction and then analyzed whether or not the teacher attended to those moments, and how she reconsidered the nature of the tasks based on those instances.

Within the context of the mathematical tasks, the Mathematics Tasks Framework characterizes three phases through which tasks pass: first, as they are in the curricular materials; next, as tasks are set up by teachers; and last, as they are applied by students in the classroom (Stein, Grover and Henningsen, 1996). All these are believed to have an important impact on students' learning process. The cognitive demand of mathematical tasks emphasized in the second phase of the framework refers to "the cognitive processes students are required to use in accomplishing [tasks]" (Doyle, 1988, p. 170). It is classified into four categories, which are memorization, procedure without connection, procedures with connection

and doing mathematics (Stein et al., 2000). Tasks with a low cognitive demand (memorization and procedure without connection) require students to memorize facts, rules and procedures without relational and conceptual understanding and do not lead students to engage in high-level mathematical thinking, such as problem solving, reasoning, connection and critical thinking (Stein & Lane, 1996). On the other hand, mathematical tasks with a high level of demand include multiple entry points rather than a single answer. In other words, high level tasks entail explorations of mathematical ideas by thinking critically and reasoning.

Although researchers emphasized that the high-level tasks are key to acquiring mathematical ideas (Stein, Grover, & Henningsen, 1996), tasks themselves, even high-level ones, may not result in high level understanding. At that point, the role of the teacher during the preparation and implementation of mathematical tasks have emerged as a crucial aspect in teaching mathematics conceptually (Doyle, 1988). Indeed, teachers should be responsible for changing the cognitive demand of tasks during classroom implementations (Smith, Grover & Henningsen, 1996). Hence, teacher knowledge could be regarded as one of the important factors impacting teachers' way of altering task features to meet student needs.

Methods

Context and Participants

The case study research methodology is used to respond to “how” or “why” questions in detail (Yin, 2013). Since the main aim of the study was to analyze and reflect on complex classroom practices, the responses to the research questions of the study were sought by utilizing the single case study methodology. In a project, six novice teachers were selected based on their willingness to participate in the study and on their high-level of achievement in the teaching method courses. The participants were provided with a (two-hour) seminar on the Smith and Stein's categorizations of mathematical tasks. The seminar was held to familiarize them with each level of the cognitive demand of the tasks. It was believed that this familiarity would enable them to critically analyze the features of the tasks with respect to how students think and present mathematical opinions. Subsequent to the seminar, they were expected to prepare a lesson plan including tasks with a low or high level of cognitive demand. Elif, a novice mathematics teacher, volunteered to teach a class; therefore, Elif's lesson was selected for the present case study.

The pre-service elementary mathematics teacher, Elif, was in her fourth year at a public university in Turkey. Thus, Elif had completed Teaching Mathematics Method courses and Practice Teaching I course aiming at providing an opportunity to observe teachers' the way of teaching and student learning. In addition, she was experiencing the teaching for the course of Practice Teaching II (practicum). She planned lessons to meet the requirement of Practice Teaching II (practicum) and we focused on one of her lessons.

Data Collection and Analysis

The lesson plan, video recordings of her lesson and the audio-record of the semi-structured pre- and post-interviews were used as data sources. The pre-interview lasted 50 to 70 minutes in a one-on-one setting

to determine her perceptions regarding the nature of the tasks selected for the lesson and her opinions regarding unexpected ways of student thinking related to the tasks. After her lesson, she was asked to observe the video of her teaching by using the classification features of cognitive demand tasks as a guide. Finally, we performed a semi-structured post-interview to gain information regarding her views on the way she responded to contingencies and redesigning the task. Sample questions from the post-interview are as follows: “How would you deal with that response?” The tasks as data in the processes of planning, acting and revision were analyzed using the cognitive demand levels in the mathematics task analysis guide (Stein et al. 2000). In addition, the lesson episodes including the implementation phase of the first and second tasks were transcribed and then analyzed based on the contingent trigger categories of Rowland et al. (2015) and different kinds of teachers’ responses to them.

Overview of Elif’s lesson

Elif taught algebra for 7th grades. The learning outcome of the lesson required learners to be able to describe how two variables having linear relationship with each other vary by using table, graphic and equations. There were 22 students in the class, 12 boys and 10 girls. They were seated at tables in front of the board and Elif stood at the board and walked around the seats for some time. The lesson started with a task at the level of ‘memorization’. More specifically questions: “what is the meaning of linear relationship?”. Then Elif continued with the second task which was related to the relationship between two variables varying together designed at the level of ‘procedures without connection’ provided below.



Interpret the changes in volume of the beaker and time.

Figure 1: The Second Task

Findings

Contingent moments emerged during enactment of the first task and Elif’s responses to the moments provided as follow:

Linearity: Speed, Time and Position

After Elif presented the first task to the class, three or more students defined the linearity between two variables and then two of students mentioned speed and time. She accepted the responses and got students to think of the relations among those variables, namely time, speed and distance, as in the following conversation:

- Elif: Yes, speed increases as time increases, right? Or is speed constant?
- Student 1: Speed can change; for instance, the speed can be 61 km/h during half of the distance. Then, the car can go at 59 km/h during the other half of the distance. Then, the speed will be 60 km/h and [hence] constant.

Elif: Do you think that speed is constant as time increases, or speed increases as time increases. Which one?

Student 1: Overall, the speed did not change.

However, some responded by saying “Constant”.

Elif: Now consider that time increases, and speed is constant. Only one variable is changes. Yes? So, what does linear relationship mean?

Then she drew a graph of time versus speed (speed is constant) and explained that speed had one value as time increased. Then she asked a question “Is this a linear relationship?” by pointing to the graph. One student responded by saying, “it [the value for y-axis] might be distance.” Then she drew the graph of time versus distance when speed is constant, and she continued to say:

Elif: If we go back to the speed example, should the speed increase in time? How does speed change? Is it constant, increases constantly or how?

Student 2: It should be [increasing] at certain intervals. 60,120,180...

Student 3: Certain ratios

Elif: Yes, another example?

Student 1: [For instance] the pupil read 10 pages of a book on the first day, and on the second day the pupil read 20 pages of the book?

Elif: [By interrupting the student’s speech] If I said there is a linear relationship, it should be increased by certain ratios or number. [By pointing to the second speed versus time graph] Do you understand now why I cannot say that there is a linear relationship?

This contingent moment related to confusion in the concept of constant rate of change arose based on students’ responses to the first question and students’ spontaneous responses during the discussion. The response of Students 1 led Elif to hold a discussion on the linearity of variables in the context of time and distance. During the post-interview based on the first task, Elif stated that she had not expected such an example as time and speed instead of time and distance; hence, she was confused.

Elif channeled students towards considering the one possible correct example that as time increased, distance also increased in the condition when speed was constant. Thus, this might indicate that she acknowledged the opinion of Student 1 regarding the ‘linear relationship between the average speed (speaking of two constant speeds) and time’, but it was ignored, perhaps because Elif did not understand the student’s idea and its relationship with linearity or she was challenged in elaborating the misconception. During the discussion, despite Elif’s directions, some students responded to the question by saying that the relationship between the time and speed was linear. She did not attend to those responses either, and she stated in the post-interview that her focus was solely placed on receiving distance versus time as a correct answer from the students. In this regard, it could be inferred that Elif focused on receiving the same answer that was on her own mind and was not open to any other alternative response.

Linearity: Graphs

The second contingency and Elif's response to it was as follows:

Student 1: [The line in] the graph must pass through the origin. Right?

Elif: No, it is wrong, in our examples there can be a starting point.

Student 1: How?

This unanticipated situation was related to the student's tendency to create a graph with a line passing through the origin for linearity. The teacher addressed the student's unexpected opinion by correcting it. However, the opinion was not discussed by using any representations. She presented the reasons for her action during the post-interview by saying she did not know how to combine the situation with their graphs, and thus, judged the idea as being unworthy for discussion in the class. The changes in the first task recommended by Elif are presented under the next heading.

Perceptions on Modifying the Task

Two contingent moments and Elif's reactions to those moments have been described above. During the post-interview, Elif suggested changes in the properties of the task, in its sequence, and the time allocated for the task, as can be observed in the following conversation:

Interviewer: If you had the chance to apply these tasks, how would you deal with that response?

Elif: The task: "Consider that a bus arrives at each station at each station at exactly the same time duration and the distance between each station is the same. Explain the relationship among the variables (distance, time and speed) in this situation". Then "If my speed or distance is not zero at the beginning, could we speak of similar relationships among the determined variables? Justify your examples by drawing graphs [of the quantities]".

As can be understood from the above conversation, the teacher had to ask follow-up questions to get students to consider the situation. Moreover, she had to focus on representation of the variables graphically. Moreover, Elif underlined the fact that the first and the second tasks, which were at the level of 'memorizations' and 'procedures without connection', respectively, could be merged, and there was no need to have students do the second task since the concepts of time, speed and distance were great an opportunity for discussion. By integrating the contingent moments and the properties of tasks with a high cognitive demand level, the teacher wanted to redesign the task requiring a higher level of cognitive effort and students to use representations. With the assistance of the guide, she critiqued her tasks based on whether the revised version was coherent with respect to the properties of the tasks with a high level of cognitive demand and different from the properties of the ones with a low level of cognitive demand. For instance, she believed that she expected students to become aware of the meaning of the linear relationship in the context by leading them to use appropriate representations instead of giving them an algorithm or memorized facts (the definition of linear relationship). Thus, the task was coded as one with a higher-level demand.

Discussion

The present study yielded the emergence of two contingent moments associated with *trigger type 1: responding to students' ideas*, proposed by Rowland et al. (2015). The moments were related to students' incorrect examples for linearity that stemmed from their misinterpretation of the degree of change and students' tendency to sketch graphs of variables having linear relationships with a line passing through the origin. During the pre-interview, Elif did not mention these students' possible opinions since she believed that low level tasks required limited cognitive demand and were solved by means of utilizing procedures, and she expected the students to give the definition of linear relationships as the correct answer. As the students presented different ideas related to linearity during the implementation of the task, the teacher was not able to effectively monitor and reflect different student ideas. Hence it could be stated that she had a perception that cognitive demand of a selected task did not change during the enactment of the task.

The findings related to the teacher's response to these unanticipated moments revealed that Elif became engaged in some of the students' unexpected answers, but she directed students to think only of the time versus distance example. In addition, during the classroom discussion, Elif did not attend to students' ideas; however, focusing on these ideas could have resulted in students' conceptual understanding of the mathematical idea (linearity). Combining this finding with the claim that the nature of teaching in real settings is dynamic and complex, we concluded that as a novice teacher, she was incapable in handling these moments occurring in the classroom (Foster, Wake & Swan, 2014) and could not make use of the opportunity of the unanticipated instances. For this reason, it could be maintained that she might have an answer-oriented approach that teachers rely on short recall questions and leading questions to guide students to the solely correct answers (Moyer & Milewicz, 2002) although she tried to increase the cognitive demand of the task by drawing the graphs. It could be claimed that her mathematics knowledge for teaching, a crucial factor for task implementation (Stein, et al, 2000), was weak since she could not give meaning to mathematical procedures (e.g. Charalambolous, 2010).

Although Elif was not able to orchestrate the discussion and she lacked in responding to unanticipated moments occurring during her teaching, she emphasized a need to change the nature and structure of the task addressing the second research question. In other words, these moments presented an opportunity for her to become aware of the different ways of student thinking that is concerned with proactive facet of contingent knowledge. Hence, it could be deduced that Elif benefitted from her experience (Rowland, Thwaites, Jared 2015). Moreover, the guide for task classifications was beneficial for redesigning the task for further teaching. Besides, the paper particularly provided insight into the fact that contingent moments triggered preservice teachers towards improving their low-level tasks and reconsider the sequences of the tasks, and this may, in turn, enhance their knowledge of mathematical tasks. In the light of the study, it could be claimed that more exposure to contingency moments through video clips by knowing the classifications of the mathematics tasks within the scope of the teaching practice courses can prepare pre-service teachers to actual classroom environments. In conclusion, the study contributed to the literature with information regarding the impact of contingent moments on the implementation of low-level tasks. However, analyzing data of merely two low level tasks and basing the study on the

reflections of one pre-service teacher could be regarded as the limitations for the study. Hence, further studies are needed to portray the relationship between unanticipated student responses and the ways that pre-service teachers achieve high cognitively level tasks.

References

- Chapman, O. (2013), Mathematical-task knowledge for teaching. *Journal of Mathematics Teacher Education*, 16, 1–6. DOI 10.1007/s10857-013-9234-7.
- Doyle, W. (1988). Work in mathematics classes: The context of students' thinking during instruction. *Educational Psychologist*, 23(2), 167–180.
- Fernández, C., Llinares, S., & Valls, J. (2012). Learning to notice students' mathematical thinking through on-line discussions. *ZDM: The International Journal on Mathematics Education*, 44(6), 747–759.
- Foster, C., Wake, G., & Swan, M. (2014). Mathematical knowledge for teaching problem solving: lessons from lesson study, In Oesterle, S. et al. (Eds.). *Proceedings of the Joint Meeting of PME38 and PMENA36. Vol. 3.* 97–104. Vancouver, Canada: PME.
- Hurst, C. (2017). Provoking contingent moments: Knowledge for 'powerful teaching' at the horizon. *Educational Research*, 59(1), 107–123.
- Rowland, T., Huckstep, P. & Thwaites, A. (2005). Elementary teachers' mathematics subject knowledge: the knowledge quartet and the case of Naomi. *Journal of Mathematics Teacher Education*, 8(3), 255–281.
- Rowland, T., Thwaites, A. & Jared, L. (2015). Triggers of contingency in mathematics teaching. *Research in Mathematics Education*, 17(2), 74–91. doi:10.1080/14794802.2015.1018931.
- Stein, M. K., & Lane, S. (1996). Instructional tasks and the development of student capacity to think and reason: An analysis of the relationship between teaching and learning in a reform mathematics project. *Educational Research and Evaluation*, 2(1), 50–80.
- Stein, M. K., & Smith, M. S. (1998). Mathematical tasks as a framework for reflection: From research to practice. *Mathematics Teaching in the Middle School*, 3, 268–275.
- Stein, M. K., Grover, B. W., & Henningsen, M. (1996). Building student capacity for mathematical thinking and reasoning: An analysis of mathematical tasks used in reform classrooms. *American Educational Research Journal*, 33(2), 455–488.
- Tekkumru Kisa, M., & Stein, M. K. (2015). Learning to see teaching in new ways: A foundation for maintaining cognitive demand. *American Educational Research Journal*, 52(1), 105–136.
- Thwaites, A., Jared, L., & Rowland, T. (2011). Analysing secondary mathematics teaching with the Knowledge Quartet. *Research in Mathematics Education*, 13(2), 227–228.
- Yin, R. K. (2003). *Case study research: Design and methods* (3rd ed.). Thousand Oaks, CA: Sage.

Using the Knowledge Quartet to analyse interviews with teachers manipulating dynamic geometry software

Nicola Bretscher

UCL Institute of Education, London, UK; n.bretscher@ucl.ac.uk

This paper reports the use of the Knowledge Quartet as a tool for analysing mathematical knowledge in teaching arising in interviews with four secondary mathematics teachers based around a pre-configured GeoGebra file involving circle theorems. This research was part of larger doctoral study, where the Knowledge Quartet was chosen as a means of providing a fine-grained analysis focusing on mathematical knowledge in teaching. The sub-codes of the Knowledge Quartet were originally grounded in classroom observation and have been rarely exemplified through situations involving teachers use of technology. A tension is identified in applying the Knowledge Quartet to an interview situation involving technology centring around the sub-code 'adherence to textbook', with wider implications for how the framework is applied to situations involving teachers' use of (technological) tools.

Keywords: Knowledge Quartet, teacher knowledge, technology.

Introduction

Using digital technologies, such as the dynamic software package GeoGebra, can place significant demands on teachers' mathematical knowledge (Laborde, 2001) and hence provide opportunities for making such knowledge visible and available for exploration. The research reported in this paper forms part of a larger doctoral study investigating mathematical knowledge in teaching using technology. The Knowledge Quartet (Rowland et al., 2005) is a widely used and influential framework for analysing mathematical knowledge in teaching, (see previous TWG20). The framework is composed of four supra-categories Foundation, Transformation, Connection and Contingency, generated by grouping 18 sub-codes representing prototypical classroom situations where mathematical knowledge for teaching is called upon, derived from analysis of classroom observations. The strengths of the Knowledge Quartet, in terms of this study, lie in the framework's focus on mathematical knowledge for teaching and the grounding of its codes in classroom observation, thereby maintaining strong face and content validity. For these reasons, the Knowledge Quartet was chosen as a means of providing a fine-grained analysis focusing on mathematical knowledge in teaching, as opposed to technology-focused frameworks such as the Technology Pedagogy and Content Knowledge (TPACK) framework (Mishra & Koehler, 2009). In addition, research on the importance of variation to structure sense-making (Marton & Booth, 1997; Watson & Mason, 2006) suggests the code *choice and use of examples* (Transformation) may be advantageous as a tool for analysing mathematical knowledge for teaching using technology in the context of the semi-structured GeoGebra interviews, since dynamic variation is central to such software (Leung & Lee, 2013).

The sub-codes of the Knowledge Quartet have rarely been exemplified through situations involving teachers use of technology. One such instance of a situation involving teachers' use of technology resulted in the addition of a new sub-code *responding to the (un)availability of tools and resources*

to the Contingency category of the Knowledge Quartet (Rowland et al., 2015). Hence extending the use of the Knowledge Quartet to analyse situations beyond its original evidence-base may provoke further refinement of the framework. This paper seeks to address the following research question:

What tensions are exposed in using the Knowledge Quartet as a tool for analysing the mathematical knowledge in teaching arising in interviews based on a GeoGebra file involving circle theorems?

This paper also relates to a broader concern in TWG20 in CERME11 (e.g. Montes et al. (2019, February); Codes et al. (2019, February)) of investigating how tasks, in this case manipulating a GeoGebra file on circle theorems, can be used to explore, support and develop mathematics teachers' knowledge and what the implications for teacher education may be. The next section provides the theoretical background underpinning the study, by first setting out an overarching perspective of teachers' knowledge being distributed (Hutchins, 1995) e.g. across tools and then describing the Knowledge Quartet in more detail. In the following sections, analysis of interview data reveals a tension in applying the Knowledge Quartet, centring around the sub-code *adherence to textbook*, with wider implications for how the framework is applied to situations involving teachers' use of (technological) tools.

Background

Hutchins (1995) argues that conceptualising cognition as distributed assumes that cognition is not only a property of an individual person, but also occurs through human interaction with artefacts and other humans. In particular, he argues that cognition partially resides in tools – taken to mean any artefact appropriated for use by humans – since they incorporate in their construction the results of past cognitive efforts. Hutchins' (1995) view of distributed cognition provides a means of investigating how individual teachers' knowledge is involved in a participatory relationship with technology. In this study, the terms readerly and writerly response (Bowe, Ball, & Gold, 1992, drawing on the work of Barthes) are introduced to indicate how and to what extent knowledge is distributed (Hutchins, 1995) across teacher and technology. A readerly response indicates an uncritical acceptance by the teacher of a (technological) tool for mathematics teaching. By contrast, a writerly response entails recognition that the design of such a tool is open to critique and potential modification. Departing from their original meaning, that writerly texts invite the reader to participate in meaning-making and are therefore in a sense superior to readerly texts that make no such demands, the use of these terms in this study takes a less normative view. Instead, a readerly/writerly response indicates the role of individual teachers' knowledge in interacting with technology to produce mathematical knowledge made available in the classroom – or more pertinently, in the case of this study, in the interview. A readerly response suggests that the mathematical knowledge made available through this interaction is more dependent, i.e. more distributed, upon the technology, whereas a writerly response indicates that it is less so.

For the purposes of this study, the Knowledge Quartet provides a means of focusing on and analysing individual teachers' own knowledge in relation to using technology to teach mathematics i.e. within the participatory relationship with technology. The Knowledge Quartet emerged from research aimed at developing an empirically-based conceptual framework to guide lesson review discussions between teacher-mentor and student-teacher in the practicum placement of the Postgraduate

Certificate in Education course in the UK (Rowland et al., 2005). The purpose of developing such a framework was to focus these discussions on the mathematical content of the lesson under review. The Knowledge Quartet was initially developed from 24 lesson observations of student teachers, training to teach at primary level. These observations generated 18 codes relating to the student teachers' classroom actions that appeared significant in the sense that they were informed by the trainee's mathematical knowledge for teaching. The codes were then grouped into four super-ordinate categories, named Foundation, Transformation, Connection and Contingency. The foundation category consists of propositional knowledge of mathematical concepts and the relationships between them and of significant research findings regarding the teaching and learning of mathematics (Rowland et al., 2005). The second category of transformation refers to knowledge-in-action, concerning the ways that teachers make what they know accessible to learners: this category focuses in particular on their choice and use of representations and examples (Rowland et al., 2005). Connection also refers to knowledge-in-action, regarding the manner in which the teacher makes connections between different concepts, representations and procedures; and decisions about sequencing e.g. of topics. Contingency concerns the teacher's ability to 'think on one's feet', to provide an appropriate response to unanticipated pupil contributions, and also notable 'in-flight' teacher insights (Thwaites, Jared, & Rowland, 2011). While there are clearly no pupils to provoke contingencies in an interview context, technology can be a source of disruption to teachers' mathematical knowledge (Laborde, 2001). Indeed, in this study, contingent moments did arise through teachers' use of the GeoGebra file, however these are not the focus of this paper. The Knowledge Quartet has subsequently been examined in classrooms at secondary level (Thwaites et al., 2011) and in classrooms outside the UK, specifically in Ireland and Cyprus (Turner & Rowland, 2011), resulting in the addition of new codes and alteration of some of the original codes. Although Rowland et al (2005, p. 260) make use of an acquisition metaphor, implying individualist assumptions about knowledge by describing their foundation category as being about "knowledge possessed", Turner and Rowland (2011, footnote on p. 200) suggest that "this 'fount' of knowledge can also be envisaged and accommodated within more distributed accounts of knowledge resources". Hence the framework may be compatible with an account of teachers' knowledge as distributed e.g. across (technological) tools.

Methodology

Four teachers were selected from a group of English mathematics teachers who took part in a survey of secondary school mathematics teachers' use of ICT (n=183) and who further agreed to be contacted as case study teachers (Bretscher, 2011; 2014). The four case study teachers, Robert, Michael, Edward and Anne, were chosen along two dimensions of variation likely to be associated with mathematical knowledge for teaching using technology, based on their responses to survey items. Firstly, the case study teachers were chosen to be two of the most student-centred (Robert, Anne) and two of the most teacher-centred (Michael, Edward) in their approach to mathematics teaching in general (not limited to ICT use) of those who volunteered. Secondly, two teachers were chosen to be from schools with a high level of support for ICT (Robert, Michael) and two with a low level of ICT support (Anne, Michael). In addition, the four case study teachers had described themselves as being confident with ICT. As technology enthusiasts, the case study teachers were likely to display mathematical

knowledge for teaching using technology; the variation in case selection aimed to highlight such knowledge – making it more ‘visible’.

Semi-structured interviews based around a GeoGebra file on circle theorems provided a common situation across which the case study teachers’ use of technology for teaching mathematics could be contrasted. The case study teachers were prompted to show and discuss how they would use a diagram presented in the GeoGebra file (see Figure 1) to demonstrate the angle at the centre theorem to their pupils. Circle theorems were chosen since it is a topic, in the English mathematics curriculum, which is commonly identified with the use of dynamic geometry software (Ruthven et al., 2008). It was therefore reasonable to assume that the case study teachers would be familiar with technological resources similar to the diagrams presented in the GeoGebra file and might even have previously used such resources in their own teaching. Thus they would be likely to have some mathematical knowledge for teaching circle theorems using the GeoGebra file, even if they were unfamiliar with the particular software. In addition, the topic of circle theorems is at the apex of geometry in the compulsory English mathematics curriculum, since it is typically where proof is introduced. Hence it provided a potentially challenging context even for experienced teachers who were both mathematically and technologically confident.

The GeoGebra file comprised three diagrams, all initially arranged in an ‘arrowhead’ configuration, relating to the circle theorem stating that angle at the centre of the circle, subtended by an arc, is double the angle at the circumference subtended by the same arc. The GeoGebra file also incorporated some text, setting the task of manipulating the diagrams in the pedagogical context of planning how to introduce pupils to this circle theorem based on a demonstration using these diagrams. In this paper, the analysis presented below focuses on the teachers’ discussion of the first diagram (D1) only which was designed to be similar to resources found on a web-search. Thus the case study teachers were likely to have at least some familiarity with a dynamic diagram like D1 and possibly have even used something similar in their own lessons.

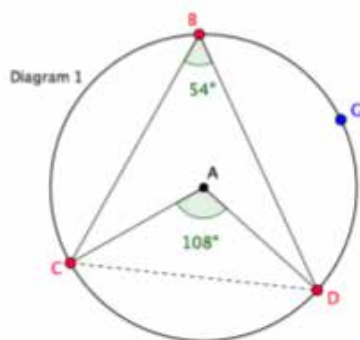


Figure 1 Diagram 1 (D1) in the GeoGebra interview file on circle theorems

Before opening the GeoGebra file on circle theorems, the case study teachers were asked to practise ‘thinking-aloud’ whilst manipulating a GeoGebra file contrasting two constructions of a square. The semi-structuring of the interview allowed the author some flexibility to respond to events during the interview, whilst maintaining an overall structure that would allow for and facilitate comparison. The GeoGebra interviews generally took place in a mathematics classroom at the case study teacher’s school that was not being used for teaching at that time. The author’s laptop with mouse attached was

arranged on a desk so that both the author and the case study teacher could comfortably see the screen and use the mouse to manipulate D1, enabling collaboration on the task. Both the visual and audio aspects of the GeoGebra interviews were recorded on the author's laptop.

Results and analysis

Adhering to the starting configuration

Robert was the only case study teacher to consider modifying the starting configuration of D1 to suit his own pedagogical requirements. He suggested he might alter D1 so that the initial numerical example displayed when opening the GeoGebra file would be an almost implausibly 'nice' pair of numbers, setting the angle at the circumference to 60 degrees and the angle at the centre to 120 degrees as an example.

Robert: I'd probably I'd have it so when it [D1] came up I'd probably have it set up with I guess fairly nice numbers [drags D1 so angle CBD=60; CAD= 120] that they should be able to spot quite easily and I'd probably ask them what the relationship is. And then before dragging this point I'd probably you know I'd probably have it set up so that maybe it looks a bit well this is a kind of this is a nice symmetrical, that's horizontal, they almost look vertical you know. And so I'd probably ask them well what happens if I move this over here? Is it going to get bigger? Is it going to get smaller?

Interviewer, I: Can you show me?

Robert: So I probably would be, if this was an interactive whiteboard I'd be hovering over this and not actually touching it and saying I'm going to drag this this way. What's going to happen? And I'd probably try to lead them into, I probably wouldn't give them the option of it staying the same. I'd probably ask them is it going to get bigger or going to get smaller? To I guess when they see that it does stay the same to provide a bit of conflict there. And then I'd drag it and we'd drag it all the way around here and show that it never changes. [Rob-GGb-int, 13.6.2012]

His intention was to set up a situation that appeared 'too good to be true' so that pupils would assume no relationship was likely to exist and would therefore sustain cognitive conflict when the angle at the circumference remained invariant under drag, hopefully making the result more memorable. The other three case study teachers uncritically accepted the starting configuration, questioning neither the numerical example nor the geometric configuration. For example, Edward explained how he would begin using the diagram, without making reference to the starting position:

Edward: What I'd start with is look, just move B between C and D but don't cross it and move D just so it doesn't go further round than CD being a diameter. [Ed-GGb- int, 20.6.2012]

The geometric nature of the starting configuration, in particular, is important since it provides an implicit pedagogic structuring. For example, opening the GeoGebra file so that D1 initially displays an 'arrowhead' configuration implies a choice and use of examples and a decision about sequencing that alternative configurations will occur as a consequence of the arrowhead configuration, potentially

reinforcing the impression of the arrowhead as the standard configuration of the angle at the centre theorem. An alternative would be to open the GeoGebra file so that D1 initially displays the convex quadrilateral configuration as a means of challenging this apparent orthodoxy. In addition, the starting configuration tends to impose decisions about sequencing, since some configurations are more difficult to obtain depending on whether they require dragging point B, C or D only or a combination of these points.

The case study teachers' adherence to or modification of the starting configuration appears to coincide with the meaning of the code *adherence to textbook*, in the Foundation category of the Knowledge Quartet, in the sense that it describes a situation involving mathematical knowledge for teaching where a teacher decides either to adhere to or to modify the pedagogic structuring of mathematics by a teaching resource. The teacher's decision, implicit or explicit, regarding the pedagogic structure of the teaching resource provides an indicator of foundational knowledge. An implicit (i.e. uncritical) adherence to the pedagogic structure of the teaching resource implies a negative reading of the code. Thus Anne, Edward and Michael's uncritical acceptance of the starting configuration suggests they lack foundational knowledge that the starting configuration of D1 might be (usefully or otherwise) critiqued in terms of the pedagogic structuring it provides. Hence they make a readerly response to D1 (Bowe et al., 1992). Nevertheless, a readerly response might apparently result in a positive choice and use of examples say, if the pedagogic structuring of the resource was sound. Thus, confusingly, a readerly response could also be interpreted as a positive example of the code adherence to textbook.

A writerly response (Bowe et al., 1992) to D1 would entail a recognition that the starting configuration of D1 might be critiqued in terms of the pedagogic structuring it provides, resulting in an explicit decision either to adhere to or to modify the pedagogic structuring of the teaching resource. This suggests a positive reading of the code *adherence to textbook*. Indeed, an explicit decision to adhere to the pedagogic structuring of the teaching resource would be a positive example of the code *adherence to textbook* if the pedagogic structuring of the resource were sound. On the other hand, such a decision could also be interpreted as a negative example of the code if the pedagogic structuring turned out to be flawed in some way. An explicit decision to modify the pedagogic structuring of the teaching resource which resulted in improvement, would again indicate a positive example of *adherence to textbook* – this latter is also dealt with by the new code *use of instructional materials* under the Transformation category introduced by Petrou and Goulding (2011). However, Robert's decision to modify the starting configuration could be interpreted as a deterioration in the pedagogic quality of the initial choice of example: it is geometrically too close to being symmetric and the numbers are exceptional. Thus Robert's modification could be interpreted both as a positive and negative instance of the code *adherence to textbook* under Foundation and a negative example of *use of instructional materials*. This analysis is rather cumbersome and symptomatic of the Knowledge Quartet's relative lack of focus on knowledge in relation to teaching resources in general.

Finally, there is a slight discordancy in using this code to describe the case study teachers' adherence to or modification of the starting configuration, since the code specifically refers to a textbook and not a digital resource such as the GeoGebra file on circle theorems. The specificity of the *adherence to textbook* code derives from the non-digital technology context in which it was grounded. The discordancy may be ameliorated by a minor alteration to the code, so that it refers to a more generic

teaching resource as in *use of instructional materials* (Transformation) or *responding to the (un)availability of tools and resources* (Contingency).

Discussion

The analysis presented in the previous section shows that the Knowledge Quartet remained a useful tool for focusing analysis on mathematical knowledge despite the shift away from the classroom context in which the framework was originally developed and grounded. This finding is not entirely surprising since although the classroom is a particularly important context, it is not the only context in which teachers are likely to employ their mathematical knowledge for teaching.

In addition, the analysis of the GeoGebra interview data suggested some minor modifications to the Knowledge Quartet, in relation to technology context, that might prove useful when re-applied back to the original classroom setting or to other settings where teachers employ their mathematical knowledge for teaching. The cumbersome analysis of situations involving the code adherence to textbook is symptomatic of the Knowledge Quartet's lack of focus on knowledge in relation to (digital) technology. The difficulty with this code is that it categorises situations involving the application of foundational knowledge both in perceiving the technology as something requiring a pedagogic critique and in terms of the quality of the critique applied to the teaching resource. The former relates to the teachers' foundational knowledge in adopting a readerly or writerly approach to the resource (Bowe et al., 1992). The latter is also dealt with under the Transformation category, specifically the code use of instructional materials, which additionally reflects back onto the teachers' foundational knowledge indicated by the quality of the pedagogic critique applied to transform the resource for the purpose of teaching. There is no easy way to ameliorate this difficulty within the Knowledge Quartet, however, adherence to textbook could be modified to reflect a broader range of teaching resources rather than privileging this paper-based technology. Furthermore, as a result of new codes added by a range of researchers, the codes of the Knowledge Quartet use an impromptu variety of terms to refer to teaching resources including textbook, instructional materials, tools and resources. The variety of terms is not intended to make any productive distinctions, as far as I am aware, thus it might simplify and improve the coherence of the Knowledge Quartet to settle on a particular term or group of terms to refer to teaching technologies. Finally, the analysis above provides an exemplification of the Knowledge Quartet in relation to digital technologies, albeit not in a classroom context. This exemplification might be useful in helping teachers to use the Knowledge Quartet as a tool for professional development in relation to their use of technology, as described in Turner and Rowland (2011).

References

- Bowe, R., Ball, S., & Gold, A. (1992). *Reforming education and changing schools: Case studies in policy sociology*. London: Routledge.
- Bretscher, N. (2011). A survey of technology use: The rise of interactive whiteboards and the MyMaths website. In M. Pytlak, T. Rowland & E. Swoboda (Eds.), *Proceedings of the Seventh Congress of the European Society for Research in Mathematics Education CERME7* (pp. 2228–2237). Poland: Rzeszow.

- Bretscher, N. (2014). Exploring the quantitative and qualitative gap between expectation and implementation - a survey of English mathematics teachers' use of ICT. In A. Clark-Wilson, O. Robutti & N. Sinclair (Eds.), *The mathematics teacher in the digital era* (pp. 43–70). Dordrecht: Springer.
- Codes, M., Climent, N., & Oliveros, I. (2019, February). *Prospective primary teachers' knowledge about the mathematical practice of defining*. Paper presented at the Eleventh Congress of the European Society for Research in Mathematics Education CERME11, Utrecht, Netherlands.
- Hutchins, E. (1995). *Cognition in the wild*. Cambridge, MA: MIT Press.
- Laborde, C. (2001). The use of new technologies as a vehicle for restructuring teachers' mathematics. In F. L. Lin & T. J. Cooney (Eds.), *Making sense of mathematics teacher education* (pp. 87–109). Dordrecht: Kluwer Academic Publishers.
- Leung, A., & Lee, A. M. S. (2013). Students' geometrical perception on a task-based dynamic geometry platform. *Educational Studies in Mathematics*, 82(3), 361–377.
- Marton, F., & Booth, S. (1997). *Learning and awareness*. Mahwah, NJ: Lawrence Erlbaum.
- Mishra, P., & Koehler, M. J. (2006). Technological Pedagogical Content Knowledge: A framework for teacher knowledge. *Teachers College Record*, 108(6), 1017–1054.
- Montes, M., Climent, N., Carillo, J., & Contreras, L.C. (2019, February). *Constructing tasks for primary teacher education from the perspective of Mathematics Teachers' Specialised Knowledge*. Paper presented at the Eleventh Congress of the European Society for Research in Mathematics Education CERME11, Utrecht, Netherlands.
- Petrou, M., & Goulding, M. (2011). Conceptualising teachers' mathematical knowledge in teaching. In T. Rowland & K. Ruthven (Eds.), *Mathematical knowledge in teaching* (pp. 9–26). London: Springer.
- Rowland, T., Huckstep, P., & Thwaites, A. (2005). Elementary teachers' mathematics subject knowledge: The Knowledge Quartet and the case of Naomi. *Journal of Mathematics Teacher Education*, 8, 255–281.
- Rowland, T., Thwaites, A., & Jared, L. (2015). Triggers of contingency in mathematics teaching. *Research in Mathematics Education*, 17(2), 74–91.
- Rowland, T., & Ruthven, K. (2011). *Mathematical knowledge in teaching*. London: Springer.
- Thwaites, A., Jared, L., & Rowland, T. (2011). Analysing secondary mathematics teaching with the Knowledge Quartet. *Research in Mathematics Education*, 13(2), 227–228.
- Watson, A., & Mason, J. (2006). Seeing an exercise as a single mathematical object: Using variation to structure sense-making. *Mathematical Thinking and Learning*, 8(2), 91–111.

An analysis of the nature of the knowledge disseminated by a mathematics teacher training policy: The PROFMAT case

Marlova Estela Caldato¹ and Miguel Ribeiro²

¹ Federal Technological University of Paraná – UTFPR, Brazil; maracaldatto@yahoo.com

² State University of Campinas – UNICAMP, Brazil; cmribas78@gmail.com

This paper discusses the nature of the knowledge disseminated by the Brazilian public policy PROFMAT for training teachers on natural numbers, based on the analysis of one of the textbooks that outline the formative activities developed in this program. This discussion was structured and developed from a conceptual and analytical model of the mathematical knowledge of teachers-Mathematics Teacher's Specialized Knowledge (MTSK). The analyses and discussions developed suggest that this public policy favors only part of the knowledge taken by the literature as essential for the practice of the mathematics teacher in the school.

Keywords: Mathematics teacher's specialized knowledge, PROFMAT, public policy.

Introduction

Educational policies are configured as sources pertinent to the investigative processes that seek to identify the specificities of the teacher's knowledge (Stylianides & Ball, 2004), since they demonstrate the response produced by the government bodies to an issue that permeates the educational discussions related with what teachers need to know in order to teach mathematics adequately (Ball, Lubienski, & Mewborn, 2001).

Thus, the object of discussion of this article is a Master's Program in Mathematics (PROFMAT), aimed at the continuous training of mathematics teachers (lower and upper secondary), developed in all Brazilian states and financed by the country's government – assuming the character of Public Policy. According to the official documents, such a Program aims to provide in-depth and relevant mathematical training for teaching in Basic Education, seeking to give teachers a certified qualification for the mathematics teacher profession (Bsm, 2017).

The role played by the mathematical knowledge of teachers to improve the quality of learning opportunities justifies, at least in part, the growing focus of research on teachers' mathematical knowledge (Stylianides & Stylianides, 2014). This knowledge has been widely studied and, from different points of view, diverse conceptualizations of teacher knowledge have emerged (e.g., Knowledge Quartet - Rowland & Turner, 2007, MKT - Ball, Thames & Phelps, 2008; COACTIV – Kleickmann et al., 2015; MfT-Stylianides & Stylianides, 2014; MTSK-Carrillo et al., 2018). In this text, we focus on the Mathematics Teacher's Specialized Knowledge - MTSK conceptualization (Carrillo et al., 2018) as the analytical model of this type of knowledge. Thus, we will support the MTSK to discuss teacher training developed within the scope of PROFMAT, seeking to answer the following question: what knowledge about Natural Numbers and their teaching are presented (and not presented) in the textbook that guides a part of the training developed in PROFMAT?

Theoretical framework

The MTSK is an analytical model that assumes that the professional practice of the math teacher requires a set of specific knowledge strictly related to the teaching of mathematics. This includes the meanings, properties and definitions of particular topics, means that favor the construction of the understanding of the subject, connections between mathematical items, knowledge of mathematics teaching and characteristics associated with learning mathematics, among others (Carrillo et al., 2018). In this sense, the MTSK model (Figure 1) considers three subdomains in Mathematical Knowledge (MK) and three in Pedagogical Content Knowledge (PCK). In this way, MK is subdivided into: Knowledge of Topics (KoT), Knowledge of the Structure of Mathematics (KSM) and Knowledge of the Practice of Mathematics (KPM), while PCK is subdivided into: Knowledge of Mathematics Teaching (KMT), Knowledge of Features of Learning Mathematics (KFLM) and Knowledge of Mathematics Learning Standards (KMLS).

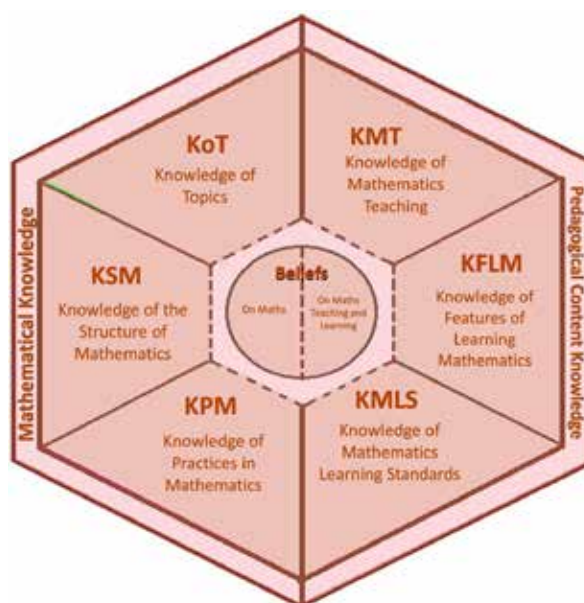


Figure 1: Sub-domains of the MTSK
(Carrillo et al., 2018)

The KoT includes phenomenological aspects, meanings of specific concepts and examples that characterize specific aspects of the topic addressed, aside from contemplating the disciplinary content of the mathematics addressed by textbooks and other materials of a pedagogical nature. KSM refers to the understanding that the knowledge of teachers, besides including concepts as isolated elements, must integrate them into a system of connections, which allows the teacher to understand certain advanced concepts from an elementary perspective and develop certain concepts from an advanced perspective.

KPM covers aspects related to mathematical thinking, such as knowledge of the different ways of defining, arguing or proving in mathematics, as well as knowledge of mathematical syntax. The teaching action involves the knowledge of how this teaching can and should be developed, so the KMT contemplates knowledge as knowing different teaching strategies that allow the teacher to foster the development of procedural and conceptual mathematical capacities. In the same way, this

subdomain predicts that the teacher needs to know examples that awaken the intuition in the student about some concepts, as well as resources that allow the teacher to induce his students to learn, through manipulation, certain mathematical concepts. Knowing how students learn mathematical content is knowledge that every teacher should possess. Thus, KFLM encompasses the knowledge of the characteristics of the process of understanding the different contents by the students, the errors, difficulties and obstacles associated with each concept and the language used by students in relation to the concept worked in the classroom. The KMLS refers especially to the teacher's knowledge of the curriculum adopted by the institution in all stages / levels of education. This knowledge can be complemented with information present in the productions originating from research in the area of mathematics education, with information provided by experienced teachers about the expected learning in each stage (For further deepening and detailing the subdomains see Carrillo *et al.* 2013, Flores-Medrano *et al.*, 2016 , Carrillo *et al.* 2017).

The context of the study: The PROFMAT

PROFMAT is a teacher training program promoted by the Brazilian Federal Government and developed in partnership with 96 higher education institutions (universities and colleges) that train teachers of mathematics (lower and upper secondary), organized in the format of professional **masters**. This program has a length of 2 years and is basically composed of a list of 9 subjects, each with a 120-hour workload. Of these, 7 of them are considered as mandatory and titled "Real Numbers and Functions", "Discrete Mathematics", "Arithmetic", "Geometry", "Problem Solving", "Calculus Fundamentals" and "Analytical Geometry". The "elective" disciplines can be chosen by students from the following list: Topics of Mathematics History; Topics of Number Theory; Introduction to Linear Algebra; Differential and Integral Calculus Topics; Mathematics and Actuality I; Mathematical Modeling; Algebraic Polynomials and Equations; Spatial Geometry; Topics of Mathematics; Probability and Statistics; Educational Evaluation; Numerical Calculation; Mathematics and Actuality II. The final course work refers to the production, by the academic under the guidance of a university professor, of a product/work that can be presented in different formats (dissertation, literature review, article, patent, applications, teaching and instructional materials , media programs) and that addresses topics relevant to the Mathematics curriculum of Basic Education and promotes the impact on didactic practices in the classroom.

These disciplines are based on the collection of textbooks entitled "PROFMAT Collection", whose elaboration is the responsibility of mathematicians, and each discipline is based on a textbook from the collection, which is adopted by all 96 institutions where PROFMAT is developed.

Here we focus on analyzing and discussing one of the elements that make up the teacher training process developed in the scope of PROFMAT from the analytical model MTSK. However, the analyzes presented here are part of a project that has analyzed a multiplicity of elements of the PROFMAT: policy texts, textbooks that guide the training activities; class episodes; and PROFMAT academic productions (answers to questionnaires, works, etc.).

In this analysis, we classify all the contents that compose the textbooks (definitions, axioms, theorems and demonstrations, properties, activities, exercises, explanations, etc.), from the subdomains of the MTSK framework, with the objective of identifying the presence and absence of knowledge related

to the teacher's practice in mathematics teaching, as proposed by Carrillo and contributors (Carrillo *et al.*, 2013, Flores-Medrano *et al.*, 2016, Carrillo *et al.*, 2017, Carrillo *et al.*, 2018).

It is highlighted in this scenario that, through the following discussion presented, we will seek to note indications of the nature of the knowledge disseminated by PROFMAT, since the knowledge produced from a textbook depends on the manipulation that is made of this didactic material, particularly, the manipulation developed by the teacher who uses it.

Due to limitations of space, we focus here on two chapters of one of the textbooks used in PROFMAT called "real numbers and functions" (which describes the work developed in the mandatory subject that has the same name). We chose to analyze this textbook because it guides the teaching activities of one of the four compulsory subjects developed during the course of the PROFMAT, besides addressing mathematical themes that permeate themes also common to the school curriculum, such as numerical sets and functions (NCTM, 2000). In this analysis, we will focus on "Natural Numbers" and for the analysis, we use MTSK as a theoretical lens as a way of discussing the nature and focus of such a course. With this, in the sequence, we will present some representative examples of the analyzes that we developed.

Analysis and discussion

The textbook "Real Numbers and Functions" (Lima, 2013) is structured from the following sequence of themes (chapters): Sets; Natural Numbers; Cardinal Numbers; Real Numbers; Related Functions; Quadratic Functions; Polynomial Functions; Exponential and Logarithmic Functions; Trigonometric Functions. This organization is justified by the author, who states "Mathematics deals primarily with numbers and space. Therefore, the sets most frequently found in Mathematics are numerical sets, geometric figures (which are sets of points) and the sets that derive from them, such as the function sets, those of matrices" (Lima, 2013, pp. 02). This structure presents opportunities for the development of MK, in particular KSM, by teachers in training, since it favors the (potential) development of connections between the numerical sets and functions that establish relations between subsets of \mathbb{R} .

The chapter "Natural Numbers" is initiated by the author with a description of the meaning of the term "numbers" as being "abstract entities, developed by man as models that allow to count and measure, therefore to evaluate the different quantities of a magnitude" (Lima, 2013, pp. 22). "Mathematical definition" is described as "a convention consisting of using a name, or a brief sentence, to designate an object or property, the description of which would normally require the use of a longer sentence" (Lima, 2013, pp. 23), axiom and primitive concept. These descriptions can be associated with MTSK by means of KPM, as it returns to the fundamentals associated with mathematical proceedings.

The author also presents a description of the axiomatic method and in relating it to the school argues that "[...] it is not appropriate to present Mathematics in an axiomatic form. But it is necessary for the teacher to know it can be organized in the manner outlined above "(Lima, 2013, pp. 23). As this fragment shows, the author argues that it is necessary for the teacher to know that mathematics can be organized in the axiomatic form (KPM), but it does not elucidate, for example, why it is necessary

for the teacher to know this form of mathematical exposition (KoT), nor "how" (KMT) and "when" (KMLS) this method would aid in the teaching of mathematics.

Lima (2013, pp. 26) links natural numbers to historical aspects (potential indications of KPM) by saying that "Slowly, to the measure that it has become civilized, mankind has taken over this abstract model of counting (one, two, three, four, ...) which are the natural numbers". The author also argues that, currently, the set of natural numbers can be described as "concise" and "precise" by Peano's theory, which states that "N is a set, whose elements are called natural numbers. The essence of the characterization of N lies in the word "successor" (if $n, n' \in N$, then n' is the successor of n means that n' comes soon after n , there being no other natural numbers between n and n'), which is considered a primitive concept because it is not explicitly defined. The author then mentions that "everything" about natural numbers "can be demonstrated" from Peano Axioms¹.

According to Lima (2013, pp. 27), "an ingenious process, called a decimal number system, allows us to represent all natural numbers with the help of the symbols 0, 1, 2, 3, 4, 5, 6, 7, 8 and 9. In addition, the first natural numbers have names: the successor of number one is called two, the successor of two is called three, etc." This presentation of decimal numbering systems can be linked to KoT (knowing the set) on the one hand, and on the other, to KPM (knowing the role of the successor and the associated mathematical structure – e.g., continuity, density). Meanwhile, the author avoided discussing, for example, the different aspects of the mathematical knowledge underlying the construction and use of the decimal system (KoT), such as the notion of grouping, the language involved in the reading of numbers and the idea of positional value (KoT; KPM). In this case, it is important to highlight the lost opportunity for elaborating some discussions on, for example, the resources and examples in and for teaching such topic (KMT), concerning the students' difficulties (KMLM) and the content of the official documents (KMLS).

Lima (2013, pp. 27) then argues that the set $N = \{1, 2, 3, \dots\}$ is a "sequence of abstract objects that are, in principle, empty of meaning" and that "each of these objects has only one place determined in this sequence". Since "Every number has a (single) successor and, with the exception of 1, it also has a single predecessor. Viewed in this way, we can say that natural numbers are ordinal numbers: 1 is the first, 2 is the second, etc.". In this fragment, Lima presents a powerful scenario for an exploratory work of KoT (when discussing the definition of natural numbers); however, although the author recognizes that the objects of the sequence of natural numbers are abstract and are in principle empty of meaning, he does not discuss, for example, what the teacher's work could be in addressing this content in the school environment (PCK), in addition to the symbol of "..." being placed in the representation of the set of natural numbers, but without making any comment about the meaning of this symbol (KoT and KPM). Lima also does not present indicatives of "how" (KMT) and "when" (KMLS) Peano axioms could be addressed in math classes at school.

¹ I) Every natural number has a single successor; II) Different natural numbers have different successors; III) There is a single natural number, called one and represented by the symbol 1, which is not a successor to any other; IV) X is a set of natural numbers (that is, $X \subset N$). If $1 \in X$ and if, in addition, the successor of every element of X still belongs to X, then $X = N$.

The author also defines the "fundamental" operations among natural numbers, and the addition of numbers $n, p \in \mathbb{N}$ corresponds with the sum " $n + p$ " and multiplication associates the product " np " (Lima, 2013). It also re-elaborates them in such a way as to present the sum " $n + p$ " as "the natural number that is obtained from applying n p times following the operation of taking the successor", so that " $n + 1$ is the successor of n , $n + 2$ is the successor of the successor of n , etc." (Lima, 2013, pp. 29) and presents, as an example, the addition of $2 + 2 = 4$, where " 4 is the successor of the successor of 2 ". For the product and defined as $n \cdot 1 = n$ and, when $p \neq 1$, " np is the sum of p plots equal to n ". In this context, it is argued that "until we know how to use natural numbers to make counts, there is no point in speaking in 'p times' and 'p plots'. Therefore, fundamental operations must be defined by induction" (Lima, 2013, pp. 29). In the following, Lima defines Addition and Multiplication by induction (KPM - from a level of knowing how to perform). However, the operations are not linked to the practices of mathematics teachers, which could have been done by discussing how these operations are approached in the school curriculum (KMLS), what kind of resources - and their intentionality - could be used to explore such operations with students (KMT) in order to understand what they do and why; and the students learning processes linked to understanding multiplication mainly as a solely repeated additions (KFLM).

In addition, the author constructs the set of natural numbers and only two of their operations (addition and multiplication), omitting the definition of the operations of subtraction and division between natural numbers (KoT), which are also used by teachers in school. The author also does not link the definitions of addition and multiplication (and consequently of subtraction and division) to the algorithms commonly used by school materials (KMLS) and used in calculating these operations (KoT). Another relevant observation refers to the non-linking of this work with one of the main practices of the Mathematics teacher, to give meaning to the operations among the natural ones through problem situations and problem history (KMT).

In addressing the Natural Numbers, Lima (2013) presents the order relationship between natural numbers in terms of addition ("Given $m, n \in \mathbb{N}$, it is said that m is less than n , and we write $m < n$ to mean that there is some $p \in \mathbb{N}$ in which $n = m + p$ ") and presents the properties of Transitivity, Trichotomy, Monotonicity of Addition and Multiplication, and Good Ordination. This fragment highlights the potential of the work in the development of KoT and KPM. However, the author does not present any indication of discussions regarding PCK subdomains.

In the thread of the work the author presents and demonstrates properties of \mathbb{N} : Associative property of Addition, Commutative property of Addition, Distributive property, Commutative property of Multiplication, Cancellation Law for Addition, Transitive Order Relationship, Trichotomy, Monotonicity, Cancellation Law for Inequalities and the Principle of Good Ordination. Lima argues that the adoption of this approach was because it expresses "[...] some basic facts about natural numbers, which are used very often, most of the time without us stopping to ask how to prove them." He argues further that the "[...] objective is to show how such facts result from Peano axioms. There is no creative reasoning or elaborate methods to prove them. In all demonstrations, the central role is played by the Induction Axiom" (Lima, 2013, pp. 31).

This approach of N properties again highlights the potential of the material in relation to the development of KoT and KPM. However, at no point in the work does the author present any discussion that may be associated with the development of PCK. For example the author does not discuss, whether these demonstrations are accessible to students of basic education, whether they need to be adapted (KMT) to become accessible to school students (KFLM) and in which years it is possible to use them (KMLS).

Final comments

The developed analyses of a textbook that guides the formative practice in a discipline of PROFMAT show indications of the nature of the knowledge disseminated through this public policy of continuous training of teachers that aims to impact the quality of the learning of Brazilian students. Thus, based on the MTSK, it was found that elements of MK are considerably favored, particularly those associated with properties and definitions (KoT) and mathematical practice (KPM), such as the forms of validation and demonstration and the use of formal language. On the other hand, this material presents very few indications of the presence of knowledge related to the PCK, such as those related to the characteristics of the teaching (KMT) and learning (KFLM) of Natural Numbers and how this content is included in the school curriculum (KMLS).

The results presented provide us with indications that this public policy favors only part of the knowledge taken by the literature (Carrillo *et al.*, 2013; Flores-Medrano *et al.*, 2016; Carrillo *et al.*, 2017; Scheiner *et al.*, 2017; Carrillo *et al.*, 2018) as essential for the practice of the mathematics teacher in school. With this, it is possible to affirm that PROFMAT will not be able to fully achieve the objectives it proposes, which is to change the mathematical education of the country qualitatively and quantitatively, especially if we consider that the work developed in this program follows rigid evaluation standards that are guided by the textbooks (see Caldatto, 2015, Caldatto, Pavanello & Fiorentini, 2016).

References

- Ball, D., Thames, M., & Phelps, G. (2008). Content knowledge for teaching: What makes it special? *Journal of Teacher Education*, 59(5), 389-407.
- Ball, D. L., Lubienski, S., & Mewborn, D. (2001). Research on teaching mathematics: The unsolved problem of teachers' mathematical knowledge. In RICHARDSON, V. (Ed.), *Handbook of research on teaching*. 4a ed. New York: Macmillan, pp. 433-456.
- Brazilian Society of Mathematics (BSM) (2017). *PROFMAT: a reflection and some results*. BSM, Rio de Janeiro.
- Caldatto, M. E. (2015). The PROFMAT Program and Mathematics Teacher Education: a curricular analysis from a procedural and decentralizing perspective. *Tesis* (doctorate degree in Education for Science and Mathematics). State University of Maringá, Maringá.
- Caldatto, M. E., Pavanello, R. M., & Fiorentini, D. (2016). The PROFMAT Program and Mathematics Teacher Education: a curricular analysis from a procedural and decentralizing perspective. *Bolema* [online], 30 (56), 906-925.

- Carrillo-Yañez, J., Climent, N., Montes, M., Contreras, L. C., Flores, E., Escudero, D., Mora, D. V., Rojas, N., Flores, P., Aguillar, A., Ribeiro, M., & Munoz-Catalan, M. C. (2018). The Mathematics Teacher's Specialised Knowledge (MTSK) Model. *Research In Mathematics Education*, 1-18.
- Carrillo, J., Climent, N., Contreras L. C., & Muñoz-Catalán, M. C. (2013). Determining specialised knowledge for mathematics teaching. In B. Ubuz, Ç. Haser & M. Mariotti (Eds.), *Proceedings of the Eighth Congress of the European Society for Research in Mathematics Education* (pp. 2985–2994). Antalya, Turkey: ERME.
- Carrillo J., Climent, N., Contreras, L. C., & Ribeiro, M. (2017). Mathematics Teacher's Specialized Knowledge (MTSK) in the “dissecting an equilateral triangle” problem. *RIPEM*, 7(2), 88-107.
- Flores-Medrano, E., Montes, M. A., Carrillo, J., Contreras, L. C., Muñoz-Catalán, M. C. & Liñán, M. M. (2016). El Papel del MTSK como Modelo de Conocimiento del Profesor en las Interrelaciones entre los Espacios de Trabajo Matemático. *Bolema*, 30(54), 204- 221.
- Kleickmann, T., Richter, D., Kunter, M., Elsner, J., Besser, M., Krauss, S., Cheo, M., Baumert, J. (2015). Content knowledge and pedagogical content knowledge in Taiwanese and German mathematics teachers. *Teaching and Teacher Education*, 46, 115-126.
- Lima, E. (2013). *Real Numbers and Functions* (PROFMAT Collection). Rio de Janeiro: BSM.
- NCTM. (2000). *Principles and standards for school mathematics*. Reston: National Council of Teachers of Mathematics.
- Rowland, T., & Turner, F. (2007). Developing and Using the ‘Knowledge Quartet’: A Framework for the Observation of Mathematics Teaching. *The Mathematics Educator*, 10(1), 107-123.
- Scheiner, T., Montes, M. A, Godino, J. D., Carrillo, J., & Pino-Fan, L. R. (2017). What Makes Mathematics Teacher Knowledge Specialized? Offering Alternative Views. *International Journal of Science and Mathematics Education*, 16(90), 1-20.
- Shulman, L. (1986). Those who understand: Knowledge growth in teaching. *Educational Researcher*, 15(2), 4-14.
- Stylianides, A. J., & Ball, D. L. (2004). Studying the mathematical knowledge needed for teaching: The case of teachers' knowledge of reasoning and proof. *Annual Meeting of the American Educational Research Association*, San Diego.
- Stylianides, A. J., & Stylianides, G. J. (2014). Viewing “mathematics for teaching” as a form of applied mathematics: Implications for the mathematical preparation of teachers. *Notices of the American Mathematical Society*, 61(3), 266–276.

Prospective primary teachers' knowledge about the mathematical practice of defining

Myriam Codes¹, Nuria Climent¹ and Isabel Oliveros¹

¹ University of Huelva, Huelva, Spain

myriam.codes@ddi.uhu.es, climent@uhu.es, isabeloliverosescobar@gmail.com

This study concerns the knowledge of two prospective primary teachers about the mathematical practice of defining. Starting with their analysis of a video recording of a primary lesson on constructing a definition of a polygon, the trainees discussed what it means to define in mathematics. Through analysis of the content of this discussion, we identified what they considered to be the nature of this practice and the features they felt a good definition should embody. The findings demonstrate that students tend to consider demonstrations as the touchstone of mathematical practice, and that they do not consider the use of examples as a valid element of formal mathematics. At the same time, they recognize that definitions must meet the criteria of hierarchy and minimality but see no need for the criteria of existence and arbitrariness.

Keywords: Teachers' knowledge, mathematical practice, defining, student teacher.

Introduction

Defining is a common practice in mathematics classes at all levels but is something not always dealt with in all its facets: establishing the necessary and sufficient conditions of a concept, preferably the minimum necessary, using only previously defined concepts without utilising the word assigned to the concept in the definition itself (Zazkis & Leikin, 2008).

What is more, definitions can be arbitrary, in the sense that concepts can be defined in different ways according to the particular aspect one wishes to foreground. This arbitrariness can disconcert students (Vinner, 1991), and it is the teacher's job to manage such uncomfortable facts of mathematical life and decide when his or her students are ready to meet them.

Involving students in the process of defining promotes the construction of knowledge (Edwards & Ward, 2008; Leikin, Berman & Zaslavsky, 1998; Villiers, 1988). Regardless of whether the teacher decides to tackle certain aspects of defining (such as their arbitrariness) with their students at a particular moment, if he or she wants them to generate definitions for themselves rather than memorise given definitions, they will necessarily have to learn how to define in mathematics. Hence, achieving a certain depth of understanding regarding the meaning of the practice of defining, the characteristics of a good definition and the role it plays in mathematics learning enables the teacher to base their classroom practice on sound foundations. In this respect, Zazkis and Leikin (2008) regard teachers' conceptions of the notion of defining as a fundamental requirement for successful teaching.

In this paper, we describe two prospective primary teachers' knowledge about the notion of defining in mathematics, based on their discussion of a video. This understanding forms a part of their knowledge of practices in mathematics, as we explain in the theoretical framework below.

Theoretical framework

Defining, like demonstrating or arguing, is one of the basic elements of the work of mathematics. We can say, then, that these elements form a part of mathematics practice, in the sense that they allow us to do mathematics. Knowledge of practices in mathematics supposes knowledge of the syntax of mathematics consistent with Schwab (1978). A teacher's knowledge of practices in mathematics (henceforth KPM), together with their knowledge of topics and the structure of mathematics constitute the mathematical knowledge which in the *Mathematics Teacher's Specialised Knowledge* model (MTSK) is considered necessary for teaching the subject (Carrillo-Yañez et al., 2018). In addition to mathematical knowledge, the model takes account of the domains of pedagogical content knowledge and beliefs about mathematics and mathematics teaching and learning. However, in this study, we deal with neither prospective teachers' beliefs nor pedagogical content knowledge.

Understanding the notion of defining involves recognition of the role that definitions play in mathematics and the characteristics they embody, or at least it is desirable for them to embody (Zaslavsky & Shir, 2005). Zaslavsky & Shir (2005) suggest the following features as characteristic of a good definition:

... a mathematical definition must be *noncontradicting* (i.e., all conditions of a definition should coexist) and *unambiguous* (i.e., its meaning should be uniquely interpreted). In addition, there are some features of a mathematical definition that are imperative only when applicable: A mathematical definition must be *invariant* under change of representation; and it should also be *hierarchical*, that is, it should be based on basic or previously defined concepts, in a *noncircular* manner. (Zaslavsky & Shir 2005, p. 319)

Van Dormolen and Zaslavsky (2003) offer logically necessary criteria for a good definition, among others, the criterion of hierarchy (it should be described as a special case of a previously determined more general concept). In contrast to Zaslavsky and Shir (2005), the former regard hierarchy as a necessary characteristic. In addition to this feature, they include the criteria of existence (there must be proof of the existence of at least one instance of the new concept), equivalence (where more than one definition exists, they must be demonstrated to be equivalent), and axiomatization (it should fit into a deductive system such that when one reaches the point where the criterion of hierarchy can no longer be applied, we can resort to axioms or postulates).

There are other features for which there is a lack of agreement as to whether they are necessary or not. Foremost among these is the criterion of minimality.

A definition is considered minimal if it is economical, with no superfluous unnecessary conditions or information. That is, a minimal definition should consist only of information that is strictly necessary for identifying the defined concept. (Zaslavsky & Shir, 2005, p. 320)

A study by Leikin and Winicki-Landman (2000) involving secondary teachers highlights the rigour of a definition, although from a pedagogic point of view, other features are underlined, such as the definition being intuitive, being written clearly enough for the students to grasp with ease, combining what they already know with what they need to know, being appropriate for solving problems and

enabling generalisations to be made. Relaxing the rigour with which one applies the criterion of minimality tends to be motivated by pedagogical considerations.

There have been various studies into teachers' and prospective teachers' notions of what constitutes a mathematical definition. These have found, among other things, that prospective teachers do not always know the difference between a theorem and a definition (Leikin & Zazkis, 2010) and are sometimes unaware of the arbitrariness of definitions in geometry (Linchevsky, Vinner & Karsenty, 1992).

Escudero, Gavián and Sánchez-Matamoros (2014), in their study about prospective primary teachers, describes various ways in which they understand what a mathematical definition is and tracks the changes in this understanding. From this progression, from naming to giving a list, from naming to giving a list of minimal features, and from giving a list of features to equivalent definitions, the authors infer the assimilation of some of the criteria of mathematical definitions discussed above. In particular, the recognition of minimality and equivalence is indicative of a more advanced understanding of what constitutes a mathematical definition. Elsewhere, Sánchez and García (2014), again with prospective primary teachers, find potential points of conflict between criteria associated with mathematical definitions (understood within the study as mathematical norms) and sociomathematical norms. For example, minimality comes into conflict with the sociomathematical norm which requires students to explain themselves as fully as possible in response to a classroom task, or that they should make use of all the data and properties in a figure. Conflicting requirements such as these could account for the difficulty which students experience with some of the mathematical attributes.

Data collection and analysis

In Spain, the initial education for teachers on Primary Education corresponds to a four-year degree. Then they can obtain a general teaching graduate or specific on sports, music, foreign language or special education. At the University of Huelva, for each year, a compulsory Mathematic subject is planned. These subjects deal with content knowledge and pedagogical content knowledge about problem solving (first year), numbers and arithmetics (second year), statistics and measurements (third year) or geometry (fourth year). In these subjects, some concepts are reviewed in depth with regards to the Knowledge of Practices in Mathematics, like heuristics to solve Mathematical problems, proofs, types of proofs, and language and notation role.

This study takes the form of a one-on-one teaching experiment (Cobb & Gravemeijer, 2008) in which three prospective primary teachers trialled activities ultimately intended for use with a group of primary trainees on the subject Mathematics Education: Geometry. The participants' selection was intentional because of their particular disposition towards reflection on mathematics teaching and learning, and their sound knowledge of mathematics. We make use of only two participants' data in this paper; they will be called Ismael and Ramón. At the time of the study, they both were in the third year of their degree, so they have not taken the subject on Geometry. The purpose behind the choice of these particular students was to measure the development potential of the activities in a favourable environment.

Here we focus on the first part of the teaching experiment, in which the prospective teachers individually watched and analysed a video recording of an actual primary lesson. After writing their individual impressions, which they handed in to the teacher educators, the group came together to discuss the lesson, with one of the educators/researchers in the role of moderator.

The video analysed by the trainees featured a year 5 primary group (11 years old), in which their teacher introduced the topic of defining polygons by showing the pupils a bag with polygons and non-polygons shaped cards. The lesson was conducted as a whole-class activity, with pupils going up to the board one by one to take a figure from the bag and place it in one of two groups (they could create two groups, without being given any previous criteria). The teacher expected the pupils to apply the criteria “is a polygon”. The classification task formed the basis of the follow-up activity in which the class constructed a definition of polygon together. This video has been chosen as it exhibits the mathematical practice of defining and it allows us to show teacher’s knowledge about this practice. One of the objectives of this activity (the analysis of the Primary education class), is that future teachers must do a reflection about what is a definition within a mathematical context and which characteristics a mathematical definition could have.

The research question we are intending to respond to, is which knowledge about the mathematical practice of defining both prospective primary teachers (henceforth PPTs) show.

Data to solve the research question come from the individual analysis document of the PPTs and the transcription of the oral discussion (audio recorded). The units we will show belong to the discussion transcription. In this discussion and also for everything concerning to knowledge about the practice of defining, the main objective of the researcher and moderator is, for the first instance, to make the PPTs to glimpse their ideas. During the individual PPTs analysis, some comments came up concerning to characteristics of the definition built in the Primary lesson (e.g. “they have repeated elements”). The most frequent questions to the PPTs (during the discussion of their individual analysis) focused on their interpretation of the definition practice. Consequently, the responses showed which characteristics the PPTs linked to a mathematical definition.

The group discussion of the video was itself audio-recorded and subsequently transcribed. Below we analyse the transcript in terms of the elements discussed in the theoretical framework, essentially the features of a good mathematical definition. Therefore, we made a content analysis in which we selected those fragments in which PPTs considered the mathematical practice of defining developed in the Primary lesson and they related the features associated to a mathematics definition. We connected these fragments to the characteristics of a mathematics definition from the theoretical framework. This analysis is first undertaken by each researcher individually and afterwards jointly agreed. This process let us build our common explanation from our observation.

Knowledge of the mathematical practice of defining

One of the aspects which two of the prospective teachers focus on in their analysis is mathematical definitions, and in particular the role of examples in constructing a definition:

Educator: What do you think is the aim of the first task?

- Ismael: ...what he's looking for is the definition, what's happening is that he's starting from examples so that they see the differences between what it [a polygon] is and what it isn't.
- Educator: What do you think about the fact that he starts from examples to get there, to get them to construct the definition of a polygon?
- Ismael: As an item of mathematics, it is not mathematically correct to construct a definition from examples. [...] Maybe it's good in terms of getting the pupils to understand, but not in terms of mathematics.
- Ramón: Is it more correct or less correct in mathematical terms? Yeah, starting from examples could be less correct, but for primary children it's an introduction. And besides, in our lessons when we do demonstrations what do we do first? Try a few numbers to see and then afterwards do the demonstration well.

Ismael appeals to the argument of *rigour* which features in the literature in contradistinction to pedagogical considerations (Leikin & Winicki-Landman, 2000; Zazkis & Leikin, 2008). In his view, the use of examples does not meet the standards of rigour demanded by mathematics, but justifies their use for the pedagogical advantage they afford in making a mathematical concept accessible to the primary pupils. Ramón concurs, criticising the use of examples to construct a definition. Both prospective teachers settle on demonstrations as a prototypical practice of formal mathematics, and, aware that in formal mathematics it is not considered valid to perform a demonstration via examples, they extrapolate the proscription to definitions. The use of examples is not intrinsic to formal mathematics. It can serve to make a mathematical object accessible, such as the rubric in demonstrations, but it is not a rigorous procedure.

Both the prospective primary teachers (henceforth PPTs) seem to dispense with the *criterion of existence* for definitions, whereby examples serve as proof of the existence of at least one mathematical object fulfilling the definition.

However, at another point in the debate, Ramón appraise the use of examples to define a mathematical concept, in reference to the examples given by the cardboard cut-out figures:

- Ramón: If the pupils are given a figure with edges, how are they going to know what is inside and what is outside?

The PPTs insist that a new mathematical concept should be generated on the basis of differentiating the properties of pre-existing concepts (*the criterion of hierarchy*), while also making a contrast with properties the concepts do not have. In other words, it is not sufficient to present images (examples) which illustrate the properties of a concept, rather it is necessary to include images which illustrate these very properties by their absence. In this way, a deeper understanding is achieved of the concept being defined. This appraisal might also be associated by the PPTs with the pedagogical advantages it affords more than with mathematical practice itself.

The *criterion of arbitrariness* does not seem to be considered by the prospective teachers, who, it would seem, believe that mathematical concepts can have only one formal definition. Accordingly,

in the following turn, Ramón gets impressed by how the definition built in the primary school classroom is so exact (to which he believes is the unique right definition):

Ramón: [...] the idea of the activity is that they do the classifying, as if polygons had never been classified before and they were doing it for the first time, so that they realise that the classification system they come up with is similar to the actual one. [...] It surprised me how well they managed it, coming up with a definition from examples, that primary children can make such identical definition simply from examples.

On the other hand, the prospective teachers do recognize the *criterion of minimality* as a desirable attribute of a mathematical definition, when they come to consider the wording of the definition the class finally agree on (a polygon is *a flat shape, it has angles, it has vertices, it has straight sides and no curves; all the sides are joined at the end*):

Ramón: It made me laugh when they put in the definition “it has straight sides and no curves,” it’s the same thing.

Educator: Would you have cut that out?

Ramón: At the end of the recording, one pupil says that not having any curved lines is the same as having all the sides straight, and it wasn’t necessary to say both things.

Ismael: I think that if that’s the first time they’ve done this and the children have reached that conclusion, then it’s fine, even if it’s redundant. I’d leave it like that, and then next time we did the topic I’d suggest we cut out that bit. You work on it a bit so it looks a bit more like the definition we have.

Discussion and conclusions

The prospective teachers involved in this study seem to identify formal mathematics practices with the practice of demonstrating. Their touchstone in this regard is mathematical rigour, which exerts its influence over the practice of defining. In particular, the use of examples falls short of the demands of rigour, and can be justified only on pedagogical grounds or as a means of making a mathematical object more accessible before defining it formally. They recognise that a mathematical definition should meet the criteria of hierarchy and minimality, whilst they do not see the need for the criteria of existence or arbitrariness. This lack of recognition of the criterion of arbitrariness mirrors the results of other studies (Linchevsky, Vinner & Karsenty, 1992). The prospective teachers also tend to regard the practice of defining as supplying a list of minimal features, a result consistent with the findings in Escudero, Gavilán and Sánchez-Matamoros (2014).

In the course of the PPTs’ debate about the essential features of a good definition, they frequently consider pedagogical criteria over mathematical considerations about a good definition. This posture is consistent with the professional profile of primary teacher and coincides with practices observed at other levels of education (Leikin & Winicki-Landman, 2000; Zazkis & Leikin, 2008).

These findings are particularly relevant to the context of developing teaching strategies for training prospective teachers in terms of their knowledge of practices in mathematics, specifically in this instance the nature of definitions. In particular, with respect to the initial training provided for

prospective primary teachers at the university in which the study was carried out, there is cause for rethinking the role given to demonstrations, as their pre-eminence on the syllabus vis-à-vis other practices seems to be leading students to regard it as the touchstone of mathematical practices.

At the same time, before their initial training, the prospective teachers have little knowledge of formal mathematics as the mathematical knowledge they know is with regards to scholar mathematics. Taking the opportunity presented by their training to approach the nature of different mathematical practices should enable them to develop a more advanced view of what constitutes mathematics, building a bridge between school and advanced mathematics (issue that is also addressed in Crisan, 2019, February). The transition, however, from knowledge based on intuitions to that based on formal definitions and their features is not without its challenges (Bampili, Zachariades & Sakonidis, 2017).

In this paper, we have focused our analysis on the knowledge of two prospective primary teachers about the mathematical practice of defining, although data also reveal their conceptions about mathematics and about teaching and learning. The video recording was used as a starting point to reflect on the mathematical practice of defining and to validate this practice inside school mathematics. It might be considered the relationship between the selected video and the knowledge that prospective primary teachers have shown, for example, the fact that the polygon definition was built from polygon and non-polygon examples in the context of a primary school classroom. For future work, we will investigate on these issues. Also, we will consider extending this study to prospective kindergarten teacher and secondary teacher, in order to design task to strengthen their knowledge about the mathematical practice of defining.

Acknowledgement

This study was funded by the University of Huelva, within the project *The development of teaching material based on analysis of good practice in the primary mathematics classroom*.

References

- Bampili, A. C., Zachariades, T., & Sakonidis, C. (2017). The transition from high school to university mathematics: A multidimensional process. In T. Dooley & G. Gueudet (Eds.), *Proceedings of the Tenth Congress of the European Society for Research in Mathematics Education (CERME10, February 1-5, 2017)*. Dublin, Ireland: DCU Institute of Education and ERME.
- Carrillo-Yañez, J., Climent, N., Montes, M., Contreras, L. C., Flores-Medrano, E., Escudero-Ávila, D.; Vasco, D.; Rojas, N.; Flores, P.; Aguilar-González, A.; Ribeiro, M. & Muñoz-Catalán, M. C. (2018). The mathematics teacher's specialized knowledge (MTSK) model. *Research in Mathematics Education*, 20(3), 236-253. doi:10.1080/14794802.2018.1479981
- Cobb, P., & Gravemeijer, K. (2008). Experimenting to support and understand learning processes. In A. E. Kelly, R. A. Lesh, & J. Baek (Eds.), *Handbook of design research Methods in Education. Innovation in Science, technology, Engineering and Mathematics Learning and Teaching* (pp. 68–95). Mahwah, NJ: Lawrence Erlbaum Associates.
- Crisan, C. (2019, February) *Empowering teachers conceptually and pedagogically through supporting them in seeing connections between school mathematics and relevant advanced*

mathematics knowledge. Paper presented at the Eleventh Congress of the European Society for Research in Mathematics Education CERME11, Utrecht, Netherlands.

- Edwards, B., & Ward, M. (2008). The role of mathematical definitions in mathematics and in undergraduate mathematics courses. In M. Carlson & C. Rasmussen (Eds.), *Making the connection: Research and teaching in undergraduate mathematics education* (pp. 223-232). Washington, DC: Mathematical Association of America. doi:10.5948/UPO9780883859759.018
- Escudero, I., Gavilán, J. M., & Sánchez-Matamoros, G. (2014). Una aproximación a los cambios en el discurso matemático generados en el proceso de definir. *Revista Latinoamericana de Investigación en Matemática Educativa*, 17(1), 7–32.
- Leikin, R., Berman, A., & Zaslavsky, O. (1998). Definition of symmetry. *Symmetry: Culture and Science*, 9(2/4), 375–382.
- Leikin, R., & Winicki-Landman, G. (2000). On equivalent and non-equivalent definitions: Part 2. *For the Learning of Mathematics*, 20(2), 24–29.
- Leikin, R., & Zazkis, R. (2010). On the content-dependence of prospective teachers' knowledge: A case of exemplifying definitions. *International Journal of Mathematical Education in Science and Technology*, 41(4), 451–466.
- Linchevsky, L., Vinner, S., & Karsenty, R. (1992). To be or not to be minimal? Student teachers' views about definitions in geometry. In W. Geeslin, & Graham(Eds.), *Proceedings of the 16th conference of the international group for the psychology of mathematics education, vol. 2* (pp. 48–55). Durham, NH: PME.
- Sánchez, V., & García, M. (2014). Socio-mathematical and mathematical norms related to definition in pre-service primary teachers' discourse. *Educational Studies in Mathematics*, 85(2), 305–320.
- Schwab, J. (1978). Education and the structure of the disciplines. In I. Westbury, & N. Wilkof (Eds.), *Science, curriculum and liberal education: Selected essays* (pp. 229–272). Chicago, IL: University of Chicago Press.
- Van Dormolen, J., & Zaslavsky, O. (2003). The many facets of a definition: the case of periodicity. *Journal of Mathematical Behavior*, 22, 91–106.
- Villiers, M. (1988). To teach definitions in geometry or teach to define? In A. Olivier & K. Newstead (Eds.), *Proceedings of the Twenty-second International Conference for the Psychology of Mathematics Education: Vol. 2*. (pp. 248–255). University of Stellenbosch: Stellenbosch.
- Zaslavsky, O., & Shir, K. (2005). Students' conceptions of mathematical definition. *Educational Studies in Mathematics*, 36(4), 317–346.
- Zazkis, R., & Leikin, R. (2008). Exemplifying definitions: a case of a square. *Educational Studies in Mathematics*, 69(2), 131–148.

Empowering teachers conceptually and pedagogically through supporting them in seeing connections between school mathematics and relevant advanced mathematics knowledge

Cosette Crisan

UCL Institute of Education, University College London, UK; c.crisan@ucl.ac.uk

Since ‘advanced mathematics knowledge’ (AMK) was first conceptualized by Zaskis and Leikin (2009), researchers have striven to determine whether teachers’ ability to identify explicit connections between AMK and the mathematics taught in school is a rare gift of only a few teachers or whether specific prompting is needed to develop this ability in teachers. In this paper we provide empirical evidence showing that those teachers who attended a CPD designed to support them to ‘see’ and make explicit such connections, have increased their awareness of the implications for the teaching and learning of school mathematics topics in ways that allow for creating a solid foundation for development of further, more advanced ideas in the school mathematics curriculum. We thus propose that any mathematics teacher, irrespective of their academic background, could benefit from professional development opportunities where explicit guidance is provided in terms of the relevant AMK and how it informs school mathematics teaching and learning.

Keywords: Advanced mathematics knowledge, mathematics knowledge for teaching, specialized knowledge, continuous professional development (CPD).

Introduction

There is agreement amongst researchers all over the world that teachers need to have both subject knowledge of mathematics per se, and mathematical knowledge for teaching in order to teach effectively. There is also agreement that teachers must know in detail the school mathematics they are expected to teach and a bit more, beyond the level they are assigned to teach. But ‘how much more?’ and ‘More of what?’

This body of *more* mathematics knowledge acquired through studying mathematics beyond school level is referred to in literature as ‘academic mathematics’ or ‘advanced mathematics’. Moreira and David (2008) refer to academic mathematics as that large part of the mathematics that a ‘major’ of mathematics is required to learn and which consists of that “scientific body of knowledge as produced and organized by the professional mathematicians” (p. 24). Similarly (and somehow a more influential terminology) is Advanced Mathematical Knowledge (AMK) put forward in 2009 by Zaskis and Leikin and defined as “*systematic formal mathematical knowledge beyond secondary mathematics curriculum, likely acquired during undergraduate studies*” (p.2368).

However, what and in which ways this body of knowledge of ‘AMK’ or ‘academic mathematics’ is necessary or useful to functioning effectively as a teacher of mathematics at school level is still under much debate, as there is little agreement amongst researchers worldwide about how completing these courses influences future teachers’ instruction (Zaskis & Leikin, 2010) or improves their students’ subsequent achievement in the subject (Darling-Hammond, 2000).

The Research Question

This paper thus reports on a study which was aimed at investigated if and in what ways (re)engagement with relevant AMK related to a school mathematics topic, functions in particular, empowers teachers conceptually and pedagogically.

Theoretical Influences – brief overviews

Teachers' knowledge for teaching

The study of teachers' knowledge of subject matter and its relationship to the quality of classroom instruction has grown substantially since Lee Shulman launched a call for researching teachers' different components of a professional knowledge base for teaching (Shulman, 1986). While there is no agreement amongst the mathematics education community about the relationship between these components, research flourished in an effort to conceptualize mathematics teachers' professional knowledge base for teaching.

One of such effort which builds on and refines Shulman's (1986) initial categorization of types of knowledge of a teacher of any subject, namely subject matter knowledge and pedagogical content knowledge, and which has proven to be very to be influential is the mathematics specific framework advanced by Ball, Thames and Phelps (2008). Their Mathematical Knowledge for Teaching (MKT) framework lays the foundation for a practice-based theory for mathematical knowledge for teaching. The authors divided Shulman's second category of Pedagogical Content Knowledge (PCK) into two other sub-domains, Knowledge of Content and Students (KCS) and Knowledge of Content and Teaching (KCT), while Shulman's third category of Curricular Knowledge (CK) was also relocated under PCK as Knowledge of Content and Curriculum.

Similarly, Shulman's category of Subject Matter Knowledge was divided into three sub-domains: Common Content Knowledge (CCK), Specialized Content Knowledge (SCK), and Horizon Content Knowledge (HCK). Recently, a few other researchers (e.g., Zaskis & Leikin 2010, Even 2011) proposed positioning advanced mathematical knowledge (AMK) as an important aspect of MKT and in the following we will briefly review these categories and how they complement each other.

Common Content Knowledge (CCK) and Specialized Content Knowledge (SCK)

CCK is knowledge used in the work of teaching, but also used in ways that correspond with how it is used in settings other than teaching. SCK encompasses knowledge of mathematics needed by teachers, but not necessarily used by others, such as knowledge of a particular mathematical model or representation useful for teaching a certain concept.

Development of such SCK usually starts in teacher education programmes. Indeed, teachers acquire SCK through learning about how to use number lines, hot-air balloons or any other representations and metaphors that would enable them to teach about operations with negative numbers. For instance, while an engineer knows that the product of two negative numbers is a positive number, s/he does not need to know or give a mathematical reason for why this rule works or be able to provide a conceptually-sound explanation for the 'minus and minus make plus' metaphor. This kind of

knowledge and reasoning should be an intrinsic part of a teacher's everyday classroom teaching, knowledge of the mathematics underlying rules, approaches, representations. However, far too often the implicit assumption is that prospective teachers already know the mathematics, to include the what and the why. But this is not the case. Many studies (e.g., Tirosh, Fischbein, Graeber, & Wilson, 1999) have revealed that school teachers possess a limited knowledge of mathematics, including the mathematics they teach. The mathematical education they received, both as pupils in school education and in teacher preparation, more often than not did not provide them with appropriate or sufficient opportunities to learn mathematics relationally (Skemp, 1976) and as a result, teachers themselves may know the facts and procedures that they teach but often have little or weak understanding of the conceptual basis underlying those rules and procedures (Ball, 1990).

Horizon Content Knowledge

HCK (horizon content knowledge), the third sub-domain of subject matter knowledge in the MKT framework was tentatively defined by Ball and colleagues as 'an awareness of how mathematical topics are related over the span of mathematics included in the curriculum' (Ball et al., 2008, p. 403). Defined, interpreted and re-interpreted, HCK means different things to different researchers (e.g., Ball & Bass, 2009, Jakobsen et al., 2013); what is common ground amongst these interpretations is that it is knowledge that goes beyond that included in school mathematics curriculum, that influences teaching!

Ball et al. (2008) themselves describe HCK domain of knowledge as "a kind of mathematical 'peripheral vision' needed in teaching, a view of the larger mathematical landscape that teaching requires" (p.1), including "the vision useful in seeing connections to much later mathematical ideas" (p.403). The authors acknowledged that "we do not know how horizon knowledge can be helpfully acquired and developed" (ibid, 2009, p.11)

Advanced Mathematics Knowledge

While engaging with the MKT framework, Zaskis and Mamolo (2011) proposed to view HCK through the notion of viewing elementary (school) mathematics from an advanced standpoint, thus positioning advanced mathematical knowledge (AMK) as an important aspect of MKT. The notion of horizon content knowledge is given by Zaskis and Mamolo in terms of the application of the notion of 'advanced mathematical knowledge', which they define as the "knowledge of the subject matter acquired during undergraduate studies at colleges or universities" (Zaskis & Leikin, 2010 p. 264).

Wasserman (2016), and later Stockon and Wasserman (2017) narrowed down the description of AMK to knowledge outside the typical scope of what a school mathematics teacher would likely teach, in that AMK is relevant, the advanced mathematical ideas are connected to the content of school mathematics, but also that these forms of knowledge of advanced mathematics are in some way productive for the teaching of school mathematics content.

Since Zaskis and Leikin's (2009) first conceptualisation of AMK, the authors also launched a call for further research to determine whether teachers' ability to identify explicit connections between AMK and the mathematics taught in school is a rare gift of only a few teachers or whether specific prompting is needed to bring this ability to surface.

The study: the England, UK context

Rather than relying on individual teachers' gift to identify explicit connections between AMK and the mathematics they are expected to teach, in this paper we propose that teachers of mathematics should be explicitly supported in becoming aware of these connections.

However, unlike other countries where teacher training is undertaken alongside undergraduate mathematics studies, and where such opportunities could be offered to prospective teachers as part of their undergraduate studies (e.g., Wasserman et al., 2017), the UK context is different. The teachers in the UK complete their training in a one-year postgraduate course, meaning that they would have studied advanced mathematics as part of their undergraduate studies not related with teacher education. Thus, for them the study of advanced mathematics had no explicit relation to school mathematics content.

Hence the study presented in this paper is a step forward in response to Zaskis and Leikin's (2009) call, but suited to the UK approach to teacher training, and where such interventions are offered to teachers after they completed their undergraduate studies, either as part of their initial teacher training postgraduate course or as a professional development opportunity after they qualify as teachers.

Methodology

In this paper, I will be reporting on a two-hour CPD workshop designed to support the teaching of specific areas of the school curriculum, namely functions, and aimed at increasing teachers' familiarity with a variety of representations of functions in the school mathematics and their awareness of how these representations interconnect. The CPD workshop was designed and taught by the author of this paper, and the tasks attempted were of both mathematical and pedagogical nature, aimed at developing a deeper conceptual and pedagogical understanding of this topic, in ways suggested by research findings on ways of teaching about functions at various levels of students' education (e.g., Ayalon et al. 2013, Nardi, 2001).

Each workshop was designed to start by posing a school mathematics question or a problem situation that teachers could do but where they may encounter some difficulties in answering it correctly and completely; in order to overcome the difficulties, the teachers will be guided towards recalling/reengaging with some relevant AMK; this will then be followed by a classroom-inspired scenario, of a pedagogical nature, where the teachers will be applying their new learning and become explicitly aware how their new learning supports their teaching.

Data sources

Textual data was collected through field notes that detailed some of the group interactions. Post-session written reflections were solicited and collected at the end of the session. The teachers were asked to comment on the activities in relation to their own learning, their pupils' mathematical learning, and their preparedness of teaching this topic. Written notes about the teachers' comments, questions, written work, were also made down by the myself throughout the workshop.

The participants

The participants were eight early career teachers of mathematics attending the two-hour CPD workshop. They were practicing mathematics teachers who wanted to refresh their knowledge about functions, given the high profile of this topic in the new re-vamped mathematics curriculum in England, UK. Features of and operations with functions such as: domain, range, inverse and composite functions, which were traditionally studied by older learners (16 to 18 year old learners or even undergraduates) are now to be studied by 14 to 16 year old learners. Hence, all secondary mathematics teachers need to be able to teach this topic. The eight teachers gained their qualified teacher status as a result of studying on a one-year teacher training course. As expected, they studied some mathematics at undergraduate level: six teachers studied for mathematics degrees, one had an engineering background, while one other teacher had an economics background and introduced himself as a non-specialist mathematics teacher. Consent to collect any observational and written notes throughout and after the workshop was sought from all the eight teachers.

Data Analysis and discussion

The workshop started by posing a school mathematics question or a problem situation that teachers could do but where it was envisaged they may encounter some difficulties in answering it correctly and completely, as suggested by previous research (e.g., Nardi, 2001). The teachers were provided with an activity which required sketching the graph of functions that shared the same rule (one such example being $f(x) = x^2$), but which had different domains of definition. The teachers worked in pairs, and each pair was provided with a different domain for the function. The domains were: the whole set of real numbers, open and closed intervals, and discrete sets of real numbers. At the start of the activity, the teachers were not aware of the functions allocated to the other pairs.

Teachers' engagement with (partial) representations of a function: The graphs produced by each pair looked more or less the same; a smooth curve in the shape of a parabola, carefully drawn to look symmetric about the y-axis. When the graphs were shared with the whole group, the teachers became aware of the similarities, but also the differences in their tasks; despite all sharing functions described by the same rule, the domains for each function were different, and so the discussion led naturally to a discussion about what a function was.

Teachers' re-engagement with the formal definition of a function: In the discussion, some teachers seemed to recall having studied about the formal definition of a function in their undergraduate studies, while others did not seem to have such a recollection or even an awareness of ever encountering such a definition. In what followed, disparate suggestions from teachers were recalled and put forward such as domains, co-domains, ranges, one-to-one, correspondence, notation conventions, and with some guidance from me, they reached the formal definition of a function of one real variable, which some recognised as having encountered them in their undergraduate mathematics course.

This is evidence of teachers reaching for *more* advanced mathematics knowledge (in this case, the formal definition) related to functions, in the need to complete the task successfully. The 'starter'

activity provided them with the impetus to reach for *more* than the school mathematics they were all too familiar with. Tapping into that knowledge, and once recalled (or newly learned, in the case of two teachers) there was evidence that it supported teachers completing the activity successfully. The teachers revisited the graphs they initially produced and each pair produced different graphs: either a smooth continuous parabola, or a pointwise graph, or a piece-wise graph, depending of the given domain of definition.

Even though a few of the teachers had an awareness of the formal definition of functions and were able to recall some ‘bits’ of it, they commented that “it did not occur to me to relate this activity with the formal definition”, and “that was high level mathematics not much used after the [undergraduate] course”. The teachers seemed to be much more influenced by the current limited description of functions in the school curriculum, where domains and ranges of functions are not explicitly considered until the more advanced years of school level education.

Pedagogical implications: developing an awareness of building up to the formal definition of a function: The ‘starter’ activity was then followed with a discussion of how the concept of function develops in the school mathematics curriculum. Representations of functions as they chronologically appear in the school curriculum were discussed: One-to-one or many-to-one mappings, Input/output machines, Relations between particular x-values and y-values; Expressions to calculate the y-values from given x-values, and Graphs. Each time, the teachers were encouraged to relate these representations with their recalled or newly learned AMK about functions. In doing so, the teachers came to realise that each of these representations explains particular aspects/features of the concept without being able to describe it completely! And a realization that overreliance on one representations or lack of connections between such representations gives way to misconceptions when working with functions, just as pointed out by Ayalon, Lerman and Watson (2013).

Indeed, the teachers themselves became explicitly “aware of stages of building up to the definition of a function”. A teacher in particular was able to illustrate this new learning eloquently. She stated that she learned about: “Different representations of functions – I’ve always seen them as disconnected representations, but they complement each other nicely towards understanding functions” and exemplified with how in the lower secondary school curriculum, functions are portrayed as a computational process and are seen as an input-output machine that processes input values into output values. Such representation emphasizes the rule aspect in the definition of functions, seeing thus functions as an instruction to calculate one numerical set from another. This view leads to a perception of graphical representation of functions amongst pupils as points (usually with integer coordinates) plotted on the set of axes, which are then joined up with segments, with no explicit awareness that any other point lying on those segments could be just as good a candidate in the table of values. And in fact, the teacher herself realized that she never discussed or pointed this out in her teaching when plotting graphs.

Pedagogical empowerment - addressing ambiguities in the treatment of school maths topics: For the final task of this workshop, the teachers were asked to think about how they introduce and teach pupils of different ages about square roots. Sharing of own experiences immediately led into disputes over the numerical value of the square root of a number: a positive, a negative or a \pm value. Most teachers defended the \pm value, and attempted to justify their answers in a variety of ways: “this is

how I was taught myself”, “this is how it is presented in textbooks”, “this is how it appears in marking schemes of examination board”, “This has always been the case.” I then prompted the teachers to think about how this school maths concepts related to their learning about functions gained in the session up to that point and I suggested that perhaps it could help them settle the inconsistency in their answers.

The teachers were indeed able to call upon their recollection of the more advanced knowledge about functions (extended at this point to inverse functions and relationships between domains and ranges) and agreed on the positive answer only, despite feeling uncomfortable about dismantling a long-held belief about a piece of knowledge about square roots, they themselves inherited from their secondary school maths education and unfortunately still perpetuated by current mathematics school textbooks (Crisan, 2014).

Concluding remarks

The teachers on this CPD course had revisited some of their AMK of functions, which provided them with a better understanding and an awareness of the developmental trajectory in learning about functions. They became aware of how representations in the school curriculum are particular instances of the concept itself, and how teaching towards a complete/full understanding of functions requires teachers to be aware of what each of these representations contribute to the complete understanding of the concept of functions: “Today’s session helped me understand how I could have addressed the [pupils’] errors and how I can clarify things in the future.”, while another teacher shared his learning in the session: “What I have learnt today? About advanced mathematics knowledge and its place in classroom and planning.”.

On a pedagogical level, AMK of functions empowered the teachers to justify why pupils make mistakes, and thus increased their knowledge for teaching this topic in the future.

The task in which the participants were involved in this workshop provided a context in which they recalled AMK related to functions, while in the case of some other teachers, they acquired new AMK (the teachers with an engineering and economics background). The teachers gained conceptually, as the mathematics tasks created some instability in what they knew about functions and their graphical representations, and in order to address the differences in their tasks, the teachers need to engage with *more* advanced mathematics knowledge of functions was brought out into the open.

However, this study has shown that even when teachers possess the AMK, they are not necessarily aware of manifestations of AMK in the school mathematics curriculum, thus they need to be supported in develop such awareness and make it explicit. One cannot simply assume that teachers will make connections without some intervention. This paper proposes that, in the UK context this should be the remit of courses preparing teachers of mathematics (either initial teacher training and/or CPD). All teachers, irrespective of their academic background, should be supported to look at school mathematics from an advanced standpoint and to examine school mathematics topics by engaging with advanced mathematics knowledge, while guidance is provided in terms of what AMK is relevant and how it informs school mathematics.

References

- Ayalon, M., Lerman, S., & Watson, A. (2013). Development of students' understanding of functions throughout school years. *Proceedings of the British Society for Research into Learning Mathematics*, 33(2), 7-12.
- Ball, D. L., Thames, M. H., & Phelps, G. (2008). Content knowledge for teaching: What makes it special?. *Journal of teacher education*, 59(5), 389-407.
- Ball, D.L. (1990). The mathematical understandings that prospective teachers bring to teacher education. *Elementary School Journal*, 90, 449 – 466.
- Crisan, C. (2014) The case of the square root: ambiguous treatment and pedagogical implications for prospective mathematics teachers. In: Pope, S, (ed.) *Edited proceedings of BCME 8, University of Nottingham, Apr 2014*, (pp.75-82). British Society for Research into Learning Mathematics: Nottingham, UK.
- Darling-Hammond, L. (2000). Teacher quality and student achievement. *Education policy analysis archives*, 8, 1.
- Even, R. (2011). The relevance of advanced mathematics studies to expertise in secondary school mathematics teaching: practitioners' views. *ZDM*, 43(6-7), 941-950.
- Jakobsen, A., Thames, M. H., Ribeiro, C. M., & Delaney, S. (2012, July). Using practice to define and distinguish horizon content knowledge. In *12th International Congress in Mathematics Education (12th ICME)* (pp. 4635-4644).
- Moreira, P. C., & David, M. M. (2008). Academic mathematics and mathematical knowledge needed in school teaching practice: Some conflicting elements. *Journal of Mathematics Teacher Education*, 11(1), 23-40.
- Nardi, E. (2001). Domain, co-domain and relationship: Three equally important aspects of a concept image of function. In *Proceedings of the Conference of the British Society of Research into the Learning of Mathematics* (Vol. 21, No. 1, pp. 49-54).
- Shulman, L. S. (1987). Knowledge and teaching: Foundations of the new reform. *Harvard Educational Review*, 57(1), 1-22.
- Stockton, J. C., & Wasserman, N. (2017). Forms of Knowledge of Advanced Mathematics for Teaching, *The Mathematics Enthusiast*, 14 (1), 575-606.
- Tirosh, D., Fischbein, E., Graeber, A. O., & Wilson, J. W. (1999). Prospective elementary teachers' conceptions of rational numbers. *Retrieved May*, 5(2005), 669-683.
- Wasserman, N. H. (2016). Abstract algebra for algebra teaching: Influencing school mathematics instruction. *Canadian Journal of Science, Mathematics and Technology Education*, 16(1), 28-47.
- Zazkis, R., & Leikin, R. (2009). Advanced mathematical Knowledge: How is it used in teaching. In *Electronic proceedings of the Sixth Conference of the European Society for Research in Mathematics Education (CERME-6)* (pp. 2366-2375).
- Zazkis, R. & Leikin, R. (2010). Advanced mathematical knowledge in teaching practice: Perceptions of secondary mathematics teachers. *Mathematical Thinking and Learning*, 12(4), 263-281.
- Zazkis, R. & Mamolo, A. (2011). Reconceptualizing knowledge at the mathematical horizon. *For the Learning of Mathematics*, 31(2), 8-13.

Teacher educators' understanding of mathematical knowledge for teaching

Matthew Dahlgren¹, Reidar Mosvold² and Mark Hoover³

¹University of Michigan, USA; mdahlg@umich.edu

²University of Stavanger, Stavanger, Norway; reidar.mosvold@uis.no

³University of Michigan, USA; mhoover@umich.edu

Researchers conceptualize mathematical knowledge for teaching in different ways, but a coherent approach to the mathematical education of teachers requires teacher educators' understanding to be robust and shared. At present, we know little about how teacher educators interpret and operationalize this important domain. Our analysis of interview data indicates two sites of divergence in teacher educators' understanding. Some view this knowledge as a resource for the mathematical work of teaching, treating it as distant from actual practice, whereas others view it as a slice of the dynamic and situational work. Also, some view the mathematical work of teaching, and its knowledge demands, as detached from particulars of students and schooling, while others view this work as inseparable from student identities and the larger environments within which instruction occurs, thus integrating regard for equity. Implications are discussed.

Keywords: Mathematical knowledge for teaching, Teaching, Teacher educators.

Introduction

Mathematics educators and researchers agree that the mathematical knowledge teachers need is not simply advanced mathematics — it is specialized, teaching-specific mathematical knowledge. Shulman's (1986) pedagogical content knowledge continues to stimulate the field. Ma's (1999) profound understanding of fundamental mathematics exposed subtle depth in the mathematical demands of teaching. Scholars continue to expand conceptual models (e.g., Ball, Thames, & Phelps, 2008; Carrillo-Yañez et al., 2018; Rowland, Huckstep, & Thwaites, 2005; Thompson, 2015) and measures (e.g., Baumert et al., 2010; Hill, Schilling, & Ball, 2004; Saderholm, Ronau, Brown, & Collins, 2010). Although scholars agree such knowledge is important, different constructs have been proposed, with underdeveloped theoretical grounding, and measures often operationalize a specific construct in different ways (Hoover, Mosvold, Ball, & Lai, 2016).

Awareness that mathematical knowledge for teaching is specialized and teaching-specific creates an imperative for the mathematical education of teachers. Unfortunately, shifting to teaching of mathematical knowledge for teaching is not a simple matter of introducing new content. Understanding the new content is a challenge and teaching it requires different instructional practices with new demands on teacher educators. A number of researchers have begun to investigate these demands. For example, some have used records of practice from teacher education courses or professional development programs to unpack the mathematical demands of such work (e.g., Chick & Beswick, 2018; Superfine & Li, 2014; Zopf, 2010). Others have examined teacher educators' collaborative work, by either drawing from reflections on their practice (Masingila, Olanoff, & Kimani, 2018), or interviewing teacher educators directly (Zazkis & Zazkis, 2011). Each

of these efforts has focused on the connection between mathematical knowledge for teaching and the mathematical demands of teacher education.

While this investment in conceptualizing an analogous specialized knowledge for mathematics teacher education is valuable and timely work, a more basic question is whether teacher educators mean the same thing when referring to mathematical knowledge for teaching. Of course, individual interpretations vary, but meaning needs to be sufficiently shared for communication and programs to be effective. Teacher educators may believe they are each working on mathematical knowledge for teaching in their courses but could in fact be focusing on different issues. Alignment among instructional materials, courses, and instructors is crucial. As Cohen (2011) argues, absent a sufficiently shared notion of the content and aims of education (or in this case teacher education), efforts to assess and improve the quality of teaching will be much more difficult, if not impossible. In our own work with professionals concerned with the mathematical education of teachers, we have found that ambiguity often leads to individuals or groups talking past one another, even as they allegedly invest in the same content. In addition, if teacher educators' understandings of mathematical knowledge for teaching differ, then studies that seek to understand the mathematical demands of mathematically educating teachers could be scrutinizing arguably different aspects of professional practice and ignoring ambiguity that might lead to additional or different results. As the larger community of mathematics teacher educators (including mathematicians, teacher educators, and school-based personnel) learns about mathematical knowledge for teaching and becomes convinced of its importance, mixed understanding looms large.

Despite these implications, we know surprisingly little about teacher educators' conceptualizations of mathematical knowledge for teaching. In this study, we analyze interviews with teacher educators to better understand their thinking, and in so doing, we contribute to the growing literature on the teaching of mathematical knowledge for teaching.

Conceptual and contextual background

Before laying out the particulars of our study, we briefly describe the study context and the perspectives we bring to our analysis. Our team relies on a conception of mathematical knowledge for teaching that understands knowledge to be embedded in teaching and considers specialized content knowledge to be mathematical knowledge unique to the work of teaching (Ball, 2017; Ball et al., 2008). We conceptualize teaching as the management of interactions of instruction in environments (Brousseau, 1997; Cohen, Raudenbush, & Ball, 2003; Jaworski, 1994; Wickman, 2012). In this, we understand attention to equity to be inherent to teaching that is educative and consequently to be inherent in the dynamic mathematical work of teaching. We understand equity in the sense of both “reasonableness and moderation in the exercise of one’s rights, and the disposition to avoid insisting on them too rigorously” as well as “recourse to general principles of justice (the *naturalis æquitas* of Roman jurists) to correct or supplement the provisions of the law” (Equity, 2018). For this study, we are interested in the many different ways that equity might be considered in teaching and the mathematical dimensions and demands of this work.

As a means of building capacity among teacher educators concerning specialized content knowledge, our team has run a series of workshops that bring together different professional

communities with the purpose of collectively creating tasks for teachers that address specialized content knowledge. Workshops are organized around a cycle of constructing, discussing, and reviewing tasks. Whereas some of our previous projects have focused on developing multiple-choice items for assessment or measurement purposes, we have adopted a more inclusive interpretation of task type in the present workshops with the intention of using task development as a tool for building understanding and instructional materials.

In the first year of the project, four workshops were held. Each consisted of roughly 30 to 50 participants. Some participated in more than one workshop, but over 150 professionals participated in at least one. They came from over 25 states of the United States, as well as Brazil, Canada, Norway, Turkey, and Iran. Their professional roles varied. Some were higher education faculty from mathematics departments and schools of education. Some were professional developers, teacher leaders, curriculum specialists, or other school-based personnel. Some were state leaders. All were involved in the mathematical education of teachers. Consistent with discussions above, our framing of specialized content knowledge at the workshop emphasized that the mathematical work of teaching requires coordination of pedagogical and mathematical entailments while simultaneously attending to, and acting against, patterns of marginalization and inequity.

Our aim is to understand how those responsible for the mathematical education of teachers understand mathematical knowledge for teaching and the extent to which they shared a coherent vision of it. The design of our study is to examine differences in understanding among our participants. We acknowledge that our workshop participants constitute a limited sample of professionals engaged in the mathematical education of teachers. They have likely read some of the same research, self-selected to attend our workshop, and listened to our workshop framing of mathematical knowledge for teaching and task development. This suggests that they may hold more similar views than those held in the broader community. We argue that, because we are examining differences among participants, our sample may actually strengthen our claims, revealing patterns that are likely alive and well in the broader professional community.

The study

To investigate teacher educators' understanding of specialized content knowledge, we interviewed 13 teacher educators after the fourth workshop, held in July 2017. These interviewees varied in terms of demographics, number of workshops attended, professional affiliation, perceived fluency with the ideas, etc. Interviews were conducted via video conferencing and recorded. In addition to probing their experiences at the workshops, we asked explicitly about their views of specialized content knowledge, teaching, and equity. To elicit interviewees' understanding of specialized content knowledge, we asked them to comment on a recording of a discussion that occurred at the workshop. The focus of the workshop discussion was a video of teaching where a Black girl named Aniyah is called to the board to show $\frac{1}{3}$ on the number line (see Ball, 2017 for analysis). The aim of the workshop discussion was to use the classroom video as a seed for developing specialized content knowledge tasks. The aim of viewing the workshop discussion in the interview was to provide a context for expressing understanding of mathematical knowledge for teaching.

After the interviews were completed, a larger team of seven researchers processed the data, created collective summaries of the interviews, and decided on four cases to highlight in this paper. The four chosen, Paula, Alyssa, Ranesh, and Daniele (names are pseudonyms), provided a spectrum of different roles and of different perspectives visible in the 13 interviews (Table 1). The larger team also piloted preliminary frames and coding schemes and developed an approach using the instructional triangle to categorize components of the mathematical work of teaching evident in participants' responses. The first two authors then created detailed characterizations (individually, then jointly reconciling differences) and identified common patterns. It should be noted that our goal here is not to say something about the effects of the workshop but rather to unpack how participants understand the construct.

Results and discussion

Our preliminary analysis of interview data revealed two divergences in teacher educators' understanding of specialized content knowledge. The first relates to the nature of such knowledge and its connection to the mathematical work of teaching. The second relates to the relationship between such knowledge and regard for equity, in particular regard for the development of students' identities and the larger environments in which instruction occurs.

<i>Interviewee (Role)</i>	<i>Nature of knowledge</i>	<i>Regard for equity</i>
Paula (Math education faculty)	Static, stable, prerequisite resource	Not integrated
Alyssa (K-12 school-based)	Dynamic, situational slice of work	Integrated
Ranesh (Math faculty)	Dynamic, situational slice of work	Partly integrated
Daniele (Math education faculty)	Partly dynamic	Not integrated

Table 1: Summary of interviewees

Nature of knowledge

The first site of divergence lies in how teacher educators understand the nature of specialized content knowledge. For example, Paula often collapsed real-time decision making with particular students and particular settings with the kind of work that one might do outside the classroom, independent of those students and settings. Although she insisted that teachers need to be able to see what each student knows and understands, at times, her focus was squarely on knowledge that is *required for teaching*. In particular, when Paula spoke about her attempts to assess such knowledge, she referred to it as something teachers “need to know” in order to be an effective teacher, rather than speaking about specialized content knowledge as something present in (and arising from) particular demands in teaching. It seems as though, for Paula, having particular knowledge outside the classroom ensures success inside the classroom. This kind of conceptualization of the mathematical work of teaching is consistent with a didactical or instructional triangle that ignores certain bidirectional interactions between the vertices. Thus, students, environments, and content often did not seem to affect the kinds of mathematical work that Paula envisioned for the teacher.

Several other participants drew clear lines between knowledge and knowledge-in-use but viewed both as essential to teaching well. For example, while Alyssa contended that “teachers need broad knowledge of content” as well as “a really specific knowledge of mathematics” in order to “see what kids are doing, to see how kids are accessing problems”, she distinguished this knowledge from that which is embedded in the mathematical work of teaching. For her, the mathematical work was “what [teachers] are doing with that knowledge, and what they’re doing with the data they are gathering in the moment...like how they are facilitating a classroom environment with that understanding.” She also referred to how “content knowledge empowers [teachers] to make ... strategic real-time decisions with the information they have.” Similarly, Ranesh also considered specialized content knowledge to be related to, but distinct from, the mathematical work of teaching. In his interview, he spoke about how the mathematical work of teaching was about “knowing *what* to do, and *how* you would do that in the classroom.” In his view: “SCK is the noun, and the mathematical work as a teacher ... that would be the verb.” In their interviews, Ranesh and Alyssa each seemed to pay more attention to the dynamic interactions present in instruction and this focus seemed to help them make a distinction between knowledge and knowledge-in-use. From their perspective, specialized content knowledge is necessary, but not sufficient for successful execution of the mathematical work.

Our analytic framing of teaching as management of interactions among teachers, students, content, and environments suggests that teacher educators’ views of mathematical knowledge for teaching differ in sophistication. In particular, Paula’s view of it as static, stable, prerequisite knowledge overlooks certain interactional pairings central to teaching. In contrast, Alyssa’s and Ranesh’s view of it as a dynamic, situational slice of work reflects their fuller understanding and skill in thinking about the full range of interactions central to teaching.

Mathematical knowledge for teaching and integration of student identities and environments

A second site of divergence is the extent of integration of equity concerns, in particular student identities and environmental factors, into mathematical knowledge for teaching. Alyssa, for example, when shown specific instances of teaching, referenced the larger environments in which instruction occurs and how the mathematical work in those moments is shaped by such considerations. For instance, when commenting on the record of practice referenced in our interview, Alyssa highlighted how the teacher calls upon “a student like Dante” at a particularly crucial moment in a class discussion about naming fractions on the number line. In the video, several other students had each put forward correct pieces of the final answer (one solution drew attention to the need for equal partitioning of the whole, while another correctly identified the whole as the unit interval from zero to one) but each student had a different incorrect answer on the board. Dante also did not have the correct answer in his notebook, but when he is called on, he attempts to articulate his thinking and goes on to ask a question about how the previously presented solutions relate to each other. Alyssa described this moment as an act of empowerment for Dante (a Black student in the classroom video being discussed in the workshop video) and declared that the teaching move allows Dante to be a “bearer of mathematical knowledge”, a position not typically offered to students “like him” (perhaps referencing how non-standard responses of Black boys are often interpreted). She also asserted that calling on Dante at this moment does more than just

empower a particular student, it also disrupts systemic patterns of injustice and racism. Alyssa explicitly connected this idea to the mathematical work of teaching, maintaining that, “part of the work of teaching is knowing your students and knowing how to strategically call on students at set times.” Even though it is apparent that Dante is “a student who understands quickly and is good at synthesizing other people’s thoughts”, she believes many teachers would not choose to call on him in that moment, especially since he does not have the correct answer. However, Alyssa contended that the teacher in the video intentionally “*creates* the situation where a student like Dante could then say, ‘what is the connection?’” and she saw this mathematical and pedagogical work as intertwined with issues of equity. Through her comments, we see concerns for each of the components of the instructional triangle — mathematics, teachers, students, and environments — as well as their interactions. Her regard for equity in relation to the mathematical work of teaching is coincident with her mutual consideration of the intertwined interactions of teaching.

By contrast, in her interview, Daniele seemed to acknowledge the general possibility that student identity and patterns of systemic inequity can interact in ways that shape the mathematical trajectory of a class, but admitted that she does not think much about equity in her own work. When asked about the video of the workshop discussion, Daniele remained focused on mathematical content and failed to consider comments about how Dante’s race/ethnicity shapes the kind of mathematical work the teacher must do in that moment.

Daniele never mentioned Dante’s identity as a Black boy as something that might relate to the mathematical work of teaching. Instead, Daniele suggested that calling on Dante was a way of including other students in the class discussion and gaining access to their thinking. She explained the teacher’s choice to call on Dante in the following way:

We think about the students that are maybe up in front talking, but that’s not the whole class. That’s only two students in the class and it’s a large class. And so, what are the other students doing and thinking about? And we think about the behavior issue, and that stands in the forefront, but if we really actually listen to kids that have behavior issues potentially ... then we can think about well what is Dante saying and how is *he* thinking about this task?

Viewed in this light, the teacher might have called on any particular student at that moment rather than Dante specifically. For Daniele, the only things about Dante that seem to be relevant for the work of teaching are his particular classroom behaviors and the mathematical concerns he raises. Daniele’s comments are fundamentally about the content of Dante’s questions rather than Dante as an individual or about the environments that shape both his identity and the work of teaching. Daniele seemed to be articulating that issues of equity are not embedded in the work of teaching, but are an optional add-on — something that is not central. This conceptualization of the mathematical work of teaching, is consistent with an instructional triangle would have little or no interaction with particulars of the environment.

Again, our analytic framing of teaching as management of interactions among teachers, students, content, and environments suggests that teacher educators’ integration of concerns for student identities and environmental factors with mathematical knowledge for teaching differ in sophistication. In particular, Daniele’s disregard for student identities and environmental factors in

her consideration of mathematical issues contrasts with Alyssa's nuanced consideration of their import for the mathematics at hand.

Conclusions

As the instructional triangle emphasizes dynamic interactions among teachers, students, content, and environments, it seems natural that such a framing would draw out the absence or presence of dynamic interactions. But it is clear that certain interactions are more uniformly understood than others (at least within our data). None of the teacher educators we interviewed could be characterized as not attending to the dynamic interaction between teacher and mathematical content. This is significant given observed divergences. The two primary divergences we found thus say something important about the ways in which teacher educators understand mathematical knowledge for teaching. They suggest sites where a shared conceptualization breaks down or areas where there is considerable variation in understanding. These may be fundamentally different conceptualizations, built on different foundations, or they may be developmental issues related to their understanding of teaching. Regardless, we suggest that appreciating differences in these conceptualizations and being able to name and talk about constituents of teacher educators' understandings are useful building blocks for the field.

References

- Ball, D. L. (2017). Uncovering the special mathematical work of teaching. In G. Kaiser (Ed.), *Proceedings of the 13th International Congress on Mathematical Education* (pp. 11–34). Springer.
- Ball, D. L., Thames, M. H., & Phelps, G. (2008). Content knowledge for teaching: What makes it special? *Journal of Teacher Education*, 59(5), 389–407.
- Baumert, J., Kunter, M., Blum, W., Brunner, M., Voss, T., Jordan, A., ..., Tsai, Y. (2010). Teachers' mathematical knowledge, cognitive activation in the classroom, and student progress. *American Educational Research Journal*, 47(1), 133–180.
- Brousseau, G. (1997). *Theory of didactical situations in mathematics: Didactiques des mathématiques, 1970–1990* (N. Balacheff, M. Cooper, R. Sutherland, & V. Warfield, Trans.). Dordrecht: Kluwer.
- Carrillo-Yañez, J., Climent, N., Montes, M., Contreras, L. C., Flores-Medrano, E., Escudero-Ávila, D., ... Muñoz-Catalán, M. C. (2018). The mathematics teacher's specialized knowledge (MTSK) model. *Research in Mathematics Education*, 20(3), 236–253.
- Chick, H., & Beswick, K. (2018). Teaching teachers to teach Boris: A framework for mathematics teacher educator pedagogical content knowledge. *Journal of Mathematics Teacher Education*, 21, 475–499.
- Cohen, D. K. (2011). Learning to teach nothing in particular: A uniquely American educational dilemma. *American Educator*, 34(4), 44–46, 54.
- Cohen, D. K., Raudenbush, S., & Ball, D. L. (2003). Resources, instruction, and research. *Educational Evaluation and Policy Analysis*, 25(2), 1–24.

- Equity. (2018). In *OxfordDictionaries.com*. Retrieved from <http://www.oed.com/view/Entry/63838?redirectedFrom=equity#eid>
- Hill, H. C., Schilling, S. G., & Ball, D. L. (2004). Developing measures of teachers' mathematics knowledge for teaching. *Elementary School Journal*, *105*, 11–30.
- Hoover, M., Mosvold, R., Ball, D. L., & Lai, Y. (2016). Making progress on mathematical knowledge for teaching. *The Mathematics Enthusiast*, *13*(1–2), 3–34.
- Jaworski, B. (1994). *Investigating mathematics teaching: A constructivist enquiry*. London: Falmer Press.
- Ma, L. (1999). *Knowing and teaching elementary mathematics: Teachers' understanding of fundamental mathematics in China and the United States*. Mahwah, NJ: Lawrence Erlbaum Associates.
- Masingila, J. O., Olanoff, D., & Kimani, P. M. (2018). Mathematical knowledge for teaching teachers: knowledge used and developed by mathematics teacher educators in learning to teach via problem solving. *Journal of Mathematics Teacher Education*, *21*, 429–450.
- Rowland, T., Huckstep, P., & Thwaites, A. (2005). Elementary teachers' mathematics subject knowledge: The knowledge quartet and the case of Naomi. *Journal of Mathematics Teacher Education*, *8*, 255–281.
- Saderholm, J., Ronau, R., Brown, E. T., & Collins, G. (2010). Validation of the Diagnostic Teacher Assessment of Mathematics and Science (DTAMS) instrument. *School Science and Mathematics*, *110*(4), 180–192.
- Shulman, L. S. (1986). Those who understand: knowledge growth in teaching. *Educational Researcher*, *15*(2), 4–14.
- Superfine, A. C., & Li, W. (2014). Exploring the mathematical knowledge needed for teaching teachers. *Journal of Teacher Education*, *65*(4), 303–314.
- Thompson, P. W. (2015). Researching mathematical meanings for teaching. In L. D. English & D. Kirshner (Eds.), *Third handbook of international research in mathematics education* (pp. 435–461). New York: Taylor & Francis.
- Wickman, P. O. (2012). A comparison between practical epistemology analysis and some schools in French didactics. *Éducation et Didactique*, *6*(2), 145–159.
- Zazkis, R., & Zazkis, D. (2011). The significance of mathematical knowledge in teaching elementary methods courses: Perspectives of mathematics teacher educators. *Educational Studies in Mathematics*, *76*, 247–263.
- Zopf, D. (2010). Mathematical knowledge for teaching teachers: The mathematical work of and knowledge entailed by teacher education. Unpublished doctoral dissertation. Retrieved from http://deepblue.lib.umich.edu/bitstream/handle/2027.42/77702/dzopf_1.pdf.

Exemplifying mathematics teacher's specialised knowledge in university teaching practices

Rosa Delgado-Rebolledo¹ and Diana Zakaryan²

¹ Pontificia Universidad Católica de Valparaíso, Chile; rosamdelgadorebolledo@gmail.com

² Pontificia Universidad Católica de Valparaíso, Chile; diana.zakaryan@pucv.cl

Extant research on the teachers' knowledge includes limited studies focusing on teachers at university level. In this work, based on the Mathematics Teacher's Specialised Knowledge (MTSK) model and through an instrumental case study, knowledge of a lecturer in a real analysis course for prospective mathematics teachers is analyzed. We exemplified lecturer knowledge in different subdomains of the MTSK model. These results contribute to the understanding and characterization of the components of mathematics teacher's specialised knowledge at the university level.

Keywords: lecturer knowledge, specialised knowledge, university level, real analysis, real numbers.

Introduction

The mathematics education research focusing on the teachers' knowledge has traditionally been conducted at the elementary and secondary level. However, the study of mathematics lecturer's knowledge has recently emerged as a line of research that seeks to understand this knowledge, its development, and how it is reflected in university teaching practices (Biza, Giraldo, Hochmuth, Khakbaz, & Rasmussen, 2016). Among the scarce account of research about mathematics lecturer's knowledge, the work of Breen, Meehan, O'Shea, and Rowland (2018) is a first approximation of teaching at the university level using Knowledge Quartet model (Rowland, Huckstep, & Thwaites, 2005). In addition, the studies conducted by Vasco, Climent, Escudero-Avila, and Flores-Medrano (2015) and Vasco and Climent (2017) highlight the utility of the Mathematics Teacher's Specialised Knowledge model (Carrillo, Climent, Contreras, & Muñoz-Catalán, 2013) and its corresponding analytical categories for understanding mathematics lecturers' knowledge. Other research in the same line, indicate that it is important to obtain empirical evidence pertaining to the components of specialised mathematics lecturer's knowledge (Delgado-Rebolledo & Zakaryan, 2018) and deepening the understanding of these components in situations other than lecturers' classroom practices (Vasco & Climent, 2018).

Taking into account this background, we propose the following research question: Which knowledge, according to the Mathematics Teacher's Specialised Knowledge model, arises in the teaching practice of a mathematics lecturer? Teaching practice is considered in a broad sense, including lesson planning, liaising with colleagues, giving lessons, and taking time to reflect on them afterwards (Carrillo et al., 2018). In this sense, with the aim of answering the research question, we have studied one mathematics lecturer teaching a real analysis course in a mathematics teachers' training program, and reflecting on his performance. In this paper, we present examples of the different subdomains of this lecturer's specialised knowledge. We do not consider his characteristics as a mathematics teacher educator. A discussion about mathematics teacher educator's knowledge is exposed in the paper of Almeida, Ribeiro and Fiorentini (in this volume).

Theoretical Framework

In the Mathematics Teacher's Specialised Knowledge (MTSK) model, two domains of teacher knowledge are distinguished, Mathematical Knowledge (MK) and Pedagogical Content Knowledge (PCK). The model also considers teacher's beliefs about mathematics and about mathematics teaching and learning (Carrillo et al., 2018).

MK refers to teacher knowledge of mathematics within the educational context, considering some of its characteristics as a scientific discipline. MK includes the Knowledge of Topics (KoT), Knowledge of the Structure of Mathematics (KSM) and Knowledge of Practices in Mathematics (KPM) subdomains. KoT contains knowledge about definitions, properties and their foundations, procedures, registers of representation, phenomenology, and applications (e.g., knowledge of the field properties of rational numbers; knowledge of definitions of real numbers). KSM encompasses knowledge of connections among mathematical items: connections associated with an increase in complexity or with simplification, and inter-conceptual connections (e.g., knowledge of relationships between infinity and the Archimedean property of the real numbers). KPM comprises knowledge about demonstrating, justifying, defining, making deductions and inductions, giving examples, and understanding the role of counterexamples (e.g., knowledge of how to prove the density property of the rational numbers in real numbers).

On the other hand, PCK is a specific type of knowledge of pedagogy in which the mathematical content determines the teaching and learning that takes place. PCK includes the Knowledge of Mathematics Teaching (KMT), Knowledge of Features of Learning Mathematics (KFLM), and Knowledge of Mathematics Learning Standards (KMLS) subdomains. KMT includes knowledge of theories of mathematics teaching, teaching resources, and strategies, techniques, tasks, and examples (e.g., knowledge of particularities of a real analysis textbook that makes it more convenient than others for use in a course, or use of analogy to illustrate the features of the existential quantifier). KFLM comprises the knowledge of theories of mathematical learning, strengths and weaknesses associated with learning, ways in which students interact with mathematical content, and emotional aspects of learning mathematics (e.g., awareness of analysis being more difficult for students than calculus; knowledge of difficulties students encounter when working with real numbers). Finally, KMLS contains the knowledge of sequencing of topics, expected learning outcomes, and the expected level of conceptual or procedural development (e.g., the sequencing of the completeness theorem topics, characterization of the greatest element, and the Archimedean property of the real numbers).

Methodological aspects

In this research, based on an interpretive paradigm and a qualitative methodology, an instrumental case study (Stake, 1995) was conducted. The case pertains to a lecturer and mathematics researcher that was developing a real analysis course. Real analysis is a second-year course in a mathematics teachers' training program in a Chilean university. In the first two years, the students take calculus, algebra, and geometry courses, whereas, from the third year, the courses focus on teaching practices, general pedagogy, and didactics of mathematics (numerical systems, functions, geometry, and statistics).

The lecturer, who will be called Diego, has more than 20 years of teaching experience at the university level and this is the sixth time in recent years that he has developed the real analysis course. Diego's classes are of 90-minute duration, and each was videotaped, transcribed, and organized in class episodes according to Diego's tacit or explicit goals. For example, we consider a *class episode* the period since Diego begins until he finishes presenting a definition. In each episode, Diego's interventions that show knowledge according to the MTSK model (a knowledge that could be classified in an analytical category of some subdomain of the model) are chosen as *analysis units*. The analysis units that allow us to affirm the presence of a teacher knowledge were named *evidence*. Others, where we suspected the existence of teacher knowledge, but additional information was needed in order to confirm or refute this suspicion, were denoted as *indication*. An indication provided a reason to investigate in more detail the lecturer's knowledge. Hence, the differentiation between evidence and indication (Moriel-Junior & Carrillo, 2014) is considered with the aim to refine our interpretations and deepen the understanding of the subdomains of lecturer's knowledge.

The data obtained through video recordings was complemented with a semi-structured interview that was divided in two sessions for a total duration of three hours. The interview was audio-recorded and subsequently transcribed, reproducing Diego's speech with the highest fidelity possible. A template of questions was constructed to prompt Diego to think about some of his expressions and performances during the classes. For example, in one of Diego's classes, he referred to a YouTube video as a complementary material. Thus, in the interview, we asked Diego why he used that video and what was its intended objective. In addition, some questions were formulated with the intention to examine indications of knowledge and to explore the subdomains of specialised knowledge that has not been present in class episodes. Video clips of the classes were shown to stimulate Diego's recollection, because the interview was conducted once the course was completed. Transcriptions of the interview were analyzed in a similar manner to classes, considering each response to a particular question as an analysis unit.

Results

In this section, we exemplify with evidence the subdomains of Diego's specialised knowledge during a class session on real numbers. Diego starts this class by enunciating some concepts and properties studied in the previous class, such as the least-upper bound property and the Archimedean property of real numbers. Next, he uses these elements with the aim to construct, together with the students, the density of the rational and irrational numbers in the real numbers proof.

Diego's mathematical knowledge

As a part of his KoT, Diego knows axioms for the real numbers, constructions of this numerical system (e.g., Cauchy sequences or Dedekind cuts), definition of real numbers as a complete ordered field, and properties of real numbers. For example, Diego *knows the Archimedean property of the real numbers* (KoT) because he enunciates the property ($\forall x, y \in \mathbb{R}, x > 0, \exists n \in \mathbb{N}$ such that $nx > y$) and comments on that in the following way:

Diego: And, this property, which was not specified by Archimedes, but Euclid, is equivalent to saying that, for all small natural number ε , there exists a natural number n such that $\frac{1}{n} \leq \varepsilon$.

Later, Diego writes on the blackboard the following proposition: Let $a_n < b_n$, and $I_n = [a_n, b_n]$, if I_n is a set of closed and bounded intervals, there exists $x \in \mathbb{R}$, such that $a_n < x < b_n, \forall n \geq 1$. Next, he makes a comment regarding this statement.

Diego: This proposition indicates that, every time that I intercept closed and bounded intervals, that are nested... I forgot to say that they have to be nested, if not, it is not true. If the intervals are not nested, then the intersection is empty. For example, if you take the $[0,1]$ interval and later the $[10,12]$ interval, in the intersection you will have nothing because they are not nested. Then, to say that they are nested, I add to the proposition [writes on the blackboard, $\forall I_n \supset I_{n+1}$]

Diego *knows the nested intervals property* (KoT), and deepening his discussion on the property, he emphasizes that the intervals must be nested in order to have an intersection that is not empty. Also, he understands how this sufficient condition gives sense to the implication expressed in the property. This *knowledge of use of formal language* as a way of communicating the mathematical idea expressed in the nested intervals property, belongs to the KPM subdomain.

On the other hand, starting from an indication of Diego's knowledge about the importance of the density of \mathbb{Q} in \mathbb{R} property, in the interview, when we asked Diego about the meaning of this property, he responded as follows:

Diego: The density is everywhere, because you cannot do anything if you do not have a dense and numerable set. The fact that the rational numbers are dense in the real numbers is very important, because you can take any real number and approximate it by a rational number. The real numbers have a cardinality greater than aleph 0, so you cannot count using them... Then, in this process of approximation, the rational numbers are important because, in practice, our calculations are limited to rational numbers.

In this excerpt, Diego demonstrates his *knowledge of a connection to items within the same topic* (KoT) because he points out that properties of \mathbb{Q} such as its density in \mathbb{R} and its numerability are essential to work approximation and calculation processes with real numbers. When the lecturer said, "*in practice, our calculations are limited to rational numbers*", he referred to the processes mentioned above, which are also important in applications of mathematics, such as in modelling or numerically solving differential equations. In this sense, Diego's knowledge of uses and applications of properties of \mathbb{Q} is identified as a part of his KoT subdomain.

Likewise, Diego refers to the density property of the rational and irrational numbers in real numbers. Given an interval $[a, b] \in \mathbb{R}$, it holds $\mathbb{Q} \cap [a, b] \neq \emptyset$ and $\mathbb{R}/\mathbb{Q} \cap [a, b] \neq \emptyset$. Diego particularizes the proposition for the case of an interval with $a = 0$ and $\varepsilon = (b - a)/2$. Using the Archimedean property, he establishes the following lemma: Given $\varepsilon > 0$, and $n, m \in \mathbb{N}$, the interval $(0, \varepsilon)$ contains a rational number $1/n$ and an irrational number $\sqrt{2}/m$. Hence, Diego shows his *knowledge of establishing preliminary results to facilitate the development of the density of rational numbers in real numbers proof*. This knowledge of a way of proceeding in mathematics is a part of Diego's KPM. Moreover, Diego considers the case of a positive rational number a , extending his previous

arguments, and demonstrates his knowledge of *process of particularization and generalization of a proposition* about real numbers (KPM) as a way of proceeding in mathematics.

Continuing with the development of the density of the irrational numbers in real numbers proof, the lecturer expresses:

Diego: Using the previous lemma, there exists a number z , real and not rational number, such that z is between 0 and ε . Then, if I add a to this inequality, I have [writes on the blackboard $a < a + z < a + \varepsilon < b$]. a is a rational number and z is an irrational number, then, where is $a + z$? . . . If I can argue that $a + z$ is not in \mathbb{Q} , then I can find an irrational number in $[a, b]$. Why is $a + z$ not in \mathbb{Q} ? Because, if $a + z$ was a rational number and I add another rational number, I will have to obtain a rational, because the rational numbers are a field. So, when I add two rational numbers, the answer is a rational number. Then, what can I add to $a + z$, conveniently, to get a contradiction?

Student: $-a$

Diego: Ok, if I add $-a$ to the inequality, the addition $-a + a + z$ is equal to z . That should be a rational, but I know that this is not true, so $a + z$ cannot be a rational number. Ok, I win.

In this episode, lecturer's knowledge of ways of validating in mathematics is identified. Diego demonstrates his knowledge of *how proofs by contradiction method are done* (KPM). The lecturer understands the logic underpinning this method of proof because he exposes what should be assumed ($a + z$ is in \mathbb{Q}), how a contradiction is constructed (adding $-a$ conveniently considering properties of the rational numbers) and what must be concluded ($a + z$ is not in \mathbb{Q}).

Diego's pedagogical content knowledge

Regarding Diego's PCK, in the class, Diego referred to the textbooks that he uses to develop the course. Later, in the interview, Diego elaborated on the reasons behind this literature selection.

Diego: In the real analysis course, I use the Spanish edition of a famous textbook; the original edition is in Portuguese, but in Spanish, it has two editions, detailed and summarized. I do not use the detailed version because that textbook has a lot of information. Instead, I use the summarized edition that provides the most essential parts and, if I am lacking something, then I complement it with other textbooks.

In the exposed fragment, we observe that Diego not only knows both editions of the analysis textbook (detailed and summarized), he also knows the specific characteristics of each one, which allows him to select the textbook that makes it more convenient to develop the real analysis course. This knowledge of the *teaching resource* belongs to Diego's KMT subdomain.

Likewise, Diego exposes the reasons behind the use of YouTube videos as a complementary material to the classes.

Diego: I like these videos because they are produced by the author of the textbook that we use in the course. The teacher worked in a prestigious university in Brazil and these

videos are from a course intended for postgraduate students. The course duration is two months. I present the course [the same content] in a semester, with more time and I share the videos with the students, although the videos are in Portuguese and the language could be a problem.

Diego highlights the advantages of YouTube videos (they are created by the textbooks' author and he can develop the content in more detail). However, Diego knows that this digital resource has the limitation of language that is unfamiliar for some students. In this sense, Diego shows his knowledge of the advantages and limitations associated with the videos as a *digital teaching resource*. This knowledge is included in Diego's KMT subdomain.

On the other hand, an indication of Diego's knowledge was confirmed in the interview when Diego talked about students' understanding of the real numbers.

Diego: The trouble with real numbers is the least-upper bound property, a historical difficulty that comes from Greeks. To humanity, it took more than 2000 years to comprehend the continuum . . . and maybe more, because I say until Newton, but actually, the formulation comes from Weierstrass. Then, this difficulty, this epistemological obstacle, inevitably emerges when you talk about real numbers.

Diego knows *students' weaknesses pertaining to the understanding of real numbers* (KFLM). He explains this issue considering historically intrinsic difficulties in conceptualizing real numbers due to the presence of the continuum as an epistemological obstacle.

Linked with the above, Diego comments:

Diego: The other issue is that, in high school, real numbers are reduced to an algorithmic point of view only. I do not claim that this is wrong, but it should not be restricted to only that.

In the previous statement, Diego shows his knowledge of how are taught real numbers in high school. He refers to "*an algorithmic point of view*" highlighting deep level regarding the approach given to real numbers in learning standards in some Chilean high schools. This knowledge of *the expected level of procedural development* belongs to Diego's KMLS subdomain.

Final remarks

In this research, we have shown some examples of how the mathematics teacher's specialised knowledge could be identified and characterized in the case of a mathematics lecturer. In the pedagogical content knowledge, we exemplified the three subdomains (KMT, KFLM, and KMLS) and in mathematical knowledge we exemplified the KoT and KPM subdomains. Evidence of KSM was not supported by our findings in line with the results reported by Vasco et al. (2015). However, we obtained some indications of knowledge which supply several ideas to deepen in the KSM in the case of mathematics lecturers. Furthermore, descriptors of KPM regarding ways of communicating and ways of validating in mathematics are exposed in this work. Descriptors about ways of proceeding and ways of validating were reported by Delgado-Rebolledo and Zakaryan (2018), although the descriptors' grouping into categories is still under study. Establishing categories of KPM is an important topic of research in the MTSK model, and descriptors obtained in this study focusing

on one mathematics lecturer are a good starting point for investigating components of this subdomain in teachers at other educational levels, given that scarce evidence of KPM has been reported in the research literature (Zakaryan & Sosa, 2019).

Additionally, in some examples, we observed possible relationships among the subdomains of knowledge. For instance, when the lecturer exposes the nested intervals property, his KPM regarding use of formal language allows him to understand this property in his KoT. Also, in the lemma used to develop the density of the irrational numbers in the real numbers proof (KPM), the lecturer relies on his knowledge of the Archimedean property (KoT). In a similar manner, relationships within pedagogical content knowledge domain could be established. For example, the lecturer ascribes students' weaknesses to the epistemological obstacle associated to real numbers, which allows him to understand the procedural approach to this notion in high school. Then, when the lecturer refers to the approach to real numbers adopted in high school (KMLS), he also demonstrates his awareness of students' weaknesses when working with real numbers (KFLM).

Thus far, relationships between disciplinary knowledge and pedagogical content knowledge have been reported in studies of secondary teachers (e.g., Sherin, 2002). We propose that this type of relationships could also be established in the knowledge of mathematics lecturer. These relationships are an opportunity to investigate the development of lecturer's mathematical and pedagogical knowledge.

In line with the above, the identification of the mathematics lecturer's specialised knowledge contributes to understand mathematics lecturers' knowledge and how this knowledge is reflected in their teaching practice (Biza et al., 2016). However, more research is necessary to deepen the understanding of the nature and the components of mathematics lecturer's knowledge. In this sense, we propose to explore the relationships between the different subdomains of mathematics lecturer's knowledge as a topic for further research.

Acknowledgment

Beca de Doctorado año 2017 CONICYT, folio 21170442.

References

- Biza, I., Giraldo, V., Hochmuth, R., Khakbaz, A., & Rasmussen, C. (2016). *Research on Teaching and Learning Mathematics at the Tertiary Level: State-of-the-art and Looking Ahead*. Switzerland: Springer.
- Breen, S., Meehan, M., O'Shea, A., & Rowland, T. (2018). An analysis of university mathematics teaching using the Knowledge Quartet. In V. Durand-Guerrier, R. Hochmuth, S. Goodchild, & N.M. Hogstad (Eds.), *Proceedings of the Second Conference of the International Network for Didactic Research in University Mathematics* (pp. 383–392). Kristiansand, Norway: University of Agder and INDRUM.
- Carrillo, J., Climent, N., Contreras, L., & Muñoz-Catalán, M. (2013). Determining specialised knowledge for mathematics teaching. In B. Ubuz, Ç. Haser, & M. A. Mariotti (Eds.), *Proceedings of the Eighth CERME* (pp. 2985–2994). Antalya, Turkey: ERME.

- Carrillo-Yañez, J., Climent, N., Montes, M., Contreras, L. C., Flores-Medrano, E., Escudero-Ávila, D.; Vasco, D., Rojas, N.; Flores, P., Aguilar-González, A., Ribeiro, M. & Muñoz-Catalán, M. C. (2018). The mathematics teacher's specialized knowledge (MTSK) model. *Research in Mathematics Education*, 20(3), 236-253. doi:10.1080/14794802.2018.1479981.
- Delgado-Rebolledo, R., & Zakaryan, D. (2018). Knowledge of the practice in mathematics in university teachers. In V. Durand-Guerrier, R. Hochmuth, S. Goodchild, & N.M. Hogstad (Eds.), *Proceedings of the Second Conference of the International Network for Didactic Research in University Mathematics* (pp. 393–402). Kristiansand, Norway: University of Agder and INDRUM.
- Moriel-Junior, J. G., & Carrillo, J. (2014). Explorando indícios de conhecimento especializado para ensinar matemática com o modelo MTSK [Exploring indications of specialized knowledge for mathematics teaching through MTSK model]. In M. T. González, M. Codes, D. Arnau, & T. Ortega (Eds.), *Investigación en Educación Matemática XVIII* (pp. 465–474). Salamanca: SEIEM.
- Rowland, T., Huckstep, P., & Thwaites, A. (2005). Elementary teachers' mathematics subject knowledge: The knowledge quartet and the case of Naomi. *Journal of Mathematics Teacher Education*, 8(3), 255–281.
- Sherin, M. (2002). When teaching becomes learning. *Cognition and instruction*, 20(2), 119–150.
- Stake, R. (1995). *The art of case study research*. London: Sage.
- Vasco, D., Climent, N., Escudero-Avila, D., & Flores-Medrano, E. (2015). The characterisation of the specialised knowledge of a university lecturer in linear algebra. In K. Krainer & N. Vondrová (Eds.), *Proceedings of the Nine CERME* (pp. 3283–3288). Prague, Czech Republic: ERME.
- Vasco, D., & Climent, N. (2017). Relationships between the knowledge and beliefs about mathematics teaching and learning of two university lectures in linear algebra. In S. Zehetmeier, B. Rösken-Winter, D. Potari, & M. Ribeiro (Eds.), *Proceedings of the Third ERME Topic Conference on Mathematics Teaching* (pp. 177–186). Berlin, Germany: ERME.
- Vasco, D., & Climent, N. (2018). El estudio del conocimiento especializado de dos profesores de Álgebra Lineal [The study of the specialised knowledge of two Linear Algebra lecturers]. *PNA Revista de Investigación en Didáctica de la Matemática*, 12(3), 129–146.
- Zakaryan, D., y Sosa, L. (2019). ¿Cómo los profesores hacen prácticas matemáticas en sus aulas? [How teachers do practices in mathematics in class?] In R. Olfos, E. Ramos., & D. Zakaryan (Eds.), *Formación docente: Aportes a la práctica docente desde la didáctica de la matemática* (pp. 281–300). Barcelona: Graó.

The probability subjective view: developing teachers' knowledge to give sense to students' productions

Rosa Di Bernardo¹, Maria Mellone², Ciro Minichini³ and Miguel Ribeiro¹

¹State University of Campinas Brazil; rosadibernardo92@gmail.com, cmribas78@gmail.com

²University Federico II, Faculty of Mathematic, Naples, Italy; maria.mellone@unina.it³INDIRE,
Naples, Italy; ciro.minichini@gmail.com

Keywords: Probability, teacher's interpretative knowledge, teacher education.

In the last years, the importance of probability in the context of teaching mathematics is increasing together with its weight in the International Assessment Project. In particular, the presence of the content of “uncertainty and data” in the PISA framework has motivated the trend toward the relevance of this topic in the mathematics curricula all over the world. The epistemological peculiarities and the difficulties related to teaching and learning probability, is also related with the complexity to catch the differences and, at the same time, the intrinsic coherence between the three different approaches to be considered within such topic. This crucial aspect puts probability in a core position within the topics to be focused on researches in the Mathematics Education field. In particular, the subjectivist approach (de Finetti, 1931), hailing a subjective judgement influenced by a person's information and knowledge, is hardly considered in the international panorama of the school curricula, as stressed by Batanero (2015): “the subjective view, that takes into account one-off decisions, which are frequent in everyday life, and where we cannot apply the frequentist view, is hardly considered in the curriculum” (p. 43). Furthermore, we can recognize in the subjectivist approach to probability a powerful link with the psychological and cognitive attempt to measure the degree of reliability that an event occurs in the form “how much I am minded to bet on it”. Following the perspective pointed out by Batanero (2015), the subjective view of probability could support the teachers in designing meaningful educational contexts in this topic. Indeed, it is well known that teachers' knowledge has a great impact on pupils' knowledge/learning and it is essential to focus on teacher education if we want to improve pupils' learning. To make this possible, it is necessary to think about what kind of tasks in teacher education can be conceptualized and implemented in order to support teachers in developing knowledge about probability that includes also the subjective approach to it. Starting from these premises we present here a task, that is a part of a wider research project that has the goal to conceptualize and to implement tasks for teacher education in the context of probability. With this task we want to address a first research question that is: which kind of difficulties or potentialities do teachers show during the work with this task?

The task was conceptualized including pupils' productions, in order to develop the so called teacher's Interpretative Knowledge (Ribeiro, Mellone, & Jakobsen, 2016). The Interpretative Knowledge allows teachers to give sense to pupils' productions, even if such productions are considered as “non-standard, adequate answers that differ from those teachers would give or expect, or answers that contain errors” (Mellone, Tortora, Jakobsen, & Ribeiro, 2017, p. 2949). In this frame we would like to address a second research question: What kind of interpretative knowledge teachers need to recognize crucial elements to re-design the class work according with pupils' knowledge?

In particular, the task we are referring is conceptualized starting from a practice-based approach, that means to assume that teacher education should be in a direct relationship with practice. One of the ways of achieving this aim is to include pupils' productions to be discussed in the task. In particular, in this case we insert some pupils' productions came from previous research developed by the first and third authors in a fourth grade (Di Bernardo, 2017). During such research, one of the activities



Figure 1: bar graph from previous research

developed was to involve pupils in a measuring process of the length of a set of spaghetti out of a commercial box (about 1000 of spaghetti) and representing the outcomes by a bar graph (Figure 1).

The subjective approach of probability was faced using a betting game. In fact, after the measuring activity, the pupils were invited to imagine a game in which they had to guess the length of a spaghetti

randomly extracted from the box they were took off during the measuring activity. To do that, pupils were divided into two groups: *i*) the group of bookmakers, who had to create “quotas” for each event; *ii*) the group of players, who had to choose their preferred bookmaker and bet on the chosen event. We hypothesized that the pupils can use the previous representation by the bar graph evaluating in a qualitative way the inverse relationship between the frequency of a length with the “quotas” they are available to pay for a betting on this length. Starting from this educational path, we built the task for teacher education. In the first part of the task we asked teachers to create “quotas”, on the base of the bar graph in fig.1. The request was quite open in order to leave teachers free to attribute quotas for the precise measure or in terms of ranges of measures, and to express it in additive or multiplicative way. Therefore, they had to decide “how many times” to pay the player's stake both in case the player bets on a precise measure of the length of the spaghetti and in the case the player bets on a range of measure of the length of spaghetti.

References

- Batanero, C. (2015). Understanding randomness: Challenges for research and teaching. In K. Krainer & N. Vondrová (Eds.), *Proceedings of CERME9* (pp. 34–49). Prague: European Society for Research in Mathematics Education.
- de Finetti, B. (1931). Sul significato soggettivo della probabilità. *Fundamenta Mathematicae*, T. XVII, 298–329.
- Di Bernardo, R. (2017). *Probabilità e statistica nella scuola primaria: un percorso sperimentale* (Unpublished master's thesis). University of Naples Suor Orsola Benincasa.
- Mellone, M., Tortora, R., Jakobsen, A., & Ribeiro, M. (2017). Prospective teachers interpret student responses: Between assessment, educational design and research. In T. Dooley & G. Gueudet (Eds.), *Proceedings of CERME10* (pp. 2948–2955). Dublin: Institute of Education, Dublin City University and ERME.
- Ribeiro, C. M., Mellone, M., & Jakobsen, A. (2016). Interpretation students' non-standard reasoning: insights for mathematics teacher education. *For the Learning of Mathematics*, 36(2), 8–13.

“Sometimes it goes wrong!” – Teachers’ beliefs concerning experiments in mathematics

Sebastian Geisler¹ and Sarah Beumann²

¹Ruhr-University Bochum, Faculty of Mathematics, Germany; Sebastian.geisler@rub.de

²Bergische Universität Wuppertal, Faculty of Mathematics, Germany; beumann@uni-wuppertal.de

In didactic literature there are many practical materials to use experiments in mathematics classroom. Even though, experiments seem to be beneficial in mathematics education, little is known about what teachers think concerning this method. In this explorative study we want to examine the teachers’ beliefs about experiments and which relations they see between experiments and mathematics. We asked teachers from various school types in Germany, with an open-ended questionnaire. Our results indicate that most teachers see experiments either as controlled and planful procedure or as “trial and error”. Furthermore, teachers state mainly two relations between experiments and mathematics.

Keywords: Experiments, teachers’ beliefs, grounded theory

Introduction

Despite the fact, that teachers’ beliefs have been of increasing interest in educational research, the lack of a common shared definition or understanding of beliefs is obvious (Pajares, 1992; Philipp, 2007). Most authors locate beliefs within the affective domain but attest beliefs to be more cognitive and stable than attitudes and emotions (McLeod, 1992; Philipp, 2007; Hannula, 2012). We refer to beliefs as “Psychologically held understandings, premises, or propositions about the world that are thought to be true” (Philipp, 2007, p. 259). It has been proven that beliefs influence teachers’ activity (Grigutsch, 1996). Thus, beliefs are the basis for later actions and are part of the teacher's professional knowledge (Kuntze & Reiss, 2005).

However, during the last years the focus of interest has changed from rather global beliefs to domain specific beliefs or beliefs concerning single methods (e.g. Eichler & Schmitz, 2018). One method, that has not been taken into account so far, are experiments or hands-on laboratory activities. Since experiments play an important role in both scientific mathematics and mathematics education, we want to shed light on teachers’ beliefs concerning the nature of experiments and the relations between experiments and mathematics.

Experiments

Experiments play a crucial role in the epistemology of nature science. The experimental testing of hypotheses, which have been derived from theories, can be seen as the core of scientific work in subjects like physics and chemistry. It is, therefore, not surprising that experiments have an outstanding position in science education as well. For example, in physics lessons experiments and laboratory work fill about 30% of the time spent in class (Tesch & Duit, 2004). Before illustrating the role of experiments in mathematics we will give a brief overview of the discussion about the question what exactly an experiment is.

Characteristics of Experiments

It is rather surprising that there is no common shared definition of experiments. Borba and Villarreal (2005) summarized definitions from several dictionaries concluding that “in an experiment, conditions or factors are manipulated and facts are observed in order to prove or disprove a given hypothesis” (p. 66). They added that besides the testing of hypotheses, experiments can be used to “discover something unknown [...] or to provide examples of a known truth” (p.66). Ganter and Barzel (2012) stress that experiments form a cyclical process, starting with a concrete hypothesis, the planning of an experiment and followed by the performing of the experiment itself and analysing the results – which themselves can lead to a following cycle. It should not remain unmentioned that in every day sense – and even in some dictionaries – every hands-on activity or laboratory work is considered to be an experiment, even if the process is not controlled and follows rather the principles of “trial and error” (Borba & Villarreal, 2005).

Experiments and (the Learning of) Mathematics

Even if it is not often mentioned or recognized: experiments and empirical observations play an important role in mathematics and the learning of the same. Polya (1945) described that:

“mathematics has two faces; it is the rigorous science of Euclid but it is also something else. Mathematics presented in the Euclidean way appears as a systematic, deductive science; but mathematics in the making appears as an experimental, inductive science. Both aspects are as old as the science of mathematics itself” (p. vii).

Experiments are part of the proving process in the sense that they help to identify structures and they give ideas how to proof theorems (Kortenkamp, 2014). A (young) subdomain of mathematics that uses (mainly) computer-supported experiments and simulations for this purpose is called experimental mathematics (Borwein et al., 2004). Besides the role experiments play in the proving process, mathematics and experiments meet each other in the experimental processes as it is performed in nature science, too. Quantitative experiments cannot be analyzed without mathematics – the data derived from an experiment undergoes a mathematical modeling process. Henning (2013) postulates that one of the most important functions of mathematics lies in supporting the understanding of our world.

The role of experiments in the mathematics classroom is closely connected to the relations between experiments and mathematics in scientific settings. In the existing literature we identified three learning situations related to experiments in mathematics:

- *Proving processes:* Regardless that proving is less present in school than in scientific mathematics, experimental work plays the same role in the proving process in school. Experiments can help to find a rule that could be proved and the ideas for the proof itself (Kortenkamp, 2014). “Experimental proofs” are part of the proving process of secondary students at school (Brunner, 2014).
- *Modeling:* Modeling is a key competence in mathematics lessons (Blum & Niss, 1991). But since modeling activities can be performed with “real” data derived from experiments as well as with data found in textbooks, the question arises whether the implementation of

experiments can enrich the modeling process. Following Carreira and Baioa (2018; 2011), experiments can enhance the credibility of modeling tasks and foster students' understanding of the real situation that is modeled and the involved mathematics. The use of "real" data from experiments can also enrich the validation of models and opens teachers' and students' view for the question what characterizes a good model and how one should act upon measurement errors which are inherent of experiments (Carrejo & Marshall, 2007).

- *Learning of new concepts:* Furthermore, experiments can support students' learning of new concepts. Ganter and Barzel (2012) showed that experiments can create a fruitful start for the learning of functional relations and, in particular, the manipulation of a variable during an experiment can help students to distinguish between dependent and independent variable.

Furthermore, experiments can increase students' interest in mathematics and their motivation (Beumann, 2016). As conclusion one might say that experiments can enrich mathematics lessons in various ways and learning situations. However, experiments are neither explicitly mentioned in the German mathematics curriculum, nor do they play a crucial role in teacher education. Thus, teachers' beliefs concerning experiments and the teachers' use of experiments in the classroom is widely unexplored. This contribution is a first step to investigate teachers' beliefs concerning experiments and their connection to mathematics.

Beliefs and Experiments

Some recent studies addressed the beliefs of teachers in nature sciences concerning the role of experiments in the classroom and the goals obtained by using experiments. Science teachers' reasons to use experiments in their teaching practice include that experiments involve hands-on-activities, increase students' motivation and their conceptual and procedural understanding of nature sciences (Lavonen, 2012). In the special case of mathematics, teachers value the use of hands-on activities in classroom and believe that mathematics lessons should be student-centered (Wang & Cai, 2007) – experiments fall within both: hands-on activities and student-centered methods.

However, to the best of our knowledge there is currently no study (neither in science education nor mathematics education) focusing on teachers' beliefs concerning the nature of experiments and how experiments are connected to mathematics and mathematics learning. For a profitable use of experiments in class, teachers need to have appropriate beliefs about this method itself as well as about the relation to mathematics.

Research Questions

Since on the one hand experiments can be beneficial for the learning of mathematics, and on the other hand teachers' beliefs affect their classroom practices (Grigutsch, 1996), we want to explore beliefs that teachers hold concerning experiments. This leads to the following questions:

- 1) Which beliefs are held by mathematics teachers concerning the notion experiment?
- 2) Which relations between experiments and mathematics do mathematics teachers see?

Methods

Since the answers in liker-scale surveys are not easy to interpret when dealing with beliefs (Phillips, 2007) we decided to use open-ended questions within a paper and pencil questionnaire. The questions

where formulated as follows: 1) What do you understand under the notion “Experiment”? Give a brief explanation and typical characteristics. 2) In which way do experiments and mathematics fit together? Which relations between mathematics and experiments do you see?

The questionnaire was handed to 50 in-service teachers who worked at different types of schools in North Rhine Westphalia, Germany (primary school, lower and upper secondary schools). All of them were mathematics teacher and 24 taught another STEM-subject (like chemistry or physics) as well. All teachers participated voluntarily. We choose that variety of participants in order to gain a more global (yet not necessarily generalizable) picture of the teachers’ beliefs. However, not all teachers answered every question in the questionnaire.

The data analysis of this study is based on the “Grounded Theory” by Glaser and Strauss (1998). We constantly compared the data with each other by using open codes. Thus, we identified various beliefs concerning experiments. These beliefs have been discussed and grouped in categories. Given the limited space, we only give an overview of the main categories in this contribution.

Results

Category	Description	Example	Quantity
<i>Procedure (characteristics of the experimental process)</i>			
Experiments as planful and controlled procedure	Experiments are characterized by planful and controlled actions to verify a given hypothesis	“An experiment is an action, that is conducted under fixed circumstances [...] to check a hypothesis or generate one.”	17
Experiments as “trial and error”	Experiments are not planful or controlled. They do not need a hypothesis and are characterized by trying out and attempting different things.	“Try things out – involves that sometimes it goes wrong.”	22
Experiments as autonomous hands-on activity	Every kind of hands-on activity that provides autonomous working is viewed as experiment – regardless if it is planful or just trying.	“To solve a task with hands-on activities and practical solutions.”	10
<i>Aim (aims connected to experiments)</i>			
Experiments aiming on (better) understanding	The aim of experiments is to (better) understand previously known things.	“Better understand relations.”	13
Experiments aiming at (new) knowledge	The aim of experiments is to provide new (at least from the viewpoint of the experimenting person) insights and knowledge.	“Experiments are a method to gain new insights.”	16

Table 1: Beliefs concerning the nature of experiments

Regarding the nature of experiments, we distinguish beliefs concerning the procedure of experimenting and the aims which are connected to experiments. Most teachers stated that they see experiments as either a controlled and planful action to check a given hypothesis or as uncontrolled trying without guiding hypothesis and plan. However, some teachers wrote that they see every hands-on activity as an experiment as far as it involves autonomous working. Besides these characteristics of the conduction of an experiment, most teachers stated that experiments aim at a certain goal: 16 teachers believe that experiments should lead to new insights and new knowledge – at least this knowledge should be subjectively new for the person that obtains the experiments. Other teachers focus more on the aim to better understand previously gained knowledge (Table 1).

Concerning the relation between mathematics and experiments we could identify two main beliefs (Table 2): 13 teachers stated that experiments are part of the process to generate new mathematical knowledge. Experiments are the inductive starting point of this process. 9 teachers see mathematics as part of the experimental process in other sciences – in this view mathematics is used to describe and model experiments. Two teachers stated no direct connection between mathematics and experiments but listed characteristics that both have in common. 3 teachers wrote that they see no relation between mathematics and experiments. However, despite the fact that we explicitly asked for a connection between experiments and mathematics, many teachers only wrote about the connection of experiments and classroom practices.

Category	Description	Example	Quantity
Experiments as a method in the mathematical process	Experiments are used in the mathematical process to generate new hypothesis that can be proven later.	“Mathematical statements are the result of a long process, obtained with the help of experiments”	13
Mathematics as toolbox in the experimental process	Mathematics is used to describe and evaluate experiments in other sciences and everyday life.	“Experiments and their results can usually be described with mathematics.”	9
Common characteristics of Mathematics and Experiments	Mathematics is not part of the experimental process or vice versa but both have common characteristics.	“Mathematics as well as experiments is based on plans to solve certain problems, the systematic conduction of the plan and the reflection upon the results.”	2

Table 2: Beliefs concerning the relation between mathematics and experiments

Like beliefs concerning the nature of mathematics, beliefs about experiments are not disjoint in the sense that teachers can either believe that experiments are planful and controlled or trial and error. The different beliefs can be held in various combinations. We illustrate this fact by describing the beliefs of three teachers more precisely:

Mr. A teaches mathematics and biology at an upper secondary school and wrote that he used experiments in his mathematics lessons before. For him a “clear mandatory setting and procedure” characterizes experiments. But he is aware of the fact that in every day life “experimenting” can be

viewed as less playful and less controlled: “Colloquial, experimenting can be aimless without mandatory setting and determined procedure.” He sees the connection between mathematics and experiments in modeling activities: “Insights from experiments can be mathematically modeled. The mathematical models themselves can be used for further predictions concerning the phenomenon. These predictions can be checked by new experiments. Mathematics and experiments can support each other in this sense.”

Mr. B teaches mathematics and physics at an upper secondary school and used experiments in his mathematics lessons before. For him, experiments follow a very clear and determined procedure: “Experiments consist of the observation of results, the investigation of dependences from single parameter, a defined procedure, and the reflection on the objects and used methods.” In contrast to Mr. A he sees no direct connection between mathematics and experiments but he stresses that the experimental process and the process of creating new mathematical knowledge have some characteristics in common: “Similar to experiments, an appropriate question and the development of ideas, hypothesis and conceptions belong to mathematics. On this basis theories can be developed and later be proven.”

Mrs. C works at an upper secondary school, too, but teaches no nature science and has not used experiments in her lessons so far. Mrs. C’s beliefs concerning the nature of experiments are less sophisticated. For her experimenting means to “try things out.” However, in her opinion experiments are an integral part of mathematical discoveries: “Mathematics is based on experimental work, like searching and finding schemas – that’s how discoveries are made!”

The exemplary comparison of Mr. A and Mr. B reveals, that the teachers’ beliefs concerning the nature of experiments as well as their background (both are teaching a second STEM-subject and used experiments in their lessons before) do not directly determine which connections to mathematics they see. Both teachers stress that experiments follow a defined procedure. However, Mr. A sees a clear connection between experiments and mathematics, while Mr. B does not see this connection. This result was observed amongst many teachers in our sample. Furthermore, we found no effect of STEM-teaching on the teachers’ beliefs concerning the nature or experiments.

Discussion and Outlook

The teachers’ beliefs concerning the nature of experiments mainly reflect the discussion on a scientific definition of experiments (Borba & Villarreal, 2005) with the two (extreme) poles “experiments as trial and error” and “experiments as controlled procedure”. Given the fact, that modeling plays an important role in modern mathematics education, it is rather surprising that not more teachers saw this connection between mathematics and experiments. Especially since many teachers in our sample taught a nature science as well and, therefore, should be familiar with experiments. In our understanding, every analysis of a quantitative experiment in nature sciences needs mathematical modeling to some degree. However, 25% of the teachers reported that they see experiments as part of the process to gain new mathematical knowledge which is in line with Brunner’s (2014) model of proving processes in school. Furthermore, (computer-supported) mathematical experiments are of growing importance in scientific mathematics which should be reflected in mathematics education as well, according to Kortenkamp et al. (2014).

One limitation for our analysis is that we have no information about the teachers' beliefs concerning the nature of mathematics (mathematical worldview). These beliefs might affect which connections teachers see between experiments and mathematics.

With this pilot study we made a first step to understand teachers' beliefs concerning experiments in mathematics. Our ongoing research will now focus on two facets: 1) The reasons that lie behind teachers' beliefs concerning experiments (e.g. teachers' background and connections between teachers' beliefs concerning the nature of mathematics and their beliefs concerning experiments) and 2) the question whether (and how) mathematics teachers implement experiments in their mathematics lessons. In order to gain deeper insights into the connection of the teachers' beliefs and their use of experiments in mathematics lessons, semi-structured interviews as well as classroom observations will be used.

References

- Beumann, S. (2016). *Versuch's doch mal – Eine empirische Untersuchung zur Förderung von Motivation und Interesse durch mathematische Schülerexperimente*. (Doctoral dissertation) Ruhr-Universität-Bochum. Retrieved from <https://hss-opus.ub.ruhr-uni-bochum.de/opus4/frontdoor/deliver/index/docId/5122/file/diss.pdf>.
- Blum, W. & Niss, M. (1991). Applied mathematical problem solving, modelling, applications and links to other subjects – State, trends and issues in mathematics instruction. *Educational Studies in Mathematics*, 22(1), 37–68.
- Borba, M. C., & Villarreal, M. E. (2005). *Humans with Media and the Reorganization of Mathematical Thinking. Information and Communication Technologies, Modeling, Visualization and Experimentation*. Springer.
- Borwein, J., Bailey, D., Girgensohn, R. (2004). *Experimentation in Mathematics. Computational Paths to Discovery*. New York: A K Peters/CRC Press.
- Brunner, E. (2014). *Mathematisches Argumentieren, Begründen und Beweisen. Grundlagen, Befunde und Konzepte*. Heidelberg: Springer.
- Carreira, S., & Baioa, A. M. (2011). Students' Modelling Routes in the Context of Object Manipulation and Experimentation in Mathematics. In G. Kaiser et al. (Eds.). *Trends in Teaching and Learning of Mathematical Modelling* (pp. 211–220). Springer:
- Carreira, S., & Baioa, A. M. (2018). Mathematical modelling with hands-on experimental tasks: On the student's sense of credibility. *ZDM - Mathematics Education*, 50(1–2), 201–215.
- Carrejo, D. J., & Marshall, J. (2007). What is mathematical modelling? Exploring prospective teachers' use of experiments to connect mathematics to the study of motion. *Mathematics Education Research Journal*, 19(1), 45–76.
- Eichler, A., & Schmitz, A. (2018). Domain Specificity of Mathematics Teachers' Beliefs and Goals. In B. Rott, G. Törner, J. Peters-Dasdemir, A. Möller, & Safrudiannur (Eds.), *Views and Beliefs in Mathematics Education. The Role of Beliefs in the Classroom*. (pp. 137–146). Berlin: Springer.

- Ganter, S. & Barzel, B. (2012). Experimentell zum Funktionalen Denken: Eine empirische Untersuchung zur Wirkung von Schülerexperimenten als Ausgangspunkt mathematischer Begriffsbildung - Teilprojekt 7. In W. Rieß, M. Wirtz, B. Barzel & A. Schulz (Eds.), *Experimentieren im mathematisch-naturwissenschaftlichen Unterricht. Schüler lernen wissenschaftlich denken und arbeiten.* (pp. 265–284). Münster: Waxmann.
- Glaser, B. G., & Strauss, A. A. L. (1998). *Grounded theory: Strategien qualitativer Forschung.* Bern: Huber.
- Grigutsch, S. (1996). *Mathematische Weltbilder von Schülern. Struktur, Entwicklung, Einflußfaktoren.* (Doctoral dissertation) Universität Duisburg.
- Hannula, M. S. (2012). Exploring new dimensions of mathematics-related affect: Embodied and social theories. *Research in Mathematics Education, 14*(2), 137–161.
- Henning, H. (Ed.) (2013). *Modellieren in den MINT-Fächern.* Münster: Verlag für wissenschaftliche Texte und Medien.
- Kortenkamp, U. (2004). Experimental Mathematics and Proofs in the Classroom. *ZDM - International Journal on Mathematics Education, 36*(2), 61–66.
- Kuntze, S. & Reiss, K. (2005). Situation-specific and generalized components of professional knowledge of mathematics teachers – Research on a video-based in-service teacher learning program. In H. L. Chick & J. L. Vincent (Hrsg.), *Proceedings of the 29th Conference of the International Group for the Psychology of Mathematics Education (PME), Vol. 3* (pp. 225–232). Melbourne: University.
- Lavonen, J., Jauhiainen, J., Koponen, I. T., & Suonio, K. K. (2012). Effect of a long-term in-service training program on teachers' beliefs about the role of experiments in physics education. *International Journal of Science Education, 26*(3), 309–328.
- McLeod, D. B. (1992). Research on Affect in Mathematics Education: A Reconceptualization. In D. A. Grouws (Ed.), *Handbook of research on mathematics learning and teaching* (pp. 575–596). New York: Macmillan.
- Pajares, M. F. (1992). Teachers' Beliefs and Educational Research: Cleaning Up a Messy Construct. *Review of Educational Research, 62*(3), 307–332.
- Philipp, R. A. (2007). Mathematics teachers' beliefs and affect. In F. K. Lester (Ed.), *Second handbook of research on mathematics teaching and learning* (pp. 257–315). Charlotte: Information Age.
- Tesch, M., & Duit, R. (2004). Experimentieren im Physikunterricht - Ergebnisse einer Videostudie. *Zeitschrift Für Didaktik Der Naturwissenschaften, 10*, 51–69.
- Wang, T., & Cai, J. (2007). United States teachers' views of effective mathematics teaching and learning. *ZDM - International Journal on Mathematics Education, 39*(4), 315–327.

Chinese and Dutch mathematics teachers' beliefs about inquiry-based learning

Luhuan Huang, Michiel Doorman and Wouter van Joolingen

Utrecht University, Freudenthal Institute for Science and Mathematics, Utrecht, The Netherlands;
L.huang@uu.nl; m.doorman@uu.nl; W.R.vanJoolingen@uu.nl

Teachers' beliefs are expected to have impact on the implementation of inquiry-based learning (IBL) in mathematics education. Moreover, Chinese and Dutch teaching cultures in mathematics seem to be very different. This paper presents results from semi-structured interviews with 30 Chinese and 19 Dutch mathematics teachers' beliefs about IBL. Statements were connected to main codes and ranked for each country. Dutch teachers focused on students' taking responsibility in IBL while Chinese teachers put extra emphasis on teacher guidance, they also talked about student discussion and collaboration. Chinese teachers paid attention to the benefits of IBL on mathematical thinking while Dutch teachers to the benefits on mastery and appliance of knowledge. In addition to the lack of time and suitable tasks as difficulties, Chinese teachers also mentioned students' lack of motivation and performance, while Dutch teachers mentioned the demands and openness of IBL.

Keywords: Mathematics education, inquiry-based learning, comparative study, teacher belief, lower-secondary education.

Introduction

As an intentional student-centered pedagogy rooted in the Western teaching culture, inquiry-based learning (IBL) encourages students to take responsibilities in the learning process, to explore by themselves, and to construct knowledge through actively participating in cycles like questioning, hypothesizing, designing, investigating, analyzing and reflecting (Swan, Pead, Doorman, & Mooldijk, 2013).

The understanding and implementing of IBL may be impacted by teaching cultures, while teaching culture of the East Asia is considered remarkably different from that of the West. These two teaching cultures have been identified and compared, which seemed to produce some stereotypes (Leung, 2001). From these stereotypes, the East Asia emphasizes learning content and related skills (Correa, Perry, Sims, Miller, & Fang, 2008; Leung, 2001) and values in-depth knowledge (Norton & Zhang, 2018), while the West emphasizes learning process (Leung, 2001) and values practical knowledge (Norton & Zhang, 2018); the East Asia conducts instruction to the whole class of students, while the West adopts individualized learning and group work (Leung, 2001); the East Asia considers teachers as the center and conducts well-organized directive instruction to deliver knowledge to students (Leung, 2001), while the West considers students as the center and encourages them to construct knowledge actively (Liu & Feng, 2015); the East Asia makes students learn by memorizing and practicing repetitively (Liu & Feng, 2015; Tan, 2015), while the West encourages meaningful learning (Leung, 2001); the East Asia motivates students by external factors such as examinations, while the West motivates students by internal factors such as interests (Leung, 2001).

These stereotypes about teaching cultures in the East Asia and the West also apply to the subject of mathematics. While the conceptualization of IBL in mathematics is less obvious (Artigue & Blomhøj, 2013). A large part of existing research focused on IBL in science, including research on science teachers' beliefs and practices of IBL (Wallace & Kang, 2004), a few of these research also included mathematics teachers (Marshall, Horton, Igo, & Switzer, 2009; Song & Looi, 2012). More attention needs to be paid to IBL specifically in mathematics.

As for the concept of IBL itself, no consensus has been reached about the definition, there exist a variety of interpretations about the IBL way of teaching approach (Furtak, Seidel, Iverson, & Briggs, 2012), especially about the amount of support provided to students, which makes IBL complicated to understand and implement for practitioners. Teachers may not have a complete understanding of IBL (Chin & Lin, 2013), and their beliefs about the detailed content of IBL tend to be diverse (Chan, 2010). In addition, IBL seems not yet a common practice embedded in daily teaching (Dobber, Zwart, Tanis, & Van Oers, 2017). Teachers' beliefs may shape their decisions and practice of implementing IBL (Saad & BouJaoude, 2012; Song & Looi, 2012; Wallace & Kang, 2004). While some studies also found a disconnect (Engeln, Euler, & Maass, 2013; Ramnarain & Hlatswayo, 2018) or a more complicated impact (Chan, 2010) between the beliefs and practice in regard to IBL. A deep understanding of teachers' beliefs towards the "complicated" IBL makes sense and may provide potential for better understanding their practice.

In an investigation into the beliefs and practices of IBL in mathematics, we explored from a students' perspective, and took China and the Netherlands as representing countries of the two teaching cultures (the east Asia and the West). The results showed that Chinese students reported more experience and preference of IBL than Dutch students, which challenge the stereotypes about the two teaching cultures. In this study, a teachers' perspective is to be explored.

The aim of this study is to present and compare Chinese and Dutch mathematics teachers' beliefs about IBL. The research questions are: What kinds of beliefs do lower-secondary mathematics teachers in China and the Netherlands have about inquiry-based learning (IBL)? What are the main similarities and differences on this issue between the two countries?

Methods

Participants

We interviewed 30 teachers from 15 Chinese schools and 19 teachers from 13 Dutch schools, all of them were teaching lower-secondary mathematics. 28 of the Chinese teachers and 9 of the Dutch teachers are female. The average age was 38 for Chinese teachers and 42 for Dutch teachers. As for the average years of teaching, it was 15 for Chinese teachers and 11 for Dutch teachers.

In China, generally a permission from school leaders makes it convenient to enter a school and conduct interviews, while teachers in the Netherlands have more freedom to accept an interview. Therefore in China we mainly contacted school leaders first, also a few local administrations, and some mathematics teachers directly, while in the Netherlands we invited individual teachers and included all teachers with interests. In both countries, participants were contacted mainly through an interpersonal network. Because of the large areas in China, we only collected data at Beijing, where

differences exist between urban and suburban schools, thus we ensured a balanced selection of eight urban schools and seven suburban schools to better represent the situation. In the Netherlands, schools at different areas are quite similar, we included different types of secondary schools¹.

Instruments

Data was collected through semi-structured interviews, which provided opportunities for teachers to express views and suit the research questions well. Without much presume about the definition or model of IBL, we left it open for teachers about their understanding of IBL.

We constructed an interview outline including general questions such as “what is your understanding of IBL” and two IBL example tasks as context to promote discussion. The tasks were chosen from materials of Primas project² and had potential for IBL, while they were not defined as IBL tasks in the interview, participants were asked questions such as “can it be used in an IBL lesson/do both versions represent IBL”.

The interview outline and example tasks were originally in English and translated into Chinese. The outline and tasks were piloted with two Dutch teachers and two Chinese teachers to make sure the questions and guidelines were clear enough and led to information we expected to collect. The pilot interviews also helped to prepare for practical issues that may happen during interviews.

Data collection and analysis

Dutch participants were interviewed from April to June of 2017, and Chinese participants from October to November in the same year. Each participant was interviewed individually for around 40 minutes, the language was English for Dutch teachers and Chinese for Chinese teachers. The participant was asked if recording can be accepted. If not, the interview would not go on. Generally, questions from the interview outline were asked in sequence, and extensive questions related to the topic were also allowed. Similar introduction and guideline were given to each participant.

All the interview recordings were turned into transcripts. The original codes were constructed mainly based on the questions from the interview outline, “teachers’ responsibility” and “students’ responsibility” were derived from literature. All transcripts were imported into Nvivo 11 and divided into sets of fragments. Each fragment represents a single idea. In the process of coding - including individual coding and discussing differences – sub codes with example quotations were developed to create a better understanding of the main codes. The coding scheme (shown in Table 1) was adjusted for several rounds to be better connected to the transcripts³.

¹ In the Netherlands, students choose after primary school (grade 6) for one of three types of secondary education: pre-vocational secondary education (VMBO), senior general secondary education (HAVO) or pre university education (VWO) (source: <https://www.government.nl/topics/secondary-education>).

² The Primas project: Promoting inquiry-based learning (IBL) in mathematics and science education across Europe.

³ For Chinese data, we analyzed and coded the original transcripts, then we translated statements and important quotations from Chinese into English.

Table 1: Coding scheme of the study

Main code	Sub code	Example
<ul style="list-style-type: none"> • General views-Basic understanding of IBL • Attitudes-Overall tendency towards IBL, Whether in favor of IBL • Prerequisite-Factors considered before implementing IBL in lessons 	Task	<ul style="list-style-type: none"> • “It is...about doing something different than just making the exercises from the book”
	Students	<ul style="list-style-type: none"> • “I think it is very useful for the basis, but I think you cannot use it as the only way of teaching.” • “I think this one (Unstructured Version B) will (represent IBL), this one (Structured Version A) not, this is too structured.” • “I think it is a very good group, I would maybe change this a bit, then I would give (Unstructured) Version B. In a lower grade like HAVO, then I would do this (Structured Version A), because otherwise they will not come any further.”
	Teacher	<ul style="list-style-type: none"> • “You need to have a repertoire of dealing with different things, you have to build that repertoire also”
	Context	<ul style="list-style-type: none"> • “They have to be ready to think about something new, even if it's very small detail, you must make them ready to do it, and sometimes you do not succeed because the circumstances are not ideal.”
<ul style="list-style-type: none"> • Activity-Things going on when implementing IBL in lessons; They are expected or planned to happen in the teacher's lessons • Outcome-Results of implementing IBL 	Students' responsibility	<ul style="list-style-type: none"> • “They need some time for themselves to try and succeed or try and fail”
	Teachers' responsibility	<ul style="list-style-type: none"> • “I think here you should be more encouraging, and maybe come and ask how things are going, and if they need help, then ask questions.”
	Cognitive & Positive	<ul style="list-style-type: none"> • “They learned to think, and to think deeper, and to persuade the other person”
	Cognitive & Negative	<ul style="list-style-type: none"> • “And the risks, risk of if every student learns enough, it's not guaranteed”
<ul style="list-style-type: none"> • Reasons For-Factors for teachers to implement IBL • Difficulties-difficulties in implementing IBL 	Motivational & Positive	<ul style="list-style-type: none"> • “I think they would like mathematics more”
	Motivational & Negative	<ul style="list-style-type: none"> • “I think some of the kids will get discouraged, less encouraged, demotivated from like this.”
<ul style="list-style-type: none"> • Reasons For-Factors for teachers to implement IBL • Difficulties-difficulties in implementing IBL 	Lead to positive results	<ul style="list-style-type: none"> • “I think it can really motivate students, it can really help them learning fast”
	Related to conditions	<ul style="list-style-type: none"> • “I just don't find the time to do it”
	Related to students	<ul style="list-style-type: none"> • “That the kids get stuck”
<ul style="list-style-type: none"> • Strategies-Tips for implementing IBL 	Related to teachers	<ul style="list-style-type: none"> • “They can go really deep, and then they come into an area that you really don't know the answer any more. That's scary.”
		<ul style="list-style-type: none"> • “Not to take too big steps, make sure that is the right question for the right age, make sure it's a statement that they really discover something, like this.”

When about half of the interviews had been coded, we introduced an external researcher to the interview outline and the coding scheme, and asked her to randomly choose one Chinese interview and one Dutch interview to code. The Chinese interview was coded together, and next the Dutch interview was coded by herself, resulting in a 69% agreement.

After coding, we arranged fragments with similar views together and extracted representative statements from those groups of fragments. For each statement, we counted how many teachers expressed this view during interviews. Based on the number, we ranked all the statements within each main code and kept the four highest-ranking statements to provide an overview of beliefs that the two groups of teachers have about IBL. If there existed multiple statements at the same ranking, all of them were kept or quitted. We counted and ranked for Chinese teachers and Dutch teachers respectively, then we compared the results between two countries.

Results

As preliminary results of this study, Table 2 shows 30 Chinese teachers and 19 Dutch teachers' beliefs on three important aspects through the four highest ranking statements within each main code. For example, 12 of the 30 Chinese teachers talked about “students explore and find a way to the problem”.

Table 2: High-ranking statements of Chinese and Dutch teachers on three aspects

Main code	CN statements	n	NL statements	n
General Views	· Students explore and find a way to the problem	12	· Students explore and find a way to the problem by themselves	15
	· Students discuss and collaborate with peers	12	· Teachers do not provide explanations before students' exploration	5
	· Teachers guide the IBL process	8	· The problem can be solved in different ways	4
	· Students think during the process	8	· Students think during the process	4
	· Students come to the conclusion	8	· Students do activities to solve the problem	4
Reasons For	· IBL develops mathematical thinking	17	· IBL leads to a better understanding, mastery and appliance of knowledge	8
	· IBL leads to a better understanding, mastery and appliance of knowledge	14	· IBL gives rise to more interests and motivates students	7
	· IBL gives rise to more interests and motivates students	11	· IBL is a way to develop general skills also necessary outside school and in future academic life and professional life	6
	· IBL is a way to develop general skills also necessary outside school and in future academic life and professional life	4	· IBL develops mathematical thinking	4
			· To prepare for examinations	4
Difficulties	· Some students do not think or participate actively	11	· Lack of time to prepare and do IBL sufficiently	12
	· Lack of time to prepare and do IBL sufficiently	10	· IBL asks for a lot from teachers to design and implement it well	10
	· Students may not perform well in IBL tasks	9	· Lack of suitable IBL tasks at hand	8
	· Lack of suitable IBL tasks at hand	7	· Teachers don't want the unpredictable results and insecurity that IBL brings	6

Note: “CN” is the abbreviation of China, and “NL” of the Netherlands. “n” means the number of teachers who expressed this view during interviews. Content in bold were the shared statements for Chinese and Dutch teachers.

Chinese teachers' beliefs about IBL

As is shown in Table 2, Chinese teachers talked about students' exploring, solving, thinking and getting the conclusion in IBL, they also connected IBL with student discussion and collaboration. In addition, emphasis was put on teacher guidance during the process. As for the reasons to implement IBL, Chinese teachers mainly focused on the benefits of IBL on mathematical thinking, knowledge and motivation, while only a few teachers paid attention to general skills developed from IBL. As for difficulties that teachers encountered in IBL, Chinese teachers pointed out factors related to students including the lack of motivation and performance in IBL, they also talked about factors related to conditions including lack of time and lack of suitable tasks.

Dutch teachers' beliefs about IBL

As is shown in Table 2, Dutch teachers emphasized students' taking responsibility in IBL. They paid attention to students' exploring, solving, thinking and doing activities (such as drawing and calculating) in IBL, and they made it explicit that students explore by themselves without getting

explanations from teachers about the theory or problem-solving procedures. They also noticed that the problem used in IBL usually provided enough space for students to explore from different approaches. When it comes to the reasons for IBL, Dutch teachers talked about the benefits of IBL on knowledge, motivation, general skills and mathematical thinking, they considered IBL as preparation for examinations as well. As for the difficulties in IBL, Dutch teachers pointed out factors related to conditions including lack of time and lack of suitable tasks, they also included factors related to teachers, namely they were required a lot from IBL, and they expressed dislike about the uncertain and uncontrollable feature of IBL.

Comparisons between Chinese and Dutch teachers' beliefs about IBL

As is shown by statements in bold in Table 2, Chinese and Dutch teachers shared some beliefs about IBL. Teachers in both countries paid attention to students' responsibility in IBL and mentioned students' exploring, solving and thinking. They both took the four benefits of IBL (on knowledge, mathematical thinking, motivations and general skills) as reasons to implement it. Moreover, they listed two common difficulties related to conditions, namely lack of time and lack of suitable tasks.

The differences between Chinese and Dutch teachers' beliefs about IBL are apparent in Table 2. As for the general views of IBL, Dutch teachers mainly emphasized students' responsibility in IBL while Chinese teachers also paid attention to teacher guidance (such as promoting students by questions) during the process. Chinese teachers talked about student discussion and collaboration and the attainment of results in IBL as well. The shared four benefits of IBL rank differently as reasons for IBL that Chinese teachers emphasized mathematics thinking most while Dutch teachers focused on knowledge most. Dutch teachers talked more about general skills, they also mentioned IBL as preparation for examinations. As for the difficulties in IBL, Chinese teachers listed factors related to students about their lack of motivation and performance in IBL, while Dutch teachers mentioned factors related to teachers that they considered IBL as demanding, uncertain and difficult to control.

Discussion

Our findings are based on the samples from convenient sampling. Chinese data was only collected at Beijing with more advantaged educational resources, most Dutch teachers had connections with universities or research institutes, participants may be more active in exploring new teaching approaches. In addition, this study was limited to reported beliefs and lacked observations of actual lessons. Finally, although we tried to ensure a shared understanding of IBL by providing example tasks during interviews, the data might be biased if participants having different interpretations of a term like "inquiry" that originated from science education (Beumann & Geisler, 2019)

Despite the limitations of the study, some findings are in line with stereotypes about teaching cultures in the East Asia and the West. The attention of Chinese teachers on attainment of results, student performance, mastery and appliance of knowledge as well as teacher guidance in IBL match the stereotypes that the East Asia emphasizes learning content (Correa et al., 2008; Leung, 2001) and teachers' role in instruction. The attention of Dutch teachers on students' doing activities, general skills, students' taking responsibility before teacher explanation and student motivation match the stereotypes that the West emphasizes learning process (Leung, 2001) and practical knowledge

(Norton & Zhang, 2018), encourages students' constructing knowledge (Liu & Feng, 2015) and meaningful learning, and values students' internal motivations (Leung, 2001).

However, some findings are not in line with the stereotypes. The attention of Chinese teachers on students' exploring, solving and thinking, on student discussion and collaboration as well as on student motivation do not match the stereotypes that the East Asia conducts teacher-centered directive instruction to deliver knowledge (Leung, 2001), makes students learn by memorizing and practicing repetitively (Liu & Feng, 2015; Tan, 2015), conducts instruction to the whole class with little group work (Leung, 2001) and ignores students' internal motivations. The attention of Dutch teachers on knowledge and preparing students for examinations do not match the stereotypes that the West focuses on learning process more than learning content, and emphasizes students' internal motivations more than external motivations such as examinations (Leung, 2001).

Follow-up study will analyze other topics from the interviews such as IBL activities and IBL outcomes, we will also include the reported IBL practice of Chinese and Dutch teachers to see to what extent the reported practice match their beliefs about IBL, whether the beliefs shape the practice in regard to IBL or there exists a more complicated relation between them as suggested by literature.

Acknowledgment

This work was supported by scholarship from the China Scholarship Council (CSC) [grant number 201606040155]. The authors thank Prof. Dongjiao Zhang, Dr. Xianglan Zhang as well as colleagues and friends that helped to contact teachers, and participants involved in this study for their contribution.

References

- Artigue, M., & Blomhøj, M. (2013). Conceptualizing inquiry-based education in mathematics. *ZDM*, 45(6), 797–810.
- Beumann, S., & Geisler, S. (2019). “Sometimes it goes wrong!” – Teachers' beliefs concerning experiments in mathematics. In U. T. Jankvist, M. van den Heuvel-Panhuizen, & M. Veldhuis (Eds.), *Proceedings of the Eleventh Congress of the European Society for Research in Mathematics Education*. Utrecht, the Netherlands: Freudenthal Group & Freudenthal Institute, Utrecht University and ERME.
- Chan Hok On. (2010). *How do teachers' beliefs affect the implementation of inquiry-based learning in the PGS Curriculum? A case study of two primary schools in Hong Kong* (Doctoral dissertation). Retrived from <http://etheses.dur.ac.uk/320/>
- Chin, E. T., & Lin, F. L. (2013). A survey of the practice of a large-scale implementation of inquiry-based mathematics teaching: from Taiwan's perspective. *ZDM*, 45(6), 919–923.
- Correa, C. A., Perry, M., Sims, L. M., Miller, K. F., & Fang, G. (2008). Connected and culturally embedded beliefs: Chinese and US teachers talk about how their students best learn mathematics. *Teaching and Teacher Education*, 24(1), 140–153.
- Dobber, M., Zwart, R., Tanis, M., & Van Oers, B. (2017). Literature review: The role of the teacher in inquiry-based education. *Educational Research Review*, 22, 194–214.

- Engeln, K., Euler, M., & Maass, K. (2013). Inquiry-based learning in mathematics and science: A comparative baseline study of teachers' beliefs and practices across 12 European countries. *ZDM*, 45(6), 823–836.
- Furtak, E., Seidel, T., Iverson, H., & Briggs, D. C. (2012). Experimental and Quasi-Experimental Studies of Inquiry-Based Science Teaching: A Meta-Analysis. *Review of Educational Research*, 82(3), 300–329.
- Leung, F. K. S. (2001). In search of an East Asian identity in mathematics education. *Educational Studies in Mathematics*, 47(1), 35–51.
- Liu, S. N., & Feng, D. M. (2015). How culture matters in educational borrowing? Chinese teachers' dilemmas in a global era. *Cogent Education*, 2(1), 1046410.
- Marshall, J. C., Horton, R., Igo, B. L., & Switzer, D. M. (2009). K-12 science and mathematics teachers' beliefs about and use of inquiry in the classroom. *International Journal of Science and Mathematics Education*, 7(3), 575–596.
- Norton, S., & Zhang, Q. (2018). Primary mathematics teacher education in Australia and China: What might we learn from each other?. *Journal of Mathematics Teacher Education*, 21(3), 263–285.
- Ramnarain, U., & Hlatswayo, M. (2018). Teacher beliefs and attitudes about inquiry-based learning in a rural school district in South Africa. *South African Journal of Education*, 38(1), 1-10.
- Saad, R., & BouJaoude, S. (2012). The relationship between teachers' knowledge and beliefs about science and inquiry and their classroom practices. *Eurasia Journal of Mathematics, Science & Technology Education*, 8(2), 113–128.
- Song, Y., & Looi, C. K. (2012). Linking teacher beliefs, practices and student inquiry-based learning in a CSCL environment: A tale of two teachers. *International Journal of Computer-Supported Collaborative Learning*, 7(1), 129–159.
- Swan, M., Pead, D., Doorman, M., & Mooldijk, A. (2013). Designing and using professional development resources for inquiry-based learning. *ZDM*, 45(7), 945–957.
- Tan, C. (2015). Education policy borrowing and cultural scripts for teaching in China. *Comparative Education*, 51(2), 196–211.
- Wallace, C. S., & Kang, N. H. (2004). An investigation of experienced secondary science teachers' beliefs about inquiry: An examination of competing belief sets. *Journal of research in science teaching*, 41(9), 936–960.

Preservice teachers' mathematical knowledge for teaching combinatorial thinking

Veronika Hubeňáková¹ and Ingrid Semanišínová¹

¹Pavol Jozef Šafárik University, Faculty of Science, Košice, Slovakia;

veronika.hubenakova@upjs.sk ingrid.semanisinova@upjs.sk

In the paper, we conceptualize Mathematical Knowledge for Teaching as introduced and elaborated by Ball et al. (2008) for the topic of combinatorics using Lockwood (2013) model of combinatorial thinking. We developed test consisting of three combinatorial problems and 6 connected tasks (for each problem) focused on the Common Content Knowledge (CCK), Specialized Content Knowledge (SCK), Knowledge of Content and Students (KCS) and Knowledge of Content and Teaching (KCT) to answer our research question: What are the differences in the combinatorial PCK between preservice teachers with regard to their combinatorial CK? We analyse and discuss data collected from 10 preservice teachers concerning one of the combinatorial problems and its connected tasks.

Keywords: Preservice teachers, combinatorics, pedagogical content knowledge, content knowledge.

Introduction and background

Combinatorial topics form an important part of the Slovak mathematics curriculum at middle and high school levels, as they are thought to provide a rich environment for the development of problem-solving skills (Rosenstein et al., 1997). However, Slovak curriculum documents and textbooks lead students to value formulas more than the ideas. Our aim in teaching preservice teachers (PSTs) is to broaden their knowledge to enable them to scaffold their future students' combinatorial thinking instead of the blind use of formulas. The motivation for our research is to inform our practice by both understanding more deeply how knowledge necessary to teach combinatorics is learnt and scaffolding such learning during the university studies of PSTs.

Theoretical framework

In this chapter, we are going to frame topic-specific (combinatorial) preservice teacher mathematical knowledge. We build on the theoretical framework of Mathematical Knowledge for Teaching (MKT) as introduced and elaborated by Ball et al. (2008). More specifically, we focused on CCK, SCK, KCS and KCT. We use Lockwood (2013) model of combinatorial thinking to specify combinatorial MKT. We are going to explain the framework using the following combinatorial task (Batanero, 1997): Four children: Anna, Barbara, Cyril and Daniel went to spend the night at their grandparents' house. Their grandparents have two separate bedrooms for them (one downstairs and another upstairs). In how many different ways can the grandparents assign children to bedrooms? For example: Anna, Barbara, Cyril and Daniel will sleep in the room upstairs and nobody will sleep downstairs.

The task can be solved in at least six different ways as depicted at the Figure 1 (see the next page). We can see two different ways how to group them. In the first way, there are three groups: S1-S2, C1-C2, F1-F2. We can see different types of solutions here. The first group, there are *sets of outcomes* (S), collections of the objects being counted. In the second group, *counting process* (C) is clearly elaborated. In the third group, the solution stands on the using of the *formula* (F). The second way for

grouping the solutions is the following: S1-C1-F1 and S2-C2-F2. Each of the group of the solutions can be characterized by the same mathematical idea and they differ by the level of abstraction.

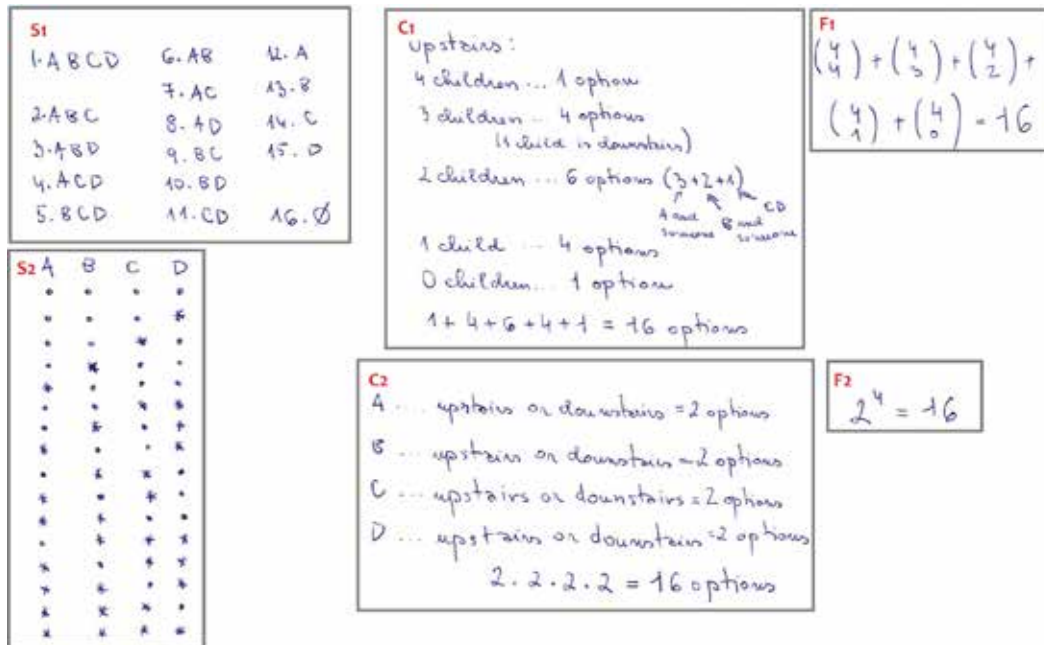


Figure 1: Six different solutions of the combinatorial problem

Lockwood model highlights the importance of developing the relationships between sets of outcomes, counting processes, and formulas/expressions. “For a given counting problem, a student may work with one or more of these components and may explicitly or implicitly coordinate them.” (Lockwood, 2013, p. 253).

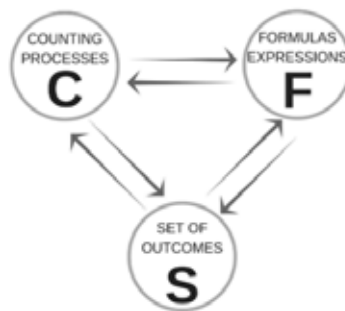


Figure 2: Model of combinatorial thinking (adapted from Lockwood, 2013)

Now, we are ready to frame combinatorial MKT. **CCK**: PST can solve a combinatorial problem using one direction in Lockwood model, usually it is $S \rightarrow C$ or $C \rightarrow F$ and/or perceive some direction from the proposed correct solution, usually it is $F \rightarrow C$ and/or $C \rightarrow S$. **SCK**: PST can solve a combinatorial problem in at least two different ways and perceives (not necessarily suggests) all directions of the Lockwood model. **KCS**: PST realizes that student solving the problem in the way S1-C1-F1 can have difficulties to understand the solutions S2-C2-F2 and perceives different levels of abstraction. Moreover, PST is familiar with possible student combinatorial misconceptions. **KCT**: PST’s response to the student’s solution is scaffolding in the sense of the Lockwood model, meaning that it shifts students to the proximal level of abstraction.

Context and research question

The teacher education at bachelor's level (3 year program) at our university is, concerning MKT, currently focused on advanced mathematics knowledge, with SCK partially addressed. At the master's level (2 year program), the goals are framed mostly in terms of KCS and KCT development. This model is in line with the claim of Depaepe, Verschaffel and Kelchtermans (2013) from their literature review, which says: "Based on studies that use distinct test items to measure CK and PCK it is concluded that both knowledge components are positively correlated and that CK is a necessary, though not sufficient, condition for PCK." (Depaepe, Verschaffel, & Kelchtermans, 2013, p. 21) However, none of the papers these authors reviewed concerned combinatorics. What is more, the profound understanding of specific mathematical content is one of the possible points of focus for the research in teacher knowledge suggested at CERME 9 (Ribeiro et al., 2015). Therefore, we are interested, in accordance with the theoretical underpinnings and the needs of the field, to find the answer to the research question: What are the differences in the combinatorial PCK between PSTs with regard to their combinatorial CK?

Research Methodology

Participants

12 PSTs in the academic year 2017/2018 were finishing their master mathematics teaching programme, 10 of them participated in the data collection. They had already passed all mandatory courses, including *Discrete mathematics*, which aimed to develop advanced content knowledge concerning combinatorics, *Methods of mathematics problem solving* where among other things SCK was addressed and *Didactics of mathematics*. Therefore, we chose these participants to gain insight into our current practice of teacher education. However, their PCK could be developed outside of their mandatory courses. Thus, we needed to know whether the PSTs used other options to develop their PCK. Based on the short interviews, we found out that the university courses and mandatory school practices were more or less the only experience with mathematics education for 3 out of the 10 PSTs (*no additional experience*), 3 of them provided regular tutoring and/or lecturing (*narrow additional experience*), 4 out of the 10 PSTs, furthermore, have written diploma thesis in mathematics education (*broad additional experience*).

Test design and its evaluation

We developed a research tool to capture PSTs' CK and PCK in domain of combinatorics in accordance with our theoretical perspective. As explained by Depaepe, Verschaffel and Kelchtermans (2013), if cognitive perspective to teacher knowledge is taken in account (what is the case here), then test is very relevant tool to measure it. The research tool consisted of three combinatorial problems with six connected tasks each. The first and the third connected task to the combinatorial problem measured the level of CK (Lockwood, 2013). The remaining connected tasks measured PSTs' level of PCK (Ball et al., 2008). All connected tasks were open-ended purposely, to let the PSTs display their CK and PCK without any restrictions or guidance.

All PSTs solved one standard combinatorial problem and one of two, randomly chosen, non-standard combinatorial problems. In the paper, we analyse 10 PSTs' solutions of the already introduced combinatorial problem (Batanero, 1997) and the following connected tasks (time allocated for the task is given in the brackets):

1. Solve the problem in several different ways (at least two). (8')
2. Which of your solutions is mathematically the most valuable? Explain why. (2')
3. There is solution 2^4 stated in the textbook. What set of outcomes corresponds with this solution? Write several elements of this set of outcomes. Explain. (5')
4. Imagine, this problem was solved by your students. Write down two examples of students' solutions containing mistakes which are expected by you. Explain them. (10')
5. Imagine, you are a high school teacher and you are solving this problem during the lesson. There are following students' solutions stated in their notebooks (in the Figure 3a and 3b). Explain these solutions and write down, how would you react. (5')
6. Look at the following students' solutions (see Figure 3b, 3c and 3d). Order them according to the level of abstraction (1 – the most abstract solution, 3 – the least abstract solution). Explain. (5')

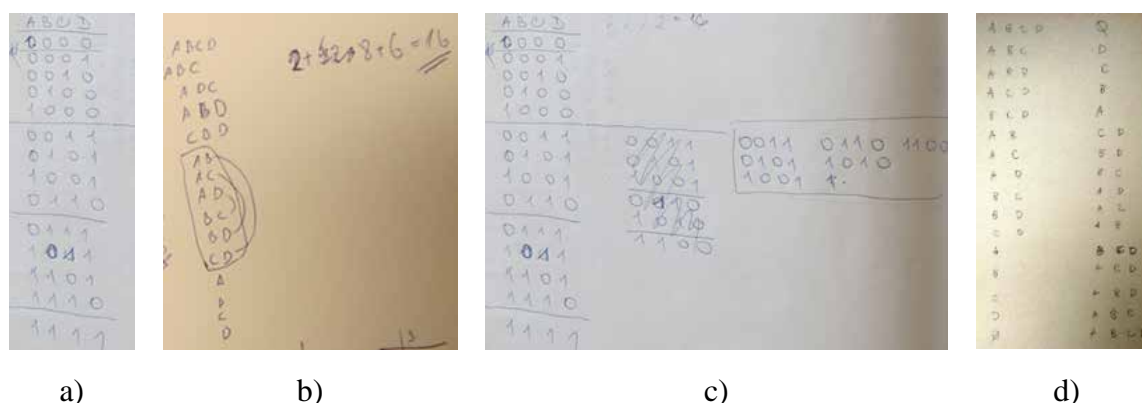


Figure 3: Examples of students' solutions for the connected tasks 5 and 6

The test was firstly verified by 6 PhD students in mathematics (5 of them had already finished their mathematics teaching programme) in order to prescribe the sufficient time for each individual task, to refine formulations, and suggest the coding. Table 1 briefly summarizes the coding. The authors coded PSTs solutions separately, afterwards the coding was compared and few inconsistencies were discussed and resolved. According to CK (see Table 2), we categorized PSTs into three groups. The low CK group included the PSTs who demonstrated neither CCK nor SCK. The medium CK group included the PSTs who demonstrated only CCK. Finally, the high CK group included the PSTs who demonstrated both CCK and SCK.

			PCK
Task	Aim	What PCK components were coded?	
KCS	Task 4	Formulation of misconceptions	<u>Is misconception typical and connected to combinatorics?</u> <u>Is explanation of the misconception focused on student's thinking?</u>
	Task 6	Level of abstraction	<u>Are solutions ordered according to level of abstraction?</u> <u>Are the reasons for ordering well explained?</u>
KCT	Task 5	Response on student's solution	<u>Does PST understand student's solution?</u> <u>Would the response which was suggested by PST scaffold student's learning?</u>

Table 1: Evaluation of PCK

CK		
	CCK	SCK
Conditions	Problem solved correctly and/or understanding of the standard correct solution.	Problem solved at least in two different ways and correct mathematical argumentation.
Combinatorial thinking	One direction from Lockwood's model	All directions: $S \rightarrow C$; $C \rightarrow F$; $C \rightarrow S$; $F \rightarrow C$; $S \rightarrow F$; $F \rightarrow S$

Table 2: Evaluation of CK

Findings & discussion

First, we describe the distribution of the participants into different categories. Table 3 illustrates that our research sample covered most of the possible categories. Only the category with low CK is not fully covered, however as the assigned combinatorial problem was standard, it is not surprising. Given the distribution into coded categories and subject numbers, we will analyse these data in qualitative and interpretative way.

Content Knowledge \ Additional Experience	Additional Experience		
	None	Narrow	Broad
Low	1	0	0
Medium	1	2	1
High	1	1	3

Table 3: Numbers of PSTs grouped in categories

Second, we take a deeper look into each of the PCK components given in the Table 1. We will provide examples of PSTs responses to explain how they were coded.

Formulation of possible student misconceptions¹

Example A

Maybe they say: I choose who out of 4 children will be downstairs.
and they write down (4) out of 4
But they figure out it is equal 1 and thus it is nonsense.

Example B

Children will be in the rooms like this:

1 st room	2 nd room	} 5 options
4 children	0 children	
3 children	1 child	
2 children	2 children	
1 child	3 children	
0 children	4 children	

Figure 4: Examples of misconceptions

As we can see, in the Example A (Figure 4), PST tried to formulate misconception, however it is artificial and not connected to combinatorial idea. On the other hand, Example B (Figure 4) is very common one, it is called confusing the type of object (e.g. Batanero, 1997), it is clearly connected to combinatorics.

¹ We translated PSTs answers from Slovak language and re-wrote it to preserve the structure used by PSTs.

Level of abstraction

Example C

“Solution 3 (Figure 3d) seems the least abstract to me, because the student is writing down the set of outcomes from which it is clear what is happening in each of the rooms. It is obvious that he can imagine what is going on in there. Solution 2 (Figure 3c) is the most abstract because the student is grouping those people, however he probably does not really understand what he is doing.”

Example D

“In the solution 3 (Figure 3d), there is clearly written which child is in which room ... students can immediately imagine – from the representation – how the children are split into two rooms. In the solution 1 (Figure 3b), there is some intermediate step from the specific solution to the abstract one, or an attempt to simplify, to shorten process of writing down the set of outcomes. The solution 2 (Figure 3c) – lot of children would be probably lost in such kind of solution. It is logical, however quite symbolic. Unlike the other two solutions, here are rooms assigned to children not children to rooms.”

In both examples, PSTs ordered the solutions in the correct way. The difference is, the PST from the Example C, did not notice different mathematical idea behind the solution 2 compared to solutions 1 and 3. On the other hand, PST from the Example D explains this difference.

Response on student’s solution (depicted in the Figure 2a)

Example E

“I would call 4 volunteers, and I would ask the student with this solution to arrange them in all the possible ways when two of them are in the same room.”

Example F

“I would probably give 50% for understanding and coding. I want the student to realize that the set of outcomes is not the most adequate solution.”

Example G

“I would ask the student to check the set of outcomes whether it is complete. I would praise him for the representation of set of outcomes he came up with.”

Student’s solution in the Figure 2a is the set of outcomes connected with the formula 2^4 . The activity suggested in the Example E is not related to this formula; therefore, it would probably not be scaffolding. In the Example F, PST would prompt student to use formula, which would not necessarily scaffold the student’s combinatorial thinking if the student is not ready to see the relevance of formula to the situation. In the Example G, the PST recognized that she cannot orient the student to the counting process or formula without the student first comprehending how the set of outcomes is generated, thus it was coded as scaffolding response.

Third, we present which of the coded PCK components, were (+) or were not (-) observed in the particular categories of PSTs (see Table 4, the next page). In the Table 4, results of PSTs with medium and high CK are presented, the one PST with low CK demonstrated no PCK.

		None experience		Narrow experience		Broad experience	
		No SCK	SCK	No SCK	SCK	No SCK	SCK
KCS	Misconceptions	+	-	+	-	+	+
	Level of abstraction	-	-	-	+	-	+
KCT	Understanding	+	+	+	+	+	+
	Scaffolding response	-	-	-	-	-	+

Table 4: PCK components demonstrated / missing in particular PSTs categories

Formulation of possible student misconceptions as part of the KCS was missing only for PSTs with high CK without *broad additional experience*. These PSTs did not have an opportunity to learn from their own mistakes and the lack of experience was not supporting them to learn from mistakes of others. This could be the reason why they were not able to estimate what kind of misconceptions are common.

Level of abstraction as part of the KCS was observed only when PSTs had high CK and at least *narrow additional experience*. These differences can possibly be explained by the role of SCK as we defined it in combinatorics. If PSTs perceive all connections between possible solutions as suggested in the Lockwood's model, they are able to understand how abstract particular student's solution is.

Understanding of the student's solutions was managed by all PSTs except the one with the low CK. Obviously, the PST with low CK could not distinguish the nature of the error correctly, also she had troubles to reason the correct one. While the error was quite familiar, and the solution was the standard one, the other PSTs were able to explain the student's solution using only CCK, it was not necessary to activate SCK here.

Concerning **scaffolding response**, only the group of PSTs with high PCK and *broad additional experience* was able to provide scaffolding reactions. Moreover, the scaffolding reaction was suggested only if the level of abstraction was perceived and explained clearly.

Conclusions

Let us return to the research question: What are the differences in the combinatorial PCK between PSTs with regard to their combinatorial CK? On the one hand, PSTs with low or medium CK displayed less PCK. On the other hand, when it comes to formulation of misconceptions, they outperformed those, who had high PCK and *none or narrow additional experience*. Thus, the high CK did not automatically meant good combinatorial PCK. It seems that the other necessary condition for combinatorial PCK development was *broad additional experience*. It supported PCK development especially when the PST had high level of CK. This is important, because PST who becomes a novice teacher is expected to learn mostly through their own teaching experience.

Back to our first motivation for the research, the findings will feed back to our research and practice in the following ways: **(1)** we need to inquire and specify how to develop combinatorial SCK effectively during the bachelor's level programme. **(2)** We need to identify the key factors of the *additional experience*, which scaffolded PSTs learning and subsequently design the PST education to promote these factors. Therefore, we need to focus on the task construction and design similarly to

Policastro, Mellone, Ribeiro and Fiorentini (2019) and Montes, Climent, Carrillo and Contreras (2019).

Moreover, we will reframe the research with the model of Mathematics Teachers' Specialized Knowledge (Carrillo, et al., 2018) which address the limitations we experienced using MKT model (Ball, et al., 2008). We suggest that such reframing and the subsequent comparison could bring more clarity into mathematical teacher knowledge needed for teaching combinatorics.

Acknowledgements

This work was partially supported by the Slovak grant VEGA 1/0265/17 and by the National project IT Academy – Education for the 21st Century.

References

- Batanero, C., Navarro-Pelayo, V., & Godino, J. (1997). Effect of the implicit combinatorial model on combinatorial reasoning in secondary school pupils. *Educational Studies in Mathematics*, 32, 181–199.
- Ball, D., Thames, M. H., & Phelps, G. (2008). Content knowledge for Teaching. *Journal of Teacher Education*, 59(5), 389-407.
- Carrillo, J., Climent, N., Montes, M., Contreras, L.C., Flores-Medrano, E., Escudero-Ávila, D., Vasco, D., Rojas, N., Flores, P., Aguilar-González, A., Ribeiro, M., & Muñoz-Catalán, M.C. (2018). The Mathematics Teacher's Specialised Knowledge (MTSK) model. *Research in Mathematics Education*. (Online). DOI 10.1080/14794802.2018.1479981.
- Depaepe, F., Verschaffel, L., & Kelchtermans, G. (2013). Pedagogical content knowledge: A systematic review of the way in which the concept has pervaded mathematics educational research. *Teaching and Teacher Education*, 34, 12-25.
- Lockwood, E. (2013). A model of students' combinatorial thinking. *Journal of Mathematical Behavior*, 32, 251– 265.
- Montes, M., Climent, N., Carrillo, J. & Contreras, L.C. (2019). Constructing tasks for primary teacher education from the perspective of Mathematics Teachers' Specialised Knowledge. Manuscript in preparation.
- Policastro, M., Mellone, M., Ribeiro, M, & Fiorentini, D. (2019). Conceptualising tasks for teacher education: from a research methodology to teachers' knowledge development. Manuscript in preparation.
- Ribeiro, M., Aslan-Tutak, F., Charalambous, Ch., & Meinke, J. (2015). Introduction to the papers of TWG20: Mathematics teacher knowledge, beliefs, and identity: Some reflections on the current state of the art. In K. Krainer & N. Vondrová (Eds.), *Proceedings of the Ninth Congress of the European Society for Research in Mathematics Education (CERME9, 4-8 February 2015)* (pp. 3177-3183). Prague: Charles University in Prague, Faculty of Education and ERME.
- Rosenstein, J. G., Franzblau, D. S., & Roberts, F. S. (1997). *Discrete mathematics in the schools* (Vol. 36, Discrete Mathematics and Theoretical Computer Science). Providence, RI: American Mathematical Society, National Council of Teachers of Mathematics.

Malawian preservice teachers' perceptions of knowledge at the mathematical horizon

Everton Lacerda Jacinto¹ and Arne Jakobsen²

¹University of Stavanger, Norway; evertonl.jacinto@uis.no

²University of Stavanger, Norway; arne.jakobsen@uis.no

This paper examines how preservice primary teachers perceive mathematical horizon content knowledge for teaching in Malawi. Drawing on the practice-based theory of mathematical knowledge for teaching, the study highlights the importance of mathematical concepts and historical aspects needed for teaching, according to preservice primary teachers, at the beginning of their teaching education. Findings from the two cases revealed that despite differences in their perceptions, similarities also existed. This result provides a starting point for a better understanding of what composes mathematical horizon content knowledge and discusses implications for teacher-education training programs in Malawi.

Keywords: Malawian primary teacher education, mathematical horizon content knowledge, preservice teachers' perceptions.

Teacher's content knowledge for teaching

Becoming a professional at any workplace demands skills and knowledge to perform specific tasks, make decisions, and attend to what the profession requires. In this sense, becoming a teacher demands a specific type of knowledge that enables one to create sufficient conditions to trigger the students' learning (Davydov, 1999), develop their intellectual actions and mental functions (Vygotsky, 1987), and help them make sense of the world (Leontiev, 2007). In this context, why is this type of knowledge necessary to teach a subject properly? What difference does this knowledge have for the teaching of mathematics, and what are the implications for students learning in different contexts?

For decades, researchers around the world have investigated practices that can contribute to shaping teachers' knowledge. Shulman (1986), with his studies about teacher training in the USA, stands out in importance with his description of pedagogical content knowledge that extends beyond the specific topics of the curriculum. This type of knowledge represents a knowledge base that combines reflections on practical experiences and reflection on theoretical comprehension for teaching, a foundation that englobes the knowledge of the content, curriculum, students, contexts, and purposes/philosophies of teaching. Those elements, according to Shulman (1986), must be part of any educational program that forms primary and secondary teachers.

Of particular interest for mathematics teaching, Ball, Thames, and Phelps (2008) extended Shulman's (1986) ideas into two subcategories: *pedagogical content knowledge* (PCK) and *subject matter knowledge* (SMK). Whereas PCK includes the knowledge of content and students (KCS), knowledge of content and teaching (KCT), and the knowledge of content and curriculum (KCC), SMK comprises the common content knowledge (CCK), specialized content knowledge (SCK), and horizon content knowledge (HCK). Together, these six components offer a holistic perspective of what is useful and important for teaching. It also serves as a resource for addressing the mathematical demands of specific teaching tasks in primary classrooms (Hill, Rowan, & Ball, 2005) and a potential tool that

allows teachers to concentrate on what is essential for effective mathematics instruction (Ball et al., 2008).

Our focus is on teachers' mathematical knowledge beyond the school curriculum, HCK. Ball and Bass (2009) defined HCK as "a kind of mathematical 'peripheral vision' needed in teaching, a view of the larger mathematical landscape that teaching requires" (p. 1). It provides an awareness of "how the content being taught is situated in and connected to the broader disciplinary territory" (Jakobsen, Thames, Ribeiro, & Delaney, 2012, p. 4642) and "how mathematics topics are related over the span of mathematics included in the curriculum" (Ball et al., 2008, p. 403). Ball and Bass (2009) still explain that the knowledge at the mathematical horizon "is advanced knowledge that equips teachers with perspective for their work; it is not knowledge of the kind which they need to understand in order to explain it to students" (p. 27). Different from the other components in the teacher's MKT, the domain of HCK pays special attention to the processes involved in the creation and use of mathematical content rather than the content knowledge itself. It is a distinct knowledge that helps teachers engage and assist students to make sense of what is being taught from a global view of the subject matter.

In this article, we will focus on only one component of teachers' knowledge: HCK. Our aim is to provide a better understanding of how HCK is perceived in a different setting for teaching from which the theory was developed. To sustain this goal, we analyzed two cases taken from a larger research project that examines the preservice teachers in the context of Malawi. The main question addressed is: How do Malawian preservice primary teachers perceive the knowledge at the mathematical horizon at the beginning of their teacher education?

The study context

The study presented here is drawn from a larger research examining the preservice teachers' sense-making process of mathematical knowledge for teaching in Malawi. Twenty-three students from a two-years teacher-training program volunteered to participate. In this program, the mathematics education aims to develop preservice teachers' critical awareness of mathematical concepts, and its connections and ways of being used for solving problems in a social, environmental, cultural, and economic context (Malawi Institute of Education, 2017). The mathematical program's curricular structure and syllabus allow future teachers to interim practice and theory by integrating content and pedagogy during their mathematical lessons at the college. In the first two of six terms of the program, preservice teachers should take theoretical courses (arithmetic and algebra subjects, accounting and business studies, measurement and data handling, and teaching and learning theories), followed by monitoring visits in local schools. The two middle terms are dedicated to teaching practices. They go onto the field in pairs to gain practical and professional experience in teaching under the supervision of practicing teachers. In the last two terms, the preservice teachers go back to college. The program is now committed to the reflection on preservice teaching experiences, inclusion and further discussion about teaching methods, subject contents, educational policies, and frameworks.

In the larger study, we adopted two approaches to generate data from the participants. The first approach was set up through preservice teacher notions on what types of knowledge and skills they thought could be most suitable for teaching mathematics in primary schools in Malawi. The main research instruments were a questionnaire including topics related to the participants' teaching

experiences and subject preferences, and individual interviews addressing the constituents needed for carrying out the work of teaching in Malawi. The interview structure was designed to cover most of teaching scenarios from which the six domains of mathematical knowledge for teaching theory could emerge (Ball et al., 2008). The second approach – only applied in a subsequent phase of the study – focused on observations of the preservice teachers' lessons. By selecting “teaching episodes” from which particular aspects of MKT domains manifest, we create reflection moments with the preservice teachers aimed to explore how they perceive the utility of those domains in practice.

Once more, in this paper we explore one aspect of teachers' knowledge: HCK. The following data stem from a case study (Stake, 2006) with two Malawian preservice primary teachers presenting distinctive ways to perceive HCK. The data collected was transcribed and condensed into a summary format. This format helped us establish analysis categories, with the MKT framework as a base. Those categories were expected to emerge from the preservice teachers' responses during the interviews, and the first pieces of evidence were projected to provide information on how the participants perceive HCK in the Malawian school settings. The idea was also to explore the basis and influences that shape the preservice teachers' perceptions before they went to the field work.

Preliminary Findings

Intendance of placing contextual knowledge in teachers' HCK

In this category, we analyzed the case of Patrick, a 20-year-old student possessing no teaching experience prior to entering the teacher training college. His parents are workers from the rural area and live in a village nearby the college. His favorite subjects in high school included biology, physics, and mathematics, while his interests lie in teaching mathematics and foundations studies.

During the interview, Patrick recognized the need to distinguish the knowledge and skills needed for teaching mathematics in primary school in Africa. This position, followed by the passage below, were pieces of evidence for understanding what Patrick might perceive as an HCK. The passage occurred during a discussion about the knowledge needed for teaching mathematics beyond the primary school curriculum.

Researcher: Ok Patrick, now... let's talk about the knowledge that a teacher needs to know beyond the curricular content.

Patrick: Sorry, I don't understand the question. Can you repeat, please?

Researcher: Yes... we talked about the importance for teachers to know the content, the curricular content in primary school, right? They also need to know the students, ok? But, is there anything else teachers need to know apart from those we have discussed? For example, numbers. If I decide to become a teacher in Malawi, what do I need to know to teach numbers? If I know the content, the students, and a couple of teaching techniques, is that enough?

Patrick: Hum... No! I think you should know more about Malawi... the Malawian context!

Researcher: Ah... Ok! You can say that! So, let's put it this way... In terms of mathematics teaching, you said a teacher needs to have good knowledge of the curricular

mathematics. But how about the mathematics outside of curriculum? [primary school curriculum]

Patrick: Yes, it is also important! Because there are other concepts that can explain some situations better. And also, you can apply those concepts to a situation. What is in the curriculum is good for planning, you know... but sometimes, the concepts in the curriculum are not enough. So, you can put them... you can mix them with those that are in the curriculum to explain something. So I think it's very important to do so.

Researcher: Can you give an example of that?

Patrick: In mathematics, for example... in Malawi we do farming. So, when you are teaching maybe some examples could be about farming, they [primary school teachers] should go further about agriculture, so the learners can reflect on what they do in their families as they do farming.

Researcher: So, is it important to give examples like this in class?

Patrick: Yes, when you are teaching, you have to give many examples. Those examples should be linked to real-life situations because it will be easy for them [students] to reflect on what they know, so they can understand and apply it [mathematics] in real life.

The forward reference shows that Patrick acknowledges not only the importance of curricular concepts in teaching but also the limits of teaching mathematics using only those concepts. He identifies that although the curriculum is essential for the teachers' planning activities, it might restrict the work of teaching from a general perspective. Patrick's perception of knowledge outside the school curriculum does not seem to corroborate with the suggested definition by Jakobsen et al. (2012), but it arises as part of a broader framework where mathematical knowledge takes place. Zazkis and Mamole (2011) explain that teachers' knowledge at the mathematical horizon also includes aspects in both the inner and outer horizons of an object. It encompasses the "connections between different disciplinary strands and contexts in which the object may exist" (p. 9). Students will only benefit from some of those features.

HCK as a contextual feature in teacher's knowledge is also a subject of interest for Zhang, Zhange, and Wang (2017). They pointed out that although HCK is directly connected to knowledge of a pure mathematical content, contextual factors can be adapted to the definition provided by Ball and Bass (2009), a type of knowledge that embraces

aspects of the mathematics that, while perhaps not contained in the curriculum, are nonetheless useful to pupils' present learning, that illuminate and confer a comprehensible sense of the larger significance of what may be only partially revealed in the mathematics of the moment (p. 6).

Therefore, in Patrick's case, we can see that this dimension manifests in the form of cultural values and explicit knowledge of the ways and tools needed in the discipline (Jakobsen et al., 2000), but it does not relate directly to the aspects of mathematical content contained in the curriculum. The example of the agricultural field provided by Patrick might not be transferred to mathematics, but it

represents the great world in which mathematics exists. *If a teacher wants to create in students the need for understanding and applying the concepts, he or she needs to think beyond the school curriculum*, explains Patrick.

Shoemaker (1989) explains that the acknowledgment of the relevance of contents hosted outside the traditional curriculum helps prospective teachers increase the opportunities for students to make meaningful associations with other areas of study, and develop new forms of abstractions of the real world. As a result, school subjects become more attractive, and students can appropriate concepts that are inherent to the world (D'Andrade, 1981). By doing so, teachers can facilitate students' learning by using concrete ideas and expanding them into abstract forms and new, concrete applications (Davydov, 1999).

HCK as an awareness of students' future needs and history of mathematics

Our focus now is on Mario's case, a preservice teacher six years older than Patrick. Mario used to live with his family in a district in the central region of Malawi. His mother and father are retired, but both had worked as primary school teachers. After completing high school, he worked as an assistant teacher in a public primary school for three years. His favorite subjects were agriculture and social studies. At the teacher-training program, he still demonstrated a preference for teaching in those areas, including English and the local Malawian language, Chichewa.

In the interview, Mario presented two distinct ways to perceive the knowledge beyond the school content needed for teaching. He made emphasis not only to the importance of knowing the primary curricular contents but also to the knowledge needed to improve the quality of primary education by linking those to superior educational levels. The passage below occurred at our first interview with Mario, and it illustrates how he perceives the importance of having knowledge outside of the primary curriculum in Malawi.

- Researcher: Mario... what does a teacher need to know to teach in a primary school in Malawi? Does he need to know the content, right?
- Mario: Yes, because knowing the content you will be able to teach, and without the content, you don't know what to tell the learners.
- Research: But he needs to know just the contents of the curriculum?
- Mario: The content in the curriculum is important, but also you can extend it to the curriculum of secondary level. You can go higher! So you know what the upper classes is particularly doing about a particular topic is good because you can make a link to that. For example... in mathematics, we have geometry in upper level... we teach them how to find the angles or areas of triangles, so you if you don't have that knowledge you can not teach triangles in lower classes. So a primary teacher needs that knowledge!

By analyzing Mario's comments on what is needed for a teacher to know rather than what the curriculum suggests, we can see that he values the idea of establishing connections between the primary school curricular concepts and concepts from higher classes. In Mario's view, the benefits

of knowing mathematics from higher classes appear to be relevant because it facilitates the teacher's work in covering ideas that can be related to the current school mathematics content.

The suggestion that teachers' knowledge demands more than just knowing curricular contents is pertinent to understanding what Mario believe to be necessary for teaching mathematics in primary schools in Malawi. However, the idea of knowing how curricular mathematical topics are related to a more general curricular concept represents only a small portion of what constitutes HCK. Jakobsen et al. (2012) attempted to clarify that HCK implies not only the knowledge about curricular development of the contents but it also involves the knowledge about "how the content being taught is situated in and connected to the broader disciplinary territory" (p. 4642). It should go beyond the merely curricular progression where scholar concepts take place; in the case of the advanced mathematics, HCK emerges in understanding elementary mathematics from an advanced viewpoint, and vice versa (Klein, 2016).

The next passage is a sequence of the transcription above from which Mario expressed a second idea about the type of knowledge needed for a teacher to know rather than just curricular demands. The dialogue occurred when we asked him about what type of knowledge and skills are needed for planning a lesson activity in mathematics.

Researcher: When a teacher plans a lesson in Mathematics what things does he or she needs to know? I mean... beyond what the curriculum suggests?

Mario: As a teacher, you have to know why is there mathematics and who discovered the mathematics. Because when you are teaching learners, they have so many questions that if you don't know how to answer those questions you cannot help them. Some learners need to know why we need mathematics, who discovered this theory and these concepts? Who came up with this formula? And why? So he or she should be able to answer those questions. And for you to answer those questions, you should know the history behind the mathematics.

Researcher: So do you agree that it is important for primary school teachers to know the history of mathematics, I mean... the processes that led people to create the concepts?

Mario: Yes, I agree with that!

Researcher: But is it not too much for teachers? Generally, teachers give a task and some exercises.

Mario: No, it is not too much! This is part of the work. Because I want to take the learners from the very deep so they can easily understand what is about... so I want to take them from the very deep of what is really mathematics and all about mathematics. So they will be able to understand whatever the teacher is saying.

In the first part of the passage above, Mario argued in favor of the ability to think about the mathematical concepts critically. He suggested that knowing only the present form of concepts might not be enough for learners to have a complete conceptual understanding of what is being taught, so a teacher needs to be aware of the meaning and general principles that grip the existence of mathematics. Thus, the knowledge about the historical development that formed the concepts

reinforces teachers' conceptual understanding by giving insights into how the concepts were formulated and transmitted culturally (Shulman, 1982). Such awareness, consequently, permits them to establish associations and generalizations among other areas (D' Andrade, 1981).

Knowledge about the historical development of concepts is also important for one to perceive mathematics as a human production (Moretti, 2007). Studies by historical-cultural theorists have shown that the historical development of concepts occurred from concrete situations from which humans felt the need to solve them. Caraças (1984) explains that a number system, for instance, should not be seen as a pure product of human thinking because humans did not acquire the idea of numbers and then began to count. Natural numbers were formed slowly due to the daily practice of counting, rational numbers from measurements, real numbers from the logical compatibility of different acquisitions (Caraças, 1984). Being aware of the logical-historical aspects of mathematics, teachers have an opportunity to create conditions for students to establish systematic ways to understand the dialectical principles of concepts (Davydov, 1982). This type of knowledge, according to Jankvist, Mosvold, Fauskanger, and Jakobsen (2015), is one of the main characteristics that comprises the mathematical horizon knowledge of teachers.

Conclusion

In the course of a larger research that investigates the preservice teachers' sense-making process of mathematical knowledge for teaching, the present article provided analyses on the perceptions of two participants regarding HCK. The findings revealed that both preservice teachers possess distinct ways of perceiving the knowledge outside of the curriculum and that those perceptions can contribute to a better understanding of what primary preservice teachers believe to be needed for knowing further than what the mathematical curriculum suggests.

These findings also have important implications for further research and teacher education practices. Knowledge about topics that might arise in learners' future studies is important for a teacher to possess, but it does not necessarily cover the idea of the advanced mathematical horizon proposed by the literature. HCK, in the sense of advanced mathematics horizon, encounters the understanding of concepts teachers want to teach in its totality considering its historical and cultural processes of production, representation, and validation (Shulman, 1986). In the context of teacher education, these results vindicate for teacher training programs provide even more insights, supports, and opportunities for reflections on the types of knowledge that anchor the broader disciplinary territory where mathematics takes place.

References

- Ball, D. L., & Bass, H. (2009). *With an eye on the mathematical horizon: knowing mathematics for teaching to learners' mathematical futures*. Paper presented at the 2009 Curtis Center Mathematics and Teaching Conference, Los Angeles, CA.
- Ball, D. L., Thames, M. H., & Phelps, G. (2008). Content knowledge for teaching: What makes it special? *Journal of Teacher Education*, 59, 389–407. doi:10.1177/0022487108324554
- Caraça, B. (1984). *Conceitos fundamentais da matemática*. Lisbon, Portugal: Livraria Sá da Costa.
- D' Andrade, R. G. (1981). The cultural part of cognition. *Cognitive Science*, 5, 179–195.

- Davydov, V. V. (1982). *Tipos de generalización en la enseñanza*. Havana, Cuba: Pueblo y Educación.
- Davydov, V. V. (1999). What is the learning activity? In M. Hedegaard & J. Lompscher (Eds.), *Learning activity and development* (pp. 123–138). Aarhus, Denmark: Aarhus University Press.
- Hill, H. C., Rowan, B., & Ball, D. L. (2005). Effects of teachers' mathematical knowledge for teaching on student achievement. *American Educational Research Journal*, 42(2), 371–406.
- Jakobsen, A., Thames, M. H., Ribeiro, C. M., & Delaney, S. (2012). Using practice to define and distinguish horizon content knowledge. In International Congress in Mathematics Education (Ed.), *Proceedings of the 12th International Congress in Mathematics Education* (pp. 4635–4644). Seoul, Korea.
- Jankvist, U. T., Mosvold, R., Fauskanger, J., & Jakobsen, A. (2015). Analysing the use of history of Mathematics through MKT. *International Journal of Mathematical Education in Science and Technology*, 46(4), 495–507.
- Klein, F. (2016). *Elementary mathematics from a higher standpoint: arithmetic, algebra, analysis* (Vol. 1). Berlin, Germany: Springer. (Original work published 1908)
- Leontiev, D. (2007). Approaching worldview structure with meanings technique. *Journal of Humanistic Psychology*, 47(2), 243–266.
- Malawi Institute of Education. (2017). *Syllabus for initial primary teacher education: Mathematics Ministry of Education, Science and Technology*. Domasi, Zomba: Malawi Institute of Education.
- Moretti, V. (2007). *Professores de Matemática em Atividade de Ensino. Uma perspectiva histórico-cultural para a formação*. São Paulo, Brazil: Tese de Doutorado em Educação, Faculdade de Educação, Universidade de São Paulo.
- Shoemaker, B. (1989). Integrative education: a curriculum for the twenty-first century. *Oregon School Study Council Bulletin*, 33(2), 43–46.
- Shulman, L. S. (1986). Paradigms and research programs in the study of teaching. In M. C. Wittrock (Ed.), *Handbook of research on teaching* (3rd ed., pp. 3–36). New York, NY: MacMillan.
- Stake. R. E (2006). *Multiple case study analysis*. New York, NY: The Guilford Press.
- Vygotsky, L. S. (1987). Thinking and speech. In R. W. Rieber & A. S. Carton (Ed.), *The Collected Works of L. S. Vygotsky* (pp. 39–285). New York, NY: Plenum. (Original work published 1934)
- Zazkis, R & Mamolo, A. (2011). Reconceptualizing knowledge at the mathematical horizon. *For the Learning of Mathematics* 31(2), 8–13.
- Zhang, Y. Zhang, H & Wang, Y. (2017). Horizon Content Knowledge: Is it a part of content knowledge or contextual factor? *Proceedings of The Six International Conference of Educational Innovation through Technology* (pp.148-151), Osaka, Japan.

Applying the Knowledge Quartet to student teachers' lesson plans: An intervention

Lena Karlsson

Linnaeus University, Sweden Lena.Karlsson@lnu.se

The Knowledge Quartet

The Knowledge Quartet is a theoretical framework for analysing and developing mathematics teaching developed by Rowland, Turner, Thwaites, and Huckstep (2009) and elaborated on by Rowland (2014). The framework comprises four categories – Foundation, Transformation, Contingency, and Connection – that together constitute the mathematical knowledge needed by teachers. Within each of these four categories, several codes have been developed with which to identify and evaluate the knowledge of student teachers based on observations of classroom teaching. This poster presents and discusses an intervention addressing whether and how the Knowledge Quartet can also be used to evaluate the knowledge of student teachers based on their lesson plans. In teacher education, there are often few occasions to observe student teachers' teaching, which is why it is of interest to explore whether some of the knowledge to be revealed (or revealed to be missing) by using the Knowledge Quartet can also be revealed in reflections of lesson plans.

The intervention

The intervention was conducted within a mathematics education course in lower primary school teacher education. In this course, the student teachers were to produce lesson plans for a series of lessons, implement one to two of these lessons, and then reflect on the series of lessons and on their implementation. The lesson implementation, however, was not observed by the teacher educators. The task was conducted in two groups of student teachers. In one group, the students were to write their reflections, and in the other group, the students were to record their reflections orally in video. For this poster, five reflections were randomly selected from each group.

In the written reflections, *Foundation* and *Connection* were the two dominant categories that were evident. In *Foundation*, a huge variety of codes was evident, the two most common ones being reflections on student beliefs (code A1) and reflections on the course (code A6). *Connection* was the second-largest category, and here the most common code was the student teacher's expectations about classroom complexity (code C1). In *Transformation*, the most common code was representations used in lessons (code B2). *Contingency* was only evident in one written reflection, in which one student teacher wrote about how she responded to and acted on her pupils' answers in the lesson (code D2).

In the oral reflections, *Foundation* and *Connection* were also the two dominant categories. In *Foundation*, several reflections addressed how assessment was to be carried out in the classroom (code A8), and another common code was the importance of using correct mathematical terminology and mathematical language even in lower primary school (code A7). *Connection* was the second largest category, and here the most common code was student teacher expectations about complexity in the classroom (code C1). The classroom setting was also common in the oral reflections code (code C6). In *Transformation*, the recordings of oral reflections featured how the student teachers chose examples and questions to be able to reveal student knowledge and understanding (code B1).

Contingency was the least common category in the oral reflections, though it was more common here than in the written reflections. The most common codes were how students could deviate from the lesson plan (code D3) as well as how the student teachers responded to their pupils' questions and answers (code D2). Even code D1, which deals with how the student teachers handle and act with pupils during instructions occurred.

New codes and sub-codes detected during analysis of the students' lesson plans

In *Foundation*, a new code was added concerning students' thoughts about assessment. Among other things, the students reflected on complexity in assessment and teaching, and on the difficulty of finding the right teaching level and of fairly judging pupil knowledge. In *Connection*, two new sub-codes of code C1 (expectations of classroom complexity) were defined. One sub-code focused on pupils needing special support, in which the student teachers reflected on and discussed how to teach mathematics so as to include all pupils. This was obvious in both the written and oral reflections. The second sub-code connected to C1 was self-reflections on teaching, in which the student teachers reflected on the lesson structure and outcome, though this sub-code was only evident in the oral reflections. Another common sub-code, of code C6, in both the written and oral reflections was classroom framing. Socio-mathematical norms as well as ability grouping versus inclusion were important elements of this code; how pupils' language abilities influence their mathematics learning was also included as a sub-heading.

Reflection

The Knowledge Quartet is a theoretical framework designed to be applied to observations of student teachers in the classroom. In this study the framework has been applied to two different forms of examination in a teacher program which generated new codes and sub codes not visible in the original framework. These codes and sub-codes might be specific to observe students' *reflections* on teaching. Through the new codes and sub-codes, it is visible that there is a tendency that the student teachers' reflections become clearer and broader examined through the film than through the text assignment. Hence, based on the intervention, I would argue that the refined framework of the Knowledge Quartet can be used to analyse students' reflections in lesson plans. However, the analysis of lesson plans differs from that of teaching as performed, as it indicates only whether the student teachers have the theoretical knowledge needed to teach a lesson, not whether they have the practical skills. Though, there are often few occasions to observe student teachers' teaching in teacher education, which is why it is of interest to explore knowledge to be revealed in reflections of lesson plans.

References

- Rowland, T. (2014). The Knowledge Quartet: The genesis and application of a framework for analysing mathematics teaching and deepening teachers' mathematics knowledge. *SISYPHUS Journal of Education*, 1(3), 15–43.
- Rowland, T., Huckstep, P., Turner, F., & Thwaites, E. A. (2009). *Developing primary mathematics teaching: Reflecting on practice with the Knowledge Quartet*. London: Sage Publications Ltd.

Preservice teachers' noticing of mathematical opportunities

Hulya Kilic¹, Oguzhan Dogan¹, Nil Arabaci² and Sena Simay Tun²

¹Yeditepe University, ²Bogazici University, Turkey; hulya.kilic@yeditepe.edu.tr

The aim of this study was to investigate the effects of a faculty-school collaboration program on preservice mathematics teachers' professional knowledge and skills. Seven preservice teachers worked with a group of students from the collaboration school such that they attempted to understand and support students' mathematics through the implementation of mathematical tasks. Video tapes and written documents were used to detect any changes in preservice teachers' noticing of mathematical opportunities emerged from students' mathematics. A coding scheme was developed to understand the pattern in their noticing skills. The results revealed that preservice teachers were able to attend to mathematical opportunities during the implementations as well as in oral and written reflections took place after implementations. Furthermore, they began to enrich their interpretations of students' mathematics by giving examples from students' work and their interactions with students.

Keywords: Noticing, preservice teachers, mathematical opportunities, faculty-school collaboration.

Introduction

For effective teaching, teachers should support students' mathematical understanding by organizing appropriate learning environment for students and giving various learning opportunities for students as well as providing necessary scaffolding for their learning (Ball, Thames, & Phelps, 2008). Teachers' such ability of eliciting and interpreting students' mathematics and scaffolding their understanding is a sign of both their *Mathematical Knowledge for Teaching* (MKT) (Ball et al., 2008; Stockero, Rupnow, & Pascoe, 2017) and also their noticing skills (Jacobs, Lamp, & Philipp, 2010; Schoenfeld, 2011; van Zoest et al., 2017). Because MKT involves in knowledge of how students learn and understand mathematics while noticing entails attending to learning opportunities occurred during instruction, interpreting students' thinking and taking an action for fostering students' understanding (Jacobs et al., 2010). In other words, MKT and noticing skills of teachers are interrelated (Stockero et al, 2017; van Zoest et al., 2017). Indeed, in-service teachers have opportunity to improve such knowledge and skills in schools throughout years such that they could enrich their repertoire of students' thinking styles, capabilities and needs in mathematics as well as teaching strategies that are appropriate for their students. However, recent studies on preservice teachers' training (PSTs) revealed that intervention studies conducted under teacher education programs were likely to support development of PSTs' MKT and noticing skills to some extent as well (e.g., Barnhart & van Es, 2015). In the light of such findings, we developed a faculty-school collaboration program for PSTs to investigate the nature and the development of their professional knowledge and noticing skills. As a requirement of the program, PSTs worked with a group of students on the mathematical tasks in a school setting throughout a year such that they videotaped all implementation sessions and then reflected on the implementations both orally and in written.

Theoretical framework

Noticing entails paying attention to important instances occurred in the classroom however it is difficult to decide what is noteworthy or not. In this study, we decided to focus on students'

mathematical thinking and understanding and we used Leatham and his colleagues' (Leatham, Peterson, Stockero & van Zoest, 2015) definition of *Mathematically Significant Pedagogical Opportunity to Build on Student Thinking* (MOST) as a unit of analysis to investigate PSTs' noticing skills. They described MOST as a composition of three sequential components such that it should be emerged from student's mathematical thinking, be mathematically significant and be a pedagogical opportunity (see for details Leatham et al., 2015). For instance, finding the answer of $-8+5$ as -13 might be counted as a MOST if it occurs while teaching operations with integers. In this case, the student thinks that addition of a negative and a positive integer is utilized as addition of natural numbers such that the sign of the first number is omitted first but then it is attached to the result. Because such an answer is observed while teaching integers, it is both mathematically significant and also a pedagogical opportunity to be discussed at that time in the class. Leatham and his colleagues also noted that not only students' misconceptions or incomplete reasoning but also their correct answers based on use of different strategies or approaches, mathematical contradictions or "why" questions might be coded as a MOST instance.

We adopted Jacobs and her colleagues' (Jacobs et al., 2010) definition of *professional noticing of students' thinking* to analyze PSTs' noticing skills. They defined noticing as having three interrelated components as attending to students' strategies, interpreting their understanding and deciding how to respond to students' mathematics. In this study, we analyzed PSTs' noticing in terms of whether or not they attended to MOST instance, how explicitly and accurately they interpreted students' thinking or student mathematics and how they responded to the MOST instance. We attempted to investigate PSTs' noticing during implementations (in-the-moment) and after implementations (in oral and written reflections). The implementation videos provided data about *attending* and *responding* while written and oral reflections used for *attending* and *interpreting* components of noticing. Although we asked PSTs to comment on their responding actions in oral and written reflections we did not count them as responding component but as a sign of interpretation of student mathematics as well as an indicator of their MKT.

Methodology

Research setting and participants

This study was conducted under a university-school collaboration program between a large university in Turkey and a local middle school in the neighborhood of the university. In the line of the collaboration, we took the responsibility of administration of an elective mathematics course offered for the seventh grade students in the school such that we grouped students and assigned a volunteer PST to work with these students on the mathematical tasks.

Seven preservice teachers attended to the program both in fall and spring semesters. Four of them were sophomore (Asya, Aydan, Ayla, Aysun) and three of them were junior (Bahar, Berna, Beste) undergraduate students of mathematics education program.

At the beginning of fall semester, a couple of weeks, we discussed about design and implementation of mathematical tasks as well as students' common misconceptions, and effective ways of understanding and supporting students' mathematical thinking. We discussed these issues via some sample videos and student work that we had in our repertoire from our earlier studies. Then we

assigned a group of four students for each PST that they would work with in the school for a year. Each group consisted of mixed ability students in terms of mathematics achievement.

We followed a 4-step intervention process for PSTs: pre-implementation discussion, task implementation, post-implementation discussion and written reflection. During pre-discussions we talked about the students' possible performance on the tasks as well as any modifications in the tasks before the implementation. Then, PSTs implemented the tasks in the school such that they allowed students worked on the tasks individually at first and then students discussed their answers as a group and finally PSTs began to interact with students to address mathematical opportunities occurred during the implementations. During post-discussions, each PST talked about how students performed on the tasks and how they addressed to students' mistakes or misconceptions. Each of these discussion sessions and implementations were videotaped. Then we asked PSTs to write reflection reports based on their videos and students' worksheets.

As the research team, we prepared 20 tasks such that 5 of them were about numbers, 7 of them were algebra, 5 of them were geometry and 3 of them were data and statistics. We also asked PSTs to prepare at least one task for each content area for their own groups and implement them. We used 2 lesson hours (80 min.) for each task implementation and we spent a total of 25 weeks in the school.

Data collection and analysis

We used discussion and task implementation videos, and PSTs' written reflections as the main source for PSTs' noticing skills. Furthermore, we used task implementation videos and students' worksheets to identify MOST instances. We determined MOST instances according to Leatham and his colleagues' (2015) framework. Based on Jacobs and her colleagues' (2010) definition of noticing we developed a coding scheme to identify PSTs' noticing skills in terms of attending to MOST, interpreting student mathematics and responding to students. While developing the coding framework we used similar frameworks in the literature (e.g., van Es, 2011) and also made a workshop with math educators to get their suggestions. The scheme that we used for coding is presented in Table 1.

	Attending	0	Missed the MOST
		1	Attended to the MOST
In the moment (Interaction)		Answer-focused	
	Responding	0	<i>(No attempt)</i> Only tells to the students that their answers/solutions are wrong; no guidance for students
		1	<i>(Explanation)</i> S/he or other students tells/explains the procedure or solution
		2	<i>(Orientation)</i> Attempts to make students find out the correct answer through short-answer, Yes/No type, prompting (directs students to correct answer like "...,isn't it?), no-follow up, non-specific type of questions or b) asking them to re-read, re-do, re-think
	Mathematical understanding-focused		
		3	<i>(Exploration)</i> Attempts to elicit students' thinking by asking probing questions (why, how, what if, ...) but either conversation is not concluded or in case of existence of misconceptions /misunderstandings she fails to address the gap in student's mind because her guidance involves partially incorrect issues such as lack of terminology, inappropriate examples or representations

		4	<i>(Elaboration)</i> Attempts to elicit students' thinking by asking probing questions and guiding students through appropriate examples, representations, connections between concepts and representations	
Oral reflection	Attending	0	Missed the MOST	
		1	Attended to the MOST	
	Interpreting	0	No interpretation	
		1	Non-specific about student mathematics	
		2	Specifically mentioned about student mathematics	
Written reflection	Attending	0	Missed the MOST	
		IR	Attended to the MOST both during Interaction and in Report	
		I	Attended to the MOST only during Interaction	
			R	Attended to the MOST in Report
	Interpreting	0	Does not provide any interpretation or states that she did not understand what the student did/thought about	
		1	Just rephrases students' written procedures and/or points out students' mistakes	
		2	Comments on the possible reasoning behind student mathematics but provides limited justification such as blaming student for lack of knowledge or her comments about student mathematics is partially correct	
		3	Comments on the possible reasoning behind student mathematics by providing examples from students' work or vignettes from student-teacher interaction but do not explain the justifications explicitly	
		4	Gives a detailed explanation about possible reasoning behind student mathematics by providing valid justifications	

Table 1: Framework for teachers' noticing skills

We used different identifiers and levels for interpreting component of written and oral reflections because during oral reflections we gave a limited time for PSTs to talk however, they had enough time to write about implementation and students' performances. Furthermore, as the research team we discussed all MOST instances and codes for PSTs' noticing skills together. Thus, we have achieved a consistency in coding of each PSTs' noticing and MOST instances, in other words, we fully achieved interrater reliability.

Findings

In this paper, we present the data collected from seven PSTs who attended to the program in both semesters. A total of 354 MOST instances (approximately two MOST instances per week for each PST) were detected throughout the year. Although Leatham et al. (2015) discussed various sources of MOST instances, including students' alternative solutions or their answers for "why" questions, in this study majority of MOSTs emerged from students' misconceptions. Furthermore, because we mentioned about students' possible misconceptions during pre-implementation discussions, PSTs were somewhat familiar to such instances before the implementations. Indeed, 45% of MOST instances were already mentioned in the pre-implementation discussions while 55% of them were new for the PSTs. The frequency distribution of how PSTs attended to those MOST instances is presented in Table 2.

		Interaction							Oral Reflection					Written Report								
		Attending		Responding					Attending		Interpreting			Attending				Interpreting				
		0	1	0	1	2	3	4	0	1	0	1	2	0	I	R	IR	0	1	2	3	4
Asya	Fall	3	18	1	10	6	1	0	6	15	6	1	14	1	5	2	13	0	6	3	3	3
	Spring	5	24	0	13	7	2	2	6	23	6	0	23	2	2	3	22	0	5	14	2	4
Aydan	Fall	8	11	2	6	3	0	0	6	13	6	7	6	4	5	4	6	0	3	2	0	5
	Spring	3	24	0	17	5	2	0	3	24	3	3	21	0	3	3	21	0	4	8	6	6
Ayla	Fall	2	19	0	10	9	0	0	6	15	6	4	11	0	2	2	17	0	4	6	5	4
	Spring	3	25	0	7	12	5	1	4	24	4	2	22	0	0	3	25	0	5	7	6	10
Aysun	Fall	3	18	0	14	4	0	0	5	16	5	7	9	1	1	2	17	0	7	7	1	4
	Spring	4	22	0	15	7	0	0	8	18	8	2	16	0	0	4	22	0	4	10	3	9
Bahar	Fall	0	25	3	12	8	1	1	7	18	7	3	15	0	5	0	20	0	16	3	1	0
	Spring	3	26	1	11	10	4	0	5	24	5	4	20	3	2	0	24	0	10	7	6	1
Berna	Fall	2	21	1	11	9	0	0	8	15	8	3	12	2	4	0	17	0	7	6	2	2
	Spring	2	25	0	18	6	0	1	6	20	6	9	11	2	3	0	22	0	7	9	4	2
Beste	Fall	0	25	5	7	12	1	0	11	11	11	3	8	0	5	0	20	0	9	7	4	0
	Spring	1	32	2	17	11	1	1	6	27	6	3	24	1	8	0	24	0	8	12	4	0
Total	Fall	18	137	12	70	51	3	1	49	103	49	28	75	8	27	10	110	0	52	34	16	18
	Spring	21	178	3	98	58	14	5	38	160	38	23	137	8	18	13	160	0	43	67	31	32
		11%	89%	2%	55%	33%	8%	3%	19%	81%	19%	12%	69%	4%	9%	7%	80%	0%	25%	39%	18%	18%

Table 2: Coding of preservice teachers' noticing skills

When we analyzed data about noticing during implementations, we observed that the PSTs attended to majority of MOST instances in both fall and spring semesters (88% and 89%, respectively). In terms of responding to MOST instances, it was observed that PSTs attempted to guide students in some ways (totally 91% in Fall and 98% in Spring) but they mostly preferred answered-focused actions in both semesters (totally 88% for each semester). However, it was seen that in the spring semester they attempted to elicit students' mathematics in the form of *exploration* and *elaboration* more in comparison to fall semester (totally 3% in Fall, 11% in Spring).

In terms of written and oral reflections after implementations it was also observed that PSTs attended to MOST instances occurred during implementations. During post-implementation discussions the instructors from the research team asked about how implementation went and what PSTs observed about students' mathematical performances. When discussion videos were analyzed it was observed that PSTs mentioned about the MOST instances occurred during the implementations (68% in Fall and 81% in Spring). Furthermore, they attempted to give justifications for students' performances such that the percentage of such specific comments about students' mathematics increased in spring semester (50% in Fall, 69% in Spring).

The PSTs attended to some of the MOST instances that they missed during the implementations in their written reports such that in total they attend to 10 of the 18 missed MOSTs in fall (approx. 56%) and 13 of the 21 missed MOSTs in spring (approx. 62%). However, there were cases that PSTs did not write about the MOST instances even though they attended to them during the interactions. When we compared the semesters, the number of such cases decreased in spring semester from 17% to 9% as seen in Table 2. That is, PSTs attended to MOST instances in both during interaction with students and in their written reports (71% in Fall and 80% in Spring). We also analyzed how PSTs interpreted student mathematics in their written reports. It was observed that all PSTs attempted to interpret students' mathematical thinking behind the MOST instances. Although in fall semester the percentage of the cases that PSTs only wrote about what students did (Level 1 in coding scheme) was high, it decreased in the spring semester (43% in Fall, 25% in Spring). That is, they began to comment on students' mathematics by providing justifications from their interactions with students and students' written work (totally 56% in Fall and 75% in Spring).

We also analyzed how each PST's noticing varied in fall and spring semesters. As shown in Table 3, we analyzed their responding actions during interactions in terms of answer-focused vs mathematical-understanding focused. We also categorized their interpretation of students' mathematics in terms of providing justifications or not. As seen Table 3, Aydan showed a progress in terms of attending to MOST instances in the moment of implementations. In terms of responding actions, except Aysun, PSTs attempted to elicit or elaborate students' mathematical understanding during the interactions such that there were more instances coded as "3" or "4" in spring semester. The PSTs also attended to MOST instances and specifically mentioned about students' mathematics during oral reflections. This fact was more evident in Asya's, Aydan's and Ayla's cases as shown in Table 3. Although all PSTs attempted to provide justifications for their interpretations of students' thinking in their reports, the change in Aysun's and Bahar's written reflections during spring semester was noteworthy. For instance, in fall semester Bahar was just writing about what students did or she blamed students having lack of knowledge however in spring semester she began to explain the reasoning behind

students' mathematics by providing examples from student work or sample vignettes of group discussions.

		Interaction			Oral reflection			Written reflection		
		Att.	Res.		Att.	Int.		Att.	Int.	
		1	0--2	3--4	1	0--1	2	IR	0--2	3--4
Asya	Fall	86%	95%	5%	71%	33%	67%	62%	60%	40%
	Spring	83%	83%	17%	79%	21%	79%	76%	76%	24%
Aydan	Fall	58%	100%	0%	68%	68%	32%	32%	50%	50%
	Spring	89%	92%	8%	89%	22%	78%	78%	50%	50%
Ayla	Fall	90%	100%	0%	71%	48%	52%	81%	53%	47%
	Spring	89%	76%	24%	86%	21%	79%	89%	43%	57%
Aysun	Fall	86%	100%	0%	76%	57%	43%	81%	74%	26%
	Spring	85%	100%	0%	69%	38%	62%	85%	53%	47%
Bahar	Fall	100%	92%	8%	72%	40%	60%	80%	95%	5%
	Spring	90%	85%	15%	83%	31%	69%	83%	71%	29%
Berna	Fall	91%	100%	0%	65%	48%	52%	74%	76%	24%
	Spring	93%	96%	4%	77%	58%	42%	81%	73%	27%
Beste	Fall	100%	96%	4%	50%	64%	36%	80%	80%	20%
	Spring	97%	94%	6%	82%	27%	73%	73%	83%	17%

Note: Att.: Attending, Res.: Responding, Int.: Interpreting

Table 3: Variations in preservice teachers' noticing skills

Discussion

In this study, we attempted to create an opportunity for PSTs to investigate nature and development of their in-the-moment noticing skills as well as noticing based on analysis of their own videos. As aligned with the findings of intervention studies mentioned in the literature (Barnhart & van Es, 2015; Stockero et al., 2017) this faculty-school collaboration contributed to PSTs' noticing. Firstly, PSTs were able to attend majority of MOST instances occurred during implementations. Pre and post implementation discussions might help PSTs to recognize the MOST instances because we talked about students' possible misconceptions and difficulties as well as how to eliminate such misconceptions during the discussions. Furthermore, as they got to know their students they got better in predicting their students' performances so that they had prepared for MOST instances which were likely to occur during implementations. This fact could be thought as an improvement in their MKT specifically in their specialized content knowledge and knowledge of students and content. Secondly, we observed changes in PSTs' responding actions throughout the year such that almost all PSTs achieved a transition from "No attempt" to "Elaboration" type of responding. However, such transition was not in progressive fashion (Barnhart & van Es, 2015) most probably because variations in students' prior knowledge and the context of the tasks (Kilic, Dogan, Tun, & Arabaci, 2018). For further studies, PSTs might be trained more for eliciting and elaborating type of responding actions before implementations of the tasks with students. Thirdly, analysis of own videos supported PSTs' noticing skills (Barnhart & van Es, 2015; Stockero et al., 2017) such that they were able to recognize

and wrote about the MOST instances that they missed during interactions in their reflections. Furthermore, written reflections provided an evidence for how PSTs interpreted students' thinking which was implicit in implementation videos.

Briefly, in addition to their theoretical courses, teacher educators should provide hands-on experiences for PSTs to promote their professional knowledge and skills. Although analysis of own teaching videos contributed to PSTs' noticing skills, for in-the-moment noticing, they should be given opportunities to work with students or teach in a classroom for a long period of time.

Acknowledgment

This research was supported by The Scientific and Technological Research Council of Turkey (TUBITAK, Grant no: 215K049)

References

- Ball, D. L., Thames, M. H. & Phelps, G. (2008). Content knowledge for teaching: What makes it special? *Journal of Teacher Education*, 59, 389–407.
- Barnhart, T. & van Es, E. (2015). Studying teacher noticing: Examining the relationship among pre-service science teachers' ability to attend, analyze and respond to student thinking. *Teaching and Teacher Education*, 45, 83–93.
- Jacobs, V. R., Lamb, L. L., & Philipp, R. A. (2010). Professional noticing of children's mathematical thinking. *Journal for Research in Mathematics Education*, 41(2), 169–202.
- Kilic, H., Dogan, O., Tun, S. S., & Arabaci, N. (2018). Supporting preservice teachers' in-the-moment noticing. In E. Bergqvist, M. Österholm, C. Granberg, & L. Sumpter (Eds.) *Proceedings of the 42nd Conference of the International Group for the Psychology of Mathematics Education* (Vol. 3, pp. 203–210). Umeå, Sweden: PME.
- Leatham, K. R., Peterson, B. E., Stockero, S. L., & van Zoest, L. R. (2015). Conceptualizing mathematically significant pedagogical opportunities to build on student thinking. *Journal for Research in Mathematics Education*, 46(1), 88–124.
- Schoenfeld, A. H. (2011). Noticing matters. A lot. Now what? In M. G. Sherin, V. R. Jacobs, & R. A. Philipp (Eds.), *Mathematics teacher noticing: Seeing through teachers' eyes* (pp. 223–238). New York: Routledge.
- Stockero, S. L., Rupnow, R. L., & Pascoe, A. E. (2017). Learning to notice important student mathematical thinking in complex classroom interactions. *Teaching and Teacher Education*, 63, 384–395.
- Van Es, E. (2011). A framework for learning to notice student thinking. In M. G. Sherin, V. R. Jacobs, & R. A. Philipp (Eds.), *Mathematics teacher noticing: Seeing through teachers' eyes* (pp. 134–151). New York: Routledge.
- Van Zoest, L. R., Stockero, S. L., Leatham, K. R., Peterson, B. E., Atanga, N. A., & Ochieng, M. A. (2017). Attributes of instances of student mathematical thinking that are worth building on in whole-class discussion. *Mathematical Thinking and Learning*, 9(1), 33–54.

Design of repertory grids for research on mathematics teacher conceptions of process-related mathematical thinking

Peter M. Klöpping¹ and Ana Kuzle²

¹University of Potsdam, Germany; peter.kloepping@uni-potsdam.de

²University of Potsdam, Germany; ana.kuzle@uni-potsdam.de

Research on teacher knowledge and beliefs in mathematics has a long history (Philipp, 2007). However, research on teacher knowledge and beliefs with respect to process-related thinking is relatively new. Even though studies have been conducted in this area, especially regarding proof and proving, most did not focus on primary grade teachers' knowledge and beliefs. Moreover, when researching mathematical knowledge and beliefs on process-related mathematical thinking, an adequate methodological tool is still an issue of concern. The goals of this paper are twofold: (1) to present an alternative approach to capture mathematics teacher conceptions on the basis of Kelly's (1955) theory of personal constructs, and (2) to discuss a design of a repertory grid to research primary grade teacher conceptions of argumentation. In the end, we discuss the potential of repertory grids as a tool to grasp teacher conceptions on process-related thinking in general.

Keywords: Teacher conceptions, process-related mathematical thinking, semi-structured interviews, repertory grid, elementary school teachers.

Introduction

Process-related competences, such as argumentation and problem solving are essential for learning mathematics. When introducing habits of mind in an educational context, Cuoco, Goldenberg, and Mark (1996) highlight amongst others these activities for mathematics classroom. They argue that in school mathematics specific results are of little importance in contrast to habits of mind as used by mathematicians and that teachers should help students to “learn and adopt some of the ways that mathematicians think about problems” (Cuoco et al., 1996, p. 376). As teachers play a vital part in enabling this type of learning, it is necessary to understand their practices. Consequently, examining teacher knowledge, beliefs, and identity is a relevant research focus. Similarly, at CERME9, the TWG20 on teacher knowledge, beliefs and identity underpinned this claim. Moreover, as a group they considered these areas “as the core of a teacher's practices, with each area influencing and being influenced by others” (Ribeiro, Aslan-Tutak, Charalambous, & Meinke, 2015, p. 3178).

As outlined in Philipp (2007), plethora of research in the area of affective domain has been conducted, where the focus primarily lied on mathematics as a subject or on specific content areas. When focusing on process-related mathematical thinking, teacher beliefs about proof and proving are dominant research areas, but merely consider secondary and tertiary education (e.g., Conner, Edenfield, Gleason, & Ersoz, 2011). Investigating more specifically teachers' actions, the case analysis by Ayalon and Even (2016) showed how teachers' understanding of mathematical argumentation influenced their way of teaching, pointing out how opportunities of engaging students in argumentative activities are made available, and shaped by the teacher. In primary education, researchers have shown that teachers play an important part in initiating argumentative processes and

determine how students participate in these processes in class (e.g., Forman, Larreamendy-Joerns, Stein, & Brown, 1998). Thus, it is vital to understand teacher conceptions of argumentation, as discussed as well by Ayalon and Naama in this TWG20 at CERME11. Extending the research from secondary to primary education seems appropriate and beneficial.

In this direction, we conducted an exploratory case study guided by the question what conceptions primary grade teachers hold specifically with respect to mathematical argumentation (Klößing & Kuzle, 2018). For that purpose, we developed a guideline for a semi-structured interview. Although the exploratory study already yielded some noteworthy results, such as that mathematical argumentation was seen by the teachers as processes of understanding or as a tool for critical analysis of results, the instrument needs to be revised in order to facilitate the comparison between teachers, and to make it feasible for larger samples. Furthermore, the connection between the teachers' conceptions and their classroom practice should be emphasized in order to understand this multi-faceted phenomenon better.

On the foundation of our case study (Klößing & Kuzle, 2018), we present an alternative methodological approach for exploring teacher conceptions of process-related mathematical thinking, and discuss this approach in the following. The article contributes to the demand to highlight the connection between “aspects of mathematics teaching and learning” and “teachers' intertwined knowledge” (Ribeiro et al., 2017, p. 3221).

A few remarks on researching teacher knowledge and beliefs

In 1992, Thompson coined the term conception as “a general notion or mental structure encompassing beliefs, meanings, concepts, propositions, rules, mental images, and preferences” (Philipp, 2007, p. 259). The distinction between knowledge and beliefs is not made very clear, therefore, the term conceptions arose which acknowledges the important relationship between these two mental structures and combines both notions (Philipp, 2007). Researching these mental structures, especially beliefs, Philipp (2007) found generally two methodological approaches to be present: studies following a case analysis approach and research using assessment instruments. The latter includes surveys using Likert-type scale to measure mathematical beliefs and testing theory, whereas the former approach used for building theory is more common (Philipp, 2007). Both approaches use a wide variety of research instruments exploring “beliefs about students' mathematical thinking, about curriculum, and about technology” as the “three major areas” (Philipp, 2007, p. 281).

Research on teacher beliefs about process-related mathematical thinking started in the domain of proof and proving (e.g., Conner et al., 2011; Knuth, 2002). When referring to other process-related competences, research on teacher knowledge and beliefs can be found within the teaching of conjecturing and argumentation (e.g., Bergqvist, 2005; Katsh-Singer, McNeill & Loper, 2016). Following this line of research, we explored teacher conceptions (knowledge and beliefs) regarding mathematical argumentation in German primary education using semi-structured interviews (Klößing & Kuzle, 2018). Questions within the interview guide concerned either argumentation in the field of mathematics (e.g., What purpose does argumentation serve in mathematics?) or argumentation in the context of teaching (e.g., How do you envision the role of argumentation in your classroom? How important is it for you?). However, we found comparing the teachers' conceptions

and connecting these conceptions with their classroom practice as unnecessarily difficult, leading to a search for alternative research methods.

An alternative approach to mathematics teacher conceptions research

In 1955, Kelly introduced the term *personal constructs* and thought of them as a way for individuals to describe their personality and their surroundings in terms of how some subjects, objects or situations equal one another and are yet different from other things. The constructs are labeled as “personal” because they vary from person to person. This mirrors Kelly’s interest in individual aspects of self-concepts and the social perception of individuals (Westmeyer, Weber, & Asendorpf, 2014). On the foundation of this psychological cognitive theory, Kelly (1955) derived an instrument – the so-called *role construct repertory test* (or shorter repertory grid) – that can give insight into personal constructs which indicate how individuals think, act, and feel. This approach can be seen as a methodology for mapping cognitive structures, which includes shared and unique elements of persons’ cognitive systems (Kelly, 1955; Tan & Hunter, 2002).

In praxis, a repertory grid is a technique employed within an interview. On the basis of the interview’s topic, *elements* are selected first. This selection is an essential part of a grid as it defines the underlying material. Grounded on Kelly’s theory of personal constructs, the nature of these elements always permits that a pair of elements can either be differentiated or be seen as equal when examined through personal *constructs*. A repertory grid finally establishes a *link* between all elements and the personal constructs which came up during the interview. Applying it as an instrument for research in mathematics education demands careful deliberation of these components.

Elements in a repertory grid should belong to the same category to ensure that elicited or given constructs are applicable to all elements. This call for homogeneity does not mean that there should not be distinctive or contrasting pairs of elements. Quite the opposite, it should be thought of a representative coverage including contrasts to allow for a wide range of constructs (Easterby-Smith, 1980). Additionally, Easterby-Smith (1980) implies that all interviewees should be “able to relate directly to the elements specified” (p. 4).

Constructs are utilized to attribute characteristics to elements helping to distinguish between them and reveal how the elements differ according to the subjects understanding. Eliciting constructs from triads of elements is, according to Easterby-Smith (1980), the classical approach of generating constructs where the subject has to state “in what way two of the elements [in a triad] are alike and in what way the third element is different from the other two” (p. 6). In this process, a construct with two opposing poles is produced followed by a new selection of elements for the next triad.

As far as the *linking mechanism* is concerned two general options are on hand: rating or ranking elements. Ranking forces the participants to differ between elements regarding a certain construct even if they see no difference. This is why rating scales are common and most often used varying from dichotomous scoring to five, seven or even more point scales (Tan & Hunter, 2002). Nowadays, technology allows for more subtle grading why a visual analog scale could as well be a viable option, but it has, to our knowledge, never been used in a repertory grid.

Philipp (2007) points out that cognitive structures, such as knowledge, beliefs and attitudes are intertwined. Since a repertory grid does not explore these areas separately, but in a more holistic manner, we see great potential to the field of knowledge and beliefs research. Upon this methodological consideration, a design of a repertory grid in the context of process-related mathematical thinking exemplified through argumentation will be elaborated in the following section.

Design of a repertory grid on conceptions of argumentation

As noted earlier, in our exploratory case study with three German primary grade teachers we employed a guideline for a semi-structured interview as a data collection tool (Klöppling & Kuzle, 2018). Taking into consideration the discussed perspective on researching mathematics teacher conceptions, re-thinking the nature of the interview guide may be beneficial. To explore in this way teacher knowledge and beliefs from a different angle, a repertory grid will be integrated in the existing guideline. The integration of Kelly's ideas should be rather thought of as a methodological synergy than a rejection of established approaches.

Within the conducted exploratory case study, the interviewees were asked to evaluate fictional student explanations. We identified this section as a promising part to integrate a repertory grid. First, the participants were shown the following mathematical statement: For any positive integers a and b , if $a + b$ is an odd number, then one of a or b is an odd number and the other is an even number. Then, fictional student arguments which underpin the mathematical statement were presented asking the participants to discuss these by referring to the following guiding questions:

- What do you think of this argument?
- Would you expect this argument from an elementary school student?
- Do you think this argument would convince elementary school students? Why or why not?

The teachers' answers show significant shreds of evidence to explain what their beliefs on mathematical argumentation, their knowledge, and their expectations for classroom interaction and implementation of argumentation are. Herein, distinct functions of argumentative structures in the classroom were emphasized by the teachers. In the interviews, mathematical argumentation was seen as processes of understanding, as practical knowledge, as a tool for critical analysis of results, and as supportive for self-reflection among other (Klöppling & Kuzle, 2018). Nevertheless, the approach missed the opportunity to link and relate the teachers' perspectives on the fictional student explanations to one another. Difficulties arose as well when the teachers' evaluations of the student explanations were compared among each other. At this exact point, we see potential in the application of a repertory grid to better understand teacher conceptions of argumentation.

The evaluative section on fictional students' arguments can be changed into the format of a repertory grid. First, the teachers are shown the mentioned mathematical statement on parity and develop their own argument, which will be used as one element. Then they are asked to discuss the students' arguments applying the method of a repertory grid. Table 1 shows exemplified components of such a grid where the fictional student explanations from the former guideline still exist, but are now supplied as elements instead. Evaluation and discussion of all arguments within a repertory grid needs Kelly's personal constructs. Each construct (see Table 1 on the left) has a counterpart: a contrast (on the right). For example, a teacher could describe an argument as "mathematically correct" whereas

on the opposite side of the same scale other arguments can be seen by that teacher as “improper”. The exemplified linking mechanism includes a dichotomous scoring and a five-point rating scale.

		<i>Elements</i>					<i>Contrasts</i>
		Ana's Argument	Benjamin's Argument	Clara's Argument	...	Teacher's Argument	
<i>dichotomous score</i>	<i>Constructs</i>				...		
	mathematically correct (✓)	-	-	✓	...	✓	improper (-)
	comprehensible (✓)	✓	-	✓	...	✓	abstract (-)
<i>five-point rating scale</i>	helps to understand the statement (5)	1	3	5	...	4	confusing (1)
	adequate for primary (5)	3	5	4	...	5	higher mathematics (1)

Table 1: Example layout of a repertory grid on argumentation with different linking mechanisms

As elements relate directly to the topic of the interview, they should be the starting point when thinking about the design of a grid. Easterby-Smith (1980) recommends to use a small grid with clearly specified elements. Selecting elements can be done by supplying them, by providing descriptions of roles or situations, or by discussing the research topic with the subject and choosing elements jointly (Easterby-Smith, 1980). In our suggestion above, elements will mainly be supplied as all fictional students' arguments are determined in advance. This supplement of elements is adequate as it securely allows for interpersonal comparison, which requires the elements in all grids to be equal or at least to be equivalent.

Given that the elements are to be fictional students' arguments and that all elements together should reach representative coverage, a theoretical foundation for the supplied elements is needed. Balacheff (1988) introduced a taxonomy of proofs and proving, namely naive empiricism, crucial experiment, generic example and thought experiment. Further elaboration of this theory showed that it helps as well to distinguish types of arguments (Reid & Knipping, 2010). For the elements in a repertory grid on conceptions of argumentation these categories can be used and we suggest that each one is covered at least by one element to ensure that they incorporate all important types of arguments.

We present two fictional student explanations to give an idea of the anticipated grid's elements (see Figure 1). Benjamin's argument is a *generic example* (Balacheff, 1988) in which the generality of the statement can easily be seen. On the other hand, Clara's argument shows a *naive empiricism* (Balacheff, 1988) with loosely connected examples. To this pool of supplied elements (in our case arguments) the teacher's own argument in favor of that statement is added as another element. Such

procedure may allow for a more explicit connection between knowledge and beliefs of the interviewed teacher. Within a repertory grid, the following evaluation of these arguments is done with the help of personal constructs.



<p><i>Benjamin's Argument</i></p> <p>I add two even numbers. The sum will be even. Here:</p>  <p>I add two odd numbers and the sum will also be even. See:</p> 	<p><i>Clara's Argument</i></p> <p>I add 1 and 2. The result is 3, an odd number.</p> <p>If I add 5 and 6 then that is also an odd number.</p> <p>And 7 plus 4 is 11. Which again, is an odd number.</p>
--	--

Figure 1: Examples of elements in a repertory grid on argumentation

While supplying constructs is a quick and easy way to begin linking them to elements, respectively to evaluate the arguments through them, it is difficult to assure that the supplied constructs mirror the conceptions of all interviewees and, furthermore, to assume that the subjects have “an adequate understanding of what [the constructs] mean” (Easterby-Smith, 1980, p. 6) seems delicate. The exemplified construct “mathematically correct” in Table 1 can be understood very differently. One teacher might think of it as the opposite of improper or false whereas another teacher judges the arguments correctness by its rigor. As teacher conceptions of mathematical argumentation in primary education have not been sufficiently studied, supplying constructs might end in misleading interpretations, and results. Hence, it seems more adequate to generate them from triads of elements, as it is the classical approach in a repertory grid.

However, making use of the methodological synergy, an alternative could be to as well emerge some constructs during the open question part of the interview. In our exploratory case study (Klöpping & Kuzle, 2018), the question “What makes an argument convincing?” lead to a possible construct as shown in Table 1. One teacher stated that if an argument is comprehensible then it is also convincing. Using this statement as a construct in a repertory grid, the contrasting pole must be clear. In this case, the teacher meant it as the opposite of “abstract”. With this understanding all arguments, respectively elements, can be rated on a scale from “comprehensible” to “abstract”. This way of evaluating and interpreting persons, objects, or situations is the core idea of the repertory grid (Kelly, 1955). Moreover, this highlights how open questions from a semi-structured interview can contribute to a repertory grid. In return, the linking mechanism of the grid addresses quantitative evaluations.

Following established research methods, we suggest to use a five-point rating scale as the linking mechanism, because this lays the basis for a comparison with research using a five-point Likert-type scale. Dichotomous scoring, on the other hand, can decide whether an element fulfills a characteristic or not, which might be helpful in some cases. The adequate linking mechanism depends strongly on the constructs, which signifies that no general decision can be made.

Conclusion and final thoughts

Following an alternative approach in researching mathematics teacher conceptions, the repertory grid seems to be a promising tool that meets the demands in the context of mathematics education research. Especially in a domain where the research objects are intertwined in many ways, the repertory grid might help to better understand such multi-faceted phenomena. Furthermore, the data provided by a repertory grid can be analyzed from different angles as both qualitative and quantitative methods can be applied (Tan & Hunter, 2002). This does justice to a research area which in itself has multiple perspectives. As we discussed the methodological approach in general, the repertory grid per se is not limited by cultural aspects. Nevertheless, when designing it for a certain purpose the educational setting and background of the teachers should not be ignored. This especially concerns the selection of elements in a grid as all interviewees should be able to relate to them. Additionally, the elements strongly define the emerging data.

The presented methodological discussion for a repertory grid on teacher conceptions of argumentation should be seen as an example in the field of process-related mathematical thinking which can be adapted. Replacing the elements, respectively arguments and explanations, with student solutions to a problem-solving activity or with different mathematical models of the same real-world problem can open the door to a repertory grid focusing on teacher conceptions of problem solving or mathematical modeling. Moreover, at CERME10 it was discussed how teacher knowledge is related to classroom practice and students' learning (Ribeiro et al., 2017). This demand should probably not be limited to teacher knowledge, but should as well take teachers' beliefs, orientation or attitudes towards mathematical principles, concepts or ideas in an educational setting into account. Slightly adapting the presented grid design could be beneficial for exploring these relations further. Instead of fictional students' arguments, real arguments from the teacher's class could be taken. This would link the teacher's knowledge and beliefs directly to classroom practices.

Concluding the methodological discussion, we plan a qualitative interview study with German primary grade teachers on conceptions of mathematical argumentation. From a research perspective, our contribution hopefully enriches this research area which can surely take different paths. However, this discussion is a call for a methodology which takes strong interconnections into consideration, but does not lose the focus on the teacher as an individual being before exploring more general structures.

References

- Ayalon, M., & Evan, R. (2016). Factors shaping students' opportunities to engage in argumentative activity. *International Journal of Science and Mathematics Education*, 14(3), 575–601.
- Balacheff, N. (1988). Aspects of proof in pupils' practice of school mathematics. In D. Pimm (Ed.), *Mathematics, teachers and children* (pp. 216–235). London, England: Hodder and Stoughton.
- Bergqvist, T. (2005). How students verify conjectures: Teachers' expectations. *Journal of Mathematics Teacher Education*, 8, 171–191.
- Conner, A., Edenfield, K. W., Gleason, B. W., & Ersoz, F. A. (2011). Impact of a content and methods course sequence on prospective secondary mathematics teachers' beliefs. *Journal of Mathematics Teacher Education*, 14, 483–504.

- Cuoco, A., Goldenberg, E. P., & Mark, J. (1996). Habits of mind: An organizing principle for mathematics curricula. *Journal of Mathematics Behavior*, 15, 375–402.
- Easterby-Smith, M. (1980). The design, analysis and interpretation of repertory grids. *International Journal of Man-Machine Studies*, 13, 3–24.
- Forman, E. A., Larreamendy-Joerns, J., Stein, M. K., & Brown, C. A. (1998). “You’re going to want to find out which and prove it”: Collective argumentation in a mathematics classroom. *Learning and Instruction*, 8(6), 527–548.
- Katsh-Singer, R., McNeill, K. L., & Loper, S. (2016). Scientific argumentation for all? Comparing teacher beliefs about argumentation in high, mid, and low economic status schools. *Science Education*, 100(3), 410–436.
- Kelly, G. A. (1955). *The psychology of personal constructs*. Oxford, England: W.W. Norton.
- Klöpping, P. M., & Kuzle, A. (2018). Critical incidents shaping teachers’ conceptions of argumentation in primary education. In E. Bergqvist, M. Österholm, C. Granberg, & L. Sumpter (Eds.), *Proceedings of the 42nd Conference of the International Group for the Psychology of Mathematics* (Vol. 5, p. 89). Umeå, Sweden: PME.
- Knuth, E. J. (2002). Teachers’ conceptions of proof in the context of secondary school mathematics. *Journal of Mathematics Teacher Education*, 5, 61–88.
- Philipp, R. A. (2007). Mathematics teachers’ beliefs and affect. In F. K. Lester (Ed.), *Second handbook of research on mathematics teaching and learning* (pp. 257–315). Charlotte, NC: Information Age.
- Reid, D., & Knipping, C. (2010). *Proof in mathematics education: Research, learning and teaching*. Rotterdam, the Netherlands: Sense Publishers.
- Ribeiro, M., Aslan-Tutak, F., Charalambos, C., & Meinke, J. (2015). Introduction to the papers of TWG20: Mathematics teacher knowledge, beliefs and identity: Some reflections on the current state of the art. In K. Krainer & N. Vondrova (Eds.), *Proceedings of the Ninth Conference of European Research in Mathematics Education* (pp. 3177–3183). Prague, Czech Republic: Charles University in Prague, Faculty of Education and ERME.
- Ribeiro, M., Aslan-Tutak, F., Kuntze, S., Martignone, F., Rø, K., & Toor, A. (2017). Introduction to the papers of TWG20: Mathematics teacher knowledge, beliefs, and identity. In T. Dooley & G. Gueudet (Eds.), *Proceedings of the Tenth Congress of the European Society for Research in Mathematics Education* (pp. 3220–3223). Dublin, Ireland: DCU Institute of Education and ERME.
- Tan, F. B., & Hunter, M. G. (2002). The repertory grid technique: A method for the study of cognition in information systems. *MIS Quarterly*, 26(1), 39–57.
- Thompson, A. G. (1992). Teachers’ beliefs and conceptions: A synthesis of the research. In D. A. Grouws (Ed.), *Handbook of research on mathematics teaching and learning* (pp. 127–146). New York, NY: Macmillan.
- Westmeyer, H., Weber, H., & Asendorpf, J. (2014). Theorie der persönlichen Konstrukte. In M. A. Wirtz (Ed.), *Dorsch – Lexikon der Psychologie* (18th ed., p. 1552). Bern, Switzerland: Hogrefe.

Constructing tasks for primary teacher education from the perspective of Mathematics Teachers' Specialised Knowledge

Montes, Miguel¹, Climent, Nuria¹, Carrillo, José.¹, Contreras, Luis Carlos¹

¹ Universidad de Huelva, Huelva, Spain

miguel.montes@ddcc.uhu.es, climent@uhu.es, carrillo@uhu.es, lcarlos@uhu.es

Developing tasks to help prospective teachers construct professional knowledge is an under-researched area of teacher education. In this paper we focus on describing the process of generating tasks in a research project at the University of Huelva. Using the model Mathematics Teachers' Specialized Knowledge we designed tasks to prompt the construction of specific elements of knowledge necessary for teaching mathematics, with the involvement of educators and prospective teachers selected ad hoc. As an example, we describe elements from a task focused on the notion of a polygon.

Keywords: Mathematics Teacher Education, Tasks, MTSK, Polygons.

Introduction

Mathematics teachers' knowledge has been the subject of discussion for over thirty years during which time various forms of modelling this knowledge have emerged, representing a wide variety of perspectives, foundations and proposals (see Montes, Ribeiro, & Carrillo, 2016). In this study we take on the challenge of applying insights from this body of research into professional knowledge to our teacher education programmes (Neubrand, 2018).

We are currently working on a research project at the University of Huelva which aims to develop a series of tasks for working with students following a degree in Primary Education. In the medium term, our objective is to structure the course content (with respect to mathematics) around research findings. Here we offer a progress report on the development of tasks for the prospective primary teachers which focus on the construction of professional knowledge, and which are underpinned by the research model, Mathematics Teachers' Specialised Knowledge (Carrillo et al., 2018). The first stage of development involved an experimental one-to-one teaching session (Cobb & Gravemeijer, 2008) with a specially selected group of students working alongside a team of experienced and less experienced teacher educators.

First we describe the theoretical foundations of the model of professional knowledge underpinning the study; then we give a detailed description of the first stage of the process for creating the tasks; finally, we offer some reflections on the development process, and the implications, limitations and potentials in taking it forward. This will contribute to give some light to our research question: how can a teacher's knowledge framework contribute to the design of tasks in teacher education? In particular, here we show the design process of a task concerning mathematical knowledge.

Theoretical Foundations

There are three main aims in studying mathematics teachers' professional knowledge: enriching our understanding of its nature, evaluating its quality, and studying how it relates to performance through the study of competencies.

In terms of the first of these, the majority of models currently available attempt to identify the different components of knowledge which a mathematics teacher needs to carry out his or her work. Shulman's (1986) proposal, dividing teachers' knowledge into three broad domains (Subject Matter Knowledge, Pedagogical Content Knowledge, and Pedagogical Knowledge), has served as the basis for a multitude of subsequent conceptualizations offering more detailed subdomains, components and facets. Among these, the work of Ball, Thames and Phelps (2008) deserves mention for its identification of the kind of mathematical knowledge which distinguishes practitioners of mathematics education from all other professionals within the field of mathematics.

Among studies describing teachers' professional knowledge, particularly those focused on the extent to which teacher training enables teachers to construct the knowledge required for teaching the subject, we can highlight the TEDS-M comparative studies (Tattoo et al., 2008), which evaluate initial teacher training programmes, alongside the development of evaluative measures and instruments in studies at national scale (e.g. LMT – Learning Mathematics for Teaching – Hill, Ball, & Schilling, 2008, which aims to measure the knowledge of teachers practising in the US).

Finally, several studies have been carried out focussing on the connection between knowledge and action, in particular through the use of the notion of competence, understood as knowledge with the potential for use in different professional practices (Godino, Batanero, & Font, 2011). The aim of the research described here was to develop properly grounded tasks for training primary teachers consistent with design research centred on professional development (Cobb, Jackson, & Dunlap, 2016). Studies such as these draw on theoretical frameworks for the interpretation of how participants engage in the dynamic of professional development; in our case, we use the Mathematics Teachers' Specialized Knowledge (MTSK) model, developed by the team of educator-researchers who designed the task.

Mathematics Teachers' Specialized Knowledge (MTSK)

The MTSK model derives from the aim to understand and analyse the teacher's knowledge specific to the teaching and learning of mathematics, and seeks to construct a detailed analytical tool. Since its inception (Carrillo, Climent, Contreras, & Muñoz-Catalán, 2013) the model has been discussed in various forums and we have given considerable attention to its theoretical foundations (e.g. Montes, Ribeiro, & Carrillo, 2016); at the same time, the model has been put to use with teachers in different educational contexts to analyse their work across a wide variety of mathematical content, and as a result, we have been able to develop a system of analytical categories within the subdomains constituting the model (Carrillo et al., 2018). The model itself contemplates three domains – mathematical knowledge, pedagogical content knowledge and beliefs and conceptions about mathematics and its teaching and learning, the first two of which acknowledge the legacy of Shulman (1986) and Ball et al., (2008), among others. Mathematical knowledge (MK) encompasses a thoroughgoing knowledge of mathematical content (Knowledge of Topics, KoT), its structure

(Knowledge of the Structure of Mathematics, KSM) and its syntax (Knowledge of Practices in Mathematics, KPM). Pedagogical content knowledge can be broken down into knowledge of mathematics teaching (KMT), knowledge of the features of learning mathematics (KFLM) and knowledge of mathematics learning standards (KMLS). As mentioned above, one of the features of the model that we would highlight is the detailed classification of categories within the subdomains, which enables the model to make a fine-grained analysis of the knowledge deployed by the teacher. Other features of note are the redefinition of mathematical knowledge and pedagogical content knowledge as intrinsic to mathematics; the integration of the teacher's beliefs into the model; and the intention to recognise that knowledge involves an intricate pattern of connections between subdomains.

Task design from an MTSK perspective

In our view, the process of designing a task should involve representatives of all those participating, with different degrees of responsibility. In the case we present here, those involved were: three experienced primary educators with more than twenty years' experience in training and research into primary education; two primary educators with from five to ten years' experience in training primary and/or secondary teachers, both also researchers into mathematics education; two new entrants to teacher education with less than three years' experience, and in the process of completing their doctoral studies in the group; one student on a master's course who was studying the process; and three primary trainee teachers (PTTs), one in their final and two in their penultimate year of study. The educators constituted virtually the sum total of educators specialising in mathematics education at the University of Huelva. The PTTs were selected *ad hoc*, with an emphasis on those students with high grades in subjects related to mathematics, with a good capacity for reflection and analysis, a willingness and availability to meet with (part of) the team of educators, and a disposition to both provide and receive positive criticism regarding the training programme in which they were participating.

Tasks have a form, a function, and a specific focus (Grevholm, Millman, & Clarke, 2009). The task we describe here pertains to a set of teacher training tasks designed to stimulate the trainees' construction of professional knowledge of geometry, specifically the concept of a polygon. To achieve this goal, three tasks were designed around exemplification, the notion of a polygon, definition and classification. In acknowledgement of the potential of video as a tool for initial training (Schoenfeld, 2017), we decided that each set of tasks would be prefaced by a recording of pupils responding to some relevant mathematical content as a way of leading into the task. This obviously meant that any recorded material that might be used need to be carefully analysed first for its potential. In this instance, we used a recording of a teacher introducing her pupils to the notion of polygon by presenting a variety of cardboard shapes for them to group together and subsequently arrive at an acceptable definition of a polygon. The teacher included a number of non-standard shapes, and by presenting them as cardboard cut-outs, and hence non-static, she avoided the risk of standard positioning influencing the pupils. The video illustrated how the teacher acted as guide, largely leaving the pupils free to make groupings according to their own criteria, and encouraging them to reflect on these.

The process of planning the associated task followed several stages:

- 1) *Watching the video*: the three representative PTTs watched the recording and recorded their impressions against a checklist of the following items: teaching strategies used by the teacher; pupils' thinking strategies, intuitive ideas and difficulties; mathematical content in play and specific aspects of the content brought to the fore; task type; resources used – potential, limitations and use; appropriateness for the syllabus; examples given, representations of the content and resultant problems; teacher's knowledge of the content; teachers knowledge of the teaching and learning of the content. The checklist, drawing on the MTSK model, was designed to focus trainees' attention on relevant aspects of the excerpt while they watched, always with a mind to the mathematics involved. The PTTs were asked to follow up the viewing with an individual analysis in the form of a written report.
- 2) *Informal seminar*: The three PTTs met with one of the educators to discuss the video and identify the key items which had sparked their reflection. The educator took the role of interviewer, drawing out from the collaborating students their impressions of what they had watched. The aim of this session was to explore what the educators might reasonably expect trainee teachers to make of the recording, and in fact the PTTs' perception of the potential of the recording for use with trainees was also discussed, making them participants in the design process. The complete seminar was video recorded.
- 3) *Designing small group tasks*: The team of educators agree a focus for each of the three tasks and establish a sub-group for each one, making sure that each contains an experienced as well as a novice educator. The foci derive from areas of interest arising from the students' analysis (issues deemed by them to be relevant to their professional training). Keeping in mind the previously agreed objectives, each group selected the subdomains and categories of the MTSK model which they felt were most compatible with each objective, and created sub-tasks dealing with each objective, along with an 'ideal' solution to the problem specifying which elements of knowledge they expected to be brought into play (making reference to the MTSK indicators).
- 4) *Educators discussion group*: Each sub-group presented its task to the whole group, and this was discussed and refined, returning to step 3 if necessary. The discussion aimed to ensure that (i) the task matched the agreed objectives, (ii) the MTSK indicators facilitated the objectives, and (iii) the sub-tasks contributed to the construction of the elements of knowledge reflected in the indicators. The main objective of these discussions was to improve the task, but at another level there was a secondary aim to aid the development of the novice educators. When the task was generally considered to be ready to use, it was given to the PTTs to be carried out individually.
- 5) *Small group implementation*: Once the PTTs had done the problem individually, they met with an experienced and novice educator to talk through their solutions. The PTTs took turns to present their solutions, which the group then discussed, also taking the opportunity to consider any digressions from the task which the educator deemed interested. After the discussion, the PTTs were asked to reflect on (i) the potential and limitations of the task for use on their training programme, (ii) the likely response of their fellow trainees to the task and

how they would likely tackle it, and (iii) the extent to which they felt the task was appropriate to their training.

- 6) *Closing discussion*: All the educators met to evaluate whether the task had enabled the students to reach the agreed objectives. To do this, the knowledge deployed by the three students was measured against the MTSK model, on the basis of which the task was further fine-tuned into its final version ready to be used with the whole group, and was added to the collection of completed tasks. The process then looped back to stages 3 and 4 until the remaining tasks were completed in the same way.

One of the tasks, dealing with the definition of a polygon and focusing only on mathematical knowledge, is described below as an example.

In their analysis of the recording of the primary lesson on polygons, the PTTs provided contrasting definitions and images of a polygon. The key features they agreed on were that a polygon was a closed, flat figure with straight sides, and could be considered in terms of both the interior and boundary. To this extent they largely agreed with the definition which was constructed in the course of the lesson (a polygon “is a flat shape, it has angles, it has vertices, it has straight sides and no curves; all the sides are joined at their extreme points”), barring the tautological “straight lines and no curves”. They consider this definition to “be close to the correct one” (which, it seems they believe, is unique). They also dismiss size as integral to the concept of a polygon, differentiating between mathematical qualities (which play a role in the definition) and those qualities which they denominate “physical” (which play no role in the mathematical concept). They consider that a polygon has to have the same number of sides, vertices and angles. A doubt emerges as to whether a segment of curved line can be called a side (for example, can we say that a circular sector has three sides?). In this respect, one of the PTTs considers that “a curved side is infinite sides” since, as they go on to explain, “the circumference is the limit of a succession of polygons in terms of the number of sides.” For the educators, this contribution to the discussion represented an opportunity within the task for studying degeneracy. For their part, the PTTs recognise as polygons rectangles, squares, triangles, regular and irregular polygons, and concave and convex polygons; and they reject as polygons circumferences, circular sectors and polyhedra.

We saw the opportunity from the above to take the students further into the concept of polygon, its key features and possible definitions. With this in mind, we planned an activity which started by asking them to discuss different definitions of a polygon (giving examples of figures which complied with the definition and those which didn't). They were also asked to compare each definition with the one they had previously deemed correct. Below is a selection of the definitions they were given:

- a) A polygon is a flat figure with an edge.
- b) A polygon is a continuous line with an angle between each segment.
- c) A polygon is the flat region delimited by a jagged line where I can differentiate the inside from the outside.
- d) A polygon is the flat region delimited by a closed polygonal line, and which has the same number of vertices, sides and angles.

- e) A polygon is a region delimited by a closed polygonal line, such that given any two points on it, the segment joining the two is always within said region.

The aim of this activity was to encourage the PTTs to explore the properties of polygons, the interconnections between these, and what can be considered essential properties. In particular, it sought to highlight the notions of concavity and convexity, connected components, examples and counterexamples of polygons (KoT – definitions, properties and foundations), the uniqueness of a concept's definition and the equivalence of definitions (KPM), geometric vocabulary (KoT – registers of representation) and comparison of definitions (KoT – procedures). In the course of the activity, the PTTs become immersed in a process of coming up with examples and counter-examples, attempting to find what they themselves term 'unusual polygons'. Some of the definitions, such as (a) and (b), struck them as very natural; in others, such as (e), they had to think back to the case of concave polygons. The discussion of the remaining definitions led them to consider whether two shapes (Figure 1) were polygons.

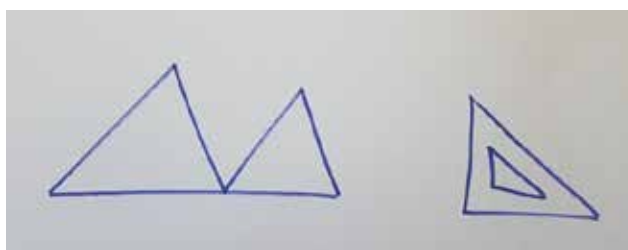


Figure 1: Shapes suggested by the primary trainee teachers

Student 1: For me, the shape that looks like a 'set square' [referring to the technical drawing aid] is very striking. I think it is a polygon, but it's got that hole, which is 'unusual'.

Educator: And what would the sides be?

[Student 1 indicates the 'exterior' boundary]

Student 2: Yeah, it's the same for me, those should be the sides, but the ones inside... What could they be? It's the same with the two triangles joined at the base, is that one side or two? If you turn one of the triangles slightly, leaving them joined at the vertex, then they'd be two, but the number of vertices, sides and angles don't add up.

This debate led them to consider the relationship between sides, vertices and angles that a polygon must fulfil (KoT), or, more formally, the number of connected components that the interior of a figure should have in order to be a polygon (KoT). At the same time, they also recognised that in mathematics it is possible to look for relationships between different definitions of the same object so as to tell if they really define the same object (KPM). For the educator, this presented an opportunity to consider the limits of the degree of complexity that can be demanded from the students' understanding.

The discussion that ensued revealed it had been interesting for the PTTs to consider which of the figures – among those that struck them as common, or even particular to the interaction of the pupils

with the educational material (as in the case of the set square) – prompted a richer discussion of mathematics, and they recommended exploring examples such as these as a means of extending trainees’ knowledge beyond the standard examples of school mathematics.

In summary, the confluence of carefully developing the task, using the MTSK indicators, and drawing on the experience of the educators and the impressions of the specially chosen PTTs enabled professionally-oriented training tasks to be devised, which tap into the specific elements of specialised knowledge required for teaching. Including the contributions of prospective primary teachers in the development process will undoubtedly help to ensure that future students engage in the tasks with a high degree of motivation.

Final reflections

One of the chief aims of primary teacher education should be the construction of the knowledge base which will enable newly qualified teachers to meet the challenge of their first classroom experiences with success. To this end, the work described here uses a model of professional knowledge to define suitable aims and points of focus. The model, MTSK, guides the choice of elements to include in the process of construction, such as the properties of polygons in the task described above (KoT), and the coordination of different definitions (KPM). A remaining challenge is how to evaluate the knowledge aimed to be developed with this task and the relationship between the elements of the task and the knowledge built, which will be addressed further. Likewise, we assume a second challenge, consisting in the necessity of scaling up from task designing for/with some PPT to design for ‘many’ of them (Prediger, Schnell, & Rösike, 2016).

A good starting point to face this necessity is the design of tasks developed from one-on-one teaching experiments (Cobb & Gravemeijer, 2008), which can then be presented to the whole group. The involvement of high profile PTTs for appraising the task in terms of its training potential provides an opportunity to collate suggestions on how it might be improved and implemented. Likewise, the dynamic of the discussion group, involving both experienced and novice educators represents a context for constructing trainers’ knowledge, MTSK also playing a structuring role in this training, as suggested by Kilpatrick and Spangler (2016).

References

- Ball, D. L., Thames, M. H., & Phelps, G. (2008). Content knowledge for teaching: What makes it special? *Journal of Teacher Education*, 59(5), 389–407.
- Carrillo, J., Climent, N., Contreras, L.C., & Muñoz-Catalán, M.C. (2013). Determining Specialised Knowledge for Mathematics Teaching. In B. Ubuz, C. Haser, & M.A. Mariotti (Eds.), *Proceedings of the CERME 8* (pp. 2985–2994). Antalya, Turkey: METU and ERME.
- Carrillo, J., Climent, N., Montes, M., Contreras, L.C., Flores-Medrano, E., Escudero-Ávila, D., Vasco, D., Rojas, N., Flores, P., Aguilar-González, A., Ribeiro, M., & Muñoz-Catalán, M.C. (2018). The Mathematics Teacher’s Specialised Knowledge (MTSK) model. *Research in Mathematics Education*. 20(3), 236–253. DOI 10.1080/14794802.2018.1479981.
- Cobb, P., & Gravemeijer, K. (2008). Experimenting to support and understand learning processes. In A.E. Kelly, R. A. Lesh, & J. Baek (Eds.), *Handbook of design research Methods in Education*.

- Innovation in Science, technology, Engineering and Mathematics Learning and Teaching* (pp. 68-95). Mahwah, NJ: Lawrence Erlbaum Associates.
- Cobb, P., Jackson, K., & Dunlap, C. (2016). Design research. An analysis and critique. In L. English, D. Kirshner (Eds.), *Handbook of international research in mathematics education* (pp. 481-503). New York: Routledge.
- Godino, J. D., Batanero, C., & Font, V. (2011). The Onto-Semiotic Approach to Research in Mathematics Education. *ZDM*, 39(1-2), 127–135.
- Grevholm, B., Millman, R., & Clarke, B. (2009). Function, Form, and Focus: The role of Tasks in Elementary Mathematics Teacher Education. In B. Clarke, B. Grevholm, R. Millman (Eds.), *Tasks in Primary Mathematics Education: Purpose, Use and Exemplars* (pp. 1–5). New York: Springer.
- Hill, H. C., Ball, D. L., & Schilling, S. G. (2008). Unpacking pedagogical content knowledge: conceptualising and measuring teachers' topic-specific knowledge of students. *Journal for Research in Mathematics Education*, 39(4), 372–400.
- Kilpatrick, J., & Spangler, D.A. (2016). Educating future mathematics education professors. In L. English, & D. Kirshner (Eds.), *Handbook of International Research in Mathematics Education (Third Edition)* (pp. 297–309). London: Routledge.
- Montes, M., Ribeiro, C.M., & Carrillo, J. (2016). Conceptual issues in developing a framework for examining teachers' knowledge. In S. Zehetmeier, B. Rösken-Winter, D. Potari, & M. Ribeiro (Eds.), *Proceedings of ERME Topic Conference on Mathematics Teaching, Resources and Teacher Professional Development* (pp.187–196). Berlin: ERME.
- Neubrand, M. (2018). Conceptualizations of professional knowledge for teachers of mathematics. *ZDM*, 50, 601–612. <https://doi.org/10.1007/s11858-017-0906-0>
- Prediger, S., Schnell, S., & Rösike, K.-A. (2016). Design Research with a focus on content-specific professionalization processes: The case of noticing students' potentials. In S. Zehetmeier, B. Rösken-Winter, D. Potari, & M. Ribeiro (Eds.), *Proceedings of the Third ERME Topic Conference on Mathematics Teaching, Resources and Teacher Professional Development* (pp. 96–105). Berlin: Humboldt-Universität zu Berlin / HAL.
- Schoenfeld, A.H. (2017). Uses of video in understanding and improving mathematical thinking and teaching. *Journal of Mathematics Teacher Education*, 20(5), 415–432.
- Shulman, L.S. (1986). Those who understand. Knowledge growth in teaching. *Educational Researcher*, 15(2), 4–14.
- Tatto, M. T., Schwille, J., Senk, S., Ingvarson, L., Peck, R., & Rowley, G. (2008). *Teacher education and development study in mathematics (TEDS-M): Policy, practice, and readiness to teach primary and secondary mathematics. Conceptual framework*. East Lansing, MI: Michigan State University.

A Look into Turkish Preservice Teachers' Translation Skills: Case for Model Representations

Zeynep Pehlivan¹ and Fatma Aslan-Tutak²

¹Bogazici University, Faculty of Education, Istanbul, Turkey; zynpehlivan@gmail.com

² Bogazici University, Faculty of Education, Istanbul, Turkey; fatma.tutak@boun.edu.tr

Multiple representation enables students to connect different ideas and gain a deeper understanding of the mathematical concepts involved. The integration of mathematical model representation in order to model and interpret physical phenomenon and solve real world problems is one of the major objectives of mathematics learning in high school curriculum (NCTM, 2000). In this respect, this study focused on Turkish preservice teachers' process of translation of model representation among four representation types. The result of this study indicate that Turkish preservice teachers lacked knowledge on the competencies of translation to and from model representations. Results also indicate Turkish preservice teachers' tendency to use another representation type as transitional stage to model representations.

Keywords: Multiple Representation, Mathematics Education, Preservice Teachers, Teacher Knowledge.

Literature Review

Employing multiple embodiments of the concept in the learning environment is essential in mathematics education not only its role in exemplifying abstractions but also creating a solid conceptual understanding of a single concept by illustrating interconnectedness between the representations. While the problems are analyzed, using different mathematical demonstrations such as creating table and graph or using algebraic expressions efficiently play a central role in the process of conceptual understanding as well as application of inquiry. In this respect, Friedlander and Tabach (2001) call attention to consider both advantages and disadvantages of each representation since in the case mathematics learning, the use of symbolic, tabular, graphical and modeling representations aids learners to create their mental constructions and lead the way to effective and meaningful learning.

In addition to applying multiple representations, the process of model representation is other fundamental components of mathematical education. Jacobson (2014) described the ability to model as requiring students to "use their understanding of arithmetic operations to make mathematical sense of problem situations and to relate this sense making to functions represented by equations, tables, and graphs" (p. 155). NCTM Standards (2010) for school mathematics emphasized that mathematical model representations encourage students learn how mathematics works in the real world and sense about what they have done during the mathematical process. NCTM Standards (2010) for school mathematics emphasized that mathematical model representations encourage students learn how mathematics works in the real world and sense about what they have done during the mathematical

process. In this sense, investigating Turkish preservice teachers' mathematical models helps researchers to a better understanding of how one simplifies, constructs and works mathematically on a problem, which are key elements of mathematical thinking. In light of this, the purpose of this study is to gain insight into Turkish preservice secondary school mathematics teachers' representational practices of mathematical models in the context of mathematical functions. The data collection process was completed before preservice teachers studied multiple-representation topic in the secondary mathematics teaching methods course. The purpose of this selection of data collection timing was purposeful in order to depict what secondary school teacher candidates would know without addressing multiple representations in methods class.

Methodology

Participants and Settings

This study is a part of a larger study that examined the Turkish preservice teachers' translation process among six representation models. Twenty-four senior-year preservice teachers from a public university in Istanbul voluntarily participated in this study. The students of this department had to take high scores from university entrance exam, in other words, these participants were successful high school graduates who had to score pretty high in mathematics. Furthermore, senior students of the department have to take various advanced level mathematics courses like group theory, analysis, probability and statistics from mathematics department of the university. Thus, the a common assumption for Turkish context is that the senior year preservice teachers from this department are pretty well equipped in terms of content knowledge. So, one purpose of this study was to investigate how mathematically high achieving preservice teachers perform in terms of translation between representations for functions, a central concept that they will teach.

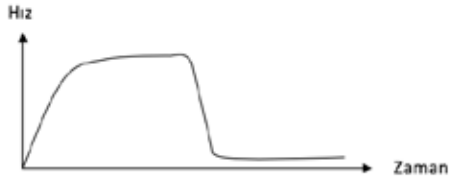
A questionnaire was designed to address participants' way of representing combination of translation pairs among graphical, model, tabular and algebraic. The participants had to translate those modes univocally without the intervention of the researchers. In order to maximize return rates and ensure data trustworthiness and credibility, the researcher was in charge of recruiting and collecting data from questionnaire. In this sense, data collection process took place within one-hour research method course while the preservice teachers were attending the course early in the academic year under researcher's supervision.

Instruments

The questionnaire questions were derived from manuscripts (Carlson et al. 2002; Leinhardt, Zaslavsky and Stein, 1990; Shell Centre for Mathematical Education (University of Nottingham) and adopted in Turkish by the researchers. Since this study was a part of a larger study, six questions particularly related to translation pairs including model representations were used in this research. The figure 1 below illustrates two of the examples in the questionnaire which illustrated translation from graphical representation to model representation and from model representation to graphical representation respectively. The question on the left side required participating preservice teachers to indicate which sport among fishing, pole vaulting, sky diving and javelin throwing. would produce a graph like in the given shape below. This question is related to translation from graphical representation to model representation. The other question on the right side asked preservice teachers

sketch a rough graph to demonstrate how the distance from A will vary with the distance from B and this question is related to translation from model representation to graphical representation.

Aşağıda verilen grafik hangi spor dalı ile ilgili olabilir? (Shell Centre for Mathematical Education (University of Nottingham), 1985)



Balık Tutma

Sırıkla Atlama

Paraşütle Atlama

Cirit Atma

Ok ile gösterilen araçlar aşağıda gösterilen dairesel yol üzerindeki yönlü hareketi takip ederek sabit hızla hareket etmektedir. Verilen modele göre aşağıda verilen grafikleri tamamlayınız. (Leinhardt, Zaslavsky, & Stein, 1990)

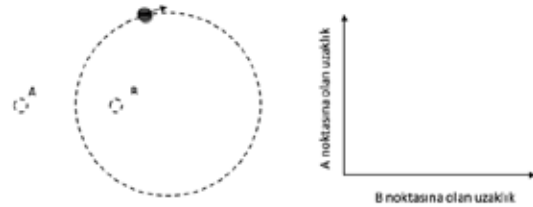
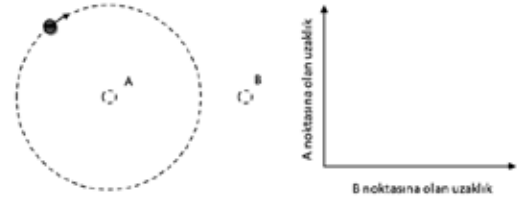


Figure 1. Two tasks in the questionnaire

After collection of 24 preservice teachers' results in the questionnaire, researchers decided to evaluate questionnaire data quantitatively, in which participants were scored by criterion referenced standards according to their translation scores. Total translation score reflects the sum of the translation score of participants and obtained by preservice teachers' score in translating among tabular, graphical, algebraic and model representations between a minimum score of 0 (indicating limited correct translation activity), a score of 1 (indicating a partially correct translation activity) and maximum of 2 (indicating correct translation activity). Limited correct translation activity included participating preservice teachers' mathematically incorrect attempts to translate into specified translation type. Partially correct translation activities comprised preservice teachers partially correct mathematical procedures and calculations in the given translation pairs. Preservice teachers who completed all procedures correctly were given correct translation activity score. The sample preservice teachers answer in the second question in Figure 1 are shown in Figure 2. The following examples in Figure 2 illustrates between limited translation, particular translation and complete translation points for the translation pair of from model representation to graphical representation.

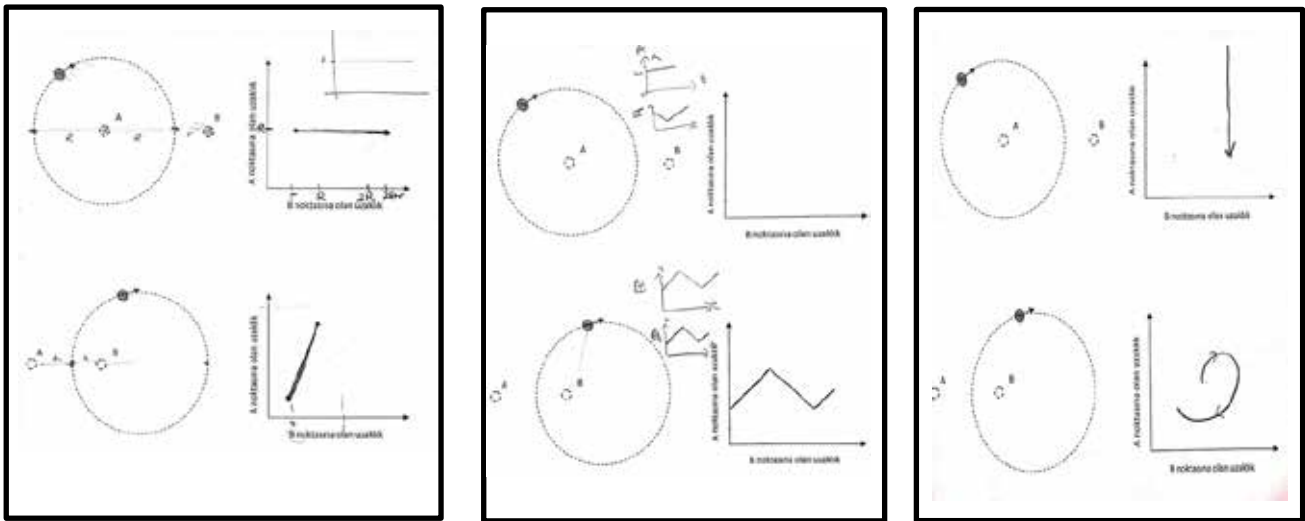


Figure 2. An example of correct translation activity, partial translation activity and limited translation activity respectively

While academic experts examined the items and provided comments and reflections for content appropriateness, a Turkish language teacher reviewed the questionnaire’s grammar, punctuation, and word selection, and three experienced mathematics teachers checked the participants’ responses to ensure interrater reliability.

Results

As this study aimed to examine the Turkish preservice teachers’ ways of translating from and to the model representation of functions, it was expected the Turkish preservice teachers to coordinate the given representations and model representations. The results of Turkish preservice teachers’ responses concerning their translation scores in the questionnaire were summarized in Table 1.

Representation types	Limited Translation (0)	Partial Translation (1)	Correct Translation (2)
Model → Graphical	4 (16,66%)	13(54,16%)	7 (29,16%)
Model → Tabular	6 (25%)	15 (62,5%)	3 (12,5%)
Model → Algebraic	16*(66,67%)	8 (33,33%)	0*(0%)
Graphical → Model	9 (37,5%)	11(45,83%)	4 (16,66%)
Tabular → Model	6 (25%)	16 (66,67%)	2 (8,33%)
Algebraic → Model	4 (16,66)	13 (54.16 %)	7(29,16)

Table 1. Number of Turkish preservice teachers in each group

The table showed the number of preservice teachers in three categories that formed according to their scores in each translation types. The translation score reflects how accurate preservice teacher’s translation process in which tabular, graphical and algebraic representations are mapped

onto model representations and vice versa. Preservice teachers were given a minimum score of 0 (indicating limited translation activity), a score of 1 (indicating a partial translation activity) and maximum of 2 (indicating ability to translate among multiple representations).

Besides, 24 Turkish preservice teachers' mean score for each translation pairs were presented in Table 2.

	Model → Graphical	Model → Tabular	Model → Algebraic	Graphical → Model	Tabular → Model	Algebraic → Model
Mean Score of Each Group	1,12*	0,87	0,33*	0,79	0,83	1,12*

Table 2. Mean Score of Each Translation Pair

According to Table 1 and Table 2, the translation pair from model representation to algebraic representation has the lowest rate in mean scores. The participating Turkish preservice teachers' ability to establish meaningful links from model representation to algebraic representation was considered weak. In parallel with this, 16 Turkish preservice teachers out of 24 got zero translation points when translating from model representation to algebraic representation whereas no participants could perceive the goal of making conceptual shift between these two kinds of representations.

However, translation pair from algebraic representation to model representation was recorded having the highest mean rate with 1,12. The question relating to translation from model representation to algebraic representation was based on cumulative quadratic functions whereas its reverse pair was written as an example of linear functions. When looking to participants' responses, Turkish preservice teacher was unable to define dependent and independent variables in the context of model representations in this translation pairs. In conclusion, we can easily conclude that the score of participant Turkish preservice teachers were accumulated in partial translation score which points their limited ability to translate among several representation types.

Discussion

An important element of effective mathematics teaching at secondary school is using multiple representations and guiding students to translate between the representations (NCTM, 2000). Demonstrating model representation of functions is not only algorithmic process, it is also related to formulating problem situation, choosing appropriate variables according to given representations, determining the relationships between representations and verifying the model and its implication. Within this context, integration of model representation as mathematical practice in teaching and learning mathematics is targeted an area of interest in revised mathematics curriculum (MoNE, 2018). The department of curriculum studies of the Ministry of Education (Talim ve Terbiye Kurulu Başkanlığı, TTKB, 2017) identified symbolic, model, graphical and tabular representations as a way for developing appropriate solution strategies for real life problems. In this line, effective and fluent usage of model representation is an important practice associated within this goal. In that respect, this study is important since this research evaluated Turkish preservice teachers' translation ability from one type of representation to another.

Yet, as functions are the concept of interest in translation items, the results also shed light on the underlying algebraic ideas such as variable, covariation etc. behind the translation procedure. When examining participating Turkish preservice teachers' responses, they achieved to translate from algebraic representation to model representation, in which they were required to write a real-life example according to a linear equation. On the other hand, participants failed to satisfy necessary requirements to write a reasonable algebraic expression which is suitable for a quadratic growth. This evidence suggested that participating Turkish preservice teachers might have a lack of knowledge on functions since not only did they show difficulties to recognizing expressions in the different types of models, but also complications in explaining the models' specificities of the models in the context of tasks given. It is also important to note that participants had difficulty when stating independent and dependent variables in the graphical and algebraic representation. Thus, the results of this study support notion of addressing content knowledge in methods courses which have main purpose of mathematics teaching methods.

Furthermore, the findings collaborate with other studies reporting Turkish preservice teachers' difficulty with covariational thinking of functions (Carlson, Jacobs, & Larsen, 2001; Zeytun, Çetinkaya & Erbas, 2010). It is pointed in the literature that well developed understanding of function is possible by exploiting relationships between two variables (Carraher & Schliemann, 2002). Participants' limited conceptual understanding on functions cause them to struggle interpreting the given type of representations and finding a model representation.

References

- Carraher, D. W., & Schliemann, A. D. (2002, April). Designing and implementing early algebra activities: From finding unknowns to representing variables. Paper presented at the annual meeting of the National Council of Teachers of Mathematics, Las Vegas, NV
- Carlson, M., Larsen, S., & Jacobs, S. (2001). An investigation of covariational reasoning and its role in learning the concepts of limit and accumulation. *In Proceedings of the 23rd annual meeting of the North American Chapter of the International Group for the Psychology of Mathematics Education* (Vol. 1, pp. 145-153).
- Deal, J. T. (2015). Students' mathematical modeling in algebra. *Unpublished Doctoral dissertation*.
- Friedlander, A., & Tabach, M. (2001). Promoting multiple representation in algebra. In A. Cuoco (Ed.), *The roles of representation in school mathematics. 2001 Yearbook of the National Council of Teachers of Mathematics* (pp.173-184). Reston, VA: National Council of Teachers of Mathematics
- Jacobson, E. (2014). Using Covariation Reasoning to Support Mathematical Modeling. *Mathematics Teacher*, 107(7), 515-519. Reston, VA: National Council of Teachers of Mathematics.
- Leinhardt, G., Zaslavsky, O., & Stein, M. M. (1990). Functions, graphs, and graphing: Tasks, learning and teaching. *Review of Educational Research*, 60, 1e64.
- Moschkovich, J., Schoenfeld, A., & Arcavi, A. (1993). Aspects of understanding: On multiple perspectives and representations of linear relations and connections among them. In T.

Romberg, E. Fennema, & T. Carpenter (Eds.), *Integrating research on the graphical representation of function* (pp. 69-100). Hillsdale, NJ: Lawrence Erlbaum Associates.

Ministry of National Education, Turkey, “Ortaoğretim Matematik Dersi 9, 10, 11 ve 12. Sınıflar Öğretim Programı”, Milli Eğitim Bakanlığı Talim Ve Terbiye Kurulu Başkanlığı, Ankara: Devlet Kitapları Müdürlüğü Basım Evi, 2018

National Council of Teachers of Mathematics. (2000). *Principles and standards for school mathematics*. NCTM: Reston, VA.

Shell Centre for Mathematical Education (University of Nottingham) (1985). *The language of functions and graphs: An examination module for secondary schools*. Nottingham. UK: JMB/Shell Centre for Mathematical Education.

Talim Ve Terbiye Kurulu Başkanlığı (2017). *Müfredatta Yenileme Ve Değişim Çalışmalarımız Üzerine*, Ankara. Türkiye: Devlet Kitapları Müdürlüğü.

Zeytun, A. S., Çetinkaya, B., & Erbas, A. K. (2010). Mathematics teachers' covariational reasoning levels and predictions about students' covariational reasoning abilities*. *Kuram Ve Uygulamada Eğitim Bilimleri*, 10(3), 1601-1612.

Prospective primary teachers' knowledge of problem solving process

Juan Luis Piñeiro, Elena Castro-Rodríguez and Enrique Castro

University of Granada, Spain

juanluis.pineiro@gmail.com - elenacastro@ugr.es - ecastro@ugr.es

Studies on teachers' understanding of processes such as problem solving have focused primarily on their beliefs and conceptions to the detriment of features indicative of their professional knowledge. This study analyses the knowledge about problem solving process revealed by prospective primary teachers. A questionnaire specifically designed for the study was administered to 61 undergraduates beginning and 53 ending their training. Although characterising solving as a dynamic process, both groups, in their description of stage characteristics and strategy identification, revealed that their knowledge was essentially theoretical.

Keywords: Problem solving, Teacher knowledge, Pre-service teachers

Researchers have engaged in the study of teachers' knowledge in an attempt to identify the type of expertise required to teach mathematics effectively. Problem solving (PS) forms part of such expertise, as it is a fundamental process in classroom mathematics, which should cover both problem-solving skills and elements that help students become better problem solvers.

To teach PS, teachers need to know what to do, when to do it and the implications of their actions (Lester, 2013). Unfortunately, teachers have been found to exhibit limitations in that regard (Andrews & Xenofontos, 2015). Research in the area has targeted their ideas and their own problem-solving skills (Lester, 2013), eclipsing factors indicative of their professional knowledge. These considerations led us to pose the following research question: what knowledge do prospective primary teachers have about PS process? Specifically, this study analyses and describes the differences in the theoretical knowledge about the PS process exhibited by prospective primary teachers at the beginning and end of their training with a view to helping fill that gap.

Teachers' knowledge of mathematical PS.

Mathematical knowledge for the teaching is understood as a wider knowledge than the mathematical subject. Therefore, "the knowledge needed to effectively teach PS should be more than general problem-solving ability" (Chapman, 2015, p. 19). Lester (2013) pointing out that the teachers' ability to solve complex, cognitively demanding problems does not suffice to guarantee appropriate PS instruction. In addition this author points out that it is necessary to clarify what aspects, other than the teacher's competence as a problem solver should be part of the knowledge of the mathematics teacher. However, shortcomings for determining teachers' professional proficiency with previous theoretical frameworks have been identified, regarding to overlap or the need to broaden the theoretical approach to supplement analyses. More specifically, research on teachers' ability to teach PS is not organised in the usual manner (Chapman, 2015), which leads among other limitations to omissions around the nature of PS (Foster, Wake, & Swan, 2014).

Teacher knowledge models have a tendency to be more content-focused, provoking the omission on some aspects of the nature of the PS. PS could be part of mathematics practice (in MTSK' terms,

Carrillo et al. 2018), in the sense that allows us to do mathematics (Codes, Climent, & Oliveros, 2019). Carrillo et al., (2018) establish that this sub-domain "encompasses teachers' knowledge of heuristic aids to PS and of theory-building practices" (p. 245). However, for a math task to become a problem, it necessarily needs the solver' perspective. PS is a process with personal nature, in which a problem is defined according to the solver. Under this perspective, tension emerges in the description of a mathematical knowledge disconnected from the students.

The knowledge for teaching PS in primary education needs to embrace more than the algorithms involved, how to apply them efficiently or possible mental calculation or representational strategies. To use the problem to its full potential teachers must also understand it as such, as well as the process for solving it. More specifically: a) the *problem*, i.e., the underlying mathematics, but also its type and format and the extent to which it may be a problem for students; b) *solving the problem*. The phases needed to solve: understanding what each data item means, how they are inter-related... But also is necessary the applicable strategies may vary, from algebraic; guess and check, or even tables or diagrams to visualise the relationships among quantities; c) the *disposition* it may generate in students; d) the *mistakes* they may make; e) the *potential* for developing cognitive features such as the various strategies, and non-cognitive features such as the belief that problems can be solved in different manners or that discussion of a problem is part of the learning process; f) the *changes* that can be made in the amounts of the variables or their inter-relationships to render the problem harder or easier; and g) classroom *organisation*, i.e., the approach to use or emphasise. Given that the characteristics of the problem accommodate the consideration of different strategies, prioritising teaching *about* PS would appear to be the most suitable approach.

Identifying professional knowledge about PS teaching calls, firstly, for addressing teachers' knowledge of processes rather than their mathematical content knowledge, the perspective adopted in traditional teachers' knowledge models. Based on mathematical and PS proficiency theories, PS is understood here to mean the action taken by a subject who identifies a problem, proceeds to solve it by deploying a strategy involving a series of not necessarily linear steps and confronts the challenge with a favourable disposition. Based on this idea, teaching PS proficiency draws on a complex network of interdependent knowledge. Chapman (2015) proposes a model consisting of a) teacher PS proficiency; b) knowledge of problem content, solving and posing; c) pedagogical knowledge of students as problem solvers and of teaching practice; and d) a dimension comprising affective factors and beliefs that impact teaching and learning this skill.

We have applied the Chapman' framework to six curricular guidelines in order to identify the knowledge required to teach PS (Piñeiro, Castro-Rodríguez, & Castro, 2016). This analysis has led to modifications (Piñeiro, Castro-Rodríguez, & Castro, 2019), in which we distinguish three elements on teacher's knowledge, its own proficiency to solve problems, and two related to teaching (one referred to PS theoretical knowledge, and another to aspects of learning and teaching). Figure 1 shows the components of our framework related to PS knowledge and PS pedagogical knowledge. Here we focus on teachers' PS process knowledge, distinguishes four key components: PS stages and their characterization, strategies, metacognition, and non-cognitive factors (Piñeiro et al, 2019). This study is confined with static knowledge related to PS, that is, the theoretical aspects of PS process (Blanco, 2004).

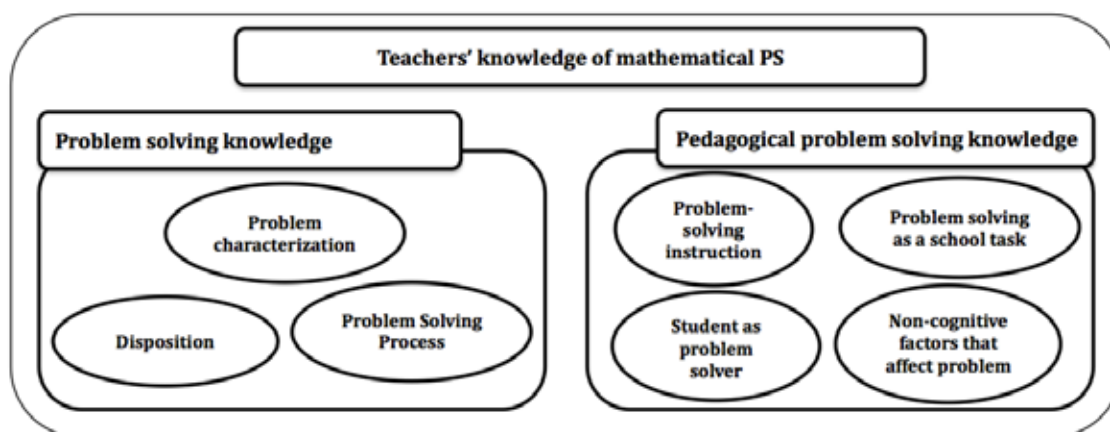


Figure 1: Teacher knowledge components for teaching problem solving

Theoretical knowledge about PS process.

In our approach to Teachers' PS knowledge, PS process can be broken down into four areas: solving stages and their characterisation, solving strategies, metacognition, and affective factors (Piñeiro et al, 2019).

The first area, solving stages, adapts naturally to Pólya's (1945) postulates on how solvers proceed: comprehension, planning, action and evaluation. Awareness of those stages helps teachers adapt the assistance needed to the circumstances. One factor common to all four is their configuration as personal cognitive processes, not observable directly but only through what the solver says or does in each stage (Mayer & Wittrock, 2006). The process is non-linear, for as Wilson, Fernandez, and Hadaway (1993) explained, it is flexible, accommodating both forward and backward movements. Teachers aware of these elements can stand by their students and mediate in their development of PS proficiency.

In connection with the second area, solving strategies, Schoenfeld (1985) distinguished two types of decision-making. Strategic decisions include the definition of objectives and the decision to adopt a course of action. Tactical decisions are geared to implementing strategic decisions. Whilst together they constitute what is understood as strategy, singly they are of no use for a number of reasons, including the role of metacognition (Schoenfeld, 1985). Strategies must be taught carefully, for that endeavour covers all the overlapping components addressed in this section. More specifically, decision-making on what to do and how to do it depends on an understanding and mental representation of the problem. It is also affected by metacognition, for the success of the strategy is partly determined by its conscious use. Backtracking further reinforces this process and helps determine the aptness of the initial decision. The entire process is mediated by the emotions that may arise, the attitudes prompted and the beliefs held during PS.

The third area is metacognition. Schoenfeld (1985) expanded research perspectives by showing the importance of metacognition and affect. Metacognition is described as the manner in which solvers self-regulate, monitor, and control; their heuristics and mathematical knowledge to solve a problem, enabling them to apply appropriate decisions to the task at hand.

The fourth and last area covers non-cognitive factors and their essential role, for they determine how the solver confronts problems. It is generally agreed that depending on the suitability of the challenge posed to students, they bring their emotions into play, which in turn mobilises their intellect (Mason, 2016).

Method.

To characterize the knowledge about PS of prospective primary teachers, we have used a questionnaire for the purpose that this type of instrument to collect information to, among others, describe the knowledge of the people (Fink, 2003). The questionnaire was designed and administered to university undergraduates beginning and ending their pre-service teacher training to analyse and describe the differences between them. A dual analysis was subsequently performed.

Context and participants.

The participants in this study were 114 undergraduates working toward a degree in primary teacher education at the University of Granada. They were grouped by the training received, 61 first year (G1) and 53 fourth year (G2) undergraduates. G1 had received no university mathematics training. G2 had taken three requisite subjects on mathematics teaching: classroom mathematics content; teaching and learning core classroom mathematics topics; and the primary education mathematics curriculum. In these three subjects, PS is treated as a transversal goal. Specifically, when discussing meanings and modes of use of mathematical concepts. The activities in which they have involved are mainly of two types: master classes in which are presented, guided and synthesized some of the courses' topics. The second type, called practical activities can have two orientations, laboratory and TIC. In laboratory practices, work with manipulative materials, and TIC practices will focus on the management of educational software and Internet resources. They had also taken an elective addressing (among others) PS content, in which they were introduced to strategies and heuristics, problem posing and strategies for teaching PS. Specifically, in activities such as: a) characterization and exemplification of the role of PS in the learning of mathematics and its link with mathematical competence, b) development and application of strategies and heuristics for PS, c) application of criteria for posing problems, and d) analyze appropriate teaching strategies for teaching PS.

Instrument.

The questionnaire was developed following phases: a) theoretical analysis on the notion of PS proficiency; b) study on the primary education curricular syllabus related to PR; c) research review about PS with primary teachers; d) construction of the pilot version of the instrument; e) review by expert judgment and pilot application; and f) construction of the final version of the questionnaire. These phases originate a specific questionnaire with two sections and 66 items. A closed binary design was adopted to elicit ideas that would denote the presence or absence of certain types of knowledge (Fink, 2003). The first section of the questionnaire (Figure 2) was sub-divided into PS stages and their characterisation, metacognition, and non-cognitive factors. The second sought to determine trainees' ability to recognise specific strategies in students' hypothetical answers to problems, in which, eight items were formulated as multiple choice questions. The options were: 1a) building a table; 1b) work backwards; 2a) draw a diagram; 2b) guess and check; 2c) look for a pattern; and 2d) operating.

1. A student solved the problem set out below as shown:

A dragonfly, the fastest-flying insect, can fly 50 metres in 2 seconds. How long would it take it to fly 375 metres?

Dragonfly => 375 metres => time? → 1

Dragonfly flies 25 metres per second → 2

It needs 375/25 seconds to fly that distance → 3

$375:25 = 15$ → 4

It takes the dragonfly 15 seconds to fly 375 metres → 5

$25+25+25+25+25+25+25+25+25+25+25+25+25+25+25$
 $\underbrace{\hspace{10em}}_{375}$ → 6

a. The problem was identified when the student described what the dragonfly does and the distance it needs to fly and posed the question about time. (Step 1)

b. The student drew up the solving plan when mentally found the distance per second and proposed the operation: $375/25$ (Steps 2 and 3)

c. The student implemented the plan when divided 375 by 25. (Step 4)

d. The student verified the answer when counted or summed up the metres per second. (Step 6)

11. A student solved this problem. Answer YES or NO to the assertions, as appropriate.

A dragonfly, the fastest-flying insect, can fly 50 metres in 2 seconds. How long would it take it to fly 375 metres?

As follows:

- The dragonfly can fly 50 meters in 2 seconds
- 4 seconds would be 100 meters
- Then 6 seconds would be 200 meters
- 8 seconds would be 300 meters
- 9 seconds would be 350 meters
- As there are 25 meters left, we put half
- Then the dragonfly takes 9 seconds and a half to fly 375 meters

a. No error, the answer is right.

b. The student understood the problem.

c. There are operational errors.

d. The student verified the answer.

2. When solving a classroom mathematics problem, students advance toward the solution without backtracking.

3. Problem solving is a dynamic process in which the solver backtracks if necessary to find the solution.

4. Students solve problems step-by-step.

5. Which of the following do you believe might be present when solving a problem?

a. Representing the problem
 b. Reading the problem
 c. Doing the operations
 d. Understanding the problem
 e. Exploring different ways to solve the problem
 f. Solving similar problems
 g. Verifying the solution
 h. Writing out the answer

6. A classroom mathematics problem must be understood to be solved.

7. A solving plan can be suitably implemented without understanding the problem.

8. Representing a problem in different ways may help understand it.

9. Understanding a problem entails determining what information is available and how it is structured.

10. Drawing a diagram or graph is a useful tool for understanding a problem.

12. When someone solves a problem they perform mental exercises that reveal when they've made a mistake.

13. An awareness of one's own knowledge helps choose the most suitable way to solve a problem.

14. When tackling a problem it's helpful to know several ways to solve it.

15. A strategy is a procedure that guides the choice of the knowledge that should be used in each stage of a problem.

16. Once a problem is solved, it's advisable for the solver to know what would happen if some of the data were changed.

17. If a student finds the answer to a problem, no more action is needed.

18. Re-reading the question after finding the solution helps determine the suitability of the procedures and the result.

19. Once the answer to a problem is found, alternative ways to solve it should be sought.

20. Identifying the characteristics of a problem enables solvers to create families of problems that can be solved in similar ways.

21. It's important to know how to solve problems, but it's more important to want to.

22. A problem can be successfully solved even when there's no motivation to do so.

23. When students are confronted with a problem-solving situation, it's important for them to be motivated.

24. Students don't need to want to solve a problem: what they need to do is listen to and obey the teacher.

25. Students don't need to be interested in solving a problem. What they need is to understand the mathematical content.

Figure 2: Items on section 1 of the questionnaire

In the validation process, we contemplate two aspects. The first one is related to ensuring that the content is relevant and was made from the selection of knowledge related to PS on Primary Education school curricula. We have discussed this process somewhere else (Piñeiro et al., 2016). The second aspect corresponds to a test of the validity of the items, for which it was submitted to expert judgment. The experts' judgment makes possible a qualitative evaluation of the statements. Five Spanish mathematics education experts conducted the process. Also, a pilot application was made with the main goal was to increase reliability, validity and feasibility (Cohen, Manion, & Morrison, 2011). Our piloting was focused on assessing aspects such as the adequacy of the total time, clarity and comprehension of the statements.

Analysis and results.

This study aims to characterize the theoretical knowledge about the PS process manifested by prospective primary teachers. This has motivated the use one of the forms of interpretation of multidimensional scaling, allowing identifying the groupings that emerge from their answers, describing the common feature of these and labelling the attribute present in them (Bisquerra, 1989). Therefore, respondents' replies were processed first with dimensional scaling multivariate analysis using ALSCAL (SPSS) software, in which the dimensions defined were *agreement* or *disagreement* with the item (from here on, these terms will be used only to refer to the dimensions found). A second descriptive analysis was subsequently performed, in which responses were reviewed in terms of inter-group differences and the ideas defended in the literature.

PS stages and their characterisation.

This answers elicited high levels of agreement, although the percentage of agreement was higher in G2. Both groups acknowledged that the process could comprise several stages. For example, on the

stages' identification on a hypothetical solution, agreement percentages increase in the G2. Specifically, in the G1 a 97% identifies the understanding phase, 82% planning, 90% on carrying out the plan, and 80% on revision. In G2, 94% is the lowest percentage of recognition in any phases. At the same time, both groups characterize the process as flexible (98% in both groups), in which progress is made towards the solution (G1: 97%; G2: 100%), and they also admit the possibility of moving backwards if necessary (G1: 79%; G2: 83%). Both groups accept several moments on the PS process. Particularly, G1 states that, for example, representations (93%), reading (97%), calculations (95%) or verifications (95%) may appear. Likewise, in the same questions, the G2 presents positive answers in approximately 98% of the students. However, in this section one of the notorious differences can be found. In G1 only 46% respond positively to the possibility that similar problems can be solved, and 77% to the exploration of other resolution' paths. Conversely, G2 states that they can appear in 94% and 80%, respectively. On the questions that delve into the phases' features, there is majority agreement in both groups. For example, they recognize the usefulness of the representations to understand a problem (98%; 100%), and also that problems should not be solved without understanding them (97%; 98%). Nonetheless, in the questions that inquire about the value of the review phase, a difference was observed: only 49% of G1 state that it is advisable to pose similar problems, while 92% of the G2 states that it is necessary. Likewise, 67% on G1 indicates that it is appropriate to look for alternative forms of solution, as opposed to 91% on G2.

Knowledge of strategies.

The strategies that best recognize G1 were: operating (95%), draw a diagram (92%), building a table (90%), and look for a pattern (74%). A lower identification' degree was found on strategies works backwards (64%) and guess and check (46%). The strategies that best identify on G2 were: operating (93.6%), draw a diagram (87.2%), works backwards (83%), and look a pattern (80.9%). The strategies that have a lower percentage of recognition were building a table (72.3%), and guess and check (40.4%). Interestingly, in G1, work backwards was mistaken for operating by 31% of respondents, whilst 34% confounded guess and check with building a table and 15% with look for a pattern. Similarly, 30% of G2 confounded guess and check with look for a pattern and 21% with building a table.

Knowledge of metacognition.

Although most of the responses to the metacognitive items were agreement, a number of disagreements were recorded. Specifically, both indicate 92% state that the existence of monitoring that allows awareness of the errors committed. However, there are also some interesting answers. For instance, in one of the questions (11) on the reasons for operational errors in answers to problems, both groups identified the error. Their replies nonetheless differed about whether it should be attributed to a misunderstanding of the problem or to the calculation itself. In addition, both groups agree that the adequacy of the response was not verified.

Knowledge around non-cognitive factors.

Most of the items on non-cognitive factors elicited agreement. The percentage of agreement was slightly higher among the G2, however. However, the agreement percentages are slightly higher in

the G2. For example, in a question that inquires into the disposition to solve a problem, 77% of the G1 agrees, while the percentage rises to 91% on G2. Also, there are some doubts that need to be highlighted. Disagreement was expressed in a number of items. In particular, although the future teachers in both groups deemed motivation to be important to PS, a smaller percentage believed it to be instrumental to a successful outcome. For example, both groups state that it is important to be motivated to face an PS process (G1: 90%; G2: 96%), however, only 39% on G1 and 40% of the G2 believe that this can determine success in finding a solution.

Discussion and conclusions.

The findings showed that participants' replies were in line with the knowledge reported in the literature. They nonetheless co-existed with ideas that may prevent the translation of such knowledge into teaching practice.

Both groups' replies were consistent with a dynamic, cyclical interpretation of the stages described by Pólya (Wilson et al., 1993). The differences between the two groups studied in connection with knowledge of solving stages and their characterisation had to do with the variety of elements that may be involved in the solving process, specifically in the review stage. However, they do not consider posing problem as part of the PS process, one of the key moments to understand the process as cyclical (Wilson et al., 1993). That characterisation may fail to have practical implications, however, for the stages of PS about which respondents showed least agreement were the exploration of different solutions and problem posing. Given that those two approaches are determinants in characterising the process as dynamic and cyclical (Wilson et al., 1993), respondents may possibly be presumed to hold contradictory belief. Simultaneously, the present findings also seem to imply that the university training received has a scant impact on a command of PS theoretical knowledge, for the replies to the items on strategies between the two groups were essentially similar. The strategies with which both were most familiar were operating and drawing, whilst neither was well acquainted with guess and check. The inference is that although their knowledge was compatible with an understanding of solving as a dynamic and cyclical process, their approach continued to be linear. That conclusion is supported by the fact that the strategy least recognised, guess and check, is related to authentic PS.

In general, findings on teacher' PS process knowledge show little differences between groups. This seems to indicate that the knowledge they have, does not change during their training, despite having specific courses. This result could be explained because it is one of the areas stressed in curricula and textbooks (Wilson et al., 1993). Hence, we believe it is necessary for training programs to be concerned about this aspect, fostering skills that make it possible a deeper understanding of the PS process. On the other hand, the contrast between that finding and the actual belief exhibited by future teachers when confronting PS activities (Andrews & Xenofontos, 2015) raises the question of whether the relationship between mathematical knowledge and pedagogical knowledge is the same when a process such as PS is involved.

Acknowledgement

Spanish National R&D Project EDU2015-70565-P; and Chilean PhD. scholarship folio 72170314.

References

- Andrews, P., & Xenofontos, C. (2015). Analysing the relationship between the problem-solving-related beliefs, competence and teaching of three Cypriot primary teachers. *Journal of Mathematics Teacher Education*, 18(4), 299-325.
- Bisquerra, R. (1989). *Introducción conceptual al análisis multivariable: un enfoque informático con los paquetes SPSS-X, BMDP, LISTEL y SPAD*. Barcelona, Spain: PPU.
- Blanco, L. J. (2004). Problem solving and the initial practical and theoretical education of teachers in Spain. *Mathematics Teacher Education and Development*, 6, 31-42.
- Carrillo, J., Climent, N., Montes, M., Contreras, L. C., Flores-Medrano, E., Escudero-Ávila, D., ... Muñoz-Catalán, M. C. (2018). The mathematics teacher's specialised knowledge (MTSK) model. *Research in Mathematics Education*, 20(3), 236-253.
- Codes, M., Climent, N., & Oliveros, I. (2019, February). *Prospective primary teachers' knowledge about the mathematical practice of defining*. Paper presented at CERME11. Utrecht, Netherlands.
- Chapman, O. (2015). Mathematics teachers' knowledge for teaching problem solving. *LUMAT*, 3(1), 19-36.
- Cohen, L., Manion, L., & Morrison, K. (2011). *Research methods in education* (7th ed.). London, UK: Routledge.
- Fink, A. (2003). *How to ask survey questions* (2nd ed.). Thousand Oaks, CA: Sage Publications.
- Foster, C., Wake, G., & Swan, M. (2014). Mathematical knowledge for teaching problem solving: Lessons from lesson study. In S. Oesterle, P. Liljedahl, C. Nicol, & D. Allan (Eds.), *Proceedings of the Joint Meeting of PME 38 & PME-NA 36* (Vol. 3, pp. 97-104). Vancouver, Canada: PME.
- Lester, F. K. (2013). Thoughts about research on mathematical problem-solving instruction. *The Mathematics Enthusiast*, 10(1&2), 245-278.
- Mason, J. (2016). When is a problem...? "When" is actually the problem! In P. Felmer, E. Pehkonen, & J. Kilpatrick (Eds.), *Posing and solving mathematical problems* (pp. 263-285). New York, NY: Springer.
- Mayer, R. E., & Wittrock, M. C. (2006). Problem solving. In P. A. Alexander & P. H. Winne (Eds.), *Handbook of Educational Psychology* (pp. 287-303). New York, NY: Routledge.
- Piñeiro, J. L., Castro-Rodríguez, E., & Castro, E. (2016). Resultados PISA y resolución de problemas matemáticos en los currículos de educación primaria. *EDMA 0-6: Educación Matemática en la Infancia*, 5(2), 50-64.
- Piñeiro, J. L., Castro-Rodríguez, E., & Castro, E. (2019). Componentes de conocimiento del profesor para la enseñanza de la resolución de problemas en educación primaria. *PNA*, 13(2), 104-129.
- Pólya, G. (1945). *How to solve it*. New Jersey, NY: Princeton University Press.
- Schoenfeld, A. H. (1985). *Mathematical problem solving*. Orlando, FL: Academic Press.
- Wilson, J. W., Fernandez, M. L., & Hadaway, N. (1993). Mathematical problem solving. In P. S. Wilson (Ed.), *Research ideas for the classroom* (pp. 57-78). New York, NY: MacMillan.

Conceptualising tasks for teacher education: from a research methodology to teachers' knowledge development

Milena Policastro¹, Maria Mellone², Miguel Ribeiro¹ and Dario Fiorentini¹

¹State University of Campinas – UNICAMP Brazil; mitapolicastro@gmail.com; cmribas78@gmail.com; dariofiore@terra.com.br

²University Federico II, Italy; maria.mellone@unina.it

In this paper, we discuss the process of conceptualising tasks for teacher education as a research methodology that may improve the understanding of the features of teachers' knowledge, as well as refine the specificities of the Mathematics Teachers' Specialized Knowledge (MTSK) conceptualisation. We focus our discussion on a task for teacher education conceptualised to develop teachers' knowledge of connections between measurement and fractions. The discussion of the process of designing a task emphasises the role of using a teacher's knowledge conceptualisation (MTSK) as a tool for such design, in a dialectic relation with the aim to develop a methodological tool to be employed in shaping teacher education and to develop teachers' knowledge.

Keywords: Teacher education, task design, teacher knowledge, mathematical connections.

Introduction

Teacher education involves a broad set of dimensions and may thus be investigated from different perspectives. One of the core aspects of mathematics teacher education is related to identifying the most problematic areas, not only in terms of the topics that present difficulties to both students and teachers—when learning and teaching, respectively—but also in terms of how the teachers' knowledge should be considered and developed.

It is well known that teachers' knowledge has a great impact on pupils' knowledge/learning (Grossman, 2010). In that sense, it is essential to focus teacher education on the core aspects of such knowledge, which demands a particular attention to both the process of conceptualising tasks and to how they are implemented. Moreover, it is necessary for the tasks conceptualised for teacher education to be in a direct relationship with practice, thus assuming a practice-based approach. One of the ways of achieving this aim is to include pupils' productions (containing errors or not but, in particular, those considered as non-standard), whenever aiming to contribute to the development of what has been termed as Interpretative Knowledge (Mellone, Tortora, Jakobsen, & Ribeiro, 2017).

Considering that the principles related to the school mathematics (NCTM, 2000) provide a set of five standards of mathematical process—connections, representations, problem solving, reasoning, and communication—teacher education must be concentrated on developing teachers' knowledge of those principles. Amongst them, connections and representations are particularly relevant for the work we are developing, as it focuses on teachers' knowledge. Since the representations and their use are directly linked to the learning process in mathematics, it is required to broaden and deepen the understandings about what kind of relationships can be established between various forms of representations, such as verbal, pictorial, numerical, symbolic, algebraic, and graphical.

In terms of mathematical topics in which representations play a central role, rational numbers are considered the most problematic, both in terms of learning and teaching, mainly because of the different meanings they assume across different contexts. When we consider the variety of interpretations of rational numbers—part-whole, measure continuous quantities, quotient, operator and ratio—it is not surprising that pupils experience difficulties in understanding and dealing with this concept. Besides that, because of the intrinsic relationship between the construct of rational numbers and the phenomenological process of measurement—since it is one of the meanings of the fraction representation for rational numbers (Charalambous & Pitta-Pantazi, 2005)—it is essential to focus on the connections between these two topics (rational numbers, fractions in particular, and measurement) in order to propose effective interventions in the context of teaching and learning, and specifically in the context of teacher education.

Considering, therefore, the central role that teachers' knowledge plays in pupils' learning, and the importance of improving such knowledge, allowing teachers to help students in developing the understanding about connections and (between) representations, this work focuses on the question: *which are the features required in conceptualising a task for developing the specificities of teachers' knowledge?*


Theoretical Framework

Several conceptualisations of teachers' mathematical knowledge have been developed (e.g., Ball, Thames, & Phelps, 2008; Carrillo et al., 2018), most of which include, explicitly or implicitly, connections as a part of the dimensions of teachers' knowledge. This inclusion can be perceived as an awareness of the central role that connections assume in teachers' practice, for example, to establish a coherence on the work plan, that is, to the sequence of the tasks they prepare and implement. Another aspect related to the teachers' practice in which connections are essential is the need to give sense to students' productions (Mellone et al., 2017), treating them as a starting point to develop and broaden their mathematical knowledge.

We treat connections as a dimension of teachers' knowledge, which is related to the relationships teachers, consciously and deliberately, establish among different constructs within the same topic (intra-conceptual connections) and/or among different topics (inter-conceptual connections), in order to develop students' mathematical knowledge. In that sense, we assume a teachers' knowledge conceptualisation (Mathematical Teachers' Specialised Knowledge – MTSK – Carrillo et al., 2018) that considers such differentiation, both in terms of the type of connections, and the intentionality behind establishing such connections. The MTSK conceptualisation is conceived as a theoretical and analytical tool to better understand teacher's knowledge specificities, from two main dimensions, named Pedagogical Content Knowledge (PCK) and the Mathematical Knowledge (MK) domains. Each domain includes three subdomains related to: the content itself; the connections between topics and how one proceeds in mathematics (MK); the features of teaching and learning each topic and the awareness of the curriculum (PCK).

In this work, we focus on three of the six subdomains—Knowledge of Topics (KoT) and Knowledge of Structures of Mathematics (KSM)—related to, respectively, intra-conceptual and inter-conceptual connections and Knowledge of Features of Learning Mathematics (KFLM).

The KoT subdomain includes the teachers' knowledge on definitions, procedures, characteristics of results, foundations, properties, distinct types of representations, and phenomenology and applications. In the scope of rational numbers, it includes knowledge of the different meanings associated with the rational number (e.g., part-whole, ratio, operator, quotient, and measure – Charalambous & Pitta-Pantazi, 2005). Another aspect included in the KoT refers to the knowledge of the models and representations, for example, within contexts like percentage, ratio, and proportion, in which rational numbers can be applied. When a teacher establishes relationships amongst the

representations 50%, $\frac{1}{2}$, and , connecting them to the notion expressed by the term “a half,” and intentionally contextualises these representations in different situations, we would say that he/she reveals knowledge of intra-conceptual connections (KoT). In this context, the specialisation of the knowledge is related to connecting, intentionally and deliberately, the concept image (in the sense of Tall & Vinner, 1981) associated with a construct to its concept definition (as specific equivalence class), in each particular case, which is thus associated with intra-conceptual connections (KoT).

The KSM subdomain concerns the knowledge related specifically to (inter-conceptual) connections, and it comprises four categories. Because of the space limitation, we will discuss only two of such categories: the auxiliary and transverse connections. The auxiliary connection category is related to teachers' knowledge of the need to consider a notion (procedure or construct) as a support to the process of developing students' understanding of a certain concept (procedure or notion). In this case, we can take an example of a kindergarten teacher implementing a task involving a measurement activity, whereby he/she evokes the procedures of measuring (iteration of the unit and assigning a quantity to the number of times the unit fits within the whole).

The transverse connections pertain to the knowledge grounding the establishment of relationships between several topics with common features, even if those common features are not necessarily evident at first sight. An example of this concerns connecting the experience of measuring a magnitude, using different units of measurement, with the inverse proportional relationships between the number of units of measurement used and the correspondent values obtained for such measurement. In this case, considering the same whole, the smaller the unit of measurement, the bigger the number expressing the result of the measurement.

In relation to the work we are developing focusing on teachers' knowledge on connections, one other core aspect concerns the knowledge on students' mathematical thinking, learning and knowledge development when engaging with mathematical tasks, which is part of the KFLM subdomain from the MTSK conceptualisation. It also includes the knowledge of the types of tasks and examples, and common errors or areas of difficulty, as well as misunderstandings and misconceptions when proceeding in mathematics. For instance, a teacher should know the students' misunderstanding of a rational number as a measurement (quantity) and not only as a part-whole relationship.

Such specialised knowledge grounds teachers' practice, and in order to develop such practice having as a starting point what their students know and how they know it, it is required that the teachers interpret and give meaning to the students' productions and comments. When considering teachers' knowledge required to interpret students' productions, the notion of Interpretative Knowledge (IK)

has been developed (Mellone et al., 2017). It is defined as “the knowledge that allows teachers to give sense to pupils’ answers, in particular to ‘non-standard’ ones, i.e., adequate answers that differ from those teachers would give or expect, or answers that contain errors”, (Mellone et al., 2017, p. 2949). The aim of the educational process should be to develop teachers’ IK, so that they transition from an evaluative perspective (traditional—associated with a teacher’s establishment of a relation between the students’ answer and the elements of his/her own (im)possible and mathematically (in)adequate set of solutions for a problem, named *space of solutions*) to a real interpretation for the educational design, that is, when a teacher “revises his/her mathematical formalization in order to ensure that it is coherent with students’ productions” (Mellone et al., 2017, p. 2950).

Considering, therefore, the specificities and particularities associated with teachers’ knowledge, in the context of teacher education, the tasks conceptualised to develop such knowledge must also have a specialised nature (Ribeiro, 2016). This means that the MTSK and the IK perspectives, as tools for supporting the process of designing tasks conceptually, on one hand, aim at accessing and developing some aspects of the specialised knowledge related to the mathematical topic(s) to be taught. On the other hand, including students’ productions from which the mathematical reasons that sustain eventual errors or non-standard responses can be explored, the task conceptualisation relies on the notion of broadening teachers’ *space of solutions* and, ultimately, developing teachers’ ability to support the development of pupils’ mathematical knowledge, starting from their own reasoning.

Context

The current work is a part of broader research project which focus on the dimensions of teacher’s knowledge related to connections. The goals of such research project include identifying and describing some categorisations of connections that teachers elaborate (or should be developed) when discussing tasks specifically conceptualised for teacher education.

All the tasks conceptualised are conceived to be implemented in different contexts of teachers’ training programs and they comprise of two parts (described in detail in the next section). The first part of the task discussed in this paper (denoted as “A half”) was designed to last about four hours, including both teachers’ reflections and the whole group discussions. The second part of the task was designed to last about two hours, also including teachers’ reflection and the whole group discussions.

Analysing the conceptualisation of a task for teacher education

The MTSK conceptualisation considers, as mentioned before, six subdomains of teacher’s knowledge, with several associated descriptors. When conceptualising a task for teacher education using the MTSK as a tool for approaching the complexity of teachers’ knowledge, those descriptors will serve as guiding principles for the work of accessing and developing (this last process occurring specifically in the context of the task implementation) teacher’s specialised knowledge. Thus, after identifying the mathematical subject matter to be explored in the task, the task designer must choose the main aspects of teacher’s knowledge he/she wants to develop, and then must associate it to the descriptors included within the subdomains.

For instance, one of the questions of first part of the task (named “A half”) aimed at accessing (and not assessing) teachers’ knowledge of the meaning of the concept/construct of “a half”: a rational

number that can be understood as a quantity resulting from the phenomenological process of measurement; the meanings of a fraction; and/or result of a division (operation – which is a mathematical process). *“Imagine you are on the street and someone stops you and poses a question: ‘What is a half?’ What would your answer be? Respond to this question for yourself, using your own mathematical knowledge.”* - KoT. Another question included in this part of the task aimed at accessing teachers’ knowledge about types of representations associated with a concept (*“Present two distinct representations for ‘a half.’ Justify why you consider these representations as distinct from each other.”*) – KoT. Moreover, they were considered in the first part of the task the type of problems/different contexts the concept/construct of fraction can be applied to, and procedures associated with, the characteristics of the result (number sense – number as a quantity) contexts in (*“Pose two distinct situations (or word problems) in which the term (and the concept) ‘a half’ is explicit.”*) – KoT and KFLM.

As the background of the aspects approached of the questions aforementioned, they were considered as contents of the teacher’s knowledge to be accessed the role of the whole when measuring and the foundations of the measuring activity (What is “to measure” something? What can be measured?) – KSM.

The conceptualisation involved in the tasks we have been assuming for teacher education includes the perspective that any situation students would encounter must be experienced by the teachers. In the “A half” task, two situations for students were included, denoted as “The secret envelopes.” Specifically, three different envelopes containing a stick and a piece of string are distributed to students and each pupil is asked to measure the stick using a piece of string. In the first situation, the three envelopes contain sticks of the same length, but the length of the strings corresponds to 4, 2 and $\frac{1}{2}$ of the stick length, respectively. In the second situation, the envelopes contain both sticks and strings of different lengths, but the relation between the stick and string lengths in each envelope is always $\frac{1}{2}$.

Teachers are stimulated to solve the students’ task by assuming that they are not involved in a teaching context. Then, they are invited to reflect on the teaching process involved in the students’ task from questions explicitly linked to PCK subdomains. For doing so, questions such as *“What kind of knowledge do students need to solve the task?”* and *“How do you consider a 2nd grade student would solve the task? Try to present some examples of possible difficulties, mistakes, or misunderstandings a child could experience.”* are posed – KFLM.

In order to access teachers’ knowledge on: i) connections between the measurement process and the concept of a fraction as a number (quantity) including the different types of representations associated to it (KoT); and ii) connections between the inverse proportional concept and the characteristics of results obtained by a measurement process (KSM) a question linked to the students’ task was included (*“What are the mathematical topics/contents (that can be) explored within these tasks? Do you consider those topics/contents as related to each other? Give examples.”*).

The second part of the task is conceptualised according to the IK perspective (Mellone et al., 2017). For doing so, a transcription (Fig. 1) of a discussion between a teacher and a 2nd grade for “the secret envelopes” is presented¹. Teachers are invited to interpret the last student’s statement, considering the mathematical adequacy and correction. They are subsequently instructed to propose a continuity of the dialogue to develop the student’s mathematical knowledge related to the topic of the task.

Part II

During “The secret envelopes” task implementation with a 2nd grade children, teacher Alice has a dialogue with one of her students, as it is followed:

Alice: *Matheus, how many [pieces of] string you needed to measure the stick?*


Matheus: *I need a half...*

Alice: *Cool. So, you go back to your seat and do not tell anything to the girls, right? You must keep this secret! You only must keep this number in your mind, so that we can discuss after, ok?*

Matheus: *Number? Which number? A half is not a number.*

Figure 1: The second part of the “A half” task

When interpreting the last student’s statement, teachers must evoke their MTSK related to the meaning of the construct “a half”, that is, as a rational number that can be represented by a quantity (resulting from the phenomenological process of measurement). This teacher’s specialised knowledge is associated to the KoT and KSM subdomains explored on the first part of the task. For instance, if in the first part of the task a teacher provides a representation of “a half” that is somehow associated with a magnitude (length, for example), he/she would be able to understand that the student is not comprehending the construct “a half” as a number because he/she is not considering a number as a magnitude (a quantity yielded by a measurement process).

One of the principles of the measurement process is to attribute a value to the measure, that is, a number. Therefore, in order to develop student knowledge about the number sense related to the concept “a half,” teachers should be aware of the need to redesign the educational process (Mellone et al., 2017), establishing connections among the numeric representation $\frac{1}{2}$, the pictorial representation , and the notion of a phenomenological process of measuring. Moreover, a teacher should be reflecting on how the special role played in the society by the rational number $\frac{1}{2}$ is reflected in the natural language. Indeed, in many (all?) languages, we can find at least two ways to express it, like "a half" and "one on two", and while this second way suitably arranged works for all the fractions, the first is only for $\frac{1}{2}$, stressing its special role.

Obviously, this (re)design of the educational process is associated with teachers’ specialised knowledge about the connections, both between different types of representation of a construct (in this case “a half”) and the meaning(s) of such construct (fraction as a measure). In that sense, it is important to highlight that, in order to develop the IK in teachers, it is necessary to simultaneously develop their MTSK.

¹ In the context of a task conceptualisation we have been developing, students’ responses as written or oral commentaries are considered as “student productions.”

Final Comments and Remarks for the Future

In this paper, we presented a process of conceptualising a task based on a methodological and analytical tool focusing on the teachers' specialised knowledge (MTSK) and its relation to the process of intentionally developing their Interpretative Knowledge. Considering the features of the teacher's knowledge—which differs from students' knowledge and from that well-educated individuals possess—tasks aimed at teacher education must explore and develop the diverse dimensions and features of such knowledge (specialised and interpretative). The first part of the task involves a combination of the knowledges the students are expected to possess that is rooted in a deeper, formal, and rigorous understanding. The second part of the task is conceptualised by the IK perspective and is essential the inclusion of student's productions, preferably those in which the mathematical aspects can be explored in a broaden and deepen way.

When implementing a task conceptualised from these two perspectives about teacher's knowledge in a teachers' training context (initial or continuous), it is essential to emphasise the role of the teacher educator, who must be aware of the need for improving the specialised and interpretative teachers' knowledge. This should be done by not only following the questions posed in the task, but also by scrutinising the diverse types of (possible) interactions that teachers should present with the task. This awareness that teachers' educator must provide during the implementation is related to both his/her own mathematics specialised knowledge about teachers' knowledge and his/her own Interpretative Knowledge. In the context we have been working, the teacher educator (who is also a researcher) uses the particularities of both teacher's knowledge perspectives (MTSK and IK) as conceptual bases in the process of designing the task, implementing it in the teacher's training programs and analysing the data gathered from such implementation.



Figure 2: Relationships to be considered in teacher education

The process of conceptualising a task for teacher education described here is one of the several ways to perceive the methodology of designing tasks aiming at accessing and developing the specificities of teacher's knowledge. Both MTSK and IK perspectives are in process of development in different contexts (Spain, Norway, Italy, Brazil, etc.). In that sense, it is understandable (and desirable) that different teacher's knowledge conceptualisations are being used as tools for designing tasks for teacher education, from different perspectives (e.g., Montes, Climent, Carrillo & Contreras, 2019). In the context of the broad research we have been developing, we have been considering it extremely relevant to focus on the relationships between what we consider to be three pillars which sustain the process of

conceptualising a task for teacher education: the task design process and its implementation; the task implementation and the analysis; and the results of the analysis and the task design process. All these aspects are certainly influencing and are being influenced by the MTSK and IK perspectives, since both perspectives are considered in a dialectic relation with the aim to develop a methodological tool to be employed in shaping teacher education.

Acknowledgments

To Capes for the financial support of the PhD study, and to São Paulo Research Foundation (FAPESP) which has been partially supporting this research by the grant #2016/22557-5.

References

- Ball, D., Thames, M. H., & Phelps, G. (2008). Content Knowledge for Teaching: What makes it special? *Journal of Teacher Education*, 59(5), 389–407.
- Carrillo, J., Climent, N., Montes, M., Contreras, L.C., Flores-Medrano, E., Escudero-Ávila, D., Vasco, D., Rojas, N., Flores, P., Aguilar-González, A., Ribeiro, M., & Muñoz-Catalán, M.C. (2018). The Mathematics Teacher's Specialised Knowledge (MTSK) model. *Research in Mathematics Education*. 20(3), 236–253. DOI 10.1080/14794802.2018.1479981.
- Charalambous, C. Y., & Pitta-Pantazi, D. (2005). Revisiting theoretical model on fractions: implications for teaching and research. In *Proceedings of the 29th Conference of the International Group for the Psychology of Mathematics Education* (Vol. 2, pp. 233–240). Melbourne: PME.
- Grossman, P. (2010). *Learning to practice: The design of clinical experience in teacher preparation*. Washington, DC: American Association of Colleges for Teacher Education & National Education Association
- Mellone, M., Tortora, R., Jakobsen, A., & Ribeiro, M. (2017). Prospective teachers interpret student responses: Between assessment, educational design and research. In T. Dooley & G. Gueudet (Eds.), *Proceedings of the 10th Congress of the European Society for Research in Mathematics Education* (pp. 2948–2955). Dublin: Institute of Education, Dublin City University and ERME.
- Montes, M., Climent, N., Carrillo, J., & Contreras, L. C. (2019). Constructing tasks for primary teacher education from the perspective of Mathematics Teachers' Specialised Knowledge. In *Proceedings of CERME11*. Utrecht, Netherlands: ERME.
- NCTM. (2000). Principles and standards for school mathematics - National Council of Teacher of Mathematics. Reston, VA.
- Ribeiro, M. (2016). Tareas para alumnos y tareas para la formación: discutiendo el conocimiento especializado del profesor y del formador de profesores de matemáticas. In *XX Actas de las Jornadas Nacionales de Educación Matemática* (pp. 31–39). Valparaíso: Chile.
- Tall, D., & Vinner, S. (1981). Concept image and concept definition in mathematics with particular reference to limits and continuity. *Educational Studies in Mathematics*, 12, 151–169.

Kindergarten teachers' knowledge in and for interpreting students' productions on measurement

Milena PolICASTRO¹, Miguel Ribeiro¹ and Alessandra Rodrigues de Almeida²

¹State University of Campinas – UNICAMP, Brazil; mitapolicastro@gmail.com;
cmribas78@gmail.com

²Pontifícia Universidade Católica de Campinas, PUCCAMP, Brazil;
alessandraalmeida628@gmail.com;

Keywords: Teacher's interpretative knowledge, Measurement.

One of the core aspects of teachers' practice grounds (at least should) on the need to interpret students' productions and comments, not only for helping pupils to overcome their possible difficulties, misunderstandings or explore alternative approaches but also to (re)design the teaching approaches having such aspects as a starting point. Such knowledge required in and for interpreting students' productions has been termed as Interpretative Knowledge – IK (Jakobsen, Ribeiro, & Mellone, 2014). The IK is perceived as the knowledge that allows teachers to “give sense to pupils' answers, in particular to ‘non-standard’ ones, i.e., adequate answers that differ from those teachers would give or expect, or answers that contain errors” (Mellone, Tortora, Jakobsen, & Ribeiro, 2017, p. 2949).

Such IK needs to be (and it is desirable it is) developed in the context of teacher education, since it does not developed merely with teaching experience (Mellone et al., 2017). Such development requires to explore, in the context of teacher education, tasks specifically conceptualised to such aim¹. One of the perspectives included in the tasks conceptualised for teacher education is related to teachers' anticipation of student's responses, a process associated with accessing teacher's *space of solutions* (Di Martino, Mellone, Minichini, & Ribeiro, 2016). Essentially, IK is related to the teacher's Mathematical Knowledge (MK) evoked when analyzing a student's production– which does not exclude his/her Pedagogical Content Knowledge (PCK) in this process. Moreover, anticipating student's responses plays a central role on the process of developing the IK, and it is also related to teacher's MK and PCK, as this capacity of anticipation depends, among other aspects, on his/her knowledge of different procedures associated to a concept, and students difficulties and facilities related to a mathematical topic. Besides, anticipating student's responses is associated with the feedback teachers would provide to students, that is, the set of decisions to be taken in order to implement significant mathematical practices. Amongst the mathematical topics teachers need to cover, measurement assumes (or it should) a major role since it is a core construct of mathematical learning, as it serves as a “bridge between the two critical domains of geometry and numbers” (Clements & Sarama, 2007, p. 517) and research shows that early cognitive foundations are not limited to number concepts. With such a core role in students' understanding, measurement is one of the topics needed to be explored with pupils since kindergarten—in order to allow them to start grounding their mathematical understanding and knowledge since early age. The content and nature of teachers' knowledge shape the learning opportunities provided to pupils (Hiebert & Grouws,

¹ For more information on such tasks conceptualisation see, for example, PolICASTRO, Mellone, Ribeiro and Fiorentini (submitted).

2007), and researches focusing on kindergarten teachers' knowledge on measurement and its impact on students' performance (Grossman, 2010) is scarce. In that sense, we assume as one of the foci of attention in the research we are developing, the role of such knowledge in supporting (or inhibiting) the development of pupils' mathematical knowledge. In the context of a broader research project (in a continuous professional development context) we have been working with five kindergarten and primary teachers focusing on discussing some tasks with students' productions (aimed at improving their IK) in the scope of measurement. In a posterior moment the group prepare, discuss and implement tasks in their classrooms and afterwards a process of reflection upon the implementation occurs. In this poster we focus on presenting and discussing the methodological approach for the research. Complementary we discuss one episode emerging from the implementation of one of the tasks (with a group of 5-year-old pupils) focusing on one of the teachers IK when giving meaning to a student comment on "measuring a wale". The results of this study enhance the role of teachers' interpretative knowledge as one of the pillars that sustains the capacity to engage children in a mathematical discussion. The interrelationship between anticipating students' answers and the set of answers teachers would provide, allow them to make informed decisions and implement significant mathematical practices even in contingency moments.

Acknowledgement

To São Paulo Research Foundation (FAPESP) which has been partially supporting this research by the grant #2016/22557-5.

References

- Clements, D. H., & Sarama, J. (2007). Early childhood mathematics learning. In F. K. Lester (Ed.), *Second handbook of research on mathematics teaching and learning* (Vol. 1, pp. 461–555). New York: Information Age Publishing.
- Di Martino, P., Mellone, M., Minichini, C., & Ribeiro, M. (2016). Prospective teachers' interpretative knowledge: giving sense to subtraction algorithms. In S. Zehetmeier, M. Ribeiro, B. Roesken-Winter, & B. Potari (Eds.), *Proceedings ERME topic Conference Mathematics Teaching, Resources and Teacher Professional Development* (pp. 66–75). Hall: ERME.
- Grossman, P. L. (2010). Learning to Practice: the design of clinical experience in teacher preparation. *Nea Policy Brief*.
- Hiebert, J., & Grouws, D. (2007). The effects of classroom mathematics teaching on students' learning. In *Handbook of Research on Mathematics Teaching and Learning* (pp. 371–404). New York: Information Age Publishing.
- Jakobsen, A., Ribeiro, M., & Mellone, M. (2014). Norwegian prospective teachers' MKT when interpreting pupils' productions on a fraction task. *Nordic Studies in Mathematics Education*, 19, 135–150.
- Mellone, M., Tortora, R., Jakobsen, A., & Ribeiro, M. (2017). Prospective teachers interpret student responses: Between assessment, educational design and research. In T. Dooley & G. Gueudet (Eds.), *Proceedings of the 10th Congress of the European Society for Research in Mathematics Education* (pp. 2948–2955). Dublin: Institute of Education, Dublin City University and ERME.

Developing an identity as a secondary school mathematics teacher: Identification and negotiability in communities of practice

Kirsti Rø

Norwegian University of Science and Technology (NTNU), Norway; kirsti.ro@ntnu.no

The paper reports from analyses of one Norwegian secondary school mathematics teacher (Isaac) in his transition from university teacher education to employment in secondary school. The process of becoming a mathematics teacher is studied in terms of identity, based on the teacher's participation within and at the boundaries of communities of practice at university and school. Adopting a longitudinal case-study design and methods from narrative analysis, the case of Isaac displays tensions between desires for own mathematics teaching and experiences of possibilities in practice. The case illustrates how the concept of identity is helpful for gaining insight into mathematics teachers' ability and legitimacy to contribute to, and take responsibility for, the meanings that matter regarding mathematics, its teaching and learning, in their professional debut.

Keywords: Identity, community of practice, secondary mathematics teaching, narrative analysis.

Introduction

Mathematics teacher identity has been explored from a range of theoretical perspectives, spanning from categorising aspects of teacher identity in order to describe it and better understand the possible influences on teachers' practice, to viewing identity as a function of participation in different communities of practice (Beauchamp & Thomas, 2009; Darragh, 2016; Lutovac & Kaasila, 2017). In their overview, Beauchamp and Thomas (2009) find identity to be considered across the literature as dynamic and a constantly evolving phenomenon, being under the influence of a range of individual and external factors. They discuss a variety of issues that surface in the attempt of defining the concept of identity: the role of agency and emotion in shaping identity, the power of stories and discourse in understanding teachers' identity, and the contextual factors that promote or hinder identity development. Similarly, Lutovac and Kaasila (2017) find studies on mathematics teacher identity to address multiple themes, for instance theoretical models for defining identity, affective relationships with mathematics and changes in teacher identity, and the link between identity and teaching practices. However, studies focusing on social practices and structures within which teacher identities develop seem to predominate in the research field. In this paper, I adopt identity as a theoretical concept for better understanding the participative experiences of one newly educated mathematics teacher, when entering a secondary mathematics classroom. The purpose of the study is to gain insight into the dynamics of one mathematics teacher's learning, as he moves across different mathematics practices at the university and at school and unites his experience into a role as a secondary school mathematics teacher. According to Palmér (2013), studies on mathematics teachers often provide an external perspective, where the researcher observes and evaluates teaching in order to describe the teacher's knowledge and/or beliefs across contexts. However, in order to understand better mathematics teachers' challenges and opportunities when entering the profession, I instead search for in this paper the individual teacher's own meaning-making of himself as an actor of mathematics teaching, and the development of this meaning-making in the professional debut. Studying teacher

learning within and across practices, the notion of identity becomes then a conceptual tool for investigating how a mathematics teacher negotiates meaning with others and how he regulates his participation according to reactions of others to him (Ponte & Chapman, 2008). The research reported is based on a larger study of three Norwegian secondary mathematics teachers' entrance into the teaching profession (Rø, 2018), from which the overarching research question is: *How do three prospective secondary school mathematics teachers identities develop in the transition from university teacher education to school?* In the subsequent section, I present the theoretical basis for investigating mathematics teacher identity, in which it is considered as a dual process of identification and negotiability from participating in communities of practice (Wenger, 1998). Adopting a longitudinal case-study design and methods from narrative analysis, I further report on and discuss results from a series of interviews with one newly qualified mathematics teacher, Isaac, during his first year as an upper secondary school mathematics teacher. Thus, this paper seeks to answer the following sub-question: *What are the participative experiences of one newly educated mathematics teacher, when entering a secondary mathematics classroom?*

Mathematics teacher identity in communities of practice

Within the frames of Wenger's (1998) social learning theory, a prospective mathematics teacher's movement between university teacher education and employment in school implies various forms of participation in communities of practice, and the work of reconciling memberships across the community boundaries (Akkerman & Bakker, 2011). The concept of *community of practice* refers here to a set of relationships between people, who share some kind of competence through interaction, communication and negotiation of meaning (Wenger, 1998). When moving between practices, the prospective mathematics teacher is then negotiating ways of being a person in a community, e.g. being a student teacher in mathematics, being a schoolteacher, a teacher colleague, and an employee. Hence, the existence of a community of practice concerned with mathematics teaching and learning is a negotiation of related identities. On this basis, Wenger (1998) defines *identity* as negotiated experience of self when participating within and between communities of practice. Developing an identity as a mathematics teacher can thus be characterised as "increasing participation in the practice of teaching, and through this participation, (...) becoming knowledgeable in and about teaching" (Adler, 2000). A gradual change in participation, from the periphery towards the centre of a community of practice, is by Wenger (1998) described in terms of three modes of belonging: engagement, imagination and alignment. For instance, a prospective mathematics teacher might *engage* with ideas of inquiry based mathematics teaching through involvement in communicative practices with other community members (e.g. teacher educators, tutors, fellow student teachers, students in the classroom, teacher colleagues) during teacher education or in school. Consequently, he takes part in ideas of mathematics teaching through *imagination*, by envisioning himself as a teacher in a future classroom who is implementing the community's practice. Doing what it takes to play part in the community, the prospective teacher also *aligns* with the conditions or characteristics of the community's practice. This can take place through reading and sharing relevant literature with other actors, implementing inquiry based activities in own mathematics teaching and being involved in professional development projects on inquiry based mathematics teaching. Further, each of the three presented modes of belonging can be a source of the dual process of identification and

negotiability (Wenger, 1998). *Identification* concerns a person's investment in various forms of belonging to community practices, being both participative ("identifying with") and reificative ("identifying as"). In other words, identifying *with* a mathematics teaching practice or a group of actors of mathematics teaching is simultaneously a process of being identified *as* a special kind of mathematics teacher. Processes of identification with community practices thus define which meanings matter to the prospective teacher regarding mathematics teaching and learning. As an example, a mathematics teacher can identify himself with a community of inquiry based mathematics teaching by aligning with a joint learning objective of facilitating students' mathematical confidence and social empowerment. These learning objectives are related to perspectives of the subject of mathematics as being a social construction: "tentative, growing by means of human creation and decision-making and connected with other realms of knowledge, culture and social life" (Ernest, 1991, p. 209). Through inbound participation in the community, the teacher's identity will then develop in correlation with the negotiated perspectives on the nature of the discipline. However, processes of identification does not determine the teacher's ability to negotiate these meanings. *Negotiability*, then, refers to the "ability, facility, and legitimacy to contribute to, take responsibility for and shape the meanings that matter within a social configuration" (Wenger, 1998, p. 197). As an example, the meanings that a mathematics classroom community (teacher and students) produce of mathematics, its teaching and learning, are not only local meanings. They are also part of a broader *economy of meaning* in which different meanings are produced in different locations and compete for the definition of what mathematics teaching and learning is or should be. Consequently, some meanings of mathematics teaching and learning achieve special status. Wenger's (1998) notion of *ownership of meaning* refers here to the teacher's or the students' ability to take responsibility for negotiating the meanings of mathematics within the classroom community. The interplay between the mathematics teacher's expressed identification and his voiced negotiability displays therefore possible tensions between how he desires his mathematics teaching to be and what he experiences as possible in practice. Thus, it gives insight into the characteristics of mathematics teacher identity development in the beginning of a mathematics teacher career.

A narrative approach to mathematics teacher identity

Taking an operational approach to the concept of identity, I follow Elliott (2005) and Sfard and Prusak (2005), who link identity to the activity of communication. According to them, narratives provide the practical means by which a person can understand himself as living through time, and thus, make identity accessible and investigable. Through a narrative lens, a prospective teacher can make sense of his process of becoming a mathematics teacher by selecting elements of experience regarding mathematics teaching and learning, and patterning the chosen elements in ways that reflect stories available to the audience. This temporal characteristic of narratives is in line with Wenger's (1998) interpretation of identity as a *learning trajectory*, when incorporating "the past and the future in the very process of negotiating the present" (p. 155). Similarly, Carter and Doyle (1996) state that a narrative approach to identity emphasises the negotiated nature of becoming a mathematics teacher. Mathematics teacher identities are not simply formed by life experience prior to, during or after teacher education programmes. Rather, the teachers are active participants in interpreting their experience, "searching for and constructing images that capture the essential features of their

understanding of the tasks they encounter in [mathematics] teaching” (Carter & Doyle, 1996, p. 134). This paper presents identifying narratives of one newly educated mathematics teacher (Isaac), based on three consecutive semi-structured interviews distributed across his first year as a mathematics teacher in upper secondary school. Inspired by Elliott (2005), each interview was introduced by an invitation to talk freely about experiences from undergoing subject studies in mathematics, university teacher education, and/or experiences from being a newly qualified mathematics teacher. To cover important parts of Isaac’s life as a learner and teacher of mathematics, the storytelling was followed by questions outlined in an interview guide. The follow-up questions concerned Isaac’s first mathematics teaching experience, memories of good and less good mathematics lessons, peaks and disappointments regarding mathematics teaching and learning, and his expectations about the future. Adopting methods from narrative analysis (Polkinghorne, 1995), I sought to create coherence across themes and plots in what was told throughout the interviews. I divided the interview transcripts into segments where a certain topic was discussed. Based on comparison and contrast of the segments within and across interviews, I developed labels due to the segments’ thematic focus. Further, I sorted the labels into greater categories or *emergent themes* of Isaac’s accounts. The emergent themes developed from analysis of the first interview were brought into the analysis of the second interview, being confronted by labels given to segments in the transcripts. If necessary, the emergent themes were refined or new themes were developed. The narrative analysis led to three emergent themes in which Isaac’s building of a mathematics teacher identity is expressed: *confidence in mathematics and mathematics teaching*, *perspectives on mathematics and its role in mathematics teaching* and *feedback available within the school environment*. For each emergent theme, I interpreted the associated accounts by means of the theoretical framework. Hence, I searched for evidence of Isaac’s participation in communities of practice, based on Wenger’s (1998) two components of identity: identification and negotiability. Making a longitudinal approach to the accounts, I further looked for changes in Isaac’s expressed identification and negotiability. I identified discontinuities by comparing labels across interviews, marking out repeated accounts of turning points and recognising changes in attitudes and expressed perspectives regarding mathematics practices. In the subsequent analysis, I focus on Isaac’s accounts belonging to the emergent theme *perspectives on mathematics and its role in mathematics teaching*. They provide evidence of identity development in terms of Isaac’s strengthened affiliation towards the practices of mathematics teacher education, yet, his struggles of realising his ambitions in own mathematics teaching.

The case of Isaac

In Norway, two university teacher education programmes qualify for mathematics teaching in secondary school (grades 8-13): a five-year Master’s programme in mathematics and natural sciences including teacher education (1), and a one-year, post-graduate teacher education programme (PPU) (2). In both (1) and (2), the students undergo longer periods of school placement in lower and upper secondary school, and they take courses in general pedagogy and mathematics education. Isaac comes from the latter programme, building on a Bachelor’s degree in chemistry and about 60 ECTS credits in mathematics. I approached him to be a participant in the larger study based on his responses to a set of questions that was given to all last-year student teachers in mathematics belonging to either the five-year Master’s programme or the one-year PPU programme, within one Norwegian university. In

addition to reporting that he planned to work as a mathematics teacher after graduation, Isaac ticked off “agree” on the statements “I perceive myself as a teacher” and “I perceive myself as a mathematics teacher”. After graduating from PPU, Isaac took a temporary position as a mathematics and science teacher at an upper secondary school, teaching mathematics and science within both the general education programme and the vocational education programme Technical and Industrial Production. Two weeks into his new job, he looks back at PPU and describes it as a positive experience. Isaac elaborates on a changed view on teacher education with terms such as becoming part of the way of thinking and mastering the language of a new discipline.

Isaac: I’ve liked that kind of studies, actually, much more than I had thought that I would like it because I’m used to solving problems with two underlines underneath the answer, and it was more fun than I thought writing papers [laughing]. (...) it has motivated me to think now I’m going to change the math classroom (...). And I feel that I have a lot of commitment, many things I would like to do, because of things I’ve learned in for example the math education lessons.

Isaac: After the first semester (...), I didn’t yet get the hang of it, mastering the discipline and its format properly (...) didn’t get the message of what we were learning and doing, as well as I did in the second period. Because then I was part of the way of thinking, then I kind of felt I had an eye-opener about how to work with the discipline, how to understand the discipline. (...) I got into the literature, and suddenly understood what all these authors wanted to tell, I understood the language, the way of thinking.

Isaac portrays teacher education as something that has turned out as more interesting and enjoyable than expected. He elaborates on his changed view by describing a difference between the first and second semester at PPU, from not “get[ting] the hang of it” and not “get[ting] the message”, to understanding “the language, the way of expressing (...) and thinking”. He tells about having an eye-opener into the language and mind-set of the teacher education programme, where the lectures provided motivation for “chang[ing] the math classroom”. To make the change of his mathematics teaching possible, Isaac has signed up for an in-service course in order to try out inquiry based mathematics teaching in his own classroom and share his experience with the other participants.

Isaac: I signed up for a course (...), the topic is inquiry based teaching, I chose a math project, in which I will try to, to a greater extent, inquiry, landscape of investigation, and see how it works, and try to break the instinct of standing and chanting at the blackboard. (...) Then I have committed myself to it through this project (...) so it becomes binding.

However, in an interview conducted three months later into his first year of teaching, Isaac accounts for an experience of stagnation when trying to change his mathematics teaching according to his ambitions. He struggles to find the resources for developing new activities, both in terms of having enough time to implement it and to getting the good ideas for inquiry based mathematics activities.

Isaac: I run dry of ideas when I’m supposed to find out how they can make the sign charts inquiry based. I’ve tried, but it has been a lot harder than I expected, to find these

activities (...). Sometimes I've managed it (...) but not close to the amount that I wished for. I've done enough to meet the requirements of the in-service course, but I'm not able to do much more than that. I wanted a lot more. I have ambitions about doing more.

Instead of being a trigger for changing his teaching, the in-service course on inquiry based mathematics teaching has happened in parallel with Isaac's classroom teaching. Yet, he still holds on to his ambition of changing his teaching practice in the future. Despite having a "way to go to get the right tools for it", he imagines becoming a teacher who provides the students with a need to approach mathematics differently than seeking the one, correct answer on a series of tasks.

Isaac: I want to become the teacher who basically does two things. First of all, makes the students understand why, not knowing, but understanding, that's my first ambition, and the second ambition is to be the one who makes you eager for knowledge. The one who makes you wanting to know, wanting to understand (...) and to reach that, I think I have to change the teaching in a way that students don't get away with rattling off, or, they have to see the value in and the need of understanding. (...) I think I have a way to go to get the right tools for it.

In the final interview, taking place six months into his first year of teaching, Isaac voices a similar limited ability for establishing a different mathematics practice in the community of secondary mathematics teaching. Although he endeavours to invite the students into mathematics activities with no one, correct answer to the problems being posed, some of the students seem to hold on to their previous developed learning strategies. These students find comfort in solving textbook tasks with clear instructions, and they simultaneously avoid solving open problems that require a more flexible approach to the mathematics content. Isaac thus expresses lack of progress regarding his ambitions of teaching mathematics for understanding.

Isaac: What I've tried to do is not giving them access to the procedures so easily, meaning, the algorithms. I have tried to limit it, quite simply, the possibilities to memorise, not giving them any choice. And then tried to give them some open tasks, meaning, not a, b, c, d, which leads to something, but instead give them only d. But they don't succeed. I don't succeed, even if I try. If I only give them the task d, then I get kind of, resigned, almost tearful looks (...). Then I have to hold their hands the whole way, and I can never take off the support wheels.

The narrative analysis of Isaac's accounts displays a story of overcoming a discontinuity regarding mathematics, its teaching and learning, when undergoing teacher education. Looking back at the PPU programme, Isaac explicates differences between university mathematics with its "two underlines underneath the answer" and the imperfect and corrigible knowledge of the social sciences that were represented in teacher education. However, he also tells a story of expanding his perspectives on the practices of PPU, of changing his view on teacher education, its literature and modes of reasoning. His motivation for changing his mathematics teaching in line with what is communicated at PPU indicate thus an inbound movement within the practices of the teacher education programme. Due to his descriptions of having the need to change his teaching in direction of inquiry based mathematics

practices, Isaac's accounts further indicate inbound participation within a community of inquiry based mathematics teaching. He identifies with the community practices by exercising both engagement and imagination. The engagement involves signing up for an in-service course at his new school of employment, while imagination involves picturing himself as a future teacher who exercises mathematics teaching in line with what was communicated at PPU. However, Isaac also reports on a kind of conflict regarding the meaning of mathematics teaching and learning in the secondary mathematics classroom, which can be understood as the work of reconciling memberships across community boundaries (Akkerman & Bakker, 2011; Wenger, 1998). The reconciliation involves Isaac's continued identification with practices in the community of inquiry based mathematics teaching, his and his students' attempt of establishing a community of secondary mathematics teaching, as well as his students' former memberships in communities of mathematics teaching and learning in previous schooling. Isaac's attempt of establishing a meaning of mathematics teaching and learning in his secondary mathematics teaching is thus an issue of negotiability. Since the meanings that he and his students produce for mathematics are not only local and delimited by the classroom, different meanings compete for the definition of what mathematics teaching is or should be. Based on Isaac's accounts, the meanings of mathematics teaching and learning stemming from the students' previous mathematics practices seem to rule. He expresses limited ability to define what is appropriate regarding understanding in mathematics (understanding *why*, not only knowing what to do), with the consequence of being pulled away from his initial ambitions of exercising inquiry based teaching. Instead of establishing a new mathematics practice, the outcome is an ongoing conflict between him and the students regarding how mathematics should be taught and learned. Accordingly, Isaac gives descriptions of a limited ownership of meaning, in the form of undesired stagnation in his mathematics teaching practice.

Discussion

I have reported on the participative experiences of one individual mathematics teacher during his first year in upper secondary school. The study is based on the assumption that teacher learning is more than coming to know content, skills and practices. Rather, prospective mathematics teachers are active participants, who negotiate their experiences and create images of themselves and their challenging tasks and dilemmas in mathematics teaching (Carter & Doyle, 1996). Similarly, Sfard and Prusak (2005) claim that "human beings are active agents who play decisive roles in determining the dynamics of social life and in shaping individual activities" (p. 15). Developing a teacher identity thus brings with it "a sense of agency, of empowerment to move ideas forward, to reach goals or even to transform the context" (Beauchamp & Thomas, 2009, p. 183) in which mathematics teaching takes place. Although agency is not a term used by Wenger (1998), his theorisation of identity as identification and negotiability has in this study provided a conceptual tool for gaining insight into Isaac's ability and legitimacy to contribute to and take responsibility for the meanings that matter regarding mathematics teaching and learning in a secondary mathematics classroom. The results display some inconsistency between, on the one hand, his increased identification with mathematics teaching through inquiry, and on the other hand, his sense of negotiability regarding inquiry based mathematics teaching in the classroom. Identification with reform-oriented practices of mathematics teaching and learning is an important first step towards change and development of mathematics

teachers' practices. However, in order to explain further the possibilities for Isaac to develop his identity as a mathematics teacher in terms of changes in his practice, negotiability has appeared in this study as an important construct. Based on his accounts, Isaac seems to exercise imagination in a community of inquiry based mathematics teaching, by picturing a changed mathematics teaching practice. Yet, the results suggest that further participation by engagement, including active negotiation with other actors of a reform-oriented enterprise, is needed in order to alter the economy of meaning, and thus, to enable Isaac to implement the desired changes into his classroom teaching.

References

- Adler, J. (2000). Social practice theory and mathematics teacher education: A conversation between theory and practice. *Nordic Studies in Mathematics Education*, 8(3), 31–53.
- Akkerman, S. F., & Bakker, A. (2011). Boundary crossing and boundary objects. *Review of Educational Research*, 81(2), 132–169.
- Beauchamp, C., & Thomas, L. (2009). Understanding teacher identity: An overview of issues in the literature and implications for teacher education. *Cambridge Journal of Education*, 39(2), 175–189.
- Carter, K., & Doyle, W. (1996). Personal narrative and life history in learning to teach. In J. Sikula (Ed.), *Handbook of research on teacher education* (pp. 120–142). New York, NY: Macmillan.
- Darragh, L. (2016). Identity research in mathematics education. *Educational Studies in Mathematics*, 92, 1–15.
- Elliott, J. (2005). *Using narrative in social research*. London: Sage.
- Ernest, P. (1991). *The philosophy of mathematics education*. London: Falmer Press.
- Lutovac, S., & Kaasila, R. (2018). Future directions in research on mathematics-related teacher identity. *International Journal of Science and Mathematics Education*, 16(4), 759–776
- Palmér, H. (2013). *To become – or not to become – a primary school mathematics teacher: A study of novice teachers' professional identity development*. (Doctoral dissertation), Linnaeus University, Växjö, Sweden.
- Polkinghorne, D. E. (1995). Narrative configuration in qualitative analysis. In J. Hatch & R. Wisniewski (Eds.), *Life history and narrative* (pp. 5–23). London: Falmer Press.
- Ponte, J. P. d., & Chapman, O. (2008). Preservice mathematics teachers' knowledge and development. In L. D. English, M. B. Bussi, G. A. Jones, R. A. Lesh, B. Sriraman, & D. Tirosh (Eds.), *Handbook of international research in mathematics education* (pp. 223–261). London: Routledge.
- Rø, K. (2018). *Developing an identity as a secondary school mathematics teacher: A narrative case study of three mathematics teachers in their transition from university teacher education to employment in school*. (Doctoral dissertation), University of Agder, Kristiansand, Norway.
- Sfard, A., & Prusak, A. (2005). Telling identities: In search of an analytic tool for investigating learning as a culturally shaped activity. *Educational Researcher*, 34(4), 14–22.
- Wenger, E. (1998). *Communities of practice: Learning, meaning and identity*. Cambridge, UK: Cambridge University Press.

Students' abilities on the relationship between beliefs and practices

Safrudiannur^{1,2} and Benjamin Rott²

¹Mulawarman University, Indonesia; [safrudiannur.safrudiannur@uni-koeln.de](mailto:sufrudiannur.safrudiannur@uni-koeln.de)

²University of Cologne, Germany; benjamin.rott@uni-koeln.de

Most studies that deal with possible influences of the social context related to students' abilities on the connection between beliefs and practices involve only a small number of participants (e.g., 1 – 3 teachers). Thus, we have designed a new quantitative questionnaire (named TBTP) which is intended to examine these influences for a larger number of teachers (here: N = 43). Then, for a further qualitative investigation, we interviewed and observed lessons of three of those teachers. The results show that the 43 teachers distinguish their style of teaching in different contexts of students' abilities. The correlation between beliefs about mathematics and the styles of teaching can be seen in the context of low ability students rather than in the context of high ability students. In the further investigation, this correlation is supported by the three teachers' descriptions of their general teaching of mathematics and their real practices in classes containing many low ability students.

Keywords: Teachers' beliefs, teaching and learning of mathematics, students' abilities.

Introduction

Some researchers have shown that there is a connection between teachers' beliefs and practices (see Philipp, 2007). Other researchers, however, have reported that there may be inconsistencies between teachers' beliefs and their practices (Raymond, 1997; see Philipp, 2007). Buehl and Beck (2015) argue that such inconsistencies should not be a reason to discount the power of beliefs, but that other factors like social contexts support or hinder the connection between beliefs and practice. Several studies (e.g., Raymond, 1997; Cross Francis, 2015) have revealed that social contexts in a classroom might cause teachers to act in a way that differs from the way that fits their beliefs. However, most of the studies revealing the influence of social contexts are case studies involving only a small number of teachers such as one, two, or three teachers (see Raymond, 1997; Cross Francis, 2015).

Studying teachers' beliefs and practices by doing intensive case studies involving interviews and observations may provide convincing data (Philipp, 2007), but they are too expensive for large samples of teachers. The use of self-report instruments is cost-effective, but their accuracy and validity are criticized (e.g., Di Martino & Sabena, 2010). Most self-report instruments measuring beliefs use closed questions, mainly Likert scale items. However, Di Martino and Sabena (2010) question the use of the Likert scale since it amplifies problems related to social desirability. The social desirability problem may arise when items being rated are viewed as inherently positive by respondents (McCarthy & Shrum, 1997). Thus, teachers' responses to rating or Likert scale items may reflect what is socially accepted and should be done rather than what actually is done (Fang, 1996). Furthermore, Likert scale items provide less or no contexts (Philipp, 2007), whereas, as we pointed out before, social contexts at school may affect teachers' practices in a classroom.

We offer an approach to minimize the social desirability problem and consider the social contexts at school in order to increase the accuracy of the prediction of teachers' beliefs and practices. We have

developed a questionnaire for studying teachers' beliefs on their practice (named TBTP). We use rank-then-rate (a combination of ranking and rating) items. McCarthy and Shrum (1997) show that using rank-then-rate items may reduce respondents' tendency to give high ratings towards items viewed inherently positive socially. Moreover, we consider students' abilities as the social context in a classroom since several researchers (e.g., Raymond, 1997; Beswick, 2018) have shown that students' abilities may influence teachers' beliefs and practices.

We conduct this pilot study to evaluate whether the TBTP gives us insight into the relationship between beliefs and practices in different contexts of students' abilities. Ribeiro et al. (2019) suggest that considering beliefs and practices in diverse contexts may contribute for a better understanding on the beliefs and practices in order to improve the quality of teacher education.

Theoretical framework

Beliefs of the nature of mathematics and its association with teaching and learning of math

Philipp (2007, p. 259) defines "beliefs as psychologically held understandings, premises, or propositions about the world that are thought to be true". Teachers may hold various beliefs about mathematics since they may see mathematics with different views. Ernest (1989) summarizes three views about the nature of mathematics: *the instrumentalist view* (mathematics as an accumulation of facts and rules to be used in the pursuance of some external end), *the Platonist view* (mathematics as a static but unified body of knowledge), and *the problem-solving view* (mathematics as a dynamic process which is continually expanding field of human creation and invention). Nonetheless, Ernest (1989) argues that teachers may merge elements from more than one of the three views.

Ernest (1989) further argues that the three views about the nature of mathematics can be associated with the models of teaching mathematics: (1) the instrumentalist view is linked with the role as an instructor who demonstrates math skills correctly; (2) the Platonist view is linked with the role as an explainer who describes the relation of concepts; and (3) the problem-solving view is linked with the role as a facilitator who likes doing problem solving or posing activities.

Students' abilities as a social context

Empirically, Ernest's association between beliefs about mathematics and teaching of mathematics has not been demonstrated well. Ernest (1989) argues that social contexts such as students' behaviors may cause inconsistencies between teachers' beliefs and practices. Raymond (1997) has shown that students' abilities, attitudes, and behaviors have strong influences on teachers' practice. Moreover, Zohar, Degani, and Vaaknin (2001) found that most teachers believe that teaching with higher order thinking is only appropriate for high-achieving students, not for low-achieving students. Therefore, in this study, we consider students' abilities as the social context which may affect teachers' practices.

Research questions and method

As pointed out before, studies revealing the influence of the social context on teachers' practices involved only small numbers of teachers. In this study, we will examine the influence of the social context related to students' abilities for a larger number. The questions are: (1) How and why do teachers differentiate their style of teaching and learning of mathematics because of students' abilities? And (2) how do students' abilities influence the relationship between teachers' beliefs about

mathematics and their styles of teaching? To answer the questions, we use a multi-method design by combining the TBTP questionnaire with interviews and classroom observations.

The TBTP. This questionnaire has ten rank-then-rate items grouped into three themes presented in the Appendix (see Safrudiannur & Rott, 2018, for the evaluation of the reliability and validity of the TBTP). In this paper, since we focus on teaching of mathematics, we only discuss teachers' responses to items of Themes 1 and 3. Each item consists of three statements. The first, second, and third statement are always associated with the instrumentalist, the Platonist, and the problem-solving views, respectively. To consider students' abilities as the social context, the items of Theme 1 are posed twice: for classes dominated by high ability (HA) and by low ability (LA) students (see Figure 1). Please note that we define the terms HA and LA by using the students' achievements (see Appendix), following Zohar et al. (2001) who use the terms achievement and ability interchangeably.

Item 1: When you teach the formula in a class dominated by HA students , what is important for you?	Item 2: When you teach the formula in a class dominated by LA students , what is important for you?																																																																
RANK	RANK																																																																
Please order the three statements below by giving a rank 1 (the most important), 2, or 3 (the least important).	Please order the three statements.																																																																
<table border="1"> <thead> <tr> <th>Statements</th> <th>Rank</th> </tr> </thead> <tbody> <tr> <td>R1. You demonstrate how to use the formula correctly by giving some examples.</td> <td style="text-align: center;">3</td> </tr> <tr> <td>R2. You explain concepts related to how to get or to prove the formula.</td> <td style="text-align: center;">2</td> </tr> <tr> <td>R3. You let your students discover the formulas in their own ways.</td> <td style="text-align: center;">1</td> </tr> </tbody> </table>	Statements	Rank	R1. You demonstrate how to use the formula correctly by giving some examples.	3	R2. You explain concepts related to how to get or to prove the formula.	2	R3. You let your students discover the formulas in their own ways.	1	<table border="1"> <thead> <tr> <th>Statements</th> <th>Rank</th> </tr> </thead> <tbody> <tr> <td>Statement R1</td> <td style="text-align: center;">2</td> </tr> <tr> <td>Statement R2</td> <td style="text-align: center;">1</td> </tr> <tr> <td>Statement R3</td> <td style="text-align: center;">3</td> </tr> </tbody> </table>	Statements	Rank	Statement R1	2	Statement R2	1	Statement R3	3																																																
Statements	Rank																																																																
R1. You demonstrate how to use the formula correctly by giving some examples.	3																																																																
R2. You explain concepts related to how to get or to prove the formula.	2																																																																
R3. You let your students discover the formulas in their own ways.	1																																																																
Statements	Rank																																																																
Statement R1	2																																																																
Statement R2	1																																																																
Statement R3	3																																																																
RATE BASED ON YOUR RANK ABOVE	RATE BASED ON YOUR RANK ABOVE																																																																
Please rate the level of importance of each statement based on your rank above.	Please rate the level of importance of each statement.																																																																
<table border="1"> <thead> <tr> <th>Statements</th> <th colspan="7">Rate</th> </tr> </thead> <tbody> <tr> <td>Statement R1</td> <td style="text-align: center;">1</td> <td style="text-align: center;">3</td> <td style="text-align: center;">4</td> <td style="text-align: center;">5</td> <td style="text-align: center;">6</td> <td style="text-align: center;">7</td> <td style="text-align: center;">7</td> </tr> <tr> <td>Statement R2</td> <td style="text-align: center;">1</td> <td style="text-align: center;">2</td> <td style="text-align: center;">3</td> <td style="text-align: center;">5</td> <td style="text-align: center;">6</td> <td style="text-align: center;">7</td> <td style="text-align: center;">7</td> </tr> <tr> <td>Statement R3</td> <td style="text-align: center;">1</td> <td style="text-align: center;">2</td> <td style="text-align: center;">3</td> <td style="text-align: center;">4</td> <td style="text-align: center;">6</td> <td style="text-align: center;">7</td> <td style="text-align: center;">7</td> </tr> </tbody> </table>	Statements	Rate							Statement R1	1	3	4	5	6	7	7	Statement R2	1	2	3	5	6	7	7	Statement R3	1	2	3	4	6	7	7	<table border="1"> <thead> <tr> <th>Statements</th> <th colspan="7">Rate</th> </tr> </thead> <tbody> <tr> <td>Statement R1</td> <td style="text-align: center;">1</td> <td style="text-align: center;">2</td> <td style="text-align: center;">3</td> <td style="text-align: center;">4</td> <td style="text-align: center;">6</td> <td style="text-align: center;">7</td> <td style="text-align: center;">7</td> </tr> <tr> <td>Statement R2</td> <td style="text-align: center;">1</td> <td style="text-align: center;">2</td> <td style="text-align: center;">3</td> <td style="text-align: center;">4</td> <td style="text-align: center;">5</td> <td style="text-align: center;">6</td> <td style="text-align: center;">7</td> </tr> <tr> <td>Statement R3</td> <td style="text-align: center;">1</td> <td style="text-align: center;">3</td> <td style="text-align: center;">4</td> <td style="text-align: center;">5</td> <td style="text-align: center;">6</td> <td style="text-align: center;">7</td> <td style="text-align: center;">7</td> </tr> </tbody> </table>	Statements	Rate							Statement R1	1	2	3	4	6	7	7	Statement R2	1	2	3	4	5	6	7	Statement R3	1	3	4	5	6	7	7
Statements	Rate																																																																
Statement R1	1	3	4	5	6	7	7																																																										
Statement R2	1	2	3	5	6	7	7																																																										
Statement R3	1	2	3	4	6	7	7																																																										
Statements	Rate																																																																
Statement R1	1	2	3	4	6	7	7																																																										
Statement R2	1	2	3	4	5	6	7																																																										
Statement R3	1	3	4	5	6	7	7																																																										

Figure 1: An example how Fitria responded to item 1 and item 2 (identical statements) of the TBTP

To respond to an item, a respondent firstly orders the three statements of the item by assigning a rank 1, 2, or 3, and then rate each of them from 1 to 7 based on his ranks (see Figure 1). Thus, there will be two sets of data: ranking and rating data. For data analyses, we only use rating data, because ranking data is included. The purpose of the ranking part is only to make respondents discriminate three statements of each item before rating them and to minimize the impact of the social desirability.

We asked 43 Indonesian math teachers who accompanied their students in a math competition to respond to the TBTP (their background in detail, sex: 33 females, 7 males, and 3 did not state; school: 14 from primary, 16 from lower secondary, 10 from upper secondary, and 3 did not state; teaching years: 7 for less than two years, 10 in between two and five years, 9 in between five and ten years, 16 for more than ten years, and 1 did not state).

Interviews and Observations. Three (all from lower secondary) of the 43 teachers volunteered for a further investigation: Elisa (female), Fitria (female), and Dony (male). Elisa and Dony were math teachers for two to five years, and Fitria for more than ten years. We chose them since they could represent lessons in HA and LA classes. The interviews aimed at finding information about their beliefs about mathematics and general teaching of mathematics. We identified key words/ statements reflecting their beliefs. We also videotaped one lesson from each teacher. We used the coding system from the TIMSS Video Study 1999 to interpret the lessons. We categorized the interaction (*Public*,

Mix, Private) and the content activity (*Non-problem* or *Problem Segment*) of the lesson (we explain each term directly in the description of each lesson in the result section to save space). Both authors of this paper and one expert from Indonesia made the interpretation of interviews and lessons. The lowest percentage agreement is 70 % (we did discussions [consensual validation] to solve disagreements).

Results

Responses to the TBTP questionnaire

Tables 1 and 2 summarizes the responses of all 43 teachers to the TBTP. The results of paired t-tests show that teachers significantly differ their reported styles of teaching between HA and LA classes. Table 1 shows that teachers gave higher rates to the statements associated with the instrumentalist view for LA classes than to those for HA classes. In contrast, the statements associated with the problem-solving view for LA classes have lower rates than those for HA classes.

No	Statements of Theme 1 (views associated with the statements)	Teachers (n=43)		t-values (df=42, two tailed)	Elisa		Fitria		Doni	
		HA class Mean (sd)	LA class Mean (sd)		H A	L A	H A	L A	H A	L A
1 and 2	R1 (Instrumentalist view)	4.09 (1.66)	5.65 (1.13)	-6.19 ^a	5	7	2	5	2	6
	R2 (Platonist view)	5.02 (1.39)	5.44 (1.42)	-1.46	6	5	4	7	4	4
	R3 (Problem-solving view)	5.33 (1.55)	3.47 (1.24)	6.35 ^a	4	4	5	2	6	2
3 and 4	S1 (Instrumentalist view)	4.07 (1.49)	5.35 (1.15)	-4.99 ^a	3	5	2	5	5	6
	S2 (Platonist view)	5.86 (1.19)	5.47 (1.32)	1.57	7	7	5	7	6	3
	S3 (Problem-solving view)	5.44 (1.05)	3.79 (1.81)	5.52 ^a	6	4	6	4	4	1

^a significant for $p < 0.004$ (The adjustment of $\alpha = 0.05$ by Bonferroni's correction for 12 multiple t-test)

Table 1: Teachers' responses to items of Theme 1 and the results of the paired sample t-test

There are no differences between rates related to the statements regarding the Platonist view. This indicates that explanation and understanding for both HA and LA classes are essential to the teachers.

No	Statements of Theme 3 (views associated with the statements)	Teachers (n=43) Mean (sd)	Correlations with statements of Theme 1 in the same view		Elisa	Fitri	Doni
			HA class	LA class			
9	P1 (Instrumentalist view)	5.37 (1.43)	R1 (0.29), S1 (0.39 ^b)	R1 (0.42 ^b), S1 (0.34 ^a)	6	6	5
	P2 (Platonist view)	4.95 (1.19)	R2 (0.30 ^a), S2 (0.28)	R2 (0.18), S2 (0.33 ^a)	5	5	3
	P3 (Problem-solving view)	4.70 (1.39)	R3 (0.28), S3 (0.26)	R3 (0.25), S3 (0.20)	4	4	2
10	Q1 (Instrumentalist view)	5.09 (1.54)	R1 (0.07), S1 (0.29)	R1 (0.44 ^b), S1 (0.53 ^b)	5	6	6
	Q2 (Platonist view)	5.14 (1.49)	R2 (0.33 ^a), S2 (0.36 ^a)	R2 (0.32 ^a), S2 (0.39 ^b)	3	4	3
	Q3 (Problem solving view)	4.42 (1.26)	R3 (0.09), S3 (0.07)	R3 (0.53 ^b), S3 (0.54 ^b)	4	3	5

^a significant for $p < 0.05$; ^b significant for $p < 0.01$

Table 2: Teachers' responses to items of Theme 3 and the results of the Pearson correlation

Table 2 summarizes the responses of all 43 teachers' to the two items of Theme 3. Most of the teachers gave higher rates to statements associated with the instrumentalist view (P1 and Q1). Interestingly, the correlation analyses indicate that the rates to the statements of Theme 3 (about the nature of mathematics) significantly correlate to the rates to the statements of Theme 1 (about teaching and learning of mathematics) for LA classes, particularly in the instrumentalist view.

Interviews

All three teachers' reports about their beliefs of the nature of mathematics seem to be in line with their responses to the items of Theme 3 of the TBTP presented in Table 2 (all gave higher rates to both statements P1 and Q1 associated with the instrumentalist view than to the other statements).

Elisa: I often meet people who love mathematics so much. I think, I am not like that. I am amazed by people who can (...) such as (...) can understand fast, and fast in solving problems or anything. I am not, honestly, I understand slowly. So, I think, math is a collection of facts, formulas, which make me confused.

Fitria also expressed that mathematics consists of a lot of formulas and rules which are useful for solving problems and their truth is absolute. Doni also expressed that the truth of mathematics is absolute since its contents result from absolute agreements which could not be changed. He stressed that mathematics is useful for humans for solving problems and that it can be applied universally. Additionally, all three interviewees emphasized the importance of memorizing math formulas for their students. These expressions seem to indicate that they dominantly hold the instrumentalist view since they view mathematics as a toolbox consisting of utilitarian facts and rules to be used by the skillfully trained artisan in the pursuance of some external end (Ernest, 1989).

All interviewees described that they usually taught mathematics by demonstrating formulas and giving examples (in line with their responses to items of Theme 1 for LA classes, see Table 1). They spent lots of time providing many examples and often repeated their explanation to ensure that students understood mathematics. They assessed that many of their students were LA students. They argued that if their classes were dominated by HA students, they would be able to apply their ideal teaching. They believed that only HA students could discover mathematical formulas by themselves.

Doni: Ideally, teaching in HA class. In my class, the abilities are heterogenous. I tend to... just did ordinary teaching. Giving them examples (...) cases (...) basic examples.

Unlike Elisa and Fitria who rarely met HA students, Doni reported that he had a club whose members were HA students from different classes. These students were trained to follow mathematics competitions. In the club, he gave his HA students difficult math tasks taken from math competitions.

Observed Lessons

Elisa taught her students solving a geometry task in the videotaped lesson in her LA class. Before handing out the task, a non-problem (NP) segment (*a segment containing math information but no tasks/problems*) took place. The interaction during this NP segment was coded as Public (*a public dialogue conducted by the teacher and other students must listen to it*) since Elisa led students to recall some math formulas and concepts. Public interactions also dominated the interaction during the problem segment (PS, *a segment containing math tasks/problems*) since Elisa often asked her students questions to make them recall some math formulas which were useful to solve the task. If students did not recall formulas, she reminded them of the formulas. Moreover, Elisa demonstrated, slowly explained, and guided students on how to use the formulas in the observed lesson.

There was no NP segment in Fitria's lesson in her LA class. Fitria taught about the application of mathematical operation sets in the real world by giving four tasks. The interaction during the PS

segment of the first two tasks was only Public since Fitria demonstrated and explained the way to solve the two tasks. The interaction during the PS segment of the last two tasks was Private (*students individually worked on the two tasks*). However, during the Private interaction, Fitria reminded the students that they needed to refer to the way of solving the first two tasks, to be able to solve the last two. Moreover, when students got stuck, Fitria gave them mathematical clues to help them.

There was also no NP segment in Doni's lesson in his club (HA class). At the beginning of PS, Doni gave his HA students a sheet with 25 tasks. After that, he let students work individually (only Private interaction) without providing any clues to help them. After a break, Doni showed his students how to solve some of the tasks from the sheet, and the students checked their answers (Public interaction). During the show, Doni emphasized some math formulas that were important for students to memorize since the formulas were often used for solving tasks in mathematics competitions.

Discussion and Conclusion

In this study, we examine the influence of social contexts related to students' abilities in a classroom on a large number of teachers (43 teachers). The results indicate that students' abilities have an impact on the link between teachers' beliefs about mathematics and the style of teaching mathematics.

Firstly, we found that the 43 teachers report significantly different styles of teaching mathematics between HA and LA classes (Table 1), indicating that students' abilities influence teachers' beliefs and practices (Beswick, 1998; Raymond, 1997). The responses to items of Theme 1 for LA classes show that most of the participants gave high rates to both statements (R1 and S1) associated with the instrumentalist view. Interestingly, they gave low rates to both statements (R3 and S3) associated with the problem-solving view. In contrast, they rated R3 and S3 for HA classes higher than they did for LA classes. The three teachers in the further investigation believed that only HA students could discover math formulas by themselves, whereas LA students would understand mathematics slowly and should memorize mathematical formulas. Without memorizing, LA students could not solve math tasks or problems in their opinions.

However, Table 1 also indicates that teachers do not distinguish their teaching styles related to the Platonist view. The average rates of R2 and S2 are high for both HA and LA classes. This indicates that explanation is an essential part of their teaching, and generally, teachers want their students, both HA and LA students, to understand what they teach (Van de Walle et al., 2013).

Secondly, we found that 43 teachers' rates to statements about the nature of mathematics (Theme 3) correlate with their rates to statements about teaching and learning of mathematics (Theme 1) for LA classes (see Table 2), particularly on the instrumentalist view. Our further analyses with the three teachers seem to support this correlation. Table 2 indicates that those three teachers' rates about teaching and learning of mathematics for LA classes reflect what they believed about mathematics. For example, Elisa and Fitria seemed to hold the instrumentalist view dominantly. Their high rates to R1 and S1 of the TBTP for LA classes (see Table 1) seem to reflect their instrumentalist view of mathematics. Further, their descriptions of their general teaching, as well as their actual practices, also indicate the influences of the instrumentalist views since they played a role as an instructor who demonstrates skills correctly (Ernest, 1989).

In contrast, the three teachers' responses to Theme 1 for HA classes (see Table 1) which seem to be in line with their ideal teaching may not reflect their beliefs about mathematics. Although they seemed to hold the instrumentalist view, they gave low rates to R1 or S1 associated with the instrumentalist view but high rates to R3 or S3 associated with the problem-solving view. However, we still can see the impact of the instrumentalist view from the responses; e.g., Doni's high rates to S1 indicate the significance of memorizing formulas for HA students. In the observed lesson, he emphasized that his HA students should be able to memorize some formulas. This fact confirms the indication.

There are some limitations in this study. First, all three teachers in the qualitative investigation dominantly hold the instrumentalist view. Second, the characteristics of tasks used in the TBTP may not cover the complexity of teaching mathematics. For example, the task of item 1 (or item 2) only provides three statements about lesson learning a formula in the geometry topic (see Appendix), whereas, the way how teachers give their lessons in their own classes may be more complex than those three statements. Therefore, since this study is our pilot study and we plan to continue this study with larger number of teachers, we are going to add rank-then-rate items from other math topics and open questions in the TBTP. Furthermore, in the qualitative investigation, we will involve teachers from other views of mathematics (besides the instrumentalist view) in order to have better insight into the influence of students' abilities on the relationship between beliefs and practices.

References

- Beswick, K. (2018). Systems perspectives on mathematics teachers' beliefs: Illustrations from beliefs about students. In E. Bergvist, M. Österhom, C. Granberg & L. Sumpter (Eds.), *Proceedings of the 42nd Conf. of the Int. Group for the PME* (Vol. 1, pp. 3-18). Umeå, Sweden: PME.
- Buehl, M. M. & Beck, J. S. (2015). Beliefs and teachers' practices. In H. Fives & M. G. Gill (Eds.), *International Handbook of Research on Teachers' Beliefs* (pp. 66–84). Newyork: Routledge.
- Cross Francis, D. I. (2015). Dispelling the notion of inconsistencies in teachers' mathematics beliefs and practices: A 3-year case study. *Journal of Mathematics Teacher Education*, 18(2), 173-201.
- Di Martino, P. & Sabena, C. (2010). Teachers' beliefs: The problem of inconsistency with practice. In M. Pinto & T. Kawasaki (Eds.), *Proc. of the 34th Conf. of the Int. Group for the Psychology of Mathematics Education* (Vol. 2, pp. 313–320). Belo Horizonte, Brazil: PME.
- Ernest, P. (1989). The impact of beliefs on the teaching of mathematics, in P. Ernest (Ed.), *Mathematics teaching: The state of the art* (pp. 249–254). London: Falmer Press.
- Fang, Z. (1996). A review of research on teacher beliefs and practices. *Ed. Research*, 38(1), 47–65.
- McCarty, J. A. & Shrum, L. J. (1997). Measuring the importance of positive constructs: A test of alternative rating procedures. *Marketing Letters*, 8(2), 239–250.
- Philipp, R. A. (2007). Mathematics teachers' beliefs and affect. In F. K. Lester (Ed.), *Second handbook of research on mathematics teaching and learning: A project of the national council of teachers of mathematics* (pp. 257–315). Charlotte, NC: Information Age Publishing.
- Raymond, A. M. (1997). Inconsistency between a Beginning Elementary School Teacher's Mathematics Beliefs and Teaching Practice. *Journal for Research in Math. Ed.*, 28(5), 550–576.

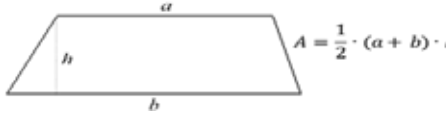
Ribeiro, M., Aslan-Tutak, F., Martignone, F., Rø, K. & Kuntze, S. (2019). *CERME11: Thematic Working Group 20 (Mathematics Teacher Knowledge, Beliefs and Identity)*. https://cerme11.org/wp-content/uploads/2018/03/TWG_20_cfp.pdf

Safrudiannur & Rott, B. (2018). The evaluation of a questionnaire for studying teachers' beliefs on their practice (TBTP). In B. Rott, G. Törner, J. Peters-Dasdemir, A. Möller, & Safrudiannur (Eds.), *Views and Beliefs in Mathematics Education: The Role of Beliefs in the Classroom* (pp. 227–238). Berlin: Springer.

Van de Walle, J. A., Bay-Williams, J. M., Lovin, L. H., & Karp, K. S. (2013). *Teaching student-centered mathematics: Developmentally appropriate instruction for Grades 6-8 (Volume III, 2nd Edition)*. Pearson Education.

Zohar, A., Degani, A., & Vaaknin, E. (2001). Teachers' beliefs about low-achieving students and higher order thinking. *Teaching and Teacher Education*, 17(4), 469-485.

Appendix

<p>General note: As a mathematics teacher, you have experience with high and low ability students in mathematics. Consider these definitions: <i>A high ability (HA) student is a student who generally shows a good understanding in your lessons and regularly has high scores in your tests.</i> <i>A low ability (LA) student is a student who generally does not show a good understanding in your lessons and often has low scores in your tests.</i></p>	
<p>Theme 1 (teaching and learning of mathematics): You are going to teach a lesson learning the formula to calculate the area of a trapezoid. Please imagine this situation to answer the items 1 to 4.</p>	
<p>Items 1 and 2*: When you have the lesson in an HA/LA class, what do you think that is important for you? R1. You demonstrate how to use the formula correctly by giving some examples (<i>the instrumentalist view</i>). R2. You explain concepts related to how to get or to prove the formula (<i>the Platonist view</i>). R3. You let your students discover the formula in their own ways (<i>the problem-solving view</i>).</p>	
<p>Items 3 and 4*: When you have the lesson in an HA/LA class, what do you think that is important for students? S1. They memorize and use the formula correctly (<i>the instrumentalist view</i>). S2. They understand the concepts underlying the formula from your explanation (<i>the Platonist view</i>). S3. They can draw logical conclusions to deduce the formula (<i>the problem-solving view</i>).</p>	
<p>Theme 2 (teaching and learning of problem solving): items 5-8, not discussed in this study.</p>	
<p>Theme 3 (the nature of mathematics): Mathematics contents taught at school can be divided into several sub-domains such as numbers, algebra, geometry, measurements, statistics, and probability. The classifications of mathematics contents, in general, are more complicated, for example, classical algebra, linear algebra, number theory, differential geometry, calculus, statistics, probability theory, etc.</p>	
<p>Item 9: In general, what do you think of the contents of mathematics? P1. Mathematics is an accumulation of facts and skills, which are useful for human life. (<i>the instrumentalist view</i>) P2. The contents are interrelated and connected within an organizational structure (<i>the Platonist view</i>). P3. Mathematics is a dynamic process of human activities. The contents of mathematics expand and change to accommodate new developments (<i>the problem-solving view</i>).</p>	
<p>Item 10: What do you think of the truth of the contents of mathematics? Q1. The truth is absolute. The contents are free of ambiguity and conflicting interpretations (<i>the instrumentalist view</i>). Q2. Mathematical ideas are pre-existing; humans just discover the contents of mathematics. Thus, the truth-value of mathematics is objective, not determined by humans (Q2, <i>the Platonist view</i>). Q3. The contents are created by human and therefore, their truth-value is also established by humans (Q3, <i>prob. sol.</i>).</p>	

* Items 1 = 2 and 3 = 4, but with different classes (1 and 3 for HA, 2 and 4 for LA classes). See Figure 1.

Secondary school preservice teachers' references to the promotion of creativity in their master's degree final projects

Alicia Sánchez¹, Vicenç Font¹ and Adriana Breda¹

¹University of Barcelona, Spain; asanchezb@ub.edu, vfont@ub.edu, adriana.breda@gmail.com

What do preservice teachers think about creativity and the ways to promote it in their classes? In this study, we analyze the references to creativity that appear in the master's degree final projects of a group of secondary school preservice teachers of mathematics. The projects hold the preservice teachers' reflections on their own practice, but it is important to note that the master's degree does not include any specific training in creativity. In our analysis, we first searched for explicit references to creativity in the projects and registered them. Then, we classified the comments depending on the elements of the teaching and learning process that are related to creativity in each case. We observe a good variety of comments and more than half of the preservice teachers mention creativity, although some of them just do it superficially.

Keywords: Preservice teachers, creativity, master's degree final project, didactic suitability.

Introduction

In recent years, creativity has become an important focus of interest of social sciences. Creativity could be related to the development of other abilities such as critical thinking, problem solving, communication and the use of new technology, current challenges in the globalized society (Pásztor, Molnár, & Csapó, 2015). In education, creativity has also gained importance and its development is a goal in modern curricula (Pásztor et al., 2015). In addition, many authors (Mann, 2006; Silver, 1997; Sriraman, 2005) claim that creativity should be fostered at school by inclusive activities, working with every student and not only with those considered gifted students. However, mathematics lessons at school are commonly associated with repetitive procedures and regardless of students' creativity.

Research on the promotion of students' creativity by improving the teachers' training (Hosseini & Watt, 2010; Panaoura & Panaoura, 2014) and research on teachers' conceptions of creativity (Lev-Zamir & Leikin, 2011) disregards the following question: how do the teachers consider the promotion of students' creativity in their learning sequences, when they do not receive specific training in this subject? In order to answer this question, in this study, we focus on how preservice teachers conceive the promotion of students' creativity when they analyze their own practice and propose some changes to improve it, in their master's degree final projects.

Theoretical framework

There are several definitions and conceptualizations of creativity (Kampylis, & Valtanen, 2010; Kaufman, & Sternberg, 2006). Kaufman and Beghetto (2009) propose a model with different types of creativity: Big-C, which refers to eminent people whose creations have had an impact on a field; little-c, which is associated with everyday creativity which appears in daily activities; Pro-C, which is present in those professional activities that are generally considered specially creative; and mini-c, which they define as "the novel and personally meaningful interpretation of experiences, actions, and events" (Beghetto & Kaufman, 2007, p.73). Mini-c creativity is related to learning processes, since it

implies a personal interpretation of new facts based on previous experiences and knowledge. In our research, we consider the development of creativity at secondary school level, so we use the term in accordance with the definition of mini-c creativity.

Then, a question emerges: how is creativity generated in a teaching and learning process? Regarding this question, the first step is assuming that creative thinking is a complex process that can be studied as a process that emerges from others, as Malaspina and Font (2010) explained with the intuitive process. These authors propose that a method to investigate complex processes is decomposing them into more simple processes and they use the metaphor of the vector space: the more complex process, creative thinking in this case, can be understood as a linear combination of the basis vectors (other processes). This approach to creativity as a process emergent from other more simple processes, was also considered in the European project *A Computational Environment to Stimulate and Enhance Creative Designs for Mathematical Creativity (MC2)* (Sala, Font, Barquero, & Giménez, 2017):

Then, when we concluded that the way to conceptualize the creative process in mathematics is decomposing it into other processes, we considered, together with the MC2 team, that the best way to go further in its study was adopting the method proposed by the Ontosemiotic Approach [Malaspina & Font (2010)] ...but introducing an important variant. Instead of using a "basis" of processes defined a priori by the theoretical framework, we would use the "basis" that would be the result of a brainstorm performed by the participants in the project ...MC2 when each of them explained what they understood by "creative process".... As a consequence, the following aspects were revealed: a) When the members ...[participants in the project] aim at determining the criteria of design and assessment, they do not directly refer to the concept of CMT [Creative Mathematical Thinking], but they consider its decomposition into different dimensions, or processes, of mathematical activity, whose integration, through task design, [participants] think that would help to develop the CMT. b) There is a shared assumption that "the mathematical creative thinking will emerge from the interaction and integration" of these different dimensions or processes (p. 4–5).

On this line, in the master's degree final project -a document where the preservice teachers propose some changes to improve their own practice-, we could expect to find: 1) comments about creativity, since enhancing creativity is usually regarded as positive; and 2) in these comments, creativity would appear as a consequence of working other aspects that improve the instructional process.

Several studies on teachers' training suggest the reflection on the own practice as a key strategy to professional development and the improvement of instruction processes. On this line, the construct of didactic suitability of the Ontosemiotic Approach (Breda, Pino-Fan, & Font, 2017) has been used as a tool to structure the teachers' reflection in some teachers' training programs in Spain, Chile, Panama, Argentina and Ecuador (Breda, Font, & Lima, 2015).

The theory of didactic suitability originates from the need to have an instructional theory to help teachers to make decisions in designing, implementing and assessing their practice. Didactic suitability (Breda et al., 2017; Sullivan, Knott, & Yang, 2015) comprise six types of suitability. The epistemic suitability deals with the quality of the mathematics that are taught, and how the explained content is representative of the complexity of the mathematical object. The cognitive suitability is

about, on the one hand, the adequacy of students' previous knowledge for learning the intended content and, on the other hand, the relation between what students should learn a priori and what they have learnt indeed after the implementation. The mediational suitability has to do with the availability of time and material resources necessary in the teaching and learning process. The interactional suitability is the effectiveness of interactions (teacher-students or between students) to identify and solve conflicts of meaning and improve students' autonomy. The affective suitability refers to the students' involvement in the teaching and learning process. Finally, the ecological suitability is the adequacy of this process to the school's educational project, the curriculum and the social environment. In order to use these criteria as an assessment tool, some observable components and characteristics are associated with each criterion. They were used in the design of a practical rubric that can be found in Breda et al. (2017). As an example, we show the components and characteristics of epistemic suitability in Table 1.

Components	Characteristics
Errors	Practices considered mathematically incorrect are not observed.
Ambiguities	Ambiguities that could confuse students are not observed; definitions and procedures are clear and correctly expressed, and adapted to the target level of education; explanations, evidence and demonstrations are suitable for the target level of education, the use of metaphors is controlled, etc.
Diversity of processes	Relevant processes in mathematical activity (modelling, argumentation, problem solving, connections, etc.) are considered in the sequence of tasks.
Representation	The partial meanings (constituted of definitions, properties, procedures, etc.), are representative samples of the complexity of the mathematical notion chosen to be taught as part of the curriculum. For one or more partial meanings, a representative sample of problems is provided. The use of different modes of expression (verbal, graphic, symbolic...), treatments and conversations amongst students are part of one or more of the constituents of partial sense.

Table 1: Components and characteristics of epistemic suitability (Breda et al., 2017, p. 1903).

In our study, we distinguish which components of the different types of suitability preservice teachers relate to creativity in their comments, while they use the criteria to analyze their own practice.

Context

The program of the master's degree in teaching in secondary school (specialization in Mathematics) includes a work placement in a secondary school divided into two periods. In the first period, that lasts two weeks, preservice teachers attend classes of their supervisors and know the group of students with which they will work later. The second period lasts six weeks, and the preservice teachers should implement a learning sequence that they have prepared. After the work placement, in the subject of

Innovation and research in Mathematics education, the didactic suitability criteria (Breda et al., 2017), with their components and characteristics, are introduced. Then, preservice teachers should use them in the analysis of the learning sequence that they implemented. The master's degree final project (MFP) includes this analysis and, based on it, the preservice teacher's proposal with some changes in the learning sequence that could help to improve the suitability of the teaching and learning process.

Research questions and method

The aim of this study is to examine preservice teachers' ideas about promotion of students' creativity, while they analyze their own practice and justify some changes of the learning sequence to improve it, in their MFP. Preservice teachers do not receive any specific training in how to develop students' creativity during the master's degree. Our research questions are: 1) Do preservice teachers frequently include comments about the promotion of creativity in their MFP? 2) Which aspects of the teaching and learning process are related to the promotion of creativity in the preservice teachers' comments?

We considered the 198 MFP from the years between 2009-2010 and 2014-2015. First, we made a register with some information of each MFP (name of the preservice teacher, year, title of the learning sequence, level). We searched for explicit references to creativity or other words of the same word family (creative, creation, creator, create) in the MFP and made a second register with only those projects that include these comments (we used a reduced list of keywords in comparison with other studies, such as the one of Joklitschke, Rott and Schindler [2018]). Registered data of these MFP include the extracts with the explicit references to creativity, as shown in Table 2.

Then, we read the MFP with references to creativity and tried to find common patterns or characteristics in the comments in order to infer a classification of comments. Since the preservice teachers use the didactic suitability criteria to structure their analysis, we also used them to distinguish aspects that are associated with the promotion of creativity in the comments. It means that, in this first phase, we used the didactic suitability criteria as previous categorization to analyze the preservice teachers' discourse. Finally, in a second phase, we classified the comments into the different categories that we had formed inductively from the data.

For example, in the MFP of Fontalba (2014) we found two explicit references to creativity (shown in Table 2). In her analysis of the implemented learning sequence, the epistemic suitability is one of the worst valued. When she analyzes this suitability, she remarks that the learning sequence should include activities that enhance creativity (first extract in Table 2). Then, in the new proposal, she adds an activity in which the students have to create their own problems (second extract in Table 2). We consider that this comment is related to the diversity of processes (a component of the epistemic suitability) and, in particular, to the process of posing problems.

Title and year	Geometry in space. 2013 - 2014
Preservice teacher's name	F.D.
Level	3 rd course of Secondary School (14-15 years old)
Branch of mathematics	Geometry
References to creativity	Yes

Number of references	2
Extract	Diversity of processes. The mathematical quality of the learning sequence could be improved and one of the key components is the diversity of processes. The student should make, should learn through trial and error, manipulation, experimentation and exploration. There is an excess of algorithmic activities, to calculate and execute procedures, therefore activities that hold curiosity, creativity, imagination and discoveries should be included. (Fontalba, 2014, p. 4)
	Competence 4. Generating mathematical questions and posing problems. Clearly, this competence is developed since the goal of the contest is the creation and resolution of problems. (Fontalba, 2014, p. 11)
Comments	She refers to the development of creativity in the assessment of epistemic suitability, and she says that the diversity of processes should increase. Then, in the new proposal, there is a task in which the students have to create problems.

Table 2: Example of the data of a MFP with some explicit references to creativity

Results

We found explicit references to creativity in 119 of the 198 MFP of the master's degree in teaching in secondary school from years between 2009-2010 and 2014-2015: in 2009-2010, 9 of 15 MFP include references to creativity; in 2010-2011, there are 16 out of 21 MFP; in 2011-2012, 20 out of 34; in 2012-2013, 14 out of 24; in 2013-2014, 25 out of 47; and in 2014-2015, 35 out of 57. In the MFP with references to creativity, we found different elements of the teaching and learning process associated with creativity. In the following lines, we describe the main categories that we distinguished and then we focus on one of them. The development of creativity is related to:

a) Tasks with notable processes (epistemic suitability). In some projects, the preservice teachers explain activities where students have to do some hypothesis, plan a resolution method, justify or put in practice other processes that are especially important while learning mathematics. In this category, we include those comments in which creativity is related to this type of activities. These preservice teachers expect to develop creativity using it to solve the activities. At the same time, epistemic suitability improves, since so does the diversity of processes, which is one of its components. 61 MFP include comments in this category.

b) The use of manipulatives and technology (mediational suitability). In this case, preservice teachers explain activities where students' creativity could be fostered by the use of computers and other material resources. Sometimes, preservice teachers do not refer to a mathematical creativity, but a plastic or artistic creativity that students practice in making a certain object that would be used in a mathematical activity later. 13 MFP include comments in this category.

c) The development of other skills that are useful in the current society (ecological suitability). In some MFP we found comments about a responsible use of creativity. Preservice teachers relate creativity to critical thinking or the development of the students' social competence. We associated these comments with the ecological suitability because they refer to some skills that are useful for living in society nowadays. 3 MFP include comments in this category.

d) Cooperative tasks (interactional suitability). In other MFP, preservice teachers explain activities in which cooperation between students plays a key role. Students' cooperation is necessary to solve the task and it would help to develop their creativity, while sharing their ideas in the resolution. 5 MFP include comments in this category.

e) The assessment procedures of the learning sequence (cognitive, interactional and affective suitability). In this category, we include the references to creativity that appear in the assessment criteria of the learning sequence or in the objectives of a certain activity that the preservice teacher proposes. Usually, in the corresponding MFP there are some changes in the assessment tools. For example, preservice teachers design new rubrics. They often oppose the traditional understanding of evaluation, proposing a competency based assessment and sharing the responsibility with the students through auto-evaluation and co-evaluation. These changes relate to several components: the learning, as a component of the cognitive suitability; the autonomy and the formative evaluation, as components of the interactional suitability; and attitudes and emotions, as components of the affective suitability. 18 MFP include comments in this category.

General comments. In some comments, we could not identify a clear connection between creativity and a particular element of the teaching and learning process, so we refer to them as general comments. In this category, there are references to the creative nature of the mathematical activity, references to the teachers' creativity when designing tasks to their students, and references to the role of creativity in the constructivism paradigm.

We observed that in 66 MFP there are more than one reference and, in some cases, several aspects of the learning sequence are related to the development of students' creativity. Most of the comments that are associated with a certain suitability criterion are in the category in which creativity is related to the diversity of processes. Therefore, we focused on this category, distinguishing different characteristics of the activities that the preservice teachers propose.

With regard to the comments in the first category, we found that in 14 MFP the development of students' creativity is associated with the resolution of problems, especially open-ended problems. Sometimes, creativity is specific to the phase of devising a plan to solve the problem. In 12 MFP, preservice teachers mention creativity when they ask the students to invent problems, think on significant contexts or create different representations. In 12 MFP, preservice teachers consider that the students' creativity can be fostered by working with real situations. 5 MFP include comments about developing creativity through project based learning. Five preservice teachers propose mathematical activities in the form of games that could enhance students' creativity. In the same category, there are some references to processes that preservice teachers relate to creativity: creation of arguments or justification (in 6 MFP), intra and interdisciplinary connections (in 5 MFP), creation of formulas and hypothesis (in 6 MFP), creation of mathematical models (in 5 MFP).

Conclusions

Even when the preservice teachers do not receive a specific training in how to promote students' creativity during the master's degree, more than half of the MFP include references to creativity. First, we conclude that a significant number of preservice teachers in our sample implicitly consider that creativity can be developed in the mathematics lessons. There seems to be an implicit general agreement on the positive effect of the development of students' creativity on mathematics learning.

Second, preservice teachers' comments evidence that creativity is a complex topic and there are different ways to understand and promote it. We observe various elements or aspects of the teaching and learning process that are somehow related to the development of creativity in the preservice teachers' comments. Note that preservice teachers not only refer to mathematical creativity, their comments cover a wide view of creativity. Categories of the classification that we present here could change and evolve with the incorporation of new results from the analysis of the MFP of the following years of the master's degree. We conclude that preservice teachers consider that creativity is something that emerges from the interaction and integration of other aspects (especially different mathematical processes).

This study can contribute with results to other research on preservice teachers' education, showing evidence of the preservice teachers' perspective on creativity and its promotion in their learning sequences, when they do not receive any specific training in how to promote students' creativity. It could be interesting to observe how specific training in fostering students' creativity would affect the analysis that preservice teachers do in their MFP. We could also consider the possibility of using more keywords related to creativity to find comments in the MFP. As Joklitschke et al. (2018) explain, there are several conceptualizations of creativity and it is important to be aware that other words could be used to describe or conceptualize creativity. Then, we should consider other words that preservice teachers could use as synonyms of creativity. On the other hand, sometimes, the use of the word "creativity" does not seem to be relevant to the meaning of the whole comment or it is ambiguous (for instance, it is not clear whether it refers to teacher's or students' creativity). A possible solution would be revising the comments and rating their validity concerning their ambiguity.

Acknowledgment

This work is part of the research project REDICE18-2000 (ICE-UB). Alicia Sánchez is funded by the grant FI 2018.

References

- Beghetto, R. A., & Kaufman, J. C. (2007). Toward a broader conception of creativity: a case for "mini-c" creativity. *Psychology of Aesthetics, Creativity, and the Arts, 1*(2), 73–79.
- Breda, A., Font, V., & Lima, V. M. R. (2015). A noção de idoneidade didática e seu uso na formação de professores de matemática. *Jornal Internacional de Estudos em Educação Matemática, 8*(2), 1–41.
- Breda, A., Pino-Fan, L., & Font, V. (2017). Meta didactic-mathematical knowledge of teachers: Criteria for the reflection and assessment on teaching practice. *EURASIA Journal of Mathematics Science and Technology Education, 13*(6), 1893–1918.

- Fontalba, D. (2014). *Treball final de màster. Millora de la unitat didàctica: Geometria en l'espai* (Unpublished master's degree final project). University of Barcelona, Spain.
- Hosseini, A., & Watt, A. (2010). The effect of a teacher professional development in facilitating students' creativity. *Educational Research and Reviews*, 5(8), 432–438.
- Joklitschke, J., Rott, B., & Schindler, M. (2018). Theories about mathematical creativity in contemporary research: A literature review. In E. Bergqvist, M. Österholm, C. Granberg, & L. Sumpter (Eds.). *Proceedings of the 42nd Conference of the International Group for the Psychology of Mathematics Education* (Vol. 3, pp. 171–178). Umeå, Sweden: PME.
- Kampylis, P. G., & Valtanen, J. (2010). Redefining creativity – Analyzing definitions, collocations, and consequences. *The Journal of Creative Behavior*, 44(3), 191–214.
- Kaufman, J. C., & Beghetto, R. A. (2009). Beyond big and little: the four C model of creativity. *Review of General Psychology*, 13(1), 1–12.
- Kaufman, J. C., & Sternberg, R. J. (2006). *The International Handbook of Creativity*. Cambridge: Cambridge University Press.
- Lev-Zamir, H. & Leikin, R. (2011). Creative mathematics teaching in the eye of the beholder: focusing on teachers' conceptions. *Research in Mathematics Education*, 13(1), 17–32.
- Malaspina, U., & Font, V. (2010). The role of intuition in the solving of optimization problems. *Educational Studies in Mathematics*, 75(1), 107–130.
- Mann, E. L. (2006). Creativity: the essence of mathematics. *Journal for the Education of the Gifted*, 30(2), 236–260.
- Panaoura, A., & Panaoura, G. (2014). Teachers' awareness of creativity in mathematical teaching and their practice. *Issues in the Undergraduate Mathematics Preparation of School Teachers*, 4, 1–11.
- Pásztor, A., Molnár, G., & Csapó, B. (2015). Technology-based assessment of creativity in educational context: the case of divergent thinking and its relation to mathematical achievement. *Thinking Skills and Creativity*, 18, 32–42.
- Sala, G., Font, V., Barquero, B., & Giménez, J. (2017). Contribución del EOS en la construcción de una herramienta de evaluación del pensamiento matemático creativo. In J. M. Contreras, P. Arteaga, G. R. Cañadas, M.M. Gea, B. Giacomone & M. M. López (Eds.). *Actas del Segundo Congreso Internacional Virtual sobre el Enfoque Ontosemiótico del Conocimiento y la Instrucción Matemáticos*. Retrieved from enfoqueontosemiotico.ugr.es/civeos.html
- Silver, E. A. (1997). Fostering creativity through instruction rich in mathematical problem solving and problem posing. *ZDM*, 29(3), 75–80.
- Sriraman, B. (2005). Are giftedness and creativity synonyms in mathematics? *The Journal of Secondary Gifted Education*, 17(1), 20–36.
- Sullivan, P., Knott, L., & Yang, Y. (2015). The relationships between task design, anticipated pedagogies, and student learning. In A. Watson & M. Ohtani (Eds.), *Task Design in Mathematics Education* (pp. 83–114). New York: Springer.

The problem of $0.999\dots$: Teachers' school-related content knowledge and their reactions to misconceptions

Verena Spratte¹, Laura Euhus² and Judith Kalinowski³

¹University of Göttingen, Germany; verena.spratte@mathematik.uni-goettingen.de

²University of Göttingen, Germany; laura.euhus1@stud.uni-goettingen.de

³University of Göttingen, Germany; judith.kalinowski@stud.uni-goettingen.de

The identity $0.999\dots=1$ connects to a variety of mathematical concepts and therefore allows for an investigation of teachers' school-related content knowledge (SRCK). This is a facet of their content knowledge (CK) that emphasizes links between school mathematics and the mathematics acquired in tertiary education. Some numerously reported misconceptions and potentially conflicting ideas on $0.999\dots$ were presented to secondary school teachers in interviews. Especially in the case of conflicting ideas the relation between SRCK and teachers' reactions as part of their pedagogical content knowledge (PCK) was examined. The results showed that SRCK, as well as CK in general, is a prerequisite to successfully applying PCK. Further they lead to a discussion of the SRCK model's use in qualitative research.

Keywords: Qualitative research, Mathematics teachers, Secondary school mathematics, SRCK, Misconceptions

Introduction

Many research projects throughout the last four decades have shown that $0.999\dots<1$ is a common misconception among students from secondary school and university, especially among pre-service mathematics teachers. Studies report that between a quarter and half of pre-service mathematics teachers agree that $0.999\dots<1$ (Bauer, 2011; Buchholtz et al., 2012). Even among those who choose $0.999\dots=1$, only a minority is able to give appropriate reasons. Among German pre-service mathematics teachers, the most common argument for equality refers to a rounding process (Buchholtz et al., 2012). According to Bauer (2011), there seems to be no difference between high school students' and pre-service teachers' answers, and Yopp, Burroughs and Lindaman (2011) suggest that this robust misconception is found among primary level in-service teachers as well.

Nevertheless, there is a need for teachers to deal with $0.999\dots$: In the federal state of Lower Saxony (Germany) the local curriculum explicitly requires that high school students after grade 10 “explicate the equality $0.999\dots=1$ as a result of an infinite process” (Niedersächsisches Kultusministerium [NK], 2015, p. 26, translated by the authors). Answering questions on $0.999\dots$ requires well-founded knowledge of its nature. The mathematical background links to notions of infinity, convergence of series and the non-uniqueness of decimal representations. The concept of school-related content knowledge (SRCK), recently introduced by Dreher, Lindmeier, Heinze, and Niemand (2018), emphasizes such links between less formal school mathematics and formal academic mathematics.

Throughout this paper, we will focus on teachers' SRCK regarding the identity $0.999\dots=1$ and their reactions to students' erroneous comments. In line with Yopp et al. (2011), Buchholtz et al. fear that

the academic knowledge in this field [0.999..., authors' remark] is not active, and so no substantial link between university and school mathematics can be made. (Buchholtz et al., 2012, p.116)

In that case, the high potential of cognitive conflicts that is intrinsic in this identity could be left unused: Teachers' deep understanding of the topic is necessary for successful teaching towards conceptual changes (Scott, Asoko, & Driver, 1991; Tall & Vinner, 1981). If it is missing, "teachers have the potential of undermining student understanding of important concepts" (Yopp et al., 2011, p. 313). To our knowledge, there is neither a study addressing in-service secondary school teachers' understanding of 0.999... nor addressing their teaching practices regarding that topic. This paper tries to step into the gap by an explorative interview study with eight in-service mathematics teachers from secondary schools.

Theoretical background

Recently, Dreher et al. (2018) conceptualized problems around the old question of which knowledge is necessary for teachers with a new model of teacher knowledge emphasizing links between school mathematics and related university concepts. Their model refines Shulman's taxonomy as sketched in Figure 1. Dreher et al. (2018) split content knowledge (CK) into formal academic mathematics and more intuitive school mathematics.

In the German context, those two areas are linked by the secondary schools' curriculum, in which "fundamental ideas" (Dreher et al., 2018, p. 326; Kuntze et al., 2011) represent the structure of academic mathematics in school. They organize the curriculum's content and are revised by the students throughout the grades in a spiraled structure: Under the idea of "Numbers", Number systems develop from natural (grade 4) to nonnegative rational (grade 6) to rational (grade 8) to real numbers (grade 10). "Functions" start in verbal descriptions of dependencies (grade 6) and continue over tabular, graphical and formal descriptions of simple functions (grade 8) to more and more complicated ones (NK, 2015).

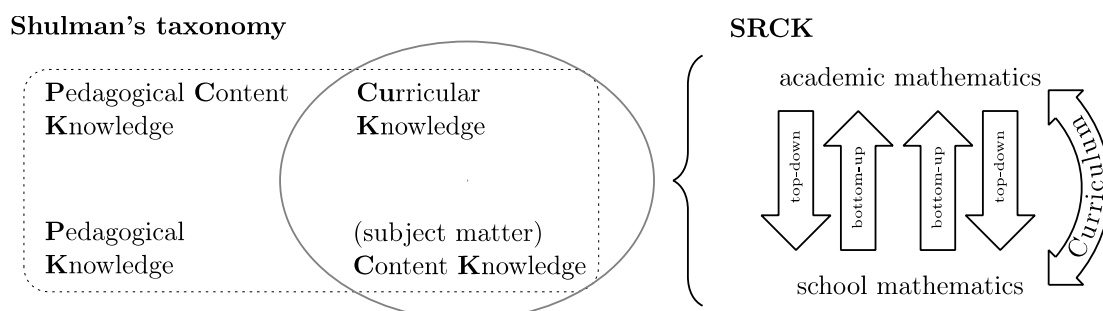


Figure 1: Model of secondary school teachers' knowledge (inspired by Dreher et al., 2018, p. 330)

In addition to curricular links between mathematics at school and in academics, Dreher et al. (2018) consider top-down relations – for example, during lesson planning, when teachers break down their academic knowledge to school level – and bottom-up relations that e.g. link students' "creative questions and answers" (Dreher et al., 2018, p. 328) to underlying mathematical concepts. Basing the links in teaching situations and the curriculum, the SRCK model is strongly related to the classroom. The representation of academic mathematics in the curriculum leads us to understand curricular knowledge as part of SRCK.

Dreher et al. (2018) assessed SRCK using a questionnaire and showed that the concept is empirically separable from general CK and from PCK. Yet they left it open to identify cognitive processes of SRCK as well as how to identify them in qualitative ways. As we will see, the identity $0.999\dots=1$ inherits a broad variety of connections to academic mathematics. Therefore, analyzing the mathematics in teachers' reactions to students' responses on this topic seems a suitable way to observe SRCK. As students' erroneous statements are clearly part of PCK (Chick & Baker, 2005), this approach needs to separate knowledge about misconceptions from knowledge about the mathematics behind. We think that this is possible and, even more so, that the reactions to misconceptions linked to big ideas of mathematics reveal both SRCK and PCK and allow insight into their connections (Kuntze et al., 2011). So far, it seems that on the one hand the width and depth of CK predetermine how teachers implement their PCK in the classroom. On the other hand, without PCK, CK cannot be applied at all (Baumert & Kunter, 2013).

The identity of $0.999\dots=1$ in academic mathematics and school mathematics

The mathematical symbol $0.999\dots$ has a variety of meanings: It is a recurring decimal number as well as a sequence of finite decimals or of partial sums (in the dynamic sense of Weigand (2016)) or the limit of this sequence (in the static sense of Weigand (2016)) and a geometric series. These meanings cannot be clearly separated and may occur simultaneously (Bauer, 2011).

In school, $0.999\dots$ is first met when working on decimal representations for fractions, which is one of the early experiences of infinity (Gardiner, 1985). Generalizing procedures like subtracting from finite decimals to their infinite counterparts at this stage happens unquestioned and is often used to show that $0.999\dots=1$ (Bauer, 2011; Eisenmann, 2008). Yet Eisenmann (2008) points out that, for secondary school students, the decimal $0.999\dots$ is very different from $0.111\dots$ in its nature, as the latter one appears as a result of the (illegitimate but widely spread) written division algorithm for $1:9$. Never may $0.999\dots$ be constructed as a result of $1:1$, $2:2$ etc., which might cause the doubts about $0.999\dots=1$, as reported in the introduction. Other reasons for the widely spread misconception that $0.999\dots<1$ might be found in the language of limits, where terms like "approach" mislead to "but never reaches", or in the understanding of decimal expansions, including the representation's non-uniqueness (Tall & Vinner, 1981; Weller, Arnon, Dubinsky, 2009).

In academic mathematics, the interpretation of $0.999\dots$ as the limit of a geometric series is the most present one (Buchholtz et al., 2012). Thus, the question why $0.999\dots=1$ is related to the topology of the real numbers and in nonstandard analysis is no longer true (Richman, 1999). In standard analysis, proving $0.999\dots=1$ requires an understanding of converging sequences and series, including links to the big idea of "dealing with infinity" (Kuntze et al., 2011).

Teachers' reactions to cognitive conflicts

Secondary school students might know from the introduction of decimal numbers in grade 6 that $0.999\dots=1$. This can later contrast their concept image of convergence of the series $0.999\dots$ towards 1, as it is reported in some students' answers in Bauer (2011):

Mathematically it is 1, nevertheless I think there is always something remaining, even if it is however small. (Bauer, 2011, p. 90, translated by the authors)

Here, the student openly presents what Tall and Vinner (1981) call “potential conflict factors”: His concept image does not allow a limit to be actually reached, which leads to $0.999\dots < 1$ (Tall & Vinner, 1981). This is closely related to a dynamic limit concept emphasizing potential and neglecting actual infinity (Weigand, 2016). Yet the student knows and states the mathematically correct answer. Though it cannot be seen from the quote whether he feels the conflict and a need to settle it, the potential for a cognitive conflict is evident. Despite a number of publications on how to evoke cognitive conflicts in the classroom, much less seems to be known on how teachers can help their students overcome them (Scott et al., 1991).

Research questions and study design

The large number of possible connections from $0.999\dots$ to academic mathematics and the lack of knowledge about teachers’ reactions to cognitive conflicts leads to three research questions: How do secondary school teachers react when students bring up misconceptions or potentially conflicting factors concerning the identity $0.999\dots = 1$? How do they refer to academic mathematics in their answers? And how do the reactions and the academic knowledge shown relate to each other?

In this explorative study, we report on interviews with eight teachers from different secondary schools in Lower Saxony. According to the curriculum (NK, 2015, pp. 26 and 58), all participants were expected to have experience in teaching $0.999\dots = 1$. The interviews were conducted in an eased situation without any time pressure. First the teachers were asked about their contact with the topic in school. Then student’s response A (see Figure 2, responses taken from Bauer (2011)) was handed out in printed form. The participants were asked to comment on it and to explain how they would react. Then student’s response B – containing potential conflict factors as the quote above – was treated the same way. Finally, the teachers were asked to comment on a quote by Gardiner (1985; see Figure 2), especially on difficulties in putting his suggestion into practice.

<p>Instead of $0.99999\dots$ (and so forth) we also write $0.\bar{9}$. Which of the following statements is true? Tick and give a reason.</p> <p><input type="checkbox"/> $0.\bar{9} < 1$ <input type="checkbox"/> $0.\bar{9} = 1$ <input type="checkbox"/> $0.\bar{9} > 1$</p>	<p>Student's response A:</p> <p>$0.\bar{9}$ is unimaginably close to 1, but never reaches 1</p>	<p>Student's response B:</p> <p>Mathematically, $0.\bar{9} = 9/9 = 1$. But as you can put infinitely many digits of 9 behind, this number is always smaller than 1.</p>	<p>Quotation from Gardiner (1985), University of Warwick:</p> <p>No sensitive teacher would try to banish such ideas [misconceptions]: they are the raw material on which we must build.</p>
--	--	--	--

Figure 2: Material given to the teachers (translated by the authors unless originally English)

The interviews were recorded, fully transcribed and analyzed using an inductive qualitative content analysis (Mayring, 2015). The transcripts were coded openly in two separate rounds: first for any eye-catching differences and for teachers’ reactions, second with focus on SRCK. In both rounds, the relevant teachers’ phrases were paraphrased in a common linguistic style. Then the paraphrases were shortened and rewritten more abstractly to receive possible categories. Those were unified and reduced to the most important categories, which were finally sorted into dimensions. In both rounds, coding manuals were written and given to an independent analyzer who recoded all transcripts. In cases of diverging ratings, consensus was reached. If necessary, examples were added to the manual or categories were renamed carefully.

Results

Tables 1-3 show most of the categories found in the material in the left column. On the right, they provide the results of the rating. Dimensions are written in bold text, categories normally.

Teachers' SRCK on 0.999...

From the broad range of links to academic mathematics, only a few were actually made by the teachers. All of them understood $0.999\dots$ as a limit process in the dynamic sense. Only two teachers showed understanding of a static limit concept as well. Surprisingly, no teacher referred to a geometric series. Probably they had in mind that series are not taught in Lower Saxony schools.

Table 1: SRCK dimensions shown by the teachers

	T1	T2	T3	T4	T5	T6	T7	T8
Nature of 0.999...								
is an object different from 1				X	X			X
is a different representation for the same number as 1	X						X	X
is a dynamic limit	X	X	X	X	X	X	X	X
is a static limit	X					X		
The identity $0.999\dots=1$								
knows proof(s) for the identity	X		X	X			X	X
understands the presented proof	X	X		X		X	X	X
doubts the presented proof			X		X			X
... is a definition								X
... is the result of a rounding process					X		X	
... does not hold					X			

One teacher denied that $0.999\dots=1$ and one read the equality as a definition. Both of them saw no need in spending much time on the students' responses. Further, two teachers referred to rounding. Five teachers knew a proof for $0.999\dots=1$, four of them using $0.999\dots=9/9=1$ or $0.999\dots=3/3=1$ and one subtracting $0.999\dots$ from 1. All of them applied techniques from finite decimal representations to infinite ones without justification. Three teachers doubted student B's claim that $0.999\dots=9/9$, though two of them claimed that $0.999\dots=3/3$. Teacher T8 later accepted the equality.

Reactions to the students' responses

	T1	T2	T3	T4	T5	T6	T7	T8
Dealing with student A's answer								
link to underlying concepts			X	X				
arithmetical proofs	X	X	X	X		X	X	
correcting the fact		X					X	X
ignore							X	X
no specific reaction mentioned					X		X	X
Dealing with student B's answer								
link to underlying concepts	X		X			X	X	
arithmetical proofs		X		X		X		
no specific reaction mentioned					X			X

Table 2: Teachers' reactions to both students' answers (shortened by non occurring)

Inductively, we found five categories of teachers' reactions that applied to reactions on both students' responses. Most of the teachers responded to student's response A by showing an arithmetical proof for $0.999\dots=1$. Only two teachers went beyond by stressing notions of infinity or the static limit concept. Three pointed out the importance of correcting the student so that he would not memorize something wrong. The fourth reaction was to ignore, which two of the teachers intended. Teacher T7 named a broad variety of strategies depending on the students' grade.

As we comment on the teachers' reactions to student's response B, it should be noted that not all teachers noticed the conflicting factors in it (see Table 3). Only two teachers clearly named them. Both reacted by stressing the decimal representations' non-uniqueness; especially, they changed their approach compared to how they dealt with response A.

	T1	T2	T3	T4	T5	T6	T7	T8
Contact with $0.999\dots=1$ in school	sometimes	never	often	often	sometimes	rarely	-	rarely
Noticed the potential conflict factors	fully	no	no	partially	no	partially	fully	partially

Table 3: Further four dimensions in teachers' responses

Three teachers felt some conflict in the student's text but could not make sense of it. Some claimed that the student B had already disproved himself. Two of them (and another teacher who did not see any conflict at all) indicated that stressing the proof again should convince the student that $0.999\dots=1$. One wanted to use the proof to focus on a static limit concept, thus falling into both categories *link to underlying concepts* and *arithmetical proof*. Another link was made to the notion of infinity.

Discussion

Regarding to our first two research questions, we need to conclude: Even though the topic of $0.999\dots$ offers many possible links to academic knowledge, only the two concepts of non-unique representation and static limits were actually, and rarely, named by this study's participants. Further, several teachers' answers showed inconsistencies in their SRCK: One teacher claimed that $0.999\dots$ and 1 are two representations for the same number and nevertheless referred to the process as rounding. Some claimed that $0.999\dots=3/3$ but would not equal $9/9$. This strengthens our doubts about the teachers' access to academic mathematical knowledge, though all successfully finished at least two semesters of advanced mathematics at university. It especially raises the question on how to teach those links between school and academic mathematics to (pre- and in-service) teachers. An example of model-based task design for teacher education is given in Montes, Climent, Carillo, and Contreras (2019) in these proceedings; adopting this approach to the SRCK-model seems fruitful for both evaluating the task design process and improving teacher education programs.

In general, the teachers tend to respond to the misconception $0.999\dots<1$ by showing an arithmetic proof. Some of them believed so much in the convincing power of proofs that they reacted to student B by restating and emphasizing the proof the student had already given. Only two participants fully recognized the potential conflict in student's response B; their common way of reacting was to establish a link to the decimal representations' non-uniqueness.

Linking SRCK to the teachers' reactions

Except for T8, all teachers who showed at least one link to academic mathematics in their SRCK chose to talk about underlying concepts when confronted with the conflicting factors. This suggests that SRCK provides a most convenient way to react to cognitive conflicts, and thereby – as already known for CK in general – is a preliminary to successfully applying PCK (Baumert & Kunter, 2013). Yet in T3, we found a teacher who focused on the very general topic of (actual) infinity, thus establishing a link to one of the big ideas in mathematics (Kuntze et al., 2011) without showing much academic knowledge on $0.999\dots=1$.

Teachers who have more contact with the topic 0.999... in school more often relate it to underlying concepts. Whether experience mediates between SRCK and the reactions shown (Yopp et al., 2011) or whether teachers with higher SRCK spend more time and effort on 0.999... and thus gain more experience, cannot be answered from the data. Similarly, fully noticing the cognitive conflict seems to be linked to an approach of relating to underlying concepts as well as linked to high SRCK.

Using the SRCK model in qualitative research

In our study, we used the SRCK model and qualitative content analysis to create detailed, comparable insight into teachers' knowledge. Yet the identity $0.999...=1$ reveals boundaries of the distinction between academic and school mathematics: NK (2015) requires understanding limit processes without ever mentioning infinity. So does understanding infinity belong mainly to school or to academic mathematics? In the first case, the reactions of T3 that linked to this notion could form a new category *horizontal links within school mathematics*, whereas the other links are *vertical links to academic concepts*. This distinction would also foster independence of the curricular – hence cultural – background of our study: All mathematical links could be recorded before splitting them into horizontal and vertical ones depending on the local curriculum. This opens the door to an international curriculum-sensitive, yet comparable approach to SRCK.

Inductively developing dimensions brought to light some aspects of beliefs, for example, on the functions and nature of proofs. In subsequent studies, a multilayer model of teachers' knowledge including convictions – as suggested by Kuntze et al. (2011) – should be taken into account. Furthermore, studies like ours may help understand which of the many possible links from the curricular content to underlying concepts are a substantial part of SRCK in teachers' opinions.

The dimensions and categories developed for teachers' reactions allowed a clear distinction with broad consensus among all analyzers. In studies of a larger sample, they should be refined; especially, questions on their impact on students' learning and on their adequacy throughout different school grades arise.

References

- Bauer, L. (2011). Mathematik, Intuition, Formalisierung: Eine Untersuchung von Schülerinnen- und Schülervorstellungen zu 0,9. [Mathematics, intuition, formalization: A study of students' conceptions of 0.999...] *Journal für Mathematik-Didaktik*, 32, 79–102. doi:10.1007/s13138-010-0024-9
- Baumert, J. & Kunter, M. (2013). The effect of content knowledge and pedagogical content knowledge on instructional quality and student achievement. In M. Kunter, J. Baumert, W. Blum, U. Klusmann, S. Krauss, & M. Neubrand (Eds.), *Cognitive activation in the mathematics classroom and professional competence of teachers: Results from the COACTIV project* (pp. 175–206). New York: Springer.
- Buchholtz, N., Leung, F. K. S., Ding, L., Kaiser, G., Park, K., & Schwarz, B. (2012). Future mathematics teachers' professional knowledge of elementary mathematics from an advanced standpoint. *ZDM Mathematics Education*, 45, 107–120. doi:10.1007/s11858-012-0462-6

- Chick, H.L. & Baker, M.K. (2005). Investigating teachers' responses to student misconceptions. In H.L. Chick & J.L. Vincent (Eds.), *Proceedings of the 29th Conference of the International Group for the Psychology of Mathematics Education*: (Vol. 2, pp. 249–256). Melbourne: PME.
- Dreher, A., Lindmeier, A., Heinze, A., & Niemand, C. (2018). What kind of content knowledge do secondary mathematics teachers need? *Journal für Mathematik-Didaktik*, 39, 319–341. doi:10.1007/s13138-018-0127-2
- Eisenmann, P. (2008). Why is it not true that $0.999... < 1$? *The Teaching of Mathematics*, 11, 35–40.
- Gardiner, T. (1985). Infinite processes in elementary mathematics. How much should we tell the children? *The Mathematical Gazette*, 69(448), 77–87. doi:10.2307/3616921
- Kuntze, S., Lerman, S., Murphy, B., Kurz-Milcke, E., Siller, H.-S., & Winbourne, P. (2011, February). *Professional knowledge related to big ideas in mathematics. An empirical study with pre-service teachers*. Paper presented at CERME7, Rzeszów, Poland.
- Mayring, P. (2015). Qualitative content analysis: Theoretical background and procedures. In A. Birkner-Ahsbahs, C. Knipping, & N. Presmeg (Eds.), *Approaches to qualitative research in mathematics education: Examples of methodology and methods* (pp. 365–380). Dordrecht: Springer.
- Montes, M., Climent, N., Carrillo, J., & Contreras, L.C. (2019). *Constructing tasks for primary teacher education from the perspective of Mathematics Teachers' Specialized Knowledge*. Paper presented in TWG20 at CERME11, Utrecht, Netherlands.
- Niedersächsisches Kultusministerium (2015). *Kerncurriculum für das Gymnasium: Schuljahrgänge 5-10. Mathematik*. [Core curriculum for secondary schools: Grades 5-10. Mathematics.] Retrieved from http://db2.nibis.de/1db/cuvo/datei/ma_gym_si_kc_druck.pdf
- Richman, F. (1999). Is $0.999... = 1$? *Mathematics Magazine*, 72, 396–400.
- Scott, P.H., Asoko, H.M., & Driver, R.H. (1991). Teaching for conceptual change: A review of strategies. Retrieved from <https://www.univie.ac.at/pluslucis/Archiv/ICPE/C5.html>
- Tall, D. & Vinner, S. (1981). Concept image and concept definition in mathematics with particular reference to limits and continuity. *Educational Studies in Mathematics*, 12, 151–169. doi:10.1007/BF00305619
- Weigand, H.-G. (2016). Zur Entwicklung des Grenzwertbegriffs unter stoffdidaktischer Perspektive. [On the development of the limit concept from the subject matter didactical perspective] *Mathematische Semesterberichte*, 63, 135–154. doi: 10.1007/s00591-016-0161-4
- Weller, K., Arnon, I., & Dubinsky, E. (2009). Preservice teachers' understanding of the relation between a fraction or integer and its decimal expansion. *Canadian Journal of Science, Mathematics and Technology Education*, 9, 5–28. doi:10.1080/14926150902817381
- Yopp, D.A., Burroughs, E.A., & Lindaman, B.J. (2011). Why it is important for in-service elementary mathematics teachers to understand the equality $.999... = 1$. *Journal of Mathematical Behavior* 30(4), 304–318. doi:10.1016/j.jmathb.2011.07.007

“In school you notice the performance gap and how different it is between the students” – Student teachers’ collective orientations about the learners’ heterogeneity in mathematics

Ann-Kristin Tewes¹, Elisa Bitterlich¹, Judith Jung¹

¹Technical University Dresden, Germany, ann-kristin.tewes@tu-dresden.de

Collective orientations about the heterogeneity of the learners emerge on the basis of experiences that are unique to the individual, but in many ways structurally similar. Guided by the assumption that collective orientations significantly influence the practice of (student) teachers, our goal is to reconstruct (student) teachers’ ways of thinking in the context of heterogeneous learning groups in mathematics education using the documentary method. In the data of the project HeLeA¹, it became apparent that one main focus of the group discussions was the variety of student performance. The differences in the achievement of the students, especially in mathematics, seem to be a great challenge for student teachers. Furthermore, there are discontinuities between the everyday discourse of student teachers and the academic discourse on the topic of heterogeneity.

Keywords: Heterogeneity, group discussion, teacher beliefs, collective orientation, teacher education.

Introduction

Heterogeneity is a central term of current debates regarding education and school system in Germany. In the educational context, it is associated with various categories of difference such as language, culture, gender or (dis)ability, and it is perceived to express “difference as a challenge to be dealt with actively” (Sliwka, 2010, p. 213). In Germany, discussions on heterogeneity in classrooms have recently been stimulated by educational policies like the ratification of the UN Convention on the Rights of Persons with Disabilities and social and demographic changes, e.g. increased linguistic-cultural differences because of a higher number of children with an immigrant background (Decristan et al., 2017). Due to changes in the main areas of attention – which are mostly oriented towards current political and social debates – different facets of heterogeneity and difference have been at the centre of focus (for some periods) lately. The impetus for a renewed focus on heterogeneity in Germany has been provided by the results of international comparison studies – in particular PISA, 2000/2009 (Klieme et al., 2010) – which have highlighted especially the sizeable differentiation in student achievement, the alarmingly high number of very low-achieving pupils, and a close relationship between social background and academic success (Döbert et al., 2004; Trautmann & Wischer, 2011).

¹ “Heterogeneity in teacher education from the start” (Heterogenität in der Lehrerbildung von Anfang an – HeLeA) is a sub-project of “TUD-SYLBBER” which is part of the “Qualitätsoffensive Lehrerbildung”, a joint initiative of the Federal Government and the Länder which aims to improve the quality of teacher training. The programme is funded by the Federal Ministry of Education and Research. The authors are responsible for the content of this publication.

The HeLeA project addresses this central debate about heterogeneity. The main assumptions of the project are that teachers' and student teachers' orientations, knowledge and attitudes play an important role in creating effective learning environments for all learners and in the development of an inclusive school that considers the learners' heterogeneity as something positive and normal (Booth, 2011; Reynolds, 2001). The quality of education depends to a high degree on the teaching staff, who play a key role in preparing their learners to take their place in society (Savolainen, 2009). Through qualitative (group discussion) and quantitative methods (questionnaire), the project aims at the reconstruction of student teachers' ways of thinking, speaking and feeling concerning the heterogeneity of learners in school, especially in mathematics. On the basis of the survey results, the project intends to design concepts for the education of student teachers in order to sensitize them to different facets of heterogeneity. The goal is to prepare them for encountering heterogeneity among their prospective pupils and to equip them with approaches for dealing with it in mathematics and also other school subjects. In this article, the focus is on the qualitative approach from HeLeA, as it provides interesting and emotional insights into the current state of teachers' opinions. Based on group discussions with high school mathematics students, the focus of this paper is on: "What collective orientations about the learners' heterogeneity in mathematics do student teachers have?"

Theoretical background

The pedagogical discourse indicates multiple unresolved problems, and there is some criticism of previous approaches dealing with heterogeneity in school, like the homogenisation of learning groups through selection and forms of external differentiation (Trautmann & Wischer, 2011). At the same time, however, there is no lack of existing ideas and concepts for improving these approaches. Didactic-methodological concepts for internal differentiation have been discussed since the 1970s (Sliwka, 2010; Trautmann & Wischer, 2011). Strikingly, however, for most student and practising teachers the question of how to deal with heterogeneity nevertheless represents an important problem area in planning and teaching lessons. Schönknecht and de Boer (2008) point out that in describing heterogeneity, student teachers often seem influenced by polarisations and dichotomisations, as well as a limited perspective focusing on supposed "problem children". Many studies emphasise the individual and personal views of teachers and student teachers about heterogeneity (cf. Bitterlich & Jung, 2019). Most of these studies focus on teachers' beliefs and stereotypes² (Winheller, Müller, Hüpping, Rendtorff & Büker, 2012; Zobrist 2012). We focus on student teachers' collectively shared orientations concerning the learners' heterogeneity. In contrast to studies about teachers' and student teachers' beliefs and stereotype-threat, studies about collective orientations reconstruct those experiences and types of knowledge that can be considered as shared within the group of teachers. In this regard, collective orientations could be seen as "socially-agreed-upon knowledge base [...]. The

² Following Allport (1954), stereotypes – "the pictures in our head" – simplify our thinking and produce expectations about what other people are like and how they are likely to behave. In this sense, based on prior information (e.g. a student's test scores, social class, gender, ethnicity, race) a teacher develops expectations about the ability of the learner. Similar to this, beliefs are representative bits of information that a person has about an object, person or group of individuals based on certain facts or personal opinions (Ajzen & Fishbein, 1980).

key assumption behind them is that the members of the respective groups share a more or less common experience of enculturation into these groups” (Gellert, 2008).

Following Mannheim (1982), teachers tend to have the same or similar experiences and opinions because they belong to a ‘conjunctive space of experience’ (*konjunktiver Erfahrungsraum*).

Those who have biographic experience in common, have commonalities in their history of socialization and, thus, have a common or conjunctive experiential space, understand each other immediately insofar as these biographical commonalities become relevant in interaction and discourse. (Bohnsack, 2010, p. 105)

Teachers as well as student teachers represent a professional group whose conjunctive experiences materialise, on the one hand, via practical experience and, on the other hand, via conceptual-theoretical involvement with teaching and the didactic handling of heterogeneity (Sturm, 2012). The interweaving, or double structure, of their conceptual-theoretical conjunctive space of experience based on their own practical experiences, allows their participation in the social practice of teaching, and indeed creates it (Bohnsack, 2017).

In this context, Gellert (2008) emphasises that teaching should be perceived as a cultural practice that takes place in communities rather than an individual and independent practice that takes place in isolation behind closed classroom doors. In his findings, he emphasizes that the mathematics primary school teachers’ collective orientations about their own professional development sometimes work as obstacles against development. “Mutual validation can turn experience into law. [...] Collective teaching experience can be blind to alternative conceptions of teaching” (Gellert, 2008). Schieferdecker (2016) carried out group discussions with several groups of teachers about heterogeneity in society. The focus of his research is on the reconstruction of collective orientation patterns of teachers that can contribute to a broader understanding of the perception and management of heterogeneity in the educational practice of teachers. In this regard, the aim is to identify structures (which he assumes to be collectively shared) that teachers use in order to cope with the notions of social heterogeneity and heterogeneity in pedagogical practice. He reconstructs a tension between the conception of feasibility and the experience of powerlessness. On the one hand, teachers see themselves as solely responsible for the learning success of their students. On the other hand, they fail to ‘pick up every student where he or she stands’. But the reasons for their failure are suspected outside school (e.g. with parents). Even experienced teachers tend to see learners’ heterogeneity as a problem of increasing complexity which complicates successful teaching processes. To handle learners’ heterogeneity, teachers – and this is something that is collectively shared – homogenise them and create polarisations (e.g. high- and low-achieving learners) (Schieferdecker, 2016).

The aim of this paper is to reconstruct the collective orientations of student teachers in relation to mathematics. The performance heterogeneity³ of the students is of great importance in Germany, as the school system aims for homogenisation (Trautmann & Wischer, 2011). We therefore believe that

³ Helmke and Weinert (1997) point out, that in addition to subject-related and teaching aspects, the individual characteristics of the pupils, e.g. language, intelligence and learning strategies are of great relevance to the students’ performance (Helmke & Weinert, 1997).

the factor of performance differences in mathematics is particularly important to student teachers when talking about their experience in teaching math and when reflecting their own teacher education. We suspect that in a subject such as mathematics, the differences in performance become particularly clear. In this context, Thompson (1992) describes that American teachers consider mathematics as something static that contains a set of rules and procedures. To teach mathematics and to get a correct result, these have to be used, no matter if they have been understood. Since mathematics is often considered as a subject with ‘clear answers’, formal procedures and easily comparable results, student teachers might hold the (collective) orientation that especially in mathematics differences in achievement are more noticeable and with a higher weight than, e.g., in language-based subjects where different opportunities exist to express something or to write an essay.

Methodology and procedures

One way to access collective and action-leading orientations of prospective teachers is through group discussions (e.g. Przyborski & Wohlrab-Sahr, 2014). Group discussions can help to identify and analyse the implicit or tacit knowledge of the participants while they talk about a specific topic (e.g. heterogeneity). The self-dynamic of the discussion process, without any interruptions by the researcher, is important to discover conjunctive spaces of experience, which become visible through ‘focusing metaphors’ in which the group adjusts itself to those specific topics that are most relevant in its members’ common experience (Bohnsack, 2010).

Concerning group discussions, the immanent meaning comprises that stock of knowledge which is made explicit by the participants themselves. This has to be distinguished from knowledge of experience, which is so much taken for granted by the participants that it must not and often cannot be made explicit by themselves. The participants understand each other because they hold common knowledge without any need to explicate it for each other. (Bohnsack, 2010, p.103)

The documentary method is a suitable method to analyse data from group discussions to identify and reconstruct collective experiences and common (used) ways of acting (Weller & Malheiros da Silva, 2011). In the identification, description and reconstruction of the (future) teachers’ collective perceptions, we see one possible way to gain an impression of the current perspectives of teachers and student teachers on dealing with the learners’ heterogeneity, especially in mathematics.

The documentary method offers [...] an access to the pre-reflexive or tacit knowledge, which is implied in the practice of action. Asking for the documentary meaning can [...] be understood as asking for *how*: how is practice produced or accomplished. (Bohnsack, 2010, p. 103)

So far, six group discussions have been held during which teacher students spoke about the general question: What kind of experiences have you made concerning the difference of learners in school and in class? The groups were homogeneous in terms of the participants’ school type. In each discussion, between four and seven student teachers spoke together for around one hour about their experiences in dealing with heterogeneity in the school context. Each discussion was video recorded and transcribed. This paper focusses on statements on the performance heterogeneity of students in relation to mathematics. We compare transcript scenes from two different group discussions (number two and four), because there the student teachers are from the same school type (high school) and all are teaching mathematics. As we described above, the teachers, in our case mathematic high school

teachers, tend to have the same or similar experiences and opinions. Because of their academic background they belong to a ‘conjunctive space of experience’. To answer the research question “What collective orientations about the learners’ heterogeneity in mathematics do student teachers have?” the scenes are analysed with a reflective interpretation. Within the framework of the documentary method, the stage of reflective interpretation is particularly promising for the identification and reconstruction of the ‘conjunctive space of experience’ (Mannheim, 1982).

Results

From the very beginning of both group discussions, the focus was less on education in general than on mathematics, as the student teachers seem to have a ‘conjunctive space of experience’ concerning this topic. Differences in the learners’ achievement was a meaningful aspect of the discussion. Following the research question, we could identify the collective orientation that, especially in mathematics, performance differences are visible and challenging. We will illustrate this by showing short transcript extracts of group discussion number two and four, each followed by a brief analysis of the scene.

Group number two

Wiebke: I think in school you notice the performance gap and how different it is between the students. I think, especially in the subject math you always have these, [laughs] that are bomb in math and those, who do not understand it at all. To arrange the lessons in a way that all can somehow follow or are not under-challenged is quite difficult.

Natalie: Yes. What is also always a topic are differentiated tasks, in a way, that either the tasks get more difficult in the end or the top-performing pupils get more tasks. And at the beginning the easier tasks. That is also addressed in teacher education. And also, that you should have extra tasks for those who are faster so they still have something to do or talk about. That happens all the time.

Wiebke: But I think it is only about these differentiated tasks and for the faster pupil new tasks. I had a seminar, not in math but in English, where another heterogeneity, like language differences, was mentioned. And this could be transferred to math. Maybe a child is super good at math but just does not understand what's in the task. I think, you don't learn anything about this at university.

The first reaction on the impulse of the discussion concerned the differences in the learners’ performance. Wiebke argues, that in mathematics there are ‘always’ pupil who are extremely high achieving, what she illustrates with the metaphor of a bomb (which is a common expression in Germany) while there is also ‘always’ a group of pupils who do not understand mathematics at all. Through this dichotomous distinction, she describes from personal experience that it is ‘quite difficult’ to arrange lessons. The metaphorical use of ‘bomb’ for something exploding and powerful illustrates that such ‘bomb’ students are not necessarily considered by her as something positive. Natalie seems to understand Wiebke and argues that in university they ‘always’ heard something about how to use differentiated tasks and how to make sure they work. This could be seen as something positive. But in contrast to Natalie, Wiebke is not satisfied with this one-sided preparation

with the focus on achievement and tasks. In her opinion, it is also important to ‘learn’ something about other facets of heterogeneity, like language differences, which she emphasizes with the comparison to her studies in English. She notes that it is important for students to understand the tasks in order to solve them because linguistic competences are often needed to show mathematics performance. But her claim, to learn ‘nothing’ about this in university, could also be seen as an exaggeration.

Group number four

Konrad: Especially during internships, I have seen great differences in the performance and skills. When you walk around during times of individual work, you could really see what the student is currently thinking about the task. As trainee that is usually very noticeable because you do not stand in front of the class but you help students in the back or walk around during individual work.

Niklas: Yes, I also noticed that. Either in middle school or in ‘pure’ high school classes. In one such pure high school it was such a monotony and all students were well-mannered and from suburban areas and tagged along even during the worst lessons. But even there you recognized achievement differences in mathematics like in middle school classes. Even in urban areas you have the same differences.

As in group discussion two, in discussion number four the reaction on the impulse for the discussion is about differences in achievement. Konrad's statement shows, that it seems easier to ‘see’ the learner’s heterogeneity when you are not the person teaching in front of the class. Konrad seems to protect teachers as they are not able to ‘see’ differences when they have to concentrate on the lesson itself. Perhaps, he himself also made the experience of not being able to perceive so many achievement differences and to adequately respond to them when teaching himself. Niklas enlarges this topic by comparing different types of school and different environments. Either in (lower-achieving) middle school classes or in (higher-achieving) ‘pure’ high school classes, he claims that in mathematics the same differences in achievement exist. This also applies for urban and suburban areas. He points out one class of well-mannered students, which is a ‘pure’ high school class in a suburban area, which tolerates even the worst and most boring lessons.

Discussion

Especially in the group discussion with high school student teachers for mathematics, differences in achievement was a central point of the discussion. In both conversations we could reconstruct the view, that especially in mathematics differences in achievement are suspected to be ‘visible’ and that teachers have to react to them through (differentiated) tasks. This aspect could therefore be seen as the most important for student teachers when they consider the heterogeneity of their prospective class in mathematics. It is noticeable, that it is less discussed, how differentiation of the content or the social formation in the class could look like. Differences in achievement seem to be important for the student teachers but possibly they don’t know how to deal with this heterogeneity. The predication of Nathalie shows that theoretical knowledge of how to deal with heterogeneity and differentiated tasks has apparently been taught in the university. However, the two excerpts show that this knowledge cannot be applied in practice. This result also coincides with the four other group

discussions of the HeLeA project. Similarly to Gellert (2008) and Schieferdecker (2016), tensions were reconstructed which have to do with the problem of making pedagogical specialist knowledge (learned in university) compatible with the practice of teaching a heterogenic learning group. In all six group discussions, it was possible to reconstruct discontinuities between the everyday discourse of student teachers and the academic discourse on the subject of heterogeneity. One result of the HeLeA project is that the theoretical knowledge seems to be incompatible with the student teachers' experiences in school practice. To ensure that future teachers are more capable to apply the theory they have learned in practice, we have to give them tools to reflect their own lessons and train their ability to interpret situations. Personal practical experiences should be constantly analyzed and reflected in professional life – one possibility for this is team teaching. The results collected so far already provide initial insights into mathematics student teachers' collective orientations and guiding ideas on heterogeneity in mathematics (c.f. Bitterlich & Jung, 2019). One limitation of the used group discussions approach is that only collectively shared orientations can be reconstructed. What remains in the individual is hidden. But if we follow the assumption that teachers can be seen as a common group with shared experiences, collective orientations could be more important in certain circumstances.

References

- Allport, G. (1954). *The nature of prejudice*. New York: Doubleday.
- Ajzen, I., & Fishbein, M. (1980). *Understanding attitudes and predicting social behavior*. Englewood Cliffs, NJ: Prentice-Hall.
- Aronson, J. (2002). Stereotype threat: Contending and coping with unnerving expectations. In J. Aronson (Ed.), *Improving Academic Achievement* (pp. 279–302). New York: Elsevier.
- Bitterlich, E., & Jung, J. (2019). 'This has to be done without bending over backwards': Collective orientations and experiences of student teachers in relation to heterogeneity in school. In D. Kolloosche, R. Marcone, M. Knigge, M. G. Penteadó, & O. Skovsmose (Eds.), *Inclusive mathematics education: State-of-the-art research from Brazil and Germany* (pp. 607–623). Cham: Springer International Publishing.
- Bohnsack, R. (2010). Documentary method and group discussion. In R. Bohnsack, N. Pfaff & W. Weller (Eds.), *Qualitative analysis and documentary method in international educational research* (pp. 99–124). Opladen: Budrich.
- Bohnsack, R. (2017). *Praxeologische Wissenssoziologie* [Praxeological sociology of knowledge]. Opladen & Toronto: Budrich.
- Booth, T. (2011). Curricula for the common school: What shall we tell our children? *Forum*, 53(1), 31–48.
- Decristan, J., Fauth, B., Kunter, M., Büttner, G., & Klieme, E. (2017). The interplay between class heterogeneity and teaching quality in primary school. *International Journal of Educational Research*, 86, 109–121.
- Döbert, H., Klieme, E., & Sroka, W. (2004). *Conditions of school performance in seven countries*. Münster: Waxmann.
- Gellert, U. (2008). Routines and collective orientations in mathematics teachers' professional development. *Educational Studies in Mathematics*, 67, 93–110.

- Helmke, A., & Weinert, F.E. (1997): Bedingungsfaktoren schulischer Leistungen [Conditional factors of academic achievement]. In: Weinert, F.E. (Ed.): *Psychologie des Unterrichts und der Schule* [Psychology of teaching and school] (pp.71-176). Göttingen, Germany: Hogrefe.
- Klieme, E.; Artelt, C.; Hartig, J.; Jude, N.; Köller, O.; Prenzel, M.; Schneider, & W.; Stanat, P. (2010). *PISA 2009. Bilanz nach einem Jahrzehnt* [Balance sheet after one decade]. Münster: Waxmann.
- Mannheim, K. (1982). *Structures of thinking*. London: Routledge.
- Przyborsky, A., & Wollrab-Sahr, M. (2014). *Qualitative Sozialforschung. Ein Arbeitsbuch* [Qualitative social research. A workbook]. Oldenbourg: Wissenschaftsverlag.
- Reynolds, M. (2001). Education for inclusion, teacher education and the teacher training agency standards. *Journal of In-Service training*, 27(3), 465–476.
- Savolainen, H. (2009). Responding to diversity and striving for excellence: The case for Finland. *Prospects*, 39(3), 281–292.
- Schieferdecker, R. (2016). *Orientierungen von Lehrerinnen und Lehrern im Themenfeld Heterogenität. Eine rekonstruktive Analyse* [Orientations of teachers on the topic of heterogeneity. A reconstructive analysis]. Opladen, Berlin, & Toronto: Budrich.
- Schönknecht, G., & de Boer, H. (2008). Heterogenität aus der Perspektive von Studierenden oder der Wunsch nach Normalität [Heterogeneity from the perspective of student teachers or the desire for normality]. In J. Ramsegger & M. Wagener (Eds.), *Chancenungleichheit in der Grundschule. Ursachen und Wege aus der Krise* [Unequal opportunities in primary school. Reasons and ways out of the crisis] (pp. 255–258). Wiesbaden: VS Verlag.
- Sliwka, A. (2010). From homogeneity to diversity in german education. In OECD (Ed.), *Educating teachers for diversity* (pp. 205-217). Paris.
- Sturm, T. (2012). Praxeologische Unterrichtsforschung und ihr Beitrag zu inklusivem Unterricht [Praxeological education research and its contribution to inclusive education]. *Inklusion online*, 1. <http://www.inklusion-online.net/index.php/inklusion/article/view/151/143>. Accessed 26 October 2017
- Trautmann, M., & Wischer, B. (2011). *Heterogenität in der Schule. Eine kritische Einführung* [Heterogeneity in school. A critical introduction]. Wiesbaden: VS Verlag.
- Thompson, A. G. (1992). Teachers' beliefs and conceptions: A synthesis of the research. In D. A. Grouws (Ed.), *Handbook of research on mathematics teaching and learning* (pp. 127–146). New York, NY: Macmillan.
- Weller, W., & Malheiros da Silva, C. (2011). Documentary method and participatory research: Some interfaces. *International Journal of Action Research* 7(3), 294–318.
- Winheller, S., Müller, M., Hüpping, B., Rendtorff, B., & Büker, P. (2012). *Professionalisierung von Lehrkräften für einen reflektierten Umgang mit Ethnizität und Geschlecht in der Grundschule* [Professionalization of teaching staff for a reflective dealing with ethnicity and gender in primary school]. Paderborn: Zentrum für Bildungsforschung und Lehrerbildung.
- Zobrist, B. (2012). *Zum Umgang mit Heterogenität auf der Sekundarstufe I am Beispiel des Mathematikunterrichts. Eine explorative Studie* [On dealing with heterogeneity in secondary school using the example of mathematics lessons. An explorative study]. http://edudoc.ch/record/116903/files/15024_Zobrist.pdf. Accessed 19 March 2018.

Teachers' noticing of language in mathematics classrooms

Carina Zindel

TU Dortmund University, Germany; carina.zindel@math.tu-dortmund.de

Many studies point out teachers' crucial role in mathematics classrooms. This role is also emphasized through the increasing need of language-responsive teaching due to language diversity in the classrooms. The paper presents a qualitative study of teachers noticing mathematically relevant language issues in a video on a whole class discussion on variables. The study investigates which language resources and language obstacles the teachers notice and how they activate didactic categories of their content knowledge. It seems to be crucial to not only know the categories as disposition but also to activate them in a content-specific way.

Keywords: Pedagogical content knowledge, noticing, language-responsive teaching

Introduction

One important part of teachers' professional competence is their pedagogical content knowledge (PCK) (Shulman, 1986). Depaepe, Verschaffel, and Kelchtermans (2013) show that PCK has often been considered under perspectives of students' (mis)conceptions, instructional strategies, curriculum and others. Due to the increasing language diversity in mathematics classrooms, there is an increasing need of language-responsive teaching. However, only few studies deal with teachers' resources and obstacles when developing language-responsive mathematics classrooms (Radford & Barwell, 2016; Prediger, Sahin-Gür, & Zindel, 2018; Prediger, submitted). The aim of this study is to identify which language issues teachers notice in a classroom discussion and to analyze how they activate didactic categories when noticing these language issues. The article presents (1) the theoretical background of PCK and its role when noticing language issues, (2) the methods of the study, and (3) empirical insights which (mathematically relevant) language aspects teachers notice and how they activate didactic categories.

Background of the study

Identifying PCK in the connection from categories and practices

An important part of teacher knowledge is the pedagogical content knowledge (PCK) (for a literature review concerning different conceptualizations see Depaepe et al., 2013). In this context, Ball, Thames, and Phelps (2008) differentiate "knowledge of content and students" and "knowledge of content and teaching" (Ball, Thames, & Phelps, 2008, p. 399). They assume that "a clearer sense of ... content knowledge for teaching might inform the design of support materials for teachers as well as teacher education and professional development" (ibid., p. 405). This study aims at contributing to this clearer sense of content knowledge. Thereby, the study follows suggestions to focus not only the knowledge as dispositions but also on teacher practices (Depaepe et al., 2013) and the continuum from teachers' dispositions to performances in a situated perspective (Bloemeke, Gustafsson, & Shavelson, 2015). Our overarching project (Prediger, submitted; Prediger et al., 2018) is especially interested in the connections between teachers' (simulated) classroom practices and the knowledge

activated for these practices, following Bromme's (2001) conceptualization. More precisely, this study deals with the categories teachers activate for noticing in language-responsive teaching.

Noticing as a relevant teacher practice in language-responsive teaching

In general, noticing is described as the process of making “sense of complex classroom environments in which they cannot be aware of or respond to everything that is occurring” (Jacobs, Lamb, & Philipp, 2010, p. 170). Noticing aspects consists of two processes: first “attending to particular events in an instructional setting” and second “making sense of events in an instructional setting” (Sherin et al., 2011, p. 5). Interpreting these events involves “relating observed events to abstract categories” (ibid., p. 5). Abstract didactic categories are the mental schemes that structure situations. This study defines these events or aspects as those utterances and actions that teachers could identify as language resources or language obstacles when activating abstract categories and relating them to learners' specific utterances or actions (Figure 1). Hence, the aspects teachers notice depend on their background pedagogical content knowledge (Prediger & Zindel, 2017).

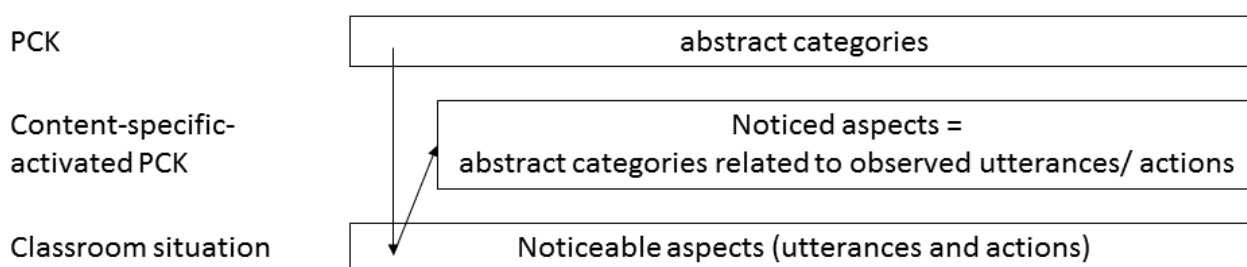


Figure 1: Noticing as activating PCK in a content-specific way

In the case of language-responsive mathematics teaching, *noticing language* has been identified as one of five typical situational demands (Prediger, submitted). Here, *noticing language* is the foundation for further jobs such as *supporting language* or *developing language*. With respect to the relevant categories, noticing language requires attending to learners' obstacles, but even more on learners' language resources in order to take decisions for an adaptive support. Other studies also focus on noticing the resources. Kilic et al. (2019) for example investigate the effects of a faculty-school collaboration program with regard to preservice teachers' noticing of mathematical opportunities emerged from students' mathematics.

For the case of language-responsive teaching, it is important that teachers know how the language issues are tied to the teaching of their subject (Bunch, 2013, p. 299). Hence, language-responsive teaching requires knowledge on mathematically relevant language demands and adequate teaching practices. In order to consider both, teachers' knowledge and their practices, this study focuses on teachers' processes in PD-integrated diagnostic activities.

This study focuses on two (abstract) didactic categories, which several studies highlight when dealing with language responsive teaching: *word* level and *discourse* level (Moschkovich, 2015; Prediger, submitted). Studies have shown that students' obstacles and resources differ on these levels and that especially the discourse level is important for mathematics learning as language and mathematics are strongly connected on this level (Moschkovich, 2015).

Focus of the investigation

Based on these theoretical backgrounds, the aim of this study is to identify which language issues teachers notice in a classroom discussion and to analyze how they activate didactic categories when noticing these language issues. Hence, the research questions are:

- (RQ1) *Which language resources and language obstacles do teachers notice when watching a video on a whole class discussion about the meaning of variables?*
- (RQ2) *How do teachers activate the categories word level and discourse level when noticing these language obstacles and language resources?*

Methods

Data gathering: PD-integrated diagnostic activity

In the overarching project, we conducted several PD-integrated diagnostic activities due to two reasons. First, these activities offer insights in teachers' knowledge and second, the facilitator can directly react and use the results in the PD. In this paper, the focus is on diagnostic activities of *noticing language*. We collected $n=12$ written products on the diagnostic activity translated in Figure 2. The sample consisted of German middle and high school mathematics teachers in their third session of a volunteer professional development series on language-responsive mathematics classrooms. The transcript teachers should analyze after watching the video scene contains many different language resources and language obstacles (Figure 3, Figure 4). This richness allows analyzing which of these aspects teachers focus on and thereby teachers' noticing.

A grade 10 class worked on the following task and conducted a whole class discussion on the match:

Classroom task: Ms. Maier buys presents for her colleagues. One bottle of wine costs 3 Euro. Additionally, she needs one bag for 1 Euro. Does the function equation $f(x) = 3x + 1$ fit to this situation?

Activity for the teachers: Watch the video of the whole class discussion and analyze the corresponding transcript [here printed in Figure 4] with regard to the learners' conceptual and language resources and obstacles.

Figure 2: PD-integrated diagnostic activity on noticing language and identifying language issues

In order to identify potential starting points for learning processes, teachers should identify mathematically relevant language obstacles and mathematically relevant language resources. A coding scheme of content-specific language resources (R) and language obstacles (O) that teachers could notice in this scene (Figure 3, Figure 4) was developed by, and discussed within, our research group. There is no hierarchy in the list. This list is not a complete list, so the coding scheme allows for additional individual categories (R9 and O7). Each noticeable aspect contains an (abstract) category (here: the discourse level/ different discourse practices) related to the observed event (i.e. utterance and/or action; Figure 1). After watching the video scene of the classroom discussion in the PD, the teachers should analyze the transcript with regard to conceptual and language obstacles and resources. We collected teachers' written products on this task and videotaped the whole PD including the group discussions in order to gain insights in the PD-processes.

- (R1) Differentiating the amount of colleagues and the amount of bottles
 (R2) Explaining the meaning of x as number of bottles/colleagues
 (R3) Explaining the meaning of the constant “3” as price of one bottle and the meaning of “1” as price of one bag
 (R4) Generalizing the number of bottles/ colleagues
 (R5) Describing a general relationship between the number of colleagues/bottles and the price by calculating values
 (R6) Generalizing the number of bags
 (R7) Describing a general relationship (between any amount of bottles/colleagues/bags/prices)
 (R8) Explaining the meaning of variables as unknowns and generalizers
 (R9) Further resource
 (O1) No identifying the meaning of “1” as price of one bag
 (O2) No generalization of the amount of colleagues/bottles
 (O3) No explanation of the meaning of $f(x)$ as total price
 (O4) Inappropriate basis for argumentation when explaining the (non)match of the function equation
 (O5) Overstressing the relevance of “colleagues” as singular or plural (A/N: both have the same spelling in German)
 (O6) No explication of the functional relationship between the number of colleagues/bottles and the price
 (O7) Further obstacle

Figure 3: Coding scheme for noticeable aspects (utterances and actions) in the scene

2	David	Hm, Ms. Maier buys [...] presents for her colleagues. One bottle of wine costs 3 Euro. Additionally, she needs one bag for 1 Euro.	
3	Max	[5s] For?	O1
5	Celina	Well, I don't think that fits, because hm I think (...) $f(x)$ equals 3 plus 1...	O2, O4
6	Fynn	I don't think that fits either, because it doesn't say how many bottles she buys (...)	R1 O2
7	Alexandra	I think that fits, because the function equation has $3x$ plus one. And three is then (...) the value of the bottles, x are the colleagues. And plus 1 is what you only have to pay once, because the 3 are always with the colleagues (...)	R2, R3, O3
9	Altin	Hm. I think that fits, because hm x is simply intended for the colleagues. So, if she had three colleagues, she would have to pay nine Euros.	R4, R5
10	Nils	[3s] It depends on hm whether she buys more than one bottle of wine. Because, if more bottles were bought, you could take the amount as x and then the question fits.	R2, R4
11	Tatjana	Well I think it doesn't fit because the number of colleagues is unknown.	O4
12	Ben	I think, it also doesn't fit because the text says colleagues. And these are several and our function equation says $3x$ (...)	O4, O5
13	Christian	And if $3x$, so the number of bottles is unknown, then you don't know how many bags you need either. Then this should be x , too. You don't know how many bags she takes.	R6, R7, O6
17	Fynn	Well this does not fit because it is not given how many bottles the woman wants to buy.	O4
19	Max	It doesn't fit because the number [...] is not given, how many – for how many colleagues she needs how many bottles. Because it needs to be better [...] explained or presented.	R1, R7
21	Nils	It fits because the number of colleagues is x . It is a non-determined number. That means, you can choose the number, how many colleagues there are.	R8
22	Alexandra	Well it says that the wine costs three Euro. And three is three times x and x is the unknown. That means that this is the number of colleagues. And it says she needs <u>one</u> bag. So she only buys one bag and therefor plus 1.	R2, R3, O3
24 - 26	Altin	The problem is, how big is the bag? Because [...] if there are more colleagues, then I don't think that all bottles fit into one bag and then she has to buy a second one. And then there would have to be plus two.	R6, R7

Figure 4: Transcript of the discussion and noticeable language resources (R) and obstacles (O)

Data analysis procedures

This paper focuses on the results of teachers' written analysis of the classroom discussion. These written products of the teachers were analyzed by collecting the noticed language aspects and comparing them with the aspects R1-R9 and O1-O7 (Figure 3 shows the inductively generated coding scheme for noticeable aspects). As teachers do not make the distinction of resource and obstacle explicit in their products, also utterances or aspects that *could* be used as a resource are coded as noticed resource (This reflects a resource-oriented positioning towards teachers' products.) Following the conceptualization of "noticed aspects" as "abstract categories related to specific utterances or actions" (Figure 1), teachers' written products were also analyzed with regard to the question *how* they activate the (abstract) categories *word level* and *discourse level* and especially whether they activate them in a content-specific way.

Results

Insights into three cases

In a first approach, the paper presents three cases of teachers' written products (Figure 5) in order to illustrate the functioning of the coding scheme (language-related aspects are highlighted in black).

<p>Camilla Lippott</p> <ul style="list-style-type: none"> - Meaning of $f(x)$ and x is not clear for many learners, as well as the meaning of the 1 - changing meaning of $x \Rightarrow$ number of colleagues; number of bags - David: only reads aloud, does not participate in the discussion (O7) - Max: does not recognize the meaning of the variable - Alexandra seems to have understood the assignment, but has difficulties in verbalizing (O7) - Celina does not give reasons at all (O4) 	
<p>Selma Ludwig</p> <p><u>Mathematical resources & difficulties</u></p> <ul style="list-style-type: none"> • Meaning of the variable x not clear (Fynn, Max, Celina) • Notion of variable not clear • Additional variable for bags (Altin, Christian) 	<p><u>Language resources & difficulties</u></p> <ul style="list-style-type: none"> • Colleagues $\neq 3x$? (O7) • Meaning of "Does the function equation fit?" not clear (O7) • <u>One bag</u> (O1) • Explanation linguistically vague (Alexandra) (O7) • Number of colleagues \neq Colleagues (O5)
<p>Peter Tremnitz</p> <ul style="list-style-type: none"> - Max for? unknown (by, for) (O1) - Celina creates a model on her own (and in a wrong way) instead of analyzing the given term - Fynn struggles with interpreting the x as variable - Alexandra has understood the problem, but she can only insufficiently verbalize the meaning of the 1 (for one bag) \Rightarrow clarifies it later (O6) - Tatjana does not find a concrete number of colleagues – obstacle in functional relationship - Ben: $3x$ – not interpreted variable - Christian: it remains unclear whether he imposes an upper limit for one bag or whether he regards the number of bags as proportionally increasing. The task says that she needs only one bag. (R6, R7) - Altin: +1 incorrectly interpreted repeatedly 	

Figure 5: Three cases of teachers' written products and their coding

Camilla points out that David only reads aloud and does not participate in the discussion (O7). Hence, she activates the category discourse level in terms of participating in the classroom discourse. Besides, she states that Alexandra struggles with verbalizing the functional relationship (O7). Thereby, she names the discourse practice of verbalizing, but she does not explicitly relates it to the observed

utterance. It remains unclear which difficulties Alexandra might have and whether these are difficulties in finding correct words on a lexical level or whether she has difficulties in explaining on the discourse level for example. A similar category could underlie her observation that Celina does not give any reasons at all (resp. inappropriate basis for argumentation, O4).

In contrast to the two other teachers, Selma makes an explicit distinction between mathematical aspects and language aspects. She identifies five language obstacles: O1, O5 and three further obstacles that are summarized under O7. The further obstacles are (1) identifying the meaning of “3x” as number of colleagues, (2) no understanding of the question, and (3) explanation linguistically vague. Thereby, Selma activates the category “discourse level”, too. However, she describes the aspects only partly by only naming the abstract category (“explanation vague”) or by only naming a part of the situation (“one bag”). It remains unclear which categories she relates to which observed utterances.

Peter recognizes the possible idea of generalizing the number of bags R6 as “proportionally increasing” (R7). Thereby, he notices an utterance that could be used as a resource for the discursive demand of generalizing and describing a general relationship, even though this is not the relationship focused by the task. Peter activated the category “discourse level”, too, by explicitly relating the discourse practices to the observed utterances in most cases.

Whereas Camilla and Selma only notice obstacles, Peter also identifies a potential resource, although he does not make explicit that it is a resource. Nevertheless, noticing such aspects is presumably a first step towards responding to those utterances in an appreciative way.

Teachers’ noticing of language resources and language obstacles

Figure 6 presents a summary of the coding of all twelve teachers’ products with regard to the amount of noticed resources and noticed obstacles, sorted by teachers (Figure 6, left) and sorted by aspects (Figure 6, right).

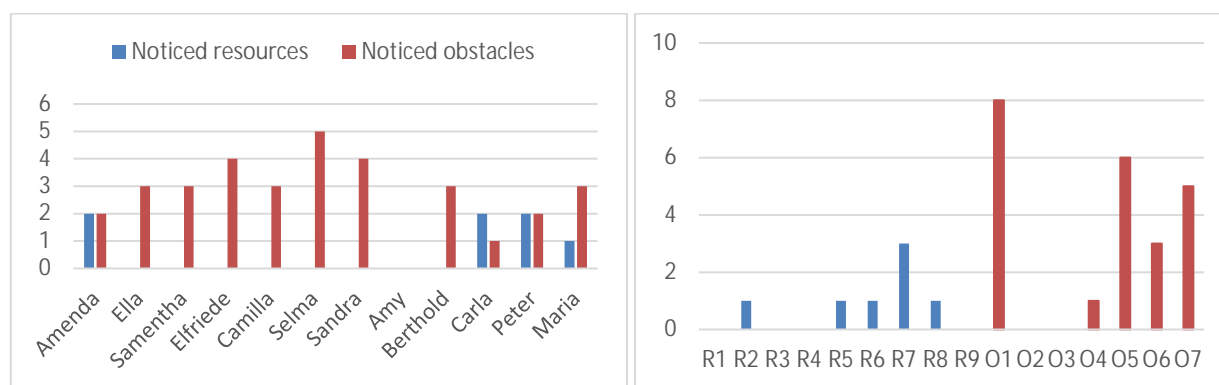


Figure 6: Amount of noticed resources and noticed obstacles by teacher (left) and by aspect (right)

It is striking that teachers notice much more obstacles than resources (Figure 6). Only four teachers notice resources at all, but even these four teachers notice only one or two utterances that could be used as resources in the whole scene (Figure 6, left). These observations raise the question, why teachers notice some aspects very often, whereas other aspects are not noticed at all. In order to identify possible reasons for these observations, the following section investigates teachers’ underlying categories in their noticing.

Teachers' activated categories in their noticing of language obstacles and resources

As teachers focus much on the aspects O1 and O5 (Figure 3), they seem to focus on demands on a *word level*. This problem is already well known (Moschkovich, 2015; Prediger et al., 2018). Both aspects describe obstacles that result from wrongly understood words in the text. For noticing other aspects it would have been necessary to activate further categories like other discourse practices on the discourse level and relating them to learners' utterances.

In the three presented cases, all teachers activate the category *discourse level*, although they do this on different ways. Some teachers remain on the discourse level in a general way (like Camilla), others differentiate several discourse practices (but name only the category or only the utterance like Selma) and others differentiate discourse practices and relate them explicitly to the observed utterances or actions (like Peter). The same phenomena become visible in other cases, too. These observations are paralleled by the fact that some teachers differentiate single students whereas other teachers describe to resources and obstacles of the class as a whole.

Summing up, teachers focus much more on language obstacles than on language resources. If they identify language resources, they remain on the word level. Only few teachers notice different discourse practices that could be built on although there are many different noticeable discourse practices in the scene that could be used as a resource in a further classroom discussion (Figure 3, Figure 4). If activated at all, the categories on the discourse level are often activated in a general way, i.e. that the abstract categories are not explicitly related to the observed utterances or actions.

Discussion and outlook

Noticing aspects consists of two processes, "attending to particular events" and "making sense of events" (Sherin et al., 2011, p. 5). For the case of language-responsive teaching, this paper has investigated which aspects teacher notice and how they activate the in this case important didactic categories *word level* and *discourse level* (concerning the two categories cf. Moschkovich, 2015; Prediger, submitted). The results show that teachers focus much more on language obstacles than on language resources. Such a deficit-oriented focus presumably leads to unused learning opportunities, as the existing resources are not identified as possible starting points for learning processes.

Teachers' noticing depends on teachers' background knowledge of didactic categories (Prediger & Zindel, 2017). However, it seems to be not enough to know the categories as teachers remain very vague in their articulation of the noticing. So knowing a category seems to be only a first step in a category-based noticing. A further step is activating a category in a content-specific way, i.e. not only naming the abstract category, but also relating it to the observed mathematical issue (cf. Figure 1). It might be helpful if PDs dealt with possible language resources and language obstacles that could be expected in different math contents. Hence, PDs should support teachers in acquiring didactic categories as well as activating them in a content-specific way in order to support teachers' noticing.

Of course, the results gained by a sample of $n=12$ must be interpreted cautiously. We continue the data gathering in following PDs, so that this sample will be enlarged. Furthermore, we are going to analyze how this first noticing develops in group-discussions in the PDs. We will analyze the video material of the PD in order to gain deeper insights in teachers' noticing and its development.

Acknowledgement. The presented study has been conducted within the project MuM-innovation which is financially supported by the German Ministry of Education and Research (BMBF-research grant no. 03VP02270 to S. Prediger) in the framework of DZLM, the German Center for Mathematics teacher education (which is financially supported by the German Telekom-Foundation).

References

- Ball, D., Thames, M. H., & Phelps, G. (2008). Content Knowledge for Teaching. *Journal of Teacher Education*, 59(5), 389–407.
- Bloemeke, S., Gustafsson, J.-E., & Shavelson, R. J. (2015). Beyond Dichotomies. *Zeitschrift für Psychologie*, 223(1), 3–13.
- Bromme, R. (2001). Teacher Expertise. In N. J. Smelser & P. B. Baltes (Eds.), *International encyclopedia of the social & behavioral sciences* (pp. 15459–15465). London: Pergamon.
- Bunch, G. C. (2013). Pedagogical Language Knowledge. *Review of Research in Education*, 37(1), 298–341.
- Depaepe, F., Verschaffel, L., & Kelchtermans, G. (2013). Pedagogical content knowledge. *Teaching and Teacher Education*, 34, 12–25.
- Jacobs, V. R., Lamb, L. L.C., & Philipp, R. A. (2010). Professional Noticing of Children's Mathematical Thinking. *Journal for Research in Mathematics Education*, 41(2), 169–202.
- Kilic, H., Dogan, O., Arabaci, N., Tun, S. S. (2019). Preservice teachers' noticing of mathematical opportunities. Paper presented at CERME11.
- Moschkovich, J. N. (2015). Academic literacy in mathematics for English Learners. *The Journal of Mathematical Behavior*, 40, 43–62.
- Prediger, S. (submitted). Promoting and investigating teachers' pathways towards expertise for language-responsive mathematics teaching. Submitted to *Mathematics Education Research Journal*.
- Prediger, S., & Zindel, C. (2017). Deepening prospective mathematics teachers' diagnostic judgments. *European Journal of Science & Mathematics Education*, 5(3), 222–242.
- Prediger, S., Şahin-Gür, D., & Zindel, C. (2018). Are teachers' language views connected to their diagnostic judgements on students' explanations? In E. Bergqvist, M. Österholm, C. Granberg, & L. Sumpter (Eds.), *Proceedings of PME 42* (Vol. 4, pp. 11–18). Umea, Sweden: PME.
- Radford, L., & Barwell, R. (2016). Language in mathematics education research. In A. Gutiérrez, G. Leder, & P. Boero (Eds.), *The second handbook of research on the psychology of mathematics education*. (pp. 275–313). Rotterdam: Sense.
- Sherin, M. G., Jacobs, V. R., & Philipp, R. A. (2011). *Mathematics Teacher Noticing: Seeing through Teachers' Eyes*. *Studies in mathematical thinking and learning*. London: Routledge.
- Shulman, L. S. (1986). Those Who Understand: Knowledge Growth in Teaching. *Educational Researcher*, 15(2), 4–14.

TWG21: Assessment in mathematics education

Introduction to the papers of TWG21: Assessment in mathematics education

Paola Iannone¹, Michal Ayalon², Johannes Beck³, Jeremy Hodgen⁴ and Francesca Morselli⁵

¹Mathematics Education Center, Loughborough University, UK; p.iannone@lboro.ac.uk

²Department of Mathematics Education, University of Haifa, Israel, mayalon@edu.haifa.ac.il

³Department of Mathematics Education, University of Wuerzburg, beck@dmuw.de

⁴UCL Institute of Education, University College London, UK, jeremy.hodgen@ucl.ac.uk

⁵DIMA Mathematics Department, University of Genoa, Italy, morselli@dim.unige.it

Keywords: Summative assessment, formative assessment, validity, feedback, assessment methods.

Introduction

TWG21 met for the second time in Utrecht at CERME11 and in this conference we sought to continue the work started at CERME10. The aim of the previous meeting was to ascertain where the interest of our community is when thinking about assessment, and to maintain the focus firmly on mathematics. At CERME11 we discussed 14 papers and 3 posters which helped defining such interest. We noticed again a variety of focal points: from validation of large-scale assessment instruments, to the affordances and drawbacks of online assessment – especially in the university context - to the details of construction of individualised feedback. As in the previous meeting the papers also presented a variety of methodologies: from large quantitative studies to more nuanced qualitative investigations. Among the submissions we also received papers related to students' perspectives and teachers' perspectives on assessment. These themes were not prominent in the past meeting of the group and we welcomed the new perspectives they brought. Finally, we decided to group papers together that indicated the role that mathematics has in the assessment: this is to say papers that focus on the specifics of mathematics, such as assessing proof.

Thematic clusters

We identified 5 overarching themes that will serve to organise the papers submitted to TWG21. Below, we describe each of these themes in turn.

Large scale standardised assessment: There is strong interest in our community for the use and validation of large-scale standardized assessment, both for benchmarking national students' attainment and for mapping common misconceptions across educational stages. Garuti and Martignone present the introduction of the INVALSI standardised tests in Italy and then investigate the possibility to assess argumentation through the multiple-choice questions included in the INVALSI tests. By using Toulmin's model (1958) to analyse the structure of arguments included in the tests the authors find that although standardised multiple-choice arguments can identify only certain aspects of argumentation, this is not to say that the aspects that these tests do identify have no educational value. They conclude by proposing that the Toulmin's model (1958) could be used to guide the construction of such tests. Klegseth, Kaspersen and Solstad use Rash Analysis to determine

whether non-standardised test included in Norwegian textbooks are a valid and reliable indicator of mathematical competence. In order to do so the authors focused on the concept of function. The items tested were divided into 5 competencies categories and the authors found that, with a careful selection of such test items, the set they identified can be a reliable and valid measure of mathematical competences for these students. Driike-Noe and Siller present a newly developed test with easy tasks which assesses basic mathematical competencies that are essential for vocational training. The test is used in years 8 and 9 in Germany. From both a content-oriented and a process-oriented perspective, preliminary test results reveal a substantial lack of these competencies in all academic tracks, and differential effects were found with respect to year and class that need to be examined beyond curricular analyses. Finally, Lasorsa, Garuti, Desimoni, Papa, Costanzo and Ceravolo also worked from the database generated by the INVALSI test for mathematical proficiency in Italy and investigated the psychometric and qualitative-educational properties of a pool of these questions. They seek to find specific cognitive obstacles that the students need to overcome to reach the desired competence levels.

Assessment with technology and Computer Aided Assessment (CAA): As in CERME10 we received papers on the use of technology for assessment, both papers at university level. Sangwin reports the development and evaluation of an online linear algebra examination administered using the system STACK (Sangwin, 2013). The aim of this study is to investigate whether common questions in linear algebra could be assessed automatically, which was the case for most of the questions tested. The implication for the assessment of mathematics are that tools need to be created and tested to assess explanation, justification and reasoning, and that the current questions of paper-pencil test should be reconsidered since they often focus on mechanical processes. Barana and Marchisio report the implementation of automatic assessment methods both in classroom activities and in online homework tasks to enact formative assessment strategies. The aim of such implementation was to foster self-regulation in the students. Their findings illustrate how formative assessment strategies can be implemented into such a blended-learning setting and how students perceived the effectiveness of the experiment.

Assessment of mathematics: the teachers' perspective: We received four contributions on this topic, all reporting research in school settings. Horoks, Pilet, Coppé, De Simone and Grugeon-Allys present the design of a large-scale questionnaire aimed at analysing teachers' assessment practices and how teachers use the information they gather to promote students' learning, in the context of algebra. The authors discuss the design of suitable questions to gather information on the diversity of teachers' assessing practices. Kaplan, Kan and Haser present a study that investigated preservice middle school mathematics teachers' (PST) professional development related to formative assessment practices and focus on how preservice teachers' practices changed during the teacher education program. The authors explored PSTs' performance on a task where they were asked to analyse a lesson plan without any formative assessment opportunities built in and found PSTs did not always realise the lesson plan lacked any formative assessment, especially if they had not yet attended to measurement and assessment courses and methods of teaching courses. Moreover, PSTs were keener to suggest assessing strategies based on their role as teachers, and less to insert peer assessment into the plan. Sangari, van den Heuvel-Panhuizen, Veldhuis and Gooya report preliminary results of

a survey of Iranian teachers aimed at investigating to what extent teachers engaged with Descriptive Assessment, an approach for evaluating students' achievement by collecting and documenting evidence regarding their learning and performance. The survey showed that teachers engage with some of the formative assessment tasks, although not as frequently as it would be desirable. Finally, Prendergast, Treacy and O'Meara presented a study concerning teachers' perceptions of the Bonus Point Initiative (BPI) in Ireland. This initiative consists in awarding an extra 25 points in final examination results to those students who choose to study mathematics at higher level. The study adopted a mixed-method design. Findings show that, although teachers recognized the value of the BPI initiative in promoting the study of mathematics and recognizing the effort paid by students in studying maths at higher level, many of them feared that the BPI may decrease the standard of students attending to higher level courses.

Assessment of mathematics: the students' perspective: These papers focused on the impact of assessment on students' experiences and attitudes both at school and university levels. Demosthenous, Christou and Deetra Pitta-Pantazi propose a framework for designing different types of assessment tasks to elicit evidence about how students respond to the mathematical ideas presented in learning trajectories. The authors illustrate the application of the framework by drawing on a learning trajectory of fraction division for sixth grade students and discuss how the enactment of the trajectory in classroom could be adjusted to students' current understanding. Häsä, Rämö and Viii Virtanen discuss a study part of an ongoing larger project concerning student self-assessment skills in university courses. The authors developed a method enabling large cohorts of students to assess their own learning outcomes and to give their own course grades with the help of an automatic verification system. The paper explores whether the self-assessed grades correspond to the students' actual skills, and how well the automatic system can detect issues in the self-assessment. Based on an expert's evaluation of the skills of two students, the study concludes that although for large part the model works as intended, there are some cases where neither the self-assessment nor the computer verification seem to be accurate. Bóra and Juhász discuss pair-work testing. Their pilot study consisted of four tests: twice students were tested in pairs and twice students were tested individually. The researchers recorded the marks and overall performance of the two-two sets of each type of tests. Online questionnaires revealed that in general students had a positive attitude towards paired testing: they rated positively the concept and they rated their testing experience positively. In addition, the overall level of paired work was high. The authors point to the need to continue the study with a larger number of students to learn more about how paired testing improve collaboration and mastery of skills.

Aspects specific to the assessment of mathematics: Starting from the work in our previous meeting we wanted to emphasise the role of mathematics in the assessment, e.g. the specifics of assessing mathematics. We received four contribution to this topic. Bolondi, Ferretti and Santi use the framework of didactical situations (Duval, 1995) to investigate the persistence of certain mathematical misconception across educational stages (e.g. from school to university mathematics). By analysing the data collected in the database generated by the INVALSI test for mathematical proficiency in Italy the authors found that certain misconceptions concerning the operations between exponentials persist across the school to university transition, for low as well as medium attaining

students. Watkins, Lamm, Kohli and Kimani investigate the relation between characteristics, beliefs, background and perception of students on student attainment in the context of US Community Colleges, a much under-researched area. Using linear regression on a large database collected for the study they are able to individuate some predictors of student achievement and conclude that rich professional development opportunities for teachers have the potential to enhance teachers' effectiveness in this context. Cusi and Telsoni describe the design of individualized teaching/learning paths in the context of formative assessment at university level. The paths are designed to be tailored to the students' responses to online test and provide tailored feedback at each stage of the test. Preliminary results show how students interact with the feedback received and highlight that few students are aware both of the difficulties they have in solving the problems and how to overcome them. The individualized teaching/learning paths have the potential to develop the awareness of strategies to overcome difficulties. Finally, Turiano, Boero and Morselli explore the emergence of a 'culture of theorems' (Boero, 2007) through assessment involving narratives in a 10th grade classroom. After the students were taught some Euclidian geometry they were given as part of their assessment the task to write to a friend in another school and explain what a theorem is. Preliminary analysis of the narratives shows instances of students' meta-mathematical knowledge regarding the culture of theorems.

Conclusions

The papers that were presented in the TWG21 indicated once more the variety of interests in the assessment of mathematics community, both in terms of focus and of methodologies. Again we received papers adopting quantitative methods (such as Rasch analysis) and papers focusing on small in depth case studies. This reflects the variety of approaches in our field and it is normal that this variety emerges on the work of our group. However, while in the past meeting we found that authors were concerned by the lack of a shared language to discuss assessment, this time we welcomed more agreement on basic definitions. The emphasis that we detected on students' and teachers' perspectives also indicate the need for investigating how assessment affects those participating in it, following the observation we made at CERME10 of a lack of studies on this topic. Again, we sought to maintain the focus on mathematics – e.g. we highlighted the impact of the discipline characteristics on the way in which we think about assessment, both summative and formative. Finally, we plan to meet again at CERME12 in Bolzano (Italy) to push forward the work of the group and out thinking on the assessment of mathematics.

References

- Boero, P. (Ed.) (2007). *Theorems in school*. Rotterdam: Sense Publishers.
- Duval, R. (1995). *Sémiosis et pensée humaine: Registres sémiotiques et apprentissages intellectuels*. Berne: Peter Lang.
- Sangwin, C. J. (2013). *Computer aided assessment of mathematics*. Oxford, UK: Oxford University Press.
- Toulmin, S. (1958). *The use of arguments*. Cambridge: University Press.

Strategies of formative assessment enacted through automatic assessment in blended modality

Alice Barana¹ and Marina Marchisio²

¹Department of Mathematics of the University of Turin; Turin; Italy; alice.barana@unito.it

²Department of Mathematics of the University of Turin; Turin; Italy; marina.marchisio@unito.it

This paper intends to contribute to the research on formative assessment in Mathematics providing a model of automatic assessment aimed at enhancing learning and self-regulation. The model was developed at the Department of Mathematics of the University of Turin (Italy). The main features of the model are: availability, algorithmic questions, open answers, immediate feedback, interactive feedback, and real-life contextualization. The effectiveness of the model to enact formative strategies is discussed through the results of a didactic experimentation involving 299 students of 8th grade, where automatically assessed assignments have been used both during Mathematics classes and as online homework.

Keywords: Automatic assessment, computer assisted instruction, feedback, formative assessment.

Introduction

It is widely acknowledged that assessment has a great influence on learning, impacting on when and how students work and learn. In particular, formative assessment practices help develop understanding and motivation, encouraging positive attitudes toward learning. Being responsive to the users' actions, digital technologies can make new room for formative assessment: with their capabilities of computing grades and offering feedback in real time, they can return information to students and teachers that is relevant to support and enhance learning processes. Web-based digital materials with automatic assessment can be used in face-to-face, blended or online courses; according to the modality adopted, they can facilitate personalized approaches as well as foster peer discussion.

This paper intends to contribute to the research on computer aided assessment in Mathematics, by proposing a model of automatic formative assessment and interactive feedback developed by the Department of Mathematics of the University of Turin (Italy). After a brief review of the literature on formative assessment, feedback and automatic assessment, the paper shows a model of automatic formative assessment using a system based on an Advanced Computing Environment, particularly effective for Mathematics. The model is discussed through some results of a didactic experimentation which involves 8th grade students.

Theoretical framework

Formative assessment

The term “formative evaluation” was coined by Michael Scriven in 1966 in opposition to “summative evaluation”, to describe a practice aimed to collect information during a course in order to develop the curriculum (Scriven, 1966). Benjamin Bloom borrowed the term to indicate a strategy for mastery learning, namely a set of diagnostic-progress tests which should assess the achievement of the small units in which the program is divided (Bloom, 1968). Bloom's studies evidenced the effectiveness of

this strategy to motivate students to forge ahead with the learning path. In 1989 D. Royce Sadler highlighted the role of feedback as a key distinction between formative and summative assessment. Sadler conceptualized formative assessment as the way learners use information from judgments about their work to improve their competence (Sadler, 1989).

More recently, Paul Black and Dylan Wiliam contributed to the development of a theoretical framework for the formative assessment, with particular reference to Mathematics Education. They spoke about formative practice, giving the well-known definition:

practice in a classroom is formative to the extent that evidence about student achievement is elicited, interpreted, and used by teachers, learners, or their peers, to make decisions about the next steps in instruction that are likely to be better, or better founded, than the decisions they would have taken in the absence of the evidence that was elicited. (Black & Wiliam, 2009)

They individuated five key strategies through which formative practices can be enacted, involving students, peers and teachers: clarifying and sharing learning intentions and criteria for success; engineering effective classroom discussions and other learning tasks that elicit evidence of student understanding; providing feedback that moves learners forward; activating students as instructional resources; and activating students as the owners of their own learning.

Feedback

The provision of feedback is the most distinctive feature of formative assessment. The power of feedback emerges in Hattie's metanalysis where it is considered one of the most effective strategies for learning (Hattie, 2009). John Hattie and Helen Timperley expanded upon the model of good feedback, conceptualizing it as "information provided by an agent (e.g., teacher, peer, book, parent, self, experience) regarding aspects of one's performance or understanding" (Hattie & Timperley, 2007). Effective feedback, whose purpose is to reduce the discrepancy between current and desired understanding, indicates what the learning goals are, what progress is being made toward the goal and what activities need to be undertaken in order to make better progress. Feedback can work at four levels: the task level, giving information about how well the task has been accomplished; the process level, showing the main process needed to perform the task; the self-regulation level, activating metacognitive process; the self-level, adding personal evaluations about the learner.

Sadler emphasizes the focus on the learner's processing of feedback, noticing that if the information is not elaborated by the learner to alter the gap between current and reference performance, it will not have any effect on learning (Sadler, 1989). In order for feedback to be effective, students have to possess a concept of the standard being aimed for, compare the actual level of performance with the standard and engage in appropriate action, which leads to some closure of the gap.

Besides improving understanding, feedback can also be effective to enhance self-regulation, a process whereby learners set goals for their learning and monitor and regulate their cognition, motivation and behavior through internal feedback (Pintrich & Zusho, 2007). The process of generation of internal feedback can be facilitated by well-designed feedback which, according to Nicol and Macfarlane-Dick (2006), should clarify what good performance is; facilitate the development of self-assessment; deliver high quality information to students about their learning; encourage teacher and peer dialogue

around learning; encourage positive attitudes, motivation and self-esteem; provide opportunities to close the gap between current and desired performance; and provide information to teachers that can be used to help shape the teaching.

Automatic assessment

Automatic assessment is one particular form of Computer Aided Assessment, characterized by the automated elaboration of students' answers and provision of feedback. Multiple choice is the most common question format; it is supported by the majority of online platforms, even though it considerably limits the cognitive processes involved in answering, especially in Mathematics (Bennett, 2012). To overcome this limitation, research centers and universities started to develop systems that are able to process open-ended answers from a mathematical point of view and to establish if they are equivalent to the correct solutions. Examples of similar Automatic Assessment Systems (AAS) are STACK, relying on the Computer Algebra System (CAS) Maxima (Sangwin, 2015) and Maple T.A., running on the engine of the Advanced Computing Environment (ACE) Maple (Barana, Marchisio, & Rabellino, 2015). By exploiting programming languages or mathematical packages, these AASs allow to build interactive worksheets based on algorithms where answers, feedback and values are calculated over random parameters and can be shown in different representational registers. Thus, new solutions for computer-based items can be conceived, including dynamic explorations, animations, symbolic manipulation that offer students experiences of mathematical construction and conceptual understanding (Stacey & Wiliam, 2013).

A model of formative automatic assessment for Mathematics

The Department of Mathematics of the University of Turin has designed a model for creating questions conceived for the formative assessment of Mathematics, using Moebius Assessment. (formerly known as Maple T.A.). This AAS was chosen for its powerful grading capabilities, for the robust mathematical engine running behind the system and for the possibility of integration within the Virtual Learning Environment (VLE) Moodle (Barana & Marchisio, 2016).

Aiming at enhancing learning and self-regulation, automatically assessed assignments should have the following features (Barana, Conte, Fioravera, Marchisio, & Rabellino, 2018):

- availability: students can attempt the assignments, integrated in a VLE, at their own pace, without limitation in data, time and number of attempts;
- algorithm-based questions and answers: random values, parameters or formulas make questions, and their answers, randomly change at every attempt. Though variables based on algorithms, random parameters, mathematical formulas, graphics and even animated plots can be shown in questions and feedback;
- open-ended answers: the multiple-choice modality is avoided whenever possible; open answers, given in different representational registers (words, numbers, symbols, tables, graphics) are graded through algorithms which verify if the student's answer matches the correct one, independently of the form;
- immediate feedback: results are computed in a very brief time and they are shown to the students while they are still focused on the task. Brief assignments are advised, in order to increase the immediacy of feedback;

- interactive feedback: just after giving an incorrect answer, the system can go through a step-by-step guided resolution that interactively shows a possible process for solving the task, which recalls previous knowledge and engage students in simpler tasks. They can gradually acquire the background and the process that enables them to answer the initial problem. They earn partial credits for the correctness of their answer in the step-by-step process;
- real-life contextualization: whenever possible, questions refer to real-world issues, which contributes to the creation of meanings and to a deeper understanding, as students can associate abstract concepts to real-life or concrete objects.

The feedback provided through this model acts not only at the task level, giving information about the correctness, but also at the process level, showing the steps toward the solution. Moreover, it can also act at the metacognitive level, providing opportunities for self-assessment, engaging less motivated students in active drills and offering partial credits for correct answers. This feedback satisfies the conditions individuated by Nicol and Macfarlane-Dick (2006) for the development of self-regulation. This model is particularly relevant in making students elaborate the feedback, as it is displayed interactively while they are still engaged with the task. Feedback can be effective according to Sadler's model: in fact, the interactive feedback offers a concept of standard that students can actively possess; immediate feedback helps them compare the actual level of performance with the standard; when trying the assignment again, students find similar tasks with different values, so that they are engaged in an activity that makes them repeat the process until mastered.

Research questions

The focus of this paper is to show how automatic assessment, implemented in a blended modality through classroom activities and online work, allows the enactment of formative strategies in order to enhance learning and self-regulation. In particular, the paper investigates whether the interactive feedback can be effective according to Sadler's model and whether the blended use of the automatic assessment can support formative assessment's strategies.

Didactic experimentation and data collection

A set of materials designed according to the model illustrated above has been proposed to 13 8th grade classes of 6 different lower secondary schools in the town of Turin, for a total of 299 students, during the school year 2017/2018. Interactive materials with automatic assessment, organized in 10 different units, were created by university experts and inserted in a dedicated VLE. The tasks were mainly designed using items from the INVALSI surveys, the national standardized tests that take place annually in Italy, in collaboration with an INVALSI expert, expanded and adapted to the automatic assessment. Mathematics teachers, working in close connection with the researchers, could use the materials in two modalities:

- in the classroom, with the support of the Interactive Whiteboard (IWB), where tasks were displayed. Students, in small groups of 3 or 4, were asked to solve one task. All the answers were collected by the teacher, one was collectively selected to be checked using the AAS. After verifying whether it was correct, all the groups, in turn, had to show their solving process to the others. The interactive worksheets displayed at the IWB supported the collective discussion and gave prompts for deeper reflection.

- for homework, using the online assessment and the interactive feedback to check understanding. Students could autonomously navigate within the platform and make one or more attempts to the assignments.

One example of question is shown in Figure 1. It asks students to solve a problem about linear models, open to different approaches. Students who give the incorrect answer to the main task are engaged with the exploration of the situation through a table to complete and a graphic to draw interactively. This question has been used online with some classes and in the classroom with others. On the platform, students were guided through the solving process and could repeat the problem with different data; in classroom, only the main task was displayed initially and the different solutions made by the groups of students were shared and discussed, with the support of the automatic assessment. During the experimentation, a PhD student participated to the lessons regarding the module on functions and modeling, the target topic of the experimentation. Lessons were videotaped and all data from platform usage were extracted in order to study the use of the assignments. The appreciation of the activities was measured through a questionnaire distributed at the end of the school year.

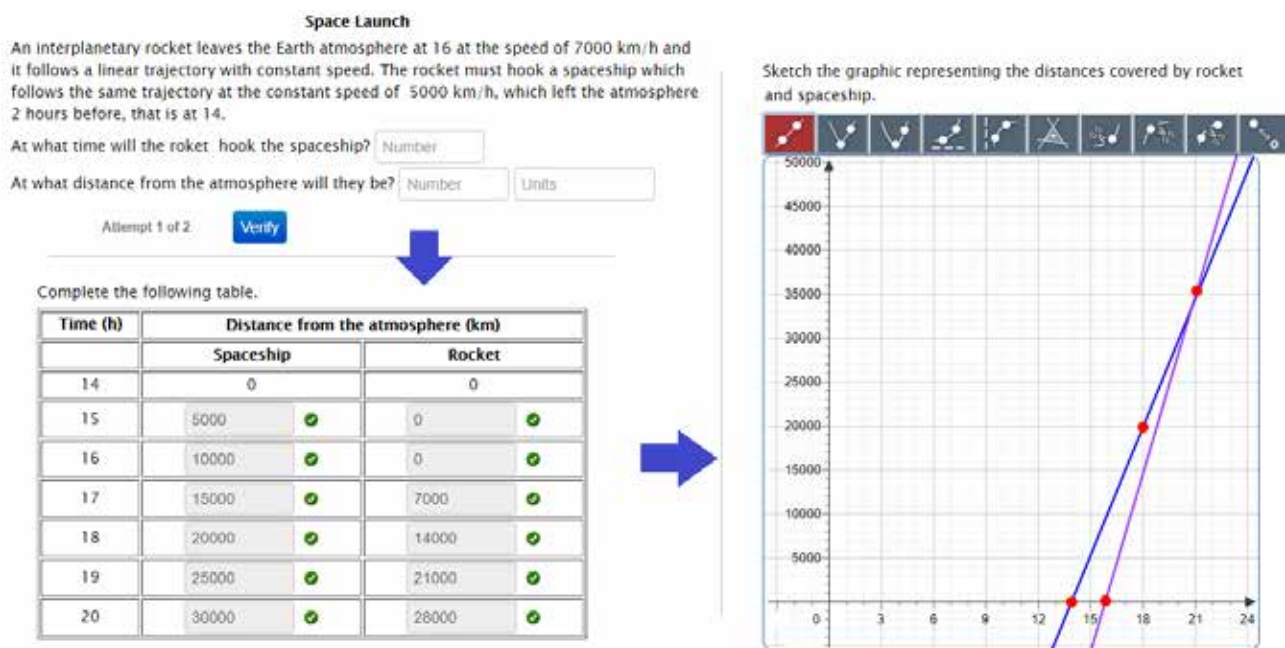


Figure 1: Example of automatically assessed question

Results and discussion

In order to evaluate whether the interactive feedback was effective according to Sadler's model, the usage and results of online assignments were analyzed. For each student the average number of attempts per assignment has been computed: it ranges from 1 to 12, with an average value of 1.70, which expresses students' tendency to repeat the questions. Then, the average grade each student earned in their first assignment attempt was compared with the average grade they earned in their last attempt through a pairwise Student t-test: the mean of initial grades resulted to be 51.55/100 (standard deviation: 19.63), while the mean of final grades was 59.02/100 (standard deviation: 19.87); the

increase is statistically significant ($p < 0.0005$). These results show that students used the information provided in the feedback to improve their results in subsequent activities.

Answers to the final questionnaire show students' perceived effectiveness of the automatic assessment. Table 2 reports the percentage of students' answers, given in a Likert scale from 1 (completely disagree) to 5 (completely agree). In particular, it emerges that students appreciated the usefulness of the group work in the classroom, supported by the use of the platform, and the online tests with immediate feedback. The low percentages of negative answers show that the feedback obtained through automatic assessment and peer work was useful to develop conceptual knowledge, since students could better understand the topics; it was also effective at a process level, to understand how to solve the problems; and at a metacognitive level, developing awareness of one's preparation.

Questions	1	2	3	4	5
Working in group was useful.	1.4%	6.3%	23.1%	38.5%	30.8%
Class activities were useful to better understand some Mathematical topics.	1.4%	4.5%	29.1%	45.9%	19.1%
Using the platform during classroom lessons was useful.	0.5%	3.6%	32.1%	47.1%	16.7%
I appreciated the possibility to revise the material used in class through the platform.	0.0%	8.2%	35.3%	36.4%	20.0%
The online exercises were useful to better understand the topics.	2.5%	5.6%	20.5%	46.0%	25.5%
The online exercises helped me make clear if I understood the topics.	2.5%	14.3%	26.7%	37.3%	19.3%
It is useful to have the correct answer displayed immediately after answering.	1.2%	3.7%	13.0%	36.0%	46.0%
The immediate assessment helped me understand how to answer the questions.	1.2%	5.0%	19.9%	32.3%	41.6%
Problems with step-by-step guided resolution helped me understand how to solve the exercises.	1.2%	8.7%	26.7%	34.2%	29.7%
Online exercises helped me to be aware of my preparation.	3.7%	8.1%	28.6%	40.4%	19.3%

Table 2: Student's answers to the final questionnaire, given in Likert scale 1 to 5

The open answers to the questions "what did you appreciate the most?" and "what were the online assessments useful for?", evidenced how the use of automatic assessment both in classroom and online supported the enactment of the strategies of formative assessment. Comments such as: "in my opinion, online exercises are useful to better understand the process to build a formula", "the platform was very useful to better understand both the current topic and the resolution of problems" and "I think that the online tests were useful, because they showed me the many possibilities to solve one

problem” show how online assignments could clarify and share criteria for success. Tasks in the online tests were effective to elicit evidence of students’ understanding, as other students report: “online tests were useful because only by doing them I was able to acknowledge whether I had understood a topic or not”, “online tests were useful to individuate the points where I should improve”. Other comments prove that automatic and interactive feedback supported learning improvements: “I could have immediate access to the result to understand where I made a mistake and I had the chance to make another attempt with different data to drill”, “with the book you can do the assignments but you can’t acknowledge if your resolution is correct, while the platform always shows you both the correct answers and the solving processes”, “if you don’t understand a topic, with guided exercises you can gradually learn how to solve them autonomously”, “in classroom it often happens that I think I have understood a topic, but the next day I can’t understand it anymore, while with the platform I can work whenever I need to”. The assignments were also effective to activate students as owners of their own learning, as they themselves report: “technology encourages youngsters to work hard with homework, therefore they can better understand Mathematics”, “during classwork or homework I often felt willing and happy to solve the exercises, and they were useful to understand the lesson”, “I appreciated the online tests because they made me reason and work hard; sometimes I also had fun when doing Mathematics”. Groupwork was very appreciated and it allowed students to be activated as learning resources one for another, as their comments show: “classroom lessons were useful because, besides solving problems, we had to interact with each other and this allowed us to better understand the tasks”, “I appreciated reasoning together on the things that we were not able to do”, “I appreciated sharing ideas with classmates and helping each other”.

Conclusions

The results of the experimentation reported above show that the blended use of the online assessment made it possible to activate all the agents of the formative assessment (students, peers and teacher) and all the 5 key strategies individuated by Black and Wiliam: in the classroom, students received feedback from discussion and sharing ideas with peers, while on the platform the interactive feedback offered a guided support for understanding concepts and processes. This conception of automatic assessment provides enhancements with respect to paper-and-pen work and traditional book exercises: students can individuate their mistakes and make more attempts to improve their understanding, they can be actively engaged in Mathematical work and even have fun, although items are not game based. The results of this experimentation gave prompts for the activation of other research projects, aimed at studying the impact of these methodologies on students of different levels and backgrounds, as well as for the application of this model of formative automatic assessment to the learning of other subjects, even outside the STEM area, thus starting interdisciplinary collaborations.

Acknowledgments

We would like to thank Stefano Boffo, Francesco Gagliardi (CNR) and Rodolfo Zich (Fondazione Torino Wireless) for promoting the project and for participating to its realization. We are also grateful to Rossella Garuti (INVALSI) who collaborated to the development of the didactic materials.

References

- Barana, A., Conte, A., Fioravera, M., Marchisio, M., & Rabellino, S. (2018). A Model of Formative Automatic Assessment and Interactive Feedback for STEM. In *2018 IEEE 42nd Annual Computer Software and Applications Conference (COMPSAC)* (pp. 1016–1025). Tokyo, Japan.
- Barana, A., & Marchisio, M. (2016). Ten Good Reasons to Adopt an Automated Formative Assessment Model for Learning and Teaching Mathematics and Scientific Disciplines. *Procedia - Social and Behavioral Sciences*, 228, 608–613. <https://doi.org/10.1016/j.sbspro.2016.07.093>
- Barana, A., Marchisio, M., & Rabellino, S. (2015). Automated Assessment in Mathematics. In *2015 IEEE 39th Annual Computer Software and Applications Conference* (pp. 670–671). Taichung, Taiwan: IEEE. <https://doi.org/10.1109/COMPSAC.2015.105>
- Bennett, R. E. (2012). Inexorable and Inevitable: The Continuing Story of Technology and Assessment. *The Journal of Technology, Learning, and Assessment*, 1(1), 1–22.
- Black, P., & Wiliam, D. (2009). Developing the theory of formative assessment. *Educational Assessment, Evaluation and Accountability*, 21(1), 5–31.
- Bloom, B.S. (1968). Learning for Mastery. *Evaluation Comment*, 1(2).
- Hattie, J.A.C. (2009). *Visible Learning: A Synthesis of Over 800 Meta-Analyses Relating to Achievement*. Routledge.
- Hattie, J., & Timperley, H. (2007). The Power of Feedback. *Review of Educational Research*, 77(1), 81–112. <https://doi.org/10.3102/003465430298487>
- Nicol, D.J., & Macfarlane-Dick, D. (2006). Formative assessment and self-regulated learning: a model and 7 principles of good feedback practice. *Studies in Higher Education*, 31(2), 199–218.
- Pintrich, P.R., & Zusho, A. (2007). Student motivation and self-regulated learning in the college classroom. In R.P. Perry & J.C. Smart (Eds.), *The Scholarship of Teaching and Learning in Higher Education: An Evidence-Based Perspective* (pp. 1–8). Springer, Dordrecht.
- Sadler, D.R. (1989). Formative assessment and the design of instructional systems. *Instructional Science*, 18(2), 119–144.
- Sangwin, C. (2015). Computer Aided Assessment of Mathematics Using STACK. In S.J. Cho (Ed.), *Selected Regular Lectures from the 12th International Congress on Mathematical Education* (pp. 695–713). Cham: Springer International Publishing.
- Scriven, M. (1966). *The methodology of evaluation*. Lafayette, Ind: Purdue University.
- Stacey, K., & Wiliam, D. (2013). Technology and Assessment in Mathematics. In M.A. Clements (Ed.), *Third International Handbook of Mathematics Education* (Vol. 27, pp. 721–751). New York: Springer Science+Business Media.

National standardized tests database implemented as a research methodology in mathematics education. The case of algebraic powers.

Giorgio Bolondi¹, Federica Ferretti², George Santi³

¹University of Bolzano, Faculty of Education, Bolzano, Italy; giorgio.bolondi@unibz.it

²University of Bolzano, Faculty of Education, Bolzano, Italy; federica.ferretti@unibz.it

³University of Bolzano, Faculty of Education, Bolzano, Italy; gesanti@unibz.it

In this work we show the use of the INVALSI database as an instrument to collect organized data from national standardized tests in order to study students' mathematical thinking on a large scale. It allows us to create appropriate correlations to single out the behavior of the students relative to a specific mathematical topic or a cognitive issue. In this study we have used the INVALSI database to study how grade 10 students work with powers in the domain of algebra. We analyze the quantitative data within a semiotic theoretical framework. Analyzing items taken from the INVALSI tests we are able to single out a general behavior that involves a population of Italian students and that persists in time. We interpret the results within our theoretical framework, thereby giving a quantitative validation to a theoretical perspective that has been proven consistent by qualitative investigations.

Keywords: Standardized assessments, qualitative and quantitative methodologies, algebra, semiotics, powers.

Introduction.

It is more than 10 years that the Italian Ministry of Education (MIUR) has established national standardized tests (INVALSI) in mathematics. In detail, every year since 2008 INVALSI administers Italian and Mathematics (and since 2018, English) large-scale assessment tests to Italian students from Primary School to High Secondary School. The tests are devised according to a robust theoretical framework that has been developed according to mathematics education research. As we will see, a key tool that made it possible to focus our investigation was a database containing data about the INVALSI assessment.

The aim of this paper is to show how the INVALSI database can be effectively used also for research purposes. We study how high school students deal with powers analyzing their answers to items that have been administered throughout several school years. The items have been collected using the INVALSI database GESTINV (Gestinv, 2018) in order to single out consistent data regarding powers.

Our research interest focused on syntactic aspects because INVALSI tests show that Italian high school students have severe difficulties in handling the meaning of algebraic formalism when dealing with powers. This is particularly interesting if we take into account the efforts and attention that both students and teachers devote to algebraic calculations in the first two years of high school.

Our study wants to shed some light on the following issues:

What information can standardized assessments provide about student's learning difficulties regarding powers? What research tools can we use?

What information can we acquire from standardized assessments about mathematical practices in Italian high schools?

Theoretical framework.

Gestinv is a database which includes all the administered INVALSI tests in Italy. There are now 13,000 users amongst in service and preservice teachers and researchers. As regards mathematics there are almost 1700 items available.

Gestinv contains all the items of the INVALSI tests indexed according to the National Curricula, the results from the statistical point of view, the content, the key words, the percentage of correct, wrong and invalid answers and other characteristics. It is possible to carry out searches correlating these indexes. It has been used as a research tool in several researches to single out difficulties in specific mathematics topics or problems, for example in Ferretti and Gambini (2018), or in Ferretti, Giberti and Lemmo (2018). Gestinv allows both a fine grain and a coarse grain analysis of mathematics didactical phenomena and the data can be organized according to the basic contents and the indications of the Italian national curriculum.

To create a consistent framework for our study, it is necessary to combine the potentialities of Gestinv with a theoretical lens that allows us to look into the complexity of the didactical phenomenon that we want to investigate with the database. In the case of this paper our aim is to use Gestinv to observe the behavior of students in algebra, in particular when working with powers.

The learning of algebra is a key research issue in mathematics education, that involves a leap from procedural to relational and general cognitive functioning. Such a change in cognitive perspective is underpinned by the use of semiotic representations that in algebra implies the use of symbolic language intertwined with other semiotic systems.

Duval's (1995, 2008) semiotic approach highlights a specific cognitive functioning in mathematics, due to the special epistemological nature of its objects that do not allow ostensive references. Thinking and learning in mathematics is identified with the coordination of semiotic registers via treatment and conversion. Treatment is a semiotic transformation from a representation into another within the same register and conversion is a semiotic transformation from a representation in one register into another representation in another register.

The inaccessible nature of mathematical objects leads the student in a cognitive paradox that obliges him to identify the mathematical object with its semiotic representations (Duval, 1993). The cognitive paradox can hinder the student's meaning making processes since he is unable to establish the correct relationship between the mathematical object (the signified) and several representations (its signifiers). Conversion is particularly difficult to carry out because there is no syntactic rule that binds the first representation in one register with the second in the other register. In conversion, the pupil ends up with a series of unrelated representations that he is unable to refer to the same mathematical concept. According to Duval, conversion is the key cognitive function that guarantees the conceptual acquisition of mathematical objects.

Treatments instead rest on the structure of the semiotic register that provides the pupil with the syntactic rules to go from one representation to the other via the semiotic transformation. Therefore, we expect that students are able recognize that different representations involved in treatment transformations refer to the same mathematical object. Within this framework our research questions are: Q1: What precise information, regarding powers, can we acquire from a research that implements Gestinv? Q2: Is it possible to collect information that is coherent with solid research findings? Q3: What methodological tools does Gestinv provide?

Methodology.

Our research methodology intertwines qualitative and quantitative methodologies according to Johnson and Onwuegbuzie (2004) and Iori (2018). In our research design we mixed quantitative

and qualitative methodologies according to the following scheme: QUAL -----> QUAN -----> QUAN+QUAL. From a qualitative point of view our aim was to ascertain higher school students' difficulties in algebra. In particular our focus was on the students' ability to give meaning to the syntactic structure of algebra. Gestinv allowed us to carry out a quantitative analysis based on the INVALSI grade ten mathematics items, selecting the ones with lower scores. Among these we noticed that the management of powers yielded the worst results, in particular the tasks involving treatment operations. At this point we carry out a Quan/Qual analysis that combines our semiotic lens (Qual) with the study of the characteristic curves and the distractor plots (Quan).

In Figure 3 we see an example of our basic tool. On the x-axis are the students' level of competence, measured on the basis of the whole test and on the y-axis are the probabilities of answers to the distractors in function of the level of competence. The solid line represents the curve predicted by the model (characteristic curve) whereas the dotted lines are the empirical results of the test, plotted by deciles. Characteristic curves and distractor plots are an effective quantitative tool to highlight correlations between the students' answers to a specific item according to the basic contents and the indications of the Italian national curriculum, which informs the structure of the INVALSI test.

We point out the fact that we selected items close to the kind of algebra activity usually performed in Italian high schools during the first two years of secondary school. Moreover the items were selected according to the INVALSI theoretical framework, which considers the ability to handle semiotic transformations as one of the basic cognitive processes. We used the functions of Gestinv to choose items that matched our research needs in terms of cognitive processes, mathematical content and learning objectives. We turned out with items that highlight students' difficulties in giving sense to algebraic representations as they undergo treatment transformations. It is important to keep in mind that in Italy students, when learning algebra, are mainly exposed to complicated, heavy, and long algebraic calculations, basically treatments. This is also true for the teaching and learning of powers.

Results.

The following task was administered in 2017 Mathematics Grade 10 INVALSI test.

You can write the expression $\left(a - \frac{1}{a}\right)^2$ like:

A. $a^2 + \frac{1}{a^2} - 2$

B. $\frac{a^4 + 1}{a^2}$

C. $a^2 - \left(\frac{1}{a}\right)^2$

D. $\frac{a^2 - 2a + 1}{a^2}$

Figure 1: Task in Mathematics Grade 10 INVALSI Test 2017

This INVALSI test was administered to 540.000 grade 10 students; the results refer to a sample of about 48.000 students representative of the whole population. The task requires to perform a

treatment operation in the algebraic register, applying a well-known identity. As we can see in the following figure (Figure 2), only 34% of the students gave the correct answer; the majority of students who did not solve the task correctly chose option C. This item disproves Duval's claim that conversion is the key semiotic transformation and that treatment supports students in the construction of the correct meaning of mathematical concepts, in this study, powers. All the incorrect options reveal difficulties in the treatment operations and the mathematical meaning is completely lost. For example, option C formally resembles the original algebraic expression but there is no link to the correct mathematical meaning of powers. It is interesting how the students do not rely on the algebraic transformation rules to give sense to their mathematical activity. This item provides a quantitative confirm of qualitative researches that show how treatment transformations can result in a change or loss of meaning (D'Amore, 2007; Santi, 2011). Such researches show that meaning cannot be reduced to the structure of semiotic systems, but it is rooted in the range of social activity, at a personal and cultural level. In absence of a meaningful personal activity, the student, according to the cognitive paradox, interprets the semiotic representations as if they were unrelated mathematical objects, thereby losing the reference to the common mathematical object, even if he can rely on precise transformation rules. Rules and procedures that Italian students have trained over and over again in their algebra classes.

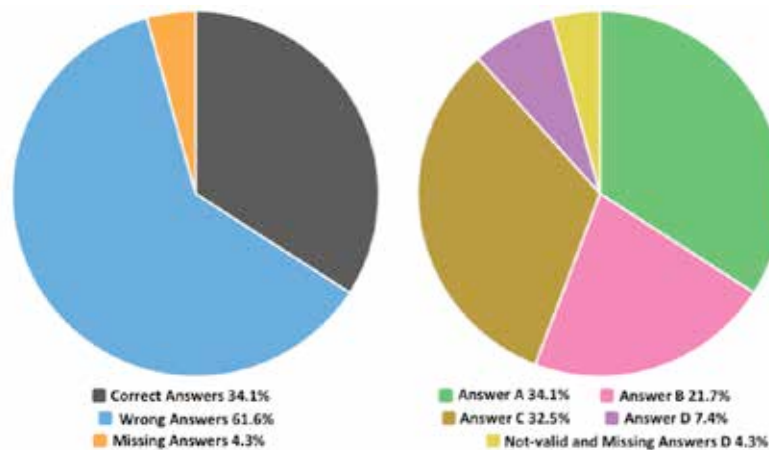


Figure 2: Results referred to the task in Mathematics Grade 10 INVALSI Test 2017

As we can see in the following graph (Figure 3), among the various options of incorrect answers, option C is the most frequently chosen at all levels of competence, up to medium-high skill levels. It testifies that this loss of meaning roots in convictions and beliefs that affect even the most competent students.

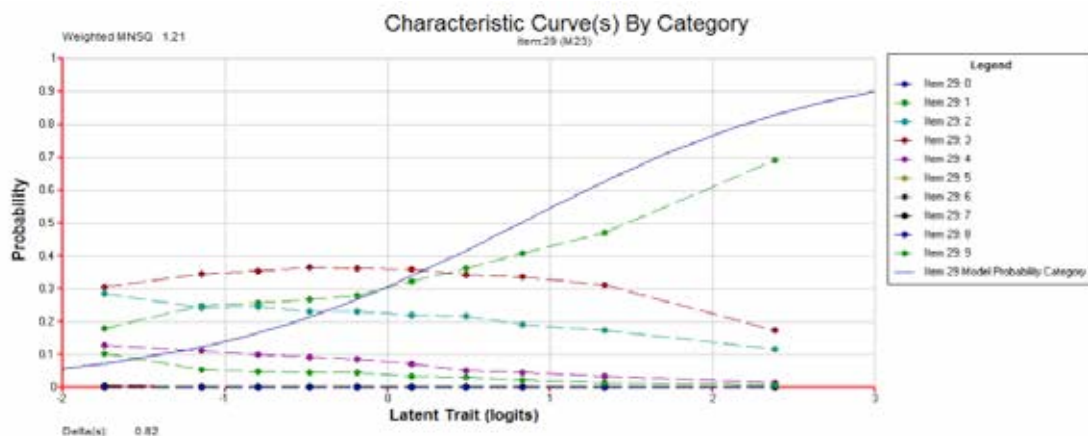


Figure 3: Characteristic Curve referred to the task in Mathematics Grade 10 INVALSI Test 2017

The following task was administered in Mathematics Grade 10 INVALSI Test in the year 2015.

The expression $a^{43} + a^{44}$ is equal to:

- A. a^{44-43}
 B. $a^{43} \cdot (a+1)$
 C. a^{87}
 D. $2a^{87}$

Figure 4: Task in Mathematics Grade 10 INVALSI Test 2015

In 2015 almost 550000 Grade 10 students performed this INVALSI test, and the national results referred to a sample of 48440 students. As we can see in the following graphs, only a third of Italian students provided the correct answer; among the incorrect options, the most chosen option is C. In option C the exponents of the two powers in the text are summed. Again, this protocol shows a loss of meaning, due to a treatment, when the student goes from the original $a^{43} + a^{44}$ to a^{87} . The expression $a^n + a^m$ puzzles the student who is not able to frame it appropriately in the context of powers, thereby he resorts to the well-known identity $a^n \cdot a^m = a^{(n+m)}$ which leads to a loss of the original meaning. This result suggests that factoring out the GCF is meaningless to most students, despite the thorough practice in terms of treatment transformations they are exposed to. Meaningless in the sense that they confuse the algebraic representations (signifiers) with the mathematical object (signified) and they are not able to establish the correct semiotic reference to the mathematical object.

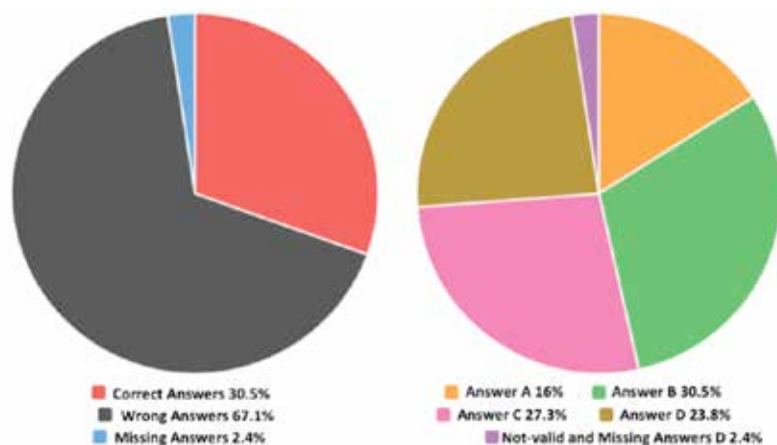


Figure 5: Results referred to the task in Mathematics Grade 10 INVALSI Test 2015

The Characteristic Curve (Figure 6), shows that, among the incorrect options, Option C is the most chosen at all levels of competence.

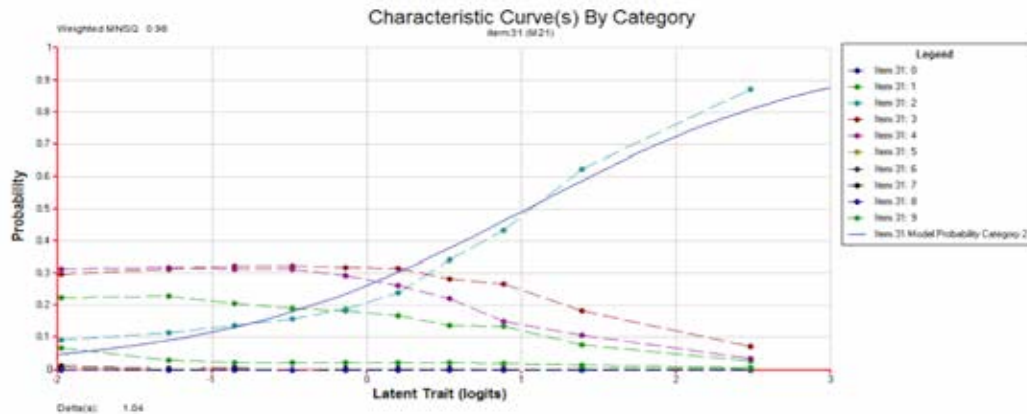


Figure 6: Characteristic Curve referred to the task in Mathematics Grade 10 INVALSI Test 2015

The following question was in the Mathematics INVALSI test that was administered in Italy in 2012 to all Grade 10 students. Almost 533.000 students performed the test and the results referred to a sample of almost 50.000 Grade 10 Italian students. To answer the task correctly, it is necessary to manipulate the exponents of an algebraic expression with two terms.

The expression $a^{37} + a^{38}$ is equal to:

- A. $2a^{75}$
- B. a^{75}
- C. $a^{37}(a+1)$
- D. $a^{37 \cdot 38}$

Figure 7: Task in Mathematics Grade 10 INVALSI Test 2012

As we can see in the following graphs (Figure 8), only 35% of the students answered correctly. More than 25% of students chose option B, in which the exponent of the power is the sum of the exponents of the power in the text. Also, in this situation, option B is the most chosen incorrect option at all levels of competences (Figure 9). If we compare this item we the former we can see that the behavior of the students is exactly the same both in terms of scores and of its characteristic curves. The combination of the last two items shows how Gestinv provides quantitative and qualitative information that we can compare across time to gain further insight on a teaching-learning phenomenon

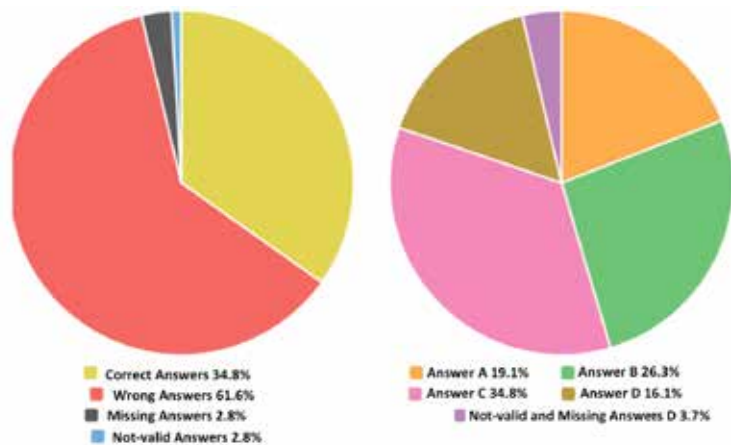
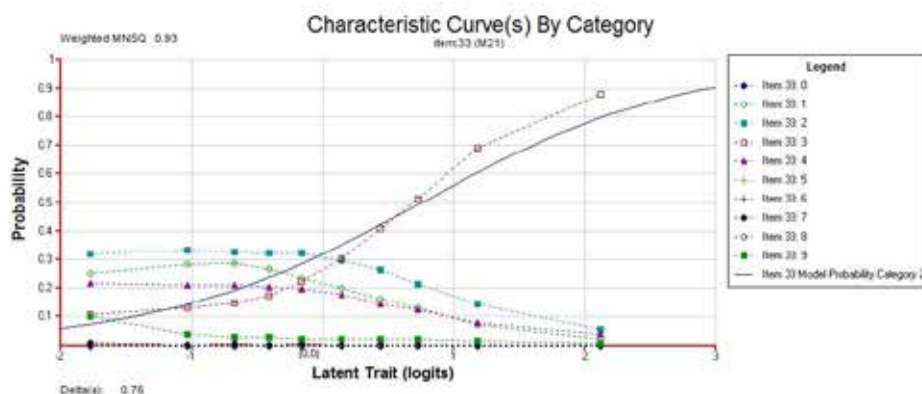


Figure 8: Results referred to the task in Mathematics Grade 10 INVALSI Test 2012**Figure 9: Characteristic Curve referred to the task in Mathematics Grade 10 INVALSI Test 2012****Answer to the research questions.**

A1) At a coarse-grained level, Gestinv highlights rooted difficulties in students facing treatments regarding powers. This is a quantitatively relevant macro phenomenon that persists with the same features across time.

A2) At a fine-grained level, Gestinv provides data that are coherent with solid research findings. In particular, it unveils at a quantitative level the phenomenon of change/loss of meaning due to treatment semiotic transformations. Several studies (D'Amore, 2007; D'Amore & Fandiño Pinilla, 2007; Santi, 2011) have shown that at all school levels, including prospective teachers, also treatment bewilders students who experience a loss or a change of meaning in treatment transformations. The loss and/or change of meaning due to treatment transformations implies that mathematical cognition in general and in particular the algebraic one cannot be reduced to a complex transformation of signs. Meaning is beyond the mere relation sign-object and it is necessary to take into account other basic features that characterize sense-making processes in mathematics. Moreover, data easily available in Gestinv show that this phenomenon also affects students with medium-high levels of competences. Thus teacher's didactical awareness is not only aimed at helping weak students but also the so-called stronger ones, devising an effective didactical transposition and didactical engineering that encompass the complexity of mathematical thinking and learning.

A3) Gestinv is an effective tool that entangles quantitative and qualitative research methodologies. As regards the quantitative approaches, they are based on a statistically significant population. It allows us to provide a quantitative validation of theoretical results, confirmed at a qualitative level. Furthermore, the characteristic curves are a powerful tool to intertwine quantitative and qualitative analyses.

Conclusions.

Gestinv implements a new research method that combines quantitative and qualitative approaches. In this study, it allowed us to highlight a macro didactical phenomenon that is quantitatively relevant. Thanks to the combination of the quantitative and qualitative approaches we were able both to frame the students' behavior within an appropriate theoretical framework and provide a statistically based quantitative validation of such a theoretical result.

From an educational point of view, Gestinv shows how the school mathematical practices confirm the research results of mathematics education.

Further research is required to understand if Gestinv, implemented as a research method, is able to single out new didactical phenomena that cannot be framed in the current perspectives and therefore prompts new theoretical research.

References

- D'Amore, B. (2007). Mathematical objects and sense: how semiotic transformations change the sense of mathematical objects. *Acta Didactica Universitatis Comenianae*, 7, 23-45.
- D'Amore, B. & Fandiño Pinilla, M.I. (2007). Change of the meaning of mathematical objects due to the passage between their different representations. How other disciplines can be useful to the analysis of this phenomenon. *Rome, Symposium on the occasion of the 100th anniversary of ICMI, March 2008. WG5: The evolution of theoretical framework in mathematics education*, organizers: Gilah Leder and Luis Radford. www.unige.ch/math/EnsMath/Rome2008.
- Duval, R. (1993). *Registres de représentations sémiotique et fonctionnement cognitif de la pensée. Annales de Didactique et de Sciences Cognitives*, ULP, IREM Strasbourg, 5, 37-65.
- Duval, R. (1995). *Sémiosis et pensée humaine: Registres sémiotiques et apprentissages intellectuels*. Berne: Peter Lang.
- Duval, R. (2008). Eight problems for a semiotic approach in mathematics education. In L. Radford, G. Schubring, & F. Seeger (Eds.), *Semiotics in mathematics education: Epistemology, history, classroom, and culture* (pp. 39–61). Rotterdam: Sense Publishers.
- Ferretti, F., & Gambini, A. (2017). A vertical analysis of difficulties in mathematics from secondary school to university level; some evidence stems from standardized assessment. In T. Dooley & G. Gueudet (Eds.), *Proceedings of the Tenth Congress of the European Society for Research in Mathematics Education*. Dublin, Ireland: DCU Institute of Education & ERME.
- Ferretti, F., Giberti, C., & Lemmo, A. (2018). The Didactic Contract to Interpret Some Statistical Evidence in Mathematics Standardized Assessment Tests. *EURASIA Journal of Mathematics, Science and Technology Education*, 14(7), 2895-2906. <https://doi.org/10.29333/ejmste/90988>
- Gestinv 2.0. (07.01.2018). *Archivio interattivo delle prove Invalsi*. Retrieved from <http://www.gestinv.it>.
- Iori, M. (2018). Teachers' awareness of the semio-cognitive dimension of learning mathematics. *Educational Studies in Mathematics*, 98(1), 95-113.
- Johnson, R. B., & Onwuegbuzie, A. J. (2004). Mixed methods research: A research paradigm whose time has come. *Educational Researcher*, 33(7), 14-26.
- Santi, G. (2011). Objectification and semiotic function. *Educational Studies in Mathematics*, 66(77), 285–311.

Students' attitudes and responses to pair-work testing in mathematics

Eszter Bóra¹ and Péter Juhász²

¹Eötvös Loránd University, Hungary; eszterbora@gmail.com

²Alfréd Rényi Institute of Mathematics, Hungary; juhasz.peter@renyi.mta.hu

Keywords: Pair-work testing, 21th century skills.

Introduction

In Hungary, mathematics teachers usually teach every topic separately, one after the other. At the end of each topic the students write a test, these results are the main factors contributing to the final evaluation of a student work during the year. Other popular forms of assessments used daily are short oral individual assessments typically at the beginning of the class, short written tests (between 5-20 minutes) and checking the homework problems (OECD, 2015). There are several problems with these traditional tests taking practices.

First, the problem with the longer, end-of-topic tests are, that they can also contribute to the development of bad studying habits (e.g. last-minute studying, bad time-management), being these tests are often infrequent and their dates are known beforehand.

Second, in general, writing a test is not a perfect option for assess one's understanding of a concept or level of mastery. Since a worrying number of students develop text anxiety over the years, and so, it is hard to tell how well they mastered the given topics. In Hungary there is a surprisingly high level of test anxiety among children (Bodas & Ollandick, 2005). For these reasons, we started to experiment with routines of testing with a novel approach. We want to encourage students to perceive testing situations more like an interesting challenge, as a part of the learning process. With a group of students, we tried pair-work tests. Our reasoning behind this idea is the following: if one of them run out of ideas, the other can help. If none of them has an idea, they can realize the problems are indeed hard and they can try to develop new ideas together. If they fail to solve a problem hopefully they will not attribute it to their own failure, lack of skills, because they see their pairs struggling with it as well. Thus it helps to develop a healthy attribution theory, or mindset to mathematics, and in general, to learning.

An additional factor encouraging us to experiment with this type of test is that collaborative skills are well sought after in the workplaces. Unsurprisingly, according to many researchers the necessary 21th century skills (Voogt, 2012) are: collaboration experience, critical thinking, problem-solving skills. Unfortunately, in Hungary the mathematical educational culture is only started to develop and practice more group working, cooperative techniques in a wider context (Andrews, 2003). So, we think it is important to develop, adopt these cooperative techniques in our local contexts as well.

The novelty of our work is to examine collaboration in a testing scenario in Hungarian mathematics education.

Our study

In our current pilot study there were four tests: twice students were tested in pairs and twice students were tested individually. We recorded the marks and overall performance of two-two sets of each type of tests. The tests had the same format and length, similar difficulties and recurring topics.

The pairs were randomly selected for the pair-work tests. They did not know beforehand who their partner will be for the test. If the number of students was odd, then the first step was to know which students is willing to work alone.

After the pair-work tests we conducted an online questionnaire. Where we asked the following five questions. What percentage of the test was your contribution? How do you like the concept of writing tests in pair? How would you rate your experience during the test? How did you like your pair before the test? How did you like your pair after the test?

We made an unstructured interview with the teacher about his observations during the test, and about his opinion about the possible long-term impacts of the paired testings.

What are the students' attitudes to paired testing? We can assume from the result of the questionnaire that most student perceived the test as a fair one. We can also assume more confidently, that students have a positive attitude towards paired testing: they rated positively the concept, and they also rated their testing experience positively, despite, as in some cases, their initial not so positive attitude to their partners.

How did students respond to paired testing? Their attitudes towards each other improved. The overall level of paired work was high, the style of writing had more clarity than solo work. According to the teacher's interview, in general, students collaborated intensely but quietly, not disturbing each other.

Given the small sample size and time-frame, further research is needed to determine how paired testing improve collaboration and mastery of skills.

References

Andrews, P. (2003). Opportunities to learn in the Budapest mathematics classroom. *International Journal of Science and Mathematics Education*, 1(2), 201-225.

Bodas, J., & Ollendick, T. H. (2005). Test anxiety: A cross-cultural perspective. *Clinical Child and Family Psychology Review*, 8(1), 65-88.

OECD (2015). *Education Policy Outlook: Hungary*. Retrived from: www.oecd.org/education/policyoutlook.htm

Teppo, A. R. (2015). Grounded theory methods. In A. Bikner-Ahsbahs, C. Knipping, & N. C. Presmeg (Eds.), *Approaches to qualitative research in mathematics education* (pp. 3-21). Springer, Dordrecht.

Voogt, J., & Roblin, N. P. (2012). A comparative analysis of international frameworks for 21st century competences: Implications for national curriculum policies. *Journal of curriculum studies*, 44(3), 299-321.

Classroom assessment tasks and learning trajectories

Eleni Demosthenous, Constantinos Christou and Demetra Pitta-Pantazi

University of Cyprus, Cyprus; edemos03@ucy.ac.cy, edchrist@ucy.ac.cy, dpitta@ucy.ac.cy

Abstract. One of the purposes of assessment is to inform the classroom teacher about students' current understanding in order to improve the teaching and learning processes. Learning trajectories present a developmental progression towards increasing understanding of mathematical ideas and are commonly found in curriculum materials to assist teachers in planning instruction. Assessing students' learning along the trajectory could serve as a mediator for adjusting the pacing and the selection of opportunities during the classroom enactment. We propose a framework for designing different types of assessment tasks to elicit evidence about how students respond to the mathematical ideas presented in the trajectory. We illustrate the application of the framework by drawing on a learning trajectory of fraction division for sixth grade students and discuss how the enactment of the trajectory in classroom could be adjusted to students' current understanding.

Keywords: Classroom assessment, learning trajectories, assessment tasks.

Introduction

Research evidence indicates that assessment could enhance learning, double the speed of learning and reduce the achievement gap between low and high achievers (e.g. Black & Wiliam, 1998; Kluger & DeNisi, 1996). The aforementioned is commonly referred to as formative assessment or assessment for learning. Even though there are differences in the use of these terms (Swaffield, 2011), their focus is on providing feedback to the teacher and student to improve the teaching and learning. In this paper, we use the term “classroom assessment for learning” to highlight that the classroom is the context in which assessment takes place and that the purpose is to elicit evidence about students' current understanding for making instructional decisions to enhance the learning processes.

The learning trajectory can affect and enhance the classroom assessment for learning (Ebby & Petit, 2018; Sztajn, Confrey, Wilson & Edgington, 2012). According to Clements and Sarama (2004), a learning trajectory includes the learning goal, the developmental progressions of thinking and learning, and the sequence of instructional tasks. A learning trajectory takes into account theoretical and empirical data to form a learning route that involves processes to develop increasing sophistication in understanding, which is linked with an instructional sequence (Heritage, 2008; Clements & Sarama, 2004). Classroom assessment could then be closely linked with these cognitive pre-designed learning trajectories as they inform the teacher about the desired learning goal and a progression towards developing understanding. Thus, they can help teachers interpret how students respond to these goals and how they move along the progression path by making informed decisions (Ebby & Petit, 2018).

Literature review

Assessment tasks could provide information about where students stand regarding the learning trajectory and students' levels of understanding and misunderstanding (Bennett, 2011). The design of assessment tasks has been mainly an issue of discussion for high-stake assessments and standardized tests but it is time to include clear descriptions of the form and key features of classroom assessment in order to enrich the current research base (Kingston & Nash, 2011).

Different types of tasks elicit evidence about various facets of students' understanding. Existing frameworks of assessment tasks rely on categorizations based on the format of tasks or the level of processes students are expected to engage with. Phelan, Choi, Vendlinski, Baker and Herman (2011) categorized tasks into basic computational tasks, partially worked examples, word problems, graphic problems and explanation tasks. Webb, Alt, Ely and Vesperman (2005) and deLange (1999) identified levels of assessment tasks. Webb et al. (2005) suggested that tasks could engage students in recall of information, skills and concepts, strategic thinking, and extended thinking. deLange (1999) categorized tasks into those of reproduction, procedures, concepts and definitions; connections and problem solving; mathematization, mathematical thinking, generalization and insight.

It seems that there is consensus that assessment tasks should elicit evidence from students' engagement with recall procedures to complex reasoning. However, the field lacks a systematic way for making connections between assessment tasks, increasing complexity and learning trajectories. In this paper, a framework is presented towards this aim in order to contribute to the discussion of learning trajectories and assessment for learning. The framework describes types of tasks for classroom assessment for learning which are linked with the learning trajectories aiming (1) to elicit evidence about how students respond to the mathematical ideas presented in the learning trajectory and (2) to inform as well as adjust accordingly the enactment of the learning trajectory as it unfolds in classroom.

Sztajn et al. (2012) mentioned that teachers make sense of students' ideas and respond accordingly by relying on students' reasoning when they follow a learning trajectory since they help teachers identify common misconceptions beforehand. Then, the levels of learning "could serve as reference points for assessments designed to report where students are along the way to meeting the goals of instruction and perhaps something about the problems they might be having in moving ahead" (Daro, Mosher & Corcoran, 2011, p. 29). In addition, it is critical to interpret appropriately the evidence for planning instructional adjustments. The majority of studies, so far, do not elaborate on the possible instructional adjustments based on the evidence from various assessments approaches (McMillan, Venable & Varier, 2013). Instructional adjustments include differentiation for remediation, reteaching using different strategies and changing the pacing of instruction (Hoover & Abrams, 2013).

Development of framework

The framework was formulated by relying on existing categorizations of tasks (i.e., deLange, 1999; Webb et al., 2005), international studies (e.g. TIMSS, PISA) and online resources (e.g. map.mathshell.org). We identified key points of learning, critical features of tasks, ways to capture increasing complexity and then designed tasks for grades 4 to 6. In total, 161 tasks were piloted in real classroom settings during a school year. Based on the feedback from teachers' comments and the coding of students' responses, the types of tasks were refined through several cycles of revisions. In this paper, we present only assessment tasks for a selected learning trajectory for sixth grade.

The framework describes different types of tasks for the purpose of classroom assessment for learning and presents the role of learning trajectories in designing assessment tasks and in planning instructional adjustments. Learning trajectories are foundational since assessment elicits evidence of how students' learning develops towards the expected goal and supports teachers in deciding for their

next teaching actions (Heritage, 2008). A learning trajectory as presented in the curriculum could inform the development of assessment tasks and the evidence from the assessment tasks then shapes the enactment of the learning trajectory in classroom (Figure 1). The fact that teachers in the Cypriot educational context follow closely the learning trajectories as presented in the curriculum materials and particularly in textbooks facilitated the process of designing assessment tasks that were aligned with the learning trajectories by identifying key points in learning. However, the classroom enactment is not expected to be identical to the intended curriculum. Indeed, the evidence from students' responses in the assessment tasks could contribute in adjusting the enactment in classroom to students' ongoing needs.

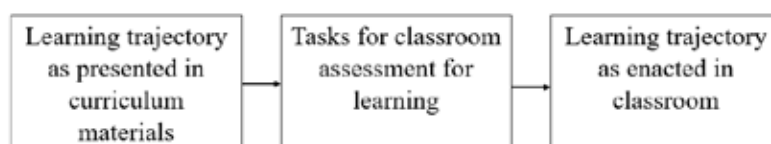


Figure 1: Classroom assessment tasks and learning trajectories

We define a task for classroom assessment to consist of a single request of what students are expected to do and the necessary information to respond to that request. Three different types of tasks were formed and two task features were selected. Table 1 presents the three types of tasks with their respective description. The different tasks aim to elicit evidence regarding students' progression along the learning trajectory and be aligned to the increasing expertise and sophistication as expected by the trajectory. These tasks are not intended to be seen as consecutive and linear steps of learning (e.g., it is not assumed that necessarily “apply and connect” tasks will be used after “recall and reproduce”). These tasks could be used in classroom according to how the learning trajectory unfolds and inform of the ways students develop increasing expertise.

Type of Task	Description of Tasks
Recall and Reproduce	Students are able to respond to these tasks because they can use taught procedures and technical skills.
Apply and Connect	Students are able to respond to these tasks because they can apply the mathematical ideas in various contexts and make connections between representations and mathematical ideas.
Reflect and Generate	Students are able to respond to these tasks because they can investigate mathematical ideas, structures and contexts, and develop their own mathematical products.

Table 1: Types of classroom assessment for learning tasks

Familiarity and complexity are two features that characterize the tasks. The familiarity of the task is determined by students' previous experiences with the requests of the task and the information provided. The complexity of the task is determined by (a) the number of steps to complete the assessment task, (b) the amount and nature of information that students need to handle, and (c) the possible deviations that alter the complexity according to the mathematical topic (e.g. the place of the unknown in an equation, the choice of numbers).

Application of the framework

In this paper, we discuss the application of the framework to design tasks for a learning progression on fraction division, which serves as the context to present examples of the three different tasks for assessment for learning. Fraction division was selected since on one hand it is not a difficult topic when students work only procedurally to invert and multiply. On the other hand, it is conceptually demanding since fraction division could be represented using various ways and connected with other mathematical ideas (Li, Chen & An, 2009).

There are different approaches in the learning trajectories in textbooks around the world (e.g., Li et al., 2009). Only the trajectory found in the Cypriot curriculum materials is presented since it shaped the design of assessment tasks. This trajectory is not presented as an exemplary one but rather as a medium to exemplify the types of assessment tasks, to illustrate how the increasing sophistication in understanding could be captured and to discuss possible instructional adjustments. The selected trajectory is designed to engage students first with whole numbers divided by fractions by making links with quotative division of whole numbers. Then, students are engaged with fractions divided by whole numbers by making links with partitive division of whole numbers. Afterwards, they are introduced to fractions divided by fractions, where again the quotative division appears and they engage also with division of mixed numbers. Students are expected to have the opportunity to learn different procedures (i.e., invert and multiply, convert to fractions of common denominator and divide the numerators), represent fraction division using number line and area models, interpret representations, and solve word problems.

The first type of task aims to assess whether students can reproduce the procedure of fraction division. The procedure is expected to have been taught and practiced. Hence, students would have extensive familiarity. Figure 2 presents an example of “recall and reproduce” tasks. These are different mathematical expressions in order to identify which of these students can complete fluently and flexibly. The last two expressions have increased complexity due to the position of the unknown. This example consists of expressions with different number characteristics and it is not intended to present a step of the instructional sequence but a medium for capturing increasing understanding.

Find the unknown v .	
(a) $6 \div \frac{3}{4} = v$	(b) $\frac{3}{10} \div 5 = v$
(c) $\frac{1}{3} \div \frac{1}{6} = v$	(d) $2\frac{5}{6} \div 1\frac{1}{2} = v$
(e) $1\frac{1}{3} \div v = \frac{2}{3}$	(f) $v \div \frac{1}{4} = \frac{4}{5}$

Figure 2: Example of “Recall and Reproduce” tasks

The second type of assessment tasks intend to assess whether students understand the underlying mathematical concept, in this case, the way in which fraction division could be interpreted and represented. It is anticipated that this type of task will bring to the surface students’ reasoning and misconceptions. Figure 3 shows examples of “apply and connect” tasks. Students are asked to represent the fraction division using an area model and a number line. In the first case, students would need to interpret the fraction division as “ $\frac{3}{4}$ divided by 2” and represent it (e.g., divide the rectangle

in 4 equal stripes, shade 3 out of the 4 and then divide the shaded area into two equal regions). In the second case, students would need to interpret the fraction division as “how many $\frac{1}{4}$'s are in $\frac{3}{4}$,” and represent it (i.e., draw three jumps of $\frac{1}{4}$). Deviation to the complexity of the tasks could be achieved without providing the area model and the number line or asking students to provide more than one representation of the mathematical expression (e.g., verbal and pictorial). The last example is a word problem in which students would not only need to identify which procedure to pursue but also to interpret and communicate their thought process.


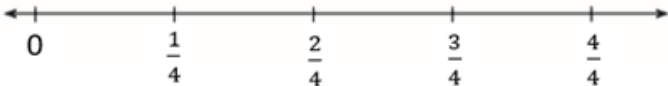
<p>Represent the mathematical expression using a rectangular model and find the quotient.</p> $\frac{3}{4} \div 2 =$ 
<p>Represent the mathematical expression on the number line and find the quotient.</p> $\frac{3}{4} \div \frac{1}{4} =$ 
<p>Mr. Apostolos has a piece of wood of $\frac{5}{6}$ m length. He wants to cut it into equal pieces of $\frac{1}{8}$ m. Explain the way in which Mr. Apostolos can work to find beforehand whether it is possible to make 7 such pieces.</p>

Figure 3: Examples of “Apply and Connect” tasks

Students are expected to have worked on representing fraction division using a variety of representations and solving word problems. Hence, the requests of the tasks would be familiar to the students. However, depending on the given context of representation and word problem, students would need to decide how to apply the procedure of fraction division and how to interpret it.

The third type of assessment tasks intend to assess whether students can investigate independently mathematical ideas, structures and contexts, and develop their own mathematical products. For example, students could engage in evaluating arguments, generating justifications, forming examples and non-examples. Students are expected to have limited familiarity with the request of the tasks in order to engage in generating an idea instead of recalling it. Figure 4 presents examples of “reflect and generate” tasks. The first task asks students to generate a word problem based on the given mathematical expression. Students are anticipated to have had opportunities in solving word problems but they are now asked to formulate their own word problem by taking into account the given numbers and an appropriate real life situation. The next task, which was adapted from Askew et al. (2015), presents a statement and students are asked to explore whether it is always true, sometimes or never.

Students would need to compare the quotient and the dividend in different cases of numbers (e.g., division of two integers, division of two fractions).

Write a word problem that corresponds to the mathematical expression $\frac{6}{9} \div \frac{1}{3}$.
Marios says: “When I divide two numbers, the quotient is always smaller than the dividend” Do you think that this is always, sometimes or never true? Explain.

Figure 4: Examples of “Reflect and Generate” tasks

A less complex task could be designed by asking students to complete the description of a word problem based on a given mathematical expression while a more complex task could ask students to write a word problem for a mathematical expression consisting of two operations (e.g. $5 + (\frac{6}{9} \div \frac{1}{3})$). Another option is to modify the nature of the information by reducing the complexity such as “Find the cases for which the division of two numbers gives a quotient larger than the dividend”. In this way, students would need to identify cases of numbers that confirm the statement instead of exploring all possible cases of numbers to decide whether Marios’ argument holds true in all, some or none of these cases.

Discussion

The framework aims to contribute to the discussion about how classroom assessment could be linked with learning trajectories (e.g., Ebby & Petit, 2018; Heritage, 2008). Different types of tasks were formed based on the pre-designed trajectory in curriculum materials that aim to elicit evidence about students’ understanding along the increasing expertise of the learning trajectory in order to make informed decisions of how the enactment of the learning trajectory in classroom could be adjusted. Hence, we rely on students’ understanding to discuss about teachers’ instructional adjustments.

The adjustments elaborate on differentiation, reteaching and changing the pace of instruction (Hoover & Abrams, 2013). Students’ responses to “recall and reproduce” tasks could inform the classroom teacher whether students reproduce the procedure of dividing fractions correctly. If students use the procedures incorrectly (e.g. invert the dividend instead of the divisor and multiply), the teacher might need to provide more opportunities in reteaching the procedure and in using other procedures (e.g. converting into like fractions) to develop understanding. If students complete incorrectly the last two mathematical expressions (in which the place of the unknown differs), then the teacher might make explicit links between division of whole numbers and division of fractions. If students seem to make minor arithmetical mistakes (e.g. in converting mixed numbers to improper fractions), then either they face difficulties with previously taught mathematical concepts or they need further practice. Hence, along the enactment of the learning trajectory in classroom, more time and relevant opportunities could be planned. The evidence elicited from “apply and connect” tasks could indicate whether students are facing difficulty in making sense of fraction division, in using different representations, in identifying fraction division in various contexts and even making connections with fraction multiplication. If students find difficulties with the area model and the number line, then either more opportunities are needed to make sense of what fraction division means or more

opportunities are needed with the particular representational formats (e.g. by corresponding various fraction division expressions with their respective representations). If students solve the problem incorrectly (e.g. they mention that it is possible to make 7 such pieces), then either more opportunities are needed to address previously taught concepts (e.g., converting into like fractions) or more opportunities to develop understanding of how fraction division could be interpreted. The “reflect and generate” tasks could inform teachers whether students could extend their understanding of mathematical ideas and exhibit higher-order thinking. If students find difficulties in writing a word problem that corresponds to the given mathematical expression, then students might need further opportunities to reflect on the structure of relevant word problems and opportunities to write word problems using for example integer numbers. Students who are not able to respond fully or complete at all the last task might need further opportunities that engage them in reflecting about the structure of numbers and to develop arguments that justify or refute a statement.

Decisions about instructional adjustments would also be regulated by the number of students facing constraints and time limitations. The number of students will determine whether adjustments will involve the whole class, groups of students or individual students. The teachers’ role is quite demanding in making decisions for the pacing of instruction and for the selection and amount of learning opportunities. Particularly, teachers find most difficult the process of using assessment information to plan instructional actions (Heritage, Kim, Vendlinski & Herman, 2009) while some teachers may not even use the information to adapt their instruction (Zhao, Van den Heuvel-Panhuizen & Veldhuis, 2017).

The presentation of the framework, in this paper, is limited to its application in the design of assessment tasks based on a learning trajectory for fraction division. The framework could be validated and further refined by developing tasks for other grade levels. Further empirical evidence could provide insight into the potential and limitations of the framework from its application in real classroom settings. Further research could also explore what kind of evidence is purposeful for teachers to be elicited from assessment tasks and how decisions about instructional adjustments could be planned to move students towards increasing expertise along the learning trajectory.

References

- Askew, M., Bishop, S., Christie, C., Eaton, S., Griffin, P., Morgan, D., & Wilne, R. (2015). *Teaching for Mastery: Questions, tasks and activities that support assessment (Year 6)*. Oxford: Oxford University Press.
- Bennett, R.E. (2011). Formative assessment: a critical review. *Assessment in education: principles, policy & practice*, 18(1), 5–25.
- Black, P., & Wiliam, D. (1998). Assessment and Classroom Learning, *Assessment in Education: Principles, Policy & Practice*, 5(1), 7–74.
- Clements, D.H., & Sarama, J. (2004). Learning trajectories in mathematics education. *Mathematical thinking and learning*, 6(2), 81–89.
- Daro, P., Mosher, F.A., & Corcoran, T.B. (2011). Learning trajectories in mathematics: a foundation for standards, curriculum, assessment, and instruction (CPRE Research Reports). Retrieved from http://repository.upenn.edu/cpre_researchreports/60

- deLange, J. (1999). *Framework for classroom assessment in mathematics*. Utrecht: Freudenthal Institute and University of Madison.
- Ebby, C.B., & Petit, M. (2018). Using learning trajectories to elicit, interpret, and respond to student thinking. In E.A. Silver & V.L. Mills (Eds.), *A fresh look at formative assessment in mathematics teaching* (pp. 81–102). Reston: NCTM.
- Heritage, M. (2008). Learning progressions: Supporting instruction and formative assessment. *Paper prepared for the Formative Assessment for Teachers and Students (FAST) State Collaborative on Assessment and Student Standards (SCASS) of the Council of Chief State School Officers (CCSSO)*. Washington: Council of Chief State School Officers.
- Heritage, M., Kim, J., Vendlinski, T., & Herman, J. (2009). From evidence to action: a seamless process in formative assessment? *Educational measurement: issues and practice*, 28(3), 24–31.
- Hoover, N.R., & Abrams, L.M. (2013). Teachers' instructional use of summative student assessment data. *Applied Measurement in Education*, 26(3), 219–231.
- Kingston, N., & Nash, B. (2011). Formative assessment: a meta-analysis and a call for research. *Educational measurement: issues and practice*, 30(4), 28–37.
- Kluger, A.N., & DeNisi, A. (1996). The effects of feedback interventions on performance: a historical review, a meta-analysis, and a preliminary feedback intervention theory. *Psychological Bulletin*, 119(2), 254–284.
- Li, Y., Chen, X., & An, S. (2009). Conceptualizing and organizing content for teaching and learning in selected Chinese, Japanese and US mathematics textbooks: the case of fraction division. *ZDM*, 41(6), 809–826.
- McMillan, J.H., Myran, S., & Workman, D. (2002). Elementary teachers' classroom assessment and grading practices. *The journal of educational research*, 95(4), 203–213.
- McMillan, J.H., Venable, J.C., & Varier, D. (2013). Studies of the effect of formative assessment in student achievement: So much more is needed. *Practical Assessment, Research & Evaluation*, 18(2), 1–15.
- Phelan, J., Choi, K., Vendlinski, T., Baker, E., & Herman, J. (2011). Differential improvement in student understanding of mathematical principles following formative assessment intervention. *The journal of educational research*, 104(5), 330–339.
- Swaffield, S. (2011). Getting to the heart of authentic assessment for learning. *Assessment in education: principles, policy & practice*, 18(4), 433–449.
- Sztajn, P., Confrey, J., Wilson, P.H., & Edgington, C. (2012). Learning trajectory based instruction: towards a theory of teaching. *Educational researcher*, 41(5), 147–156.
- Webb, N.L., Alt., M., Ely, R., & Vesperman, B. (2005). *Web Alignment Tool (WAT) Training Manual*. Washington, DC: Council of Chief State School Officers.
- Zhao, X., Van den Heuvel-Panhuizen, M., & Veldhuis, M. (2017). Using classroom assessment techniques in Chinese primary schools: effects on student achievement. In T. Dooley, & G. Gueudet (Eds.), *Proceedings of the Tenth Congress of the European Society for Research in Mathematics Education* (pp. 3604–3611). Dublin: CERME.

Diagnosis of basic mathematical competencies in years 8 and 9

Christina Drüke-Noe¹ and Hans-Stefan Siller²

¹ Pädagogische Hochschule Weingarten, Weingarten, Germany; druekenoe@ph-weingarten.de

² Universität Würzburg, Würzburg, Germany; hans-stefan.siller@mathematik.uni-wuerzburg.de

In this paper we present a newly developed test with easy tasks which assesses basic mathematical competencies that are essential for vocational training. This test is used in years 8 and 9 in Germany. From both a content-oriented and a process-oriented perspective, preliminary test results reveal a substantial lack of these competencies in all academic tracks, and differential effects can be found with respect to year and class that need to be examined beyond curricular analyses.

Keywords: mathematics tasks, diagnostic test, assessment, basic competencies, vocational training.

Many professions require at least basic mathematical competencies to understand or to implement work processes, and such competencies are a prerequisite to successfully begin vocational training. Consequently, in mathematics these competencies should have been acquired beforehand by means of working on tasks. So far and especially in international comparative tests, the relation between tasks, basic mathematical needs and vocational training has hardly been examined as the few initial approaches to adult education primarily focus on social participation and necessary mathematical understanding. In this paper we present our task-based approach to testing secondary students' basic mathematical competencies and raise ideas how to support these students adequately and in time.

The role of tasks in Mathematics

Especially in Mathematics tasks are essential and thus they are being used from various perspectives in both research and teaching. In any case they require engagement with a certain mathematical content (e.g. Christiansen & Walther, 1986), and they are understood here as orally or written set assignments to students to carry out a subject-oriented activity (Drüke-Noe et al., 2017).

In research, tasks can serve as documents of mathematics instruction. This applies e.g. to the project COACTIV in which tasks are used not only to assess teachers' professional knowledge but also to get insight into the level of cognitive activation potentially realized in teaching or assessing mathematics (Kunter et al., 2013). Tasks also form the linking element between curricular standards and the professional knowledge of teachers on the one hand and the aimed-at knowledge, skills and competencies of students on the other hand (Neubrand, Jordan, Krauss, Blum, & Löwen, 2013).

Furthermore, tasks are essential in tests to assess the achievement of learning goals. For this purpose, oral and especially written tests are regularly set in Germany. These tests, which are either set internally or externally, comprise a range of tasks of a certain cognitive demand to examine competencies either formatively or summatively. Due to their backwash effect on teaching as well as their impact on the students' further educational career, centrally set external examinations at the end of various stages of education are quite prominent examples of summative written tests. Interestingly though, in several European countries as well as in different federal states of Germany such centrally set exams are often of a relatively low level of cognitive demand and cover only a limited range of competencies (Kühn & Drüke-Noe, 2013; Drüke-Noe & Kühn, 2017). This also applies to internally

written mathematics tests in Germany, so called class tests (Drüke-Noe, 2014). From a normative perspective, however, adequate compilations of tasks in tests are crucial as they “summarize the core components of an instructional unit and ultimately specify the level of mathematical achievement that teachers require” (Neubrand et al. 2013, p. 128) and thus make social expectations transparent for both teachers and students.

It can be concluded that tasks are “actively configurable content-related and didactic elements that serve to structure mathematics instruction” (Neubrand et al., 2013, p. 126; see also Zaslavsky, 2007, p. 434) that “provide the basis for students’ cognitive activities” (Neubrand et al., 2013, p. 127) and therefore play an essential role in teaching, learning and assessing mathematics.

Tests and Basic Competencies

In Germany, as a consequence from only mediocre results in international comparative studies like e.g. TIMSS and PISA, educational standards have been implemented in almost all subjects in the last fifteen years. In the course of this, the focus of attention shifted towards regular formative examinations of learning goals and competencies, and several centrally set formative tests were introduced nationwide in Germany that serve as diagnostic instruments. These tests are designed on the basis of the German Educational Standards and are in accordance with the standards’ conception. Therefore, their tasks cover all five content strands (quantity, measuring, space and shape, change and relationships, uncertainty and statistics), all six competencies (argumentation, problem solving, modeling, use of representations, working technically, communication) and all three levels of cognitive demand (low, medium, high). Two different kinds of tests are set: A first kind is compulsory comparative tests which are set in the years 3 and 8 (9-year- and 14-year-olds) which are administered as well as corrected within schools. The test results are to provide diagnostic information in which areas both teaching and learning should be improved to prepare students for a successful completion of compulsory education one or two years later at ISCED-level 2. A second kind of tests is centrally set every six years in the years 4 and 9. Its conception is standard-based, too, but this nationwide test is only taken by a representative sample of students and its results are only used by the education administration to monitor the school system with respect to the successful achievement of the educational standards. For both years 4 and 9 and especially for the latter one results reveal regularly that on average one quarter of all German students miss minimal educational standards (Pant et al., 2013). Very similar findings come up in a German longitudinal study on Bavarian secondary students of different school tracks (vom Hofe & Hafner, 2009) as well as in regular international studies like PISA (e.g. Neubrand & Neubrand, 2004).

To summarize, there is much empirical evidence for the mathematical achievement of year 9-students that firstly implies that 16-year-olds, who leave school at the end of lower secondary education and are about to enter a phase of vocational training, lack substantial basic skills such as a reflective use of knowledge and abilities. Secondly, these students presumably lack not only the basis for an understanding of routines beyond their mechanical application but also knowledge of problem solving activities. Consequently, it seems not only necessary to diagnose such basic competencies well beforehand but also – which is even more important – to support these low-achievers in time both on a class-level and individually, too. More efforts need to be taken so that in the future less students fail

minimal standards since a successful achievement of at least minimal standards is a precondition to successfully begin (and complete) a vocational training after the end of year 9 (or year 10).

These necessities form the basis of our task-based project „Diagnostic scaffolding of basic mathematical competencies for vocational training“. In this project we assess basic mathematical competencies well before students leave school. We test entire classes and can provide teachers with quantitative and qualitative feedback on the test results. Teachers can use this feedback to support their students to better achieve basic competencies by the end of compulsory education.

Basic Competencies and the Start of Vocational Training

Based on the German Educational Standards we designed a test that only assesses basic mathematical competencies relevant for vocational training. As an adequate selection of tasks for such a test substantially relies on both an understanding of basic competencies as well as of what is necessary to successfully start a vocational training, we briefly outline essential elements of both here.

In Germany, there are different empirical and normative approaches to defining basic competencies for the end of compulsory education, which is usually the end of lower secondary education irrespective of successfully obtaining a formal school leaving certificate. However, there is no consensus as to whether basic competencies characterize what is really necessary to be prepared for a life as a citizen, for a successful start and/ or completion of a vocational training. It is equally diverse who defines basic competencies; is it teachers or researchers or those who continue working with these students after a certain stage of education? Some other task-based approaches to defining basic competencies which are relevant for our one and only focus on the end of lower secondary education are briefly outlined in the following: One primarily normative concept by Sill and Sikora (2007) considers empirical results from national comparative studies and defines basic mathematical competencies needed for further education, everyday life and society. It comprises three so-called competency levels that distinguish whether certain knowledge and abilities should be immediately and automatically applicable or be easily re-activated or be only exemplary and episodal. A second concept is essential for our approach as it is explicitly based on the German Standards. It combines a normative with an empirical approach and defines basic mathematical competencies as those

which all students of all educational levels must at least and permanently have at the end of compulsory education. These competencies are a prerequisite for sovereignly mastering everyday life and actively participating as politically mature citizens in social and cultural life. These competencies are equally a prerequisite for a successful and promising start into a vocational training and a pursuance of one's profession. Those who do not have these basic competencies will presumably not sufficiently be able to get along in these situations without help. These students must timely and particularly intensively be supported (Drüke-Noe et al., 2011, p. 8).

A third German and predominantly empirical approach is the “Model of Competency Levels for the Educational Standards for a qualified school leaving certificate at the end of year 9 and at the end of year 10” which was passed by the Standing Conference of the Ministers of Education and Cultural Affairs. Based on results from several large scale studies and applying probabilistic test theories which relate task difficulties to students' abilities, this model is based on a competency scale which

distinguishes six competency levels. These levels describe students' abilities on the basis of task properties. The lowest two levels, which we only focus on here, define the minimal standard as a set of competencies that all students must have achieved by the end of a certain educational stage. Students at or below this minimum standard can only comprehend or apply the most simple standard argumentations or problem solving activities, use simple models or well-known visualizations, apply one-step routines or extract single pieces of information from simple texts (Kultusministerkonferenz, 2011, p. 29ff).

Several other international approaches to basic mathematical competencies also relate structural errors to procedural processes: Brown and Burton (1978) already do so in their "Diagnostic Models for Procedural Bugs in Basic Mathematical Skills" and stress the close relation between basic skills, procedural and conceptual knowledge. In his analyses of structural errors with respect to procedural knowledge Wu (1999, p. 1) stresses that "in mathematics, skills and understanding are completely intertwined". Ritter-Johnson, Siegler and Alibali (2001, p. 346) equally claim that "conceptual and procedural knowledge influence one another [...] and develop iteratively, with increases in one type of knowledge leading to increases in the other type of knowledge".

Consequently, a traditionally rather content-focused perspective on teaching (and testing) ought to be widened to a more comprehensive one which considers both content and processes not only when putting curricular regulations into practice but also when teaching and testing basic competencies which – amongst others – are necessary to work successfully on mathematics tasks. With respect to vocational training, Weißeno and colleagues (2016, p. 3) additionally point out that "mathematical skills play an important role in developing job specific competencies in a number of occupations that require intermediate qualifications." Thus, learners do not have to be experts in the field of mathematics, but they must be able to implement the necessary basic skills, as well as be able to critically reflect upon and to apply processes in the course of solving tasks to correspond with the concept of "Higher General Education" as developed by Fischer (2001).

In our project, we designed a task-based test to assess students' basic mathematical competencies relevant for vocational training. Due to our test conception we can derive information on these competencies from both a content- and a process-oriented perspective. Furthermore, this information and deeper test analyses allow us to deduce a specific feedback to support teachers and students.

Test Conception and Task Features

To both evaluate basic competencies and consider a prospective ability to take up vocational training, our test addresses students who aim at getting a qualified school leaving certificate at the end of year 9 or at the end of year 10 (ISCED-level 2). To allow for sufficient time for compensation before leaving school, both versions of this test (see below) can be taken well before, i. e. in year 8 (14-year-olds) and/ or in year 9 (15-year-olds) and can be set in all school tracks.

Since the test's conception is based on the Educational Standards, it covers all five content strands, all six competencies and all three levels of cognitive demand (see Table 1). All tasks were selected correspondingly and thus allow analyses from a content- and a process-oriented perspective. Based on cognitive analyses we can describe the content addressed and the competencies needed when

solving a task, which we briefly outline below by means of three examples. As only basic competencies are to be assessed, only relevant content areas of the curriculum of the preceding years 7 and 8 are tested. This curricular validity has been approved by experts. Almost all tasks are presumed to be empirically easy (i. e. at least 80 % correct answers are expected) as they were developed in accordance with characteristics of the two lowest levels of the competency level-model (KMK, 2011). However, from our perspective relevant basic competencies not only comprise the ability to apply certain routines and procedures to show *how* something works but also to use them critically and/ or to explain *why* something works: Therefore, we intentionally included some presumably empirically more difficult tasks in the test and only for these we anticipated less than 80 % correct answers.

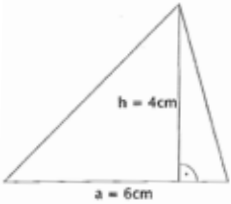

<p>Calculate the area of the triangle.</p> 	<p>Use the illustration to explain why the area of a parallelogram is determined by applying the rule $Area = Length\ of\ Base \cdot Height$.</p> 	<p>Heike's savings book shows 180 € The interest rate is 2 % per annum.</p> <p>Calculate the amount of interest after 4 months.</p>
--	--	---

Figure 1: The tasks “Triangle” (left), “Parallelogram” (middle) and “Savings book” (right)

Three tasks (see Figure 1) are to illustrate our approach: The task „Triangle“ is cognitively easy and it tests *how* something works. The representation immediately leads to a procedure to calculate the area by means of the given lengths of the triangle's base and height. This task ought to be empirically easy as calculating the area of this elementary figure requires just one step with small numbers. The task “Parallelogram” represents those that test *why* something works. The rule to determine the area of this quadrilateral is explicitly named. Using the representation students need to develop a strategy to explain *why* the area can be calculated by means of this rule. According to the competency level-model (KMK, 2011) it must be assumed, though, that this is no empirically easy task as it requires an argumentation. In the task “Savings book” students must initially extract relevant information from a simple text (communication) to then design a strategy and apply a basic mathematical model to calculate the amount of interest (problem solving, modeling, working technically).

Test version	Competence						Level of cognitive demand		
	Argumentation	Problem solving	Modeling	Use of Representations	Working technically	Communication	low	medium	high
B	4	2	4	11	9	7	3	11	1
E	8	7	5	9	8	12	2	11	2

Table 1: Numbers of tasks that require one or more of the six competencies and numbers of tasks of the given level of cognitive demand

The two test versions (B: basic version, E: extended version) comprise 15 tasks each with three tasks per content strand that all require open answers. Eight tasks are identical in both versions and almost all the remaining seven ones are parallel versions of each other which differ either only as regards their presumed task difficulty or as regards the track-specific curriculum. The students have

45 minutes to work on the test, and they may only use pens, a ruler and a device to measure angles. Before the test was finally used, it was tried and tested beforehand and improved further.

By means of a coding scheme and applying a dichotomous coding with double digits, different types of correct, partly correct or wrong answers are identified. Further analyses of the test results allow us to provide teachers with quantitative feedback (charts on types of answers with respect to content strands) and with qualitative feedback on missing basic competencies. Thus, this diagnostic test with its combined content- and process-oriented design and the subsequent detailed feedback may not only close a gap PISA leaves but also provides teachers with class-specific information on (missing) basic competencies of prospective school leavers. Teachers can then use this detailed information to develop suitable interventions to better support their students to acquire basic competencies.

Sample and preliminary results

The test was set to a non-representative sample of students (N=367) in 16 academic and nonacademic classes (see Table 2) from two German states (Baden-Württemberg, Rhineland-Palatinate). The test took place at the beginning of the second semester in the school year 2016/17.

Test version	Academic track	Nonacademic track
B	---	Baden-Württemberg: 2 classes in year 8 (N=52), 2 classes in year 9 (N=45)
E	Rhineland-Palatinate: 2 classes in year 8 (N=52), 8 classes in year 9 (N=189)	Baden-Württemberg: 2 classes in year 9 (N=29)

Table 2: Sample of classes and students that took the diagnostic test

In accordance with the standard-based test conception we present preliminary findings firstly from a **content-oriented perspective** and then from a process-based one. Irrespective of track and year, hardly one quarter of all students (23 %) correctly solved both tasks on the area of elementary figures (see Figure 1), and almost equally many students (26 %) solved none of these two correctly. It is interesting to note that the task „Triangle“, which rather focuses on procedures (knowing *how*), was solved considerably better by students from the nonacademic track (nonacademic track: 76 %, academic track: 64 %). However, considering both this task's features and the predominance of routines in Germany, a much higher percentage of correct answers could have been expected. Less surprising, far more students from the academic track were able to solve the task „Parallelogram“ (nonacademic track: 6 %, academic track: 42 %) which rather focusses on understanding (knowing *why*). As expected, in both tracks students of year 9 solved both tasks better than those in year 8 but from a content-based perspective the overall results of both tasks are rather astounding as the area of such basic figures is an integral part of every curriculum. Error analyses reveal that students typically fail when distinguishing formulae (here: area of a rectangle and that of a parallelogram) or when explaining a rule (see “Parallelogram”) although it is explicitly given here.

For analyses from a **process-oriented perspective** we focus on modeling here. Detailed analyses of the students' work rely on steps of the modeling cycle by Blum and Leiß (2005). As expected and irrespective of track and year, in all six modeling tasks students primarily find it difficult to understand the real situation and then to constitute a situation model. Furthermore, validating a result

proves to be another difficult step even for students of the academic track. Surprisingly, in year 9 only 39,2 % of the students in the academic track solved “Savings book” correctly (non-academic track: 20,7 %) and many typically failed when validating an even obviously wrong result like e. g. an annual amount of interest of 9000 €. Based on detailed analyses of this kind we provide teachers with both quantitative and qualitative feedback on their students’ basic competencies. The qualitative feedback is based on cognitive analyses of all tasks which serve as a basis for class-specific descriptions of the most frequent mistakes per task. All these descriptions help to characterize existing and lacking basic mathematical competencies within each class and can support teachers in their successive work.

Summary and Implications

The preliminary results of our test correspond with results from representative national and international studies. Beyond this, our test which is curricular valid *and* addresses basic mathematical competencies relevant for vocational training once more highlights a discrepancy: Though these competencies are broadly considered to be essential, considerably high proportions of students can neither use nor apply them and thus lack crucial preconditions to successfully start a vocational training and succeed in their later professional careers. This leaves many things to do: From both a scientific and a diagnostic perspective, further analyses beyond curricular ones are necessary to explain unexpected differential effects as regards tracks, years and classes. Secondly, far greater efforts are needed to turn *all* students into citizens of age (cf. Fischer, 2001) and to provide them with basic mathematical competencies. We are currently developing adaptive lesson material to be implemented (and evaluated) in teaching. This material specifically addresses students’ typical difficulties as regards acquiring and keeping basic mathematical competencies. The material aims at supporting students to better solve tasks on *how* something works as well as those on *why* something works, which means that all students should be able to write down argumentations or to validate results to name just a few examples. Last but not least it will be necessary to improve not only the tasks but also the kinds of feedback we provide the teachers with.

References

- Blum, W. & Leiß, D. (2005): Modellieren im Unterricht mit der „Tanken“-Aufgabe. *mathematik lehren*, 128, Seelze, Germany: Friedrich Verlag, 18–21.
- Brown, J. S. & Burton, R. R. (1978). Diagnostic Models for Procedural Bugs in Basic Mathematical Skills, *Cognitive Science*, 2 (2), 155–192.
- Christiansen, B. & Walther, G. (1986). Task and Activity. In B. Christiansen, A. G. Howson & M. Otte, M. (Eds.), *Perspectives on mathematics education* (pp. 243–307). Dordrecht, The Netherlands: D. Reidel Publishing Company.
- Drüke-Noe, C. (2014). *Aufgabenkultur in Klassenarbeiten im Fach Mathematik. Empirische Untersuchungen in neunten und zehnten Klassen*. Wiesbaden, Germany: Springer Spektrum.
- Drüke-Noe, C. & Kühn, S. M. (2017) Cognitive Demand of Mathematics Tasks set in European Statewide Exit Exams – Are some Competences more demanding than others? In T. Dooley & G. Gueudet (Eds.), *Proceedings of the Tenth Congress of the European Society for Research in Mathematics Education* (pp. 3484–3491). Dublin, Ireland: DCU Institute of Education and ERME
- Drüke-Noe, C., Maier, U., Kleinknecht, M., Metz, K., Hoppe, H., & Bohl, T. (2017). Lehrkräfte bei der Auswahl und Gestaltung von Aufgaben professionalisieren: Wie verändert eine Fortbildung zu Merkmalen

- kognitiv-aktivierender Aufgaben die aufgabenbezogene Unterrichtsplanung von Lehrkräften? In K. Zierer & S. Wernke (Eds.), *Die Unterrichtsplanung: Ein in Vergessenheit geratener Kompetenzbereich?! - Status Quo und Perspektiven aus Sicht der empirischen Forschung* (pp. 208-223). Bad Heilbrunn, Germany: Klinkhardt.
- Drüke-Noe, C., Möller, G., Pallack, A., Schmidt, S., Schmidt, U., Sommer, N., & Wynands, A. (2011). *Basiskompetenzen Mathematik für den Alltag und Berufseinstieg am Ende der allgemeinen Schulpflicht*. Berlin, Germany: Cornelsen Verlag.
- Fischer, R. (2001). Höhere Allgemeinbildung. In A. Fischer, A. Fischer-Buck, K.-H. Schäfer, & D. Zöllner (Eds.), *Situation und Ursprung von Bildung. Franz-Fischer-Jahrbuch 2001* (pp. 151–161). Leipzig, Germany: Universitätsverlag.
- Vom Hofe, R. & Hafner, T. (2009). Zum Problem von Mindeststandards und der sogenannten Risikogruppe. *Beiträge zum Mathematikunterricht* (pp. 617–620). Hildesheim, Germany: Franzbecker.
- Kühn, S. M. & Drüke-Noe, C. (2013). Qualität und Vergleichbarkeit durch Bildungsstandards und zentrale Prüfungen? - Ein bundesweiter Vergleich von Prüfungsanforderungen im Fach Mathematik zum Erwerb des Mittleren Schulabschlusses. *Zeitschrift für Pädagogik*, 59 (06), 912–932.
- Kultusministerkonferenz (2011). *Kompetenzstufenmodell zu den Bildungsstandards für den Hauptschulabschluss und den Mittleren Schulabschluss im Fach Mathematik*. (<https://www.iqb.hu-berlin.de/bista/ksm/Kompetenzstufenm.pdf>).
- Kunter, M., Baumert, J., Blum, W., Klusmann, U., Krauss, S., & Neubrand, M. (2013). *Cognitive Activation in the Mathematics Classroom and Professional Competence of Teachers*. New York, USA: Springer.
- Neubrand, M., Jordan, A., Krauss, S., Blum, W., & Löwen, K. (2013). Task Analysis in COACTIV: Examining the Potential for Cognitive Activation in German Mathematics Classrooms. In M. Kunter, J. Baumert, W. Blum, U. Klusmann, S. Krauss, & M. Neubrand (Eds.), *Cognitive Activation in the Mathematics Classroom and Professional Competence of Teachers* (pp.125–144). New York, USA: Springer.
- Neubrand, J. & Neubrand, M. (2004). Innere Strukturen mathematischer Leistung im PISA-2000-Test [Internal structures of mathematics achievement in the PISA 2000 test]. In M. Neubrand (Eds.), *Mathematische Kompetenzen von Schülerinnen und Schülern in Deutschland: Vertiefende Analysen im Rahmen von PISA 2000* (pp. 87–107). Wiesbaden, Germany: VS Verlag für Sozialwissenschaften.
- Pant, H. A., Stanat, P., Schroeders, U., Roppelt, A., Siegle, T., & Pöhlmann, C. (2013). (Eds.). *IQB-Ländervergleich 2012. Mathematische und naturwissenschaftliche Kompetenzen am Ende der Sekundarstufe I*. Münster, Germany: Waxmann.
- Ritter-Johnson, B, Siegler, R., & Alibali, M. W. (2001). Developing conceptual understanding and procedural skill in mathematics: An iterative process. *Journal of Educational Psychology*, 93 (2), 346–362.
- Sill, H.-D. & Sikora, C. (2007). *Leistungserhebungen im Mathematikunterricht. Theoretische und empirische Studien*. Hildesheim, Germany: Verlag Franzbecker.
- Weißeno, S., Seeber, S., Kosanke, J., & Stange, C. (2016). Development of mathematical competency in different German pre-vocational training programmes of the transition system. *Empirical Research in Vocational Education and Training*, 8 (14). <https://doi.org/10.1186/s40461-016-0040-1>
- Wu, H. (1999). *Basic Skills versus Conceptual Understanding. A Bogus Dichotomy in Mathematics Education*. *American Educator*, 23 (3), 14–19.
- Zaslavsky O (2007). Mathematics-related tasks, teacher education, and teacher educators: the dynamics associated with tasks in mathematics teacher education. *Journal of Mathematics Teacher Education*, 10(6), 433–440. doi: 10.1007/s10857-007-9060-x.

Assessment and argumentation: an analysis of mathematics standardized items

Rossella Garuti¹ and Francesca Martignone²

¹INVALSI, Rome, Italy, rossella.garuti@libero.it

² Università del Piemonte Orientale, Alessandria, Italy, francesca.martignone@uniupo.it

In this paper, after a brief description of Italian National Guidelines and Evaluation System, we present and analyze two examples of standardized items focused on argumentation. The qualitative analysis is carried out by using theoretical lenses coming from studies about mathematical argumentation: in particular, we use Toulmin's model to identify common features in the structure of these standardized items. The first results of our analysis give us the elements to reflect on the multiple-choice items structures that could be used for identifying specific aspects about argumentation and for assessing students' skills.

Keywords: Assessment, argumentation, standardized tests.

Introduction

Since many years, mathematics education research has dealt with teaching and learning argumentation and proof (Hanna, 2007). The importance of argumentation in mathematics education was perceived also at the institutional level and has led to important changes in the orientation of different countries curricula (from primary to secondary school) all over the world.

Also, in the frameworks of the main international surveys, as IEA TIMSS and OECD PISA, argumentation is an important milestone. In the Mathematics Framework of IEA TIMSS 2019 (IEA, 2017) one of the three cognitive domains (*reasoning*) is described as:

Reasoning mathematically involves logical, systematic thinking. It includes intuitive and inductive reasoning based on patterns and regularities [...]. Reasoning involves the ability to observe and make conjectures. It also involves making logical deductions based on specific assumptions and rules, and justifying results. (TIMSS 2019 Mathematics Framework, p. 24)

As regards OECD PISA survey, in the recent version of the mathematical framework, we read:

Mathematical literacy therefore comprises two related aspects: mathematical reasoning and problem solving. Mathematical literacy plays an important role in being able to use mathematics to solve real-world problems. However, mathematical reasoning also goes beyond solving problems in the traditional sense to include making informed judgements in general about that important family of societal issues which can be addressed mathematically. It also includes making judgements about the validity of information that bombards individuals by means of considering their quantitative and logical implications. (PISA 2021, Mathematics Framework, First draft, p. 10)

In this paper we examine how Italian mathematics standardized tests try to assess specific aspects related to argumentation skills: we analyse two items selected from grade 5 (primary school) national standardized tests. We use theoretical lenses taken from research in mathematics education in order

to highlight the argumentation features that these two standardized items focused on. Our reflections are grounded in the studies on argumentation processes carried out by some Italian researchers (Boero, Garuti & Lemut, 2007; Boero, Douek, Morselli & Pedemonte, 2010; Arzarello & Sabena, 2011).

Italian National Guideline and standardized tests

In the last ten years, new Italian National Guideline (NG) for the first cycle of instruction (i.e. pre-primary, primary and middle school) have been proposed by the Ministry of Education (Ministero dell'Istruzione, Università e Ricerca, MIUR). For primary and middle school (grades 1 to 8), the NG were first published in 2007 with the latest version arriving in 2012 (MIUR, 2012). Italian legislation does not lay down a strict curriculum, but it indicates the goals for competence development at the end of grades 3, 5 and 8.

Some of these goals refer explicitly to the argumentative skills that students should acquire:

[the student] constructs reasoning by formulating hypotheses, by supporting his/her ideas and by dealing with others' points of view (grade 5, end of primary school, MIUR 2012, p. 50, translation by the authors)

[the student] produces arguments based on the theoretical knowledge acquired [...] [the student] supports his/her beliefs by choosing examples and counterexamples and by using concatenations of claims; [the student] agrees to change his/her opinion recognizing the logical consequences of a correct argument" (grade 8, end of middle school, MIUR 2012, p. 51, translation by the authors).

The Italian Ministry of Public Education has established the standardized assessment of the Italian educational system, and commissioned the INVALSI (www.invalsi.it) to carry out annual surveys nationwide to all students in the second and fifth grades of primary school, grade 8, and high school (grades 10 and 13). INVALSI is a research institute with the status of legal entity governed by public law. INVALSI carries out periodic and systematic checks on students knowledge and skills (about reading comprehension, grammatical knowledge and mathematical competency), and on the overall quality of the educational offers from schools and vocational training institutions; in particular, it runs the National Evaluation System (SNV). The INVALSI standardized tests were created for system evaluation and this is their primary purpose. The statistical representative sample comprises approximately 30,000 students (with tests administered under controlled conditions). Moreover, the tests are administered at census level and students results are provided to each school institution. The SNV Framework defines what type of mathematics is assessed by the SNV tests and how it is evaluated. It identifies two dimensions along which the items are built: the mathematical content, divided into four major areas (Numbers, Space and Figures, Relations and Functions, Data and Uncertainty), and the mathematical processes involved in solving the items (Knowing, Problem Solving, Arguing and Proving). These dimensions are closely and explicitly related to the goals for competence development of NG. The framework adopted by SNV assessment includes aspects of mathematical modelling as in PISA survey (Niss, 2015), and aspects of mathematics as a body of knowledge logically consistent and systematically structured, characterized by a strong cultural unity (Arzarello, Garuti, & Ricci, 2015). The INVALSI tests are designed by expert teachers, educational

and disciplinary researchers, statisticians and experts of the school system. (Garuti & Martignone, 2015; Garuti, Lasorsa, & Pozio, 2017).

Argumentation in INVALSI tests

As stressed before, taking into account the NG suggestions, INVALSI tests aim to assess also argumentation skills. Therefore, our research questions are: which aspects related to argumentation skills can be assessed by a standardized test? And in which way? These are very general questions that we faced starting from a more specific investigation about which elements were taken into account in the construction of some INVALSI argumentative items.

In a INVALSI booklet there are approximately 40-50 items and about 10% of these are about argumentation. A standardized test cannot assess all the argumentative skills quoted in the NG (e.g. formulating hypotheses or exploring a problem situation in order to produce conjectures), but it can propose tasks that ask students to support his/her statements, to show examples and counterexamples, and to recognize the logical consequences of a correct argument. In the SNV framework the limits of standardized tests in the assessment of mathematical competencies, particularly with regard to the argumentative skills, are well explained, but it is also clear that some aspects of this capability can be assessed. For example, by means of items that ask to choose the correct answer and the right justification of it among the options proposed, or to produce and justify the answer. In INVALSI tests, two item-format types are used to assess the argumentative skills: open constructed-response items and selected-response (multiple-choice) items. The first may ask the student to explain how the answer was reached or to justify the answer of a given statement; the second requires to select one response among a number of options.

In this paper we analyze two multiple-choice items selected from grade 5 tests. We joined the groups of teachers and experts, who produced the INVALSI tests, therefore we can argue about the choices made during items productions. These choices are the results of discussion in which Mathematical Knowledge for Teaching (Ball, Thames, & Phelps, 2008), the experiences developed in the classrooms, and knowledge about educational research studies merged.

Any discourse cannot be accepted as an argumentation, “[...] a reason or reasons offered for or against a proposition, opinion or measure” (Webster Dictionary), and may include verbal arguments, numerical data, drawings etc. Argumentation can indicate both the process which produces a logically connected discourse about a given subject and the text produced by the process (Douek, 2007).

In order to describe the structure of mathematics argumentations, as texts produced, different studies use Toulmin’s model (1958). In the next paragraph we show some interpretative tools proposed by this model.

An interpretative tool for the argumentation structure

Toulmin’s model (1958) has been used for the analysis of arguments in mathematics education (Pedemonte, 2007) as a tool to analyses structural features of mathematics argumentation both with pre-service teachers (Arzarello & Sabena, 2011) and primary students (Douek & Scali, 2000). Many studies report the limitations of this model in order to analyze mathematical argumentation (Nielsen 2011), in particular to study the dialogical and dialectical elements of verbal interaction that take

place in the classroom. The “argumentation” is much more complex than the arguments that make it up, but Toulmin’s model can be used to identify the argument structure, in particular to break down arguments into their constituent parts. In Toulmin’s basic model an argument comprises three elements: the Claim (C), i.e. the statement; the Data (D), i.e. the data that justify the claim C; and the Warrant (W), i.e. the inference rule which allows data D to be connected to claim C.

We use this way of breaking down arguments into their constituent parts to identify and compare some elements in the structure of multiple-choice options of INVALSI argumentative items.

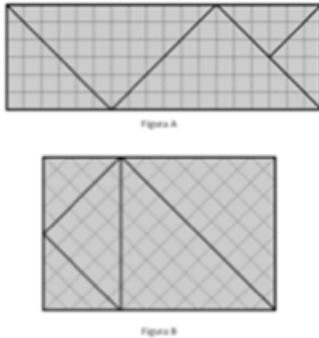
Research questions

In our study we focus on written texts, in particular INVALSI multiple-choice items in which students have to choose among different sentences. In this frame, we refine our initial research questions: can we identify common structures in the different answer options in INVALSI tests? How can we carry out a *posteriori* analysis of the argumentative items by using some interpretative tools coming from Toulmin’s model?

Examples of INVALSI argumentative items

The first example (Figure 1) is a geometry item relating to equivalence between plane figures.

Observe the following figures:



Do the two figures have the same area?

A. No, because the two figures have different dimensions	30.3%
B. Yes, because the triangles that make up the figure A are the same ones that make up the figure B	41.4%*
C. No, because the two figures have different perimeters	19.6%
D. Yes, because each of the two figures is filled with right triangles	7.4%
	Omissions 1.3%

*correct

Figure 1: Item from SNV 2016, grade 5 (indicating the percentage for each option) (translation by the authors)

The student must choose the correct answer: the options are built up by two “Yes” and two “No” followed by arguments that have to justify correctly the answer. The stem consists of two figures and

a question that is common in activities about geometrical objects in primary school. This example shows a structure in the construction of the item that we identified as very common in the INVALSI argumentative items. In the different options, the student has to choose not only if the answer is Yes or No, but also the correct argumentation: i.e. the argumentation that is relevant and useful to answer correctly the question. For these reasons, all the sentences after Yes and No are true sentences, but in only one is there a correct argument. In particular, options A and C (together are chosen by about the 50% of students) are both referring to the fact that the dimensions of the rectangles are different: these may refer to a misconception like "if the sizes are different then the area must be different" quite common in primary school. Option D (chosen by 7.4% of the students) is weaker and refers to invariance of shapes (right triangles). Using the Toulmin's model to interpret the item structure, we can identify Data (D) (i.e. the representation of two equivalent rectangles made by the same triangles), Claim (C) (i.e. the recognition of the equivalence of the figures: "Yes, they have the same area" or "No, they don't have the same area") and Warrants (W) (i.e. the inference rule which allows Data (D) to be connected to Claim (C) about the identification of the same area of the rectangles). Therefore, focusing on the structure of the four options, the students have to choose the options where they recognize both the right answer to the question about the equivalence of the figures area and the right justification of it. The second example (Figure 2) deals with a situation framed in a field of experience external to mathematics.

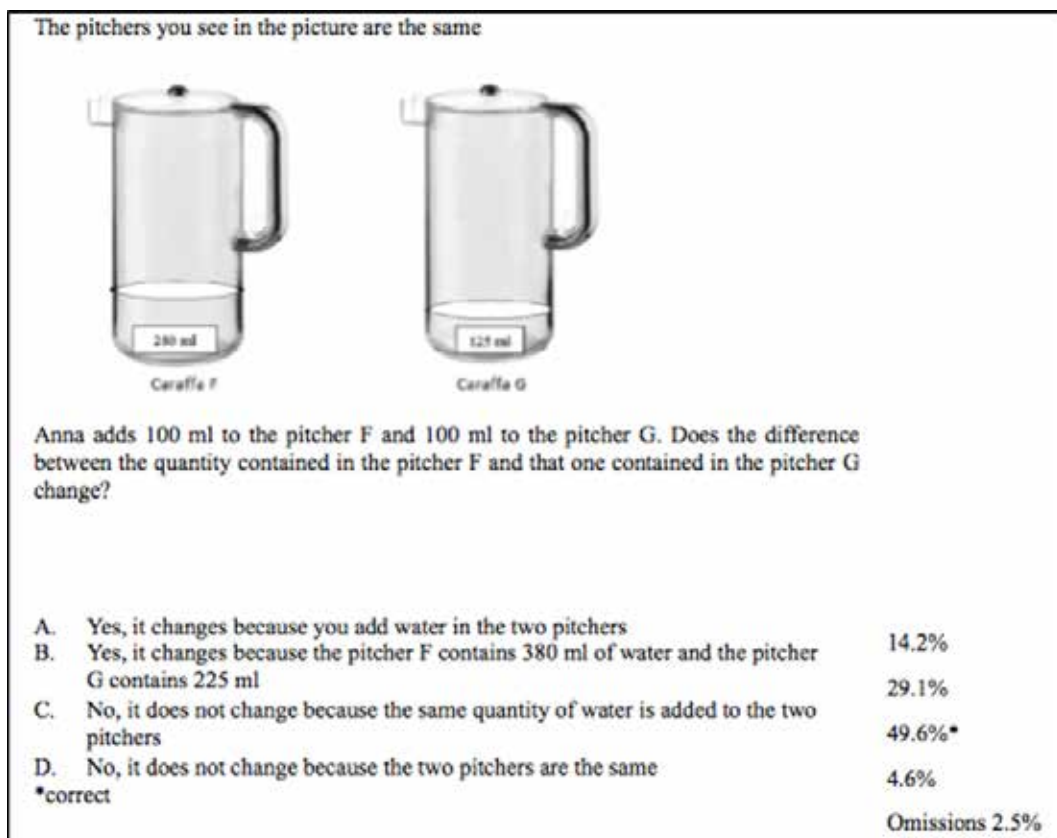


Figure 2: Item from SNV 2016, grade 5 (indicating the percentage for each option) (translation by the authors)

This item requires to understand that the difference in the amount of water contained in equal pitchers doesn't change if we add the same amount of water in each one of them. The students have to recognize the correct statement that justifies this invariance. The incorrect options highlight misconceptions related to the situation of invariance or difficulties in identifying a condition that is necessary, but not sufficient. In this example, the students can identify arguments (Warrants) linked also to everyday life experience, or can use forms of reasoning for general principles about adding quantities to different initial amounts. The statistical data show that this item has a higher percentage of correct answers: we can conjecture that it is because it refers to everyday life experiences. The option B focuses on the difference between relative and absolute increase and it was chosen by many students (29.1%). In fact, the other options show more general arguments about shape and content of the pitchers.

Using the Toulmin's model: data (D) is represented by the figure and the text of the question that describes the situation. Claim (C) is about the increase of water in the two pitchers after the addition of the same quantity of water. Warrant (W) is given by the arguments in support of responses (two for answer Yes and two for answer No). Although the mathematical content and context are very different from the previous example, we identify the same structure: all the arguments are true, but only one is adequate in order to support the correct answer.

Summarizing, the analysis of the structure of these two items show that all the Warrants are true and pertinent (i.e. relating directly) to the mathematical content of the item, but only one is adequate, that is useful to support the Claim.

Discussion

In this paper we discussed some features of INVALSI items focused on argumentation: multiple-choice items where the student has to identify the right arguments to support his/her answer concerning a given statement. Analyzing this tests, we demonstrate how certain aspects of argumentation can be assessed through the use of standardized items. In particular, the ability of the students to choose the correct argument to support a statement. We are aware that the analysis of other argumentative skills, such as the production of justifications to support a claim, requires analysis tools other than the Toulmin's model, which provides us with information only on the structural aspects of the argumentation. By means of two examples, we show some characteristics of argumentative items and we use Toulmin's model as *a posteriori* interpretative tool to describe and interpret the structure of these items. We chose Toulmin's model as an interpretative tool because it allows us to analyze retrospectively the structural aspects of argumentative items focusing on the characteristics of the justifications (Warrant), regardless of the mathematical content involved. The analysis carried out in this paper wants to show how, even if we chose two items that deal with different topics and contexts, we can identify in the structure of the items some similar characteristics: i.e. structural characteristics that the use of Toulmin's model can clearly highlight.

In the examples presented here all the justifications (Warrants) are true and pertinent, but in INVALSI tests we can also find items where all the justifications (Warrants) are true but only one is pertinent or items where the incorrect options are false but pertinent. In the latter case, as regards the first example (Figure 1), the three incorrect response options could have been as follows: *No, because the*

two figures have different areas; No, because the two figures have a different number of triangles; Yes, because the two figures are congruent. The justifications are false, but directly relevant (i.e. pertinent) to the context of the question.

It is clear that, as underlined at the very beginning of the paper, standardized items can evaluate only some features of argumentation, as well as the Toulmin's model can identify only specific types of argumentation structures, but this doesn't mean that a study about these elements cannot give us some educational information about the assessment on argumentation and helpful tips for designing other kinds of standardized items about argumentation. As a matter of fact, in the further steps of our study, we are investigating if the Toulmin's model can become a useful *a priori* tool in order to construct items in which the argumentations have different structures: i.e. items with the same structure of those presented here; items where it is explicit that the answer is No (or Yes) and the students have to choose the only warrant that justifies it; items in which, starting from the data and by a given warrant, the students have to choose which statement, among those proposed, is justified by the argument (from Warrant to Claim).

Therefore, in our study the Toulmin's model is being transformed from a *a posteriori* analysis tool that sheds light on the passage from Claim to Warrant (I have a Claim and I have to identify which Warrant is adequate to justify that Claim) to a tool for constructing argumentative items, that to say to a *a priori* analysis tool.

References

- Arzarello, F., & Sabena, C. (2011). Semiotic and theoretic control in argumentation and proof activities. *Educational Studies in Mathematics*, 77(2-3), 189- 206.
- Arzarello, F., Garuti, R., & Ricci, R. (2015). The impact of PISA Studies on the Italian National Assessment System. In Stacey K. & Turner R. (Eds.), *Assessing Mathematical Literacy. The PISA experience*. (pp. 249–260). Switzerland: Springer International Publishing.
- Ball, D. L., Thames, M., & Phelps, G. (2008). Content knowledge for teaching: What makes it special? *Journal of Teacher Education*, 59(5), 389- 407.
- Boero, P., Garuti, R., & Lemut, E. (2007). Approaching Theorems in grade VIII. In P. Boero (Ed.), *Theorems in school: From history, epistemology and cognition to classroom practice* (pp. 249–264). Rotterdam: Sense Publishers.
- Boero, P., Douek, N., Morselli, F., & Pedemonte, B. (2010). Argumentation and proof: a contribution to theoretical perspectives and their classroom implementation. In M. M.F. Pinto & T.F. Kawasaki (Eds.), *Proceedings of the 34th conference of the International Group for the Psychology of Mathematics Education: Vol. 1*. (pp. 179- 209). Belo Horizonte: PME.
- Douek, N., & Scali, E. (2000). About argumentation and conceptualization. In T. Nakahara & M. Koyama (Eds.), *Proceedings of the 24th conference of the International Group for the Psychology of Mathematics Education, Vol. 2*. (pp. 249- 256). Hiroshima: PME.

- Douek, N. (2007). Some remarks about argumentation and proof. In P. Boero (Ed.), *Theorems in school: From history, epistemology and cognition to classroom practice* (pp. 163- 181). Rotterdam: Sense Publishers.
- Garuti, R., & Martignone, F. (2015). The SNV (INVALSI) experience. Teaching and learning mathematics: resources and obstacles. *Proc. of CIEAEM 67, Quaderni di ricerca didattica*, 25(2), 95- 98.
- Garuti, R., Lasorsa, C., & Pozio, S. (2017). The Italian national education assessment system: building mathematics items. In Dooley, T., & Gueudet, G. (Eds.), *Proc. of the Tenth Congress of the European Society for Research in Mathematics Education* (pp. 3545–3552). Dublin, Ireland: DCU Institute of Education and ERME.
- Hanna, G. (2007). The ongoing value of proof. In P. Boero (Ed.), *Theorems in school: From history, epistemology and cognition to classroom practice* (pp. 3- 16). Rotterdam: Sense Publishers.
- International association for the evaluation of Educational Achievement (IEA). (2017). Mathematics Framework. In Ina V.S. Mullis and Michael O. Martin (Eds.). *TIMSS 2019 Assessment Frameworks* (pp. 14- 25),. Boston, U.S.A.
- Ministero dell'Istruzione, Università e Ricerca (MIUR). (2012). *Indicazioni nazionali per il curricolo della scuola dell'infanzia e del primo ciclo di istruzione*. Rome: Author. Retrieved from http://www.indicazioninazionali.it/documenti/Indicazioni_nazionali/indicazioni_nazionali_infanzia_primo_ciclo.pdf
- Nielsen, J. (2011). Dialectical features of students' argumentation: A critical review of argumentation studies in science education. *Research in Science Education*, 43(1), 371- 393.
- Niss, M. (2015). Mathematical Competencies and PISA. In Stacey K., & Turner R. (Eds.), *Assessing Mathematical Literacy. The PISA experience* (pp. 35–55). Switzerland: Springer International Publishing.
- Organisation for Economic Co-operation and development (OECD). (2018). *Pisa 2021 Mathematics framework* (first draft). Stockholm, Sweden.
- Pedemonte, B. (2007). How can the relationship between argumentation and proof can be analyzed? *Educational Studies in Mathematics*, 66, 23- 41.
- Toulmin, S. (1958). *The use of arguments*. Cambridge: University Press.

Evaluating students' self-assessment in large classes

Jokke Häsä¹, Johanna Rämö² and Viivi Virtanen³

University of Helsinki, Finland; ¹jokke.hasa@helsinki.fi, ²johanna.ramo@helsinki.fi,
³viivi.virtanen@helsinki.fi

This study is part of an ongoing larger project concerning student self-assessment skills in university courses. We have developed a method enabling large cohorts of students to assess their own learning outcomes and to give their own course grades with the help of an automatic verification system. This paper explores the question of accuracy, namely, whether the self-assessed grades correspond to the students' actual skills, and how well the automatic system can pick up issues in the self-assessment. Based on an expert's evaluation of the skills of two students, we conclude that although for large part the model works as intended, there are some cases where neither the self-assessment nor the computer verification seem to be accurate.

Keywords: Self-assessment, assessment for learning, digital assessment, accuracy, large classes.

Introduction

The ability to judge the quality of one's own work is one of the core skills that should be developed during university studies. Self-assessment has been viewed as a valuable assessment process through which student can learn to understand the expectations, criteria and standards used in assessment, and further, to be able to regulate own learning and acquire skills for lifelong learning (Falchikov & Boud, 1989; Kearney, Perkins, & Kennedy-Clark, 2016). However, academic community seem to be resistant to change the prevailing assessment practices focusing on testing and grading, and practices such as self-assessment are scarcely implemented at course level (Boud et al., 2018; Postareff, Virtanen, Katajavuori, & Lindblom-Ylänne, 2012).

In this paper, we draw attention to assessment practices in university first-year mathematics by examining an implementation of student self-assessment processes into large class setting. During this process, students frequently evaluated the quality of their learning outcomes, received feedback on their performance, and finally decided their own grades according to particular criteria. The intended learning outcomes were made transparent through a rubric including both content knowledge and generic skills, such as writing mathematics. The digital environment gave opportunity for monitoring learning process and giving real-time formative feedback in line with previous research on online assessment (Ćukušić, Garača, & Jadrić, 2014; Gigandi, Morrow, & Davis, 2011; Ibabe & Jauregizar, 2010), and further, it formed a basis of assessment of the student's progress. The emphasis of self-assessment was in developing student capability in making evaluative judgements (Ajjawi, Tai, Dawson, & Boud, 2018) and building their metacognition skills (Mok, Lung, Cheng, Cheung, & Ng, 2006), so that the students' ability to self-regulate their learning for current and future learning would improve. We fill the gap in research by showing how, in the case of summative self-assessment, the problems aroused by large class setting were resolved by using digital and automatic verification and real-time feedback.

Self-assessment as a tool for learning

Self-assessment can be defined as a process during which student evaluate their own achievements and judge about their own performance (Falchikov & Boud, 1989). The judgements students make are based on information and evidence about their own performance collected from various sources (Yan & Brown, 2017). In this paper, we refer to self-assessment as a process in which the students evaluate their own progress and performance and give justifications for the result of their evaluation according to teacher-given criteria showing intended learning outcomes.

The use of self-assessment has been shown to improve student engagement and motivation (e.g. Andrade & Du, 2007; Mok et. al, 2006), self-efficacy (Kissling & O'Donnell, 2015) and academic performance (Ibabe & Jauregizar, 2010), while the ability to self-assess is reportedly intermingled with ability to self-regulate own learning (Panadero, Brown, & Strijbos, 2016) and with life-long learning skills (Kearney et al., 2016). Consequently, the literature encourages the use of self-assessment for formative purposes. Research shows that in large class settings digital environments with effective formative online assessment can foster a learner-centred focus and engagement in learning (Gigandi et al. 2011; Ibabe & Jauregizar, 2010). Recent results show that online self-assessment can also improve students' academic success (Ćukušić et al. 2014). However, the debate concerning students generating their own grades by self-assessing their own work is more complicated and constantly questioned (Boud et al., 2018; Tejeiro et al., 2010). One of the main challenges regarding self-assessment for grading is the question of accuracy: How can we be sure that students' grades are valid and reliable?

The question of accuracy

Many studies have found high correlations between self- and teacher-ratings (Falchikov & Boud, 1989; Kearney et al., 2016). The results indicate that students are able to make reasonable accurate judgements if they are properly provided with training and background information to the process. Also, students vary in their capability to evaluate their performance e.g., high achievers tend to underestimate their performance whereas low achievers tend to overestimate it (Boud & Falchikov, 1989; Boud et al., 2013; Kearney et al., 2016). However, the accuracy of student self-assessments can be improved through using criteria and standards (Andrade & Du, 2007), while students need to have multiple opportunities for practising self-assessment in relation to given criteria, with feedback to help calibrate the judgements (Hosein and Harle, 2018; Kearney et al., 2016). On the other hand, Boud, Lawson and Thompson (2013) argue that increase in accurate self-assessment is not immediately transferable, because standards and criteria are somewhat domain-specific. Hence, we suggest that in order to understand the expectations, criteria, and disciplinary standards of mathematics, and to develop capabilities to make accurate and realistic assessments on own learning processes and outcomes, it is required that self-assessment processes are implemented in first-year university mathematics. However, in large class setting, typical to that learning context, the challenge how to give evidence-based feedback for improving the accuracy needs to be resolved.

The DISA model

This study is part of a research project centred around an assessment model called DISA (**D**igital **S**elf-assessment). In the model, students assess their own learning outcomes throughout the course

by using a detailed rubric articulating the subgoals of the ultimate intended learning outcomes. Learning goals and criteria are clearly identified, and through self-assessment activities the students are actively engaged with them. Evidence of learning is elicited during the course, and students receive feedback for their self-assessment from an automatic digital system.

The feedback is generated in the following way. Every course task has been linked with the learning objectives it is supporting. This enables the automatic system to compute, based on the student's coursework, an index from 0 to 1 for each learning objective. This index estimates how well the student has acquired the learning objective. From these indices, the system then computes tentative grades in each course topic. These tentative grades are compared to the student's self-assessed grades, and the student is advised either to consider a higher or a lower grade for themselves.

In addition, self-assessment is used for summative purpose in the end of the course, as the students self-assess and justify how well they have achieved the intended learning outcomes, and proceed in deciding their own course grade based on the self-assessment. In order to prevent abuse of the self-assessment process, the system described above is used to verify the validity of the course grades. If the self-assessed topic grades differ too much from the computed ones, the student's final course grade is disputed. Earlier results imply that the model supports students in using deep learning approach, and encourages them to study for themselves, not for an exam (Nieminen, Rämö, Häsä, & Tuohilampi, 2017).

Aim of the study

This study aims at gaining a better understanding of the use of self-assessment as an integral part of assessment in a large first-year university mathematics course. In the course context, self-assessment is used to give students an opportunity to think metacognitively about their learning. We hypothesise that student active engagement into self-assessment processes is enhanced if these processes are valued in grading, but then, the question of accuracy needs to be resolved. This question is two-fold: firstly, we are interested in the validity of the student grades, in other words, whether they reflect true learning, both in content knowledge and domain-specific generic skills such as writing mathematics. Secondly, we need to examine the reliability of the automatic verification system: can it spot the cases where self-assessment is inaccurate? The research questions in this study are:

1. How do the students' evaluations of their own skills compare with evaluations performed by the automatic verification system?
2. How does an expert judge the student's acquired skills in cases where the automatic verification disagrees with student's self-assessment?

Method

This study uses data collected from students taking a first year mathematics course at a major research-intensive university in Finland. The second author was the lecturer for the course. The course was a proof-based linear algebra course dealing with finite-dimensional vector spaces, and it lasted for seven weeks (half a term). During the course, students were given weekly problems to solve, part of which were assessed and given feedback on. Some of the tasks were assessed by the tutors, some by an automatic assessment system called Stack (Sangwin, 2013). Some tasks were also peer-reviewed.

The course was not graded with a final exam, but grading was done by self-assessment using the DISA model. The self-assessment was based on a detailed learning objectives matrix prepared by the teacher. The learning objectives were divided into 10 topics: six content-specific and four generic skills topics, and the students were asked to give themselves a grade from 0–5 in each of these topics, 0 meaning fail. They were also asked to write down reasons for choosing that grade. In the end of the course, students chose their own final grade. They were left to decide by themselves how to combine the grades from the different topics. The DISA system was used to verify the final self-assessment.

It is worth noting that, in the Finnish context, although the teacher is responsible for the course grades, these can be awarded by any means the teacher chooses. There is little fear of distorting the grades, as the final grade of a first-year mathematics course carries very little weight in the final outcome of a student's study programme. Also, all courses and exams can be usually retaken as many times as the student wishes.

The participants of this study were 158 students who took the linear algebra course described above, gave themselves their own grades using the DISA model, and gave consent for using their data. Most of the students were majoring in either mathematics, mathematics education or some other field related to mathematics such as computer science, physics or chemistry. Most students were first year students, but the cohort included also older participants, up to post-doctoral level.

We narrow our study to two of the ten learning objective topics of the course: (1) “Matrices” (content-specific) and (2) “Reading and writing mathematics” (generic skill). These two topics were chosen since both are among the most central topics of the course and there were relatively many tasks linked to them. Also, we wanted to compare self-assessments on a content-specific topic with those on a generic skill. Henceforth, these topics are abbreviated as [M] and [RW]. Examples of learning objectives pertaining to these topics are given in Table 1.

Topic	Skills corresponding to grades 1-2	Skills corresponding to grades 3-4	Skills corresponding to grade 5
Matrices [M]	I can perform basic matrix operations and know what zero and identity matrices are	I can check, using the definition of an inverse, whether two given matrices are each other's inverses	I can apply matrix multiplication and properties of matrices in modelling practical problems
Reading and writing [RW]	I use course's notation in my answers	I write complete, intelligible sentences that are readable to others	I can write proofs for claims that concern abstract or general objects

Table 1: Part of the learning objectives matrix of the course. In total, there were 10 topics and 10–15 learning objectives in each topic

To answer Research question 1, we compared the grades students gave themselves on the two topics in the final self-assessment with the results of the automatic verification of that self-assessment. The computations were done with R version 3.5.0. For Research question 2, coursework and final self-

assessment of two students whose self-assessment was poorly in line with the automatic verification were chosen for closer inspection. In this manuscript, we call them Student A and Student B. The two students' anonymised answers to all of the written tasks as well as their Stack exercise points were analysed by the second author. This author was also the teacher of the course and can be regarded as an expert in the subject. When the expert was grading the students, she did not know how the students had assessed themselves. The expert read every written solution the student had submitted, and evaluated which learning objects in topics [M] and [RW] the student had reached.

Every time the expert could see the student mastering a learning object, she made a note in the learning objectives matrix. After that, there were learning objectives for mastering of which the student had not provided any evidence in the written solutions. The expert then looked at the Stack exercises that were linked to these learning objectives to see how many points the student had received from them. She used the information in determining whether the student had reached the remaining learning objectives. When the expert had considered each learning objective, she awarded the student a grade in both topics by looking from the learning objectives matrix which grade the reached learning objectives corresponded to. In borderline cases, the expert used her expertise as a mathematician and teacher of the course. For the topic "Reading and writing mathematics", the expert could only evaluate the student's skills in writing as there were no tasks that were linked to reading skills.

Results

Research question 1: comparison of self-assessed grades with automatic verification

The distributions of the self-assessed grades in the two topics [M] (Matrices) and [RW] (Reading and writing mathematics) are shown in Table 2. We see that the students gave the grades 3 and 4 more often for [RW] than for [M], but the top grade 5 was more common in [M] than in [RW].

Grade	1	2	3	4	5
[M]	3	10	25	47	73
[RW]	2	10	37	58	51

Table 2: Frequencies of each grade in the two topics

The computer verification system computed tentative grades for the two topics for each student. The distribution of differences between the computed grade and student self-assessed grade are reported in Table 3.

Difference	-5	-4	-3	-2	-1	0	1	2
[M]	1	1	5	20	26	86	19	0
[RW]	0	2	6	15	20	75	34	6

Table 3: Frequencies of the differences: computed grade minus self-assessed grade in the two topics

We see that the computer and student grades agree well. In [M], there are 86 matches, 53 cases in which the self-assessed grade was higher than the computed grade (negative difference), and only 19 cases in which the self-assessed grade was lower (positive difference). In [RW], there are 75 matches,

43 cases in which the self-assessed grade was higher, and 40 cases in which the self-assessed grade was lower. In both topics, between 81-83 % of self-assessed grades lie within 1 grade point from the computed grade.

Research question 2: Expert opinion in conflicted cases

Student A's self-assessed grades were lower than the computed ones. For both topics, the self-assessed grade was 4 and computed grade 5. The expert's evaluation agreed with the computed grades. The expert observed that Student A had done almost all tasks during the course. Even though not all the answers were correct, all the learning objectives in topic [M] were fulfilled. Students were asked to make corrections to some tasks, and student A had always resubmitted solutions written in good mathematical style. The student's explanations were concise and readable, and the student was able to construct proofs concerning abstract mathematical objects. Based on this, the expert's grade for topic [RW] was 5.

Student B's self-assessed grades were greater than the computed ones. For topic [M], the self-assessed grade was 5 and the computed grade 3. The expert's evaluation yielded grade 4, that is, something in between. For [RW], the self-assessed grade was 3 and the computed grade 1. The expert's evaluation agreed with the self-assessed one. The expert observed that Student B had submitted only a fraction of the course tasks. However, the expert was able to evaluate from the solutions that Student B accomplished almost all learning objectives in [M]. Some of Student B's skills were shown in the intermediate steps of tasks that were not directly linked to topic [M]. For example, the student determined whether given vectors are linearly independent by forming a system of linear equations and calculating the determinant of the coefficient matrix. This showed that the student knew how invertibility of matrices is connected to the number of solutions of a system of linear equations even though the topic of the task was linear independence. Student B had not corrected any solutions when encouraged to. According to the expert, the student reached partially all the learning objectives in [RW], but did not fully master any of them, not even the ones corresponding to grade 1. For example, the student mixed up equivalence arrows with equality signs, wrote long, confused sentences and used "if-then" structures inside a proof in the place of assumptions and conclusions. However, the overall structures of the proofs were correct. Based on this, the expert's interpretation was that the student's grade for [RW] was 3.

Discussion

In this study, a new model of determining course grades via self-assessment was examined with a focus on the accuracy of the self-assessed grades. The students gave themselves grades in all course topics, and these grades were automatically verified by comparing them against the course work the students had done. We analysed the results of the verified self-assessment in two topics, one content-specific topic (matrices) and one subject-related generic skill (reading and writing mathematics).

The students' self-assessment agreed well with the automatic verification. Most discrepancies are within one grade point, which can be explained by the coarseness of the grading scale: the "real" skill level is often between two grade points and must be forced to one or the other direction. The high agreement is not surprising, as previous studies have shown that explicit criteria and standards support self-assessment, as does frequent practice and feedback (Andrade & Du, 2007; Kearney et al., 2016).

It remains to be studied how great an effect the feedback that the students received for their self-assessment exercises had on their final self-assessment.

The students gave fairly good grades to themselves in both examined topics. For reading and writing mathematics, the grades were more concentrated around the second-best grade, whereas for matrices, the top grade was clearly the most common grade. Perhaps it was easier for the students to understand the learning objectives as well as recognise their achievements in the mathematical topic, and without clear evidence for mastery, they were hesitant to award themselves the best grade in a generic skill. Our results could be understood in the view of previous results (Falchikov & Boud, 1989) showing that in science courses, self-assessment was more accurate than in other fields.

We examined more closely two students whose self-examined and computed grades differed. In the first case, self-evaluated grades were below the computed ones. The expert's evaluation agreed with the computed grade. The student was a high achiever, and from previous studies we know that such students tend to underestimate their performance (Boud et al., 2013; Kearney et al., 2016). In the second case, the self-evaluated grades were above the computed ones. The expert's evaluation was between the two for the mathematical topic and agreed with the self-assessed grade for the generic skill. In this case, the student had skipped many tasks which made it difficult for the automatic system to estimate the grade fairly. Also, the expert noted that the student seemed to have some skills from all grade categories in the learning objectives matrix, but not to have fully reached any. This kind of case would be very difficult for the automatic verification system to estimate correctly.

The study used a method in which an expert evaluated students' skills based on all the work they had done on the course, evaluating against the intended learning outcomes, not by grading individual tasks. The method suffered from some of the maladies related to teacher evaluation, such as time restriction and personal bias. The accuracy of teacher-grading is not an issue to be taken as obvious truth (Brown, 1997). One should also note that neither the expert nor the automatic system were able to evaluate students' reading skills even though they were included in the self-assessed grades.

This study opened a new way to critically examine a self-assessment model as a viable option for grading students. We did not find any fundamental problem with reliability. However, at least in one of the studied cases, the verification system did not estimate the student's skills very well. A larger sample needs to be studied in order to find out whether such issues are common. Also, we need to study students' written justifications for their grades in order to better understand what is involved when the self-assessment process does not go as intended.

References

- Ajjawi, R. Tai, J., Dawson, P. & Boud, D. (2018). Conceptualising evaluative judgement for sustainable assessment in higher education. In *Developing Evaluative Judgement in Higher Education* (pp. 23–33). Routledge.
- Andrade, H. & Du, Y. (2007). Student responses to criteria-referenced self-assessment. *Assessment & Evaluation in Higher Education*, 32(2), 159–181.
- Boud, D., Lawson, R., & Thompson, D. (2013). Does student engagement in self-assessment calibrate their judgement over time?. *Assessment & Evaluation in Higher Education*, 38(8), 941–956.

- Boud, D., Dawson, P., Bearman, M., Bennett, S., Joughin, G., & E. Molloy. (2018). Reframing assessment research: through a practice perspective. *Studies in Higher Education*, 43(7), 1107–1118.
- Brown, G., Bull, J., & Pendlebury, M. (1997). *Assessing student learning in higher education*. London: Routledge.
- Ćukušić, M., Garača, Ž., & Jadrić, M. (2014). Online self-assessment and students' success in higher education institutions. *Computers & Education*, 72, 100–109.
- Falchikov, N. & Boud, D. (1989) Student Self-Assessment in Higher Education: A Meta-Analysis. *Review of Educational Research*, 59(4), 395–430.
- Gikandi, J. W., Morrow, D., & Davis, N. E. (2011). Online formative assessment in higher education: a review of the literature. *Computers & Education*, 57(4), 2333–2351.
- Hosein, A. & Harle, J. (2018). The relationship between students' prior mathematical attainment, knowledge and confidence on their self-assessment accuracy. *Studies in Educational Evaluation*, 56, 32–41.
- Ibabe, I. & Jauregizar, J. (2010). Online self-assessment with feedback and metacognitive knowledge. *Higher Education*, 59, 243–258.
- Kearney, S., Perkins, T. & S. Kennedy-Clark (2016). Using self-and peer-assessment for summative purposes: analysing the relative validity of ASSL (Authentic Assessment for Sustainable Learning) model. *Assessment & Evaluation in Higher Education*, 41(6), 843–861.
- Kissling, E. & O'Donnell, M. (2015). Increasing language awareness and self-efficacy of FL students using self-assessment and the ACTFL proficiency guidelines. *Language Awareness*, 24(4), 283–302.
- Mok, M.M.C., Lung, C.L., Cheng, D.P.W., Cheung, R.H.P. & Ng, M. L. (2006). Self-assessment in higher education: experience in using a metacognitive approach in five case studies. *Assessment & Evaluation in Higher Education*, 31(4), 415–433.
- Nieminen, J. H., Häsä, J., Rämö, J., & Tuohilampi, L. (2017). Replacing Exam with Self-Assessment: Reflection-Centred Learning Environment as a Tool to Promote Deep Learning. Proceedings of the 20th Meeting of the MAA Special Interest Group on Research in Undergraduate Mathematics Education. San Diego: RUME
- Panadero, E., Brown, G.T.L. & J.W. Strijbos. (2016). The future of student self-assessment: A review of known unknowns and potential directions. *Educational Psychology*, 28(4) 803–830.
- Postareff, L., Virtanen, V., Katajavuori, N., & Lindblom-Ylänne, S. (2012). Academics' conceptions of assessment and their assessment practices. *Studies in Educational Evaluation*, 38(3–4), 84–92.
- Sangwin, C. (2013). *Computer aided assessment of mathematics*. OUP Oxford.
- Yan, Z. & Brown, G. (2017). A cyclical self-assessment process: towards a model of how students engage in self-assessment. *Assessment & Evaluation in Higher Education*, 42(8), 1247–1262.

Large scale analysis of teachers' assessment practices in mathematics

Julie Horoks¹, Julia Pilet¹, Sylvie Coppé², Marina De Simone² and Brigitte Grugeon-Allys¹

¹ Laboratoire de didactique André Revuz, Université Paris-Est-Créteil, France; julie.horoks@u-pec.fr; julia.pilet@u-pec.fr; brigitte.grugeon-allys@u-pec.fr

² FAPSE, Université de Genève, Suisse; sylvie.coppe@unige.ch; marina.desimone@unige.ch

In this paper, we present a questionnaire that we have designed to establish a picture of secondary school teaching assessment practices in mathematics. This research follows a request from the Ministry of National Education, to take into account a specific mathematical content (algebra) in the analysis of teachers' practices at a large scale (1200 teachers). We begin by presenting our theoretical and methodological tools to characterize teacher assessment practices, and then present the project and the methodology adopted to link teachers' practices and their students' learning. We then give some examples of questions that we have designed for the teachers' survey, to be implemented in the fall of 2018.

Keywords: Assessment, teachers' practices, algebra, national surveys, teacher survey.

General presentation of the project

The DEPP (Directorate for Evaluation, Prospective and Performance) is responsible for the design, management and operation of the statistical information about the education system in France. It contributes to the evaluation of policies conducted by the Ministry of National Education. It has already developed an expertise about assessment, through national and international surveys on education, which focuses mainly on generic teaching conditions and practices, and not on practices related to a specific content. At the same time, the DEPP periodically assesses 5th graders (last year of elementary school) and 9th graders (last year of middle school) in the curriculum's disciplines by the CEDRE test (Cycle of Disciplinary Evaluations carried out on a Sample basis).

The new cycle of student's assessment which began in June 2018 is the first opportunity to establish a picture of teaching practices on a specific mathematical content. In this context, the goals of the PRAESCO 2017-2019 programme (Enquiry on Teaching Practices based on Specific Contents) are to make available to policy-makers and the educational community a set of indicators on teaching practices in mathematics, and to research the effects of these practises on the students' learning of specific mathematical contents (numbers and calculation for the 5th graders and algebra for the 9th graders). The role of the researchers commissioned by the DEPP is to build a questionnaire based upon a theoretical framework for identifying variables in mathematics teaching modalities, and to bring a scientific and didactic dimension to the analysis of this survey. In this paper, we focus on the design of the survey about teachers' assessment practices at the 9th grade level. Our theoretical and methodological frameworks

We explain our theoretical framework for the analysis of teachers' practices and more particularly for assessment practices in relation to students' learning in mathematics. We also explain our choice to select algebra as the specific mathematical content for the survey.

Teachers' practices and students' learning in mathematics

Our hypotheses on teaching and learning are based on the adaptation of the Activity Theory for didactic (Vandebrouck, 2018): it is mainly through students' mathematical activities that their learning takes place, activities caused, in large part, by the tasks they are given to do. The tasks therefore have a central place in our analyses, to anticipate possible learning for the students, but also to characterize teachers' practices through their choice of tasks for the students and the actual implementation of the work around those tasks in class.

To have a more comprehensive view of teachers' practice, we adopt the theoretical framework of the Double Approach (Robert & Rogalski, 2005), taking also into account some determinants of teacher practices that are not only related to the targeted students' learning. We consider the various constraints that influence the teaching profession, which leads us to include in our analysis of teachers' practises, institutional, social and personal components of the teaching profession, in addition to cognitive and mediative ones.

In this large panorama of teachers' professional activities and context, we consider that assessing students plays a significant role in the teaching and learning process, as it allows the students' actual mathematical activities to be taken into consideration by the teacher, to build appropriate teaching, in the short or long term. This is why our questionnaire includes a section about assessment practices, that we will describe below.

Assessment

In our previous work (Horoks et al., accepted; Pilet & Horoks, 2017), we have built a framework for analysing the assessment practices of secondary school teachers in mathematics, considering the specificities of the mathematical content. The various definitions of *assessment*, found in the literature and on which we rely, highlight three dimensions in the act of evaluation: taking information, interpreting it and using it for decision-making. We characterise *assessment practices*, using De Ketele's (2010) definition, through everything the teacher does to take information about students' mathematical activities (what they do, know, say, write) and how the teachers use this information, especially to promote students' learning. For De Ketele (*ibid.*), this information must be sufficiently relevant, valid and reliable, leading the teacher to examine its degree of adequacy with a set of criteria, linked to the teacher's goals, to make a decision. For Black & Wiliam (1998) also:

The term 'assessment' refers to all those activities undertaken by teachers, and by their students in assessing themselves, which provide information to be used as feedback to modify the teaching and learning activities in which they are engaged. (Black & Wiliam, 1998, pp.7-8)

Depending on the function given to assessment by the teacher, this collection and exploitation of information can be done in different ways, more or less formal and with greater or lesser effects on teachers' subsequent choices for their class.

For Black & Wiliam (1998), students' assessment is called *formative* when the information collected by the teacher is used to meet students' needs and when the students can self-evaluate through the realization of the tasks that they have been given. Ash & Levitt (2003) argue that formative assessment is a joint teacher-student activity, which remains fairly close to what the student already

knows how to do. The teacher collects clues about one student's activity in order to analyse this activity and plan the next step to help this student evolve.

Algebra

In this project, our approach to analyse teachers' practice, focuses on the mathematical contents to be taught, which led us to choose the field of elementary algebra, by consensus among the participants of the project, and for several reasons. First of all, because elementary algebra represents an important challenge for the future of students' studies in secondary and higher education, but also because teachers often express difficulties in teaching algebra (Kieran, 2007). It is also a choice that allows us to build on existing research results in mathematics education about the teaching of algebra. We have relied on the work of (Grugeon et al., 2012; Pilet, 2015; Sirejacob, 2017) who, on the basis of an epistemological study, have established a reference for a *mathematical organization* (Chevallard, 1999) of the teaching of algebra at this school level. The latter provides the types of tasks representative of the algebraic domain, which makes it possible to question the coverage of this domain by the tasks proposed by teachers, and the pertinence of these tasks (for learning or for assessment). This reference also provides information on the levels of reasoning expected from the students, and on the properties that can be brought forward by the teacher to institutionalize knowledge, validate or invalidate students' productions.

Presentation of the methodology

General protocol

Our framework to analyse assessment practices has already been used for studies involving fewer teachers, but over a longer period (several years). The transition to a larger scale requires a specific methodology, that we have been designing with the DEPP during the first year of the project. The general protocol is presented in Table 1. This study is based on statistical and didactical analyses performed by the researchers.

Period of time	Protocol
January – September 2018	Design of the questionnaire
September - November 2018	Selection of teachers for the first version of the questionnaire
December 2018	Experiment (teacher's first version of the questionnaire and assessment of the students' algebraic skills)
January-February 2019	Analysis of the experimental data and classroom observation for a sample of 50 teachers, improvement of the questionnaire
April – May 2019	Selection of teachers for the final version of the questionnaire, with a sample of 1200 secondary mathematics teachers
June 2019	Implementation of the final version of the questionnaire
June 2019 – February 2020	Analysis of the data

Table 1: General protocol

In an attempt to overcome the fact that a questionnaire can only give access to declarative practices, we chose to complete the analyses by observing some teachers in their classes. For that purpose, the first experiment, to be carried out from December 2018, involves only 50 teachers, chosen as a representative sample of teachers in France among the 1200 teachers (in terms of experience, teaching environment and geographical context) selected for the first version of the questionnaire. These teachers will also fill the questionnaire while their students are assessed through a mathematical test.

Later on, they will be observed while teaching algebra in their classroom (on the cognitive and mediative components of their practises, as defined by the Double Approach (Robert & Rogalski, 2005) and also asked questions about their work outside of class. This first step is smaller by the number of teachers involved, but more demanding for the researchers, because of the observation accompanying the questionnaire. It should help us identify whether the questions of the questionnaire are reliable and relevant for characterising teachers' actual practices through their answer to the questionnaire and improve the final version of the questionnaire that will be proposed at a larger scale in June 2019.

In the same perspective, we ask the teachers, in the beginning of the questionnaire, to choose one of their 9th grade classes, and to answer the questions with this particular class in mind. We believe that the identification of a reference class and the choice of a precise mathematical content allow us to get as close as possible to the real practices of the teacher. In addition, an assessment of the students in the teachers' reference class is conducted (around 30 000 students in total), in order to investigate a crucial issue: the impact of practices, and more specifically teacher assessment practices, on their students' learning.

Designing the questionnaire

To design the questionnaire, we brought together a team of researchers in mathematics education and experienced mathematics teachers in secondary education. Regular meetings, some of which were held with the members of the DEPP involved in the project, allowed us to agree on the formulations for the questions, in order to be able to perform a valid analysis of the teachers' answers, both from a statistical and didactical point of view. The questionnaire was then tested on teachers, whom we contacted individually, to ensure that the questions were understood and to have a better idea of the time required to complete the questionnaire, which final online version should not exceed 45 minutes for the teachers to answer.

The questionnaire consists of 121 questions (530 sub-questions in total). For statistical analysis purposes, the questions are closed-questions with multiple choices, with 4 level - scales (of frequency, difficulty, opinion, or adequacy to content or to students). Some of the questions focus specifically on algebraic contents, others focus more broadly on practices when teaching mathematics in general. To support possible results, we sometimes question the same aspect of practices in several questions but with different formulations throughout the questionnaire.

The questionnaire consists of 4 sections, with questions about:

- the teaching context and the teacher's background (experience, training, institutional constraints and possibilities, uses of technology for teaching and personal views on teaching and learning, especially about algebra)
- classroom preparation (resources, selection of algebraic tasks, time allotted to specific contents and tasks)
- management of classroom teaching (classroom work arrangements in the different phases of a mathematics session, interactions in class)
- and student's assessment (20 questions, 106 sub-questions, including 31 sub-questions about algebra).

In this presentation of the 9th grade level survey, we are focusing on teaching practices in elementary algebra, and in particular the practices of the teachers to assess their students' learning on this content. We make the hypothesis that assessment can play a rather important part in students' learning, but of course it is not easy to separate these particular practices, and their effects on students, from the rest of teachers' actions.

Questions about the assessment practices

In the last section of the questionnaire, we ask questions about teacher's relationship with assessment as well as the way he or she implements assessment in class. Concerning the teachers' relationship to assessment, we want to characterize in particular the functions given to assessment by teachers, including or not a better learning for their students (grade, rank, distribute, sanction, etc. Merle, 2015). In terms of teachers' assessment practices, we have applied the definition of assessment - *taking information, interpreting it and using it for decision-making* - to design this part of the questionnaire.

We want to identify the moments (Chevallard, 1999), where teachers gather information on their students' knowledge (before beginning to teach algebra in their reference class, or at the end of this chapter, and throughout the teaching of this subject), and the means used to do so, through formal or informal processes (Allal & Mottier-Lopez, 2007) and through which type of algebraic task), made more or less obvious for the students by the teachers' discourse.

We also try to appreciate the way teachers interpret some information about their students' possible answers to given tasks, by asking them to comment on student's productions (cf. Figure 1, with a question concerning also the decision making based on this interpretation). It might also give us access to the teachers' relationship to algebra, and the role of error in their vision of mathematics teaching, as well as their consideration of the students' procedures rather than their only results.

Here is the text of a summative assessment task and Guillaume's production:

Here is a calculation program:
 Choose a number, Add 7, Multiply the result by 4, Subtract 3 to the last result
 What is the result of this program if at the beginning the chosen number is 6?
Guillaume's answer: $6+7=13 \times 4=52-3=49$

When I assess Guillaume's production, I consider that:

	I disagree	I rather disagree	I rather agree	I agree
The result is correct, and I won't give Guillaume any feedback on the calculation, as he will understand later why it is not correct				
The answer is correct, but I will write a comment to explain that it is not correctly written mathematically				
If a lot of students have written the calculation this way, I will take a moment to clarify it with the entire class				
The result is false, because the way it is written is not correct				

Figure 1 – Example of a question about the judgment on a student's production in a summative test

We also question the teachers about the exploitation they usually do, of the information about their students' knowledge or know-how: if and how they adapt their teaching consequently, for some students or the entire class, and with which support on the mathematical contents.

In fact, several questions about assessment practices appear in other sections of the questionnaire. In the first part, about the context and personal information, we ask teachers if they feel the need for further training about students' assessment, among other topics. We also ask them about the possible origins for their students' difficulties in mathematics, and their students' needs to understand what is at stake in algebra, which can be linked to diagnostic assessment. The choice of tasks that they make for their *reference class*, largely questioned in the third part of the questionnaire, focusing on teachers' preparation of the class, can also be compared with the tasks chosen for assessment, to spot possible gaps between the two.

In the questionnaire's part about the management of the teaching in the classroom there are questions about the collective work on students' productions on a given task, that we link to assessment. Some questions in this part also (see Figure 2) focus on students' error management and ask the teachers to position themselves on the levels of mathematical discourse they generally use with their students (from almost never to very often). The following proposals (figure 2) participate, more or less, to a process of *formative assessment*. For example, Proposal 4 (figure) doesn't rely on the mathematical properties linked to the preservation of equality, but is referring to the gestures accompanying the technique, which we do not believe to be rich enough to help the students understand their mistakes and learn from them (Sirejacob, 2017).

In my class, when solving the equation $8x+5 = 3x+20$, a student writes:
 $8x-3x=20-5$ so $5x=15$ so $x=10$

Here are different proposals for the teacher to address the error made by this student. Give your opinion on each of these proposals:

- 1) *The teacher asks the student to recognise the operation between 5 and x, and draws the student's attention on the difference between addition and multiplication.*
- 2) *The teacher asks the student to replace x by 10 to see if 10 is a solution of the equation.*
- 3) *The teacher asks the student to look up in his or her textbook to find the mathematical property to be used here*
- 4) *The teacher asks the student to tell how the 5 can be passed on to the other side of the equation*

Figure 2 – Example of a question about the management of a student's error in class

About the particular case of summative assessment, which is the kind of assessment that is the one most associated to the act of evaluation by teachers in France (De Ketele, 2010), the questionnaire asks about its frequency, duration and formats, with a particular interest for the teachers' choice of tasks for that purpose. This choice reveals a potential link with the algebraic tasks chosen for this chapter in the *reference class*, in terms of domain coverage, pertinence for assessment or learning, and also, in terms of complexity and variety among all the possible tasks. The practices for correcting these summative assessments are also investigated (through the scoring, the feedback to students) as they allow us to better understand the function of these assessments and their potential formative dimension (see Figure 3).

After a summative test is taken in my class:

	Almost never	Sometimes	Often	Very often
I give the correction in class for every task in the test				
I give the correction in class only for some of the tasks				
I organise a moment for questions after the students have consulted their corrected paper				
I select some of the students' answers to be discussed collectively in class only for some of the tasks				
I return the students' corrected papers without spending any additional time on it				
I provide a version with the correct answers to the test				

Figure 3 - Example of a question about the feedback to the students after a summative test

Analysing the questionnaire

In order to analyse the teachers' answers to the questionnaire, computed by the DEPP after the implementation of the large-scale survey, and to link them to their students' results to the test in algebra, we rely on hypotheses about the possible impact of assessment practices on students' learning. We suppose that some choices might better promote learning: for example, organising a regular feedback for the students, as part of a formal or informal assessment, comparing different possible students' answers and highlighting the algebraic properties at work behind each procedure, to explicit and validate or invalidate the students' work. From these hypotheses, that will be challenged by the confrontation of the teachers' practices to their students' results, we define several teachers' profiles, including assessment practices in algebra, but also more widely, practices for the teaching of mathematics, in a given context.

This paper is focused today mainly on the design of this survey, as it displays a very ambitious methodology, and because we do not have results to show about this study at the moment. But we should be able to present already some preliminary findings at the time of the conference, about the next steps of the survey.

Conclusion

This project presents major challenges, since it is the first requested by the DEPP in France to focus on the diversity of teaching practices relating to specific disciplinary content, at a large scale. The survey is not a protocol for assessing a teacher's individual performance but aims to appreciate the diversity of teaching practices. The simultaneous test addressed to the students along with the teachers' questionnaire, might also allow us to link teaching practices and students' learning at a large scale.

References

- Allal, L. & Mottier Lopez, L. (Ed.) (2007). *Régulation des apprentissages en situation scolaire et en formation*. Bruxelles : De Boeck.
- Ash, D., & Levitt, K. (2003). Working within the Zone of Proximal Development: Formative Assessment as Professional Development, *Journal of Science Teacher Education*, 14(1), 1-313.
- Black, P., & Wiliam, D. (1998). Assessment and Classroom learning, *Assessment in Education: Principles, Policy & Praticce*, 5, (1), 7-74.

- Chevallard, Y. (1999). L'analyse des pratiques enseignantes en théorie anthropologique du didactique. *Recherches en didactique des mathématiques*, 19(2), 221-266.
- De Ketele, J.M. (2010). Ne pas se tromper d'évaluation, *Revue française de linguistique appliquée*, 15-1, 25-37.
- Grugeon, B., Pilet, J., Chenevotot, F. & Delozanne, E. (2012). Diagnostic et parcours différenciés d'enseignement en algèbre élémentaire. *Recherches en didactique de mathématiques*, Enseignement de l'algèbre, bilan et perspectives, hors série, 137-162.
- Horoks, J., Kiwan, M., Pilet, J., Roditi, E., & Haspekian, M. (to appear). Régulation des apprentissages et évaluation formative : quels regards didactiques ? In S. Coppé & E. Roditi (Eds), *Actes de la XIXème Ecole d'été de didactique des mathématiques de l'ARDM*, Paris.
- Kieran, C. (2007). Learning and Teaching Algebra At the Middle School Through College Levels. Building Meaning for Symbols and Their Manipulation. In J. Lester F. K. (Ed.), *Second Handbook of Research on Mathematics Teaching and Learning* (Vol. 2, p. 707-762). Charlotte, NC : I.A.P.
- Merle, P. (2015). *Les notes. Secrets de fabrication*. Presses universitaires de France.
- Pilet, J. (2015). Réguler l'enseignement en algèbre élémentaire par des parcours d'enseignement différencié. *Recherches en Didactique des Mathématiques*, 35(3), 273-312.
- Pilet, J. & Horoks, J. (2017). Assessment in mathematics as a lever to promote students' learning and teachers' professional development, In Dooley, T., & Gueudet, G. (Eds.) *Proceedings of the Tenth Congress of the European Society for Research in Mathematics Education (CERME10, February 1-5, 2017)*. Dublin, Ireland: DCU Institute of Education and ERME, 3572-3580.
- Rey, O. & Feyfant, A. (2014). Évaluer pour (mieux) faire apprendre. *Dossier de veille de l'Ifé*, 94. Lyon.
- Robert, A., & Rogalski, J. (2005). A cross-analysis of the mathematics teacher's activity. An example in a French 10th-grade class. In *Beyond the Apparent Banality of the Mathematics Classroom* (pp. 269-298). Springer US.
- Sirejacob, S. (2017) *Le rôle de l'enseignant dans l'organisation de l'étude personnelle hors la classe de collégiens : le cas des équations du premier degré à une inconnue*. Thèse de Doctorat. Université Paris-Diderot, Paris. <https://tel.archives-ouvertes.fr/tel-01686587>
- Vandebrouck, F. (2018) *Activity Theory in French Didactic Research*. In: Kaiser G., Forgasz H., Graven M., Kuzniak A., Simmt E., Xu B. (eds) *Invited Lectures from the 13th International Congress on Mathematical Education*. ICME-13 Monographs. Springer, Cham.

Preservice Middle School Mathematics Teachers' Development in Formative Assessment

Gözde Kaplan Can¹ and Çiğdem Haser²

¹Middle East Technical University, Ankara, Turkey; gkaplan@metu.edu.tr

²University of Turku, Finland; cigdem.haser@utu.fi

The study was conducted to investigate preservice middle school mathematics teachers' professional development in formative assessment practices they plan to implement in classrooms. Basic qualitative research method was employed in this study. Incomplete and Improper Lesson Plan Task developed by the researchers was implemented to 47 2nd year, 37 3rd year, and 27 4th year preservice middle school mathematics teachers. Findings of the study indicated that participants who took measurement and assessment course and methods of teaching courses (3rd year and 4th year preservice teachers) emphasized integrating formative assessment strategies more than 2nd year preservice teachers. None of the participants mentioned to give opportunity to students to assess themselves or provide feedback to the students in order to enhance their learning. 3rd year and 4th year preservice teachers were also more successful in detecting the improperness of the lesson plan.

Keywords: Preservice mathematics teachers, formative assessment, professional development.

Introduction

Formative assessment is used to collect evidence about students' current level of understanding a concept and their learning progress. Hence, it does not serve for certifying students' competence (Black & Wiliam, 1998). Formative assessment provides information to both students and teachers about their performance and instruction (Sadler, 1989). Any assessment is formative if this information is used as an evidence to make necessary changes in the teaching ways and strategies to meet students' learning needs and to promote their learning (Black & Wiliam, 1998; Wiliam, 2007). Wiliam and Thompson (2008) suggested a formative assessment framework shown in Table 1 considering peer-teacher-learner interactions and three instructional processes; *where the learners are in their learning, where they are going and what needs to be done to get them there* as underlined in Ramaprasad's (1983) definition of feedback.

	Where the Learner is Going	Where the Learner is Right Now	How to Get There
Teacher	Clarifying and sharing learning intentions and criteria for success	Engineering effective classroom discussions and tasks that elicit evidence of learning	Providing feedback that moves learners forward
Peer	Understanding and sharing learning intentions and criteria for success	Activating students as instructional resources for one another	
Learner	Understanding learning intentions and criteria for success	Activating students as the owners of their own learning	

Table 1: Framework relating strategies of formative assessment to instructional processes (Wiliam & Thompson, 2008, p.63)

The framework consists of five key strategies and it has one *big idea* that evidences of students' processes can be used to make adjustments in instruction in line with students' needs (Wiliam, 2007). According to the five key strategies: Teachers need to clarify and share learning intention and success criteria with the learners in order to provide them with an understandable picture of the learning targets (Wiliam, 2007). In this way, learners can comprehend the meaning of the lesson objectives and be aware of what they are supposed to do in order to achieve learning targets. Sharing success criteria or rubric with the learners is also crucial with regard to formative assessment because whether the learners grasp the success criteria need to be ensured before expecting good performance from them (Moss & Brookhart, 2009). Additionally, teachers need to reveal learners' current level of knowledge so that they can adjust their instruction according to students' needs and plan further instructional steps (Black, Harrison, Lee, Marshall, & Wiliam, 2003). Teachers can elicit students' learning by engineering effective classroom discussion through asking qualified questions and observing students' learning progress (Schachte, 2009).

Feedback has a crucial role in formative assessment especially when it is used to improve learners' performance (Wiliam, 2007). Providing feedback to the students can increase their participation to the tasks and facilitate their learning (Black & Wiliam, 1998). Being responsible for their own learning improves students' ability to judge themselves and effectiveness and quality of learning (Panadero, Jonsson, & Botella, 2017). Learners' communications and interactions in the classroom activities and lesson content are also essential for formative assessment (Moss & Brookhart, 2009) because they improve learners' motivation, make them cooperative workers (Sadler & Good, 2006) and increase their achievement.

Achieving quality in evidences collected about students' current level of understanding depends on carefully planned formative assessment practices. Based on Tyler's (1950) linear-relational model of instructional planning, teachers are supposed to decide how to evaluate students' learning and how they will make inferences from learning outcomes before instruction begins (as cited in Campbell & Evans, 2000). Hence, lesson planning is a significant process in the implementation of qualified formative assessment practices.

Knowing how to plan and implement formative assessment is crucial for teachers and for preservice teachers. Hence, teacher education programs need to train preservice teachers to increase their awareness of the significance of formative assessment and capabilities of planning and implementing formative assessment in their classrooms efficiently. Therefore, how teacher education programs train preservice teachers on formative assessment needs to be investigated.

The current study aimed to investigate preservice middle school mathematics teachers' (PST) professional development in formative assessment they plan to implement in classrooms. More specifically, the research question guided to the study was "How does PSTs' formative assessment practices change as they progress in middle grades mathematics teacher education program?" This question was sought by exploring PSTs' performance on a task where they were expected to realize the lack of formative assessment practices and suggest practices to improve the task. The nature of the mathematical tasks was not the focus of the study.

Methodology

Basic qualitative research method (Merriam, 2009) was employed in this study in order to reveal PSTs' professional development in formative assessment they plan to implement in classrooms. The formative assessment framework given in Table 1 guided the researchers in the preparation of the data collection instrument and analysis of the participants' responses.

Participants and Context of the Study

Participants of the study were 111 PSTs (47 2nd year, 37 3rd year, and 27 4th year PSTs) enrolled in four-year middle grades (grades 5-8) mathematics teacher education program at a public university in Turkey. The program offers mathematics and introductory education courses in first two years. Instructional principles and methods course is offered in the fall; measurement and assessment course is offered in the spring semester of the second year. PSTs take mathematics teaching courses in the third year while school experience and practice teaching courses are offered to them in the fourth year of the program.

Instructional principles and method course focuses on how to write observable and measurable objectives and prepare a lesson plan which includes beginning, middle, end, and assessment sections. Measurement and assessment course focuses on different assessment types including formative assessment and the development process of assessment instruments with rubrics based on objectives. In methods of teaching courses, PSTs are introduced basic principles of mathematics teaching, teaching methods and materials. Every week, they are expected to prepare a lesson plan including assessment part related to that week's topic and discuss these plans in terms of classroom activity and lesson flow. There is not specific emphasis on how PSTs plan to carry out assessment part of the plan in this course. Within the context of school experience course, PSTs are expected to observe their mentor teachers' instruction. They are required to prepare lesson plans for their teaching practice for at least two class hours in practice teaching course and to implement at least one of these plans in the practice school. Data of the study were collected in the fall semester which means that 2nd year PSTs have not completed measurement and assessment course yet, 3rd year PSTs have only been offered one mathematics teaching course and 4th year PSTs have not taken practice teaching course yet.

Instruments and Data Collection

Data were collected through a task which consists of an incomplete and improper lesson plan and a case where PSTs pretended being in-service mathematics teachers implementing this lesson plan. Lesson plan aimed to cover three 6th grade objectives related to equivalent fractions and included a group work activity sheet. Fractions concept was chosen since it forms a basis for other content areas (Siegler et al., 2012) and PSTs had fractions tasks in all mathematics education courses. The plan was incomplete because any wording that imply formative assessment strategy as stated in Table 1 was excluded from the lesson plan. It was improper since one of the three lesson objectives was immeasurable and unobservable, there was not any activity or question related to one other objective, there were inconsistencies between objectives and questions in the assessment part, and there was no rubric for the questions in the assessment part. Moreover, the structure of the questions in the assessment part was weak since they were true-false questions which were limits gathering feedback about students' learning. Task also included four questions guiding PSTs to suggest formative

assessment strategies to strengthen the lesson plan. Expert opinions of three in-service mathematics teachers who graduated from the same teacher education program, three teaching assistants who often gave feedback to PSTs' lesson plans and one mathematics education researcher were obtained in order to ensure the content related-evidence of validity. They were asked to comment on if the questions were qualified to elicit PSTs' formative assessment strategies they preferred to integrate in a lesson plan. Pilot study of the task was also conducted with three recent graduates of the same program as they completed the same courses with the targeted PSTs to finalize the data collection instrument. The modifications included directing phrases were added to questions related to the strength and weakness of the lesson plan in order to keep PSTs in focus.

During the task implementation, PSTs were expected to realize the incompleteness and improperness of the lesson plan, write the strength and weakness of the plan considering the lesson design, mathematics content, objectives and assessment part of the lesson plan. They were also asked to suggest some ways to improve the plan in line with weaknesses they found. Participants gave written answers to the questions; they did not implement the lesson plan in a real classroom environment.

The task was implemented in the courses taken by 2nd year, 3rd year, and 4th year PSTs. Preservice teachers who attended the courses were asked if they would like to participate in the study. The researchers explained that their interest was about how PSTs would redesign the given lesson plan which they would conduct in a real class setting. Participants of the study completed the task between 40-60 minutes. Data were analyzed through content analysis. PSTs' formative assessment practices were categorized based on the framework in Table 1. PST's expressions which implied formative assessment were grouped under the five strategies indicated in the formative assessment framework. Participants' comments related to the improperness of the lesson plan were also examined considering improperness criteria indicated above. Peer review strategy was utilized in order to ensure the categorization.

Findings

Incompleteness of the Lesson Plan

Findings of the study indicated that there was an increase in the emphasis on integrating formative assessment strategies in the lesson plan as the students progressed in the program. However, participants did not address all formative assessment strategies together in any year level. For instance, participants did not mention using the strategy "activating students as the owners of their own learning" (self-assessment). Besides, "activating students as instructional resources for one another" strategy (peer-assessment) was integrated into the lesson plan by only two 2nd year PSTs from the total of 111 participants. This shows that 3rd or 4th year PSTs did not propose to integrate self- and peer-assessment strategies in the lesson plan. Participants also did not make any comment about the integration of the "providing feedback that move learners forward" strategy to the lesson plan.

A total of 21 PSTs suggested asking questions for "engineering effective classroom discussions". Six percent of the 2nd year (n=3), 22% of the 3rd year (n=8), and 37% of the 4th year (n=10) PSTs recommended to include question-answer part in the lesson plan. 2nd and 3rd year PSTs made general comments about the necessity to include the questions: "questions that will guide the teacher during

the implementation of the lesson plan and students' possible answers to these questions need to be added to the lesson plan" (3rd year PST-3P16). On the other hand, most of the 4th year PSTs specified the part of the lesson plan where they would include the questions and explained the reasons why they needed to include them. Some 4th year PSTs also exemplified these questions. For instance, one of them, 4P27, criticized the lesson plan and improved it as follows:

First of all, at the beginning of the lesson plan, questions such as "What is the meaning of the fraction?", "What do numerator and denominator mean?" need to be asked in order to activate students' previous knowledge.

A few participants also emphasized the necessity to include classroom observation to be able to "engineer effective classroom discussion" in the lesson plan. Four percent of the 2nd year (n=2), 11% of the 3rd year (n=4), and 7% of the 4th year PSTs (n=2) suggested observing students while they were studying on the activity in order to elicit their learning. According to them "the teacher could observe each student while they were studying on the activity individually. In this way, assessment of students' progress would be easier" (3P26).

Six percent of the 2nd year (n=3), 11% of the 3rd year (n=4), and 15% of the 4th year PSTs (n=4) recommended to include some sentences which may imply the clarification of learning intentions in the lesson plan. For instance, one of the 2nd year PSTs, 2P8, suggested to "give more information to the students related to the lesson content at the beginning of the activity." She thought that "giving information about the activity would lead to an increase in the number of students who successfully finished the activity" (2P8). On the other hand, not any participants gave suggestion to include success criteria in the lesson plan for neither the classroom activity nor the questions in the assessment part.

Impropriety of the Lesson Plan

Findings of the study showed that participants who took measurement and assessment course and methods of teaching courses were more successful in detecting that there was not any activity in the lesson plan related to one of the lesson objectives. While only 11% of the 2nd year PSTs (n=5) noticed this impropriety, 32% of the 3rd year (n=12) and 30% of the 4th year (n=8) PSTs underlined this impropriety and indicated that "students cannot achieve the objective at the end of the lesson" (3P20) "since there were not any activity or question in the lesson plan related to it" (3P3). Although some PSTs realized that there was an inconsistency between the objectives and lesson content, less number of PSTs discerned the inconsistency between objectives and questions in the assessment part of the lesson plan in any year level. Six percent of the 2nd year (n=3), 22% of the 3rd year (n=8) and 15% of the 4th year (n=4) PSTs noticed that questions in the assessment part were not sufficient and qualified to understand whether the students achieve the all objectives of the lesson. Another criterion for the impropriety of the lesson plan, immeasurable and unobservable lesson objective, was detected more by 2nd year PSTs. While only one 4th year PST (4%) and three 3rd year PSTs (8%) realized this impropriety, six 2nd year (13%) PSTs addressed the impropriety and emphasized that "objectives need to be measurable. In the contrary case, how we can understand that students achieve the objectives?" (2P43).

Almost all participants made comments about the weak structure of the questions in the assessment part in all year levels; however, they proposed different reasons. In general, participants criticized the

type of the questions, true-false questions, since students have 50% chance to answer the question correctly. They also indicated that “asking only this type of question was not sufficient to assess students understanding of equivalent fractions” (4P26). Almost half of the 4th year PSTs (44%, n=12) suggested to include questions about modeling the fractions in the assessment part of the lesson plan. Some PSTs also recommended to ask students explain the reasons for why they gave “true” or “false” answer to the questions. For instance, 4P10 explained her reasoning in suggesting these kinds of open ended questions in this way:

Questions asking students draw some models could have been included in the assessment. Or, students could have been asked to explain why they preferred to answer the question as “true” or “false”. Only in this way, a teacher can elicit students’ misunderstandings or misconceptions.

Especially 3rd year PSTs underlined the fact that the questions in the assessment part did not assess all lesson objectives and they suggested to include question which were designed to assess all lesson objectives in the assessment part of the lesson plan (22%, n=8). Only two 2nd year PSTs emphasized that the assessment part of the lesson plan needs to be graded. However, none of the participants mentioned the necessity to include the rubric for the questions in the assessment part which was one of the reasons for the improperness of the given lesson plan.

Discussion and Conclusion

Finding of the study revealed that PSTs seemed to make little or no benefit of formative assessment strategies which could be utilized to enhance students’ learning process. None of the participants preferred to integrate self-assessment strategy into lesson plan and only two 2nd year PSTs mentioned the necessity of peer assessment. The reason for not addressing these strategies might be the preservice teachers’ thoughts that students were not able to assess their peers’ and their own performances objectively (William, 2007). They might also perceive assessment as only their responsibility since they believed that only they would have expertise to assess students’ learning (Sadler, 1989). PSTs also did not refer to provide feedback to students. This might be due to the nature of the data collection instrument. Since students’ possible responses were not provided to the participants, they might not need to give feedback to students in order to enhance their learning.

Questioning and observing are the most used methods for gathering information about students’ progress (Antoniou & James, 2014). Although more 3rd and 4th year PSTs suggested to include questions and observation in the lesson plan, the number of participants who took attention to these strategies was very limited. This little emphasis on including questions in the lesson plan might be due to the fact that PSTs thought that they did not need to write questions in the lesson plan since they would keep them in their mind. However, when the questions were written before the instruction began, teachers could have an opportunity to explore particular strategies for increasing students’ attention to the key mathematical concepts (Black et al., 2003). Moreover, the reason more 3rd and 4th year PSTs suggested to include question in the lesson plan compared to 2nd year PSTs might be that they had more experience on the preparation of lesson plan and conducted more discussion of classroom activity in the lesson plan and lesson flow. Since 4th year PSTs also had opportunity to observe their mentor teachers’ instruction in school assessment course, they might have specified the part of the lesson plan where they would include the questions and they explained the reasons why

they needed to include them. Moreover, PSTs did not reflect explicitly on making observation while students were working on the class activity. Similarly, teachers have been reported to focus mainly on the learning product and did not monitor students' learning processes in their plans (Ruys, Van Keer, & Aelterman, 2012).

Findings of the study also indicated that not many participants were able to detect the improperness criteria of the lesson plan in general. Participants who took measurement and assessment course and methods of teaching courses were more successful in detecting the inconsistency between both objectives and classroom activity, and objectives and questions in the assessment part. However, still the number of PSTs who detected this improperness was very low. Although ensuring the consistency between objectives-classroom activity and objective-plan's assessment is one of the basic concerns that should be taken into account in lesson planning (Moss & Brookhart, 2009; Ruys, Van Keer, & Aelterman, 2012), and necessity of consistency between those has been emphasized especially in instructional principles and method, and measurement and assessment course, such limited number of participants who emphasized on this feature was unanticipated. Additionally, more 2nd year PSTs detected one of the other reasons for the improperness of lesson plan, immeasurable and unobservable lesson objective, than 3rd and 4th year PSTs. Since 2nd year PSTs recently have learnt how to write lesson objectives in instructional principles and method course, they might have been aware of this improperness. This might also show that 3rd and 4th year PSTs have not internalized why the objectives were supposed to be measurable and observable through their university education despite the strong emphasis on these characteristics.

Majority of the PTSs (regardless of their year levels) were able to detect the improperness of the assessment part resulting from the structure of the questions. Participants mainly proposed that they could not know if the students achieved the objectives or not with true-false type questions. Especially 4th year PSTs proposed to add different types of questions to the assessment part. The reason for suggesting to include question in the assessment might be due to their awareness of the requirement of the alignment between objectives and the questions in the assessment. Additionally, participants did not specify any success criteria or rubric for the assessment part of the lesson plan. The nature of the questions in the assessment part might be the reason for omitting the success criteria. PSTs might not need to include any rubric for the scoring since the questions were in true-false type. Another reason for not including rubric in the lesson plan might be PSTs' thoughts about the usage of assessment. They might have preferred not to score students' work and use it for formative purposes.

Although instructional principles and method, and measurement and assessment course provided necessary knowledge to the PSTs about formative assessment, PSTs had difficulty in integrating intended formative assessment strategies in the given lesson plan. PSTs who took methods of teaching courses and school experience course (3rd and 4th year PSTs) were more successful than 2nd year PSTs in detecting incompleteness and improperness of the lesson plan. Preparing lesson plan, having opportunity to discuss it with their peers in methods of teaching courses and observing mentor teachers' instruction in middle schools in school experience course might help PSTs to see the whole picture of the lesson plan in terms of the usage of formative assessment strategies. Also having these experiences might provide PSTs to criticize the lesson plan with different perspective.

References

- Antoniou, P., & James, M. (2014). Exploring formative assessment in primary school classrooms: Developing a framework of actions and strategies. *Educational Assessment, Evaluation and Accountability*, 26, 153-176.
- Black, P., Harrison, C., Lee, C., Marshall, B., & Wiliam, D., (2003). *Assessment for learning: Putting it into practice*. Buckingham, UK: Open University Press.
- Black, P., & D. Wiliam (1998). Assessment and classroom learning. *Assessment in Education: Principles, Policy & Practice*, 5(1), 7-71.
- Campbell, C., & Evans, J. A. (2000). Investigation of preservice teachers' classroom assessment practices during student teaching. *Journal of Educational Research*, 93, 350-355.
- Merriam, S. B. (2009). *Qualitative research: A guide to design and implementation*. San Francisco, CA, United States: John Wiley & Sons, Inc.
- Moss, C. M., & Brookhart, S. M. (2009). *Advancing formative assessment in every classroom: A guide for instructional leaders*. Alexandria, VA: ASCD.
- Panadero, E., Jonsson, A., & Botella, J. (2017). Effects of self-assessment on self-regulated learning and self-efficacy: Four meta analyses. *Educational Research Review*, 22, 74-98.
- Ramaprasad, A. (1983). On the definition of feedback, *Behavioral Science*, 28, 4–13.
- Ruys, I., Van Keer, H., & Aelterman, A. (2012). Examining pre-service teacher competence in lesson planning pertaining to collaborative learning. *Journal of Curriculum Studies*, 44(3), 349-379.
- Sadler, D. R., (1989). Formative assessment and the design of the instructional system. *Instructional Science* 18, 119-144.
- Sadler, P. M., & Good, E. (2006). The impact of self- and peer-grading on student learning. *Educational Assessment*, 11(1), 1–31.
- Schachte, W. F. (2009). *Voices that emerge: Understanding formative assessment from the students' eye view* (Doctoral dissertation). Available from ProQuest Dissertations and Theses database. (UMI No. 3376384)
- Siegler, R. S., Duncan, G. J., Davis-Kean, P. E., Duckworth, K., Claessens, A., Engel, M., & Chen, M. (2012). Early predictors of high school mathematics achievement. *Psychological Science*, 23(7), 691-697.
- Wiliam, D. (2007). Keeping learning on track: Classroom assessment and the regulation of learning. In F. K. Lester (Ed.), *Second handbook of research on mathematics teaching and learning*, (pp. 1053-1094). Charlotte, NC: Information Age Publishing.
- Wiliam, D., & Thompson, M. (2008). Integrating assessment with instruction: What will it take to make it work? In C. A. Dwyer (Ed.), *The future of assessment: Shaping teaching and learning* (pp. 53–82). Mahwah, NJ: Erlbaum.

An assessment of non-standardized tests of mathematical competence for Norwegian secondary school using Rasch analysis

Morten Riise Klegseth, Eivind Kaspersen and Trygve Solstad

Norwegian University of Science and Technology, Faculty of Social and Educational Sciences,
Department of Teacher Education, Trondheim, Norway

Morten-Riise.Klegseth@ou.trondheim.kommune.no; eivind.kaspersen@ntnu.no;
trygve.solstad@ntnu.no

Do non-standardized, publisher-provided tests for lower secondary school provide valid and reliable measures of mathematical competence? We analysed a sample of items pooled from tests accompanying three different Norwegian textbooks using Rasch analysis. The pooled sample of items was found to be sufficiently unidimensional for measuring function competence, with four strands of sub-competencies in accordance with theory. The competence associated with an increasing difficulty of items could be qualitatively characterised by shifts from a) identifying through constructing to reasoning about representations, b) using visual to using algebraic representations, and c) local to global interpretations of functions. While the individual tests differed substantially in the distribution of items across strands of mathematical competence, minor adjustments to the combined instrument were sufficient for providing a valid and reliable measure of mathematical competence.

Keywords: Competence, assessment, rasch, functions.

Introduction

Background

Teachers rely strongly on written tests when determining final grades for secondary school pupils (Brookhard, 1994). In Norway, final grades are to a large degree based on results on non-standardized midterm exams and shorter tests provided by textbook publishers (Prøitz & Borgen, 2010). Publisher-provided tests are composed by experienced textbook authors without explicit reference to a theoretical framework for the mathematical competence the tests aim to assess. Because mathematical functions are central to the field of mathematics and to the Norwegian secondary school curriculum, and because they are typically introduced in the 10th grade, the topic constitutes a relevant and convenient source of information about how such tests are composed and what they measure. In this study we asked a) how competence in linear functions is operationalised in tests accompanying Norwegian mathematics textbooks, and b) to what extent these tests provide valid and reliable measures of mathematical competence.

Theoretical framework for competence in mathematical functions

As a starting point for describing mathematical competence, we took the widely used Danish KOM model, which distinguishes eight partially overlapping mathematical *competencies* (Niss & Jensen, 2002). Briefly, these competencies are i) Mathematical thinking, ii) Mathematical problem solving and -posing, iii) Mathematical modelling, iv) Mathematical reasoning, v) Handling mathematical representations, vi) Handling mathematical symbols and formalisms, vii) Mathematical communication, and viii) Using aids and tools.

The tests we analysed were dominated by questions concerning transformations of different representations of functions, warranting a further characterization of this competency. Representations form the foundation of many theoretical frameworks for mathematical competence and have been central to describing competence in functions. O’Callaghan (1998) presents a model with four main components: 1) *Modelling*, the transformation from a problem situation to a mathematical representation using functions, 2) *Interpretation*, the transformation from a mathematical representation of a function to the description of a problem situation, 3) *Translation* between representations of functions, like symbols, tables, and graphs, 4) *Reifying*, the creation of a mental object from what was initially perceived as a process or procedure, and 5) *Procedural skills* for operating within a representation system.

Levels of competence

The present manuscript focuses on the role that textbook tests have in determining students’ final grades. These tests are typically administered after each mathematical topic has been covered in class and can be considered high stakes in the sense that they collectively make up part of the basis for a teacher’s end-of-school assessment. However, these tests often serve formative as well as summative purposes. While the summative aspect differentiates students according to their levels of competence, qualitative characterizations of each level of competence within a competency can both address issues of test validity and be useful in a formative perspective on assessment.

The perceived difficulty of a question about mathematical functions has been shown to depend on the cognitive demand of providing a valid answer to a problem. In particular, *interpreting* or *recognizing* properties of a given representation or statement is easier than *recalling* or *constructing* a solution to a problem when a target representation is not given. *Explaining* why a solution is valid typically requires the student to explicate relations between multiple representations and is perceived as more difficult than identifying and constructing valid representations (Leinhardt et al., 1990; Nitsch et al., 2015).

Representations of functions and transitions between representations can be interpreted from a local or global perspective. Whereas local interpretations of a function involve accessing single values of the representation, global interpretations involve reasoning about how the function behaves as a whole or within certain intervals of the domain. Global interpretations are important for accessing more advanced mathematics and are associated with higher levels of mathematical competence (Leinhardt et al., 1990; Gagatsis & Shiakalli, 2004; Duval, 2006; Bossé et al., 2011).

These perspectives on what characterizes different levels of competence served to aid our analysis of the test items from the non-standardized textbook tests.

Methods

Selection of test items

Three tests accompanying 10th grade textbooks from three major Norwegian publishers were selected as a source of common test items in Norwegian schools. When two or more tests contained very similar items, only one item was selected for our instrument. Items that did not address the subject of linear functions were excluded from the study. One item was excluded because it could not be

faithfully translated into digital form. Items requiring a global interpretation of functions were missing from the original tests, and we added two items in order to assess this category of competence. After this selection process our pooled test consisted of 31 test items.

Modification of test items

After a pilot study, Rasch analysis identified some items as unreliable. In particular, multiple choice items did not provide good fits to the Rasch model and were converted into explanation items. One original item used specific numbers that produced ambiguous answers, and a new set of more suitable numbers was chosen. For a few items, we adjusted the specific numbers used in order to obtain a more uniform distribution of item difficulties in the instrument as a whole.

Categorization of test items

The test items were categorized according to the theoretical frameworks discussed in the introduction. While no items fell into the ‘reification’ category, several items asked about specific concepts. Reification was therefore substituted with a separate category for Concepts, and we used the following categories for the analysis: Interpretation, Translation, Modelling, Concepts, Coordinates and Others. The three first categories were generated directly from the theory of competence for functions. Concepts can be considered part of mathematical thinking in the KOM framework (Niss & Jensen, 2002, p. 47), and coordinates can be considered a part of “symbols and formalisms” in the KOM framework (Niss & Jensen, 2002, p. 58). Items in the “others” category were excluded from the study as they were not directly related to competence in linear functions, like items requiring competence in nonlinear functions, solving equations, and general competence with digital tools.

An anticipation of item difficulty was estimated (“easy”, “medium”, or “difficult”) for each item based on whether the item required a) identification or interpretation of a given solution, b) construction of a valid solution, or c) an explanation for a mathematical statement (Nitsch et al., 2015; Leinhardt et al., 1990). The anticipated difficulty was adjusted according to whether the item required a) a local or global interpretation of the given function, and b) one or multiple transformations between representations of the given function.

Participants

A convenience sample of fourteen school classes with a total of 250 tenth grade pupils from 5 out of 13 secondary schools in the city of Trondheim, Norway, participated in the study. All pupils had completed classroom instruction in linear functions between one week and two months before they participated in the study. Participation was voluntary, and all answers were anonymous.

Data collection

The test items were digitized and answers to the items were collected using a web platform developed at the Department of Teacher Education, NTNU. After a 5-minute presentation of the testing tool and informed consent, pupils had 55 minutes to complete the test. Test items were presented in randomized order. If no answer was given to a test item, the answer was coded as “missing data”.

Analysis

As most items in the tests asked for a single correct answer, each item was scored either 0 or 1 point (dichotomous model). Quantitative data was analysed with the Rasch model (Rasch, 1960) using the Winsteps software (Linacre, 2017). In the Rasch model, the probability that person v scores 1 point on item i depends on the difference between the ability of person v , β_v , and the difficulty of item i , δ_i , according to

$$P \{X_{vi} = 1 | \beta_v, \delta_i\} = \frac{e^{(\beta_v - \delta_i)}}{1 + e^{(\beta_v - \delta_i)}}$$

Winsteps implements the joint maximum likelihood estimation (JMLE) algorithm for estimating the parameters of this model, and principal component analysis (PCA) of normalized residuals for investigating the dimensionality of the dataset.

Validity

Assessment of the validity of the instrument was based on the framework presented in Wolfe and Smith (2007) which expands on Messick (1995). Here, we considered the following six aspects of validity: *i) Content* (e.g. relevance, representativeness, and technical quality), *ii) substantive* (e.g. theoretical foundation), *iii) structural* (e.g. evidence of unidimensionality), *iv) generalizability* (e.g. generalization across sample and context), *v) consequential* (e.g. fairness and possible biases), and *vi) interpretability* (e.g. the relationship between quantitative measures and qualitative meaning).

Results

Classification of item competence

We collected test items from three publisher-provided tests in functions for Norwegian secondary school. The items were classified into five competence categories and assigned an anticipated level of difficulty (depending on cognitive demand, number of representational transformations, and local vs global perspective on functions). While the combined set of items covered a broad range of competence categories, individual tests differed substantially in their emphasis on each competence category (Table 1). In particular, tests B and C put opposite emphasis on interpretation, translation and concepts, while items from test A were more evenly distributed among the categories.

Test	Concept	Interpretation	Translation	Modelling	Coordinates	Excluded
A	4	4	5	2	1	5
B	0	7	1	3	1	3
C	4	1	6	4	4	5

Table 1: Number of items in each competence category for each of the tests in the study.

Measurement properties

In general, the data fit well with the Rasch model, contributing to the instrument's content validity (Wolfe & Smith, 2007). Person reliability, analogous to Cronbach's alpha, was 0.86. Item infit mnsq

was 1.01 ± 0.18 (mean \pm std) and item outfit mnsq was 0.9 ± 0.34 (mean \pm std), which means that the variance in pupils' responses to single items generally fit well with the Rasch model (infit mnsq = outfit mnsq = 1).

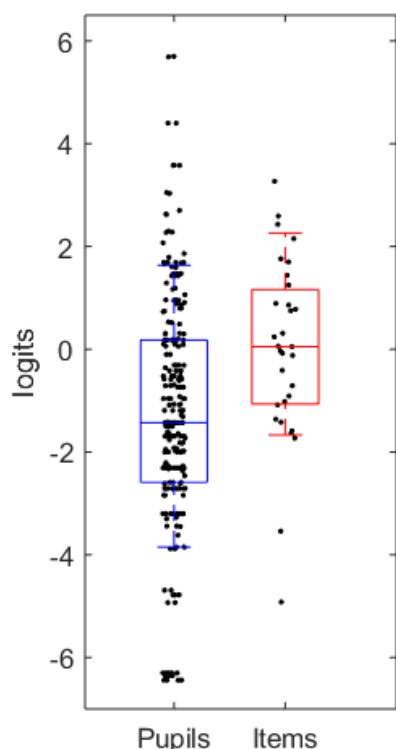


Figure 1. Competence level of pupils (blue boxplot) and item difficulty (red boxplot) on the same logit scale. Boxplots indicate 10th, 25th, 50th, 75th and 90th percentiles.

The item difficulties ranged from -4.9 to 3.3 logits, but the distribution of items was uneven with 28 out of 31 items between -1.7 and 2.6 logits (Figure 1, red boxplot). This contrasted with the distribution of pupil achievement level: only about half (52%) of the pupils achieved within this range of item difficulties, and almost 75% of pupils achieved below the mean item difficulty (Figure 1, blue boxplot). The low attainment might be related to the time of testing and the perceived distance to final exams.

Only two items were positioned to discriminate achievement levels below the -1.7 logit mark where 42% of pupils were measured. These items might be considered at the entry level to competence with functions, and as a tool for summative assessment the instrument distinguishes well between pupils above that competence level. However, the large gaps between easy items, producing an abundance of low test scores, leaves a large proportion of students without feedback about their competence level beyond an unintended subtext of failure. From the view of formative assessment, the scarcity of easy items detracts from the instrument's content and consequential validity (Wolfe & Smith, 2007).

Item difficulty was largely invariant to the pupils' achievement level, as determined by comparing the difficulty level of each item between the highest achieving and lowest achieving pupils. Pupil achievement level affected the difficulty of only 2 out of

the 31 items (at the $p = 0.0016$ level; Bonferroni corrected for multiple comparisons from $p = 0.05$), contributing the instrument's generalizability validity (Wolfe & Smith, 2007). The first of these items favoured high-achieving pupils and was the only item involving a function with negative slope. The second item favoured low-achieving students by unintentionally allowing the zooming in on a graph to read off the solution directly rather than reasoning about it.

Empirical categories of competence

The competence categories were taken from theoretical frameworks for competence with functions. To investigate if these categories could be identified in the empirical data, we conducted a PCA on standardized residuals of the data (Linacre, 2017). PCA identified two contrasts with potential subdimensions. The first contrast (eigenvalue = 2.4) clearly separated Interpretation items (the six items with the highest positive loading) from Translation items (the six items with the highest negative loading). In addition, all 13 items in the cluster with negative loading included symbolic expressions. The second contrast (eigenvalue = 1.9) separated the full set of five Concept items

together with the single coordinate item from the main dimension of the instrument. The Modelling items did not deviate from the main dimension defining competence levels for linear functions.

While 49% of the variance in the data could be explained by the measures, the additional variance explained by the four clusters combined was around 7%, which can be usefully considered sub-dimensions of the main variable. Taken together, the instrument can be considered unidimensional for measuring competence in linear functions, which adds to its structural validity. At the same time, the dimensionality analysis lends empirical support to the notion that competence in linear functions is composed of four strands, each dominated by one of the four main competence categories Concept, Interpretation, Translation, and Modelling. This correspondence between empirical clusters and theoretical foundation speaks to the instrument's substantive validity.

Empirical levels of competence

What is the qualitative meaning of the quantitative measure along the competence scale?

First, the distribution of item difficulty did not differ significantly between competence categories, either in variance ($p = 0.15$; Levene's test) or mean difficulty ($p = 0.13$; one-way ANOVA; Figure 2). However, the two most difficult items in the Interpretation category were added to the original items because a global perspective of functions was missing from the original tests. Without these two items, the mean difficulty of Interpretation items was significantly lower than for items in the other categories ($p = 0.01$; one-way ANOVA).

Two items in the Interpretation category stood out as easier than other items. These items asked pupils to read off a value in a coordinate system and count the number of constant parts of a graph. Arguably, both items could be classified as prerequisite for, rather than part of, graphical representations of functions. At the same time, the competence of as much as 40% of the students were estimated to be within this prerequisite level of function competence, challenging the validity of the test as a formative tool. Beyond the fact that both students and teachers are deprived of the positive effects of feedback for learning, close-to-zero test scores counteract a fair assessment of competence and are potentially harmful to students' motivation for learning (e.g. Schinske & Tanner, 2014). To fulfil its role as a formative tool and guide low-attaining students towards proficiency with functions, the test set should be supplemented with items about prerequisite competencies for functions.

Second, the predicted item difficulty fit well with the empirically estimated item difficulties (different colours in Figure 2). Three exceptions were of interest. These three items were measured to be more difficult than anticipated from theory and shared a pattern in the kinds of mistakes pupils made in answering them: The second and third most difficult Concept items (see Figure 2) asked pupils to identify the slope of a function expression. Most pupils either a) mistook the constant term for the slope, or b) included the variable with the slope in their answers ($\frac{x}{4}$ and $3x$). These very common mistakes resulted in higher-than anticipated measures for these two items. The unexpectedly high estimate of the coordinate system item was also due to a widespread mistake. The item asked pupils to plot a line between two given points, and a surprisingly large proportion of pupils interpreted the two coordinates as four points in the coordinate system instead of two.

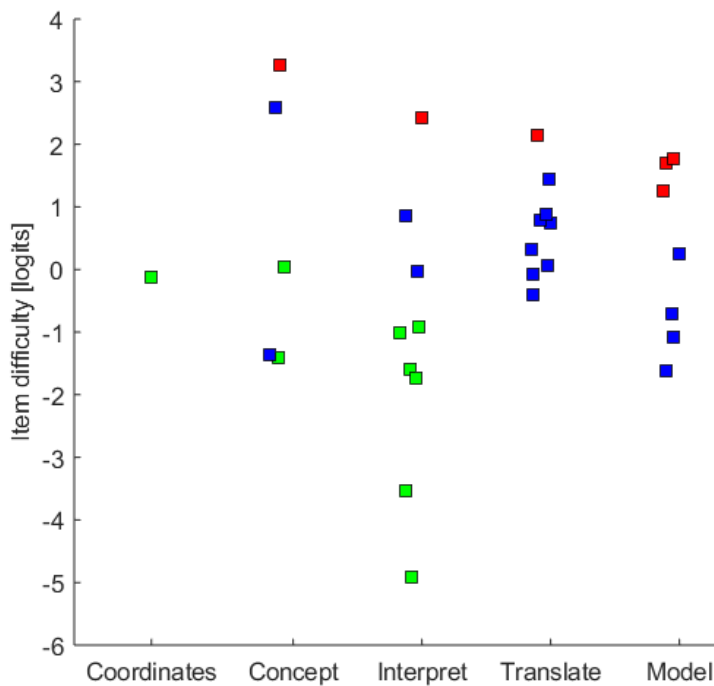


Figure 2: Item difficulty plotted by competence category on x-axis and coloured by anticipated difficulty. Green: easy item, blue: intermediate item, red: difficult item.

Third, 8 out of the 9 items with difficulty less than -1 logit did not concern symbolic expressions. The one item that did was the easiest Modelling item, and asked pupils to form an equation rather than a function from a written context. The item could be solved using an additive strategy without noticing a functional relationship between two variables. -1 logit seems to mark a threshold above which competence with the algebraic symbol system for functions is required. 58% of the pupils in this study scored below the level requiring competence with symbolic expressions for functions.

The qualitative stratification of items along the difficulty scale gives the instrument interpretability validity (Wolfe & Smith, 2007). The stratification is also useful for formative assessment, but only for pupils that have acquired a minimum level of competence with functions.

Conclusions

We have presented an analysis of a test pooled from three publisher-provided tests of competence in linear functions. The analysis shows that, with minor modifications to some test items, the test set as a whole is a reliable and valid measurement instrument that can be considered one-dimensional for its intended purpose yet consists of empirically identifiable strands of competence that correspond closely to the theoretical framework for mathematical competence outlined in the introduction.

The study suggests that if items are sampled in a balanced manner across both different subdimensions and difficulty levels according to the theoretical framework, calibrated standardized tests might not be necessary to obtain reliable and valid summative assessment of mathematical competence on small scale tests for secondary school. However, adding items on topics prerequisite to competence with functions would strengthen the instrument's value as a formative tool.

Acknowledgements

These results were previously presented in Norwegian in the Master thesis of Morten R. Klegseth.

References

- Bossé, M. J., Adu-Gyamfi, K., & Cheetham, M. R. (2011). Assessing the difficulty of mathematical translations: Synthesizing the literature and novel findings. *International Electronic Journal of Mathematics Education*, 6(3), 113–133.
- Brookhart, S.M. (1994). Teachers' grading: Practice and theory. *Applied Measurement in Education*, 7(4), 279–301.
- Duval, R. (2006). A cognitive analysis of problems of comprehension in a learning of mathematics. *Educational Studies in Mathematics*, 61(1), 103–131.
- Gagatsis, A., & Shiakalli, M. (2004). Ability to translate from one representation of the concept of function to another and mathematical problem solving. *Educational Psychol.*, 24(5), 645–657.
- Leinhardt, G., Zaslavsky, O., & Stein, M. (1990). Functions, graphs, and graphing: Tasks, learning, and teaching. *Review of Educational Research*, 60(1), 1–64.
- Linacre, J. M. (2017). *Winsteps® Rasch measurement computer program. User's Guide*. Beaverton, OR: Winsteps.com.
- Messick, S. (1995). Validity of psychological assessment: Validation of inferences from persons' responses and performances as scientific inquiry into score meaning. *American Psychologist*, 50, 741–749.
- Niss, M., & Jensen, T. H. (eds.) (2002). *Kompetencer og matematiklæring: Idéer og inspiration til udvikling af matematikundervisning i Danmark. Uddannelsesstyrelsens temahæfteserie 18*. Copenhagen, Denmark: The Danish Ministry of Education.
- Nitsch, R., Fredebohm, A., Bruder, R., Kelava, A., Naccarella, D., Leuders, T., & Wirtz, M. (2015). Students' competencies in working with functions in secondary mathematics education—empirical examination of a competence structure model. *International Journal of Science and Mathematics Education*, 13(3), 657–682.
- O'Callaghan, B. R. (1998). Computer-intensive algebra and students' conceptual knowledge of functions. *Journal for Research in Mathematics Education*, 29(1), 21–40.
- Prøitz, T.S., Borgen, J.S. (2010). *Rettferdig standpunktbedømming—det (u)muliges kunst?: Læreres setting av standpunktkarakter i fem fag i grunnsopplæringen*. Oslo, Norway: NIFU STEP Report, 16/2010.
- Rasch, G. (1960). Probabilistic models for some intelligence and attainment tests. *Copenhagen, Denmark: Danish Institute for Educational Research*. Expanded edition, 1980. Chicago, IL: University of Chicago Press.
- Schinske J., Tanner K. (2014). Teaching more by grading less (or differently). *CBE—Life Sciences Education*, 13(2), 159–166.
- Wolfe, E. W., & Smith, J. E. (2007). Instrument development tools and activities for measure validation using Rasch models: Part II—validation activities. *Journal of Applied Measurement*, 8(2), 204–234.

Mathematics described proficiency levels: connecting psychometric and teaching analyses

Cristina Lasorsa¹, Rossella Garuti¹, Marta Desimoni¹, Donatella Papa¹, Antonella Costanzo¹ and Rosalba Ceravolo¹

¹INVALSI; Rome, Italy: cristina.lasorsa@invalsi.it; rossella.garuti@libero.it; marta.desimoni@invalsi.it; donatella.papa@invalsi.it; antonella.costanzo@invalsi.it; rosalba.ceravolo@invalsi.it

Keywords: National assessment, psychometric analysis, mathematics standardized items.

Introduction

Large scale assessment in education often aims at measuring proficiency in subject areas, thus considering latent variables that are not directly observable but defined through a theoretical framework and operationalized through standardized tests. For each subject area, a numerical test score (proficiency score) is typically computed in order to locate the students on the variable continuum (learning metrics or proficiency scale) defined by the test items, i.e. the proficiency score quantifies how much of the measured variable (for example mathematics ability) is present (Turner, 2014). Reporting test results only in terms of numerical test score, however, does not provide substantial information on what students typically know and can do. A substantial description of the location along the proficiency scale is needed in order to support practitioners in interpreting test results and in order to convert them into effective teaching practices (van der Linden, 2017).

In the last years a growing number of national (e.g., National Assessment of Educational Progress, MEETS NAEP GUIDELINES) and international (Program for International Student Assessment, PISA; Trends in International Mathematics and Science Study, TIMSS; Progress in International Reading Literacy Study, PIRLS) testing programs has been developing descriptive proficiency scales, in order to report test results not only as proficiency scores but also in terms of described proficiency levels. The goal is to illustrate what the scores represent in terms of students' skills, understanding and competencies (van der Linden, 2017). This goal has been recently pursued by the Italian National Institute for evaluation of the education and training system (INVALSI), that yearly carries out standardized tests to assess students' achievement in mathematics and reading (i.e. reading comprehension and grammatical knowledge), and to evaluate the overall quality of the educational offering of schools and vocational training institutes.

INVALSI experience

INVALSI returns data as descriptive proficiency levels for reading (reading comprehension and grammatical knowledge) and mathematics, for the first time in the school year 2017-2018. Basing on the INVALSI Reference Framework, and coherently with the National Guidelines for the Curriculum's goals (MIUR 2012), proficiency scales have been developed through an extensive Rasch item bank, administered by computer based tests (CBT) (https://invalsi-areaprove.cineca.it/docs/2018/INVALSI_tests_according_to_INVALSI.pdf). Five proficiency levels have been identified considering the distribution on the same scale of both the items' difficulty and

the students' ability (Desimoni, 2018). The five levels have been described basing upon the items' content. The consistency between the item ordering basing on the psychometric data and the item ordering predicted from theory represents a fundamental aspect for the scale validity, an issue widely investigated during the scale construction.

The present contribution will investigate the psychometric and qualitative-educational properties of a pool of sample items (Garuti et al., 2017), from the INVALSI Item Bank, in order to better investigate this aspect: which are the item properties highlighted from the concurrent psychometric and qualitative teaching analyses? Beyond an overview of the development of the mathematics' described proficiency scale, the study will focus on five items, of an increasing level of difficulty (scaled from 1 to 5), and referring to same content (Numbers) and to the same learning goal (Operation between numbers and numbers ordering), in order to identify the typical item characteristics determining its placement within a level. Specifically, which are the cognitive obstacles that students need to overcome to pass, for instance, from level 3, "link and integrate multiple fundamental pieces of knowledge concerned with processing, ordering between rational numbers and representations of mathematical objects" to level 4, "integrate and make connections between basic pieces of knowledge where the relationships are provided implicitly or derived from a representation".

From a practical perspective, we found interesting results, that might be supportive to the development of new items for the INVALSI Item Bank. Finally, we also discuss potential implications of our results in the teaching process.

References

- Desimoni, M. (2018). I livelli per la descrizione degli esiti delle prove INVALSI. Retrieved from https://invalsi-areaprove.cineca.it/docs/2018/Livelli_INVALSI_g8.pdf.
- Garuti, R., Lasorsa & C., Pozio, S. (2017). The Italian national education assessment system: building mathematics items. In Dooley, T., & Gueudet, G. (Eds.), *Proc. of the Tenth Congress of the European Society for Research in Mathematics Education* (pp. 3545–3552). Dublin, Ireland: DCU Institute of Education and ERME.
- Ministero dell'Istruzione, Università e Ricerca (MIUR). (2012). *Indicazioni nazionali per il curricolo della scuola dell'infanzia e del primo ciclo di istruzione*. Rome: Author. Retrieved from http://www.indicazioninazionali.it/documenti/Indicazioni_nazionali/indicazioni_nazionali_infanzia_primo_ciclo.pdf.
- Turner, R. (2014). *Described proficiency scales and learning metrics. Assessment GEMs no.4*. Melbourne, Australia: Australian Council for Educational Research (ACER).
- Van der Linden, W.J. (2017). *Handbook of Item Response Theory*, Volume Three: Applications. van der Linden, W. J. (ed.). Boca Raton: Chapman and Hall/CRC, p. - (Chapman & Hall/CRC Statistics in the Social and Behavioral Sciences).

Teachers' Perceptions of Using Incentives in State Examinations to Increase the uptake of Higher Level Mathematics

Mark Prendergast¹, Páraic Treacy² and Niamh O'Meara³

¹The University of Dublin, Trinity College, School of Education, Dublin, Ireland;
mark.prendergast@tcd.ie

²University of Brighton, School of Education, Brighton, UK; P.Treacy@brighton.ac.uk

³University of Limerick, EPI*STEM, Limerick, Ireland; Niamh.OMeara@ul.ie

Keywords: Education policy, state examinations, incentives, teacher perceptions.

Background to the Study

In Ireland, all students sit a summative state examination known formally as the Leaving Certificate (LC) at the end of Senior Cycle (upper secondary level). The LC acts as a gatekeeper to tertiary level education with students awarded points based on their six best graded subjects. Different points are also awarded pending the level of which the subject was studied. For example, the majority of subjects have two levels. The most challenging level is Higher Level (HL - often referred to as Honours) and the next level down is Ordinary Level (OL - often referred to as Pass). Since 2012 mathematics has been assigned a special status within the Irish post-primary school curriculum with the introduction of a Bonus Points initiative (BPI). Students are now awarded an extra 25 points in their LC examination results if they achieve a passing grade at HL. The awarding of these extra points was introduced to encourage students to study mathematics at HL. Such incentive schemes for studying mathematics and improving student performance in the subject are not a new phenomenon. Similar schemes exist in Australia and Israel (Treacy, 2018).

In Ireland while the numbers opting for HL mathematics have nearly doubled since the introduction of the BPI, anecdotally there have been many mixed reviews. Hence, while there have been calls in some quarters to extend this initiative to other subjects, it is important that the impact of the BPI on the study and assessment of mathematics is first appraised. This paper investigates the advantages and disadvantages associated with the BPI from the perspective of mathematics teachers (n=266) and aims to address the following research question: What are mathematics teachers' perceptions of the Bonus Points Initiative as an incentive in state examinations?

Methodology

The methodology of this study involved the distribution of a questionnaire to a representative sample of HL mathematics teachers in Irish post-primary schools (n = 723). The instrument was designed specifically for this study and was developed by the authors with the assistance of an advisory group involving five experienced post-primary mathematics teachers. It comprised of four main sections. Section 4, which is the focus of this submission, inquired of teachers' perceptions of the BPI through a series of multiple choice and open-ended questions. The finalized questionnaires were distributed (two to a stratified sample of 400 post-primary schools) in early April 2018. The response rate was 266 second level teachers (approx. 33%). The open-ended questionnaire data was analysed thematically in two stages. Firstly, the first coder coded the two sets of data (perceived advantages

and disadvantages) himself two weeks apart, and the *intra*-coder agreement percentages were equally high (> 90%). The second coder subsequently coded around a third of each dataset and once again the inter-coder agreement percentages were > 90% for the perceived advantages and disadvantages, highlighting that the coding frameworks that we developed for this study's analysis were reliable.

Findings and Discussion

Findings from both the qualitative and quantitative data in this study indicate that teachers hold many mixed opinions regarding the BPI. While 46% of respondents indicated that they agree with the BPI, the rest were either not sure or did not agree. The main advantage of the initiative was that it increased uptake and perseverance of mathematics at HL. However, while the numbers taking HL may have increased, respondents noted some concerns about the standard of students now persisting at HL. A greater proportion of students that would have typically attempted the OL examination, were it not for the BPI, were now attempting the HL examination and thus there was an increase in those achieving low grades (SEC 2015). There were also fears that the LC HL mathematics examination would be 'dumbed down' to cater for the surge in students now taking it. It was feared that "*Students of a stronger mathematics ability may not be extended to the same degree*".

However, while these concerns are real, there were also many advantages of the BPI which were noted by the participating teachers. The second most cited benefit was that it rewarded students for the time and effort required for the course. Concern has long been expressed at the workload and timeframe of the LC HL mathematics curriculum in Ireland (Cosgrove et al., 2013). In addition to the workload and timeframe, a study carried out by Smyth, Banks, and Calvert (2011) found that mathematics is considered to be among the top five most difficult LC subjects. Thus the BPI rewards students for their exertions and supports the view that mathematics is not 'just another subject' (McDonagh & Quinlan, 2012).

However, the findings of this study indicate that while there are clear advantages to the special status that the BPI has given mathematics within the Irish post-primary school curriculum, there was also a number of interlinking disadvantages which must be considered if such incentive schemes are to be maintained, and indeed expanded.

References

- Cosgrove, J., Perkins, R., Shiel, G., Fish, R., & McGuinness, L. (2012). *Teaching and learning in Project Maths: Insights from teachers who participated in PISA 2012*. Dublin: Educational Research Centre.
- McDonagh, S., & Quinlan, T. (2012). *Maths national competitiveness: a discussion document submitted to the national competitiveness council*. Dublin: National Competitiveness Council.
- Smyth, E., Banks, J., & Calvert, E. (2011). From Leaving Certificate to leaving school: A longitudinal study of sixth year students. *Economic and Social Research Institute (ESRI) Research Series*.
- State Examinations Commission (SEC). *State examinations statistics*. Published: State Examinations Commission (SEC). 2015. Available from: <https://www.examinations.ie/statistics/>
- Treacy, P. T. (2018). Incentivizing advanced mathematics study at upper secondary level: the case of bonus points in Ireland. *International Journal of Mathematical Education in Science and Technology*, 49(3), 417-436.

Teachers' use of *Descriptive Assessment* methods in primary school mathematics education in Iran

Ali Akbar Sangari¹, Marja van den Heuvel-Panhuizen¹², Michiel Veldhuis¹⁴ and Zahra Gooya³

¹Freudenthal Group FSW, Utrecht University, the Netherlands; a.a.sangari@uu.nl;
m.vandenheuvel-panhuizen@uu.nl; m.veldhuis@uu.nl

²Nord University, Bodo, Norway

³Shahid Beheshti University, Tehran, Iran; zahra_gooya@yahoo.com

⁴iPabo University of Applied Sciences, Amsterdam, the Netherlands

Keywords: Assessment methods, descriptive assessment, primary mathematics education, Iran.

Introduction

Iran has a centralized education system, with national textbooks that are used for every school subject, including mathematics. In this education system, the assessment regulation and educational policy determine what type of student assessment teachers carry out. The latest version of this assessment regulation in primary school is called *Descriptive Assessment*. This is an approach for evaluating students' achievement by collecting and documenting evidence regarding their learning and performance. Teachers can collect this evidence through different methods including observations of students during the classes, interviews, students' portfolios, performance tasks, and various kinds of tests (Ministry of Education [MoE] & Organization for Educational Research and Planning [OERP], 2011; Supreme Council for Education [SCE], 2009). In this poster, we investigate the research question: *To what degree have the suggested assessment methods from the Descriptive Assessment regulations been implemented in the classroom practice of Iranian primary mathematics teachers?*

Method

For this we performed a multiple case study of which we present the first results at CERME11. We provide data on the assessment practice of seven Grade 4 female mathematics teachers (age $M=46$, [min, max] = [38, 54]) in Tehran. These teachers were first contacted by telephone and agreed to participate in this research. The data we used for this case study originated from four sources:

1. The teachers responded to an Iranian version of a questionnaire on teachers' assessment practice in mathematics education (Veldhuis, Van den Heuvel-Panhuizen, Vermeulen, & Eggen, 2013).
2. We interviewed the teachers individually by asking them to explain answers they provided in the questionnaire and to discuss their lesson plan for the lesson that would be observed.
3. The ensuing lesson on the development of first notions of probability was observed and videotaped.
4. We conducted a post-observation interview in which the teachers were asked to reflect on their taught lesson.

In the analyses of these data, we focused on the teachers' use of assessment methods and compared that to their prescribed use in the regulations on *Descriptive Assessment*. In two important documents,

the Teacher's Guidance for *Descriptive Assessment* (MoE & OERP, 2011) and the Academic Assessment Regulation for Primary School (SCE, 2009), a variety of assessment methods is suggested such as, observing students in class, asking questions in class, administering written test, having individual assessment conversation, offering performance tasks and having students working on project. As described in the guidelines, performance tasks are an instrument for measuring students' activity and attempts in practical and observable situations. Performance tasks focus on both students' knowledge and skills. Asking students to write a mathematics problem and its solution is an example of a performance task.

Result and conclusion

Currently, the data of our study have not yet been fully analyzed, therefore in this poster proposal, we only include a description of one assessment method (see Table 1, teachers' use of performance tasks). In the table, the information from the four data sources are combined to show whether teachers reported or showed that they use a particular type of performance task for a particular purpose and with which frequency.

Table 1: Teachers' practices and beliefs about using performance tasks

Performance task		T.1	T.2	T.3	T.4	T.5	T.6	T.7
Type	Designing something	ü		ü	ü	ü		
	Using a tool	ü	ü	ü			ü	ü
	Giving a presentation	ü	ü		ü	ü		ü
	Writing a text			ü	ü	ü	ü	
	Participating in a project							
Purpose	To improve students' learning skill	ü	ü	ü				
	To motivate students	ü						ü
	To involve students in the teaching process		ü		ü			
	To make teaching efficient						ü	
Frequency	More frequently than monthly					ü		ü

We expect to have finalized our analyses before CERME11. So, at the conference we can present the results in full detail and answer the research question.

References

- Ministry of Education (MoE) & Organization for Educational Research and Planning (OERP) (2011). *Teacher's guidance for descriptive assessment*. Tehran: Author [PERSIAN]
- Supreme Council of Education (SCE) (2009). *The Academic Assessment Regulation for Primary School*. Tehran: Author. [PERSIAN]
- Veldhuis, M., Van den Heuvel-Panhuizen, M., Vermeulen, J. A., & Eggen, T. J. (2013). Teachers' use of classroom assessment in primary school mathematics education in the Netherlands. *Cadmo*, 21(2), 35-53.

Developing and evaluating an online linear algebra examination for university mathematics

Christopher Sangwin¹

¹ University of Edinburgh, School of Mathematics; C.J.Sangwin@ed.ac.uk

In this paper I report development of an automatically marked online version of a current paper-based examination for a university mathematics course, and the extent to which the outcomes are equivalent to a paper-based exam. An online examination was implemented using the STACK online assessment tool which is built using computer algebra, and in which students' answers are normally typed expressions. The study group was 376 undergraduates taking a year 1 Introduction to Linear Algebra course. The results of this experiment are cautiously optimistic: a significant proportion of current examination questions can be automatically assessed, and the quantitative outcomes are moderately correlated with the paper examination.

Keywords: Mathematics, undergraduate study, high stakes tests.

Introduction

To what extent can we produce an automatically marked version of a paper-based examination for methods-based university mathematics courses using contemporary technology? To what extent are the outcomes of this exam equivalent to the outcomes of a paper-based exam? In this paper I report a pilot to develop, use, and evaluate an online examination for a university linear algebra course.

My work is based upon the epistemological position that to successfully automate a process it is necessary to understand it profoundly. It follows that automation of a process necessitates the development of a certain kind of understanding and we learn a lot about the underlying process through automation. Assessment provides students with challenge, interest and motivation: assessment is a key driver of students' activity in education. To many students mathematics is defined in a large part by what we expect students to do in examinations, (Burkhardt, 1987).

The STACK online assessment tool (Sangwin, 2013) is built using computer algebra and students' interactions move significantly beyond multiple choice questions with their well-known difficulties for mathematics, see (Sangwin & Jones, 2017). In particular STACK uses the computer algebra system Maxima to generate random questions; interpret students' typed algebraic expressions; establish objective mathematical properties of students' answers; and assign outcomes such as feedback and marks. Online automatic assessment has for many years been used widely in formative settings, see (Sangwin, 2013). Developing high-stakes final examinations is a natural extension of automation of formative assessment. Automation also has practical benefits, such as reducing the marking load, better test reliability, and potentially speeding up examination process. However, changing written examinations, with centuries of custom and practice, is a high-stakes and high-risk undertaking. When I examined school-level examinations (Sangwin & Kocher, 2016) the results were cautiously optimistic: a significant proportion of current questions could be automatically assessed. In this paper I extend this work and create online examination questions and trial their use with a large group of university students.

Methodology

Changing examination processes is both high-stakes and high-risk. Furthermore, there are serious ethical problems with running an experiment in these circumstances without serious and authentic trial exams. Hence, for this study I added a mock online examination to an existing course: Introduction to Linear Algebra (ILA). This is a year 1, semester 1, mathematics course worth 20 credits taken by mathematics, computer science and other undergraduate students. Students normally take 120 credits per year, in two semesters. The course is defined by (Poole, 2011) Chapters 1 to Chapter 6.2, with a selection of the applications included and selected topics omitted. ILA had over 600 students, of whom 578 took the final written examination and had a non-zero examination mark.

Students had requested exam practice, but it was impractical to administer and mark students' attempts in the short period between the end of teaching and the scheduled examination. Students would have expected more detailed formative feedback than provided by the genuine exam, and the genuine exam takes approximately 35 person-days to mark. In context, a mock examination was likely to be taken seriously by a significant proportion of the student cohort as a valuable practice and learning opportunity. Since the mock examination did not contribute to the overall course grade there was no incentive for students to cheat, or to be impersonated. Introduction to Linear Algebra, has an “open book” examination and so possible access to materials is less of a threat to this experiment than would be the case for a closed-book examination. The lack of certainty over who was sitting the online tests, the circumstances of participation, and the potential use of internet resources is certainly a compromise. Such uncertainty does not affect the extent to which I could produce questions at a technical level, or the effectiveness of the scoring mechanism in the face of students' attempts, which themselves constitute important results and generate key points for discussion. The results consist of a report on the extent to which current questions can be faithfully automated, and I give a report on students' attempts.

Results

The existing paper-based ILA examination takes 180 minutes and consists of Section A: compulsory questions worth 40 marks, and Section B: four questions each of 20 marks from which we take the student's best three marks. Students may use any standard scientific calculator but graphical calculators with matrix functions are not permitted.

The primary teaching goal was to provide students with an online examination which was as close as possible to the forthcoming paper-based summative course examination. The research goals were to evaluate the effectiveness of this, and to provide evidence for a discussion of equivalence with the genuine examination. ILA has been running for many years, with a stable (but not invariant) syllabus, and I had access to examinations going back to December 2011 (two per year: the main exam and an equivalent resit paper). I therefore decided to remove the oldest exam papers from easy access through the course website and base the online examination on those questions. Using as few papers as possible helps provide a representative online examination. Technically it is difficult to operate a “best 3 out of 4” mark scheme in the STACK online system and in any case for a formative mock exam this makes little sense.

In deciding how to allocate marks I have taken a very strict interpretation. Specifically, where the original intention of the examiners included “with justification”, I only awarded those marks which could be given for the answer only online. For example, Q5 on our online exam asked the following.

5. Is it possible for A and B to be 3×3 rank 2 matrices with $AB = 0$? True/False.

The original paper awarded 7 marks for the answer and justification, whereas only one mark was awarded for the correct answer. I did ask students to provide typed free-text justifications even though these would not be marked and no automatic feedback was provided. Ultimately I used two papers (120 marks each) to create the online exam. In this 59 marks of the online exam were from Dec-11 and 50 marks from Aug-12. I took one question from Dec-13 to add a mark to Section A to make the online exam total 110 marks.

Of the paper-based questions selected for the online exam, 44 marks are not awarded online. These missing marks are for justification which cannot, at this time, be automatically assessed. This resulted in Section A having fewer marks than would be the case with a paper based submission. Of the 240 marks available on the Dec-11 and Aug-12 papers, 109/240 marks 45% were automated in a way faithful to the original examinations. I think this is a remarkably high proportion, and discuss this in more detail below. However, the online versions as implemented for this study do lack some partial credit and do not (in this experiment) implement follow on-marking, which in some Section B questions is substantial. This is not a limitation of the system itself, but rather in the time available to implement more elaborate automatic marking schemes.

(d) What is the condition on the numbers p, q, r such that the plane $px + qy + rz = 0$ contains the line L derived above? (Your answer should be an equation with variables p, q, r)

$p - 2q + r = 0$

Your last answer was interpreted as follows:

$$p - 2q + r = 0$$

The variables found in your answer were: $[p, q, r]$

Find the equation of the plane in general form that contains the line L and contains the point $[1, 1, 4]$.

$3x + y - z = 0$

Your last answer was interpreted as follows:

$$3x + y - z = 0$$

The variables found in your answer were: $[x, y, z]$

Figure 1: Question 19d of the current study in STACK

Note that STACK requires students to type in an algebraic expression as their answer, and an example question is shown in figure 1. For ILA, online course work quizzes were already implemented using STACK. All students were expected to sit 30 online quizzes using the STACK system as part of the ILA course before the mock examination, and would be thoroughly familiar with how to enter answers into the system. The online examination was made available to students to do in their own time for a period of one week in December 2017, between the end of formal teaching and the scheduled paper-based exam. Students could choose when to sit the online examination, but were given one attempt of 180 minutes to do so to simulate examination practice. All data was downloaded

from the online STACK system, and after ratification by the exam board, combined with overall achievement data. Students were assigned a unique number to ensure anonymity, and the data loaded into R-studio for analysis.

There were 395 attempts at the mock online exam in December 2017. One student who was granted a second attempt for technical reasons had their first attempt disregarded, giving 394 attempts. There were no other significant technical problems affecting the conduct of the online examination. For the online exam (including those who scored zero) the mean grade was 47.9% with standard deviation of 23.2%. The coefficient of internal consistency (Cronbach Alpha) for the online exam was 0.87. There was a moderate positive correlation between time taken ($M=132$ mins, $SD=48.6$ mins) and the online exam result ($M=47.9\%$, $SD=23.2$) $r(392)=0.517$, $p<10^{-16}$, as might be expected. Despite a small number of outlier questions, the mock online exam appears to have operated successfully in its own right as a test.

The final mark for ILA is made up of coursework (20%) and a final paper-based exam (80%). There were 394 attempts at the online mock examination, and all but one of these students also sat the paper-based examination. Note that 17 students scored 0 for the online exam, perhaps indicating students who looked at the online questions but made no serious attempt at them. Technically there is a difference between students who never sat the online exam, and those who opened the exam and scored 0. For the analysis I excluded the 17 students who scored 0 in the online exam: this leaves the study group of $N=376$ students with paper and mock exam information.

For the study group, the online exam results had ($M=50.2$, $SD=21.3$) and paper exam ($M=68.0$, $SD=17.3$). For all students who sat the ILA paper exam ($M=63.1$, $SD=21.6$). Histograms of achievement are shown in figure 2. The “online exam” refers to scores on the online mock. The “study group paper” is the achievement of the study group on the genuine paper examination. “Paper examination” refers to the whole cohort of ILA in the genuine paper exam. There is a significantly larger failure rate (score less than 40%) in the online examination, and a significantly lower mean. These differences could be explained by the level of engagement: the online exam carried no credit, and students may have lost motivation when tired.

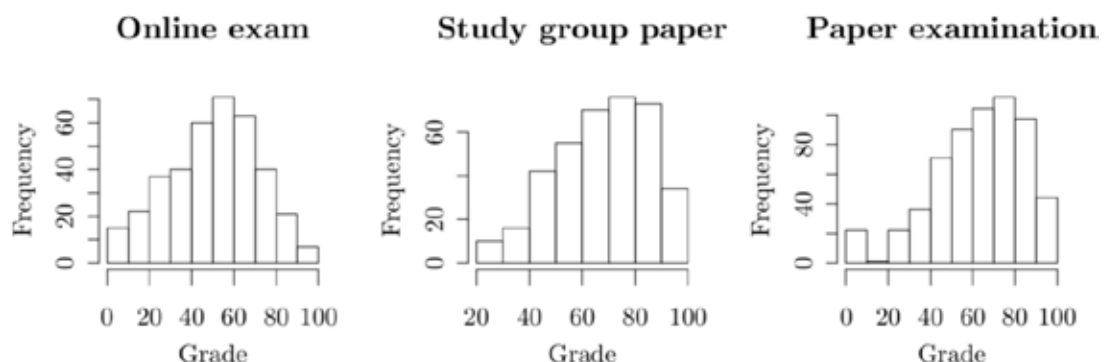


Figure 2: Histograms of achievement in the online mock and paper based examinations

A scatter plot of the online mock exam grades vs paper exam grades is shown in figure 3, together with a linear regression model. The blue dashed line shows the (ideal) linear relationship in which the online mock examination has identical outcomes with the paper-based exam. The mock exam grades and paper exam grades were moderately correlated, $r(374)=0.593$, $p<10^{-15}$. Notice the online exam scores are clearly below those of the paper exam, supporting the hypothesis that students may have lost motivation when tired and not performed to their full potential in the online mock exam. Indeed, students scoring less than 40% in the online exam and more that 70% in the genuine exam are very likely not to have taken the online test seriously, perhaps confident (with good reason) about their ability.

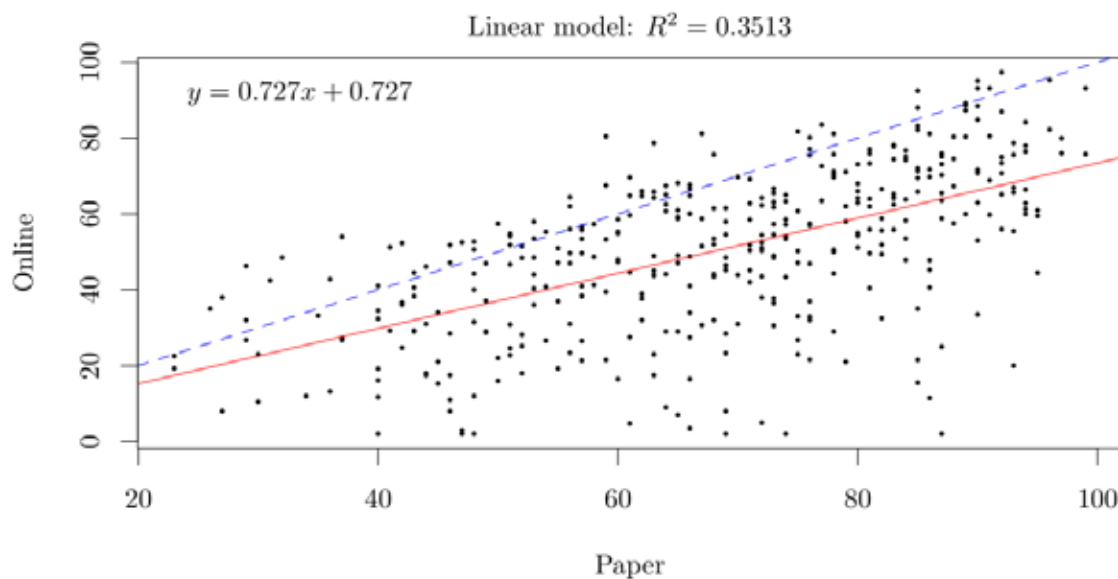


Figure 3: Online mock exam grades vs paper exam grades for the study group

The number of non-empty free text responses to each of the “justify” questions is worthy of mention here. While no planned evaluation of the responses was part of this study, it is clear reading through the free-text responses that over 200 students took the exercise seriously, providing sensible (and often correct) justifications in good English. For the Section A questions included in this study there were 59 marks available in the paper format, whereas in the online exam only 24 marks were awarded. I did not expect students to make serious use of the free-text entry. The fact students entered sensible justification to many of these questions, and received no marks or feedback, could easily account for the difference in mean scores between the paper-based and online exam. There were a large number of empty responses (as there are on paper as well), together with some incoherent utterances, and some plaintive messages. I did not assess these free-text responses, or subject them to comprehensive analysis for the purposes of this paper. However, in a genuine online examination such responses could be assessed (1) manually in the traditional way on-screen, (2) using automatic assessment technology such as described in (Butcher & Jordan, 2010; Jordan, 2012), or (3) using comparative judgment for longer passages, see (Jones, Swan, & Pollitt, 2014; Pollitt, 2012).

Discussion

The implementation of the mock online examination for linear algebra was a modest success. There were no serious technical problems during the conduct, and no students complained of inaccurate or

unfair marking. The results of the online examination were broadly comparable with a paper-based exam, with the consistently lower online performance explained by a combination of (1) potential disengagement in a low-stakes setting, (2) lack of assessment of students' justification (which is typically rather generous), and (3) lack of partial credit and follow through marking.

This research has done nothing to address serious practical problems associated with online examinations in general. Problems include the need for invigilation to reduce plagiarism and impersonation, and security to eliminate communication during the exam (such as answer sharing) or access to unauthorised resources. Indeed, while technology has the potential to support examination processes, there is technology specifically designed to undermine traditional examinations as well. For example the Ruby Calculator (<https://rubydevices.com.au> retrieved September 2018) is designed to aid unauthorized communication during exams. Either these examination conduct problems must be solved, or we need new models of assessing students. But these examination conduct problems have nothing to do with mathematics as a subject.

I think it is remarkable that 109/240 (45%) of the marks available on paper were automated in a way faithful to the original examinations. Further, by selecting existing questions from two existing past papers I was able to create a fully online exam, with broadly similar syllabus coverage. However, this result can be interpreted as a comment on the mechanical nature of the subject, and of the assessments we use in the traditional examination. If the assessment of students' answers can be automated, then certainly the underlying processes can be automated by the computer algebra system. Why then are students still learning to perform these mechanical processes, e.g. in the context of ILA row reduction, and calculation of determinants and eigenvalues/vectors? Both partial credit and follow through marking are technically possible in STACK, but are expensive (in staff time) to implement. To take this work further we need tools which automate assessment of explanation, justification and reasoning. In particular "proof checking" software, as applied to students' understanding, is necessary to move beyond assessing only a final answer to a full mathematical answer. In this study, only students' final answers were subject to automatic assessment which is a serious limitation to the award of partial credit and method marks. However, progress is being made to assess working especially in the area of reasoning by equivalence as discussed briefly in (Sangwin & Kocher, 2016). The work on reasoning by equivalence is essential for assessing questions in calculus and algebra, two other pillars of pure mathematics. For this reason, I am confident the cautious optimism expressed here about linear algebra exams also extends to mathematics more broadly in year 1 and 2 university methods-based examinations and mathematics examinations at the school/university interface.

I was surprised at the extent to which existing questions could be automatically assessed. However, there is nothing sacrosanct about current examination questions. Why should the online examination be exactly the same as a paper-based examination? Current questions are written explicitly for the paper-based format, and it is sensible to seek to write questions which are tuned to, or indeed take advantage of, the online format as appropriate. For many true/false questions the justification requires appropriate examples. Computer algebra is ideally suited to assessing answers, such as counter-examples, which expect the teacher to perform some time-consuming and potentially error-prone

calculation. For this research I did not rephrase such questions to “give me examples, such that ...”, but this would be one option. Specifically we could certainly have

5. Give examples A and B of non-zero 3×3 matrices for which $AB = 0$.

A computer algebra system is ideally a much better tool for assessing such answers than a human marker. Hence, it would be much more sensible to design an online examination with the format in mind. Indeed, often human examiners do not ask students to “give examples of”, only because of the work entailed in marking these by hand. That said, to establish face-validity for the online examination it is useful to understand the extent to which we can assess existing questions and to establish that the technical assessment processes are equivalent.

The practical benefits of online automatic examinations include increased reliability, reduction in costs and in swifter marking times. This is very attractive to all stake holders in the process, including students, teachers and end-users of the results. It is highly likely that automatic examinations will become the norm in the near future. Online examinations will happen, but there is no need for them to be restricted to multiple choice formats. Indeed, as a community of educators we can do much better than that. However, there is a real danger that national examination boards, universities, and others with responsibilities for examinations will replicate traditional examinations online without a critical reassessment of the purpose of mathematics education.

This analysis raises the question of whether we, as a mathematics community, believe current mathematics examinations are a valid test of mathematical achievement. Do current examinations actually represent valid mathematical practice, as undertaken by researchers, industrial mathematicians and for pure recreation as an intellectual pursuit? Construct validity is a central educational concern, but it is not relevant to the research question of whether we can actually automate current exams. My personal views about the nature of mathematics broadly align with those expressed in (Polya, 1954) and (Lakatos, 1976). That is, that setting up abstract problems and solving them lies at the heart of mathematics. (Polya, 1962) identified four patterns of thought to help structure thinking about solving mathematical problems. His “Cartesian” pattern is where a problem is translated into a system of equations, and solved using algebra. Note that the algebraic manipulation is the technical middle step in the process: setting up the equations and interpreting the solutions are essential parts to complete this pattern. My previous work (Sangwin & Kocher, 2016) examined questions set in school-level examination papers and found that line-by-line algebraic reasoning, termed *reasoning by equivalence*, is the most important single form of reasoning in school mathematics. However, many examination questions do not relate to a problem at all, rather they instruct students to undertake a well-rehearsed set of techniques, isolated from any problem. Many questions in the ILA examinations also rely on predictable methods which can be well-rehearsed.

Informal discussions with colleagues, particularly during the thematic working group 21 during CERME, strongly suggest that online examinations are a concern for many working in mathematics education. The question of validity of all examinations, on paper and online, is central as is the difficult question of retaining validity if an examination format changes. Changing to online examinations provides some unique opportunities but it will be essential for stake-holders to retain confidence in any new assessment regimes, regardless of any significant merits the format brings.

Using sophisticated assessment tools such as STACK we can create a fully automatically marked examination, which is broadly equivalent to current paper-based examinations at the technical level and in terms of outcomes for students. With other tools, we can create a more rounded online examination, perhaps incorporating some human assessment of free-text justification. However, the attempt to automate assessment of students' answers reveals much about what we really ask students to do in examinations.

References

- Burkhardt, H. (1987). What you test is what you get. In I. Wirszup & R. Streit (Eds.), *The dynamics of curriculum change in developments in school mathematics worldwide*. University of Chicago School Mathematics Project.
- Butcher, P. G., & Jordan, S. E. (2010, September). A comparison of human and computer marking of short free-text student responses. *Computers and Education*, *55*(2), 489–499. doi: 10.1016/j.compedu.2010.02.012
- Jones, I., Swan, M., & Pollitt, A. (2014). Assessing mathematical problem solving using comparative judgement. *International Journal of Science and Mathematics Education*, *13*(1), 151–177.
- Jordan, S. (2012). Student engagement with assessment and feedback: Some lessons from short answer free-text e-assessment questions. *Computers and Education*, *58*(2), 818–834.
- Lakatos, I. (1976). *Proofs and refutations*. Cambridge University Press.
- Pollitt, A. (2012). The method of adaptive comparative judgement. *Assessment in Education: Principles, Policy & Practice*, *19*(3), 281–300. doi: 10.1080/0969594X.2012.665354
- Polya, G. (1954). *Mathematics and plausible reasoning. vol.1: Induction and analogy in mathematics. vol 2. patterns of plausible inference*. Princeton University Press.
- Polya, G. (1962). *Mathematical discovery: on understanding, learning, and teaching problem solving*. London, UK: Wiley.
- Poole, D. (2011). *Linear algebra: a modern approach* (Third ed.). Brooks/Cole, Cengage learning.
- Sangwin, C. J. (2013). *Computer aided assessment of mathematics*. Oxford, UK: Oxford University Press.
- Sangwin, C. J., & Jones, I. (2017). Asymmetry in student achievement on multiple choice and constructed response items in reversible mathematics processes. *Educational Studies in Mathematics*, *94*, 205–222. doi: 10.1007/s10649-016-9725-4
- Sangwin, C. J., & Kocher, N. (2016). Automation of mathematics examinations. *Computers and Education*, *94*, 215–227. doi: 10.1016/j.compedu.2015.11.014

The role of formative assessment in fostering individualized teaching at university level

Annalisa Cusi¹ and [Agnese Ilaria Telloni](#)²

¹Sapienza University of Rome; annalisa.cusi@uniroma1.it

²University of Ancona; agnesetelloni@gmail.com, telloni@dipmat.univpm.it

In this paper we present the design of individualized online teaching/learning paths at university level, within a formative assessment frame. Moreover, we discuss the preliminary results of a pilot study aimed at investigating the students' perception of the impact of these online paths to support their learning, their elaboration of the external feedback that the digital environment provides and their awareness about their difficulties and the strategies they could activate to overcome them.

Keywords: Formative assessment, individualized teaching, tertiary level, teaching/learning of probability.

The individualization of teaching/learning at university level by means of e-learning environments

This paper focuses on a pilot study aimed at investigating how a formative assessment (FA) frame could support the design of a sequence of tasks to foster individualized teaching at university level. Many obstacles are encountered by teachers and students at university level: the large number of students per teacher, the heterogeneity of students' background, the small number of hours per course, the impossibility of creating a close and frequent relationship between lecturer and students (De Guzman, Hodgson & Villani, 1998). In relation to this, Nardi (2017) stresses that there is an “aspiration (institutional but not only) for a more approachable, more inclusive and more engaging learning experience in university mathematics that is tailored to individual student needs” (p.10) and suggests that e-learning could give a significant answer to this aspiration.

In the past few years, research highlighted the effectiveness of designing e-learning environments to support the teaching-learning processes at tertiary level (Descamps et al. 2006; Albano & Ferrari 2008; Albano 2011; Bardelle & Di Martino 2012; Calvani 2005). In fact, these environments allow teachers to keep trace of students' work and mistakes, to provide an automatic or semi-automatic evaluation and to share feedback and comments. Moreover, they enable students to overcome the fear of being judged and of revealing lack of knowledge by requesting clarifications. In this way gaps in students' knowledge can be reduced, even within the heterogeneity of large classes.

These last observations make us concentrate our attention on the crucial role that e-learning could play in fostering individualized and personalized teaching at university level (Bardelle & Di Martino 2012; Albano & Ferrari 2008; Albano 2011). Bardelle and Di Martino (2012) stress that an e-learning environment could be an effective context through which it is possible to counteract students' mathematical difficulties in the tertiary transition, since it enables to foster both the personalization of the learning path and the students' collaboration during the activity. Also, Albano and Ferrari (2008) discuss the strong impact that these online environments could have at all levels

of learning (cognitive, metacognitive and affective), allowing the automatic individualization of learning path according to the student's profile.

Theoretical framework: FA as a tool to support individualized teaching/learning

In this study, we refer to the distinction between individualization and personalization proposed by Baldacci (2006). According to Baldacci, *individualizing* means differentiating the didactical paths in order to enable all the students to reach common objectives, while *personalizing* is differentiating the formative goals and objectives to promote individual potentialities.

In our research we focus on the individualization of teaching/learning paths because, in our opinion, the specific characteristics of university teaching, such as the large number of students per teacher and the impossibility of differentiating formative goals (since all students need to reach minimum levels to attend subsequent courses), prevent from realizing a complete personalization. Moreover, we think that individualization could represent a useful approach to support students in the gaps of knowledge due to the heterogeneity of their background.

Jenkins (2004) suggests to looking at web technologies to promote the use of different assessment methods, especially in the context of higher education, stressing that this kind of technologies can encourage collaborative and reflective styles of learning and can also become adaptive. In tune with these ideas, we decided to set the design of a sequence of tasks for university students within a FA framework, where FA strategies are conceived as critical tools to foster the individualization of teaching/learning.

We refer to the model for the use of technology to support FA developed within the European project FaSMEd (Cusi, Morselli & Sabena, 2017). The model extends the one introduced by Wiliam and Thompson (2007), which considers two main dimensions. These are the agents involved in FA processes (the teacher, the learner, the peers) and the key strategies for FA: (a) clarifying and sharing learning intentions and criteria for success; (b) engineering effective classroom discussions and other learning tasks that elicit evidence of students' understanding; (c) providing feedback that moves learners forward; (d) activating students as instructional resources for one another; (e) activating students as the owners of their own learning. According to Wiliam and Thompson, FA should be designed with the aim of enabling the teacher and the students to establish: *where the learners are in their learning; where they are going; what needs to be done to get them there*. Within FaSMEd, a third dimension has been added, that is the functionalities of technology that could support FA: sending and displaying; processing and analyzing; providing an interactive environment.

Another important element for our framework is the role played by feedback in FA. Nicol and Macfarlane-Dick (2006) define feedback as an “information about how the student's present state (of learning and performance) relates to goals and standards” (p.2). The authors propose a model that distinguishes between *internal feedback*, generated by students' monitoring of their interactions with the task and the internal and external outcomes of their work, and *external feedback*, provided by the teacher, by a peer or by other means; external feedback must be interpreted, constructed and internalized by students to have a significant influence on subsequent learning. We refer also to

Hattie and Timperley's (2007) distinction between different levels of feedback. In particular, we focus on feedback about (i) the task; (ii) the processing of the task; (iii) self-regulation.

The tree of tasks: the design of individualized teaching/learning paths

In this section, we present a sequence of online tasks that is conceived as an intertwined collection of individualized teaching/learning paths. The tasks are organized in a tree (the tree of tasks, TT) and dynamically connected, so that the learners could face them within intertwined different paths, depending on the answers they give and the difficulties they encounter. The TT has been designed with the aim of supporting undergraduate students in the learning of basic topics of elementary and conditional probability. It is constituted by five main tasks, implemented with Geogebra and submitted to the students by using the university Moodle platform.

The diagram in figure 1 summarises the structure of the TT. All the possible intertwined paths begin with the same task (E1), concerning the definition of conditional probability, the probability of the intersection and of the complementary events. For all the tasks, students are required to give open (numerical) or multiple-choice answers to some questions and can choose to ask for specific hints. An immediate *feedback about the task* is provided whenever a student gives an answer and an overall feedback (*again about the task*) is given both at the end of the task and the whole path. The functionalities of technology that are activated to carry out this online self-assessment are *processing and analyzing* and *providing an interactive environment*.

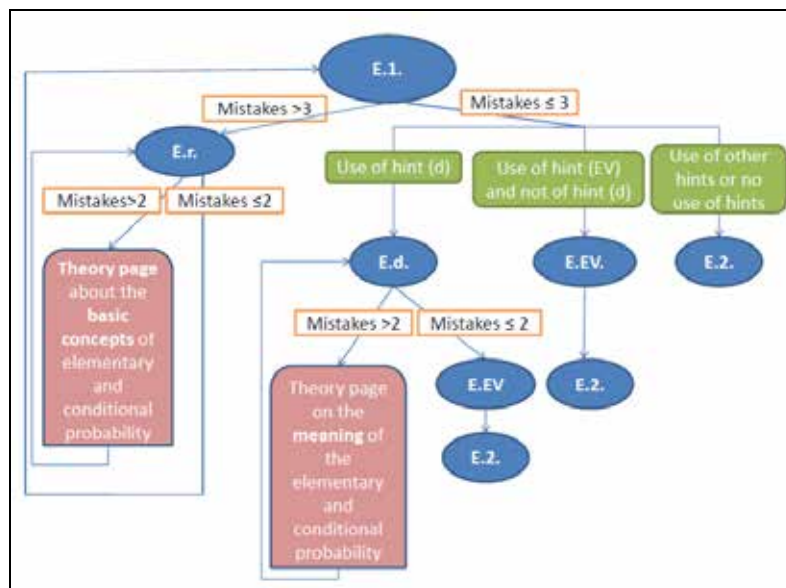


Figure 1: The tree of tasks

According to the number of mistakes and the kind of hints the students ask for, they are directed to different tasks. For example, if students make more than three mistakes in E1, they are directed to the task Er. After this, if they make more than two mistakes, they are directed to a theory page and then again to Er, otherwise they are directed to E1.

Because of space limitations, here we present only task E1 and the corresponding feedback and hints. Within this task, a brief text in natural language, introducing some events and their probabilities (their values are random), appears on the screen (see fig. 2). The student is required to

fill six input fields by inserting the probability of various events: the probability of A and its complementary, the probability of the intersection $A \cap B$ and the probability of the conditional events $B|A$, $\bar{B}|\bar{A}$ and $\bar{B}|A$. Three of the required values are given in the text, so that the students should carefully interpret it; the other three input fields can be filled by using the definition of conditional probability, the property that a conditional probability is a real probability with respect to the conditioned event and the generalized rule for the probability of the intersection event. If all the six fields are correctly filled, two other questions, about the independency and the incompatibility of the events A and B, appear on the screen (see fig. 2).

When facing task E1, the students can ask for five different hints (see fig. 2): a summary of the data given within the text, represented through symbolic expressions (d), the Euler-Venn diagrams of the events (EV), a calculating machine (c), a sheet and a pen (sp) and a list of useful formulae (f).

As summarised earlier, if a student makes more than three mistakes, he/she is directed to a reinforcement task (Er), which is focused on the probability of the complementary of an event and on the definition of conditional probability. If not, the next task depends on the specific hints that are required: if a student asks for the hint d, he/she is directed to a specific task about the understanding of the given elements in a text expressed in verbal language (task Ed); if he/she does not ask for the hint d, but he/she asks for the hint EV, he/she is directed to a specific activity about the meaning of events in terms of set operations (task EEV); if the student does not ask nor for hint d, neither for hint EV, he/she is directed to task E2.

Calculate the following events' probabilities, by assuming that

The event A happens with probability $\frac{1}{5}$. If A has happened, B verifies with probability $\frac{7}{8}$. By knowing that A did not happen, B does not verify with probability $\frac{3}{4}$.

P(A) <input type="text" value="1/5"/> Right	P($A \cap B$) <input type="text" value="3/4"/> Be careful!	
P(\bar{A}) <input type="text" value="3/5"/> Be careful! \bar{A} is the complementary event of A!	P($B A$) <input type="text" value="1/8"/> Right	
P(B A) <input type="text" value="7/8"/> Right	P($\bar{B} \bar{A}$) <input type="text" value="7/8"/> Be careful! $B \bar{A}$ is NOT the complementary event of $B A$!	

Answer the following questions (1=yes, 0=no)

Are the events A and B independent?	<input type="text" value="0"/>	Right
Are the events A and B incompatible?	<input type="text" value="1"/>	Be careful! A and B are incompatible if $A \cap B = \emptyset$

let's go to the reinforcement activity

If you need, you can choose one or more hints to perform the task.

- write the problem data
- give me the Euler-Venn diagrams of the events
- give me a calculator
- give me a sheet and a pen
- give me the formulae

$$P(A) = \frac{1}{5}, P(B|A) = \frac{7}{8}, P(\bar{B}|\bar{A}) = \frac{3}{4}$$

Figure 2: A screenshot from task E1

All the tasks are designed by taking into account misconceptions and typical mistakes that affect the teaching/learning of elementary and conditional probabilities (Diaz & de la Fuente, 2002). Moreover, as the above description highlights, the TT is engineered in order to gather information not only about students' mistakes, but also about their preferred approaches, displayed thanks to the hints they ask for. Students' behaviour and choices within the interactive environment determine the sequence of tasks proposed to them, that is the *individualized path* within which each of them is involved. We can speak about individualized paths because students are stimulated through various learning channels (graphical, symbolic, verbal ...), they are given the possibility to follow their own

aptitude and skills, and, finally, they can access to online resources when they prefer, so their learning rhythms are respected.

As for FA processes, it is possible to highlight a continuous activation of FA strategy C (*providing feedback that moves learners forward*), through both the direct *external feedback about the task* given to students, and the *indirect external feedback* that they receive when they are directed to specific tasks. This kind of feedback is on the *processing of the task* and on *self-regulation*, because it is aimed at making students reflect on specific aspects of their knowledge, on their own difficulties and on the role that each hint could play.

In order to collect evidence about students' typical approaches and mistakes, we have designed an open-ended questionnaire, composed of sets of questions to which the students have to answer after the completion of each task (8 questions for each task) and at the end of the learning path (3 questions). Some of the 8 questions focused on the specific mathematical contents to which each task refers and require students to write argumentations *about the processing of the tasks* they faced. The remaining questions focus on metacognitive aspects, such as the difficulties met by students in facing each task, the role of the hints they required, the ways in which each task could support their learning.

The request for argumentation is aimed, on the one hand, to assess students' capability of justifying their own strategies, and, on the other, together with the request for specific reflections, to guide them in monitoring their interactions with the tasks and in making explicit their interpretation of the received *external feedback*. In this way, students could gradually become aware of the possible strategies to face the task and on the reasons behind them, generating their own *internal feedback*. Two other FA strategies are therefore activated through the TT: strategy B (*engineering learning tasks that elicit evidence of students' understanding*) and strategy E (*activating students as the owners of their own learning*).

Research focus and methodology

In this paper, we aim to highlight the effects of students' interaction with the activities we designed to foster individualized learning paths, in terms of: (1) students' development of awareness about their own learning progresses and needs (that is, their awareness about "*where they are*" in their learning and "*where they are going*"); (2) students' declared perception of the impact of the implemented online tasks on their learning (that is their ideas about the role that the tasks could play in making them aware of "*what needs to be done*" to reach the learning objectives).

The activity presented in the previous paragraph was proposed to a group of 15 engineering Master degree students. In this paper we focus on their answers to the following metacognitive questions, which are part of the open-ended questionnaire introduced in the previous paragraph: (1) Did you meet some difficulties in facing the task? (2) Did you use the hints? If yes, what hints did you use? (3) Were the hints useful? (4) Would you have preferred to use additional or different hints? (5) Did the task help you clarify the concepts used from elementary and conditional probability? These questions are aimed at highlighting the *internal feedback* generated by the students' monitoring of their interaction with each task.

We developed a qualitative analysis of the students' answers to the metacognitive questions, referring to our research foci. The analysis of questions 1-2-3-4 was aimed at detecting evidences of students' awareness about: (a) their difficulties in facing the tasks (possibly connected to their general difficulties in mathematics), (b) the gaps in their learning and (c) the role played by the hints they chose (research focus 1). In particular, we looked for possible categories of students answers in relation to their level of awareness about these aspects (a, b, c).

The analysis of question 5 was aimed at investigating students' perception of the impact of the tasks on their learning (research focus 2). In particular, we focused on the identification of the ways in which the students interpret the hints and the external feedback provided by the TT as supports for their learning.

Each researcher coded the students' answers separately in relation to our research objectives. Afterwards, problematic codes were discussed together so that researchers came to an agreement.

Analysis of students' answers

Referring to the *research focus 1*, we can identify at least three different categories of answers, depending on students' level of awareness about their own learning progresses and needs. The answers belonging to the *first category* show that students are deeply aware of the difficulties they faced in the resolution process, able to explain the reasons behind them and to put them in relation with their typical difficulties with the mathematical topic. Often, this kind of answers is associated to students' capability of recognizing their needs and asking for the suitable hints, when it is necessary. An example is S1 answer to question 1 after the completion of task E1: *"I did not meet many difficulties in facing this task, but it took me some time to understand what kind of probability was given in the text of the problem. Since it is a kind of difficulty that I often have, especially in understanding the distinction between conditional probability and the probability of the intersection of events, I tried to be particularly careful"*. This answer represents an evidence of S1's capability of connecting the specific task to her general difficulties (in understanding verbal texts), and of reconstructing both the learning path and the reflections made in facing the activity.

The *second category* of answers is characterized by the fact that students are only partially aware of their difficulties and show an inadequate control of the strategies to be activated to overcome them. An example of answer belonging to this category is the one of S2, who writes that his failure in facing task E1 is due to the fact that he was not able to *"remember the formula for $P(\bar{B}|\bar{A})$ and $P(\bar{B}|A)$ "*, but he asks for hint d (the representation of data through symbolic expressions), which is not useful for him, and answers to question 4 only stating *"I don't know"*.

The answers belonging to the *third category* are those that are given by the students who do not recognize their difficulties at all or recognize some difficulties but do not activate adequate strategies to overcome them. The typical approach of these students is, for example, the one of S3, who declares that his usual difficulties are related to the understanding of the data within the verbal text of the problem, but answers to question 2 (after task E1) stating *"I have not considered the hints at all"*. The choice of not asking for hints clashes also with the fact that he completed task E1 making more than 3 mistakes.

As regards *research focus 2*, our analysis of question 5 highlighted the students' general appreciation of the TT. The most frequent reasons of this appreciation are connected to the fact that an interaction with a non-human tutor enables students to avoid their fear of being judged, as S4 stresses in his answer: *“Working alone on these online activities was great: not having the pressure of the teacher or a classmate who looks at my work and judges it allowed me to reason calmly, without the fear of making mistakes. It was like being a trapeze artist with the safety net”*.

Most of the students seem to not fully understand the advantages of the individualized learning path in which they were involved, but they recognize the TT as a learning resource useful to explore multiple representations and promote transformations between them. The direct *external feedback* given by the software is interpreted as useful support to students' learning. For example, S5, referring to task E1, writes: *“I used the rules to determine the probability of the complementary event and the message that appeared when I inserted the value of $P(\bar{B}|\bar{A})$ reminded me that $\bar{B}|\bar{A}$ is not the complementary of $B|A$ ”*. Another aspect that is particularly valued by students is the usefulness of the hints. Some students stress the role played by the hint EV (Euler-Venn diagrams) in reinforcing the meaning of the compound events by the graphical representation of events as sets.

Finally, it is interesting to observe that none of the students refers to the aim of passing the examination. They in general consider the TT as a good self-assessment tool and as a way to point out some critical aspects in the theory of elementary and conditional probability. For example, S6 declares: *“Yes, I found this task (E1) useful because it is focused on the difference between incompatibility and independence of events. The task has enabled me to clarify that I can consider $P(A \cap B)$ to investigate both the concepts, but I have to use it in different ways...”*.

Final remarks

In this paper we presented preliminary results from a pilot study developed to investigate university students' perceptions of the impact of individualized online teaching/learning paths designed within a FA frame. In particular, the analysis enabled us to highlight students' elaboration of the external feedback received during their work on the TT, in terms of information about where students are in their learning and what they need to do to reach the learning objectives. The students participating to the pilot study showed different levels of awareness about these aspects: few of them were both aware of their difficulties and capable of activating the necessary strategies to overcome them. A common trend is that students recognize the value of the TT as an effective environment to support their learning, but they do not completely realize the level of individualization provided by the TT. For this reason, we will test a redesign of the methodology of use of TT, characterized by the fact that the individualized activity with the TT will be followed by a collective meta-level discussion during which the university teacher and the students will compare the individual interactions with the online tasks and will reflect on their usefulness.

Most of the students show that they are not used to carry out the kind of reflections that the questionnaire forced them to develop. This suggests the need of re-designing the questionnaire as an integrated part of the TT and as a tool to support self-assessment.

As a future development of this research, we will explore the use of this approach with reference to other knowledge domains of mathematics. Moreover, we will focus on the teachers' perspective,

investigating the ways in which the information gathered through this online environment (the track of students' interaction with TT, the hints they ask, the argumentations and reflections they produce...) could represent a useful feedback for university teachers in revealing cognitive and metacognitive difficulties of students and in suggesting suitable re-design of the tasks to better support students in overcoming these difficulties.

References

- Albano, G. (2011). Mathematics Education: Teaching and Learning Opportunities in Blended Learning. In A.J. Angel et al. (Eds.), *Teaching Mathematics Online: Emergent Technologies and Methodologies* (pp. 60-89). Hershey, NY: InformationScienceReference.
- Albano, G., & Ferrari, P.L. (2008). Integrating Technology and Research in Mathematics Education: The Case of E-Learning. In F.J. García-Peñalvo (Ed.), *Advances in E-Learning: Experiences and Methodologies* (pp.132-148). Hershey, NY: InformationScienceReference.
- Baldacci, M. (2006). *Personalizzazione o individualizzazione?* Edizioni Erickson.
- Bardelle, C., & Di Martino, P. (2012). E-learning in secondary–tertiary transition in mathematics: for what purpose? *ZDM Mathematics Education*, 44 (6), 787-800.
- Calvani, A. (2005). E-learning at University. Which direction?, *Journal of e-Learning and Knowledge Society*, 3(3), 139-146.
- Cusi, A., Morselli, F., & Sabena, C. (2017). Promoting formative assessment in a connected classroom environment: design and implementation of digital resources, *ZDM Mathematics Education*, 49 (5), 755-767.
- De Guzman, M., Hodgson, B.R., & Villani, V. (1998). Difficulties in the passage from Secondary to Tertiary Education. In A.K. Louis et al. (Eds.), *Proc. of ICM* (Berlin), vol. 3 (pp. 747-762).
- Descamps, S.X., Bass, H., Bolanos Evia, G., Seiler, R., & Seppala, M. (2006). E-learning mathematics. In M. Sanz-Solé et al. (Eds.), *Proc. of ICM* (Madrid), vol. 3(1743-1768).
- Díaz, C., & De la Fuente, I. (2007). Assessing students' difficulties with conditional probability and Bayesian reasoning. *International Electronic Journal of Mathematics Education*, 2 (3), 128-143.
- Hattie, J. & Timperley, H. (2007). The power of feedback. *Review of Educational Research*, 77 (1), 81-112.
- Jenkins, M. (2004). Unfulfilled Promise: formative assessment using computer-aided assessment. *Learning and Teaching in Higher Education*, 1, 67-80.
- Nardi, E. (2017). From advanced mathematical thinking to university mathematics education: A story of emancipation and enrichment. In T. Dooley & G. Gueudet (Eds.), *Proc. of CERME10* (pp. 9-30).
- Nicol, D.J., & Macfarlane-Dick, D. (2006). Formative assessment and self-regulated learning: A model and seven principles of good feedback practice. *Studies in Higher Education*, 31(2), 199-218.
- William, D. & Thompson, M. (2007). Integrating assessment with instruction: What will it take to make it work? In C. A. Dwyer (Ed.), *The future of assessment: Shaping teaching and learning*, 53–82. Mahwah, NJ: Erlbaum.

Teaching, learning and assessing in grade 10: an experimental pathway to the culture of theorems

Fiorenza Turiano¹, Paolo Boero² and Francesca Morselli³

¹ I.I.S. Arimondi-Eula, Savigliano, Italy; fiorenza.turiano@gmail.com

² DISFOR, Università di Genova, Italy; boero@dima.unige.it

³ DIMA, Università di Genova, Italy; morselli@dima.unige.it

This report deals with the design of a teaching and learning pathway that encompasses an assessment method coherent with the educational long term goal chosen by the teacher. More specifically, it is aimed at contributing to promote high school learners' culture of theorems – i.e. mastery of conjecturing and proving supported by meta-mathematical knowledge. The assessment method, which combines formative assessment all during the teaching sequence and final assessment based on student's self-reflective report on her learning trajectory, has been implemented in 10th grade classes. A written essay, in form of letter written by the students to a fictitious schoolmate at the end of the pathway, is analysed in order to evaluate the potential of the implemented course.

Keywords: Formative and summative assessment, proving, secondary school.

Introduction

In this contribution, we address the following issue, as outlined in the call for papers of TWG21: “The assessment of specific mathematics domains – such as for example algebra or geometry - or capabilities such as problem solving or mathematical modelling”. More specifically, we refer to the teaching and learning of mathematical proof and proving, conceptualized as the development of a specific “culture of theorems” (Boero, 2007). In our research group, we have been working for many years in the development of specific constructs and related experimental activities concerning proof and proving. In particular, we designed methods to foster students' awareness of crucial aspects of proving concerning their inherent strategies, what warrants the truth of the statements, and the logic-linguistic features of proof (Boero, Douek, Morselli & Pedemonte, 2010). Here we focus on the design of a whole teaching and learning pathway that encompasses also formative assessment strategies and final assessment of the individual competencies. From one side, we believe in the efficacy of formative assessment strategies in promoting the development of a culture of theorems. From the other side, we recognize that promoting a culture of theorems, in order to be effective in the institution, requires a coherent method of final assessment. For this reason, we inserted an innovative method of summative assessment in the project. The aim of this report is to present the teaching-learning (and assessing) pathway as it was implemented in two 10th-grade classes, and to illustrate data that provide some initial evidence of its effectiveness.

The culture of theorems

We refer to Mariotti (2001)'s construct of theorem: the theorem is made up of the statement, together with its proof within a theory. For the same statement, it is possible to consider different ways of proving it, according to different methods of proof and different theories. In that perspective,

competencies in conjecturing and proving concern, in particular, the mastery of meta-mathematical knowledge regarding: the shape of statements (hypothesis, thesis); different methods to validate a statement; the distinct role of previously proved theorems (as synthesizers of deductive chains needed to build up the proof) and axioms (as founding stones of a theory); the distinction between the construction and plausibility of a conjecture (based on different processes: induction, abduction, analogy, etc.) and the construction of a proof (which aims at a deductive enchaining of propositions within a theory). The development of a culture of theorems requires: autonomy in acting as problem solvers in conjecturing and proving; awareness of meta-mathematical issues (like the epistemic constraints and logic-linguistic features of proof – Stylianides & Ball, 2008), which play a crucial role both in understanding a proof produced by others, and in conjecturing and proving by themselves. Promoting a culture of theorems in classroom means to foster students' awareness of these aspects and to make students develop a meta-mathematical knowledge (Boero et al, 2010) that supports the self-regulation of the process of conjecturing and proving.

The crucial role of assessment

We believe that assessment must be consistent with teaching's aims and with task design. As a starting point, we refer to the known distinction between formative assessment and summative assessment. Summative assessment occurs at the end of the learning activity with the goal of estimating the individual student's achievement (McIntosh, 1997), and is generally used as part of the grading process. Formative assessment is performed during the learning activity with the aim of improving learning. It is also called "assessment for learning" and may be considered a method of teaching where "evidence about student achievement is elicited, interpreted, and used by teachers, learners, or their peers, to make decisions about the next steps in instruction." (Black & Wiliam, 2009, p.7). Wiliam and Thompson (2007) describe five key strategies to promote formative assessment in classroom, involving three agents: the teacher, the students and the peers. The five strategies are: a) clarifying and sharing learning intentions and criteria for success; b) engineering effective classroom discussions and other learning tasks that elicit evidence of student understanding; c) providing feedback that moves learners forward; d) activating students as instructional resources for one another; e) activating students as the owners of their own learning. Moreover, Nicol and Macfarlane-Dick (2006) argue that formative assessment may promote students' self regulated learning. Recognizing formative assessment as crucial for learning does not mean to deny the crucial role of summative assessment. At the same time, it is important to move beyond a summative assessment that confines itself to a mere "final test", that hardly provides reliable information on the competencies that are acquired. For instance, Taras (2001) describes a research where cycles of summative self-assessment, tutor feedback on self-assessment and final revised self-assessment are carried out. The issue of summative assessment in mathematics becomes crucial when it has to be set up after innovation teaching and learning sequences. Assessment methods based on individual problem solving and answering teacher's questions usually have a negative impact on the development of students' autonomy and responsibility as learners in the classroom social context. In the special case of the teaching and learning of proof, traditional individual assessment tasks (presenting learnt proofs, adapting learnt proofs to similar situations, only seldom producing and validating conjectures), result in students' focusing on the products and their features.

Assessment in a “culture of theorems” perspective

In our teaching and learning pathway, we aimed at creating a formative and summative assessment that is coherent with the whole educational plan, aimed at promoting a culture of theorems. In the culture of theorems, it is important to make students active and autonomous, willing to take the responsibility of creating their own proofs and critically analyse the proofs produced by others. Accordingly, we created activities where students give constructive feedback to their mates and take profit from mate's feedback, becoming at the same responsible of their own learning and resources for the mates; in this way, formative strategies d) and e) (Wiliam & Thompson, 2007) are promoted. The formative assessment activities are integrated with a summative assessment method based on the student's self-reflective report on the personal learning trajectory, so as to assess whether the student is able to exploit the previous formative assessment activities and act as an autonomous learner. We hypothesize that thanks to the sequence of activities students not only are more free to take intellectual risks in conjecturing and proving, but may be induced to use meta-mathematical aspects of conjecturing and proving as key tools to regulate their productive and reflective activities – given their role (supported by the teacher) in analysing their fellows and their own conjecturing and proving performances. We also hypothesize that a final assessment method, based on their self-reflective reports on their learning trajectory, might offer them the opportunity to get acceptable results and at the same time would offer them (also thanks to the kind of work performed in the classroom) key tools to re-orient and improve their work. Such an assessment method might also be useful for another reason, related to the condition of so many students who enter high school in our country (and in others too) with low self-confidence and scarce willingness to take intellectual risks. Failures in traditional assessment tasks would confirm them in their disposition towards classroom work (Boaler & Greeno, 2000). We note here that such a form of summative assessment may be considered as an integral part of the teaching and learning pathway and, then, the boundary between formative and summative assessment is not strict in the project. A more detailed description of the teaching and learning method, as well as of the assessment strategies, is provided in the subsequent paragraph.

An innovative teaching and learning (and assessing) project

The context

Our teaching method and assessment choices was implemented in one 10th-grade class of 21 students in the year 2016/17 and in two 10th-grade parallel classes (of 31 and 19 students) in 2017-18. The classes belong to the scientific-oriented high school, which in our country prepares students for all academic courses, especially for the studies in STEM. We focused on the geometry course, that is taught 2 hours each week, from October to May, in parallel with 3 hours devoted to algebra (first and second degree equations and systems of equations, functions, etc.) and probability, taught by the same teacher. The course consists of 3 modules of about 16 hours each; it concerns some content of Euclidean plane geometry, typically taught in our country in the first two years of high school: (first module) to construct a tangent circle to two intersecting straight lines; to construct the tangent circle inside a given triangle; (second module) to study different cases of triangles inscribed in a circle (rectangle, isosceles, equilateral triangles), with related necessary and sufficient conditions; to study the relations between peripheral angle and central angle; (third module) given a circle, to study the

relationships between its tangent and intersecting straight lines; and, given a circle, to deal with some problems concerning inscribed and circumscribed quadrilaterals. The geometry course in grade 10 follows a grade 9 course in Euclidean plane geometry of triangles and quadrilaterals, which, in our case, was taught by the same teacher. All the lessons were given by the teacher (author FT); one researcher (the author PB) was present and acted as participant observer.

The course: teaching and formative assessment

In our pathway, a sequence of classroom activities (“module”) usually consists of some cycles, each of them starting with an individual work on a worksheet, which includes one task and some information and framing of it. The task is open, possibly with some general suggestions about how to deal with it; it involves one of the following activities: conjecturing, with the aim of getting a statement conforming to the requirement of Euclidean geometry; constructing a geometric figure (which corresponds to the “building-up” part of Euclid’s constructions); proving of produced conjectures, or justifying produced constructions (after they have been shared and better formulated under the guide of the teacher in classroom discussions); analysing mates’ productions of previous tasks; identifying salient meta-mathematical aspects of produced texts. We note again that peer review is an efficient way of carrying out formative strategies d) and e) (Wiliam & Thompson, 2007). Each initial individual task of the cycle may be followed by an individual (or small group) analysis of some representative students’ solutions to the task, chosen by the teacher; and/or by a direct classroom discussion of those solutions, guided by the teacher. In this way, formative assessment strategies b), d) and e) are activated (Wiliam & Thompson, 2007). Discussion is addressed to identify gaps, mistakes, points of strength, differences of produced strategies, linguistic issues and meta-mathematical aspects. Students are particularly motivated to engage in these activities, because they will turn to be useful for the the preparation of the final personal report (the key material for their summative assessment- see below). Usually, the second phase of the cycle ends with a synthesis, guided by the teacher, about one (or some) different ways of solving the problem – special care being devoted to the organization of the proof text (in the case of tasks asking for a proof of a given statement) according to meta-mathematical constraints. The synthesis is a key moment for clarifying and sharing learning intentions and criteria for success (strategy a), Wiliam and Thompson, 2007). For some crucial steps of the sequence, students are then requested to write the refined, shared solution for the same task; or to identify hypothesis, thesis, theorems or axioms used as warrants, etc. in a proof text written by the teacher. Table 1 summarizes the activities that were carried out, in reference to the activated formative assessment strategies (as described by Wiliam & Thompson, 2007).

Activity	Formative assessment strategy
Class discussion on selected productions	b) engineering effective classroom discussions that elicit evidence of student understanding; c) providing feedback that moves learners forward; d) activating students as instructional resources for one another; e) activating students as the owners of their own learning
Peer review of selected productions	d) activating students as instructional resources for one another; e) activating students as the owners of their own learning

Class discussion to synthesize and organize the final product, with a focus on meta-mathematical aspects	a) clarifying and sharing learning intentions and criteria for success; b) engineering effective classroom discussions and other learning tasks that elicit evidence of student understanding
--	--

Table 1: Activities and related formative assessment strategies

The final assessment

Final assessment is made up of two parts: part A is performed at home, part B is done in classroom. In part A students are requested to prepare (at the end of each of the three modules of the geometry course) a written revision of each of the worksheets produced during the module, followed by a synthesis paper. Students' revision work of personal filled worksheets concerns: identification of gaps, mistakes, difficulties and lacking knowledge at the content and at the meta-level; remediating gaps and mistakes, but in strict agreement (when appropriate) with the personal line of thought. According to our hypothesis, students are engaged in using criteria of meta-mathematical type to identify their difficulties and mistakes, with an inner questioning: "Does my conjecture contain a hypothesis and a thesis? (...) Are there some gaps in my enchaining of propositions?". This questioning at the intra-personal level would echo what should have happened at the inter-personal level in the classroom interactions managed by the teacher, and would contribute to enter the culture of theorems. The synthesis paper concerns: difficulties met during the module, and when and how (and if) they have been overcome; and on relevant learning progresses, and how they occurred, taking the collective classroom work into account. In part B, performed in classroom, students are asked to do the written revision of three worksheets, chosen by the teacher (one of them produced by a schoolfellow, the others by the student herself – thus, a second revision for them). Its purpose is to avoid that the student merely relies on help provided by some more competent fellow (or another expert person). There is no other assessment task for the geometry course. The final grade is given to each student taking into account the involvement during all the pathway (participation to the individual and groupwork and to the discussions) and the final assessment (parts A and B). Criteria for assessing parts A and B concern students' ability in: revising mistakes; improving written productions in terms of completeness, correctness and clarity; reflecting on the personal learning pathway. Essential features of the *assessing method* are similar to those implemented at the university level as described in (Guala & Boero, 2017).

Evaluation of the project: preliminary results

Our evaluation of the educational project is aimed at understanding whether the pathway was efficient in promoting students' culture of theorems, with specific reference to autonomy and awareness of meta-mathematical issues. For the evaluation, as we'll detail hereunder, we rely on direct observation of the students' activities and fieldnotes, as well as on the qualitative analysis of a special reflective task that was carried out by the students at the end of the pathway.

From the direct observation of students' activities and the fieldnotes of the teacher and the observer, we got some preliminary evidences of the fruitfulness of the adopted method. First, students' relationships with their mistakes and pitfalls during the individual work on their worksheets gradually

evolved (at the beginning, mistakes and wrong paths to the solution were carefully erased or whitened in order to hide them; gradually students realized that the memory of wrong paths and mistakes is useful to prepare their self-reflective report, but also to better take part in discussions). Second, there was a growth in the attention paid by students to meta-mathematical aspects: gradually, more and more teacher's (or peers') comments on those aspects are reported in students' notebooks. Third, there was an evolution on kind of students' requests and comments concerning meta-mathematical aspects addressed to the teacher (or their schoolfellows) during classroom discussions.

At the end of the three modules, the students were proposed a reflective task: they were asked to write a letter to a fictitious schoolmate, describing the way of working with theorems they lived during the year. The idea of asking students to narrate their experience to a fictitious schoolmate is coherent with the learning-teaching pathway, where students were encouraged to act as resources for the peers; moreover, the request to write a letter was aimed to promote an informal style, where each student could feel free to insert personal reflections on the pathway. Here is the text of the task:

Paolo, a student of your age, will move to our school and will attend the second year course. By now, he did not do any specific activity on theorems (maybe he has some idea of what is a theorem). Since he heard that your class worked a lot on the statement and the proof of theorems, he would like to contact you to get a clearer idea on the theme. Write a letter to Paolo, telling briefly your experience; explain in particular what is the statement of a theorem and what does "proving it" mean.

We analysed the written letters, looking for elements of meta-mathematical knowledge, as well as reflections on the way students lived the pathway. We realized a qualitative analysis of the texts (performed by the authors separately and after compared and discussed so as to reach an agreement), that we summarize in the subsequent part of the paragraph. Concerning mathematical and metamathematical knowledge related to theorems, most students are able to discuss the key features of a theorem. They point out relevant elements of the statement (hypothesis, thesis) and are able to discuss the issue of validity of the theorem.

Ema: the statement is made of two parts: hypothesis and thesis. The hypothesis is often introduced by "IF", and it is the sentence that you suppose to be true or it is necessary to start your proof. The thesis is often introduced by "THEN" and it is that sentence that you proved in your proof and that, thanks to your proof, is true.

Giu: In mathematics, the **THEOREM** is a statement that, starting from initial assumptions that are taken as true, draws some conclusions, by means of a precise proof. Proving a theorem means to affirm its validity, following precise properties or mathematical laws.

We note that students are also able to describe proving as a process aimed at producing a final product, which is a relevant metamathematical issue.

Lor: there are different ways to think of a proof, I'll propose you some of them. The most common is to see a theorem as a mathematical problem; in both cases [the theorem and the problem] there are starting points and final points, justified by calculations or known theorems, that is to say already proven. But the interpretation [of theorem] I like the most is another one: you must imagine

the theorem as a travel. [...] Before starting the travel, but also during the travel, you must keep in mind the final destination (the thesis) and avoid roads that may lead you to a wrong reasoning. Like in a travel, there can be different roads that lead to the same destination, the thesis.

Giu: a good proof must be organized into three parts: exploration, with the construction of the figure, and observation of all possible relations between the parts of the figure; search for relations that are useful for the proof, with the support of mathematical laws and theorems that allow to affirm that a given thing is true; synthesis of all the process with letters, so that it is precise, well formulated and synthetized.

The letters contain also many hints on efficient ways to perform the process. This is again an evidence of awareness of metamathematical issues; moreover, the fact of being able to describe the process and “give advices” to the fictitious mate reveals that the students became responsible of their own learning, real protagonists of the pathway, and also ready to act as resources for the mates.

Giu: In general, during the proof you must observe the figure with careful and “wise” eyes, so as to reach a conclusion. [...] I suggest you to pay attention to the text of the task and to the figure, to write down all your observations and, even if you think they are un-correct, because they will become useful for the subsequent auto-correction activity. I suggest you to carry out the activities with a lot of care, for me it was very useful.

Mar: I suggest you not to focus on a single aspect of the statement, but to have a wider view and try to think of known theorems that could be useful.

The letters contain a description of the learning pathway, often intertwined with personal reflections on the way the students lived such an experience.

Marco: I liked very much this pathway, because it made me appreciate more geometry, that I did not like very much until last year. This system of activities (proving, constructing, experimenting) made some arguments nicer and helped me to learn them in a better way.

Ser: before starting the pathway I felt unsecure and skeptical, but I changed my opinion. I started the pathway with a little knowledge (few theorems and laws), that I had to review and re-discuss. During the pathway I thought again to that period of time when children ask the reason for everything, because by means of the activities we questioned many things that we had always taken for granted. [...] You can't imagine how many times I struggled with wrong ideas that did not lead me anywhere, or we had an idea that we could not develop.

Some students even reveal a good awareness of the rationale of the educational pathway they experienced.

Giu: for me, the activity of correcting our mates' answers was very useful, because we had to understand his reasoning and possibly correct some imperfections.

Mat: do not worry if at the beginning you can't find the good proof or fill the worksheets, because this is a new method for you, as it was for us. Indeed, the teachers do not judge the mistakes but evaluate your ability to recognize and correct mistakes by yourself. Moreover, this pathway will help you to get into another mate's reasoning and complete or correct it.

Discussion and further developments

The preliminary analysis of the letters provided some evidence for the effectiveness of our pathway, with particular reference to the students' development of meta-mathematical knowledge concerning the culture of theorems and growing assumption of responsibility as learners. The research is still ongoing and we are currently analysing the reflective reports provided by the students at the end of the three modules. Some issues need further reflection. One crucial issue is: how to grade self-reflective reports in an objective way? Sharing with students precise criteria might better orient their work and make more explicit the teacher's expectations, but it could lead students to conform their reflections to a model. Another aspect which needs careful consideration is the development of students' awareness about their growing up as learners in the classroom context. It was put into evidence in a few final letters, while it is relevant for the development of competencies.

References

- Boaler, J., & Greeno, J.G. (2000). Identity, agency and knowing in mathematics worlds. In J. Boaler (Ed) *Multiple perspectives on mathematics teaching and learning* (pp. 171-200). Westport, CT: Greenwood Publishing Group, Inc.
- Boero, P. (Ed.) (2007). *Theorems in school*. Rotterdam: Sense Publishers.
- Boero, P., Douek, N., Morselli, F., & Pedemonte, B. (2010). Argumentation and proof: A contribution to theoretical perspectives and their classroom implementation. In M. F. Pinto & T. F. Kawasaki (Eds.), *Proc. 34th Conf. of the Int. Group for the Psychology of Mathematics Education* (Vol. 1, pp. 179-205). Belo Horizonte, Brazil: PME.
- Guala, E. & Boero, P. (2017). Cultural analysis of mathematical content in teacher education: The case of elementary arithmetic theorems. *Educational Studies in Mathematics*, 96 (2), 207-227.
- Mariotti, M. A. (2001). Introduction to proof: The mediation of a dynamic software environment. *Educational Studies in Mathematics*, 44 (1/2), 25-53.
- McIntosh, M.E. (1997). Formative Assessment in Mathematics. *The Clearing House: A Journal of Educational Strategies, Issues and Ideas*, 71:2, 92-96.
- Nicol, D.J. & Macfarlane-Dick, D. (2006). Formative assessment and self-regulated learning: a model and seven principles of good feedback practice. *Studies in Higher Education*, 31:2, 199-218.
- Stylianides, A. J. & Ball, D. L. (2008). Understanding and describing mathematical knowledge for teaching: Knowledge about proof for engaging students in activities of proving. *Journal of Mathematics Teacher Education*, 11 (4), 307-332.
- Taras, M. (2001). The Use of Tutor Feedback and Student Self-assessment in Summative Assessment Tasks: Towards transparency for students and for tutors. *Assessment & Evaluation in Higher Education*, 26:6, 605-614.

Using student and instructor characteristics to predict student success in Algebra courses

Laura Watkins¹, Rik Lamm², Nidhi Kohli³, Patrick Kimani⁴, and the AI@CC Research group¹

¹Glendale Community College, Glendale AZ United States; laura.watkins@gccaz.edu

²University of Minnesota, St Paul, MN United States; lammx020@umn.edu

³University of Minnesota, St Paul, MN United States; nkohli@umn.edu

⁴Glendale Community College, Glendale AZ United States; patrick.kimani@gccaz.edu

This paper explores the relationship between characteristics, beliefs, backgrounds and perceptions of students and instructors with students' grade earned in algebra courses at two-year post-secondary institutions in the U.S. using multiple linear regression. We present the results of an analysis of data collected during the Fall 2017 semester. From this analysis we seek to highlight a few predictor variables with significant influence on the outcome variable of student grade in the course and provide interpretations of these results.

Keywords: Algebra, grade prediction, post-secondary institutions, multiple regression analysis.

Community colleges in the US enroll 43% of all undergraduate students enrolled in two-year post-secondary institutions (Blair, Kirkman, & Maxwell, 2018). These institutions offer students the opportunity for remediation, transfer to four-year undergraduate institutions, vocational training, general education, continuing education, and worker retraining (Mesa, 2017) thus providing students of all income levels access to higher education at a minimal cost. As a result of the open access policies of community colleges, students bring a variety of backgrounds in terms of age, educational attainment, and family/work/socioeconomic status to math classrooms. To meet the needs of these students, the mathematics courses taught at a typical community college range from developmental courses (review of arithmetic and algebra courses) through courses offered during the first two years of an undergraduate mathematics major. Bahr (2010) noted the algebra courses at these colleges have failure rates ranging from 30% to 70%. Thus, there is a need to better understand factors that affect student success in these courses. Towards this end we investigate the relationship between the characteristics of instructors teaching these courses and their students' percent grade.

Sadler and Sonner (2018) found that high school students who master coursework preparatory to calculus, including algebra, geometry and precalculus, perform well in college calculus courses.

¹ The AI@CC Research group includes: Megan Breit-Goodwin, Anoka-Ramsey Community College; Anne Cawley, California State University, Pomona; April Ström, Chandler-Gilbert Community College; Randy Nichols, Delta College; Anna Bright, Patrick Kimani, Fern Van Vliet, and Laura Watkins, Glendale Community College; Angeliki Mali, Groningen University; David Tannor, Indiana Wesleyan University; Jon Oaks, Macomb Community College; Nicole Lang, North Hennepin Community College; Carla Stroud, and Judy Sutor, Scottsdale Community College; Saba Gerami, and Vilma Mesa, University of Michigan; Irene Duranczyk, Dexter Lim, and Nidhi Kohli, University of Minnesota. Colleges and authors are listed alphabetically.

These courses are often considered a mathematical gateway to a career in science, technology, mathematics, and engineering (STEM) as well as careers in other fields. Among the topics key to future success are linear equations/functions, rational equations/functions and exponential equations/functions—topics typically taught in Intermediate Algebra (IA) and College Algebra (CA) courses at community colleges. These courses are designed for US students who desire to enter a STEM or Business-related field but have inadequate mathematical preparation. In the US, high school graduation requirements vary by state and a student entering a community college may not have had the opportunity to take a course equivalent to IA or CA in high school. In fact, the majority of high school students do not take any mathematics beyond a 9th grade algebra course (Champion & Mesa, 2018), a course preparatory to IA. Thus, a student who enrolls in IA or CA either never took the opportunity to complete the work in high school or may have taken one or both of these courses in high school but did not achieve a sufficient level of proficiency to advance. For these reasons, the IA and/or CA courses are unintentional gatekeeper courses for many community college students; hence, our desire to better understand what factors lead to student success.

Algebra Instruction at Community Colleges: An Exploration of its Relationship with Student Success (AI@CC) is a National Science Foundation funded collaborative project (Watkins et al., 2016) investigating faculty who teach IA or CA at one of the eight participating community colleges which represent three different regions of the US (Southwest, Plains and Great Lakes). Although topics contained in an IA or a CA course may vary across the participating colleges, our analyses showed a significant intersection of topics within each type of course and across the colleges. Thus, our study focused on instruction around the topics within this intersection.

In this observational study we attend to the following three elements: (1) the faculty (who they are, what they believe, what they say, and what they do for planning, enacting, and assessing instruction); (2) the students (who they are, what they believe, what they learn, and how they perceive the instruction they receive), and (3) the content (its richness, how it is organized and presented). Learning in the *AI@CC* study is operationalized as student knowledge at the conclusion of an algebra course, which may be measured by initial tests and final tests, letter grade in the course, and/or their Pass/Fail status. In this paper we share our findings about the relationships between a community college student's knowledge of algebra at the conclusion of a course as measured by course grade, represented by the percentage earned by a student in their community college algebra course, with substantively meaningful student-level and instructor-level variables.

Methods

Drawing from knowledge generated in K-12 and four-year undergraduate institutions, the *AI@CC* study endeavored to measure variables associated with student learning and performance. Instruments used by the project include the Algebra Precalculus Concept Readiness–Community College (APCR-CC) inventory (Peralta et al., under review), a student beliefs survey (Kloosterman & Stage, 1992), patterns of adaptive learning scales (PALS) survey (Midgely et al., 2000) and teacher behavior inventory (TBI, Murray, 1987; Murray & Renaud, 1995). The psychometric properties of the instruments and the measures resulting from them have been validated (Peralta et al., under review; Peralta, 2017). Additionally, demographic information about students and instructors, students' self-

reported current GPA, and their course grade as both a letter grade and a percentage were collected. We present the results of a model that uses instructor and student level characteristics as predictor variables for course grade (see Figure 1).

This model posits the existence of predictive variables at student and instructor levels that help explain the variation in student learning and performance in the algebra courses. The student-level variables include personal characteristics, APCR-CC final score, and perceptions of self. Instructor level variables include personal characteristics, behavior, knowledge and attitudes towards innovative teaching practices, knowledge of algebra for teaching and beliefs about mathematics.

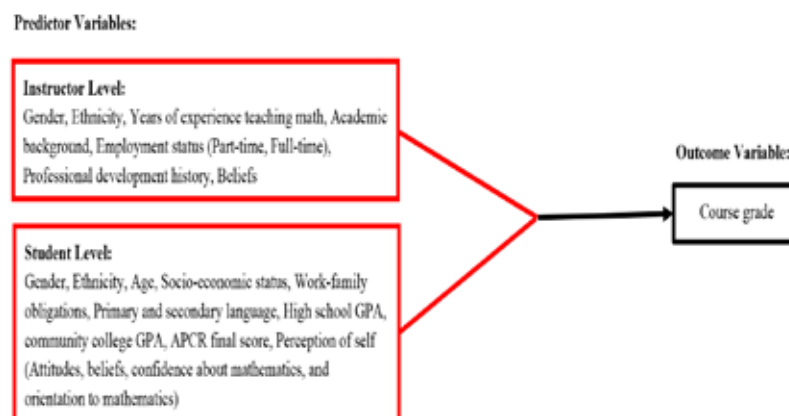


Figure 1: The AI@CC model for course grade

Measures

APCR-CC Initial and Final Scores. This 25-item assessment, measuring a single construct called quantitative reasoning (Peralta, et. al., under review), was created to measure readiness for college-level algebra and precalculus courses. The APCR-CC was administered to students twice in each of the courses observed (IA and CA). Identical versions of the test were administered at the beginning of the Fall 2017 semester (APCR-CC Initial Score) and at the end of the semester (APCR-CC Final Score). Each student's total score was determined by the sum of correct responses (one score per task) for a maximum score of 25.

Student Beliefs. The student beliefs survey was created from a survey related to motivation and achievement in the context of problem-solving following work by Kloosterman and Stage (1992). The survey, given at the beginning of the semester, had 36 items measuring personal beliefs. Of the instruments' six beliefs: (1) I can solve time-consuming problems, (2) There are word problems that cannot be solved with simple, step-by-step set procedures, (3) Understanding concepts is important in mathematics, (4) Effort can increase mathematical ability, (5) Word problems are important in mathematics, and (6) Mathematics is useful in daily life, the last two constructs were excluded from the analysis because of their low reliability (Peralta & Kohli, 2017). The score for each construct is calculated as the sum of the scores on the individual items.

Patterns of Adaptive Learning Scales. The Patterns of Adaptive Learning Scales (PALS) survey, given mid-semester, has 49 items (Midgley et al., 2000) that "are used to investigate the relation between a learning environment and a student's motivation, affect, and behavior" (Statistics Solutions, 2017). Of the instruments' nine constructs, the predictive model explored here used the three constructs: Academic Self-Efficacy, Student Performance and Teacher Mastery. The score for each construct is calculated as the sum of the scores on the individual items.

Instructor Level Variables. Demographic variables at the instructor level including gender, full-time or part-time employment status, and years of mathematics teaching experience. Continuous variables describing the amount of formal math specific professional development, formal non-math specific professional development, and informal professional development were also included. In addition, we incorporated instructional practices, instructor beliefs and instructor knowledge of mathematics for teaching into the analyses. The Mathematical Knowledge for Teaching–Algebra developed by ETS and the University of Michigan as part of the Measures of Effective Teaching Project (Melinda Gates Foundation and Educational Testing Services, 2012) was administered to faculty participants prior to the start of the Fall 2017 semester to measure their knowledge for teaching. The Faculty Beliefs about Mathematics and Mathematics Teaching survey developed at the University of Maryland (Campbell, 1990) was used to gather faculty beliefs. Midway through the semester student perceptions of the instructional practices of their instructor were collected via the TBI (Murray, 1987; Murray & Renaud, 1995), a 56-item instrument that describes the instructional practices experienced by students in the classroom.

Outcome Variable. Participating instructors provided the students' final grades as a letter grade and as a percentage from 0 to 1. Scales used to assign letter grades vary by institution, so we chose to continue our analysis using students' percentage grade as opposed to the letter grade for the outcome variable.

Models

Multiple linear regression was performed to study the effect of student-level and instructor-level variables on the outcome of percent grade. The data used in the model was gathered from 20 IA instructors with 272 students and 24 CA instructors with 365 students across the participating institutions. The main effects in the model, identical for IA and CA groups, were built using the demographic variables, APCR-CC

$$\begin{aligned} \overline{\text{PercentGrade}} = & \beta_0 + \beta_1(\text{Male}) + \beta_2(\text{Age}) + && \text{Intercepts, Gender and Age} \\ & \beta_3(\text{Hispanic}) + \beta_4(\text{Asian}) + \beta_5(\text{Black}) + \beta_6(\text{Mixed}) + \beta_7(\text{Other}) + && \text{Race or Ethnic Group} \\ & \beta_8(\text{FirstLanguage}) + \beta_9(\text{Caregiver}) + \beta_{10}(\text{Work}) + && \\ & \beta_{11}(\text{GPA}) + \beta_{12}(\text{MinorAssistance}) + \beta_{13}(\text{MajorAssistance}) + && \text{Other Demographics} \\ & \beta_{14}(\text{APCR Posttest}) + && \text{Score on APCR Posttest} \\ & \beta_{15}(\text{DifficultProblems}) + \beta_{16}(\text{Understanding}) + && \\ & \beta_{17}(\text{Effort}) + \beta_{18}(\text{Useful}) + && \text{Student Beliefs} \\ & \beta_{19}(\text{SelfEfficacy}) + \beta_{20}(\text{StudentPerformance}) + \beta_{21}(\text{TeacherMastery}) + && \text{PALS} \\ & \beta_{22}(\text{MaleTeacher}) + \beta_{23}(\text{FullTime}) + && \text{Teacher Demographics} \\ & \beta_{24}(\text{MathPD}) + \beta_{25}(\text{NonMathPD}) + \beta_{26}(\text{InformalPD}) + && \text{Professional Development} \\ & \beta_{27}(\text{TASMD}) + \beta_{28}(\text{TMIM}) + \beta_{29}(\text{TASSP}) + \beta_{30}(\text{MKT}) && \text{Teacher Behavior Inventory} \end{aligned}$$

Equation 1: Regression model for IA and for CA groups

final score, student beliefs factors, PALS, and instructor level variables (see Equation 1). Student demographics included are gender, age, race or ethnic group, if English is their first language, if they are a primary caregiver, if they are employed at least 40 hours per week, and high school GPA (coded dichotomously: less than 2.5 as 0 and greater than or equal to 2.5 as 1).

Preliminary Findings

Standardized results for both IA and CA are presented in Table 1. In both groups, APCR-CC final scores and PALS Academic Self Efficacy were statistically significant at a $p < 0.05$ level. For every one standard deviation increase in APCR-CC final score, on average, the predicted percent grade

Variable	Model 1 (College Algebra)	Model 2 (Intermediate Algebra)
APCR Final Score	0.064 (0.031)*	0.089 (0.033)**
Male (student)	-0.112 (0.028)***	-0.043 (0.032)
Age	0.002 (0.036)	0.102 (0.039)*
Race		
Hispanic or Latino	-0.157 (0.032)***	-0.054 (0.033)
Asian American	0.032 (0.030)	0.035 (0.032)
Black or African American	-0.090 (0.034)**	-0.044 (0.033)
Mixed race	0.008 (0.026)	0.012 (0.031)
Other	0.027 (0.024)	0.051 (0.032)
English as first language	-0.031 (0.033)	0.030 (0.035)
Primary care giver	-0.043 (0.033)	-0.013 (0.034)
Full time job	-0.043 (0.033)	-0.074 (0.035)*
HS GPA < 2.5	0.000 (0.032)	-0.056 (0.035)
Public assistance		
Minor source	0.028 (0.027)	-0.055 (0.032)
Major source	0.022 (0.029)	-0.041 (0.030)
Student beliefs		
Difficult problems	-0.040 (0.036)	0.012 (0.040)
Understanding	-0.017 (0.031)	0.041 (0.036)
Effort	0.033 (0.033)	0.001 (0.036)
Useful	-0.016 (0.034)	-0.030 (0.040)
PALS		
Academic self-efficacy	0.197 (0.035)***	0.182 (0.041)***
Student performance	-0.010 (0.028)	-0.026 (0.030)
Teacher mastery	-0.049 (0.031)	-0.061 (0.038)
Male (instructor)	0.090 (0.041)*	-0.053 (0.035)
Full time instructor	-0.094 (0.042)*	0.011 (0.041)
Years of teaching experience	0.002 (0.033)	0.091 (0.040)*
Professional development		
Math specific	0.104 (0.043)*	0.069 (0.054)
Non-math specific	0.005 (0.044)	0.056 (0.069)
Informal	0.210 (0.048)***	-0.076 (0.048)
Teacher beliefs		
TASMD	-0.020 (0.033)	0.000 (0.051)
TMIM	0.062 (0.046)	0.010 (0.048)
TASSP	0.001 (0.046)	0.018 (0.043)
MKT	0.041 (0.043)	-0.084 (0.046)
Intercept	0.402 (0.027)***	0.449 (0.030)***
R ²	0.33	0.29
Adjusted R ²	0.27	0.20
n	365	272

Note. ***p<0.001, **p<0.01, *p<0.05

Table 1: Standardized coefficients for linear regression

increase in Math Specific Formal Professional Development, on average, the predicted percent grade increases by 0.104 standard deviations, and for every one standard deviation increase in Informal Professional Development, on average, the predicted percent grade increases by 0.21 standard deviations for the CA group. There were other variables in either of the two groups that were statistically significant (see Table 1).

The analysis with CA students and with IA students both had adjusted R² values that, while not overly large, are considered substantial for an observational study in education (Hill, et. al., 2008). The adjusted R² values for the two groups are in the range of 20% – 30%. That is, the model predictors explain 20% – 30% of the variance in the outcome variable, percent grade.

Discussion

The preliminary results from these analyses suggest that (a) the APCR-CC final score, (b) PALS Academic self-efficacy score, and (c) instructors' years of mathematics teaching experience and exposure to professional development opportunities are positively associated with the students' outcome on course percent grade. The demographics of students taking these courses and the nature of the content taught in these two courses may explain the degree to which the APCR-CC can be used as a predictor and the extent to which these instructor factors affect the students' opportunities to learn.

increases by 0.064 standard deviations in the CA group and 0.089 standard deviations in the IA group, respectively. For every one standard deviation increase in PALS Academic Self-Efficacy, on average, the predicted percent grade increases by 0.197 standard deviations for the CA group and 0.182 standard deviations for the IA group, respectively. Moreover, Years of Teaching Experience was statistically significant for the IA group, where the predicted percent grade increases by 0.091 standard deviations, on average, for every one standard deviation increase in Years of Teaching Experience. For the CA group, both Math Specific Formal Professional Development and Informal Professional Development were statistically significant. For every one standard deviation

Given that the APCR-CC was designed to measure readiness for CA and pre-calculus, it is not surprising that APCR-CC final scores are a good predictor of students' final grades in both courses. Students who were able to do well on the APCR-CC, which tested conceptual understanding, were more likely to do well in their course. What might be surprising are the respective effects of APCR-CC final score increases to the grade increase for both IA and CA group of students. IA students' grades seemed to respond more to APCR-CC score increases than their CA counterparts. This main effect was somewhat tempered in the CA courses, which command a deeper conceptual understanding of proportionality, linearity, covariational reasoning, exponential growth, rational function behavior, and an ability to leverage these ideas to create models for problem solving.

Since the PALS Academic Self-efficacy scale measures academic related perceptions, beliefs, and strategies of the student, it is not surprising that students who have a higher score in the academic self-efficacy scale perform better in their course. Research has shown that a students' self-efficacy appears to be a critical factor for student success and performance with an extensive body of research showing a positive association between academic self-efficacy and college grades (Barber, 2009). Thus, we confirm prior research regarding the role of motivation on performance, with the very specific population of community college students taking algebra courses (Mesa 2012).

The students' opportunities to deepen their understanding of concepts taught in these algebra courses were positively impacted by the instructors' years of teaching experience and exposure to professional development (PD). We posit that duration of teaching experience had a positive impact on the IA course because: (i) the course is calculational in nature, and (ii) students in these courses may be repeating the course (after previously seeing the content in high school). These two factors make years of teaching experience a valuable trait for an instructor teaching this course because the instructor becomes efficient in teaching ways of doing (as opposed to ways of thinking), and instructors can also anticipate students' common pitfalls and offer pre-remediation. On the other hand, exposure to PD had a positive impact on CA students' opportunities to learn. These students are typically encountering the largely conceptual content taught in this course for the first time. IA courses tend to be more about simplifying expressions and solving equations while CA tends to be more about reasoning about and modelling with functions. Thus, teaching IA involves developing students' fluency with algorithms while teaching CA involves developing students' facility with functions, a topic that is historically elusive to students and slow to develop. The complexity of teaching mathematics (Potari, 2012) in ways that develop students' conceptual understanding, especially on elusive challenging topics such as functions, puts extra demands on instructors to teach in innovative ways, that are largely different from the ways the instructors encountered mathematics instruction when they were students. Professional development opportunities, both formal and informal have the potential to positively affect instructors' efficacy (Zambo & Zambo, 2008) by exposing instructors to the nature of mathematics and to effective practices in mathematics education that lead to developing students' conceptual understanding. There is much we still need to learn through our analyses of these instructors' teaching practices, which might shed further light into this issue. For example, we do not know the specific types of PD these instructors were exposed to, or how those PD opportunities impacted the instructors teaching practices. Based on these preliminary results, we recommend increasing PD opportunities for community college instructors, research into

the specific types of PD these instructors are receiving, along with their corresponding impact on teaching and students' learning.

Moreover, all of the instruments (e.g., PALS) and the assessment (e.g., APCR-CC) used in the study were rigorously evaluated to establish the appropriate psychometric properties to ensure that the data collected during the course of the study were both valid and reliable. This psychometric validation process in itself is novel in the field of post-secondary mathematics education. We looked at the effects of each of these instruments and assessment on the outcome variable of percent grade in isolation, that is, after factoring out the variance from other variables in the model (e.g., demographic variables). We found significant effects of APCR-CC final scores, and the subscale - Academic self-efficacy from PALS survey on the outcome of percent grade, along with some other demographic variables. Analyzing each of these instruments and assessment in relation to the others can give us new perspectives on the relationships, which would otherwise be unavailable to us. Viewing research in this integrated way can help with the analysis of important outcomes of interest in a more comprehensive way. These findings have the potential to impact the way we measure student learning and consequently, the development of any professional development for the instructors, and/or student learning interventions. This work strived to provide a more holistic perspective on assessment and may provide direction for future creation of diagnostic assessments/instruments for assessing students in other contexts. Considerations for creating or modifying such diagnostic assessments/instruments for use by the research community should include the diversity of curricula, impact of culture, teaching techniques, and language as well as other factors that impact students' learning differently in different parts of the world.

Acknowledgements

Funding for this work was provided by the National Science Foundation award EHR #1561436. Any opinions, findings, and conclusions or recommendations expressed in this material are those of the author(s) and do not necessarily reflect the views of the National Science Foundation. We thank the faculty who participated in the project—without them this work would not have been possible.

References

- Andersen, M. (2011). *Knowledge, attitudes, and instructional practices of Michigan community college math instructors: The search for a knowledge, attitudes, and practices gap in collegiate mathematics*. (PhD Dissertation), Western Michigan University, Kalamazoo, MI.
- Bahr, P. R. (2010). Revisiting the efficacy of postsecondary remediation: The moderating effects of depth/breadth of deficiency. *Review of Higher Education*, 33, 177–205.
- Barber, M. (2009). *The impact of academic self-efficacy and socio-demographic factors on academic achievement of first-generation community college students*. (PhD Dissertation), Appalachian State University, Boone, NC.
- Campbell, P. B. (1990). *Project IMPACT Mathematics Beliefs Scales*. College Park, MD: University of Maryland, Center for Mathematics Education.
- Champion, J., & Mesa, V. (2018). Pathways to calculus in U.S. high schools. *PRIMUS*, 28(6), 508–527. doi:10.1080/10511970.2017.1315473

- Hill, C. J., Bloom, H. S., Black, A. R. and Lipsey, M. W. (2008), Empirical benchmarks for interpreting effect sizes in research. *Child Development Perspectives*, 2, 172–177.
- Kloosterman, P., & Stage, F. K. (1992), Measuring beliefs about mathematical problem solving. *School Science and Mathematics*, 92, 109–115. doi:10.1111/j.1949–8594.1992.tb12154.x
- Melinda Gates Foundation and Educational Testing Service. (2012). *Measures of Effective Teaching Project* [Measurement instrument]. <missing city, publisher>
- Mesa, V. (2012). Achievement goal orientation of community college mathematics students and the misalignment of instructors' perceptions. *Community College Review*, 40(1), 46–74. doi:10.1177/0091552111435663
- Mesa, V. (2017). Mathematics education at public two-year colleges. In J. Cai (Ed.), *First compendium for research in mathematics education* (pp. 949–967). Reston, VA: National Council of Teachers of Mathematics.
- Midgley, C., Maehr, M. L., Hruda, L. Z., Anderman, E., Anderman, L., Freeman, K. E., & Urdan, T. (2000). *Manual for the Patterns of Adaptive Learning Sciences (PALS)*. University of Michigan, Ann Arbor, MI.
- Murray, H. G. (1987). Acquiring student feedback that improves instruction. *New Directions for Teaching and Learning*, 32, 85–96. <http://doi.org/10.1002/tl.37219873210>
- Murray, H. G., & Renaud, R. D. (1995). Disciplinary differences in teaching and in teachers' beliefs, attitudes, and perceptions. *New Directions for Teaching and Learning*, 64, 31–39.
- Peralta, Y., & Kohli, N. (2017). *Psychometric evaluation of the student- and teacher-related scales*. (Report No. 1). Minneapolis, MN: University of Minnesota, Department of Educational Psychology.
- Peralta, Y., Kohli, N., Ström, A., Duranczyk, I., Mesa, V., & Watkins, L. (under review). A psychometric analysis of the Algebra and Precalculus Concept Readiness assessment. *Journal of Psychoeducational Assessment*.
- Potari, D. (2012). The complexity of mathematics teaching and learning in mathematics teacher education and research. *Journal of Mathematics Teacher Education*, 15(2), 97–101.
- Sadler, P., & Sonnet, G. (2018). The path to college calculus: the impact of high school mathematics coursework. *Journal for Research in Mathematics Education*. 49(3), 292–329.
- Statistics Solutions. (2017). Patterns of Adaptive Learning Scales (PALS). Retrieved from <http://www.statisticssolutions.com/patterns-of-adaptive-learning-scales-pals>
- Zambo, R., & Zambo, D. (2008). The impact of professional development in mathematics on teachers' individual and collective efficacy: the stigma of underperforming. *Teacher Education Quarterly*, 35(1), 159–169.
- Watkins, L., Duranczyk, I., Mesa, V., Ström, A., & Kohli, N. (2016). Algebra instruction at community colleges: Exploration of its relationship with student success (EHR#831882). Washington, DC: National Science Foundation.

TWG22: Curriculum resources and task design in mathematics education

Introduction to the papers of TWG22:

Curriculum resources and task design in mathematics education

Birgit Pepin¹, Sean Delaney², Andreas Eckert³, Nataly Essonnier⁴, and Andreas J. Stylianides⁵

¹Eindhoven University of Technology, Eindhoven School of Education, NL; b.e.u.pepin@tue.nl

²Marino Institute of Education, Dublin, Ireland; sean.delaney@mie.ie

³Örebro Universitetet, Institutionen för Naturvetenskap och Teknik, Örebro, Sweden:
andreas.eckert@oru.se

⁴Claude Bernard University Lyon 1, Villeurbanne, France; nataly.essonnier@gmail.com

⁵University of Cambridge, Faculty of Education, UK; as899@cam.ac.uk

Introduction

The Thematic Working Group 22 (*Curriculum Resources and Task Design in Mathematics Education*, hereafter TWG22) was launched at CERME10 in recognition of the growing area of research in the field of curriculum resources (Pepin & Gueudet 2018; Stylianides, 2016), their design and use by teachers and students, and the specific design of mathematical tasks, mostly by teachers acting as designers (Laurillard, 2012; Jones & Pepin, 2016) but also their place in textbooks (e.g., Stylianides, 2014). While this field shares approaches, methods and research topics found in other areas in mathematics education research (e.g. TWG15, 16), it has its own distinctiveness. It focusses on the design and use of curriculum materials (digital and non-digital) for various educational purposes, including the design of classroom-based interventions to promote important but hard-to-teach and hard-to-learn learning goals (e.g., Komatsu, 2017; Saxe, Diakow, & Gearhart, 2013; Stylianides & Stylianides, 2009). Moreover, leaning on work by Pepin, Choppin, Ruthven, and Sinclair (2017), we make here a clear distinction between (digital) curriculum resources and educational technology, as research on (digital) curriculum resources (in the area of mathematics) pays particular attention to

- the aims and content of teaching and learning mathematics;
- the teacher's role in the instructional design and task design process (i.e., how teachers select, revise, and appropriate curriculum materials; how teachers design tasks);
- students' interactions with (digital) curriculum resources in terms of how they navigate learning experiences within a digital or non-digital environment;
- the impact of (digital) curriculum resources in terms of how the scope and sequence of mathematical topics (and tasks) are navigated by teachers and students;
- the educative potential of (digital) curriculum resources in terms of how teachers develop capacity to design pedagogic activities and tasks. (amended from Pepin, et al. 2017, p. 647)

We acknowledge that “curriculum resources” is an elastic term: ranging from particular tasks and activities, over one-off worksheets or tests, to a full-blown curriculum program, and all of these notions were addressed in the different sessions at CERME10 and CERME11.

The role and importance assigned to curriculum resources and task design in the last decades has led to an enormous variety of approaches to research in this area. At CERME10, 17 papers and 6 posters

were accepted, and at CERME11 the number of papers submitted to TWG22 has increased: 22 papers and 8 posters were accepted. In terms of organization, the paper contributions were presented (by the lead author) and discussed (by an ‘independent’ TWG colleague). The presentation/discussion sessions (see below) were followed by parallel table discussions (colleagues could choose which table to join), and finally a plenary, where amanuenses of each table/paper reported back on the main issues discussed.

The sessions were organized under the following six themes (distributed over six sessions):

1. International textbook studies
2. Teacher thinking and competences
3. Task design
4. Digital curriculum resources and task design
5. Particular task design and theories
6. School and workplace mathematics

Although there was considerable overlap between some of the sessions, for clarity we briefly discuss each theme separately below. During the first part of session 7 the eight posters were presented and discussed in a “poster walk”. The second part of session 7 was devoted to a discussion of the issues raised during the six thematic sessions.

Within CERME, the 22 papers and 8 posters presented in TWG22 at CERME11 drew upon research from 25 countries across 4 continents, and offered a wide spectrum of perspectives. Outside CERME, we saw an increase in handbook chapters, special issues, and whole books focusing on the design and use of curriculum resources (e.g. Pepin, Gueudet, Yerushalmy, Trouche, & Chazan, 2016; Pepin & Choppin, 2017; Stylianides, 2014, 2016). At the same time, the work of TWG22 overlapped with research in the field of, for example, digital technology in mathematics education, or teacher education. New conferences have been initiated (e.g. ICMT; MEDA) with colleagues from TWG22 involved in their set-up and as IPC members.

Themes and paper contributions

In session 1 international and comparative research was presented, predominantly related to textbook studies. In two paper presentations (Memis; Ruwisch & Huang) a particular topic area (e.g. reasoning; length measurement) was compared in two countries’ textbooks (Japanese & Turkish textbooks; German & Taiwanese textbooks). Results showed that, for example, in Taiwanese textbooks the emphasis was on concrete actions, whereas in the German textbooks it was on abstract and mental procedures; and the Japanese textbooks provided more “creative” mathematical reasoning opportunities (in the area of proportions) than the Turkish books. A third textbook study of Malawian primary textbooks (Lisnet) examined grade 1 textbooks with respect to mathematical opportunities (with respect to the number concept), whilst teachers’ pedagogical design capacity with respect to using textbooks was investigated in another (Chowdhuri). A comparison of naming systems (of curriculum resources) by Chinese and Mexican teachers was conducted in Wang et al.’s study, which highlighted the problem of conceptual equivalence in international studies (see permeating themes).

In session 2 issues related to teachers’ use of curriculum resources, their lesson planning and related instruction were discussed. Whilst in the paper by Siedel examined teachers’ knowledge of their resource options in order to support and further their design of effective instruction, another group of

researchers (Allsopp, et al.) explored teachers' use of a curriculum framework (involving mathematical competencies) for teaching activities. The team of Delaney and Gurhy investigated task characteristics and teacher practice that supported differentiated instruction and work on challenging tasks.

In session 3 core issues of task design was addressed. These related to the design of tasks with particular characteristics (e.g. self-explanation prompts - Dyrvold & Bergvall); to task design on particular mathematical topic areas (e.g. slope of a curve - Bos, et al.) or with focus on particular challenges (e.g. conceptual and/or creative challenges - Jaeder); to task design fostering students' engagement (e.g. construction of examples on a particular topic – Cusi & Olsher), and to the design of a task progression framework (e.g. Courtney & Glasnovic Gracin).

In session 4 core issues of task design continued to be addressed, also in relation to digital curriculum resources. Whilst the study by Essonnier et al. addressed collaborative design (in an EU project) of a digital resource and the linked social creativity, the study by Eckert and Nilsson investigated the design of digitally enriched classroom talk. In her research Rafalska focused on the teaching and learning of 'algorithmics' in terms of resource design, whilst Geti and Ding examined the use of variation theory for problem-based task design.

In session 5 task designs related to particular theories were examined. These theories included the Hypothetical Learning Theory for the learning of rules for manipulating integers (Schumacher & Rezat) and for the learning of Calculus (Breen, et al.), and the Theory of Conceptual Fields for the analysis of textbooks on the concept of function (Sureda & Rossi).

In session 6 curriculum resource design related to school and workplace mathematics was explored. Studies included those that investigated the 'building of bridges' between school and workplace mathematics (Herheim & Kacerja), and the integration of inquiry-based learning and workplace mathematics into mathematics teaching (Kalogeria & Psycharis).

In session 7 the eight posters were presented. The issues addressed in the posters ranged from those related to the design of the mathematics curriculum (e.g. Solano, et al.) and tools for such design (e.g. Noehr, et al.; Katona); over those linked to task characteristics (e.g. Misailidou & Keijzer; Martin); to teachers' selection and use of curriculum resources (e.g. Kock & Pepin; Varga; Jukic Matic & Glasnovic Gracin).

Issues raised across the six sessions

The sessions were organized under six themes, and naturally issues related to those themes were discussed in those sessions. However, there were also selected permeating strands/themes that ran across the themed sessions. The following themes permeated all six sessions: (1) terminology; (2) teacher learning and student learning; (3) networking of theories; (4) particular theories: hypothetical and actual learning trajectories; (5) methodologies; (6) theory and practice; and (7) context.

Terminology

Questions such as the following were raised:

1. What constitutes a task? - An activity in a textbook? A lesson? A learning trajectory?

2. Where does task design finish? Should implementation be included in the design?
3. When is a task educative for students?
4. When is a task educative for teachers? E.g. in a teacher guide?

The issue of ‘terminology’ (and ‘naming’) was raised in the first session, initially because several comparative studies were presented (e.g. Memis; Ruwisch & Huang; Wang et al.). In the comparative studies the researcher/s have tried to establish ‘equivalence of concepts’, so that they could establish validity of concepts for the comparisons. This was linked to the translation from one language to another, and the meaning making of particular notions, so that the researchers could actually compare ‘like with like’. It was also questioned what it means to design a ‘task’ (see also session 3 and 4): first, is a task similar, or equivalent, to an activity in a textbook, or do we mean a lesson, or even a whole lesson series, when we speak of a task? Second, what does ‘task design’ mean? Is it linked to task/lesson preparation, or is the enactment part of task design? Third, when is a task educative for students, and when for teachers? The issue of “educative materials” (Davis & Krajcik, 2005; Pepin, 2018) was raised, and educative for whom. Clearly, educative curriculum materials for students (e.g. in textbooks) are likely to be different from those for teachers (e.g. in teacher guides that accompany textbooks).

Teacher learning and student learning

Issues and questions such as the following were raised:

- It is often (naively) assumed that students “automatically” learn when using a particularly designed task
 - How do we investigate that?
- How does teacher learning take place when working with tasks and materials?
 - If tasks are developed in a community, how does this affect teacher learning?
- What kind of teacher learning is required for choosing, designing, interpreting, and implementing tasks?
 - What is the possible role of educative curriculum materials?

The issue of ‘teacher and student learning’ links to the above-mentioned questions raised concerning educative curriculum materials. It was discussed in which ways teachers learn when working with curriculum materials (e.g. textbooks; digital curriculum materials) and mathematics tasks. How does one know that teachers learn when interacting with curriculum materials, and as importantly, what do they learn? And if they work in a collective, do they learn more, or less likely, or otherwise? Indeed, it seems to be necessary to establish under which conditions teachers learn best, and with which kinds of curriculum materials. Effective educative materials (for teachers) must have particular characteristics/heuristics.

Networking of theories

Issues and questions such as the following were raised:

- Abundance of theories
 - Activity Theory
 - Variation Theory
 - Theory of Conceptual Fields

- Documental Approach to Didactics
- What are their boundaries/ domains of application/ similarities & differences/ limitations?
- Can they be combined/ networked?
 - Is any combination viable?
- How can they be linked to design principles?

In session 5 particular theories were emphasized as bases for the analysis and design of tasks (e.g. variation theory). Moreover, it was questioned whether particular theories could be combined or networked (e.g. Bikner-Ahsbals & Prediger 2014), and under which circumstances this might be useful. For example, the theory of Hypothetical Learning Theory (HLT, Simon 1995) was seen as a theory supportive of teachers to design a coherent learning trajectory for their students. However, this particular theory might not suffice for defining particular design principles of a learning trajectory; for design principles particular curriculum design tools, or task design principles, would be also be needed (e.g. variation theory). Furthermore, issues related to the use of a theory outside of the context where it was ‘born’ were discussed, and whether a theory might be differently interpreted in different contexts.

Particular theories: Hypothetical and actual learning trajectories

Issues and questions such as the following were raised:

- What do they mean?
 - Issue of singular (trajectory) vs. plural (trajectories)
 - Common/joint/collaborative learning path vs. individual learning path
- What does the comparison of the two tell us?
 - Implications for task design(ers)
- How do they link (or how might they be linked) to design principles?

Linked to the above, it was questioned whether the envisaged hypothetical learning theories would actually develop into actual student learning/study paths (e.g. Pepin & Kock – this conference; Weber, Walkington, & McGalliard 2015), and in which ways the comparison of the two would provide indications of design criteria/principles (for task/curriculum designers) or the efficacy of an intervention (Stylianides & Stylianides, 2009).

Methodologies

Issues and questions such as the following were raised:

- Design (based) research as a methodology tailored to bridging theory and practice.
- How do theories inform methodologies for studying task design, implementation...?
- Are some methodologies better suited to study task design, implementation than others?
- How do we measure effectiveness of the task design, implementation, stability, for example? Is comparison of HLTs and ALTs a viable way to do this?

In terms of empirical research, questions were discussed linked to the ‘measurement’ of the design and implementation of tasks, the design and evaluation of processes expected to help students (and teachers) to develop deeper understandings of the mathematics and its learning (and teaching).

Theory and practice

Issues and questions such as the following were raised:

- Role of users
 - Teachers as designers
- Researchers and teachers working together
 - Collaboration/cooperation?
 - Role of researcher/s and teacher/s
- How can research findings inform practice and how can practice inform research?

Several studies presented in the TWG22 used a design-based research approach. This methodology was seen to bridge theory and practice, as theoretically underpinned designs/interventions are evaluated in practice, and subsequently re-designed and evaluated in iterative cycles to reach the desired results. One of the questions on design-based research links to the role/s of the designer and users: for example, when do teachers act as designers; when are they the ‘implementers’ of commercial designs (e.g. from textbooks), who are expected to appropriate the design/s, or even enact the design/s ‘with fidelity’? What does ‘teacher design’ mean, and does design include creativity and novel design? Or is teacher design when teachers make small amendments to mathematical tasks during their lessons? Perhaps more importantly, it was questioned in which ways research findings can help teachers in their daily practice of ‘task design’, and how teachers’ practice informs and stimulates research that addresses the issues relevant for teachers.

Context

Issues and questions such as the following were raised:

- Researchers are often not explicit about particular contexts, and societal influences are sometimes difficult to determine, so are particular teaching cultures (e.g. textbooks – or lack of them – play different roles in different places).
 - What might we be able to infer from a textbook analysis in terms of student learning opportunities in the classroom?
 - Affordances and limitations of textbook analysis
- Exploratory study – are the systems stable? What has changed and what stays the same, when
 - Curricula change?
 - Resource systems vary?
- Technology, and the changes it brings, can render some tasks redundant or unworkable

One of the permeating strands throughout the six sessions related to the context of the design and enactment of curriculum resources. Mathematics teachers work under very different conditions with different kinds of curriculum resources, inside and outside the classroom. In some contexts, textbooks are crucial/mandatory resources, in others teachers prefer to ‘pick and choose’, or design their own materials. In some contexts, teachers can dedicate half of their time to the design of curriculum resources and learning trajectories, in others they are expected to ‘teach by the book’. It became clear that what we measure as researchers might be valid for one particular school or region, or true for a

particular time, but that parameters change with time and context, and hence research only provides glimpses of particular phenomena.

Possible directions for future research

Whilst there was a clear overlap of research themes (and directions) between CERME10 and CERME11 in TWG22 (e.g. task design, plurality of theoretical frames), at CERME11 issues related to international studies and international comparisons emerged as important points for discussion. This also related to theoretical frames, or those that were developed in one context and used in another. Moreover, teacher professional development practices and their work with curriculum resources were compared from one context to another, and this led the way to question the scalability of particular curricular practices and design activities.

The following directions for future research emerged from the discussions in TWG22:

- Understanding better the appropriation of tasks by practitioners (teachers, lecturers) and the impact on students (and teachers) would be a valuable focus. Teacher design often includes appropriation.
- There is additional potential to look at professional development around particular tasks.
- Students and their learning experiences should be included in considerations for task design. They are typically included in design-based research, where selected aspects of student response (to tasks) are often included.
- There is abundant potential to research the notion of ‘task design’, in particular when researchers or task designers let go of designs and hand them over to practitioners/teachers (e.g. in terms of the fidelity to the intended design of the task). Confrey and her team (Sztajn, Confrey, Wilson, & Edgington, 2012) have developed learning trajectories for the common core standards, which have fidelity to the common core curriculum.
- We discussed fidelity of resources that are passed on to teachers, but we have not sufficiently discussed fidelity of design to research on tasks or to the theory used and this may be addressed in future work.
- Scalability of processes was not a strong focus of the working group. The mathematics education community is still more concerned about small groups of teachers implementing tasks. However, for example, Chinese mathematics education research has moved towards scalability of tasks/materials.

References

- Bikner-Ahsbabs, A. & Prediger, S. (Eds.). (2014). *Networking of theories as a research practice in mathematics education*. Cham: Springer.
- Davis, E. A., & Krajcik, J. S. (2005). Designing educative curriculum materials to promote teacher learning. *Educational Researcher*, 34(3), 3–14.
- Jones, K., & Pepin, B. (2016). Research on mathematics teachers as partners in task design. *Journal of Mathematics Teacher Education*, 19(2/3), 105–121.
- Komatsu, K. (2017). Fostering empirical examination after proof construction in secondary school geometry. *Educational Studies in Mathematics*, 96(2), 129–144.
- Laurillard, D. (2012). *Teaching as a design science: Building pedagogical patterns for learning and technology*. London: Routledge.
- Pepin, B. (2018). Enhancing teacher learning with curriculum resources. In L. Fan, L. Trouche, C. Qi, S. Rezat, & J. Visnovska (Eds.), *Research on mathematics textbooks and teachers' resources - advances and issues* (pp.359–374). ICME 13 Monograph. Cham, Switzerland: Springer.
- Pepin, B., Choppin, J., Ruthven, K., & Sinclair, N. (2017). Digital curriculum resources in mathematics education: foundations for change. *ZDM Mathematics Education*, 49(5), 645–661.
- Pepin, B., Gueudet, B., Yerushalmy, M., Trouche, L. & Chazan, D. (2016). E-textbooks in/for teaching and learning mathematics: A disruptive and potentially transformative educational technology (p. 636-661). In L.English & D. Kirshner (Eds.), *Handbook of Research in Mathematics Education*, 3rd Edition. New York, NY: Taylor & Francis.
- Pepin, B., Gueudet, G. & Trouche, L. (2017). Refining teacher design capacity: Mathematics teachers' interactions with digital curriculum resources. *ZDM Mathematics Education*, 49(5), 799–812.
- Pepin, B., & Gueudet, G. (2018). Curricular resources and textbooks. In S. Lerman (Ed.), *Encyclopedia of mathematics education*. Cham: Springer.
- Saxe, G. B., Diakow, R., & Gearhart, M. (2013). Towards curricular coherence in integers and fractions: A study of the efficacy of a lesson sequence that uses the number line as the principal representational context. *ZDM Mathematics Education*, 45(3), 343–364.
- Simon, M. A. (1995). Reconstructing mathematics pedagogy from a constructivist perspective. *Journal for Research in Mathematics Education*, 26(2), 114–145.
- Stylianides, G. J. (Ed.). (2014). Special issue on “Reasoning-and-proving in mathematics textbooks: From the elementary to the university level.” *International Journal of Educational Research*, 64, 63–148.
- Stylianides, G. J. (2016). *Curricular resources and classroom use: The case of mathematics*. New York: Oxford University Press.
- Stylianides, G. J., & Stylianides, A. J. (2009). Facilitating the transition from empirical arguments to proof. *Journal for Research in Mathematics Education*, 40(3), 314–352.
- Sztajn, P., Confrey, J., Wilson, P.H., Edgington, C. (2012). Learning trajectory-based instruction: toward a theory of teaching. *Educational Researcher*, 41(5), 147–156.
- Weber, E., Walkington, C., & McGalliard, W. (2015). Expanding notions of “learning trajectories” in mathematics education. *Mathematical Thinking and Learning*, 17(4), 253–272.

Exploring teachers' assignment of mathematical competencies to planned lessons using Epistemic Network Analysis

Benjamin Brink Allsopp¹, Jonas Dreyøe¹, Andreas Lindenskov Tamborg¹,
Brendan Eagan², Sara Tabatabai², David Williamson Shaffer^{1,2} and Morten Misfeldt¹

¹Aalborg University, Denmark, ben@learning.aau.dk;

²University of Wisconsin - Madison, USA.

In this paper, we explore teachers' use of a curriculum framework involving mathematical competencies in planning teaching activities. We have used data from a pilot learning management system and Epistemic Network Analysis to plot a visualisation of a 2D space displaying a network of teachers' associations of mathematical competencies to their teaching activities. We interpret this visualisation to create a conceptual model for how teachers understand mathematical competencies when planning classroom activities.

Keywords: Epistemic network analysis, learning management systems, mathematical competencies, teacher planning.

Introduction

There is a long history of constructing *theoretical* conceptual models in educational research. In mathematics education in Denmark, there is an elaborated understanding of what characterizes mathematical activity. During the last 15 years, the concept of mathematical competencies has been developed and elaborated (Niss & Højgaard, 2011; Niss & Højgaard, 2002). In this context, these competencies are described as "... a well-informed readiness to act appropriately in situations involving a certain type of mathematical challenge" (Brooks, Greer & Gutwin, 2014).

The Danish Ministry of Education identifies six competencies in the mathematics curriculum for primary and lower secondary (UVM, 2014). *Problem tackling* is about being able to pose and solve mathematical problems, where a mathematical problem is a task where it is obvious that an answer must exist but the method of solution is unclear and can have different outcomes. The *modelling* competency is about being able to analyse, build and utilize mathematical models about other fields. *Reasoning* is about being able to follow and assess mathematical reasoning, and being able to devise and carry out informal and formal arguments as well as understand what constitutes a mathematical proof. Furthermore, it is about being able to think mathematically, where you know what questions could be posed and what answers are expected in mathematical contexts. The *representing* competency, on the other hand, is about being able to utilize different representations and switch between them as well as being able to choose the most meaningful representation. It also includes being able to handle mathematical symbol-language and mathematical formalism. The *communicating* competency is about being able to communicate in, with and about mathematics - to be able to understand and interpret expressions and texts as well as being able to express oneself about mathematics to different audiences. The *tools and aids* competency concerns the ability to operate and relate to tools and aids for mathematical operation, including Information Technology. It is also about being able to meaningfully reflect upon the choice of which tool or aid to use.

Although the individual competencies can be presented separately as above, they are considered to relate. For example, the so-called flower model (Brooks, Greer & Gutwin, 2014; Collins, 2004) depicts competencies as separate petals that overlap towards the centre, or as a set of dimensions, which together encompass the overall mathematical competence. However, the authors of this model recognize it as a purely theoretical development when they claim that “quite obviously it is impossible to produce scientific documentation that this is theoretically and empirically the case” (Brooks, Greer & Gutwin, 2014). In this paper we recognise the competencies framework as a central curriculum resource used to inform mathematics teachers in their practice. We are interested in exploring how a framework like this is understood and utilized by teachers when planning their lessons. And more specifically if it is possible to use quantitative data to develop conceptual models of how teachers relate the mathematical competencies. Hopefully such models would hold the potential to support the critical reflections of individual teachers.

Aims, data & methods

This paper describes a pilot project conducted in anticipation of large amounts of data generated from learning management systems, which have recently been adopted in Denmark. At the time of writing, this data set is not available, and instead, we use an inferior data set with the goal to explore a specific approach to visualizing data, and using these visualisations in hypothesis and heuristic building.

The data set used in this experiment was collected using the Goal Arrow software. The software was specifically designed to investigate the opportunities and challenges of digitally supporting teachers' goal-setting for teaching activities. In the Goal Arrow, ca. 70 mathematics teachers associated one or more of the six mathematical competencies with their various teaching activities. Nothing was done to ensure that the teachers were representative, and the data included both empty submissions and repeated submissions due to a lack of user input validation. The latter was corrected manually, but with a total of only 182 records remaining, the data set here is not expected to support claims to the generality of a derived conceptual model.

In this study, we employ Quantitative Ethnography (Shaffer, 2017) to provide a method where qualitative and quantitative methods blend together completely by grounding quantitative results in a qualitative understanding of data. It aims at theoretical saturation of statistical models and using quantitative results to enable thick ethnographic descriptions (Shaffer, 2017). More specifically we used the Epistemic Network Analysis (ENA) tool which examines connections in data and uses Singular Value Decomposition (SVD) to represent it as dynamic network model that maximizes the variance in the data using a reduced number of dimensions (Shaffer, Collier & Ruis, 2016).

Quantitative Ethnography describes coding as assigning meaning to observable actions or elements of the discourse observed in one context of a specific culture. In this study, the contexts are individual teachers' teaching activities and the coding is done by the teachers themselves when they assign relevant mathematical competencies to their individual teaching activities. In the data, each competency is represented in its own column where its absence or presence in each record of teaching activity is indicated by 0 or 1.

We imported this data into ENA and defined an *ENA set* where we specified the codes (the competencies), the conversations (individual teaching activity records) and the units (which we do

not use here, but allow us to filter and group records in the visualisations). We plotted the ENA set using default settings to produce the visualisation of the competencies' interrelations depicted in Figure 1.

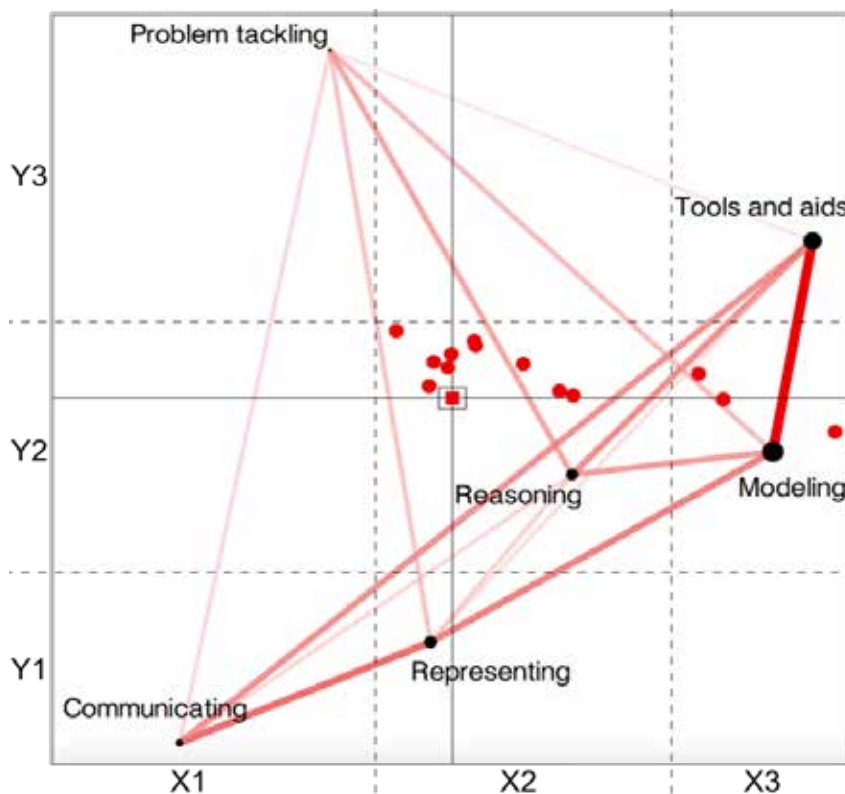


Figure 1: The space of mathematical competencies

The plotting uses SVD, which reduces the number of dimensions while still showing the maximum variance of co-occurring competencies (Shaffer, Collier and Ruis, 2016). The first dimension (the x axis) explains the most variance, and the second dimension (the y axis) explains the second most variance in the data. Individual teaching activities become the red plotted points. These seem fewer in number than the 182 records because they often overlap and should not be confused with the nodes in the network. The black plotted nodes in the network represent the individual competencies (codes). The lines between nodes represent co-occurrence of the competencies in teaching activities. The strength of the connections between competencies, determined by their frequency of co-occurrences, is represented using the thickness and saturation of the lines between nodes.

The positions of competencies (the nodes) in this network graph can be used to interpret the dimensions in the space and this can explain the positions of individual teaching activities (red points). This can provide a conceptual frame (Shaffer & Ruis, 2017) to interpret different combinations of mathematical competencies in teaching settings. It is our ability to do this interpretation that becomes the measure of this approach to generating empirically driven conceptual models.

Interpretation

By looking at the visualisation generated by ENA shown in Figure 1, we identified and used two different approaches to characterizing the axes.

1. For each axis, we look at the nodes with the greatest distance.
2. For each axis, we split the competencies into three groups and compare these groups.

First, we looked at the *opposites* on the y-axis which are *problem tackling* and *communicating*. From the definitions of these competencies, we understand *communicating* to be about being able to communicate in, with and about mathematics versus *problem tackling* which is about working in the nitty gritty with mathematical tasks that require the activation of more than routine skills. It is tempting to tentatively recognize the y-axis as being about “talking the talk” versus “doing actual mathematics”, or using Collins’ (2004) concepts, *interactional expertise* versus *contributory expertise*. But how well is this supported when we consider the other competencies that also vary on the y-axis?

With regards to splitting the competencies into three groups, we overlaid the visualisation with a grid that segregated the competencies, as shown with the dashed lines in Figure 1, such that the following groups on the y-axis were identified: Y1) *communicating* and *representing*, Y2) *modelling* and *reasoning* and Y3) *tools and aids*, and *problem tackling*.

By considering *communicating* and *representing* as a group (Y1) we see something different about the lower end of the y-axis than when we only considered *communicating*. *Representing* is not about saying the “right” things but more about getting the meaning across, by having something stand for something else. *Representing* is therefore concerned with getting the actual meaning across by any means and if necessary by multiple means, and not just to other people, but also to oneself. In other words, the lower end of the y-axis is not categorizable as mere *interactional expertise* but also requires *contributory expertise*. Combined with our understanding of *communicating*, the bottom end of the y-axis seems more precisely to be about describing and explaining mathematical issues, topics or problems in different ways in different situations.

We revisit the other end of the y-axis in the same way as above. By considering *problem tackling* and *tools and aids* as a group (Y3) we do not have to change our understanding of the top end of the y-axis, from when we only considered *problem tackling*. The *tools and aids* competency is about being able to utilize tools and aids in a mathematical context, and being able to choose the right tool for the job. *Tools and aids* are thus like *problem tackling* concerned with working on or with mathematical problems, tasks and so on efficiently. The top end of the y-axis seems to remain something to do with the actual doing of mathematics with a focus on pragmatic and efficient choices of means for mathematical work.

We must still consider the two remaining competencies, *reasoning* and *modelling*, which form the middle group (Y2). However, the interpretation of their positioning does not disturb the understanding of the y-axis discussed above. The position of *reasoning* near the centre of the y-axis can be explained by the perceived need for *reasoning* along the entire y-axis. It is needed both for describing and explaining as well as working with mathematical problems. The position of *modelling* near the centre

of the y-axis can be explained slightly differently as a necessary bridge between talking about problems from other domains, that we want to apply mathematics to as well as being able to work on those problems with mathematics.

By looking at the placement of competencies along the y-axis, firstly with a focus on the extremes and secondly in three groups, we understand the y-axis as representing a continuum from talking about, drawing, describing and explaining mathematics over *modelling* to actually doing mathematical moves, actions, and solutions with tools and aids. A continuum from describing and explaining to doing mathematics.

The x-axis does not in the same way as the y-axis have a clear pair of *opposites* to help us interpret it, but we did attempt to compare the two competencies with the most extreme distance on the x-axis; *communicating* and *tools and aids*. It was tempting to tentatively recognize the x-axis as being about psychology and cognition versus interacting with something tangible or material. But how well is this supported when we consider the other competencies that also vary on the x-axis. We approached this by splitting the competencies into, and interpreting the three groups: X1) *communicating* and *problem tackling*, X2) *representing* and *reasoning* and X3) *modelling* and *tools and aids*.

Considering the competencies *tools and aids* and *modelling* (X3) we first identified for each of these a new concept that a) seemed to relate to its respective competency and b) seemed to relate to the other concept. The definition of *tools and aids* clearly defines it to be very much about technical tools and not about mental tools (e.g. about straight edges and not about theorems). This gave us the concept “materiality”. We interpreted the definition of *modelling* to be an especially map-like portrayal in the sense that it closely resembles (although simplifies) the object being studied. Together, the concepts materiality and map-like suggested something being tangible or close to the world at the right end of the x-axis. Of course, both competencies are not physical objects in the world, they are psychological and cognitive in nature, but there seems to be an immediacy of attention to things outside of a purely mental realm; to material or non-abstract things. Loosely speaking, to things in the world.

The above immediacy of attention to things outside of a purely mental realm seemed much less necessary when we considered the two competencies *problem tackling* and *communicating* (X1). Of course, both *problem tackling* and *communicating* may relate to something in the world beyond mental or linguistic gymnastics, but the necessary immediacy does not seem to be there because *communicating* and *problem tackling* does not to the same degree have to relate to something concrete but can remain in the abstract. Although all competencies are in virtue of being competencies psychological and cognitive in nature, the competencies on the left end of the axis can be more symbolic or interpretive, and less immediately connected to the world. Loosely speaking, to things in the mind.

The remaining two competencies, *representing* and *reasoning*, which make up the middle group (X2) of the x-axis also do not (like the middle group of the y-axis) seem to disrupt our interpretation of the x-axis. *Reasoning's* position near the middle of the x-axis can (like its position near the centre of the y-axis) be explained in terms of it being needed across the whole axis. regardless of how directly one engages in the world, mathematical thinking requires reasoning. *Representing's* position near the middle of the x-axis can (like *modelling's* position near the centre of the y-axis) be explained as a

necessary bridge between the two ends of the x-axis. To be able to apply abstract mathematical thinking or communicate to the world we need to portray the world, but those portrayals need not be as map-like as those used in *modelling*. Other representations are also needed. One of these representations is natural language explanations, which must be considered an important part of the *communicating* competency.

By looking at the placement of competencies along the x-axis in three groups, we understand the x-axis as representing a perceived continuum from working in the abstract to working more directly in the world. We have summarized this as a continuum from “in-the-mind” to “in-the-world”.

Together these considerations allow us to identify the dimension of greatest variance (the x-axis) as a continuum between “in the mind” and “in the world”, and the dimension with the second greatest variance (the y-axis) as a continuum between “describing and explaining” and “doing mathematics”.

Limitations & discussion

We have discussed earlier that the available data is inferior. The small number of teachers and registered teaching activities, the fact that no effort was made to ensure that the involved teachers were representative, and the uncertainty due to the lack of user input validation, prevent us from drawing confident conclusions.

This paper and our use of Goal Arrow data is a pilot application of the method we have described. The emphasis in this paper is on exploring an approach, and especially the extent to which we can meaningfully interpret the visualisations. Our interpretation of the current data has allowed us (as a hypothesis or heuristics building exercise) to define a space of mathematical competences. In this space, we define the dimension of greatest variance (the x-axis) as a continuum between “in the mind” and “in the world”, and the dimension with the second greatest variance (the y-axis) as a continuum between “describing and explaining mathematics” and “doing mathematics”.

What is most important is that we expect to be able to use ENA for visualizing massively more of the same sort of data when made available from the learning management systems currently being implemented in Denmark. We now have reason to believe that this data and their visualisation in ENA can be interpreted meaningfully. We must recognize that these interpretations are based on what teachers have expressed about their lessons, which may differ from what they have actually planned, and to a greater degree from what is actually enacted in class. However, the process of associating lessons with competencies is well established in Denmark.

Defined spaces like the one above can be thought of as adding user friendliness or simplifying an existing understanding of mathematical competencies; we are looking at a 2D space instead of a six-columned table. However, there is also a sense in which the defined space is a development of an understanding of mathematical competencies in its own right. When the teachers relate the competencies in individual teaching activities, they are adding information. They are pointing at how mathematical competencies are likely to be engaged together. They are also negotiating between the formal breakdown of the competencies and their own understanding of what mathematics requires. Because of this, we can think of these defined spaces as new conceptual models of mathematical competencies developed using leaning analytics.

We can think of these conceptual models as a complement to the competency flower model. Most obviously, they give us another way to think about the competencies. When planning lessons, a space such as the one presented in this paper may work as a tool to support teachers' reflection and discussion on the direction of their teaching activities. Supported interactively, we can imagine teachers aiming their teaching activities at locations in the space, registering teaching activities by associating these locations to teaching activities and compare their teaching activities to those of other teachers' or their own over time. Such empirically driven conceptual models could also potentially support research and policy. For example, they could direct the attention to challenges or differences in the progression of mathematics education. Specifically, it can raise flags for individual grades, that seem to lack certain areas or have significantly different networks.

Conclusion

In this paper, we consider the context in which mathematical competencies are used in Denmark, and use data collected in the Goal Arrow software, where teachers associate competencies to their teaching activities. We describe the creating of an ENA set and the plotting of a visualisation comprising a 2D space displaying a network based on the co-occurrence of mathematical competencies in teaching activities. Notwithstanding limitations on the data, we attempt a thorough interpretation of the visualisation which allows us to explore the approach as a way of understanding how teachers use the competencies framework in their lesson planning.

References

- Brooks, C., Greer, J., & Gutwin, C. (2014). The data-assisted approach to building intelligent technology-enhanced learning environments. In B. White, & J.A. Larusson (eds.). *Learning analytics: From research to practice* (123-156). New York: Springer.
- Collins, H. (2004). Interactional expertise as a third kind of knowledge. *Phenomenology and the cognitive sciences*, 3(2), 125–143. <https://doi.org/10.1023/B:PHEN.0000040824.89221.1a>
- Johnson, L., Adams Becker, S., & Hall, C. (2015). *2015 NMC Technology outlook for Scandinavian schools: A horizon project regional report*. Austin, Texas: The New Media Consortium.
- Niss, M. A., & Højgaard, T. (2011). *Competencies and mathematical learning: Ideas and inspiration for the development of mathematics teaching and learning in Denmark*. Roskilde: Roskilde University, Department of Science, Systems and Models.
- Niss, M., & Højgaard Jensen, T. (2002). *Kompetencer og matematiklæring - Ideer og inspiration til udvikling af matematikundervisning i Danmark* (Uddannelsesstyrelsens temahæfteserie, Undervisningsministeriet 2002 (18)). Copenhagen: Undervisningsministeriet.
- Shaffer, D. W. (2017). *Quantitative ethnography*. Madison, Wis.: Cathcart Press.
- Shaffer, D. W., Collier, W., & Ruis, A. R. (2016). A tutorial on Epistemic Network Analysis: Analyzing the structure of connections in cognitive, social, and interaction data. *Journal of Learning Analytics*, 3(3), 9–45. <https://doi.org/10.18608/jla.2016.33.3>

- Shaffer, D. W., & Ruis, A. (2017). Epistemic Network Analysis: A worked example of theory-based learning analytics. In C. Lang, G. Siemens, A. Wise, & D. Gašević (Eds). *Handbook of learning analytics* (pp. 175–187). SOLAR. <https://doi.org/10.18608/hla17.015>
- UVM (Ministry of Education). (2014). Fælles Mål (Common Goals) located at <https://www.emu.dk/omraade/gsk-lærer/ffm/matematik>, November 23rd., 2018.
- White, B., & Larusson, J. A. (2014). Identifying points for pedagogical intervention based on student writing: Two case studies for the “Point of Originality”. In B. White & J. A. Larusson (eds.). *Learning analytics* (pp. 157–190). New York, NY: Springer. https://doi.org/10.1007/978-1-4614-3305-7_8

Supporting the reinvention of the slope of a curve in a point: A smooth slope to slide is a smooth slide to slope

Rogier Bos¹, Michiel Doorman¹, Kristijan Cafuta², Selena Praprotnik², Sanja Antoliš³, Matija Bašić⁴

¹Freudenthal Institute, Utrecht University, Utrecht, The Netherlands

²Faculty of Electrical Engineering, University of Ljubljana, Slovenia

³XV. Gymnasium, Zagreb, Croatia

⁴Department of Mathematics, Faculty of Science, University of Zagreb, Croatia

This paper discusses a task, designing a slide, to support the reinvention of the notion of slope of a curve in a point. The field test show that the lesson scenario allows teachers to utilize students' informal models to introduce slope more formally.

Keywords: Mathematics education, reinvention, slope.

Introduction

Introducing slope of a curve in a point and the derivative to students is a didactical challenge for teachers. It is tempting to choose for an instrumental approach swiftly progressing to differentiation techniques, both easier to teach and to learn. Without conceptual understanding this entails merely meaningless manipulation of symbols and execution of recipes. The meaning of limit, difference quotient and other concepts related to the slope of a curve at a point form serious obstacles for students (e.g. Tall, 2013; Zandieh, 2000).

This paper discusses an attempt to deal with these obstacles inspired by design heuristics from the theory of Realistic Mathematics Education (RME) suggesting that a way for students to learn mathematics in a meaningful way is to involve them in a process of reinvention (Freudenthal, 1991). A common approach in RME is to introduce a new concept through a task of which the context provides opportunities for students to focus on reasoning and representations related to the notion aimed at. As Gravemeijer and Doorman (1999) state it

The students should first experience a qualitative, global, introduction of a mathematical concept. This qualitative introduction then should create the need for a more formal description of the concepts involved. (p. 113)

This study reports initial experiences of an attempt to support students in (re)inventing the notion of slope of a curve in a point and related representations (e.g. Zandieh, 2000). Students, collaborating in groups of three, are asked to design a slide consisting of a bended and a straight part joining *without bumps*. The desired outcomes are concrete equations describing a line and a curve that meet smoothly (imagine the purpose is to feed these equations into a 3D-printer to print the slide). The task aims for students to discuss what it means for the line and curve to meet in a not-bumpy, i.e. smooth, way. They should search for methods to design a slide and to decide to what extent smoothness is achieved. The hypothesis is that they will come up with ideas that are essential to the notion of slope of a curve in a point. Informal building blocks, meaningful to the student, that can be used by the teacher to afterwards introduce the slope of a curve in a point more formally.

The context of the task is a non-kinematic one. Previous research (e.g. Doorman, 2005) exploited kinematic contexts. Historically this approach makes sense, given the origin of the notion of derivative in mechanics. The presence of dimensions (like meters/second) helps to understand the meaning of slope and more generally to make a connection from derivative in mathematics to the physics curriculum. The slide-context offers opportunities that are not present in the kinematic approach. Students have a tactile and visual understanding of what it means for a surface (or better, a curve) to be *smooth*, as also pointed out by Tall (2013). He suggests students slide their hands along a curve to sense the changing slope. The slide task allows students to mathematize this tactile and visual experience. A main merit of the slide task is that it is formulated in a very *open* way: it allows for various approaches by students. We discern three options: the standard textbook approach through secants of the curve, the locally linear/linear approximation/"zooming in" approach (Tall, 2013), and a (more algebraic) approach based on local bounding lines. The most important advantage of the slide task is that it allows the teacher *connect the student's work to any or all of these approaches*, depending on what students produce, possibly providing *multiple views on the notion of slope*.

The design of the lesson plan (scenario) for the task is based on the Theory of Didactical Situations (TDS) (Brousseau, 2002). We investigated whether combining RME and TDS as frameworks for the design of an inquiry based mathematics lesson can lead to a successful scenario. This approach of combining ideas from RME and TDS to task design for inquiry based mathematics teaching (IBMT) is pioneered in the Erasmus+ project Meria (Winsløw, 2017).

The research question addressed in this paper is: How do RME-inspired task characteristics and a TDS-inspired teaching scenario support students' invention of the notion of slope of a curve in a point?

RME perspective on the slide task

The design of the task originates from the RME-principle of a *didactical phenomenology* (Freudenthal, 1983) of the slide context:

What a didactical phenomenology can do is ... starting from those phenomena that beg to be organized, and from that starting point teaching the learner to manipulate these means of organising. (Didactical phenomenology of mathematical structures)

The challenge of realizing a smooth connection in the slide context is a phenomenon that begs to be organized by the tangent line. Visually at first, but then it begs for symbolic means to decide whether the candidate line and curve really join in a smooth way. Some questions that arise are: *how good is the slide at begging?* Does it lead students to mathematize in direction of the learning goal, or even reinvent the slope of a curve at a point? What can be expected from students can be explained using the *emergent models* design heuristic (Doorman & Gravemeijer, 2009). The context-problem is expected to invite students to develop their own situation-specific solution methods. These methods will have to be discussed and compared. A (situational) model expected to emerge from the slide task is that of the slope of a curve at a point as the slope of a tangent line. This is a model *of*, produced after one episode of mathematizing. At best, this is a starting point for further mathematizing towards symbolic and computational aspects of the slope at a point and the derivative.

The slide task as a TDS-scenario

How to organize the classroom for a reinvention activity? Freudenthal (1991) claims that “guiding means striking a delicate balance between the force of teaching and the freedom of learning” (p. 55). TDS might provide a suitable framework to balance the two. Central to the theory is the difference between didactical and adidactical situations (Brousseau, 2002). In a didactical situation the teacher acts intentionally to share his knowledge. In an adidactical situation the teacher purposefully withdraws, leaving space for students to develop their own activities. Students need this space to invoke their own meaningful strategies to address the slide problem.

For Brousseau it served another purpose: to change the expectations the students and the teacher have of each other. He calls it *finding a new didactical contract*. During this adidactical situation the teacher cannot be expected to be involved in the mathematizing process. Instead (groups of) students interact with the *milieu*. For the slide task the milieu consists of the problem itself together with the artifacts that may be needed to tackle it, for example GeoGebra.

The slide task lesson plan is set up according to phases from TDS and starts with the teacher explaining the problem and introducing artifacts that can be used to work on it. Then the teacher symbolically hands over the milieu to the students and withdraws. What follows is an adidactical *action phase* of 20 to 30 minutes. In this phase students work on the problem in groups of three. They may apply any approach they think is useful. The teacher, even though not interacting with the students, is not inactive: she registers solution strategies from the students and identifies examples that might be used in the following *formulation phase*. The teacher makes sure that for groups that have different strategies one student explains their approach on the blackboard. Then follows a *validation phase*. The teacher asks: “are some solutions better than others? Is there a best solution? How do you know?”. The classroom discussion that these questions provoke form the input for the last phase: the *institutionalization phase*. In this phase the teacher is expected to be able to organize the ideas and strategies presented by students into solution models of the slide problem. The teacher makes a start with transforming the emerging *model of* the situation produced by students into a *model for* mathematical reasoning.

Method

Context. This task was conceived during a project meeting of the Erasmus+ project Meria on inquiry based mathematics teaching. A working group designed a detailed scenario describing teacher and student activities and possible solution strategies.

Procedure. The data for this pilot include self-reports, including students work, of pilot lessons by three Dutch teachers (from now on referred to as teacher A, B and C). Teacher B is involved with the whole Meria project as a teacher who performs pilots; the other two teachers signed up for the course after reading about it in a national newsletter. They were trained to give the lesson in a three hour course taught by the authors. In the course we had a try-out of the scenario and discussed the scenario in detail. The potential of the adidactical phase(s) was stressed as this is an uncommon position for teachers to be in. At some point in the following four weeks they taught the lesson. After the lesson

teachers assembled the work of the students and wrote a report including their observations and experiences during the lesson. In a second meeting, after those four weeks, we discussed the experiences of the pilot and their reports with the teachers.

Other data is the self-report on a pilot conducted by the first author.

Analysis.

In an a priori analysis we discerned three hypothetical student approaches, based on three formal approaches to the tangent line. In the a posteriori analysis, we consider signs or traces of each approach as an indicator of a *situational student model*, which may later be *vertically mathematized* into a more formal mathematical model given by the definition.

1. (Bounding line approach) Students choose a free line and then move (translate and rotate) it until there seems to be just one intersection point in the area of focus. This informal approach relates to a formal definition of the tangent line as a unique local bounding line (this we will explain more precisely in the continuation of this research project).
2. (Secant lines approach) Students choose one point on the curve, the intended point of tangency. Then they choose another point on the curve, draw the line between the two points, and move the second point closer to the first (this works best in Geogebra or similar) to obtain a smoother fit. This informal approach relates, of course, to the standard school book approach of the tangent line and slope.
3. (Linear approximation approach) Students choose one point on the curve, draw a line and then try to adjust the slope so that it fits best against the curve (perhaps by wiggling their ruler). In GeoGebra or similar this can be done by moving the second point needed to draw the line. This informal approach relates to the more formal approach of the tangent line as the best linear approximation at a point of the curve (this will also be explained more precisely in future work).

The main distinction between the approaches is in the way the smoothness of the slide designs is evaluated or controlled by the students in the slider context: (1) by looking for intersection points, (2) by moving the point closer and closer and (3) by looking for intuitive smoothness. If students allow GeoGebra to compute the intersection point of the line and the curve, then approach 1 and 3 will resemble approach 2, since they will see the two intersection points approaching each other as they move closer to the desired line. In approach 1 students fix the slope and search for corresponding point, whereas in approach 2 they fix the point and find the corresponding slope. In approach 3 both options are present.

After students have drawn some lines and curves and written corresponding equations, they will have to find out whether their solution is ‘smooth’ enough. In a second a priori analysis, of what might be discussed by the students and/or the teacher in the validation phase, we expect three possible ways for students to evaluate their own design (in line with Zandieh, 2000):

- I. (Visual). Some will rely on their visual evaluation of the design: if it looks good, then it is good. Students may also choose to zoom in on the curve (work on a smaller scale), for example

- using GeoGebra or similar, to check whether their fit is smooth. Zooming in the curve should more or less coincide with line (see the Locally Straight Approach in Tall 2013).
- II. (Algebraic). The students may compute whether their system of equation has the intended intersection point as a solution. Moreover, students could try and compute that there is *precisely* one solution to the system of two equations (at least locally). For example, if the curve is described by $y = x^2$ and the line is translated, so $y = x + b$. Finding the value of b for which the discriminant of the equation $x^2 = x + b$ is zero, gives the desired line. For general algebraic curves one could study for which value of b the intersection point has multiplicity ≥ 2 .
- III. (Numerical). As a continuation of the second and third approach it would seem natural to choose the second point very close to the first and see how the slope of the obtained line compares to the suggested line. For example, if $y = x^2$ and $y = 2x - 1$, the line through $(x_0, y_0) = (1, 1)$ and $(x_1, y_1) = (1.001, 1.001^2)$ has a slope very close to 2. Students may even study a sequence of points (x_1, y_1) ever closer to $(1, 1)$, which would bring them very close to the definition of a derivative through the difference quotient.

We collected the work of the students. In some cases that was individual paper work, but in most cases groups handed in one A4 with their notes and solutions. Furthermore, the teachers reported about the lessons, what they observed during the action phase, to what extent they were able to follow the scenario and what they saw as main results of the lesson. We analyzed the data for occurrences (of traces) of approaches 1, 2 and 3 during the action phase. In addition, these resources were used to find occurrences of the evaluation methods I, II and III during the *action phase* and *validation phase* (possibly the teacher introducing them during a *didactical validation phase*). These traces were used to hypothesize what informal situational mathematical models emerged from the students' work.

Finally these observed approaches were analyzed for their connection to what the teachers reported to have *institutionalized* in the final phase of the lessons. In particular, we tried to decide whether the potential in the students' work was seen and used by the teacher.

Results

We discuss the work of some groups that represent various observed approaches. A group of grade 8 pre-university school students from teacher A used approach 1: in GeoGebra they translated the line with fixed slope until it seemed to be tangent to the hyperbola $y = \frac{10}{x}$ (see Figure 1). The suggested line has equation $y = -x + 6,4$. This looks acceptable (evaluation method I), but actually the two intersection points are approximately 2 apart. Clearly these students have neither computed the intersection points (algebraic evaluation) nor zoomed in on the graphs (enhanced visual evaluation).

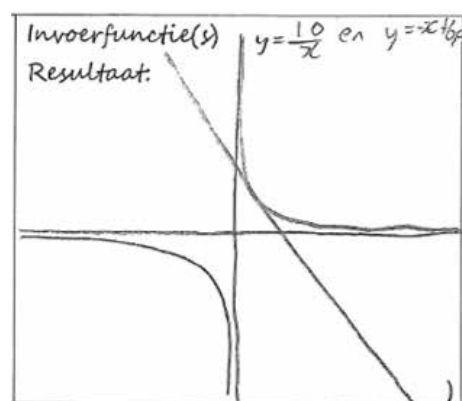


Figure 1. Sample student work

The teacher reports that students mention that they are looking for the line such that there is one intersection point. So these students' informal model of the situation relates to the bounding line definition of tangent line. The teacher writes in her report that she is disappointed that the students did not arrive at the notion of slope of a curve at a point. But, in this case, in the institutionalization phase the teacher could have used the students' explanation of their strategy and the fact that students mention that they are looking for one intersection point to discuss the tangent line as a bounding line. Next, with the students, she could discuss evaluation method II as a step towards the target knowledge. This makes clear that there is a difficulty for teachers to realize the potential in the informal solutions students present. The challenge is to relate students' models to the target knowledge.

A group of grade 10 vocational school students from teacher B draws a tangent line to $y = x^2$ at the point $(-2,4)$ (see Figure 2). First they seem to have drawn a secant line through $(-1,1)$ and $(-2,4)$, but this is then dismissed for the sequel. They somehow come up with a $\Delta y = 5.7$ for this candidate tangent line on the interval $[-3, -1]$. They compute the slope of the line. What follows is unfortunately nonsense, but nevertheless the teacher was very excited about their approach and let them present it at the blackboard during the formulation phase. Rightfully so, since these students' informal solution method is precisely the model one needs to introduce the slope of a curve at a point. The teacher writes in her self-report: "The notion of ... slope in a point became meaningful".

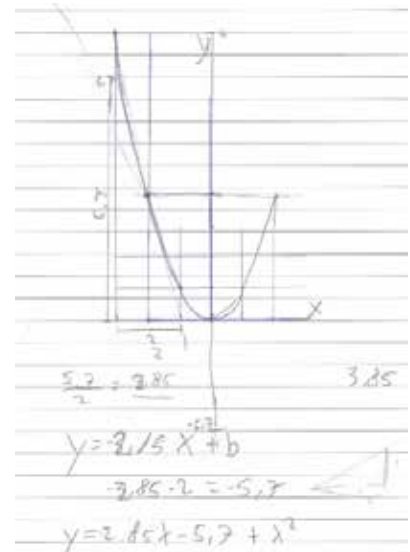


Figure 2: Sample student work

Another group from teacher B goes through a sequence of improved slide designs (see Figure 3). The first one has an asymptote; students write "does not have a straight bit". The second one is correct, but is dismissed, because the straight bit is horizontal instead of going up. The third is still with decimal coefficients, but the next four all are clearly attempts at exact solution (5 and 6 the same). Their approach can be classified as type 3. Teacher B told the class that zooming in was a good idea, so all students had a means of evaluating their solutions (method I). What happens in the last attempt is a "nice number wonder": by choosing nice numbers -2 and $\frac{1}{2}$ the students hit the bull's eye.

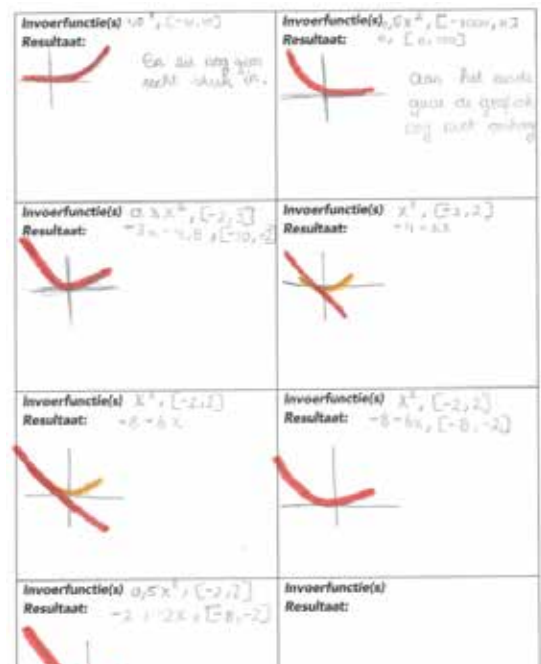


Figure 3: Sample student work

Teacher C did not formulate the task properly. She said: "Figure out in groups which functions could describe this curve". As a consequence, most students did not work with a line and a non-linear curve and the teacher got stuck trying to institutionalize the target knowledge as aimed for in the scenario.

The first author performed a pilot study with twelve grade 9 pre-university students equally divided in three groups. One group made drawings of circle segments and approximate tangent lines, using that the radius is perpendicular to the tangent. Within a few minutes they say: "the slope of the tangent line is important". Then they solve the problem by choosing a circle $x^2 + y^2 = 2$ which goes through the point $(-1, -1)$. For this point they infer that the slope of the tangent line is -1 (also visually obvious), which leads them to the equation $y = -x - 2$. This group's approach seems to be a case of vertical mathematization. Tangents to circles were already meaningful to them and for them solving the problem easily changes into symbolic work: doing some computations. After they showed the teacher their solution, he asked them to find a solution using a parabola. Their quick solution was a vertical line ($x = 0$) and a parabola ($x = y^2$). Then they asked: "How can you decide the right slope for a different point on the parabola?". This was a very welcome question, later referred to by the teacher in the institutionalization phase.

Another group quickly decided they wanted to use a tangent line with a parabola and a line design and surprisingly knew the algebraic way (II) to evaluate it: using the discriminant to decide whether the intersection point is unique. It turned out that the class made an exercise about exactly this a few weeks ago. Still the group took a long time to decide on a suitable line, finally settling for a correct one. According to the students this was obtained by guessing!

In the institutionalization phase the teacher used the students' solution strategies and remarks to stress the importance of the slope of the tangent line (both in the circle solution and parabola solution). He explained this was called the slope of the curve at a point. With the students they decided that for a circle they could compute the slope in every point, but for the parabola new techniques would be necessary. This would be the subject for later lessons.

Discussion

Did the task and scenario provide opportunities for students to "experience a qualitative, global, introduction" to the slope of a curve in a point, as was the goal of the task? More concretely: did students come up with ideas that are essential to the notion of slope of a curve in a point? Based on the observations above one could conclude the students did.

Two ideas that are essential to the notion of slope did not come up naturally for students in the pilot. Firstly, the secant lines approach (2) did not occur in any of the pilot lessons, neither did any numerical evaluation of the design (III). This indicates that for the students in the pilot this approach does not come naturally (given the current Dutch curriculum and the task). Many students do have a dynamical approach, in the sense that they try to improve their initial and following attempts by varying parameters of the curve or the line to end up with a (visually) seemingly smoother result. But using two points on the curve to construct such a sequence of better and better fitting lines seems not a natural idea to come up with. On the positive side: the dynamical approach of "improving on your previous line" is a first step toward understanding the tangent line as the result of limit *procedure*. Secondly, the idea of *zooming in* or *changing scale* as an evaluation method has not occurred naturally to students. Once told by teacher B, students immediately grasped the idea and could use it, but they did not reinvent it. Students seem to prefer to stick to the scale at which they drew their first picture and work with reasonably nice numbers within that scale.

If students discover that some of their solutions have two intersection points, in the institutionalization phase the teacher could try and use this discovery to form a bridge to approach 2 and the difference quotient. As soon as you have two intersection points the idea of moving one of them to find a new line is a reasonable step.

A more radical conclusion in line with RME principles would be to go with the students' informal models all the way, instead of trying to facilitate a bridge towards the traditional way to introduce the slope. If the students' approach suggests the bounding line definition of a tangent line is the more meaningful for them, then the teaching sequence should be based on it. One can design instructional sequences following on approach 1 and 3 (in addition to existing sequences based on approach 2). These questions will be topic of study during the next steps in the context of this project.

Finally, in this project we combined principles from TDS and RME. This experience showed that the TDS emphasis on organizing didactic and adidactic phases by a teacher, in connection with the RME principle of reinvention guided by emergent models during these phases, supported the design of an inquiry-based scenario for students.

Acknowledgment

The authors would like to thank the members of the Meria project-team for their contributions to the development and evaluation of the slide task.

References

- Brousseau, G. (2002). *Theory of didactical situations in mathematics*. Dordrecht: Springer.
<https://doi.org/10.1007/0-306-47211-2>
- Doorman, L. M. (2005). *Modelling motion: From trace graphs to instantaneous change* (Doctoral dissertation). Retrieved from <https://dspace.library.uu.nl/handle/1874/1727>
- Doorman, L. M., & Gravemeijer, K. P. E. (2009). Emergent modeling: Discrete graphs to support the understanding of change and velocity. *ZDM - International Journal on Mathematics Education*, 41(1–2), 199–211. <https://doi.org/10.1007/s11858-008-0130-z>
- Freudenthal, H. (1983). *Didactical phenomenology of mathematical structures*. Dordrecht: Reidel publishing.
- Freudenthal, H. (1991). *Revisiting mathematics education: China lectures*. Dordrecht: Kluwer.
- Gravemeijer, K., & Doorman, M. (1999). Context problems in realistic mathematics education: A calculus course as an example. *Educational Studies in Mathematics*, 39(1/3), 111–129.
<https://doi.org/10.1023/A:1003749919816>
- Tall, D. (2013). *How humans learn to think mathematically: Exploring the three worlds of mathematics*. Cambridge: Cambridge University Press.
<https://doi.org/10.1017/CBO9781139565202>
- Winsløw, C. (Ed.). (2017). *Practical guide to inquiry based mathematics teaching*. Retrieved from <https://meria-project.eu/activities-results/practical-guide-ibmt>
- Zandieh, M. (2000). A theoretical framework for analyzing student understanding of the concept of derivative. *CBMS Issues in Mathematics Education*. 8, 103–127.

Conjecturing tasks for undergraduate calculus students

Sinéad Breen¹, Caitríona Ní Shé^{1,2} and Ann O'Shea²

¹Dublin City University, Ireland; sinead.breen@dcu.ie, caitriona.nishe2@mail.dcu.ie

²Maynooth University, Ireland; ann.oshea@mu.ie

We present a hypothetical learning trajectory for a sequence of tasks designed for a calculus module. The purpose of the tasks was to give undergraduates opportunities to use technology to experiment and make conjectures while developing their understanding of the effects of translations on graphs. We consider data from task-based interviews with two students. The hypothetical learning trajectory for this sequence of tasks is compared with the actual learning trajectory of the students, and we conclude there was some evidence that our learning goals were achieved.

Keywords: task design, undergraduate mathematics; conjecturing.

Introduction

The types of tasks that students work on can influence the reasoning and learning processes in which they engage (Jonsson, Norqvist, Liljekvist, & Lithner, 2014). In Ireland, recent studies have highlighted that the majority of tasks both in secondary school textbooks and in undergraduate calculus modules could be solved with imitative reasoning, that is by memorization or following a familiar algorithm (O'Sullivan, 2017; Mac an Bhaird, Nolan, Pfeiffer, & O'Shea, 2017). In this context it is important to design tasks which give students opportunities to develop higher-order mathematical thinking skills, such as conjecturing and generalizing, to move them away from rote-learning. The first and last authors (Breen & O'Shea, 2018) designed a framework of task types for undergraduate calculus modules with the aim of developing mathematical thinking skills such as those suggested by Mason & Johnston-Wilder (2004, p. 109). Subsequently, interactive versions of some of the tasks were developed using the dynamic geometry software GeoGebra. In this paper we will consider a hypothetical learning trajectory (Simon, 1994) for a set of two conjecturing tasks designed using Geogebra on the topic of graph transformations and present data from task-based interviews to explore the actual learning trajectories engendered by this sequence of tasks.

Theoretical Framework

Task Design

The framework of mathematical task types used here has six task types: evaluating mathematical statements; generating examples; analysing reasoning; visualizing; using definitions; conjecturing and generalizing (Breen & O'Shea, 2018). We will focus here on the last of these; we will first review the literature to present a rationale for this task type and for using technology in the design.

The acts of conjecturing and generalizing are well-known to be part of the tools of a professional mathematician (Bass, 2015); indeed, Bass describes the progress of most mathematical work as starting with exploration and discovery, then moving on to conjecture, and finally culminating in proof. He identifies two phases of reasoning here: *reasoning of inquiry* (incorporating exploring and conjecturing) and *reasoning of justification* (rooted in proof). The acts of conjecturing, generalising, experimenting and visualising are included in the list of processes which aid mathematical thinking

given by Mason and Johnston-Wilder (2004); these authors also discuss ‘natural’ powers that learners possess such as the ability ‘to imagine and detect patterns,..., to make conjectures, to modify these conjectures in order to try to convince themselves and others’ (Mason & Johnston-Wilder, 2004, p. 34). They stress the importance of creating a ‘conjecturing atmosphere’, so that students can participate in inquiry and develop their mathematical thinking skills.

Dreyfus (2002) defines generalizing as “to derive or induce from particulars, to identify commonalities, to expand domains of validity” (p. 35). He acknowledges the important role played by generalizing in the process of abstraction, in moving from a particular instance to a generality, and notes the difficulty that many students have with generalization. Swan (2008) explains that the process of identifying general properties of a concept from particular cases is one with which a student must be able to engage in order to come to truly understand a concept.

Breda and Dos Santos (2016) examined how GeoGebra tools can enable students to conjecture and provide mathematical proof, and recommended such tools be used to support the study of complex functions. The use of technology has a number of advantages: for instance, information can be gathered and processed quickly so that teachers and students can make decisions efficiently to exploit learning opportunities; moreover, the burden of computation can be removed or reduced to allow students to explore and experiment. Borwein (2005) described specific benefits of the use of technology to mathematicians, including: to gain insight and intuition, to discover new patterns and relationships, to expose mathematical principles through graphs, to test and falsify conjectures, to explore a possible result to see if it merits formal proof, to do lengthy computations. All of these have an important role to play in responding to a conjecturing/generalizing task.

Hypothetical Learning Trajectory Construct

Simon (1995) introduced the notion of a hypothetical learning trajectory (HLT) as part of a model of mathematics teaching. The HLT is made up of three parts: learning goals (as set by the instructor); learning activities (designed or selected by the instructor); and the hypothetical learning process (the instructor’s prediction of how student thinking will develop during the learning activities). Simon describes the symbiotic relationship between the learning activities and the hypothetical learning processes – the ideas which underlie the learning activities are based on the instructor’s beliefs about student learning, and these in turn are influenced by what is observed during the learning activities. Thus theory informs practice and vice versa.

Simon and Tzur (2004) advocate the use of HLTs in task and curriculum design (especially for ‘problematic’ topics) as a mechanism to ensure that adequate thought is given to how student learning might evolve during activities, and as a means to study the success of learning activities. The HLT construct has been used to study teaching tasks and sequences of tasks in a variety of settings including undergraduate mathematics courses. Andrews-Larson, Wawro and Zandieh (2017) note that HLTs are useful ways of tying theory to practice, and use the notion of HLT to outline how certain tasks could lead to undergraduate students developing new understanding in Linear Algebra. Stylianides and Stylianides (2009) compared HLTs and actual learning trajectories to provide evidence that an instructional sequence of tasks had achieved the desired goals.

Our Task Sequence and Hypothetical Learning Trajectory

We will consider the HLT for our task sequence and the actual learning progression of two students.

Learning Goals

Eisenberg and Dreyfus (1994) discuss the fundamental importance of developing 'function sense' with undergraduate students. They describe facets of this as including dependence, variation, co-variation and the effects of operations on functions. One of the most important components of function sense is the flexibility to move between multiple representations of a function. The key to solving many problems is to think of them visually, using a graph - including problems encompassing the main facets of functions mentioned above. However, Eisenberg and Dreyfus report that many students (even those more advanced mathematically) are reluctant to do so.

The function operations that we focus on in this paper are graph transformations, specifically vertical and horizontal translations of the graph of functions from \mathbf{R} to \mathbf{R} . The learning goals are:

1. observing and articulating the effects of translations on graphs: in particular, describing the relationship between the graphs of $y = F(x)$ and those of $y = F_i(x)$ for $i = 1, 2$ (where $F_1(x) = F(x) + a$ and $F_2(x) = F(x + a)$);
2. observing that, in general, the functions $F_1(x)$ and $F_2(x)$ are different when $a \neq 0$;
3. making conjectures, in particular generalizing data from examples observed;
4. using the technology to undertake experiments.

Note that we have both local (1 and 2) and more global (3 and 4) learning goals for student reasoning and skill development arising from our task sequence. Goal 1 targets the flexibility to move between representations of a function. The goals of the task sequence do not include students providing proofs for their conjectures since our tasks deal with Bass's (2015) *reasoning of inquiry* rather than *reasoning of justification*.

The Task Sequence

For the last number of years, we have been developing a bank of tasks using our framework. Originally these tasks were paper-based and aimed to give students opportunities to explore, spot patterns, and make conjectures based on their observations. We noticed that some students had difficulties drawing the graphs of the functions mentioned and so were not able to generalize or make a conjecture. In 2016, we redesigned these tasks using GeoGebra; we will refer to these as Tasks A and B. (Task A is shown in Figure 1 and Task B is similar except with $f(x) = (x + a)^3$ etc.). The computational burden was thus removed from the students and we hoped that this would allow them more freedom to experiment and conjecture appropriately. In contrast with the paper-based tasks, the use of GeoGebra allowed us to enable students to quickly see graphs of the form $y = F(x) + a$ (**Task A**), and $y = F(x + a)$ (**Task B**), for values of a ranging over an interval. Both tasks, and others from this project, can be found at <http://mathslr.teachingandlearning.ie/GeoGebra/>.

Hypothetical Learning Progression

As students engage with the task sequence we expect the following activity and learning from them:

- experimenting with the sliders;

- noticing how the graph of the function f changes as a changes, in particular noticing the difference in behaviour for positive and negative values of a ;
- remarking in the case of Task A (respectively Task B) on the vertical (respectively horizontal) shift of the graph and expressing the relationship between f and f_1 (respectively f_2) mathematically;
- noticing analogous relationships in the cases of g and h to identify a pattern;
- using the data from f , g , and h to make a conjecture about the effects of transformations of the types in Task A and B on graphs;
- amalgamating the relationships observed to realise that, in general, the functions $f_1(x)$ and $f_2(x)$ are different when $a \neq 0$.

Task A: (GeoGebra Task) Use the slider on each graph to change the values of a in the functions $f(x) = x^3 + a$, $g(x) = \frac{1}{x^2} + a$, $h(x) = 3^x + a$.

- What is the relationship between the pair of graphs $y = f(x)$ and $y = f_1(x)$ below?
[The graphs of $y = f(x)$ (with a initially set at 1) and $y = f_1(x) = x^3$ are shown as well as a slider which allows a to range from -5 to 5. When the value of a changes the graph $y = f(x)$ changes accordingly.]
- What is the relationship between the pair of graphs $y = g(x)$ and $y = g_1(x)$ below?
[The graphs of $y = g(x)$ (with a initially set at 1) and $y = g_1(x) = \frac{1}{x^2}$ are shown as well as a slider which allows a to range from -5 to 5.]
- What is the relationship between the pair of graphs $y = h(x)$ and $y = h_1(x)$ below?
[The graphs of $y = h(x)$ (with a initially set at 1) and $y = h_1(x) = 3^x$ are shown as well as a slider which allows a to range from -5 to 5.]
- Can you make a general conjecture about the relationship between the graphs of $y = F(x)$ and $y = F(x) + a$ from your observations about the graphs of the pairs of functions above? What happens when $a > 0$? What happens when $a < 0$? What happens when $a = 0$?

Figure 1: Task A

Data collection and analysis

In order to investigate the use and effectiveness of the tasks, the second author carried out a series of task-based interviews with a sample of students from a first-year calculus module in which some GeoGebra tasks were trialed. Four students were asked to think aloud while completing a selection of the tasks. Pre and post-tests, each consisting of the same four questions (where one question had two parts), were used at the beginning and end of the interviews in order to help determine if the students' mathematical thinking had changed as a result of completing the tasks. The interviews, which lasted about an hour, used purpose built software to record video, audio, screen and mouse movements. Each student completed between four and seven GeoGebra tasks depending on how quickly they moved through them. The interviews were transcribed by the second author using the audio recording to which she added a summary of what was happening onscreen at that time. The transcriptions were analysed for significant incidents by two of the three authors, and their results were compared and agreed on.

Results

We will consider in some detail the responses of two of the three students who completed the pre-test, then worked on Tasks A and B in the task-based interviews, and subsequently completed the post-test (see Table 1 below). One question which appeared on the pre-test and post-test was the following:

Q4(ii) Suppose $f(x)$ is a function defined for all real values of x . Decide if the statement is true or false. Explain your answer. *If a is any real number then $f(x+a) = f(x)+a$ for all values of x .*

All three students answered Q4(ii) correctly on the post-test but two of them (given pseudonyms Áine and Seán) gave incorrect answers on the pre-test.

Student	Q4(ii) on pre-test	Task A	Task B	Q4(ii) on post-test
Áine	Says 'It's a function' and writes 'true'. Later she says she thought that the question was asking whether the expression $f(x+a)=f(x)+a$ describes a function.	Is able to verbalise the relationship between the graphs and is able to make the expected conjecture.	Is able to verbalise the relationship between the graphs and is able to make the expected conjecture.	Writes: if $a=0$ but not for other values of a . Explains by referring to the GeoGebra tasks.
Seán	Writes 'True' and gives example with $f(x)=x$, $a=1$, $x=1$. Later when asked what he thought this question was asking: <i>I took it as a set [particular] function rather than an arbitrary function.</i>	Notices that the y-intercepts of the graphs of f and h depend on the choice of a . For g , he notices that the horizontal asymptotes depend on a , (but does not use correct terminology). Is able to make the expected conjecture.	Notices that the x-intercept varies according to choice of a . (He calls it the origin). Is able to make the expected conjecture.	Says the statement is false and explains by referring to graph transformations.

Table 1: Student responses in task-based interview

Both Áine and Seán were able to use the sliders to obtain graphs of the different translations of the functions in question. Áine worked quickly on both tasks (she spent 2-3 minutes on each of them), she spotted the pattern and was able to verbalise it using mathematical language. For the first pair of functions on Task A she said:

So as I can see here as I am taking values away from x^3 the graph shifts down the y-axis and as I add values it shifts up the y-axis.

She did the same for the graphs of the translations of g , predicted what would happen with h , and was able to conjecture:

when $a > 0$ the graph of f moves up the y-axis and when it's less than zero it moves down.

Similarly on Task B, she was able to use the slider to generate vertical translations of the three functions, and she made a conjecture generalizing the pattern she observed.

Seán spent about 6 minutes working with the three graphs on Task A. He used the slider to examine how the functions changed for the range of values of a . He also was able to spot a pattern but focused on certain features of the graphs instead of the whole graph; for the translations of f and h he spoke about their y -intercepts (but used the term *origin*), and for the translations of g he noticed that the horizontal asymptotes depend on a (but did not use this term). For the general conjecture he scrolled back to the first pair of graphs, moved the slider, then looked at the other pairs of graphs:

All the graphs shift upwards in the y direction by the value whichever value a is from the original position of $y = f(x)$. When $a < 0$ all the graphs shift down in the y direction by whatever value a is in the... by whatever value a is from wherever $y = f(x)$ happens to be.

Seán worked through Task B in a similar manner for about 6 minutes. However, when asked to give a general conjecture this time Seán gave an appropriate response immediately without having to scroll back up through the three functions, as he did for the general conjecture in Task A.

Discussion

We have only presented evidence from two students who worked on a pair of conjecturing/generalizing tasks. However, from these case studies, we can draw some conclusions for these students' learning. Our data suggests that both students achieved learning goals 1, 3 and 4 as they were able to use the technology to experiment with the translations, they spotted patterns and were able to verbalise them, and they were able to make conjectures based on their experiments. The students' responses to question 4(ii) on the pre- and post-tests give us cause to believe that the students have also achieved learning goal 2 during the task sequence. Both students gave an incorrect answer in the pre-test but in the post-test both revised their answers. Áine recognized that the statement is true for $a = 0$ but not otherwise, and used her experiences on Tasks A and B to explain her reasoning. In the pre-test Seán considered one numeric example in order to explain his response to question 4(ii). When Seán completed the post-test question 4(ii) he immediately stated that his original response was incorrect and referred to the vertical and horizontal translations from Tasks A and B. Finally, at the end of the interview, Seán was asked if he considered any of the tasks helped him respond to the post-test questions, and he said:

[Tasks A and B] helped me to see and distinguish the differences in changing the values of a because I didn't fully grasp what it was in the beginning.

It is clear from the task-based interviews that GeoGebra took away the burden of computation; if we had asked students to draw the graphs of the three pairs of functions in Task A by hand, then it would probably have taken them a long time and they may have made mistakes. The use of the sliders in GeoGebra, allowed the students to watch how the graphs changed as the values of a changed, and they were then able to spot the pattern and then make a conjecture. Eisenberg and Dreyfus (1994) found that the students involved in their teaching experiment seemed to view function transformations as a sequence of two static states (the initial and final graphs) rather than as a dynamic process. They concluded that this may have been as a result of the graphing software available to them in which there was no means to see the continuous transformation developing before the students' eyes. The advent of dynamic geometry software, such as GeoGebra, means that this is no longer an issue: the

students we interviewed for our study seemed to have developed an understanding of function transformation as a dynamic process.

The use of software like GeoGebra makes visualization more immediate for students and we posit that this can help with engagement. We saw, probably because of the ease of visualization in Tasks A and B, that both students felt comfortable in making a conjecture. This corresponds with Borwein's (2005) description of how mathematicians use technology in their own work, and we suggest that giving students the opportunity to use technology in this manner might encourage them to develop mathematical thinking skills (Mason & Johnston-Wilder, 2004).

Furthermore, in the pre-test Seán seemed to see Q4(ii) as referring to a single function, but in the post-test he immediately recognizes that it is a general statement. We suggest that it is his experience of working on Tasks A and B that accounts for this change in perspective, although it may be that he is recalling earlier understanding rather than developing it during the task sequence. We note that the ability to appreciate the distinction between an instance and a generality is crucial in the development of mathematical thinking (Dreyfus 2002). Seán's response could also be interpreted as a move towards seeing functions as objects rather than simply actions.

Eisenberg and Dreyfus (1994) suggested that students found transformations in the horizontal direction (e.g. $f(x) \rightarrow f(x + a)$) more difficult than those in the vertical direction (e.g. $f(x) \rightarrow f(x) + a$). They contended that one reason for this may simply be that more is involved in visually processing $f(x+a)$ than $f(x)+a$. However, we found no evidence of this in the think-aloud interviews with our students. In fact, the students were quicker to conjecture, and more articulate in their description of, a general relationship between the graphs of $f(x)$ and $f(x+a)$ (Task B) than between $f(x)$ and $f(x)+a$ (Task A) which we supposed was due to the order in which the tasks were presented.

It may be that our students would have had more difficulties justifying their conjecture in Task B rather than Task A, but such justifications were not part of our task sequence. One might criticize our task sequence as not being cognitively challenging, but we wanted to focus on conjecturing rather than proving. The tasks could easily be modified to allow students to input other functions in order to check their hypothesis, and could be expanded to ask for justifications or proofs.

We agree with Simon and Tzur (2004) that the HLT construct is useful in task design as it highlights the importance of having clear learning goals and an informed view of how learning might take place at all stages of the design process. We feel that it can help when designing new versions of tasks if the original learning goals are not met, and furthermore provides a way of evaluating tasks by comparing the hypothetical learning process with actual learning.

We have found some evidence that conjecturing tasks can encourage students to experiment and explore. We note that Bass (2015) sees this exploration as the first step in most mathematical work, and therefore it is a necessary skill that students should develop to improve their mathematical thinking. With this aim in mind, we hope to continue to design and evaluate tasks of this type.

Acknowledgment

Nairtl and The National Forum for the Enhancement of Teaching and Learning funded this study.

References

- Andrews-Larson, C., Wawro, M., & Zandieh, M. (2017). A hypothetical learning trajectory for conceptualizing matrices as linear transformations. *International Journal of Mathematical Education in Science and Technology*, 48(6), 809-829.
- Bass, H. (2015). Mathematics and teaching. *Notices of the American Mathematical Society*, 62(6), 630-636.
- Borwein, J.M. (2005). The experimental mathematician: The pleasure of discovery and the role of proof. *International Journal of Computer for Mathematical Learning*, 10, 75-108.
- Breda, A.M., & Santos, J.M.D.S.D., (2016). Complex functions with GeoGebra. *Teaching Mathematics and its Applications*, 35(2), 102-110,
- Breen, S., & O'Shea, A. (in press). Designing mathematical thinking tasks. *PRIMUS*.
- Dreyfus, T. (2002). Advanced mathematical thinking processes. In Tall, D (eds) *Advanced mathematical thinking* (pp. 25-41). Mathematical Education Library, vol 11. Springer, Dordrecht.
- Eisenberg, T., & Dreyfus, T. (1994). On understanding how students learn to visualize function transformations. *Research in Collegiate Mathematics Education*, 1, 45-68.
- Jonsson, B., Norqvist, M., Liljekvist, Y., & Lithner, J. (2014) Learning mathematics through algorithmic and creative reasoning. *The Journal of Mathematical Behavior*, 36, 20-32.
- Mac an Bhaird, C., Nolan, B. C., O'Shea, A., & Pfeiffer, K. (2017). A study of creative reasoning opportunities in assessments in undergraduate calculus courses. *Research in Mathematics Education*, 19(2), 147-162.
- Mason, J., & Johnston-Wilder, S. (2004) *Designing and using mathematical tasks*. St Alban's: Tarquin Press.
- O'Sullivan, B. (2017). *An analysis of mathematical tasks used at second-level in Ireland* (Unpublished doctoral dissertation), Dublin City University, Dublin, Ireland.
- Simon, M. A. (1995). Reconstructing mathematics pedagogy from a constructivist perspective. *Journal for Research in Mathematics Education*, 26, 114-145.
- Simon, M. A., & Tzur, R. (2004). Explicating the role of mathematical tasks in conceptual learning: An elaboration of the hypothetical learning trajectory. *Mathematical Thinking and Learning*, 6(2), 91-104.
- Stylianides, G. J., & Stylianides, A. J. (2009). Facilitating the transition from empirical arguments to proof. *Journal for Research in Mathematics Education*, 40(3), 314-352.
- Swan, M. (2008). Designing a multiple representation learning experience in secondary algebra. *Educational Designer*, 1(1), 1-17.

Developing the task progressions framework

Scott A. Courtney¹ and Dubravka Glasnović Gracin²

¹Kent State University, School of Teaching, Learning, and Curriculum Studies, USA;

scourtn5@kent.edu

²University of Zagreb, Faculty of Teacher Education, Zagreb, Croatia; dubravka.glasnovic@ufzg.hr

The authors present a framework for use by: (1) teachers as they select, (re-)design, modify, or create mathematical tasks for a lesson, including out-of-class assignments, or a sequence of lessons; and (2) researchers to analyze the quality, diversity, and complexity of tasks in a lesson or sequence of lessons. The Task Progressions Framework integrates components of existing task analysis frameworks, notions of ‘rich’ tasks, task formats, differentiated instruction, and learning progressions to develop a guide for use in assembling or analyzing a set of tasks that help students develop particular mathematical ideas (concepts and procedures) and particular mathematical habits of mind.

Keywords: Task analysis, lesson planning, learning progressions.

Introduction

Over the past two decades, there has been significant growth in the number of classification or categorization systems designed to characterize the complexity of tasks used by mathematics teachers during instruction and on assessments. Concurrent with this increase has come an expanded interest in the notion of ‘rich’ tasks. Not surprisingly, the meaning of ‘rich’ task employed, and the system utilized to classify tasks as being ‘rich’ are culturally, politically and institutionally dependent. For example, task-complexity classification systems utilized by teachers in the U.S are typically district- or school-dependent and can vary widely (e.g. Smith & Stein, 1998). Research on learning progressions in mathematics education has increased significantly over this same time period. According to Lobato and Walters, learning progressions “document students’ movement through benchmarks that are predetermined as a result of researchers’ rational analysis of particular content” (2017, p. 75). Therefore, learning progressions can “inform teachers about what to expect from their students . . . [and] provide an empirical basis for choices about when to teach what to whom” (Daro, Mosher, & Corcoran, 2011, p. 12).

In the following sections, we present the *Task Progressions Framework* for use by: (1) teachers as they select, (re-)design, modify, or create mathematical tasks for a lesson or a sequence of lessons; and (2) researchers to analyze the quality, diversity, and complexity of tasks in a lesson or sequence of lessons. The goal of the framework is to support teachers in assembling, and researchers in analyzing, a sequence of tasks that helps students develop or use particular mathematical ideas and associated mathematical habits of mind. The framework allows teachers and researchers to ascertain the focus, coherence, and ‘richness’ of a sequence of tasks comprising a lesson (or lessons). As such, the framework integrates learning progressions and task-complexity classification systems to support instruction that helps students develop grade- or course-appropriate mathematical ideas and habits of mind. This paper seeks to concisely describe the framework, its development, and how researchers might utilize aspects of the framework to address the following research question: How can learning

progressions support analysis of the quality, diversity, and complexity of tasks in a lesson or sequence of lessons?

Background

Prior to examining the framework's development and anticipated use, it is necessary to first clarify specific terminology that will be utilized throughout the discussion. Such clarification will help make our perspectives explicit. In addition, it will be worthwhile to describe existing criteria and perspectives that served to inform the development of the Task Progressions Framework.

Mathematical Tasks and Rich Tasks

We employ Umland's (2011, p. 1) definition of a *mathematical task* as a “problem or set of problems that focuses students' attention on a particular mathematical idea and/or provides an opportunity to develop or use a particular mathematical habit of mind . . . [where] *mathematical idea* includes both mathematical concepts and procedures”. Tasks can be further differentiated in terms of their use or purpose, where *teaching* or *instructional tasks* are “designed to support students' mathematical learning or development and *assessment tasks* are designed to evaluate the development of students' mathematical knowledge and/or habits of mind” (Umland, 2011, p. 1). Aligned with Umland's (2011) terminology, we will call the mathematical idea and/or habit of mind that a task is intending to develop or assess, along with its intended use, the *purpose of the task*. We also drew upon a variety of ‘rich’ task criteria to develop the Task Progressions Framework. Grootenboer (2009, p. 697) describes key aspects of rich mathematical tasks to include: academic and intellectual quality; group work; catering for diversity through multiple entry points, multiple solution pathways; connectedness; and multi-representational. For Swan (2005, p. 9), a rich task (a) is accessible and extendable; (b) allows for decision making by the learner; (c) involves testing, explaining, proving, interpreting, and reflecting; (d) promotes communication and discussion; (e) encourages invention and originality; (f) encourages questions that focus on ‘what if’ and ‘what if not’; and (g) is enjoyable and provides an opportunity for surprise.

Learning Progressions

The National Research Council (2007, p. 214) characterize learning progressions as “descriptions of the successively more sophisticated ways of thinking about a topic that can follow one another as [students] learn about and investigate a topic over a broad span of time” (p. 214). For Daro et al. (2011, p. 12) “Learning progressions identify key waypoints along the path in which students' knowledge and skills are likely to grow and develop in [mathematics]”.

Framework

We employed a networking of theories approach to coordinate and combine theoretical approaches into developing a framework to support teachers' assembly, and researchers' analysis, of tasks grounded on learning progressions. Textbooks have a major influence on teachers' practices and students' mathematics opportunities, because textbooks are considered to be one of the most important and powerful curriculum resources in mathematics education (Fan, Zhu & Miao, 2013). In addition, teachers often re-design or modify textbook problems to meet the mathematical needs of individual students or promote particular mathematical habits of mind. Such activity is a form of

problem-posing on the part of teachers (Rowland, Huckstep, & Thwaites, 2003). We realize that a teacher’s capacity to modify or create her own tasks is a function of the education system in which she operates, and countries with national, centralized mathematics curricula offer different affordances and constraints than countries with decentralized curricula. Two existing frameworks were foundational to the development of the Task Progressions Framework—one focusing on textbook tasks (Glasnović Gracin, 2018), the other on teachers’ mathematical problem posing (Courtney, Caniglia, & Singh, 2014). Glasnović Gracin (2018) developed a five-dimensional framework to examine the requirements in textbook tasks (Figure 1).

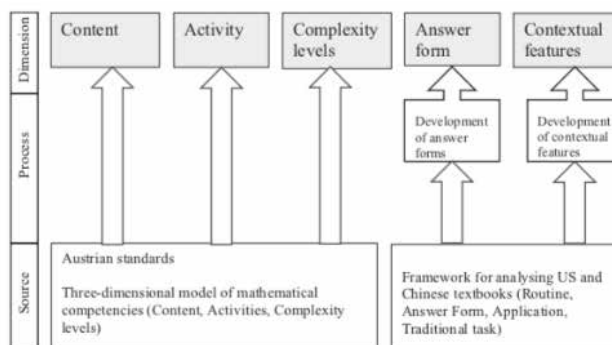


Figure 1: Five-dimensional framework outline (Glasnović Gracin, 2018, p. 6)

The five-dimensions are comprised of two distinct theoretical sources (Glasnović Gracin, 2018, p. 6): a three-dimensional model of mathematical competencies (Content, Mathematical Activities, Complexity Levels) based on the Austrian educational standards, and a two-component framework for analysing U.S. and Chinese textbooks involving Answer Forms and Contextual Features. Courtney et al. (2014) developed seven criteria to operationalize the characteristics of rich mathematics problems or tasks. These criteria emerged through meta-analysis of existing research (Table 1). The proposed Task Progressions Framework was developed by incorporating Glasnović Gracin’s framework and Courtney et al.’s criteria with research on learning progressions. Several areas of overlap occur between Glasnović Gracin’s framework (Figure 1) and Courtney et al.’s criteria (Table 1), including: (1) ‘Complexity levels’ and Characteristic #1 (High cognitive demand); (2) ‘Activities’ and Characteristics #3 and #4 (Require justification or explanation; Make connection between two or more representations); and (3) ‘Answer form’ and Characteristic #5 (Openness).

Rich mathematics problem / task characteristic	Operational criteria
1. High cognitive demand	Problem involves creating, evaluating, and analyzing (comparing) versus remembering or statically using or applying procedures, facts, or skills.
2. Significant content	Problem meets one or more content standard.
3. Require justification or explanation	Problem includes a statement or question specifically asking students to justify or explain their answer.
4. Make connection between two or more representations	Problem incorporates two or more of the following representations: real life, manipulative, pictures, diagrams, or symbols.
5. Open-ended: a) Strategy, b) Solution	Problem includes more than one solution strategy; more than one solution.
6. Allows multiple entry points	Problem allows for a variety of entry points.

7. Allows multiple ways to show competence	Problem allows for more than one way to show competence (e.g., draw, write, or graph answer); the emphasis is on the product.
--	---

Table 1: Operationalized criteria of rich mathematics tasks (Courtney et al., 2014, p. 148)

The proposed Task Progressions Framework consolidate areas of convergence. In addition, we attempted to allow for the framework's use over both national (i.e. Italy's *Indicazioni*, Japan's *Courses of Study*) and decentralized curricula and various habits of mind classifications (e.g. Cuoco, Goldenberg, & Mark, 1996).

Task Progressions Framework

The proposed Task Progressions Framework is comprised of four primary categories or dimensions, as illustrated in Figure 2: (1) content, (2) mathematical habits of mind, (3) task format, and (4) task features. Each dimension plays a unique role in the framework, and each sub-category or process (e.g. Type of Student Engagement) is of equal importance within a given dimension (i.e. there is no hierarchy within a dimension). Figure 2 also provides proposed scoring information for researchers attempting to utilize the framework to analyze the quality, diversity, and complexity of tasks in a lesson or sequence of lessons. Finally, each of the four dimensions is given equal weight, regardless of the number of processes or sub-categories.

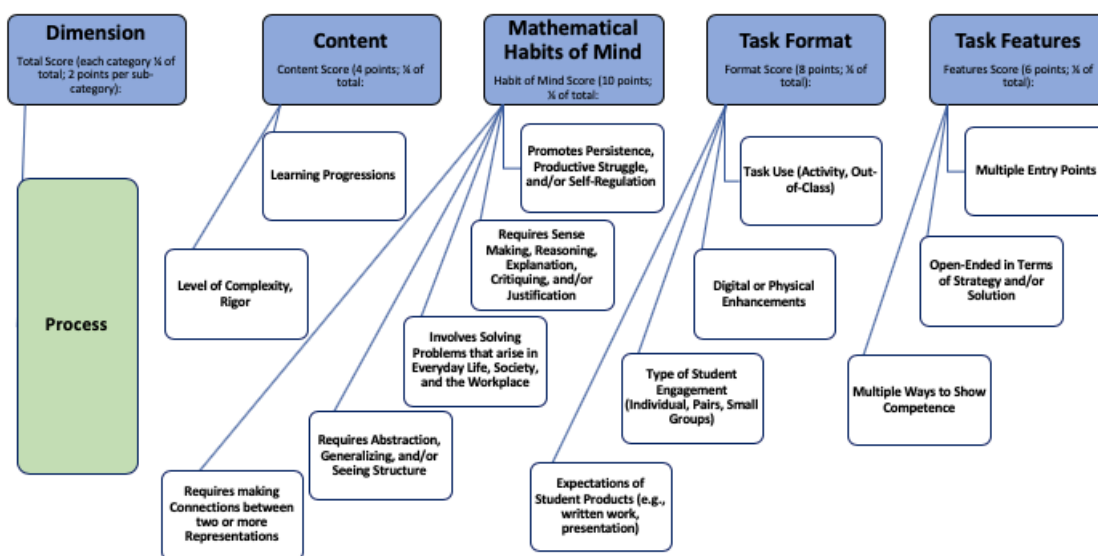


Figure 2: Task Progressions Framework

Content refers to the learning goals for what students should know and be able to do at the end of instruction (e.g. standards). The framework allows for a variety of content to be utilized, such as: Common Core State Standards for Mathematics (NGA Center & CCSSO, 2010) or the National Curriculum Framework Mathematics Area (Ministry of Science, Education and Sports, Republic of Croatia, 2010). Critical to content are the complexity of the knowledge and skills students need to engage productively in the task (i.e. level of complexity or rigor) and where a task's content is situated in a learning progression. The Mathematical Habits of Mind involve the mathematical processes and proficiencies that support students in creating, inventing, conjecturing, and experimenting (Cuoco et al., 1996). The framework addresses habits of mind by requiring teachers to identify where and how

a sequence of tasks: (i) promote persistence, productive struggle, and/or self-regulation; (ii) requires sense making, reasoning, explanation, critiquing, and/or justification; (iii) involves solving problems that arise in everyday life, society, and the workplace; (iv) requires abstraction, generalizing, and/or seeing structure; and (v) requires making connections between two or more representations. Such habits of mind are not isolated and frequently interact and overlap with one another. Task Format identifies the manner in which students are expected to engage with the sequence of tasks (in-class activity, in pairs), how students are expected to illustrate their task products (e.g. presentation) and whether tasks are digitally enhanced or involve physical manipulatives (e.g. algebra tiles). Finally, Task Features involve meeting the needs of all students in the classroom (e.g. differentiated instruction) by requiring the sequence of tasks provide: (a) multiple entry points; (b) multiple ways to show competence; and (c) open-ended strategies and/or solutions. Unfortunately, limitations in space do not allow for a more robust elaboration of the framework and its development.

Utilizing the Task Progressions Framework

Next, we address the research question by providing an example for how researchers might utilize aspects of the framework, those connected with learning progressions, to analyze a sequence of 8th grade mathematics lessons (covering approximately 80 minutes of instruction) involving the Common Core standards (NGA Center & CCSSO, 2010)—used by 42 of 50 U.S. states. The lessons were created by an 8th grade math teacher to help his students develop proficiency with the content standard identified by the alphanumeric indicator or code ‘8.EE.8a’ (see Table 2). All tasks used during the lessons derive from the class textbook *Big Ideas Math: Modeling Real Life, Grade 8* (Larson & Boswell, 2018). Due to limitations in space, we focus the discussion on *whether* and *how* the sequence of tasks (sets of problems) address content indicated by considering learning progressions. Standards-based coherence map resources (e.g. Student Achievement Partners, 2013) utilizing learning progressions and our own reflecting on students’ development of successively more sophisticated ways of thinking about systems of linear equations in two variables, identified those content standards with the potential to be taught concurrent with and standards essential as prerequisite to standard 8.EE.8a (see Table 2). In addition, we determined that it was important for students to recall what it means for a linear equation to have a solution, no solution (e.g. $2x + 3 = 2x + 5$), and infinitely many solutions (e.g. $3x - 4 = 3x - 4$), and to interpret the “equation $y = mx + b$ as defining a linear function, whose graph is a straight line” (NGA Center & CCSSO, 2010, p. 55).

Alphanumeric Indicator / Code	Grade Level / Domain	Standard Statement
8.EE.8.a	8 th Grade / Expressions and Equations (EE)	8a - Understand that the solution to a pair of linear equations in two variables corresponds to the point(s) of intersection of their graphs, because the point(s) of intersection satisfy both equations simultaneously.
8.EE.8.b (Concurrent)	8 th Grade / Expressions and Equations (EE)	8b - Use graphs to find or estimate the solution to a pair of two simultaneous linear equations in two variables. Equations should include all three solution types: one solution, no solution, and infinitely many solutions. Solve simple cases by inspection.
8.EE.8.c (Concurrent)	8 th Grade / Expressions and Equations (EE)	8c - Solve real-world and mathematical problems leading to pairs of linear equations in two variables. (Limit solutions to those that can be expressed by graphing.)

8.EE.6 (Prerequisite)	8 th Grade / Expressions and Equations (EE)	6 - Use similar triangles to explain why the slope m is the same between any two distinct points on a non-vertical line in the coordinate plane; derive the equation $y = mx$ for a line through the origin and the equation $y = mx + b$ for a line intercepting the vertical axis at b .
7.EE.4.a (Prerequisite)	7 th Grade / Expressions and Equations (EE)	4a - Solve word problems leading to equations of the form $px + q = r$ and $p(x + q) = r$, where p , q , and r are specific rational numbers. Solve equations of these forms fluently. Compare an algebraic solution to an arithmetic solution, identifying the sequence of the operations used in each approach.
6.EE.5 (Prerequisite)	6 th Grade / Expressions and Equations (EE)	5 - Understand solving an equation or inequality as a process of answering a question: which values from a specified set, if any, make the equation or inequality true? Use substitution to determine whether a given number in a specified set makes an equation or inequality true.

Table 2: Content or Practice associated with standard 8.EE.8.a

The lessons utilized several tasks or sets of problems as examples or assigned as in-class or out-of-class practice. Regarding prior topics and standards, the teacher assigned four problems as in-class practice (to be worked on in student pairs) from the ‘Review & Refresh’ section of the textbook (see Figure 3). None of these four problems focus on any of the standards 6.EE.5, 7.EE.4a, or 8.EE.6 (see Table 2) identified as important prerequisite content. As such, the teacher is not able, at least through this set of problems, to ascertain whether students have developed necessary prerequisite understandings and skills.

Review & Refresh		Solve the system by graphing.		
In-Class Practice (Students work in pairs)		Example Problem	Example Problem	In-Class Practice (Work in pairs)
Write an equation in point-slope form of the line that passes through the given point and has the given slope.		A) $y = 2x - 2$	B) $y = -4x - 7$	5. $x - y = 5$
1) $(3, -4); m = 1$	3) $(1, 0); m = -\frac{1}{4}$	$-x + 2y = -4$	$x + y = 2$	$-3x + y = -1$
Solve the equation. Check your solution.		Out-of-Class Practice (Individual Work)		
4) $\frac{3}{4}c - \frac{1}{4}c + 3 = 7$	6) $6x - 3(x + 8) = 9$	11. $y = 2x + 5$	12. $x + y = 27$	14. $x - y = 7$
		$y = \frac{1}{2}x - 1$	$y = x + 3$	$0.5x + y = 5$

Figure 3: Practice problems (Larson & Boswell, 2018, p. 201, 203)

Furthermore, although problems #1 and #3 (Figure 3) focus on ‘point-slope’ form, $y - y_1 = m(x - x_1)$, rather than ‘slope-intercept’ form ($y = mx + b$) of the equation, they do provide some sense for interpreting the equation as defining a linear function whose graph is a straight line. Finally, problems #4 and #6 provide practice with linear equations having one solution, but there are no ‘Review & Refresh’ problems involving linear equations with no solution or infinitely many solutions. Therefore, regarding the portion of the framework focusing on ‘Content: Learning Progressions’ (Figure 2), the set of problems demonstrate little in terms of addressing prerequisite understandings and skills.

Several practice problems request that students, “Solve the system by graphing” (Figure 3). Each of these practice problems has a solution, which limits the degree to which interdependent content standard 8.EE.8b (Table 2) is involved. Although none of the practice problems include a real world context, they each require that students “[s]olve ... mathematical problems leading to pairs of linear equations in two variables ... [with] solutions ... that can be expressed by graphing” (NGA Center & CCSSO, 2010, p. 55); thus, partially incorporating content standard 8.EE.8c (Table 2). The last set of problems, utilized by the teacher as an in-class (students work in pairs) and out-of-class (individual

work) assignment, are identified by the textbook as ‘Open-Ended’, ‘Reasoning’, ‘Dig Deeper’, or ‘Problem Solving’ in nature (Figure 4).

In-Class Assignment (Students work in pairs)

OPEN-ENDED

Write a system of linear equations that fits the description. Use a graph to justify your answer.

22. The solution of the system is a point on the line $y = -9x + 1$.

DIG DEEPER

24. A graph of a system of two linear equations is shown (at right). Write the system of linear equations represented by the graph. What is the solution of the system?

REASONING

26. Is it possible for a system of two linear equations to have multiple solutions? Explain your reasoning.



Out-of-Class Assignment (Individual Work)

PROBLEM SOLVING

20. A generator contains 60 gallons of fuel and uses 2.5 gallons per hour. A more efficient power generator contains 40 gallons of fuel and uses 1.5 gallons per hour. After how many hours do the generators have the same amount of fuel? Which generator runs longer? Justify your answers.

OPEN-ENDED

Write a system of linear equations that fits the description. Use a graph to justify your answer.

23. The solution of the system is $(3, -1)$.

Figure 4: System of linear equation problems (Larson & Boswell, 2018, p. 204)

Problem #26 asks whether a system of linear equations can have multiple solutions, which intimates at interdependent content standard 8.EE.8b (Table 2) but to a limited degree. Problem #20 includes a real world context, thus incorporating content standard 8.EE.8c into the lesson. Therefore, continuing to focus on the ‘Content: Learning Progressions’ portion of the framework, the set of problems address concurrent understandings and skills to a limited degree. Considering both prerequisite and concurrent content standards in the ‘Learning Progression’ sub-category (Figure 2), we gave the sequence of tasks an overall ‘Learning Progressions’ score of 0.75/2—scoring low on addressing all of the pre-requisite standards (6.EE.5, 7.EE.4a, and 8.EE.6) and concurrent standard 8.EE.8b. Therefore, the complete sequence of tasks would receive a score of 37.5% on the ‘Content: Learning Progressions’ sub-category (or process). Although the remaining dimensions (Mathematical Habits of Mind, Task Format, and Task Features) and the ‘Content: Level of Complexity, Rigor’ sub-category (Figure 2) would need to be addressed to determine the overall quality, diversity, and complexity of the tasks in these lessons, the example presented here provides some indication as to the impact incorporating learning progressions can have on such analysis.

Conclusion

In this report, we presented a framework for use by: (1) teachers to select, (re-)design, modify, or create mathematical tasks for a lesson or a sequence of lessons; and (2) researchers to analyze the quality, diversity, and complexity of tasks in a lesson or sequence of lessons. The proposed Task Progressions Framework integrates components of existing task analysis frameworks (e.g. Courtney et al., 2014; Glasnović Gracin, 2018), notions of ‘rich’ tasks, task formats, differentiated instruction, and learning progressions to develop a guide for teachers to assemble, and researchers to analyze, a sequence of tasks that help students develop or use particular mathematical ideas and particular mathematical habits of mind. We are currently working with in-service (or practicing) 6th-11th grade mathematics teachers (students ages 11-18 years) to utilize the framework in their practices with the intent to examine its effectiveness. We anticipate the need for modifications to the framework to make it more practical for teachers (as they create lessons) and researchers (as they analyze lessons).

References

Courtney, S. A., Caniglia, J., & Singh, R. (2014). Investigating the impact of field trips on teachers’ mathematical problem posing. *Journal of Experiential Education*, 37(2), 144-159.

- Cuoco, A., Goldenberg, E. P., & Mark, J. (1996). Habits of mind: An organizing principle for mathematics curricula. *Journal of Mathematical Behavior*, 15, 375-402.
- Daro, P., Mosher, F. A., & Corcoran, T. (2011). *Learning trajectories in mathematics: A foundation for standards, curriculum, assessment, and instruction* (Consortium for Policy Research in Education Report #RR-68). Philadelphia, PA: Consortium for Policy Research in Education.
- Fan, L., Zhu, Y., & Miao, Z. (2013). Textbook research in mathematics education: development status and directions. *ZDM - The International Journal on Mathematics Education*, 45(5), 633-646.
- Glasnović Gracin, D. (2018). Requirements in mathematics textbooks: a five-dimensional analysis of textbook exercises and examples. *International Journal of Mathematical Education in Science and Technology*, 49(7), 1003-1024.
- Grootenboer, P. (2009). Rich mathematical tasks in the Maths in the Kimberley project. In R. Hunter, B. Bicknell & T. Burgess (Eds.). *Crossing divides. Proceedings of the 32nd conference of the Mathematics Education Research Group of Australasia, Vol. 1* (pp. 696-699). Sydney: MERGA.
- Larson, R., & Boswell, L. (2018). *Big ideas math: Modeling real life, grade 8*. Erie, PA: Big Ideas Learning.
- Lobato, J., & Walters, C. D. (2017). A taxonomy of approaches to learning trajectories and progressions. In J. Cai (Ed.), *Compendium for research in mathematics education* (pp. 74-101). Reston, VA: National Council of Teachers of Mathematics.
- Ministry of Science, Education and Sports (Republic of Croatia). (2010). *National curriculum framework for pre-school education and general compulsory and secondary education*. Zagreb, Croatia: Ministry of Science, Education and Sports.
- National Governors Association Center for Best Practices, Council of Chief State School Officers. (2010). *Common core state standards for mathematics*. Washington, DC: NGA Center and CCSSO. Retrieved from <http://www.corestandards.org/Math/>
- National Research Council. (2007). *Taking science to school: Learning and teaching science in grades K-8*. Washington, DC: The National Academies Press.
- Rowland, T., Huckstep, P., & Thwaites, A. (2003). The knowledge quartet. In J. Williams (Ed.), *Proceedings of the British Society for Research into Learning Mathematics*, 23(3), 97-103.
- Smith, M. S., & Stein, M. K. (1998). Selecting and creating mathematical tasks: From research to practice. *Mathematics Teaching in the Middle School*, 3(5), 344-350.
- Student Achievement Partners (SAP). (2013). *Coherence map*. Retrieved from <https://achievethecore.org/content/upload/ccssmgraph.pdf>
- Swan, M. (2005). *Improving learning in mathematics: Challenges and strategies*. Sheffield, England: Teaching and Learning Division, Department for Education and Skills Standards Unit.
- Umland, K. (2011). *What is a task and what makes a good task?* Mathematical musings: Standards, curriculum, and teaching. Retrieved from <http://commoncoretools.me/>

Combining Differentiation and Challenge in Mathematics Instruction: A Case from Practice

Seán Delaney and Ann Marie Gurhy

Marino Institute of Education, Ireland; sean.delaney@mie.ie; annmarie.gurhy@mie.ie

Despite the challenges of teaching mathematics to diverse learners and the importance of students engaging in cognitively demanding tasks, practice-based research on instruction that combines these priorities is relatively rare. In this paper, a primary mathematics laboratory is used as the setting for implementing such instruction. Records of practice – including video records of teaching, lesson plans, and student work – are analysed to identify task characteristics and teacher actions that supported differentiated instruction and work on challenging tasks. Among the themes identified are the teacher actively guiding the students' learning, the establishment of classroom norms, and enabling all students to act as resources for one another's learning.

Keywords: Individualised instruction, Productive struggle, Problem sets, Difficulty level, Teaching methods, Classroom environment.

Introduction.

In many countries classrooms are increasingly diverse and teachers need to cater for students from a wide variety of intellectual, linguistic, cultural, social and economic backgrounds. However, relatively few supports are available to help teachers differentiate instruction so that all students, despite their differences, can meaningfully participate in mathematics lessons. Furthermore, using challenging tasks has the potential to improve students' learning (e.g. Stein, Grover and Henningsen, 1996) by engaging students in productive struggle (Warshauer, 2015). One problem is that sometimes in classroom practice only high-achieving students are challenged or differentiated instruction is intended only for some students. Until relatively recently, few studies combined a focus on challenging students mathematically while simultaneously differentiating instruction (e.g. Brown et al., 2017; Lynch et al., 2018; Sullivan et al., 2013). This paper presents a case study of one teacher attempting to engage students in cognitively demanding work over the course of a lesson while simultaneously differentiating instruction.

The following research question is addressed: What steps taken by the teacher supported differentiation and maintained or modified the challenge of the task?

Theoretical Framework.

Two areas of research inform this study. The first is the mathematical task framework proposed by Stein and Smith (1998) which classifies mathematical tasks into those with lower-level demands (consisting of memorisation tasks and procedures without connections) and higher-level demands (consisting of procedures with connections and doing mathematics). This framework was necessary to identify times when the teacher maintained, raised or lowered the cognitive demand of the task. Although specific tasks may be initially classified using these categories, the classification may change over the course of instruction, as the teacher sets up the task for students and as the task is implemented in the classroom.

Tomlinson's work (2000) on differentiating instruction provides the second pillar of the framework because the teacher's goal is for all students to experience challenge in line with their readiness for it. Tomlinson identifies four elements which teachers can differentiate to meet the needs of all students: content, process, product, learning environment. Content of tasks can be differentiated by presenting information to students in multiple communication modes such as written or oral, or by providing supports to help them read the text. Differentiating the process allows students to complete a task in various ways depending on their preferences; this may involve providing materials, varying the time allocated, permitting individual or group effort, or breaking a task into smaller parts for some students. The product may be differentiated if students are allowed to present their work in multiple ways and to receive credit for diverse skills that are evident in the completed product. Finally, the learning environment may be differentiated by providing quiet space in the classroom for some students, being explicit about how help may be accessed if a student is stuck, and making available culturally familiar support materials to students as necessary.

The twin lenses provided by combining insights from Stein and Smith (1998) and Tomlinson (2000) will help to identify steps taken by the teacher to address both goals of instruction: productive struggle and differentiation.

Method.

Context.

The study is based on a mathematics laboratory that took place over four days (approximately eight hours) in July 2018. The classroom was convened specially to provide mathematics teaching for students, with a focus on differentiated instruction and challenging all students. Furthermore, the laboratory was a site for professional development with over 20 researchers, teachers and teacher educators observing the teaching and subsequently discussing it. Finally, the laboratory was a site for research with extensive records of practice being collected, including video recordings, student work, other classroom artifacts, and teacher planning notes.

Participants.

Twenty-four children – 10 girls and 14 boys – were in the class which lasted for two hours per day over four days. The children had completed fifth class in 11 different schools. Parents and guardians applied for places in the school for their children for multiple reasons, such as their child finding mathematics difficult, their child liking mathematics, or because a friend was attending. In other words, although parents opted to send their child to this class, a wide range of levels of mathematics and motivation could reasonably be expected among those participating.

The teacher has substantial experience as a primary teacher (11 years) and a primary mathematics teacher educator (19 years). He works as a researcher on a project that is focused on mathematics instruction that is differentiated and challenging for students. For several years he has taught children mathematics in a laboratory format as a form of professional development for teachers but this was the first time that the focus was explicitly on differentiation and challenge.

Over the four days of the laboratory, the students worked on four mathematical tasks, each for two hours. One was based on volume, two on fractions, and one, the subject of this paper, on algebra (see Figure 1).

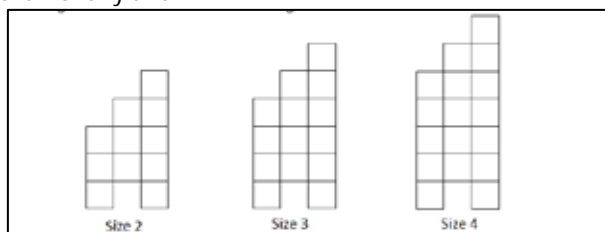
Data.

Four sources of data were used in this study. First, the task itself, which went through several iterations before being used. Second, the lesson plan that was used as the basis of the lesson. Third, a video recording of the lesson as it was enacted will be analysed. Finally, students' work on the task will be presented.

Data analysis.

Open coding in which data are scrutinised and concepts identified (Corbin & Strauss, 2008) was used for analysing the four data sources. This involved closely and repeatedly reading the written materials and closely watching and re-watching the video data. The second author identified initial categories and themes, using methods outlined by Corbin and Strauss (2008). Although the coding was open, in that the data were decomposed and concepts were sought and named, the coding complemented a deductive approach to data analysis (Gale et al., 2013) which was informed by the frameworks of Stein & Smith (1998) and Tomlinson (2000).

Alex uses identical tiles to make different sized chair designs for a school art project. The pictures on the sheet show the first three designs created, size 2, size 3 and size 4. Alex wanted a *rule* that would help work out the number of tiles needed for a chair of any size.



Q 1

- (a) If Alex wanted to create a size 5 chair, what would it look like? Can you draw it or use other materials to represent it? How many tiles would be used?
- (b) Work out the number of tiles needed for the size 6 and size 7 chairs. Explain how you did this.
- (c) Draw or make the size 1 chair. How many tiles did you need?

Q 2

- (d) Do you notice any pattern between the chair size and the number of tiles needed each time? Discuss this pattern with your partner(s).

Q 3

- (e) Alex wanted to create a size 20 chair. Talk with your partner(s) about a *rule* that would help Alex work out the number of tiles needed for this chair.
- (f) Would this rule work for the previous chair sizes?
- (g) If yes, write out this *rule* in words.
- (h) Discuss if it would work for a chair of any size.

Q 4

- (i) Could you re-write this rule using symbols/letters?

Q 5

- (j) Use the *rule* to calculate the number of tiles needed for a "size 50" chair?

Figure 1: Algebra task (without enablers or extensions)

Findings.

In terms of the framework/task analysis guide by Stein & Smith (1998), the chosen task is deemed to make “higher level demands” on learners and it has characteristics of both procedures with connections (e.g. use of a table for the first bullet point; writing a rule for the second; getting students to compare solutions for the third) and doing mathematics.

In analysing video recordings of the two hours of teaching, three themes were identified: Teacher actively guiding the students, teacher establishing classroom norms that facilitated differentiation and work on challenging tasks, teacher facilitating students to be resources for each other’s learning. Each of these themes will now be elaborated on in more detail.

Teacher actively guiding the students.

Six ways in which the teacher actively guided the students were identified by analysing the tasks used, the lesson plans and the video. The first related to the choice of task and planning. Each task was chosen carefully so that all students had the opportunity to make some progress on it and some students could complete it all. For example, the basic algebra task (See Figure 1) was complemented by preliminary “enablers”, for students who struggled to start or make progress on the task and more challenging “extensions”, for students who successfully completed the basic task. One enabler suggested organizing data in a table and another commenced a rule pattern which could be continued. An extender presented for comparison three different methods used by other “students” to find the rule to calculate the number of squares needed for any size chair.

During autonomous work, when two students were working on tasks, clear instructions were issued to students. For example, the teacher suggested that “to make things easier for yourselves, make sure you label the different chairs.”

The teacher deliberately directed students’ attention to particular ideas or concepts. For example, at different times he found ways to introduce the idea of a row, a constant, and a variable. These concepts were introduced in response to comments or confusions from the students and would be help them in working towards a general rule.

The teacher sought opportunities to highlight ideas he believed would support students’ work. As students worked on the task, the teacher asked them to pause their work and he introduced the following idea to support their work:

Just one thing I want to show you. This is just a convention and it might be helpful for some of you. Some of you have already moved on to this step. In algebra, which is what you’re doing now, this is called algebra, this kind of maths. One of the things you do in algebra sometimes is that you use letters as well as numbers so sometimes you might use x and y . Sometimes you might use a and b or sometimes you might use n .” (5533 @23:32)

In Lilly’s work (Figure 2), it appears from what she has written that she sees the pattern. However, although she is aware that the letters may be used, she is unable to integrate them into the general solution that she has identified. In contrast, Abby was able to express one general formula that could be used to calculate the number of tiles in a chair, where y is the size of the chair and $y \times 3 + 5$

gives the number of tiles (Figure 3). Note that Abby also uses the term “constant” in her written answer.

The teacher questioned students for clarification. For example, using Lilly’s idea of a chair of size 0, he asked “Can anyone explain what Lily has just said or put it into your own words?” (5527@8:40). On another occasion he used revoicing (O’Connor & Michaels, 2007), when he attempted to clarify what a student was saying, “so you’re saying the shape is always the same except for....” (5534@19:12).

The teacher attempted to increase the challenge for students. For example, he asked if anyone could come up with a rule that works for any size chair (video clip 5527, 5:03) and on another occasion he set the following challenge for students: “Now I want everyone to think carefully. How does David’s rule compare with Tim’s rule? (Clip 3527 @ 15:55).

Finally, the teacher’s active guiding of students involved giving them time to think. After posing a question, he allowed students sufficient time to think of an answer before calling on someone to answer.

Teacher establishing classroom norms that facilitated differentiation and work on challenging tasks.

A second theme identified relates to how the teacher established and promoted classroom norms that facilitated differentiation and work on challenging tasks. One such norm that was encouraged was that confusion is okay on the path to learning/understanding. At one point the teacher said “Remember it’s really important to say that you’re confused. Have you followed anything at all of what Tim has said?” (5527@11:05). This followed a contribution from Tim that would lead towards a solution to the task.

Other norms evident in the video include the use of talking about mathematics. Students do not just write their solutions but they are encouraged to share their ideas with their classmates and to have them questioned and critiqued by their peers.

Students are encouraged to take responsibility for their learning. The nature of learning is discussed. For example, students are told that like working out in the gym, learning mathematics requires effort. That doesn’t mean that “maths is difficult” or you are “no good at maths” but that over time, the effort will lead to learning.

Manipulative materials are made available to students (e.g. square tiles) and students are encouraged to use what they need if using the materials will help them grasp the concept. Students are given autonomy in deciding to use or not use the materials.

Finally, students are encouraged to represent their solutions in visual form. In particular, they are encouraged to explain ideas for their parents using representations. This differs from a more common approach in schools where students simply present their solutions in their own notebooks in numerical form.

Teacher facilitating students to be resources for each other's learning.

The third theme identified from the video data was the teacher's encouragement of students to be resources for one another's learning. At the outset of the summer school the teacher explicitly stated to the students that "you can learn a lot from your classmates." The idea of students being resources for each other's mathematics learning was encouraged throughout the summer school.

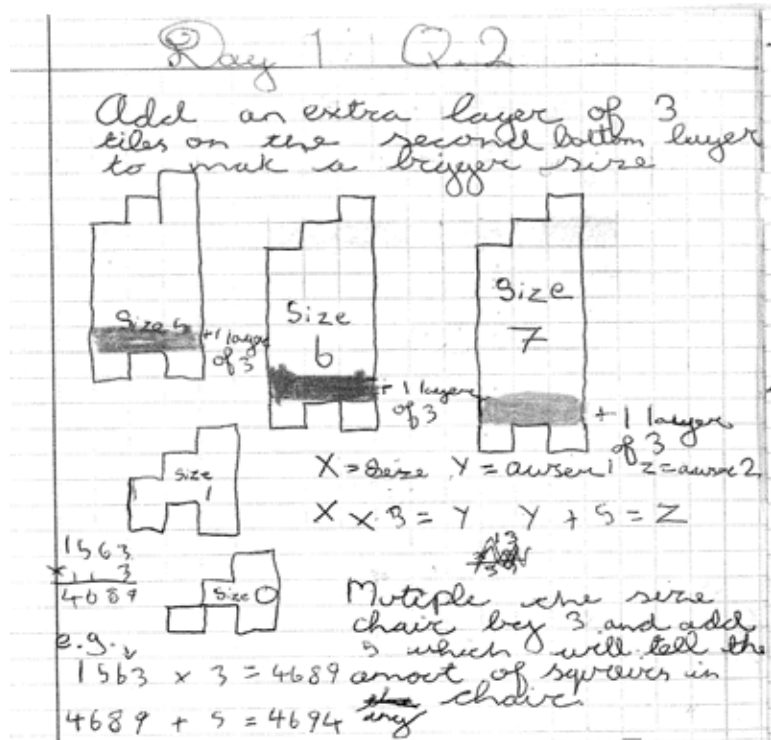


Figure 2: Lilly's work on the algebra problem

One way the teacher did this was to ensure that students or groups of students were given opportunities to share their solutions. Attempts were made to sequence the sharing in a way that progressed from more naïve to more sophisticated solution strategies.

Students' sharing of solutions was complemented by several examples of the teacher asking students to repeat, revoice, or explain what was said. This had the potential to amplify what students said (by hearing them a second time), to clarify what was said (through explanations) and it encouraged students to listen to one another because they realise that they may be asked to respond to another student's input.

Students were required not only to listen to contributions from their classmates; the teacher frequently asked students to analyse and compare different solutions and ideas. This affirms students' solutions but it further has the potential to help them see where some solutions might be more efficient than others.

Finally, students are frequently asked to clarify their ideas or those of their peers by using words and representations. For example, on one occasion when students were working on the task, the

teacher asked a student to “Come up and show us how you laid it out in your notebook” (5527 @9:20).

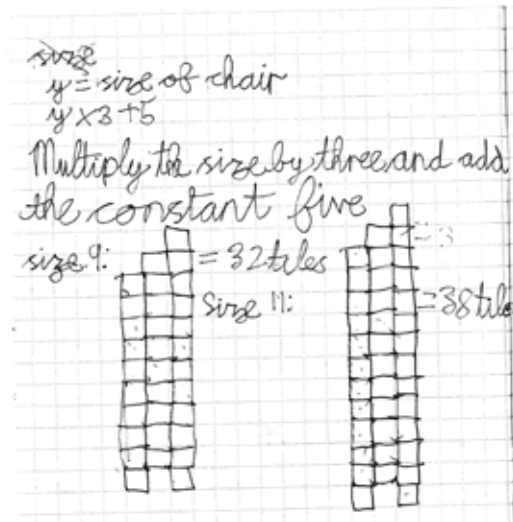


Figure 3: Abby’s work on the algebra problem

Discussion/Conclusion.

We return now to the research question that we posed at the start of this paper about how the teacher supported differentiation and maintained or modified the challenge of the task. Modification of the task was planned in advance through the use of enablers and extenders. In the course of the lesson three themes were identified to capture ways in which the teacher implemented differentiation and cognitive demand. He actively guided the students to take responsibility for working on the task. He established and maintained classroom norms that supported these aims and he encouraged students to act as resources for each other’s learning.

What these findings suggest is that through intentional and deliberate actions, a teacher can combine both differentiation and challenge in mathematics instruction. The need for differentiated instruction may be imposed on a teacher by the different rates at which students complete tasks. However, in order to engage students in challenging tasks, teachers must set that as a specific instructional goal and must have the required knowledge to implement it (Henningsen & Stein, 1997). Although the importance of teacher guidance and establishing appropriate norms have been identified as factors in supporting the use of challenging tasks independently, the additional factor of students acting as resources for one another was found to apply when challenge was combined with differentiated instruction.

References

Brown, R.E., Mackiewicz-Wolfe, Z., Tily, S. (2017). Using push and support cards for differentiation. *Ohio Journal of School Mathematics*, 76(2), 1–7.

- Corbin, J. & Strauss, A. (2008). *Basics of qualitative research: Techniques and procedures for developing grounded theory* (3rd edition). Thousand Oaks, CA: Sage Publications.
- Gale, N.K., Heath, G., Cameron, E., Rashid, S., & Redwood, S. (2013). Using the framework method for the analysis of qualitative data in multi-disciplinary health research. *BMC Medical Research Methodology*, 13(1), 117–124.
- Henningsen, M. & Stein, M. K., (1997). Mathematical tasks and student cognition: Classroom-based factors that support and inhibit high-level mathematical thinking and reasoning. *Journal for Research in Mathematics Education*, 28(5) 524–549.
- Lampert, M. (2001). *Teaching problems and the problems of teaching*. New Haven, CT: Yale University Press.
- Lampert, M. & Ball, D. L. (1998). *Teaching, multimedia, and mathematics: Investigations of practice*. New York: Teachers' College Press.
- Lynch, S. D., Hunt, J. H., & Lewis, K. E. (2018). Productive struggle for all: Differentiated instruction. *Mathematics Teaching in the Middle School*, 23(4), 194–201.
- O'Connor, C. & Michaels, S. (2007). When is dialogue dialogic? *Human Development*, 50(5), 275–285.
- Smith, M.S. & Stein, M.K. (2011). *5 practices for orchestrating productive mathematics discussions*. Reston, VA: National Council of Teachers of Mathematics.
- Stein, M.K., Grover, B.W., & Henningsen, M. (1996). Building student capacity for mathematical thinking and reasoning: An analysis of mathematical tasks used in reform classrooms. *American Educational Research Journal*, 33(2), 455–488.
- Stein, M.K. & Smith, M. S. (1998). Mathematical tasks as a framework for reflection: From research to practice. *Mathematics teaching in the Middle School*, 3(4), 268–275.
- Sullivan, P., Aulert, A., Lehmann, A., Hislop, B., Shepherd, O. & Stubbs, A. (2013). Classroom culture, challenging mathematical tasks, and student persistence in Steinle, V., Ball, L. & Bardini, C. (Eds.) *Mathematics education: Yesterday, today and tomorrow*. Proceedings of the 36th annual conference of the Mathematics Education Research Group of Australasia, (pp. 618–625). Melbourne: Mathematics Education Research Group of Australia.
- Tomlinson, C. (2000). *Differentiation of instruction in the elementary grades: ERIC Digest*. Washington D.C.: Office of Education Research and Improvement (ERIC Document Reproduction Service, No. ED443572).
- Warshauer, H. K. (2015). Productive struggle in middle school mathematics classrooms. *Journal of Mathematics Teacher Education*, 18(4), 375–400.
- This study has been conducted in the context of project “Enhancing Differentiated Instruction and Cognitive Activation in Mathematics Lessons by Supporting Teacher Learning (EDUCATE)”, which has been funded with support from the European Commission. This publication reflects the views only of the authors, and the Commission cannot be held responsible for any use which may be made of the information contained therein.*

Designing tasks with self-explanation prompts

Anneli Dyrvold & Ida Bergvall

Uppsala University; anneli.dyrvold@edu.uu.se; ida.bergvall@edu.uu.se

This paper presents some results from an ongoing review on self-explanation prompts. An emphasis is laid on design principles based on empirical research. The review is grounded in scaffolding theory, which means that the self-explanation prompts are seen as a temporary support that the student shall learn to manage without. Three themes identified in the review are described and discussed in relation to design and implementation of tasks with self-explanation prompts: prompts with different purposes, the necessity to adapt prompt to students' prior knowledge, and factors of importance for students' engagement in the prompts. Examples of tasks with prompts for which these design aspects have been taken into account are given in the paper.

Keywords: Scaffolding, ZPD, reading, multimodal, review.

Introduction

In mathematics classrooms, individual and group work on mathematical tasks is a frequent activity. Besides the mathematical complexity of the task, different design aspects also have bearing on students' learning. In this paper, we focus on design aspects concerning *self-explanation prompts* (hereafter SEPs), and how they can be used in tasks or instructions to scaffold students' learning.

The use of SEPs has been investigated in previous studies, often with pre- and post-tests, and some design aspects regarding SEPs have proven to be more effective than others when it comes to students learning (e.g., Berthold, Eysink & Renkl, 2009; Lin, Atkinson, Savenye & Nelson, 2016; Rau, Aleven, & Rummel, 2015). In this study, we utilize a qualitative perspective in order to highlight aspects concerning how tasks or instructions with self-explanation prompts can be successfully designed and used to scaffold students' learning in mathematics in relation to the zone of proximal development (ZPD). The study is based on an ongoing literature review of previous empirical studies on SEPs and their effectiveness. We also take a broad stance and include studies on SEPs in different subjects. A bottom-up perspective is used to search for prominent characteristics in the sample of studies on SEPs. More precisely, the following research question is answered in the current paper: *Which important aspects are there to consider in task design in order to scaffold students' learning in mathematics aided by self-explanation prompts?*

Studies on task design refer to either domain specific or domain transcendent aspects (Thanheiser, 2017). Domain specific aspects concern for example how tasks can be designed to support conceptual understanding. Domain transcendent aspects on the other hand takes a more interdisciplinary stance on, for example, reasoning, life skills, or reading of multimodal texts. In this paper, we focus on domain specific aspects with a focus on pupils' development of conceptual understanding, as well as on domain transcendent aspects, mainly regarding how SEPs can be used to support students' ability to read multimodal mathematical texts. In this study the emphasis is laid on the resources natural language, images, and mathematical notation.

Scaffolding and self-explanation prompts

Scaffolding is theoretically founded in a socio-cultural tradition. It is a metaphor which illustrates how people are assisted to reach learning goals that would not easily have been reached without scaffolding. In accordance with scaffolding theory, SEPs are meant to support learning in the zone of proximal development (ZPD) and therefore scaffolding needs to be adapted to the pupil and his or her needs and level of understanding. Another aspect of the scaffolding metaphor is that when the building is finished, that is, when the student has developed the targeted knowledge, the scaffolding needs to be removed. Finally, the scaffolding includes a transfer of responsibility from the teacher to the student (Bakker et al., 2015).

Traditionally, scaffolding has been referred to as the interaction between teacher and student, but the term was expanded to also include, for example, artefacts or instruction plans (Bakker et al., 2015). In the present paper, we study SEPs as a particular form of scaffolding of importance for task design.

In several previous studies, self-explanations are described as a successful means to increase students' knowledge and ability to solve problems (e.g., Chi, de Leeuw, Chiu & LaVancher, 1994; Rittle-Johnson, 2006). The self-explanations are explanations of a concept, a relation, or procedure given by the student to him or herself. SEPs has proved especially effective in subject areas such as mathematics and science, which often consist of general principles with few exceptions (Rittle-Johnson & Loehr, 2017). By explaining to oneself, it is possible to reconcile new information and to make inferences to prior knowledge (Chi et al., 1994; Berthold et al., 2009). What gives effect is the process to formulate an explanation, either to oneself or to others. Self-explanations however, are nothing that students usually do spontaneously and therefore prompts to self-explain have a large potential.

Method

The search for articles for the review has been limited to articles published after 2009. We both searched ERIC, with the search terms *self*, *explain*, and *prompt* and forward tracked selected key papers. Criteria for inclusion was a focus on prompts requesting students to self-explain while working on a typical written task or expository text. The collection of 41 relevant articles was analysed in an iterative process where categories were created and re-created based on what was revealed in the articles. Initially the articles were coded regarding choice of variables, method, and results, with a particular focus on how SEPs were defined and implemented. New categories both emerged and were dismissed based on what was eminent in the articles. The use of this iterative analysis resulted in a few final themes for which rich qualitative data could be derived from several of the analysed studies. Three of these themes are presented in the current paper.

Results

The answer to the question about which important aspects there are to consider in task design in order to scaffold student's learning in mathematics aided by SEPs is presented in three themes.

Theme 1: Using prompts for different purposes

Among studies that reveal positive effects of self-explanations, the prompts are used for three different purposes. Firstly, SEPs can scaffold the students in how to process the content and therefore enhance learning concerning domain specific aspects. The most prominent purpose is to encourage

inferences. Inferences are provoked by SEPs including a *why* question (e.g., Roelle & Berthold, 2013; Nokes et al., 2011) or by explicitly requesting arguments (Berthold et al., 2011). The advantage with SEPs that provoke inferences has also been revealed in comparisons with other SEPs (Roelle, Müller, Roelle, & Berthold, 2015; Neubrand & Harms, 2017). Inference prompts are superior for the acquisition of conceptual knowledge. It is evident that the *active* construction of the self-explanation is intrinsic since other prompts given in combination with explanations of the inferences requested by the inference prompts are less beneficial (Roelle et al., 2015).

Secondly, SEPs can be used in a domain transcendent manner to support reading, and therefore enhance learning. SEPs focusing on reading have shown positive effects on learning outcomes when the SEPs are designed to induce focused processing of the text and to avoid shallow reading. For example, SEPs providing reading guidance in terms of higher order questions that require the learner to actively generate inferences about unfamiliar content, have proven to be effective means to develop conceptual knowledge (Roelle & Berthold, 2013). Gap-filling prompts that support reading by prompting the student to make inferences and by that add coherence to the text, also lead to greater learning, as shown by Nokes, Hausmann, VanLehn, and Gershman (2011). Particularly effective are step focused prompts, supporting students in the reading by drawing attention to each step in an example, with prompts to explain, elaborate and summarize (ibid.). Studies that evaluate the use of SEPs in multimodal text reveal different benefits in relation to the use of such prompts. When reading multimodal text, it is intrinsic to understand how the different representations relate and SEPs can successfully facilitate such an understanding. SEPs can scaffold the reading by prompting the reader to relate parts of, and explain relations within the text (Rau et al., 2015) as exemplified in Figure 1.

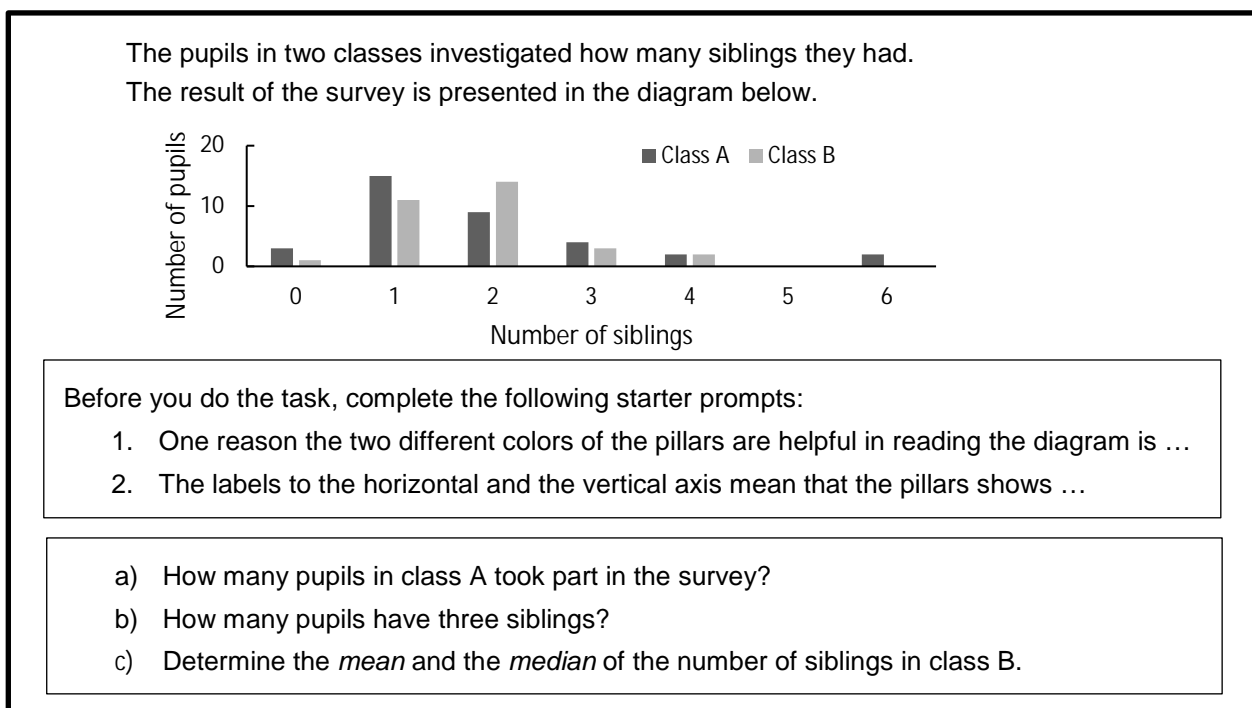


Figure 1: *Open-ended prompts to make inferences and to relate between modalities*

For example, the student can be prompted to self-explain which perceptual features of graphic representations that depict corresponding concepts and complementary information (Rau et al., 2015).

Such prompts to relate and translate between representations lead to better learning results compared to general prompts to self-explain (e.g. ‘explain your answer’) (van der Meij & de Jong, 2011). SEPs are particularly useful when many representations must be related to deeply understand key concepts (Rau et al., 2015). Figure 1 is an example of how prompts can be used to support reading of multi-modal texts. The first prompt draws attention to how the bars in two different colours represent the two classes mentioned in the text. The second prompt foster attention to the meaning of the axes in the graphic representation and demand the reader to relate information given in natural language and visually. The knowledge of how to read and understand the various parts of the diagram is essential.

Lastly, SEPs can diminish the cognitive load and therefore contribute to the fulfilment of the first two purposes (support reading and processing of the content). If SEPs are designed to guide the attention to relevant principles in a text, extraneous cognitive load can be decreased, and as a result, learning can be improved (Wang & Adesope, 2017). There is however a potential opposite effect; SEPs can increase extraneous cognitive load if they do not suit the reader, for example if the prior knowledge is high and the prompted inferences therefore are perceived as redundant and distracting.

Theme 2: Adaptation of prompts to students’ prior knowledge

The positive outcomes from the work with SEPs is dependent on the match between the student and the prompt. In particular, the students’ prior knowledge is crucial. For example, prompts to make inferences are demanding. Neubrand and Harms (2017), who categorizes inference building prompts as high-knowledge prompts, do however reveal that even for medium knowledge learners the most positive impact with regard to quality of SEPs is created by using a combination of less demanding prompts (paraphrasing, recourse of previously given information, searching for relevant relations between parts of the text) and high demanding prompts (anticipative, inference-building and with recourse to prior knowledge).

In some studies, interventions with SEPs do not lead to better learning outcomes than for the control group. One possible explanation for the lack of effect of SEPs is either that the knowledge level with abstract concepts is too high for the students (Hsu & Tsai, 2013), or that the level is too low and that the prompted self-explanations hinder the students in their work (Roelle & Berthold, 2013). In a socio-cultural perspective, this can be understood as if the concepts are not held within the students’ ZPD. If the new information is at an overly high level, the students will not have the opportunity to make the connections between new information and previous knowledge, which are required for learning. The intended effect of SEPs can also be missing if the level of the concepts or procedures that students should develop is too low. In a study by Neubrand et al., (2016) it appeared that worked examples (WE) with SEPs are effective for students with medium-level of prior knowledge. For students with good knowledge of the subject, WE with SEPs were negative for learning outcomes, no matter how they were designed. SEPs then presents a disadvantage for the students since the previous knowledge and the information given in the WE simply becomes redundant and perhaps boring or distracting. Figure 2 shows a task with different prompt options which can be used for students at different levels of knowledge.

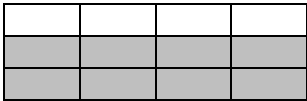
<p>a) Calculate the product of $\frac{3}{4}$ and $\frac{2}{3}$</p> <p>b) The rectangle represents the whole. Use the rectangle to illustrate the product $\frac{3}{4} \cdot \frac{2}{3}$</p>	
<p><u>Prompt version 1</u></p> <p>The grey part of the rectangle represents $\frac{2}{3}$. Try to mark $\frac{3}{4}$ of the whole rectangle with dots in such a way that $\frac{3}{4}$ of the grey area are dotted at the same time. The dotted grey area represents $\frac{3}{4}$ of $\frac{2}{3}$ and also the product of the fractions. Why?</p>	<p><u>Prompt version 2</u></p> <p>You know that $3 \cdot \frac{2}{3}$ can be interpreted as taking $\frac{2}{3}$ three times. It is however difficult to imagine taking something $\frac{3}{4}$ times (as in the task). Use your illustration and explain what the multiplier $\frac{3}{4}$ means and how your explanation relates to 3 in the product $3 \cdot \frac{2}{3}$</p>

Figure 2: Task with two versions of self-explanation prompts

The first version of a prompt is intended for students with less prior knowledge. Students who are very unfamiliar with this type of task can also be given a worked example with a starter prompt. Version 1 gives more scaffolding and gives recourse to representations in the task and is therefore adapted to less prior knowledge. Version 2 offers less scaffolding, and encourages the student to use prior knowledge while making inferences and is therefore adapted to medium to high prior knowledge.

Theme 3: Designing tasks and self-explanation prompts that engage students

A crucial factor in achieving the intended outcome from the use of SEPs is student engagement in the explanations. In several studies (e.g., Hsu & Tsai, 2013) the students' answers to the given SEPs were not sufficiently well processed and the quality was insufficient. However, the results in these studies also showed that students who actually produced well-developed and high-quality responses also showed good results in the post-test. The reasons why students did not engage in the SEPs varied. Pre-formulated self-explanations in a game environment for primary school children is one example of SEPs that was not sufficiently engaging for students to give any effect on learning (Hsu & Tsai, 2013). Another reason for students not to engage actively in the work with SEPs was that the students experienced the SEPs as demanding and simply skipped them (Lin et al., 2016).

Students' lack of engagement in SEPs can also be explained by the extensiveness of the SEPs. In a study by Kapli (2010), no effect on conceptual knowledge or problem solving performance were found if SEPs were given together with supportive instructions. The scaffolding given by the SEPs was however not gradually faded out, rather the scaffolding was continuously accessible for the students. This may have had the effect that students did not take sufficient effort to understand the concepts; instead, they could use the support at any time. However, the study also showed a positive correlation between quality in the students' self-explanations and the acquisition of conceptual knowledge.

Figure 2 is sufficient as an example of design aspects in relation to student engagement, since there is a relation between prior knowledge and student engagement in a task. With prompt options a student can choose no prompt, or prompts adjusted to more or less prior knowledge and to their willingness to engage in deep learning in a particular task. In accordance with theory about scaffolding, students are supposed to learn to manage by themselves what the prompts scaffold and therefore one

optional version of a prompt is not always sufficient. In Figure 1, the student needs to take an active role in constructing the knowledge requested by the SEPs, which might be engaging. If the prompts on the other hand were formulated as multiple choice alternatives the prompts are likely to be less engaging (see e.g., Hsu & Tsai, 2013).

Discussion

The current paper contributes to previous research on SEPs with a qualitative perspective and a focus on design aspects. The design of tasks with SEPs is done in relation to a target group, but the usefulness of a particular prompt can vary between students in a class and therefore our results is applicable also in relation to the implementation of the prompted tasks. We argue the usefulness of SEPs is dependent on a match between the task, the prompt, and the student. This interrelation is relevant in relation to all three themes presented in the paper.

It is also apparent that the three presented themes are related. Theme 1 about the prompt's purpose is related to both the other themes since the purpose must be taken into account when prior knowledge and students' engagement are considered. Theme 2 and theme 3 are also interrelated since engagement is often dependent on prior knowledge. This means the adaptation to all three themes in design of SEPs could be highly beneficial in providing opportunities for learning, when they are combined and taken into account simultaneously. Figure 3 illustrates how the three themes overlap in a common intersection. According to the results of this study, tasks that can be described as belonging in this intersection, offer the best opportunities for learning.

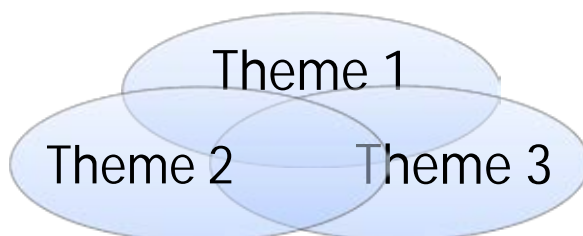


Figure 3: *Three interrelated themes, appropriate to consider together*

In the everyday practice when using SEPs in mathematics there is several aspects to consider. Firstly, SEPs can scaffold different types of learning and the teacher, or task designer, must know what he or she intends to achieve with SEPs. Students may benefit from SEPs when new concepts are introduced since the SEPs support them in integrating knowledge to what they have learnt previously (e.g., Nokes et al., 2011) and from SEPs that support reading text with different representations of a concept (e.g., Rau et al., 2015).

Secondly, the SEPs must be adapted to students' prior knowledge that is relevant in relation to the content of the mathematics text. Since prior knowledge vary in a group of students we argue for a flexibility in the use of SEPs, both by utilizing variants of SEPs (Figure 2) and by encouraging students to be flexible in the use of SEPs in such a way that they will only be used when needed. As the students develop their understanding, the SEPs need to be taken away since scaffolding shall be seen

as a temporary support when new abilities and knowledge are developed (Bakker et al., 2015). Such an adaptation to the students is important also since redundant SEPs may increase the cognitive load or distract students and accordingly the teacher needs awareness of this.

Thirdly, SEPs are effective only if students engage thoroughly in the self-explanations. As mentioned previously the fit between students' knowledge and the SEPs is crucial if the SEPs shall lead to the intended learning (Neubrand & Harms, 2017) and too demanding or too trivial prompts can reduce students' commitment to the SEPs. SEPs to make inferences are demanding but also very efficient. An implication for teaching is thus that students need to be given the opportunity to practice more demanding self-explanation in classroom. Students may need to practice on how to formulate appropriate answers to these types of prompts, and to get feedback on their answers. In this way, students can understand what is expected and also understand that the answers are important, which can motivate students to work with their answers to make them high quality.

Lastly, when working with SEPs it is important to bear in mind that the scaffolding has to fade out as students' knowledge increase. This can be done in different ways. In teaching materials, scaffolding ought to be used in tasks initiating a new topic or concept and in such occasions the scaffolding fills a function, for example, in supporting reading of multimodal texts. As the teaching proceeds and the students improve their ability to read multimodal text, the scaffolding become superfluous. It is also possible for the teacher to take an active role in the use of scaffolding, by carefully following the development of the students' knowledge in order to use SEPs only to students considered in need for this support. To conclude, we see a large potential in the use of SEPs but the design of prompts and the adjustments to the student group is a delicate task to achieve the intended learning.

References

- Bakker, A., Smit, J., & Wegerif, R. (2015). Scaffolding and dialogic teaching in mathematics education: introduction and review. *ZDM*, *47*(7), 1047-1065.
- Berthold, K., Eysink, T. H., & Renkl, A. (2009). Assisting self-explanation prompts are more effective than open prompts when learning with multiple representations. *Instructional Science*, *37*, 345–363.
- Berthold, K., Röder, H., Knörzer, D., Kessler, W., & Renkl, A. (2011). The double-edged effects of explanation prompts. *Computers In Human Behavior*, *27*(1), 69-75.
- Chi, M. T. H., de Leeuw, N., Chiu, M. H., & Lavancher, C. (1994). Eliciting self-explanations improves understanding. *Cognitive Science*, *18*, 439–477.
- Hsu, C., & Tsai, C. (2013). Examining the effects of combining self-explanation principles with an educational game on learning science concepts. *Interactive Learning Environments*, *21*(2), 104-115.
- Kapli, N. V. (2010). *The Effects of Segmented Multimedia Worked Examples and Self-Explanations on Acquisition of Conceptual Knowledge and Problem-Solving Performance in an Undergraduate Engineering Course*. PhD dissertation. The Pennsylvania State University, College of Education.

- Lin, L., Atkinson, R. K., Savenye, W. C., & Nelson, B. C. (2016). Effects of visual cues and self-explanation prompts: empirical evidence in a multimedia environment. *Interactive Learning Environments*, 24(4), 799-813.
- Neubrand, C., Borzikowsky, C., & Harms, U. (2016). Adaptive prompts for learning evolution with worked examples-highlighting the students between the "Novices" and the "Experts" in a classroom. *International Journal of Environmental and Science Education*, 11(14), 6774-6795.
- Neubrand, C., & Harms, U. (2017). Tackling the difficulties in learning evolution: effects of adaptive self-explanation prompts. *Journal of Biological Education*, 51(4), 336-348.
- Nokes, T. J., Hausmann, R., VanLehn, K., & Gershman, S. (2011). Testing the instructional fit hypothesis: the case of self-explanation prompts. *Instructional Science*, 39(5), 645-666.
- Rau, M., Aleven, V., & Rummel, N. (2015). Successful learning with multiple graphical representations and self-explanation prompts. *Journal of Educational Psychology*, 107(1), 30-46.
- Rittle-Johnson, B. (2006). Promoting transfer: Effects of self-explanation and direct instruction. *Child Development*, 77(1), 1-15.
- Rittle-Johnson, B. & Loehr, A. M. (2017). Eliciting explanations: Constraints on when self-explanation aids learning. *Psychon Bull Rev*, 24, 1501-1510.
- Roelle, J. & Berthold, K. (2013). The expertise reversal effect in prompting focused processing of instructional explanations. *Instructional Science*, 41(4), 635-656.
- Roelle, J., Müller, C., Roelle, D., & Berthold, K. (2015). Learning from Instructional Explanations: Effects of Prompts Based on the Active-Constructive-Interactive Framework. *PLoS ONE* 10(4).
- Tanheiser, E. (2017). Commentary on mathematical tasks and the student: coherence and connectedness of mathematics, cycles of task design, and context of implementation. *ZDM*, 49(6), 965-969.
- van der Meij, J., & de Jong, T. (2011). The effects of directive self-explanation prompts to support active processing of multiple representations in a simulation-based learning environment. *Journal of Computer Assisted Learning*, 27(5), 411-423.
- Wang, Z., & Adesope, O. (2017). Do Focused Self-Explanation Prompts Overcome Seductive Details? A Multimedia Study. *Journal of Educational Technology & Society*, 20(4), 47-57.

Designing for digitally enriched Math Talks – The case of pattern generalization

Andreas Eckert¹ and Per Nilsson²

¹Örebro University, School of Science and Technology, Örebro, Sweden; andreas.eckert@oru.se

²Örebro University, School of Science and Technology, Örebro, Sweden; per.nilsson@oru.se

Mathematics education is still behind in the implementation of digital technology. Digital technology can support classroom talk, but this potential needs to be further explored. This study reports on a project that develops and explores task design principles, through a series of interventions, that are intended to utilize digital technology to enrich mathematics lessons. The results consist of three design principles together with their theoretical and empirical arguments from analysis of a lesson series about pattern generalization. The three principles exploit opportunities provided by technology to make reasoning available for examination to all students, and to focus students' attention between different aspects of mathematical reasoning.

Keywords: Math-talk, design principle, digital technology.

Digital technology has been recognized for its potential for teaching and learning mathematics. Task designs relying on digital technology offer students amplified opportunities to explore, re-invent and explain mathematical concepts using tools imbedded in technology-rich environments (Leung, 2011). However, Lagrange and Monaghan (2009) argue that digital technology adds to the complexity of teaching mathematics. It challenges traditional teaching practices by creating new classroom situations and possibilities (Drijvers, Doorman, Boon, Reed, & Gravemeijer, 2010). Pierce and Ball (2009) argue that teachers need to make it their own, and relate technology rich lessons to their usual practice. We propose that one way forward is to take a modest approach, to digitally enriching mathematics classroom talk by using material from actual teaching practices and show how to enhance these practices with the use of digital technology; i.e. to create designs that shift between a digital and an analogue environment within the mathematics classroom. However, the research on uses of digital technology to enrich and support classroom talk is in its infancy and needs more exploration (Mercer, Hennessy, & Warwick, 2017).

Design principles are thought of as guidelines for task design (Bakker, 2018) that can inform on how to recreate learning opportunities in other classrooms than the intervention ones. The aim of the present paper is to propose task design principles for developing a digitally enriched math-talk learning community (Huffered-Ackles, 2004), focused on algebraic reasoning. The research question we attempt to answer is: *what are important task design principles for a technology enriched pattern task to gain potential for math-talk?*

Theoretical background

Students act upon mathematical objects on the basis of their assigned meaning of that object, and their interpretation of others' actions towards those objects (Blumer, 1986). As the students and the teacher interact with each other, and the tasks, they negotiate the mathematical content and create a joint interpretation of that content. For example, in a pattern task: a student suggests an algebraic

expression to represent the number sequence behind the pattern, and the teacher asks for a clarification on the student's reasoning in relation to the pattern. Such expressions can be created through the use of visual structure reasoning (Rivera, 2010). Students can reason with visual structure units of n in visual patterns as a tool for writing an algebraic expression. Figure 1 shows an example of color coding to highlight visual structure units. With this particular partition, red is n and blue is $n+1$, forming the expression $n+(n+1)+n$. Such tasks open up for student interaction to negotiate both how to partition a visual pattern in visual structure units, and how to formulate the expression, creating a math-talk learning community.

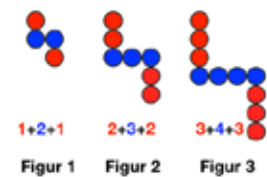


Figure 1: The pattern task

A Math-talk learning community is “a classroom community in which the teacher and students use discourse to support the mathematical learning of all participants” (Hufferd-Ackles, Fuson, & Sherin, 2004, p. 82). It is a learning community where students are encouraged to negotiate meaning and gain some responsibility for the mathematics forming in the classroom. The teacher should strive to shift the responsibility of the questioning and the source of the mathematical ideas from the teacher to the students (Hufferd-Ackles et al., 2004). The students are encouraged and supported to take an active role, focusing on mathematical thinking and reasoning rather than waiting to answer leading questions from the teacher, to create investigative discussions in mathematics. Digital technology has the potential to amplify students' opportunities to explore, re-invent and explain mathematical concepts in such practice (Leung, 2011), which we believe enriches their Math-talk learning community.

To understand the complexity of classroom practices with human/machine interaction, Trouche (2004) introduced the idea of instrumental orchestration. The idea is that teachers create opportunities for students to negotiate mathematical meaning by organizing available artefacts, i.e. didactical configuration (DC), and determining how to utilize these artefacts, i.e. exploitation mode, combined with the ad hoc decisions made by the teacher in the classroom, i.e. didactical performance (Drijvers et al., 2010). A DC including a projector offers the possibility to make a student's visual structure reasoning public and available for all students to interpret and react upon. When the projection is directed at a (interactive) whiteboard it also allows the teacher to exploit the possibility to allow students to indicate and manipulate digitally and analogous what is projected in a collaborative effort to negotiate meaning and develop students' reasoning (e.g. Taylor, Harlow, & Forret, 2010).

Task design combines elements of the DC with ways of exploiting that configuration in line with the teachers intended learning goal. A task design for research interventions relies on implicit or explicit design principles that are intended to produce favorable classroom situations. Van den Akker (2013) suggests the following elements of a design principle:

- *If you want to design intervention X [for purpose/function Y in context Z]*
- *Then you are best advised to give that intervention the characteristics C1, C2, ..., Cm [Substantive emphasis]*
- *And to do that via procedures P1, P2, ..., Pn [methodological emphasis]*
- *Because of theoretical arguments T1, T2, ..., Tp*
- *And empirical arguments E1, E2, ..., Eq*

(Van den Akker, 2013, p. 67)

It could be viewed as an expansion/formalization of the ‘didactical’ questions *what?*, *how?* and *why?* to form a design principle. The *what?* is connected to the characteristics of the intervention, a purpose of a design. The *how?* is connected to the procedures in the intervention, how a teacher should act, how a task is meant to be used, and so on. The *why?* is motivated by both theoretical arguments based on prospective analysis of prior research and teaching/learning theories, and empirical arguments where the design principles are fine-tuned by prior teaching experiences and experiences from the ongoing intervention (Van den Akker, 2013). Design principles are heuristic principles that cannot guarantee success, but they are intended to select and apply the most appropriate knowledge for specific task designs.

The previous research and theory resulted in two hypotheses connected to a potential lesson design:

- Didactical configurations with technology can be exploited to make students’ mathematical reasoning more accessible for other students to probe and develop during math-talk
- Didactical configurations with technology can be exploited to turn students’ attention to different aspects of a mathematical content and reasoning

Method

The project this paper reports on follows a design research approach as it aims to develop a research-based intervention, and construct re-usable design principles in an iterative manner (Bakker, 2018). A prototype of a lesson plan makes up a hypothetical learning trajectory (HLT) grounded in research (Simon, 1995), and is tested and refined several times. The HLT consists of the learning goal, the activity and the intended development of the students. During this iterative process, we generate data by video recording from three different angles, back of the class, front of the class and group work. Each lesson is tried and refined twice before moving on to the next lesson.

The research team consists of two elementary mathematics teachers, working with year 7 and 8, and two researchers, the authors of this paper. The project is a cooperative enterprise where we perform prospective analysis of the tasks, develops the task design, analyze the material and make changes together. Each design decision is motivated through theoretical and empirical arguments. The recorded material is used for reflective analysis between each lesson where we discuss what, how and why in different situations during each lesson and retrospective analysis of the whole lesson series after completion. Situations are evaluated regarding how digital technology enriches teacher-student and student-student interaction, especially in relation to opportunities for math talk and opportunities for students to seize initiative in the discussions. Parts of the reflective analysis is presented in the results below to reveal empirical arguments for the design principles.

Design

Lesson 1, in its initial form, aimed to develop the students’ proficiency to reason in line with different types of algebraic reasoning with visual structures. Specially to challenge naïve additive reasoning and suggest a more advanced strategy, i.e. multiplication of units, by asking them to reason about different ways of identifying visual structure units in the visual pattern. The students were given

questions and tasks individually and in pairs through Socrative¹. Figure 1 shows one of the tasks with color coded visual structure units, where the students were asked to identify an algebraic expression that fitted the coloring. The students were presented with the task through Socrative and given the following alternatives: a) $2n+2+2$ b) $n+(n+1)+n$ c) $n+1+n+n$ d) $4n+1+1$ e) none of the above. The answers were made available to both teacher and students, which was intended to make the students' reasoning available and create an opportunity for whole class discussion where they could question each other's reasoning.

Lesson 2, in its initial form, aimed to develop the students' proficiency to recognize visual templates and characteristics of patterns. In particular to recognize characteristics that make some patterns more difficult to generalize algebraically than others. The students were asked to create their own patterns in pairs and publish them on an online platform called Padlet². Next step for the students was to try to write algebraic expressions for each other's patterns. The lesson ended with a whole class discussion on which patterns were difficult to write expressions for, which were easy, and why? Padlet was intended to make each pattern accessible to each student, and easily swappable in group work as well as in the whole class discussion.

Lesson 3, in its initial form, aimed to develop the students' problem-solving proficiency and flexible reasoning. Particularly to transform patterns and use visual structure reasoning as a tool to generate algebraic expressions of more complex patterns that are not representations of standard arithmetic sequences. Figure 2 shows the initial 4 figures of the Hexagonal pattern that the students were asked to generalize. The students worked in pairs with tasks distributed through Socrative, and the main task was in a geogebra applet. The applet enabled the students to try ideas by moving and grouping the dots in each figure effortlessly, and negotiate different strategies with each other's. Our goal was that the students would recognize a possible visual template from a quadratic pattern (n^2) in the previous lesson by creating rectangles with n dots on one side and $2n-1$ dots on the other (figure 3). The whole class discussion was intended to focus on different visual structures and resulting algebraic expressions by visualizing the pattern transformation in the applet on the projector.

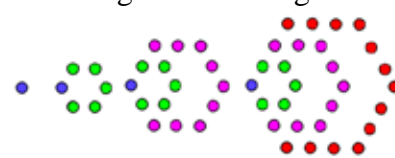


Figure 2: The Hexagonal pattern

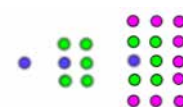


Figure 3: The Hexagonal pattern rearranged

Results

This section presents the results of the prospective analysis, and a retrospective analysis of selected episodes. We propose three design principles, that we present empirical and theoretical arguments for throughout the result section. The first principle is a development of our first hypothesis, going into the design process, and the second and third principles are a development of our second hypothesis:

¹ Socrative is an online response system where teachers post questions that show up on students' devices and allows them to post answers. Answers becomes instantly available for the teacher, and for the students too if the teacher wishes.

² Padlet is an online virtual pinboard that allows students to publish pictures and other types of contributions. Contributions becomes instantly available for the whole class on each device.

1. Exploit the possibility to project mathematical reasoning on students' devices or on the whiteboard (WB) with the classroom projector.
2. Exploit the possibility to indicate and/or manipulate objects projected on the WB collaboratively
3. Exploit the possibility to switch between individual/small group work and whole class discussion by focusing the students' attention to their own devices and the WB respectively.

Each episode presented below is from the first iteration of each lesson. The situations motivated changes in the task design and provides empirical arguments to refine the design principles. The first transcript is from Lesson 1, where the students have been engaged with task 4 "If I say 'tell me how many dots are in figure n ', what do you think I mean?" with the alternatives a) That you've mistyped b) That the last figure is called n c) That you mean a figure, anyone in the sequence d) That n means a number, any number e) Don't know. All, but one, chose either c) or d) or both.

Teacher: Two of the alternatives works. That you mean a figure, anyone in the sequence, that it could have been figure number 9 or number 1000 or number 2000000 and so on. [...] We move on.

The teacher immediately starts to summarize the results since almost everyone chose the correct alternatives. Our interpretation was that the task did not reveal much about the students' interpretations of n , or allowed them to make indications to develop their reasoning together with the class, prompting the teacher's action. We interpret the shortcomings as related to characteristics and procedures of the first two design principles. When the question is open, the students need to be able to answer more freely than with multiple choice. In relation to the second design principle, we revised the task on a procedural level, adding teacher prompts and offered whiteboard markers that encourage students to make their reasoning available both with their written answer and by approaching the board to indicate and explain in the picture. The result was a discussion where students got the opportunity to explore each other's interpretations, since they became more explicit.

Next example is from Lesson 2, where the students have written algebraic expressions to each other's patterns while working in pairs. Figure 4-6 shows the teacher going back and forward between two examples with different students accounting for their reasoning. The teacher encourages the students to apply the same visual structure reasoning in both cases. Notice how figure 2 and 3 both have some sort of visual structures indicated by color-coding or circles. The figures are in chronological order.

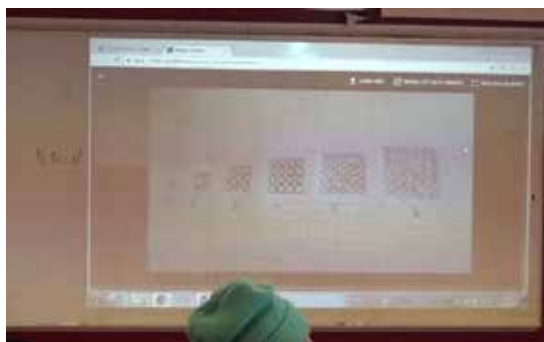


Figure 4: A student presented an algebraic expression for the square pattern task without

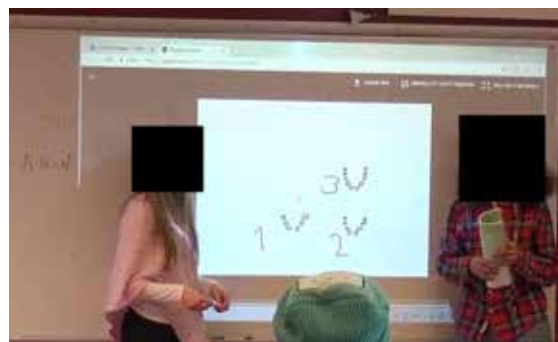


Figure 5: Two students presenting their generalization by using visual structures

Figure 4 shows the board right after a student has presented her solution, written on the left (n^2). Figure 5 shows how two students present their solution, with the aid of visual structures drawn in the pattern faintly with a yellow and a red marker. The teacher then exploits the possibility to flip back to the previous pattern and asks the students to use a similar strategy to expand on their reasoning in the quadratic pattern. The students focus on their own devices, and discuss in pairs before another round of whole class discussion. Students identified visual structures of n in multiple places in each figure. The negotiation results in the indication in square number 5, where a student has identified n both vertically and horizontally. It lead to the idea of multiplying base by height. The quadratic pattern was deemed harder than the other ones. By exploiting design principle number 3, to be able to switch students' focus between different tasks, small group and whole class, the teacher managed to create circumstances where the students could develop each other ideas and negotiate a solution that more than one student fully understood.



Figure 6: Several students have identified visual structures in the square pattern task

The third example is from Lesson 3, where the students were asked to write an expression for the hexagonal pattern shown in figure 2. The students transformed the pattern into rectangles shown in Figure 7 and 8. Two students present their visual structure reasoning by indicating on the board. Especially notice how the expressions in figure 8 corresponds with their visual structures respectively.



Figure 7: A student's use of visual structures to justify its reasoning

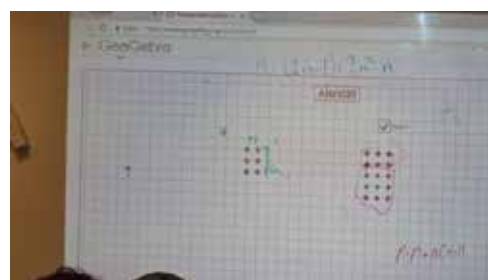


Figure 8: Students connect visual structures to their formulation of an algebraic expression

Prior to figure 7, students negotiated the best transformation of the hexagonal pattern. A student adjusted the pattern as the discussion progressed, making his interpretation of the discussion available on the board. They agreed on the rectangle, compatible with the base by height reasoning from the square pattern, and continued working on in pairs. This shift back and forth between whole class and group work provided opportunities for students to prepare to assume responsibility for creating the mathematical content in the math-talk learning community. Figure 8 shows two different types of visual structure reasoning. Looking at figure 7, the student explained the “-1” by manipulating the figure further, drawing in a fourth row that is then subtracted. She made her reasoning available to interpret, question and expand upon. In figure 8 we connect the resulting expression above with her visual structures and the *base multiplied by height* reasoning from the previous lesson. Similarly, we connect the second student's visual structure with his algebraic expression. However, he split his figure in two, identifying the square as $n \times n$ and the small rectangle as $n(n-1)$ by circling them.

To summarize, our first design principle is to exploit the possibility to project elements of mathematical reasoning directly on students' devices or with the classroom projector. The theoretical

argument is that as the teacher's and student's actions becomes available and interpreted by the class, it adds to the negotiation of mathematical properties and processes connected to the pattern task. The two main empirical arguments connected to this principle are 1) Tasks that does not allow room for individual expression of mathematical reasoning, tends to result in situations where the teacher assumes responsibility for the explanations. 2) When students were able to project their reasoning as a math-talk progressed, as in the discussion leading up to the transformation in figure 7, they reach consensus while assuming responsibility for the process.

Our second design principle is to exploit the possibility to indicate and/or manipulate objects projected on the board collaboratively. The theoretical argument is that the teacher and students can exploit the technology to further explore, justify and explain their reasoning, for example their visual structure reasoning, when incorrect or half-way ready solutions are introduced as collaborative endeavors. The empirical argument is that switching seamlessly between the analogue and digital allowed students to expand on each other's ideas, as seen in figures 4-6. By indicating directly on the board, the students used the projection and the indications together to justify their reasoning in the moment. Student work seen in Figure 7 adds to the argument, the student manipulates the pattern further by adding dots to justify elements of the algebraic expression in the ongoing math talk.

Our third design principle is to exploit the possibility to switch between individual/small group work and whole class discussion by focusing the students' attention to their own devices and the projection respectively. The theoretical argument is that students need time to formulate their arguments to become able to take more responsibility for the questioning and the source of the mathematical ideas in the math-talk learning community. The two main empirical arguments connected to this principle are 1) Switching between small group work and whole class discussion, as seen in the prior work to figure 4-6, students were able to prepare their mathematical reasoning with identical pictures on their own device as later used in the whole class discussion. Enabling them to present advanced mathematical reasoning based on numerical patterns and visual structures of patterns as part of a whole class discussion. 2) By switching focus between the whole class and small groups, as seen in the work leading up to figures 7 and 8, encouraged individual work expanding on the whole class discussions and resulting in multiple solutions to an advanced algebraic generalization task.

Discussion

The aim of this paper has been to propose task design principles for developing digitally enriched math-talk learning communities, and add to the research discourse on technology supported whole class discussions (Mercer et al., 2017). We propose three design principles, developed on the basis of empirical and theoretical arguments (Van den Akker, 2013). The principles were shown to support math-talk where students collectively were active in negotiating meanings of mathematical objects, rather than waiting for a teacher to provide explanations, corresponding to higher level of math-talk (Hufferd-Ackles et al., 2004). Pierce and Ball (2009) argues that teachers need to be able to relate technology rich lessons to their usual practice. By formulating characteristics of the three principles in a way that they utilize didactical configurations found in many classrooms today, such as projectors, and exploiting the possibility to combine projection with traditional practices, such as writing on the board, we simplify the implementation of a technology enriched mathematics lessons.

Van den Akker (2013) suggests we view these design principles as heuristics. Design principles should not be seen as a guarantee for success (Van den Akker, 2013), but likely producing opportunities for, in this case, rich math-talk. But that is not all they do, experiences from using curriculum materials creates learning opportunities for teachers (Davis & Krajcik, 2005). An actual lesson, created by tasks based on the design principles, is an opportunity to develop ones' capacity to orchestrate lessons that foster math-talk learning communities. Curricular resources are tools to enable teacher learning and to influence teaching practices (Cobb & Jackson, 2012; Davis & Krajcik, 2005). We propose that our design principles could be used in teacher training and collegial learning to discuss how to enrich mathematics lessons with digital technology on a general level. Creating concrete tasks and task design principles is perhaps a step towards a modern mathematics education that takes advantage of what digital technology has to offer to enrich mathematics teaching.

References

- Bakker, A. (2018). *Design reserach in education - A practicle guide for early career researchers*. New York: Routledge.
- Blumer, H. (1986). *Symbolic interactionism: perspective and method*. Berkeley: University of California Press.
- Cobb, P., & Jackson, K. (2012). Analyzing Educational Policies: A Learning Design Perspective. *Journal of the Learning Sciences*, 21(4), 487–521.
- Davis, E. A., & Krajcik, J. S. (2005). Designing Educative Curriculum Materials to Promote Teacher Learning. *Educational Researcher*, 34(3), 3–14.
- Drijvers, P., Doorman, M., Boon, P., Reed, H., & Gravemeijer, K. (2010). The teacher and the tool: instrumental orchestrations in the technology-rich mathematics classroom. *Educational Studies in Mathematics*, 75(2), 213–234.
- Hufferd-Ackles, K., Fuson, K., & Sherin, M. (2004). Describing Levels and Components of a Math-Talk Learning Community. *Journal for Research in Mathematics Education*, 35(2), 81–116.
- Leung, A. (2011). An epistemic model of task design in dynamic geometry environment. *ZDM*, 43(3), 325–336.
- Mercer, N., Hennessy, S., & Warwick, P. (2017). Dialogue, thinking together and digital technology in the classroom: Some educational implications of a continuing line of inquiry. *International Journal of Educational Research*.
- Pierce, R., & Ball, L. (2009). Perceptions that may affect teachers' intention to use technology in secondary mathematics classes. *Educational Studies in Mathematics*, 71(3), 299–317.
- Rivera, F. (2010). Visual templates in pattern generalization activity. *Educational Studies in Mathematics*, 73(3), 297–328.
- Simon, M. A. (1995). Reconstructing mathematics pedagogy from a constructivist perspective. *Journal for Research in Mathematics Education*, 26, 114–145.
- Taylor, M., Harlow, A., & Forret, M. (2010). Using a Computer Programming Environment and an Interactive Whiteboard to Investigate Some Mathematical Thinking. *Procedia - Social and Behavioral Sciences*, 8, 561–570.
- Trouche, L. (2004). Managing the Complexity of Human/Machine Interactions in Computerized Learning Environments: Guiding Students' Command Process through Instrumental Orchestrations. *International Journal of Computers for Mathematical Learning*, 9(3), 281–307.
- Van den Akker, J. (2013). Curricular Development Research as a Specimen of Educational Design Research. In T. Plomp & N. Nieveen (Eds.), *Educational design research Part A: An introduction* (pp. 52–71). Enschede: SLO.

Social creativity in the collaborative design of a digital resource embedding mathematics into a story

Nataly Essonnier¹, Chronis Kynigos² and Jana Trgalova¹

¹Claude Bernard University, S2HEP laboratory, Lyon, France; nataly.essonnier@gmail.com,
jana.trgalova@univ-lyon1.fr

²National and Kapodistrian University of Athens, CTI & Press “Diophantus”, Greece;
kynigos@ppp.uoa.gr

Our research was carried out in the framework of the MC2 European project (<http://www.mc2-project.eu>, 2013-2016) aiming at developing a socio-technical environment for the design of digital resources fostering creative mathematical thinking. Through a network of theories, we conceptualise and study social creativity that occurs during collaborative design of a digital resource embedding mathematics into a story. We focus on factors that trigger, or hinder social creativity and that influenced a group of designers, made up of mathematics teachers, teacher educators and researchers with diverse expertise, broadening perspectives, supported by a socio-technical environment during the design process.

Keywords: Process of collaborative design, social creativity, digital resource.

Introduction

Our research is motivated by promoting creativity in teachers and students, collaborative work and the use of digital artefacts to solve real world or interdisciplinary problems, and considering mathematics teachers as designers (Kynigos & Kolovou, 2018). It was carried out in the framework of the MC2 European project (<http://www.mc2-project.eu>, 2013-2016) aiming at developing a socio-technical environment facilitating and enhancing the design of digital resources, called c-books (c for creative), and fostering students' creative mathematical thinking. The technical part of the environment consisted of the so called C-book technology embedding an authoring tool and a collaborative tool called CoICode¹. Four communities of designers established in four partner countries, France, Greece, Spain and United Kingdom, constituted the social part of the environment. The French community, on which the paper focuses, brought together educational designers from diverse mathematical fields with manifold expertise and knowledge (researchers, teachers, software designers, etc.) because the process of designing purposeful mathematical activities in multi-representational technical environment is complex. An aspect of this complexity comes from the interrelated processes of learning to purposefully use a new technology, of designing tasks for students to initiate purposeful mathematical activity, of collating the various artefacts for the activity, of supporting students to learn to use technology, and of articulating the teacher's role in supporting the students to navigate their respective routes through the various artefacts to include interaction with the technology (Clark-Wilson & Timotheus, 2013, p. 48). In this paper, we aim at highlighting factors that foster or hinder social creativity (SC) in the collaborative design of c-books. Studying

¹ CoICode is a communication environment part of the C-book technology, offering a workspace within which members of a community engaged in a c-book design can collaborate.

these complex design processes required several theoretical perspectives leading us to network theories and concepts. We start by explaining our theoretical framework and the conceptualisation of social creativity. We pursue by refining our research questions and by exposing our methodology before presenting an analysis of one case study. We conclude with some salient results.

Theoretical framework

Collaborative design of creative digital educational resources within a socio-technical environment is a complex human activity intertwining manifold interactions and elements which are difficult to capture without any relevant lenses.

As a first lens, within the activity theory (AT), Engeström (1987)'s model of activity structure (Figure 1) helps us focus on particular elements, called entities, that intervene in the design activity: *subject* that is the group of designers, *object* that is the c-book being designed, *community* with which the designers' group interacts, mostly the designers of the C-book technology, *rules* that govern the design process, *division of labour* that occurs among the designers, *tools and signs*, such as *artefacts* used by the designers, mostly the C-book technology including the CoICode collaborative workspace, and *outcome* that is the designed resource, as well as learning that can occur during the design process. Engeström (1987)'s model highlights also interactions between these entities, which allows to describe and understand the context of the design process.

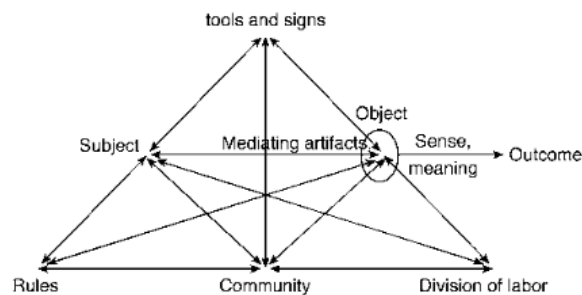


Figure 1. The structure of an activity system (Engeström, 1987, p. 78)

Engeström (2001) expands his model and sheds light and awareness on the interactions occurring between different individual activity systems, i. e., when the *subject* is a single designer. It is illustrated by the minimal structure of two interacting individual activity systems (ibid.) which allows to bring to the fore the modifications of the *object*. The *object* moves from an initial state of un-reflected, situationally given “raw material” (*object 1*) to a collectively meaningful object constructed by the activity system (*object 2*), and to a potentially shared or jointly constructed object (*object 3*). However, the models do not allow us to understand the nature of the entities. In order to capture the nature of the *subject* and *community* entities, we draw on the concepts of *community of practice* (CoP) (Wenger, 1998) and *community of interest* (CoI) (Fischer, 2001). Besides, the designers belong to various “worlds” according to their domains of expertise. These worlds have boundaries that “can be seen as a socio-cultural difference leading to discontinuity in action or interaction” (Akkerman & Bakker, 2011, p. 133). It is therefore important, while studying collaborative resource design, to pay particular attention to what happens on those boundaries. The boundary crossing approach (BC) (ibid.) enables to enlighten the weight of boundaries in the creative design process and the arising

mechanisms of *identification*, *coordination*, *reflection* and *transformation* through the concepts of *boundary object* (Star & Griesemer, 1989) and *broker*, bound to interactions between *subject – community – (artefact or object or outcome)*, or between two or more individual activity systems. Finally, in order to highlight the role of the teachers (*subjects*) involved in the design, their personal resources (*artefacts*) brought into play in the design, and the trajectory of the digital resource being designed, i.e. its different versions from *mother resources* to *daughter resource* (Hammoud, 2012) (from *object* to *outcome*), we draw on the documentational approach to didactics (DAD) (Gueudet & Trouche, 2009). To sum up, the AT was our main framework allowing to connect all others through the entities of the Engeström's activity system model. Based on this, we have been able to conceptualise our understanding of social creativity.

As a matter of fact, different types of creativity are reported in literature. We have chosen the *little-c* creativity (Craft, 2000), which is when a person realizes a new or improved way to approach an issue or accomplish a task. We draw also on the *componential* tradition of creativity assessment (Hennessey and Amabile 1999) to assess it and on the concept of communities of interest (CoI) for characterising our communities of designers. Thus, within the MC2 project, we define social creativity (SC) as the *generation of ideas* which: (a) stem from a combination of two or more individual *activity systems*, (b) result from various interactions among the CoI members, the C-book technology and tools, (c) are externalized in and through specific digital artefacts (including the *c-books*), and (d) are considered by the CoI members to be *novel*, *appropriate* and *usable* (Daskolia, 2015). Moreover, creativity, social or individual, can be modelled through phases of *divergent* (novel ideas) and *convergent* thinking (appropriate and usable ideas) (Csikszentmihalyi 1996) constituting a *creativity cycle*. Social creativity is characterised by the reification of creative ideas collectively elaborated, i.e. elaborated by at least two CoI members.

Research questions

In this paper, we address the following research questions: in the collaborative digital resource design activity,

- what interactions between *rules*, *community* and *division of labour* promote or hinder SC?
- what types of objects have the potential to become *boundary objects*, under which conditions and how can they stimulate SC?
- which members have the potential to become *brokers*, under what conditions and what is their role in stimulating SC?

Methodology

Our methodology relies on one case study, i.e., we analyse the collaborative design of one particular c-book within the French CoI. The data was mostly collected via CoIcode that keeps traces of interactions in the form of ideas posted by each designer (Figure 3), but also through minutes of manifold meetings, exchanged emails and the designed c-books. Although the methodology comprises quantitative and qualitative methods, in this paper we only focus on the qualitative analyses aiming at getting a deeper insight into social creativity processes. The data analysis was processed in two phases. First, we use the AT to describe in detail the design activity context through the activity system entities in order to situate and understand the collaborative design context of the group of

designers. Second, we use our network of theories to qualitatively analyse data and bring to the fore factors impacting the social creativity taking place among the designers.

A snippet of the collaborative design of the c-book ‘Ski’

In this section, we analyse a few episodes of the collaborative design process of a c-book on ski touring. From the AT perspective, the *object* of the design process was to create meaningful mathematical activities linked to the risks of provoking an avalanche while practicing ski touring to foster students’ mathematical learning and creativity (purposeful activities). The group of designers (*subject*, Figure 2) was composed of seven members of the French CoI (*community*), all closely related to mathematics education with knowledge on mathematics, technology and pedagogy, and sharing a constructivist background.



Figure 2: The designers of the c-book ‘ski touring’

Four members acted as the main designers: Nina (secondary mathematics and physics teacher and PhD student, with a good knowledge of the C-book technology (*artefacts*)) who moderated the group, Marie (researcher and mathematics teacher educator, expert in mathematical modelling), Fred (mathematics teacher educator, interested in real problems), and Jane (mathematics teacher educator, interested in digital technology in mathematics education) who played the role of a reviewer. The other three members, Marc (expert of digital technology such as dynamic geometry systems), Jean and Adam intervened on request or during CoI meetings (*division of labour*). The main designers’ group was constituted in a way that at least one of them was at ease with digital technologies and especially with the C-book technology (*rules*). The designed c-book (*outcome*) should be used by a teacher of an associated CoP, called MPS, which Marie belongs to (*rules*). This CoP reflects on the use of mathematics for solving interdisciplinary problems with Grade 10 students.

In order to bring to the fore the trajectory of the c-book design process through its versions, we combined documental approach to didactics, activity theory, social creativity and boundary crossing approach. We could identify four versions of the c-book. The initial version was constituted by Marie’s personal resources on the theme of avalanche and skiing (*mother resources = objet 1*), as she has already worked on this topic within the MPS CoP and experimented some activities with Grade 10 students. From her numerous resources, Marie selected several that she instrumentalised through CoIcode posts (*object 2*) (*reflection mechanism = perspective making*). Then, a divergence phase was initiated by a brainstorming amongst the CoI members. It generated nine new directions on real situations and mathematical notions (*reflection mechanism = perspective making*) and some creative ideas, i.e. judged novel, appropriate and usable by the designers. The creative ideas were related to real situations such as the avalanche risk depending on a slope leading to considering angles, the measurement of the angle of a snowy slope with ski poles that requires knowledge of

trigonometry, the shape of snow crystals leading to working on geometric figures, transformations and sequences. This phase was followed by a phase of convergence (*identification, coordination and transformation mechanisms*) characterised by the collective elaboration of some of these ideas with, for instance, some artefacts already known within the French CoI, such as GeoGebra or Cinderella, in order to simulate an avalanche to encourage students to make conjectures about the risks, or programming an avalanche victim search device in order to make students understand the notion of algorithm (*objects 3*). The two phases constituted a creativity cycle. They led to the second version of the c-book pictured through a defined structure and content based on the preparation of a ski tour as a guideline for the story that would guarantee a unity for the c-book. In the following creativity cycle, the creative ideas were mainly bound to the technology and designers' technical knowledge, such as suggesting guidelines how to use GeoGebra for creating snowflakes, devising relevant feedback for students in different ways to enrich the *milieu* of the c-book activities by using widgets that were not familiar within the French CoI, or considering the copy/paste possibilities inside the Chat tool to enable interactions between students or between the students and the teacher (social aspects). During the third creativity cycle, the main concern of the designers was the usability of the c-book by the teachers and students from Grade 10 to 12. The designers were also concerned by giving a unity between all the activities thanks to a story on ski touring and avalanche risk. Hence, the focus of the designers changed from one cycle to the other. In addition, we noticed that a divergent phase was often initiated by a review of the c-book version at stake by the reviewer or by a critical feedback from some CoI members, less involved in the design, during a meeting (*reflection mechanism*). Each version was the result of a creativity cycle, i.e., a divergent phase followed by a convergent one as modelled in Figure 3.

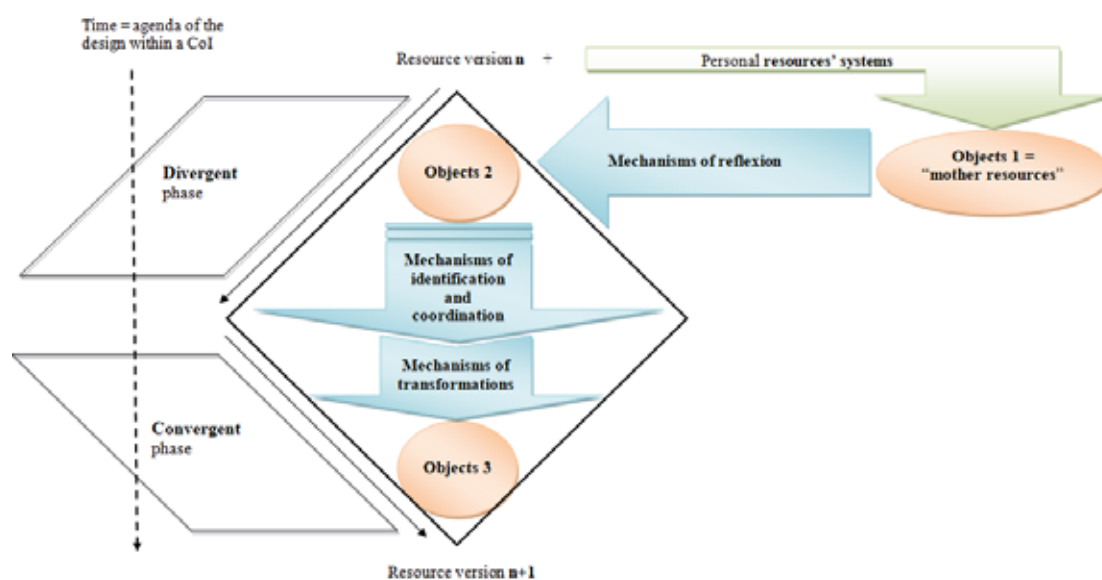


Figure 3: Model of versioning of the c-book collaborative design process (Essonnier, 2018)

Furthermore, we observed that the first creativity cycle generated ten creative ideas out of 14 ideas judged as creatives by the designers, which was more than in the other cycles. The analysis of this cycle highlights a positive effect of the compulsory use of CoICode (*rules*) during brainstorming amongst the designers. This was not the case in the other cycles where the designers used also other

media to communicate and to record their interactions, such as emails or minutes from the diverse meetings. Indeed, when the CoI members used CoICode, they had to read the ideas of the others and to react on them. Each post in CoICode obliged a designer to reflect on his/her own ideas. The latter had to choose if the idea was new or rather a reaction to another one, and what kind of reaction (opposition, contribution or alternative). Such a structured reflexion turned out to boost SC.

Finally, in order to have a deeper understanding of SC we studied the path of a creative idea, i.e. its collective elaboration. The creative idea we analysed (circled with red in Figure 4) was chosen because of its strong collective elaboration. This idea was preceded by Marie's suggestion to create an activity on algorithms bound to the search of a victim of an avalanche (*mother resource*). Then, Fred's creative idea proposed to work on algorithm with the "GeoGebra turtle". Fred was referring to explicit algorithm (*reflection mechanism*). This suggestion sparked the negotiations between Marc and Fred who expressed different perspectives of a widget around the idea of a "turtle" to model an avalanche victim research device. Marc understood and proposed a widget designed by the Greek CoI using logo language. But Fred did not know this widget. He knew another widget using Java Logo language, which could enable to create explicit algorithm but he was hesitating. Thus, they seemed to share a common frame of reference around turtle and logo, which enabled them to understand each other. The word "turtle" became a *boundary object* between them.

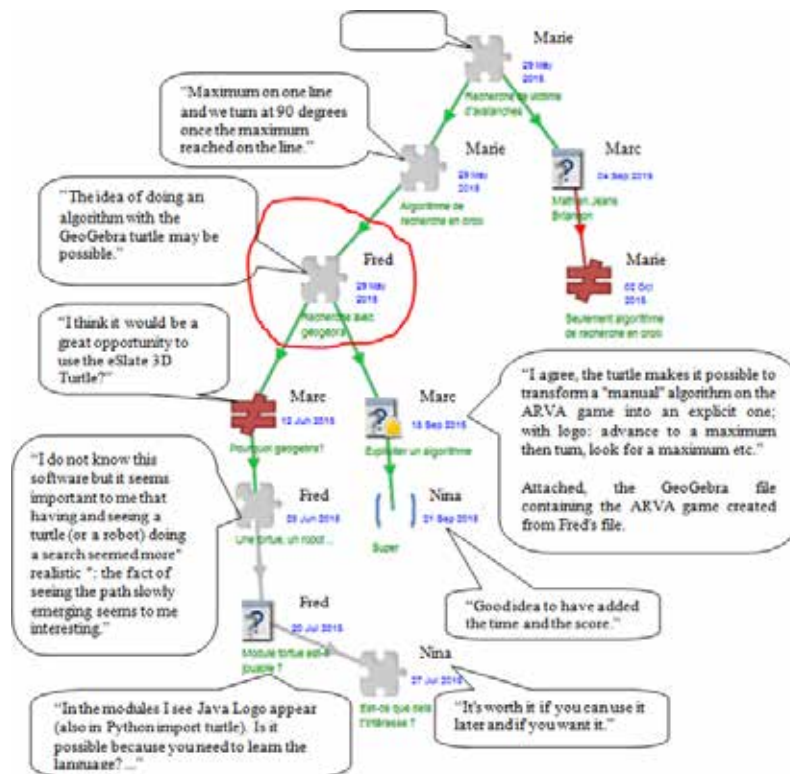


Figure 4: Extract of the CoICode workspace dedicated to the c-book 'Ski'

Nevertheless, from the meetings' minutes, Nina the moderator found that Fred was in trouble because he could not manage to finalize his widget with GeoGebra (*creative idea*) that should allow students to work implicitly on algorithms. Hence, Nina asked Marc to help Fred. She identified difficulties (*identification mechanism*), and to overcome them, she solicited another member of the CoI

(*coordination mechanism*). Marc, expert of GeoGebra, designed the widget, limited the time and added a score to foster affective aspects (*transformation mechanism = hybridization*, daughter resource). Moreover, Marc was eager to create an explicit algorithm with a widget designed within the Greek CoI, but he did not master the logo language required for working with the latter. He therefore asked the technological expert from the Greek CoI how to write the algorithm and he eventually created a new widget (*transformation mechanism = hybridization*, daughter resource). He thus played a role of *broker* looking for knowledge in another CoI (*community*).

Conclusion

The analysis of the process of design of the c-book “ski” shows that some *rules* impacted positively social creativity among the c-book designers. One of such rules applies to the constitution of the designers’ community that should be as diversified as possible. The diversity should be understood in terms of complementary expertise of its members (pedagogical, mathematical and especially technical) broadening the discussion meaning, but also in terms of roles to be assigned (moderator, designer and reviewer, *division of labour*). Indeed, the reviewer fostered a divergent phase and the moderator facilitated a convergent phase, supporting *creativity cycle*. In addition, the use of CoIcode to communicate during brainstorming seemed also to enhance SC.

In addition, we noticed that some words (e.g., turtle) allowed the designers to propose various ideas in different perspectives from other contexts, from other cultures. Such words became *boundary objects* widening the CoI perspective. Therefore, within a CoI that designs c-books, we can say that potential *boundary objects* are *malleable*, *transformable* objects, *compatible* with the *object* of the design and belonging to the designers’ common frame of reference. *Boundary objects* helped to extend the common frame of reference between the designers (*coordination*) by enlarging their perspectives.

We found that the *brokers*, who were members of the CoI, were able to identify the missing knowledge for the c-book design, to look for it and then, to share this new knowledge within the French CoI. Thus, in our context, we can say that a *broker* is a member of the CoI who identifies missing knowledge within the CoI, then can find it in another related professional world in order to bring it to the CoI. Thus, the *broker* acts as a coordination mechanism allowing the CoI members to extend their common frame of reference with new knowledge.

References

- Akkerman, S. F., & Bakker, A. (2011). Boundary crossing and boundary objects. *Review of educational research*, 81(2), 132–169.
- Clark-Wilson, A. & Timotheus, J. (2013). Designing tasks within a multi-representational technological environment: An emerging rubric. In C. Margolinas (Ed.), *ICMI study 22 task design in mathematics education* (Vol. 1, pp. 47–54). UK: Oxford.
- Craft, A. (2000). *Creativity across the primary curriculum: Framing and developing practice*. London: Routledge / Falmer.
- Csikszentmihalyi, M. (1996). *Creativity: Flow and the psychology of discovery and invention*. New York: HarperCollins.

- Daskolia, M. (Dir.) (2015). *D2.2: Operational definitions and criteria for measuring social creativity in the design of digital educational resources for CMT*. Deliverable of the MC Squared project. FP7, ICT-2013.8.1. Accessed 17 September 2016 from <http://mc2-project.eu/index.php/dissemination>
- Engeström, Y. (1987). *Learning by expanding: An activity-theoretical approach to developmental research*. Helsinki: Orienta-Konsultit.
- Engeström, Y. (2001). Expansive learning at work: Toward an activity theoretical reconceptualization. *Journal of Education and Work*, 14(1), 133–156.
- Essonnier, N. (2018). *Etude de la conception collaborative de ressources numériques mathématiques au sein d'une communauté d'intérêt*. Doctoral dissertation, Université C. Bernard-Lyon 1, France.
- Fischer, G. (2001). Communities of interest: Learning through the interaction of multiple Knowledge Systems. *Paper presented at 24th Annual Information Systems Research Seminar in Scandinavia (IRIS 24)*, Ulvik, Norway.
- Gueudet, G., & Trouche, L. (2009). Towards new documentation systems for mathematics teachers? *Educational Studies in Mathematics*, 71(3), 199–218.
- Hammoud, R. (2012). *Le travail collectif des enseignants en chimie comme levier pour la mise en œuvre de démarches d'investigation et le développement de connaissances professionnelles*. Doctoral dissertation, Université C. Bernard-Lyon 1, Université Libanaise.
- Hennessey, B. A., & Amabile T. M. (1999). Consensual assessment. In M. A. Runco, & S. R. Pritzker (Eds.), *Encyclopedia of Creativity* (pp. 34–36). New York: Academic Press.
- Kynigos, C., & Kolovou, A. (2018). Teachers as designers of digital educational resources for creative mathematical thinking. In Fan L., Trouche L., Qi C., Rezat S., Visnovska J. (Eds.) *Research on Mathematics Textbooks and Teachers' Resources*. ICME-13 Monographs. Springer, Cham.
- Star, S. L., & Griesemer, J. R. (1989). Institutional ecology, 'translations' and boundary objects: amateurs and professionals in Berkeley's Museum of Vertebrate Zoology, 1907-1939. *Social Studies of Science*, 19(3), 387–420.
- Wenger, E. (1998). *Communities of practice: Learning, meaning, identity*. Cambridge: Cambridge university press

Building bridges between school mathematics and workplace mathematics

Rune Herheim and Suela Kacerja

Western Norway University of Applied Sciences, Norway; rher@hvl.no, skac@hvl.no

In this paper, we investigate three examples from two articles written by lower-secondary students in which they identify school mathematics used in workplaces. Their articles are written as part of a project aiming to help students find mathematics relevant. The students provide documentation on advanced use of graphs, mean values, calculations, and formulas in two occupations, music management and physiotherapy. By using Evans' (1999) approach to transfer, we identify similarities and differences between school mathematics and workplace mathematics. In line with Evans' approach, we aim at building bridges between school mathematics and workplace mathematics.

Keywords: Workplace mathematics, school mathematics, building bridges, transfer, relevance.

Introduction

When doing research and following up student teachers in school practice, we hear students say “maths has nothing to do with my life”, “I don’t need maths”, and “maths is something we do in school”. These statements are in line with Masingila’s (2002, p. 37) study in which a majority of the students “think mathematics is synonymous with school mathematics”. Wager (2012, p. 10) built on this by saying that students often do not see “the connection between the mathematics in which they engage in school and the mathematics they experience out-of-school”. The national curriculum in Norway and other countries, e.g. the US common core state standards, specify that students should be able to apply the mathematics learnt in school to the workplace. However, as English (2010, p. 36) argued, “we need further knowledge on why students have difficulties in applying the mathematical concepts and abilities ... outside of school”.

When doing mathematics in school, students often ask “why do I have to learn this?” (Hernandez-Martinez & Vos, 2018, p. 245) or “when will I use this?” (Willoughby, 2017, p. 877). Answers like “you are going to have mathematics next year as well, you know” and “because we have a test coming up” (cf. Onion, 2004), do not address the core of the questions. On the contrary, they might explain the student statements in the first paragraph. Alrø, Skovsmose, and Valero (2009, p. 15) asked eighth grade students what they used mathematics for outside school, and the most frequent answer was “to do homework”. If the only purpose of learning mathematics is to do homework or to be prepared for future teaching and tests, then it is easy to understand from such circular reasoning why students question the relevance of mathematics. Hernandez-Martinez and Vos (2018) argued that students need answers regarding how, why, where, and what mathematics will be relevant because it is so closely related to their motivation to learn and to what extent they see the usefulness of what they learn. Hernandez-Martinez and Vos see usefulness as a property of the mathematics being learnt, and relevance as the potential connection between the mathematics learnt, its usefulness, and the student.

It might seem odd that mathematics, a field of knowledge so vital for today’s society, has difficulties being regarded as relevant. However, being able to give qualified answers regarding the relevance of mathematics involves detailed knowledge of the mathematics required to perform an occupation. One

cannot expect teachers to investigate a range of different workplaces in order to always have an answer when students question the relevance of a mathematical topic. Gaining insight into what extent the mathematics learnt in school is relevant to life outside school is a challenge for teachers and educators, like FitzSimons and Boistrup (2017) and Nicol (2002) found in their studies. This relevance challenge and the importance of connecting ideas and building on students' out-of-school experiences and understanding when working with mathematics in school, constitute the rationale behind the *Workplace mathematics project* referred to in this paper. About 60 lower-secondary students, three of their teachers, and a researcher (the first author of this paper) investigated what mathematics their parents/guardians needed in order to perform their work. The students then wrote articles about their findings with the help from their teachers and in collaboration with the researcher.

By investigating two of the student articles, this paper addresses the following research question: *What school mathematics are the students able to identify in the workplaces?* The analysis focuses on identifying and discussing similarities and differences between mathematics at school and at workplaces and provide a foundation for discussing potential transfer and relevance of school mathematics. We do this by presenting and extending the mathematics the students identified in two workplaces, music management and physiotherapy.

Theoretical perspectives and previous research

In the following, we clarify how the national curriculum links school mathematics with the working life and give a brief overview of perspectives and terms for out-of-school mathematics. We elaborate on the concept of workplace mathematics and on the gaps and potential transfer between school mathematics and workplace mathematics.

Links between school mathematics and working life in the national curriculum

In the Norwegian mathematics curriculum, mathematical competence is considered important for understanding and influencing what happens in society and for “pursuing further education and for participation in working life and recreational activities” (Ministry of Education and Research, 2010, p. 2). Problem solving and modelling are emphasised, and rich experiences with mathematics are regarded as an important foundation for lifelong learning. In addition, the ability to work with mathematical concepts, methods, and strategies to solve problems also “involves learning to pinpoint and describe situations where mathematics is involved” (p. 5). This is defined as an important part of mathematical competence. Thus, being able to identify the use of mathematics is considered as vital for strong mathematical competence in the national curriculum. The workplaces investigated in the project serve as rich contexts for identifying and making sense of the mathematics used.

Perspectives and terms for out-of-school mathematics

There are multiple perspectives and terms in mathematics education research regarding the contextualization of school mathematics and links between school mathematics and out-of-school experiences. *Realistic mathematics* is used to focus on creating meaningful and realistic situations in which students can learn mathematics (Freudenthal, 1991). *Genuine* or *authentic mathematics* concerns real-life situations brought into the mathematics classroom, strongly, but not necessarily, linked to mathematical modelling (e.g. Palm, 2008). *Everyday mathematics* focuses on identifying

everyday situations where mathematics is used (e.g. Nunes, Schliemann, & Carraher, 1993; Masingila, 2002). *Workplace mathematics* is used by researchers who study the mathematical knowledge and skills required to do certain work processes (e.g. Hoyles, Wolf, Molyneux-Hodgson, & Kent, 2002; Wake & Williams, 2001; Wedege, 2006). The perspectives presented have a key aspect in common – they study the potential links between school mathematics and out-of-school mathematics. The project presented in this paper takes the workplace mathematics perspective.

Workplace mathematics and transfer

In UK, two groups of researchers have investigated mathematics in workplaces from different points of view. Hoyles et al. (2002) studied seven different workplaces focusing on the mathematical knowledge and skills required of the employees and identified several mathematical skills as important in different occupations. Wake and Williams (2001) identified general mathematical competences applied in many occupations that also could be incorporated in the mathematics curriculum. Summarized, the competences and skills identified by the two groups of researchers were using proportions and percentages, handling data, using graphs, diagrams, and other tools and interpret them, modelling and solving problems, calculating and using formulas, recognizing anomalous phenomena, and doing extrapolations.

On the other hand, there are also hindrances for identifying the use of mathematics outside school. Workplace mathematics is situated and has to be combined with knowledge about the work to perform required tasks (Hoyles et al., 2002). It can be hidden caused by automation of processes and division of labour, and the nature of school mathematics can cause challenges as well (Williams & Wake, 2007). There are several differences between school and workplace mathematics that can hinder students recognizing mathematics in workplaces, Wedege (2006) argued. She identified seven categories that describe a gap several adults had experienced between workplace mathematics and school mathematics. The differences start at the number level. In the workplace, numbers have units of measurement, calculations have to be constructed, and there are often multiple solutions. In school, numbers often occur without units, the numbers as well as calculations are given, and there is only one correct solution. Solving tasks in the workplace requires collaboration and dealing with disturbing factors, it offers opportunities to use mathematics, and solutions have consequences. Solving tasks in school is often individual work without disturbing factors, and real-life contexts are used merely to create a need for using mathematics and solutions have therefore no practical consequences.

However, the hindrances are surmountable. Wake (2013, p. 315) proposed a new mathematics curriculum to overcome the challenge of transfer “by placing the study of how mathematics models reality at the core of the curriculum”. This curriculum should give students the possibility to make sense of, and develop further, the models of others. Wake considered the research done in workplace mathematics as rich initial contexts to be used by teachers who support inquiry in the classroom. Evans (1999, p. 23), when writing about transfer between mathematics in school and everyday life, linked relevance with transfer by arguing that “if schooling is to be relevant ... we need some account of how learning from the school can be ... ‘transferred’, to other contexts”. He emphasised the importance of building bridges for transfer between school and out-of-school activities by identifying fruitful overlapping and inter-relations, and by analysing similarities and differences.

Method

The background for the students articles: the Workplace mathematics project

The project was a collaboration among the teachers, the students, the students' parents/guardians, and the researcher. The teachers contacted the researcher because they wanted to do a project that could help their students see the relevance of mathematics. The teachers' idea of visiting parents/guardians' workplaces to document the use of mathematics was embraced by the students, and more than twenty parents/guardians attended an information/kick-off meeting. The parents/guardians were excited by the idea, they expressed a positive attitude towards mathematics, and agreed to be visited and interviewed. The meeting tuned them into the project and was important in order to go beyond Hoyles, Noss, Kent, and Bakker's (2013) finding that visible workplace mathematics tends to be fragmented, routine-based, and mostly simple calculations.

The students were trained to interview, document, and do pre-investigations by the researcher and the teachers. They were encouraged to gather information about the occupation, the particular workplace, and the interviewee's duties, and identify concrete examples of mathematics being used. The students were grouped in pairs and triads, they decided their approach and interview questions, and then they interviewed, observed, and collected documents and photos. One of the teachers or the researcher joined most of the groups. Many of the parents/guardians had prepared information and examples when the students came. In 2017, after working with data handling, collecting supplementary data, and editing articles according to feedback from the teachers, the researcher, and the parents/guardians, the first student articles were published in a national journal for mathematics teaching. The researcher finished the articles, extended some of the examples, and added reflections on links between the students' examples and the competency aims in the national curriculum.

Analytical approach

Evans' (1999) approach to transfer, in terms of similarities and differences, is used as analytical lens to investigate what school mathematics the students were able to identify in the work done by the physiotherapist and the music management duo. The identification of similarities are discussed according to the skills identified by Hoyles et al. (2002) and Wake and Williams (2001), and the identification of differences are discussed according to Wedege (2006). These similarities and differences are used to shed light on a potential transfer of mathematics between school and workplaces. The examples in this paper are chosen because they are interesting and contain mathematical details that make it possible to identify links to school mathematics.

Description and analysis of workplace examples from students' articles

We now present three examples and discuss the mathematics involved. The first two examples come from a music management duo (Tronstad, Graff, & Herheim, 2017). They work with several artists, and one of their main tasks is to help artists make a living of music. An essential question concerns deciding where artists should sell their music: streaming, CD, or both? Figure 1, made by the researcher based on information collected by the students, shows the sales in Norway for CDs and streaming. In 2011, the graphs intersected, and streamed music generated for the first time more money than CDs. The CD sales continued to drop, but in 2014, there seems to be a trend change.

To make a qualified decision on this requires critical reflections based on mathematical understanding by the music managers. In line with Hoyles et al. (2002) and Wake and Williams' (2001) findings, they have to handle data, understand and interpret a graph, and understand the point of intersection of the two curves in terms of income. They have to predict a trend and make a decision based on past data – typical tasks within predictive modelling. Based on these reflections, they can make knowledge-based decisions of where to sell their artist's music. However, in line with Wedege's (2006) findings on differences between mathematics in school and in workplaces, this workplace example includes disturbing factors and the use of measurement units. Furthermore, it actually requires use of mathematics, and it is a decision that has potentially huge economic consequences.

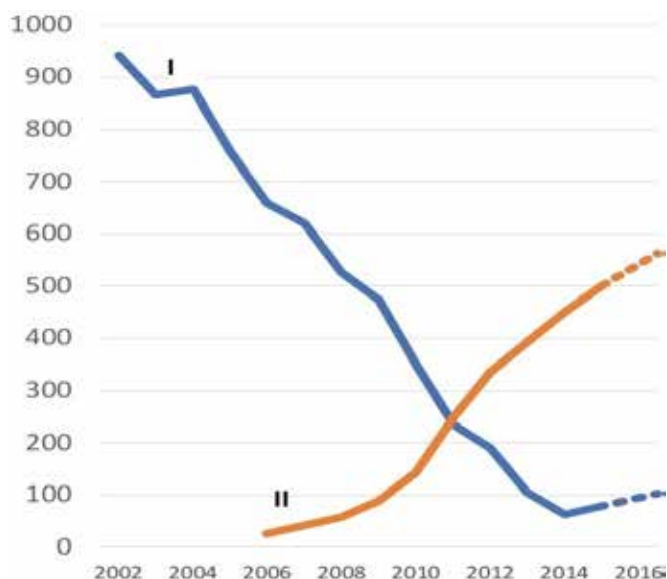


Figure 1: The sales in Norway for CDs (graph I) and streaming (graph II) in million NOK

Another aspect is the income generated from having a song played on the radio. In one of the radio channels in Norway, artists earn 60 NOK/minute. If a song lasts three minutes and 23 seconds, you get the following calculation: $3 \times 60 + (23/60) \times 60 = 203$ NOK. If the song is played 200 times/month, it provides an income of $200 \times 203 = 40600$ NOK. This resemble common calculations in school. However, there are also several differences. The managers have to find many of the numbers themselves, set up an expression including fractions, calculate it correctly in order to know the potential profit, manage different measurement units such as seconds and minutes in the same formula, and deal with practical unit rates such as NOK/minute and times/month. Again, there is an extensive use of measurement units. To summarize, in these two examples, the music managers have to apply all the competences and skills on Hoyles et al. and Wake and Williams' list. In addition, they need to gain an overview of these elements as parts of a complex system where several factors can influence their decisions such as where to sell the music, marketing, and arranging tours.

The third example comes from a physiotherapist's work with elderly and their walking ability (Berrefjord, Haugland, Nilssen, & Herheim, 2018). When a patient walks across a mat with sensors connected to a computer, a range of functional walking data is registered. The students identified a need for the physiotherapist to integrate mathematics and ICT skills as Hoyles et al. (2002) did. One issue is walking variability, arrhythmic or twitchy walk, and in order to investigate this one needs step times in seconds (see table 1):

Step no.	1	2	3	4	5	6	7	8	9	10	Mean	SD
Left	0,8		0,79		0,8		0,83		0,88		0,82	0,033
Right		0,86		0,82		0,81		0,81		0,77	0,81	0,029

Table 1: Step times

Collecting the ten step times in seconds, five for each foot, makes it possible to calculate the mean values and standard deviations (the physiotherapist and the researcher calculated the standard deviation because this is not part of the students' curriculum):

$$\bar{x} = \frac{0,8 + 0,79 + 0,8 + 0,83 + 0,88}{5} = \frac{4,1}{5} = 0,82$$

$$s = \sqrt{\frac{(x - \bar{x})^2}{5}} = \sqrt{\frac{(0,8 - 0,82)^2 + (0,79 - 0,82)^2 + (0,8 - 0,82)^2 + (0,83 - 0,82)^2 + (0,88 - 0,82)^2}{5}}$$

$$= \sqrt{0,0011} = 0,033$$

This example shows the need for dealing with decimal numbers, for setting up formulas and calculate correctly, for systematizing and presenting data, and for using statistical concepts such as mean and standard deviation. Standard deviation is frequently used by researchers to quantify the amount of variation of a set of data. Here, it gives the physiotherapist vital information about the extent to which a person's walk is unstable and influences how the physiotherapist should proceed with the physical treatment. Such use of standard deviation exemplifies that mathematics has practical and concrete consequences. The importance of correctly knowing and using mathematics becomes more visible for the students, and can help them find answers to their relevance questions.

Discussion and concluding comments

Building bridges between school mathematics and workplace mathematics, helping students see the relevance of mathematics as something more than just being able to do homework and prepare for tests, is a challenge documented by several researchers (e.g. Alrø et al., 2009; Onion, 2004). Students struggle to see connections between school mathematics and out of school mathematic (Hoyles et al., 2002; Nicol, 2002; Wager, 2012; Williams & Wake, 2007), and they find it difficult to apply mathematics outside school (e.g. English, 2010). Teachers have difficulties answering questions from students on why they "have to learn this" and when they will ever need it (Hernandez-Martinez & Vos, 2018). A possible remedy is to include genuine real life tasks, e.g. tasks situated in workplace contexts, as resources more often in the mathematics curriculum. This is one way of overcoming the differences between workplace mathematics and school mathematics identified by Wedege (2006).

In contrast to the above-mentioned challenges, the Workplace Mathematics project generated multiple examples of how school mathematics is necessary in several workplaces, e.g. the use of tables, graphs, units, mean values, calculations, and formulas. This is emphasised by the national curriculum as important for developing mathematical competence. Connections between school mathematics and its usefulness in real life were documented, including information about what kind of mathematics was used, where and how it was used, in addition to why it was needed in the workplaces.

By searching for similarities, the students also identified differences between school and workplace mathematics. The workplace tasks were more complex, had numerous units of measurement, there were several potential useful methods and not one definitive answer, and finally yet importantly, doing mathematics wrong could have severe consequences. Although Wedege argued that such differences can create a gap between school and workplace mathematics, they can also help students

develop a more flexible, nuanced view on mathematics. Identifying similarities and differences makes it possible to build bridges between school mathematics and workplace mathematics, as Evans (1999) suggested, and through this explicate the relevance of school mathematics.

The parents/guardians took part in a kick-off meeting, they were enthusiastic, and several of them were prepared when the students came. This was important for the documentation of numerous examples on how school mathematics is used in different workplaces. The students experienced that school mathematics was used and had practical consequences. Such outcomes can be used to positively influence students in viewing mathematics as relevant, and this constitutes a valuable contribution to their learning and motivation for school mathematics (Hernandez & Vos, 2018). Including links between school and workplaces in the mathematics curriculum can provide fruitful, joint reference points for students and teachers when doing tasks and make working with mathematics more meaningful. Furthermore, the examples can be used to build bridges between school and workplace mathematics by discussing e.g. the importance of choosing appropriate representations for mathematical concepts in a specific situation and moving flexibly between different representations. We therefore argue that engaging students to identify workplace mathematics is worthwhile. However, further research is needed to find ways to help students “explore how mathematics can be transformed to meet the needs of a range of diverse situations” (Wake, 2013, p. 315).

References

- Alrø, H., Skovsmose, O., & Valero, P. (2009). Matematik er noget man bruger til at lave lektier med. *MONA – Matematikk- og naturfagsdidaktik. Tidsskrift for undervisere, forskere og formidlere*, 5(2), 7–20.
- Berrefjord, O., Haugland, K. M. S., Nilssen, A., & Herheim, R. (2018). Fysioterapi og matematikk. *Tangenten – tidsskrift for matematikkundervisning*, 29(1), 27–30.
- English, L. D. (2010). Promoting student understanding through complex learning. In P. Brosnan, D. B. Erchick & L. Flevares (Eds.), *Proc. 32nd of the North American Ch. of the Int. Group for the Psychology of Mathematics Education* (Vol. 6, pp. 33–42). Columbus, OH: PME.
- Evans, J. (1999). Building bridges: Reflections on the problem of transfer of learning in mathematics. *Educational Studies in Mathematics*, 39(1–3), 23–44.
- FitzSimons, G., & Boistrup, L. (2017). In the workplace mathematics does not announce itself: towards overcoming the hiatus between mathematics education and work. *Educational Studies in Mathematics*, 95(3), 329–349.
- Freudenthal, H. (1991). *Revisiting mathematics education. China lectures*. Boston: Kluwer Academic Publishers.
- Hernandez-Martinez, P., & Vos, P. (2018). “Why do I have to learn this?” A case study on students’ experiences of the relevance of mathematical modelling activities. *ZDM Mathematics Education*, 50(1–2), 245–257.
- Hoyles, C., Noss, R., Kent, P., & Bakker, A. (2013). Mathematics in the workplace: issues and challenges. In A. Damlamian, J. Rodrigues & R. Strässer (Eds.), *Educational interfaces between*

- mathematics and industry. Report on an ICMI-ICIAM study* (pp. 43–50). Switzerland: Springer International Publishing.
- Hoyles, C., Wolf, A., Molyneux-Hodgson, S., & Kent, P. (2002). *Mathematical skills in the workplace. Final report to the Science, technology and mathematics council*. London: University of London.
- Masingila, J. O. (2002). Examining students' perceptions of their everyday mathematics practice. In M. E. Brenner & J. N. Moschkovich (Eds.), *Everyday and academic mathematics in the classroom* (pp. 30–39). Reston, VA: National Council of Teachers of Mathematics, Inc.
- Ministry of Education and Research (2010). *Mathematics subject curriculum*. Retrieved from <http://www.udir.no/kl06/MAT1-04/Hele/Formaal?lplang=eng>
- Nicol, C. (2002). 'Where's the Math? Prospective teachers visit the workplace. *Educational Studies in Mathematics*, 50(3), 289–309.
- Nunes, T., Schliemann, A. D., & Carraher, D. W. (1993). *Street mathematics and school mathematics*. New York: Cambridge University Press.
- Onion, A. J. (2004). What use is maths to me? A report on the outcomes from student focus groups. *Teaching Mathematics and its Applications*, 23(4), 189–194.
- Palm, T. (2008). Impact of authenticity on sense making in word problem solving. *Educational Studies in Mathematics*, 67(1), 37–58.
- Tronstad, T., Graff, S., & Herheim, R. (2017). Matematikk i musikkbransjen. *Tangenten – tidsskrift for matematikkundervisning*, 28(2), 23–25.
- Wager, A. (2012). Incorporating out-of-school mathematics: from cultural context to embedded practice. *Journal of Mathematics Teacher Education*, 15(1), 9–23.
- Wake, G., & Williams, J. (2001). *Using college mathematics in understanding workplace practice*. Manchester: University of Manchester.
- Wake, G. (2013). Drawing on understanding of workplace practice to inform design of general mathematics curricula. In A. Damlamian, J. Rodrigues & R. Strässer (Eds.), *Educational interfaces between mathematics and industry. Report on an ICMI-ICIAM study* (pp. 309–316). Switzerland: Springer International Publishing.
- Wedge, T. (2006). Menneskers matematikholdige kompetencer. In O. Skovsmose & M. Blomhøj (Eds.), *Kunne det tænkes? Om matematiklæring* (pp. 208–227). København: Mallings Beck A/S.
- Williams, J., & Wake, G. (2007). Black boxes in workplace mathematics. *Educational Studies in Mathematics* 64(3), 317–343.
- Willoughby, L. (2017). “When will I use this?” Preservice teachers’ beliefs and approaches to solving mathematics tasks. In E. Galindo & J. Newton (Eds.), *Proc. 39th annual meeting of the North American Ch. of the Int. Group for the Psychology of Mathematics Education* (pp. 877–880). Indianapolis, IN: PME.

Task design with a focus on conceptual and creative challenges

Jonas Jäder

Dalarna University and Umeå University, Sweden; jjd@du.se

Tasks are an important part of the education in mathematics. In an ongoing study, an analytic framework for identifying challenges in students mathematical task solving has been developed, and the conceptual and the creative challenge has been defined. Preliminary results indicate that considerations are needed to include these challenges in mathematical tasks. This paper takes off from there to describe a structure for selection and (re)design of tasks. The aim is to be able to discuss the basis for the structure. A further aim is to develop a support for teachers, test designers, textbook authors and others, in creating tasks with specific learning goals.

Keywords: Task design, challenges, mathematical concept.

Introduction

Tasks are a central aspect of the teaching and learning of mathematics. They may offer students an opportunity to learn and to gain understanding. One way of defining understanding is to manage different mathematical tasks and thereby also overcome obstacles (Sierpinska, 1994). Sriraman, Haavold and Lee (2013) however describe the concept of task difficulty as hard to define and to operationalize. One way of gaining insight into this may be to regard a task as possibly including different types of difficulties, with unique definitions. This also supports the idea of having clear intentions of what learning goals may be reached by solving a task, and to include criterion for success in line with these goals as important aspects of teaching (Brousseau, 1997; Brousseau & Warfield, 2014; Simon, 1995). The opportunities to learn depends on the design of the task and the cumulative effect of certain kinds of tasks is important to consider (Stein & Lane, 1996). Different learning goals imply the use of different kinds of tasks. The definition of two challenges, the conceptual and the creative challenge has, in an ongoing study, been developed from Lithner (2017), and an analytic framework has been developed to be able to identify and characterize these challenges. With a better understanding of tasks, their solutions, and the challenges included, a nuanced discussion of students' opportunities to learn is in focus. Central to the study has been to make it possible to make a distinction between the two challenges. However, the results also indicate that the two challenges exist together and possibly also interplay. One of the important ideas of the framework is that discrepancy between students prior understanding and experiences and what a task requires them to do, is what creates a challenge. Earlier research has indicated that students benefit from working on tasks where they are challenged to go beyond using routine procedures (Jonsson et al., 2014), solving mathematical problems, and struggling with mathematical ideas (Hiebert & Grouws, 2007). However, unfortunately, students in their task solving often use imitative approaches rather than deal with challenges (Sidenvall, Lithner, Jäder, 2015). Preliminary results from the ongoing study indicate that the sum of challenges, conceptual and creative ones, affects students' approach to the task solving. The students in the study, when overcoming conceptual challenges also overcame creative ones. There are however tasks with creative challenges, but no conceptual challenges.

This paper therefore, and supported by the framework and definitions previously developed, suggests a task design structure to include conceptual challenges to a greater extent in tasks, and specifically mathematical problems.

Background

Tasks used as artifacts in the teaching and learning of mathematics

A task in this paper is seen as an exercise intended to support the students' learning (Halldén, Scheja & Haglund, 2008). There is a clear distinction between mathematical problem solving, and other work on mathematical tasks, where a problem is a task to which the individual has no obvious method for solution (Schoenfeld, 1985). In contrast to mathematical problems, are tasks of routine character where the solution method is available to the solver as she identifies the type of question and what is a suitable, corresponding solution method. The use of mathematical tasks in the teaching and learning of mathematics highlights the relationship between task, student, teacher and the subject matter, mathematics. In this paper, the focus is on the design of the task. Brousseau (1997) suggests the arrangement of didactical learning situations, where students get to connect with specific mathematical ideas according to the learning goals of the task. The teacher, for a while, delegates the responsibility of taking actions on the task, to the student. So, the teacher acts on the student through an activity, in this case a mathematical task. It has been shown that a textbook and its tasks is important when teachers structure their teaching (Mullis, Martin, Foy, & Arora, 2012). It seems like a common way of approaching the textbook and its tasks, at least in a Swedish context, is by working from the beginning of each chapter and finish up when time has run out (Sidenvall et al., 2015). However, this may lead to students meeting few challenging tasks (Jäder, Lithner & Sidenvall, 2015). Simon and Tzur (2004) describe a relation between an activity, and the effects of performing the activity, to explain how thoughtfully designed tasks can contribute to the development of a student's conceptual understanding. To actively address specific learning goals, the selection, evaluation and possibly redesign of tasks is important.

Conceptual challenges

Mathematical concepts can be regarded as cognitive objects with different pieces of information attached to them. An ongoing encapsulation develops an elaborated picture of the concept within a person (Tall & Vinner, 1981). Conceptual understanding can be defined as the relationship between different pieces of information into an internal, mental network (Hiebert & Carpenter, 1992). Thus, the development of a conceptual understanding must have a student's current understanding as a basis (Simon & Tzur, 2004). Relationships are based on similarities and differences and, in a hierarchical way, on general and special cases, where a piece of information may include parts of another piece of information (Hiebert & Carpenter, 1992).

Tall and Vinner (1981) describe a difference between a person's concept image, and the formal concept definition. A person's concept image is the cognitive structure associated with a specific concept. It is a mental picture of properties and processes related to the concept (Tall & Vinner, 1981). The concept image develops over time, and with new experiences. The concept image, to a great deal, depends on the specific examples of the concept that a person has been presented to. Thus, a possible discrepancy between concept image and concept definition may occur with, for example, tasks

covering only a limited part of the aspects related to the concept (Niss, 2006). The part of the concept image that a student activates in a specific situation can be called the evoked concept image (Tall & Vinner, 1981). At times, a student's concept image will be challenged in some way. It may be either by meeting a situation where the mental picture is not covering enough or is not clear enough in relation to the demands of the situation. The new ideas are thus assimilated (Piaget, 1952) with what the student already knows, adding to the concept image. It may also be that the concept image is in contrast with new experiences, and requires the student to change the mental picture in some way to incorporate the new ideas. This is what Piaget (1952) describes as accommodation, which may be seen as a two-step process, where the first step is the adjustment of the existing concept image, and the second step is an assimilation of the new ideas.

For the purpose of this paper, a conceptual challenge is to make the necessary considerations of, and to properly use the (non-trivial) mathematical concepts, required in order to solve the task. For a task to include a conceptual challenge, there needs to be some kind of discrepancy between students' current (and evoked) concept image and a suitable concept image for the task.

Creative challenges

Creativity is defined as “the use of the imagination or original ideas to create something” (Creativity, n.d.). In a school setting, and relating to mathematical problem solving, mathematical creativity can be defined as a process resulting in what is, to the solver, a new solution (Sriraman et al., 2013). Hence, the solver, rather than using an available template has to create her new solution method. The definition does not contradict the idea that problem solving skills can be achieved at a basic level, as well as at a more advanced level. However, as problem solving does not mean following a given algorithm, the problem solving process is hard to predict. Explorations, and hypothesizing may well be part of a problem solving process. To argue that a familiar method is reasonable to apply in a new situation may also be defined as creating a substantial part of a solution method. The characteristics of tasks are important in catering for a learning environment where problem solving is made easily available to the students (e.g. Jonsson et al., 2014; Stein & Lane, 1996).

The definition of a creative challenge used in this research, is that the challenge is involved in the creation of what is to students, a new solution method, or the selection and modification of a familiar method in a new situation where the choice of method is not obvious. This can be either the creation of an overall method, sequencing a number of well-known and/or new sub-methods. Or it can be the creation of a new sub-method, as part of an overall solution method. Thus, for it to be a creative challenge, there needs to be a discrepancy between students' prior experiences and a conceivable method.

Task selection and (re)design to reach learning goals

The discrepancy between task requirements and students' concept image and previous experiences is here used as an indicator of the challenges of a task. Considering (reasonable) task challenges to be valuable to students' learning (Hiebert & Grouws, 2007; Jonsson et al., 2014), the discrepancy also refers to the opportunities to learn. Depending on the selection and the (re)design of tasks, different learning goals may be possible to obtain (Stein & Lane, 1996). Specific learning goals, and students' current state of knowledge are important factors for teachers when making informed teaching

decisions (Simon & Tzur, 2004). The decisions made in a selection and (re)design process can gain strength if informed by possible discrepancies and students' approaches to tasks.

Purpose

The purpose of this paper is to present and discuss a structure for the selection and (re)design of tasks, to include conceptual as well as creative challenges in a task. The aim of this is to empirically study the effects of the design structure with both students and teachers. A further aim is thus that the structure will be of help to teachers, but possibly also test designers, textbook authors and others participating in the selection and (re)design of tasks used for the teaching and learning of mathematics.

A structure for task selection and (re)design

This study, in line with the development of the framework for identifying conceptual and creative challenge, has a focus on discrepancies between students' concept image and their experiences with different methods, and what is required of them to solve a task. The discrepancy is a way to describe the opportunities to learn. By selecting and (re)designing tasks to fit a discrepancy to a specific learning goal, the opportunities to learn can be enhanced. There are assumptions about a student's knowledge, concept image, mathematical background and way of approaching a task, but may as well be assumptions of a (rather homogenous) group of students (Simon, 1995). The effects of a solution process depend on the learners' goal with the activity, possibly not tightly related to a learning goal, but for example to solve the task. Considering the importance of textbook tasks in mathematics classrooms, the structure makes use of existing tasks, gives support to an evaluation and suggests a direction for modification to these tasks.

1. The starting point of the structure is the learning goal. A well-defined learning goal is important to create a suitable task (Brousseau, 1997; Brousseau & Warfield, 2014, Simon, 1995). The learning goal is here described as aspects of a desired concept image. The description is focused on the concept(s) included in the learning goal, but also assumes that the learning goal is a clear widening of the understanding of a concept or the addition of a new concept (or property thereof).

Example: The learning goal is to develop a concept image including that unknowns can be represented as variables, and two unknowns can be related to each other through different relations and represented algebraically. An unknown can be part of several relations. Through such a system of relations each of the unknowns can possibly be determined.

2. The student's current state of knowledge (Simon & Tzur, 2004) is described in terms of a concept image and of experiences with solution methods linked to the mathematics in focus.

Example: The student's concept image is assumed to include that unknowns can be determined through the use of equations, where the unknown is represented by a variable and related to constants and coefficients in an equality. Methods for solving equations algebraically are familiar, as are trial and error approaches to tasks.

3. A candidate for a task in the area of the learning goal is found in the textbook.

Example: A group of friends visit a coffee bar. Some order coffee at the price of 16 kr per cup and some order caffè latte at the price of 24 kr per cup. When the bill arrives the total cost is 296 kr. How many had a cup of coffee and how many had caffè latte if there were 15 friends?

To be able to perform an evaluation of the suggested task a conceivable solution method and the possible creative and conceptual challenges related to these solutions are needed. The evaluation is based on the definitions of the challenges presented above.

4. Conceivable solution methods are proposed. Conceivable in this sense makes it necessary to also consider that the learners' goal is possibly not primarily the initially defined learning goal, but rather solving the task.

Example: The task can be solved in several way. Here, two example are presented.

a) The task can be solved by setting up and solving a system of equations

b) The task can also be solved by a trial and error approach.

5. Possible creative and conceptual challenges are visualized. The discrepancy between the proposed methods and students' prior experiences gives indications of creative challenges. The discrepancy between a, for each solution method suitable concept image, and an assumed concept images indicates possible conceptual challenges included in the task.

Example, creative challenge: a) Setting up a system of equations, and solving this is not familiar to the student and will thus be a creative challenge.

b) The student has experience with using trial and error to find the value of an unknown. In other context she has also experienced two unknowns, such as when suggesting a format for a rectangle a specific area. This will not be a creative challenge to the student.

Example, conceptual challenge: a) Not included in the student's concept image is how two variables can be represented in two relations. Further, the contexts, with relations based on two different quantities (number of cups and cost) requires the student to use the concept of unknowns and their relation to each other in a more flexible way. Thus, this is a conceptual challenge

b) When using a trial and error approach to solve the task, the student does not have to consider the relations of the two unknowns and how to represent them algebraically to the same extent. The approach is deemed to include no (or a low) conceptual challenge.

6. The possible challenges of the task are compared to the learning goal. The comparisons indicate in what way a task can be redesigned. If there are more than one conceivable solution method to the task, it is also important to consider all of these.

I) If the solution method avoids addressing the learning goal and the desired concept image, the task design should make the approach less favorable. Similarly, if the challenges is too small to address the learning goal, the design needs to consider this.

II) If the challenge related to the solution method is deemed to be too high, modifications to the task can be made if the learning goal can still be reached.

Example: I) The use of the method of trial and error in this case might not contribute to a conceptual challenge in a desired way, and might be possible prevent.

II) It is possible that the conceptual challenge, including a flexible use of unknowns related to two different quantities is too high. It might be possible to redesign the task so that this aspect is not included, however, still including a conceptual challenge addressing the learning goal.

7. Suggestions for adjustments of the task to meet the requests of the evaluations.

Example: II) Change the requirements to possibly lower the conceptual challenge of setting up and solving a system of equations: “Two families visit a coffee bar. Some order coffee and some order caffè latte. The Simpsons order 3 coffee and 2 latte, and the total cost is 96 kr, while the Bundys order 1 coffee and 3 latte, and their total cost is 88 kr. How much does a cup of coffee cost, and how much does a cup of caffè latte cost?”

I) Change the numbers of the task (and therefor also the context) so that trial and error is made less attractive to use: “Two families are building a shed each. For the exterior they need panel boards of different dimensions. They need thin panel boards and wide panel boards. The Simpsons buy 171,5 meters of thin panel boards and 39,5 meters of wide panel boards, and the total cost is 3692 kr, while the Bundys buy 48,2 meters of thin panel boards and 149,7 meters of wide panel boards, and their total cost is 4364 kr. How much does each of the different panel boards cost per meter?”

A redesign of the task takes into consideration all the information from the evaluation. A process of evaluating and redesigning may iterate until a desirable task where the discrepancy between the suitable concept image and the current concept image coincides with the learning goal.

Discussion

Following this theoretical paper are empirical studies of how the proposed structure for task design works in relation to both students and teachers. The next step is to try the structure, and to redesign a number of tasks starting with a specific learning goal. Yet another aspect to examine is the way teachers make use of the structure, and the way they understand the included terminology to enhance the opportunities for learning for students through task solving. There may be aspects where the theoretical construct does not oblige to the circumstances. On the other hand, the structure may possibly serve as a foundation for task design and for further elaboration on how this can be done.

One aspect to consider is how tasks work in a social context. Solving tasks and overcoming challenges together with others implies that, along with reconfiguring ones concept image, it may prove necessary to also create meaning within the group (Hiebert & Grouws, 2007). Included in such work should be considerations regarding how homogenous the concept images of a group of students really are.

The reflexive relationship between, for example a teacher’s considerations of a student’s work with a task and the design of the task, is likely to continue as the task is in use. As well as redesigning the task after the lesson, a teacher may also act in the moment to answer to a new evaluation of the situation. For example, as a teacher, it may not at all times be possible to fully capture what understanding of a concept implies. It is therefore important to let the task design structure and the evaluation phase continue during and after the task is used in the classroom. As one way of looking at understanding is to consider the difficulties a student encounters, the discrepancy between the suitable and evoked concept image may be possible to reformulate as the task is used in the classroom (Sierpiska, 1994; Simon, 1995).

References

- Brousseau, G. (1997). *Theory of didactical situations in mathematics*. Hingham: Springer.
- Brousseau, G., & Warfield, V. (2014). Didactical situations in mathematics education. In S. Lerman (Ed.). *Encyclopedia of Mathematics Education* (pp. 163-170). Dordrecht: Springer.

- Clements, D.H., Wilson, D.C., & Sarama, J. (2004). Young children's composition of geometric figures: A learning trajectory. *Mathematical Thinking and Learning*, 6:2, 163-184.
- Creativity. (n.d.). In *Oxforddictionaries.com* Retrieved from <https://en.oxforddictionaries.com/definition/creative>
- Halldén, O., Scheja, M., & Haglund, L. (2008). The contextuality of knowledge: An intentional approach to meaning making and conceptual change. In S. Vosniadou (Ed.), *International handbook of research on conceptual change* (pp. 509-532). New York: Routledge.
- Hiebert, J., & Carpenter, T.P. (1992). Learning and teaching with understanding. In D. A. Grouws (Ed.), *Handbook of research on mathematics teaching and learning* (pp. 65-97). New York: Macmillan Publishing Co, Inc.
- Hiebert, J., & Grouws, D. (2007). The effects of classroom mathematics teaching on students learning. In F. K. Lester (Ed.), *Second handbook of research on mathematics teaching and learning: A project of the national council of teachers of mathematics* (pp. 371-404). Charlotte: Information Age Pub.
- Jonsson, B., Norqvist, M., Liljekvist, Y., & Lithner, J. (2014). Learning mathematics through algorithmic and creative reasoning. *The Journal of Mathematical Behavior*, 36, 20-32.
- Jäder, J., Lithner, J., & Sidenvall, J. (2015). Reasoning requirements in school mathematics textbooks: an analysis of books from 12 countries. In J. Jäder (Ed.), *Elevers möjligheter till lärande av matematiska resonemang* (Licenciate thesis). Linköping: Linköping University.
- Lithner, J. (2017). Principles for designing mathematical tasks that enhance imitative and creative reasoning. *ZDM– The International Journal on Mathematics Education*, 49(6), 937-949.
- Mullis, I.V.S., Martin, M.O., Foy, P., & Arora, A. (2012). *TIMSS 2011 international results in mathematics*. Chestnut Hill (MA): Boston College, TIMSS & PIRLS International Study Center.
- Niss, M. (2006). The structure of mathematics and its influence on the learning process. In J. Maasz & W. Schloeglmann (Eds.), *New mathematics education research and practice* (pp. 51-62). Rotterdam: Sense Publishers.
- Piaget, J. (1952). *The origins of intelligence in children*. New York: International Universities Press Inc.
- Schoenfeld, A. H. (1985). *Mathematical problem solving*. Orlando: Academic Press.
- Sidenvall, J., Lithner, J., & Jäder, J. (2015). Students' reasoning in mathematics textbook task-solving. *International Journal of Mathematical Education in Science and Technology*, 46(4), 533-552.
- Sierpinska, A. (1994). *Understanding in mathematics*. London: Falmer.
- Simon, M. A. (1995). Reconstructing mathematics pedagogy from a constructivist perspective. *Journal for Research in Mathematics Education*, 26(2), 114-145.

- Simon, M.A., & Tzur, R. (2004). Explicating the role of mathematical tasks in conceptual learning: An elaboration of the hypothetical learning trajectory. *Mathematical Thinking and Learning*, 6(2), 91-104.
- Sriraman, B., Haavold, P., & Lee, K. (2013). Mathematical creativity and giftedness: A commentary on and review of theory. *ZDM– The International Journal on Mathematics Education*, 45(2), 215–225.
- Stein, M.K., & Lane, S. (1996). Instructional tasks and the development of student capacity to think and reason: An analysis of the relationship between teaching and learning in a reform mathematics project. *Educational Research & Evaluation*, 2(1), 50.
- Tall, D., & Vinner, S. (1981). Concept image and concept definition in mathematics with particular reference to limits and continuity. *Educational Studies in Mathematics*, 12(2), 151-169.

The Influence of Teacher Guides on Teachers' Practice: A Longitudinal Case Study

Ljerka Jukić Matić¹ and Dubravka Glasnović Gracin²

¹Department of Mathematics, University of Osijek, Croatia; ljukic@mathos.hr

²Faculty of Teacher Education, University of Zagreb, Croatia; dubravka.glasnovic@ufzg.hr

Keywords: Longitudinal case study, teacher guide, textbook mobilization.

The issues concerning the use of curriculum resources such as teacher guides and textbooks are important because they can promote a teacher's pedagogical design capacity, or a teacher's ability to use personal resources to adapt the curriculum materials and to achieve productive and beneficial instructional episodes in the classroom (Davis & Krajcik, 2005).

From the idea of teaching as design, Brown (2009) built a Design Capacity for Enactment Framework (DCE) which represents the idea that the curriculum resources and a teacher's personal resources both affect the designing and enacting of classroom instruction. Viewed together, the factors of the curriculum resources and teachers' resources provide a basis for understanding teachers' use of curriculum resources in terms of offloading, adapting, and improvising. These three concepts are different types of mobilization of curriculum resources and are best understood as a spectrum of agency or responsibility for guiding instruction (Brown, 2009). The voice of the curriculum resource refers to how the authors or designers of the materials are represented and how they communicate with the teacher (Remillard, 2012). Remillard (ibid) distinguishes between talking *through* the teacher and speaking *to* the teacher. Most curriculum resources place primary emphasis on what the teacher should do and this is denoted as talking *through* teachers. When the resource communicates with teachers about central ideas in the curriculum, this denotes speaking *to* the teacher. Some authors have argued that speaking *to* teachers is one way that curriculum resources can be designed to be educative for teachers (Davis & Krajcik, 2005). In this way, a curriculum resource offers transparent and direct guidance related to the reasons and purposes underlying task selections (design rationale) or in anticipating student responses (Stein & Kim, 2009).

Previous results on the utilization of resources in mathematics instruction in Croatia (Glasnović Gracin, 2011) show that the textbook is the primary resource in teachers' lesson preparation; the next most frequently used resource is the accompanying teacher guide. In 2014, new school textbooks were approved by the Croatian Ministry of Education for the subsequent four-year school cycle. Since the planned curriculum had not been changed, the new editions of the most frequently used mathematics textbook series did not undergo significant changes. However, in line with recommendations from the Ministry of Education, the teacher guides that accompany the textbooks were revised to include, for example, opportunities for discovery learning.

This situation, whereby the teacher guides were revised in 2014, while the planned curriculum and the textbook content remained the same, prompted us to conduct an investigation into the influence of teacher guides on teachers' practice. The study encompassed the following questions: 1) What are

the differences in the structure, textbook mobilization and voice between the two editions of the teacher guide? 2) How does the teacher guide influence the use of the textbook in the observed mathematics lessons? Do the changes in the content of the new edition of the teacher guide cause a change in teacher practice?

The study was conducted in two time spots, in 2013 and 2017. It encompassed analysis of the two editions of the teacher guide for grade six (published before and after 2014), classroom observations, and interviews with two experienced mathematics teachers in Croatia. Both of the teachers chosen for this study used the same textbook series in 2017 as they did in 2013. The analysis of the transcribed interviews, observation notes and teacher guide content focused on the different mobilizations of resources (offloading, adapting, improvising). The interviews also provided an opportunity for the teachers to explain why a particular type of resource mobilization was used.

The results show the relative stability of teaching practice, but suggest, however, that the teacher guide can have an influence on the instruction. The analysis of the teacher guides showed that both editions have the same structure. The voice of the guides can be described as talking *through* the teacher, but the design of the activities in the new edition can be defined as transparent. Moreover, the new edition contains additional activities and approaches such as discovery learning. While for most lessons the old teacher guide encourages offloading, the new guide additionally suggests numerous activities that do not use the textbook as a mediator, which promotes adapting and improvising with curriculum resources. In terms of the teachers' practice, the results show that the new edition of the teacher guide inspired the participants to design their own inquiry-based learning activities and that offloading is utilized less often. This indicates that the teacher guide can have an educative impact on teachers, supporting their use of active teaching methods in the classroom.

References

- Brown, M. (2009). The teacher-tool relationship: Theorizing the design and use of curriculum materials. In J. T. Remillard, B. A. Herbel-Eisenmann, & G. M. Lloyd (Eds.), *Mathematics teachers at work: Connecting curriculum materials and classroom instruction* (pp. 17–36). New York: Routledge.
- Davis, E. A., & Krajcik, J. S. (2005). Designing educative curriculum materials to promote teacher learning. *Educational Researcher*, 34(3), 3–14.
- Glasnović Gracin, D. (2011). *Requirements in mathematics textbooks and PISA assessment*. (Unpublished doctoral dissertation). University of Klagenfurt, Klagenfurt, Austria.
- Remillard, J. T. (2012). Modes of engagement: Understanding teachers' transactions with mathematics curriculum resources. In G. Gueudet, B. Pepin, & L. Trouche (Eds.), *From text to 'lived' resources: Mathematics curriculum materials and teacher development* (pp. 105–122). New York: Springer.
- Stein M. K., & Kim, G. (2009). The role of mathematics curriculum materials in large-scale urban reform: An analysis of demands and opportunities for teacher learning. In J. T. Remillard, B. A. Herbel-Eisenmann, & G. M. Lloyd (Eds.), *Mathematics teachers at work: Connecting curriculum materials and classroom instruction* (pp. 37–55). New York: Routledge.

Community documentation targeting the integration of inquiry-based learning and workplace into mathematics teaching

Elissavet Kalogeria and Giorgos Psycharis

National and Kapodistrian University of Athens, Greece

ekaloger@math.uoa.gr, gpsych@math.uoa.gr

In this paper we describe the process of designing and implementing inquiry-based tasks relating mathematics and workplace context, through the collaboration of four teachers from different schools. Our focus is on the factors that influence the forms of inquiry integrated in community documentation. A common open task took different forms of inquiry during the implementation depending on factors such as the students' mathematical abilities, the specificities of the different school contexts and the prerequisite mathematical knowledge. The process of teachers observing each other's classroom implementations (hetero-observation) became the incentive for subsequent transformations of the shared resources, favoring the shifts from one form of inquiry to another.

Keywords: Inquiry-Based Learning, Workplace context, Community documentation.

Introduction

The reported study took place in the context of the European-funded project Mascil (www.mascil-project.eu) that targeted mathematics and science teachers' professional development (PD) through the integration of inquiry-based learning (IBL) and workplace contexts into their teaching. In this paper, we study the process of design and implementation of resources by a group of mathematics teachers from different schools who collaborated to conceive IBL tasks stemming from the 'Kite making industry' that was selected by them as the workplace context to develop their design. The importance of introducing inquiry into the teaching and learning process has been recognized by the existing research (Boaler, 1998) and constitutes a main aim of many mathematics curricula and teacher education programmes. Also, there is a growing interest concerning the nature of resources and contexts facilitating the integration of inquiry into classroom teaching (Doorman, 2011). This integration increases the complexity of teaching as it brings to the fore issues such as the nature of the designed tasks, the teaching management and the students' learning (Artigue & Blomjoi, 2013), thus teachers are reluctant to use IBL in their everyday practices (Bruder & Prescott, 2013). At the same time, it has been indicated that workplace contexts may offer rich opportunities for teachers to introduce authentic situations into their teaching (Wake, 2014) through open problems. The design and implementation of resources for mathematics linking IBL and workplace contexts constitutes an innovation since existing curricula rarely include this type of materials, so teachers' collaboration in this direction is crucial. Existing literature indicates the facilitative role of teachers' participation in communities in their professional development and more specifically when introducing educational innovations (Lerman & Zehetmeier, 2008) such as the one targeted by Mascil. However, how teachers collaborate to design and implement innovative tasks linking IBL and workplace is an area that requires further study. Under this perspective, in this paper, we explore the factors that influence the design/implementation of IBL tasks relating mathematics and workplace contexts during collaboration among teachers from different schools.

Theoretical framework

The integration of IBL into the mathematics classrooms presupposes the transformation of the traditional teaching practices. Doorman (2011) indicates the shift in the teachers' roles from telling to supporting, scaffolding and fostering students' reasoning, while students pose questions, inquire, explain, extend, evaluate and collaborate. He highlights the need for new classroom norms and learning environments incorporating open problems with multiple solutions through the use of tools and resources. Artigue and Blomjoi (2013) also indicate the 'authenticity' of questions and students' activity that requires connection with real life and out-of-school questions fostering the experimental dimension of mathematics. Inquiry can take three forms (ibid): (a) Structured: The teacher provides the students with the appropriate method/materials to solve the given problem. (b) Guided: The teacher provides the students with the necessary materials and the students have to find the appropriate strategies for solving the given problem. (c) Open: The students have to find problems or questions they would like to solve and chose the methods/materials for solving them.

The crucial role of resources has been discussed in terms of the documentational approach of didactics (DAD, Gueudet & Trouche, 2009) focusing on teachers' interactions with resources as a way to capture teachers' professional development. The term *resource* describes a variety of artifacts such as a textbook, a piece of software, discussions with colleagues etc. An integral part of teachers' professional activity is the search, selection and modification of resources as well as their implementation in class working individually or collectively with colleagues. This process – called documentational genesis - results to a document after classroom implementations. Through a class of professional situations and teachers' experience, the existing resources are modified as documents that can be further transformed to new documents over time. The process of gathering, creating and sharing resources to achieve the teaching goals in the context of a community is called *community documentational genesis* resulting in the *community documentation* composed of “the shared repertoire of resources and shared associated knowledge (what teachers learn from conceiving, implementing, discussing resources)” (Gueudet & Trouche, 2012, p. 309). In this study, the group of participating teachers is considered as a community of practice (Wenger, 1998) characterized by mutual engagement (collaborative norms and relationships), joint enterprise (common goals) and shared repertoire (collaborative production of resources). IBL has been studied in relation to different theoretical frameworks (Artigue & Blomjoi, 2013) but not in relation to DAD and community documentation. Linking IBL and workplace contexts is a challenging research area (Triantafillou et al., 2016) in terms of the factors that influence teachers' collaborative work. In this paper, we explore the community documentation aiming to link IBL and workplace contexts by the following research question: Which factors influence the forms of inquiry integrated in community documentation of IBL tasks relating mathematics and workplace contexts?

Methodology

Context and participants

The implementation of Mascil in Greece included thirteen groups of 8-12 practicing teachers from mathematics, science and technology. In each group, the teachers collaborated in two cycles of design→implementation→hetero-observation→redesign with reflection as a core element, for a

school year with the support of a teacher educator. PD meetings took place before and after each implementation. In the first two PD meetings, teachers were introduced to the project rationale as well as to the main principles of IBL and workplace mathematics. In the next meetings, teachers collaborated in subgroups to transform existing Mascil tasks or design new ones in the same spirit and reflect on their experiences from the implementations. In the end of the project, the participating teachers were interviewed so as to address the impact of the PD program on their professional development. In this paper, we focus on a subgroup of four qualified mathematics teachers: tA (PhD), tB (Master degree, teacher educator), tC (Master degree) and tD (teacher educator). They collaborated in the design and implementation of two tasks (*Stairs* and *Kites*). Here we study the case of *Kites*. Implementation took place in different grades (Figure 1) in four public secondary schools of Athens. tB's school is experimental, i.e. it is connected to the university, it supports experimental teaching methods and students are selected after examination. Hetero-

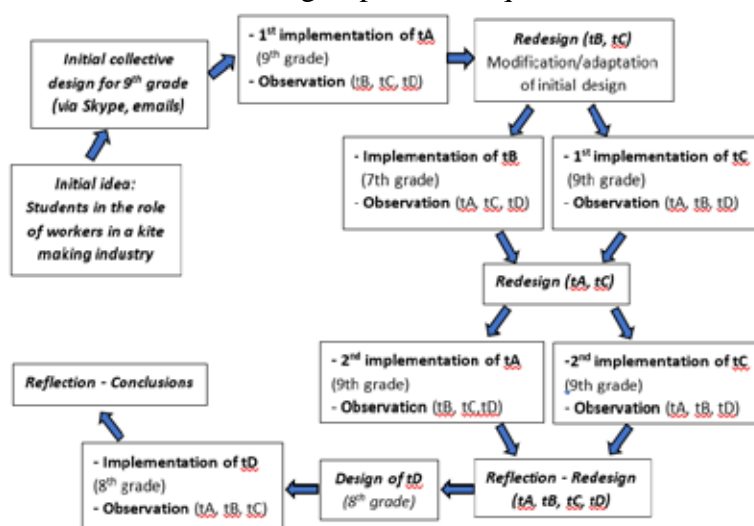


Figure 1: The process of implementation

observation informed the subsequent transformations of the initially shared resources.

The task

The task was formulated gradually through discussions among the four teachers having as a starting point the idea of kite making. Factors that influenced the task design were the multiplicity of issues inherent in the construction of kites, the targeted mathematical content and its connection to the curriculum as well as the need to leave space for the students to become partners in the formulation of the problem. The initial common assumptions were: (i) *The initial idea*: Students' adopt the role of employees in a small kite making industry aiming to optimize the amount of paper used. (ii) *Preparing the implementation*: Students work in groups, search for the following information in real-life sources and upload it in an e-class folder: (a) the kind of paper used for kites (dimensions, package, cost); (b) shapes/dimensions of kites with a focus on: regular hexagon of diameters 80cm, 100cm and 120cm respectively that can be consisted of 6 equilateral triangles, or 2 isosceles trapezoids, or 4 right trapezoids with different colors; regular octagon of diameters 80cm, 100cm and 120cm respectively consisted of 8 isosceles triangles; and rhomboid. (iii) *Integrating IBL*: Based on the students' collected information, the regular octagon and the rhomboid were excluded.

Data collection and analysis

The collected data consisted of: (1) teachers' e-mail messages; (2) transcripts of PD meetings; (3) teachers' resources (lesson plans, worksheets, ppts, digital files); (4) teachers' notes from hetero-observation; (5) teachers' activity reports; (6) teachers' interviews; (7) videos from classroom

implementations. Following DAD methodology (Gueudet & Trouche, 2012): (a) we analyze teachers' work in time periods in and out-of-class (reflexive investigation principle); (b) we address their decisions taken in order to formulate their design through its use (design-in-use principle); and (c) we consider their work embedded in and influenced by different collectives such as the PD meetings (collective principle). We used data from different time periods: excerpts from their hetero-observation notes that took place before and after their own implementation, the developed materials and their transformations over time including the arguments with which they documented their options and presented in the PD meetings and in their activity reports.

Results

Preparation and initial designs

In this phase, the teachers worked on the initial idea aiming to formulate and orient the problem. Their documents included preparatory activities for hexagonal kites of 80cm diameter (since they were the most common type) aiming to help students understand that: (1) this kind of kite cannot be constructed by a single rectangular sheet of paper, thus the hexagon has to be divided in smaller different geometrical shapes; (2) hemming is necessary (i.e. each sheet edge is creased and rolled over onto itself) in order to make the kite robust; (3) companies save paper by using the remnants for the tail; (4) paper cost depends on the type of package and paper size. The initial document of tA for the 9th grade included an open task and it was further refined collectively by the group of teachers as follows: *“We are workers in a kite making company. Our director suggests reducing the waste of paper. So today we will work in groups focusing on the case of regular hexagon kites of 80cm diameter to explore the ways by which a hexagonal kite can be composed by different geometrical figures and the amount of paper needed. The dimensions of the paper we use are 70×100, the package includes 46 pieces and costs 23€. In order to reduce the paper, our company decided to construct the kite tail with newspapers instead of the remnants (as we used to do). Thus, our aim is to minimize the remnants of the paper by exploring how to combine different geometrical figures. These figures can be: (a) 2 isosceles trapeziums; (b) 4 rectangular trapeziums; (c) 3 rhombs; (d) 2 rectangles and 2 isosceles triangles; (e) 6 equilateral triangles. For gluing the internal figures, we use adhesive tape while for the external segments comprising the perimeter of the hexagon we use hemming. The hem is an isosceles trapezium of 4cm height”.*

Students work in groups and study one of the above five cases. Below, we provide a brief description of the corresponding activities: (1) Students are given an 8×3 table (Figure 2). The first row includes two rectangles representing respectively a real sheet of paper (with known dimensions) and a 1:4 scale one. The students have to compute the dimensions of the 1:4 scale rectangle. The next six rows correspond to the above mentioned five combinations by which hexagonal kites can be constructed. In the second and the third column, regular hexagons are given representing respectively a real kite and a 1:4 scale one. For each combination of shapes the

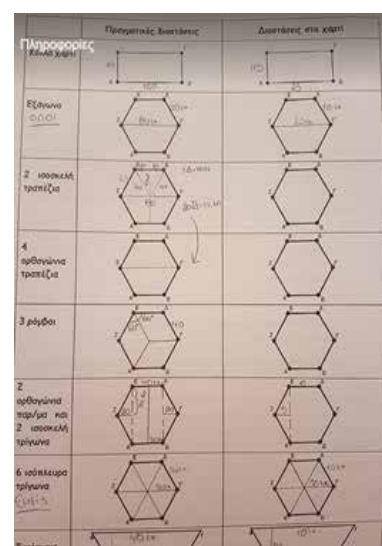


Figure 2: A completed worksheet of activity 1

students have to divide the given regular hexagon in corresponding parts and compute both the dimensions of the real kite and the ones of the 1:4 scale. In the last row, the students are asked to compute the dimensions of two given isosceles trapezoids representing the hems of the real kite and of the 1:4 scale respectively. (2) Each group announces the results to the whole class. (3) In a millimeter paper and in a 1:4 scale each group represents the real rectangular sheet and explores if a regular hexagon with peripheral hems fits within it. Then, they confirm that this construction is not possible through the use of a given Geogebra file. (4) The students cut with scissors the geometrical figures they worked on in the first activity (including their peripheral hems), put them down on millimeter papers (1:4 scale of the real paper) and glue them when achieving the best coverage (minimizing gaps). In this activity, students experiment to achieve the best coverage by combining their own geometrical figures with other groups' figures. They confirm their findings through the Geogebra file. (5) The groups exchange their cut geometrical figures to optimize their coverage.

The computations mentioned above, required the knowledge of properties of regular polygons, Pythagorean Theorem and trigonometry taught in 8th grade. The four teachers planned to implement the task as follows: tA and tC in 9th grade, tB in a 7th grade and tD in 8th grade. So, they adapted the initial design taking into account the respective curriculum and their different contexts. tC, for instance, whose class included many low achievers, expressed her concerns about her students' required knowledge. Thus, she designed a preparatory lesson aiming to remind the properties of the basic geometrical figures embedded in the kite construction as well as the steps for constructing a regular hexagon with ruler/compass. Then, the students were

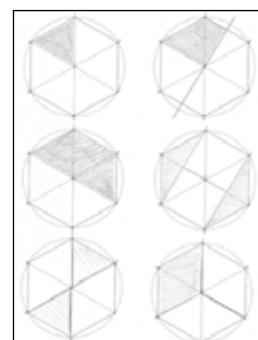


Figure 3: Dividing a regular hexagon

asked to divide given regular hexagons in corresponding parts (see a filled worksheet in Figure 3). At the same time, tB excluded the computations of the given figures' dimensions, since the 7th grade students do not have the required knowledge. His emphasis was on the concepts of scale and symmetry. In his design the regular hexagons and their geometrical components (both with peripheral hems) were given (Figure 4) and the students were asked to reproduce them in a sheet of paper (1:4 scale) and cut their components with scissors. He targeted the exchange of geometrical figures among the groups and the exploration of the best coverage with different combinations by using more than one sheets of papers. Finally, tD exploited the initial collective design for teaching the properties of regular hexagons in the 8th grade. Summarizing, community documentation in this phase revolved around a common body of activities of the initial design. Besides, they concentrate mainly on adaptations related to the curriculum and to their students' mathematical abilities/weaknesses.

	The kite	...and its components
2 isosceles trapeziums		
4 right trapeziums		
3 rhombs		
2 isosceles triangles & 2 rectangles		
2 isosceles triangles & one rectangle		
6 equilateral triangles		

Figure 4: Hems and geometrical components

Implementations and redesigns

The first implementation took place in a 9th grade classroom of tA. Despite the fact that the whole process fascinated the students, but it was time consuming since: (1) Mistakes in the calculations

and wrong application of geometric properties were noticed. (2) Each group undertook the calculations of a specific combination of geometrical components and communicated the results to the others. This process has been time consuming and students of one group may did not understand the calculations of the other groups. (3) The construction of the 1:4 scale hexagon on a millimeter paper and the cutting of its components based on the previous calculations were also time consuming. These difficulties resulted in the limitation of students' exploratory activity (e.g., there was no time left for exchanging the cut geometrical figures across the groups) and the failure to complete the lesson in the foreseen two hours.

The process of hetero-observation allowed the rest of the teachers to modify their initial designs by giving students ready-made materials (i.e. rectangles 17.5×25cm representing the real sheet for kites and regular hexagons of diameter 20cm with hems representing a real kite, all in a 1:4 scale) so as to have more time for exploration. The lesson of tB in a 7th grade classroom of his experimental school (where exploration and group work constitute common practices) embodied elements of both guided and open inquiry. He prioritized the use of manipulatives and digital representations (Geogebra) as a main element of IBL. After experimentation with different combinations for covering the 17.5×25 sheet, two groups of students decided that the optimal



Figure 5: the combination of two groups

coverage of a sheet was achieved by the use of 2 rhombs and 2 equilateral triangles (Figure 5). Thus, 3 sheets include 6 rhombs and 6 equilateral triangles and allow the construction of 3 kites (2 kites with rhombs, 1 kite with equilateral triangles). This way the numbers of equilateral triangles and rhombs needed should be multiples of 6 and 3 respectively. Since each package includes 46 pieces, the students reached the notion of Least Common Multiple (LCM) as appropriate for finding the best solution (we note that LCM was not explicitly part of the teachers' design). Therefore, with three packages (138 sheets=LCM (3, 6, 46)) they could construct 138 kites (46 with equilateral triangles and 92 with rhombs). This finding provided an incentive for other groups to optimize the final solution. The lesson closed with a whole class discussion where the best solution was chosen and the connections to the realistic context (kite making industry) became explicit.

The emergence of the notion of LCM was not taken into account in the initial design and challenged further the teachers' reflection. Thus, the second implementations of tA and tC were characterized by a more conscious attempt of the two teachers to bring to the fore the notion of LCM. However, while tA's students' exploration resulted in better solutions in terms of paper save and diversity of combinations, tC's students faced a lot of difficulties. For instance, one group of tA used 4 sheets to construct 4 kites with three different combinations (i.e. 2 kites with trapeziums, 1 with equilateral triangles, and 1 with 2 isosceles triangles and 2 rectangles). Through the use of LCM, these students concluded that with the use of 92 sheets they can construct 92 kites of the above three different combinations. During her implementation (9th grade), tC faced the difficulties of tA's first lesson and also many students did not understand the role of hemming. As a result, the notion of LCM was not exploited to offer multiple solutions. tC in her activity report mentioned "I should have engaged them in the construction of a real kite with the use of paper and wooden straws". A comparison of the two implementations shows that tA followed an open form of inquiry taking more time than

expected (3 teaching hours instead of 2), while tC - due to her students' low mathematical abilities - followed a structured form of inquiry downgrading the demands of the task.

The last implementation was carried out by tD in a 7th grade classroom. By observing the other teachers' teaching, she realized that many problems stemmed not only from the calculations but mainly by obstacles in the process of groups' exchange of geometrical components. Thus, she decided to support the communication among the groups by taking the role of 'crier', 'circulating' around and showing different geometrical figures so as to facilitate the choice of other groups' figures that minimize the free space in their sheets (i.e. she showed specific groups' solutions to the other groups highlighting the free parts of the sheet and motivating them to conceive its best coverage or its reconstruction by using some of their own geometrical figures). Besides, this choice was also related to the fact that the students' initial attempts left uncovered big parts of the sheet. In her activity report, tD considers that "A real kite construction in the classroom would have revealed to the students that a large amount of paper is lost". Her implementation embodied both guided and open inquiry: the first part of the worksheet offered guidance to the students in the introduction of the corresponding notions in the realistic context while in the second part of the lesson tD emphasized the importance of communication among the groups keeping a mediating role for her.

Discussion and concluding remarks

In the preparation and initial design phase, the main issue was the orientation of the task consisted of: (i) the openness of the task; (ii) the embodied mathematical concepts; (iii) the specificities of constructing a real kite (kinds, dimensions, hemming, paper packages, costs); (iv) the complexity of mathematical exploration (geometrical figures and their properties, multiplicity of solutions); (v) the connection to the workplace context (cost, constrains in the use of paper) and the need of students' engagement in collecting relevant information; (vi) the roles of teachers and students; and (vii) the teaching management. The data collected by the students revealed the specificities of kite construction and the teachers' documents were adapted to their different school grades/contexts.

In the implementation phase, the initial open task took different forms of inquiry. The initial open approach of tA, brought to the fore issues that took time from inquiry. The open inquiry increased the level of uncertainty and resulted in not having a solution by the end of the first lesson. The process of hetero-observation was critical since: (1) tB adopted guided and open inquiry bypassing the time-consuming elements of tA's teaching and including ready-made materials to ensure more time for inquiry. This choice facilitated the emergence of concepts not initially anticipated by the teachers (i.e. LCM) and left space for unexpected solutions to emerge. (2) tA (in her second lesson) and tD followed guided inquiry aiming to facilitate students to approach gradually the notion of LCM and help them to find as many solutions as possible. They used ready-made manipulatives and their teaching management was aligned to support IBL and communication between the groups (i.e. tD acting as crier) targeting intentionally the emergence of different solutions through the notion of LCM. This kind of activity strengthened the connections to the workplace context and led to the extension of the mathematical inquiry (i.e. multiple solutions from tA's students). Finally, the tC's belief concerning her students' low mathematical abilities resulted in a structured form of inquiry. She tended to decrease the level of uncertainty by providing resources aiming to remind

students the properties of the basic geometrical figures embedded in the kite construction. However, the low mathematical abilities of tC's and tD's students were again a factor that limited the emergence of multiple solutions. Another factor was students' difficulties in understanding the role of specific parts of kite construction (e.g. hemming). This was indicated in tC's and tD's reflections where they stressed the importance of engaging students in the construction of a real kite.

Summarizing, the factors that influenced the adopted forms of inquiry were: teachers' conceptions of their students' mathematical knowledge; the different school contexts (e.g., differences in students' prior mathematical experience, classroom norms, familiarization with IBL approaches); and the range of the prerequisite knowledge. The connection to the workplace context favored the emergence of mathematical concepts but the limited available time led teachers to structured or guided forms of inquiry. Hetero-observation facilitated the sharing of teachers' associated knowledge by promoting awareness of the above factors and became the incentive for subsequent modifications of the shared repertoire of resources, favoring shifts from one form of inquiry to another. In conclusion, these factors influenced the community documentation indicating hetero-observation as a catalyst mediating in a dynamic way the evolution of design and implementation.

References

- Artigue, M. & Blomhøj, M. (2013). Conceptualizing inquiry-based education in mathematics. *ZDM—The International Journal on Mathematics Education*, 45(6), 797–810.
- Boaler, J. (1998). Open and closed mathematics: Student experiences and understandings. *Journal for Research in Mathematics Education*, 29(1), 41–62.
- Bruder, R. & Pescott, A. (2013). Research evidence on the benefits of IBL. *ZDM—The International Journal on Mathematics Education*, 45(6), 811–822.
- Doorman, M. (2011). PRIMAS WP3 – Materials: Teaching and professional development materials for IBL (version 2). Found on: <http://www.primas.project.eu/>
- Gueudet, G., & Trouche, L. (2009). Towards new documentation systems for teachers? *Educational Studies in Mathematics*, 71(3), 199-218.
- Gueudet, G., & Trouche, L. (2012). Teachers' work with resources: Documentational geneses and professional geneses. In G. Gueudet, B. Pepin, & L. Trouche (Eds.), *From text to 'lived resources': curriculum material and mathematics teacher development* (pp. 23-41). New York:.
- Lerman, S., & Zehetmeier, S. (2008). Face-to-face communities and networks of practicing mathematics teachers. In K. Krainer & T. Woods (Eds.), *Participants in mathematics teachers education* (pp. 133–153). Rotterdam/Taipei: Sense Publishers.
- Triantafillou, C., Psycharis, G., Potari, D., Zachariades, T. & Spiliotopoulou, V., (2016). Studying secondary mathematics teachers' attempts to integrate workplace into their teaching. *Proceedings of the 3rd ERME Topic Conference: Mathematics Teaching, Resources and Teacher Professional Development* (pp. 298-307). Humboldt University of Berlin, Germany.
- Wenger, E. (1998). *Communities of practice. Learning, meaning and identity*. New York: Cambridge University Press.

The use of variation theory in a problem-based task design study

Berie Getie Kassa¹ and Liping Ding²

¹Bahir Dar University, Ethiopia & NTNU, Norway; beriekassa@gmail.com

²NTNU, Norway; liping.ding@ntnu.no

The aim of this pilot study is to test the usefulness of variation theory as a theoretical framework in guiding the researcher to design the main study of developing students' deep learning in mathematics. Both Marton's variation theory of learning and Gu's theory of teaching with variation were used in the design-based pilot study. Two teachers and 106 Grade four students from an elementary school in a large north-west city in Ethiopia participated in the pilot study. The pilot study data included transcripts of audio-recording of preparatory meetings (the first author with the two teachers) and students' interview, video-recording of lesson observation, and pre and post-tests. The pilot study topic was of learning concepts of area and perimeter of rectangles. We find that the theoretical framework of variation helped us to address the systematic use of patterns of variation and invariance in the problem-based task design and to analyze the three patterns of variation in the problem-based tasks implementation in the classroom learning.

Keywords: Variation theory, patterns of variation and invariance, problem-based task design.

Introduction

School mathematics curriculum has been significantly reformed from kindergarten to upper secondary school in Ethiopia. Consequently, school mathematics is now viewed from a dynamic and experimental perspective rather than only as a body of strict and logical knowledge already in existence (MOE, 2013). However, the national learning assessments have constantly shown that students have achieved poor results in all areas, and their achievement in mathematics is the least (MOE, 2013). For example, the fourth national learning assessment (FNLA) result has shown that the overall test performance of grade 8 students in 2013 was far below the national minimum achievement standard of 50%, and their achievement in mathematics is the lowest (the composite average became 25.65%), where 50% of the students scored at or below a score of 22.5% similar in both sampled grades 4 and 8 (MOE, 2013). According to the FNLA reports in 2013, the education of mathematics should receive special emphasis in all deliberations, for example, the use of teaching and learning resources, and professional development of teachers about innovative pedagogies.

The overall objective of this study is therefore to make a contribution to developing the quality of mathematics teaching and learning in Ethiopia. This pilot study is to test the usefulness of the variation theory as a theoretical framework in guiding the researcher to design and implement problem-based tasks to improve students learning in mathematics. In this paper, we mainly focus on the following two research questions: (1) *to what extent does the theoretical framework help to design the instruction of problem-based tasks?* (2) *to what extent does the theoretical framework help to analyze the implementation of such design in the classroom?*

Literature Review and Theoretical Framework

Marton's Variation Theory of Learning (VToL)

Ference Marton and his colleagues in Sweden and Hong Kong have developed Variation Theory of Learning (VToL) to describe how a learner might come to see, understand, or experience a given phenomenon in a certain way (Marton, 2015; Marton & Booth, 1997; Marton & Pang, 2006; Marton & Tsui, 2004). For instance, Marton and Booth (1997) emphasized that one cannot become aware of new aspects without becoming aware of differences. If certain aspects of a phenomenon are varied while its other aspects are kept constant, then those that vary will be noticed. Every concept, situation or phenomenon has particular or critical aspects, and it is important to identify the critical aspects and the focus of students' attention should always be directed to the critical aspects (Lo, 2012). In order for students to discern the critical aspects of a concept(s), they need to experience different forms of variation in which the critical aspects of the concept(s) will be varied and not varied. Moreover, VToL addresses that for learning to occur, some critical aspects of the object of learning must vary while other aspects remain constant. According to VToL, the specific knowledge/content or capability to be gained through learning is called the object of learning (Lo, 2012; Marton & Pang, 2006; Marton & Tsui, 2004). VToL takes the object of learning as the point of departure and claims that what is being learned is highly influenced by what actually comes to the forefront of students' attention. Kullberg, Runesson and Marton (2017, p. 561) explained that "when analyzing how the object of learning is handled during teaching, the 'intended', the 'enacted', and the 'lived' objects of learning are used to differentiate between the teacher's particular goal regarding what the students should learn, what is made possible to learn in the lesson, and what the learners actually learn". The theory further suggests that how students perceive a specific object of learning depends on what pattern of variation and invariance is provided by the teacher. Four patterns of variation and invariance are identified: contrast (i.e., recognizing differences between two values of an aspect), generalization (i.e., keeping the focused feature invariant and varying other out of focus aspects), separation (i.e., separating aspects with varying values from invariant aspects), and fusion (i.e., experiencing several critical aspects simultaneously) (Leung, 2012; Lo, 2012; Marton & Tsui, 2004). Marton (2015) further proposed a new pattern of variation in which only three of the four patterns, i.e., contrast, generalization, and fusion exist as the basic ones, which are observed by learners.

Gu's Teaching with Variation (TwV)

In parallel with Marton's theory of variation, a theory of mathematics teaching and learning, called Teaching with Variation (TwV) (*bianshi jiaoxue* in Chinese), has been developed by Gu Ling-yuan and his colleagues through a series of longitudinal mathematics teaching experiments in China (Gu, 1994). According to Gu's theory, which was highly inspired by the theory of cognitive constructivism, meaningful learning empowers learners to establish a significant and non-arbitrary connection between their new knowledge and their previous knowledge (Gu, Huang, & Marton, 2004). Classroom activities can be designed to help students to create this kind of connection by experiencing certain dimensions of variation. Gu's theory of TwV suggests that two types of variation are helpful for meaningful learning. One is called "conceptual variation", and the other is "procedural variation" (Gu et al., 2004). Conceptual variation refers to understanding concepts from multiple

perspectives. Procedural variation is progressively unfolding mathematics activities. That is, teaching process-oriented knowledge by enhancing the formation of concepts step-by-step, and experiencing problem-solving from simple problems to complicated problems (Gu et al., 2004).

Based on the above literature, we formed an initial analytical framework (see Table 1) to guide us in designing an instruction and implementing such design in the pilot study.

Theories	Theoretical terms	The use of the theoretical terms in both design and implementation of an instruction of problem-based tasks in the pilot study
Gu's TwV (Gu et al., 2004)	<ul style="list-style-type: none"> · conceptual variation · procedural variation · non-arbitrary connection b/n new and prior knowledge · systematic and step-by step way of problem-solving 	1. Design of the instruction of the problem-based tasks: <ul style="list-style-type: none"> · Conceptual variation (concept and non-concept variation). · Procedural variation (varying methods, problem transformations, connection within and between the problems) (for details see finding one below).
Marton's VToL (Marton, 2015; Marton & Tsui, 2004)	<ul style="list-style-type: none"> · object of learning (intended, enacted and lived object of learning) · critical aspects of the object of learning · variation and invariance · Three patterns of variation (contrast, generalization, and fusion) 	2. Implementation of such design <ul style="list-style-type: none"> · The analysis focused on how the designed tasks are planned (intended), taught (enacted), and learned(lived) (explained in the findings section). · Two critical aspects of an object of learning were designed (see Table 2). · Each critical aspect was brought into focal awareness through the systematic use of variance and invariance of values of each aspect, and all were experienced and discerned simultaneously (for details see finding two below).

Table 1: The analytical framework of Gu's and Marton's work of 'variation'

Methodology

Research Design

This study was based on the principles of design research (Cobb, Jackson, & Dunlap, 2016). According to Cobb et al. (2016), design research is a research approach that has been increasingly appreciated in mathematics education research. It can help to construct the instructional ways of promoting learning of a particular concept, while regularly studying the development of that learning, considering all components of the instructional ways, including the context in which it is carried on. According to Cobb et al. (2016), some of the main characteristics of design research approach is its highly interventionist nature, iterative design and cyclic nature. Each cycle progresses in three phases: (i) preparation and design of teaching experiments; (ii) implementation of teaching experiments; and (iii) retrospective analysis that can lead to revisions and a new cycle (Cobb et al., 2016). In this pilot study, two teaching experiments, in two fourth grade classes of 106 students, were conducted in their regular classes, during a 45 minutes period for each class. The two classes were taught by the same teachers and the study design is illustrated in Figure 1.

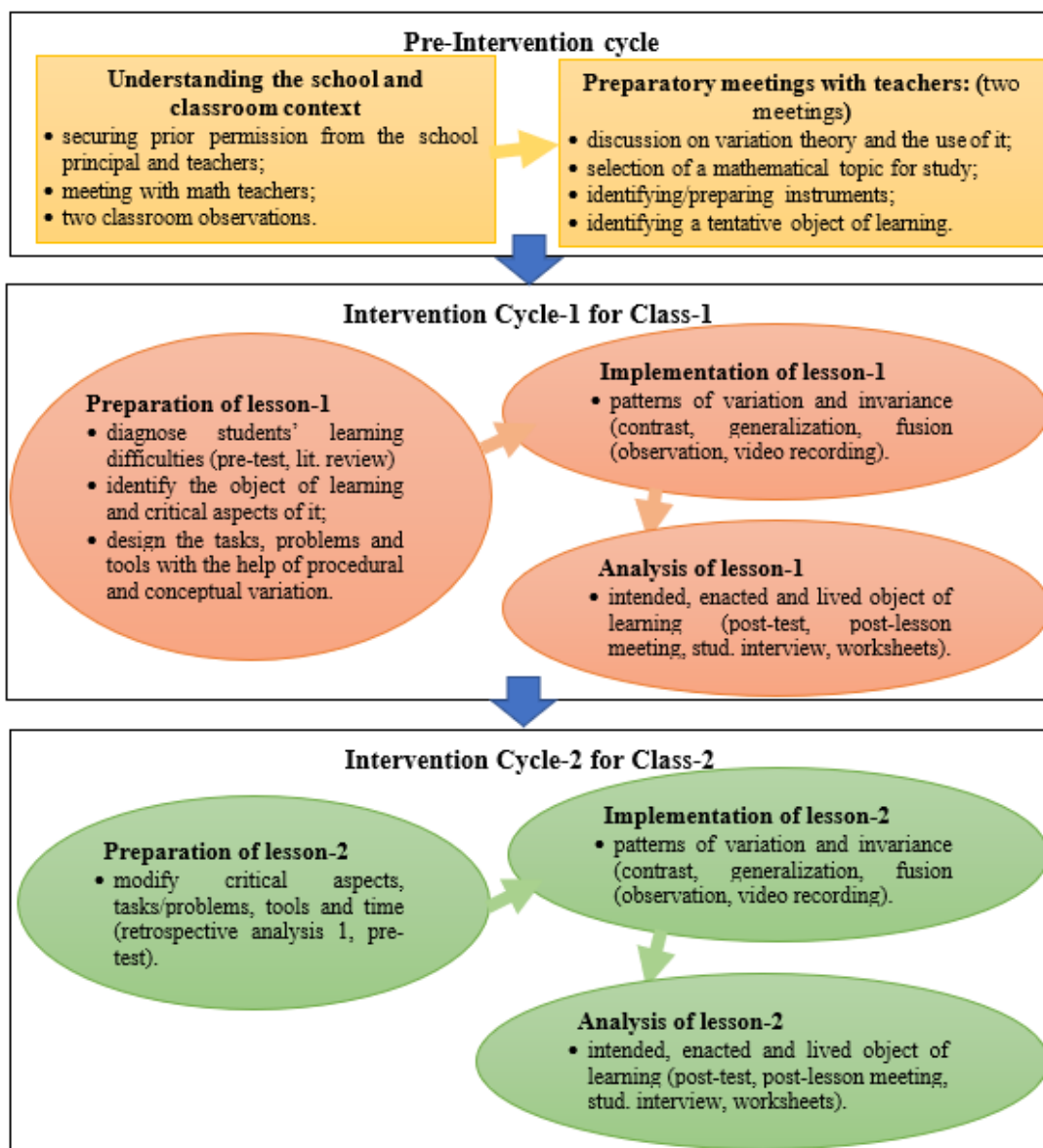


Figure 1: The research process in the pilot study

Data Collection

106 fourth-grade students from a governmental elementary school in a city in the north-west of Ethiopia participated in this pilot study. There are four mathematics teachers teaching in Grades 1- 4 (1 male, 3 females) in the school. The researcher (first author), together with one experienced teacher and one beginner teacher, formed the pilot study group. In this study, the study group collected data through preparatory meetings, pre-tests and post-tests, lesson observations and video-recordings of lessons, students' worksheets and students' interview (See Figure 1).

Data Analysis Procedure

We followed the three phases of each cycle progresses (Cobb et al., 2016) in our data analysis. The data analysis mainly focused on how the object of learning was designed and implemented in terms of patterns of variation and invariance of critical aspects of the object of learning within and between units of teaching, such as the problem-based tasks (for details see the analytical framework in Table

1). The analyses were made by watching the video recorded lessons and meetings, repeatedly focusing on what was planned (the *intended*), what was possible for students to discern (the *enacted*) and what the students actually learned (the *lived* object of learning). In addition, pre and posttests, students' worksheets and students' interview were also analyzed to find out students' discernment of the object of learning. The analysis of the first class (see the intervention cycle 1 in Figure 1) is based on the data of the study group's initial lesson plan, namely the problem-based task design and implementation in the class. The analysis of the second class (see the intervention cycle 2 in Figure 1) concerns more on the usefulness of the redesign of tasks, the effective design and use of tools, and the impact on students learning. Given the space of this paper, we will chiefly focus on our research questions in the analysis of the first class.

Findings

Finding one and two below focus on reporting our retrospective analysis of the problem-based task design (namely the stage of the preparation and design of teaching experiments of the first lesson); and classroom implementation of such design in the first lesson.

Finding one: The usefulness of the variation theory in designing the problem-based tasks

In this pilot study, we focused on designing problem-based tasks for improving students' mathematical understanding of the concept of area and perimeter of rectangles. The problem-based tasks were designed by referring to both Gu's terms of conceptual and procedural variations and Marton's terms of variation/invariance (see Table 1). The sequence of tasks used in the classroom instruction were designed with reference to the two problems and critical aspects shown in Table 2.

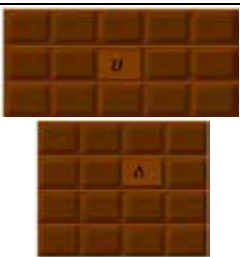
Object of learning	Critical aspects	Problems used to design sequences of tasks in the lesson
The relationship between area and perimeter of rectangles	(1) If the perimeter of rectangles is the same, then the area does not have to be the same.	(1) The figures below are two bars of biscuits. If the price of these biscuit bars is the same, which biscuit do you want to buy? Why do you choose that biscuit? What is your strategy for choosing the biscuit you want to buy? Explain your answer. Use the given grid paper to help you compare the shapes. <div style="text-align: right;">  </div>
	(2) A rectangle with dimensions closest together or the same (square) is the largest.	(2) A farmer has a 16 meters long fence and he plans to enclose a rectangular grazing field with it. Can you help the farmer to think of a way to enclose the largest grazing field? At what condition is the field smallest?

Table 2: The link between the problems and critical aspects of the object of learning

Conceptual variation was carried out to firstly emphasize certain concepts of rectangle such as its area and perimeter and hence the concepts could be more readily picked up for use in finding the relationship between area and perimeter of rectangles. In terms of procedural variation, the problems were transformed into simpler problems, so that students could solve them step by step in a progressive way, using different methods and that helped them to answer the original problem. In

addition, the second more advanced problem was designed to scale up the methods/solution techniques used by students in the first problem (connecting new and prior knowledge). Students were also used their prior measurement techniques as a procedure to find area and perimeter of rectangles. Both procedural and conceptual variation was also carried out in connecting the abstract concept, for example, mathematical formula of area ($A = \text{length} \times \text{width}$), directly to its concrete correspondence (counting unit squares).

Marton's theoretical notion 'the object of learning' (Marton et al., 2004) was also used in the pilot study in that the study group aimed to develop students' learning of the relationship between the concepts of area and perimeter of rectangles. Moreover, the study group also applied the critical aspects of the object of learning to further understand students' learning (see Table 2). The two problems shown in Table 2 were designed to bring the two critical aspects into the focal awareness of learners so that they could discern them step by step. The two problems were also used to guide the design of the sequence of tasks in the classroom instruction.

Finding two: The usefulness of the theories of variation in analyzing the implementation of the designed tasks.

The implementation of the designed instruction was guided by both Marton's VTOL and Gu's TwV. For example, the teacher used procedurally varied approaches in implementing each of the designed tasks, in a systematic and progressive way. At the beginning of each task, the teacher asked students to conjecture the answers to each problem individually and then to compare it with their colleague's work. The teacher then conducted a discussion with students on their answers without giving any hint on the correctness of students' suggestions and did not give them the correct answers. The teacher then asked students to start a group investigation of the posed problems in a small group. Students were also encouraged to use the different tailor-made resources made available by the teacher to discover patterns in their answering. Each task was finally concluded by a whole class discussion followed by summary given by the teacher.

Marton's (2015) term of 'contrast' (i.e., recognizing differences between two values of an aspect) was used to guide the task implementation. For example, students were asked to draw rectangles by fixing one dimension of the rectangle (say, length) and varying the other (width) and vice versa to find the area and perimeter of each using resources such as strings and unit square tiles. At this stage the concepts of perimeter and area of rectangles were discerned as area is the amount of surface of a region, and perimeter is the distance around the region. In addition, students were able to realize the change in area/perimeter due to the change in length/width of rectangles.

Secondly, Marton's (2015) term of 'generalization' (i.e., keeping the focused *aspects* invariant and varying other out of focus aspects) was focused in the classroom. The analysis of students recording sheet showed that most students discovered the formula for finding the area and perimeter of rectangles easily, and they were also able to understand how area formula is related to counting unit squares covering the rectangular region. Some of students' correct findings and generalizations presented in class and written in the record sheet were: the perimeter of a rectangle equals the sum of all of its sides and this can be calculated as: $\text{perimeter of a rectangle} = (2 \times \text{length} + 2 \times \text{width})$; the area of a rectangle is the total number of unit grid-squares inside the rectangles and this can be

calculated as: area of a rectangle = length x width. Students were also able to compare rectangular shapes with fixed perimeter. At this stage students discerned the first critical aspect, that is, if the perimeter of rectangles is the same, then the area does not have to be the same. Most students were able to change their conjecture for problem one that the biscuit with largest side (the first one) was chosen to buy. In the recording sheet, most students wrote a generalization that rectangles with the same perimeter can have different area and vice versa.

Finally, Marton's (2015) term of 'fusion' (i.e., experiencing several critical aspects simultaneously) was highlighted. For instance, the relationship between the two concepts was shown by varying certain aspects (length and width) while keeping an aspect fixed (perimeter of rectangles). At this stage students were able to identify the largest/smallest rectangle among all rectangles with the given fixed perimeter. Most students were also changed their conjecture on identifying the largest grazing field with the given fixed length fencing material in problem two. In the recording sheet, most students wrote a generalization that a rectangle with a fixed perimeter would have the largest area when its length and width are equal (a square).

Discussions and Conclusions

In this paper, we reported our retrospective analysis (Cobb et al., 2016) of using the theory of variation in both the designed instruction and the implementation of such design in the pilot study (see Table 1 & Figure 1). Our data analysis shows that the joint consideration of the two different but compatible frameworks of variation (see Table 1) helped the study group to focus on the systematic use of patterns of variation and invariance in the design and analysis of the implementation of the problem-based tasks in the classroom learning. In particular, it enables the researcher to analyze the implementation of such design to see how the students may experience and discern the critical aspects of the object of learning and to improve their learning in mathematics. The retrospective analysis of the pilot study would lead the researcher to revisions and new cycles for the main study. In particular, we aim to develop a more sufficient understanding of interrelationship of Marton's terms of 'the critical aspects of the object of learning', and the patterns of variation and invariance (Marton, 2015) and Gu's terms of conceptual and procedural variation (Gu et al., 2004) with the design-based approach (Cobb et al., 2016), to enable us to design and implement the problem-based tasks in the main study for engaging students in mathematical learning in a systematic process and at the same time to develop their own learning in mathematics.

The analysis of the pilot study also showed that the implementation of problem-based tasks with patterns of variation and invariance helped students to improve their understanding of the critical aspects of the object of learning (the relationships between area and perimeter of rectangles) significantly. After the implementation of the first lesson, as can be evident from the researcher's observation and video recording of lessons, most students were actively engaged in individual and group discussions and some students were able to grasp the concept quickly and began to make interesting conjectures from experiencing variations in the tasks. For example, most students showed progress in answering each question of the post-test with correct explanations. It was found that there were percentage increases of students understanding in discerning all the critical aspects (49% and 26.4% of students provided correct explanations, 47.2% and 56.6% of students provided partially

correct answers, in posttest questions related to the first and second critical aspects respectively), and paired-samples *t*-test result informed that it was statistically significant (with the sig. level, 0.01) when it is compared with their pre-test results. In addition to their significant progress in the post-test, during the post-lesson interview students said that they had achieved a better understanding of area and perimeter of rectangles by actively involving in the tasks. However, there are also few students who do not discern the critical aspects (3.8% and 17% of students were not able to answer the first and second questions of the posttest respectively). This is supported by the researcher's qualitative analysis result that the intended, enacted and lived object of learning sometimes did not coincide. According to Kullberg et al. (2017), well-designed tasks and examples, and patterns of variation (differences) and invariance(sameness) in teaching, however, are insufficient and does not guarantee learning, it can, at best, make it possible for learning to happen. From our analysis, the two theories can, however, offered tools that the study group can use to focus on the mathematical content taught, students' understanding of it and how to enable possibilities for learning.

References

- Cobb, P., Jackson, K., & Dunlap, C. (2016). Design research: An analysis and critique. In L. D. English & D. Kirshner (Eds.), *Handbook of international research in mathematics education: Third Edition*. (pp. 481–503). New York, NY: Routledge.
- Gu, L. (1994). *Theory of teaching experiment: The methodology and teaching principles of Qingpu [In Chinese]*. Beijing: Educational Science Press.
- Gu, L., Huang, R., & Marton, F. (2004). Teaching with variation: An effective way of mathematics teaching in China. In L. Fan, N. Y. Wong, J. Cai, J., & S. Li (Eds.), *How Chinese learn mathematics: Perspectives from insiders* (pp. 309–345). Singapore, China: World Scientific.
- Kullberg, A., Runesson, U., & Marton, F. (2017). What is made possible to learn when using the variation theory of learning in teaching mathematics? *ZDM- International Journal on Mathematics Education*. 49(4). <https://doi.org/10.1007/s11858-017-0858-4>
- Lo, M. L. (2012). *Variation theory and the improvement of teaching and learning*. Gothenburg, Sweden: Acta Universitatis Gothoburgensis.
- Leung, A. (2012). Variation and mathematics pedagogy. In J. Dindyal, L. P. Cheng, & S. F. Ng (Eds.), *Proceedings of the 35th Annual Conference of the Mathematics Education Research Group of Australasia* (pp. 433–440). Singapore: MERGA.
- Marton, F. (2015). *Necessary conditions of learning*. New York: Routledge.
- Marton, F., & Booth, S. (1997). *Learning and awareness*. Mahwah: Erlbaum Associates Publishers.
- Marton, F., & Pang, M. F. (2006). On some necessary conditions of learning. *The Journal of the Learning Sciences*, 15(2), 193–220.
- Marton, F., & Tsui, A. B. (2004). *Classroom discourse and the space of learning*. Mahwah: Erlbaum.
- MOE. (2013). *Ethiopian Fourth National Learning Assessment (EFNLA) of Grade 4 & 8 Students, Data Analytic Report*. Addis Ababa: Government of Ethiopia.

Web of problem threads (WPT) – a theoretical frame and task design tool for inquiry-based learning mathematics

Dániel Katona

Hungarian Academy of Sciences, Alfréd Rényi Institute of Mathematics, Budapest, Hungary; & ELTE Eötvös Loránd University, Budapest, Hungary; danikatona@gmail.com

Keywords: web of problem threads, connected task-design, anthropological theory of the didactic, reverse didactic engineering

Goal, Context and Methodology

The poster presented the basic concepts and a sample of the *web of problem threads* (WPT), the core element of a theoretical framework under development, and a tool for task-design in mathematics education, based on the qualitative analysis of the Pósa-method for inquiry-based learning mathematics. The WPT is the result of the research aiming at, on the one hand, theorizing the ‘intuitively’ developed Pósa method, a ‘good practice’ as it is widely used in Hungarian talent care education, and on the other hand, providing theoretical background for the development and reconstruction of the method to be applied in public education.

The term *Pósa method* refers to the nationally well-reputed three-decade-long teaching practice of Lajos Pósa, in Hungarian out-of-school weekend mathematics camps for highly talented 12-18 years old students, who form a study group for 6 years. They solve connected mathematical problems (tasks) of various kinds (regarding content area), but the focus is on discovering and discussing the mathematical ideas connecting the problems and the corresponding ‘ways of thinking’, or kernels, according to our WPT framework. The Pósa-method was developed “based in teaching as craft knowledge” (Watson & Ohtani, 2015, p. 5), lacking the construction of, or building on any theoretical framework. There is also a demand (by the Hungarian Academy of Sciences) for the re-design of the method to be applied in public education, based on a theoretical background to be built. The main goal of the research is to subsequently (re)construct the theoretical frame and the tools of the task-design of the Pósa method. The term ‘*reverse didactic engineering*’ is suggested for this research methodology (also based on the discussion in TWG 17 of CERME11).

Theoretical Background, Steps of Theorizing and some Results

Based on mathematical content analysis, the web of problem threads has been theorized as the first step of theorizing, focusing on specific kinds of connections, common features (called the *kernels*) between the mathematical tasks (problems). According to this theorization, a set of connected tasks, in a partially fixed order, creates a *thread* of the problems. Kernel is the manifestation of a kind of connection (common feature) that creates the thread (that can actually have multiple kernels). As some problems belong to several threads, threads cross each other, forming a web, the *WPT*. The problems are selected and created (partially) for giving birth to the kernels, and not (usually) for their own sake.

In the 2nd chapter of the 22nd ICMI study (Watson & Ohtani, 2015), C. Kieran, M. Doorman and M. Ohtani categorize theoretical frames into grand, intermediate-level, and domain-specific frames.

Our study aims at (re)constructing an intermediate-level framework, which we call the Theory of WPTs (TWPT), and links this to already established frameworks, such as the *anthropological theory of the didactic* (ATD) and its application, known as study and research paths (SRP) (Chevallard, 2007; Bosch & Gascón, 2014; Watson & Ohtani, 2015, pp. 260–272). The first step of theorizing will in a second step be analyzed through the lenses of ATD, where WPT is considered as part of the *technology* and *theory* elements of the studied *praxeologies* (Bosch & Gascón, 2014), which, similarly to SRPs, focuses on the connections between tasks (or questions). Therefore, considering ‘*distribution as a dilemma*’ in the categorization of design elements of tasks along 5 dilemmas by P. Sullivan, L. Knott and Y. Yang in the 3rd chapter of the 22nd ICMI study, both task-design approaches favour creating “doing mathematics” tasks (Watson & Ohtani, 2015, pp. 91–94).

The poster is to present a sample of a WPT (see Figure 1 below) linked preliminarily to the ATD, with tasks, solutions, and the analysis of the highlighted ‘kernels’ *yieldingness* and *invariant* (*quantities*). In Task B (Can you tell a power of 3 that ends with 127?), we do not need to consider divisions by 10^3 , it is enough (*yieldingness*) by its divisor, 8, as any power of 3 divided by 8 gives 1 or 3 as the *remainder*.



Figure 1: A sample of the Pósa WPT

Some other kernels in the TWPT are *experimentation*, *bounds* (upper and lower), *recursion* (*recursive thinking*), *induction*, and *proof of impossibility*. The collection and analysis of a (more) complete set of kernels is one of the main future goals of the present research.

References

- Bosch, M., & Gascón, J. (2014). Introduction to the Anthropological Theory of the Didactic (ATD). In A. Bikner-Ahsbahr & S. Prediger (Eds.), *Networking of theories as a research practice in mathematics education* (pp. 67–83). Dordrecht, The Netherlands: Springer.
- Chevallard, Y. (2006). Steps towards a new epistemology in mathematics education. In M. Bosch (Ed.), *Proceedings of the Fourth Congress of the European Society for Research in Mathematics Education* (pp. 21–30). Sant Feliu de Guíxols, Spain: FUNDEMI-IQS – Universitat Ramon Llull.
- Watson, A., & Ohtani, M. (Eds.). (2015). *Task design in mathematics education: An ICMI study 22*. New York, NY: Springer.

Secondary school mathematics teachers' selection and use of resources

Zeger-Jan Kock and Birgit Pepin

Eindhoven University of Technology, Eindhoven School of Education, the Netherlands;

z.d.q.p.kock@tue.nl

Keywords: Teacher resources, Secondary school mathematics, Survey.

Introduction

Secondary school mathematics teachers rely on multiple resources to select materials for classroom use, prepare lessons, and design their curriculum. These include traditional curriculum resources (e.g. textbooks), social resources (e.g. discussions with colleagues) and various digital resources, such as mathematics apps, e-textbooks (Pepin, Choppin, Ruthven, & Sinclair, 2017), and online platforms for sharing digital materials, and constructing lesson series and curricula (Gueudet, 2018). A plethora of digital resources have become available for teachers (Pepin & Gueudet, 2018). Understanding the role of resources in mathematics teachers' work may inform the design of (digital) resources and platforms. To foster this understanding knowledge about the actual use of the various resources is important. In the Netherlands, a survey on the use of learning materials has taken place periodically (Blockhuis, Fisser, Grievink, & Ten Voorde, 2016). However, this general survey does not focus on mathematics teachers and the specific combinations of resources they select.

In this exploratory survey study, we focused on the resources selected and used by secondary school mathematics teachers to prepare their lessons, including resources they use to find materials for classroom use (e.g. student tasks). The research question was: which kinds of resources are selected by secondary school mathematics teachers for lesson preparation, and what do they use them for?

Theoretical framework: the lens of resources

In line with the documentary approach to didactics (Trouche, Gueudet, & Pepin, 2018) we assume that teachers' use of resources has an impact on their teaching. Teachers look for resources, adapt them to their needs and arrange selected resources into learning sequences for their students. This *documentation work* is an essential characteristic of a teacher's work and takes place at the different levels: curriculum, lesson series, and (parts of) individual lessons. The types of resources used by teachers fall into different categories. Pepin and Gueudet (2018) distinguish (1) curriculum resources, (2) social resources, and (3) cognitive resources. Curriculum resources are "developed and used by teachers and students in their interaction with mathematics in/for teaching and learning, inside and outside the classroom". They are further categorized as (a) text resources (e.g. textbooks, syllabi, websites), (b) digital curriculum resources (e.g. e-textbooks, educational platforms), and other material resources (e.g. calculators, digital instructional technology). What distinguished digital curriculum resources from digital instructional technology is the possibility of arranging content and activities in line with the curriculum requirements. Social resources refer to human interactions, for example conversations with colleagues, or feedback from students. Cognitive resources refer, for example, to the mathematical frames and routines used by teachers, and are not considered in this study. By *use of resources*, we denote the selection of resources, their appropriation, and eventually modification by teachers to fulfill particular educational goals (e.g. determining mathematics content,

designing classroom activities or homework tasks). The results of a recent Dutch learning material survey show that textbooks and related materials have still been among the most important resources used by secondary school teachers independent of the subject, although teachers and school managers expect their importance to go down with time (Blockhuis et al., 2016). The most important digital resources for teachers are interactive student exercises. Teachers have indicated that they need guidance, particularly in selecting digital resources.

Method

A survey was administered in June/July 2018 to secondary school mathematics teachers, who were invited to participate by means of a brief text and a link in an electronic newsletter¹. We received 78 complete responses from mathematics teachers. The survey consisted of 14 questions and was partly based on a survey on digital resources for teachers in France (Gueudet, 2018). Items included, among others, teacher background information; (digital) resources selected to prepare lessons; the purpose of the selected resources; and classroom material retrieved or adopted from digital resources.

Results and conclusion

The survey results indicate that the most widely used resources for lesson preparation were national documents (e.g. syllabi), teachers' own notes, interactions with colleagues, mathematics apps, and the website belonging to the textbook. General educational platforms and social media were mentioned least often. Resources were mostly consulted to find materials for classroom activities, although interactions with colleagues covered all aspects of lesson preparation. In terms of digital resources, Geogebra was mentioned most often, followed by a digital version of the textbook with its associated website, and online video clips. Least often, general educational platforms were used, in which teacher could create and share materials, in spite of efforts to promote these platforms and their transformative potential (Pepin et al., 2017). It appears that the mathematics teachers were mostly led by the school's mathematics textbook and its associated (digital) materials.

References

- Blockhuis, C., Fisser, P., Grievink, B., & Ten Voorde, M. (2016). *Leermiddelenmonitor 15/16: Leermiddelen in het po en vo. [Monitor of teaching materials 15/16: Teaching materials in primary and secondary education.]*. Enschede, the Netherlands: SLO.
- Gueudet, G. (2018). *Online platforms: New connections and new possibilities for teacher documentation work?* Poster presented at the 5th ERME topic conference: Mathematics education in the digital age, Copenhagen, Denmark.
- Pepin, B., Choppin, J., Ruthven, K., & Sinclair, N. (2017). Digital curriculum resources in mathematics education: Foundations for change. *ZDM - The International Journal on Mathematics Education*, 49, 645-661. doi:10.1007/s11858-017-0879-z
- Pepin, B., & Gueudet, G. (2018). Curriculum resources and textbooks in mathematics education. In S. Lerman (Ed.), *Encyclopedia of Mathematics Education*. Cham: Springer.
- Trouche, L., Gueudet, G., & Pepin, B. (2018). Documentational Approach to Didactics. In S. Lerman (Ed.), *Encyclopedia of Mathematics Education*. Cham: Springer.

¹ See <http://www.wiskundebrief.nl/>, newsletter sent to approximately 4800 addresses.

Multiplicative reasoning task design with student teachers in Scottish schools: valuing diversity, developing flexibility and making connections

Helen Martin

School of Education, University of Aberdeen, Scotland; h.martin@abdn.ac.uk

Keywords: multiplicative reasoning, teacher education, task design.

Introduction

The aim of this poster is to present the development of a synthetic landscape of multiplicative reasoning constructed by student teachers. It explores the implications of working in a way that integrates literature from three different perspectives: maths recovery (MR), cognitively guided instruction (CGI) and realistic mathematics education (RME). The aim is to better understand how working in this way affects the way student teachers interact with learners, the questions they ask, the tasks they design: their capacity to value diversity in literature and develop their flexibility in practice.

There is a pattern of superficial adoption of findings from research in teaching mathematics in Scottish schools that often relies on dissemination of a product where teachers have not been a part of the process of constructing understanding. This often leads to a series of short lived interventions that rarely produce the positive effects expected. In which case, what can we use within teacher education to inform ourselves, our student teachers, our professional colleagues that accepts the natural dilemmas of teaching and might improve professional and ethical decision-making in an ever-increasing political world of curriculum design and change?

To address this question the author alongside a teaching colleague developed and have redeveloped a year 3 undergraduate mathematics education course over the past four years to consider how to better support student teachers entering this environment. They need to be able to adapt quickly to changing priorities using informed professional decision-making. To create the space and time to think more slowly, the course focuses on the key shift in thinking from additive to multiplicative reasoning. The first semester explores additive reasoning working with children aged 4–7 years old and the second semester focuses on multiplicative reasoning working with children aged 8–12 years old. Each semester consists of six 3-hour sessions followed by five weeks in a school. This poster uses the second semester course where the assignment requires student teachers to report on their analysis of the children's multiplicative reasoning.

Theoretical Background

Rather than taking one piece of major research and focusing on this to the exclusion of others we looked at using several significant studies. In this study, alongside the formal curricular guidelines in Scotland, Curriculum for Excellence (Scottish Government, 2009), three different theoretical perspectives are used: Realistic Mathematics Education (Fosnot & Dolk, 2001), Cognitively Guided Instruction (Carpenter, Fennema, Franke, Levi & Empson, 2015) and Maths Recovery (Wright, Ellemor-Collins & Tabor, 2012). The course is designed to consider the benefits and limitations of each in a complementary rather than a competitive manner. It is by synthesizing ideas from different

perspectives that have different foci that student teachers can become much more aware of the similarities and differences: complementary strengths and non-overlapping weaknesses. Similarly, the sessions include tasks focused on student teachers as learners of mathematics, researchers and teachers of mathematics to build a sense of themselves as mathematicians, researchers and teachers.

Methods

This design research (Gravemeijer & Cobb, 2006) takes an iterative approach to studying and refining task design within a mathematics education classroom: to develop our understanding of the embodied process of developing theory *through* practice and the means that are designed to support that learning. The design principles are based on mathematics as a constructive activity (Watson & Mason, 2005) with an emphasis on mathematical practices and a more participatory view of learning and teaching mathematics.

This poster will illustrate the latest cycle of this design research using multimodal data provided by the most recent cohort of 38 students during academic session 2017/18: student teacher's assignments, planning documents, videos and transcripts of task-based interviews with children and images of child jottings to better understand how the design of the course influences the tasks designed by student teachers.

Findings

Preliminary findings indicate that most student teachers have shifted their focus to a more participatory view of learning mathematics, discussing a range of strategies and models used by the children. Some of the student teachers take informed risks, experiment with different pedagogical approaches and are beginning to design their own tasks however very few student teachers understood the underlying structure of number strings (Fosnot & Dolk, 2001).

References

- Carpenter, T.P., Fennema, E., Franke, M.L., Levi, L., & Empson, S.B. (2015). *Children's mathematics: Cognitively guided instruction* (2nd ed.). Portsmouth, NH: Heinemann.
- Fosnot, C. T., & Dolk, M. (2001). *Young mathematicians at work: Constructing multiplication and division*. Portsmouth, NH: Heinemann.
- Gravemeijer, K., & Cobb, P. (2006). Design research from a learning design perspective. In J. Van den Akker, K. Gravemeijer, S. McKenney & N. Nieveen (Eds.), *Educational design research* (pp. 17-51). London: Routledge.
- Scottish Government. (2009). *Curriculum for excellence numeracy & mathematics: Experiences and outcomes*. Edinburgh: Scottish Government.
- Watson, A., & Mason, J. (2005). *Mathematics as a constructive activity: Learners generating examples*. Mahwah, NJ: Lawrence Erlbaum Associates.
- Wright, R.J., Ellemor-Collins, D., & Tabor, P. D. (2012). *Developing number knowledge: Assessment, teaching and intervention with 7-11 year olds*. London: Sage.

Comparison of Japanese and Turkish textbooks: Giving opportunities for creative reasoning in terms of proportion

Yasin Memiş

Anadolu University, Turkey; yememis@anadolu.edu.tr

Empirical research indicates that students, when solving tasks, frequently use superficial similarities to find the right algorithm. Furthermore, mathematics textbooks continue to use a teaching design that supports rote learning. This kind of approach creates difficulties in terms of promoting proportional reasoning as well as other mathematical skills. The purpose of this study is to examine the extent to which selected Grade 7 Japanese and Turkish textbooks provide opportunities to use creative mathematical reasoning, in terms of proportion topics. The results imply that proportion topics in the selected Turkish textbook mostly design opportunities for students to use algorithmic mathematical reasoning. However, Japanese textbook provides more creative mathematical reasoning opportunities.

Keywords: Mathematical creative reasoning, proportional reasoning, textbook analysis.

Introduction

Proportional reasoning is a very important skill that students must acquire in middle school. The National Council of Teachers of Mathematics (NCTM) (2000) has highlighted that proportional reasoning should be “an integrative theme in the middle grades mathematics program” (p. 212). Being able to reason proportionally, on the one hand, plays a key role in the meaning of many mathematical content areas (e.g. similarity, trigonometry, probability), while at the same time constituting the basis of the concepts (e.g. speed, density) often encountered in real life (Lesh, Post, & Behr, 1988). However, most students struggle with developing proportional reasoning, and one of the reasons for this failure is related to weak teaching-design methods. Typically, a textbook on the subject of ratio and proportion starts by showing the different ways of writing the ratio, and the proportion is defined as two equal ratios. Then, students usually focus on finding answers to similar questions in the cross-multiplication algorithm. Students frequently decide that a task involves a proportion following superficial cues such as, “the problem gives 3 numbers, and 1 other number is missing”. When solving this type of proportion task, students only need to recognise the task, insert the relevant numbers, and perform the calculation (Labato & Ellis, 2010). In this process, only the result is important; students do not usually concern themselves with proportional reasoning. The correct solution to this kind of example or task used by students is insufficient to show that a degree of proportional thinking has occurred at the desired level. The repetition of similar questions will allow for more practice of multiplication and division rather than improving proportional thinking. Furthermore, the continuance of such algorithmic questions will result in the student not being sufficiently educated about the multiplicative relationship required for proportional thinking. Instead, situations in which students create their own solutions will provide opportunities for them to connect with previous information and, in particular, allow them to improve multiplicative thinking (Labato & Ellis, 2010).

Unfortunately, this kind of instructional design that uses highly algorithmic tasks is presented in the textbooks. Textbooks frequently provide questions that are similar to each other, and students are

expected to engage in solving them (Boesen, Lithner, & Palm, 2010; Hiebert, 2003). Studies also show that students who decide on which algorithm to use when solving a problem with superficial evidence usually try to remember the algorithm and then try to find the result (McNeal, 1995; Kamii & Dominick, 1997). This situation is similar to proportional reasoning in Turkish and other countries' textbooks. The research indicates that proportional reasoning tasks in various countries' textbooks are mostly low-level and contain highly familiar routine problems (da Ponte & Marques, 2007; İncikabı & Tjoe, 2013). Learning to reason proportionally takes effort and time, and in addition to routine problems, non-routine problems are also needed to help students develop. The algorithms presented without letting students create the ideas they need will not provide them with opportunities to improve their proportional reasoning skills (Labato & Ellis, 2010).

Textbooks play a key role in many important areas, such as teaching design and student achievement. Since mathematics textbooks are a bridge between students and teachers, it could be said that textbooks are effective tools that offer students learning opportunities (Rezat, 2006). Due to this important role of the textbook, it could be considered as a mediator between the intended and the implemented curriculum (Schmidt, McKnight, & Raizen, 1997), and therefore, textbooks are important research areas in terms of mathematics education. Due to the important roles of textbooks and proportional reasoning, it is possible to find both national (Bayazit, 2013; Dole & Shield, 2008) and cross-national studies (da Ponte & Marques 2007; İncikabı & Tjoe, 2013). Although there are studies on how the Turkish reform curriculum handles mathematics education, studies about how to design the contents of proportional reasoning in textbooks are very limited. For this reason, this cross-national study will make an important contribution to those who prepare education programmes, as well as textbook authors.

The aim of this research is to compare the extent to which selected Grade 7 Japanese and Turkish textbooks provide opportunities for creative mathematical reasoning in terms of proportion.

The two central research questions in this investigation are as follows:

1. To what extent does the teaching design of selected Japanese and Turkish textbooks support the development of creative reasoning in the chapters on proportion?
2. What kind of reasoning is expected from students for solving the tasks presented in the textbooks?

Conceptual framework

Algorithms are important components in mathematics education; however, algorithms presented to students without preparing an adequate background prevent the development of mathematical skills. The students will use the algorithms they have learnt to solve the questions that they classify as superficial. This process, like any mathematical skill, will prevent the development of the desired level of proportional thinking (Labato & Ellis, 2010). Lithner's framework of mathematical reasoning types sets apart algorithmic and creative reasoning, and so it could present a different perspective that examines the extent to which textbooks promote the development of proportional reasoning.

In this study, Lithner's framework of mathematical reasoning types will be used (Lithner, 2008), which was first created as a result of empirical studies in the field (Bergqvist et al., 2007; Lithner,

2004, 2008). Throughout those studies, reasoning was defined as “the line of thought adopted to produce assertions and reach conclusions in task-solving” (Lithner, 2008, p. 257).

Lithner (2008) identified two main reasoning types: Imitative Reasoning (IR) and Creative Reasoning (CR). The main distinction between these two reasoning types is that IR can be identified as copying a solution process or as using an algorithm directly from a source example or from a textbook narrative, whilst CR creates a product from a creative mathematical thinking process (Figure 1).

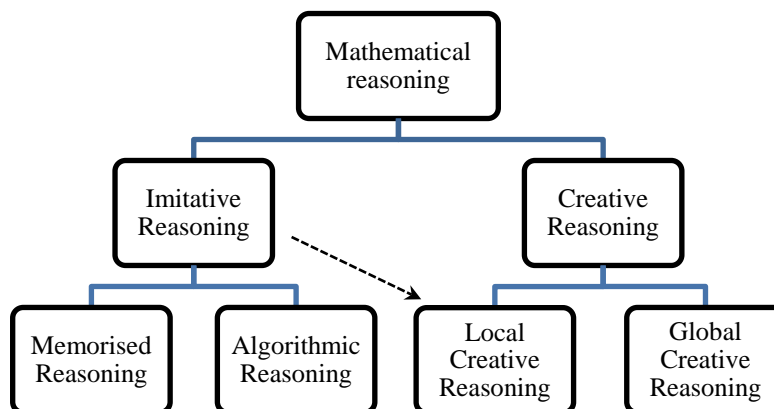


Figure 1: An overview of Lithner’s (2008) mathematical reasoning framework

There are two other forms of reasoning that fall under the category of IR, which are Memorised Reasoning (MR) and Algorithmic Reasoning (AR).

MR is characterised by the idea that “the strategy choice is founded on recalling a complete answer, the strategy implementation consists only of writing it down” (Lithner, 2008, p.258). An example of this is writing a proof step that has already been memorised. The AR sequence should function as follows: “the strategy choice is to recall a solution algorithm. The remaining reasoning parts of the strategy implementation are trivial for the reasoner, only a careless mistake can prevent an answer from being reached” (Lithner, 2008, p. 259).

CR can also be separated into two sub-categories: Local Creative Reasoning (LCR) and Global Creative Reasoning (GCR).

LCR contains major parts of IR (e.g. recalling facts and using algorithmic sub-procedures), and minor parts of CMR. This means that a LCR task solution is always based on algorithms, although the student needs to modify the algorithm locally in a “non-trivial” way. A GCR task does not have a solution that is based on an algorithm, and therefore requires CR throughout the whole task-solving process. GCR may contain construction of an example, proof of something new, or modelling (Bergqvist et al., 2007).

CR fulfils the following three properties:

1. “Novelty: a new (to the reasoner) reasoning sequence is created or a forgotten one is re-created”.
2. “Plausibility: there are arguments supporting the strategy choice and/or strategy implementation motivating why the conclusions are true or plausible”.

3. “Mathematical foundation: the arguments are anchored in intrinsic mathematical properties of the components involved in the reasoning” (Lithner, 2008, p. 266).

For the analysis of this study, textbooks will be examined as having two main parts: the tasks and examples provided to the students. In this study, a mathematical task is defined as a question that requires a solution from students, whilst an example is defined as a question that is given with an appropriate solution or solution process.

Method

Japanese and Turkish textbooks were selected for this study. The reason for this choice is primarily the success of Japanese students in international examinations, such as Trends in International Mathematics and Science Study (TIMSS). The 2015 TIMSS results saw 15-year-old Japanese students ranked 5th, and Turkish students ranked 40th, in terms of mathematics performance. The results of the 2015 TIMSS for Grade 8 students on the topics of “ratio, proportion and percent” emphasised the difference between the achievements of students from these countries. In response to questions within this study, 67% of Japanese students got the correct answers, compared with just 34% of Turkish students.

The textbooks that have been chosen for analysis in this study are Mathematics International Grade 7 (Fujii & Matano, 2012), published by Tokyo Shoseki, and Mathematics Textbook Grade 7 (Bilen, 2017), published by Gizem in Turkey. These two textbooks were passed through an approval process by their respective governments for use in classrooms in these two countries. The Tokyo Shoseki series, which has been translated into English, has a big market in Japan (Miyakawa, 2017). For the purpose of this study, only the proportion chapter was examined. The proportion topic is included in the Grade 7 textbook in both countries. In the Grade 7 Turkish textbook, the chapter on proportion is presented with two subdivisions, including nine examples and ten tasks. In the Grade 7 Japanese textbook, there were only three examples and 18 tasks in the proportion chapter.

The examples and tasks were examined for analysis and were classified according to mathematical reasoning frameworks. Although the CR process is similar to the solution structure of non-routine problems, the framework is more focussed on the distinction between imitation and creation (Lithner, 2017). For this reason, templates and solutions were considered. If the example/task could be solved with previous algorithms without any modification, they were classified as AR, whilst if the example/task could be solved with previous solution processes yet needed some modification to this process, they were classified as LCR. However, if the example/task did not have a solution that was based on an already-given algorithm and required CR throughout the whole solution process, it was classified as GCR.

Figure 2 shows two examples from the Grade 7 Turkish textbook in the proportion chapter. These examples were classified as AR, as they present a teaching design that simply requires replacing the appropriate numbers in the template solutions in order to do the calculations correctly.

<p>ÖRNEK</p> <p>Bir piring pilavı tarifinde 2 bardak pirinç 3 bardak su konuyorsa 1 bardak pirinçe kaç bardak su konulması gerektiğini bulalım.</p> <p>ÇÖZÜM</p> <p>Pirinç miktarının su miktarına oranı $\frac{2}{3}$'tür. 1 bardak pirinçe konulacak su miktarı x bardak olsun.</p> <p>pirinç miktarı $\frac{2}{3} = \frac{1}{x}$ su miktarı $x = \frac{3}{2} = \frac{3 \cdot 2}{2 \cdot 2} = \frac{1 \cdot 6}{1} = 1,5$ bulunur.</p> <p>ÖRNEK</p> <p>50 mL'lik limon kolonyasının 12 tanesi 15 TL olduğuna göre 50 mL'lik 1 limon kolonyasının kaç lira olduğunu bulalım.</p> <p>ÇÖZÜM</p> <p>50 mL'lik 1 limon kolonyasının fiyatı a lira olsun.</p> <p>kolonya sayısı $\frac{12}{15} = \frac{1}{a}$ kolonya sayısı $a = \frac{15}{12} = \frac{15 \cdot 12}{12 \cdot 12} = \frac{1 \cdot 25}{1} = 1,25$ TL bulunur.</p>	<ol style="list-style-type: none"> 1. You need 2 cups of rice and 3 cups of water to cook rice. In this case, how much water is needed for 1 cup of rice? 2. 12 small bottles of 50ml cologne costs 15 TL. If you want to buy 1 small bottle of 50ml cologne, how much would it cost?
--	---

Figure 2: Grade 7 Turkish textbook examples (p.127)

There are five tasks at the end of the chapter, which students are required to solve. However, to complete these tasks, they only need to remember the previous solution process. Students need to replace the numbers in the template and perform basic calculations to obtain the solution. For this reason, the task below (in Figure 3) is classified as AR.

<p>1) 3 yolcu otobüsünde 132 koltuk varsa aynı tür 1 yolcu otobüsünde kaç koltuk vardır?</p> <p>A) 44 B) 45 C) 46 D) 48</p>	<p>1) If 3 buses have 132 seats, how many seats are there in 1 bus?</p>
--	---

Figure 3: Grade 7 Turkish textbook task (p.128)

The task below (in Figure 4), taken from the Japanese textbook, was determined to be of the LCR type. There are no similar tasks from previous examples, and so students cannot solve them by directly using cross multiplication algorithms ($a:b=c:d$); instead, they need to carry out local modifications to the previous solution methods ($160+4x:60+3x=2:1$).

Let's Try

There are two water tanks, A and B. In tank A, water is poured continuously at 4L per minute, and in tank B, 3L per minute of water is being poured. At 10:00, when the amount of water was measured, there were 160L of water in tank A and 60L of water in tank B.

(1) What time will it be when the amount of water in tank A will be twice as much as the amount of water in tank B?

Figure 4: Grade 7 Japanese textbook task (p.112)

The example below (in Figure 5), taken from the Japanese textbook, was determined to be GCR. This example investigates whether “3: 4 = 6: 8” is true. There is an argument given that “if $a: b = m: n$ then $a \cdot n = b \cdot m$ ”, and it is then proved using mathematical foundations. Finally, the example presents a generalisation, which provides the student with a totally new creative process with regards to the proofing argumentation.

Investigate to see if the property of proportions on the previous page holds true with $3 : 4 = 6 : 8$. The values of the ratios of $3 : 4 = 6 : 8$ are equivalent.

$$\frac{3}{4} = \frac{6}{8}$$

If we multiply both sides by the denominators, 4 and 8, it becomes

$$\frac{3}{4} \times 4 \times 8 = \frac{6}{8} \times 4 \times 8$$

$$3 \times 8 = 6 \times 4$$

The relationship of $a : b = m : n$ holds true when any number is used for a, b, m or n .

Extension

When using letters to represent it will become the following.
The value of the ratios, $a : b = 991 : 98$ are equal therefore

$$\frac{a}{b} = \frac{991}{98}$$

When both sides are multiplied by the denominators b and 98 , it will be

$$\frac{a}{b} \times b \times 98 = \frac{991}{98} \times b \times 98$$

$$a \cdot 98 = b \cdot 991$$

Figure 5: Grade 7 Japanese textbook simple example (p.99)

Results

In this chapter, the pilot study results of the classified mathematical reasoning types in the proportion chapters in Turkish and Japanese textbooks are presented (Tables 1 and 2).

	Example	Task	Total
MR	0	0	0
AR	9	10	19
LCR	1	0	1
GCR	0	0	0
IR (MR + AR)	9	10	19
CR (LCR + GCR)	1	0	1

Table 1: Classification of tasks and examples in the Turkish textbook

	Example	Task	Total
MR	0	0	0
AR	2	11	13
LCR	0	6	6
GCR	1	1	2
IR (MR + AR)	2	11	13
CR (LCR + GCR)	1	7	8

Table 2: Classification of tasks and examples in the Japanese textbook

The first conclusion drawn from the report of the study is that the Turkish textbook features no GCR-type tasks or examples, and furthermore, ten of the tasks within the chapter do not even require any CR reasoning. These results show that the Turkish textbook only provides limited and weak opportunities for students to perform CR. In addition, the Turkish textbook's teaching style mostly shows the necessary algorithm for solving a specific task within the examples, which means that when the students are solving the tasks at the end of the chapters, these algorithms can be used directly. This type of teaching style mostly supports IR, especially AR. In contrast, within the Japanese textbook's proportion chapter, there is a total of three examples. Two of these examples are classified as AR, and the other example is classified as GCR. There are 18 tasks for the students to solve, with seven of these tasks requiring CR. This result reveals that the Japanese textbook provides more, and stronger, opportunities for CR than the Turkish textbook in the proportion chapter.

Discussion

The development of proportional thinking is a milestone for students, especially for those who take many years to progress. In this process, students will be supported by different problem-solving situations as much as possible, to support healthy development. The mathematical reasoning framework has shown that the Grade 7 Turkish textbook mostly provides opportunities for AR only in terms of learning proportion, in contrast to the Grade 7 Japanese textbook.

Algorithms have an important place in mathematics, as they are an effective solution to a general class task. There are short-term gains and benefits, such as the ‘quick response to tasks’; however, AR can be a barrier to obtaining effective skills that can be used in the long term. Using algorithms in proportional reasoning can create the same problem. A teaching design based solely on using algorithms will, in the long term, allow students to solve familiar tasks that they recognise as only being superficial. The fact that students are engaged in different problem situations that require CR will lead them to understand the components of proportionality (multiplicative thinking, absolute thinking, etc.) in greater depth. Proper use of CR in the textbooks would contribute to the solution of this problem and should enable further development of students’ mathematical ability. The results of this study offer useful information on content design for educators, especially textbook authors. Applying the process should provide teachers with insights into the strengths and weaknesses of the textbooks being employed and enable them to make effective decisions about the selection and use of textbooks. In future studies, the comparison of different book series from different countries will provide new data that could be used to evaluate the results of the study in a wider context.

References

- Bayazit, I. (2013). Quality of the tasks in the new Turkish elementary mathematics textbooks: The case of proportional reasoning. *International Journal of Science and Mathematics Education*, *11*(3), 651–682.
- Bergqvist, T., Lithner, J., & Sumpter, L. (2007). Upper secondary students task reasoning. *International Journal of Mathematical Education in Science and Technology*, *39*(1), 1–12.
- Boesen, J., Lithner, J., & Palm, T. (2010). The relation between types of assessment tasks and the mathematical reasoning students use. *Educational studies in mathematics*, *75*(1), 89–105.
- Bilen, O. (2017). *Ortaokul matematik 7 ders kitabı*. Ankara: Gizem.
- da Ponte, J. P., & Marques, S. (2007). Proportion in school mathematics textbooks: A comparative study. In D. Pitta—Pantazi & G. Philippou (Eds.), *5th Congress of ERME, the European Society for Research in Mathematics Education* (pp. 2443–2452). Larnaca, Cyprus: University of Cyprus and ERME.
- Dole, S., & Shield, M. (2008). The capacity of two Australian eighth-grade textbooks for promoting proportional reasoning. *Research in Mathematics Education*, *10*(1), 19–35.
- Fujii, T., & Matano, H. (Eds.). (2012). *Mathematics International Grade 7*. Tokyo: Tokyo Shoseki.
- Hiebert, J. (2003). What research says about the NCTM standards. In Kilpatrick, J, Martin, W.G., Schifter, D, (Eds.), *A research companion to principles and standards for school mathematics* (pp. 5–23). Reston, VA: National Council of Teachers of Mathematics.

- İncikabı, L., & Tjoe, H. (2013). A Comparative Analysis of Ratio and Proportion Problems in Turkish and the US Middle School Mathematics Textbooks. *Journal of Kirsehir Education Faculty*, *14*(1), 1-15.
- Kamii, C., & Dominick, A. (1997). To teach or not to teach algorithms. *Journal of Mathematical Behavior*, *16*(1), 51–61.
- Lamon, J. S. (1999). *Teaching fractions and ratios for understanding: Essential content knowledge and instructional strategies for teachers*. Mahwah, NJ: Lawrence Erlbaum Associates.
- Lesh, R., Post, T., & Behr, M. (1988). Proportional Reasoning. In J. Hiebert & M. Behr (Eds.), *Number Concepts and Operations in the Middle Grades* (pp. 93–118). Reston, VA: Lawrence Erlbaum & National Council of Teachers of Mathematics.
- Lithner, J. (2004). Mathematical reasoning in calculus textbook exercises. *Journal of Mathematical Behavior*, *23*(4), 405–427.
- Lithner, J. (2008). A research framework for creative and imitative reasoning. *Educational Studies in Mathematics*, *67*(3), 255–276.
- Lithner, J. (2017). Principles for designing mathematical tasks that enhance imitative and creative reasoning. *ZDM*, *49*(6), 937-949.
- Lobato, J., & Ellis, A. (2010). *Developing Essential Understanding of Ratios, Proportions, and Proportional Reasoning for Teaching Mathematics: Grades 6-8*. Reston, VA: National Council of Teachers of Mathematics (NCTM).
- McNeal, B. (1995). Learning not to think in a textbook-based mathematics class. *Journal of Mathematical Behavior*, *14*(2), 205-234.
- Miyakawa, T. (2017). Comparative analysis on the nature of proof to be taught in geometry: the cases of French and Japanese lower secondary schools. *Educational Studies in Mathematics*, *94*(1), 37–54.
- Mullis, I. V. S., Martin, M. O., Foy, P., & Hooper, M. (2016). *TIMSS 2015 International Results in Mathematics*. Retrieved from Boston College, TIMSS & PIRLS International Study Center website: <http://timssandpirls.bc.edu/timss2015/international-results/>
- NCTM. (2000). *Principles and Standards for School Mathematics*. Reston, VA: National Council of Teachers of Mathematics.
- Rezat, S. (2006). *A model of textbook use*. In J. Novotná, H. Moraová, M. Krátká, & N. Stehlíková (Eds.), *Proceedings 30th Conference of the International Group for the Psychology of Mathematics Education* (pp. 409–416). Prague, Czech Republic: Charles University.
- Schmidt, W. H., McKnight, C. C., Valverde, G., Houang, R. T., & Wiley, D. E. (Eds.). (1997). *Many visions, many aims: A cross-national investigation of curricular intentions in school mathematics (Vol. 1)*. Netherlands: Springer Science & Business Media.
- Schoenfeld, A. (1985). *Mathematical problem solving*. Orlando, FL: Academic.

Making Mathematics fun: The ‘Fear Room’ game

Christina Misailidou¹ and Ronald Keijzer²

¹National and Kapodistrian University of Athens, Department of Education, Athens, Greece;
C.Misailidou@primedu.uoa.gr

²iPabo University of Applied Sciences, Amsterdam, The Netherlands; r.keijzer@ipabo.nl

Keywords: Mathematics task design, Mathematics curriculum resources, Aids for Mathematics teaching and learning.

Introduction

Despite its importance, mathematics is often perceived as boring and difficult. The demand for exciting mathematical experiences resulted in the Netherlands in a yearly event called the ‘Big Maths Day’ (Abels et al., 2016). During such a day, pupils are not taught their usual curriculum: instead, they are involved in playful mathematical activities. In this report, we present selected results from a study that involved the design and implementation of a ‘Maths Day’ (‘MD’) in a Greece.

Theoretical Background

The MD activities were designed drawing on ‘Realistic Mathematics Education’ (‘RME’) and ‘Inquiry Based Learning’ (‘IBL’). According to RME, teaching mathematics should be a process of ‘guided reinventing’ (Freudental, 1991). Pupils, guided by their teacher, reinvent and construct mathematics concepts from meaningful situations. Such reinvention can be successful, when it is based on ‘inquiry’. ‘Inquiry based learning’ is an educational approach, which is ‘driven more by a learner’s questions than by a teacher’s lessons’ (p. 1, EDC, 2016). Pupils try to find the answers they are looking for, by working in groups, on meaningful activities guided by their teachers.

Methodology

The Greek MD took place in a primary school located in the capital of Greece, Athens. Different mathematical activities were planned for different classes. This report focuses on the 3rd and 4th year classes, which consisted of 34 pupils with an age span of 8-10 years. Their day was labelled ‘Amusement Park’ and consisted of three parts: the ‘Introduction’, the ‘Circuit Form’ and the ‘Open Problem’ activities. The pupils were divided in six groups and were guided by four researchers/teachers. Data were collected from observations and interviews. Results from one group of pupils working and on a ‘Circuit Form’ activity called the ‘Fear Room’ will be presented below.

Results

The ‘Fear Room’ activity is essentially a variation of the board game ‘Snakes and Ladders’. A giant board is set up on the floor, made of A4 paper sheets with the numbers 1 to 40 written on them (Figure 1). There are ‘traps’ (the sheets with the plastic snake, bat and spider on them) and ‘bonuses’ (the sheets with small colourful papers on them). Two opponent teams would play the game each time. One member from each team would be chosen as a ‘pawn’. There was a stack of cards from which each team had to choose one every time they played. Each card ‘ordered’ the players to perform a combination of mathematical operations. The players had to choose numbers for the selected

operations. The aim of the game was to come up with a result that would lead them to a ‘bonus’ rather than a ‘trap’. The learning objective of this activity was ‘tackling mental calculations with numbers up to 100’.



Figure 1: A team playing in the ‘Fear Room’

Initially, the group that we focus on, encountered difficulties with the calculations. Nevertheless, as the game went on, they got used to the procedure of finding the right operations and the right results. All the pupils emphasised that they liked this game and that the funniest part of it was ‘being a pawn’.

Conclusion

The ‘Fear Room’ activity provoked ‘inquiry based learning’ and on the same time the pupils perceived it as ‘a very funny game’. Such findings indicate that mathematics-despite its ‘bad’ reputation as a difficult and boring subject can become interesting and appealing when it is enriched by ideas from RME and IBL.

Acknowledgments

1. We would like to gratefully acknowledge the financial support of the Department of Education of the National and Kapodistrian University of Athens for this project.
2. We would like to thank Barbara Douka, Marianna Bikini, Simos Pasinios and Maria Sanida for participating in the design and implementation of the ‘Maths Day’.

References

- Abels, M., Jonker, V., Keijzer, R. & Wijers, M. (2016). *Let’s have a look behind the code*. Utrecht: Freudenthal Institute.
- Education Development Centre (EDC). (2016). *Inquiry-based learning: An approach to educating and inspiring kids*. Retrieved from YouthLearn: http://youthlearn.org/wp-content/uploads/Inquiry_Based_Learning.pdf
- Freudenthal, H. (1991). *Revisiting mathematics education. China lectures*. Dordrecht: Kluwer Academic Publishers.

Examination of mathematical opportunities afforded to learners in grade 1 Malawian primary mathematics textbooks

Lisnet Mwadzaangati

University of Malawi, Faculty of Education, Malawi; lmwadzaangati@cc.ac.mw

This paper present findings from a study which aimed at examining mathematical opportunities available in Malawian grade 1 textbook and their ability to enhance learners' understanding of number concept through outcome based education (OBE). Two elements (examples and tasks) of the Mathematics Discourse in Instructional analytic framework for Textbook Analysis (MDITx) were used to guide analysis of the textbook. The results show that the textbook has provided learners with mathematical opportunities to understand the number concept using different levels of examples which are presented with real life graphics. However, lack of variety in terms of the tasks provided in the textbooks is viewed as a limiting factor to enhancing learners' understanding of number concepts through independent practice and critical thinking, hence not achieving some of the goals of OBE.

Keywords: Mathematics textbook, number concept, examples, tasks, outcome based education.

Introduction and background.

The results of Southern and Eastern Africa Consortium for Monitoring Education Quality (SACMEQ) show that Malawian pupils consistently perform very poorly on primary mathematics especially in number concept and operations (SACMEQ, 2011). For example SACMEQ 1 and 3 project results showed that Malawian grade 6 learners achieved poorly in numeracy, specifically in number concept and operation as compared to the other Southern African Countries (SACMEQ, 2011). Kasoka, Jacobsen and Kazima (2017) bemoans the Malawi SACMEQ results as worrisome because number concept and operations define numeracy. This implies that it might be difficult for Malawi to improve numeracy levels which are very low among its citizens if the causes of learners' inability to understand number concept and operation are not addressed.

As one way of addressing the problem of learners' low achievements in mathematics and science, the Government of Malawi through the ministry of education proposed a shift from objective education model (OEM) to outcome based education model (OBE). The underlying argument for the shift was that OEM was teacher centred, hence teacher played a more active role in achieving learning objectives than the learners. As such, OBE was assumed to be a major solution to improving and promoting learners' active participation and performance in all school subjects including mathematics (Malawi Institute of Education [MIE], 2006). The Malawi OBE curriculum emphasises learners' achievement through active participation in classroom and out of classroom activities which promote independent learning and critical thinking. In OBE, the content and focus of the curriculum determines the content and structure of curriculum material including textbooks, hence the value of a textbook is determined by the degree to which it contributes to students' achievement of the learning outcomes (Chang & Salalahi, 2017). This means that the goals of OBE curriculum are expected to be highlighted and achieved through the textbook. As Fujita, Jones and Kunimune (2009) argue, textbooks constitute much to curriculum implementation, hence they are widely used due to their

potential in mediating between the intended and the implemented curriculum. This implies that studying of textbooks is important because of their influence to both teachers and learners. However, since the implementation of OBE curriculum in Malawian primary education, no study has been conducted to analyse the content of the textbooks and their affordances in learners' achievement of the learning outcomes and OBE goals. As such, the purpose of this study was to analyse the effectiveness of the content of grade 1 primary mathematics textbooks in helping the learners to achieve intended learning outcomes. Specifically, the study aimed to answer the following questions:

1. What opportunities are available for Malawian grade 1 learners to learn number concept from primary school mathematics textbook?
2. How do opportunities to learn number concept in the textbooks relate to the goals of outcome based education curriculum?

This study is timely in Malawian context for effective achievement of OBE curriculum goals. The study also makes relevant contribution to global literature on textbooks as there are fewer topic specific studies on mathematics textbooks analysis (Chang & Salalahi, 2017).

Theoretical framework

Ronda and Adler (2016) proposed a framework for analysing mathematics textbooks which is known as Mathematics Discourse in Instructional analytic framework for Textbook analysis (MDITx). The MDITx tool was adapted from Mathematical Discourse in Instruction (MDI) framework which was developed to analyse opportunities available for learners to learn mathematics (Ronda & Adler, 2016). MDITx is rooted from the sociocultural perspective that foregrounds the importance of mathematics in a coherent manner. MDITx comprises of five key elements; object of learning, examples, tasks, naming/word use and legitimations. The object of learning is the main focus of the lesson (Adler & Ronda, 2015). The object of learning might contain the key content (mathematical concept) as well as the expected capability (like simplifying, solving or proving). Examples are particular case of a larger class used for drawing reasoning and generalisations (Ronda & Adler, 2016). Learners' textbooks are expected to contain examples which would enable learners to attend to understand a particular object of learning. The examples might be worked (to illustrate the procedure), or not worked (as learners' exercise). Tasks are what learners are asked to do with the examples like solving or drawing (Ronda & Adler, 2016). Different examples and tasks offer learners different opportunities to learn mathematics. Naming/word use is the way of naming mathematical concepts and procedures. Ronda and Adler (2016) argue that the way we name mathematical concepts and procedures might affect learners' focus during the lesson. Legitimations are the mathematical concepts and mathematical criteria communicated to legitimise or justify key moves or steps in a procedure.

Analysis of the textbooks focused on two elements of MDITx which are examples and tasks. The study focused on examples and tasks because it is commonly assumed that examples and tasks play a central role in the development of mathematics as a discipline (Olteanu, 2018). The second reason for choosing examples and tasks was that at this level, the learners have not reached the level of reading, as such, there would be little naming/word use and legitimation in the grade 1 textbook. MDITx framework was suitable for analysing number and operations topic because its elements are

similar to characteristics of OBE. As already explained, OBE emphasises on achievement of learning outcomes and measures the learners' achievement using examples and tasks. Furthermore, OBE defines learning outcomes as what learners are supposed to learn. This definition is similar to that of object of learning in the MDITx framework.

Methodology

I analysed grade 1 mathematics textbook for learners by the Malawi Institute of Education publisher. This is the only textbook available for use by Malawian grade 1 learners. The minimum age for grade 1 learners in Malawi is 6 years. According to the OBE mathematics curriculum, learning outcomes for the units of number and operation in grade 1 are; count up to 9, identify and write numbers up to 9, add numbers with sum not exceeding 9, subtracting of numbers within the range of 0 to 9, apply number concept in daily life. In my textbook analysis, I only focused on Unit 1 and Unit 4 which are about counting and writing of numbers 0 to 9. This is because ability to count and write these numbers is a foundation for understanding other mathematical operations. As Aunio and Niemivirta (2010) argues, learners understanding of number concept is very important in the learning of mathematics, hence learners without sound understanding of number concept skills struggle to excel in learning mathematics. Table 1 presents a summary of the codes that I used to analyse the examples and the tasks as adapted from Ronda and Adler (2016).

Examples	Tasks
Level 1-at least one of the pattern of variation (C-Contrast, G-Generalisation, F-Fusion).	Level 1-carry out the known procedure or use known concepts related to the object of learning (KPF only).
Level 2- any two of C, G, or F	Level 2-carry out procedures involving the object of learning (includes current topic procedure-CTP).
Level 3-all the patterns of variations.	Level 3-Carry out level 2 tasks plus tasks that involve multiple concepts and connections (includes CTP and Application/making connections-AMC)

Table 1: codes for analysing textbook examples and tasks

Example space belonged to Level 1 if only one pattern of variation is used throughout (the examples were the same), or Level 2 if there was contrasting (there was variations which signified two aspects of object of learning), or Level 3 if there was fusion of more than one aspect of the object of learning (single pattern as well as contrasting examples present). A task belonged to Level 1 if it only involved Known Procedure Facts (KPF) from previously learned knowledge, or to Level 2 if it involved the current topic procedure (CTP) or required learners to apply the procedure that is being introduced in the current lesson, or to Level 3 if it included the current topic procedure as well as Applications/Making Connections (AMC) among different concepts.

Results and discussion

Table 2 presents a summary of the findings from analysis of the examples and tasks from unit 1 to unit 4 of the grade 1 learners' mathematics textbook.

Unit	Object of learning	Examples	Tasks
1	Counting and writing numbers up to 5 (25 example spaces)	G (11 example spaces) C (8 example spaces) F (6 example spaces)	KPF (5 tasks) CTP (18 tasks) AMC (2 tasks)
4	Counting and writing numbers up to 9 (15 example spaces)	G (6 example spaces) C (4 example spaces) F (5 example spaces)	KPF (4 tasks) CTP (9 tasks) AMC (2 tasks)
	Legend	G: generalisation C: Contrast F: Fusion	KPF: Known procedure and facts CT: Current topic and Procedures AMC: Application/making connections

Table 2: summary of nature of examples and tasks in grade 1 learners' mathematics textbook

Column 1 indicates textbook units where learners are introduced to number concept in the grade 1 learners' textbook. Column 2 indicates the objects of learning under each of these units. Column 3 indicates codes assigned to example spaces under each unit. Column 4 indicates the codes assigned to learners' tasks against each unit. The table shows that out of the 40 example spaces, 17 example spaces belonged to level 1 (G) as they required same ways of either counting or identifying numbers. This implies that more examples leaned toward generality of numbers through noticing of similarity. 12 examples belonged to level 2 (C) as they required different demands like identifying what a particular number concept is and what it is not. 11 example spaces belonged to level 3 (F) because they contained examples which required understanding of different learning outcomes like counting, identifying numbers and writing numbers. This implies that most example spaces contained one pattern of variation (generalisation or contrasting) and few had a combination of different patterns of variation (fusion). This means that the textbook offers few opportunities for learners to achieve several outcomes in a single example space.

Analysis of the tasks showed that out of the 40 tasks, 27 tasks were under CTP as they required learners to use knowledge of the number concept that was being learnt. 9 tasks were under KPF as they required learners to use their previous knowledge of counting. 4 tasks were under AMC as they involved comparing the magnitude of different numbers (ordering of numbers in either ascending or descending order). This shows that the 2 units mainly contained level 2 (CTP) tasks. This implies that most of the tasks aimed at mediating learners' capabilities with respect to the current topic (Ronda & Adler, 2016). Table 3 present figures which show example spaces and tasks presented in the textbook with an aim of mediating meaning of number 1 concept.




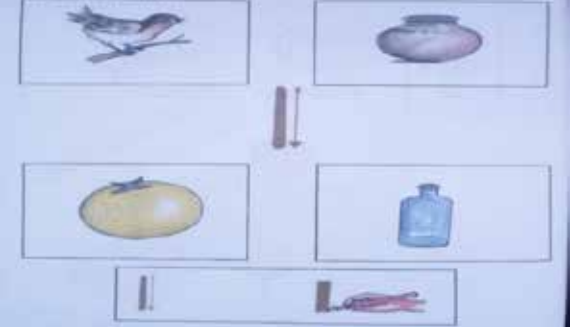
Example space	Description of the task
 <p data-bbox="284 678 746 712">Figure 1: counting number of objects</p>	<p data-bbox="882 297 1428 331">Count the number of objects in each box.</p>
 <p data-bbox="247 1111 778 1144">Figure 2: identifying of boxes with 1 object</p>	<p data-bbox="882 734 1337 768">Identify boxes containing 1 object.</p>
 <p data-bbox="247 1520 778 1554">Figure 3: drawing number 1 using a model</p>	<p data-bbox="882 1167 1329 1200">Drawing number 1 using a model.</p>
 <p data-bbox="256 1933 767 1966">Figure 4: counting and writing number 1</p>	<p data-bbox="882 1581 1433 1659">Counting and writing the number of objects in each box</p>

Table 3: examples spaces and tasks

Discussion on the example spaces

The figures in table 3 provide a general layout on example spaces and tasks provided in units 1 and 4 of the textbook. These are the units which introduce learners to number concepts from 0 to 9. The task and the object of learning for learners textbooks for grade 1 to 4 are in local language as per the education system in Malawi. The study found that both units introduced the numbers in a similar manner. Firstly, each unit started with an example space for counting of objects. Secondly the unit presented an example space for identifying objects of a specific number. Thirdly the unit presented an example space for drawing number 1 using drawing materials. Lastly the unit presented example space for counting and writing number of objects.

I coded example space in figure 1 under generalisation (G) because there is one object in each box, hence representing number 1. As such the examples in figure 1 were coded under generalisation because they enable learners to generalise that number 1 represent single object. This also implies that the example space only focused on single outcome of counting number of objects, hence it is at low level (level 1). I coded example space in figure 2 under contrasting (C) because there are different numbers of objects in each box. This means that the learner has to make similarities and contrasts between or among number and objects when identifying boxes containing only 1 object. In so doing the learners understand the difference between objects used to represent the number 1 and those which do not represent the number 1. This shows that example space in figure 2 is at medium level (level 2). I coded an example in figure 3 under G because it was only about drawing a number 1. This means that the aim of the example in figure 3 was to help learners to have a general picture of how the number 1 can be drawn. As such the example in figure 3 is at low level (level 1). I coded example space in figure 4 under Fusion (F) because it contained 2 learning outcomes which are counting number of objects and writing number 1. This means that the example space in figure 4 is at higher level (level 3).

I found that example spaces in units 1 and 4 provided learners with opportunities to understand number concepts properly because they mediate the learning outcome and real life visual features. For example, example spaces in figures 1, 2 and 4 contain pictures of a girl, book, bicycle, fish, house, money, tomato, pencil and so on. These are real like features which are familiar and used by the learners in their daily life. This implies that these features would enhance learners' understanding of the number concept. Therefore the most important feature in both units of the textbook is that they are dominated by real life graphics, hence they can help the learners to understand the number concepts. As Olteanu (2018) argues, learners' understanding of mathematical concepts is visually mediated through diagrams, graphs, and drawings.

Discussion on the tasks

The learning outcome for figure 1 task is counting number 1, and the accompanying task is about counting the number of objects in each box. I coded this task under current topic procedures (CTP) because it is mainly related to the current learning outcome. The learning outcome for figure 2 is identifying number 1 concept and the accompanying task is to identify boxes containing 1 object. I coded this task under applications/making connections as it offers learners opportunities to further understand the number 1 concept through making of judgment about what it should contain and what

it should not contain. The task for figure 2 also offer learners opportunities to justify their choices regarding the chosen boxes in relation to those that are not chosen. The learning outcome for figure 3 is drawing number 1 and the accompanying task is to draw number 1 using a drawing number pattern tool. I coded the task in figure 3 under CTP because it mediates learners' capabilities in writing or representing number 1 concept symbolically. The learning outcomes for the task in figure 4 are counting and writing number 1. I coded the task in figure 4 under AMC because it is about counting objects and writing their corresponding number which is 1 using free hand. This shows that the task provides learners with opportunities for further understanding of the number concept through making connections between quantities of objects, the number concept as well as writing its symbol.

I found that the tasks under units 1 and 4 would provide learners with mathematical opportunities to make their own judgments in terms of the meaning of a specific number concept and in representing quantity using numbers (Ronda & Adler, 2016). This is because the tasks are achievement based, activity based, hence they are learner centred. This implies that these example spaces and tasks can foster OBE to some extent because they are achievement oriented and activity based. I however found that the AMC tasks which mediate learners' capabilities in counting and writing are very few in both units 1 and 4. Although there is demonstration of how numbers from 0 to 9 can be written (for example task in figure 4), the textbook does not provide more opportunities for learners to practice writing the numbers. Furthermore, it is unlikely that the learners can manage to write the numbers without first attempting to trace these numbers on dotted number patterns. As such it would be better if learners were first given an example space where they could trace out the numbers. Provision of more dotted number patterns would also increase learners' capabilities in number concept by fostering learners' active interaction with the numbers through independent practice as demanded by the OBE curriculum (MIE, 2006).

The other limitation is that there are no tasks which provide learners with opportunities to represent number with objects to increase their mastery level of the number concept. For example, there are no tasks which require learners to draw a given quantity of objects to represent a number or to colour objects based on given number. This implies that there is lack of variety in terms of tasks provided to the learners through the textbook. Provision of little opportunities for writing numbers and representing them might limit learners' understanding of the number concept due to lack of practice, creativity and application.

Conclusion

This paper has presented findings from textbook analysis study which aimed at examining mathematical opportunities available for grade 1 learners to understand number concept through OBE curriculum. The study has found that the textbook has provided learners with different levels of example spaces ranging from low to high level. However, the high level examples which would help learners to engage with various thinking patterns simultaneously are few. In terms of tasks, the study has found that the textbook has provided learners with opportunities to understand number concept mainly through counting objects but not through writing or representations. As a result, the textbook might not foster learners' active involvement and independent learning as required by the OBE curriculum goals. As these findings are only based on textbook analysis, there is need for further

studies to focus on how learners engage with this textbook in classroom to find out how these opportunities materialise.

Acknowledgment

This study was kindly funded by Norwegian Programme for Capacity Building in Higher Education and Research for Development (NORHED) under the Strengthening Numeracy Project.

References

- Adler, J., & Ronda, E. (2015). A Framework for Describing Mathematics Discourse in Instruction and Interpreting Differences in Teaching. *African Journal of Research in Mathematics, Science and Technology Education*, 19(3), 237-254. doi:10.1080/10288457.2015.1089677
- Aunio, P. & Niemivirta, M. (2010). Predicting children's mathematical performance in grade one by early numeracy. *Learning and Individual Differences*, 20, 427-435.
- Chang, C. C. & Silalahi, S. M. (2017). A review and content analysis of mathematics textbooks in educational research. *Problems of education in the 21st century* 75(3), 235-251.
- Fujita, T., Jones, K., & Kunimune, S. (2009). The design of textbooks and their influence on students' understanding of 'proof' in lower secondary school. In Lin, F., Feng-Jui, H., Gila, H & de Villiers, M. (Eds), *Proceedings of the ICMI Study 19 conference: Proof and Proving in Mathematics Education*. Vol 1, (pp.172-177). Taipei, Taiwan: National Taiwan Normal University.
- Kasoka, D., Jacobsen, A. & Kazima, M. (2017). Pre-service primary school teachers' mathematical knowledge for teaching; Does secondary mathematics ability count? In Mhlolo, M. K., Matoti, S. N. & Fredricks, B. (Eds.), *Proceedings of the 25th Southern African Association for Research in Mathematics, Science and Technology Education* (pp. 77-87). Free State, South Africa: Central University of Technology.
- MIE (2006). *Primary curriculum and assessment reform; journeys through PCAR 4*. Malawi, MIE.
- Government of Malawi (2008). National Education Sector Plan. Lilongwe: Ministry of Education, Science and Technology.
- Olteanu, C. (2018). Designing examples to create variation patterns in teaching. *International Journal of Mathematical Education in Science and Technology*. 1-16. DOI: 10.1080/0020739X.2018.1447151
- Ronda, E., & Adler, J. (2016). Mining Mathematics in Textbook Lessons. *International Journal of Science and Mathematics Education*, 1-18. DOI: 10.1007/s10763-016-9738-6
- SACMEQ (2011). *Trends in achievement levels of grade 6 learners in Malawi*. Policy Brief Report. Retrieved August 3, 2014 from www.sacmeq.org.
- Soko, C., Mwale, L., Mphando, B., Mulauzi, S. B., & Whayo, D. (2006). *Malawi Primary education: Mathematics Learners' Textbook*. Malawi Institute of Education, Domasi.

Two primary school teachers' pedagogical design capacity of using mathematics textbooks in Delhi, India

Meghna Nag Chowdhuri

University of Cambridge, Faculty of Education, Cambridge, UK; nc.meghna@gmail.com

India introduced a new National Curriculum framework in 2005, which included reformed goals for primary school mathematics in an attempt to make them more inclusive and student-centred. One of the efforts towards operationalizing the framework was to create new primary mathematics textbooks. In a context where textbooks are seen as the basis of all curricular activity – from sequencing, to teaching, to examination, it becomes important to understand how such reform-based textbooks are used by teachers. Drawing from a multiple case study in the context of government-run primary schools in Delhi, this paper reports that teachers seem to primarily reject these reform-based textbooks. Further it shows that while using the textbook, teachers have varied levels of design capacities to productively interpret the textbook tasks. The findings imply that curriculum and policy makers need to develop materials that teachers are firstly willing to engage with, and also provide space for teachers' design capacity to develop.

Keywords: Mathematics curriculum, primary teacher, pedagogic design capacity

Introduction

India, much like the rest of the world and especially the Global South, is attempting to improve teaching and learning practices in mathematics not just to increase learning outcomes, but also to ensure equity in its processes. In post-colonial India, quality and equity have remained fundamental to its Education system. These ideals are explicitly reflected in the National Curriculum Framework – 2005 (NCF 2005), which forefronts “processes” in mathematical activities as well as connecting mathematics to the lives of children (NCERT, 2005, p. 9). Another important feature of the Indian education system which is recurring in the literature is its ‘textbook culture’ (Kumar, 2005). The textbook continues to be the only resource in the classroom; and for state-run schools, prescribed and made available to students free. Kumar (2005) even claims that textbooks act as “de facto curriculum” (p. 67), despite an official curriculum framework and syllabus. Thus, it was not surprising that the textbook series (NCERT *Math-Magic*) was chosen as the first (and only) point of intervention to operationalize the visions of NCF 2005. Yet very little is known in India about how the textbook is navigated in classrooms. In this paper, which comes from a larger PhD study, I focus on the following research question:

In what ways do teachers use reform-based textbooks in their mathematics classrooms?

Theoretical framework

Keeping the context in mind, as we explore the Anglophone literature in Mathematics education on the relationship between the teacher and the textbook (or other curricular resources), we see various developments. Different frameworks are used by researchers to make sense of these aspects based on how they conceptualise the teacher-textbook relationship as well as textbook as a resource. In this paper, I use Brown's (2003) framework of “design capacity for enactment” (p. 4), to explore how

teachers in the Indian context use textbooks. Central to Brown's idea is that teachers design textbook use by *offloading-adapting-improvising* based on the degree of responsibility they share with the textbook and their own resources. Thus, while using the textbooks, teachers may place agency primarily on the textbook (*offloading*), or change the activity based on their own needs (*adapting*), or change the course of the work altogether, making it very different from the textbooks (*improvising*) (Brown, 2003). While there is no prescribed hierarchy to their choice of offloading-adapting-modifying (one is not better than the other), these indicate the relevance and priority given to the textbook as a resource in teaching. Furthermore, this use is a function of both textbook *affordance* (textbooks' own attributes) and teachers' *pedagogical design capacity*. The notion of *pedagogical design capacity* – “teacher's capacity to perceive and mobilize existing resources in order to craft instructional episodes” (Brown, 2011, p. 29) – is evaluative in nature signifying teachers' capacity to use the textbook in productive ways. More recently Pepin, et al. (2017) have further described ‘teachers' design' as a “deliberate/conscious act” of “creating something new” (p. 801); thus, bringing dimensions of intentionality and genesis to the fore. They further distinguish between ‘design’ (during planning); and ‘design-in-use’ (during enactment). This exploratory paper, only focuses on teachers' ‘design-in-use’, as they mobilise textbooks' affordances and create lessons (without considering teachers' intentions). By doing so, I examine limited yet crucial facets of the notion of teachers' pedagogical design capacity.

Methodology

Sample: The larger study (a part of which is presented in this paper) is a multiple case study of ten teachers in four government-run municipality schools using *Math-Magic* textbooks. Delhi government schools, mandated to use these textbooks, were the site for the study. Importantly, these schools are low resourced both in terms of infrastructural resources, as well as teaching and learning resources. Getting permission to conduct my field work in these under-studied sites was particularly difficult. The ten primary school teachers were thus chosen based on convenience sampling, in schools which allowed me to conduct my study. However, I ensured that all the teachers had more than eight years of experience, including experience of using the textbook from the time of its introduction. Also, I focused on grades 4 and 5 teachers, where these textbooks were being used.

Data collection: Keeping the theoretical framing in mind, I focused on the three parts of the design capacity framework, and collected data on textbook affordances (the textbooks themselves), teachers' textbook use and thinking (through classroom observation and teacher interviews). While collecting *classroom observation data* (which is the data that I am analysing in this paper), I was given permission only to audio-record the classrooms, which was sufficient to capture the textbook use dimensions of teachers' teaching. The audio-recording was supplemented by observation notes, where I noted how the textbook was treated in the classroom (were the teachers reading it before starting the lesson, were they showing the textbook to students, did they provide time for students to read the text etc). In total, for each of ten teachers, I observed 3-4 lessons.

Data analysis: After transcribing and translating the audio recordings, the lessons were categorised into episodes which were defined on the basis of the tasks that teachers chose, so that an equivalent unit of analysis could be used to compare the textbook tasks with the teachers' chosen tasks. A total

of 34 lesson observations from the ten teachers, were categorised into 152 episodes (each episode corresponding to a task from the textbook analysis). These episodes were coded based on Brown's notion of offload-adapt-improvise. However, while doing so, two differences arose. First, teachers seemed to be using tasks of their own (or with the help of some other resource material) which were completely unrelated to tasks in the textbook. Thus, a notion of 'insertion' was necessary which accounted for such episodes, as done by Leshota and Adler (2018) in their adaptation of Brown's framework. Moreover, a second difficulty arose in defining the difference between adaptation and improvisation. One of the findings of the textbook analysis was that clearly stated goals for the tasks were missing, often leaving the tasks open to interpretation (perhaps even purposefully so) (e.g. Rampal & Subramanian, 2012). Thus, any modification to the tasks in the textbooks was coded as adapted use, without attempting to code episodes as being closer to the goals of the textbook task or not. As a result, a suitable adaptation to the 'offload-adaptation-improvisation' framework was made by identifying textbook task use in terms of 'direct use-adapted use-inserted use' which closely supported my data.

Overall findings

Teacher acceptance or rejection of the textbook: Figure 1 below shows details of the textbook use of each of the ten teachers. There are two notable results from this analysis. Firstly, we can see that four teachers are using the textbook directly for majority of their teaching, and the remaining six teachers are using their own insertions for more than half of their episodes. This is a clear indication that the textbook is not being used most of the teachers in my sample, who are *rejecting* them.

Direct use of textbook tasks: While analysing the episodes of 'direct textbook use', there were two ways in which teachers used tasks. One was by following each sentence in the book, (often teachers would read the text, or ask students to read it out), thus addressing every aspect of the book as a script. The second way of using which seemed more flexible was to pick and choose tasks (or elements of them) as the teacher felt suitable. These two kinds of approaches to directly using the tasks were especially exemplified by teachers Jagdeesh and Kamala, discussed in the next section.

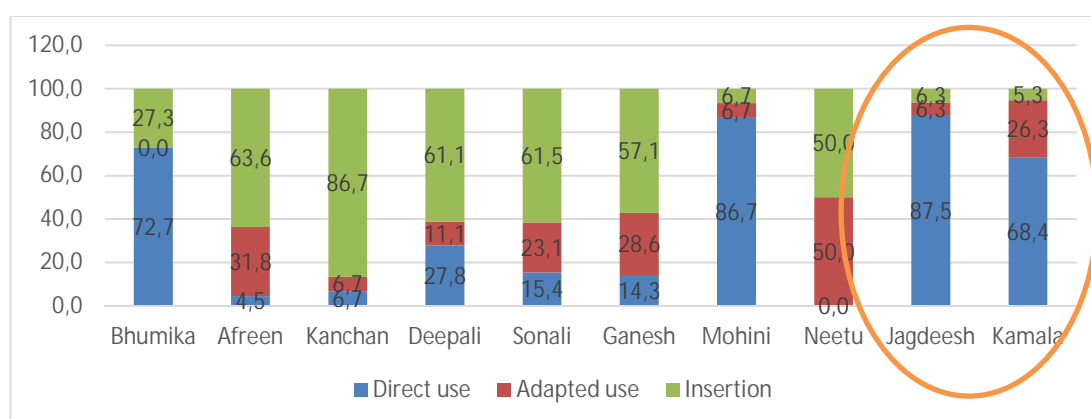


Figure 1: Per cent of episodes observed categorised as direct, adapted or inserted textbook use

Contrasting cases of teacher design capacity

As discussed in my theoretical framework, the use patterns analysed above do not indicate the evaluative aspect of use; i.e teachers' pedagogical design capacities. Design capacities can be

explored within each of these three types of textbook engagements. For this paper, I look at two frequent direct users and their contrasting interpretations and mobilisations of the textbook affordances; i.e. their design-in-use. Jagdeesh and Kamala, both have eight years of teaching experience and both teach grade 4 in the same school. Jagdeesh tended to follow every task given in the textbook, while Kamala was pickier in terms of what she chose to include in her class. In the following section, I analyse how two focus tasks (Figure 2, 3) were used by Jagdeesh and Kamala; as they *designed* two very different lessons. While Jagdeesh used the textbooks' affordances in productive ways (as afforded by the textbook), Kamala does not do so.

Focus tasks chosen for analysis and its affordances

The task in Figure 2 has two kinds of questions – ‘Have you heard about marathon races?’ invites students to engage with the context of the problem which follows. Such questions which were posed to students encouraging them to talk about their thinking, life experiences and feelings were coded as *expression tasks*. The following two questions are *specified tasks* (fill the blanks) where students are expected to answer the pre-formulated question. It is crucial to note that the text breaks down (possibly for support) the specified tasks into two stages, first asking students to find distance covered in 10 rounds (laps), and indicate its use to find the number of rounds for the 40 km.

Have you heard about marathon races in which people have to run about 40 kilometres? People run marathons on roads because the track of a stadium is only 400 metres.

10 rounds of a stadium track = _____ km

So, if you run a marathon on a stadium track, you will have to complete _____ rounds!

Figure 2: Expression task and Specified task within Book 4 chapter 2

In the second task shown below (Figure 3), we see another typical problem from the textbook which I refer to *generation tasks*. Here, the task is not pre-formulated, and to answer all these questions students have to bring in information from their own experiences or surrounding to answer the question. These particular aspects are viewed as task ‘affordances’, which are also aligned with the NCF reforms aiming to make mathematics process oriented and linked with everyday life.

* How long does your school assembly take? _____

How long is your lunch break? _____

How long is your games period? _____

Is it the same as all the other periods? _____



Figure 3: Generation task within Book 4 chapter 4

Comparison of teacher use of focus tasks:

Table 1 below, shows the different approaches taken by Jagdeesh and Kamala, while attempting these tasks. To provide some context, these teachers teach all the subjects for their class and are free to allot any time for each of the subjects, including for mathematics. Thus, the amount of time for each task or subject depends on the teachers' own goals for the lesson (there are institutional time limitations due to administrative work which are not discussed in this paper).

Teacher	Expression task	Specified task	Generation task
Jagdeesh (productive design)	<i>Expanded discussion</i>	<i>Explanatory approach</i>	<i>Opening the task</i>
Kamala (unproductive design)	<i>Omitted</i>	<i>Direct approach</i>	<i>Closing the task</i>

Table 1: Comparison of teacher use of focus tasks

Omitting versus expanding the expression task: Jagdeesh, instead of approaching the first *expression task* as a yes or no response, spends 10 minutes discussing different aspects of the context – what is a marathon, how a stadium looks like, what sports can be played in a stadium. He even encourages students to bring forth their own understandings, by listing the different sports they have heard being played in a stadium. He thus expands this expression task further creating his own probing questions supporting the task. On the other hand, Kamala omits this question all together, and only focuses on the specified tasks.

Direct versus explanatory approach to specified task: In his approach to the specified tasks, as possibly intended by the task, Jagdeesh uses the first question as the first step to the solution of the second question. That is, first finding distance travelled in 10 rounds and then discussing how many 10 rounds would be needed for 40 km. Throughout these stages he focuses on a detailed explanation of the solution procedure (spending 20 minutes), by breaking down the bigger question into smaller parts, which are more easily answered by the students. For example:

T: [We have to run] 40 kilometres. Now in 10 rounds, [we covered] 4000 meters that is 4 kilometres. In the next 10 rounds, how much will it be? In the next 10, if we add more, then how much is it adding 4 and 4? 8 km. After that another 10 rounds if we add?

Thus, Jagdeesh focuses more on the process of the solution (with some support from the structure of the specified task) rather than presenting formal operations for solutions – such as multiplication.

Kamala on the other hand only spends 10 minutes in total on the task. She introduces the stadium with circumference 400 m at the beginning of the lesson and draws it on the blackboard to help model the stadium. Consequently, she only focuses on the first questions of the given task unlike Jagdeesh's use of the both the questions to explain the process of the solution. Instead of an elaborate explanation, we see Kamala giving direct procedures.

T: Now, this is given in your book. If you take 10 rounds of this stadium, then what will you get?
 [] If you take one round of this stadium, then how much will it be? 400. You will multiply 400 with 10 rounds, then we will get how many metres we have run.

As we can see above, she directly tells the students that 400 needs to be ‘multiplied’ by 10 and consequently she writes the solution on the blackboard using the standard column algorithm form of multiplication. It is also important to note here, that Kamala was using an unofficial privately published guidebook while discussing this chapter alongside the textbook. The guidebook (see Figure 4) which acts like an answer book, provides a solution to each task in the textbook which just like her approach are also direct and formalised rather than process oriented (interestingly the guidebook even has a calculation error). Thus, instead of using the affordance within the textbook task (two questions as support for process explanation), Kamala takes a direct approach as given in the guidebook.

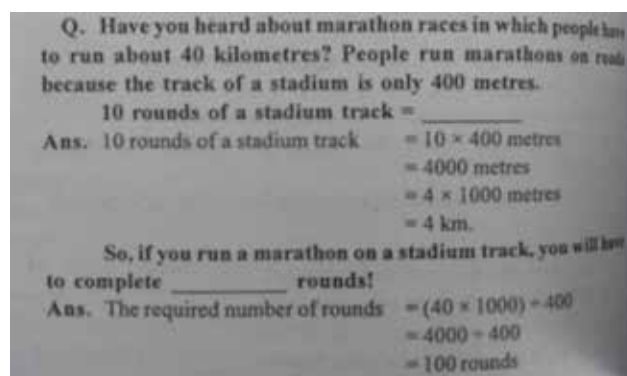


Figure 4: Page C-10, Apollo guidebook

Opening versus closing the generation task: While attempting the generation task (shown in Figure 3), we again see two very different approaches by Jagdeesh and Kamala. Jagdeesh while addressing this question (See Figure 3: How long does your assembly take?), tries to bring to fore the fact that the answer will vary based on the activity conducted during the assembly:

T: Hmm. Sometimes it is 15 minutes and sometimes it is 30 minutes. Sometimes, when there is a children’s meeting, it may take longer, otherwise the time for prayer meeting is about 20 minutes which includes the national song.

This shows that the Jagdeesh is open to the possibility that generation tasks can have many answers and the aim is to keep that in mind while answering. In contrast, Kamala gives definite answers which the students have to write down.

T: Who said it is 30 minutes? It is only 20 minutes. Write down 20 minutes.

As we can see above, in Kamala’s approach to the generation tasks, no openness is accommodated. Instead she renders the answer ‘30 minutes’ given by a student wrong and goes on to give a ‘correct’ answer to the student. Thus, despite the question being open (depending on the student’s perspective), she closes the kind of answers it can have.

If we look back at Table 1, along with the description of these episodes, we can see that while Jagdeesh seemed to interpret the key affordances within the tasks in alignment with the task’s rationale; Kamala’s interpretations contradict them. We can thus say that Jagdeesh seems to have a

higher pedagogical design capacity with respect to these textbooks; compared to Kamala. It is important to note that here I have not included evidence from teachers' own thinking which will enhance our understanding of the dimension of 'intentionality' motivating these designs-in-use. Furthermore, this does not imply that Jagdeesh and Kamala will always teach in these ways, and thus these are not fixed labels for teachers rather helpful indicators to help situate teachers' work in relation to the textbooks.

Conclusion

In this paper, I have discussed primary school teachers' relationship with mathematics textbooks, in the context of Delhi, a city where there is hardly any research in understanding how teachers interact with textbooks. Especially the perspective of viewing teachers as designers (and not just 'implementers'), actively participating while using the textbooks, is completely missing from the Indian policy discourse. Although the need for reforming curriculum and textbook has been articulated strongly in the last 15 years, there is a need to now put teachers at the centre of the discussion. In such a context, using this approach to study Indian teachers is a novel idea (even though in other parts of the world this idea has been developed in innovative ways). By focusing on such a framework, with some adaptation in terms of categories and unit of analysis, this paper reports two findings.

Firstly, the finding that majority of the teachers in my sample are rejecting the textbooks, is a common finding across the globe when teachers encounter reforms. Yet this finding has severe consequences in a context where officially, this is the only textbook provided to teachers, and the schools are not resourced to provide supplementary materials. As we have seen, this might mean that teachers rely on unofficial privately published guidebooks which often have contradictory pedagogical suggestions. Or teachers might rely on their own traditional notions of teaching, thus reforms miss the opportunity of using the textbook's potential of becoming 'educative material' (Davis & Krajcik, 2005).

Secondly, within the group of teachers who were primarily accepting and directly using textbook tasks, by focusing on two teachers we were able to more closely investigate teachers' design capacities as they engaged with the textbook's affordances. In case of the two teachers we clearly see two different ways of perceiving and mobilizing the resource around the tasks; ie their pedagogical design capacity. Jagdeesh is attempting to approach the tasks more openly, attempting to engage students with the contexts integrated in the text and also giving more explanatory solutions. On the other hand, Kamala does not pick up the opportunity of engaging children with the context, and tends to give direct formulaic solutions and closes tasks which are more open. While Jagdeesh seemed to interpret the key affordance within the textbook productively, Kamala does not. Recognising that teachers' design capacities are not homogenous is important in terms of not just curriculum designing but also the accompanying teacher support. Small scale initiatives are starting in science education, such as Ramadas (2017) – where teachers' varied experiences with curriculum feeds back into curriculum design. Yet, these are almost absent in primary Mathematics. Developing partnerships of designing needs to be the next step for the Indian curricular context; which extends the view of teachers as designers and integrates that into curriculum designing (at national, state, school or

classroom level) (Jones & Pepin, 2017). After more than 10 years of introduction of reform-based textbooks such as *Math-magic*, conceptualising ways of developing design capacities needs to become central.

In this paper, I have explored different designs-in-use of the teachers, yet not discussed notions of intentionality: Are teachers consciously making these design choices? What are their intentions and goals behind them? By exploring designs-in-use across the three levels of textbook use: direct use-adapted use-inserted use, along with teachers' rationales for those choices, my larger study aims to develop this notion of 'pedagogical design capacity' further.

References

- Brown, M. W. (2003). *Teaching by design: Understanding the intersection between teacher practice and the design of curricular innovations*. Evanston, IL: Center for Learning Technologies in Urban Schools, Northwestern University.
- Brown, M. W. (2011). The teacher–tool relationship: Theorizing the design and use of curriculum materials. In Remillard, J.T., Herbel-Eisenmann, B.A., & Lloyd, G.M. (Eds.), *Mathematics teachers at work* (pp. 37–56). Routledge.
- Davis, E. A., & Krajcik, J. S. (2005). Designing educative curriculum materials to promote teacher learning. *Educational Researcher*, 34(3), 3–14.
- Jones, K., & Pepin, B. (2016). Research on mathematics teachers as partners in task design. *Journal of Mathematics Teacher Education*, 19(2), 105–121.
- Kumar, K. (2005). *Political agenda of education: A study of colonialist and nationalist ideas*. SAGE Publications India. SAGE Publications India.
- Leshota, M., & Adler, J. (2018). Disaggregating a mathematics teacher's pedagogical design capacity. In Fan, L., Trouche, L., Qi, C., Rezat, S., & Visnovska, J. (Eds.), *Research on Mathematics Textbooks and Teachers' Resources* (pp. 89–117). Springer.
- National Council for Educational Research and Training (2005). *National curriculum framework*. New Delhi: NCERT. Retrieved from <http://www.ncert.nic.in/html/pdf/schoolcurriculum/framework05/nf2005.pdf>.
- Pepin, B., Gueudet, G., & Trouche, L. (2017). Refining teacher design capacity: Mathematics teachers' interactions with digital curriculum resources. *ZDM*, 49(5), 799–812.
- Ramadas, J. (2017, June). *The textbook as motivator of teacher discourse*. Paper presented at RVEC Conference for Elementary School Science Teachers, June 2-3, 2017, Bangalore, India.
- Rampal, A., & Subramaniam, J. (2012). Transforming the elementary mathematics curriculum: Issues and Challenges. In R. Ramanujan & K. Subramaniam (Eds.). *Mathematics education in India status and outlook* (pp. 63-88). Mumbai: Homi Bhabha Centre for Science Education.

Ability maps in the context of curriculum research

Lisbeth Liv Nøhr, Mia Onsvig Gregersen,

Andreas Lindenskov Tamborg, Jonas Dreyøe and Benjamin Brink Allsopp,

Aalborg University, Learning and Philosophy, Copenhagen, Denmark; ben@learning.aau.dk;

Keywords: Curriculum development, rationalistic, dialogical, ability maps.

Background

As mathematics teachers and course planners, we have hands on experience, negotiating learning objectives with our colleagues and students. One important challenge we have noticed in this process has been overviewing and disambiguating potential learning objectives (Hansen, 2018). We have attempted to address this challenge by drawing what we call ability maps – network representations of potential learning goals. The ability maps have the purpose of structurally relating knowledge and skills within a certain field – a subset of this would then be the curriculum. The notation involves a simple syntax. Any potential learning objective, no matter how small, is considered an ability and is represented by a node. Whenever we agree that one ability includes another ability, we represent this with an arc pointing from the including ability to the included ability. There are additional rules about redundancy and layout to make these networks easier to explore.

Our experience from initial workshops is that these maps help co-located participants to identify and discuss potential learning goals. Furthermore, implemented digitally, the above is aided by interactive support, dynamic layout, and remote participation. More ambitiously it supports a process of online social evaluation of individual includes arcs to enable emerging consensus on what is considered important. We have developed a basic prototype and are currently considering a number of research and design questions involving ability maps. These workshops were held with mathematics teachers, but we think of ability maps as context independent both regarding subject and nationality. An additional challenge we have noticed in the process of negotiating learning objectives, and when introducing new users to ability maps, has to do with the proper (although often implicit) purposes of curriculum development. With this in mind, we ask: Which foundational perspectives in curriculum research explain the disagreement and how do ability maps fit into these perspectives? This question thereby investigates the different perspectives among researchers not practitioners.

Method

Our approach is to orient ourselves in the literature to identify positions on curriculum research before considering how ability maps could be characterized by the perspectives. By reviewing the perspectives in the literature, we intend to discuss how and to what extent ability maps can address the challenges from the existing knowledge and discussions in curriculum research. In our search for literature we used the snowballing procedure. Snowballing is an approach in which a reference list, citations keywords in one or several papers are used to identify additional papers (Wohlin, 2014). The snowball methods often begin by identifying a tentative *start set* of papers. We began our search with the keywords: “Rationalistic”, “Tyler”, “Approach”, “Curriculum”, “Education”, which we searched for in Google and Google Scholar. We read 15 abstracts and 10 full papers. As the work presented in this poster is early stage research, we use the initial insights retrieved from the start set.

Within this process we found a framework for categorizing the role of curriculum, based on few authors which proved to be helpful in pinpointing the differences in the above literature and the potential role of ability map. The literature we read suggest two ways of approaching curriculum development referred to as a rationalistic and a dialogical approach. The rationalistic approach, represented by Tyler (1949), is described as technical and linear and focuses on structuring specific learning content. The dialogical approach is on the other hand dynamic and focuses on interactivity and flexibility (John, 2006). We adopt the distinction between these approaches as central.

Preliminary results from the review

The two perspectives seem to explain much of the disagreement when negotiating learning objectives, however it was not so straightforward to place ability maps in either of these perspectives. At first glance, ability maps may seem to epitomize a rationalistic approach as it involves a high degree of structuring, detailed breakdown of objectives and has ambitions of technical implementations. However, the structure is not linear, but captures rich relations that are the result of negotiation and collaboration. Also, the structure does not dictate how teachers teach but only provides a map within which they can navigate. Furthermore, the identified abilities are not necessarily objectives. Deciding on which abilities to consider as objectives are an independent step from working with the maps and may not even happen until in the classroom. Finally, the ambition of technical implementation must not be interpreted as enforcing a mechanistic approach.

Ability maps thereby seem to transcend the dichotomy of a rationalistic approach and a dialogical approach. Although the division of rationalistic and dialogical approaches are beneficial in segregating views on curriculum, it is not helpful in categorizing ability maps. On the contrary, the dichotomy between these notions can represent a barrier in developing novel approaches to curriculum development. In this respect, ability maps seem to contribute with nuances that can support the practical aspects of curriculum development.

Further exploration

To further explore and qualify these findings, a more comprehensive literature review is needed. This will contribute in nuancing and better understanding ongoing discussions in curriculum research and development and the potential contribution of ability maps. Further, ability maps are still at an early stage and experiments on its usage and usability is needed.

References

- John, P. D. (2006). Lesson planning and the student teacher: re-thinking the dominant model. *Journal of Curriculum Studies*, 38, 4, 483-498.
- Smith, M. K. (1996, 2000). Curriculum theory and practice - the encyclopedia of informal education, retrieved 9th of September 2018 from www.infed.org/biblio/b-curric.htm
- Wohlin, C. (2014). 18th International Conference on Evaluation and Assessment in Software Engineering, EASE 2014. Guidelines for snowballing in systematic literature studies and a replication in software engineering. ACM International Conference Proceeding Series.
- Hansen, R. (2018). Målstyret kompetenceorienteret matematikundervisning. Aarhus: DPU.

Task design fostering construction of limit confirming examples as means of argumentation

Annalisa Cusi¹ and Shai Olsher²

¹La Sapienza University, Rome, Italy; annalisa.cusi@uniroma1.it

²University of Haifa, Faculty of Education, Haifa, Israel; olshers@edu.haifa.ac.il

Tasks that require students to construct examples that meet certain constraints are known to be used in mathematics education. It is also well established that while examples are not proofs (for general statements), they have a supporting role in the preliminary stages of making sense of a certain mathematical phenomenon. In this study we examine a task design in which students are required to submit a supporting example to their explanation negating an existential statement. We introduce the idea of limit confirming examples and present their use in an analytical geometry task in a 10th grade class in Italy, along with the explanations they support in negating an existential statement. The results show that the design was effective in fostering the construction of limit confirming examples that could be considered as means of argumentation in the initial parts of proof construction.

Keywords: Reasoning with examples, limit confirming examples, automatic online assessment,

Theoretical Background

Alongside with computerized environments in mathematics education recent developments of online assessment platforms enable students to submit open ended tasks that are automatically assessed (Olsher, Yerushalmy, & Chazan, 2016). One challenge in designing tasks for these environments is to design means of mathematical argumentation that could be automatically analyzed (Yerushalmy, Nagari-Haddif, & Olsher, 2017).

One form of open ended that elicits different characteristics in student answers, and serves means of argumentation about them is by providing examples (Buchbinder & Zaslavsky, 2009). Examples could serve as inductive of general example-based arguments (Dreyfus, Nardi, & Leikin, 2012), thus providing an initial step in the proving process. Although there are limitations to the use of empirical examples as proof (Zaslavsky, 2018), research recognizes merit in arguing why characteristics of a certain example would work for any other one as well (ibid).

Students use at times systematic exploration of examples as a proving strategy, referring to their examples as cases, and then *prove by cases* (Buchbinder, 2018). When constructing cases, the literature recognizes several strategies that could lead to constructing refutations. One of these strategies, generating *limit cases*, might be constructed by creating an auxiliary problem in which the condition of the initial problem is transitioned to the limit (Balk, 1971), and is also referred to as *extreme cases* (Clement, 1991) or *boundary cases* (Ellis, Lockwood, Williams, Dogan, & Knuth, 2013).

In this paper, we present a task design aimed at fostering students' construction of a specific type of examples - *limit confirming examples*. We introduce this term as a theoretical result of our a-priori analysis of the task (for this reason, we will define and exemplify this concept after presenting the task). Our hypothesis is that limit confirming examples represent possible effective means of

argumentation (Stylianides, Beida, & Morselli, 2016) towards persuasion that certain characteristics could not co-exist in a specific mathematical context. This study is part of a wider collaboration for studying the design and use of online formative assessment activities using the STEP platform¹ (Olsher, et al., 2016).

Methodology

We adopted a design-based research approach (Cobb, et al., 2003), characterized by cycles of design, enactment, analysis and redesign. The pilot study on which this paper is focused has been developed within the first cycle of design. In particular, here we present aspects of both the design phase and the analysis phase.

The participants were 25 secondary Italian students, from a 10th grade class (students aged 15-16) of a scientific lyceum, in Italy. We focus on the students' resolution of a task that is part of an online activity within the context of analytical geometry, specifically lines intersecting a segment. The online activity was proposed to the group of students at the end of the school year, when they had already studied some basis of analytic geometry (in particular, coordinates of point, equations of lines, conditions of perpendicularity and parallelism).

The activity comprised three tasks designed as interactive diagrams describing a geometrical context on a Cartesian axis, using the STEP platform. The interactive diagrams were constructed using GeoGebra, and enabled the participants to construct or drag a set of elements in the diagram, according to the predefined characteristics determined by the designers of the task. The context was described in the task. The participants needed to submit examples satisfying different conditions. Students had to complete the whole activity within one hour.

The task

The task requires the students to consider the segment connecting the points A(2,4) and B(-3,2) and the family of lines $y=mx$ (see figure 1), and addresses the following existential statement: “*There are two lines of the family perpendicular to each other and both intersecting the segment AB*”. The students are asked to state if the statement is true or false, then, in case they think it is true, to submit the equations of two lines that satisfy it, or, in case they think it is false, to explain why and submit a screenshot that supports their choice.

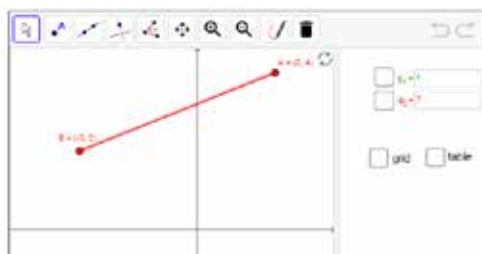


Figure 1: Applet accompanying task requiring an explanation and a supporting example

¹ Seeing the Entire Picture - STEP – is a formative assessment platform developed at the University of Haifa's Center for Mathematics Education Research and Innovation (MERI). For more detail about this platform, see www.visustep.com.

The existential statement could be formulated as follows: “*There are two lines that satisfy all of the following three properties: (A) the two lines belong to the family $y=mx$; (B) the two lines are perpendicular to each other; (C) the two lines intersect the segment AB* ”. Therefore, it could be thought as $A \wedge B \wedge C$, that is an intersection of three conditions. Proving that this statement is false requires to prove that the universal statement $\neg(A \wedge B \wedge C)$ is true, which is logically equivalent to each of the following statements: $(A \wedge B) \rightarrow \neg C$; $(B \wedge C) \rightarrow \neg A$; $(A \wedge C) \rightarrow \neg B$

So, in order to prove that the existential statement “*There are two lines of the family perpendicular to each other and both intersecting the segment AB* ” is false, it is enough to prove one of the following universal statements:

- 1) “*If two lines belong to the family $y=mx$ and are perpendicular to each other, then they do not both intersect the segment AB* ” ($(A \wedge B) \rightarrow \neg C$)
- 2) “*If two lines belong to the family $y=mx$ and both intersect the segment AB , then they are not perpendicular to each other*” ($(A \wedge C) \rightarrow \neg B$)
- 3) “*If two lines both intersect the segment AB and are perpendicular to each other, then they do not both belong to the family $y=mx$* ” ($(B \wedge C) \rightarrow \neg A$)

Students should be aware of the fact that identifying a *confirming example* for each of the universal statements 1, 2, and 3 is not enough to prove them. Yet, students’ choice of the examples that should support their claim that an existential statement is false could represent an important sign to highlight their awareness about what kind of examples could be the starting point for the construction of argumentations.

Limit confirming examples

We define *limit confirming examples* (for a universal statement) as specific limit, or boundary examples that incorporate within them all other possible confirming examples. The characteristic of incorporating all possible confirming examples makes limit confirming examples effective supports for construction of complete argumentation about the truthfulness of a universal statement because they foster the activation of a “domino effect”, enabling students to highlight why all the other possible examples that can be constructed will confirm the statement (in the following, we refer to the confirming examples that are not limit confirming examples as *not-limit confirming examples*).

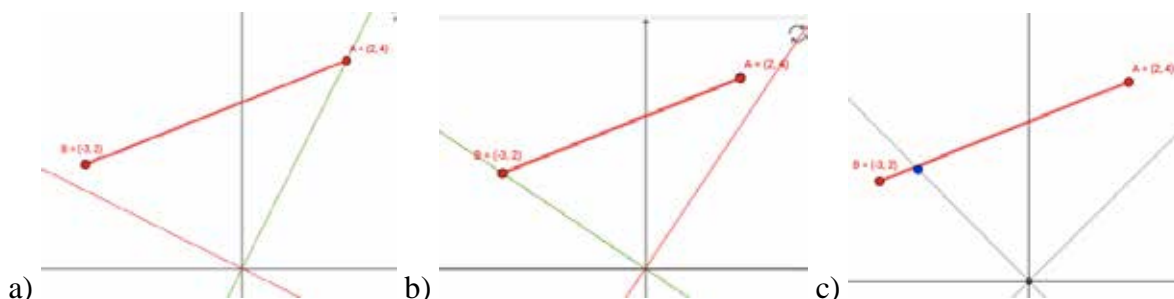


Figure 2: Limit confirming examples (a, b) and a not-limit confirming example (c) for statement 1

We refer to the task introduced in the previous paragraph to exemplify this idea. There are two limit confirming examples (Figure 2, a and b) for statement 1 (“If two lines belong to the family $y=mx$ and are perpendicular to each other, then they do not both intersect the segment AB ”).

These two examples are characterized by the fact that one of the two lines intersects the segment at one of its edges. They are *limit confirming examples* because, if we consider other examples constructed in the same way (two lines passing through the origin and perpendicular to each other), if one line intersects the segment in a point that is not an extreme for AB , the other line certainly does not intersect AB , as highlighted in Figure 2 (c), a screenshot submitted by a student.

As regards statement 2 (“If two lines belong to the family $y=mx$ and both intersect the segment AB , then they are not perpendicular to each other”), there is one *limit confirming example* (Figure 3a) characterized by the fact that the two lines considered are those that intersect the segment in its extreme points. We can consider it a *limit confirming example* because all the other couples of lines intersecting the segment and belonging to the family (Figure 3b) form an angle that is smaller than the one highlighted in figure 3a, meaning that the two lines are not perpendicular.

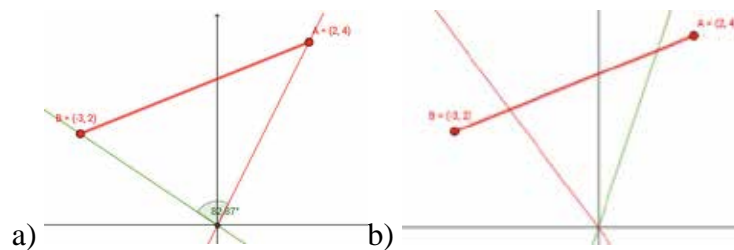


Figure 3: Limit and non-limit confirming example for statement 2

The limit confirming example (Figure 4a) for statement 3 (“If two lines both intersect the segment AB and are perpendicular to each other, then they do not both belong to the family $y=mx$ ”) is characterized by the fact that the two lines considered are perpendicular to each other, intersect the segment AB in its edges and intersect each other in the point that is at a minimal distance from the origin (that is the point of intersection between the circumference whose diameter is AB and the line passing through the origin and the center of this circumference). This is a *limit confirming example* because all the other possible couples of lines perpendicular to each other and intersecting the segment AB intersect each other in a point of the circumference that is at a greater distance from the origin (Figure 4b) or in a point inside the circumference whose diameter is AB (Figure 4c), so they do not belong to the family $y=mx$.

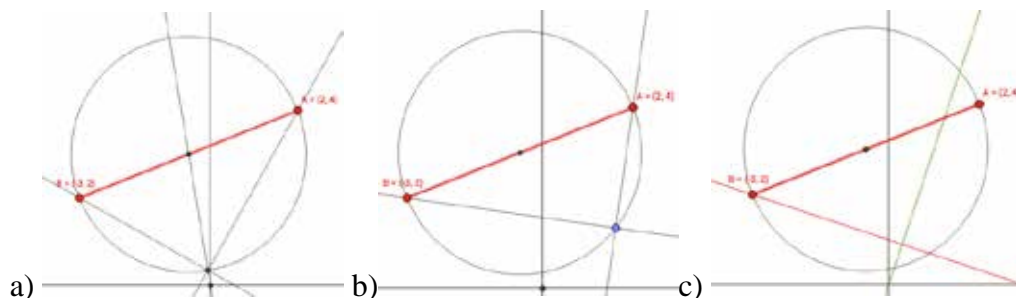


Figure 4: The limit confirming example for statement 3 (a) and two not-limit confirming example incorporated within it (b, c)

Methodology of analysis

Some important elements of the context must be added before presenting the methodology of analysis and the results. First of all, we did not share with students the logical analysis of the statement, that is the identification of A , B , C and the reflection on the logical equivalence of $\neg(A \wedge B \wedge C)$ and each of the statements $(A \wedge B) \rightarrow \neg C$; $(B \wedge C) \rightarrow \neg A$; $(A \wedge C) \rightarrow \neg B$. Moreover, we did not explain what limit-confirming examples are, neither we asked them to find out examples with specific characteristics.

The aim of our analysis was, on one side, to highlight if the design of the task was effective in fostering students' construction of limit-confirming examples and, on the other side, to detect, in students' answers, elements that could contribute to the construction of complete argumentations. Our units of analysis were the answers given by students to the task, including three main aspects: (1) students' claims about the truthfulness of the statement (level 1); (2) students' choices of the examples to be sent to support their claims (level 2); (3) students' verbal arguments to justify their claims (level 3)..

As regards the second level of analysis, we: (a) initially distinguished between the answers characterized by the submission of a limit confirming example and the answers characterized by the submission of a not-limit confirming example; and (b) subsequently distinguished, among the limit confirming examples sent by students, between the categories of limit confirming examples presented in the previous paragraph (that is those referred to statement 1, or 2, or 3).

The analysis of the verbal arguments sent by students to support their claims (level 3) was developed at a qualitative level, focusing on: (a) the reference to the chosen example and the coherence/incoherence between the choice of the example and the content of the verbal argument; (b) hints of students' awareness about the role that the examples they chose could play to support the construction of a complete argumentation to justify their claim.

Results

As regards level 1 of analysis, all students correctly stated that the statement is false.

Focusing on the examples they sent (level 2 of analysis), most of them (22 out of 25) submitted a limit confirming example. Among the 3 remaining students, two submitted a not-limit confirming example, while the third one did not submit any example. Further analysis of students' choice of limit confirming examples shows that most of them (17) submitted the limit confirming example related to statement 2 (Figure 3a); 3 students submitted a limit confirming example related to statement 1 (Figure 2); one student sent the limit confirming example referred to statement 3 (Figure 4a); one student sent a limit confirming example related to statement 1, containing also the sketch of the circumference whose diameter is AB .

In the following, we present some results of the analysis of students' verbal arguments (level 3).

Among the 17 students submitting a limit confirming example related to statement 2 (Figure 3a), 7 show some form of consideration to the fact that their example incorporates all other possible examples. Some of the students explicitly refer to the other possible examples incorporated into the limit confirming example, as shown in Figure 5.

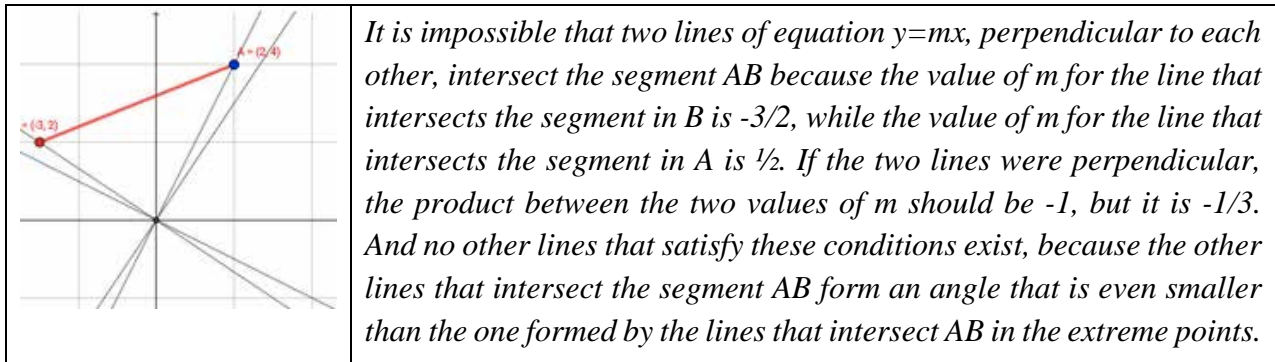


Figure 5: The screenshot submitted by S8 and the corresponding argumentation

Other answers show an implicit reference to the set of examples that can be generated starting from the submitted limit confirming example. For example, the argument proposed by S9 (Figure 6) refers to the idea of “widest angle”, making an implicit reference to the set of possible couples of lines passing through the origin and intersecting AB.

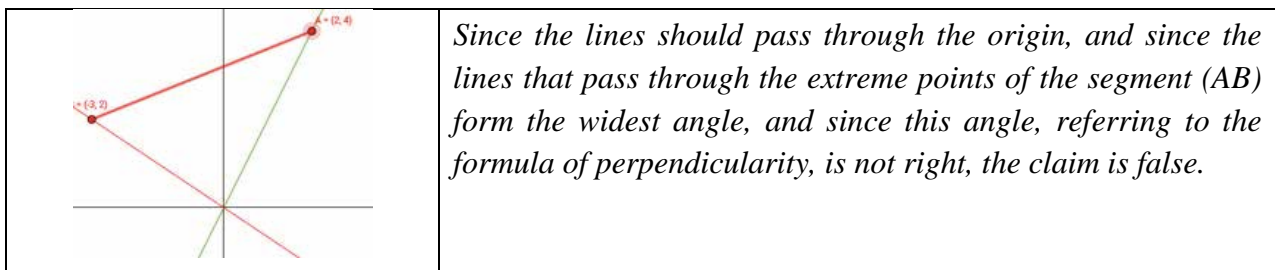


Figure 6: The screenshot submitted by S9 and the corresponding explanation

The other 10 students that submitted a limit confirming example related to statement 2 either did not submit an explanation (1 student), or submitted explanations with no evidence about of the role of a limit confirming example. These incomplete argumentations included either a repeated statement about the claim not being true, or an additional verbal description of the submitted example, or referred to aspects not directly linked to the provided example.

The choice of the limit confirming example to be submitted seems to influence the construction of the related argumentation. In fact, none of the three students who sent a limit confirming example referred to statement 1 (figure 2) show some form of consideration to the fact that their example incorporates all other possible examples: One of them do not submit an explanation. The second student reformulated the claim about the initial statement not being true, and the third student (S16, Figure 7) referred to the relation between the slopes of two perpendicular lines, without focusing on the possibility of creating other examples starting from the limit confirming one.

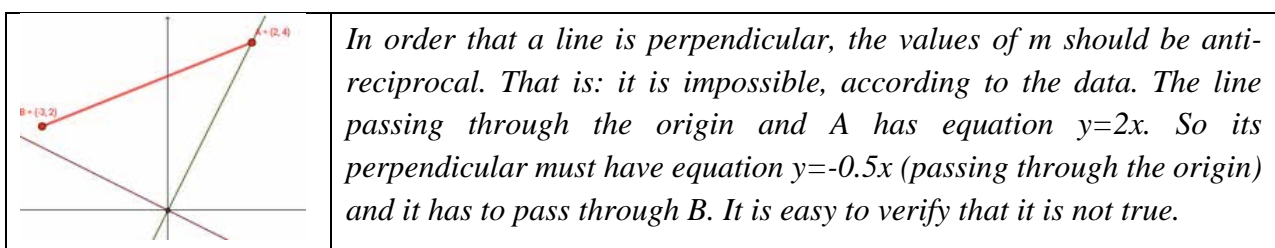


Figure 7: The screenshot submitted by S16 and the corresponding explanation

The single explanation submitted along with a limit confirming example referred to statement 3 (S18, Figure 8) does not highlight a consideration to the fact that their example incorporates all other possible examples.

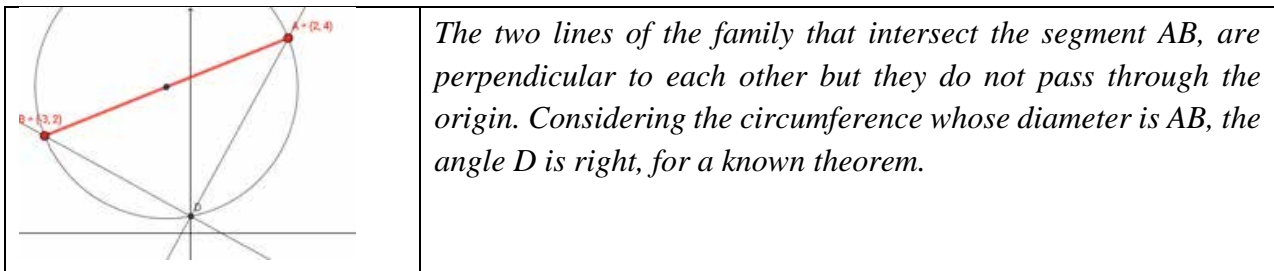


Figure 8: The screenshot submitted by S18 and the corresponding explanation

Conclusions

The most unambiguous outcome of this limited study is that 22 out of 25 students (88 percent) submitted limit confirming examples to support an explanation that disproves an existential statement in the form $A \wedge B \wedge C$. Disproving this statement is equivalent to proving one of the universal statements $(A \wedge B) \rightarrow \neg C$; $(B \wedge C) \rightarrow \neg A$; $(A \wedge C) \rightarrow \neg B$. The students provided the limit confirming examples without being previously introduced to these ideas, mostly since students should be aware that a confirming example is not enough for a proof (Buchbinder & Zaslavsky, 2009; Zaslavsky, 2018), in the same way in which a non-confirming example for the existential statement is not enough to disprove it. Yet, identifying limit confirming examples for one of the statements $(A \wedge B) \rightarrow \neg C$; $(B \wedge C) \rightarrow \neg A$; $(A \wedge C) \rightarrow \neg B$ was something that most students could come up with on their own as a supporting example. This result supports the notion that these examples might be an easier starting point in the argumentation process, opening the way to the construction of a complete argumentation somewhat aligned with example-based arguments (Dreyfus, Nardi, & Leikin, 2012) as means of argumentation (Stylianides, Beida, & Morselli, 2016) in an initial stage of the proving process.

Since many students that submitted a limit confirming example were not able to construct rich argumentations, our study also shows that, although choosing to submit a limit confirming example could be promising in fostering students' construction of complete argumentations, it is not sufficient. While the topic of the tasks in this study is analytical geometry, and used 3 properties, we believe that additional mathematical strands could be explored, while not necessarily limiting the number of properties to 3, but our final conclusions in terms of task design are driven straight from the finding of this study and the tasks studied: We suggest the following criteria for the creation of effective tasks aimed at developing learners' abilities in creating and using limit confirming examples: (a) analysis of complex false existential statements involving at least 3 properties to be satisfied by the elements of a precise domain; (b) possible deconstruction of the statement to corresponding universal statements to be proven; (c) requirement of argumentation and a supporting example about the truthfulness of one of these universal statements.

Limitations and future steps of the research

This research included a single task and a small sample of students. In order to further investigate and reaffirm the findings more tasks should be developed using this design, and tested in different settings. Furthermore, the use of the STEP environment could support the teacher in automatically having the student submissions categorized, thus providing grounds for research about teacher use.

References

- Balk, G. D. (1971). Application of heuristic methods to the study of mathematics at school. *Educational Studies in Mathematics*, 3(2), 133-146.
- Buchbinder, O. (2018). Systematic exploration of examples as proof: Analysis with four theoretical frameworks. In A. J. Stylianides & G. Harel (Eds.), *Advances in mathematics education research on proof and proving* (pp. 253-268). Cham: Springer.
- Buchbinder, O., & Zaslavsky, O. (2009). A holistic approach for designing tasks that capture and enhance mathematical understanding of a particular topic: The case of the interplay between examples and proof. *Task design in mathematics education. Proceedings of ICMI Study 22*, 27-36.
- Clement, J. (1991). Non-formal reasoning in experts and in science students: The use of analogies, extreme cases, and physical intuition. *Informal reasoning and education*, 1, 345-362.
- Cobb, P., Confrey, J., diSessa, A., Lehrer, R., & Schauble, L. (2003). Design experiments in education research. *Educational Researcher*, 32(1), 9–13.
- Dreyfus, T., Nardi, E., & Leikin, R. (2012). Forms of proof and proving in the classroom. In G. Hanna & M. de Villiers (Eds.), *Proof and proving in mathematics education* (pp. 191–214). New York: Springer.
- Ellis, A. E., Lockwood, E., Williams, C. C. W., Dogan, M. F., & Knuth, E. (2013). Middle school students' example use in conjecture exploration and justification. In L. R. Van Zoest, J. J. Lo, & J. L. Kratky (Eds.), *Proceedings of the 34th Annual Meeting of the North American Chapter of the Psychology of Mathematics Education*. (pp. 135–142). Kalamazoo, MI: Western Michigan University
- Olsher, S., Yerushalmy, M., & Chazan, D. (2016). How might the use of technology in formative assessment support changes in mathematics teaching? *For the Learning of Mathematics*, 36(3), 11-18.
- Stylianides, A. J., Bieda, K. N., & Morselli, F. (2016). Proof and argumentation in mathematics education research. In A. Gutierrez, G.C. Leder, & P. Boero (Eds.), *The second handbook of research on the psychology of mathematics education* (pp. 315-351). Rotterdam: Sense Publishers.
- Yerushalmy, M., Nagari-Haddif, G., & Olsher, S. (2017). Design of tasks for online assessment that supports understanding of students' conceptions. *ZDM – The International Journal on Mathematics Education*, 49(5), 701-716.
- Zaslavsky, O. (2018). Genericity, conviction, and conventions: Examples that prove and examples that don't prove. In A.J. Stylianides, & G. Harel (Eds.), *Advances in mathematics education research on proof and proving* (pp. 283-298). Cham : Springer.

Towards improving teaching and learning of algorithmics by means of resources design: a case of primary school education in France

Rafalska Maryna

rafalska.maryna@gmail.com

This article is devoted to the problem of design of resources in algorithmics for teachers of primary school in France. We investigate what elements should contain such resource in order to support the learning intended by authors of the resource, during its implementation by teachers who works in different contexts. To contribute to this question, we study the design principles of a particular resource in algorithmics. We follow this resource from the moment of its creation by a researcher and an experienced teacher to its appropriation and usage by three ordinary teachers. Paper describes how the results of analysis of lessons observations, interviews and collective discussions with teachers pointed to missing elements of the resource and, hence, contributed in its enhancement. The results of the study aim to bring some elements for improving the teaching of algorithmics by means of resources and, as a result, to support the learning of the involved concepts.

Keywords: Algorithms, resources, primary education, teacher.

Introduction

Algorithmics (Lagrange, 2014) is more and more present in school education of different countries. In France, the elements of algorithmics and programming were introduced in primary and middle school curricula in 2016. In our previous work, we analysed the didactical transposition (Chevallard, 1985) of the main concepts of algorithmics in French curriculum of cycle 4 (grades 7-9) and showed its partial nature with a focus on the effectiveness aspect of algorithm and on the usage of algorithm as a tool (Modeste & Rafalska, 2017). The following analysis of didactical transposition of concepts of algorithmics in French curriculum resources for cycle 3 (grades 4-6) showed the existence of the same orientations.

In French curriculum of cycle 3, content related to algorithmics and programming is included in the chapters “Mathematics” and “Sciences and technologies”. For example, in the theme “Space and geometry”, it is suggested to make an introduction to programming by using activities of spotting and displacement (coding the movement of a robot or a character on the screen) as well as geometrical activities (construction of simple figures and figures composed of simple figures). In the theme “Materials and technical objects”, it is mentioned that the notion “algorithm” could be discovered by pupils using “visual applications”. Curriculum guidelines for teachers (published by Ministry of education of France) highlight the importance of development of pupils’ knowledge of “the basic principles of algorithmics and software design” and indicate that the usage of unplugged activities could be the first step for introducing pupils to the notion of algorithm. However, the concept of algorithm is not defined and it seems that the main learning objectives of such activities is the development of rigor. Most of given examples present algorithm through programming tasks, using robots or different environments (like Scratch, Scratch JR, Géotortue, etc.). Analysed textbooks for cycle 3 (in particular, collections Nathan and iParcours for grade 5, Delta for grade 6) follow the recommendations of the curriculum and teacher’s guides, and propose mostly programming tasks

(usually about drawing figures on the screen) and games in Scratch without distinguishing the notions of algorithm and program. Such focus on programming leaves out other important aspects of algorithm, for example, the role of algorithms for problem solving.

Interviews with teachers of primary school revealed that many of them have never been trained either in algorithmics or in programming, and don't understand completely the goals and relation of the new topic to other parts of the curriculum. To prepare their lessons, they tend to use curriculum texts, teachers' guides, textbooks and existing online resources (that also propose mostly tasks of programming in Scratch). In spite of changes in French curriculum made in 2016, there are still many teachers of primary school who have not yet made lessons in this topic. This leads to the situations when in the same class of grade 6 (the first year of middle school) there are pupils with different levels of knowledge in algorithmics and programming.

We make the hypothesis that one of the ways to overcome the institutional constraints, to improve the teaching and, in consequence, learning of algorithmics, is the development of resources for teachers that takes into account different aspects of the notion of algorithm. However, the existed studies, like Aldon et al. (2017), showed that a teacher in interactions with a resource can interpret it in different ways. Sometimes, the didactical situation designed by a teacher on the base of a resource has different intentions comparing to the intentions of the authors of the resource. Thus, the elaboration of resources in algorithmics requires the design of tasks as well as the development of resources design principles that could "assure" their distribution and following usage with the relevance to initial learning goals. The research question that we investigate in this article is the following:

What elements should contain a resource in algorithmics in order to support the learning intended by the authors of the resource, during its implementation by teachers who works in different contexts?

To contribute to this question, we investigate the design principles of a particular resource in algorithmics. In the next sections, we present the theoretical framework, the methodology choices and the project framework in which our study is anchored. Then, we propose some elements of data analysis and the corresponding results. In the last section, we answer the research question and draw our conclusions.

Theoretical framework

This study refers to the documentational approach to didactics (Trouche et al., 2018), which proposes a holistic approach to teachers' work, taking into account the new universe of resources to teacher use, design and re-design. The central role in this approach is given to the notion of resource that is used in the sense of a tool that "re-source" the teacher's work (Adler, 2000). In addition to the material resources (like textbooks, curriculum materials, etc.), this approach also takes into consideration such resources as discussions with colleagues and researchers, students' answers, etc. Teacher integrate resources in their system of resources and design on their base his/her documents related to a certain class of situations. In Pepin, Gueudet, & Trouche (2017), the notion of document is presented as a combination of the resources adapted and re-combined, the ways the teacher uses them (which include the stable organisations of associated activities and particular usages), and contain the 'knowledge' guiding the usages.

The documental approach to didactics provides the tools for following the evolution of a resource during its adaptation and usage by a teacher. As in this study we are also interested in the results of resource implementation in class, we refer to the theoretical framework of the structuring of the milieu as well (Brousseau (1998); Margolinas (1995, 2002); Bloch & Gibel (2011)). It allows to analyze both a teacher's and pupils' positions in a didactical situation. Thus, taking the pupils' point of view leads to bottom-up or ascending analysis starting from the moment when a generic pupil is confronted with a material environment (milieu), i.e. without *a priori* didactical intentions, to the institutionalization of knowledge, including the phases of experience or action during which the knowledge at stake is encountered. Top-down or descending analysis corresponds to the teacher's point of view. It starts from the confrontation of a teacher with a construction milieu in an unfinalized situation, includes the phases of development of teacher's global project (concerning a theme of study that involves one or several lessons) and local project (concerning a particular lesson), and ends with the devolution and observation of pupils' activities in a didactical situation.

In our paper, we also use the notion of didactical bifurcation proposed by Margolinas (2005) for modelling the case when pupils confronted with a material milieu, invest themselves in a situation that is different from the one intended by a teacher. Margolinas distinguishes two types of marginal branches of a situation: a-didactical marginal branch (when pupils acquire new knowledge that is not in the teacher's project) and nildidactical marginal branch (when pupils don't acquire new knowledge). In analogy with the notion of didactical bifurcation, Aldon et al. (2017) proposed the notion of bifurcation of construction: when the construction situation (in which a teacher confronts with a resource and interprets its intentions for constructing his/her own project) carries the intentions distinct from those of the resource and, in consequence, it leads to a didactical situation different from the didactical situations potentially carried by the resource.

Methodology

Our study is anchored in the French PREMaTT project¹. The objective of the project is to stimulate the collaborative design of resources for teaching, in a network of schools, supported by researchers and a monthly meeting in a "laboratory for innovative design" (Trouche, 2019). In particular, in frame of the project the teachers and researchers worked on the design of tasks and resources for teaching of algorithmics aiming to make them useful for other teachers. Collaboration between researchers and practitioners is widely used in design-based research for bringing solutions to problems of practice (in particular, by producing new artefacts) and for contributing in the research by identification of design principles.

Our methodology is based on the confrontation of *a priori* analysis (built around the intentions of authors of the resource's, analysis of the resource and situations carried by it) with a posteriori analysis (built on the observation and analysis of implemented situations by ordinary teachers) as well as on the analysis of revealed dysfunctions, if any.

¹ PREMaTT: thinking the resources of mathematics teachers in a time of transitions (<http://ife.ens-lyon.fr/ife/recherche/groupes-de-travail/prematt>)

For our study, we constituted two teams. The first one involved a researcher and an experienced teacher who had been working part-time at a research laboratory and part-time in a primary school in the city centre for many years. The team worked on the design of didactical situations aimed to familiarize pupils with different properties of the notion «algorithm» and to show the role of algorithms in problem solving. The effectiveness of the developed tasks for supporting the intended learning was validated in result of confrontation of a priori analysis with a posteriori analysis of situations implemented in a class of grade 5 (10 years old pupils) by the experienced teacher.

The scenario of lessons developed by the team was chosen as the first version of the resource to transmit to the ordinary teachers. This choice was based on the hypothesis that this scenario, which takes into account both learning constraints and constraints of teacher practice, would constitute a sufficient support for teachers in order to design their own lessons project that will foster the intended learning. It included the description of the developed tasks (in particular, necessary material support, problems for pupils to solve, guidelines for teachers concerning implementation of the situations in class) and information about managing the lessons (timing, forms of class organization of pupils, etc.).

The second team involved three teachers (Natalie, Victor, Ida) who had been working together at a primary school in a socially disadvantaged part of the city for more than 5 years. The teachers obtained their initial education in different subjects²: Natalie in biology, Victor in literature and Ida in informatics. All of them at the time of the study taught in class of grade 5. Except Ida, who worked at the beginning of her career as a database operator for 10 years, the teachers have never been trained either in algorithmics or in programming. Natalie made a few lessons in programming in Scratch, while the others have never taught this topic. The teachers' mission was to prepare lessons using the scenario and to make them in their classes as well as to give the reflexive feedbacks during interviews and collective meetings with the first team. Ida, Natalie and Victor were also asked to elaborate a scenario that could be a possible continuation of the proposed one. The members of the first team didn't intervene in the work of the teachers (except a short presentation of the elaborated tasks by the researcher).

Collected data and their exploitation

For our study we collected the following data: answers of teachers to the questionnaire about their education, professional path, teaching experience, system of resources in mathematics and participation in collective work; video of collective work of Ida, Natalie and Victor before the implementation of the scenario in their classes; videos of the lessons of three teachers; pupils' written production; interviews with Ida, Natalie, Victor after the lessons; scenario proposed by three teachers as a possible continuation of the first one; videos of two collective meetings of the members of both teams (the first one, concerning the results of the implementation of the scenario in three classes; the second one – a collective discussion about a possible continuation of the first scenario).

² In France, in order to enter a teacher training program, candidates must have at least a Bachelor degree in any speciality.

We used the lessons videos to make the *a posteriori* ascending analysis of didactical situations implemented by each teacher and confronted it with the *a priori* analysis. We were particularly interested in the episodes that show existence of pupils' activities that were not expected. In such cases we questioned the reasons of appearance of didactical bifurcations and identified the type of marginal branches (regarding the didactical project of the authors of the scenario). We used the video of class observations to analyse teachers' actions in the class (particularly, the devolution of the situations made by the teachers) and their possible influence on the appearance of alternative pupils' projections of a didactical situation based on the material milieu. In the video of collective discussions of the teachers before and after experimentations as well as in the interviews with them, we were looking for episodes that could bring to light the logic of their actions in class and their choices made during the construction of the situations on the base of the scenario. To understand teachers' considerations about the role and possible place of constructed didactical situations in their global project of teaching algorithmics and programming, we analysed the scenario developed by Ida, Natalie and Victor as a possible continuation of the first one as well as the video of its collective discussion. The revealed dysfunctions in construction of didactical situations (bifurcations of constructions) as well as in their implementation in class allowed to revise the design choices made *a priori* and to identify what elements were missing in the resource.

Analysis of lessons observations

Due to space restrictions, we present in this section the elements of the analysis of Ida's, Natalie's and Victor's lessons and show how it contributed to the identification of missing elements of the resource. We start from a short description of the first two situations proposed in the scenario. Then, we show how Natalie, Ida and Victor made the devolution of the second situation in their classes and the corresponding pupils' activities.

The proposed scenario included the sequence of situations with a didactical dimension (Bloch, 2000) during the work on which pupils "re-invent" sorting algorithms. Implementation of the situations doesn't require a computer and propose the following material support: playing cards and grid with defined places for putting cards on it in an aligned list.

In the first situation of the sequence, pupils choose randomly 7 cards from 13 cards of one colour and put them face down on the grid. The goal is to sort the cards by returning only two cards at a time. The situation is used to introduce the material milieu (cards, grid and three allowed operations: "to take two cards", "to put them in the right order", "to place them on an empty place of the grid") and prepare pupils for the following tasks. The target knowledge includes the understanding that at a time one can put two cards in "local" but not necessarily in "global" (between all cards) order, as well as the comprehension of the possibility to sort the cards in a finite number of permutations using the defined operations. The results of experimentations in the class of the teacher from the first team showed that most of pupils' procedures in this situation are based on the usage of the memory.

In the second situation, one pupil should sort the cards of another one by giving him instructions with respect to the allowed operations. The pupil, who has cards, doesn't show their values to the pupil who gives instructions. All cards could be turned over only after the "pupil-speaker" says "stop". The objective of the task (that imitate, in some sense, the relation between a human and a machine) is to

foster the development by pupils of sorting strategies that will be generalised in the following situations.

Natalie made devolution of the second situation, emphasizing on the phrases that pupils can use for giving instructions to their classmates: “take card number ... and number ...”, “put them in the right order”, “place them on the grid”, “stop”. She highlighted that the use of other sentences is not allowed. The observation of pupils’ activities in this class showed that all pupils invested themselves in the main branch (regarding the didactical project of the authors of the scenario) and were working on the development of sorting strategies.

Ida and Victor, while explaining the challenge of the second situation, mentioned only that pupils “will do the same thing like in the first task, but this time, there is one pupil who gives instructions and another one who executes them”. They didn’t discuss with pupils the phrases that they are allowed to use for giving instructions, emphasising only on the necessity that “the ‘executor’ have to do exactly what the speaker says” and “that it is very important to be precise in the language”. Victor gave in his class the following criterion of success in the task: “if the cards are in the right order, it means that ‘the speaker’ was very good”. Such devolution of the situation led to its different interpretations by pupils and evoked pupils’ activities which were not intended by the authors of the scenario. For example, part of pupils in the class of Ida, for whom it was not evident which phrases to use, invested themselves in the nildidactic branch. They used the commands “exchange the cards” or “put back without exchanging”, factually trying to guess if the cards, they claimed to take, are in the right order or not. In the class of Victor, we observed one pupil who was searching for the optimal formulation of the sentence for sorting the cards of his classmate. He proposed the following solution: “you take two cards that you want, sort them and put them on the grid, and you continue like this until all cards will not be in the right order”. This answer was not accepted by Victor which produced a protest from the pupil who was sure of the correctness of his answer.

Thus, in the classes of Ida and Victor we identified the marginal branches that were not expected by *a priori* analysis. It happened due to the way chosen by the teachers for the devolution of the situation. The following analysis of collected data showed the differences between Ida’s and Victor’s interpretations of the objectives of the first two situations with those intended by the authors of the scenario. For example, Victor, expecting that pupils would find the sorting strategies during the work on the first situation, saw the goal of the second one in the development of pupils’ competencies to verbalise the solving procedures. This explains his choice of devolution for the second situation, when he left open the possibility of different formulations of pupils’ strategies.

The obtained results of the analysis contributed to improve the resource. More specifically, the identified bifurcations of construction showed the necessity to describe the expected pupils’ procedures in the first situation and the target knowledge in the second one as well as to provide the help for the devolution of the second situation (to insist on the “authorised” sentences for giving instructions with a link to the property of feasibility of algorithm).

Discussion and conclusion

Our study puts the light on certain difficulties that teachers of primary school could have in interactions with resources in algorithmics (and, more generally, with resources that involves the

concepts in which teachers don't have enough knowledge) and their influence on pupils' learning. In the case of Victor, flaws in a priori analysis of the proposed situations (in particular, wrong anticipation of possible pupils' procedure and identification of target knowledge) led to the construction of a didactical situation distinct from the one supposed by the authors of the resource. In consequence, the evoked learning activities of pupils didn't comply with intended ones.

It seems, that more pertinent choice of devolution of the second situation made by Natalie could be explained by the fact that she had taught a few lessons in Scratch before the experimentations took place and, as she said, "the usage of the given phrases for sorting cards is similar to the usage of blocs in Scratch for constructing a program". However, we also identified a few dysfunctions in her class that could influence on the learning outcomes. For example, Natalie didn't recognise in the pupils' answers the "germs" of the sorting algorithm with which she was not familiarized before. Hence, she didn't take them into account in the validation phase. Another example, which is common for the lessons of three teachers, is the lack of decontextualization in the phases of conclusion.

From the interview with Ida, Natalie and Victor as well as the analysis of the scenario proposed by them as a possible continuation of the first one, we draw the conclusion that they don't see all didactical potentiality of the resource proposed by the first team, focusing mostly on the effectiveness aspect of algorithm (Modeste, S., 2012). Moreover, analysis of the collective discussion about the possible prolongation of the first scenario showed that the situations, even didactically pertinent, could be discarded by the teachers if they don't see the connection between the target knowledge and curriculum requirements.

Revealed dysfunctions pointed to key elements to transmit to teachers by means of a resource in algorithmics in order to support the intended learning: *a priori* didactical analysis of situations proposed by a resource; target knowledge and ways of its gradual decontextualization in class; principal results of experimentations carried out in class (e.g. the examples of pupils' procedures, frequent errors, etc.); information regarding the basic theoretical and epistemological aspects of concepts involved in a resource; possible place of a resource in learning progression with link to curriculum requirements. Due to the fact that the transmission of the mentioned elements by means of a particular resource could make it too long and, in a result, not usable by teachers, the question of the structure of a resource in algorithmics need to be addressed.

Results presented in this paper, concerned only the first cycle of experimentation with the resource. The next step is to refine the design principles of a resource in algorithmics via the following cycles of experimentations with the revised resource as well as with other resources. Future work is also likely to investigate the impact of the resources designed on the base of the results of the study, on teaching and learning algorithmics at primary school.

References

- Adler, J. (2000). Conceptualizing resources as a theme for teacher education. *Journal of Mathematics Teacher Education*, 3, 205–224.
- Aldon, G., Gardes, M., & Front, M. (2017). Des intentions de l'auteur aux usages en classe, première réflexion sur la cohérence des usages d'une ressource. *Éducation et didactique*, 3(11), 9–30.

- Anderson, T., & Shattuck, J. (2012). Design-based research: a decade of progress in education research? *Educational Researcher*, 41(1), 16–25.
- Bloch, I. (2000). Dimension adidactique et connaissance nécessaire : un exemple de 'retournement' d'une situation. *Actes du colloque Guy Brousseau*. Bordeaux, France : Université Bordeaux 2.
- Bloch, L., & Gibel, P. (2011). Un modèle d'analyse des raisonnements dans les situations didactiques. Etude des niveaux de preuve dans une situation d'enseignement de la notion de limite. *Recherches en didactique des mathématiques*, 31(2), 191–228.
- Brousseau, G. (1998). *Théorie des situations didactiques*. Grenoble, France: La Pensée Sauvage.
- Chevallard, Y. (1985). *La transposition didactique – Du savoir savant au savoir enseigné*. Grenoble, France: La Pensée Sauvage.
- Lagrange, J-B. (2014). Algorithmics. In S. Lerman (Ed.), *Encyclopedia of Mathematics Education* (pp. 32–36). New York, NY: Springer.
- Margolinas, C. (1995) La structuration du milieu et ses apports dans l'analyse a posteriori des situations. In C. Margolinas (Ed.), *Les débats de didactique des mathématiques* (pp.89–102). Grenoble, France: La Pensée Sauvage.
- Margolinas, C. (2002). Situations, milieux, connaissances : analyse de l'activité du professeur. In J.-L. Dorier, M. Artaud, M. Artigue, R. Berthelot & R. Floris (Eds.), *Actes de la 11ème Ecole d'Eté de Didactique des Mathématiques* (pp. 141–156). Grenoble, France: La Pensée Sauvage.
- Margolinas, C. (2005). Les bifurcations didactiques : Un phénomène révélé par l'analyse de la structuration du milieu. In A. Mercier & C. Margolinas (Eds.), *Balises en didactique des mathématiques* (pp.1–12). Grenoble, France: La Pensée Sauvage.
- Modeste, S. (2012). *Enseigner l'algorithme pour quoi ? Quelles nouvelles questions pour les mathématiques ? Quels apports pour l'apprentissage de la preuve ?* (Doctoral dissertation, Université de Grenoble, Grenoble, France). Retrieved from: <https://tel.archives-ouvertes.fr/tel-00783294>
- Modeste, S., & Rafalska M. (2017). Algorithmics in secondary school: a comparative study between Ukraine and France. In T. Dooley & G. Gueudet (Eds.), *Proceedings of the Tenth Congress of the European Society for Research in Mathematics Education (CERME10, February 1 – 5, 2017)* (pp. 1634–1641). Dublin, Ireland: DCU Institute of Education & ERME.
- Pepin, B., Gueudet, G., & Trouche, L. (2017). Refining teacher design capacity: Mathematics teachers' interactions with digital curriculum resources. *ZDM Mathematics Education*, 49(5), 799–812. doi:10.1007/s11858-017-0870-8.
- Trouche, L., Gueudet, G., & Pepin, B. (2018). Documentational approach to didactics. In S. Lerman (Ed.), *Encyclopedia of Mathematics Education*. Cham, Switzerland: Springer. doi: 10.1007/978-3-319-77487-9_100011-1
- Trouche, L. (2019). Evidencing missing resources of the documentational approach to didactics. Towards ten programs of research and development for enriching this approach. Manuscript submitted for publication.

Length measurement in the textbooks of German and Taiwanese primary students

Silke Ruwisch¹ and Hsin-Mei E. Huang²

¹Leuphana University Lueneburg, Germany, ruwisch@uni.leuphana.de

² University of Taipei, Taiwan R.O.C., hhuang22@utapei.edu.tw

Length measurement plays a prominent role in most countries. The purpose of this study was to examine similarities and differences in Taiwanese and German elementary written textbooks concerning the treatment of length understanding, measurement, and estimation. Our analysis showed that procedural affordances dominate the conceptual learning situations in both countries, even more in Germany than in Taiwan. Although ‘units can be converted’, ‘reasoning and justification’ and ‘benchmark learning’ were the most common conceptual elements in both countries, their importance differed. The comparison of procedural elements showed that both countries mainly focused on ‘unit conversion’, ‘measuring with a ruler’, and ‘addition and subtraction of length’. The Taiwanese textbooks concentrated more on concrete actions, whereas the German textbooks focused on more abstract and mental procedures.

Keywords: length measurement, textbook analysis, binational comparison, primary school

Introduction

Length measurement plays a prominent role in measurement education in most countries (Buys & de Moor, 2008, Clements & Bright, 2003). Nevertheless, researchers all over the world continuously report poor learning outcomes especially concerning the underlying measurement concepts behind the measurement procedures (Smith III, van den Heuvel-Panhuizen, & Treppo, 2011). Although there seems to be a great consistency about the aspects of those concepts (Barrett, Sarama, & Clements, 2017; Lehrer, 2003; Clarke, Cheeseman, McDonough, & Clarke, 2003), differences in the curricula and teaching practice are assumed as well (Lee & Smith III, 2011).

Being interested in cross-cultural differences and similarities in length estimation, we’re looking closer to Taiwan and Germany as first examples, motivated by two aspects: Taiwan and Germany are two examples of very different cultural backgrounds—one Asian and one European country, and both with an official language different from English—and the learning outcomes in both countries differ enormously at 4th grade.¹ In contrast to the international results, the preliminary findings of our pilot study on length estimation did not show these differences in the overall estimation abilities. Looking closer to the answers we considered specific differences, which, perhaps, may be explained by different learning opportunities on length learning. Therefore, this textbook analysis serves as a basis for looking to the learning opportunities on length learning in both countries.

¹ Although TIMSS 2015 reported significant above average scores for German fourth-graders (overall score: 522, s.e. 2.0; ‘geometric shapes and measures’ score: 531, s.e. 2.5), Taiwanese fourth-graders performed much better (overall score: 597, s.e. 1.9; ‘geometric shapes and measures’ score: 597, s.e. 3.0)

[for details see: <https://nces.ed.gov/timss/timss2015/> [last check: 21-11-2018]]

Theoretical background

Core concept of lengths and its measurement

Length understanding, length measurement, and length estimation are thought to be a complex concept with different conceptual underpinnings as well as concrete actions. According to Lehrer (2003), Clarke et al. (2003), Stephan and Clements (2003), and others the most important foundations are

- (1) Understanding of the attribute and its relation to the units used to measure with.
A length must be understood as the distance between two points in the space. The length of an object can be found by quantifying the distance between its endpoints.
- (2) Logical operations: conservation and transitivity.
The length of a given object isn't dependent on its location, nor is it variant under special transformations, whereas other transformations don't conserve the length. The transitivity of the equivalence and order relation are one basis for the comparisons of lengths.
- (3) Mental partitioning into parts.
Being able to partition the length of an object mentally and being sure that adding the measures of the parts will give the length of the whole.
- (4) Iterative tiling with identical units and counting them.
The measuring process consists of using a unit (standardized or non-standardized) iteratively by placing it end to end without gaps or overlaps. Whether a subdivision of the unit is necessary depends on the precision the measurer looks for.
- (5) Numerical interpretation of the iteration process.
Either every iteration-step has to be counted during the process, or the number of different identical units can be counted at the end of the tiling-process. The counted number has to be understood as the measure.
- (6) Understanding of measurement tools.
The children need not only the procedural knowledge how to measure and draw with a ruler, but they need to understand the scaling itself. Crucial is the difference between a point on the scale and the length measured, being asserted to the distance between two scale-points.
- (7) Measures as the relation between unit and number.
The relation between the unit and the number of units needed to tile a length is inversely proportional. Besides this children have to learn the conventional conversions between different standardized units, including fractions and decimals.

Conceptual and procedural knowledge in length measurement

In the literature, it has been stated since a long time that measurement learning is much more concentrated on superficial procedural aspects than on the underlying concepts (e.g. Lehrer, 2003; Stephan & Clements, 2003). In sharpening the meaning of conceptual and procedural knowledge in measurement learning, the STEM research group at Michigan State University (e.g. Lee & Smith III,

2011, Smith III, Males, Dietiker, Lee, & Mosier, 2013) developed iteratively a coding scheme with conceptual, procedural, and conventional codes. They included all measurement actions children are asked to carry out into the term ‘procedures’ and ‘procedural knowledge’, whereas they use ‘concepts’ and ‘conceptual knowledge’ “to designate the general principles that underlie and justify procedures” (Smith et al., 2013, 399). The third category, ‘conventional knowledge’ was used to code aspects, which are contingent and culturally defined, like the metric of units or aspects of rulers etc.

Their analysis of three US and one Singapore textbook series showed strong emphasis on procedural aspects in all grades and both countries (Lee & Smith III, 2011). If concepts are focused and explicitly addressed, they are not in line with the procedures but appear much later in the curriculum (Smith III et al., 2013).

Length estimation

In the sense of Bright (1976) we consider length estimation as being a mental process of determining a length for an attribute without the aid of measurement tools. Although children’s estimates in length are more accurate than in other measurement areas (Joram, Subrahmanyam, & Gelman, 1998), children are even worse in estimating than in measuring lengths. Researchers stress the importance of strategies (Jones, Taylor, & Broadwell, 2009; Huang, 2015) and their conjectures to the underlying measurement concepts and procedures. Different learning environments based on different curricula might lead to different knowledge (e.g., different estimation strategies). Since most studies on estimation focus on one country with the underlying assumption that the curriculum for measurement estimation will be similar across countries (Jones et al., 2009; Ruwisch, Heid, & Weiher, 2017), we try to get deeper insights into similarities and differences in the lengths curriculum and its focus on learning length estimation. The study of the STEM-project only referred to length estimation at the edge. Nevertheless, they reported great differences in the frequencies among the three US textbook series, and concluded that “despite the frequent calls to estimate lengths, little attention was given in any curriculum to specify the estimation process” (Smith III et al., 2013, 416).

Research questions

The purpose of this study was to examine similarities and differences in Taiwanese and German elementary written textbooks concerning the treatment of length understanding, measurement, and estimation. Specifically, we were interested in those aspects which may lead to different understandings of length estimation.

Q1: On a coarse and organizational level: Are there differences in the main syllabus—number of units, instructional time—on length learning between Taiwan and Germany?

Q2: Do procedural aspects also dominate the Taiwanese and the German curriculum as it has been reported from the USA and Singapore?

Q3: Which concrete differences in the opportunities to learn length understanding, measurement, and estimation can be observed between Taiwan and Germany?

Method

Choice of written curricula and scope of analysis

In both countries, elementary school mathematics textbooks were developed on the curriculum guidelines for compulsory mathematics education mandated by the responsible ministry that has them licensed (Lan 2005 in Chinese for the Taiwanese procedure; Stöber 2010 in German for the German procedure). We examined four German elementary textbook series and three from Taiwan which were chosen by the ranking of publishers (see Ruwisch 2017).

A primary textbook series in both countries normally includes a package for each grade. Since the additional materials differ from series to series and are optional for a teacher, the only materials included in our analysis are the main textbooks for each grade.

Locating the length content

For the purpose of this comparison, we focused on those pages of the textbooks that were designated as length measurement units by the authors, excluding the units involving perimeters of shapes. So our analysis was a first step to come to a deeper analysis as such of Lee and Smith III (2011).

Coding process of the length content

For coding the different aspects of length content we adopted the coding scheme of Lee and Smith III (2011, 689). We also differentiated between conceptual and procedural knowledge. The analysis presented here is coarser than the very fine one of Lee and Smith III in one sense and broader in another one: The coding unit was not the sentence or question but normally the task, which could contain more than one sentence. Sometimes, there were two different requests in only one sentence. As a consequence, some tasks got more than one code, although normally we tried to decide which element is more important in a special situation. Therefore, we restricted ourselves to tendencies here. In applying the scheme to our data, we also needed to extend the coding scheme. *BL* was added as a conceptual element for tasks that ask students for exploration and learning the measures of benchmarks or personal reference objects for estimation. *CS* is a conceptual code for the definitions of curve versus straight line. A category for reasoning and justification was added (*RJ*), which we think is a linking category between conception, procedure, metacognition, and language.

Exemplary for our differentiation between the procedure and the underlying concept we look closer to “unit conversion”. If the task asked the child to “write the measures given in mm”, this was coded with the procedural code “unit conversion”. If a short description or definition of conversion was given—“Sometimes the unit centimeter is too rough. We then need the finer unit millimeter. 1 cm = 10 mm; 1 m = 1,000 mm.” — we coded this with the conceptual code “units can be converted”.

Results

Syllabus, units and time

In Taiwan, the learning of length measurement starts at the first semester of grade 1 in all textbook series. In every grade, length measurement units are included in the textbooks. Whereas in grades 1

and 2, two length measurement units are allocated in every textbook series—one per semester—, only one unit is included in all series for grade 3 and 4, respectively.

Most schools in Germany start length learning in second grade. Only *Das Zahlenbuch* gives an opportunity for learning length measurement in grade one, but only by one page in a book of 132 pages. Nearly every textbook contains one special unit about length learning per grade—with the exception of *Das Zahlenbuch*, which offers two units in grade three and none in grade four.

Table 1 gives detailed information about both countries. On the one hand, the total numbers of pages on length measurement in the Taiwanese textbooks are more than three times of those contained in the German textbooks. On the other hand, comparing the intended instructional time in both countries does not reflect this great difference. German teachers seemed to be asked to refer for a longer period of teaching time to the same page of the textbook.

Grade	German textbook series				Taiwanese textbook series		
	Denken und Rechnen	Flex & Flo	Welt der Zahl	Zahlenbuch	Han-Lin	Kuang-Hsuan	Nan-I
1	—	—	—	1/132 = 0.75% (no time given)	14/224 = 6.25% 6 (240 min.)	15/218 = 6.9% 7 (280 min.)	15/238 = 6.3% 6 (240 min.)
2	10/133 = 7.5% ~10 (450 min.)	6/148 = 4% ~10 (450 min.)	2/133 = 1.5% ~5 (225 min.)	3/132 = 2.3% (no time given)	22/256 = 8.6% 10 (400 min.)	19/219 = 8.7% 10 (400 min.)	21/246 = 8.5% 10 (400 min.)
3	7/117 = 6% ~ 8 (360 min.)	8/156 = 5% ~ 8 (360 min.)	9/125 = 7.2% ~ 8 (360 min.)	7/132 = 5.3% (no time given)	13/268 = 4.85% 5 (200 min.)	8/260 = 3.1% 4 (160 min.)	9/258 = 3.5% 5 (200 min.)
4	3/117 = 2.6% ~ 8 (360 min.)	5/144 = 3.5% ~ 4 (180 min.)	4/125 = 3.2% ~ 8 (360 min.)	—	7/276 = 2.5% 2 (80 min.)	9/256 = 3.5% 5 (200 min.)	11/278 = 4% 6 (240 min.)
Total	20/500 = 4% ~ 26 (1170 min.)	19/596 = 3.2% ~ 22 (990 min.)	15/416 = 3.6% ~ 21 (945 min.)	11/528 = 2.1% (no time given)	56/1024 = 5.5% 23 (920 min.)	51/953 = 5.4% 26 (1040 min.)	56/1020 = 5.5% 27 (1080 min.)

Note: The first row gives the proportion by the number of pages: Pages of the length measurement unit in proportion to the whole number of pages. The second row gives the intended teaching time for the units.

Table 1: The opportunities for learning length measurement

In both countries, most time for learning length is spent in second grade. The comparison between both countries suggests that length learning in Germany seems to be more concentrated than in Taiwan: starting in second grade and offering only one unit per grade.

Conceptual versus procedural affordances

In the German textbooks, the total numbers of conceptual codes were nearly the same in all four series, whereas the number of procedural codes differed. *Das Zahlenbuch* and *Welt der Zahl* got twice as many procedural codes than conceptual ones, *Denken und Rechnen* and *Flex & Flo* got three times as many procedural as conceptual codes.

The Taiwanese textbook series showed little differences in the total numbers of procedural elements, but differed in the number of conceptual codes. Whereas *Kuang-Hsuan* and *Nan-I* were about close in the number of conceptual codes, the third series, *Han-Lin*, only contained about 60 % of the number of *Kuang-Hsuan*, the series with the most conceptual elements. Therefore, this textbook series (*Han-Lin*) contained more than twice as many procedural than conceptual elements. The other two have about one third more procedural than conceptual elements.

Thus, in the German and the Taiwanese curriculum also the procedural affordances dominate, a tendency which is stronger for the German than the Taiwanese textbook series.

Main categories of conceptual and procedural affordances

The main concepts in all German textbook series are *benchmark learning* and *reasoning and justification*. The latter normally is combined with benchmark learning (more conceptual) or with proportional reasoning as in distance-time-relationships and scale (more procedural). The third most common conceptual category is *units can be converted*, normally at the top of a page, on which the students are asked to convert units in the following tasks.

The main concept involved in all Taiwanese textbook series is *units can be converted*. It occurs about twice as often as *reasoning and justification*, which is the second important conceptual element. Although *benchmark learning* occurs as the third often coded element of conceptual categories in Taiwanese textbooks, it is much rarer than the other two.

Looking to the procedural elements, the most common one in all series of both countries is *conversion of units*.

We differentiated between those procedures that ask for a concrete measurement action, and more abstract procedures, which are presented on the symbolic level. In German textbooks only about one third of the tasks asks for concrete procedures, another third for the *conversion of units*, and the last third for other symbolically presented procedures. In Taiwan nearly one half of the coded tasks ask for concrete and the other half for more abstract procedures, if *conversion of units* is included in the latter one.

Concerning the concrete procedures the most common one in both countries was *measure with a ruler*, when the object is shorter than the ruler. In Germany *draw with a ruler* (also objects shorter than the ruler) and *visual estimation* were the second and third common ones, whereas in the Taiwanese textbooks *measuring with sufficient non-standard units* and *visual estimation* and different kinds of *direct and visual comparisons* were found more often than drawing activities. No *direct comparison* was coded in the German textbooks.

The most common abstract procedures in the Taiwanese textbook series were generating the *sum and differences of length given through word descriptions and representations*, and doing so *given word descriptions only*. In Germany, *word problems with lengths*, sometimes *with the aid of a representation*, also dominate the abstract procedures—besides the conversion of units—, followed by *the comparison or order of length which were given in a symbolic*.

Discussion and conclusion

The analysis showed similarities and differences between the countries as well as between the textbook series concerning the opportunities for learning length understanding, measurement, and estimation.

Although all textbooks show a dominance of procedural aspects over conceptual elements, this tendency is stronger in the German textbooks. The Taiwanese textbooks focus much more on conceptual elements than the German did. If this difference in the frequency of the opportunities to understand length measurement is crucial for better results in international comparative studies,

needs further investigation. As a first step, our analysis itself can be deepened insofar that we will look, if and how the procedural and underlying conceptual knowledge elements are temporally interlocked or decoupled like in the US textbooks (Smith III et al., 2013).

Although *units can be converted, reasoning and justification* and *benchmark learning* are the most common conceptual elements in both countries, their importance differs. The Taiwanese textbooks mainly stress the idea of conversion, whereas the German textbooks focus more on benchmark learning. Although there were only a few problems involving ‘visual estimation’ as a procedure, we did not yet deepen our analysis in this point to get to know, if the content of this request differs in both countries: Is the procedure itself specified? And if so, how? Is a specific strategy shown? Benchmark knowledge and estimation strategies are seen as crucial elements for good length estimation (Jones et al., 2009; Joram et al., 1998; Huang, 2015).

The comparison of procedural elements showed that both countries very often focus on unit conversion, measuring with a ruler, and addition and subtraction of length. In the Taiwanese textbooks more tasks ask for direct comparison and measurement with nonstandard units, whereas the German textbooks stress visual estimation. Overall, the Taiwanese textbooks ask much more for concrete actions, whereas the German textbooks stress more abstract and mental procedures. How are these results connected to length understanding and estimation abilities?

In concluding these preliminary findings we have to point out that we ourselves are examples of cultural differences. Up to now, every person coded the textbooks of her own country. So the coding procedure has to be done vice versa or perhaps with a person who can translate Chinese directly to German. We also want to broaden and deepen our analysis to get a better understanding of the differences. If we take a broader corpus besides the textbooks, we may get a deeper insight in the differences how teachers and students work with the textbooks in both countries, and how the denser curriculum in the German textbooks is implemented differently from the Taiwanese in classrooms. A much deeper analysis with regard to the coding scheme of Lee and Smith III (2011) as well as qualitative analyses may help to get a better understanding of the so far superficial suggestion that German length learning is more abstract and mental than the Taiwanese one and may result in other length estimation abilities.

References

- Barrett, J. E., Sarama, J. & Clements, D. H. (Eds.) (2017). *Children’s measurement: A longitudinal study of children’s knowledge and learning of length, area, and volume*. Reston, VA: NCTM.
- Bright, G. W. (1976). Estimation as Part of Learning to Measure. In D. Nelson, & R. E. Reys (Eds.), *Measurement in School Mathematics* (pp. 87–104). Reston, VA: NCTM.
- Buys, K., & De Moor, E. (2008). Domain description measurement. In M. van den Heuvel-Panhuizen, & K. Buys (Eds.), *Young children learn measurement and geometry* (pp. 15–36). Rotterdam: Sense Publishers.
- Clarke, D., Cheeseman, J., McDonough, A., & Clarke, B. (2003). Assessing and Developing Measurement with Young Children. In D. H. Clements & G. Bright (Ed.), (pp. 68–80).
- Clements, D. H., & Bright, G. (Eds.) (2003). *Learning and Teaching Measurement*. Reston, VA:

NCTM.

- Van den Heuvel-Panhuizen, M., & Buys, K. (Eds.) (2008). *Young children learn measurement and geometry*. Rotterdam/Taipei: Sense Publishers.
- Huang, H.-M. E. (2015). Children's Performance in Estimating the Measurement of Daily Objects. In K. Beswick, T. Muir, & J. Wells (Eds.). *Proceedings of 39th Conference of the International Group for the Psychology of Mathematics Education* (Vol. 3, pp. 73–80). Hobart: PME.
- Jones, G., Taylor, A., & Broadwell, B. (2009). Estimating linear size and scale: Body rulers. *International Journal of Science Education*, 31(11), 1495–1509.
- Joram, E., Subrahmanyam, K. & Gelman, R. (1998). Measurement estimation: Learning to map the route from number to quantity and back. *Journal of Educational Review*, 6, 413–449.
- Lan, Shun-Der (2005). Textbook policy and system. (In Chinese). Taipei, Taiwan: Wu-Nan Cultural Publishing Enterprise Cooperation Ltd.
- Lee, K., & Smith III, J. P. (2011). What is different across an ocean? How Singapore and US elementary mathematics curricula introduce and develop length measurement. *ZDM Mathematics Education*, 43(5), 681–696. [DOI 10.1007/s11858-011-0339-0]
- Lehrer, R. (2003). Developing Understanding of Measurement. In J. Kilpatrick, W. G. Martin, & D. Schifter (Eds.), *A Research Companion to Principles and Standards for School Mathematics* (pp. 179–192). Reston, VA: NCTM.
- Ruwisch, S., Heid, M., & Weiher, D. F. (2017). Children's estimation competences in length and capacity. In B. Kaur, W. K. Ho, T. L. Toh, & B. H. Choy (Eds.). *Proceedings of the 41st Conference of the International Group for the Psychology of Mathematics Education*, (Vol. 2, p. 75). Singapore: PME.
- Ruwisch, S. (2017). Requests for mathematical reasoning in textbooks for primary-level students. In B. Kaur, W. K. Ho, T. L. Toh, & B. H. Choy (Eds.). *Proceedings of the 41st Conference of the International Group for the Psychology of Mathematics Education*, (Vol. 4, pp. 113–120). Singapore: PME.
- Samara, J., Clements, D. H., Barrett, J., Van Dine, D. W., & McDonel, J. S. (2011). Evaluation of a learning trajectory for length in the early years. *ZDM Mathematics Education*, 43(5), 667–680. [DOI 10.1007/s11858-011-0326-5]
- Smith, J. P., van den Heuvel-Panhuizen, M., & Teppo, A. R. (2011). Learning, teaching, and using measurement: introduction to the issue. *ZDM Mathematics Education*, 43(5), 617–620. [DOI 10.1007/s11858-011-0369-7]
- Smith III, J. P., Males, L. M., Dietiker, L. C., Lee, K., & Mosier, A. (2013). Curricular treatments of length measurement in the United States: Do they address known learning challenges? *Cognition and Instruction*, 31(4), 388–433.
- Stephan, M., & Clements, D. H. (2003). Linear and area measurement in prekindergarten to grade 2. In D. H. Clements, & G. Bright (Eds.), (pp. 3–16).

A Hypothetical Learning Trajectory for the learning of the rules for manipulating integers

Jan Schumacher and Sebastian Rezat

Paderborn University, Germany; jan.schumacher@math.upb.de; srezat@math.upb.de

In this paper, we first outline a Hypothetical Learning Trajectory (HLT), which aims at a formal understanding of the rules for manipulating integers. The HLT is based on task formats, which promote algebraic thinking in terms of generalizing rules from the analysis of patterns and should be familiar to students from their mathematics education experiences in elementary school. Second, we analyze two students' actual learning process based on Peircean semiotics. The analysis shows that the actual learning process diverges from the hypothesized learning process in that the students do not relate the diagrams on the different levels of the task sequences in a way that allows them to extrapolate the rule for the subtraction of negative numbers. Based on this finding, we point out consequences for the design of the tasks.

Keywords: integers, negative numbers, permanence principle, induction extrapolatory method, hypothetical learning trajectory, semiotics, diagrammatic reasoning

Introduction

The difficulties and obstacles related to the concept of negative number and their operations are well documented in the history of mathematics (Hefendehl-Hebeker, 1991) and a growing body of recent research (e.g. Schindler, Hußmann, Nilsson, & Bakker, 2017).

According to Steinbring (1994, p. 279) the notion of negative numbers and the related understanding of their manipulations require autonomous and formal rules, which are comparable to the rules of algebra. He argues that the consistent system of rules for manipulating negative numbers is neither deduced from reality nor is it directly applicable to real world contexts, in which numbers represent magnitudes. According to Hefendehl-Hebeker (1991, p. 30), it was not until the 19th century that these obstacles were overcome in the history of mathematics by a shift of view:

The change consisted in the transition from the concrete to the formal viewpoint. Subsequently, the concept of number could be introduced in a purely formal manner without consideration of the concept of magnitude.

Therefore, a full understanding of the rules for manipulating negative numbers might be not achievable by referring to real world contexts, such as assets and debts or temperature, in which negative numbers are easily perceived as magnitudes. The introduction of negative numbers might also require a shift from the concrete to the formal viewpoint.

Our overarching aim is to understand how students make sense of negative numbers and their manipulation rules in a Hypothetical Learning Trajectory (HLT), which aims at such a mathematical understanding of these rules from a formal viewpoint. The different meanings of the minus sign as unary, binary or symmetrical present a particular obstacle for students (Vlassis, 2004), which

becomes most evident related to the subtraction of negative numbers. Therefore, we focus on the question how students can develop a formal understanding of the rule for subtracting negative integers in this paper.

We first outline a HLT for the learning of the rules for manipulating integers, which aims at such a mathematical understanding of these rules from a formal viewpoint. Second, we give a first insight into students' actual learning processes related to subtracting negative numbers.

Theoretical Framework

According to the seminal definition by Simon (1995) a Hypothetical Learning Trajectory (HLT) “consists of the goal for the students' learning, the mathematical tasks that will be used to promote student learning, and hypotheses about the process of the students' learning” (Simon & Tzur, 2004, p. 93). A HLT “is based on the understanding of the current knowledge of the students involved” (Simon & Tzur, 2004, p. 93).

The goal of our learning trajectory is that students develop an understanding of the rules for manipulating integers from a formal viewpoint, i.e. to understand that the calculation laws for integers are defined the way they are, because they “are uniquely determined as extensions of certain laws governing the positive numbers” (Freudenthal, 1983, p. 434). Freudenthal called this the “algebraic permanence principle” and propagates the “induction extrapolatory method” (Freudenthal, 1983, p. 435) in order to introduce the negative numbers. Our HLT draws on this method. The tasks we used to implement this method relate to students' prior experiences, because we use task formats that are familiar to students from the learning of arithmetic in elementary school. As pointed out earlier, we do not use real-world contexts, since the rules for manipulating integers are not deducible from them. Therefore, our notion of understanding refers to what Wittgenstein has termed the sign game, in which “the meaning of the signs, symbols, and diagrams does not come from outside of mathematics but is created by a great variety of activities with the signs within mathematics” (Dörfler, 2016, p. 27). In our case, the meaning of the signs is explored in what Peirce (1976) calls “diagrammatic reasoning”.

According to Dörfler (2005, p. 58) diagrams in the sense of Peirce are inscriptions, which have a specific structure depending on the relationships among their parts and elements. Based on their structure diagrams are the objects of rule governed operations. These operations allow to transform, compose, decompose, and combine the inscriptions and can be called the “internal meaning of the respective diagram” (Dörfler, 2016, p. 25). Diagrammatic reasoning according to Peirce then is

reasoning which constructs a diagram according to a percept expressed in general terms, performs experiments upon this diagram, notes their results, assures itself that similar experiments performed upon any diagram constructed according to the same percept would have the same results, and expresses this in general terms. (Peirce, 1976, pp. 47-48)

Summarized, it “is a rule-based but inventive and constructive manipulation of diagrams for investigating their properties and relationships” (Dörfler, 2016, p. 26). Though they are rule-based the manipulations are still imaginative and creative and not just mechanic or purely algorithmic (Dörfler, 2016, p. 26).

A HLT for the learning of manipulating negative numbers

The learning trajectory is structured into six parts: 1. introduction of negative numbers, 2. ordering of negative numbers, 3. subtraction with a positive subtrahend, 4. addition of negative numbers, 5. subtraction with a negative subtrahend, and 6. multiplication of negative numbers. Each part of the learning trajectory has the same structure. It starts with sequences of tasks using the induction extrapolatory method (Figure 1) in order to foster students' diagrammatic reasoning. Every sequence consists of six to eight tasks and shows a pattern that the learners are supposed to identify. The learners know these task sequences from learning arithmetic in primary school. Therefore, they know that the sequences have patterns and they are familiar with completing these patterns. For every sequence of tasks, the learners have to work on three tasks: The first task is to describe the identified pattern verbally using phrases like 'the minuend/subtrahend/difference remains constant/increases/decreases by one/two/...'. Thereafter, the learners have to complete the sequence of tasks according to the identified pattern. The last task is to transfer the tasks into a table, where they can further explore task relations. Based on the insights from their explorations, the learners either have to formulate a rule and consolidate this rule by working on further examples or they have to verify the given rule. These activities are based on Pierce's notion of diagrammatic reasoning. Students' need to manipulate diagrams according to rules that they perceive by exploring the structure of the diagrams. By formulating rules, they have to express the result of their explorations in general terms.

$$\begin{array}{r}
 3 - 2 = \underline{\quad} \\
 3 - 1 = \underline{\quad} \\
 3 - 0 = \underline{\quad} \\
 3 - \underline{\quad} = \underline{\quad} \\
 3 - \underline{\quad} = \underline{\quad} \\
 3 - \underline{\quad} = \underline{\quad}
 \end{array}$$

Figure 1: Sequence of Tasks at the beginning of the section

In this paper, we focus on the subtraction of negatives (part 5 of the HLT). The first sequence of tasks in this section is shown in Figure 1. In this sequence, there are different diagrams in the sense of Pierce, which are on two different levels of the task sequence. On the first level, every task is a diagram in itself, because it represents the relation of the minuend, the subtrahend and the result. On the second level, the whole sequence is also a diagram because the single tasks are related and exhibit a particular pattern. In the case of the task sequence in Figure 1, the minuend of all the tasks is fixed (3) and the subtrahend is reduced by one from one task to the next. Consequently, the results increase by one from one task to the next.

In terms of the students' learning process, we hypothesize that the students have to work on diagrams on both levels when solving the tasks. First, they can solve tasks one to three in the sequence, which should be familiar to them from natural number arithmetic. Referring to the ideas of diagrammatic reasoning, these are manipulations on diagrams on the first level. In the next step, they need to explore the structure of the sequence on the second level. In other words, they have to investigate the properties and relationships of the second level diagram. After exploring the structure, they can complete the tasks four to six, which are new to them, by referring to the structure. These are also manipulations on diagrams on the second level. For learning, how to subtract a negative number from an integer, it is important to switch in between the diagrams on the different levels and relate to them once again as described above. The students have to recognize how the calculations of the tasks

including the subtraction of negative numbers are carried out. Relating to the idea of diagrammatic reasoning, this is the investigation of properties and relationships of the diagrams on the first level.

In summary, we hypothesize that the students' learning process related to the subtraction of negatives involves an interaction between the diagrams on two different levels. The students need to operate on diagrams on the first level, then refer to the structure of the diagram on the second level and get back to the diagrams on the first level in order to solve the tasks. By deriving the results of tasks that involve the subtraction of negatives from the structure of the diagram, they are able to get an insight into the algebraic permanence principle and thus could develop a formal understanding of the rule for subtracting negatives.

Methodology

Data was collected in five 6th-grade classrooms in a German secondary school. The students worked on the HLT in pairs in a separate room. Altogether, we videorecorded eight pairs of students while working on the HLT.

In order to reconstruct the diagrammatic reasoning of the students, we use Toulmin's (2003) "pattern of an argument" as an analytic tool. Toulmin's core structure – or "first skeleton" as he puts it – of an argument has been used productively in mathematics education research to analyse students' reasoning (e.g. Fetzer, 2003; Reid, et al. 2008). The core structure of an argument is composed of three components: The *data* are the facts, which are the basis of the *conclusion*, "whose merits we are seeking to establish" (Toulmin, 2003, p. 90). *Warrants* are propositions like rules, principles and inference licenses. They are used "to show that, taking these data as a starting point, the step to the original claim or conclusion is an appropriate and legitimate one" (Toulmin, 2003, p. 91).

Arguments and diagrammatic reasoning are linked by the role of rules. Diagrams are embedded in a system which has rules and the manipulation of diagrams in the sense of diagrammatic reasoning is rule-based. The warrants in students arguments related to relationships and properties of a diagram should explicate the rules of the diagram as the students explored them. Therefore, the analysis of students' reasoning based on Toulmin's scheme provides an analytic tool to reconstruct the rules on which their diagrammatic reasoning is based.

In a first step, we reconstruct students' argumentation based on Toulmin's pattern of an argument. We further frame each argument in terms of the level of diagrams it relates to: level 1 or level 2. Finally, we draw conclusions about students' diagrammatic reasoning based on an interpretation of their argumentation.

An example analysis of students' actual learning process

In this exemplary analysis, we focus on the learning process of two girls, Mia and Marlen. They are working together on the HLT. We are focusing on the beginning of the section "We subtract negative numbers" and especially on their work on the sequence of tasks shown in Figure 1. Due to space limitations, we can only analyze two short episodes from the whole learning process.

The episode in Table 1 starts at the beginning of the students' work. Their task is to describe the pattern of the sequence:

		level 1	level 2	
8	Mia:	It's decreasing in a). In a) the first [points on the minuends] remains constant and the second [points on the subtrahends] decreases by one.	D1	
9	Marlen:	But we also have to describe the ... The result decreases o... No...	C1a	
10	Mia:	Heh?		
11	Marlen:	... increases by one.		
12	Mia:	No.		
13	Marlen:	Sure, the result always increases by one.		
14	Mia:	Decreases ... by one. There are negative numbers, Marlen.	C1b/ W1b	
15	Marlen:	No, look. Three minus two is one. Three minus one is two. Three minus zero is three. ...	W1c	
15a	Marlen:	... Three minus one ...		D2
16	Mia:	... minus one ...		
17	Marlen:	... minus minus one. That would be ... two ...		C2
17a	Marlen:	... Then it's decreasing. Well, the difference first increases and then decreases, right?	C1c	

Table 1: First episode from the transcript 6b_Subtraktion2_1

In line 8, students express data (D1), which is the starting point of their argument (The minuend remains constant and the subtrahend decreases by one). From this data they draw three different conclusions. The first conclusion (C1a) is that the results increase by one. This argument is not explicitly supported by a warrant. According to Fetzer (2003, p. 33), this is a simple inference, which has only data and a conclusion and no legitimation through a warrant. Their second conclusion (C1b) is that the results in the sequence of tasks decrease by one. It is legitimated by the warrant "There are negative numbers" (W1b). The last conclusion Marlen draws from (D1) in this episode is that the results first increase and then decrease (C1c). The warrant (W1c) is the calculation of tasks one to four in this sequence.

All arguments based on D1 in this episode are on the level of the sequence, i.e. on the diagram on the second level. Additionally, there is a simple inference on the task level, i.e. on level 1 (lines 15a and 17) with the task $3 - (-1)$ as data (D2) the result "2" as the conclusion (C2). This simple inference is important, because it is one essential part of warrant (W1c), which supports to the conclusion (C1c) that the results first increase and then decrease.

Following the episode in Table 1, the teacher asks the students to reason, why the results first increase and then decrease. He further asks them to fill in the blanks in the task sequence. After they finished filling in the blanks, the following episode starts.

		level 1	level 2
27	Teacher: [...] Well, and if you recognize, after you have got up to the three. Did we have sequences of tasks, in which the results first increase and then decrease or vice versa?		D5
28	Both: No.		
29	Teacher: And what's the next result?		
30	Mia: Probably it goes on and on. ...		C5b
31	Marlen: Probably four.		C5a
32	Teacher: Right.		
33	Mia: ... Because here (points at another sequence) it is the same, but here the first summand changes.		W5b
34	Teacher: Yes It means, when continuing the pattern, the next result is ...		C5a
35	Marlen: ... four.		
36	Teacher: Right.		
37	Mia: Heh? It decreases by one. It decreases, Marlen.		
38	Marlen: But we didn't have a sequence so far, in which the results first increase and then decrease suddenly. It is a kind of pattern, but I don't understand why it is.		W5a

Table 2: Second episode from the transcript 6b_Subtraktion2_1

In this episode, the data of all conclusions is given in line 27: The results of the first three tasks in the sequence are “1”, “2” and “3”. The first conclusion (C5a) based on this data (line 31) is that the next result is (probably) four. This is a simple inference without a warrant. The second conclusion (C5b) in line 30 is justified by warrant (W5b) in line 33, which refers to another sequence of tasks on the same page. In line 34, the teacher repeats the conclusion (C5a), but now Marlen provides a warrant (W5a): She refers to other known sequences of tasks. There it never occurred that the results of the tasks first increase and then decrease or vice versa.

Discussion and Conclusion

In our description of the hypothesized learning process, we argued that diagrammatic reasoning, which relates diagrams on two levels of the task sequence in Figure 1, is crucial for students' formal understanding of the rule for subtracting negative integers. The students have to work on diagrams on the first level to see the pattern of the diagrams on the second level. Referring to the pattern of the

diagram on the second level, they can solve the tasks (diagrams on the first level) which include manipulations on the new mathematical objects, i.e. negative numbers. Comparing the eight pairs of students reveals that most of them actually follow this hypothesized learning process. Only two pairs struggle with the sequence shown in Figure 1. Both of them are only working on the diagrams on the first level, i.e. they try to solve all the tasks before referring to the structure of the task sequence. As opposed to the pair of students described in this paper, the other pair is not sticking as consequent to the idea that instead of subtracting a negative number they can subtract the additive inverse.

However, the reconstruction of Mia's and Marlen's argumentation in the two columns behind the transcript reveals that the students work on diagrams on both levels, but not in the hypothesized way. The crucial point in their diagrammatic reasoning occurs in lines 15-17. We hypothesized that for a formal understanding, it is important to refer to the structure of the task sequence in order to derive the result of the task $3 - (-1)$. The analysis shows that the students conclude that the result of this task is 2 (C2 in line 17). Because of the missing warrant in this argument, it is not possible to reconstruct the rule of their manipulation on the diagram on level one. According to their reasoning, the inner relationship of this diagram on the first level is, that the difference of "3" and "-1" is "2". As opposed to our hypothesized learning process, the students do not infer the result of the task from the relationships of the diagram on level two, but vice versa. Their further reasoning reveals that the simple inference $D2 \Rightarrow C2$ (lines 14-17) is part of the warrant for the conclusion that the results first increase and then decrease, which relates to the inner relationship of the level 2 diagram. Consequently, instead of inferring the rule for manipulating the level one diagram $3 - (-1)$ from the relationships of the level two diagram, they do it the other way around.

With the intervention of the teacher they get the correct results for the 'new' tasks, but as a result of lines 15-17 the students do not understand why the results are correct (lines 29-30). From the point of view of diagrammatic reasoning, the students use the structure of the sequence to complete the tasks, but they are not able to recognize the rules for manipulating tasks comprising the subtraction of negative numbers.

The comparison between the hypothesized and the actual learning process shows that it is very important how students relate to diagrams on the different levels in their diagrammatic reasoning in order to develop a formal understanding of the rule for subtracting negative integers. The analysis of two students' reasoning revealed that relating the diagrams on the two levels other than in the hypothesized way might lead to inferences that violate the permanence principle. Therefore, students might need support in our HLT in order to relate the diagrams on the two levels in productive ways. As in our case, the support could be provided by the teacher. A different option is to redesign the task in a way that it will guide students more closely to consider the relation of the diagrams on the two levels. This could be achieved by splitting the task sequence into two parts, a familiar part (tasks one to three of the sequence) and a 'new' part (tasks four to six in the sequence). After solving the tasks in the familiar part, students are asked to analyze the structure of the task sequence and continue the task sequence accordingly. Based on their analysis they are asked to draw conclusions about the results of tasks four to six.

In our analysis, the theory of diagrammatic reasoning helped to identify the crucial obstacle in both, the hypothesized and the actual learning process. The in-depth analysis has proven to be very fruitful in order to better understand students learning processes related to particular task types. Based on the findings, it was possible to derive substantiated ideas for the redesign and the implementation of the task and thus, the inductive extrapolatory method. However, the analysis carried out in this paper does not provide evidence that a formal perspective rather than one focused on real-world scenarios is helpful in developing understanding in this area.

References

- Dörfler, W. (2005). Diagrammatic thinking. In M. H. G. Hoffmann, J. Lenhard, & F. Seeger (Eds.), *Activity and sign* (pp. 57–66). Boston: Springer.
- Dörfler, W. (2016). Signs and their use: Peirce and Wittgenstein. In A. Bikner-Ahsbahs (Ed.), *Theories in and of mathematics education* (pp. 21–31). Cham: Springer.
- Fetzer, M. (2011). Wie argumentieren Grundschul Kinder im Mathematikunterricht? Eine argumentationstheoretische Perspektive. *Journal für Mathematik-Didaktik*, 32(1), 27–51.
- Freudenthal, H. (1983). Didactical phenomenology of mathematical structures. Dordrecht: Reidel.
- Hefendehl-Hebeker, L. (1991). Negative numbers: Obstacles in their evolution from intuitive to intellectual constructs. *For the Learning of Mathematics*, 11(1), 26-32.
- Peirce, C. S. (1976). The new elements of mathematics. Mathematical philosophy (Vol. 4). The Hague, Paris: Mouton Publishers.
- Reid, D., Knipping, C., & Crosby, M. (2008). Refutations and the logic of practice. In O. Figueras, J. L. Cortina, S. Alatorre, T. Rojano, & A. Sepúlveda (Eds.), *Proceedings of the Joint Meeting of PME 32 and PME-NA XXX* (Vol. 4, pp. 180–187). México: Cinestav-UMSNH.
- Schindler, M., Hußmann, S., Nilsson, P., & Bakker, A. (2017). Sixth-grade students' reasoning on the order relation of integers as influenced by prior experience: An inferentialist analysis. *Mathematics Education Research Journal*, 29(4), 471-492.
- Simon, M. A., & Tzur, R. (2004). Explicating the role of mathematical tasks in conceptual learning: An elaboration of the Hypothetical Learning Trajectory. *Mathematical Thinking and Learning*, 6(2), 91-104.
- Steinbring, H. (1994). Symbole, Referenzkontexte und die Konstruktion mathematischer Bedeutung - am Beispiel der negativen Zahlen im Unterricht. *Journal für Mathematik-Didaktik*, 15(3-4), 277-309.
- Toulmin, S. E. (2003). *The uses of argument*. Cambridge: Cambridge University Press.
- Vlassis, J. (2004). Making sense of the minus sign or becoming flexible in 'negativity'. *Learning and Instruction*, 14(5), 469-484.

“First you have to know it exists.”

Cultivating teachers’ thinking about resource options

Helen Siedel

Visiting Research Associate, Wolfson College

Cambridge University, UK

helensiedel@hotmail.com

Professional development activity with a secondary school mathematics department in England aimed to further teachers’ knowledge of their resource options in order to better inform the resource choices they make and support their ability to use resources to design effective instruction. Participants conceptualized individual resources as representatives of resource types, drafted a model to represent types, and compared types using indices (exponents) as a focal topic. This paper reports on a study of that activity. Findings suggest that learning more about resource options assists and interests teachers and that using a focal topic to explore, characterize, and compare resources has merit. Organizing resources by type for use as a tool for finding resources and coordinating their use in a resource system appears beneficial, but would require work over time.

Keywords: Mathematics education, resources, curriculum resources, resource system, resource selection

Introduction

Resource options for teachers are burgeoning. However, despite calls for providing opportunities to develop teachers’ resourcing skills (e.g., Rolando, Salvador, & Luz, 2013), and the recognition that teachers choose to use multiple resource types even in countries where prepared curriculum materials such as textbooks have dominated (e.g., Webel, Krupa & McManus, 2015), little is known as yet about how to help mathematics teachers select resources advantageously on behalf of student learning. One question that arises is whether teachers are familiar enough with the full range of available resources to make well-informed selections. In order to select and use a resource, a teacher must first know that it exists, as suggested by the quote from a secondary mathematics teacher in England in the title of this paper. Unknown resources are effectively inaccessible.

Siedel and Stylianides (2018), in a study of secondary mathematics teachers in England, found that teachers with considerable autonomy and responsibility for resource selection did not know about or were not selecting several potentially useful types of resources. To investigate further, the authors introduced a construct called “the pool of possibilities” (p. 121) to represent all instructional resource options for a teacher population, including human, cultural, social, material and digital resources. Teachers in the study discussed here, the Resource Types study, had an opportunity to learn more about their resource options by exploring their pool of possibilities.

Although the pool of possibilities and the work teachers undertake to find resources in a pool of possibilities have received limited attention in studies of teacher-resource interactions, literature about teachers’ selection, adjustment and construction of resources was pertinent to the Resource

Types study (e.g., Pepin, Gueudet, & Trouche, 2017). One premise for the study was that knowledge of resource options, including familiarity with the range of resource types, supports what is described as teachers' "mathematics-didactical design capacity" (Pepin, Gueudet, & Trouche, 2016, p. 2), that is, their ability to use or construct resources to plan effective instruction. The "focal topic approach" introduced in this paper, for example, illustrates that examining and comparing a variety of resource types for a particular mathematical topic might augment teachers' knowledge of mathematics, of teaching, of student learning, or of resource features. Knowledge of options can thus support the development of other resources, regardless of whether a teacher chooses the options for further use.

The idea of "resource system," an "evolving notion" in mathematics education (Ruthven, 2018, slide 2), framed the study. When teachers interact with various resources in various ways, they typically acquire a collection of individual resources to support their work. As described by Ruthven (2018), a collection of resources becomes a resource system by application of an organizing principle intended to make the collection function more effectively. Often the organizers are teachers, who may seek to unite stand-alone resources in some way to produce a coherent whole, a resource system. Teachers in the Resource Types study were invited to organize resources using the principle that individual resources are representatives of resource types that can be usefully classified and related. Participants applied this principle to a wide range of individual resources and types of resources from their pool of possibilities, not all of which were familiar. The supposition was that identifying types of resources and classifying by types could, first, enable and motivate teachers to select from a wider range of options in their pool of possibilities by increasing the number of resources familiar to and thus accessible to them. Second, regardless of how teachers prefer to use or construct resources, knowing more about a variety of types, and comparing types, might support more advantageous resource selection and ultimately a stronger resource system.

The research question for this study was:

What sorts of professional development activities enable secondary mathematics teachers to draw on a wider range of resources when developing their resource system?

Methods

The two-hour Resource Types session occurred in the final month of a nine-month pilot study about the mathematical symbol known as the minus sign, conducted with the mathematics department for 11 to 16 year olds at a state secondary school in the South East Region of England. All eight teachers in the department were present for the Resource Types session. At the inaugural session of the overall pilot, teachers were introduced to instructional resources as a topic of interest for their department that would be folded into the minus sign exploration; they also completed surveys about their resource use. Indices (exponents), the mathematical topic for the Resource Types session, was included in the pilot as one of the topics where the minus sign is known to be problematic.

The Resource Types session had two parts. Part 1 introduced the idea of classifying resources by type. In Part 2, using the "focal topic approach," indices (exponents) was a focal topic for comparing diverse resource types featuring content specific to that topic. Both parts included guided discussion. The full session was audiotaped using two recorders; slides used during the session were

posted afterwards. At the department meeting one week after the Resource Types session, participants completed a follow-up survey and had an opportunity to sketch their thinking about a typology for resource types. Participants were encouraged to add comments.

In Part 1, using the “list approach,” teachers worked in pairs to brainstorm categories for types of resources and began to organize the types, first using a list of sixteen familiar resources, then a list of twenty-two others, less familiar, and thirdly a proposed list of categories for resource types accompanied by commentary and questions. The department head, also a teacher participant, led discussion after the group had time with each list. Part 1 was open-ended and fast-paced, not intended to lead conclusively to any well-developed classification by types. Part 1 concluded with the group’s first attempt to graphically organize “types of resources.”

In Part 2, participants reviewed the treatment of indices in a researcher-selected set of resources representing types, in order to examine, characterize, and compare types. The set of types included two contrasting blogs, a research article, traditional curriculum materials, a site to design assessments, a book with rationale for mathematics procedures, a mathematics information site, and a mathematics educator’s website with teaching suggestions for numerous topics. These represent some types of resources not mentioned by most teachers in the Siedel and Stylianides study (2018).

Part 2 initially focused on two blog posts by Dan Meyer (dy/dan, 2015; dy/dan, 2016) because these exemplified the value of searching for resources using non-British mathematical terms (“exponents” rather than “indices”), contained rich user discussion that mentioned other resource types, included a “research into practice” example, and included a variety of teaching strategies and activities. Those posts and the research article (Cangelosi, et al., 2013) were characterized and compared as types. Due to time constraints, examination of the remaining types was brief.

The follow-up survey was administered at the department meeting a week post-session. Drawing on Guskeys’s (2016) levels of evaluation for professional development, which also informed data collection and analysis for the session itself, the survey was designed to determine participants’ affective response to the Resource Types session, their learning about individual resources or about the idea of resource types, and whether as individuals or as a department they were likely to use what they learned. At that post-session meeting, as part of a separate activity, teachers were also invited to diagram or otherwise describe their current thinking of how types might relate.

Results

Data were identified by researcher observation of the session, review of the audiotapes, and teachers’ written responses in the follow-up activity. Data from conversations in Parts 1 and 2 of the session were qualitative. Teachers appeared fully engaged throughout the session; there was evidence they were learning about individual resources and about resources as exemplars of types. Quantitative survey data (Table 1) and teachers’ written comments (Table 2) supported this.

During Part I, resources in the first of three lists participants worked with were familiar to most. They were asked to use the list to generate categories for resources from the new perspective of resources as types. They quickly generated categories that appeared to be based on what a resource facilitates, such as “problem-solving,” “worksheets and homework,” “develops ideas,” “direct

teaching.” With the second list, however, the resources were less familiar; much of that conversation consisted of teachers trying to learn about a resource in order to identify it by type. For example, someone familiar with a resource could describe it to others. This was an opportunity for participants to learn about the existence of a resource. Categories for types from this list included “technology” and “what level it addresses.” These were broader categories, less activity specific. The third list, a proposition of types, surprised teachers because there were many (twenty) types.

As teachers worked with the 3rd list, teachers remarked about some they had not thought of, such as “books.” Later, in Part 2, reviewing types of resources for indices, the group decided to purchase a book that was mentioned; they had not known about the book. Such incidents were evidence that participants were learning about previously unknown resources or broadening their range of types.

During Part 2, participants had an opportunity to evaluate the pre-selected set of individual resources representing a variety of types for the topic indices. Teachers thus learned about these individual resources, while other individual resources were mentioned in the discussion. For example, a discussion about an assessment site prompted mention of a forthcoming resource for UK educators associated with the assessment site. Most participants had not known of its existence.

Results from the follow-up survey, shown in Tables 1 and 2, indicate that as a result of the session, some teachers were already visiting online resources in the following week. One teacher, for example, went to a site providing information about mathematics to look up definitions. In the last comment of Table 2 (Teacher 8) the participant expresses an interest in using as wide a range of resources as possible, which would likely involve searching for new resources.

The tables indicate teachers were likely to use ideas about “types of resources” to organize their own interactions with resources or to consider relationships among resource types. The data in Table 1, from the follow-up survey, attest to interest in, ongoing thinking about, and discussion of resource types. Most teachers found the session useful; some had been actively engaged afterwards. Table 2 suggests that some teachers will continue using the teacher-student dichotomy they generated as the basis for a typology (Teacher 2). Comments in response to a question about what stayed with them after the session suggest that these teachers are likely to think about the benefits of classifying resources (Teacher 4), but are aware that there are many types (Teacher 3). Thinking of types promotes learning about their work with resources (Teachers 5 and 8) and, for some, relating them. It also indicates awareness of the difficulty of organizing by type (Teacher 6), with fewer categories a possible objective. Some want to pursue this further (Teacher 7).

Teachers’ attempts to graphically organize resources as types also contributed data. Asked to diagram the categories for resource types during the session itself, one pair proposed two unlinked central categories, labeled “teacher resources” and “student resources.” The group accepted this. They began to place other categories they generated from the first list as subcategories. At this point the visual resembled a pair of main idea webs. One teacher noted that a resource could also be “mixed,” with provisions for both teachers and students. A week later, at the department meeting where participants completed the follow-up survey, but as part of activity apart from the survey, teachers were asked to diagram or discuss their current thinking about how to diagram the relationship of resource types. Five teachers responded. Four used the teacher-student dichotomy,

however one of these drew an arrow from teacher to student, linking the two. Another drew three intersecting circles, as in a Venn diagram. These were labeled “teacher,” “students,” and “online;” directional arrows indicated two-way interaction. The teacher who did not use the teacher-student dichotomy instead began a main idea web with “resource” at the center and two ideas as subcategories. One was labeled “needed for”; the other was not yet labeled.

Table 1: Affirmative responses to post-session survey items (N=8)

Frequency of “Yes” responses to 14 questions	Statements to which they were responding
8	Found the session interesting
8	Learned something about resources
8	Thought about resource types later
6	Found the session useful
6	Looked for information as a result of something in the session
5	Thought about doing something different with learners as a result of the session
5	Noticed resources more explicitly
4	Discussed the session with colleagues
4	Went to a resource directly as a result of the session
4	Noticed the minus sign more explicitly
3	Learned some mathematics
3	Noticed indices more explicitly
2	Learned strategies for teaching
1	Did something differently with learners as a result of the session

Table 2: Selection of teacher comments from post-session survey (N=8)

Teacher 2	(Mentioned a site she went to) “I like this site as being a useful resource for teaching but it is not necessarily so for learning.”
Teacher 3	(What took root?) “The wide range of resources available”
Teacher 4	(What took root?) “It’s easier when resources are in categories and you know where to go for what”
Teacher 5	(What took root?) “Made me think about what resources I was using for what reason”
Teacher 6	(What took root?) “The difficulty in classifying resources”
Teacher 7	(What she planned to do) “Look online for resource categories & how to ‘type’ them”

Teacher 8	(What took root?) “Types of resources and how we use them in planning and teaching”
Teacher 8	(What took root?) “The need to include <u>all</u> categories including research”

Discussion

This small study represents a first step towards explicit investigation of a pool of possibilities as a way to enhance teachers’ work with instructional resources. Results suggest that opportunities to classify resources by type can amplify teachers’ knowledge of their resource options, thus making more resources in their pool of possibilities available to them. Results also point to the complexity of organizing resources by type. More time would have been necessary for participants to fully classify resources and link the classification to the development of a resource system.

With respect to the research question, results seem to imply that the activities developed for the session were responsible for favorable results. However, other factors might account for what occurred with this particular group, who, as colleagues, represent an important resource in their pool of possibilities. These factors include: (1) participant teachers were a team who worked together daily with the same student population, were accustomed to and enjoyed working together on the types of activity in the Resource Types session; (2) two mathematical topics for the session, indices and the minus sign, were important to this group, and possibly a motivating factor; (3) the larger pilot in which the Resource Types session was embedded featured a monthly topic and accompanying materials that tacitly, but consistently, evidenced the idea that there are a variety of resources to explore for any topic, including resources not specifically for student activity. Participants were accustomed to exploring multiple types of resources for a topic.

Despite this, participants’ reactions to the activities in Parts 1 and 2 suggest that the “list approach” and the “focal topic approach” have the potential to influence teacher thinking in ways that support more deliberate selection from a wider range of resources. During Part 1, participant thinking evolved. With the first list, it seemed straightforward to organize resources by pedagogical activity, but the second list seemed to indicate that resources could be conceptualized various ways, and that organizing by type could be challenging. In response to the third list, of resource types, teachers were not in favor of having too many categories for types, even when, or perhaps especially when, they saw how many types there could be. Part 1 discussion showed that teachers’ thinking about the merits of classifying by types varied. Like many mathematics departments in England, this department had not adopted a textbook (e.g., Siedel & Stylianides, 2018); guided by the national curriculum, they were responsible for their own curriculum development and resources. One teacher wanted to use as many resource types as possible to guide searches, so that the department would not miss knowing about important ideas, new developments, or any potentially useful resources; the teacher also emphasized the importance of finding “research-based” resources. Another teacher was less interested in broad-based searching by types; this teacher was motivated by “what you do with it” or “what you want it for.” In a later session, this teacher defined a high quality resource as one where, “You stop looking! No need to look ... again as it does the job perfectly.”

As a result of the comparison of types for indices, a participant visited a resource she uses regularly to check its treatment of indices, particularly of zero as a superscript, exemplifying that the “focal topic approach” may influence teachers’ work with resources they already have. When one variable

that characterizes resources, the mathematical topic, is controlled for, it is easier to compare and comprehend other characteristics, such as the affordances and constraints of each as a type. At the same time, because each resource features the same topic, this activity may augment teachers' knowledge of the topic.

One way in which a typology of resource types for developing a resource system might affect student learning is by possibly reducing the variation in teachers' individual resource collections. Siedel and Stylianides referred to the existence of variable collections of resources within the same school as "plurality and variation" (2018, p. 130). If teachers' individual sets of resources include multiple resources, with sets varying considerably even among teachers at the same school, there may also be variation in opportunities for children to learn mathematics, known to be problematic in education (e.g., Morris & Hiebert, 2011). The question of whether or not they should all be using the same resources for a topic was posed to this group, but limited time did not allow discussion.

Two related questions for the mathematics education community emerged from this Resource Types study. The first concerns teachers' understanding of the expression "evidence-based." What types of resource can be considered evidence-based and how can teachers weigh these for resource selection? When comparing blog postings and the Cangelosi et al. (2011) research study, one teacher said the research article was evidence-based but the blog was characterized by opinions. The implication was that the research article had more worth. Would this mean that ideas developed from experience, such as long-term practice, are less trustworthy? What about the work of influential educators who guide mathematics teachers but may not be conducting systematic research? For their work to be trustworthy is formal review by other educators necessary? Teachers might benefit from opportunities to identify types but also to weight them.

The second, related question deserving attention in studies of teachers' resource skills is how to help mathematics teachers find research articles such as Cangelosi et al. (2011) that contain valuable information for mathematics teachers. Cangelosi et al. (2011) describes misconceptions about indices held by university students. The article includes activity that secondary mathematics teachers could readily implement to forestall similar misconceptions among their own students. Unfortunately, the inclusion of material in Search Engine Results Pages (SERP) seems to change over time. Cangelosi et al. (2011), for example, at one time appeared in the results of an online search for "negative exponents" and seemed to be openly accessible, but that no longer seems to be the case. Familiarity with the notion of open access articles and pre-publication copies may not aid teachers. Potentially helpful resources may be inaccessible, even when teachers know they are "out there." This becomes significant for questions about whether a resource exists for teachers.

Overall, the results of this study advocate for repeating the activities in a context outside of the pilot study, with more time to pursue the proposition that these activities might strengthen resource systems on behalf of student learning. The results suggest that in the process of classifying types of resources to develop a professional model for improving their resource systems, teachers can extend their knowledge of resource options in ways that benefit all of their work with resources.

References

- Cangelosi, R., Madrid, S., Cooper, S., Olson, J., & Hatter, B. (2013). The negative sign and exponential expressions: Unveiling students' persistent errors and misconceptions. *The Journal of Mathematical Behavior*, 32, 69-82.
- dy/dan. (2015, July 1). If exponent rules are aspirin then how do you create the headache? [Blog post]. Creative Commons Attribution 4.0 International. Retrieved from <http://blog.mrmeyer.com/2015/if-exponent-rules-are-aspirin-then-how-do-you-create-the-headache/>
- dy/dan (2016, September 21). Teaching for tricks or sensemaking [Blog post]. Creative Commons Attribution 4.0 International. Retrieved from <http://blog.mrmeyer.com/2016/teaching-for-tricks-or-sensemaking>
- Guskey, T. R. (2016). Gauge impact with 5 levels of data. *The Journal of Staff Development*, 37(1), 32-37.
- Morris, A. K., & Hiebert, J. (2011). Creating shared instructional products: An alternative approach to improving teaching. *Educational Researcher*, 40(1), 5-14.
- Pepin, B., Gueudet, G., & Trouche. Mathematics Teachers' Interaction with Digital Curriculum Resources: Opportunities to develop teachers' mathematics-didactical design capacity. AERA annual meeting, Apr 2016. Washington D.C. United States. 2016. <hal-01312306>
- Pepin, B., Gueudet, G., & Trouche, L. (2017). Refining *teacher design capacity*: Mathematics teachers' interactions with digital curriculum resources. *ZDM Mathematics Education*, 49(5), 799-812.
- Rolando, L. G. R., Salvador, D. F., & Luz, M. R. M. P. (2013). The use of internet tools for teaching and learning by in-service biology teachers: A survey in Brazil. *Teaching and Teacher Education*, 34, 46-55.
- Ruthven, K. (2018). *The construct of 'resource system' as an analytic tool in understanding the work of teaching*. Plenary lecture at international Re(s) sources conference at the Institut Francais de 'Education, Ecole Normale Supérieure de Lyon, May 2018. Lecture slides retrieved from https://resources-2018.sciencesconf.org/data/Re_s_sources_2018_Ruthven.pdf
- Siedel, H., & Stylianides (2018). Teachers' selection of resources in an era of plenty: An interview study with secondary mathematics teachers in England. In L. Fan, L. Trouche, C. Qi, S. Rezat, & J. Visnovska (Eds.), *Research on mathematics textbooks and teachers' resources: Advances and issues* (pp. 119-144). Springer.
- Webel, C., Krupa, E. E., & McManus, J. (2015). Teachers' evaluations and use of web-based curriculum resources in relation to the Common Core State Standards for Mathematics. *Middle Grades Research Journal*, 10(2), 49-64.

Alignment of mathematics curriculum to standards at high schools in Colombia

Silvia Solano¹, Pedro Gómez¹ and María José González²

¹Universidad de Los Andes, Faculty of Education, Bogotá, Colombia;
sp.solano10@uniandes.edu.co; argeifontes@gmail.com

²Universidad de Cantabria, Spain; mariaj.gonzalez@unican.es

The design of Mathematics curriculum in Colombia has been influenced by the curricular guidelines (MEN, 1998) and Basic Standards of Competence (MEN, 2006). These official documents have been the baseline to decide how to conduct the math curriculum parameters in schools. Specially, the basic standards of competence document provides teachers with a set of guidelines for what students are expected to know and be able to do, defining the intended curriculum. However, there is a lack of coherence between these parameters and what the teachers design in their school curricula. We analyzed the alignment between the mathematics curriculum of a sample of Colombian schools and the document of basic standards of competences at high schools in Colombia. We found an inadequate alignment between the schools' mathematics curriculum and the official document of basic standards of competence.

Keywords: Alignment, Mathematics curriculum, Standards

Law 115 of 1994 and curricular autonomy

The curriculum in Colombia has suffered many different changes or transformations based on political parameters or requirements. In 1994, the Ministry of National Education (MEN) stated the Law 115. This law organized the educational services in Colombia, through general rules. In this law, the government established the curricular autonomy of schools. This means that schools have autonomy to make and adapt their curricula. Also, the Ministry of National Education has proposed some guidelines in terms of learning expectations called Basic Standards of Competence (MEN, 2006).

Basic Standards of Competence (2006)

Mathematical competences are related to mathematical thinking and mathematical systems. The standards are based on these mathematical thinking and systems. These guidelines contemplate the competences that a student must achieve when a cycle of two school years ends.

Alignment to standards

In the past, the most common educational use of the concept of alignment referred to the match between an assessment instrument (or instruments) and a curriculum (Webb, 1997). Alignment does not only refer to a comparison between one assessments instruments with a curriculum, but extends to a set of assessment instruments or the assessment system. However, Webb has defined the alignment as “the degree to which expectations and assessments are in agreement and serve in conjunction with one another to guide the system toward students learning what they are expected to know and do” (1997, p. 12). An area plan is a curricular document that has the objectives, the

methodology, the distribution of time, and the evaluation criteria for a subject, in our case, the area of mathematics. The area plan becomes the roadmap that guides the implementation of the mathematics curriculum within schools. The alignment with standards is a characteristic of Colombian area plans. We assume the alignment with the standards as the measure to which the mathematics area plans approach the contents proposed in the standards. With this attribute, we seek to determine how much is covered of the subjects in the area plans according to what it is stated in the official document of the standards. For a specific syllabi and specific topics, the alignment should indicate to what extent that area plan meets the standards proposed to these issues.

Methodology

We collected a sample of 212 syllabi throughout the country taking into account three main variables: geographical area (rural and urban), type of institution (public and private) and type of secondary education (academic and technical). In addition, we built code trees based on the didactic analysis carried out on three subjects of school mathematics. The topics chosen are the conic sections, the derivative and the descriptive statistics. The process of coding the 212 area plans consisted in identifying the text segments that allude to the proposed topics. Once these text segments were identified, they were assigned to label each one with a code of the code tree in N-Vivo program. Similarly, we coded the standards document as if this document were an area plan. After coding the documents, we proceeded to make a comparison between each area plan and the standards. Once the sources were compared, we proceeded to count the codes that each syllabi document shares with the standards document. We constructed a statistical variable with this measure. The value of this variable for an area plan is equal to the quotient between the number of codes that the area plan shares with the standards document and the total number of codes assigned to the standards document.

Results

We found that the sample mean of the variable is 29,19%, with a standard deviation of 13,36% which means that there is a low alignment and a great variability in the alignment percentage of the area plans and the standards document. At 95% confidence, we found a confidence interval of the population mean of Colombian area plans of (27.31%, 31.07%). The area plans should be aligned to the curricular parameters and standards; however, we found evidence that these plans do not fit what the Law established causing a gap on secondary education, mainly on tenth and eleventh grades.

References

- MEN. (1994). *Ley 115 de Febrero 8 de 1994. Por la cual se expide la ley general de educación*. Bogotá: Author.
- MEN. (2006). *Estándares básicos de competencias en lenguaje, matemáticas, ciencias y ciudadanas*. Bogotá: Author.
- Webb, N. L. (1997). *Criteria for Alignment of Expectations and Assessments in Mathematics and Science Education*. Research Monograph No. 6

The concept of function in secondary school textbooks over time: An analysis made with the Theory of Conceptual Fields

Patricia Sureda¹ and Laura Rossi²

¹ CONICET - UNICEN, Tandil- Bs. As., Argentina; psureda@exa.unicen.edu.ar

² UNICEN, Córdoba, Argentina; lauraro737@gmail.com

The purpose of this paper is to analyse how functions have been taught throughout 22 secondary school textbooks over the last 50 years. We have adopted a temporal perspective, as the books examined were published from 1953 to 2010. Firstly, the definition of concept (situation, meaning, system of representation) was the one proposed in the theory of conceptual fields, in order to analyse the concept of "function" taught in each book. Secondly, the books were categorized according to a focus on Sets, Analytical - Graphic or Hybrid. Finally, the meaning of function emphasized in each approach was analysed according to the representational system. The analysis showed that the meaning changed over time, as well as the difference in each representational system.

Keywords: Mathematics teacher resources, textbooks, high school teachers, Theory of Conceptual Fields.

Introduction

The conceptual field of functions is taught from the first up to the sixth grade of high school. Its importance lies in its increasingly broad field of application.

In high school, the knowledge that the teacher selects for his teaching practice is the knowledge that is in his textbooks. Thus, the book is an unavoidable framework for both, the teacher and the student, and generates much of the mathematical discourse manifested in the teacher's practice.

The analyses of the 23 books were divided in two parts. In the first part, the teaching of functions was classified in three categories, proposed by Sureda and Otero (2007): Approach of Sets, Analytical Graph and Hybrid. Then, we analysed the proposal through the term of "Concept" taking into account the Theory of Conceptual Fields (Vergnaud, 1990). Accordingly, the situations used in the books to propose the functions were analysed along with the tasks and their resolutions, inferring from them the set of Operational Invariants presented in each representational system. The Operational Invariants can be inferred as the textbook proposed the tasks simultaneously with the correct resolutions, its definitions, and explanations.

Literature Review

Due to the variety of investigations related to functions, we only mention those analysed in books, or those focused on in the analysis of representational systems. The latter can be found in the work of Lavaque, Méndez, and Villarroel (2006), who analysed the instruction of the notion of function through a coherent articulation of Duval's representational registers.

With regards to the research related to the secondary level textbooks, the work of Cordero, Cen Che and Téllez (2010) is worth mentioning, who proposed the use of graphic representations presented in school books, in order to use them to understand the institutionalization of the concept of function.

$(y = 2x^2 + 4)$. **RS Second Order Algebraic:** Algebraic procedure in which parameters are not initialized ($y = ax + b$). **RS Analytical-graphic:** Graph on Cartesian Axes. **RS Verbal Written:** written linguistic forms. **RS Pictorial:** Refers to the construction of schematic drawings such as the Venn Diagrams.

This analysis allowed us to classify them in the three mentioned approaches (Sureda & Otero, 2007). **Approach of Sets:** It is a teaching of the concept of function centred on the Theory of Sets. The study of the functions includes the teaching of ordered pair, Cartesian product, relations, equivalences, functions, set of departure and arrival, domain, image, etc. In this way, this approach is more precise and does not present ambiguities in the development of the concept of function. **In the Analytical-Graphic Approach,** the concept of function is determined through the graphical representation in Cartesian axes of a problem or concrete situation, in which a functional relation between variables is established. The analysis of the function and its properties is performed from the graph: domain, image, notable points, asymptotes, increasing or decreasing, etc. **The Hybrid Approach** has characteristics of the two already mentioned organizations. It establishes a relationship between variables, and also uses a set concepts such as set of departure and arrival, and allocation rules. However, it is problematic when giving meaning to the concepts it borrows from set theory.

These three approaches allowed textbooks to be classified into three disjoint and exhaustive categories, since those textbooks which did not correspond to the approach of sets, nor to the analytical-graphic, were a combination of both.

Data Analysis and Results

Approach of Sets: The books analysed which fit in the Approach of Sets are: **1)** *Arithmetic and Algebra 3*, Publisher Estrada (1953); **2)** *Mathematics 4 Commercial Course*, Eds. Estrada (1961); **3)** *Elements of Calculus Difference and Integral*, Eds. Alsina (1970); **4)** *Mathematics 3*, Eds. Estrada (1980); **5)** *Mathematics 3*, Eds. Plus Ultra (1987); **6)** *Mathematics II For the Aula Taller*, Eds. Plus Ultra (1988); **7)** *Modern Mathematics 2*, Eds. Stella (1970); **8)** *Directed study of mathematics 3*, Eds. A-Z (1989). These books were published between 1950 and 1989. The analysis is similar to the one made to the book *Mathematical 4 Commercial Course* published in 1961 (from Eds. Estrada), presented below.

The reference [S]: The textbook introduces the concept of function (figure 1) through the definition: "Any binary relation between two sets – or just in one set- that corresponds each element of the domain to a single element of the counter domain is called function, application, or transformation".

Then, various Venn diagrams are presented, in which three examples of relationships are indicated. In the example 1) the relation "x was born in y" is proposed (figure 1), indicated as a function. In example 2) the relation "a x corresponds to the desk y" is proposed, indicated as a function. In example 3) the relation "x is a multiple of y" is proposed, indicated as a non-function. Each example is accompanied by a Venn diagram in which the output sets A domain of R the arrival set D codomain of R ; and the relationship by the arrow $x R y$. Finally, the ordered pairs of the function are indicated.

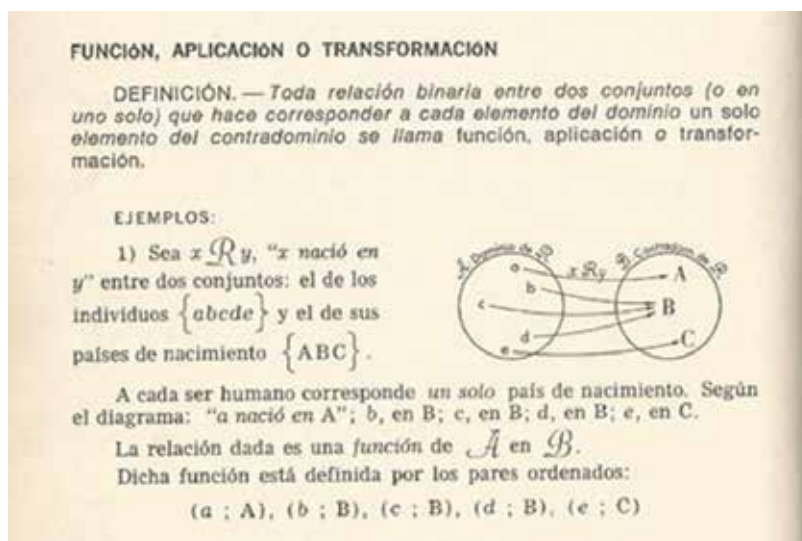


Figure 1: Definition of Function - Mathematics 4 Commercial Course, Publisher Estrada 1961

The signifier [I]: The textbook uses the RS Verbal Written for the definition of Function; the Second Order Algebraic RS to define the sets and relationships of the example, and the Pictorial RP for the representation in Venn diagrams.

In short, the textbooks with this approach present the concept of function from the notions of ordered pair, cartesian product, and relationships. The sequence that these textbooks follow to accomplish it, is: theory - example - exercise. The Representation Systems used are: Verbal Written, Algebraic of Second Order and Pictorial. Thus, we can determine that another characteristic of the set theory is the relevance given to mathematical notation.

The meaning [I]: The Theorems and Concepts in Action that emerge from the concept of Function in this approach are the following. **RS Verbal Written:** *A Function is a binary relation between two sets that corresponds to each element of the domain in a single element of the codomain - If a Relationship complies with the uniqueness and existence, it is a Function - The Domain of a Function is included in the Reach set - The Image is included in the Range of a Function.* **RS Second Order Algebraic:** *The expression of a function is $y = f(x)$ - Given the sets $A = \{a, b, c, d, e\}$ and $B = \{A, B, C\}$, the relationship formed by the pairs $(a; A) (b; B) (c; B) (d; B) (e; C)$ is a function of A in B - The Domain of a Function is included in the Scope set - The Image is included in the Range of a Function.* **RS Pictorial:** *Functions can be represented by Venn diagrams - From each element of the set called Domain, a single arrow appears towards an element of the set called Codomain.*

These Theorems-in-Action propitiate a static idea of the concept of Function. This can be seen in the examples and activities proposed. For example, the textbook presents the sets A and B by extension, and then defines the relationship between both sets. That is, the function can be defined by extension and there is no rule for assigning the variables.

Analytical - Graphical Approach: The textbooks analysed included in the Analytical - Graphical Approach are the following six: **1)** *Mathematics Bachillerato 2*, Eds. Anaya (1987); **2)** *Mathematics II*, Eds. Anaya (1989); **3)** *Mathematics 9*, Eds. A-Z (1997); **4)** *Mathematics 1*, Eds. Kapeluz (2004); **5)** *Mathematics 9*, Eds. McGraw Hill (1998); **6)** *Mathematics 3*, Eds. Puerto de Palos (2009). These textbooks were published between 1987 and 1998, yet there is one exception of 2009. The analysis

is similar to the one made in the textbook *Mathematics 3* published in 2009 by Puerto de Palos, presented below.

The reference [S]: The textbook introduces the concept of function (figure 2) by means of the definition: "A function is a relation between two variables in which each value of the first corresponds to a single value of the second".

Then, it presents a graph that represents the users of the Web worldwide, and interprets it. Thus, the textbook indicates that for each value of time (independent variable) there is a unique number of users (dependent variable). That is, 1574 million users are the image of the year 2008, and 2008 is the preimage of 1574. Then, the textbook defines the domain as all the values that can be taken by the independent variable, in this case all the years greater or equal than 1989 and less than or equal to 2008; and all the values that the independent variable can take as the image set, formed by all users greater than 0 or less than or equal to 1574 million.

The signifier [I]: The textbook uses the RS Written Verbal for the definition of Function and domain and image set; and the RS Analytical - Graph to represent the function.



Figure 2: Function Definition Book "Mathematics 3" - 2009, Edited by Puerto de Palos

The meaning [I]: The Theorems and Concepts in Act that we reconstruct from the concept in this approach are the following. **RS Verbal Written:** *A Function is a Relationship between two variables in which each value of the independent variable corresponds to a single value of the dependent variable - The independent variable is x , which is represented on the abscissa axis - The dependent variable is y , which is represented on the ordinate axis - To find the characteristics of a Function, the problematic situation it represents must be taken into account.* **RS Analytical – Graph:** *A Function is represented through a graph in the Cartesian Axes – It is a Function if a single element of the vertical axis corresponds to each point of the horizontal axis - It is not a Function if the drawing of a vertical line from any point of the horizontal axis cuts the graph in more than one point.*

These Theorems-in-Action give a dynamic idea of the concept of Function. In short, the books of this approach propose some situations of everyday life through a graph in Cartesian axes, describing the relationship between variables as a function, and then analyse its characteristics such as the analysis

of variables, growth and decrease, maximum and minimum points, constant function, periodic function and zeros. In all cases, the definition is made in the RS Verbal Write and refers to a relation between variables that meet certain characteristics.

Hybrid Approach: The books analysed framed in the Hybrid Approach are the following: **1)** *Mathematics 2*, Eds. Santillana (1989); **2)** *Mathematics 3*, Eds. Santillana (1995); **3)** *Mathematics 8*, Eds. Santillana (2002); **4)** *Pythagoras 8*, Eds. SM (2004); **5)** *Mathematics, functions and Statistics*, Eds. A-Z (2005); **6)** *Functions 1*, Eds. Longseller (2002); **7)** *Mathematics I*, Eds. Estrada (2004), **8)** *Elementary Functions to construct mathematical models*, Eds. Inet (2010); **9)** *Mathematics 4*, Eds. Estrada (2010). These textbooks were published between 1995 and 2010, yet there is one exception in 1989. The analysis is similar to the one made in the book *Mathematics 3* published in 1995 by Santillana, presented below.

The reference [S]: The textbook introduces the concept of function by means of a real-life problem relative to the rate of a taxi according to the kilometres travelled, and then solves it. Based on the problem, it establishes the following (figure 3): "In this real-life problem, we observe the presence two sets; set D, formed by the distances that can be covered in a taxi, and another set P, which is the price corresponding to those distances. As seen above, each distance D corresponds to a single price of the set P. In mathematics, we call this correspondence function of D in P".

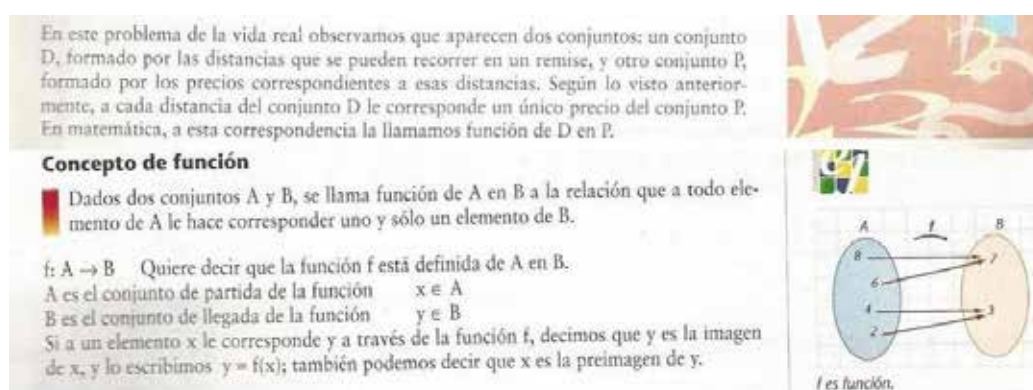


Figure 3: Definition of Function, Book "Mathematics 3" - 1995, Publisher Santillana

Then, the formal definition of function is written, as well as the image and preimage, using elements of the set theory.

The signifier [Γ]: The textbook uses the Written Verbal Representation Systems, Numeric, Analytical - Graphic and Pictorial to define and represent the function and concepts of image, preimage and domain.

The meaning [I]: The Theorems and Concepts in Act reconstructed from the concept in this approach, are the following. **RS Verbal Written:** *A Function is a specific relationship between two variables - The variable x is the independent variable - The variable y is the dependent - Each value of " x " corresponds to a single value of " y " - The Domain is the set of all the values that the independent variable " x " can take - The Image is the set of all the values that the dependent variable " y " can take - The Image is obtained by applying the Function to the elements of the Domain.* **RS Numeric:** *A function can be represented by a table - In the first column the values of the independent*

variable are located - In the second column the values of the dependent variable are located. **RS Analytical – Graphic:** A Function can be represented in Cartesian axes - The values of x are exemplified by the horizontal axis - The values of y are located on the vertical axis - The graph represents the points (x,y) , to draw the figure that represents the function - When drawing lines parallel to the y axis, they must cut the graph at a single point to be Function. **RS Pictorial:** Functions can be represented by Venn diagrams - From each element of the set called Domain, a single arrow appears towards an element of the set called Codomain.

These Theorems-in-Action give a dynamic idea of the concept of Function, yet they preserve elements of the Sets approach. In synthesis, in these books, the proposed situations correspond to a situation directly connected to a certain context, with its formula or chart and analysis, using elements of the two previous approaches.

Conclusion

The analyses of the concept of function showed that - except for some few exceptions- the approaches usually corresponded to a particular set of years, and that the changes in the textbooks coincided with the dates in which national laws on education were sanctioned in the country. The Approach of Sets (1953-1990) prevailed in the period of Law 1420 of Education. Then, the Graphic Analytical Approach (1993-2006) was consolidated during the Federal Education Law (24.195), passed in 1993. Finally, the Hybrid Approach corresponds to the current period, coinciding with the last National Education Law 26.206 enacted in 2006. At the same time, the analyses of the textbooks showed that the Operational Invariants, about function changes according to the approach.

The **Approach of Sets** emphasizes the idea of a binary relation between sets that complies with existence and uniqueness (for example " x was born in y "), but relegates the dependence between variables. However, the positive aspect of this approach is the fact that it uses a lot of the RS Second Order Algebraic, which allows to have the symbolic notation and rigor characteristic of Mathematics. In the **Analytical - Graphical Approach**, the idea of the function is built on the system of graphic representation, in which the written verbal language explains that a Function is a Relationship between two variables, and that each value of the independent variable corresponds to a single value of the dependent variable. The independent variable is x , represented on the abscissa axis, and the dependent variable is y , represented on the ordinate axis. This approach manages to link the use of functions with everyday life but loses mathematics in the process. Finally, the **Hybrid Approach** presents the functions as a relation between two variables, but tries to recover elements from the focus of the approach of sets, such as Range, ordered pair, etc. Likewise, this approach tries to make sense of the functions by linking them with everyday life, while at the same time there is an effort to recover the proper notations of mathematics. However, this effort is limited by the lack of elements typical of set theory, conditioned by its use.

Finally, the analysis of the reconstructed theorems-in-action for each RS showed that, as affirmed by Sureda and Otero (2013), the meaning of function changes according to the representational system. For it is not the same to think of functions as a relation that achieves "*from each element of the set called Domain a single arrow goes to an element of the set called Codomain*", to think of a Function

as a relation in which "each point of the axis horizontal corresponds to a single element of the vertical axis", or that can be represented by a formula. Moreover, not only there is a change in meaning, but also a change in the operative invariants linked to them that are characteristic of the RS. For example, RS Graph has a number of operative invariants linked to the scale, and to the location of the points in the plan, which the Venn diagram lacks. The meaning of a concept is much more than the systems of representation; however, it is impossible to conceptualize complex concepts without any representation system. Particularly in secondary school, it is essential to foster situations that demand the use of the different representation systems which constitute the concept.

References

- Cordero, F., Cen Che, C., & Suárez Téllez, C. (2010). Los funcionamientos y formas de las gráficas en los libros de texto: una práctica institucional en el bachillerato. *Revista Latinoamericana de Investigación en Matemática Educativa*, 2, 187-214.
- Lávaque Fuentes J., Méndez, N., & Villarroel, Y. (2006). Concepciones de los alumnos de la noción de Función. *Revista de Educación Matemática*. Número especial. Disponible en: <https://revistas.unc.edu.ar/index.php/REM/article/view/10467/11152>. Fecha de acceso: 10 May. 2019.
- Sureda, P., & Otero, R. (2011). Nociones fundamentales de la teoría de los campos conceptuales. *Revista Electrónica de Investigación en Educación en Ciencias (REIEC)*, 6(2), 124-138.
- Sureda, P., & Otero, M. R. (2013). Estudio sobre el proceso de conceptualización de la función exponencial. *Revista Educación Matemática*, 25(2), 89-118.
- Vergnaud, G. (2013). Conceptual development and learning. *Revista Currículum*, 26(3), 39-59.
- Vergnaud, G. (2007). ¿En qué sentido la teoría de los campos conceptuales puede ayudarnos para facilitar aprendizaje significativo? *Investigações em Ensino de Ciências*, 12(2), 285-302.
- Vergnaud (1998). A comprehensive theory of representation for mathematics education. *Journal of Mathematical Behavior*, 17(2), 167-181.

The potential of Problem Graphs as a representational tool with focus on the Hungarian Mathematics Education tradition

Eszter Varga

Eötvös Loránd University, Faculty of Science, Doctoral School of Mathematics, Budapest, Hungary; evarga@bpg.hu; vargaesztermail@gmail.com

Keywords: Series of Problems, Hungarian mathematics education, teacher design capacity

Introduction

Capturing teachers' principles and working methods in instructional design can pose some challenges, as well as its representation and dissemination. In this work in progress, we suggest a new representation tool, the Problem Graph, that has the potential to reveal some of the Teacher Knowledge embedded in series of problems and task sequences. Problem Graphs are developed with dual purpose: as an analytical tool to explore the structure of existing resources through a priori analysis, and as a design tool that can help teachers plan their instructional sequences and long term learning trajectories. The potential of Problem Graphs in developing teachers' design capacity were also investigated in two pilot experiments with the objective of introducing them in teacher education and PD programs.

Initially, this work is strongly rooted in the Hungarian Mathematics Education tradition, but both the approach in question and the representation tool is relevant to the international community for its special handling of Mathematical Knowledge for Teaching (Ball et al., 2008).

Background

My present and prospective work with Problem Graphs is a part of a large scale research project launched by the Hungarian Academy of Sciences.¹ The project focuses on the Hungarian "Guided Discovery" approach, that was experimentally implemented nationwide by a reform movement led by Tamás Varga in the 1960s and 70s (see Gosztonyi et al., available in pre-Proceedings of ICMI 24; Varga, 1988). This approach is highly recognized among Hungarian experts. The research project is assigned to describe the approach and examine its background as reflected in the recent theoretical frameworks as well as revisiting the reform and communicating it to both national and international audiences.

In a preliminary study, Gosztonyi identified Series of Problems as a characteristic aspect of teachers' work in the Guided Discovery approach. The research group started to analyze Series of Problems as a special type of resource, using the frames of the Documentational approach (Gosztonyi, 2018; Gueudet, Pepin, & Trouche, 2012). In this course of work, a need emerged for an efficient visual representation of the inner structure of Series of Problems, to which the graph representation came

¹The poster is made with the financial support of the MTA-ELTE Complex Mathematics Education Research Group, working in the frame of the Content Pedagogy Research Program of the Hungarian Academy of Sciences (ID number: 471028).

up quite naturally as one of the possible answers. Problem Graphs were built to some of the examined Series of Problems and discussed in details with experts. In these structures, nodes represent the individual problems, while edges show the explored connections. The connections reflects Mathematical Knowledge for Teaching, one-way arrows show precedent-consequence relations. For the standards of further classification, the domains suggested by Ball et al. might be a good starting point, but this work is only at its first steps at the moment.

The poster will demonstrate that the name Series of Problems covers a notion that is more complex than a task sequence, and seems to be indigenous in the Hungarian tradition. Nevertheless, the graph representation can be an effective tool to support the analysis of other learning sequences independent from this cultural context.

Dealing with problem Graphs led to the idea that this type of work on set of problems could benefit teachers' professional development greatly, especially if conducted in groupwork. Planning on investigating this opportunity, we conducted two pilot experiments with 10 and 18 participating teachers. In both experiments, teachers worked in groups on the same subset of a Problem Field which was examined previously by the research group. During the sessions, the teachers built a Problem Graph from the selected problems, followed by a whole group discussion and a questionnaire in the second experiment.

Poster Content

The poster will summarize some major principles of the Guided Discovery approach as a context. It will also give a working definition for Series of Problems. Limitations in space will not allow to provide full examples for Series of Problems, but some key problems will be highlighted. In the main part, Problems Graphs will be displayed, with one extensive example representing a Series of Problems from the field of Elementary Geometry in the center, with some specification of the connections. Graphs built by teachers from the same problems will also be presented, accompanied with some teacher responses from the questionnaires. This will allow us to draw some conclusion from the pilot experiment regarding the potential usage of the Problem Graph.

References

- Ball, D.L., Thames, M. H., & Phelps, G. (2008). Content knowledge for teaching: What makes it special? *Journal of Teacher Education*, 59(5), 389-407.
- Gosztonyi, K. (2018). Teachers documentary work with series of problems. In V. Gitirana, T. Miyakawa, M. Rafalska, S. Soury-Lavergne, & L. Trouche (Eds.). *Proceedings of the Re(s)ources 2018 international conference* (pp 195-198). ENS de Lyon
- Gosztonyi, K., Vancsó, Ö., Pintér, K., Kosztolányi, J., Varga, E. (to be published). Varga's "Complex Mathematics Education" Reform: at the crossroad of the New Math and Hungarian Mathematical Traditions. *Accepted to the ICMI Study 24: Curricular Reforms conference*.
- Gueudet, G., Pepin, B., & Trouche, L. (Eds.). (2012). *From text to 'lived' resources: Mathematics curriculum materials and teacher development*. Springer Netherlands.
- Varga, T. (1988) Mathematics education in Hungary today. *Educational Studies in Mathematics*, 19, 291. <https://doi.org/10.1007/BF00312449>

From teacher's naming system of resources to teacher's resource system: Contrasting a Chinese and a Mexican case

Chongyang Wang^{1,2} Ulises Salinas-Hernández³ and Luc Trouche²

¹ECNU, China; ²IFÉ, ENS de Lyon, France; chongyang.wang@ens-lyon.fr

³CCH-UNAM, Mexico; ulisessh@cch.unam.mx

With an interest on curriculum resources of mathematics teachers, this study works as part of an emerging research program of analyzing teachers' resource systems through their naming systems of resources in contrasting contexts. This study presents the preliminary analysis results of two cases from China and Mexico. Using a conceptual framework drawn on Documentational Approach to Didactics (DAD) and Cultural-Historical Activity Theory (CHAT), we explored teachers' resources within a linguistic and cultural background. Three key resources of each case were selected and analyzed for finding their features and links with the teachers' resource system. By contrasting the two cases, we find that naming system provides us a lens on teachers' resource system (both the content and structure), and evidences the influences from linguistic and culture contexts.

Keywords: Curriculum resources, mathematics teachers, resource system, naming system, international comparison

Introduction and research questions

In 2018, the Re(s)ources 2018 International Conference¹ was hold, dedicated to teachers' resources work analysis with reflections on DAD for the past ten years. A young researcher workshop session was organized (Gitirana *et al.*, 2018, p. 373) specifically for exploring secondary teachers' resource work by analyzing their lexicons in naming and describing their resources and their documentation work (Trouche, to be published). A name is a syntactic entity denoting an object, and "a naming system resembles a restricted database system that infers the object(s) referenced by a name" (Bowman, 1993, p. 795). In addition, considering the views of the teachers, and the influences from their own languages, cultural and institutional contexts, we refer to two cross-cultural comparative projects: the Lexicon Project (Clarke *et al.*, 2017), which investigates the pedagogical naming systems used by different research communities speaking different languages to describe the phenomena of the mathematics classroom; and the project of Remillard *et al.* (2014), which addresses the influences from cultural contexts and educational traditions.

We situated our study as part of the research program "contrasting naming systems used by teachers in describing their resources and documentation work: towards a deeper analysis of teachers' resource systems" (Trouche, to be published). Holding a similar concern of Lexicon Project on the cultural contexts and educational traditions through cross-cultural analysis, this program involves researchers from eight languages/cultural contexts (Algerian, Brazilian, Chinese, Dutch, French, Mexican, Turkish and Ukrainian) for a better understanding of teachers' resource work through documenting lexicons (naming systems) on resources employed by teachers. Particularly in this

¹ <https://resources-2018.sciencesconf.org>

study, to deepen the understanding of teachers' resource systems, two contrasting cases (Chinese and Mexican) are analyzed from two research questions: (1) How understanding teachers' resource system through their naming systems? (2) To what extent each case can illuminate the other one?

Conceptual framework

The resource concerned in the project is from Adler (2000), anything with potential "to source again or differently" (p. 207) teachers' activities, "encompassing materials and also all elements intervening 'upstream' of teaching" (Gueudet, Pepin & Trouche, 2013, p. 1003). However in this study we focus more on the curriculum resources from Pepin and Gueudet (online first): all the *material resources* that are developed and used by teachers and students in their interactions with mathematics in/for teaching and learning, inside and outside the classroom.

This study is situated in the theoretical field of Documentational Approach to Didactics (DAD) and Culture-History Activity Theory (CHAT). DAD is an empirical approach to teachers' work and professional development through a lens of resource. The creative work of mathematics teachers' interactions with resources in their daily work is coined as documentation work (Trouche, Gueudet, & Pepin, online first). As a process of appropriation and transformation of resources, the interaction includes selecting, modifying and creating new resources, by individual or by a group of teachers working together, in- and out-of-class (Gueudet & Trouche, 2009). During these interactions, teachers develop *schemes of usage* that are attached to the resources for a same class of situations, and generate a document as outcome (resources + scheme of usage = document). A resource is never isolated, "each resource must be viewed as a part of wider 'set of resources'" (ibid, p. 200), and the "set of resources" is named as his/her *resource system*. Originated from Vygotsky (1978), CHAT (Engeström, 2001) emphasizes that the dynamic of consciousness is essentially subjective and shaped historically by social and cultural experiences. The structure and development of human psychological processes emerge through cultural mediation, historical development, practical activity, and the three are interrelated (Cole, 1996). CHAT inspires us that individual teacher' documentation work could be situated into the cultural/social/linguistic contexts where they work in. Tools inspired by these two theories will be introduced in the following methodology part.

Methodology

The naming system project adapts the methodology of *reflective investigation* from DAD, emphasizing the involvement of teachers throughout research with five principles: (1) long-term follow up; (2) in- and out-of-class follow up; (3) broad collection of resources; (4) reflective follow-up; and (5) confronting teacher's views on his/her documentation work (Trouche et al., online first). As a preliminary work, this study mainly takes the fifth principle. To differ the views of teachers from the researchers', we use the methodological tool of Reflective Mapping of the Resource System (RMRS) (Wang, 2018), where the teacher is invited to draw a RMRS by reflecting on his/her resources, and linking them into a structured way with his/her own naming and category of resources. RMRS emphasizes the teacher's views through his/her continuous reflections: the namings of resources and the structure of RMRS are all from teachers, and it could be incomplete with different versions, and improved along with the development of teacher's resource system, and teacher's deeper understanding on it.

This is a qualitative study performed through cases study. For feasibility and convenience reasons, we chose the teachers from schools associated to the authors' universities (in China and Mexico), which allows us to do further research with them. The criteria of the cases are: middle career mathematics teachers; from secondary schools in big cities (not from rural areas); with willingness to join our research and improve his/her teaching; "open minded" towards new resources.

Gao graduated in 1993, majored in education management (bachelor), then she started to teach mathematics in middle schools. She was the ex leader of mathematics Teaching Research Group (TRG) in her school, a school-based non-administrational professional group composed by teachers who teach the same discipline, where the leader is usually the most experienced teacher and in charge of organizing teachers' collective teaching research activities (Pepin *et al.*, 2016). She had two classes in grade 8 and 5 lessons for each class per week. In China, curriculum program is national. There are a limited number of textbooks edited under the control of the national government. Teachers cannot decide which textbooks to use, but they have diverse learning-aid materials as supplementary resources to choose.

For the Mexican part, Brenda is a high school mathematics teacher majored in mathematics (bachelor) and Earth sciences (master). During her bachelor study, she attended a mathematics teaching seminar. Then after graduated, she started to work as a volunteer in elementary schools teacher training. Till the interview, she worked as coordinator of mathematics in a primary school. In Mexico, private high schools can use the national curriculum -coordinated by the government- or the curriculum of the autonomous (public) university of the state where the school is located. Brenda works in a private high school, which follows (with some adjustments made by the school) the curriculum of an autonomous university.

Both of Gao and Brenda were interviewed concerning: (1) their working experience, current work and the teaching equipment conditions of their school; (2) their resources used in daily teaching, including the name, the content, the usage, the source, and the way to maintain and organize these resources; (3) an example of resources integration for a lesson preparation about functions (or algebra); (4) a RMRS by reflecting on her/his resources mentioned. The analysis of the interview was made following a common grid: with the interview transcription texts, we selected out the *names* of the *resources* most frequently mentioned by the teacher with personal features/preferences, and analyzed them combining the language and culture with the teacher's description on the usages, then situated these resources into the RMRS to infer the structure of teacher's resource system.

Results

This section presents the results of each case.

Selected resources from resource system in the Chinese case of Gao

In the Chinese case of Gao, a most frequently mentioned character is “题(tí)”. In Chinese language morphology, word is formed by a combination of characters. In Gao's interview, by combining with other characters, “题(tí)” forms into words like “习题(xí tí)” (exercise), “试题(shì tí)” (examination/test question), “例题(lì tí)” (example), “问题(wèn tí)” (question/ problem) etc. In Gao's case, the three selected resources (see in Table 1) are the sources of the “题(tí)”.

Naming in Chinese	Translated name in English	Description in English	Transcriptions examples
教辅材料 (jiào fǔ cái liào)	Learning-aid materials	The commercial textual materials (e.g. books) for students, with exercises or exam questions or knowledge explanations (available in bookstore).	“Before the new semester, I will go (to the bookstore) to check the new learning-aid materials.”
习题笔记 (xí tí bǐ jì)	Exercise note	The personal notes of Gao, in which she used for collecting the exercises she considered as valuable.	“I keep notes when I find valuable exercises, I made four (notebooks) last year.”
校本习题册 (xiào běn xí tí cè)	School-based exercise booklet	Booklet with exercises for the students, developed collectively by all the mathematics teachers inside Gao’s school (not for sell)	“This school-based exercise booklet was developed by me...which selected from my exercise notes.”

Table 1: Three typical expressions on resource naming by Gao

(1) Learning-aid materials (教辅材料, jiào fǔ cái liào) is a kind of printed and bound materials sold in bookstores, to “aid” learning. It generally contains examples, knowledge explanations and exercises. Gao knew the learning-aid material market well due to her experiences working as an author of a learning-aid book some years ago: “The learning-materials also have life-cycle, and have to be updated regularly”, so she visited the bookstore almost before new academic year, to see if there is anything new in the materials that she was following. She bought lots of learning-aid materials as her self-owned resources, and she had an awareness of following the trends of the learning-aid material markets, selecting and accumulating the valuable ones.

(2) Exercise note (习题笔记, xí tí bǐ jì) is a personal paper-pencil notes of Gao. She kept such habits for several years: after a whole day’s work, she liked to do exercises (e.g. from the learning-aid materials), and keeps the notes of the valuable ones. She also did the category of these exercises according to the contents (e.g. functions) or types (e.g. drawing). The source of the exercises is not limited to the learning-aid materials, but also from Internet. Many big professional websites/forums for mathematics teaching propose their enterprise applications with the popularization of smart mobile phone. Besides these apps, Gao used a social communication application “Wechat”, with which she can discuss and share resources (as file or picture) with colleagues, receive articles about exercises explanation, analysis on knowledge, information about exams, or even videos of other teachers’ lessons. She kept all the valuable information in her notes.

(3) School-based exercise booklet (校本习题册, xiào běn xí tí cè) is a series booklets developed collectively by the mathematics TRG in her school. As a teacher of grade 8, Gao was in charge of the two booklets in her grade. The booklets are sent to students as homework, consisted mainly with exercises, as Gao explained, “most of them were selected from my exercise notes.”

Crossing the three resources, there appears a chain: the learning-aid materials nourish her exercise notes (self-owned resource), which in return “re-source” her exercise booklets (self-developed

resource). This evidenced a kind of “resource cycle” in her resource system (Figure 1 left, the red circles and arrows were marked by the author according to Gao’s explanation in the interview).

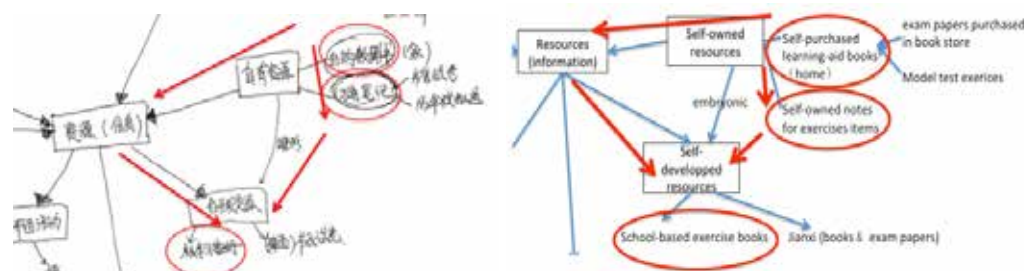


Figure 1: Part of RMRS of Gao (original left, and digital transposition by the researcher right)

When situating these resources in Gao’s RMRS, we find the different roles of resources as “input”, “output” and “hub” (evidenced by the arrows). For the inputs, Gao had resources from learning-aid materials, feedbacks from students in their homework; for the output, she developed her self-owned resources into self-developed resources: her personal exercise notes worked as a hub. Gao selected exercises carefully for students, and kept their feedbacks as important resources. This could be referred to her education background (education management): “I pay much attention on students, and try to maintain good relationship with them, they will like mathematics if they like me.”

Selected resources from resource system in the Mexican case of Brenda

Three selected resources of the Mexican case were presented in Table 2.

Naming in Spanish	Translated name in English	Description in English	Transcriptions examples
Manual (Versions for teacher/student)	Textbook	School textbook produced by the school, adjusted and improved by the teachers every year.	“Then we [teachers] use a manual, where we all see the same [contents].”
Diagramas (Figure 2a) / esquemas (Figure 2b)	Diagrams	A geometric drawing with which one gets the resolution of a problem, the relationships between different parts of a set or a system.	“I make diagrams to see what is my objective and what do they need.” “Then [at the end] those schemes, I give them copies of the scheme or I give them blank to be filled.”
Calendario escolar	School calendar	Teaching schedule designed institutionally to mark dates of activities at school. It is a reference for planning lessons.	“I need a calendar, because the time is very important; [we have] the normal calendar, the school calendar...”

Table 2: Three typical expressions on resource naming by Brenda

(1) Textbook (manual) is the resource that guides the development of the different topics that are addressed throughout the school year. The elaboration of each textbook (for each of the three secondary degrees) is based on the curriculum (another important resource not analyzed in this study)

of the largest university in the country and to which the school where the interview was conducted is incorporated. The work of (re)elaboration of the textbooks is directed by a coordinator of mathematics (who is also the teacher of the school). However, teachers are free to suggest and contribute any concerns or observations they may have. Table 2 shows how collaborative work guides the activity of teachers in a particular way: “...we all see the same”. In the use of the textbook as a resource, all stages of Brenda's documentation work (review, analysis of resources, adaptation, reorganization, implementation and reflection) are involved. It is also interesting to notice that in Spanish, “manual” refers to something “we have in hands” and something related and available to the usage, whereas quite different with textbooks. The translation makes one lose the meaning-production universe around.

(2) Two resources (diagramas/esquemas) in which Brenda emphasized its use, during the interview, were the use of diagrams/schemes. It is important to note that both words (diagram and scheme) were used by indistinctly to refer to the same resource: diagram (Figure 2). However, the term “scheme” is incorporated to show how the teachers name their resources in relation to their teaching activities. Brenda elaborated the diagrams according to her teaching contents. The diagramas were initially used as a way of learning by Brenda when she was a student. This stage is closely related to the analysis of the textbook (manual), as she pointed out: “I make diagrams to see what my objective is and what they [students] need to know for reaching that goal” (see in Table 2). Then, during the lessons, Brenda incorporated the resource as learning material for the students: “I give them copies of the scheme, or blank ones to be filled.”

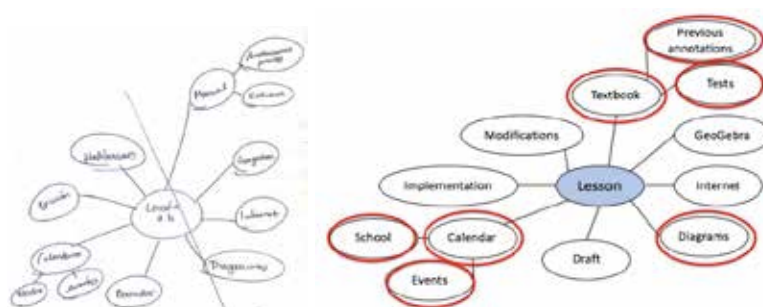


Figure 2: Part of RMRS of Brenda (original left, and digital transposition by the researcher right)

(3) School calendar (Calendario escolar). In relation to the resources selected from the interview, the use of the textbook and the elaboration of diagrams are closely related to the teaching plan and lesson design. This includes both the textbook that will be addressed in each class and the elaboration of diagrams for each topic. These two resources are organized from a school calendar.

Crossing the three resources within her RMRS (Figure 2), they are all resources for her “lesson”. Brenda did not draw her RMRS centered on “resource” like the Chinese case. However, considering the particularity of the textbook she used, we can still infer that the textbook bridges Brenda’s individual documentation work with her collective work with others: The textbook is developed based on the university curriculum with the involvement of the school teachers, and as a teacher, Benda worked as both user and usage feedbacks provider; To implement the curriculum and textbook, she adapted her personal learning strategy (diagram) into classroom teaching, and diffused it with other teachers through resources related to school calendar (teaching plan).

Discussion and perspectives

Resource system is not easy to be inferred from or interviews. In this paper, we took a method of combining teacher's naming system and her/his RMRS, with two contrasting cases from different cultural contexts, China and Mexico, to have more elements (theoretical and methodological) to analyze teacher's resource system. Far more work need to be done for a deeper understanding on their resource systems. Although Gao and Brenda are two very different cases -in terms of their teaching activity and their sociocultural context-, one from public middle school and using national curriculum, and one from private high school using a university curriculum. However, by documenting the name/content/usage as well as their positions in RMRS, we can still find some features that allow us to develop and deepen our further analysis works.

Related to research question (1): In the Chinese case, the resource naming system showed an emphasis on “tí(exercise in English)”, and the three selected resources evidenced its position of central element in the teacher's resource system, linking both the teacher's personal working habits (taking notes) and the cultural context (exams-emphasized culture and huge learning-aid material markets) of mathematics education. In the Mexican case, the resource naming system evoked an adaption of personal choices (e.g. diagram adapted from learning teaching) and consideration on others' work (e.g. school calendar), mediated by a collective used/developped/revised manuel (textbook). For research question (2): Crossing the two cases, they are both following a fixed curriculum (national curriculum and local unified textbook in Chinese case, unified curriculum and textbooks produced by the university in Mexican case); they are both trying to integrated the supportive resources (learning-aid materials in Chinese case, disciplinary academic books in Mexican case); they are both organizing their resource work centered on students (selecting exercises from diverse sources and paying attention on their feedbacks in the Chinese case, adapting her own learning strategy, diagram, into classroom teaching in the Mexican case). Additionally, there are school-based resources involving the two teachers in both two cases: the school-based exercises booklets collectively developed by the mathematics TRG in the Chinese case, and the university-curriculum based textbooks developed and revised by the school mathematics teachers in the Mexican case. In the case of Gao, the different terms related to “tí(exercise) reveal a potential resource category from the teacher's view. In the case of the Mexican teacher, the ambiguity of naming the same resource in two different ways infers a more individual work of the teacher.

To summarize, analyzing teacher' naming systems on resources by actuating it within specific cultural contexts could be a promising method for us researchers to deepen the understanding on teacher's resource system. Due to the limited space, we were not able to analyze the mathemtics components of their resource system. As a beginning of this exploration, we hope that involving other cases and crossing with other projects will help us to go further in this direction.

References

- Adler, J. (2000). Conceptualizing resources as a theme for teacher education. *Journal of Mathematics Teacher Education*, 3(3), 205–224.
- Bowman, M., Debray, S. K., & Peterson, L. L. (1993). Reasoning about naming systems. *ACM Transactions on Programming Languages and Systems*, 15(5), 795-825.

- Clarke, D., Mesiti, C., Cao, Y., & Novotna, J. (2017). The lexicon project: examining the consequences for international comparative research of pedagogical naming systems from different cultures, In T. Dooley, & G. Gueudet (Eds.) . *Proceedings of the Tenth Congress of the European Society for Research in Mathematics Education (CERME 10, February 1–5, 2017)* (pp. 1610–1617). Dublin, Ireland: DCU Institute of Education and ERME.
- Cole, M. (1996). *Cultural psychology: A once and future discipline*. Cambridge, MA: Harvard University Press.
- Engeström, Y. (2001). Expansive learning at work: Toward an activity theoretical reconceptualization. *Journal of Education and Work*, 14(1), 133–156.
- Gitirana, V., Miyakawa, T., Rafalska, M., Soury-Lavergne, S., & Trouche, L. (Eds.) (2018). *Proceedings of the Re(s)ources 2018 international conference*. ENS de Lyon, <https://hal.archives-ouvertes.fr/hal-01764563>
- Gueudet, G., & Trouche, L. (2009). Towards new documentation systems for mathematics teachers? *Educational Studies in Mathematics*, 71(3), 199–218.
- Gueudet, G., Pepin, B., & Trouche, L. (2013). Collective work with resources: an essential dimension for teacher documentation. *ZDM - Mathematics Education*, 45(7), 1003–1016.
- Pepin, B., & Gueudet, G. (online first). Curriculum resources and textbooks in mathematics education. In S. Lerman (Ed.), *Encyclopedia of Mathematics Education*. New York: Springer.
- Pepin, B., Xu, B., Trouche, L., & Wang, C. (2016). Developing a deeper understanding of mathematics teaching expertise: Chinese mathematics teachers' resource systems as windows into their work and expertise. *Educational studies in Mathematics*, 94(3), 257–274, <http://rdcu.be/koXk>
- Remillard, J.T., Van Steenbrugge, H., & Bergqvist, T. (2014). A cross-cultural analysis of the voice of curriculum materials. In K. Jones, C. Bokhove, G. Howson, & L. Fan (Eds.), *Proceedings of the International Conference on Mathematics Textbook Research and Development (ICMT–2014)* (pp. 395–400). Southampton: University of Southampton.
- Trouche, L. (to be published). Evidencing missing resources of the documentational approach to didactics. Towards ten programs of research and development for enriching this approach. In L. Trouche, G. Gueudet, & B. Pepin (Eds.). *The 'resource' approach to mathematics education*. Springer.
- Trouche, L., Gueudet, G., & Pepin, B. (online first). The documentational approach to didactics. In S. Lerman (Ed.), *Encyclopedia of Mathematics Education*. New York: Springer.
- Vygotsky, L. S. (1978). *Thought and language*. Cambridge: MIT Press.
- Wang, C. (2018). Mathematics teachers' expertise in resources work and its development in collectives. A French and a Chinese Cases. In L. Fan, L., Trouche, C. Qi, S. Rezat, & J. Visnovska (Eds.), *Research on Mathematics Textbooks and Teachers' Resources: Advances and issues* (pp. 193–213). Cham: Springer.

TWG23: Implementation of research findings in mathematics education

Introduction to the papers of TWG23: Implementation of research findings in mathematics education

Mario Sánchez Aguilar¹, Ana Kuzle², Kjersti Wæge³ and Morten Misfeldt⁴

¹Instituto Politécnico Nacional, CICATA Legaria, Mexico; mosanchez@ipn.mx

²University of Potsdam, Germany; kuzle@uni-potsdam.de

³Norwegian Centre for Mathematics Education, Norwegian University of Science and Technology (NTNU), Norway; kjersti.wage@matematikkenteret.no

⁴Aalborg University, Denmark; misfeldt@learning.aau.dk

In this introduction, we briefly present the origin of a young Thematic Working Group 23 (TWG23) on implementation of research findings in mathematics education, and its development from CERME 10 to CERME 11. We then address the construct “implementation research” by looking at the model proposed by Century and Cassata (2016). Drawing from this model, we attempt to categorize the papers and posters of TWG23. In addition, we report on the results from two thematic discussions that focused on the topic of “Methodology in implementation research” and “Replication studies”. Lastly, we offer a collective, still in-progress definition of implementation research as a result of the summarizing discussion in the TWG23 during CERME 11.

Keywords: Implementation research, research findings, replication studies, innovation, change.

Origin of the Thematic Working Group 23

During five decades, the field of mathematics education research has generated a multitude of products, such as theoretical frameworks, concepts, didactic designs, solid findings, etc. Although the research community has always been concerned with the theory-practice relationship, it remains an open and a challenging problem how such products could be used and applied in practice. Many mathematics education researchers work on (large) developmental projects that rely heavily on previously documented research results. However, reporting on these projects in mathematics education scientific outlets have proven to be challenging, since such projects do not necessarily fall under the usual paradigms of research in mathematics education. Before CERME 10, this issue was identified. More concretely, there was no forum to discuss important issues related to implementation of research findings. For that reason, TWG23 was founded with the idea of being a forum dedicated to presenting and discussing empirical and theoretical studies focused on elucidating the enablers and general conditions that favor or inhibit the implementation of research products generated in our field in practice as well as reporting on research-based designs themselves. The original concern of the group was “*How can we apply and implement stable research findings in «real life»?*” and “*How can we bring the accumulated research knowledge into practice?*”

These questions remained to be in the focus of TWG23 also at CERME 11. We were embracing for papers and poster proposals addressing, from both empirical and theoretical perspectives, issues related to the implementation of research findings. In particular, we wanted to focus on a wide variety

of “good examples” of implementation of research findings and products into practice, aiming at improving the teaching and learning of mathematics at all educational levels. Moreover, we were interested in empirical research and theoretical discussions that address the challenges and possibilities of “implementation research”, as well as in-depth literature reviews that provide general and updated views of the state of development of this type of research in the field of mathematics education. Thus, the work of the group was organized around the idea of closing the identified “gap” and acting as a bridge between research and practice by focusing on multiple perspectives of implementation research.

Evolution of the TWG 23

At CERME 10, the working group undertook initial attempts to make sense of the construct of implementation. In the call for papers for the TWG23 at CERME 10, the construct “implementation research” was operationalized rather broadly, as a wide range of different kinds of didactical design, from task design, (model) lesson design, teaching modules and courses to design of entire programs at all educational levels. Furthermore, “implementation research” was inclusively treated as research on aspects of developmental projects, intervention projects, as well as research on aspects of the development and use of educational media, such as textbooks, apps, software and learning platforms. However, the call for papers required to make explicit connections between the reported designs and findings or insights from mathematics education research. As a result, many examples of implementation of research findings in mathematics education were presented, including process models, determinant frameworks, classic theories, implementation theories and evaluation frameworks (Jankvist, Aguilar, Bergman Arlebäck, & Wæge, 2017). Many examples had been presented also at CERME 11, however, a new general theme in considering them have gradually emerged. At CERME 11, both the papers and posters as well as our discussions, reflected an effort to articulate more clearly what implementation research in mathematics education actually is, as well as the growing interest in theorizing it.

Understanding our emerging “paradigm” and its blind-spots and tacit assumptions

It was apparent at CERME 11 that many of the contributions shared certain ideas of what implementation in educational situations is. The ideas were shared both in terms of terminology and in terms of key references. Two key concepts apart from implementation are worth mentioning, namely *innovation* as described by Rogers (1962) and his famous work on the diffusion of innovations, and central factors of “implementation” as proposed by Century and Cassata (2016). This means that many of us considered “implementation” as innovation that causes a change when enacted in ordinary practice, and that the change is stipulated by relationships between the nature of the innovation, influential factors and key stakeholders.

Furthermore, we internalized the Rogers (1962) idea that innovations spread through different user segments, from innovators that participate in developing and realizing the innovation, over early adopters to a majority who instantly or relatively soon take up the innovation, and then to the late majority – taking the innovation up late – and laggards who might never change practice.

The five factors that influence innovation proposed by Century and Cassata (2016), were actively used in a number of the contributions in the group, as a lens to study the implementation and implementability of initiatives. These five factors are: characteristics of the individual users, organizational and environmental factors, attributes of the innovation, implementation support strategies, and implementation over time.

Apart from referring to the Rogers' and Century and Cassata's (2016) "standard models" for implementation (as something that causes a purposeful change, related to factors and stakeholders) in the group discussions, we also spent some time investigating the downsides of looking at changes in the educational sector through this lens.

First of all, we observed that the "standard models" tend to fetishize the "manifestation" of a change as an innovation. Change in the educational sector is typically not caused by one "thing". Rather, it is better studied as an interplay between many factors and forces. The constant focus on "innovation" in our work and discussions might have a problematic downside here. Another problem with the term "implementation as enactment of innovation" is that it overplays the intentional aspects of educational change. Many changes come as organic developments rather than as purposeful implementations.

We also began understanding the implementation paradigm by drawing a parallel to Stein, Remillard, and Smith's (2007) phases of curriculum, which was brought to the discussion by Boris Koichu. In Stein et al.'s (2007) model, the curriculum can be seen as consisting of different categories, namely written, intended, enacted, and attained curriculum based on what phase of the teaching and learning process one is focusing on. If we replace the written curriculum with (stable) *research findings*, a new model emerges (see Figure 1). Thus, in this new model published research refers to the research findings available to the teachers. *Intended implications* refer to the set of objectives to be accomplished in practice on the basis of research findings. *Enacted implications* refer to various learning activities or experiences of the learners on the basis of research findings in order to achieve the intended implications. Lastly, *attained implications* refer to the implementation outcomes with respect to student learning on the basis of the intended and enacted implications.



Figure 1: Phases of implementation of research findings into practice

Introduction to the papers and posters presented at the TWG23

Twelve papers and two posters were presented at CERME 11, all of them addressing a wide variety of topics and using different approaches. In this section we use the five categories proposed by Century and Cassata (2016) in order to present an overview of the works discussed in this thematic working group. Although not mutually exclusive, to some extent these categories allow us to group the works presented in the TWG23 according to their interests and perspectives.

Inform innovation design and development

The research study by Ioannis Papadopoulos and Nafsika Patsiala falls into this category. They describe a pilot study, aiming at capturing the landscape of problem posing in a Greek grade four classroom. It is intended that the information produced by this pilot study informs and helps to setup a year-long intervention in the classroom aiming to develop the problem posing abilities of the students.

Understand whether (and to what extent) the innovation achieves desired outcomes for the target population

Two papers belong to this category. The first work, by Inga Gebel and Ana Kuzle, presents a problem-solving innovation for students in grades 4-6 has been designed and evaluated. During the evaluation phase, the researchers analyze students' problem-solving solutions with respect to their fluency and flexibility, and present the (dis-)advantages of the innovation in regular mathematics lessons.

The second work is by Helena Gil Guerreiro, Cristina Morais, Lurdes Serrazina, and João Pedro da Ponte. These authors try to understand, in a context of teachers' collaborative group, how emphasizing multiple representations can contribute to the learning of the rational numbers by elementary school students.

Understand relationships between influential factors, innovation enactment, and outcomes

Three of the papers presented in the TWG23 focus on identifying factors that influence innovation enactment. One of them was developed by Rikke Maagaard Gregersen, Sine Duedahl Lauridsen, and Uffe Thomas Jankvist, who focus on identifying the enablers and barriers for the implementation of the so-called *Swedish Boost for Mathematics*, which is one of the largest initiatives on improving mathematics teaching and learning in the Nordic countries in recent times.

The paper presented by Johan Prytz also analyzes the implementation of the Boost for Mathematics initiative, but this paper adopts a historical and comparative approaches. Through this perspective, the author shows the role that research and models of governance played in the New Math project in the 1960s and 1970s, and later in the Boost for Mathematics project.

Finally, the paper by Dorte Moeskær Larsen, Mette Hjelmberg, Bent Lindhart, Jonas Dreyøe, Claus Michelsen, and Morten Misfeldt describes a recent attempt to implement on a large-scale an inquiry-based mathematics teaching in Danish compulsory school. In their analysis, they identify critical factors for this large-scale implementation.

Improve innovation design, use, and support in practice settings

Most of the works presented fall into this category. For instance, Tomas Højgaard and Jan Sølberg refer to a longitudinal project called KOMPIS (a Danish acronym that stands for "Competency Goals in Practice"). In particular, they present a two-dimensional content model derived from the KOMPIS project that aims at supporting competence-based curriculum development and teacher planning.

In turn, Morten Elkjær discusses the design of a dynamic online diagnostic tool aimed at assessing students' mathematical misconceptions in lower secondary school. The design of such online tool is

based on the application of research findings on mathematical misconceptions in algebra and numeracy when working with equations.

The implementation of notions from the inquiry-based mathematics teaching perspective (IBMT) is the focus of the work presented by Per Øystein Haavold and Morten Blomhøj. In particular, they discuss how the design of a four-year professional development project called SUM (A Norwegian acronym that stands for “Coherence through inquiry based mathematics teaching”), can support the implementation of research findings related to the IBMT approach.

The large-scale implementation of alternative models for multiplication is the focus the paper by Anna Ida Säfström, Ola Helenius, and Linda Marie Ahl. They make use of Vergnaud’s theory of conceptual fields to produce a teaching design where models in the form of iconic representations serve as a means for creating patterns that make multiplicative invariants and structures visible.

The work by Nina Ullsten Granlund reports on a professional development project where preschool teachers are offered theoretical tools – in particular Bishop’s theory of mathematical activity – so that they can think about their teaching in a structured and explicit way, but respecting the play-based tradition on which Swedish preschool education is based.

The last article located in this category is the one presented by Boris Koichu and Alon Pinto. They report on the TRAIL project (Teacher-Researcher Alliance for Investigating Learning), which is a co-learning project between mathematics teachers and mathematics education researchers. They illustrate how this project favors teachers’ adaptation of research procedures and ideas in their classrooms as part of participation in community educational research.

Develop theory

The main emphasis of the works included in this category is in the conceptualization of the implementation of research findings. This focus is clearly reflected in the work of Uffe Thomas Jankvist, Mario Sánchez Aguilar, Jonas Dreyøe, and Morten Misfeldt. Taking as a reference implementation research frameworks from outside the field of mathematics education, they try to outline what an implementation research framework in mathematics education could encompass.

Finally, Andreas Lindenskov Tamborg argues in his paper that in order to synthesize the research results in implementation research as an independent sub-field in mathematics education research, there is a need for a consistent vocabulary. He then proposes to combine Century and Cassata’s (2016) definition of implementation research with theoretical notions developed in the realm of the documentational approach to didactics.

Results of the thematic group discussions

During our sessions, we organized two thematic discussions. The first thematic discussion focused on the topic of “*Methodology in implementation research*”, while the second one concentrated on “*Replication studies*”. Below we mention the main ideas that were addressed during those group discussions.

Methodology in implementation research

As of 2017, we as a community of mathematics educators interested in implementation research, got a forum to talk about and publish our “implementation” research, while analyzing our data from multiple perspectives. Here, different dependent variables can be considered: climate variables, learning variables, system variables or independent variables. Yet, in the wider community this type of research does not necessarily fall under the usual paradigm of “research in mathematics education”. As a consequence, it is not highly-recognized and often is not considered for publishing in high ranking peer-reviewed articles, due to different factors. That said, the following question naturally arises: “*What would count as a high-quality implementation research (recognized by the community and having impact in high-ranked journals)?*” In order to answer this question, we had small group discussions organized around the following questions:

1. What perspective of implementation research does each project follow? Ones identified, what is the purpose of one’s perspective?
2. How is innovation within each project measured and analyzed? What are methodological challenges faced by each “implementation” project?
3. Which of perspectives and purposes from (1) are closely aligned with the usual paradigm of “research in mathematics education”?
4. Which of these perspectives would count as high-quality implementation research? If so, why? If not, why not?
5. What implications would the decision from (4) have with respect to our methodology (e.g., instruments, units of analysis, such as products, processes, evaluation of particular factors, analysis)?
6. What challenges do arise in implementation research (e.g., related to data analysis, to ethical issues) and how could one go about them?

The discussions have shown that TWG23 is at its early stage where many fundamental issues are not yet completely clear. Both thematic discussions as well as the paper discussions made us enter a pathway towards formulating a more precise collective definition of the construct “implementation research in mathematics education” (see last section of this paper). Another issue identified was the complexity of implementation research, which consequently implies the variety of theories needed in order to inform it. Given the length limitation of publications in most of the high-ranked journals, it makes is extremely difficult to report on implementation research in its full complexity – although this is also the case for other types of research. Lastly, in our community implementation of research findings is still not highly recognized by many colleagues. Hence, we discussed the need of a community building and raising awareness with respect to potential of implementation research for the field mathematics education.

Replication studies

The interest in replicating didactic designs and empirical studies has been present in the community of mathematics educators for several years. In the 1970s Phillip M. Eastman (1975) wondered why there were no more studies of replication in our field, while arguing for relevance of such studies. During the 1980s several reproducibility studies were carried out – mainly in the French teaching

community – focused on understanding the conditions that allowed a didactic design to be implemented with enough fidelity in different scenarios, preserving the effects in student learning.

Simply put, a replication study can be seen as the attempted repetition of a study or an experiment that has been published in a peer-reviewed journal or book. However, since in the social sciences there cannot be two identical qualitative studies (i.e., there is no duplication), the development of qualitative replication studies involves maintaining certain variables similar to the original design, such as investigating a similar population, using the same didactic design, or applying the same modes and categories of analysis or coding. This kind of replication is known as *conceptual replication* (Hüffmeier, Mazei, & Schultze, 2016). Yet, this characterization does not exclude the possibility of developing quantitative approaches to replication studies.

Lately, replication studies are gaining the attention of the mathematics education community (and beyond). An example of this is the working group on replication in mathematics education, which met for the first time at the PME 42 conference in Umeå, Sweden. Another indicator is that some specialized journals are beginning to receive and publish replication studies, for example the *Journal for Research in Mathematics Education* (JRME). However, despite its apparent importance, replication studies have found some obstacles to establishing themselves as an “accepted” type of study in our field. As expressed by Hugh Burkhardt (2013) “Replication, a key element in scientific research, is simply not sexy” (p. 225).

There are several arguments for this lack of “sexiness”. One is that the academic system privileges the publication of original and innovative works, and devalues works that are not perceived as novel. Additionally, some published research does not provide sufficient methodological and empirical details that allow them to be replicated (Schoenfeld, 2018).

With these ideas in mind, the second thematic group discussions revolved around the following questions:

1. Can replication studies be useful for the development of implementation research in mathematics education? If yes, in what way? If not, why not?
2. What characteristics should a replication study have in order to be useful for the development of implementation research in mathematics education?

Although there was no definitive answer to these questions, it did appear a feeling in the group that replication studies could help us identify conditions that allow (or prevent) certain innovations to be reproducible in different scenarios, or even help us investigate the effects of a particular treatment under different conditions or populations, which in turn would allow us to advance the implementation of research results. However, it was also acknowledged that for this type of development to happen in the field of educational mathematics different conditions must be in place. For example, it would be necessary to promote a culture of data sharing where the research protocols, data sets, and other elements on which the research is based are not only public, but also shared among researchers through data repositories.

Toward a new definition of implementation research in mathematics education

In TSG23, we feel that we are witnessing the emergence of a new and vibrant research area within the field of mathematics education. In plan to continue looking for a common ground on what do we understand as implementation research in our future work, because once we have a more precise understanding of what implementation research is, we be able to think more precisely about what its methodological implications and challenges are. A first collective attempt to formulate a chain of definitions of the key concepts of “implementation” and “implementation research in mathematics education” was led by Boris Koichu at the last meeting of the group. At the end of this discussion, the group formulated the following proposal.

Implementation is a change-oriented process of adapting and enacting a particular resource (e.g., an idea, a tool, an innovation, a framework, a theory, an action plan, a curriculum, a policy) that occurs in partnership of two communities, *a community of the resource proponents* (CRP) and a *community of the resource adapters* (CRA). These communities differ but can intersect. At the beginning of the process, the CRP has the ultimate agency over the resource. The process of adapting a resource by CRA includes some of the following: (1) constructing an agency over the resource, (2) changes in ways of communicating, and (3) changes in practice. Accordingly, *implementation research in mathematics education* is research that focuses on aspects of implementation, as specified above, in the context of mathematics education.

As we progress in our work, we will certainly refine our working definition. However, we feel that the above proposal adequately captures many ideas and concerns discussed in the group at CERME 11 and that the journey aimed at further theorizing and characterizing implementation research in our field is worth taking.

References

- Burkhardt, H. (2013). Methodological issues in research and development. In Y. Li & J. N. Moschkovich (Eds.), *Proficiency and beliefs in learning and teaching mathematics: Learning from Alan Schoenfeld and Günter Törner* (pp. 203–236). Rotterdam, The Netherlands: Sense.
- Century, J., & Cassata, A. (2016). Implementation research: Finding common ground on what, how, why, where, and who. *Review of Research in Education*, 40(1), 169–215.
- Eastman, P. M. (1975). Replication studies: Why so few? *Journal for Research in Mathematics Education*, 6(2), 67–68.
- Jankvist, U. T., Aguilar, M. S., Ärlebäck, J. B., & Wæge, K. (2017). Introduction to the papers of TWG23: Implementation of research findings in mathematics education. In T. Dooley & G. Gueudet (Eds.), *Proceedings of the tenth congress of the European society for research in mathematics education* (pp. 3769–3775). Dublin, Ireland: DCU Institute of Education and ERME.
- Nilsen, P. (2015). Making sense of implementation theories, models and frameworks. *Implementation Science*, 10(53), 1–13.
- Rogers, E. M. (1962). *Diffusion of innovations*. New York, NY: Free Press of Glencoe.
- Schoenfeld, A. H. (2018). On replications. *Journal for Research in Mathematics Education*, 49(1), 91–97.
- Stein, M. K., Remillard, J., & Smith, M. S. (2007). How curriculum influences student learning. In F. Lester (Ed.), *Second handbook of research on mathematics teaching and learning* (pp. 319–369). Reston, VA: National Council of Teachers of Mathematics.

Identification and diagnosis of students' mathematical misconceptions in a dynamic online environment

Morten Elkjær

Danish School of Education, Aarhus University, Denmark; me@edu.au.dk

Keywords: Formative assessment, implementation research, misconceptions, diagnostic test.

This poster aims to present the ideas behind the design of a dynamic online tool to assess students' mathematical misconceptions in lower secondary school. These ideas and this tool are part of an industrial PhD project, which is a collaboration between the Danish School of Education, the doctoral candidate, and the company Edulab.

Edulab is a Danish private company that has developed an online mathematical learning platform for the Danish elementary school. In Denmark, 75% of elementary schools subscribe to this platform. In fact, every day Danish school students answer 1.5 million tasks on this online platform. This creates a unique opportunity to implement didactical research results regarding mathematical misconceptions directly into practice. The industrial PhD project aims to provide Edulab with an evidence-based tool to capture students' misconceptions, understood as concept images differing from the formal concept definition (Tall & Vinner, 1981). Thereby providing the teachers in lower secondary school with easily accessible formative assessment of their students in the fields of algebra and numeracy in working with equations. Cai et al. (2017) claimed that linking intervention with implementation through iterations of design research is a strong way for researchers to have an impact on practice.

From reviewing the literature on misconceptions, it concludes that the community knows a great deal about mathematical misconceptions and learning difficulties related to algebra, equations and numeracy in lower secondary school (e.g., Booth, McGinn, Barbieri & Young, 2017). Such research-based findings in combination with an online mathematics platform that communicates directly to the end user (i.e., the students) provides a unique opportunity to shorten the implementation time span between the research findings and the end user as was pointed out by Century and Cassata (2016). The project goal is to investigate: How can an online diagnostic tool for lower secondary school be designed, utilizing existing research findings on mathematical misconceptions in algebra and numeracy when working with equations?

To answer the question the aim is to design, and develop an online diagnostic test. Designing an online diagnostic test aimed at lower secondary school students is going to be an iterative process. The literature review will give rise to a categorization of algebraic misconceptions. The idea is to use the 'Concepts in Secondary Mathematics and Science' projects diagnostic tests (Hart, Brown, Kerslake, Küchemann & Ruddock, 1985) in algebra and number operations in a modernized, digital version in order to locate students holding misconceptions fitting this categorization. Based on the algebraic tasks the students have interacted with on the platform, it should be possible for machine learning algorithms to create a "platform behavior" fitting the categorization. It is worth noting that students having greater usage of the platform are a preferable choice for diagnosis in order to create a more precise platform behavior for the different categories of misconceptions. Design-Based Research (e.g., Barab & Squire, 2004; diSessa & Cobb, 2004) will pave the way for the knowledge

generated through iterations of the work with the diagnostic tests and the machine learning algorithms. The project's hypothesis is that math teachers in Denmark, based on collected data, have a unique opportunity to organize, plan and complete their teaching. The point of the continuous diagnosis of all students using Edulab's platform is to catch if students are using the platform as if they are holding one or more misconception(s). The teachers are provided with a formative assessment report, generated for each student that possibly holds misconceptions, describing the student's behavior and the misconceptions present. Thereby, providing an in-depth explanation of which algebraic concepts and processes in which the students' concept image is conflicting with the concept definition may give the teacher the opportunity to aid the student avoid further progress in constructing a deeper rooted and conflicting concept image. Lucariello, Tine and Ganley (2014) emphasize the importance of teachers having access to formative assessment regarding individual student's misconceptions in order not to impede the student's future learning. This formative assessment report should contain ideas and guidelines for how the teacher further teaches the student in the form of literature-based explanations of the origin of the diagnosed misconceptions, and how the concept image may be changed.

Ultimately, the industrial PhD project is looking to generate knowledge and perspectives on how mathematical online diagnostic testing together with mathematical online formative assessment can be implemented in order to help teachers, and thereby students in Danish lower secondary school.

References

- Barab, S., & Squire, K. (2004). Design-based research: Putting a stake in the ground. *Journal of the Learning Sciences*, 13(1), 1–14.
- Booth, J. L., McGinn, K. M., Barbieri, C., & Young, L. K. (2017). Misconceptions and learning algebra. In S. Stewart (Ed.), *And the rest is just algebra* (pp. 63–78). Cham, Switzerland: Springer.
- Cai, J., Morris, A., Hohensee, C., Hwang, S., Robison, V., & Hiebert, J. (2017). Making classroom implementation an integral part of research. *Journal for Research in Mathematics Education*, 48(4), 342–347.
- Century, J., & Cassata, A. (2016). Implementation research: Finding common ground on what, how, why, where, and who. *Review of Research in Education*, 40(1), 169–215.
- diSessa, A. A., & Cobb, P. (2004). Ontological innovation and the role of theory in design experiments. *Journal of the Learning Sciences*, 13(1), 77–103.
- Hart, K., Brown, M., Kerslake, D., Küchemann, D., & Ruddock, G. (1985). *Chelsea diagnostic mathematics tests: Teacher's guide*. Windsor, England: NFER-Nelson.
- Lucariello, J., Tine, M. T., & Ganley, C. M. (2014). A formative assessment of students' algebraic variable misconceptions. *The Journal of Mathematical Behavior*, 33, 30–41.
- Tall, D., & Vinner, S. (1981). Concept image and concept definition in mathematics with particular reference to limits and continuity. *Educational Studies in Mathematics*, 12(2), 151–169.

Implementation research in primary education: Design and evaluation of a problem-solving innovation

Inga Gebel¹ and Ana Kuzle²

¹University of Potsdam, Germany; inga.gebel@uni-potsdam.de

²University of Potsdam, Germany; ana.kuzle@uni-potsdam.de

Problem solving is a binding process standard that is often neglected in school mathematics, and generally reserved for motivated and gifted students only. Researchers also call for the development of problem-solving competences, starting already in primary school to promote the habits of mind, that can be applicable in situations varying from challenges in school to those in life. Different questions emerge in this context. What tasks are suitable to reach all students? What might a differentiated problem-solving classroom look like that would attain to individual student needs? In this article, we present a problem-solving implementation research project. For this purpose, a problem-solving teaching concept with an accompanying type of task for primary education was developed based on both theory and projects on problem solving. The first results indicate positive outcomes with respect to meeting the requirements of practical suitability, and sustainability.

Keywords: Implementation research, problem solving, differentiation, primary education.

Introduction

New implementations in schools often involve different protagonists (e.g., teachers, students, researchers, policy makers), each contributing different expertise, but also having their own demands. Design-Based-Research (DBR) is a flexible methodology that aims to improve learning and teaching in naturalistic settings through iterative cycles of design, implementation, analysis and re-design, where both researchers and practitioners collaborate towards a common goal. Over time, this can lead to changes in the implementation, such as target group, material, teaching concept, which are then re-evaluated in the next cycle (e.g., Wang & Hannafin, 2005).

DBR is the basis for two research projects, namely SymPa and DiPa¹, that focus on implementation of problem solving in school settings. In both projects, problem solving is regarded as an educational goal, namely development of students' problem-solving competences in a targeted manner by learning heuristics. In the context of the SymPa project, theory-based and practice-oriented materials were developed for motivated students in grades 4-6 (Kuzle & Gebel, 2016). Even though Kuzle and Gebel (2016) reported on variables, and conditions that favored and hindered the implementation of the material on the basis of two DBR cycles using the feedback from the students and the teachers, several crucial inhibiting factors unraveled once researchers themselves observed the implementation, and planned the lessons with the preservice teachers (Gebel & Kuzle, 2019). In particular, the teaching concept focused around systematical introduction of different problem-

¹ SymPa stands for *Systematic and material-based development of problem-solving competences*; DiPa stands for *Differentiated development of problem-solving competences*. In German: *Systematischer und materialgestützter Problemlösekompetenzaufbau* and *Differenzierter Problemlösekompetenzaufbau*, respectively.

solving heuristics, which inhibited individual problem-solving processes of the students. Though the problem-solving tasks allowed students to choose different problem-solving paths, the teacher guided the students to use a particular heuristic in focus. Consequently, these factors impacted student motivation. In addition, the teaching concept was not aligned with the typical lesson structure, which resulted in preservice teachers needing support when planning their lessons. Even though one could expect that motivated students are a homogeneous group, we experienced that the tasks did not necessarily invoke problem-solving behaviors. Thus, the problem tasks need to offer more freedom with respect to a problem-solving approach (e.g., subtasks with different levels of difficulty), but on the other hand challenge students to use their knowledge in a complex way.

Based on the above listed inhibiting factors, the SymPa project was further developed into the DiPa project. The main goal of the project is to make implementation of problem solving in primary school mathematics suitable, and sustainable by developing a problem-solving teaching concept aligned with the typical lesson structure, and a type of tasks that would address the individual needs of each student (Gebel & Kuzle, 2019). In the following sections, we outline relevant theoretical foundation used to develop criteria for differentiated problem-solving tasks, and the teaching concept for primary education, before showing how these got implemented, and report on the evaluation of the pilot study (initial DBR cycle). Leading questions for the evaluation are: To what extent does the teaching concept consider necessary differentiating approaches to problem solving? What are the differences depending on the level of performance comparing to fluency and flexibility? What are the (dis-) advantages of the innovation in regular mathematics lessons? As a result of the evaluation, we discuss the findings with respect to possibilities, and limitations of the teaching concept and the nature of the problem-solving task in the context of grade 5 mathematics. With regard to implementation research, this article provides an overview of the development of our innovation (i.e., problem-solving teaching concept and task), and the identification of the first core elements of the innovation (e.g., Century & Cassata, 2016). Detailed answers are not delivered at this time, but rather an insight into the first DBR cycle is given.

Theoretical foundation guiding the design process

A plethora of research on problem solving undergoing since the 1970s identified several pivotal areas for a problem-solving curriculum. Here, we outline only a small portion of this research that was crucial for the project based on German standards' conception of problem solving (KMK, 2004).

Learning problem solving

Problem-solving competence relates to cognitive (here heuristic), motivational and volitional knowledge, skills and actions of an individual required to overcome a personal barrier in unfamiliar situations (e.g., Bruder & Collet, 2011; Schoenfeld, 1985). Thus, routine procedures are not sufficient to solve a problem, but rather heuristics may be helpful. *Heuristics* can be defined as

kinds of information, available to students in making decisions during problem solving, that are aids to the generation of a solution, plausible in nature rather than prescriptive, seldom providing infallible guidance, and variable in results. (Wilson, Hernandez, & Hadaway, 1993, p. 63)

In the field of problem solving there are two different approaches to learning heuristics. In an *implicit heuristic training*, it is assumed that the students internalize and unconsciously apply strategies they have learned through imitating practices of the teacher, and through sufficient practice. On the other hand, *explicit heuristic training* refers to making a given heuristic a learning goal, which is practiced step by step (e.g., Schoenfeld, 1985). For instance, Bruder and Collet (2011) pursued an explicit problem-solving training focusing around Lompscher's (1975) idea of "flexibility of thought". *Flexibility of thought* is expressed by manifestations of mental agility, namely reduction, reversibility, minding of aspects, change of aspects, and transferring. Untrained problem solvers are often unable to consciously access the above outlined flexibility qualities. In their research at lower secondary level, Bruder and Collet (2011) were able to show that less flexible students (e.g., students with difficulties in reversing thought processes or transferring an acquired procedure into another context) profit from explicit problem-solving training. Concretely, they were able to solve the problems just as well as more flexible students, who solved the problems intuitively. Thus, problem solving can be trained by learning heuristics corresponding to these aspects of intellectual flexibility in combination with self-regulation (e.g., Bruder & Collet, 2011; Schoenfeld, 1985).

Criteria for differentiated problem solving tasks

In addition to the choice of the teaching approach, the problem selection is also a key factor for a successful development in problem-solving competences (e.g., Pehkonen, 2014). In the SymPa project we used different types of problems (i.e., open-ended, closed, subtasks with different levels of difficulty) (Kuzle & Gebel, 2016), but always oriented on the specific mathematical content as outlined by the mathematics curriculum (KMK, 2004). During the implementation, it became apparent that the subjective barriers of the students were very different: some tasks represented a challenge for some students, and for others there were routine tasks (Gebel & Kuzle, 2019).

Since differentiation is the core idea of the DiPa project, we developed specific criteria for our type of a problem-solving task, namely *Problem-based Learning Environments* (PLE), that address the previously mentioned drawbacks² and fit the framework of the DiPa project. In addition to the criteria of general learning environments (Wälti & Hirt, 2010), a heuristic core is the key aspect of the PLE, whereas the mathematical content is present, but not in the foreground. With a PLE, we refer to a collection of related problems, that are linked by certain guiding principles based on an intra-mathematical and heuristic structure, and fulfill the following criteria: accessible to *all* learners, *variety* of possible solutions and ways of thinking (use of different heuristics), high *cognitive activation potential*, independent activity by means of *enactive or iconic representations*, *implicit mathematical content*, and *social exchange*. In itself they offer more freedom; each student can decide independently in what depth he or she works on the PLE. With each subtask the students are compelled to use their knowledge in a more complex way. During this process they may use enactive or iconic material to support their problem-solving process.

² For the sake of completeness, it should be said that there are already problem-solving task formats in the literature that also consider individual approaches. For example, Pehkonen (2014) showed the potential of using problem fields to engage all students in problem solving.

Problem-solving teaching concepts

A few teaching concepts exist that focus on a longitudinal development of problem-solving competences. Here, we report on the teaching concepts of Bruder and Collet (2011), Rasch (2001), and Sturm (2018), and their limitations for everyday implementation in primary school mathematics. The five-phase teaching concept of Bruder and Collet (2011) has been successfully implemented in the context of lower secondary school. The core idea of the teaching concept lies upon a long term systematical, and explicit training of heuristics through the phases of familiarization, explicit strategy acquisition, productive practice phases, context expansion, and awareness of the own problem-solving model. Even though this teaching concept has been empirically evaluated, its implementation in primary grades showed some limitations (Gebel & Kuzle, 2019), as was noted earlier. For that reason, we follow Rasch (2001) and argue for a less specific step-to-step teaching concept. Hence, we need a teaching concept, that would first allow all students (in primary school) access to problem solving in an intuitive manner, before explication of particular heuristics is initiated.

Sturm (2018) conducted a problem-solving training in primary school focusing on external representations. The teaching concept included three phases that spread over two mathematics lessons. During the first lesson the students solved a given problem intuitively, whereas the students' solutions with respect to used heuristics were made explicit during the second lesson, after the teacher gained insight into students' solutions between the two lessons (Rasch, 2001; Sturm, 2018). Taken the extensive analysis of students' solution, we find this structure difficult to implement in practice. Although the implicit (intuitive procedures) and explicit ideas (reflection of the solution path) of heuristic trainings were taken into account, we assume that due to implementation once per month, the students have difficulties recalling their problem-solving processes and therefore, the reflection process may be too abstract. Here, a 90-minute lesson, focusing on several different heuristics – and not just on external representations – may be more plausible.

Based on this limitations, and the results from the SymPa project (Gebel & Kuzle, 2019), the DiPa project pursues an alternative teaching concept (see Table 1), in which both implicit and explicit heuristic training are combined. Furthermore, its structure corresponds with a typical lesson structure, which may unburden teachers when planning their lessons. In addition, the second exploration phase represents a novelty. Other problem-solving teaching models (e.g., Rasch, 2001; Sturm, 2018) terminate after the third phase (explicit strategy acquisition), so that heuristic strategies are only transferred in the case of structurally similar tasks, which could represent an additional hurdle. Alternatively, in our proposed problem-solving teaching concept (see Table 1), the students have the opportunity to apply the heuristics even to the same subtask.

1. Introduction	The basic problem is presented. Comprehension questions are discussed in plenum.
2. Exploration I	The students work independently, and intuitively on a given PLE. They document their work on their worksheets. Teaching material on an enactive or iconic level creates differentiation opportunities.
3. Explicit strategy acquisition	The students gain an insight into the procedures of their fellow students. Relevant heuristics are discussed in plenum, and documented on a strategy poster.
4. Exploration II	The students continue working on the PLE, and apply the heuristics that were discussed in the phase 3.
5. Reflection	Students reflect on their problem-solving process by analyzing the heuristics they used, and changes in their approach. If necessary, new heuristics mathematical ideas are discussed in plenum.

Table 1: Teaching concept for problem-solving lessons in the DiPa project

Evaluation: Data sample, instruments and procedure

The evaluation of the pilot study had several objectives: (1) to evaluate the teaching concept with respect to differentiation during problem solving, (2) to analyze students' problem-solving solutions with respect to their *fluency* (creating a large number of ideas) and *flexibility* (changing perspective and using different strategies) and in contrast to their level of performance, and (3) to present the (dis-)advantages of the innovation in regular mathematics lessons.

For this study, an exploratory qualitative research design was chosen. The study participants were two fifth grade classes ($n = 40$) from one urban school in the federal state of Brandenburg (Germany) (Gebel & Kuzle, 2018). Main sources of data were student worksheets, and a semi-structured interview with the teacher.


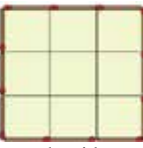

<p>PLE: Paper squares</p> <p>Tina has 12 matches and some paper squares. The side length of one square is as long as one match:</p>  <p>Here you can see a figure with 12 matches and 9 paper squares.</p>  <p>The squares must meet at the sides. Therefore, the following does not apply:</p> 	<p>Task a)</p> <p>Can Tina lay a figure with 12 matches that includes 5 paper squares?</p>	<p>Task b)</p> <p>How many different figures can you find, which are laid out of 12 matches and include 5 paper squares?</p>
	<p>Task c)</p> <p>Can Tina also lay figures with 12 matches that include 6/7/8 paper squares? Which figures can you find?</p>	<p>Task d)</p> <p>Which figure includes the most and which figure includes the least paper squares? (<i>Use 12 matches.</i>)</p>
	<p>Task e)</p> <p>What is the minimum number of matches to enclose 10/11/12/... paper squares?</p>	<p>Task f)</p> <p>What is the highest number of matches to enclose 10/11/12/... paper squares?</p>
	<p>Task g)</p> <p>Can you find a relation between the count of paper squares and the highest number of matches? What is the minimal number of matches to enclose 100 squares?</p>	<p>Task h)</p> <p>Invent further tasks.</p>

Figure 1: Problem-based Learning Environment “Paper squares”

The research data were collected in a school setting during a 90-minutes lesson. The first author of the paper taught the lesson structured around the teaching concept, whilst the class teacher observed the lesson. The students were first introduced to the PLE “Paper squares” (see Figure 1). The students read introduction to the problem, and misunderstandings were discussed (phase 1). Afterwards, they worked individually on its different subtasks. Each student received its own working sheet with grids, and enactive material (e.g., matches and paper squares) (phase 2). In phase 3 a museum exposition took place; the students laid their worksheets on the table and got insight into the solutions of their classmates. Afterwards, we discussed clever strategies and noted them on a strategy poster. Before working on further subtasks or working again on the same subtasks using the newly noted strategies on the strategy poster (phase 4), they drew a red line to denote their work in the second exploration phase. At the end of the lesson, students' solutions were discussed in plenum. In addition, new strategies were noted on the strategy poster, and their mathematical discoveries were discussed (phase 5). The same procedure was used with the second fifth grade class. A semi-structured interview with the class teacher took place, and lasted about 45 minutes. It was used to assess the teaching concept, and the individual problem-solving behaviors of the students compared to regular mathematics lesson.

The student work on subtasks a) and b) was analyzed after all the data had been collected. As suggested by Patton (2002), multiple stages of the analysis were performed. For the within analysis each student was treated as a comprehensive case. The analysis procedure for both classes consisted

of counting the number of basic figures (see Figure 2), and their duplicates³ on the basis of each student's worksheet, which provided an insight into their fluency. For the cross analysis the students were clustered into three groups based on their mathematical performance: high (grade 1), average (grade 2) and low (grade 3/4) achieving students, in order to compare the particular performance groups against each other. Both researchers coded the student data independently. Adjustments were subsequently made after which the interrater reliability was 100%.

Results

Table 2 gives an overview of students' results during the first and the second exploration phase when working on the first two subtasks of the PLE. What is particularly striking here, is that the students from the group of low achievers ($n_{3/4} = 6$), who again worked on subtasks a) and b), had a particular increase in the number of solutions in the second exploration phase (from 2,83 solutions to 9,5 solutions). Even though the sample size, and the orientation towards the mathematics grade represent limitations of the pilot phase, it can be assumed that especially low achievers profited from the explicit strategy acquisition phase. Those, who were less able to develop strategies on their own in the first exploration phase, were able to produce many different solutions in the second exploration phase due to insight into their classmates' solution, and discussion in plenum (Gebel & Kuzle, 2018).

	n₁	n₂	n_{3/4}
Data sample	11	19	10
Absolute frequencies of solutions (tasks a and b)	12,27	8,11	8,2
Students, who worked further on task b in exploration II	4 (3)	9	6
Absolute frequencies of solutions in exploration I	6 (7,67)	4,44	2,83
Absolute frequencies of solutions in exploration II	12,5 (10,3)	9,11	9,5

Table 2: Results of the pilot study



Figure 2: Basic solution figures of the PLE "Paper squares"

The analysis of the strategies used during the problem-solving process has shown to be a big challenge. The majority of the students were not able to describe their solution behavior in writing. Here, alternative research instruments are needed to discern student thinking when problem solving. Nevertheless, we recognized huge differences in the solutions between the sample groups. For example, figure "staircase" was found by average and high-achieving students only (see yellow figure in Figure 2). In addition, the students had lively discussions about the permission of reflected and rotated figures. The worksheets of the high- and average-achieving students showed tendencies towards systematical rotations, and reflections of basic figures. In the semi-structured interview, the teacher particularly emphasized that *all* pupils had access to problem solving. Moreover, they were able to work on the PLE at different levels: she observed different forms of representation, such as

³ It was left to the student if reflected/rotated figures were to be documented, as this was not explicitly given in the PLE.

enactive material, iconic representations, written descriptions. Students' pervasiveness and perseverance during the lesson were also positively evaluated. In addition, she mentioned that – in contrast to SymPa teaching concept – the strategies emerged from the students' solutions and were not given by the teacher. Thus, the students started solving the problem intuitively followed by explicit strategy naming based on students' solutions. Her assessment of the second exploration phase is consistent with the analysis of the students' solutions. She saw a great benefit of it for the low-achieving students by getting insight into their classmates' solutions. Nevertheless, she stated that the students had difficulties describing their problem-solving processes in writing. Last but not least, the teacher asserted that all students had fun doing mathematics when solving the given PLE.

Conclusion

Despite different endorsements for making problem solving a vital part of school mathematics (e.g., KMK, 2004), problem solving has not yet been fully implemented in school mathematics. In order to reach this goal, we need to understand what variables and conditions, such as tasks, teaching concepts support and/or inhibit a sustainable implementation in school settings. In the DiPa project we have consciously decided to establish problem solving in regular mathematics lessons in order to simultaneously (1) develop suitable practice-oriented materials, (2) to develop a sustainable problem-solving teaching concept for all students, and (3) to gain realistic insights into individual students' learning processes. The results have shown that a synergy of the teaching concept, and the PLE allows all students access to problem solving. Low-achieving students benefited the most, especially through the use of concrete material, the nature of the task, and the insight into classmates' solutions. With respect to fluency, difference between the high and average/low-achieving students was minimal. However, student flexibility was rather difficult to measure. So far, we used one PLE with two fifth grade classes from one school. Hence, the evaluation of our innovation is limited to these conditions. Nevertheless, they suggest the next step in our research, namely to conduct a study with a larger data sample using several PLEs over a longer period of time in a wider variety of settings. Our goal is to examine the development of the students' problem-solving competences as well as factors affecting this development. Here, we plan to videotape students during problem solving in order to obtain a holistic view of their problem-solving learning. This process will then guide our focus with respect to teaching and learning problem solving from both theoretical and practical points of view.

References

- Bruder, R., & Collet, C. (2011). *Problemlösen lernen im Mathematikunterricht* [Learning problem solving in mathematics]. Berlin, Germany: Cornelsen.
- Century, J., & Cassata, A. (2016). Implementation research: Finding common ground on what, how, why, where, and who. *Review of Research in Education*, 40(1), 169–215.
- Gebel, I., & Kuzle, A. (2018). Problem solving for all: Evaluation of a problem solving teaching concept for primary education. In E. Bergqvist, M. Österholm, C. Granberg, & L. Sumpter (Eds.), *Proceedings of the 42nd Conference of the International Group for the Psychology of Mathematics* (Vol. 5, p. 234). Umeå, Sweden: PME.

- Gebel, I., & Kuzle, A. (2019). Problemlösen lernen und unterrichten im SymPa-Projekt: Darstellung einer Projektentwicklung im Rahmen eines Campusschulen-Netzwerkes [Learning and teaching problem solving in the SymPa project: Presentation of a project development within the campus school network]. In K. Kleemann, J. Jennek, & M. Vock (Eds.), *Kooperation von Universität und Schule fördern. Schulen stärken, Lehrerbildung verbessern* (pp. 183–207). Opladen, Berlin, Toronto, Germany: Budrich.
- Kultusministerkonferenz [KMK] (2004). *Bildungsstandards im Fach Mathematik für den mittleren Schulabschluss* [Educational standards in mathematics for the middle school]. Bonn, Germany: KMK.
- Kuzle, A., & Gebel, I. (2016). Development of materials for problem solving instruction in the context of lessons for promoting and improving specific mathematical competences using design based research. In T. Fritzlar, D. Assmuss, K. Bräuning, A. Kuzle, & B. Rott (Hrsg.), *Problem solving in mathematics education. Proceedings of the 2015 Joint Conference of ProMath and the GDM Working Group on Problem Solving. Ars Inveniendi et Dejudicandi 6* (S. 159–172). Münster: WTM-Verlag.
- Lompscher, J. (1976). *Verlaufsqualitäten der geistigen Tätigkeit* [course of mental activity]. Berlin, Germany: Volk und Wissen.
- Patton, M. Q. (2002). *Qualitative research and evaluation methods*. Thousand Oaks, CA: Sage.
- Pehkonen, E. (2014). Open problems as means for promoting mathematical thinking and understanding. In A. Ambrus & É. Vásárhelyi (Eds.), *Proceedings of the 15th ProMath conference* (pp. 152–162). Eger, Hungary: Mathematics Teaching and Education Center.
- Rasch, R. (2001). *Zur Arbeit mit problemhaltigen Textaufgaben im Mathematikunterricht der Grundschule* [On working with problem-based word problems in primary school mathematics]. Hildesheim, Germany: Franzbecker.
- Schoenfeld, A. H. (1985). *Mathematical problem solving*. London, England: Academic Press.
- Sturm, N. (2018). *Problemhaltige Textaufgaben lösen. Einfluss eines Repräsentationstrainings auf den Lösungsprozess von Drittklässlern* [Solving problem-based word problems. Influence of a representation training on the solution process of third graders]. Wiesbaden, Germany: Springer.
- Wälti, U., & Hirt, B. (2010). *Lernumgebungen im Mathematikunterricht* [Learning environments in mathematics teaching]. Seelze-Velber, Germany: Kallmeyer.
- Wang, F., & Hannafin, M. J. (2005). Design-based research and technology-enhanced learning environments. *Educational Technology Research and Development*, 53(4), 5–23.
- Wilson, J. W., Fernandez, M. L., & Hadaway, N. (1993). Mathematical problem solving. In P. S. Wilson (Ed.), *Research ideas for the classroom: High school mathematics* (pp. 57–77). New York, NY: Macmillan.

Operationalizing implementation theory in mathematics education research - identifying enablers and barriers in the Swedish “Boost for Mathematics”

Rikke Maagaard Gregersen¹, Sine Duedahl Lauridsen² and Uffe Thomas Jankvist³

¹Danish School of Education, Aarhus University, Denmark; rmg@edu.au.dk

²VIA University College, Denmark; sidl@via.dk

³Danish School of Education, Aarhus University, Denmark; utj@edu.au.dk

In this paper, we identify a number of implementation enablers and barriers in the Swedish ‘Boost for Mathematics’ (BM). Through an analysis of two selected BM modules’ use of sensitizing and prescriptive theoretical constructs from mathematics education research, we attempt to link the existence of enablers and barriers to identified policy dimensions of the BM. Besides the two modules on the web portal (the Lärportal), the study’s empirical data also consist of surveys of four involved teachers and interviews with two involved researchers and module designers. The analyses also make use of the innovation’s novelty and value, the degree of merit in how it is imparted and Rogers’ three determinant factors of an innovation.

Keywords: Implementation research, enablers and barriers, policy dimensions, degree of merit.

Introduction

This paper looks at one of the largest initiatives on improving mathematics teaching and learning in the Nordic countries in recent times, namely *the Swedish Boost for Mathematics* (from now on referred to as BM), which was implemented from 2012 to 2016. The BM was a national professional development initiative with the goal of enhancing students’ mathematics performance in Swedish primary and secondary school. The initiative was a reaction to continuously disappointing result in international tests, such as TIMSS (Bentley, 2008) and PISA (Utbildningsdepartementet, 2012). BM was designed and developed as a collaboration between the Ministry of Education and Research, the Swedish National Agency for Education, and the Swedish national resource centre for mathematics. The BM involved 260 municipalities, 37,000 mathematics teachers, and had a cost of Skr. 649,000,000 (Nyström, 2018). The BM has been evaluated in a handful of reports (e.g., Österholm, Bergqvist, Liljekvist, & Bommel, 2016; Ramböll, 2016). In this paper, however, we consider the BM from an implementation research perspective, meaning that we apply theoretical constructs from implementation research to address selected aspects of the implementation. process. From such theory, it is well known that the success of an implementation process to some extent depends on its enablers and barriers, i.e., people or factors that either enhance aspects of the implementation or somehow diminishes them (e.g., Nilsen, 2015). Like many other initiatives concerning the improvement of mathematics instruction and learning, the BM drew on and sought to implement research results and findings from mathematics education research. We thus consider the BM as an implementation program in a mathematics education context. The research question that we ask is: *What enablers and barriers for implementing mathematics education research results and findings in practice can be determined in the Swedish Boost for Mathematics initiative?* The study reported in

this paper and the empirical data that it builds upon stem from a master's thesis in mathematics education at the Danish School of Education, Aarhus University (Lauridsen & Gregersen, 2017).

Theoretical constructs related to implementation research

First, we elaborate on our understanding of implementation and innovations, and then we introduce the terms and constructs applied in the analysis.

“Implementation takes place when an individual puts an innovation into use” (Rogers, 2003, p. 20). But what is an *innovation* in the context of mathematics education? If we view the BM as an implementation process, mathematics education research results are the innovations. Hence, a clarification of innovation is in order. In the original definition by Schumpeter (1934/1961), an innovation entails a valuable change in practice. According to Rogers (2003), an innovation, on the other hand, has to be considered novel, not necessarily in common understanding, but for the individual doing the implementation. We shall draw on both positions and define an innovation in the context of mathematics education as: Mathematics education research results that are subjectively novel and bring valuable changes into practice once implemented (Lauridsen & Gregersen, 2017) – taking into account that what is to be considered valuable is of course also to some extent subjective.

To determine enablers and barriers (see Nilsen, 2015) within the implementation program, we draw upon parts of Rogers' (2003) theory of diffusion of innovations. Rogers claims that there are three determinant factors for an innovation to be implemented: the *awareness-knowledge* of the existence of the innovation; *how-to knowledge*, which is knowing how to apply the innovation; and *experience of relevance* of the innovation. Each factor is influenced by an undefined number of variables, which either enable or barricade the implementation (Nilsen, 2015). The aim of analyzing enablers and barriers is to obtain insight, nuance and challenge the determinant factors. We also use Rogers' (2003) term *principles-knowledge*, which refers to understanding how and why the innovation works. Principles-knowledge is not a determinant factor but is seen as a valuable contributor to a successful implementation, hence in this context it can be seen as an enabler for implementation. To gain further insight into barriers and enablers, the BM's theoretical content is viewed as either *prescriptive* or *sensitizing* (Nilsson, Ryve, & Larsson, 2017). Prescriptive theories supply the teacher with actions that should be applied in practice, whereas sensitizing theories supply insights into learning processes. Sensitizing theories can be seen as a way to obtain theoretical principles-knowledge, and the prescriptive theories as a way to obtain theoretical how-to knowledge. This comparison allows us to connect theoretical content to the knowledge framework from implementation theory.

To classify the BM, we adopt the notion of *policy dimensions* by Trouche, Drijvers, Gueudet, and Sacristán (2013). They use this notion to classify the policies concerning implementations of technological developments in mathematics education. Our use differs slightly, however, as we consider implementations of mathematics education research results. Trouche et al. (2013) define three policy dimensions: *top-down/bottom-up* referring to the origin of the implementation process initiative; *offering access/supporting integration* referring to the extent to which the implementation process is supported beyond supplying access to the research results; and *collective/individual* referring to whether the process of implementation is conducted with colleagues or not. Trouche et

al. (2013) claim that bottom-up, supporting and collective policies promote implementation, yet in our understanding it must be the variables connected to a policy that act as enablers/barriers.

Educational background, research methods and empirical data

In the BM, groups of mathematics education researches and mathematics teacher educators were asked to author modules for an online open-access resource platform, the so-called Lärportal (<https://larportalen.skolverket.se/#/>), which now contains more than 30 modules. A module contains eight segments, each working through a four-phase process: (A) individual preparation, where participating teachers read texts and watch videos; (B) collegial work, discussing text and preparing lessons/activities; (C) individual execution of lessons/activities; and (D) collegial evaluation of learnings and classroom experiences. Four didactical perspectives are common to all modules: Classroom norms/socio-mathematical norms; teaching by the mathematical competences, assessment of learning and teaching in mathematics; and routines and interaction in the classroom (Österholm et al., 2016). School leaders and counsellors were educated to support and guide teachers in the process (Skolverket, 2017). All Swedish mathematics teachers were granted attendance of two modules. After that, it was up to the individual schools to finance further participation.

The method of the paper is a case study of two selected modules within the BM program: “Algebra module grades 7-9” and the “Problem solving module, grades 7-9” (Skolverket, 2017). The main theoretical construct behind the algebra module is that of variation theory (Marton, 1981), although it also contains a range of topic specific constructs concerning the learning and teaching of equations, variables and formulas. The main theoretical constructs of the problem solving module are the “five step model” (Stein, Engle, Smith, & Hughes, 2008) for planning and conducting problem solving lessons and the “four phased problem solving process” (Skolverket, 2017) for organizing students’ problem solving.

The empirical data on which this study relies was gathered as part of the previously mentioned master’s thesis (Lauridsen & Gregersen, 2017). The data was obtained by three different methods:

- Coding of the module content in regard to whether texts and videos were communicated primarily in a prescriptive or sensitizing manner (Nilsson et al., 2017).
- Interviews with two representative researchers who participated in the development of the algebra module (Researcher 1) and problem solving module (Researcher 2), respectively.
- A questionnaire answered by four available teachers, three who had completed the problem solving module (Teachers 1, 2, 3), and one who had completed the algebra module (Teacher 4).

Policy analysis and coding of module content

In regards to the three policy dimensions (Trouche et al., 2013) the dominant policies of the BM are top-down, supportive, and collective, which of the top-down policy is not considered favourable in an implementation process. Despite the top-down policy, the teachers’ workflow has been highly organized in consideration to teachers’ needs, in terms of influence and practical relevance. We also see this in the developers’ (Researcher 1 and 2) awareness on imparting content in the modules towards teachers. This indicates that a top-down policy under certain conditions can support and organize several enablers. The supportive policy of the BM appears, for example, in the financial

contribution to participating schools and in the teachers' access to counsellors. The financial support is limited to two modules, which lessens the extent of the support dimensions of the future use of the Lärportal. The BM was primarily influenced by a collective policy, which was central to the design of the Lärportal, with a few individual elements (Lauridsen & Gregersen, 2017).

The coding of the content in the algebra module determines that it mainly contained sensitizing theoretical constructs and only a few elements of prescriptive theoretical constructs. On the contrary, the problem solving module mainly contained prescriptive theoretical constructs and only a few sensitizing constructs. These conclusions were confirmed by Researchers 1 and 2 (Lauridsen & Gregersen, 2017). Please note that the article 'Programming and programming process' has been added to the Algebra module April 2018 and is not included in the coding. When comparing the questionnaires answered by the teachers, some interesting statements about their learning outcomes become apparent. Teacher 4 stated that she mainly developed how she teaches the concept of equality and the meaning of the equality sign. This is particularly notable as the main theory in the algebra module was variation theory (Marton, 1981). For this reason, we analyzed the algebra module for content on the equality sign and the conformity of the presented and used theoretical constructs. We found that there were only a few mentions of actual research results on students' difficulties and misconception on the concept of equality (Lauridsen & Gregersen, 2017). Kieran (1992) is cited, but the key findings on the need for experiences of complex arithmetic of the form $ax + b = cx + d$ is left out. This fact leaves you wondering to what extent the changes in Teacher 4's practice may have been supporting her students' concept formation of equality. It thus becomes a question of merit concerning the accuracy in which research results are imparted to teachers, with which the definite findings and conclusions of the research are referenced in the text.

Implementation analysis – enablers and barriers

In this section, we analyze the BM for influential variables related to the three determinant factors of considering them as enablers or barriers, and further relate them to the policy dimensions as well as the categorized module content.

Firstly, we analyze for enablers and barriers in relation to *awareness-knowledge*. Following Rogers (2003), access to mass media is a certain source to knowledge of the existence of the innovations. In the BM, the Lärportal represented a mass media where the teachers were able to achieve awareness-knowledge on a range of mathematics education research. In continuation of this, it may be of a certain importance that the content was conveyed to teachers in a way that was understandable and therefore also accessible. Both Researchers 1 and 2 stressed that it had been an important part in the development of the modules that communication was targeted the teachers as receivers in the Lärportal. This indicates that the ways in which innovations are imparted to the receiver may be considered an enabler of awareness-knowledge. In the section above, we noticed the importance of imparting innovations with a certain degree of merit, to support guidance of teachers. The question is whether the teachers really do achieve awareness-knowledge, if the presentation of the innovation is not communicated with a certain degree of merit, e.g., that the key findings are stressed when research is referred. Hence, the lack of merit of the innovation conveyed, may be regarded as a barrier of the awareness-knowledge and hereby also the following implementation process in the BM.

Secondly, concerning *how-to knowledge*, teachers may obtain such throughout the implementation process. The Lärportal is a major source of how-to knowledge. Teacher 1, 2 and 4 described using the Lärportal, as they searched for videos and written suggestions for classroom activities to find inspiration during and after the BM. Consequently, the access to a mass media, containing how-to knowledge, can be considered an enabler in the BM. When comparing the types of knowledge in the algebra and the problem solving modules, the latter module mainly contains how-to knowledge (cf. above). Teacher 1 and 2 both implied that they now use the five-step model (Stein et al., 2008) as well as the four-phased process (Skolverket, 2017) in their practice (cf. above), i.e., the main theoretical constructs of the module. This suggests that mass-media access to how-to knowledge such as task suggestions and videos of classroom examples may be considered enablers. Teacher 4 had not, in the same manner, implemented the main theory, variation theory (Marton, 1981), in the algebra module, but she had gained a new perspective on planning classroom presentations focusing on students' misconception. This implies that the teacher had gained some how-to knowledge through the planning and execution of the experimental practice in phase B and C as a way of implementing the principles-knowledge gained in phase A (cf. above). On this account, the experimental practice can also be understood as an enabler for how-to knowledge about the gained principles-knowledge and hereby for implementation. According to Rogers (2003), the more complex an innovation is, the more how-to knowledge is needed. This might be the case for Teacher 4. Complex theoretical constructs, such as variation theory, may become a barrier, when not supported with sufficient how-to knowledge. Another example of this is found in the lack of development of socio-mathematical norms (Yackel & Cobb, 1996), which is documented in an evaluation of the BM (Österholm et al., 2016). Researcher 2 confirms this:

Researcher 2: [...] it is very easy to say that these norms are important, but how should you act as a teacher to change them? The norms are not something you can get to grips with. My guess is that teachers have been presented with too few concrete examples on how to work with these norms.

Recall that the BM can be characterized as a collective policy. This entails that for the majority of the process, the teacher has access to an interpersonal source of how-to knowledge. This gives teachers access to colleagues' experimental how-to knowledge. Trouche et al. (2013) argue that collective policies can be a support for implementing a technology. The same argument seems to withstand when it comes to implementing research findings in mathematics education into practice. The collective processes in the BM may, therefore, be viewed as enablers for how-to knowledge.

Thirdly, we analyze enablers and barriers regarding the last determinant factor for implementation (Rogers, 2003), i.e., the subject's experience of *relevance* of the innovation. We do so based on two examples of the teachers' work with the two modules. The first example is based on that we previously made it clear how Teacher 4 continued the use of her new knowledge of the equality sign after having ended her work with the BM. Following Rogers (2003), this continuous use of the mathematics didactical knowledge is a sign of a successful implementation. In relation to relevance of the theoretical constructs, Teacher 4 expressed her experience of relevance of the didactical research concerning the equal sign: "...as it is so important and frequently used in mathematics" (our translation). Our second example is from Teacher 3, who verbalized:

Teacher 3: I do not think the Boost for Mathematics was a good “boost”. The information it provided was for example the kind of material that we had used in our school for several years [...]. There was no new and inspiring tasks to use, which was sad in the view of it all. (our translation)

We regard this as an expression of a lack of experience of relevance. Teacher 3 was already aware of the presented strategies and theories in her current practice. This is of course not the same as her considering the content of the problem solving module irrelevant, only it was not relevant to her. This indicates that if the teachers are not presented with anything new, i.e., no innovation, it can become a barrier for their experience of relevance of the BM. In our further analyses of Teacher 3’s questionnaire answers, we see no indication of a use of theories from the BM. Hence, for Teacher 3 the BM must be considered an unsuccessful implementation.

To understand the enablers and barriers of the teachers’ possibilities of having an experience of relevance, we examine the primary differences at the two modules. Recall from the previous section that the theoretical content in the algebra module was mainly sensitizing while it was mainly prescriptive in the problem solving module. It is relevant to consider the extent to which this might influence enablers or barriers in the teachers’ experience of relevance. Previously we illustrated the connection between prescriptive theory and how-to knowledge and sensitizing theory and principles-knowledge, respectively. In the second example, Teacher 3 primarily met prescriptive theoretical constructs in the module and thereby descriptions of phases and steps about how to teach problem solving. ‘Unfortunately’ Teacher 3 already had an existing practice built on these phases and steps. According to Rogers (2003), a principles-knowledge can contribute to a better understanding of why something works. This understanding of ‘why’ can qualify ‘how’ one does things in practice. Therefore, a sensitizing theory might possibly have contributed with an understanding as to why Teacher 3 already did as she did in her practice, and thus support further development. In this way, the principles-knowledge can become an enabler of the teachers’ experiences of relevance in the BM. In the first example, Teacher 4 primarily met principles-knowledge. This gave her an opportunity to understand why the teaching of the concept of equality is important and not just how she should teach it. This again indicates that principles-knowledge is an enabler for the teachers’ experience of relevance in the BM. As mentioned earlier, one of the policies of the BM was a top-down policy. In contrast to a bottom-up policy, this increases the probability of one encountering already known innovations that might already part of one’s daily practice. Based on the analyses of Teachers 3 and 4 and in the context of BM’s top-down approach, it might be an advantage that the teachers also acquire principle-knowledge, since principles-knowledge may act as an enabler of experience of relevance in the top-down policy context.

Conclusion

In the analysis, we have identified a number of enablers and barriers in the BM and we have attempted to link the existence of these to the identified policy dimensions of the BM as well as the modules’ use of sensitizing and prescriptive theoretical constructs from mathematics education research.

In particular, the main findings concern implementation programs with a top-down policy. Within this policy we see that the experience of relevance is challenged if the content is mainly how-to

knowledge. We support this claim by the example of Teacher 3 not experiencing anything new in the BM. To accommodate this we argue that principles-knowledge can support the teachers' further insight into the innovation. Such understanding of 'why' may upgrade the quality of 'how' the teachers do things in practice, and make the content relevant for the teachers. Following this argument, we find that principles-knowledge enables the experience of relevance, which is determinant for implementation. With this in mind, we suggest that future mathematical education implementation programs with a top-down policy consider the content balance of how to-knowledge and principles-knowledge. Furthermore, it could be an object of investigation in the research community to understand the balance and synergy of knowledge-types in implementation programs.

In addition, the degree of merit that innovations are imparted with influence all three determinant factors. It can be argued that the importance of selecting relevant innovations and how they are conveyed is fundamental to avoid misguidance of teachers' practice. It becomes clear that success of implementation in a mathematics education context is not limited to Rogers' (2003) definition of an innovation merely being put into use; the implementation of the innovation must lead to a change for the better – not least as perceived by the end uses, in our case the teachers. We must take into account Schumpeter's (1934/1961) claim that an innovation should entail a valuable change in practice. This supports the need for defining innovations as subjectively novel, which bring about valuable changes in practice when dealing with implementation processes in mathematics education. Before determining content knowledge in implementation programs, conducting reviews and using solid findings (Education Committee of EMS, 2011), may be one feasible way to accommodate valuable changes.

References

- Bentley, P.-O. (2008). *TIMSS 2007 Swedish pupils' mathematical knowledge* (Report No. 323). Stockholm, Sweden: Skolverket.
- Education Committee of the European Mathematical Society. (2011). 'Solid findings' in mathematics education. *EMS Newsletter*, 2011, 46–48.
- Kieran, C. (1992). The learning and teaching of school Algebra. In D. A. Grouws (Ed.), *Handbook of research on mathematics teaching and learning* (pp. 390–419). New York, NY: Macmillan.
- Lauridsen, S. D., & Gregersen, R. M. (2017). *Implementation of mathematics education research results in mathematics education: A case study of two modules from the Swedish Matematiklyft* (Unpublished master's thesis). Aarhus University, Emdrup, Denmark.
- Marton, F. (1981). Phenomenography – Describing conceptions of the world around us. *Instructional Science*, 10(2), 177–200.
- Nilsen, P. (2015). Making sense of implementation theories, models and frameworks. *Implementation Science*, 10(1), 1–13.
- Nilsson, P., Ryve, A., & Larsson, M. (2017). Characterizing theories aimed at supporting teachers' mathematical classroom practices. In Dooley, T. & Gueudet, G. (Eds.), *Proceedings of the Tenth*

Congress of the European Society for Research in Mathematics Education (pp. 3865–3872). Dublin, Ireland: DCU Institute of Education & ERME.

- Nyström, P. (2018). Presentation: *Matematiklyftet – utveckling av kompetensutvecklingskultur och undervisningskultur* [Boost for Mathematics – development of competency development culture and teaching culture] [PowerPoint]. Retrieved from <http://www.gymnasieforskning.dk/konference-med-paul-cobb-udvikling-af-matematikundervisningen-hvad-skal-der-til/>
- Österholm, M., Bergqvist, T., Liljekvist, Y., & Bommel, J. v. (Eds.). (2016). *Utvärdering av matematiklyftets resultat: Slutrapport*. [Evaluation of Boost for Mathematics: Final report] Umeå, Sweden: Umeå University, Department of Science and Mathematics Education.
- Ramböll. (2016). *Slututvärdering: Utvärderingen av matematiklyftet 2013-2016*. [Final evaluation: Evaluation of Boost for Mathematics 2013-2016] Retrieved from <https://www.skolverket.se/publikationer>
- Rogers, E. M. (2003). *Diffusion of innovations* (5th ed.). New York, NY: Free Press.
- Schumpeter, J. A. (1961). The fundamental phenomenon of economic development (R. Opie, Trans.). In *The theory of economic development: an inquiry into profits, capital, credit, interest and the business cycle* (pp. 57–94). New York, NY: Oxford University Press. (Reprinted from *The theory of economic development: an inquiry into profits, capital, credit, interest and the business cycle* (pp. 57–94), by Schumpeter, J. A., 1934, Department of Economics of Harvard University).
- Skolverket. (2017). *Lärportalen*. Retrieved from <https://larportalen.skolverket.se/#/>
- Stein, M. K., Engle, R. A., Smith, M. S., & Hughes, E. K. (2008). Orchestrating productive mathematical discussions: Five practices for helping teachers move beyond show and tell. *Mathematical Thinking and Learning*, 10(4), 313–340.
- Trouche, L., Drijvers, P., Gueudet, G., & Sacristán, A. I. (2013). Technology-driven developments and policy implications for mathematics education. In M. A. Clements, A. J. Bishop, C. Keitel, J. Kilpatrick & F. K. S. Leung (Eds.), *Third international handbook of mathematics education* (pp. 753–789). New York, NY: Springer.
- Utbildningsdepartementet [The Ministry of Education and Research]. (2012). *Regeringsbeslut: Uppdrag att svara för utbildning*. [Government decision: Responsibility for educational assignment] (I:44). Stockholm Sweden: Statens skolverk.
- Yackel, E., & Cobb, P. (1996). Sociomathematical norms, argumentation, and autonomy in mathematics. *Journal for Research in Mathematics Education*, 27(4), 458–477.

A learning path for rational numbers through different representations

Helena Gil Guerreiro¹, Cristina Morais², Lurdes Serrazina³ and João Pedro da Ponte⁴

¹Agrupamento de Escolas Braamcamp Freire, Instituto de Educação, Universidade de Lisboa, Portugal; hg@campus.ul.pt

²Externato da Luz, Instituto de Educação, Universidade de Lisboa, Portugal; cristina.morais@campus.ul.pt

³Escola Superior de Educação de Lisboa, Instituto de Educação, Universidade de Lisboa, Portugal; lurdess@eselx.ipl.pt

⁴Instituto de Educação, Universidade de Lisboa, Portugal; jpponte@ie.ulisboa.pt

Abstract. *In this paper, we aim to understand, in a context of teachers' collaborative group, how emphasizing multiple representations can contribute to the learning of the rational numbers by elementary school students. We report part of a Design Based Research, within which a learning path for rational numbers was constructed and implemented in grade 3 classes. Data was collected through audio recordings of the collaborative group sessions, written records of the teachers' and students' interactions, as well as photo records of classroom work. We analyse two tasks focusing on students' rational number learning of two classes, through discussion and reflection in the collaborative group. The results show that enactive and iconic representations, used as models in a recurrent way, support an intertwined understanding of symbolic representations. We conclude that the collaborative group work was essential to bring research into the classroom.*

Keywords: *Rational numbers, representations, elementary school, collaborative work.*

Introduction

In mathematics education research, learning and understanding rational numbers is a very important and complex topic (Behr, Lesh, Post, & Silver, 1983; Tian & Siegler, 2018). This complexity relates to the multiple representations and meanings that rational numbers can assume. Although research provides clues about how different representations can be articulated, with understanding, at an early stage of students' learning (e.g., Moss & Case, 1999), its effective implementation in the work carried out in the classroom seems hard to reach. Thus, we seek to implement mathematics education innovations into practice within an implementation research perspective (Century & Cassata, 2016). In this paper, we aim to understand, in the context of the collaborative work of a group of teachers, how research-based ideas on emphasizing multiple representations and models (Guerreiro, Serrazina, & Ponte, 2018; Morais, Serrazina, & Ponte, 2018) may contribute to the learning of the rational numbers, by elementary school students.

Multiple representations in learning rational numbers

When learning rational numbers¹, students should realize that the same rational number might be expressed in different symbolic representations, such as decimal number, percentage or fraction.

¹ We use the term "rational numbers" to designate non-negative rational numbers.

Besides these, enactive and iconic representations (Bruner, 1999), actions and images, respectively, and oral and written language (Ponte & Serrazina, 2000), a supporting mode of representation at the early grades, should also be considered. These types of representations are considered useful in the development of students' conceptual understanding as they help them to track ideas and inferences when reflecting and structuring a problem.

Moving across different types of representations is essential for the recognition that each representation presents a different perspective of rational numbers, and students' understanding develops as the number of perspectives increases (Ponte & Quaresma, 2011; Tripathi, 2008). Gravemeijer (1999) reinforces that a model emerges when it is underpinned by representations. In this emergent modelling process, representations become models, as they allow a direct modelling of a contextualized situation and support the development of more formal mathematical knowledge (Gravemeijer, 1999). Consequently, learning rational numbers through models, at the elementary grades, may be a dynamic process required to co-develop representation and conceptual understanding.

Contexts, within which representations can be perceived as models, are fundamental to understand and establish complex and meaningful relations (Brocardo, 2010). The number line, with an implied measure meaning, and the *decimat* (Roche, 2010) that emphasizes a part-whole meaning, are useful representations that highlight the multiplicative structure of rational numbers. Post, Cramer, Behr, Lesh, and Harel (1993) highlight the role of representations in understanding rational numbers, relating it to the flexibility with transformations between and within rational number representations. Thus, students' flexibility in making transformations involving different representations can show their understanding of the rational numbers involved (Post, Wachsmuth, Lesh, & Behr, 1985).

Recognizing the same rational number across different representations is an outcome of a global coordination of representations, which in turn empowers mathematical reasoning (Duval, 2006). The transformations of representations, which support translation between different representations of rational numbers, are central in the mathematical activity (Duval, 2006), and the analysis of these transformations provides a lens to access students' mathematical reasoning processes, as solving strategies and justification (Mata-Pereira & Ponte, 2017).

Methodology

This study follows a design-based research approach (Cobb, Jackson, & Dunlap, 2016). It focuses on two grade 3 classes (8 years old) students' learning. These classes belong to two teachers that participate on a collaborative group of five teachers, with the first author as a regular member. The group has been meeting weekly for about ten years to plan classes lessons together. In different ways, all teachers have connections to the research field, in which they seek to support their professional practice.

To face the demand of learning rational numbers in grade 3 (a national curriculum determination) with understanding, the group decided to construct a learning path, a trajectory for learning rational numbers, that promoted an active engagement of students in the construction of knowledge through meaningful tasks. Thus, along with the first author, the second author also integrated the group as invited researcher, with the purpose of sharing key ideas of ongoing studies to be discussed in the group (Guerreiro, Serrazina, & Ponte, 2018; Morais, Serrazina, & Ponte, 2018) and support the

construction, implementation and reflection of tasks. Together, teachers and researchers, collaborated for developing the learning path, meeting those students, with the aim of implementing theoretical ideas identified as key in the learning of rational numbers, understood as innovations (Century & Cassata, 2016). All the three teachers put the learning path into action, but only two, Hélia and Sandra, actively participated in all the sessions of collaborative group, thus being participants in this research. These sessions were held once a week, according to the school calendar, between February and June of 2018.

The need to intertwine different symbolic representations of rational numbers, supported by several representations used as models, like common batteries icons or status bars, but also the multibase arithmetic blocks (MAB) or the decimat, which make explicit the “ten-ness” of the base ten place value system (Roche, 2010). This was one of the guiding principles of the learning path constructed and implemented, within this design-based research. This path privileged the symbolic representations of percentage (Phase 1), decimal number (Phase 2 and 3), and fraction (Phase 4), using part-whole and measure meanings, according to the sequence presented in Figure 1.

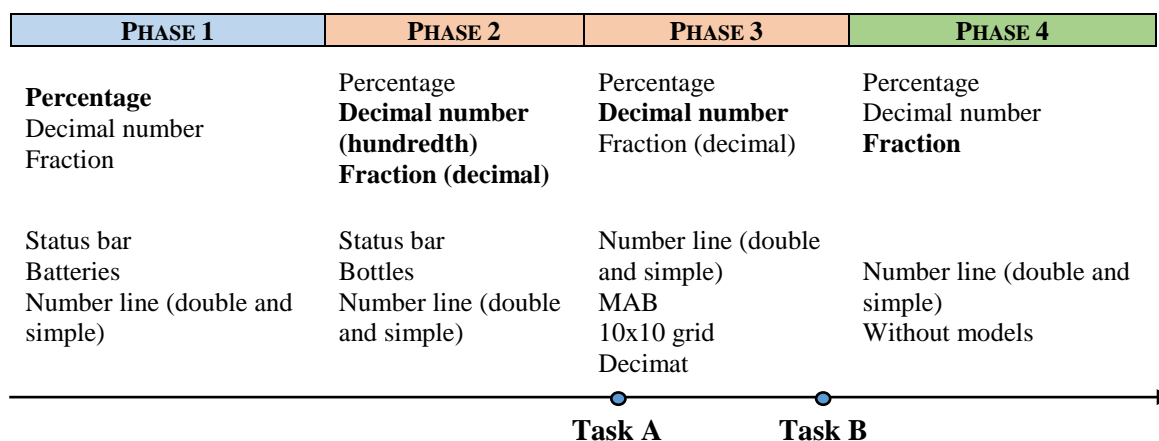


Figure 1: Implemented learning path of rational numbers

Data was collected through audio recordings of the group sessions, collection of written records of the teachers, the written works of students (brought by the teachers for the sessions), as well as photo records made by teachers during classroom work.

We focus the analysis on two tasks, Task A and Task B, solved by students, which were carried out in Phase 3 of the learning path. Data analysis is centered on students’ use of representations as models, and on how they use and relate different symbolic representations.

Results

Task A

Before task A, students were asked to fill and empty five bottles in order to establish relationships between their capacities, and associate labels written in decimal numbers to each bottle (Figure 2).



Figure 2: Labeling bottles task

Two bottles had the same capacity, and two labels represented the same quantity: $0.5\ l$ and $0.50\ l$. At the group session when the work carried out in this task was discussed, the teachers identified the need to lead students to justify the equality between the representations 0.5 and 0.50 :

Hélia: Now that we have finished [the task] the filling of the bottles and they realized that five tenths are equal to fifty hundredths but they don't know why. . . So, we could go from there...

Helena: To the equivalence with different representations.

. . .

Hélia: So, I will ask why fifty hundredths are the same as five tenths, because I want them to be able to justify...

Although Sandra suggested that the status bar could be used as a support representation for task A, the group discussed that it would be important to promote the use of the number line, recognizing the need to evolve to a more formal representation.

Sandra, referring to her students, suggested that the double number line could be presented with marks corresponding to tenths and, eventually, to hundredths:

Sandra: In my class... I usually focus their [students] attention on “Into how many [parts] is [the unit] divided? So, they are how many of how many?” That's why we came to this [suggested way to divide the number line] . . .

This suggestion stems from the fact that Sandra acknowledges that her students had already explored rational numbers mainly with a part-whole meaning, which had been associated with the fraction representation. Hélia recalls that her students used, above all, the decimal fraction with denominator one hundred, because percentage was a reference for them:

Hélia: When I call upon fraction it's always decimal fraction with hundredths . . . Because for them percentage is... Is their guiding line!

Thus, in anticipating how her students would relate 0.5 and 0.50 , Hélia suggests that 50% should be already presented in the double number line:

Hélia: Let's just start by asking. They will realize that fifty is because it is divided... The percentages here... I think that it should be 50% already represented...

However, the group discussed that by dividing the number line in that way, in order to include other symbolic representations, could restrain students when choosing a representation to justify. Therefore, the group decided to present only the representation in decimal number to, on one hand, focus the question in this specific equivalence and, on the other hand, to allow the students to mobilize representations on their own.

The task implementation showed that the students used different kinds of justifications. Sandra mentioned that her students justified the equality between 0.5 and 0.50 by presenting arguments based on an enactive representation, related to what they had experienced in the labeling bottles task:

Sandra: They concluded that five tenths are equal to fifty hundredths because these bottles had the same capacity...

These arguments seem to show that, in this task, the students understood the symbolic representation of a decimal number as a label that identifies a certain amount of water, an understanding that is strongly linked to the context. The meaning that the students give to the decimal number symbolic representation was based on an enactive representation.

The arguments used by Hélia's students show an understanding of the symbolic representations involved without needing to refer to their experience in the task of labeling bottles.

Hélia: Almost all the groups [of students] concluded that in five tenths we have the unit divided in ten parts, and that in fifty hundredths we have the unit divided in one hundred parts...

The meaning that the students assign to the symbolic representation in decimals is supported by the interpretation of the number line and other representations, such as the decimal fraction (Figure 3).

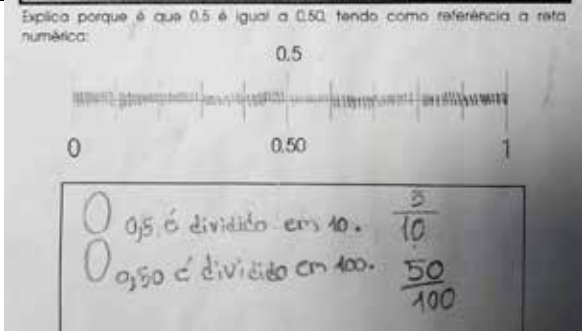
	<p>Explain why 0.5 is equal to 0.50, considering the number line:</p> <p><i>0.5 is divided in 10. 5/10</i></p> <p><i>0.50 is divided in 100. 50/100</i></p>
--	---

Figure 3: Written record of a student from Hélia's class – Task A

In this way, the students seem to recognize the same number in different representations, which they mobilize to justify the equivalence between 0.5 and 0.50. In this phase of the learning path, in addition to the enactive representation of the bottles and the number line iconic representation, the decimat was another important representation for the understanding of the decimal number representation.

Task B

In Task B, the students were asked to represent the shaded areas of the decimat, in percent, decimal number and fraction. The written record presented in Figure 4 illustrates how a student from Sandra's class used the decimat as a model, as the student gives meaning to this representation, using percentage to keep track of the relations established.

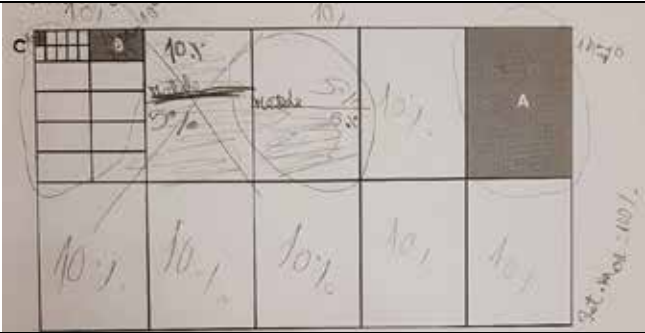
	<p><i>10%, half 5%</i> [rectangle A]</p> <p><i>1%, I have divided into 10 the 100</i> [hundredth, rectangle B]</p> <p><i>1000</i> [rectangle C]</p> <p><i>Larger rectangle = 100%</i></p>
---	---

Figure 4: Written record of a student from Sandra's class – Task B

The student interpreted the decimat that she named as the larger rectangle, as 100%, associating each rectangle A to 10%. She identified half of 10% as 5%, which she justified by tracing half of a rectangle A. She interpreted rectangle B as 1%, justifying it with the division of 100, which she seems to relate to one hundredth, by 10. She also pointed rectangle C as “1000”, which seems to show that the student identified the relation $1/1000$ of this rectangle with the larger one. Thus, the student seemed to have understood the relationship between each shaded area in the decimat.

Hélia agreed that this model allowed her students to visualize and mobilize different symbolic representations, facilitating their interrelation. This is evident when Hélia reflected on another task involving the decimat:

Hélia: For my students it was a systematization... This construction was essential. For example, my students looked at the decimat and most of them said that it was [shaded] 30%.

The use of this iconic representation was highly valued by the teachers as a “systematization representation”, as Hélia mentioned, considering the phase of the learning path in which it was used. Although the decimat representation is usually perceived as related to the decimal number representation, it supported and triggered other representations such as percentage.

Final remarks

Considering that the aim of this study was to understand how emphasizing multiple representations could contribute to the learning of rational numbers in the elementary school, this study shows that a work involving the interrelation of percentage, decimal number and fraction, is very promising in the initial approach of the learning of rational numbers.

We emphasize that the understanding of these symbolic representations, and their relations, is supported by the use of enactive and iconic representations (Webb, Boswinkel, & Dekker, 2008), in a recurrent way. Enactive and iconic representations were used as models, leading students into the establishment of relationships (Gravemeijer, 2004), between and within the same type of representation. Therefore, enactive and iconic representations allowed the emergence of symbolic representations with understanding.

Even though the learning path was constructed according to the sequence of symbolic representations, percentage – decimal number – fraction, the students mobilized the representation that they considered most appropriate to justify the equivalence relation. This ability shows an apparent confidence in working with rational numbers, considering the initial stage of these students' learning of this concept. In this way, a work focused on the understanding that the same number can assume different representations, not only symbolic, but also enactive and iconic, contributed to the students' conceptualization of rational number.

The fact that the Portuguese curriculum does not emphasize percentage at grade 3, as a rational number representation, could be considered an obstacle to the implementation of the intervention. However, the fact that the collaborative group was willing to develop a learning path comprised by key research findings overcame this obstacle. The teacher group already had a joint work routine prior to this study facilitated the sharing environment created. This was a factor that influenced the

effectiveness of this intervention. Those teachers used to plan and reflect together and, with researchers, they got confidence in constructing and implementing the learning path, a common aim that provided a desirable gateway for implementing research in the classroom. A discussion about how to echo this experience on a larger scale is still much needed to enhance its beneficial effects in new contexts (Century & Cassata, 2016).

We highlight the relationship between theory and practice in this study: theory found a way to support practice, identifying the guiding principles of this intervention, and practice provided clues for problematizing theory, necessarily refining those principles. On one hand, the learning path of rational numbers was constructed based on previous research, which emphasizes the crucial articulation among symbolic representations of rational numbers (e.g., Moss & Case, 1999; Ponte & Quaresma, 2011; Tripathi, 2008). On the other hand, the practice informed that not only this articulation is possible at the elementary school grades, but also that it benefits from a continuous work that embeds other types of representations.

Acknowledgment

This research is supported by national funds through Universidade de Lisboa by grant to the first author and through FCT – Fundação para a Ciência e Tecnologia to the second author (SFRH/BD/108341/2015).

References

- Behr, M. J., Lesh, R., Post, T. R., & Silver, E. A. (1983). Rational-number concepts. In R. Lesh & M. Landau (Eds.), *Acquisition of mathematics concepts and processes* (pp. 91–126). New York, NY: Academic Press.
- Brocardo, J. (2010). Trabalhar os números racionais numa perspectiva de desenvolvimento do sentido de número [Working the rational numbers in a perspective of number sense development]. *Educação e Matemática*, 109, 15–23.
- Bruner, J. S. (1999). *The process of education*. Cambridge, MA: Harvard University Press.
- Century, J., & Cassata, A. (2016). Implementation research: Finding common ground on what, how, why, where, and who. *Review of Research in Education*, 40(1), 169–215.
- Cobb, P., Jackson, K., & Dunlap, C. (2016). Design research: An analysis and critique. In L. D. English & D. Kirshner (Eds.) *Handbook of international research in mathematics education* (3rd edition, pp. 481–503). New York, NY: Routledge.
- Duval, R. (2006). A cognitive analysis of problems of comprehension in a learning of mathematics. *Educational Studies in Mathematics*, 61(1), 103–131.
- Gravemeijer, K. (1999). How emergent models may foster the constitution of formal mathematics. *Mathematical Thinking and Learning*, 1(2), 155–177.
- Gravemeijer, K. (2004). Local instruction theories as means of support for teachers in reform mathematics education. *Mathematical Thinking and Learning*, 6(2), 105–128.
- Guerreiro, H. G., Serrazina, L., & Ponte, J. P. (2018). A percentagem na aprendizagem com compreensão dos números racionais. *Zetetiké*, 26(2), 354–374.

- Mata-Pereira, J., & Ponte, J. P. (2017). Enhancing students' mathematical reasoning in the classroom: teacher actions facilitating generalization and justification. *Educational Studies in Mathematics*, *96*(2), 169–186.
- Morais, C., Serrazina, L., & Ponte, J. P. (2018). Mathematical reasoning fostered by (fostering) transformations of rational number representations. *Acta Scientiae*, *20*(4), 552–570.
- Moss, J., & Case, R. (1999). Developing children's understanding of the rational numbers: A new model and an experimental curriculum. *Journal for Research in Mathematics Education*, *30*(2), 122–147.
- Ponte, J. P., & Quaresma, M. (2011). Abordagem exploratória com representações múltiplas na aprendizagem dos números racionais: Um estudo de desenvolvimento curricular [Exploratory approach with multiple representations in the learning of rational numbers: A curriculum development study]. *Quadrante*, *20*(1), 55–81.
- Ponte, J. P., & Serrazina, L. (2000). *Didáctica da Matemática para o 1.º ciclo do ensino básico* [Didactics of Mathematics for the elementary school]. Lisboa, Portugal: Universidade Aberta.
- Post, T. R., Cramer, K. A., Behr, M., Lesh, R., & Harel, G. (1993). Curriculum implications from research on the learning, teaching and assessing of rational number concepts: Multiple research perspective. In T. Carpenter & E. Fennema (Eds.), *Learning, teaching and assessing rational number concepts: Multiple research perspective* (pp. 327–362) Mahwah, NJ: Lawrence Erlbaum.
- Post, T. R., Wachsmuth, I., Lesh, R., & Behr, M. J. (1985). Order and equivalence of rational numbers: A cognitive analysis. *Journal for Research in Mathematics Education*, *16*(1), 18–36.
- Roche, A. (2010). Decimats: Helping students to make sense of decimal place value. *Australian Primary Mathematics Classroom*, *15*(2), 4–10.
- Tian, J., & Siegler, R. S. (2018). Which type of rational numbers should students learn first? *Educational Psychology Review*, *30*(2), 351–372.
- Tripathi, P. (2008). Developing mathematical understanding through multiple representations. *Mathematics Teaching in the Middle School*, *13*(8), 438–445.
- Webb, D. C., Boswinkel, N., & Dekker, T. (2008). Beneath the tip of the iceberg: Using representations to support student understanding. *Mathematics Teaching in the Middle School*, *14*(2), 110–113.

Coherence through inquiry based mathematics education

Per Øystein Haavold¹ and Morten Blomhøj²

¹Arctic University of Norway, Department of Education, Tromsø, Norway;

per.oystein.haavold@uit.no

²Roskilde University, Department of Science and Environment, Roskilde, Denmark;

blomhoej@ruc.dk

SUM is a four-year research and developmental project with the aim of contributing to coherence in children's and students' motivation for, activities in, and learning of mathematics throughout the educational system from kindergarten to higher education. The concept of inquiry is key in the project, and it involves the implementation of different types of theories and methods related to inquiry based mathematics teaching (IBMT) at three systemic levels: (1) The students' inquiry in and with mathematics. (2) The teachers' use of inquiry based mathematics teaching as a means for supporting the students' learning and inquiry into their own practice across a particular transition. (3) Inquiry into the interplay between the development of teaching practice and research in IBMT. In this paper, based on the project design and preliminary findings from the implementation, we discuss the project as an implementation of theory at these three levels, with a particular focus on level 2.

Keywords: Professional development, teacher collaboration, inquiry, mathematics.

Introduction

In this paper, we present and discuss how the design of a four-year professional development project called SUM can facilitate the implementation of research findings related to Inquiry Based Mathematics Teaching (IBMT) as a means for creating better coherence across important transitions in the educational system. Strategically, the project focuses on five transitions in the educational system where particular challenges with developing and retaining students' motivation for and learning of mathematics are evident in teaching practice and in research. The principles behind the design of the project are based on research findings in the mathematics education literature specifically related to IBMT. Therefore, this paper can be seen as a case study on how professional developmental projects can be a vehicle for implementation of theories in the practice of mathematics teaching.

The project design is based on a broad understanding of IBMT going back to the educational philosophy of Dewey (Artigue & Blomhøj, 2013). More specifically, in SUM we conceptualize and operationalize the inquiry concept at three different systemic levels developed by Jaworski (2004, p. 24): (1) the children's and students' inquiry in and with mathematics; (2) the teachers' inquiry into their own practice and their use of IBMT as a means for supporting students as learners; (3) inquiry into the interplay between the development of teaching practice and research in IBMT. These three levels of inquiry have formed the project design and structured the application. In that sense, as a research and professional development project, SUM is an implementation of a general theory of inquiry also used in other projects (Bjuland & Jaworski, 2009).

Coherence is another key concept in the project. In SUM, the fundamental premise and proposition is that we can help create and sustain coherence at each of the three levels through inquiry. However, as with the term inquiry, the term coherence takes different meanings at each of the three systemic levels. At level 1, the focus is on children's and students' motivation for, activities in, and learning of mathematics. The term coherence here refers to how students can make sense of mathematics,

maintain their joy of, and develop a deep understanding of mathematics. In other words, coherence means that students' experience mathematics as a meaningful, relevant, and consistent subject. However, we cannot expect students to develop these desirable characteristics on their own. Students need opportunities to develop productive habits and deep conceptual knowledge for creating and maintaining a joy of and to make sense of mathematics (Schoenfeld, 2014). This leads us to level 2.

At level 2, coherence refers to the teacher's practices and their knowledge and beliefs about IBMT and challenges related to students' learning in general, and across the particular transitions in the system of mathematics teaching in particular. For students to experience mathematics as a meaningful endeavor both in general and across transitions, teachers have to, among many things, create a learning environment that involves inquiry through investigative activities such as experiments, problem solving, and modelling. The aim of the project is that the teachers can develop mathematical and didactical competences, through inquiry into their own practice and IBMT, for a practice of teaching that provide students with these types of learning environments.

At level 3, the focus is on the coherence between the development of practices of teaching and research in mathematics education. Nearly all professional practitioners, including teachers, experience a gap between theory and practice (Schön, 1983). This dilemma is also closely related to what Nilsen (2015) calls determinant frameworks. Determinant frameworks describe and help identify types of determinants, which act as barriers and enablers that influence implementation outcomes. Determining barriers and enablers, both at a systemic and individual level, is a key element in creating coherence between research in IBMT and development of teaching practice

At each of the three systemic levels, coherence also refers to the issues related to academic transitions in mathematics. As students move through the school system, the mathematics instruction, opportunities to engage, expectations, mathematical concepts and ideas, classroom norms etc. are all likely to change – in particular in transitions between key academic levels. These transitions are a potential risk to students' academic progress, unless they are managed well (McGee, Ward, Gibbons & Harlow, 2003).

The basic premise of the SUM project, and central claim of this paper, is that IBMT has a potential for meeting these demands at the three systemic levels. In this paper we address the following research question with a particular emphasize on the implementation of inquiry at level 2:

In what way does the design of the SUM project support the implementation of IBMT as a means for creating better coherence?

To answer this question, we will explain how research related to IBMT has been implemented in the design of the project, and report on some preliminary findings that show how this design of the SUM project has helped create better coherence. In this paper we explain how inquiry is implemented – i.e. conceptualized and operationalized – in the design of the project at each of the three systemic levels, and how it can help create better coherence across academic transitions. Due to the limited scope of this paper, we then focus more closely on one of the systemic levels, and provide an example of how theory related to IBMT has been implemented at level 2. We highlight in particular a 3-phased didactical model that has been developed to help organize and design IBMT lessons. Finally, we present some preliminary findings from the project, and discuss how this implementation of inquiry at level 2 in the design of the project has helped teachers incorporate investigative activities in their own practice – and thus helped create a better coherence between teachers' practice of teaching and the intentions for the development of students' beliefs about mathematics and their mathematical learning.

The organizational structure of SUM

However, a quick description of the project is needed. SUM is the acronym in Norwegian for “Sammenheng gjennom Undersøkende Matematikkundervisning”. In English, the title is “Coherence through inquiry based mathematics teaching”. The project is based at the Arctic University of Norway in Tromsø (UiT), and financed by The Norwegian Research Council for the period 2017- 2021. The SUM project is organized around five transitions in the educational system where students typically experience a discontinuity in their mathematics teaching:

Kindergarten (T1) [®] Primary school (T2) [®] Middle school (T3) [®]
Lower secondary (T4) [®] Upper secondary (T5) [®] University

The organizational structure of SUM is in accordance with what we know about effective professional development (PD). Research has shown that effective high-quality PD possesses a robust content focus, features active learning, is collaborative and job embedded, aligned with relevant curricula and policies, and provides sufficient learning time for participants (Desimone, 2009).

The SUM project has a robust content focus that is also aligned with current curriculum reforms in Norway. An important part of the work in the transition groups is to identify challenges related to the transition in question. These challenges are related to the learning of key mathematical concepts such as for example the number line as a model for natural, whole and rational numbers at the transitions T1-T3, or on how to support the coherence and progression across a transition with regard to particular mathematical competences such as for example mathematical reasoning or modelling competence. Such competences and deep learning of key concepts are playing a dominant role in an ongoing curriculum reform for mathematics teaching from primary to upper secondary level in Norway (Kunnskapsdepartementet, 2016).

The SUM project also has a clear focus on active learning, job-embedded collaboration, and sufficient learning time. For each of the mentioned transitions, a group of 8-14 mathematics teachers from school and/or kindergarten (as for T1) is formed. There are at least two teachers from each participating school. Each group is led by two or three mathematics educators from the project team at the university. Currently, around 55 teachers are participating in the project. For three consecutive school years each group work together on identifying and discussing challenges regarding students’ learning of mathematics across a particular transition. In collaboration and with support from the group leaders the teachers develop, implement and evaluate IBMT with the explicit aim of helping the students to overcome the identified challenges and to contribute to a better coherence across the transition in focus for the group.

It should be mentioned that SUM includes a particular focus on IBMT as a means for developing a cultural responsive approach for supporting the coherence in mathematics teaching for Sámi children. One of the transition groups consist of teachers at a Sámi school working at both T1 and T2.

Implementing IBMT in the SUM project

As mentioned, the inquiry concept is coming into play differently at the three systemic levels. At level 1 and 2 it is in the form of IBMT, while at level 3 it is inquiry as part of the research process. The implementation of inquiry at each of the three systemic levels consists of a further conceptualization and operationalization, which is discussed below.

At level 1, inquiry means that students are learning mathematics through exploration in tasks and problems in the classroom. The aim is to help students develop and maintain the joy of, motivation for, and coherence in their learning. For students to experience mathematics as a meaningful endeavor, they need to, among other things, struggle with “important mathematics”. The term struggle

does not mean that students should waste time on extreme levels of challenges that lead to needless frustration. Struggle, in this context, means that students should expend effort, explore, investigate and make sense of problems and situations that are not immediately apparent (Hiebert & Grouws, 2007). This view of learning as a result of reflective inquiry and meaningful struggle is a key aspect of IBMT. In the SUM project, we put special emphasis on IBMT as a means for developing and maintaining the students' interests for and joy of working with mathematics, both in general and across the transitions. Through problem oriented activities the students should have the opportunity to experience the joy of solving problems, which they to begin with find challenging.

At level 2, inquiry means that teachers explore and reflect on the design and implementation of tasks, problems and activity in classrooms. The teachers use inquiry as a tool to explore teaching, alongside researchers and other teachers who offer both theoretical and practical support. The teachers also develop their practice through successive cycles of inquiry, working in their own classroom, interpreting a design they have produced in collaboration with researchers and other teachers (Jaworski, 2004). Through this inquiry into their own practice and IBMT, the aim of the SUM project is that the teachers can develop mathematical and didactical competences for a practice of teaching that provide students with learning opportunities that help them develop and maintain the joy of, motivation for, and coherence in their learning of mathematics – with a particular focus on challenges related to academic transitions. In the transition groups we present and discuss with the teachers a number of different activities spanning the options of IBMT at that particular transition, Together with the didactical structure presented below, these examples and the related discussion help the teachers in developing their own inquiry based activities.

At level 3, the focus is on how to facilitate interplay between developments of practice and research of IBMT. Here, inquiry is a tool used by both researchers and teachers for understanding the relationship between theory and practice. This is primarily accomplished through co-learning partnerships, in which researchers and practitioners are both participants in processes of using inquiry as a tool for understanding the relationship between theory and practice. Through a close collaboration in designing, implementing, and reflecting on IBMT, both teachers and researchers can develop a better understanding of each other's' worlds (Jaworski, 2004). The SUM project is designed for providing exactly such opportunities for collaboration over three school years between teachers representing different grade levels, and in some cases also different institutions, and researchers in mathematics education. In close collaboration the groups will go through the process of designing, testing and evaluating inquiry based courses three times each school year and nine times during the project. In that sense the design of SUM builds on what is known about developing IBMT in interplay with research (Boaler, 2008; Artigue & Blomhøj, 2013).

Implementing IBMT at level 2: The teachers' development of IBMT in their practice

In the beginning, the work in the transition groups focus on level 2. The teachers need support for seeing IBMT as a didactical means for engaging the students in formulating and solving mathematical problems and using mathematics to describe and analyze real life situations. In addition, it is important for the teachers to see that such activities can motivate students and, at the same time, help them understand mathematical concepts and ideas that are essential for their mathematical learning across a particular transition.

The teachers need support for developing and teaching IBMT in their own classes. To that effect at the first seminar in the transition group, the teachers were introduced to a 3-phased didactical model for structuring inquiry based activities or courses. The model was exemplified with different types of inquiry based activities and courses relevant for the particular transition. The examples varied with respect to duration from one-lesson activities to 5-8 lessons courses, the degree of freedom given to

the students, and the degree to which the activities was stirred by a mathematical focus or by an extra mathematical problem or situation.

The 3-phased didactical model for structuring IBMT includes these elements:

Phase 1: *Setting the scene for the students' inquiry work.* This phase could involve: telling a story, refer to or create student experiences to motivate the inquiry work; establishing a challenge or a problem in a context that makes sense for the students; creating classroom dialogues about the meaning of the situation; motivating the activity or problem—how could this be fun or interesting and important for life and/or mathematics?; establishing and communicating the didactic environment for the students' work, i.e. the temporal and practical conditions of the work; and presenting and arguing for the product requirements and assessment format.

Phase 2: *The students' independent (of the teacher) investigative work.* In this phase the students' should have: sufficient time, freedom, resources and support for their investigative work; support through dialogues with the dominant questions to groups or individual students being: What are you thinking?, How did you find out?, Why is it right?, What if ..?

Phase 3: *Supporting the students' learning of mathematics through sheared reflections in class.* In this phase the teacher should: let the students shear their experiences and results and related reflections; organize the students' presentation of their working process, products and results; facilitate classroom dialogues focused on the mathematical elements in the work; help systematizing the results for the class; pinpoint key ideas, concepts and methods in the students' work; try to build sheared mathematical knowledge in the class rooted in the students' work; use multiple mathematical representations and make connections to the students' previous mathematical knowledge.

This 3-phased model provide a good starting point for the collaboration among the teachers and between teachers and the researchers in the transition groups. The model was presented in the transition groups together with lists of essential student and teacher activities in each of the three phases. In addition, in each group some examples of inquiry based activities relevant for the transition in question were presented and discussed. The examples varied from relatively closed mathematical or practical problems over systems of connected problems forming a landscape of investigation to more open thematic investigations and modelling activities as illustrated in (Artigue & Blomhøj, 2013). Together, these elements supported the teachers in developing and planning inquiry based activities in their own teaching. At the transition groups meetings, the model structured the discussions and made it possible to focus on specific issues of IBMT at the transition in question. For instance, at the first meeting, the focus was on establishing a challenge or a problem in a context that makes sense for the students, and to set scene for the students' inquiry activities. This is in line with several other development projects on IBMT (see vol. 45, issue 6 of ZDM, 2013), where this or similar models has shown to be instrumental for the teachers' operationalization of IBMT.

A short example illustrates how the teachers used the 3-phased model. In this example, taken from upper secondary school, both the teacher and the students had little experience with IBMT. The students had been working on quadratic equations for a few weeks, and the teacher wanted to use IBMT in order for the students to get a better understanding of what each term in the equations meant. In one of the lessons, the teacher first set the scene by showing the students a visual proof of the identity $(a + b)^2 = a^2 + 2ab + b^2$. She then asked the students to make a visual proof of $(a - b)^2 = a^2 + 2ab + b^2$. During the second phase, the students' investigative work, she tried to provide constructive feedback that led the students in a productive direction. At the end of the lesson, the students were asked to present their solutions, and their findings were tied into how they could solve quadratic equations by completing the square.

This example illustrates how one of the teachers used the 3-phase model to implement, gradually, IBMT into her own teaching. Although this particular lesson is a structured and strongly guided example of IBMT, it is an example of how the 3-phased model helped the teachers to gradually include IBMT in their own teaching. The teacher expressed that the 3-phased model had helped her plan and implement IBMT when she first joined the project, as it had reduced the larger and more complex task of developing IBMT lessons into smaller sub-tasks in each of the 3 phases. In particular, the 3-phased model had helped clarify her role during an IBMT lesson.

Research context and methods

The main research goal of the SUM project is to contribute to the further theoretical development of IBMT and researching its potentials and limitations for overcoming challenges in the practice of mathematics teaching related in particular to the five transitions. In order to fulfill this and other sub-objectives, several methods of data collection have been, and will be, employed. In this paper we report on some preliminary findings specifically related to the implementation of IBMT at level 2. More detailed analyses will be presented in later papers, with more specific scopes. The findings in this paper are based on preliminary analyses of focus group interviews and recordings of transition group meetings throughout the first year in transition group five (TG5).

TG5 consists of six mathematics teachers from three upper secondary schools, three mathematics instructors who teach mathematics at tertiary level, and two mathematics education researchers. Each meeting of TG5 during the first year of the project was recorded. The participants of TG5 was also interviewed in focus groups at the end of the first year of the project. These transition group meeting recordings and focus group interviews covered a large set of subjects and themes, but for the purpose of this paper we focused only on statements and discussions related to the teachers' exploration and reflections on the design and implementation of IBMT in their classrooms.

Both the transition group meeting recordings and focus group interviews were first transcribed, and then analyzed using an inductive qualitative content approach. For each interview and transition group meeting, we extracted all text components that captured some aspects of the design and implementation of IBMT in the teachers' own classrooms. We then formed categories, across the interviews and transition group meetings, which summarized the teachers' experiences and reflections. In the next section we report on some of the key findings from this analysis.

Findings

We found that the 3-phased model, and the design of the SUM project in terms of inquiry at level 2, in general helped the teachers design and implement IBMT in their own lessons. There were several reasons for this, most of which were tied to specific challenges in designing or implementing IBMT.

One of the strongest findings was related to the design of IBMT. All of the teachers said they had little experience with open-ended activities and problems, and therefore found it difficult to design such activities themselves. One teacher said for instance that she "didn't know how to come up with problems and activities like the examples they were given in TG5". Other teachers expressed similar thoughts, and said it was difficult coming up with good tasks or activities that were open-ended, relevant for the content-specific syllabus, and also interesting for the students.

There were also several issues related to the implementation of IBMT lessons and tasks. The teachers found it slightly uncomfortable to give up control of the lessons, and allow the students to investigate and explore more freely. A majority of the teachers said that it was difficult to let students work on tasks and problems, without correcting the students. Three of the teachers even said that this lack of clear instructions and corrections could lead to students developing content-related misconceptions. They explained further that misconceptions had to be dealt with early and resolutely. Another

challenge, was the large difference in terms of skills and knowledge between the students. Some students struggled with even the most basic aspects of the IBMT lessons, while other students solved the more difficult tasks with a fair bit of ease.

However, in spite of the challenges related to the design and implementation of IBMT, all of the teachers in TG5 expressed that the 3-phased didactical model alleviated to some extent these challenges. The teachers agreed that it provided them with a more structured approach for designing IBMT for their own practice. Instead of tackling a large and intimidating challenge of designing full lessons of IBMT, the 3-phased model reduced a large and complex task to several smaller less complex tasks. Together with the examples of IBMT provided in the TG5 meetings, the 3-phased model simplified a large and abstract task into a set of smaller and more concrete sub-tasks. Furthermore, the teachers said that the 3-phased model helped them remind them about their and their students' role at each phase of IBMT. As one teacher said, "it was a nice reminder of what she should do and what the students should do, and it gave a nice partition of the lesson".

We also noticed that the teachers seemed to find the collaborative and job-embedded structure, and inquiry-focus, of SUM to be meaningful and productive. The teachers said that developing, implementing, and reflecting on IBMT, in collaboration with other teachers, provided them with a better understanding of what IBMT is and how IBMT lessons can be developed. The teachers expressed in particular that implementing IBMT in their own classes, made the activities more important and relevant as the teachers had an "ownership" of the lessons. Furthermore, a majority of the teachers said that discussing both the model and the examples of IBMT in the TG5 meetings helped them to better understand the key characteristics of IBMT and the purpose of it.

Summing up in relation to our research question, at level 2, the 3-phased model with concrete examples and the organization for the work in the transition groups seem to be instrumental for implementing IBMT in order to help creating better coherence in the participating teachers' practice across the respective transitions. Within implementation theory the 3-phased model for IBMT together with the organization of the transition groups can be considered as an innovation for implementing IBMT in the practice of mathematics teaching. Rogers (2003) identify three levels of knowledge, which has to be developed among practitioners—here teachers—as a necessary condition for a successful implementation of an innovation in relation a problematic in an existing practice. Concretized in relation to the SUM, these are (1) knowledge of and experiences with challenges regarding the students' motivation and learning in mathematics teaching across the transitions; (2) knowledge about how to use the 3-phased model for planning, conducting and evaluating IBMT; (3) knowledge about and experiences with cases where the 3-phased model has been effective as a didactical means for supporting students' investigative activities and their learning of mathematical concepts and methods. So far, we have some evidence that the transition group meetings have enabled the teachers to share experiences with and to reflect about challenges regarding coherence in the students' motivation for and learning of mathematics across the transition in question. The 3-phased model has been instrumental for structuring the presentations and discussions of IBMT in the transition groups. Also, the model has shown to be a tool for the teachers in designing and implementing IBMT in their own practice. It is still to be seen if the teachers will reach the third level of knowledge and experience IBMT as an effective didactical means for improving the students' motivation for and learning of mathematics across the transitions.

Large developmental projects running over several years and with funds for establishing close collaboration between selected teachers and researchers is one very important way in which theories can come into play in the development of teaching practice – as support by Rogers (2003). Therefore, it is relevant to analyze the role and function of theories from mathematics education research in the design of such research based developmental projects. In this paper, we have analyzed how elements

of theory related to IBMT come into play in the SUM project at the systemic level focusing on the teachers' experimental practice and their related reflections.

References

- Artigue, M., & Blomhøj, M. (2013). Conceptualising inquiry-based education in mathematics. *ZDM – The International Journal on Mathematics Education*, 45(6), 797–810.
- Boaler, J. (2008). Bridging the gap between research and practice: International examples of success. In M. Menghini, F. Furinghetti, L. Giacardi & F. Arzarello, F. (Eds.), *The first century of the International Commission on Mathematical Instruction (1908-2008). Reflecting and shaping the world of mathematics education* (pp. 91–104). Roma: Istituto della Enciclopedia Italiana.
- Bjuland, R., & Jaworski, B. (2009). Teachers' perspectives on collaboration with didacticians to create an inquiry community. *Research in Mathematics Education*, 11(1), 21–38.
- Desimone, L. M. (2009). Improving impact studies of teachers' professional development: Toward better conceptualizations and measures. *Educational Researcher*, 38(3), 181–199.
- Hiebert, J., & Grouws, D. A. (2007). The effects of classroom mathematics teaching on students' learning. In F. K. Lester Jr. (Ed.), *Second handbook of research on mathematics teaching and learning* (pp. 371–404). Charlotte, NC: Information Age Publishing.
- Jansen, A., Smith, J., Schielack, J., & Seeley, C. (2012). School Mathematics Articulation: Conceptualizing the Nature of Students' Transitions (and Teachers' Participation in Them), K-16. In L. R. Van Zoest, J.-J. Lo & J. L. Kratsky (Eds.), *Proceedings of the 34th annual meeting of the North American Chapter of the International Group for the Psychology of Mathematics Education* (pp. 23-37). Kalamazoo, MI: Western Michigan University.
- Jaworski, B. (2004). Grappling with complexity: co-learning in inquiry communities in mathematics teaching development. Plenary address at PME 28. In *Proceedings of the 28th Conference of the International Group for the Psychology of Mathematics Education* (Vol. 1, pp. 17–36). Bergen, Norway: Bergen University College.
- Kunnskapsdepartementet. (2016). *Fag – Fordypning – Forståelse. En fornyelse av Kunnskapsløftet*. Stortingsmelding 28. Oslo: Kunnskapsdepartementet.
- McGee, C., Ward, R., Gibbons, J., & Harlow, A. (2003). *Transition to secondary school: A literature review*. Waikato: New Zealand Ministry of Education.
- Nilsen, P. (2015). Making sense of implementation theories, models and frameworks. *Implementation Science*, 10(53), 1–13.
- Rogers, E. M. (2003). *Diffusion of innovations* (5th ed.). New York, NY: Free Press.
- Schoenfeld, A. H. (2014). What makes for powerful classrooms, and how can we support teachers in creating them? A story of research and practice, productively intertwined. *Educational Researcher*, 43(8), 404–412.
- Schön, D. (1983). *The reflective practitioner: How professionals think in action*. London: Temple Smith.
- ZDM (2013). Implementation of inquiry-based learning in day-to-day teaching. *ZDM – The International Journal on Mathematics Education*, 45(6), 779–923.

Competencies and curricula: Danish experiences with a two-dimensional approach

Tomas Højgaard¹ and Jan Sølberg²

¹Danish School of Education, Aarhus University, Denmark; tomas@edu.au.dk

²Department of Science Education, University of Copenhagen, Denmark; jans@ind.ku.dk

Curricula around the world make more and more use of goals trying to capture different kind of processes for the students to master. In Denmark, these ambitions have most recently been described in terms of subject specific competencies. However, bringing such ambitions into the actual teaching practices has proved challenging. KOMPIS was a longitudinal project aimed at developing and examining ways of dealing with some of these challenges in lower secondary Danish classrooms in collaboration with teachers. In this paper, we present aspects relevant to mathematics curricula. As a key point of this analysis, we present a two-dimensional content model derived from KOMPIS that proved useful in supporting competence-based curriculum development and teacher planning. We argue that curriculum descriptions of competency objectives need to be clear and distinct as well as independent of subject matter to be operational.

Keywords: Competence, mathematical competencies, the KOMPIS project, two-dimensional content framework.

Introduction

KOMPIS is an acronym for KOMPetenceMål i PraksIS, which is Danish for “Competency Goals in Practice”. It was a longitudinal research and development project conducted in the years 2009-2012. The project was based on collaboration between teachers, teacher educators and researchers working to implement competency-oriented teaching in mathematics, science and Danish language classes for grades 7-9. A number of these model and concepts were subsequently incorporated into the national curriculum (Undervisningsministeriet, 2014).

In this paper, we focus on the curricular aspects of the KOMPIS project within mathematics by analyzing the following question: *How can we describe curriculum in a way that enables teachers to structure their planning in a manner that focusses on competency development?* Firstly, the background for KOMPIS is briefly described. Secondly, we describe the two-dimensional content model for mathematics education that was developed for and challenged by the experimental teaching conducted during the KOMPIS project. Finally, we describe the experiences regarding planning and organizing of teaching and the conclusions drawn from these experiences regarding curriculum development.

Background

In Denmark, as well as in many other countries, competencies are used more and more to describe curriculum goals. Internationally this is partly due to the initiation of what has since been called the Bologna process, aimed at making transfer of educational merits between countries of the EU easier

(European Ministry of Education, 1999). To accomplish this a unified description of educational standards was needed, and it was decided to describe these standards in terms of competencies.

Alongside this political process, there has been theoretical and practical development of competencies as an educational concept. One of the most significant developments was the appointment of a workgroup called Description and Selection of Competencies (DeSeCo). In their final report, they formulated a well-conceived and holistic definition of the term and presented their recommendations for “key competencies for the good life and the well-functioning society” (Rychen & Salganik, 2003).

Syllabusitis

Analytically, another educational approach to the concept of competence can arise from asking the question (cf. Blomhøj & Jensen, 2007, pp. 46-47, which this and the next section is based on): What constitutes a subject, e.g. mathematics? “Mathematics is the subject dealing with numbers, geometry, functions, calculations, etc.” is not a rare type of answer.

What, then, does it mean to master a subject? With reference to the above, it is tempting to identify mastering mathematics with proficiency in mathematical subject matter. However, this belief if transformed into educational practice is severely debilitating for students’ ability to make reason of the subjects and to apply them in future contexts. The debilitating effect is potentially severe enough that the phenomena has been given a name that evokes images of a disease, namely syllabusitis (Jensen, 1995; Lewis, 1972). A curriculum infected by syllabusitis tends to focus only on the ability to reproduce subject matter and therefore fails to set an appropriate level of ambition and puts the teachers in a position where they struggle to cover the prescribed subject matter.

The KOM project, competency and mathematical competencies

The issue of syllabusitis was one of the main issues to be addressed by the Danish so-called KOM project, running from 2000-2002. The core of the project was to identify, explicitly formulate and exemplify a set of mathematical competencies as independent dimensions in the spanning of mathematical competence (see Figure 1) (Niss & Højgaard (to appear) provides a presentation and analysis of the project and an English translation of the original report).

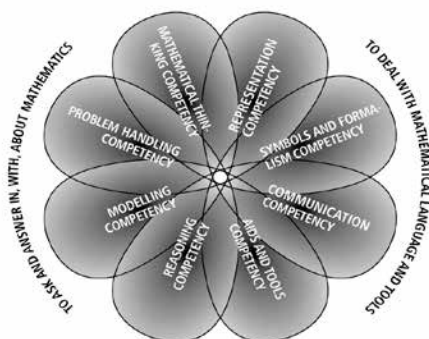


Figure 1: A visual representation – the “KOM flower” – of the eight mathematical competencies presented and exemplified in the KOM report (Niss & Højgaard, to appear)

Such a set of mathematical competencies has the potential of replacing the syllabus as the focus of attention when working with the development of mathematics education, simply because it offers a vocabulary for a focused discussion of what it means to master mathematics (Jensen, 2007). Often when a syllabus attracts all the attention in a developmental process, it is because the traditional specificity of the syllabus makes us feel comfortable in the discussion.

The definition of the term “competence” in the KOM report (Niss & Jensen, 2002, p. 43) was semantically identical to the one we use: Competence is someone’s insightful readiness to act in response to the challenges of a given situation (cf. Blomhøj & Jensen, 2003). In definite form, a mathematical competency is consequently defined as someone’s insightful readiness to act in response to a certain kind of mathematical challenge of a given situation.

The initial KOMPIS analysis

Following the approach of the KOM project, the endeavour to incorporate subject specific descriptions of competencies in mathematics curricula should primarily be guided by an attempt to fight syllabusitis. In this perspective, it was important to focus on the interplay between subject specific competencies and the subject matter traditionally described in the syllabus.

A two-dimensional content model

In the KOM report the proposal for such an interplay is to separate subject specific competencies and subject matter areas as two independent dimensions of content (Niss & Højgaard, to appear). Subsequent research and development work prior to the KOMPIS project (Jensen, 2007) supported the importance of such an approach to curriculum development, and added the general hypothesis that a goal oriented (yearly) planning is supported by a curriculum that is systematically developed for enhancement of transparency, offering itself as a thinking tool for the teachers. The model in Figure 2 was a proposal for such a transparent representation of the core of the by then (2009) newly revised National Standards for mathematics (Undervisningsministeriet, 2009).

In a curricular perspective, the defining point of such two-dimensional content models is that the subject specific competencies can function as “the missing link” between the overarching purpose of an education and a concrete syllabus, by pointing out what types of challenges the students must be able to act in relation to.

Competency \ Subject matter area	Numbers and algebra	Geometry	Statistics and probability
Math. thinking comp.			
Math. problem handling comp.			
Math. modelling comp.			
Math. reasoning comp.			
Math. representation comp.			
Math. symbols and form. comp.			
Math. communication comp.			
Math. aids and tools comp.			

Figure 2: A two-dimensional model for description of the content of grade K-9 mathematics teaching (Højgaard et al., 2010, p. 15)

The KOMPIS project and the methodological approach chosen here

The experimental teaching included 16 teachers from four schools together with three university researchers and three teacher educators split into three subject groups—math, science and Danish. The groups had three-hour meetings at alternating schools once every month to discuss the teachers' experience and reflections regarding their competency-based lesson plans and the teaching they tried out between meetings. Furthermore, all participants met (including representatives from the municipality) twice a year for full-day seminars to exchange experiences across subjects.

Our participation in this longitudinal experimental process gave us access to knowledge and ideas from the different participants, and to follow the developmental processes among the teachers on an ethnographic basis. In this paper we report on our analysis of how the two-dimensional content framing influenced two aspects of these processes; planning and organization of teaching.

Hence, the “implementation element” of the paper in the sense described by Century & Cassata (2016) is the two-dimensional model displayed in Figure 2, used as a tool for helping teachers to plan and organize a teaching focused on the development of certain mathematical competencies.

KOMPIS experiences regarding planning and organization of teaching

The common distinction between planning and organization of teaching is useful for describing some of the results of the KOMPIS project. Following Larsen (1969) we consider planning of teaching as the process of making decisions regarding the content of the teaching, whereas organization of teaching deals with selecting appropriate (relative to the content and the learning ambitions associated with it) teaching methods and making decisions regarding the course of the teaching.

Planning competency-oriented teaching

In this sense of the phrase, planning of teaching inevitably boils down to an endeavor with one dominating dimension: Time. Since time is a scarce resource when teaching takes place within a formal educational system like compulsory schooling, it is of little surprise that the two-dimensional content model in figure 2 acted as a systematically induced challenge to the planning of the teaching. One of the consequences of this approach is that it makes didactical considerations necessary when planning from a two-dimensional content structure to a one-dimensional yearly teaching plan. Planning of competency-oriented teaching is ideally about creating a connection between the two dimensions in such a way that the work with a given subject matter area can be explained and motivated by development of competencies, which make the students able to handle new types of situations or known situations in a more competent way. This often requires more prolonged and successive teaching time making it necessary to plan teaching in modules wherein the students get to build a chosen competency.

This approach can be modelled by dividing the year up into modules and deciding early on which areas of subject matter, competencies or combination of the two to focus on, cf. the modelling of this approach in figure 3. This model can function as a planning and reflection tool for teachers as well as a model that teachers can use when they discuss what the objectives of a given teaching session is with colleagues and students (Højgaard, 2010).

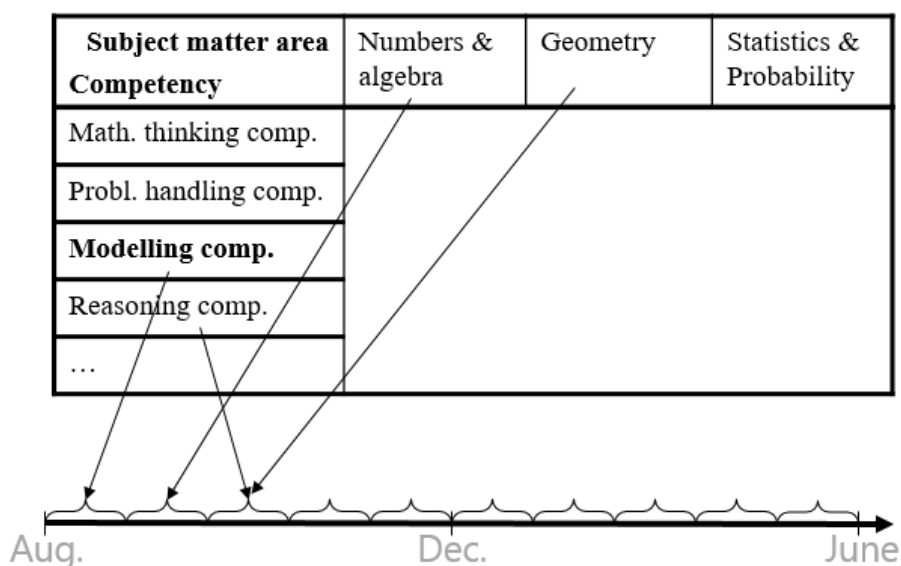


Figure 3: The two-dimensional model used as a tool for planning of teaching by creating modules of some weeks in duration, each appointed with explicitly stated learning objectives consisting of subject specific competencies and/or objectives related to specific subject matter

Hence, an important part of implementing competency objectives in teaching turned out to be linked to planning for extended periods of time, where students and teachers could focus on a few selected competency objectives. KOMPIS was designed to ensure that teachers included such periods in their yearly planning from year two of the project. When the mathematics teachers involved were interviewed subsequently, they assessed the explicit use of the model in figure 3 as a planning tool as both challenging, constructive and meaningful. Challenging because the representation of the competencies as a separate dimension in the model forced them to be explicit about their ways of thinking and working with this new kind of objectives. Constructive because the model turned out to be a comprehensible thinking tool when planning their teaching, not least by explicating the role of the competencies in their answer to the fundamental planning question posed above: When are the students to learn what? Meaningful because they experienced the mathematical competencies as a way of making some of their more fundamental ambitions as mathematics teachers explicit.

Organizing competency-oriented teaching

Following the planning approach by dividing the year up into modules, the dominant organizational approach used by the teachers in the KOMPIS project was project work where the students could concentrate on a selected competency objective. In the mathematics group, Tomas followed one teacher closely. She deliberately and explicitly organized the project work modules with the following general characteristics:

- a) The teacher decided on a given mathematical competency objective to focus on for the project period.
Six projects were oriented towards the mathematical modelling competency and two towards mathematical reasoning competency.
- b) Approximately, one week was spent on helping students develop an understanding of the given competency objective.

An example of this was that in the first project focusing on mathematical reasoning, where the teacher let the students spend the first week gaining different experiences with mathematical reasoning by alternating between short tasks that required students to use mathematical reasoning and group discussions about their reflections. This led to the development of a model that presented the students ideas about central elements involved in mathematical reasoning (Sølberg, Bundsgaard, & Højgaard, 2015).

- c) Once the class had reached a common understanding of the given competency, each project group was required to come up with relevant problems involving the given competency. They then spent the rest of the allotted time—most often two weeks—working on problems through which they developed the given mathematical competency.

For example, one group of students chose to work on the mathematical reasoning involved in solving and producing Sudokus, while another group worked on developing simple mathematical proofs.

The process ensured that students and teacher reached a mutual understanding of a competency objective before the students were challenged to find ways of developing it. Such an approach turned out to be supported by choosing one and only one competency as the guiding learning objective for each project work. From this perspective, the important attribute of the two-dimensional content model is the separation of competencies and subject matter areas, so it is for the teacher to decide whether the learning objectives for a given module should come from a mathematical competency, a mathematical concept or a combination of the two. In previous one-dimensional Danish curricula a mixing of the two types of learning objectives were the dominant approach chosen.

Another advantage of employing a set structure was that the students became familiar with the template. After the first couple of projects, they did not need as much instruction during the project work and gradually gained significant ownership of the process.

Curricular perspectives

Applying a teachers' perspective on curriculum, there are at least two important perspectives regarding the use of competency objectives to be derived from KOMPIS. *Firstly*, the project confirmed that teachers require help in formulating learning objectives to be able to plan teaching explicitly aimed at building student competence. To formulate such more specific learning objectives, however, there is a need for *clear and distinct* competency descriptions in the curriculum. At the same time, to avoid syllabusitis it is necessary to be able to distinguish between competencies and subject matter as two independent dimensions of content descriptions. The model in figure 2 demonstrates how this could be achieved for mathematics, and we propose that similar two-dimensional models of content could be generated for other subjects.

Secondly, being able to formulate competency-oriented learning objectives can help teachers plan their school year in a way that allows them to maintain focus on a *few key subject specific competencies* and thereby create the necessary conditions for sustained development of both teacher and student competencies. In addition, being able to focus on a few learning objectives at a time enables the students to better understand the meaning behind the learning objectives which in turn enables the students to pursue them more independently.

Final remarks

One of the goals behind the KOMPIS project was to experiment with curriculum development from a teacher's perspective. We wanted to engage teachers in developing an approach to competency-oriented teaching that was not only meaningful but also practical for teaching. To make a long story short, our experience from this longitudinal study is twofold (Højgaard, 2012): Firstly, one of the main advantages of using a two-dimensionally structured competency perspective is that it inherently fosters reflections among teachers about the essence of the competencies involved. Secondly, such reflections promote the implementation of the more ambitious kind of work processes that mathematics education aims for as long as the teachers involved (as has been the case in the KOMPIS project) get the necessary time and support to learn how to use the two-dimensional structure as a developmental tool. Hence, KOMPIS indicates that there is significant promise from a teachers' perspective in applying the two-dimensional model presented here for mathematics teaching.

The experiences from KOMPIS have come to influence the subsequent national curriculum revisions. The two-dimensional model has been incorporated into the current curriculum for mathematics (Undervisningsministeriet, 2014), and at the time of writing (2018) it is being revised to emphasize this approach even more. Thus, Danish mathematics teachers are now officially encouraged to use the two-dimensional model in planning their teaching.

References

- Blomhøj, M., & Jensen, T. H. (2003). Developing mathematical modelling competence: Conceptual clarification and educational planning. *Teaching Mathematics and its Applications*, 22(3), 123–139.
- Blomhøj, M., & Jensen, T.H. (2007). What's all the fuss about competencies? Experiences with using a competence perspective on mathematics education to develop the teaching of mathematical modelling. In W. Blum, P. L. Galbraith, H.-W. Henn, & M. Niss (Eds.), *Modelling and applications in mathematics education – The 14th ICMI-study* (pp. 45–56). New York, NY: Springer.
- Century, J., & Cassata, A. (2016). Implementation research: Finding common ground on what, how, why, where, and who. *Review of Research in Education*, 40(1), 169–215.
- European Ministry of Education. (1999). *The Bologna declaration of 19 June 1999*. Retrieved from https://www.eurashe.eu/library/modernising-phe/Bologna_1999_Bologna-Declaration.pdf
- Højgaard, T. (2010). Communication: The essential difference between mathematical modeling and problem solving. In R. Lesh, P. Galbraith, C. Haines, & A. Hurford (Eds.), *Modeling students' mathematical modeling competences* (pp. 255–264). New York, NY: Springer.
- Højgaard, T. (2012). Competencies and the fighting of syllabusitis. In ICME 12 LOC (Ed.), *Pre-proceedings of ICME 12* (pp. 6412–6420). Seoul, South Korea: ICME 12 LOC.
- Højgaard, T., Bundsgaard, J., Sølberg, J., & Elmoose, S. (2010). Kompetencemål i praksis – foranalysen bag projektet KOMPIS [Competency objectives in practice – initial analysis for the KOMPIS project]. *MONA*, 3, 7–29.

- Jensen, J. H. (1995). Faglighed og pensumitis [Subject understanding and syllabusitis]. *Uddannelse*, 9, 464–468.
- Jensen, T. H. (2007). *Udvikling af matematisk modelleringskompetence som matematikundervisningens omdrejningspunkt – hvorfor ikke?* [Development of mathematical modelling competency as the center point of teaching mathematics – why not?] (Doctoral dissertation). IMFUFA-tekst 458. Roskilde, Denmark: University of Roskilde. Retrieved from <http://milne.ruc.dk/imfufatekster/pdf/458.pdf>
- Larsen, C. A. (1969). *Didaktik: om didaktikken som planlægningsvirksomhed og om dens systematiske placering i pædagogikken* [Didactics: on didactics as a means for planning teaching and its systematic place in relation to pedagogy]. Copenhagen, Denmark: Royal Danish School of Educational Studies.
- Lewis, J. L. (1972). *Teaching school physics. A UNESCO source book*. Baltimore, MD: Penguin Books.
- Niss, M., & Højgaard, T. (to appear). *Mathematical competencies in mathematics education: Past, present, and future*. New York, NY: Springer.
- Niss, M., & Jensen, T. H. (2002). *Kompetencer og matematiklæring: Idéer og inspiration til udvikling af matematikundervisning i Danmark* [Competencies and mathematical learning: Ideas and inspiration for the development of mathematics teaching in Denmark]. Copenhagen, Denmark: Ministry of Education.
- Rychen, D. S., & Salganik, L. H. (2003). *Key competencies for a successful life and a well-functioning society*. Cambridge, MA: Hogrefe & Huber.
- Sølberg, J., Bundsgaard, J., & Højgaard, T. (2015). Kompetencemål i praksis – hvad har vi lært af KOMPIS? [Competency objectives in practice – lessons learned from KOMPIS]. *MONA*, 2, 46–59.
- Undervisningsministeriet. (2009). *Fælles Mål 2009 – Matematik* [National Standards 2009 – Mathematics]. Copenhagen, Denmark: Ministry of Education.
- Undervisningsministeriet. (2014). *Læseplan for faget matematik* [Curriculum for the subject mathematics]. Copenhagen, Denmark: Ministry of Education.

Adapting implementation research frameworks for mathematics education

Uffe Thomas Jankvist¹, [Mario Sánchez Aguilar](#)², Jonas Dreyøe³ and Morten Misfeldt⁴

¹Aarhus University, Denmark; utj@edu.au.dk

²Instituto Politécnico Nacional, CICATA Legaria, Mexico; mosanchez@ipn.mx

³Aalborg University, Denmark; jmd@learning.aau.dk

⁴Aalborg University, Denmark; misfeldt@learning.aau.dk

Although there have always been investigations in the field of mathematics education that concern implementation research, it is not yet clear how to structure such a research area. In this paper, we take a step towards this. Taking as reference frameworks elaborated in other fields where implementation research is more advanced, we attempt to outline what an implementation research framework in mathematics education could encompass. We illustrate this with an example of implementing the Danish innovation of the mathematics competency framework (KOM).

Keywords: Implementation research; innovation; theory of change; value.

Introduction

Implementation research has received an increase in attention within mathematics education during the last few years (e.g. Cai et al., 2017; Jankvist, Aguilar, Ärlebäck, and Wæge, 2017). But the discussion of implementation is neither new in educational research in general, nor in mathematics education in particular. Already Fullan and Pomfret (1977) remarked that “implementation is not simply an extension of planning and adoption processes. It is a phenomenon in its own right.” (p. 336). Even if the discussion of implementation has been around for some time, both the work presented and carried out during CERME 10 and the recent discussions in JRME (e.g. Cai et al., 2017) illustrate clearly that there is still a large potential indeed in addressing initiatives within mathematics education from an implementation research point of view. However, it is not at all clear how exactly to do this. Hence, we first need to ask ourselves which existing implementation research frameworks that are applicable to which initiatives in mathematics education as well as how and why? The purpose of this paper is to take some initial steps towards addressing this big question. As a reference point we take implementation frameworks from other research fields to try to sketch an implementation research framework in mathematics education. Then we “test” it on an illustrative example of the decentralized implementations of the Danish mathematical competencies framework—KOM—in selected mathematics programs of the Danish educational system.

Implementation research frameworks

Within the context of health science, Nilsen (2015) proposed a taxonomy of three aims for the use of theoretical approaches in implementation science, and five categories of theories, models and frameworks. The first aim of theoretical approaches is to *describe and/or guide the process of translating research into practice*. Process models lay out specific steps to implement research into practice, and thus provides practical guidance in planning and carrying out implementation. The second aim concerns *understanding and/or explaining what influences implementation outcomes*. Three different types of frameworks and theories are found to support this aim. The first type is the determinant frameworks that identifies barriers and enablers, which influence the implementation outcomes as well as specifying the relationships between barriers and enablers. The second type is

the classic theories, which are theories that originate from fields outside of implementation science, but may be applied to understand some aspects of implementation. The last type related to this aim are actual implementation theories, which are those developed with the sole purpose of explaining aspects of implementation. The third and last aim concerns *evaluating implementation*. This aim can be supported by the category of evaluation frameworks that may provide a structure for evaluating implementation.

In their review of implementation research within education, Century and Cassata (2016) offer the following (working) definition:

Implementation research, by our working definition, is the systematic inquiry of innovations enacted in controlled settings or in ordinary practice, the factors that influence innovation enactment, and relationships between innovations, influential factors, and outcomes. Thus, frameworks that inform the organization of implementation research address two main concerns—how to conceptualize and describe the innovation itself, and how to identify and organize the contexts, conditions, and characteristics that influence innovation enactment (influential factors). These two fundamental concepts—(a) characteristics of the innovation and (b) influential factors—are basic elements of varied theories of change and a key part of most recent research syntheses or metaframeworks depicting innovations in context. (p. 181)

This definition builds on two other terms, the meaning of which will have to be explained as well; namely those of innovation and change. Century and Cassata (2016) operate with a definition of *innovations* as “programs, interventions, technologies, processes, approaches, methods, strategies, or policies that involve a change (e.g., in behavior or practice) for the individuals (end users) enacting them” (p. 170). More traditionally, an innovation is oftentimes considered to be new ideas creating economic value (Darsø, 2012), or as the middle part of the CIE (Creativity, Innovation and Entrepreneurship) model for value creation and change (Paulsen and Harnow, 2012). However, the dependence on economic bottom line thinking makes this definition difficult to apply to educational situations. Nevertheless, if we instead consider innovation as changes of practices and technologies for the better, then we set ourselves free from the problem of economy as the core goal for innovation. This however leaves open what kind of normative change for the better that we should value in innovation. We should ask what (kind of) value and for whom. The definition of educational innovations provided by Century and Cassata (2016) focuses on *the change for end users* (e.g. teachers and students) and simply views innovations as the object of implementation research. While this is indeed an important perspective, we suggest that the notions of value and stakeholders are critical; an innovation is only an innovation if it creates value for some stakeholders (Krainer, 2014), but the stakeholders do not necessarily have to be the end users. Value can be for the society in general, for educational administrations, school management, etc. We thus define educational innovations as *change in educational practice that are valued by some stakeholders*. However, in order to conceptualize any change, it is necessary to acknowledge that change may take place at different levels (at the individual level, classroom level, school level, etc.), but also that change is mediated by people and institutions who can adopt, modify or even reject the intended innovation implementation. Thus, as pointed out by Century and Cassata (2016), a question that lies at the heart of the implementation research is: “what does it take for people, organizations, and systems to change?” (p. 178).

To address a question like that in the context of mathematics education, we need to draw on a wide range of conceptual and methodological tools from within and outside the field. For example, to try to identify and organize the conditions that influence innovation enactment at the classroom level, it would be important to understand the intentions and individual motives that a mathematics teacher has to adopt or not an educational innovation. Research on curricular implementation in

mathematics education has shed some light on this type of issues (e.g. Remillard and Heck, 2014). If we refer to change beyond the classroom and on a larger scale, say at the institutional level, it could be useful to resort to studies on organizational change from different disciplines such as medicine (Rohrbach, Grana, Sussman and Valente, 2006) and management science (Burnes, 2005), which can provide us with theories and methodological approaches to help us understand how to produce large-scale change behaviors in school systems. Here studies on mathematics education with an institutional perspective could also be useful (e.g. Castela, 2004). On a wider scale, Rogers (1962) has developed a frequently cited theory describing how innovations are spread across a social group (see for example Koichu and Keller, 2017). He distinguishes several groups of adopters; innovators (adopting a new technology instantly), early adopters, early majority, late majority and laggards (who adopts very late). Rogers shows that the distribution of adoption is similar to a normal distribution with the bulk of people in the early and late majority category. Implementation is obviously related to how people adopt. If you aim for mainstream implementation of an innovation, when it is only adopted by innovators, you are bound to fail.

Five factors that influence implementations

The identification of the factors that influence innovation enactment is a fundamental component of implementation research. For years educational researchers have tried to identify the variables that influence the implementation of educational innovations; these variables can be classified in the following five spheres of influence (Century and Cassata, 2016).

Characteristics of the individual users: The change that an educational innovation is aimed at generate, it is mediated by the people involved in the implementation process. Hence, it is important to know their individual characteristics. We distinguish between (a) *characteristics of the individual in relation to the innovation* (mathematical background, experience using the materials or resources involved in the innovation, etc.) and (b) *characteristics of the individual that exist independently of the innovation* (willingness to try new teaching methods, attitudes towards new artefacts in the classroom, etc.).

Organizational and environmental factors: In the case of an innovation implemented in a mathematics classroom, organizational factors refer, on the one hand, to the characteristics of the setting itself (number of students, characteristics of the physical space, access to material resources, etc.), and on the other hand to the collective beliefs and behaviors of the members of the class (identity, sociomathematical norms, didactic contract, etc.). Environmental factors refer to those outside the organization, but which have an influence on how an innovation is adopted and implemented (economic conditions, educational policies, priorities of government agencies, etc.).

Attributes of the innovation: The attributes of the innovation can influence its implementation, however, it is important to distinguish between the *actual* attributes of the innovation (objective characteristics) and the *perceived* attributes of the innovation (subjective characteristics perceived by the user). Of course, the perceived attributes may vary from user to user.

Implementation support strategies: It is important that an innovation initiative comes accompanied by an intentional and planned support for the final users and their institutions. Such support strategies can be professional development, specific resources, etc.

Implementation over time: Another factor that influences the implementation of an innovation is time. Thus, it becomes relevant to study innovation endurance over time: how can we promote that an innovation, besides being adopted, is preserved over time until it is routinized? It is in this branch of the implementation research where longitudinal studies will become essential to answer questions like the one previously stated.

The KOM framework - an “implementation story”

As an illustrative example of an implementation, we take a historical and chronological look at the Danish mathematics competency framework, referred to as KOM, which was first published in Danish (Niss and Jensen, 2002), and later in an English translation (Niss and Højgaard, 2011). This framework has heavily influenced mathematics education in Denmark, where it has been implemented in primary and lower secondary school through the so-called “Fælles Mål” (common goals) (Undervisningsministeriet, 2014), and in both the technical stream (htx) and business stream (hvx) of upper secondary school—to a lesser extent in the classical stream (stx)—in the mathematics teacher education program as well as in some of the mathematics-related programs in tertiary education. On an international level, KOM’s competencies descriptions were an integral part of the PISA assessment framework for mathematics from approx. year 2000 through 2018. The description has also been influential in mathematics programs in several countries’ (see Niss and Højgaard, in progress). Now, in itself the KOM framework constitutes a normative text, which is not directly translationable/implementable in the various mathematics programs. But KOM’s competencies description, with its eight distinct yet interconnected mathematical competencies, was never meant as a standalone. It must be implemented together with a curriculum for the mathematics program at a given educational level. One distinct feature of the KOM approach is its matrix thinking that links specific competencies to various mathematical areas, i.e. competencies in the rows and mathematical areas, e.g. algebra, geometry, in the columns of a matrix. From an implementation perspective, however, KOM makes up an interesting case.

When published in 2002, KOM was supplemented with an implementation support strategy of meetings and seminars debating specificities of the framework and the value of placing development of mathematical competencies as the key feature. But besides this, the implementation support strategies must be characterized as ad hoc and rather scattered. Still, KOM’s competency description was adopted by a large part of the teacher educators in Denmark. It was implemented in the national standards for compulsory school, partly between 2003 and 2006 and more thoroughly in 2009. Furthermore, it was implemented in the teacher education standards in 2012 and in upper secondary school in 2013 and again in 2017. In 2012 the impact of the competencies framework was evaluated as part of a general evaluation of the national standards (Danmarks Evalueringsinstitut, 2012), showing that teachers were neither using the standards nor the eight competencies to a very large extent. In 2014 the K-9 curriculum was reformed towards an outcome-oriented curriculum, and the competencies were now embedded in this structure (“Fælles Mål”). Furthermore, the number of competencies was changed from eight to six. A transformation that was heavily criticized by the people behind KOM (see e.g. Niss, 2016). As of now, the overall structure of the output-oriented curriculum is being debated again and will be partly rolled back. Nevertheless, for the eight competencies this transformation actually appears to have increased their impact and the outreach of the KOM framework. These days more teachers do seem to know more about the competencies than before; partly due to timing in terms of adoption and partly because the 2010 reform made everyone aware of the curriculum/standards and hence the competencies. As mentioned above, such awareness concerning KOM does not seem to be present at the classical stream of upper secondary school, stx, which is by far the largest of the three upper secondary school programs. Why is this? The answer to this question—we believe—is to do with environmental (and institutional) factors as well as the characteristics of the different individual users.

The characteristics of the individual users in the various institutions are quite different. Danish K-9 mathematics teacher educators are mainly educated at the Danish School of Education, where they are exposed to and thus become accustomed to an educational approach that relies heavily on the competency framework (e.g. Højgaard and Jankvist, 2015). In their future professions at the

university colleges, these teacher educators thus often come to act as enablers for the implementation of KOM, not least in relation to the teachers that they educate. The K-9 mathematics educational system, however, is a big ship to turn since it is comprised of teachers of all ages educated under various different educational paradigms and reforms. Hence, as mentioned above, the prevalence of awareness of the eight competencies was a lengthy process. One indicator of this is the fact that many teachers reacted negatively against the PISA 2012 assessment in mathematics, despite the fact that the 2012 PISA mathematics framework was perfectly aligned with KOM and thus also the national standards of 2009. Yet, as part of these standards, an explicit matrix structure between the competencies and mathematical areas was developed for each grade level. This has played a major role in the implementation of KOM in K-9.

When it comes to the upper secondary stx mathematics teachers, they oftentimes hold a master's degree in mathematics from a university mathematics program. Their teachers at the university typically hold a PhD in some area of mathematics, and hence are not necessarily very well versed in the area of mathematics education research, including the competency approach. This of course serves as a barrier for the implementation of KOM in stx. The reason that the situation is a bit different in the two other streams of upper secondary school, as mentioned above, is most likely to do with the fact that the mathematics teacher population there has a more varied background, e.g. at htx several teachers have a background as engineers. Another identified barrier is to do with the lack a matrix structure in the stx curricular documents. Although these do mention a selection of KOM's eight competencies, then mainly do so on a rhetorical level, i.e. the various competencies are not linked to actual mathematical areas and concepts. To a much larger extent this is done in the curricular documents of both htx and hhx (for a further discussion, see Niss and Højgaard, in preparation).

Implementing the KOM framework has taken time. As described above different stakeholders have adopted the framework to different degrees. Even though all these stakeholder groups are distributed across Rogers' (1962) different adoption-types, it is still possible to distinguish groups that overall are moving faster than others. The teacher educators, for instance, have adopted KOM much faster than the K-9 teachers. However, in the case of the K-9 teachers time seems to work for the implementation of KOM, even though adoption is slow. The 2014 K-9 reform was timewise in a place where the innovators and early adopters was already using the competencies framework. This is to say that the timing was working for the competencies, and the curriculum reform thus acted as a catalyst for the early and late adopters to embrace the framework. In the case of the stx teachers, we are less sure to what extent the adoption and implementation will progress over time. KOM has the learning of mathematics at its core, and hence it should be relevant for this population of teachers as well. Still, the lack of an implemented matrix structure in the curricular documents of stx, which, as described above, is an essential attribute of the innovation, does not hold a lot of promise. Due to the stx curricular documents' use of the competency terms only on a rhetorical level, the actual attributes of KOM and the stx teachers' perceived attributes may simply not be aligned.

Discussion and analysis

Referring back to Nilsen's framework as presented above, the analysis of the implementation of KOM in Denmark mainly addresses the second aim of understanding and explaining what influences implementation outcomes. Here both aspects of what Nilsen refers to as determinant frameworks are in play, as the project identified certain barriers and enablers which influence the implementation outcome. Century and Cassata's (2016) description of factors that influence implementation (see above) was useful alongside Rogers' (1962) focus on stakeholders' adoption. Hence, these implementation research frameworks have provided us with some general perspectives

of where to look and focus our attention, but in themselves they are not detailed enough for cases such as KOM - or any case of mathematics education, we predict. In particular in relation to Nilsen's first and third aim, the description of the implementation process and the evaluation of implementation, one thing that the general frameworks often cannot supply us with is a *theory of change*. Which on one hand can guide the process of implementation and on the other hand is used to evaluate the success of an implementation. The parameters on which to measure change may oftentimes be found within theoretical constructs from mathematics education itself. Let's exemplify.

In mathematics education there are of course many different kinds of innovations, but for the sake of simplicity let us distinguish two. One type concerns that of implementing normative frameworks such as KOM, which in a sense call for a philosophical or cultural change in mathematics programs as to what it means to master the subject. Another type are the grand scale initiatives as for example the Swedish Boost for Mathematics (BM), which offered a further education program to the majority of Swedish mathematics teachers. Although the BM did include a framework, involving e.g. didactical contract, socio-mathematical norms, etc., it was in itself not a framework such as KOM is. This means that when assessing qualitative aspects of the implementation of the innovation, KOM becomes its own theory of change, whereas BM does not. We are not claiming that this necessarily is a problem; only that we should be aware of this when discussing implementations in mathematics education. Another difference is that the implementation of the BM was top-down, whereas many of the local implementations of KOM were more bottom-up. Also, the difference in scale of the two implies that the evaluations of them may be of different nature. While the BM was often evaluated on quantitative terms, e.g. how many schools and teachers participated, etc., KOM to a larger extent was only evaluated on qualitative terms. The qualitative theory of change parameters of both KOM's and BM's evaluative frameworks come from within mathematics education research, while the quantitative parameters of BM's evaluation do not necessarily do so. Nilsen's (2015) framework also includes theories which focus on change from other fields than implementation science, the category of classic theories. However, this category concerns something different than what we call a theory of change, since we regard a theory of change to be something that is locally developed in conjunction with the framework being implemented. The benefits of the close relation between innovation and evaluative framework is that we set us free from binary and simple evaluative categories. In a sense, it is like choosing between relevance and accuracy/circular inference (begging the question/circular argument) in the evaluative frameworks.

Concluding remarks

Century and Cassata (2016) provided us with a definition of implementation research that has been useful in our effort to begin to explore how implementation research in the field of mathematics education might look. However, this conceptualization of implementation research is not exempt from criticism, nor from competing visions in the conceptualization of this area of research. For instance, one could point out the fact that the conceptualization made by Century and Cassata does not take into consideration—at least explicitly—the role of adopters in the implementation process of an innovation. A conceptualization like this runs at risk of positioning innovation as an imposition for the adopters, who may perceive it as an external element and alien to their own didactical ecosystems. To address this issue, we could consider complementing such conceptualization with other already existing theoretical frameworks from the field of mathematics education. For example, a documentational approach could help us to consider the process through which an innovation can be reshaped and transformed by the adopters.

Thus, although implementation frameworks can be useful to focus our attention on key elements of an implementation process and even to conceptualize them, in the case of mathematics education some of these key elements will be of a general nature, while others may be of a more specific nature and connected to mathematics education. Thus, it is feasible to suggest that the implementation research in mathematics education needs to be based on a bricolage of different constructs and theoretical frameworks typical of research in mathematics education, in combination with constructs from implementation of research in other disciplines with a longer research tradition in this regard. However, there is a lot of work to be done to achieve such integration of theoretical frameworks and constructs. A natural step in this effort may be to begin to identify and organize the already accumulated research in the field of mathematics education that addresses aspects of implementation.

References

- Burnes, B. (2005). Complexity theories and organizational change. *International Journal of Management Reviews*, 7(2), 73–90.
- Cai, J., Morris, A., Hohensee, C., Hwang, S., Robison, V., & Hiebert, J. (2017). Making classroom implementation an integral part of research. *Journal for Research in Mathematics Education*, 48(4), 342–347.
- Castela, C. (2004). Institutions influencing mathematics students' private work: A factor of academic achievement. *Educational Studies in Mathematics*, 57(1), 33–63.
- Century, J., & Cassata, A. (2016). Implementation research: Finding common ground on what, how, why, where, and who. *Review of Research in Education*, 40(1), 169–215.
- Danmarks Evalueringsinstitut (2012). *Fælles Mål i Folkeskolen: En Undersøgelse af Lærernes Brug af Fælles Mål* [Common goals in K-10: A survey of teachers' use of common goals]. Copenhagen: Danmarks Evalueringsinstitut.
- Darsø, L. (2012) *Innovationspædagogik: Fremtidens Læring in Innovation i Skolen* [Innovation pedagogy: The future's learning in innovation in school]. Århus: Tidsskriftet KVAN, 92, 18–29.
- Fullan, M., & Pomfret, A. (1977). Research on curriculum and instruction implementation. *Review of Educational Research*, 47(2), 335–397.
- Højgaard, T., & Jankvist, U. T. (2015). Educating mathematics teacher educators: A competency-based course design. In H. Silfverberg, T. Kärki & M. S. Hannula (Eds.), *Nordic Research in Mathematics Education: Proceedings of NORMA14* (pp. 81–90). Turku: The Finnish Research Association for Subject Didactics.
- Jankvist, U. T., Aguilar, M. S., Ärlebäck, J. B., & Wæge, K. (2017). Introduction to the papers of TWG23: Implementation of research findings in mathematics education. In T. Dooley & G. Gueudet (Eds.), *Proceedings of the Tenth Congress of the European Society for Research in Mathematics Education* (pp. 3769–3775). Dublin, Ireland: DCU Institute of Education and ERME.
- Koichu, B., & Keller, N. (2017). Implementation enterprise through the lens of a theory of diffusion of innovations: A case of online problem-solving forums. In T. Dooley & G. Gueudet (Eds.), *Proceedings of the Tenth Congress of the European Society for Research in Mathematics Education (CERME10, February 1-5, 2017)* (pp. 3841–3848). Dublin, Ireland: DCU Institute of Education and ERME.
- Krainer, K. (2014). Teachers as stakeholders in mathematics education research. *The Mathematics Enthusiast*, 11(1), 49–60.

- Nilsen, P. (2015). Making sense of implementation theories, models and frameworks. *Implementation Science*, 10(53), 1–13.
- Niss, M. (2016). Målstyret matematikundervisning?! [Goal oriented mathematics teaching?] *MONA-Matematik-og Naturfagsdidaktik*, 1, 69–73.
- Niss, M., & Højgaard, T. (in progress). *Mathematical Competencies in Mathematics Education: Past, Present and Future*. Springer.
- Niss, M., & Højgaard, T. (Eds.). (2011). *Competencies and Mathematical Learning Ideas and Inspiration for the Development of Mathematics Teaching and Learning in Denmark*. IMFUFA tekst no. 485. Roskilde: Roskilde University.
- Niss, M., & Jensen, T. H. (Eds.). (2002). *Kompetencer og matematiklæring — Ideer og inspiration til udvikling af matematikundervisning i Danmark* [Competencies and Mathematical Learning Ideas and Inspiration for the Development of Mathematics Teaching and Learning in Denmark.]. Copenhagen: Undervisningsministeriet.
- Paulsen, M., & Harnow, K. S. (2012). *Innovation & læring: Filosofiske og Kritiske Perspektiver* [Innovation & learning: Philosophical and critical perspectives]. Aalborg: Aalborg Universitetsforlag.
- Remillard, J. T., & Heck, D. J. (2014). Conceptualizing the curriculum enactment process in mathematics education. *ZDM—The International Journal on Mathematics Education*, 46(5), 705–718.
- Rogers, E. M. (1962). *Diffusion of innovations*. New York, NY: Free Press of Glencoe.
- Rohrbach, L. A., Grana, R., Sussman, S., & Valente, T. W. (2006). Type II translation: Transporting prevention interventions from research to real-world settings. *Evaluation & the Health Professions*, 29(3), 302–333.
- Schumpeter, J. A. (1934). *The Theory of Economic Development: An Inquiry into Profits, Capital, Credit, Interest and the Business Cycle*. Cambridge, MA: Harvard Economic Studies.
- Undervisningsministeriet (2014). *Forenkledede Fælles Mål* [Simplified common goals]. Denmark: Undervisningsministeriet. Retrieved from <https://www.emu.dk/omraade/gsk-lærer/ffm/matematik>

Implementation through participation: Theoretical considerations and an illustrative case

Boris Koichu and Alon Pinto

Weizmann Institute of Science, Israel; boris.koichu@weizmann.ac.il; alon.pinto@weizmann.ac.il

This paper explores a particular model of implementation of research: teacher adaption of research procedures and ideas in their classrooms as part of participation in community educational research. The TRAIL (Teacher-Researcher Alliance for Investigating Learning) project seeks to guide the design and conduct of co-learning partnerships between mathematics teachers and mathematics education researchers. In TRAIL, mathematics teachers actively participate in formulating research goals and designing research tools, and then collect data in their classrooms and analyze together the shared data corpus. In the first part of the paper, we present theoretical underpinnings of implementation through participation in TRAIL. In the second part, we examine implementation through participation in an illustrative case, in which a group of teachers designed and explored classroom situations aimed at promoting student questions in the classrooms.

Keywords: Co-learning partnerships, student questions, design and implementation.

Introduction

Implementation of educational research in practice is tricky. On one hand, it is customary to conclude a research paper with suggestions regarding possible implications for practice. For example, when a study includes an intervention component, the researchers may recommend teachers to implement the intervention principles or activities in their classrooms. Or, when a study results in identification of strategies that students engage with, in the context of a mathematical task, the researchers may invite teachers to get acquainted with these strategies in order to better prepare themselves to possible scenarios while enacting similar tasks with their students. On the other hand, it is widely recognized that existing strategies for applying research-based suggestions in practice are far from being satisfactory (Burkhardt & Schoenfeld, 2003). As Kieran, Krainer and Shaughnessy (2012) point out, “[t]he primary responsibility of teachers is *to teach* their students, not to read research papers, and there is some evidence that most teachers don't read such papers very often” (p. 366, emphasis in the original). The scholars then review prevalent strategies by which researchers attempt to familiarize teachers with research findings in various professional development settings and conclude that these strategies, as widespread as they are, have their significant limitations, partly due to the implied view of teachers as recipients or alumni of educational research.

An alternative approach for bridging between research and practice builds on the notions of teachers as stakeholders in educational research, co-producers of professional knowledge, or potential co-producers of scientific knowledge (Kieran et al., 2012; Krainer, 2014). The rationale for this approach stems from in-depth analyses of what teachers may be expected to take to their own practice from mathematics education research. For example, Bishop (1977, cited in Kilpatrick, 1981) points out that teachers can borrow from researchers their procedures, the data and some of research-produced theoretical constructs and models. Even (2003) suggests that mathematics education research is

relevant for teachers as means for gaining insights into teaching and learning that might not be gained through practice, such as: “mathematical knowledge is constructed in ways that do not necessarily mirror instruction” or “knowing is a 'slippery' notion” (p. 38). Teachers are more likely to gain access to these kinds of ‘products’ of research as participants in research. Additionally, viewing teachers as co-producers of professional and scientific knowledge rather than recipients of research findings is well aligned with the notion of learning as an active process. It is well documented that students are more likely to succeed in implementing new knowledge when they are actively engaged in co-constructing it. By the same principle, teachers are more likely to implement new knowledge of mathematics education if they are actively engaged in producing it (Taylor, 2017; Wagner, 1997).

The goal of this paper is to draw on the view of teachers as active participants in educational research and present a particular mechanism of research implementation, in which teachers act as partners of mathematics education researchers. In what follows, we unpack this mechanism, first theoretically and then by means of an illustrative example of an authentic study aimed at findings ways to promote meaningful student questions in mathematics lessons. This example demonstrates how teachers can adapt methods and ideas from past research as tools for inquiring into and reflecting on their practice.

Theoretical considerations

To conceptualize and study implementation through participation, we developed a theoretical-organizational framework called TRAIL - Teacher-Researcher Alliance for Investigating Learning. TRAIL consists of a system of theoretical premises and heuristics for guiding the design and conduct of research-practice co-learning partnerships aimed at generating and implementing new knowledge in mathematics education. In this section, we provide a concise outline of the TRAIL framework (for a more detailed discussion, see Koichu & Pinto, 2018).

Underpinnings

The TRAIL framework draws on theoretical constructs and ideas developed in three bodies of the professional literature: the literature on mathematics teacher inquiry, the literature on modes of research-practice partnership and the literature on Citizen Science.

The literature on mathematics teacher inquiry tells us that different types of inquiry are (or at least should be) inseparable parts of teaching as a professional occupation (Menter, Elliot, Hulme, Lewin, & Lowden, 2011; Watson & Barton, 2011). We learn from the literature that the term *teacher inquiry* is used broadly, so that it embraces mathematical modes of inquiry, practitioner educational research, and other forms of inquiry that teachers engage with in their daily work, when preparing to the lessons, conducting them or reflecting on them. For the purposes of this study, we draw on Menter et al.’s (2011) in conceptualizing *teacher inquiry* as a systematic effort to develop and disseminate new knowledge or understanding in an educational setting carried out by someone working in that setting, in collaboration with practitioners working in similar settings and with education researchers.

The literature on research-practice partnerships tells us that different forms of interactions between teachers and researchers have different pragmatic, moral and political expectations and implications for the involved parties. Particularly relevant for this article is a co-learning partnership, as described by Wagner (1997). In co-learning partnerships, researchers and practitioners join forces to inquire

together and aid one another in order to learn something new and worthwhile about their worlds and themselves. The goals, methods and principles of inquiry are negotiated openly to maximize the learning and professional growth of both sides. Therefore, co-learning agreements essentially reduce asymmetry in the roles of the researchers and practitioners. Such agreements make the border between conducting research and implementing it somewhat blurred.

Finally, the TRAIL framework is informed by the literature on Citizen Science (CS). CS is a rapidly growing form of conducting scientific research that involves members of the public in association with scientists to collectively gather, categorize or analyze large quantities of data in order to address real-world problems (Bonney et al., 2009). We learn from Bonney et al. (2009) that an option to engage different participants in the same study at different levels of participation should be thought through when planning a CS project. We also learn, from Wiggins and Crowston (2011), that CS projects can be conducted by local communities that collaborate with researchers as consultants who assist the members of the community to turn their concerns into researchable questions and to construct feasible procedures for pursuing the questions and disseminating the results.

In the case of interest, the teachers were engaged in a research cycle that included design and implementation of classroom activities inspired by past research and by the participants' experiences. The teachers were encouraged to participate in research not only for personal professional growth and improvement of their practices, but also for the joy of being part in producing new knowledge. Likewise, the researchers (the authors of the paper) were interested not only in pursuing their research agenda with the help of the teachers, but also in refining the agenda so that it would be aligned with the teacher-participants agendas.

The TRIAL framework

Based on the described underpinnings, we have formulated, in Koichu and Pinto (2018), the TRAIL premises and heuristics. Four premises are particularly relevant to the concerns of this article.

Professional Growth through Involvement in Research premise: Active involvement in the various stages of educational research generates opportunities for teachers to enhance their abilities to engage effectively in inquiry, noticing and reflection as part of the day-to-day practice.

Authenticity premise: Teachers' engagement in research is more likely to produce positive effects if conducted in the context of an authentic educational research rather than an exercise in doing research. Accordingly, it is advantageous for teachers and researchers to take part in research that is drawn by questions of potential importance to both communities.

Choice premise: Teacher participation in educational research can be stable and productive if the teachers can choose in which research projects to take part, in what capacity and to which extent.

Shared Agency premise: Alliance of the communities of teachers and education researchers can be stable and productive if the opportunity to share the agency over the partnership is available for both communities. This means that individual members of each community are to be involved in the partnership in ways that can advance their peculiar goals and needs, including the needs to contribute, develop professionally and have room for expressing personal creativity.

A relevant subset of TRAIL design heuristics is as follows.

- The research goals and questions that underlie TRAIL partnerships are openly negotiated and deal with issues that have the potential to resonate with dilemmas and challenges that mathematics teachers encounter in their daily work at the level of a class, a small group or an individual student.
- TRAIL partnership must have “clear utility” for practitioners that can be convincingly communicated without heavily relying on the scientific literature in which the research is situated. In a similar vein, a TRAIL partnership must have “clear utility” for researchers, that is, have the potential to yield insights of importance to the education research community at large.
- TRAIL partnerships enable teachers to be involved as research assistants or researchers, but not as objects of research. However, both teacher-participants and researcher-participants can be objects of a study about aspects of TRAIL.
- TRAIL partnerships employ accessible data-collection and data-analysis procedures. We call a research procedure accessible if it can be mastered by an interested individual with no background in education research after a brief training period, and if its use requires reasonable time and effort. Examples include: conducting a questionnaire in a classroom, writing a reflective summary of a lesson, or responding to a summary by another participant.
- TRAIL partnerships offer channels of interaction among the participants as well as channels for providing feedback on contributions of the participants. For example, a teacher who contributes a summary of her lesson to the shared database of the project will obtain structured feedback on his or her contribution from the fellow participants and from the researchers.
- TRAIL partnerships comply with the ethics codes for conducting educational research. In particular, the shared databased of a TRAIL partnership should consist only of properly anonymized data.

An illustrative case

A group of 25 experienced high-school mathematics teachers participated in a 60-hour professional development program (PD hereafter) during the 2017-18 school year. Broadly speaking, the PD’s goals were to enhance their participants as leaders of their school communities. About 1/3 of the PD’s time, and the final assignment, were devoted to designing and conducting a pilot TRAIL study.

From researchers’ perspective

At the first meeting with the participants, we briefly introduced the project and offered the group the following question: Suppose your school hires a professional mathematics education researcher in order to help you improve your practice, what questions about your teaching or your students' learning would you like to ask him or her to explore? The teacher responses were highly diverse. For example: *“What can mathematics education research offer for my teaching?”*; *“How can I help my students to deal with the stress of matriculation exams?”*; *“How to teach in a heterogeneous class?”*; *“What is the validity and reliability of the tests that I offer in my classes?”*; *“How can I encourage my students to be more independent?”*; *“How can I know if my students really understand me?”*; *“Which questions do I ask in my lessons and how these questions affect student learning?”*; *“How can technology help me in teaching trigo?”* The rest of the meeting consisted of the negotiation towards a short list of research topics that would be researchable and of interest for both the teacher-participants and the researcher-participants. We chose to inquire into two topics: (1) the roles of questions asked during

the lessons and (2) indicators of student “understanding”. By the end of the meeting, each teacher-participant enlisted herself in one of two sub-groups that corresponded to the two chosen topics.

The second meeting was conducted in two sub-groups. We prepared for each group a three-page document for orienting the teachers of how the chosen topic can be explored. Each file consisted of a brief literature review and elaborated summaries of two studies chosen by us as examples. A study used in both documents, by Leikin, Koichu, Berman and Dinur (2017), discerned different types of questions (e.g., *elaboration questions* and *clarification questions*). The study also exemplified how transcripts of task-based classroom discussions can be analyzed according to the types of the questions students ask in order to gain insight into the understandings students develop. The paper contained four classroom episodes; two episodes in the context of proving in geometry, and two – in the context of exploration of functions. A common characteristic of the episodes was that the student questions have not been elicited but arose spontaneously. The feasibility of designing such situations in the teacher-participants classes was discussed. The discussions in sub-group (1) converged to the realization that teachers ask much more questions than students do and that creating situations rich with the student questions is a challenge that can be handled in a variety of ways. The discussion in sub-group (2) resulted in realization that students' understanding cannot be assessed directly but ways of understanding can sometimes be induced from student questions and responses. An additional discussion at that meeting was about data-collection tools. We considered a videotaped episode from VIDEO-LM study (Karsenty & Arcavi, 2017) and discussed affordances and limitations of videotaping, audiotaping and making notes.

For the third meeting, we prepared a draft of a research program based on the inputs from the second meeting. The sub-groups were reunited. The document included the following questions:

RQ1: How do experienced mathematics teachers construct in their lessons situations that are rich with student questions? What are characteristics of these situations?

RQ2: What types of questions do students ask in these situations?

RQ3: How can student questions be used as indicators of their ways of understanding of the material taught?

The document also included our suggestions for the next steps, including a time schedule. The first stage was to refine and agree upon the research program. At the second stage, each teacher was required to plan one or more classroom activities that would be appropriate for addressing the above research questions and discuss her ideas with peers in an online forum. The third stage consisted of the individual data collection: each teacher was required to enact his or her ideas in a classroom and document three classroom episodes. It was up to each teacher either to try the same activity in three classes or enact three different activities in the same class. The fourth stage was planned as a group discussion, at the next meeting, of the classroom experiences. It was also planned to discuss at that meeting how to create the shared database of the study and how to conduct data analysis. The last two stages consisted the data analysis and writing final reports.

This plan was fully realized. Each stage was supported by a corresponding document prepared by us and shared with the teacher-participants. Of note is that the program was devised so that it left room

for teacher choices. In particular, it left room for choosing individually appropriate mathematical content and context. The teachers were also encouraged to choose two out of three research questions to address and two out of three data-collection tools. It is also of note that the agreed program left room as to whether to implement the research procedures from the studies considered as examples or to devise their own procedures in spirit of the considered examples.

From teacher-participants' perspective

The concluding task of the PD was a term-paper assignment in which the participating teachers presented findings and conclusions from their analysis of data collected in one lesson activity they designed, and one lesson activity designed by another participant. An analysis of the teachers' products is beyond the scope of this paper, yet in this section we provide a glimpse into one aspect of research implementation, as reflected in the reports of two teachers: Michelle and Libby.

Both Michelle and Libby included in their reports elaborated reflections on their goals, dilemmas and decisions while enacting the research program. Michelle noted in her introduction that she was always curious to find out to what extent teachers' professed values and beliefs, including her own, actually shape teaching practices and learning environments in the classroom. Accordingly, she chose to explore RQ1 and RQ3, recognizing an opportunity to investigate this issue in the context of a belief that was collectively endorsed by the PD teachers: students would gain a deeper understanding of the material taught if they ask more questions in lessons. She specifically looked to examine whether other teachers' reflections on their practices and on student learning will be aligned with this professed belief. To this end, she chose to analyze interventions of a teacher who was teaching at the same grade level she was teaching, believing she would be more sensitive to implicit considerations and assumptions guiding the other teacher as she was designing and conducting the intervention. Similarly, while analyzing her own intervention, Michelle discussed in length her own considerations and assumptions. Thus, Michelle drew on the research literature and the research questions to reflect on and inquire into her practice and her colleagues' practice in accordance with her own agenda.

In the introduction of her term paper, Libby notes that she generally agrees with Leikin et al. (2017) that student questions are instrumental in the development of understanding, but that after reading the paper she was left wondering whether "silence [...] could also be considered as a form of student-teacher interaction", and what would silence afford in terms of student questions. In her assignment, Libby wanted to investigate this issue by comparing the affordances of different teaching approaches to student questions. Accordingly, she designed three lesson episodes, one in which she would "restrain as much as possible from intervening in the classroom discussion", one in which she would "try to guide students towards answers [...] without providing the solution", and one where she would "take up the reins" and "be the center of discussion". While presenting her analysis of these episodes, Libby noted that she found the categorization between *elaboration questions* and *clarification questions* proposed by Leikin et al. (2017) was insufficient for distinguishing student questions in the data she collected. Accordingly, she suggested refining the category elaboration questions into two sub categories, and illustrated this refinement in her analysis.

Michelle and Libby's reflections on their decisions throughout the term-paper assignment indicate that they drew on research methods and constructs in their inquiries. They interpreted the agreed in

the group research questions in light of their own goals for professional growth, and made consequent decisions regarding data collection and analysis. We consider this a particular case of implementation through participation, as discussed in the next section.

Concluding remarks

In the literature on implementation research in education (e.g., Century & Cassata, 2016), the word “implementation” is sometimes paired with such objects as “innovation”, “program” or “reform” (as in “implementation of an innovation”). Such collocations frequently imply co-existence of two distinctly different agencies, creators of an innovation or a program and those who put it into practice. Tensions and issues related to alignment and coordination between these agencies are repeatedly pointed out (e.g., Penuel, Fishman, Cheng, & Sabelli, 2011). Simultaneously, there are voices (e.g., Century & Cassata, 2016; Penuel et al., 2011) that treat implementation of an innovative idea as a multiparty enterprise. We join these voices by presenting and illustrating the TRAIL framework.

TRAIL is a theoretical-organizational tool for devising and conducting co-learning partnerships between teachers and researchers. As illustrated, teacher-participants in a TRAIL study typically consider the products of past studies critically, and draw on them mainly as a resource supporting reflection on and inquiry into their practice. Thus, in TRAIL, the distinction between practitioner inquiry and implementation of research in practice is blurred, and teachers act as co-producers of new knowledge rather than as consumers of the existing knowledge (Kieran et al., 2012). Of note is that while only a few of the participating teachers referred explicitly in their works to the research literature they had been exposed to, many teachers stressed in their feedbacks the importance of exposure to and active participation in educational research to their professional growth.

In summary, this paper illustrates some of the theoretical and practical considerations underlying implementation of research products through teacher participation in research. More precisely, we treat *implementation of research* as active adaptation of research ideas and procedures by practicing mathematics teachers while being involved in doing authentic educational research, in collaboration with mathematics education researchers. We put forward an idea that past research products are likely to influence practice (also) when they are adapted rather than adopted, and when implementation is not the goal but a means on the way to resolving pedagogical problems of importance to the teachers. To this end, the implementation of research products can be seen as intertwining ideas developed by others with one's own experiences and ideas.

Acknowledgement

This study is supported by a research grant from the Abramson Family Center for Young Scientists. We wish to thank Yonah Amir and Abraham Arcavi for their advice and encouragement, and the participating teachers for their collaboration, dedication and creativity.

References

- Bonney, R., Ballard, H., Jordan, R., McCallie, E., Phillips, T., Shirk, J., & Wilderman, C. C. (2009). *Public participation in scientific research: Defining the field and assessing its potential for informal science education. A case inquiry group report*. Washington, D.C.: Center for Advancement of Informal Science Education (CAISE).

- Burkhardt, H., & Schoenfeld, A. H. (2003). Improving educational research: Toward a more useful, more influential, and better-funded enterprise. *Educational Researcher*, 32(9), 3–14.
- Century, J., & Cassata, A. (2016). Implementation research: Finding common ground on what, how, why, where, and who. *Review of Research in Education*, 40(1), 169–215.
- Even, R. (2003). What can teachers learn from research in mathematics education? *For the Learning of Mathematics*, 23(3), 38–42.
- Karsenty, R., & Arcavi, A. (2017). Mathematics, lenses and videotapes: a framework and a language for developing reflective practices of teaching. *Journal of Mathematics Teacher Education*, 20(5), 433–455.
- Kieran, C., Krainer, K., & Shaughnessy, J. M. (2012). Linking research to practice: Teachers as key stakeholders in mathematics education research. In M. A. Clements, A. Bishop, C. Keitel, J. Kilpatrick, & F. Leung (Eds.), *Third international handbook of mathematics Education* (Volume B, pp. 361–392). Dordrecht, The Netherlands: Springer.
- Kilpatrick, J. (1981). The reasonable ineffectiveness of research in mathematics education. *For the Learning of Mathematics*, 2(2), 22–29.
- Koichu, B., & Pinto, A. (2018). Developing education research competencies in mathematics teachers through TRAIL: Teacher-Research Alliance for Investigating Learning. *Canadian Journal of Science, Mathematics and Technology Education*, 18(1), 68–85.
- Krainer, K. (2014). Teachers as stakeholders in mathematics education research. *The Mathematics Enthusiast*, 11(1), 49–60.
- Leikin, R., Koichu, B., Berman, A., & Dinur, S. (2017). Does general giftedness play a role in classes of students motivated to study mathematics at a high level? Focus on students' questions. *ZDM Mathematics Education*, 49(1), 65–80.
- Penuel, W. R., Fishman, B. J., Cheng, B. H., & Sabelli, N. (2011). Organizing research and development at the intersection of learning, implementation, and design. *Educational Researcher*, 40(7), 331–337.
- Taylor, L. A. (2017). How teachers become teacher researchers: Narrative as a tool for teacher identity construction. *Teaching and Teacher Education*, 61, 16–25.
- Wagner, J. (1997). The unavoidable intervention of educational research: A framework for reconsidering researcher-practitioner cooperation. *Educational Researcher*, 26(7), 13–22.
- Watson, A., & Barton, B. (2011). Teaching mathematics as the contextual application of modes of mathematical enquiry. In T. Rowland & K. Ruthven (Eds.), *Mathematical knowledge in teaching* (pp. 65–82). London, England: Springer.
- Wiggins, A., & Crowston, K. (2011). From conservation to crowdsourcing: A typology of citizen science. In Sprague, R. (Ed.), *Electronic Proceedings of the 44th Annual Hawaii International Conference on Systems Sciences* (pp. 1-10), Koloa, Hawaii. Available online at <https://citsci.syr.edu/sites/crowston.syr.edu/files/hicss-44.pdf>

Designing inquiry-based teaching at scale: Central factors for implementation

Dorte Moeskær Larsen¹, Mette Hjelmberg², Bent Lindhart³, Jonas Dreyøe⁴, Claus Michelsen⁵ and Morten Misfeldt⁶

¹LSUL, University of Southern Denmark, Denmark; dmla@imada.sdu.dk

²UCL, University College, Denmark; medh@ucl.dk

³University College Absalon, Denmark; bli@pha.dk

⁴Aalborg University, Denmark; jmd@learning.aau.dk

⁵LSUL, University of Southern Denmark, Denmark; cmich@imada.sdu.dk

⁶Aalborg University, Denmark; misfeldt@learning.aau.dk

In this paper, we describe and discuss a recent attempt to implement inquiry-based mathematics teaching in Danish compulsory school. After a description of the project and an example of the teaching sequences involved, we will introduce a framework for understanding implementation issues in mathematics education, and use this framework to discuss the problems and potential that our project might encounter when it is considered part of a larger implementation of inquiry-based teaching in Danish mathematics education. We found at least three critical factors for implementation: stakeholders, teacher resources, and the balance between well-prepared and more open teaching materials.

Keywords: Implementation, inquiry-based mathematics, teacher development.

Introduction: Implementation and inquiry – a story of potential without impact

This paper addresses the implementation of inquiry-based teaching in mathematics. The idea of developing an investigative and problem-oriented approach to teaching mathematics is not new. Even though the discourse around inquiry-based mathematics teaching only dates back to the late 1990s (National Research Council, 1996), the goal of refocusing mathematics education to practice where students are actively investigating and developing mathematical content at play dates back much further (e.g., Dewey, 1938; Freudenthal, 1991; Papert, 1980). Crucial for bringing about changes to mathematics education is dissemination of experiences and processes to a larger group of schools and teachers. This calls for large scale and long-term capacity building providing pedagogical support for teachers so that they can develop the repertoire of skills and understandings required to teach for inquiry-based mathematics. Furthermore, a sustainable impact depends on a good balance of internal and external resources and support (Krainer & Zehetmeier, 2013; Schoenfeld & Kilpatrick, 2013).

More recently, several European development projects have focused on articulating, testing, and implementing inquiry-based approaches to teaching mathematics, science, and engineering (<http://www.primasproject.eu>, <http://www.fibonacci-project.eu>).

These projects have generally reported positive results showing the potential of inquiry-based approaches to teaching mathematics. However, despite the fact that Denmark participated in a number of these projects, the findings have not given rise to significant changes in the teaching of mathematics

at scale (Mogensen, 2011; Østergaard, Sillasen, Hagelskjær, & Bavnhøj, 2010). With this in mind, the Danish government has initiated a three-year project called KiDM (Quality in Danish and Mathematics Education) focused on developing the quality of teaching in both mathematics and first language (Danish).

One of the goals in the KiDM project is to identify and investigate the enablers and constraints for a large-scale implementation of inquiry-based mathematics teaching. This will be addressed in the present paper, where we describe the inquiry-based activities from KiDM and report on how they are received by the teachers, in order to plan and support the implementation. Using a framework for implementation research (Century & Cassata, 2016), we then try to pinpoint important stakeholders and factors that support, hinder, and alter the implementation of the activities of KiDM. In order to discuss problems, potentials, and relevant foci for KiDM as a large-scale implementation project.

Description of “Better Quality in Danish and Mathematics” (KiDM)

KiDM is a three-year, design-based research and development program named “Kvalitet i Dansk og Matematik” (Better Quality in Danish [first language] and Mathematics); its aim is to make the teaching in Danish compulsory school more inquiry-based. The program involves (1) surveying the literature on inquiry in teaching mathematics and Danish, (2) developing inquiry-based teaching activities for a four-month mathematics teaching approach for 4th and/or 5th grade implemented at 107 schools, and (3) testing the effect of the intervention with a Random Controlled Trial. The control schools and intervention schools are randomly selected with respect to geography, size and ethnicity. They participated with 2-4 classes each, the intervention concerns all lessons in mathematics for a whole semester. The control schools only participated in the tests.

Initial investigations and design principles

The literature survey (Dreyøe, Larsen, Hjelmberg, Michelsen, & Misfeldt, 2018) as a preliminary investigation of KiDM, was conducted to gain insight into the most important issues and main concerns associated with Inquiry Based Mathematics Education (IBME). A systematic search of six of the highest-ranked journals led to five important themes/issues: 1) The literature survey stresses that *communication in the mathematics classroom* should be facilitated as open, inquiring, and related to the students’ activities with a starting point in the students’ prior knowledge. 2) *Mathematical skills and competences* are critical to participation in inquiry-based teaching. The modeling view of problem activities especially holds the greatest learning potential for students in inquiry-based teaching. Inquiry-based teaching has a positive impact on students’ mathematical creativity. 3) The students should be allowed to *move in and out of the mathematical domain*, and hence it is important to use a wide spectrum of activities in teaching. This requires students to be flexible thinkers and prepares them to cope with situations outside of school. Furthermore, the literature survey contained examples of and knowledge about both 4) *tools and resources for planning and implementing inquiry-based learning*, and 5) *professional development and collaboration*. In relation to planning (4), the literature survey suggested that teachers should try to predict the students’ answers and prepare general and specific questions to scaffold, extend, and promote the students’ ability to generalize mathematical ideas. Regarding development and collaboration (5), it is worth noting that any change

to a teacher's approach is a lengthy process. By utilizing pre-planned teaching units, one can contribute to a teacher's ability to reflect on how IBME differs from his/her own approach to teaching.

Apart from surveying the literature, we also interviewed six supervisors in mathematics prior to developing the specific designs in KiDM (Michelsen et al., 2017). Diplomas (60 ECTS) in mathematics supervision have been available since 2009, and many schools have a local supervisor in mathematics who initiates changes and supervises fellow teachers. The supervisors are organized in a national network. The interviews revolved around similar themes and to the need for supporting teacher-teacher and student-student collaboration – “We need time to cooperate inventing and exploring”.

From the above, we formulated three principles which implications were important for the didactical intervention of the design for KiDM:

- Principle 1: An exploratory, dialogical, and application-oriented teaching method with room for student participation increases the effect of the student's understanding of mathematical concepts and develops appropriate ways of working.
- Principle 2: In order to enhance motivation and learning, we prioritize that the students' experience of the teaching and the content should be meaningful both from an internal mathematical perspective and from the perspective of the situation of application/inquiry.
- Principle 3: An exploratory, dialogical, and application-oriented teaching approach with room for student participation increases the possibility of implementing mathematical competences.¹

To assess the students' development of mathematical concepts and mathematical competences related to inquiry-based teaching, a pre- and post-test was used in intervention schools and control schools; student and teacher surveys were also conducted focusing on changes in the students' motivation and experiences and the teachers' extent of implementation and experiences, respectively.

The intervention

The inquiry-based mathematics intervention was developed in collaboration with school teachers, supervisors in mathematics, teacher educators, researchers, and professors in an iterative process during which the intervention was tested in a number of cycles in special development schools. The intervention was then tested in a pilot study in 14 schools and adjusted before the actual program began. The program runs for three subsequent semesters in the years 2017-2018. The results for the entire program are expected in 2019.

The KiDM intervention consists of a website that contains a detailed teacher's guide and accompanying student pages with various student activities that take into consideration students' prior experiences, students' opportunity for participation and appropriate ways of working with exploration, applications and mathematical competences especially communication, reasoning, and

¹ Mathematical competences (Niss & Højgaard, 2011) is a key concept in the Danish curricular standards.

modeling (principle 1, 2 and 3). In addition to activity descriptions, the teacher's guide also contains specific instructions on how the activities should be introduced, what hints can be given along the way, and how the collective discussion should be designed. The activities are designed to be open for the pupils to engage in mathematizations on a number of different levels. One example of such an activity is to count the number of books in the local library, where the pupils are invited to develop strategies for addressing this question in a structured manner. In Figure 1 we see the activity "How many knots?", where students produce their own data sets by tying knots on a string. The students start by tying as many knots as they can in one minute. Afterwards, every student must count how many knots each have made. In groups of 3–4, students must make charts of the numbers. The assignment is: "If a man comes through the door and asks how many knots a student in this class can tie in one minute, what could you tell him?"



Figure 1: Strings from the activity "How many Knots?"

In the above example, the students' participation is crucial; they create and use their own data. In a meaningful, explorative way of working they get the opportunity to reason about the data, communicate their result by developing their own model.

All supervisors and teachers in the intervention are required to participate in three project meetings during the semester; they are also required to participate in three group meetings with all school mathematics teachers. All the meetings are clearly facilitated in detail on the website, where short video clips are viewed and discussed in the group meetings. Finally, there is an evaluation sheet that must be completed after each meeting. The group meeting focuses on the establishment of IBME teaching, the action phase in IBME teaching, and the validation phase in IBME education. For instance, the teachers and the supervisors reflected on the validation phase of the lessons they have tried out. The supervisor in mathematics is essential for the implementation by arranging, facilitating and evaluating these structured meetings. Lastly, the intervention teachers, supervisors, and, if possible, the headmasters participate in an all-day introductory meeting focused on the intervention, including both didactical and practical organization of the project, and an all-day evaluation meeting at the regional university. During the intervention, one teacher educator or one researcher will visit the school; this visit may focus either on observation of lessons or participation in a group meeting or project team meeting. The schools receive a stipend for each class participating in the project to cover expenses.

KiDM as an implementation project

In the following section, we will provide some concepts from implementation research and try to use them as a lens to investigate KiDM as an implementation project. We build on the definition of

implementation research from the work of Century and Cassata (2016,) as: “systematic inquiry regarding innovations enacted in controlled settings or in ordinary practice, the factors that influence innovation enactment, and the relationships between innovations, influential factors, and outcomes” (p. 170). Century and Cassata (2016) provided a description of important factors for the implementation of educational innovations. These factors are related to (1) *the users*, (2) the broader *organization*, (3) the *actual innovation*, (4) the *strategies supporting* its implementation, and (5) the *timewise dimension* of the implementation. In relation to the individual end users, we should be aware that the changes that educational innovation aims for are mediated by the people involved in the implementation process and aimed at their “change”. Century and Cassata (2016) distinguished the characteristics of individuals that build on their relation to the innovation (such as prior experience with the approach) from the characteristics of individuals that exist independently of the innovation (such as willingness to try new things). What Century and Cassata (2016) referred to as organizational and environmental factors are both characteristics of the specific setting (e.g., the classroom, the colleagues at the school) and to the broader ecology it sits in (e.g., the municipality or school district). Furthermore, these factors can also be completely outside the specific school or district (e.g., national policies). We can also distinguish between the actual and the perceived attributes of the innovation. This distinction highlights the difference between the explicit blueprints and detailed plans and the subjective (and often diverse) experiences of using these plans. The last factor that Century and Cassata (2016) discussed is implementation over time. Time is always a factor in the implementation and diffusion of practices and innovations.

Methods and data

The supervisors were responsible for the local implementation of the KiDM project and they were in charge for the evaluation sheets developed by the project, concerns implementation of KiDM, e.g. the explication of the teacher guide and inquiry-based teaching in general, e.g., key issues and challenges. To understand the status and challenges of KIDM as an implementation project we use the lens from Century and Cassata (2016). In the following section, we use the five factors from above to analyze our project. By reviving and coding the free-text information from the supervisors’ evaluation sheets that the local supervisors wrote as part of the documentation of the group meetings and project meetings. The sentences (i.e., citations) were categorized first individually by the first and second author of this paper according to the five factors but also in connection to enablers and constraints in implementation. Afterwards the coding was discussed in the whole group.

Characteristics of individual end users of KiDM

The end users of the KiDM project are teachers of mathematics, supervisors in mathematics at the participating schools, and students. Intervention schools were randomly selected according to a number of parameters, and therefore, we assume that we consider all types of mathematics teachers. However, there was a request that teachers had mathematics as their main subject and teaching experience in mathematics. This request was not met for all schools. Another request was that the school provide a coordinator who is a supervisor in mathematics. Some schools were unable to fulfill this, and their coordinators were participating teachers or the headmaster. We take into consideration the heterogeneity of the teachers by being very explicit with detailed plans in the teacher’s guide.

However, in terms of explication, there were still challenges, “It is very hard for a teacher who doesn’t have math as their main subject to read the teacher’s guide”. In a similar vein, “Preparation of the activities is hard work. We are only two educated math teachers in a group of six teachers, so we have to do most of the work”. Others found the material to be very explicit, “The didactic description is very thorough. A teacher who doesn’t have math as their main subject would be able to teach if he had the time and opportunity to read the description”.

The teachers are a critical part of the end users and the data we currently have suggest that one important aspect of the project’s ability to satisfy this group is to provide enough information so that the instructions are clear (since inquiry-based approaches are new to some of the teachers) while not providing so much information that the workload becomes too great.

Organizational and environmental factors

The project is funded by the Danish Ministry of Education and supported by the Danish Union of Teachers. The school receives a stipend, which covers extra time for preparation and participation in meetings; this is important for the participants, “We have spent a lot of time reading the teacher’s guide. If there had been no extra time given in the project, we would not be able to use such an extensive teacher’s guide”.

The intervention is planned in accordance with the national curriculum, yet some of the participants questioned the extent of this, “Do we meet the needs for the National Test?” and “Are the curriculum in play equivalent to half a year’s work?”

As described above, the supervisors play an important role at most of the participating schools since they organize the meetings and local progress in the project. The project meetings are important for cooperation and for shift in collective attitudes: “We have cooperated far more than we have ever done”, “Wonderful to ‘nerd’ with mathematics at the meetings”, and “It has been liberating to be able to engage in discussions about mathematics and didactics at the group meetings”.

The important organizational factors are economic resources/time, legislative support, and collaborative structures. Furthermore, we can see that the supervisors in mathematics becomes critical as the person who plans and facilitates the activities.

Attributes of the innovation

The degree of specification of what teachers and students must do in KiDM is high. The operationalization is not left to the teachers to perform by themselves. This tight scaffolding can be seen as critical to the success of KiDM. On the homepage, the teachers have access to a teacher guide that includes specific questions to ask in all phases of the activities, the aims of the activities, and agendas for all project meetings and group meetings. The agenda includes questions for discussion, links to short videos to watch and discuss, and tasks to solve and discuss. The teacher’s guide has some flexibility in the material, for example, to differentiate between 4th and 5th grade or to include students who are especially talented in mathematics.

The teachers in the project have varying attitudes toward this detailed and tight operationalization; some teachers said that having a very strict teacher manual helped them in the beginning, but at the end of the intervention, some of the teachers did not follow the manual entirely.

Implementation support strategies

The implementation strategies in KiDM are very broad. One important strategy is the meetings held at the local schools, where the focus is on discussion, operational planning, and professional development among mathematics teachers at the school. There were various comments about the idea that the teachers in the project must present their work at the larger mathematical group meeting at the local schools – “It does not work. You cannot involve the entire school in something that three teachers participate in” – but most of the teachers responded very positively about these meetings – “We have discussed teaching and reflected about teaching and learning much more than we usually do. We hardly ever say, ‘How about page 87?’” The supervisor has an important role in these meetings because he/she must facilitate these meetings. If these meetings are not successful, it will affect the implementation at the school. The supervisor in mathematics can therefore be seen as a *change agent*. In addition, the KiDM teachers are given more time than usual for their lesson preparation and their extra meetings, which can also be considered an implementation strategy in the hopes that this additional resource can support further development of teachers.

Implementation over time

It is not yet possible to determine whether the teachers’ methods of inquiry-based teaching have been implemented, as the project is still ongoing. At this point, it is not possible to determine whether the teachers are at a specific developmental stage (from awareness to initial adoption to sophisticated innovation), but some teachers have stated that they already have ideas for how they will implement an inquiry-based approach in the future: “We have applied for a workday where all the math teachers will try to formulate a strategy for how to implement inquiry-based mathematics” and “All classes from the 1st to the 5th grade receive one extra hour per week. This hour must be used for inquiry-based mathematics”. However, there are other variables that also come into play, such as the involvement of school leadership: “It is a turning point, the head of school is interested”, or “We don’t have a final agreement for the continuation of the work with the head of school yet”. The involvement of the mathematics group at the school is also important over time: “Despite the skepticism at the start (from the teachers not participating in the project), everybody is much more positive about the project as well as discussing didactics topics at the meetings”.

Implementation as core stakeholders, resources, and an act of balancing

In answering our question about enablers and constraints for KiDM considered as a large-scale inquiry-based project in Denmark, we see at least three factors that are critical, namely core stakeholders, balance, and resources. The first is the existence of core stakeholders in this change; Denmark is lucky to have a relatively newly educated group of supervisors in mathematics that can act as such. In a survey initiated by the Danish Ministry of Education (Mogensen, Rask, Lindhardt, Østergaard, & Rostgaard, n.d.), supervisors seem to be very influential in implementing government initiatives. The supervisors and group meetings are crucial organizational factors in KiDM. Hence, the supervisors in mathematics have the potential to act as change agents in future large-scale implementations. The second factor that we see as critical is the existence of time and money to support the work. This is stressed repeatedly by the participants. However, rather than just providing more money to the schools, we can see that the visibility of the project resources for the teachers

involved is critical, at least in our case. Therefore, necessary resources should be available to the end users (in this case, the teachers). The last factor is that of *balance* between well-prepared material/structures and the freedom to change and modify. In this project, we have been quite precise about what has been prepared, and this has worked particularly well when teachers and supervisors adopted the approach and made it their own.

These three themes have been in the way that we describe the envisioned output and evaluation criteria of the project and hence as a part of the theory of change of the project.

References

- Century, J., & Cassata, A. (2016). Implementation research: Finding common ground on what, how, why, where, and who. *Review of Research in Education*, 40(1), 169–215.
- Dewey, J. (1938). *Logic: The theory of inquiry*. New York, NY: Holt.
- Dreyøe, J., Larsen, D. M., Dreier Hjelmberg, M., Michelsen, C., & Misfeldt, M. (2018). Inquiry-based learning in mathematics education: Important themes in the literature. In E. Norén, H. Palmér, & A. Cooke (Eds.), *Nordic Research in Mathematics Education: Papers of NORMA 17* (pp. 329–337). Stockholm, Sweden: Swedish Society for Research in Mathematics Education.
- Freudenthal, H. (1991). *Revisiting mathematics education. China lectures*. Dordrecht, The Netherlands: Kluwer.
- Krainer, K., & Zehetmeier, S. (2013). Inquiry-based learning for students, teachers, researchers, and representatives of educational administration and policy: reflections on a nation-wide initiative fostering educational innovations. *ZDM Mathematics Education*, 45(6), 875–886.
- Michelsen, C. Dreyøe, J., Hjelmberg, M., Larsen, D., Lindhart, B. & Misfeldt, M. (2017). *Forskningsbaseret viden om undersøgende matematikundervisning* [Research based knowledge about inquiry-based mathematics teaching.] Retrieved from http://vbn.aau.dk/files/265214078/Vidensnotat_matematik_2.PDF
- Mogensen, A. (2011). *Point-driven mathematics teaching. Studying and intervening in Danish classrooms*. (Doctoral dissertation). Roskilde University. IMFUFA-tekst: i, om og med matematik og fysik, No. 484. Retrieved from <http://milne.ruc.dk/imfufatekster/pdf/484web.pdf>
- Mogensen, A., Rask, L., Lindhardt, B., Østergaard, K., & Rostgaard, P. (n.d.). Fagteamsamarbejde og matematikvejlederfunktion i grundskolen. [Subject specific team collaboration and the function of math-councillors in primary school.] København, Undervisningsministeriet.
- National Research Council. (1996). *National science education standards*. Washington, DC: National Academy Press.
- Niss, M., & Højgaard, T. (2011). Competencies and mathematical learning. Ideas and inspiration for the development of mathematics teaching and learning in Denmark. Roskilde: Roskilde University. IMFUFA-tekst: i, om og med matematik og fysik, No. 485. Retrieved from https://pure.au.dk/portal/files/41669781/THJ11_MN_KOM_in_english.pdf
- Østergaard, L. D., Sillasen, M., Hagelskjær, J., & Bavnhøj, H. (2010). Inquiry-based science education – har naturfagsundervisningen i Danmark brug for det? [Inquiry-based science education – is it needed for Danish STEM teaching?]. *MONA*, 2010(4), 25–43.
- Papert, S. (1980). *Mindstorms. Children, computers and powerful ideas*. New York, NY: Basic Books.
- Schoenfeld, A. H., & Kilpatrick, J. (2013). A US perspective on the implementation of inquiry-based learning in mathematics. *ZDM Mathematics Education*, 45(6), 901–909.

Towards a common understanding of implementation research in mathematics education research

Andreas Lindenskov Tamborg

Aalborg University, Department of learning and Philosophy; alt@learning.aau.dk

Keywords: Implementation research, documentational genesis, implementation frameworks.

Introduction and aim

By reading the papers from TWG 23 in CERME 10, implementation research in mathematics education research appears to integrate diverse sub-fields from the community such as students' proportional reasoning, teachers' professional development, and curriculum design (Jankvist, Aguilar & Wæge & Ärleböck, 2017). Often, these fields are defined by different research objects, core questions, ongoing discussions and mainstream theoretical and methodological approaches. This is also evident in the papers where the research object being studied is reflected in the choice of theoretical framework, for example, a study of the implementation of proportional reasoning draws on theory of proportional reasoning (Ahl, 2017). This characteristic has several substantial benefits. Firstly, the domain-specific theories developed within sub-areas of mathematics education research have been refined for decades to study the specific objects or processes for which they are developed. Secondly, whether implicit or explicit, domain-specific theories within mathematics education research often involve concepts and a vocabulary to investigate and articulate implementation matters (Jankvist, Aguilar, M. S., Wæge, K., & Ärleböck, 2017). The use of different theories originating from diverse sub-fields, however, represents a threat in accumulating a solid foundation of knowledge. The aim of this poster is to show that explicitly relating domains-specific theories to implementation research can contribute in overcoming this potential pitfall while simultaneously preserving the advantages of using domain-specific and well-established frameworks. For this poster, I will illustrate how the documentational approach to didactics' (DAD) (Gueudet & Trouche, 2009) perspective on implementation can be articulated by taking an outset in Century and Cassata's (2016) definition of implementation research.

Theoretical frameworks

Century and Cassata (2016) define implementation research as:

(...) the systematic inquiry regarding innovations enacted in controlled settings or in ordinary practice, the factors that influence innovation enactment, and the relationships between innovations, influential factors, and outcomes. (Century & Cassata, 2016, p. 170)

This definition involves four central elements, namely enactment, factors of influence, innovation and outcome. *Enactment* refers to a given end user's usages of what is being implemented. The *innovation* is what is being implemented, and it might appear in the form of a concept, training program, technology, etc. *Factors of influence* are what affects the enactment and may be attributes of the end user, organizational/environmental factors etc. Finally, *the outcome* is the result of implementation. It is a central point of Century and Cassata (2016) that these four elements are conceptualized and investigated differently in implementation research, as the aim, context and

theoretical approach of a given research question shapes the understanding of these concepts differently.

Central concepts in a framework called DAD can be considered an interpretation of the four elements in this definition of implementation. DAD is developed to study mathematics teachers' appropriation and usage of resources and considers the result of teachers' combination of resources, usages, and knowledge a document (Gueudet & Trouche, 2009). The framework draws on an understanding of resources as "a range of (...) human and material resources, as well as mathematical, cultural, and social resources" (p. 210). Teachers' work with resources is considered dialectic, where usages and resources mutually affect each other (Gueudet & Trouche, 2009). A *document* is defined as the combination of resources, usages, and knowledge. In DAD, teachers' enactment of digital learning platforms are goal-oriented appropriation and usage of resources. The innovation may be the resource, which a teacher use. The outcome may be considered the documents that are produced, and the implications that these might have for teachers' teaching and pedagogical work. In DAD, the influencing factors can be considered emerging instrumentations and instrumentalizations, which may be caused by resources, students, and teachers' interpretation of the learning platform or the like. Moreover, implementations of innovations are considered a bidirectional process where the user may affect the innovations, but the innovation may also affect the user. To synthesize the research results in implementation research as an independent sub-field in mathematics education research there is a need for a consistent vocabulary. In this poster, I have suggested using Century and Cassata's definition of implementation research to create common grounds. Using such an approach can synthesize results generated from diverse frameworks that are otherwise difficult to integrate.

References

- Adler, J. (2000). Conceptualising resources as a theme for teacher education. *Journal of Mathematics Teacher Education*, 3(3), 205–224.
- Ahl, L. M. (2017). Designing a research-based test for eliciting students' prior understanding on proportional reasoning. In Dooley, T., & G. Gueudet (Eds.), *Proceedings of the Tenth Congress of the European Society for Research in Mathematics Education* (pp. 3784–3791). Dublin, Ireland: DCU Institute of Education Dublin University and ERME
- Century, J., & Cassata, A. (2016). Implementation Research: Finding Common Ground on What, How, Why, Where, and Who. *Review of Research in Education*, 40(1), 169–215.
- Gueudet, G., & Trouche, L. (2009). Towards new documentation systems for mathematics teachers? *Educational Studies in Mathematics*, 71(3), 199–218.
- Jankvist, U. T., Aguilar, M. S., Wæge, K., & Ärlebäck, J. B. (2017). Introduction to the papers and posters of TWG23: Implementation of research findings in mathematics education. In Dooley, T., & G. Gueudet (Eds.), *Proceedings of the Tenth Congress of the European Society for Research in Mathematics Education* (pp. 3776–3783). Dublin, Ireland: DCU Institute of Education Dublin and ERME
- Nilsen, P. (2015). Making sense of implementation theories, models and frameworks. *Implementation Science*, 10(53), 1–13.

Capturing Problem Posing landscape in a grade-4 classroom: A pilot study

Ioannis Papadopoulos¹ and Nafsika Patsiala²

¹Aristotle University of Thessaloniki, Greece; ypapadop@eled.auth.gr

²Aristotle University of Thessaloniki, Greece; npatsiala@eled.auth.gr

In this pilot study, grade-4 students in a Greek primary school are invited to pose problems in three different situations (no feedback, peers' feedback, teacher's suggestions). The aim was to capture the problem posing landscape of the classroom in terms of the complexity of the problems the student pose in these situations. The posed problems were examined in terms (a) of mathematical complexity in the sense of the number of semantic relations they involve, and (b) of linguistic complexity. The findings give evidence that as the students become progressively aware of the initial problem's attributes, they start to pose more complex problems by increasing both the number of problems that involve at least 2 semantic relations and the number of linguistic instances.

Keywords: Problem posing, primary school, mathematical complexity.

Introduction

Problem posing has been recognized as an important intellectual activity in school mathematics and integral part of a balanced mathematics curriculum (Hansen & Hana, 2015). The truth is however, that in the school setting students are merely asked to solve problems rather than pose (Stoyanova, 2003), and therefore they often face difficulties in posing mathematical problems (Silver & Cai, 1996). Even though research findings support that students are capable of posing interesting and important mathematical problems (Cai, Hwang, Jiang & Silber, 2015) most of these problems are mainly cognitive undemanding and textbook-like (Crespo & Sinclair, 2008). This contradiction makes apparent the potential role of an intervention and many research studies (Crespo, 2003; English, 1998) seem to agree that a proper intervention might help students to learn posing problems given that they already have experience in solving problems similar to those they are asked to pose and actually this highlights also the teacher's role in this process.

In this paper, we make a preliminary effort to capture the problem posing landscape in a Greek grade-4 classroom in terms of the complexity (mathematical and/or linguistic) of the generated problems in a variety of situations. The findings will feed the design of a year-long intervention aiming to foster the students' problem posing abilities. Thus, our research question is: How the level of complexity in the problems posed by primary school students varies according to the setting in which the problem posing takes place?

Literature Review and Theoretical Framework

'Are students able to learn to pose problems?' If yes, what is the proper way to achieve that? Brown and Walter (1983) claim that problem posing can be taught. For each problem students can ask what kind of information the problem gives us (known), what kind of information is unknown and what

kinds of restrictions are placed on the answer. Then many new problems can be generated if the solvers remove, change or loosen the restrictions. In essence, solvers are asked to list the attributes of the problem, to take an attribute and ask “What-If-Not” that attribute.

Exploring students’ problem posing performance is not new (English, 1998; Silver & Cai, 1996). Research findings reveal that even primary school students are able to pose good/meaningful mathematical problems. Lowrie (2002) claims that through a supportive and motivating learning environment, grade-1 students increasingly generated more sophisticated problems that were open-ended in nature. Gade and Blomqvist (2015) worked with grade-4 and grade-5 students who posed problems in three different stages (formulating written questions, problem posing in dyads and posing problems to one another) using slips of papers. Through these three stages, remarkable progress was made so as in the problems posed by the students as well as in the way they used the slips of papers. Chen, Van Dooren and Verschaffel (2015) implemented a training program aiming to develop grade-4 Chinese students’ problem-posing abilities. After the implementation, the problems generated from the students were significantly better proving that elementary students can be taught to pose better and meaningful problems. Cifarelli and Sevim (2015) connect the development of the problem posing abilities with successful problem solving. By focusing on episodes of two grade-4 students they explain how both problem posing and solving coevolve during the solution activity and also how the development of problem posing abilities contributed beneficially in the students’ problem-solving abilities, too.

According to the literature the problems posed by students can be more interesting when they have been previously solving similar problems themselves, when the posed problems are addressed to people outside the classroom and when they are prompted by informal instead of formal symbolic contexts (Crespo, 2003; English, 1998). Winograd (1997) working with fifth-grade students found that they were highly motivated to pose problems that their classmates would find interesting or difficult without losing their interest during the process of sharing posed problems. Problem posing is rather redefining the way students learn mathematics since they are actively engaged in the learning process by being encouraged to set questions and generate problems instead of being passive receivers of knowledge (Brown & Walter, 1983).

The problems posed by the students can be evaluated on the basis of three criteria (Silver & Cai, 2005): Quantity, Originality and Complexity. Quantity refers to the number of the generated problems. More specifically, the number of the mathematically correct problems may be indicative of the progress the students accomplished. Originality refers to the number of unusual responses and thus rareness is a way to measure it (they refer to these answers as atypical or original). The third criterion, complexity, can be examined at least from two different perspectives: the mathematical and linguistic complexity. Linguistic complexity focuses on linguistic structures (presence of an assignment, relational and conditional propositions in the statement of the problem). Mathematical complexity is related to the mathematical structure found in the posed problems and one plausible way to measure it is by enumerating distinct semantic relations using a classifications scheme of arithmetic word problems developed by Marshall (1995). This includes five categories of relations: Change, Group, Compare, Restate, and Vary. The Change schema applies when an initial quantity changes over time (increase or decrease). The Group schema relates to a situation where a number of small quantities are combined into a larger one. The Compare schema involves situations where two

things are contrasted with an emphasis on the relation between them (greater, smaller, more, less, etc.). Restate schema involve situations where there is a relation between two variables at a given frame only (e.g., exchange rates). Finally, Vary schema involves a fixed relationship between two variables that persists over time (e.g., relation between euros and cents).

Mathematical complexity has attracted the interest of several researchers on problem posing. According to Silver and Cai (1996) the complexity of the problems posed by the students tend to increase when students generate sequences of chained problems using the results of the simpler problems to pose more complicated ones. Ellerton (1986) comparing the problem posing abilities of high- and low-ability students found that high-ability students generated more complex problems. Finally, it seems that certain interventions influence the quality of the generated problems (Crespo, 2003; English, 1998). English (1997) conducted an intervention to grade-5 students and found that after the program the students posed a greater number of problems that were also more complex.

Design of the study

This study is the first in a series of small pilot studies aiming to capture the landscape of Greek primary students' problem posing abilities. The students were asked to pose problems in three different settings to compare the variation on the complexity of the problems posed in each setting. Apart from the first setting, the following two settings were developed during the implementation taking into consideration the students' answers. Eighteen grade-4 students from a private school participated in this study. The intervention took place in parallel to the normal teaching of mathematics in the sense that an hour per week is dedicated in math tasks aiming to develop students' mathematical thinking. The students had no prior experience on relevant problem posing activities.

In the first phase, the students were given the starting sentence of a potential problem: "Peter has 75 cents..." and they were asked to complete the problem in as many as possible different ways without having to solve their problems afterwards. Silver and Cai (2005) consider this kind of activities appropriate for assessing students' problem posing abilities. The teacher did not give any clue about the operations or the mathematical concepts the students could involve in the produced problems. This session was followed by a whole class discussion and the students had the chance to present their examples. One of the students presented an example that initiated the second phase of the study. In his example he actually dropped an attribute of the problem using a "What-If" approach and produced a problem that attracted the attention of his peers. The attribute was the kind of currency and his question was "What if instead of euros the currency was lev?" (the currency of the adjacent country of Bulgaria).

Based on his suggestion the students were asked to pose new problems in the same spirit using the same "What-if" technique of their classmate even though they did not have similar experience before (2nd phase). No discussion on the notion of listing and dropping attributes took place. Again, a whole discussion followed the session and the students presented their problems.

Finally, during the third phase, certain attributes were explicitly provided to the students by the teacher. More precisely, the teacher asked them to pose problems by considering certain attributes such as the total number of coins, the kind of the coins/currency and the value of coins.

The problem in its incomplete form makes apparent one attribute in an explicit way: the total amount of money. Therefore, students are left to involve and negate more attributes that could potentially be part of the problem such as the number or the kind of coins.

The students' worksheets with the problems they generated during the three phases constituted the data for this study. The written responses were analyzed based on the assessment tools developed by Silver & Cai (2005) and Marshall (1995). According to these tools, the responses are organized in three major categories depending on whether the questions included in the problem were mathematical, nonmathematical or whether there was merely a statement in the problem rather than a question. Then, the mathematical questions were evaluated on their solvability (solvable and nonsolvable). Finally, the solvable ones were examined for indications of mathematical and/or linguistic complexity. We determined how many of the five semantic structural relations (Marshall, 1995) co-existed in each problem. Problems that involved a larger number of semantic relations are considered more mathematically complex compared to those that involve less relations. A comparison followed across all the three phases. All the responses were evaluated independently by the two authors and validity and reliability were established by comparing sets of independent results, clarifying categories until agreement.

Results and Discussion

Phase One

As already mentioned, during the first phase of the study, the students were given the first sentence of a problem and were asked to pose as many as possible problems without feedback neither from their classmates nor their teacher. Each student posed one or two problems. Table 1 summarizes the results of the first phase. All the mathematically complex problems are distributed further according to whether they involved 1, 2 or 3 semantic relations. Moreover, sometimes linguistic and mathematical complexity might co-exist in the same problem and this explains why the partial sums in Table 1 are not in agreement with the total number of solvable problems.

Total number of Responses: 23				
Nonmath Questions: 0	Math Questions: 22			Statements: 1
	Solvable: 19		Nonsolvable: 3	
	Math Complex. 19		Ling Complex. 2	
	1 relation	2 relations	3 relations	
	8	8	3	

Table 1: Results of Phase-1

As it can be seen, in this phase most of the responses (19 out of 23) were solvable problems exhibiting to a certain degree mathematical and/or linguistic complexity. The problems more or less copy the problems the students are familiar with and are included in their mathematics textbooks. Mainly they were problems including 1 or 2 relations that could be solved in one or two steps using more the addition and/or subtraction operations (instead of multiplication or division). One example with 1

relation was: *Peter has 75 cents. He gave 30c to one poor child and later he gave 7c to another. How much are left?* (1 relation, Change). Another example including 2 relations was: *Peter had 75c. His grandmother gave him 95c but later took 25c from him. His grandfather gave him two more euros but took 125c from him. How many euros will Peter have?* (Change, Vary). This problem combines addition/subtraction to find partial results (Change) but at the same time the concurrent use of cents and euros involves converting cents to euros and vice versa (Vary) which means that multiplication and/or division (depended on how the problem will be solved) are also necessary. Another example of mathematically complex problem which exhibited three semantic relations (change, group and vary) exhibiting at the same time linguistic complexity was: *Peter has 75c. At New Year's Eve his dad gave him 87€ and 46c. In March he bought 8 gums per 27c each. In April he bought an ice cream for 36€. Two weeks ago, he bought a skateboard for 19€ and 29c. a) How much money did he spend on February in order to have 75c now? b) How much € did all the gums cost? and c) How much did he spend for all of them?* The solver has now to interpret the existing information. 'New Year' refers to January and the chain of expenses refer to the period from January to May (the 'two weeks' is related to the time the session took place in school. It was during May). However, February is not mentioned. The initial amount of money is interpreted as the money Peter owns and the end. So, it is a multistep problem involving almost all the four operations and requires thought and interpretation of the information provided by the statement of the task.

There was finally an instance (1 out of 22) the students made a statement. That was: *Peter had 75 cents. He wants to buy a toy for 100€.* It is obvious that the student did not pose any question. During the whole classroom discussion one student posed the question (addressing it rather to the teacher than his classmates): *'What if instead of euros the currency was lev? Would you be able to solve the problem?'*. As already has been mentioned this question initiated the next phase.

Phase Two

During Phase 2 the students were invited to generate new problems in the spirit of the 'What-if' approach exhibited by their classmate in the previous phase. There was not any explicit reference to the list of the problem's attributes and their negation. The results of this phase are summarized in Table 2.

Total number of Responses: 21				
Nonmath Questions: 1	Math Questions: 18			Statements: 2
	Solvable: 16		Nonsolvable: 2	
	Math Complex 16		Ling Complex 0	
	1 relation	2 relations	3 relations	
	8	7	1	

Table 2: Results of Phase-2

Most of the students' responses were solvable problems (16 out of 21). There was only one problem asking a question that was considered nonmathematical: *Peter has 75 cents. What if he loses all of his money and cannot buy anything?* Furthermore, no linguistic complexity was detected in the students' responses in this phase.

What is interesting is that almost all the students followed the instruction to use the ‘What-If’ approach but actually they copied the problem of their classmate in the sense that they just focused and/or negated the attribute of currency. For example: *Peter has 75 cents. What if Peter had a friend from Japan and he wanted to trade yen with 75c?* (restate). Or in another example: *Peter has 75 cents. What if his money was alien money. If an alien cent has the same value as 9€ and wants to buy a wallet which costs 49€, how much change will he get?* (restate and change). In these responses, the students engage the potential solver with currency conversions (which means true statements for a short period of time), and the solution of the posed problem relies heavily on the relationships between the two currencies. During the whole classroom discussion, the teacher shifted the focus on identifying and negating more attributes of the problem and this initiated the third phase of the study.

Phase 3

During this phase of the study, certain problem’s attributes were provided to the students such as the number, value and kind of the coins and they were asked to consider them in order to pose new problems. The results of this phase are summarized in Table 3. An example of a ‘What-If’ approach considering the kind of coins was: *Peter has 75 cents. If he only has 5c coins, how many coins are in his pocket?* (vary). It looks like a common problem. However, the choice of division as the necessary operation to solve the problem is not met frequently in the students’ responses. An example of a moderate complex problem in this phase is: *What if there were also 7€ and 16€ coins and Peter has in his pocket sixteen 7€ coins and three 16€ coins. He spent 5.27€ and then lost 3.25€? How many euros are left? How many cents are they?* (Change, Vary, Group). The solver must be familiar with this new element of the weird coins that is not common at our linguistic repertoire and then must relate euros with these new coins and depending on the strategy there will be necessary to use multiplications and/or divisions for the interplay between euros and cents.

Total number of Responses: 32				
Nonmath Questions: 1	Math Questions: 31			Statements: 0
	Solvable: 29		Nonsolvable: 2	
	Math Complex 29		Ling Complex 8	
	1 relation	2 relations	3 relations	
	9	16	4	

Table 3: Results of Phase-3

The students’ awareness of the attributes of the problems seems to stimulate both the number and the quality of the posed problems. There was a noticeable increase in the number of the problems (almost 1,5 times more). More precisely, the number of problems that include at least 2 relations was 20 out of 29 problems. This increased number of semantic relations (Silver & Cai, 1996) indicate the presence of mathematical complexity. Furthermore, in this phase, there was a significant number of instances (8 problems) exhibiting a sense of linguistic complexity: *Peter has 75 cents. Is it possible to have only 2c coins?* The linguistic element in this problem is that its question differs significantly from the ones posed in the first two phases. The word “possible” must be interpreted correctly given

that the participants are grade-4 students and a certain language competency is required to negotiate phrases such as “at least”, “possible”, “the more” that are included in mathematical problems.

Conclusion

The purpose of this (first among others that will follow) pilot study was to capture the landscape of problem posing in a Greek grade-4 classroom in order to setup a year-long intervention in the classroom aiming to develop the problem posing abilities of the students. The students were invited to pose their problems in three different setting and the results give evidence that given certain circumstances grade-4 students can pose interesting mathematical problems. Almost all the students were able to pose mathematical questions. Only a couple of statements or nonmathematical questions were identified. Moreover, the complexity and the sophistication of the generated problems tend to increase along with the evolution of the sessions.

During the first phase of the study, students posed without any external influence a series of solvable problems. Most of these solvable problems included one or two semantic relations resembling textbook like problems dealing with the four operations and specifically addition and subtraction which is in accordance with Crespo and Sinclair (2008). There were also a few instances of three relations or linguistic complexity signs that were identified in some of the answers.

In the next phase of the study, a “What-if” technique was used by one of the students who negated the currency attribute of the problem. This was an opportunity to invite students posing new problems under the light of this new approach. The situation was more or less similar to the previous one, and the posed problems were merely mimicking the one posed by their classmate. So, the students did actually drop the attribute of currency not as an action of negating the structural elements of the task but as a way to follow an example that seemed to be successful. No signs of problems’ linguistic complexity were identified.

During the final phase of the study, the students became aware of certain attributes that were highlighted by the teacher. This awareness seemingly helped the students to increase the number of posed problems increasing at the same time the number of the involved semantic relations per problem. Also, more evidence of linguistic complexity emerged.

Given the lack of any relevant experience on problem posing and its strategies the students were able to take advantage of the feedback provided during the whole classroom discussion either from their peers or their teacher. This feedback actually shifted their attention to specific attributes of the task. It is very interesting that the students’ answers determined the design of the next two phases. This study, being a pilot one, feeds the design of a future intervention aiming to create a class environment that will encourage students to raise questions and pose problems. This small-scale study encourages the idea that a systematic teaching on problem posing may develop students’ posing abilities which is in alignment with English (1997).

References

Brown, S. I., & Walter, M. I. (1983). *The art of problem posing*. Hillsdale, NJ: Lawrence Erlbaum Associates.

- Cai, J., Hwang, S., Jiang, C., & Silber, S. (2015). Problem-posing research in mathematics education: Some answered and unanswered questions. In F. Singer, N. Ellerton & J. Cai (Eds.), *Mathematical problem posing. From research to effective practice* (pp. 3–34). New York, NY: Springer. doi: 10.1007/978-1-4614-6258-3_1
- Chen, L., Van Dooren, W., & Verschaffel, L. (2015). Enhancing the development of Chinese fifth-graders' problem-posing and problem-solving abilities, beliefs, and attitudes: A design experiment. In F. Singer, N. Ellerton & J. Cai (Eds.), *Mathematical problem posing. From research to effective practice* (pp. 309–329). New York, NY: Springer. doi: 10.1007/978-1-4614-6258-3_15
- Cifarelli, V. V., & Sevim, V. (2015). Problem posing as reformulation and sense-making within problem solving. In F. Singer, N. Ellerton & J. Cai (Eds.), *Mathematical problem posing. From research to effective practice* (pp. 177–194). New York, NY: Springer. doi: 10.1007/978-1-4614-6258-3_8
- Crespo, S. (2003). Learning to pose mathematical problems: Exploring changes in preservice teachers' practices. *Educational Studies in Mathematics*, 52(3), 243–270. doi: 10.1023/A:1024364304664
- Crespo, S., & Sinclair, N. (2008). What makes a problem mathematically interesting? Inviting prospective teachers to pose better problems. *Journal of Mathematics Teacher Education*, 11(5), 395–415. doi: 10.1007/s10857-008-9081-0
- Ellerton, N. F. (1986). Children's made up mathematics problems: A new perspective on talented mathematicians. *Educational Studies in Mathematics*, 17(3), 261–271. doi: 10.1007/BF00305073
- English, L. D. (1997). The development of fifth-grade children's problem-posing abilities. *Educational Studies in Mathematics*, 34(3), 183–217. doi: 10.1023/A:1002963618035
- English, L. D. (1998). Children's problem posing within formal and informal contexts. *Journal for Research in Mathematics Education*, 29(1), 83–106. doi: 10.2307/749719
- Gade, S., & Blomqvist, C. (2015). From problem posing to posing problems via explicit mediation in grades 4 and 5. In F. Singer, N. Ellerton & J. Cai (Eds.), *Mathematical problem posing. From research to effective practice* (pp. 195–213). New York, NY: Springer. doi: 10.1007/978-1-4614-6258-3_9
- Hansen, R., & Hana, G. M. (2015). Problem posing from a modelling perspective. In F. Singer, N. Ellerton & J. Cai (Eds.), *Mathematical problem posing. From research to effective practice* (pp. 35–46). New York, NY: Springer. doi: 10.1007/978-1-4614-6258-3_2
- Lowrie, T. (2002). Designing a framework for problem posing: Young children generating open-ended tasks. *Contemporary Issues in Early Childhood*, 3(3), 354–364. doi: 10.2304/ciec.2002.3.3.4
- Marshall, S. P. (1995). *Schemas in problem solving*. New York: Cambridge University Press.
- Silver, E. A., & Cai, J. (1996). An analysis of arithmetic problem posing by middle school students. *Journal for Research in Mathematics Education*, 12(3), 521–539. doi: 10.2307/749846
- Silver, E. A., & Cai, J. (2005). Assessing students' mathematical problem posing. *Teaching Children Mathematics*, 12(3), 129–135.
- Stoyanova, E. (2003). Extending students' understanding of mathematics via problem posing. *Australian Mathematics Teacher*, 59(2), 32–40.
- Winograd, K. (1997). Ways of sharing student-authored story problems. *Teaching Children Mathematics*, 4(1), 40–47.

Models of school governance and research implementation.

A comparative study of two Swedish cases, 1960–2018

Johan Prytz

Uppsala University, Department of Education, Uppsala, Sweden; johan.prytz@edu.uu.se

This paper concern the role of research and models of governance in two Swedish reform programs: the New Math project in the 1960s and 70s and the Boost for Mathematics project in the 2010s. This historical comparison study aims to deepen our understanding of how research results in mathematics education are implemented in Swedish schools today. Theory and results from implementation research are used to pinpoint and justify the choice of the object of analysis. The analysis focuses on the role of research and the researcher in the preparation of the two projects. The main sources are reports and governmental decisions concerning the two projects, but sources also include material used in these projects.

Keywords: Governance, Educational change, Educational research, Innovation, Implementation.

Introduction

Between 1960 and 2018, the policy of governance of Swedish schools has shifted from being primarily centralised to being primarily decentralised (Prytz, 2017). To a great degree, this shift meant that teachers had more autonomy to choose what teaching methods and teaching materials to use. For example, since 1994, the national curriculum does not provide guidelines about teaching methods. About the same time, the review of textbooks was abolished. However, little is known about how this overall change in governing policy has influenced how research findings are implemented in schools.

In Sweden, the development of research on mathematics education has paralleled the change from centralisation to decentralisation. The number of researchers has increased greatly and mathematics education has become an established field of research at most Swedish universities. However, this does not entail that research in mathematics education did not exist in the 1960s – it did. However, in the 1960s research was conducted to a large extent by the central school authorities rather than by researchers in universities. Perhaps it is not entirely correct to refer to this enterprise as research, but there was cooperation with researchers and the methodologies were similar to those found in educational research today.

The study presented in this paper deepens our understanding of how research results in mathematics education are implemented in Swedish schools today. To this end, this paper compares two historical cases: The New Math project (1960–1975) and The Boost for Mathematics project (*Matematiklyftet*) (2011–2016). The two projects differ in many respects, but they also share some characteristics: both projects were run by central school authorities and both emphasised teachers using research findings to develop teaching strategies. The analysis is descriptive and concerns how the implementation of these projects was prepared. The analysis and the research question address the function of educational science as a base of knowledge for designing teaching innovations.

More precisely, I describe different phases in the preparation process and the role of research in this process. Further details are presented in the section ‘Theory and method’.

The paper contains five sections: ‘Theory and method’, ‘Contribution to previous research’, ‘The New Math project’, ‘The Boost project’, and ‘Conclusions and discussion’. ‘The New Math project’ and ‘The Boost project’ sections include a short background of each project as well as a more detailed description of the role of research in each project. In ‘Conclusions and discussion’, the two projects are compared with each other and I discuss the role of research and modes of governance.

Theory and method

Innovation is a key concept in research about implementation as it is the innovation that is to be implemented (cf. Century & Cassata, 2016; Fullan & Pomfret, 1977). This paper concerns the preparation of the innovation. In an early overview on research about implementation and education, Fullan and Pomfret (1977) note that this phase can be determinant for the rest of the implementation process.

In a more recent overview, Century and Cassata (2016) discuss research about implementation and education and how innovation relates to knowledge. In an educational setting, knowledge can come from two sources: research and practice. This paper focuses on how educational research or science has functioned as a base of knowledge when innovations were designed; in brief, I call this the function of research.

In comparative historical studies in education and other subjects, it is imperative to have a common unit of comparison (Bray et al., 2007). In my analysis of the function of research in the two projects, the common unit is the researcher. The basic question of this paper is formulated as follows: How did researchers prepare the innovations? For example, the researchers can design the innovation by compiling results from other researchers outside of the project or the researchers can design the innovation by doing their own experiments or trials.

This analysis relies on official reports about the New Math project and the Boost project and teaching materials. However, when discussing the New Math project, I do not refer to the original sources but to a previous study, Prytz (2017), which includes an analysis of the New Math project in Sweden.

In addition, I analyse the organisational factors influencing the function of research. According to Century and Cassata (2016), these factors can influence the implementation of an innovation. In particular, I am interested in how policies of governance (centralisation or decentralisation) and scientific policies influenced the role of the researchers: How extensively have researchers been pursuing policies of governance and science?

As to the historical context of governance of each case, I have not done my own analysis but have relied on extensive previous research. Of course, there are different views on certain aspects, but there is strong agreement about the overall narrative: from about the mid-1970s up to about 2000, the policy of governance of the Swedish school system changed from mainly centralised to mainly decentralised. In all three areas of governance (economical, judicial, and ideological), the general

ambition was to give local actors the power to make decisions (e.g., local politicians, headmasters, or teachers). We also find this overall narrative in university textbooks and in research papers (see Prytz 2017 for an overview).

Contribution to previous research

Focusing on methodology, this paper shows how historical studies can be used in research about implementation and education. Historical comparison is a rarely used methodology in research about implementation and education as evident in its lack of mention in quite old as well as more recent international overviews (cf. Century & Cassata, 2016; Fullan & Pomfret, 1977). The lack of historical comparisons is also evident in the field of mathematics education, where implementation research is a fairly new topic. For example, historical studies about implementation have not been an issue at the previous CERMEs.

A principal argument of doing historical comparisons is that they provide perspectives on contemporary phenomenon, a view that cannot be attained through the study of contemporary sources alone. Typically, historical comparisons help bring into relief what is stable and what is not (cf. Tosh, 2000). This study found that the role of educational research and the researchers preparing reforms co-vary with basic policies of governance. This co-variance can be a problem if we believe that research should be autonomous and follow its own logic.

This paper also contributes to the research about the Boost project. As with this study, Boesen et al. (2015) focused on design and planning to examine how the project was informed by research. However, Boesen et al. considered how references were made to different types of research publications, whereas my study focuses on the role of researchers. Another difference is my historical perspective and my comparisons of policies of governance. The Boost project has also been evaluated two times and a third is on the way. One of the evaluations (Österholm et al., 2016) uses a scientific approach. Not in any of the evaluations, the preparation of the program and the role of researchers are considered; the focus is on the outcome.

The New Math project

The New Math can be seen as an international reform movement that aimed to innovate and improve school mathematics from year 1 to 12. The innovations were supposed to be based on contemporary science: The content of the teaching should be updated to reflect the advancement of the scientific discipline of mathematics, and teaching methods should be based on modern psychological and pedagogical research. By the end of the 1950s, the movement had accumulated great momentum. Internationally prominent researchers supported the project, including the mathematician Jean Dieudonné and the psychologists Jean Piaget and Jerome Bruner. In addition, international organizations such as OECD and UNESCO contributed by funding conferences and publishing reports (Prytz, 2017).

Quite early, Sweden became part of the movement. In the late 1950s, representatives from Sweden attended the international conferences on the New Math. In the early 1960s and in cooperation with other Nordic countries, except Iceland, development began on a new curriculum based on New

Math. The project was initiated, financed, and driven by central school authorities. These preparations lasted until 1968 (Prytz, 2017).

The role of the researchers during the preparations of New Math in Sweden was to lead and work in a research-like enterprise gathering and analysing extensive empirical data. The development of the innovations, which largely concerned the development of textbooks, was an extensive enterprise. The testing of new textbooks involved thousands of students in the Nordic countries. In addition, teachers completed questionnaires that addressed how teaching had progressed and how the material could be improved. In one part of the project, a new type of textbook based on New Math went through five rounds of development and trials. At the end of another part of the project, trials with experimental groups and control groups were conducted that lasted for two or three years. These trials ended with knowledge testing. The tests indicated that the new material was functional and which groups of students were served best by the new material (Prytz, 2017).

A central component of the New Math was set theory. The idea was that set theory, already from year one, should form the basis of all other areas of school mathematics, such as arithmetic, geometry, algebra, and statistics. The inspiration came from the scientific discipline of mathematics, where set theory functioned as a basis for other parts of mathematics. In school mathematics, however, it was not just a question of adding a common ground for the content of the courses; set theory also had an educational or methodological purpose. It was supposed to create clearer connections between the various topics, both for teachers and for students. In addition, explanations and illustrations should be based on concepts from set theory. Interestingly, concepts from set theory alone did not fill this role. The 1969 curriculum also emphasised the number line and images of numbers as positions on a number line (Prytz, 2017). Thus, the New Math project brought not only a general theory about teaching and learning, but also detailed guidelines about how teachers should communicate with students.

It was in connection with the methodological ideas about set theory that Piaget and Bruner were of particular significance. They argued that there are similarities between mental structures and mathematical structures, which they thought should be used in teaching. The idea was that a stronger focus on structures would provide better understanding, which in turn would result in better learning. Set theory, but also the number line, would provide a structure to create better learning. For this reason, set theory, along with the number line, should primarily be seen as a methodological innovation that concerned all parts of school mathematics (Prytz 2017).

However, Piaget's and Bruner's theories should be considered hypothetical guidelines. Few studies provided specific guidelines for how to design teaching. In the final report about the Nordic New Math project, we see only a few examples of these types of studies. A centre piece of that report is the development phase and the trials of new types of textbooks (Prytz, 2017).

In the 1970s, the reform was being implemented. The new curriculum based on the New Math was ready in 1969 and it took effect in 1970. By and large, all teachers in mathematics in year 1–9 received further education in New Math. A large majority of the textbooks followed the new curriculum (Prytz, 2017).

The Boost project

The Boost project was an in-service training program for teachers and was prepared between 2011 and 2012 and was launched in 2013. The final decision about launching the program was taken in 2012. It ended in 2016 although much of the material is still accessible through the central school authority's website. It was a major program as 76% of all mathematics teachers (1–12) followed the program (Source B). At this point, we can spot a great difference in comparison with the New Math project: the time allotted for preparations.

Unlike the international New Math movement, the Boost project was an all Swedish enterprise. The justification of the project was that the results of the Swedish students had decreased for about 15 years, according to national as well as international evaluations. This was clearly stated in the final government decision to start the Boost project (Source A). The results in PISA and TIMSS had indeed decreased significantly, especially in the ten years before the Boost project. In fact, the decrease was greater than in any other country.

The same government document identified the cause of the problems. On the basis of several investigations, the document concluded that students mainly worked alone with the textbook and too little of the teaching were led by teachers, limiting the possibilities to learn about reasoning and argumentation (Source A). This view of the problem was reflected in the overall aims of the project. The aims were to change the culture of teaching and develop a new in-service training culture (Source B). Neither the justification nor the aims of the project had any direct connections to the new curriculum that was launched in 2011.

The Boost project was administered by the central school authorities in co-operation with the national centre for mathematics education at Gothenburg University (Source A). To ensure scientific quality, the work to develop the educational material, so-called modules, was distributed among several university departments with research in mathematics education (Source B).

The basic principle for organizing the program was peer learning among teachers with support from external experts. Experts in this case were researchers at the university departments. However, experienced and highly skilled teachers led the peer learning sessions with the teachers (Source A). These experienced and highly skilled teachers received special training at the university departments for eight or nine days. As I understand it, the researchers' main responsibility was the teaching material and the special training of the highly skilled teachers.

The choice of a peer learning program was justified by a reference to a report issued by the Ministry of Finance (Åman, 2010). In turn, the author of that report referred to another report (Timperley, 2007) issued by the Ministry of Education in New Zealand, an international overview of research on teacher training. The report clearly recommended peer learning, but it provides no explicit recommendations about how researchers, or experts, and teachers should interact. However, the report implied that this relationship is crucial since it emphasised the importance of the content of the teacher training program; in fact, this was considered more important than anything else.

This leads us to the teaching material and how it was developed by the researchers. The material, or modules, comprised scientific articles in mathematics education along with films, audio clips, web

texts with instructions, and questions for lesson activities and peer learning (Source B). Each module covered one topic (arithmetic, geometry, etc.) in the curriculum. In addition, each module focused on four areas: abilities, formative assessment, interaction, and socio-mathematical norms.

The scientific articles in the modules included different types of texts: an international overview of each topic and the four areas mentioned above and articles about Swedish mathematics education. The later type of texts was by no means dominant (Source C). My point here is that the research results presented to the teachers largely did not stem from research on Swedish students and teachers.

One major role of the researcher was to use information from previous research to produce the modules. To secure high quality material, each module was also reviewed by several other researchers. According to the final report about the project, there were no trials of the modules with teachers before they were published and used (Source B). However, in the same report, it is stated that there were follow-ups (school visits, interviews, and surveys) after the publication and these resulted in revisions of the modules (Source B). To what extent and for how long these follow-ups lasted is unclear. Another report noted that there was a test round with 300 teachers in the autumn of 2012. The program was then launched in the autumn of 2013 (Source B). Thus, it appears there was only one round of trials where the teachers could provide the researchers with feedback.

Conclusions and discussion

The role of the researchers in the New Math project and the Boost project fits the narrative of an educational system that changed from a centralised to a decentralised system. In the New Math project, the state-financed researchers applied one specific theory about cognition and learning to find out what is efficient teaching in all subtopics for all school years. This research ended in detailed guidelines about how to teach all parts of mathematics such as how to explain new concepts and what type of illustrations or pictures should be used. These guidelines were then dispersed through the national curriculum. Thus, the decision about what is good teaching was centralised and the researchers were supposed to deliver detailed guidelines about teaching that all teachers were to apply. In the Boost project, much of the decisions related to learning and teaching were decentralised. The researchers did not have to apply one specific theory on cognition and learning. Moreover, the role of the researchers was not to provide more definitive answers, for example, through guidelines in the national curriculum about what is an efficient teaching practice. Moreover, the idea of peer learning theory, which was the overarching theory of the Boost project, is that teachers, with support from researchers, should develop their own teaching strategies. Another aspect of decentralisation was that the teachers choose to study two of several modules. Thus, the teachers decided which part of their teaching needed most development. As I see it, the role of the researchers in the Boost project was to gather a smorgasbord of teaching solutions the teachers could choose from. Thus, in both projects, the researchers were operating according to the policy of governance of each period.

Now we turn to the issue of pursuing scientific policies. The New Math project was driven according to one explicit general theory about cognition and learning mathematics. However, this theory was hypothetical as it did not deliver concrete solutions about how to teach. In practice, this meant

developing and testing teaching and support material, not the least of which were textbooks, for six years. During this time, new material was tried in five development cycles. The project involved thousands of teachers and students, and the material was also tested with experimental and control groups after two or three years of teaching. Important to notice is that the many years of testing were relevant from a scientific point of view since little empirical research results were available to develop the New Math project. In the Boost project, the situation was different. Time for development was brief, about a year, and the material given to the teachers, the modules, was tested just once and with few teachers. That is, rather than relying on results from trials (i.e., applying a more empirical and inductive mode of reasoning), the researchers had to work in a more deductive fashion (i.e., take and derive solutions from previous research results).

I am not saying the Boost way of preparing materials for teachers is unscientific or ineffective, but I am questioning if it is optimal. Are we today in the position to replace or drastically reduce the type of preparations we see in the New Math project? The methods applied in the New Math preparations still are relevant for development projects and they are a part of normal research methodology. Moreover, is it possible to derive functional material, both with respect to design and content, in a brief period from research results that in many cases do not stem from studies on Swedish students and teachers? If we consider the overview on implementation research by Century and Cassata (2016), their view seems not to include positive answers to these questions:

It is not uncommon for developers to be unsure about which elements are indeed most critical [...], and there is a tendency for innovation creators to identify the majority of components as “very important” [...] and to hold holistic views of their innovations (i.e., as “packages”), leading to component descriptions that lack specificity. [...] For these reasons, researchers are encouraged to use multifaceted approaches to identifying innovation components that combine information from developers and other experts, from end users, from observations of innovations in practice, and from reviews of artefacts, such as practice guides and other program materials. (Century & Cassata, 2016, p. 182)

This passage indicates that the development of the innovation should take some time to identify and develop core components in different ways. In fact, the preparations of the New Math reform fits this passage quite well since it combined information from developers, experts, and users as well as observations of innovations in practice.

So, why was the Boost project prepared in this way? Why was not more time and resources allocated to researchers and the development of the material? I suggest this decision, at least in part, was related to a policy of governance – i.e., decentralisation. This policy does not fit the idea of researchers in a central position deciding what is good material for all teachers. Moreover, the absence of more precise material, which Century and Cassata (2016) are asking for, is less of a problem if teachers are supposed to make decisions on their own. Here it is important to notice that the scientific report referred to in the planning of the Boost project that recommended peer learning (Timperley, 2007) gave no explicit recommendations about how researchers and teachers should interact. However, the report did imply that this relation is crucial since it emphasised the importance of the content of the teacher training program.

In the future, I think researchers as well as politicians and school administrators should consider the relation between governance and research more closely as they plan major development projects. To a great degree, they are probably interested in the same goal: to change the behaviour of teachers and students. However, their means to achieve the goal may or should not always be the same.

Sources (unpublished)

- A. Regeringsbeslut I:44, 2012-03-29, Uppdrag att svara för utbildning [Government decision I:44, 2012-03-29, Assignment to be responsible for education]
- B. Redovisning av regeringsuppdrag Dnr: 2011:643, Slutredovisning av Uppdrag att svara för utbildning [Report of government assignment Dnr: 2011:643, Final report of Assignment to be responsible for education]
- C. Skolverkets webbaserade lärportal för matematik. <https://larportalen.skolverket.se/#/moduler/1-matematik/alla/alla> [Web-based learning portal of the Swedish National Agency for Education]

References

- Boesen, J., Helenius, O., & Johansson, B. (2015). National-scale professional development in Sweden: Theory, policy, practice. *ZDM Mathematics Education*, 47(1), 129–141.
- Bray, M., Adamson, B., & Mason, M. (Eds.) (2007). *Comparative Education Research: Approaches and methods*. Hong Kong: Comparative Education Research Centre, University of Hong Kong.
- Century, J., & Cassata, A. (2016). Implementation Research: Finding Common Ground on what, how, why, where, and who. *Review of Research in Education*, 40(1), 169–215.
- Fullan, M., & Pomfret, A. (1977). Research on curriculum and instruction implementation. *Review of Educational Research*, 47(2), 335–397.
- Prytz, J. (2017). Governance of Swedish school mathematics — where and how did it happen? A study of different modes of governance in Swedish school mathematics, 1910-1980. *Espacio, Tiempo y Educación*, 4(2), 43–72.
- Timperley, H. (Ed.) (2007). *Teacher professional learning and development: Best evidence synthesis iteration (BES)*. Wellington, N.Z.: Ministry of Education.
- Tosh, J. (2000). *The pursuit of history: Aims, methods and new directions in the study of modern history*. Harlow: Longman.
- Åman, J. (2011). *Att lära av de bästa: En ESO-rapport om svensk skola i ett internationellt forskningsperspektiv* [To learn from the best: An ESO report on the Swedish school in an international research perspective]. Stockholm: Finansdepartementet, Regeringskansliet.
- Österholm, M., Bergqvist, T., Liljekvist, Y., & van Bommel, J. (2016). *Utvärdering av Matematiklyftets resultat. Slutrapport* [Evaluation of the results of Boost for mathematics. Final report]. Umeå: Umeå universitet.

Implementing alternative models for introducing multiplication

Anna Ida Säfström¹, Ola Helenius² and Linda Marie Ahl³

¹Halmstad University, Sweden; anna_ida.safstrom@hh.se

²University of Gothenburg, Sweden; ola.helenius@ncm.gu.se

³Stockholm University, Sweden; linda.ahl@mnd.su.se

The research literature provides plenty of examples of epistemological analyses of multiplication and descriptions of the complexity of the conceptual field of multiplication. Nevertheless, multiplication is often introduced as repeated addition, although decades of research have identified this pedagogical choice as leading to persistent problems in students' conceptualisation of multiplication. In this paper, we describe a teaching design that aims to implement theoretical and empirical research results regarding multiplication in classroom practice. Within our design, models in the form of iconic representations serve as a means for creating patterns that make multiplicative invariants and structures visible. The teaching we have designed is currently tested in a mid-scale randomized controlled trial and in a large-scale professional development project.

Keywords: Multiplication, primary school, models, implementation.

Introduction

Multiplicative structures constitute a vast part of compulsory school mathematics. The importance of the concept of multiplication for students' possibilities to develop mathematical competence cannot be overstated. When multiplication is introduced in school mathematics, children start a journey that should take them to advanced mathematical knowledge about fractions, ratio, rate, slope, similarity, trigonometry, probability and vector spaces. In addition, physics and social science are heavily reliant on multiplicative reasoning and proportional relationships, e.g., statements of equality of ratios $a/b = c/d$. Hence, multiplication is a fundamental concept, and it is therefore crucial to learn from educational research and to implement gained insights into classroom practice.

Up until today, research has gathered extensive knowledge on students' understanding of multiplication (e.g., Clark & Kamii, 1996; Fischbein, Deri, Nello & Marino, 1985; Harel & Confrey, 1994; Larsson, 2016; Thompson & Saldanha, 2003). We know that concepts preferably develop over long periods, through experience of a large number of situations (Vergnaud, 1988). We also know that the "whole number bias" leads students to a solid belief that *multiplication makes bigger* and that multiplication is synonymous with *repeated addition*. However, we do not yet know how to transform research results about students' understanding of the properties of multiplication into classroom practice in order to obviate the whole number bias. In this paper, we will describe an ongoing project, aiming to bridge the gap between research findings and teaching practice through an innovation (Century & Cassata, 2016): a carefully designed teaching sequence implementing alternative models for the introduction of multiplication. The implementation is carried out in Sweden, where multiplication traditionally is introduced in school year 2, at age 8–9 years. Research on the effects of the implementation is an integral part of the project.

The whole number bias

The whole number bias is “a tendency to use the single-unit counting scheme applied to whole numbers to interpret instructional data on fractions” (Ni & Zhou, 2005, p. 27). This bias may be a result of an unchallenged presentation of multiplication as repeated addition with whole numbers. The consequences of a biased conceptualisation have been long known. Bachelard (1938) concluded that knowledge that has been formed and tested for validity in action tends to form a consolidated belief concerning the nature of the concept. When the concept is later challenged in new situations, assimilation might be more complex than if initial knowledge was absent. This is why an introduction of multiplication as repeated addition may become an epistemological obstacle for students. Fischbein et al. (1985) conclude that:

The initial didactical models seem to become so deeply rooted in the learner’s mind that they continue to exert control over mental behavior even after the learner has acquired formal mathematical notions that are solid. (p. 16)

There are two misconceptions of the properties of multiplication specifically linked to the whole number bias: conceptualising multiplication as an additive relation rather than a multiplicative relation, and a belief that a product will always be bigger than each of its factors. As long as multiplication is limited to whole numbers, these misconceptions will not constrain children’s reasoning, and are therefore unlikely to be challenged. However, as soon as children are introduced to multiplication with fractions and decimals their conceptualisation will no longer be sufficient. Products such as $\frac{1}{2}$ times 5 cannot be calculated as repeated addition, and the law of commutativity, which could be helpful in this situation, is difficult to explain in terms of repeated addition. Furthermore, a firm belief that multiplication makes bigger will undermine the children’s possibilities to interpret situations with operations like $0.22 \cdot 1.20$ (Bell, Swan & Taylor, 1981), since the answer is less than 1.20, which is not compatible with a conceptualisation of multiplication built on additive reasoning with whole numbers. In summary, conceptualising multiplication as repeated addition works when dealing with whole numbers but will become a misunderstanding of multiplicative properties when extended to rational and real numbers. This is a strong argument for finding alternative ways to introduce multiplication, and thereby avoiding the whole number bias.

Alternative models for introducing multiplication

The complexity of multiplication is reflected in the body of research, and might be one reason why innovative designs are scarce in both research and practice. The efforts to describe dimensions and aspects of multiplicative knowledge are diverse, and show less agreement than, for example, the literature on additive knowledge (Nunes & Bryant, 1996). In Vergnaud’s (1988) terms, multiplicative structures can be seen as a conceptual field, consisting of situations, invariants and symbolic representations. Compared to additive structures, multiplication embraces a much more diverse family of situations. Already in the simplest case, with two factors, multiplication unifies qualitatively different situations, which can be both one-dimensional, like scaling, and two-dimensional, like one-to-many correspondence, area, intensity and Cartesian products (Harel & Confrey, 1994; Nunes & Bryant, 1996; Vergnaud, 1988). In line with the theory of conceptual

fields, our teaching design comprises both activities focused on situations and activities focused on invariants, with care taken to link established symbolic notation to both types of activities (see Table 1).

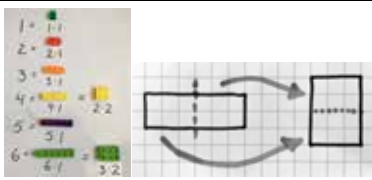

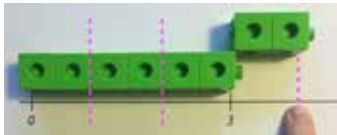

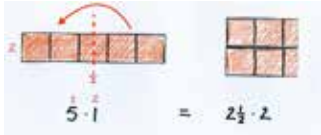


Week 1		Factorization (multiplicative grouping) of numbers with lattice models. Regrouping of lattices.														
Week 2		Connecting lattices to symbolic notation for multiplication and division. Constructing the multiplication table by sorting lattices by factors.														
Week 3		Placing numbers on number lines by measuring with skips and cubes. Discovering proportional relationships.														
Week 4		Measuring number lines with halves. Equating different numeric expressions for multiple halves.														
Week 5		Regrouping lattices by halving and doubling. Multiplication with half-integers.														
Week 6	<table border="1" data-bbox="338 1240 756 1352"> <thead> <tr> <th>FOLDS IN HALF</th> <th>1</th> <th>2</th> <th>3</th> <th>4</th> <th>5</th> <th>6</th> </tr> </thead> <tbody> <tr> <th>NUMBER OF PARTS</th> <td>2</td> <td>4</td> <td>8</td> <td>16</td> <td>32</td> <td>64</td> </tr> </tbody> </table>	FOLDS IN HALF	1	2	3	4	5	6	NUMBER OF PARTS	2	4	8	16	32	64	Exponential relationships and associativity in the context of repeated folding (inspired by Empson & Turner, 2006).
FOLDS IN HALF	1	2	3	4	5	6										
NUMBER OF PARTS	2	4	8	16	32	64										
Week 7		Equal grouping situations: partition, quotation and one-to-many correspondences.														
Week 8		Proportions: double, half, times four and fourth.														

Table 1: Overview of the sequence of multiplicative activities. Week 1–5 focus on investigating multiplicative patterns and structure, while week 6–8 focus on modelling multiplicative situations

However, since classifications of multiplicative situations, including examples of classroom activities, have been thoroughly described elsewhere, we will focus this paper on the use of models in the form of iconic representations, and how such models may aid the discovery of invariants. Since multiplicative situations can be both one- and two-dimensional, we have chosen to use both one-dimensional number lines and two-dimensional lattices as models.

A coherent conceptualisation of multiplication requires an appreciation of multiplicative invariants across situations. In other words, one has to recognise patterns in different situations as manifestations of the same structure. Within the implementation, patterns and structure (Mulligan & Mitchelmore, 2013) has proven to be a useful terminology for conveying the importance of invariants to teachers, and for describing the purpose of activities where patterns are created and described. Seeing patterns calls for experience of a breadth of cases, rather than focusing on one particular situation at the time. Therefore, the first five weeks focus on exploring specific models of numbers (see Table 1).

From the perspective of embodied cognition, Lakoff and Núñez (2000) argue that arithmetic is a conceptual blend, resting on four conceptual mappings from concrete situations. These mappings, or metaphors, each contribute to the concepts of number and arithmetic in their own way, implying that no single metaphor can reflect these concepts in full. Our lattice models are related to the first two of the grounding metaphors: object collection and object construction, while number lines are related to the latter two: measuring with a stick and movement along a path. There is a particularly close relationship between multiplication and measuring. Both simple proportions and area build on two important ideas: unitizing and norming (Lamon, 1994). Unitizing is described as the ability to construct a reference unit or a unit whole, and norming is then to interpret a situation in terms of that unit. In other words: creating a measure and then using it for measurement. This idea is also mirrored in verbal expressions on the form “two threes”, where the number three becomes the unit six is measured in.

We will now describe how lattices, number lines and verbal expressions are used as models in our teaching design. In particular, we will detail how these models convey important properties of multiplication.

Lattice models

Lattice models are in many situations exchangeable with arrays, but they do have some advantages. In arrays, each unit is separated from the others and pictured as indivisible. In lattices, the units are placed in a continuum, which makes the idea of dividing units by adding new lines attainable. Furthermore, open arrays are visually closer to lattices than arrays. Within our teaching design, both interlocking cubes and drawn grids are used to create lattice models. The activities using interlocking cubes could often be done in the same way with arrays of tickers or other objects, but that would make the step to drawn grids larger. By using cubes and grids of the same size ($2 \cdot 2$ cm), the two representations are easily compared, and lattices of both kinds can be used in the same systematic arrangements.

Lattices can be seen as ‘bar models for multiplication’, in that they provide a way to represent different multiplicative groupings of numbers, just as bars can represent different additive groupings. Within the design, the class has previously worked with finding number bonds to ten by building ten bars and naming them “_ + _”. Multiplication can then be seen as a *different* way to group numbers (see Figure 1). Our choice of introducing multiplication by lattices hence introduce multiplication not as an additive relation, but as something different than addition. The criteria for multiplicative groupings are easily established by discussion in class, distinguishing proper lattices

from other shapes. The existence of different lattices for a number calls for expressions of the form “ $_ \cdot _$ ” to be introduced as names for lattices. Finding different lattices for each number then becomes an explorative activity, leading to discussions of which lattices are the same (commutativity), and why some numbers have more lattices than others (primes and composite numbers) (Week 1, Table 1). Hence, important multiplicative invariants, which are hidden when multiplication is conceptualised as repeated addition, are made visible already in the first activity.

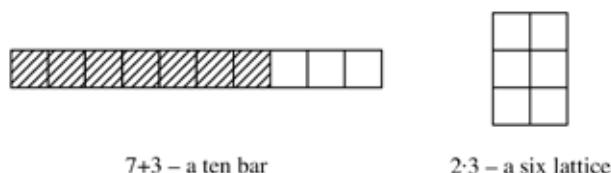


Figure 1: Bars and lattices as two different ways of grouping numbers

Arranging lattices according to products reveal that multiplicative groupings do not form a pattern as simple as for additive groupings. Finding patterns in lattices therefore requires more careful instruction. Directing attention to lattices of twos leads to the discovery of even numbers and could be generalised to multiples of other numbers. This idea will inspire to a different arrangement of the lattices, focusing on factors rather than products. Building lattices of twos, threes, fours, etc. and ordering them in rows will result in the multiplication table (Week 2, Table 1). The table will spark a new exploration of patterns in the products, and the lattices will provide a means for explaining those patterns. For example, you can see two copies of the product in the second row in the corresponding product in the fourth row (a basis for the distributive law and powers), and that the products in the second column are the same as the products in the second row, because the lattices in the column are just rotated versions of the lattices in the row (commutativity).

Using interlocking cubes facilitate successive adding and subtracting of columns and rows, which are mainly additive strategies. However, they also allow for multiplicative regrouping of numbers. When comparing the two twelve lattices $6 \cdot 2$ and $3 \cdot 4$, you can split one of the lattices and rearrange the parts, in order to see how one lattice can be regrouped into the other (Week 1, Table 1). Paper grids enable generalisation of such multiplicative regroupings to half-integers (numbers of the form $n + \frac{1}{2}$), since paper can be cut and arranged to illustrate e.g., $2 \cdot 5 = 4 \cdot 2.5$. This immediately gives rise to multiplications where the product is smaller than one of the factors, such as $4 = 8 \cdot 0.5$ (Week 5, Table 1). The model hence enables the discovery of cases where multiplication does not make bigger, within the first weeks of introducing multiplication.

Number lines

Number lines are important tools for arithmetic reasoning. Approximate use of empty number lines can both aid and communicate reasoning even in complex arithmetic problems. However, for empty number lines to be meaningful, one needs to be aware of the properties of linearity, closely linked to multiplication. Within our design, the class will use a variation of number lines, which put different properties of linearity in the fore.

During choral counting, a number line with markings and numbers, placed on the wall, is often used for pointing at numbers while skip counting (e.g., 0, 2, 4, 6, etc.). In some activities, a floor number

line is used. This number line has evenly spaced markings, with every fifth marking a little longer than the others, and a collection of number cards which can be placed in different ways in different activities. Every placement of two numbers raises the question of where other numbers should be and leads to discussions of equal spacing of numbers. In week 3 this is done with 0, and 1 or 2 in different positions (see Table 1). When starting with 1, the situation is a pure one-to-many correspondence, while starting with 2 requires more complex proportional reasoning. When justifying a proposed placement of numbers, or figuring out a placement, the children walk along the line, taking e.g., two-steps or three-steps. When documenting the work, teachers use verbal expressions and symbolic notation e.g., “you take three two-steps, so it’s three twos, we write $3 \cdot 2$ ”. A similar activity is done with semi-empty number lines on paper, where only markings for specific numbers are present, e.g., 0 and 3. The task is to place markings for the missing numbers between 0 and 6, using interlocking cubes as a measuring tool. This activity is also provided at different levels, with some restricted to pure one-to-many correspondences.

As in the case with the lattice model, these activities are easily extended to fractions, starting with halves. Walking in regular or half-steps to different numbers creates an opportunity to introduce multiplication of fractions in an intuitive context. Since multiple double or triple steps were called twos or threes and represented as $n \cdot 2$ or $n \cdot 3$, it makes perfect sense to call multiple half-steps halves and represent them as $n \cdot \frac{1}{2}$. Documenting the number of each type of step it takes to reach different numbers will result in a pattern with a proportional structure: the number of half-steps is always twice the number of regular steps (Week 4, Table 1). After whole class exploration of these patterns on the floor number line, children work in pairs to place half-integers on empty number lines, using interlocking cubes as a measuring tool, this time with 1 cube = $\frac{1}{2}$.

Verbal expressions

In relation to both lattices and the number line, care is taken to use sustainable verbal expressions of the form “two threes” and “five halves”. As emphasized by Thompson and Saldanha (2003), there is a principal difference between “two threes” and “add three two times”. It is possible to generalise the first expression beyond integers, to e.g., “one and a half threes” or “one and a half third”, while “adding three one and a half time” is harder to conceptualise. Phrases of the first form mimic phrases used in measurement, making a number the measuring unit: “one and a half threes” – “one and a half meter”. While such phrases are used to discuss both models, they relate to each model a bit differently. Each phrase, e.g., “three twos”, labels a certain way of walking to a number or a series of skips to a number, which is different from what “two threes” labels. In contrast, both expressions can be linked to the same lattice, and the corresponding ways of seeing the lattice are made explicit, pointing out the three twos and the two threes in this six lattice.

Implementation of the alternative models for multiplication

Taken together, our design covers a variety of advanced aspects and properties within the first weeks of the introduction of multiplication. The handling of advanced content is made possible by the highly structured material organising the teaching of each week in a cycle with six phases, including whole class discussions as well as pair work and individual documentation. This cyclic teaching structure has been previously described and tested in preschool (Sternier & Helenius,

2015). The material developed for the implementation of the design includes explicit instructions on what the teacher should do and say in each phase, and in reaction to different student actions and reasoning. Each activity also contains a detailed description of the mathematical concepts and procedures involved, as well as the purpose of each activity in relation to children's learning. Activities, as well as instructions, were tried and evaluated by small groups of teachers during the development of the material, increasing the quality and functionality of the design. Thorough testing of the activities is important for the teachers' trust in the material, which is particularly important due to the high level of prescription in the design.

The teaching design has been implemented in an intervention research project covering 15 weeks in grade 2, where the multiplicative part covers 8–9 weeks. The project is a randomized controlled trial with 28 participating teachers in grade 2 (14 using our material, 14 in a control group). Data from the pre- and post-tests are currently being analysed. In a parallel project we are developing similar teaching sequences for grades 1 and 3. Including sequences dealing with additive structures and number, the complete material will cover most of the area of number and operations for grades 1–3. These sequences will also be tried and evaluated by small groups of teachers during development, together with auxiliary professional development material. In collaboration with 5 municipalities, we will implement the teaching design together with professional development for around 500 teachers starting in the fall of 2020.

Closing reflection

The literature on the downsides of relying on multiplication as repeated addition is substantial. Still, teaching experiments with alternative models for multiplication are sparse, one example being Nunes, Bryant, Evans, and Bell (2010), who report on two studies covering only a few sessions. Also among teachers and textbook authors the dominance of repeated addition as the model for introducing multiplication persists. Fishbein et al. (1985) suggest that this model is chosen because it fits the mental requirements of children in the first years of schooling. It is simply hard for teachers to resist building on addition, since it is a concept that children are already familiar with at the time when multiplication is introduced. However, as seen above, multiplication in fact has several complementary roots that are not additive, such as measuring and one-to-many correspondence (Lamon, 1994; Nunes & Bryant, 1996). Many of these roots are intuitive for children and can hence be used as alternative bases for introducing multiplication.

According to Century and Cassata (2016), there are three key foci for implementation research: the innovation, the aligned outcomes, and the influential factors. This paper has described the innovation of an ongoing, large scale implementation project: a teaching sequence introducing multiplication by means of deliberately chosen models for making multiplicative patterns visible and comparable, which in turn inspire discussions where multiplicative structures are explicated. The analysis of test results in the randomised controlled trial will reveal to what extent this innovation achieves the desired outcomes, while the grade 1–3 project will provide opportunities to study the influential factors, as well as to further develop the innovation.

Acknowledgment

This work was supported by the Swedish Research Council, Grant number 721-2014-2468.

References

- Bachelard, G. (1938). *La formation de l'esprit scientifique* [The formation of the scientific mind]. Paris, France: Vrin.
- Bell, A., Swan, M., & Taylor, G. (1981). Choice of operation in verbal problems with decimal numbers. *Educational Studies in Mathematics*, 12(4), 399–420.
- Century, J., & Cassata, A. (2016). Implementation research: Finding common ground on what, how, why, where, and who. *Review of Research in Education*, 40(1), 169–215.
- Clark, F. B., & Kamii, C. (1996). Identification of multiplicative thinking in children in grades 1-5. *Journal for Research in Mathematics Education*, 27(1), 41–51.
- Empson, S. B., & Turner, E. (2006). The emergence of multiplicative thinking in children's solutions to paper folding tasks. *Journal of Mathematical Behaviour*, 25(1), 46–56.
- Fischbein, E., Deri, M., Nello, M. S., & Marino, M. S. (1985). The role of implicit models in solving verbal problems in multiplication and division. *Journal for Research in Mathematics Education*, 16(1), 3–17.
- Harel, G., & Confrey, J. (Eds.). (1994). *The development of multiplicative reasoning in the learning of mathematics*. Albany, NY: State University of New York Press.
- Lakoff, G., & Núñez, R. E. (2000). *Where mathematics comes from: How the embodied mind brings mathematics into being*. New York, NY: Basic Books.
- Lamon, S. (1994). Ration and proportion: Cognitive foundations in unitizing and norming. In G. Harel & J. Confrey (Eds.), *The development of multiplicative reasoning in the learning of mathematics* (pp. 89–121). Albany, NY: State University of New York Press.
- Larsson, K. (2016). *Students' understandings of multiplication* (Doctoral dissertation). Retrieved from <http://su.diva-portal.org>
- Mulligan, J. T., & Mitchelmore, M. C. (2013). Early awareness of mathematical pattern and structure. In L. D. English & J. T. Mulligan (Eds.), *Reconceptualizing early mathematics learning* (pp. 29–45). Dordrecht, The Netherlands: Springer.
- Ni, Y., & Zhou, Y. D. (2005). Teaching and learning fraction and rational numbers: The origins and implications of whole number bias. *Educational Psychologist*, 40(1), 27–52.
- Nunes, T., & Bryant, P. (1996). *Children doing mathematics*. Oxford, England: Blackwell.
- Nunes, T., Bryant, P., Evans, D., & Bell, D. (2010). The scheme of correspondence and its role in children's mathematics. *British Journal of Educational Psychology*, 2, 83–99.
- Sterner, G., & Helenius, O. (2015). Number by reasoning and representations – the design and theory of an intervention program for preschool class in Sweden. In O. Helenius, A. Engström, T. Meaney, P. Nilsson, E. Norén, J. Sayers & M. Österholm (Eds.), *Development of mathematics teaching: design, scale, effect* (pp. 159–168). Linköping, Sweden: SMDF.
- Thompson, P. W., & Saldanha, L. (2003). Fractions and multiplicative reasoning. In J. Kilpatrick, G. Martin & D. Schifter (Eds.), *Research companion to the principles and standards for school mathematics* (pp. 95–113). Reston, VA: National Council of Teachers of Mathematics.
- Vergnaud, G. (1988). Multiplicative structures. In J. Hiebert & M. Behr (Eds.), *Number concepts and operations in middle grades* (pp. 141–161). Reston, VA: National Council of Teachers of Mathematics.

Implementing theories for preschool teaching with play-based pedagogies

Nina Ullsten Granlund

Stockholm University, Sweden; nina.ullsten@gmail.com

The play-based Swedish preschool is facing new challenges due to demands from the Swedish Schools Inspectorate to evaluate how the teaching of mathematics is carried out in practice. This demand has evoked a dilemma for the preschool teachers that find it unclear what teaching in a preschool means. A professional development project was set up, aiming to implement theoretical tools from research into preschool mathematics teaching. The project started in 2016 with 45 teachers over a duration of seven months. An integral part of the project is to conduct research on the impact of the preschool teachers' conceptualization of mathematics as a subject, and what counts as a mathematical situation. The participating preschool teachers collected video recordings of mathematical situations from their respective practice. The professional development is an ongoing project, the impact of the implementation of theories are currently being researched.

Keywords: Preschool mathematics teaching, play-based environment, professional development.

Introduction

The Swedish preschool is facing new challenges, it has a tradition of caring and educating and is built upon a playful custom of will on behalf of the child. The preschool is not organized in formal lessons and its curriculum does not define any subjects like mathematics or biology, but suggests a thematic way of arranging the practice so that the learning goals found in the curriculum can be met in line with the principles of social pedagogy (Bennet, 2005). Yet, since the national curriculum for preschools was introduced in 1998, some of the goals have been obviously concerned with mathematical matters and these goals were sharpened in 2010 and has now again in 2018 been slightly revised (Skolverket, 2018, valid from 2019).

Having particular goals for mathematics means that the children's learning cannot just be expected to happen through general everyday activities, but must be planned for by the preschool teachers. In previous national curricula, there has been no explicit mentioning of teaching, despite that teaching has been the overarching term used in the Education Act to describe the goal directed processes aiming for learning and development. Since 2018 however, teaching is an explicitly mentioned concept in the revised curricula (Skolverket, 2018). The changes in terminology, and perhaps also policy, came after the Swedish Schools Inspectorate expressed that there is a problem with an overall unclarity about what teaching in preschool means and how it should be done (Skolinspektionen, 2016). The dilemma is that in the play-based tradition, the organization of learning is quite different from a typical school setting. For example, children's own initiatives are much more foregrounded than the time children spend in situations that are guided by a teacher (Helenius, 2018). When the concept of teaching is imported from school to preschool, the play-based tradition is endangered. Voices have been raised, indicating that the teaching of mathematics might be particularly prone to act as a trojan horse for importing values and beliefs on teaching from school that might not necessarily fit very well in a play-based preschool practice (Fosse, Lange, Hope Lossius & Meaney, 2018).

The present paper reports on a professional development (PD) project aiming to offer the preschool teachers¹ theoretical tools for how they can think about the mathematics taught and how to think about the teaching in a structured and explicit way, that still respects the play-based tradition. Research on the effects on the teachers is an integral part of the project.

Implemented theories in the PD project

When the play-based pedagogy of Swedish preschool works at its best, it integrates a play-based pedagogy with learning of mathematics in accordance with the curriculum goals. This can not only be done by planning regular teaching activities, since it would affect the preschool activities in a direction away from play in favor of formal schooling. Teaching must thus also be organized by means of planning the environment and using spontaneous situations in deliberate ways. A theory of play-based preschool teaching must account for that. At the same time, preschool teachers have difficulties verbalizing what constitutes teaching acts. Preschool teachers tend to not regard themselves as teaching teachers (Skolinspektionen, 2016). Therefore, a theory for play-based teaching should help the teachers to structure the type of work that is involved in play-based teaching by explicating particular components of such teaching (Helenius, 2018). A structured way of thinking about teaching can be a tool for teaching in a more deliberate way. This is a way to give teachers concepts and words for discussing with colleagues and plan their teaching in a play-based environment.

Theorizing preschool teaching

A structured way of viewing the complexity of mathematics preschool pedagogy is through defining three dimensions of teacher action, with respect to mathematical pedagogy: pedagogical explication, teacher participation and situational planning (for more information see Helenius, 2018). They are not suggestions of normative categories, but examples of how the complex pedagogical practice of teaching preschool mathematics could be explicated.

First, in a *dimension of pedagogic explication* of the teaching and learning of mathematics, two different ways of including mathematics can be identified. One way is a classical teaching situation, where the participants know that the activity concerns the learning of some specific mathematical content. Following Walkerdine (1988), such situations are called pedagogical with respect to the mathematical content (Helenius et al., 2015; Walkerdine, 1988). The other way is when the situation is fundamentally about something else, but some mathematical activity is included in the situation. Such situations are called instrumental. In this theorization the child's experience of a situation as instrumental rather than pedagogical does not mean there are not pedagogical intentions from the teacher's point of view. For example, as exemplified in Helenius (2018), a teacher's decision to make a robot available to children have pedagogical intentions, but children playing with it are not thinking of it as a situation which they are supposed to learn mathematics. Teachers can make an active choice of explicating the mathematical content of a situation or not. This choice can be made beforehand, in planning, or on the fly, when a teacher observes a mathematical situation that she chooses to either act on by shifting the children's focus to the learning of some mathematics, or not. Similarly, when children act on their own, with no teacher involvement, in a situation that contain mathematics, the learning may or may not be visible for the children. Thus, when the children perceive the situation as being about learning something mathematical, that situation is 'pedagogical'.

¹ We include all employees who work with teaching in the participating preschools, although not everyone has a formal teacher education.

Second, a *dimension of teacher participation* is quite obvious for children in preschool because they spend a lot of time conducting activities without any teachers involved. They know when the teacher is arranging activities, or not. The unarranged situations can provide children with opportunities to use mathematical knowledge and participate in mathematical activities. Therefore, time spent in preschool with no pedagogue involved can contribute to children's mathematical development in important ways. The same is true for time spent outside preschool, but the difference is that teachers can influence the mathematical content as well as children's experience of mathematics in situations in the preschool environment. One obvious example is planning specific activities that the teachers ask the children to do. But, there are also more subtle ways, such as planning and modifying the environment, in and around the preschool facilities so that it stimulates mathematical activities. For example, children can play with a programmable toy robot, only available to children for their free play.

This third *dimension of situational planning* relates to what Ginsburg, Lee and Boyd (2008) calls "teaching moments" or "acting in the moment", in contrast to formally planning learning situations in Swedish preschool mathematics pedagogic discourse. It is of course important for teachers to use the option to plan situations where they participate themselves. Planning has a distinct advantage in giving the teachers time to predict what may happen in a situation, and prepare for different possibilities. But mathematically interesting situations can also occur outside planning. It is important to acknowledge that situations that are not directed by the teacher also allow for play in situations where children may use mathematics. Moreover, preschool teachers can affect what happens during "free time" in many ways. This is also a part of the planning. However, preschool teachers have choices concerning what situations they want to plan and which to deliberately leave unplanned.

The Schools Inspectorate evaluation of the preschool 2015-2017 points out that preschools see that children learn a lot from playing but they also found that teachers have a strong belief that children should not be disturbed when playing. This can lead to overlooking possibilities for learning and development. The evaluation also observes that mathematics mainly occurs in planned activities lead by an adult. The theory presented above attends to this dilemma by using the tool of documentation. If a teacher notices interesting activities in free play, these can be noted and documented and the teacher can later plan for how the experiences gained in the documented situations can be reused later. This can be done either by retrospectively challenging the children that were in the original situation, but also by using ideas from the documented situation for a planned activity with other children.

Theorizing mathematical activities

One aspect of the theory above is using mathematics instrumentally. Therefore there is a need for a conceptualization of mathematics that views mathematics as something that can come out of practical problem situations, that is, a conceptualization that does not only view applications of mathematics as something you do with mathematics that is already learned or known. Moreover, a conceptualization of mathematics that is to be useful for preschool also needs to bridge everyday mathematics with formal mathematics, preferably in a rather seamless way. It has previously been argued that one theory that fulfils these requirements is Bishop's theory of mathematical activity (Bishop, 1988b; Helenius, 2018; Helenius et al., 2015; Johansson, 2015).

The background for Bishop's work is anthropological. By studying the use of mathematics in different cultures, he concluded that mathematics, just like rituals and cooking, occurs in all cultures. He also found that mathematics is different depending on where and in which culture it is evolved. And yet, certain regularities also occur in these studies and Bishop (1988a; 1988b) characterizes these in terms of six distinct mathematical activities that he claims are found in every culture and can be seen as the roots of mathematical thinking. The descriptions below are from Bishop (1988a; 1988b):

- Counting: The use of a systematic way to compare and order discrete phenomena.
- Measuring: Quantifying qualities for the purposes of comparison and ordering, using objects or tokens as measuring devices with associated units or ‘measure-words’.
- Locating: Exploring one’s spatial environment and conceptualizing and symbolizing that environment, with models, diagrams, drawings, words or other means.
- Designing: Creating a shape or design for an object or for any part of one’s spatial environment. It may involve making the object, as a ‘mental template’, or symbolizing it in some conventionalized way.
- Playing: Devising, and engaging in, games and pastimes, with more or less formalized rules that all players must abide by.
- Explaining: Finding ways to account for the existence of phenomena, be they religious, animistic or scientific.

The purpose of basing the view of mathematics on a theory is that through an increased awareness and knowledge about the role of mathematics in everyday context, the teacher can in a more deliberate way consider several options when planning for situations where children can develop knowledge in mathematics. This may lead to using a wider class of situations in a more systematically way, adapted to children’s interests, needs, experiences and qualifications.

The project's theoretical framework is focused on a mathematics based on the six mathematical activities of Bishop (1988a; 1988b), which is well established in the curriculum (Skolverket, 2018).

Implementation of the theories through professional development

The project is now running for the third time in a medium-sized Swedish city, where you can find approximately 40 preschools for children aged 1-5 years. The first round was carried out from May to December 2016. Two preschools participated. The participants were 45 teachers, with different educational backgrounds. The second round run with four preschools during August 2017 to March 2018.

Both theories that the PD is built on have the potential to be normative in the sense of putting restrictions on what preschool teachers believe are the sanctioned ways of teaching mathematics. This is a dilemma from an implementation point of view, because if a point of both the theories and the PD is that it should be helpful for describing and improving existing preschool practice rather than to introduce normative ways of thinking about this practice.

To avoid such normativity, we tried to make the PD itself very tightly tied to the existing practice of the participating teachers by using videos produced by the participants of their practice as a basis for discussion. The recordings were done as a response to loosely formulated tasks concerning, for example, what mathematics might mean or what type of mathematics the teachers should focus on. As an example, one of the early tasks was: *Videotape one planned mathematical situation and one situation that is not planned but where you think there is some mathematics going on.* The recording from this task was then analyzed by a researcher before the next session with the aim of explicating examples of Bishop’s activities as well as examples of the three dimensions of preschool teaching described above. The submitted material represented choices made by the teachers themselves. Moreover, the loose phrasing also created a large variation in the interpretations of what was considered interesting mathematical activities to submit. This variation was intended, and when the videos were discussed at the next session, the discussion leader (the researcher involved in the project)

could ground the presentation of Bishop's six activities in the variety of mathematical activities already present in current preschool practice (even if all of the activities did not show up in the videos, and some therefore had to be pulled out of Bishop's hat).

Moreover, the set of videos could also be used as a basis for discussion when planned and unplanned situations were good, if the mathematics was pedagogical or instrumental and how teacher participation might have affected the situations. In other words, even these first set of videos could be used as an introduction to all three dimensions in the theory of play-based teaching.

In subsequent assignments, the teachers were asked to do more and more pedagogically complex things, like planning for a situation that characterized by a particular combination of the dimensions in the theory of play-based teaching.

Other questions that were discussed in the sessions concerned progression: Watch a videotaped situation and analyze what mathematics occurred in the situations. Think about this in terms of progression. Are there more basic ways of dealing with the mathematical ideas and concepts that are visible in the situation? What would constitute a more advanced way of dealing with those concepts? How an activity that would bring children toward a more advanced way of dealing with the same mathematical ideas could look?

In total, for each PD group, the PD included three such sessions and associated tasks distributed for half a year. This is not much, but it has to be taken into account that preschool teachers have much less time for both planning and competence development than school teachers. In addition to the PD-pedagogy described above, in between the sessions with the researcher, the preschools also got support from a local school developer and the teachers were also given time to discuss the different issues of the project on every workplace meeting (approximately once a month).

Researching the effect of the implemented educational theories

Discussions with the teachers indicate that they find the six activities of Bishop to be both easy to understand and helpful for identifying different mathematical activities. The framing of activities as planned and unplanned, but still being mathematical situations, may at a first glance be a relief for the teachers. The project is all about creating mathematical situations that stimulate and challenge the children with different kind of questions and it is built on the curiosity and interest of the children. The teachers seem to be happily provided with teaching tools for framing their profession.

Still, these indications must be consolidated in a proper study. To investigate if the teachers' perception of teaching and mathematical activities has been improved by the project, a systematic data collection was carried out during the fall of 2018. The methodology is built upon using documentation from the PD rounds, new submitted video material, and interviews with teachers that will be analyzed in relation to the theoretical perspectives used in the PD. During the first two rounds of the PD project, we have collected data in the form of videotapes from planned and unplanned mathematical activities that the teachers encounter between the monthly meetings. We are now about to analyze the impact of the implementation of theories for theorizing preschool teaching and for theorizing mathematical activities. Because the objective of the PD was to help the teachers develop an elaborate and structured way to view (think and talk about, analyze, plan, etc.) the play-based mathematics teaching in preschool, the research question I ask is: Do the teachers that have completed the PD display an elaborate way of discussing mathematics learning activities in preschool? The term 'elaborate' will here be taken to mean using concepts (though not necessarily terminology) from the two theories that form the basis of the PD when discussing preschool activities. To evaluate this question, the following method will be used. A sample of five teachers will be asked to submit new

videos and documentation responding to the same set of tasks that were given during the PD. Using a stimulated recall methodology, the teachers will be asked to discuss both the old and new videos. Stimulated recall is a method very well suited for situations where you record the activity, using sound or video (Calderhead, 1981). The participants are given the chance to see or listen to what was recorded and are given the chance to make comments, either freely or guided by interview questions. The recorded material is a way of stimulating, or challenging, the respondent's way of thinking when it comes to the filmed or recorded episode (Haglund, 2003). By using the pedagogical documentation from the project, which consists of the filmed planned and unplanned educational activities, as well as notes taken during the activities, the purpose is to go back and investigate teachers' own perception of their conceptualization about mathematics, and the teaching of mathematics in preschool. By also including new material, teachers are given the chance to also reflect on developments of their practice. Progress will be coded both in terms of if teachers after the program can analyze and talk about a depicted situation in a deliberate way in line with the theories used in the PD, and in terms of if teachers can suggest a larger and more relevant spectrum of alternate teacher actions, or ways of challenging the children in depicted situations. This part of the methodology has previously been suggested by Lembrér, Kacerja and Meaney (2018).

Concluding reflection

The quality of the pedagogy is of great importance for the learning of children. Pedagogical quality depends on how the teachers structure their work. By clarifying the special ingredients of the mathematics in Swedish preschools, as well as the role of the preschool teacher, I claim that quality can be improved. This is the intention of the described PD project.

In the PD project, participating preschools teachers can work with how to think about teaching and how to think about mathematics as a subject to be taught in preschool. The hypothesis is that an increased awareness of what mathematics is and what can be categorized as mathematical situations will be used by the preschool teachers for developing the teaching. As described above, the implemented theoretical tool for framing teaching preschool mathematics is the six mathematical activities of Bishop (1988a; 1988b), for sorting, planning and connecting different elements in the different activities. A theoretical tool for framing the planned and unplanned situations is given by Helenius' (2018) three dimensions for theorizing preschool teaching.

This paper has described a project aiming to implementing theories from research into preschool teaching practice. Next, we will evaluate the impact of our PD project by conducting research on the participating preschool teachers' conceptualization of mathematics as a subject, and mathematical situations as planned or unplanned activities. Data will be collected after the third round of the PD project, making research on the implementation of theories an integral part. By the time of the conference CERME 11, we will be able to report on the impact of the project.

References

- Bennett, J. (2005). Curriculum issues in national policy-making. *European Early Childhood Education Research Journal*, 13(2), 5–23.
- Bishop, A. J. (1988a). Mathematics education in its cultural context. *Educational Studies in Mathematics*, 19(2), 179–191.
- Bishop, A. J. (1988b). *Mathematical enculturation: A Cultural Perspective on Mathematics Education*. Dordrecht, The Netherlands: Kluwer.
- Calderhead, J. (1981). Stimulated recall: A method for research on teaching. *British Journal of Educational Psychology*, 51(2), 211–217.
- Fosse, T., Lange, T., Hope Lossius, M., & Meaney, T. (2018). Mathematics as the Trojan horse in Norwegian early childhood policy? *Research in Mathematics Education*, 20(2), 166–182.
- Ginsburg, H. P., Lee, J. S., & Boyd, J. S. (2008). Mathematics education for young children: What it is and how to promote it. *Social Policy Report: Giving Child and Youth Development Knowledge Away*, 22(1), 3–22. New York, NY: Columbia University & Society for Research in Child Development.
- Haglund, B. (2003). Stimulated Recall. Några anteckningar om en metod att generera data. [Stimulated Recall. Some notes about a method to generate data.] *Pedagogisk forskning i Sverige*, 8(3), 145–157.
- Helenius, O. (2018). Explicating professional modes of action for teaching preschool mathematics. *Research in Mathematics Education*, 20(2), 183–199.
- Helenius, O., Johansson, M. L., Lange, T., Meaney, T., Riesbeck, E. & Wernberg, A. (2015). Analysing instrumental and pedagogic situations in preschools using the didactic space. In O. Helenius, A. Engström, T. Meaney, P. Nilsson, E. Norén, J. Sayers, & M. Österholm (Eds.), *Development of mathematics teaching: design, scale, effects. Proceedings from Madif 9* (pp. 57–66). Linköping, Sweden: SMDF.
- Johansson, M. (2015). *Perceptions of mathematics in preschool: “Now we have a way of talking about the mathematics that we can work with”* (Unpublished doctoral dissertation). Luleå University of Technology, Sweden.
- Lembrér, D., Kacerja, S., & Meaney, T. (2018). Preservice teachers recognising and responding to young children’s engagement with mathematics. In C. Benz, A. Steinweg, H. Gasteiger, P. Schöner, H. Vollmuth, & J. Zöllner (Eds.), *Mathematics education in the early years* (pp. 27–46). Cham, Springer.
- Skolinspektionen. (2016). *Förskolans pedagogiska uppdrag- Om undervisning, lärande och förskollärares ansvar [Preschool’s educational assignment-About teaching, learning and preschool teachers’ responsibility]*. Stockholm: Skolinspektionen.
- Skolverket. (2018). *Läroplan för förskolan Lpfö98 reviderad 2018 [Curriculum for preschool Lpfö98revised 2018]*. Stockholm, Sweden: Skolverket.
- Walkerdine, V. (1988). *The mastery of reason: cognitive development and the production of rationality*. London, England: Routledge.

TWG24: Representations in mathematics teaching and learning

Introduction to the work of TWG24: Representations in mathematics teaching and learning

Anna Baccaglini-Frank¹, Carla Finesilver², Samet Okumus³ and Michal Tabach⁴

¹University of Pisa, Italy; anna.baccaglinifrank@unipi.it

²King's College London, UK; carla.finesilver@kcl.ac.uk

³Recep Tayyip Erdogan University, Turkey; samet.okumus@erdogan.edu.tr

⁴Tel-Aviv University, School of Education, Israel; tabachm@post.tau.ac.il

Introduction

This Thematic Working Group explicitly welcomed papers from a variety of different theoretical approaches and methodological frameworks addressing the role of representations of different types in teaching and learning processes, in particular those involving visualization (considered here as defined by Arcavi (2003)). From its first appearance at CERME10 when it was made up of 24 participants from 13 countries with 16 accepted papers and 2 posters, at CERME11 TWG24 grew: there were 31 participants (authors, co-authors, and some other participants), from 16 countries with 18 accepted papers and 4 accepted posters. The structure of the working sessions allocated for discussion of each paper or poster was designed to stimulate interaction and collaboration among participants: each paper or poster was allocated to a working session in which a same or similar theme was addressed (to the extent possible); all participants were asked to read all papers ahead of time, concentrating on those they found most appealing; presenting authors were asked to prepare a short presentation, followed by open questions and a brief analysis of how the work presented contributed to the open questions in the TWG's call for proposals. After the short presentation by the presenting author, a general discussion was initiated and conducted for a total of 30 minutes for papers and 15 minutes for posters. The last session was completely devoted to summing up the main issues that had emerged from the group discussions. The four themes are: 1) theories, language and categorizations used to study representations (theories, language and categorization), 2) embodied and enactive perspectives on the use of representations in mathematics education (embodied and enactive perspectives), 3) forms of representation implemented through technological approaches (technological approaches), 4) pedagogical implications in the choice and use of representations in the teaching and learning of mathematics (pedagogical implications).

Theories, language, categorization

The researchers in TWG24 did not share a common theoretical framework for the use of the term representations. We see the diversity as a source of strength of our community, as different theoretical emphasis may illuminate various aspects of teaching and learning mathematics. We do share the need for having an explicit theoretical stance towards what is representation in our research.

The role of theory for the researchers in the group varied. Some articulated a theoretical perspective for designing tasks (e.g., Günster; Johnson et al.; Tabach & Koichu), while others view theory as a tool to guide their data analysis (e.g., Miragliotta; Lisarelli, Antonini & Baccaglini-Frank).

Some of us consider as representation what is accepted as such by the mathematical community (e.g., Duijzer et al.), while others see them as a collection of inscriptions produced by students for a given

mathematical situation (e.g., what Dahl called ‘self-invented representations’). We discussed tensions that might arise, during the learning process, between students’ unique-created representations and the need for students to be familiar and work with classical representations.

The group also discussed the issue of internal/external representations: we cannot directly access internal representations, hence it is difficult to assess; across papers and posters there was variation in the extent to which internal versus external representation was theorized. This methodological-theoretical issue is important to acknowledge, even if we do not see a direct way to resolve it.

Moreover, discussions highlighted a general move away from dichotomous categories of representation towards continuous spectrums, in both research design and analysis of data.

The advance of technological tools and our ability to design complex and dynamic learning environments seems to be increasing. Our theoretical language, however, is not yet well-enough developed to allow consistent “talking about” dynamism in representations. This might be a challenge to handle in the coming years. For example, do we have a theoretical language allows us to differentiate between representing a mathematical phenomenon with dragging a finger over a touch screen, versus representing the same mathematical phenomenon with ones’ whole body?

Embodied and enactive perspectives

In our call for papers we explicitly noted that ‘representations’ should be interpreted broadly to encompass pictures, gestures, sounds, stories, metaphors and more (as well as more conventional classroom formats). Several presenters included material on the embodied and enactive representations employed by diverse participants (children and adults, from very high to very low mathematical attainment, with and without disabilities) within a wide variety of mathematical topics and contexts (educational, professional and recreational).

Several papers considered the salience of how hands, in particular, are used in embodied mathematical thinking. Miragliotta’s work on geometrical predictions analysed both discursive and gestural aspects of older school and university students’ geometrical problem-solving activity, highlighting the interplay both between language and motion, and perception and reasoning processes. One of the foci of Finesilver’s microgenetic case study of a teenager with severe numeracy difficulties was the significance of the regular pattern of hand movements in ‘dealing’ out units into equal groups. In keeping with the emerging theme of continua, this motion aspect, along with mixed-mode representation, enabled transition from concrete to graphic representation. In contrast, Wille and Schreiber focused not on informal gesture but the communication of mathematics in sign language, with a comparison of how explanations of geometrical terminology function in a visual signed language versus a spoken mode of communication. The subsequent discussion clarified that while sign language should be considered distinct from gesture, it may be productive to consider a continuum between them.

The intertwining of enaction and language was also considered by Arnoux and Soto-Andrade, with a focus on the significance of metaphor in understanding and representing mathematics. Their paper on moving between concrete and abstract forms also addressed affective concerns, and highlighted the way that metaphors may be particular to communities based on local phenomena and experiences. Meanwhile, O’Brien and de Freitas presented research from one particular community; that of those

engaged in textile arts who, while they may not consider themselves to be ‘doing mathematics’, are creating complex haptic and visual representations of mathematical patterns. Their *fibre mathematics* includes technical-aesthetic considerations of topological dimension and connectivity as well as space, mechanics and computation.

This year’s working group took a particular interest in the relationships between different representational forms, and discussion of enactive aspects also arose in the various discussions on graphical representations of time (Lisarelli et al.), motion (Duijzer, Van den Heuvel-Panhuizen, Veldhuis & Doorman), and relationships between quantities (Johnson, McClintock & Gardner). The discussions considered the different characteristics, affordances and limitations of creating moving representations with one’s hands, manipulating external physical objects, and elements displayed on a screen. There was particular interest in how changing the subject of operation (objects, the environment, oneself) could affect perception of mathematical relationships.

The embodiment and enaction of mathematics can work in many different ways. However, being so fundamental to human experience, it may particularly help learners to ground concepts and form connections between mathematical ideas that they tend to see as isolated.

Technological approaches

A number of contributions presented studies in which different forms of technology were used to create or interact with representations of mathematical concept. Indeed, through technological artifacts, representations can become both dynamic and interactive. For example, Duijzer, Van den Heuvel-Panhuizen, Veldhuis and Doorman studied students creating distance-time graphs by describing their own movements in front of a motion sensor; Lisarelli, Antonini and Baccaglioni-Frank analyzed students’ written discourse about an experience in a dynamic interactive digital environment in which functions were represented in one dimension, as dynagraphs; and Johnson McClintock and Gardner explore students’ transfer of covariational reasoning intertwined with their creation and interpretation of dynamic graphs on the Cartesian plane. Dynamism – seen as interactive, controlled motion – can be very useful for learning about particular mathematical concepts related to functions: covariation, input-output relationship, effect of parameters.

The studies also suggested that dynamical software influence students’ practice and, afterwards, their drawings and verbal representations. This seems to be the case both when the whole body is involved and when only some parts of the body are used to interact with the technological artifact. For example, when a student walks in front of motion sensors and software captures and represents whole body movement, new expressions emerge such as “walking the graph” (e.g., Duijzer et al.). However, also after experiencing covariation in one-dimensional dynagraphs students use arrows in their drawing to describe movement, and words such as ‘motion’, ‘then’, ‘before’, ‘dragging’ (e.g., Lisarelli et al.). Furthermore, studies suggested that interacting with technological artifacts that produce dynamical interactive representations may also change the way students think of mathematical concepts (Duijzer et al.; Lisarelli et al.; Johnson et al.; Miragliotta; Tabach & Koichu). The group discussed how these could eventually become psychological tools as in the case of “dragging” (e.g. Baccaglioni-Frank & Antonini, 2016).

The use of dynamic representations was also discussed within the proposal of a theoretical framework providing the foundation to design tasks aimed at promoting students’ functional thinking (Günster).

Finally, a different technological approach to representations was provided by O'Brien and de Freitas who used the loom to unpack the relationship between making, mathematics, and technology.

Much work remains to be done regarding how to employ technology's full potential in learning trajectories (including those for other topics than the ones discussed), and on how to foster the development of these experiences into formal mathematics.

Pedagogical implications

Representations play a vital role in mathematics teaching and learning. However, as researchers, we experience a constraint in communicating our findings in 'snapshots' – we noticed how many studies begin as small scale endeavors. Thus, researchers need ways to scale up from small scale studies and to bring what we are learning to teachers and their students. During the presentations and discussions, the group attempted to establish connections between representations and the pedagogical implications in the choice and use of such representations. For example, Milinkovic, Mihajlovic and Dejjic found that students who managed to solve mathematical problems were able to connect different mathematical representations. However, in mathematics classrooms, teachers generally stimulate algebraic/symbolic representations to solve mathematical problems more than other types. Pressures may exist for teachers to move quickly to help students have swift ways to solve problems and represent processes promoting one of the representations more than others, and these pressures may prematurely curtail students' intuitive approaches when engaging in problem solving.

Some discussions focused on how teachers should be able to use incorrect answers as an opportunity for mathematical investigation. While some teachers may prefer to ignore or dismiss an incorrect answer and focus on teaching correct ways to represent mathematical problems, others decide to use an incorrect strategy to engage in a class discussion. Tabach and Koichu used the potential of incorrect strategies for the solution of a problem with a novel method, namely in a "who is right" form in which students are given scenarios and asked to pick their sides (if any) for the correct solution of a problem. Okumus and Dede introduced students misleading representations without letting them know that graphs tweaked information. Alternatively, some may prefer to be more explicit and provide specific representations (e.g., Hough et al.; Böcherer-Linder et al.). Teachers pedagogical decisions will influence how these tasks move students' thinking forward or how they will hinder their learning.

References

- Arcavi, A. (2003). The role of visual representations in the learning of mathematics. *Educational Studies in Mathematics*, 52(3), 215–241.
- Baccaglioni-Frank, A. & Antonini, S. (2016). From conjecture generation by maintaining dragging to proof. In C. Csíkós, A. Rausch & J. Sztányi, *Proceedings of the 40th conference of the International Group for the Psychology of Mathematics Education, Vol.2*, (pp. 43-50), Szeged, Hungary: PME.
- Presmeg, N.C. (2002). Preface. In F. Hitt (Ed.), *Representations and mathematics visualization*. North American Chapter of the International Group for the Psychology of Mathematics Education, (pp. ix–xvi).

From concrete to abstract and back: Metaphor and Representation

Pierre Arnoux¹ and Jorge Soto-Andrade²

¹University of Aix-Marseille, Department of Mathematics, Marseille, France;
pierre@pierrearnoux.fr

²University of Chile, CIAE & Faculty of Science, Mathematics Department, Santiago, Chile;
sotoandrade@uchile.cl

We are interested in exploring from an enactivist perspective the role of metaphor and representation in the emergence of the abstract from the concrete and also in sense making of abstract mathematical notions. After introducing our theoretical framework, we present and comment on some illustrative examples, explored with several cohorts of learners, which include both prospective mathematics secondary teachers and first year university students studying science and the humanities.

Keywords: Metaphor, Representation, Enaction, Concrete, Abstract.

Introduction

We claim that representation and metaphor (between which we distinguish, see below) play a key role in the teaching and learning of mathematics. More precisely, in this paper we focus on the ways in which *metaphorising* and *representing* can foster the emergence of abstract concepts from concrete a-didactic situations (Brousseau, 1998) and backwards, making (concrete) sense of abstract concepts. We argue, moreover, that taking advantage of such concrete situations can afford insights and motivations for classical abstract mathematical notions, which are friendlier to the learners than the traditional approach where such notions are quite often “parachuted from Olympus”. Indeed, many mathematical concepts emerge as procedural computations, which are not supposed to take a meaning by themselves. Every time a new representation, or metaphor, is found for such a “procedural” concept, this results in a deeper understanding, and quite often in new questions and results. A very famous example is that of complex numbers, invented as “impossible” numbers to solve cubic equations, whose now classical geometric representation via the complex plane was only found two centuries later. Other examples, like the metaphor of “arithmetic geometry,” are now at the base of important mathematical research programs. We argue that it is important to help students develop such representations explicitly, rather than treating them as trivial side-products of teaching. It is however a big challenge to figure out under which conditions representing and metaphorising foster mathematical thinking processes as hypothesised above.

We intend here to pursue our recent research on metaphorising, representing and enacting (Arnoux & Finkel, 2010; Diaz-Rojas & Soto-Andrade, 2015; Soto-Andrade, 2007, 2014, 2018), by presenting and commenting some non-obvious examples of enactive metaphors and representations of mathematical concepts and their use in a-didactic situations (Brousseau, 1998). The contextual background of our examples involves several cohorts of learners in Chile and France, mainly prospective secondary mathematics teachers.

Research questions

We single out a couple of research questions, among those involved in our research:

1. Which sorts of metaphorising and representing can foster the emergence of abstract notions from concrete situations and convey a better grasp of them for the students?
2. How can teachers support, in a friendly manner, learners in developing their representational and metaphorical competences?

Theoretical background

Metaphorising and Representing in cognitive science and mathematics education

Metaphorising and Representing nowadays play undoubtedly a key role in cognitive science and mathematics education. See Goldin (2014) and Soto-Andrade (2014) for related comprehensive surveys. Notice that we prefer to focus in on *metaphorising*, a verb denoting a process, rather than on *metaphor*, a noun denoting an object. Indeed, what is a metaphor for someone may not be a metaphor for someone else, and for yet another person it could be a representation instead (see below). What we observe is actually the *process* of metaphorising carried out by someone, a cognitive subject.

Regarding metaphorising (“looking at something and seeing something else”, in metaphorical terms), widespread agreement has arisen in cognitive science that our ordinary conceptual system, in terms of which we both think and act, is fundamentally metaphorical in nature (Gibbs, 2008; Johnson & Lakoff, 2003). In mathematics education metaphor typically appears not just as a rhetorical device, but as a powerful cognitive tool, that helps us in grasping or constructing new concepts, as well as in solving problems in an efficient way and user-friendly way (English, 1997; Lakoff & Núñez, 2000; Sfard, 2009; Soto-Andrade, 2007, 2014).

Although in the literature the same object is sometimes described either as a representation or as a metaphor, here we draw a distinction: we *re-present* something given beforehand, usually to explain concepts already constructed, but we *metaphorise* to try to fathom something unknown or to construct a concept. Recall that Lakoff and Núñez (2000) highlight the intensive use we make of conceptual metaphors that appear – metaphorically – such as inference-preserving mappings (arrows) “going upwards” from a rather concrete ‘source domain’ into a more abstract ‘target domain’, enabling us to fathom the latter in terms of the former. Then representations naturally appear as arrows going the other way around, downwards from the more abstract domain to the more concrete one (Soto-Andrade, 2014).

Indeed, our approach to the learning of mathematics emphasises the *poietic* (from the Greek *poiesis* = creation, production) role of metaphorising, which brings concepts into existence. For instance, we bring the concept of probability into existence when, while studying a symmetric random walk on the integers, we look at the walker (a frog jumping on a row of stones in a pond, say) and we see it *splitting* into two equal halves that go right and left instead of being equally likely to jump right or left (Diaz-Rojas & Soto-Andrade, 2015). This ‘metaphoric sleight of hand’ which turns a random process into a deterministic one, allows us to reduce probabilistic calculations to deterministic ones, where we just need to keep track of the walker’s splitting into pieces: The probability of finding the walker at a given location after n jumps is just the portion of the walker landing there after n splittings.

In the same vein, imagine that one is trying to figure a struggle between two producers A and B for a consumer market, who each month – as a consequence of intensive marketing strategies – entice consumers of the other brand to change their choice, say 20% of consumers of A going to B but only

10% conversely. If one is familiar with jumping frogs, one could metaphorise the evolution of the market as the random walk of a frog between two rocks, tagged A and B, with corresponding transition probabilities. However, someone who is more familiar with market struggles would rather metaphorise the frog's random walk as a market evolution, to benefit of his/her economic intuition.

It can be argued that we often introduce new concepts via metaphor, but giving a new meaning (and often, just meaning) to a concept that has already been taught involves a representation. We may have *internal representations* (Goldin & Janvier, 1998; Goldin, 2014) which are operationally equivalent to metaphors, as the ways a cognitive subject has of figuring out concepts unfamiliar or still opaque.

Methodology and experimental background

Our methodology relies mainly on qualitative approaches like participant observation techniques and ethnographic methods (Brewer & Firmin, 2006; Spradley, 1980).

Regarding our experimental background, several cohorts of students have participated in preliminary tests at the University of Aix-Marseille, France: 60 first year university students majoring in science and humanities in a mathematics course in 2015-2018 (usually organized in 10 groups of 6) and 40 fifth year teacher students in 2 mathematics courses, of 20 students each, in 2016-2018 (usually organized in 5 groups of 4 each).

At the University of Chile, in Santiago, three cohorts of prospective secondary school mathematics and physics teachers (45 students each, on the average), in a one-semester yearly course in elementary number theory, have been involved in our teaching and learning following a metaphoric and enactivist approach, from 2016 to 2018. Working most of the time in random groups of 3 to 4, (defined by blind picking of coloured Lego cubes from a bag) they were observed and monitored by the teacher and an assistant as participant observer or ethnographer (Spradley, 1980; Brewer & Firmin, 2006).

Since we were especially interested in evaluating the impact of our approach on the student's engagement and problem solving and problem posing abilities, we observed mainly: their level of participation and horizontal (peer) interaction, the emergence of "research questions", i.e. questions they ask themselves, to be tackled by themselves (not questions addressed to the teacher to ask for a clarification or explanation) and (idiosyncratic) metaphors, arising spontaneously or under prompting, accompanying gestural language of learners and teacher, expression and explicit acknowledgement of affective reactions. Snapshots of their written products in problem solving activities were taken and processed in a worksheet, also for evaluation purposes, and some videos of their enacting moments were recorded.

Illustrative examples and case studies

We present and discuss here a couple of paradigmatic examples, regarding concrete ways to introduce and motivate in a friendly way Pythagorean triples as well as arithmetical congruences. In fact, we could describe them under the same roof as arithmetic in a discrete "modular universe": a 2D pixelated, grid-like one (the lattice \mathbb{Z}^2) in the first case, and a 1D cyclic one (the polygon $\mathbb{Z}/m\mathbb{Z}$ formed by the integers modulo m) in the second case. For other examples, related to computer science (finite automata) and probability, see Arnoux and Finkel (2010), Diaz-Rojas and Soto-Andrade (2015) and Soto-Andrade (2018).

Example 1: Pythagorean triples, with Lego bricks

This activity has been carried out at the University of Aix-Marseille, in several contexts, with the cohorts described above: first year science and humanities students and fifth year teacher students (last year of teacher initial formation in mathematics).

It has been tested informally in the last two years, using qualitative monitoring by an assistant, and posterior evaluation by the participants; we are setting up now an interdisciplinary team (mathematicians, didacticians and cognitive scientists) to study it more in depth in the framework of a methodology unit next year.

We give to groups of 4 to 6 science and humanities students or teacher students one 16×16 horizontal plaque, two elementary 1×1 bricks, and one 1×16 brick. The question is: *for which positions on the plaque can the small bricks be connected by the long one?* See Figure 1, showing a 8×8 plaque, two 1×1 bricks in a good position, and a 1×8 brick superposed on them; it is of course cumbersome to explain this in writing, but the real model leaves no room for hesitation.



Figure 1: Linking brick for Pythagorean triples

By construction, the plaque is endowed with a discrete grid (a metaphor for \mathbb{Z}^2 with the canonical metric, points being the centres of the small circles and 1×1 bricks playing the role of dots); no explanation of this is needed. But some time is needed to understand that the long brick can only be set on the pair of small bricks if the distance between these two bricks is an integer multiple of the unit distance: after half an hour, most groups discover the concept of Pythagorean triples as implied by this situation (they all know the Pythagorean Theorem, but not Pythagorean triples). This exercise is very rich. It works well, because all the distances are quadratic numbers, hence, if they are not integers, they are quite far from an integer: *at small distance*, there are only exact solutions, no “near-solutions”. It is also very engaging for students, because it is concrete. It evolves naturally into finding the classical Babylonian solutions (it may be pertinent at that point to present the famous Plimpton 322 tablet). One can then ask to find non-trivial rational points on the unit circle; students usually start by trial and error, and come first to the conjecture that there are no such points. It takes some time to make the relation with the previous question; this can be continued with a geometric parametrisation by the rational lines through the point $(-1,0)$, which makes the link with the quadratic equation, and, via elementary geometry, with the formula for sine and cosine as a function of the tangent of the half-angle: these formulas appear as a reformulation of the Babylonian formula. Most students seem surprised to see that there can be links between very different domains of mathematics. This can be taken to much more elaborate questions, like the number of triples within a bounded distance, and in fact to difficult research questions. One remark is that, in our experience, it is not important whether or not the students have already studied these notions: in the case of prospective teachers, they are always surprised by the exercises, and do not immediately link them to notions they know quite well, but in an abstract way.

Example 2: Congruence mod m and dynamical systems

We report on some developments of our metaphoric enactive approach to arithmetic congruences, with third year prospective maths and physics secondary teachers taking a one semester course in elementary number theory, in 2016, 2017 and 2018, at the University of Chile. Since congruences mod m are unavoidable in this course, we wanted to motivate them or make their study friendlier. To this end, following a radical enactivist approach (Proulx & Maheux, 2017; Soto-Andrade, 2018), we just proposed a *situational seed* first and let the action emerge freely.

From our theoretical perspective, taking into account the previous mathematical training of our teacher students, at secondary school and also in most courses of their initial formation, we could predict a “metaphoric deficit” in their understanding of arithmetical congruences. Eventually they will be able to recite the definition and calculate, but without having a favourite metaphor (or representation) for them, and also with no appreciation of their usefulness. Notice that if they metaphorise the integers mod m as a finite “shadow” of the integers, they might easily have the idea that a necessary condition for a property to hold for the integers is that it holds for its projection onto their arithmetical shadows, something much easier to investigate. So, if a Diophantine equation is solvable (in the integers) its shadow should be solvable in the shadow integers mod m . In this way, they get necessary conditions for a Diophantine equation to be solvable, which allows them to prove unsolvability in several cases.

Indeed, we found that although our prospective teachers know by heart the definition of congruence mod m in the integers, when we ask them how they imagine, metaphorise or visualise congruence mod m or which are their internal representations for it in the sense of Goldin (2014), they are at a loss. After a while, some of them think of kangaroos, rabbits, frogs, jumping on the integer line, or they begin to paint the integers in different colours (five colours for congruence mod 5). Slowly the metaphor emerges in several groups, of winding the integer number line on a polygon, e. g. a pentagon for congruence mod 5. They naturally carry out a spiral-like winding on the plane to begin with. If nobody suggests a different way, we ask them what they do when they want to wind up a long garden hose. They realise then that it is smarter to wind it in 3D, cylinder like. From there they come to visualise congruence mod 5, say, as a helical winding of the integer line above a regular pentagon. They metaphorise then this congruence relation as a covering space! Typically, however, this helix does not remind them of the intuitive construction of the imaginary exponential that they were exposed to in Calculus 1, where the real line was wound around or above the unit circle. Our enactivist theoretical perspective emphasises *processes and dynamics* more than (the more traditional) *objects and static structures*. So setting the integers mod m as a stage, for instance $m = 12$ (or even $m = 6$ or 7, for simpler examples of different nature), we prompt the students to wonder what interesting phenomena may arise in these universes with just 6, 7 or 12 sites, where they can add and multiply.

Among other ideas, they can look at the transformation M_2 given by multiplying by 2, for example, which when iterated launches a *dynamical system* in the integers mod 12. The students try then to study the generated dynamics, something more natural for those who have developed a systemic perspective on phenomena, more often biology and physics students or humanistic students than mathematics students. Working for an hour, in random groups of 3 to 4 (defined by blind picking of coloured Lego cubes from a bag), a class of 30 to 40 students dutifully iterates M_2 and tries to

represent the phenomenon. They explore then M_3 and so on. See Figure 2, which shows some drawings by the students, for $m = 7$ and $m = 12$. More generally, they investigate the dynamics spawned by the multiplication by an integer k in the integers mod m , discovering its variegated (forward) orbit structure. They metaphorise idiosyncratically these orbits as forward trajectories and they see fixed points, sinks, attractors, 2 – cycles, 3-cycles, etc., and become able to figure out the “fate” of different integers mod m . They begin to conjecture on the number of orbits, or the number of n -cycles for a given n . Level of engagement and participation is high, as well as their horizontal interaction, where several ideas and approaches meet. Some of them want to find an arithmetical explanation of this dynamic geometric behaviour. Others do not. But we suggest everyone to look at this geometric phenomenon with arithmetical eyes and vice versa. Most of them draw pictures, but others just write down numbers and tables, and compare. We prompt them to exert some hermeneutical effort (Isoda & Katagiri, 2012), so that all try to understand other’s viewpoints. In this way, some predict the existence of an “ubiquitous orbit” for some k for prime m . The students are quite excited and motivated by this challenge when working in small random groups, where horizontal interaction is fostered. Quite often some groups want absolutely to show the teacher and assistant their progress so far. Each group summarises its findings in a report on a sheet of their notebooks, which is photographed by the teacher and assistant. Samples of their work are shown in Figure 2. These reports are evaluated, and a huge worksheet is set up with the corresponding grades.

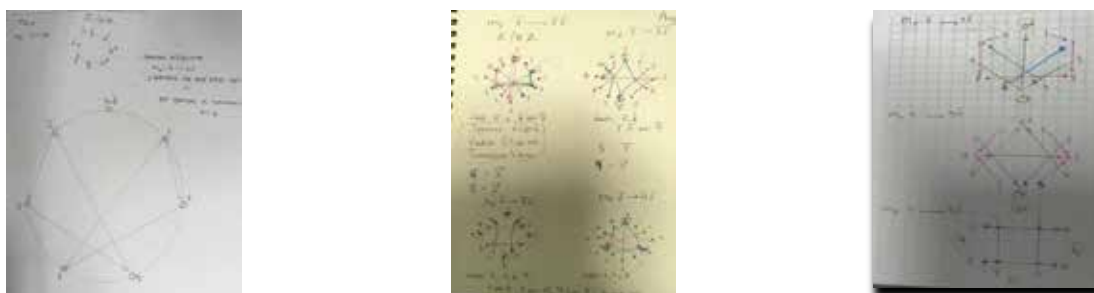


Figure 2: Orbit structure for M_k ($k = 2, 3, 4, 5$) in the integers mod 7 and mod 12

At the end of the course each student gets a grade in group work which is only taken into account if it is higher than the average the grades in the usual compulsory traditional tests taken by the student during the course. Interestingly, in our courses the percentage of (the non-compulsory) student attendance is much higher than the average (80 to 85% against 50%).

Overall, we see that students previously exposed to traditional teaching show a severe metaphorical and dynamical deficit, remaining confined in the arithmetic-algebraic realm. However, progressively, most of them turn out to be able to open up to geometric and dynamical insights, even though initially they remain tied to the purely arithmetical approach that they are more familiar with. At the end of the work session consensus arises on the importance of being able to “change register” and move seamlessly between the arithmetic-algebraic realm and the geometric-visual one. Most students seem surprised to discover, in this way, links between domains of mathematics usually perceived as being far apart, like arithmetic and dynamical systems.

Discussion and open ends

We have shown how Pythagorean triples can be concretely embodied and enactively explored and also how a dynamical systems approach can make the arithmetic modulo m more lively, visual and motivating.

Our examples show that concrete embodiment of abstract mathematical notions and properties, before or instead of their “abstract parachuting”, may bear a dramatic impact on the level of participation and engagement of the students in otherwise unappealing tasks. Such impact is also seen on their mathematical performance and their ability to put forth their own research questions, like investigating the “fate” of various numbers mod m or wondering about an arithmetical explanation of the dynamical phenomena observed in the universe of integers mod m .

Our didactic activities are not staircases to climb sequentially but a rather highly intertwined space to explore, where moving flexibly among several representations or metaphors is a must for a meaningful and fruitful mathematical experience.

Our examples also show that representations and metaphors appear sometimes deeply intertwined in a circular relationship, so that it may be somewhat artificial to try to separate them. If we focus in on *metaphorising* and *representing* it may very well happen that in a class, some students are metaphorising while others are representing.

Also, quite often the teacher will be striving to represent – in a friendly way for the students – a notion that she is familiar with (maybe in a rather abstract way though), while students will be metaphorising the same notion, which they hardly fathom. This is visible in our preliminary example of the frog’s random walk: the teacher will be eventually representing the probability of finding the frog in a given stone after m jumps by the portion of the frog landing there, while the students will be metaphorically just constructing this probability as the frog’s portion landing in this stone.

The same holds for Pythagorean triples and arithmetical congruences. Some arithmetically minded students may realise for the first time that Pythagorean triples may be embodied as an integer fitting phenomenon on a grid and that congruence modulo 5 may be represented by winding the integer number line over a regular pentagon. Other students may discover arithmetical congruences, which they ignored or felt to be an esoteric notion, with the help of this enactive geometric winding. Notice here the emerging connection between arithmetical congruences and geometric congruences.

A recurring observation in all our examples, is the surprise that arises among the learners when they realise hitherto hidden connections between realms of mathematics which seemed to lie far apart. Furthermore, it appears that usual problem solving, as found in the literature, tends to neglect the important role of metaphorisation and representation, as a learner’s first reaction when tackling a problem that looks opaque to him or her. Not only because this may allow him or her to solve an otherwise unyielding problem but also because it may allow him or her to “see” a solution, turning a hitherto blind calculation into pellucid insight.

The various metaphors we have presented here are only a sample; there are many others, in analysis, probability, computer science, etc. Invariably, when these metaphors are presented or emerge, they attract the attention of students, and make for a motivating and meaningful classroom experience. They may be however hard to find, so a systematic “catalogue” of them would be most commendable.

Acknowledgment

Funding from PIA-CONICYT Basal Funds for Centres of Excellence Project BF0003 and DAAD Project 573 35022 D (Uni. Bielefeld - U. of Chile) is gratefully acknowledged.

References

- Arnoux, P., & Finkel, A. (2010). Using mental imagery processes for teaching and research in mathematics and computer science, *International Journal of Mathematical Education in Science and Technology*, 41(2), 229-242.
- Brewer, P., & Firmin, M. (2006). *Ethnographic and Qualitative Research in Education*. New Castle, UK: Cambridge Scholars Press.
- Brousseau, G. (1998) *Théorie des situations didactiques*. Grenoble: La pensée sauvage.
- Díaz-Rojas, D., & Soto-Andrade, J., (2015). Enactive Metaphoric Approaches to randomness. In K. Krainer, & N. Vondrová (Eds.). *Proceedings of CERME9* (pp. 629–636). Prague: Charles University in Prague & ERME.
- English, L. (1997). *Mathematical reasoning: Analogies, metaphors, and images*. London: Lawrence Erlbaum Associates.
- Gibbs, R. W. (2008). *The Cambridge Handbook of Metaphor and Thought*. Cambridge, UK: Cambridge University Press.
- Goldin, G. (2014). Mathematical Representations. In Lerman, S. (Ed.) *Encyclopedia of Mathematics Education* (pp. 409–413). Berlin: Springer-Verlag.
- Goldin G.A., & Janvier, C. (1998). Representations and the psychology of mathematics education: Parts I and II (special issues). *Journal of Mathematical Behavior*, 17(1,2).
- Isoda, M., & Katagiri, S. (2012). *Mathematical thinking*. Singapore: World Scientific.
- Johnson, M., & Lakoff, G. (2003). *Metaphors we live by*. New York: The Univ. of Chicago Press.
- Lakoff, G., & Núñez, R. (2000). *Where Mathematics comes from*. New York: Basic Books.
- Proulx, J., & Maheux, J.-F. (2017). From problem solving to problem posing, and from strategies to laying down a path in solving: taking Varela's ideas to Mathematics Education Research, *Constructivistic Foundations*, 13(1), 161-167.
- Sfard, A. (2009). Metaphors in education. In H. Daniels, H. Lauder & J. Porter (Eds.), *Educational theories, cultures and learning : a critical perspective* (pp. 39–50). New York: Routledge
- Soto-Andrade, J. (2007). Metaphors and cognitive styles in the teaching-learning of mathematics. In D. Pitta-Pantazi, & J. Philippou (Eds.). *Proceedings of CERME5* (pp. 191-200). Larnaca, Cyprus: University of Cyprus & ERME.
- Soto-Andrade, J. (2014). Metaphors in Mathematics Education. In Lerman, S. (Ed.) *Encyclopedia of Mathematics Education* (pp. 447–453). Berlin: Springer-Verlag.
- Soto-Andrade, J. (2018). Enactive metaphorising in the learning of mathematics. In G. Kaiser, H. Forgasz, M. Graven, A. Kuzniak, E. Simmt, & B. Xu (Eds.). *Invited Lectures from the 13th International Congress on Mathematical Education* (pp. 619-638). Cham, Switzerland: Springer
- Spradley, J.P. (1980). *Participant observation*. New York, NY: Holt, Rinehart & Winston.

“He’s so fast at drawing” – Children’s use of drawings as a tool to solve word problems in multiplication and division

Heidi Dahl

Norwegian University of Science and Technology, Norway; heidi.dahl@ntnu.no

This paper examines how young pupils (age 8–9) use drawings as a tool in exploring multiplicative situations. Analysis shows that drawings play an important role in their problem-solving process. Drawings are mainly used as information holders and as a tool to organise calculations for problems with a relatively easy structure; in problems with a more complex structure, drawings are more frequently used as a tool for reasoning. The results show no connection between the degree of abstraction in the drawing and the sophistication of the calculation strategy.

Keywords: Mathematical representations, Drawings, Word problems, Elementary school students.

Introduction

Representations are central to all mathematical activity and are needed both to construct understanding and to communicate mathematical ideas. Throughout the history of mathematics, conventional notation, symbols, figures and diagrams have been developed and agreed upon by the mathematical community in order to serve these purposes in an efficient manner. However, Greeno and Hall (1997) claim that, when a child is about to explore a mathematical concept for the first time, nonstandard representations can be more useful than formal ones. Self-invented representations can help pupils to keep track of ideas and connections they have already discovered, and can assist them in organising their work. Moreover, encouraging pupils to create their own representations will provide opportunities to consider the advantages and disadvantages of different forms of representation, and to use those representations as tools to build conceptual understanding.

When entering a new mathematical domain, such as multiplication and division, a simple word problem will be a mathematical problem for a pupil. Carpenter, Ansell, Franke, Fennema and Weisbeck (1993) claim that modelling, either through the use of counters or by drawing, is a natural problem-solving strategy for most kindergarten and primary-grade children. However, older pupils seem to abandon these meaningful approaches in favour of more mechanical and algorithmic ones, and may even consider arguments based on drawings as a form of cheating (Crespo & Kyriakides, 2007). To help pupils build upon and extend their intuitive modelling skills, it is worthwhile to look more closely at how primary-grade pupils use self-invented representations in problem solving in different content areas. The research question for this paper is thus: *What kind of drawings do third-graders produce when they explore a multiplicative context, and what are the function(s) of these drawings in the problem-solving process?*

Background

Young children’s knowledge of multiplication and division

Multiplicative thinking is fundamental for understanding more complex concepts such as ratios, fractions and linear functions. According to Steffe (1994), a multiplicative situation is characterised as one where “it is necessary to at least coordinate two composite units in such a way that one of the

composite units is distributed over the elements of the other composite unit” (p. 19). Depending on the situation, at least four different multiplicative structures can be distinguished: equal groups, multiplicative comparison, rectangular area and Cartesian product (Greer, 1992). Each structure gives rise to problems in both multiplication and division. Multiplication is often introduced prior to division, but research shows that young children spontaneously relate them and do not necessarily find division more difficult than multiplication (Bakker, van den Heuvel-Panhuizen & Robitzsch, 2014; Carpenter et al., 1993; Mulligan & Mitchelmore, 1997). However, multiplicative reasoning differs significantly from additive reasoning in terms of complexity. It is therefore not surprising that multiplicative thinking takes time to develop (Clark & Kamii, 1996). Despite this, it is widely documented that children are able to solve word problems in multiplication and division long before they receive any formal instruction in this domain. Mulligan (1992) found that most third-grade pupils are able to solve multiplicative word problems using a wide variety of strategies, and Carpenter et al. (1993) established that this is the case even for kindergarten children who have been exposed to such problems over some time. In a more recent study, these findings were sustained and extended by Bakker et al. (2014), who found that first-grade pupils are not only able to solve word problems, but to some extent are also successful in solving bare-number problems.

Young children’s strategies for solving multiplicative word problems can be classified as calculation strategies and modelling strategies (Mulligan & Watson, 1998). Calculation strategies involve increasingly sophisticated counting methods such as direct counting, rhythmic counting and skip counting, additive strategies based on repeated addition, and multiplicative strategies. Modelling strategies involve the use of physical objects or drawings. Kindergarten children almost always use direct modelling (Carpenter et al., 1993), while primary-grade children tend to use calculation strategies for small-number problems, but revert to modelling for problems involving larger numbers (Mulligan, 1992). Teachers need to assist pupils in widening their repertoire of calculation strategies. Mulligan and Mitchelmore (1997) suggest that a first step to achieve this is to help pupils to model different semantic structures so that they successfully can apply direct counting. Thereafter, pupils can be encouraged to use the equal-group structure to develop more efficient addition strategies, before these strategies are transferred to other structures. When pupils are able to use repeated addition across different semantic structures, the idea of a multiplicative operation can evolve.

Problem solving and the use of drawings

Polya (1985) describes a four-step approach to problem solving: understand the problem, devise a plan, carry out the plan and look back. Pupils might, of course, move back and forth between these phases before they reach a solution to the problem. The use of representations in general, and drawings in particular, has been highlighted as a tool in the problem-solving process (e.g. van Essen & Hamaker, 1990; Polya, 1985). Van Essen and Hamaker (1990) claim that by translating a word problem into a picture, pupils are forced to pay attention to the given relationships in the problem. Furthermore, some problem characteristics may be more easily inferred from a drawing because they become more explicit, while drawings also relieve working memory. Yet, research on children’s use of drawings in early-years mathematics is still limited (Bakar, Way & Bobis, 2016). Some studies focus on drawings as a product, and look for (possible) relationships between the abstractness of pupils’ drawings and their success in mathematical problem solving. The findings of these studies are

mixed, but there seems to be a tendency towards stating that pupils using iconic (or schematic) drawings are more successful than pupils using pictographic drawings (e.g. Crespo & Kyriakides, 2007; Veles & da Ponte, 2013). Bakar et al. (2016), however, found no such trend in their study. An *iconic* drawing contains only simple lines and shapes to embody the intended object, while a *pictographic* drawing has realistic depictions of the objects involved in the problem (Bakar et al., 2016). It is also important to determine the *mathematical matching*; that is, to what extent are the word problem and the drawing informationally equivalent? (Ott, 2017)

When it comes to viewing drawing as a process, Stylianou and Silver (2004) examined the use of representations by expert mathematicians in problem solving. They found that mathematicians consider drawings as a legitimate tool for reasoning and argumentation, and they use visual representations actively and for different purposes during the problem-solving process. Drawings can be means to understand information, recoding tools, tools that facilitate exploration, and monitoring and evaluation devices (Stylianou, 2011, p. 271). In a follow-up investigation involving middle-school pupils, Stylianou (2011) detected that pupils' use of representations resemble the experts' use in many ways. However, the use of representations as a monitoring tool is fairly limited and not very sophisticated. She recommends that teachers make pupils explicitly aware of the purposes of the representations they use, and that pupils are given opportunities to discuss and negotiate the meaning of various representations. In addition, pupils need to “develop the habit of exploring [a representation], generalising and abstracting from it, and using it as a springboard for connections among tasks and content in mathematics” (p. 277).

Methodology

Context and data collection

This study is part of a larger project entitled “Language Use and Development in the Mathematics Classroom” (LaUDiM), a video-based intervention project where two teachers from different primary schools and university researchers work together on planning and discussing teaching sequences. The empirical data for this particular study is drawn from a teaching sequence in one of the schools where the aim was to provide pupils with experience of different multiplicative situations. The teaching sequence consisted of two consecutive sessions, two days apart, and took place when the pupils had just entered third grade (age 8–9). In the Norwegian curriculum, multiplication and division are introduced and formalised during grades three and four, meaning the pupils in this study had not received any formal teaching on these subjects prior to this particular teaching sequence.

The pupils worked in pairs to solve word problems in multiplication and division. The context for all tasks was preparation work for a fictional school party. The teacher encouraged the pupils to write arithmetic problems or to produce drawings, but she gave no examples of what to write or draw. On the first day, two randomly chosen pairs of pupils were videotaped. In addition, a hand-held camera was used to capture glimpses of the pupils' work. On the second day, three pairs of pupils were videotaped. There was a partial overlap in terms of the pupils videotaped on the first and second day. The pupils' written work was also collected.

Data analysis

As the research question for this paper focuses on how children use drawings in their problem-solving process, only video recordings showing the entire process of solving a given problem were considered data material. When looking through the recordings, 15 episodes were identified, where an episode is defined as “one pair of children working on a particular task, from the time they read the problem until they move on to the next task”. These episodes, together with the corresponding written work, constitute the data material for this study.

The first stage of the data analysis involved watching and transcribing all episodes. The drawings were categorised as mainly *iconic* or mainly *pictorial* (Bakar, 2016), the *mathematical matching* (Ott, 2017) was examined and the *solution strategy* (Mulligan & Watson, 1998) was identified. In the next step, the episodes were re-watched several times with the purpose of identifying the functions of the drawings. A more detailed description of the production and use of drawings, in the form of pointing, making additional markings and so on, was added to the transcripts, and an inductive analysis was conducted. Examples of questions asked about the material are “in what phases of the problem solving is the drawing produced and/or used?” and “how is the making and the use of the drawing linked to the solution strategy?”. Polya’s (1985) description of the four phases of a problem-solving process served as a tool for structuring this work. The analysis yielded several parameters, such as problem structure, abstractness, mathematical matching, solution strategy and different uses of drawings. The analyses of the 15 episodes were compared and contrasted with regard to these parameters to look for possible interrelationships.

Findings

Pupils’ drawings

One or more drawings are produced in all 15 episodes. Two of the drawings can be seen as mainly decorative as they do not resemble the mathematical structure. Figure 1 provides an example of a decorative drawing related to the problem of how many eggs one needs to make twelve portions of muffins, given that one needs four eggs for one portion. The pupils begin by drawing three rows of four eggs, which seems to resemble the equal-group structure of the problem, but then they add three more eggs to each row. After counting a total of 21 eggs, the pupils erase the additional eggs and decide to draw the entire baking process, from the beating of the eggs to ready baked muffins.

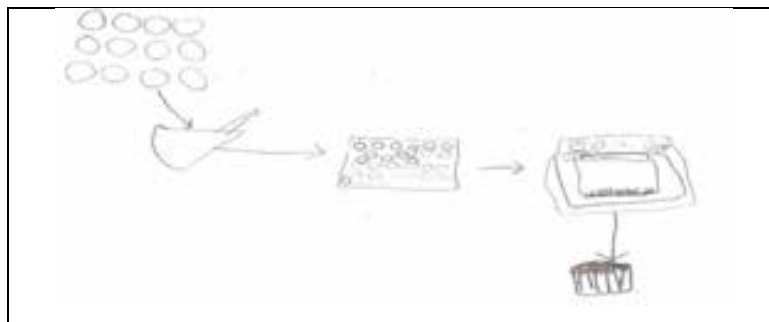


Figure 1: A decorative drawing

Of the thirteen remaining drawings, three are categorised as pictographic, and the rest as iconic. Figure 2 provides examples of both a pictographic and an iconic drawing of the problem of how many tables are needed for twenty-four people if there can be six at each table.



Figure 2: A pictographic and an iconic drawing of the table problem

All of the pictographic drawings are produced by the same male pupil. One girl initially starts to draw pictographically (using coloured pencils), but is encouraged by the teacher and her peer to change to an iconic drawing:

Teacher: Stop for a while. This is very nice, and it works well, but can it be done in a different way so that you don't have to draw every one? There is still a lot remaining.

Peer: Draw circles.

Girl: Can write 6.

The drawing produced in this episode is seen as the drawing on the right-hand side in Figure 3.

The iconic drawings still relate to the given context, as eggs, muffins and cookies are drawn as circles or dots, tables and trays drawn as circles or quadrilaterals, and pencils drawn as tally marks. This might suggest that classifying drawings from pictographic to iconic on a continuum, is more fruitful than seeing it as a dichotomy. All drawings, apart from the purely decorative ones, are considered to have a high degree of mathematical matching. As one can see in Figure 2, both drawings show the right number of people for each table, and twenty-four people in total. Three of the drawings involve number symbols as an important element. Figure 3 shows two of those, both produced in relation to the problem of how many pencils there are in twenty boxes, given that there are six pencils in each box. The pupils are successful in solving the word problems, barring minor counting errors, in all but two of the episodes. The two episodes where the pupils fail to solve the problem are the ones where only a decorative drawing is produced.



Figure 3: Drawings with number symbols for the pencil problem

Pupils' strategies and use of drawings

The pupils' solution strategies are dominated by direct counting. For the multiplication tasks, there are only two examples of more advanced strategies. One is seen in the drawing on the left in Figure 3, where a strategy based on doubling is used; for the other drawing in Figure 3, the pupils count by ones, tapping a finger rhythmically six times for each box of pencils. The other example of a more advanced strategy is seen when a pair of pupils work on the problem of how many muffins there are on seven trays if there are ten muffins on each tray. They draw an iconic picture of all the trays and all the muffins, before they count ten muffins on each tray, simultaneously writing $10+10+10+\dots$ on the paper. They reach the answer of 70 muffins with no further counting or visible reasoning.

For the multiplication problems, the drawing is usually produced immediately after the pupils have read the text. This indicates that they instantly visualise the problem situation and use the drawing as an information holder. In cases where the pupils struggle to understand the problem, they call for a teacher to help them re-read the text and explain particular words. When the drawing of all objects is completed, the pupils use the drawing as a calculation tool. Usually, the drawing is used to execute a counting plan, but in one case it acts as a means to develop a more advanced doubling strategy, as seen in Figure 3. There are instances where the pupils count one by one, even though the video recordings reveal that they master more advanced strategies. We see this, for example, in connection to the problem of finding the total number of muffins on a tray consisting of five rows with seven muffins in each row. The pupils first find the answer by direct counting, but later they write the addition problem $5+5+5+5+5+5+5$ and skip count to 35.

For the division problems involving smaller numbers, such as the table problem (see Figure 2), all pairs use direct counting in groups of six. For the division problems involving larger numbers – 48 cookies being distributed equally between four tables – one pair use direct counting to distribute one cookie at a time until there are no cookies left. In the other two episodes involving this task, the pupils state that there will be ten cookies for each table and then divide the remaining eight cookies. One of these pairs draw all the cookies (first ten on each table, then adding two more), while the other pair write number symbols after performing calculations in their heads. Figure 4 shows the corresponding drawings for this problem.



Figure 4: Drawings of the cookie problem

The use of drawings in solving division problems differs somewhat from the use of drawings for multiplication. The actual calculations are more often made based on the numbers, not on the drawing. Nevertheless, the drawing is important for reasoning and for devising and executing a calculation

plan. This is exemplified by the following short extract from an episode related to the cookie problem. A pack of cookies has been drawn, with the number 48 above, as we enter the situation (drawing is seen to the far right in Figure 4):

Pupil 1: You have to draw four tables with people. No, just four tables without any people.
(P2 draws four tables)

Pupil 2: We have to divide those by four. (P2 points to the pack of cookies)

Pupil 1: Yes, that is what I plan to do. Ten. (P1 points to each of the tables) 11, 11, 11, 11.
(P1 points to each of the tables) 12, 12, 12, 12. (P1 points to each of the tables)

This extract demonstrates how the drawing offers a visual support for the mental calculations by giving meaning to the numbers and the operation.

Discussion and implications

It is not surprising that the pupils successfully solve word problems, as this result has emerged in previous research (e.g. Bakker et al., 2014). Somewhat more surprising is that there is no evidence in the material showing that iconic drawings are used in a more sophisticated way than pictographic drawings; rather, the opposite is true, but the data material in this study is rather limited.

When it comes to pupils' strategies and use of drawings, the amount of drawing and counting is striking. The pupils are not discouraged by higher numbers, such as 20:6; as one girl exclaims about her partner in relation to the pencil problem: "He's so fast at drawing". This supports the impression that even though the pupils are capable of using more advanced strategies, they prefer drawing and direct counting. One hypothesis is that the pupils in this particular class are used to showing their thinking, and that they consider drawings more suitable for this purpose than number symbols. Overall, they appear to regard drawing as a legitimate way to reason and argue, a view that needs to be acknowledged and nurtured by the teacher (Crespo & Kyriakides, 2007). Another hypothesis is that drawing serves as a form of confirmation for the pupils. Because multiplication and division are a new school topic for them, they need to model the situations in order to fully grasp the meaning of the numbers and the relations between them. There is therefore no rush for the teacher to push for more advanced strategies at this point; instead, they can use the pupils' work to discuss, compare and contrast the different multiplicative situations and possible ways to represent them. As claimed by Carpenter et al. (1993), children who are taught to approach problem solving as an effort to make sense out of problem situations, may come to believe that learning and doing mathematics involves the solution of problems in ways that always make sense. (p. 440)

References

- Bakar, K. A., Way, J. & Bobis, J. (2016). Young children's drawings in problem solving. *Mathematics Education Research Group of Australasia*.
- Bakker, M., van den Heuvel-Panhuizen, M. & Robitzsch, A. (2014). First-graders' knowledge of multiplicative reasoning before formal instruction in this domain. *Contemporary Educational Psychology*, 39(1), 59–73.

- Carpenter, T. P., Ansell, E., Franke, M. L., Fennema, E. & Weisbeck, L. (1993). Models of problem solving: A study of kindergarten children's problem-solving processes. *Journal for Research in Mathematics Education*, 24(5), 428–441.
- Clark, F. B. & Kamii, C. (1996). Identification of multiplicative thinking in children in grades 1–5. *Journal for Research in Mathematics Education*, 27(1), 41–51.
- Crespo, S. M. & Kyriakides, A. O. (2007). To draw or not to draw: Exploring children's drawings for solving mathematics problems. *Teaching Children Mathematics*, 14(2), 118–125.
- Essen, G. V. & Hamaker, C. (1990). Using self-generated drawings to solve arithmetic word problems. *The Journal of Educational Research*, 83(6), 301–312.
- Greeno, J. G. & Hall, R. P. (1997). Practicing representation: Learning with and about representational forms. *Phi Delta Kappan*, 78, 361–367.
- Greer, B. (1992). Multiplication and division as models of situation. In D. Grouws (Ed.), *Handbook of research on mathematics teaching and learning* (pp. 276–296). New York: Macmillan.
- Mulligan, J. (1992). Children's solutions to multiplication and division word problems: A longitudinal study. *Mathematics Education Research Journal*, 4(1), 24–41.
- Mulligan, J. T. & Mitchelmore, M. C. (1997). Young children's intuitive models of multiplication and division. *Journal for Research in Mathematics Education*, 28(3), 309–330.
- Mulligan, J., & Watson, J. (1998). A developmental multimodal model for multiplication and division. *Mathematics Education Research Journal*, 10(2), 61–86.
- Ott, B. (2017). Children's drawings for word problems – Design of a theory and an analysis tool. In T. Dooley & G. Gueudet (Eds.), *Proceedings of the Tenth Congress of the European Society for Research in Mathematics Education* (pp. 3984–3991). Dublin, Ireland: CERME.
- Polya, G. (1985). *How to solve it. A new aspect of mathematical method* (2nd edn.). Princeton, New Jersey: Princeton University Press.
- Steffe, L. P. (1994). Children's multiplying schemes. In G. Harel & J. Confrey (Eds.), *The development of multiplicative reasoning in the learning of mathematics* (pp. 3–39). Albany, NY: State University of New York Press.
- Stylianou, D. A. (2011). An examination of middle school students' representation practices in mathematical problem solving through the lens of expert work: Towards an organizing scheme. *Educational Studies in Mathematics*, 76(3), 265–280.
- Stylianou, D. A. & Silver, E. A. (2004). The role of visual representations in advanced mathematical problem solving: An examination of expert-novice similarities and differences. *Mathematical Thinking and Learning*, 6(4), 353–387.
- Velez, I. & da Ponte, J. P. (2013). Representations and reasoning strategies of grade 3 students in problem solving. In B. Ubuz, C. Haser & M. A. Marioti (Eds.), *Proceedings of the Eight Congress of the European Society for Research in Mathematics Education* (pp. 383–391). Ankara, Turkey: CERME.

Functional representations produced and used by students during their introduction to the concept of derivative: a window on their understanding processes

Sarah Dufour

Université du Québec à Montréal, Faculté des sciences de l'Éducation, Montréal, Canada;

dufour.sarah.2@courrier.uqam.ca

This article is about student understanding processes during their introduction to the concept of derivative that were constructed as part of a doctoral dissertation. The observation of these understanding processes is made from the standpoint of representations in the sense of Duval (1993) and Hitt (2006). More specifically, two aspects of the models of the comprehension process are underlined. First, the fact that students can sometimes work well in different registers, but that they can not necessarily do a proper coordination of these representations is put forward. In addition, the particular role played by the verbal register is also discussed.

Keywords: Understanding process, derivatives, representations, teaching experiment.

Introduction

The concept of derivative is the subject of many scientific studies in the field of teaching and learning mathematics. The work of Biza and Zacharides (2010) on the concept of tangent is an example of documented difficulties that students in the calculus course may encounter. Or the work of Sierpiska (1985) around the concept of limit is also a landmark for all those who are interested in the learning and teaching of concepts in differential calculus. Other researchers shed light on factors that may explain these difficulties and have proposed possible solutions to help students overcome these difficulties. For example, Zerr (2010), Haciomerogolu, Aspinwall, and Presmeg (2010), among others, provide insights into the elements that lead to a so-called “conceptual” understanding of the concepts of differential calculus. Among these authors, Zandieh, at the turn of the 2000s, proposes a theoretical framework for the analysis of students’ understanding of the concept of derivatives. But, as Zandieh (2000) mentions, this schema does not comment on how and why students are approaching the concept of derivative in a certain way. In addition, Hähkiöniemi (2006) also proposes a diagram that identifies elements that can allow students to deepen their understanding of the derivative. However, this schema is based on the observation of the students after they have seen the concept in class. The observation of students in action, engaged into a process of understanding the concept of derivative, which is new for them, could allow to add a new dimension to these models.

This article, based on Dufour’s PhD (2018), reports on a study that aims to model the students’ understanding of derivative with regard to the process aspect of this understanding and the implementation of an analytical framework to observe and describe these processes. It is not possible to detail the models obtained in the thesis in this paper. However, this article exemplifies two elements in relation with the representations used by students, that seems for us, key moments in the understanding processes of students of the derivative.

Theoretical Framework

An orientation on the concept of understanding must be taken in order to accurately model one or more understanding processes. Among the studies about differential calculus, some mentions the different representations of mathematical concepts as part of a solution or as a possible explanation to the students' difficulties (Eisenberg and Dreyfus, 1991; Biza and Zachariades, 2010). By insisting on this particular aspect of representations, it was possible to detail the model in depth in this sense. Two visions on the representations, one in continuity with the other, are gathered. First, Duval's theory of registers of semiotic representations (1993, 2006) puts forward important cognitive activities related to representations in different semiotic registers. Actions on and with representations, which are essentials, especially in the case where we are interested in introducing a new concept to students, are described by Duval. These actions are *recognition*, *treatment* (to process or manipulate), *production*, *conversion* and *articulation* (coordination). *Recognition* makes it possible to recognize a concept by a given representation. *Processing* makes it possible to modify a representation within the same register in order to obtain a new representation. *Production* produces a representation related to a certain concept. The *conversion* makes it possible, from a given representation, to produce a new representation in a different register from the one of departure. This action is more complex than the others since it requires to recognize the rules of two registers. Finally, the *articulation (coordination)* between representations in different registers is, for Duval, a cognitive activity related to the conceptual apprehension of a mathematical object. Beyond being able to produce a representation in a register or to convert a representation to a new register, it is a question of being able to go back and forth in different registers according to what is recognized as necessary (Duval, 2006) to carry out a mathematical activity.

The representations described by Duval are part of different semiotic registers which are described by a set of rules of conformity (Duval, 1993), and which are the subject of a certain consensus in the mathematical community. By this rather strict definition, we place Duval's representations in the category of institutional representations. However, as the objective of the research presented here is to learn about the "process" aspect of student understanding, a vision of representations that particularly considers intuitive representations of students is necessary. The concept of functional representations of Hitt (2003) describes intuitive representations in construction. Functional representations make it possible to associate representations produced or manipulated by students to a certain register, although the latter do not completely respect the rules established in this register.

Thus, along with the theoretical framework, an analytical framework is drawn up to describe the students' processes of understanding when they are introduced to a new mathematical concept into the classroom. Indeed, we can now describe these processes by the actions taken by the students on and with representations belonging to different registers of representations and having a certain nature: institutional or functional. On the other hand, it is advisable to specify the different registers likely to be encountered during the observation of the mathematical activity of the students. Due to the nature of the targeted concept, the derivative, which belongs to the mathematical domain of analysis, the registers of representations are: graphic, tabular, verbal (whether written or oral), algebraic and numerical.

Methodology

Two key elements were taken into account in the choice of a methodology for this study. First, the observation of students understanding processes will be in the form of constructing one or more models of these processes. The chosen methodology must therefore be consistent with this central objective. In addition, the goal also installs the research in a particular context of teaching sessions designed to encourage the use of different representations. The Teaching Experiment (TE) was ideal for this project. Indeed, this methodology aims to document, through the production of a model, the mathematical development of students by observing, among other things, their learning process and their conceptions in a teaching context (Steffe and Thompson, 2000).

The theoretical position on understanding of this research, in particular Hitt's (2003) perspective suggesting these student's representations evolve through interactions with the teacher and other students, sets a particular context for the TE. It is therefore inspired by the position of Cobb (2000), among others, that the TE took its shape in this project. Cobb supports the need to conduct a TE in the classroom through the individual and social aspects of learning, which is consistent with the position taken in this research. However, a completely natural classroom context would have made the fine observation of the different representations used difficult. A "hybrid" form that lies between the individual interview outside the classroom and the natural classroom context is used. A TE with a small group of six students, which allows for individual, team or large groups work with the teacher-researcher and spans over five sessions, has been put in place.

The teaching sessions were videotaped and a journal was written before and after each session. The videotapes were translated into transcripts that were analysed with specific regard on the representations produced and used by students. The analysis of the transcripts and students' productions took place in four steps, or iterations, inspired by Powell, Francisco and Maher (2003)' analysis model. Table 1 resumes the different layers of analysis.

Layer of analysis	Description
First	<ul style="list-style-type: none"> · Identify key moments in the student's understanding process in order to use these moments as a basis for building the other sessions. · Record the privileged or used registers of representations in the session.
Second	From the transcripts (coding) : <ul style="list-style-type: none"> · Identify the different representations used, produced or processed by the students. · Identify some actions on these representations by the students. · Add comments on the transcripts.
Third	From the coded and commented transcripts: <ul style="list-style-type: none"> · Write, as a story, the development of the session by dividing it into key moments. · For each of these moments, identify and interpret, from the perspective of the theoretical framework, the representations used or produced by the students and the actions taken on these representations. · Support these interpretations with excerpts from transcripts of the sessions or figures from students' productions.
Fourth	From the story written before: <ul style="list-style-type: none"> · Identify the moments that are directly related to the concept of derivative. · Highlight from these moments the elements that can be part of the description of the process of understanding students. · Support this analysis with excerpts of transcripts of the sessions or figures from students' productions.

Table 1: Layers of analysis

Results and Discussion

The TE put in place and the many layers of analysis allowed us to build two collective models (for two teams of three students) of understanding processes of the concept of derivative during its introduction to students around 18 years old. Since the models take the form of a follow-up text revealing the different representations produced and used by the students and especially the way in which they have used and modified them during the different interactions between them and with the teacher-researcher, it is impossible to report the whole of them in this article. We will instead offer some excerpts that seem particularly rich to better understand the understanding processes of students with a particular focus on the necessity of a coordination between different registers. The first excerpt illustrates the ability of students to produce and process representations of a concept in different registers without being able to demonstrate a real coordination between the registers. The second emphasizes the particular role of the verbal register in the understanding processes of students.

Production of Representations in Different Registers Without Achieving Coordination

First, during the fourth session, a problem of bacterial proliferation was proposed to students through a scenario in words and a table of values. The question posed in this problem was to identify when an antibiotic administered to a patient allows the reduction of the bacterial population present in the patient. We are particularly interested here in the work of Guillaume, Jérémie and Antoine's team (see figure 1 showing Jeremie's work).

Temps écoulé en heures depuis la prise de l'antibiotique (t)	0	2	4	10	12	14
Nombre de bactéries dans la population (b(t))	1 000 000	1 025 200	1 044 800	1 067 200	1 067 200	1 058 800
		12600 $25200/2$	9800 $19600/2$	22400 $22400/2$	2800	4700 $(8400)/2$

Figure 1: Treatment of the Table of Values and Numerical Representations (Dufour, 2018, p. 152)

The three students were able to produce, from a few treatments on the table of values, verbal representations of the situation that are related to the concept of derivative (see Table 2, translated from Dufour, 2018). Table 2 shows the representations and actions made by the three students during their work on this problem. These representations and actions are also interpreted in this table.

Although these functional representations are incomplete or even erroneous, the students associated them with the concept of derivative. They could thus have used the recognition of this concept (derivative) to produce algebraic representations implying the concept of derivative at a point which would be null and which could have allowed them to solve the problem. Unfortunately, this conversion did not take place and the students finally found another way to answer the question, but this solution is not what interests us here.

Type of representations and actions on these representations	Student	Interpretations
<p>Conversion from TR → NR (Tabular representation) → Numerical Representation From a table of value, calculations of different average rates of change. (see figure 1)</p>	Jérémie	Jérémie makes a good use of the data in the given table to calculate the rate of change on different intervals. However, he doesn't go further on the interpretation of what he could do with this new information.
<p>Conversion NR → VR (verbal representation) Because I asked, he produces a VR for his calculations (average rate of change) which is “means” (VR).</p>	Jérémie	<p>Although this VR is <u>incomplete</u>, Jeremy is not wrong. Indeed, his various calculations can be associated with the concept of mean in the sense that he obtains a number of bacteria produced/dead for each hour in this interval, that is to say, a number of bacteria produced each hour if the same number of bacteria was produced every hour over this interval.</p> <p>This is an incomplete VR in the sense that it does not identify NRs as “rates of change” (VR), which is an important conversion for the rest of the problem and especially for the process of understanding the derivative.</p>
<p>Conversion NR + VR → VR + VR Conversion from the average rate of change calculated (NR) and the verbal representation “mean” (VR) to the verbal representations “slope” (VR) and “variation” (VR).</p>	Guillaume	Guillaume uses the representation “slope” to talk about what Jérémie calculated (average rate of change). These two VRs can indeed designate the same concept. It can be emphasized that the term “slope” is more often used with reference to the graphic register which is not necessarily the case here, although some links with the graphical register are formed later.
<p>Conversion NR + VRs → VR Conversion from the average rate of change calculated (NR) and the verbal representations “mean” (VR), “slope” (VR) and “variation” (VR) to the verbal representation “derivative” (VR)</p>	Antoine	Antoine continues the discussion by introducing the term “derivative”. It is true that what Jérémie calculates (average rate of change) is not very far from the concept of derivative (instantaneous rate of change). Recall that what distinguishes these two concepts is that the average rate of change is related to a given interval or secant line to the function involved. Whereas the instantaneous rate of change (derivative at a point) is related to the rate of change for a value of the independent variable in particular or the rate of change of a tangent line at a point of a function. Therefore, the use of the RV “derivative” is erroneous in this case.
<p>Conversion NR + VR → VR + VR Conversion from the average rate of change calculated (NR) and the verbal representation “derivative” to two verbal representations: “The derivative between 12 and 14” (VR) and “the tangent between 12 and 14” (VR)</p>	Antoine	Antoine goes further by producing the VR “the derivative between 12 and 14” and the VR “the tangent between 12 and 14”. For the same reasons as those raised above, these two VRs are erroneous. Indeed, a derivative or a tangent line can't be associated with an interval of this kind. In this case, Antoine should have used the representations “average rate of change” or “secant line between 12 and 14”, for example, so that the different representations in this discussion are coordinated coherently.

Table 2: Representations Produced by Students and Our Interpretations (Dufour, 2018, p. 157)

Later, the teacher-researcher directly suggested to the team to use the concept of derivative to solve this problem. At this point, the three students produced algebraic representations of the derivative at a point such that the derivative at this point would be zero (see Figure 2 for an example). They even managed to manipulate these representations to find that famous moment when one can observe a change of growth of the function.

$$\lim_{h \rightarrow 0} \frac{f(t+h) - f(t)}{h}$$

$$= \frac{-700(t+h)^2 + 14000(t+h) + 10^6 - (-700t^2 + 14000t + 10^6)}{h}$$

$$= \frac{-700(t^2 + 2th + h^2) + 14000t + 14000h + 10^6 + 700^2 - 14000t - 10^6}{h}$$

$$= \frac{-700t^2 - 1400th + 700h^2 + 14000t + 14000h + 10^6 + 700^2 - 14000t - 10^6}{h}$$

$$\lim_{h \rightarrow 0} \frac{-1400th - 700h^2 + 14000h}{h}$$

$$= \lim_{h \rightarrow 0} (-1400t - 700h + 14000)$$

$$= -1400t + 14000$$

$$y = 14000x + b$$

$$y' = 14000$$

$$f'(t) = 14000$$

Figure 2: Treatment of an algebraic representation of the derivative of a function by Guillaume (Dufour, 2018, p. 166)

What is interesting to observe here is the completely parallel use of the different registers. Indeed, their work in “closed vases” did not allow them to coordinate coherently the different representations they can produce and thus achieve a better understanding of the concept of derivative. However, their use of the derivative in the algebraic register to solve the problem might suggested that once the concept was identified, which they had done verbally before (see Table 2), they could had completed the problem by processing an algebraic representation. Although their functional verbal representations were not completely adequate, the students identified them as the derivative. They could had allowed them to move to an algebraic representation as they did later at the request of the teacher.

The Particular Role of the Verbal Register in the Coordination of Different Representations

According to the position on the understanding adopted in this article, to understand, one must coordinate different representations of various registers. However, beyond this necessity, the models constructed make it possible to identify the verbal register as being a central element of this coordination. In fact, the register is at least a mirror that can reflect the understanding of students. Indeed, it was often when the students were brought to produce such type of representations that we can observed if the coordination between the representations was coherent or not. The representations in this register sometimes revealed to students themselves that they cannot articulated representations in different registers.

As an example, some of the functional verbal representations showed in table 1 are not coherent with the concept of derivation such as “the derivative **between** [an interval]”. Other functional verbal representations produced by the same student later such as “the slope of a derivative is a tangent” and “the derivative **line** is the **slope** of a tangent” are also examples of incoherent representations of the

derivative. This kind of functional verbal representations let us realized that, even if some representations were coherent and complete in their own register (algebraic for example), the concept of derivative still provoked a confusion to the observed students. Even more important, when the students were asked, by the teacher-researcher or by their colleagues to explain what they were doing in a certain register (often algebraic), they, themselves, realized that they often cannot explained or justified the representations they produced or used. This was, then, a key moment for them in their understanding process.

Another example appeared when the students had to identify in different registers the concept of rate of change to be able to go through their idea of using derivative to solve a problem. Some examples of this difficulty were observed during the TE sessions. One of them was when we proposed a problem from Selden, Mason and Selden (1989) (see figure 3).

Find values of a and b so that the line $2x+3y=a$ is tangent to the graph of $f(x) = bx^2$ at the point where $x=3$.

Figure 3: Problem proposed to the students during the fifth session

The students, in both team of three participants, were able to identify in the verbal register the need to equal the rate of change of the given linear function and the derivative of the given function f for $x=3$. However, they were not able to articulate the verbal representation to a coherent algebraic representation. It needed some interventions from the teacher-researcher to finally be able to coordinate these representations. In this case too, the verbal representation was important for two reasons. First, it sheds light on the fact that the students were able to recognize the usefulness of the derivative. Second, it helped to determine that the problem was not directly the concept of derivative, in that case, but that it was the concept of rate of change. This coordination of different representations of the concept of rate of change seemed to be confusing for students. We must precise that if the concept of derivative is new for them, they work with the concept of rate of change since at least three school years. However, it seemed that this concept in particular still is of high importance in the understanding process of the derivative.

Conclusion

The few examples given above are only some of the important elements that the construction of models of understanding processes of the concept of derivative made it possible to underline. The use of representations in different registers in a rather parallel way than in a coordinated way had been observed several times during the construction of the understanding processes models. Certainly, this step, working in close vases, may be inevitable and part of a deep understanding process of the concept. However, it must certainly be considered in teaching by attempting to provoke, not only representations in a variety of registers, but treating them in a coordinated manner. It's about emphasizing how these various registers are related to each other. The verbal register seems appropriate to allow such disclosure of the links between the registers.

References

Biza, I. and Zachariades, T. (2010). First year mathematics undergraduates' settled images of tangent line. *The Journal of Mathematical Behavior*, 29 (4), 218–229.

- Cobb, P. (2000). Conducting teaching experiments in collaboration with teachers. In R. A. Lesh & A. E. Kelly (Eds.), *Handbook of research design in mathematics and science education* (p. 307–333). Hillsdale, NJ: Erlbaum.
- Dufour, S. (2019). *Des processus de compréhension sous l'angle des représentations: un teaching experiment autour de la dérivée* (Doctoral thesis). Manuscript submitted for publication.
- Duval, R. (1993). Registres de représentation sémiotique et fonctionnement cognitif de la pensée. *Annales de didactique et de sciences cognitives*, 5, 37–65.
- Duval, R. (2006). A Cognitive Analysis of Problems of Comprehension in a Learning of Mathematics. *Educational Studies in Mathematics*, 61 (1-2), 103–131.
- Eisenberg, T. and Dreyfus, T. (1991). On the reluctance to visualize in mathematics. In W. Zimmermann et S. Cunningham (Eds.), *Visualization in teaching and learning mathematics*. MAA Series.
- Haciomeroglu, E. S., Aspinwall, L. et Presmeg, N. C. (2010). Contrasting cases of calculus students' understanding of derivative graphs. *Mathematical Thinking and Learning: An International Journal*, 12 (2), 152–176.
- Hähkiöniemi, M. (2006). *Hypothetical learning path to the derivative* (Doctoral thesis). Retrieved from <https://jyx.jyu.fi/bitstream/handle/123456789/22530/1/rep104.pdf> .
- Hitt, F. (2003). Le caractère fonctionnel des représentations. *Annales de didactique et de sciences cognitives*, 8, 255–271.
- Powell, A. B., Francisco, J. M. et Maher, C. A. (2003). An analytical model for studying the development of learners' mathematical ideas and reasoning using videotape data. *The Journal of Mathematical Behavior*, 22(4), 405–435.
- Selden, J., Mason, A. and Selden, A. (1989). Can average calculus students solve non-routine problems? *Journal of Mathematical Behavior*, 8, 45–50.
- Sierpinska, A. (1985). Obstacles épistémologiques relatifs à la notion de limite. *Recherches en didactique des mathématiques*, 6(1), 5–67.
- Steffe, L. P. et Thompson, P. W. (2000). Teaching experiment methodology: Underlying principles and essential elements. In R. Lesh at A. E. Kelly (Eds.), *Research design in mathematics and science education* (p. 267–307). Hillsdale, NJ: Erlbaum.
- Zandieh, M. J. (2000). A theoretical framework for analyzing student understanding of the concept of derivative. *CBSM Issues in Mathematics Education*, 8, 103–127.
- Zerr, R. J. (2010). Promoting students' ability to think conceptually in calculus. *Primus*, 20 (1), 1–20.

Moving towards understanding graphical representations of motion

Carolien Duijzer¹, Marja Van den Heuvel-Panhuizen^{1 2 3}, Michiel Veldhuis^{1 4} and Michiel Doorman²

¹Freudenthal Group, Utrecht University, Faculty of Social and Behavioural Sciences, the Netherlands; a.c.g.duijzer@uu.nl; m.veldhuis@uu.nl

²Freudenthal Institute, Utrecht University, Faculty of Science, the Netherlands; m.doorman@uu.nl

³Nord University, Norway; m.vandenheuvel-panhuizen@uu.nl

⁴iPabo University of Applied Sciences, Amsterdam, the Netherlands

Making connections between variables and proficiently constructing graphical representations is key to higher-order thinking activities within mathematics and science education. In our research, we make use of a learning environment informed by embodied cognition theory to promote students' graphical understanding. In the teaching sequence offered to fifth graders, students created distance-time graphs describing their own movements in front of a motion sensor. In a pretest-intervention-posttest design, we investigated whether task-related bodily movements enhanced students' understanding of graphs of motion, as reflected in their competence in interpreting and constructing graphs. Preliminary results point to important links between students' motion experiences and their ability to reason about the relationship between distance and time as represented in graphs.

Keywords: Graphs, primary mathematics education, embodied cognition, motion, modelling.

Introduction

Students' difficulties with understanding graphs is a much-studied topic. Such difficulties become especially apparent when graphs include a time-dependent variable, as for example in distance-time or speed-time graphs. Then, students can be prone to focus on surface characteristics of the graphs, such as the slope and interpreting it as an indication of moving up or the height and viewing it as an indication of highest point (e.g., Glazer, 2011). However, good understanding requires that students discover the deeper connections underlying the represented data and start to think about the relationship between multiple variables and "their pattern of covariation" (e.g., Leinhardt Zaslavsky, & Stein, 1990, p. 11). According to Friel et al. (2001) students have to develop *graph sense*, which "develops gradually as a result of one's creating graphs and using already designed graphs in a variety of problem contexts that require making sense of data" (Friel, Curcio, & Bright, 2001, p. 145)".

Developing graph sense can be seen as higher-order thinking. It implies reasoning about graphs, including interpreting, constructing, changing, combining, and comparing graphs (e.g., Boote, 2014). In order to foster students' understanding of graphs and related reasoning, we designed a teaching sequence in which students are given ample opportunities to experience firsthand how their own bodily movements are represented as a graph. The idea that bodily experiences can be beneficial for learning, is captured within the theory of embodied cognition.

Theoretical background

Embodied cognition theory states that when we interact with our physical environment valuable perceptual-motor experiences are acquired through which our cognition is shaped. This makes our

acting body one of the most important factors for learning (e.g., Wilson, 2002). According to embodied cognition theory this learning does not only include the acquisition of lower-level cognition (e.g., motor development) but it also incorporates the acquisition of higher-level cognitive processes (e.g., language and mathematics) (e.g., Barsalou, 2010). Evidence for the idea that thinking and learning are embodied has inspired researchers to incorporate bodily movements in educational environments in order to improve student learning. Often this involves activities in which students are instructed to make whole- (or part-)bodily movements, or to observe movements (e.g., Ruiter, Loyens & Paas, 2015). Whereas all these bodily experiences are considered to be embodied, some researchers argue that activities in which the whole body partakes have some additional benefits. For example, the body might become a mathematical object itself (e.g., *being a number, being the graph*) and, in a more collaborative vein, the body might become an object for collective sense-making (Kelton & Ma, 2018; Ma, 2017).

Embodied learning environments supporting students' understanding of graphing change are based on the premise that providing students with valuable bodily experiences that are immediately linked to the target concepts could alleviate students' difficulties with graphs representing change over time (e.g., distance-time graphs). In the context of modelling motion, this would imply a strong grounding of the concept of change in experienced (own) motion. For a recently carried out literature review (Duijzer, Van den Heuvel-Panhuizen, Veldhuis, Doorman, & Leseman, 2019), embodied learning environments supporting students' understanding of how to graph change were characterized on the degree of bodily involvement (own and others/objects' motion) and immediacy (immediate and non-immediate). Immediacy refers to whether a learning environment deals with on- or off-line cognitive activities. Off-line cognitive activities become grounded through embodied mechanisms such as mental simulation or imaginative activities (e.g., Barsalou, 2010). For example, when students walk in front of a motion sensor and see the graph of their own movements appear in real-time on the screen of the computer, the activity is "on-line" and the experience immediate. When students obtain this graph of their own movements at a later stage, the activity is "off-line" and hence the experience non-immediate. The review unveiled that learning environments making use of students' own movements immediately linked to their representation were most effective in terms of learning outcomes. These learning environments often made use of motion sensor technologies to immediately track a dynamic event as a line in a graph. This immediate link between one's own movement and a graphical representation of this movement was found to be an important mediating factor of these embodied learning environments.

Although over the past couple of decades much research has been published showing that one's own motion experiences might be helpful in learning motion graphs, practical applications are still scarce. Most of the research investigating the role of perceptual-motor activities on primary school students' understanding of graphical representations of motion has been done with individual students, looking at micro processes of development (e.g., Ferrara, 2014). We wanted to shift this accentuation a bit and investigate how the use of embodied learning environments translates to whole classrooms. In doing so we built on work done by others. For example, Deniz and Dulger (2012), showed positive effects of an inquiry-based instruction condition enriched with real-time graphing technology in which fourth graders were asked to replicate given motion situations. The other instruction condition

used traditional laboratory equipment (i.e., a bottle of water with a hole and measuring tape). In the traditional laboratory condition students were allowed to move as well, but the immediate real-time link between motion and graph was missing. Considering these findings, it could be argued that having the opportunity to move, as well as immediately seeing your movements reflected as a graphical representation is helpful for learning about graphs of motion for students of this age. Therefore, we further explored this issue by contrasting a group of students participating in classroom activities including immediate whole-bodily movements with a group of students participating in regular classroom activities, without having the experience of moving yourself.

Current study

In this study, we investigated the effects of an intervention, comprising a teaching sequence including immediate task-related whole-bodily movements, on students' understanding of graphing change. Our research question was: *What is the effect of a classroom intervention including students' own whole-bodily movements on students' ability to interpret and construct motion graphs?* We hypothesized that an intervention in which task-relevant bodily movements were made, would result in better learning and test performance on interpreting and constructing graphs than an intervention in which students were not given this opportunity.

Method

To answer the research question, we set up a quasi-experiment in a classroom setting with a pretest-intervention-posttest design containing two experimental conditions in which students were offered a teaching sequence on graphing change in motion and a control condition in which the students did not get this teaching sequence. Instead these students received a teaching sequence (similar in intervention duration and time of intervention) on probability to take into account the effect of having an intervention on students' learning gains. The first experimental condition was embodied, meaning that the students were allowed to move around freely, while in the second experimental condition, the non-embodied one, the students did not have this opportunity. Therefore, the main difference between both conditions was the dynamicity of the movement presented to the students as well as the opportunity to physically experience the target concept of graphically represented motion.

Participants

Participants were 218 fifth-grade students (94 female, mean age = 10.29 years, $SD = 1.46$) from 9 classes of 8 Dutch elementary schools. The classes were randomly divided over three conditions: embodied experimental condition ($n = 70$), non-embodied experimental condition ($n = 68$), and control condition ($n = 80$). The research was conducted in accordance to the ethical guidelines of the Institutional Review Board of the faculty of Social and Behavioral Sciences at Utrecht University.

Procedure

The participants in the experimental conditions participated in a teaching sequence of six lessons on graphing change in motion, participants in the control condition participated in a teaching sequence of six lessons on probability. The students received the teaching sequence at different time periods throughout the year, see Figure 1. All participants took four identical macro tests at fixed time points

spread over the year and six micro tests which were administered after each lesson. All lessons on graphing change were given by the same teacher, the first author of this paper.

Condition	N Classes (students)	M1	Phase 1 (October-November)	M2	Phase 2 (January-February)	M3	Phase 3 (April-May)	M4
			Lesson 1-6		Lesson 1-6		Lesson 1-6	
1	(n = 21)	M1	Lesson 1-6	M2		M3		M4
	(n = 22)	M1		M2	Lesson 1-6	M3		M4
	(n = 27)	M1		M2		M3	Lesson 1-6	M4
2	(n = 24)	M1	Lesson 1-6	M2		M3		M4
	(n = 23)	M1		M2	Lesson 1-6	M3		M4
	(n = 21)	M1		M2		M3	Lesson 1-6	M4
3	(n = 25)	M1	Lesson 1-6	M2		M3		M4
	(n = 30)	M1		M2	Lesson 1-6	M3		M4
	(n = 25)	M1		M2		M3	Lesson 1-6	M4

Figure 1: Research design

Teaching sequence

The main learning objective of the teaching sequence was to foster students’ understanding of motion graphs. In the lessons we focused on graphs representing dynamic situations, where distance changes over time. The teaching sequence started with an activity in which students were asked to develop their own representation of a familiar motion event (i.e., their journey from home to school). After this, students received motion situations involving the representation of motion as discrete graphs, followed by the representation of motion as continuous graphs. Throughout the remaining part of the teaching sequence students were asked to draw graphs of given motion situations and reconstruct possible events from continuous graphs. See Figure 2 for an overview of the instructional sequence.







Informal graphs		Discrete graphs		Continuous graphs	
LESSON 1 Motion: reflecting and representing	LESSON 2 From discrete to continuous graphs	LESSON 3 Continuous graphs of ‘distance to’ (1)	LESSON 4 Continuous graphs of ‘distance to’ (2)	LESSON 5 Scaling on the graphs’ axes	LESSON 6 Multiple movements and their graphical representation
From home to school 					

Figure 2: Overview teaching sequence

In the embodied experimental condition, the teaching sequence was enriched with students’ own motion experiences. These motion experiences varied in extent and duration over the different lessons. In the first lesson, students had to enact two slightly differing motion situations by walking along a straight line. The non-embodied experimental condition practiced this exercise differently.

They received the motion situations on the digital blackboard, as well as on paper, and had to discuss these in small groups without enacting them. From the second lesson onwards, motion sensor technology was used in the embodied experimental condition. In the second and the sixth lesson the whole classroom was involved in these activities, whilst in the third till the fifth lesson students worked together in smaller groups. This gave each student the opportunity to physically experience how their movements related to the line in the graphical representation. Again, students in the non-embodied experimental condition performed the same tasks, but without enacting the movements themselves.

Motion sensor technology

In order to provide the students with an immediate link between a dynamic situation (moving in space) and its graphical representation (restricted to distance to a point over time) we included two Motion sensors, developed by CMA, in conjunction with Coach6 Software (Heck, Kedzierska, & Ellermeijer, 2009). The tool was connected to the digital blackboard (Lesson 2 and Lesson 6) or to laptop computers (Lesson 3-5). The motion sensor was set to provide a single graph representing the distance between the sensor and the nearest object over a 30 second period. Moving backwards in front of the sensor, resulted in an increase of distance between the sensor and the student, while moving forwards resulted in a decrease of distance between the sensor and the student. To familiarize students with the motion sensor they were asked to replicate a distance-time graph of a back-and-forth movement (see Figure 3 on the left), which resulted in student created graphs (see Figure 3 on the right). In Lesson 3 till Lesson 5, students had many individual opportunities to move in front of the sensor. In Lesson 2 and Lesson 6, most students observed other students who were walking.

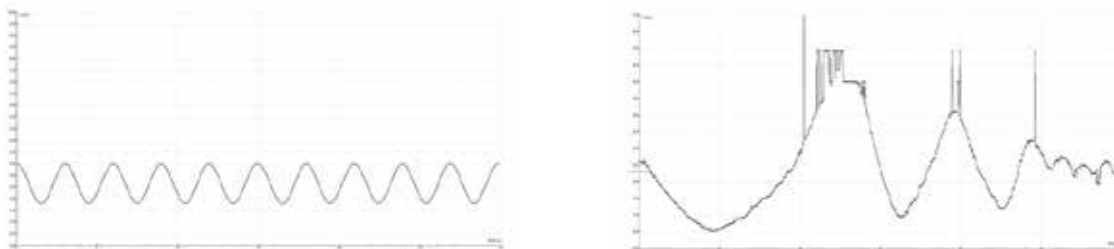


Figure 3: Given graph of a back-and-forth movement (left) and graph produced by a student in front of the motion sensor (right)

Measures

The paper-and-pencil macro test was administered to the students in order to measure their understanding of motion graphs as an indication of domain-specific mathematical higher-order thinking. Students completed five problems that assessed their knowledge of graphing. The test consisted of three graph interpretation items and two graph construction items. Two example items are shown in Figure 4. Four items could be answered correctly or incorrectly (i.e., a score of 1, 0). One item could be answered correctly, partially correctly, or incorrectly (i.e., a score of 1, 0.5, 0). This resulted in a possible maximum score of 5 and a minimum score of 0. We also coded students'

answers on their level of reasoning. We included four levels of reasoning. For this paper, we only look into students' correct or incorrect answers.

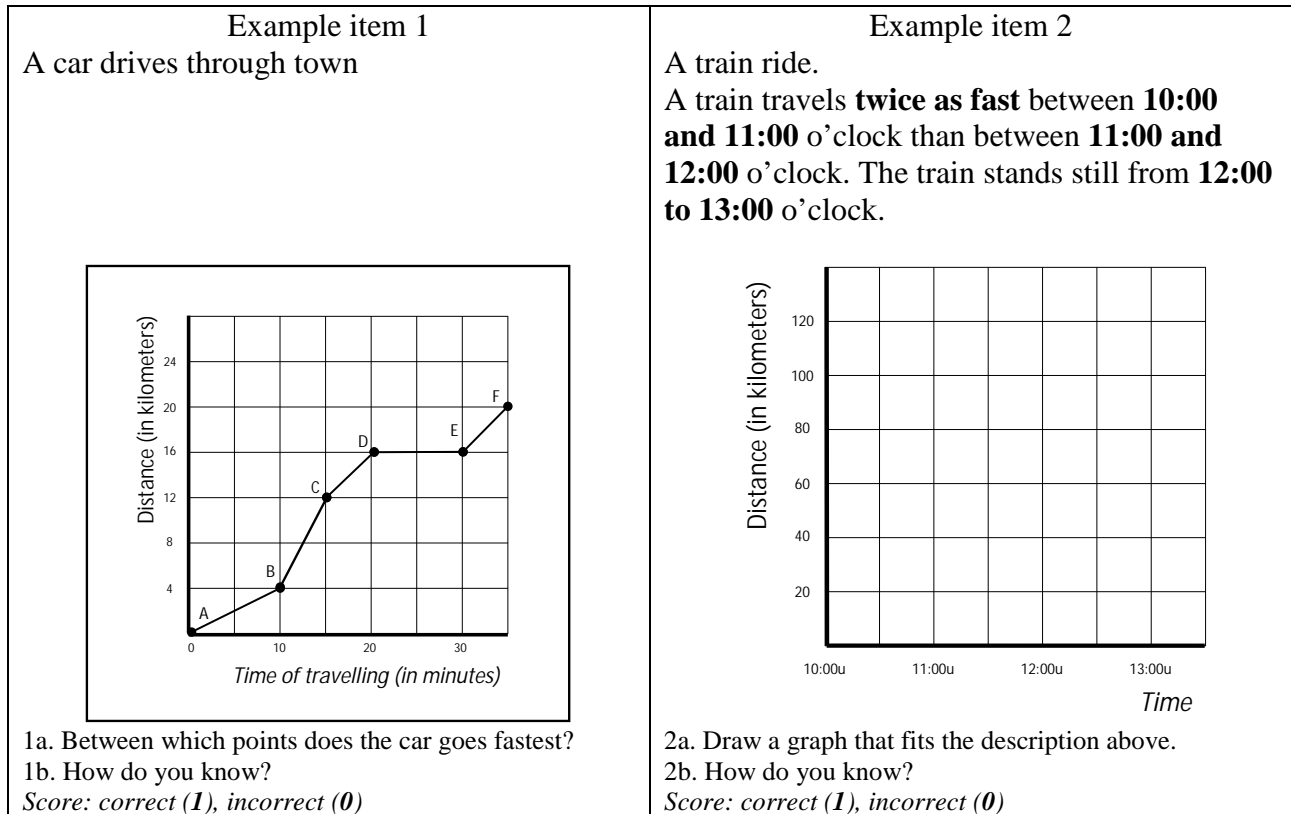


Figure 4: Items macro test

Analysis

A mixed 3 (condition: embodied experimental, non-embodied experimental, control) x 4 (time of testing; pre-, post, and/or follow-up) staged comparison design with repeated measures was used. For now, we will focus on the tests administered before and after taking part in the intervention, see Figure 1. Our dependent variable was students' achievement on the mathematical higher-order thinking test.

Results

In this paper we only provide the descriptive statistics of student' scores on the graphing motion test based on the correctness of the students' answers. Table 1 shows the pre- and post-test graphing motion scores for students in each of the three research conditions. On average the students in the intervention conditions increased in their understanding of motion graphs, regardless of whether they received an intervention on motion graphs. However, the embodied experimental condition showed higher gains from pre- to posttest ($M_{dif} = 1.33$), when compared to the non-embodied experimental condition ($M_{dif} = 0.62$), and the control condition ($M_{dif} = 0.25$).

Phase	Intervention condition	Macro test				
		Pre-test		Post-test		Gain score
		<i>M</i>	<i>SD</i>	<i>M</i>	<i>SD</i>	<i>M_{dif}</i>
1	Embodied experimental	1.21	0.94	3.20	1.15	1.99
2	Embodied experimental	2.70	1.38	3.73	1.17	1.03
3	Embodied experimental	2.65	1.60	3.70	1.37	1.05
Total		2.24	1.50	3.57	1.25	1.33
1	Non-embodied experimental	1.88	1.26	3.31	1.04	1.43
2	Non-embodied experimental	3.50	1.11	3.52	1.29	0.02
3	Non-embodied experimental	2.90	1.39	3.40	1.28	0.50
Total		2.74	1.42	3.36	1.25	0.62
1	Control condition	1.58	1.03	1.74	1.36	0.16
2	Control condition	2.50	1.51	2.70	1.41	0.20
3	Control condition	2.02	1.51	2.46	1.45	0.44
Total		2.06	1.41	2.31	1.45	0.25

Table 1: Descriptive statistics of the students' macro test scores for the three conditions

Discussion

Based on the descriptive statistics of students' scores on the macro test we found that students who participated in a six-lesson embodied teaching sequence on graphing motion showed higher gains in their understanding of motion graphs than students in the non-embodied experimental condition or in the control condition. Moreover, students' dynamic interaction with the, by motion sensor technology created, graphical representation of their own movements indicates that the embodied learning environment contributed to their understanding. In particular, this is in line with studies which have found that immediate own motion experiences are effective for learning (e.g., Duijzer et al., 2018). Moreover, our results do not only support the findings of previous research that incorporated motion sensor technology, but they also add to our knowledge of using embodied learning environments in whole classroom settings. As such, our results extend earlier findings of Deniz and Dulger (2012).

Classic theories of cognitive science assume the creation of mental structures to guide or develop mathematical understanding. Another perspective is the embodied perspective taken in the current study. According to Nemirovsky, Kelton and Rhodehamel (2013), mathematical understanding is constituted on the basis of perceptual and motor experiences. In line with this, we assume that the mathematical understanding that arose in our students was strengthened by the graphical representation of their own movements immediately created by the motion sensor. Hence, students' mathematical understanding of motion graphs became grounded in their sensorimotor experiences (i.e., continuous transformations of whole-bodily activity) that they gained when moving in front of the motion sensor, while sharing and discussing their experiences with other students.

References

- Barsalou, L. W. (2010). Grounded cognition: Past, present, and future. *Topics in Cognitive Science*, 2(4), 716–724. doi:10.1111/j.1756-8765.2010.01115.x

- Boote, S. K. (2014). Assessing and understanding line graph interpretations using a scoring rubric of organized cited factors. *Journal of Science Teacher Education*, 25(3), 333–354. doi:10.1007/s10972-012-9318-8
- Deniz, H., & Dulger, M. F. (2012). Supporting fourth graders' ability to interpret graphs through real-time graphing technology: A preliminary study. *Journal of Science Education and Technology*, 21(6), 652–660. doi:10.1007/s10956-011-9354-8
- Duijzer, C., Van den Heuvel-Panhuizen, M., Veldhuis, M., Doorman, M., & Leseman, P. (2019). Embodied learning environments for graphing change: A systematic literature review. *Educational Psychology Review*. doi:10.1007/s10648-019-09471-7
- Ferrara, F. (2014). How multimodality works in mathematical activity: Young children graphing motion. *International Journal of Science and Mathematics Education*, 12(4), 917–939. doi:10.1007/s10763-013-9438-4
- Friel, S. N., Curcio, F. R., & Bright, G. W. (2001). Making sense of graphs: Critical factors influencing comprehension and instructional implications. *Journal for Research in Mathematics Education*, 32(2), 124–158. doi:10.2307/749671
- Glazer, N. (2011). Challenges with graph interpretation: a review of the literature. *Studies in Science Education*, 47(2), 183–210. doi:10.1080/03057267.2011.605307
- Heck, A., Kędzierska, E., & Ellermeijer, T. (2009). Design and implementation of an integrated working environment for doing mathematics and science. *Journal of Computers in Mathematics and Science Teaching*, 28(2), 147–161.
- Kelton, M. L., & Ma, J. Y. (2018). Reconfiguring mathematical settings and activity through multi-party, whole-body collaboration. *Educational Studies in Mathematics*, 98(2), 177–196. doi:10.1007/s10649-018-9805-8
- Leinhardt, G., Zaslavsky, O., & Stein, M. K. (1990). Functions, graphs, and graphing: Tasks, learning, and teaching. *Review of Educational Research*, 60(1), 1–64. doi:10.3102/00346543060001001
- Ma, J. Y. (2017). Multi-party, whole-body interactions in mathematical activity. *Cognition and Instruction*, 35(2), 141–164. doi:10.1080/07370008.2017.1282485
- Nemirovsky, R., Kelton, M. L., & Rhodehamel, B. (2013). Playing mathematical instruments: Emerging perceptuomotor integration with an interactive mathematics exhibit. *Journal for Research in Mathematics Education*, 44(2), 372–415. doi:10.5951/jresmetheduc.44.2.0372
- Ruiter, M., Loyens, S., & Paas, F. (2015). Watch your step children! Learning two-digit numbers through mirror-based observation of self-initiated body movements. *Educational Psychology Review*, 27(3), 457–474. doi:10.1007/s10648-015-9324-4
- Wilson, M. (2002). Six views of embodied cognition. *Psychonomic Bulletin & Review*, 9(4), 625–636. doi:10.3758/BF03196322

A training in visualizing statistical data with a unit square

Andreas Eichler¹, Carolin Gehrke¹, Katharina Böcherer-Linder³ and Markus Vogel⁴

¹University of Kassel, Germany; eichler@mathematik.uni-kassel.de, carolin-gehrke@web.de

³University of Freiburg, Germany; boecherer-linder@math.uni-freiburg.de

⁴University of Education Heidelberg, Germany; vogel@ph-heidelberg.de

Recent research yielded empirical evidence for a unit square being a useful visualization of Bayesian situations. However, most of the studies in the research field of visualizing Bayesian problem situations were conducted in well-controlled experimental settings with university students as participants. Therefore, we focus in this paper on a training study with 38 eleventh graders in school about visualizing statistical data with a unit square for coping with Bayesian problem situations. Firstly, we outline some theoretical and empirical basics concerning research about Bayesian situations and a unit square as a facilitating visualization tool. Afterwards, we present a short training sequence in using the unit square effectively. We report on methods, implementation and results of a pilot study in school. The promising results were discussed at the end.

Keywords: Bayesian reasoning, visualization of statistical data, unit square, school training study.

Introduction

According to Arcavi (2003) it is an important task of mathematics education research to investigate visualizations as specific graphical representations of mathematical objects in a theoretical and empirical way. Thus, we focus in our ongoing research about the unit square as a powerful visualization of Bayes' formula on theoretical and empirical insights. The unit square is shown in Figure 1 visualizing a Bayesian situation which are situations where the Bayes' formula could be applied.

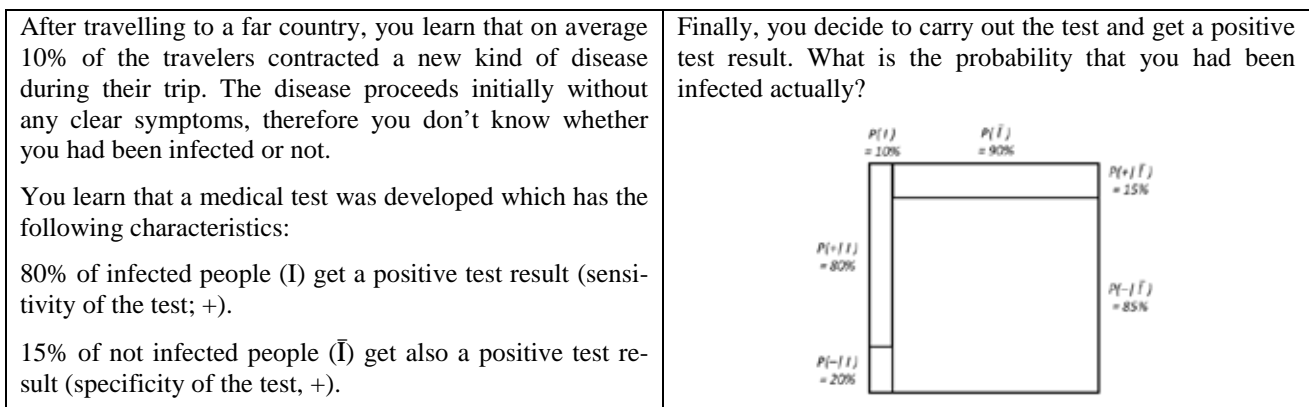


Figure 1: Bayesian situation and visualization with the unit square

Given for example a Bayesian situation as described in Figure 1 the unit square would look like as displayed in Figure 1 in the right side. All essential information is represented in a numerical *and* a geometrical way. Thus, a unit square facilitates via different strategies the computation of the essential probability, that is, the probability of being infected given a positive test result $P(I|+) = \frac{80\% \cdot 10\%}{80\% \cdot 10\% + 15\% \cdot 90\%} \approx 37,2\%$.

Focusing on facilitating strategies in Bayesian situations in detail is the main goal of this paper: We refer to certain visualization features of a unit square which makes it an effective facilitator for coping with Bayesian situations and for adequately applying Bayes' rule which is a fundamental model for dealing with risk in situations of uncertainty. For this we provide first a brief literature review to discuss the advantages of the unit square in comparison to further visualizations of Bayesian situations. Afterwards we refer to the design and the results of a quasi-experimental training study with 38 students in grade 11 which compares the performance of a treatment group vs. a control group. Our question for this step in an ongoing research project was whether it is possible to improve students' dealing with Bayesian situations by a brief training that is based on representing Bayesian situations by natural frequencies and by a unit square. Implications and conclusions are discussed at the end of the paper.

The unit square as facilitator of Bayesian situations

Despite the Bayes' rule's relevance for real life situations, psychological and educational research gained evidence that people often fail when applying Bayes' rule (Diaz, Batanero, & Contreras, 2010; Gigerenzer & Hoffrage, 1995; Kahneman, Slovic, & Tversky, 1982). In their meta-analysis McDowell and Jacobs (2017) concluded that only about 5% of participants in various studies were able to solve a problem as exemplarily given in Figure 1 without any facilitating strategy.

A widely accepted strategy to increase people's performance in Bayesian situations is representing the statistical information via natural frequencies instead of using percentages (e.g. Gigerenzer & Hoffrage, 1995). In Figure 2, the Bayesian situation given in Figure 1 is displayed by using natural frequencies. The meta-analysis of McDowell and Jacobs (2017) provides empirical evidence that by using natural frequencies as the only information format people's performance in coping with Bayesian situations increases from about 5% to about 25%.

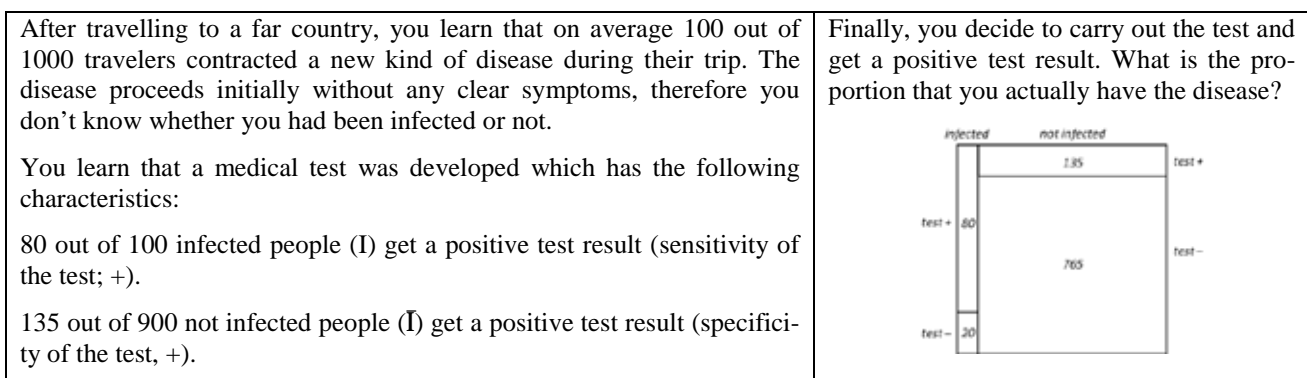


Figure 2: Bayesian situation with natural frequencies

A further facilitating strategy is to provide additional visualizations (e.g. Brase, 2009; McDowell & Jacobs, 2017). However, there are ambiguous research findings about which visualization properties could effectively facilitate dealing with Bayesian situations.

From a theoretical point of view, three properties could be suggested to have a facilitating effect. The first is to use icons as "real, discrete and countable" objects (Cosmides & Tooby, 1996, p. 33). However, from a practical point of view (in terms of time costs) this strategy turns out to be hardly realizable in regular classroom instruction where students have to create visualizations. Further-

more, results of our own research suggest that icons actually have an additional, but small facilitating effect compared to a unit square as shown in Figure 2 (Böcherer-Linder & Eichler, 2019).

The second facilitating strategy is to make the nested-sets structure transparent which constitutes fundamentally every Bayesian situation (Oldford, 2003). Sloman, Over, Slovak, and Stibel (2003, p. 302) stated that “any manipulation that increases the transparency of the nested-sets relation should increase correct responding”. Actually, our own research revealed empirical facts that the unit square allows exactly for such a manipulation (Böcherer-Linder & Eichler, 2017, 2019). The subsets that have to be identified for successfully solving a task with the Bayes’ formula are directly neighbored in the unit square (cf. Figure 1) and, by this means, they are transparently visualized. In particular, in different experimental studies, we yielded empirical evidence that the unit square makes the nested sets-structure of a Bayesian situation more transparent than the commonly used tree diagram and showed further that the unit square is more effective to facilitate dealing with Bayesian situations (Böcherer-Linder & Eichler, 2017). Actually, compared to only using natural frequencies the additional use of a unit square could further increase people’s performance in coping with Bayesian situations from about 25% (cf. above) to about 65%-70%.

A third facilitating strategy is to use area-proportional representations of statistical information (e.g. Talboy & Schneider, 2017). Going beyond pure numerical information a unit square provides additionally the statistical information by displaying exact graphical proportions of the rectangular subplots. When comparing a unit square with a 2x2-table which differs from a unit square regarding the missing area-proportionality we found evidence for the effectiveness of the area-proportionality (Böcherer-Linder & Eichler, 2019). Nevertheless, understanding Bayesian situations is not fully reached by only solving tasks as shown in Figure 1 (Borovcnik, 2012). Moreover, understanding also includes the adequate influence-judging of parameters in these Bayesian situations, that is, the base rate or the conditional probabilities that are called sensitivity and specificity in a medical diagnosis situation. For this purpose, we also investigated the facilitating effect of a unit square compared to a tree diagram by regarding the influence of changing parameter values in Bayesian situations (Böcherer-Linder, Eichler, & Vogel, 2017). In this research, we found a significant supremacy of a unit square compared to a tree diagram. Although we have not yet compared a 2x2-table and a unit square concerning these kinds of changing parameter tasks in Bayesian situations, we hypothesize based on theory (Eichler & Vogel, 2010) that a unit square is of advantage by means of additional visualizing changing proportions.

The research discussed so far is mostly conducted in well controlled studies without a systematic training. However, training should be understood as a fourth strategy which provides facilitating effects additional to the effective strategies mentioned before. However, these very few training studies reported so far were not focused on facilitating properties of visualizations and, they were mostly carried out with university students as participants (e.g. Sedlmeier & Gigerenzer, 2001; Talboy & Schneider, 2017). For this reason, we conducted a training study that addressed learning how to adequately deal with Bayesian situations based on using natural frequencies and, in addition, on using a unit square. Referring to a sample of university students, the results of a pilot study suggest a positive effect of the training with a unit square (Böcherer-Linder, Eichler, & Vogel, 2018). In this paper, we present a training study with students of grade 11. The main question in this study was

whether students' performance in Bayesian situations as well as students' understanding of Bayesian situations in terms of judging the influence of changed parameters could be improved in a brief training based on representing Bayesian situations by natural frequencies and a unit square.

The training



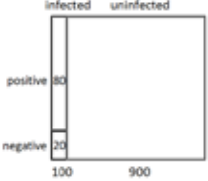
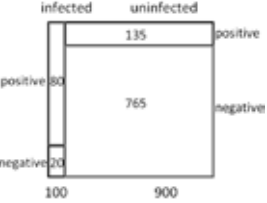
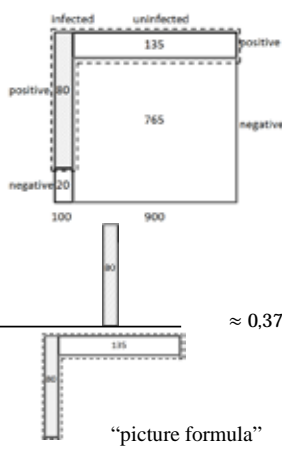
<p>Step 1: Choice of the sample size</p> <p>For solving the problem, we first consider the question of what the probabilities mentioned in the text imply for a concrete group of travelling people. We choose a sample size of 1000 people.</p> <p>We represent the group of 1000 people by drawing a unit square.</p>	
<p>Step 2: Construction of the frequency representation</p> <p>Since 10% of the travelling people contracted the disease during their trip, 100 out of the 1000 people are expected to be infected. 900 out of the 1000 people are expected to be uninfected.</p> <p>Thus, we divide the unit square in vertical direction for "infected" and "uninfected" at the ratio of 100 to 900. At the bottom of the narrow rectangle we write "100" and at the bottom of the broader rectangle we write "900".</p>	
<p>Since 80% of the infected people get a positive test result, 80 out of the 100 infected people are positively tested. Accordingly, 20 out of the 100 infected people are tested and result negative.</p> <p>Therefore, we subdivide the narrow rectangle horizontally into two parts and write "80" and "20" into the resulting areas.</p>	
<p>Since 15% of the uninfected people get a positive test result, 135 out of 900 uninfected people get a positive result after testing (because 15% of 900 is 135). Accordingly, the other 765 uninfected people get a negative test result.</p> <p>Therefore, we subdivide the broader rectangle horizontally into two parts for "positive" and "negative" and write the numbers into the resulting areas.</p>	
<p>What needs to be found is the probability that a person with a positive test result is actually infected. Thus, we have to calculate which proportion of the people resulting positive is actually infected. For this aim, we surround all positive people with a dashed line in the unit square and emphasize with grey color all of them, that are infected.</p> <p>We read out the following numbers:</p> <p>Number of infected and positive to the test: 80</p> <p>Number of all positive to the tested: 80+135=215</p> <p>We calculate:</p> $\frac{\text{infected and positive}}{\text{all positive}} = \frac{80}{80 + 135} \approx 0,37$ <p>This proportion corresponds to the requested probability of 37%.</p>	 <p style="text-align: right;">"picture formula"</p>

Figure 3: First intervention in the training study ("picture-formula", cf. Eichler & Vogel, 2010)

Due to an ecological validity, we presented the problems in the probability-text-version (see Figure 1) and trained the students to translate the probabilities into natural frequencies and, secondly, to graphically represent the statistical information in the process of problem solving. The training had

two phases: phase 1 (10 minutes) contained three steps. It was a worked example showing how to solve the problem of Figure 1 with the help of the unit square (Figure 3; translated from German).

Phase 2 (10 minutes) included an exercise that was structurally identical to the worked out example (Figure 2 and Figure 3) but had another context (Trisomy). An oral explanation and a presentation of the correct solution were given. Even though it was possible to draw a unit square true to scale in this case, we only showed a rough drawing of a unit square, since we wanted to enable the participants to work with the visualization as a thinking tool for problem solving which did not necessarily imply a precise drawing.

Finally, we added a brief exercise (5 minutes) on the change of parameters. For this, we only show the instruction referring to the change of the base rate (Figure 4).

<p>3. Change of the base rate</p> <p>The base rate indicates the proportion of an individual having trisomy (5% of the children of women of age 45). An increase of the base rate results in an increase of the area of the thin rectangle on the upper left side of the unit square and, accordingly, a decrease of the area of the rectangle on the upper right side.</p> <p>If the base rate increases to 10%, there would be 90 true-positive people and 90 false-positive people. The change of the base rate changes the proportion as shown below:</p> $\frac{90}{90 + 90} = \frac{90}{180} \approx 50 \%$ <p>Actually, the result shows a considerable change of the probability.</p>	
---	--

Figure 4: Part of the training to changed parameters

Method

Our sample included 38 students in grade 11, from two classes. By choosing two different classes of students which were not grouped randomly we conducted a quasi-experiment. The class to which we administered the training included 22 students. The class that represented the control group consisted of 16 students.



Figure 5: Design of the training study

The design of the quasi-experiment is shown in Figure 5. Since there were not all of the students present in the three phases shown in Figure 5, our analysis is based on 16 students (treatment group) and 13 students (control group).

Both the pre-test and post-test consisted of two Bayesian situations. One of the situations in both tests was the same, the other situation differed to prove whether repeating a task has an effect on performance in Bayesian situations. In the pre-test, one situation included only a performance-task and the second situation included both a performance task and a task in which the influence of

changed parameters was to be estimated. In Figure 6 we show the task that was identical in both tests and include both forms of tasks (translated from German).

There are tests for diagnosing people if they have infectious diseases like measles or scarlet. Concerning such an infectious disease and the corresponding test the following information is given:

The probability of having the infectious disease is 2%. Given there is a patient having the disease, the test yields in 90% of all cases a “positive” result, which means it indicates correctly the infectious disease. Given there is a non-infected patient, the test shows in 5% of all cases also a “positive” result, which means it indicates the infectious disease by mistake.

- a) What is the probability of a patient having actually the disease given a “positive” test result?
- b) How changes the probability of section a) if the probability of having the disease is higher?

Figure 6: A test item (translated from German)

Results

Regarding the few items the values of Cronbach’s alpha of 0.63 (pre-test) and 0.85 (post-test) appear to be good. Thus, we summarized the scores in each test referring to the performance test-items a).

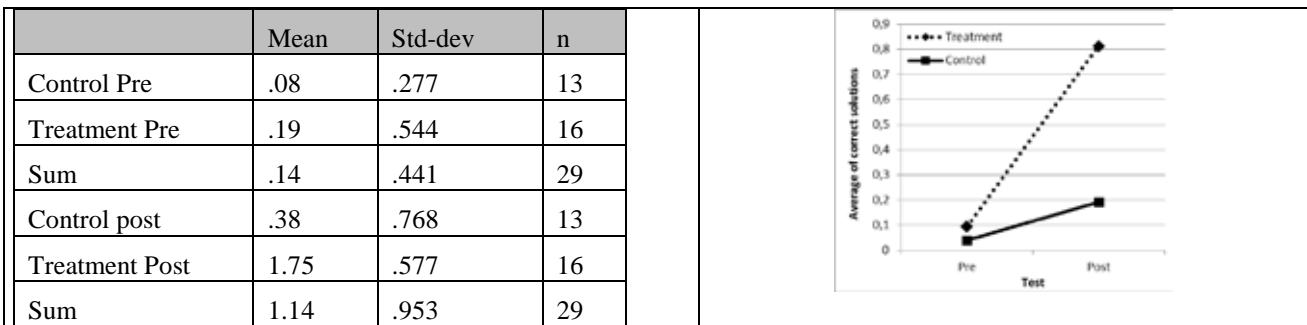


Figure 7: Descriptive results of the training concerning item a)

We applied a mixed ANOVA (within-factor: performance in the pre-test and post-test; between factor: group) to investigate the training effect in the treatment group compared to the control group. According to the robustness of an ANOVA (Schmider, Ziegler, Danay, Beyer and Bühner, 2010), we did not regard non-normality and differences in variances. In a descriptive way, Figure 7 (left) reports the results referring to the pre-test and the post-test. Figure 7 (right) visualizes a clear effect of the treatment referring the means.

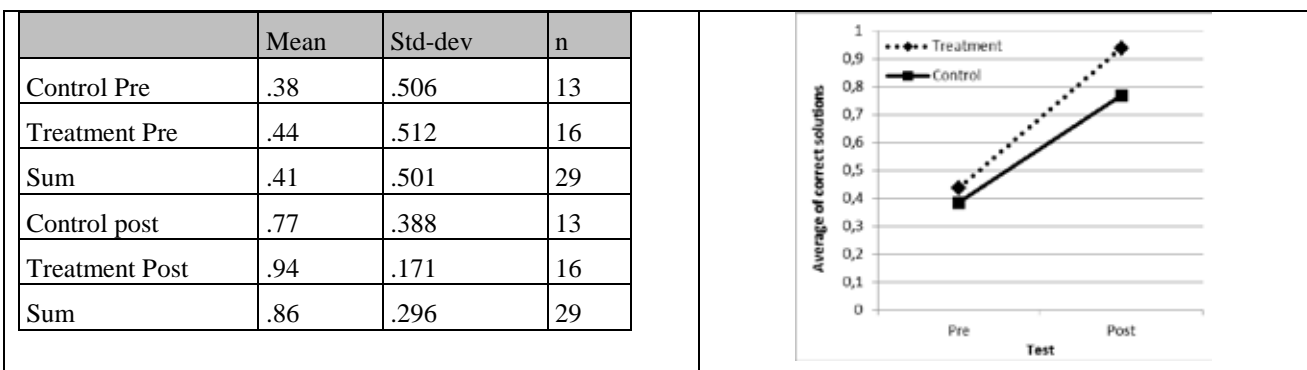


Figure 8: Descriptive results of the training concerning item b)

As expected, the ANOVA yields a significant effect ($F=20,733$, $p=0,000$) of the treatment with a strong effect ($\eta_p^2=0,434$). Regarding item b) the results were not as expected (Figure 8). Actually, also the control group has an increased average of correct solutions and the differences between the treatment group and the control group are not significant concerning the ANOVA ($F=0,424$, $p=0,520$, $\eta_p^2=0,015$). By contrast, there is a significant main effect for both groups regarding the difference between the pre-test and the post-test ($F=24,938$, $p=0,000$, $\eta_p^2=0,480$).

Discussion

Regarding the results of the performance tasks it could be stated that a training with the unit square turns out to be helpful for students in school. This finding is in line with the results of our recent study in school investigating the effect of the visualization (cf. Vogel & Böcherer-Linder, 2018). Furthermore, this is particularly emphasized within a practical point of view, a unit square's effective use can be trained within a very short time (in Germany 45 minutes corresponds to one lesson). Regarding the tasks of estimating the effect of changing parameters it should be mentioned that these kinds of tasks were estimated to be more difficult by going beyond the demand of only building a ratio as the Bayes problem's solution. However, most of the students in both groups were able to find the correct solution, even in the control group and, thus, the significant difference between pre- and posttest indicates a learning progress. Particularly the missing difference between the treatment group and the control group could firstly be explained by the high guessing probability of one third, or even one half, if the question "How changes" is interpreted as either increasing or decreasing. Moreover, maybe the students intuitively guessed that the conditional probability would be higher if the base rate increased without analyzing the parameter dependence. However, we expect tasks which necessitate an analysis of the parameter dependency to be trainable as successfully as the performance tasks. This effect is focused on in subsequent studies being conducted currently.

References

- Arcavi, A. (2003). The role of visual representations in the learning of mathematics. *Educational Studies in Mathematics*, 52(3), 215–241. doi:10.1023/A:1024312321077
- Böcherer-Linder, K., & Eichler, A. (2019). How to Improve Performance in Bayesian Inference Tasks: A Comparison of Five Visualizations. *Frontiers in Psychology*, 10, 297. doi:10.3389/fpsyg.2019.00267
- Böcherer-Linder, K., Eichler, A., & Vogel, M. (2018). Visualizing statistical information with unit squares. In M. A. Sorto, A. White, & L. Guyot (Eds.), *Looking back, looking forward. Proceedings of the Tenth International Conference on Teaching Statistics (ICOTS10, July, 2018), Kyoto, Japan*. Voorburg, The Netherlands: International Statistical Institute. iase-web.org
- Böcherer-Linder, K., Eichler, A., & Vogel, M. (2017). The impact of visualization on flexible Bayesian reasoning. *Avances De Investigación En Educación Matemática - AEIM*, 11, 25–46.
- Böcherer-Linder, K., & Eichler, A. (2017). The Impact of Visualizing Nested Sets. An Empirical Study on Tree Diagrams and Unit Squares. *Frontiers in Psychology*, 7(1186), 241. doi:10.3389/fpsyg.2016.02026

- Borovcnik, M. (2012). Multiple perspectives on the concept of conditional probability. *Avances de Investigación en Didáctica de la Matemática*, 2, 5–27. doi: <https://doi.org/10.35763/aiem.v1i2>
- Brase, G. L. (2009). Pictorial representations in statistical reasoning. *Applied Cognitive Psychology*, 23(3), 369–381. doi: [10.1002/acp.1460](https://doi.org/10.1002/acp.1460)
- Cosmides, L., & Tooby, J. (1996). Are humans good intuitive statisticians after all?: Rethinking some conclusions from the literature on judgment under uncertainty. *Cognition*, 58(1), 1–73. doi: [10.1016/0010-0277\(95\)00664-8](https://doi.org/10.1016/0010-0277(95)00664-8)
- Diaz, C., Batanero, C., & Contreras, J. M. (2010). Teaching independence and conditional probability. *Boletín De Estadística E Investigación Operativa*, 26(2), 149–162.
- Eichler, A., & Vogel, M. (2010). Die (Bild-)Formel von Bayes [The (picture-)formula of Bayes]. *PM - Praxis der Mathematik in der Schule*, 52(32), 25–30.
- Gigerenzer, G., & Hoffrage, U. (1995). How to improve Bayesian reasoning without instruction: Frequency formats. *Psychological Review*, 102(4), 684–704. doi: [10.1037/0033-295X.102.4.684](https://doi.org/10.1037/0033-295X.102.4.684)
- Kahneman, D., Slovic, P., & Tversky, A. (Eds.). (1982). *Judgment under uncertainty: Heuristics and biases*. Cambridge: Cambridge University Press.
- McDowell, M., & Jacobs, P. (2017). Meta-Analysis of the Effect of Natural Frequencies on Bayesian Reasoning. *Psychological Bulletin*. Advance online publication. doi: [10.1037/bul0000126](https://doi.org/10.1037/bul0000126)
- Oldford, R. W. (2003). Probability, problems, and paradoxes pictured by eikosograms. Retrieved from <http://www.stats.uwaterloo.ca/~rwoldfor/papers/venn/eikosograms/examples/paper.pdf>
- Schmider, E., Ziegler, M., Danay, E., Beyer, L., & Bühner, M. (2010). Is It Really Robust? *Methodology*, 6(4), 147–151. <https://doi.org/10.1027/1614-2241/a000016>
- Sedlmeier, P., & Gigerenzer, G. (2001). Teaching Bayesian reasoning in less than two hours. *Journal of Experimental Psychology: General*, 130(3), 380–400. doi: [10.1037//0096-3445.130.3.380](https://doi.org/10.1037//0096-3445.130.3.380)
- Sloman, S. A., Over, D., Slovak, L., & Stibel, J. M. (2003). Frequency illusions and other fallacies. *Organizational Behavior and Human Decision Processes*, 91(2), 296–309. doi: [10.1016/S0749-5978\(03\)00021-9](https://doi.org/10.1016/S0749-5978(03)00021-9)
- Talbot, A. N., & Schneider, S. L. (2017). Improving Accuracy on Bayesian Inference Problems Using a Brief Tutorial. *Journal of Behavioral Decision Making*, 30(2), 373–388. doi: [10.1002/bdm.1949](https://doi.org/10.1002/bdm.1949)
- Vogel, M., & Böcherer-Linder, K. (2018). The effect of visualizing statistical information in Bayesian reasoning problems. In M. A. Sorto, A. White, & L. Guyot (Eds.), *Looking back, looking forward. Proceedings of the Tenth International Conference on Teaching Statistics (ICOTS10, July, 2018), Kyoto, Japan*. Voorburg, The Netherlands: International Statistical Institute. iase-web.org

Learning to ‘deal’: A microgenetic case study of a struggling student’s representational strategies for partitive division

Carla Finesilver

King’s College London, UK; carla.finesilver@kcl.ac.uk

This paper focuses on the arithmetical understandings and behaviours of one fifteen-year old student with very low attainment in mathematics, as she worked on a sequence of scenario-based partitive division (sharing) tasks with individually-tailored verbal and visuospatial support. The student’s independent and co-created visuospatial representations of arithmetical structures, along with her verbal comments, were analysed qualitatively using a multimodal microgenetic approach. This paper focuses on three particular excerpts which illustrate the fundamentally componential nature of the concept and practice of division, some difficulties that may be experienced when modelling ‘sharing’ tasks, and the pedagogical importance of spatial structuring when a learner is moving between different kinds of representation.

Keywords: Visuospatial representation, multiplicative thinking, numeracy, low attainment, special education.

Introduction

I encountered Paula during a larger project investigating low-attaining students’ representational strategies for multiplicative structures. Attending a comprehensive school in inner London, she turned fifteen during the study; however, in certain respects her quantitative reasoning more resembled that of a pre-school child. Her particular stage of arithmetical thinking (struggling with the move from additive to multiplicative reasoning) has been of particular interest to researchers, and her reliance on unitary counting-based strategies is a well-known phenomenon. Atypical for Paula’s age, but common in younger learners, was her heavy use of enactive representation with physical media such as cubes. These several factors, along with the slow progress, provided an excellent opportunity for microanalytic case study: to examine this individual’s arithmetical-representational strategies in fine detail, and note even very small changes taking place. Thus, I focused on an arithmetical concept which the participant did not yet comprehend (division), building on an activity in which she was comfortable (counting), within scenario tasks that allowed for multiple representational variations. This paper presents and discusses some brief but illuminative excerpts from my work with her.

Theoretical background

There is a strong tradition of research into various aspects of early numeracy, such as counting-based arithmetical strategies, taking place in naturalistic teaching/learning environments. Those which focus on children’s own representations of number are often quasi-ethnographic in nature, where (usually very young) children are observed in their mark-making (e.g. Atkinson, 1992) or block-play (e.g. Gura, 1993), and their representations analysed for ‘emergent’ mathematics. Key to this body of work is that it focuses on children’s own, often non-standard, representational strategies; this is in the pedagogical tradition of “de-centring” (Donaldson, 1978), i.e. to shift from an adult perspective and imagine what a scenario, phrase or object might mean to a child. While the details and exact

terminology can vary, in psychological research paradigms some kind of representational progression is also generally assumed, moving from the most intuitive/enactive/concrete models of arithmetical relationships, through iconic/pictorial/drawn forms, to the incorporation of abstract symbols and eventual full formal symbolic notation (e.g. Bruner, 1973). The development of mathematical concepts has also been linked to increasing awareness of pattern, and the ability to make connections between one mathematical representation and another, i.e. to notice similarities and differences, is important for a learner's developing relational thinking. Low attaining students often lack visualisation skills and flexibility, and may indeed find it difficult to replicate and organise representations of groups and patterns (Mulligan, 2011).

Nunes & Bryant (1996), among many others stretching all the way back to Piaget, suggest that to understand multiplication/division represents a significant qualitative change in children's thinking (compared to addition/subtraction) – and so is deserving of particular attention. Regarding the increased complexity, Anghileri (1997) points out that a counting strategy in a multiplication or division task requires three distinct counts: the number in each set, the number of sets, and the total number of items. The second of these – tallying sets rather than units – may be particularly unintuitive for some. Notwithstanding, Carpenter et al.'s (1993) study of kindergarten students (i.e. age 5-6, with <1 year of formal schooling) demonstrated that they could carry out a wider range of division tasks, with greater success, than had formerly been realised – provided the tasks were presented in the form of scenarios which could be directly modelled. Furthermore, they argued that many older students abandon their fundamentally sound problem-solving approaches for the mechanical application of formal arithmetic procedures, and would make fewer errors if they applied some of the intuitive modelling skills of their younger counterparts.

Given this, it is appropriate to combine a subject focus of early division with an analytical focus on informal, nonstandard, and intuitive representational strategies. A previous example is Saundry and Nicol's (2006) investigation of the drawings young children used in division-based tasks, including a 'sharing biscuits' scenario, as used in this study; they describe students manipulating pictures on the page, moving, eliminating, sharing and distributing them, in some cases with patterns of movement resembling the use of physical manipulatives. This is in contrast to much prior research which has analysed visuospatial representations more simply, by organising them into broad categories. However, a third way is possible: considering students' changing representations via an analytical framework of multiple interrelating aspects (Finesilver, 2014).

Research questions

1. What arithmetical-representational strategies does the student use in division tasks?
2. What do the strategies tell us about their particular weaknesses and capabilities?
3. How do the student's arithmetical-representational strategies change over time and input?

Methodology

The dataset for this study is taken from a series of four 1:1 problem-solving interviews, each lasting 45 minutes, carried out by the author. While some sessions did include other types of multiplication- and division-based activity (reported elsewhere), a significant proportion of this particular student's time was given over to the 'sharing' tasks described here. It employs microgenetic methods, which

were developed for the study of the transition processes of cognitive development (Siegler & Crowley, 1991). They have been widely used in studies of children's arithmetical strategies and particularly in case studies of individuals with difficulties in mathematics (e.g. Fletcher et al., 1998).

Paula had been described in a past Educational Psychologist's report as having "particularly severe" difficulties with numeracy. This was confirmed through classroom observation by the author, discussion with her mathematics teacher, and a 1:1 qualitative assessment of arithmetical and representational capabilities (see Finesilver, 2014). She demonstrated confident ascending counting and writing of two-digit numbers, and appeared to understand the principles of addition and subtraction well (although made frequent errors in practice). This information was used formatively in devising appropriate in situ tasks and support for developing a basic understanding of division.

In each session, Paula was set a series of partitive divisions expressed via the scenario of a given number of biscuits to be shared between a given number of people. The quantities used were two-digit numbers under 30 that divided exactly by 3, 4 or 5. Numbers were chosen in situ, depending on her arithmetical-representational functioning that day and in previous sessions. Representational media were a particular concern to Paula's teacher, as she was approaching high-stakes national examinations where concrete manipulatives would be unavailable. Thus, scenarios and representation types were chosen that allowed working on first with enactive concrete models, then translation of these visuospatial configurations to graphic form. I gave verbal and visuospatial prompts whenever independent activity came to a halt, up to and including co-creating representations with her.

All sessions were audio recorded, all markings on paper collated, and (when it would not interfere with her work) photographs of concrete representations taken. All markings in purple ink are by the researcher. Each task attempt was considered in terms of the thirteen-aspect analytical framework developed in Finesilver (2014), which covers the type of representation created (*media, mode, resemblance*), the relationships between representation and calculation (*motion, unitariness, spatial structuring, consistency, completeness, enumeration, errors, success*), and teacher-student interactions (*verbal and visuospatial prompts*). Particular attention was paid to any attempts where change in one or more of the aspects was observed; these are considered microgenetic 'snapshots'.

Data (selected excerpts)

Due to restrictions of space, only a small sample of data may be reproduced in these proceedings; more are included in the accompanying presentation and other publications by the author.

Excerpt 1: Difficulties co-ordinating division requirements, Session 1: $15 \div 3$ (Figure 1)

Paula having made no independent attempt at the task "fifteen biscuits shared between three people", I give her a pile of 15 cubes. She first pushes them into two roughly but not exactly equal groups. I restate that **three equal** groups are required, and she distributes them into groups of three. I then draw three *unit containers*, and she pushes three cubes into each. I restate the requirement to share out **all** the cubes, and she adds 1-3 more (unequally) to each circle. I ask if the groups are **equal**, and she counts each group, then adjusts, re-counting, until she can present me with three groups of five. She appears to understand my individual comments, but have difficulty co-ordinating the requirements.

Later in this session, I demonstrate the ‘dealing’ process, emphasising the regular repeating motion. Paula is able to replicate this procedure without error, but does not seem confident that the groups will be equal, and counts each to check.

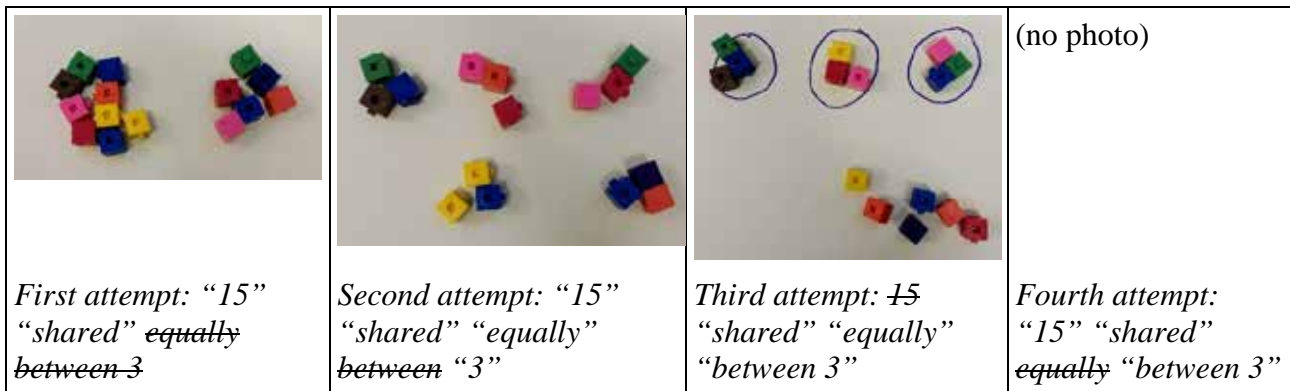


Figure 1: Sequence of task attempts; change in *spatial structuring* to introduce unit containers

Excerpt 2: Moving from modelling to drawing, Session 2: $15 \div 3$, $15 \div 5$ (Figure 2)

Paula had been given three drawn circles (as previously) and asked to try to complete the sharing without using cubes. Here she first makes 13 dots in each circle (likely intending 15). I draw new circles, and draw 15 dots above (as a non-concrete analogue for the initial pile of cubes in previous tasks). I demonstrate ‘taking’ dots from the ‘pile’ (by crossing them out) and ‘moving’ them (by redrawing them) into the circles. After watching four dots being dealt out in this way, Paula takes over and continues the pattern of motion, successfully adding dots to the circles in a cyclic sequence (apart from one error in the form of an extra dot, subsequently crossed out). She completes the following task independently and without errors.

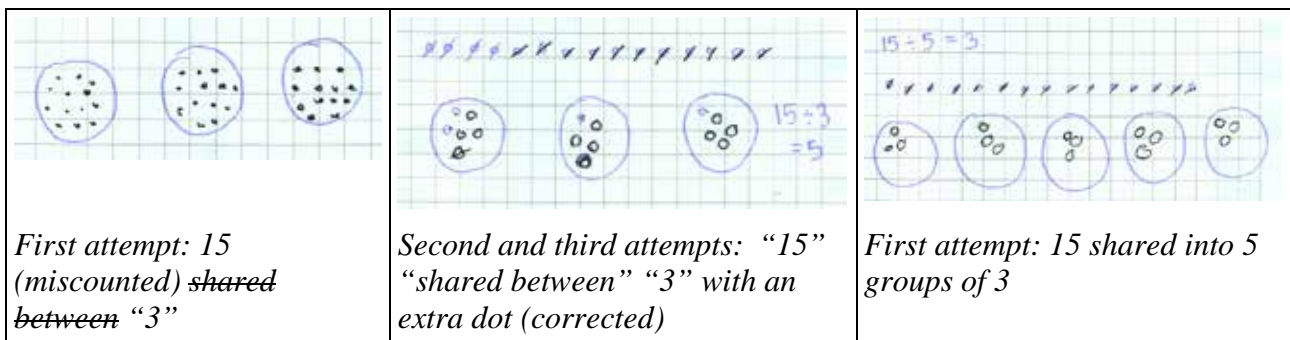


Figure 2: New mode/media, retaining previous *spatial structuring* and *motion*

Excerpt 3: Confidence in the ‘dealing’ procedure, Session 4: $24 \div 4$

Paula counts out 24 cubes for herself, and deals them cyclically into four circles. However, she pauses in confusion when almost finished. She places her last cube, counts that group and the one next to it, finds them unequal, and twice moves a cube then re-counts (each time finding three groups of six and one group of five) with dissatisfaction. She looks around and finds the last cube (hidden in her sleeve), allowing her to complete the final group. She verbally states “six each” as her solution.

These three ‘snapshot’ excerpts are selected to illustrate particular points for discussion regarding components of division and arithmetical-representational strategies.

Discussion

What representational and arithmetical strategies does the student use?

Paula did not initially have any working representation of her own for use in sharing tasks, and exhibited a ‘helpless’ non-response. While she could read and write number symbols, she could not use them for multiplicative reasoning. However, with a relatively small amount of teacherly input and encouragement, she proved capable of successfully using visuospatial representational strategies to represent equal-groups structures and solve tasks that had previously seemed impossible to her.

Paula’s initial preference was for simple modelling with cubes. However, mixed-media/mixed-mode representations (concrete units in drawn containers) were actually most successful, due to the enhanced spatial structuring of the groups provided by the container forms. At first, she distributed and pushed cubes between groups unsystematically, counting to check for equality, adjusting, and recounting. Later, she adopted the more structured ‘dealing’ procedure.

Paula was willing to move from physical modelling to using fully-drawn representations, with some success. Key to this was keeping both the spatial structuring (i.e. the initial ‘pile’ and container circles) and the dealing motion (repeating hand movement back and forth between the pile and each of the containers in turn) the same as it had been when modelling with cubes, and emphasising this similarity.

What do the strategies tell us about their particular weaknesses and capabilities?

Initially it could be stated with certainty only that Paula knew the division operation required starting with an initial quantity and separating it into a number of smaller quantities (as this was a consistent response in all attempts). This may seem trivial; however, it is not only a necessary component of division, but may be seen as the most fundamental meaning of ‘divide’, prior to any notions of dividends, divisors, quotients, or equality.

Paula made two types of error of particular interest in our sessions on partitive division. On eight occasions she broke the rule that groups must be equal (e.g. Excerpt 1, first attempt), and on seven that the initial number of units must be preserved, i.e. no cubes left over, and no increase through taking extra cubes or drawing extra dots (e.g. Excerpt 1, third attempt). Generally either one or the other of these errors occurred, and sometimes correcting one caused the other to occur. This indicates she experienced a tension in trying to satisfy these apparently-competing demands at the same time.

Paula’s producing of unequal groups implies either that she did not see it as important for groups to contain an equal number, and/or that she did not know a reliable method for distributing them fairly. The latter is indicated, as when reminded, she counted each individual group and took action to even them up. When group sizes were unequal, they only varied by one or two cubes: it is possible that she considered these groups sufficiently equal. For students who struggle significantly with number, it may seem quite reasonable to treat, say, 20 cubes as a continuous rather than a discrete quantity, and thus to perform an approximate rather than an exact division.

Paula's non-preservation of total units implies either that she did not initially see it as important that all of the initial quantity should be distributed, that she believed that including them in the groups already created would conflict with another requirement of the task, and/or that she had simply forgotten about them. The second interpretation seems most likely, as she distributed the remainder when asked, and then re-counted the group sizes to check for equality. There is a small but highly significant difference in Excerpt 3 (compared to previous task attempts): she realises independently that it is impossible to adjust the groups to make them equal, and deduces there is something wrong – I had specified equal groups, and this is impossible unless there is a missing cube.

These observations together suggest that Paula had a three-part conception of division, corresponding to three independent requirements: separation of the initial quantity into groups, that the groups are of equal size, and that all of the initial quantity have been distributed. The priority relationship between the second two requirements was not constant. For most students using a unit-based concrete model, these three stages would be subsumed into one through 'dealing' units cyclically into groups until all of the initial quantity is gone. It is notable that Paula did not initially do this, instead using an unsystematic distribution process. It seems inconceivable that a 15-year-old in mainstream education has never encountered dealing; however, Paula initially did not independently think to use it in these situations. Furthermore, when first trying dealing, she seemed unconvinced of its reliability in delivering 'fair shares'; this implies not initially connecting the structure of the physical dealing action with the numerical structure, visual pattern, or arithmetical operation. The observation that she later stopped checking by counting (when the deal worked out as expected) implies increasing acceptance of it incorporating the structure of, and thus ensuring, equal groups.

Paula's extreme focus on individual countable units, taken with the instances of her sharing into an incorrect number of groups, indicate the possibility (in line with Anghileri, 1997) that she may have difficulty with the very idea of *groups being countable objects*, i.e. with shifting her focus from unit-level to group-level. This interpretation is consistent with both the fact that my drawn containers were helpful to her (through visually reinforcing groups-as-units), and the fact that, despite this, she was somewhat disinclined to draw them independently.

How do the student's arithmetical-representational strategies change over time and input?

Given the level of support required for working with Paula, it is more helpful to consider the overall content of my input and its effect on Paula, rather than individual instances. In summary, I emphasised the three requirements for 'fair sharing', and introduced a practical method for accomplishing this: dealing. I explicitly encouraged visuospatial unitary representation, and introduced an alternative mode (drawing). These were both influential on Paula's ongoing task strategy choices and behaviours.

Although there was a high number of 'teacher-student' interactions, I followed the principle of keeping each teacherly input minimal. Verbal prompts each related to a specific rule that was broken (e.g. unequal sharing) or a single aspect of the task that was misunderstood (e.g. number of groups). In each case, Paula immediately corrected her error (although sometimes making another while doing so). My visuospatial interactions consisted of drawing containers and demonstration or miming of dealing; in each case, Paula was able to take over, complete the representation and use it to obtain an answer to the division task, and then eventually use the same strategy independently. These kinds of

mimicking behaviours may seem trivial to the casual observer, but I argue that for this kind of student it is a significant achievement and important development just to carry out replicatory-structured pattern creation successfully.

While within individual sessions Paula switched from modelling with cubes to drawing, in each subsequent session this temporary confidence had been lost somewhat, and it was necessary to return to the cubes. However, progressively less time was spent in concrete mode, and she also began to draw her own container forms in which to distribute units (examples not included in this paper). It is reasonable to speculate that with further experience, the connections might be strengthened, and the drawn forms regained more quickly and retained for longer.

After I had explicitly demonstrated the dealing process, Paula began increasingly to use this method. While it is true that she required reminding of it in each of the subsequent sessions, she could be observed carrying out the action with increasingly sure and efficient movements. It may be inferred that the repeated success of dealing strengthened her belief in its reliability as a means of fair sharing.

Early on, where Paula had distributed cubes or dots in a disordered way, she often looked at her representation and made adjustments to it via visual approximation, which nevertheless often still resulted in unequal groups. She also presented many incorrect solution representations to me without any attempt to check her work, and simply waited for my response. However, in later sessions, she made attempts to co-ordinate the division requirements herself, for example, checking that all cubes/dots had been distributed and that the resulting groups were equal, addressing these issues if not (e.g. Excerpt 3). Additionally, rather than simply performing a sharing procedure and presenting the representation, she also started to state the group size as her ‘answer’.

Concluding comments

A microgenetic level of analysis of this student’s arithmetical struggles illuminates certain specific difficulties in conceptualising and carrying out division-based tasks which may be unexpected and go unrecognised in classrooms. It also demonstrates the possibility of improvement even in such severe cases, and has pedagogical implications.

Regarding the concept of division, a three-part deconstruction may be seen: (a) the separation of a quantity into a given number of parts, where (b) those parts are equal, and (c) the original quantity is preserved. Also highlighted is the interplay, and potential for tension, between those requirements, or the overriding of one or the other by partial fragmentary understandings. Where there is difficulty considering more than one ‘rule’ at a time, what would have been a simple one-stage calculation thus becomes a complex multi-stage process.

Regarding representational modes, the ease with which Paula switched from concrete to graphic representations of numeric relationships is also significant. Translation between representational modes is commonly considered difficult to achieve, particularly for low-attaining students. It was managed here thanks to carefully-designed scenario tasks and representations that maximised and emphasised correspondences and similarities in visuospatial form and structure, and in hand motion.

The nature and degree of Paula's individual difficulties made progress not only extremely slow and effortful, but uneven and unstable; nevertheless, these excerpts indicate changes, however small when

measured against the progress of typically-attaining teenagers. These changes may be considered microprogressions in arithmetical and multiplicative thinking. While it is true that children may sometimes carry out action sequences without understanding their significance, Paula's insecure start but increasingly confident use of dealing – combined with changes in representational mode and accompanying enumeration – indicate a strengthening understanding of the links between the repeated distribution action and the partitioning of quantities into exactly-equal groups. While meaningful symbolic thinking about multiplicative structures may have still been a long way off for Paula, her efforts and achievements in 'learning to deal' deserve appreciation.

References

- Anghileri, J. (1997). Uses of counting in multiplication and division. In I. Thompson, (Ed.), *Teaching and learning early number* (pp. 41–51). Maidenhead: Open University Press.
- Atkinson, S. (1992). *Mathematics with reason: the emergent approach to primary maths*. London: Hodder & Stoughton.
- Bruner, J. S. (1973). The growth of representational processes in childhood. In *Beyond the information given: Studies in the psychology of knowing* (pp. 313–324). W. W. Norton & Company.
- Carpenter, T. P., Ansell, E., Franke, M. L., Fennema, E., & Weisbeck, L. (1993). Models of problem solving: A study of kindergarten children's problem-solving processes. *Journal for Research in Mathematics Education*, 24(5), 428–441. doi:10.2307/749152
- Donaldson, M. (1978). *Children's minds*. London: Fontana.
- Finesilver, C. (2014). *Drawing division: emerging and developing multiplicative structure in low-attaining students' representational strategies* (PhD). Institute of Education, London. Retrieved from <http://eprints.ioe.ac.uk/20816/>
- Fletcher, K. L., Huffman, L. F., Bray, N. W., & Grupe, L. A. (1998). The use of the microgenetic method with children with disabilities: Discovering competence. *Early Education & Development*, 9(4), 357. doi:10.1207/s15566935eed0904_3
- Gura, P. (1993). Becoming connoisseurs and critics: making sense of blockplay. *Early Child Development and Care*, 92(1), 69–81. doi:10.1080/0030443930920109
- Mulligan, J. (2011). Towards understanding the origins of children's difficulties in mathematics learning. *Australian Journal of Learning Difficulties*, 16(1), 19–39.
- Nunes, T., & Bryant, P. (1996). *Children doing mathematics*. Oxford: Blackwell.
- Schoenfeld, A. H., Smith, J. P., & Arcavi, A. (1993). Learning: The microgenetic analysis of one student's evolving understanding of a complex subject matter domain. In *Advances in instructional psychology* (Vol. 4, pp. 55–175). Hillsdale, NJ: Lawrence Erlbaum Associates.
- Siegler, R. S., & Crowley, K. (1991). The microgenetic method: A direct means for studying cognitive development. *American Psychologist*, 46(6), 606–620.

Utilizing dynamic representations to foster functional thinking

Stephan Michael Günster

Julius-Maximilians-University Würzburg, Germany; stephan.guenster@uni-wuerzburg.de

This article proposes a theoretical framework concerned with fostering functional thinking in Grade 8 students in relation to dynamic representations. To explore how functional thinking can be promoted through dynamic representations, tasks were varied systematically for the implementation in the classroom – as evidenced by two exemplar problems presented in this paper. Students' perceptions of engaging with these tasks were ascertained through interviews conducted with Grade 8 students using tablet technology as part of an evaluation of the study. The focus of this evaluation was the effectiveness of the designed tasks for the development of functional thinking and students' skills when dealing with interactive dynamic representations.

Keywords: Functional thinking, dynamic representation, variation, tablet.

Introduction

The development of the concept of function is an important part of a mathematical education. Working with representations of functions and how to translate between different forms are core skills in this area of learning (Duval, 2006; Höfer, 2008). While there is considerable research concerning the understanding of functions and especially the associated difficulties (e.g. Nitsch, 2015), the increasing availability of digital tools provides the possibility for working with interactive, dynamic and multiple representations. The way students use these representations when developing an understanding of functions has been the focus of substantial research, for example, studies that investigated how students use dynamic representations in connection with different dragging modalities in geometry (Baccaglioni-Frank & Mariotti, 2010) or when students explore functional dependence through the use of a dynamic algebra and geometry environment (Lisarelli, 2016). While the benefit of dynamic representations to students is not yet resolved, there is evidence that in certain learning arrangements they are advantageous compared to static representations for the development of functional thinking (Rolfes, 2018) and that computer-simulations are more beneficial than material-based experiments (Scheuring & Roth, 2017).

However, even though interactive, dynamic and multiple digital representations are available, the main goal in mathematics teaching and learning is to develop appropriate mental representations (Weigand, 2014). In this paper, a theoretical framework is proposed as the foundation to design tasks aimed at promoting students' functional thinking through the use of dynamic representations. To this end tasks are designed to support moving from visual to mental representations and foster functional thinking. Insight into this process is provided via the implementation of sample tasks within a Grade 8 classroom. This paper presents the initial findings of this study exemplified through the analysis of two interview protocols.

Theoretical Framework

This section describes the theoretical framework which was applied to design tasks to foster functional thinking by utilizing interactive dynamic representations.

Functional Thinking

The teaching and learning of functional thinking have been widely discussed. Usually three characteristic aspects are distinguished (e.g. Doorman, Drijvers, Gravemeijer, Boon, & Reed, 2012; Dubinsky & Harel, 1992; Vollrath, 1989). In the framework utilized in this study, Vollrath's notion is used:

- Assignment aspect: a function creates a relation between two variables. For a given input, an output is calculated. The level of understanding can be determined by how relations are recognized and worked with in different forms of representation.
- Co-variation aspect: a function describes how changes of the independent affect the dependent variable. Typical activities for this aspect are to plan, execute or analyze variations of the independent variable and the resulting covariations.
- Object aspect: a function can be seen as a whole and therefore be dealt with as a mathematical object. This means that attributes can be used to describe a function as a whole (e.g. high points, slope) but can also be derived from it. Furthermore, one can treat functions like mathematical objects in their own right that can be operated on (e.g. add or substitute).

All aspects can be visualized and analyzed if typical representations are seen under a special perspective. However, some representations are more suitable for certain aspects than others. For example, graphs offer the opportunity to display a wide range of pairs of values. This is helpful to view the function as a whole whereas a table only shows a limited number of values. A learner should therefore be able to not only work with but also choose a suitable representation flexibly (Acevedo Nistal, van Dooren, & Verschaffel, 2012).

The operative principle to develop functional thinking

According to Dubinsky et al. understanding a concept starts with an action as “an action is a repeatable mental or physical manipulation of objects” (Dubinsky & Harel, 1992, p. 85). As actions are repeated and reflected, they may be interiorized as mental processes and later encapsulated into new objects to which then actions can be applied (for details see Arnon et al., 2014, pp. 17–26). Those mental processes are also called operations. Operations can be characterized as reversible, associative and that they can be composed (Piaget, 1967, 47 ff.). However, actions as well as operations cannot be viewed on their own but must be considered as they act on an object. The changes caused to the object by these actions and operations and its properties and relations are to be evaluated. As Wittmann comments “to comprehend objects means to investigate how they were constructed and how they behave when operations are applied on them” (transl. by author from Wittmann, 1985, p. 9). In order to use an investigative approach in the learning process, one should adapt tasks by varying the involved objects, operations or the relations between them to find interesting effects or invariants. Such an approach is referred to as the operative principle (Wittmann, 1985).

The operative principle is useful for developing functional thinking utilizing interactive dynamic representations via digital tools for various reasons. Actions can be performed directly on the given objects, for example, by dragging points or using sliders and the changes can be viewed accordingly. Thereby one can investigate invariances and variations. Relations between different variables can be

studied by varying one variable and examining the changes caused to a dependent one. This can be viewed from all aspects of functional thinking.

To use the operative principle in the classroom, tasks need to be developed which guide the learner to view the problem's different aspects by varying relevant ones. Usually there is a starting condition provided to which operations must be applied to get a target configuration. It seems, therefore, constructive to begin by varying one of those attributes.

In this article we try to answer the following research questions:

1. What is the form of a theoretical framework that describes the relationship between the aspects of functional thinking and the operative principle?
2. How can interactive and dynamic tasks be developed and implemented in order to develop a relationship between aspects of functional thinking and the operative principle?
3. How do students utilize dynamic representations in the context of the developed tasks and how do they reflect and elaborate on their functional thinking?

The Function-operation-matrix (FOM)

In figure 1 these three aspects of tasks and the three aspects of functional thinking are arranged in a grid – the function-operation-matrix (FOM). To create tasks the problem definition has to first be analyzed regarding which aspect of functional thinking is of interest and its setting (e.g. what is given, what is the target). The FOM is meant to serve as a guide for developing meaningful tasks by selecting cells and varying the problem accordingly.

		Functional thinking		
		<i>Assignment</i>	<i>Co-variation</i>	<i>Object</i>
Variation as proposed by the operative principle	<i>Starting condition</i>			
	<i>Operations</i>			
	<i>Target configuration</i>			

Figure 1: Function-operation-matrix (FOM) as a guide to create meaningful tasks using dynamic representations for the development of functional thinking

Sample tasks

To illustrate this concept two sample sequences of tasks are presented. One typical change of representation which is practiced repeatedly in the beginning of learning about functions is from symbolic formula to a corresponding graph. A coordinate system and a formula are provided, and the learner is required to sketch the graph. One possibility could be to vary the starting condition: Instead of the coordinate system a line is provided and the task is to adjust the coordinate system in such a way that the line represents the given formula (Herget, 2017, p. 9). Using a GeoGebra learning arrangement the coordinate system can be stretched, shrunk, rotated about the origin or shifted as a

whole by dragging the blue points (see figure 2a). Afterwards the result can be checked by comparing the resulting function equation with the given one. The task is described as follows: “A line is given. Adjust the coordinate system in such a way that the line corresponds to the function $f(x) = 2 \cdot x + 1$.” This task would be categorized in the FOM within the cell *starting condition – object*, as the learner has to operate with the function as a whole and use its attributes to find the proper configuration. In varying this task further, operations can be restricted, which means moving to the cell *operations – object* (Günster, 2017). For this variation the wording of the task is: “Revisit task 1, with the following restriction. Do not use a) rotation b) shrinking/stretching of the axis.”

A task concerning proportional functions reads as follows: “There is a square ABCD with a side length of 2 cm given. How much does the perimeter of the square change when the side becomes 1 cm longer?” In the FOM, this variation would be located at *starting condition – co-variation* because the change of the dependent variable, the perimeter, under the influence of the starting condition, the length of the side, should be evaluated. As a second subtask one could ask by how much the side must be lengthened to get a perimeter which is 6 cm longer, therefore varying the task according to the cell *target configuration – co-variation*. Subsequently, it can be discussed whether this depends on the initial length of the side of the square or how the problem changes if, rather than a square, a triangle or hexagon is treated. The task then reads as: “For comparison consider an equilateral triangle and regular hexagon. For which figure do you need to change the length of the side the most, to obtain the same change of the perimeter. Explain your answer!” This means extending the task with respect to the cell *target configuration – object*. A dynamic representation is a powerful tool in this case, as the variation of the side can be realized and the relation between the length of the side and the perimeter viewed as a whole by using the trace facility (see figure 2b).

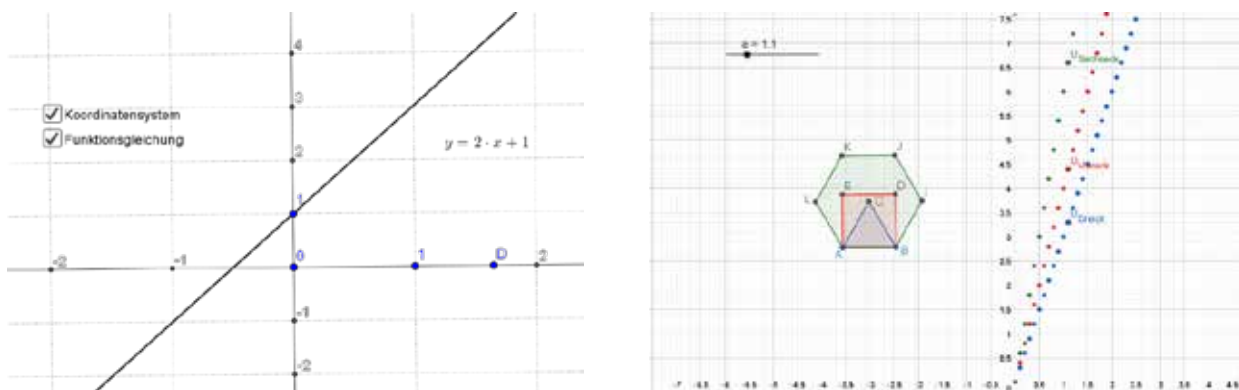


Figure 2: (a) possible solution ($y = 2 \cdot x + 1$) by shifting the coordinate system and stretching the x-axis (b) studying the relation between the length of the side and the perimeter of regular polygons

Methods of the empirical investigation

The interviews presented in the following section were conducted as part of a study at four German Gymnasien (grammar schools) where students are offered the choice of joining a tablet class. Two of the schools made use of iPads, one utilized Android tablets and one used Microsoft Surface devices. In total, five grade 8 classes without and five with tablets were included – a total of $n = 216$ participants. Teachers were given access to tasks designed according to the FOM described above to use them freely in regular class.

Students were administered a pen-and-paper test at the beginning and at the end of the school year to examine their knowledge regarding functional thinking. Additionally, selected students of different skill levels were interviewed in pairs after half and the full year. Questionnaires evaluated the general usage in school as well as at home through teachers, parents and students. As the study was conducted in the school year 2017/18, only preliminary results are available at this point.

In this paper parts of two interviews are discussed which were run after half a year of working with the tablet in the classroom. The first two students were both female and rated as mathematically capable by the teacher. For the second interview, student 3 was female and student 4 was male while both were estimated to be average students. The students already studied linear functions in class. Both interviews featured first some general questions about the usage of the tablets in class and at home, a few pen-and-paper tasks and, most importantly, two tasks to be solved using GeoGebra for which the screen was recorded using screen capture. The first problem was the one already described above as a sample task to adjust a coordinate system in such a way that a given line corresponds to the function equation $y = 2 \cdot x - 1$.

The interviews are analyzed and categorized via qualitative content analysis regarding three guiding questions: how did the students adopt their practiced routines in this scenario? In what way did students use the given dynamic representation? Which aspects of functional thinking did students show? While for the first two questions categories are extracted inductively from the transcripts, the aspects of functional thinking – assignment, covariation and object – are set deductively from the theoretical framework.

Findings

The presentation of the initial findings is structured according to the three guiding analysis questions.

Application of routines

First, both student groups adjusted the coordinate system in order to get the correct y-axis intercept. This is in line with their practiced procedure as it is always the first step to draw in the y-axis intercept. For the first group it was possible to just rotate the coordinate system as they rearranged it while testing a number of options, the second one used the shift-option by dragging the origin. This was followed by attempts to try to match the slope.

Again, the students tried to follow their routine implementing the slope by calculating Δy and Δx and thereby finding a second point the line must pass through. They then adjusted the coordinate system accordingly (see figure 3.1). In their first attempt, they made the careless mistake of selecting (1,2) instead of (1,1) since the slope is $\frac{\Delta y}{\Delta x} = \frac{2}{1}$ but were able to correct it on their own while at the same time explaining their thinking processes. The second group determined the slope by gradually turning and shifting it to make the line pass through to two calculated points. However, they made the common mistake of mixing up Δy and Δx (see figure 3.3) (Nitsch, 2015). Checking their result with the function equation and a little help from the interviewer, the students were able correct the error.

In summary, three possible steps can be identified in students' solution processes: draw in the y-axis intercept; identify Δy and Δx and calculate the slope from the y-axis intercept; or calculate two points and make the line run through those.

Use of dynamic representation

In implementing these steps using the given dynamic representation, students used similar strategies. For the y-intercept they used whichever tool was available to move the point to the intended position making no difference between them. To make the line run through two calculated points however, they gradually shifted and rotated the coordinate system, e.g.:

Student 2: First, I looked for the y-axis intercept and then I tried to use the rotate turn ... with the slope 2, to pass through this point. And then the y-intercept moved again and again, but then one just has to readjust.

As for implementing Δy and Δx it seemed to the students more appropriate to use the shrink and stretch feature. The second group even adjusted the slope with the line running through the origin and then shifted the coordinate system to match the y-intercept (see figure 3.4.)

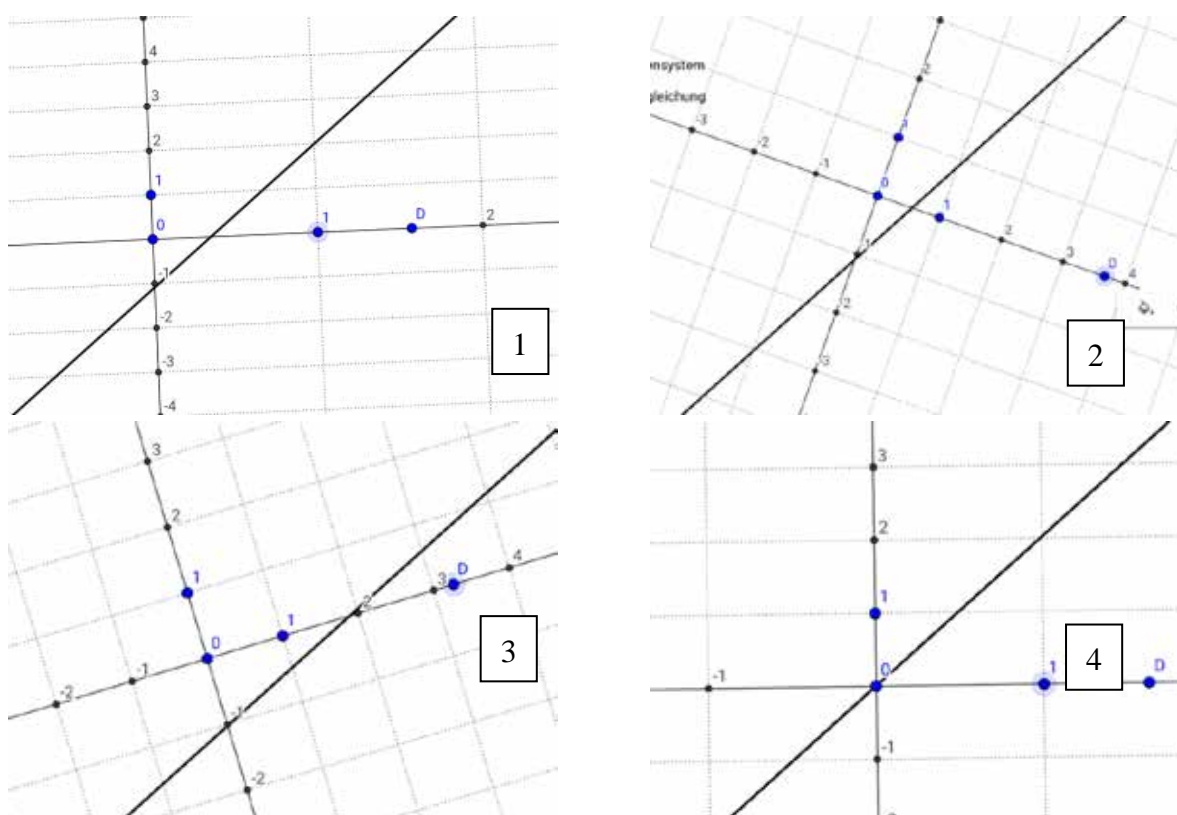


Figure 3: Screenshots taken during the solving process to adapt the coordinate system so that the line corresponds to the function equation $y = 2 \cdot x - 1$

Aspects of functional thinking

The students show only the assignment – through calculating points – or at times the co-variation aspect of functional thinking. For example, when asked about the changes they caused by varying the x-axis, they answer:

Interviewer: What changed, when you were varying the axis?

Student 3: The boxes got larger, when one was at 1 the boxes got like longer.

- Interviewer: When we are talking about linear functions, did the y-axis intercept change? Did the slope change?
- Student 3: No, because it's still 1 to the right and 2 up.
- Interviewer: And regarding this line, which is here...what changes when one varies the x-axis? Does the y-axis intercept change?
Students are shrinking and stretching the x-axis.
- Student 3: Mhm. No.
- Interviewer: What does change, though?
- Student 4: Actually, it is only getting more precise.
- Student 3: Only the slope? [...]

The students are able to describe the dynamic representation as they used it, stating that the boxes got larger as well as that it seemed like the coordinate system was getting more precise because of this, since visually it resembles zooming in. However, they have difficulties relating it to the line and the changes which arise through it. They are therefore not able to view the line as a function as a whole.

Conclusion

This paper describes and illustrates a framework – the function-operation-matrix (FOM) – utilised for the design of tasks used to foster functional thinking via dynamic representations. The FOM combines the operative principle and three aspects of functional thinking. The goal behind this is to develop appropriate tasks for the development of mental representations of functional thinking. Interactive dynamic representations are capitalised upon by visualizing situations and associated mathematical connections and to change these representations through performing actions related to the different aspects of functional thinking.

Two sample tasks demonstrate how the FOM can be used to develop tasks related to different cells within the framework. One can also vary a single problem regarding multiple cells of the FOM. This offers the opportunity to inspect different aspects of the problem and of functional thinking. Thereby, it can also serve as an intuitive way to prepare the focus on the object aspect of functional thinking.

The analysis of the students' solution processes shows that the students had few problems using the given dynamic representations. They adopted their practiced routines for drawing the graph of a linear function according to the available tools. However, they seem to lack the ability to view the changes they made to the representation in respect to the function as a whole – the object aspect of functional thinking. Nevertheless, the task offered a situation in which this aspect could be discussed based on the interactions of the students with the graphical representation. Future research will include additional analysis of other interviews and concerning other tasks in order to confirm the preliminary finds presented in this paper.

References

- Acevedo Nistal, A., van Dooren, W., & Verschaffel, L. (2012). What counts as a flexible representational choice? An evaluation of students' representational choices to solve linear function problems. *Instructional Science*, 40(6), 999–1019.

- Arnon, I., Cottrill, J., Dubinsky, E., Oktaç, A., Fuentes, S. R., Trigueros, M., & Weller, K. (2014). *APOS theory: A framework for research and curriculum development in mathematics education*: Springer Science & Business Media.
- Baccaglioni-Frank, A., & Mariotti, M. A. (2010). Generating conjectures in dynamic geometry: The maintaining dragging model. *International Journal of Computers for Mathematical Learning*, 15(3), 225–253.
- Doorman, M., Drijvers, P., Gravemeijer, K., Boon, P., & Reed, H. (2012). Tool use and the development of the function concept: From repeated calculations to functional thinking. *International Journal of Science and Mathematics Education*, 10(6), 1243–1267.
- Dubinsky, E., & Harel, G. (1992). The nature of the process conception of function. *The Concept of Function: Aspects of Epistemology and Pedagogy*. (25), 85–106.
- Duval, R. (2006). A Cognitive Analysis of Problems of Comprehension in a Learning of Mathematics. *Educational Studies in Mathematics*, 61(1), 103–131.
<https://doi.org/10.1007/s10649-006-0400-z>
- Günster, S. (2017). Die Bedeutung des operativen Prinzips für die Entwicklung funktionalen Denkens im Tablet-unterstützten Unterricht. *Beiträge Zum Mathematikunterricht, 2017*, 345–348.
- Herget, W. (2017). Aufgaben formulieren (lassen): Weglassen und Weg lassen - das ist (k)eine Kunst. *Mathematik Lehren, 2017*(200), 7–10.
- Höfer, T. (2008). *Das Haus des funktionalen Denkens: Entwicklung und Erprobung eines Modells für die Planung und Analyse methodischer und didaktischer Konzepte zur Förderung des funktionalen Denkens*: Franzbecker.
- Lisarelli, G. (2016). Students' use of movement in the exploration of dynamic functions. *Proceedings of the 10th Congress of European Research in Mathematics Education*.
- Nitsch, R. (2015). *Diagnose von Lernschwierigkeiten im Bereich funktionaler Zusammenhänge: Eine Studie zu typischen Fehlermustern bei Darstellungswechseln*. Wiesbaden: Springer Fachmedien Wiesbaden.
- Piaget, J. (1967). *Psychologie der Intelligenz* (3. Aufl.). Stuttgart: Rascher Verlag.
- Rolfes, T. (2018). *Funktionales Denken: Empirische Ergebnisse zum Einfluss von statischen und dynamischen Repräsentationen*: Springer.
- Scheuring, M., & Roth, J. (2017). *Computer-Simulationen oder gegenständliche Materialien – Was fördert funktionales Denken besser?* (Beiträge zum Mathematikunterricht 2017).
- Vollrath, H.-J. (1989). Funktionales Denken. *Journal Für Mathematik-Didaktik*, 10(1), 3–37.
- Weigand, H.-G. (2014). Looking back and ahead—didactical implications for the use of digital technologies in the next decade. *Teaching Mathematics and Its Applications: an International Journal of the IMA*. (33), 3–15.
- Wittmann, E. C. (1985). Objekte-Operationen-Wirkungen: Das operative Prinzip in der Mathematikdidaktik. *Mathematik Lehren, 1985*(11), 7–11.

Connecting the everyday with the formal: the role of bar models in developing low attainers' mathematical understanding

Sue Hough, Steve Gough and Yvette Solomon

Manchester Metropolitan University; s.hough@mmu.ac.uk, s.j.gough@mmu.ac.uk,
y.solomon@mmu.ac.uk

Use of the bar model has gained momentum in England in recent years through the introduction of Singapore maths. Yet bar models originating from the Dutch approach known as Realistic Mathematics Education (RME), such as the fraction bar, the percentage bar and the double number line, have been available since the late 1990s. In this paper, we discuss the use of the bar in an intervention with low-attaining students in which we employed the RME approach. RME bases understanding in the everyday, where the role of the bar is to sustain modelling across multiple contexts, building on students' informal models. We argue that this context-driven 'bottom up' use of the bar is crucial in supporting progress towards formal mathematics, highlighting important issues to consider in the use of bar modelling, particularly with low attaining students. We suggest a consequent need for caution in use of the Singapore bar as a potential 'top down' model.

Keywords: Bar model, realistic mathematics education, singapore bar, low attainers.

Background: different versions of the bar model

The Singapore bar

The success of the Pacific Rim countries in international tests such as PISA (OECD, 2016) has led to the promotion of approaches from Shanghai and Singapore in England, with 'Singapore maths' gaining considerable popularity. Drawing on the work of a number of theorists, but in particular on Bruner's enactive, iconic and symbolic modes of representation (Bruner, 1966), Singapore maths' Concrete, Pictorial, Abstract (CPA) framework focuses on the shift from concrete to abstract via pictorial representations, and features bar modelling as a means of analyzing and solving arithmetic and algebraic word problems.

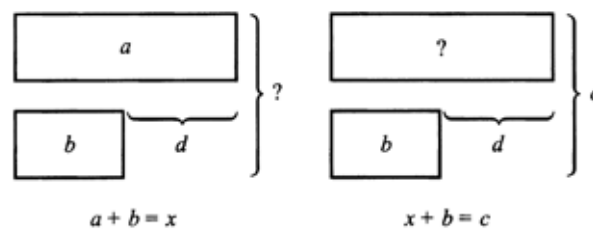


Figure 1: Comparison bar model with arithmetic form on the left, algebraic form on the right (from Ng & Lee, pp. 287-8)

Children in Singapore are taught the method in first or second grade, beginning with the introduction of pictorial representations of quantities using familiar objects such as teddy bears before moving to rectangles in the bar model (Ng & Lee, 2009). Students are taught to recognize a problem type (part-whole, comparison, before-after) and then apply the bar model procedure to find the solution (Ban

Har, 2010). Figure 1 shows the basic comparison bar model. Taken up by the influential National Centre for Excellence in Teaching Mathematics (NCETM) in England, bar modelling ‘is introduced within the context of part/whole relationships... It exposes the relationships within the structure of the mathematics, which are used to find the unknown elements and thus supports the development of algebraic thinking’ (Griffin, nd). Presented in this way, bar modelling focuses on applying a model once the problem structure has been analysed, or as part of the process of its analysis, with the teacher supplying the model and its associated method.

The RME use of the bar

In RME, bar models – including the fraction bar, the percentage bar, the double number line and the ratio table – also take the role of bridging the gap between the learner’s informal understanding of ‘reality’ on the one hand, and the understanding of more formal systems on the other. However, the connection between reality and formal mathematics differs quite fundamentally, in that models are generated from students’ understandings of the context, rather than being offered by the teacher. Mathematical activity emerges from students’ informal models, in contrast to the Singapore use of the bar model which focuses from the outset on the structure of the mathematical problem and the relationships between the numbers involved. This emergent characteristic of RME models means that context plays a crucial role in the process of formalization, supporting extended discussion of models which are then generated as mathematizations of reality rather than being presented as tools for solving particular types of problems¹.

RME materials expose students to multiple contextual situations which can be represented by a ‘model of’ each particular situation. Designers deliberately choose contexts with potential for developing mathematical thinking; for example, asked to depict how to share a subway sandwich, students may begin by making ‘realistic’ drawings, showing round ends and fillings, but in time will move to a rectangular bar ‘model of’ a sandwich with the ends squared off. Producing a drawing to show how to share the sandwich fairly, marking cuts on the rectangular representation and labelling the pieces with fractions, leads to a bar model picture - a fraction bar. Other contexts such as shading in a rectangular cinema layout to represent the number of seats sold would lead to a percentage bar type of bar model. For some contexts such as marking bottle stops on a race route, it may be more appropriate to draw a line showing distance on one side and bottle stop positions on the other. This is sometimes described as a ‘double number line’ but would still be classed as a type of bar model, where the bar has been flattened to look like a line. Overall, models in RME “should ‘behave’ in a natural, self-evident way. They should fit with the students’ informal strategies – as if they could have been invented by them...” (Van den Heuvel-Panhuizen, 2003, p. 14).

Conceptualising progress and the role of the bar model

How models are used in teaching has implications for the conceptualisation of progress. Whereas the Singapore model is based on Bruner’s enactive-iconic-symbolic framework as a progression heuristic, in RME, progress is indicated when students start to see the similarities between ‘models

¹ It is important to note that in RME ‘real’ means imaginable (Van den Heuvel-Panhuizen, 2003, pp. 9-10).

of' situations, and are consequently able to generalise the use of these models and apply them to other problems. At this point they are able to make a shift towards using a bar to represent a situation which is *not* obviously 'bar like', using a bar as a 'model for' solving a problem. Thus progress is defined in terms of formalisation of models (Van den Heuvel-Panhuizen, 2003), and in particular the progression from 'model of' to 'model for' (Streefland, 1985). So, for example, students may begin to see how they can use a bar to represent survey data, and to develop connections between segmented bars, pie charts and fractions, ultimately using a bar to compare and add fractions. This shift is also described as vertical mathematisation (Treffers, 1987), where students recognise the mathematical similarity between different problems and are able to choose an appropriate model to solve a problem. Models, in this view, are far more than given strategies for solving problems; they are central to building the understanding needed to deconstruct a problem. In particular, models in RME depend on a 'bottom-up' process in contrast to a 'top down' approach which offers the model ready-made, to be overlaid onto the problem.

The contrasts between the use of models in RME and the Singapore method raise some questions regarding the current popularity of the Singapore bar – in particular, “what is being modelled, and by who?” The Singapore bar appears to be introduced by the teacher as a ready-made *model for* a mathematical problem rather than being generated by the learner from a context that will support the development of a situated *model of* that has meaning for them, and on which they can build to generate a *model for* which they genuinely own. In this paper, we explore how a group of low-attaining students worked with the bar in an RME-based intervention which aimed to support them to progress beyond poorly learned algorithms towards a deeper understanding of mathematics which is based on their own informal models. Thus, we ask the following research questions:

1. How do students use the bar within an RME context?
2. To what extent do students make progress in terms of moving towards 'model for'?

We consider the implications for the widespread adoption of Singapore bar modelling in the English context of pressure to move quickly towards formal mathematics and algorithmic approaches.

Methodology

In England, a large percentage (around 30%) of students fail to gain an acceptable pass grade in mathematics in national examinations (GCSE) at the age of 16 each year, and resit success rates are poor (DFE, 2017). Resit courses tend to be short (around 8 months) and focus on revising the same methods which students have already failed to learn and remember, hence the larger study of which this is a part investigated the impact of materials based on RME in four GCSE resit classes across three different sites in the North-West of England, during 2014-15. The research team developed and delivered two short modules focusing on number (12 hours) and algebra (9 hours), employing a quasi-experimental design. For reasons of space, we focus on the number module in this paper. Number teaching materials were designed to draw on contexts that supported students in producing situation-dependant bar-type representations and solutions, thus enabling the natural emergence of the bar as a 'model of'. For example, fair sharing problems required students to share out candy strips, pizzas and ribbon, all of which were chosen for their rectangular and hence bar-like properties. Lessons were delivered by three members of the research team, all experienced RME teachers. They followed the

RME practice of emphasis on discussion of the context, moving from students' informal (and life-like) representations of the context (e.g. buying ribbon, mapping water stops on a fun run, sharing a subway sandwich) to discussion of their various strategies for problem solution, and finally to bar models produced by the students.

One of the questions for this intervention is whether students can recognise the potential of the bar model and associated strategies as '*models for*' tackling problems where use of the bar is not suggested by situation-specific imagery (see Van den Heuvel-Panhuizen, 2003, pp 17-29). All students took a short test prior to and at the end of each module. The number test problems were chosen to reflect a range of topics in proportional reasoning, and covered ratio, proportion, finding a percentage of an amount, finding a fraction of an amount, comparing two rates and a reverse percentage calculation. Each question made reference to a context, but unlike in the teaching materials, the contexts were not suggestive of a bar-like representation. Questions were designed to reflect typical GCSE questions on the target subject matter, but students were additionally asked to explain their answers in order to reveal differences in levels of conceptual understanding.

Seventy-five students participated in the intervention classes and 72 in control classes. In the main study, independent evaluators found small but significant gains for the intervention group on the number post-test ($F_{1,93}=4.55$, $p=0.035$, Cohen's $d = 0.26$). They also found a significant correlation between students' improvement from pre- to post-test and the extent to which they used an RME approach (use of the bar or ratio table to solve the problem) ($r = .258$, $n = 86$, $p = .016$) (see Hough et al, 2017, Appendix 8.5). Here, we investigate these findings further through qualitative analysis of the number pre- and post-test scripts in order to identify how students used the bar and its contribution to their learning. Our analysis involved comparing pre-test and post-test solutions by categorising responses given in terms of:

- (1) use of the bar or ratio table versus standard methods/trial and error;
- (2) correct labelling/division of bar parts, and scaling accuracy;
- (3) the bar strategies employed, for instance partitioning/ adding;
- (4) error types: inappropriate halving, incorrect adding, incorrect bar representation; and
- (5) evidence of progress.

Findings

The extent to which students could vertically mathematise their use of the bar

In post-test scripts, 73 % of intervention students chose to draw a bar-type model for at least one of the questions. In contrast, methods used in their pre-test scripts referred to operations denoted purely by numbers and symbols. Control group students were highly unlikely to draw a pictorial representation in order to solve a problem. These overall statistics suggest that the intervention led many students to recognise the potential of the bar model as a model *for* tackling a variety of problems, and in that sense to vertically mathematize.

However, it is not enough for students to simply apply the bar model method to the problem. One of the factors which distinguishes RME models is whether the learner perceives the model to be 'emergent' or 'imposed'. Emergent models are described by Gravemeijer and Stephan (2002) as one

of the key design heuristics of RME: models are grounded in reality, they make sense to the learner and even when the model progresses to a more formal version, the learner can always fall back on the original meaning in order to make sense – they are ‘bottom up’ (p. 146). But although the designer may intend engagement with the model to be ‘bottom up’, this does not necessarily guarantee the model will be experienced in this way. Hence, there may be cases where a learner’s experience of working with RME-based models results in a classical ‘top down’ engagement whereby the model is imposed by the teacher in the traditional sense of demonstrating formal procedures. In the next two sections, we look at examples of students using the RME bar model from both a ‘bottom up’ and ‘top down’ perspective.

The bar model as a ‘bottom up’ sense making strategy / model

For many post-16 GCSE resit students, their experience of learning mathematics involves being shown formal procedures which they can make little sense of, and which they are rarely able to accurately reproduce. The pre-test scripts contained numerous mis-representations of formal procedures, for example writing 17% of £3300 as $\frac{3300}{17} \times 100$, calculating $\frac{5}{8}$ of £600 by replacing $\frac{5}{8}$ with 0.58, and incorrect additive strategies for two proportionally related quantities. However, analysis of the post-test scripts revealed several examples of sense-making through use of an RME bar model, as in the following three examples.

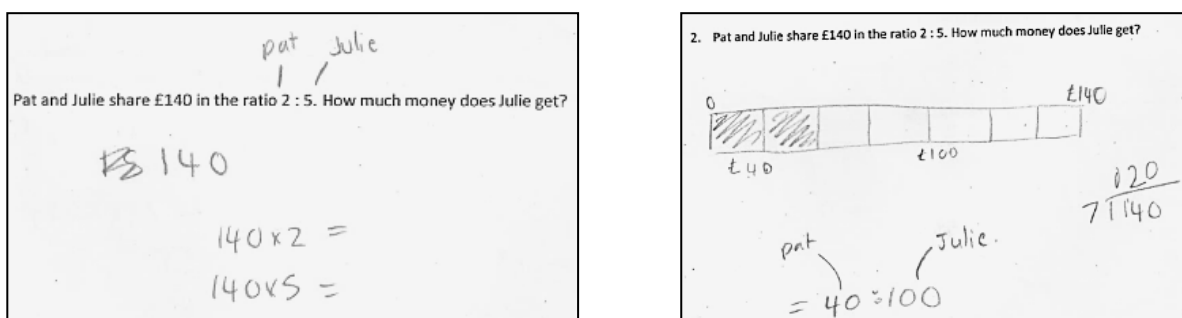


Figure 2: Student A pre-test (left) and post-test (right)

Student A’s pre-test solution (Figure 2, left) may be interpreted as an example of a half-remembered procedure - multiply something by 2 and something by 5. In the post-test (Figure 2, right), in an answer typical of 33% of scripts, she has drawn a bar split into 7 parts and labelled as a continuum from 0 to £140, and she has used shading to distinguish the portions on £140 allocated to Pat and Julie. Here, the student has created a bar model representation which correctly depicts the required sharing processes.

In the next example, Student B demonstrates knowledge of the standard formal procedure used to find a fraction of an amount in her pre-test, but is unable to go any further, commenting that she does not know how to calculate the division $600 \div 8$ (Figure 3, left). In the post-test, and in common with 20% of scripts, she was able to work out an alternative strategy, targeting the values of $\frac{4}{8}$, $\frac{2}{8}$, $\frac{1}{8}$ of £600 and combining these to find $\frac{5}{8}$ (Figure 3, right). Her successful modelling of the problem on a bar enabled her to employ informal approaches to see the relationships between the numbers.

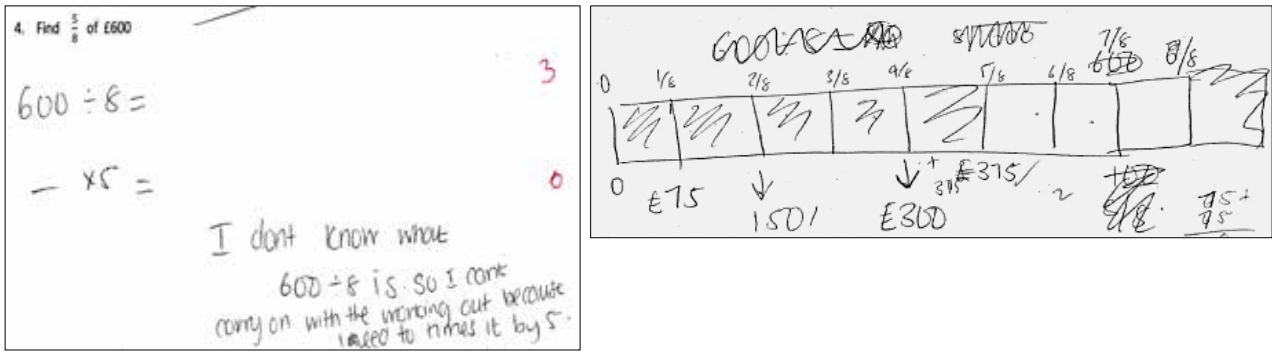


Figure 3: Student B pre-test (left) and post-test (right)

The third example concerns a question requiring students to find the original price of a car, when the current price of £6820 is 20% less than the original. Although none of the control students were able to answer this question in either the pre- or the post-test, 18% of intervention students used a bar to model and solve the problem (Figure 4).

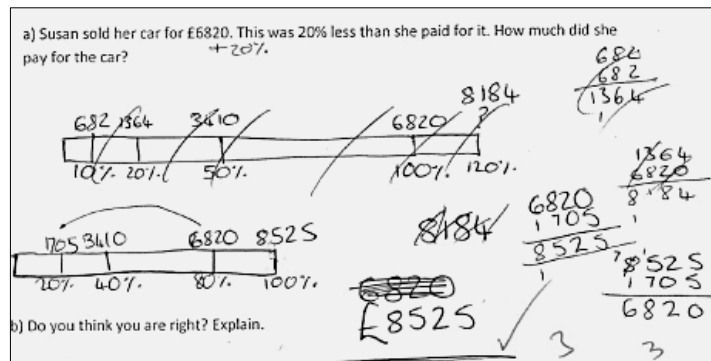


Figure 4: Representing reverse percentage on the bar

Reverse percentage problems of this type are notoriously difficult for students to access, not least because the standard method involves setting up an equation in one unknown. Representing the information on a bar enables further sense-making in terms of providing opportunities for filling in what else the student knows, and enabling them to build up to the required percentage amount.

The bar model as yet another ‘top down’ procedure/model

We have seen examples above where students used the bar as a *model for*, enabling them to represent the question and link it to mathematical strategies which they could make sense of and therefore use effectively. However, in the next two examples, we see students able to operate with the bar model, but their subsequent strategies suggest that they are unable to connect the model with meaningful mathematical activity. For example, the student in Figure 5 (left) applied several cycles of halving and combining chunks to fill in as far as the $\frac{1}{16}$ th way point on his bar, but given that the bar is split into 7 pieces, these calculations served no purpose in finding one part. Some students – around 10% - always marked the half- and quarter- way points of their bars, even when the divisor was an odd amount, suggesting a top down use of the strategy. Figure 5 (right) shows a bar model being used to solve a question which asks how long a photocopier takes to produce 30 copies if it takes 18 seconds

to produce 12 copies. The student has used a bar to model the situation for 24 copies, marking up the bar in one second segments, but has then simply extended the bar by 6 segments to reach 30 copies, omitting to realise that the model shows that one copy takes 1.5 seconds. The error of adding one second for every copy implies that drawing the bar has not provided this student with genuine insight into the underlying structure of this problem. Rather, the bar model has been used as a ‘top down’ model, here, applied without real linkage to the context.



Figure 5: Top down use of the halving strategy (left) and Using the bar in top-down fashion (right)

Discussion

These findings show that the bar has the potential to enable progress. Drawing a bar-type model enabled students to represent problems in helpful ways, allowing some to engage with informal sense-making strategies. The model enabled them to fill in other quantities in order to provide a more complete and detailed representation of the problem. Many students applied an RME method to several post-test questions, suggesting that they were beginning to recognise the unifying potential of the models as a strategy for answering questions across a range of topics in number, and that they were beginning to vertically mathematise and see how to apply their context-specific models to a range of problems.

However, the transition to using a bar model is not unproblematic, and it does not provide an instant solution. Indeed, the issue of inappropriate halving suggests that students can move towards treating the bar as yet another algorithmic method. The intervention was short and as such represented an over-simplification of the RME process, but this served to expose the fragility of these particular students with regard to number sense and their ability to make connections. The complexity of their response to the bar, and the importance of its use for sense-making and not just method raises questions for the Singapore approach to bar-modelling. The significance of this issue is highlighted by Ng and Lee's (2009) analysis of Singapore 5th-graders' solutions to a variety of problems, in which high achievers scored well, but mid-level achievers' strategies often showed erroneous use of the model. Incorrect solutions involved the omission or misrepresentation of crucial information, changing unit generators mid-solution, failure to keep the overall goal in mind, or lack of necessary conceptual knowledge (of fractions, for example) - children were using the method algorithmically, failing to monitor what they were doing. Arguing for the importance of discussion in the classroom about different strategies for solution and the development of meta-cognition in problem

representation, Ng and Lee (2009) note that the bar model must be used ‘as a problem-solving heuristic that requires children to reflect on how they would accurately represent the information presented in word problems This art of representation has to be taught, but it is then the children’s responsibility how they choose to use this heuristic effectively’ (pp.311-2). Ng and Lee’s warning underlines the potential danger in the Singapore bar’s reliance on formal conventions in terms of which bar model is required to solve a problem and how the bars should be labelled. From an RME perspective, we would ask what are the contextual mediums that enable struggling students to gain access to these conventions. The model offers learners a way to represent algebraic word problems, but how do students lacking number sense negotiate meaning once the bars can no longer be drawn to scale, or when, as Ng and Lee (2009, p. 308) note, they are challenged by the concept of fraction and represent the relationship between rectangles erroneously? We suggest that these considerations need to be taken into account in the adoption of Singapore bar modelling, where students, not the teacher, need to own the model.

References

- Ban Har, Y. (2010) *Bar Modelling A Problem-Solving Tool*. Marshall Cavendish, Singapore.
- Bruner, J. S. (1966). *Toward a theory of instruction*. MA: Harvard University Press.
- DfE (2017). Guide to GCSE results for England, 2017, accessed 28/07/18 <https://www.gov.uk/government/news/guide-to-gcse-results-for-england-2017>
- Gravemeijer, K. & Stephan, M. (2002) Emergent models as an instructional design heuristic, in K. Gravemeijer, R Lehrer, B. Van Oers & L. Verschaffel (eds) *Symbolizing, Modeling and Tool Use in Mathematics Education* Dordrecht: Springer.
- Griffin, P. (nd) Using Representations, accessed 27/07/18 from <https://www.ncetm.org.uk/public/files/18892470/Using+Representations.pptx>
- Hough, S., Solomon, Y., Dickinson, P. & Gough, S. (2017) *Investigating the impact of a Realistic Mathematics Education approach in Post-16 GCSE resit classes* MMU/The Nuffield Foundation
- Ng, S.F. & Lee, K. (2009). The model method: Singapore children’s tool for representing and solving algebraic word problems. *Journal for Research in Mathematics Education*, 40 (3), 282-313.
- OECD (2016). Graph I.5.2, in PISA 2015 Results (Volume I), OECD Publishing, Paris, available from <http://dx.doi.org/10.1787/9789264266490-graph63-en>
- Streefland, L. (1985). Wiskunde als activiteit en de realiteit als bron [Mathematics as an activity and reality as a source]. *Nieuwe Wiskrant*, 5(1), 60-67.
- Treffers, A. (1987). *Three dimensions: A model of goal and theory description in mathematics instruction: The Wiskobas project*. Dordrecht: Reidel.
- Van den Heuvel-Panhuizen, M. (2003). The didactical use of models in realistic mathematics education: an example from a longitudinal trajectory on percentage. *Educational Studies in Mathematics*, 54 (1), 9-35.

Visualization of fractions – a challenge for pre-service teachers?

Ellen Konstanse Hovik and Camilla Markhus Rodal

Oslo Metropolitan University, Norway; ellehov@oslomet.no and camilro@oslomet.no

Most pre-service teachers (PSTs) are familiar with the algorithm for addition of fractions. The work for teacher education is to help PSTs to "unpack" the algorithm in order to gain breadth and depth in their understanding. In this paper, we investigate which representations PSTs prefer to use when asked to visualize and explain addition of fractions on a national exam in Norway. We discuss in which ways they demonstrate why and how the standard algorithm works. Our analysis shows that the PSTs prefer to illustrate the sum of two fractions using the sub-construct part-whole in a rectangle shaped area model.

Keywords: Visualization, explanation, fractions, pre-service teachers.

Introduction

There is a widespread agreement that teachers need a certain understanding of mathematics in order to explain not only *how*, but also *why* different approaches work. Therefore, in teacher education by focusing on different methods of representation in the learning of mathematics topics, PSTs will be better able to analyse and understand their pupils' mathematical thinking and thereby be able to provide the best possible support and help in their teaching (Ma, 2010; Lovin, Stevens, Siegfried, Wilkins, & Norton, 2016). Through a national exam, PSTs at all of Norway's teacher education institutions are tested to find out whether they possess such knowledge, for example of fractions.

We will investigate which methods Norwegian PSTs undertaking the national exam, choose to use when asked to illustrate and explain addition of fraction to pupils in school. Our research questions are: Which representations do the PSTs prefer to use? In which ways do they demonstrate why and how the algorithm works?

Research background and theoretical underpinnings

There is broad agreement that many pupils find the concept of fractions and calculations with fractions problematic. "*Fractions are without doubt the most problematic area in mathematics education*". (Streefland, 1991, p. 6). One reason for this could be the great conceptual leap from whole numbers to fractions (Ni & Zhou, 2005; Lamon, 2012). Another reason may be the introduction of algorithms without understanding (Mack, 1993), or too little variation in forms of representation (Sowder, 1998). A third reason for pupils' difficulties could be the complexity of the concept of fractions.

Fractions can be interpreted in different ways. In conceptual terms, fractions can be seen as both the ratio between two whole numbers and as one number. Behr, Lesh, Post, and Silver (1983) describe five sub-constructs: *part-whole*, *ratio*, *quotient*, *operator* and *measure*. A too narrow focus on only one sub-construct of fractions can lead to inadequate understanding (Behr et al., 1983). Although fractions as a part-whole seems more concrete than, for example, fractions as a measure, this sub-construct has its limitations, particularly when the fraction is greater than one (Mack, 1993).

It is possible to use individual forms of representation or a combination of several. When teachers present fractions to their pupils, it is important that they are aware of the strengths of different representations and how they can work together to reinforce each other. Lesh, Post, and Behr (1987) propose five different forms of representation: *manipulative models*, *static pictures*, *real scripts*, *spoken language* and *written symbols*. These forms of representations apply to all sub-constructs of the fraction concept. A single focus on the sub-construct part-whole can lead teachers to use solely representations such as rectangles, circle sectors or other variants of area models. From naming fractions as parts of areas to identifying fractions as points on the number line is a significant turning point for pupils. They have to understand that, on the number line, the whole is defined as the interval from 0 to 1 (Ball, 2017). Freudenthal (1973) describes the number line as “the most valuable tool (...) it can be an excellent means of visualizing the four main arithmetical operations”.

How teachers choose to teach can vary greatly from teacher to teacher. Ma (2010) states that it is important for teachers to have what she describes as a “*profound understanding of fundamental mathematics* (PUFM)”. A teacher with PUFM can present different and varied approaches to a solution, in addition to seeing the advantages and disadvantages of the approaches and is able to offer different explanations to the pupils, focusing on basic concepts and principles of mathematics, and demonstrating horizontal knowledge. A teacher with such qualities shows understanding and sees connections in mathematics in a thorough manner, which can result in greater understanding both in breadth and in depth for the pupils.

In the article “*Toward a theory of proficiency in teaching mathematics*”, Schoenfeld and Kilpatrick (2008) present a provisional framework for proficiency in the profession, where “*Knowing school mathematics in depth and breadth*” is the first category. Breadth refers to teachers being able to provide multiple ways of conceptualising relevant subject matter knowledge, knowing varied forms of representation, understanding key aspects of the different topics and seeing connections with other topics at the same level. Depth refers to knowledge about the basis for and further development of the curriculum in the subject and knowledge of how mathematical ideas are conceptually developed.

Method

We have collected our material from 114 PSTs’ answers on the national exam in fractions in spring 2017. The exam is compulsory and is held by all institutions during the semester in which the primary and lower secondary teacher education programmes have fractions on their course plan. The exam consists of 20 tasks, we have focused on one of the tasks.

The exam question we have analysed: *Draw an illustration with an explanation that can be used in primary and lower secondary schools to show the solution to the problem $\frac{3}{5} + \frac{1}{2}$.*

It is important that the examiners grade the papers as similarly as possible. For this reason, a team of examiners from different institutions was established. They made grading guidelines pointing out which answers should give two, one or zero points:

To be awarded two points, the candidate must include an illustration with a good explanation either by using fractions or by converting to decimal numbers and arrive at the correct solution. If the answer is greater than 1, it is most appropriate to use a length/number line

model, but other models for fractions can also be used. To be awarded one point, the candidate must find the correct solution to the problem but provide an illustration or explanation with shortcomings. Answers that only include algorithmic calculations are awarded zero points. (Our translation) (NOKUT, 2017).

Additionally, all answers were graded by two examiners chosen by the Norwegian Agency for Quality Assurance in Education (NOKUT).

We have analysed 114 answers, which constitutes approximately 10% of all the answers in the exam. The answers are anonymised with respect to both the PSTs identity and what institution they are affiliated to. This was done before the answers were coded. The 114 answers are therefore randomly selected and can be said to represent primary and lower secondary PSTs in Norway.

We coded the answers in two rounds (shown in Table 1 and 2). The codes were entered in SPSS together with the points awarded by the examiners and analysed. We were both involved in grading the submissions in the national exam. Experience from this work, combined with the grading guidelines and Lesh et al.'s (1987) five different forms of representation formed the basis for our initial codes (Table 1). In the first round of coding, we used three different codes for the models: *Area model rectangle*, *area model sector* and *number line*. The code “*good explanations of transition to a common denominator*” is used for a written text that explains the transition to the common denominator by combining the static picture of the models with the calculation. The initial coding revealed a need for a more detailed coding of the methods of explanation, particularly the use of illustrations, language and how they worked together. In the second round of coding, we therefore reviewed all answers that had been awarded one or two points (Table 2).

Results and analysis

We started the analysis by looking at all the 114 answers. Of these, 65 candidates were awarded two points by the sensor team from NOKUT, 34 were awarded one point and 15 got zero points. The answers that were awarded zero points contained purely algorithmic calculations or had arrived at the wrong answer and were for that reason left out for the rest of the analysis, leaving us with 99 answers. In the first phase of coding, we focused on different illustration methods and solution strategies. Using the codes given in Table 1 we wanted to see how the different models/forms of representation were distributed. In Table 1, we distinguish between those who were awarded two and those awarded one point by the examiners chosen by NOKUT. We wanted to see if there were any evident differences.

Strategies, models and representations used	Two points (65)	One point (34)
Changing to common denominator	51 (79%)	29 (85%)
Changing to decimal numbers	1	0
Number line	2	1
Area model rectangle	58 (89%)	27 (79%)
Area model sector	4	4
Draws one tenth as part of the whole	44 (68%)	10 (29%)
Good explanation of transition to a common denominator	36 (55%)	4 (12%)

Table 1: Coding results – first round

Table 1 shows that some of the main differences between those awarded two points and those awarded one point are whether they have included a good explanation of how to find the common denominator and whether they illustrate one tenth as part-whole. This indicates that the PSTs rewarded two points show a depth and breadth in their understanding of this particular task (Schoenfeld & Kilpatrick, 2008). The form of representation preferred by most of the PSTs, regardless of the points they received, is the rectangle. Very few PSTs choose to use sectors and even fewer use a number line.

As many as 51 of the 65 answers that were awarded two points, have been coded with a good explanation of how to find the common denominator. 25 of the 51 answers are coded for both a good explanation of how to find the common denominator and the conversion to the common denominator. This shows that many PSTs find the common denominator without linking it to a good contextual or visual explanation of the conversion itself. Nearly all the answers (33 of 36) that were coded for a good explanation of how to find the common denominator use a rectangle to illustrate this. This could indicate that this way of illustrating the problem is regarded as a suitable way of explaining the need for a common denominator. Rectangles are easy to divide into equally sized congruent parts that can then be added together.

Amongst the PSTs awarded one point, 85% find the common denominator. This could be due to the fact that PSTs who use a visual explanation of the addition without proceeding through the calculation of the common denominator are awarded two points (for an example of such an answer, see Figure 4). The exam text does not require them to find the common denominator. Here as well, we see that the four PSTs (Table 1) who have been coded for a good explanation of how to find the common denominator have used a rectangle. One explanation for them, nonetheless only being awarded one point, could be that they do not draw the proper fraction part of the mixed number in the correct way. Instead, they choose to draw a separate part without linking it to the whole.

During the first round of coding (shown in Table 1), we saw that many PSTs use illustrations to show the calculations they have made, rather than the other way around. For example, some use illustrations to show the need to divide the rectangles into equal parts to be able to perform the addition. After analysing the answers based on which strategies and models/forms of representation are used, we saw a need to further examine whether the PSTs based their answer on an arithmetic calculation and how they choose to illustrate the algorithm. During the second round of analysis, we therefore looked more closely at the connections in the explanations, whether algorithms are generated or only presented and what role the illustrations and textual explanations play. By algorithm, we mean the following calculation method:

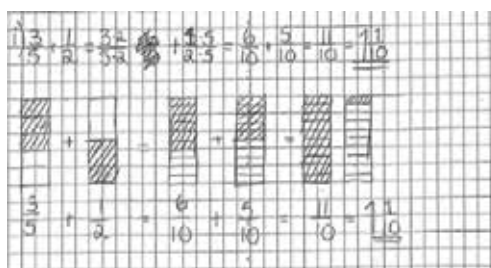
$$\frac{3}{5} + \frac{1}{2} = \frac{3 \cdot 2}{5 \cdot 2} + \frac{1 \cdot 5}{2 \cdot 5} = \frac{6}{10} + \frac{5}{10} = \frac{11}{10}$$

Codes	Explanation of the codes	Number of respondents
A1	Illustrates the whole calculation	20
A2	Illustrates the common denominator and the answer	19
A3	Illustrates only the answer	3
A4	Good written explanation of the calculation	17
A5	Illustrates the calculation, not the answer	3
A6	Illustrates the task and the answer	10

A7	Illustrates only the task	4
B	Generates the algorithm	7
C	Good visual and written explanation. Without arithmetic calculation	19
C2	No good explanation, no arithmetic calculation	19

Table 2: Coding results – second round

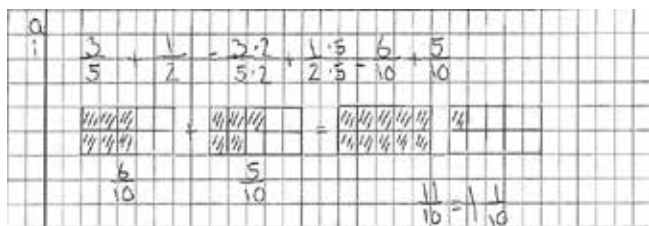
Table 2 shows that there is variation in the methods of explanation among the 99 answers, where we see that different variants of code A are the most common. These PSTs have calculated the common denominator by using the algorithm and have illustrated the whole or some of the steps of the algorithm. Figure 1 shows an example where all the steps are illustrated. This PST has first shown detailed arithmetic calculations and repeated them under the rectangles. The PST has also included a good written explanation. This is an example of the three different representations working together. According to Ma (2010), different approaches such as arithmetic, illustration and a good explanation of how to solve the problem are important. The drawings and text underline and confirm the calculation without deriving the calculation method.



Text: What I have done is to draw big 'boxes' of equal size divided into $\frac{3}{5}$ and $\frac{1}{2}$. To solve this, we must first find the common denominator and I have therefore drawn up two boxes and divided them into 10 sections, as this is the common denominator of both fractions. We then shade the number of sections that are in the nominator and add these to find out that the answer will be $1\frac{1}{10}$.

Figure 1: Answer paper coded A1

In the second round of analysis, we saw that some PSTs illustrated the calculation and answer, but not the problem, before expanding the fractions. Figure 2 shows an answer where the 'last part' of the algorithm is illustrated. There is no visual generation of the algorithm itself, it does however give a good illustration of the answer. The PST manages to convey that it is more than a whole. The problem with choosing an area model in the illustration of a task where the answer is an improper fraction, is to illustrate it in a way that makes it easy for the pupils to see that it is $1\frac{1}{10}$, and that the tenths are clearly shown in the illustration. This PST has also used a real-life context in the written explanation, as described by Lesh, Post and Behr (1987).



Text: Ola has $\frac{6}{10}$ of a bar of chocolate. He gets $\frac{5}{10}$ of a bar of chocolate from Kari. He is then left with $\frac{11}{10}$, which is a whole bar of chocolate plus $\frac{1}{10}$.

Figure 2: Illustration showing the common denominator and solution, coded A2

As shown in Table 1, most PSTs choose to use rectangles in their illustrations. We find some interesting differences in those answers who drew rectangles divided into equal sized smaller rectangles. As shown in Table 2, different steps of the calculation are illustrated. During our work on the analysis, we also saw examples of lack of clarity in relation to equivalent fractions. An example is shown in Figure 3, two rectangles, described as fifths and halves, are divided into 10 parts. Ma (2010) emphasises that it is important to work thoroughly on connections with breadth and depth. For pupils, it is difficult to see this connection if they do not know that $6/10$ is equivalent to $3/5$. Then the illustration in Figure 3 will be hard to understand.

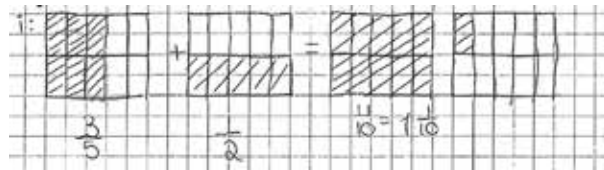
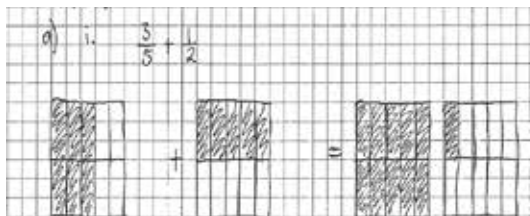


Figure 3: Example of tenths being referred to as fifths and halves

The task in this national exam does not specifically ask for the algorithm and we used the codes C and C2 for the answers without the algorithm (C or C2 depending on how good the explanation/illustration is). Figure 4 shows an answer where the PST illustrates and explains well without showing the algorithm arithmetically (Code C). The answer, together with the explanation, demonstrates a breadth and depth of understanding, highlighting how the PST can vary the forms of representation used, and use them to complement each other. Both Ma (2010) and Schoenfeld and Kilpatrick (2008) describe these as important elements in showing good understanding.



Text: First, I draw a rectangle, then I divide it into 10 equal parts and shade $\frac{3}{5}$ of them, which is 6 of the parts. Then I draw a similar rectangle, with just as many and equally large parts and shade $\frac{1}{2}$ of these, i.e. 5 parts. When I add the shaded parts, I find that I get a full rectangle where all 10 parts are shaded and a rectangle with the same amount of parts of equal size, where only one is shaded. The answer will then be $1\frac{1}{10}$

Figure 4: Good explanation of the steps of the calculation, coded C

Very few students choose to interpret the task in such a way that there is a need to generate the algorithm, for example using an inductive approach where the need for the algorithm ‘makes itself known’. Such an approach has been coded B. This code has been difficult to use since most students start their written response by showing the algorithmic calculation.

Concluding remarks

These analyses show that PSTs in Norwegian teacher education programmes prefer to illustrate the sum of two fractions using rectangles and the sub-construct part-whole. This finding is in conflict with what the grading guidelines suggest as most natural, namely using a length/number line model. The PSTs prefer to use an arithmetical representation and a written text in addition to the illustration.

Most of them starts with the arithmetical calculation before they explain the steps further with the other two representations.

The fact that so few PSTs chose other forms of representation than the area model rectangle could be because the PSTs as a group have not developed the qualities that Ma (2010) describes as important for becoming a teacher with PUFM, namely the ability to vary approaches to solving a problem. It could well be the case that the PSTs are familiar with the different sub-constructs of fractions, but that many of them regard the area-model rectangle as the best illustration for explaining addition of fractions with different denominators to pupils. The rectangle model is easier to divide efficiently than for example the area model sector. We see that many PSTs point out that they divide the rectangles into equal parts (Figure 1 and Figure 4). As seen in Figures 1 – 4 the examination paper delivered from NOKUT to all PSTs during the exam has grid lines. This might also have led some of the PSTs to the use rectangles. Although most PSTs use the rectangle as an illustration, the analysis shows great differences in how this is done. Some of them illustrate all the steps, from the calculation to the answer, while others only illustrate how they find the common denominator or only illustrate the task (Table 2).

There were also major variations in the ways the PSTs show how and why the algorithm works, not only between PSTs awarded one or two points for this particular task in the national exam, but also within the group that received two points. In teacher education, the PSTs encounter concepts such as forms of representation and solution strategies, and they work on examples where they combine these in order to help pupils understand fractions. If you calculate the common denominator and then illustrate this calculation with a rectangle, it will be possible to see that they work together because the illustration underpins the calculation and provides a visual expression of the calculation.

Because of the way in which this particular task is worded, it could be understood to mean that the illustration should generate the algorithm (Code B), and that the need for a common denominator can be apparent from an illustration. This approach could entail an interpretation of the illustration as a tool for helping pupils discover the need of equal parts before the algorithm is presented. Very few PSTs interpreted the task in this way. This suggests that they currently lack the mathematical understanding that breadth and depth proficiency in school mathematics entails (Schoenfeld & Kilpatrick, 2008). At the same time, some of those who start to show the calculation of the answer have good illustrations and good explanations (Code A4, Table 2) and are close to generating an algorithm. Many of the answers contain strategies and representations that can serve as support for pupils who are working on the addition of fractions with different denominators, which is after all promising for the teachers of the future. On the other hand, maybe the reason that so many PSTs respond in a similar way to this task is that they see it as an algorithm for “illustration with an explanation”.

Our material is collected from a written school exam, which has its limitations when it comes to identifying breadth and depth in the PSTs knowledge. Among other things various forms of representation like the oral explanation, and the gesticulation and dialogue that are part of a teaching situation are lost. It is also important to emphasise that the PSTs in our study are halfway through a learning process and that they still have several years to go before they are qualified teachers.

References

- Ball, D. L. (2017). Uncovering the special mathematical work of teaching. In *Proceedings of the 13th International Congress on Mathematical Education* (pp. 11–34). New York: Springer.
- Behr, M., Lesh, R., Post, T. & Silver, E. (1983). Rational number concepts. I R. Lesh & M. Landau (Red.), *Acquisition of Mathematics Concepts and Processes* (pp. 91–125). New York: Academic Press.
- Freudenthal, H. (1973). *Mathematics as an educational task*. Dordrecht: Riedel.
- Lamon, Susan J. (2012). *Teaching fractions and ratios for understanding. Essential Content Knowledge and Instructional Strategies for Teachers*. New York: Routledge
- Lesh, R., Post, T. & Behr, M. (1987). Representations and Translations among Representations in Mathematics Learning and Problem Solving. I Claude Janvier (Red.) *Problems of Representations in the Teaching and Learning of Mathematics* (pp. 33–40). Hillsdale, NJ: Lawrence Erlbaum Associates.
- Lovin, L. H., Stevens, A. L., Siegfried, J., Wilkins, J. L., & Norton, A. (2016). Pre-K-8 prospective teachers' understanding of fractions: An extension of fractions schemes and operations research. *Journal of Mathematics Teacher Education*, 21(3), 207–235.
- Ma, L. (2010). Knowing and Teaching Elementary Mathematics. *Teachers' Understanding of Fundamental Mathematics in China and the United States* (pp. 118–124). New York: Routledge
- Mack, N.K. (1993). Learning fractions with understanding. The case of informal knowledge. In T. P. Carpenter, E. Fennema, & T. A. Romberg (Eds.), *Rational numbers: An integration of research* (pp. 85–106). Hillsdale, NJ: Erlbaum.
- Ni, Y., Zhou Y.D. (2005). Teaching and Learning Fractions and Rational Numbers: The Origins and Implications of Whole Number Bias. *Educational Psychologist*, 40(1), 27–52
- NOKUT (2017). *Assessment guidelines*. Retrieved from: Internal document
- Schoenfeld, A. H., & Kilpatrick, J. (2008). Toward a theory of proficiency in teaching mathematics. In D. Tirosh & T. Wood (Eds.), *International handbook of mathematics teacher education, Vol. 2*, (pp. 321–354). Sense Publishers.
- Sowder, J. T. (1988). Mental computation and number comparisons: The role in development of number sense and computational estimation. I J. Hiebert & M. Behr (Eds.), *Number concepts and operations in the middle grades* (pp. 182–197). Reston, VA: Lawrence Erlbaum and National Council of Teachers of Mathematics.
- Streefland, L. (1991). *Fractions in Realistic Mathematics Education. A Paradigm of Developmental Research*. Dordrecht: Kluwer Academic Publishers.

Leveraging difference to promote students' conceptions of graphs as representing relationships between quantities

Heather Lynn Johnson, [Evan McClintock](mailto:evan.mcclintock@ucdenver.edu), and Amber Gardner

University of Colorado Denver, School of Education and Human Development, Colorado, USA;
heather.johnson@ucdenver.edu, evan.mcclintock@ucdenver.edu, amber.gardner@ucdenver.edu

By creating different Cartesian graphs to represent the same relationship between quantities, students can expand their conceptions of what graphs represent. Interweaving Marton's variation theory and Thompson's theory of quantitative reasoning, we designed digital task sequences to promote students' conceptions of graphs as representing relationships between quantities. In the tasks, which link animations and dynamic graphs, students created different graphs to represent the same relationship between quantities. We report results of a qualitative study (n=13) investigating secondary students' interactions with the digital tasks in an individual interview setting. We found that the digital tasks were viable for promoting students' creation of graphs to represent relationships between quantities. Our findings have implications for task design. Namely, students should have opportunities to create different graphs to represent the same relationship between quantities.

Keywords: Graphs, Computer Simulation, Instructional Design, Learning Theories, Secondary school mathematics

The term *representation* can have many meanings (e.g., Kaput, 1998). We use representation as both a noun and a verb. Employing the term representation as a noun, a student can conceive of a graph as a representation of a relationship between quantities. Employing the term representation as a verb, a student can engage in representation by creating a Cartesian graph to represent a relationship between quantities. Interweaving Thompson's theory of quantitative reasoning (Thompson, 1993; 2002) and Marton's variation theory (Kullberg, Kempe, and Marton, 2017; Marton, 2015), we designed digital task sequences linking dynamic animations and graphs to engender secondary students' creation of Cartesian graphs to represent relationships between quantities. In this study, using individual clinical interviews, we investigated what secondary students (n=13) intended to represent when interacting with digital tasks linking Cartesian graphs and dynamic animations.

Theoretical and conceptual framing

Representation and intention

We distinguish a representation from an inscription, the latter of which refers to some observable artefact (e.g., Kaput, 1998). From our perspective, an inscription can only be a representation if that inscription represents something for an individual or group. When we claim that a student is "representing," we interpret that the student did something more than just creating some observable artefact (e.g., a graph). We mean that the student intended to represent some "thing" with that graph, and that we have evidence to support our claim.

We aim to study what students *intend* to represent when working on digital tasks linking Cartesian graphs and dynamic animations. In any task setting, there are tensions between the intentions of the task designers/researchers and the intentions of the students engaging with the tasks (Johnson, Coles,

& Clarke, 2017). Theoretically, we acknowledge that we cannot know the intentions of others. We can only infer those intentions based on observable evidence. Furthermore, we do not assume that students will share a stated task aim with that of the designer/researcher. For example, we intended to provide students multiple opportunities to create different Cartesian graphs to represent the same relationship between quantities, and we did not assume that students interacting with the tasks would share our intentions.

Interweaving Marton's variation theory and Thompson's theory of quantitative reasoning

To frame our study, we interweave two theories: Thompson's theory of quantitative reasoning (Thompson, 1993; 2002) and Marton's variation theory (Kullberg et al., 2017; Marton, 2015). In his theory of quantitative reasoning, Thompson explains students' mathematical thinking in terms of students' conceptions of attributes. Thompson (1993) posited that quantities were something different from units of measure. Rather, quantities depend on students' conceptions. If a student can conceive of the possibility of measuring some attribute, then that attribute is a quantity for the student. For example, a student may view an animation of a "Cannon Man," who is shot vertically into the air, then comes back down to the ground. In this situation, there are many different attributes. Cannon Man's total distance traveled—both up and down—would be a quantity for that student only if she can conceive of the possibility of measuring Cannon Man's total distance.

Difference, rather than sameness, forms the essence of variation theory (e.g., Kullberg et al., 2017; Marton, 2015). With variation theory, Marton and colleagues explain how designers can develop instructional sequences to promote students' discernment of critical aspects of objects of learning. Kullberg et al. (2017, p. 560) link discernment and variation, core components of variation theory, positing "Discernment cannot happen without the learner having experienced variation." Furthermore, the type of variation matters. If a designer intends for students to discern critical aspects of an object of learning, students should have opportunities to experience variation (difference) in those critical aspects (Marton, 2015).

In designing our study, we intended to provide opportunities for students to conceive of a graph as representing a relationship between quantities. Drawing on Marton's variation theory, we argue that students' conceptions of what is possible for Cartesian graphs to represent is inseparable from their experiences with different Cartesian graphs. Drawing on Thompson's theory of quantitative reasoning, we argue that designers' choices of attributes can impact students' opportunities to conceive of Cartesian graphs as representing relationships between quantities.

Students' conceptions of what Cartesian graphs can represent

It is useful for students to have opportunities to conceive of graphs as representing relationships between quantities (e.g., Bell & Janvier, 1981; Johnson & McClintock, 2018; Kerslake, 1977; Leinhardt, Zaslavsky, & Stein, 1990; Moore, Silverman, Paoletti, & LaForest, 2014; Thompson, 2002). Yet, researchers have documented secondary students' challenges with creating and interpreting Cartesian graphs (Bell & Janvier, 1981; Johnson & McClintock, 2018; Kerslake, 1977; Leinhardt, Zaslavsky, & Stein, 1990). We identify three key challenges. First, students may interpret graphs as needing to share characteristics with a physical object, such as a hill (Bell & Janvier, 1981; Leinhardt et al., 1990). Second, students may interpret graphs as sharing physical characteristics with

the physical path of an object, such as a person's walk from one location to another (Bell & Janvier, 1981; Kerslake, 1977). Third, students may interpret graphs as representing a single varying quantity, rather than as a relationship between quantities (Johnson & McClintock, 2018).

To engender opportunities for students to interpret graphs as relationships between quantities, designers can incorporate variation in individual attributes within a single graph and variation across different graphs incorporating the same attributes. Thompson (2002) argued that students could use their fingers as tools, sliding them along each axis of a graph, to represent change in individual attributes. In a study investigating prospective secondary teachers' reasoning, Moore et al. (2014) incorporated different graphs representing the same attributes on different axes. When making choices about the kinds of variation to incorporate within and across our digital task sequences, we drew inspiration from the work of Thompson and Moore.

The digital task sequences

We report on two digital task sequences: The Cannon Man and the Toy Car. In each digital task sequence, students engaged in five main tasks, shown in Table 1. We drew on Thompson's theory of quantitative reasoning and Marton's variation theory to design and sequence the tasks in each situation. First, students had opportunities to discern and conceive of measuring attributes (Tasks V, A1). Second, students had opportunities to represent change in individual attributes (Task A2). Third, students had opportunities to represent attributes changing together (Task G1). In Task G2, we introduced a difference, against a background of invariance—a different Cartesian graph, with the same attributes represented on different axes. Across the digital task sequences, the Cannon Man and Toy Car situations served as different backgrounds.

Task	Description
V	View video animation. Students viewed a video animation of a situation depicting an object in motion, identified attributes in the situation, and discussed how they might measure those attributes.
A1	Identify task attributes. Johnson stated attributes on which that task would focus. If students had not already identified those attributes, they then discussed how they might measure the task attributes.
A2	Represent individual attributes. Students dragged dynamic segments along the axes of a Cartesian plane to represent change in individual attributes. Then, students viewed a computer-generated video of the dynamic segments changing together.
G1	Represent attributes changing together. Students sketched a single Cartesian graph relating both attributes. Students discussed how their graphs showed (or did not show) both attributes at the same time. Then, students viewed a computer-generated graph.
G2	Re-represent attributes in a new Cartesian plane. In a new Cartesian plane, with the same attributes represented on different axes, students re-represented individual attributes, then attributes changing together (Repeat tasks A2, G1).

Table 1: Descriptions of tasks in the Cannon Man and Toy Car digital task sequences

Methods

Setting/participants

We implemented the digital task sequences with 13 high school students in a high performing suburban high school in the metropolitan area of a large US city. Five students were in ninth grade (~15 years), and currently enrolled in an Algebra I course. Eight students were in eleventh grade (~17 years), and currently enrolled in an Algebra II course. At the school, 52% of students identified as students of color, and 36% of students qualified for free or reduced lunch (an indicator of low socioeconomic status).

We conducted the study over a 4 week time period near the end of the school year. Students volunteered to participate in the study. Johnson conducted a series of three clinical interviews with individual students (39 interviews). Interviews occurred once or twice per week, with at least one day between interviews. Students who participated in all three interviews received a graphing calculator, which they could use for exams and classwork at their school. We conjecture that students who participated in the study were motivated, in part, by the opportunity to receive a graphing calculator.

Research methods: Clinical interviews, exploratory teaching

During the clinical interviews, Johnson engaged in exploratory teaching (Steffe & Thompson, 2000) to investigate the viability of the digital tasks for promoting students' conceptions of graphs as representing relationships between quantities. In the interview design, Johnson included questions to gather evidence of what students were intending to represent when sketching a graph. These questions included: "What you are trying to graph?"; "Can (How does) your graph show both ___ and ___ (the task attributes)?" ; "Look at a point on your graph, can (how does) this point give you information about ___ and ___ (the task attributes)?"

The first interview, which served as a preassessment, involved a Ferris wheel situation. In the Ferris wheel situation, students engaged in tasks V, A1, and G1 in the digital task sequence (See Table 1). The second and third interviews, which incorporated the digital task sequences described in this paper, involved a Cannon Man and a Toy Car situation, respectively. In all interviews, students worked on a digital tablet (an iPad).

Ongoing and retrospective data analysis

All interviews were video recorded. During each interview, either McClintock or Gardner wrote field notes. To promote consistency, we used a field note template, which broke down each interview into sub tasks, to write field notes for each student in each interview. Field notes included evidence of students' conceptions of task attributes as possible to measure and capable of varying, as well as evidence of students' intentions to use a graph to represent a relationship between quantities.

We focused retrospective analysis on students' responses to the Cartesian graphing tasks (Tasks G1 and G2, see Table 1). Across the set of three interviews, students had opportunities to sketch five Cartesian graphs. Johnson and McClintock viewed video of each student's work on each of the Cartesian graphing tasks. In the first pass, we described three aspects of students' work: Sketches of (or attempts to sketch) a viable graph; Explanations of their graph (or attempt) in terms of both attributes; Gestures related to their graphs. In the second pass, we made inferences about students'

representing. We used different codes to characterize students' representing. Table 2 provides descriptions of each code. In the third pass, we examined students' shifts in representing across the Cartesian graphing tasks in each interview, building from observable evidence to develop explanations to account for students' shifts.

Code	Description of code
Relationships between quantities	Students sketched (or attempted to sketch) a single graph. Students described or showed how a single graph could represent a relationship between two quantities.
Individual quantities	Students sketched two separate graphs. Students described each graph in terms of only one quantity (e.g., the "height" graph).
Motion of objects	Students sketched a graph that showed the motion of an object in the situation (e.g., a toy car moving along a path). Students described the graph in terms of motion.
Iconic/Familiar objects	Student sketched a graph that looked like an iconic object or familiar graph. Students described the graph in terms of its physical characteristics.

Table 2: Descriptions of codes characterizing students' representing

Viewing video alphabetically by students' pseudonyms, we completed the first and second passes for each Cartesian graph task in the Ferris wheel and Cannon Man situations. Next, we analyzed the Toy Car situation, which resulted in refinements to our codes. In particular, we expanded the code for relationships between quantities to include attempts to represent quantities not explicitly represented (e.g., time). In each pass, we first coded individually, then vetted codes as a team.

Although some students demonstrated evidence of more than one form of representing within a task, we elected to use a single code for students' representing within that task. When we coded a form of representing for a task, a student may have shifted to engaging in that form of representing after an "aha" moment or engaged in that form of representing throughout their work on the task. If a student demonstrated partial evidence of one form of representing, but engaged more consistently in another form of representing, we weighed the evidence, then coded the form of representing that we interpreted to best characterize the students' reasoning in that task.

Results

We found that the digital task sequences were viable for promoting students' creation of Cartesian graphs to represent relationships between quantities. Table 3 shows the numbers of students engaging in each type of representing across the Ferris Wheel, Cannon Man, and Toy Car graphing tasks. In the Ferris Wheel preassessment graphing task (Ferris Wheel G1, see Table 3), four students (two ninth grade; two eleventh grade) created graphs to represent relationships between quantities. All four of these students continued to represent relationships between quantities in the Cannon Man and Toy Car graphing tasks (Cannon Man G1 and G2, Toy Car G1 and G2, see Table 3). We share results from the nine students who, in the Ferris wheel preassessment graphing task (Ferris Wheel G1), demonstrated forms of representing other than relationships between quantities. By the end of the Cannon Man and Toy Car task sequences, four of these nine students shifted to representing relationships between quantities (Harun, Aisha, David, and Amanda). Five of these nine students

(Kara, Gemma, Carmen, Keshia, and Eliza) continued to represent (or shifted to representing) the motion of objects.

Code	Ferris Wheel G1	Cannon Man G1	Cannon Man G2	Toy Car G1	Toy Car G2
Relationships between quantities	4	6	9	7	8
Individual quantities	2	2	2	1	0
Motion of Objects	4	5	2	5	5
Iconic objects /familiar graphs	3	0	0	0	0

Table 3: Students engaging in each type of representing across tasks

Shifts to representing relationships between quantities

The two students (Harun, eleventh grade; Aisha, ninth grade) who represented individual quantities on the Ferris Wheel preassessment graphing task (Ferris Wheel G1) represented relationships between quantities by the end of the interview sequence. Harun shifted to representing relationships between quantities on the first Cannon Man graphing task (Cannon Man G1). Across the Cannon Man and Toy Car task sequences, Aisha continued to represent individual quantities for the first graphing tasks (Cannon Man G1, Toy Car G1). It was only on the second graphing task in each sequence (Cannon Man G2, Toy Car G2), that Aisha shifted to representing relationships between quantities.

The three students who represented iconic objects/ familiar graphs on the Ferris Wheel preassessment graphing task (Ferris Wheel G1) were in eleventh grade. Two of those students, David and Amanda, shifted to representing relationships between quantities in the Cannon Man task sequence. Amanda shifted in the first graphing task (Cannon Man G1), relating directions of change in Cannon Man's height and distance. In contrast, in the first graphing task (Cannon Man G1), David represented the path of Cannon Man. It was not until the second graphing task (Cannon Man G2) that David worked to represent relationships between Cannon Man's height and distance. Notably, David was the only student who shifted from representing motion of objects to representing relationships between quantities.

Two of the four students (Kara, eleventh grade; Gemma, ninth grade) who represented motion of objects on the Ferris Wheel preassessment graphing task (Ferris Wheel G1) demonstrated partial evidence of representing relationships between quantities on the Cannon Man graphing tasks (Cannon Man G1, G2). In the second Cannon Man graphing task (Cannon Man G2), both Kara and Gemma explained how their graphs represented Cannon Man's height and distance. Yet, in both Toy Car graphing tasks (Toy Car G1, G2), they attempted to represent the physical path of the toy car.

Shifts to other forms of representing

Two of the four students (Carmen, eleventh grade; Keshia, ninth grade) who represented motion of objects on the Ferris Wheel preassessment graphing task (Ferris Wheel G1) shifted to representing change in individual attributes on at least one of the Cannon Man graphing tasks. In the second

Cannon Man graphing task (Cannon Man G2), both Carmen and Keshia attempted to represent change in Cannon Man's height and distance. Yet, in both Toy Car graphing tasks (Toy Car G1, G2), they attempted to represent the physical path of the toy car. Furthermore, one of the students who represented iconic objects/ familiar graphs (Eliza, eleventh grade) shifted to representing the motion of objects in the first Cannon Man graphing task (Cannon Man G1). Once shifting to representing the physical path of Cannon Man, Eliza continued to represent motion of objects in the rest of the tasks.

Discussion

We aimed to leverage difference to promote students' conceptions of graphs as representing relationships between quantities. By interweaving Marton's variation theory and Thompson's theory of quantitative reasoning, we worked to achieve our aim. Drawing on Marton's variation theory, we incorporated difference within and across task sequences. Within each task sequence, students had opportunities to create different graphs to represent the same relationship between quantities. Across task sequences, we incorporated different backgrounds (Cannon Man/Toy Car), as well as different kinds of graphs (linear/nonlinear). Thompson's theory of quantitative reasoning informed our choices about the kinds of differences that might engender students' quantitative reasoning. Because Cartesian graphs represent relationships between quantities, students had opportunities to vary each quantity represented in a graph. Furthermore, we argue that variation within a graph is insufficient to foster students' conceptions of a graph as some "thing" capable of representing a relationship between quantities. Drawing inspiration in part from the tasks reported in Moore et al. (2014), we incorporated different graphs representing the same relationship between quantities.

We posit that our descriptions of codes indicate increasing levels of sophistication in students' representing with Cartesian graphs; however, we do not claim that each of these levels is a necessary step in a progression of reasoning. When representing iconic objects/familiar graphs or the literal path of an object in motion, students are representing physical phenomena in a situation. When representing quantities, or relationships between quantities, students are mathematizing a situation in terms of attributes they can conceive of as possible to measure. We argue that engendering students' shifts from representing iconic objects/familiar graphs or motion of objects to representing individual quantities and relationships between quantities is important for expanding students' conceptions of what graphs can represent.

Students' conceptions of the direction and nature of the motion of objects in a situation can impact their opportunities for representing relationships between quantities. The Toy Car situation proved useful for investigating the stability of students' representing relationships between quantities, in part because the graphs did not share physical characteristics with the literal path of the toy car (e.g., a graph moving up and down as did the Cannon Man). To promote students' creation of Cartesian graphs to represent relationships between quantities, task designers should incorporate graphs that do not share physical characteristics with motion of the objects in task situations.

Acknowledgement

The development of the digital task sequences was supported by a US National Science Foundation Grant (DUE-1709903). This study was supported by a Faculty Development Grant from the

University of Colorado Denver. Opinions, findings, and conclusions are those of the authors. We thank Dan Meyer for his support of the development of the digital task sequences in Desmos.

References

- Bell, A., & Janvier, C. (1981). The interpretation of graphs representing situations. *For the Learning of Mathematics*, 2(1), 34-42.
- Johnson, H. L., Coles, A., & Clarke, D. (2017). Mathematical tasks and the student: navigating “tensions of intentions” between designers, teachers, and students. *ZDM: The International Journal on Mathematics Education*, 49(6), 813–822.
- Johnson, H. L. & McClintock, E. (2018). A link between students’ discernment of variation in unidirectional change and their use of quantitative variational reasoning. *Educational Studies in Mathematics*. 97(3), 299-316.
- Johnson, H. L., McClintock, E., Hornbein, P., Gardner, A., & Grieser, D. (2017). When a critical aspect is a conception: Using multiple theories to design dynamic computer environments and tasks to promote secondary students’ discernment of covariation. *10th Congress of European Research in Mathematics Education*. Dublin, Ireland. Retrieved September 12, 2018 from <https://goo.gl/Y5oqtT>.
- Kaput, J. J. (1998). Representations, inscriptions, descriptions and learning: A kaleidoscope of windows. *Journal of Mathematical Behavior*, 17(2), 265-281.
- Kerslake, D. (1977). The Understanding of Graphs. *Mathematics in School*, 6(2), 22–25.
- Kullberg, A., Kempe, U. R., & Marton, F. (2017). What is made possible to learn when using the variation theory of learning in teaching mathematics? *ZDM: The International Journal on Mathematics Education*, 49(4), 559–569.
- Leinhardt, G., Zaslavsky, O., & Stein, M. K. (1990). Functions, Graphs, and Graphing: Tasks, Learning, and Teaching. *Review of Educational Research*, 60(1), 1–64.
- Marton, F. (2015). *Necessary conditions of learning*. New York: Routledge.
- Moore, K. C., Silverman, J., Paoletti, T., & LaForest, K. (2014). Breaking conventions to support quantitative reasoning. *Mathematics Teacher Education*, 2(2), 141-157.
- Steffe, L. P., & Thompson, P. W. (2000). Teaching experiment methodology: Underlying principles and essential elements. In R. A. Lesh & A. E. Kelly (Eds.), *Research design in mathematics and science education* (pp. 267-306). Hillsdale, NJ: Lawrence Erlbaum Associates.
- Thompson, P. W. (1993). Quantitative reasoning, complexity, and additive structures. *Educational Studies in Mathematics*, 25, 165-208.
- Thompson, P. W. (2002). Didactic objects and didactic models in radical constructivism. In K. Gravemeijer, R. Lehrer, B. van Oers & L. Verschaffel (Eds.), *Symbolizing, modeling, and tool use in mathematics education*. Dordrecht, The Netherlands: Kluwer.

Diagrammatic representations for mathematical problem solving

Vinay Kathotia¹ and Elizabeth Kimber²

¹Manchester Metropolitan University, United Kingdom; v.kathotia@mmu.ac.uk

²Bishop Grosseteste University, Lincoln, United Kingdom; elizabeth.kimber@bishopg.ac.uk

Keywords: Representations, diagrams, lived-in spaces.

Introduction

Noble, Nemirovsky, Wright, and Tierney (2001) provide multiple references regarding the “strong support in the mathematics education community for the view that students should encounter mathematical concepts in multiple mathematical environments” (Noble et al., 2001, p. 85) and be able to connect these. This poster explores, via a case study, some of the related challenges for the restricted setting of using diagrammatic or graphical representations for arithmetic and algebraic problems. It uses a framing of ‘lived-in spaces’ (Nemirovsky, Tierney, & Wright, 1998) and the underlying research question is, “how can we support the use of diagrammatic or graphical representations becoming a ‘lived-in space’ for users?”

The case study is structured around a particular problem, set out as follows. There are three circular cardboard discs. A number is written on the top of each disc: (6), (7), (8). There is also a number (not necessarily the same) written on the reverse side of each disc. Throwing the discs in the air, and then adding the numbers on the faces, I have produced the following eight totals: 15, 16, 17, 18, 20, 21, 22, 23. Can you work out what numbers are written on the reverse side of each disc? (Association of Teachers of Mathematics (ATM), 1977).

In at least two instances, one – a professional development workshop with a group of 40 secondary mathematics teachers in England, and two – an online discussion group of mathematics educators, none of the initial shared approaches used a graphical representation of the problem, even when unknown variables were denoted by x , y and z , and could have suggested 3-D Cartesian space. This is striking as a graphical analysis of the problem can help bring to the fore much of the underlying structure. To clarify this, in our case study, two mathematicians, one who had solved the problem graphically and one who had solved it non-graphically, worked on it together for an hour. This was captured and analysed using multimodal microanalysis as by Nemirovsky and Smith (2013).

Theoretical Background

Those working on the above problem had access to graphical representations but what seemed absent is the creation of a *graphical space* (Nemirovsky et al., 1998) – a ‘common place’ where symbols and their referents are made accessible and sensible. Nemirovsky et al. (1998) develop three themes: *tool perspectives*, *fusion*, and *graphical spaces* to analyze students’ use of a computer-based motion detector in the context of graphing. These three themes are not dependent on the technological nature of the tool and, we propose, apply equally to our setting, with graphical representation being the tool. Indeed, as Nemirovsky et al. (1998) observe, “Tool perspectives look at development of graphical space through simultaneously exploring the qualities of the tool and relation between actions and symbols. Fusion is about the blending of action and symbol in discourse within the graphical space”

(Nemirovsky et al., 1998, p. 124). The growing familiarisation with a graphical space as it is populated with experiences and actions, which make it a space for purposeful and creative activity, is encapsulated by the notion of lived-in space. Noble et al. (2001) propose that “the mathematics that students learn from working in a given environment emerges from their process of making that environment into a lived-in space for themselves” (Noble et al., 2001, p. 86). Our work aims to draw out how the use of graphical representations can become a lived-in space.

Methodology and results

This case study uses a conversation between two mathematicians to investigate what actions and experiences contribute to fluid and effective approaches to solve the problem and how this can enable the fostering of a related lived-in space. Audio and video data were captured and analysed using constructs from the above referenced papers. The findings have two aspects: (i) an analysis of graphical and non-graphical solutions of the problem and (ii) observations on how the relevant lived-in space can be fostered, and related conclusions. We briefly outline the graphical approach:

1. The chosen number on a disc is independent of the other discs so choices can be modelled in 3-D space, one dimension for each disc. A choice of numbers, e.g., (6,7,8) gives a point in this space.
2. Flipping a disc results in a fixed addition or subtraction – representable by a translation vector.
3. It follows that there are eight choices of 3-tuples and these correspond to vertices of a cuboid.
4. The resulting constraints on the possible sums enable all possible solutions to be determined.

In relation to lived-in spaces, moving to-and-fro between different representations, translating expressions that are clear or articulable in one realm to the other, considering their affordances and constraints, and reflecting on these, provides opportunities for learners to make the graphical space a more familiar lived-in space. This also enables learners to experience and exercise graphical representation in ways which move it from being a representational tool to a more expressive tool.

References

- Nemirovsky, R., & Smith, M. (2013). Diagram-Use and the emergence of mathematical objects. In B. Brizuela & B. Gravel (Eds.) *"Show me what you know" Exploring representations across STEM disciplines* (pp. 143–162). New York, NY: Teachers College Press.
- Noble, T., Nemirovsky, R., Wright, T., & Tierney, C. (2001). Experiencing change: The mathematics of change in multiple environments. *Journal of Research in Mathematics Education*, 32(1), 85–108.
- Nemirovsky, R., Tierney, C., & Wright T. (1998). Body motion and graphing. *Cognition and Instruction*, 16(2), 119–172.
- Association of Teachers of Mathematics (ATM). (1977). *Points of Departure 1*. Derby: ATM.

Capturing ‘time’: characteristics of students’ written discourse on dynagraphs

Giulia Lisarelli¹, Samuele Antonini² and Anna Baccaglini-Frank¹

¹Università di Pisa, Italy; giulia.lisarelli@dm.unipi.it, anna.baccaglinifrank@unipi.it

²Università di Pavia, Italy; samuele.antonini@unipv.it

We study high school students’ written discourse about an experience in a dynamic interactive digital environment in which functions were represented in one dimension, as dynagraphs. In a dynagraph of a real function one variable can be acted upon while the other varies as a consequence of the movement induced on the independent variable. Students were asked to write about their experience with the dynagraphs, and their written productions were collected and analyzed using a classification, that emerged a posteriori, in “snapshots, live-photos and scenes”. This classification is presented as a tool of analysis that allows to put discourse about dynagraphs in relation with discourse about functions. Examples of excerpts analyzed through this tool are given.

Keywords: Covariation, dynagraph, dynamism, function, time.

Functions, covariation, graphs, and dynagraphs

Functions and their graphs have always had a leading role in mathematical practice, including school practices. Being able to interpret the Cartesian graph of a function and to construct a graph starting from the function’s properties are essential processes in mathematical thinking. However, these processes include an understanding of the meaning of *variable* and of the *relation between variations* of the variables, that is *covariation*; and several kinds of difficulties that students encounter when grappling with these ideas are widely reported in the literature (e.g.: Tall, 1992, 2009; Kaput, 1992; Monk & Nemirovsky, 1994; Carlson, Jacobs, Coe, Larsen & Hsu, 2002; Thompson & Carlson, 2017).

A Cartesian graph is defined as the set of points $(x, f(x))$ with real coordinates on the Cartesian plane, where x belongs to the domain of the function and $f(x)$ is its image; these constitute a curve incorporating the functional relation between the two variables. Students encounter various difficulties when dealing with graphs, one being in recognizing that each point on the graph is a coordinated presentation of two pieces of information (Colacicco, Lisarelli & Antonini, 2017). This leads them to consider the curve to be the function itself and to identify a point on the curve only as its $f(x)$ value. Both the asymmetric relation between the variables and their covariation are lost.

In this paper we focus on the use of a particular technological artifact to represent functions, realized through a dynamic interactive environment (DIE). Many research studies support the use of technology in the teaching of functions (Healy & Sinclair, 2007; Falcade, Laborde & Mariotti, 2007). Here we are interested in representing functions through DynaGraphs (Goldenberg, Lewis & O’Keefe, 1992), dynamic representations in which the domain variable is dynamically draggable on a line and it is presented separately from its image. Both the x - and y -axes are horizontal; originally, they were referred to as “the x Line” and “the $f(x)$ Line”. DynaGraphs cannot be constructed without using a DIE, where objects can be moved on the screen.

The independence of the x variable is realized by the possibility of freely dragging a point, bound to a line (the x Line), and the resulting movement visually mediates the variation of the point within a specific domain. Whereas the dependence of the $f(x)$ variable is realized by an indirect motion: the dragging of the independent variable along its axis causes the motion of a point, bound to another line (the $f(x)$ Line), that cannot be directly dragged. The use of dragging can visually mediate the discourse on functional dependency, since it can help students interpret the exploration in terms of logical dependency between two different types of motion: direct and indirect motion.

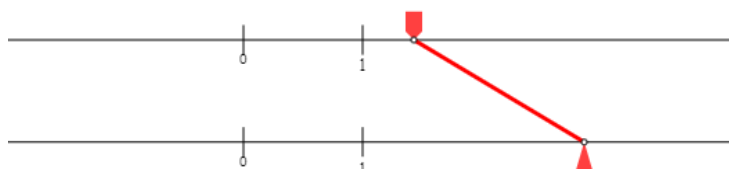


Figure 1: Screenshot of a dynagraph used in this study

The authors, together with Nathalie Sinclair, built on the original idea of DynaGraphs to realize functions as in Figure 1, within the dynamic geometry software Sketchpad (a similar design was adopted also in Lisarelli, 2018) which will be called *dynagraphs* (no capitals, to distinguish them for the original ones) in this paper. Many properties of a function can be recognized in a dynagraph. For example, looking at the movements of the two variables that either follow the same direction or move in opposite directions, an expert can recognize when a function is increasing – if both variables have the same direction of movement – or when it is decreasing – if the variables move in opposite directions. The movement and the identification of invariants are central in the exploration of dynagraphs, since the DIE enables students to deal with the dependence relation in terms of possible or impossible movements; we are interested in how this dynamic and temporal experience can be narrated on a static sheet of paper – a process that is frequent in mathematics.

Many researchers have described the relations between movement, time and mathematics, in particular in calculus. Tall (2009) describes calculus as the mathematical field that begins with the desire to quantify how things change, the function, the rate at which they change, the derivative, and the way in which they accumulate, the integral. So, this field is fundamentally dynamic: even the calculation of static quantities, such as areas or volumes, involves dynamic processes of adding up a large number of very tiny elements. At a certain historical moment, a transformation took place and calculus turned into rigorous definitions, developing into the formal theory of mathematical analysis which is used today by textbooks and by many teachers. This transformation led to the teaching of calculus based on the definition of limits, which satisfies mathematicians' logical needs, but it proves to be rather complicated for students (Tall, 1992). However, even if formal mathematical discourse aims at eliminating time and dynamism, this does not imply that mathematicians engage in purely a-temporal modes of thinking. Indeed, they seem to frequently communicate in ways that suggest they think of mathematical objects in motion (Sinclair & Gol Tabaghi, 2010).

Theoretical background and research focus

For this study we make use of discourse analysis; in particular, we adopt the commognitive theoretical perspective (Sfard, 2008). According to Sfard, communication and cognition are two manifestations

of a same phenomenon and mathematics can be considered as a special type of discourse, or communication. Mathematical learning is the process by which students become able to communicate about mathematical objects, that, unlike others, are purely discursive objects that can have different *realizations* (p. 165). Moreover, mathematical discourse, as a particular kind of discourse, involves a frequent use of *visual mediators*, visible objects realizing the object of the discourse (p. 133).

In this study, we use dynagraphs as particular realizations of the mathematical object ‘function’ within a DIE, in order to allow students to experience the dependency between two covarying quantities in terms of motion. This approach brings temporality into play. We intend to study how students deal with the temporal dimension that characterizes their experience in the DIE, when they are asked to describe it through a written explanation. Moreover, we are interested in the mathematical aspects expressed in these written explanations, especially in how variation of variables and covariation – the relation between variations – are conveyed.

The research question that led the design and the development of this study is the following:

What are characteristics of students’ written discourse on dynagraphs related to their management of the movement and time experienced during the exploration that can be put in relation with discourse about functions (as mathematical objects)?

Methodology

We designed 7 dynagraphs of functions to be explored. The markers realizing the two variables had no labels, because we wanted to allow students to decide which words or symbols to use. We consider this to be an important process related to distinguishing the two variables and the asymmetric relation between them. The two points 0 and 1 were marked on the lines with ticks in order to provide the unit segment and to highlight that the lines visually realize two copies of the real numbers.

Students belonging to four different 10th grade classes of Canadian high schools worked in pairs on as many dynagraphs as they had time for during one lesson (60 minutes). Their task was to “explore the dynagraphs on the iPad and write down their observations about them” on the whiteboard and/or on paper. We collected these written productions. This task was designed to “force” the students to describe in writing an experience which was completely time-and-motion-immersed.

Tools of analysis: snapshots, live-photos, and scenes

From analyses of the high school students’ written productions we reached a characterization that was later refined through further rounds of analysis of the excerpts. Coherently with our research interest in gaining insight into how movement (the variation of position in time) enters students’ written discourse we introduced a first possible characterization of written accounts of the experiences in the DIE, using a terminology that refers to images in the context of photos and videos. In Table 1 we define the main types of accounts and describe characteristics of the discourse it characterizes, both in the case in which the discourse is about the dynagraph (which may or may not be related to the notion of function for the students) and when it is about the function realized through the dynagraph.

Type of account of the DIE experience	Discourse about dynagraph	Discourse about function	
snapshot	<u>snapshot</u> : photo at a certain position showing one or more properties	provides an instantaneous shot in which movement is stopped at a certain position	pointwise properties
	<u>snapshot-album</u> : set of snapshots, each showing something in particular	expresses properties in selected positions; these constitute a finite discrete set; each property is shown in one snapshot	pointwise properties at a particular set of points
	<u>snapshot-cluster</u> : set of snapshots showing relationships between them	one or more properties are described through a comparison of snapshots of the dynagraph; the focus is on the relationships between snapshots; it may be in a sequence coherent with the order on the line or not.	properties that refer to variation and/or to invariants in specific intervals identified by analyzing and comparing different points
live-photo	<u>live-photo</u> : animated photo showing what happens a bit before and a bit after a certain instant.	one or more properties that depend on the nearby positions are described at a certain position; certain positions of the dynagraph are shown close to a specific position	local properties of functions, at a specific point and the variations in any neighborhood of the point.
scene	<u>scene</u> : video showing movement over a period of time; it can be realized through snapshots, or live-photos, in an album or cluster.	description of one or more properties of the movement over an arc of time, in an interval of real numbers, or in the space covered by the point moving along the line; it includes various positions. The intervals can be limited or unlimited; the scene can be described statically or dynamically	properties of functions that are global, general, or present in a whole interval

Table 1: Characterization of students' written discourse

Table 1 shows the main types of accounts (snapshot, live-photo and scene) and their further characterization with respect to ways in which more than one could be used (as albums or clusters) in the excerpts of written discourse that we will now analyze.

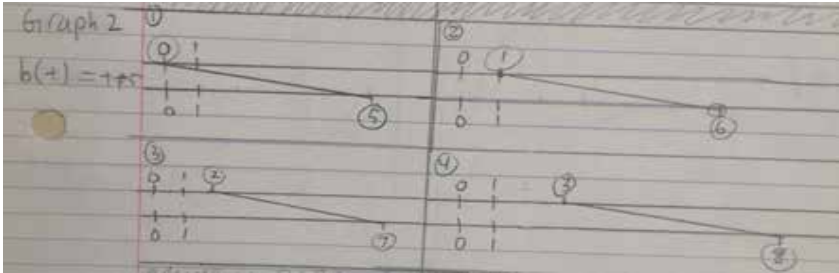
We observe that live-photos may also be found in albums and in clusters. A live-photo album is set of live-photos, each showing something in particular; it expresses properties in selected positions, which constitute a finite discrete set; each property is shown in one live-photo. From a mathematical point of view, these correspond to local properties in neighborhoods of a particular set of points. A live-photo cluster is a set of live-photos showing relationships between them.

Analysis of students' written products

This section contains examples of analyses of students' written products using the characterization.

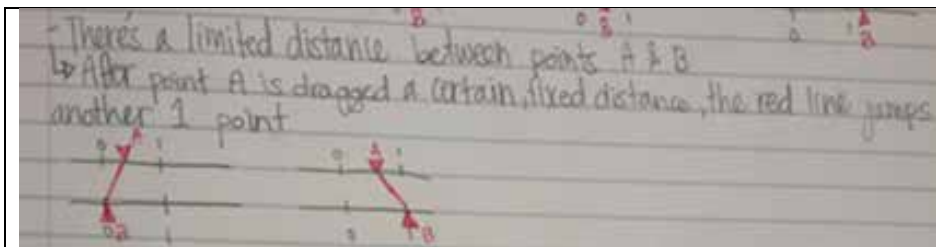
Excerpt 1: Scene of snapshots depicted through written words and diagrams

- When the top number was zero, the bottom number was between 4 and 5
 - When the top was at 1, the bottom was about 5 or 6
 - I'm guessing that the equation would be $b(t) = t + 5$

**Figure 1a,b: Scene of snapshots**

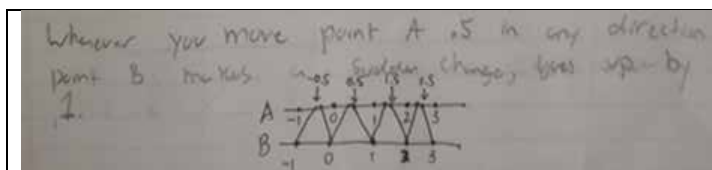
“When the top number was zero, the bottom number was between 4 and 5. When the top was at 1, the bottom was about 5 or 6. I’m guessing that the equation would be $b(t) = t + 5$.”

Excerpt 1 contains discourse about the dynagraph of the function $f(x) = x + 5$; Figure 2a and 2b depict a scene through snapshots presented using written text and visual mediators. The first property in Figure 2a is described through a snapshot taken ‘when the top number was zero’. The first drawing in Figure 2b presents this specific instance. The second property is described analogously as a snapshot taken “when the top number was at 1”; the second drawing in Figure 2b presents this specific instance. The third property in the scene is described through the algebraic formula “ $b(t) = t + 5$ ”.

Excerpt 2: Live-photo depicted through two snapshots showing ‘initial’ and ‘final’ states**Figure 2: Live-photo**

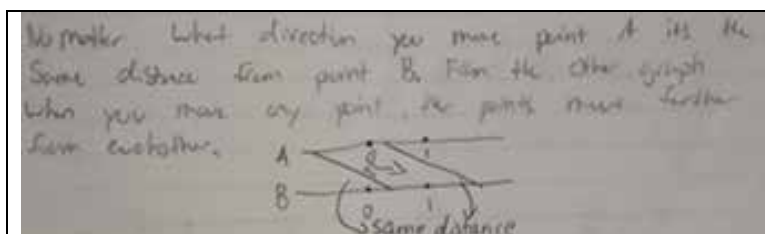
“There’s a limited distance between points A & B. After point A is dragged a certain fixed distance, the red line jumps another 1 point.”

The dynagraph in excerpt 2 realizes the nearest integer function. The students describe the jumping of the red line as A is dragged across the midpoint of the interval $[0,1]$. This part of their discourse appears to be a live-photo depicted through two visual mediators that are particular snapshots showing an ‘initial’ and a ‘final’ state of the dynagraph as A moves in a neighborhood of 0.5.

Excerpt 3: Album of live-photos**Figure 3: Album of live-photos**

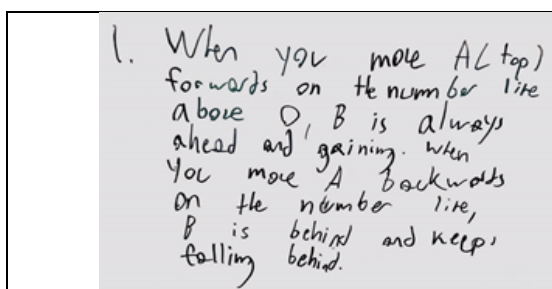
“Whenever you move point A .5 in any direction point B makes a sudden change, goes up by 1.”

The dynagraph in excerpt 3 realizes the nearest integer function. The students produce a single visual drawing realizing the dynagraph’s interval $[-1,3]$ on both axes (Figure 4), and describe its behavior written in words. Each live photo shows A near the midpoint of a unit interval. We see these as live-photos because each ‘sudden change’ is shown by a position of the segment AB immediately before and immediately after the transition of A across the midpoints (the ones realized are $-0.5, 0.5, 1.5, 2.5$) of the unit intervals.

Excerpt 4: Scene depicted through a cluster of snapshots**Figure 4: Scene**

“No matter what direction you move point A it’s the same distance from point B. From the other graph when you move any point the points move further from each other.”

The dynagraph discussed in Figure 5 realizes the function $f(x)=x+5$. The students who author the discourse in excerpt 4 emphasize the invariance of the distance of A from B, conveyed through the words “no matter what direction” and through the visual mediation of two congruent parallel segments in the drawing with in between a double-headed arrow and two arrows pointing to the words “same distance”. The written text and the visual mediators appear to be a cluster of snapshots depicting the invariant property identified.

Excerpt 5: Scene album depicting two properties of a dynagraph**Figure 5: Scene album**

“When you move A (top) forward on the number line above 0, B is always ahead and gaining. When you move A backwards on the number line, B is behind and keeps falling behind.”

In excerpt 5 (Figure 6) the students use only written words to outline the behavior of dynagraph of $f(x)=2x$. They consider a whole interval of time (and space): this is suggested by their use of the adverb “always”, and by the fact that they make several references to possible movements and to the reciprocal position of the two variables (“forwards”, “ahead”, “backwards”, “behind”). Moreover, the

students start with the present tense of the verb “to be” (“B is always ahead [...] B is behind”), which gives their statements the form of an absolute observable truth, but then they add details on the quality of movement, passing to the “-ing form” of other verbs, indicating spatial dynamic features (“always [...] gaining”, “keeps falling behind”). This could suggest that the students see the movement as not ending even when it cannot be seen anymore within a large interval.

Conclusions

The analytical tool we have introduced to describe written accounts of the DIE experience allows to characterize different ways used by students to realize movement and time experienced during the exploration of dynagraphs, and puts them in relation with mathematical discourse about functions. In particular, it highlights how the choice of the time interval being described, that can be identified in students’ discourse by looking at the verb tenses, adverbs and at their use of visual mediators to realize movement, corresponds from a mathematical point of view to different properties of the functions realized through the dynagraph. The classification has value at the cognitive, didactical and epistemological levels. From a cognitive point of view, the tool is important because the classification proposed was identified *a posteriori*, through empirical analysis of the data collected, and it seems to be a powerful tool for analyzing all the data collected. Epistemologically, the types of accounts can be put in relation with different mathematical properties of functions in formal mathematical discourse, as shown in Table 1.

Thinking about properties that are pointwise, local or global, the discourse – even that of experts – that can emerge about these may have characteristics such as those we have found in students’ discourses, focusing on “instants” that capture the behavior of isolated points, systems of points, sequences, neighborhoods of points, points as limits, intervals... Moreover, experts’ discourse can capture properties at certain points, variations and invariants. For example, a description of what happens in a neighborhood of a point can be conveyed through a live-photo, while the behavior at infinity requires a scene, since a neighborhood of infinity can be seen as a scene “from a certain point on”, that is, as a live-photo at infinity.

From a didactical point of view the classification is important, assuming that we value promoting various forms of students’ discourse, and therefore students’ flexibility in constructing such discourse. The teacher can interpret students’ discourse from a mathematical point of view, seeing it as a ‘mirrored image’ (with some possible distortions) of experts’ discourse about pointwise properties, local or global properties, variations, and invariants. Doing this, the teacher can then promote these forms of discourse through appropriate tasks (e.g., by using the behavior of dynagraphs in certain positions, intervals, etc.), knowing what to expect and how to gradually foster the transition to more formal mathematical discourse. One particularly fruitful type of discourse seems to be that involving transitions from pointwise to local properties, and thus discourse involving live-photos. However, this needs to be studied in future research currently under development.

Acknowledgments

We graciously thank Nathalie Sinclair for her support in the realization of the activities described in this paper, and for all the fruitful conversations she has engaged in with us. This study has been partially supported by GNSAGA of INdAM.

References

- Carlson, M., Jacobs, S., Coe, E., Larsen, S., & Hsu, E. (2002). Applying covariational reasoning while modeling dynamic events: A framework and a study. *Journal for Research in Mathematics Education*, 33(5), 352–378.
- Colacicco, G., Lisarelli, G., & Antonini, S. (2017). Funzioni e grafici in ambienti digitali dinamici. *Didattica della Matematica: dalla ricerca alle pratiche d'aula*, 2, 7–25.
- Falcade, R., Laborde, C., & Mariotti, M. A. (2007). Approaching functions: Cabri tools as instruments of semiotic mediation. *Educational Studies in Mathematics*, 66(3), 317–333.
- Goldenberg, E. P., Lewis, P., & O'Keefe, J. (1992). Dynamic representation and the development of an understanding of functions. In G. Harel & E. Dubinsky (Eds.), *The Concept of Function: Aspects of Epistemology and Pedagogy*. MAA Notes, 25.
- Healy, L., & Sinclair, N. (2007). If this is your mathematics, what are your stories? *International Journal of Computers for Mathematics Learning*, 12(1), 3–21.
- Kaput, J. (1992). Patterns in students' formalization of quantitative patterns. In G. Harel & E. Dubinsky (Eds.), *The concept of function: Aspects of epistemology and pedagogy*. MAA Notes, 25.
- Lisarelli, G. (2018). How dragging mediates discourse about functions. In E. Bergqvist, M. Österholm, C. Granberg, & L. Sumpter (Eds.), *Proceedings of the 42nd Conference of the IGPME* (Vol. 3, pp. 323–330). Umeå, Sweden: PME.
- Monk, S., & Nemirovsky, R. (1994). The case of Dan: Student construction of a functional situation through visual attributes. In E. Dubinsky, A. H. Schoenfeld, & J. Kaput (Eds.), *Research in Collegiate Mathematics Education. I. CBMS Issues in Mathematics Education* (pp. 139–68). Providence, RI: American Mathematical Society.
- Sfard, A. (1991). On the dual nature of mathematical conceptions: reflections on processes and objects as different sides of the same coin. *Educational Studies in Mathematics*, 22, 1–36.
- Sfard, A. (2008). *Thinking as communicating: Human development, the growth of discourses, and mathematizing*. Cambridge: Cambridge University Press.
- Sinclair, N., & Gol Tabaghi, S. (2010). Drawing space: mathematicians' kinetic conceptions of eigenvectors. *Educational Studies in Mathematics*, 74(3), 223–240.
- Tall, D. (1992). The Transition to Advanced Mathematical Thinking: functions, limits, infinity and proofs. In D. A. Grouws (Eds.), *Handbook of Research on Mathematics Teaching and Learning* (pp. 495–511). Macmillan, New York.
- Tall, D. (2009). Dynamic mathematics and the blending of knowledge structures in the calculus. *ZDM – The International Journal on Mathematics Education*, 41(4), 481–492.
- Thompson, P. W., & Carlson, M. P. (2017). Variation, Covariation, and Functions: Foundational Ways of Thinking Mathematically. In J. Cai (Ed.), *Compendium for research in mathematics education* (pp.421–456). Reston, VA: NCTM.

Effective choices of representations in problem solving

Jasmina Milinkovic¹, Aleksandra Mihajlovic² and Mirko Dejjic³

¹University of Belgrade, Teacher Education Faculty, Serbia; milinkovic.jasmina@yahoo.com

²University of Kragujevac, School of Education, aleksandra.mihajlovic@gmail.com

³University of Belgrade, Teacher Education Faculty, Serbia; mirko.dejjic@uf.bg.ac.rs

This paper investigates the types of representations used by high-achieving eleven-year-old pupils in their argumentation in the process of mathematical problem solving. The literature review addresses pedagogical and psychological aspects of knowing representations and using them in the process of problem solving. In our empirical study we examine a sample of 109 eleven-year-old pupils who took part in the final round of a national mathematical competition in Serbia. A total of 656 problem solutions was analyzed. The results show that these pupils used and often combined inventive iconic and conventional numerical/symbolical representations in their argumentation. We discuss pupils' choice of representations which lead to correct solutions and adjusted representations corresponding to the type of problem (algebraic or logical-combinatorial). The aim of the paper is to draw attention to the importance of studying representational approaches pupils take when solving problems.

Keywords: Representations, problem solving, argumentation, solution representation.

Introduction

There has been rising interest among mathematics educators in the usefulness of representations in the process of learning and problem solving. Competent use of representations in problem solving appears to be a significant indicator of level of mathematics literacy (De Lange, 2003). Then, it is a plausible assumption that investigations on how high-achieving pupils use representations in problem solving could lead to the development of strategies for choosing adequate representations in problem solving process.

Some of the principal objectives of mathematics education are to enable pupils to be good problem solvers (Schoenfeld, 1992). Solving problems in various ways on one hand and “decoding, encoding, translating, distinguishing between, and interpreting different forms of representations of mathematical objects and situation” on the other hand are recognized as some of the key competences needed for mathematical literacy as it is defined by national curriculums worldwide (De Lange, 2003, p.77). Representations, as tools for presenting problems, are considered to be means for understanding. It is also advocated that using multiple representations in problems may contribute to higher achievement (Cai, 2013). Role of representations in problem solving is recognized as important issue (Janvier, 1987; Cuoaco & Curcio, 2003; Shoenfeld, 1992). Two important issues are 1) which representations pupils invent when solving non-routine tasks and 2) which representations more often assure successful argumentation.

Theoretical background

In numerous conceptualizations of mathematical competences and mathematical thinking, ability to use representations (symbolic, numerical, visual, or verbal expressions) is identified as important parameter of mathematical abilities. Tchoshanov (2002) discusses types of representations on the

concrete to abstract continuum as they reflect different modes of representation: concrete (real object, physical model, manipulative), pictorial (photograph, picture, drawing, sketch, graph), abstract (sign, symbol, written, verbal language). Matteson (2007) identified five categories of mathematical representations in problem solving: numerical, iconic, verbal, symbolic, and dual. Numerical representation focuses on specific numerical values in a variety of formats, such as decimal, fraction, percentage, or a numerical list (such as a list of numbers appearing as outcomes of probability). According to Matteson, iconic representations encompass different visual representations, from pictorial, (realistic) models, horizontal charts, vertical charts to graphs and coordinates graphs. Pictorial representations are pictures of real-world objects such as toys, dice, etc. As we slightly depart from Matteson's classification, we will consider iconic representation as distinct from pictorial (which closely resembles real world objects). For example, an apple may be "iconically" represented as a dot. Verbal representations require application of written (or spoken) language to express understanding, to describe, analyze, explain, or reflect upon numerical, algebraic, or graphic representation (which does not include brief phrases such as directions for solving the problem). Symbolic representations involve symbolic notation and include usage of variables and formulas such as: equation, expression, algebraic equation, algebraic expression, and formula (Matteson, 2007). Yet pupils may not use only one representation in problem solving. Under the term "dual representation" Matteson considers dealing with two categories of representations in problem solving (e.g. numerical and verbal). Matteson claims that "problems' (solutions) incorporating multiple representations generally result in more incorrect solutions" (Matteson, 2007, p. 60).

Some researchers pointed out that visual representations play an important role in supporting reflection and as a tool of communicating mathematical ideas (Arcavi, 2003; Gagatsis et. all, 2010; Sfard, 1991). The main functions of visual representation are to illustrate symbolic representation and to resolve conflict between intuition and symbolic solution. Successfully arriving at solutions to mathematical problems utilizes a combination of problem representation skills and symbol manipulation skills (Brenner et al., 1997). The first mentioned function involves skills which "include constructing and using mathematical representations in words, graphs, tables, and equations" (ibid). Lesh and colleagues argue that besides the significance of each representational system, attention should be directed toward translation among representational systems as well as to transformation within them (Lesh et al, 1987). They point their research shows that the act of representing tends to be "plural, unstable and evolving". Along the line, Duval discusses changes of register of representation in terms of cognitive operations: 1) transformations within the same register, like for example in case of algebraic operations or numerical computation, 2) translation of representation into different register, which is more cognitively challenging (Duval, 1999, 2003).

Several researchers attended to multiple representations in problem solving (Lowrie, 2001; Hegarty and Kozhevnikov, 1999; Matteson, 2007). Lowrie (2001), in a study of the relationship between different forms of problem representation and pupils' performance in problem solving, has found that high-achieving middle school pupils tend to use nonvisual methods when solving problems. He pointed out that most studies examining representational preferences along a visual-nonvisual continuum have considered preference alone and did not attend to effectiveness of method (ibid). Lowrie found that those "pupils' who were able to use visual representations regularly and in an

efficient manner, were able to solve mathematics problems in a more effective manner than pupils' who were more inclined to use nonvisual aids on a regular basis" (Lowrie, 2001, p. 360).

Stylianou and Silver (2004) examined differences in using representations between mathematicians and undergraduate students (as novices). They found that experts construct visual representations more frequently and use qualitatively better way to understand problem situation. School teachers are traditionally inclined to rely on symbolic, analytical representations. Consequently, pupils tend to do the same. The role of different types of representation in problem solving, particularly the effects of the usage of multiple representations is not fully explored.

Methodology

We investigated types of representations used by high-achieving eleven-year-old pupils in solving problems. The main research questions were: 1. what representations pupils most frequently use when solving problems; 2. what representations are associated with correct solutions; and 3. how many representations used at the same time in argumentation are most often associated correct argumentation. Our questions were proposed based on previous research from Matteson, Lowrie, and Brenner and colleagues.

The data was collected in the final round of a national mathematics competition "Mislisa", similar to "Kangaroo without borders" In this competition, mathematics relevant for solving problems is not strictly limited to the national curriculum. Successful problem solving in this competition requires critical thinking and applying knowledge in non-standardized situations. The problems range from the simplest computation problems, to algebraic, logical, and combinatorial problems most often set in realistic context. The competition promotes the value of mathematics literacy in pupils.

The study sample consists of 109 pupils who qualified for the finals of the competition by achieving the maximum score in the preliminary round of competition. We examined problem solutions from all finalists. The subset of 8 problems in which competitors were explicitly asked to provide explanation was analyzed in our study. Descriptive statistics was done for those eight problems.

Solutions for two of the problems are analyzed qualitatively in greater details. Our preliminary analysis of all solutions, resulted in selection of *The Bottle problem* and *The Castle problem* as exemplars for the points we make. They are the following:

The Bottle problem There is three times more milk in the first bottle than in the second one. If 3l of milk is added in the first bottle, and 5l of milk in the second, than there would be two times more milk in the first bottle than in the second one. How many litres of milk has been in the bottles at the beginning? Explain your answer.

The Castle problem A Castle has 6 towers. Each tower has a room. Each room has one door. Each door has a lock. All rooms are locked and keys are mixed up. What is the maximum number of trials a guard needs to check, in order to open the doors?

In the Bottle problem, finding way(s) to represent relationships between amount of milk in the first and the second bottles is the key for finding the solution. Problems similar to this are commonly solved in schools with the strategy of forming an algebraic expression (symbolic representation). But there are alternative strategies for solving this problem such as 1) the "method of segments" which

relies on expressing relationships between quantities on line segments (iconic representation) or 2) the “method of trials” (involving number representation) or 3) simply explaining the solution in words (verbal representation) or 4) some other creative approach.

The Castle problem is logical-combinatorial. The maximum number of trials in the first cycle to get to the door that can be unlocked is obviously equal to the number of rooms. In the following cycle of trials, one door is already unlocked so five doors remained to be checked in. There is no one “school” strategy for solving this problem.

Results and Discussion

Here we present descriptive analysis of pupils’ solutions. A total of 656 problem solutions are taken as units of analyses. Out of them, 355 items were solutions to algebraic problems and 301 items solutions to logical-combinatorial problems.

Table 1 shows that choice of representations for algebraic problems did not match representations used in combinatorial problems. Since pupils often used more than one representation, the percentages in each column do not add to 100.

Type of representation	Algebraic problems	Logical-combinatorial problems
Numerical	31,9%	57,8%
Iconic	22%	20,8%
Verbal	21,8%	61,2%
Symbolical	45,9%	8,3%

Table 1: Percentages of problem solutions with particular type of representation

In accordance to Duval’s claim, pupils tended to use non-visual representations. To explain algebraic problem solutions, pupils most frequently used symbolical representation. It is not surprising since traditionally solving algebraic problems in a way other than writing down equivalent equations is undervalued in classrooms. In contrast, the logical-combinatorial problem solutions pupils primarily relayed on verbal and numerical representations. Particularly, verbal representations were often used for argumentation in solving logical combinatorial tasks, rarely for algebraic problems.

We examined whether there is an association between number of used representations (1, 2 or 3) and correctness of solution (False/Partially correct/Correct). The percentages are presented in the Table 2. Percentage of correct solutions including more representation, were bigger than of correct solutions with smaller number of representations used. We performed the χ^2 test of independence for variables Number of used representations (1, 2 or 3) and Correctness of solution (False/Partially correct/Correct) on problems. There is a significant relationship between “number of used representations (1,2,3)” and “Correctness of solution (false, partially correct, correct)”. ($\chi^2=67,478$, $df=4$, $N=656$, $p<0,001$). Cramers’s V coefficient of 0,227, $p<0,001$ suggests moderate correlations. Thus, successful problem solvers constructed significantly more representations than unsuccessful problem solvers. Our finding confirm Lesh’s observation about plural and evolving nature of the act

of representing. The finding does not reinforce Matteson’s statement that “multiple representations result in more incorrect solutions” (Matteson, 2007)

Number of representations	False solution	Partially correct solution	Correct solution
1	35,4%	23,7%	40,9%
2	20,7%	10,4%	68,9%
3	4,5%	9,1%	86,4%
Total	27,3%	17,2%	55,5%

Table 2: Percentages of number of used representations according to correctness of solution

Iconic representations are considered to be more intuitively comprehensible and closer to reality than symbolic representations which involve abstraction and generalization in mathematics domain (Liu, 2012). Yet sufficient experience with such representations is a prerequisite for their’ appreciation. The high-achieving pupils in our study had a tendency to use symbolic representations in algebraic problems. Almost half of the solutions involved using of symbolic representation in those problems. The test of independence showed that there is significant association between correctness of problem solution and use of symbolic representation ($\chi^2=62,417$, $df=2$, $p<0,001$). The strength of relationship is medium (Cramer’s $V=0,419$, $p<0,001$).

Many pupils obviously assumed that they were expected to use pictures when explaining their solutions. But often pictures were neither sufficient nor effective aid in argumentation. Some pupils combined pictorial with numerical representation (e.g. counting up number of attempts in the Castle problem). The others combined pictorial with symbolic and verbal representations by creating number sentences and written explanations of steps.

Prototypical representations in pupil’s solutions

Pupils created diverse representations for their argumentation. In the Castle problem a significant number of pupils used numerical representation. Yet, others supported argumentation with pictorial representation in combination with other representations. Figure 1 shows an example of argumentation based on dual representation (pictorial and numerical).

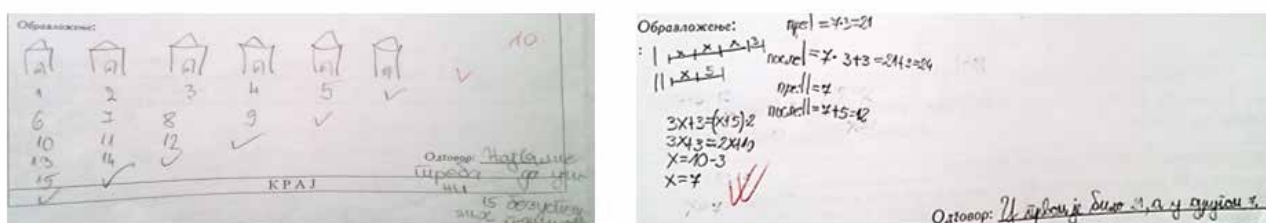


Figure 1: Dual representation - pictorial and numerical (left)

Figure 2: Dual representation - number line and algebraic expressions (right)

When using iconic representation, most commonly the pupils relied on number line and the method of segments. This method is commonly taught in Serbian schools. Figure 2 illustrates an example of argumentation based on number line representation in solving the Bottle problem. In her problem

solution, Ana used the method of segments (number line representation) to show the relationship between elements in the initial state and the final state (so this pupil represented how the situation changed by drawing two pairs of number line segments). Ana switched from the number line representation to symbolic ones as she wrote a chain of equivalent equations.

An example of the solution of the Castle problem, solely based on iconic representation is presented in Figure 3. Marko put a key for his iconic presented argumentation on the right, where “x” meant unsuccessful attempt, “√”, successful attempt, and “-“ that the door cannot be opened.



Figure 3: Iconic representation

Figure 4 shows Sara’s solution, assessed to be a creative argumentation involving Roman and Arabic numerals in solving the Castle problem. The solution consisted of five equalities. Sara counted the cycle of attempts by Roman numerals. She used Arabic numerals to show number of attempts in the particular cycle. Formally, without (absent) supplementary explanation the record was not mathematically correct as it stated e.g. $I = 6$ and $V = 1$. Sara used different numeration to distinguish between number of attempts and number of trials in the cycle, overlooking meaning of the equality sign. Her solution was assessed to be too sketchy and although the answer was correct, she did not earn points for argumentation.

Pupils often combined different representations in solving problems. In those cases they usually started with pictorial representation, than they turned to verbal or symbolic representation. Using pictorial representation, enabled them to provide simpler explanation. An effective presentation of thought process with no verbal explanation is presented in Figure 1.

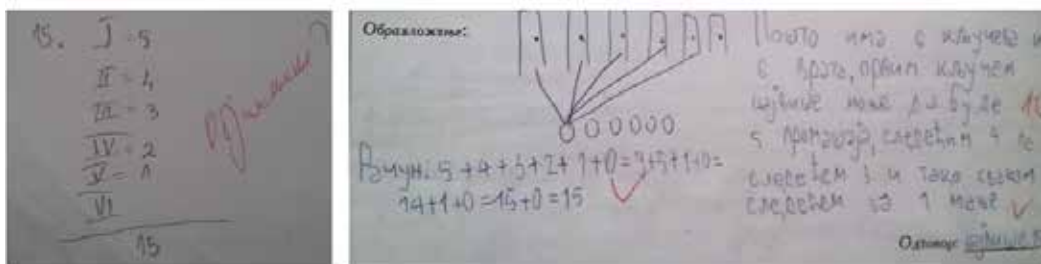


Figure 4: Combined numerical representations (left)

Figure 5: Multiple representations - pictorial, verbal and numerical (right)

In Figure 5 is Luka’s solution of The Castle problem with multiple representations. He initially used pictorial and numerical representations along with verbal explanation and finalized the solution with numerical calculation. The realistic picture of doors itself hardly helped in solving the problem. Nevertheless Luka used it as a tool in argumentation. He probably meant to indicate with that picture

that all 6 doors were checked with one key. The other cycles of tries were not visually presented in Luka's solution. But his verbal explanation presented on the right side of the picture was accurate. Luka wrote: "Since there were 6 keys and 6 doors, with the first key there could be no more than five failed attempts, in the next step 4, than 3, and so on, in each successive step 1 less".

Conclusion

Successful problem solvers construct significantly more representations than unsuccessful problem solvers. Our results do not endorse previous arguments that multiple representations are associated with more incorrect solutions. Using combined representations often results in correct solution. Typically, pupil's argumentation starts with pictures, than turns to verbal or symbolic representation. Using pictures frequently enables pupils to provide sound explanation.

We found that talented pupils had a tendency to use symbolic representations. Pupils' choice of representation could be a consequence of limited experience in using different representations in the past. Ultimately teachers need to help pupils to develop flexibility in using different representations and ability to combine representations (or move in argumentation from one to another one).

In particular, future research should test whether pupils should be encouraged to provide argumentation by 1) combining numerical and verbal representations in the case of logical combinatorial problems and 2) numerical pictorial and iconic representations in the case of algebraic problems. More generally, we need to focus on developing methods for improving pupils' abilities to visualize and verbalize thought process and to be flexible in combining representations in the process of problem solving.

References

- Arcavi, A. (2003). The role of visual representations in the learning of mathematics *Educational studies in mathematics*, 52, 215-241 Netherlands: Academic Press.
- Brenner, M. E., Mayer, R. E., Moseley, B., Brar, T., Duran, R., Smith Reed, B and Webb, D. (1997). Learning by Understanding: The Role of Multiple Representations in learning Algebra. *American Educational Research Journal*, 34(4), 663-689.
- Cai, J. (2013). Mathematical Problem Posing as a Measure of Curricular Effect on Pupils' Learning. *Educational Studies in Mathematics* 83(1). Springer.
- Cuoco, A. & Curcio, F. (Eds.) (2003). *The roles of representations in school mathematics, 2001 Yearbook*, (pp. 173-186). NCTM: Macmillan Publishing Company.
- De Lange, J. (2003). Mathematics for Literacy. In B.L. Madison & L.A. Steen (Eds.), *Quantitative Literacy. Why Numeracy Matters for Schools and Colleges* (pp. 75- 89). Princeton, NJ: The National Council on Education and the Disciplines.
- Doerr, H. M., & English, L. D. (2003). A modelling perspective on pupils' mathematical reasoning about data. *Journal for Research in Mathematics Education* 34(2), 110–136.
- Duval, R. (2006). A cognitive analysis of problems of comprehension in a learning of Mathematics. *Educational Studies in Mathematics*, 61, 103–131. Springer.

- Duval, R. (1999). Representation, Vision and Visualization: Cognitive Functions in Mathematical Thinking. Basic Issues for Learning. *Proceedings of the Annual Meeting of the North American Chapter of the International Group for the Psychology of Mathematics Education* (21st, Cuernavaca, Morelos, Mexico, October 23-26, pp. 3-26.
- Gagatsis, A., Agathangelou, S., Papakosta, V. (2010). Conceptualizing the role of pictures in Problem solving by using the implicative statistical analysis, *Acta Didactica Universitatis Comenianae Mathematics*, Issue 10, pp. 19–34. Comenius University Press.
- Hegarty, M. & Kozhevnikov, M. (1999). Types of visual-spatial representations and mathematical problem solving. *Journal of educational psychology*, 91(4) 684–689.
- Lesh, R., Post, T., & Behr, M. (1987). Representations and Translations among representations in Mathematics Learning and Problem Solving. In C. Janvier (Ed.), *Problems of representation in the teaching and learning of mathematics* (pp. 33–40). Hillsdale, NJ: Lawrence Erlbaum Associates.
- Liu, Z. (2012). Survey of primary pupils' mathematical representation status and study on the teaching model of mathematical representation. *Journal of Mathematics Education*, 5(1), pp.63–76. Education for all.
- Lowrie, T. (2001). The Influence of Visual Representations on Mathematical Problem Solving and Numeracy Performance. *24th Annual MERGA Conference*, Sydney, July 2001 Retrieved on 19.6. 2017 at https://www.merga.net.au/documents/RR_Lowrie.pdf
- Matteson, S. M. (2007). *Middle school pupils' representational understandings and justification schemes: gleanings from cognitive interviews*. Doctoral dissertation, Texas A&M University. Retrieved at <http://oaktrust.library.tamu.edu/bitstream/handle/1969.1/ETD-TAMU-1682/MATTESON-DISSERTATION.pdf?sequence=1>
- Milinkovic, J. (2012). Pre-service teachers' representational preferences. Tso, T. Y. (Ed). *Proceedings of the 36th Conference of the International Group for the Psychology of Mathematics Education: Opportunities to Learn in Mathematics Education, Vol 3*, 3-209 - 3-217. Taipei, Taiwan: PME.
- Shoenfeld, A.H. (1992). Learning to think mathematically: problem solving, metacognition, and sense making in Mathematics. In D. Grouws (Ed.), *Handbook of Research on Mathematics Teaching and Learning*, pp. 243–275. New York: Macmillan.
- Sfard, A. (1991). On the dual nature of mathematical conceptions: Reflections on processes and objects as different sides of the same coin. *Educational Studies in Mathematics*, 22(1), 1–36.
- Stylianou, A. & Silver, E. (2004). The role of representations in advanced mathematical problem solving: an examination of expert-novice similarities and differences. *Mathematical Thinking and Learning*, vol 6 (4), 353-387.
- Tchoshanov, M. A. (2002). Representation and Cognition: Internalizing Mathematical Concepts. In Fernando, Hitt (Ed.) *Representations and Mathematics visualization*, pp. 207- 218. North American Chapter of the International Group for the PME.

Geometric prediction: proposing a theoretical construct to analyze students' thinking in geometrical problem-solving

Elisa Miragliotta

University of Modena and Reggio Emilia, Department of Physics, Computer Science and Mathematics, Modena, Italy; elisa.miragliotta@unimore.it

We consider geometric prediction (GP) as a mental process through which a figure is manipulated, and its change imagined, while certain properties are maintained invariant. In this paper, we explain our interest in this process and how we define it. Furthermore, we describe a tool for analyzing students' productions. In particular, we present brief analyses of students' interviews while they are solving a geometric open problem explicitly designed to elicit processes of GP. Finally, we summarize some preliminary results about the features of this construct. These results are part of a doctoral project aimed at gaining insight into the process of GP.

Keywords: Spatial reasoning, visualization, intuition, figural concepts.

Introduction

It is well known that spatial reasoning and visualization are topics of interest for mathematics educators (e.g. Duval, 1995; Presmeg, 2006) to the extent that Cuoco, Goldenberg and Mark (1996) have proposed to organize curriculum around *mathematical habits of mind*, which include visualization and tinkering. These are described as being at the heart of mathematical research and, therefore, crucial for helping students learn to think like mathematicians. These habits are particularly involved in geometrical problem-solving. Indeed, when solvers approach a geometrical task they can interact with visual or mental images in several ways. Cognitive Psychology explains this interaction by the intervention of several *visuo-spatial abilities* such as *imagery generation ability* and *imagery manipulation ability* (Cornoldi & Vecchi, 2004).

In a previous study (Miragliotta & Baccaglioni-Frank, 2017) we tried to analyze students' solution processes when solving a geometrical task, but found shortcomings in using the visuo-spatial abilities for at least two reasons: much effort goes into establishing which abilities are used during each analyzed process, and interpretation plays a large role and is not consistent across researchers; none of the abilities explicitly deal with the Theory of Euclidean Geometry within which figures and their properties are defined, when the reasoning is carried out in this context. This is because as mathematicians we know that, when we solve a geometrical task, we can imagine consequences of (mental) transformations on a geometrical object which are consistent with theoretical constraints, given or induced by a particular construction. Indeed, mathematical objects have a particular nature, the investigation of which usually requires theoretical elements which refer to a domain different from the one of perception. In line with Neisser (1989), we consider perceiving and thinking as different cognitive activities. *Perception* "is immediate, effortless, and veridical" in one word "direct"; *thinking* is "indirect", because it "may not depend on the immediate environment at all, it is often anything but effortless or immediate, and frequently goes astray" (Neisser, 1989, p. 11).

In the specific domain of 2D Euclidean Geometry, in order to cope with the difficulties listed above, we defined a new theoretical construct called *geometric prediction (GP)*. Although at the moment, we are working towards a finer operative definition, it seems to be an interesting construct to use in

order to shed light onto problem solving processes in geometry. Furthermore we expect it to be trainable, that is to ameliorate through appropriate educational practices. The aim of our research is to gain insight into the process of GP. So we set out to observe and analyze what happens during the resolution of particular open problems, focusing on instances of *geometric prediction* in solvers' discourse, gestures, drawings, and dragging modalities used in a second phase of the resolution of the given problem in a Dynamic Geometry Environment (DGE). Because of what we present in this paper, in which the role of the DGE is marginal, and since the space limited, we will not discuss this second phase. In this paper, we present the construct of GP and describe a tool used for analyzing its emerging features in students' data that are collected in task-based interviews.

Theoretical framework

In the specific domain of Mathematics Education, under the umbrella of *spatial reasoning* literature collects a large set of definitions, which share the reference to the activity of imagining objects and interact with them through mental transformations (rotation, stretch, reflection, etc.). Among these definitions, we have considered *spatial reasoning* as defined by the Spatial Reasoning Study Group: “the ability to recognize and (mentally) manipulate the spatial properties of objects and the spatial relations among objects” (Bruce et al., 2017, p. 146). We considered *visualization*, according to Presmeg's (2006) description, as “taken to include processes of constructing and transforming both visual mental imagery and all of the inscriptions of a spatial nature that may be implicated in doing mathematics” (p. 206). Here visualization is considered to be explicitly linked to mathematical activity, and it could involve mental images.

Geometric prediction

Previous research on visualization informs us that when solvers face a geometrical task, they can interact with mental images; they can imagine the consequence of (mental) manipulation of the geometrical figure. Moreover, it seems that in this process the theoretical elements play an important role. With “theoretical elements” we mean those related to the Theory of Euclidean Geometry (TEG). The process of *geometric prediction* is “a mental process through which a figure is manipulated, and its change imagined, while certain properties are maintained invariant” (Mariotti & Baccaglini-Frank, 2018, p. 157).

Products of GP may or may not be coherent with theoretical constraints. Indeed, in order to take into account all theoretical constraints, the solver must *theoretically control* the figure, that is “mentally impose on a figure theoretical elements that are coherent in the Theory of Euclidean Geometry” (Mariotti & Baccaglini-Frank, 2018, p. 156).

Fischbein's Theory of Figural Concepts and Intuitive knowledge

In order to explain the nature of geometrical objects, we refer to the *Theory of Figural Concepts* (Fischbein, 1993), according to which they have a dual nature. Geometrical objects are completely described and controlled by an axiomatic system of definition and theorems, but at the same time they maintain certain figural aspects of images. Fischbein (1993) thinks of a *figural concept* as a complex mental entity (different from pure concepts and pure images) “which simultaneously possesses both conceptual and figural properties” (p. 144), realizing a fusion between the conceptual and the figural components.

A construct which seems to be involved in GP is *intuition* (Fischbein, 1987). It is a kind of cognition, characterized by self-evidence and immediacy, different from perception, and implying an extrapolation of information beyond that directly accessible. Intuitions can have an anticipatory role. Indeed, anticipatory is a kind of intuition, which belongs explicitly to problem-solving activity; it provides a global view of a solution, which precedes the analytical one.

Research questions and methodology

The data we present are part of a doctoral research project on GP for which 6 geometrical problems were designed and proposed to 37 Italian high school students (ages 14-18), undergraduates, graduate and Ph.D. students in mathematics (ages 19-33), during the months of February and April 2018. The problems were designed to elicit processes of GP and they were used within task-based interviews (Goldin, 2000). We decided to use a semi-structured type of interview: the first question is always the same; then there is a sequence of questions defined a priori and a set of stimuli in order to elicit students' comments.

Consistently with our purposes, we designed a particular kind of open problems (Arsac, Germain, Mante, 1998; Silver, 1995), *prediction open problems*, in which the solver is asked to describe possible alternative arrangements of a geometric configuration (imagined, given by a drawing and/or by a step-by-step construction) maintaining given properties. Predictions could be asked for explicitly or not.

Although all data have not yet been thoroughly analyzed, we use some of the data to present a preliminary report on the following questions: (a) How can we characterize GP processes (in the case of the prediction open problems given)? (b) In solving a prediction open problem, what kind of gestures, words and drawings are performed by solvers? What do these allow us to infer about the GP processes?

In the following section we report on an example of the task used during interviews.

The “locus of P” problem

The task used in this study is composed of two parts. The first one is:

Read and perform the following step-by-step construction: fix two points A and B ; connect them with a segment AB ; choose a point P on the plane; connect A and P with a segment AP ; construct M as the midpoint of AP ; construct the segment MB and name its length d . A and B are fixed, and the length of MB has to always be d .

Then the interviewer asks: “What can you say about the point P ?”

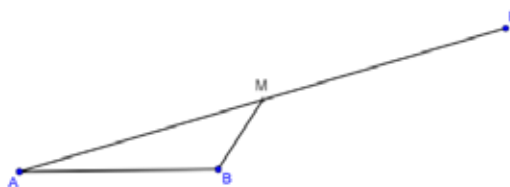


Figure 1: Instance of figure obtained by step-by-step construction

The step-by-step construction could be accomplished with paper and pencil (obtaining a construction like the one in Figure 1). Once the solver had proposed a solution or stated that s/he was not able to

find one, part two of the task was given: the interviewer opened a dynamic geometry sketch and she asked the solver to move P in the figure, consistently with her/his prediction, or else to explore the figure to help reach a solution. As highlighted before, in this paper we will not focus on this second phase.

Construction of a new tool for data analyses

In our data analyses, we have been highlighting instances of GP by spotting and analyzing students' gestures, drawings and discourse. In particular, we are trying to identify elements which belong to the students' conceptual component and their figural component of the geometrical objects in focus. In order to analyze solvers' GPs, we collect these elements in a sort of "funnel" (Figure 2) which shows a product of GP in gestural and/or discursive form.

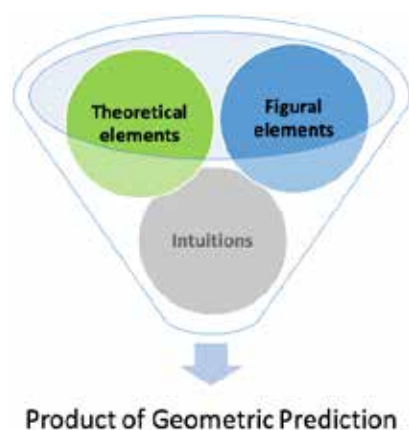


Figure 2: Elements collected in the funnel and its product

The tool, as shown in Table 1 and sketched out in Figure 2, is composed of 3 columns. In the first and in the third there are, respectively, *theoretical elements* and *figural elements*, referred by solvers in gestural or discursive way or inferred by us (in square brackets). These two constructs are defined and identified according to Fischbein's (1993) distinction between conceptual and figural components of geometrical objects. In the center column, we used two different colors to highlight which element of the two columns is expressed by the solver at a specific moment. Indeed, the vertical order of boxes follows the chronological sequence in which solvers made elements explicit. Furthermore, we added an "X" when the element is mathematically incorrect or incoherent with respect to the given geometrical construction. At the end of the funnel, there is the product of the GP. Each funnel represents the sequence of the observable steps of a new GP.

As an example, here we show the construction of the funnel referred to an excerpt of Student A's interview. She is solving the "locus of P " problem. This excerpt begins right after the interviewer asked the first question.

Student A: The point P ...meanwhile is **part...of the straight line** in which...on which there is also... AM and is **outside the triangle AMB** .

Student A: In this case – but I think it is a particular case – **perpendicular** to...not the point P ! It is **a straight line** on which there is the point P that is **perpendicular to MB** , but it is a particular case, I think!

Interviewer: Ok. Make a prediction. Do you think that the point P can have other positions?

Student A: If I draw again...if **the length of MB must always be d** , it could be **like a mirror**, so it could take the place...the same position, only **on the other side of the segment**.

In this excerpt, we recognize some figural elements (and underlined them), like segment AM and triangle AMB . We use bold type to highlight the identifiable theoretical elements, like perpendicularity and (line) symmetry. We recognize a product of a GP in the last student's statement: P takes a symmetric position with respect to AB . The GP is both discursive and gestural (the student shows the expected position of P using a pen (Figure 3a)). Then, she undertakes another GP, strictly connected with the figural elements observed before. Indeed, she claims:

Student: Yes, it [point P] moves along the segment M ...along the **half-line MP** and then etcetera, etcetera... along the half-line that would continue, because it does not interfere with the **triangle**.



Figure 3: Gestures performed by (a) Student A (b) Student C (c) Student D

We collected all elements in two funnels, as shown in Table 1 (see Student A). The blue arrow highlights how the product of the second GP (named GP2) is directly connected with and derives from the product of the first GP (named GP1).

Preliminary findings

Funnels as a tool to gain insight into solvers' processes of GP

At the moment we have analyzed 15 interviews during which the “locus of P ” problem was proposed. Here we show only four examples of funnels (Table 1): Student A is a 9th grade student (15 years old); Student B is a 13th grade student (18 years old); Student C is an undergraduate student and Student D had just completed a master's degree in mathematics. The chosen funnels summarize some of the solvers' common behaviors during the resolution of the first part of the task and highlight how this tool can be used to gain insight into the process of GP.

The first funnel (Student A) represents an example of a mathematically incorrect GP during which the student focuses on particular figural elements of the given configuration. Indeed, Student A explicitly mentioned the triangle ABM and then the segment MP . Our analyses reveal that in all cases in which the triangle is mentioned (5 interviewees), the solvers seem to have considered the configuration as made up of two completely independent figural elements: a triangle and a segment. This hypothesis is consistent with the solvers' stated predictions about the behavior of the configuration and it is confirmed by instances of surprise observed during the subsequent exploration in a DGE. The relation between figural elements induces Student A to speak of moving P along a half-line, maintaining MB not only constant in length, but also in the same position. Possibly, it is the lack of theoretical control that induces the solver to infer the necessity of maintaining invariant so many properties. In this case, the invariance of the length is maintained by the invariance of the whole

triangle. Furthermore, we notice that our analytical tool allows us to notice that during the second GP the student mostly referred to figural elements.

On the contrary, Student C and Student D provide examples of GPs that explicitly make use of theoretical elements. In particular, in the funnel of Student C, we observe an ongoing dialectic between figural and theoretical elements. In this case, we notice another common phenomenon: observing the development of the fourth GP (whose outcome is GP4), Student C recalls the prototype of circle (defined as the locus of points at a given distance from a given point); she reproduces its construction using her fingers as a compass (Figure 3b), making the circle (or some parts of it) into a figural element, even if it was not actually drawn on paper.

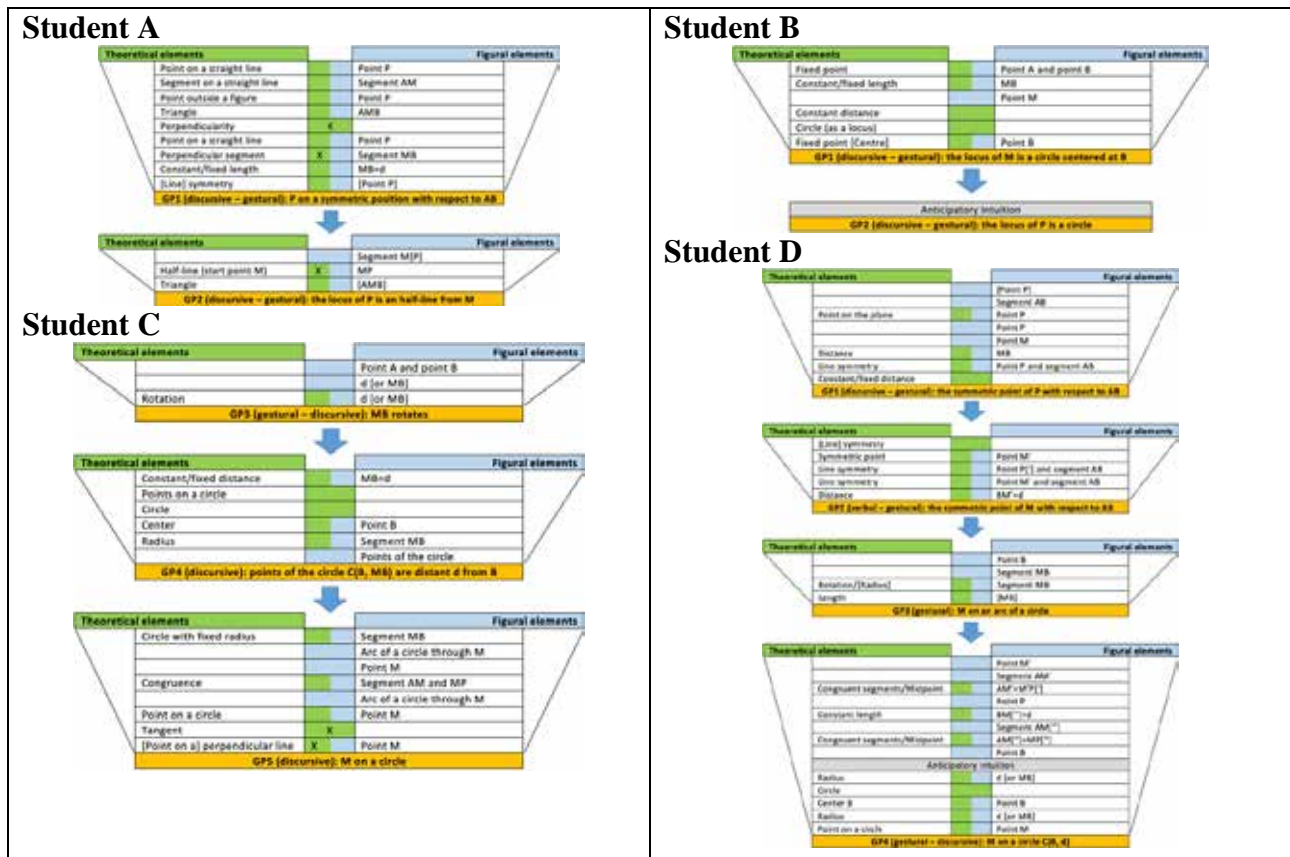


Table 1: Four examples of solvers' funnels

Such a phenomenon is evident also in Student D's production. First of all, she produces a GP about P . Suddenly, the point constructed as a symmetric point of P becomes in its own right one of the figural elements involved in the subsequent GP. We can see this effect also in the last funnel. Student D imagines to construct some points by rotating MB (Figure 3c). These points become part of the configuration, even if they are not visible on the drawing.

These findings allow us to highlight two features of GP processes. They are independent of each other, but they come in a sort of flow or chain of predictions. Furthermore, often their products seem to "freeze" for the student (see Student C and Student D), becoming integral parts of the configuration even if they are not drawn, and they become starting points for new GPs.

We stress how important is the role of the theoretical elements. Although Student D and Student A start from a similar product of GP regarding point P , Student D's GP is accompanied by more detailed

and coherent (with the TEG) theoretical elements. Moreover, she does not mention triangles, but she focuses only on segments and points. This seems to allow her to refine the first product of her first GP and, finally, to reach the last one (point M on a circle).

Student D's processes of GP highlight another emergent feature of GPs: often they are accompanied by intuitions. In particular, we observe a kind of intuition which appears during a solution process and that expresses an immediate and global view of a solution: *anticipatory intuition*. The occurrence of this kind of intuition could explain what happens in short chains of GP, like the one performed by Student B. His funnel shows a chain of GP in which most rows contain theoretical elements and no other elements could be recognized between the two products of GP: GP1 and GP2. This could be explained by his resorting to intuitive knowledge.

Conclusion

The analyses of students' videos and transcripts reveal that GP is a process involving an interplay between perception and reasoning processes. Indeed, GP seems strictly related to figural components. In the case of the problem analyzed, it seems that students who see the configuration as a triangle and an independent segment do not reach a mathematically correct (or coherent with the TEG) product of GP. The notion seems to be in line with Duval's (1995) findings related to perceptual apprehensions of a geometric configuration and dimensional change. Nevertheless, GP also involves theoretical elements which belong to the TEG, and it has a strong relation with the idea of students' theoretical control over a figure. Indeed, theoretical control that is coherent with the TEG should lead to correct predictions (see Student C and D). Moreover, GP is related to conceptual components to the extent that in the case of Student B the discursive element "the length of MB must always be constant" fostered recollection of the definition of circle, leading to immediate recognition of the locus of M . So, it seems that theoretical elements play an important role in the immediacy and correctness of GPs. Student B reveals how for an "expert" solver GP can become an immediate and automatic process. This finding is promising for the trainability of GP through appropriate educational practices.

Furthermore, we notice that often GP is coupled with *anticipatory intuition* (see Student B and Student D). Nevertheless, the two constructs are not identifiable. Indeed, in other cases (see Student C) correct products of GPs are produced without any recognizable intuitive knowledge.

In conclusion, processes of GP seem to be observable through the solver's productions; funnels are useful tools for shedding light onto this process, but they must be accompanied by qualitative analyses of transcriptions for gaining deeper insight into the GP. Moreover, GP seems to be an interesting construct in order to shed light onto problem solving processes in geometry.

We believe that this kind of research can provide new insights into students' difficulties in learning geometry. Moreover, awareness of prediction processes could be very helpful for teachers. Outcomes of GPs seem to be windows onto students' mental images and processes generating them. Such knowledge could help in guiding mathematical teaching and learning, because teachers could know which properties students are imposing on a given configuration by asking them to make explicit their GPs. If students are imposing on a figure too many or incorrect properties, the teacher can intervene appropriately. Moreover, geometrical activities to strengthen students' theoretical control by fostering awareness of their conceived invariants can be designed.

References

- Arsac, G., Germain, G., & Mante, M. (1991). *Problème ouvert et situation-problème*. Université Claude Bernard Lyon I.
- Bruce, C. D., Davis, B., Sinclair, N., McGarvey, L., Hallowell, D., Drefs, M., ... & Okamoto, Y. (2017). Understanding gaps in research networks: using “spatial reasoning” as a window into the importance of networked educational research. *Educational Studies in Mathematics*, 95(2), 143–161.
- Cornoldi, C., & Vecchi, T. (2004). *Visuo-spatial working memory and individual differences*. Hove (UK): Psychology Press.
- Cuoco, A., Goldenberg, P. E., & Mark, J. (1996). Habits of mind: An organizing principle for mathematics curricula. *The Journal of Mathematical Behavior*, 15(4), 375–402.
- Duval, R. (1995). Geometrical pictures: Kinds of representation and specific processing. In R. Sutherland, & J. Mason (Eds.), *Exploiting mental imagery with computers in mathematics education* (pp. 142–157). Berlin: Springer.
- Fischbein, E. (1987). *Intuition in science and mathematics: An educational approach*. Reidel, Dordrecht, The Netherlands: Kluwer Academic.
- Fischbein, E. (1993). The theory of figural concepts. *Educational studies in mathematics*, 24(2), 139–162.
- Goldin, G. (2000). A scientific perspective on structures, task-based interviews in mathematics education research. In R. Lesh, & A.E. Kelly (Eds.), *Research design in mathematics and science education*. Erlbaum, Hillsdale, pp. 517–545.
- Mariotti, M. A., & Baccaglini-Frank, A. (2018). Developing geometrical exploration skills through dynamic geometry. In S. Carreira, N. Amado, & K. Jones (Eds.), *Broadening the scope of research on mathematical problem solving: A focus on technology, creativity and affect* (pp. 153–176). Springer.
- Miragliotta, E., & Baccaglini-Frank, A. (2017). Visuo-spatial abilities and Geometry: a first proposal of a theoretical framework for interpreting processes of visualization. In T. Dooley, & G. Gueudet (Eds.), *Proceedings of the Tenth Congress of the European Society for Research in Mathematics Education* (pp. 3952–3959). Dublin, Ireland: DCU Institute of Education and ERME.
- Neisser, U. (Ed.). (1989). *Concepts and conceptual development: Ecological and intellectual factors in categorization*. Cambridge University Press.
- Presmeg, N.C. (2006). Research on visualization in learning and teaching mathematics. In A. Gutierrez, & P. Boero (Eds.) *Handbook of research on psychology of mathematics education: Past, present and future*, (pp. 205–235). Rotterdam/Taipei: Sense Publishers.
- Silver, E. A. (1995). The nature and use of open problems in mathematics education: Mathematical and pedagogical perspectives. *Zentralblatt fur Didaktik der Mathematik/International Reviews on Mathematical Education*, 27(2), 67–72.

Fibre mathematics: exploring topological forms through material practices

Kate O'Brien and Elizabeth de Freitas

Manchester Metropolitan University, Manchester, UK; katherine.obrien@mmu.ac.uk,

l.de-freitas@mmu.ac.uk

Through its focus on “fibre mathematics,” this paper contributes to discussions of how mathematical representations entail complex mixtures of matter and form. Drawing on inclusive materialism (de Freitas & Sinclair, 2014) as a way of rethinking the material labour of mathematics, we analyze data collected in a two-week weaving workshop, focusing on how participants worked with the mathematical concepts of dimension and connectivity in problems that were at once topological and material. Focusing on one student’s work, “Akari’s Problem,” we explore how the loom operates as a rich experimental field for the (re)creation of mathematical concepts. This paper takes up issues associated with mathematical representations by focusing on the haptic, visual, and material way that mathematical forms come to life through making processes.

Keywords: Textile art, dimension, topology, materiality.

Introduction

The term *fibre mathematics* refers to the mathematical activity entailed in textile arts. Studies of fibre mathematics have been pursued within ethnomathematics – for instance, research on the weaving practices in the Bedouin culture of the Negev desert (Katsap & Silverman, 2016) and Quechua speaking communities in Peru and Bolivia (Ascher & Ascher, 1981; Urton & Llanos, 1997). These studies point to how these practices are not (only) representations of Western mathematical concepts, but entail innovative ways of *doing* mathematics through various maker processes. The challenge is then to study material practices of various kinds, no matter their location, for how they *engender* distinctive mathematical concepts. We argue that different modalities and representations entail distinctive meaning, precisely because they involve different materialities. Our shared earthbound status means that humans are likely to work with similar mathematical concepts and materials across the planet, although these will be bound up with the particular corporeal habits valued in different localities. Our approach thus questions theories of representation which treat the concept-matter relationship as one which assumes *concept as form-shaper* and *matter as passive form-taker*.

Our research indicates that students learning textile arts are often also learning complex mathematical concepts and exploring challenging mathematical problems. We show how one student’s work (“Akari’s problem”) entailed creative interventions that were both technical (associated with the loom and other materials) and mathematical (associated with formal and aesthetic goals). Through analysis of video footage and interview data, we show how problem solving in such cases involves the loom as an “open machine” with a distinctive “technicity” – two terms defined by the philosopher of technology, Gilbert Simondon (1958/2017). We explore how a technical “hack” of a traditional craft tool opened up new conceptual space, allowing research participants to invent new fibrous forms and explore complex geometric shapes that broke with classically Euclidean representations of space.

The research questions we explore in this paper are: (1) How do problems in the textile arts offer opportunities to explore rich mathematical thinking? (2) How does weaving as a material practice entail the mathematical concepts of dimension and connectivity? (3) In studying maker processes as mathematical, does representation best describe the relationship between concept and materiality?

Theoretical Framework

Simondon (1958/2017) defines the “technicity” of a technical object as that which concerns its fundamental structure rather than its use. Attending to technicity is a way of better understanding the mode of being of the technical object, across various situations. This requires a genetic history of the technical object (in this case the loom), so that we can compare different manifestations and identify key elements of its structure. We do this to better understand how technology and mathematical practices are linked, and how material media are essential in mathematics, be they writing surfaces, touch screens, or paper and pencil. The work of Simondon offers us new materialist ways of thinking about how mathematics is made and performed outside of mainstream mathematical representations.

This philosophical framing of our approach sets the stage for a study of mathematical practices in contemporary textile arts. Following Simondon, who advocates for historical and philosophical studies of technology, we see technology as more than a tool that enhances human interests, more than a device for representing concepts conceived in the mind. Our relationship with technics is more complicated and we benefit from considering more nuanced ways of understanding the force of the technical object in our cultural practices (including mathematics). Writing just at dawn of cybernetics and the “information age,” Simondon argues we must examine our technologies to understand how our concepts are implicated in them, not as representations, but in a more direct assemblage.

We consider mathematical behavior as an ontogenerative practice (a making practice) that brings new concepts into the world, and in so doing reshapes the world. Learning mathematics becomes “an indeterminate act of assembling various kinds of agencies rather than a trajectory that ends in the acquiring of fixed objects of knowledge” (de Freitas & Sinclair, 2014, p. 52). This implies an understanding that mathematics takes no definite or final form, but rather it continually (re)emerges within the material practices of the workshop or the classroom. Our non-dualist approach argues that representations of mathematical ideas cannot be isolated from the phenomenon to which they are wedded. In particular, this paper focuses on technological interventions/actions that enable new formal and aesthetic choices that mobilize new conceptions of dimension and connectivity.

Weaving is performed with an ancient but ever-changing technology, called a loom. The loom creates a problem space for exploring pattern, texture, dimensionality, connectivity and number. The loom is both an “open machine” and an “associated milieu” for the technical-aesthetic activity of weaving (Simondon, 1958/2017). As an open machine, the loom itself can be undone and remade, maintaining its structural integrity while allowing for inventive alterations that enable students to build complex topological shapes. Indeed, weaving of all kinds, be it planar cloth or a three-dimensional objects, operates through the relationship between the discrete and the continuous, using thread, yarn or other continuous matter to create patterns that often achieve their aesthetic impact through discretization of and contrast between *individuated* units of color or texture. Many weaving practices operate through this pixelated effect, with links to the history of computing and digital image making (Plant, 1995;

Bachmann, 1998). Given this aesthetic aspect, and the pivotal role of the relationship between discrete and continuous magnitude in fueling mathematical invention (de Freitas, 2017), we consider weaving an excellent case study for examining the material labour of mathematics, and for rethinking the role of representation in mathematical behaviour. This perspective supplements research that has explored the aesthetic aspect of mathematics (Coles & Sinclair, 2019), the sensory capacity of the body (de Freitas, 2016), and the more-than-human and ontological nature of mathematics (Gutiérrez, 2017).

Methods and Data

Research data was generated through participant observation and informal interviews conducted in the weaving studio of a craft school in the eastern United States, during a two-week weaving workshop called: “Weaving Origami and Other Dimensional Possibilities.” Twelve students (including the first author), motivated by personal interest in the proposed course, applied and were accepted into the class by the craft school selection committee. Most of the twelve participants – who spent at least eight hours/day weaving during the workshop – had more than five years of weaving experience. Data consisted of field observation writing and sketching, video recording during studio sessions, and interviews of nine participants. Cameras were both fixed (to walls and looms) and worn on persons, to obtain diverse perspectives on the material and ritual practices entailed in weaving. Interviews focused on artifacts and instruments from the studio, and questions targeted participants’ manner of describing the various problems they encountered during the two-week course.

The workshop focused on a distinctive challenge – how to weave “dimensional” cloth. The workshop’s title, “Weaving Origami,” describes a specific technique developed by the workshop instructor, Sue Taylor, which involves weaving short bands of cloth that jut out from the classically two-dimensional woven plane. These bands can fold into various origami forms (Figure 1). The technique for generating these three-dimensional bands derives from a common weaving trick used to repair broken warp strings. The instructor showed students how to use the free weights employed in this technique to alter how the loom distributes tension. Students began by directly imitating the instructor’s work. After two days, many in the classroom quickly moved to innovate on this thinking.

In this paper, we describe the work of one participant (Akari), by looking at the way that “Akari’s Problem” involved complex topological forms and became a gathering point for workshop participants. To illustrate, we discuss two woven objects Akari produced during the workshop (Figures 2 & 3). These woven forms offer a snapshot of a generative material-mathematical challenge. In our analysis, we draw on video from a chest-mounted GoPro video camera Akari wore while she worked on her first weaving and a loom-side interview with Akari, as she made her second sample.

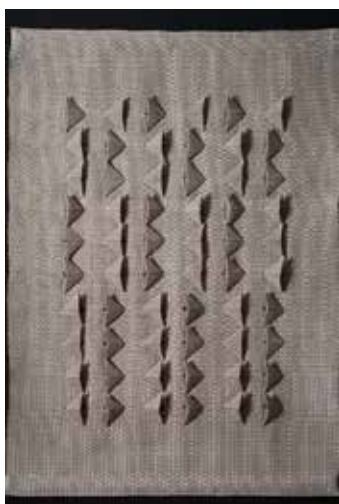


Figure 1: Susie Taylor Figure 2: Akari's first sample Figure 3: Akari's second sample

Discussion

Dimension is a hugely important mathematical concept on which our ideas about measurement and space depend. Mathematicians in different specialized fields define dimension in many different ways (Pearse, 2003). The concept, however, proved problematic in the late 19th century, when various mathematicians (Cantor, Peano, Brouwer) paradoxically demonstrated how to map the interval to the plane (Pearse, 2003). New theories of dimensionality emerged in the 20th century from Lebesgue, Hausdorff, and others, alongside the study of fractals and fractional dimensions. Plugging into our intuitions of space as it crisscrosses mathematical domains, the concept of dimension is multiple. Freudenthal (1983) suggests we consider dimension within three frameworks: Euclidean (an integer property of objects and spaces), Analytic (determined by the number of variables needed to describe an object), and Topological (pertaining to freedom of movement and boundary relationships).

Panorkou and Pratt (2016) contend that mathematics classrooms rarely address dimension directly. Skordoulis, Vitsas, Dafermos, and Koleza (2009) argue that a Euclidean notion of dimension is typically assumed and sometimes in conflict with an Analytic framework. Most mathematics students will not interrogate the concept of dimension, despite its incredibly opaque and open-ended nature. In the workshop, however, dimension was an incredibly common buzzword. Participants struggling to invent dimensional cloth on the loom engaged with the concept directly. Moreover, they each had distinctive aesthetic problems to solve, which allowed for an open and diverse group inquiry.

Due to the technical requirements of the loom and soft pliable nature of cloth, the working of woven form into three dimensions already involves the kind of contortions conceptualized mathematically by topology. Topology is a field of mathematics that investigates how objects remain unchanged after stretching, bending and twisting. It is often referred to as “rubber sheet geometry” (O’Shea, 2007) because objects studied by topologists can be pulled and stretched without changing their topological properties. Topology lends itself to the study of non-rigid forms, as in the case of weaving. Although weaving requires the heavy use of counting and anticipatory calculation in planning projects, the production of cloth is an essentially connective process in which lines of fibre fuse according to a systematic relationship to produce planar cloth. Weaving techniques developed to double the

capacities of the human arm span further enhance the complex connective possibilities of the loom. These techniques allow one to interconnect several layers of cloth in a manner limited only by the scope of the loom itself and the amount of time a weaver wishes to commit to her project.

To explore how fibre mathematics and topological concepts of dimension can be productively entangled, we begin by articulating Akari's original problem and analyzing her two weavings from a topological perspective. After experimenting at length with paper models, Akari planned a complex folded weave involving five parallel bands of cloth that emerge a ground cloth (Figure 4). Akari hoped to fold and twist these bands to reveal and conceal the colorful underside of each band. Because, in weaving, color forms through interlacing warp and weft, Akari planned a complex structure in which she would weave a cylindrical form made up of two intersecting planes (Figure 5, where these planes are colored pink and purple). This would allow two distinctive colors to alternate in prominence, depending on the pattern of folding. Looking to analyze the weaving topologically, we began by imagining the weaving as made up of a ground cloth with five pinched tori. (The pinched torus (Figure 6a) is called a pseudomanifold because there is a singularity at the pinch, creating an obstacle that cannot be traversed continuously. Pseudomanifolds are, however, still orientable.) However, further examination of the weaving revealed that there was not a singular pinch but rather a *crease* at the end of each tube (Figure 6b). Akari's cloth had five protrusions, which were neither manifold nor pseudomanifold, but something else altogether (Figure 6c).

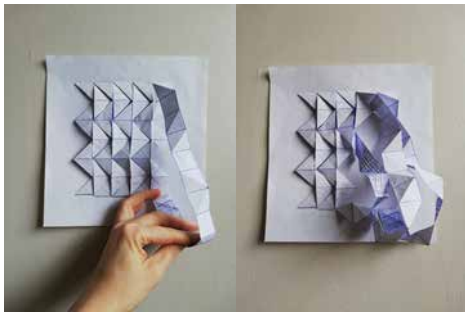


Figure 4: Paper models of the cloth

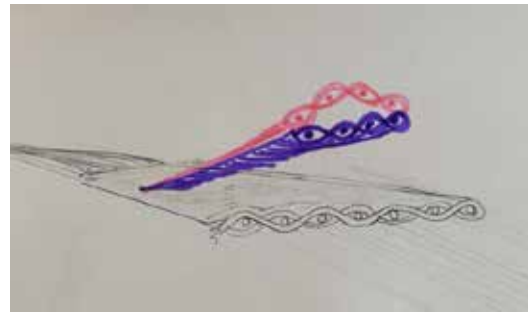


Figure 5: A diagram of Akari's layers

These moments of creasing, where the weaving branches to form five bands, make this artifact complex in both the making and the mathematics. The creases represent a fundamental break in the object's basic Euclidean texture. If we select one such crease, and zoom in far enough, to see what is going on, we find four planar cloths all intersecting in the line (Figure 6d). If we keep zooming in, further and further, in search of the basic Euclidean plane, we will never be able to find it. No matter how close we get, every point on that line will belong to neighborhoods in four planes, breaking Euclidean rules, and making the crease singularity quite problematic. Akari's problem, in other words, involved making a mathematical form with yarn that exceeded conventional Euclidean geometry, and indeed exceeded conventional rules of behavior for manifolds and pseudomanifolds. Although ostensibly her weaving is made of two-dimensional surfaces, topologically it cannot be modelled as a two-dimensional manifold. This is because the cloth is not "locally Euclidean" precisely at these creases. Hacking the loom allowed Akari to break with the planar grid in regulated but inventive ways. At these intersections, no matter how closely you stretch and examine the material, Akari's cloth will never behave like a flat two dimensional plane.

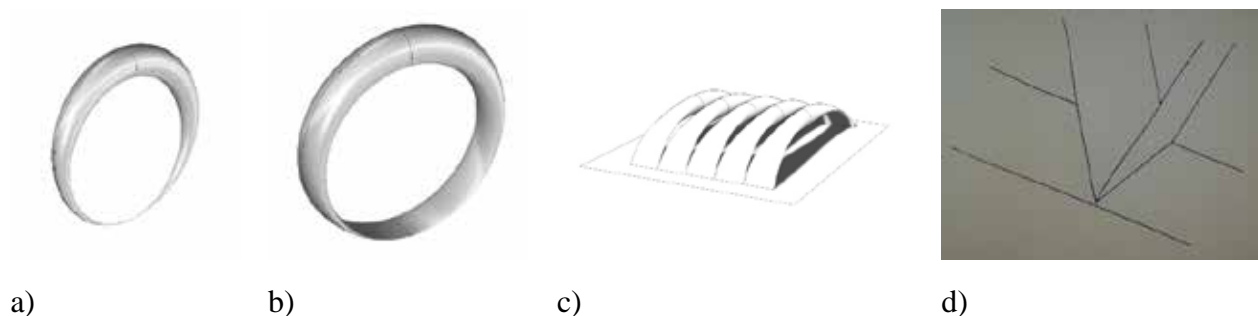


Figure 6: a) Pinched torus, b) Akari's tube, c) Rendering Akari's cloth, d) Four planes of cloth

Akari came to know the properties of this shape not through this mathematical vocabulary or instruction but through an elaborate pattern of passes, which she developed to construct each of the five tubes. She noted in her interview how difficult this was: “My head was like wait! Wait! Wait!” Watching her activity on video, we see that Akari taps into a rhythm measured out by gestures made with and towards the loom. To keep her place in a 22-step progression of movements, she neatly organizes her threads to mark out visually her place in the pattern.

Despite her best efforts to plan her work, the materiality of Akari's concept broke away from the representation she had generated in her paper model. About 20cm into her project, Akari discovered that her double-layered tubes of cloth are structurally too dense to fold according to her plans. Video footage from the chest-mounted GoPro shows Akari pausing to examine her work. Sensing this break, six workshop participants gather around to observe and comment on her work. In the video footage, Akari shares her thinking aloud, while manipulating the cloth. A key conversation ensues about how to best explore the new freedoms opened up by the technological transformations that all participants have performed on their looms. At a climactic moment, three participants point to the loom's new tensioning system and exclaim in chorus “Cause they're weighted! They're weighted separately!” They point out that the new distribution of tension, now controlled by water bottles swinging off the back of the loom, works as a third dimensional coordinate in Akari's cloth. This marks a collective realization about the dimensional possibilities opened up by the redistribution of tension on the loom. Analysis of this episode reveals how the coupling of tension with dimension was not simply the *representing* of an immaterial concept (dimension) in a material form (a thread under tension), but was instead a matter of delving deeper into the potentiality of mathematical concepts as they inhere and mutate within matter.

Concluding Comments

This paper builds on previous work on topological thinking in mathematics education, and the challenges of representing (or enlivening) complex manifolds in material form (de Freitas & McCarthy, 2014; Strohecker, 1991). It seeks to contribute to a growing body of literature on the role of technology in developing mathematical aspects of spatial sense (de Freitas, 2017; Ferrara & Mammana, 2014; Panorkou & Pratt, 2016) and it offers new possibilities for exploring mathematics in informal learning settings (Nemirovsky, Kelton, & Rhodhamel, 2013), pointing to the importance of aesthetically structured activities in mathematics teaching and learning (Coles & Sinclair, 2019).

Our study shows how maker and craft practices are an important site for innovative and unconventional representations of mathematical concepts. Although the usual question posed to those studying informal mathematics is “where is the mathematics?,” we suggest that mathematics is found in the material practices embodied by the weavers. These weavers are not mathematicians (and they might be the first to admit that!) and although there was no *direct* instruction as to how to use topological concepts to build the dimensional cloth, the problem space created an opportunity for doing mathematics through *direct* engagement with technical objects (the loom, the threads, etc.). These problem spaces are engendered by the loom, *but the solutions paths are not scripted* by the loom, especially in this case, where the loom is an *open machine* and literally modified by individual participants (hacked with weighting) as they each explored their own problem space, driven by their aesthetic goal. The loom thus operates as a kind of generative problematics. The various goals of the weavers entailed different mathematical relationships, which had to be mobilized in order to create the desired patterns and asymmetries. The specific technicity of the loom has particular structural features that create opportunities to work with particular mathematical concepts.

When educators speak of mathematical representations, they typically point to an object or diagram or symbol as that which stands in for (or refers to) an immaterial mathematical concept. Does it make sense to speak of Akari’s cloth as a *representation* of a mathematical concept? Our case study shows how a weaving problem can engender a very complex mathematical form, indeed a form so complex it might be deemed the sort of “monster” that Lakatos wrote about when he discussed the intellectual labour of mathematical invention. Mathematical monsters are initially barred, but then you realize you want to play with them, and the rules need to change so that you can. Akari’s cloth is the result of a weaving process that played with the conventional tension of the loom, in order to dive into the indeterminacy of the concept of dimension. Once we attend more carefully to the way material media play a big role in mathematical labour, and perhaps rethink the nature of representation in terms of making processes, the question “where is the mathematics?” becomes even more interesting. Of course, one needs to attend to the differences between the material labour of a mathematician working with chalk or software and the material labour of a weaver at the loom. Our claim is that more attention to these material media will open up our understanding of mathematics in all its diversity, demonstrating how representation is entangled in making processes.

References

- Ascher, M., & Ascher, R. (1981). *Code of the quipu a study in media, mathematics, and culture*. Ann Arbor: University of Michigan Press.
- Bachmann, I. (1998). Material and the promise of the immaterial. In I. Bachmann & R. Scheuing (Eds.), *Material matters: The art and culture of contemporary textiles* (pp. 23–34). Toronto, Canada: YYZ Books.
- Coles, A., & Sinclair, N. (2019). Ritualisation in early number work. *Educational Studies in Mathematics*, 101(2), 177–194.
- Ferrara, F., & Mammana, M. (2014). Seeing in space is difficult: An approach to 3D geometry through a DGE. In S. Oesterle, P. Liljedahl, C. Nicol, & D. Allan (Eds.), *Proceedings of the joint meeting of PME 38 and PME-NA 36* (Vol. 3, pp. 57–64). Vancouver, Canada: PME.

- de Freitas, E. (2017). The new materialism of Charles Hinton: Spatial reasoning in 4D digital mazes. In E. Faggiano, F. Ferrara, & A. Montone (Eds.), *Innovation and technology in mathematics education* (pp. 237–257). Cham, Switzerland: Springer Verlag.
- de Freitas, E., & McCarthy, M. (2014). (Dis)orientation and spatial sense: Topological thinking in the middle grades. *PNA*, 9(1), 41–51.
- de Freitas, E., & Sinclair, N. (2014). *Mathematics and the body: Material entanglements in the classroom*. Cambridge, England: Cambridge University Press.
- Freudenthal, H. (1983). *Didactical phenomenology of mathematical structures*. Dordrecht, Netherlands: Reidel.
- Gutiérrez, R. (2017). Living mathematx: Towards a vision for the future. *Philosophy of Mathematics Education Journal*, 32(1), 1–34.
- Katsap, A., & Silverman, F. (2016). *Ethnomathematics of Negev Bedouins' existence in forms, symbols and geometric patterns*. Rotterdam, Netherlands: Sense Publishers.
- Nemirovsky, R., Kelton, M.L. & Rhodehamel, B. (2013). Playing mathematical instruments: Emerging perceptuomotor integration with an interactive mathematics exhibit. *Journal for Research in Mathematics Education*, 44(2), 372–415.
- O'Shea, D. (2007). *The Poincaré conjecture: In search of the shape of the universe*. New York, USA: Walter and Company.
- Panorkou, N., & Pratt, D. (2016). Using google SketchUp to develop students' experiences of dimension in geometry. *Digital Experiences in Mathematics Education*, 2(3), 199–227.
- Pearse, E. J. (2003). *An introduction to dimension theory and fractal geometry: Fractal dimensions and measures*. (Talk Notes) Presented: UC Riverside Mathematical Physics Seminar.
- Plant, S. (1998). *Zeros + ones: Digital women + the new technoculture*. London, England: Fourth Estate.
- Simondon, G. (1958/2017). *On the mode of existence of technical objects* (C. Malaspina & J. Rogove, Trans.) Minneapolis, USA: Univocal.
- Skordoulis, C., Vitsas, T., Dafermos, V., & Koleza, E. (2009). The system of coordinates as an obstacle in understanding the concept of dimension. *International Journal of Science and Mathematics Education*, 7(2), 253–272.
- Strohecker, C. (1991). Elucidating styles of thinking about topology through thinking about knots. In I. Harel & S. Papert (Eds.), *Constructionism* (pp. 215–234). Norwood, USA: Ablex.
- Urton, G., & Llanos, N. (1999). *The social life of numbers: A Quechua ontology of numbers and philosophy of arithmetic*. Austin, USA: University Texas Press.

Prospective mathematics teachers' extrapolative reasoning about misleading bar graphs

Samet Okumus and Ercan Dede

Recep Tayyip Erdogan University, Turkey; samet.okumus@erdogan.edu.tr,
ercan.dede@erdogan.edu.tr

This study investigates prospective mathematics teachers' (PSTs) reasoning about magnitudes in misleading bar graphs. We report results from three student teachers who worked in a group. They made sense of vertically-oriented bar graphs whose vertical axis was not equi-spaced or y-axis did not start with zero. We analyze PSTs' extrapolative reasoning that refers to the ways they identified implicit relationships in graphs. The results demonstrated that PSTs modified or re-produced the bar graphs to overcome the misleading information, and re-labeled the numerical values of the categorical variables. They focused on arithmetic calculations and used them as a checking tool when they modified the bar graphs. They changed the location of the zero baseline and tended to keep the lengths of the bars invariant.

Keywords: Prospective mathematics teachers, misleading bar graphs, magnitude, extrapolation.

Introduction

Huff (1993) emphasizes that we are often exposed to misleading statistics in daily life. Scaling is one of the most common types of misleading statistics. In most cases, large increments of data display could compress the graph vertically. However, if the increments get smaller, the vertical graph could seem curved or the graph could have zigzags (Huff, 1993). It is also common to put a break in the scale on the vertical axis. This change places the different intervals for the axes to represent the variables, which shows different relationships between the variables other than they actually have. Graphs that incorporate a third dimension are most often confusing for the graph reader, particularly when comparing two or more values. In this sense, the height of neighboring bars affects the accuracy of measuring one value (Huff, 1993).

When students learn to recognize misleading statistics, they develop a new understanding of presenting data. Even in classroom environments and in textbooks, it is possible to encounter misleading or incorrect examples. In particular, statistical studies may be misleading and “at the heart of the matter lurks a black box, the fuzzy and multifaceted ‘context’ or ‘personal factors’ or ‘subjective meaning’, which cast doubt on both simple counts and causal explanations” (Wolf, 2007, p.26).

Bar graphs represent categorical data with rectangular bars that signify measured values. Also, bar graphs show frequency or proportion of categorical data. They highlight relative magnitudes and allow for encoding absolute values of discrete data (Friel, Curcio, & Bright, 2001; Curcio, 2010). Friel, O'Connor, and Mamer (2006) emphasize that “a bar's height is not the value of an individual case but rather the number (frequency) of cases all have that value” (p.125). Although

previous research studies have highlighted students' difficulties reading bar graphs (see Shah & Hoeffner, 2002), there is little research that indicates how students reason about magnitudes in bar graphs with a misleading representation. The purpose of this study is to investigate prospective mathematics teachers' reasoning about magnitudes in bar graphs when they modify or re-produce the graphs to overcome the misleading information. The research question of this study is: "In what ways do prospective mathematics teachers reason about the magnitudes in misleading bar graphs while they go beyond the data?"

Theoretical framework: Graph comprehension

Friel et al. (2001) describe *graph comprehension* as "graph readers' abilities to derive meaning from graphs created by others or themselves" (p.132). The researchers identified three important components of graph comprehension. According to the first component, the graph reader "must understand the conventions of the graph design" (p.152) to be able to obtain information from the graph. For example, "a bar graph highlights relative magnitudes, which are considered analog information; numerical values can be approximated only through scale interpolation" (p.140). In this sense, the graph reader should be able to read the *specifiers* and *labels* on bar graphs. Specifiers are visual representations that signify the data values (e.g., bars on bar graphs) or marks that indicate relationships between the data values on a graph (e.g., the box in a box plot that signifies the interquartile range). Curcio (2010) refers to the level of graph comprehension that "requires a literal reading of the graph" as *reading the data*. The *background* information (coloring, grid, etc.) may help the reader identify the specifiers in the graph (Friel et al., 2001). Also, Friel et al. (2001) refer to the axes, scales, grids and reference markings as the *framework* of a graph.

The second component of graph comprehension emphasizes manipulating "the information read from a graph" (Friel et al., 2001, p.152). Manipulation of the obtained information from specifiers in a graph requires making comparisons (e.g., quantities) and calculations (e.g., addition, division) to combine and integrate the data – that is also known as *interpolation*. For example, one may compare the relative heights or lengths on a vertically- or horizontally-oriented bar graph, and find the proportional relationship between the values of individual specifiers. Curcio (2010) associates this level of graph comprehension with *reading between the data*.

The third component of graph comprehension emphasizes processing the information in the graph taking into consideration the context of the data "to generalize, predict or identify trends" (Friel et al., 2001, p.152) – that is also known as *extrapolation*. In extrapolative reasoning, students read *beyond the data* and find patterns or relations that go beyond values already displayed or known. As Curcio (2010) highlights, "whereas reading between the data might require that the reader make an inference that is based on the data presented in the graph, reading beyond the data requires that the inference be made on the basis of information in the reader's

head, not in the graph” (p.9). Extrapolative reasoning ability may require modifying or re-producing a graph to present and demonstrate new information that is not found in the graph.

Methods

The participants of this research study were selected from a group of prospective middle school mathematics teachers who were enrolled in a methods course about teaching mathematics with technology. The class met two hours per week and the first author was the instructor. The participants were in their third year of the program. One week prior to the study, prospective mathematics teachers (PSTs) learned about making graphs (e.g., bar graphs, histograms, etc.) in Microsoft Excel and GeoGebra. However, the instructions for making graphs aimed to develop PSTs’ technological knowledge. The data were collected from nine PSTs (four female, five male) outside the regular class hours. The PSTs were not taught how to make misleading graphs in the computer programs. The participants worked in groups of three. For this study, we report on results from one of the groups. The group members were Nese, Sevgi, and Umut (all names are pseudonyms). Nese and Sevgi are female, and Umut is male.

The participants solved three tasks, and worksheets guided them to investigate vertically-oriented bar graphs. The PSTs were not informed that the graphical displays were misleading. Also, the worksheet questions did not ask the participants to modify or re-produce the bar graphs. For each task, they were given a color-printed worksheet with four additional black and white copies. After the completion of the three tasks, a whole-class discussion was generated. In the first worksheet, the vertical axis of the bar graph was not equi-spaced (see Figure 2a). The graph with some data labels indicated the amount of money a child was given by his family members. The PSTs used the horizontal lines on the graph to identify the missing data labels on the y-axis. We asked them to find the relative ratios of money of the child’s family members (e.g., the ratio of money with grandfather and uncle). In the second worksheet, the 2015 PISA scores of three countries (USA: 470, Croatia: 464 and Greece: 454) were represented with a bar graph whose y-axis did not start with zero (see Figure 3). In this task, The PSTs most often reasoned about counter examples. For example, they were asked how they would respond to a child who claimed that the score of Croatia was 6 times of the score of Greece. The third worksheet asked the participants to compare the number of singles a music recording studio sold using the information from a bar graph that incorporated a third dimension. However, in this study, results from the third task were not reported.

While the participants were solving the tasks, the first author monitored them. Also, he became involved in group discussions, gave prompts, and asked follow-up questions. A video camera for each group was placed at a fixed view. Also, the second author videotaped the interactions among the PSTs while the instructor was monitoring their progress. The PSTs’ gestures were captured from the video recordings. After the study, the researchers constructed verbatim transcripts coordinated with gestures and written responses of the participants.

In this study, we did not focus on the PSTs' literal reading of the graphs. Rather, we were interested in identifying moments when the PSTs made sense of information that was not provided directly in the graphs. The participants' reasoning about the graphs to obtain information was categorized into two: interpolative and extrapolative. On the one hand, the PSTs' use of specifiers (e.g., horizontal lines on the graphs) to find an unknown value, comparison/manipulation of information in the graphs and arithmetic calculations were identified as their interpolative reasoning. On the other hand, we categorized the PSTs' strategies for rescuing the graphs from misleading information as their explorative reasoning, in particular when they modified or re-produced the graphs. We focused on in what ways they took into consideration the magnitudes of the bar graphs and estimated a value following a pattern in their new data displays. For example, we identified whether they preserved the lengths of the bars when they modified the graphs. The central focus of the results was on the PSTs' extrapolative reasoning in the process in which they rescued the graphs from misleading information. We also analyzed the PSTs' interpolation process to show how they laid the foundations for their explorative reasoning. In other words, the interpolation process was helpful in identifying how they linked their modified/re-produced graphs with their interpolative reasoning to indicate the true relationships between the categorical variables.

Results

In the first task, the graph indicated the amount of money a child was given by his family members. The PSTs found the missing specifiers on the y-axis counting the lines between two known numeral values using them as reference markings using their interpolative reasoning. Then, they focused on the arithmetic calculations as asked in the worksheet. When they were asked if they could identify the relationships between the categorical variables without making any calculations, they considered the magnitudes of the bars. The researcher's prompt encouraged them to modify the graph. For example, Sevgi measured the length of the grandfather's bar placing her thumb and index fingers on the bottom and top of it as shown in Figure 1a. Then, she kept the same distance between her fingers and made a part-to-part comparison between the lengths of bars of uncle and grandfather (Figure 1b). Finally, she figured out that the length of the grandfather was two and a half times of the uncle's. However, in their earlier arithmetic calculation, they found the ratio of money with grandfather and uncle was 3.

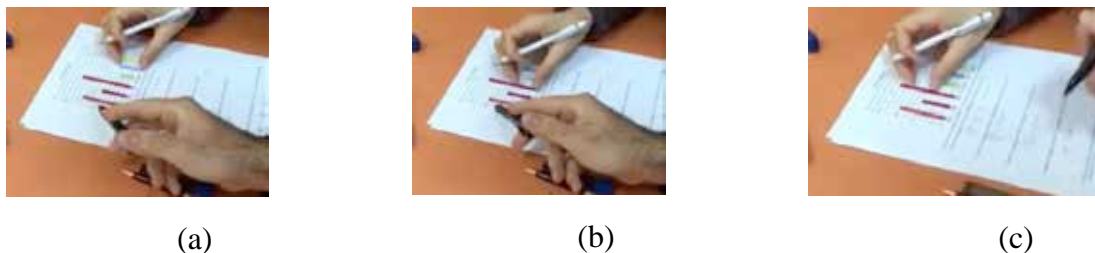


Figure 1: (a) Sevgi takes the length of the bar of the uncle as a reference, (b) She makes a part-to-part comparison between the lengths of the bars of the uncle and the grandfather, (c) She notices

the length of the grandfather is two and a half times of the uncle's

Then, using explorative reasoning, they modified the bar graph to be able to use the lengths of the bars and to check whether the ratios between the categorical variables were consistent with their calculations.

The PSTs equalized the scale of the axis and increased the numeral values of the y-axis by 2. However, this modification gave rise to changing the amount of money given by the family members. For example, the numeral value of the mother changed from 28 to 16. Then, they cut off the bars from the value of 2, and added the cut-outs onto the corresponding bars as shown in Figure 2a. This strategy allowed them to make the intervals increasing by 4. They located the cut-outs onto each bar by adding 2, and preserved the lengths of the bars. Then, they referred to the intervals between the horizontal lines as units and counted them (Figure 2a). Umut said: "Then, if we look at the amount of the money the grandfather and father gave: 1-2-3-4-5-8-9 [pauses]. Isn't it one half [means 9.5]? If we count the father's: 1-2-3-4 and a half. 9.5 and 4.5." Using interpolative reasoning, the PSTs noticed that the re-labeled specifiers (increments) did not match with their arithmetic calculations. The strategy of adding cut-outs onto the corresponding bars did not satisfy the participants. They investigated new strategies to overcome the misleading information.

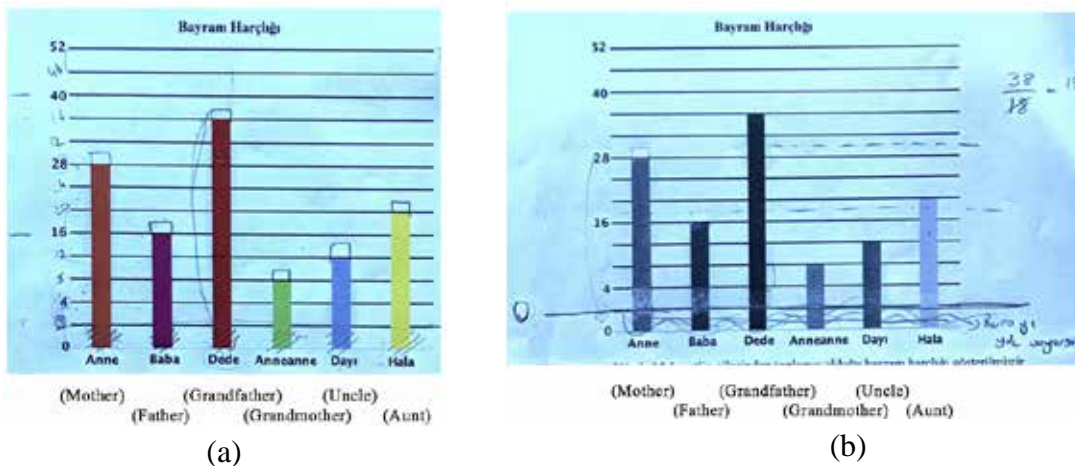


Figure 2: (a) PSTs cut off the bars from the value of 2 and added the cut-out bars onto the corresponding ones, (b) They quit adding the cut-out bars onto the corresponding bars

Nese noticed that if they canceled out the cut-outs (Figure 2b) and counted the intervals between the horizontal lines, the ratios between the categorical variables were the same as those in their earlier calculations. Nese's strategy made the graph equi-spaced and allowed them to count the intervals between the horizontal lines. Then, the PSTs compared the magnitudes of the grandmother and the aunt in their new strategy. For example, in their earlier calculation, they found the ratio of money with aunt and grandmother as 2.5 ($20/8$), and Nese used this information to support her claim. The below excerpt indicates Nese's approach to the problem.

- Nese: For example, let's do not think of that portion [the cut-out] as if it was not there. Let's write zero here and when we count the intervals [between the horizontal lines], we find the same ratios.
- Umut: Let's check aunt's and grandmother's. Let me check the aunt's.
- Nese: 5 is for the aunt, and 2 for the grandmother.
- Umut: 2.5 [the ratio]. Exactly [the same].
- Sevgi: Yes. Give me a high five!

In the second task, the participants most often talked about a child's claim that the PISA score of Croatia was six times of the score of Greece. The PSTs read the specifiers and concluded that the claim of the child in the problem context was false. However, Sevgi emphasized that, in the first task, they changed the location of the zero baseline and used the intervals between the horizontal lines. She suggested re-labeling the zero baseline, as it was 452 in the original. In other words, she considered the relative magnitude 452, and subtracted it from the numerical values of the bars. Accordingly, she revised the numeral values of the countries as shown in Figure 3 (USA: 18, Croatia: 12, Greece: 2). Nese and Umut did not agree with Sevgi, and they convinced her by saying:

- Umut: We can compare proportionally as they have equal intervals [in the first task], can't we? But, the student [child] is misled here because the graph [y-axis] does not start with zero. It [the child's claim] would count right if this [Figure 3] started with zero...
- Sevgi: We removed [the cut-outs] here in this bar graph [refers to the first task]. We removed the same values from all. We can think of it "6" [the ratio of scores with Croatia and Greece] when we take away the same numeral values from all.
- Umut: Since it asks for the total score, I think we should not take them away. Especially, we will consider it 470 (for USA) and they [the scores] cannot be reduced.

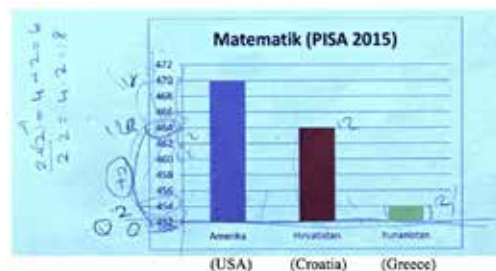


Figure 3: Sevgi re-labels the numeral values of the countries

The PSTs made a decision to start the graph at zero, in order to be able to show the true relationships between the scores of the countries. They extended the magnitudes of the bars to

the zero baseline (Figure 4a). When the instructor became involved in the group discussion, Umut made a gesture as shown in Figure 4b to demonstrate that they extended the zero baseline. He said:

Umut: To able to show the actual magnitudes. The graph shows the score of Greece with an increment of 2, but it actually earned a high score, 452. Namely, there is not much difference [in magnitudes] between 452 and 470. It shows only the upper section [of the bar graph] with an increment of 2. It looks like it [the graph] conceals the actual graph in the background. So, we wanted to make it clear that it [the ratio of scores with Croatia and Greece] is not 6. Eventually, the child numerically sees that 464 is not six times of 454.



Figure 4: (a) PSTs extend the magnitudes of the bars to the zero baseline, (b) Umut makes a gesture that signifies the extension of the bars

Concluding remarks and implications

The results of this research suggest that the PSTs focused on performing arithmetic calculations in their early reasoning about the task without considering the graphical displays were misleading. They performed arithmetic calculations to find the proportional relationships between the variables. When the instructor gave a prompt about finding the relationships without making any arithmetic calculations, the PSTs stressed the misleading information. They identified the proportional relationships taking into consideration the lengths of the magnitudes of the bars, and figured out that the relative ratios did not match with their earlier arithmetic calculations. Then, they became more interested in modifying or re-producing the graphs to show the true relationships between the variables. They used their calculations as a checking tool when they modified or re-produced the bar graphs, and re-labeled the numeral values of the variables to overcome the misleading information. The PSTs modified the zero baseline to make the y-axis equi-spaced, cut off the bars from specifiers, and added the cut-outs onto the corresponding bars. They tended to preserve the lengths of the bars invariant when they modified the location of the zero baseline. After they checked their arithmetic calculations, the PSTs noticed that the relationships between the categorical variables were not consistent with their calculations. In this sense, their arithmetical calculations (interpolative reasoning) laid the foundations for their explorative reasoning.

We observed differences in graph comprehension abilities of the participants. For example, Sevgi focused on the magnitudes of the bar graphs when she made an inference. On the other hand, Nese and Umut took into account the arithmetic calculations as a checking tool. As Friel et al. (2001) state, graph comprehension requires spatial judgments or modifications in specifiers and labels in graphs. Future research may indicate how individual differences may affect graph comprehension of students when they make sense of misleading graphs.

One of the limitations of our study was that the PSTs reasoned about vertically-oriented bar graphs. However, the affordances of vertically- and horizontally-oriented bar graphs differ (Shah & Hoeffner, 2002). For example, “horizontally oriented bars may be better for other dimensions for which the horizontal dimension is more meaningful, such as in depicting data about the distance traveled (p.51)”. Researchers may investigate how students’ making sense of misleading graphs differs in vertically- and horizontally-oriented bar graphs.

It is important to examine not only the axes of bar graphs and check whether they are starting with zero (when graphing positive values) but also if the axes are equi-spaced. If the y-axis is not equi-spaced or does not start with zero, the graph may cause misleading information for the reader. However, a bar graph with a zero baseline may also give rise to missing the relevant information of data. For example, suppose we measure the body temperature of a person with fever in Fahrenheit for a day, at intervals of an hour. If we show the body temperature of the person using a zero baseline in a line graph, it may indicate almost a straight line and conceal the jumps between the neighboring hours. In this sense, the context of the data matters.

References

- Curcio, F. R. (2010). *Developing data-graph comprehension in grades K-8* (3rd ed.). Reston, VA: National Council of Teachers of Mathematics.
- Huff, D. (1993). *How to lie with statistics*, New York: W. W. Norton & Company.
- Friel, S. N., Curcio, F. R., & Bright, G. W. (2001). Making sense of graphs: Critical factors influencing comprehension and instructional implications. *Journal for Research in Mathematics Education*, 32(2), 124–158.
- Friel, S. N., O'Connor, W., & Mamer, J. D. (2006). More than "meanmedianmode" and a bar graph: What's needed to have a statistical conversation? In G. Burrill (Ed.), *Thinking and reasoning with data and chance: Sixty-eighth yearbook* (pp. 117–137). Reston, VA: National Council of Teachers of Mathematics.
- Shah, P., & Hoeffner, J. (2002). Review of graph comprehension research: Implications for instruction. *Educational Psychology Review*, 14(1), 47–69.
- Wolf, A. (2007). Misleading statistical studies. *Policy Quarterly*, 3(4), 22–29.

The role of students' drawings in understanding the situation when solving an area word problem

Manuel Ponce de León Palacios¹ and Jose Antonio Juárez López²

¹ Popular Autonomous University of Puebla State, México; manuel.poncedeleon@upaep.mx

² Meritorious Autonomous University of Puebla, México; jajul@fcfm.buap.mx

Keywords: Graphic representations, drawings, visualisation, word problems, geometry.

Introduction and theoretical background

The use of drawings when working with geometry word problems will emerge naturally in students; however, the strategic use of representations to solve the problem does not. The contribution of visualisation to mathematics education, and especially in geometry, is undeniable; however, it is worth noting that to make effective use of this tool in the solution of word problems, the student will need specific prior knowledge and certain cognitive skills (Schnotz, 2002). Mathematics relies heavily on visualisation because it deals with abstract objects (Arcavi, 2003), the possibility to "see" the mathematical objects and express numerical information through graphical representations helps students understand concepts and solve problems (Edens & Potter, 2007).

Although the drawings with pictorial characteristics do not seem to be related to performance in mathematical modelling and the correct solution, they can serve as a preliminary step to more schematic representations (Rellensmann, Schukajlow, & Leopold, 2016). This sequential process from pictorial to schematic drawings contributes mainly to the understanding of the situation and the task, which has shown to be particularly useful for students who have more difficulty making the transition between the real world and the mathematical world.

Method

Research question: What is the role of the drawing that students do when they solve a problem of geometry in which they are asked to find the area of a figure that is not presented explicitly but results from the relationship of the elements?

Participants: 20 students of the 9th grade from a public school in Mexico (12 girls and 8 boys) with an average age of 14 years.

Procedure

For the research, a worksheet was developed including one area problem: *A dog is tied to a chain that allows a maximum range of 2 metres, attached to a ring that moves in a bar in the shape of a right angle whose sides measure 2 metres and 4 metres. What is the area of the region that the dog can cover?*

The worksheet was applied in a single session with all the participants without any previous intervention. This study only considered the analysis of the drawings made by the students on the worksheet to solve the problem.

In the analysis of the representations, two processes were carried out: a classification process and a qualitative analysis of the drawings. Three levels of classification of the drawings were made considering (1) level of abstraction, (2) relationship with the statement of the problem and (3) the explicit inclusion of information in the drawing that is mathematically relevant to solve the problem. The qualitative analysis consisted of a finer revision of the characteristics of the representations considering the students' proposed figure; the information included; the proportionality of the presented elements; and the transitions between pictorial, schematic, operations and result domains.

Results

None of the participants was able to draw the expected figure or reach the correct result. Most of the students showed some difficulties, inadequately representing the proportions of the objects in the situation and paying excessive attention to mathematically irrelevant details, such as flowers, clouds and the dog's house.

The analysis of the drawings showed how the students carry out the transition between the real domain posed by the problem and the mathematical domain. Some students make a gradual transition, while others move directly from the representation of the situation to mathematical operations. Given the above, we can classify the transitions into three groups: (1) pictorial to pictorial with data, (2) pictorial to schematic, and (3) pictorial to numerical.

Conclusion

Although the use of drawings in solving geometry problems emerges naturally in students, effective use of graphic representations must be worked on through activities in the classroom. If the drawing activity is kept away from mathematics classes, it is very likely that the students may assign a purely decorative function to the drawings. The representations generated by the students can be a handy tool for observing their reasoning in such a way that allows us to understand better what they know and how they know it.

References

- Arcavi, A. (2003). The role of visual representations in the learning of mathematics. *Educational Studies in Mathematics*, (52), 215–241. <https://doi.org/ED419696>
- Edens, K., & Potter, E. (2007). The relationship of drawing and mathematical problem solving: “Draw for math” tasks. *Studies in Art Education*, 48(3), 282–298. <https://doi.org/10.1080/00393541.2007.11650106>
- Rellensmann, J., Schukajlow, S., & Leopold, C. (2016). Make a drawing. Effects of strategic knowledge, drawing accuracy, and type of drawing on students' mathematical modelling performance. *Educational Studies in Mathematics*, 95(1), 53–78. <https://doi.org/10.1007/s10649-016-9736-1>
- Schnotz, W. (2002). Commentary: Towards an integrated view of learning from text and visual displays. *Educational Psychology Review*, 14(1), 101–120. <https://doi.org/10.1023/A:1013136727916>

Exploring Strategies Used to Solve a Non-Routine Problem by Chilean Students; an Example of “Sharing Chocolates”

Farzaneh Saadati and Mayra Cerda

Universidad de Chile, Chile; farzaneh.saadati@gmail.com, mayra.cerda@ciae.uchile.cl

Keywords: Mathematical thinking, problem solving, representation strategy.

Introduction

In Chile, mathematical problem solving has been incorporated in the school curriculum. However, it has been shown that problem solving activities are practically absent in the classrooms (Felmer & Perdomo-Díaz, 2016). Furthermore, despite an emphasis on problem solving in the new curriculum for grades 1-8 (MINEDUC, 2012), teachers appear reluctant or unable to incorporate rich problem solving practices in their classrooms. Cai and Nei (2007) suggested that students’ performance in problem solving is affected by the cultural context, teachers’ beliefs and their practices. In another study, we found a mismatch between Chilean mathematics teachers’ beliefs and practices (Saadati, Cerda, Giaconi, Reyes, & Felmer, 2018). Teachers have sort of reformed beliefs about problem solving, however in classrooms, problem solving is predominantly seen as a set of concrete techniques, and teachers focus on the repeated practice of procedures. These conditions and circumstances can obviously have an impact on students’ problem-solving ability and on their mathematical thinking. In this study, we are going to explore Chilean students’ representation strategies to solve the problem on sharing chocolates:

3 boys share 2 bars of chocolate equally and 8 girls share 6 bars of chocolate equally. Who gets more chocolate, the boys or the girls? Explain or show how you found your answer.

This problem is a process-constrained problem categorized as a non-routine problem for Chilean elementary students since they are not familiar with this type of problem. To solve this problem, they might fail to consider all of the information presented in the problem, or “compute first and think later” (Hegarty, Mayer, & Monk, 1995). Students’ representation might be directed towards using division because of the presence of the term “share” and the numbers. It can be represented as $\frac{3}{2}$ or $\frac{2}{3}$. We refer to this form of representation as *direct-translation*. The students could also try to construct a representation of the situation being described in the problem (Hegarty et al., 1995). The representation constructed based on this approach is usually a more meaningful and concrete way that involves the construction of a mental model. We call it a *meaning-making* representation strategy which can become a basis for construction of a solution plan. In this study, we explore the dominant and most accurate representation strategies and the rate of success among students.

Methodology and Results

The students were asked to solve three problems presented by Cai (2000). Here we discuss the problem “sharing chocolates”. Participants were 143 students from several public schools; 72 girls, and 71 boys, included 52 sixth graders, 52 seventh graders, and 39 eighth graders.

There were 74 students who had a plan to solve the problem by following the three-step process. In contrast, 52 students did not devise any plan to solve the problem. These students skipped the first

two steps and tried to answer only the third part of the problem which was the sense-making question. The rest of the students (17) did not try to solve the problem and left it blank. The results revealed that 46 out of 74 (32% of students who followed the three-step process) were able to finish it, and 28 students stopped before reaching the third part or sense-making question. Among the students who followed the process, 17 students out of 74 showed a direct-translation representation – correctly or incorrectly – to solve the problem. The rest of the students used a meaning-making strategy. By using the meaning-making strategy, 45 students pictorially represented their solution (drawing only or mixed with a verbal explanation), the other 12 students just verbally explained their solutions. Finally, only 9 students could solve the problem completely without any mistakes; 3 students used a direct-translation and 6 got the answer by using the meaning-making representation strategy.

Discussion

The results of the Chilean grade 6th to 8th students revealed that using the meaning-making representation was more prevalent among them. The students' performance was comparable with U.S. students in a similar study done by Cai (2000). However, there was a large rate of failures among these students and just a few of them (about 6%) could solve the problem successfully. We believe, the mismatch between teachers' beliefs and practice can explain the gap between their tendency of using meaning-making strategies and their failure. The teachers' reformed beliefs may lead them to put more value on meaning-making representation strategies, while their traditional teaching approach explain their students' lack of skills and inexperience with non-routine problems. In fact, the failure highlights the necessity of a shift of instruction towards more student-centered practices in order to give students more space to develop their mathematical thinking while working with those non-routine problems. Therefore, we suggest changing school practices and organizing effective and related teachers' professional development programs.

Acknowledgment

The research is financially supported by CONICYT/Fondecyt Postdoctoral Project 3170673. PIA-CONICYT Basal Funds for Centers of Excellence Project FB0003 are gratefully acknowledged.

References

- Cai, J. (2000). Mathematical thinking involved in US and Chinese students' solving of process-constrained and process-open problems. *MTL*, 2(4), 309–340.
- Cai, J., & Nie, B. (2007). Problem solving in Chinese mathematics education: Research and practice. *ZDM*, 39(5-6), 459–473.
- Felmer, P., & Perdomo-Díaz, J. (2016). Novice Chilean secondary mathematics teachers as problem solvers. In P. Felmer, E. Pehkonen, & J. Kilpatrick (Eds), *Posing and solving mathematical problems* (pp. 287–308). Cham: Springer International Publishing.
- Hegarty, M., Mayer, R. E., & Monk, C. A. (1995). Comprehension of arithmetic word problems: A comparison of successful and unsuccessful problem solvers. *Journal of educational psychology*, 87(1), 18–32.
- Saadati, F., Cerda, G., Giaconi, V., Reyes, C., & Felmer, P. (2019). Modeling Chilean Mathematics Teachers' Instructional Beliefs on Problem Solving Practices. *International Journal of Science and Mathematics Education*, 7(5), 1009–1029.

Who is right? Theoretical analysis of representational activities

Michal Tabach¹ and Boris Koichu²

¹Tel-Aviv University, School of Education, Tel-Aviv, Israel; tabachm@post.tau.ac.il

²Weizmann Institute of Science, Rehovot, Israel; boris.koichu@weizmann.ac.il

A theoretical discussion of possible connections between some non-conventional external representations (i.e., textual tasks of a particular format) and their corresponding internal representations (i.e., perceptions of these tasks by mathematics learners) is presented in this paper. Our goal is to analyze the interplay between external and internal representations in relation to non-conventional textual tasks of "who-is-right?" format. Such tasks involve a relatively long textual story introducing a situation that can be interpreted in (at least) two contradictory ways, which are explicitly given. The solvers of the task are required deciding which interpretation is correct and support their decision by an argument that would convince their peers. The presented theoretical analysis in terms of representations can serve as a tool for teachers and teacher educators in designing tasks specifically tailored to their students' needs.

Keywords: Experientially real representations, socially shared representation, task design, controversy.

Introduction

Ways in which mathematical ideas are represented are fundamental for how people learn and use these ideas (Heinze, Star, & Verschaffel, 2009). Goldin and Kaput (1996) refer to *representation* as a configuration of some kind that corresponds to, or is referentially associated with, or symbolizes something else. According to the National Council of Teachers in Mathematics (NCTM, 2000), *representation* refers "to the act of capturing a mathematical concept or relationship in some form and to the form itself" (p. 4). In other words, representations refer to both processes and products of learning and doing mathematics.

Goldin and Kaput (1996) differentiate between internal and external representations. Internal representations allude to possible mental configurations of individuals. As such, they cannot be observed directly. Rather, they can be inferred based on theoretical analysis, and when appropriate – based on behavioral clues, like gestures, speech and acts. In contrast, external representations allude to physically embodied, observable configurations such as texts, graphs, pictures, or mathematical symbols. These are in principle accessible to observation.

The theoretical discussion of possible connections between some non-conventional external representations (i.e., textual tasks of a particular format) and their corresponding internal representations (i.e., perceptions of these tasks by mathematics learners) in this paper corresponds with the Call for Papers of CERME11 TWG24 in the following way. We concern with creation, interpretation and reflection on external representations in learners' minds, with the purpose of depicting and communicating information, thinking about and developing mathematical ideas, and advancing understandings. Hence, we address the following question posed in the Call: "How can non-conventional representational activity contribute to mathematical thinking?" Specifically, our

goal in this paper is to analyze the interplay between external and internal representations in relation to non-conventional textual tasks of "who-is-right?" format.

In the sections below, we present a "who-is-right?" task format, followed by analysis of examples in the contexts of algebra and geometry, with particular focus on conjectured internal representations. The conjectures, though theoretical, are supported by our experiences of enacting the presented tasks with various audiences. The concluding discussion is related to aspects of designing tasks of "who-is-right?" format, specifically to taking some conventional mathematical tasks and turning them into un-conventional ones.

The "who-is-right?" task format

An external representation of "who-is-right?" format (henceforth, WIR task) involves a relatively long textual story introducing a situation that can be interpreted in (at least) two contradictory ways. Rather than asking students to interpret the situation, the contradictory interpretations are explicitly given in the voices of two or more virtual characters. As a rule, each interpretation involves argument based on attention to some aspects of the story; otherwise, the argument supporting the interpretation must be revealed by actual solvers of the task. The actual solvers of the task are required deciding which interpretation is correct and support their decision by a convincing argument.

Such tasks have several representational characteristics. First, the textually presented situation alludes to experientially real world of the potential solvers of the task (Gravemeijer & Doorman, 1999). That is, the situation is rooted in solvers' perception of experientially real, everyday-life phenomena. Second, the task is presented in everyday language, which might be ambiguous once referring to mathematical objects or mathematical objects in disguise. Third, the task does not require solving a textbook-like mathematical problem, at least not explicitly. Instead, two contradictory claims about the situation are presented. The learners are asked to take a stance and defend it. In order to be able to do so, the learners need to build two internal representations of the situation by taking into account each of two contradictory claims. This activity has the potential to advance their ability to overcome the limitations of the experientially real (but subjective) representations, towards building a shared representation based on mathematically valid argument that can convince the other learners when non-mathematical argument fails to do so. Fourth, the mathematically valid answer to the question "who is right?" may be not only of the "one of the characters is right" format but also of non-conventional formats such as "both are right", or "both are wrong", or "it depends". Such options potentially add an element of surprise to the task. Fifth, WIR tasks can be sequenced so that dealing with the next task requires not only a comparison between two interpretations of the given situation but also comparison of a new situation with the previous one.

Several WIR tasks have been used in previous studies as research instruments. For example, researchers (Buchbinder, 2010; Buchbinder & Zaslavsky, 2013; Healy & Hoyles, 2000) have used such tasks for revealing the student conceptions of proof and examples. In particular, Buchbinder and Zaslavsky (2013) designed a WIR task based on a claim "For every natural n , $n^2 + n + 17$ is a prime number" plus two responses to this claim by virtual student-characters. The first student-character argued that the claim is correct because she checked its validity for the first 10 integers, and the second student-character claimed that the statement is false because $n^2 + n + 17$ is not prime for

$n = 16$. Then 12 high-school students were exposed to the task and asked to determine who was right and explain why. All students exhibited indicators of understanding that for a universal statement to be true it has to hold for all cases. At the same time, some of these students remained convinced that a statement can be 'proven' through examination of several confirming examples.

Another WIR task was used in a teaching experiment conducted by Koichu (2012) with a group of pre-service teachers. The teachers were exposed to two pictures: a picture of the famous Penrose triangle and a picture representing a sculpture of the Penrose triangle taken from an angle that created an impression that the Penrose triangle can be made as a real 3D object. The students were required deciding whether the Penrose triangle indeed could be a 3D object or prove otherwise. This study resulted in a description of a particular set of instructional conditions in which mathematical defining and proving could be intellectually necessitated for the students.

In spite of the fact that in both tasks one of the included responses was intuitively more appealing than the other one, the tasks proved themselves as triggers for evoking uncertainty in their solvers, as well as useful tools for revealing the students' (mis)conceptions and reasoning. These tasks stimulated our interest in further developing WIR representational activities as research and teaching tools that would correspond to curriculum-determined mathematical topics. In the next section, we present two WIR activities, one in algebra and another in geometry, and discuss their common features as well as subtle differences inherited in their design.

Examples and analysis

The WIR tasks presented in this section are designed for the use with middle-school students. The forthcoming discussion of internal representations associated with these tasks is based on our experience of enacting and discussing the tasks with two groups of in-service teachers.

Example 1: Subtle matters related to percentages

Figure 1 presents the first task in the sequence of three tasks.

Towards the end of the summer holidays, suitcases are sold with a 30% discount. The final price of a suitcase includes VAT of 17%.	
In calculation of the price, one can first take into account the discount and then calculate VAT or otherwise. It appears that a buyer and a tax collector have different opinions on this matter.	
Advice from Buyer: I think that one needs first to calculate the price including VAT and then the discounted price. In this way, the discount would apply to a greater number and the final price would be lower.	Advice from Tax Collector: I think that one needs first to calculate the discounted price and then to add VAT. In this way, the sum of VAT would not be influenced by the discount and the final price would be higher.
<ol style="list-style-type: none"> 1. What do you think? 2. How would you convince a peer who disagrees with you? 3. How can we decide who is right? 	

Figure 1: The first task (discount and tax)

We now outline a conjectured scenario of dealing with this task. The student reads the story and decides who is right (a buyer or a tax collector) based on the mainly emotionally loaded process of taking the perspective of a buyer or of an authority. It was our intention to make the buyer's and the tax collector's responses more or less equally plausible for the solver. The process of the task comprehending requires the students to create competing internal representations of the situation, but at the individual level, one of two internal representation eventually prevails, and the student convinces herself that "a buyer is right" or "a tax collector is right". At the collective level, the class splits (always worked in our teaching), so that each student can see that his or her opinion is not the only possible one. At this stage, many students cannot think of an argument in support of the opposite opinion, so the split is perceived as a surprise. When asked by the teacher to convince the opponents, the students attempt to explicate their internal representation and produce explanations in everyday language often accompanied by gestures. Then, the students are surprised even more when they find out that these explanations are incomprehensible or perceived as too vague for their counterparts in order to be convincing. A collectively shared need to find a way of getting to the common ground arises. At this stage, an option to employ mathematical apparatus emerges, usually as a spontaneous suggestion of one of the participants. This is probably because of the general context: after all, the discussion occurs at a mathematics lesson. Some meta-level questions arise with the help of the teacher. For example, what argument can be convincing? How can the buyer's or the tax collector's argument be expressed mathematically?

Next, the teacher suggests the students to attempt to mathematize the situation, in the hope to construct a shared (external) representation that would be convincing for all. The students begin using mathematical language, first in order to test the correctness of their initial claims; then in order to assess their claims as well their opponents' claims. In this process, the classroom map of agency changes, and the teacher does not act as a source of knowledge about the correct solution but as a facilitator of establishing the new discursive rules (Sfard, 2002), and as a mediator of the discussion. In this way, the teacher stops being an authority whose role is to approve or disapprove the student solutions, but becomes an authority who can support or disregard (for example, by re-voicing) types of arguments produced by the students. This situation promotes the individual student argumentative talk based on gradually established rules (Hershkowitz, Tabach, Rasmussen, & Dreyfus, 2014).

Eventually, the surprising to many students resolution of the given situation – the buyer method and the tax collector method lead to the same final price – may ease the emotional tension in class. This would be a good moment to present the next task of the sequence (Figure 2).

Presenting this task second, one cannot but compare it with the first task. In this context, the individual may create an internal representation of the task by attending to the following parallels: decreasing the length of one side is the counterpart of the discount, and increasing the length of the other side is the counterpart of the VAT. This may overshadow for the students an important difference between the external representations of the tasks. It is now not about the multiplication operations performed sequentially, where the second operation is applied on the result of the first operation, hence the final answer does not depend on the order. In the second task, each of two multiplication operations is applied to the same initial number, and then the results of these two operations are multiplied to find the area of a new shape, hence the final result may change.

The area of any square equals to the area of a rectangle built from that square by increasing one side by 10% and decreasing the perpendicular side by 10%. Is it so?	
Michael: Yes. The square sides are of equal length. Therefore, adding 10% and cutting 10% of the side lengths imply that what you add and what you cut is the same.	Josef: No. If the side length is 10 cm, the area is 100 cm ² . The rectangle will have 9 and 11 as side lengths, and the area will be 99 cm ² .
<ol style="list-style-type: none"> 1. What do you think? 2. How would you convince your peer who disagrees with you? 3. How can we decide who is right? 	

Figure 2: The second task (changing the area)

In this case, using the same 10% change for the adjusted sides of the square may add to the internal representation that leads to the (wrong) conclusion that "nothing changes". For these reasons, reading Josef's explanation may serve as an eye-opener, in line with the counterexample for $n = 16$ in the task from the Buchbinder and Zaslavsky's (2013) study, as presented above. The calculations of Josef are easy to follow and validate. Hence, we expect that the discussion of the WIR question would rather be quick, and that the discussion of the question "how are the first and the second tasks different?" would be longer. Then, the discussion might develop, again, with the help of the teacher, in an epistemological direction. Namely, the class may discuss what can be concluded from just one counterexample and what argument can be made about whether the Josef example more convincing.

Our suggested sequence does not stop here. The third task is ready to be presented (Figure 3).

The perimeter of any squares equals to the perimeter of a rectangle built from that square by increasing one side by 10% and decreasing the perpendicular side by 10%. Is this correct?	
Ron: No. We just solve this problem and saw that it would not be the same.	Gal: Yes. Two sides became larger and two become smaller. The additions and cut-outs are of the same size; hence, the perimeter will not change.
<ol style="list-style-type: none"> 1. What do you think? 2. How would you convince your peer who disagrees with you? 3. How can we decide who is right? 	

Figure 3: The third task (changing the perimeter)

Reading the third tasks may immediately raise a déjà-vu feeling of we have already solved this one, and, indeed, Ron's claim gives room for this feeling. Yet, reading Gal's argument may lead the learners to re-consideration of Ron's stance. We believe that for this task to be the third in the sequence, middle school students may turn to the search for (external) mathematical representations of the situation quicker than in the previous two tasks. And once more, a surprise would await them

(after all, Gal is right!), which may evoke a hot discussion of how this task is different from the previous one. From our experience, elaboration on the differences between the external representations of all three tasks in tacit association with students' internal representations, which gradually emerge in the classroom discourse, is a non-trivial endeavor. This was true even for the in-service mathematics teachers, who were exposed to the sequence, and even for those of them who were familiar with a variation of the first task. All the teachers acknowledged the plausibility of the above scenarios and expressed the wish to use the sequence with their students.

Example 2: Dynamic loci of points

A task presented in Figure 4 follows the WIR format, but it differs from the previous example in (at least) three important aspects: (1) it concerns geometry; (2) it requires reconstruction of two different arguments rather than comprehending the given arguments, hence the questions to the solvers are not as in Example 1; (3) the answer to the task is of "it depends" format.

Einat and Sarah like touring and exploring. One day they found an old wooden box containing a note, written, apparently, by pirates. The note said: "There is no choice, we retreat. The treasure is too heavy and we are forced to hide it. The treasure is in 200 steps from a segment connecting the tallest eucalyptus tree and the tallest maple tree of this area, and in 300 steps from the midpoint of this segment."	
Einat and Sarah found the eucalyptus and maple trees, but then argue what to do next.	
Einat: There is no chance to find the treasure. It just does not exist.	Sarah: Let's try. With small effort, we have a chance to find the treasure.
<ol style="list-style-type: none"> 1. What might be the Sarah argument? 2. What might be the Einat argument? 3. Unver which conditions could Einat or Sarah be right? 	

Figure 4: The treasure task

With no exception, the solvers begin from drawing a sketch (external representation), as the one presented in Figure 5.

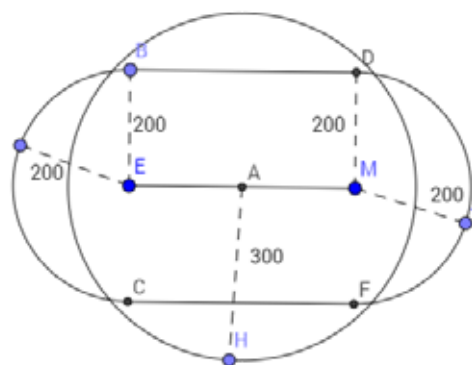


Figure 5: A sketch for treasure task (E stands for the eucalyptus, M stands for the maple)

At first glance, the sketch supports Sarah's opinion, because the stadium-like shape (represents the locus of points at the distance of 200 steps from segment EM) and the circle (represents the locus of points at the distance of 300 steps from the middle of EM) intersect in exactly four points. Therefore, according to the sketch, the treasure must be located in one of these points, and checking only four points is a feasible task. Of note is that creating the above sketch has been proven as difficult for the solvers. With in-service teachers, the most interesting discussions revolved around two questions: "How can the distance between a point and a segment be defined?" and "What is the locus of points?"

The most challenging part of the task is to re-construct the argument that may underlie the Einat's opinion. The tentative (but supported by practice) scenario of doing the task relies on the following assumption: Any external representation of the task situation by means of a drawing relies on an internal representation that includes an assumption about the length of line segment EM . Most of the learners intuitively assume that it is longer than 200 steps, as in Figure 5. However, if $EM = 200$, the locus of points described in the situation would consist of exactly two points. Furthermore, if EM is less than 200 steps, the locus becomes an empty set, and in this case Einat is right. Since the story does not include information about the length of EM , but only the information that Einat and Sarah found the trees, each of them can be right. Hence, the answer to the task is "it depends".

The readers are invited to explore the situation by means of a dynamic GeoGebra applet at <https://www.geogebra.org/m/n5mRrtMf> (consider varying the position of point B at the applet).

Of note is that whether or not a dynamic external representation of the task by means of GeoGebra is used, dealing with the task requires the learner to create a dynamic internal representation of the situation. This is an additional point of difference: in Example 2, the dynamic representation might be continuous, and dealing with the change in Example 1 might require creation of a discrete series of static representations.

Discussion

On the face of it, turning "conventional" tasks into WIR tasks is simple. Instead of concluding a textual description of a situation by an open-ended question (e.g., "would the price change?" or "make a map and denote the treasure"), an additional layer of two contradictory arguments by virtual characters is added. Yet, we seek arguments that can be perceived by the learners as plausible, so that the class would split between favoring one argument over the other. Hence, designing worthy WIR tasks is not as simple as it may seem.

As mentioned in the introduction, any analysis in terms of internal representation cannot be conclusive just because these are not directly accessible. Accordingly, we do not assume that the above-presented scenarios are realistic or that we can realistically describe what is going in the minds of the solvers. Yet, the value of our analysis is in that it can serve as a design heuristic for teachers and teacher educators, like in thought experimentation, when designing WIR tasks.

Our hypothetical analysis of the interplay between internal and external representations was mostly at the level of an individual solver, and thus is in line with the claim made by Rittle-Johnson and Star (2011): "comparison is a fundamental part of human cognition and a powerful learning mechanism" (p. 221). In addition, we approached the interplay between the individual and the social in

implementation of the WIR tasks. In sum, we have argued that a WIR task can present students opportunities to engage with classroom-level argumentative talk based on an emerging need to resolve conflicting opinions expressed by individuals, and hence to be a step towards constructing some socially shared internal representations of the task.

Acknowledgment

Our study is partially supported by the Israeli Scientific Foundation, grant no. 2699-17.

References

- Buchbinder, O. (2010). The role of examples in establishing the validity of universal and existential mathematical statements. *Unpublished Doctoral Dissertation* (in Hebrew). Technion – Israel Institute of Technology.
- Buchbinder, O., & Zaslavsky, O. (2013). Inconsistencies in students' understanding of proof and refutation of mathematical statements. In A. M. Lindmeier, & A. Heinze (Eds.) *Proceedings of the 37th conference of the International Group for the Psychology of Mathematics Education* (vol. 2, pp. 129–136). Kiel, Germany: PME.
- Healy, L., & Hoyles, C. (2000). A study of proof conceptions in algebra. *Journal for Research in Mathematics Education*, 31(4), 396–428.
- Heinze, A., Star, J.R. & Verschaffel, L. (2009). Flexible and adaptive use of strategies and representations in mathematics education. *ZDM Mathematics Education*, 41(5), 535–540.
- Hershkowitz, R., Tabach, M., Rasmussen, C., & Dreyfus, T. (2014). Knowledge shifts in a probability classroom: a case study coordinating two methodologies. *ZDM Mathematics Education*, 46(3), 363–387.
- Goldin, G. A., & Kaput, J. J. (1996). A joint perspective on the idea of representation in learning and doing mathematics. In L. P. Steffe, P. Nesher, P. Cobb, G. A. Goldin, & B. Greer (Eds.), *Theories of Mathematical Learning* (pp. 397–430). Mahwah, NJ: Erlbaum.
- Gravemeijer, K., & Doorman, M. (1999). Context problems in realistic mathematics education: A calculus course as an example. *Educational Studies in Mathematics*, 39, 111–129.
- Koichu, B. (2012). Enhancing an intellectual need for defining and proving: A case of impossible objects. *For the Learning of Mathematics*, 32(1), 2–7.
- National Council of Teachers of Mathematics (NCTM). (2000). *Principles and standards for school mathematics*. Reston, VA: Author.
- Rittle-Johnson, B., & Star, J. R., (2011). The power of comparison in learning and instruction: Learning outcomes supported by different types of comparisons. *Psychology and Motivation*, 55, 199–225.
- Sfard, A. (2002). The interplay of intimations and implementations: Generating new discourse with new symbolic tools. *The Journal of the Learning Science*, 11(2-3), 319–357.

Teaching practice regarding grade 3 pupils' use of representations

Isabel Velez¹, João Pedro da Ponte² and Lurdes Serrazina³

¹ Instituto de Educação da Universidade de Lisboa, Portugal; velez@campus.ul.pt

² Instituto de Educação da Universidade de Lisboa, Portugal; jpponte@ie.ulisboa.pt

³ Escola Superior de Educação, Instituto Politécnico de Lisboa, Portugal; lurdess@eselx.ipl.pt

In this paper we analyze the practice of a grade 3 teacher. We focus our analysis on teacher-pupils interaction in the classroom, aiming to understand how she strives to promote her pupils' use of representations. Data were collected through video recording of lessons and were analyzed in the introduction of a task, during pupils' autonomous work, and in a whole class discussion. The results show that the teacher's actions change according to her pupils' activity and difficulties and also vary depending on the moment of the classroom work. To promote her pupils' use of representations, the teacher adapts the type of questioning and her actions to the difficulties of her pupils.

Keywords: Representations, elementary school teachers, teacher's practice, questioning.

Introduction

Pupils' understanding of representations constitutes a fundamental basis for their mathematics learning, making it very important to know the way teachers deal with representations in their practice (Stylianou, 2010). A representation may be defined as a mental or physical construct that stands for a concept and enables to relate it to other concepts (Goldin, 2008). The fact that mathematical representations are related to each other in different ways creates difficulties for pupils' understanding and learning of representations (Goldin, 2008). Tripathi (2008) indicates that, in order to facilitate pupils' understanding of a given concept, teachers must use different kinds of representation. Some researchers, like Acevedo Nistal, Doreen, Clarebout and Verchaffel (2009), suggest that, as a starting point for learning symbolic representations, teachers must encourage pupils to create their own informal representations. In this study we aim to understand how an elementary school teacher explores a task with her pupils in the classroom, with special attention to the way she strives to promote the use of representations.

Teachers' practice, representations and questioning

An important aspect of teaching practice is the way teachers explore tasks in the classroom (Ponte & Chapman, 2006). Pupils' activity on a task is determined by the actions of teachers, the role that teachers assume, how they introduce the task, the questions that they ask, and the way how they lead whole class discussions (Swan, 2007). Ponte (2005) indicates that the classroom work on a task may involve three main moments: (i) introduction of the task which may involve negotiations of meaning (Bishop & Goffree, 1986), (ii) pupils' autonomous work, (individually, in pairs or groups), and (iii) whole class discussion.

Representations play an important role in mathematics. Their understanding is a complex process because a representation may have different meanings and in turn, a meaning may have several representations (Goldin, 2008). For example, the representation "5" may mean the 5th floor, 5 pm, or 5 as a quantity and, in turn the meaning of 5 as a quantity, can be represented as "|||||", "5" or "V".

For that matter, Duval (2006) indicates that, to understand the features of a mathematical object, we need to be able to make changes within a representation (treatment) or to change a representation in another representation (conversion).

To support pupils' learning of concepts, procedures and problem solving processes, the teacher may introduce new representations, linking them to pupils' previous knowledge (Stylianou, 2010). As Bishop and Goffree (1986) indicate, teachers must facilitate the interpretation of representations and encourage the establishment of connections among representations.

As pupils work on a task, the teacher's actions can be analyzed regarding how they promote the understanding of representations (Table 1). We defined four categories for pupils' activity that are related to teachers' actions: (i) support the pupils' design or selection of a representation; (ii) promote the use of a given representation; (iii) promote the transformation of a given representation; and (iv) promote pupils' reflection about representations. In table 1 we assume that there is a mutual influence between pupil's activity and teachers' actions. This way, pupils' activity can affect teachers' actions and teachers' actions promote pupils' activity. This framework about teacher actions is a specification of the general framework indicated in Ponte and Quaresma (2016).

Pupils' activity regarding representations	Teachers' actions
Choosing/ Designing	Promoting the free choice of a representation
	Challenging to choose a different representation
	Guiding about an adequate representation
	Providing explicit suggestions or examples
Using	Challenging to use a representation
	Asking to interpret a representation
	Guiding about the use or interpretation of a representation
	Informing pupils about how to interpret or how to use a representation
Transforming	(In)validating a representation chosen by pupils
	Challenging to establish treatments, conversions and connections
	Guiding to establish connections
	Guiding to identify possible treatments and conversions
Reflecting	Inform about treatments and conversions
	Challenging to systematizations
	Leading to systematizations
	Informing about systematizations

Table 1: Teachers' actions in different moments of the pupils' activity

Each teacher communicates in a different way with his/her pupils and how and when they do it. To Purdum et al. (2015), pupils' knowledge is influenced by teachers' questioning. Mason (2000)

indicates three different aims in teachers' questioning: (i) focusing, that is when the teacher question pupils through a funneling effect in order to focus them in a certain aspect; (ii) testing, in which the teacher analyses pupils' comprehension, and how they articulate ideas and establish connections and (iii) inquiring, in which the teacher questions pupils to understand what they are thinking. Regarding questioning, Blosser (1975) identifies four main categories or question types: (i) managerial, to give operating instructions; (ii) rhetorical, used to emphasize an idea; (iii) closed, with a limited number of possible answers (iv) open, with a large variety of possible answers, a type of questions used to promote a class discussion or pupils' interactions. In this way, we considered three different types of questions, with some subtypes (Table 2).

Type	Subtype	Examples
Focusing	Rhetorical	We saw this already, didn't we?
	Processual	Could you open your books on page 58?
		What if we look back into the task?
Orienting	What if you sum it all?	
Confirmation	Closed	How many will we have if you add 10?
Inquiring	Open	Do you agree with your colleagues' answer? Why?

Table 2: Different types of teachers' questions

Research methodology

This paper is a part of a wider research about teachers' practices regarding mathematical representations. The participant of this study is a grade 3 teacher, Sónia, from a school cluster in the surroundings of Lisbon (where she has been for the last 10 years) and her 20 pupils (teacher and pupils' names are pseudonyms) who have been together since grade 1. During the research, Sónia was a member of a team of four teachers with whom she worked regularly, preparing and analyzing their teaching. The group indicated that the pupils were used to solve problems similar to the one reported on this paper, however, they chose this task taking into account their perception that it could be solved using a diversity of representations. Although the main research includes the analysis of pre and post classroom sessions, in this paper we only present and analyze teacher-pupils interactions during the classroom work, showing how Sónia promotes pupils' use of representation as they work on the following task: "In a theatre play performed by grade 3 pupils, João, Pedro and Ulisses wanted to be the King. On the other hand, Ana, Inês and Estrela wanted to play the Queen. How many pairs King/Queen may be formed?". Data was gathered by video recording during class observations and through collecting pupils' written work. It was analyzed through content analysis in the moments of introduction of the task, pupils' autonomous work and whole class discussion. Teacher's actions were categorized according to teachers' actions indicated in Table 1 and to teachers' questioning presented in Table 2.

Sónia's Class

Introduction of the task

To introduce the task, Sónia starts reading the statement of the problem and asks a pupil to go on reading it. Then, she guides pupils about the interpretation of the task (she focuses on number of boys and girls and the awareness that a problem may have more than one answer) and questions pupils through confirming questions about the conditions of the problem. At a certain point, a negotiation of meaning took place, since the pupils did not know what a “pair” was. Sónia challenges them to interpret this meaning through inquiring questioning (“Can I have two pairs and a half?”, “What is a pair?”), but the pupils remain silent. Then she decides to question them through confirmation questions (“How many persons do I have in a pair?”), getting the interpretation from a pupil as “A group of two!”

Pupils' autonomous work

The pupils work autonomously for ten minutes, but Sónia notices that some of them struggle to understand what to do and she decides to discuss their difficulties collectively. She questions the pupils with confirming questions in order to guide them about the interpretation the statement of the problem (“Who can be the King and Queen?”, “Only a boy can be the King”, “Who are they?”). She suggests a specific representation to help the pupils to interpret the statement of the problem, by using an active representation, referring to the pupils' reality as if they were, at the time, involved in the school theatre play (“Imagine that . . . I am going to pick the King and Queen!... These three girls would raise their arms . . . And these three boys wanted to be the King... And now... Which are the possibilities?”). At the end of the discussion she challenges the pupils to use an adequate representation through inquiring questioning (“Let us discover!?”).

A pupil, Angelo, says that it is possible to get three different pairs (Figure 1a). Sónia challenges him to interpret his representation through inquiring questioning (“Can you explain me what this is...?”). The pupil says that he made a “table” picking the boys and girls randomly. Sónia guides him about the use of his representation through inquiring questioning (“Why João does not like Inês or Estrela? Is he angry with them?”). As Angelo does not understand that his answer is incomplete, Sónia changes her actions again and informs Angelo that he did not consider that each boy could be paired with three different girls (“How many are the possibilities? It does not say: ‘Tell me three [possibilities]...’”). When the pupil acknowledges that he has an incomplete answer she lets him continue working. Later Sónia comes back to see his work (figure 1b) and she challenges him to interpret the chosen representation through inquiring questioning (“What are you doing?”, “What are you repeating here?”). Angelo then explains why he considers nine pairs as he describes his representation (“If the first [group] is made... It has three [pairs]! Other [group]... It has one pair, another pair, another pair... They are three [groups]! (pointing to the third group) One pair, another pair, another pair... Three [more pairs]!”).

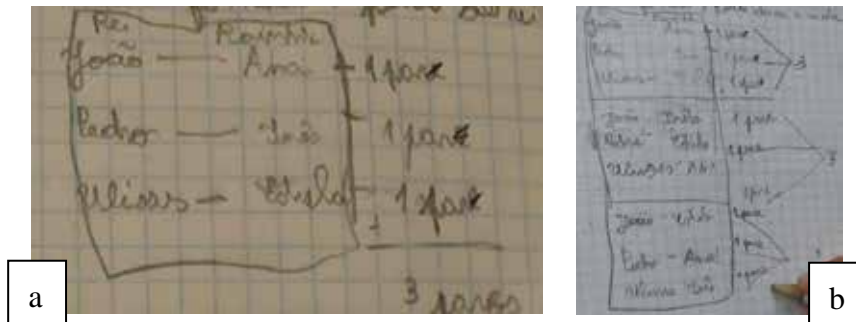


Figure 1 (a and b): Angelo's representations before and after Sónia actions

Later, another pupil, Joaquim, begins to complain loudly, because he feels that he is spending too much time on his representation (he drew every Queen and King in detail). Assuming he had to draw, Joaquim questions Sónia. Noticing that more pupils are using similar representations, she decides to guide pupils with confirming questioning (“Did anyone told you: Spend a lot of time on drawings!? Or to draw all the Kings and Queens?”). Another pupil, Fernando answers (“No! Why [should we draw]?! They have names!”) and fulfils the aim of Sónia. Then, she reinforces the pupils’ free choice of a proper representation (“If you think that you are taking too much time... Don’t do it...”). A few moments later, she returns to see his work) (figure 2).

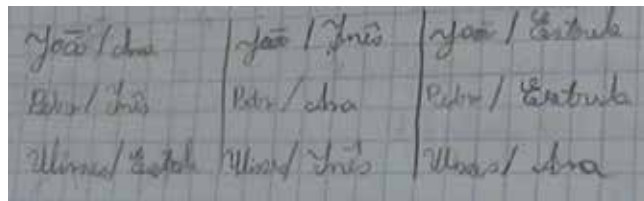


Figure 2: Joaquim's representation

Sónia challenges Joaquim to interpret his representation using inquiring questioning (“What are you doing?”) and he responds correctly (“I made the first group! Then I draw a line and divided the first group from the second! João, Inês. Pedro, Ana. Ulisses, Inês... And João, Estrela. Pedro, Estrela. Ulisses and Ana! And there are no more [pairs]!”). At a certain point most of pupils had solved or tried to solve the task and Sónia decides to begin the whole class discussion.

Whole class discussion

During the pupils’ autonomous work Sónia noticed that many of them had trouble in choosing a proper representation and in identifying the number of possible pairs. She decides to begin the whole class discussion by inviting Luís to present his solution (he has an incomplete answer). She asks him to interpret his representation using confirming questions (“Why did you not consider João and Estrela?”). Based on the representation of Luís she suggests another representation – a scheme with circles, arrows and crosses (Figure 3a), and the pupils acknowledge that it was an incomplete answer (Luís: “Ah! He can [also be paired] with Ana!”).

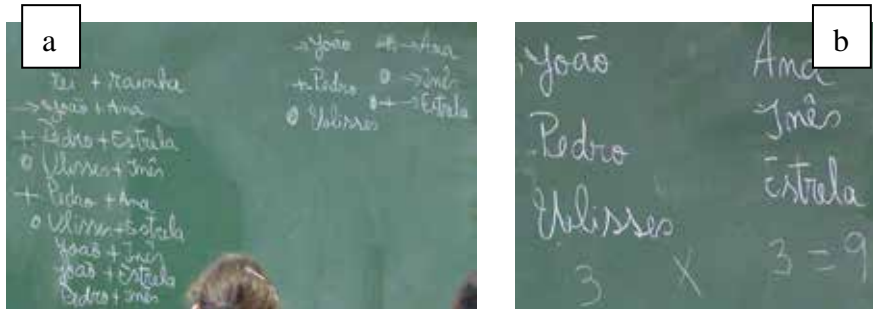


Figure 3 (a and b): Sónia's representations

During the remaining of the discussion, Sónia's actions vary greatly. Sometimes she challenges pupils to systematize through inquiring questioning ("Why have not you done that?", "Are there more possibilities?") but when they do not respond, she leads the pupils to establish connections and to identify conversions and she informs the class about systematizations.

This task had a follow up question "During the rehearsals, Inês decided that she wanted to drop out of the play. How many pairs are now possible?" During the moment of autonomous work, only the fastest pupils got to solve this question. However, faced with the class difficulties in the whole class discussion, Sónia decides to solve it in whole class and she challenges the pupils:

Sónia: How many pairs are there right now? (some pupils answer "six" loudly) Why?

Laura: Because João can be [a pair with] Ana and Estrela. . . Pedro can be with Ana and Estrela . . . And Ulisses can make [a pair] with Ana and Estrela... It's six!!

Sónia: So Laura says that João can be a pair with Ana or Inês (she writes the names on the board and she connects João with Ana and Estrela as she speaks)... So... Two possibilities for João (she writes the number "two" on the left of the first representation)... Pedro can be a pair with Ana and Estrela... [He has as well] two possibilities and Ulisses with Ana and Estrela (she continues both representations as she speaks) (figure 4)! So... All together (she transforms the "two" into a vertical calculus)...

Pupils: Six!!!! (the teacher writes "six" below the vertical column of 2s)



Figure 4: Teacher's diagram and symbolic representations

As Sónia challenges her pupils to interpret the question, Laura explains easily to the class how she thought. Sónia transforms Laura's explanation into a written representation (figure 4), in order to lead her pupils to establish connections between representations. Afterwards, Sónia leads them to make connections between all representations (figures 2a, 2b and 3). She ends the discussion by suggesting the multiplication sign ("If we have... Three boys [she writes "3" below the boys' names] and three girls ([she writes "3" below the girls' names]... I have (she puts the \times sign writing 3×3)... Nine! Nine possibilities!").

Conclusion

During the introduction of the task, most of Sónia's actions were focused in promoting pupils' understanding of the statement of the problem, by guiding them through confirming questions (Who? How? How many?). As several pupils had trouble with the meaning of the word "pair", Sónia handled this problem leading a negotiation of meaning, challenging the class through inquiring and guiding questioning. In that way, Sónia's actions begun by addressing the understanding of the statement of the problem, so that pupils could think about how to solve it and figure out what type of representation is more adequate.

During the moment of autonomous work, Sónia led the pupils to write their answers and representations and to justify them. She made the pupils to convert their mental representations into written ones. While interacting with the pupils, Sónia used challenging actions through inquiry questions ("Explain me that...", "I am not understanding..."). When this did not work, she changed her actions and questioned pupils with confirming questions, leading them to explain their representation. Usually, she seemed to re-evaluate her pupils' activity and shifted between actions in order to take them to use adequate representations. At the beginning of pupils autonomous' work, Sónia promoted pupils' free choice of representations and did not influence her pupils' work. Later, while pupils were using and transforming their representations, she did not suggest alternatives nor guided them to find conversions or treatments, even when they were struggling. In that way, her actions (i) enabled the emergence of a large variety of representations to be considered during the whole class discussion, (ii) supported the establishment of connections; and (iii) promoted pupils' reflective activity about their own representations.

In the whole class discussion, most actions of Sónia were informing about new representations and informing and guiding the pupils to figure out the connections and transformations that they could do. Due to her pupils' difficulties during their autonomous work, she felt compelled to systematize all the information and to act with more guiding actions. As in McClain (2000), the pupils' representations had less relevance. In fact, Sónia used pupils' representations as a starting point for discussion, and then she introduced her own representations. At the end of the discussion, she suggested the sum and multiplication signs as adequate representations and connected them to her first representation (that she made from a pupil's explanation). However, since there was no further discussion, it is unclear what understanding pupils made of that.

In summary, during the three phases of the work, Sónia's actions tended to change according to her pupils' answers and difficulties. At the introduction of the task, Sónia considered necessary to support the conversion of the statement of the problem into a different representation. Although pupils knew the multiplication sign, this did not mean that they knew how it can be used to model situations as in this problem (Acevedo Nistal et al., 2009). In that way, at the end of the discussion, the teacher felt the need to guide her pupils about the use and interpretation of the multiplication sign. Only in future classes, one may know if this led the pupils to understand the use of symbolic representation in this kind of situations. In this study, we see that Sónia changed her actions according to pupils' activity in order to promote their use of representations. When pupils had an organized strategy and an adequate but incomplete representation, she questioned them, so they could review their strategies

and representation and find out how they could finish the task. When pupils had a disorganized strategy and an adequate but incomplete representation she tried to help them to understand why the representation was incomplete, focusing in the need of using a more organized strategy. And when the pupils had an inadequate representation she questioned them, guiding the pupils to choose a different representation and strategy.

References

- Acevedo Nistal, A., Dooren, W. V., Clarebout, G., Elen, J., & Verschaffel, L. (2009). Conceptualizing, investigating and stimulating representational flexibility in mathematical problem solving and learning: A critical review. *ZDM Mathematics Education*, *41*(5), 627–636.
- Bishop, A., & Goffree, F. (1986). Classroom organization and dynamics. In B. Christiansen, A. G. Howson & M. Otte (Eds.). *Perspectives on mathematics education* (pp. 309–365). Dordrecht: D. Reidel.
- Blosser, P. E. (1975). *How to ask the right questions*. Washington, DC: National Science Teachers Association.
- Duval, R. (2006). A cognitive analysis of problems of comprehension in a learning of mathematics. *Educational Studies in Mathematics*, *61*, 103–131.
- Goldin, G. (2008). Perspectives on representation in mathematical learning and problem solving. In L. English (Ed.), *Handbook of international research in mathematics education* (pp. 178–203). New York, NY: Routledge.
- Mason, J. (2000). Asking mathematical questions mathematically, *International Journal of Mathematical Education in Science and Technology*, *31*(1), 97–111.
- McClain, K. (2000). An analysis of the teachers' role in supporting the emergence of symbolizations in one first-grade classroom. *Journal of Mathematical Behavior*, *19*, 189–207.
- Ponte, J. P. (2005). Gestão curricular em Matemática. In GTI (Ed.). *O professor e o desenvolvimento curricular* (pp. 11–34). Lisboa: APM.
- Ponte, J. P., & Chapman, O. (2006). Mathematics teachers' knowledge and practices. In A. Gutierrez & P. Boero (Eds.). *Handbook of research on the psychology of mathematics education: Past, present and future* (pp. 461–494). Rotterdam: Sense.
- Ponte, J. P., & Quaresma, M. (2016). Teachers' professional practice conducting mathematical discussions. *Educational Studies in Mathematics*, *93*(1), 51–66.
- Purdum-Cassidy, B., Nesmith, S., Meyer, R. D., & Cooper, S. (2015). What are they asking? An analysis of the questions planned by prospective teachers when integrating literature in mathematics. *Journal of Mathematics Teacher Education*, *18*, 79–99.
- Stylianou, D. A. (2010). Teachers' conceptions of representation in middle school mathematics. *Journal of Mathematics Teacher Education*, *13*, 325–343.
- Swan, M. (2007). The impact of task based professional development on teachers' practices and beliefs: A design research study. *Journal of Mathematics Teacher Education*, *10*, 217–237.
- Tripathi, P. N. (2008). Developing mathematical understanding through multiple representations. *Mathematics Teaching in the Middle School*, *13*(8), 438–445.

Explaining geometrical concepts in sign language and in spoken language – a comparison

Annika M. Wille¹ and Christof Schreiber²

¹Universität Klagenfurt, Austria; annika.wille@aau.at

²Justus-Liebig-Universität Gießen, Germany; christof.schreiber@math.uni-giessen.de

The explaining of mathematical terms is part of both learning and teaching mathematics. In this study, explanations, in the forms of a video in sign language, a video and an audio recording in spoken language (all on the subject of quadrilaterals), are compared. Therewith, the explanation process is understood as semiotic mediation, as proposed by Hasan (2002, 2005). The question regarding which role the modality plays in transitioning from specific geometric forms to general statements of the geometric forms is also pursued.

Keywords: Semiotic mediation, sign language, spoken language, use of representations.

Introduction

The explaining of mathematical terms is part of both learning and teaching mathematics. With this, the process of explanation can be understood as semiotic mediation (Hasan, 2002, 2005), which refers to a “mediation by means of the modality of language” (Hasan, 2002, p. 112) This study focuses on the modality of language, or to be more specific, on the differences in explanations in sign language and in spoken language. For the subject matter of the ‘House of Quadrilaterals’ (a hierarchic structure of different quadrilaterals; see figure 1), three medially different explanations were developed along the lines of the same subject analysis: one video and one audio product, both in German spoken language, along with one video in Austrian Sign Language (ÖGS¹). Thus, this study focuses on the question: What roles do modalities of spoken and sign language play in transitioning from specific geometric forms to general statements of the geometric forms?

Semiotic mediation of a geometrical concept

Hasan (2002, 2005) considers ‘semiotic mediation’ as a process, in which a mediator mediates something to a mediatee, the addressee. Though, the details of the mediation, regarding modality and where it took place, can differ (cf. Hasan, 2005). For the process of mediation, Hasan (2002, p. 115) distinguishes between acting by doing and acting by saying, which she defines as *material action* and *verbal action*, respectively. In the context of this paper, for example, material action includes writing down or pointing at mathematical inscriptions on blackboard or on pinboard (see Figure 2). Both forms of action can take place independently, though possibly in the same place or even simultaneously. In the last case, Hasan differentiates between *ancillary verbal action*, where “verbal action is assisting in the conduct of the ongoing material activity” (p. 116) and *constitutive verbal action*, where the verbal action is not “running in parallel” (p. 116) with the material action, but is pivotal for the topic of a discussion. Hasan primarily considers daily conversations, wherein a

¹ ÖGS stands for “Österreichische Gebärdensprache“.

physical action is commented on and, after a *shift* from ancillary to constitutive verbal action, the discussion then distanced from the physical level to then focus on topics, which go beyond the physical level. Hasan considers this shift to be of importance because, after such a change, an additional invisible mediation can take place in which habits of mind can be communicated.

Mathematical inscriptions (on paper, on the chalkboard, etc.) and experimentation with these is a fundamental part of mathematical activity (cf. Dörfler, 2016), which is principally of material nature. With the help of inscriptions, one can not only provide for concrete propositions, but can also generalize these. This is especially visible in geometry when, for example, quadrilaterals are compared and general propositions are made. Dörfler (1991) describes this as an “empirical generalization”, though the “basic process is to find a common quality or property among several or many objects or situations (mostly from sense perceptions) and to notice and record these qualities as being common and general to these objects or situations” (p. 65). For example, the figurative forms of geometric inscriptions can be compared and then generalizations can be made. For instance: ‘Every square is a rectangle, but not every rectangle is a square.’

How can an explanation, which leads to a generalization, differ with different language modalities such as sign language and spoken languages? Sign languages are natural languages, just like spoken languages. Though, these are visual, in contrast to auditory spoken languages. The consequence of this is that different visual levels can be processed simultaneously (cf. Grote & Linz, 2003). Particularly, signs utilize space in a distinct manner: Often times, in narratives, a “singular aspect” is focused on and located in the sign space. This point of focus is referred back to throughout the narration (cf. Grote, 2016, p. 144). One example is the description of a picture: In spoken language, a picture is typically described in a linear fashion, for example, from left to right. Contrasting to this, in sign language, a central object is described and all other objects are then related to it.

A further central characteristic of sign language is the iconicity and indexicality of many signs, especially in terms of mathematical signs (cp. Krause, 2017; Wille, submitted). An icon, understood in the sense of Peirce, represents relations (cp. Hoffmann, 2007, p. 3; Peirce EP II 13). Mathematical signs rather frequently picture either the apparent relational structure of mathematical inscriptions or are similar to operations with the inscriptions. This is not limited to geometric forms only (cp. Wille, submitted), even if such are the focus of this study. To provide for an example, in Austrian Sign Language (ÖGS), the sign RECTANGLE² is communicated by tracing the geometrical form of a rectangle with the fingers. The sign ROTATION, on the other hand, resembles the actual operation of rotating a geometric form (cf. Schreiber & Wille, submitted). This principally means that mathematical ÖGS signs often look like concrete inscriptions. Although signs are used symbolically, just as often as words in spoken languages, this “does not imply that the iconic dimension of a linguistic sign becomes completely blended out or deleted” (Grote & Linz, 2003, p. 35). In the following, the question regarding how the transition from specific forms to general propositions can take place in sign language is compared to spoken language.

² In this study, ÖGS signs are written in gloss with capital letters as is common in sign language literature. (cf. Skant et al., 2002).

Three different explanations regarding quadrilaterals

Three medially different explanations on how a square is related to other quadrilaterals were developed on the basis of the same subject analysis at the universities of Giessen and Klagenfurt:

For the video in spoken language, based on the subject analysis, a script was prepared with different scenes, containing the action of the students, the spoken text and material to use in the video (see the example below). This script was critically discussed with the students and optimized. In the video, reproductions of the geometrical figures were successively pinned to the board. These figures were discussed and relationships between the figures were identified and explained.

For the audio recordings, the script dialogue was developed so that a pair of both male and female speakers reciprocally demonstrated the relationships between the quadrilaterals, which, in this case, are not presented in the form of a picture.

The realization into Austrian Sign Language (ÖGS) took place in cooperation with a deaf colleague from the center for sign language and hearing-impaired communication of University Klagenfurt. For this, a script in German written language served as the basis for a discussion in sign language, concerning how this text could be properly realized. This was then transferred to a teleprompter, in gloss, which was signed with slight variation in the video. Geometrical forms were also attached to a bulletin board. For the spoken language realizations, in the forms of both audio and video, scripts also served as the foundation. Though, these scripts were not changed, due to the fact that there was only a shift from “writtenness” to “orality” (see Schreiber, 2013, p. 1598).

These videos and the audio do not have the purpose of replacing lessons, but were rather developed with the intention of comparing various modalities of the mathematical explanation. For this reason, the influence of such explanations on students is not being focused upon.

Analysis of videos in sign language from the standpoint of Hasan’s theoretical perspective

In contrast to mathematical terminology in spoken language, mathematical signs feature an inherent form of materiality. In ÖGS, forms such as the square, rectangle and rhombus are traced with the fingers. The sign ROTATION not only depicts that something is being rotated, but one can also see the type of object. Furthermore, for the sign PARALLELOGRAM, a right-angled parallelogram is transformed into a non-right-angled parallelogram (see Figure 1). This means that in ÖGS, the difference between material action and verbal action is not as distinguishable as in German spoken language.



Figure 1: The ÖGS signs SQUARE, RECTANGLE, PARALLELOGRAM and ROTATION

Which shifts from ancillary to constitutive verbal action are thus discernable in the ÖGS video? At first, the ÖGS video will be compared to the corresponding script. In the next section, a comparison to the spoken language video and audio follows.

When comparing the script text for the ÖGS video with the actual transcript for the ÖGS video in gloss, it can be seen that in the ÖGS video, ancillary verbal action increases and, simultaneously, constitutive verbal action decreases. The following section demonstrates this noticeably.

The following text is an excerpt of the script of line 42 to 47:

Script Text in German

42 Also: Dieses Rechteck ist kein Quadrat.
 43 Es besitzt nicht alle Eigenschaften, die das Quadrat hat.
 44 Aber wie sieht es andersherum aus?
 45 Ist ein Quadrat ein Rechteck? – Ja!
 46 Jedes Quadrat ist ein Rechteck. Es ist ein besonderes Rechteck.
 47 Es besitzt alle Eigenschaften eines Rechtecks.

English Translation

So, this rectangle is not a square.
 It does not possess all the properties of the square.
 But, what about the other way around?
 Is a square a rectangle? – Yes!
 Each square is a rectangle. It is a specific rectangle.
 It has all the properties of a rectangle.

The corresponding transcript (in gloss) for the ÖGS videos is the following:

Transcript for the ÖGS videos in gloss

42 IX RECHTECK NICHT INHALT QUADRAT
 43 NICHT ALLE EIGENSCHAFT
 44 IX QUADRAT INHALT JA RECHTECK
 45 AUFPASSEN QUADRAT IX BESONDERS INHALT ALLE EIGENSCHAFT DA DA DA
 46 ABER RECHTECK NICHT IMMER QUADRAT
 47 BEISPIEL IX RECHTECK INHALT KEIN QUADRAT

Translation in English

This rectangle is not a square because it does not have all the properties.
 This square is indeed a rectangle.
 It should be noted that this square is a specific one (a special rectangle), since all properties are fulfilled.
 But a rectangle is not always a square.
 For example, this rectangle is not a square.

In the section above, there is a shift to constitutive verbal action. First, in lines 42 and 43, it states: “So, this rectangle is not a square. It does not possess all the properties of the square.” This refers to the specific rectangle, which is attached to the bulletin board in the background and was used to speak about reflections, rotations, parallel sides and right angles. After this, at line 44, there is a transfer to constitutive verbal action, since all squares are now being talked about in a general way: “But, what about the other way around? Is a square a rectangle? – Yes!” Instead of speaking about “this square”, it is now called “a square”. Thus, the verbal action changes from speaking about the concrete forms to then speaking about forms of one type in general.

In contrast to this, the verbal action in the corresponding part of the ÖGS video is, with the exception of line 5, ancillary. The ÖGS sign IX is an indexical sign, with which the pointer finger signs. It can be translated with “this”. It is noticeable that only in line 46 there is constitutive verbal action. This means that only one shift from ancillary to constitutive verbal action is between lines 46 and 47. The

expression “a rectangle is not always a square” can be described in no other manner than generally. All other sentences concretely reference the rectangle on the bulletin board.

A second thing is noticeable in this section, when comparing the ÖGS video with the script text: In the script, a concrete rectangle is at first discussed and then the discussion moves to only generally talk about squares. In contrast to this, “IX RECHTECK” (this rectangle) seems to act as an anchor in the ÖGS video. This occurs at both the beginning and the end and acts as the central point to which the rest then references. Such concurs with the observations, noted above, stating that sign language narratives often place something singular in the focus of attention, which is then referenced back to. In this section it’s “this rectangle”. In the context of the whole ÖGS video, however, “IX QUADRAT” (this square) takes on this role.

For example, such can be seen in the following excerpt (line 63 to 65), concerning the relationship between the rhombus and the square. In the script, solely constitutive verbal action can be observed:

Script Text in German

- 63 Ist eine Raute ein Quadrat? – Nein! Sie besitzt nicht alle Eigenschaften des Quadrats.
 64 Ist ein Quadrat eine Raute? – Ja! Jedes Quadrat ist eine besondere Raute.
 65 Alle Eigenschaften der Raute sind erfüllt.

English Translation

- Is a rhombus a square? - No! It doesn't possess all the properties of a square.
 Is a square a rhombus? - Yes! Each square is a special rhombus.
 All properties of a rhombus are fulfilled.

Whereas one can observe the following in the ÖGS video segment:

Transcript for the ÖGS videos in gloss

- 63 IX RAUTE INHALT QUADRAT? NEIN
 64 ABER AUFPASSEN IX QUADRAT INHALT RAUTE? JA
 65 WARUM? IX ALLE EIGENSCHAFT RAUTE DA DA
 a IX QUADRAT BESONDERS RAUTE

Translation in English

- Is this rhombus a square? No!
 But watch out! Is this square a rhombus? Yes.
 Why is that so? All properties – are fulfilled – those discussed earlier
 This square is a special rhombus.

The script’s linear-constructed text in the ÖGS video is once again changed. In the last part, “IX QUADRAT” (this square) is referred to multiple times.

In addition, it seems as if this is all ancillary verbal action. Nevertheless, there is something here, which cannot be equally expressed in spoken language. The ÖGS sign “IX” in line 64, is signed toward the bulletin board (see Figure 2, left-hand side). Here, a reference is being made to the concrete square. Though, later in line a^3 , “IX” is signed to the front, toward the audience (see Figure 2, right-hand side). This can be understood as an intermediate step for generalization, respectively as an intermediate shift between ancillary and constitutive verbal action. In this case the second phrase “IX QUADRAT” (this square) in line a not only refers to the concrete square, but also to the square as a paradigmatic example, which stands for the general case.

³ This line in the transcript does not correspond to a line in the script. Therefore, this additional line is marked with “a”.

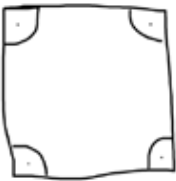


Figure 2: The ÖGS sign “IX” in line 64 (left-hand side) and line *a* (right-hand side)

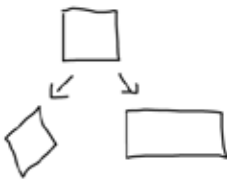
In comparison: ancillary and constitutive verbal action of spoken language in video and audio

Due to a lack of space for this study, both the spoken language video and the audio recording can only be briefly outlined, in order to substantiate the indications. More detailed examples can be found in Schreiber & Wille (submitted).

The explanations in the video, in spoken language, are categorized as verbal action, while the material action takes place through either pointing at the constituting properties of the forms, drawing in properties or by drawing in arrows to indicate relationships between the quadrilaterals. For example, this is apparent in the excerpt of the script, example *a*:

<i>Scene</i>	<i>Action</i>	<i>Spoken Text</i>	<i>Depiction</i>
2	The person points to the angles and the sides.	It's directly noticeable that there are four equally long sides. The sides are in a certain position in respect to each other. Adjacent sides build a right angle and opposite sides are parallel.	

In this video, concrete forms are referred to in the sense of ancillary verbal action (see example *a*). Forms are recurrently referred to in a general sense, utilizing constitutive verbal action to illustrate general relationships, like in example *b*:

<i>Scene</i>	<i>Action</i>	<i>Spoken Text</i>	<i>Depiction</i>
4	The camera zooms out so that all figures are visible. The person draws an arrow between the square and rhombus.	It's also noticeable that this rhombus has properties similar to the square. Both have four equally long sides but different angles and, because of this, different symmetries. We are drawing an arrow from the square to this rhombus. The square is a special form of the rhombus, actually a rhombus, which has four right angles.	

Initially, the concrete rhombus is referred to, which is located on the bulletin board. It is directly compared to “the square”, though this does not necessarily refer to the concrete square, which is

located on the board. “The square is a specific kind of rhombus” is already formulated in a general sense, which is emphasized by referring to the properties, a “rhombus, which has four right angles”.

In the audio, exclusively general cases are described. One can only speak of forms in general, due to the absence of the visual mode of presentation. Thus, constitutive verbal action is utilized throughout this special setting. Such can be seen with student 1’s initially posed question and student 2’s corresponding answer:

- s1 Honestly, what is actually so special about a square? It’s really just a very basic quadrilateral.
s2 The square combines the properties of all the other quadrilateral.

No specific square is being referred to, even though *the* square is noted. In particular, this square can readily be compared to all quadrilaterals. Such is also the case at a later point, when student 2 compares the general rhombus with the general square and when student 1 explains the general rhombus more in-depth:

- s2: That’s right. For the rhombus, the difference to a square is that the four angles mustn’t be right angles, right?
s1: Yes, the angles don’t have to be right angles for the rhombus.

The utilization of material action is omitted and, in the here-discussed example, ancillary verbal action is not present.

Conclusion

A comparison of the three medially different explanations shows that the prevalence of ancillary to constitutive verbal actions differ. In the ÖGS video, concrete forms are recurrently referred to. As previously discussed, when the ÖGS sign “IX” (this) is signed toward the front, this can be interpreted as a reference to a paradigmatic example.

Hasan (2002) explains that, in terms of constitutive verbal action, habits of mind can be mediated. She calls this invisible mediation. A typical mathematical “habit”, in the sense of empirical generalization, is that of considering concrete mathematical forms, equations, structures, etc., to reach generalizations. It can be observed that the modality of a visual language changes an explanation, in relation to spoken language.

Acknowledgment

We wish to thank Christian Hausch from the center for sign language and hearing-impaired communication of University Klagenfurt, Austria, for his cooperation during the production of the videos in Austrian Sign Language.

References

- Dörfler, W. (1991). Forms and means of generalization in mathematics. In A. J. Bishop et al. (Eds.), *Mathematical Knowledge: Its Growth Through Teaching* (pp. 63–85), Netherlands: Kluwer.
- Dörfler, W. (2016). Signs and their use: Peirce and Wittgenstein. In A. Bikner-Ahsbahr, A. Vohns, O. Schmitt, R. Bruder, W. Dörfler (Eds.), *Theories in and of Mathematics Education. Theory Strands in German Speaking Countries* (ICME 13 Topical Surveys) (pp. 21–31). Berlin: Springer.

- Grote, K. & Linz, E. (2003). The influence of sign language iconicity on semantic conceptualization. In W. G. Müller & O. Fischer (Eds.), *From sign to signing: Iconicity in language and literature 3* (pp. 23–40), Amsterdam/Philadelphia: John Benjamins Publishing Company.
- Grote, K. (2016). Der Einfluss von Sprachmodalität auf Konzeptualisierungsprozesse und daraus abgeleitete Konsequenzen für die Hörgeschädigtenpädagogik. *Hörgeschädigtenpädagogik*, 4, 140–146.
- Hasan, R. (2002). Semiotic mediation and mental development in pluralistic societies: some implications for tomorrow's schooling. In G. Wells & G. Claxton (Eds.), *Learning for Life in the 21st Century: Socio-cultural Perspectives on the Future of Education* (pp. 112–126). London: Blackwell.
- Hasan, R. (2005). Semiotic mediation, language and society: Three exotripic theories – Vygotsky, Halliday and Bernstein. In J. J. Webster (Ed.), *Language, society and consciousness: Raqaiya Hasan* (pp. 130–156). London: Equinox.
- Hoffmann, M. H. G. (2007). Cognitive Conditions of Diagrammatic Reasoning. *Georgia Tech's School of Public Policy Working Paper Series, 24* [PDF file]. Retrieved from <https://smartech.gatech.edu/bitstream/handle/1853/23809/wp24.pdf>
- Krause, C. (2017). Iconicity in signed fraction talk of hearing-impaired sixth graders. In B. Knaur, W. K. Ho, T. L. Toh & B. H. Choy (Eds.), *Proceedings of the 41st Conference of the International Group for the Psychology of Mathematics Education*, Vol. 3 (pp. 89-96). Singapore: PME.
- Peirce (EP). The Essential Peirce. Selected Philosophical Writings. Vol. 1 (1867-1893), Vol. 2 (1893-1913) (= ed. by Nathan Houser and Christian Kloesel, Peirce Edition Project). Bloomington and Indianapolis 1992 +1998: Indiana University Press.
- Schreiber, C. (2013). PriMaPodcast – Vocal representation in mathematics. In B. Ubuz, C. Haser, & M. A. Mariotti (Eds.), *Proceedings of the eighth congress of the European society for research in mathematics education* (pp. 1596-1606). Antalya: ERME.
- Schreiber, C. & Wille, A. M. (submitted). Semiotische Perspektiven auf das Erklären von Mathematik in Laut- und Gebärdensprache. Manuscript submitted for publication.
- Skant, A., Dotter, F., Bergmeister, E., Hilzensauer, M., Hobel, M., Krammer, K., Okorn, I., Orasche, C., Orter, R., & Unterberger, N. (2002). *Grammatik der Österreichischen Gebärdensprache*. Klagenfurt: Forschungszentrum für Gebärdensprache und Hörbehindertenkommunikation, Band 4.
- Wille, A. M. (submitted). Mathematische Gebärden der Österreichischen Gebärdensprache aus semiotischer Sicht. Manuscript submitted for publication.

Characterizing fraction addition competence of preservice teachers using Rasch analysis

Marius Lie Winger, Julie Gausen, Eivind Kaspersen and Trygve Solstad

Norwegian University of Science and Technology, Norway; marius.l.winger@ntnu.no,
juliegausen@gmail.com, eivind.kaspersen@ntnu.no, trygve.solstad@ntnu.no

Keywords: Fraction addition, competence, representations, Rasch analysis.

Research topic and theoretical framework

Norwegian preservice teachers (PSTs) produce lower scores on tests of prerequisite mathematical knowledge than other student groups, and fractions is a particularly difficult topic (Bjerke et al., 2013; Ånestad et al., 2014). The low mathematical competence in turn poses a hindrance to acquiring didactical competence from courses in mathematics education.

Several theoretical frameworks for mathematical competence emphasize the role of representations and transformations between representations (e.g. Niss & Højgaard, 2011). If the target and source representation are the same, this transformation is called a *treatment*, whereas it is called a *conversion* if they are different (Duval, 2006). For example, a calculation in the symbolic representation is a treatment of the mathematical object, while graphing a function from a table is a conversion. Conversions between representations have been suggested to be a common source of incomprehension for students, where the direction of the conversion could substantially affect the perceived difficulty of a mathematical problem (Duval, 2006). As a step towards understanding and strengthening PSTs' competence with mathematical representations, we ask:

What characterizes PSTs' competence in representations of fraction addition as they enter mathematics education, and how does their competence develop through teacher training?

In this poster, we report on the development of a Rasch measurement scale for answering these questions, and present quantitative and qualitative results from a group of PSTs at the beginning of their teacher training. By using Rasch analysis we will obtain an invariant measurement scale ensuring that the results can be compared confidently over a time period. Furthermore, this approach provides insight into the dimensionality of competence in representations of fraction addition.

Method

A Rasch instrument including 18 items on fraction addition was developed. The items concerned the transformation between symbolic and two kinds of diagrammatic (area and number line) representations of fraction addition. Data was collected from a group of 98 first-year PSTs who had not yet had instruction in fractions in their mathematics education courses. The group therefore reflects a wide range of experiences with fraction representations from classrooms across the country. The student answers were analysed qualitatively and scored according to pre-defined criteria developed in a pilot study.

Result and discussion

First-year PSTs were highly competent at solving fraction addition problems in the symbolic representation register. At the same time, there was large variability in the PSTs' competence in converting addition problems between the symbolic and diagrammatic representation registers, where conversion from symbolic to diagrammatic form was the most challenging.

Principal Component Analysis (PCA) of the instrument indicated two potential dimensions, or *contrasts*, in the data. The first contrast separated items according to which diagrammatic representation was involved (linear vs area model). The second contrast separated the items according to the direction of conversion between symbolic and diagrammatic representations, which could be considered a subdimension of the instrument. This can be interpreted as saying that competence in representation of fraction addition should be measured using more than one variable.

We conclude that competence in fraction addition was a multidimensional construct for the group of first-year PSTs. The PSTs' high level of competence in the fraction addition procedures did not necessarily transfer to representing fraction addition in a diagrammatic model, and producing diagrammatic representations was more difficult than interpreting diagrammatic representations, likely reflecting a difference in experience with the different kinds of conversion. These quantitative results were reflected in the qualitative analysis. The coding and scoring process showed that although many of the students that performed well on the area model tasks tended to apply part-whole interpretations to the number line. These results lend support to the theory that different aspects of competence in a single concept can be developed independently (Usiskin, 2015).

The present study provides a foundation for investigating whether different representation registers of fraction addition, and transformations between these, become increasingly associated towards a coherent concept as PSTs progress through the teacher education program.

References

- Bjerke, A. H., Eriksen, E., Rodal, C., & Ånestad, G. (2013), Når brøk ikke er tall-Eksemppler på misoppfatninger knyttet til brøk som tallstørrelse, In Pareliussen, B. B., Moen, R. A., & T. Solhaug (Eds.), *FoU i praksis 2012*, Trondheim: Akademika forlag
- Duval, R. (2006). A cognitive analysis of problems of comprehension in a learning of mathematics. *Educational Studies in Mathematics*, 61(1-2), 103–131.
- Niss, M. A., & Højgaard, T. (Eds.) (2011) *Competencies and mathematical learning. Ideas and inspiration for the development of mathematics teaching and learning in Denmark*. Roskilde: Roskilde Universitet. IMFUFAttekst: i, om og med matematik og fysik, No. 485
- Ånestad, G., Rodal, C., & Eriksen, E. (2014). Et innblikk i lærerstudenters forkunnskaper innen brøk. In Reinertsen, A. B., Groven, B., Knutas, A., & Holm, A. (Eds.), *FoU i praksis 2013*, (pp. 273–282). Norway: Akademika forlag.
- Usiskin, Z. (2015). What does it mean to understand some mathematics?. In Cho S. (Ed.) *Selected Regular Lectures from the 12th International Congress on Mathematical Education*, (pp. 821–841). Cham, Switzerland: Springer.

TWG25: Inclusive Mathematics Education – challenges for students with special needs

Introduction to the work of TWG25: Inclusive Mathematics Education – challenges for students with special needs

Petra Scherer¹, Evelyn Kroesbergen², Hana Moraová³, Helena Roos⁴

¹University of Duisburg-Essen, Faculty of Mathematics, Germany; petra.scherer@uni-due.de

²Radboud University, The Netherlands; e.kroesbergen@pwo.ru.nl

³Charles University, Faculty of Education, Czech Republic; hana.moraova@pedf.cuni.cz

⁴Linneaus University, Faculty of Technology, Sweden; Helena.Roos@lnu.se

Keywords: Inclusive mathematics, special education, teacher education, special needs in mathematics education, differentiation, diversity.

Introduction

For CERME11, a new TWG about inclusive mathematics education has been established, with its first meeting at CERME11. This group was created due to an arising need for a forum to discuss issues of inclusion in the light of special needs in mathematics (SEM) in educational research. This branch of research has been developed in relation to general educational research about special educational needs (SEN) over the last decades, and has come to include not only disability and psychological issues, but also social, cultural and educational issues (Magne, 2006) Hence, the notion of SEM covers different epistemological fields as well as touching upon issues of normality (Skovsmose, 2019).

The scope and focus of TWG25 is hence SEM and inclusion, in the intersection of mathematics education research and special education research. Since this scope is broad, the TWG-papers compromised grades 1-12, teacher professionalization and teacher education programs, types of inclusive settings in mathematics, concepts and models for instruction and subject matter didactics, special educational needs and child characteristics, and content related decisions for inclusive mathematics education.

During CERME11 there were 17 participants in TWG 25 from 10 countries – colleagues from Europe, and also from Canada and Hong Kong. 10 papers and 2 posters were presented during the week, and the thematic schedule was oriented towards the topics of the submitted papers and posters (presenting authors below). The first session was spent on a discussion about the aims and objectives of this new TWG and an exchange of overarching issues of the situation of SEM in the different represented countries. In the following TWG-sessions, two or three papers were presented each time, under an overarching theme. The themes were: (1) *Development of materials, tools, learning arrangements, settings, etc.* (2) *Research on classroom situations, out-of-school situations* (3) *Research on teacher education (pre-service and in-service).*

The themes were discussed in the initial session in order to include all participants.

(1) Development of materials, tools, learning arrangements, settings, etc.

This theme includes discussions of how to develop tools to identify students in SEM, but also how to promote their learning, including the research aims: for example, seeking to know the place of mathematics education in dyscalculia research, how to reconcile approaches to reach a better understanding of the disorder and provide professional development activities for both, pre-service and in-service teachers, regarding the multicultural education and presenting all attributes of a designed learning software.

Florence Peteers: Diagnosis tools of dyscalculia – contribution of didactics of mathematics to numerical cognition

Janka Medová: Designing Mathematical Computer Games for Migrant Students

(2) Research on classroom situations, out-of school situations

This theme includes discussions of inclusion in relation to SEM students, mathematics classrooms and out-of school situations, where the focus lied in the challenges and possibilities in mathematics education. Examples of research questions within this theme are: How are inclusion and disability constructed in the discourses of teaching staff and pupils in mainstream mathematics classrooms? (paper Stylianidou & Nardi) How do SEM-students perceive their participation in terms of learning and teaching in an inclusive mathematics classroom to have optimal opportunities to learn? (paper Roos).

Helena Roos: I just don't like math, or I think it is interesting, but difficult ... Mathematics classroom setting influencing inclusion

Laurie Bergeron & Audrey Perreault: Strategies that promote the mathematical activity of students with language disorders: an analysis of language interactions

Kinga Szücs: Do hearing-impaired students learn mathematics in a different way than their hearing peers? Challenges and possibilities of cognitive enrichment in inclusive mathematics classrooms – a review

Angeliki Stylianidou: Mathematical discourses of a teacher and a visually impaired student on number sequences: Divergence, convergence or both?

(3) Research on teacher education (pre-service and in-service)

This theme includes discussions of inclusive education and SEM in relation to teacher education and teachers' views. How are teacher education programmes related to inclusion and what are adequate strategies for teachers to develop inclusive mathematical settings. Examples of research questions within this theme are: How should didactical courses in teacher education be designed to address the topic 'inclusive mathematics'? (paper Scherer). What challenges do

mathematics teachers experience when teaching students with mathematics learning difficulties in an inclusive classroom and what potential measure do they use? (paper Hamukwaya) What is the effect of improving the knowledge of braille display and Text-To-Speech synthesizer support of mathematics teachers on braille reader's achievement in mathematics? (paper Van Leendert)

Petra Scherer: The potential of substantial learning environments for inclusive mathematics – student teachers' explorations with special needs students

Laura Korten: An in-service training to support teachers of different professions in the implementation of 'inclusive education' in the mathematics classroom

Chun-ip Fung & Dichen Wang: Teaching mathematics to students with intellectual disability: What support do teachers need?

Sarah Buró & Susanne Prediger: Low entrance or reaching the goals? Mathematics teachers' categories for differentiating with open-ended tasks in inclusive classrooms

Annemiek van Leendert: Supporting braille readers in reading and comprehending mathematical expressions and equations

Shemunyenge Taleiko Hamukwaya: K-12 Namibian Teachers' Views on Learning Difficulties in Mathematics: Some reflections on teachers' perceptions

Introductory discussion – overarching issues of the situation of SEM

The world is changing very fast and so are the demands on teachers. School classrooms are growing increasingly heterogeneous – with respect to language, culture and abilities. This requires differentiation with regards to learning goals, instruction strategies and individual tasks, to accommodate the classroom to enhance every students learning (Bishop, Tan, & Barkatsas, 2015).

Internationally, a trend is visible towards inclusion, a comprehensive school for all, where students with very different levels of abilities and different skills are educated together (Bishop et al., 2015). Some European countries have a very long tradition of inclusion, while in other countries it is relatively new, since students with more marked disabilities used to be educated in special schools. The change in the system generated a passionate discussion on the advantages and disadvantages that inclusive education brings, which reflects the negative attitudes that teachers might have towards inclusion (e.g. De Boer, Pijl, & Minnaert, 2011).

Inclusive education brings many challenges to schools. Often it is connected to a lot of administrative load in many countries. For example, some school systems and governments require detailed and individualized progress reports and education plans to include every student, and this has to be done in so-called multi-professional teams for which they might not be prepared (see Ritter, Wehner, Lohaus, & Krämer, 2018). All this applies to mathematics education, too. A mathematics teacher is expected to cope with the demands within the inclusive classroom, to plan lessons where all students will receive appropriate support and challenge. At the same time, they

often have to deal with more administration, and often with more rules and monitoring from the management or government. This could even lead to teachers feeling stressed and opposing the whole idea of inclusive education. Although large differences between countries exist, the problems are recognized to a smaller or larger extent in all countries. The work in TWG25 showed that there are ways that can help pre-service and in-service teachers and teacher educators to support these processes. If teachers are better trained for teaching in a heterogeneous classroom and have adequate tools, methods and techniques to make it work, they will be much more motivated and willing to support the system.

During almost all sessions in TWG25, one big question was circling, namely how do we understand inclusion in mathematics? Is it static? Is it depending on national and cultural settings? How do the teachers, the learners and/or the researchers describe and understand it? Do they understand it the same, or differently? Is the way, inclusion is understood affected by the perception of students *in* need, or *with* need? Is it dependent on the perception of the student? These questions are immersed and reflected (implicitly or explicitly) in the overarching themes that emerged from the discussions of TWG25, and described below.

Overarching issues of TWG25

Research in the field of inclusive mathematics covers a wide range. This can be seen in the directions taken in research covering disability, psychological, pedagogical and didactical issues. It can also be seen in how research covers aspects on either societal level or classroom level working with notions such as equity and diversity (Roos, 2019; Kollosche, Marcone, Knigge, Godoy Pentead, & Skovsmose, 2019), and several trends in mathematics instruction were presented in the papers of TWG25. All papers focus on some aspects of mathematics teaching and learning in relation to SEM and deserve due attention. During the TWG-sessions based on the paper presentations, the following points were discussed, especially how they are linked with each other.

Inclusive system or special schools?

As stated in the introductory part, there are countries where special schools have a relatively long tradition (e.g. more than 100 years in the Netherlands) (Evans, 2004). Their clear advantage is that the staff has a specialized knowledge to work with and help special needs children. The number of students in classes is relatively low and thus the teacher has the time to individualize work. These schools have been criticized in the past by the EU for their exclusive nature, and many countries extended or built up inclusive systems according to the realization of the UN conventions (see UN, 2006). Inclusive education means each child has the right to be educated in the local school. However, in some countries, there is still a debate whether this is for the benefit of the student.

Teacher education in relation to SEM

Depending on the tradition of inclusive education, SEM is taken into consideration to a greater or lesser degree in the mathematics classroom. In countries with a longer tradition the system has more experience and mathematics teachers are more experienced to take SEM into consideration in their teaching.

Without any doubt the education must adapt to the situation and much more attention has to be paid to special needs in mathematics – taking children with mental or physical disabilities, students in great access to mathematics or second language learners into account. These different directions are discussed in the TWG-papers by *van Leendert et al.*, *Hamukwaya*, *Stylianidou & Nardi*, *Roos*, *Szücs* and *Bergeron & Perreault*. Also teacher education needs to prepare fresh graduates to know possible methods, techniques, and activities that will enable them to differentiate and individualize lessons. Teachers must have the theoretical background knowledge about different disabilities, in addition to practical examples of how to manage the classroom, what activities to use are essential. With all these special competences, the different forms of knowledge, subject specific knowledge included, is essential (cf. Shulman, 1986). Teacher education should reflect the findings of current research on work with special needs children as this is a fast developing area. This is discussed in the TWG-papers by *Scherer*, *Korten et al.* and *Fung & Wang*.

Change of teaching and learning strategies?

Does SEM imply using new teaching and learning strategies? Taking an inclusive standpoint in the classroom asks for differentiation and individualization of work and take the individual student as a point of departure as discussed in the TWG-paper by *Roos*. Then the teacher's role is changing to the role of a facilitator, to the role of the person who plans the lesson and activities and then monitors students' work and helps wherever is needed. One of the ways of allowing inclusive classes to learn is to focus on how tasks can be designed and used to differentiate between students of different levels, like the paper by *Buró & Prediger* shows. Teachers are not always aware what kind of adjustments are needed for the different levels amongst their students.

Another point of discussion is whether constructivist approaches could help as all students build their own knowledge in a way that is suitable for their needs. However, there is no clear empirical evidence that this is the best way to teach students in SEM as the research result might be contradictory (e.g. Chodura, Kuhn, & Holling, 2015; Scherer, 1997).

How can mathematics teachers be motivated to work with SEM?

The issue of motivating teachers to work with SEM is essential. Inclusive education is reality and teachers must be ready to face it. If they are well motivated, they are more likely to cope with the situation well. This, and how to work with teachers and different methods to use is discussed in the TWG-papers by *Scherer*, *Fung & Wang* and *Korten et al.*

One way to motivate teachers is to equip them with such tools that they will feel confident enough when facing a heterogeneous classroom with students with very diverse educational needs. Having diverse teaching methods and techniques that enable differentiation and motivation will help. Also having experience with managing a classroom where an assistant is present will help and will give the teacher the needed self-confidence. Not everyone is happy with having a “critical” eye in all lessons.

Another way to increase teachers' motivation is providing them enough opportunities to improve their knowledge and skills in the area. Pre-service teacher programs must pay enough attention to

the issue, and high quality in-service teacher training programs should be available. If possible they should be designed and run by a number of specialists from different areas (special pedagogues, psychologists, but especially experienced teachers of a particular subject).

Once methodology and techniques of work with special needs students become more widespread and results will be tangible, motivation of teachers will become easier.

Who is in SEM?

The large heterogeneity of the students with special needs in mathematics was discussed in TWG25, ranging from low IQ to gifted, from specific learning disabilities like dyscalculia (discussed in the TWG-paper by *Peteers & Ouvrier-Bufferet*) to behavioral and developmental disorders, including students with different cultural backgrounds (as discussed in the TWG-paper by *Medová et al.*). Also teachers' views on special needs as presented in the TWG-paper by *Hamukwaya* was discussed. The question arose why we use the term special, and what is perceived as 'normal' (see Skovsmose, 2019). Wouldn't it be better to talk about heterogeneity and take the individual differences as norm?

Conclusion and further directions of TWG25

Reflecting back on the arguments made in the papers of TWG25 and on the discussions, there are, as prior discussed, diverse issues concerning inclusion in mathematics education and challenges for students with special needs in mathematics. In the TWG-papers about development of materials, tools, learning arrangements and settings, arguments are made for both developing sustainable ways of identifying dyscalculia in mathematics education (paper *Peteers & Ouvrier-Bufferet*) and developing learning software for both, pre-service and in-service teachers (paper *Medová et al.*).

In the TWG-papers about research on classroom situations and out-of school situations the focus was on challenges and possibilities in the classroom from different perspectives. Strategies promoting mathematical activities in relation to students with language disorders were discussed: Too often teachers tend to reduce learning opportunities within mathematical tasks by focusing on their cognitive characteristics and behavior, although the reported research shows that if a teacher offers space for dialogue with students and questions them in order to trigger their mathematical activity it becomes a powerful driver of student activities in a classroom context where the teacher offers a space where all voices are legitimized (paper *Bergeron & Perreault*). Another issue in relation to how to work in classroom was how a classroom setting influences inclusion in mathematics, and the importance to consider how to plan the classroom to include everybody (paper *Roos*). In relation to work in the classroom, mathematical discourses of a teacher and a visually impaired student were investigated highlighting the interaction teacher – student (paper *Stylianidou & Nardi*). Also a review highlighting the learning of hearing-impaired students and the challenges and possibilities of cognitive enrichment (paper *Szücs*) was discussed within this theme.

In the TWG-papers about research on teacher education the focus was on how teachers view inclusion and SEM, and how teacher education can work to help teachers work inclusively. The

potential of substantial learning environments (Wittmann, 2001) for inclusive mathematics in relation to student teachers' explorations with special needs students were reflected upon with the conclusion of the importance to include such type of explorations and reflections of inclusion in the teacher education (paper Scherer). In relation to this, it was discussed how in-service training can support teachers of different professions in the implementation of 'inclusive education' in the mathematics classroom (paper Korten et al.). Support to teachers was also discussed in relation to teaching mathematics to students with severe intellectual disability (paper Fung & Wang), with the conclusion that it is mathematics that must be in the centre of attention when discussing SEM, something that may sound too trivial to consider, yet often too easy to overlook. The development, testing, and refinement of didactical action plans involves studying various phenomena and their corresponding mathematical meanings, which can only be done from within mathematics Support to students by supporting teachers in relation to braille readers in reading and comprehending mathematical expressions and equations through specific instructions was problematised (paper van Leendert et al.). When looking into mathematics teachers in relation to inclusion and SEM the way teachers categorise for differentiating in inclusive classrooms were highlighted, problematising low entrance (paper Buró & Prediger). Also teachers' perceptions in relation to learning difficulties in mathematics was problematised (paper Hamukwaya).

The major question, still left to be answered, is how we understand inclusion in mathematics, and how we can have a common ground in research despite the diversity of research directions and cultural and national differences. Still, it is interesting to see that even if there are very diverse issues concerning inclusion in mathematics education, there are similarities too. This can be seen in the themes of the TWG-papers. Hence, there seem to be opportunities to build a common ground regarding inclusive mathematics teaching and challenges for students with special needs. enrichment in inclusive mathematics classrooms.

Looking forward to CERME12 the community got a challenge to build further on the work at CERME11 and build a common ground to address issues within the scope of TWG25.

References

- Bishop, A., Tan, H., & Barkatsas, T. N. (2015). *Diversity in Mathematics Education. Towards Inclusive Practices*. Cham, Switzerland: Springer.
- Chodura, S., Kuhn, J. T., & Holling, H. (2015). Interventions for children with mathematical difficulties. *Zeitschrift für Psychologie*, 223(2), 129–144.
- De Boer, A., Pijl, S. J., & Minnaert, A. (2011). Regular primary schoolteachers' attitudes towards inclusive education: A review of the literature. *International Journal of Inclusive Education*, 15(3), 331–353.
- Evans, P. (2004). A Comparison of Inclusion practice in OECD countries. *Education Canada*, 44(1), 32–35.

- Kollosche, D., Marcone, R., Knigge, M., Godoy Penteadó, M., & Skovsmose, O. (Eds.). (2019). *Inclusive Mathematics Education. State-of-the-Art Research from Brazil and Germany*. Cham, Switzerland: Springer.
- Magne, O. (2006). Historical Aspects on Special Education in Mathematics. *Nordic Studies in Mathematics Education*, 11(4), 7–35.
- Ritter, R., Wehner, A., Lohaus, G., & Krämer, P. (2018). Multi-professional and mono-professional collaboration and their association with teacher trainee's attitudes towards concepts of inclusive education. *Empirische Sonderpädagogik*, (2), 185–203.
- Roos, H. (2019). Inclusion in mathematics education: an ideology, a way of teaching, or both? *Educational Studies in Mathematics*, 100(1), 25–41.
- Scherer, P. (1997). Productive or reproductive exercises – what is appropriate for low attainers? In C. van den Boer & M. Dolk (Eds.), *naar een balans in de reken-wiskundeles – interactie, oefenen, uitleggen en zelfstandig werken* (pp. 35–49). Utrecht, The Netherlands: Freudenthal instituut.
- Shulman, L. S. (1986). Those who understand: Knowledge growth in teaching. *Educational Researcher*, 15(2), 4–14.
- Skovsmose, O. (2019). Inclusions, Meetings, and Landscapes. In D. Kollosche, R. Marcone, M. Knigge, M. Godoy Penteadó, & O. Skovsmose (Eds.), *Inclusive Mathematics Education. State-of-the-Art Research from Brazil and Germany* (pp. 71–84). Cham, Switzerland: Springer.
- UN – United Nations (2006). *Convention of the rights of persons with disabilities*. New York, NY: United Nations.
- Van den Heuvel-Panhuizen, M. (1996). *Assessment and realistic mathematics education*. Utrecht, The Netherlands: Freudenthal Institute.
- Wittmann, E. C. (2001). Developing mathematics education in a systemic process. *Educational Studies in Mathematics*, 48(1), 1–20.

Strategies that promote the mathematical activity of students with language disorders: an analysis of language interactions

Raquel Isabel Barrera-Curin¹, Laurie Bergeron² and Audrey Perreault³

¹Université du Québec à Montréal, Faculty of Education, Canada; barrera.raquel@uqam.ca

²Université du Québec à Montréal, Faculty of Education, Canada; bergeron.laurie.2@uqam.ca

³Université du Québec à Montréal, Département of Psychology, Canada; aud.perreault@gmail.com

This article outlines the methods of a teacher of mathematics who works with a class of students with language disorders related to autism. By adopting the theoretical framework of the Dual Approach (ergonomics and didactics) and Maturanian epistemology, we show how an analysis of language interactions allows for a better understanding of teaching practices and their influence on the mathematical activity of students. We explore the nature of the language interactions, both verbal and non-verbal, within a specific learning project, when it comes to reinvesting, in a non-explicit way, basic mathematical objects. Our analysis highlights the richness of a practice in which the teacher proposes different types of help to trigger the mathematical activity of her students.

Keywords: Language interactions, mathematical activity, teaching practice, language difficulties.

Problematic

In Quebec, approximately 15 000 students have an autism spectrum disorder. In general, these students present difficulties related to language, communication and social interaction with their peers (MSSS, 2017). Moreover, since language interactions are an integral part of the teaching practice, finding ways to carry out a project represents a significant challenge in the context of a special class for students with autism (Odier-Guedj & Gombert, 2014). For the teaching of mathematics, this phenomenon is particularly problematic given the difference in the meaning of words in everyday language and those used in mathematical language. Although the Ministry of Education prescribes guidelines encouraging teachers in Quebec to adapt their practice according to their students' characteristics (MELS, 1999), operational means are not proposed. Thus, teachers are required to determine and implement their own means of adaptation. In this context, research in psychology of ergonomics and didactics (Robert & Rogalski, 2002) has led us to question the way that teachers adapt their practice in order to meet the specific needs of their students, and to inquire whether these adaptations and this help contributes to the mathematical activity of their students.

This paper focuses on the richness of the language interactions and the types of help offered by a teacher to trigger the mathematical activity of her students. In this article, we present a part of our analysis of the practices of a teacher within the context of a project requiring students with autism spectrum disorder to build a birdhouse to reinvest basic mathematical notions. We begin by outlining our epistemological stance, our conceptions of language and mathematical activity, as well as the types of help offered by the teacher to trigger the students' activity. After highlighting our framework for the analysis of teaching practices, we reveal an overview of our results.

Epistemological foundation and theoretical context

What is mathematical activity

Mathematical activity accounts for the process of appropriation and reasoning required to answer or mathematize a given problem or situation (e.g. Freudenthal, 2012; Proulx, 2015). Within the framework of our research, mathematical activity exists as a process of “coordinations of coordinations of doings” (Maturana & Verden-Zöller, 2008). In this process, teacher and student actions take place within an ethical space where their legitimacy is mutually recognized. Their immediate actions and their respective historical and cultural experiences (Radford, 2010) are interrelated to their representation of mathematics and shared by and through different forms of language (Barrera-Curin, Bergeron, & Perreault, in press). According to Maturana and Verden-Zöller (2008), interactions emerge within and through language as a way of coexisting in the coordination of coordinations of actions. Language, in all its forms, becomes a fundamental element to consider when studying interactions within an educational context.

Language and the specificity of teaching practices

Many recent studies in the fields of didactics of mathematics and mathematical education have focused on the link between language interactions, language and mathematics (e.g. Bulf, Mithalal, & Mathé, 2015; Morgan, 2013; Moschkovich, 2010; Sfard, 2008). Within the framework of our research (Barrera-Curin, Bulf, & Venant, 2016), the language of mathematical activity is considered as a dialogical and situated activity involving not only language with its written and verbal codes, but also the diversity of its manifestations. The appropriation of mathematical objects, “does not necessarily result in the same consequences for all persons, because it is a historical, situated and individual process” (Bauersfeld, 1995). As Bauersfeld (1995) raises it: “only across social interaction and permanent negotiations of meaning can “consensual domains” emerge” (p. 275).

In order to study language interactions where students’ language difficulties are added to the already existing constraints influencing teaching practices, it is necessary to observe these practices in a localized way. In studies that articulate didactic, psychological and ergonomic concepts (Robert & Rogalski, 2002; Roditi, 2013) the teacher’s task is viewed as the management of a diverse, dynamic and complex environment where interventions focus on knowledge acquisition and on students, while considering that students progress according to their participation and interactions in the classroom. The mediating and cognitive components of a teacher’s practice are central to the didactical organization of the mathematical tasks proposed by the teacher and adapted through interactions with the students. Thus, a teacher’s practice includes the targeted mathematical content, the choice of tasks and their organization, the types of help offered, classroom management, the language forms chosen by the teacher, and the different forms of student work. As we enrich the dual approach with Maturana and Varela’s framework as seen below in Figure 1, the teacher’s activity is viewed as a process of adaptation resulting from the coordination of the coordinations of actions between a teacher, their students and the environment.

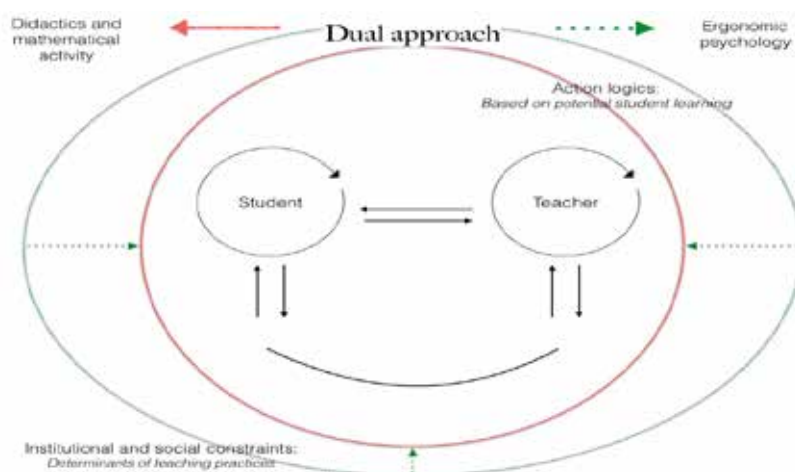


Figure 1: Modeling teaching activity (Barrera-Curin, Bergeron, & Perreault, 2018)

The teaching activity can be grasped by analysing beyond the immediate observation of interactions in the classroom: institutional constraints, historical background, action logics of the teacher and personal beliefs, didactical implication and interaction in context. Therefore, analysing this activity must take into account different components of the action *in situ*. To identify those components, the Dual Approach (Robert & Rogalski, 2002) propose the observables concept, which take place within the language interactions between the students and their teacher. The observable categories consist in types of helps, task enrollment attempts and interaction surrounding mathematical objects (Barrera-Curin et al., in press). Procedural helps act directly on the initial task by dividing it in a series of simpler ones. Constructive helps focuses on questioning the student in order to serve his knowledge construction. Compensatory helps aim to compensate a disorder of the student that could slow down or prevent his mathematical activity.

In the present work, we focus on the articulation of these types of help with the mathematical tasks proposed to the students in order to observe in which ways mathematical actions are brought forth. In other words, we study how different types of help within language interactions carried on by the teacher trigger the mathematical activity of the students in the context of a specialized class.

Analyzing the articulation of language and mathematics

Five teaching sessions were observed and videotaped with focus on language and interactions surrounding mathematical objects. Interviews were conducted with the teacher before and after each observations and focused on the teacher's choices (before) and her explanations about the progress of the session (after). In this paper, we focus on the first session and the corresponding interviews.

First, we analyzed the interviews to conduct a didactical analysis of the mathematical tasks and objects (Robert & Rogalski, 2002) planned for the session as well as the teacher's chosen form of teaching (action logics and constraints). Secondly, we identified episodes in the first session according to the richness of language and social situated interactions surrounding a mathematical object. Those episodes were then described according to the observable categories (types of help). Finally, we analyzed how those interactions trigger the mathematical activity of the students.

Hélène's Project

Hélène teaches in a class for students with autism spectrum disorder designed to prepare them with skills for the workforce. The students are between 16 and 20 years of age and their mathematical knowledge varies from sixth grade of primary school to the second year of high school.

The project to build a birdhouse

The teacher's focus was for students to reinvest geometrical concepts through a project of constructing birdhouses. Project based teaching of mathematics is not the usual approach within the context of special education. In special needs classes, teachers seek to respond to institutional expectations by conventional methods, in particular the evidence based model. In this case, Hélène plans to focus her sessions on dialogue and on the problematization of her students' questions. She proposes to her students to design their own birdhouse. During the session, she brings sheets of white paper and milk cartons. She wants each student to make a 2D model of their birdhouse using a set of 3D objects. She anticipates that the students would use these objects as points of reference for measuring the faces of the birdhouse. She plans 4 sessions to allow time for students to: design the paper plan, reproduce the plan with drawing software, perform laser cutting, and assemble a wooden birdhouse. To carry out this project, students must understand the relationship between the faces of the solid (incidence relations) and anticipate the operationalization of the solid as it passes from 2D to 3D. In this paper, we focus on the first session, particularly on some interactions that has led Hélène to add an unexpected session in order to work on the incidence relations.

Creating conditions that trigger language interactions: help that becomes constructive

During her interactions with students, Hélène realized that she had not anticipated certain difficulties related to the 2D modeling of a 3D object. In fact, during the first session, she noticed that several students had designed a plan that did not include incidence relations. Up until that point, her questioning of students regarding the feasibility of their respective plans had not led to adjustments desired. Therefore, printing on wood without anticipating results was not possible. She decided to add a session in which students would cut out the development of their solid in paper form, build it and modify it as needed. At the end of the first session, the teacher decided to involve her students in a process of reflection regarding their final product. In the following excerpt, the questions raised by Hélène help to build her students' knowledge collectively as they are focusing on the students and the task at hand (constructive help).

Hélène: If we ever cut it in the wood and it doesn't work? What happens (pointing the plan), once cut, it will make a birdhouse?

Student 1: We'll make a simulation.

Hélène: We'll make a simulation with what?

Student 2: With the computer?

Hélène: We will have to ask the technician, but what if we don't have a computer, a bit like what we did with Phil and his roof?

Student 1: We make the sketch and we will cut out?

By analyzing language interactions, we notice that the teacher allows her students to reflect on a real issue related to the construction of the birdhouses. She does not present herself to the students as having the solution to their problem, but instead, she offers them a space to reflect where the end product of the task remains their responsibility, because “at any stage the child is an informant child as the teacher is an informed expert” (Bauersfeld, 1995, p. 278). When the teacher speaks, she considers the student’s proposal repeating the words that they used, while guiding them by reframing her questioning towards the more precise elaboration of a solution. In doing so, she creates an ethical space where her students’ legitimacy is recognized and where classmates listen to each other. H  l  ne’s place in the interaction remains central, but the context of the project and the way that she engages her students by raising questions promotes the expression of their ideas and encourages their participation in the collective reflection. Through a superficial analysis of this session, we could attribute to H  l  ne the status of a teacher who puts into place compensatory and procedural helps, but a more in-depth analysis of language interactions reveals that the help is constructive because of the importance given to dialogue as well as the activity it triggered.

Another moment during the first session reveals students seeking to validate their product by their teacher before continuing their work. But the teacher does not respond by answering or refusing her students’ request. Instead, she questions them. This management of the process is particularly important in terms of its mediating and cognitive components (Figure 2) because the task remains the responsibility of the students while H  l  ne presents herself as a trigger of their mathematical activity. At that particular moment in the session, the mathematical task at hand required identifying the appropriate measurements in order to optimize the production of the pieces of the birdhouse.

Student 3: So far, my floor is done.

H  l  ne: Yes, what's missing after the floor ... we said?

Student 3: Ummm... The sides!

H  l  ne: What measurements are they going to have? [...]

Student 3: Ummm, the height of my side ... Wait! If that ..., if we counted 25 cm, that's it?

H  l  ne: Hum, hum. (she agrees)

Student 3: Maybe 25 too?

H  l  ne: 25 ... how much is your floor?

Student 3: Ummm ... 20 cm!

H  l  ne: So ... does it ... have to be wider or more narrow than your floor... your side? Your wall is going to go like this. (She takes a pint of milk to show it to the student on his sheet.) Here I will ... We'll go up like this. You want the wall to come to where?

Student 3: Maybe equal?

H  l  ne: Equal? So how much would it be?

Student 3: Uh 20 ...?

- Hélène: 20. With a height of how much?
- Student 3: ... ummm ...
- Hélène: There will be the floor like that 20, and... a height of?
- Student 3: 25. (hesitates a little)
- Hélène: So, two walls of?
- Student 3: 25 cm! [...]
- Hélène: And with a width of?
- Student 3: ... 20 ...
- Hélène: Two times 20 by 25. (She mimes two times the width and then the height.)
- Student 3: Wait, kind of like... 20 here, 25, 20? (He shows the sides with his hands.)

The teacher addresses the student's questions, but procedural help is suggested by the new questions that she raises - she helps the student to organize the steps for developing his plan without giving him the answers. The student, in turn, adapts in a flow of interactions by trying to answer her questions. When he experiences difficulty formulating his answers, the teacher proposes compensatory help, in this case, modeling the incidence relation between the floor and the wall with the help of material. At the language level, the teacher models the measurements with the help of gestures that the student will repeat afterwards in order to appropriate them (Figure 2).



Figure 2: Teacher and student's gestures to model and appropriate measurement

However, the help that the teacher puts into place does not change the mathematical objectives of the task. She triggers mathematical activity by putting in place different types of help (procedural and compensatory) in the form of questions that promote explanations from the student. Therefore, Hélène's help becomes constructive regarding the mathematical activity of this student.

Discussion

To sum up, the proposed approach for making meaning of teaching practices allows us to reveal the influence of language interactions in a classroom where a teacher offers space for dialogue with students and questions them in order to trigger their mathematical activity. Through the preceding examples, we have the opportunity to see in a new light how different types of help, that may modify the task or the mathematical object, can become a powerful drivers of student activity in a classroom context when the teacher offers a space where all voices are legitimized. The Dual Approach combined with the Maturanian foundation allows us to investigate the teachers practice at a macrostructural level as well as microstructural. Those two dimensions help us understand some

reasons for the action of the teacher but also to analyze how those action logics (in reference to the teacher beliefs about his practice and his students) and institutional constraints come to act. If H el ene can promote language interactions that enable students to socially build their knowledge, it's because, among others, few institutional constraints represent obstacles in terms of planning the delivery of her courses and her choices in terms of content and form of teaching. This teacher shares with researchers that she appreciates that a rigid educational program is not imposed on her. This greater professional freedom allows H el ene to consider broader possibilities for the mathematical activity of her students by seeking to maximize the usage of the tasks proposed and to be in sync with her conception of teaching. According to our analysis, H el ene prioritizes open and authentic questioning that encourages her students to engage in a process of reflection regarding the tasks at hand. Thus, it is both the supple institutional framework and the teacher's conception of the importance of student dialogue that promote the emergence of the language interactions observed.

As a final reflection, we want to underscore that the interactions we witnessed in this classroom diverge from the usual expectations for the behavior of students on the autism spectrum. Hence, we hypothesize that the importance that H el ene places on the collective dimension of her classroom promotes the emergence of language interactions, which may not be possible in a special class with a more prescriptive environment. Those results lead us to reconsider dominant teaching practices in Qu ebec and to place in the foreground the richness of mathematical reflections possible among all students, even those with a language disorder, when the classroom environment encourages authentic language interactions. What we witnessed in this class of students with language disorders related to autism, in terms of interactions around a mathematical object, is not so different of what we can observe in an "ordinary class". Unfortunately, H el ene's case is an isolated one. What we observed in other "special classes" within this research is merely comparable. In fact, other teachers tend to reduce learning opportunities within mathematical tasks (see Buro & Prediger, 2019, in this volume) by focusing on their cognitive characteristics and behavior. Thus, our analysis leads us to question the learning environment provided for students with language disorder. Therefore, we must reconsider the teachers' formation in an institution that promotes differentiated instruction and the impact of this instruction model on the inclusion of students with a language disorder.

Acknowledgement. This project is supported by Fonds de Recherches du Qu ebec (FQRSC).

References

- Barrera Curin, R.I., Bulf, C., & Venant, F. (2016). Didactique, S emantique et M etaphore: Analyses des langages en classe de g eom etrie. *Annales de Didactique et de Sciences Cognitives*, 21, 39–78.
- Barrera-Curin, R.I., Bergeron, L., & Perreault, A. (in press). Analyse des interactions dans une classe o  les  l eves pr esentent une difficult  langagiere: l'influence d'une pratique enseignante sur l'activit  math ematique des  l eves. *Revista latinoamericana de investigaci n en matem tica educativa*.
- Bauersfeld, H. (1995). "Language games" in the mathematics classroom: Their Function and Their Effects. In P. Cobb & H. Bauersfeld (Eds.), *The emergence of mathematical meaning: interactions in classroom cultures* (pp. 271–291). Hillsdale, NJ: Erlbaum Associates.

- Bulf, C., Mithalal, J., & Mathé, A.C. (2015). Langage et construction de connaissances dans une situation de résolution de problèmes en géométrie. *Recherches en Didactique des Mathématiques*, 35(1), 7–36.
- Freudenthal, H. (2012). *Mathematics as an educational task*. Dordrecht, The Netherlands: Springer Science & Business Media.
- Maturana, H. R., & Varela, F. J. (1998). *The tree of knowledge: The biological roots of human understanding*. Boston, MA: New Science Library/Shambhala Publications.
- Maturana, H. R., & Verden-Zöllner, G. (2008). *The origin of humanness in the biology of love*. Charlottesville, VA: Andrews UK Limited.
- Ministère de l'éducation des loisirs et du sport. (1999). *Une école adaptée à tous ses élèves: Projet de politique de l'adaptation scolaire*. [Québec]: Gouvernement du Québec, Ministère de l'éducation.
- Ministère de la santé et des services sociaux. (2017). *Des actions structurantes pour les personnes et leur famille: plan d'action sur le trouble du spectre de l'autisme 2017-2022*. <http://collections.banq.qc.ca/ark:/52327/2797297>.
- Morgan, C. (2013). Language and mathematics: A field without boundaries. In B. Ubuz, C. Haser, & M. A. Mariotti (Eds.) *Proceedings of the Eighth Congress of the European Society for Research in Mathematics Education* (pp. 50-67). Ankara, Turkey: European Society for Research in Mathematics Education.
- Moschkovich, J. N. (Ed.). (2010). *Language and mathematics education: Multiple perspectives and directions for research*. IAP. Charlotte, NC: Information Age Publishing.
- Odier-Guedj, D. & Gombert, A. (2014). « Interactions en classe avec des élèves présentant un trouble du spectre de l'autisme, une déficience intellectuelle ou un trouble du langage oral. Des activités signifiantes à la littérature jeunesse », in Beaupré P. *Déficiences intellectuelles et autisme. Pratiques d'inclusion scolaire*. Presses de l'Université du Québec, Canada: 121–165.
- Proulx, J. (2015). Mathematics education research as study. *For the learning of mathematics*, 35(3), 25–27.
- Robert, A., & Rogalski, J. (2002). Le système complexe et cohérent des pratiques des enseignants de mathématiques: une double approche, *Revue canadienne de l'enseignement des sciences, des mathématiques et des technologies*, 2(4), 505–528.
- Roditi, E. (2013). Une orientation théorique pour l'analyse des pratiques enseignantes en didactique des mathématiques. *Recherches en didactiques*, 15, 39–60.
- Radford, L. (2010). The anthropological turn in mathematics education and its implication on the meaning of mathematical activity and classroom practice. *Acta Didactica Universitatis Comenianae Mathematics*, 10, 103–120.
- Sfard, A. (2012). Developing mathematical discourse: Some insights from communicational research. Special issue of. *The International Journal of Educational Research*, 51/52, 1–9.

Low entrance or reaching the goals? Mathematics teachers' categories for differentiating with open-ended tasks in inclusive classrooms

Sarah Buró and Susanne Prediger

TU Dortmund University, Germany

sarah.buro@tu-dortmund.de & prediger@math.uni-dortmund.de

Open-ended inquiry tasks are considered a powerful approach for addressing the diversity of inclusive mathematics classrooms due to their potential for natural differentiation. However, this potential can only unfold when the teachers know how to work with the tasks. This article investigates teachers' personal categories for differentiating with an open-ended task, especially with respect to providing support for students with special needs. In a qualitative case study, a category-eliciting activity was conducted within a professional development session. Data gathering comprised 14 secondary mathematics teachers' and special needs teachers' video-taped group discussions and written answers, which were analyzed qualitatively. The results show that most teachers' ideas for support provided for the students with mathematical learning disabilities only addressed the low entrance, but not the core learning goals and the required basic conceptual knowledge.

Keywords: Inclusive education, natural differentiation, professional development, teacher knowledge.

Most German secondary schools only recently shifted to an inclusive system, so many secondary mathematics teachers and special needs teachers currently learn how to differentiate in inclusive mathematics classrooms. As effective PD programs need to take into account teachers' typical starting points, we investigate teachers' perspectives to deal with various differentiated teaching approaches, here specifically with respect to differentiating with open-ended inquiry tasks (Scherer, Beswick, DeBlois, Healy, & Moser Opitz, 2016).

The paper starts with presenting the teaching approach of open-ended tasks and its potential for natural differentiation (Scherer & Krauthausen, 2010). The necessary teacher expertise for differentiating with open-ended tasks is conceptualized in the framework of Bromme (1992). The qualitative case study based on this conceptual framework uses category-eliciting activities for pursuing the following research question in the empirical part of the paper:

Which categories and self-reported practices do teachers activate for differentiating in inclusive mathematics classrooms with an open-ended task? And how can this be supported by facilitation?

Background on classroom level:

Open-ended inquiry tasks for natural differentiation

Inclusive mathematics classrooms call for differentiated instruction with joint whole-class experiences and specific support for students with special needs (Lawrence-Brown, 2004; Tomlinson et al., 2003). One of the teaching approaches which have proven useful (Scherer et al., 2016), applies rich open-ended inquiry tasks with the potential of so-called *natural differentiation*:

Open-ended tasks with a low entrance and high ceiling provide the potential for natural differentiation if they allow for multiple representations, diverse solution pathways and different cognitive activities along the trajectory of discoveries (Scherer & Krauthausen, 2010).

One example for such an open-ended task for Grade 5 is printed in Figure 1. It aims at discovering the multiplicative structure of the volume of cuboids, and has a wide differentiating potential (see Figure 2). The task has a *low entrance* as all students succeed in finding at least one cuboid. The task's *core goal* is to discover that counting in rows and layers leads to a multiplicative structure of the volume. The *high ceiling* for students with strong mathematical potentials covers the combinatorial challenge to find all cuboids, usually by considering the multiplicative decomposition of 24 in three factors.

Open-ended task: Build many cuboids

Here, you have 24 wooden cubes. Which cuboids can you build with them? Document all cuboids which you have found. How many do you find?



Possible differentiating prompts:

- Do you find one cuboid?
- Do you find many cuboids?
- Do you find all cuboids?
- How can you be sure that you have found all?

All possible cuboids:

$1 \times 1 \times 24$, $1 \times 2 \times 12$, $1 \times 3 \times 8$, $1 \times 4 \times 6$, $2 \times 3 \times 4$, $2 \times 2 \times 6$.

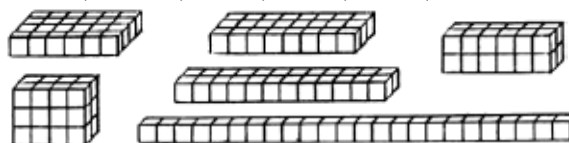


Figure 1: Open-ended task for discovering the multiplicative structure of volumes (Prediger, 2009)


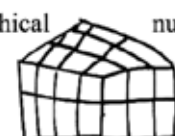


<p>Diverse ways of using material and structures</p> <ul style="list-style-type: none"> · longer or shorter use of hands-on material · later or earlier discovery of structures · more or less systematic search for all cuboids · more or less strive for justifying completeness 	<p>Multiple representations for the documentation</p> <div style="display: flex; justify-content: space-around;"> <div style="text-align: center;">  <p>graphical</p> </div> <div style="text-align: center;">  <p>numerical</p> </div> </div> <div style="margin-left: 800px;"> $2 \cdot 12 = 24$ $4 \cdot 6 = 24$ $2 \cdot 6 \cdot 2 = 24$ $2 \cdot 4 \cdot 3 = 24$ $(2 \cdot 3 \cdot 4 = 24)$ $3 \cdot 8 = 24$ $1 \cdot 24 = 24$ </div> <div style="margin-left: 100px;"> <p>language</p> <div style="display: flex; justify-content: space-around;"> <div style="text-align: center;">  </div> <div style="text-align: center;">  </div> </div> <p>4 runter 6 nach links 8 runter 3 nach links 12 runter 2 nach links 24 runter 1 nach links 2 nach oben 4 nach unten 3 nach Center 2 nach oben 2 nach unten 6 nach Center</p> </div>
<p>Possible steps in the trajectory of discoveries</p> <p>Step 1 Build with the cubes and count separately</p> <p>Step 2 Build with the cubes and count rows and / or layers and sum up these partial results</p> <p>Step 3a Build with the cubes, multiply for areas in each layer and add layers (partly use multiplicative structure)</p> <p>(OR Step 3b Build the cuboid, decompose it in layers and discover their multiplicative structure)</p> <p>Step 4 Build only parts and mentally imagine the rest and / or partly use multiplicative structures</p> <p>Step 5 Mentally imagine the cuboid and use multiplicative structures for rows and layers</p> <p>Step 6 Purely use multiplicative structures for rows and layers</p>	<p>Necessary basic mathematical concepts</p> <ul style="list-style-type: none"> · entry level: definition of cuboid as shape with rectangular faces · access to goal: mental model of multiplication as counting in groups

Figure 2: Differentiating potential of the open-ended cuboid task as empirically identified by Prediger (2009)

Teacher expertise for differentiating with open-ended tasks

The degree to which rich and differentiating tasks are really productive for inclusive mathematics classrooms depends on the teacher's expertise for really ensuring responsiveness, not only in a reactive way (i.e. ad hoc repairing occurring obstacles), but also proactively in preparing specific support for students in need for it (Tomlinson et al., 2003). Especially, low expectations have often been problematized (Büscher, submitted) as research shows that students with mathematical learning disabilities can reach more than often expected if responsive, proactive support is provided (Peltenburg, 2012). That is why the teachers must be prepared for these challenges. In order to base professional development offers on teachers' starting points, the study presented in this paper aims at capturing the teachers' current categories for differentiating with open-ended tasks.

Personal categories are a crucial part of Bromme's (1992) conceptualization of teacher expertise. He defines teacher expertise as the teacher's capability to cope with complex situations in subject matter classrooms, comprising (a) the teacher's practices by which they cope with situational demands (the so-called jobs), (b) the orientations, e.g. the (content-specific or content-independent) attitudes guiding the prioritization and interpretation of the jobs and (c) the categories which implicitly or explicitly guide their perception and practices (see Prediger, 2019 for a more general discussion of this conceptualization). Especially, Bromme suggests a powerful "heuristic to search for the 'natural' categories in expert knowledge" (Bromme, 1992, p. 88, translated by the authors) by analyzing the situational demands with respect to the relevant practices and their underlying implicit categories.

Based on the large literature on differentiating in inclusive mathematics classrooms (Tomlinson et al., 2003; Lawrence-Brown, 2004; Scherer et al., 2016), we identified three sub-jobs for the larger job of differentiating with open-ended tasks:

- (1) analyzing tasks with respect to students' potentially diverse solution pathways and approaches
- (2) identifying differentiating potential in a task and possible obstacles for reaching the core goals
- (3) providing support for students with specific needs for reaching the core goals.

Job 1 is a preliminary job for Job 2 and 3, which is necessary in order to unpack the mathematical structure and the possible steps on the trajectory of discovery (see Figure 2). The differentiating potential identified in Job 2 can refer to these steps and the multiple ways or representations, but also to possible obstacles, mainly those lying in required basis concepts. The later is crucial for proactively providing support in Job 3, especially for students with specific needs (in our case, students with mathematical learning disabilities, with or without the official status of having special needs).

Taking into account that effective differentiation is always knowledge-centered (Tomlinson et al., 2003), the teachers should have a focus on the six steps of the trajectory of the discovery as well as on the required basic knowledge in understanding the underlying mathematical concepts (as Scherer et al., 2016 emphasize). In the concrete task, this concerns the concept definition of cuboid and, even more importantly, the mental model of multiplication as counting in groups which is required for the transition of counting separately (Step 1) to counting in rows or layers by multiplication (Step 2-4). Providing support for students with specific needs should not only guarantee the low entrance of the task, but also the possibility of reaching the core goal, here the multiplicative structure of the volume. At the same time, the high ceiling (finding all cuboids with 24 cubes) provides challenges for the students with strong mathematical potentials.

Methods of the qualitative study for investigating teachers' starting points

Given that teachers' expertise is often implicit in their practices, the research question (Which categories and self-reported practices do teachers activate for differentiating in inclusive mathematics classrooms with an open-ended task? And how can this be supported by facilitation?) was pursued in a qualitative study based on a category-eliciting activity.

Methods for data gathering by a category-eliciting activity on three jobs

Sample. The sample consisted of 14 secondary math teachers who participated in their first session of a volunteer professional development series on inclusive mathematics classrooms. They had between 2 and 20 years of experiences in math teaching. 8 of them held a teacher degree as mathematics teachers (PCK⁺SNK⁻, i.e. with a formal qualification in pedagogical content knowledge in mathematics education, abbreviated PCK⁺, but no formal qualification in special needs knowledge on specific needs of students with learning disabilities, abbreviated SNK⁻), 1 of them was special needs teacher without a degree in mathematics education (PCK⁻SNK⁺), and 5 of them were special needs teachers with a degree in mathematics education (PCK⁺SNK⁺).

Category-eliciting activity. For eliciting teachers' personal categories and self-reported practices for differentiating with the open-ended task, the teachers' activity in Figure 3 was structured according to the jobs introduced in the next section. The teachers were asked to write down their ideas and discuss them in small groups during the PD session. The group discussions were video-taped and partly transcribed.

Students' task: Build many cuboids

Here, you have 24 wooden cubes. Which cuboids can you build with them? Document which one you have found. How many do you find?

Questions for teachers:

- (1) Which solution pathways and approaches would you expect from your students for this task?
- (2) Which potential for differentiation does the task provide?
- (3) How would you support students with mathematical learning disabilities?



Figure 3: Category-eliciting activity for three jobs

Methods for qualitative data analysis

The qualitative data analysis was based on deductive-inductive procedures (Mayring, 2015), starting from the prospective analysis of differential potential and possible obstacles (see Figure 2), but open for teachers' further personal categories. The articulated personal categories were inductively subsumed under the most relevant categories (results listed in Table 2). The elicited categories along the three jobs were compared between the three subsamples PCK⁺SNK⁺, PCK⁺SNK⁻, PCK⁻SNK⁺.

The video data was analyzed qualitatively with respect to the inductively developed categories and their emergence in the discussions. The video data was of specific importance for determining not only what teachers miss, but also how the facilitator could activate inert knowledge after a while.

Insights into teachers' practices and categories for differentiating

Main focus on low entrance in Step 1 instead of learning goals and basic concepts

Table 1 shows exemplary answers written by three teachers, together with the category assigned to the answers in the data analysis. Table 2 embeds these three cases into the complete group of 14 teachers (if only 13 teacher occur, one has not answered this part).

	Melanie (PCK ⁺ SNK ⁺)	Dieter (PCK ⁻ SNK ⁺)	Hayat (PCK ⁺ SNK ⁻)
Job 1: Analyzing the task	<ul style="list-style-type: none"> Some kids just start → trial & error some find pattern and use them (de-composition of 24 in multiplication tasks with 3 factors) → Step 1; Step 2-6 in one line	<ul style="list-style-type: none"> one self-confident student (most probably with no special needs) overtakes the task attitude to work [...] trial → affective/social factors, low expectations, implicit Step 1	<ul style="list-style-type: none"> Students find cuboids with same volume and same lengths Students find cuboids with different lengths and same volume Just start and build → Step 1; systematic or trial & error
Job 2: Unfolding differential potential	<ul style="list-style-type: none"> Some kinds only find one cuboid by trial and error; others find many / all cuboids by mathematical thinking; commutativity (different cuboids by shifting factors) → natural differentiation along the steps and diverse ways <ul style="list-style-type: none"> different modes of documentation → natural differentiation regarding documentation & high ceiling	<ul style="list-style-type: none"> Preset the layers make writing task more precise → no natural differentiation but reduce complexity	<ul style="list-style-type: none"> Students find some cuboids or only one Students find pattern → natural differentiation along the steps
Job 3: Planning specific support	<ul style="list-style-type: none"> For some students: no support for students with physical disorders: larger cubes support for articulation → support for documentation surface level (material) no basic concepts addressed	<ul style="list-style-type: none"> Less cubes present basic face? → kills fun → reduce complexity; no basic concepts addressed	<ul style="list-style-type: none"> Working in pairs → surface level (grouping); no basic concepts addressed

Table 1: Examples of teachers' written answers and the assigned categories

In **Job 1** (Analyzing the task), Dieter and Hayat only focused on Step 1 of the trajectory of discovery (see Figure 2), only Melanie also considered further steps (even if condensed in one line without unpacking the necessary steps). Within the group of all teachers (see Table 2), Melanie was an exception, whereas many teachers (6 of 13 teachers) only focused on Step 1 of students' trajectory, but not how to reach the core goal of the task, discovering the multiplicative structure of the volume. Other categories teachers activated in Job 1 concerned social and affective factors, many of the teachers expressed low expectations like Dieter and two of them even expect that students get no possibility to build a cuboid.

In **Job 2**, it is interesting to see that Dieter (and with him three other teachers) could not identify the potential for natural differentiation and immediately started to provide specific support for weaker students. Those who identified potential for natural differentiation like Melanie and Hayat focused on the steps (7 of 13), the students' diverse ways of using material and structures (2 of 13), or on multiple representations for documentation (2 of 13). Teachers with PCK⁺SNK⁺ could identify more potential for natural differentiation than the teachers with PCK⁺SNK⁻. The teacher with PCK⁻SNK⁺ found none. The required basic concepts (cuboid, multiplying as counting in groups) were only addressed by one teacher in Job 2. With respect to **Job 3**, most teachers have some resources for planning support for students with mathematical disabilities, this is shown by the fact that only three teachers planned their support exclusively on surface levels of grouping strategies or taking larger wooden cubes.

However, as a consequence of the strong focus on Step 1 in Job 1, the planned support in **Job 3** mainly focused on Step 1/2 again. That means, 2 of 5 teachers with PCK⁺SNK⁺ and 4 of 8 with PCK⁺SNK⁻ only provide support for guaranteeing the low entrance. By this focus, they miss the core

goal of the task, which was discovering the multiplicative structure of the volume. As a consequence of the limited view on the necessary basic concepts, only three teachers with PCK⁺SNK⁺, provided support for overcoming limitations in the basic concepts, and none of PCK⁺SNK⁻ did. Among the three who took care of basic concepts, two made sure that the definition of cuboid as shape with rectangular faces is accessible also for students with mathematical learning disabilities, and only one single teacher's support addressed the potentially missing mental model for multiplication as counting in groups.

	Subsample PCK ⁺ SNK ⁺ (n=5)	Subsample PCK ⁻ SNK ⁺ (n=1)	Subsample PCK ⁺ SNK ⁻ (n=8)
Job 1: Elicited categories for analyzing the task			
Sole focus on Step 1	1 out of 4	1 out of 1	4 out of 8
Also focus on Step 2/3	0	0	2 out of 8
Also focus on Step 5/6 (not on Step 4)	3 out of 4	0	2 out of 8
Affective / social factors	0	1 out of 1	0
Low expectations on students	0	1 out of 1	3 out of 8
Job 2: Elicited categories for unfolding differential potential			
Natural differentiation identified along steps	3 out of 5	0	4 out of 7
Natural differentiation identified re diverse ways	1 out of 5	0	1 out of 7
Natural differentiation identified re representations	2 out of 5	0	0
No natural differentiation identified	1 out of 5	1 out of 1	2 out of 7
Focus on necessary basic knowledge	1 out of 5	0	0
Affective / social factors	0	0	1 out of 7
Job 3: Elicited categories for planning specific support for students with mathematical disabilities			
No support required due to natural differentiation	1 out of 5	0	1 out of 8
Focus on basic knowledge	3 out of 5	0	0
Reducing complexity by presetting the first sub-step	2 out of 5	0	2 out of 8
Reducing complexity by reducing from 24 to 12 cubes	0	1 out of 1	1 out of 8
Support only for Step 1 / 2	2 out of 5	1 out of 1	4 out of 8
Support for Step 3	0	0	1 out of 8
Support for Step 4-6	0	0	0
Support for documentation	3 out of 5	0	3 out of 8
Support only on surface level (grouping, material)	1 out of 5	0	2 out of 8

Table 2: Quantitative overview on elicited categories

Shifting teachers' categories by prompts to further steps

In order to avoid a deficit-oriented inventorization of teachers' perspectives, it is crucial to consider how the teachers' activation of categories can be supported by facilitation in the PD session.

When the facilitator collected teachers' ideas of the aspects of natural differentiation and for supporting students with mathematical learning disabilities after the first group discussions in the PD session, she became aware of the exclusiveness of teachers' focus to the first steps of the trajectory. After acknowledging all teachers' efforts for guaranteeing low entrance for everybody and collecting the diverse aspects of potential for natural differentiation, she shifted the focus to the central learning goal, emphasizing the multiplicative structures of counting in rows and layers for determining the volume. She sent the teachers back into their group discussions with the following prompt which started an interesting process of eliciting further categories:

143 Facilitator	What do we do know [<i>means for the students with learning disabilities</i>] that they can really...? So what kind of support can we give so that they can learn - not only what to calculate, but also understand why to use multiplication?	How to come to Step 2-5?
-----------------	--	--------------------------

144 Melanie	The levels while layering, there are the layers [<i>shows the layers with her hands</i>]	Step 2
...		
149 Melanie	And then coloring, well anyway, really draw the picture as three-dimensional and mark the layers and reflect, how many cubes are in one layer	Step 2+3a
150 Hayat	I mean, when you have worked adequately, then they know this, this with lying the dot plates [<i>she refers to rectangular arrays such as printed here</i>]	Basic concept multiplication
151 Carmen	I was just gonna say, the point system and with it, you can take the cuboids of one layer.	Step 3a
152 Hayat	Yeah.	
153 Carmen	And then the point system behind, then they will get it, length times width.	Step 4, High expectation
154 Hayat	Exactly, I have first..#	
155 Carmen	#That is then, the remediation of the rectangle [...]	basic concept
157 Christiane	Yes.	
158 Carmen	Area, isn't it [...]	
160 Melanie	And then the rectangle.	Step 4
161 Carmen	And then the multiplication [...] You have the dot frames and the rectangle – that is what I would remediate here, and then there are the layers, though. [...]	basic concept
- 165	And then, if you color that, you are, easy peasy, in multiplication.	Step 4
...		
169 Christiane	You mean, decomposing it, actually, after it, decompose into the same forms.	Step 3b
...		
173 Melanie	But then, of course, you are still in the hands-on, and you have to anyway, ehm.	Step 5
174 Carmen	Or you come into the multiplication. [...]	relevance of
-177	IF you have remediated it thoroughly, before.	basic concept

The analysis of the transcript with respect to the implicitly or explicitly addressed categories from Table 2 shows that after the facilitator-initiated shift of attention from the low entrance to reaching the core goal, the group discussion at the observed table quickly turns to carefully thinking through all steps of the trajectory of discovering multiplicative structures (as marked next to the transcript). During this reflection, the teachers also identify the most important basic concept, the mental model of multiplication in the rectangular array (addressed by the teachers with different idiosyncratic terms – the dot plates, the point system, etc. – but exactly that meaning).

It is only now that the teachers discover an important form of differentiating with the open-ended task: When planning how to provide support for students with mathematical disabilities, the basic concepts required for reaching the learning goals of the task must be identified and possibilities for integrated remediations of these basic concepts have to be searched. In addition, teachers can express higher expectations.

Discussion and outlook

Although the sample of 14 teachers is much too small to take the quantitative comparisons of teachers' different backgrounds as statistically representative, these first insights into an ongoing project can already point to teachers' resources and blind spots for differentiating with open-ended tasks:

- Open-ended tasks can only *unfold their potential of natural differentiation* if teachers can unpack this potential. In our sample, 9 teachers started to unpack it, which is a good starting point.
- Their focus is mainly on the start of the trajectory of discovery, and as a consequence, the provided support for students with mathematical learning disability is concentrated on the first steps, but not on the steps towards reaching the learning goal. As a consequence, also the *support is not yet concentrated on the core goals*.

- The observation that only three teachers provide *support for overcoming obstacles posed by potentially missing basic conceptual knowledge* is a very strong concern as students cannot reach the learning goals without getting access to the basic mathematical concepts.
- Within the PD session, the facilitator succeeded to shift the participants' focus from the low entrance to possible *supports for reaching the core goals*, so with adequate prompts, the teachers can activate categories in their PCK that help them. These include especially the basic concepts.
- Further questions: Which other blind spots for differentiation can be identified and how can they be processed?

Acknowledgment

The paper has grown within the research in the German National Center for Mathematics Teacher Education (DZLM, funded by the Deutsche Telekom Foundation). The research is organized in the PD research project MATILDA, funded by the German Ministry of Education (grant no. 01NV1704 to S. Prediger & J. Kuhl). We thank our project partners for the collaboration, especially Christian Büscher for the coordination.

References

- Büscher, C. (2019). Conceptual learning opportunities in teachers' differentiated task designs for inclusive mathematics education. In U. T. Jankvist, M. van den Heuvel-Panhuizen, & M. Veldhuis (Eds.), *Proceedings of CERME 11*. Utrecht, The Netherlands: Freudenthal Group & ERME.
- Bromme, R. (1992). *Der Lehrer als Experte*. Bern, Switzerland: Huber.
- Lawrence-Brown, D. (2004). Differentiated instruction: Inclusive strategies for standards-based learning that benefit the whole class. *American Secondary Education*, 32(3), 34–62.
- Mayring, P. (2015). Qualitative content analysis: Theoretical background and procedures. In A. Bikner-Ahsbans, C. Knipping, & N. Presmeg (Eds.), *Approaches to qualitative research in mathematics education* (pp. 365–380). Dordrecht, The Netherlands: Springer.
- Peltenburg, M. (2012). *Mathematical potential of special education students*. Utrecht, The Netherlands: Freudenthal Institute
- Prediger, S. (2009). Quader bauen aus 24 Würfeln – Kinder auf dem Weg zur Volumenformel. *MNU Primar*, 1(1), 8–12.
- Prediger, S. (2019). Promoting and investigating teachers' pathways towards expertise for language-responsive mathematics teaching. *Mathematics Education Research Journal*, 31(4), 367–392.
- Tomlinson, C. A., Brighton, C., Hertberg, H., Callahan, C. M., Moon, T. R., Brimijoin, K., Conover, L.A., & Reynolds, T. (2003). Differentiating instruction: A review of literature. *Journal for the Education of the Gifted*, 27(2/3), 119–145.
- Scherer, P., & Krauthausen, G. (2010). Natural differentiation in mathematics – the NaDiMa project. *Panama-Post*, 29(3), 14–26.
- Scherer, P., Beswick, K., DeBlois, L., Healy, L., & Moser Opitz, E. (2016). Assistance of students with mathematical learning difficulties: How can research support practice? *ZDM – Mathematics Education*, 48(5), 633–649.

Teaching mathematics to students with intellectual disability: What support do teachers need?

Chun-ip Fung¹ and Dichen Wang²

¹The Education University of Hong Kong, Hong Kong; cifung@eduhk.hk

²The Education University of Hong Kong, Hong Kong; dwang@eduhk.hk

Abstract: Mathematics teachers in Hong Kong find they have no confidence in designing effective instructional plans for students with intellectual disability (ID). Based on our four-year experience of dealing with mathematics teaching problems faced by teachers of students with ID, we claim that an understanding of mathematics knowledge structure is the pre-condition of generating hypothetical learning trajectories. To illustrate this point, a study on developing a progressive learning framework for teaching mental objects to students with moderate or severe ID is presented here.

Keywords: Design science, intellectual disability, mathematics teaching, teacher professional development.

Introduction

Over the last four years, we have been engaged in a professional development programme for supporting mathematics teachers of students with intellectual disability (ID). ID is a disability characterized by significant limitation in intellectual functioning and daily adaptive behaviors (AAIDD, 2010). Students with ID face serious obstacles in abstract thinking, reasoning, comprehension, and communication (Taylor, Richard, & Brady, 2005), which greatly influence their learning performance in mathematics. The cognitive limitation suggests that the mathematics learning trajectory for students with ID cannot possibly be the same as those for students with normal intelligence.

In the local community where we are working, the government provides teachers with a total of 250 hours of training for support students with special educational needs (SEN), including students with ID (Education Bureau, 2018). The majority of time is spent on developing teachers' skills and strategies in supporting students learning and instilling teachers' knowledge in handling students' cognition, behavioral, emotional, sensory, communication, and physical needs. Subject content (such as mathematics or science) is rarely covered. It seems that policymakers regard the enhancement of teachers' knowledge for teaching mathematics to students with SEN as just adding generic pedagogical knowledge to whatever mathematics specific preparation teachers have already acquired in previous training.

Similarly, in the research community, the importance of mathematical knowledge for teaching SEN students has not received much attention. Allsopp and Haley (2015) conducted a synthesis of research and found that, during 2004 to 2014, only 16 studies included the criteria of teacher education, mathematics, and students with learning disabilities. On the topic of intervention studies for ID students' mathematics education, only 16 papers were found to have been published between 1989 to 1998 (Butler, Miller, Lee, & Pierce, 2001), and 7 papers were found to have been published between 1999 to 2010 (Hord & Bouck, 2012). After a glance of the very limited literature on mathematics

education for students with SEN, it is easy to discover that studies on intervention based on a mathematics-specific perspective are rare.

The pedagogical content knowledge (cf. Shulman, 1986) for teaching mathematics to SEN students is an under-addressed area. Is mathematics for teaching SEN students the same, in both content and form, as mathematics for teaching students without SEN? Or how different are the two? To what extent do generic knowledge and skills about SEN students' learning enable teachers to carry out mathematics teaching that is effective to SEN students? We attempt to discuss these questions based on our experience with teacher development in recent years.

The paper describes data from a study in which we collaborate with school teachers to develop an instructional framework for students with moderate (IQ from 35 to 50) or severe ID (IQ below 35). We use this study to illustrate teachers of students with moderate and severe ID need support for designing appropriate mathematical experiences for their students, a point that is overlooked by most teacher training programmes of special education.

Fourteen teachers from five special schools in Hong Kong participated in this study, six of whom teach students with moderate ID, and eight teach students with severe ID. Qualitative data are collected, approved by participating schools, teachers, and students' parents, including written notes of the meetings, video recording of teaching experiments, and audio recording of interviews with three teachers who took part in the teaching experiment.

Generating a hypothetical learning trajectory

In each of the participating schools, teachers have been trying hard to find ways to expand their students' possibilities in mathematics learning. When teachers were asked about their difficulties in teaching, the following comment, made by Teacher 1, was common among the teachers:

When I prepare to teach a piece of mathematics content, I think that I learned that content by this way, but for children with ID, how do they learn?

It shows that teachers understand that the learning trajectories of ID students are different from what they experienced themselves in schools during their years as students, but they have no experience of what it is like to learn mathematics with the limitation that their students have. Given all this, teachers usually are left alone to make up the details of their teaching – extrapolating from whatever mathematics textbooks or other learning resources might offer. However, most of the available materials are designed for students without ID, and teachers would easily find themselves being left in the unknown area of teaching.

In what follows, we outline general steps by which we help teachers to arrive at a hypothetical learning trajectory for students with ID. The procedure resembles the French approach of didactical engineering (Artigue, 1994), in which a serious analysis of the teaching contents and constraints at epistemological, cognitive, and didactical levels constitutes an essential component.

Step 1

We listen to the teachers talk about the teaching problem they are confronted with and have an observation about the target student groups, during which, we try to answer the following questions as far as we can:

- What is the teaching problem?
- What is the goal that the target students need to achieve?
- Is there any constraint that need to be considered?

The answers to these questions provide us with a general picture of our mission.

Step 2

Before we start designing a hypothetical learning trajectory of a topic, we carry out an epistemological analysis of the content structure, which aims to portray a longitudinal picture of knowledge acquisition. During the process, we try to reconstruct a path of knowledge development that on the one hand links up well with prior learning experiences, and on the other hand, contributes to effective subsequent learning. The structures identified in this stage underpin a skeleton of the hypothetical learning trajectory, which ensures the resulting trajectory will be mathematically sound.

Step 3

The skeleton of the hypothetical learning trajectory provides teachers with a direction for generating an instructional plan. In the third step, we need to work with teachers to insert various intermediate stages, with attention paid to characteristics of students, classroom constraints, curriculum constraints etc. With teachers' input, we begin with a thought experiment (cf. Freudenthal, 1991), imagining how the teaching-learning processes will proceed and spotting out the gaps in the proposed learning trajectory that will impede students' knowledge construction.

Step 4

Lastly, teachers, with some help from the researchers perhaps, fill in the fine details to arrive at a detailed instructional action plan for their own students. Afterwards, it will be field-tested and open to amendment based on implementation evidence.

An illustrative example: developing a framework to teach mental objects to students with moderate or severe ID

The learning of mathematics involves creating mental objects (Freudenthal, 1991). Number, length, angle, circle, square, weight, straight line, ... are mental objects commonly encountered in mathematics lessons. They, being intuitively clear among children with normal IQ, are often found to be very difficult for students with moderate or severe ID. Unfortunately, these difficulties are usually unknown to their teachers who were once children with normal IQ in their younger days.

When teachers try to communicate the meaning of mental objects, how can they convey those messages to students with ID? And, how can they check if students indeed acquire what their teachers intend to communicate? The situation becomes worse for students with specific language impairment. When verbal communication fails, is there any possibility of conveying abstract mental objects to

students? In short, how can we draw students' attention to mental objects without relying on language? This is the situation we were confronted with in Step 1 after discussions with teachers. The main teaching problem is how to convey the meaning of a mathematical concept (which is, in essence, a mental object) to students with moderate or severe ID? As these students often do not have satisfactory verbal communication skills, teaching is constrained to using a minimal amount of verbal communication. The goal to achieve is that students can identify the mental object from among others in a multiple-choice question.

In Step 2, we proceeded to analyze the knowledge structure concerned. Indeed, a mathematical term sometimes refers to a relation, as in the case of 'being less', an operation, as in the case of 'subtract', or a class of objects, as in the case of 'straight line'. For example, in Figure 5, we will say "This is a straight line" when we point to each of the three different straight lines. In essence, the term 'straight line' refers to the class of figures in which no two of them are indeed identical. Teaching involves conveying a class of objects that shares certain properties without ever going explicitly into those properties in detail. When language is not the vehicle of communication, we are left with the scenario that students can only 'sense' the meaning through examining a large number of examples and non-examples. This understanding forms the basis of the Pick the Odd One (POO) framework.

POO is a framework for designing a series of multiple-choice activities under which a student could progressively develop a sense of a mental object without relying too much on verbal communication. Although the teacher is free to employ any verbal explanation during its execution, the main thrust that drives students to the target mental object comes from the teacher's confirmation of the correctness of a student's choice, which may well be done using body language or facial expression.

In Step 3, we had to portray various intermediate stages of the POO. These stages should encompass sufficient variation across examples and non-examples of the mental object to be conveyed. To begin with, there should be a key concept, or a focus mental object, that will appear in the series of multiple-choice activities. Going through the series of multiple-choice activities, the student will systematically visualize or experience these variations. Each multiple-choice item includes a total of four or five choices, with at least one choice corresponding to the focus mental object, and at least one choice corresponding to the other. The student should indicate (by pointing or other means) the odd one out. Through systematically varying these choices, the student's attention is drawn to the focus mental object. Timely feedback from the teacher serves to shape how the mental object is developed, and hence is an indispensable component of the activities.

There are four stages of the POO. In Stage 1, each item consists of exactly one choice corresponding to the focus mental object (straight line in this case), while the remaining are identical choices in identical orientation (Figure 1). In Stage 2, each item consists of exactly one choice not corresponding to the focus mental object, while the remaining are identical choices corresponding to the focus mental object, in identical orientation (Figure 2). Variations of the forms of the mental object and the otherwise across items should strive for comprehensive coverage as far as possible (see Figure 3 and Figure 4). In Stage 3, each item consists of exactly one choice not corresponding to the focus mental object, while the remaining choices correspond to the focus mental object in different forms (Figure 5). Up to this point, the student should have seen or experienced a large number of examples and non-

examples of the focus mental object. The teacher could now reveal relevant terminology in written or oral form. In Stage 4, no specific restriction is imposed on the choices and the student is required to pick out the unique choice corresponding to the focus mental object by its name (Figure 6). In other words, the student tackles multiple-choice questions commonly found in regular mathematics class only at Stage 4. All the previous activities are designed to fill the gap before the student is capable of handling this.



Figure 1: POO stage 1



Figure 2: POO stage 2

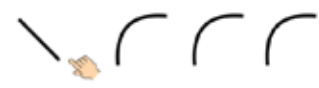


Figure 3: Variations of stage 1



Figure 4 Variations of stage 2



Figure 5: POO stage 3

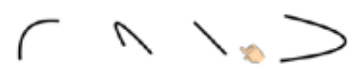


Figure 6: POO stage 4

In principle, this framework can be applied to teach a variety of mathematical mental objects or informal notions such as straight line, circle, emptiness, being long, inner part, being heavy, many, etc.

In Step 4, teachers proceed to design the details of the series of multiple-choice activities. Pilot tests carried out by teachers indicated that there should be a preparatory stage (see Figure 7 and 8) to confirm that the student is capable of matching object or picture at hand with a group of identical objects or pictures not necessarily in the same orientation.

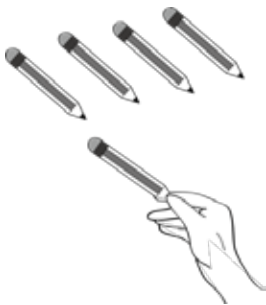


Figure 7: Exactly identical objects

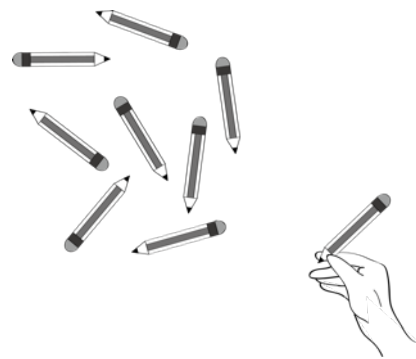


Figure 8: Identical objects in different orientations

After inserting the preparatory stage, the second round of teaching experiments was conducted. The progress in moderate schools was very obvious, in which most students could correctly choose the unique straight line among the four choices after two weeks' training, and some of them could classify straight lines and curves (in the form of physical objects and printed figures) in the third week. Teaching experiments were also conducted with four students (S1, S2, S3, and S4) with severe ID who have little ability of communication. One of the students, S4, is with autism spectrum disorder, and he always exhibits restricted and repetitive behaviours. The learning pace of the students was slow, but progress was still observable as shown in Table 1.

Student	1st video recorded lesson	2nd video recorded lesson (after 6 weeks)
S1	Able to choose the straight line from four choices (POO Stage 4)	Able to classify straight line and curves
S2	Cannot choose the straight line from four choices (POO Stage 1)	Can choose the curve from four choices (POO Stage 2)
S3	Cannot classify the straight line and curves	Able to classify straight line and curves
S4	Cannot give teacher an identical object	Able to put two identical objects into a group

Table 1: Severe ID students' learning performance in two video recorded lessons

Students' learning progress was also observed by the interviewed teachers. They all agreed that the framework helped their students learning mental objects. Teacher 1 who applied the framework to teaching her students with moderate ID the mental object 'being less', told us:

For example, I would like to teach them the concept of 'being less'. During the activity, 'being less' will be the different one among the choices. If you directly point to the group with less objects and tell the student "this is being less" [without drawing their attention to the difference in amount], they will mistakenly name the objects they see 'being less'. Actually, they do not get what you mean, and they haven't even compared them [the quantity]. However, in this framework, they need to identify the difference first and then, we teach them the difference is 'being less'. Before we applied this framework in teaching, our students' performance of 'being less' was not stable, but through the framework, I pointed to the difference and told them it is 'being less', they soon have a grasp of the concept.

Teacher 1 found the framework provided a way for teachers to communicate with moderate ID students. She had never thought that POO could be an effective starting point to learn a mental object.

Teacher 2, who was in her second year of teaching students with severe ID, found that POO not only assisted her students' learning but also enhanced her professional competence in teaching students with severe ID.

Interviewer: What changes have you had after participating in this teaching experiment?

Teacher 2: Before this teaching experiment, I didn't know what content I should teach [to students with severe ID]. Now, when I teach mathematics, I have something to follow. I can make a reference to the framework. There are many levels and steps, so I can evaluate what level a student has achieved and know what learning activities should be assigned to the child in the next level. This makes lesson planning easier because the framework enables me to plan my teaching for each individual student.

Interviewer: What changes do your students exhibit?

Teacher 2: One student could pick the odd one only when it differs from the others significantly, now she is able to do it with even a small difference. I found that when they are familiar with the learning activity, they can make progress much faster. It is good for them to learn different topics under one progressive learning framework. Before this teaching experiment, I included a variety of learning activities in my class because I believed it would make a fruitful lesson. However, from the perspective of students with severe ID, this is not the case. They cannot handle a frequent switch of contents and learning methods, and consequently make little progress.

Interviewer: Did your students perform up to your expectation?

Teacher 2: More than half of the students performed better than I expected.

Interviewer: What was your expectation before?

Teacher 2: Before? I didn't expect much. I just gave them some manipulatives related to mathematics and hoped they could explore by themselves. I was satisfied if they could touch and play with them. But now, I expect more. I hope they can make some mathematical sense out of the activity instead of just playing.

Teacher 3, who has more than twenty years of experience in teaching moderate ID students, also mentioned:

We have learned more about mathematics. This is because that part of mathematics falls onto the blind spot of our knowledge. We were not able to see them because we skipped them quickly when we learned. As our starting point [of learning] was not that low, it is natural that we missed all the steps that our students need to have. Therefore, we would not think of these steps in our teaching. Fortunately, the learning trajectory developed explicitly lists those steps out, reminding us of what we missed in our teaching.

Concluding remarks

Our experience with the framework POO reveals the following observation that deserves serious attention. Teachers need support on creating a knowledge structure for understanding and planning for students' progress. Such a structure should enable teachers to divide teaching into small steps that can possibly engage students with moderate or severe ID. This is especially important when teachers cannot possibly draw on their own previous learning experience where those intermediate learning stages were virtually absent. To produce such a knowledge structure and subsequent action plan constitutes the design science of mathematics education (Wittmann, 1995, 2001). It involves studying various phenomena and their corresponding mathematical meanings, which can only be done from within mathematics (Freudenthal, 1983). Judging from students' performance and teachers' feedback, this approach is seen to have a positive impact on improving the quality of learning of ID students. It re-confirms the importance of mathematics in mathematics education (Akinwunmi, Höveler, & Schnell, 2014), something that may sound too trivial to consider, yet often too easy to overlook.

References

- Akinwunmi, K., Höveler, K., & Schnell, S. (2014). On the importance of subject matter in mathematics education: A conversation with Erich Christian Wittmann. *EURASIA Journal of Mathematics, Science & Technology Education*, 10(4), 357–363.
- Allsopp, D. H., & Haley, K. C. (2015). A synthesis of research on teacher education, mathematics, and students with learning disabilities. *Learning Disabilities: A Contemporary Journal*, 13(2), 177–206.
- AAIDD – American Association on Intellectual and Developmental Disabilities. (2010). *Intellectual disability: definition, classification, and systems of supports*. Washington, DC: American Association on Intellectual and Developmental Disabilities.
- Artigue, M. (1994). Didactical engineering as a framework for the conception of teaching products. In R. Biehler, R. W. Scholz, R. Strässer, & B. Winkelmann (Eds.), *Didactics of Mathematics as a Scientific Discipline* (pp. 27–40). Dordrecht, The Netherlands: Kluwer.
- Butler, F. M., Miller, S. P., Lee, K., & Pierce, T. (2001) Teaching mathematics to students with mild-to-moderate mental retardation: A review of the literature. *Mental Retardation*, 39(1), 20–31.
- Education Bureau. (2018). *Teacher professional development on catering for students with special educational needs (SEN)*. Retrieved from <http://www.edb.gov.hk/en/edu-system/special/sen-training/index.html>. Accessed 10.04.2019.
- Freudenthal, H. (1983). *Didactical Phenomenology of Mathematical Structures*. Dordrecht, The Netherlands: Reidel Pub. Co.
- Freudenthal, H. (1991). *Revisiting Mathematics Education: China Lectures*. Dordrecht, The Netherlands: Kluwer Academic Publishers.
- Hord, C., & Bouck, E. C. (2012). Review of academic mathematics instruction for students with mild intellectual disability. *Education and Training in Autism and Developmental Disabilities*, 47(3), 389–400.
- Shulman, L. S. (1986). Those who understand: Knowledge growth in teaching. *Educational Researcher*, 15(2), 4–14.
- Taylor, R. L., Richards, S., & Brady, M. P. (2005). *Mental retardation: Historical perspectives, current practices, and future directions*. Boston, MA: Pearson.
- Wittmann, E. C. (1995). Mathematics education as a “Design Science”. *Educational Studies in Mathematics*, 29(4), 355–374.
- Wittmann, E. C. (2001). Developing mathematics education in a systemic process. *Educational Studies in Mathematics*, 48(1), 1–20.

K-12 Namibian teachers' beliefs on learning difficulties in mathematics: Reflections on teachers' practice

Shemunyenge Taleiko Hamukwaya

University of Turku, Finland; shtaha@utu.fi

This paper explores K-12 Namibian mathematics teachers' beliefs on difficulties associated with learning mathematics in school and examines their perceptions of problems affecting Mathematics Learning Difficulties (MLD). 231 teachers (100 primary and 131 secondary teachers) completed the survey. The findings reveal that teachers frequently frame students' difficulties within a deficit framework seeing students' difficulties as emanating from cognitive disabilities. Teachers' identification of potential causes of MLD is discussed. The paper concludes by considering the pedagogical implications of providing additional support to students with MLD and by providing recommendations for future research on changing teachers' negative perceptions towards students with MLD to optimize students' performance.

Keywords: Learning difficulties, teachers' perceptions, mathematics learning difficulties, beliefs.

Introduction

Many countries across Africa have reported poor mathematics performance among their students (International Mathematics Union Report, 2014). According to the Organization for Economic Co-Operation and Development (OECD), mathematics becomes a stumbling-block for the majority of students (OECD, 2014). In Namibia, like many other countries, mathematics is a compulsory subject in the K-12 curriculum because of its significance and practical value in everyday applications (Tjikuua, 2000). However, in the last three decades, since Namibia's independence in 1990, majority of students perform poorly in mathematics. Literature on mathematics education highlighted numerous factors leading to poor performance including students' difficulties in learning mathematics (e.g. Siyepu, 2013). To better understand students' difficulties in Namibia from the teachers' perspective, this study examines Namibian mathematics teachers' perceptions on Mathematics Learning Difficulties (MLD) and challenges experienced in teaching students with learning difficulties. Preliminary research shows that little is known about Namibian mathematics teachers' perspectives on MLD, rather past studies have focused on learning and teaching of specific content in mathematics, instead of understanding MLD. Therefore, the study's aim is twofold: contribute to the research on mathematics teachers' beliefs and mathematics education in terms of how teachers cater diverse learning needs of students with MLD and suggest potential ways for teachers' intervention starting by changing teachers' beliefs to improve the academic performance of Namibian students.

Theoretical background

Mathematics education researchers describe MLD in different ways. Morgan, Farka and Wu (2009) associate MLD to risks in mathematics proficiency. Karagiannakis, Baccaglioni-Frank and Papadatos (2014) describe MLD as a variety of obstacles that lead to difficulties in processing numbers. While some researchers claim that MLD is the result of sociocultural norms around developing

mathematical skills or comprehending arithmetic relations (Kaufmann & von Aster, 2012, p. 767), other researchers assert MLD is related to cognitive functions (Mazzocco, 2007). All students with MLD work slowly in mathematics (Wang, Du, & Liu, 2009) and perform poor academically (Jitendra et al., 2013). Building on the previous literature, this study considered MLD as any limitations or constraints that are believed have negative effect on students' achievement, and leads to difficulties in learning and poor performance of mathematics.

Several reasons and factors that might cause the learning problems in teaching students with MLD have been identified, including poor foundation in content knowledge, unwillingness to learn, and teachers' incompetency (Siyepu, 2013). The literature also reveals several causes that teachers attribute to mathematical difficulties, which include the lack of student motivation and the medium of instruction (Wang et al., 2009; Siyepu, 2013). Students tend to develop positive attitudes towards mathematics in early grades; however, some lose interest in mathematics as they move to higher grades (Lee, 2009) and experience difficulties in mathematics and perform poorly due to lack of interest in the subject (Tella, 2007).

To address the needs of students with MLD, Torbeyns, Verschaffel, and Ghesquire (2004) suggest that teachers pay special attention to effective teaching techniques at a slower pace, as this will improve student performance. However, such implementation requires understanding teachers' perspectives of MLD which has not been investigated before. Thus, this study explores Namibian teachers' beliefs about the difficulties associated with learning mathematics and how they perceive MLD. The perceptions of teachers are important in the identification of difficulties and factors involved in MLD and ultimately have a significant influence in changing practices (Kasanda, 2015) towards a more inclusive mathematics teaching.

Mathematics teachers' beliefs and practice

Mathematics teachers have a wide set of beliefs regarding mathematics content and the nature of mathematics, but also on effective teaching and learning of mathematics. These beliefs are often based on a teacher's own knowledge base, or his or her own experiences acquired through his or her adapted teaching practice (Maab & Schlöglmann, 2009). This study has adopted the definition of beliefs from Ajzen and Fishbein (1980), who define beliefs as whatever a person regards as true in a certain situation. These beliefs include thoughts, attitudes and principles adopted by individuals through a shared environment. Researchers on mathematics teachers' beliefs agree that beliefs play a critical role in determining how teachers teach and what they do (Thompson, 1992). Research also suggests more studies on beliefs on teaching and learning mathematics as well mathematics itself as a subject (Perry, Tracey, & Howard, 1999, p. 39). Also, Haser and Star (2009) suggest more belief studies are needed in different educational contexts to better understand how teachers deal with different situations. The present paper extends the work of Perry (1970), who explored mathematics teachers' epistemology beliefs – whereby the study will look at beliefs based on the experiences of teaching students with MLD to determine their notion of an inclusive setting. This perspective acknowledges that the personal beliefs of teachers might influence their teaching practice. According to Ernest (1991), a teacher's perspective is an individual belief system about the nature of mathematics. Ernest (1991) further found that mathematics teachers' perspectives, which are regarded

as beliefs or thoughts, influence a teacher's social context of teaching and the level of teacher's thought. Furthermore, educational researchers emphasize that teachers' beliefs and the social context affect the nature of how mathematics is taught or learned (Ernest, 1991). Thus, educational programs need to reshape those beliefs that may hinder effective mathematics teaching (Maasepp & Bobis, 2015). Researchers suggest that teachers' beliefs regarding teaching and learning affect their own practices (Thompson, 1992). It has been found that there is a strong relation between teachers' perspective of teaching and their perspective of students' mathematical knowledge (Sosniak, Ethington, & Varelas, 1991). Ernest (1991) concluded that to change the nature of teaching and learning of mathematics, changes in a teacher's belief structure is needed, while acknowledging that belief change is difficult. On account of this, the present study intends to answer the following questions:

1. What are Namibian mathematics teachers' beliefs about mathematics learning difficulties?
2. What challenges do mathematics teachers experience when teaching students with mathematics learning difficulty in an inclusive classroom and what potential measure do they use?

Methodology

Instrument

A survey with closed (teaching experience, education background) and open-ended questions (Kelley, Clark, Brown, & Sitzia, 2003), was administered, to get the perspectives of mathematics teachers' on MLD by asking the following questions: (i) What do you understand by 'learning difficulties' in mathematics? (ii) What challenges do you experience in teaching students with learning difficulties in mathematics? (iii) How do you deal with such challenges? The instrument also collected information on teachers' views about challenging topics to students as well as their estimation on difficulty among mathematics students as they move from primary to secondary level which are not reported in this paper because of limited space. The design process followed the recommendation of Zhanga and Zhou (2016) about the design of the questionnaire, that it should allow participants flexibility to provide rich data. The survey was designed by the author and revised by two experienced researchers in the field in terms of wording as well as its content for validity.

Participants and procedure

A total of 231 primary and secondary (100 and 131 respectively) teachers voluntarily completed the survey. Participants' teaching experience ranged from one to twenty years, and their educational backgrounds varied. Only five of the participants did not have the minimum teaching requirements, a diploma as per Namibian teaching requirements, and the majority taught at rural public schools.

The survey was given to teachers during an annual Namibian mathematics teachers' congress in 2017 where 232 teachers teaching at both primary and secondary phases participated. This congress is a venue where mathematics teachers across the country come together to share their experience and challenges encountered in teaching mathematics. This was a better platform for the author to obtain representatives from all fourteen educational regions to contribute to the study. Permission to conduct the survey was obtained from the conference coordinator. Teachers were briefed about the research objective and they were informed that their participation was anonymous and confidential. Teachers

were told to base their answers to what they experienced. Completion of the survey was done at the same time, about 30 minutes. One hundred and six teachers opted to submit the survey through Google Drive while one hundred and twenty-five placed the surveys in a drop box that was allotted for this purpose at a conference venue.

Data analysis

Responses to closed-ended questions were for comment on participants' background information. A qualitative approach was most appropriate to understand and interpret the data of the study, which were the respondents' answers to the open-ended questions. Data were analyzed using a thematic analysis (Ritchie & Lewis, 2003) based on the research questions mentioned earlier. According to Braun and Clarke (2006), descriptive themes enhance meaningful insights of data with deeper understanding. Every individual statement was considered for data analysis and all related features of the data were coded after data familiarization. Key words used in coding include "disabilities", "unable", "less ability", "lack of interest", and "struggling". Categories were identified and refined to make descriptions of the data understandable. The coding process generated three themes. Some of the descriptions are illustrated as direct quotes to support claims and to have a coherent conclusion.

Findings and discussions

The findings reveal that teachers have a wide range of beliefs. In general, the study reveals that teachers' beliefs illustrate that they are unaware of the causes of MLD. Three themes emerge from this study: Difficulties as the result of learning competency, students' low interest in mathematics, and insufficient mathematics learning foundation. However, this paper will only address competency in learning and students' low interest in mathematics.

Difficulties as a results of learning competency

The most interesting and emergent finding is related to teachers' perceptions on students' ability to learn mathematics. Data analysis showed that Namibian teachers are pessimistic about the ability of students to learn mathematics. They believed that students are unable to perform, they cannot learn in certain settings, or that students' potential to learn mathematics is limited. These teachers' perceptions revealed that Namibian teachers tend to associate MLD to a student's cognitive ability. These beliefs are shared by Mazzocco (2007) in her study as she described that student's ability to learn mathematics is cognitive-based, focused on what students cannot do, instead of what they can do or know. This belief is illustrated by the data, which identifies common key words in the data set, such as: "unable", "inability", "lack", "slower", "struggle", "not achieve", "cannot do", "not able", "poorly", "obstacles", or "hardly catch up". The analysis indicates Namibian teachers consider students to have learning difficulties if they cannot acquire certain skills or have difficulties meeting the learning objectives. Similar findings were addressed by Wang et al. (2009), where teachers stated that students with MLD develop a poor sense of numbers, they have low competency in learning mathematics and need individual support. Moreover, the data report that students with MLD are hardly able to catch-up as they exhibit disabilities when trying to meet the required skills and are unable to function at base level. One teacher reported that, "students struggle[d] to use acquired mathematics skills." While another teacher who based his/her remarks on student arithmetic skills

stated that, “learners demonstrate slow or inaccurate recall of basic arithmetic facts”. Teachers’ beliefs about MLD are illustrated below:

These are challenges that learners face in the classroom setting which contribute [...] to poor performance and misunderstanding of mathematics [...]. Remedial is needed.

I consider a learner to have learning difficulties if they cannot acquire certain skills or have difficulties meeting the learning objectives.

As illustrated in the above quotations, teachers’ perceptions indicate that MLD are regarded as problems that hinder a students’ learning process, they negatively affect students’ academic performance, and consequently cause students to perform poorly in mathematics. Teachers further disagree on the performance levels of students in relation to the competency to be achieved at a certain stage or level. Teachers believe students with MLD cannot master the skills one is expected to attain at a certain level or in a certain learning area. Hence, one teacher mentioned additional learning support for students with MLD:

... [If a] learner is unable to master 40% of the competencies a learner will need special attention apart from [the] normal allocated time for the period. So, such a learner will be given some extra classes for improvement.

Further, majority of teachers reported that by offering a variety of teaching methods, students with MLD could improve their performance in mathematics. Teachers’ seem to believe that not only students with MLD experience difficulty, but even the gifted ones, too. They believe that every individual has some specific learning difficulties, as reported in the previous studies (Eisenberg, 2002). Further, the identification of learning support strategies was helpful in improving student performance across the board. This indicates that learning support can be explored to remedy challenges facing students with MLD as stated below:

With learning difficulties, I do understand that not only the slow learners experience learning difficulties, but the gifted learners can also experience learning difficulties [and ...] compulsory teaching/support can remedy the situation.

Another teacher who stressed the use of learning support materials reported that she used array of teaching methods, including the use of, “concrete materials, remedial teaching and learning support, games [...], opportunities to work together and practical examples.” These examples would require a demonstration of the correction between those techniques/methods and higher student performance. Moreover, a handful of participants believed that regular learning activities and those that accommodate all student abilities might improve overall student performance.

Students’ low interest in mathematics

Additionally, the survey results indicate that teachers believe learning difficulties are associated with a student’s low interest in the subject. Mathematics education literature stresses that the promotion of students’ interest enables greater student success (Hulleman & Harackiewicz, 2009). The data analysis reveal that MLD is often identified to be the cause when students are “not academically good” in mathematics, as a results of “low enthusiasm” in the subject. Findings indicate that students with MLD “lose interest” in the subject, are considered “not serious,” and “usually [do] not participate

in math class.” However, teachers report that despite learning difficulties, some of these students are willing to learn mathematics, particularly if they receive support, and are given positive reinforcement. These responses are similar to those reported by (Zakaria, Chin, & Daud, 2010) as they found that, individual students’ needs should be supported with effective teaching and learning. As one teacher reported, “these are learners who are willing to learn but they have difficulties in the learning process.” As another teacher stated, students with MLD need positive reinforcement, so for “those who lose interest, [that teacher...] gave them positive feedback.” Similarly, another teacher said, “I used to buy them sweets when they did better in a test and also do remedial teaching in the afternoon.” This shared belief by teachers was summarized by another teacher:

Learners must be encouraged by means of positive feedback, such as ‘very good,’ ‘excellent,’ [or] ‘you are doing well.’ Learners [...] experience success by giving them classwork and by giving them immediate feedback. The more success learners [...] experience, the more they become confident and hence learning will take place.

Conclusions and future perspectives

The survey results show that the personal beliefs of the participants may have a negative influence on their teaching practices related to students with MLD. According to the personal beliefs of the participants, and Karagiannakis et al. (2014), mathematics learning difficulties are seen as obstacles that hinder the learning of mathematics, including learning environments and social contexts. Participants indicated they believe these obstacles result in shortcomings in mathematics comprehension, and result in a student’s inadequate development of a mathematics foundation in certain topics or the subject area as a whole. According to the findings, Namibian teachers also believe that MLD delay the learning process and negatively affect students’ academic performance. Responsive statements from the survey show that some of the negative views teachers had might affect their perceptions of students with learning difficulties, and have the potential influence their teaching process (Kasanda, 2015; Thompson, 1992). Further, the majority of participants frame learning difficulties to intellectual aptitude but they did not connect these beliefs to lack of interest or lack of math knowledge though it is mentioned in the literature (Siyepu, 2013; Tella, 2007). Thus, to improve performance outcomes for students experiencing MLD, there is a need of belief change among mathematics teachers, as suggested by Ernest (1991). However, the question remains: How to change teachers’ negative perceptions towards students with MLD? This could be a direction for future research in order to optimize the current study’s outcomes. Furthermore, problems persist as identified by teachers for students with MLD, as these students not only perform poorly in the classroom, but they present low participation and demonstrate little interest in the subject, among others factors. Yet, the majority of Namibian teachers, participated in this study believe that MLD result from an inadequate mathematics foundation, as stressed by Siyepu (2013). However, this current study shows negative connotations of students with MLD, though they may acquire mathematics skills through extra learning support as highlighted in the findings.

References

- Ajzen, I., & Fishbein, M. (1980). *Understanding attitudes and predicting social behavior*. Englewood Cliffs, NJ: Prentice-Hall.
- Braun, V., & Clarke, V. (2006). Using thematic analysis in psychology. *Qualitative Research in Psychology*, 3(2), 77–101.
- Eisenberg, T. (2002). Functions and associated learning difficulties. In D. Tall (Ed.), *Advanced mathematical thinking* (pp. 140–152). Dordrecht, The Netherlands: Springer.
- Ernest, P. (1991). *The philosophy of mathematics education*. Hampshire, United Kingdom: The Falmer Press.
- Haser, Ç., & Star, J. R. (2009). Change in beliefs after first-year of teaching: The case of Turkish national curriculum context. *International Journal of Educational Development*, 29(3), 293–302.
- Hulleman, C. S., & Harackiewicz, J. M. (2009). Promoting interest and performance in high school science classes. *Science*, 326(5958), 1410–1412.
- International Mathematical Union report (2014). Mathematics in Africa: challenges and opportunities. Retrieved July 30, 2017, from https://www.mathunion.org/fileadmin/CDC/cdc-uploads/CDC_MENAO/Africa_Report.pdf
- Jitendra, A.K., Rodriguez, M., Kanive, R., Huang, J., Church, C., Conroy, K.A., & Zaslofsky, A. (2013). Impact of small-group tutoring interventions on the mathematical problem solving and achievement of third-grade students with mathematics difficulties. *Learning Disability Quarterly*, 36(1), 21–35.
- Karagiannakis, G., Baccaglioni-Frank, A., & Papadatos, Y. (2014). Mathematical learning difficulties subtypes classification. *Frontiers in Human Neuroscience*, 8(57), 1–5.
- Kasanda, C. D. (2015). Provision of mathematics continuous professional in Namibia. *International Journal of Educational Sciences*, 8(1), 189–197.
- Kaufmann, L., & von Aster, M. (2012). The diagnosis and management of dyscalculia. *Deutsches Ärzteblatt International*, 109(45), 767–778.
- Kelley, K., Clark, B., Brown, V., & Sitzia, J. (2003). Good practice in the conduct and reporting of survey research. *International Journal for Quality in Health Care*, 15(3), 261–266.
- Lee, J. (2009). Universals and specifics of math self-concept, math self-efficacy, and math anxiety across 41 PISA 2003 participating countries. *Learning and Individual Differences*, 19(3), 355–365.
- Maab, J., & Schlöglmann, W. (2009). *Beliefs and attitudes in mathematics education. New research results*. Rotterdam, The Netherlands: Sense Publishers.
- Maasepp, B., & Bobis, J. (2015). Prospective Primary Teachers' Beliefs about Mathematics. *Mathematics Teacher Education and Development*, 16(2), 89–107.

- Mazzocco, M. (2007). Defining and differentiating mathematical learning disabilities and difficulties. In D. Berch & M. Mazzoco (Eds.), *Why is math so hard for some children? The nature and origins of mathematics learning difficulties and disabilities* (pp. 29–47). Baltimore, MD: Paul H. Brookes Publishing.
- Morgan, P. L., Farka, G., & Wu, Q. (2009). Five-year growth trajectories of kindergarten children with learning difficulties in mathematics. *Journal of Learning Disabilities, 42*(4), 306–321.
- OECD (2014). Education indicators in focus. Retrieved July 30, 2017, from [http://www.oecd.org/education/skills-beyond-school/EDIF%202014--N22%20\(eng\).pdf](http://www.oecd.org/education/skills-beyond-school/EDIF%202014--N22%20(eng).pdf)
- Perry, B., Tracey, D., & Howard, P. (1999). Head mathematics teachers' beliefs about the learning and teaching of mathematics. *Mathematics Education Research Journal, 11*(1), 39–53.
- Perry W. G. (1970). *Forms of intellectual and ethical development in the college years*. New York, NY: Holt, Rinehart and Winston.
- Ritchie, J., & Lewis, J. (2003). *Qualitative research practice*. London: Sage Publication.
- Siyepu, S. (2013). The zone of proximal development in the learning of mathematics. *South African Journal of Education, 33*(2), 1–13.
- Sosniak, L. A., Ethington, C. A., & Varelas, M. (1991). Teaching mathematics without a coherent point of view: Findings from the IEA Second International Mathematics Study. *Journal of Curriculum Studies, 23*(2), 119–131.
- Tella, A. (2007). The impact of motivation on student's academic achievement and learning outcomes in mathematics among secondary school students in Nigeria. *Eurasia Journal of Mathematics, Science & Technology Education, 3*(2), 149–156.
- Thompson, A. G. (1992). Teachers' beliefs and conceptions: A synthesis of research. In D. A. Grouws (Ed.). *Handbook of research on mathematics teaching and learning* (pp. 127–144). New York, NY: Macmillan.
- Tjikua, C. (2000). *Science education reform in Namibia*. Washington, DC:World Bank.
- Torbeyns, J., Verschaffel, L., & Ghesquiere, P. (2004). Strategic aspects of simple addition and subtraction: The influence of mathematical ability. *Learning and Instruction, 14*(2), 177–195.
- Wang, G., Du, H., & Liu, Y. (2009). Case study on improving high school students with learning difficulties in mathematics. *Journal of Mathematics Education, 2*(2), 122–133.
- Zakaria, E., Chin, L. C., & Daud, M. Y. (2010). The effects of cooperative learning on students' mathematics achievement and attitude towards mathematics. *Journal of Social Sciences, 6*(2), 272–275.
- Zhanga, Y., & Zhou, X. (2016). Building knowledge structure by testing helps children with mathematical learning difficulty. *Journal of Learning Disabilities, 49*(2), 166–175.

An in-service training to support teachers of different professions in the implementation of ‘inclusive education’ in the mathematics classroom

Laura Korten¹, Marcus Nührenbörger¹, Christoph Selter¹, Franz Wember² and Tobias Wollenweber¹

¹ TU Dortmund University, Faculty of Mathematics, Germany; marcus.nuehrenboerger@tu-dortmund.de; christoph.selter@t-online.de; laura.korten@math.tu-dortmund.de; tobias.wollenweber@mathematik.tu-dortmund.de

² TU Dortmund University, School of Rehabilitation Sciences, Germany; franz.wember@tu-dortmund.de

Keywords: Inclusive mathematics education, teachers’ in-service training, blended learning.

Introduction

In the German project “GLUE – Gemeinsame LernUmgebungen Entwickeln” (‘developing collaborative learning environments’), an in-service program was developed with the aim to support teachers of different professions (special needs teachers, school teachers) in the implementation of inclusive mathematics education. The program is based on a German website (pikas-mi.dzlm.de), which provides teaching resources and instructional materials for an inclusive mathematics classroom. These materials enhance existing conceptions of mathematics teaching (e.g. Scherer, Beswick, DeBlois, Healy, & Moser Opitz, 2017). In the focus is the development of ‘collaborative learning environments’ for diverse learners to enable every child to participate in mathematical activities, as these are main characteristics of the definition of ‘inclusive education’ in this project.

The main features of the in-service program:

- 1) Self-directed web-based learning is combined with workshop activities (*blended learning*).
- 2) The *workshops* include theoretical inputs as well as practical examples of ‘collaborative learning environments’ for diverse learners in an inclusive mathematics classroom.
- 3) During the workshops participants will adapt, develop, explore and reflect ‘collaborative learning environments’ for their own classes (*transfer from theory to practice*).

Well-founded design elements for in-service trainings for teachers will be taken into account (Barzel & Selter, 2015; Borko, 2004).

Research design

The GLUE-project faces research interests on the *level of design* – with the aim of designing an effective in-service training – and on the *level of research* to evaluate the effectiveness.

All together one-hundred teachers will participate in the study. One half of these participants are special needs teachers, the other half are primary and lower secondary school teachers, to encourage collegial support and reflection between different professions (Bräuning & Nührenbörger, 2010; Wember, 2013). All participants are split in two groups: treatment group and control group.

A *pre-post-follow-up-test design* includes standardized questionnaires (quantitative) and interviews (qualitative) to gain information about the participants' *self-efficacies*, *adaptive mathematical didactical competencies* and their *attitudes* towards inclusive education before and after their participation, to evaluate the effectiveness of the program. Also, the *acceptance* towards the developed in-service program gets surveyed (see exemplary items below).

First results

Until now, the in-service program of the treatment group and the analyses of first pre- and post-tests have started. The first results indicate some high effect sizes concerning the perceived *self-efficacy* by the target group, as the following questionnaire-items show.

Exemplary item 1: *I know instruments for the diagnostically founded support of mathematical competences (e. g. four-phases model).*

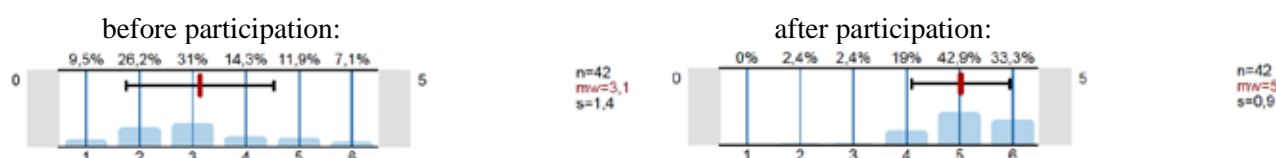


Figure 1: Results of item 1 (paired sample: p-value <0,00; d = 1,500758; effect size high)

Exemplary item 2: *I can adapt instruments for the diagnostically founded support of mathematical competences (e. g. four-phases model) to plan my lessons for the inclusive mathematics classroom.*

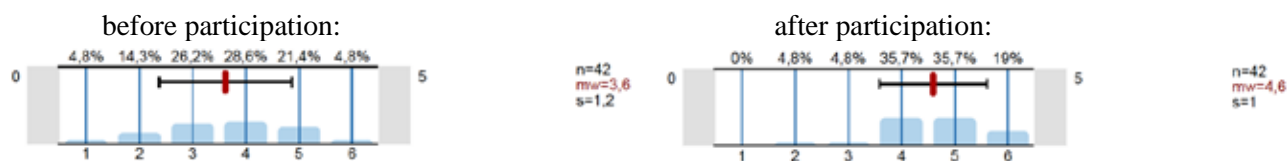


Figure 2: Results of item 2 (paired sample: p-value <0,001; d = 1,001214; effect size high)

References

- Barzel, B., & Selter, C. (2015). DZLM-Gestaltungsprinzipien für Fortbildungen. *Journal für Mathematik-Didaktik*, 36(2), 259–284.
- Borko, H. (2004). Professional development and teacher learning. *Educational Researcher*, 33(8), 3–15.
- Bräuning, K., & Nührenböcker, M. (2010). Teachers' collegial reflections of their own mathematics teaching processes. In V. Durand-Guerrier, S. Soury-Lavergne, & F. Arzarello (Eds.), *Proceedings of CERME6* (pp. 934–943). Lyon, France: INRP.
- Scherer, P., Beswick, K., DeBlois, L., Healy, L., & Moser Opitz, E. (2017). Assistance of Students with Mathematical Learning Difficulties – How Can Research Support Practice? – A Summary. In G. Kaiser (Ed.), *Proceedings of ICME13* (pp. 249–259). Cham, Switzerland: Springer.
- Wember, F. B. (2013). Herausforderung Inklusion. Ein präventiv orientiertes Modell schulischen Lernens und vier zentrale Bedingungen inklusiver Unterrichtsentwicklung. *Zeitschrift für Heilpädagogik*, 64(10), 380–388.

Designing mathematical computer games for migrant students

Janka Medová, Kristína Bulková and Soňa Čeretková

Constantine the Philosopher University in Nitra, Faculty of Natural Sciences, Department of Mathematics, Nitra, Slovakia; jmedova@ukf.sk, kristina.bulkova@ukf.sk, sceretkova@ukf.sk

Keywords: Language of instruction, educational games, computer games.

In recent years a high percentage of students are (first or second generation) immigrants not only due to the open labour market in the European Union. The current affairs regarding immigrants might indicate the future increment of this ratio. Lot of research has been conducted with the aim at influencing the formal education in the language which is not the mother tongue of students (e.g. Meyer, Prediger, César, & Norén, 2016). According to teachers experienced in working with immigrant-students, the materials suitable for students with a limited knowledge of the language of instruction should be based on symbolic and visual features and elements, implicitly using only a restricted amount of text elements (Kijáková, 2018).

Other crucial factors influencing the school performance are the different personal cultures of immigrant-students. The contexts of problems are suitable when they are part of students' everyday life, familiar to the learner, up to date, and do not focus too much on any social issues (Rossouw, Hacker, & de Vries, 2011). Intercultural teaching materials can be beneficial for all students, not only for immigrants. Materials should be built on the culture-related context, respecting the background of every individual student.

The educational computer games have the potential to motivate students to learn mathematics (Papastergiou, 2009), hopefully also under difficult circumstances. Despite of it that there are plenty of electronic materials available for mathematics classrooms, however, there is only a limited amount developed for multicultural learning situations, especially for the specific situation of immigrant-students.

The main aim of this poster is to promote the project **Innovative Mathematics Learning Software for Migrant Students – immiMATH** supported by the Erasmus+ programme and to describe the principles leading the design of the educational software for a specific group of students.

Principle 1: Designed software should **minimize the amount of text**.

Principle 2: Designed software should **relate to the everyday life** of students.

Principle 3: Dividing into levels should allow students to **monitor their progress**.

Two kinds of games were designed (see Table 1): (i) motivational games showing students the role of mathematics in their everyday life; (ii) games for revising the acquired knowledge in the manner decreasing the anxiety and increasing students' self-confidence in solving mathematics tasks. The project team consists of university teachers (mathematics teacher educators), school teachers and software-company experts experienced in designing educational software. The designed software will be evaluated by project partners and piloted in selected schools. Each piece of software will be tested twice. The software will be adjusted according to the first pilot trial that will be carried out with future mathematics teachers with special focus on migrant students. The second version will be piloted by

regular students, including immigrant-students. The second objective of the project is to provide professional development activities for both, pre-service and in-service teachers, regarding the multicultural education and presenting all attributes of the designed learning software.

Software for motivation			Software for practice		
Name	Topic	Grade	Name	Topic	Grade
Trip through Europe	Linear Functions	9 to 10	Journey around the World	Linear Functions	9 to 10
The Algebraic Garden	Algebraic Expressions	8 to 10	Penny Bank	Financial Literacy	4 to 6
Save Europe!	Percentage	8 to 11	Geometria Land	Planimetry	9 to 11
The Math Princess' Tower	Number Sense (Integers)	4 to 5	The Little Architect	Spatial Geometry	4 to 6
Multicultural Logic Train	Logic	4 to 6	Building a city	Functions and Graphs	9 to 11
Deli Shop	Fractions	4 to 8	Birthday Party	Measurements	4 to 6

Table 1: List of the designed software

Acknowledgement

The poster was created within the project Innovative Mathematics Learning Software for Immigrant-Students - immiMATH that is carried out with the support of the European Community in the framework of the ERASMUS+, Call: 2017 - KA2 - Cooperation for Innovation and the Exchange of Good Practices KA201 - Strategic Partnerships for school education, the project number: 2017-1-AT01-KA201-035005. The content of this project does not necessarily reflect the position of the European Community, nor does it involve any responsibility on the part of the European Community.

References

- Kijáková, Z. (2018). Inclusive education from practicing teacher's point of view. Paper presented at *International Conference of Interdisciplinary STEM Studies* held in Nitra, Slovakia on 28th August 2018.
- Meyer, M., Prediger, S., César, M., & Norén, E. (2016). Making use of multiple (non-shared) first languages: State of and need for research and development in the European language context. In R. Barwell et al. (Eds.), *Mathematics Education and Language Diversity*. New ICMI Study Series. (pp. 47–66). Cham, Switzerland: Springer
- Papastergiou, M. (2009). Digital game-based learning in high school computer science education: Impact on educational effectiveness and student motivation. *Computers & Education*, 52(1), 1–12.
- Rossouw, A., Hacker, M., & de Vries, M. J. (2011). Concepts and contexts in engineering and technology education: An international and interdisciplinary Delphi study. *International Journal of Technology and Design Education*, 21(4), 409–424.

Diagnosis tools of dyscalculia – contribution of didactics of mathematics to numerical cognition

Florence Peteers¹ and Cécile Ouvrier-Bufferet²

¹Paris Diderot University, France; peteers@math.univ-paris-diderot.fr

²Paris-Est Créteil University, France; cecile.ouvrier-bufferet@u-pec.fr

Research about dyscalculia must still be developed. The dominant perspective focuses on the individual's cognitive characteristics. We seek to know the place of mathematics education in this research and how to reconcile approaches to reach a better understanding of the disorder. We present here a methodology of analysis for tests which are designed to evaluate basic mathematics skills with various theoretical frameworks (cognitive sciences, psychology or didactics). We highlight some biases in tests from numerical cognition thanks to didactic frameworks and open perspectives to build a mathematical difficulties detection tool to facilitate the exchanges between teachers and speech therapists by providing a common inventory of the child's difficulties.

Keywords: Dyscalculia, mathematical learning disabilities, tests, numerical cognition.

Context

These last decades are clearly marked by an increase of the research and a better understanding of learning disabilities. While some disorders are now well identified and managed (dyslexia for example), others remain more complex and less studied (Lewis & Fisher, 2016). That is the case for the *mathematical learning disabilities* (MLD) which would affect 5 to 8% of students (Geary, 2011). There is currently no consensus about the definition of this trouble (Lewis & Fisher, 2016). MLD are often reduced to difficulties in processing numerical quantities and arithmetic calculation (thus the use of the term of dyscalculia). But an increasing number of studies indicate that MLD are heterogeneous (Fias, Menon, & Szűcs, 2013) and affect several aspects of mathematical skills (Kaufmann & al., 2013). These definition problems make the diagnosis and its methodological validity debatable (Lewis & Fisher, 2016). From the educational point of view, politics are concerned by the difficulties in the learning of mathematics and the processes of “inclusion” (e.g. “Loi pour la Refondation de l'École”, since 2013 in France). We claim that specific studies should be structured and developed in mathematics education regarding MLD in order to improve the identification and the remediation of MLD in an educational context. In particular, that implies a better knowledge of the existing research dealing with MLD. In fact, MLD are studied by different disciplinary fields and each of them develops its own models and hypothesis (Giroux, 2011). We can highlight two distinct approaches: the cognitive sciences approach is centered on the cognitive functioning and individual characteristics (Wilson & Dehaene, 2007), while the mathematics education approach focuses on knowledge specificities as well as the didactic characteristics of learning situations. The difficulties are not only due to an individual's dysfunction: it is also necessary to look for what prevents or stimulates the learning in the interaction between the student, the knowledge and the didactic situations. This compartmentalization of approaches is not without consequences. Indeed, many professionals who surround children with and are not leaning on the same approaches of the disorder: cognitive sciences for the paramedical professionals and

mathematics education for the teachers. The dialogue between these actors is therefore sometimes difficult, especially as medical confidentiality prevents the dissemination of some information. This is particularly problematic in the case of the exchanges between teachers and speech therapists.

Objectives

Research about MLD are mainly focused on the cognitive approach so we question the place of mathematics education and the way to reconcile the different points of view to a better understanding of MLD. We consider more precisely the reconciliation of approaches through the creation of a mathematical difficulties detection tool that can be used both by teachers and speech therapists. This device should facilitate the exchanges between these two types of professionals by proposing a common inventory of child's difficulties that can be used by each of them (for a diagnosis and for pedagogical adaptations). To develop this tool, we conducted an analysis of existing tests designed to evaluate mathematical basic skills at the end of kindergarten or at the entry to elementary school. To ensure the diversity of the theoretical foundations, we selected diagnostic tests used by medical professionals (for the most part from research in numerical cognition), but also tests used to evaluate the child in school (from mathematics education area). The final selection contains Francophone diagnostic tests (*MathEval*, *Examath*, *ECPN* and *UDN-II*) and school tests (grade 1) (a numerical skills test of basic school program, *ERMEL*, and the device "*Quatre étapes*"). We also selected an Anglophone diagnostic test (*Woodcock-Johnson*) and diagnostic tests translated into several languages used internationally (*Zareki-R* and *Tedi-Math*). Figure 1 points out the main backgrounds of these tests and their distribution into the research areas.

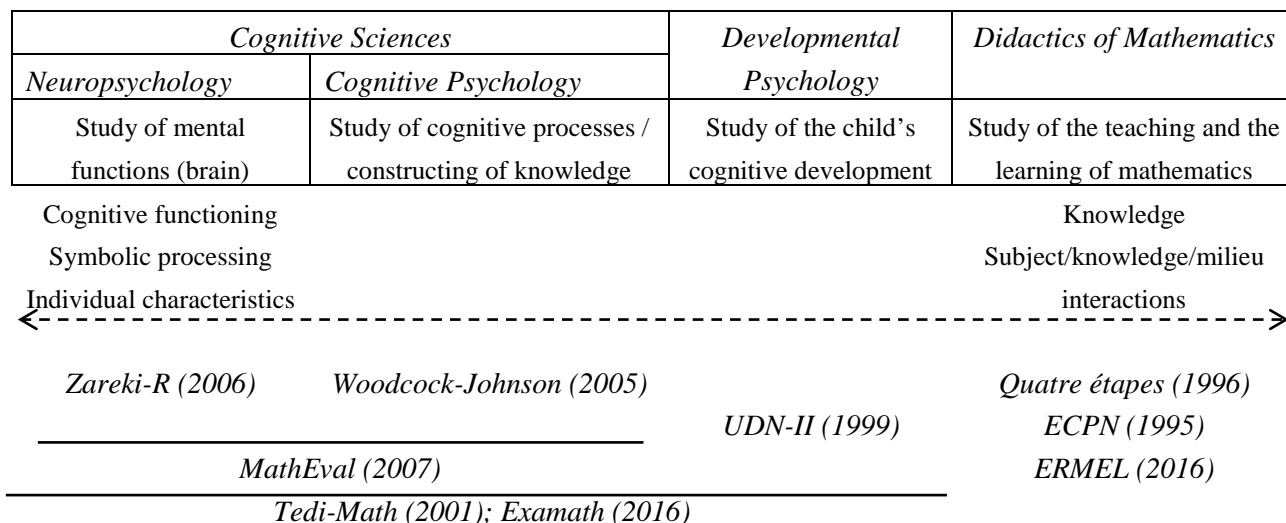


Figure 1: Analyzed tests in numerical cognition and didactics of mathematics (following the organization of research areas studying mathematical learning difficulties of Giroux (2011, p. 152))

Methodology

In order to define our analysis criteria, we made a state of the art about number construction and first number learning in didactics of mathematics and in numerical cognition. Thus, we highlight different number tasks and the variables that can affect the complexity of these tasks or the resolution strategies. These variables constitute our analysis criteria. In mathematics education, Brousseau's Theory of Didactical Situations (1997) allowed us to identify situations giving

meaning to number as well as their didactic variables. Moreover, thanks to Vergnaud's Theory of Conceptual Fields (1996), we could identify criteria for analyzing additive problems. In numerical cognition, we identified characteristics of numerical representations according to the different number processing models (especially the Dehaene's triple code model, 1992, the McCloskey's model, 1985, and the Von Aster's developmental model, 2007). We have also drawn analysis criteria for cognitive functioning of mathematical activities, based on the calculation model of Shrager and Siegler's strategy choice model (1998) or the transcoding's model of Barrouillet, Camos, Perruchet and Seron (2004). Finally, we studied the impact of some underlying cognitive functions like working memory, attentional functions, visuo-spatial abilities or digital gnosis in mathematical activities. Indeed, it has been shown that problems with these cognitive functions are generally associated with low mathematical performance (see Finnane (2006) for example). To articulate our criteria within a functional analysis table, we identified four categories of task based on our state of art (tasks where the number is used to express a quantity or a position, operation resolution tasks, digital code and transcoding tasks and tasks used to evaluate mental representation of numbers). Then we listed the tasks related to these four categories in the tests and used the criteria identified in state of art to analyze them. For this article, we choose to describe the analysis tables and to illustrate them with some examples. The whole analysis is available in Peteers (2018).

Tasks where the number is used to express a quantity or a position

Numbers allow us to express quantities (cardinal aspect) and positions (ordinal aspect). We therefore searched in each test if these two functions were present. For the use of numbers to express quantities, we analyzed in detail the four quantification procedures identified in our states of art (didactics of mathematics and numerical cognition): term-to-term correspondence, counting, estimation and subitizing. Figure 2 summarizes the criteria used to analyze these types of tasks.

For example, the Tedi-Math (Van Nieuwenhoven, Grégoire, & Noël, 2001) does not contain tasks in which numbers are used in their ordinal aspect. For the quantification procedures, only counting is evaluated through different items. Some evaluate the procedure itself (Gelman and Gallistel's principles) and others evaluate the spontaneous use of counting (construction of an equipotent collection to a given one). If we analyze more precisely these tasks, we can notice that the collections used in counting tasks are always composed of non-manipulable objects, which makes the "enumeration"¹ more difficult (Briand quoted by Ouvrier-Bufferet, 2013). For the construction of an equipotent collection, the model collection remains accessible, which does not stimulate the use of counting procedures because the term-to-term correspondence remains possible. However, the task will be considered successful only if the child uses counting.

¹ Briand (1999) has underscored several preliminary steps in the learning of counting. In the series of actions required for counting, the pupils have to look over all the elements of a finite collection one time and only one. This task characterizes a non-taught knowledge, called by Briand "enumeration". Enumeration is clearly linked to the one-to-one principle (Gelman & Gallistel, 1978). The number word is a tag (and such a tag is a convention) but a tag is not necessarily a number word. Learning "enumeration" is not an explicit part of teaching. The research of Briand (1999) proves the necessity of activities involving "enumeration" in the pre-numerical domain.

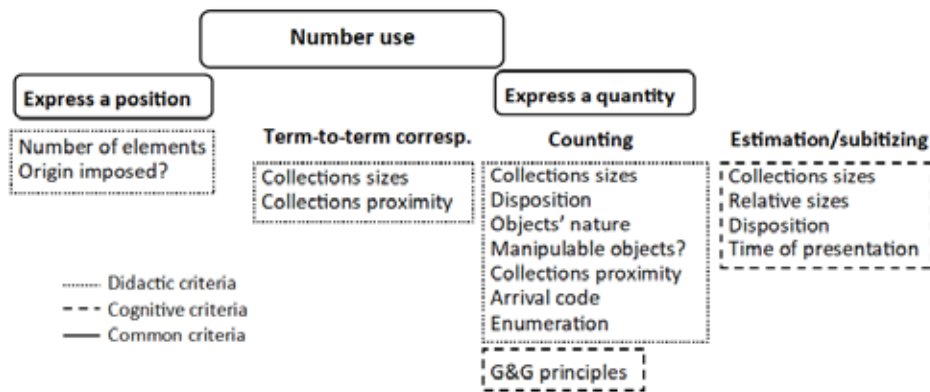


Figure 2: Analysis criteria for tasks regarding number use (quantity or position)

Tasks used to evaluate mental representation of number

There are different theories in numerical cognition about the nature of representations of numbers magnitude (Noël, 2005). In each test, we therefore looked for the two types of representation (decimal or analogical) evaluated and how these representations are evaluated. We identified three types of tasks that can be used to evaluate analogical representations: analogical comparison tasks, comparison tasks involving oral or arabic code and tasks consisting in positioning numbers on a number line. For the evaluation of decimal representations and the comprehension of our number system, we considered two types of tasks: tasks related to writing numbers and tasks involving material collections. Figure 3 shows the criteria used for the analysis of these types of tasks.

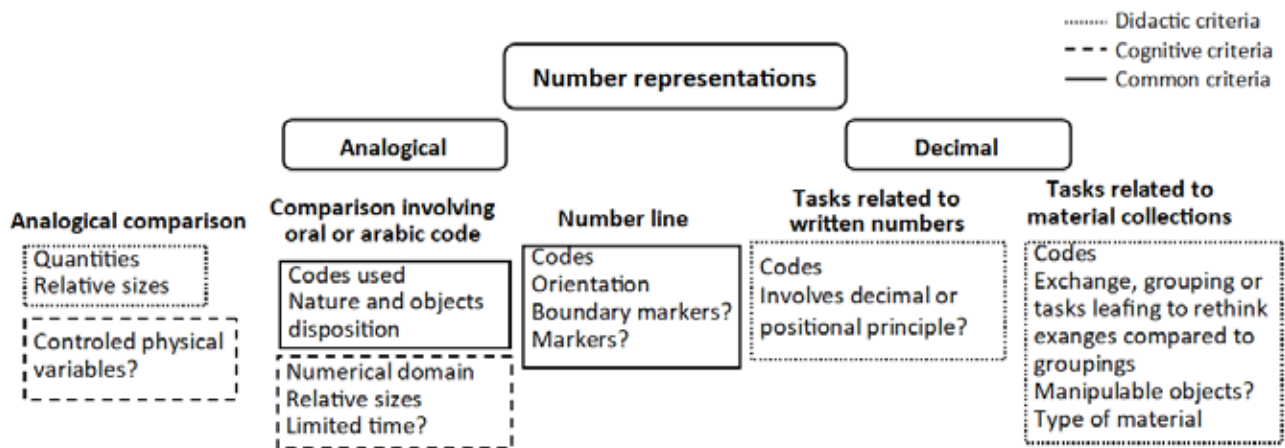


Figure 3: Analysis criteria for number representations tasks

Digital code and transcoding tasks

We identified in the tests the tasks used to determine the mastery of oral code (extension of the stable and conventional part of the verbal number sequence and its organization). We also made an inventory of other tasks designed to evaluate the mastery of oral code and we did the same for the written code. For the transition from one code to another, we chose the following criteria (Figure 4).

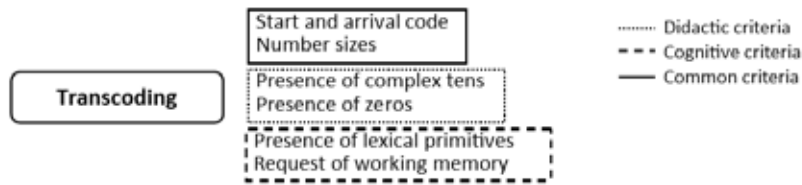


Figure 4: Analysis criteria for transcoding tasks

For example, here are two transcoding tasks (Table 1, from oral to arabic code), one from the Zareki-R (Dellatolas & Von Aster, 2006) and the other from the UDN-II (Meljac & Lemmel, 1999).

Dictated numbers in Zareki-R	Dictated numbers in UDN-II
14 – 38 – 1200 – 503 – 169 – 4658 – 756 – 689	3 – 5 – 9 – 15 – 18 – 27 – 54 – 76 – 89 – 93 – 138 – 272 – 605 – 1061 – 4396 – 7042 – 10001

Table 1: Transcoding tasks from the Zareki-R and UDN-II

We can see that, in both tests, the writing of numbers containing zeros is well evaluated. However, unlike the task proposed in UDN-II, we find in Zareki-R only few complex tens and lexical primitives. The numbers proposed in this test are relatively large and their transcoding strongly solicits working memory. This type of task does not allow us to precisely identify the source of errors. The task proposed in UDN-II makes a more precise characterization of the difficulties.

Operation resolution tasks

Finally, we identified among the tasks proposed in the tests, three categories of tasks requiring the resolution of an operation: analogical operations involving a material support, symbolic operations involving written or oral code and operations with verbal wording consisting in resolving a problem involving an operation. The criteria used to analyze these types of tasks are summarized in Figure 5.

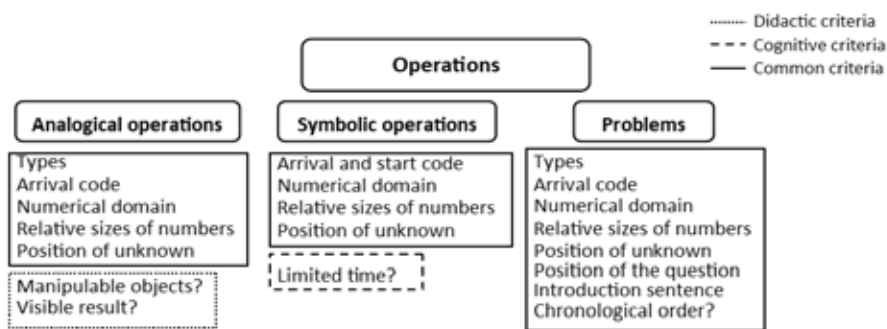


Figure 5: Analysis criteria for operation resolution tasks

Results

Based on our analysis table, we wrote a descriptive analysis of each test. We present here some general results (see Peteers (2018) for more details). We can note that all the tests are different in terms of the knowledge and skills evaluated. The differences are particularly marked for the numerical cognition tests, which is not surprising since these tests are based on different models. Then, we can notice that some types of tasks are specific to theoretical frameworks. In other words, there are tasks specific to the numerical cognition tests (estimation or subitizing tasks, analogical comparison tasks, ...) and others specific to the didactic tests (tasks in which the number is used to

express a position, tasks in which the child must extract a given number of elements from a collection, ...). We can also find some types of tasks in every test regardless of their theoretical foundation (numerical cognition or mathematics education). This is the case for the counting tasks, the evaluation of the numerical verbal sequence, the transcoding tasks, the analogical operation resolution tasks, ... However, the variables of these tasks change depending on the tests. In counting tasks for example, the number of objects in the collection and their disposition vary in each test. There are also differences depending on the theoretical foundations. In our example of counting, the tasks proposed in the cognition tests focused more on the counting procedure (with statements like “how many elements are there?”). In the didactic tests, the focus is on the types of situations in which the child can use a resolution procedure based on counting. The manipulability of the objects also differs according to the theoretical foundations of the tests considered. The cognition tests propose only counting tasks with non-manipulable objects unlike the didactic tests. From a didactic point of view, two elements can be underlined. We note that some knowledge and skills highlighted in our state of art in mathematics education are not evaluated in any of the tests (in both cognitive or didactic tests). This is the case of “enumeration” for example (Briand quoted by Ouvrier-Bufferet, 2013). However, the choice of variables used in the counting tasks in the cognition tests does not always facilitate enumeration. Indeed, the objects used in this type of task are not manipulable (like our example with Tedi-Math), so, the separation between counted and not counted objects must be done mentally. Enumeration difficulties can therefore impact the resolution of counting tasks and are not identified because any task allows the evaluation of this specific skill. We can also notice that the choices of variables used in the tests are not always appropriate. Indeed, if we take again the example of the equipotent collection construction task in the Tedi-Math, the model collection is always accessible during the construction of the equipotent collection which does not stimulate the use of counting because the tasks can be resolved without using the number (using term-to-term correspondence for example).

Conclusion and perspectives – towards a detection tool

We have shown in this article a part of the results of our PhD thesis. We can point out that the mobilized didactic frameworks (Theory of Didactical Situations and Theory of Conceptual Fields) allow us to structure our analysis table, and also bring us another perspective about numerical cognition tests which are not used for school environment. They provide us a framework for critical analysis to highlight some biases of these tests in relation to what is taught and to mathematics education knowledge (non-evaluated elements such as enumeration or questioning of the choices of variables in some tasks). These elements confirm the interest of didactics of mathematics in research about MLD, in particular regarding the diagnosis. We have identified a set of tasks and variables that can be used by the different professionals involved (especially teachers and speech therapists). We now have bases (theoretical tools from didactics of mathematics and numerical cognition frameworks and analysis of the most frequently used tests) to build a mathematical difficulties detection tool (presented in Peteers, 2018). This device uses digital technologies environment but also concrete manipulations for tasks like equipotent collection construction in order to avoid visuo-spatial difficulties for instance. This tool is made of four units (Prerequisites; Cardinal and ordinal aspects; Representations of number; Operations). Each unit is composed by

tasks coming both from numerical cognition and didactics of mathematics. For each task, variables are chosen depending on the age of the pupils (three levels of difficulty are defined) and the well-known learners' difficulties identified in didactics of mathematics. The "Prerequisites" unit deals with: analogical comparison, subitizing and estimation, enumeration, term-to-term correspondence, verbal number sequence. The "Cardinal and ordinal aspects" unit explores the spontaneous use of counting, the Gelman & Gallistel's principles, the counting up process, and the identification of the position of a number (ordinal aspect). The "Representations of number" unit takes into account transcoding tasks, number line and numbers' comparison tasks, and situations requiring decimal positional principle. Finally, the "Operations" unit proposes tasks involving analogical operations, symbolic operations and problems. For each task, we define a coloring code (green, orange, red) to evaluate the success or the failure. A synthesis is then automatically generated for the teacher: it helps her/him build remedial interventions. After such interventions, the teacher can reuse some tasks of the test in order to evaluate the impact of them. In case there are no benefits, the whole synthesis of the test can help teacher to orientate the child to a paramedical professional and inform the speech therapist. We have conducted a first experiment to test our detection tool. Considering the results of this experiment, our tool is currently the subject of a new development (exclusion of some tasks and inclusion of new ones; improvement of the coding process and the synthesis etc.). We still have to normalize it. We will give more details about this device during the conference.

References

- Barrouillet, P., Camos, V., Perruchet, P., & Seron, X. (2004). ADAPT: a developmental, asemantic, and procedural model for transcoding from verbal to Arabic numerals. *Psychological Review*, *111*(2), 368–394.
- Briand, J. (1999). Contribution à la réorganisation des savoirs pré-numériques et numériques. Étude et réalisation d'une situation d'enseignement de l'énumération dans le domaine pré-numérique. *Recherche en Didactique des Mathématiques*, *19*(1), 41–76.
- Brousseau, G. (1997). *Theory of didactical situations in mathematics*. Dordrecht, The Netherlands: Kluwer.
- Dehaene, S. (1992). Varieties of numerical abilities. *Cognition*, *44*, 1–42.
- Dellatolas, G., & Von Aster, M. (2006). *Zareki-R: batterie pour l'évaluation du traitement des nombres et du calcul chez l'enfant*. Paris, France: ECPA.
- Fias, W., Menon, V., & Szűcs, D. (2013). Multiple components of developmental dyscalculia. *Trends in neuroscience and education*, *2*(2), 43–47.
- Finnane, M. (2006). Verbal memory span limitations as a factor in early mathematical learning difficulties. In J. Novotná, H. Moraová, M. Krátká N., & Stehlíková (Eds.), *Proc. 30th Conf. of the Int. Group for the Psychology of Mathematics Education*, Vol. 3 (pp. 81–88). Prague, Czech Republic: PME.
- Geary, D. D. (2011). Consequences, characteristics, and causes of mathematical learning disabilities and persistent low achievement in mathematics. *Journal of Developmental & Behavioral Pediatrics*, *32*(3), 250–263.

- Gelman, R., & Gallistel, C. (1978). *The Child's Understanding of Number*. Cambridge, MA: Harvard University Press.
- Giroux, J. (2011). Pour une différenciation de la dyscalculie et des difficultés d'apprentissage. In V. Freiman, A. Roy, & L. Theis (Eds.), *Actes du colloque du Groupe de Didactique des Mathématiques du Québec* (pp. 148–158). Moncton, NB: Édition.
- Kaufmann, L., Mazzocco, M. M., Dowker, A., von Aster, M., Göbel, S. M., Grabner et al. (2013). Dyscalculia from a developmental and differential perspective. *Frontiers in Psychology*, 4(516), 1–5.
- Lewis, K. E., & Fisher, M. B. (2016). Taking stock of 40 years of research on mathematical learning disability: methodological issues and future direction. *Journal for Research in Mathematics Education*, 47(4), 338–371.
- Meljac, C., & Lemmel, G. (1999). *UDN II – Construction et Utilisation du nombre*. Paris, France: ECPA.
- McCloskey, M., Caramazza, A., & Basili, A. (1985). Cognitive mechanisms in number processing and calculation: evidence from dyscalculia. *Brain Cognition*, 4, 171–196.
- Noël, M. P. (2005). La représentation sémantique du nombre : son développement et ses troubles. In M. P. Noël (Ed.), *La dyscalculie. Trouble du développement numérique de l'enfant* (pp. 105–137). Marseille: Solal.
- Ouvrier-Buffer, C. (2013). A focus on hidden knowledge in mathematics the case of “enumeration” and the example of the importance of dealing with lists. In B. Ubuz, C. Haser, & M. A. Mariotti (Eds.), *Proceedings of the Eighth Congress of the European Society for Research in Mathematics Education* (pp. 2178–2187). Ankara, Turkey: ERME.
- Peteers, F. (2018). *Un trouble à l'interface entre différents champs disciplinaires (handicap, santé et formation): la dyscalculie – Une approche didactique* (PhD Thesis, Université de Reims, France). Retrieved April 29, 2019, from: <https://hal.archives-ouvertes.fr/tel-01944017>
- Shrager, J., & Siegler, R. S. (1998). SCADS: A model of children's strategy choices and strategy discoveries. *Psychological Science*, 9(5), 405–410.
- Van Nieuwenhoven, C., Grégoire, J., & Noël, M. P. (2001). *Tedi-Math. Test diagnostique des compétences de base en mathématiques*. Paris, France: ECPA.
- Vergnaud, G. (1996). The Theory of Conceptual Fields. In L. P. Steffe, P. Meshner, P. Cobb, G. Goldin, & B. Green (Eds.), *Theories of mathematical learning* (pp. 219–240). Mahwah, NJ: Lawrence Erlbaum Publishers.
- Von Aster, M., & Shalev, R. S. (2007). Number development and developmental dyscalculia. *Developmental Medicine & Child Neurology*, 49, 868–873.
- Wilson, A. J., & Dehaene, S. (2007). Number sense and developmental dyscalculia. In D. Coch, G. Dawson, & K. Fischer (Eds.), *Human behavior, learning and the developing brain: Atypical development* (pp. 212–238). New York, NY: Guilford Press.

I just don't like math, or I think it is interesting, but difficult ...

Mathematics classroom setting influencing inclusion

Helena Roos

Linnaeus University, Växjö, Sweden; Helena.Roos@lnu.se

This research reports on a study investigating how three students perceived as being in special educational needs in mathematics (SEM), either as students in access to mathematics or as students in struggle to get access, talk about participation in mathematics education. Discourse analysis is used as a theory and a tool to investigate the students' own stories of learning and teaching in an inclusive mathematics classroom. The results show that students' participation in mathematics education is influenced by how the mathematics education is set up. That is, how the organisation of the mathematics classroom and students being in a small group influence students' participation. The results also show that even though the same issues of the organisation influence the three students, there is a diversity within the issues, calling for a critical question, is the inclusive classroom setting really inclusive in terms of participation and access to mathematics?

Keywords: Discourse analysis, inclusion, participation, special educational needs in mathematics.

Introduction

How to set up mathematics lessons to facilitate participation for every student within an inclusive classroom is not an easy task. Nevertheless, it is a particularly important educational task in order to promote an equitable mathematics education and create opportunities for every student to learn (Moschkovich, 2013; Askew, 2015). The setup of the mathematics classroom, including didactical choices of the mathematics teacher(s), is influenced by many different aspects. For example, Askew (2015) identifies a Western way of teaching mathematics with a one-size-fits-all approach, influencing the setting of the mathematics classroom. Hence, the set-up of the mathematics education is not in full an actual choice of the teacher, but a choice of the school, or even a choice of the society. This implies there are cultural, social, and institutional factors, such as social patterns, strongly impacting mathematics education settings. For example, patterns of advantage and disadvantage (Civil & Planas, 2004). Then, the awareness and the ability of the teacher to know how to act and care in the moment in order to promote learning of every student (Mason & Spence, 1999) becomes even more of importance. This implies, the awareness of factors, external of the actual classroom interaction, influencing the mathematics education, the set up, and enactment of the teaching inside the classroom is of importance to promote participation and learning. So, if defining inclusion in mathematics as processes of participation for every student (Roos, 2015), inclusion is strongly connected to the promotion of equitable mathematics education in terms of how the mathematics education is set up (Moschkovich, 2013). Moreover, since inclusive mathematics classrooms are diverse in terms of students' backgrounds (gender, ethnicity, culture, achievement etc.), the mathematics education needs to provide a diverse education (Roos, 2017). This suggests a diverse setting of the mathematics classroom considering every students' needs. Within the research field of mathematics education, the notion of inclusion is often connected to special educational needs in mathematics (SEM) (Roos, 2019a). Often when discussing SEM, the student in mind is a low

achiever, struggling to get access to mathematics education. However, a high achiever can also be in SEM even though she or he has access to the mathematics education, because she or he might need specific solutions in order to have optimal opportunities to learn. Accordingly, the notion of SEM can work in two directions, one direction towards mathematics difficulties, and one direction towards mathematics facility, showing differences in access to mathematics education. Inclusion in mathematics education for both ends of the SEM-continuum can be provided by the promotion of participation focusing on teaching practices and intervention strategies taking off from learning situations enabling meetings among differences (Scherer, Beswick, DeBlois, Healy, & Moser Opitz, 2016). Hence, setting up teaching promoting participation becomes an important challenge. To take on this challenge, we need to know the meaning(s) of students regarding participation in the inclusive mathematics classroom. Hence, the aim of this paper is to describe SEM-students meaning(s) of inclusion in their talk about learning and teaching in an inclusive mathematics classroom to have the best opportunities to learn.

Methodology

In this section the site and the participants of the study are described, as well as the theoretical and analytical approach and the data analysis.

The site and participants

A lower secondary school in an urban area in Sweden that has set out to implement inclusive work was chosen for this investigation. The inclusive work at the school aims at including all students in the ordinary teaching in every school subject, and integrate the special education into the ordinary teaching. A grade 7 and a grade 8 classroom at the school were observed during one semester. At least one approximately 50 minutes long mathematics lesson each week for each class was observed. After each observation student interviews were carried out. The selection of students for the interviews was made in cooperation with the students, parents and teachers and took ethical and organisational issues into consideration. The mathematics teachers suggested students they perceived as being in some kind of SEM. Thereafter, if the students and parents gave their consent, they were offered to take part in this study. Six students took part in the study. The interviews were conducted when the organisation and students allowed it. The interviews took place in a small room familiar to the students once a week and were based on the observations made the same week. Hence, open questions about situations and content of the mathematics education were asked in a discussion type of manor. This paper focuses on three students: Veronica in grade 7, Ronaldo and Edward in grade 8. Veronica says that “math is pretty hard” and she states “I don’t like math”. The mathematics teachers perceive her as a student who struggles to get access to mathematics. Ronaldo describes himself as a student with learning difficulties “I have difficulties within all subjects, and it’s like concentration and all that.” He also experiences that he forgets stuff “I don’t remember, I have to repeat a lot”. The mathematics teachers perceive him as a student who struggles to get access to mathematics. Both Veronica and Ronaldo have just about a passing grade. Edward describes himself as a person that thinks mathematics is really easy and does not need much help at all. He does not have to make any effort, mathematics works “automatically” for him and he “already knows” most

of what they are doing in math class. The mathematics teachers perceive him as a student with access to mathematics, and he has the highest grade possible in mathematics (grade A¹).

Theoretical and analytical approach

When investigating students' stories of their own participation in mathematics education, there is a need to identify critical aspects of learning and teaching in the stories. In this research this identification is made by using Discourse Analysis (DA). DA is a helpful tool since the focus of DA is the study beyond text, and because DA has an explanatory power of social contexts. Thus, by analysing the use of language in a certain type of situation we can say something about the social world. When going beyond the text in this particular study, construed discourses of what influences students' participation in mathematics education makes it possible to describe the social world from the students' perspective. In this study, the perspective of Gee (2014a, 2014b) is used, since Gee's focus on DA is descriptive and this study aims at describing students' view of participation in an inclusive mathematics classroom to have optimal opportunities to learn.

Big and small discourses (henceforth Discourse with capital D and discourse with lowercase d) are used by Gee (2014a, 2014b) as theoretical notions in the use of DA. Here Discourse(s) are describing a social and political context and are always embedded in many various social institutions at the same time. For example, a Discourse can be "school mathematics". Discourses are language plus "other stuff" (Gee, 2014a, p. 52), such as actions, interactions, values, beliefs, symbols, objects, tools and places. Small d discourse has a focus on written and spoken language in use, what stretches of languages are visible in the stories we investigate (Gee, 2014a). Stretches of languages is Gee's notion to describe small conversations within the stories. In this study, big and small discourses will be the theoretical perspective. Gee provides a toolkit for analysing different forms of language, both spoken and written. These tools highlight the communication and pose questions to the text to investigate what is beyond the text in terms of Discourses and discourses. In this paper, the toolkit is used as a methodological tool and is exemplified in the section data analysis. Summarising, DA is used both as a theory and an analytical tool and provides a set of theoretical lenses in this study.

Data analysis

In this paper seventeen interviews, five with Veronica, six with Ronaldo and six with Edward and eight classroom observations have been analysed. The observations were used as contextualisation for the interviews as well as for supporting construction of Discourse(s). The analysis of the data was guided by questions asked to the text. These questions were adapted from Gee's (2014b) toolkit, and with their help both small and big discourses could be constructed. That is, the questions were posed to the text and the answers made stretches of language(s) visible, indicating small discourses. When adding analysis of the data from the observations, such as text on the blackboard and events in the classroom, big Discourses could be construed. The analysis opened up for the construction of three Discourses, the Discourse of assessment (described in Roos, 2018), the Discourse of accessibility

¹ In the Swedish grading system A is the highest grade, then B, C, D, E and F. E is the lowest acceptable grade and F is the grade you get when you don't pass.

(described in Roos, 2019b) in mathematics education and the Discourse of mathematics classroom setting. In this paper the Discourse of mathematics classroom setting is in focus.

The Discourse of mathematics classroom setting

From the stretches of language identified in the texts from interviews with Ronaldo, Edward and Veronica, three (d)iscourses were construed, indicating a (D)iscourse of mathematics classroom setting influencing the students' participation. The three small discourses are described below.

The discourse of classroom organisation

This discourse is construed by stretches of language where the students highlight how the organisation of the education influences their participation.

A topic visible in the talk of all three of the students was the use of the textbooks. The textbook used in mathematics in both classes has six chapters divided into sections with specific mathematical areas. Each section has four levels, where "level one is easy tasks and level four gives real challenges". Veronica says "I start at level one or two [in the textbook]. Well, it is easier to start, so that you don't start with something difficult right away, that you don't master. Because it is a little easier. So, I don't make mistakes later on. I usually work by myself". She mentions the textbook in relation to preparing for tests "Before a test, we have the mixed tasks that sum up what we have done in the whole chapter." Also how to write in her notebook "well, it's like these small squares in it, so I usually try to write in them, so it doesn't get too big so you have space". Even Ronaldo mentions the notebook, and it seems like he struggles with the writing of the tasks "well it gets, if I write it often gets bloody smudgy, it gets so bloody messy [in the notebook]". Edward mentions the textbook as the one deciding the severity "It is the book that chooses what level you want". He also talks about the levels in the book. "I skip it [skip the first out of four levels in each chapter of the text book], it is too easy (laughing). To have a soft start in the specific area [he starts with level two]". For Edward the textbook also guides him in solving tasks, this is visible when he says that "I look in the key first, or I test first, then I look in the key and then I can see how it should be". Even Edward talks about the notebook in terms of what he doesn't write "when I just calculate ordinary in my book, in the textbook, then it's mostly mental calculations". [...] "It is more convenient not to write everything down". In the observation notes it is visible that teaching by the textbook, where the students sit and work separately or in pairs, is the most common way the mathematics education is organised in both classes. Ronaldo talks about the textbook in terms of sections he feels secure or insecure of as well as levels in the textbook: "Well, I start, I think that number one has become easier now [level one in the textbook], because it feels like I have become better at math now, so I sort of starting with number two.

Another topic regarding organisation influencing the students' participation being visible in the talk of all three students was to talk, discuss and work with peers in the classroom. Veronica talks about this as a hinder in her participation "Well, I have always been like afraid of that if I raise the hand, I am wrong and everybody thinks like.. that you are.. like... [...] I get unsure of myself, if I am right or wrong, and don't dare..." She also feels insecure when having discussions with peers in the classroom "Well, I have trouble with explaining... I don't know why. I don't know what to say, so they (the peers) get it. Ronaldo sees discussions both as a hinder and as a help for his participation. When he talks about discussion, he says that he can discuss "in groups, but not as much in the whole

class. Or I can, but I don't want to." He says that the reason is that he is uncomfortable, but in a group situation he perceives it as a help "I like to cooperate. It is fun to be with others, like Edward or Leo, because they are really good at math and they can explain really well. So you get it more". Though, it depends on whom he cooperates with, "I feel comfortable with everybody in the group sort of ... well some I can trust, or I know better than others. So it depends on whom you have in the group". Also for Edward it's an issue of with whom to discuss. "It's not super easy... because often I have come a lot further, so I have to explain to them ... it never happens that I discuss ... I mean with somebody else, that we discuss like that.. [...] It depends on whom I sit next to". When Edward gets the question if there is somebody in the class that he feels that can challenge him, he says that there are two, but he does not sit next to them, but he would like to "I think I would get more out of it".

Going through² was yet another topic all of the three students discussed. Veronica reflected on when she thinks she learns the best by saying "I think it is when it is going through and when I work by myself actually". Describing what's good with going through, she says that "I don't really know (laughs), it's just nice when he [the teacher] stands there and talks, shows and explains". Ronaldo talks about going through in relation to him forgetting and implies that others think he should have more going through by saying: "I was supposed to have an extra going through like this, it is just as well, so that I don't forget that, too". He refers to going through in a negative way "it is so bloody much of going through now. It is so boring, you can't stand listening" and he says that "going through does not matter that much I think". Although, he thinks that "sometimes it [going through] can be good, but well, if you are entering a new area, you are supposed to work with, it's good to have a going through. But then, like we have now, a going through each lesson, about the same thing. It is ... well I do know it's just to repeat and all that, but it is so damn hard". This implies going through is a challenge for Ronaldo's participation. Edward says that he listens and learns from going through, but not always. He thinks they have a lot of going through, but that they aren't always good, and when they interfere with his previous way of solving, it gets messy. "I think it gets messy when you have to mix in a lot of stuff to think, because I have my own way of thinking, so it only gets messy to mix in something else". He also thinks the tasks in the going through are basic "it is not really that advanced up on the blackboard, but, well, it's enough that I get the basics, then I can work from there" implying he would like more challenges, and that he is left alone to work further. Edward mentions that he liked the going through of a substitute teacher "I thought it was good when we had that secondary teacher, then I learned a lot in the going through. [...] I learned a lot, because it was kind of on another level. It feels like it was a much higher level than the regular teachers".

Yet another topic talked about by all the students was teaching approaches. Veronica talks about the need of hearing stuff, "it is good to listen [to the teacher], like I always learn a little more when we have going through". She likes it when the teachers "talk". She also states that when she is working by herself, she learns the best. Also, she likes problem solving, because "you can choose what you

² In Swedish mathematics education, it is common for the lesson to start or end with a "going-through" (in Swedish, *genomgång*). Andrews and Nosrati (2018) point out three instances of what can be considered "going-through": when the teachers inform the students of what to work with, when presenting new models, and when demonstrating solutions to problems the students find difficult.

want to use, and, like which way you [can] think. [...] It is really fun!” Ronaldo on the other hand talks about problem solving as something he “despises more than anything” as he finds it hard to “connect the text to the task, it is too much”. When asked how the mathematics education could be more fun for him, he says that he doesn’t know and “I just don’t like math, or I think it’s interesting, but difficult”. When he elaborates on teaching approaches he likes, he says “[...] you should have more math games or something”. In another interview he elaborates on how he learns best and says “not just sit down and work, but like be more active also, you might do some math outdoors, or like do math games or something, not just sit down with the text book all the time, it gets so bloody trite, or like really boring in the end. So, vary things”. Here, Ronaldo indicates that he would like variations of ways of working to enhance his participation. This is emphasized in another interview when Ronaldo contrasts variations with working in the textbook. “It is a bloody lot of [work in the textbook] ... you could play more math games or stuff like that”. Even Edward highlights this contrast when he states “when you are doing more practical stuff, then it is fun, instead of having the nose in the textbook all the time.” “Instead of keeping turning pages, drawing lines and writing the number of the task and all that, these things takes such a long time”, he would like “those whiteboards in front of you, and sit and sketch and experiment. Because then it’s much faster. I want to spend the time on the math”. Hence, Edward thinks that the work with the textbook and notebook hinders him from spending time on math, consequently it hinders him from participation.

The discourse of being in a small group outside the classroom

This discourse focuses students’ talk about being outside the classroom in a small group. This is mostly mentioned by the students struggling to get access in mathematics, Ronaldo and Veronica. Both Veronica and Ronaldo address feelings when they talk about being in a small group sometimes.

When Veronica was asked if she has been outside the classroom during lessons, she answers “Yes, god yes!” and laughs. Veronica often talks about being in a small group outside the classroom and often says that it “feels good”, and that she feels secure in the small group. The reason why she feels good is that “you get help right away and doesn’t have to sit and wait (for help) so long” and “it is an extra time, so if you didn’t get it when Oliver [the ordinary mathematics teacher] did the going through, you get it [the going through] once more”, “It’s like you get an extra occasion. If you don’t get it the first time, you can get one more time”. Also she says that she feels good because “It’s less people, it like just three or four persons”. Ronaldo says that “I dare to say stuff to, it feels like I am developing more” and “when you are in smaller groups, you dare to say more”, when he talks about being outside the classroom. He contrasts it with the way it was before and says that “it has become a lot better now, we have started to be outside [the classroom] in small group, which we didn’t do before, and it is much better now. I concentrate better and it is peaceful and quiet”. This implies he needs a place where he can feel secure and a place where it is calm to be able to concentrate. Also, he connects being in a small group to the level of security in relation to the mathematical content “But if I feel in between [of being sure or unsure], or a bit insecure like don’t really know, then I go [to the small group]”. Even Edward talks about the small group, but in a different way. When he gets the question if he is in the small group sometimes, he laughs and says “No, but she [the special teacher] takes the ones who wants to go through the basics, she usually takes [them] with her and does some going through and stuff like that. [...] I don’t think I would get something out of it, I don’t.” Here

Edward talks about “them”, as the ones who want to go through the basics” and he does not include himself in that group. The observation notes show that on several occasions the special teacher brings a few students with her out into a small room beside the classroom. Often it is Ronaldo and Veronica.

Discussion

The Discourse of mathematics classroom setting pinpoints critical issues for the three students’ participation in the mathematics education in terms of the organisation and being in a small group. It seems like the Western way of teaching with a one-size-fits-all mathematics education (Askew, 2015) influences the setting of the mathematics classroom, which is visible in the students’ description of the use of the textbook, the mathematical discussions and the going through. This certainly “turns diversity into a problem” (Askew, 2015, p. 129), since there seem to be contradictions in the students’ stories, even though they talk about the same issue, it’s not in the same way. For instance, Veronica thinks she learns best when listening at going through, but Ronaldo seems mostly frustrated, and Edward thinks they are too basic. Also, when Ronaldo talks about going through in relation to him forgetting, he is placing the struggle getting access to mathematics within himself, creating frustration. Hence, how to realize going through in the classroom is a critical issue. The “problem with diversity” is also seen in the way the students describe discussions. Veronica feels insecure and does not know how to explain her thinking to her peers. Ronaldo on one hand feels the same as Veronica, insecurity when it comes to whole class discussions, but on the other hand he really likes discussions with peers, mostly because they can explain well to him. Hence, it is not him discussing, but using the peers, for instance Edward, as tutors. Edward recognises this, that he has “to explain to them”, and he feels that most often he does not get any challenges in the discussions. In this study, textbooks and the work the students do in the notebooks, seem to govern the mathematics education, and is an important factor for participation. This can be seen in the way the students describe how the different levels in the textbook affect their participation, and how they are supposed to write in the notebooks. Thus, it is not just the decisions of the teachers influencing the setting, but also the textbook and the mathematical norms that are established, play a crucial role. This makes the textbook, how it is organized and how it provides access to knowledge, as well as how to write in the notebook important factors to consider, which is also seen internationally (Fan, Zhu, & Miao, 2013). Is being in a small group outside the classroom including or excluding the students? Both students struggling to get access talk about the small group as a secure space and the classroom as an insecure space. Edward on the other hand laughs and does not think he would gain anything from the small group. Veronica answers “Yes, god yes!” and laughs when she is asked if she has gone out of the classroom sometimes. The laughter can be an indication of roles taken by the students as either students in access or in struggle to get access, and the roles seem to influence the students’ participation. This is indicated by the fact that the struggling students feel insecure in the classroom situation. This is in line with the finding of Civil and Planas (2004), that participation is influenced by organizational structures. Consequently, the result in this study calls for a critical question: Is the inclusive classroom really inclusive for the students in terms of participation and access to mathematics?

References

- Andrews, P., & Nosrati, M. (2018). Gjenomgang and Genomgång: Same or Different? In H. Palmér & J. Skott (Eds.), *Students' and Teachers' Values, Attitudes, Feelings and Beliefs in Mathematics Classrooms* (pp. 113–124). Cham, Switzerland: Springer.
- Askew, M. (2015). Diversity, Inclusion and Equity in Mathematics Classrooms: From Individual Problems to Collective Possibility. In A. Bishop, H. Tan, & T. N. Barkatsas (Eds.), *Diversity in Mathematics Education – Towards Inclusive Practices* (pp. 129–145). Cham, Switzerland: Springer.
- Civil, M., & Planas, N. (2004). Participation in the Mathematics Classroom: Does every student have a voice? *For the learning of mathematics*, 24(1), 7–12.
- Fan, L., Zhu, Y., & Miao, Z. (2013). Textbook research in mathematics education: development status and directions. *ZDM Mathematics Education*, 45, 633–646.
- Gee, J. P. (2014a). *An introduction to discourse analysis: Theory and method*. New York, NY: Routledge.
- Gee, J. P. (2014b). *How to do Discourse Analysis: A toolkit*. (2nd ed.). London, United Kingdom: Routledge.
- Mason, J., & Spence, M. (1999). Beyond mere knowledge of mathematics: The importance of knowing-to act in the moment. *Educational Studies in Mathematics*, 38(1–3), 135–161.
- Moschkovich, J. (2013). Principles and Guidelines for Equitable Mathematics Teaching Practices and Materials for English Language Learners. *Journal of Urban Mathematics Education*, 6(1), 45–57.
- Roos, H. (2017). Diversity in an inclusive mathematics classroom: A student perspective. In T. Dooley & G. Gueudet (Eds.), *Proceedings of the tenth congress of the European society for research in mathematics education* (pp. 1433–1440). Dublin, Ireland: DCU Institute of Education and ERME.
- Roos, H. (2018). The Influence of Assessment on Students' Experiences of Mathematics. In H. Palmér & J. Skott (Eds.), *Students' and Teachers' Values, Attitudes, Feelings and Beliefs in Mathematics Classrooms* (pp. 101–111). Cham, Switzerland: Springer.
- Roos, H. (2019a). Inclusion in mathematics education: an ideology, a way of teaching, or both? *Educational Studies in Mathematics education*, 100(1), 25–41.
- Roos, H. (2019b). Challenges at the border of normality: Students in special educational needs in an inclusive mathematics classroom. In J. Subramanian (Ed.), *Proceedings of the tenth international mathematics education and society conference* (pp. 928–940). Hyderabad, India: Sri Satya Sai Designing Studio Pvt Ltd.
- Scherer, P., Beswick, K., DeBlois, L., Healy, L., & Moser Opitz, E. (2016). Assistance of students with mathematical learning difficulties, how can research support practice? *ZDM Mathematics Education*, 48(5), 633–649.

The potential of substantial learning environments for inclusive mathematics – student teachers’ explorations with special needs students

Petra Scherer

University of Duisburg-Essen, Faculty of Mathematics, Germany; petra.scherer@uni-due.de

Although in Germany there exists a long research tradition concerning common instruction and inclusive education, more research is needed concerning the subject-matter specific programs for inclusive teacher education. The paper reports on the project ProViel (‘Professionalisierung für Vielfalt’ – ‘professionalisation for diversity’). Within the project inclusion is pursued as a common objective for all subjects and disciplines. In addition, sub-projects concentrate on selected subjects as ‘Mathematics Inclusive’. For this sub-project concepts and modules for teacher education will be developed, tried out and reflected with respect to inclusive mathematics. The paper presents the mathematics project’s aims and objectives, followed by data concerning the concrete course ‘Learning Mathematics with Substantial Learning Environments (SLEs)’ and primary teacher students’ practical experiences and reflections.

Keywords: Pre-service teacher education, special needs students, inclusive education, substantial learning environments, field studies.

Introduction

In Germany students with special needs either visit special schools for handicapped children or regular schools in inclusive settings (cf. Klemm, 2015). According to the realization of the UN conventions (see UN, 2006), the proportion of students with special needs in inclusive settings has increased continuously over the years. In Germany, for the school year 2013/14 about 50 % of the students with special needs on the primary level visited regular schools (Klemm, 2015). But actually a decrease or stagnations can be observed in some states (Klemm, 2018). Inclusive settings show extremely heterogeneous groups in classrooms, so that a high degree of differentiation is needed.

Teacher education programs preparing for an inclusive school system are in the state of development at the moment, and corresponding research is done. As an important field for research the subject-matter specific preparation of teachers has been pointed out (see Heinrich, Urban, & Werning, 2013). The paper presents first results of a study that aims at implementing substantial mathematics for all.

The project ‘Mathematics Inclusive’ within the project ProViel

The project ProViel ‘Professionalisierung für Vielfalt’ (‘Professionalisation for Diversity’; <https://www.uni-due.de/proviel/>) at the University of Duisburg-Essen is funded by the Federal Ministry of Education within the frame of a program for teacher education (1st phase: 2016–2019; 2nd phase: 2019–2023). Numerous university departments are involved to ensure the development of a coherent conceptual program for teacher education. One field of action is ‘Diversity & Inclusion’,

and numerous sub-projects might cover the wide facets and dimensions in this field (cf. Bishop, Tan, & Barkatsas, 2015; Good & Brophy, 2008).

Following a design based research approach, the sub-project ‘Mathematics Inclusive’ aims at implementing subject-specific concepts and modules for inclusive mathematics education. The central research questions are the following:

- (1) How should didactical courses in teacher education be designed to address the topic ‘inclusive mathematics’? (firstly, for the primary BA-/MA-program, later on for the secondary BA-/MA-program)
- (2) What are student teachers’ prerequisites concerning inclusive mathematics?
 - 2a) experiences with mathematics instruction
 - 2b) existing attitudes and beliefs
- (3) Which changes of student teachers’ attitudes and beliefs and competence developments can be identified after they had completed a course that addresses inclusive mathematics?
- (4) Which modifications for the didactical courses arise from experiences and results of the empirical testing (based on research question 1 to 3)?

Research questions 2 and 3 will be answered on the basis of quantitative as well as qualitative data, whereas the questions 1 and 4 concentrate on qualitative data and methods.

Concept and objectives of the course ‘Learning Mathematics with SLEs’

The developmental work to answer research question 1 firstly concentrates on the course ‘Learning Mathematics with Substantial Learning Environments (SLEs)’ (3rd year, BA-program for primary mathematics). The didactical concept of working with SLEs, and by this realizing a natural differentiation is in line with a constructivist understanding of teaching and learning, and has been proved to be suitable for heterogeneous learning groups in primary mathematics (cf. Hirt & Wälti, 2008; Krauthausen & Scherer, 2013; Scherer & Krauthausen, 2010). These projects also focused on the realization in in-service courses whereas the current paper concentrates on pre-service teacher education, especially with regard to inclusive mathematics.

The design process started in 2016, and the first course has been running during the winter semester 2016/17, followed by the second and third one during the winter semester 2017/18 and 2018/19.

Competencies the student teachers should develop within this course, as formulated in the BA-curriculum for primary, are the following:

- The student teachers are able to design a mathematical learning environment on the basis of mathematical und didactical foundation according to a particular focal point.
- The student teachers are able to carry out and analyze an interview with primary students including subject-specific perspectives (according to a particular focal point).

The course concept is as follows: The course contains a weekly 90-minute lecture combined with a weekly 90-minute seminar. The lecture should be attended by the whole cohort of student teachers, and it covers the theoretical background of SLEs and the concept of natural differentiation in contrast to more traditional concepts of differentiation.

SLEs can be defined by the following four constituting demands (Wittmann, 2001; Krauthausen & Scherer, 2013; Scherer & Krauthausen, 2010): (1) They represent central objectives, contents and principles of teaching mathematics at a certain level. (2) They are related to significant mathematical contents, processes and procedures beyond this level, and so they are a rich source of mathematical activities. (3) They are flexible and easily adaptable to special conditions of a classroom. (4) They integrate mathematical, psychological and pedagogical aspects of teaching mathematics, and so they form a rich field for empirical research.

In addition, the constituent characteristics of the concept of natural differentiation are: All students get the same learning offer, and this offer must be holistic, and may not fall below a specific extent of complexity and mathematical substance. Holistic contexts in that sense by nature contain various levels of demands which must not be determined in advance. In addition to the level the students decide to work on, they can freely make their own decisions concerning the ways of solution, use of manipulatives and facilities, kinds of notation, etc. The postulate of social learning from and with each other is fulfilled in a natural way as well (cf. Wittmann, 2001; Krauthausen & Scherer, 2013; Scherer & Krauthausen, 2010).

During the lecture not only the theoretical background is given, but also examples for planning and designing concrete learning arrangements as well the analyses of concrete interview or classroom situations for various SLEs and various mathematical contents, for example taken from former studies (see Scherer & Krauthausen, 2010).

For the corresponding seminars, the cohort is distributed in groups of about 15 student teachers. The seminars are related to different focal points like *differentiation*, *difficulties in language* or *inclusive mathematics*. The latter one is part of the sub-project 'Mathematics Inclusive'. During the whole semester, in the seminars the student teachers have to work in small groups up to four persons. They have to design and carry out clinical interviews with pupils from primary school working on selected SLEs. For the seminar focusing on 'inclusive mathematics' each student teacher has to interview two or more children with and without special needs. The student teachers should offer one and the same substantial learning environment and tasks to the different pupils and videotape the interviews. Within their small group as well as in the seminar group they have to analyze and reflect on the interviews in general, the concrete learning processes and pupils' existing competences as well as existing difficulties.

The course should enable student teachers to design common learning situations and learning within a common topic and mathematical content. The course concept cannot cover all dimensions of effective instruction but focuses on the dimensions *teacher*, *students* and *teaching approaches* (cf. Hattie, 2009).

Questionnaire and interviews with student teachers

Pre-post questionnaire: To answer research questions 2 and 3 a standardized questionnaire was used in a pre-post-design. The initial questionnaire contains items concerning experiences as well attitudes and beliefs with respect to inclusion and inclusive mathematics (cf. Meyer, 2011). The latter ones are also included in the post-test. The relevance of beliefs and attitudes can be assumed (cf. Sullivan,

Clarke, & Clarke, 2013, p. 18 f.), and with the pre-post-design one of the questions will be, if and how student teachers' attitudes and beliefs changed after completing the course.

Retrospective self-assessment: Moreover, to answer research question 3 for the post-test six items for a retrospective self-assessment for the development of individual competencies were added (cf. Nimon, Zigarmi, & Allen, 2011), and the student teachers had to rate their competencies before the course and at the end of the course. These items were designed according to the curriculum objectives focusing on substantial learning environments, clinical interviews and analyses of students' thinking and learning processes (see section 2.1). The student teachers had to rate their competencies for these three aspects on the one hand in general, on the other hand concerning the relevance for inclusive mathematics. For example, the two statements referring to clinical interviews were (see section 3):

General: *I know the relevance of clinical interviews for mathematics teaching.*

Relevance for inclusive mathematics: *The use of clinical interviews seems relevant to me to support special needs students in inclusive classrooms.*

Additional interviews: For deeper analyses, additional interviews with selected student teachers were carried out. The interviews comprised selected items of the questionnaire (attitudes and beliefs), and asked for more detailed explanations of the student teachers' experiences before the course. Moreover, the interview focused on the concrete experiences the student teachers had made during the course (example: *In what way could you gain experiences for inclusive mathematics?*) as well as perspectives for their future teaching (example: *In what way can you imagine to use your insights for your future teaching of mathematics?*).

Results

In the following section exemplary results will be reported. Firstly, student teachers' pre-experiences with inclusive mathematics (data from pre-test), and secondly, the retrospective self-assessment for the development of individual competencies with respect to substantial learning environments (data from post-test and selected interviews).

Pre-experiences: For detailed results concerning student teachers' individual pre-experiences with inclusive mathematics (research question 2a; open item: *Which experiences have you made so far with inclusion in mathematics instruction?*) see Scherer (2019). For the here reported course, the following results are relevant: Although the participating student teachers had completed in their BA-program at least one or two practical phases at school of about 5 weeks in total before, it showed that only about 50 % of the student teachers have made school-related-experiences whereas the others had no experiences or made experiences out of school or in other fields. The school-related-experiences cover a wide spectrum of aspects: Apart from organizational or personal requirements of inclusive settings, the statements could be specific for mathematics education or be more general.

One could identify *main categories for mathematics* that are of great importance for the course concept 'Learning Mathematics with SLEs', namely *differentiated learning offers* and forms of *inner or outer differentiation*. The student teachers' school-related-experiences most frequently could be assigned to these categories. Looking in more detail at the category *differentiated learning offers* one could identify a wide range of aspects: offering more time, more/less number of tasks, different

worksheets or tasks on different levels of difficulty, different textbooks or mathematical topics, additional materials and manipulatives, additional help, learning step-by-step, more repetitions.

Although a questionnaire does not allow in-depth analyses of the underlying concepts of teaching and learning or of the underlying concept of differentiation, one might assume that the classroom situations the student teachers have experienced did not follow the concept of a natural differentiation and the children did not work on common subjects, problems and tasks, as the student teachers rarely report situations that pupils work on common topics or SLEs. Some of the student teachers' statements might lead to the conclusion that the teaching and learning setting more or less represents an exclusive setting with separate learning situations than inclusive education (see also Scherer, Beswick, DeBlois, Healy, & Moser Opitz, 2016, p. 640 ff.). In contrast, the course 'Learning Mathematics with SLEs' focuses on common learning situations for *all* students, enabling individual as well as cooperative learning situations, for example by realizing the concept of a natural differentiation (cf. Krauthausen & Scherer, 2013; Scherer & Krauthausen, 2010; section 2.1).

Retrospective self-assessment: So one interesting question would be how the student teachers rate the development of their competencies concerning SLEs, especially the relevance for inclusive mathematics (research question 3). On a Likert scale from 1 to 6 (1 = not at all true; 6 = extremely true) the student teachers had to rate the following statements referring to SLEs:

General: *I know the characteristics of substantial learning environments for mathematics teaching.*

Relevance for inclusive mathematics: *The use of substantial learning environments seems relevant to me to support special needs students in inclusive classrooms.*

Figure 1a, b and Figure 2a, b show the results (N = 90, missings in Figure 2a): Before the course, many student teachers already know the characteristics of SLEs (Figure 1a) as about 45 % agree to this statement ($M = 3.32$, $SD = 1.22$). This result is plausible as the topic is touched in different courses in the 1st and 2nd year of the BA-program. Nevertheless, the self-assessed development of competencies is obvious and shows a significant effect (Figure 1b; $M = 4.98$, $SD = .66$), as after the course nearly all student teachers agree to the statement. A similar result occurs with respect to inclusive mathematics (Figure 2a: $M = 3.91$, $SD = 1.06$; Figure 2b: $M = 4.98$, $SD = .85$; significant effects). This shows an important development, as the student teachers' pre-experiences had shown quite different classroom situations they had observed.

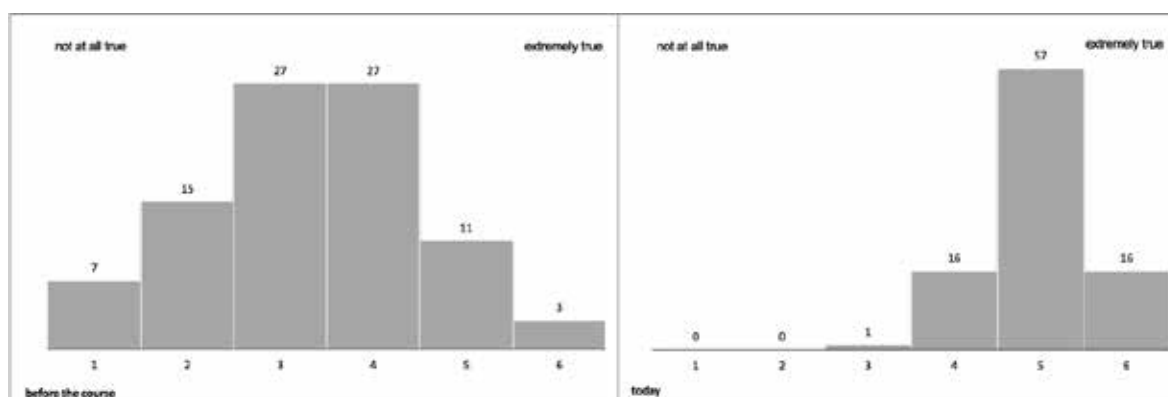


Figure 1a, b: Results for the self-assessment item with respect to SLEs (general)

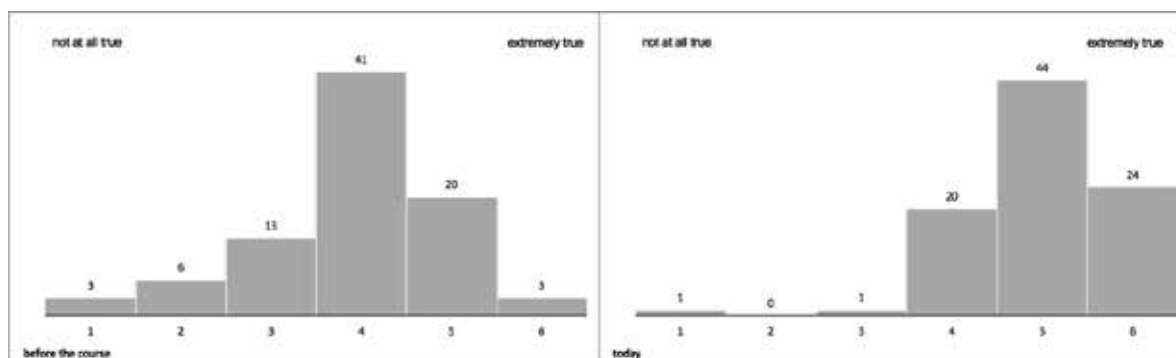


Figure 2a, b: Results for the self-assessment item with respect to SLEs (relevance for inclusive mathematics)

Interviews: For a deeper analysis of these outcomes, one can refer to the interviews, and two exemplary statements are cited:

Transcript 1 (student teacher 1 – ST1):

54 ST1: Well. What I knew before, just as a term and not put into action, were the substantial learning environments. And, well, what I didn't know either before, that you meet the needs of all students with these substantial learning environments. ... I did not know that you can find a task format that students work on for oneself and that differentiation takes place in a natural way. That became clear in my mind by the course. Before, I was aware that you have to work individually but not that you can work with the students on a common topic.

Transcript 2 (student teacher 2 – ST2):

32 ST2: Well, to be honest, before, I had no idea how inclusive education in mathematics should look like. And, well, it did help me that the different learning environments were presented and that it was also said what a learning environment should contain that I can use them for inclusive classrooms.

Whereas ST1 refers strongly to the potential of SLEs concerning inclusive settings, ST2 also links this relevance to the design of SLEs and their characteristics. Both statements focus on the constituting demand of didactical flexibility (see section 2.1), and the mathematical substance or central objectives or principles for teaching and learning mathematics are not named explicitly. It might be that this is too obvious for the student teachers and that the own planning, the fact that those SLEs might fit for all students and the practical experience dominate and might be impressive. Nevertheless, the content related objectives will be stressed in further courses.

Conclusions

The first results of the course show that the underlying didactical concept of using SLEs and realizing a natural differentiation, is suitable for inclusive classrooms. Moreover, the course concept with the combination of theoretical elements, concrete video examples and pupils' documents (lecture) and practical experiences (interviews at school) with a common reflection (seminar) could reach the above mentioned project objectives. As a consequence, for the overall structure and concept of the course

no changes were necessary. But setting SLEs into practice of this more or less new field of inclusive mathematics is a great challenge for student teachers. However, the value of SLEs became obvious.

Analyses and reflections on videos, materials and examples given in the lecture have a high value. Extended by the student teachers' own experiences and common reflections in a seminar can increase their knowledge and teaching repertoire for the future. The above mentioned aspects are important for all kind of teaching situations, but seem to be more challenging in inclusive settings. On the one hand, student teachers have to cope with the mathematical content and be flexible in reacting to different students with their variety of strategies and ways of thinking. On the other hand, student teachers have to be aware of a variety of difficulties. When being confronted with those difficulties, a tendency of reproducing some of the patterns they experienced at school could be observed, for example more traditional forms of differentiation that special needs students need different learning offers, different tasks and materials on different levels or a prescribed program. These concrete experiences have to be made a subject of discussion to widen the repertoire of student teachers (cf. Scherer & Steinbring, 2006). This was already done when repeating the course, and will be strengthened in the future running of the course.

Moreover, the student teachers' pre-experiences have to be considered. As reported, many of their observed classroom situations did not represent common learning situations but exclusive settings with the separation of students with special needs. Those experiences have to be discussed and reflected in the lecture as well as in the seminars and practical experiences.

The next steps in the project will be the data analyses concerning the specific focal points of the seminars. One of the questions is whether the specific focal point 'inclusive mathematics' shows specific results concerning attitudes and beliefs as well as competence development. In the long-term the connection of mathematics education modules – like 'Learning Mathematics with SLEs' – with mathematics modules will be addressed, so that a coherent program will be developed, as terms and theoretical aspects have to be put into action.

Acknowledgment

The project is supported by grant FKZ 01 JA 1610 and FKZ 01 JA 1910 in the frame of the program 'Qualitätsoffensive Lehrerbildung' (Quality Offensive for Teacher Education) funded by the Federal Ministry of Education and Research.

References

- Barkatsas, A. T., & Seah, W. T. (2015). Learners' preferred mathematical task types: the values perspective. In A. Bishop, H. Tan, & T. N. Barkatsas (Eds.), *Diversity in mathematics education. Towards inclusive practices* (pp. 63–79). New York, NY: Springer.
- Bishop, A., Tan, H., & Barkatsas, T. N. (Eds.). (2015). *Diversity in mathematics education. Towards inclusive practices*. New York, NY: Springer.
- Good, T. L., & Brophy, J. E. (2008). *Looking in classrooms*. Boston, MA: Pearson/Allyn and Bacon.
- Hattie, J. (2009). *Visible learning. A synthesis of over 800 meta-analyses relating to achievement*. London, United Kingdom: Routledge.

- Heinrich, M., Urban, M., & Werning, R. (2013). Grundlagen, Handlungsstrategien und Forschungsperspektiven für die Ausbildung und Professionalisierung von Fachkräften für inklusive Schulen. In H. Döbert & H. Weishaupt (Eds.), *Inklusive Bildung professionell gestalten – Situationsanalyse und Handlungsempfehlungen* (pp. 69–133). Münster, Germany: Waxmann.
- Hirt, U., & Wälti, B. (2008). *Lernumgebungen im Mathematikunterricht. Natürliche Differenzierung für Rechenschwache bis Hochbegabte*. Seelze, Germany: Kallmeyer.
- Klemm, K. (2015). *Inklusion in Deutschland. Daten und Fakten*. Gütersloh: Bertelsmann Stiftung.
- Klemm, K. (2018). *Unterwegs zur inklusiven Schule. Lagebericht 2018 aus bildungsstatistischer Perspektive*. Gütersloh, Germany: Bertelsmann Stiftung.
- Krauthausen, G., & Scherer, P. (2013). Manifoldness of tasks within a substantial learning environment: designing arithmetical activities for all. In J. Novotná & H. Moraova (Eds.), *SEMT 2013. International Symposium Elementary Maths Teaching. Proceedings: Tasks and tools in elementary mathematics* (pp. 171–179). Prague, Czech Republic: Charles University.
- Meyer, N. (2011). *Einstellungen von Lehrerinnen und Lehrern an Berliner Grundschulen zur Inklusion. Eine empirische Studie* (Master-Thesis). Berlin, Germany: FU Berlin.
- Nimon, K., Zigarmi, D., & Allen, J. (2011). Measures of program effectiveness based on retrospective pretest data: Are all created equal? *American Journal of Evaluation*, 32(1), 8–28.
- Scherer, P. (2019). Professionalisation for inclusive mathematics – Challenges for subject-specific teacher education. In D. Kollosche, R. Marcone, M. Knigge, M. Godoy Penteadó, & O. Skovsmose (Eds.), *Inclusive Mathematics Education. State-of-the-Art Research from Brazil and Germany* (pp. 625–638). Cham, Switzerland: Springer.
- Scherer, P., & Krauthausen, G. (2010). Natural Differentiation in Mathematics – the NaDiMa project. *Panama-Post*, 29(3), 14–26.
- Scherer, P., & H. Steinbring (2006). Noticing children’s learning processes – teachers jointly reflect their own classroom interaction for improving mathematics teaching. *Journal for Mathematics Teacher Education*, 9(2), 157–185.
- Scherer, P., Beswick, K., DeBlois, L., Healy, L., & Moser Opitz, E. (2016). Assistance of students with mathematical learning difficulties: how can research support practice? *ZDM – Mathematics Education*, 48(5), 633–649.
- Sullivan, P., Clarke, D. M., & Clarke, B. A. (2013). *Teaching with tasks for effective mathematics learning*. New York, NY: Springer.
- UN – United Nations (2006). *Convention of the rights of persons with disabilities*. New York, NY: United Nations.
- Van den Heuvel-Panhuizen, M. (1996). *Assessment and realistic mathematics education*. Utrecht, The Netherlands: Freudenthal Institute.
- Wittmann, E. C. (2001). Developing mathematics education in a systemic process. *Educational Studies in Mathematics*, 48(1), 1–20.

Mathematical discourses of a teacher and a visually impaired pupil on number sequences: Divergence, convergence or both?

Angeliki Stylianidou and Elena Nardi

University of East Anglia, UK

A.Stylianidou@uea.ac.uk, E.Nardi@uea.ac.uk

Research on the inclusion of visually impaired (VI) pupils in mainstream classrooms is underdeveloped in mathematics education. This paper investigates mathematical discourses of a teacher and a VI pupil in a classroom episode on number sequences. We see that, while the teacher considers the pupil's enthusiastically demonstrated mathematical contribution which differs from the institutional one, she draws on it to guide him in responding within the institutional mathematical discourse. We then see the pupil responding within the teacher's expectations but less enthusiastically. We explore the teacher's reaction in terms of whether it evidences valuing of the pupil's initial mathematical contribution and whether it is potentially excluding. We propose an alternative, more explicitly inclusive way forward in which the teacher can play along with non-prevalent mathematical contributions and bring these also to the whole class, to the benefit of all.

Keywords: Discourse, inclusion, VI pupils.

Introduction

Inclusive education has been an issue of international consideration especially since the Convention on the Rights of Persons with Disabilities (CRPD) (United Nations, 2006). According to Article 24 of the CRPD, the signatory countries are committed to ensuring the right of persons with disabilities to education within an inclusive education system. Educational benefits from inclusive education are not limited to persons with disabilities though: “[T]here are educational benefits for all children inherent in providing inclusive education” (UNICEF, 2012, p. 11). But is this good intent implemented in the classroom? And if so, how – and, how is it experienced by staff and pupils?

In the study we draw from in this paper – part of the first author's doctoral thesis – we focus on the inclusion of VI pupils in mathematics lessons. We see inclusive education as occurring when the VI pupils are invited to participate in a lesson activity on an equal basis with everyone else in class, albeit not necessarily with the same sensory, material and semiotic tools. Apart from equitable participation, we consider equitable value as an equally important element of inclusive education. With the latter, we denote the value attributed to VI pupils, even in those contributions which differ from the prevalent, institutional ones, potentially as a result of the different tools through which VI pupils may construct and convey mathematical meaning. Reference to participation and value as contributors to inclusive education is present in international documents (e.g. United Nations, 2006) as well as in research studies (e.g. Nardi, Healy, Biza, & Fernandes, 2018). We consider equitable participation and equitable value as interrelated elements of inclusive education: our study's rationale is that one element exclusive of the other does not suffice for implementation of inclusive education. Our discussion of the data we present in this paper evidences the necessity of both elements for what we call “inclusive education”.

In this paper, we first discuss key developments in the inclusion of VI pupils in mathematics classrooms. We then zoom in on the study's focus and research questions and present the study's theoretical framework and methodology. Finally, we sample from the study's data and analysis with an episode from a Year 1 (Y1) class.

Literature review and theoretical framework

A limited number of studies have been conducted in the area of inclusion of VI pupils in mathematics classrooms. The existing literature focuses mainly on the following themes: VI pupils' experiences in mainstream mathematics classrooms (e.g. Bayram, Corlu, Aydın, Ortaçtepe, & Alapala, 2015); VI pupils' forms of accessing, expressing mathematics and development of inclusive teaching strategies (e.g. Nardi et al., 2018); and, design of inclusive mathematics teaching and learning materials to be used by VI and sighted pupils (e.g. Leuders, 2016). While the existing literature has certainly set the foundations towards more inclusive mathematics classrooms, research studies that investigate how VI pupils are included in the classroom are sparse. We argue that an investigation of VI pupils' inclusion in mainstream mathematics classrooms combined with the existing foundations for such an inclusion can lead to even more inclusive mathematics classrooms. As our study explores (e.g. in the episode sampled in this paper), there may be significant gaps between inclusive education policy and practice: while appropriate inclusive education aspirations may appear in international and national policy documents, institutional, curricular and attitudinal constraints may lead to these gaps. Our study aims to investigate these and eventually contribute towards their reduction.

Our study has two phases and investigates: (a) how inclusion and disability are constructed in the discourses of teaching staff and pupils in mainstream mathematics classrooms (both phases); (b) how collaboratively designed mathematics lessons impact upon teaching staff's and pupils' discourses on inclusion and disability (Phase 2). We endorse a sociocultural theoretical framework that draws upon: Vygotskian sociocultural theory of learning (Vygotskii, 1978); Sfard's discursive perspective, known as the theory of commognition (Sfard, 2007); the social model of disability (Oliver, 2009); and, the theory of embodied cognition (Gallese & Lakoff, 2005). We discuss such use briefly in Stylianidou and Nardi (2018) and exemplify this use in this paper.

In the episode we present in this paper, we focus on the discursive activity of a teacher and a VI pupil, in interaction concerning number sequences. Our Vygotskian influence is evidenced in our focus on: the semiotic and sensory tools used by the two interlocutors in the setting of the school classroom; and, the mathematical meaning each interlocutor conveys as a result of using the particular tools. We show how particular elements from Sfard's discursive perspective – word use and visual mediators – are played out in the mathematical discourse of each interlocutor and we examine a case of commognitive conflict (Sfard, 2007) arising as a result of the teacher's and the pupil's different, incommensurable discourses. The visual mediators in the particular episode constitute the gestures, made by both the teacher and the pupil. Apart from speech, the gestures act too as a vital tool for mathematical communication and the construction, and conveying, of mathematical meaning. This role of gestures makes the theory of embodied cognition (Gallese & Lakoff, 2005) pertinent in our analysis of the episode.

In what follows, we present the study's context, participants and methods. We then sample from the data with an episode from a Y1 lesson on number sequences. We conclude with implications that this episode has for our ongoing analyses, particularly those included in the first author's doctoral thesis.

Methodology: the context, participants and methods of the study

Data collection was conducted in four UK mainstream primary mathematics classrooms (Y1, Y3 and two Y5 classes; pupils' ages: 6-10). The VI pupils' presence and the willingness of teaching staff and pupils to participate in the study constituted our criteria for the selection of the classrooms. We collected data after securing ethical approval by our institution's Research Ethics Committee and ensuring participant anonymity, confidentiality and right to withdraw from the study.

We collected data through observations of 29 mathematics lessons (33.5 hours in total); individual interviews with 5 class teachers (6 interviews, 2 hours and 10 minutes in total); individual interviews with 4 teaching assistants (6 interviews, 2 hours and 15 minutes in total); focussed-group interviews with 35 pupils (16 interviews, 2 hours in total); 2 ten-minute individual interviews with one pupil; written transcripts of the teaching staff's contributions in the design of the three Phase 2 lessons; photographs of the pupils' work in the three Phase 2 classes; and, pupils' evaluation forms of the Phase 2 lesson in two classes. During observations, written notes were kept in all lessons. 21 lessons were audio-recorded and 14 lessons were also video-recorded. All interviews were audio-recorded, except four, following interviewee requests. For these, written notes were kept instead.

Data collection for Phase 1 was completed in March 2018 and for Phase 2 in July 2018. Data analysis is ongoing. While a major rationale for Phase 2 is to explore the impact of the co-designed mathematics lessons upon the participating teaching staff and pupils, we note that the Phase 2 episode we have selected to discuss in this paper does not stress the elements of co-design and its impact upon the participants. Instead, our emphasis here is on the mathematical discourses of a teacher and a VI pupil in a classroom incident in which we discern a genuine mathematical contribution by the pupil that diverges from the one expected by the teacher. We discuss the different mathematical discourses of the teacher and the pupil and explore the challenges of implementing inclusion. We first present a factual account – and then a preliminary analysis – of the episode. We conclude with a discussion of the episode in the context of the entire study.

A Y1 episode

A factual account of the episode

The episode is from a lesson on number sequences in a Y1 class. Ned is the VI pupil of this class and has severe, congenital visual impairment in both his eyes. The class has two general teaching assistants who support pupils that need help at particular instances and their role does not focus on supporting the VI pupil specifically. The class was asked to find the next number in a number sequence, which was on a worksheet that each pupil had in front of them. The number sequence was 8 10 12 14 16. The following dialogue occurs between the teacher and Ned:

- 1 Teacher: Is it increasing or decreasing?
- 2 Ned, *happily*: *Creasing. Ned puts his hand straight up, doing a similar gesture to the one the teacher had done when, earlier, she explained "increase".*

- 3 Teacher: Increasing or decreasing? “Increase” means it gets bigger, or is it getting smaller. *Whilst saying “bigger”, the teacher does a similar gesture to the one Ned had just done. Whilst saying “smaller”, she does a gesture, too, pointing down.*
- 4 Ned: Increasing. *He says this with less enthusiasm than before and without doing any gestures this time.*
- 5 Teacher: Yeah. You are right.

A preliminary analytical account of the episode

Ned’s reaction to the teacher’s question (2)

Ned responds to the teacher’s question in (1) by resorting to verbal and gestural discourse. His word “creasing” may suggest that he does not recall the difference in the meanings of the words “increasing” and “decreasing”. Ned uses the root word, “crease”¹, of both verbs to show, possibly, that he refers to one of the two verbs, although it is unclear from his speech per se whether he means “increasing” or “decreasing”, thus whether he answers the teacher’s question correctly.

His gesture, which accompanies his speech, makes it clear that Ned refers to the term “increasing”. Here, the gesture is vital in Ned’s conveying the mathematical meaning he has constructed of what an increasing sequence of numbers is. Ned’s re-enacting of the teacher’s gesture for the term “increasing” resonates with the theory of embodied cognition, according to which concepts are embodied (Gallese & Lakoff, 2005): “the *sensory-motor* system can characterise a sensory-motor *concept*, not just an action or a perception, but a *concept* with all that that requires” (p. 468).

As mentioned above, Ned’s speech alone does not suffice for our understanding as to whether Ned refers to “increasing” or “decreasing”. Similarly, we can argue that his gesture alone does not suffice either for our understanding of Ned’s mathematical expression. His gesture, isolated from his speech, may signify a variety of things, one of which is the term “increasing”. The combination of Ned’s speech and gesture, though, strengthens our speculation that Ned refers to the term “increasing”.

The contribution of both speech and gesture in Ned’s mathematical expression, and in our interpretation of it, demonstrates how merging Vygotskian (1978) sociocultural theory of learning and the theory of embodied cognition (Gallese & Lakoff, 2005) is important in our analysis. Take, for example, Ned’s response in (2) where we need both his speech and his gesture to grasp how he conveys what he means by “increasing”. Both theories – speech as the vital tool for mathematical meaning making and expression (Vygotskii, 1978) and the embodied nature of concepts (Gallese & Lakoff, 2005) – are combined to help us analyse Ned’s response in (2). One theory, deployed exclusively, would not suffice for our interpretation of Ned’s response.

In (2), we mention the adverb “happily”. With our use of an adverb that indicates emotion, we aim to show that we are interested not only in what our participants utter but also in how they feel as they do so. The ‘how’ part may be expressed with tone of voice, facial expressions and gestures and it provides us with information that frequently adds to, and further illustrates, the ‘what’ part. Ned’s

¹ “crease” originates from the latin word “crescere” [“grow”, Oxford English Dictionary (<http://www.oed.com/>)].

happiness is evidenced in his tone of voice and facial expression – when he says “creasing” – as well as in his gesture – we see excitement in the way he gestures. We attribute his happiness to a sense of fulfilment he may derive from the correctness of his answer. Later, we see that this correctness is cast into doubt, if not disapproved, by the teacher. Our exploration of the relation between emotion and cognition resonates with discussions in the literature of the relation among mathematical achievement, enjoyment and self-efficacy in mathematics. For example, we agree with Goldin, Epstein, Schorr, & Warner (2011, p. 553) that “affect, cognition and motivation interact to influence students’ mathematical engagement in classroom social environments”. Another reason why we have included a reference to Ned’s emotion is to later compare this emotion to that in his second answer, in (4), and associate the fluctuation between the two with the teacher’s reactions in the two cases.

Teacher’s reaction to Ned’s response (3)

The teacher does not explicitly react to Ned’s response, either by approving it or by disapproving it. We see in her response, though, implicit dissatisfaction: Ned’s answer does not include any of the two terms that the teacher expects to hear. Hence, the teacher repeats her previous question, albeit with a different sentence and tone of voice.

Her omission of the part “Is it”, which is in (1), and her direct use of the verbs separated with “or” show her emphasis on these two verbs, which she seems to expect from her interlocutor too. She pronounces the underlined prefixes “in” and “de” in (3) in a different tone of voice. This may indicate some concern about Ned’s wording, which does not include any of the two prefixes.

We interpret the teacher’s explanation of each of the two terms in (3) as showing her interpretation that Ned may not recall the meaning of the two terms. As with her question, her explanations suggest, too, her emphasis on the two mathematical words, which she expects to hear from Ned.

While the teacher’s mathematical discourse is mostly verbal-institutional and the teacher expects such kind of discourse from Ned, too, in this part of the episode, the teacher accompanies her speech with gestures. Thus, she creates a verbal-institutional and gestural mathematical discourse, with each of its components – speech and gesture – serving the same purpose: that of explaining the meaning of the key terms. We interpret the teacher’s use of a similar gesture to Ned’s one as a manifestation of “attuning” (in the sense of Nardi et al., 2018) to the gestural part of her pupil’s mathematical contribution and of her approval of gesturing as a form of mathematical expression, albeit not independently from ‘approved’ speech. Through her gesture, we see that the teacher considers Ned’s gesture, too, but – alongside speech – she draws on it to guide him in responding within the mathematical discourse which she, and the educational institution she represents too, approves. Therefore, the teacher seems to be concerned about Ned’s wording but she seems to partially approve his gesture. Her expectation is of an answer within the verbal discourse aligned with institutional (the National Curriculum’s) standards. The teacher’s attuning to Ned’s gesture resonates with the first camp of participants in (Nardi et al., 2018, p. 157): that of using the VI pupil’s contribution to focus on a more conventional contribution.

Drawing upon Sfard’s (2007) theory of commognition, we see evidence of commognitive conflict in the exchange between the teacher and Ned. We define commognitive conflict as the situation occurring when seemingly conflicting narratives originate in different, incommensurable discourses

(Sfard, 2007). We see the different mathematical discourses of two interlocutors, both of whom aim to convey their mathematical meaning of an increasing sequence of numbers. We see the commognitive conflict in the teacher's non-playing by the meta-discursive rules set by Ned: she considers Ned's speech in isolation from his gesture and vice versa. Indeed, as discussed in (1), Ned's speech isolated from his gesture – and Ned's gesture isolated from his speech – do not suffice for conveying the meaning he seems to have constructed of an increasing number sequence. We see that the commognitive conflict arose as a result of the teacher's consideration of Ned's mathematical discourse as consisting of two separate, unrelated elements: speech and gesture. We argue that, had the teacher considered Ned's verbal-gestural discourse as an entity, commognitive conflict might have been avoided: instead, an acknowledgement of two different, but equally acceptable, mathematical discourses might have occurred.

Ned's reaction to the teacher's response on his answer (4)

We then see that Ned changes communicational mode from verbal-non-institutional – which was seen as problematic by the teacher (3) – and gestural – which was partially accepted by the teacher (3) – to verbal-institutional – which, as he knows from (3), is accepted by the teacher. Here, Ned responds to the teacher's question by playing by the meta-discursive rules set by the teacher, which, as discussed in (3), puts the emphasis on endorsed forms of speech. However, his shift in communicational mode does not seem to be a pleasant experience. His tone of voice and his facial expression evidence this reduced enthusiasm. This raises issues on how included Ned feels his mathematical contribution in (2) is. We see that in (3) the teacher's non-developing of Ned's mathematical contribution in its own right – the camp of teachers' developing of VI pupils' contributions in their own right is the second camp discussed by Nardi et al. (2018, p. 158) – is excluding. The teacher restricts Ned to responding within the boundaries of an institutionally endorsed mathematical discourse and this limitation seems to dissatisfy Ned. Drawing upon the relation between affect and cognition, we associate Ned's apparently reduced enthusiasm with the teacher's concern over his initial contribution and her expectation of his responding in one, particular way. Ned's non-gesturing here may be attributed to several reasons. It may be attributed to the non-contribution of a gesture to his conveying of his mathematical construction of an increasing number sequence, since his use of speech suffices as an answer to the teacher's question, unlike in (2). It may also be attributed to Ned's interpretation from (3) that gesturing is not a necessary, or even appropriate, form of mathematical communication.

Teacher's reaction to Ned's response (5)

We then see that the teacher clearly approves Ned's response: his response in (4) resonates with the teacher's expectations, in which speech seems to dominate over gestures.

Discussion of the episode in the context of the entire study

This episode is selected to evidence mathematical discourses of a teacher and a VI pupil in a mainstream classroom and discusses the extent to which mathematical communication is achieved between the two interlocutors.

Zooming out to the entire study, we see that, despite the invitation towards VI pupils to participate in the mathematics lesson on an equal basis with their peers, their mathematical contributions – which may differ from the ones expected by the teacher – may not always be as valued as they could. In other words, we see evidence of equitable participation but not equitable value in the mathematics classroom. We see this discrepancy as a hurdle to implementing inclusion. We are unsure whether this discrepancy arises as a result of undervaluing of the mathematical discourses of VI pupils, as a result of a persistent adherence to the institutional mathematical discourse, as a result of both and/or other influences. In the episode we discuss here, though, we do not consider the teacher's concern with the VI pupil's initial mathematical contribution as ableist² and we note that there was hardly any evidence of ableism in the observation and interview data from this teacher. We attribute her concern to this contribution's divergence from the prevalent one and we thus stress that her concern in similar cases is likely to occur with every pupil, not just with a VI one.

In the episode, we see the reported interaction as associated – but possibly not limited – to visual impairment. We argue that the pupil's contribution may be seen through existing findings on visual impairment: for example, VI pupils use their hands to construct and convey mathematical meaning (Nardi et al., 2018). We also argue that the teacher's response in (3) was specific to the pupil's genuine mathematical contribution.

Regardless of the reason attributed to the teacher's concern with Ned's mathematical contribution, we set the following questions. Do we, as educators, need to accept only those mathematical contributions that resonate with the institutional ones? Or, do we need to reflect upon the different contributions of our pupils, discern whether they are mathematically valid too and act accordingly to include them in the lesson? Without ignoring the necessity for the pupils' familiarisation with, and endorsement of, established mathematical discourse, we propose that we should heed the reactions of our pupils, even in cases when we, either explicitly or implicitly, have concerns about mathematical contributions which differ from the institutional ones: different pupils construct different meanings of mathematics. This is how we see inclusive education implemented in the classroom: through equitable participation and equitable value. We argue that our valuing, attuning and integrating of pupils' non-prevalent mathematical contributions into lessons may not only encourage participation in the mathematics lesson but may also benefit all pupils in class, who may experience mathematics from a different, and potentially enriching, point of view.

Acknowledgements

We thank: UEA's Research in Mathematics Education Group and Professor Anna Sfard for their invaluable feedback on the episode, discussed in a commognition workshop at UEA on 21/06/2018; the participating teaching staff and pupils for their commitment to the study; and, UEA for funding the study through a Social Sciences Faculty Doctoral Studentship.

² Ableism is defined as “a network of beliefs, processes and practices that produce a particular kind of self and body (the corporeal standard) that is projected as the perfect, species-typical and therefore essential and fully human. Disability, then, is cast as a diminished state of being human” (Campbell, 2001, p. 44).

References

- Bayram, G. İ., Corlu, M. S., Aydın, E., Ortaçtepe, D., & Alapala, B. (2015). An exploratory study of visually impaired students' perceptions of inclusive mathematics education. *British Journal of Visual Impairment*, 33(3), 212–219.
- Campbell, F. (2001). Inciting legal fictions: 'Disability's' date with ontology and the ableist body of the law. *Griffith Law Review*, 10(1), 42–62.
- Gallese, V., & Lakoff, G. (2005). The brain's concepts: the role of the sensory-motor system in conceptual knowledge. *Cognitive Neuropsychology*, 22(3-4), 455–479.
- Goldin, G. A., Epstein, Y. M., Schorr, R. Y., & Warner, L. B. (2011). Beliefs and engagement structures: behind the affective dimension of mathematical learning. *ZDM Mathematics Education*, 43(4), 547–560.
- Leuders, J. (2016). Tactile and acoustic teaching material in inclusive mathematics classrooms. *British Journal of Visual Impairment*, 34(1), 42–53.
- Nardi, E., Healy, L., Biza, I., & Fernandes, S. H. A. A. (2018). 'Feeling' the mathematics of disabled learners: supporting teachers towards attuning and resignifying in inclusive mathematics classrooms. In R. Hunter, M. Civil, B. Herbel-Eisenmann, N. Planas, & D. Wagner (Eds.), *Mathematical discourse that breaks barriers and creates space for marginalized learners* (pp. 147–170). Rotterdam, The Netherlands: Sense Publishers.
- Oliver, M. (2009). *Understanding disability: from theory to practice* (2nd ed.). Basingstoke, United Kingdom: Palgrave Macmillan.
- Sfard, A. (2007). When the rules of discourse change, but nobody tells you: making sense of mathematics learning from a commognitive standpoint. *The Journal of the Learning Sciences*, 16(4), 565–613.
- Stylianidou, A., & Nardi, E. (2018). Inclusion and disability in the primary mathematics classroom: Examples of teaching staff discourses on the participation of visually impaired pupils. In J. Golding, N. Bretscher, C. Crisan, E. Geraniou, J. Hodgen, & C. Morgan (Eds.), *Research Proceedings of the 9th British Congress on Mathematics Education* (pp. 167–174). Warwick, United Kingdom: University of Warwick.
- UNICEF. (2012). *The right of children with disabilities to education: A rights-based approach to inclusive education*. Retrieved from https://www.unicef.org/disabilities/files/UNICEF_Right_to_Education_Children_Disabilities_En_Web.pdf
- United Nations. (2006). *United Nations Convention on the Rights of Persons with Disabilities*. Retrieved from <http://www.un.org/disabilities/documents/convention/convoptprot-e.pdf>
- Vygotskii, L. S. (1978). *Mind in society: the development of higher psychological processes*. Cambridge, Massachusetts and London, United Kingdom: Harvard University Press.

Do hearing-impaired students learn mathematics in a different way than their hearing peers? – A review

Kinga Szűcs

Friedrich-Schiller-University Jena, Germany; kinga.szuecs@uni-jena.de

In the last few years, the concept of inclusion has become more and more prevalent in school education. Accordingly, teachers in mathematics classrooms have to face not just a wide range of heterogeneity related to social background, language skills and performance abilities, but also various impairments like physical, sensory and mental disabilities. To facilitate gainful inclusive mathematics education, it is important to understand the aspects of mathematical concept formation and of mathematics performance which differ between disabled and not-disabled children. The main focus in the current paper is on the differences between hearing and hearing-impaired students when doing mathematics. Empirical studies from the last two decades are summarized and some guidelines for inclusive mathematics settings with hearing and hearing-impaired children are derived.

Keywords: Inclusive education, hearing impairments, concept formation, mathematics education.

Background

There is an overwhelming amount of literature related to deaf children's learning, a significant part of which discusses aspects of mathematics performance. Even if it is not possible to seek completeness, a short overview on some well-selected articles can give a useful insight into the main research questions and already ascertained results. For this reason, 24 articles (mainly from two highly relevant journals, the Educational Studies in Mathematics and Journal of Deaf Studies and Deaf Education) regarding hearing-impaired students' learning in mathematics (mainly reports on empirical studies about differences between the performance of hearing and hearing-impaired students) were chosen predominantly from the last two decades, such that all education levels from kindergarten to college are represented. Additionally, some of the papers discuss adults' mathematical performance long after completing school education. The main goal in this paper is to identify relevant differences between hearing and hearing-impaired students when doing mathematics and to derive their possible influence on an inclusive classroom. According to Ziemer (2017), the term inclusion will be used in the current paper as overcoming of all kind of marginalization, discrimination and stigmatization, which includes especially the respect and appreciation of handicapped students in co-educated classrooms.

There is a common agreement in the relevant literature, that hearing-impaired students' performance in school mathematics is on average far below the average performance of their hearing peers and that this delay corresponds to a disadvantage of 2 to 4 school years. However, there is no consensus regarding when this delay first appears, or which parts of the language skills and cognitive abilities are affected. Three different areas of related research can be identified: Studies that mainly focus on detecting and describing cognitive differences between hearing and hearing-impaired pupils, studies that look for reasons for those disadvantages, and studies that suggest interventions for hearing-impaired students and measure their effectiveness. Table 1 shows an overview of all reviewed papers, categorized according to the main focus and the examined educational level. Please note that some

of the papers include more than one study and therefore more than one of these aspects; it also happens, that a study was carried out on more than one education level. Thus, several papers are registered more than once. In the next sections, research results in the identified three areas (differences, reasons and interventions) will be summarized.

main focus	differences	reasons for differences	intervention
preschool	Ansell & Pagliaro, 2006; Kritzer, 2009; Pagliaro & Kritzer, 2013; Zarfaty, Nunes, & Bryant, 2004	Kritzer, 2008	
primary school	Ansell & Pagliaro, 2006; Frostad & Ahlberg, 1999; Nunes et al., 2009	Pagliaro & Ansell, 2002	Nunes & Moreno, 1998; Nunes & Moreno, 2002;
	Frostad, 1999; Zevenbergen, Hyde, & Power, 2001		Nunes et al., 2009
secondary school	Blatto-Vallee et al., 2007; Searle, Lorton, & Suppes, 1974	Kelly, Lang & Pagliaro, 2003; Lang et al., 2007	
	Zevenbergen et al., 2001		
college, university	Blatto-Vallee, Kelly, Gaustad, Porter, & Fonzi, 2007	Kelly & Gaustad, 2007	Marshall, Carrano, & Dannels, 2016
	Bull, Blatto-Vallee, & Fabich, 2006; Kelly, Lang, Mousley, & Davis, 2003; Marschark et al., 2015		
adults	Korvorst, Nuerk, & Willmes, 2007; Kramer & Grote, 2009 Masataka, 2006		

Table 1: Main focus of the reviewed articles categorized by education level

Before looking into the content of the papers it is important to remark that, although the term ‘deaf’ is commonly taken to mean profound hearing loss, most of the papers use the term in a wider sense. For example, Nunes et al. (2009) examine the performance of children with moderate to profound hearing loss in their first study and the performance of children with mild to profound hearing loss in their second reported study. In Frostad’s (1999) case study the pupils have moderately severe to

profound hearing loss, and Zarfaty, Nunes and Bryant (2004) also work with children with moderate to profound hearing loss. All these papers use the term 'deaf'. Others, for example Pagliaro and Kritzer (2013) emphasize the difference between partial and complete hearing loss and make use of the term 'deaf and hard-of-hearing'. Because of this inconsistent and confusing use of terms, in this paper the term 'hearing-impaired' will be employed and used in the sense which incorporates all the meanings of related terms in the reviewed papers. So, by hearing-impaired will be meant all kinds of hearing loss, which exceed the threshold of normal hearing (hearing loss 15 dB at the most).

Differences between hearing and hearing-impaired students when doing mathematics

Because of the main consensus about the delayed performance of hearing-impaired students in school mathematics, researchers started to pay more attention to preschool mathematics in order to answer the question of whether those differences are already present before starting school. A surprising and also promising result from Zarfaty, Nunes and Bryant (2004) with children in the age range of 3 to 4 years, is that they could remember and reproduce numbers as well as their hearing peers when the task was offered in a sequence, but they outperformed the hearing children, when the task was organized spatially. Contradictory to these findings, hearing-impaired children did not benefit from the visual-spatial problem presentation in the study of Ansell and Pagliaro (2006). With respect to arithmetic story problems, preschool and primary school hearing-impaired children do not use linguistic markers in the story, instead reacting more to the assumed mathematics operation (Ansell & Pagliaro, 2006). Similarly, not only do 4- to 6-year-old hearing-impaired children already present a developmental delay in both informal and formal mathematics tasks relative to hearing peers, but also, not even participants with high mathematical ability could make relationships between the numbers and the story in a word problem (Kritzer, 2009). The results from Pagliaro and Kritzer (2013) can further differentiate the picture: In their study, 3- to 5-year-old hearing-impaired children showed strength especially in geometry.

In accordance with the results of Ansell and Pagliaro (2006), Frostad and Ahlberg (1999) found that hearing-impaired primary school children typically approach word problems as numbers and procedures without reflecting on the semantic relations in the text. Frostad (1999) found additionally that primary school hearing-impaired children do not use their knowledge base for deriving the answer, instead reverting to counting. Similarly, hearing-impaired primary and secondary school students rely on trigger words in the text as well as ignore key words in decontextualized problems (Zevenberger et al., 2001). In the study of Nunes et al. (2009), hearing-impaired primary school children under-performed their hearing peers in multiplicative reasoning tasks.

At the secondary school level, the findings of Zevenberger et al. (2001) are already reported above. In contrast to that, Searle, Lorton and Suppes (1974) found among grade 4-6 deaf and deprived students that terse and story-free problems are especially difficult for them to solve. Another relevant result in this study was that the length of the word problems did not affect the mathematical performance. Blatto-Vallee, Kelly, Gaustad, Porter and Fonzi (2007) examined the use of visual-spatial schematic and visual-spatial pictorial representations among secondary school and college students when solving word problems. Hearing-impaired students tended to utilize more visual-

spatial pictorial representations, which encode only the visual appearance of objects described in the problem and are therefore on a lower cognitive level than visual-spatial schematic representations, which encode the spatial relationships described in the problem.

Kelly, Lang, Mousley and Davis (2003) examined the consistency hypothesis during solving arithmetic word problems among hearing-impaired college students. The hypothesis postulates that students perform better on word problems in which the order of the information is consistent with the order of the corresponding mathematical operation; supporting evidence has been found previously among hearing students. The results of the Kelly et al. (2003) study support the consistency hypothesis: Hearing-impaired students performed similarly. On the other hand, they made – regardless of reading ability – more goal monitoring mistakes than hearing peers. Bull, Blatto-Vallee and Fabich (2006) found that on subitizing tasks (instantaneous recognition of the cardinality of small sets), both hearing and hearing-impaired college students' performance have a similar pattern. Surprisingly, hearing-impaired students did not perform better on a special skew dot format, even if this was anticipated due to their assumed better visual-spatial skills. Accordingly, Marschark et al. (2015) report that hearing university students outperformed their hearing-impaired peers in visual-spatial tasks. Note, that this contradicts to the findings of Zarfaty et al. (2004) on the preschool level.

Masataka (2006) investigated the number sense of hearing-impaired adults and their hearing peers. In this study the hearing-impaired participants outperformed the hearing peers on tasks which used non-symbolic numerosity, but they did worse, when the same tasks were offered in a formal mathematical way. Kramer and Grote (2009) compared the performance of hearing-impaired adults on basic mathematics operations with that of hearing peers. Even if the performance of hearing-impaired adults is far below the performance of people with the lowest level certificate of secondary school in Germany, the two groups showed in a language-free test almost the same cognitive ability. The authors also found a performance benefit for deaf adults with deaf parents and concluded that the language (not exclusively sign language) used in mathematics classrooms has a negative effect on their learning. In accordance with this, Korvorst, Nuerk and Willmes (2007) found hearing-impaired adults' performance on complex numerical information-extracting tasks was quite similar to the performance of their hearing peers, when the tasks were offered in sign language.

Possible reasons for differences in mathematical performance

At the primary level, Pagliaro and Kritzer (2013) conclude that the detected delayed development of hearing-impaired children related to basic concepts in mathematics can be caused by absent, inappropriate, or misguided learning opportunities. Similarly, Kritzer (2008) found in a qualitatively analyzed case study with hearing-impaired 4- to 6-year-old children and their parents, that the four mathematically based concepts (numbers, quantity, time and/or sequence, categorization) were used more frequently by the parents of children with high mathematical ability than by parents of children with lower mathematical ability. The first group of children was also exposed to mathematically based concepts in a way that was more purposeful and meaningful.

Even if sign language number symbols have many of the characteristics of analogue representations, the efficiency of those numbers for counting can delay the development of conceptual knowledge in hearing-impaired primary school children (Forstad, 1999). So, the use of sign language is beneficial,

but can also lead to disadvantages. Zevenbergen et al. (2001) described a similar dilemma: If the teacher reorganizes the word problems so as to make them more accessible for hearing-impaired pupils, students are not challenged cognitively and do not get access to the highly specific register of the discipline. Totally in accordance with these findings, Pagliaro and Ansell (2002) concluded based on a questionnaire with teachers of third-grade hearing-impaired students, that they do not encounter story problems early enough and often enough, so they are not provided sufficient opportunities to form problem-solving strategies.

Because the study of Zevenbergen et al. (2001) was made with first- to seventh-grade hearing-impaired children, the statement above is also valid for the secondary school level. Additionally, Kelly, Lang and Pagliaro (2003) found that not only do teachers of hearing-impaired students not challenge them cognitively in solving mathematics word problems, but also that they have low perceptions and expectations about the students' abilities and therefore do not offer them meaningful problem-solving situations. Also, the teachers associated limited English skills with a primary barrier to learn, and thus emphasized comprehension strategies rather than problem-solving strategies. However, difficulties can also be caused by other factors: In a case study with teachers, Lang et al. (2007) determined that visual representations of science concepts (among others technical science signs) may lead to misconceptions, but also, that for the majority of science terms there is no published or recorded sign.

There is some evidence that mathematics performance is affected by language abilities, especially at higher levels of education. Kelly et al. (2003) found that, even if the rate of goal-monitoring errors was much higher among hearing-impaired college students than among hearing peers, this rate nevertheless decreased with increasing reading ability. Marschark et al. (2015) examined the executive functioning behaviors (such as comprehension and conceptual learning, factual memory, attention and so on) of hearing and hearing-impaired first-year university students in everyday life with a self-report questionnaire. They found better scores for the hearing than for the hearing-impaired students, but also, that difficulties in executive functioning among participants with cochlear implant are the result of both, language delay and auditory deprivation. In accordance with this, Kelly and Gaustad (2007) could demonstrate, that specific morphological competencies in English in addition to reading ability level, are significantly related to mathematics performance. Bull et al. (2006) concluded that hearing and hearing-impaired students do not differ from each other in the format of numerical representation and the level of automatic activation of magnitude information. Thus, this aspect cannot be the reason for later difficulties with arithmetic.

Based on his study with hearing and hearing-impaired adults, Masataka (2005) concluded that, difficulties in mathematics are related to the formal, symbolic side of the discipline, and that this is modulated by the environment and the culture. Kramer and Grote (2009) came to a similar conclusion: They found the language used in mathematics classrooms to be responsible for the mathematics difficulties of deaf (native sign-language user) individuals, but they also mention missing and deficient opportunities for developing language skills and everyday-life-knowledge. In accordance with this and also with the findings of Bull et al. (2006) above, Korvorst et al. (2007) did not find evidence for core differences between hearing and hearing-impaired adults in solving

bisection tasks, which require the extraction of complex numeric information, when hearing-impaired participants used (their native) sign language.

Interventional methods and their effectiveness

Nunes and Moreno (1998) applied a non-traditional method for calculating, namely the signed algorithm, in a mathematics classroom with solely hearing-impaired primary school children. While solving addition and subtraction problems, the pupils showed systematic errors similar to the ones in written computation related to place value understanding and the mechanics of written algorithms. Thus, the authors suggest to try out this method as an alternative and make use of the systematic errors to optimize teachers' instruction. Nunes and Moreno (2002) also developed an interventional program for hearing-impaired students in primary school which involved two main aspects: Giving opportunities to learn basic mathematical concepts, which can be learnt informally by hearing students, and promoting connections between informal and formal mathematical concepts. The interventional group performed significantly better in the posttest not just in comparison with the baseline group, but also with their own previously estimated performance. The intervention led also to motivational benefits. Furthermore, Nunes et al. (2009) adapted an intervention program on multiplicative reasoning – originally developed for hearing children at risk for difficulties in learning mathematics – for hearing-impaired students. However, the intervention was also applied to a hearing experimental group. Both hearing and hearing-impaired children benefited significantly from the intervention, but in a delayed posttest the performance of the hearing-impaired children decreased. A possible reason for this fact could be the long-term poorer problem-solving environment for hearing-impaired pupils.

Responding to missing everyday opportunities and problem-solving strategies of hearing-impaired students, Marshall, Carrano and Dannels (2016) developed an intervention program based on the concept of experimental learning, on best-practice experiments and on the concept of plan-do-check-act. During the lessons, hearing-impaired students become more and more familiar with the solving of real, work-related problems. The sessions featured sign-supported explanatory videos. Significant improvements were found between the performance in the pre- and posttest for the long term.

Conclusions for inclusive mathematics classrooms

According to Pagliaro and Kritzer (2013), Kritzer (2008) and also to Kramer and Grote (2009), the main focus in the preschool education should be on offering opportunities primarily to develop informal mathematics knowledge such as numbers, quantity, time, events in a sequence, categorization and to improve language skills.

In primary and secondary school, word problems seem to be the most challenging for hearing-impaired students. Intervention programs such as suggested by Nunes and Moreno (2002) and Nunes et al. (2009) could and should be implemented and extended for other areas and for secondary level, for the following reasons: (1) Hearing-impaired students could compensate their deficient informal mathematics knowledge and language skills (2) both hearing-impaired and hearing students could develop high-level problem-solving strategies (3) these activities could also be beneficial for socioeconomically disadvantaged pupils and students at a risk for difficulties in learning mathematics. It is also important to make use of visual-spatial schematic representations when solving word

problems (Blatto-Vallee et al., 2007) and to discuss story-free word problems (Searle et al., 1974). Children with profound hearing loss could use the sign algorithm as an alternative (Nunes & Moreno, 1998) and should use their native language (sign language) (Kramer & Grote, 2009; Korvorst et al., 2007), perhaps with the help of a native sign-user translator. At college and university education level, the support of language skills – including technical (sign) language – is recommended.

References

- Ansell, E., & Pagliaro, C. M. (2006). The relative difficulty of signed arithmetic story problems for primary level deaf and hard-of-hearing students. *Journal of Deaf Studies and Deaf Education*, 11(2), 153–170.
- Blatto-Vallee, G., Kelly, R. R., Gaustad, M. G., Porter, J., & Fonzi, J. (2007). Visual–spatial representation in mathematical problem solving by deaf and hearing students. *Journal of Deaf Studies and Deaf Education*, 12(4), 432–448.
- Bull, R., Blatto-Vallee, G., & Fabich, M. (2006). Subitizing, magnitude representation, and magnitude retrieval in deaf and hearing adults. *Journal of Deaf Studies and Deaf Education*, 11(3), 289–302.
- Frostad, P. (1999). Deaf children's use of cognitive strategies in simple arithmetic problems. *Educational Studies in Mathematics*, 40, 129–153.
- Frostad, P., & Ahlberg, A. (1999). Solving story-based arithmetic problems: Achievement of children with hearing impairment and their interpretation of meaning. *Journal of Deaf Studies and Deaf Education*, 4(4), 283–293.
- Kelly, R. R., & Gaustad, M. G. (2007). Deaf college students' mathematical skills relative to morphological knowledge, reading level and language proficiency. *Journal of Deaf Studies and Deaf Education*, 12(1), 25–37.
- Kelly, R. R., Lang, H. G., Mousley, K., & Davis, S. M. (2003). Deaf college students' comprehension of relational language in arithmetic compare problems. *Journal of Deaf Studies and Deaf Education*, 8(2), 120–132.
- Kelly, R. R., Lang, H. G., & Pagliaro, C. M. (2003). Mathematics word problem solving for deaf students: A survey of practices in grades 6–12. *Journal of Deaf Studies and Deaf Education*, 8(2), 104–119.
- Korvorst, M., Nuerk, H.-C., & Willmes, K. (2007). The hands have it: Number representations in adult deaf signers. *Journal of Deaf Studies and Deaf Education*, 12(3), 362–372.
- Kramer, F., & Grote, K. (2009). Haben Gehörlose beim Rechnen mehr Schwierigkeiten als Hörende? *Das Zeichen Zeitschrift für Sprache und Kultur Gehörloser*, 82, 276–283.
- Kritzer, K. L. (2008). Family mediation of mathematically based concepts while engaged in a problem-solving activity with their young deaf children. *Journal of Deaf Studies and Deaf Education*, 13(4), 503–517.

- Kritzer, K. L. (2009). Barely started and already left behind: A descriptive analysis of the mathematics ability demonstrated by young deaf children. *Journal of Deaf Studies and Deaf Education*, 14(4), 409–421.
- Lang, H. G., LaPorta Hupper, M., Monte, D. A., Babb, I., Brown, S. W., & Scheifele, P. M. (2007). A study of technical signs in science: Implications for lexical database development. *Journal of Deaf Studies and Deaf Education*, 12(1), 65–79.
- Marshall, M. M., Carrano, A. L., & Dannels, W. A. (2016). Adapting experiential learning to develop problem-solving skills in deaf and hard-of-hearing engineering students. *Journal of Deaf Studies and Deaf Education*, 21(4), 403–415.
- Marschark, M., Spencer, L. J., Durkin, A., Borgna, G., Convertino, C., Machmer, E., Kronenberger, W. G., & Trani, A. (2015). Understanding language, hearing status, and visual-spatial skills. *Journal of Deaf Studies and Deaf Education*, 20(4), 310–330.
- Masataka, N. (2006). Differences in arithmetic subtraction of nonsymbolic numerosities by deaf and hearing adults. *Journal of Deaf Studies and Deaf Education*, 11(2), 139–143.
- Nunes, T., Bryant, P., Burman, D., Bell, D., Evans, D., & Hallett, D. (2009). Deaf children's informal knowledge of multiplicative reasoning. *Journal of Deaf Studies and Deaf Education*, 14(2), 260–277.
- Nunes, T., & Moreno, C. (1998). The signed algorithm and its bugs. *Educational Studies in Mathematics*, 35, 85–92.
- Nunes, T., & Moreno, C. (2002). An intervention program for promoting deaf pupils' achievement in mathematics. *Journal of Deaf Studies and Deaf Education*, 7(2), 120–133.
- Pagliaro, C. M., & Ansell, E. (2002). Story problems in the deaf education classroom: frequency and mode of presentation. *Journal of Deaf Studies and Deaf Education*, 7(2), 107–119.
- Pagliaro, C. M., & Kritzer, K. L. (2013). The math gap: A description of the mathematics performance of preschool-aged deaf/hard-of-hearing children. *Journal of Deaf Studies and Deaf Education*, 18(2), 139–160.
- Searle, B. W., Lorton, P. Jr., & Suppes, P. (1974). Structural variables affecting CAI performance on arithmetic word problems of disadvantaged and deaf students. *Educational Studies in Mathematics*, 5(1), 371–384.
- Zarfaty, Y., Nunes, T., & Bryant, P. (2004). The performance of young deaf children in spatial and temporal number tasks. *Journal of Deaf Studies and Deaf Education*, 9(3), 315–326.
- Zevenbergen, R., Hyde, M., & Power, D. (2001). Language, arithmetic word Problems, and deaf students: Linguistic strategies used to solve tasks. *Mathematics Education Research Journal*, 13(3), 204–218.
- Ziemen, K. (2017). Inklusion. In K. Ziemen (Ed.), *Lexikon Inklusion* (101). Göttingen, Germany: Vandenhoeck & Ruprecht.

Supporting braille readers in reading and comprehending mathematical expressions and equations

Annemiek van Leendert¹, Michiel Doorman², Paul Drijvers², Johan Pel³ and Johannes van der Steen³

¹ Royal Visio, the Netherlands; annemiekvanleendert@visio.org

² Utrecht University, the Netherlands; m.doorman@uu.nl and p.drijvers@uu.nl

³ Erasmus University Medical Center; the Netherlands; j.pel@erasmusmc.nl and j.vandersteen@erasmusmc.nl

Braille readers create an overview of an expression by reading one braille character after another or listening to a voice saying the expression or equation aloud. The specific skills and knowledge that mathematics teachers need to assist this complicated process are often lacking. The purpose of this study was to investigate the effect of an intervention consisting of a course focused on braille display support in combination with Text-To-Speech synthesizer for mathematics teachers on the mathematical performances of braille readers. A quasi-experimental approach was taken to answer this question. Five teachers of an experimental group received the intervention whereas the teacher of the control group did not. Both the experimental group, consisting of 10 braille readers, and the control group, consisting of five braille readers, took a pre- and post-test. The results indicated that there was a very small positive effect of the intervention.

Keywords: Braille display, braille reader, algebra, speech synthesizer, TPACK model.

Introduction

Reading and comprehending mathematical expression and equations has always been difficult for students who use braille or braille in combination with speech synthesis as their primary reading medium (hereafter braille readers). Mathematics teachers need to have specific skills and knowledge to assist this complicated process. Braille readers read and comprehend mathematical expressions and equations by touching or hearing in a sequential pattern (Millar, 1994, 1997). They need to build an overview by reading one braille character after another or listening to a voice saying the expression or equation aloud. Expressions and equations have to be represented in a linear notation because braille and speech are both linear output modalities (Stöger & Miesenberger, 2015). Hence, braille readers have a small perceptual view and have to read expressions in a linear notation. This means that they can't benefit from the layout of an expression that helps the sighted student to understand the structure of an expression at a glance (Karshmer & Bledsoe, 2002).

In many countries, braille readers in secondary and higher education use a laptop in mathematics class. Screen Reader software sends the mathematical text on the screen to a refreshable braille display, which is connected to the keyboard of the laptop, or to a Text-To-Speech (TTS) synthesizer. Consider, for example, the next expression:

$$\frac{2x^2+1}{3} \quad (1)$$

In this representation, the expression can't be sent to the braille display or TTS synthesizer. It must first be converted to a linear representation (hereinafter pre-braille notation), e.g. $(2x^2 + 1)/3$.

The notation on the braille display is to a certain degree static. This allows for at least a limited spatial overview (Archambault, Stöger, Batusic, Fahrengruber, & Miesenberger, 2007). On the other hand, every character on the braille display has to be read individually and sequentially which makes braille reading exhaustive rather than selective (Hughes, 2011; Hughes, McClelland, & Henare, 2014). That makes it rather difficult to get an overview over an expression or equation (Van Leendert, Doorman, Drijvers, Pel, & van der Steen, 2019). Moreover, braille characters have a low redundancy, which means that the characters are hard to distinguish from each other (Tobin & Hill, 2015). This can lead to errors in decoding the braille characters into correct elements of the expression or equation.

In addition to the braille display, the TTS synthesizer is a useful screen reader device for reading mathematical expressions and equations. The Screen Reader that controls the speech and that we used in this study is JAWS, which stands for Job Access With Speech. An advantage of speech over braille is the pace of reading because spoken language can be much quicker comprehended than braille characters. Mathematical expressions and equations can be spelled or read aloud. When an expression is spelled, each element in the expression is approached separately. When an expression is read, a speech dictionary determines the spoken text. This dictionary can be extended with a mathematics vocabulary (also influencing how non-mathematical text is read) and can be further extended with mathematical symbols on so-called verbosity levels. The way in which an expression is spoken aloud depends on the content of the dictionary and the verbosity levels and on the verbosity level at which the braille reader reads. For example, " $2(x^2 + 4)$ " can result in "two x squared plus four" when using a low verbosity level and in "two open bracket x squared plus four closed bracket" when using a high verbosity level. In this case, the meaning is lost when the braille reader uses a low verbosity level. In general, braille readers (should) use a low verbosity level for reading non-mathematical text and a high verbosity level for mathematical text. By default, the settings are not adjusted to mathematical text. In that case, choosing a high verbosity level doesn't help.

In summary, the Screen Reader's software can be adjusted in such a way that (almost) all expressions are spelled and read in mathematical vocabulary. This supports the braille reader in learning the mathematical vocabulary, which is vital for the development of mathematical skills (Riccomini, Smith, Hughes, & Fries, 2015). Moreover, this vocabulary corresponds to the vocabulary used by the mathematics teacher in the classroom. This is particularly useful for braille readers in inclusive classrooms, because individual support is not always available.

Both assistive devices, the braille display as well as the TTS synthesizer, have their strengths and weaknesses. Ideally, using both devices one combines their individual strengths to overcome the weakness of each of the two methods (Bernsen, 2008). For example, uncertainties in braille can be verified or checked by spelling aloud.

The previous sections demonstrate that reading and comprehending mathematical expressions and equations while using the braille display or the TTS synthesizer is not easy. Teachers often don't know how to guide this complicated process. To map out the qualifications of mathematics teachers, the TPACK model can be used. TPACK includes knowledge of technology (TK), pedagogy (PK) and

content (CK), as well as insight into the complex interaction between these knowledge components (Mishra & Koehler, 2006). The idea behind TPACK is that the pedagogical use of (assistive) technology devices is strongly influenced by the content domains on which these devices are situated (Graham, Burgoyne, Cantrell, Smith, St Clair, & Harris, 2009). For example, the teacher knowledge required to effectively integrate technology in a mathematics classroom may be very different from that required for a language classroom.

This study aims at improving the integration of the braille display and the TTS synthesizer in the mathematics classroom. We addressed the following research question:

What is the effect of improving the knowledge of braille display and Text-To-Speech synthesizer support of mathematics teachers on braille reader's achievement in mathematics?

We expected that braille readers will better perform in mathematics because the adjusted settings of the Screen Reader software are more appropriate for reading mathematical text and the mathematics teachers have the knowledge to teach the braille readers how to use the braille display and the TTS synthesizer in mathematics lessons.

Methods

Design

In this study, the braille readers' mathematics teachers took part in a professional development (PD) course on integrating the braille display and the TTS synthesizer into mathematics lessons. The first part of the course was aimed at assisting each teacher in adjusting the settings of the Screen Reader software. As a result, the braille readers were able to listen to how expressions and equations were spelled and read aloud in mathematical vocabulary. The second part of the course was aimed at improving the knowledge to teach the braille readers how to use the braille display and the TTS synthesizer in mathematics lessons. In order to answer the proposed research question, a quasi-experimental approach was taken, using a pre- and post-test. The experimental group consisted of 10 braille readers whose teachers took part in the PD course. The control group consisted of five braille readers whose teacher did not participate in this course.

Context and participants

In the Netherlands, more than 50% of all braille readers in secondary education go to special schools for students with a visual impairment. Organization A and B provide education for these students. The first author was affiliated with organization A. Therefore, five mathematics teachers from two different schools of organization A participated in the PD course, while the teacher who worked at the school of organization B did not. None of the teachers ever received any training in teaching mathematics to braille readers. The mathematics teachers who worked at organization A were qualified teachers, but they were not, with the exception of one, qualified to teach mathematics. In contrast, the mathematics teacher who worked at organization B was a qualified mathematics teacher. The braille readers of organization A were assigned to the experimental group and the braille readers of organization B were assigned to the control group. This resulted in an experimental group of 10 and a control group of five braille readers. The three schools were very similar in terms of demographic characteristics of students and the degree of educational performance. The braille

readers were all in seventh to twelfth grade in secondary education. They differed in their mathematical skills and in their ability to use the braille display and the TTS synthesizer.

Intervention: a professional development course

Part of the intervention consisted of the adjustments of the settings of the Screen Reader software. The control group worked with the “old” settings, and (often) used one verbosity level when reading. As a result, too few symbols and punctuation marks were read aloud in mathematical text, or too many punctuation marks were read aloud in non-mathematical text. Moreover, (almost) no mathematical vocabulary was used. For the experimental group, the verbosity settings of the Screen Reader were adjusted. The speech dictionary was extended with a mathematical vocabulary and all punctuation marks and symbols, used in pre-braille notation, could be spelled aloud in mathematical vocabulary. The braille readers could choose a verbosity level with which they could read the whole expression aloud in mathematical vocabulary, without missing elements.

The face-to-face PD course consisted of four sessions of three hours each, which lasted over a period of four months. The design of the course was based on TPACK. Much attention has been paid on how to integrate the braille display and the TTS synthesizer into the mathematics lessons. For the first homework task, the mathematics teachers were asked to support a braille reader in obtaining an overview over an expression or equation. For the second homework task, they were asked to write down their experiences with the adjustments of the Screen Reader software and to discuss this with their braille readers. For the third task, they were asked to do an activity to provoke collaborative work and mathematical communication between students.

Pre- and post-test

We decided that we could use identical pre- and post-tests because the time interval was more than four months. The braille readers were asked to answer the two tasks orally, because that would save time and be less tiring for them.

The tasks were not too complex but required careful reading skills due to the use of various operations and brackets. In the first task, “synthetic speech comprehension”, the braille readers had to select information from expressions or equations that were spoken aloud. The items could be spoken aloud several times at the request of the braille reader. The items were:

- a) $1/7 + 7 - 2/5 + 8 = ..$ What are the fractions in this expression?
- b) $4 - (5 + -(6 + 3)) = ..$ Where do you start calculating?
- c) $4 * (.. - 5) = 8$ Solve this equation.

In the second task, “mathematical braille reading skills”, the braille readers were asked to read the mathematical text on the braille display and verbalize this text in mathematical vocabulary. With item b we expected to be able to investigate whether they were supported by context. The items were:

- a) $y = 2 \frac{1}{2} * 3$
- b) The volume is 12 m^3
- c) $y = \sqrt{2/(x + 3)^2}$

(2 1/2 is a mixed number, a combination of a whole number and a proper fraction). Before the start of the pre- and post-tests, the braille readers were interviewed about their visual impairment, their assistive devices and the support they receive in mathematics lessons. This information helped to interpret the results of the tests.

Procedure

The research followed this order: pre-interview, pretest, intervention, post-interview, posttest, all within a maximum of five months. The interviews and the pre- and post-tests took place at the schools of the braille readers. All sessions, consisting of an interview and a pre- or post-test, were scheduled for 25 minutes but sometimes lasted longer due to technological problems with the braille readers' laptops. Within two weeks of completing the pretests, the Screen Reader software of the experimental group was adjusted and the mathematics teachers' development course started. Within a month after the end of the course, the braille readers did the posttest. The control group received the same interviews and pre- and post-tests in the same period but without intervention.

Data collection and analysis

For investigating the research question data was collected during the pre- and post-test through audio and video recordings. For "synthetic speech comprehension", data were collected on whether the braille readers gave a correct answer and on how much time they needed to give this answer. For each group, the average time was calculated. For "mathematical braille reading skills", data were collected on whether the braille readers could verbalize the expression, how much time they needed to give a correct answer and on the kind of errors they made. For each group, the average time was calculated.

Results

The results in Table 1 show that for synthetic speech comprehension, the pretest percentage of correct answers was 57% for the experimental and 47% for the control group. For the posttest, the percentage of correct answers was (again) 57% for the experimental and 80% for the control group. The experimental group needed in the pretest, on average 46.1 seconds (SD = 27.0) and in the posttest, on average, 34.1 seconds (SD = 16.0) to give the correct answers. The control group needed in the pretest, on average, 45.4 seconds (SD = 25.1) and in the posttest, on average, 32.4 seconds (SD = 14.3) to give the correct answers. For both groups, the standard deviations were high.

For mathematical braille reading skills, the pretest percentage of correct answers was 20% for the experimental and 53% for the control group. In the posttest, the percentage of correct answers was 37% for the experimental and 60% for the control group. The experimental group needed in the pretest, on average, 18.2 seconds (SD = 26.8) and in the posttest, on average, 15.3 seconds (SD = 8.7) to give the correct answers. The control group needed in the pretest, on average, 9.0 seconds (SD = 3.1) and, in the posttest, on average 9.8 seconds (SD = 8.4) to give the correct answers. Also for this task, the standard deviations were high. The errors were categorized. E(d) is an error made due to difficulties with decoding the braille characters. This could be ascribed to difficulties with recognizing the location of the raised dots or to difficulties with decoding the braille characters into correct elements of a mathematical expression (e.g., "x" "∧" "2"). E(v) is an error due to difficulties in recognizing and verbalizing the whole expression (e.g. "x squared") and E(b) is an error due to

malfunctioning of one of the technology devices. For both groups and for all tests, almost all errors were decoding errors. For both groups, most decoding errors occurred at decoding symmetric or translated characters (e.g. ⠠⠠ and ⠠⠠) and mixing up six dot braille with eight dot braille. The E(b) error occurred only, two times, in the pretest of the experimental group.

Table 1: Results from pretest and posttest for synthetic speech comprehension and mathematical braille reading skills

Condition	Number of students	Pretest		Posttest	
		Percentage of correct answers	Average time on correct answers (s.)	Percentage of correct answers	Average time on correct answers (s.)
Synthetic speech comprehension	E (10)	57%	46.1 (SD = 27.0)	57%	34.1 (SD = 16.0)
	C (5)	47%	45.4 (SD = 25.1)	80%	32.4 (SD = 14.3)
Mathematical braille reading skills	E (10)	20%	18.2 (SD = 26.8)	37%	15.3 (SD = 8.7)
	C (5)	53%	9.0 (SD = 3.1)	60%	9.8 (SD = 8.4)

E denotes experimental and C control group

Finally, we illustrate the decoding practices of two braille readers of the experimental group reading “The volume is 12 m³” on the braille display (see Table 2). In this example, I. tried to read 12 m³ as one number “2393”. He did not recognize the “^” character in braille and stopped. F. also started with reading 12 m as one number, but corrected the error. Both braille readers mixed up “m” with “3”. and spent a lot of time reading "12 m³" compared to reading "The volume is".

Table 2: Results of two individual braille readers on mathematical braille reading skills

Braille reader I. (pretest)		Braille reader F. (posttest)	
Time (s)	Utterances	Time (s)	Utterances
00– 04	The volume is	00 – 01	The volume is
04 – 17	Two thousand three hundred ninety-three Wait two thousand What should this be?	01 – 19	Eh hundred three and twenty No no twelve I think this is cubic 12 cubic meters
17 – 22	The volume is		
22 – 40	one, two three no wait a two m s three I do not know if that is an s. It looks a bit strange ... {stop}		

Conclusions and discussion

This study aims at improving the integration of the braille display and the TTS synthesizer in the mathematics classroom. For “synthetic speech comprehension”, the percentage of correct answers for the experimental group (57%) did not change during the intervention. This means that, for this the

task, there was no evidence that the intervention was successful. For the control group, this percentage was 47% in the pretest and 80% in the posttest. It is remarkable that this group achieved much better on the posttest. For “mathematical braille reading skills”, the experimental group improved more than the control group. It is remarkable that the pretest percentage of correct answers of the experimental group (20%) was much lower than that of the control group (53%). In the posttest, the percentage was 37% for the experimental and 60% for the control group. For both groups, most errors were errors in decoding the braille characters showing that braille readers already stumble in the first phase of the solving process. Table 2 shows that braille reader I. and F. needed more time and made more errors when reading mathematical text (“ $12 m^3$ ”) compared to reading non-mathematical text (“The volume is”). Both braille readers mixed the symmetric characters “3” and “m”, which is a common mistake (Tobin & Hill, 2015). In summary, the results of the tasks on mathematical braille reading show a very small positive effect of the intervention. We expected a greater effect. Finally, the high values for standard deviation, in all tests, showed that the individual differences were large.

This study had some limitations. A first limitation was the small number of braille readers that participated in this study, especially the number of participants in the control group. A second limitation was the limited information we had of the braille readers about the frequency that they used the adjustments of the Screen Reader software in the period between the two tests. From a teacher’s point of view, we don’t know, exactly, if and how they changed their daily practice. This feedback was asked during the second interview, yet the braille readers found it difficult to reflect on this.

Moreover, there were differences between the experimental and control group that may have affected the results. Firstly, the braille readers of the control group were obliged to use the braille display, whether or not in combination with the TTS synthesizer, during their mathematics lessons. This was not obliged for the braille readers of the experimental group. Secondly, the mathematics teacher of the braille readers of the control group was a qualified mathematics teacher. This was not the case for the mathematics teachers, with the exception of one, of the experimental group.

We did not anticipate that braille readers would make so many decoding errors while reading mathematical text. Overall, the control group performed better on both tasks than the experimental group. This may be due to the strict rules for the use of the braille display and the differences in background of the mathematics teachers. This could be examined in more detail in future studies.

Overall, this study adds to the small number of studies into ways to support braille readers in mathematics (e.g. Figueiras & Arcavi, 2014). Findings from this type of research should enable teachers to better support braille readers in doing mathematics.

Acknowledgments

This work is part of the research program ‘Improving the mathematical abilities of Braille-dependent students’ (023004048), which is financed by the Netherlands Organization for Scientific Research (NWO). This study was approved by the medical ethical committee of the Erasmus Medical Centre (MEC-2012-097 and MEC-2012-524) and adheres to the tenets of the Declaration of Helsinki (2013) for research involving human subjects. Informed consent was obtained from the participants.

References

- Archambault, D., Stöger, B., Batusic, M., Fahrengruber, C., & Miesenberger, K. (2007). A software model to support collaborative mathematical work between braille and sighted users. *Proceedings of ASSETS 2007 9th International ACM SIGACCESS Conference on Computers and Accessibility* (pp. 115–122). New York, NY, USA: ACM. DOI: 10.1145/1296843.1296864.
- Bernsen, N. (2008). Multimodality Theory. In D. Tzovaras (Ed.), *Multimodal User Interfaces. Signals and Communication Technologies* (pp. 5–29). Berlin, Heidelberg, Germany: Springer.
- Figueiras, L., & Arcavi, A. (2014). A touch of mathematics: coming to our senses by observing the visually impaired. *ZDM – Mathematics Education*, 46(1), 123–133.
- Graham, R. C., Burgoyne, N., Cantrell, P., Smith, L., St Clair, L., & Harris, R. (2009). Measuring the TPACK confidence of in-service science teachers. *TechTrends*, 53(5), 70–79.
- Hughes, B. (2011). Movement kinematics of the braille-reading finger. *Journal of Visual Impairment & Blindness*, 105(6), 370–381.
- Hughes, B., McClelland, A., & Henare, D. (2014). On the nonsmooth, nonconstant velocity of braille reading and reversals. *Scientific Studies of Reading*, 18(2), 94–113.
- Karshmer, A.I., & Bledsoe, C. (2002). Access to Mathematics by Blind Students. In K. Miesenberger, J. Klaus, & W. Zagler (Eds.), *Computers Helping People with Special Needs. ICCHP 2002* (pp. 471–476). Berlin, Heidelberg, Germany: Springer.
- Millar, S. (1994). *Understanding and representing space: Theory and evidence from studies with blind and sighted children*. Oxford, United Kingdom: Clarendon Press/Oxford University Press.
- Millar, S. (1997). Theory, experiment and practical application in research on visual impairment. *European Journal of Psychology of Education*, 12(4), 415–430.
- Mishra, P., & Koehler, M. J. (2006). Technological pedagogical content knowledge: A framework for teacher knowledge. *Teachers College Record*, 108(6), 1017–1054.
- Riccomini, P. J., Smith, G. W., Hughes, E. M., & Fries, K. M. (2015). The language of mathematics: The importance of teaching and learning mathematical vocabulary. *Reading & Writing Quarterly*, 31(3), 235–252.
- Stöger, B., & Miesenberger, K. (2015). Accessing and dealing with mathematics as a blind individual: state of the art and challenges. In G. Kouroupetroglou (Ed.), *Proceedings of the International Conference on Enabling Access for Persons with Visual Impairment. ICEAPVI 2015* (pp.199–203). Athens, Greece: National and Kapodistrian University of Athens.
- Tobin, M. J., & Hill, E. W. (2015). Is literacy for blind people under threat? Does braille have a future? *British Journal of Visual Impairment*, 33(3), 239–250.
- Van Leendert, A., Doorman, M., Drijvers P., Pel J., & van der Steen, J. (2019). An exploratory study of reading mathematical expressions by braille readers. *Journal of Visual Impairment & Blindness*, 113(1), 68–80.

TWG26: Mathematics in the context of STEM education

Introduction to TWG26: Mathematics in the context of STEM education

Behiye Ubuz¹, Koeno Gravemeijer², Michelle Stephan³ and Patrick Capraro⁴

¹Middle East Technical University, Turkey; ubuz@metu.edu.tr

²University of Technology, Netherlands; koeno@gravemeijer.nl

³University of North Carolina Charlotte, USA; Michelle.Stephan@uncc.edu

⁴Technische Universität Kaiserslautern, Germany; capraro@mathematik.uni-kl.de

TWG26 (*Mathematics in the Context of STEM Education*) was introduced in the CERME 11 in recognition of its importance in mathematics education. Science, Technology, Engineering and Mathematics (STEM) education merges a variety of subjects in the fields of science, technology, engineering and mathematics to solve real world problems (Sanders, 2012). Since the discrete subjects of science, technology, engineering, and mathematics were conjoined into the ubiquitous STEM acronym teachers, researchers, policy makers, and funders have worked to integrate the discrete subjects. The process of integration begins with the introduction of new instructional materials and practices, typically through curriculum development, publication of supporting materials, and professional development (Sanders, 2012). The challenge of integrating STEM lies at the nexus of teacher preparation and in-service teacher professional development (deMora & Wood 2014). Teaching STEM in a more connected manner, especially in the context of real-world issues, can make the STEM subjects more relevant to students and teachers (Honey, Pearson, & Schweingruber, 2014). This in turn can enhance motivation for learning and improve student interest, achievement, and persistence (Honey, Pearson, & Schweingruber, 2014).

What level of integration should be strived for, however, is not undisputed. Especially, if and how mathematics fits such an integrated approach is debatable. A specific point of attention concerns the fact that mathematics education asks for careful vertical planning, which might be compromised in an integrated approach. Mathematics encompasses more fields of application than science, technology, and engineering alone. So, real-life applications involving modeling, engineering design and the integration of various disciplines has to be taken into account in mathematics as it prepares students for the future.

This working group particularly aimed at addressing mathematics in the context of STEM education. Mathematics encompasses more fields of application than science, technology, and engineering alone. So, the integration of a broader variety of disciplines has to be taken into account in mathematics to prepare students for the future. Papers and posters submitted to the group focused on tasks, courses, curriculum, students, and in-service teachers mainly using qualitative methodology and interpretative approach. The issues and ideas emerged are discussed in reference to seven central themes. The mathematical contents concerned various topics (e.g., Numbers and Operations, Geometry (i.e., angles, parallel lines), and Data Organisation and Processing, second-order differential equations, matrices, linear equations).

Thematic areas

Here we present the issues and ideas that emerged in reference to the seven central themes.

Mathematical preparedness and value

Within this theme two papers were presented. First paper by Lave and Walshe concerned the preparedness of high-school students for tackling the mathematical aspects of STEM courses in tertiary education. The second paper by Nelleke den Braber and et al centered on the value of mathematics for an inter-disciplinary STEM course.

The first paper within this theme concerned the high non-completion/dropout rates in STEM courses at tertiary level in Ireland. It was noticed that even students with good marks might struggle with the mathematical aspects of third-level science and engineering courses. Lave and Walshe therefore searched for other factors that might affect the preparedness of the students. They investigated the perceptions of three stakeholders, teachers, students and lecturers with questionnaires. They further aimed to clarify what teachers and students themselves currently understand by interdisciplinary STEM education.

Factors that were taken into account are,

- students have to know how to use math knowledge in other subjects;
- mathematics has to be taught in an integrated way;
- high-school teachers should teach with students' future third-level degrees in mind;
- teachers are unaware of the benefits of integration.

In the reaction, it was argued that an alternative explanation might be in how mathematics is taught. In this respect a reference was made to Freudenthal, who argued that mathematics should be taught as to be useful. He argued that, "In an objective sense the most abstract mathematics is without doubt also the most flexible. But not subjectively, since it is wasted on individuals who are not able to avail themselves of this flexibility" (Freudenthal, 1968, p.5). Another remark was that next to benefits of integration of STEM subjects, there are also costs. These concern sustained facilities at school level (time, funding, schedule, room), teacher commitment, professional development and teacher support (Gresnigt, Taconis, van Keulen, Gravemeijer, & Baartman, 2014).

The second paper elaborated on the value of mathematics in an interdisciplinary STEM course. The key concept in this paper was that of disciplinary perspectives. It was argued the problems we face in today's world in the context of STEM call for perspectives and knowledge from many different areas. Against this background the researchers tried to get a handle on the value of mathematics in the context of a successful interdisciplinary STEM course in the Netherlands. With open questions Nelleke den Braber and et al investigated how students and teachers think about the value of mathematics. They introduced a model for the value of mathematics for interdisciplinary STEM courses. This encompassed, an overall sense of what mathematics is, ways of working and thinking, modeling, reasoning and problem solving. This model was used to analyze answers of students and teachers on an open questionnaire. It showed that both teachers and students had little awareness of the value of mathematics as a discipline. If the students mentioned mathematics, it was mainly that it was used. It seemed that the role of mathematics was not really noticed by them.

In the reaction it was noticed that the value of mathematics appeared to be equated with its usefulness. Which appeared not to be the intent. It was further argued that in practice the use of mathematics by workers was limited. As the actual mathematical work would be delegated to experts or machines. Therefore, being able to communicate about the mathematics might be more important. Following Kaput (1997) it was further argued that one should understand the key underlying ideas and mechanisms. Freudenthal was quoted again to make a distinction between mathematical activity as “organizing subject matter in reality and organizing mathematical subject matter”. The latter seemed to be missing in the model of the value of mathematics. It was further noticed that Freudenthal would not be surprised about the lack of awareness of the role of mathematics. In 1977 he predicted that, “In 2000 mathematics will have been gone as a separate subject in education. Mathematics is there to be experienced, and lived, just like reading, writing, tinkering, drawing, singing, breathing, in integrated education.”

Product and STEM

In this theme two papers were presented. The first one by Wohak and Frank revolved around the value of inverse problems in making students aware of the role of mathematics in applications. The second one by Bock, Bracke and Capraro aimed at such awareness but tried to realize this with product-oriented tasks.

The first paper made a case for the development of interactive, problem-oriented material for high school students, in order to make students see the potential of mathematics for solving real life problems. The example in the paper concerned so-called inverse problems. The concrete case being the problem of computer tomography. Computer tomography is used to establish the internal structure of an object—such as a human body—on the basis of the entry and exit intensity of the X-ray radiation. The objects are irradiated with parallel beams at different fixed angle settings, and the challenge is to infer the structure of the object from the patterns of the imprint the X-ray make after passing through the object. This is an inverse problem as it is the inverse of predicting what the imprint would be when the structure of the object is known. Where the latter is rather straightforward, the former is complex and not always possible as small variations may cause big errors. Wohak and Frank show that the mathematics for solving a simplified version of this type of problem is doable for high school students. They argue that by working on this problem, students will come to see the potential of mathematics to solve real-life problems.

One of the points of critique was on the strong focus on the mathematical solution of the problem. It was argued that today mathematics is done by computers and that the remaining mathematical work resides in the translation of the practical problem into a mathematical problem. It was further noted that there was little attention for the capabilities that are needed for mathematical modeling. In this respect the detailed list of capabilities that the PISA Mathematics framework offers (OECD, 2017) was mentioned.

The second paper focused on product-oriented modeling. The starting point being the task of making a product brings with it unique characteristics—which are lacking in school problems. For, the success criteria are dictated by whether the solution is actually working and feasible, often decisions have to be made, and restrictions apply. Two product-oriented modeling tasks were discussed. Both were aiming at showing the usefulness of Fourier analysis. The first concerned the

task of making a musical fountain. Two sub-groups decided not to solve the original task but focused on loudness & rhythm instead. So, there was no need for Fourier analysis. One sub-group did find mathematical techniques to smooth the highly irregular amplitude-time-function. The other sub-group worked on an algorithm that could find an underlying rhythm in a song. The second task involved building a light organ. Here also two sub-groups emerged. One worked with electronic frequency filters, and thus did not need Fourier analysis. The other group wanted to use mathematics and was supported in using Fourier analysis (in a piece-by-piece manner).

One of the questions that was brought up by the discussing was whether the students of the last group really understood the Fourier analysis in terms of the underlying concepts and mechanisms. Further similar remarks could be made about the intended use of Fourier analysis as were made on the reverse-problems paper. In this case, however, part of the students was involved in translating practical problems into mathematical problems. As was the case with the loudness and rhythm-problems. Doubts were expressed about the feasibility of upscaling such projects.

Engineering design and mathematical modelling processes

Three papers were presented in this thematic area. The first paper by Abou-Hayt, Dahl and Rump concerned with the exemplification of the integration of the engineering design process (EDP) and the mathematical modelling process in two university students' projects. Abou-Hayt, Dahl and Rump used the characteristics of engineering design process (Tayal, 2013) and mathematical modelling process (Blomhøj & Jensen, 2003) to analyze the projects. Their conclusion was that the both processes were visible in the projects. This paper led to raising some further questions: What is the sign for showing student learn best when they are actively participate and apply theory?; What is students learning in this context?; How is the interaction between the lecturer and students?; How can we compare traditional and this form of teaching outcome?; and What is the meaning of mathematics in abstract and real world?

The second paper by Costa and Domingos elaborated on the development and the implementation of mathematical interdisciplinary task related to STEM integration, in the context of a collaborative Continuing Professional Development (PD) Program targeted at primary school teachers. Costa and Domingos concluded that a PD program can only be successful if teachers can implement the task developed with their students. The following questions led the discussion regarding to this paper: What is the meaning of STEM integration in the context of a collaborative Continuing Professional Development Program targeted to primary school teachers?; How can teacher educators help teachers to develop mathematical interdisciplinary tasks related to STEM integration? Are they different for prospective teachers' education and in-service teachers?; What are the expectations from the teachers while developing mathematical interdisciplinary tasks related to STEM integration?; What are the expectations from the teachers while implementing mathematical interdisciplinary tasks related to STEM integration?; How could different types of knowledge and skills regarding the integration of STEM be promoted in pre- and in-service teacher education?

In the third paper, Ubuz used the characteristics of EDP outlined by Berland, Steingut, and Ko (2014) to analyze the curriculum learning outcome of a Technology and Design course offered to 7th grade students in Turkey. By identifying the most common verbs and objects contained within the learning outcomes of the curricular documents guiding the 7th grade course, Ubuz found that 23

of the learning outcomes contained EDP knowledge and 29 of them concerned EDP skills. The conclusion is that the EDP knowledge and skills recommended by Berland et al. (2014) are largely present in the 7th grade curriculum. Ubuz suggests that these findings can help teachers integrate similar EDP knowledge and skills in science and mathematics curriculum in middle school.

Design research

A paper by Pugalenti, Stephan, and Pugalee was presented in this thematic area. This paper sought to capture the students' conception of angles and parallel lines in order to design engineering context based instructional sequences for middle grades (7th grade) mathematics classroom. This research was comprised of a pre-interview to assess the existing conceptions of angles and parallel lines, design and implementation of engineering-based instructional sequences and a post-interview to assess the changes in conceptions of angles and parallel lines. This research paper, however, focused mainly on the analysis of the pre-interview questions dealing with angles and parallel lines along with preliminary discussion of the design of the instructional sequence regarding designing a residential community. The students' conceptions of angles and parallel lines were traced under three themes: Prototypes or reference images, tracing of the lines, and decoupling versus decomposing. This paper leads to raising some further questions: What is mathematical instructional task with an engineering problem?; How the difficulties identified could be prevented through mathematical instructional tasks with an engineering problem?; How mathematical instructional tasks with an engineering problem let to dive deeply into a topic and use mathematics to create a solution?; How the difficulties identified do lead us to develop mathematical instructional tasks with an engineering problem such as designing a residential community?; How could the mathematical difficulties identified be prevented through designing a residential community?; What is effective STEM integration?; How could we provide training or prior skills regarding engineering content and principles to the teachers?

Statistics in STEM

Under this theme one paper was presented. The paper written by Oliveira, Henriques, and Batista dealt with the preservice teachers (PT) perspectives about the role of statistics in a learning scenario with one 8th grade class, fostering the integration of physics and statistics. It was claimed that successful STEM integration depends on teachers' perspectives and their competence to choose learning materials which are suitable in this context. Previous studies showed that teachers had a negative perception of STEM education based on the feeling that they were unprepared to teach within an interdisciplinary curriculum.

The data (group lesson plans and PT's reflections regarding planning and enacting learning scenario) were analysed with a focus on the dimensions of the model of *authentic integration* (Treacy & O'Donoghue, 2014): Application to real-world scenarios, high order thinking processes, and knowledge development, synthesis and application. According to the paper the PTs concluded that the mathematical content (in this case statistics) was not only incidental to the STEM context, but had a great centrality in the learning scenario. Mathematics did not only appear in the sense of calculation methods, since high order thinking processes took place that were supported by statistics. Furthermore, the role of technology, in this case with statistical software, was pointed out. The collaboration with colleagues of other subjects was perceived as beneficial for the PTs.

Questions raised during the discussion were: If teachers gain experience with interdisciplinary classroom activities, do they perform better in a future approach, even if the topic is different? Is it a lack of knowledge from other disciplines or rather a lack of experience that makes teachers feel underprepared?

Approaches to introduce STEM

In this theme two papers were presented. Both had in common that they used game-like structures to enhance the students' motivation in their particular learning environment. One paper written by Viamonte and Figueiredo was about gamification in an e-learning tool for university students. In that paper dropout rates as well as the personal opinion of the students who used the e-learning tool were examined. A significantly lower dropout rate compared to earlier years could be measured, which supports the claim that gamification can be used to stimulate motivation. Also, the students' responses concerning the competitive elements seemed to confirm the expected influence, although not all reactions of the students had been positive. The issues raised to be discussed were:

- Although the statistical data concerning dropout rates show a significant impact, it could be possible that there are effects involved that can't be measured easily (e.g. a new teaching concept increases motivation, but the effect decreases over a longer period of time). One could think about examining further iterations, maybe with slight variations.
- Similarly, could the effect be decreasing if gamification was used in a broader extent (i.e. not only one lecture, but all lectures the students attend during the same semester)?
- The data are probably not representative for the whole university population. The participants were engineering students only, and furthermore most of them (93%) were male. Is it possible to transfer the conclusions to a broader range of students?

In the other paper written by Abboud, Hoppenot, and Rollinde a classroom situation was analysed, where students experienced the orbits of astronomical objects from our solar system in a role-playing activity. The aim was to enhance activity theory (Abboud et al. 2018; Vandebrouck 2012) by the notion of bodily perception. Several implementations of the Human Orrery project were analysed qualitatively with questionnaires and interviews. It was suggested that participating students experience STEM-related concepts from an emotional perspective and describe them as "more real". With regard to this paper the issues raised to be discussed were:

- How can we measure the impact of bodily perception on the motivation at a quantitative level?
- How is it possible, after a certain STEM-related concept was experienced in this framework, to have a smooth transition to a more theoretical approach to the topic? This might be interesting when working with older students.

STEM teacher preparation

In this theme, one collaborative team consisting of mathematics and physics educators from Vietnam and Germany aimed to create a teacher preparation program that invited mathematics and physics teachers to participate in classes that utilize both theoretical and practical aspects of teaching these two disciplines. The theoretical part would provide opportunities for physics and mathematics teachers to compare and contrast epistemological foundations of each discipline,

thereby illuminating the differences and similarities in the mathematics and physics. In particular, teachers would explore the meaning and practices of *modelling* from mathematics and physics perspectives. These theoretical foundations would then support teachers to create lessons that potentially integrate physics and mathematics that they would then use in their classrooms. Although the project is still in development, Krause and et al intend to videotape the implementation of these lessons by project teachers and determine to what extent physics teachers focused on mathematics in their class and how much mathematics teachers integrated physics into their class. The critical issues raised by this paper harken back to earlier papers in which questions about the extent to which modelling from different disciplines can be mutually supportive. It also calls to the forefront what it means to genuinely integrate science and mathematics. Finally, the crucial problem that Krause and et al attempt to solve is how to design appropriate instruction for teachers who are knowledgeable about physics and mathematics separately so that they are knowledgeable about the means of integrating the two.

Critical issues

We would like to close our introduction by including some critical issues that the participants expressed during the sessions.

- Experts within and across the STEM disciplines model for different purposes and, thus, in different ways; given this diversity of modeling, how do we characterize modeling in STEM?
- Teachers are not experts in all STEM disciplines. In the real world, there is also no such thing as a STEM expert. Rather, discipline-specific experts are invited into a project when there is a need for their expertise. This implies that teachers should work collaboratively to design and implement STEM units. Does this change the goal of STEM education from *STEM integration* to *STEM collaboration*?
- How do we design curriculum so that mathematics is not just a tool for doing the other three content areas? And what is really meant by technology use in curriculum?
- What kinds of research experiments are needed to understand STEM education? While creating nice STEM lessons has potential, there is a need to go beyond studies that make claims about the success of these lessons that are based upon one student. Rather, future research on effective STEM curricula should involve collective student learning.

References

- Abboud, M., Goodchild, S., Jaworski, B., Potari, D. Robert, A. & Rogalski, J. (2018). Use of activity theory to make sense of mathematics teaching: A dialogue between perspectives. *Annales de didactique et de sciences cognitives*, SI-2018, 61-92.
- Berland, L., Steingut, R., Ko, P. (2014). High school student perceptions of the utility of the engineering design process: Creating opportunities to engage in engineering practices and apply math and science. *Journal of Science Education and Technology*, 705–720.
- Blomhøj, M., & Jensen, T. H. (2003). Developing mathematical modelling competence: Conceptual clarification and educational planning. *Teaching Mathematics and Its Applications*, 22(3), 123–139.

- de Mora, J. C., & Wood, K. (2014). *Practical knowledge in teacher education: Approaches to teacher internship programmes*. London: Routledge.
- Freudenthal, H. (1986). *Didactical phenomenology of mathematical structures* (Vol. 1). Springer Science & Business Media.
- Gresnigt, R., Taconis, R., van Keulen, H., Gravemeijer, K., & Baartman, L. (2014). Promoting science and technology in primary education: A review of integrated curricula. *Studies in Science Education*, 50(1), 47-84.
- Honey, M., Pearson, G., & Schweingruber, A. (2014). *STEM integration in K-12 education: Status, prospects, and an agenda for research*. Washington: National Academies Press.
- Kaput, J. J. (1997). Rethinking calculus: Learning and thinking. *The American Mathematical Monthly*, 104(8), 731-737.
- OECD (2017). *PISA 2015 Assessment and Analytical Framework: Science, Reading, Mathematic, Financial Literacy and Collaborative Problem Solving, revised edition*, PISA, OECD Publishing, Paris. <http://dx.doi.org/10.1787/9789264281820-en>
- Sanders, M. (2012). Integrative STEM education as 'best practice'. *Explorations of Best Practice in Technology, Design and Engineering Education*, 2, 102–117.
- Tayal, S. P. (2013). Engineering design process. *International Journal of Computer Science and Communication Engineering*, 1–5.
- Treacy, P. & O'Donoghue, J. (2014). Authentic integration: A model for integrating mathematics and science in the classroom. *International Journal of Mathematical Education in Science and Technology*, 45(5), 703–718.
- Vandebrouck, F. (Ed.) (2012). *Mathematics classrooms students' activities and teachers' practices*. Rotterdam: Sense Publishers.

Enhancing mathematics and science learning through the use of a Human Orrery

Maha Abboud¹, Philippe Hoppenot² and Emmanuel Rollinde¹

¹University of Cergy Pontoise, LDAR, France; maha.blanchard@u-cergy.fr ;
Emmanuel.rollinde@u-cergy.fr

²University of Evry, LDAR, France; p.hoppenot@iut.univ-evry.fr

We present in this paper an innovative approach to introduce STEM topics in the classroom through the context of the Solar System. Our pedagogical tool consists in a Human Orrery modeling at a human scale the Solar System dynamics. While learners walk along planetary orbits, they enact different mathematical and scientific notions. Previous experimentations were centered on science concepts and have shown an enhanced motivation and well-being and a better understanding. We discuss here the connection with the cognitive science theory of enactivism and with the activity theory, both already used in the field of mathematics education. New pedagogical sequences are proposed that deeply combine mathematics and science contents. Those will be set up in a classroom context before the CERME conference.

Keywords: Astronomy, enactivism, instructional innovation, STEM education.

Introduction

STEM literacy is a crucial issue for European educational policies today as emphasized by successive trans-European studies since the Rocard report (2006). Numerous difficulties have been revealed by science and mathematics education researchers in knowledge acquisition of scientific notions of movements, velocity, proportionality and functions. Many of them arise from the gap between children's sensorial or everyday life experiences and the abstract scientific explanations.

The study presented in this paper explores the use of astronomy to teach mathematics and physics. We consider that astronomy should not be taught and considered in education science as an independent subject but as a specific application of general laws of physics and of application of mathematics concepts. The European ROSE project (Sjoberg & Schreiner, 2010) has shown that the subject that interests both girls and boys was found to be life outside earth. We confirm in our experiments that the study of the Solar System motivates students to do sciences, while a large number of mathematical subjects may be easily introduced through the observation and understanding of planets' motion. The tool that we use to this purpose is a Human Orrery modeling at a human scale the Solar System dynamics in ways that can enhance the learner's perception of mathematics and physics concepts in a real world apparatus.

In the following sections, we will provide a description of this tool and its affordance and the potentials within a STEM approach. We will also present our theoretical frame and the outcomes of first preliminary experiments. This background presentation enables us then to introduce a large scale project in progress and to give some examples of settings that are being currently designed in order to be implemented, observed and evaluated in several European countries.

The Human Orrery

An Orrery is a mechanical instrument showing circular orbits of the planets. The first Orrery to be created at a human scale was done in Japan (Dynic Astropark) and then at the Armagh Observatory (Asher, Bailey, Christou, & Popescu, 2007). The design of a Human Orrery is made such that users may walk along orbits of different bodies around the Sun that is located at the center of the design. The Human Orrery that we use is printed in a large map of 12m by 12m (see Figure 1). It allows one to follow the orbits of the inner planets (Mercury, Venus, Earth and Mars) and Jupiter; the inner planets are located inside the asteroid belt that is materialized with a grey color together with the orbit of the largest asteroid known, Cérès. The highly eccentric orbits of two comets are also used: Encke (the smallest elliptical orbit) and Chury. This choice of objects illustrates different type of movements while keeping the size of the Orrery reasonable. Earth is at one meter from the Sun, while Jupiter's orbit has a diameter of 10,5m. The orbits of all bodies are materialized by dots at constant intervals of times, with accurate elliptical shapes. Note that, orbits are near-circular for the five planets and Ceres.

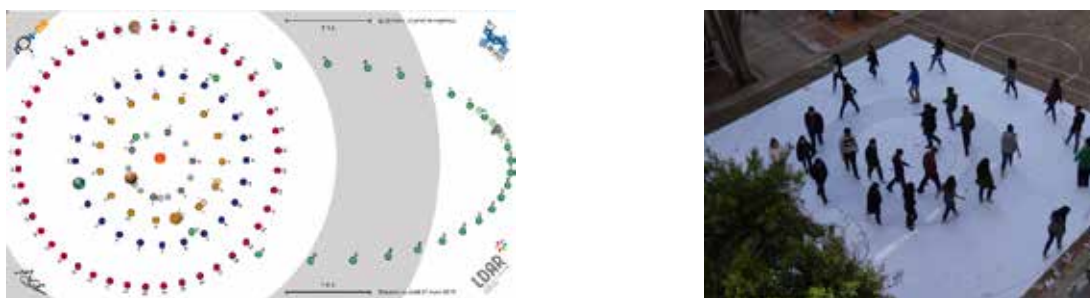


Figure 1 – Left: The map of the Human Orrery (inner planets and one comet only, see text for details). Right: Pupils walking along the different orbits up to Jupiter.

The interval of time may be different for each orbit, but is always a multiple of 16 terrestrial days: For Earth, there are 23 dots separated by 16 days, which would make a period of 368 days. For Jupiter, there are 54 dots separated by 80 days, which makes a period of 4320 days instead of the real period of 4332,59 days. A sound (either a clock or hand claps) is heard regularly. The interval of time between two sounds corresponds to 16 terrestrial days. Every user makes one step during this time interval. Then, the person that enacts Earth walks from one point to the next (distance) in one step (duration), while “Jupiter” has to do five steps (five times 16 days) to reach the next point. All rules are described in details in Rollinde (2017). By acting according to those rules, the movements on the Human Orrery illustrate the correct relative velocities of all Solar System bodies.

Both constructing and enacting on Human Orrery involve topics from mathematics and science and enhance a STEM approach of scientific notions usually perceived as abstract concepts by students. We shall discuss in more details the use of the Human Orrery and its future perspective for STEM education after a discussion of the theoretical framework underlying this innovative pedagogy.

Theoretical framework

The use of a Human Orrery in education is based on the assumption that bodily perceptions help the learning of abstract concepts. In other words, “abstract symbols used in formal education—words and syntax in reading, numbers and operators in math—need to be grounded in bodily experience”

(Glenberg, 2010). In the context of the Solar System, the objects under scrutiny can neither be touched nor seen directly in the classroom, duration is very long, and very little is expected to happen in the classroom situation. By physically enacting the objects and their movements, the situation changes completely: dynamic properties are revealed and experienced; the invisible and impalpable acquire a certain degree of “palpability” allowing learners to deeply understand them as walking along the Human Orrery.

The cognitive science theory of enaction (Varela, Thompson, & Rosch, 1991) may provide a theoretical foundation to those assumptions. Torrance (2005) describes enactivism as the nature of the mind, defined by its relation to the world: “(...) the organism’s world is “enacted”, brought forth by sensorimotor activity: world and organism are co-determined, they co-emerge. [For the mind], awareness of its self and of its world is a central feature of its lived embodiment in the world.” Transposed into Mathematics Education (we refer the reader to the review by Reid, 2014), enactivism theory has been used successfully, for example to explain the emergence of formal mathematical thought from pre-mathematical experiences in the course of a lesson sequence on three-dimensional geometry for 6-year-old children (Roth, 2011). Similarly, in the context of a numerical sequence, Radford (2014) shows that, “through an intense interplay between various sensorial modalities and different signs, the students’ perception and the concomitant mathematical thinking have gained a theoretical dimension that they did not have before”. More generally, learning can be facilitated to the extent that lessons are created that map to and activate sensorimotor systems (see for example Johnson-Glenberg, Megowan-Romanowicz, Birchfield, & Savio-Ramos, 2016 in the context of digital platforms).

This line of argument may sound contrary to early researches in science education that rather tend to show that our observations and interactions with the world often produce naïve conceptions in conflict with formal physical laws (e.g. Hestenes, Wells, & Swackhamer, 1992). Difficulties in knowledge acquisition in science seem to arise from the gap between children’s sensorial experiences and the abstract scientific explanations. We make here the assumption that it is necessary to promote a “mindful attention to perception” (Varela et al., 1991). In the context of the Human Orrery, our goal is to build a complex learning world filled by metaphors: a simple map becomes the empty interplanetary space; series of dots become the elliptical structure of an orbit; peers become planets with different velocities; duration is heard while distance is felt... The Human Orrery (a human-scaled technological object) acquires a meaning through the learner’s cognition and his/her mindful perception of this world and thus activates new cognition.

To theoretically ground our observations, analyses of teaching and learning within the Human Orrery context we plan to make use of Activity Theory as used today in Mathematics education (Abboud et al., 2018; Vandebrouck, 2012). Roth and Jornet (2013) acknowledge that original works on Activity Theory by “Soviet social psychologists explicitly ground their ideas in theories in which thinking, acting and environment are part of the same analytic unit.” Indeed, the Activity Theory, in particular the notion of subject-object interactions mediated by an instrument enables to study the activities of subjects (teachers and learners) using tools (the Orrery itself but also the set of technological tools involved) and their impact on the processes of learning physical and mathematical concepts at stake when experiencing the Human Orrery. Yet, current use of Activity Theory in education does not

mention the role of bodily perception. “Mental processes (speaking, thinking, reading or writing) need to be understood in terms of complex ecologies: neuromuscular and physiological processes AND cultural historical origin and nature” (Roth & Jornet, 2013). Our intention is thus to work towards an “Embodied Activity Theory” which would be a framework adapted to our research and that would develop over time in a dynamic interaction between analyses of data and design and use of theoretical tools.

Outcomes from first experiments

The main use of Human Orrery in the literature has been the introduction of astronomy in open schooling contexts (e.g. Asher et al., 2007; Francis, 2005; LoPresto, 2010). Since 2014, our team focuses on the use of a “human Orrery” to learn science rather than astronomy only in different pedagogical context, from primary school to University. Through our initiative, seven Human Orreries were built in France (one for a science center, one in a public place in Paris, five in primary or secondary schools), one was drawn in a Lebanon school and one map was purchased by a science center in Vietnam. Human Orreries are used thereafter by different teachers (physics, mathematics, technology and sports) in those seven places plus about five other schools who use our trap only. Questionnaires and interviews were used to quantify the amount of learning and the students’ motivation. The sequences are discussed and improved after each application. They have also been used in teacher education for two years, and may be obtained upon request to the authors. More details on these first experiments and derived conclusions as described here may be found in Rollinde (2017).

The implemented sequences have focused on the one side on the motivation and interests of the learners and on the other side on specific scientific notions. Among the key concepts introduced through the Human Orrery are kinematic ones. The embodiment of duration and length allows to alleviate the confusion related to the use of those concepts in the common language. The manipulation of those two concepts to compute the velocity requires to deal with three variables, which is known to be source of cognitive overload. As an example, almost every groups express a confusion between large velocity and small orbital period, or between small period and small perimeter; they all reduce the reasoning to a simple comparison between two variables. The enaction is expected to lighten the abstract mathematical task by providing diverse sensory-motor experiences as proposed in the sequence described in the next section. Additional difficulties encountered regularly include: the Moon that cannot be seen given the scale used (she would be behind the disc of the Earth); the confusion between 24h and one year for one orbital period of Earth (which is strengthened by the 23 dots used for the orbit of Earth); the very low speed of Jupiter is also a source of astonishment. Comments made by undergraduate students actually showed their surprise that so much may be learnt with this tool. For instance, one student declares: “There was joy, emotions. Here, it is wonderful what is going on’. She continues then: ‘Universe is not made of mathematics numbers and equation of physics, this is something else, and it has to be understood in another way.’” Another student suggested that “illustrating a concept with a movement makes it more real. We feel that we live it.”.

Project and examples of settings

The authors of this paper aim at incorporating more STEM contents into future works. We propose in the following an example of such settings, that we are currently designing, tackling the study of

speed's meaning and proportionality factor. More examples could be given particularly concerning the construction of the Human Orrery and associated mathematical notions at play, but this goes beyond the scope of these proceedings.

A detailed enacted sequence on speed

In the science class, speed is understood as the length of a displacement for a given time unit (e.g. year or second). This sequence will provide a way to enact three concepts (time, distance and speed) using bodily perceptions and tools. In the mathematic class, speed is understood as the proportionality factor in the relationship between distance and duration. Ayan and Bostan (2018) have shown that proportionality relationship is often approached by superficial characteristics of the problems, namely the monotonous relation expected between two variables, and lack clear, quantitative, arguments. Modestou and Gagatsis (2010) express the metacognitive aspect that underlines the awareness of (non)-proportionality and may explain this lack of coherence in reasoning about proportionality. There is thus an obvious need for a renewed approach to proportionality and speed.

The sequence we designed uses the Human Orrery, a clock that sounds regularly (each sound is called a clap) with a given tempo, blue ropes and red ropes and markers (to materialize different positions along the ropes). There are four stages: (i) Enaction of space and time while walking freely on the Orrery under spatial and time constraints. (ii) Following a right planetary walk to enact different displacements for different durations. (iii) Enaction of the speed of the planets and the proportionality relationship. (iv) Determination of the speed of the planets (optional). The first two stages can easily be implemented in primary school; the second two are more adapted to lower secondary school.

Enact space and time

The initial proposed goal is to invent a coherent way to walk on the Human Orrery. The action is then to walk, while focusing on two perceptions: looking and hearing. The students' task explained by the teacher may be: "you have to find a way to walk coherently while accounting for dots on the map and claps. At the end, you will have to explain your choices." We expect that different rules may be proposed. For instance, each step should last the duration between two claps or each step should go from one dot to the next one, whether the students focus on what they hear or what they see. According to the rules proposed, we seek for answers to questions such as: Are they going to make a connection with speed too? Are they going to use local rules (their steps only) or global rules (the entire orbits or their relation with each other)? Are they going to describe what they are doing or global observations (who is going faster or when to end)? All those possible and expected actions (or wording here) will be useful to understand what is enacted and how.

According to the effective actions, different proximity-in-action (Abboud et al., 2018) may be foreseen to ensure coherence among the group. The students' activity could either remains on a minima level e.g. by proposing to focus on one set of dots that follow one orbit or at on a maxima level, e.g. by going faster or slower and to propose different ways to use the rhythm or the dots

Enact the planets' movement

The first action will probably end up with different solutions for a coherent walk. In the process, most learners should have noticed that the drawing is related to the Solar System. The teacher confirms

and describes the different orbits. The learners want to know and understand their own role in this planetary walk. The next goal is then to measure their movement while walking as planets.

The associated task requires organisation and mathematical skills: “You will work by groups of 3. Each group chooses either Earth or Jupiter. You start to walk when you hear one sound and continue to walk until you hear “n” additional sounds. You must then find a way to show to the entire class the length of your displacement in order to compare or combine the different measures”. The number “n” is explicitly given but is different for each group. For Earth, some group will work with 3 claps, some with 7 claps. For Jupiter, some will work with 5 and some with 9. Those numbers are chosen so that none is a simple combination of others by the use of addition, in order to favour the use of multiplication later on. To achieve this task, each group has a rope (blue for Earth and red for Jupiter) and markers that can be attached to the rope.

Due to the complexity of the task (follow the rules, do not measure the line but the circular length, keep record of the measured length for comparison), specific proximity-in-action are required to go through it. First, every group has to respect the planetary rules. Then, the length of a circular displacement will be measured with the rope and some markers. For groups that have completed the first task, the teacher may propose to measure the distance while starting from another point in the same orbit or to do the same measurement for another orbit with a different rope. It is important to ask them to walk and measure simultaneously, in order to enact the displacement together with the duration.

Enact the proportionality relationship between length of displacement and duration

To keep the learners focused on the subject of planets, the next goal is directly related to planets while the action will be made on ropes only. By this shift, the reasoning is made slightly more abstract. The required task is not a physical action but a reasoning one in order to answer the question: “how do the speeds of Jupiter and Earth compare?” This may sound like a simple task if it was a simple account of what they have played. Indeed, it is to compare the speed of Jupiter and Earth during the planetary walk. To avoid this shortcut, the teacher asks for a material, or visual, proof using the ropes. This reformulated task becomes complex and fully associate science and mathematics skills and concepts.

A first prediction may be searched for: How should the length of the rope of the faster planet compare to the slower one (a minima)? Such a comparison requires using a common duration, or the same number of sounds. This is our first sub-task. Let’s call N the common number of claps associated to this common duration. N may be equal to 10 (this number may be obtained with the available lengths through the sum of 7+3 for Earth and the product 2 times 5 for Jupiter).

The next sub-task is then to derive the length that would have had the rope of the two planets for this common duration. The teacher proposes then to measure the length of the displacement after one clap only. To realise this task, one has to divide the rope in N parts and then use the ruler... or use the ruler for the full length of the rope and divide by N!

Enact a non-proportionality relationship

Exposing learners to a non-proportional situation is a way to face the well-known bias of proportionality and to encourage students to develop a critical mind. The Human Orrery provides us

with an interesting situation: the case of a comet. Unlike the planets' orbits which are near-circular, the orbit of the comet Encke is a highly eccentric ellipse. During the movement on its orbit, the speed of the comet varies strongly: learners have to make either very large steps near the Sun or cannot even put one foot between two dots far away from the Sun. This usually creates either laugh or stress but never leave the learners insensitive in that case, duration and travelled distance are thus related monotonously, but are not proportionally linked. Using the same methodology as for Earth and Jupiter, learners will discover that the length of the rope measured for different initial position and different duration is not proportional to the duration.

The examples of pedagogical sequence that we presented above are the first of a set of settings that will be designed and implemented in several countries and in different cultural contexts as part of a European project we are currently setting up. We note that activities on the Human Orrery may also be used as an introduction to more formal mathematical activities; for example, on the derivation of Kepler laws using power laws and interpolation or on the understanding of Newton laws using differential equations.

Conclusion and perspectives

The perspective that we adopt in our project is that of STEM being taught through an interdisciplinary approach that incorporates an embodied dimension and draws on real-world modeling. The use of the Human Orrery enables students to enact or “experience” scientific concepts and the dynamics of their properties by evolving in an adapted environment. Until recently, we only focused on the dissemination of Human Orreries and on a proof-of-concepts in terms of motivation and interest. Different sequences have been co-constructed by teachers and researchers and have led to preliminary positive results on learning too. The current dynamic of the project is to motivate more classes from different levels and teachers from subjects other than mathematics and physics such as art, technology, music, languages (native or foreign), physical education and sport. In 2018-2019, four additional classes have decided to join the project in France: two primary schools in the context of interdisciplinary projects and one secondary school through a project on Mars involving science and technology. At the European level, we are expecting to submit a H2020 project involving research in mathematics and science didactics together with science centers (museum, observatories and associations). Our next objective is then to design sequences that fit into the STEAM approach and that will be used as experimental situations for the theoretical framework of enactivism, complemented with the framework of Activity Theory in the context of science education. Our focus will be as much on the didactical learning as on the motivation and awareness of the learners during the activity.

References

- Abboud, M., Goodchild, S., Jaworski, B., Potari, D. Robert, A., & Rogalski, J. (2018). Use of activity theory to make sense of mathematics teaching: a dialogue between perspectives. *Annales de didactique et de sciences cognitives*, SI-2018, 61-92.
- Asher, D.J., Bailey, M.E., Christou, A.A., & Popescu, M.D. (2007). The human orrery: A new educational tool for astronomy. *The Astronomy Education Review*, 5(2), 159-176.

- Ayan, R., & Bostan, M.I. (2018). Middle school students' reasoning in nonlinear proportional problems in geometry. *International Journal of Science and Mathematics Education*, 16(3), 503-518.
- Francis, P. (2005). Using role-playing games to teach astronomy: An evaluation. *Astronomy Education Review*, 4(2), 1-9.
- Glenberg, A.M. (2010). Embodiment as a unifying perspective for psychology. *Wiley Interdisciplinary Reviews: Cognitive Science*, 1(4), 586-596.
- Hestenes, D., Wells, M., & Swackhamer, G. (1992). Force concept inventory. *Physics Teacher*, 30, 141-158.
- Johnson-Glenberg, M. C., Megowan-Romanowicz, C., Birchfield, D. A., & Savio-Ramos, C. (2016). Effects of embodied learning and digital platform on the retention of physics content: centripetal force. *Frontiers in Psychology*, 7, 1819.
- Lopresto, M.C., Murrell, S.R., & Kirchner, B (2010). Assessment of a solar system walk. *The Physics Teacher*, 48, 236-239.
- Modestou, M., & Gagatsis, A. (2010). Cognitive and metacognitive aspects of proportional reasoning. *Mathematical Thinking and Learning*, 12(1), 36-53.
- Reid, D. A. (2014). The coherence of enactivism and mathematics education research: A case study. *Avant*, v (2). doi: 10.12849/50202014.0109.0007.
- Rocard, M., Csermely, P., Jorde, D., Lenzen, D., Walberg-Heriksson, H., & Hemmo, V. (2006). *Science education now: A new pedagogy for the future of Europe*. Report for the European Commission.
- Rollinde, E. (2017). Learning science through enacted astronomy. *International Journal of Science and Mathematics Education*, 17(2), 237-252. doi: 10.1007/s10763-017-9865-8
- Roth, W. M. (2011). *Geometry as objective science in elementary school classrooms: Mathematics in the flesh*. New-York: Routledge.
- Roth, W. M., & Jornet, A. (2013). *Situated cognition*. Wiley Interdisciplinary Reviews: Cognitive Science, 4(5), 463-478.
- Sjøberg, S., & Schreiner, C. (2010). *The ROSE project: An overview and key findings*. Oslo: University of Oslo, 1-31.
- Torrance, S. (2005). In search of the enactive: Introduction to special issue on enactive experience. *Phenomenology and the Cognitive Sciences*, 4(4), 357-368.
- Vandebrouck, F. (Ed.) (2012). *Mathematics classrooms students' activities and teachers' practices*. Rotterdam: Sense Publishers.
- Varela, F., Thompson, E., & Rosch, E. (1991). *The embodied mind: Cognitive science and human experience*. London: MIT Press.

Integrating the methods of mathematical modelling and engineering design in projects

Imad Abou-Hayt,¹ Bettina Dahl,¹ and Camilla Østerberg Rump²

¹ Aalborg University, Denmark; imad@plan.aau.dk, bdahls@plan.aau.dk

² University of Copenhagen, Denmark; cr@ind.ku.dk

In this paper, we show how an integration of the engineering design method and the mathematical modelling method can be applied in engineering. This is exemplified through two student projects in the first-year modules ‘Dynamics and Vibrations’ and ‘Models, Mechanics and Materials’, which are compulsory in the Sustainable Design engineering programme at Aalborg University, Denmark. We first describe and discuss the definitions of the two methods and argue that they have many similarities and that the differences appear to vanish once they are combined in an introductory engineering project. We argue that when students experience how the two methods are applied in a project, they may develop a better holistic understanding of the problems they may encounter as future engineers. They are thus better equipped to solve future real-life problems by having applied mathematics and engineering sciences as integrated activities.

Keywords: Engineering design, mathematical modelling, problem-based learning.

Introduction

One of the major functions of design engineers is to solve problems for the society in which they live. Design engineers work on products and systems that involve adapting and using engineering and mathematical techniques and they usually work with a team of engineers and other designers to develop conceptual and detailed designs that ensure a product works and is suitable for its purpose. In this paper, we will describe and discuss an example of how the engineering design process, mathematical modelling, and problem-solving activity are integrated through introductory first-year projects in the Sustainable Design engineering programme at Aalborg University (AAU) in Copenhagen, Denmark. Underlying the example is an assumption that by combining the engineering design process and the mathematical modelling process in an engineering context, students will be much more prepared to tackle the real-life problems that they might encounter in their future profession as engineers.

As we will show in this paper, the integration of the two methods conforms to the method of Problem-Based Learning (PBL) that AAU has adopted since it was founded in 1974. As argued by Kolmos, Holgaard, and Dahl (2013), there is not one single AAU PBL model, but nevertheless, the programmes at AAU are all organized around shared PBL principles described by Barge (2010) and Askehave et al. (2015). These principles are problem orientation, project organization, integration of theory and practice, participant direction, a team-based approach, and collaboration and

feedback. The students therefore work in teams on open problems and the work includes all the steps from problem identification and problem analysis to problem solving. PBL is thus a student-centred learning method that uses real problems as a stimulus or starting point for the acquisition and integration of new knowledge. The teacher acts as an initiator and facilitator in the collaborative process of knowledge transfer and development. Parallel to the projects, the students also undertake modules which typically follow a more traditional style with lectures and exercises. The major characteristics of PBL projects include adaption to students' *prior* knowledge and experience, *integration* of knowledge, and teaching in relevant *contexts*.

The purpose of this paper is to show how to integrate the teaching of mathematics and engineering mechanics within the framework of PBL in order to enhance the students' understanding of both subjects as well as to introduce them to real-life situations, where the real problems they meet are mostly combinations of engineering, technology, and mathematics. When working on such problems in the real world, engineers, designers and applied mathematicians work together as a team to create new products. We aim to "transfer" these situations to the classrooms so that the students can develop an early acquaintance with the "real thing". This requires carefully designed teaching scenarios that help make both mathematics and engineering interesting to learn.

The main research questions of this paper are therefore: Can we design didactical situations that integrate mathematics and engineering mechanics through design projects that resemble practical problems? Is it possible to teach mathematics in connection with engineering courses so that the students can capture the essence of both subjects through design projects? To answer these questions, we investigate mathematics teaching through design projects, using mathematical modelling as a didactic tool. The problem that we address here is the lack of interest in mathematics courses among engineering students (Härterich et al., 2012). This issue may eventually lead to poor understanding and performance on engineering science courses that depend on the mathematical concepts taught in traditional mathematics modules. The significance of the paper is therefore that it suggests a method that might solve this problem by offering teaching experiments that integrate some real-life problems with some central concepts in engineering mathematics. The aim of the student projects is to make mathematics more interesting for engineering students and to improve their understanding of engineering and mathematics courses.

The processes of mathematical modelling and engineering design

Mathematical modelling as a design process

Mathematical modelling is used in a variety of disciplines. A mathematical modelling competence is considered central in both engineering and mathematics education. When doing mathematical modelling, a part of reality is encoded into a set of mathematical rules and equations. There are in fact many "models" or descriptions of the mathematical modelling process. Due to page restrictions, we show only one example of such a model (Blomhøj & Jensen, 2003). The one chosen was developed for use in education and is thus relevant. Every mathematical modelling process must begin with a problem or an observation, which is a process that fits well with a PBL project which also starts with open problems that require a solution. The problem can be either a well-defined physical question requiring a mathematical solution or a loosely described technical

problem requiring a solution but with no obvious choice of mathematical model. However, since a mathematical model is an abstraction and mathematics itself is an abstract discipline, the starting point of the modelling process is to decide which aspects of the “real world” to observe and which to ignore.

The mathematical modelling process is as creative as the engineering design process, as engineers need to model devices and processes if they want to design these devices and processes. Just like the design of a certain product, a model of a specific physical situation may be good or bad, simplistic or sophisticated, aesthetic or ugly, useful or useless, but a model or design cannot be considered true or false. A mathematical model is therefore designed to correspond to a prototype, which may be a physical, biological, social, or psychological entity or yet another conceptual one. According to Tayal (2013), the engineering design process is a sequence of steps that a designer takes to go from identifying a problem or need to developing a solution that solves the problem or satisfies the need. If we just replace the words “design” and “designer” with “modelling” and “modeller”, we arrive at a definition of mathematical modelling that is close to the one described above by Blomhøj and Jensen (2003). The engineering modelling process is therefore the set of steps that a modeller takes to go from first identifying a problem or need to ultimately creating and developing a solution that solves the problem or meets the need. Thus, the two processes have *identical* objectives and, in fact, can be broken down into a series of *similar* steps, as seen in Table 1. The table constitutes the theoretical framework of this article. Both processes are different from the scientific method although they also have some things in common. As argued by Dowling, Carew, and Hadgraft (2013), the two processes begin with an open task, but while the engineering process begins with a problem or a need, the scientific method begins with a question. Furthermore, engineers look for suitable solutions while scientists look for suitable hypotheses to answer the question, that is, ultimately some generalized knowledge. Thus, engineers create new products using a more pragmatic modelling approach in which the models are convenient approximations to specific parts of reality.

Table 1: A comparison of the modelling and design processes

The mathematical modelling process	The engineering design process
1a) Begins with a problem	1b) Begins with a problem
2a) Select relevant objects, relations, and data and idealize these	2b) Do background research to define suitable criteria and constraints for problem solution
3a) Translate the objects into a mathematical representation	3b) Specify requirements for solutions
4a) Use mathematical methods to arrive at results	4b) Evaluate the solutions against the criteria. Are there alternative solutions?
5a) Interpret the results in relation to the initial question	5b) Choose a suitable solution and build a prototype
6a) Evaluate the model	6b) Make recommendations; test and redesign as necessary
7a) Communicate the results	7b) Communicate the results

The table shows that the mathematical modelling process and the engineering design process are quite analogous. Below, we design two teaching situations that can provide some justification for Table 1 as these situations integrate mathematics and engineering mechanics in realistic design projects.

Mathematics in an engineering context: An example

The study of differential equations has always been a major part of the mathematics curriculum in engineering education. This is expected as many engineering problems involve equations that relate the changes in some key variables to each other. Therefore, differential equations are used to investigate a wide variety of problems in sciences and engineering.

Below we present a classical problem from engineering dynamics that illustrates the use of Table 1 in differential equations, specifically second-order differential equations. The mechanical system is shown in Figure 1. Besides being a standard textbook problem, it is also seen in real-life problems such as modelling the suspension system of a car or the vibration of a wind turbine blade. Such real-life problems fit a PBL education model well as they can be quite open and can thus be approached by a problem-based strategy. At the same time, they also fit the framework shown in Table 1, as items 1a and 1b in Table 1 indicates that the starting point is a problem. The problems require analysis and simulation before a solution is reached. The analysis and simulation can be identified as items 2–5 for both processes in Table 1:

- Create the idealization and formulate constraints (items 2a and 2b)
- Encode the system into mathematical language, specify the requirements (items 3a and 3b)
- Solve the resulting equation(s) and check the results (items 4a and 4b)
- Interpret the results and build a prototype (items 5a and 5b)

To apply Table 1, we begin by assuming constant parameters for the spring and the damper (items 2a and 2b). Using Newton's second law, the mechanical system can be described by the second-order linear differential equation with constant coefficients (items 3a and 3b):

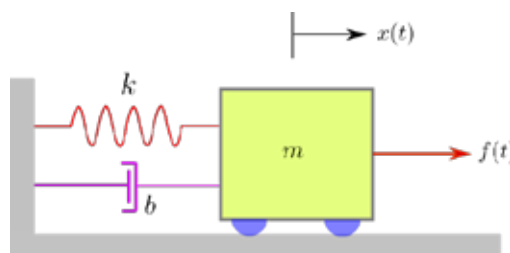


Figure 1: A mechanical system

$$m\ddot{x} + b\dot{x} + kx = f(t) \quad (1)$$

Here $x(t)$ is the position of the mass m , b is the damping constant, k is the spring constant, and $f(t)$ is the force applied on the mass. The students have already completed a mathematics module involving *linear* second-order differential equations. The purpose is to illustrate the different solutions of Equation (1) by changing the values of the constants b and k . By plotting the response

$x(t)$ for some chosen values of b and k (items 4a and 4b), students can see the different behaviours of the system and gain a better understanding of the underlying mathematics of the mechanical system, thus accomplish items 5a and 5b. To choose appropriate values of b and k requires that tests and a redesign be carried out, thus accomplishing items 6a and 6b. It is therefore pedagogically sound to base the teaching of *linear* second-order differential equations on systems whose behaviour students *already* intuitively understand. This illustrates that PBL, through working with open problems, can help the students achieve a better understanding of mathematics by using mathematical modelling as a didactic principle in teaching engineering mechanics and mathematics itself through the process illustrated in Table 1. Finally, the students accomplish items 7a and 7b through communicating the results to their peers and teachers as part of the module.

The students' ability to solve linear differential equations by using standard methods or formulas is therefore insufficient to understand fully the link between the mathematics learned and the other modules and projects. Students may eventually ask how we know that the parameters of the spring and the damper are constants. There are typically two different answers, we can give the students:

- Real springs and dampers have approximately linear behaviour.
- By assuming constant parameter values for the spring and damper, we can use the standard methods to solve linear differential equations, as we have a complete theory of linear differential equations, and not, e.g., a complete theory of *nonlinear* differential equations.

These answers can, however, be disputed by the fact “almost all systems are nonlinear to some extent” (Hilborn, 2000). Besides, many of the student projects in which the first author was involved as a supervisor involve nonlinear phenomena. However, as the students were only introduced to linear second-order differential equations in their mathematics module and are still in their first year of study, we will at this point assume linear behaviour of the systems involved.

Mathematical modelling in action

Model of a Lego van and a caravan: Example 1

In a project in the second-semester module “Dynamics and Vibrations” for the Sustainable Design engineering programme, the students should construct a mathematical model of the popular van and caravan playset by the Danish company Lego. In the context of Table 1, the problem of the project is to determine the response of the caravan if the van moves on a straight road with a constant acceleration a . This corresponds to items 1a and 1b in Table 1. Ideally, the caravan should follow the *kinematics* of the van as closely as possible. The project can illustrate the use of PBL as a framework in teaching an engineering mechanics module, where mathematics and mechanics are integrated in a realistic project through the process of mathematical modelling. The PBL project thus conforms to Table 1, as it starts with a problem that requires mathematical tools to arrive at acceptable results. A simplified model of the system is shown in Figure 2. Many students immediately see the similarity of this concrete system with the ideal one in Figure 1: The constant acceleration of the van gives rise to a constant force on the caravan. Some also realize that the *flexible linkage* between the van and the caravan can be *modelled* as a spring and a damper.

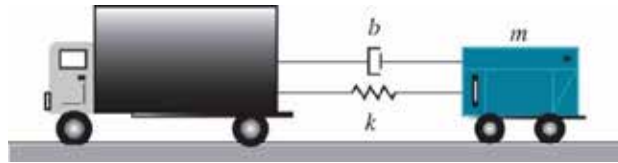


Figure 2: A model of the Lego project

If we let $x_1(t)$ and $x_2(t)$ denote the positions of the van and the caravan respectively, Newton's second law (Hibbeler, 2017) leads to the differential equation of the model:

$$m\ddot{x}_2 + b(\dot{x}_2 - \dot{x}_1) + k(x_2 - x_1) = 0 \quad (2)$$

As the van's acceleration is constant, we have $\dot{x}_1 = at$ and $x_1 = \frac{1}{2}at^2$, where the initial conditions are assumed to be zero. Equation (2) can finally be written as

$$m\ddot{x}_2 + b\dot{x}_2 + kx_2 = abt + \frac{1}{2}akt^2 \quad (3)$$

Comparing Equations (3) and (1), the students see that $bat + \frac{1}{2}kat^2$ corresponds to the force $f(t)$. We are led to a second-order non-homogeneous differential equation where the unknown function is $x_2(t)$. This is exactly the type of differential equation, which the students have met in their mathematics module; they now meet it in an *engineering context*. Thus, Table 1's items 2a, 2b, 3a, and 3b are now satisfied. The students now see an old friend in action! Thus, we anticipate that this will offer some justifications to the students in answer to their eternal question "Why do we need to study differential equations?" in the context of their experience.

Student simulation of the model

The students were given the values $m = 0.50$ kg and $a = 1$ m/s² for which they ran a simulation of the model for two different combinations of the spring constant k and the damping constant b :

- $k = 10$ N/m and $b = 0$ (no damping)
- $k = 10$ N/m and $b = 0.50$ N · s/m (with damping)

The students used MATLAB to plot the position $x_2(t)$ of the caravan in the two cases (Figure 3).

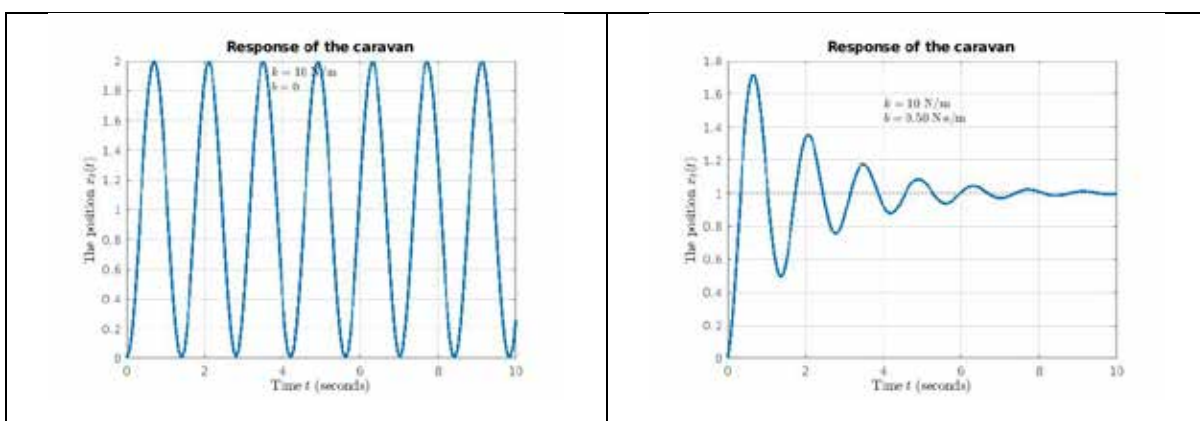


Figure 3: Response of the caravan. Left: no damping; Right: with damping

The case without damping obviously leads to an unacceptable model of the system. In contrast, the presence of damping ensures a smooth response of the caravan. Many students now realize why a damper should be included as a part of modelling the linkage, even though it is not out there! Thus, by changing the value of b (and of k for that matter) we get two different *designs* and *that* will result in two different mathematical *models*. By referring to items 4 to 6 for both processes in Table 1, we see that these are accomplished, as we are testing the models and comparing designs. The design process and the mathematical modelling process are therefore closely related to the extent that, in real-life engineering practice, separating the two processes would not be easy. It is therefore artificial to separate modules in mathematical modelling and engineering design in teaching situations, as engineering programmes ought to correspond to and be compatible with realistic situations that the future engineers might encounter.

The connection between mathematical modelling and engineering design: Example 2

To further illustrate the relation between the mathematical design process and the engineering design process, we mention here an example taken from a project by the first author introduced in the first-semester module “Models, Mechanics and Materials”. Briefly, the problem is to find the internal forces in the three cables of the hanging lamp (see Figure 4) and to redesign it if possible. The students themselves should provide realistic values for the weight and dimensions of the hanging lamp. They should also measure the lengths and diameters of the wires. The students should first make a model of the hanging lamp and then try to redesign it. This is an open problem with several solutions.



Figure 4: A hanging lamp

The modelling process consists of writing the equilibrium equations of the lamp using statics. The students discovered that they could not find the internal forces in the three wires: They got two equations with three unknowns. By arriving at an indeterminate system of equations, the students then had a justification for why the middle wire was *redundant*. Some other students added the extra equation using deformation theory in the topic of strength of materials. In that way, they could determine the internal forces in the three wires by writing them down in matrix form. Changing the geometry and materials of the wires (i.e., design) leads to another system of equations (i.e., a new model). Other students chose to remove the middle wire, thus arriving at a consistent system of equations with a unique solution. Thus, the design the students choose will affect the mathematical model of the lamp. Conversely, the mathematical model of the lamp will influence its design and redesign. Here, we can see that the items of each pair in Table 1 interact together in a fusion process to produce a solution to the problem. The main purpose of this course project is to relate topics from mathematics, specifically matrices and linear equations, to engineering mechanics and materials in

the framework of Table 1. We believe that through these kinds of course projects, mathematics teaching will be more motivating for the students, so they can see the relevance of the mathematical topics they encounter in their study programme.

Discussion and conclusion

In the paper, we have used Table 1, which incorporates the engineering design and mathematical modelling processes as a theoretical framework for two student projects. The items in the table can be identified in the processes the students go through in two design projects. Here we also saw that the items in both the mathematical modelling process and the engineering design process became visible. We believe that this identification strengthens the argument that *engineering* mathematics should be taught in *an engineering* context, through well-designed teaching situations that allow engineering students to work with real-life problems. As stated in the introduction, design engineers work on projects that involve adapting and using engineering and mathematical techniques, and *in reality*, these are intertwined. We also believe that this strategy can be generalized to other situations where STEM integration is involved.

References

- Askehave, I., Prehn, H. L., Pedersen, J., & Pedersen, M. T. (Eds.). (2015). *PBL: Problem-based learning*. Aalborg: Aalborg University Press.
- Barge, S. (2010). *Principles of problem and project-based learning: The Aalborg PBL model*. Aalborg: Aalborg University Press.
- Blomhøj, M., & Jensen, T. H. (2003). Developing mathematical modelling competence: Conceptual clarification and educational planning. *Teaching Mathematics and Its Applications*, 22(3), 123–139.
- Dowling, D. Carew, A., & Hadgraft, R. (2013). *Engineering your future: An Australian guide*, second edition. Milton, QLD: John Wiley and Sons Australia.
- Härterich, J., Kiss, C., Rooch, A., Mönnigmann, M., Darup, M. S., & Span, R. (2012). “Mathepraxis”: Connecting first-year mathematics with engineering applications. *European Journal of Engineering Education*, 37(3), 255–266.
- Hibbeler, R. C. (2017). *Engineering mechanics dynamics*. Harlow: Pearson.
- Hilborn, R. C. (2000). *Chaos and nonlinear dynamics: An introduction for scientists*. Oxford: Oxford University Press.
- Kolmos, A., Holgaard, J. E., & Dahl, B. (2013). Reconstructing the Aalborg model for PBL: A case from the Faculty of Engineering and Science. In K. Mohd-Yusof, M. Arsat, M. T. Borhan, E. de Graaff, A. Kolmos, & F. A. Phang (Eds.), *PBL Across Cultures* (pp. 289–296). Aalborg: Aalborg University Press.
- Tayal, S. P. (2013). Engineering design process. *International Journal of Computer Science and Communication Engineering*. IJCSCE Special issue on “Recent Advances in Engineering & Technology” NCRAET, 1–5.

Mathematics and art in primary education textbooks

Teresa F. Blanco¹, Valeria González-Roel¹ and Jose Manuel Diego-Mantecón²

¹University of Santiago de Compostela (USC), Spain; teref.blanco@usc.es

valeria.gonzalez.roel@rai.usc.es

²University of Cantabria, Spain; diegojm@unican.es

Keywords: Mathematics, primary education, school textbooks, STEAM, visual arts.

Introduction

This research aims to analyze how the relationship between art and mathematics is established in the Spanish primary education. We analyze the art-mathematics connections in school textbooks, as this is the educational tool most widely used by teachers. In recent years, the educative community has become increasingly aware of the impact of modern art on society and the emergence of new forms of artistic expression. In fact, official documents promote interdisciplinary learning through a STEM approach that incorporates the creative and aesthetic dimension of Art into the so-called STEAM education. According to Holland (2017) students who follow a learning process based on STEAM develop creative skills, becoming better problem solvers and critical thinkers. The Spanish curriculum (MEC, 2014) specially connects Mathematics and Visual Arts. The Mathematics curriculum emphasis a competency-based learning grounded on the applicability of mathematics into daily life contexts, and aiming to connect this subject with the science, technology and art disciplines. Similarly, the Visual Arts subject offers a valuable opportunity to interact with other school subjects in particular, with mathematics (Brezovnik, 2015), through the analysis of different art forms including drawing, painting, sculpture, and photography (Freedman, 2003).

Method

The present study was undertaken under a documentary analysis approach (Bardin, 1991), adopting a simplified version of Diego-Mantecón et al.'s (2018) framework which lays down six dimensions that we turned out into four: (1) the use of 'artistic representations' and 'mathematical objects' with an *ornamental purpose*; (2) the use of art and mathematics as *a context to carry out activities*; (3) the use of art as a way of *learning mathematical concepts* and the use of mathematics to *illustrate artistic concepts*; and (4) the *creation* of art through mathematics. The data were collected from a purposive sample of 72 Mathematics and 24 Visual Art school textbooks, being the one most often used in the Spanish primary education. The textbooks analyzed cover all six years of compulsory primary education (6 to 12 years old). Textbooks were released between 2009 and 2015. The analysis focused on identifying 'artistic representations' (e.g. sculpture, drawings, and mosaics) and 'mathematical objects' (e.g. identification of types of lines and proportion relations) in the Mathematics and Visual Art textbooks and analyzing how the art-mathematics connection is established in the textbooks.

Results and conclusions

As Figure 1 shows, the analysis revealed that in both the Mathematics and Visual Arts textbooks the ornamental dimension (1) prevails (81,18% in Mathematics and 40,74% in Visual Arts Education textbooks) over the remaining dimensions. In Mathematics textbooks Art works fundamentally as a purely illustrative and decorative element, without any reference to the name of the artistic work nor to its author. In Visual Arts textbooks, Mathematics plays a more active role, expanding part of the artistic content with geometric concepts and measurement procedures which contextualize the exercise (39,81% %, contextual dimension (2)). In Mathematics textbooks, this dimension has one much lower percentage (16,85%). By other side, in Mathematics and Visual Arts only 5,94% and 13,89% respectively of the artistic manifestations and mathematical objects are included in the conceptual dimension (3). Creative dimension (4) is non-existent in Mathematics textbooks, and it has a very limited presence in the Visual Arts books (15,74%).

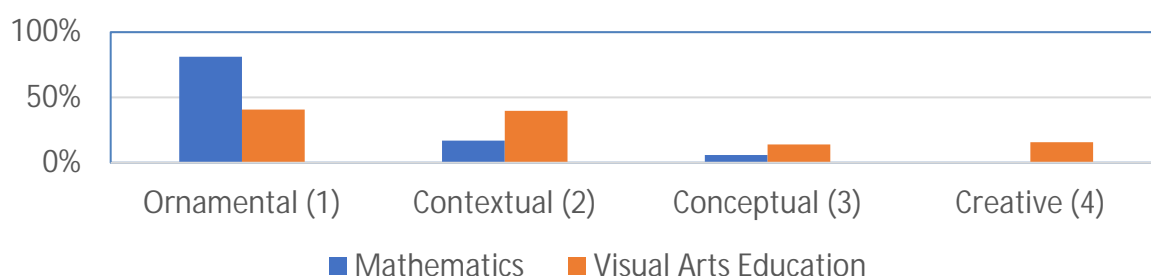


Figure 1: Percentage of dimensions in textbooks

From this, preliminary results, we can conclude that the textbooks analysed do not reflect the art-mathematics connection, at the level suggested in the Spanish curriculum.

Acknowledgment

This work is funded by FEDER/Ministerio de Ciencia, Innovación y Universidades- Agencia Estatal de Investigación/Proyecto EDU2017-84979-R.

References

- Bardín, L., (1991). *Análisis de contenido*. Madrid, España: Ediciones Akal.
- Brezovnik, A., (2015). The benefits of fine art integration into mathematics in primary school. *Center for Educational Policy Studies Journal*, 5(3), 11-32. Retrieved from: <https://eric.ed.gov/?id=EJ1128967>
- Decreto 105/2014, del 4 de septiembre por el cual se establece el currículum de la E.P. en Galicia. Diario oficial de Galicia. Retrieved from: <https://www.xunta.gal/diario-oficial-galicia/>.
- Diego-Mantecón, J. M., Blanco, T.F. Búa, J. B. y Sequeiros, P. G (2019). Is the relationship between art and mathematics addressed thoroughly in Spanish secondary school textbooks? *Journal of Mathematics and the Arts*, 13(1-2), 25-47.
- Freedman, K. (Addison and Burgess). (2003). *Issues in art and design teaching*. London, Great Britain: Routledge.
- Holland, L. (2017). *How to teach children woodworking through STEAM fields*. Cambridge Public Schools: Cambridge, England.

Mathematical modeling of musical fountains and light organs – where is the M in interdisciplinary STEM projects?

Wolfgang Bock, Martin Bracke and Patrick Capraro

Technische Universität Kaiserslautern, Department of Mathematics, Germany;

bock@mathematik.uni-kl.de, bracke@mathematik.uni-kl.de, capraro@mathematik.uni-kl.de

We discuss a modeling project, in which students have to build a device that acts simultaneously to music – either a musical fountain or a light organ. We show how the incorporated university level mathematics can be reduced to the level of secondary education. Being product oriented, the modeling activity has a strong interdisciplinary character. We focus on two implementations of the project with high school students and discuss their results. Here we draw the attention to the role of mathematics in a STEM project, where the presence of programming and engineering seems more obvious than the mathematical content.

Keywords: Interdisciplinarity, modeling, product orientation.

Introduction

Some of the most important real-life applications of mathematical modeling we find in engineering and related activities, where products are developed and improved. At the university of Kaiserslautern industrial mathematics plays an important role in research and teaching. It also had an influence in mathematical modeling activities with high school students (see Bock & Bracke, 2015). In these cases, the process of mathematical modeling is closely connected to the product that should be developed.

In Kotler et.al. (2006), p. 230, the term *product* is defined from an economical point of view as “anything that can be offered to a market that might satisfy a want or need”. Hence a product can take various forms, it can be a device that is actually being assembled, it can be a computer software or just the answer to a question. Here the production process closely affects the modeling activity. Even a sophisticated mathematical model has its flaws, if it can’t be applied in the desired situation or if it doesn’t solve the given problem adequately. Furthermore, the more production steps are needed to advance from the mathematical model to the product, the more impact the production process has on the mathematical model (compare to Bock, Bracke & Capraro, 2017).

Product oriented mathematical modeling immediately calls for high interdisciplinarity and involves all aspects of STEM, especially if the product is not only a theoretical concept, but the implementation of the solution actually takes place (Bock, Bracke, Capraro & Lantau, 2017).

In our technology driven world, complex computations can easily be done by computers and other electronic devices. Often there is no need for the programmer (or engineer) to know all the details of the involved mathematical tools. Here the question arises, if product oriented mathematical modeling and engineering in general can be done with a minimum of mathematical activity (see also Tosmour-Bayazit & Ubuz, 2013).

Here we present a modeling project, in which students have to build a musical fountain or a light organ. Both projects contain similar mathematics at a university level (Fourier analysis), which can be hidden in numeric tools and used by students with a basic mathematical knowledge at a secondary school level. The project has a strong interdisciplinary character, since programming is essential for data processing, and building a working model of the product or at least creating a simulation is requested.

We have a look at two implementations of the project. We find that even if the computer is used in a large extent, there still are enough mathematical challenges for students.

The modeling task and mathematical background

The students are given the task of modeling the regulation of a musical fountain or a light organ (both lead to similar mathematical problems). The students get a short introduction in a programming language to be able to read audio files and get access to the raw data. Furthermore we teach basic ideas of Fourier analysis to enable the students to compute frequency spectra and analyze them.

```
from scipy.io import wavfile
from scipy.fftpack import fft
import matplotlib.pyplot as plt
import math
import numpy as np
[Fr,g]=wavfile.read('test.wav')      #Fr=frame rate, g=sample data
if(len(g.shape)==2):                #if stereo, combine the channels
    channel1=np.array(g[:,0])
    channel2=np.array(g[:,1])
    g=channel1+channel2
G=fft(g)                             #Fourier transform
p=plt.plot(abs(G))                   #plot sqrt(A_n^2+B_n^2)
plt.show()
```

Listing 1: A code example in python. The program reads a wav-file and plots the frequency spectrum.

Fundamental is the Fourier series, that states that a T -periodic function g (with certain conditions to integrability or Lipschitz-continuity) can be decomposed to a series of trigonometric functions

$$g(t) = A_0 + \sum_{n=1}^{\infty} A_n \cos(2\pi nft) + B_n \sin(2\pi nft), \quad f = \frac{1}{T}, \quad (1)$$

where the coefficients A_n , B_n give the amplitude of the corresponding frequency nf . By the orthogonality of trigonometric functions, we can derive formulae for the coefficients

$$A_n = \frac{2}{T} \int_{-\frac{T}{2}}^{\frac{T}{2}} g(t) \cos(n2\pi ft) dt, \quad B_n = \frac{2}{T} \int_{-\frac{T}{2}}^{\frac{T}{2}} g(t) \sin(n2\pi ft) dt. \quad (2)$$

From this the Fourier transform (3.1) arises, which gives the frequency spectrum G of the function g . If we process the data g on a computer, it isn't given as a function but rather as a vector with finitely many entries. In this case we have the discrete Fourier transform (3.2), where the integral becomes a sum

$$G(f) = \int_{-\infty}^{\infty} g(t) \exp(2\pi itf) dt, \quad (3.1) \quad G_m = \sum_{t=1}^n g_t \exp\left(\frac{2\pi i}{n}(t-1)(m-1)\right). \quad (3.2)$$

Two more results about discrete Fourier transform are substantial when the spectra are going to be interpreted. For a data vector g with n real valued entries, we have $G_m = G_{n+1-m}^*$, i.e. the second half of the spectrum is just a (complex conjugate) copy of the first. Furthermore, we have the sampling

theorem, which states that for a data sample g with frame rate Fr , the spectrum can be computed for frequencies up to $Fr/2$. For a data set of n samples, the value $G_{n/2}$ corresponds to the frequency $Fr/2$.

Breaking down Fourier analysis to high school level

Fourier analysis involves mathematical concepts that are located at the final years of high school education or even at university level, like integrals, complex numbers and convergence of functions. Nevertheless, if we see Fourier analysis as a numerical tool, the barriers to implement it in school are quite low. Fourier transform can be introduced as a black box. Certainly, for all well known programming languages there already exists an implementation of the code and that's all we need to know. On the other hand, if there is enough time to do so, the discrete Fourier transform (equation 3.2) can easily be understood and applied as soon as the students know the concept of trigonometric functions.

Understanding overtones and the Fourier series

The Fourier series is strongly connected to instruments and the concept of overtones: If we play a tone on an instrument, we do not only produce the fundamental frequency f of the tone itself, but also overtones with frequencies $2f$, $3f$, $4f$, etc. From a mathematical point of view this is obvious, since acoustic waves are represented by periodic functions. The period of the acoustic wave is the same as the period of the fundamental frequency. Hence the overtones do not disturb the pitch of the observed tone.

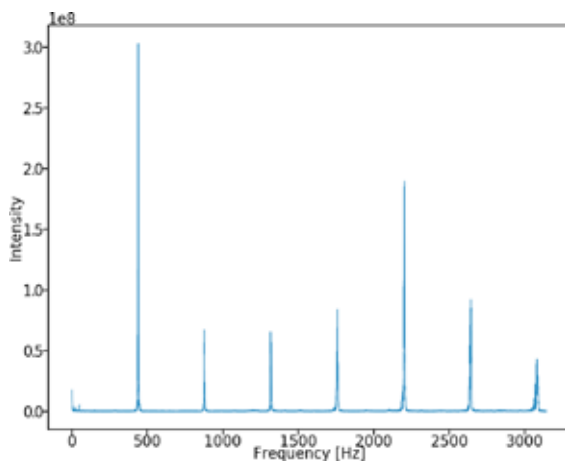


Figure 1: The frequency spectrum of a violin. The fundamental frequency is 440 Hz. The peaks around 0 Hz are possibly due to edge effects or noise.

The characteristic sound of an instrument is strongly determined by the relative intensities of these overtones. This real-life phenomenon can be used as a motivation to understand and use the ideas of Fourier series.

If the students do not know the concept of overtones, we could create and analyze frequency spectra (e.g. by playing tones on instruments, recording them and using computer software to obtain the spectra, compare to Fig. 1). The pattern in the graphs that are created could motivate a further investigation of the mathematical concepts behind. This could also be the starting point for an interdisciplinary project between mathematics, music and physics classes.

How to deal with complex numbers?

Fourier transform involves complex numbers and the complex exponential function. As we know, the exponential function with imaginary exponent decomposes in real and imaginary parts with trigonometric functions and real valued arguments. Hence, we have the interpretation, that the vector entries in G take 2-dimensional real values

$$G_m = \left(\sum_{t=1}^n g_t \cos\left(\frac{2\pi}{n}(t-1)(m-1)\right), \sum_{t=1}^n g_t \sin\left(\frac{2\pi}{n}(t-1)(m-1)\right) \right). \quad (4)$$

The intensity of the frequency represented by G_m is then given by the length of the vector.

Deriving formulae for the Fourier coefficients

Equation (2) is a consequence of the orthogonality relations of trigonometric functions

$$\int_{-\pi}^{\pi} \cos(nt) \cos(kt) dt = \int_{-\pi}^{\pi} \sin(nt) \sin(kt) dt = \begin{cases} \pi, & n = k, \\ 0, & n \neq k, \end{cases} \quad \int_{-\pi}^{\pi} \cos(nt) \sin(kt) dt = 0.$$

Older students who know the concept of integrals can prove these identities. The basic idea is to use integration by parts two times, until right hand side and left-hand side show the same integral (with a prefactor and an additive constant).

With equation (2) the definition of the Fourier transform can easily be understood. Hence in this case there is no need to see the Fourier transform as a black box tool or a formula given by the teacher without any theoretical background.

Sampling theorem

If the students are using a discrete Fourier transform to obtain frequency spectra, they surely will encounter two questions: Why is there an axial symmetry in the spectrum? And how can we read the frequencies on our axes? To answer these questions, we can give the students the above mentioned results about the Fourier transformed data vector G . A quantitative discussion why these results are true is omitted due to the complexity of the involved mathematics.

Two examples for interdisciplinary modeling projects

In Kaiserslautern, mathematical modeling activities involving acoustic phenomena have been implemented in various situations with high school students and university students. Here we present two cases.

Modeling of a musical fountain with a time frame of 15 hours

This implementation was done in August 2018 with 6 high school students who participated at a *Fraunhofer math talent school for girls*. The participating students (upper secondary level) came from different schools in Germany and worked on 4 different projects at the *Fraunhofer institute for industrial mathematics* in Kaiserslautern. The students had the opportunity to vote for their preferred projects. In the musical fountain project 5 of 6 students told us that they had a strong connection to music (all 5 played an instrument) and therefore chose this project. Also, the sixth student voted for the project as her first choice. Some of the students had programming experience, some of them didn't. The group was supervised by two university members.

There were 4 working phases (3 hours each) at the first two days. At the third day, there were 3 hours for preparation and execution of the presentations. Due to the restricted time frame, the students were given selected mathematical input at the beginning of the course.

First working phase: Introduction to Fourier analysis (frontal instruction); reading audio files and plotting spectra with python (frontal instruction and exercise); after a strongly teacher driven

opening, the students had the chance to create audio files and analyze them with python or other computer software, like audacity. They did this in groups of 2 students.

Second working phase: The students were asked to develop mathematical criteria that could be used for the regulation of the fountain, but had no further instructions. They chose to stay in the previously formed groups and analyze different aspects of the graphs they could create (group work). After first ideas were established, an additional programming course in python was given (frontal instruction and exercise).

Third working phase: The ideas of the second working phase were implemented in python code. Some ideas were dropped, others could be improved. One group found mathematical techniques to smooth the highly irregular amplitude-time-function, another one worked on an algorithm that could find an underlying rhythm in a song.

Fourth working phase: It was discussed, if the students wished to build a real-life model of a small fountain with 4 solenoid valves. The students preferred to do a computer visualization of their mathematical results instead. The students used the remaining time to further develop their python code and to decide how their result should be used to regulate the fountain. They also started to work on the visualization.

Presentation day: The students had 2 hours to prepare their presentations and finish the work on the visualization of the fountain regulation. Each of the 4 project groups had 15 min. for their presentation.

In the simulation, the analyzed song and the visualization of the processed data were replayed simultaneously. It became apparent that the data and the perceived sound matched adequately.

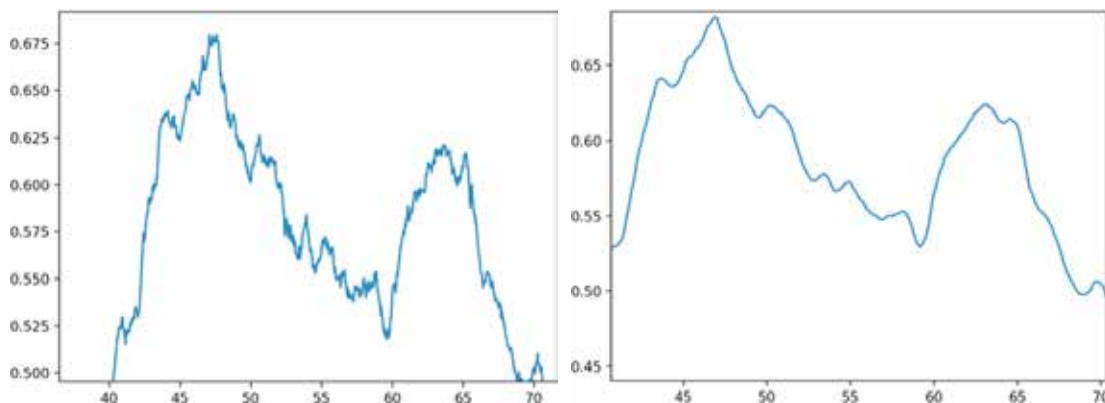


Figure 2: Loudness of a song vs. time. The students wanted to use *increasing and decreasing loudness* to control the fountain. Since the irregularity of the sample data caused problems, they found methods to smooth the data (left: first iteration of the smoothing process, right: second iteration).

Modeling of a light organ with a time frame of 5 days

The light organ was one of 8 projects at a mathematical modeling week in February 2018. At a modeling week the students (upper secondary level) spend 5 days at a youth hostel and work on their own responsibility for 4 days (from 9 am to 18:30 pm with several breaks for lunch and coffee as well as an excursion on one afternoon). On the 5th day the presentations are given.

The students can choose their preferred project. There were 4 students working on the light organ. They chose the project with different motivations, concentrating on different aspects of STEM. They were supervised by one university member and by 2 teachers. For the teachers, the participation was part of a teacher training.

With a rather generous time frame, the projects at the modeling week are open to a great extent. The students were asked to build a light organ that would work without a microphone. Instead they should get the data directly from the electronic device, where the song is played, or use digital information. They were provided with electronic components such as a Raspberry Pi, Arduino microcontrollers, LEDs, cables, resistors, etc.

One of the students immediately took the initiative and started to work on his idea of building electric circuits that would work as frequency filters. He started with some first experiments involving the Arduino microcontroller and the question how to record the audio signal. The other students helped him but didn't participate in the creative process.

During the last hours of the first day the group experienced a crisis: 2 of the students were unsatisfied with the progress that was mainly based on ideas from physics and electrical engineering. Both wanted to focus on mathematical and computational aspects of the project. They discussed their ideas with the supervisor. Together a solution was worked out that would be based on the audio information that is stored in music files. From this point on the students worked on two different solutions.

At the second day, the students with the mathematical and computational focus asked for some mathematical background about frequencies. They were given the same information as in the musical fountain project. Only this time not as frontal instructions, but rather in a *piece by piece* manner. The students were given some mathematical input and had the chance to do some experiments or online research. When they asked deeper questions, they received further details.

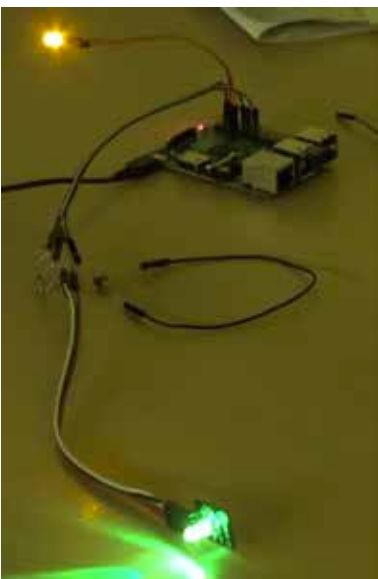


Figure 3: The light organ. The yellow LED is controlled by the loudness, the RGB LED by the frequency-spectrum.

Later they were able to implement a Fourier transform in python and run the program on a Raspberry Pi. At this point the students worked on 2 tasks simultaneously, one improving the python program, the other controlling an RGB LED on the Raspberry Pi. Questions to the supervisor were mainly about the involved programming languages and the operating system of the Raspberry Pi. At the end, they could split a piece of music in time intervals, compare the intensity of different frequency intervals and assign color and brightness of the LED to the frequency values.

From a mathematical point of view, the students had to deal with problems related to esthetical questions: How should the frequencies be assigned to different colors, such that the light effects won't be too monotonous? If the brightness of the lights is going to be related to the loudness of the music, which level of loudness should be defined as 100%? Are these thoughts independent of the music

genre? Is it sufficient to analyze the song locally (i.e. each time frame individually) or do we need global data?

To questions like these there is no right answer, but rather a wide range of possible approaches. Here mathematical experience helps us to give a structure to our problems and quantize the vague questions asked above. Mathematical skills help us to evaluate the information that is hidden in the given data

The other group with the focus on electrical engineering worked almost without supervision. Their main problem was the lack of capacitors with a suitable capacity. This could be solved when one of the supervising teachers asked at a nearby school if she could borrow some material.

In this group mathematical activities took place on a rather basic level, e.g. when the students had to choose the threshold of their frequency filters and compute the resistance and capacity of the electric components that were needed.

Misconceptions of the students about algorithms and computers

When confronted with a subject that most people know very well from their everyday life (like music in our case), the students come up rather quickly with interesting ideas. Some of them are based on the misconception that computers can do complicated tasks on their own, while the programmer doesn't need to fully understand the situation.

In the musical fountain project, there were ideas about recognizing different instruments in the music or finding certain patterns in the rhythm automatically. Those tasks are difficult to implement in an algorithm. The students were surprised how complicated their mathematical model had to be to find a quite simple rhythm in their song (and they didn't even elaborate further steps to make the algorithm work for arbitrary music). In the light organ project, similar situations took place.

The project clearly helped the students to get a better idea of what algorithms are capable of and where the limitations could be. One of the main consequences in the project was that if we want an automated solution to a problem we have to provide a detailed mathematical description.

Conclusion

Using acoustic phenomena in terms of mathematical modeling is a rich field for interdisciplinary activities. It naturally includes physics and music. The link between both topics we find in Fourier analysis, where concepts of music theory, like overtones, become obvious in the mathematical description of waves.

Computer science (or rather programming) is not only helpful, but essential to manage huge amounts of data and extensive computations. Technical aspects can be included by posing a product oriented problem. Hence all aspects of STEM can be addressed.

If all calculations are done by computers, one might fear that the mathematical aspects of such a project will only appear in theory lessons, but won't be applied by the students. In our examples, we have seen that there still is a strong potential to include mathematical aspects that go beyond the computational part. The raw data could be in a bad state for data processing (compare to Figure 2), where elaborate mathematical ideas are needed to overcome the problems. On the other hand, like

in the case of the light organ, assumptions have to be made and decisions have to be taken, where an intuitive evaluation of the given data is necessary.

Of course, with a modeling task that is openly posed, there always is the possibility that students find another way of solving the problem. One part of the light organ group used a completely technology based approach, where no mathematics beyond basic arithmetic was needed. On the other hand, from our experience it is essential to let the students choose their approach with the least amount of regulation. Otherwise, if the teacher tries to force certain solutions and mathematical tools, this could have a devastating impact on the students' motivation.

This can lead to serious difficulties for the teacher, since he or she must be able to adapt the ideas of the students quite fast and try to figure out possible outcomes or obstacles for an approach that wasn't considered beforehand. If this new approach requires expert knowledge from another discipline, either the teacher has to have that knowledge (or acquire it fast enough). If this isn't the case, the teacher must be confident that the students can work on their solution relying on their own expertise (why would they have chosen this approach if they don't have any knowledge about the topic?). Additionally, not knowing all the details of a solution for a given problem is an unfamiliar situation for most teachers. It requires a certain amount of self-confidence to let the students proceed anyway.

Acknowledgements

The close collaboration with the Fraunhofer Institute for Industrial Mathematics as well as the financial support of the European Social Fund for the modeling weeks are thankfully acknowledged.

References

- Armstrong, G., Kotler, P., Harker, M. and Brennan, R. (2009). *Marketing: An introduction*. Harlow, England: Pearson Education.
- Bock, W. and Bracke, M. (2015). *Applied school mathematics – made in Kaiserslautern*. In: Neunzert, H., Prätzel-Wolters D. (Eds.), *Currents in Industrial Mathematics: From Concepts to Research to Education*. Berlin, Heidelberg: Springer.
- Bock, W., Bracke, M. and Capraro, P. (2017). Product orientation in modeling tasks. In Dooley, T. and Gueudet, G. (Eds.), *Proceedings of the Tenth Congress of the European Society for Research in Mathematics Education* (pp. 1028–1031). Dublin: ERME.
- Bock, W., Bracke, M., Capraro, P. and Lantau, J.-M. (2017). How does a product-based and action-orientated modelling project promote interdisciplinary teaching and learning? To appear in: *Proceedings ICTMA-18*.
- Tosmour-Bayazit, N. and Ubuz, B. (2013). Practicing engineer's perspective on mathematics and mathematics education in college. *Journal of STEM Education*, 14(3), 34–40.

STEM analysis of a module on Artificial Intelligence for high school students designed within the I SEE Erasmus+ Project

Laura Branchetti¹, Olivia Levrini², Eleonora Barelli², Michael Lodi², Giovanni Ravaioli²,

Laura Rigotti², Sara Satanassi² and Giulia Tasquier²

¹University of Parma, Italy; laura.branchetti@unipr.it

²University of Bologna, Italy

Keywords: Artificial intelligence, big ideas, STEM education.

The I SEE ERASMUS+ Project

The EU ERASMUS+ project I SEE (inclusive STEM Education to enhance the capacity to aspire and imagine future careers) stems from the awareness that one of the main challenges for mankind today, above all for the young, is to recover a good relationship with time, merely with the future. We live in a multi-speed society in which the capacity to predict sudden changes are decreasing and this causes a compulsive search for opportunities. The educational system is not able to keep up with social acceleration. This project bet on STEM education as a breeding ground for preparing young people for uncertainty and making them developing future scaffolding skills, i.e. skills that enhance their capacity to aspire, envisage themselves as agents of change, and push their imagination towards future careers in STEM (Branchetti, Cutler, Laherto, Levrini, Palmgren, Tasquier & Wilson, 2018). STEM education can give two main contributions in this direction, one epistemological and the other technical. From the epistemological point of view, the issue of uncertainty related to future predictions is intrinsic to science: the perspective of complexity values uncertainty and probability as sources of a non-deterministic and non-linear paradigm which opens horizons of possibilities, instead of a unique inescapable path and ground the discourses about possibilities on a rational basis. On the technical side, STEM disciplines investigate potentialities, limits and applications of innovations in the present, hypothesizing their possible impact on the future; this enlarges students' and teachers' imagination towards future challenges and careers.

The structure of I SEE modules and the case of Artificial Intelligence

Among the results of the first two years of research within the project, there are concrete teaching/learning modules for high-school, already tested in real contexts with 18-19 years old students. Although the issues addressed are very different (e.g. climate change, artificial intelligence, quantum computing), all the modules have a common structure in which the students are encouraged to: i) encounter the focal issue; ii) engage with the interaction between scientific ideas and future; iii) synthesise the ideas and put them into practice (Branchetti et al., 2018). The design and implementation of the Italian module about Artificial Intelligence (AI) were carried out by a team of researchers in Mathematics, Physics and Informatics education, together with high school teachers and experts in engineering, applied physics, epistemology of science and complex systems. The students encounter the focal issue thanks to a group activity, about AI applications in many fields, and two seminars, about: i. the relationship between AI and complexity science; ii. the history of AI. In the second phase, they are showed different approaches to AI (imperative,

logical/declarative, machine learning) applied to the Tic-Tac-Toe game; then, they are introduced to applications of AI in STEM research and to the future-relevant concepts of complexity (system, feedback, projection, scenario, non-linearity, agent/model-based simulations). In the last phase, students are involved in group activities about the imagination of a future ideal city, more or less influenced by AI, and are asked to design actions to do in the present with an eye to desirable futures, thinking about future careers, also in the STEM fields.

STEM analysis of the I SEE module on AI: Integration and “Big Ideas”

Since the project aims to propose guidelines and examples of inclusive and future-oriented STEM education, we wondered what aspects of our research could be relevant for contributing to the emerging debate about how STEM education should be conceived and concretely realised. As framework we chose the STEM “big ideas”, defined as key ideas that link various discipline understandings into coherent wholes, mediating the construction of in-depth knowledge (Chalmers, Carter, Cooper & Nason, 2017). We analysed our module separating its S-T-E-M components, discussing their integration and searching for different kinds of big ideas underlying it (encompassing, cross-disciplines, and within-disciplines big ideas).

The STEM disciplines are all included and structurally integrated within the module, since the topic allows to show the dialectic relationship between the technology/engineering and pure scientific/mathematical issues. Mathematics is relevant, not only in terms of concept and methods technically necessary, but also of thinking tools and skills. As content encompassing big ideas, we recognised AI and Future. As conceptual encompassing big ideas, we identified paradigms like linearity/complexity or practices like problem posing and solving. The cross-discipline big ideas we used are the concepts like algorithm, which are transversal to the STEM domains. There also within-disciplines big ideas that have an application in the other disciplines, like cost function, which is a mathematical optimization concept relevant to other STEM disciplines.

Results and conclusions

The main results of our analysis are three: a) the lens of the “big ideas” is effective to flesh out the connections among the S-T-E-M disciplines within our module on AI; b) the analytic separation of the contributions of the different disciplines and the search for their integration allows to emphasise the specificity of each of them; c) our module can be considered an example of a meaningful integration between disciplines, with STEM “big ideas” connecting them.

References

- Branchetti, L., Cutler, M., Laherto, A., Levrini, O., Palmgren, E.K., Tasquier, G., Wilson, C., (2018). The I SEE project: An approach to futurize STEM education. In L. Colucci-Gray, E. Camino and M. Dodman (eds). *Visions for Sustainability. Special Issue: Science education futures*, 9, 10-26.
- Chalmers, C., Carter, M., Cooper, T., Nason, R. (2017). Implementing “big ideas” to advance the teaching and learning of science, technology, engineering, and mathematics (STEM). *International Journal of Science and Mathematics Education*, 15(1), 25–43.

Promoting mathematics teaching in the framework of STEM integration

Maria Cristina Costa^{1,3} and António Domingos^{2,3}

¹Instituto Politécnico de Tomar, Portugal; ccosta@ipt.pt

²Faculdade de Ciências e Tecnologia, Universidade Nova de Lisboa, Portugal; amdd@fct.unl.pt

³UIED* - Research Education and Development Unit, Universidade NOVA de Lisboa, Lisbon, Portugal.

*This work is supported by national funds through FCT - Foundation for Science and Technology, I. P., in the context of the project PTDC/CED-EDG/32422/2017

A growing number of studies and reports all over the world refer to the importance of integrating Science, Technology, Engineering and Mathematics (STEM), in order to meet the increasing challenges of the 21st Century. In particular, STEM education can be an innovative way of learning and teaching mathematics. But, despite recommendations to relate these subjects, there is lack of research about STEM integration and there is the need of more empirical research about this subject. This paper presents an empirical study about the development and implementation of mathematical interdisciplinary tasks related to STEM integration in the context of primary school teachers Continuing Professional Development. With a qualitative methodology and an interpretative approach based on a case study, findings of our research show that it is possible to promote the teaching of mathematics in the framework of STEM integration by supporting teachers in the development and implementation of interdisciplinary tasks.

Keywords: Hands-on, mathematics education, primary school, professional development, STEM education.

Introduction

A growing number of studies and reports, all over the world, refer to the importance of integrating Science, Technology, Engineering and Mathematics (STEM) in order to meet the increasing challenges of the 21st Century (Baker & Galanti, 2017; Rocard et al., 2007). In addition, integrative approaches among STEM subjects have positive effects on student attainment, with better results in elementary school (Becker & Park, 2011). In particular, “Integration of mathematics with Science, Technology and Engineering (STE) provides students with the context in which they can make meaningful connections between mathematics and STE subjects” (Becker & Park, 2011, p.25).

This paper aims to contribute to research by presenting an empirical study about the development and implementation of mathematical interdisciplinary tasks related to STEM integration, in the context of a collaborative Continuing Professional Development Program (CPDP) targeted to primary school teachers. In this regard, our research question is: how to promote the teaching of mathematics in the framework of STEM integration? In our STEM integration framework, we refer to tasks related to all the STEM subjects, i.e., tasks that integrate Science, Technology, Engineering and Mathematics. In these tasks, we intend to emphasize Mathematics. Based on the case study of a

primary teacher, who participated in the CPDP, we analyse the STEM tasks designed and implemented by the teacher.

Literature Review

Despite the increasing calls for the promotion of STEM education, there is no agreement about a definition. In this regard, Baker and Galanti (2017) refer that the academic community “struggle to define STEM integration” (p. 2). For example, several authors refer to STEM by only integrating two disciplines (Ríordáin, Johnston, & Walshe, 2016; Treacy & O’Donoghue, 2014). Concerning this matter, Stohlmann (2018) refers different interpretations of several authors and claims that mathematics should be more emphasized in STEM integration. In this sense, STEM education can be a form of innovation for teaching mathematics (Fitzallen, 2015) and to increase mathematical performance (Stohlmann, 2018).

However, despite relating STEM subjects has been widely advocated by several authors, there is lack of research about STEM integration and there is a need for more empirical research about this subject (Becker & Park, 2011). Also, there is the need to develop research to understand how STEM integration can promote mathematics education (Baker & Galanti, 2017). In particular, there is lack of research about science and mathematics integration (Treacy & O’Donoghue, 2014), mainly concerning in-service teachers (Ríordáin et al., 2016).

Kim and Bolger (2017) sustain the creation of a curriculum that integrates STEM, being crucial to involve teachers into interdisciplinary lessons adequate to this approach. In this regard, there is the need to promote their Professional Development (PD) by providing mentoring and support to face the multiple challenges related to sustainable STEM pedagogy (Baker & Galanti, 2017). Also, resources are crucial for teachers and they shape them according to their individual preferences, this being a process of interpretation and design of the resources (Pepin, Gueudet & Trouche, 2013). For Gimeno Sacristán (2000), tasks are teaching and learning activities, carried out in school environments, being inserted into the curriculum in action. The way how tasks are introduced and conducted by the teacher in the classroom is essential for teaching effectiveness (Ponte, 2005).

To improve teaching and learning, it is crucial to develop a partnership between researchers and designers, in order to develop appropriate pedagogical approaches to integrate tasks in the classroom (Geiger, Goos, Dole, Forgasz, & Bennison, 2014). Also, it is fundamental to create a network that motivates teachers and contributes to the sustainability of their professional development (Hewson, 2007; Rocard et al., 2007). A PD program will only be successful if teachers can apply in their classrooms what they learned and experienced during training (Buczynski & Hansen, 2010). In fact, a PD only achieve real effects if innovation is appropriated by the teachers and transformed into their own practice (Zehetmeier, Andreitz, Erlacher, & Rauch, 2015).

Methodology

Based on the literature review recommendations, a partnership amongst university teacher’s educators, local schools and a *Continuing Training Centre* was established, in 2015, in order to develop a CPDP that is adequate to local primary school teachers’ needs (Costa & Domingos, 2017, 2018). With a total duration of 26 hours, the program lasts an entire school year (September to June)

and includes STEM related workshops with a 2-3 hours duration. By the end of each school year teachers present a portfolio with a critical account on the CPDP and their proposals and implementation of innovative practices. In this context, teachers may choose a science theme to develop in the classroom with their students by integrating with the other STEM topics. So far, more than 70 teachers participated in the CPDP from 2015/2016 to 2017/2018 school year.

In this research, we use a qualitative methodology and an interpretative approach by resorting to a case study. According to Yin (2005), a case study is an empirical investigation that looks at a contemporary phenomenon within its real-life context, allowing a generalization of the obtained results. Data collected include participant observation (first author of the paper is a participant observer) and portfolios compiled by the teachers (Cohen, Lawrence, & Keith, 2007). Participant observation takes place in the workshops with the teachers (to learn and practice what they are expected to implement) and at their classrooms (to support and observe them in action). When necessary, some semi-structured interviews are conducted to better interpret the case. In a first stage documental analysis was performed in teachers' portfolios in order to look for evidence of STEM contents. It was verified that most teachers chose astronomy or sound to implement in the classroom, and electricity is always at the bottom of their choices. This is the main reason why we decided to present the case study of Josefina (fictitious name) who chose electricity experiments to develop mathematical interdisciplinary tasks.

Teacher Josefina (42 years old, 18 years of service, in charge of a 3rd and 4th grade class) participated in the CPDP during the school year 2016/2017 and decided to conduct electricity experiments in her classroom with the educators help. The teacher's educators visited her class for two afternoons to observe and/or to help her implement some hands-on tasks. At the end of the CPDP, teacher Josefina (like all the other teachers) presented a portfolio with a critical account about the CPDP and documentary evidence of the activities that she performed with her students.

Data analysis, results and discussion

In this section, we begin by analyzing the case study of teacher Josefina that shows the development and implementation of mathematical tasks within the context of STEM integration, in particular related to electricity.

Josefina's case study

Based on classroom observations, semi-structured interviews and the teacher's portfolio, we realized that, in the first session, Josefina introduced the electrical current topic by calling students' attention to sustainable development using videos and information from the Internet. After, she asked the students to bring to class batteries that they had at home and that did not work.

In a second class, using the batteries, she asked the students to organise them according to their sizes and models (Figure 1). Next, they counted the different types of batteries and with this data, students produced graphics and diagrams, amongst other mathematical tasks.

In another class, with the educators' help, the teacher introduced concepts like potential difference (p.d.) and asked the students to verify if the batteries still had "energy" using multimeters. The students were organised in groups, and each group used a multimeter to measure the p.d. of each

- Student: It will be about half of the orange.
- Josefina: Cut the orange in two pieces and measure the p.d. of each piece!
- Student: No! It's not right! It gave almost the same as the orange!
- Josefina: Cut those two pieces in another two pieces and measure again! What do you think it will happen?
- Student: Maybe it will happen the same! Yes! The size of the fruit doesn't count!
- Josefina: Do you need three oranges to light the lamp?
- Student: No! Let's see ... I think three pieces are enough. Let's see what happens...It worked!

After an explanation and discussion about the experiments, the teacher continued the inquiry. Each group had different pieces of fruit or vegetables at their table.

- Josefina: Each group is going to choose different pieces of fruit or vegetable and measure its potential difference and give me the result!

While students told the results, the teachers registered them on the black board. After having all the results registered, she continued the inquiry:

- Josefina: Which is the fruit with the bigger potential difference?
- Student: The tomato!
- Josefina: Which biological battery has the least potential difference?
- Student: The mushroom!

The teacher continued asking questions while introducing the concepts. For another section, she created a worksheet to perform more mathematical tasks such as organisation and processing of data from the measurements obtained in the last class. She also created problems to be solved by students. The above dialogue shows that she was able to perform mathematical tasks from the hands-on experiments, in particular mathematical tasks in the framework of STEM integration.

Indeed, Josefina developed hands-on tasks based on concepts and procedures from mathematics and science while incorporating the design methodology of engineering and using appropriate technology (Shaughnessy, 2013). In particular, mathematics was worked in all the tasks, namely "Numbers and Operations" when students organized and counted the old batteries; "Geometry" when they organized the batteries according to their patterns and sizes and draw the different types of batteries; and "Data Organisation and Processing" when building tables to register and work the collected data from the batteries (Figure 1). Also, Josefina was able to introduce biological batteries and to teach the students to perform several measurements such as the p.d. in volts (V) and to develop the hands-on tasks using inquiry to lead the students to reflect on the performed experiments and discuss in order to obtain conclusions.

Concerning the way teacher Josefina introduced and implemented the tasks, we consider these are exploratory, investigative tasks. In this regard, students performed the tasks guided by the teacher who asked questions to lead them to search for answers. One example is related to the question "How much potential difference does the lamp need to light up?" and "Do you need three oranges to

light the lamp?” To answer the questions students developed several activities in order to understand and gain knowledge about this theme.

Table 1 shows the contents of the STEM tasks developed and implemented by teacher Josefina.

Table 1. Contents of the tasks implemented by teacher Josefina

Science	Technology	Engineering	Mathematics
Electricity.	Computer Internet Video Multimeters, Lamps, interrupters, etc.	Planning, designing and performing electrical circuits.	Measuring the p.d. of the batteries in volts. “Numbers and Operations” when students organized and counted batteries. “Geometry” when they organized the batteries according to their patterns and sizes and draw the different types of batteries. Data Organisation and Processing” when building tables to register and work the collected data from the batteries.

Next, we present some excerpts of the teacher’s reflections that she wrote in her final report.

I was able to apply some new practices and methodologies in the context of the classroom, incorporating mathematics and science experiments (Josefina final report, June 2017).

The overall results of this training workshop are clearly positive: (...) enabled me to acquire / apply new knowledge in the context of the classroom (...); as well as collaboration including the sharing of good practices and the difficulties experienced (Josefina final report, June 2017).

In summary, teacher Josefina recognised that she gained skills to innovate her practices by highlighting the collaborative context of the CPDP. In addition, she developed exploratory, investigative tasks to work mathematics topics related to STEM.

Final considerations

This paper aims to contribute to existing literature by presenting an empirical study about the development and implementation of mathematical tasks in the framework of STEM integration. To face challenges related to STEM integration it is recommended to develop an adequate teachers’ PD context (Baker & Galanti, 2017; Treacy & O’Donoghue, 2014), being crucial to provide a collaborative environment that supports the teachers to innovate their practices (Capps & Crawford, 2013; Costa & Domingos, 2017). According to Buczynski and Hansen (2010), a PD program will only be successful if teachers can implement, in practice, with their students, what they learned and experienced during their training. Also, Zehetmeier et al. (2015) sustain that innovations should be appropriated by those who implement them and transformed into their practice to have real effects. We believe this is what happened to teacher Josefina who designed and implemented interdisciplinary tasks that are not part of teachers’ traditional practices. In fact, Josefina was able to introduce commercial and biological batteries and to teach the students to perform several measurements such as the p.d. in volts (V). She also developed several hands-on tasks using inquiry to lead the students to reflect on the performed experiments and obtain conclusions.

Based on Josefina’s case study, it was verified that she implemented several mathematical tasks in the framework of STEM integration (Table 1). Indeed, Josefina developed hands-on tasks based on concepts and procedures from mathematics and science while incorporating the design methodology of engineering and using appropriate technology (Shaughnessy, 2013).

Josefina's example shows how to develop exploratory and investigative mathematical tasks from hands-on STEM experiments. Mathematical tasks proposed by the teacher and performed by the students included problems and exercises related to several topics of the Portuguese curriculum such as "Numbers and Operations", "Geometry", and "Data Organisation and Processing", including tables, graphics and diagrams.

We observed that teacher Josefina promoted mathematics teaching in the framework of STEM integration by developing and implementing several interdisciplinary tasks in the classroom related to these subjects. Teacher Josefina's example shows that it is possible to work mathematics while performing several hands-on STEM tasks in class. We conclude that to promote mathematics' teaching in the framework of STEM integration it is necessary to provide teachers with a collaborative professional development context that supports them in the development and implementation of interdisciplinary tasks.

References

- Baker C K, Galanti T M. (2017). Integrating STEM in elementary classrooms using model-eliciting activities: responsive professional development for mathematics coaches and teachers. *International Journal of STEM Education*. 4(1), 1-15.
- Becker, K., & Park, K. (2011). Effects of integrative approaches among science, technology, engineering, and mathematics (STEM) subjects on students' learning: A preliminary meta-analysis. *Journal of STEM Education*, 12(5 & 6), 23-37.
- Buczynski, S., & Hansen, C. B. (2010). Impact of professional development on teacher practice: Uncovering connections. *Teaching and Teacher Education*, 26(3), 599-607.
- Bybee, R. W. (2010). Advancing STEM education: A 2020 vision. *Technology and Engineering Teacher*, 70(1), 30.
- Capps, D. K., & Crawford, B. A. (2013). Inquiry-based professional development: What does it take to support teachers in learning about inquiry and nature of science? *International Journal of Science Education*, 35(12), 1947-1978.
- Cohen, L., Lawrence, M., & Keith, M. (2007). *Research methods in education*. 6th Edition. Taylor and Francis Group.
- Costa, M. C., & Domingos, A. (2017). Innovating teachers' practices: potentiate the teaching of mathematics through experimental activities. Dooley, T., & Gueudet, G. (Eds.) (2017). *Proceedings of the Tenth Congress of the European Society for Research in Mathematics Education (CERME 10, February 1-5, 2017, pp. 2828-2835)*. Dublin, Ireland: DCU Institute of Education and ERME.
- Costa, M. C., & Domingos, A. (2018). Promoting STEAMH at primary school: a collaborative interdisciplinary project. *New Trends and Issues Proceedings on Humanities and Social Sciences*. 4(8), 234-245.
- Fitzallen, N. (2015). STEM Education: What does mathematics have to offer? In M. Marshman (Eds.). *Proceedings of the 38th Annual Conference of the Mathematics Education Research Group of Australasia, Sunshine Coast*, pp. 237-244.

- Geiger, V., Goos, M., Dole, S., Forgasz, H., & Bennison, A. (2014). Devising principles of design for numeracy tasks. In J. Anderson, M. Cavanagh, & A. Prescott (Eds.), *Curriculum in focus: Research-guided practice: Proceedings of the 37th annual conference of the Mathematics Education Research Group of Australasia* (pp. 239–246). Sydney: MERGA.
- Gimeno Sacristán, J. (2000). *O Currículo: uma reflexão sobre a prática* [The Curriculum: a reflection on practice]. Tradução [Translation] Ernani Rosa. 3rd Ed. Porto Alegre: Artmed.
- Hewson, P.W. (2007). Teacher professional development in science. In Abell, S. K., & Lederman, N. G. (Eds.), *Handbook of Research on Science Education* (pp. 1177-1202). York: Routledge.
- Pepin B, Gueudet G, Trouche L. (2013). Re-sourcing teachers' work and interactions: A collective perspective on resources, their use and transformation. *ZDM Mathematics Education*, 45(7), 929-943.
- Kim, D., & Bolger, M. (2017). Analysis of Korean elementary pre-service teachers' changing attitudes about integrated STEAM pedagogy through developing lesson plans. *International Journal of Science and Mathematics Education*, 15(4), 587-605.
- Office of the Chief Scientist (2016). *Australia's STEM workforce: Science technology, engineering and mathematics*. Canberra: Commonwealth of Australian.
- Ponte, J. P. (2005). Gestão curricular em Matemática. em GTI [Curricular management in Mathematics in GTI] (Ed.), O professor e o desenvolvimento curricular [The teacher and curriculum development] (pp. 11-34). Lisboa: APM.
- Ríordáin M N, Johnston J., Walshe G. (2016). Making mathematics and science integration happen: key aspects of practice. *International Journal of Mathematical Education in Science and Technology*, 47(2), 233-255.
- Rocard, M., Csermely, P., Jorde, D., Lenzen, D., Walberg-Henriksson, H., & Hemmo, V. (2007). *Science education now: A renewed pedagogy for the future of Europe*. Bruxelas: Comissão Europeia.
- Stohlmann, M. (2018). A vision for future work to focus on the “M” in integrated STEM. *School Science and Mathematics*, 118(7), 310-319.
- Shaughnessy, J. M. (2013). Mathematics in a STEM context. *Mathematics Teaching in the Middle School*, 18(6), 324-324.
- Treacy, P., & O'Donoghue, J. (2014). Authentic integration: A model for integrating mathematics and science in the classroom. *International Journal of Mathematical Education in Science and Technology*, 45(5), 703-718.
- Yin, R. K. (2005). *Estudo de caso: Planejamento e métodos* (3.^a Ed). Porto Alegre: Bookman.
- Zehetmeier, S., Andreitz, I., Erlacher, W., & Rauch, F. (2015). Researching the impact of teacher professional development programmes based on action research, constructivism, and systems theory. *Educational Action Research*, 23(2), 162-177.

Reflecting on the value of mathematics in an interdisciplinary STEM course

Nelleke den Braber¹, Jenneke Krüger², Marco Mazereeuw¹ and Wilmad

Kuiper²

¹NHLStenden University of applied sciences, The Netherlands; braber@nhl.nl, m.mazereeuw@nhl.nl;

²University of Utrecht, Freudenthal institute, The Netherlands; jenneke.kruger@gmail.com, w.kuiper@uu.nl

Rationales for interdisciplinary STEM courses are often based on the fact that the problems we face in today's world call for perspectives and knowledge from many different areas. In many cases this includes mathematics because it is used in many research fields and because it is part of everyday life. At the same time interdisciplinary literature suggests that mathematics gains the least from integration. In this paper we use a successful interdisciplinary STEM course in the Netherlands to illustrate how students and teachers think about the value of mathematics. To analyse teacher and student statements concerning the value of mathematics a model is introduced for a disciplinary mathematics perspective for interdisciplinary STEM courses and the opportunities this model can provide are discussed.

Keywords: Mathematics in STEM, secondary education, value of mathematics, perspective taking

Introduction

While studying epithelia tissue and the shapes of the epithelium cells in animals, biologists had questions about the shapes of densely packed cells in curved layers. Sharing their questions with mathematicians, these formalised it as a precisely defined new shape. Computer scientists then programmed the shape as a computer model, which was analysed by physicists, who confirmed the shape would be stable packed at the scale of epithelial cells. Knowing what to look for, biologists then found the modelled shape (Parker, 2018).

This example of the finding of the new mathematical shape called the scutoid is an example of how disciplines work together to solve a problem. Looking specifically at the role of mathematics it became clear that mathematical knowledge was used to model and predict a possible shape and that it therefore played a valuable role in the research process.

In general, mathematics is used in many research fields and is part of everyday life. According to the National Research Council (2013, p.2) the mathematical sciences are “becoming an increasingly integral and essential component of a growing array of areas of investigation in biology, medicine, social sciences, business, advanced design, climate, finance, advanced materials, and many more”. The Dutch branch of Deloitte tried to quantify the contribution of mathematics to the Dutch economy (Deloitte, 2013). They found that the full time equivalent of about 900,000 highly educated employees use mathematical sciences in the Netherlands, 11% of total employment and 35% of higher education employment in the Netherlands. “They include scientists, who use mathematics all the time, as well as bankers, who spend some of their time computing the value of assets, and

physicians, who use maths to interpret medical tests” (p.5). These examples indicate that mathematics is seen as valuable for society because of its frequent use.

In both reports recommendations are made about mathematics education, stating that it should reflect the development and stature of the field to have “more and better usage of mathematical sciences” (Deloitte, 2013, p.21). One way to show the use of mathematics is through interdisciplinary educational courses that require mathematics and other disciplinary knowledge to solve real-life problems, such as the epithelia problem.

In literature, such as that mentioned above, we keep coming across phrases that contain the words ‘use’ of mathematics and the ‘value’ of using mathematics. These two concepts ‘using’ and ‘valuing’ mathematics seem connected and therefore worth a closer look. In this paper we examine the distinction and the relationship between these concepts and we use the interdisciplinary STEM course NLT in the Netherlands as a case study to illustrate a model of disciplinary perspective.

Background of NLT

The Dutch curriculum for upper secondary education contains a course called ‘Nature, life and technology’ (NLT). Since its introduction in 2007 at pre-university and higher general level, the general aims of this elective interdisciplinary STEM course are to let students experience the importance of interdisciplinary coherence in the development of science and technology and to increase the attractiveness of science education for students (Stuurgroep NLT, 2007). The course is intended as a supplement to the existing disciplines in the Dutch curriculum: physics, chemistry, mathematics, biology and physical geography. It aims to offer both a broader and more in-depth educational programme for science and mathematics and is not meant as a replacement of other courses.

Within the boundaries of an examination programme teachers construct their own curriculum and can select teaching materials from a wide range of small booklets, called *modules*. Each module introduces a contemporary, context-oriented science problem that can only be solved by involving different (disciplinary) perspectives. As a consequence, it is preferred that the course is taught by a team of teachers, preferably representing the relevant disciplines. In the Netherlands such a team is called a NLT-team.

In the examination programme of NLT the nature of the course is made explicit by formulating four characteristics which should be visible throughout the curriculum (Krüger & Eijkelhof, 2010). The nature of NLT is characterized by attention to ‘interdisciplinarity’, ‘the relationship between science and technology’, ‘the orientation on higher education and occupations’ and ‘the role of mathematics in science’. Concerning the ‘role of mathematics in science’ it is said that NLT shows how mathematics is used in the sciences. However, how this should manifest itself is not clear (den Braber, Krüger, Mazereeuw & Kuiper, 2019). Our study shows that more than 20% of students doesn’t mention mathematics when asked about the disciplines that play a role in NLT. When asked why mathematics is not a part of NLT some say that only low-level mathematics is required, or that it is not similar to what they do in mathematics class. Besides this, the research shows that mathematics teachers seem to struggle more with their role in NLT than science teachers. Besides this, the added value of having mathematics teachers in an NLT-team is not always clear. When it comes to mathematics in the NLT course, the question arises, how to equip future (mathematics) teachers so

that they can help their students recognize the value of mathematics in NLT and other interdisciplinary courses.

NLT experts elaborated on the concept of interdisciplinarity by describing learning goals that state that students should have knowledge and appreciation of the different disciplines and their ways of working and thinking and how they contribute to solving a real-life problem (Eijkelhof, Boerwinkel & Krüger, 2017).

This is in accordance with Repko, Szostak and Buchberger (2017) who state that “an important step towards developing competence in interdisciplinary studies is to understand the concept of disciplinary perspective and the role of perspective taking” (p.124).

Conceptual framework

Ng and Stillman (2007) provided a framework in which the value of mathematics, mathematical confidence, and the interconnectedness of mathematics are three affective domains directly associated with interdisciplinary learning involving mathematics. In turn, they divided the domain of the value of mathematics in three categories: current relevance or usefulness of mathematics, importance of mathematics for further education and career choice, and value of mathematics in society.

In literature we see more categorizations of the value of mathematics where usefulness or current relevance of mathematics is one of the categories. Williams (2012), for instance, makes the distinction between exchange-value, enjoyment and use-value of mathematics, where the latter is viewed as a means to understand or practise competently, e.g. in engineering or science.

Ernest (2010) states that useful or necessary mathematics is primarily relevant in view of the benefit for employment and functioning in society. He declares functional numeracy or ways of thinking as being useful, but what exactly constitutes the usefulness is not made explicit. The definition of *mathematical literacy* from the PISA mathematical framework provides another perspective on what is needed to be functional in society:

Mathematical literacy is an individual’s capacity to formulate, employ, and interpret mathematics in a variety of contexts. It includes reasoning mathematically and using mathematical concepts, procedures, facts and tools to describe, explain and predict phenomena. It assists individuals to recognize the role that mathematics plays in the world and to make the well-founded judgments and decisions needed by constructive, engaged and reflective citizens. (OECD, 2016, p. 5)

The role that mathematics plays in the world brings us back to the idea of disciplinary perspective as described by Repko et al. (2017). When solving a problem requires different perspectives a mathematical perspective may well be one of them. A disciplinary perspective includes knowledge of the studied phenomena, the assumptions, the epistemology and the ways of acquiring knowledge which are characteristic to the discipline (Repko et al., 2017). To translate these ideas to secondary education we define disciplinary perspective as ways of looking at the world and ways of working and thinking that are characteristic to the field (Janssen, Hulshof & van Veen, 2018).

To specify the way mathematics looks at the world, the perspective on reality or the ‘overall sense’ (Repko et al., 2017), we look at the phenomena studied in mathematics. Defining mathematics as the science of patterns (Devlin, 1998), mathematics studies patterns or abstracts structures. A symbolic notation evolved to facilitate universal communication. The study of patterns requires abstracting and

structuring. In addition to these two, manipulating formulas, modelling, problem solving, and reasoning are formulated as mathematical thinking activities that conjoin key concepts in the Dutch mathematics school curriculum (cTWO, 2012). These six activities belong to the disciplinary perspective shown in table 1. In NLT mathematical concepts are used, but in general no new concepts are introduced. Consequently, if we compare the mathematics curriculum with the NLT examination program, abstracting and structuring seem less relevant. Further, manipulating formulas, will be taken as part of modelling. We will elaborate on the three remaining activities.

Table 1: Description of disciplinary perspective in real-life interdisciplinary context

Ways of looking at the world	
Overall sense	<p>Maths contributes to understanding the world (to describe, explain and predict phenomena)</p> <p>Maths is the study of patterns and abstract structures (with structuring, generalizing, abstracting, symbolizing)</p> <p>Maths uses a symbolic, formal and technical way to communicate</p>
Ways of working and thinking	
Modelling	Modelling processes: Formulate, Employ (working mathematically), Interpret/Evaluate
Reasoning	(logical) reasoning, argumentation and proofing
Problem solving	Devising strategies, heuristics use

The motivation for creating and interpreting mathematical models in real-life situations is to mathematize a realistic situation for the purpose of answering a practical question (Gravemeijer, Stephan, Julie, Lin & Ohtani, 2017). These authors therefore argue the importance of modelling in education as something that prepares students for the digital society of the future. There are many models that describe the modelling process (Borromeo Ferri, 2006). The PISA framework (OECD, 2015) mentions three processes, namely *formulate*, *employ* and *interpret/evaluate* to capture the complexity of the modelling cycle in real-life situations. *Employ* refers to the use of mathematical concepts, facts or procedure, also known as working mathematically (Blum & Ferri, 2009). It includes applying mathematical facts, rules, algorithms, and structures when finding solutions, manipulating formulas and using mathematical tools, including technology, to help find and approximate solutions with given models.

Problem solving can play an important role in working in real-life problems when we see problem solving as the activity of using a heuristic approach (van Streun, 2001) or devising strategies as mentioned in the PISA framework. *Reasoning* is a way of thinking that can be of use in an interdisciplinary context (Eijkelhof, Boerwinkel, & Krüger, 2017). For instance, to critique arguments, to identify weaknesses and flaws in logic, to revise arguments, and to submit to peers review (Mayes & Koballa, 2012). It is a supporting process throughout the modelling process, e.g. to

check a justification that is given, or provide a justification of statements or solutions to problems (OECD, 2015).

Summarizing, we describe the disciplinary perspective of mathematics in an interdisciplinary STEM course as shown in table 1. The model describes the contribution mathematics can make to interdisciplinary real-life problems, specifically in secondary education. It does not include the knowledge or ability required to use this disciplinary perspective even though we recognise mathematical confidence as an important domain in interdisciplinary mathematics education as also stated by Ng and Stillman (2007).

Data collection and analysis

To study how mathematics manifests itself in NLT (den Braber et al., 2019), data was collected through interviews, document analysis and teacher and student surveys over three years. The surveys in 2017 contained several additional questions related to the relevance or usefulness of mathematics to provide an insight in students and teachers perceptions of the value of mathematics in the sciences. For this paper we analysed student answers to one question and teacher answers to a related question, see table 2. The students were in their final year of secondary education and had studied NLT for two or three years. The teachers were NLT teachers with different disciplinary backgrounds.

Table 2: Analysed survey questions and number of answers

	Question	Type	Completed surveys
Teachers	What do you discuss with your students about the role of mathematics in the sciences?	open	84
Students	According to you, what is the importance of mathematics to the science?	open	416

We used table 1 to code the answers of students and teachers. Categories were ‘overall sense’, ‘modelling’, ‘reasoning’ and ‘problem solving’. For answers not fitting to any of the categories we used the category ‘other’. As subcategories of modelling we used ‘formulate’, ‘employ’ and ‘interpret’. The code ‘general’ was related when -part of- the answer reflected the process of modelling in general. If an answer contained more than one statement that could be in different categories the statements were coded accordingly, 445 coded student answers and 95 teacher answers. An example is shown in table 3. A single code was assigned to 389 student and 75 teacher answers.

Table 3: Example of coded student statements from one student answer

Highlighted statements	category	subcategory
The way of thinking (problem solving) and dealing with and converting numbers and formulas	Problem solving	
The way of thinking (problem-solving) and dealing with and converting numbers and formulas	Modelling	employ

Results

The data shows that not all answers referred to the posed questions, for both teachers and students. Instead they might express an opinion about the course, the level of mathematics or what modules were taught. These were coded as ‘other’, as were students’ statements like ‘don’t know’ or ‘don’t care’. This category was also used to code general opinions like ‘great importance’ or ‘not a lot’ and 29 students who gave general statements claiming the importance of mathematics as ‘the basis of sciences’ or other synonyms as ‘the foundation’. Also 14 teachers used general statements, using words such as ‘supportive science’ or a ‘tool’. The number of coded statements is seen in table 4.

Table 4: Number of coded statements in the categories from student and teacher answers

Category	subcategory	Students		Teachers	
		Number of statements (n=445)	Percentage of students (n=416)	Number of statements (n=95)	Percentage of teachers (n=84)
Overall sense		36	9	6	7
Modelling processes	General	4	1	4	5
	Formulate	8	2	3	4
	Employ	212	51	9	11
	Interpret/evaluate	14	3	4	5
Reasoning		14	3	0	0
Problem solving		8	2	2	2
Other		148	36	65	77

In the category ‘other’ we find 35 teacher statements, all science teachers, reflecting that they say nothing or little about the role of mathematics and there is no teacher answer mentioning reasoning or proving something. Even though we find students answers in all categories, almost half of the students reflect on the aspect of working mathematical with many statements containing the words calculate or formulas.

Inter- rater reliability with three raters was 0.79 using Fleiss Kappa.

Discussion

Rationales for interdisciplinary STEM courses are often based on the fact that the problems we face in today’s world call for perspectives and knowledge from many different areas. The possibilities for mathematics in such a course is described by Williams et al (2016) as:

interdisciplinary mathematics education offers mathematics to the wider world in the form of added value (e.g. in problem solving), but on the other hand also offers to mathematics the added value of the wider world. (p.13)

For students, however, it is not self-evident what the added value of mathematics is. For almost one third of the students it is hard to give a description of what the relevance of mathematics is or they refer to general terms as ‘great’ or ‘mathematics is the basis of the sciences’. When they do refer to categories of disciplinary perspective it is mostly ‘working mathematically’ by doing calculations and using formulas. This is in accordance with Wolfram (2010) conclusion that not all phases of a modelling cycles are equally visible in mathematics education. We can argue that the same goes for interdisciplinary education. This might also indicate that in the current NLT course, of all disciplinary perspectives the value of the mathematical perspective is recognized the least and has a lot to gain.

We see students who say that mathematics is not very important to the sciences or student who don’t acknowledge the relevance of it. Here the role of teachers becomes even more apparent. If they don’t address perspectives it seems logical that for students this remains hidden and the benefits of perspective taking in interdisciplinary situations withheld. For teachers it requires knowledge and an attitude that might be different from what they are used to since a part of interdisciplinary perspective taking is “that when taking on other perspectives often involves temporarily setting aside your own beliefs, opinions, and attitudes” (Repko et al., 2017, p. 125). This means that the metaphors of mathematics as a servant or as the queen of other disciplines are irrelevant. The goal of disciplinary perspective is not to marginalise one discipline or to promote another but the goal is to value each discipline and use the possibilities each discipline brings to the table in a real-life situation (Braber et al, 2019).

In this paper we provided a conceptual framework for the disciplinary perspective in STEM education which can be used as a conceptual tool that may help future teachers with explicating the role or usefulness of mathematics in an interdisciplinary course. The warrants and backing in our reasoning need further elaboration. Such as reasons to include elements of the PISA framework or the statement that modelling is the most important process in the disciplinary perspective and that other processes (reasoning and problem solving) are mainly supporting the modelling process. Thereby also making a distinction between an overall sense of what mathematics is about and which processes contribute to answering an interdisciplinary question.

References

- Blum, W., & Ferri, R. (2009). Mathematical modelling: Can it be taught and learnt? *Journal of Mathematical Modelling and Application*, 1(1), 45-58.
- Borromeo Ferri, R. (2006). Theoretical and empirical differentiations of phases in the modelling process. In: *Zentralblatt für Didaktik der Mathematik*, 38(2), 86-95.
- cTWO (2012). Denken & doen; wiskunde op havo en vwo per 2015. Utrecht: Universiteit Utrecht
- Deloitte (2013). *Mathematical sciences and their value for the Dutch economy*. Amsterdam: Deloitte Netherlands.
- den Braber, N., Krüger, J., Mazereeuw, M., Kuiper, W. (2019). Mathematics in an interdisciplinary STEM course (NLT) in the Netherlands. In B. Doig, J. Williams, D. Swanson, R. Borromeo Ferri

- & P. Drake (eds.), *Interdisciplinary Mathematics Education*. Cham Switzerland: Springer. DOI 10.1007/978-3-030-11066-6.
- Devlin, K. (1998). *The language of mathematics making the invisible visible*. New York: W.H. Freeman and company.
- Eijkelhof, H., Boerwinkel, D.J., & Krüger, J. (2017). *Katernen nlt-didactiek*. Utrecht: Vereniging NLT.
- Ernest, P. (2010). Why teach mathematics? *Professional Educator*, 9(2), 45–47.
- Gravemeijer, K., Stephan, M., Julie, C., Lin, F. & Ohtani, M. (2017). What mathematics education may prepare students for the society of the future? *International Journal of Science and Mathematics Education*, 15(suppl1), 105-123.
- Janssen F., Hulshof H., & van Veen, K. (2018). *Wat is echt de moeite waard om te onderwijzen?* Leiden/Groningen: ICLON/RUG.
- Krüger, J. & Eijkelhof, H. (2010). *Advies beproefd examenprogramma NLT: eindrapportage Stuurgroep NLT*. Enschede: Stuurgroep NLT.
- Mayes, R. & Kabbala, T. (2012). *Exploring the science framework; making connections in math with the common core state standards*. Retrieved from <https://ngss.nsta.org/making-connections-common-core.aspx>
- Ng, KED., & Stillman, G. (2007). *Interdisciplinary learning: development of mathematical confidence, value, and the interconnectedness of mathematics*. Paper presented at the 30th Annual Conference of the Mathematics Education Research Group of Australasia Incorporated (MERGA 2007) on “Mathematics: Essential research, essential practice”, Tasmania, Australia, 2– 6 July 2007.
- National Research Council (2013). *The mathematical sciences in 2025*. Washington, DC: NRC
- OECD (2016), PISA 2015 Mathematics Framework. In *PISA 2015 Assessment and Analytical Framework: Science, Reading, Mathematic and Financial Literacy*, OECD Publishing, Paris. <https://doi.org/10.1787/9789264255425-5-en>
- Parker, M. (2018). The scutoid: did scientist discover a new shape? [video file]. Retrieved from https://www.youtube.com/watch?v=2_NZ1ql8B8Y&t=580s.
- Stuurgroep NLT (2007). *Contouren van een nieuw bètavak; visie op een interdisciplinair vak: natuur, leven en technologie*. Enschede: SLO.
- Repko, A.F., Szostak, R., & Buchberger, M. (2017). *Introduction to interdisciplinary studies*. London: Sage.
- van Streun, A. (2001). *Het denken bevorderen*. (Inaugural address). Groningen: Universitair centrum voor lerarenopleiding.
- Williams, J. (2012). Use and exchange value in mathematics education: Contemporary CHAT meets Bordieu’s sociology. *Educational Studies in Mathematics*, 80, 57-72.
- Williams, J., Roth, W., Swanson, D., Doig, B., Groves, S., Omuvwi, M., Borromeo Ferri, R., Mousoulides, N. (2016), *Interdisciplinary mathematics education. A state of the art*. ICME-13 Topical Survey, DOI 10.1007/978-3-319-42267-1
- Wolfram, C. (2010). Teaching kids real math with computers. Youtube, uploaded by TedTalks, 15 November 2010, <https://www.youtube.com/watch?v=60OVIfAUPJg>.

Complex modeling: Does climate change really exist? – Perspectives of a project day with high school students

Maren Hattebuhr¹ and Martin Frank¹

¹Karlsruher Institut für Technologie, Steinbuch Centre for Computing, Karlsruhe, Germany;
martin.frank@kit.edu, maren.hattebuhr@kit.edu

Keywords: High school mathematics, mathematical modelling, problem-solving, statistics.

Introduction

Mathematics is at the core of many areas of everyday life in our society, in science, technology, and the economy. According to the PISA study, the aim of mathematical education is to develop an understanding of the relevance of mathematics in these areas. This should enable high school students to deal with and explain mathematical questions and problems with respect to real world life so that they can act as responsible citizens (cf. OECD, 2014). But process-oriented competences which belong to the educational standards of mathematics are often neglected due to the fact that mathematics lessons are often strongly content-oriented. Therefore, it is essential that the tasks are open, complex, realistic, authentic, problem-oriented and can be solved by carrying out a modeling process (cf. Maaß, 2006, p. 115). This is where the project Computational And Mathematical Modeling Program (CAMMP) intervenes: It offers extra-curricular possibilities for students to participate in modeling events which last between one day and one week. These events show the close connection of several subjects such as engineering, mathematics and computer science. By integrating such questions into interdisciplinary project teaching, mathematical modeling is extended by the dimension of independent experience and practical application. Students solve problems from everyday life or scientific research by using mathematical modeling. Thus, we understand CAMMP as a chance for students to solve real problems by mathematical modeling independently and to develop important future-oriented competencies. Our experiences show that by participating in CAMMP events students discover, among other things, the role of maths in our everyday life. Since the students should not use the modeling cycle as an abstract entity, but as a concrete help for the modeling process, CAMMP presents a simplified variant of Blum's modeling cycle with the four steps *simplifying*, *describing mathematically*, *computing* and *interpreting* (cf. Blum & Borromeo-Ferri, 2009, p. 46). As an example, a workshop lasting one day (CAMMP day) on the topic climate research is introduced.

Didactic reduction and realization of Climate Change Analysis in a CAMMP day

There are various simulations that predict a warming of the average temperature of the earth's surface by up to four degrees Celsius by 2100. Such warming would lead to further effects, from the emergence of deserts to rising sea levels and the disappearance of entire countries. However, many people ignore or deny climate change or the dramatic consequences that inaction would have. The report of the Intergovernmental Panel on Climate Change (IPCC) distinguishes various indicators that point to a climate change. Since climate change is a complex research field with many different forces affecting each other, a good didactical reduction is needed for teaching mathematical models

representing earth climate to high school students. Therefore, the CAMMP day – which we are currently designing – focuses on temperature analysis, an everyday parameter used to describe climate and often used in the media as a yardstick for climate change.

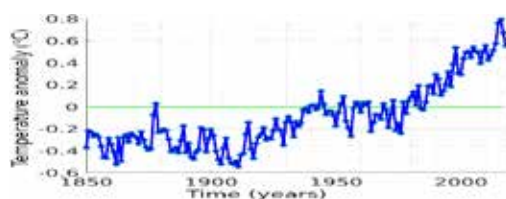


Figure 1: Global average surface temperature

The first step of modeling “Does a climate change exist?” we ask “Has the temperature increased significantly?” To answer this, the global average surface temperature from 1850 to 2018 is examined (see Figure 1). Furthermore, a linear trend is used to describe the trend since it is assumed in the IPCC report (see IPCC, 2013). For this purpose, the students first develop the methodology of regression analysis independently. One possible mathematical description is first to calculate the sum of least squares of the difference between the measured temperature function and the regression, called $e(Y_j)$ for each year $Y_j = 1900, \dots, 2018$. In a second step the sum of the least squares is minimized. The mathematical problem can be written as $\sum_{j=0}^n e(Y_j)^2 = \sum_{j=0}^n (T(Y_j) - \tilde{T}(Y_j))^2 \rightarrow \min$, where $T(Y_j)$ the measured temperature and $\tilde{T}(Y_j) := mY_j + b$ the modeled temperature value of the regression function with the unknown parameters m and b in the years Y_j are. Here the concept of differentiation is needed. It becomes obvious why the least square method is used: It is easier on high school level to differentiate a polynomial of grade 2; otherwise the absolute value function would be needed. Using real data this results in a linear trend function of $\tilde{T}(Y) = 0.008 \text{ }^\circ\text{C/year} - 15.578^\circ\text{C}$ which needs to be interpreted with respect to the real-world problem. Here the question of the quality of the adjustment for the data arises. The coefficient of determination is introduced and computed for the given data as $R^2 = 0.8$. As an additional exercise, interested students can prove that in all cases $R^2 \in [0,1]$ holds and find out which R^2 indicates a good adjustment. These results lead to the presumption that $\tilde{T}(Y)$ approximates the data well and that the temperature rises by $0.008 \text{ }^\circ\text{C/year}$. In order to investigate whether the temperature rises significantly in the last century, the coefficients of the regression function are tested with a so-called t-test. The high school students formulate the null hypothesis (H_0 : the temperature does not rise significantly) on the basis of the question as well as the test statistics. Inserting the corresponding values leads to the acceptance of H_1 . Further steps are to evaluate the influence of human being in this increase. These results do not only lead to a well-founded view on the topic of climate change, but also show the relevance of mathematics in society.

References

- Blum, W. & Borromeo-Ferri, R. (2009). Mathematical modelling: Can it be taught and learnt? *Journal of Mathematical Modelling and Application*, 1(1), 45-58.
- IPCC (2013). *Climate Change 2013 – The physical science basis*. New York, USA: Cambridge University Press.
- Maaß, K. (2006). What are modelling competencies? *ZDM Mathematics Education*, 38(2), 113-142.
- OECD (2014). PISA 2012 Ergebnisse: *Was Schülerinnen und Schüler wissen und können*. (Band I, Überarbeitete Ausgabe) [PISA 2012 results: What students know and are able to do. (Vol. 1, Revised version)], Germany: W. Bertelsmann Verlag, Bielefeld.

Inter TeTra – Interdisciplinary teacher training with mathematics and physics

Description of a project partnership between Siegen (Germany) and Hanoi National University of Education (Vietnam)

Eduard Krause¹, Nguyen Van Bien², Tran Ngoc Chat², Nguyen Phuong Chi², Frederik Dilling¹, Jochen Geppert¹, Kathrin Holten¹, Tuan Anh Le², Simon Kraus¹ and Chu Cam Tho²

¹University of Siegen, Germany; krause@mathematik.uni-siegen.de²Hanoi National University of Education, Vietnam

The benefits of interdisciplinary teaching and learning in school have been discussed for some time, but to make it be more than the additive juxtaposition of elements of knowledge from different disciplines, the universities should implement holistic concepts for integrative teacher education. In the first phase of the teacher training should clarify the advantages and tackle the challenges of an interdisciplinary education. The Inter TeTra project is a DAAD subject-related partnership between the University of Siegen (Germany) and the Hanoi National University of Education (HNUE, Vietnam). The primary outcome of this project is the design of a permanent module for the subjects mathematics and physics at the HNUE and to perform interdisciplinary on the job teacher training with the subjects mathematics and physics.

Keywords: Developing country project, interdisciplinarity, relationship of physics and mathematics, teacher training curriculum development.

Motivation of the Inter TeTra-project

A primary goal of the OECD and the educational capacities in Vietnam is to reform their educational policy by developing a more competency-oriented curriculum (Communist Party of Vietnam, 2013). Germany has two decades of experiences with these types of reforms. The adjustments of the curricula since the mediocre results of German students in the TIMSS and PISA study show the opportunities and challenges such reforms can present (KMK, 2004) and the importance of teacher training for the success of school reforms (Hattie & Beywl, 2013). The cooperation between German and Vietnamese educators offers the opportunity to avoid well-known problems in implementing such reforms. In addition, it can generate new knowledge out of the cultural and structural differences between the two societies, allowing the further development and implementation of novel and distinctive curricula. Consequently, the DAAD (German Academic Exchange Service) endorses the Inter Tetra-project (the name of the project is a short form for Interdisciplinary Teacher Training), a subject-related partnership established between the University of Siegen and the Hanoi National University of Education (HNUE). The outcomes of this project are the design of a permanent module for the subjects mathematics and physics at the HNUE and the performance of an interdisciplinary pre-service and in-service teacher training. One of the distinguishing features of this course is the view beyond the subject boundaries of mathematics and physics. Since 2000, the advantages of interdisciplinary work in teaching and learning in schools have been emphasized, mostly in the form of problem-based and cross-disciplinary teaching that is organized in projects (Labudde, 2014 or Moegling, 2010). In order to achieve the greatest educational benefits, numerous

variants of these demanding and complex learning concepts have been developed (Caviola, 2012; Labudde, 2008). The ability to systematically combine, apply and reflect knowledge from different disciplines is the goal of this project. However, in spite of all the educational advantages, interdisciplinary work also reveals many challenges. The combination of different methods of the participating subjects, overcoming communication difficulties, the identification of common research subjects, the handling of prejudices as well as the handling of group dynamic processes are only some of the problems of interdisciplinary cooperation (Defila & Di Giulio, 2002, 24). The didactic potential of subject-linking teaching and learning has been discussed for some time, especially in mathematics, natural sciences and technology (English, 2017; Kelley & Knowles, 2016; La Force, 2016; Michelsen, 1998).

Despite the many benefits of interdisciplinary teaching and learning at school, the teacher training at German as well as Vietnamese universities is still largely organized in a discipline-oriented manner. The first phase of the teacher training should clarify the advantages and tackle the challenges of an interdisciplinary education. To make interdisciplinary teaching and learning in schools be more than the additive juxtaposition of elements of knowledge from different disciplines (Wellensiek, 2002), the universities should implement holistic concepts for integrative teacher education. The inadequate fit of non-integrated teacher education with the requirements of interdisciplinary teaching (Bröll & Friedrich, 2012) is repeatedly cited by teachers in schools as an objection to integrated instruction (Jürgensen, 2012; Rehm, 2008). If interdisciplinary teaching at school is to succeed, teacher training must also be adequately designed (Brown & Bogiages, 2017; Cormas, 2017). Studies show the importance of the preservice teachers' knowledge of interdisciplinary pedagogy (An, 2017). However, it has become apparent that experienced teachers in particular have reservations about interdisciplinary teaching (Thibaut 2018). For this reason, the Inter TeTra project is planning an interdisciplinary master course and in-service teacher training. Appropriate didactic concepts have already been developed at some universities (Krause & Witzke, 2017; Witzke, 2015). The University of Siegen works currently on interdisciplinary education projects such as MINTUS, FäMaPDi and InForM PLUS (Holten & Witzke, 2017; Krause, 2017). For this purpose, the subjects of mathematics and physics seem to be the most appropriate, since these subjects have numerous epistemological parallels (Krause, 2016). First approaches for establishing subject-linking lessons already exist in Vietnam (Nguyen, 2015). In contrast, the present project does not initially focus on interdisciplinary teaching in Vietnamese schools but starts earlier by adding an interdisciplinary module to teacher education. In this way, the connecting element in the subject-linking lessons of the future is not only the common subject of instruction (which is viewed from the perspective of different subjects) but rather the embedding of lessons in the comparative discussion of didactic theories in the participating subjects from the very beginning, with the goal of concretization and implementation in the Vietnamese curricula. This approach is an innovation especially for Vietnam, where teacher training is currently very isolated and compartmentalized. While the modern application-oriented teaching of mathematics looks to physics didactic concepts for experimentation, modern physics teaching also requires mathematical didactic knowledge to deal with technical problems via mathematics (Schwarz, 2016). Consequently, the repertoire of future teachers will become richer by incorporating the didactics of neighboring subjects. So this project aims to make a meaningful and lasting impact through teacher training, combining classroom teaching with practical instructions. The aim is the

development of a competence-oriented curriculum for teacher training in Hanoi. The Vietnamese partner university is the authoritative body of educational policy reforms within the country, ensuring later dissemination of the developed module. The previously mentioned projects at the University of Siegen have demonstrated that interdisciplinary teaching in teacher education provides a deeper insight into the didactics (Witzke, 2015). The combination of didactical theory and teaching practice is particularly important to our approach.

Concept of the courses in the Inter TeTra-project

General information

The duration of the Inter TeTra-project will be four years. In the first year (2018) the colleagues from Vietnam have joined the referring projects in Siegen - the FäMaPDi and InForM PLUS projects (Krause & Holten, 2018) and both sides discussed the theoretical framework of the project. The courses for the HNUE will be designed in the year 2019 and will take place in Hanoi in 2020 and will be repeated in 2021. The idea is the implementation of an interdisciplinary course for pre-service teachers in the teacher training curriculum at the HNUE and the offering of an interdisciplinary course for in-service teachers with the subjects mathematics and physics. These courses will be composed of a theoretical and a practical part.

Theoretical part

The aim of the courses is to enable students to compare the didactical theories of their own discipline, which they have come to know during their studies, with the didactical theories of the other subject. Since only a limited number of sessions are available for the theoretical part, only a selection of topics can be found that is relevant for both subjects. In order to combine subjects in a meaningful way, one should compare the common “Big Ideas” of the subjects (c.f. Chalmers, 2017). One research desideratum that the Inter TeTra Project focuses on is to explicate topics, which are relevant for mathematics and physics education. For this reason, handbooks and conference-proceedings of mathematics and physics education will be compared systematically to identify intersections. Even if this research is still in process an exemplary selection of topics, which are suitable for an exchange between mathematics and physics education, can be listed:

Nature of science vs. beliefs of mathematics: What is physics? What role does the experiment play in physics? To what extent does a physical theory depict reality? Because questions of this kind are crucial for teaching-learning processes, the didactics of physics has been dealing with them for some time under the heading “nature of sciences” (Aydeniz et al., 2013; Dass, 2005, Hötticke & Rieß, 2007; Kahana & Tal, 2014; Kartal et al., 2018). Likewise also the mathematics didactics researches on the different views on mathematics (e.g. Grigutsch et. al, 1998; Witzke & Spieß, 2016), because the individual conceptions determine our concrete activities in science. What similarities can be identified between perceptual research in mathematics didactics and NoS research in physics didactics? What are the differences? Interesting approaches can be found in the literature: Lawson (2008) talks about Nature of Science and mathematics. Rolka and Halverscheid (2011) talk about mathematical worldviews of students.

Modelling: Modeling is considered in some publications to be a linking element between disciplines. (Blum & Niss, 1991; English, 2009; Michelsen, 2006). In physics, models (such as atomic models)

are an integral part of the theory canon. Accordingly physics education has to clarify how to deal with models in the teaching-learning process (Gilbert, 2004; Oh & Oh, 2017). It is not so common to stress that models should not just be taken over, but rather to emphasize the process of creating models. In mathematics education modeling has been discussed for many years (Burkhardt, 2006; Frejd & Bergsten, 2016; Guerro-Ortiz et al., 2018; Kaiser & Schwarz, 2006). Several models for modeling - so-called modeling cycles - have been developed. So it seems that physics education focuses on the general product while mathematics education is more interested in the process of individual modelling. It is obvious that both sides can learn from each other in this matter, even if it is more laborious than it seems (Neumann et. al, 2011).

Preconceptions: In physics didactics preconceptions are treated to different physical contents. They are often negatively connoted as misconceptions. In mathematics education one rarely speaks about misconceptions, trying to highlight positive pre-theories among learners. The term "Grundvorstellung" (vom Hofe, 1992) is certainly prominent in this context in Germany. At the same time, mathematics educators have developed more general theories on context-related learning, which can also be applied to other subjects. For example, the approach of Heinrich Bauersfeld to "Subjektive Erfahrungsbereiche" should be mentioned (Bauersfeld, 1983). Krause has sketched the transfer of this theory to physics and discussed the question of how on the other hand mathematical didactics can be fertilized by approaches of physics didactics (Krause, 2015).

Practical part

In addition to the theoretical sections the courses mentioned and planned in this project will also include lessons at schools. The fact that the didactics of a neighboring subject can be relevant to one's own subject should be clarified by the conception, implementation, and reflection of lessons that try to combine school mathematics and physics in a meaningful way. For this purpose, the interdisciplinary comparison of theories on learning and teaching mathematics and physics in schools will be used to develop research questions in the seminar, which will be examined in the course of the lesson designs developed in the seminar and tested at the cooperation school. These lessons will be videotaped and incorporated into the previously discussed theory. This combination of theoretical lessons and review is established in North Rhine-Westphalia during the practical semester in teacher training (Hoffart & Helmerich, 2016). Such a theory-based classroom reflection research is not yet part of teacher education in Vietnam. However, evaluation criteria do not refer primarily to how the lessons themselves succeeded, but to how the teaching process can be analyzed and classified on the basis of the theoretical sessions. At this stage of the seminar, students should be able to evaluate and justify didactic decisions based on theory.

Research

Explication of relevant content

The selection of topics in the theoretical part should not be made ad hoc but should reflect the intersection of mathematics and physics education research in terms of content and points of contact. The contents presented in Chapter 2 were determined by the lecturers themselves during the pilot phase in Germany. For the realization of the teaching interventions in Vietnam (which is to take place for the first time in 2020), the theoretical topics are to be systematically selected. For this

purpose, the project participants will carry out a qualitative content analysis (Mayring, 2010) of current manuals and proceedings with the question: *Which contents are relevant for an interdisciplinary exchange of mathematics and physics didactics?* Results of this analysis are still pending.

Evaluation of the teaching interventions

The evaluation of the Master's course and the teacher training should contribute to answering the following research question: How aware are the participants of the relevance of didactic theory of the other subject for their subject? Especially in Vietnam, where teachers are only trained in one subject, it is important to raise the awareness that mathematics didactics is important for physics teaching and that physics didactics is also important for teaching mathematics. The participants will be interviewed at the beginning and end of the theoretical part with an open questionnaire (which is still in the conception phase). What is special about the Inter TeTra project is, that in the practical part the participants are to hold a lesson which will be evaluated video-based. This evaluation also takes place exclusively under the question at which points of the lesson the didactics of the other subject are relevant. This approach was also used in the pilot implementation in Germany. First results may be found in Holten and Krause (2018).

Conclusion

The project's research goals are to clarify relevant topics for an interdisciplinary exchange between mathematics and physics didactics, to design and implement a corresponding course in the teacher training curriculum and a course for in-service teachers at HNUE. The performance of the courses will be evaluated in order to assess the effectiveness of interdisciplinary teaching in the subjects mathematics and physics during the training of preservice teachers.

In this project, an intellectual exchange between four institutes is taking place. Each institute will be focusing primarily on the mathematics and physics disciplines in Hanoi and Siegen as well as four components of teacher training and further education, hence the derivation of the name Inter-Tetra from the Latin "Inter" (between) and Greek "Tetra" (four) and its dual connotation for Interdisciplinary Teacher Training.

References

- An, S. A. (2017). Preservice teachers' knowledge of interdisciplinary pedagogy: the case of elementary mathematics-science integrated lessons. *ZDM Mathematics Education*, 49(2), 237-248.
- Aydeniz, M. & Bilican, K. (2014). What do scientists know about the nature of science? A case study of novice scientists' view of NOS. *International Journal of Science and Mathematics Education*, 12(5), 1083-1115.
- Bauersfeld, H. (1983). Subjektive Erfahrungsbereiche als Grundlage einer interaktionstheorie des Mathematiklernens und -lehrens. In H. Bauersfeld, (Ed.), *Analysen zum Unterrichtshandeln*, (pp.1-56). Köln: Aulis Deubner.
- Blum, W. & Niss, M. (1991). Applied mathematical problem solving, modelling applications, and links to other subjects – State, trends and issues in mathematics instruction. *Educational Studies in Mathematics*, 22(1), 57-68.

- Bröll, L., & Friedrich, J. (2012). Zur Qualifikation der Lehrkräfte für den NWA-Unterricht - eine Bestandsaufnahme in Baden-Württemberg. *Der mathematische und naturwissenschaftliche Unterricht*, 65(3), 180-186.
- Brown, R. E., & Bogiages, C. A. (2017). Professional development through STEM integration: how early career math and science teachers respond to experiencing integrated STEM tasks. *International Journal of Science and Mathematics Education*, 59 (5), 389.
- Burkhardt, H. (2006). Modelling in mathematics classrooms: Reflections on past developments and the future. *ZDM*, 38 (2), 178- 195.
- Caviola, H. (2012). Wie Fächer miteinander ins Gespräch kommen: Modelle der Fächervernetzung und ihre Lernziele. In H. Caviola, I. Widmer Märki, P. Labudde, M. Müller, G. Feurle, H. v. Fabeck, & R. Güdel (Eds.), TriOS: Nr. 2/2012 (pp. 5-36). *Interdisziplinarität*. Münster: LIT-Verlag.
- Chalmers, C., Carter, M., Cooper, T. & Nason, R. (2017). Implementing “big ideas” to advance the teaching and learning of science, technology, engineering, and mathematics (STEM). *International Journal of Science and Mathematics Education*, 15(S1), 25-43.
- Communist Party of Vietnam (2013). Resolution on “fundamental and comprehensive innovation in education, serving industrialization and modernization in a socialist-oriented market economy during international integration” ratified in the 8th session, No. 29-NQ/TW.
- Cornas, P. C. (2017). Preservice teachers` reconciliation on an epistemological issue in an integrated mathematics/ science methods course. *International Journal of Science and Mathematics Education*, 15(8), 1463-1483.
- Dass, P. M. (2005). Understanding the nature of science enterprise (nose) through a discourse with its history: The influence of an undergraduate `history of science` course. *International Journal of Science and Mathematics Education*, 3(1), 87-115.
- Defila, R., & Di Giulio, A. (2002). "Interdisziplinarität" in der wissenschaftlichen Diskussion und Konsequenzen für die Lehrerbildung. In A. Wellensiek (Ed.), *Beltz Wissenschaft: Bd. 38. Interdisziplinäres Lehren und Lernen in der Lehrerbildung. Perspektiven für innovative Ausbildungskonzepte* (pp. 17-29). Weinheim, Basel: Beltz.
- English, L. D. (2017). Advancing elementary and middle school STEM education. *International Journal of Science and Mathematics Education*, 15(S1), 5-24.
- English, L. D. (2009). Promoting interdisciplinary through mathematical modelling. *ZDM*, 41(1-2), 161-181.
- Frejd, P. & Bergsten, C. (2016). Mathematical modelling as a professional task. *Educational Studies in Mathematics*, 91 (1), 11-35.
- Gilbert, J. K. (2004). Models and modelling: Routines to more authentic science education. *Journal of Science and Mathematics Education*, 2 (2), 115-130.
- Grigutsch, S., Raatz, U., & Törner, G. (1998). Einstellung gegenüber Mathematik bei Mathematiklehrern. *Journal für Mathematik-Didaktik*, 19 (1), 3-45.
- Guerrero-Ortiz, C., Mena-Lorca, J. & Soto, A. M. (2018). Fostering transit between real world and mathematical world: Some phases on the modelling cycle. *International Journal of Science and Mathematics Education*, 16(8), 1605-1628.
- Hattie, J., & Beywl, W. (2013). *Lernen sichtbar machen (Überarb. dt.-sprachige Ausg)*. Baltmannsweiler: Schneider-Verl. Hohengehren.

- Hoffart, E. & Helmerich, M. (2016). „In der Situation ist mir das gar nicht aufgefallen!“ Reflexionsanlässe in der Lehrerbildung als Bindeglied zwischen Theorie und Praxis. In: U. Kortenkamp & A. Kuzle (Eds.), *Beiträge zum Mathematikunterricht* (pp. 433-436). Münster: WTM-Verlag.
- Holten, K.; Krause, E. (2018): InForM PLUS vor der Praxisphase – Zwischenbericht eines interdisziplinären Elements in der Lehramtsausbildung an der Universität Siegen". *Tagungsband der HerKuLes-Tagung (Herausforderung Kohärenz: Praxisphasen in der universitären Lehrerbildung)*, 260-274.
- Holten, K. & Witzke, I. (2017). Chancen und Herausforderungen fachdidaktischverbindender Elemente in der Lehramtsausbildung. *Beiträge zum Mathematikunterricht 2017*. 51. Jahrestagung der Gesellschaft für Didaktik der Mathematik vom 27.02.2017 bis 03.03.2017 in Potsdam. Münster: WTM, 465–468.
- Hötticke, D. & Rieß, F. (2007). Rekonstruktion der Vorstellungen von Physikstudierenden über die Natur der Naturwissenschaften - eine explorative Studie. *Physik und Didaktik in der Schule und Hochschule, PhyDidA*, 1(6), 1-14.
- Jürgensen, F. (2012). Das integrierte Fach Naturwissenschaften und seine Beliebtheit bei Lehrern und Schülern. In E. Rossa (Ed.), *Chemie-Didaktik. Praxishandbuch für die Sekundarstufe I und II* (2nd ed.) (pp. 197-230). Berlin: Cornelsen Scriptor.
- Kahana, O., & Tal, T. (2014). Understanding of high-achieving science students on the nature of science. *International Journal of STEM Education*, 1(1), 15.
- Kaiser, G. & Schwarz, B. (2006). Mathematical modelling as bridge between school and university. *ZDM*, 38(2), 196-208.
- Kartal, E., Cobern, W. W., Dogan, N., Irez, S., Cakmakci, G., & Yalaki, Y. (2018). Improving science teachers' nature of science views through an innovative continuing professional development program. *International Journal of STEM Education*, 5(1), 665.
- Kelley, T. R., & Knowles, J. G. (2016). A conceptual framework for integrated STEM education. *International Journal of STEM Education*, 3 (1), 237.
- KMK (2004). Standards für die Lehrerbildung: Bildungswissenschaften. Beschluss vom 16.12.2003 i.d.F. vom 12.06.2014. *Kultusministerkonferenz 16.12.2004*.
- Krause, E. (2015). Nutzen von fächerverbindender Didaktik am Beispiel von subjektiven Lernvoraussetzungen im Mathematik- und Physikunterricht. *Beiträge zum Mathematikunterricht*, 48, Münster: WTM-Verlag, 492-495.
- Krause, Eduard (2016). Erkenntnistheoretische Parallelen zwischen Schulmathematik und –physik, *Beiträge zum Mathematikunterricht*. 49, Münster: WTM-Verlag, 581-585.
- Krause, E., & Witzke, I. (Eds.) (2017). Mathematikunterricht im Kontext physikalischer Anwendungen - Grundlegungen und Konzepte zu fächerverbindendem Unterricht. *Der Mathematikunterricht*, 63(5). Seelze: Friedrich Verlag.
- Krause, E.; Witzke, I. (2015). Fächerverbindung von Mathematik und Physik im Unterricht und in der didaktischen Forschung. *Tagungsband der Frühjahrstagung der Deutschen Physikalischen Gesellschaft (PhyDidB - Didaktik der Physik)*, Beitrag DD 8.3.
- Labudde, P. (Ed.). (2008). *Naturwissenschaften vernetzen - Horizonte erweitern: Fächerübergreifender Unterricht konkret (1. Auflage)*. Seelze-Velber: Klett/Kallmeyer.

- Labudde, P. (2014). Fächerübergreifender naturwissenschaftlicher Unterricht - Mythen, Definitionen, Fakten. *Zeitschrift für Didaktik der Naturwissenschaften*, 20(1), 11-19.
- LaForce, M., Noble, E., King, H., Century, J., Blackwell, C., Holt, S., Loo, S. (2016). The eight essential elements of inclusive STEM high schools. *International Journal of STEM Education*, 3 (1), 409.
- Lawson, A. E., Oehrtman, M. & Jensen, J. (2007). Connecting science and mathematics: The nature of science and statistical hypothesis testing. *International Journal of Science and Mathematics Education*, 6(2), 405-416.
- Mayring, P. (2000). *Qualitative Inhaltsanalyse*. Weinheim. Basel: Beltz.
- Merzyn, G. (2013). Fachsystematischer Unterricht: Eine umstrittene Konzeption. *Der mathematische und naturwissenschaftliche Unterricht*, 66(5), 265-269.
- Michelsen, C. (2006). Functions: A modelling tool in mathematics and science. *ZDM*, 38(3), 269-280.
- Michelsen, C. (1998). Expanding context and domain: A cross-curricular activity in mathematics and physics. *ZDM*, 30 (4), 100-106.
- Moegling, K. V. (2010). *Kompetenzaufbau im fächerübergreifenden Unterricht. Förderung vernetzten Denkens und komplexen Handelns. Didaktische Grundlagen, Modelle und Unterrichtsbeispiele für die Sekundarstufen I und II*. Immenhausen bei Kassel: Prolog-Verlag.
- Neumann, I., Heinze, A., Ufer, S., & Neumann, K. (2011). Modellieren aus mathematischer und physikalischer Perspektive. *Beiträge Zum Mathematikunterricht* (pp. 603–606). Münster: WTM-Verlag.
- Nguyen V. B. (2015). Entwicklung interdisziplinärer Themen im Naturwissenschaftsunterricht. *Journal of Science of HNUE*, 60 (2), 61-66.
- Oh, P. S., & Oh, S. J. (2010). What teachers of science need to know about models: An overview. *International Journal of Science Education*, 33 (8), 1109–1130.
- Rehm, M., Bündler, W., Haas, T., Buck, P., Labudde, P., Brovelli, D. & Svoboda, G. (2008). Legitimationen und Fundamente eines integrierten Unterrichtsfachs Science. *Zeitschrift für Didaktik der Naturwissenschaften*, 14, 99-123.
- Rolka, K. & Halverscheid, S. (2011). Researching young students' mathematical world views. *ZDM*, 43 (4), 521-533.
- Schwarz, O. (2016). Vorwort zur zweiten Auflage. Kuhn, W. (Ed.), *Ideengeschichte der Physik*. Berlin: Springer-Verlag.
- Thibaut, L., Knipprath, H., Dehaene, W., & Depaepe, F. (2018). Teachers' attitudes toward teaching integrated STEM: the Impact of personal background characteristics and school context. *International Journal of Science and Mathematics Education*, 27 (1), 173.
- Vom Hofe, R. (1992). Grundvorstellungen mathematischer Inhalte als didaktisches Modell. *Journal für Mathematik-Didaktik*, 13 (4), 345-364.
- Wellensiek, A. (Ed.). (2002). *Beltz Wissenschaft: Bd. 38. Interdisziplinäres Lehren und Lernen in der Lehrerbildung: Perspektiven für innovative Ausbildungskonzepte*. Weinheim, Basel: Beltz.
- Witzke, I. (2015). Fachdidaktischverbindendes Lernen und Lehren im MINT- Bereich. *Beiträge zum Mathematikunterricht*, 48, Münster: WTM-Verlag, 1008-1011.
- Witzke, I. & Spies, S. (2016). Domain-specific beliefs of school calculus. *Journal für Mathematik-Didaktik*, 37 (1), 131-161.

Student mathematical preparedness for learning science and engineering at university

Ciara Lane¹ and Gráinne Walshe²

¹University of Limerick, EPI*STEM, School of Education, Limerick, Ireland; ciara.lane@ul.ie

²University of Limerick, Science Learning Centre, Limerick, Ireland; grainne.walshe@ul.ie

This paper describes a novel study that aims to explore students' mathematical preparedness for STEM education at tertiary level in the Irish context. The study addresses the issue of student retention in STEM degrees by investigating the perceptions of three stakeholders – teachers, students and lecturers – on the mathematical preparedness of students for studying science and engineering at tertiary level. The study also examines the existence and perception of interdisciplinary STEM education in preparing students for the transition to tertiary level STEM learning. In this paper, we describe the rationale and design of this pilot study at an Irish university, including the development of questionnaire instruments for teachers, students and lecturers. Further advancement of the study is also discussed, as well as the intention to design targeted support for first year students of science degrees.

Keywords: Interdisciplinary approach, mathematics, science, student attrition, STEM education.

Introduction

Internationally, there has been increased emphasis on Science, Technology, Engineering and Mathematics (STEM) education and the exigent need to provide quality STEM education at primary, secondary and tertiary levels, in order to increase the number and quality of STEM graduates (DES, 2017; Friedman, 2005; Sanders, 2009). With augmented political and economic focus in the last 20 years, STEM education and integration has come to the forefront of national and global policies. While recommendations have been made for integrative STEM education (see e.g. Breiner et al., 2012; Kennedy & Odell, 2014; Sanders, 2009), there remains some hesitancy about how exactly STEM should be integrated in an educational context (Blackley & Howell, 2015). In Ireland, there is a particular concern that students entering higher education are under-prepared to engage effectively with learning in STEM courses (DES, 2011). Mathematics and science especially are central to many STEM courses at tertiary level, with first year undergraduates often lacking the skills and knowledge in these subjects to successfully engage with their STEM degree. This paper describes a pilot study of students' mathematical preparedness for learning science and engineering at tertiary level in the Irish context. The authors aim to investigate the students' mathematical preparedness from three perspectives: first year students enrolled in science and engineering degrees at an Irish university; science and engineering lecturers teaching first year modules at the university; and senior cycle post-primary (second-level) mathematics and science teachers; as well as the existence and perceptions of interdisciplinary STEM teaching and learning. In addition, the way in which these groups use social media to develop informal networks between second and tertiary level education will be analysed. As data collection through questionnaire surveys is in process, this paper describes the rationale and design of the study.

Study rationale

Concerns about student retention in higher education is an international phenomenon, because of the very high drop-out rate from first year, and because Higher Education Institutes (HEIs) are held more accountable for students' success (Coertjens et al., 2016). In New Zealand, Jia and Maloney (2015) found that students enrolled in STEM degrees had the highest course non-completion rates. This is consistent with Rask (2010) and Chen and Soldner's (2013) findings in the US that grades and student retention rates are systematically lower in the STEM subjects of Sciences, Computing, Mathematics and Engineering. Similarly Malm *et al.* (2012) report that at the School of Engineering at Lund University, Sweden, the percentage of matriculating students who successfully complete their MSc engineering degree is about 60%. Most of the students who drop out do so during the first year, with a 21% attrition rate found in one particular year. Student progression and retention is now a national priority in Irish Higher Education, and is a major focus of national policy in recent years (HEA 2016). There has been a steady increase in student enrolments in higher education in Ireland over recent decades, with an increase of 7% between 2011 and 2016 of full-time undergraduate new entrants (HEA 2016). A report from the Higher Education Authority in Ireland found that the overall rate of non-progression (from year one to year two) was 11% for level 8 degrees in universities in the year 2012/13 (HEA 2016). Notably, prior academic achievement has been found to be the strongest predictor of non-progression in higher education (HEA, 2018). Therefore, there is a strong rationale for investigating students' transition to university, particularly for students enrolled in STEM degrees.

While several factors may impact on student progression, for science and engineering students, their level of mathematical knowledge is crucially important (HEA 2016), but even students with good marks in school mathematics can struggle with the mathematical aspects of third-level science and engineering courses. It is important to have good mathematical knowledge, but even more so to know how to use that knowledge in other subjects. However, very often mathematics is not taught in an integrated/interdisciplinary fashion at second level. Science and mathematics can be very separate as school subjects even where they share overlapping content (Czerniak & Johnson, 2014). It has been found that school mathematics teachers are often unfamiliar with the science subjects, and vice versa for science teachers (Walshe, Johnston, & McClelland, 2017). It is possible also that second level teachers are not teaching mathematics with students' future third-level STEM degrees in mind. Thus, the authors aim to address the following research questions in their study:

1. What are teachers, lecturers and first year students' perspectives on the level of mathematical preparedness of students for science and engineering degrees?
2. What understanding do teachers, lecturers and students have of STEM education, and in particular, integrated approaches to teaching STEM subjects?
3. Does social media indicate that networks exist that connect various actors across second and third level, such that the students' process of mathematical preparedness might be enhanced?

These research questions will be addressed in the first exploratory phase of the research. The authors aim to design and implement a pilot intervention for students at risk of failing their first-year science modules in the second phase which will be informed by the findings of this study.

Interdisciplinary education in STEM

Both in Ireland and internationally, education initiatives have often focused on improving individual disciplines in STEM (discipline silos) rather than integrating the collective. These efforts aim to enhance students' learning in each of the STEM disciplines through a focus on inquiry, problem solving and constructivist learning, which are essential skills for the 21st century. However, researchers have argued that for students to be fully prepared for future STEM careers in the real world, there needs to be an emphasis on interdisciplinary thinking (Asghar et al., 2012; Breiner et al., 2012). In conceptualizing what STEM means, many people do not have an interdisciplinary understanding of STEM (Breiner et al., 2012). *"Everybody who knows what it means knows what it means, and everybody else doesn't"* (Angier, 2010). In their study of faculty members' conceptualization of STEM, Breiner et al. (2012) found diverging views from both STEM and non-STEM disciplines. Becker and Park (2011) conducted a meta-analysis of STEM integration studies and found that STEM teachers are often unaware of the benefits of integration and school administrators often do not support integrative approaches as a means to motivate students' learning in STEM. Teachers' self-efficacy plays a vital role in successful teaching (Stohlmann et al., 2012) and teachers' content and pedagogical knowledge can influence their teaching self-efficacy. Stohlmann et al. noted that teachers' comfort with teaching integrated STEM lessons was also affected by their commitment to future integrative STEM teaching. Laboy-Rush (2011) avers that the success of integrative STEM initiatives is very much dependent on teachers' attitudes to changes in their teaching practice, and these attitudes can be influenced by teaching efficacy (De Mesquita & Drake, 1994). Teachers' attitudes to adopting an integrative STEM teaching approach can affect their commitment to such initiatives as well as influence their students' interest and motivation in STEM (Al Salami et al., 2017). In analysing the conceptual changes of teachers towards interdisciplinary STEM teaching, Al Salami et al. found that a year-long professional development programme elicited little or no change which is consistent with previous studies on teacher change. Findings did indicate however, a significant positive association between teachers' attitudes towards interdisciplinary teaching and attitudes to teamwork, and also between attitudes towards interdisciplinary teaching and teaching satisfaction. It should be acknowledged that while there are benefits to integrating STEM subjects, there are also costs to teachers and schools in terms of time, resources and developing expertise (Gresnigt, Taconis, van Keulen, Gravemeijer, & Baartman, 2014).

There are many definitions of interdisciplinary teaching and learning or integration, and many approaches and models suggested for how it can be applied in teaching (Hurley, 2001, Pang & Good, 2000). Terms used in the literature to describe integration include: interdisciplinary; multidisciplinary; transdisciplinary; thematic; integrated; connected; nested; sequenced; shared; webbed; threaded; immersed; networked; blended; fused; correlated, coordinated, and unified curricula (Berlin & Lee, 2005; Czerniak & Johnson, 2014). A common definition of integration does not exist, and this ambiguity is inherent in the sheer number of terms used to describe it.

Moreover, these terms can mean different things to different researchers (Czerniak & Johnson, 2014; Kysilka, 1998). Berlin and Lee note in their analysis of the literature on science and mathematics integration from 1990 to 2001 that while many theoretical models have been proposed; there is a ‘critical need for careful conceptualization and additional research on integrated science and mathematics teaching and learning’ (2005, p. 22). As part of this study, the authors aim to clarify what teachers, lecturers and students currently understand by interdisciplinary STEM education, with a view to developing interventions that could address any gaps or shortcomings that are found to exist in their current conceptualisations and practice.

Study design

The methodology for this study is Educational Design Research, characterized by iterative design and formative evaluation of interventions in complex real-world settings. Working with all stakeholders, i.e. practitioners and end-users, to inform, design, pilot and refine the elements of an educational intervention is an essential part of this methodology (Plomp & Nieveen, 2013). This paper describes the first phase of our study which is chiefly designed as exploratory, inductive research. Exploratory research aims to apply “new words, concepts, explanations, theories and hypotheses to reality with the expectation of offering new ways of seeing and perceiving how this segment of reality works, how it is organized, and more specifically how and in what way different factors relate to each other causally.” (Reiter, 2017, p. 139). This understanding of exploratory research frames our phase 1 study design in investigating students’ mathematical preparedness for learning science and engineering in first year of university. Our study is underpinned by the constructivist position that people construct knowledge and its meaning from their experiences (Driscoll, 2000). The authors hypothesize that university students’ learning of science and engineering is affected by their knowledge of mathematics and their experience of learning mathematics/science in post-primary education. The authors further hypothesize that students’ exposure to integrative, interdisciplinary-based learning in mathematics and science at post-primary level affects their mathematical preparedness for studying science and engineering at university. These hypotheses led to the formation of our four research questions in the introduction section of this paper. To answer our research questions, three questionnaires were designed, aimed at first year university students in science/engineering degrees, science/engineering lecturers and post-primary teachers teaching science and mathematics at senior cycle (the final 2 years of post-primary education in Ireland). Both quantitative, fixed-response items and qualitative, open-ended questions are employed in all questionnaires. To aid in comparative analysis, questionnaires contain similar sections and items, adapted where necessary to suit the intended participant.

All three questionnaires aim to determine the target groups’ understanding of STEM education and interdisciplinary teaching. Items were adapted from Bayer (2009) to suit the Irish context, and to suit the target audience (teachers, lecturers or students). Each questionnaire also had items specific to the target group. For example, the teacher questionnaire addressed participants’ team-teaching and collaborative planning experience, as research has suggested a link between teachers’ attitudes to interdisciplinary teaching and attitudes to teamwork (Al Salami *et al.*, 2017). Relevant parts are adapted for mathematics or science teachers. They are also asked about their use of specific teaching practices which have been highlighted in the literature as optimal in science and

mathematics teaching, and which may also be useful for interdisciplinary teaching (Stohlmann *et al.*, 2012; Zemelman *et al.*, 2005). Teachers' views on their role preparing students for third level education, and their familiarity with third-level STEM courses is also investigated. For the lecturer questionnaire, respondents are asked to rate their level of knowledge of Senior Cycle science and mathematics subject curricula, as well as the relevance of mathematics to the first year module(s) they teach. An important aspect of the lecturer questionnaire is to investigate their perceptions of the mathematical gaps that new university students may have in terms of learning science/engineering at third-level. It has long been reported that students experience difficulties with transitioning into third-level for a variety of reasons, including the very different style of learning and teaching compared to school (Harvey *et al.*, 2006; Lovatt & Finlayson, 2013). The student questionnaire therefore investigates student perceptions of their preparedness for learning at university generally, for example in terms of time management issues, critical thinking and conducting independent research (National Forum, 2015), as well as their preparedness for (understanding of and attitudes towards) utilizing their school mathematics within third-level science/engineering modules.

The second phase of our study involves distribution of the questionnaires with a sample of first year science/engineering students, science/engineering lecturers and post-primary teachers teaching senior cycle mathematics/science (currently in process). The student and teacher questionnaires are being distributed in paper form and the lecturer questionnaire will be an online version (SurveyMonkey). Once the questionnaires have been returned, the data will be analysed. Fixed-response items will be analysed statistically using the Statistical Package for the Social Sciences (SPSS). Analysis will include descriptive statistics, reliability testing and correlation of items and variables. Comparative analysis will be performed within and between participant groups. Open-ended items will be analysed using inductive content analysis to derive themes relating to the research questions. A search of social media sites such as Facebook, Twitter and Instagram will be conducted to examine existing networks between second and tertiary level in relation to student preparedness for STEM degrees.

Findings will be used to design an intervention aimed at supporting students at risk of failing first year science modules. It is intended that a more in-depth study on the issue of students' mathematical preparedness for studying science and engineering degrees as well as the existence and perceptions of interdisciplinary STEM teaching and learning will be conducted in light of the findings of this pilot study. A limitation of the pilot study is that the teachers who participate in the survey are not sourced as the prior teachers of the first year students participating in the study. As such, in the subsequent study the authors will aim to survey teachers from the post-primary schools previously attended by the first year students to enhance insight into the issue of transition to science and engineering degrees. Further study will also involve the implementation and evaluation of the designed intervention for first year science degree students.

Conclusion

This paper has described an innovative pilot study in the Irish context. The study aims to address two issues of utmost importance to STEM education interests on a national and international level.

The first issue, relating to student transition to STEM degrees and student retention in STEM degrees, is a priority not only for educators, but also for policy makers and industry. The authors seek to gain new insight into the preparedness of first year students in science and engineering courses, with a particular focus on students' mathematical preparedness. This insight will be enhanced through the perceptions of three stakeholders in the student transition process; post-primary teachers, university lecturers and students in first year of university. Our findings in this study will also be used to develop targeted support for these students. The second issue we address is perceptions and understanding of interdisciplinary STEM education, which has received increasing attention from researchers internationally, but little research exists in the Irish context. Our study seeks to fill this gap and contribute to the international research. In particular, we take a novel approach in examining the role of interdisciplinary STEM learning in student preparedness for STEM education at tertiary level.

References

- Al Salami, M. K., Makela, C. J. and de Miranda, M. A. (2017). Assessing changes in teachers' attitudes toward interdisciplinary STEM teaching. *International Journal of Technology and Design Education*, 27(1), 63–88.
- Angier, N. (2010). *STEM education has little to do with flowers*. Retrieved from: <http://www.nytimes.com/2010/10/05/science/05angier.html?pagewanted=all&r=0>. Accessed 15th July 2018.
- Asghar, A., Ellington, R., Rice, E., Johnson, F. and Prime, G.M. (2012). Supporting STEM education in secondary science contexts. *Interdisciplinary Journal of Problem-Based Learning*, 6(2), 85–125.
- Bayer, J.A. (2009). *Perceptions of Science, Mathematics, and Technology Education Teachers on Implementing an Interdisciplinary Curriculum at Blaine Senior High*. [Dissertation] Retrieved from: <http://www2.uwstout.edu/content/lib/thesis/2009/2009bayerj.pdf>. Accessed 26th July 2018.
- Becker, K. & Park, K. (2011). Effects of integrative approaches among science, technology, engineering, and mathematics [STEM] subjects on students' learning: A preliminary meta-analysis. *Journal of STEM Education*, 12(5,6), pp. 23–38.
- Berlin, D. F., & Lee, H. (2005). Integrating science and mathematics education: Historical analysis. *School Science and Mathematics*, 105(1), 15-24. doi:10.1111/j.1949-8594.2005.tb18032.x
- Blackley, S. and Howell, J. (2015). A STEM narrative: 15 years in the making. *Australian Journal of Teacher Education*, 40(7), 102–112.
- Breiner, J. M., Johnson, C. C., Harkness, S. S. and Koehler, C. M. (2012). What is STEM? A discussion about conceptions of STEM in education and partnerships. *School Science and Mathematics*, 112(1), 3–11.
- Chen, X. and Soldner, M. (2013). *STEM attrition: College students' paths into and out of STEM fields*. Washington, DC: Institute of Education Sciences.

- Coertjens, L., Brahm, T., Trautwein, C., & Lindblom-Ylänne, S. (2016). Students' transition into higher education from an international perspective. *Higher Education*, 1-13. doi:10.1007/s10734-016-0092-y
- Czerniak, C. M., & Johnson, C. C. (2014). Interdisciplinary science teaching. In S. K. Abell & N. G. Lederman (Eds.), *Handbook of Research on Science Education* (2nd ed., pp. 395-411). London and New York: Routledge.
- De Mesquita, P. B. and Drake, J. C. (1994). Educational reform and the self-efficacy beliefs of teachers implementing nongraded primary school programs. *Teaching and Teacher Education*, 10(3), 291–302.
- DES (2011). *National strategy for Higher Education to 2030 – report of the strategy group*. Dublin: Department of Education and Skills.
- DES (2017). *STEM Education policy statement 2017-2026*. Dublin: Department of Education and Skills.
- Driscoll, M. P. (2000). *Psychology of learning for instruction*. (2nd edition). Boston: Allyn & Bacon.
- Friedman, T. L. (2005). *The world is flat. A brief history of the twenty-first century*. New York: Farrar, Strauss and Giroux.
- Gresnigt, R., Taconis, R., van Keulen, H., Gravemeijer, K., & Baartman, L. (2014). Promoting science and terminology in primary education: a review of integrated curricula. *Studies in Science Education*, 50(1), 47–84. Retrieved from <http://dx.doi.org/10.1080/03057267.2013.877694>. doi:10.1080/03057267.2013.877694
- Harvey, L., Drew, S., & Smith, M. (2006). *The first-year experience: A review of literature for the Higher Education Academy*. York: The Higher Education Academy
- HEA (2016). *A study of progression in Irish higher education 2012/13 to 2013/14*. Dublin: Higher Education Authority.
- HEA (2018). *A study of progression in Irish higher education 2014/15 to 2015/16*. Dublin: Higher Education Authority.
- Hurley, M. M. (2001). Reviewing integrated science and mathematics: The search for evidence and definitions from new perspectives. *School Science and Mathematics*, 101(5), 259-268. doi:10.1111/j.1949-8594.2001.tb18028.x
- Jia, P. and Maloney, T. (2015). Using predictive modelling to identify students at risk of poor university outcomes. *Higher Education*, 70(1), 127–149.
- Kennedy, T. J. and Odell, M. R. L. (2014). Engaging students in STEM education. *Science Education International*, 25(3), 246–258.
- Kysilka, M. L. (1998). Understanding integrated curriculum. *The Curriculum Journal*, 9(2), 197-209. doi:10.1080/0958517970090206

- Laboy-Rush, D. (2011). *Integrated STEM education through problem-based learning*. [White paper]. Retrieved from: <http://www.rondout.k12.ny.us/common/pages/DisplayFile.aspx?itemId=16466975> . Accessed 13th September 2018.
- Lovatt, J., & Finlayson, O. (2013). Investigating the transition into third level science—identifying a student profile. *Chemistry Education Research and Practice*, 14(1), 62-72.
- Malm, J., Bryngfors, L. and Morner, L. L. (2012). Supplemental instruction for improving first year results in engineering studies. *Studies in Higher Education*, 37(6), 655–666.
- National Forum. (2015). *Transition from second level and further education to higher education*, Focused Research Report No. 6. Dublin: National Forum for the enhancement of teaching and learning in higher education. Retrieved from Dublin: <https://www.teachingandlearning.ie/wp-content/uploads/2015/08/Research-Report-6-Transitions-from-Second-Level-FE-to-Higher-Education.pdf>
- Pang, J., & Good, R. (2000). A review of the integration of science and mathematics: Implications for further research. *School Science and Mathematics*, 100(2), 73-82. doi:10.1111/j.1949-8594.2000.tb17239.x
- Plomp, T., & Nieveen, N. (Eds.). (2013). *Educational Design Research Part A: An Introduction* (2nd ed.). Enschede, NL: SLO, Netherlands Institute for Curriculum Development
- Rask, K. (2010). Attrition in STEM fields at a liberal arts college: The importance of grades and pre-collegiate preferences. *Economics of Education Review*, 29(6), 892–900.
- Reiter, B. (2017). Theory and methodology of exploratory social science research. *International Journal of Science and Research Methodology*, 5(4), pp. 129–150.
- Sanders, M. (2009). STEM, STEM Education, STEMmania. *The Technology Teacher*, 68(4), 20–26.
- Stohlmann, M., Moore, T. J. and Roehrig, G. H. (2012). Considerations for teaching integrated STEM education. *Journal of Pre-College Engineering Education Research*, 2(1), 28–34.
- Walshe, G., Johnston, J., & McClelland, G. (2017). Integrating mathematics into science: Design, development and evaluation of a curriculum model. In K. Hahl, K. Juuti, J. Lampiselkä, J. Lavonen, & A. Uitto (Eds.), *Cognitive and Affective Aspects in Science Education Research: Selected Papers from ESERA 2015 Conference* Dordrecht: Springer.
- Zemelman, S., Daniels, H. and Hyde, A. (2005). *Best practice: New standards for teaching and learning in America's schools* (3rd Edition). Portsmouth, NH: Heinemann.

Pre-service teachers' perspectives on the role of statistics in a learning scenario for promoting STEM integration

Hélia Oliveira¹, Ana Henriques¹ and Mónica Baptista¹

¹Instituto de Educação, Universidade de Lisboa, Portugal

hmoliveira@ie.ulisboa.pt; achenriques@ie.ulisboa.pt; mbaptista@ie.ulisboa.pt

This paper reports on a teacher education project aiming to prepare pre-service teachers (PTs) of mathematics and of physics for developing STEM integration activities in school. In this study we aim to analyze pre-service teachers' perspectives about the role of statistics in one interdisciplinary learning scenario to foster the integration of physics and statistics using technology, enacted with 8th grade students. Data collected from the group lesson plans and the written individual reflections of the 10 PTs enrolled in the project, qualitatively analysed, reveal that PTs of both subject areas recognize the central role of statistics in the learning scenario in relation with the three considered dimensions of the model of Authentic Integration adopted. However, they also document that the knowledge synthesis of the two areas involves a high level of complexity, and identify several challenges they faced concerning that process.

Keywords: Pre-service teachers, teacher education, statistics, STEM.

Introduction

A successful STEM integration depends on teachers' perspectives and knowledge to adopt this pedagogical practice, namely to choose effective learning materials and topics suitable for that integration and feel confident in adopting teaching methods beyond traditional ones (Kim & Bolger, 2017; Ní Ríordáin, Johnston, & Walshe, 2016). Thus, it is fundamental that, in their initial teacher education, future teachers have the opportunity to experience interdisciplinary situations to fill their lack of knowledge to develop experiences of articulation between diverse disciplines (Ní Ríordáin et al., 2016). However, in the case of mathematics, some studies show that this is the subject with less benefits in the STEM context (Becker & Parker, 2011) and that quite often mathematics is incidental to the purpose of the integration activities (Fitzallen, 2015). Emerging from a teacher education project with mathematics and physics secondary pre-service teachers (PTs), this study intends to contribute to the debate concerning the preparation of future mathematics teachers for STEM context. We formulated the following research question: what are PTs' perspectives about the role of statistics in a learning scenario with one 8th grade class fostering the integration of physics and statistics?

Theoretical framework

Pre-service teacher education on STEM integration

One of the main reasons for teachers' negative perception of STEM education is that they feel underprepared to teach within an interdisciplinary curriculum, due to the targeted scope of their own education (Frykholm & Glasson, 2005). In answer to that, several studies suggest introducing

pre-service teachers to curriculum integration during their teacher education programs by engaging them, for example, in developing STEM lesson plans as course work and including hands-on activities and inquiry-based strategies, in order to improve teacher effectiveness and confidence (Kim & Bolger 2017; Koirala & Bowman, 2003). The results of prior studies (e.g. Kim & Bolger, 2017) have shown that the experience of developing STEM lesson plans within the methods course had a positive influence on elementary prospective teachers' attitudes toward STEM. Specifically, the authors saw significant gain on: subject awareness; prospective teachers' perceived ability to create materials for STEM education, confidence and commitment to enact such lessons in their future classroom; their perception of the potential of integration for helping students learn in a fun and interesting way that makes learning meaningful, allowing them to see the connection between science and mathematics and its use in their lives; their perception of the necessity for using team work to accomplish that integration. Other studies (Koirala & Bowman, 2003; Ní Riordan et al., 2016) reported on how PTs viewed the challenges and benefits of firsthand experience developing STEM lesson plans. Many preservice teachers appreciated the emphasis on integration used in the course, which develop their understanding of key aspects of practice that need to be taken into consideration when planning such type of initiatives.

Despite the benefits of engaging PTs in STEM lesson planning within teacher education courses, this is a challenging activity as most of the teachers are unsure of the extent of individual topics that could be integrated within their lesson plans and of the breadth in their own content knowledge needed for teaching in multiple subject areas, due to their limited understanding of both science and mathematics concepts they are expected to teach (Brown & Bogiages, 2019). The same authors emphasized that, in order to be effective on mathematics and science integration, mathematics teachers need to be aware of the potential of science to provide meaningful contexts within which to set, for example, statistical investigations. Similarly, science teachers, who are developing methods for implementing investigations and scientific argumentation in their classrooms, need to be aware of the close ties of statistical tools with decision-making.

To explore authentic integration of science and mathematics, various authors suggest collaboration between mathematics teachers and science teachers as a way to develop their content and pedagogical content knowledge (Frykholm & Glasson, 2005). Though in many teacher education programs prospective mathematics and science teachers get to attend some pedagogy courses together, it is not usual having them discussing interdisciplinary issues of both scientific areas or cooperating in interdisciplinary projects, foreseeing their future teaching practice.

The model of “Authentic Integration”

Research has suggested diverse pedagogical approaches to meet the specific needs in the integration of mathematics and science in classrooms. Such suggestions offer important elements regarding the nature of the lessons that would provide opportunities to students to experience the recognized benefits of integrating mathematics and science. Several studies recommend that the lessons content should be contextualized and taught in an authentic manner involving hands-on, group work, inquiry, and discussion (Frykholm & Glasson, 2005; Treacy & O'Donoghue, 2014). Based on research, Treacy and O'Donoghue (2014) developed a teaching model for integrating mathematics

and science entitled “Authentic Integration” that is rooted in constructivism and requires lessons to be based on rich tasks, which relates to the real world and ensure that group work, inquiry and discussions play a central role in the classroom. The model embodies four characteristics that are considered to be fundamental for allowing that integration. The first characteristic – *knowledge development, synthesis and application* – is related to the integration of knowledge from diverse fields of Mathematics and Sciences, in which students must be able to apply knowledge of both areas to solve a problem in a real context. Another key feature of the integration model is *focused inquiry, as a means of enabling students to develop higher-level thinking* processes. Inquiry, in this study, it is understood as the work around multifaceted tasks that involve in an active way students in: making observations, posing questions, searching in diverse sources of information, planning research, reviewing what is already known about the experiment, using tools to analyze and interpret data, exploring, making predictions to answer the question, and communicating the results (Lederman, 2006). In this type of activity, students are encouraged to use evidence to answer questions and develop their arguments by linking them to scientific knowledge (Lederman, 2006). This kind of activities place students at the center of their learning, promote understanding of phenomena, support argumentation and communication, as well as their reasoning processes and critical thinking (Carlson, Humphrey, & Reinhardt, 2003). Another characteristic of the model is its *application to real-world scenarios*, allowing students to solve problems related to everyday life and to better understand phenomena that are familiar to them. Finally, the model requires lessons to be based on rich tasks, that is, these must *entail challenges based on problems that are transdisciplinary*. This model has proven to be effective in sense that, when the Authentic Instruction model was applied in the classroom, the learning which took place was relevant (Treacy & O’Donoghue, 2014).

Context and methods

This study is based on an innovative preservice teacher education project aiming to assist 10 Portuguese prospective teachers, enrolled in the first year of master’s programs in the teaching of Mathematics (n=6) and of Physics and Chemistry (n=4) at middle and secondary school levels, in developing knowledge about how to develop integrated STEM activities in school. The project involved one Didactics of Mathematics course and one Practical Preparation course of each program and was developed collaboratively by three teacher educators (the authors) who were responsible for co-teaching these courses. The Didactics of Mathematics course used an inquiry based pedagogical approach with a focus on pedagogical content knowledge to facilitate effective mathematics teaching and to help PTs to understand how to appropriately engage children in learning mathematics, particularly statistics. During one semester, the PTs attended the Practical Preparation courses together, having the opportunity to discuss interdisciplinary issues in these scientific areas and to cooperate among them (working in interdisciplinary small groups of three or four) in planning and enacting an interdisciplinary learning scenario. This learning scenario included a sequence of three lessons to be taught with one 8th grade low achievers class, based on a perspective of articulation of the two scientific areas, around an inquiry task (Thaw in Alaska) using technology. The task was created by the teacher educators in collaboration with the PTs and physics cooperating teacher of the class, aiming to promote students’ understanding of the physical

phenomenon of ice breaking by integrating statistical and physical concepts, and working autonomous and collaboratively. The context of the task is realistic as it is based on a contest that occurs every year in Nenana city, Alaska (*Nenana Ice Classic* – www.nenanaakiceclassic.com). The task asks 8th grade students to formulate conjectures on the most probable day of the year and moment of the day to occur the river's thaw, based on statistical data over the last 100 years that were available and explored by them using *TinkerPlots*TM software (Konold & Miller, 2005). Simultaneously, these students were required to use their knowledge from physics, to interpret the icebreaking phenomenon in that river and to give scientific arguments that could explain the moment when it occurs. Therefore, this inquiry task motivates students to mobilize and connect knowledge from statistics and physics.

For this study we collected the group lesson plans and the individual assignments of the 10 PTs (mentioned by fictitious names) written after they taught the planned lessons to the 8th grade class, where they were asked to reflect about their experience of planning and enacting the learning scenario in school. The qualitative data analysis carried out focuses on three dimensions of the Authentic Integration model: *application to real-world scenarios*, *high order thinking processes*; and *knowledge development, synthesis and application*. For data analyses purpose we searched in the PTs' individual assignments for instances where they explicitly mention elements concerning statistics present in the task or in students' intended or actual activity with the task, for each of the three dimensions of the model. Additionally we read all lesson plans as complementary information to the PTs' written reflections.

Results

Application to real-world scenarios

There is a shared recognition on part of these PTs that the task has a strong connection with a real-world scenario. For instance, the PTs value the fact that the situation proposed to students is related to a contest that actually occurs every year. The learning scenario is seen by the PTs as an opportunity for showing students that the statistics and physics they learn at school can be applicable to real life. From the point of view of some PTs, and due to its interdisciplinary nature, the task helps students to perceive that concepts of these two areas are not “only vague concepts and useless in the real world” (Elsa).

The specific role of statistics in the task, in relation to its context, is also recognized by the PTs. The fact that students are asked to analyse real world data is seen as an opportunity to develop new knowledge about the world and not just something they have to do to give an answer to the questions included in the task:

This task gave students the opportunity to develop their knowledge about the real meaning of statistical data and also about physical processes that occur in nature (...); this allows students to gain knowledge about the tangible world. (Carlota)

Some PTs also mention that students can explore a large amount of data by using *Tinkerplots* software, which contributes to a deeper understanding of the situation. The software potentiality to help students in the interpretation of data and to establish relationship with the real-world situation

is highlighted by some PTs: “[The software] by facilitating the interpretation of the data allows students to draw better conclusions about them and also to assign more meaning to them in the context in which they belong” (Daniela). Therefore they acknowledge the centrality of statistics in the task by the exploration students are asked to do of real data.

An aspect that is less mentioned by PTs is that the learning carried out around a real context, in this case a contest, can be mobilized in other situations. However, one of these PTs mentions that students may face challenges in the future:

that require skills and competences developed here. In fact, it is important to have the capacity to look at data and to observe how they can provide important information for future challenges, as the students looked at provided data and tried to understand how they could help them make the best bet. (Madalena)

High order thinking processes

During the work carried out in designing the learning scenario with the PTs, the teacher educators emphasized the intention that students could be involved in inquiry processes. Therefore, it is not surprising that, in their reflections, PTs’ classify the task as an inquiry and describe some high order thinking processes related to statistics present in students’ activity, such as, to make predictions and conjectures, explore and interpret data and draw conclusions, and present scientific arguments and counter-arguments. For instance, one PT recognizes several processes according to the different parts of the task as they had different features:

if an inquiry perspective is adopted for the task; in the section “My idea is ...” students have to formulate hypothesis and to investigate the veracity of these hypotheses by integrating the technology (in the section “The data collected indicate that ...”), and finally to draw conclusions, communicate the results obtained and justify them on the basis of their investigations. (Carlota)

As PTs reflect about students’ work with statistics around the exploration of data with the software, they describe high order statistical processes fostered by the task always in that context. They recognise that technology has a central role in supporting students in analysing variables in different representations to draw conclusions:

The study of the variables related to the moment of day and moment of month (...) allows clarifying the analysis done, and promotes not only a greater diversity of graphical representations and the consequent development of the capacities of reading and graphic interpretation, as well as a deepening of the conclusions obtained from these. (Madalena)

Some PTs also recognize the important role of technology in association with the inquiry task to promote other thinking processes such as interpretation and reflection: “Technology allows differentiated contact with statistics and learning is promoted by the fact that the task requires students’ interpretation and reflection and not only a mechanical work” (Elsa). By highlighting these processes, these PTs show that they ascribe an important and central role to statistics in the learning scenario.

The experience of task enactment in the classroom made it possible to recognize that the involved processes are very demanding for many students. PTs relate the difficulties they have noticed in

students both with their knowledge of mathematics and physics and their unfamiliarity with this type of proposal. For example, one PT mentioned that:

the students also showed some difficulties in being able to justify their ideas (...) and to present a scientific justification for the conclusions written from the analysis of the data, using the technological resource. (Cristina)

Also the software's potentiality of generating multiple representations has represented a difficulty for students, as they have to find out the representations that best support them in interpreting the data and drawing conclusions.

Knowledge development, synthesis and application

Within the learning scenario that has been designed there was no intention of teaching new topics in statistics or physics but to create a situation where students could mobilise their knowledge from those two subjects to support their thinking. PTs seem to have well understood that perspective and as such they have identified certain statistical topics in students' activity with the task, such as treatment and analysis of data, measures of central tendency or the concept of probability. This last concept has been mentioned by one of the Physics PTs, which is something interesting in this context: "By analyzing the students' answers, it is possible to verify that there are students who have managed to apprehend the probabilistic meaning [of the required answer] when they refer *at 15h it will be more likely to occur the thaw*" (Micaela).

The knowledge synthesis of the two areas is a key aspect in the adopted model of "authentic integration" but at the same time it encompasses a high level of complexity. When reflecting on the planning of these lessons, the PTs recognize that they haven't given the necessary attention to this process in order to support students:

I also stress the [students'] difficulty in relating the data obtained in *TinkerPlots* with the physical explanation. Some students had a tendency to respond that the temperature was responsible for the thaw, however, they did not relate the months obtained in *TinkerPlots* and the particular case of Nenana [river]. (António)

Some PTs point out the structure of the task as a limitation but also their planning and enactment of these lessons, where they could have promoted a systematization of ideas in order to help student to make connections between the reasoning they have developed within each of the two scientific areas. In fact, some PTs recognize they have conducted the whole class discussion of students' work in a way that did not provoke the intended knowledge synthesis:

We also failed in the discussion moment as we did not make a projection [to the whole class] of the students' solutions using *TinkerPlots* (...) that would have allowed debating in depth the topic of central tendency measures and (...) to give a scientific explanation for the obtained results. (Matilde)

Additionally, PTs have admitted that has been quite challenging to them to work with topics from the other subject. Their content knowledge preparation in only one of the areas was also felt by some of them as a constraint to be able to promote the synthesis of knowledge:

there is no doubt that it is a big challenge to integrate the two subjects in a single task, as during our academic trajectory we only had contact with the design of tasks that only making use of mathematics. (Cristina)

However, every PT mention the opportunity to work in small groups with colleagues from the other area which represented from their point of view an essential contribution to design and enact the learning scenario in the classroom: “some statistical concepts that I could no longer remember, the colleagues in my group helped me to remember them, and I tried to help them with some physical concepts that would be necessary to solve the task” (Carlos).

Conclusions

The design and enactment of a learning scenario within statistics and physics, adopting the model of “authentic integration” (Treacy & O’Donoghue, 2014), has proven to be an opportunity for these PTs to acquire real experience of STEM practice, which they highly value. When reflecting on this one semester experience, PTs show an awareness of the role of statistics in different activities that have been carried out in relation with the three considered dimensions of the model. In opposition to other studies where mathematics tends to be incidental to the STEM context (Fitzallen, 2015), both groups of PTs in this study considered that statistics assumes great centrality in the learning scenario that has been developed. One reason for the recognized visibility of statistics may be related to the features of the task itself as it requires students to analyse real world data (the 1st dimension considered in the model). These PTs highly value this dimension of the task in the sense of making learning meaningful and showing the usefulness of statistics (and also physics) to students, results also present in the study by Kim and Bolger (2017).

PTs also perceive that the task demanded high order thinking processes (the 2nd dimension) that were supported by statistics. The inquiry nature of the task required the exploration and interpretation of statistical data in order to make conjectures and draw conclusions, something that put into evidence the role of statistical tools for decision-making in STEM contexts (Brown & Bogiages, 2019). PTs also stress the important role of technology for promoting inquiry processes (Lederman, 2006), in this case with the statistical software.

From the formative point of view, it is also relevant that PTs show a critical stance regarding the effective opportunities provided for knowledge synthesis of the two subject areas (part of the 3rd dimension). Acknowledging that this process involves a high level of complexity, PTs recognize the challenges they faced and the need to give particular attention to this aspect when planning the lessons (Koirala & Bowman, 2003; Ní Riordan et al., 2016).

This study shows the feasibility of developing an interdisciplinary learning scenario in a pre-service teacher education program with two distinct areas, using a specific model. However, as this is a time consuming activity in its different aspects (Brown & Bogiages, 2019), from designing the task to the elaboration of the lesson plan, it needs to be reflected when designing the courses. Collaboration among peers from two different subject areas has revealed to be quite beneficial for these PTs and of significance in supporting an integrative approach to teaching mathematics and physics. Therefore the model of “authentic integration” seems to be adequate to support teachers from diverse subjects to work together in a STEM context.

Acknowledgment

This study is supported by national funds through FCT – Fundação para a Ciência e Tecnologia, *Project Technology Enhanced Learning at Future Teacher Education Lab* (contract PTDC/MHC-CED/0588/2014).

References

- Becker, K., & Park, K. (2011). Effects of integrative approaches among science, technology, engineering, and mathematics (STEM) subjects on students' learning: A preliminary meta-analysis. *Journal of STEM Education*, 12(5 & 6), 23-27.
- Brown, R. E. & Bogiages, C. A. (2019). Professional development through STEM integration: How early career math and science teachers respond to experiencing integrated STEM tasks. *International Journal of Science and Mathematics Education*, 17(1), 111-128.
- Carlson, L., Humphrey, G., & Reinhardt, K. (2003). *Weaving science inquiry and continuous assessment*. Thousand Oaks, CA: Corwin Press.
- Fitzallen, N. (2015). STEM education: What does mathematics have to offer? In M. Marshman, V. Geiger, & A. Bennison (Eds.), *Proceedings of 38th Annual Conference of the Mathematics Education Research Group of Australasia* (pp. 237-244). Sydney: Merga.
- Frykholm, J. & Glasson, G. (2005). Connecting science and mathematics instruction: Pedagogical context knowledge for teachers. *School Science and Mathematics*, 105(3), 127–141.
- Kim, D. & Bolger, M. (2017). Analysis of Korean elementary pre-service teachers' changing attitudes about integrated STEAM pedagogy through developing lesson plans. *International Journal of Science and Mathematics Education*, 15(4), 587-605.
- Koirala, H. P. & Bowman, J. K. (2003). Preparing middle level preservice teachers to integrate mathematics and science: problems and possibilities. *School Science and Mathematics*, 103(3), 145–154.
- Konold, C., & Miller, C. D. (2005). *TinkerPlots: Dynamic data exploration*. Emeryville, CA: Key Curriculum Press.
- Lederman, N. G. (2006). Syntax of nature of science within inquiry and science instruction. In L. B. Flick & N. G. Lederman (Eds.), *Scientific inquiry and nature of science* (pp. 301-317). Dordrecht: Springer.
- Ní Ríordáin, M., Johnston, J., & Walshe, G. (2016). Making mathematics and science integration happen: Key aspects of practice. *International Journal of Mathematical Education in Science and Technology*, 47(2), 233–255.
- Treacy, P. & O'Donoghue, J. (2014). Authentic Integration: A model for integrating mathematics and science in the classroom. *International Journal of Mathematical Education in Science and Technology*, 45(5), 703–718.

Student conception of angles and parallel lines in engineering context

Premkumar Pugalenti¹, Michelle Stephan² and David Pugalee³

^{1, 2 & 3} The University of North Carolina at Charlotte, United States of America

¹ ppugalen@uncc.edu; ² mstepha1@uncc.edu; ³ david.pugalee@uncc.edu

As a result of focused efforts to promote STEM education, there is an increased interest in understanding the use of engineering and technology contexts to teach mathematics in K-12 classrooms. This design research was conducted in a grade 7 classroom of a suburban school. Analysis of student interviews revealed that the students possess a rudimentary understanding of parallel lines and lack a conceptual understanding of angles. These notions were used to design and develop mathematical instructional tasks with an engineering problem as the context in order to motivate students understanding to more sophisticated notions of angles and parallel lines.

Keywords: Design research, engineering contexts, geometry, middle school, STEM integration.

Introduction

The intricacies of today's technologically advanced world have pushed educators to rethink the set of core skills and knowledge that current students should learn. Included among these skills is problem solving, gathering data, evaluating evidence, making sense of information and communicating findings with others. Science, Technology, Engineering, and Mathematics (STEM) education provides students with opportunities to develop such skills and knowledge and also the application of that knowledge (Mahoney, 2010). STEM education started as a way of providing additional rigor and depth for gifted students, but over the years it has proven effective with a range of students and, in fact, has improved disadvantaged students' motivation and performance (Kim & Law, 2012). This understanding of the importance and necessity of student-centered approaches has pushed researchers and policymakers' work towards increasing student-learning opportunities in United States (Brown, 2012). Given the emphasis, there is no surprise that there is a huge push for educational standards reforms by organizations such as National Council of Teachers of Mathematics, the National Research Council, and the International Technology Education Association. Recent educational standards reforms such as *Next Generation Science Standards* (NGSS) and *Common Core State Standards for Mathematics* (CCSSM) encourage integration of engineering and technology in science and mathematics classrooms (Kuenzi, 2008).

The underlying intent of these mathematics standards is to enculturate students into the mathematical practices that will encourage deeper understanding of the concepts (cf. Standards for Mathematical Practices, CCSSM) and help students apply mathematics to the world around them (Brown, 2012). STEM-based mathematics learning, at its heart, is an investigative process that allows the learner to dive deeply into a topic and use mathematics to create a solution. A student centric approach like STEM-based learning becomes not only a viable method of teaching and learning, but possibly a highly effective method as well (Bybee, 2010). The central idea with STEM education is promoting pedagogical practices that are student centric. That is, teachers play the role of facilitators as opposed to the traditional knowledge provider.

Teachers employ several instructional strategies including student-led presentations, problem-based learning, brainstorming sessions, small group discussions, simulations, student-led experiments and engineering designs and so on (Fairweather, 2008). In the world of mathematics, STEM-based learning allows students to use mathematics within the context of other subject areas to solve problems. This process requires students to learn math to apply to the formation of a solution or solutions. The math is never separated from other disciplines, thereby making the construction and the application of knowledge easier (Fairweather, 2008). STEM-based learning accesses the students' knowledge and engages students to be part of a community collaborating together on activities (Blumenfeld, Krajcik, Marx, & Soloway, 1994). Thus, students share what they already know with other students in the group toward finding solutions for the tasks at hand. Students discuss, justify, and argue about the mathematics as part of this collaboration. This research paper is a part of a larger research study that aimed to contribute to the ongoing dialogue regarding the efficacy of genuine STEM integration. Specifically, this study explored the process of design and implementation of a classroom-learning trajectory (Stephan, 2014) that integrated mathematics and engineering in an authentic manner to evoke STEM practices more generally. Our goal was to explore the feasibility of using engineering contexts to teach mathematics and to develop a conceptual framework for effective STEM integration. The rationale behind choosing a design based research approach was the ability to contribute to development of theory and educational practices together given that the inter-relation between them is complex and dynamic (Plomp & Nieveen, 2007).

Literature review

This review highlights the research on two notions that form the core of the arguments presented throughout the paper. The first section encompasses the present nature and understanding of STEM integration in K-12 education and the subsection on student conception of angles and parallel lines summarizes the framework for the analysis of the related student interviews.

STEM integration

While there has been a nationwide push to increase STEM in secondary schools, the debate regarding the best practices for integrating STEM across multiple subjects still exists (Stephan, Pugalee, Cline, & Cline, 2016). Therefore, new theories of best integration practices in STEM are still being conceptualized and pursued. One of the greatest challenges facing secondary STEM teachers today is seamlessly and effectively integrating STEM content as well as the related processes into their core classes. A common barrier for this integration is accurately navigating the multiple static components of a STEM curriculum. The introduction of engineering as a critical component of STEM education is especially problematic for educators who have little training or prior skills with engineering content and principles. When STEM integrated lessons are based in systems thinking, the teaching of multiple subjects becomes less rigid. Kelley and Knowels (2016) conceptual framework for integrated STEM education alludes to this idea with their pulley system model. However they place the emphasis heavily on engineering design and scientific inquiry, which can lead to fewer instances for mathematics and technology to be a central part of the STEM system. Wang, Moore, Roehrig and Park (2011) showed that successful STEM integration is

possible using their case study of three middle school teachers. Their important findings included that teachers need more content knowledge especially in engineering and technology and that their STEM classroom practices depend on their perception of the use of STEM integration, which is influenced by their primary discipline. Also, typically mathematics is taught first to solve an engineering challenge whereas in our approach instructional sequences are designed to use an engineering challenge to motivate students thinking of mathematics.

Student conception of angles and parallel lines

In this research, students' current conceptions of angles and parallel lines are explored through their concept image. Tall and Vinner (1981) defines concept image as "...the total cognitive structure that is associated with the concept, which includes all the mental pictures and associated properties and processes" (p.152). Keiser, Klee, and Fitch (2003), in their action-based research with 77 sixth grade students, highlighted the limitation posed by definitions of mathematical concepts as, "the truth is that all definitions, by their very nature, tend to limit concepts because they establish boundaries" (p.117). The idea is that a definition can focus on one aspect of the concept, which may lead to students not having a well-developed concept image. Keiser (2004) further expands this notion of angle as a concept: What exactly is being measured when referring to the size of angles?, Can angles contain curves?, and difficulties with conceiving of 0° , 180° , and 360° angles. Fyhn (2008) summarized the research on cognition of angles and the key ideas of angles: Angle as a static geometric shape, dynamic notion, and as measure; and Angle without arc (as linked line), with arc (angle space), with arrow (part of a plane) and with rotation arrow (creation can be described by rotation of a ray). Happs and Mansfield (1989) identified the following as the common misconceptions about parallel lines that students bring to lessons: parallel segments must be aligned; and presence of arrows or dots on the ends of lines affects whether or not those lines are parallel.

Methodology

The research reported in this paper aims to capture the students' conception of angles and parallel lines in order to design the engineering context based instructional sequences for a middle grades mathematics classroom. The research was conducted in a 7th grade mathematics classroom of a STEM middle school in a suburban school district in the southeast region of United States. The classroom teacher was part of the design team along with faculty specializing in mathematics education, chemistry, and engineering at a large urban university and a mathematics education faculty member from an international university. This research is comprised of a pre-interview to assess the existing conceptions of angles and parallel lines, design and implementation of engineering-based instructional sequences and a post-interview to assess the changes in conceptions of angles and parallel lines. This research paper focuses mainly on the analysis of the pre-interview questions dealing with angles and parallel lines along with preliminary discussion of the design of the instructional sequence.

Before developing the instructional sequences, 4 students (2 male and 2 female students) at different academic performance levels (as identified by the classroom teacher) were interviewed. The student's cumulative performance on prior assessments in their current classroom was used as the criteria to classify the four academic performance levels as *high*, *above average*, *average* and

low. These four students engaged in a pre-interview with questions designed to probe their understanding of angles and parallel lines and an engineering problem. The purpose of these interviews was to learn the students' current conceptions of these mathematical and engineering ideas and design the instructional sequences appropriately for the entire classroom. The interview questions probed for the students' conceptual understanding of angles, parallel lines and their strategies in solving the engineering problem. The first angles question prompted the students to identify the biggest and smallest angle from a set of angles represented diagrammatically (Figure 1). The second set of angles questions asked the students to identify the number of angles in various diagrams such as a triangle (Figure 1) and validate their solution with a mathematical argument. Similarly, the parallel lines questions asked students to identify if the given lines, curves and geometric shapes (e.g., Figure 1) have anything parallel in them and validate their solution with a mathematical argument.

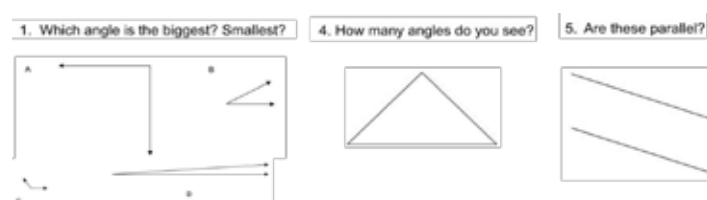


Figure 1: Sample questions from the pre-interview questionnaire

In analyzing the student responses, the constant comparative method (Glaser, 1965) was utilized in order to identify themes that are grounded within the data. The student justifications were broken down into discrete incidents. Researchers simultaneously coded and analyzed these specific incidents to inductively reason the categories for codes and their properties. Three researchers met and analyzed the student responses from the videos and identified emerging categories as the students communicated his/her mathematical arguments. The analysis also took into account the hand gestures of the students. Select portions of the videos were transcribed later for inclusion in the research. Constantly identifying and comparing the relationships between these categories led to the final themes. Once a theme emerged, data analyses were continued to either support or refute the theme until all the student responses were analyzed. This process was the same for both the angles and parallel lines questions, but analysis for each topic was performed separately.

Findings and discussion

This analysis of the students' conceptions of angles and parallel lines comes from the pre-interview data, before instruction with an engineering context to teach the same mathematical concepts. The following three themes emerged from the angles questionnaire analysis: Using Prototypes or Reference Images, Tracing of the Lines, and Decoupling versus Decomposing.

Theme one: Using prototypes or reference images

The first theme that emerged from the data analysis was the idea of using prototypes or reference images of angles to identify and define angles. All of the students shared this notion where they used reference images such as 90° -, 180° - and 360° -angles or used the definitions of acute and obtuse angles. The students associated the word 90° or 180° with the diagrammatic representation of the same without any understanding of what it means that a right angle is 90° . For instance, the

student below expressed their confusion with straight angle and straight line, likely, as they had seen a straight line referred to as both a straight angle and a straight line in the past.

Student: This is a straight...

Interviewer: Straight what?

Student: It is either a straight line or a straight angle because this is a whole 180.

Theme two: Tracing of the lines

A second theme that emerged from the data analysis was the idea of tracing the line to see if it changes direction as a rationale to identify if there is an angle. For instance, the student below, when asked to identify the number of angles in the given diagrammatic representation of the right triangle in Figure 1, reasoned that there was one angle because there was a corner which makes the line go in two different directions. The student viewed the rays of the angle dynamically in that a dot could be used to trace along one ray and then change direction to follow the other ray, thus, producing an angle. A different student traced the line as well, but the conception of angle was not as dynamic. The student viewed the two lines as two static entities connected at a point to form an angle.

Student: So here's the main line and then it's starting to go up as in 90 degrees.

Interviewer: The main line is going this way (horizontal), then the other line this way (vertical)

Student: Yes, in a 90 degree angle.

Theme three: Decoupling versus decomposing

A third theme was the idea of dissociating the original angle from the two new angles when the original angle is split into two by a new ray. In other words, the students counted the whole angle as an angle and the two new split angles; each as one but they did not worry to check if the sum of the two new angles equals the original angle when they were asked to estimate the angles.



Figure 2: Decoupling of angles

In Figure 2, the student estimated the three angles of the equilateral triangle to be 75° and then the two split angles on the top to be 25° each. We also observed another case, where the student expressed that the original angle is no longer available when it is split and only the two new angles are left. In other words, they view the new right-angled triangles as a decoupled shape as opposed to decomposing the angle from the equilateral triangle into two right-angled triangles.

The following two themes emerged from the parallel line questionnaire analysis: Never Touch and Same Shape Pattern.

Theme one: Never touch

The first theme that emerged from the data analysis was the idea that something is parallel if they never touch. This is evident in one student's use of railroad tracks as an example. The questionnaire began with sets of lines oriented in different angles and were misaligned the reasoning that they will never touch was predominately used by all students for these questions with lines.

Interviewer: How about these?

Student: Parallel, I see this mainly because they still won't touch.

Theme two: Same shape pattern

Another theme that emerged from the data analysis was the idea that for two lines or curves to be parallel they must have the same shape pattern and align in the same direction. This reasoning of having the same shape pattern emerged only when curves were introduced in the questions.

Interviewer: How do you know that they are never going to touch each other?

Student: As long as this pattern is maintained, they're never going to touch.

However, two of the students extended the curves into a line to show that either the two lines/curves touch or not touch to justify their argument of whether they are or are not parallel. For instance, in Figure 3, the student extended the curve at the bottom as a line to touch the straight line on the top instead of following the pattern of the curve at the bottom. This shows that the students preferred the never touch rule over the same shape pattern when justifying their argument as to whether they are or are not parallel.



Figure 3: Parallel lines/curves never touch

From our analysis of students' existing notions of parallel lines, the students' mathematical arguments were rudimentary and based on their prior experiences of parallel lines either in mathematics or other subject areas. This is evident in the classic railroad track example followed by the justification that the two tracks never touch. Students demonstrated difficulty in extending the notion of the lines that never touch to more sophisticated notions such as that the lines are equidistant from each other. This exploration of student's understanding of angles and parallel lines combined with perspectives from the literature was utilized to design the context of the engineering based instructional sequence for the classroom.

Design of engineering problem based instructional sequences

Gravemeijer and Doorman (1999) highlight the role of context problems as, "...context problems are intended for supporting a reinvention process that enables students to come to grips with formal mathematics" (p. 111). Combining this notion with the understanding of the students' concept images of angles and parallel lines which is rudimentary as revealed in the findings above, the instructional sequences of building parallel roads in a residential community and constructing 3D models of two-story homes was developed. The problems within the sequences were designed to capitalize on students' current conceptions of angles and parallel lines (as revealed in the

interviews), yet utilizing contextual features to revise those conceptions. The instructional activities were designed to develop students' understanding of measuring angles as the degree of turn and parallel lines as the same distance apart. Designing a residential community is the engineering problem used to provide context for the mathematical task where the students identified the design constraints from an architect's brief. In essence, the students played the role of an architect and were asked to develop the Phase II of an existing residential community given a map of Phase I.

One of the constraints was to build a road parallel to the existing road on Phase I for aesthetic reasons, the context for the first mathematical instructional sequence. Student groups explored the possibility of using pre-drawn, existing parallel roads in Phase I and measuring the distance between the two existing roads to create new parallel roads. This led to the discussion of the concept of equidistance in parallel lines. Similar instructional sequences were used to develop the notions of parallel lines using angles. A post-interview was conducted to study if the engineering based instructional sequence, which was designed based on the pre-interview questionnaire analysis helped the students improve their understanding of the mathematical concepts related to angles and parallel lines. Due to page limitations, the analysis of the post-interview and additional instructional sequences are not discussed here and instead was discussed in detailed at the congress during the presentation. Post-interview analysis revealed that there was an overall improvement in conceptual understanding of angles and parallel lines among the four students.

Current in-service mathematics teachers are asked to design and teach in STEM integrated classrooms, yet most of them are not academically trained in engineering and technology. This study is part of a larger investigation focused on a research-based framework for STEM integration. The analysis of student thinking relative to angles and parallel lines is important to this study as a foundation for informing the larger design research process. The analysis of student thinking revealed several limitations in students' current conceptualization of angles and parallel lines, both of which are critical components in the target instructional tasks embedded within the engineering context of planning the roads and houses in a community. The students' current perspectives with limited understanding of angles and parallel lines inform the larger design research study by setting up instructional tasks that specifically address these issues. This study underscores the role of visiting and revisiting student thinking as a necessary step in the design research process.

References

- Blumenfeld, P. C., Krajcik, J. S., Marx, R. W., & Soloway, E. (1994). Lessons learned: How collaboration helped middle grade science teachers learn project-based instruction. *The Elementary School Journal*, 94, 539–551.
- Brown, J. (2012). The current status of STEM education research. *Journal of STEM Education: Innovations and Research*, 13(5), 7.
- Bybee, R. W. (2010). What is STEM education?. *Science*, 329(5995), 996-996.
- Fairweather, J. (2008). Linking evidence and promising practices in science, technology, engineering, and mathematics (STEM) undergraduate education. *Board of Science Education, National Research Council, the National Academies, Washington, DC*.

- Fyhn, A. B. (2008). A climbing class' reinvention of angles. *Educational Studies in Mathematics*, 67(1), 19-35.
- Glaser, B. G. (1965). The constant comparative method of qualitative analysis. *Social Problems*, 12(4), 436-445.
- Gravemeijer, K., & Doorman, M. (1999). Context problems in realistic mathematics education: A calculus course as an example. *Educational Studies in Mathematics*, 39(1-3), 111-129.
- Happs, J. C., & Mansfield, H. (1989). Students' and teachers' perceptions of the cognitive and affective outcomes of some lessons in geometry. *Proceedings of Annual Meeting of the American Educational Research Association* (pp. 1–35). San Francisco, CA.
- Keiser, J. M. (2004). Struggles with developing the concept of angle: Comparing sixth-grade students' discourse to the history of the angle concept. *Mathematical Thinking and Learning*, 6(3), 285-306.
- Keiser, J. M., Klee, A., & Fitch, K. (2003). An assessment of students' understanding of angle. *Mathematics Teaching in the Middle School*, 9(2), 116.
- Kelley, T. R., & Knowles, J. G. (2016). A conceptual framework for integrated STEM education. *International Journal of STEM Education*, 3(1), 1–11.
- Kim, D. H., & Law, H. (2012). Gender gap in maths test scores in South Korea and Hong Kong: role of family background and single-sex schooling. *International Journal of Educational Development*, 32(1), 92–103.
- Kuenzi, J. J. (2008). *Science, technology, engineering, and mathematics (STEM) education: Background, federal policy, and legislative action*. Retrieved from Congressional Research Service Reports website: <http://digitalcommons.unl.edu/crsdocs/35>
- Mahoney, M. P. (2010). *Student attitude toward STEM: Development of an instrument for high school STEM-based programs* (Doctoral dissertation, The Ohio State University).
- Plomp, T., & Nieveen, N. (Eds.) (2007). An introduction to educational design research. *Enschede, the Netherlands: SLO*
- Stephan, M. L. (2015). Conducting classroom design research with teachers. *ZDM Mathematics Education*, 47(6), 905–917.
- Stephan, M., Pugalee, D., Cline, C., & Cline, J. (2016). *Lesson imaging in math and science: Anticipating student ideas and questions for deeper STEM learning*. ASCD.
- Tall, D., & Vinner, S. (1981). Concept image and concept definition in mathematics with particular reference to limits and continuity. *Educational Studies in Mathematics*, 12(2), 151–169.
- Wang, H.-H., Moore, T. J., Roehrig, G. H., & Park, M. S. (2011). STEM Integration: Teacher perceptions and practice STEM integration: Teacher perceptions and practice. *Journal of Pre-College Engineering Education Research (J-PEER)*, 1(2), 1–13.

Opportunities to engage in STEM practices: Technology and design course

Behiye Ubuz

Middle East Technical University, Ankara; ubuz@metu.edu.tr

Technology and design courses hold a potential to contribute to the STEM agenda. In this study I seek to explore the nature of STEM education across the courses, particularly examining 7th grade intended curriculum in Turkey in terms of engineering design process and knowledge base. By extensive examination and coding of learning outcomes together with explanation provided under each one I identified instances of engineering design process and knowledge by learning areas. 52 learning outcomes (27 with emphasis on knowledge and 25 with engineering design) were identified in the intended curriculum.

Keywords: Engineering design process, knowledge, STEM, technology and design course.

Introduction

Technology and Design (T & D) courses, or similar forms, have been taught in many countries around the world. T & D courses hold potential to contribute to the Science, Technology, Engineering and Mathematics (STEM) education agenda, however currently this is not wholly examined how. The purpose of this study was to explore the way T & D course in Turkey contributes to the STEM education agenda. Specifically, the aim was to explore how existing 7th grade T & D course intended curriculum (Milli Eğitim Bakanlığı, 2017) concretize engineering design process (EDP) together with knowledge base combined with it, with the ultimate purpose of providing direction in understanding STEM education. EDP combines knowledge and skills from a variety of fields with the application of values and understanding of societal needs to create systems, components, or processes to meet human needs (NAE, 2009, p.9). The research questions of the study were:

1. To what extent is engineering design process present in the 7th grade T & D course intended curriculum in Turkey?
2. What are the central knowledge of engineering and technology that are present in existing curriculum?
3. What are the central knowledge of mathematics and science that are present in existing curriculum?

This study provided a window into the nature of STEM education across T & D courses. This information provided educational researchers, policy makers, and K-12 teachers with a detailed picture of what STEM education is, especially when that vision of STEM education includes engineering and technology. This study was significant in order to demonstrate possibilities for a systematic integrated framework for engineering and technology in K-12.

What is the engineering design process?

EDP is the iterative process for creation and manipulation of the human-made world. It is one of the six tenets for successful STEM education (Moore et al., 2014). A number of core characteristics of

EDP are (1) the design process begins with problem definition; (2) design problems have many possible solutions and engineers must find systematic approaches to choosing between these; (3) design requires modeling and analysis; and (4) the design process is iterative (Berland, Steingut, & Ko, 2014, p.706). Figure 1 summarizes these four characteristics of engineering design, articulating the key aspects of each characteristic and highlighting the aspects that create the most opportunity for mathematics and science integration.

Characteristic of design process	Key aspects of the characteristic as identified in the literature
Defining the problem	Interviewing users and stake holders Identifying the need that will be solved Identifying sub-problems and goals Exploring existing solutions <i>Describing the need in terms of quantifiable success criteria</i> <i>Understanding key math and science principles</i>
Generating and selecting between multiple possible solutions	Identifying multiple possible solution <i>Developing systematic approach for choosing between solutions by balancing different goals of the project</i>
Modeling and analysis	<i>Modeling parts of the existing system into which the solution must fit</i> <i>Collecting, modeling, and analyzing performance data</i>
Iteration	Revisiting previously completed steps in order to improve designs <i>(some steps may require revision of math and science use previously completed)</i>

Note: Italics indicate the quantitative aspects that create the strongest opportunities for integration of traditional math and science content. Taken from Berland, Steingut, and Ko (2014, p.708)

Figure 1: Summary of the four characteristics of engineering design

Methodology

T & D course is a school subject offered as a compulsory course at the 7th and 8th grades in Turkey for two hours a week. In this context, individuals who complete the T & D course can observe and interpret objects, events, and facts in their surrounding in an analytical perspective, can develop creative and original alternative suggestions to the problems identified, and can make evaluations of these suggestions and decide on the appropriate one. T & D course intended curriculum was created according to the learning area approach. Learning areas are (A) Technology and Design Basics, (B) Design Process and Introduction (promotion), (C) Built Environment and Product, (Ç) Needs and Innovations; and (D) Design and Technological Solution.

To accomplish the aim of the study, I examined the 7th grade T & D course intended curriculum learning outcomes together with the explanations provided under each one. Learning outcomes helps to identify assumptions about what knowledge and skills the students need to bring to succeed. Although learning outcomes might differ in the ways they are written, they all express the

same idea and that is what the learner should know, do, or feel. Explanations provided under each learning outcomes assists teachers in building knowledge and skills in accordance with learning outcomes. Content analysis of learning outcomes was conducted using line-by-line analysis. The operational definitions of EDP (see Figure 1) and the five components of learning outcomes proposed by Gagné and Briggs (1974) guided the initial open coding of the outcomes. The unit of analysis during all phases of coding was the phrase. While coding the learning outcomes individually as phrases, a word analysis was deemed helpful in locating and portraying the big ideas of EDP and knowledge base. The most common verbs (see Figure 2) and objects (see Figure 3) found in the learning outcomes regarding EDP and knowledge base are provided below.

EDP	Knowledge
Apply	Compare
Create	Describe
Design	Provide
Evaluate	State
Prepare	
Present	
Reinterpret	
Restructure	
Show	
Tell	

Figure 2: Most found verbs in EDP and knowledge

All outcomes were coded using the following two primary categories: EDP, or knowledge. Outcomes that fit the category of EDP went into one of the four categories of EDP provided in Figure 1 as well as a new category labelled as presentation. Outcomes that fit the category of knowledge went into one of the three categories: Design, technology, or design and technology. An example learning outcome was: “7.A.2.1. State the elements of art/design”. This statement implies knowledge as “state” refers to capability verb pointing out verbal information and “the elements of art/design” refers to object that the learner will produce as a result of action. Additionally, the opportunities for using or integrating mathematics and science in these two main categories were also examined. Inter-rater reliability verified consistency among two individuals through descriptive statistical measures.

EDP	Knowledge
Design	Design concepts
Model	Design principles
Prototype	Elements of art/design
Product	Examples
	Technology concepts
	Technological developments

Figure 3: Most found objects in EDP and knowledge

Results

A close analysis of the 7th grade T & D course intended curriculum reveals EDP together with knowledge base in technology and design. 52 learning outcomes (27 with emphasis on knowledge and 25 with EDP) (see Table 1) were identified in the intended curriculum. Core characteristics of the EDP and knowledge base are presented in Figure 4 and 5, respectively. Some explanations were found to have explicit references to mathematics and science. Regarding mathematics, two-three dimensional space appeared for producing or demonstrating a design, ratio-proportion as one of the design principle, measurement for analyzing physical dimensions of architectural structures or buildings, and graphing for representing a design. Explicit references to science were about energy, force, pressure, durability, resistance, balance, corrosion, or geography (geographical and climate conditions).

Table 1: Number of learning outcomes at the 7th grade on knowledge and EDP by learning area

	Learning Areas					Total
	A	B	C	Ç	D	
Knowledge						
Design	3	10	7	-	-	20
Technology	2	-	-	1	-	3
Both	2	1	-	1	-	4
EDP						
Defining the problem	1	1	-	1	1	4
Generating and selecting between multiple possible solutions		1			2	3
Modeling and analysis	1	2	4	2	1	10
Iteration	1	1	1		2	5
Presentation		1		1	1	3
Total	10	17	12	6	7	52

Because of the space restriction, learning outcomes together with their coding are given only regarding to the two learning areas (see Figure 6 and 7).

Conclusion

This investigation provided a window into what STEM education look like in a T & D course within middle school. This curriculum could support teachers' integration of STEM disciplines, particularly an understanding of the nature of EDP skills that would develop their ability to effectively integrate EDP into their science and mathematics instruction. This has great implications if integrated STEM is to include EDP. The degree of integration, however, would be related to the teachers' awareness of how to make explicit and meaningful connections between the disciplines.

This study also showed that the ideas expressed by Berland, Steingut, and Ko (2014) related to characteristics of EDP were present in the document analyzed together with the new additional characteristic named as presentation and key aspects of them. This will provide opportunity to compare the results found here with what courses offered in other countries.

Characteristic of design process	Key aspects of the characteristics as identified in the curriculum
Defining the problem	Investigation of examples according to different criteria based on venue, lighting, colour, texture, physical measurements, geographical conditions, forms of life, manufacturing processes, necessary resources, security measures, environmental factors, user, applications, material Following and reading published public spots, visual-print media news, and scientific research
Generating and selecting between multiple possible solutions	Developing solution alternatives and choosing the appropriate one based on the criteria pointed out in defining problem
Modeling and analysis	Creating model, prototype, drawings, or maquette of the design
Iteration	Revisiting previously completed steps in order to re-interpret or restructure designs based on the predetermined criteria or evaluation
Presentation	Short films, computer aided presentations, promotional card, poster, flyer

Figure 4: Summary of the five characteristics of EDP identified in the curriculum

Knowledge		
Design	Technology	Design and Technology
Industrial design	Invention, discovery, science, techniques, technology, industry, industry 4	Relation between them and how they affect each other
Graphic design	Historical development of technology	Positive and negative contributions of them to daily flow of life
Architectural design	Technologies to acquire energy	The importance of them to solve problems
Environmental design		
Elements of art/design		
Ergonomics		
Mechanical properties of design		

Figure 5: Summary of the knowledge on design and technology identified in the curriculum

References

Berland, L., Steingut, R., Ko, P. (2014). High school student perceptions of the utility of the engineering design process: Creating opportunities to engage in engineering practices and apply math and science. *Journal of Science Education and Technology*, 705–720.

- Gagné, R. and Briggs, L.J. (1974) *Principles of instructional design*. Holton, Rinehart & Winston, New York.
- Milli Eğitim Bakanlığı [Ministry of Education] (2017). *Teknoloji ve tasarım dersi öğretim programı* (Ortaokul 7. ve 8. Sınıflar) [Technology and design course curriculum (Middle School 7. and 8 Grades)].
- Moore, TJ, Stohlmann, MS, Wang, H-H, Tank, KM, Glancy, A, Roehrig, GH (2014). Implementation and integration of engineering in K-12 STEM education. In J Strobel, S Purzer, M Cardella (Eds.), *Engineering in precollege settings: Research into practice*, (pp. 35–59). West Lafayette: Purdue University Press.
- National Academy of Engineering and National Research Council of the National Academies. (2009). *Engineering in K–12 education: Understanding the status and improving the prospects*. Washington, DC: National Academies Press.

7.A. Technology and design basics

Subjects	Learning outcomes and explanations	STEM
7.A.1. Learning technology and design	7. A. 1. 1. State the technology concept <i>The concepts of invention, discovery, science, technique, technology, industry, and industry 4 are emphasized.</i>	Knowledge Technology
	7. A. 1. 2. State the design concept <i>Design concept which consists of industrial design, graphic design, architectural design, and environmental design areas are emphasized.</i>	Knowledge Design
	7.A.1.3. State the relation between technology and design <i>Based on a product, relation between technology and design and how they affect each other are emphasized.</i>	Knowledge Technology and Design
	7.A.1.4. Provide examples for technology and design from the real life <i>The positive and negative contribution of technology and design to the daily flow of life are emphasized. The importance of the design and technology in solving problems faced in daily life are focused.</i>	Knowledge Technology and Design
	7.A.1.5. Compare the technological developments in Turkey and other countries <i>Based on a product, historical development of technologies (e.g. white goods, automobile, telephone, ship construction, agricultural machinery) is focused.</i>	Knowledge Technology

Figure 6: The characteristics of the 7th grade curriculum technology and design basics area

7.A. Technology and design basics

Subjects	Learning outcomes and explanations	STEM
7.A.2. Basic Design	7.A.2.1. State the elements of art/design <i>How to use elements (line, color, texture, space form) of Art/Design while expressing ideas are shown on examples.</i>	Knowledge Design
	7.A.2.2. Show the elements of art/design on a product. <i>A two or three dimensional design product might be investigated. While investigating, for example banner designs, environmental awareness and economy issues are focused.</i>	EDP Defining the problem
	7.A.2.3. Describe design principles on a product <i>Design principles including balance, rhythm, intonation, movement, unity, diversity, and ratio-proportion are given.</i>	Knowledge Design
	7.A.2.4. Reinterpret a design product around <i>After the product analysis and idea development process, a design product is re-interpreted as a drawing</i>	EDP Iteration
	7.A.2.5. Create a design using art/design elements and design principles. <i>Create a design using methods such as drawing, painting, cutting, folding, combining, tearing, gluing with emphasis on recycling and the production of product from waste materials</i>	EDP Modeling and analysis

Figure 6 continued

7.D. Design and technological solution

Subjects	Learning outcomes and explanations	STEM
7.D.1. I am designing my original product	7.D.1.1. Tells the design problem	EDP Defining the problem
	7.D.1.2. Apply the research steps to solve the design problem <i>Discussing multiple possible solutions to a problem via investigating similar examples, using right data sources, and developing the idea of an original design are emphasized.</i>	EDP Generating and selecting between multiple possible solutions
	7.D.1.3. Prepare a design plan <i>User, material, application and environmental factors to be taken into account; investigation of methods and techniques to solve problems, development of solution alternatives, chose one of the solution alternatives under the guidance of the teacher, decide on the tools and materials that are appropriate to the design</i>	EDP Generating and selecting between multiple possible solutions
	7.D.1.4. Create the model or prototype of the design <i>Investigation of manufacturing processes of the sample products and necessary resources; visualisation of the model via maquette and drawings; creating the model or the prototype of the design using appropriate tools and materials</i>	EDP Modeling and analysis
	7.D.1.5. Evaluate the design according to the determined criteria. <i>Evaluating the designed product based on the determined criteria (aesthetic, original, functional, feasibility, and sustainable). In the process of evaluation self-assessment and peer assessment are used.</i>	EDP Iteration
	7.D.1.6. Restructures the designed product according to the evaluation results.	EDP Iteration
7.D.2. I did this	7.D.2.1. Present the products <i>Promotional materials (short film, computer-aided presentation, promotional card, poster, flyer, etc.) are prepared for product(s)</i>	EDP Presentation

Figure 7: The characteristics of the 7th grade curriculum design and technological solution area

Gamification with Moodle in higher education

Ana Júlia Viamonte¹ and Isabel Perdigão Figueiredo²

¹P.Porto, ISEP, Math Department, LEMA, Portugal; ajv@isep.ipp.pt

²P.Porto, ISEP, Math Department, Portugal; ipf@isep.ipp.pt

Today, although teachers continuously seek novel pedagogical approaches, it is largely agreed that schools face major problems around student motivation and engagement. In this context, gamification can have good effects, since the gamification, when used as a teaching strategy, favors learning and the motivation. Though the gamification is a subject that is very discussed in the educational field, still's little implemented, especially in higher education. In this work we present one gamification experience with first year and first semester students in a mathematical curricular unit. The goal was reduced school dropouts, which have a traditionally very high rate in these curricular units and increase the motivation to empower students for better learning and a higher passing rate. Although this experience does not allow for conclusions, it can be verified that the students were more motivated, the dropout rate was lower, and the approval rate was good.

Keywords: Gamification, higher education, pedagogy.

Introduction

Traditional schooling is perceived as ineffective and tedious by many students and in a special way a large group of students in the first year of engineering courses, does not like math classes which leads to high dropout and failure rates. At a time when most of the young audience plays computer and video games, the gamification can be a good help, because gamification tries to harness the motivational power of games and apply them to real-world problems, in our case, students' motivational problems.

A lot of papers reporting experiences with gamification have appeared in the last years, but the idea of using thought and game mechanics to solve problems is old (Viamonte, 2018). According to Zichermann and Cunningham (2011), was the Scottish philosopher David Hume who first laid the groundwork for understanding the player's motivations at three hundred years ago. But Gamification is not only about introducing game elements, such as the distribution of rewards and medals for a given product, but it requires an in-depth approach to decide which elements will be incorporated and their conformity with the context of the goal. According Gurjanow and Ludwig (2017), prior to implementing game elements, recommend analyzing the projects target group, the conditions and the inherent activities. The result of the analysis is the definition of goals that gamification should achieve. The next step is to design and implement game elements based on the defined goals. Finally, evaluation and monitoring are useful to make further improvements (Gurjanow & Ludwig, 2017).

There is no consensus about gamification, for example, while some authors highlight the following elements of games to be observed in gamification: objective, rules and voluntary participation, Werbach and Hunter define the PBL Triad: Points, Badges, Leaderboards (Franco et al., 2015). But we can see that when we use the 'gamification' in the classroom, some transformations always occur, such as, students who become players, more challenging classes, students working autonomously

and/or in groups and working to earn points, receive medals, achieve the highest scores and enter the leaderboard...

In this work we pretended study the question: Is gamification effective in reducing dropout?

Gamification

According to Iosup and Epema (2014), gamification may have originated in the early-Communist thought and matured in the Soviet era, as a substitute for monetary incentives to perform at work and saw a reemergence in the U.S. in the early 1980s. More recently, in the 2000s gamification received various definitions, and was used with promising results in various curricular and organizational settings. For Espíndola (2014) the gamification is the use of game mechanics and dynamics to engage people, solve problems and improve learning, motivating actions and behaviors in environments outside the context of games.

According to Kapp (2015) gamification is a tool with advantages and disadvantages in different situations and environments. Gamification only uses a few game elements. Learners don't play an entire game from start to finish; they participate in activities that include video or mobile game elements such as earning points, overcoming a challenge or receiving badges for accomplishing tasks.

McGonigal (2011) highlights the following elements of games to be observed in gamification: objective, rules and voluntary participation. Werbach and Hunter (2012) define the PBL Triad (Points, Badges, Leaderboards) as an initial parameter consisting of the following elements: points, medals and rankings. The authors of this work also divided the main elements into three categories, dynamics: constraints (imposed limitations), emotions, narrative, progression and social relation; mechanical - elements that stimulate actions and involve the player: challenges, competition, feedback (performance), randomness, cooperation (teamwork), rewards and victory and components: medals (visual representation), rankings (visual representation of evolution), points (numerical representation), levels of progression, team formation, final challenge, collections and unlocking content after accomplishing the mission. (Viamonte, 2018)

Methodology

In this work we present one gamification experience that we did in a Linear Algebra course. Gamification was used in the students evaluation, and for this the classification were replaced by points that were attributed to the students as they went doing the tasks in the classes or online. The students could have earned points for completing a lesson or for doing extra research about the lesson. At the beginning of the semester, all students had a hundred starting points, and after classes started, all they did or did not, was giving them or taking them points. Each hundred points corresponded to one level and there were twenty levels corresponding to grades from zero to twenty. During the semester there were several evaluation moments, such as Moodle's tests, challenges and individual tests, that corresponded to tasks that the students had to do and there were also some medals or bombs. The medals were rewards attributed to the students for doing certain tasks, such as participating in forums, solving challenges, among others. Obtaining a medal rewarded the student with a predetermined amount of points. The bombs were penalties attributed to the students for not doing

certain required tasks such as homework, Moodle tests, among others. Bombs penalized students by taking a predetermined amount of points from them. One task that was proposed to each student at the end of each topic was the resolution of a problem related with his course and where he needed the concepts he had just learned for his solution. These problems were often suggested by the professors of engineering disciplines. Other component of the evaluation were the Moodle's tests. The students took these tests biweekly and on the weekend. During the semester, the student had to do six tests in Moodle. When he opened the test, the student chose the level he wanted to do, easy or difficult, knowing that the difficult level allowed him to get double the points he could reach with the easy level. But each student had to do at least one test of each level. In each test to perform in Moodle the student always had the possibility to make two attempts, but he knew that his classification in this test was the one obtained in the last attempt. The purpose of allowing two attempts was, when the first attempt had gone wrong, lead the student to reflect on what had not gone well on the first try, so he goes to study or look for information to solve correctly this test. So, when he tried the second time, he would be better prepared to do the test. To force this reflection, between the first and second attempts the student had to wait at least sixty minutes between the two attempts. The second attempt was optional, but if the student chose to do it, it had to be of the same level as the first.

An easy level test involved only operations with real matrices, and a difficult level test involved operations with matrices of complex numbers and matrix properties. A difficult level test could be, for example, the one presented below.

$$1. \text{ If } A = \begin{bmatrix} 1 & i & 0 \\ 1+i & -1 & 1 \\ 2i & 2 & 1 \end{bmatrix}, B = \begin{bmatrix} -i & 1+i & 0 \\ 1 & -i & 2i \\ 2 & 1-i & -2i \end{bmatrix} \text{ and } C = \begin{bmatrix} 2 & -2 & 1 \\ 0 & 1 & 0 \\ 1 & -1 & 0 \end{bmatrix},$$

then $\bar{B} + A^t C$

$$\begin{array}{ll} \ddot{y} \begin{bmatrix} i & 5+2i & 1 \\ 2 & -1+i & 2+i \\ -i & 1-i & -1+2i \end{bmatrix} & \ddot{y} \begin{bmatrix} 2+3i & -2i & 1 \\ 3+2i & -3-i & -i \\ 3 & 1+i & 2i \end{bmatrix} \\ \ddot{y} \begin{bmatrix} 2+3i & -i & 3 \\ 3+i & -3-i & 1+2i \\ 1 & -2i & 2i \end{bmatrix} & \ddot{y} \text{ None of the others is correct.} \end{array}$$

2. The statement:

"If A and B are idempotent and permutable matrices, then AB is also an idempotent matrix."

It's True False

Challenges were another component of evaluation. Each challenge had multiple choice questions related to the subjects taught from the beginning of the semester up to that time and had three levels, easy, medium, and difficult. The students started at the easy level and went up the level. To level up, the student needed to correctly solve all questions at that level. If he missed a question, he would lose a life, but he could try a new challenge of the same level again. At each challenge, the student had three lives that he could use. The final number of points depended on the number of lives he used and the level at which the student arrived. During the semester, the student met three challenges.

In the easiest level the students needed to do 3 questions that were about the subjects taught in the class. In the medium level the students needed to do 2 questions that were about the subjects taught in this class but related to a subject taught in another class of the same year and the same course. And in the difficult level the students needed to do 2 questions that were related with another subject. As they were students of Electrotechnical Engineering, a question of the medium level was, for example the one presented below.

1. Consider the electrical circuit shown in Figure 1.

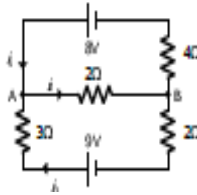


Figure 1: electrical circuit

The potential difference between the battery terminals, measured in volts (V), produces a current that leaves the positive pole of the battery (indicated by the side containing the longest vertical line). The capital letters represent the nodes of the electric circuit.

The letter i represents the current between the nodes and the arrows indicate the direction of flow, but if i is negative then the current flows in the opposite direction to the indicated one. The currents are measured in amperes and the resistors in ohms.

Based on Kirchoff's laws for electrical circuits, determine the currents in the meshes.

During the semester students performed 2 individual exams, the first in the middle of the semester and the second at the end of the semester, but with the gamification, exams were the biggest missions to perform. The grades were the result of the number of points earned through the accomplishment of the missions, and two types of missions were planned: individual and group. Students could choose to do the challenges individually or in groups. If they chose to do as a group, the group would be chosen by them, would have between 3 and 5 students and all the challenges in the semester would have to be made by the same group. Thus, each student earned points based on their individual performance and the performance of his group, which stimulated the collaborative character of the process. Each group had good and weak students and it was noted that the best students were pulling the weak so that the group performed well. Group tasks generally involved group competitions, which potentiated the competitive side of the games, but interacted with the cooperative aspect because each group functioned as a whole. A list of activities to be carried out was published weekly in Moodle and this list also indicated the medals available this week and what students would have to do to reach them. It was also published weekly in the Moodle the Leadership Chart in the form of a list, arranged in descending order of number of points, indicating the points of each student and the level of each student, and were highlighted the students placed in the first 15 places. There was a lot of competition and it was also discovered that the students made a great effort to be in the first places of the list.

At the end of the semester, students completed an inquiry into the use of gamification and how they felt in the game. The questionnaire, which was answered anonymously and via Moodle, was

developed with open and closed questions and aimed to collect data to identify a brief profile of the participants. It was intended to listen to students' opinions about the advantages and disadvantages they felt about motivation and learning.

Results

We worked with all students enrolled in the first year of the first semester of this engineering course (two hundred and ninety-four). As for sex, as one would expect in an Electrotechnical Engineering course, the majority were men, two hundred and seventy-four (93%) and only twenty (7%) of these students were women.

When gamification was introduced, classes became a more challenging experience due to the new method used. For each class in which the student was present and participated, the student earned a small amount of points until reaching the maximum stipulated, there being a large increase in the number of classes that each student went. Traditionally, in mathematics subjects from the first years of an engineering course, the percentage of students per class is small, principally in theoretical classes, this year there was a considerable increase of student's number in theoretical and practical classes. We also found that this year the rate of students who dropped out was much lower than in previous years as can be seen in Figure 2.

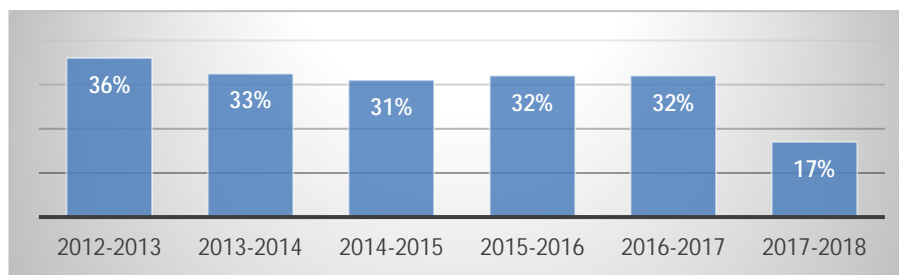


Figure 2: percentage of students who dropped out in the last years

As they wanted to “win” the game, winning all possible medals, overcoming all the challenges to reach the last level, they worked harder during the semester and this was reflected in the learning and consequently the Final Approval Rate. The percentage of students leaving the course was very low (17%) compared to usual in previous years (31% to 36%) and the rate of failed students was also lower (33%).

The survey to listen to students' opinions about the advantages and disadvantages was answered by most students (97%) and 95% said they were more motivated and worked harder, which was reflected in the average frequency and passing rate. Of the students who answered, 38% considered the experience of using gamification excellent, 42% very good and 20% good. Although some students said that the gamification experience was very laborious, none of them rated it as bad or very bad, see Figure 3.

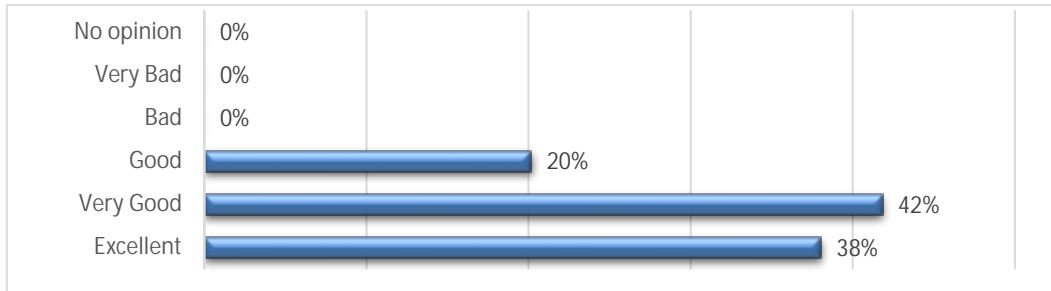


Figure 3: The feeling about gamification experience

In the questionnaire that was placed in Moodle at the end of the semester, the last question asked each student to identify which were in their opinion the positive and negative aspects of the gamification experience that they had done. The positive points more presented were

- § motivation and stimulation of learning;
- § playful and dynamic way of learning;
- § self-improvement and persistence.

And negative points more presented were

- § harder than in previous years;
- § over-competitiveness;
- § mechanization: the student plays for playing and not for learning.

In this questionnaire they were placed other following questions:

Q2 - Which type of evaluation do you prefer

Q3 - Gamification was useful for my learning

Q4 - The gamification didn't help me anything

Q5 - The gamification helped me in studying

Q6 - The gamification didn't promote my self-motivation

According their opinion the students filled for Q2 (only assessment, assessment with gamification) and for remain questions they filled (Strongly agree, Agree, Neither agree nor disagree, Disagree, Strongly disagree).

In order to verify the effect of type of evaluation, we performed a Chi-square test who revealed significant difference between two categories from question 2, as shown in table below by p-values results ($<0.05^*$ and 0.01^{**})

	Q3	Q4	Q5	Q6
Q2	0.010*	0.016*	0.002**	0.008**

Table 1: The effect of type of evaluation

The gamification had a significant contribution in motivation for doing the assessment. We detail in below the process. We assigned 100 points to each student at the beginning of the gamification process. The students had been subjected at 7 moments of evaluation corresponding to 6 moments to

Moodle actions and the other one, on the first assessment. The scores obtained by students had also a significant performance along the process of gamification.

We observed a great enthusiasm between at the beginning of the process, showed by graph, figure 4. Until the 3rd moment (before the first assessment) these good results went on, but the remains didn't give the previous impression. We observed some outliers in some moments, explained by the penalties according to the rules of the game. The outlier's presence caused a negative impact in general results which provoked the existence of significant mean differences as we can observe in Table 2.

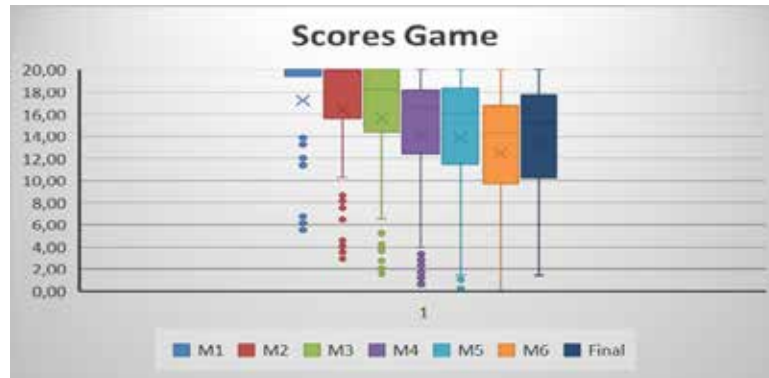


Figure 4: Scores Game

	M1	M2	M3	M4	M5	M6	Final
Mean	17.21	16.43	15.69	14.20	13.90	12.54	13.45
S.d.	0.30	0.33	0.33	0.33	0.34	0.33	0.31

Table 2: Means of Scores Game

The table above show difference significant between all moment's means (t-test, $p < 0.001$). We observed higher results at the first three moments followed by a significant break in four last moments. However, the variability has not suffered a significant changing along the gamification process.

Conclusion

During this semester, we realized that the elements of the game are valuable tools, but we need to use them with care and knowledge to get the expected results. Nowadays, most people play electronic games, so games have a strong psychological effect on people's behavior. Gamification becomes then a valid alternative to arouse emotions and, particularly in education, the gamification contributes to the student's motivation during the execution of tasks. In the learning scenario, this proposal allows a more active and practical participation of the students. But to obtain its potential benefits and reduce the risk of the student to be interested only extrinsically by the approach, aiming only rewards, fun and entertainment. It is necessary to plan the educational objectives, discuss the strategies to be used and analyze the experiences already promoted. In this work we did not do a quantitative approach because it is not possible to compare the results of this year's educational success with those of previous years because the students are different, and it is also difficult to compare with the results of other curricular units of same year because the degree difficulty is also different. To use a

quantitative approach, we would have to have a test group to make comparisons and this was not possible. However, in this semester the dropout rate was low, and the students were very involved in the classes and in the activities of the curricular unit. These facts may indicate that the impact of gamification on learning has been successful.

The positive and negative points pointed out by the students at the end of the semester were very interesting, presenting diverse and yet very coherent opinions. The listed positive points outweighed the negative ones, with motivation being a very prominent aspect. They found too the applying problems difficult but interesting as they helped them to better understand the usefulness of learning mathematics in an engineering course. The main negative point presented by the students was the fact that the curricular unit this semester was more work, which in our opinion is not negative, and was reflected in the good approval rate. Although evaluating activities as laborious, students reported feeling more motivated and interested and it may be noted that no student considered this experience to be bad or very bad.

References

- Espíndola, R. (2014). O que é a gamificação e como ela funciona? Paper retrieved from <https://www.edools.com/o-que-e-gamificacao/>
- Franco, P. M., Ferreira, R. K. R. and Batista, S. C. F. (2015). Gamificação na Educação: Considerações Sobre o Uso Pedagógico de Estratégias de Games, *Congresso Integrado da Tecnologia da Informação*. Paper retrieved from file:///C:/Users/ajv/Downloads/6950-18869-1-SM%20(1).pdf
- Gurjanow, I. and Ludwig, M. (2017). Gamifying math trails with the Mathcitymap app: Impact of points and leaderboard on intrinsic motivation. *Proceedings ICTMT13*. Paper retrieved from <file:///C:/Users/Utilizador/Downloads/proceedings ICTMT13.pdf>
- Iosup, A. and Epema D. H. J. (2014). An experience report on using gamification in technical higher education. *The 45th {ACM} Technical Symposium on Computer Science Education*, IEEE, p- 27-32.
- Kapp, K. (2015). Gamification: Separating fact from fiction. Paper retrieved from [http://ww.w.cedma-europe.org/newsletter%20articles/Clomedia/Gamification%20-%20Separating%20Fact%20from%20Fiction%20\(Mar%202014\).pdf](http://ww.w.cedma-europe.org/newsletter%20articles/Clomedia/Gamification%20-%20Separating%20Fact%20from%20Fiction%20(Mar%202014).pdf)
- Viamonte, A. J. (2016). Uma experiência de avaliação e aprendizagem com moodle. In F. Remião, J. F. Oliveira, L. Castro, M. A. Ferreira, P. R. Pinto, R. Cadima, *CNaPPES.16 Proceedings*, 481-488.
- Viamonte, A. J. (2018). A gamification experience in a class of a degree in engineering. In K. Tyner & C. Costa (Eds.). *Play2Learn Proceedings*, 243–261.
- Zichermann, G. and Cunningham, C. (2011). Gamification by design: Implementing game mechanics in web and mobile apps. O'Reilly Media. Paper retrieved from <http://storage.libre.life/Gamification by Design.pdf>

Complex Modeling: Insights into our body through computer tomography – perspectives of a project day on inverse problems

Kirsten Wohak¹ and Martin Frank²

Karlsruhe Institute of Technology, Steinbuch Centre for Computing, Germany;

¹wohak@kit.edu, ²martin.frank@kit.edu

How does an autonomous vehicle recognize a traffic sign? How can seismic measurements be used to determine the origin of an earthquake? How do you get a three-dimensional tomographic reconstruction of a body part from a medical scanner? The methods used to answer all these questions come from the field of so-called inverse problems and are central to our society. They are omnipresent in technology, science and in everyday life and include mathematics without any people being aware. The process of mathematical modeling is used to solve inverse problems. Complex problems are simplified in such a way that mathematical models are developed and then accurate solutions can be calculated. The question now arises as to whether high school students are able to independently and accurately solve these kind of questions while only using their mathematical school knowledge and the computer. An approach to show how this could be done is given in this paper.

Keywords: High school mathematics, inverse problems, mathematical modeling, MATLAB, problem-solving.

Introduction

When taking a look at maths classes in school you often find students asking: “Why do I need to study this?” Schoolbooks are very method-oriented which has the effect that students can use certain algorithms and formulas but do not recognize the usefulness of mathematics for everyday life. This is why the development of interactive, problem-oriented material for high school students should be increased. Using this kind of material as an addition to the existing units students see the potential of mathematics to solve real life problems¹.

The project presented here will be part of the CAMMP (Computational and mathematical modeling program) project of the Karlsruhe Institute of Technology² and the RWTH in Aachen³. For several years, similar projects have been carried out in one-week and one-day formats with students of different ages in Aachen (One example can be found in Greefrath & Siller, 2018, p. 137-163). Until now over 400 students have participated in a modeling week and over 2900 in a modeling day. Since the beginning of 2018 the project is also being realized in Karlsruhe.

CAMMP wants to offer ways to innovative mathematics teaching in terms of content, didactics and methodology. Concepts for this were developed and tested. CAMMP is not only involved in mathematical modelling projects with pupils and teachers, but also in research and teaching in the

¹ We understand the word problems in the sense of Heinrich, Bruder and Bauer (2015).

² <http://www.scc.kit.edu/forschung/CAMMP>

³ <https://blog.rwth-aachen.de/cammp/>

field of mathematical modelling didactics. The goal is a didactics of problem-oriented mathematical research, in particular a creative handling of mathematics. Tasks and projects are always as problem-oriented as possible and actively dealt with by the students. Adapted to the given framework conditions (e.g. modeling week, -day, regular school lessons), innovative concepts are developed to balance the dimensions active-passive and method-oriented⁴ problem-oriented.

These projects are needed because a change in teaching mathematics must take place. Many graduated students do not know a lot about mathematical modeling even though it is one of the process-related competencies of the core curriculum. And according to the educational standards of the Conference of Education Ministers, all students should be able to model mathematically by the end of their school career. That means they should be able to go through the elementary steps of the mathematical modeling cycle independently (Kultusministerkonferenz der Länder in der Bundesrepublik, 2012). Real life is not about calculating as much as possible to exercise a certain algorithm (Maaß, 2015, p. 70). Mathematics should not be used for its own sake, but rather as a tool for solving problems (Consortium for Mathematics and Its Applications, 2016). It is clear that the necessary competence for the creation of models can only be built up if the pupils carry out their own modeling independently and regularly during their school years (Maaß, 2011, p. 8). However, modeling is new and unknown to many teachers and learners. Each step of the modeling cycle represents a cognitive hurdle for the students (Heiliö & Pohjolainen 2016). On the one hand they find it difficult to understand the real situation, on the other they expect teachers to evaluate the correctness of their solution, neglecting the validation step. If teachers face each of these challenges, studies have shown that the treatment of authentic modelling has a significant positive impact on their opinion of mathematics (Borromeo Ferri, Greefrath & Kaiser (Hrsg.), 2013, p. 30-34).

The project presented in this paper makes an important contribution to developing interactive, problem-oriented material by presenting a way to include computer tomography as an example of inverse problems into maths classes. It shows that the abilities of students should not be underestimated. The basics needed to understand inverse problems are already taught during school mathematics.

Inverse problems in school and everyday life

When having a look at cause-effect relationships one can either calculate the effect with given causes or turn the problem around and draw conclusions from given effects on the cause. If you have a look at image processing you can ask yourself what a clear image would look like if the camera were focused incorrectly. When turning the problem around you get the inverse problem, which means trying to deblur an image that was taken by an incorrectly focused camera. In both cases you have to solve a system of equations, but in mathematics there is a difference between the equations you use for the two problems. In real life you never have flawless data, which means that by using some kind of measuring tool you get errors in your data. If the error stays in the same magnitude while computing

⁴ By method-oriented we mean the application and practice of mathematical methods to solve purely mathematical problems without reference to application. In the problem-oriented treatment of tasks, certain mathematical methods are only applied when they are needed to solve a real extra-mathematical problem (Heinrich, Bruder & Bauer. 2015).

the solution, everything is perfectly fine. However, what happens if a tiny error in the given data leads to enormous errors in the solution?

These problems are so called ill-posed inverse problems. Jaques Hadamard described three conditions through which one can determine whether the problem at hand is well or ill-posed (Engl, Hanke & Neubauer, 2000, p. 31): There must be at least one solution (existence). There may be no more than one solution (uniqueness). The solution must depend continuously on the data (stability).

At the moment schools mainly deal with tasks in which direct problems occur. Data is presented and a function must be applied to it. This means that you start with the cause and calculate the consequence (Lasanen, 2014). This type of task only requires students to perform prescribed operations. Students are therefore often limited in their mathematical thinking (Gardiner, 2016). In the long term, however, the inverse problems are important, since through them students learn to work more freely, flexibly, playfully and application-oriented with the mathematics they have learned (Gardiner, 2016). From the teacher's point of view it is more challenging to discuss inverse problems in school because the approaches of students to inverse problems are far more open and are therefore not well predictable. These open tasks make it more difficult to have a joint discussion in class since there are many different calculations that lead to a correct solution. On top inverse problems are a lot more complex to grade in an exam. Eventually, due to the lack of discussion, confrontation and exercise, students achieve results a lot worse when having to solve inverse problems than when dealing with direct problems (Gardiner, 2016). Thus to prepare their students and give them the opportunity to think freely in terms of mathematics, teachers should include more inverse problems into their classes especially ones that are similar to the one presented in the following.

Perspectives of a project day about computer tomography

The aim of the project day for one is to show the working principle of computer tomography, but moreover it should also show the relevance of mathematics and simulation sciences in society in general. The students should realize that already with their knowledge they can understand and compute the basic methods behind complex processes. The material is formulated in a way that different approaches are possible and welcome. By using the software MATLAB the requirements regarding programming are set very low. The students are given a prepared code in the form of a gap text in which they only have to enter missing formulas or equations, which are then checked as they run the code. This means that students receive feedback on their considerations at all times. On top it is possible to include worksheets into MATLAB, so that the surface looks rather like a digital working sheet with code lines in between than a programming software. Through all of this, one hope of the developer is that students become more involved with mathematics.

Computer tomography

For computer tomography, the internal structure of an object is determined depending on the entry and exit intensity of the X-ray radiation and conclusively depicted (Grumme, Kluge, Lange, Meese & Ringel, 1988). The objects are irradiated with parallel beams at different fixed angle settings to determine the absorption coefficients $f(x_1, x_2)$ of the different materials of the object (Mueller & Siltanen, 2012). Depending on the material the intensity of the incoming X-ray beam decreases differently. Thus, the out coming intensity depends on the absorption property $f(x_1, x_2)$ but also on

the layer thickness z of the material through which the X-ray beam passes. If a single layer is penetrated by a beam with the intensity I_0 , the output intensity is calculated by the following equation:

$$I(z) = I_0 \cdot \exp(-f(x_1, x_2) \cdot z).$$

With the help of the a transformation, the parallel beams passing through the object are described mathematically as straight lines. By doing so, the function that was originally dependent on the Cartesian coordinates x_1 and x_2 is transformed so that the function is now described along a straight line with the angle θ and the distance to the origin s (see Figure 1). The points lying on the beams are described with $\vec{x} \cdot \vec{\theta} = s$, with $\vec{\theta} = \begin{pmatrix} \cos(\theta) \\ \sin(\theta) \end{pmatrix}$.

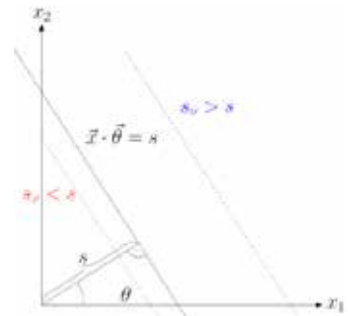


Figure 1: Illustration of the radon transformation

If you now look at different distances s_v from the line to the origin, the straight line moves to the right for $s_v > s$ (see Figure 1, blue line) and to the left for $s_v < s$ (see Figure 1, red line). This is of great importance since an object gets scanned by parallel beams. So the mathematical model also has to include several beams with a constant distance between one another. In addition, the X-ray tube is rotated around the object so that the beams are sent through the object at different angles. Due to the symmetry, it is sufficient to only look at the angles between 0° and 180° and therefore only to run a semicircle. Considering both factors one gets $N \cdot J$ beams and therefore $N \cdot J$ equations in total when having N parallel beams and J angle positions.

Assumptions and simplifications

Before the students establish a system of equations and have a look at its solubility and the reconstructed inner structure of the scanned object, simplifications must be made. Strictly speaking, an object, like a human body, consists of an infinite number of different absorption coefficients. For a first model however, it firstly is sufficient to approximate the cross-section of an object as a square and secondly to allow only a small number of different absorption coefficients. The idea is to cut the square into smaller squares called pixels and to assume that each pixel only consists of one particular material and therefore only has one absorption coefficient f_i , see Figure 2. In addition, the absorption law is simplified. Instead of looking at the influences of the absorption coefficients, where the integral would have to be used, the object is described by gray values and these are weighted and added along one beam. Thus, the measured values, depicted as m_i with $i = 1, \dots, 5$ in Figure 2, do not represent intensities but simply weighted and added gray values f_i , $i = 1, \dots, 4$, which must be correctly distributed to the respective pixels for the reconstruction of the object.

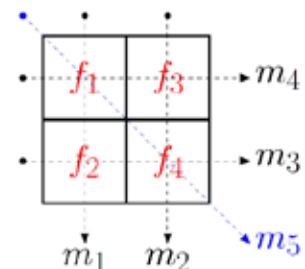


Figure 2: Five beams through four pixels

Worksheet 1: First radiography of a simplified object

With the first worksheet the students get familiar with what actually happens during computer tomography. The students start into the task, where they try to reconstruct the gray values of the pixels for the first time. Because of the simplifications and assumptions that were made beforehand the students have a first impression of how the gray values of the pixels can be reconstructed, namely simply to solve a linear system of equations. So the students are given four values for m_i with $i =$

1, ..., 4. By doing so a lot of questions arise: Can numerical values for the pixels be found so that the row and column sums are satisfied? If there are such entries, how are they determined and can they be determined in a unique way? If they do not exist, why not?

With the help of these questions, the students can independently work out the conditions of the concepts of existence and uniqueness and work out connections for solubility. They notice that with these values they do not have enough information to uniquely determine the gray values for the reconstruction of the object even though the students have four equations and four variables. The solution is not unique because the equations are not linearly independent. This first approximation to the mathematical description of the problem is done without formulas but instead using examples of possible gray values that the pixels could have with the given values m_i . Students should find a gray scale distribution and then either by comparing their own solution with other groups of students or by realizing mathematical considerations recognize that their distribution is not a unique solution. After this realization, the students are faced with the challenge of extending the problem in such a way that the gray values of the pixels can be explicitly solved. To do this, they must transmit a further beam through the object and determine the measured values of these new beams. For example it is possible to add a diagonal beam (see Figure 2), which leads to the system of equations (1) which has a unique solution.

$$\begin{pmatrix} m_1 \\ m_2 \\ m_3 \\ m_4 \\ m_5 \end{pmatrix} = \begin{pmatrix} 1 & 1 & 0 & 0 \\ 0 & 0 & 1 & 1 \\ 1 & 0 & 1 & 0 \\ 0 & 1 & 0 & 1 \\ \sqrt{2} & 0 & 0 & \sqrt{2} \end{pmatrix} \cdot \begin{pmatrix} f_1 \\ f_2 \\ f_3 \\ f_4 \end{pmatrix} \quad (1)$$

When you increase the number of pixels you keep having the same problem. Looking at the object subdivided into nine pixels (see Figure 3) it is again not enough to send nine beams through the object. The problem why this system of equations also is not uniquely solvable is that you only have eight linearly independent equations. So even more beams have to be used. Since the system of equations keeps growing it makes sense to write an algorithm that describes the beams mathematically and creates the matrix one needs to solve the system of equations. At this point of the project the algorithm can be developed, as the students have now completely penetrated the problem. In addition, the number of equations is still manageable, which also means that drawings of the object and the beams can be made without being confusing. This way errors and new solutions can be found more easily.

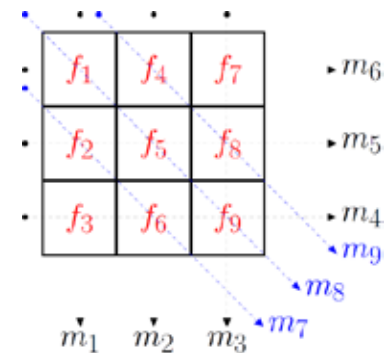


Figure 3: Nine beams through nine pixels

Worksheet 2: Mathematical description of the beams

The main goal of this worksheet is to find a mathematical model to describe the beams more generally for any number of parallel beams and angle settings, since so far the students only had the situation shown in Figure 3. The idea is to describe the beams as straight lines in \mathbb{R}^2 and then come up with an algorithm that calculates the length that a beam spends in each pixel. The last important step then is to not only get the individual lengths but to know where in the matrix the value has to be written.

For this task the students get the starting vectors $(X_{1,s} \ X_{2,s})^T$ of the points where the beams enter the object including the value of the associated angle θ for a given number of parallel beams and different angles. The standardized direction of the beam is described through the vector $\vec{r} = \begin{pmatrix} \cos(\theta) \\ \sin(\theta) \end{pmatrix}$.

Therefore the beam itself can be described as $\begin{pmatrix} X_1 \\ X_2 \end{pmatrix} = \begin{pmatrix} X_{1,s} \\ X_{2,s} \end{pmatrix} + s \cdot \begin{pmatrix} \cos(\theta) \\ \sin(\theta) \end{pmatrix}$. Students know this way of writing straight line equations from school. Nevertheless, help cards are also available to the students as support, since they may have difficulties, for example, with the use of the cosine and sine.

The points of interest are always those where either the x_1 or x_2 coordinates are equal to one of the pixel borders, namely $-1.5, -0.5, 0.5$ or 1.5 (see Figure 3). Thus to determine the interceptions the equation for the beam needs to be separated coordinate wise and solved for $s = \begin{pmatrix} s_1 \\ s_2 \end{pmatrix}$:

$$s_1 = \frac{X_1 - X_{1,s}}{\cos(\theta)}, \quad s_2 = \frac{X_2 - X_{2,s}}{\sin(\theta)}.$$

Again at this point the students have the possibility of using help cards, since they have to think of separating the coordinates and solving the equations. Some students have difficulties with deformation calculation steps. As feedback and an output of MATLAB the students get a depiction of their description of the beams through the object, so that they themselves can see whether the result seems to be consistent.

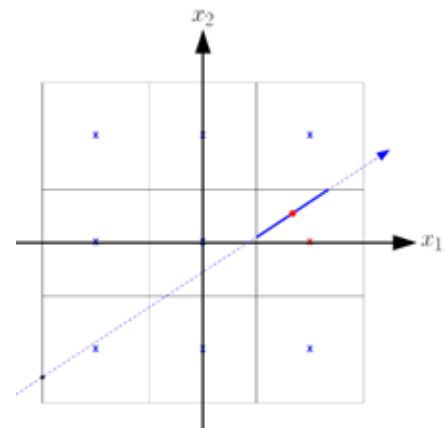


Figure 4: Illustration of the pixel number determination

Once the students achieved this task they can easily calculate the length between two neighboring interceptions which is the length a beam spends in a pixel. The hard part is to figure out in which column and row of the matrix the length has to be written. One approach is to calculate the distance between the center of the pixels and the middle of the considered distance (see Figure 4). The center to which the distance is smallest is the pixel in which the beam spends the particular length. A second approach would be to have a look at the x_1 or x_2 coordinates of both interception points. After having numbered the pixels and defined the possible values for the x_1 and x_2 one can check to which both points belong and therefore determine the pixel number. While defining the pixels you have to include the border of the pixels each time.

Worksheet 3: Reconstruction of an object

After this mathematical model for the beams the students get the chance to reconstruct an image such as the first one in Figure 5. To get this first reconstruction the students have to find the gray values f_i so that the difference between $A \cdot \vec{f}$ and the measured values get minimized. To make it a little less complicated for the students they calculate with a small matrix A and small vectors \vec{f} and \vec{m} :

$$h(\vec{f}) = \|A \cdot \vec{f} - \vec{m}\|^2 = (A_{1,1} \cdot f_1 + A_{1,2} \cdot f_2 - m_1)^2 + (A_{2,1} \cdot f_1 + A_{2,2} \cdot f_2 - m_2)^2$$

From school they know that they have to differentiate $h(\vec{f})$ after f_1 and f_2 which leads the students to the gradient of $h(\vec{f})$. They then have to set the gradient to zero to find the \vec{f} that minimizes the equation:

$$\nabla_{\vec{f}} h(\vec{f}) = 2 \cdot A^T \cdot A \cdot \vec{f} - 2A^T \cdot \vec{m} = 0.$$

The formula that results for the gray values that is, when multiplied with A , closest to the measured data, is the following:

$$\vec{f} = (A^T \cdot A)^{-1} \cdot A^T \cdot \vec{m}$$

If one uses data without errors the reconstruction is perfect. However, using flawless data does not depict reality. Every measuring device creates some kind of error so that you have to use data with a small error. Besides that in reality the scanned objects consist of more than nine different materials and therefore more than nine different absorption coefficients or in our case gray values. So on top of adding noise one has to increase the number of rows and columns in the object, which also leads to a higher number of parallel beams and more angles. If one adds 5 % noise one can already no longer recognize the original object (see Figure 5, picture 3). This is due to the fact that the problem is not stable since the matrices are singular and therefore badly conditioned. Thus the problem has to be slightly modified, so that one gets a more stable problem. This can be achieved by different mathematical methods which deliver results that come very close to the original picture (see Figure 5, picture 4 and 5).

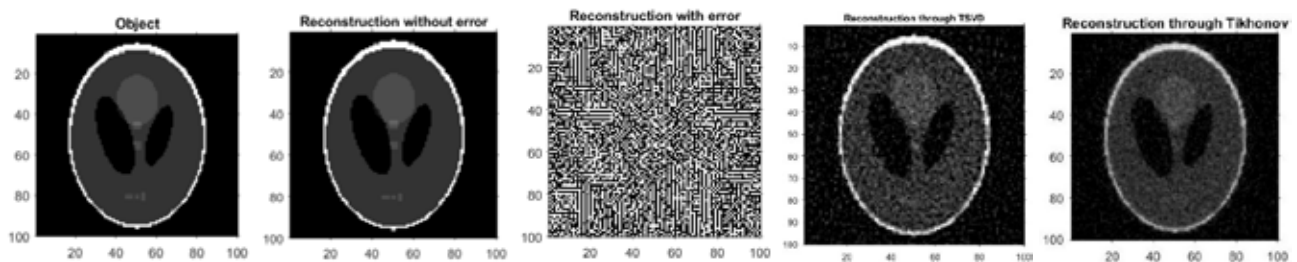


Figure 5: The object and different forms of reconstructions with 5 % noise

The aim is that the students should be guided as little as possible during the project. It would be optimal if they could independently develop a method to improve the reconstruction. At the moment this seems very hard to achieve but will be improved once the project has been realized with students.

Outlook

In the future, the existing material will be realized with high school students. Furthermore the workshop will be evaluated in order to assess what the students learned and how the material could be changed. The material will then be iteratively improved. Moreover material will be developed so that the implementation of the project can be adapted to school hours and thus be carried out in units. In addition, a draft of the described problem for an exam task will be developed.

In conclusion this project shows a possibility to treat authentic and relevant problems with the help of mathematical modeling in such a way that students are not only able to understand them but can also solve these. This should show that it is also possible to treat modelling competence in such open questions at school. The students' knowledge of mathematics is sufficient to understand the basics of

these problems from their everyday life. This example should encourage teachers to address more complex problems in class in order to train and further develop their students' mathematical modeling skills. For example, parts of this workshop can be incorporated into the classroom, allowing students to directly see an authentic application of mathematics.

References

- Borromeo Ferri, R., Greefrath, G. & Kaiser, G. (Hrsg.) (2013). *Mathematisches Modellieren für Schule und Hochschule, Theoretische und didaktische Hintergründe*. Wiesbaden: Springer Spektrum.
- Consortium for Mathematics and Its Applications (2016). *GAIMME – Guidelines for assessment & instruction in mathematical modeling education*. United States of America: SiIAM.
- Engl, H. W., Hanke, M. & Neubauer, A. (2000). *Regularization of inverse problems*. Dordrecht, Netherlands: Kluwer Academic Publishers.
- Gardiner, T. (2016). *Teaching mathematics at secondary level*. Cambridge, UK: Open Book Publishers.
- Greefrath, G. & Siller, H.-S. (2018). *Digitale Werkzeuge, Simulationen und mathematisches Modellieren. Didaktische Hintergründe und Erfahrungen aus der Praxis*. Wiesbaden: Springer Spektrum.
- Grumme, T., Kluge, W., Lange, S., Meese, W. & Ringel, K. (1988). *Zerebrale und spinale Computertomographie*. Berlin: Schering AG.
- Heiliö, M. & Pohjolainen, S. (2016). Introduction. In: Pohjolainen, S. (Ed.) *Mathematical modelling*. Switzerland: Springer.
- Heinrich, F., Bruder, R., & Bauer, C. (2015). *Handbuch der Mathematikdidaktik. Problemlösen lernen*. Berlin: Springer Verlag.
- Heitzer, J. (2012). *Orthogonalität und Approximation: Vom Lotfällen bis zum JPEG-Format, Von der Schulmathematik zu modernen Anwendungen*. Wiesbaden: Springer Spektrum.
- Kultusministerkonferenz der Länder in der Bundesrepublik (2012). *Bildungsstandards im Fach Mathematik für die Allgemeine Hochschulreife*. München: Wolters Kluwer.
- Lasanen, S. (2014). *Introduction to inverse problems*. Unpublished lecture notes. Retrieved from: http://cc.oulu.fi/~smaenpaa/inv_pk/inv_pk14_eng.pdf
- Maaß, J. (2015). *Modellieren in der Schule – Ein Lernbuch zu Theorie und Praxis des realitätsbezogenen Mathematikunterrichts*. Münster: Verlag für wissenschaftliche Texte und Medien.
- Maaß, K. (2011). *Mathematisches Modellieren – Aufgaben für die Sekundarstufe I*. Berlin: Cornelson Scriptor.
- Mueller, J. L. & Siltanen, S. (2012). *Inverse problems with practical applications*. Philadelphia: Society for Industrial and Applied Mathematics Philadelphia.